



**MITSUBISHI
ELECTRIC**

Changes for the Better

NUMERICAL CONTROL (CNC)
C70 Series



C70 MITSUBISHI CNC
Series



iQ Platform

MITSUBISHI iQ Platform-compatible CNC C70 offers the maximum-scale TCO reduction effects to manufacturing sites by taking advantage of MELSEC's great convenience.

Provides the maximum-scale TCO reduction effects.
(TCO : Total Cost of Ownership)

Advancement

provides the products equipped with the latest technologies.

Reliability

provides the proven product groups.



C70 MITSUBISHI CNC Series

iQ Platform

Continuity

provides the services matching users' life cycle.

C70 MITSUBISHI CNC Series

Manufacturing technologies (production site)

Enhanced productivity

- Reduced tact time ▶ High-speed control shortens tact time P 7
- Operation efficiency enhancement ▶ Stable productivity through automation P10

Maintenance

Shortened downtime

- Early identification of failure causes ▶ Enhanced diagnostic functions enable failure causes to be identified early P11
- Elimination of failure causes ▶ Reduction of failure rate by eliminating causes P12
- Reduction of maintenance cost ▶ Reduction of maintenance cost through efficient parts replacement P12

Design and Development

Shortened design and development period

- Streamlined design and development ▶ Streamlined design and development through subdivision and structuring of programs P13
- Unification of development software (environment) ▶ Create machine operation panel screen, CNC monitor screen and ladder edit screen in one development environment (GT Works3) P13
- Various modules suitable for each purpose/function ▶ Flexible system configurations P14

Safety and Energy-savings

Aiming for no accidents/defects, Environmental protection

- Conformity with safety standards ▶ Highly reliable safety observation function which conforms to the European safety standard EN ISO 13849-1 PL d P15
- Energy-savings ▶ Energy-savings with a high-efficiency spindle motor, servo motor and drive unit P16
- Maximization of productivity ▶ Mitsubishi Electric's FA expertise fully supports the manufacturing floor P16

C70 system configuration	P 5	Warranty	P20
Software Tools	P17	List of Components	P21
Case study	P19	Specifications	P23

* This catalog contains optional specifications.
Please refer to the list of functional specifications and the specification manual for details.

Manufacturing technologies (production site)

Maintenance

Design and Development

Safety and Energy-savings

High-performance controllers enable optimization of diverse production processes on shop floors.

■ iQ Platform is the integration platform.

iQ stands for
 "integrated Q",
 "improved Quality",
 "intelligent & Quick" and
 "innovation & Quest".

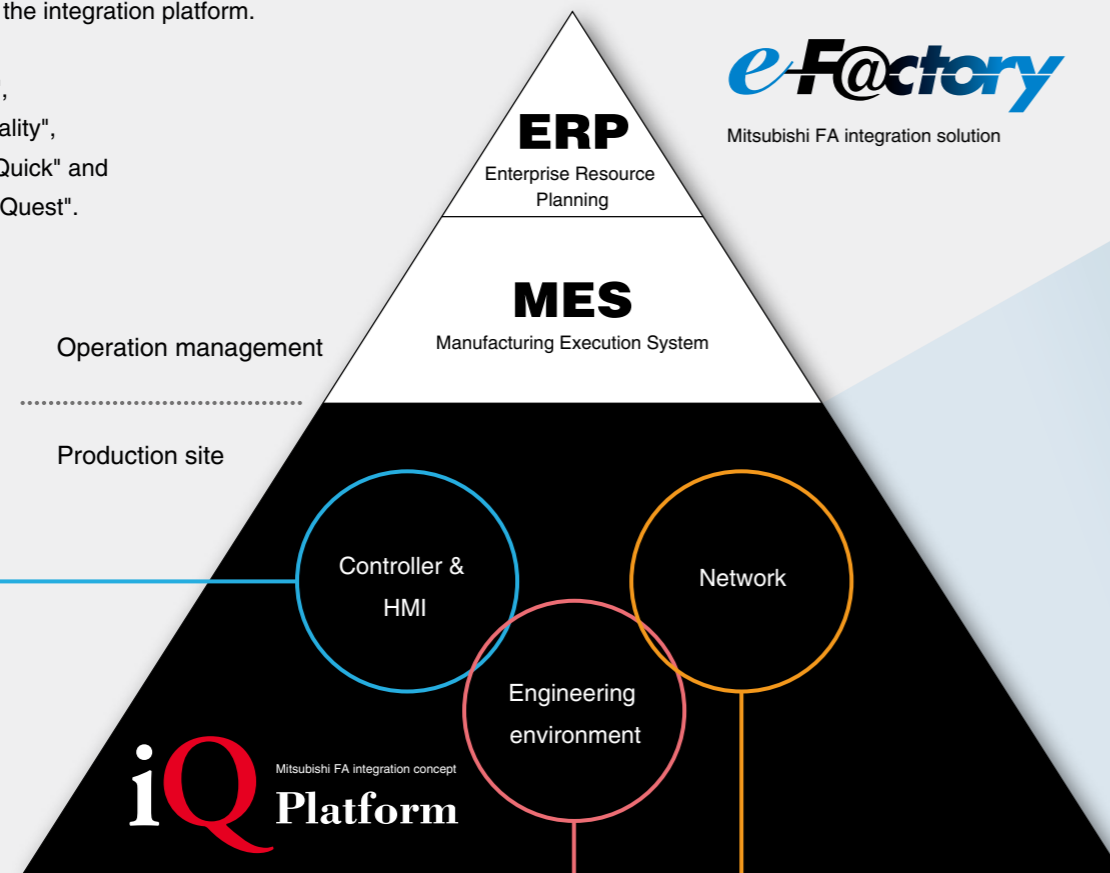

Mitsubishi Electric helps optimize customers' production lines with the iQ Platform.

■ iQ Platform enables construction of optimal systems for diverse lines.

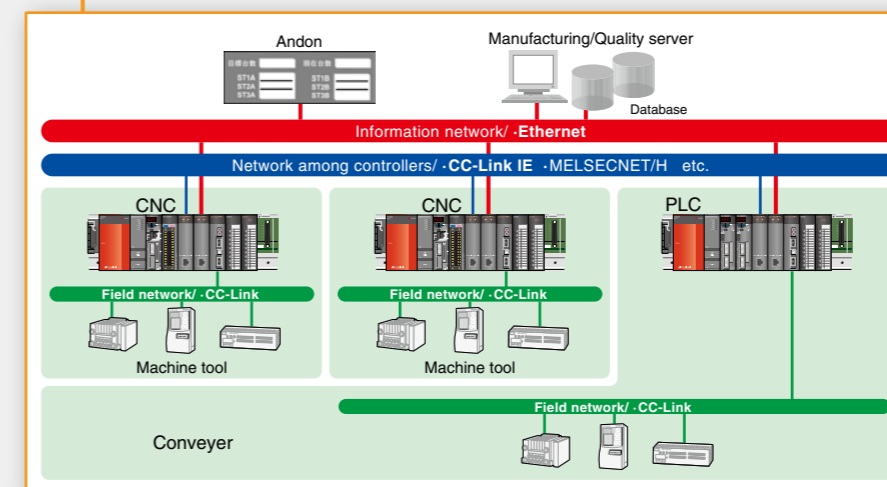
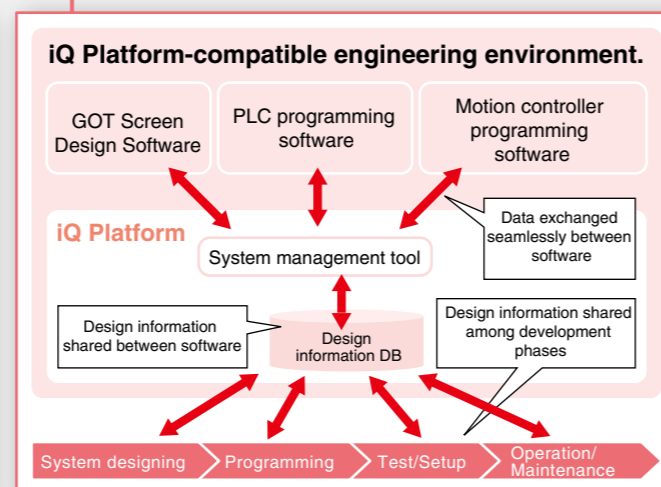
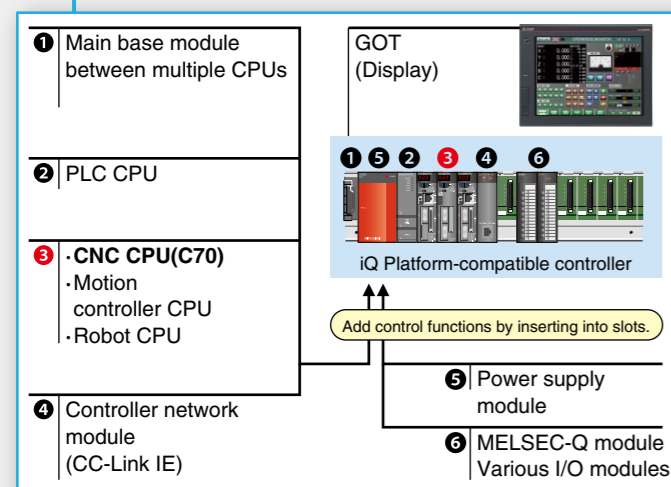
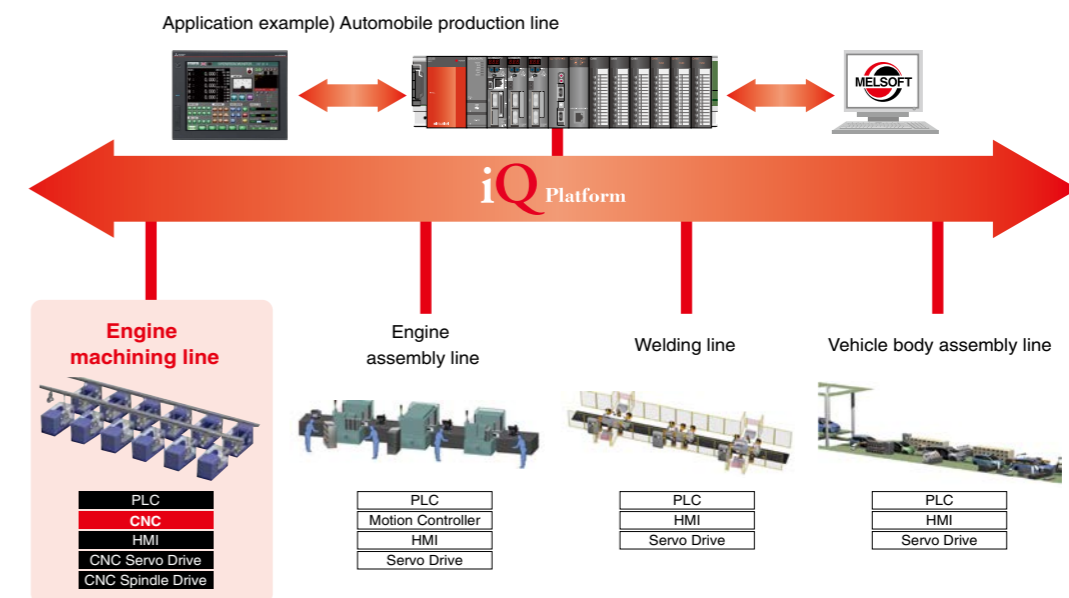

A compact module equipped with CNC functions that can control up to 7 part systems and 16 axes.

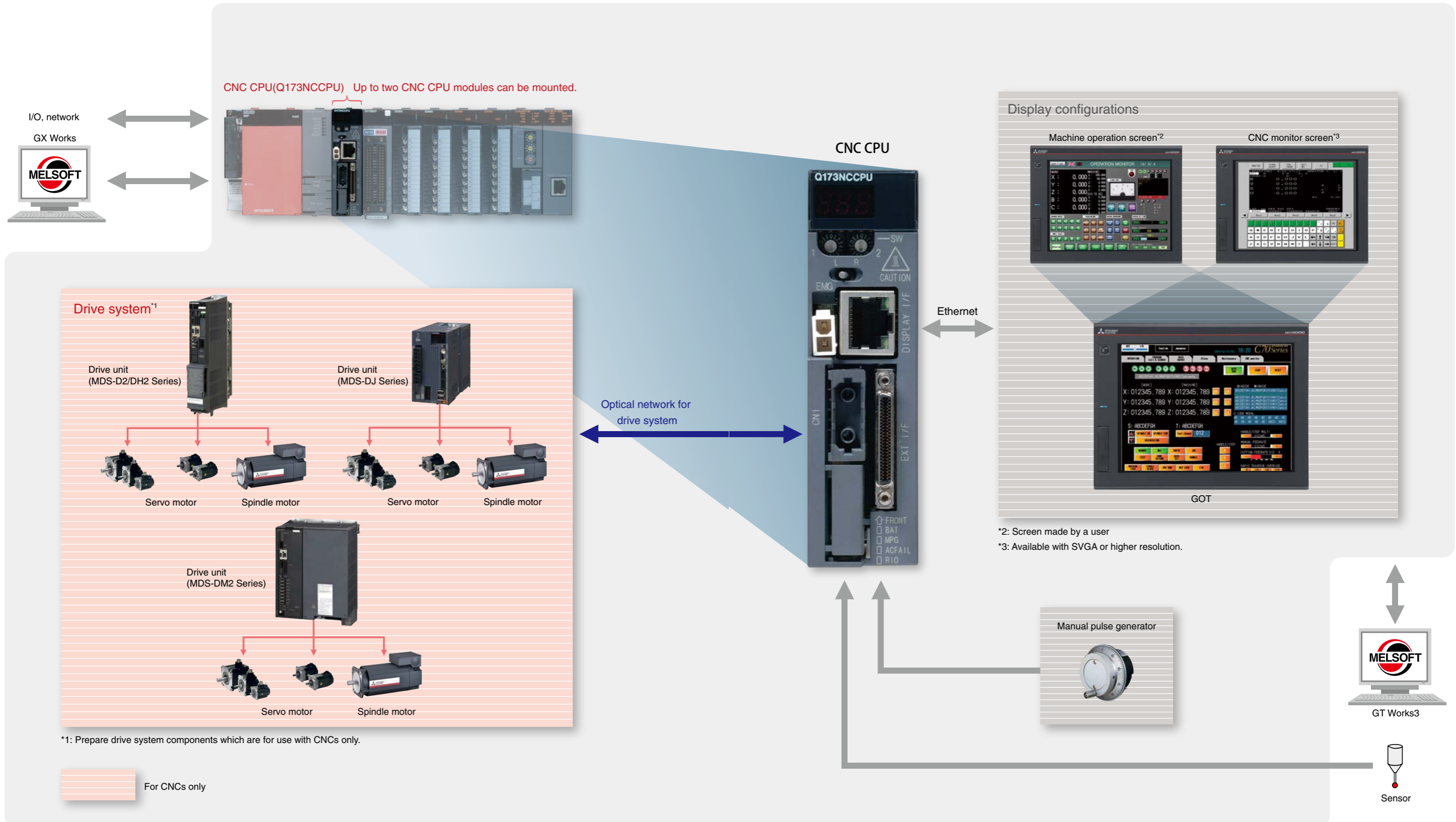

High-speed control shortens tact time

Speed enhancement by high-speed bus between multi-CPUs

Ultrahigh-speed network between CNC CPUs and PLC CPUs



For data transfer between CNC CPUs and PLC CPUs, we have newly developed a dedicated high-speed bus. Data are transferred at a high-speed cycle (0.88ms) between the high-speed shared memories of each CPU, so each CPU speed can be fully utilized.

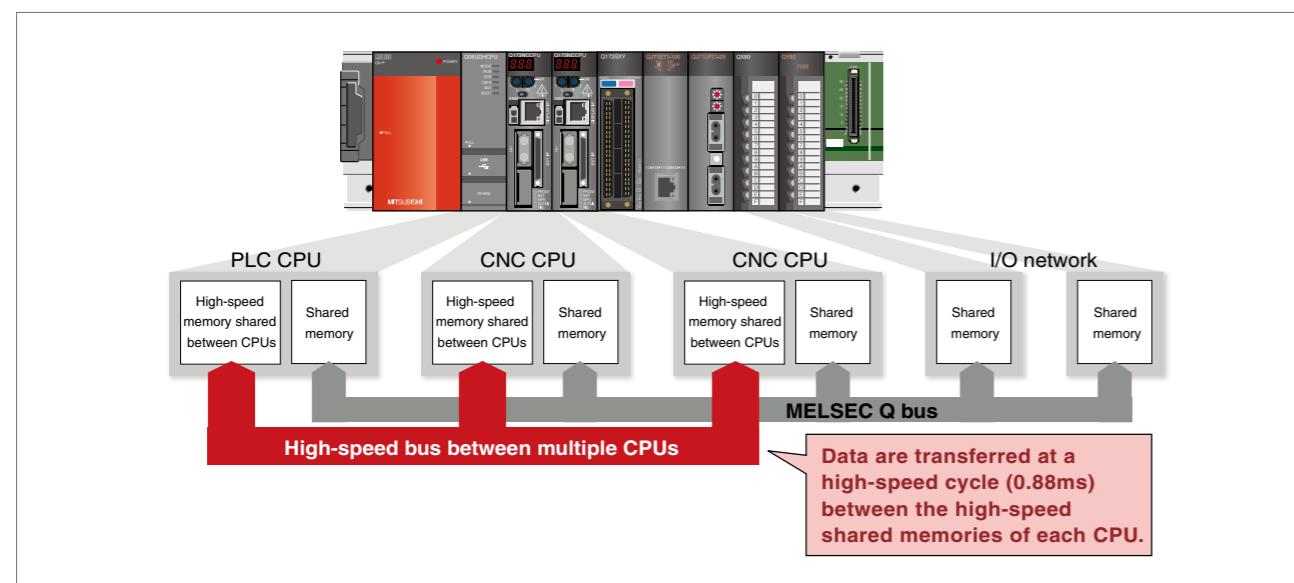

Effects of high-speed PLC CPUs, high-speed CNC CPUs and high-speed bus among the CPUs



Shortens machining cycle time.

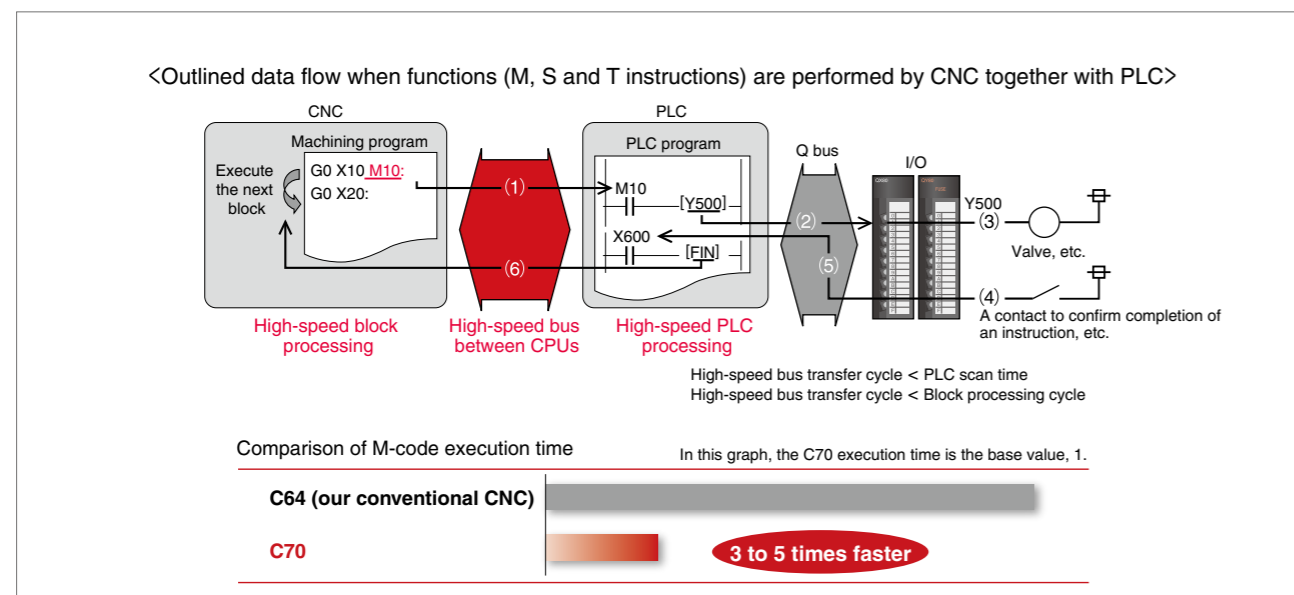

Speed enhancement by CNC functions

Programmable in-position check

When commanding positioning (G00) and linear interpolation (G01), the in-position widths can be respectively specified in a machining program. This enables designation of the optimal in-position width for each machining pattern, thereby allowing tact time to be reduced.

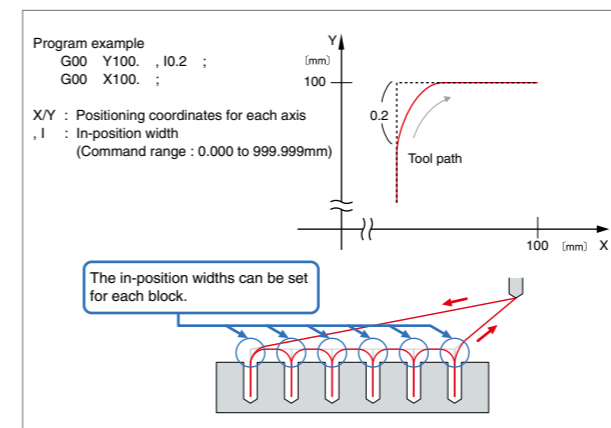

G00/G01 independent in-position check

The in-position width for positioning (G00) can be set independently of the width for linear interpolation (G01). For example, you can shorten the positioning time while maintaining the depth accuracy by setting the G01's width smaller and G00's width larger.

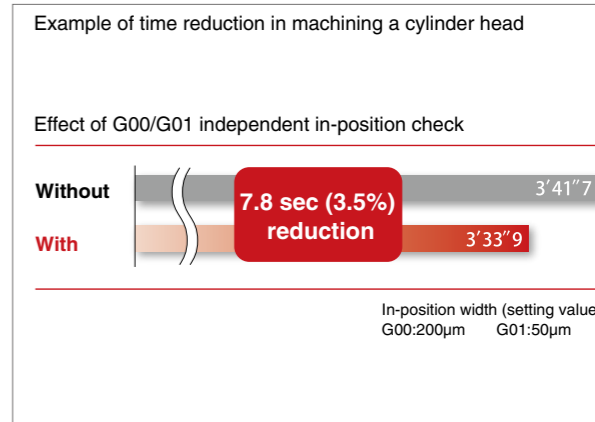

Connection with host system using e-F@ctory

Versatile network modules allow connection with the host information system.



A wide variety of Mitsubishi PLC MELSEC Q Series' network modules can be used.

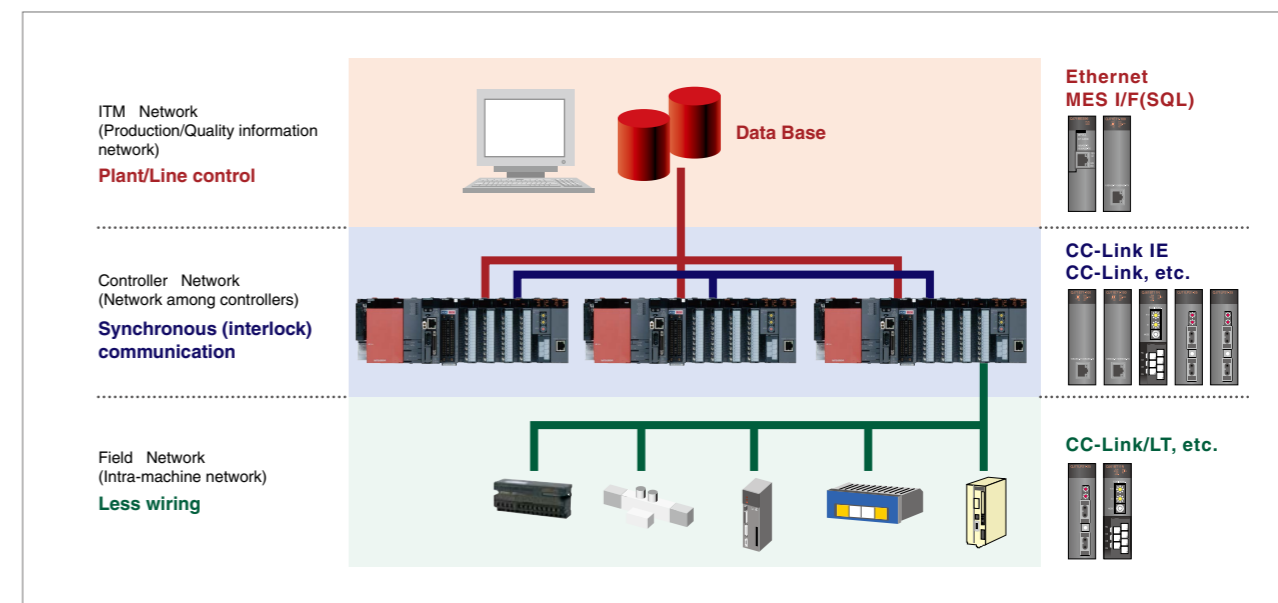

technology

High-speed control shortens tact time

Speed enhancement with drive system functions

Servo control

Basic performance has been significantly enhanced by combining the highly responsive current control (High-gain control) and a high-accuracy servo motor.

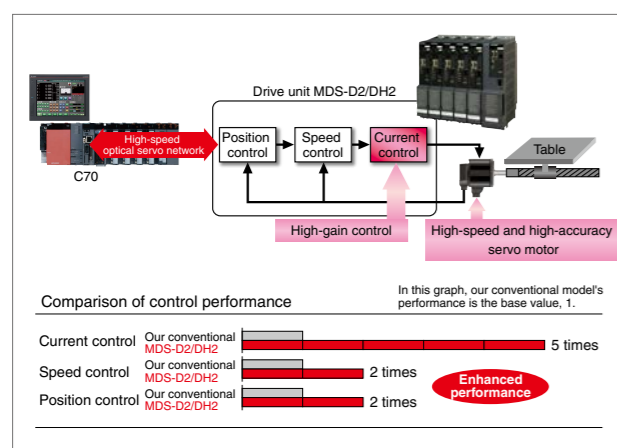

OMR-DD control (high-speed synchronous tapping)



The servo axis detects and compensates the spindle's delay directly on the high-speed optical network to minimize the synchronization error.

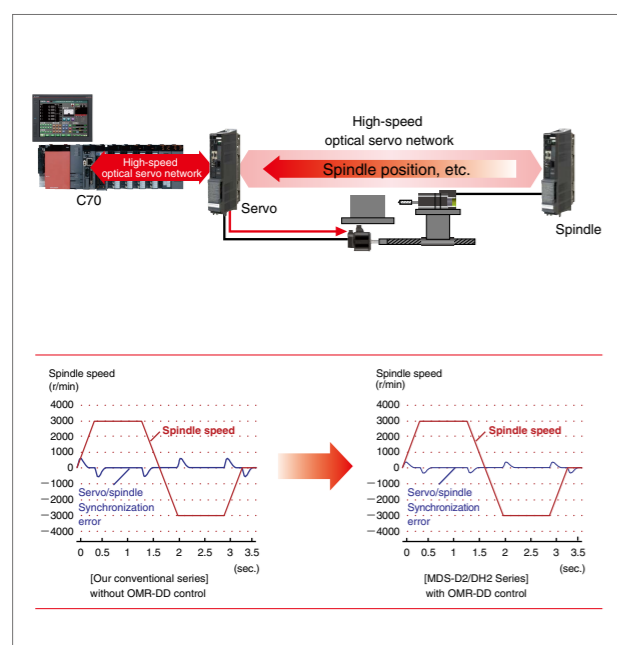

Spindle control

In addition to the high-responsive current control, lost motion compensation and an adaptive-type resonance suppression filter, etc. are installed. These can realize reduced machining time, elimination of machine vibration and enhanced machining accuracy. The connection with the detector is high-speed and highly reliable serial communication.

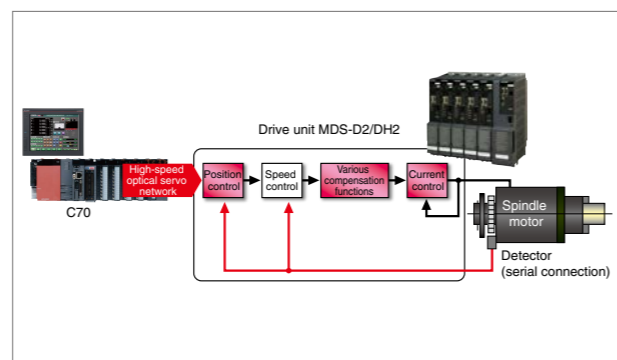

Effects of spindle's continuous position loop control

Orientation time is reduced
Under MDS-D2/DH2 Series spindle control, position loop control is constantly maintained. Thus, controlling with the maximum torque is always possible with no need for position control switching. As deceleration can be performed with the maximum torque, the spindle's orientation time has been reduced by 20%.

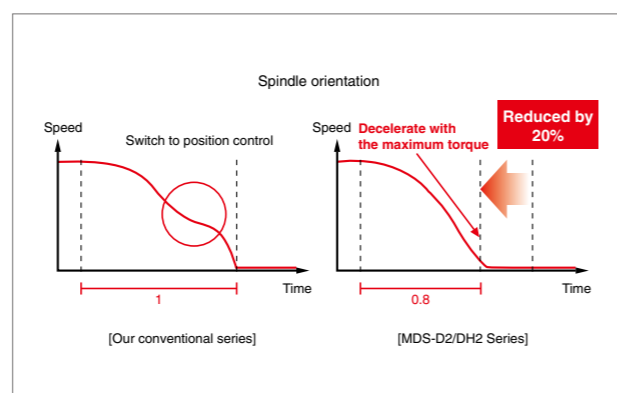

Heavy cutting performance improved

Heavy cutting performance has been improved due to the position loop of the spindle control. By lowering impact load fluctuation, the speed fluctuation rate has been reduced to less than 1/2 of our conventional system.

Stable productivity through automation

Tool life management

This function counts accumulated time and frequency of tool use and monitors usage state of tools (Tool life management I). The spare tool registration function is available in "Tool life management II".

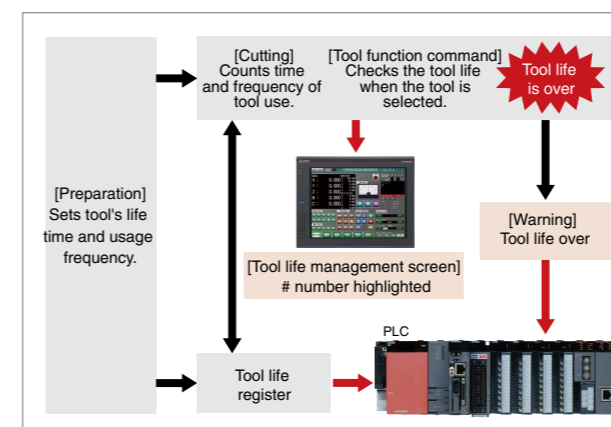

Tool radius compensation

This function corrects the actual tool center path inward or outward from the programmed path by the tool's radius amount.

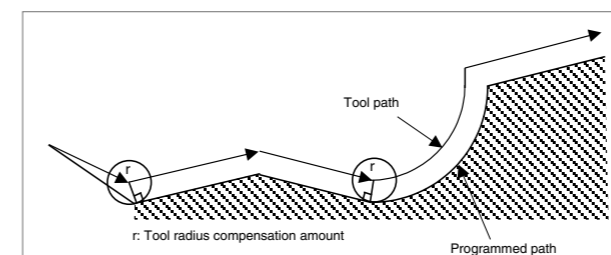

Nose R compensation

This function assumes the tool nose to be a half circle of radius R, and performs compensation so that the half circle touches the programmed path. This can correct the error caused by the tool nose roundness.

It is possible to select whether the compensation direction is fixed, or automatically determined from the tool tip and the specified movement vector.

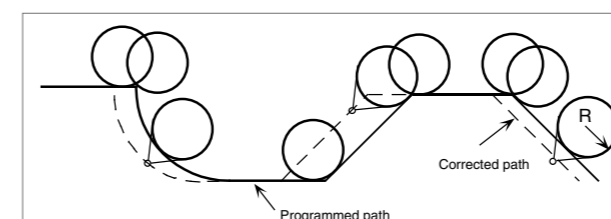

Fixed cycle

This function enables drilling, tapping, boring and other hole machining to be assigned by a patterned cycle. This allows easy programming of the same machining simply by inputting the required data.

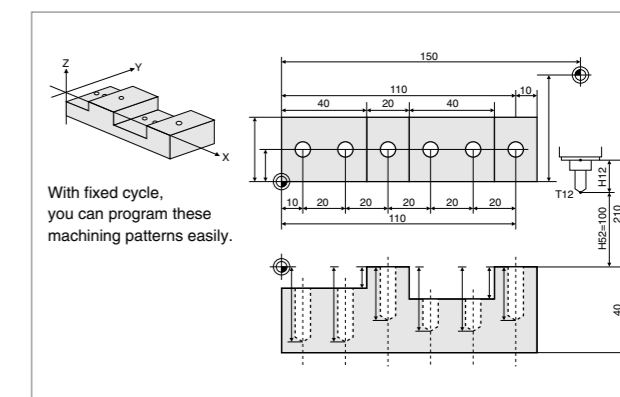

Tool length measurement

This function automatically calculates the difference between the coordinate value of the commanded measurement position and the value where the tool actually reaches to the sensor, and then determines the tool compensation amount.

If the tool has been already compensated, the compensation amount is adjusted as needed.

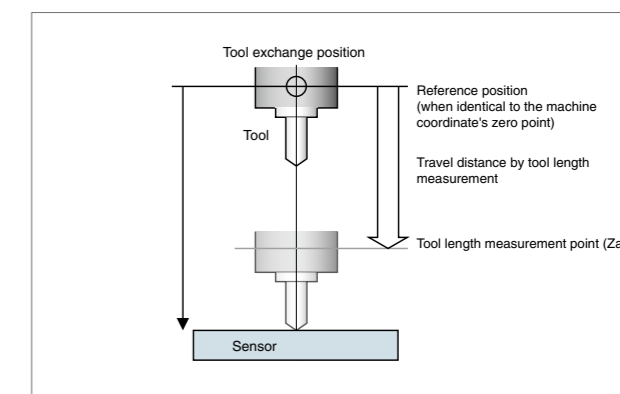

Enhanced diagnostic functions enable failure causes to be identified early

Spindle motor's temperature compensation

Suppresses the output characteristic deterioration when the temperature is low

Under this control, a built-in thermistor detects the spindle motor's temperature to compensate the motor constant fluctuation due to rise of temperature. It is also possible to monitor spindle motor's temperature on CNC screen.

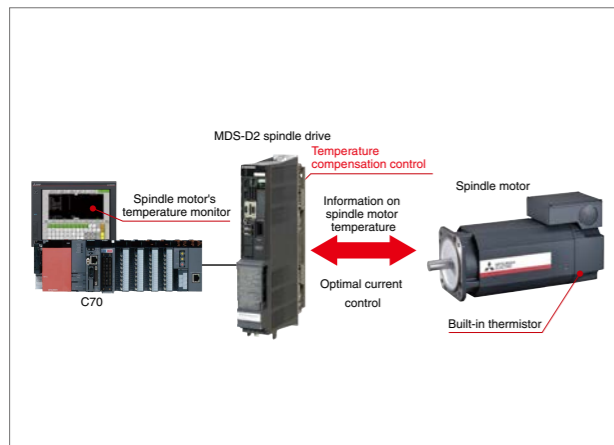

Operation history

Helps trouble diagnosis with time display

With this function, the CNC operation and time information is always stored, which is used for trouble diagnosis, etc. Operation history data include the CNC alarms, key inputs and CNC input/output signal changes, which are stored together with the occurrence times. These history data are backed up even during power shut-down.

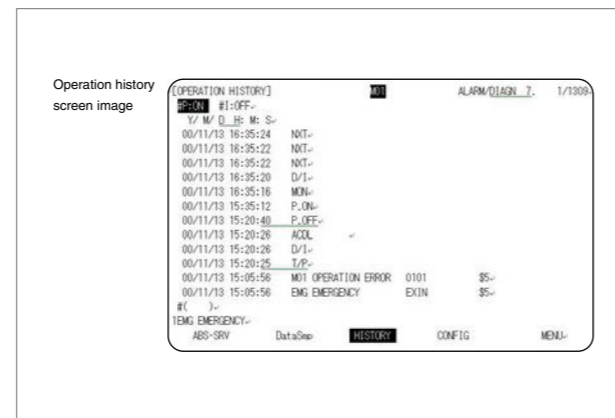

Detection of the stop of radiator fin cooling fan

Allows systematic fan replacement

Monitors cooling fan's rotation, and detects "Fan stop warning" that is output when the fan stops rotating. Previously, the motor was stopped in the event of fan stop by the module overheat alarm. With this "Fan stop warning"; however, the fan can be replaced systematically without stopping the motor.

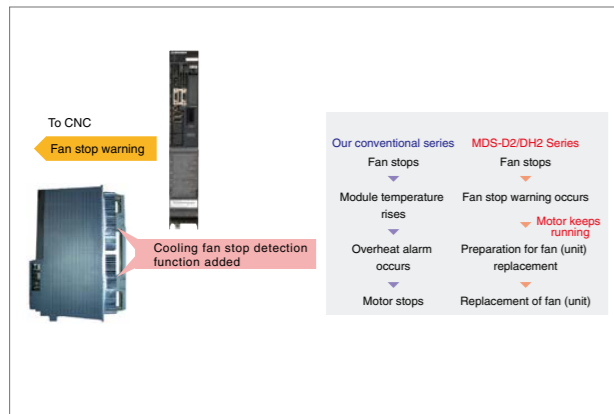

Ground fault detection for each motor

Easy to specify the faulty axis

Ground fault detection, which was formerly performed all at a time by a power supply unit, has changed so that the fault can be detected per motor. As detecting a faulty axis is possible, restore time will be shorter.

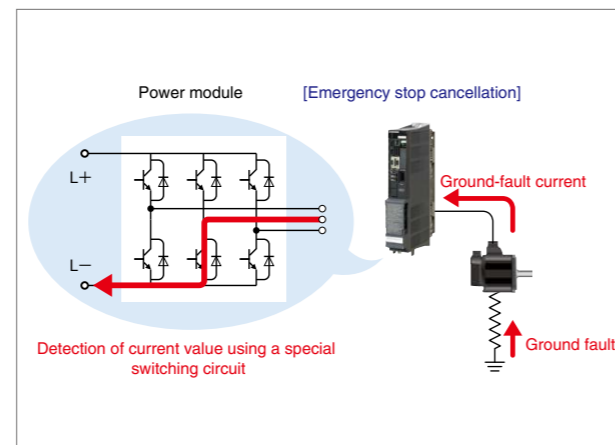

Reduction of failure rate by eliminating causes

No fans in control unit

Fans inside C70 control module have been removed, as cooling is executed by radiator fin. Thus, fan-related troubles (electric circuit failures that are caused by fan stop, inspiring moisture into the panel) can be avoided.

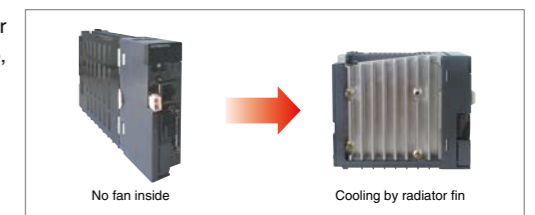

No fans and enhanced oil-resistance in drive unit

The absence of fan inside the drive unit can contribute to the avoidance of electric circuit failures that are caused by inspiring dust, oil-mist, etc. The oil resistance of radiator fin cooling fans, which are located outside the panel, has been improved by molding the stator coil (IP65).

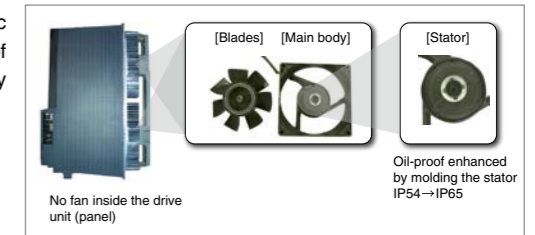

Reduction of maintenance cost through efficient parts replacement

Common maintenance parts

Maintenance parts are the same as for MELSEC, thus possible to use the same parts.

The main base, power supply and extension base are the same as those used for MELSEC, thus MELSEC Q Series' versatile I/Os and instrumentation modules are available. Possible to cut maintenance cost by using the same parts as MELSEC.

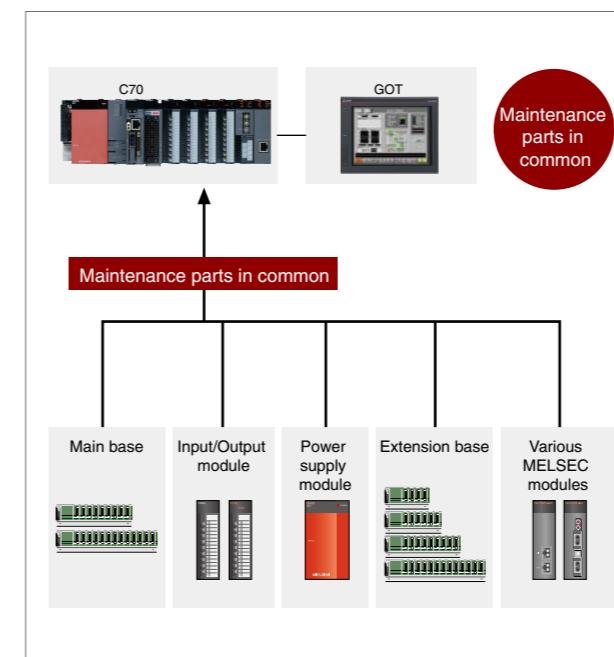

Back-up/Restore function

Quick restoration with module replacement and restoration function in case of troubles

Through a GOT screen operators can backup and restore data to an SD card, USB memory or CF card inserted into the GOT (Note). Which data needs to be backed up is automatically determined. (Note) Available devices vary according to your GOT type.

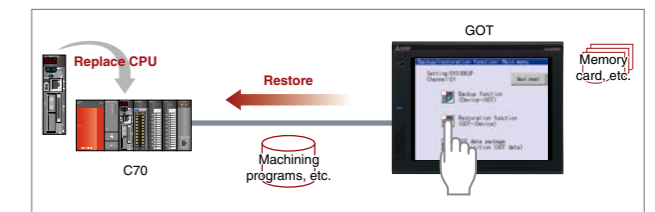

Use of connector on motor's power line

Allows for easier wiring

By using a connector on motor's power line, wiring workability has improved.

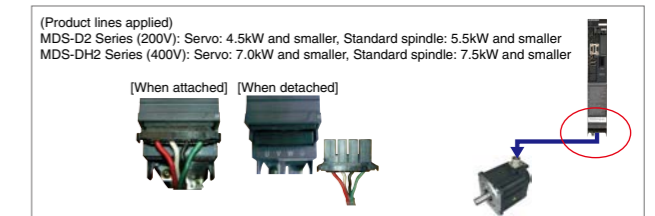

development

Streamlined design and development through subdivision and structuring of programs

PLC CPU module with large memory capacity

Large-capacity CPUs have been added to C70's PLC CPU lines. Program capacity as well as standard ROM capacity have also been extended.

Universal model	Q03UDCPU	Q04UDHCPU	Q06UDHCPU
Ethernet built-in type	Q03UDECPU	Q04UDEHCPU	Q06UDEHCPU
High-Speed Universal model (Note)	Q03UDVCPU	Q04UDVCPU	Q06UDVCPU
Program capacity	30k steps	40k steps	60k steps
Standard ROM capacity(Flash ROM)	1MB		

Large-capacity type added

Universal model	-	Q13UDHCPU	Q26UDHCPU
Ethernet built-in type	-	Q13UDEHCPU	Q26UDEHCPU
High-Speed Universal model (Note)	-	Q13UDVCPU	Q26UDVCPU
Program capacity	100k steps	130k steps	260k steps
Standard ROM capacity(Flash ROM)	2MB	4MB	

(Note) The High-Speed Universal model is compatible with the safety observation function, but not yet certified under the European safety standards "EN ISO 13849-1 Cat3 PL d" or "EN62061/SIL CL2" by TÜV.

Facilitates subdivision and structuring of sequence programs

The number of sequence programs has been extended up to 124 to enable the precise management of programs according to product or process, etc. By subdividing and structuring sequence programs, the visibility and availability of programs are enhanced.

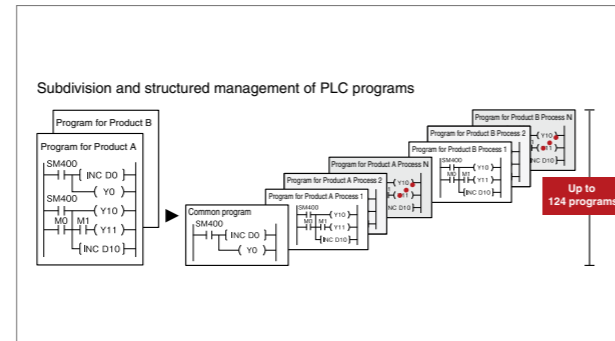

Create machine operation panel screen, CNC monitor screen and ladder edit screen in one development environment (GT Works3)

Machine operation panel computerized and aggregated

GOT Screen Design Software (GT Works3) enables simple custom screen development. Possible to operate machine with the touch panel screen, instead of the conventional machine operation panel.

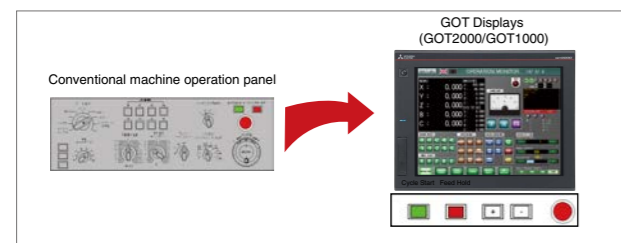

Allows editing of C70's ladder program on a GOT

PLC ladder program can be edited without GX Works, when "Sequence program monitor" of GOT2000 or "Ladder edit" of GOT1000 is applied. With this function, you can also check the operating status of a sequence program.



CNC monitor installed

CNC monitor has been installed, which allows editing of machining programs and setting each CNC data. The CNC monitor can be used simply by installing from GT Works3 thus no need to develop screen. The CNC monitor screen can be displayed by connecting to the CNC CPU's DISPLAY interface via Ethernet or by connecting to the main base via bus. CNC monitor supports only models with display resolution SVGA or more.



Flexible system configurations

Enables configuring the system optimal for your system

An independent PLC CPU allows suitable selection of the right module for your system's size and purpose, realizing an optimal hardware configuration. PLC CPU and each I/O unit, and intelligent units are connected via Q bus; thus, conventionally used power supply, I/O and network modules for MELSEC Q Series can be used.

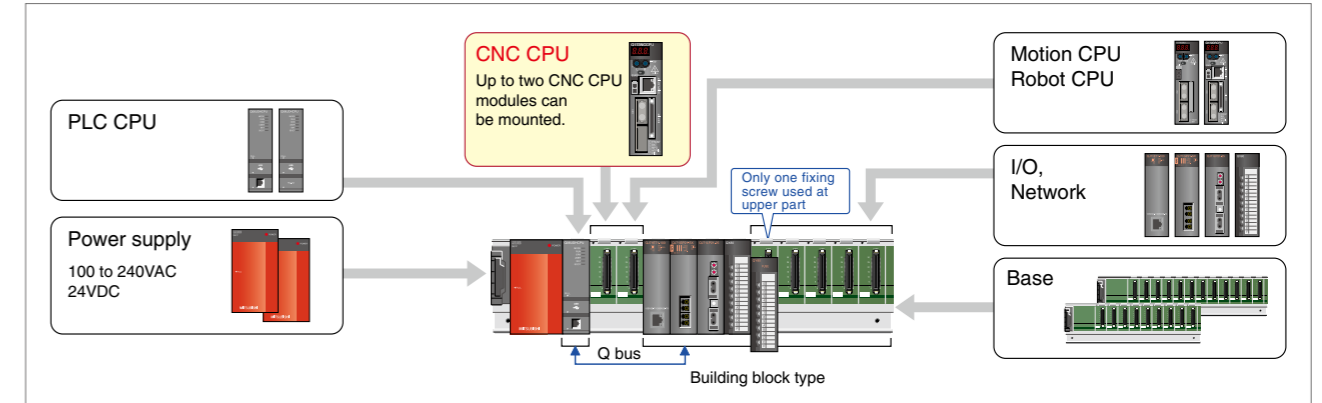

CNC CPU function expanded (macro interface function extended)

Possible to define up to 1200 sets of variables, which are able to write/read from a PLC CPU. These variable sets can be handled as system variables in the machining program. Write/Read is performed using special instructions. This function is useful when a large number of variable sets are needed, such as for a grinder.

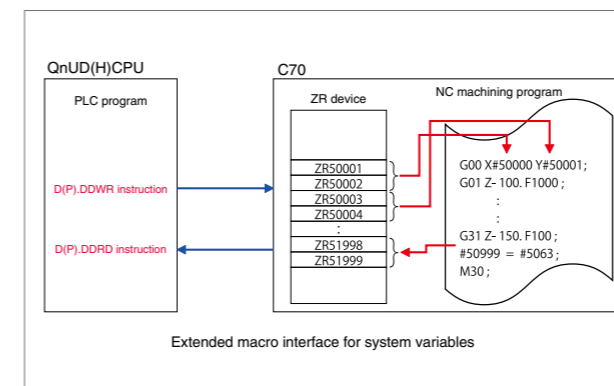

NC axis/PLC axis changeover

Even if a pallet is changed, the axis can always be controlled as an NC axis in the machining area, and as a PLC axis in the setup area, which enables setup of a rotary axis without stopping machining.

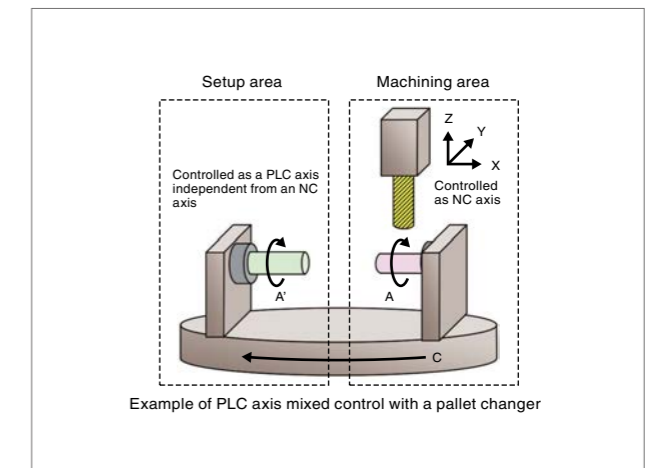

PLC axis control

An independent axis control by PLC is possible, apart from NC control axes. PLC axis control is useful for controlling the axis not involved in machining such as tool magazine and pallet changer.

Highly reliable safety observation function which conforms to the European safety standard EN ISO 13849-1 PL d

Safety observation function

This control system is compliant with the harmonized standards of European Machinery Directive: EN ISO 13849-1:2008 Category 3 PL d and EN62061/SILCL2. In addition to the safety signal monitoring function that monitors redundant signal input/output, this system is equipped with Safely limited speed (SLS), a function to monitor a moving part speed, and shutoff functions. The operating conditions of these safety functions can freely be programmed in CNC CPU and PLC CPU ladder circuits, thereby allowing you to build a safety system compatible with Safe operating stop (SOS), Safe torque OFF (STO) and Safe brake control (SBC).

Safety signal comparison (duplex safety circuit)

PLC CPU and CNC CPU observe the consistency of safety signals input/output in two systems. User's safety sequence is executed by both PLC CPU and CNC CPU. If a safety signal comparison error occurs, emergency stop will activate to shutdown power to the drive system.

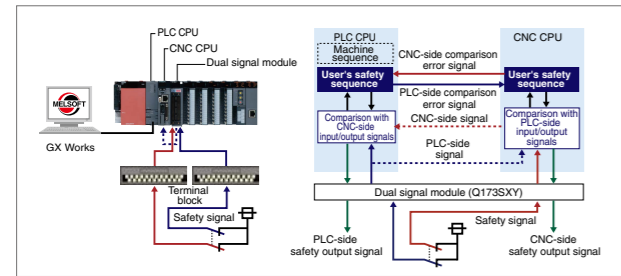

Speed observation function

CNC CPU and Drive unit CPU observe to see if motor's command speed and feedback speed exceed the safe speed when the machine's protection door is open. If an exceeding speed is detected, it causes emergency stop to shut off the drive system power. Possible to enable/disable speed observation for the axes for each door (up to 16 doors).

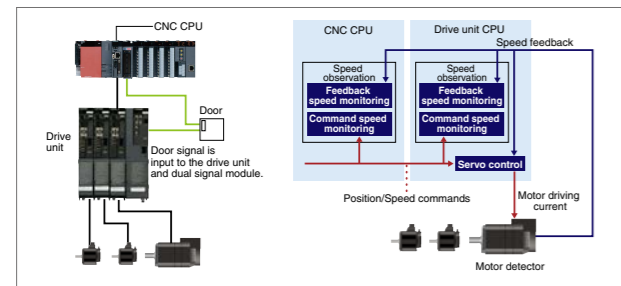

Emergency stop duplexing

CNC CPU and Drive CPU independently monitor the emergency stop inputs. Upon receiving an emergency stop signal, PLC CPU, CNC CPU and Drive CPU individually activate a contactor to shut OFF the main power.

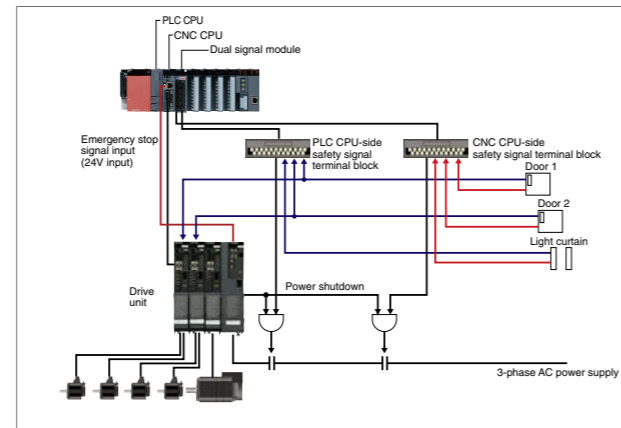

Dual signal module specification (Q173SXY)

Signals are connected to 20 input points and 12 output points in 2 systems. Up to 3 modules can be mounted.

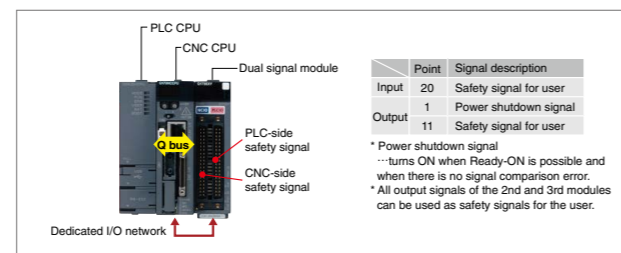

Other safety related functions

Door interlock

European Safety Standards CE Marking (machine directive) prohibits machine protection door from being opened during axis traveling. Door interlock function decelerates and stops all the control axes when door open signal is input from PLC, and then performs Ready OFF to shut down the driving power inside the servo drive unit to disable the motor driving.

Energy-savings with a high-efficiency spindle motor, servo motor and drive unit

Drive unit

Application of the power regeneration system which allows energy generated during deceleration to be efficiently used as a power supply. Use of low-loss power devices enables reductions in loss of power.

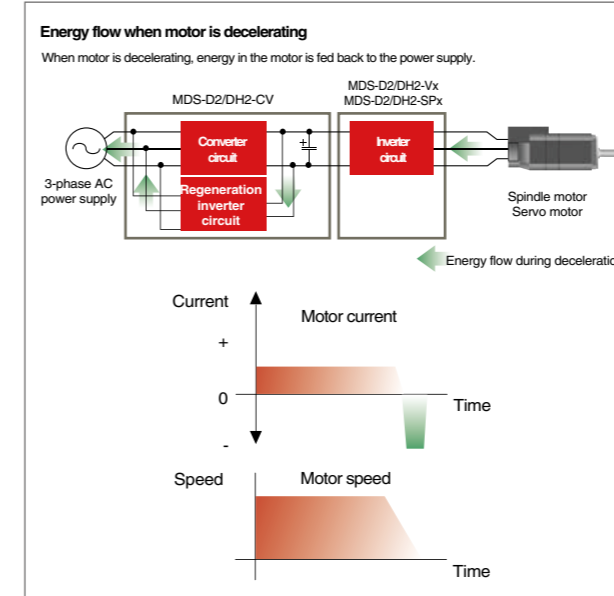

Spindle motors/Servo motors

Energy loss of spindle motors during high-speed operation has been substantially reduced. Drive current of servo motors has also been reduced by downsizing the motors while increasing the torque.

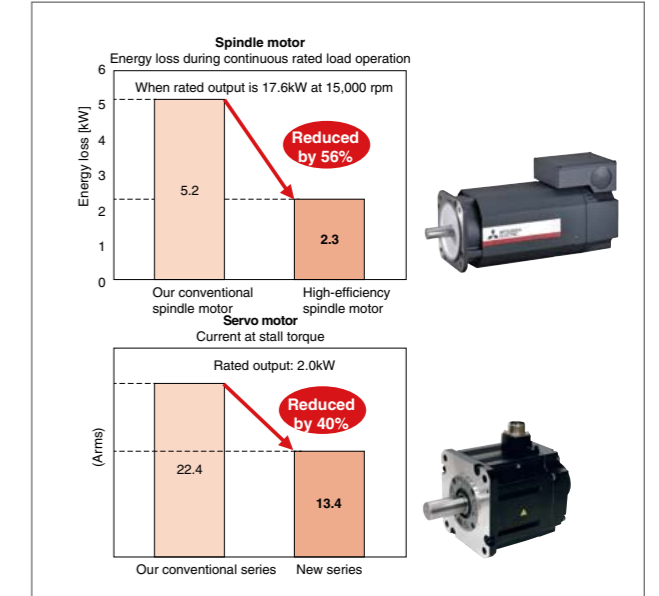

Mitsubishi Electric's FA expertise fully supports the manufacturing floor

Mitsubishi Factory Automation Solutions

We provide best suited systems for users from our accumulated Factory Automation expertise and experience. We support from lower to upper components and networks required in manufacturing, as well as the applications needed for control.

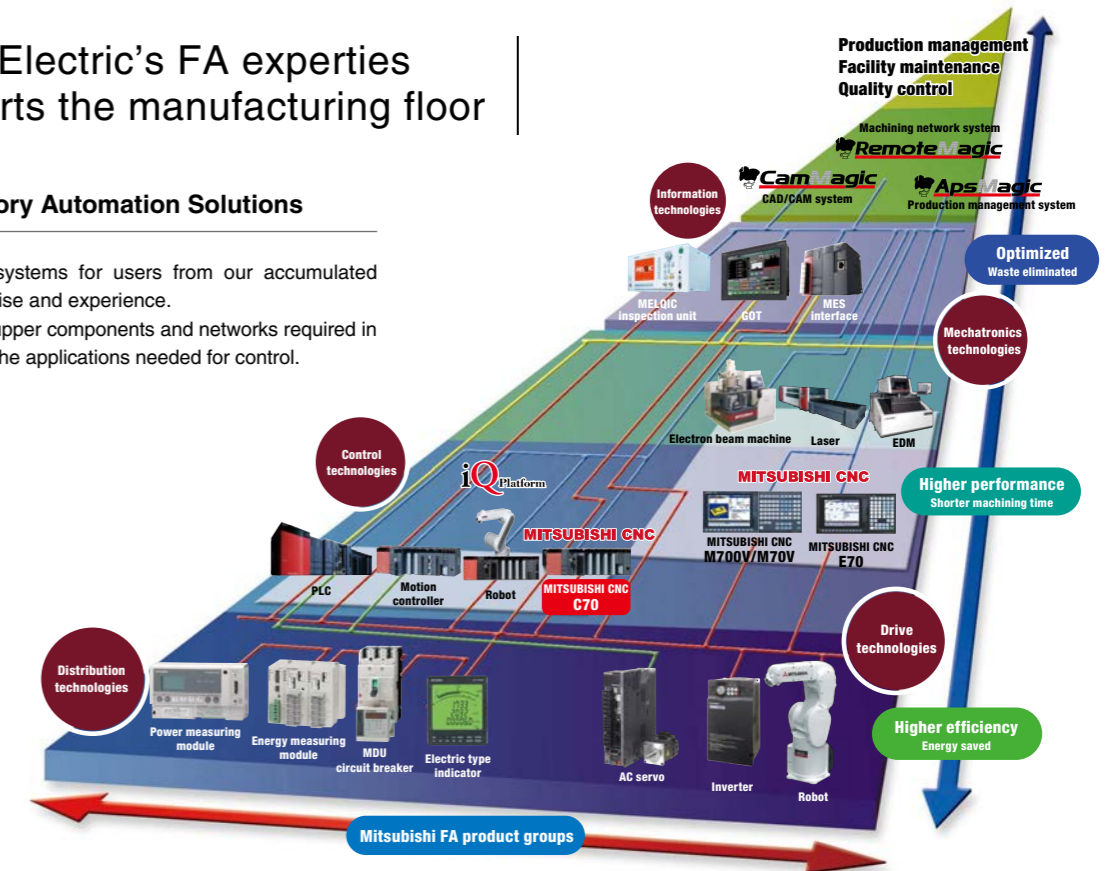



Software tools supporting CNC operation and development environments

Remote Monitor Tool

By connecting a personal computer to a CNC module, various data can be checked and set using the same HMI (Human Machine Interface) as the CNC monitor. This tool is free of charge. Please contact us.

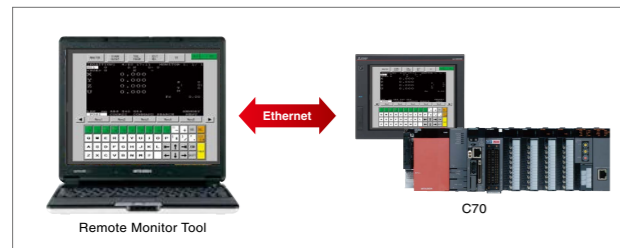

NC Analyzer/servo adjustment support tool

Servo parameters can be automatically adjusted by activating the motor with machining programs for adjustment or vibration signals, and measuring/analyzing the machine characteristics.

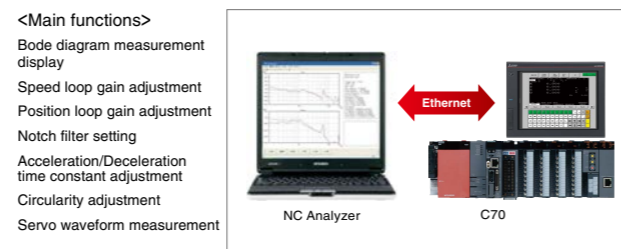

GT Works3/GOT Screen Design Software

This integrated software is used to create professional screen designs for GOTs. Developed with the concepts of "Simplicity", "Sleekness", and "User-friendliness" in mind, this is a powerful tool that pushes boundaries and delivers endless design possibilities.

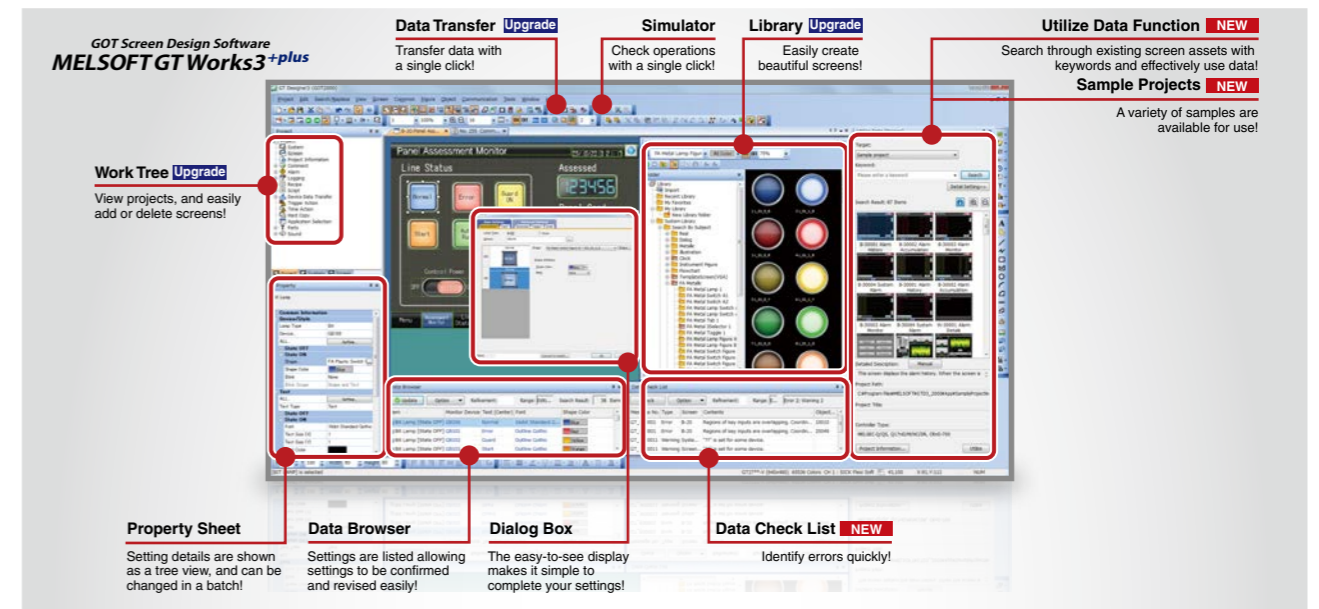

GX Works/sequence programming tool

The MELSEC programming tool, offering a wide array of functions and easy use, allows for convenient program design and debugging. Linking with a simulator or other utility allows for the efficient programming.

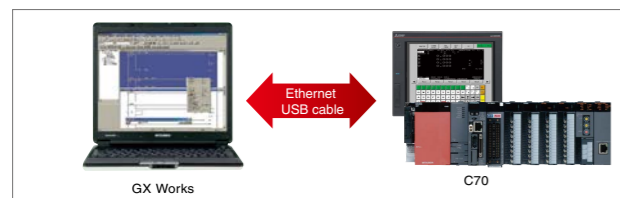

NC Configurator2/ CNC parameter set-up support tool

CNC data necessary for CNC control and machine operation (such as parameters, tool data and common variables) can be edited on a personal computer. Please contact us to purchase a full function version. (A limited function version is also available free of charge.)

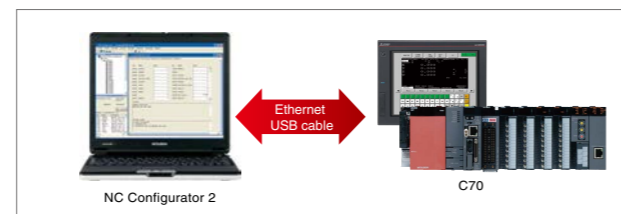

For compatible versions, please contact us.

For compatible versions, please contact us. *GT Desinger3 screen image

Servo selection tool

By selecting the machine configuration model and inputting the machine specifications, the optimal servo motor that meets the specification can be selected. Other selection functions which totally support the drive system selection are also available. This tool is free of charge. Please contact us.

<Main functions>
 Servo motor capacity selection, regenerative resistor capacity selection, spindle acceleration/deceleration time calculation, power supply capacity selection, power supply facility capacity calculation, etc.

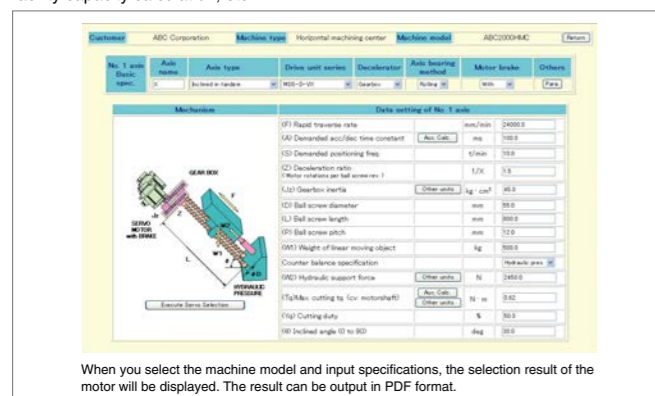

Mitsubishi Electric Corporation Date 2010-7-12 13:14:41			
Customer: ABC Corporation		Date	
Type: Horizontal machining center		Model: ABC2000K4C	
Result of Servo Selection			
No. 1 axis	Input data	No. 1 axis	Calculated data
Axis name	X	Servo motor	HF198B-K2 HF222B-K2
Servo drive unit series	MDS-D-VX	Servo drive unit	MDS-D-V1-80-K2 MDS-D-V1-40-K2
Axis type	Control in system	Regenerative resistor	
Inch/rev angle	deg 30.0		
Rapid traverse rate	mm/min 24000.0	Traverse distance per motor rev.	mm 8.0 8.0
Decelerated end time constant	ms 100.0	Max. motor speed	mm/min 4000.0 3000.0
Decelerated positioning time	ms 10.0	Motor speed in rapid tool	mm 3000.0 3000.0
Deceleration	Clearance	Speed allowance	OK
Deceleration rate	1/S	(Judgment: Motor speed in rapid tool = Max. motor speed)	
Clearance travel	kg cm/2 45.0	Ball screw travel	kg cm/2 24.91 24.91
Motor gear (pulley) inertia	kg cm/2 0.0	Gearless travel	kg cm/2 45.0 45.0
Machine gear (pulley) inertia	kg cm/2 0.0	Linear moving speed motor	kg cm/2 4.05 4.05
Ball screw diameter	mm 80.0	Travel load inertia	kg cm/2 73.87 73.87
Ball screw length	mm 800.0	Motor	kg cm/2 17.8 23.7
Ball screw pitch	mm 12.0	Criterion of load inertia ratio	% 500.0 500.0
Weight of linear moving object	kg 800.0	Load inertia ratio	% 419.5 312.1
Counter balance specification	Hydraulic press	Load inertia ratio	OK
Hydraulic support force	N 2400.0	(Judgment: Load inertia ratio <= Criterion)	
Motor cutting to low inductance	N m 0.62	Total inertia	kg cm/2 2.2 2.2
Cutting duty	% 50.0	Max. load torque	N m 93.97 99.87
Axis bearing method	Fluting	Fluting coefficient	0.1 0.1
Friction torque	N m 1900	Friction torque	N m 0.31 0.31
Position loop gain	47	Unbalance torque	N m 0.0 0.0
S-shape acceleration/deceleration	% 0.0	Steady load torque	N m 0.31 0.31
		Max. motor torque	N m 42.0 30.0
		Decelerated end time constant	ms 100.0 100.0
		Min. acc/dec time constant	ms 88.7 133.4
		Trip-point characteristics	OK
		(Judgment: Min. time constant <= Decelerated end time constant)	
		Max. used motor torque	N m 33.6 25.6
		Max. cutting load torque	N m 0.93 0.93
		Cutting torque	OK
		(Judgment: Max. cutting load torque <= Max. used motor torque)	
		Acc. dec. load torque	N m 29.93 23.83
		Acc. dec. duty	% 3.33 4.45
		Arg. cutting load torque	N m 0.62 0.62
		Cutting duty	% 50.0 50.0
		Steady load torque	N m 0.31 0.31
		Steady load duty	% 45.87 45.55
		Cont. effective load torque	N m 5.47 5.05
		Motor stall torque	N m 9.0 12.0
		Cont. effective load ratio	% 60.6 42.07
		Steady load ratio	% 3.5 2.6
		Cont. characteristics	OK
		(Judgment: Cont. effective load <= 80% Steady load ratio)	
		Max. acceleration rate	G 0.46 0.31
		Emp. stop distance (rapid)	mm - -
		Overall judgement	OK
			NG

GT SoftGOT2000 (supported by GOT2000) / HMI software

SoftGOT allows GOT functions to be executed on a personal computer. Similar to the GOT2000, a variety of industrial devices can be connected and monitored. The GT SoftGOT2000 Version 1 software is included in GT Works3, but requires a separate license key to operate.

GT SoftGOT2000 Version 1
 Monitor the production site from a remote location

For details, please refer to the GT Works3 Catalog (L (NA) 08157).



Reduce downtime
 Use GT SoftGOT2000 to monitor the production site from your office. You can collect information quickly when a problem occurs, taking necessary actions immediately.

Use GOT project data from the production site
 The GOT project file running at your production site can be reused as the GT SoftGOT2000 project file, greatly reducing your design costs.

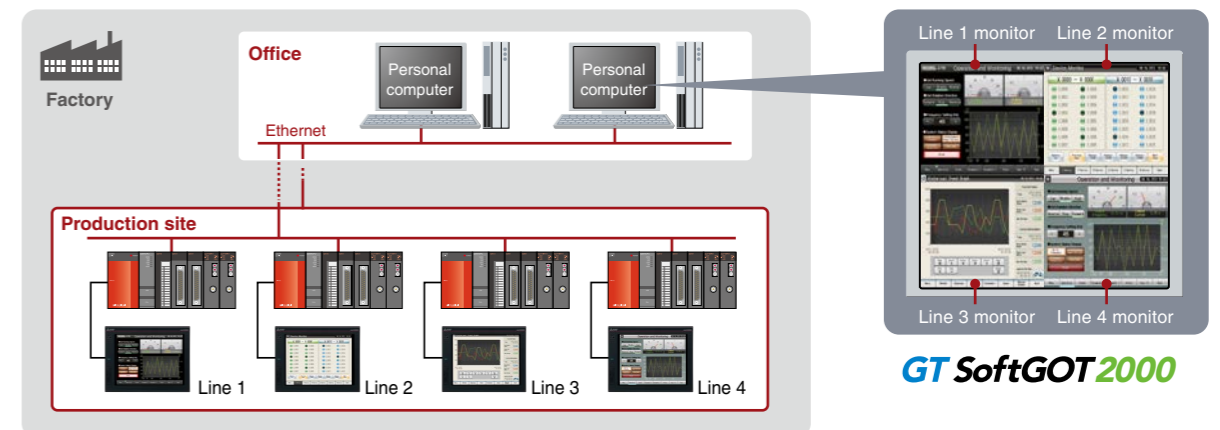

Case Study

case study

Case Study

One CNC can control up to 7 part systems and 16 axes. Up to two CNC modules can be mounted on one base. This can be applied to from multi-axis lathe and machining center to multi-axis and multi-part system transfer machine.

Compound lathe (two spindles and two turrets, equipped with workpiece conveying robot)

One CNC CPU can control both the 2-part system lathe turning and transfer loader control.
Possible to control both synchronization and separate operations between the right and left sides.



Transfer machine

One CNC CPU can control up to 7 part systems and 16 axes.
⇒ helps reduce size and wiring of the control panel.

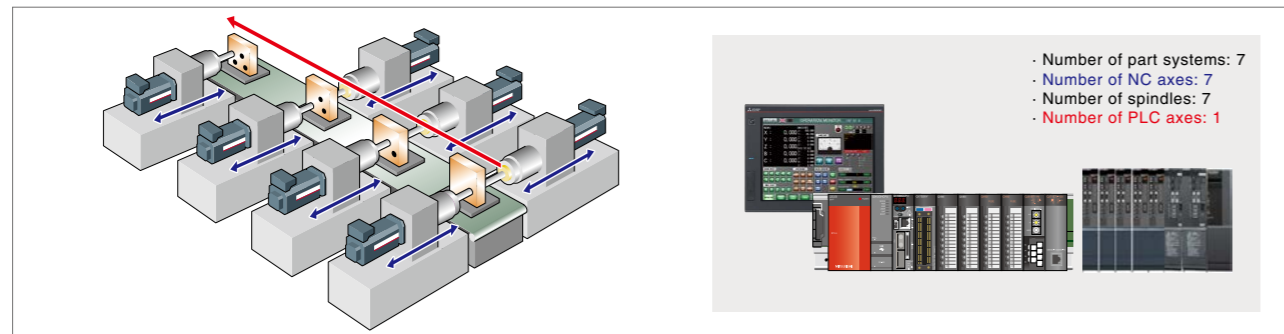

Processing robot cell

One PLC CPU plus up to three other CPUs (CNC, robot and motion controller) can be mounted on a single base.
Note that if two CNC CPUs are used, up to three CPUs including the PLC CPU can be mounted. ⇒ helps reduce size and wiring of the control panel.
Each CPU transfers the data using a high-speed bus. ⇒ helps reduce cycle time.

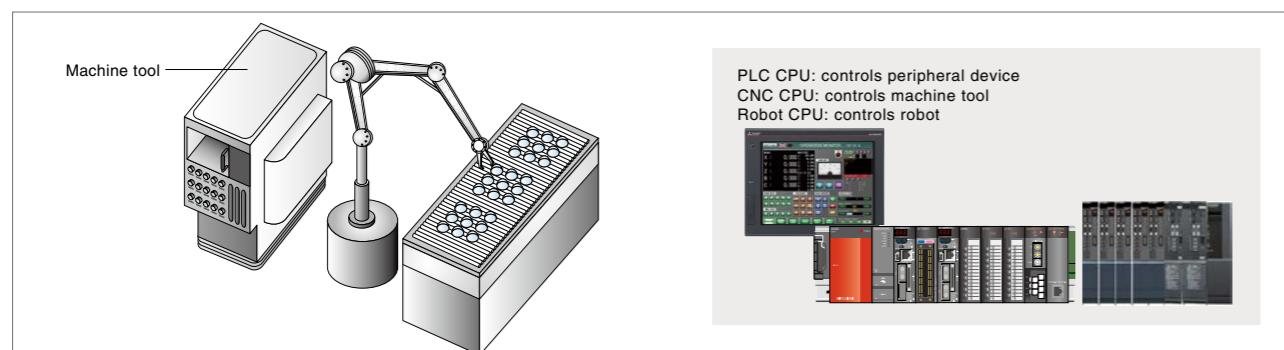

WARRANTY

Please confirm the following product warranty details before using MITSUBISHI CNC.

1. Warranty Period and Coverage

Should any fault or defect (hereafter called "failure") for which we are liable occur in this product during the warranty period, we shall provide repair services at no cost through the distributor from which the product was purchased or through a Mitsubishi Electric service provider. Note, however that this shall not apply if the customer was informed prior to purchase of the product that the product is not covered under warranty. Also note that we are not responsible for any on-site readjustment and/or trial run that may be required after a defective unit is replaced.

[Warranty Term]

The term of warranty for this product shall be twenty-four (24) months from the date of delivery of product to the end user, provided the product purchased from us in Japan is installed in Japan (but in no event longer than thirty (30) months, including the distribution time after shipment from Mitsubishi Electric or its distributor). Note that, for the case where the product purchased from us in or outside Japan is exported and installed in any country other than where it was purchased; please refer to "2. Service in overseas countries" as will be explained.

[Limitations]

- (1) The customer is requested to conduct an initial failure diagnosis by him/herself, as a general rule. It can also be carried out by us or our service provider upon the customer's request and the actual cost will be charged.
- (2) This warranty applies only when the conditions, method, environment, etc., of use are in compliance with the terms and conditions and instructions that are set forth in the instruction manual, user's manual, and the caution label affixed to the product, etc.
- (3) Even during the term of warranty, repair costs shall be charged to the customer in the following cases:
 - (a) a failure caused by improper storage or handling, carelessness or negligence, etc., or a failure caused by the customer's hardware or software problem
 - (b) a failure caused by any alteration, etc., to the product made by the customer without Mitsubishi Electric's approval
 - (c) a failure which may be regarded as avoidable, if the customer's equipment in which this product is incorporated is equipped with a safety device required by applicable laws or has any function or structure considered to be indispensable in the light of common sense in the industry
 - (d) a failure which may be regarded as avoidable if consumable parts designated in the instruction manual, etc. are duly maintained and replaced
 - (e) any replacement of consumable parts (including a battery, relay and fuse)
 - (f) a failure caused by external factors such as inevitable accidents, including without limitation fire and abnormal fluctuation of voltage, and acts of God, including without limitation earthquake, lightning, and natural disasters

- (g) a failure which is unforeseeable under technologies available at the time of shipment of this product from our company
- (h) any other failures which we are not responsible for or which the customer acknowledges we are not responsible for

2. Service in Overseas Countries

If the customer installs the product purchased from us in his/her machine or equipment, and export it to any country other than where he/she bought it, the customer may sign a paid warranty contract with our local FA center.
This falls under the case where the product purchased from us in or outside Japan is exported and installed in any country other than where it was purchased.
For details please contact the distributor from which the customer purchased the product.

3. Exclusion of Responsibility for Compensation against Loss of Opportunity, Secondary Loss, etc.

Whether during or after the term of warranty, we assume no responsibility for any damages arising from causes for which we are not responsible, any losses of opportunity and/or profit incurred by the customer due to a failure of this product, any damages, secondary damages or compensation for accidents arising under specific circumstances that either foreseen or unforeseen by Mitsubishi Electric, any damages to products other than this product, or compensation for any replacement work, readjustment and startup test run of on-site machines or any other operations conducted by the customer.

4. Changes in Product Specifications

Specifications shown in our catalogs, manuals or technical documents are subject to change without notice.

5. Product Application

- (1) For the use of this product, its applications should be those that may not result in a serious damage even if any failure or malfunction occurs in the product, and a backup or fail-safe function should operate on an external system to the product when any failure or malfunction occurs.
- (2) Mitsubishi CNC is designed and manufactured solely for applications to machine tools to be used for industrial purposes. Do not use this product in any applications other than those specified above, especially those which are substantially influential on the public interest or which are expected to have significant influence on human lives or properties.

* Trademarks
MELDAS, MELSEC, EZSocket, EZMotion, iQ Platform, MELSOFT, GOT, CC-Link, CC-Link/LT and CC-Link IE are either trademarks or registered trademarks of Mitsubishi Electric Corporation in Japan and/or other countries.
Ethernet is a registered trademark of Xerox Corporation in the United States and/or other countries.
Microsoft® and Windows® are either trademarks or registered trademarks of Microsoft Corporation in the United States and/or other countries.
CompactFlash and CF are either trademarks or registered trademarks of SanDisk Corporation in the United States and/or other countries.
DeviceNet is a trademark of Open DeviceNet Vendor Association, Inc.
Profibus-DP is a trademark of Profibus International.
Other company and product names that appear in this manual are trademarks or registered trademarks of the respective companies.

List of Components

component

CNC related module

CNC CPU module

Product name	Model name	Remarks
CNC control module	Q173NCCPU-S01	MITSUBISHI CNC C70
Battery set	-	One each of the battery holder unit with a battery unit connection cable (0.5m) (Q170DBATC or Q173NCBATC), and battery (Q6BAT)

Dual signal module

Product name	Model name	Remarks
Dual signal module	Q173SXY	IO redundant monitoring unit (up to three units)
Dual signal module	Q173SXY-2	IO redundant monitoring unit (high-speed model) (up to three units)
Terminal block	FA-LTB40P	Terminal block conversion unit (purchase from Mitsubishi Electric Engineering)
Cable	FA-CBL□□FMV-M	Terminal block conversion unit connection cable (length □□ = 05: 0.5m, 10: 1m, 20: 2m, 30: 3m, 50: 5m) (Purchase this from Mitsubishi Electric Engineering)

Drive unit

Series name	Remarks
MDS-D2/DH2 Series	Power regeneration type
MDS-DM2 Series	Multi-axis integrated, power regeneration type
MDS-DJ Series	Resistor regeneration type

Product name	Model name	Remarks
Battery box	MDS-BTBOX-36	size-D alkaline batteries LR20

Peripheral unit

Product name	Model name	Remarks
Signal splitter	FCU7-HN387	Options (necessary for 2 or 3-axis manual pulse generator)
Manual pulse generator	UFO-01-2Z9	5V specification
Manual pulse generator	HD60	12V specification, for connecting to signal splitter, need to prepare 12V power supply.

Cable for CNC CPU

Cable model name	Purpose	Max. length	Standard length (m)	Remarks
F020	Manual pulse generator : 1ch	45m	0.5, 1, 2, 3, 5, 7, 10, 15, 20	12V power supply is available.
F021	Manual pulse generator : 2ch	45m	0.5, 1, 2, 3, 5, 7, 10, 15, 20	For connection with signal splitter
G020	Manual pulse generator : 1ch	15m	0.5, 1, 2, 3, 5, 7, 10, 15	5V power supply is available.
G021	Manual pulse generator : 2ch	15m	0.5, 1, 2, 3, 5, 7, 10, 15	For connection with signal splitter
G380	Optical servo communication	20m	5, 10, 12, 15, 20	PCF-type with reinforced sheath for wiring outside the panel
G395	Optical servo communication	10m	1, 2, 3, 5, 7, 10	POF-type with reinforced sheath for wiring outside the panel
G396	Optical servo communication	10m	0.3, 0.5, 1, 2, 3, 5	POF-type without reinforced sheath for wiring inside the panel
H010	For connection with signal splitter	5m	0.5, 1, 2, 3, 5	-
H100	Emergency stop	30m	0.5, 1, 2, 3, 5, 7, 10, 15, 20	-
H200	Connection with display	20m	3, 5, 10, 15, 20	UTP cable for wiring in panel. For wiring outside of panel, prepare the STP cable separately.
H300	SKIP/MPG input	20m	0.5, 1, 2, 3, 5, 7, 10, 15, 20	-
H310	SKIP signal connection	15m	0.5, 1, 2, 3, 5, 7, 10, 15	For signal splitter connection
H400	1ch manual pulse generator 5V	20m	0.5, 1, 2, 3, 5, 7, 10, 15, 20	-
H500	Dual signal module connection	0.5m	0.1, 0.2, 0.3, 0.5	-

Use Mitsubishi CNC's dedicated drive system (drive unit, servo motor and spindle motor).

For the Mitsubishi CNC's dedicated drive system, please refer to "MITSUBISHI CNC DRIVE SYSTEM GENERAL CATALOG".

For other related units, please contact us.

MELSEC related module

Main base

Product name	Model name	Remarks
Multiple CPU high speed main base unit	Q35DB	5 slots
	Q38DB	8 slots
	Q312DB	12 slots

PLC CPU module

Product name	Model name	Remarks
Universal model QCPU	Q03UDCPU	Program capacity: 30k steps
	Q04UDHCPU	Program capacity: 40k steps
	Q06UDHCPU	Program capacity: 60k steps
	Q13UDHCPU	Program capacity: 130k steps
	Q26UDHCPU	Program capacity: 260k steps
	Q03UDECPU	Built-in Ethernet, Program capacity: 30k steps
	Q04UDEHCPU	Built-in Ethernet, Program capacity: 40k steps
	Q06UDEHCPU	Built-in Ethernet, Program capacity: 60k steps
	Q10UDEHCPU	Built-in Ethernet, Program capacity: 100k steps
	Q13UDEHCPU	Built-in Ethernet, Program capacity: 130k steps
	Q26UDEHCPU	Built-in Ethernet, Program capacity: 260k steps
	Q03UDVCPU	Q03UDVCPU High speed, Program capacity: 30k steps (Note)
	Q04UDVCPU	Q04UDVCPU High speed, Program capacity: 40k steps (Note)
	Q06UDVCPU	Q06UDVCPU High speed, Program capacity: 60k steps (Note)
	Q13UDVCPU	Q13UDVCPU High speed, Program capacity: 130k steps (Note)
	Q26UDVCPU	Q26UDVCPU High speed, Program capacity: 260k steps (Note)

(Note) The High-Speed Universal model is compatible with the safety observation function, but not yet certified under the European safety standards "EN ISO 13849-1 Cat3 PL d" or "EN62061/SIL CL2" by TÜV.

Basic power supply module

Product name	Model name	Remarks
Power supply	Q61P	Input voltage: 100 to 240VAC, output voltage: 5VDC, output current: 6A
	Q63P	Input voltage: 24VDC, output voltage: 5VDC, output current: 6A
	Q64PN	Input voltage range: 100 to 120VAC/200 to 240VAC, output voltage: 5VDC, output current: 8.5A

For other related units, please contact us.

GOT related unit

GT27 model

Model	Model name	Remarks
GT2712	GT2712-STBA	12.1" SVGA [800x600 dots] TFT color LCD 65,536 colors <Multimedia and video/RGB compliant Multi-touch compliant> 100-240VAC, User memory Memory for storage (ROM): 57MB, Memory for operation (RAM): 128MB
	GT2712-STBD	12.1" SVGA [800x600 dots] TFT color LCD 65,536 colors <Multimedia and video/RGB compliant Multi-touch compliant> 24VDC, User memory Memory for storage (ROM): 57MB, Memory for operation (RAM): 128MB
GT2710	GT2710-STBA	10.4" SVGA [800x600 dots] TFT color LCD 65,536 colors <Multimedia and video/RGB compliant Multi-touch compliant> 100-240VAC, User memory Memory for storage (ROM): 57MB, Memory for operation (RAM): 128MB
	GT2710-STBD	10.4" SVGA [800x600 dots] TFT color LCD 65,536 colors <Multimedia and video/RGB compliant Multi-touch compliant> 24VDC, User memory Memory for storage (ROM): 57MB, Memory for operation (RAM): 128MB
GT2708	GT2708-STBA	8.4" SVGA [800x600 dots] TFT color LCD 65,536 colors <Multimedia and video/RGB compliant Multi-touch compliant> 100-240VAC, User memory Memory for storage (ROM): 57MB, Memory for operation (RAM): 128MB
	GT2708-STBD	8.4" SVGA [800x600 dots] TFT color LCD 65,536 colors <Multimedia and video/RGB compliant Multi-touch compliant> 24VDC, User memory Memory for storage (ROM): 57MB, Memory for operation (RAM): 128MB

(Note) GT Designer3 Version1 (GOT2000) 1.117X or later is needed. (Note) The CNC monitor requires a GOT with SVGA or XGA resolution.

GT16 model

Model	Model name	Remarks
GT1695M	GT1695M-XTBA	15.0" XGA [1024x768 dots] TFT color LCD (high-brightness, wide viewing angle) 65,536 colors <Multimedia and video/RGB compliant>100-240VAC, Built-in flash memory 15MB
	GT1695M-XTBD	15.0" XGA [1024x768 dots] TFT color LCD (high-brightness, wide viewing angle) 65,536 colors <Multimedia and video/RGB compliant>24VDC, Built-in flash memory 15MB
GT1685M	GT1685M-STBA	12.1" SVGA [800x600 dots] TFT color LCD (high-brightness, wide viewing angle) 65,536 colors <Multimedia and video/RGB compliant>100-240VAC, Built-in flash memory 15MB
	GT1685M-STBD	12.1" SVGA [800x600 dots] TFT color LCD (high-brightness, wide viewing angle) 65,536 colors <Multimedia and video/RGB compliant>24VDC, Built-in flash memory 15MB
GT1675M	GT1675M-STBA	10.4" SVGA [800x600 dots] TFT color LCD (high-brightness, wide viewing angle) 65,536 colors <Multimedia and video/RGB compliant>100-240VAC, Built-in flash memory 15MB
	GT1675M-STBD	10.4" SVGA [800x600 dots] TFT color LCD (high-brightness, wide viewing angle) 65,536 colors <Multimedia and video/RGB compliant>24VDC, Built-in flash memory 15MB
GT1665M	GT1665M-STBA	8.4" SVGA [800x600 dots] TFT color LCD (high-brightness, wide viewing angle) 65,536 colors <Multimedia and video/RGB compliant>100-240VAC, Built-in flash memory 15MB
	GT1665M-STBD	8.4" SVGA [800x600 dots] TFT color LCD (high-brightness, wide viewing angle) 65,536 colors <Multimedia and video/RGB compliant>24VDC, Built-in flash memory 15MB

(Note) The CNC monitor requires a GOT with SVGA or XGA resolution.

Contact us for availability of the models not listed above.

For other related units, please contact us.

Specifications

specification

Installation environment conditions

CNC CPU module

Item	Specification				
Operating ambient temperature	0 to 55°C				
Storage ambient temperature	-25 to 75°C (Note 3)				
Operating ambient humidity	5 to 95%RH, non-condensing				
Storage ambient humidity	5 to 95%RH, non-condensing				
Vibration resistance	Frequency	Acceleration	Amplitude	Sweep count	
	Under intermittent vibration	10 to 57Hz	-	0.075mm	10 times each in X, Y and Z directions (80 min.)
		57 to 150Hz	9.8m/s ²	-	
	Under continuous vibration	10 to 57Hz	-	0.035mm	
57 to 150Hz		4.9m/s ²	-		
Shock resistance	147m/s ² , 3 times in each of 3 directions X, Y and Z				
Operating ambience	No corrosive gases or inflammable gases				
Operating altitude	2000m (6561.68ft.) or lower				
Installation location	Inside control panel				
Overvoltage category (Note 1)	II or less				
Pollution level (Note 2)	2 or less				

C70, which is open equipment, must be installed within a sealed metal control panel (IP54 or higher). C70 must also be used and stored under the conditions listed in the specifications table above.

The following environmental conditions are also required for the layout design.

- No large amount of conductive dust, iron filings, oil mist, salt, or organic solvents
- No direct sunlight
- No strong electrical or magnetic fields
- No direct vibrations or shocks to the C70

(Note 1) This indicate at which point this equipment is assumed to be connected between a public power distribution network and local machinery equipment.

Category II applies to equipment for which electrical power is supplied from fixed facilities. The surge voltage withstand level for the rated voltage of up to 300V is 2500V.

(Note 2) This index indicates the degree to which conductive material is generated in terms of the environment where the equipment is used.

Pollution level 2 means that only non-conductive pollution can occur. However, a temporary conductivity may be caused by accidental condensing.

(Note 3) Do not use or store the C70 under pressure higher than the atmospheric pressure of altitude 0m. Doing so may cause an operation failure.

Manual

List of manuals

The manuals relating to the C70 are listed below. For the latest versions of manuals, please contact us.

Classification	Manual title	Manual No.	Model code	Contents
C70	C70 Specifications Manual	IB-1500259	100-009	Details of hardware and function specifications
	C70 Connection Manual	IB-1500261	100-011	Installation and connection
	C70 PLC Interface Manual	IB-1500263	100-013	Control signals necessary for creating sequence programs
	C70 Setup Manual	IB-1500265	100-015	Set-up procedure and explanation of parameters and alarms
	C70 Instruction Manual	IB-1500267	100-017	Handling such as operation method and daily maintenance
	C70 Programming Manual (Machining Center System)	IB-1500269	100-019	Programming with G codes (for machining center system)
	C70 Programming Manual (Lathe System)	IB-1500275	100-007	Programming with G codes (for lathe system)
Drive system (servo/spindle)	C70 Handbook	IB-1501089	100-362	Handy lists of alarms, parameters, control signals
	MDS-D/DH Series Specifications Manual	IB-1500875	100-151	Specifications of power regeneration type units
	MDS-D2/DH2 Series Specifications Manual	IB-1501123	100-348	
	MDS-D/DH Series Instruction Manual	IB-1500025	008-360	
	MDS-D2/DH2 Series Instruction Manual	IB-1501126	100-350	Handling of power regeneration type units
	MDS-DM Series Specifications Manual	IB-1500891	100-168	
	MDS-DM2 Series Specifications Manual	IB-1501135	100-356	Specifications of multi-axis integrated, power regeneration type units
	MDS-DM Series Instruction Manual	IB-1500893	100-170	
	MDS-DM2 Series Instruction Manual	IB-1501138	100-358	Handling of multi-axis integrated, power regeneration type units
	MDS-D-SVJ3/SPJ3 Series Specifications Manual	IB-1500158	008-384	
	MDS-DJ Series Specifications Manual	IB-1501129	100-352	Specifications of resistor regeneration type units
	MDS-D-SVJ3/SPJ3 Series Instruction Manual	IB-1500193	008-483	
	MDS-DJ Series Instruction Manual	IB-1501132	100-354	

Outline drawings

CNC CPU module (Q173NCCPU)

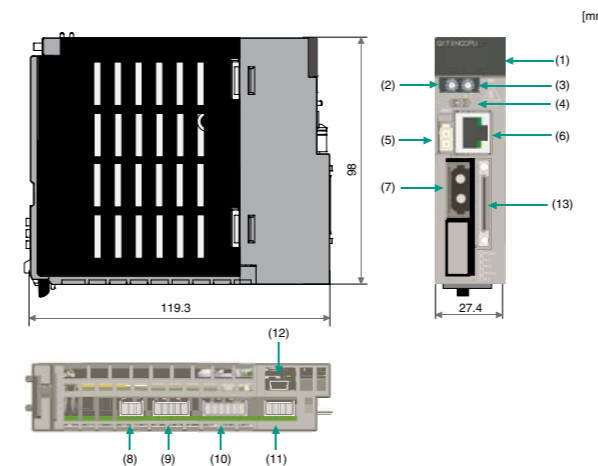

Part explanation

- (1) LED: Display of state/alarm code (with 3 digits)
- (2) SW1: Rotary switch for maintenance (usually set to "0")
- (3) SW2: Rotary switch for maintenance (usually set to "0")
- (4) SW: (Not used)
- (5) EMG: Connector for the emergency stop signal input
- (6) DISPLAY: Connector for display (GOT)
- (7) CN1: Connector for servo/spindle drive unit
- (8) RIO: Connector for dual signal module Q173SXY
- (9) AC FAIL: (Not used)
- (10) MPG: Connector for manual pulse generator
- (11) BAT: Connector for battery
- (12) Service: Connector for MITSUBISHI's servicing (Do not use)
- (13) EXT I/F: Connector for the expansion connection of skip signal/manual pulse generator

Signal splitter

(Note) Signal splitter allows DIN rail installation only.

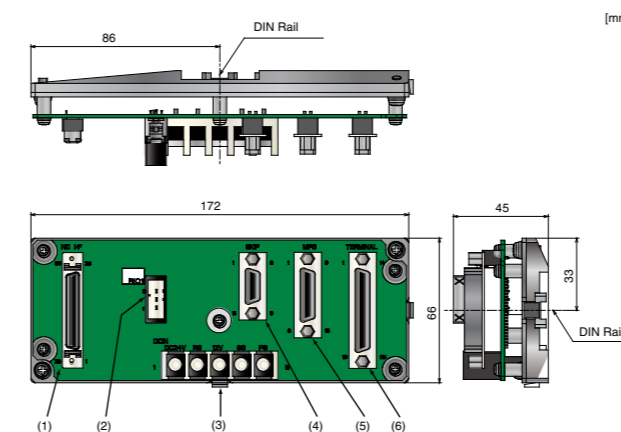

Part explanation

- (1) NC I/F: Connector for CNC CPU
- (2) RIO1: (Not used)
- (3) DCIN: Terminal block for power supply (to be used for the 12V manual pulse generator)
- (4) SKIP: Connector for skip signal
- (5) MPG: Connector for manual pulse generator
- (6) TERMINAL: (Not used)

Main base/Extension base

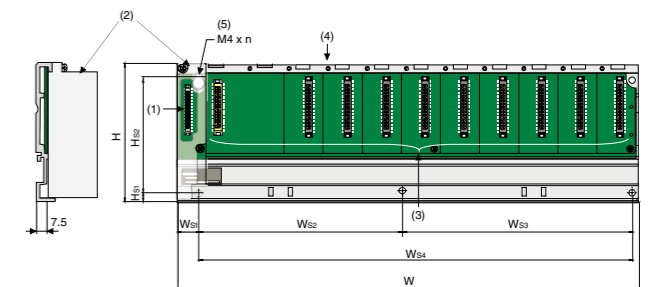

	Main base				Extension base		
	Q35DB	Q38DB	Q32DB	Q63B	Q65B	Q68B	Q612B
n	4	5	5	4	4	5	5
W	245	328	439	189	245	328	439
Ws1	15.5						
Ws2	-	170±0.3	170±0.3	-	-	190±0.3	190±0.3
Ws3	-	138±0.3	249±0.3	-	-	116±0.3	227±0.3
Ws4	224.5±0.3	-	-	167±0.3	222.5±0.3	-	-
H	88						
Hs1	7						
Hs2	80±0.3						

Part explanation

- (1) Extension cable connector
- (2) Base cover
- (3) Module connector
- (4) Module mounting screw hole
- (5) Base mounting hole

Battery for CNC CPU (Q173NCCPU)

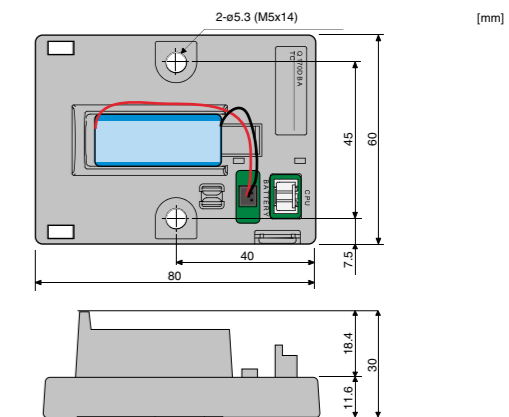

CNC CPU module model name	Lifetime of battery (Q6BAT)			
	Power-on time ratio ¹	Guaranteed value ² (75°C)	Actual service value ³ (40°C)	Back-up time after alarm ⁴
Q173NCCPU	0%	20,000hr	43,800hr	90hr (after SM51 or SM52 ON)
	30%	27,000hr		
	50%	31,000hr		
	70%	36,000hr		
	100%	43,800hr		

- ¹: The power-on time ratio indicates the ratio of C70 power-on time to one day (24 hours). (When the total power-on time is 12 hours and the total power-off time is 12 hours, the power-on time ratio is 50%.)
- ²: The guaranteed value is equivalent to the total power failure time which we have calculated based on the memory's (SRAM) characteristic value provided by the manufacturer under the storage ambient temperature range of -25 to 75°C (operating ambient temperature of 0 to 55°C).
- ³: The actual service value: equivalent to the total power failure time that is calculated based on the measured value under storage at ambient temperature of 40°C. This value is intended for reference only, as it varies with the characteristics of the memory, etc. Replace batteries every five years.
- ⁴: In the following status, the back-up time after power OFF is 3 minutes.
 - The battery connector is disconnected.
 - The battery lead wire is broken.

specification

Functional Specifications

○ Standard △ Optional □ Selection

Class	C70		General explanation		
	M system	L system			
Control axes	Number of basic control axes (NC axes)	3	2	The NC axis, spindle, and PLC axis are generically called the control axis. The NC axis can be manually or automatically operated using the machining program. The PLC axis can be controlled using the sequence program. The number of axes that is within the max. number of control axes, and that does not exceed the max. number given for the NC axis, spindle and PLC axis, can be used.	
	Max. number of axes (NC axes + Spindles + PLC axes)	16	16		
	Max. number of NC axes (in total for all the part systems)	16	16		
	Max. number of spindles	7	4		
	Max. number of PLC axes	8	8		
	Max. number of PLC indexing axes	8	8		The number of PLC axes available to be used as indexing axis.
	Number of simultaneous contouring control axes	4	4		Number of axes with which simultaneous interpolation control is possible.
Control axes	Max. number of NC axes in a part system	8	8	Max. number of NC axes possible to control in the same part system.	
	Control part system				
Control axes and operation modes	Standard number of part systems	1	1	One part system is the standard.	
	Max. number of part systems	△7	△3	Up to three part systems for the lathe system, and up to seven part systems for the machining center system.	
	Memory mode	○	○	The machining programs stored in the memory of the CNC module are run.	
Control axes and operation modes	MDI mode	○	○	The MDI data stored in the memory of the CNC module is executed.	
	High-speed program server mode	△	△	This function carries out high-speed transmission of machining programs to the large capacity buffer memory in the CNC CPU using the FTP function of Ethernet to run the programs. The operation thus requires an Ethernet connection with an FTP server such as personal computer or a GOT with FTP server function to which a CF card is connected.	
Data increment	Least command increment				
	Least command increment 1μm	○	○	Possible to command in increments of 0.001mm (linear axis) and 0.001° (rotary axis).	
	Least command increment 0.1μm	△	△	Possible to command in increments of 0.0001mm (linear axis) and 0.0001° (rotary axis).	
Unit system	Inch/Metric changeover	△	△	The unit systems of the data handled in the controller include the metric system and inch system. The type can be designated with the parameters and machining program.	
Input command	Program format			G code (program) format.	
	Program format	Format 1 for Lathe	—	○	G code list for the lathe system. The G-code list is selected by parameter.
		Format 2 for Lathe	—	○	
		Format 1 for Machining center	○	—	G code list for the machining center system.
Command value	Decimal point input I, II	○	○	For decimal point input type I, the minimum digit of a command not using a decimal point is the same as the least command increment. For decimal point input type II, when there is no decimal point, the final digit serves as the millimeter unit in the metric mode, as the inch unit in the inch mode and as the second unit in the time designation.	
	Absolute/Incremental command	○	○	When axis coordinate data is issued in a machining program command, either the incremental command method that commands a relative distance from the current position or the absolute command method that moves to a designated position in a predetermined coordinate system can be selected.	
	Diameter/Radius designation	—	○	For the axis command value, the radius designation or diameter designation can be changed over with parameters. When the diameter designation is selected, the scale of the length of the selected axis is doubled. (Only half (1/2) of the command amount moves.)	
Positioning	Positioning	○	○	This function carries out positioning at high speed using a rapid traverse rate with the travel command value given in the program.	
	Unidirectional positioning	△	—	The G code command always moves the tool to the final position in the direction determined by parameters.	
Positioning/Interpolation	Linear/Circular interpolation	Linear interpolation	○	○	Linear interpolation is a function that moves a tool linearly by the travel command value supplied in the program at the cutting feedrate designated by the F code.
		Circular interpolation (Center/Radius designation)	○	○	This function moves a tool along a circular arc on the plane selected by the travel command value supplied in the program.
	Helical interpolation	△	△	With this function, any two of three axes intersecting orthogonally are made to perform circular interpolation while the third axis performs linear interpolation in synchronization with the arc rotation. This control can be exercised to machine large-diameter screws or 3-dimensional cams.	
	Cylindrical interpolation	△	△	This function transfers the shape that is on the cylinder's side surface (shape yielded by the cylindrical coordinate system) onto a plane, and when the transferred shape is designated in the program in the form of plane coordinates, the shape is converted into a movement along the linear and rotary axes of the original cylinder coordinates, and the contours are controlled by means of the CNC unit during machining.	
	Polar coordinate interpolation	△	△	This function converts the commands programmed by the orthogonal coordinate axes into linear axis movements (tool movements) and rotary axis movements (workpiece rotation) to control the contours. It is useful for cutting linear cutouts on the outside diameter of the workpiece, grinding cam shafts, etc.	
	Hypothetical linear axis control	△	—	Using 1 linear axis and 1 rotary axis, this function composes a hypothetical linear axis which orthogonally intersects the real linear axis.	

○ Standard △ Optional □ Selection

Class	C70		General explanation		
	M system	L system			
Feed rate	Rapid traverse rate (m/min)	1000	1000	The rapid traverse rate can be set independently for each axis using the parameters.	
	Cutting feed rate (m/min)	1000	1000	This function specifies the feedrate of the cutting commands, and gives a command for a feed amount per spindle rotation or feed amount per minute.	
	Manual feed rate (m/min)	1000	1000	The manual feedrates are designated as the feedrate in jog mode or incremental feed mode for manual operation and the feedrate during dry run ON for automatic operation. The manual feedrates are set using external signals.	
	Rotary axis command speed tenfold	○	○	This function multiplies the rotary axis' command speed by ten during initial inching.	
Feed rate input methods	Feed per minute	○	○	By issuing a G command, the commands from the block are issued directly by the numerical value following F as the feedrate per minute (mm/min, inch/min).	
	Feed per revolution	△	○	By issuing a G command, the commands from the block are issued directly by the numerical value following F as the feedrate per spindle revolution (mm/rev, inch/rev).	
	F 1-digit feed	○	○	The feedrate registered by parameter in advance can be assigned by designating a single digit following address F.	
Override	Rapid traverse override	○	○	Override can be applied to manual or automatic rapid traverse using the external input signal supplied.	
	Cutting feed override	○	○	Override can be applied to the feedrate command designated in the machining program using the external input signal supplied.	
	2nd cutting feed override	○	○	Override can be further applied as a second-stage override to the feedrate after the cutting feed override has been applied.	
	Override cancel	○	○	By turning ON the external override cancel signal, the override is automatically set to 100% for the cutting feed during automatic operation mode (memory and MDI).	
Acceleration/Deceleration	Automatic acceleration/deceleration after interpolation	○	○	Acceleration/deceleration is applied to all commands automatically. The acceleration/deceleration patterns are linear acceleration/deceleration, soft acceleration/deceleration, exponent function acceleration/deceleration, exponent function acceleration/linear deceleration and any other that can be selected using a parameter.	
	Rapid traverse constant inclination acceleration/deceleration	○	○	This function performs acceleration/deceleration at a constant inclination during linear acceleration/deceleration in rapid traverse mode. Compared to the method of acceleration/deceleration after interpolation, the constant inclination acceleration/deceleration method improves cycle time.	
Thread cutting	Thread cutting (Lead/Thread number designation)	△	○	Thread cutting with a designated lead can be performed. Inch threads are cut by designating the number of threads per inch with the E address.	
	Variable lead thread cutting	—	○	By commanding the lead increment/decrement amount per thread rotation, variable lead thread cutting can be performed.	
	Synchronous tapping (with digital I/F spindle)	Synchronous tapping cycle	△	△	This function performs tapping through synchronized control of the spindle and servo axis. This eliminates the need for floating taps and enables tapping to be conducted at a highly accurate tap depth.
		Pecking tapping cycle	△	—	The load applied to the tool can be reduced by designating the depth of cut per pass and cutting the workpiece to the hole bottom for a multiple number of passes.
		Multiple spindle synchronous tapping	△	△	This function enables two or more spindles to perform synchronous tapping at a time, thereby improving the tapping efficiency.
	Chamfering	—	○	Chamfering can be enabled during the thread cutting cycle by using external signals.	
	High-speed synchronous tapping (OMR-DD)	△	△	This function increases the accuracy and shortens the cycle time of synchronous tapping by making the NC axis follow the spindle using drive unit communication.	
Manual feed	Manual rapid traverse	○	○	The tool can be moved at the rapid traverse rate for each axis separately. Override can also be applied to the rapid traverse rate by means of the rapid traverse override function.	
	Jog feed	○	○	The tool can be moved in the axis direction (+ or -) in which the machine is to be moved at the per-minute feedrate.	
	Incremental feed	○	○	The tool can be operated by an amount equivalent to the designated amount (incremental value) in the axis direction each time the jog switch is pressed.	
	Handle feed	△	△	The machine can be moved in very small amounts by rotating the manual pulse generator.	
Dwell	Dwell (Time-based designation)	○	○	The G code command temporarily stops machine movement and sets the machine stand-by status for the time designated in the program.	
Program memory/editing	Memory capacity (number of programs stored)	15KB[40m] (64 programs)	○	○	Machining programs are stored in the CNC memory.
		30KB[80m] (128 programs)	△	△	
		60KB[160m] (200 programs)	△	△	
		125KB[320m] (200 programs)	△	△	
		230KB[600m] (400 programs)	△	△	
		500KB[1280m] (1000 programs)	△	△	
		1000KB[2560m] (1000 programs)	△	△	
		2000KB[5120m] (1000 programs)	△	△	
Editing	Program editing	○	○	This function enables program editing such as correction, deletion and addition.	
	Background editing	○	○	This function enables one machining program to be created or edited while another program is running.	
	Word editing	○	○	This function allows insertion, deletion, and replacement of a program in word units.	

○ Standard △ Optional □ Selection

Class	C70		General explanation
	M system	L system	
Structure of operation/display panel	Color display (GOT)	□	Select a GOT in its lineup. For details, refer to catalogs : "GOT2000 series" and "GOT1000 series".
	Absolute value/Incremental value setting	○	When setting the data, the absolute/incremental setting can be selected from the menu.
Operation methods and functions	Single-NC and multi-display unit switch	○	Using an Ethernet hub, one CNC module can be connected to and switched between up to eight displays. (Note that the max. number of connectable displays is limited depending on the machine operation panel specifications.)
	Multi-NC and common-display unit	○	Using an Ethernet hub, one display can be connected to and switched between up to 64 CNC modules. (Note that the max. number of connectable displays is limited depending on the machine operation panel specifications.)
	Displayed part system switch	○	The part system displayed on the screen can be changed.
	Screen saver, backlight OFF	○	The GOT's screensaver function protects the display by turning the backlight OFF after the preset time has elapsed.
	Screen Capture	○	The GOT's hard copy function captures the screen image in JPEG or bitmap format.
	CNC machining program edit	○	This function allows a CNC machining program to be edited on a GOT screen.
	Operation and display	Status display	○
Clock display		○	The clock is built-in, and the date (year, month, date) and time (hour, minutes, seconds) are displayed.
Position display		○	Various information related to operation, such as the axis counter, speed display and MSTB command are displayed on the Position Display screen.
Display methods and contents (CNC monitor function)	Tool compensation/Parameter	○	Tool/Workpiece related settings, user parameter settings, manual numeric command issuing and tool length measurements can be carried out on the Tool Compensation/Parameter screen.
	Program	○	Machining program searching, creating and editing (addition, deletion, change), program list display and MDI editing can be carried out on the Program screen.
	Alarm diagnosis	○	The operations related to CNC diagnosis can be carried out on the Diagnosis screen.
	Additional languages		The languages capable of being displayed on the screen.
	Japanese	○	
	English	○	
	German	△	
	Italian	△	
	French	△	
	Spanish	△	
Chinese	△		
Simplified Chinese characters	△		
Polish	△		
Input/Output functions and devices	Machining program input/output	○	With the GOT's CNC data input/output function, CNC data can be input/output from/to the memory card mounted in the GOT.
	Tool offset data input/output	○	
	Common variable input/output	○	
	Parameter input/output	○	
	History data output	○	

○ Standard △ Optional □ Selection

Class	C70		General explanation		
	M system	L system			
Spindle control functions	Spindle digital I/F	○	The spindle rotation speed is determined in consideration of the override and gear ratio for the S command given in automatic operation or with manual numerical commands, and the spindle is rotated.		
	Spindle analog I/F	△(MELSEC I/O used)	△(MELSEC I/O used)	This interface is used to connect the digital spindle (AC spindle motor and spindle drive unit).	
	Coil switch	○	○	Spindle control can be executed using an analog spindle instead of the digital spindle.	
	Automatic coil switch	○	○	Constant output characteristics can be achieved across a broad spectrums down to the low-speed ranges by switching the spindle motor connections. This is a system under which commands are assigned from the PLC.	
	S code output	○	○	Constant output characteristics can be achieved across a broad spectrums down to the low-speed ranges by switching the spindle motor connections. This is a system under which the CNC module switches the coils automatically in accordance with the motor speed.	
	Constant surface speed control	△	△	When an eight-digit number is commanded following the address S (S-99999999 to S99999999), 32-bit binary data with a sign and the star signal will be output to the PLC.	
	Spindle override	○	○	With radial direction cutting, this function enables the spindle speed to be changed in accordance with changes in the radial direction coordinate values and the workpiece to be cut with the cutting point always kept at a constant speed (constant surface speed).	
	Multiple-spindle control	○	○	This function applies override to the rotation speed of a spindle assigned by the machining program command during automatic operation or by manual operation.	
	Multiple-spindle control I	○	○	When using a machine tool equipped with several spindles, this function controls those spindles.	
	Spindle orientation	○	○	This function stops the spindle rotation at a certain position.	
	Spindle position control (Spindle/C axis control)	△	△	This function enables one spindle drive unit to also be used as the C axis (rotary axis) using an external signal.	
	Spindle synchronization	○	○	The C axis servo ON signal is used to switch between the spindle and C axis.	
	Spindle synchronization I	△	△	In a machine with two or more spindles, this function controls the rotation speed and phase of one selected spindle (synchronized spindle) in synchronization with the rotation of the other selected spindle (basic spindle). There are two methods for giving commands: G code and PLC.	
	Spindle synchronization II	△	△		
	Spindle speed clamp	○	○	The spindle rotation speed is clamped between max. rotation speed and min. rotation speed.	
External spindle speed clamp	○	○	This function clamps the spindle rotation speed at the speed set by parameter when the external spindle clamp signal which is externally input from the sequence program turns ON.		
Tool functions (T)	Tool functions (T command)	○	○	This is used for limiting the speed when the usual speed is too fast, in a situation such as carrying out machining with the door open.	
	Miscellaneous functions	○	○	The command is issued with an 8-digit number following address T (T0 to T99999999). The tool function is used to command the tool No. in the lathe specification controller, the tool compensation (tool length compensation, tool nose wear compensation) Nos. are also indicated.	
Miscellaneous functions (M)	Multiple M codes in 1 block	○	○	When an 8-digit number (M00000000 to M99999999) is assigned following address M, the 8-digit code data and start signal are output to the PLC.	
	M code independent output	○	○	Four sets of M commands can be issued simultaneously in a block.	
	Miscellaneous function finish	○	○	When the M00, M01, M02 or M30 command is assigned during an automatic operation (memory, MDI) or by a manual numerical command, the signal of this function is output. It is turned OFF after the miscellaneous function finishes or by the "Reset & Rewind" signal.	
2nd miscellaneous functions (B)	2nd miscellaneous functions	○	○	These signals inform the CNC system that a miscellaneous function (M), spindle function (S), tool function (T) or 2nd miscellaneous function (A, B, C) has been assigned, and that the PLC which has received it has completed the required operation. They include miscellaneous function finish signal 1 (FIN1) and miscellaneous function finish signal 2 (FIN2).	
	2nd miscellaneous functions	○	○	The code data and start signals are output when an 8-digit number is assigned following the address code A, B or C — whichever does not duplicate the axis name being used.	
Tool compensation	Tool length/Tool position	○	○	These commands make it possible to control the axis movement by offsetting the position of the end point of the travel command by the amount set on the TOOL OFFSET screen.	
	Tool radius	Tool radius compensation	○	—	These commands function to provide tool radius compensation. Through a combination with the G command and D address assignment, they compensate the actual tool center path either inside or outside the programmed path by an amount equivalent to the tool radius.
		Tool nose radius compensation (G40/41/42)	—	○	Corresponding to the tool No., the tool nose is assumed to be a half circle of radius R, and compensation is made so that the half circle touches the programmed path.
		Automatic decision of nose radius compensation direction (G46/40)	—	○	The nose radius compensation direction is automatically determined from the tool tip and the specified movement vector.
	Tool offset amount	Number of tool offset sets			
		40 sets	○	—	The standard for the machining center system is 40 sets. Note that the standard for the machining center system with 3-part systems will be up to 80 sets/part system, or with 4-part systems or more, up to 40 sets/part system. For the lathe system, up to 80 sets/part system regardless of the number of part systems.
		80 sets	△	○	
100 sets		△	—		
200 sets	△	—			
Offset memory					
Tool shape/wear offset amount	○	○	This function registers the tool shape offset and wear offset amounts.		

Manufacturing technologies (production site)

Maintenance

Design and Development

Safety and Energy-savings

○ Standard △ Optional □ Selection

Class	C70		General explanation	
	M system	L system		
Coordinate system	Machine coordinate system	○	○	The machine coordinate system is used to express the prescribed positions (such as the tool change position and stroke end position) characteristic to the machine, and it is automatically set immediately upon completion of the first dog-type reference position return after the power has been turned ON or immediately after the power has been turned ON if the absolute position specifications apply.
	Coordinate system setting	○	○	By issuing a G code, the program coordinate system (zero point of program) can be changed on the workpiece coordinate system.
	Automatic coordinate system setting	○	○	After turning the power ON, even without executing the reference position return, the basic machine coordinate system and the workpiece coordinate system are set automatically.
	Workpiece coordinate system selection			
	Workpiece coordinate system selection (6 sets)	○	○	When multiple workpieces with the same shape are to be machined, these commands enable the same shape to be machined by executing a single machining program in the coordinate system of each workpiece.
	Extended workpiece coordinate system selection (48 sets) G54.1P1 to P48	△	—	
	External workpiece coordinate offset	○	○	An external workpiece coordinate offset that serves as a reference for all the workpiece coordinate systems is available outside the workpiece coordinates. By setting the external workpiece coordinate offset, the external workpiece coordinate system can be shifted, and all the workpiece coordinate systems can be simultaneously shifted by an amount equivalent to the offset.
	Local coordinate system	○	○	This function is for assigning a coordinate system on the workpiece coordinate system currently being selected. This enables the workpiece coordinate system to be changed temporarily.
	Coordinate system for rotary axis	○	○	The coordinate system of the rotary axis ranges from 0 to ±360°. Note that, however, it can be displayed from 0 to 359.999.
	Plane selection	○	○	By issuing a G code, it is possible to specify the planes for the arc, tool radius compensation, coordinate rotation and other commands.
	Origin set/Origin cancel	○	○	Using the CNC monitor, the coordinate system (current position and workpiece coordinate position) can be set to "0" by screen operations.
	Counter set	○	○	Using the CNC monitor, the position counter display can be changed to "0" by screen operations.
	Return	Manual reference position return	○	○
Automatic 1st reference position return		○	○	By commanding the G code during an automatic operation, the 1st reference position return is executed. If an intermediate point is commanded, a positioning is made to the point at rapid traverse rate, then each axis returns to its 1st reference position.
2nd, 3rd, 4th reference position return		○	○	As in automatic 1st reference position return, by commanding the G code during an automatic operation, an axis returns to a certain point of the machine (2nd/3rd/4th reference position).
Reference position check		○	○	By issuing a G code, a machining program, which has been prepared so that the tool starts off from the reference position and returns to the reference position, can be checked to see whether the tool will return properly to the reference position.
Absolute position detection		△	△	With this function, a battery stores the relation of the actual machine position and the machine coordinate kept in the CNC even during the power OFF, and an automatic operation is enabled without executing a reference position return.

○ Standard △ Optional □ Selection

Class	C70		General explanation	
	M system	L system		
Program control	Optional block skip	○	○	When "F" (slash code) is programmed at the head of a block, and the optional block skip input signal from the external source is turned ON for automatic operation, the block with the "F" code is skipped.
	Optional block skip addition	○	○	When "I" (n:1 to 9) is programmed at the head of a block, and the optional block skip input signal from the external source is turned ON for automatic operation, the block with the "I" code is skipped.
	Single block	○	○	The commands for automatic operation can be executed one block at a time (block stop) by turning ON the single block input signal.
Program test	Dry run	○	○	F code feed commands for automatic operation can be switched to the manual feedrate data of the machine operation board by turning ON the dry run input signal.
	Machine lock	○	○	When the machine lock input signal is set to ON, the CNC operations can be executed without actually moving the NC axis.
	Miscellaneous function lock	○	○	When the "External input" signal or "Miscellaneous function lock" signal is turned ON, the output signals of M, S, T, and B (2nd miscellaneous function) will not be output to the PLC. This is useful when checking only travel commands in a program check.
Operation support functions	Program search	○	○	The program No. of the program to be operated automatically can be designated and called up.
	Sequence number search	○	○	Blocks can be indexed by setting the program No., sequence No. and block No. of the program to be operated automatically.
	Program restart	△	△	When resuming a machining program after a suspension due to tool damage or other reasons, this function searches the program and the block to be resumed and enables machining to be resumed from the block.
	Automatic operation start	○	○	With the input of the automatic operation start signal (change from ON to OFF), automatic operation of the program that was found by an operation search is started by the controller (or the halted program is restarted).
	NC reset	○	○	This function enables the controller to be reset.
	Feed hold	○	○	When the feed hold signal is set to ON during automatic operation, the machine feed is immediately decelerated and stopped.
	Search & Start	○	○	If the "Search & Start" signal is input when the memory mode is selected, the designated machining program is searched and executed from the beginning.
	Manual interruption	○	○	Manual interrupt is a function that enables manual operations to be performed during automatic operation.
	Automatic operation handle interruption	○	○	The handle command can interrupt and be superimposed onto a command without suspending automatic operation, and the machine can be moved by rotating the manual pulse generator during automatic operation.
	Manual absolute switch	○	○	The program absolute positions are updated by an amount equivalent to the distance by which the tool is moved manually when the manual absolute switch signal is turned ON.
Interrupt operation	Thread cutting cycle retract	—	△	This function suspends the thread cutting cycle if a feed hold signal has been input during thread cutting cycle.
	Tapping retract	○	○	If tapping is interrupted by a reset or emergency stop signal that is input during tapping and the tap is left engaged inside the workpiece, the tap tool engaged inside the workpiece can be rotated in the reverse direction so that it will be disengaged by inputting the tap retract signal.
	Manual numerical value command	○	○	On the screen of the CNC monitor, the M, S and T (and B when 2nd miscellaneous function is enabled) commands can be executed by setting numerical values and pressing [INPUT].
	MDI interruption	○	○	This function enables MDI programs to be executed during automatic operation in the single block stop status. When the modal status is changed in the MDI program, the modal status in the automatic operation mode is also changed.
	Simultaneous operation of manual and automatic modes	○	○	This function enables manual operations to be performed during automatic operation by selecting an automatic operation mode (MDI or memory) and manual mode (handle, step, jog or manual reference position return) simultaneously. (Arbitrary feed based on the PLC is also possible.)

○ Standard △ Optional □ Selection

Class	C70		General explanation
	M system	L system	
Program			
Subprogram control	○ 8 layers	○ 8 layers	When the same pattern is repeated during machining, the machining pattern is registered as one subprogram and the subprogram is called from the main program as required, thereby realizing the same machining easily. Efficient use of programs is possible.
Macro program			
User macro	△ 4 layers	△ 4 layers	In order to execute one integrated function, a group of control and arithmetic instructions can be used and registered as a macro program.
Machine tool builder macro	△	△	Using this function, machine tool builder can register their macro programs in the NC, and a display/edit operation of these programs can be protected with password.
Macro interruption	△	△	By inputting a user macro interrupt signal from the PLC, the program being currently executed is interrupted and other programs can be called instead.
Variable command			
100 sets	○	○	Programming can be given flexible and general-purpose capabilities by designating variables instead of directly assigning numbers for addresses in programs and by supplying the values of those variables as required when running the programs. Arithmetic operations (adding, subtracting, multiplying and dividing) can also be conducted for the variables.
200 sets	△	△	
300 sets	△	△	
600 sets	△	△	
(50+50×number of part systems) sets	○	○	
(100+100×number of part systems) sets	△	△	
(200+100×number of part systems) sets	△	△	
(500+100×number of part systems) sets	△	△	
N code macro	△	△	This function calls the macro program using a pre-registered N code. The N No. and the macro program are registered using parameter settings, and up to eight can be registered. The "user macro" option is required.
Macro interface extension (1200 sets)	△	△	These variables enable direct reading/writing of the data between the CNC machining program and sequence program.
Fixed cycle			
Fixed cycle for drilling	○	○	These functions enable drilling, tapping and other hole machining cycles to be assigned in a simple 1-block program. Special fixed cycles must always be used in combination with fixed cycles.
Special fixed cycle	△	—	
Fixed cycle for turning machining	—	○	When carrying out rough cutting, etc. in turning machining, using this function, only one block is enough for a shape that normally requires several blocks. This is useful for simplifying machining programs.
Compound type fixed cycle for turning machining	—	○	
Mirror image			
Mirror image by G code	○	—	Using a program for the left or right side of an image, this function can machine the other side of the image when a left/right symmetrical shape is to be cut.
Mirror image for facing tool posts	—	△	With machines in which the base tool post and facing tool post are integrated, this function enables the programs prepared for cutting at the base side to be executed by the tools on the facing side.
Coordinate system operation			
Coordinate rotation by program	△	△	When it is necessary to machine a complicated shape at a position that has been rotated with respect to the coordinate system, you can machine a rotated shape by programming the shape prior to rotation on the local coordinate system, and then specifying the parallel shift amount and rotation angle by means of this coordinate rotation command.
Dimension input			
Corner chamfering/Corner R	△	△	This function executes corner processing by automatically inserting a straight line or arc in the commanded amount between two consecutive travel blocks.
Geometric command	—	○	When it is difficult to find the intersection point of two straight lines with a continuous linear interpolation command, this point can be calculated automatically by programming the command for the angle of the straight lines.
Axis control			
Chopping			
Chopping	△	△	This function continuously raises and lowers the chopping axis independently of program operation. During the grinding operation, chopping can produce a better surface accuracy than using abrasive grain.
Normal line control	△	—	This function controls the swiveling of the C axis (rotary axis) so that the tool is always pointing in the normal line direction for movements of the axis which is selecting the plane during program operation.
Circular cutting	△	—	A series of cuts is performed: first, the tool departs from the center of the circle, and by cutting along the inside circumference of the circle, it draws a complete circle, then it returns to the center of the circle.
Multi-part system control			
Timing synchronization between part systems	○	○	The multi-axis, multi-part system compound control CNC system can simultaneously run multiple machining programs independently. This function is used in cases when, at some particular point during operation, the operations of different part systems are to be synchronized or in cases when the operation of only one part system is required.
Start point designation timing synchronization	○	○	The synchronizing point can be placed in the middle of the block by designating the start point.
Balance cut	—	○	When a workpiece that is relatively long and thin is machined on a lathe, deflection may result, making it impossible for the workpiece to be machined with any accuracy. In cases like this, the deflection can be minimized by holding tools simultaneously from both sides of the workpiece and using them in synchronization to machine the workpiece (balance cutting). In addition, since the workpiece is machined by two tools, the machining time is reduced.
2-part system synchronous thread cutting	—	○	This function performs synchronous thread cutting for the same spindle using the 1st and 2nd part systems.
Data input by program			
Parameter input by program	△	△	The parameters set from the display can be changed using the machining programs.
Compensation data input by program	△	△	The value of the workpiece coordinate systems selected can be set or changed using program commands. The tool offset amounts, that are set from the display can be input using program commands.
Machining modal			
Tapping mode	○	○	When tapping mode commands are issued, the CNC system is set to the internal control modes required for tapping.
Cutting mode	○	○	When a cutting mode command is issued, the CNC system is set to the cutting mode that enables a smoothly cut surface to be achieved.

○ Standard △ Optional □ Selection

Class	C70		General explanation		
	M system	L system			
Program support functions	Machining accuracy support functions	Automatic corner override	○	○	To prevent machining surface distortion due to increase in the cutting load when cutting corners, this function automatically applies an override on the cutting feedrate so that the cutting amount is not increased for a set time at the corner.
		Deceleration check			This function decelerates and stops a motor before executing the next block, which lowers a shock to the machine which is caused by a rapid change of feedrate, and prevents a corner from being machined round.
		Exact stop check mode	○	○	
		Exact stop check	○	○	
	Error detection	○	○		
Programmable in-position check	○	○			
High-accuracy function	High-accuracy control1(G61.1)	△	△	This function controls the operation so the lag will be eliminated in control systems and servo systems. With this function, improved machining accuracy can be realized, especially during high-speed machining, and machining time can be reduced. Available with the 1st part system only.	
	Static accuracy compensation	Backlash compensation	○	○	This function compensates the error (backlash) produced when the direction of the machine system is reversed.
Memory-type pitch error compensation		△	△	Machine accuracy can be improved by compensating the errors in the screw pitch intervals among the mechanical errors (production errors, wear, etc.) of the feed screws.	
Memory-type relative position error compensation		△	△	Machine accuracy can be improved by compensating the relative error between machine axes, such as a production error or aging.	
External machine coordinate system compensation		△	△	The coordinate system can be shifted by inputting a compensation amount from the PLC. This compensation amount will not appear on the counters (all counters including machine position).	
Circular error radius compensation		△	△	With commands designated during arc cutting, this function compensates movement toward the inside of the arcs caused by a factor such as servo delay.	
Ball screw thermal expansion compensation		△	△	This compensates the axis feed error caused by ball screw thermal expansion, etc. using the values set by the PLC.	
Dynamic accuracy compensation	Smooth high-gain (SHG) control	○	○	This is a high-response and stable position control method using the servo system. SHG control realizes an approximately three-fold position loop gain compared to the conventional control method.	
	Dual feedback	○	○	Use position feedback with a motor-side detector in ranges with high acceleration to enable stable control. In ranges with low acceleration, use position feedback with the machine-side detector (scale). This will make it possible to increase the position loop gain. A machine-side detector (scale) is separately required.	
	Lost motion compensation	○	○	This function compensates the error in protrusion shapes caused by lost motion at the arc quadrant changeover section during circular cutting.	
Measurement	Skip				
	Skip	△	△	When the external skip signal is input during linear interpolation using the G31 command, machine feeding is stopped immediately, the remaining distance is discarded, and the commands in the next block are executed.	
	Multiple-step skip	△	△	This function realizes skipping by designating a combination of skip signals for each skip command.	
	PLC skip	△	△	This function enables skip operations to be performed by signals which are input from the sequence program.	
	Automatic tool length measurement	△	△	This function moves the tool in the direction of the tool measurement position by the commanded value between the measurement start position and measurement position. It stops the tool as soon as it contacts the sensor and calculates the difference between the coordinates when the tool has stopped and the command coordinates. It registers this difference as the tool length offset amount for that tool.	
Automation support functions	Manual tool length measurement 1	△	△	Simple measurement of the tool length is done without a sensor.	
	Tool life management	Tool life management			
		Tool life management I	△	△	Tool life management is performed using the amount of time and the frequency a tool is used.
		Tool life management II	△	△	A spare tool change function is added to "Tool life management I".
Number of tool life management sets					
80 sets	—	△	The max. number of tool life management sets. Lathe system: Up to 80 for one part system, up to 40 for two part systems Machining center system: Up to 100 regardless of the number of part systems		
100 sets	△	—			
Others	Programmable current limitation	○	○	This function allows the current limit value of the servo axis to be changed to the desired value in the program, and is used for the workpiece stopper, etc.	
	PLC axis current limit	○	○	A current limit is available for the PLC axis as well as for the NC axis. This function can be used for actions such as stopper operation.	
Safety switches	Emergency stop	○	○	All operations are stopped by the emergency stop signal input, and at the same time, the drive section is shutdown to stop movement of the machine.	
	Data protection key	○	○	With the input from the sequence program, it is possible to prohibit the setting and deletion of parameters and the editing of programs from the display.	
Safety and maintenance	Display for ensuring safety	NC warning	○	○	Warnings are output by the CNC system. When one of these warnings has occurred, a warning number is output to the PLC and a description of the warning appears on the screen. Operation can be continued without taking further action.
		NC alarm	○	○	The alarms are output by the CNC system. When one of these alarms has occurred, an alarm number is output to the PLC, and a description of the alarm appears on the screen. Operation cannot be continued without taking remedial action.
	Operation stop cause	○	○	The stop cause of automatic operation is shown on the display.	
	Emergency stop cause	○	○	When the "EMG" (emergency stop) message is displayed in the operation status area of the display, the cause of the emergency stop can be confirmed.	
	Thermal detection	○	○	When overheating is detected in the CNC CPU module, an alarm is displayed.	
	Battery alarm/warning	○	○	When it is time to change the batteries, an alarm and warning are displayed.	

Manufacturing technologies
(production site)

Maintenance

Design and Development

Safety and Energy-savings

○ Standard △ Optional □ Selection

Class		C70		General explanation	
		M system	L system		
Display for ensuring safety	Insulation degradation monitor	△	△	Insulation degradation monitor function monitors insulation degradation by insulation resistance value calculated from leakage current values of servo motors and spindle motors that are measured with a zero-phase-sequence current transformer (ZCT) (user-prepared), a leakage transducer (user-prepared), and an analog/digital conversion unit (Q66AD-DG) to assist machine breakdown prevention. NC CPU monitors the resistance value and an alarm/warning occurs when the value becomes less than the preset alarm/limit value. Users can utilize it by PLC processing or combining with an insulation degradation monitor screen for GOT, a Japanese sample of which is available (not available in other languages).	
	Stroke end (Over travel)	○	○	Limit switches and dogs are attached to the machine, and when a limit switch has kicked a dog, the movement of the machine is stopped by the signal input from the limit switch.	
Protection	Stored stroke limit			This function sets the prohibited area for the tool to enter. There are multiple choices according to the prohibited range and method.	
	Stored stroke limit I/II	○	○		
	Stored stroke limit IB	△	△		
	Stored stroke limit IIB	△	△		
	Stored stroke limit IC	△	△		
	Chuck/Tailstock barrier check	—	○	By limiting the tool nose point movement range, this function prevents the tool from colliding with the chuck or tail stock because of a programming error.	
	Interlock	○	○	The machine movement will decelerate and stop as soon as the interlock signal, serving as the external input, is turned ON. When the interlock signal is turned OFF, the machine starts moving again.	
	External deceleration	○	○	This function reduces the feedrate to the deceleration speed set by the parameter when the external deceleration input signal has been set to ON.	
	Door interlock			Under the CE marking scheme of the European safety standards (machine directive), the opening of any protective doors while a machine is actually moving is prohibited. When the door open signal is input from the PLC, this function first decelerates, stops all the control axes, establishes the ready OFF status, and then shuts off the drive power inside the servo drive units so that the motors are no longer driven.	
	Door interlock I	○	○		
Door interlock II	○	○			
Parameter lock	○	○	This function is used to prohibit changing the set-up parameter.		
Program protection (Edit lock B, C)	○	○	The edit lock function B or C inhibits machining program B or C (group with machining program numbers) from being edited or erased when these programs require protection.		
Program display lock	○	○	This function allows the display of only a target program (label address 9000) to be disabled for the program display in the monitor screen, etc.		
Safety and maintenance	Safety observation	△	△	The safety observation function supports the following features: (1) Safety signal comparison between two CPUs with redundant input/output of the safety signals (2) Redundant emergency stop in which more than one CPU monitors the emergency stop signals to shutoff the drive's main power (3) Speed monitoring that allows an operator to access a moving part of machine by opening the door without shutting OFF the power (4) Door signal observation made by two CPUs for redundantly input door signals (5) Mode signal observation made by two CPUs by monitoring the door signal status and speed observation mode signal status (6) Safe torque OFF (STO) that shuts OFF power to a torque-generating motor (7) Safe operating stop (SOS) that enables an access to a moving part without power shutoff through standstill monitoring (8) Safe brake control (SBC) that safely controls a holding brake through dual-channel brake control signals (9) Safe stop 2 (SS2) that controls the OFF/ON of the standstill monitor request signal and the delay process for deceleration through a user's safety sequence program	
	Operation history	○	○	This is a maintenance function which is useful for tracing the history and CNC operation information, and analyzing trouble, etc. This information can be output as screen displays or as files.	
	Data sampling	○	○	The data sampling function can sample the CNC internal data (speed output from the CNC to the drive unit and feedback data from the drive unit, etc.) and output it as text data.	
	NC data backup	○	○	This function serves to back-up the parameters and other data of the CNC module. The data can also be restored.	
	Servo tuning support tools			With this function, the servo parameters can be automatically adjusted by connecting the CNC and MS Configurator, which is an application that runs on a regular personal computer. (This tool is free of charge. Please contact us.)	
	MS Configurator (Need to prepare separate S/W)	○	○		
	NC Analyzer (Need to purchase separate S/W)	○	○	With this function, the servo parameters can be automatically adjusted by connecting the CNC and NC Analyzer, which is an application that runs on a regular personal computer.	
	Parameter setting tool			With this function, CNC data necessary for CNC control and machine operation can be edited by connecting the CNC and NC Configurator2, which is an application that runs on a regular personal computer. (Please contact us to purchase a full function version. A limited function version is also available free of charge.)	
	NC Configurator2 (Need to purchase separate S/W)	○	○		
	Backup	○	○	This function saves (backs up) the screen data and each controller (PLC, CNC) data to a GOT's memory card or USB memory. It also reloads (restores) that data to each device.	
Drive system	Servo/ Spindle	Servo drive unit			CNC dedicated products are used as drive units, spindle motors, and servo motors. Refer to the MITSUBISHI CNC Drive System General Catalog for details.
		MDS-D-V1/D-V2 (200V)	□	□	
		MDS-DH-V1/DH-V2 (400V)	□	□	
		MDS-D-SVJ3/SVJ3NA (200V)	□	□	
		MDS-D2-V1/D2-V2/D2-V3(200V)	□	□	
		MDS-DH2-V1/DH2-V2(400V)	□	□	
		MDS-DJ-V1(200V)	□	□	
	Spindle drive unit				
	MDS-D-SP (200V)	□	□		
	MDS-DH-SP (400V)	□	□		
	MDS-D-SPJ3/SVJ3NA (200V)	□	□		
	MDS-D-SP2(200V)	□	□		
	MDS-D2-SP(200V)	□	□		
	MDS-DH2-SP(400V)	□	□		
	MDS-D2-SP2(200V)	□	□		
	MDS-DJ-SP(200V)	□	□		
	Multi-hybrid drive unit				
	MDS-DM-V3(200V)	□	□		
MDS-DM-SPV2/SPV3(200V)	□	□			
MDS-DM2-SPV2/SPV3/SPH3(200V)	□	□			
Machine support functions	PLC functions			The PLC CPU of MITSUBISHI Programmable Controller MELSEC is used. For details, refer to the material of MITSUBISHI Programmable Controller MELSEC which can be used with MITSUBISHI CNC C70.	
	Built-in PLC basic function	△ (MELSEC)	△ (MELSEC)		

○ Standard △ Optional □ Selection

Class		C70		General explanation
		M system	L system	
PLC functions	NC exclusive instruction	△ (MELSEC)	△ (MELSEC)	CNC exclusive instructions are not MELSEC standard instructions. They are directly related to the memory in the CNC, and convenient for using a CNC. They can be programmed with the MELSEC programming tool GX Works as other standard instructions.
	Built-in PLC processing mode	○	○	This function is used when executing safety observation of significant signals using a dual signal module. For details, refer to the manual related to the safety observation function.
	PLC support functions			
	Multi-ladder program register and execution	△ (MELSEC)	△ (MELSEC)	This function stores and executes more than one sequence program.
	Ladder program writing during RUN	△ (MELSEC)	△ (MELSEC)	This function is used to write sequence programs when the CPU module is operating.
	PLC protection	△ (MELSEC)	△ (MELSEC)	With this function, it is possible to prohibit data such as sequence programs and device comments from being read/written.
	Built-in PLC capacity	□ 30k/40k/60k/100k/130k/260k	□ 30k/40k/60k/100k/130k/260k	In the program memory, it is possible to store the system area of parameters, intelligent function module parameters, sequence programs, device comments, and device initial values.
	Machine contact input/output I/F	△ (MELSEC)	△ (MELSEC)	The device is selected from the I/O modules of the MITSUBISHI Programmable Controller MELSEC Q Series.
	Ladder monitor	○	○	This function enables on GOT displays the operating status of the sequence circuit to be checked "Sequence program monitor" (GOT2000) or "Ladder edit" (GOT1000) is applied.
	PLC development			
MELSEC development tool (GX Works) (Need to purchase separate S/W)	△ (MELSEC)	△ (MELSEC)	Using GX Works, the sequence programs of the MELSEC CPU can be developed and debugged.	
Machine construction	Servo OFF	○	○	When the servo OFF signal (per axis) is input, the corresponding axis is set in the servo OFF state. When the moving axis is mechanically clamped, this function is designed to prevent the servo motor from being overloaded by the clamping force.
	Axis detachment	△	△	This function enables the control axis to be released from control.
	Synchronous control	△	—	The synchronous control is a control method whereby both primary and secondary axes are controlled with the same travel command by designating the travel command for the primary axis also to the secondary axis. This function is assumed to be used in such equipment as large machine tools, which drive one axis with two servo motors.
	Inclined axis control	—	△	Even when the control axes configuring the machine are mounted at an angle other than 90 degrees, this function enables it to be programmed and controlled in the same way as with an orthogonal axis.
	Position switch	○ (24 per part system, 16 for PLC axes)	○ (24 per part system, 16 for PLC axes)	Instead of a dog switch on a machine's axis, a hypothetical dog switch is established using a parameter to set a coordinate position to show the axis name and the hypothetical dog position. When the machine reaches the position, a signal is output to the PLC interface.
	Multi-secondary-axis Synchronous Control	△	—	Multi-secondary-axis synchronous control function serves to drive 2 or more secondary axes in synchronization with travel commands for the primary axis.
	Arbitrary feed in manual mode	○	○	This function enables the feed directions and feedrates of the control axes to be controlled using commands from the sequence program.
	PLC axis control	△	△	Over and above the NC control axes, this function enables axes to be controlled independently by commands from the PLC.
	PLC axis indexing	△	△	By setting positioning points (stations) in advance, positioning control can be performed simply by designating a positioning point No. (station No.) Up to 20 points (stations) can be set.
	NC axis/PLC axis changeover	△	△	This function enables one control axis to be dynamically switched to be used as NC axis or PLC axis. If the PLC axis is set as indexing axis, changeover is available between the NC axis and indexing axis.
PLC interface	CNC control signal	○	○	Control commands to the CNC system are assigned from the PLC. Input signals with skip inputs that respond at high speed can also be used.
	CNC status signal	○	○	The status signals are output from the CNC system. They can be utilized by referencing them from the PLC.
	PLC window	△	△	PLC window is used to read/write the operation state, axis information, parameters and tool data of the CNC through a cyclic transmission area in the CPU shared memory.
	External search	△	△	This function enables searching of the program to automatically start from the PLC. The program No., block No. and sequence No. can be designated. In addition, the currently searched details can be read.
External PLC link	CC-Link (Master/Slave)	△ (MELSEC)	△ (MELSEC)	Refer to manuals of MITSUBISHI Programmable Controller "MELSEC Q series" for information on the function and the performance.
	PROFIBUS-DP (Master)	△ (MELSEC)	△ (MELSEC)	
	DeviceNet (Master)	△ (MELSEC)	△ (MELSEC)	
	FL-net	△ (MELSEC)	△ (MELSEC)	
	CC-Link/LT	△ (MELSEC)	△ (MELSEC)	
	CC-Link IE	△ (MELSEC)	△ (MELSEC)	
ASI	△ (MELSEC)	△ (MELSEC)		
Installing S/W for machine tools	EZSocket I/F (Need to purchase separate S/W)	○	○	This middleware makes it easy to develop applications which have a Windows interface.
	APLC release (Need to purchase separate S/W)	△	△	APLC (Advanced Programmable Logic Controller) release is a function that allows the user-generated C language module to be called from NC. Control operations that are difficult to express in a sequence program can be created with C language.
GOT	GOT window	○	○	GOT window can read data such as current machining program and coordinate value from CNC CPU directly.
	CNC remote operation tool			
Others	Remote monitor tool (Need to purchase separate S/W)	○	○	The remote monitor tool is a personal-computer-compatible software tool that monitors information in the CNC module connected via Ethernet. (This tool is free of charge. Please contact us.)
	Automatic operation lock	△	△	Automatic operation lock function prevents falsification of a C language module by a third party.

DA



Manufacturing technologies (production site)

Maintenance

Design and Development





Safety and Energy-savings

Global Partner. Local Friend.

[YouTube logo] is a trademark or a registered trademark of Google LLC.

Official Mitsubishi Electric Mechatronics YouTube account
User support videos will be available, including how to backup/restore data and replace batteries as well as introduction to our products and technologies.



[Facebook logo] is a trademark or a registered trademark of Facebook, Inc. [LinkedIn logo] is a trademark or a registered trademark of LinkedIn Corporation.

Official Mitsubishi Electric CNC Facebook/LinkedIn account
Visit our page for information about exhibitions, products, technologies, and FAQ.

⚠ Safety Warning

To ensure proper use of the products listed in this catalog, please be sure to read the instruction manual prior to use.

Mitsubishi Electric Corporation Industrial Mechatronics Systems Works is a factory certified for ISO 14001 (standards for environmental management systems) and ISO 9001 (standards for quality assurance management systems)

MITSUBISHI ELECTRIC CORPORATION

HEAD OFFICE: TOKYO BLDG., 2-7-3, MARUNOUCHI, CHIYODA-KU, TOKYO 100-8310, JAPAN
<http://Global.MitsubishiElectric.com>

BNP-A1214-I[ENG]
(ENGLISH)