



Mitsubishi Electric
Programmable Controllers

MELSEC  series

MELSEC PROCESS CONTROL / REDUNDANT SYSTEM



MELSEC process control is a flexible, highly reliable platform with advanced functionality designed to cost-effectively meet the needs of a wide range of industries.

Reduce costs

Mitsubishi Electric automation products give users the flexibility to configure their systems according to their needs, unlike a distributed control system (DCS), which is developed by the vendor from the initial design phase. This can greatly reduce initial and running costs.

Implement sophisticated process control

Designed to handle large numbers of proportional, integral, and derivative operations (PID loops), Mitsubishi process and redundant CPUs are well suited for demanding control applications.

Maximize system availability

Increase reliability and prevent important processes from being interrupted by using redundant CPUs and hardware. In the event of a failure, modules can be hot swapped.

MELSEC PROCESS CONTROL / REDUNDANT SYSTEM

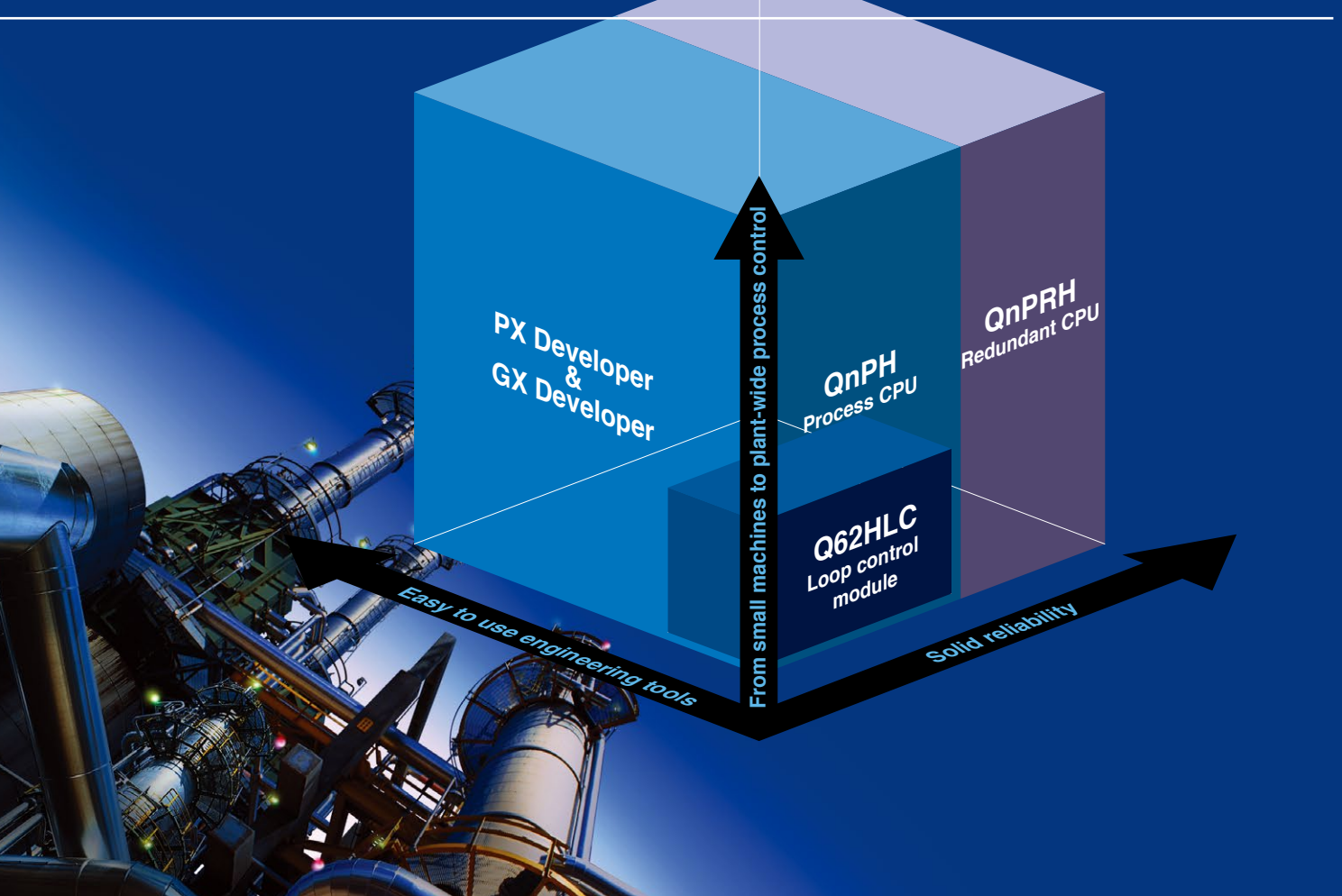



INDEX

Needs & Solutions

03

Application Examples

05

Lineup

11

MELSEC Process Control Products

15

- Process CPU
- Redundant CPU
- Redundant power supply system
- Fiber optic loop network module (with external power supply function)
- Multiplexed remote I/O network system
- CC-Link Master station duplex function
- Loop control module
- Channel isolated analog modules

Engineering Environment

31

- PX Developer
- GX Developer
- MX Component

Relevant Products

41

- GOT1000
- GT SoftGOT1000

Support

43

Product List

47

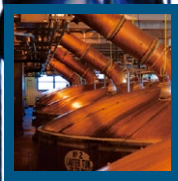

Needs

Design and create a process control system using programmable controllers.

- Similar functionality to a DCS with high speed operations
- Easy to create loop control programs
- Reduced system cost (low initial investment, maintenance, and modification)
- Same level of reliability compared to DCS

Solutions

MELSEC process control provides loop control processing, high speed analog processing, and easy to use engineering tools. Create fully redundant systems using two CPUs, two power supplies, etc.

■ Loop control

Process and redundant CPUs provide high-speed loop and sequence control with phenomenal reliability. Q series analog modules have many features including channel isolation, high accuracy, high resolution, and the ability to detect disconnections.

■ Simplified engineering

PX Developer includes as standard, all of the necessary FBs (function blocks) for loop control. Loop control programs can be created quickly and easily by drag & drop operation. (No need for ladder programming) Additionally, tuning and monitoring each loop tag is made easy thanks to a standard interface.

■ Maintenance

Temperature control, analog, I/O, and other modules may be hot swapped; that is, they can be replaced while the system is powered on and running.

■ Redundant system

The redundant system (including the CPU module, power supply module, base unit, and network module) can maximize the system uptime. Special programming is not required, and can be done just like a regular system.

Save on system costs by using MELSEC Q Series

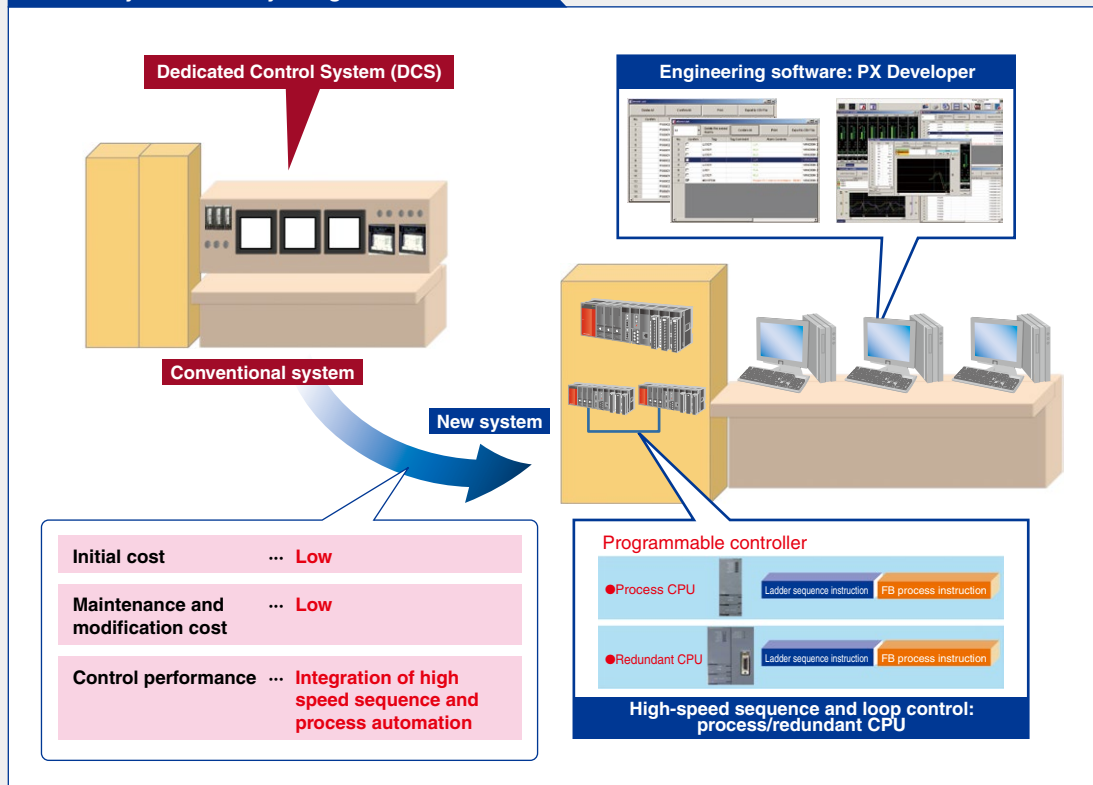

Needs

Reduce space requirements and improve operator-friendliness

- Minimize space required for control panel installation
- Easily monitor and operate the system without a PC
- User friendly operator interface

Solutions

A MELSEC controller and GOT can take the place of many loop controllers and bulky switches, indicators, etc.

Reduced space requirements

The compact size and modularity of Q Series allows significant control panel space to be saved compared to alternative systems.

Enhanced monitoring and operation capabilities

Pre-made GOT screens for alarm list, event list, and others are available to improve monitoring and operational capabilities.

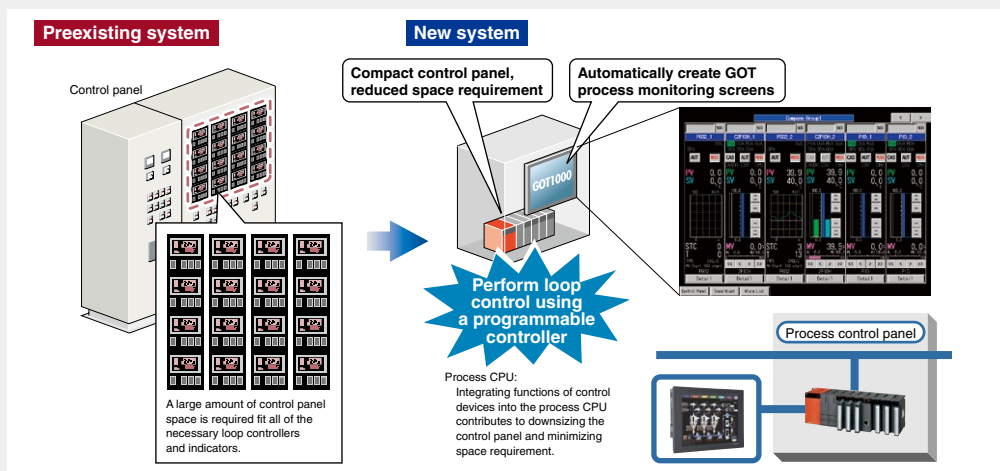

Needs

Integrate loop control and sequence control.

- There is a demand for an easy to design, modify, and maintain system that supports both loop and sequence control. (Current system design uses separate controllers)

· Separate software required for each controller.
· Complicated programming for data communication between controllers.

➔ Program design, modification, and maintenance are time-consuming.

- System scalability: expandable to other applications such as motion control and information control.

Solutions

A single process CPU can execute both loop and sequence control. Implementing a multiple CPU system is the perfect way to control other applications.

Integration of loop control and sequence control

The process CPU and redundant CPU can execute multiple programs. Therefore, loop and sequence control can be performed simultaneously at high speed.

Cover multiple control disciplines using a multiple CPU system

Any Q Series module can be used in a multiple CPU system, which allows great flexibility in system design, construction, and maintenance. Applications requiring highspeed motion control (motion CPU), information control (PC CPU), etc. can be combined.

*Redundant CPUs do not support multiple CPU configurations.

Execute sequence control and process control simultaneously

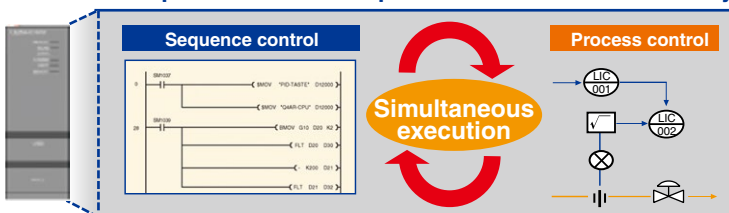

Superior performance compared to DCS

Sequence control The sequence instructions of the MELSEC-Q series can be used without any changes.

Process control There are over 50 types of process instructions available for a diverse range of applications such as cascade and feed-forward control.

2 degree-of-freedom advanced PID	Set point generation FB	Sample PI	Blend PI	Auto tuning
----------------------------------	-------------------------	-----------	----------	-------------

Food processing



Applications previously requiring separate sequence and temperature control can now be controlled using a single process CPU. When a GOT is used in conjunction with the system, a space-saving, superior monitoring and control solution can be created.

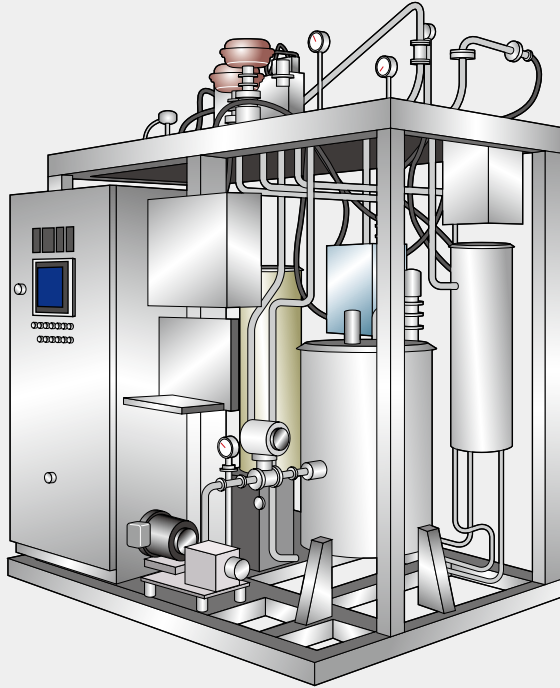

System configuration

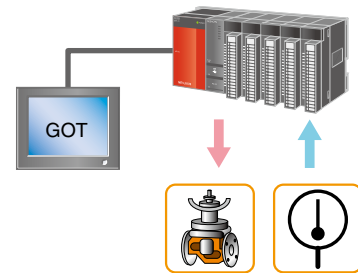

Industrial furnace



Implement process control using a wide variety of high-speed sequence and loop control instructions.

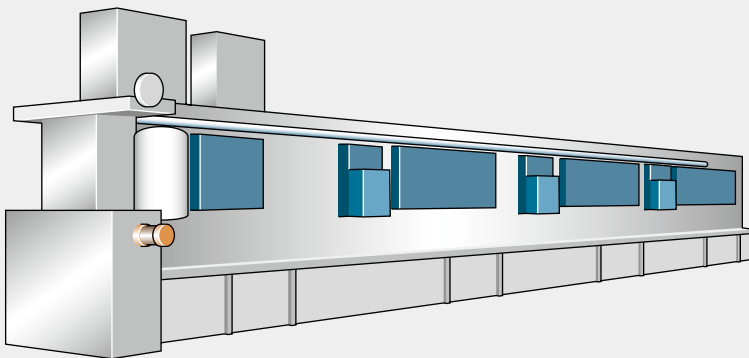

System configuration

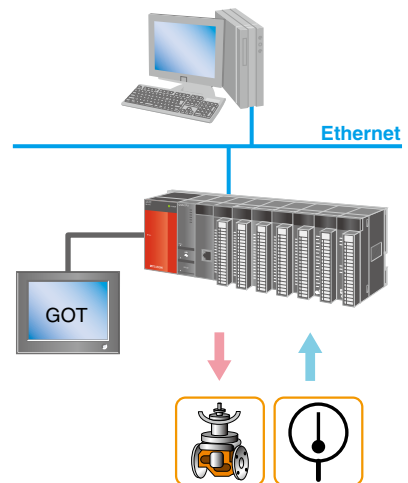

Fine chemical manufacturing

Mitsubishi Electric products help to provide integrated solutions for process automation and factory automation. Our process oriented products are well suited for manufacturing chemicals, such as medicines, paint, cosmetics, and detergent. Initial and running costs can be reduced compared to common alternatives.

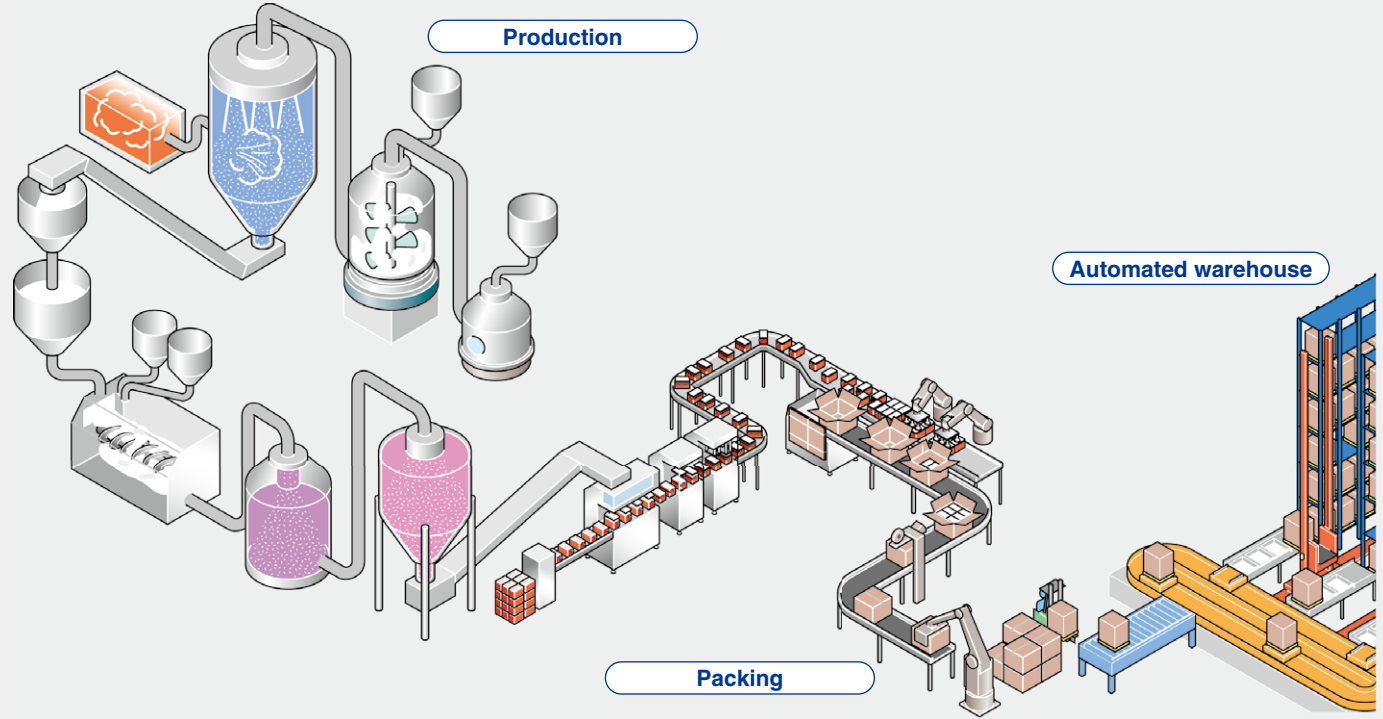

System configuration

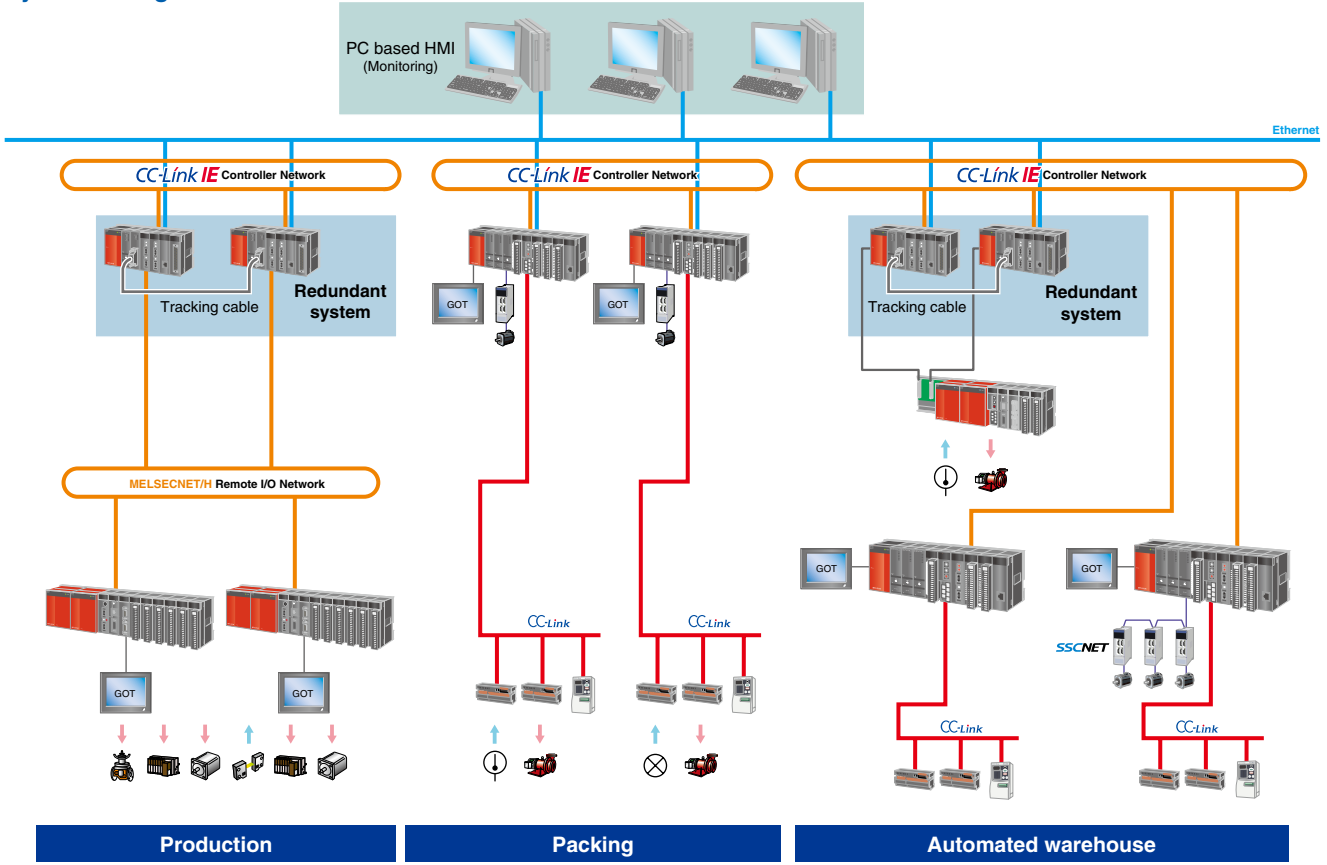

Water treatment



Create sophisticated systems for safe and stable water treatment using highly reliable redundant CPUs.

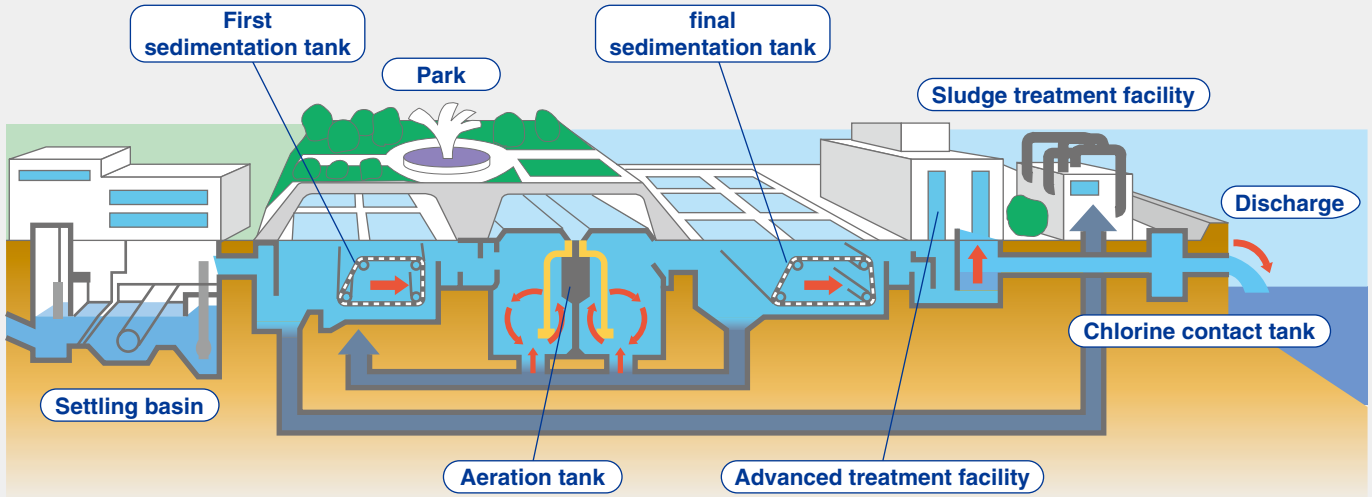

System configuration

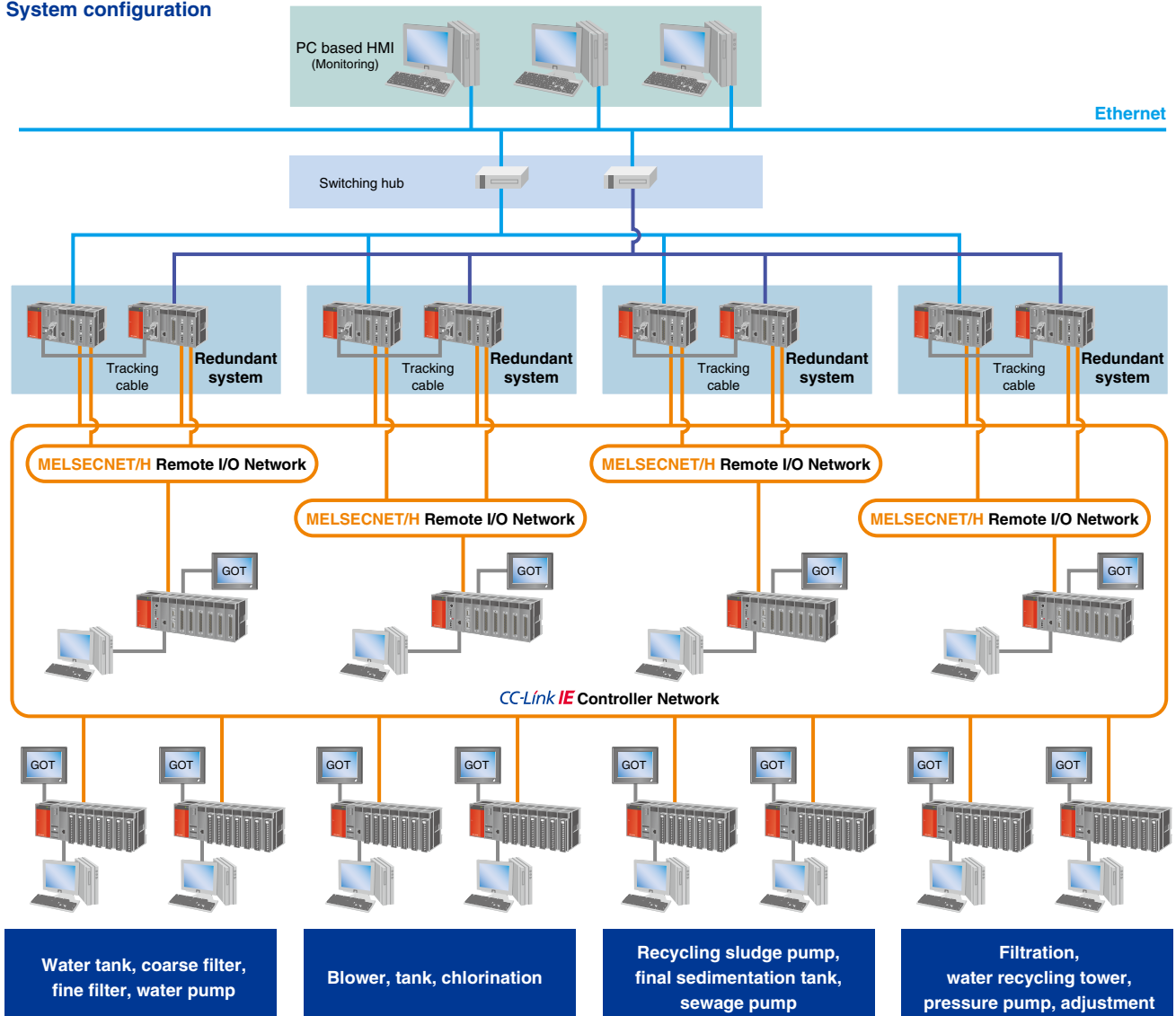

Waste incineration

Create the optimal control system to match the scale of operation.

Mitsubishi Electric process automation products are highly flexible and ready to provide the core elements necessary for a wide range of solutions and applications.

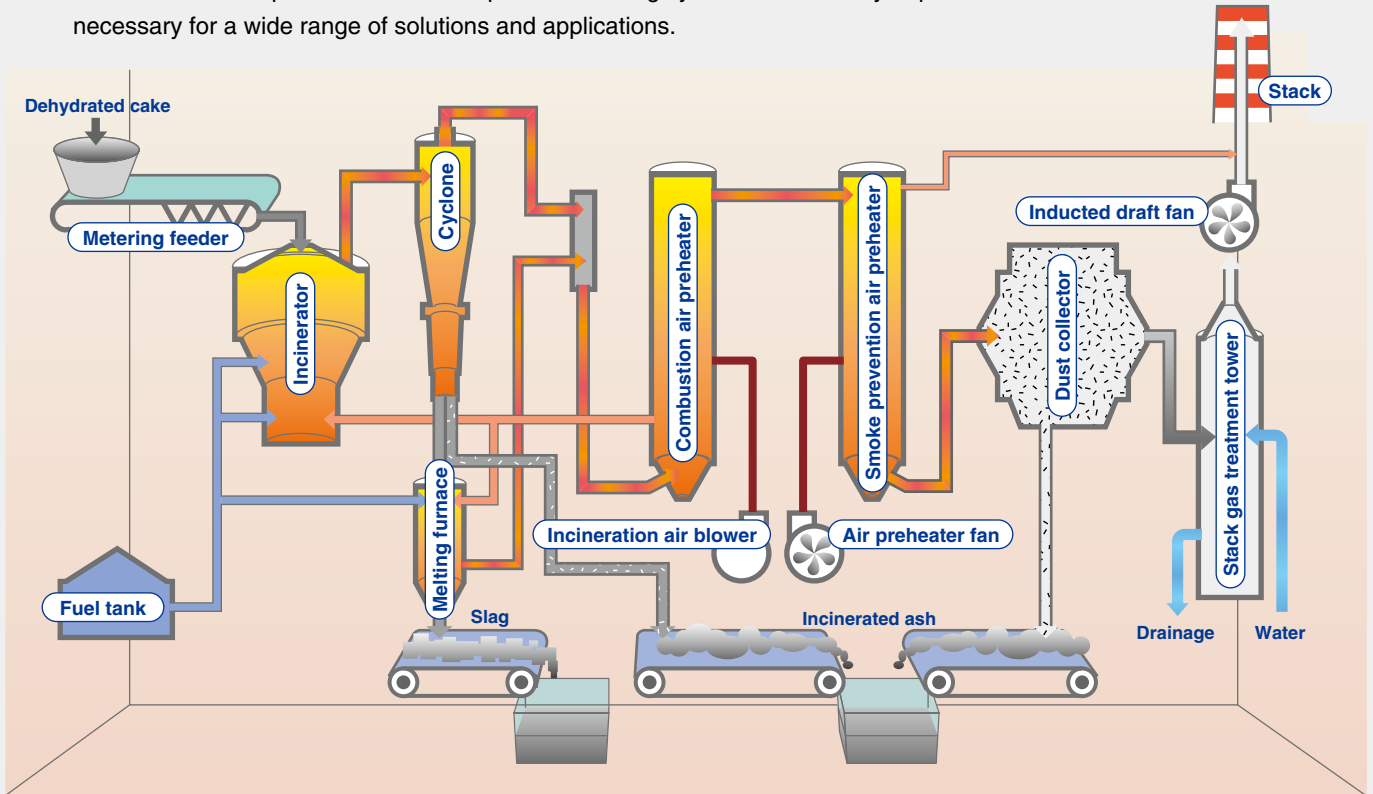

System configuration

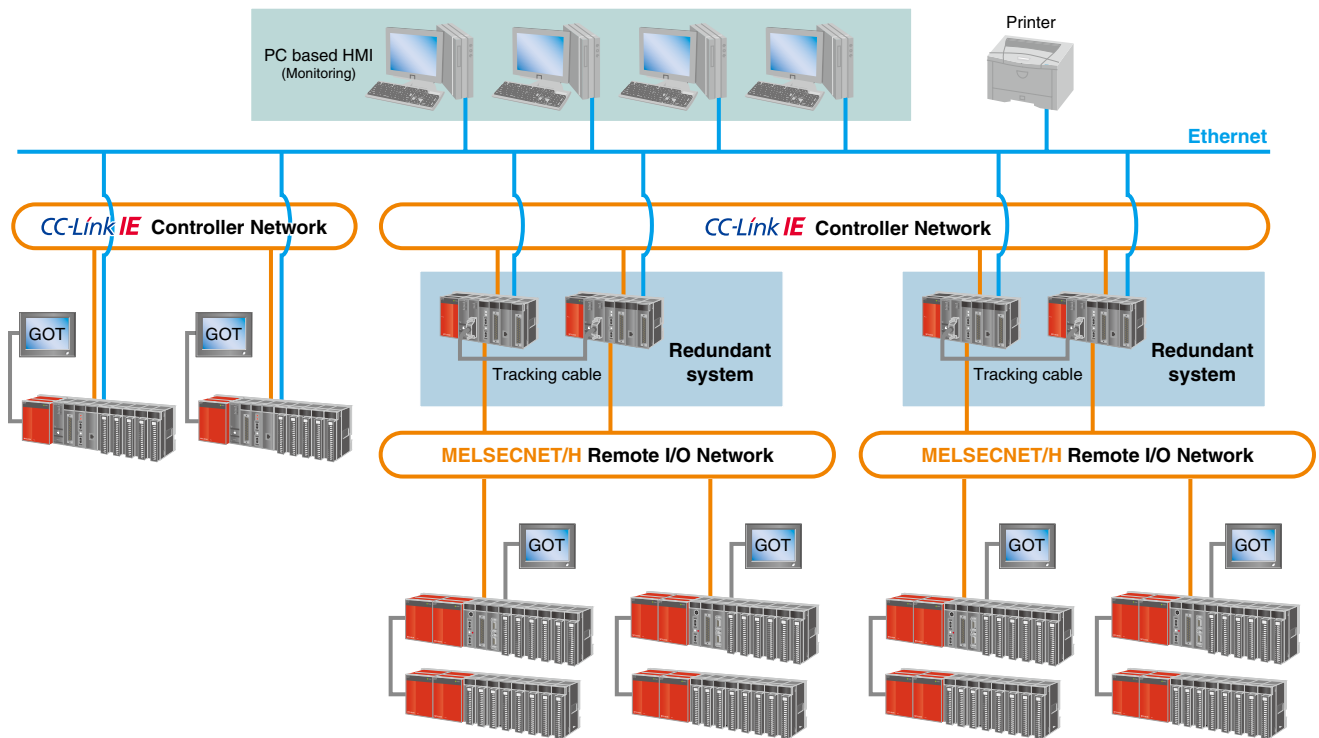

Temperature sensor, flow sensor, pressure sensor, inverter, control valve, etc.

Semiconductor manufacturing



The dependability of purified water and gas supply systems for semiconductor applications can be increased by implementing a redundant system. Even if one programmable controller happens to fail, the other CPU is ready to immediately take over control and continue the operation without interruption.

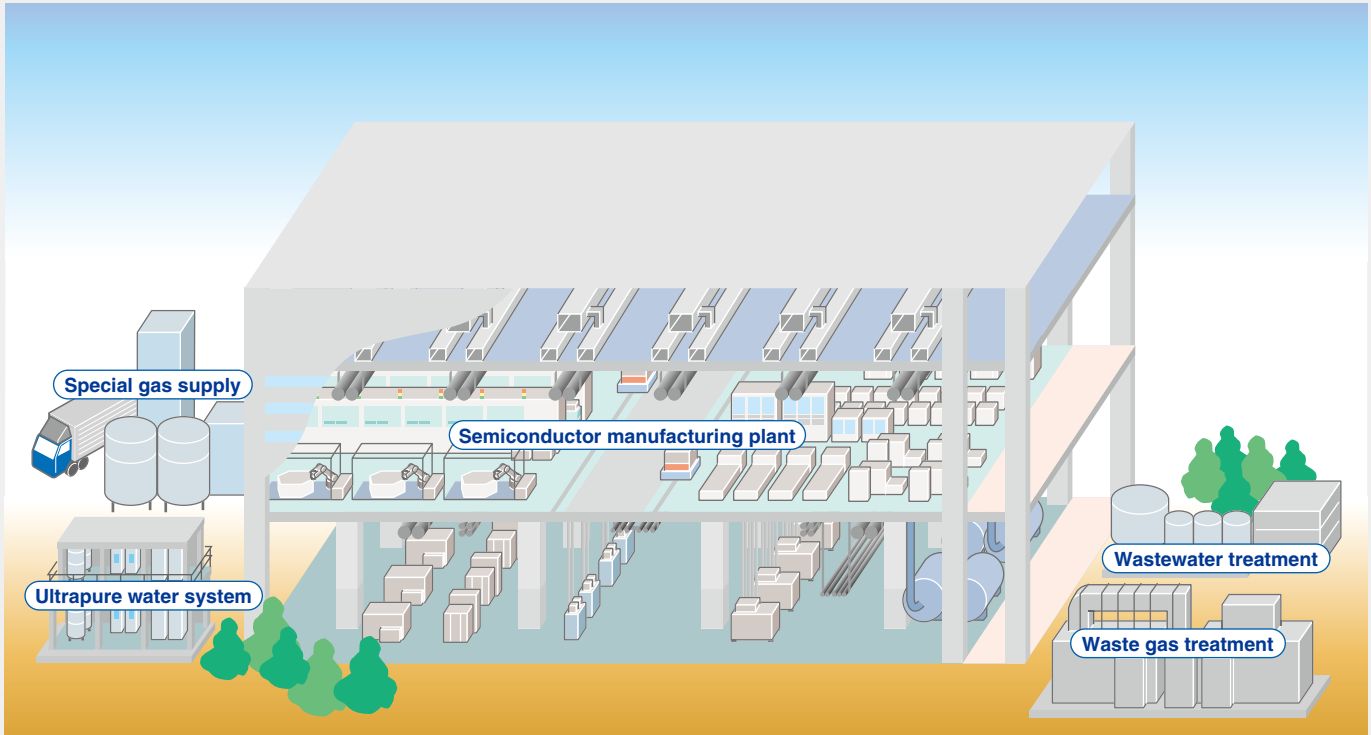

System configuration

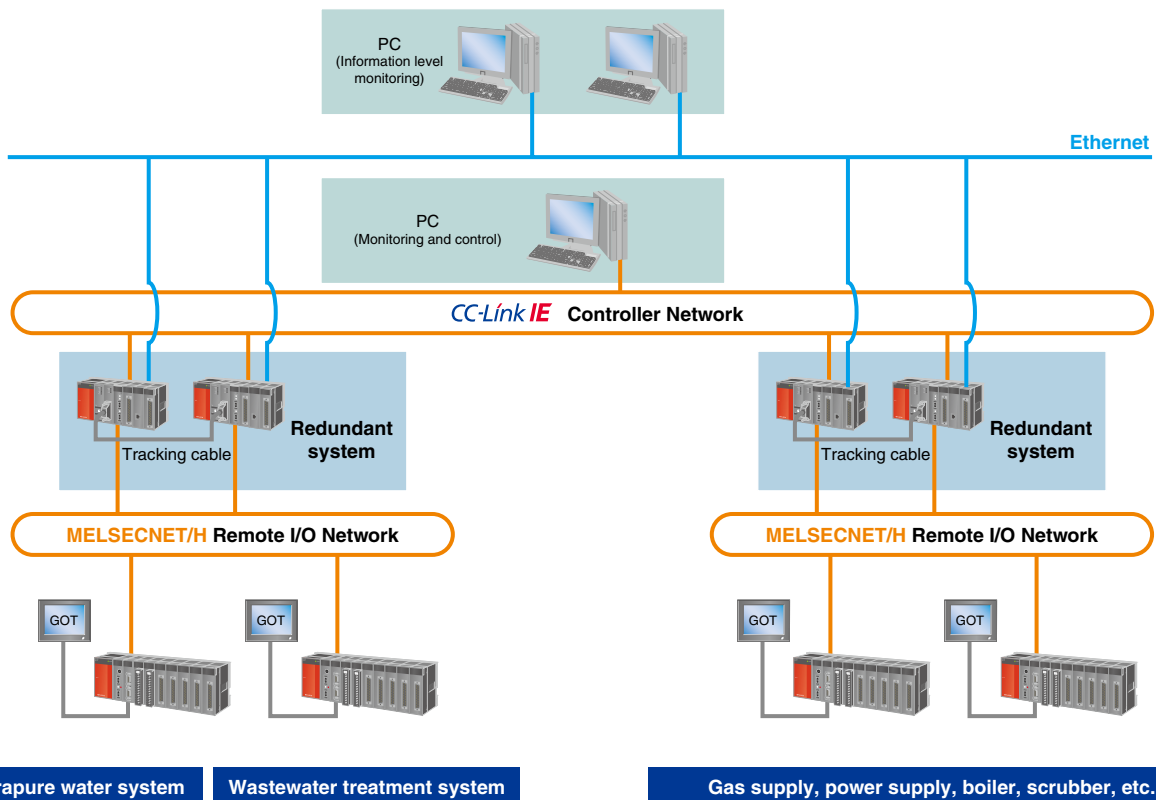

Material handling

Utilizing redundant systems for material handling applications ensures steady, consistent operation. The end result is a reduction in loading/unloading delays due to control system issues.

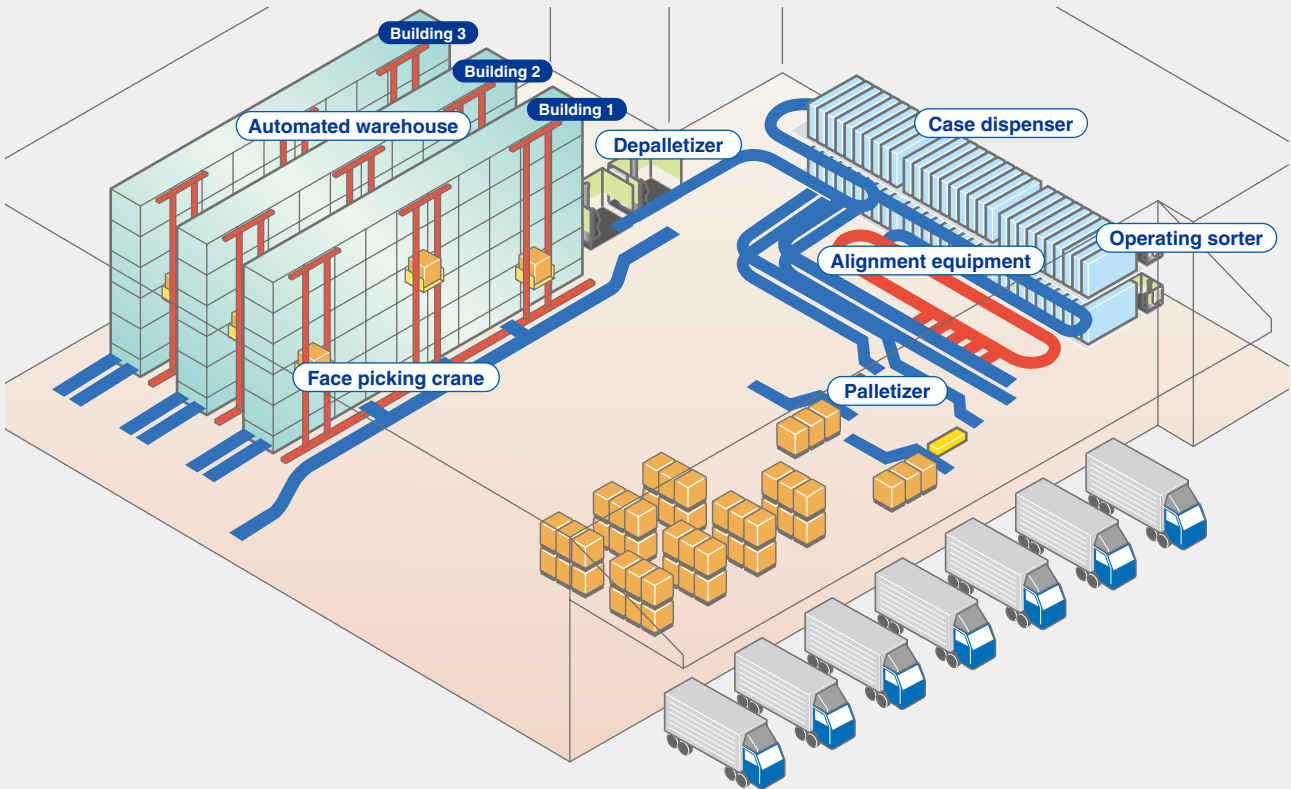

System configuration

Ethernet

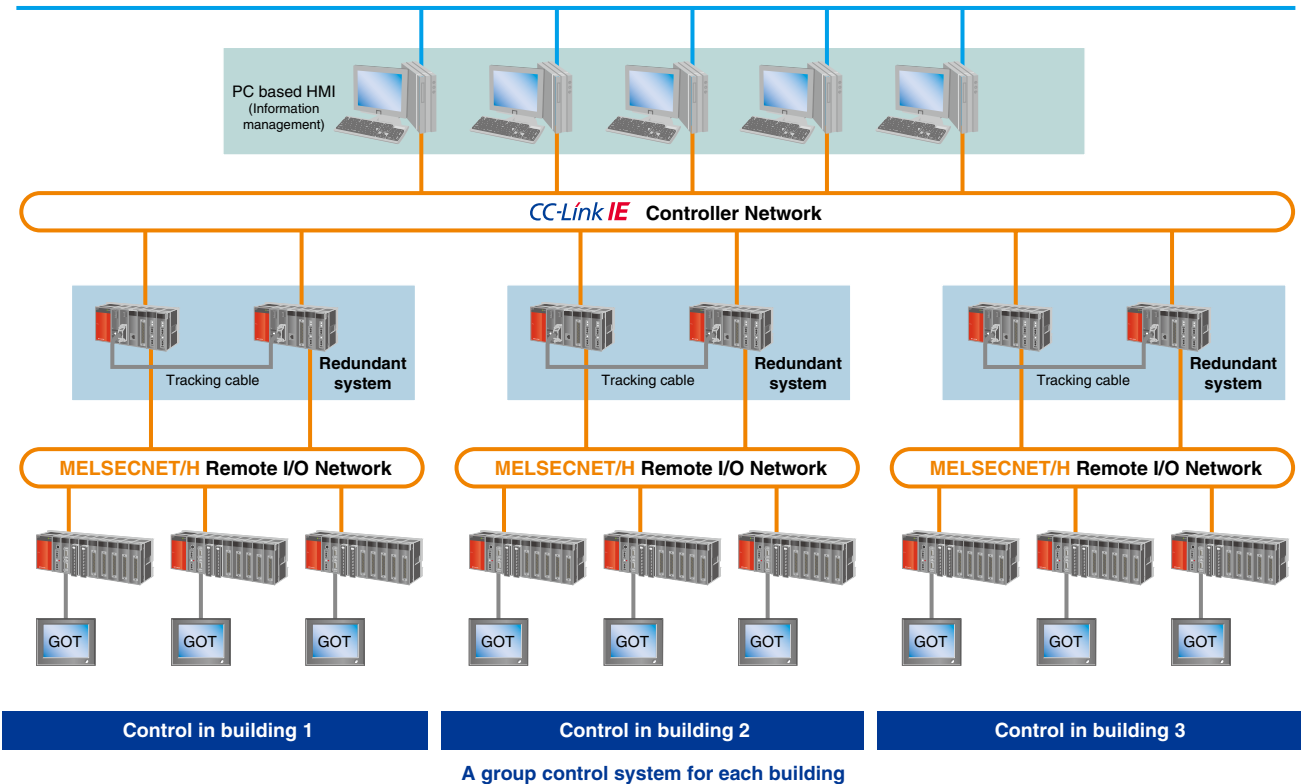

Reduce costs by combining FA (Factory Automation)

PC for monitoring and engineering

PX Developer ▶ P.31

(Process control FBD software package)





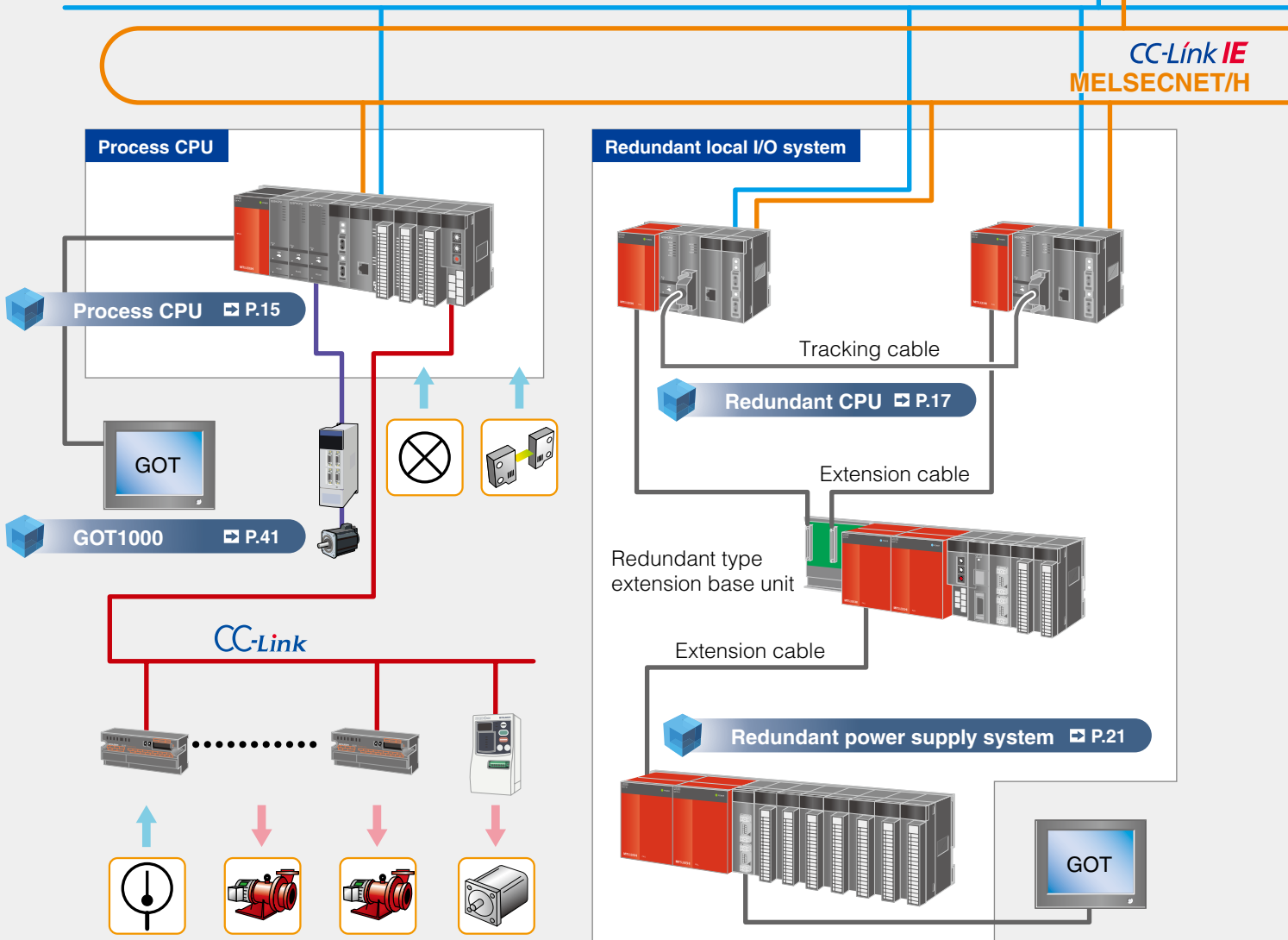

Design, debug, modify, and monitor FBD (Function Block Diagram) loop control programs.

GX Developer ▶ P.39

(MELSEC programmable controller programming software)

The primary programming, debugging, maintenance, and troubleshooting engineering tool for process and redundant CPUs.



-  Flow rate, pressure, concentration
-  Temperature
-  Sensor (i.e., limit switch)
-  Control valve
-  Solenoid valve
-  Motor
-  Pump

and PA (Process Automation) in the same platform.

MX Component ▶ P.40

(ActiveX® library for programmable controller communication)

Allows user programs (on the PC) to interface with Mitsubishi programmable controllers via the network.

GT SoftGOT1000 ▶ P.42

(HMI software)

Enables a PC to function as a graphic operation terminal using the same screen design software available for the GOT.

Ethernet

Controller Network or Network System (PLC to PLC network)

Redundant remote I/O system

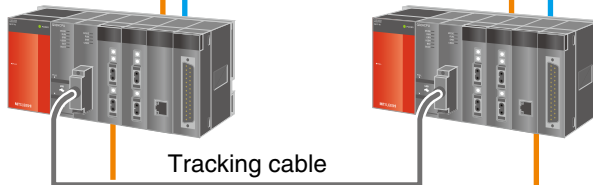

Redundant CPU ▶ P.17



Loop control module ▶ P.25

MELSECNET/H Remote I/O Network

Remote I/O station

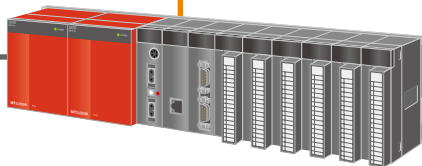

Channel isolated analog module ▶ P.27

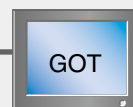
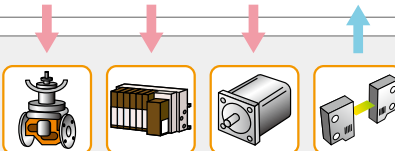
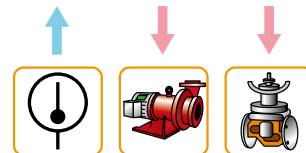
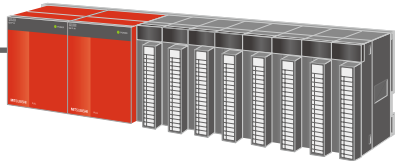

CPU (process & redundant)



Choose the optimum CPU based on the number of PID loops required and the scale of the application.

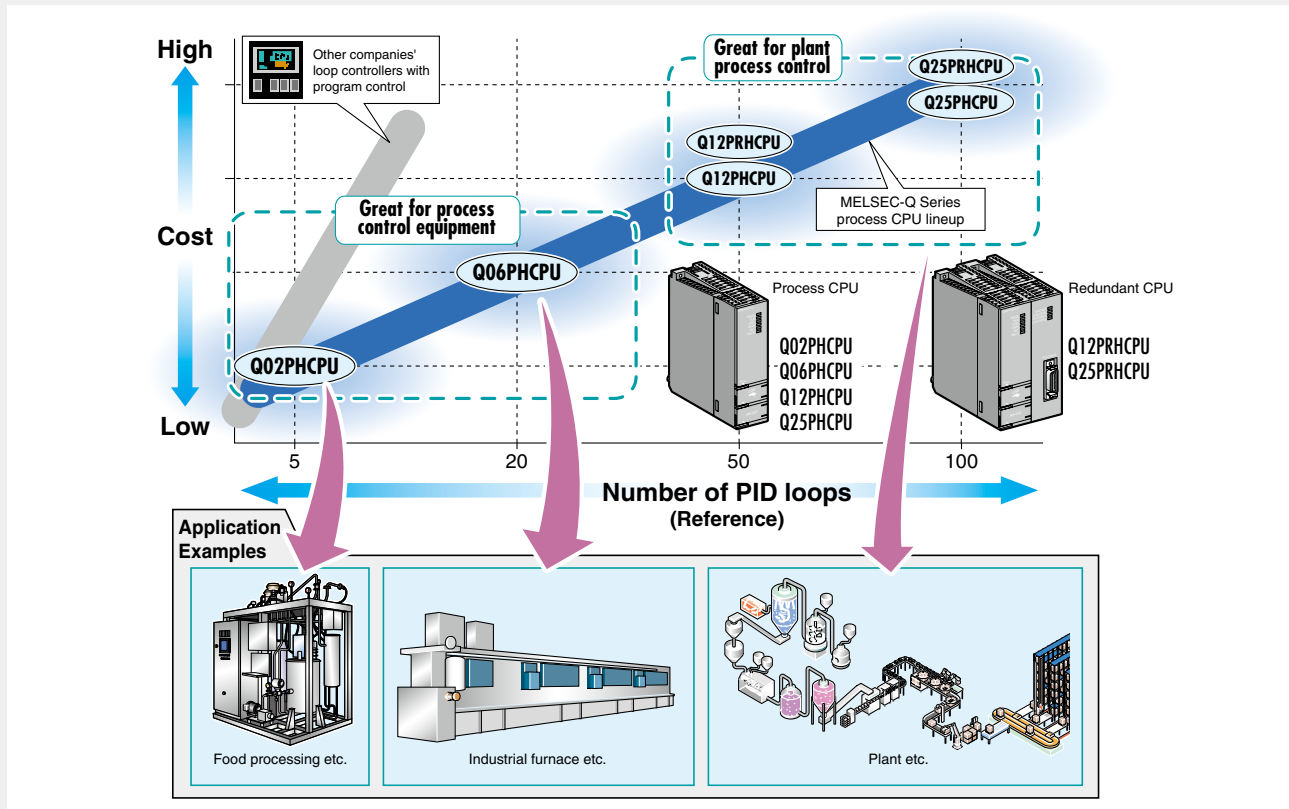

Modules best suited for loop control



Choose from a wide selection of channel isolated analog modules for loop control.

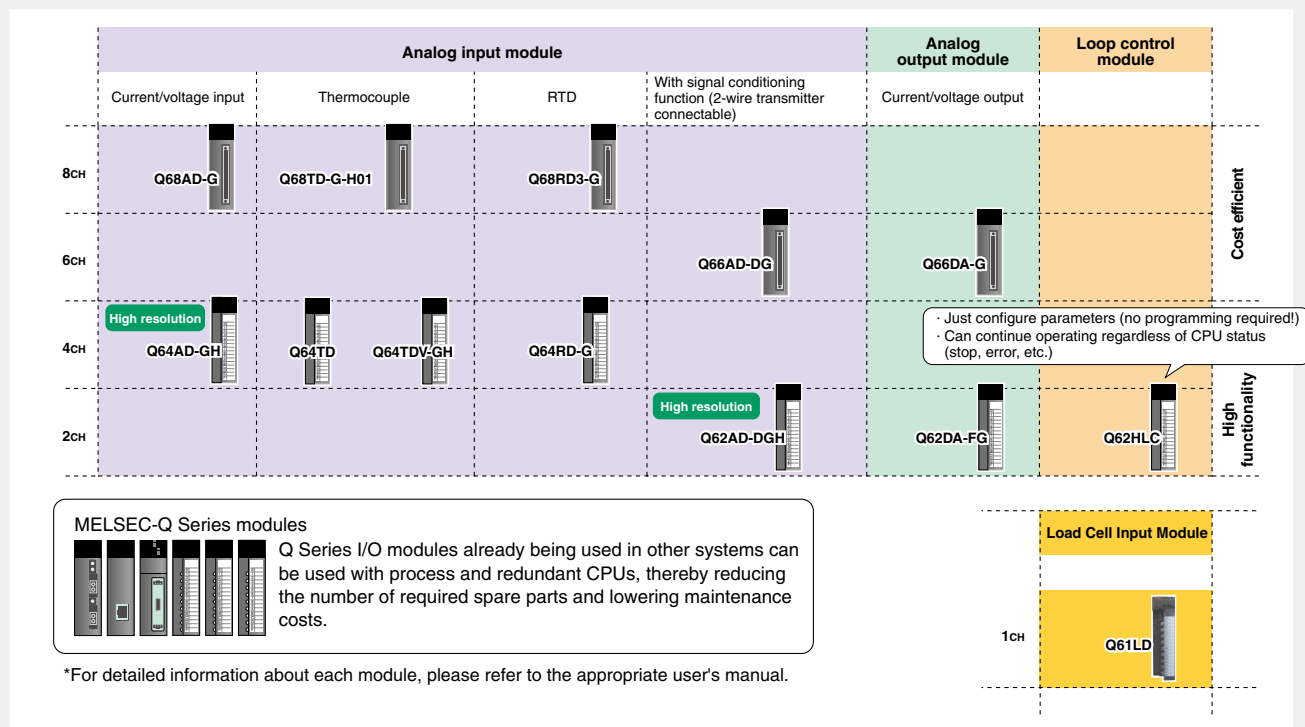

*For detailed information about each module, please refer to the appropriate user's manual.

Process monitoring solutions

Choose a control and monitoring solution that is right for the situation.

Category	Application	Solution	Feature
HMI based	General monitoring and control	GOT1000 Series GOT screen generation function	<ul style="list-style-type: none"> · Excellent environmental resistance · Compatible with high resolution (15" XGA) · Create process control and monitoring screens for the GOT1000 series automatically
PC based		Combination of PX Developer Monitor tool and SoftGOT SoftGOT interface	<ul style="list-style-type: none"> · Use GT Designer2 or GT Designer3 to create GOT screens for the PC · Graphically represent operations on the shop floor to aid the quick understanding of system status
	Complex monitoring and control	Commercial SCADA SCADA system interface	<ul style="list-style-type: none"> · Better flexibility and range of functionality · Links to enterprise system

GOT screen generation function

GOT screens for monitoring, tuning, etc. can be automatically generated from programs created using PX Developer. This feature eliminates the time consuming tasks of assigning devices and programming GOT screens to substantially reduce development time. See page 37 for details.

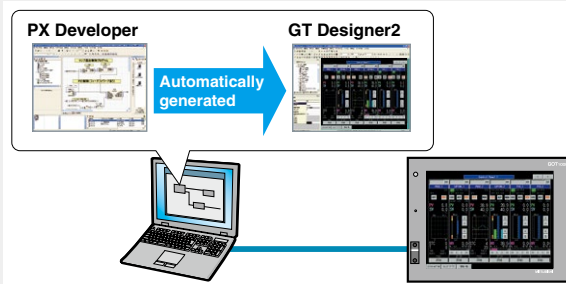

SoftGOT interface

PX Developer monitoring functions can be 'called' or opened directly from GT SoftGOT1000 screens. Consequently, the development time for creating GOT screens can be reduced.

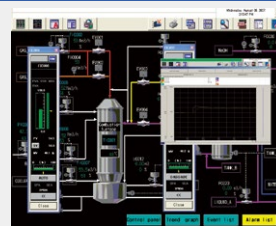

SCADA system interface

SCADA systems such as Wonderware InTouch by Invensys Systems, Inc. can be used to create advanced graphical displays of the system status. The PX Developer monitoring tool is designed to interface with SCADA software and its monitoring functions may be called and opened directly by the SCADA software.

The company and product names above are trademarked by their respective companies.

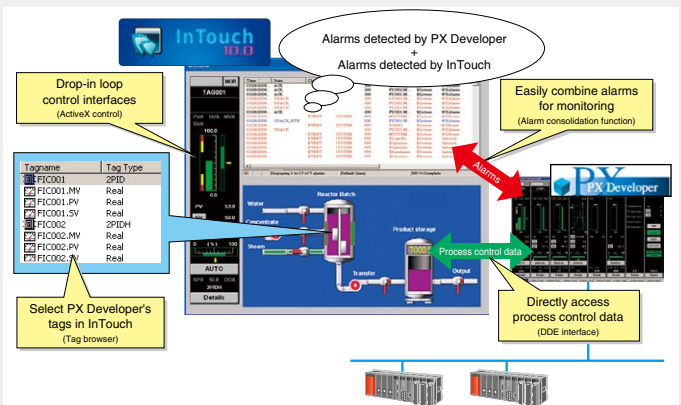

Process CPU

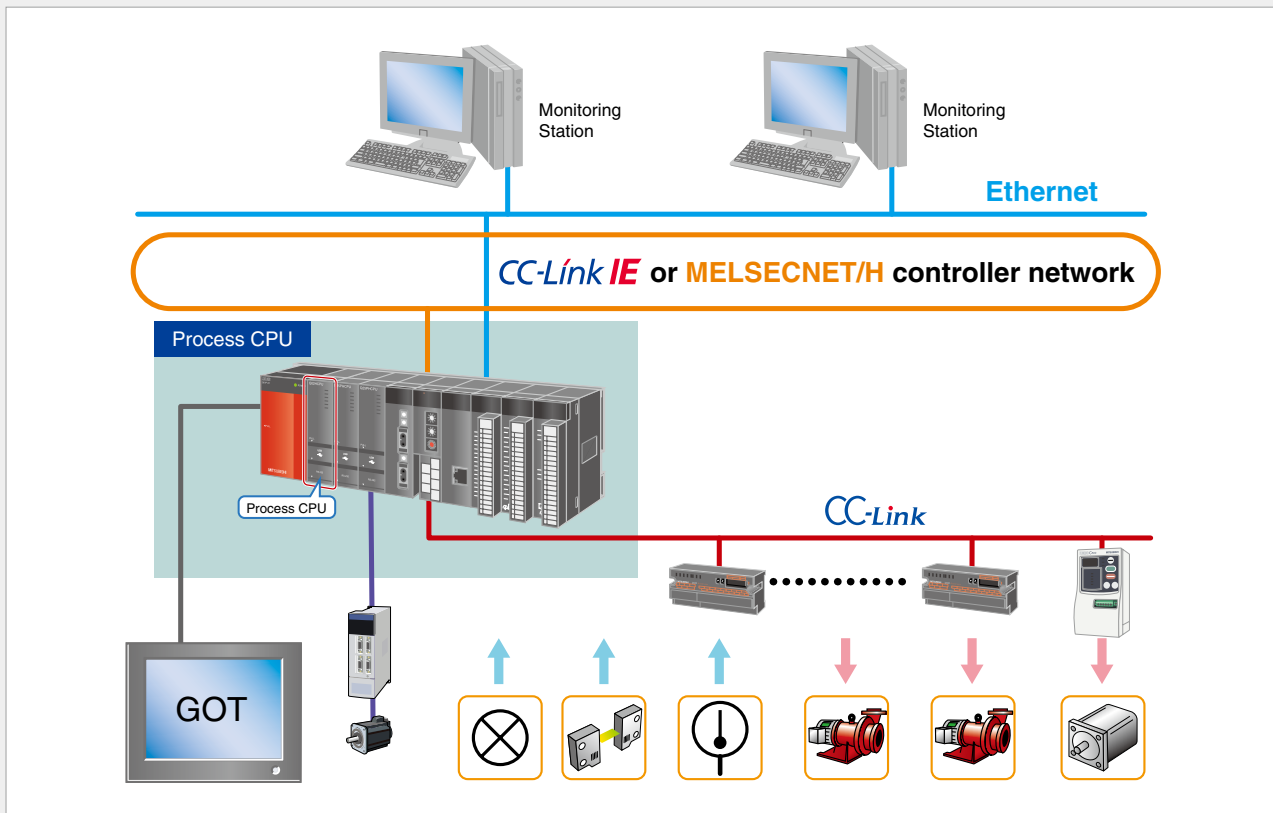

Features

1 Integrated loop control and sequence control

- A single CPU can execute multiple programs simultaneously, thus loop control and sequence control programs can be processed at high-speed by the same CPU unit.
- Process CPUs may be used in multi-CPU systems to cover different areas of control such as high-speed motion control (motion CPU), or information control (PC CPU).

2 Extensive loop control

- The MELSEC Process CPU features 52 instructions dedicated for process control including a two-degree-of-freedom PID, sample PI, auto-tuning, and other instructions to support loop control.

3 High-speed loop control

- With high-speed loop processing of approximately 400 μ s (2-degree-of-freedom PID), control cycles as short as 10 ms can be achieved. Therefore, more loops can be executed simultaneously and applications requiring high-speed control cycles can be satisfied.

4 Improved reliability and maintenance features

- When an analog or I/O module fails, it can be replaced without stopping or turning off the CPU. (Note 1) (GX Developer is required.)
- Output behavior (hold previous state, etc.) in the event the CPU stops due to error can be set via parameter.

5 Simple engineering

- Create process control programs using PX Developer, an easy-to-use FBD language engineering tool.

6 Compatibility and expandability

- The process CPU is compatible with all Q Series modules and is therefore well suited to take on a wide variety of applications.

7 Ample CPU lineup

- From small machines to plant-wide process control, a CPU is available to match the application.

8 Improved total system throughput

- In combination with the high-speed, high-bandwidth CC-Link IE controller network, operations involving remote I/O stations and other networked controllers benefit drastically by improved response time and overall productivity.

Note 1) Online module change function (Function version restrictions)

Product name	Restrictions
Input module	No restrictions
Output module	
I/O composite module	
Analog input module	Version C
Analog output module	
Temperature input module	
Temperature control module	
Channel isolated pulse input module	

Note 2) To be compatible with the CC-Link IE network module, the first five digits of the CPU module's serial number must be 10042 or later.

Specifications

Item		Q02PHCPU	Q06PHCPU	Q12PHCPU	Q25PHCPU	
Control method		Sequence program control method				
I/O control mode		Refresh				
Program language	Sequence control language	Ladder, list, ST, SFC				
	Process control language	Process control FBD (Note 1)				
Processing speed	Sequence instruction (Note 2)	LD instruction	34 ns			
		MOV instruction	102 ns			
		Floating point addition	782 ns			
	Process instruction (loop process time)	2 degree of freedom PID	400 μs			
Basic PID		350 μs				
Program capacity	Number of steps	28 k steps	60 k steps	124 k steps	252 k steps	
	Number of programs	28	60	124	252 (Note 3)	
Built-in memory	Standard RAM	128 k bytes		256 k bytes		
	Standard ROM	112 k bytes	240 k bytes	496 k bytes	1008 k bytes	
Loop control specifications	Process control instructions	52				
	Control cycle	10 ms or more/control loop (setting available per loop)				
	Main functions	2 degree of freedom PID control, cascade control, auto-tuning function, feed forward control				
Number of I/O device points (Note 4)		8192 points				
Number of I/O points (Note 5)		4096 points				
Internal relay [M]		8192 points				
Latch relay [L]		8192 points				
Link relay [B]		8192 points				
Timer [T]		2048 points				
Retentive timer [ST]		0 points				
Counter [C]		1024 points				
Data register [D]		12288 points				
Link register [W]		8192 points				
Annunciator [F]		2048 points				
Edge relay [V]		2048 points				
File register	[R]	Standard RAM	Max. 65536 points can be used by block switching in units of 32768 points (R0 to 32767)		Max. 131072 points can be used by block switching in units of 32768 points (R0 to 32767)	
		SRAM card (1 MB)	Max. 517120 points can be used by block switching in units of 32768 points (R0 to 32767)			
		SRAM card (2 MB)	Max. 1041408 points can be used by block switching in units of 32768 points (R0 to 32767)			
		Flash card (2 MB)	Max. 1041408 points can be used by block switching in units of 32768 points (R0 to 32767)			
		Flash card (4 MB)	Max. 1042432 points can be used by block switching in units of 32768 points (R0 to 32767)			
	[ZR]	Standard RAM	65536 points (R0 to 65535), block switching not required		131072 points (R0 to 131071), block switching not required	
		SRAM card (1 MB)	517120 points (R0 to 517119), block switching not required			
		SRAM card (2 MB)	1041408 points (R0 to 1041407), block switching not required			
		Flash card (2 MB)	1041408 points (R0 to 1041407), block switching not required			
		Flash card (4 MB)	1042432 points (R0 to 1042431), block switching not required			
Link special relay [SB]		2048 points				
Link special register [SW]		2048 points				
Step relay [S]		8192 points				
Index register [Z]		16 points				
Pointer [P]		4096 points				
Interrupt pointer [I]		256 points				
Special relay [SM]		2048 points				
Special register [SD]		2048 points				
Function input [FX]		16 points				
Function output [FY]		16 points				
Function register [FD]		5 points				
Number of mountable CPU modules		Max. 4				
Number of mountable modules		Max. 64				
Number of extension base stages		Max. 7				

Note 1) PX Developer is required to write programs using FBD.

Note 2) The processing time is the same even when using indexed devices.

Note 3) Up to 124 programs can be executed.

Note 4) Indicates the total number of I/O points on the main base unit and extension base units directly controlled by the CPU module and the number of I/O points controlled as remote I/O via the remote I/O network.

Note 5) Indicates the number of I/O points on the main base unit and extension base units directly controlled by the CPU module.

Note 6) Indicates the default number of points. These can be changed via parameters.

Software packages

PX Developer is used together with GX Developer.
The following software versions are required for programming the process CPU.

Product name	w/ CC-Link IE connection	w/o CC-Link IE connection	
		Q02/06PHCPU	Q12/25PHCPU
GX Developer	Version 8.68W or later	Version 7.20W or later	
PX Developer	Version 1.18U or later	Version 1.00A or later	

Redundant CPU



Redundant CPU, network, and power supply systems are provided to support various system configurations specific to application requirements.

Redundant local I/O system

The CPU directly accesses I/O modules. Ideal for systems requiring high-speed response.

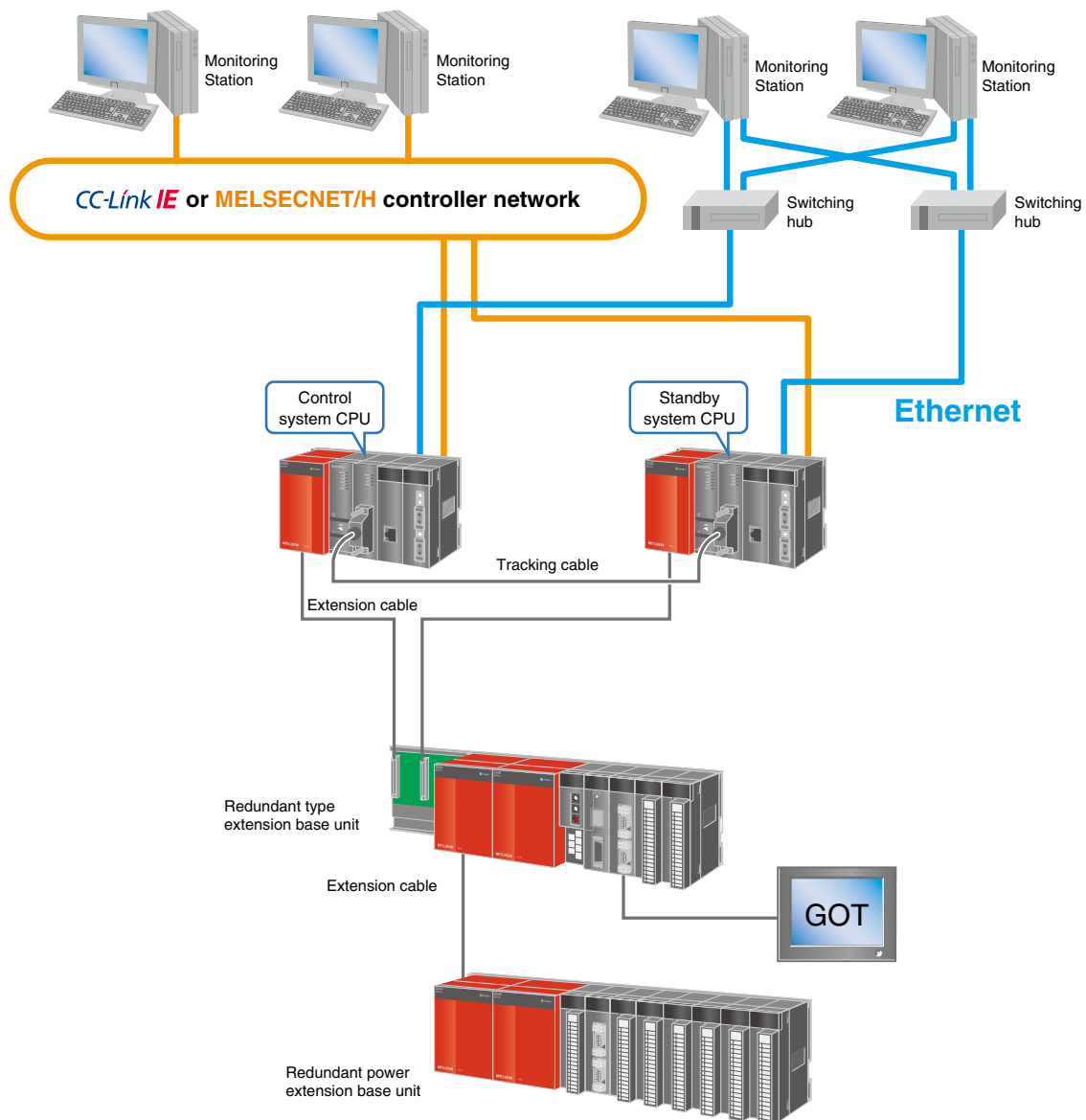

System switching time (Reference)

Approximately 50 ms
(Local I/O response time)

- Standby CPU tracking data acquisition time
- CPU switching time: Min. 32 ms (without signal flow tracking)

Redundant remote I/O system

Ideal for distributed systems with multiple remote I/O stations.

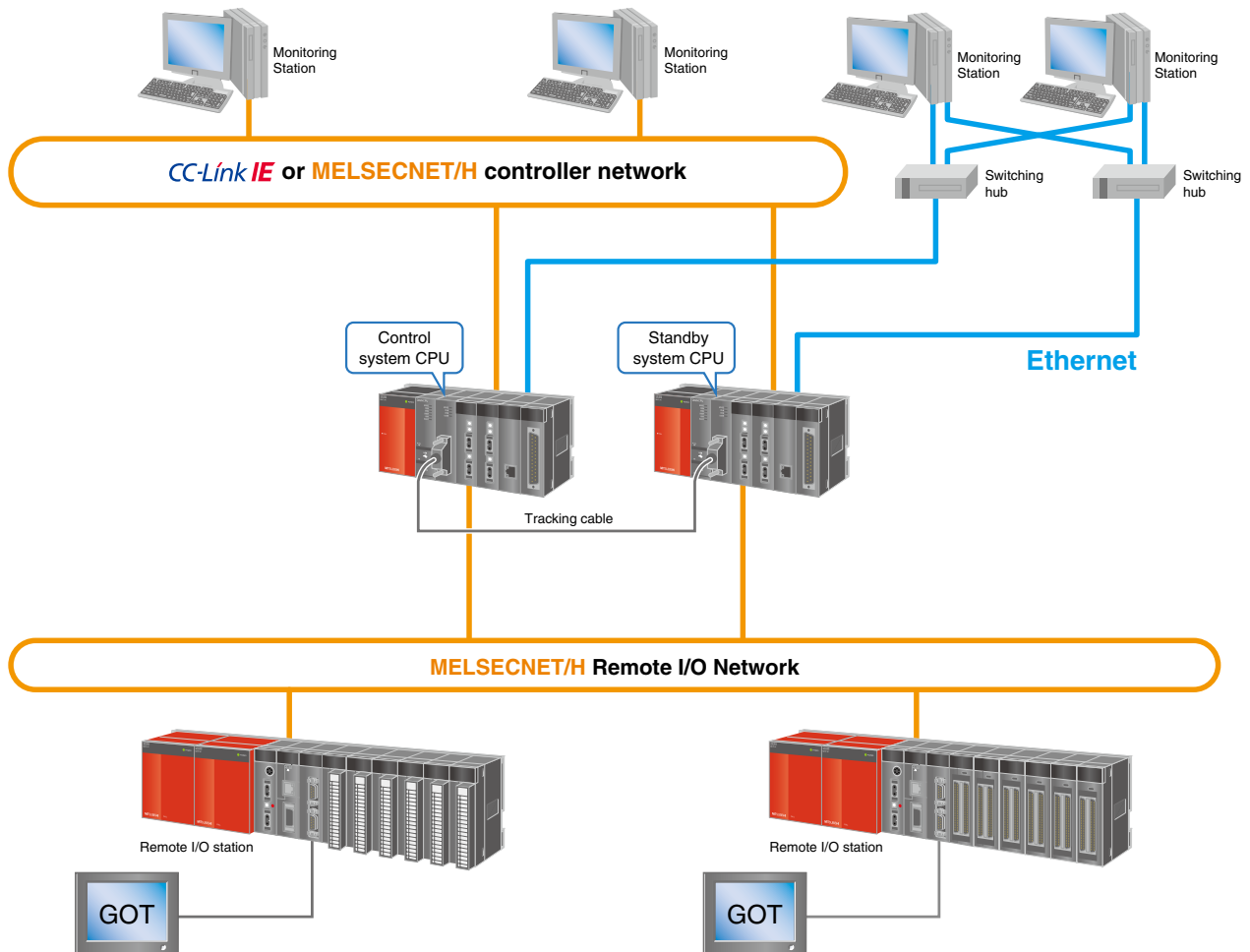

System switching time (Reference)

Approximately 800 ms
(Remote I/O response time)

- Standby CPU tracking data acquisition time
- Output holding time of remote I/O station during control system switching: 700 to 800 ms
- CPU switching time: Min. 21 ms (signal flow without tracking)

Redundant CPU



Features

1 Basic system/network with redundancy

- The basic system, including the CPU module, power supply module, base unit, and network module, can be configured with redundancy.
- Networks can be configured with redundancy. When the network module fails or cable disconnection is detected, the standby system continues control and communications.

2 Improved reliability and maintainability

- With the redundancy of the basic system, the standby system takes over the control to continue the system operation when the control system fails. (Hot standby)
- By replacing the failed module or entire system, the redundant system can be recovered quickly.
- When an I/O, analog I/O, temperature input, temperature control, or channel isolated pulse input module on the redundant extension base unit or remote I/O station fails, it can be replaced without stopping or turning off the CPU. (Note 1, 2) (Operation on GX Developer is required.)
- When the CPU module is replaced while the system is operating, the parameters and programs can be copied to the new CPU by transfer instruction from GX Developer.

3 Loop control and sequence control in one CPU

- A single CPU can execute multiple programs simultaneously, thus loop control and sequence control programs can be processed at high-speed by the same CPU unit.

4 Simple engineering

- GX Developer offers simple engineering environment for redundant system settings with the original operability.
- PX Developer facilitates creating loop control programs using FBD language.
- Writing parameters and programs is simple using GX Developer regardless of the system status (control/standby).

5 Employs existing Q Series modules

- The Q Series modules, such as I/O, intelligent function, and network modules, can be used without any changes. (Note 3)

6 Improved total system throughput

- In combination with the high-speed, high-bandwidth CC-Link IE controller network, operations involving remote I/O stations and other networked controllers benefit drastically by improved response time and overall productivity.

Note 1) The following modules on the extension base unit or remote I/O station can be replaced while online.

Product name	Restrictions	Product name	Restrictions
Input module	No restrictions	Analog output module	Version C or later
Output module		Temperature input module	
I/O composite module		Temperature control module	
Analog input module	Version C or later	Channel isolated pulse input module	

Note 2) When the redundant type extension base unit is used, I/O modules on the main base unit cannot be replaced while online.

Note 3) Use the following serial No. or version for the redundant system.

Product name	Model	Serial No. or Version
Redundant CPU	Q12PRHCPU	First five digits of the serial number are 09012 or later (when the redundant type extension base unit is used); First five digits of the serial number are 10042 or later (when the CC-Link IE Controller Network module is used)
	Q25PRHCPU	
CC-Link IE Controller Network module	QJ71GP21-SX QJ71GP21S-SX QJ71LP21-25 QJ71LP21S-25 QJ71LP21G QJ71BR11	No restrictions
MELSECNET/H master module	QJ72LP25-25 QJ72LP25G QJ72BR15	Version D or later
MELSECNET/H remote I/O module	QJ71E71-B2 QJ71E71-B5 QJ71E71-100	
Ethernet interface module	Q81BD-J71LP21-25 Q80BD-J71LP21-25 Q80BD-J71LP21S-25 Q80BD-J71LP21G Q80BD-J71BR11	
MELSECNET/H interface board		
CC-Link interface module	QJ61BT11N	
MES interface module	QJ71MES96	First five digits of the serial number are 09012 or later
Web server module	QJ71WS96	

The following functions are not available for the module mounted on the extension base unit.

- Intelligent function module dedicated instructions
- Interrupt pointer

Specifications

Item		Q12PRHCPU	Q25PRHCPU
Control method		Sequence program control method	
I/O control mode		Refresh	
Program language	Sequence control language	Ladder, list, ST, SFC	
	Process control language	Process control FBD (Note 1)	
Processing speed	Sequence instruction (Note 2)	LD instruction	34 ns
		MOV instruction	102 ns
		Floating point addition	782 ns
	Process instruction (loop process time)	2 degree of freedom PID	400 μs
		Basic PID	350 μs
	Redundant function	Tracking execution time (extended scan time)	48 k word device memory: 10 ms 100 k word device memory: 15 ms
Program capacity	Number of steps	124 k steps	252 k steps
	Number of programs	124	252 (Note 3)
Built-in memory	Standard RAM	256 k bytes	
	Standard ROM	496 k bytes	1008 k bytes
Loop control specifications	Process control instructions	52	
	Control cycle	10 ms or more/control loop (setting available per loop)	
	Main functions	2 degree of freedom PID control, cascade control, auto-tuning function, feed forward control	
Number of I/O device points (Note 4)		8192 points	
Number of I/O points (Note 5)		4096 points	
Internal relay [M]		8192 points	
Latch relay [L]		8192 points	
Link relay [B]		8192 points	
Timer [T]		2048 points	
Retentive timer [ST] (Note 6)		0 points	
Counter [C]		1024 points	
Data register [D]		12288 points	
Link register [W]		8192 points	
Annunciator [F]		2048 points	
Edge relay [V]		2048 points	
File register	[R]	Standard RAM	Max. 131072 points can be used by block switching in units of 32768 points (R0 to 32767)
		SRAM card (1 MB)	Max. 517120 points can be used by block switching in units of 32768 points (R0 to 32767)
		SRAM card (2 MB)	Max. 1041408 points can be used by block switching in units of 32768 points (R0 to 32767)
		Flash card (2 MB)	Max. 1041408 points can be used by block switching in units of 32768 points (R0 to 32767)
	[ZR]	Flash card (4 MB)	Max. 1042432 points can be used by block switching in units of 32768 points (R0 to 32767)
		Standard RAM	131072 points (R0 to 131071), block switching not required
		SRAM card (1 MB)	517120 points (R0 to 517119), block switching not required
		SRAM card (2 MB)	1041408 points (R0 to 1041407), block switching not required
		Flash card (2 MB)	1041408 points (R0 to 1041407), block switching not required
		Flash card (4 MB)	1042432 points (R0 to 1042431), block switching not required
Link special relay [SB]		2048 points	
Link special register [SW]		2048 points	
Step relay [S]		8192 points	
Index register [Z]		16 points	
Pointer [P]		4096 points	
Interrupt pointer [I]		256 points	
Special relay [SM]		2048 points	
Special register [SD]		2048 points	
Function input [FX]		16 points	
Function output [FY]		16 points	
Function register [FD]		5 points	
Number of device tracking words		Max. 102400 points	
Number of mountable CPU modules		1 (multiple CPU system not available)	
Number of mountable modules		Max. 63	
Number of extension base stages		Max. 7	
Number of remote I/O points		8192 points (max. 2048 points/station)	

Note 1) PX Developer is required to write programs using FBD.

Note 2) The processing time is the same even when using indexed devices.

Note 3) Up to 124 programs can be executed.

Note 4) Indicates the total number of I/O points on the main base unit and extension base units directly controlled by the CPU module and the number of I/O points controlled as remote I/O via the remote I/O network.

Note 5) Indicates the number of I/O points on the main base unit and extension base units directly controlled by the CPU module.

Note 6) Indicates the default number of points. These can be changed via parameters.

Software packages

PX Developer is used together with GX Developer.
The following version or later is required for programming the redundant CPU.

Product name	w/ CC-Link IE connection	w/o CC-Link IE connection	
		Redundant type extension base unit used	Redundant type extension base unit not used
GX Developer	Version 8.68W or later	Version 8.45X or later	Version 8.18U or later
PX Developer	Version 1.18U or later	Version 1.14Q or later	Version 1.06G or later

Redundant power supply system



The redundant power supply system can be configured to back up the system in the event of a power failure.

Features

Redundant power supplies supporting all CPUs

1. Even if one power supply module fails, the other one supplies the power to the system.
2. A failed power supply module can be confirmed by a "power failure detection function" or "LED indicators", allowing for quick replacement. This ensures system backup.
3. The power supply module can be replaced while online.
4. Q64RP (AC input) and Q63RP (DC input) can be used together. Creating two power supply systems (AC and DC) further enhances system reliability.

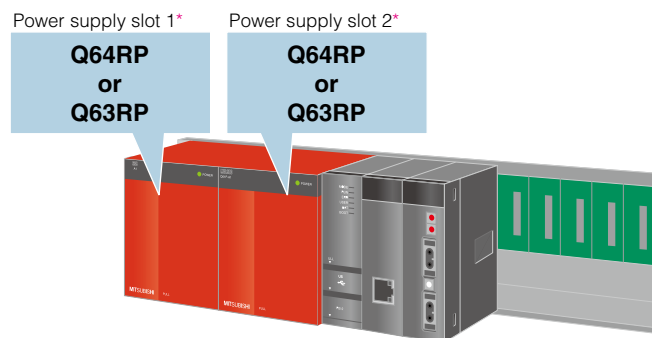

* Either Q64RP or Q63RP can be mounted on the power supply slot 1 and 2.
Also, in the event of a power failure, the power supply module can be replaced while online.

Specifications

Item	Q64RP	Q63RP
Applicable base unit	Q38RB, Q68RB, Q65WRB	
Input power supply	100 to 120 V AC/200 to 240 V AC (+10%, -15%) (85 to 132 V AC/170 to 264 V AC)	24 V DC (+30%, -35%) (15.6 to 31.2 V DC)
Input frequency	50/60 Hz ±5%	N/A
Input voltage distortion rate	Within 5%	N/A
Maximum input apparent power	160 VA	N/A
Maximum input power	N/A	65 W
Inrush current	20 A, 8 ms or less	150 A, 1 ms or less
Rated output current	8.5 A	
Overcurrent protection	9.35 A or more	
Overvoltage protection	5.5 to 6.5 V	
Efficiency	65% or more	
Allowable momentary power failure period	20 ms or less	10 ms or less (at 24 V DC input)
Contact output	Application	ERR contact
	Rated switching voltage/current	24 V DC/0.5 A
	Minimum switching load	5 V DC, 1 mA
	Response time	OFF to ON: 10 ms or less, ON to OFF: 12 ms or less
	Life	Mechanical: 20,000,000 times or more Electrical: 100,000 times or more at rated switching voltage and current
	Surge suppressor	No
	Fuse	No

Fiber optic loop network module with external power supply function

The external power supply function enables the system to continue data link when the power supply module fails.

Features

External power supply prevents the system from being affected by a power failure

Even if a power failure occurs at more than two stations in a loop system, a station in between can continue data link. This function also prevents loopback in the system. The link scan time can be stabilized, ensuring steady system operation.

When a power failure occurred in two stations:

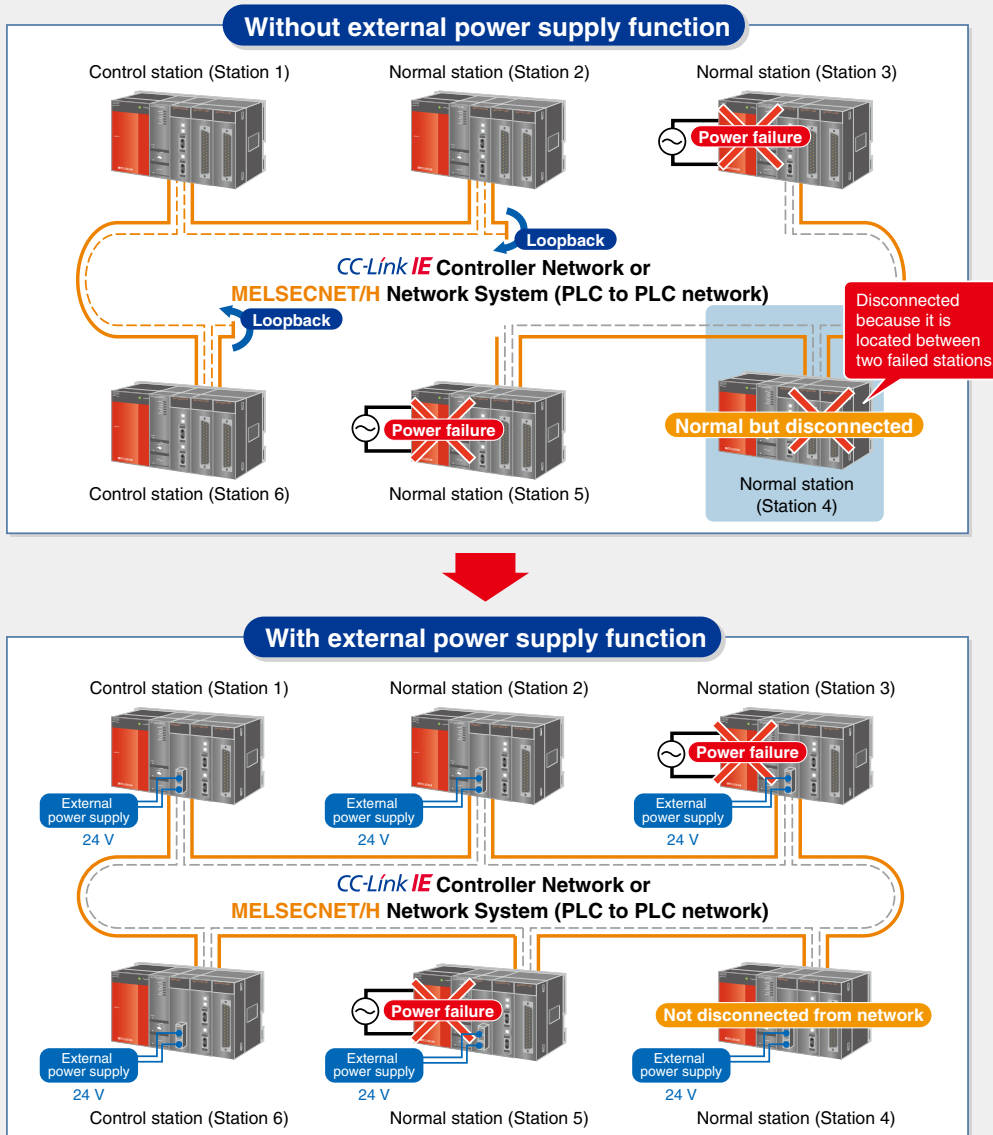

Specifications

Item		CC-Link IE Controller Network module QJ71GP21S-SX	MELSECNET/H network module QJ71LP21S-25
External power supply	Voltage	20.4 to 31.2 V DC	
	Current	0.28A	0.20A
	Terminal screw size	M3	
	Applicable solderless terminal	R1.25-3	
	Applicable wire size	0.3 to 1.25 mm ²	
	Tightening torque	0.42 to 0.58 N·m	
	Allowable momentary power failure time	1 ms (Level PS1)	
	Noise immunity	By noise simulator of 500Vp-p noise voltage, 1μs pulse width, and 25 to 60Hz noise frequency	

Multiplexed remote I/O network system



Redundant system with superior cost effectiveness by using highly reliable, high-speed network.

Features

Facilitating the multiplexed remote master station and multiplexed remote sub-master station on one remote I/O network system enables the multiplexed remote sub-master station to control the remote I/O network system instead when the programmable controller CPU in the multiplexed remote master station becomes faulty.

The multiplexed remote master station can return to normal and to system operation as a multiplexed remote sub-master station, even during the remote I/O network system control by the multiplexed remote sub-master station, thus preparing itself for a multiplexed remote sub-master station.

System configuration

- Usable CPU is Process CPU (QnPHCPU).
- The redundant system configured with QnPHCPU + MELSECNET/H (remote I/O network). ^(Note 1)
- The multiplexed remote function enables the multiplexed remote sub-master station to continue the I/O working when the multiplexed remote master station becomes faulty due to a malfunction in power supply, etc.

(Note 1) When tracking is needed, the communication module (Ethernet, etc.) to communicate the tracking data and the creation of the user program for tracking is required.

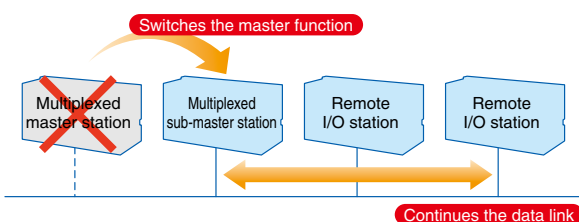
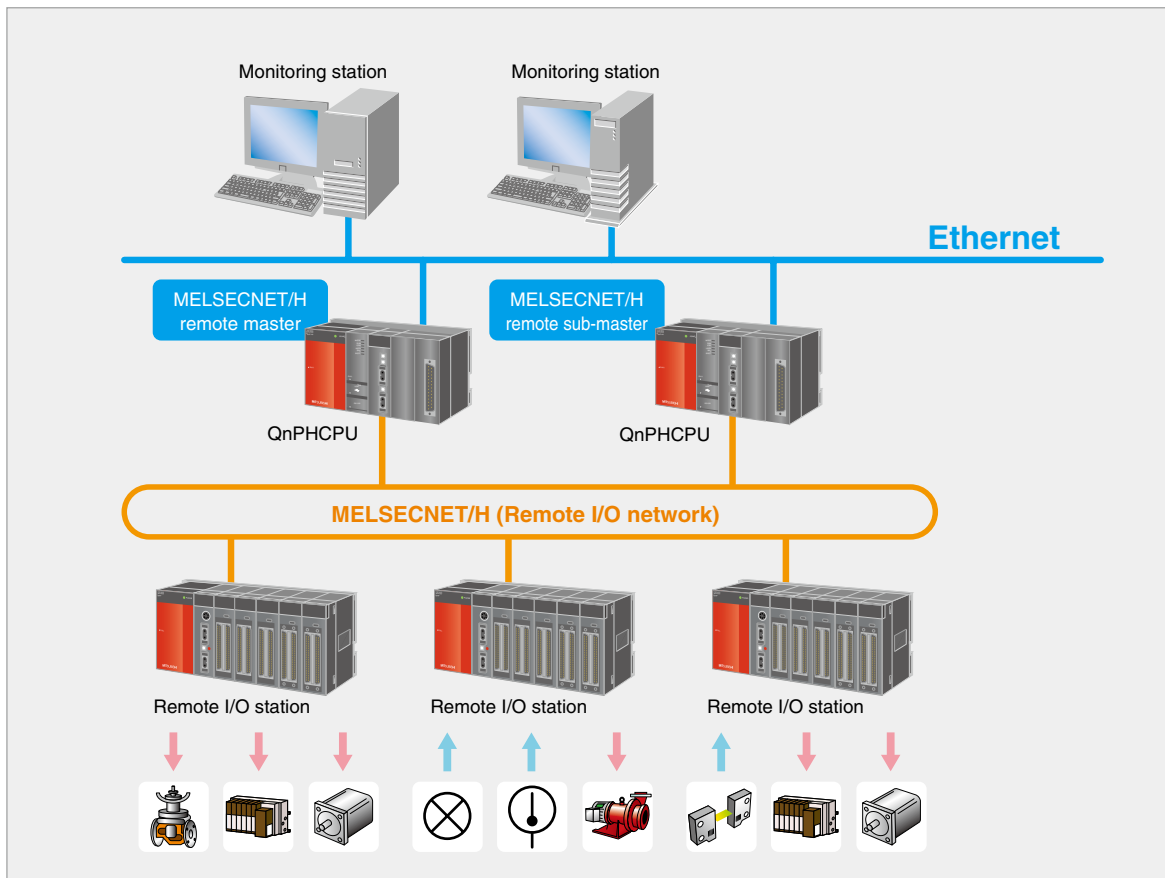

System switching time (reference time)

700 to 800ms
(when connecting 4 remote I/O stations)

· Changed by sequence scan time, link scan time.

CC-Link Master station duplex function

Cost-saving redundant system by using open field network.

Features

The CC-Link Master station duplex function enables the data link to continue working by switching the control to the standby master station (meaning a backup station for the master station) automatically if system down occurs in the master station due to a malfunction in the programmable controller CPU or power supply.

The master station can return to normal and to system operation as the standby master station, even during data-link control by the standby master station, thus preparing itself for the standby master station system down.

System configuration

- The redundant system can be configured in CC-Link network regardless of the CPU types of the master station, standby master station. (Note 2)
- The CC-Link Master station duplex function enables the standby master station to continue the data link working when the master station becomes faulty. The master station can return to normal and to system operation as the standby master station, even during data-link control by the standby master station.

Note 2) When tracking is needed, the communication module (Ethernet, etc.) to communicate the tracking data and the creation of the user program for tracking is required.

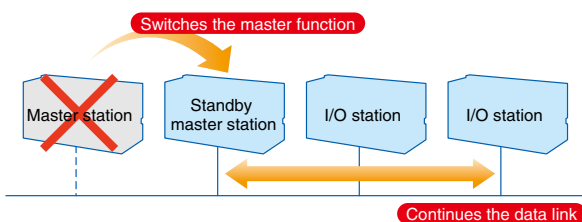
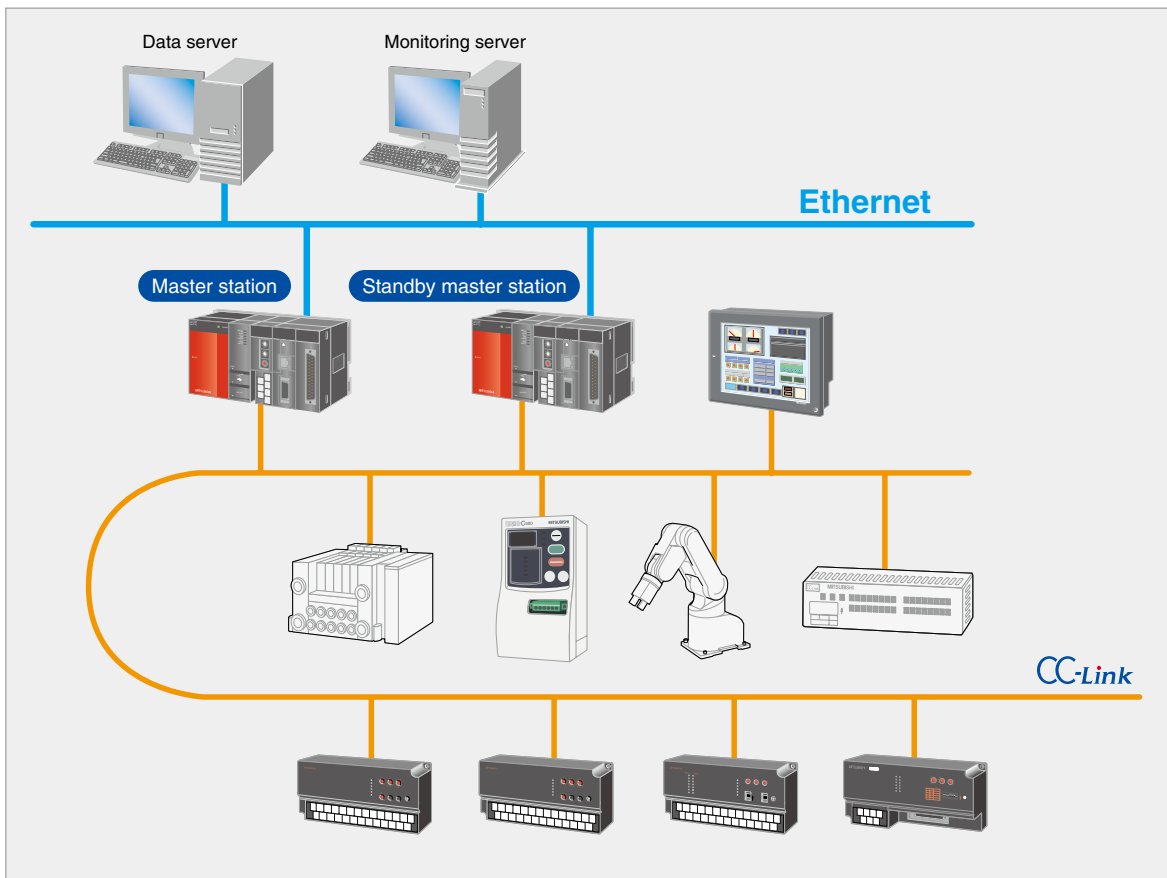

System switching time (reference time)

220 to 1500ms

· Changed by baud rate of CC-Link, sequence scan time, link scan time.

Loop control module

Ideal for fast response control such as

- Rapid temperature increase control in flip chip bond IC manufacturing
- Drying oven cooling temperature control on freeze drying machines

- Staggering 25 ms sampling and control update time, industry's fastest.
- Supports sensor types, such as thermocouple, microvoltage, and current input ranges.
- Continuous PID control by 4 to 20 mA current output results in highly stable and accurate control.

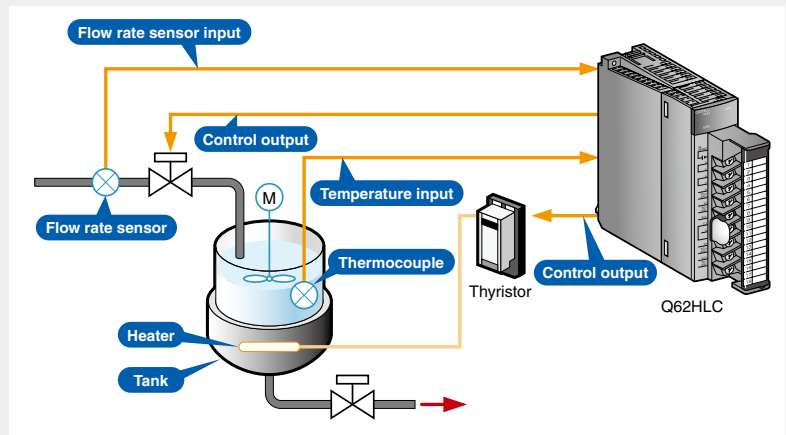

Features

1 High-speed PID control

The Q62HLC loop control module performs a continuous PID control and supports thermocouple inputs, microvoltage inputs, voltage inputs, current inputs, and current outputs. These features make the Q62HLC ideal for fast response control.

2 Connectable to thermocouples complying with major international standards

Thermocouples complying with the JIS, IEC, NBS, and ASTM standards are supported.

Items complying with any of these can be used



3 Supports a variety of input ranges

The use of an input sensor (microvoltage, voltage, and current inputs) enables analog value measurements in the ranges shown below.

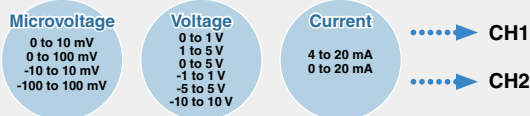

4 Program control function

Control program profiles can be specified where set values (SV) and PID constants (Proportional band, Integral time, Derivative time) are automatically changed at specified times.

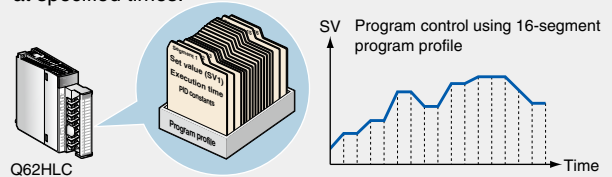

5 Cascade control function

Cascade control can be performed with channel 1 as the master and channel 2 as the slave.

Resin nozzle temperature control

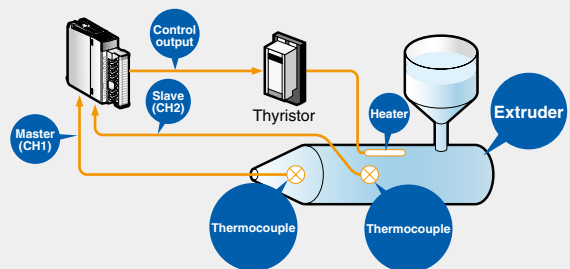

Specifications

Item	Specifications			
Number of analog I/O points	2 channels/module			
Analog input specifications		Analog output specifications		
Number of input points	2 points (2 channels)	Number of output points	2 points (2 channels)	
Analog input	See (2)	Digital input	16-bit signed binary	
Digital output	16-bit signed binary	Analog output	Current	
Usable thermocouples	K, J, T, S, R, N, E, B, PL II, W5Re/W26Re			
Input characteristics	See (1)	Output characteristics	Digital input value: 0 to 1000 (0 to 4000 when using simplified analog output) Output range: 4 to 20 mA	
Maximum resolution	See (1)	Maximum resolution	4 μA	
Accuracy (Note 2)	Indication accuracy	Ambient temperature: 23°C ± 2°C See (2) (a)	Output accuracy	Ambient temperature: 23°C ± 2°C Full scale x (±0.2%)
	Cold junction temperature compensation accuracy	Ambient temperature: 0°C to 55°C See (2) (b)		Ambient temperature: 0°C to 55°C Full scale x (±0.4%)
Conversion speed	25 ms/2channels (constant regardless of the number of channels used)	Conversion speed	25 ms/2channels (constant regardless of the number of channels used)	
Sampling period	25 ms/2channels (constant regardless of the number of channels used)	Control update time	25 ms/2channels (constant regardless of the number of channels used)	
Absolute maximum input	Microvoltage: ± 12 V, voltage: ± 15 V, current: ± 30 mA	Allowable load resistance	600 Ω or less	
Input impedance	Thermocouple, microvoltage, voltage: 1 MΩ, current: 250 Ω	Output impedance	5 MΩ	

Note 2) Accuracy is calculated as follows: [Accuracy] = [Indication accuracy] + [Cold junction temperature compensation accuracy]

(1) Usable input sensor types, measurement ranges, and data resolution

Input	Input range	Digital value	Resolution	
Thermocouple	K	-200 to 1372°C	0.1°C	
	J	-200 to 1200°C		
	T	-200 to 400°C		
	S	-50 to 1768°C		
	R	-50 to 1768°C		
	N	0 to 1300°C		
	E	-200 to 1000°C		
	B	0 to 1800°C		
	PL II	0 to 1390°C		
	W5Re/W26Re	0 to 2300°C		
Microvoltage	0 to 10 mV	0 to 20000	0.5 μV	
	0 to 100 mV		5 μV	
	-10 to 10 mV		-10000 to 10000	1 μV
	-100 to 100 mV			10 μV
Voltage	0 to 1 V	0 to 20000	0.05 mV	
	1 to 5 V		0.2 mV	
	0 to 5 V		0.25 mV	
	0 to 10 V		0.5 mV	
	-1 to 1 V	-10000 to 10000	0.1 mV	
	-5 to 5 V		0.5 mV	
	-10 to 10 V		1 mV	
	4 to 20 mA		0 to 20000	0.8 μA
0 to 20 mA	1 μA			

(2) Indication accuracy

(a) At ambient temperature of $23 \pm 2^\circ\text{C}$

Item	Error		
Thermocouple	Less than -100°C	$\pm 1.0^\circ\text{C}$	
	-100 to less than 500°C	$\pm 0.5^\circ\text{C}$	
	500°C or more	$\pm [\text{Indication value} \times (0.1\%) + 1 \text{ digit}]$	
	S, R, N, W5Re/W26Re	-50 to less than 1000°C	$\pm 1.0^\circ\text{C}$
		1000°C or more	$\pm [\text{Indication value} \times (0.1\%) + 1 \text{ digit}]$
	B	Less than 400°C	$\pm 70.0^\circ\text{C}$
400 to less than 1000°C		$\pm 1.0^\circ\text{C}$	
1000°C or more		$\pm [\text{Indication value} \times (0.1\%) + 1 \text{ digit}]$	
Microvoltage	Full scale $\times (\pm 0.1\%)$		
Voltage			
Current			

(b) At ambient temperature of 0 to 55°C

Item	Error		
Thermocouple	Less than -100°C	$\pm 2.0^\circ\text{C}$	
	-100 to less than 500°C	$\pm 1.0^\circ\text{C}$	
	500°C or more	$\pm [\text{Indication value} \times (0.2\%) + 1 \text{ digit}]$	
	S, R, N, W5Re/W26Re	-50 to less than 1000°C	$\pm 2.0^\circ\text{C}$
		1000°C or more	$\pm [\text{Indication value} \times (0.2\%) + 1 \text{ digit}]$
	B	Less than 400°C	$\pm 140.0^\circ\text{C}$
400 to less than 1000°C		$\pm 2.0^\circ\text{C}$	
1000°C or more		$\pm [\text{Indication value} \times (0.2\%) + 1 \text{ digit}]$	
Microvoltage	Full scale $\times (\pm 0.2\%)$		
Voltage			
Current			

Channel isolated analog modules



A wide selection of channel isolated analog modules are provided to meet requirements for process control and high-accuracy control.

Features

High dielectric withstand voltage

External signal converters are not required.

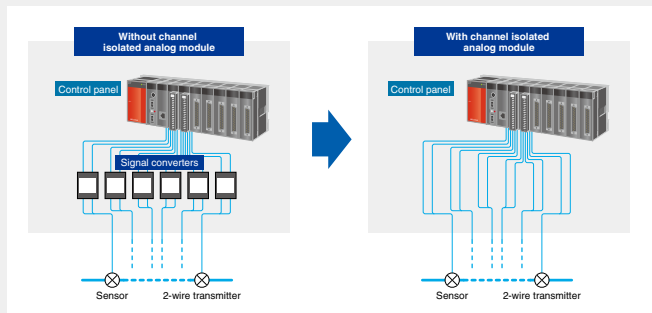

Electric disturbances such as current and noise can be isolated.

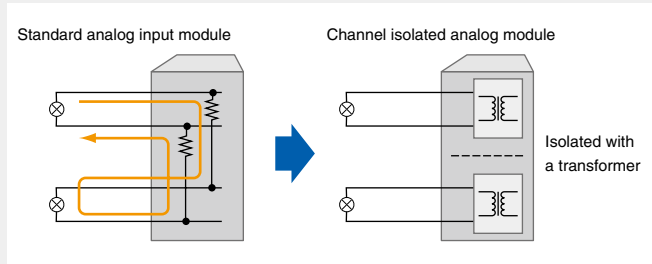

Cost and space requirement reduction (multi-channel type)

With multi-channel modules, more cost effective and small footprint systems can be configured.

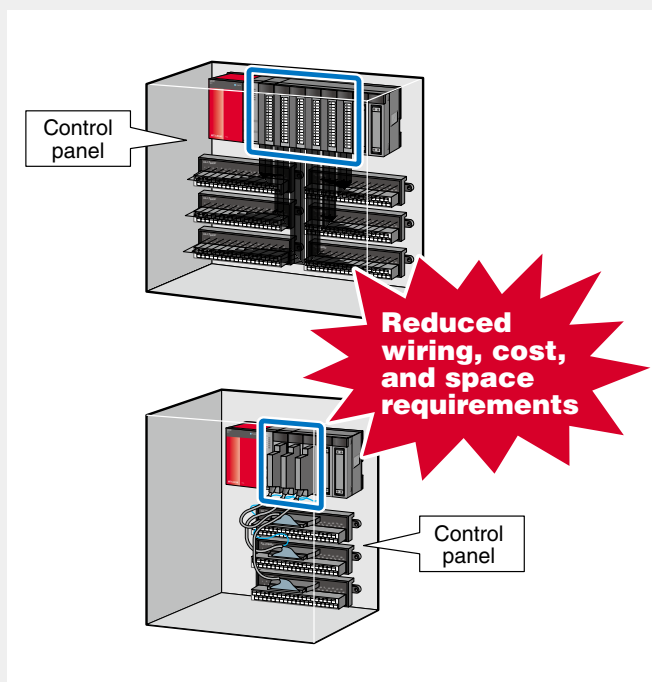

Disconnection detection function

When the analog output range is 4 to 20 mA or the user range setting of current, disconnection is detected by monitoring output values.

Warning and error detection functions

Analog modules monitor analog input signals and notify warnings and errors.

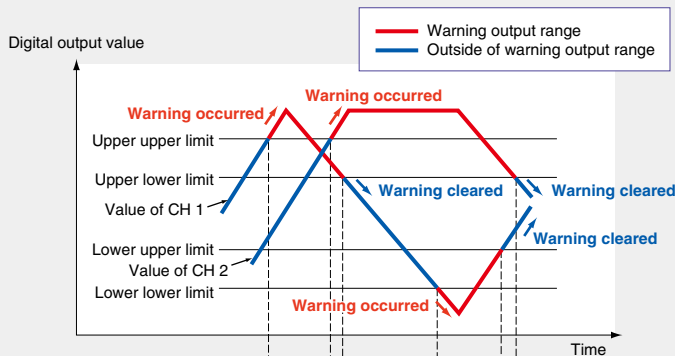

Online module change (hot swap)

Even if the analog module fails during operation, it can be replaced without stopping the system.

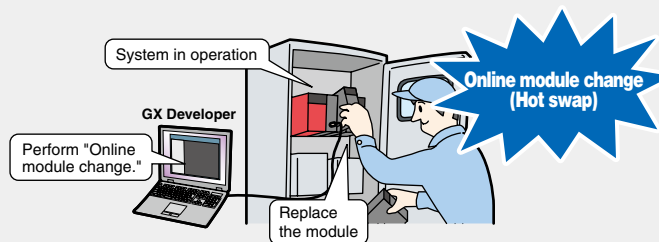

Scaling function (Q68AD-G, Q66AD-DG, Q66DA-G, Q68TD-G-H02)

A value input from an external device can be converted to an arbitrary value. This function eliminates the need for a ladder program that converts A/D conversion data to an actual physical value.

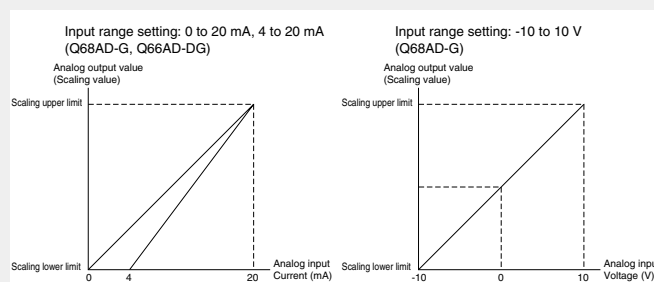

Specifications

Channel isolated high resolution analog input module

Item		Q64AD-GH
No. of analog input points		4 points (4 channels)
Analog input	Voltage	0 to 5 V DC, 1 to 5 V DC, 0 to 10 V DC, -10 to 10 V DC, user range
	Current	0 to 20 mA DC, 4 to 20 mA DC, user range
Absolute max. input		±15 V, ±30 mA
Digital output	32-bit	0 to 64000 (0 to 5 V DC, 1 to 5 V DC, 0 to 10 V DC; 0 to 20 mA DC, 4 to 20 mA DC) -64000 to 64000 (-10 to 10 V DC)
	16-bit	0 to 32000 (0 to 5 V DC, 1 to 5 V DC, 0 to 10 V DC; 0 to 20 mA DC, 4 to 20 mA DC) -32000 to 32000 (-10 to 10 V DC)
Accuracy (accuracy to max. digital output value)	Reference accuracy	±0.05% Digital output value (32-bit): ±32 digits Digital output value (16-bit): ±16 digits
	Temperature coefficient	±71.4 ppm/°C (0.00714%/°C)
Conversion speed		10 ms/4 channels
Isolation method		Between I/O terminal and programmable controller power supply: Photocoupler Between analog input channels: Transformer
No. of occupied I/O points		16 points (I/O assignment: Intelligent 16 points)
External connections		18-point terminal block

Channel isolated high resolution analog input module (with signal conditioning function)

Item		Q62AD-DGH	
2-wire transmitter connection	Input specifications	No. of analog input points	2 points (2 channels)
		Analog input	4 to 20 mA DC (input resistance: 250 Ω), user range
	Power supply specifications	Supply voltage	26±2 V DC
		Max. supply current	24 mA DC
Short-circuit protection		Yes (limit current: 25 to 35 mA)	
Check terminals		Yes	
Digital output	32-bit	0 to 64000	
	16-bit	0 to 32000	
Accuracy (accuracy to max. digital output value)	Reference accuracy	±0.05% Digital output value (32-bit): ±32 digits Digital output value (16-bit): ±16 digits	
	Temperature coefficient	±71.4 ppm/°C (0.00714%/°C)	
Conversion speed		10 ms/2 channels	
Isolation method		Between I/O terminal and programmable controller power supply: Photocoupler Between analog input channels: Transformer Between external power supply and analog input channel: Transformer	
No. of occupied I/O points		16 points (I/O assignment: Intelligent 16 points)	
External connections		18-point terminal block	

Channel isolated analog input module

Item		Q68AD-G
No. of analog input points		8 points (8 channels)
Analog input	Voltage	0 to 5 V DC, 1 to 5 V DC, 0 to 10 V DC, -10 to 10 V DC, user range
	Current	0 to 20 mA DC, 4 to 20 mA DC, user range
Absolute max. input		±15 V, ±30 mA
Digital output	High resolution mode	0 to 16000 (0 to 10 V DC), 0 to 12000 (0 to 5 V DC, 1 to 5 V DC; 0 to 20 mA DC, 4 to 20 mA DC), -16000 to 16000 (-10 to 10 V DC), -12000 to 12000 (user range)
	Normal resolution mode	0 to 4000 (0 to 10 V DC, 0 to 5 V DC, 1 to 5 V DC; 0 to 20 mA DC, 4 to 20 mA DC) -4000 to 4000 (-10 to 10 V DC, user range)
Accuracy (accuracy to max. digital output value)	Reference accuracy	±0.1% High resolution mode (0 to 10 V, -10 to 10 V): ±16 digits High resolution mode (other than the above ranges): ±12 digits Normal resolution mode: ±4 digits
	Temperature coefficient	±71.4 ppm/°C (0.00714%/°C)
Sampling cycle		10 ms/channel
Isolation method		Transformer
No. of occupied I/O points		16 points (I/O assignment: Intelligent 16 points)
External connections		40-pin connector

Channel isolated analog input module (with signal conditioning function)

Item		Q66AD-DG	
2-wire transmitter connection	Input specifications	No. of analog input points (no. of 2-wire transmitters)	6 points (6 channels)
		Analog input	4 to 20 mA DC (input resistance: 250 Ω), user range (0 to 20 mA DC without 2-wire transmitter)
	Power supply specifications	Supply voltage	26±2 V DC
		Max. supply current	24 mA DC
Short-circuit protection		Yes (limit current: 25 to 35 mA)	
Check terminals		Yes	
Digital output	High resolution mode	0 to 12000	
	Normal resolution mode	0 to 4000	
Accuracy (accuracy to max. digital output value)	Reference accuracy	±0.1% High resolution mode: ±12 digits Normal resolution mode: ±4 digits	
	Temperature coefficient	±71.4 ppm/°C (0.00714%/°C)	
Sampling cycle		10 ms/channel	
Isolation method		Transformer	
No. of occupied I/O points		16 points (I/O assignment: Intelligent 16 points)	
External connections		40-pin connector	

Specifications

Channel isolated analog output module

Item	Q62DA-FG	
No. of analog output points	2 points (2 channels)	
Digital input	16-bit signed binary (-12288 to 12287, -16384 to 16383)	
Analog output	Voltage	-12 to 12 V DC (external load resistance: 1 k to 1 MΩ)
	Current	0 to 20 mA DC (external load resistance: 0 to 600 Ω)
Analog output range	Voltage	1 to 5 V DC, 0 to 5 V DC, -10 to 10 V DC, user range setting 2, user range setting 3
	Current	0 to 20 mA DC, 4 to 20 mA DC, user range setting 1
Accuracy (accuracy to max. analog output value)	Reference accuracy	±0.1% (voltage: ±10 mV, current: ±20 μA)
	Temperature coefficient	±80 ppm/°C (0.008%/°C)
Conversion speed	10 ms/2 channels	
Absolute max. output	Voltage	±13 V
	Current	23 mA
Output monitor	Resolution	12 bits
	Reference accuracy	±0.2%
	Temperature coefficient	±160 ppm/°C (0.016%/°C)
Short-circuit protection	Yes	
Isolation method	Between I/O terminal and programmable controller power supply: Photocoupler Between analog output channels: Transformer Between external power supply and analog output channel: Transformer	
No. of occupied I/O points	16 points (I/O assignment: Intelligent 16 points)	
External connections	18-point terminal block	

Item	Q66DA-G	
No. of analog output points	6 points (6 channels)	
Digital input	16-bit signed binary (high resolution mode: -12288 to 12287, -16384 to 16383; normal resolution mode: -4096 to 4095)	
Analog output	Voltage	-12 to 12 V DC (external load resistance: 1 k to 1 MΩ)
	Current	0 to 20 mA DC (external load resistance: 0 to 600 Ω)
Analog output range	Voltage	1 to 5 V DC, 0 to 5 V DC, -10 to 10 V DC, user range setting 2, user range setting 3
	Current	0 to 20 mA DC, 4 to 20 mA DC, user range setting 1
Accuracy (accuracy to max. analog output value)	Reference accuracy	±0.1% (voltage: ±10 mV, current: ±20 μA)
	Temperature coefficient	±80 ppm/°C (0.008%/°C)
Conversion speed	6 ms/channel	
Absolute max. output	Voltage	±13 V
	Current	23 mA
Short-circuit protection	Yes	
Isolation method	Between output terminal and programmable controller power supply: Transformer Between analog output channels: Transformer Between external power supply and analog output channel: Transformer	
No. of occupied I/O points	16 points (I/O assignment: Intelligent 16 points)	
External connections	40-pin connector	

Channel isolated thermocouple/micro voltage input module and thermocouple input module

Item	Q64TDV-GH	Q64TD	Q68TD-G-H02
No. of channels	4 channels		8 channels
Output	Temperature conversion value	16-bit signed binary (-2700 to 18200: Each increment represents 0.1°C change)	
	Scaling value	16-bit signed binary	
Thermocouple standards	JIS C1602-1995		JIS C1602-1995, IEC 60584-1 (1995), IEC 60584-2 (1982)
Usable thermocouples and temperature measurement range	B: 0 to 1820°C, R: -50 to 1760°C, S: -50 to 1760°C, K: -270 to 1370°C, E: -270 to 1000°C, J: -210 to 1200°C, T: -270 to 400°C, N: -270 to 1300°C		
Micro voltage input range	-100 to 100 mV (input resistance: 2 MΩ or more)	N/A	
Cold junction temperature compensation accuracy	±1.0°C		
Conversion speed	Sampling cycle x 3	40 ms/channel	640 ms/8 channels
Sampling cycle	20 ms/channel	N/A	
No. of analog input points	(4 channels + Pt100 connection channel)/module		(8 channels + Pt100 connection channel)/module
Isolation method	Between thermocouple input/micro voltage input and ground: Transformer Between thermocouple input/micro voltage input channels: Transformer Between cold junction temperature compensation input (Pt100) and ground: Non-isolated		
Disconnection detection	Yes (each channel independently)		Yes
No. of writes to E ² PROM	Max. 100,000 times		N/A
No. of writes to flash memory	N/A		Max. 50,000 times
No. of occupied I/O points	16 points (I/O assignment: Intelligent 16 points)		
External connections	18-point terminal block		40-pin connector

Channel isolated pulse input module

Item	QD60P8-G	
Counting speed switch settings	30 kpps/10 kpps/1 kpps/100 pps/50 pps/10 pps/1 pps/0.1 pps	
No. of channels	8 channels	
Count input signal	Phase	1 phase
	Signal level	5 V DC/12 to 24 V DC
Counter	Counting speed (max.)	30 kpps/10 kpps/1 kpps/100 pps/50 pps/10 pps/1 pps/0.1 pps
	Counting range	Sampling pulse number: 16-bit binary (0 to 32767) Accumulating count value: 32-bit binary (0 to 99999999) Input pulse value: 32-bit binary (0 to 2147483647)
	Count type	Linear counter method, ring counter method
No. of occupied I/O points	32 points (I/O assignment: Intelligent 32 points)	
External connections	18-point terminal block	

Channel isolated RTD input module

Item		Q64RD-G	Q68RD3-G	
No. of channels		4 channels	8 channels	
Output	Temperature conversion value	16-bit signed binary(-2000 to 8500: Each increment represents 0.1°C change), 32-bit signed binary(-200000 to 850000: Each increment represents 0.001°C change)	16-bit signed binary (-2000 to 8500: Each increment represents 0.1°C change)	
	Scaling value	16-bit signed binary		
Measuring method (wire type)		3-/4-wire type	3-wire type	
Usable RTD		Pt100 (JIS C1604-1997, IEC 751 1983) Temperature measurement range: -200 to 850°C		
		JPt100 (JIS C1604-1981) Temperature measurement range: -180 to 600°C		
		Ni100 (DIN43760 1987) Temperature measurement range: -60 to 180°C		
Accuracy	Pt100	-200 to 850°C	±0.553°C (25±5°C), ±1.615°C (0 to 55°C)	±0.8°C (25±5°C), ±2.4°C (0 to 55°C)
		-20 to 120°C	±0.090°C (25±5°C), ±0.300°C (0 to 55°C)	±0.3°C (25±5°C), ±1.1°C (0 to 55°C)
		0 to 200°C	±0.145°C (25±5°C), ±0.470°C (0 to 55°C)	±0.4°C (25±5°C), ±1.2°C (0 to 55°C)
	JPt100	-180 to 600°C	±0.390°C (25±5°C), ±1.140°C (0 to 55°C)	±0.8°C (25±5°C), ±2.4°C (0 to 55°C)
		-20 to 120°C	±0.090°C (25±5°C), ±0.300°C (0 to 55°C)	±0.3°C (25±5°C), ±1.1°C (0 to 55°C)
		0 to 200°C	±0.145°C (25±5°C), ±0.470°C (0 to 55°C)	±0.4°C (25±5°C), ±1.2°C (0 to 55°C)
Ni100	-60 to 180°C	±0.135°C (25±5°C), ±0.450°C (0 to 55°C)	±0.4°C (25±5°C), ±1.2°C (0 to 55°C)	
Resolution		0.025°C	0.1°C	
Conversion speed		40 ms/channel	320 ms/8 channels	
No. of analog input points		4 channels/module	8 channels/module	
Isolation method		Between RTD input and programmable controller power supply: Photocoupler Between RTD input channels: Transformer	Between RTD input and programmable controller power supply: Transformer Between RTD input channels: Transformer	
Disconnection detection		Yes (each channel independently)		
No. of occupied I/O points		16 points (I/O assignment: Intelligent 16 points)		
External connections		18-point terminal block	40-pin connector	

Temperature control module

Item	Q64TCTT	Q64TCTTBW	Q64TCRT	Q64TCRTBW
Control output	Transistor output			
No. of temperature input point	4 channels/module			
Usable thermocouples/ platinum RTDs	Thermocouple (R, K, J, T, S, B, E, N, U, L, PL II, W5Re/W26Re)		Platinum RTD (Pt100, JPt100)	
Accuracy	Ambient temperature of 25±5°C: Full scale x (±0.3%) Ambient temperature of 0 to 55°C: Full scale x (±0.7%)			
Sampling cycle	0.5 s/4 channels			
PID constant range	Proportional band (P): 0.0 to 1000.0% Integral time (I): 1 to 3600 s Derivative time (D): 0 to 3600 s			
Isolation method	Between input and ground: Transformer Between input and channel: Transformer			
Heater disconnection detection	No	Yes	No	Yes
No. of occupied I/O points	16 points (I/O assignment: Intelligent 16 points)	32 points/2 slots (Default I/O assignment: Empty 16 points [first half], Intelligent 16 points [second half])	16 points (I/O assignment: Intelligent 16 points)	32 points/2 slots (Default I/O assignment: Empty 16 points [first half], Intelligent 16 points [second half])
External connections	18-point terminal block	Two 18-point terminal blocks	18-point terminal block	Two 18-point terminal blocks

Load cell

Item	Q61LD			
Analog input (load cell output) points	1 point (1 channel)			
Analog input (load cell output)	0.0 to 3.3mV/V			
Load cell applied voltage	5VDC ±5%, Output current within 60mA (Four 350Ω load cells can be connected in parallel.) 6-wire system (Combination use of remote sensing method and ratiometric method)			
Digital output	32-bit signed binary 0 to 10000			
Gross weight output (Maximum weighing output value)	32-bit signed binary -99999 to 99999 (excluding decimal point and unit symbol)			
Analog input range (load cell rated output)	0.0 to 1.0mV/V, 0.0 to 2.0mV/V, 0.0 to 3.0mV/V			
I/O characteristics, Maximum resolution	Analog input range		Digital output value	Maximum weighing capacity output value
	Load cell rated output	0 to 1.0mV/V 0 to 2.0mV/V 0 to 3.0mV/V	0 to 10000	-99999 to 99999
Accuracy (Accuracy relative to analog input (load cell rated output) of a module)	Nonlinearity: Within ±0.01%/FS (Ambient temperature 25°C) Zero drift: Within ±0.25 μV/°C RTI Gain drift: Within ±15 ppm/°C			
Conversion speed	10 ms			
Absolute maximum input	±2.5V			
Insulation method	Photocoupler insulation			
No. of occupied I/O points	16 points (I/O assignment: intelligent 16 points)			
External connections	18-point terminal block			

PX Developer



PX Developer screen configuration and screen examples

Programming tool

Project window

The project parameters, applicable modules, tags, program names, execution cycle, etc. are set in this window.

FB property window

The initial values of the data in the FB are set in this window.

Sheet

Maximum 32 sheets/program

Screen configuration

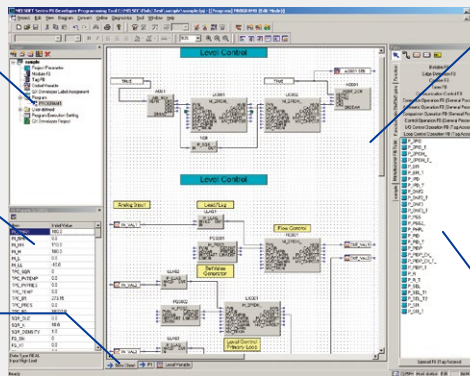

Program/FB definition window

The programs and user defined FBs are created in this window.

A program is a unit in which the process is described. Up to 200 programs can be created. One program contains up to 32 sheets. A sheet is a form used to paste FB/functions or connector lines and to describe the process.

FB/function part window

The FB/function parts which can be pasted to the programs and user defined FBs are displayed in this window.

Monitor tool

Monitor function display area

Each monitor function (control panel, trend graph, faceplate, tuning panel, alarm list, or event list) is displayed in this area.

Screen configuration

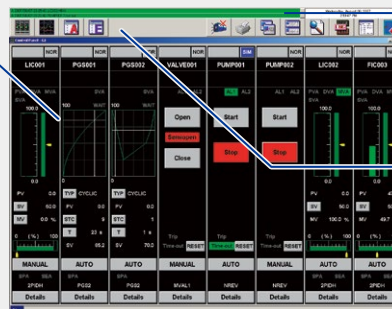

Alarm/event display area

The latest two alarms or event messages are displayed.

Tool bar

Icons that call out each monitor function are displayed.

Historical trend graph

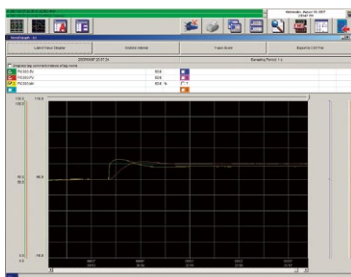

Event/alarm list

Tag Name	Tag Description	Event Message	Time	Status	Operator
FC001	2010/08/27 10:11:27
FC002	2010/08/27 10:11:27
FC003	2010/08/27 10:11:27
FC004	2010/08/27 10:11:27
FC005	2010/08/27 10:11:27
FC006	2010/08/27 10:11:27
FC007	2010/08/27 10:11:27
FC008	2010/08/27 10:11:27
FC009	2010/08/27 10:11:27
FC010	2010/08/27 10:11:27
FC011	2010/08/27 10:11:27
FC012	2010/08/27 10:11:27
FC013	2010/08/27 10:11:27
FC014	2010/08/27 10:11:27
FC015	2010/08/27 10:11:27
FC016	2010/08/27 10:11:27
FC017	2010/08/27 10:11:27
FC018	2010/08/27 10:11:27
FC019	2010/08/27 10:11:27
FC020	2010/08/27 10:11:27

Process control monitoring screen generator

The PX Developer Monitor tool can generate process control monitoring screens for GOT from process control programs created by the programming tool. Also, graphic screens can be configured by combining the following optional tools with the Monitor tool.

+

SoftGOT drawing tool



GOT catalog

The graphics screen can be created at a low price with the SoftGOT drawing tool.

+

MX Component with VB language



MELSOFT catalog

Highly flexible graphic screens can be created using VB language. MX Component facilitates communication with the process CPU.

+

commercially available SCADA software (compatible with EZSocket)



EZSocket catalog

Graphics screen can be created enough by commercially available SCADA.

▶▶▶

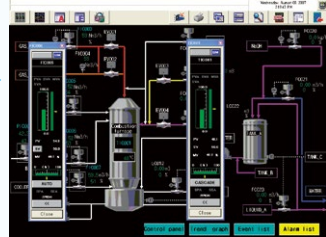

Example of graphic screen creation tool

Features

1 Substantial FBs (function blocks) and functions for loop control

- In addition to the process CPU's loop control instruction FBs, PX Developer has combined FBs that are easy to use.
- Basic FB/functions (logical operation, arithmetic operation, etc.) that comply with IEC61131-3 are also provided, allowing simple sequence control to be described in the FBD.

2 Easy programming with FBs/process tag names

- The loop control program can be created easily. Select the required FBs from the PX Developer's standard loop control FB or compensation FB, paste and connect them on the screen, and then set the parameters such as the PID constants and upper/lower limits (items configuring tags).
- When programming with tag names, the parameters in the tag can be described as "tag name.parameter name" (FIC001.PV, etc.). This enables the user to program without having to concern about the device memory addresses.

3 Analog/digital I/O processing in FB

- FBs for I/O processing of the analog and I/O modules controlled by the process CPU are equipped. Ladder programs for I/O processing are no longer required.

4 Easy to standardize and reuse programs

- PX Developer complies with the IEC61131-3 standards. Programs can be modularized (custom FB can be created). This allows for reuse in future projects requiring similar capabilities, greatly reducing development time.

5 Program event execution

- FBD programs can be executed not only periodically but also automatically upon event occurrence. (The event conditions can be described without a program.) PX Developer easily realizes the starting process for nonstationary, error, and exceptional processes.

6 Integration with sequence control programs

- Easy data exchange with ladder programs.
- Data can be exchanged between the FBD program and ladder program (created with GX Developer) using logical names (labels) instead of device memory addresses. Therefore, constants of loop control tags, SV values, etc. can be easily changed from the ladder programs.

7 Uploading/downloading FBD programs

- Graphic data of FBD programs can be stored in the programmable controller CPU by writing.
- The stored data can be recovered by reading from the programmable controller CPU. Therefore, the program can be edited with a PC in which the project is not stored.

8 Comprehensive tuning and monitoring functions

- The PX Developer has various screens (face plate, tuning trend, alarm, event list, etc.) used to tune, monitor, and operate the created control loop. Tuning and monitoring are available immediately after creating the program.
- Auto tuning can be used by the Step Response method or the Limit Cycle method.

9 Combination with SoftGOT

- Using together with SoftGOT, process control monitoring screens can be readily created. [P.37](#) [P.42](#)

10 Improved operability for redundant system

- Users can design the redundant system without repeating the same procedure for the control and standby systems, reducing the total setup and design time.

11 Supports the server/client monitoring system

- Easy to use by utilizing the Monitor tool.
- Configuring the server/client monitoring system with lower cost is possible.
- Supports the large process control systems.

PX Developer



Specifications

Programming tool

Item	Specifications
Target CPU	Process CPU (Q02PHCPU/Q06PHCPU/Q12PHCPU/Q25PHCPU) Redundant CPU (Q12PRHCPU/Q25PRHCPU)
Target network	CC-Link IE Controller Network, MELSECNET/H, MELSECNET/10 ^(Note 1) , Ethernet (10/100 Mbps), RS232 (CPU's RS-232 port), USB (CPU's USB port)
Programming languages	IEC61131-3 compliant FBD language
Number of programs	Max. 200 (max. 32 sheets/program)
Number of tags	Max. 120/process CPU (Q02/06PHCPU) Max. 480/process CPU (Q12/25PHCPU, Q12/25PRHCPU)
FB/function types	<ul style="list-style-type: none"> · General functions: 58 types (IEC61131-3 compliant basic functions) · General FB: 20 types (IEC61131-3 compliant basic FB) · Process functions: 5 types (corresponding to process instructions for CPU) · General process FB: 28 types (corresponding to process instructions for CPU) · Tag access FB: 37 types (corresponding to process instructions for CPU) · Tag FB: 46 types (high function FBs with temperature control function by combining process FBs) · Module FB: 31 types (FBs for accessing Q Series analog and I/O modules)
Program execution method	<ul style="list-style-type: none"> · Timer execution type: scan executed at high speed (200 ms cycle), normal speed (200/400/600/800 ms/1 s cycle), or low speed (1/2/4/5/10 s cycle) · Interrupt execution type: cycle interrupt (1 to 999 ms) or random interrupt (interrupt with interrupt pointer I0 to I255) (in practical use, 10 ms or more/control loop)

Note 1) When An, AnS, QnA, QnAS, and Q4AR CPUs are mixed on the network, the target network is MELSECNET/10 PLC to PLC network.

Monitor tool

Item	Specifications	
Target CPU and network	· Same as the programming tool	
Number of monitoring CPU modules and tags	<ul style="list-style-type: none"> · Number of process CPUs under monitoring: Max. 16 (Max. 16 process CPUs can be monitored from one PC.) · Number of monitor tags: Max. 7,680 For the redundant system, a pair of CPUs (control and standby systems) is counted as one CPU. 	
Monitor functions	Control panel	<ul style="list-style-type: none"> · 8 faceplates/screen (one group) x max. 500 screens = 4,000 faceplates · Lockout tag available for each faceplate
	Trend graph	<ul style="list-style-type: none"> · 8 items/screen (one group) x max. 125 screens = 1,000 items · Collection cycle: 1 s/10 s/1 min./5 min./10 min. · The chart can be output into a CSV file. · Automatically generated CSV files can be opened in the trend graph display.
	Alarm list	<ul style="list-style-type: none"> · Max. 2,000 alarms can be displayed. · The list can be output into a CSV file.
	Event list	<ul style="list-style-type: none"> · Max. 2,000 events can be displayed. · The list can be output into a CSV file.
	User application	· Max. 4 can be started.
	Tag data external I/F	· The faceplate can be displayed, monitored, and operated on an external application by using ActiveX faceplate button or faceplate control.
	GOT screen generator function	· Process control monitoring screens for GOT1000 can be automatically generated from process control programs created by the programming tool. (Max.120 tags)

Application example: Fluid level control

Application

The MELSEC process control system can be used to control fluid level at food and chemical plants. Fluid level of raw materials, intermediate products, and finished products in the tank can be maintained within the set range.

Control details

The level control loop (cascade: primary loop) inputs the tank level (analog value) and implements PI operation to achieve the set level value. The flow control loop (cascade: secondary loop) uses the operation result (primary manipulated value) of the level control loop as the set value and implements PI operation with the flow rate from the flow meter. The result is output as an analog value to the control valve, which is the secondary manipulated value.

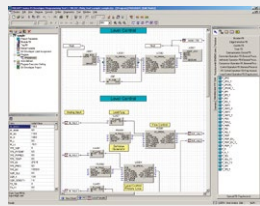

FBD programming screen



PC for engineering and monitoring

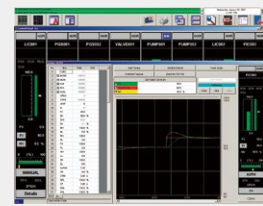

Monitoring screen

CC-Link IE Controller Network, MELSECNET/H Network System (PLC to PLC network), or Ethernet

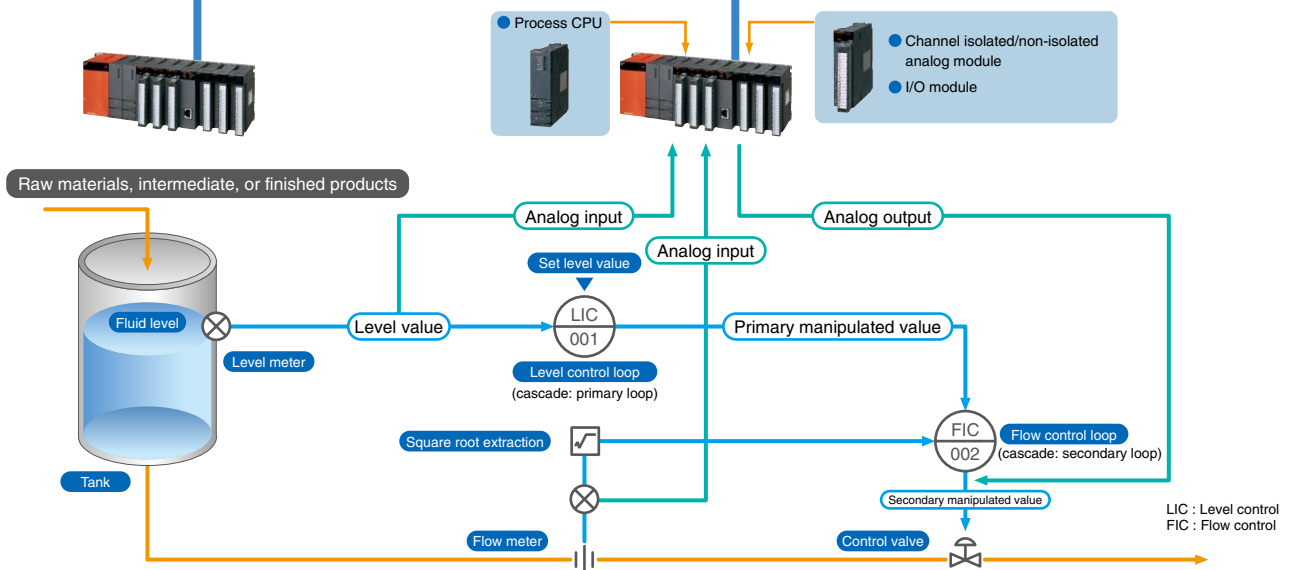

Example of describing the above loop control application with PX Developer

Analog and I/O modules are represented by FBs. The actual I/O processing can be created just by connecting the FBs.

[Fluid level control]

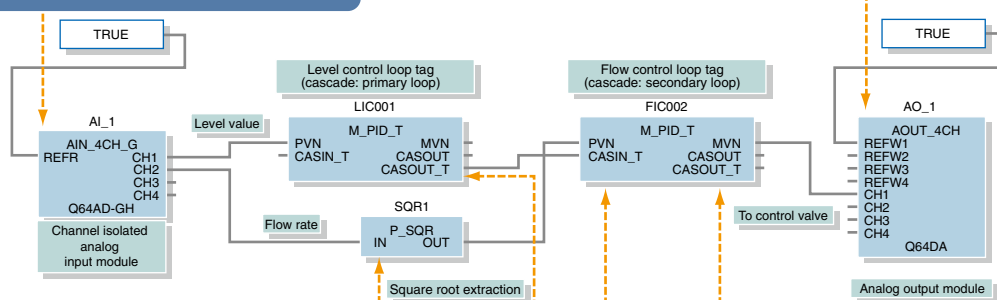

A custom FB can be created by combining multiple FBs. FBs make all programs modular, allowing for reuse in future projects. Program productivity can be improved. (e.g., PID with square root extraction can be created by combining SQR1 and FIC002.)

Cascade control can be easily created by connecting two PID control FB cascade terminals. Also, tracking by changing the mode between cascade and auto is equipped as standard.

PX Developer



Redundant system related functions (Programming tool)

Simple engineering environment

All tag information and programs are managed in a single project; programs and parameters are downloaded to both systems, just like a single system. No special consideration for redundancy is required, reducing engineering time.

No tracking setting required

Device tracking settings in PX Developer are automatically generated by compiling, reducing setup time.

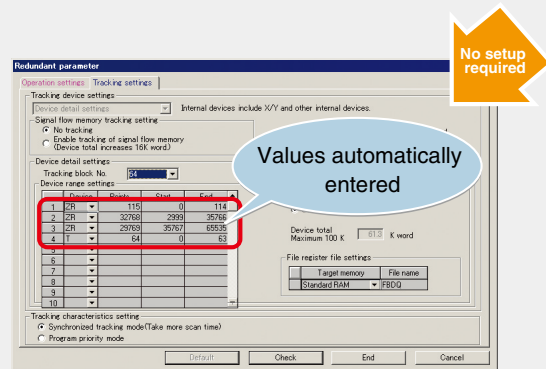
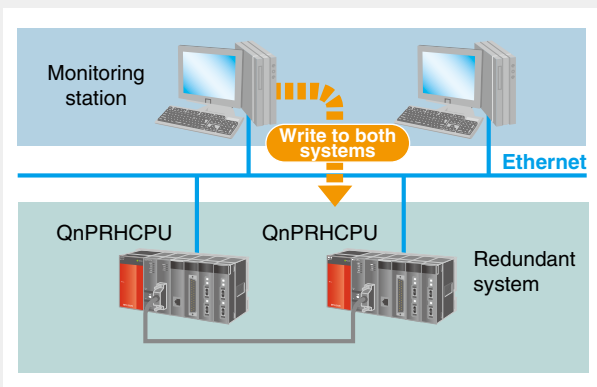

Redundant system related functions (Monitor tool)

Easy to monitor

By setting the control system as the monitoring target in the transfer setup, the new control system is automatically monitored when the system is switched. No extra setting is required for system switching.

Monitoring redundant system communication status

Both systems in the redundant system are monitored; the status of each system (control/standby) and communication errors are displayed.

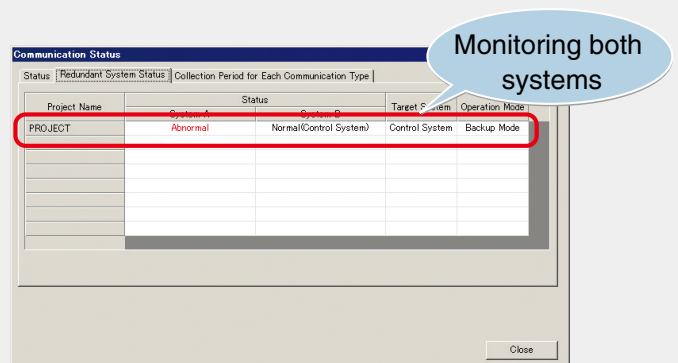
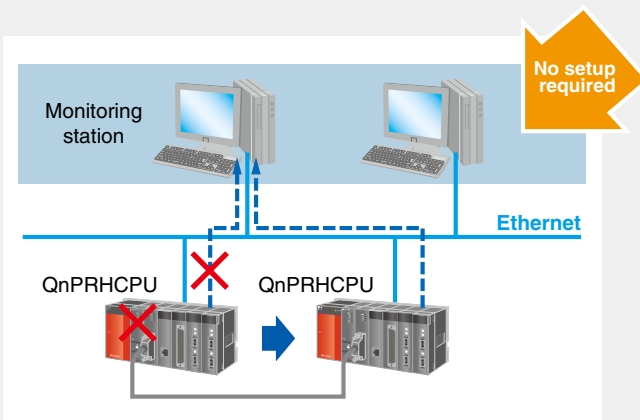

Server/client monitoring system(monitor tool)

Supporting large-scaled process control system. Easy and low-cost system configuration.

- With the server/client monitoring system, the monitoring information is shared and the monitoring operations are linked.
- Even with the expansion of monitoring PCs, the communication load with programmable controllers is controlled by the server-clients configuration to maintain the monitoring operation performance.

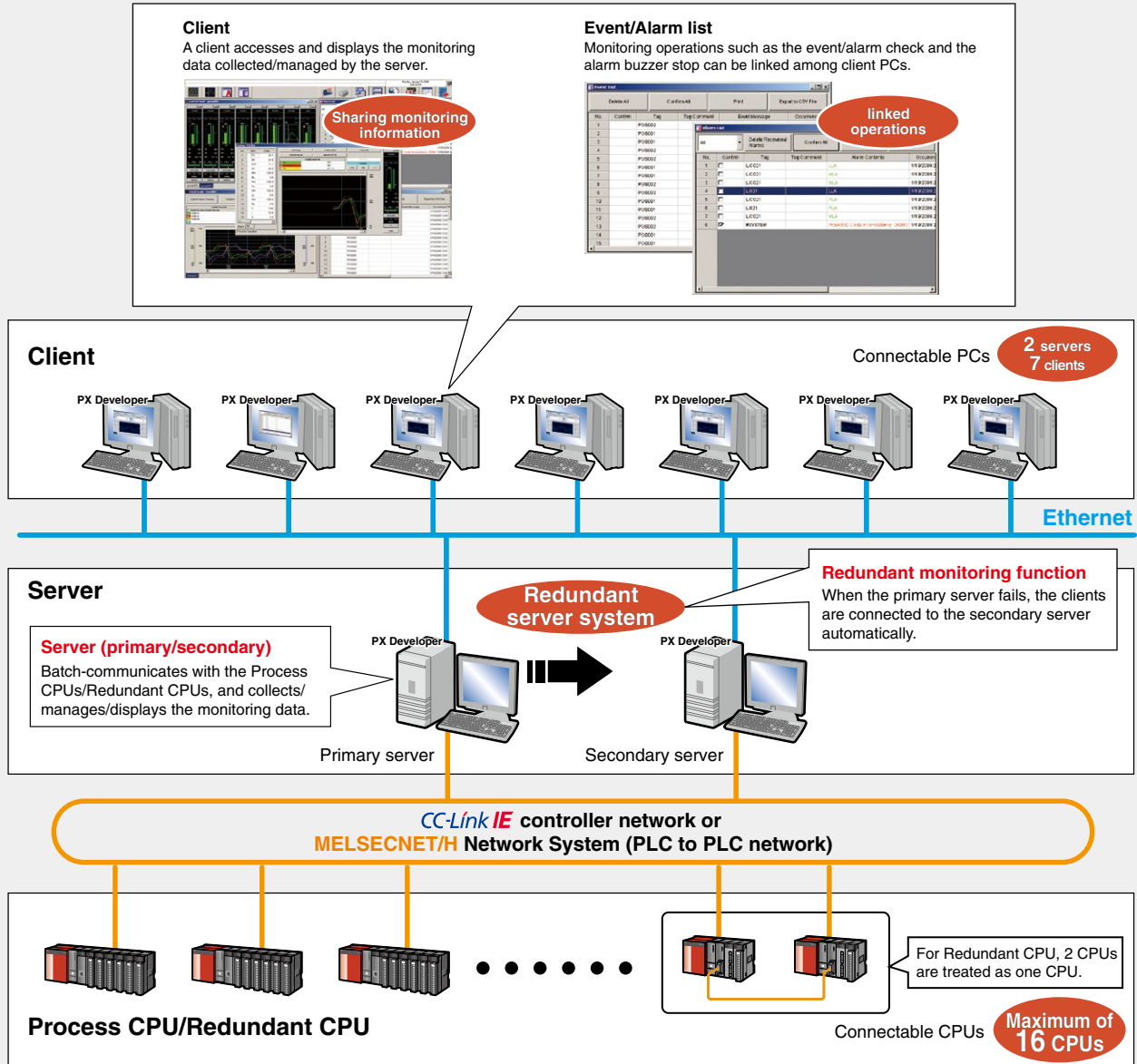

Item	Specifications
Connectable PC	2 servers(primary/secondary) Maximum of 7 clients
Compatible CPU	Process CPU (Q02PHCPU, Q06PHCPU, Q12PHCPU, Q25PHCPU) Redundant CPU (Q12PRHCPU, Q25PRHCPU) Connectable CPUs:Maximum of 16
Compatible network	CC-Link IE controller network, MELSECNET/H(10) network system, Ethernet
Function overview	<ul style="list-style-type: none"> · A server performs communication with PLCs in a batch, so communication loads on PLCs can be reduced and communication performance can be improved. · The monitoring data collected/managed by a server can be displayed on clients. In other words, the same monitor screen can be displayed with the monitor tool on every OPS. · Installing a primary server and a secondary server in the monitoring system enables continuous monitoring when an error occurs in the primary server, for clients switch the server to connect automatically. · When an operation, such as a buzzer stop and check/deletion of an alarm/event, is performed in one of OPSs in the monitoring system, its result synchronizes in every OPS in the monitoring system.

PX Developer



GOT screen generator function

Equipment/shop floor monitoring by GOT1000

GOT1000 can be used for monitoring equipment and shop floor.

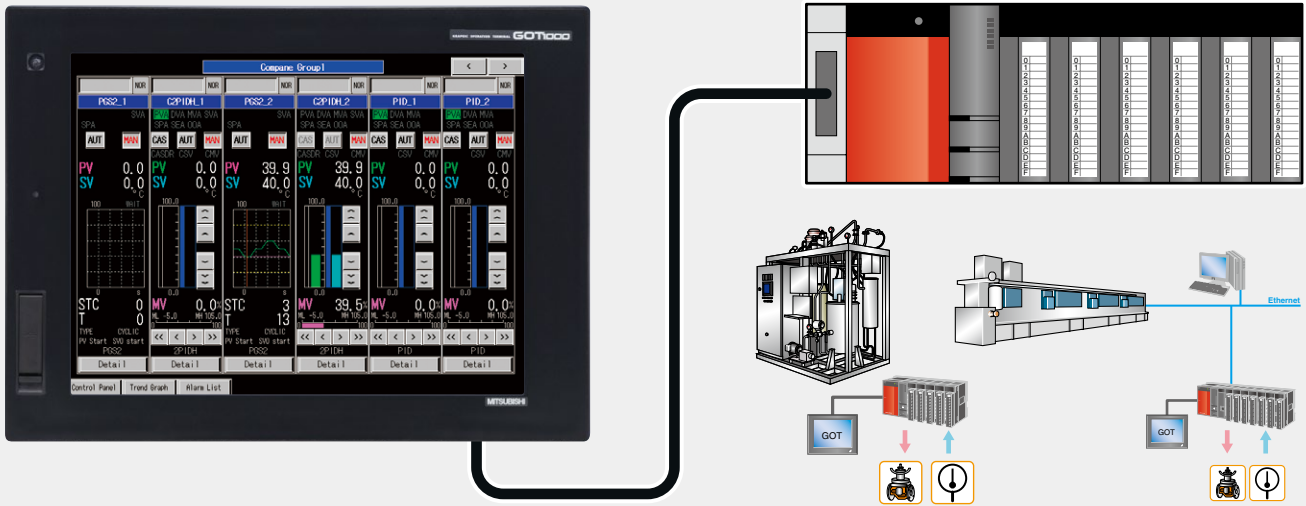

Easy to create GOT1000 process control monitoring screens

- Faceplates and tuning screens for GOT1000 can be automatically generated from PX Developer projects.
- Tag's assigned device settings or programs are not needed for the auto-generated screens.

*Only CPU which is connected to the host station can be monitored.
Multiple CPUs which are connected to other stations cannot be monitored.

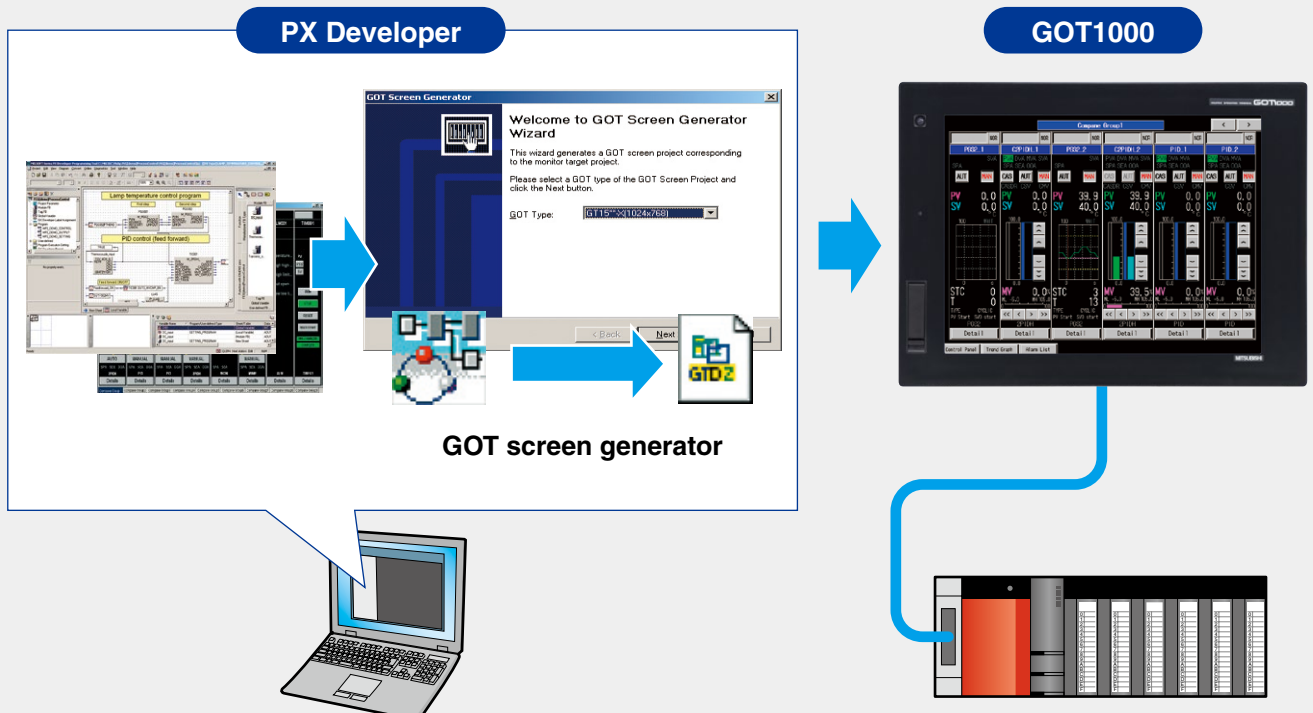

The following screens can be generated with the GOT screen generator function.

Faceplate

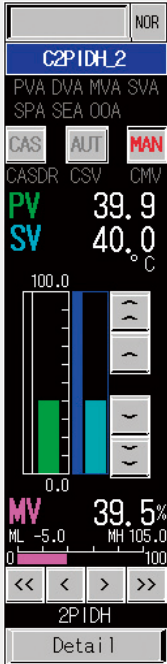

Control panel screen

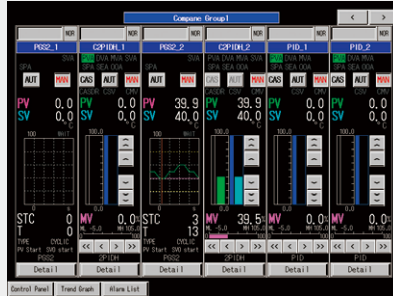

Alarm list screen



Trend graph screen



Tuning screen

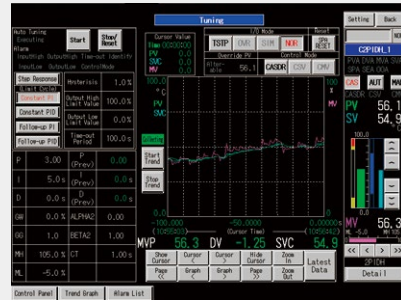

Tag setting screen

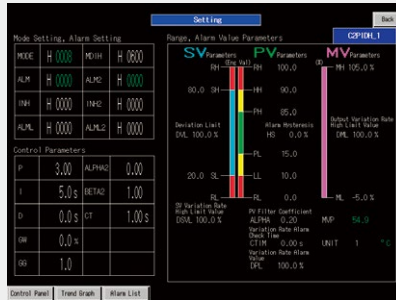

Program setting screen

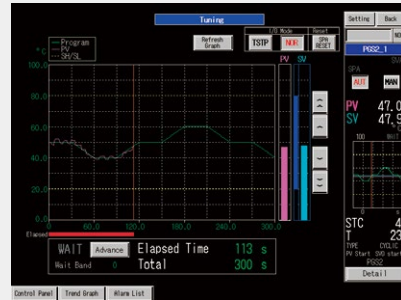

Item	Specifications
Supported CPU	Process CPU (Q02PHCPU, Q06PHCPU, Q12PHCPU, Q25PHCPU), Redundant CPU (Q12PRHCPU, Q25PRHCPU)
Supported GOT	GT15: Each model of XGA and SVGA GT16: Each model of XGA and SVGA GT SoftGOT1000 (screen size: 1024 x 768 dot [XGA], 800 x 600 dot [SVGA] only)
Supported screen design software (Note 1) (Note 2)	GT Designer2 Version 2.82L or later: Q02PHCPU, Q06PHCPU GT Designer2 Version 2.73B or later: Q12PHCPU, Q25PHCPU, Q12PRHCPU, Q25PRHCPU
Functions (outline)	<ul style="list-style-type: none"> Number of generable tags: Max. 120 (loop tags and status tags) Generable screens: Faceplate, control panel, and detailed screens (tuning screen, setting screen, alarm list screen, and trend graph screen) Number of faceplates on control panel: 8/screen (XGA), 6/screen (SVGA) Connection path: One-to-one connection between GOT1000 and target CPU (host station) <ul style="list-style-type: none"> Process CPU: CPU direct connection, bus connection, computer link connection, Ethernet connection Redundant CPU: Computer link connection, Ethernet connection (Refer to user's manual for details) Tuning trend cycle: 1 s or more

Note 1) GT Designer2 is required to use the GOT generator function.

Note 2) For GT16, changing GOT type with GT Designer2 after generating in GOT15 enables generated screens to be used in GT16.

Software supporting redundant system

GX Developer

GX Developer is a comprehensive programming tool that improves work efficiency in development, debugging, and maintenance of programmable controllers. To support the redundant system, it provides dedicated parameter settings and functions such as online program download to both systems (control/standby).

Easy to modify programs

Using the following functions, programs can be written to both control and standby systems simultaneously. These functions simplify program modifications, cutting down development time.

- ① Writing programs and parameter files to programmable controllers
- ② Online change (editing and writing programs to the programmable controllers while online)

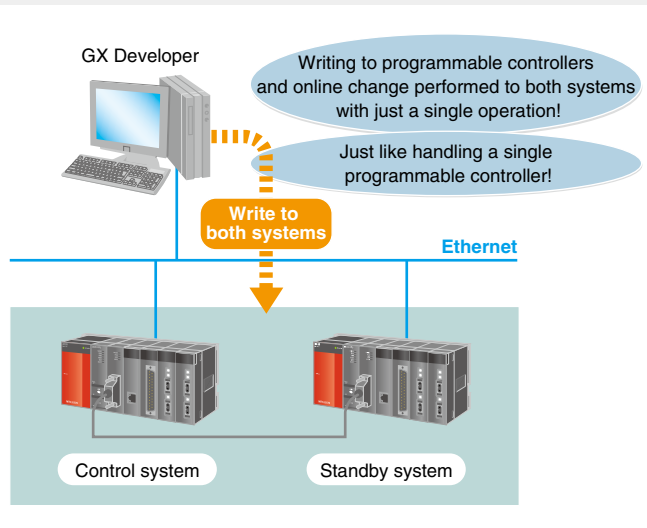

Simple parameter settings for the redundant system

The redundant system settings such as tracking settings, which maintain device status of both systems consistent, are designed in a familiar format to GX Developer users.

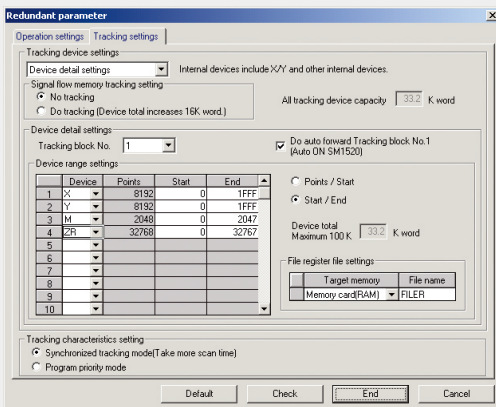

Monitoring module errors

The status of the CPUs, intelligent function modules, and redundant power supply modules can be monitored. Hence, faulty modules can be quickly identified.

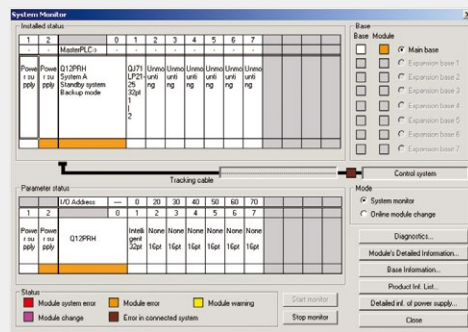

Continuous operation even at system switching

In the event of system switching due to a stop error in the CPU, the access target will be automatically switched. The operation continues smoothly, freeing the operator from having to consider system switching.

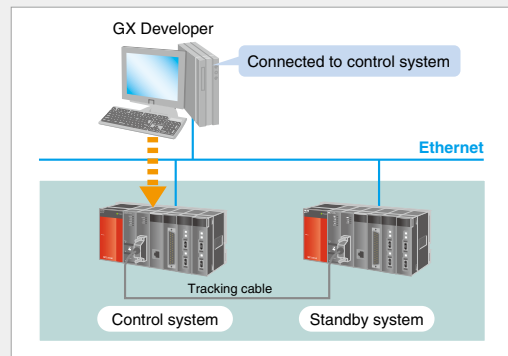

System switching

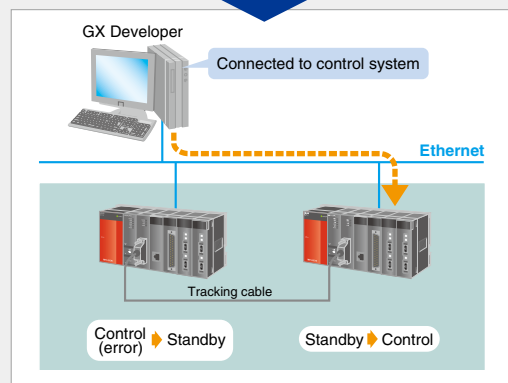

Software supporting redundant system

MX Component

MX Component is an ActiveX control library that supports all communication paths, from the PC to the programmable controller, and enables communications by simple processing. User applications can be easily configured without having to concern about system switching.

Simple communication settings

Selecting "Control system" as the target system makes the redundant system available: all other communication settings are the same as the standard system.

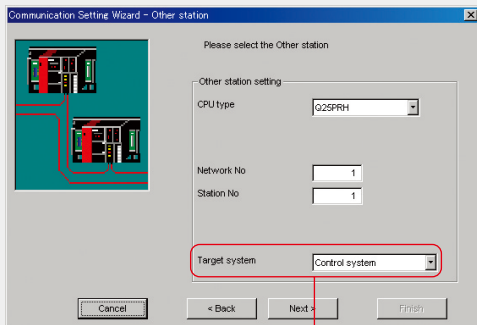

Select "Control system" for the redundant system.

Utilization of existing software

Existing user applications created with MX Component can be used for the redundant system simply by changing the communication settings.

Supports the redundant system

MX Sheet enables monitoring, logging, etc. of the programmable controller system using Excel without programming. It runs by MX Components, supporting the redundant system.

Date/Time	Tank capacity	Water flow	Oil temperature	Compressor pressure
2004.04.21 Wed 15:22:00	3	50	39	80
2004.04.21 Wed 15:22:30	4	61	41	81
2004.04.21 Wed 15:23:00	5	64	43	82
2004.04.21 Wed 15:23:30	5	66	45	83
2004.04.21 Wed 15:24:00	7	69	47	84
2004.04.21 Wed 15:24:30	8	71	49	85
2004.04.21 Wed 15:25:00	9	74	51	86
2004.04.21 Wed 15:25:30	10	76	53	87
2004.04.21 Wed 15:26:00	11	78	55	88
2004.04.21 Wed 15:26:30	12	80	57	89
2004.04.21 Wed 15:27:00	13	82	59	90
2004.04.21 Wed 15:27:30	14	84	61	91
2004.04.21 Wed 15:28:00	15	86	63	92
2004.04.21 Wed 15:28:30	16	88	65	93
2004.04.21 Wed 15:29:00	17	90	67	94
2004.04.21 Wed 15:29:30	18	92	69	95
2004.04.21 Wed 15:30:00	19	94	71	96
2004.04.21 Wed 15:30:30	20	96	73	97
2004.04.21 Wed 15:31:00	21	98	75	98
2004.04.21 Wed 15:31:30	22	100	77	99
2004.04.21 Wed 15:32:00	23	102	79	100
2004.04.21 Wed 15:32:30	24	104	81	101
2004.04.21 Wed 15:33:00	25	106	83	102
2004.04.21 Wed 15:33:30	26	108	85	103
2004.04.21 Wed 15:34:00	27	110	87	104
2004.04.21 Wed 15:34:30	28	112	89	105
2004.04.21 Wed 15:35:00	29	114	91	106
2004.04.21 Wed 15:35:30	30	116	93	107
2004.04.21 Wed 15:36:00	31	118	95	108

The system change occurred at this time.

Alarm information	Date/Time	Alarm	Status
Generation	2004.04.21 15:27:10	The system change occurred	Status

Data are logged regardless of system switching

Easy programming

The redundant system application can be programmed without being conscious of the redundancy. When system switching occurs due to a control system failure, communication is automatically continued with the new control system switched from the standby system. Programming is not required to switch the communication target, reducing development time.

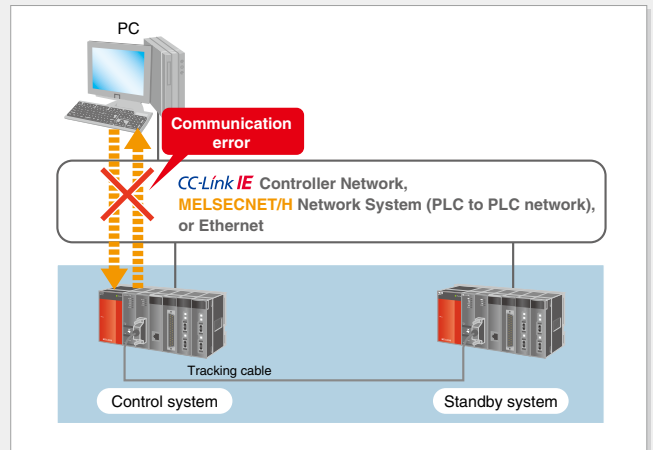

System switching

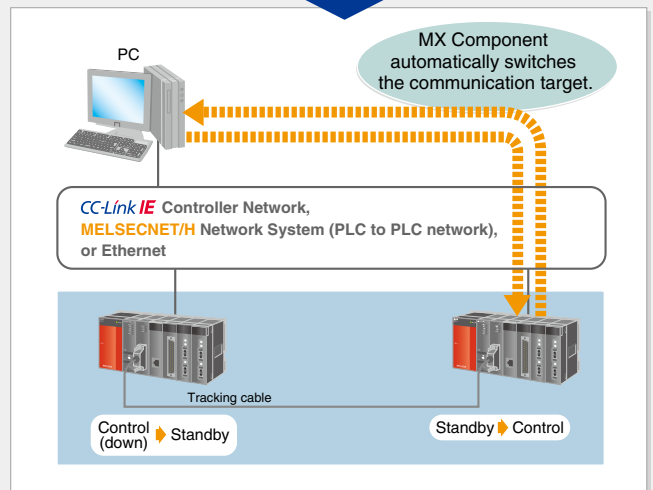

Simplifies troubleshooting after system switching

MX Component constantly monitors some of the redundant CPU devices. Hence, it is easy to know whether the currently-accessed CPU is a control system or standby system. When the system is switched, diagnostics and troubleshooting can be performed using GX Developer.

Relevant Products (GOT1000, GT SoftGOT1000)

HMI (human machine interface) enables process control system monitoring.

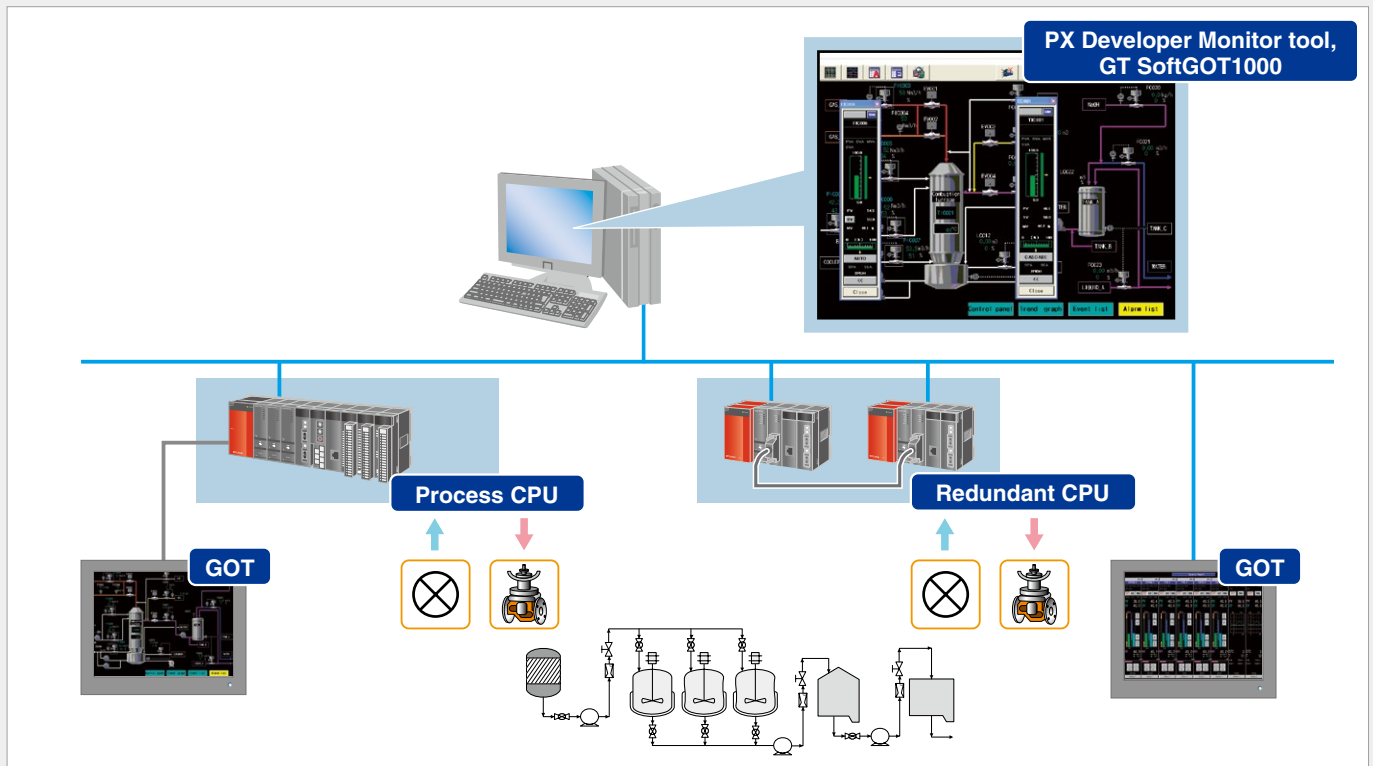

GOT1000

Features

Usable at various sites

The PX Developer's GOT screen generator function facilitates monitoring screen generation for GOT1000.

GOT1000

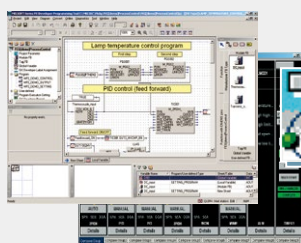

GOT screen generator



PX Developer

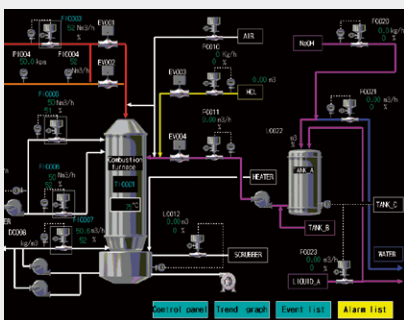

Graphic screen



PID loop control tuning screen

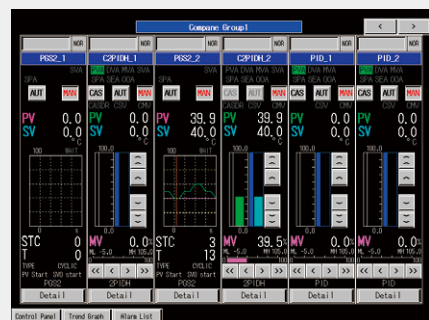

Control panel

GT SoftGOT1000

Features

Easy to create process control monitoring screen

- The standard monitor functions of PX Developer monitor tool can be called from the graphic screen of GT SoftGOT1000 and vice versa^(Note 1), dramatically reducing screen designing time.
- Can be used on a PC. It is best suited for monitoring at the office.
- GOT1000 screens can be utilized, reducing time for creating new screens.

Note 1) PX Developer 1.13P or later is required.

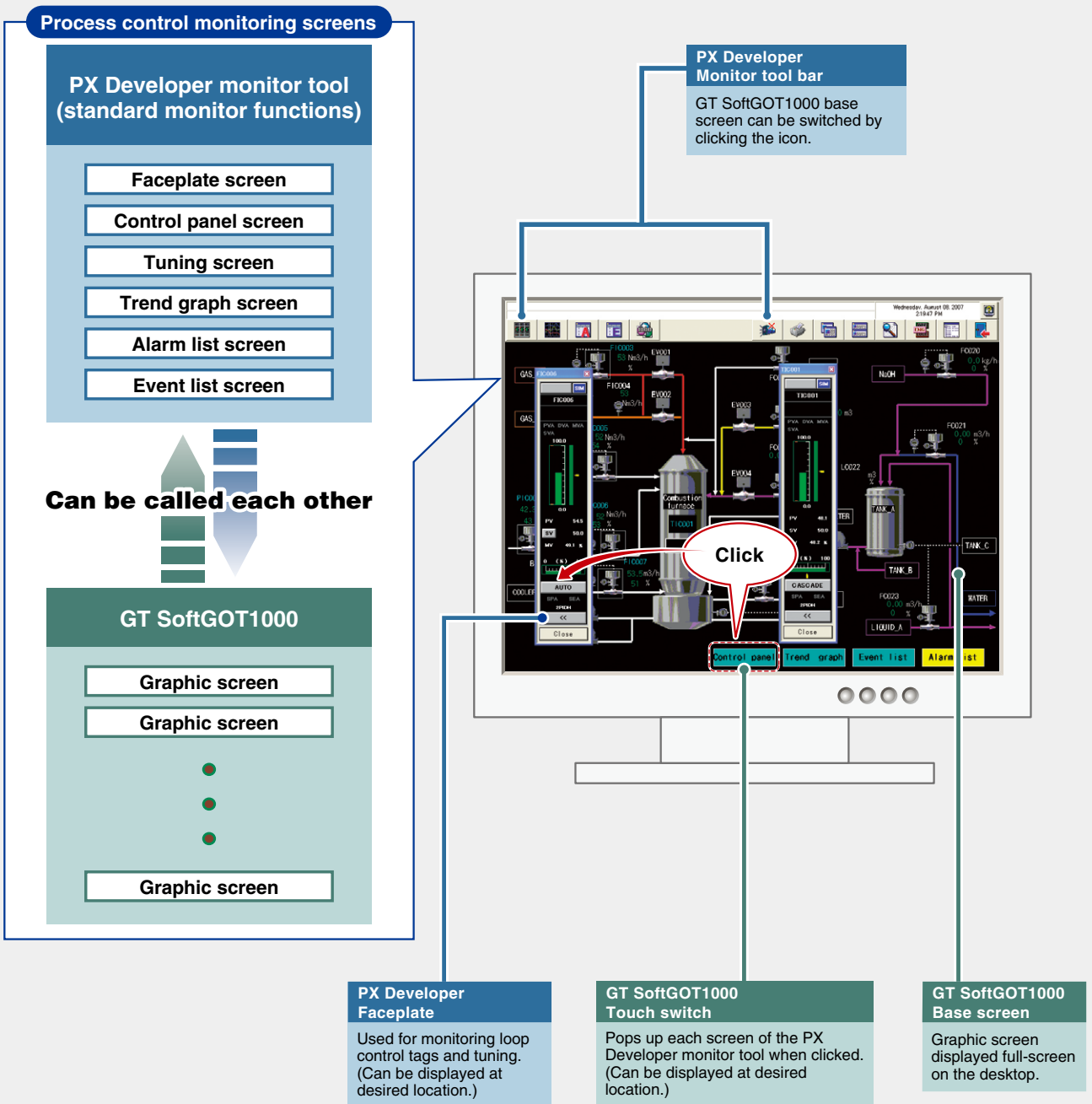

Extensive global support coverage providing expert help whenever needed

■ Global FA centers

■ EMEA

Europe FA Center

MITSUBISHI ELECTRIC EUROPE B.V. Polish Branch
Tel: +48-12-347-65-81

Germany FA Center

MITSUBISHI ELECTRIC EUROPE B.V. German Branch
Tel: +49-2102-486-0 / Fax: +49-2102-486-1120

UK FA Center

MITSUBISHI ELECTRIC EUROPE B.V. UK Branch
Tel: +44-1707-27-8780 / Fax: +44-1707-27-8695

Czech Republic FA Center

MITSUBISHI ELECTRIC EUROPE B.V. Czech Branch
Tel: +420-255 719 200

Italy FA Center

MITSUBISHI ELECTRIC EUROPE B.V. Italian Branch
Tel: +39-039-60531 / Fax: +39-039-6053-312

Russia FA Center

MITSUBISHI ELECTRIC (RUSSIA) LLC ST. Petersburg Branch
Tel: +7-812-633-3497 / Fax: +7-812-633-3499

Turkey FA Center

MITSUBISHI ELECTRIC TURKEY A.S. Umraniye Branch
Tel: +90-216-526-3990 / Fax: +90-216-526-3995

■ Asia-Pacific

China

Beijing FA Center

MITSUBISHI ELECTRIC AUTOMATION (CHINA) LTD.
Beijing FA Center
Tel: +86-10-6518-8830 / Fax: +86-10-6518-2938

Guangzhou FA Center

MITSUBISHI ELECTRIC AUTOMATION (CHINA) LTD.
Guangzhou FA Center
Tel: +86-20-8923-6730 / Fax: +86-20-8923-6715

Shanghai FA Center

MITSUBISHI ELECTRIC AUTOMATION (CHINA) LTD.
Shanghai FA Center
Tel: +86-21-2322-3030 / Fax: +86-21-2322-3000

Tianjin FA Center

MITSUBISHI ELECTRIC AUTOMATION (CHINA) LTD.
Tianjin FA Center
Tel: +86-22-2813-1015 / Fax: +86-22-2813-1017

Taiwan

Taipei FA Center

SETSUYO ENTERPRISE CO., LTD.
Tel: +886-2-2299-9917 / Fax: +886-2-2299-9963

Korea

Korea FA Center

MITSUBISHI ELECTRIC AUTOMATION KOREA CO., LTD.
Tel: +82-2-3660-9632 / Fax: +82-2-3664-0475

Thailand

Thailand FA Center

MITSUBISHI ELECTRIC FACTORY AUTOMATION (THAILAND) CO., LTD.
Tel: +66-2682-6522-31 / Fax: +66-2682-6020

ASEAN

ASEAN FA Center

MITSUBISHI ELECTRIC ASIA PTE. LTD.
Tel: +65-6470-2480 / Fax: +65-6476-7439

Malaysia

Malaysia FA Center

Malaysia FA Center
Tel: +60-3-7626-5080 / Fax: +60-3-7658-3544

Indonesia

Indonesia FA Center

PT. MITSUBISHI ELECTRIC INDONESIA
Cikarang Office
Tel: +62-21-2961-7797 / Fax: +62-21-2961-7794

Vietnam

Hanoi FA Center

MITSUBISHI ELECTRIC VIETNAM COMPANY LIMITED
Hanoi Branch Office
Tel: +84-24-3937-8075 / Fax: +84-24-3937-8076

Ho Chi Minh FA Center

MITSUBISHI ELECTRIC VIETNAM COMPANY LIMITED
Tel: +84-28-3910-5945 / Fax: +84-28-3910-5947

Philippines

Philippines FA Center

MELCO Factory Automation Philippines Inc.
Tel: +63-(0)2-8256-8042

India

India Ahmedabad FA Center

MITSUBISHI ELECTRIC INDIA PVT. LTD.
Ahmedabad Branch
Tel: +91-7965120063

India Bangalore FA Center

MITSUBISHI ELECTRIC INDIA PVT. LTD.
Bangalore Branch
Tel: +91-80-4020-1600 / Fax: +91-80-4020-1699

India Chennai FA Center

MITSUBISHI ELECTRIC INDIA PVT. LTD.
Chennai Branch
Tel: +91-4445548772 / Fax: +91-4445548773

India Coimbatore FA Center

MITSUBISHI ELECTRIC INDIA PVT. LTD.
Coimbatore Branch
Tel: +91-422-438-5606

India Gurgaon FA Center

MITSUBISHI ELECTRIC INDIA PVT. LTD.
Gurgaon Head Office
Tel: +91-124-463-0300 / Fax: +91-124-463-0399

India Pune FA Center

MITSUBISHI ELECTRIC INDIA PVT. LTD.
Pune Branch
Tel: +91-20-2710-2000 / Fax: +91-20-2710-2100

■ Americas

USA

North America FA Center

MITSUBISHI ELECTRIC AUTOMATION, INC.
Tel: +1-847-478-2469 / Fax: +1-847-478-2253

Mexico

Mexico City FA Center

MITSUBISHI ELECTRIC AUTOMATION, INC.
Mexico Branch
Tel: +52-55-3067-7511

Mexico FA Center

MITSUBISHI ELECTRIC AUTOMATION, INC.
Queretaro Office
Tel: +52-442-153-6014

Mexico Monterrey FA Center

MITSUBISHI ELECTRIC AUTOMATION, INC.
Monterrey Office
Tel: +52-55-3067-7521

Brazil

Brazil FA Center

MITSUBISHI ELECTRIC DO BRASIL COMERCIO E
SERVICOS LTDA.
Tel: +55-11-4689-3000 / Fax: +55-11-4689-3016

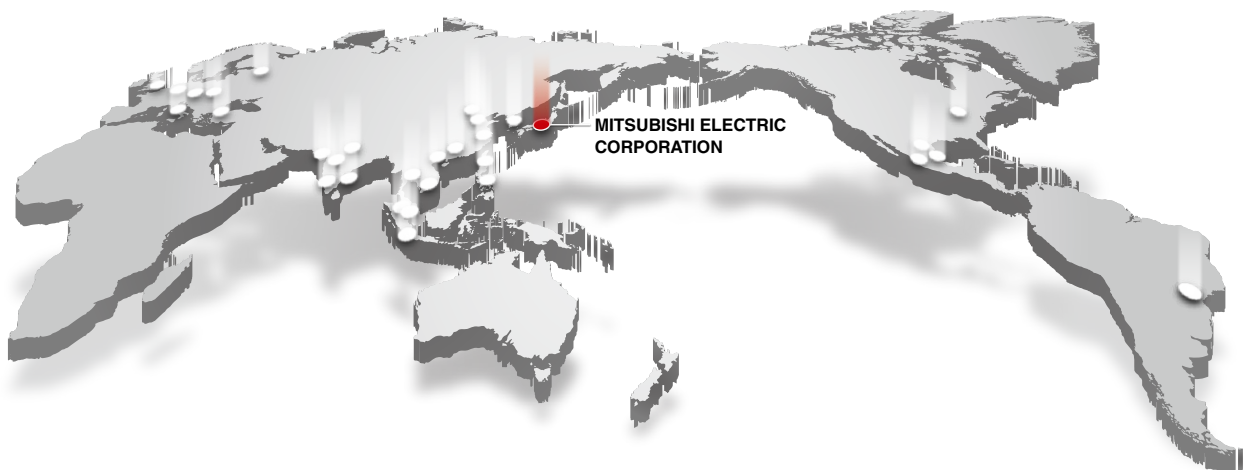

Factory Automation Global website

Mitsubishi Electric Factory Automation provides a mix of services to support its customers worldwide. A consolidated global website is the main portal, offering a selection of support tools and a window to its local Mitsubishi Electric sales and support network.

■ From here you can find:

- Overview of available factory automation products
- Library of downloadable literature
- Support tools such as online e-learning courses, terminology dictionary, etc.
- Global sales and service network portal
- Latest news related to Mitsubishi Electric factory automation

**Mitsubishi Electric Factory Automation
Global website:
www.MitsubishiElectric.com/fa**

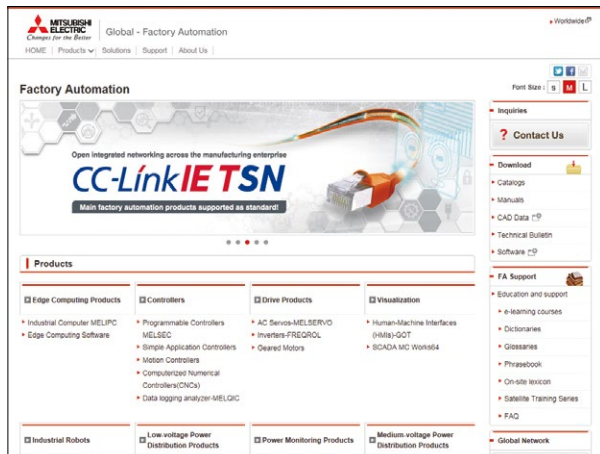

Online e-learning

An extensive library of e-learning courses covering the factory automation product range has been prepared. Courses from beginner to advanced levels of difficulty are available in various languages.



■ Beginner level

Designed for newcomers to Mitsubishi Electric Factory Automation products gaining a background of the fundamentals and an overview of various products related to the course.

■ Basic to Advanced levels

These courses are designed to provide education at all levels. Various different features are explained with application examples providing an easy and informative resource for in-house company training.

Innovative next-generation, e-Manual

e-Manual Viewer

The e-Manual viewer is a next-generation digital manual offered by Mitsubishi Electric that consolidates factory automation products manuals into an easy-to-use package with various useful features integrated into the viewer. The e-Manual allows multiple manuals to be cross-searched at once, further reducing time for setting up products and troubleshooting.

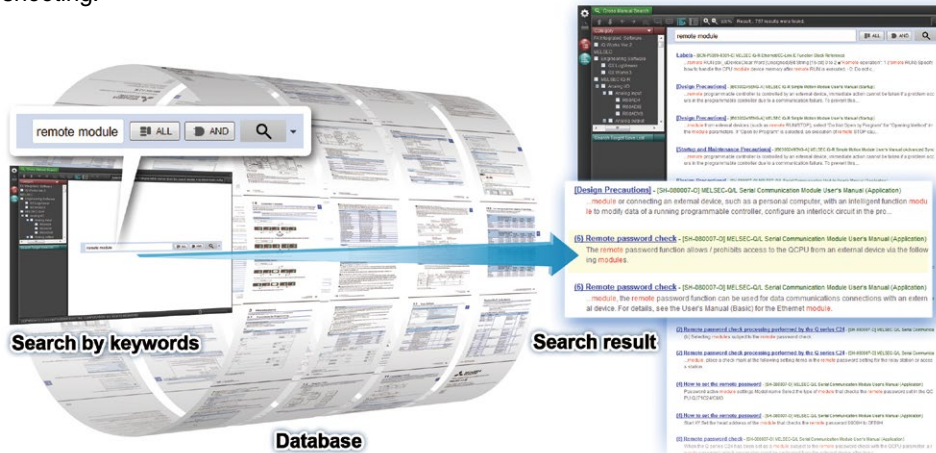

Key features included

- One-stop database containing all required manuals, with local file cache
- Included with GX Works3 engineering software
- Also available in tablet version
- Easily download manuals all at once
- Multiple users can share the latest manuals and knowhow with document sharing function
- Directly port sample programs within manuals to GX Works3
- Downloaded manuals are usable offline



e-Manual Create

e-Manual Create is software for converting word files and chm files to e-Manual documents. e-Manual Create allows users to directly refer to Mitsubishi Electric e-Manuals from user's customized device maintenance manuals and such, supporting quick troubleshooting and reduction in document creation process.

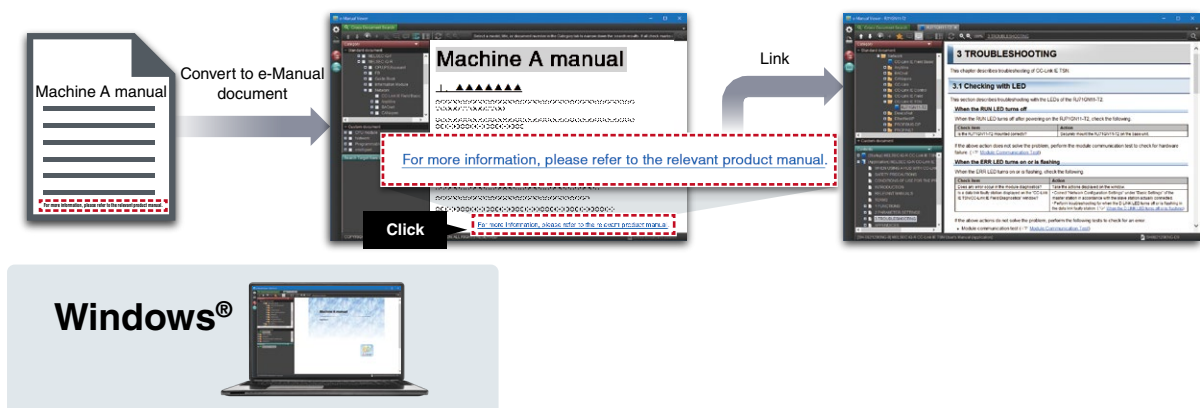

* To obtain the Windows® version of e-Manual Viewer and e-Manual Create, please contact your local Mitsubishi Electric sales office or representative.

CC-Link Partner Association (CLPA) - Actively promoting worldwide adoption of CC-Link networks

Proactively supporting CC-Link, from promotion to specification development

The CC-Link Partner Association (CLPA) was established to promote the worldwide adoption of the CC-Link open-field network. By conducting promotional activities such as organizing trade shows and seminars, conducting conformance tests, and providing catalogs, brochures and website information, CLPA activities are successfully increasing the number of CC-Link partner manufacturers and CC-Link-compatible products. As such, CLPA is playing a major role in the globalization of CC-Link.



Seminar

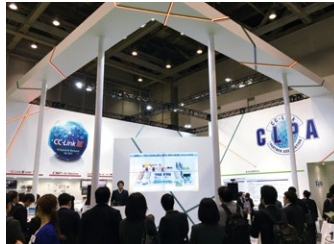

Trade show



Conformance testing lab

Visit the CLPA website for the latest CC-Link information.

URL: www.cc-link.org



CLPA Headquarters
6F Ozone Front Bldg. 3-15-58 Ozone
Kita-ku, Nagoya 462-0825, JAPAN
TEL: +81-52-919-1588 FAX: +81-52-916-8655
e-mail: info@cc-link.org



Global influence of CC-Link continues to spread

CC-Link is supported globally by CLPA. With offices throughout the world, support for partner companies can be found locally. Each regional CLPA office undertakes various support and promotional activities to further the influence of CC-Link/CC-Link IE in that part of the world. For companies looking to increase their presence in their local area, CLPA is well placed to assist these efforts through offices in all major regions.

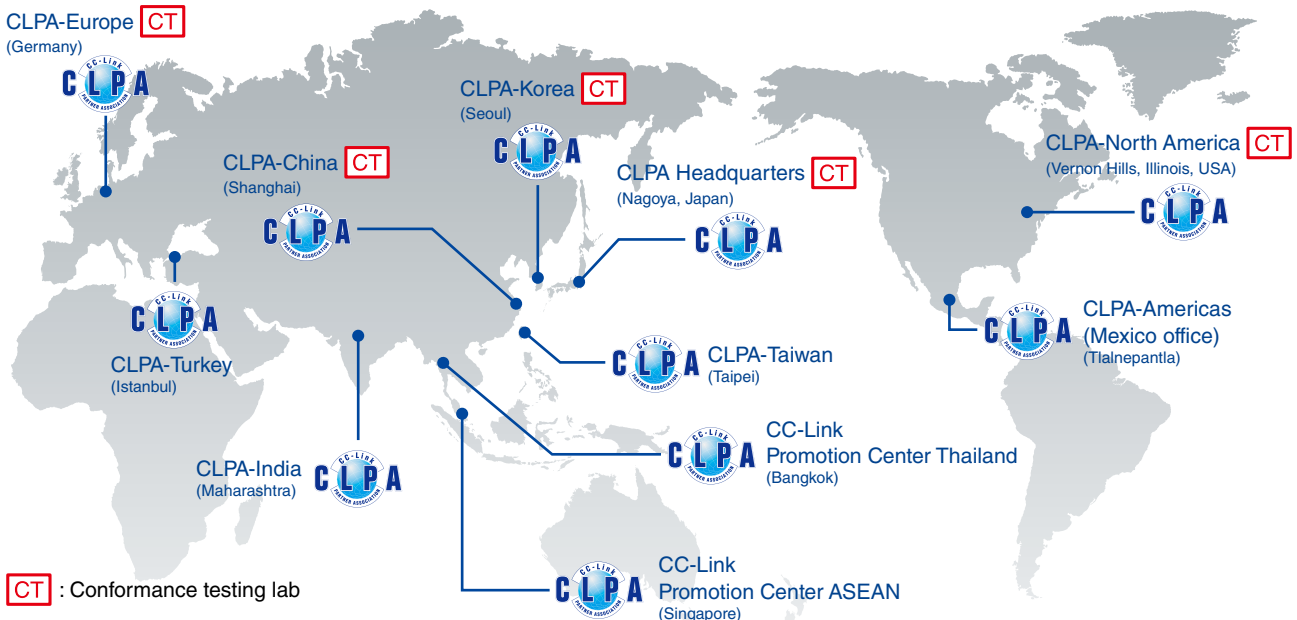

Product List

*Always refer to user's manuals for information on usable modules, restrictions, etc. before using.

*Contact your local Mitsubishi sales office or representative for the latest information on the MELSOFT versions and compatible OS.

CPU, power supply

Product	Model	Outline	
Universal model QCPU	Q00UJCPU	No. of I/O points: 256 points, no. of I/O device points: 8192 points, program capacity: 10 k steps, basic operation processing speed (LD instruction): 0.12 μ s, program memory capacity: 40 KB, peripheral connection ports: USB and RS232, no memory card I/F, 5-slot base, with 100 to 240 V AC input / 5 V DC/3 A output power supply	
	Q00UCPU	No. of I/O points: 1024 points, no. of I/O device points: 8192 points, program capacity: 10 k steps, basic operation processing speed (LD instruction): 0.08 μ s, program memory capacity: 40 KB, peripheral connection ports: USB and RS232, no memory card I/F	
	Q01UCPU	No. of I/O points: 1024 points, no. of I/O device points: 8192 points, program capacity: 15 k steps, basic operation processing speed (LD instruction): 0.06 μ s, program memory capacity: 60 KB, peripheral connection ports: USB and RS232, no memory card I/F	
	Q02UCPU	No. of I/O points: 2048 points, no. of I/O device points: 8192 points, program capacity: 20 k steps, basic operation processing speed (LD instruction): 0.04 μ s, program memory capacity: 80 KB, peripheral connection ports: USB and RS232, with memory card I/F	
	Q03UDCPU	No. of I/O points: 4096 points, no. of I/O device points: 8192 points, program capacity: 30 k steps, basic operation processing speed (LD instruction): 0.02 μ s, program memory capacity: 120 KB, multiple CPU high-speed communication, peripheral connection ports: USB and RS232, with memory card I/F	
	Q04UDHCPU	No. of I/O points: 4096 points, no. of I/O device points: 8192 points, program capacity: 40 k steps, basic operation processing speed (LD instruction): 0.0095 μ s, program memory capacity: 160 KB, multiple CPU high-speed communication, peripheral connection ports: USB and RS232, with memory card I/F	
	Q06UDHCPU	No. of I/O points: 4096 points, no. of I/O device points: 8192 points, program capacity: 60 k steps, basic operation processing speed (LD instruction): 0.0095 μ s, program memory capacity: 240 KB, multiple CPU high-speed communication, peripheral connection ports: USB and RS232, with memory card I/F	
	Q10UDHCPU	No. of I/O points: 4096 points, no. of I/O device points: 8192 points, program capacity: 100 k steps, basic operation processing speed (LD instruction): 0.0095 μ s, program memory capacity: 400 KB, multiple CPU high-speed communication, peripheral connection ports: USB and RS232, with memory card I/F	
	Q13UDHCPU	No. of I/O points: 4096 points, no. of I/O device points: 8192 points, program capacity: 130 k steps, basic operation processing speed (LD instruction): 0.0095 μ s, program memory capacity: 520 KB, multiple CPU high-speed communication, peripheral connection ports: USB and RS232, with memory card I/F	
	Q20UDHCPU	No. of I/O points: 4096 points, no. of I/O device points: 8192 points, program capacity: 200 k steps, basic operation processing speed (LD instruction): 0.0095 μ s, program memory capacity: 800 KB, multiple CPU high-speed communication, peripheral connection ports: USB and RS232, with memory card I/F	
	Q26UDHCPU	No. of I/O points: 4096 points, no. of I/O device points: 8192 points, program capacity: 260 k steps, basic operation processing speed (LD instruction): 0.0095 μ s, program memory capacity: 1040 KB, multiple CPU high-speed communication, peripheral connection ports: USB and RS232, with memory card I/F	
	Built-in Ethernet type	Q03UDECPU	No. of I/O points: 4096 points, no. of I/O device points: 8192 points, program capacity: 30 k steps, basic operation processing speed (LD instruction): 0.02 μ s, program memory capacity: 120 KB, multiple CPU high-speed communication, peripheral connection ports: USB and Ethernet, with memory card I/F
		Q04UDEHCPU	No. of I/O points: 4096 points, no. of I/O device points: 8192 points, program capacity: 40 k steps, basic operation processing speed (LD instruction): 0.0095 μ s, program memory capacity: 160 KB, multiple CPU high-speed communication, peripheral connection ports: USB and Ethernet, with memory card I/F
		Q06UDEHCPU	No. of I/O points: 4096 points, no. of I/O device points: 8192 points, program capacity: 60 k steps, basic operation processing speed (LD instruction): 0.0095 μ s, program memory capacity: 240 KB, multiple CPU high-speed communication, peripheral connection ports: USB and Ethernet, with memory card I/F
		Q10UDEHCPU	No. of I/O points: 4096 points, no. of I/O device points: 8192 points, program capacity: 100 k steps, basic operation processing speed (LD instruction): 0.0095 μ s, program memory capacity: 400 KB, multiple CPU high-speed communication, peripheral connection ports: USB and Ethernet, with memory card I/F
		Q13UDEHCPU	No. of I/O points: 4096 points, no. of I/O device points: 8192 points, program capacity: 130 k steps, basic operation processing speed (LD instruction): 0.0095 μ s, program memory capacity: 520 KB, multiple CPU high-speed communication, peripheral connection ports: USB and Ethernet, with memory card I/F
		Q20UDEHCPU	No. of I/O points: 4096 points, no. of I/O device points: 8192 points, program capacity: 200 k steps, basic operation processing speed (LD instruction): 0.0095 μ s, program memory capacity: 800 KB, multiple CPU high-speed communication, peripheral connection ports: USB and Ethernet, with memory card I/F
		Q26UDEHCPU	No. of I/O points: 4096 points, no. of I/O device points: 8192 points, program capacity: 260 k steps, basic operation processing speed (LD instruction): 0.0095 μ s, program memory capacity: 1040 KB, multiple CPU high-speed communication, peripheral connection ports: USB and Ethernet, with memory card I/F
		Q50UDEHCPU NEW	No. of I/O points: 4096 points, no. of I/O device points: 8192 points, program capacity: 500 k steps, basic operation processing speed (LD instruction): 0.0095 μ s, program memory capacity: 2000 KB, multiple CPU high-speed communication, peripheral connection ports: USB and Ethernet, with memory card I/F
	Q100UDEHCPU NEW	No. of I/O points: 4096 points, no. of I/O device points: 8192 points, program capacity: 1000 k steps, basic operation processing speed (LD instruction): 0.0095 μ s, program memory capacity: 4000 KB, multiple CPU high-speed communication, peripheral connection ports: USB and Ethernet, with memory card I/F	
Basic model QCPU	Q00JCPU	No. of I/O points: 256 points, no. of I/O device points: 2048 points, program capacity: 8 k steps, basic operation processing speed (LD instruction): 0.2 μ s, program memory capacity: 58 KB, peripheral connection ports: RS232, no memory card I/F, 5-slot base, with 100 to 240 V AC input / 5 V DC/3 A output power supply	
	Q00CPU	No. of I/O points: 1024 points, no. of I/O device points: 2048 points, program capacity: 8 k steps, basic operation processing speed (LD instruction): 0.16 μ s, program memory capacity: 94 KB, peripheral connection ports: RS232, no memory card I/F	
	Q01CPU	No. of I/O points: 1024 points, no. of I/O device points: 2048 points, program capacity: 14 k steps, basic operation processing speed (LD instruction): 0.1 μ s, program memory capacity: 94 KB, peripheral connection ports: RS232, no memory card I/F	

CPU, power supply

Product	Model	Outline	
High Performance model QCPU	Q02CPU	No. of I/O points: 4096 points, no. of I/O device points: 8192 points, program capacity: 28 k steps, basic operation processing speed (LD instruction): 0.079 μ s, program memory capacity: 112 KB, peripheral connection ports: RS232, with memory card I/F	
	Q02HCPU	No. of I/O points: 4096 points, no. of I/O device points: 8192 points, program capacity: 28 k steps, basic operation processing speed (LD instruction): 0.034 μ s, program memory capacity: 112 KB, peripheral connection ports: USB and RS232, with memory card I/F	
	Q06HCPU	No. of I/O points: 4096 points, no. of I/O device points: 8192 points, program capacity: 60 k steps, basic operation processing speed (LD instruction): 0.034 μ s, program memory capacity: 240 KB, peripheral connection ports: USB and RS232, with memory card I/F	
	Q12HCPU	No. of I/O points: 4096 points, no. of I/O device points: 8192 points, program capacity: 124 k steps, basic operation processing speed (LD instruction): 0.034 μ s, program memory capacity: 496 KB, peripheral connection ports: USB and RS232, with memory card I/F	
	Q25HCPU	No. of I/O points: 4096 points, no. of I/O device points: 8192 points, program capacity: 252 k steps, basic operation processing speed (LD instruction): 0.034 μ s, program memory capacity: 1008 KB, peripheral connection ports: USB and RS232, with memory card I/F	
Process CPU	Q02PHCPU	No. of I/O points: 4096 points, no. of I/O device points: 8192 points, program capacity: 28 k steps, basic operation processing speed (LD instruction): 0.034 μ s, program memory capacity: 112 KB, peripheral connection ports: USB and RS232, with memory card I/F	
	Q06PHCPU	No. of I/O points: 4096 points, no. of I/O device points: 8192 points, program capacity: 60 k steps, basic operation processing speed (LD instruction): 0.034 μ s, program memory capacity: 240 KB, peripheral connection ports: USB and RS232, with memory card I/F	
	Q12PHCPU	No. of I/O points: 4096 points, no. of I/O device points: 8192 points, program capacity: 124 k steps, basic operation processing speed (LD instruction): 0.034 μ s, program memory capacity: 496 KB, peripheral connection ports: USB and RS232, with memory card I/F	
	Q25PHCPU	No. of I/O points: 4096 points, no. of I/O device points: 8192 points, program capacity: 252 k steps, basic operation processing speed (LD instruction): 0.034 μ s, program memory capacity: 1008 KB, peripheral connection ports: USB and RS232, with memory card I/F	
Redundant CPU	Q12PRHCPU	No. of I/O points: 4096 points, no. of I/O device points: 8192 points, program capacity: 124 k steps, basic operation processing speed (LD instruction): 0.034 μ s, program memory capacity: 496 KB, peripheral connection ports: USB and RS232, with memory card I/F	
	Q25PRHCPU	No. of I/O points: 4096 points, no. of I/O device points: 8192 points, program capacity: 252 k steps, basic operation processing speed (LD instruction): 0.034 μ s, program memory capacity: 1008 KB, peripheral connection ports: USB and RS232, with memory card I/F	
Tracking cable	QC10TR	Tracking cable 1 m	
	QC30TR	Tracking cable 3 m	
C Controller CPU	Q12DCCPU-V	No. of I/O points: 4096 points, endian format: little endian, removable storage: CF card, OS:VxWorks Version 6.4	
	Q06CCPU-V	No. of I/O points: 4096 points, endian format: little endian, removable storage: CF card, OS:VxWorks Version 5.4	
	Option	Q12DCCPU-CB ^(Note 1)	RS-232 connection converter cable (custom mini-DIN to 9-pin D-sub connector)
		GT05-MEM-128MC ^(Note 2)	128 MB CompactFlash card
		GT05-MEM-256MC ^(Note 2)	256 MB CompactFlash card
		QD81MEM-512MBC	512 MB CompactFlash card
		QD81MEM-1GBC	1 GB CompactFlash card
		QD81MEM-2GBC ^(Note 1)	2 GB CompactFlash card
		QD81MEM-4GBC ^(Note 1)	4 GB CompactFlash card
QD81MEM-8GBC ^(Note 1)	8 GB CompactFlash card		
Battery	Q6BAT	Replacement battery	
	Q7BAT	Replacement large-capacity battery	
	Q7BAT-SET	Large-capacity battery with holder for mounting CPU	
	Q8BAT	Replacement large-capacity battery module	
	Q8BAT-SET	Large-capacity battery module with CPU connection cable	
Memory card	Q2MEM-1MBS	SRAM memory card, capacity: 1 MB	
	Q2MEM-2MBS	SRAM memory card, capacity: 2 MB	
	Q3MEM-4MBS	SRAM memory card, capacity: 4 MB	
	Q3MEM-4MBS-SET	SRAM memory card with cover, capacity: 4 MB	
	Q3MEM-8MBS	SRAM memory card, capacity: 8 MB	
	Q3MEM-8MBS-SET	SRAM memory card with cover, capacity: 8 MB	
	Q2MEM-2MBF	Linear Flash memory card, capacity: 2 MB	
	Q2MEM-4MBF	Linear Flash memory card, capacity: 4 MB	
	Q2MEM-8MBA	ATA card, capacity: 8 MB	
	Q2MEM-16MBA	ATA card, capacity: 16 MB	
Q2MEM-32MBA	ATA card, capacity: 32 MB		
Memory card adapter	Q2MEM-ADP	Adapter for Q2MEM memory card's standard PCMCIA slot	
SRAM card battery	Q2MEM-BAT	Replacement battery for Q2MEM-1MBS and Q2MEM-2MBS	
	Q3MEM-BAT	Replacement battery for Q3MEM-4MBS and Q3MEM-8MBS	
Connection cable	QC30R2	RS-232 cable for connecting personal computer and CPU, 3 m (between mini-DIN6P and Dsub9P)	
Cable disconnection prevention holder	Q6HLD-R2	Holder for preventing RS-232 cable (programmable controller CPU connection) disconnection	

Note 1) For use with Q12DCCPU-V
Note 2) For use with Q06CCPU-V

Product List

Base

Product	Model	Outline
Main base	Q33B	3 slots, 1 power supply module required, for Q Series modules
	Q35B	5 slots, 1 power supply module required, for Q Series modules
	Q38B	8 slots, 1 power supply module required, for Q Series modules
	Q312B	12 slots, 1 power supply module required, for Q Series modules
Multiple CPU high speed main base	Q38DB	8 slots, 1 power supply module required, for Q Series modules
	Q312DB	12 slots, 1 power supply module required, for Q Series modules
Slim type main base	Q32SB	2 slots, 1 slim type power supply module required, for Q Series modules
	Q33SB	3 slots, 1 slim type power supply module required, for Q Series modules
	Q35SB	5 slots, 1 slim type power supply module required, for Q Series modules
Redundant power main base	Q38RB	8 slots, 2 redundant power supply modules required, for Q Series modules
Extension base	Q63B	3 slots, 1 power supply module required, for Q Series modules
	Q65B	5 slots, 1 power supply module required, for Q Series modules
	Q68B	8 slots, 1 power supply module required, for Q Series modules
	Q612B	12 slots, 1 power supply module required, for Q Series modules
	Q52B	2 slots, power supply module not required, for Q Series modules
	Q55B	5 slots, power supply module not required, for Q Series modules
Redundant power extension base	Q68RB	8 slots, 2 redundant power supply modules required, for Q Series modules
Redundant type extension base	Q65WRB ^(Note 1)	5 slots, 2 redundant power supply modules required, for Q Series modules
Extension cable	QC05B	0.45 m cable for connecting extension base unit
	QC06B	0.6 m cable for connecting extension base unit
	QC12B	1.2 m cable for connecting extension base unit
	QC30B	3 m cable for connecting extension base unit
	QC50B	5 m cable for connecting extension base unit
	QC100B	10 m cable for connecting extension base unit
DIN rail mounting adapter	Q6DIN1	DIN rail mounting adapter for Q38B, Q312B, Q68B, Q612B, Q38RB, Q68RB, Q65WRB, Q38DB, and Q312DB
	Q6DIN2	DIN rail mounting adapter for Q35B, Q65B, and Q00UJCPU
	Q6DIN3	DIN rail mounting adapter for Q32SB, Q33SB, Q35SB, Q33B, Q52B, Q55B, and Q63B
	Q6DIN1A	DIN rail mounting adapter (with vibration-proofing bracket set) for Q3□B, Q5□B, Q6□B, Q38RB, Q68RB, and Q65WRB
Blank cover	QG60	Blank cover for I/O slot

Note 1) Only compatible with redundant CPU system.

Power supply

Power supply	Q61P	Input voltage: 100 to 240 V AC, output voltage: 5 V DC, output current: 6 A
	Q62P	Input voltage: 100 to 240 V AC, output voltage: 5/24 V DC, output current: 3/0.6 A
	Q63P	Input voltage: 24 V DC, output voltage: 5 V DC, output current: 6 A
	Q64PN	Input voltage: 100 to 240 V AC, output voltage: 5 V DC, output current: 8.5 A
Power Supply with Life Detection	Q61P-D	Input voltage: 100 to 240 V AC, output voltage: 5 V DC, output current: 6A
Slim type power supply	Q61SP	Input voltage: 100 to 240 V AC, output voltage: 5 V DC, output current: 2 A
Redundant power supply	Q63RP	Input voltage: 24 V DC, output voltage: 5 V DC, output current: 8.5 A
	Q64RP	Input voltage: 100 to 120/200 to 240 V AC, output voltage: 5 V DC, output current: 8.5 A

I/O module

Product		Model	Outline	
Input	AC	QX10	16 points, 100 to 120 V AC, response time: 20 ms, 16 points/common, 18-point terminal block	
		QX10-TS	16 points, 100 to 120 V AC, response time: 20 ms, 16 points/common, 18-point spring clamp terminal block	
		QX28	8 points, 100 to 240 V AC, response time: 20 ms, 8 points/common, 18-point terminal block	
	DC (Positive common) ^(Note 1)	QX40	16 points, 24 V DC, response time: 1/5/10/20/70 ms, 16 points/common, positive common, 18-point terminal block	
		QX40-TS	16 points, 24 V DC, response time: 1/5/10/20/70 ms, 16 points/common, positive common, 18-point spring clamp terminal block	
		QX40-S1	16 points, 24 V DC, response time: 0.1/0.2/0.4/0.6/1 ms, 16 points/common, positive common, 18-point terminal block	
		QX40H	16 points, 24 V DC, response time: 0/0.1/0.2/0.4/0.6/1 ms, 8 points/common, positive common, 18-point terminal block	
		QX41 ^{(Note 2) (Note 4)}	32 points, 24 V DC, response time: 1/5/10/20/70 ms, 32 points/common, positive common, 40-pin connector	
		QX41-S1 ^(Note 2)	32 points, 24 V DC, response time: 0.1/0.2/0.4/0.6/1 ms, 32 points/common, positive common, 40-pin connector	
		QX41-S2 NEW ^{(Note 2) (Note 4)}	32 points, 24 V DC, response time: 1/5/10/20/70 ms, 32 points/common, positive common, 40-pin connector	
		QX42 ^(Note 2)	64 points, 24 V DC, response time: 1/5/10/20/70 ms, 32 points/common, positive common, 40-pin connector	
		QX42-S1 ^(Note 2)	64 points, 24 V DC, response time: 0.1/0.2/0.4/0.6/1 ms, 32 points/common, positive common, 40-pin connector	
		AC/DC	QX50	16 points, 48 V AC/DC, response time: 20 ms, 16 points/common, positive/negative common, 18-point terminal block
	DC sensor	QX70	16 points, 5/12 V DC, response time: 1/5/10/20/70 ms, 16 points/common, positive/negative common, 18-point terminal block	
		QX70H	16 points, 5 V DC, response time: 0/0.1/0.2/0.4/0.6/1 ms, 8 points/common, positive common, 18-point terminal block	
		QX71 ^(Note 2)	32 points, 5/12 V DC, response time: 1/5/10/20/70 ms, 32 points/common, positive/negative common, 40-pin connector	
		QX72 ^(Note 2)	64 points, 5/12 V DC, response time: 1/5/10/20/70 ms, 32 points/common, positive/negative common, 40-pin connector	
	DC (Negative common) ^(Note 1)	QX80	16 points, 24 V DC, response time: 1/5/10/20/70 ms, 16 points/common, negative common, 18-point terminal block	
		QX80-TS	16 points, 24 V DC, response time: 1/5/10/20/70 ms, 16 points/common, negative common, 18-point spring clamp terminal block	
		QX80H	16 points, 24 V DC, response time: 0/0.1/0.2/0.4/0.6/1 ms, 8 points/common, negative common, 18-point terminal block	
		QX81 ^{(Note 3) (Note 4)}	32 points, 24 V DC, response time: 1/5/10/20/70 ms, 32 points/common, negative common, 37-pin D-sub connector	
		QX81-S2 NEW ^{(Note 3) (Note 4)}	32 points, 24 V DC, response time: 1/5/10/20/70 ms, 32 points/common, negative common, 37-pin D-sub connector	
		QX82 ^(Note 2)	64 points, 24 V DC, response time: 1/5/10/20/70 ms, 32 points/common, negative common, 40-pin connector	
		QX82-S1 ^(Note 2)	64 points, 24 V DC, response time: 0.1/0.2/0.4/0.6/1 ms, 32 points/common, negative common, 40-pin connector	
		QX90H	16 points, 5 V DC, response time: 0/0.1/0.2/0.4/0.6/1 ms, 8 points/common, negative common, 18-point terminal block	
		Output	Relay	QY10
	QY10-TS			16 points, 24 V DC/240 V AC, 2 A/point, 8 A/common, response time: 12 ms, 16 points/common, 18-point spring clamp terminal block
QY18A	8 points, 24 V DC/240 V AC, 2 A/point, response time: 12 ms, 18-point terminal block, all points independent			
Triac	QY22		16 points, 100 to 240 V AC, 0.6 A/point, 4.8 A/common, response time: 1 ms + 0.5 cycle, 16 points/common, 18-point terminal block, with surge suppressor	
Transistor (Sink)	QY40P		16 points, 12 to 24 V DC, 0.1 A/point, 1.6 A/common, response time: 1 ms, 16 points/common, sink type, 18-point terminal block, with overload protection function and overheat protection function and surge suppressor	
	QY40P-TS		16 points, 12 to 24 V DC, 0.1 A/point, 1.6 A/common, response time: 1 ms, 16 points/common, sink type, 18-point spring clamp terminal block, with overload protection function and overheat protection function and surge suppressor	
	QY41P ^(Note 2)		32 points, 12 to 24 V DC, 0.1 A/point, 2 A/common, response time: 1 ms, 32 points/common, sink type, 40-pin connector, with overload protection function and overheat protection function and surge suppressor	
	QY42P ^(Note 2)		64 points, 12 to 24 V DC, 0.1 A/point, 2 A/common, response time: 1 ms, 32 points/common, sink type, 40-pin connector, with overload protection function and overheat protection function and surge suppressor	
	QY50		16 points, 12 to 24 V DC, 0.5 A/point, 4 A/common, response time: 1 ms, 16 points/common, sink type, 18-point terminal block, with surge suppressor and fuse	
Transistor (Independent)	QY68A		8 points, 5 to 24 V DC, 2 A/point, 8 A/module, response time: 10 ms, sink/source type, 18-point terminal block, with surge suppressor, all points independent	
TTL CMOS	QY70		16 points, 5 to 12 V DC, 16 mA/point, 256 mA/common, response time: 0.5 ms, 16 points/common, sink type, 18-point terminal block, with fuse	
	QY71 ^(Note 2)		32 points, 5 to 12 V DC, 16 mA/point, 512 mA/common, response time: 0.5 ms, 32 points/common, sink type, 40-pin connector, with fuse	
Transistor (Source)	QY80		16 points, 12 to 24 V DC, 0.5 A/point, 4 A/common, response time: 1 ms, 16 points/common, source type, 18-point terminal block, with surge suppressor and fuse	
	QY80-TS		16 points, 12 to 24 V DC, 0.5 A/point, 4 A/common, response time: 1 ms, 16 points/common, source type, 18-point spring clamp terminal block, with surge suppressor and fuse	
	QY81P ^(Note 3)		32 points, 12 to 24 V DC, 0.1 A/point, 2 A/common, response time: 1 ms, 32 points/common, source type, 37-pin D-sub connector, with overload protection function and overheat protection function and surge suppressor	
	QY82P NEW ^(Note 2)	64 points, 12 to 24 V DC, 0.1 A/point, 2 A/common, response time: 1 ms, 32 points/common, source type, 40-pin connector, with overload protection function and overheat protection function and surge suppressor		

Note 1) "Positive common" indicates that the positive lead of a DC power supply must be connected to the common terminal. Accordingly, "Negative common" indicates that the negative lead must be connected to the common terminal.

Note 2) Connector is not provided. Separately order one of the following: A6CON1/A6CON2/A6CON3/A6CON4.

Note 3) Connector is not provided. Separately order one of the following: A6CON1E/A6CON2E/A6CON3E.

Note 4) The rated input currents are different. [QX41: approx. 4 mA, QX41-S2: approx. 6 mA, QX81: approx. 4 mA, QX81-S2: approx. 6 mA]

I/O module

Product		Model	Outline		
I/O	DC input/ transistor output	QH42P <small>(Note 1) (Note 2)</small>	Input: 32 points, 24 V DC, response time: 1/5/10/20/70 ms, 32 points/common, positive common, output: 32 points, 12 to 24 V DC, 0.1 A/point, 2 A/common, response time: 1 ms, 32 points/common, sink type, 40-pin connector, with overload protection function and overheat protection function and surge suppressor		
		QX48Y57	Input: 8 points, 24 V DC, response time: 1/5/10/20/70 ms, 8 points/common, positive common, output: 7 points, 12 to 24 V DC, 0.5 A/point, 2 A/common, response time: 1 ms, 7 points/common, sink type, 18-point terminal block, with surge suppressor and fuse		
		QX41Y41P <small>(Note 1) (Note 2)</small>	Input: 32 points, 24 V DC, response time: 1/5/10/20/70 ms, 32 points/common, positive common, output: 32 points, 12 to 24 V DC, 0.1 A/point, 2 A/common, response time: 1 ms, 32 points/common, sink type, 40-pin connector, with overload protection function and overheat protection function and surge suppressor		
Interrupt module		QI60	16 point, 24 V DC, response time: 0.1/0.2/0.4/0.6/1 ms, 16 points/common, 18-point terminal block		
Connector		A6CON1	32-point connector soldering type (40-pin connector)		
		A6CON2	32-point connector crimp-contact type (40-pin connector)		
		A6CON3	32-point connector pressure-displacement (flat cable) type (40-pin connector)		
		A6CON4	32-point connector soldering type (40-pin connector, cable connectable in bidirection)		
		A6CON1E	32-point connector soldering type (37-pin D-sub connector)		
		A6CON2E	32-point connector crimp-contact type (37-pin D-sub connector)		
Spring clamp terminal block		A6CON3E	32-point connector pressure-displacement (flat cable) type (37-pin D-sub connector)		
Terminal block adapter		Q6TE-18S	For 16-point I/O modules, 0.3 to 1.5 mm ² (22 to 16 AWG)		
		Q6TA32	For 32-point I/O modules, 0.5 mm ² (20 AWG)		
Connector/terminal block conversion module		Q6TA32-TOL	Q6TA32 dedicated tool		
		A6TBXY36	For positive common input modules and sink output modules (standard type)		
		A6TBXY54	For positive common input modules and sink output modules (2-wire type)		
		A6TBX70	For positive common input modules (3-wire type)		
		A6TBX36-E	For negative common input modules (standard type)		
		A6TBX54-E	For negative common input modules (2-wire type)		
		A6TBX70-E	For negative common input modules (3-wire type)		
		A6TBY36-E	For source output modules (standard type)		
		A6TBY54-E	For source output modules (2-wire type)		
		Cable		AC05TB	For A6TBXY36, A6TBXY54, and A6TBX70 (positive common/sink type), 0.5 m
AC10TB	For A6TBXY36, A6TBXY54, and A6TBX70 (positive common/sink type), 1 m				
AC20TB	For A6TBXY36, A6TBXY54, and A6TBX70 (positive common/sink type), 2 m				
AC30TB	For A6TBXY36, A6TBXY54, and A6TBX70 (positive common/sink type), 3 m				
AC50TB	For A6TBXY36, A6TBXY54, and A6TBX70 (positive common/sink type), 5 m				
AC80TB	For A6TBXY36, A6TBXY54, and A6TBX70 (positive common/sink type), 8 m *Common current 0.5 A or lower				
AC100TB	For A6TBXY36, A6TBXY54, and A6TBX70 (positive common/sink type), 10 m *Common current 0.5 A or lower				
AC05TB-E	For A6TBX36-E, A6TBY36-E, A6TBX54-E, A6TBY54-E, and A6TBX70-E (negative common/source type), 0.5 m				
AC10TB-E	For A6TBX36-E, A6TBY36-E, A6TBX54-E, A6TBY54-E, and A6TBX70-E (negative common/source type), 1 m				
AC20TB-E	For A6TBX36-E, A6TBY36-E, A6TBX54-E, A6TBY54-E, and A6TBX70-E (negative common/source type), 2 m				
AC30TB-E	For A6TBX36-E, A6TBY36-E, A6TBX54-E, A6TBY54-E, and A6TBX70-E (negative common/source type), 3 m				
AC50TB-E	For A6TBX36-E, A6TBY36-E, A6TBX54-E, A6TBY54-E, and A6TBX70-E (negative common/source type), 5 m				
Relay terminal module				A6TE2-16SRN	For 40-pin connector 24 V DC transistor output modules (sink type)
Cable				AC06TE	For A6TE2-16SRN, 0.6 m
		AC10TE	For A6TE2-16SRN, 1 m		
		AC30TE	For A6TE2-16SRN, 3 m		
		AC50TE	For A6TE2-16SRN, 5 m		
		AC100TE	For A6TE2-16SRN, 10 m		

Note 1) A connector is not provided. Order one of the following separately: A6CON1/A6CON2/A6CON3/A6CON4.

Note 2) The number of occupied input/output points is different. [QH42P: 32 points; QX41Y41P: 64 points (first 32 points: input / second 32 points: output)]

Analog I/O module

Product		Model	Outline
Analog input	Voltage input	Q68ADV	8 channels, input: -10 to 10 V DC, output (resolution): 0 to 4000, -4000 to 4000, 0 to 12000, -12000 to 12000, 0 to 16000, -16000 to 16000, conversion speed: 80 μ s/channel, 18-point terminal block
	Current input	Q62AD-DGH	2 channels; input, 4 to 20 mA DC, output (resolution): 0 to 32000, 0 to 64000, conversion speed: 10 ms/2 channels, 18-point terminal block, channel isolated, supplies power to 2-wire transmitter
		Q66AD-DG (Note 1)	6 channels, input: 4 to 20 mA DC (when 2-wire transmitter is connected), 0 to 20 mA DC, output (resolution): 0 to 4000, 0 to 12000, conversion speed: 10 ms/channel, 40-pin connector, channel isolated, supplies power to 2-wire transmitter
		Q68ADI	8 channels, input: 0 to 20 mA DC, output (resolution): 0 to 4000, -4000 to 4000, 0 to 12000, -12000 to 12000, 0 to 16000, -16000 to 16000, conversion speed: 80 μ s/channel, 18-point terminal block
	Voltage/ current input	Q64AD	4 channels; input -10 to 10 V DC, 0 to 20 mA DC, output (resolution): 0 to 4000, -4000 to 4000, 0 to 12000, -12000 to 12000, 0 to 16000, -16000 to 16000, conversion speed: 80 μ s/channel, 18-point terminal block
		Q64AD-GH	4 channels, input: -10 to 10 V DC, 0 to 20 mA DC, output (resolution): 0 to 32000, -32000 to 32000, 0 to 64000, -64000 to 64000, conversion speed: 10 ms/4 channels, 18-point terminal block, channel isolated
Q68AD-G (Note 1)		8 channels, input: -10 to 10 V DC, 0 to 20 mA DC, output (resolution): 0 to 4000, -4000 to 4000, 0 to 12000, -12000 to 12000, 0 to 16000, -16000 to 16000, conversion speed: 10 ms/channel, 40-pin connector, channel isolated	
Analog output	Voltage output	Q68DAVN	8 channels, input (resolution): 0 to 4000, -4000 to 4000, 0 to 12000, -12000 to 12000, -16000 to 16000, output: -10 to 10 V DC, conversion speed: 80 μ s/channel, 18-point terminal block, transformer isolation between power supply and output
	Current output	Q68DAIN	8 channels, input (resolution): 0 to 4000, -4000 to 4000, 0 to 12000, -12000 to 12000; output: 0 to 20 mA DC, conversion speed: 80 μ s/channel, 18-point terminal block, transformer isolation between power supply and output
	Voltage/ current output	Q62DAN	2 channels, input (resolution): 0 to 4000, -4000 to 4000, 0 to 12000, -12000 to 12000, -16000 to 16000, output: -10 to 10 V DC, 0 to 20 mA DC, conversion speed: 80 μ s/channel, 18-point terminal block, transformer isolation between power supply and output
		Q62DA-FG	2 channels, input (resolution): 0 to 4000, -4000 to 4000, 0 to 12000, -12000 to 12000, -16000 to 16000, output: -12 to 12 V DC, 0 to 22 mA DC, conversion speed: 10 ms/2 channels, 18-point terminal block, channel isolated
		Q64DAN	4 channels, input (resolution): 0 to 4000, -4000 to 4000, 0 to 12000, -12000 to 12000, -16000 to 16000, output: -10 to 10 V DC, 0 to 20 mA DC, conversion speed: 80 μ s/channel, 18-point terminal block, transformer isolation between power supply and output
		Q66DA-G (Note 1)	6 channels, input (resolution): 0 to 4000, -4000 to 4000, 0 to 12000, -12000 to 12000, -16000 to 16000, output: -12 to 12 V DC, 0 to 22 mA DC, conversion speed: 6 ms/channel, 40-pin connector, channel isolated
Analog input/ output	Voltage and current input/ output	Q64AD2DA NEW	Input: 4 channels Input: -10 to 10 V DC, 0 to 20 mA DC Output (resolution): 0 to 4000, -4000 to 4000, 0 to 12000, -12000 to 12000, 0 to 16000, -16000 to 16000 Conversion speed: 500 μ s/channel Output: 2 channels Input (resolution): 0 to 4000, -4000 to 4000, 0 to 12000, -16000 to 16000 Output: -10 to 10 V DC, 0 to 20 mA DC Conversion speed: 500 μ s/channel 18-point terminal block
Load cell input		Q61LD NEW	1 channel, input (load cell output): 0.0 to 3.3 mV/V, output (resolution): 0 to 10000, conversion speed: 10 ms, 18-point terminal block
Temperature input	RTD	Q64RD	4 channels, platinum RTD (Pt100 [JIS C1604-1997, IEC 751 1983], JPt100 [JIS C1604-1981]), conversion speed: 40 ms/channel, 18-point terminal block
		Q64RD-G	4 channels, RTD (Pt100 [JIS C1604-1997, IEC 751 1983], JPt100 [JIS C1604-1981], Ni100 Ω [DIN43760 1987]), conversion speed: 40 ms/channel, 18-point terminal block, channel isolated
		Q68RD3-G (Note 1)	8 channels, RTD (3-wire type, Pt100 [JIS C1604-1997, IEC 751 1983], JPt100 [JIS C1604-1981], Ni100 Ω [DIN43760 1987]), conversion speed: 320 ms/8 channels, 40-pin connector, channel isolated
	Thermocouple	Q64TD	4 channels, thermocouple (JIS C1602-1995), conversion speed: 40 ms/channel, 18-point terminal block
		Q64TDV-GH	4 channels, thermocouple (JIS C1602-1995), micro voltage (-100 to 100 mV), conversion speed: sampling cycle x 3, sampling cycle: 20 ms/channel, 18-point terminal block
		Q68TD-G-H01 (Note 1) (Note 2)	8 channels, thermocouple (JIS C1602-1995, IEC 60584-1 [1995], IEC 60584-2 [1982]), conversion speed: 320 ms/8 channels, 40-pin connector
Temperature control	Platinum RTD	Q64TCRT	4 channels, platinum RTD (Pt100, JPt100), no heater disconnection detection, sampling cycle: 0.5 s/4 channels, 18-point terminal block
		Q64TCRTBW	4 channels, platinum RTD (Pt100, JPt100), with heater disconnection detection, sampling cycle: 0.5 s/4 channels, two 18-point terminal blocks
	Thermocouple	Q64TCTT	4 channels, thermocouple (K, J, T, B, S, E, R, N, U, L, PLII, W5Re/W26Re), no heater disconnection detection, sampling cycle: 0.5 s/4 channels, 18-point terminal block
		Q64TCTTBW	4 channels, thermocouple (K, J, T, B, S, E, R, N, U, L, PLII, W5Re/W26Re), with heater disconnection detection, sampling cycle: 0.5 s/4 channels, two 18-point terminal blocks
Loop control		Q62HLC	2 channels, input: thermocouple/micro voltage/voltage/current, conversion speed (input): 25 ms/2 channels, sampling cycle: 25 ms/2 channels; output: 4 to 20 mA DC, conversion speed (output): 25 ms/2 channels; 18-point terminal block, with 5 PID control modes

Note 1) A connector is not provided. The A6CON4 connector must be ordered separately.

Note 2) The number of modules that can be installed is restricted based on the combination of power supply and base unit.

Pulse I/O and positioning module

Product	Model	Outline	
Channel isolated pulse input	QD60P8-G	8 channels, 30 kpps/10 kpps/1 kpps/100 pps/50 pps/10 pps/1 pps/0.1 pps, count input signal: 5/12 to 24 V DC	
High-speed counter	QD62 <small>(Note 1)</small>	2 channels, 200/100/10 kpps, count input signal: 5/12/24 V DC, external input: 5/12/24 V DC, coincidence output: transistor (sink), 12/24 V DC, 0.5 A/point, 2 A/common, 40-pin connector	
	QD62D <small>(Note 1)</small>	2 channels, 500/200/100/10 kpps, count input signal: EIA standards RS-422-A (differential line driver), external input: 5/12/24 V DC; coincidence output: transistor (sink), 12/24 V DC, 0.5 A/point, 2 A/common, 40-pin connector	
	QD62E <small>(Note 1)</small>	2 channels, 200/100/10 kpps, count input signal: 5/12/24 V DC, external input: 5/12/24 V DC, coincidence output: transistor (source), 12/24 V DC, 0.1 A/point, 0.4 A/common, 40-pin connector	
	QD63P6 <small>(Note 2)</small>	6 channels, 200/100/10 kpps, count input signal: 5 V DC, 40-pin connector	
	QD64D2 <small>(Note 2)</small> NEW	2 channels, 4 Mpps, count input signal: EIA standards RS-422-A (differential line driver), external input: 24 V DC, coincidence output: transistor (sink), 12/24 V DC, 0.5 A/point, 2 A/common, 40-pin connector	
Positioning	Open collector output	QD75P1 <small>(Note 2)</small>	1 axis, control unit: mm, inch, degree, pulse, no. of positioning data: 600/axis, max. output pulse: 200 kpps, 40-pin connector
		QD75P2 <small>(Note 2)</small>	2 axes, 2-axis linear interpolation, 2-axis circular interpolation, control unit: mm, inch, degree, pulse, no. of positioning data: 600/axis, max. output pulse: 200 kpps, 40-pin connector
		QD75P4 <small>(Note 2)</small>	4 axes, 2-/3-/4-axis linear interpolation, 2-axis circular interpolation, control unit: mm, inch, degree, pulse, no. of positioning data: 600/axis, max. output pulse: 200 kpps, 40-pin connector
		QD70P4 <small>(Note 2)</small>	4 axes, control unit: pulse, no. of positioning data: 10/axis, max. output pulse: 200 kpps, 40-pin connector
		QD70P8 <small>(Note 2)</small>	8 axes, control unit: pulse, no. of positioning data: 10/axis, max. output pulse: 200 kpps, 40-pin connector
	Differential output	QD75D1 <small>(Note 2)</small>	1 axis, control unit: mm, inch, degree, pulse, no. of positioning data: 600/axis, max. output pulse: 1 Mpps, 40-pin connector
		QD75D2 <small>(Note 2)</small>	2 axes, 2-axis linear interpolation, 2-axis circular interpolation, control unit: mm, inch, degree, pulse, no. of positioning data: 600/axis, max. output pulse: 1 Mpps, 40-pin connector
		QD75D4 <small>(Note 2)</small>	4 axes, 2-/3-/4-axis linear interpolation, 2-axis circular interpolation, control unit: mm, inch, degree, pulse, no. of positioning data: 600/axis, max. output pulse: 1 Mpps, 40-pin connector
		QD70D4 <small>(Note 2)</small>	4 axes, control unit: pulse, no. of positioning data: 10/axis, max. output pulse: 4 Mpps, 40-pin connector
		QD70D8 <small>(Note 2)</small>	8 axes, control unit: pulse, no. of positioning data: 10/axis, max. output pulse: 4 Mpps, 40-pin connector
	With SSCNET connectivity	QD75M1 <small>(Note 1)</small>	1 axis, control unit: mm, inch, degree, pulse, no. of positioning data: 600/axis, 40-pin connector
		QD75M2 <small>(Note 1)</small>	2 axes, 2-axis linear interpolation, 2-axis circular interpolation, control unit: mm, inch, degree, pulse, no. of positioning data: 600/axis, 40-pin connector
		QD75M4 <small>(Note 1)</small>	4 axes, 2-/3-/4-axis linear interpolation, 2-axis circular interpolation, control unit: mm, inch, degree, pulse, no. of positioning data: 600/axis, 40-pin connector
	With SSCNET III connectivity	QD75MH1 <small>(Note 1)</small>	1 axis, control unit: mm, inch, degree, pulse, no. of positioning data: 600/axis, 40-pin connector, with SSCNET III connectivity
		QD75MH2 <small>(Note 1)</small>	2 axes, 2-axis linear interpolation, 2-axis circular interpolation, control unit: mm, inch, degree, pulse, no. of positioning data: 600/axis, 40-pin connector, with SSCNET III connectivity
		QD75MH4 <small>(Note 1)</small>	4 axes, 2-/3-/4-axis linear interpolation, 2-axis circular interpolation, control unit: mm, inch, degree, pulse, no. of positioning data: 600/axis, 40-pin connector, with SSCNET III connectivity
		QD74MH8	8 axes, control unit: pulse, no. of positioning data: 32/axis, with SSCNET III connectivity
		QD74MH16	16 axes, control unit: pulse, no. of positioning data: 32/axis, with SSCNET III connectivity
	Open collector output with built-in counter function	QD72P3C3 <small>(Note 2)</small>	Positioning: 3 axes, control unit: pulse, no. of positioning data: 1/axis, max. output pulse: 100 kpps, counter: 3 channels, 100 kpps, count input signal: 5/24 V DC, 40-pin connector

Note 1) A connector is not provided. The A6CON1/A6CON2/A6CON3/A6CON4 connector must be ordered separately.

Note 2) A connector is not provided. The A6CON1/A6CON2/A6CON4 connector must be ordered separately.

Information module

Product	Model	Outline	
MES interface	QJ71MES96	MES interface module *MX MESInterface and CompactFlash card are required.	
	Option	GT05-MEM-128MC	128 MB CompactFlash card
		GT05-MEM-256MC	256 MB CompactFlash card
		QD81MEM-512MBC	512 MB CompactFlash card
		QD81MEM-1GBC	1 GB CompactFlash card
High-Speed Data Logger	QD81DL96	High-Speed Data Logger module *CompactFlash card are required	
	Option	QD81MEM-512MBC	512 MB CompactFlash card
		QD81MEM-1GBC	1 GB CompactFlash card
		QD81MEM-2GBC	2 GB CompactFlash card
		QD81MEM-4GBC	4 GB CompactFlash card
		QD81MEM-8GBC	8 GB CompactFlash card
Ethernet	QJ71E71-100	10BASE-T/100BASE-TX	
	QJ71E71-B2	10BASE2	
	QJ71E71-B5	10BASE5	
Serial communication	QJ71C24N	RS-232: 1 channel, RS-422/485: 1 channel, total transmission speed of 2 channels: 230.4 kbps	
	QJ71C24N-R2	RS-232: 2 channels, total transmission speed of 2 channels: 230.4 kbps	
	QJ71C24N-R4	RS-422/485: 2 channels, total transmission speed of 2 channels: 230.4 kbps	
Intelligent communication	QD51	BASIC program execution module, RS-232: 2 channels	
	QD51-R24	BASIC program execution module, RS-232: 1 channel, RS-422/485: 1 channel	
	SW11VD-AD51HP <small>(Note 1)</small>	Software package for QD51, AD51H-S3, and A1SD51S	

Note 1) The program is run in Windows® command prompt.

Control network module

CC-Link IE Controller Network	QJ71GP21-SX	Multi-mode fiber optic cable, dual loop, controller network (control/normal station)	
	QJ71GP21S-SX	Multi-mode fiber optic cable, dual loop, controller network (control/normal station), with external power supply function	
MELSECNET/H	Optical loop (SI)	QJ71LP21-25	SI/QSI/H-PCF/ broadband H-PCF fiber optic cable, dual loop, controller network (control/normal station) or remote I/O network (remote mater station)
		QJ71LP21S-25	SI/QSI/H-PCF/ broadband H-PCF fiber optic cable, dual loop, controller network (control/normal station) or remote I/O network (remote mater station), with external power supply function
		QJ72LP25-25	SI/QSI/H-PCF/ broadband H-PCF fiber optic cable, dual loop, remote I/O network (remote I/O station)
		Optical loop (GI)	QJ71LP21G
	QJ72LP25G		GI-50/125 fiber optic cable, dual loop, remote I/O network (remote I/O station)
	Coaxial bus	QJ71BR11	3C-2V/5C-2V coaxial cable, single bus, controller network (control/normal station) or remote I/O network (remote master station)
		QJ72BR15	3C-2V/5C-2V coaxial cable, single bus, remote I/O network (remote I/O station)
	Twist bus	QJ71NT11B	Twisted pair cable, single bus, controller network (control/normal station)
CC-Link IE Field Network	QJ71GF11-T2 <small>(Note 1)</small>	Master/local station, CC-Link IE Field Network compatible	
CC-Link	QJ61BT11N	Master/local station, CC-Link Ver. 2 compatible	
CC-Link/LT	QJ61CL12	Master station	
FL-net (OPCN-2)	Ver. 2.00	QJ71FL71-T-F01	10BASE-T, 100BASE-TX
		QJ71FL71-B2-F01	10BASE2
		QJ71FL71-B5-F01	10BASE5
	Ver. 1.00	QJ71FL71-T	10BASE-T
		QJ71FL71-B2	10BASE2
		QJ71FL71-B5	10BASE5
AS-i	QJ71AS92	Master station, AS-Interface Specification Version 2.11 compatible	

Note 1) Supported by Universal model CPUs whose (first five serial number digits are 12012 or later).
GX Works2 version 1.25B or later is required for configuration and diagnosis functions.

Replacement support MELSEC-A/QnA transition products

Product		Model	Outline
Q Large base	Main base	Q35BL <small>(Note 1)</small>	5 slots. Power supply module installation required. For Q Series large input/output module installation
		Q38BL <small>(Note 1)</small>	8 slots. Power supply module installation required. For Q Series large input/output module installation
	Extension base	Q65BL <small>(Note 1)</small>	5 slots. Power supply module installation required. For Q Series large input/output module installation
		Q68BL <small>(Note 1)</small>	8 slots. Power supply module installation required. For Q Series large input/output module installation
		Q55BL <small>(Note 1)</small>	5 slots. Power supply module installation not required. For Q Series large input/output module installation
	Large blank cover	QG69L <small>(Note 1)</small>	For gap adjustment when a previous Q Series module is installed on the Q large base
Q Large I/O	Input	QX11L <small>(Note 1)</small>	For replacement of "A" large module "AX11". 32 points, 100 to 120 V AC, response time: 25 ms, 32 points/common, 38-point terminal block
		QX21L <small>(Note 1)</small> NEW	For replacement of "A" large module "AX21". 32 points, 200 to 240 V AC, response time: 25 ms, 32 points/common, 38-point terminal block
	Output	QY11AL <small>(Note 1)</small> NEW	For replacement of "A" large module "AY10A, AY11A". 16 points, 24 V DC/240 V AC, 2 A/point; 16 A/all points, all-point independent contacts, response time: 12 ms, 38-point terminal block
		QY13L <small>(Note 1)</small>	For replacement of "A" large module "AY13". 32 points, 24 V DC/240 V AC, 2 A/point; 5 A/common, 8 points/common, response time: 12 ms, 38-point terminal block
		QY23L <small>(Note 1)</small>	For replacement of "A" large module "AY23". 32 points, 100 to 240 V AC; 0.6 A/point, 2.4 A/common, 8 points/common, response time: 1 ms + 0.5 cycle, 38-point terminal block
High Speed Counter	QD62-H01 <small>(Note 2)</small>	For replacement of "A" large module "AD61". 2 channels, 50 kpps, count input signal: 5/12/24 V DC, external input: 5/12/24 V DC, coincidence output: transistor (sync), 12/24 V DC, 0.5 A/point; 2 A/common	
	QD62-H02 <small>(Note 2)</small>	For replacement of "A" large module "AD61-S1". 2 channels, 10 kpps, count input signal: 5/12/24 V DC, external input: 5/12/24 V DC, coincidence output: transistor (sync), 12/24 V DC, 0.5 A/point; 2 A/common	
Extension base	AnS series	QA1S65B <small>(Note 3)</small>	5 slots. Requires AnS series power supply module installation. For AnS series module installation
		QA1S68B <small>(Note 3)</small>	8 slots. Requires AnS series power supply module installation. For AnS series module installation
	A series	QA65B <small>(Note 3)</small>	5 slots. Requires A series power supply module installation. For A series module installation
		QA68B <small>(Note 3)</small>	8 slots. Requires A series power supply module installation. For A series module installation
For MELSECNET (II) local station	A1SJ71AP23Q <small>(Note 3)</small>	Optic cable, duplex loop, MELSECNET (II) local station	
	A1SJ71AR23Q <small>(Note 3)</small>	3C-2V/5C-2V coaxial cable, duplex loop, MELSECNET (II) local station	
For MELSECNET/B local station	A1SJ71AT23BQ <small>(Note 3)</small>	Twisted pair cable, single bus, MELSECNET/B local station	

Note 1) Only supported only by High Performance QCPU and Universal QCPU (Excluding Q00UJCPU).

Note 2) A connector is not provided. Please order one of the following separately: A6CON1/A6CON2/A6CON3/A6CON4

Note 3) Only supported only by High Performance model QCPU.

PC interface board

















Product		Model	Outline
CC-Link IE controller network		Q80BD-J71GP21-SX	PCI bus/PCI-X bus, Japanese/English OS compatible, multi-mode fiber optic cable, dual loop, controller network (control/normal station)
		Q80BD-J71GP21S-SX	PCI bus/PCI-X bus, Japanese/English OS compatible, multi-mode fiber optic cable, dual loop, controller network (control/normal station), with external power supply function
MELSECNET/H (10)	Optical loop (SI)	Q81BD-J71LP21-25	PCI Express bus, Japanese/English OS compatible, SI/QSI/H-PCF/broadband H-PCF fiber optic cable, dual loop, controller network (control/normal station)
		Q80BD-J71LP21-25	PCI bus, Japanese/English OS compatible, SI/QSI/H-PCF/broadband H-PCF fiber optic cable, dual loop, controller network (control/normal station)
		Q80BD-J71LP21S-25	PCI bus, Japanese/English OS compatible, SI/QSI/H-PCF/broadband H-PCF fiber optic cable, dual loop, controller network (control/normal station), with external power supply function
	Optical loop (GI)	Q80BD-J71LP21G	PCI bus, Japanese/English OS compatible, GI-50/125 fiber optic cable, dual loop, controller network (control/normal station)
	Coaxial bus	Q80BD-J71BR11	PCI bus, Japanese/English OS compatible, 3C-2V/5C-2V coaxial cable, single bus, controller network (control/normal station)
CC-Link		Q81BD-J61BT11	PCI Express bus, Japanese/English OS compatible, master/local interface board, CC-Link Ver. 2 compatible
		Q80BD-J61BT11N	PCI bus, Japanese/English OS compatible, master/local interface board, CC-Link Ver. 2 compatible

Product List

*Contact your local Mitsubishi sales office or representative for the latest information about software versions and compatibility.

MELSOFT GX Series

* For details regarding compatible CPU types, refer to the "Compatible CPUs" item.

Product	Model	Outline	Compatible CPU					
			Universal model		High Performance model	Basic model	Process CPU	Redundant CPU
			QnU	QnUD(E)				
GX Works2 	SW1DNC-GXW2-E NEW	PLC engineering software (software with integrated functions including tools for programming, simulation and various module setting/monitoring)	●	●	●	●	—	—
GX Developer 	SW8D5C-GPPW-E	MELSEC programmable controller programming software	●	● (Note 1)	●	●	●	●
	SW8D5C-GPPW-EV	MELSEC programmable controller programming software (upgrade)	●	● (Note 1)	●	●	●	●
GX Simulator  (Note 2)	SW7D5C-LLT-E	MELSEC programmable controller simulation software	●	● (Note 1)	●	●	●	●
	SW7D5C-LLT-EV	MELSEC programmable controller simulation software (upgrade)	●	● (Note 1)	●	●	●	●
GX Converter  (Note 2)	SW0D5C-CNVW-E	Excel/text data converter	—	—	●	●	●	●
GX Configurator-AD  (Note 2)	SW2D5C-QADU-E	MELSEC-Q dedicated analog to digital conversion module setting/monitoring tool	●	● (Note 1)	●	●	●	●
GX Configurator-DA  (Note 2)	SW2D5C-QDAU-E	MELSEC-Q dedicated digital to analog conversion module setting/monitoring tool	●	● (Note 1)	●	●	●	●
GX Configurator-SC  (Note 2)	SW2D5C-QSCU-E	MELSEC-Q dedicated serial communication module setting/monitoring tool	●	● (Note 1)	●	●	●	●
GX Configurator-CT  (Note 2)	SW0D5C-QCTU-E	MELSEC-Q dedicated high-speed counter module setting/monitoring tool	●	● (Note 1)	●	●	●	●
GX Configurator-TC  (Note 2)	SW0D5C-QTCU-E	MELSEC-Q dedicated temperature control module setting/monitoring tool	●	● (Note 1)	●	●	●	●
GX Configurator-TI  (Note 2)	SW1D5C-QTIU-E	MELSEC-Q dedicated temperature input module setting/monitoring tool	●	● (Note 1)	●	●	●	●
GX Configurator-FL  (Note 2)	SW0D5C-QFLU-E	MELSEC-Q dedicated FL-net module setting/monitoring tool	●	● (Note 1)	●	●	●	●
GX Configurator-PT  (Note 2)	SW1D5C-QPTU-E	MELSEC-Q dedicated positioning module QD70 setting/monitoring tool	●	● (Note 1)	●	●	●	●
GX Configurator-AS  (Note 2)	SW1D5C-QASU-E	MELSEC-Q dedicated AS-i master module setting/monitoring tool	●	● (Note 1)	●	●	●	●
GX Configurator-QP 	SW2D5C-QD75P-E	MELSEC-Q dedicated positioning module QD75P/D/M setting/monitoring tool	●	● (Note 1)	●	●	●	●
GX Explorer 	SW2D5C-EXP-E	Maintenance tool	—	—	●	●	● (Note 3)	—
GX RemoteService-I 	SW2D5C-RAS-E	Remote access tool	—	—	●	●	● (Note 3)	—
GX Works	SW4D5C-QSET-E	A set of seven products: GX Developer, GX Simulator, GX Explorer, GX Configurator-AD, DA, SC, CT	(Note 4)					
	SW8D5C-GPPLT-E	A set of three products: GX Developer, GX Simulator, GX Explorer	(Note 4)					

Note 1) Not compatible with Q50UDEHCPU, Q100UDEHCPU, and QJ71GF11-T2.

Note 2) Operates at GX Developer add-in software. GX Developer is required.

Note 3) Not compatible with Q02PHCPU and Q06PHCPU.

Note 4) For details regarding set-item compatible CPUs, refer to the compatible CPUs for the single products.

MELSOFT PX Series

* For details regarding compatible CPU types, refer to the "Compatible CPUs" item.

Product	Model	Outline	Compatible CPU					
			Universal model		High Performance model	Basic model	Process CPU	Redundant CPU
			QnU	QnUD(E)				
PX Developer	SW1D5C-FBDQ-E	Process control FBD software package	—	—	—	—	●	●
PX Works	SW3D5C-FBDGPP-E	A set of six products: PX Developer, GX Developer, GX Configurator-AD, DA, CT, TI	(Note)					

Note) For details regarding set-item compatible CPUs, refer to the compatible CPUs for the single products.

MELSOFT MX Series

Product	Model	Outline	Universal model QnU	Universal model QnUD(E)	High Performance model	Basic model	Process CPU	Redundant CPU
MX Component	SW3D5C-ACT-E	ActiveX library for communication	●	●	●	●	●	●
MX Sheet	SW1D5C-SHEET-E	Excel® communication support tool	●	●	●	●	●	●
MX Works	SW1D5C-SHEETSET-E	A set of two products: MX Component, MX Sheet	(Note 1)					
MX MESInterface	SW1DNC-MESIF-E	MES interface module QJ71MES96 dedicated information linkage tool	(Note 2)					

Note 1) For details regarding set-item compatible CPUs, refer to the compatible CPUs for the single products.
Note 2) Required when using the MES interface module.

MELSOFT iQ Works

Product	Model	Outline
MELSOFT iQ Works	SW1DNC-IQWK-E (CD edition)	FA engineering software ^(Note) · System management software "MELSOFT Navigator" Upstream design, tool for linkage to iQ Works products · PLC engineering software "MELSOFT GX Works2" Tools for PLC programming, simulation and various module setting/monitoring
	SW1DND-IQWK-E (DVD edition)	· Motion controller engineering software "MELSOFT MT Works2" Total support tools for motion controller design and maintenance · Display screen creation software "MELSOFT GT Works3" Support tools for display screen creation

Note) For details concerning compatible models for each software item, refer to the relevant product manuals.

- Multiple licenses, additional licenses, and multiple license upgrades are available
- Multiple licenses and additional licenses are available.
- Multiple licenses are available.

Compatible CPUs

Item	Model	
Universal model QCPU	QnU	Q00UJ, Q00U, Q01U, Q02U
	QnUD(E)	Q03UD(E), Q04UD(E)H, Q06UD(E)H, Q10UD(E)H, Q13UD(E)H, Q20UD(E)H, Q26UD(E)H, Q50UDEH, Q100UDEH
High Performance model QCPU	Q02, Q02H, Q06H, Q12H, Q25H	
Basic model QCPU	Q00J, Q00, Q01	
Process CPU	Q02PH, Q06PH, Q12PH, Q25PH	
Redundant CPU	Q12PRH, Q25PRH	

Precautions before use

This publication explains the typical features and functions of the products herein and does not provide restrictions or other information related to usage and module combinations. Before using the products, always read the product user manuals. Mitsubishi Electric will not be held liable for damage caused by factors found not to be the cause of Mitsubishi Electric; opportunity loss or lost profits caused by faults in Mitsubishi Electric products; damage, secondary damage, or accident compensation, whether foreseeable or not, caused by special factors; damage to products other than Mitsubishi Electric products; or any other duties.

For safe use

- To use the products given in this publication properly, always read the relevant manuals before beginning operation.
- The products have been manufactured as general-purpose parts for general industries, and are not designed or manufactured to be incorporated in a device or system used in purposes related to human life.
- Before using the products for special purposes such as nuclear power, electric power, aerospace, medicine or passenger-carrying vehicles, consult with Mitsubishi Electric.
- The products have been manufactured under strict quality control. However, when installing the products where major accidents or losses could occur if the products fail, install appropriate backup or fail-safe functions in the system.

Country/Region	Sales office	Tel/Fax
USA	MITSUBISHI ELECTRIC AUTOMATION, INC. 500 Corporate Woods Parkway, Vernon Hills, IL 60061, U.S.A.	Tel : +1-847-478-2100 Fax : +1-847-478-2253
Mexico	MITSUBISHI ELECTRIC AUTOMATION, INC. Mexico Branch Boulevard Miguel de Cervantes Saavedra 301, Torre Norte Piso 5, Ampliacion Granada, Miguel Hidalgo, Ciudad de Mexico, Mexico, C.P.115200	Tel : +52-55-3067-7512
Brazil	MITSUBISHI ELECTRIC DO BRASIL COMERCIO E SERVICOS LTDA. Avenida Adelino Cardana, 293, 21 andar, Bethaville, Barueri SP, Brasil	Tel : +55-11-4689-3000 Fax : +55-11-4689-3016
Germany	MITSUBISHI ELECTRIC EUROPE B.V. German Branch Mitsubishi-Electric-Platz 1, 40882 Ratingen, Germany	Tel : +49-2102-486-0 Fax : +49-2102-486-7780
UK	MITSUBISHI ELECTRIC EUROPE B.V. UK Branch Travellers Lane, UK-Hatfield, Hertfordshire, AL10 8XB, U.K.	Tel : +44-1707-28-8780 Fax : +44-1707-27-8695
Ireland	MITSUBISHI ELECTRIC EUROPE B.V. Irish Branch Westgate Business Park, Ballymount, Dublin 24, Ireland	Tel : +353-1-4198800 Fax : +353-1-4198890
Italy	MITSUBISHI ELECTRIC EUROPE B.V. Italian Branch Centro Direzionale Colleoni - Palazzo Sirio, Viale Colleoni 7, 20864 Agrate Brianza (MB), Italy	Tel : +39-039-60531 Fax : +39-039-6053-312
Spain	MITSUBISHI ELECTRIC EUROPE, B.V. Spanish Branch Carretera de Rubi, 76-80-Apdo. 420, E-08190 Sant Cugat del Valles (Barcelona), Spain	Tel : +34-935-65-3131 Fax : +34-935-89-1579
France	MITSUBISHI ELECTRIC EUROPE B.V. French Branch 25, Boulevard des Bouvets, 92741 Nanterre Cedex, France	Tel : +33-1-55-68-55-68 Fax : +33-1-55-68-57-57
Czech Republic	MITSUBISHI ELECTRIC EUROPE B.V. Czech Branch, Prague Office Pekarska 621/7, 155 00 Praha 5, Czech Republic	Tel : +420-255-719-200
Poland	MITSUBISHI ELECTRIC EUROPE B.V. Polish Branch ul. Krakowska 48, 32-083 Balice, Poland	Tel : +48-12-347-65-00
Sweden	MITSUBISHI ELECTRIC EUROPE B.V. (Scandinavia) Hedvig Mollersgata 6, 223 55 Lund, Sweden	Tel : +46-8-625-10-00 Fax : +46-46-39-70-18
Russia	MITSUBISHI ELECTRIC (RUSSIA) LLC St. Petersburg Branch Piskarevsky pr. 2, bld 2, lit "Sch", BC "Benua", office 720; 195027 St. Petersburg, Russia	Tel : +7-812-633-3497 Fax : +7-812-633-3499
Turkey	MITSUBISHI ELECTRIC TURKEY A.S. Umraniye Branch Serifali Mah. Kale Sok. No:41 34775 Umraniye - Istanbul, Turkey	Tel : +90-216-969-2500 Fax : +90-216-661-4447
UAE	MITSUBISHI ELECTRIC EUROPE B.V. Dubai Branch Dubai Silicon Oasis, P.O.BOX 341241, Dubai, U.A.E.	Tel : +971-4-3724716 Fax : +971-4-3724721
South Africa	ADROIT TECHNOLOGIES 20 Waterford Office Park, 189 Witkoppen Road, Fourways, South Africa	Tel : +27-11-658-8100 Fax : +27-11-658-8101
China	MITSUBISHI ELECTRIC AUTOMATION (CHINA) LTD. Mitsubishi Electric Automation Center, No.1386 Hongqiao Road, Shanghai, China	Tel : +86-21-2322-3030 Fax : +86-21-2322-3000
Taiwan	SETSUYO ENTERPRISE CO., LTD. 6F, No.105, Wugong 3rd Road, Wugu District, New Taipei City 24889, Taiwan	Tel : +886-2-2299-2499 Fax : +886-2-2299-2509
Korea	MITSUBISHI ELECTRIC AUTOMATION KOREA CO., LTD. 7F to 9F, Gangseo Hangang Xi-tower A, 401, Yangcheon-ro, Gangseo-Gu, Seoul 07528, Korea	Tel : +82-2-3660-9569 Fax : +82-2-3664-8372
Singapore	MITSUBISHI ELECTRIC ASIA PTE. LTD. 307 Alexandra Road, Mitsubishi Electric Building, Singapore 159943	Tel : +65-6473-2308 Fax : +65-6476-7439
Thailand	MITSUBISHI ELECTRIC FACTORY AUTOMATION (THAILAND) CO., LTD. 12th Floor, SV.City Building, Office Tower 1, No. 896/19 and 20 Rama 3 Road, Kwaeng Bangpongpan, Khet Yannawa, Bangkok 10120, Thailand	Tel : +66-2682-6522-31 Fax : +66-2682-6020
Vietnam	MITSUBISHI ELECTRIC VIETNAM COMPANY LIMITED Unit 01-04, 10th Floor, Vincom Center, 72 Le Thanh Ton Street, District 1, Ho Chi Minh City, Vietnam	Tel : +84-28-3910-5945 Fax : +84-28-3910-5947
Indonesia	PT. MITSUBISHI ELECTRIC INDONESIA Gedung Jaya 8th Floor, JL. MH. Thamrin No.12, Jakarta Pusat 10340, Indonesia	Tel : +62-21-31926461 Fax : +62-21-31923942
India	MITSUBISHI ELECTRIC INDIA PVT. LTD. Pune Branch Emerald House, EL-3, J Block, M.I.D.C., Bhosari, Pune-411026, Maharashtra, India	Tel : +91-20-2710-2000 Fax : +91-20-2710-2100
Australia	MITSUBISHI ELECTRIC AUSTRALIA PTY. LTD. 348 Victoria Road, P.O. Box 11, Rydalmere, N.S.W 2116, Australia	Tel : +61-2-9684-7777 Fax : +61-2-9684-7245

MITSUBISHI ELECTRIC CORPORATION

HEAD OFFICE: TOKYO BLDG., 2-7-3, MARUNOUCHI, CHIYODA-KU, TOKYO 100-8310, JAPAN
www.MitsubishiElectric.com