

DIGITAL LINK SENSOR AnyWireASLINK

e-Factory

Seamless synergy between the MELSEC
programmable controller and
Anywire digital link sensor

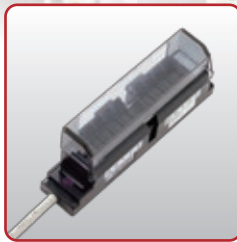

Digital Link Sensor

AnyWireASLINK



M E L S E C +

Expanding the seamless collaboration of Mitsubishi Digital Link Sensor



The digital link sensor AnyWireASLINK is designed to realize “improved productivity”, “commissioning time reduction” and “space-saving”. [AnyWire Actuator Sensor Link]

The ability to monitor the state of all sensors on the network system from a centralized location (visualize) reduces commissioning time and improves productivity.

AnyWireASLINK also helps to save space in the machine and control system that uses various sensors.

AnyWireASLINK is compatible with iQ Sensor Solution (iQSS) which is an innovative solution that realizes a reduction in TCO.

*TCO:Total Cost of Ownership

AnyWireASLINK

sensor area through
Electric and Anywire
AnyWireASLINK



Mitsubishi Electric, a global leader in industrial automation technology, is creating new sensor applications with innovative technology

As a total solution provider, Mitsubishi Electric offers a wide range of advanced industrial automation products and solutions. From IT systems to shop floor level field networks, Mitsubishi Electric can provide a seamless network solutions that optimize operations from development to maintenance.



Anywire has consistently stayed one step ahead in reduced wiring in FA industry, causing a stir in the industry with advanced technology

Starting with the original development of the world's first 'double duplex' communication chip, Anywire has created new products such as system sensors that mix sensing with wire-saving and have realized advanced sensor innovation with AnyWireASLINK.

AnyWireASLINK

AnyWireASLINK is a sensor-level network which inherits AnyWire connection system features and includes added values.

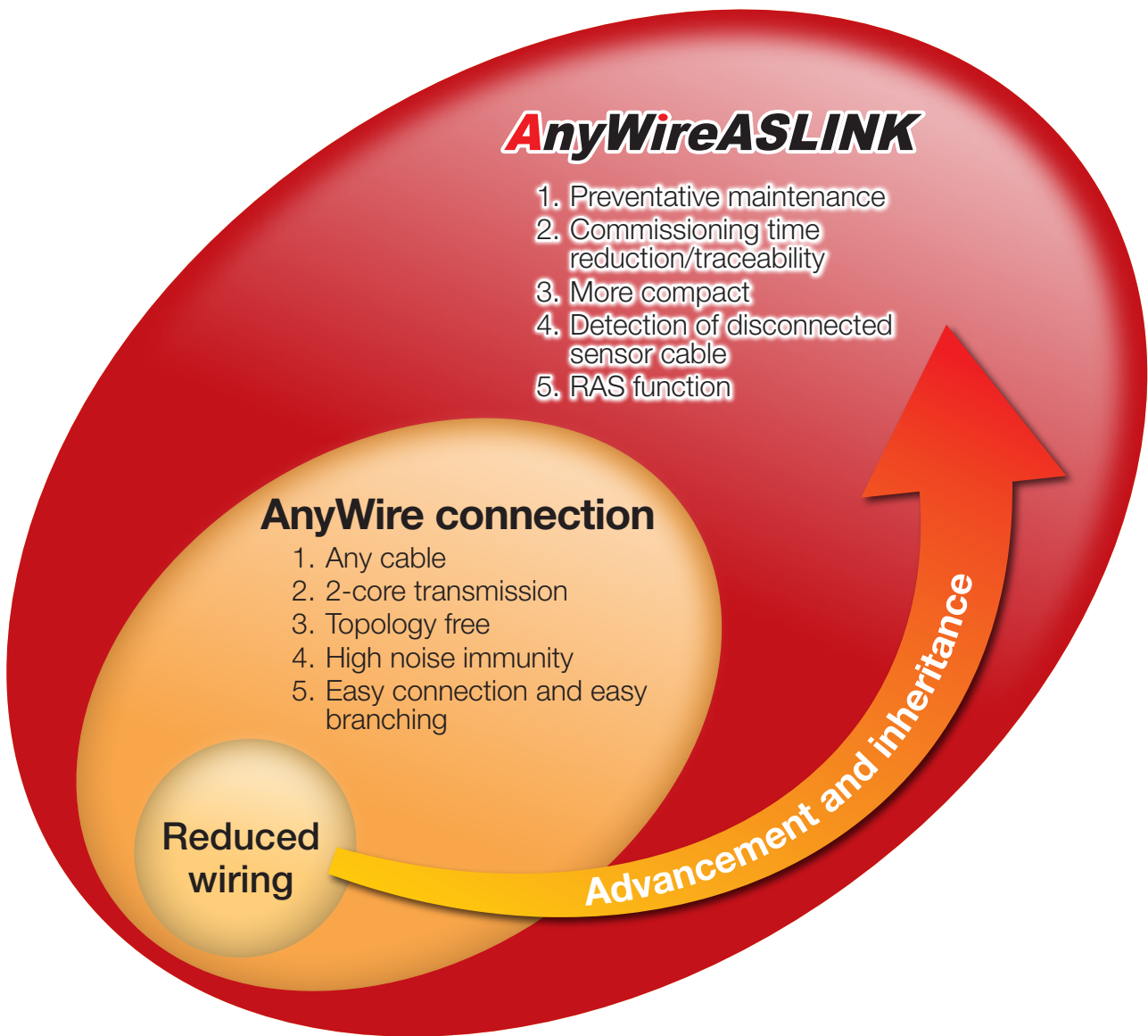

AnyWireASLINK Directly connecting to the programmable controller to centrally monitor each sensor's status!



Preventive maintenance can prevent intermittent stops, etc. by detecting disconnection of connector sensors and visualizing the internal state, contributing to **“improved productivity”**.



Sensor sensitivity and such can be set and adjusted from the programmable controller, contributing to **“commissioning time reduction”** for sensor adjustments and traceability.



“Space-saving” can be realized by using the ASLINKER or ASLINKTERMINAL which eliminates the relay box.

■ Features of AnyWire connection system

1. Any cable can be used

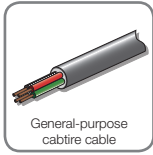

Widely available general-purpose cabtire cables can be used, reducing system construction cost. Spare cables and existing cables used in another system can be utilized if cable diameters are within the operating condition range. The link connector (for 4 poles only) for a cabtire cable is also available.

2. 2-core transmission



The AnyWire connection system employs a power supply superposition method which can transmit power and signals in 2-core using a 2-wire type (non-insulation) terminal. If current capacity on the load side is large, adding a 4-wire (insulation) type terminal that can locally supply power and a separate power source can support transmission. In addition, a system with mixing of two terminals can be built.

3. Topology free (no constraints to branching)

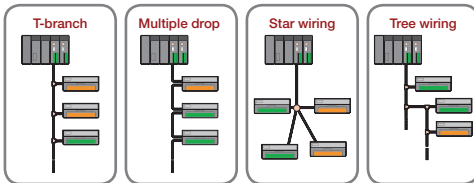

AnyWire connection system allows for flexible branching and connection. There is no constraints to the branching method and minimum distance between the respective terminals. Various wiring methods such as T-branch, multi-drop, star and tree topology can be freely selected. A system with mixing of these topologies is also supported.

*T-branch wiring is recommended in order to easily isolate at time of trouble.
*It is recommended to decrease the number of branches to less than 10 for stable transmission.

4. High noise immunity

AnyWire connection system

- 1) Transmission voltage is 24 V DC. Greater margin can be taken for noise.
- 2) Transmission clock is 27 kHz. Hardly susceptible to noise with a sufficiently large clock width.

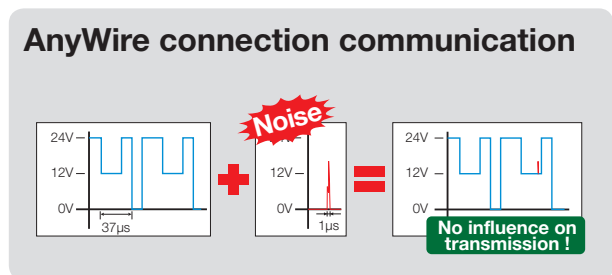
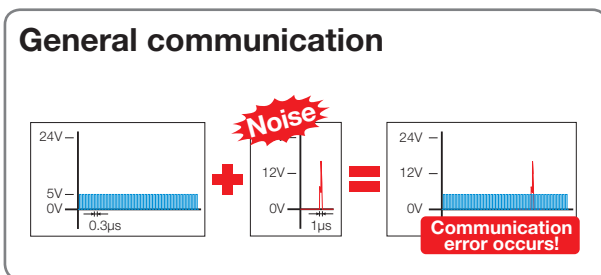

5. Easy connection and easy branching

Use of AnyWire link connector will improve wiring works.

Features of link-connector and how to use

- Crimping enables branching even in the middle of cables
- Cutting wires or stripping sheaths are not necessary, producing no waste
- Only one type (no male/female distinction)



Place cables in a sleeve. Either middle of cables or the end of cables, whichever can be placed.



Clamp a link connector with a dedicated tool.



T-branch, 4-branch, and extension are enabled. Wiring time can be significantly reduced.

■ Features-newly added values

1. Preventative maintenance ... Preventing intermittent stops

ASLINKER ASLINK TERMINAL ASLINK AMP ASLINK SENSOR

Using the AnyWireASLINK system, sensor status can be monitored/saved and parameter settings can be changed with the programmable controller. "Preventative maintenance" which prevents intermittent stops is realized.

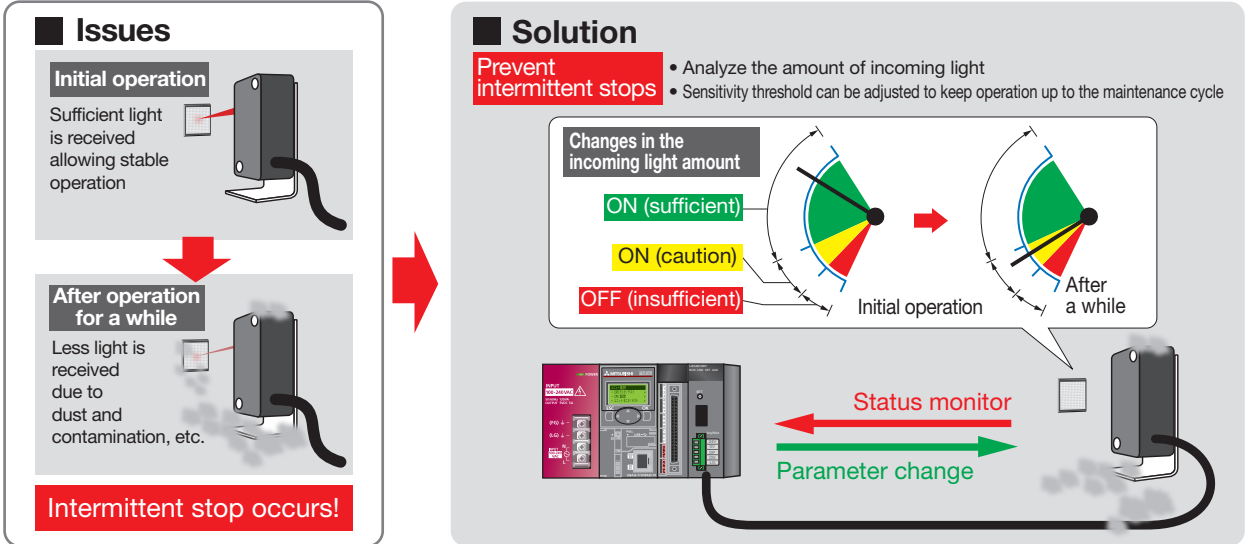

2. Commissioning time reduction/traceability

ASLINKER ASLINK TERMINAL ASLINK AMP ASLINK SENSOR

Adjusting the detection level of multiple sensor and recording the sensor values takes a lot of time. AnyWireASLINK allows the detection level to be set and the setting values to be saved in a batch from a computer or GOT(HMI). Traceability in the sensor system is realized.

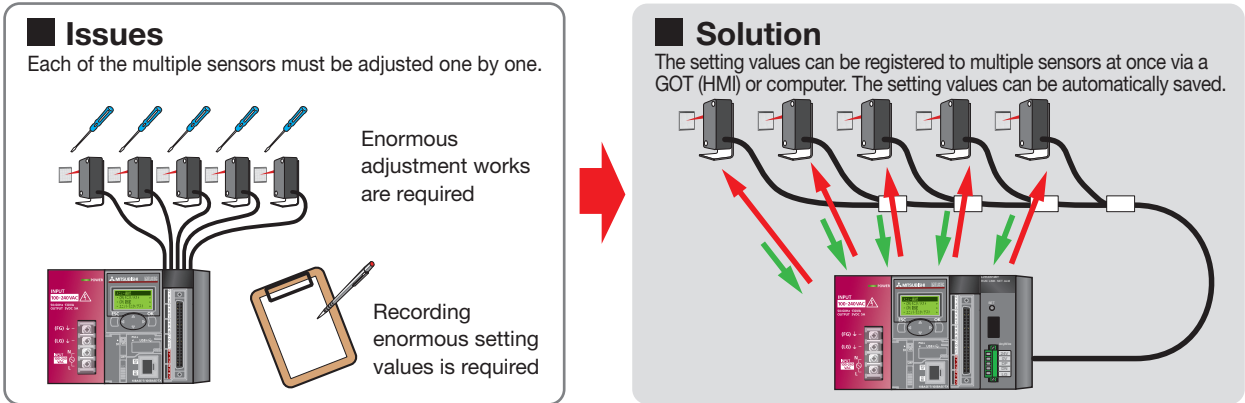

3. More compact

ASLINKER ASLINK TERMINAL ASLINK AMP ASLINK SENSOR

A relay connector-sized miniature terminal is available, which allows sensors to be dispersed in 2 point unit. Depending on the installation environment, configuration without a relay box is possible, contributing to a small system.

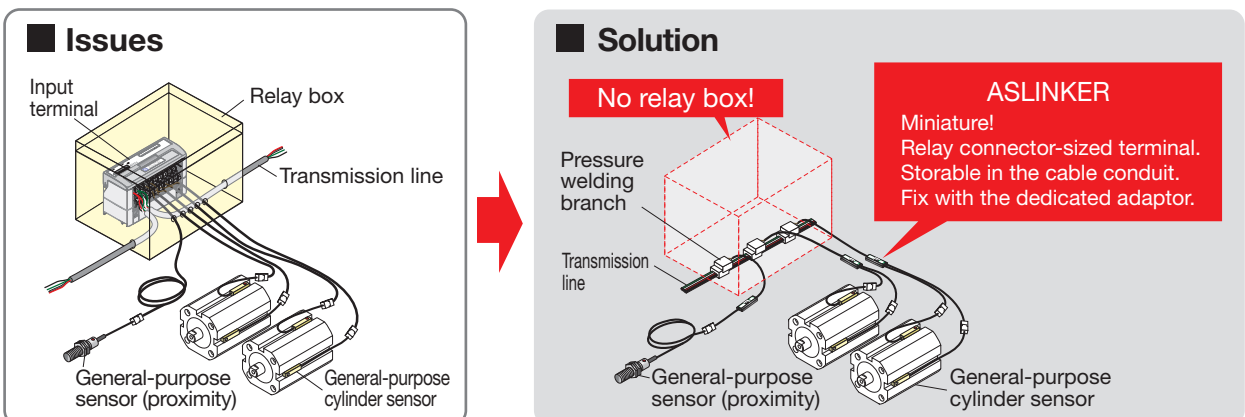

4. Detection of disconnected sensor cable (error recovery actions support)

ASLINKER ASLINK TERMINAL ASLINK AMP ASLINK SENSOR

AnyWireASLINK monitors disconnection of sensor cable and short circuit in the power cable then reports to the programmable controller. This function enables to quickly identify cause and locate error at input fault due to cable disconnection or short circuit in the power cable, supporting quick recovery.

Issues (without disconnection detection)

When a general-purpose sensor connected to the programmable controller is disconnected and causes an input error, the point has to be identified from the contact signal to check each wire to find the disconnection.

Solution (with disconnection detection)

The sensor cable disconnection is notified together with the connected device's ID (address). The disconnected point can be identified immediately.*1

Using the GOT(HMI) can quickly identify the error point

*1 2-wire type (non-insulation) ASLINKER can detect disconnection of a 2-wire type sensor. SMARTLINKER can detect disconnection of 2-wire type and 3-wire type sensors.

5. RAS function*2

ASLINKER ASLINK TERMINAL ASLINK AMP ASLINK SENSOR

In addition to the features above, the AnyWireASLINK is equipped with RAS function related to basic transmission. Transmission errors can also be monitored with programmable controller.

Transmission cable disconnection detection

If the transmission cable is disconnected, the AnyWireASLINK master module detects the disconnected slave modules, allowing to quickly identify a disconnected point in the transmission line.

Transmission cable short-circuit detection

The AnyWireASLINK master module detects short-circuits in the transmission line and stops transmission. This indicates short-circuits in the transmission line.

Transmission circuit drive power drop detection

The AnyWireASLINK master module can detect a drop in the voltage of the transmission circuit drive power (24 V DC) supplied from an external source.

Duplicate ID/unset ID detection

The AnyWireASLINK master module sends an error when it detects duplicated ID (address), making incorrect setting check of ID (address) easier.

*2 This function contributes to improving the system's Reliability, Availability and Serviceability.

AnyWireASLINK product lists

Master module

Master module supporting programmable controller (MELSEC iQ-R/F, MELSEC-Q/L/F) and FA network (CC-Link IE Field, CC-Link)

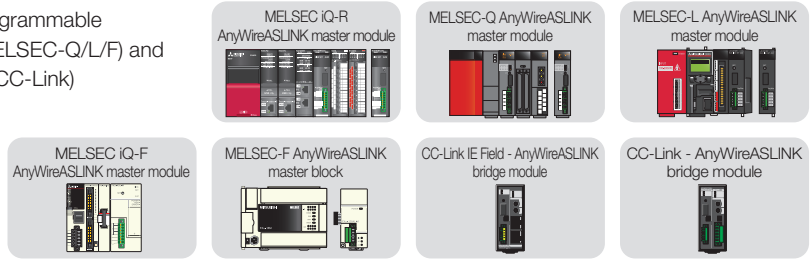

➔ P.13

Digital link module

ASLINKER

General-purpose I/O device ready module

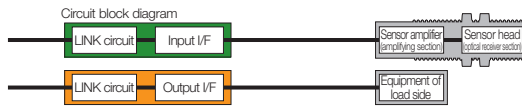

Cable type

➔ P.15

ASLINKTERMINAL

General-purpose I/O device ready terminal

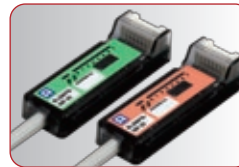
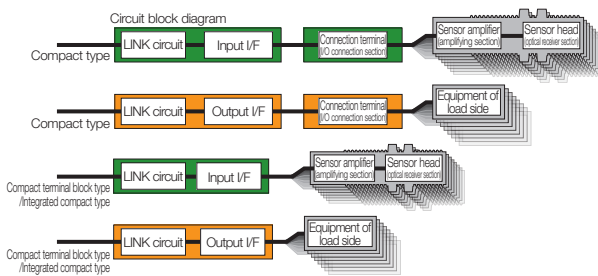

Compact type



Compact terminal block type



Integrated compact type

➔ P.17

Digital link sensor

ASLINKAMP

Multi-amplifier and analog input module compatible with general-purpose sensor head

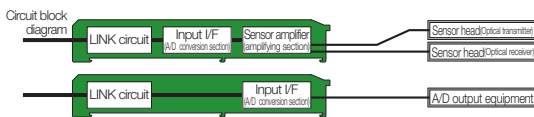

For photo electric head
For proximity head
For fiber head

➔ P.19

ASLINKSENSOR

Digital link function built-in sensor



Photoelectric type Cylinder type Proximity type Photo interrupter type Pressure type

➔ P.21

Digital link monitor

ASLINKMONITOR

Optional address sensing level display module



AnyWireASLINK small display module

Configuration of AnyWireASLINK modules

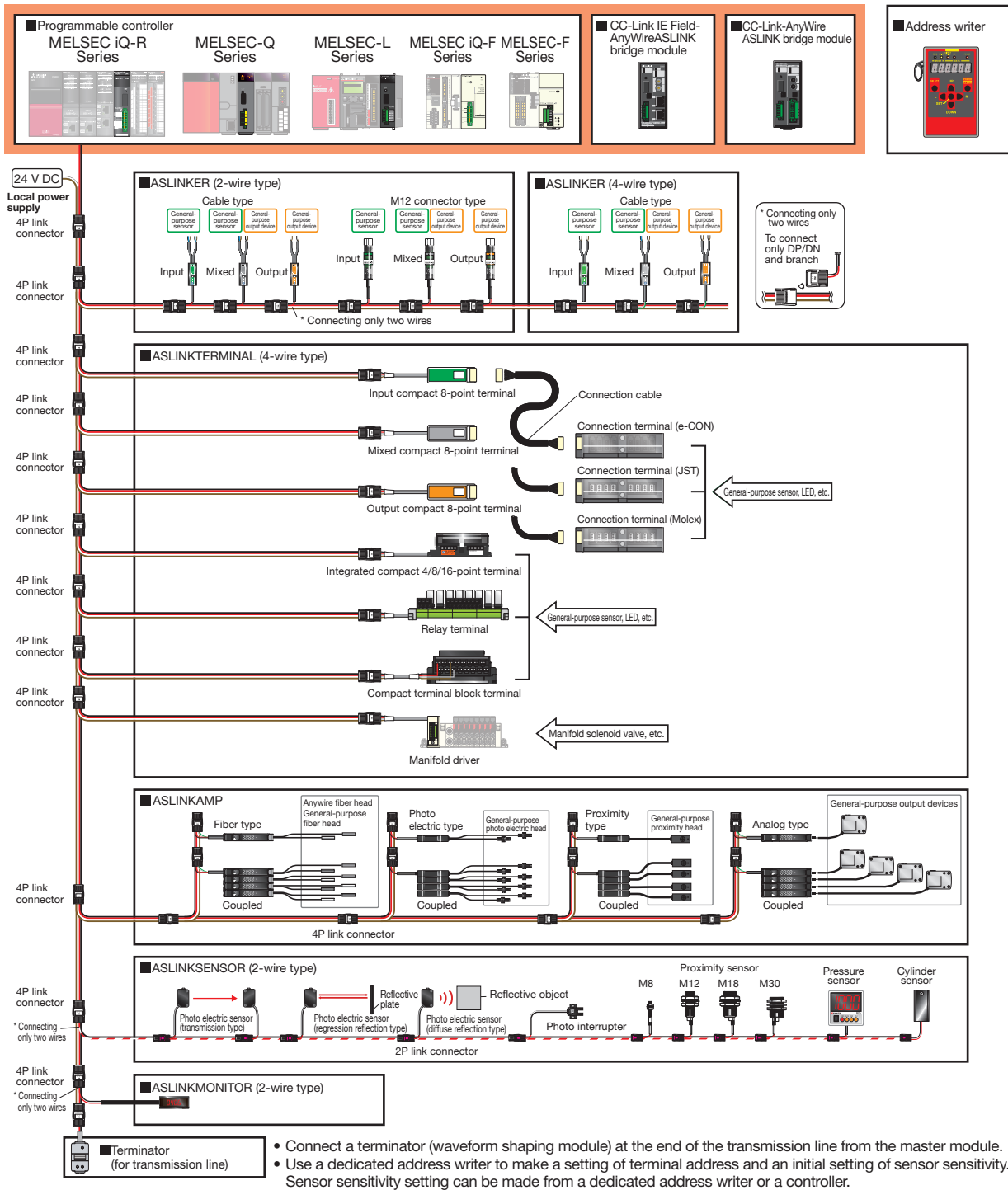

AnyWireASLINK function list according to types

Types	Specifications	Connected devices	Function					
			Improved productivity			Commissioning time reduction	Space-saving	
			Sensor cable status monitoring	Sensing level monitoring	RAS function	Write/read sensor setting value	Compact	Water-proof
ASLINKER	2 point I/O	General-purpose sensor, switch, general-purpose output device	●*1	—	●	—	●	● (Supported model available)
ASLINKTERMINAL	SMARTLINKER		—	—	●	—	●	—
ASLINKAMP	1-point sensor input, etc	General-purpose fiberhead, General-purpose photo electric head, General-purpose proximity head	—	●	●	● Sensitivity, threshold, etc.	●	● (Supported model available)
ASLINKSENSOR		-(built-in sensor)						

*1 2-wire type (non-insulation) ASLINKER can detect disconnection and power supply short circuit of a 2-wire type sensor.

*2 SMARTLINKER can detect disconnection and power supply short-circuit of 2-wire type and 3-wire type sensors.

Supporting iQ Sensor Solution (iQSS) to increase the possibilities of sensor control

—Simplifying sensor setting and monitoring—

Programmable controller

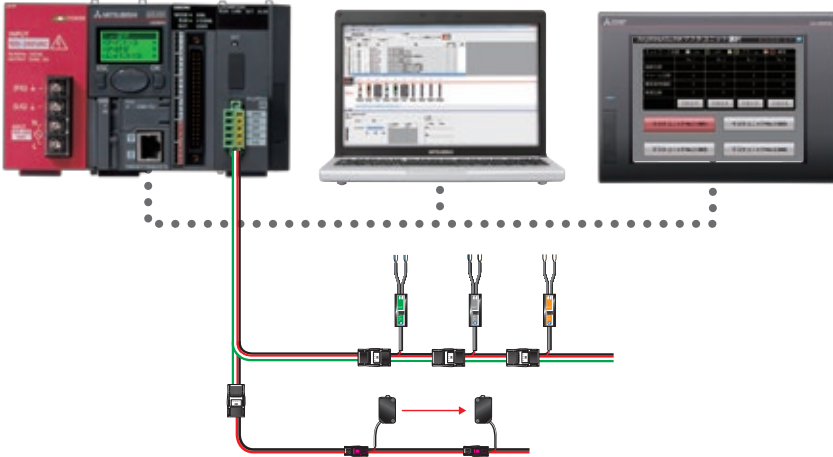

iQSS

This solution further strengthens the coordination between sensors and PLCs, GOTs(HMIs) and engineering tools, which effectively reduces the customer's TCO*.

*TCO: Total Cost of Ownership



For details, please refer to the "Sensor Solution iQ Sensor Solution Catalog L(NA)16029ENG"

Engineering Environment

GX Works2 Easily monitor and adjust sensor status and logging settings*1 in the engineering environment

Monitor the sensor status

Adjust the setting values

Backup/restore the setting values

Setting for logging output value

*1 Future support planned

Easy startup

The sensor is automatically detected and added to the system configuration diagram!

Simple programming

Sensor label names *2 can be imported!



Easily grasp the sensor status!

Easily troubleshoot! Error codes and corrective measures are displayed

No.	Class	Label Name	Data Type
1	VAR	Operation_Start	Bit
2	VAR	Operation_Ready	Bit
3	VAR	Operation_A1	Bit
4	VAR	Operation_A2	Bit
5	VAR	Initial_Setting_Flag	Bit
6	VAR	Switch	Bit
7	VAR	Emergency_Action	Bit
8	VAR	Tank_A_Temperature	Double Word(Signed)
9	VAR	Tank_B_Temperature	Double Word(Signed)
10	VAR	ModuleReady	Bit

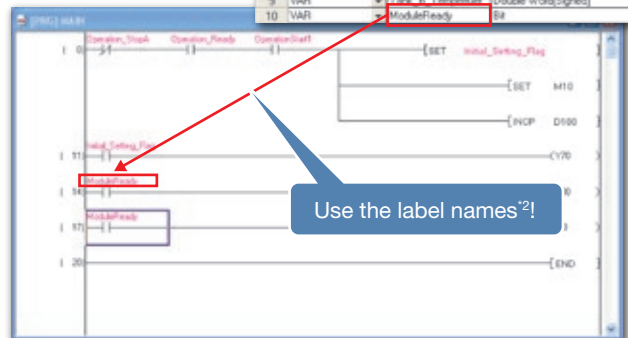

Use the label names*2!

*2 These character strings are displayed instead of the device name, and help to improve the programming efficiency and prevent mistakes when inputting devices.

GOT Display

GOT2000

Graphic Operation Terminal **GT27 compatible** **GT25 compatible**

Use the GOT(HMI) at the production site to easily monitor the sensor status, adjust the setting values, and complete the logging settings*3!

Monitor the sensor status

Adjust the setting values

Backup/restore the setting values

Setting the output value logging

*3 Future support scheduled

■ iQSS utility function*4

Enabling the iQSS utility function automatically generates monitoring screens. Manually creating dedicated monitoring screens for every sensor is unnecessary, reducing time for start-up, operation, and maintenance of the sensor system.

*4 Supported by GOT2000 only.

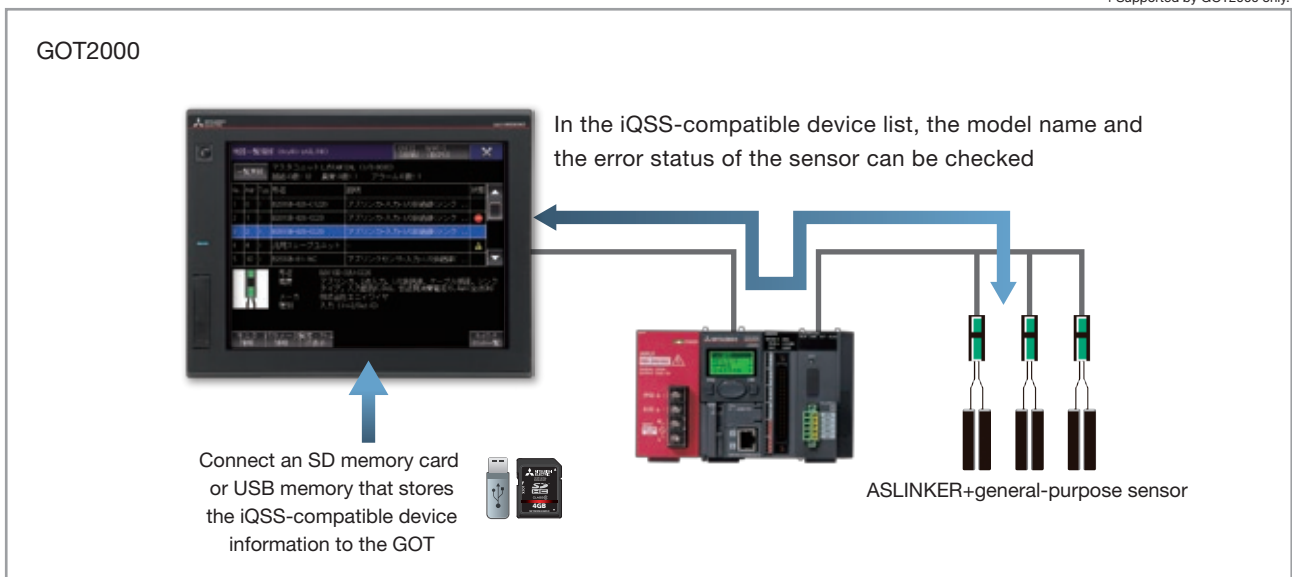

The iQSS-compatible device (AnyWireASLINK) status and parameter information can be checked on the GOT(HMI) without a computer.

■ MELSOFT Library (sample screen)

The slave module type and ID (address) status can be confirmed.

AnyWireASLINK System Map
Network Status
Modules : 10 Latest error: 202
Alarms : 1 DP/ON disconnection error
Errors : 4 1OK 1Alarm 1Error

Input Signal Monitor
Network Status
Modules : 10 Latest error: 1 DI
Alarms : 1 Errors : 4
LOW OFF Alarm Error

Module Detail
User-defined name : Input module ID: 10
Status
ID : 10 Detail : Normal
Model : B08309-01-1K0 Retry : 1
Series : ASLINKS/NS01
ID : Input Points : 1
ON/OFF : [Indicator] Sensing level : 0 / 100
Current : 30

Device parameter
Threshold : 50 Light/Dark ON switch : ON
Hysteresis : 5 Mode change : ON mode
Alarm judgment (d) : 30 Led charge mode :
Alarm judgment (e,d) : 20 Led charge mode :
Time of alarm : 5

The operation status is shown on the screen. The sensor status can be easily grasped

Detailed information can be displayed for each sensor!

The input/output status is clearly displayed!

Graphically display the measured values!

For details on how to obtain the monitor screen for adjustment shown above, please contact your local Mitsubishi Electric sales office or representative. (The GOT 2000 compatible monitor screen for adjustment is enclosed with the GOT Display Screen Creation Software (GT Works3).)

iQSS

A tool for connecting! Visualizing! For a more seamless sensor control!

e-F@ctory is the Mitsubishi Electric solution for adding value across the manufacturing enterprise by enhancing productivity, and reducing the maintenance and operations costs together with seamless information flow throughout the plant. iQ Sensor Solution (iQSS) is a solution in the sensor area in eF@ctory.

Through a collaboration with partner manufacturers, Mitsubishi Electric enhances coordination between sensors and PLCs, GOT(HMI) and engineering software and offers an engineering tool that enables intuitive configuration and maintenance of sensors, effectively reducing TCO*.

*TCO: Total Cost of Ownership



For details, please refer to "MELSEC Consolidated Catalog".
L(NA)08322ENG



For details, please refer to the "iQ Sensor Solution catalog".
L(NA)16029ENG

iQSS connects everything from general to advanced sensors

Vision sensors
 Laser displacement sensors
 Contact displacement sensors
 Pressure sensors
 Fiber sensors
 Pressure sensors
 Photoelectric sensors
 Proximity sensors
 Bar-code readers

Ethernet

CC-Link IE

CC-Link

AnyWireASLINK

iQSS

 MELSEC-F PLC
 MELSEC-L PLC
 MELSEC-Q PLC
 MELSEC IQ-F PLC
 GOT2000 HMI
 MELSEC IQ-R PLC
 GX Works2/GX Works3 Engineering software

Easy startup

Easy tuning

Dedicated linkup tool

Easy logging (TBA)

Backup/restore

Easy programming

Sensor monitoring

COGNEX

OPTEX
F A

Panasonic

MEE

Anywire

Magnescale
SPEED X PRECISION

MITSUBISHI ELECTRIC

Do you have problems to solve at your production site?

Sensor setting

Complex sensors require many setting items, increasing setup and maintenance time.



Duplicating lines

When you reorganize your factory space, the parameters for each sensor on your existing lines must be individually set. Creating multiple lines takes time.

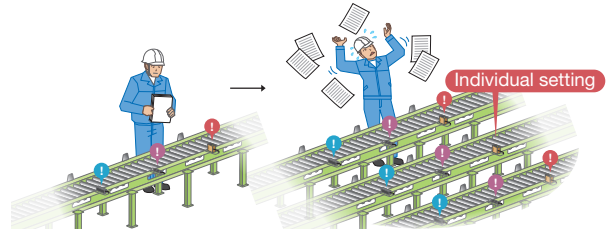

Replacing sensors

When sensors fail, they don't just have to be replaced. It is also necessary to reset the parameters for the new sensor. System recovery takes time.

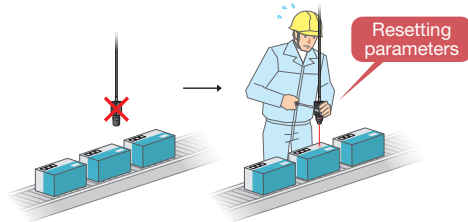

Changing the set-up

When you manufacture multiple products on a single line, sensor parameters have to be changed every time the product changes. Changing the set-up takes time.

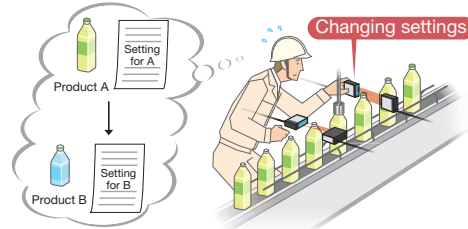

Enhanced linkups between third party partner sensors and Mitsubishi PLCs, HMIs and engineering software reduces customers' TCO.

System design

To manage projects simply, we provide a workspace tree that enables projects to be managed in a single location, and a system configuration chart that depicts the entire system graphically.



System configuration management

Implementation

Functions are provided that allow monitoring from a single screen based on the system configuration chart so that the causes of problems can be identified quickly. This also shortens the time taken to adjust sections involving multiple devices.



Monitoring

Programming

The labels used by PLCs can also be used by HMIs and sensors. This takes all the bother out of label setting. GOT sample screen libraries, sample ladders and function blocks, etc. are supported.

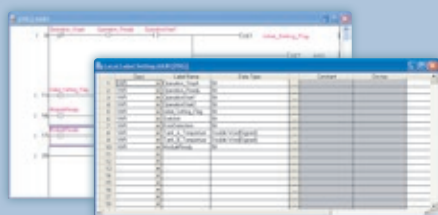

Label programming

Operation & maintenance

To make backups less laborious, batch read/write functions are provided for PLC, HMI and sensor settings

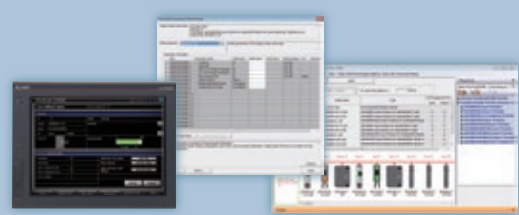

Sensor configuration read/write



iQSS eliminates the problems of conventional sensor control.

Overall length
MAX. 200 m

Topology
free

Max. number of points
512 points*1

2-wire (or 4-wire
2 transmission wires,
2 power wires)

Transmission clock
27.0 kHz

AnyWireASLINK Series

Master module

The AnyWireASLINK master module links the sensor inputs and outputs to the programmable controller. Miniature sensors can be flexibly arranged, and the 512-point*1 input/output can be controlled. The sensor power can be supplied to the AnyWireASLINK transmission line (2-wire) for communication, allowing sensors to be added easily. Disconnection detection of sensor and slave module setup are done by engineering software, substantially reducing engineering time.

*1 MELSEC iQ-F Series supports 384 points. MELSEC-F Series supports 128 points.

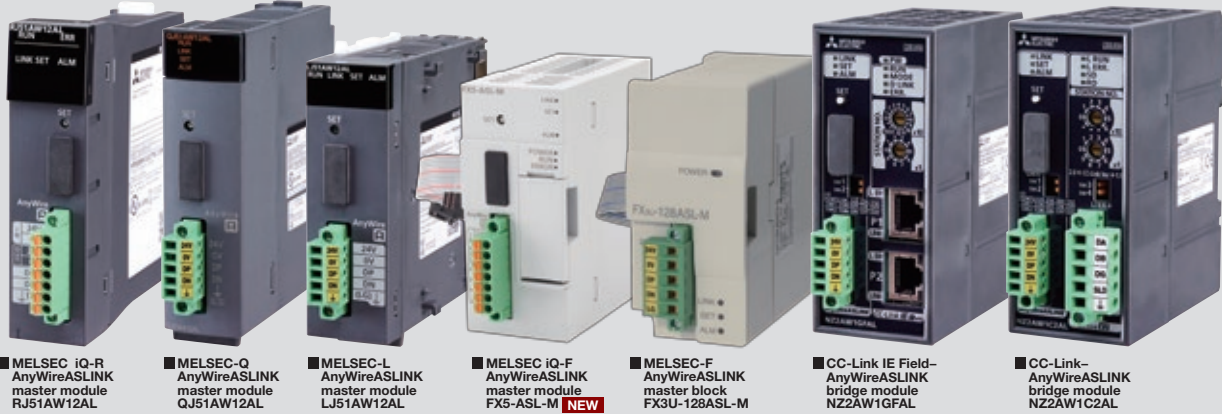

■ MELSEC iQ-R
AnyWireASLINK
master module
RJ51AW12AL

■ MELSEC-Q
AnyWireASLINK
master module
QJ51AW12AL

■ MELSEC-L
AnyWireASLINK
master module
LJ51AW12AL

■ MELSEC iQ-F
AnyWireASLINK
master module
FX5-ASL-M **NEW**

■ MELSEC-F
AnyWireASLINK
master block
FX3U-128ASL-M

■ CC-Link IE Field-
AnyWireASLINK
bridge module
NZ2AW1GFAL

■ CC-Link-
AnyWireASLINK
bridge module
NZ2AW1C2AL

Basic configuration

Either a 2-wire type or 4-wire slave module can be selected according to the load current for the AnyWireASLINK. In addition to the 2-wire type, a 4-wire type can also be used by supplying the local power.

2-wire type

If the load current is low, simplified wiring without local power feed is possible by using a non-insulated 2-wire type slave module.

4-wire type

By using an insulated 4-wire type slave module, the local power can be fed and applications with high load currents can be supported.

Configuration with 2-wire type (with no local power feed)

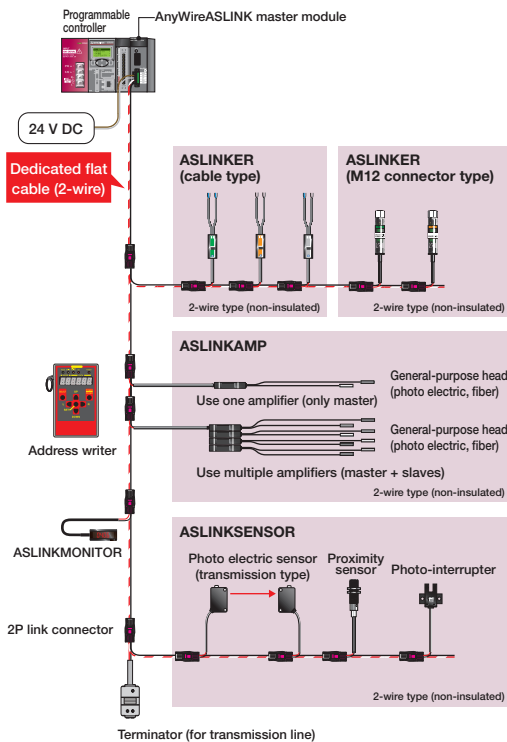

Configuration with 2-wire/4-wire type (with local power feed)

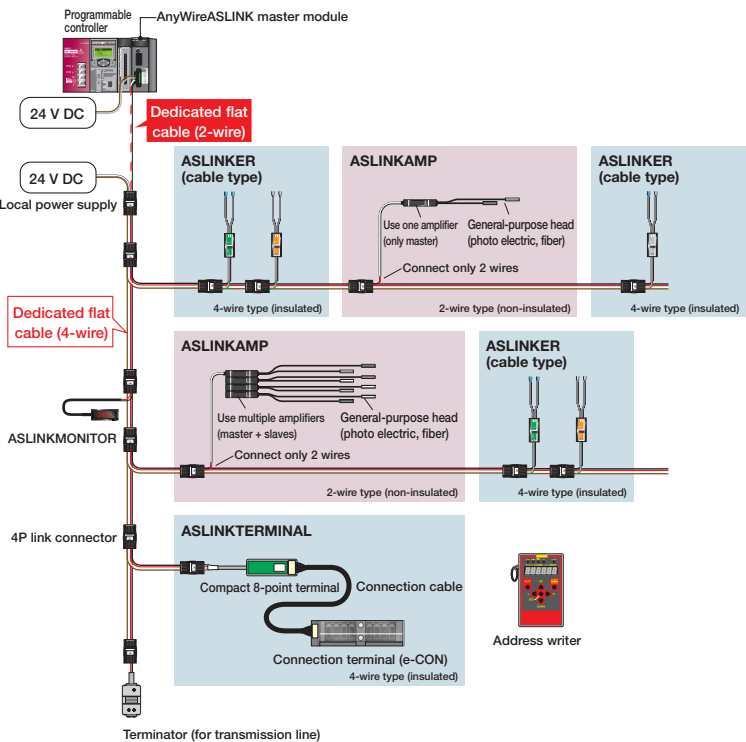

MELSEC iQ-R/F, MELSEC-Q/L/F Series AnyWireASLINK Master Module Performance

Item	RJ51AW12AL	QJ51AW12AL	LJ51AW12AL	FX5-ASL-M	FX3U-128ASL-M
Number of connectable I/O points	Max. 512 (256 input/256 output)			Max. 384 (256 input/256 output)	Max. 128 (128 input/128 output)
Number of connectable modules	Max. 128 (varies according to each slave module's current consumption)				
Max. transmission distance (overall length) ^{*1} (m)	200 ^{*2}				
Transmission method	DC power superimposed total frame cyclic method				
Connection style	Bus type (multi-drop method, T-branch method, tree branch method)				
Transmission protocol	Dedicated protocol (AnyWireASLINK)				
Error control	Checksum, double verification method				
Transmission clock (kHz)	27.0				
RAS function	Transmission cable disconnection point detection function, transmission cable short-circuit detection function, transmission power drop detection function				
Transmission cable (DP, ND)	<ul style="list-style-type: none"> * UL compatible universal 2-wire cable (VCTF, VCT 1.25 mm², 0.75 mm², rated temperature 70°C or more) * UL compatible universal cable (1.25 mm², 0.75mm², rated temperature 70°C or more) * Dedicated flat cable (1.25 mm², 0.75 mm², rated temperature 90°C) 				
Power cable (24 V, 0 V) ^{*1}	<ul style="list-style-type: none"> * UL compatible universal 2-wire cable (VCTF, VCT 0.75 ... 2.0 mm², rated temperature 70°C or more) * UL compatible universal cable (0.75 ... 2.0 mm², rated temperature 70°C or more) * Dedicated flat cable (1.25 mm², 0.75 mm², rated temperature 90°C) 				
Transmission cable supply current ^{*1}	Using 1.25 mm ² cable: Max. 2 A Using 0.75 mm ² cable: Max. 1.2 A				
Number of EEPROM write times	Max. 100,000				
Power supply	External power supply	Voltage: 21.6 ... 27.6 V DC (24 V DC -10 ... +15 %), ripple voltage 0.5 Vp-p or less Recommended voltage: 26.4 V DC (24 V DC+10 %) Module current consumption: 0.1 A Transmission cable current supply: Max. 2 A ^{*1}			
	Internal current consumption (5 V DC)	Voltage: 5 V DC±5 % Current consumption: Max. 0.2 A		Voltage: 5 V DC±5 % Current consumption: Max. 0.2 A	Voltage: 5 V DC±5 % Current consumption: Max. 0.13 A
Number of occupied I/O points	32 (I/O assignment: 32 intelligent points)			8	8
External dimensions (H×W×D) (mm)	106×27.8×124	98.0×27.4×100.0	90.0×28.5×104.5	90×40×83	90.0×43.0×95.5
Weight (kg)	0.2				

^{*1}: Refer to the following table for the relation of the overall length, transmission cable (DP, DN) wire diameter and transmission cable current supply.

In some slave modules with cables, the wire diameter of the transmission cable (DP, DN) integrated with the module may be 0.75 mm² or less.

There is no problem if the transmission cable (DP, DN) is as shown below.

^{*2}: With the slave module having an integrated transmission cable (DP, DN) and module, the length of the transmission cable (DP, DN) is included in the overall length.

Transmission cable (DP, DN) diameter	Transmission cable supply current value (A)		
	Overall length 50 m or less	Overall length 50 ... 100 m	Overall length 100 ... 200 m
1.25 mm ²	Max. 2	Max. 1	Max. 0.5
0.75 mm ²	Max. 1.2	Max. 0.6	Max. 0.3

CC-Link IE Field/CC-Link-AnyWireASLINK Bridge Module Performance

Item	NZ2AW1GFAL	NZ2AW1C2AL		
AnyWireASLINK performance	Same as MELSEC iQ-R, MELSEC-Q/L Series AnyWireASLINK master module			
CC-Link IE Field / CC-Link performance	Intelligent device station	CC-Link Ver. 2.0 remote device station		
Power supply	External power supply	Voltage	21.6 ... 27.6 V DC (24 ... -10 V DC ... +15%) ripple voltage 0.5 Vp-p or less	
		Recommended voltage	26.4 V DC (24 V DC+10%)	
		Internal current consumption (A)	0.3	0.2
		Transmission cable supply current (A)	Max. 2 ^{*1}	
External dimensions (H×W×D) (mm)	96×43×102			
Weight (kg)	0.2			

Communication performance (transmission cycle time ^{*3})

Number of transmission I/O point setting	64 (32 input, 32 output)	128 (64 input, 64 output)	256 (128 input, 128 output)	512 (256 input, 256 output)
1 transmission cycle time (ms)	2.3	3.5	5.9	10.6

^{*3}: In the transmission cycle time, I/O data of all slave modules are updated by the master module, master block and bridge module.

^{*4}: Up to 128 transmission I/O setting points can be set for the FX3U-128ASL-M.

^{*5}: Number of transmission I/O point setting of the FX5-ASL-M is up to 384 points.

iQSS compatibility of each model

Model	GX Works3 Easy setup Sensor monitoring Easy tuning Easy programming Data backup/restoration	GX Works2 Easy setup Sensor monitoring Easy tuning Easy programming Data backup/restoration	GOT2000		GOT1000	
			GT27, GT25		GT16, GT15	GT14
			Utility function	Sample screen	Sample screen	
RJ51AW12AL ^{*6}	●	—	—	—	—	—
QJ51AW12AL ^{*7}	—	●	●	●	—	—
LJ51AW12AL ^{*8}	—	—	—	—	—	—
FX5-ASL-M	● ^{*11}	—	—	—	—	—
FX3U-128ASL-M ^{*9}	—	—	—	—	—	●
NZ2AW1GFAL ^{*7*8}	—	●	—	—	—	—
NZ2AW1C2AL ^{*7*8*10}	—	—	—	●	—	—

^{*6}: Data backup/restoration is available for control program.

^{*7}: Backup/restoration function is available only when using with QnUDVCP.

^{*8}: Backup/restoration function is not available when using with L02SCPU (-P).

^{*9}: Data backup/restoration is not available.

^{*10}: Compatible when CC-Link Ver 2.0 mode is selected.

^{*11}: To be supported in the future

General-purpose sensor connected type, actuator connected type

ASLINKER

Number of I/O points: 2



ASLINKER directly connects a general-purpose sensor (input) or actuator (output) to the AnyWireASLINK transmission line. It is a compact terminal with two input and output points and has diagnosis functions such as cable disconnection detection.

* Use ASLINKTERMINAL if multiple input/output points are required.

Add AnyWireASLINK functions to general-purpose sensor

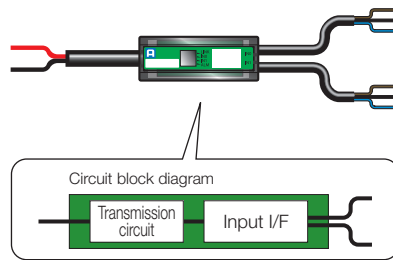

ASLINKER is the same size as a relay connector. It can be stored in a cable conduit and easily bundled with cables. The relay box previously required is no longer necessary.

Use of general-purpose sensor ①

ASLINKER can be connected to the existing sensors and switches. Downsizing of equipment is realized.

Use of general-purpose sensor ②

ASLINKER has a sensor disconnection detection function and can distinguish the sensor's OFF state from a cable disconnected state. This function enables to easily locate an error point, reducing the time to recover.

* 2-wire type (non-insulation) ASLINKER can detect disconnection of a 2-wire type sensor. SMARTLINKER can detect disconnection of a 2-wire and 3-wire type sensor.

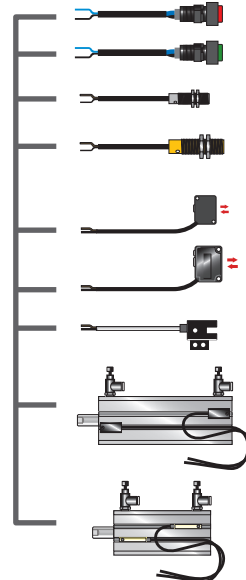

Conveyor line applications

Issues

- The sensor wiring is concentrated in the relay box making it difficult to increase or decrease sensors.
- Even if the sensor cable is cut by an interfering workpiece, it is hard to notice from appearance, causing trouble for corrective actions.
- The box housing the relay terminal is installed on the conveyor side which obstructs passage and layout.
- A relay box has to be used to prevent water splash when cleaning the conveyor. (Space cannot be saved.)



When ASLINKER is used

- The compact ASLINKER can be dispersed and connected to each sensor, making it easy to increase or decrease sensors.
- Disconnection of each sensor can be monitored with the ASLINKER sensor disconnection detection function. "Visible" feature helps shorten the recovery time.
- Compact ASLINKER allows sensors to be dispersed, eliminating a relay box.
- Water-proof ASLINKER requires no relay box, enabling system expansion easier.

Issues

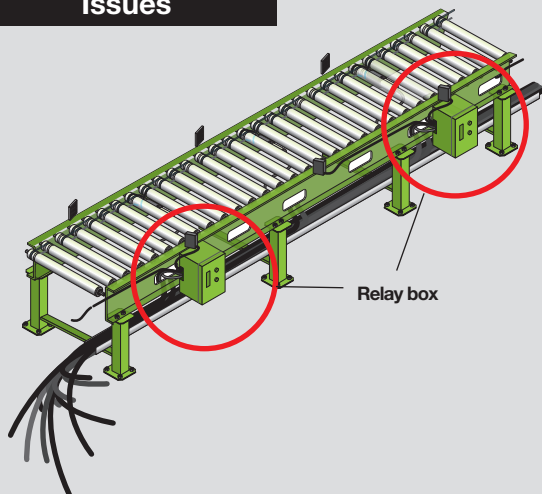

Solution

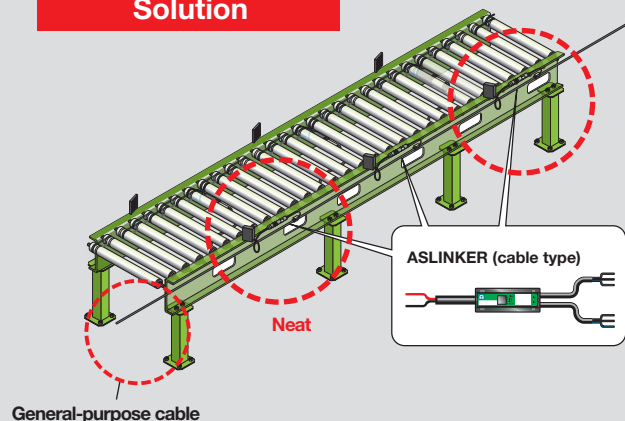

ASLINKER (SMARTLINKER) NEW

SMARTLINKER is one of ASLINKER with enhanced diagnosis function of 3-wire type sensor. SMARTLINKER can detect cable disconnection of 3-wire type sensor in addition to cable disconnection of 2-wire type sensor. Transmission cable 4-wire type (insulation) supports power supply short circuit detection, supporting quick system recovery.

Sensor cable disconnection detection

SMARTLINKER supports detection of cable disconnection of 3-wire type sensor in addition to cable disconnection of 2-wire type sensor.

This function allows quick identification of cause and error location of 3-wire type sensor disconnection supporting quick recovery.

Issues

When an input error occurs due to cable disconnection of general-purpose sensor connected with the programmable controller, it is necessary to identify the error location from contact number and check cables one by one to find disconnection point.



Solution

Notify the sensor cable disconnection together with the ID (address) of the connected device. The disconnected location can be quickly identified.

Power supply cable short circuit detection

SMARTLINKER allows monitoring of power supply short circuit of the connected sensor cable, shutting off the sensor from the trunk cable at short circuit. With this function, a system halt due to power supply failure at occurrence of power supply short circuit can be avoided. Moreover, an error location can be quickly identified by notification from a SMARTLINKER.

Issues

When the power supply of sensors is short circuited, a whole power supply system goes down, resulting in troublesome recovery.



Solution

Even if the power supply of sensors is short circuited, the entire system stop due to power failure can be avoided. Also, an error location can be quickly located, enabling faster system restoration.

General-purpose sensor connected type, actuator connected type

ASLINKTERMINAL

Number of I/O points : 4, 8, or 16 points

ASLINKTERMINAL directly connects a general-purpose sensor (input) or actuator (output) device to the AnyWireASLINK transmission line. ASLINKTERMINAL can compactly arrange wiring in equipment where many input/output devices are installed.

* Use ASLINKER when preventive maintenance using cable disconnection detection is necessary.

Device configuration

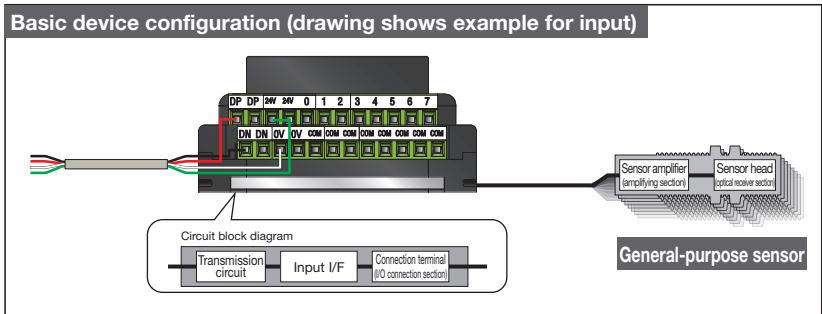
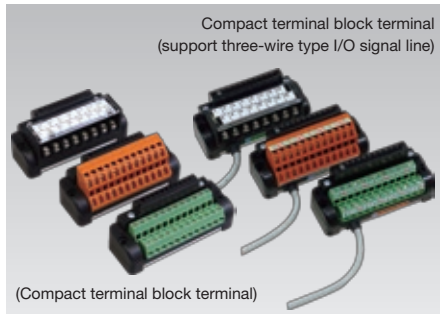
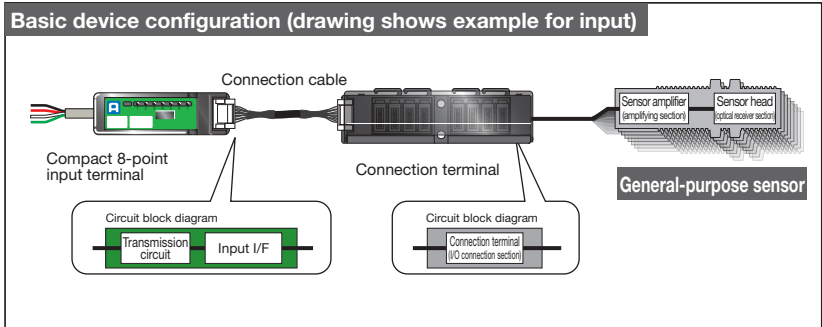
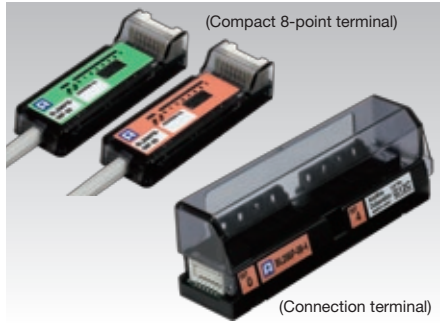

Semi-conductor manufacturing equipment

When ASLINKTERMINAL is used

Efficiently bundling sensor cables is required for semiconductor manufacturing equipment which use many sensors to respond to market demands for compact equipment.

ASLINKTERMINAL is compact and multiple sensor cables can be connected by push-to-lock using e-CON, etc. Configuration time and wiring space can be reduced, realizing a shorter delivery and downsizing of equipment.

The user-made board where sensors are densely arranged can be directly connected with ASLINKTERMINAL (compact 8-point terminal). The user-made board can be used just by configuring a connection cable.

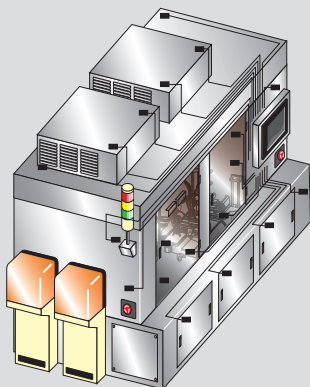

Compact 8-point terminal

Compact size that fits into wiring conduit. Adaptors for attaching on a frame are available. This terminal can be used even without a relay box.

Connection terminal

Link with a pressure welded connector such as e-CON at the frame on the bottom of the equipment, etc. This helps to reduce the configuration time.

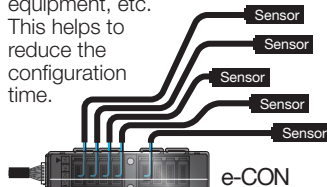

Parallel 8-point input



User-made board

Use a compound wiring board to connect to ASLINKTERMINAL where sensors of mechanical structures are densely arranged. This helps to save space.

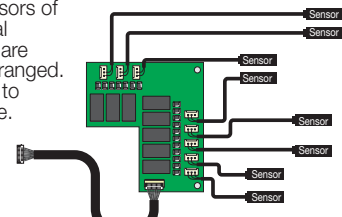

■ Compact terminal block type

Most commonly used type, including standard terminal block (screw terminal block), spring terminal block, and EURO terminal block.
 Standard terminal block (screw terminal block) Ideal for connecting load with round terminal or Y terminal
 Spring terminal block Terminal block for connecting cables with screw force. Excellent in vibration resistance.
 EURO terminal block Commonly used terminal block in Europe

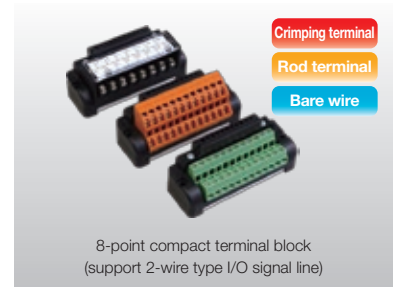
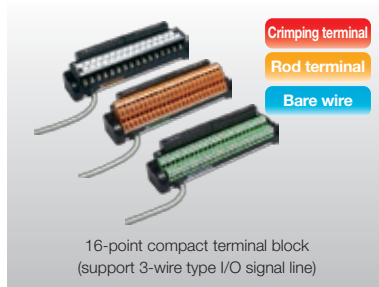
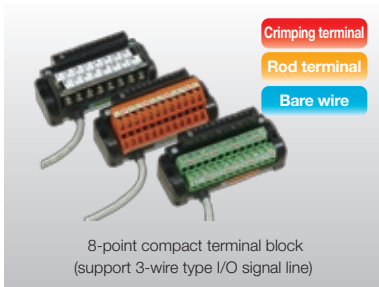

■ Integrated compact type

Terminal block which e-CON compliant connector can be pushed into. General-purpose sensor (input)/actuator (output) devices can be easily connected with e-CON connector.

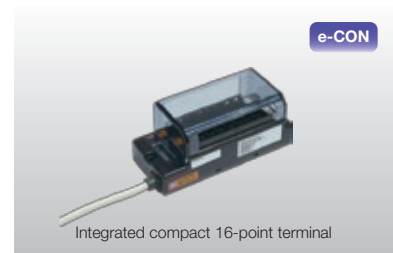
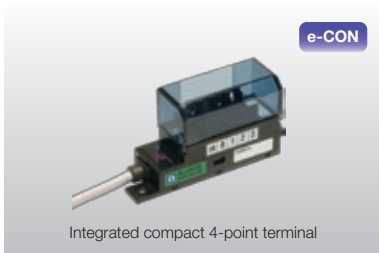

■ Compact type

The most compact terminal among ASLINKTERMINAL.
 Can be used in combination with a connection cable and a connection terminal according to application.
 Connection cable: 200 mm, 500 mm, 1000 mm/connection terminal: eCON, JST, Molex



■ Relay type

Relay embedded terminal which can easily connect output devices with different voltage and heavy load.
 Terminal without relay embedded type is available.

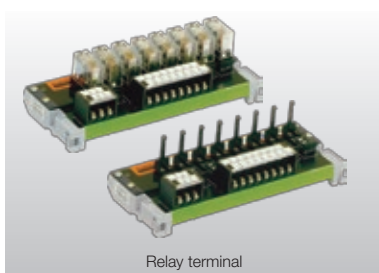

■ Manifold driver

Product to be attached to the solenoid valve manifold.
 Compatible with CKD solenoid valve manifold.

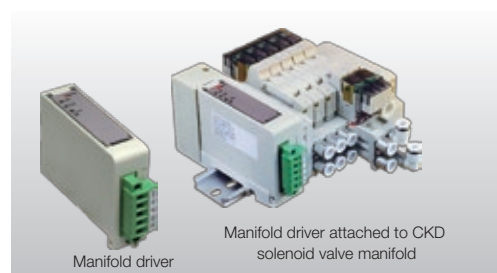

Sensor head separated type

ASLINKAMP



Number of input points: 1 for master, 1 for slave

ASLINKAMP has a built-in sensor amplifier and can directly connect a general-purpose sensor head to the AnyWireASLINK transmission line. This product offers new values such as "visualization", "preventive maintenance" and "intelligence".

AnyWireASLINK functionalities are added to sensor amplifiers

General-purpose fiber, photoelectric, and proximity heads are directly connectable.

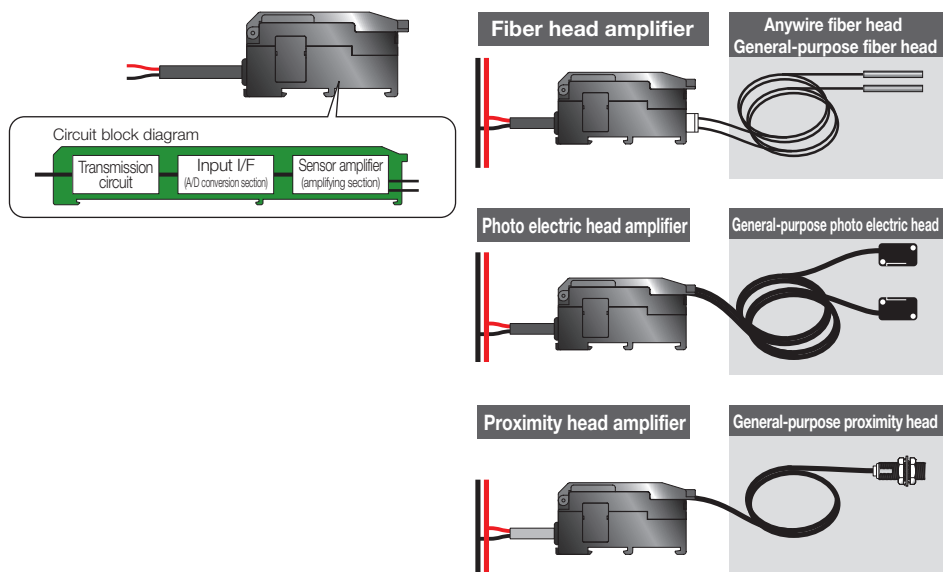

* General-purpose head may be compatible depending on the conditions.

Applied sensitivity setting for a plastic container conveyor

Issues

- On a production line where several types of clear plastic bottles are transferred, multiple sensors with different sensitivities are used to check bottles. Installation of multiple sensors take up space and control is also not easy.
- Installing multiple sensors in a small area results in interference. Measures to prevent interference are necessary.
- When multiple photoelectric sensors are used, control and adjustment of the setting values requires time and labor.

When ASLINKAMP is used

- The sensitivity can be changed by using ASLINKAMP. The sensor sensitivity can be set and changed from the programmable controller according to the type of workpiece transferred. Multiple sensors can be replaced with a single sensor.
- ASLINKAMP operates with time division. Even if there are multiple sensors, measures to prevent interference are unnecessary.
- The setting values can be read from the programmable controller, realizing automation of sensitivity check and management.

The sensitivity can be set automatically according to the workpiece

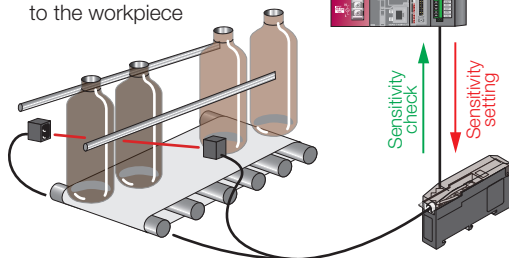

No need for interference measures

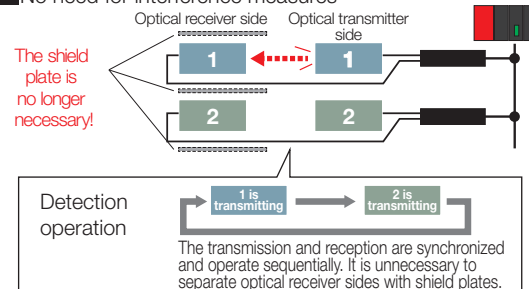

Analog input type

ASLINKAMP analog input module

Number of input points: 16 (1ch) for master, 16 (1ch) for slave



Analog input module with seven-segment display (non-insulation type between channels) can increase application ranges of AnyWireASLINK.

A single compact analog input module supports 0 to 10 V, 0 to 5 V, 1 to 5 V, 4 to 20 mA, 0 to 20 mA analog values.

Digital conversion is possible near the load without requiring complicated wiring. Input values, messages, and such can be checked by seven-segment display.

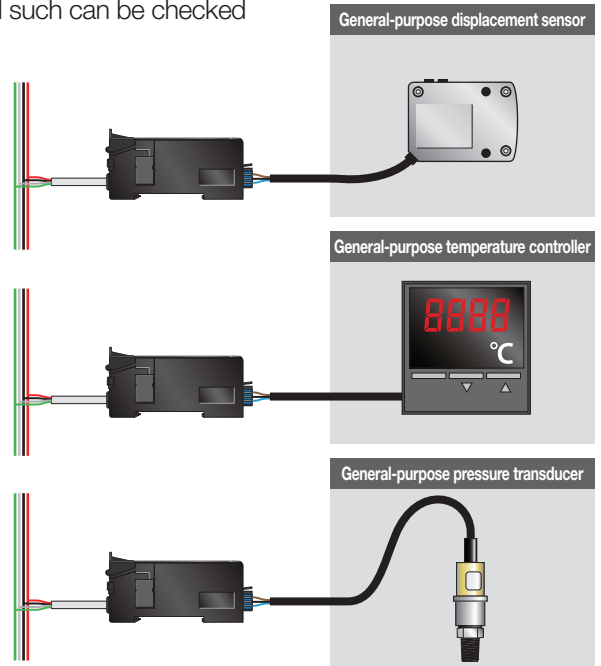
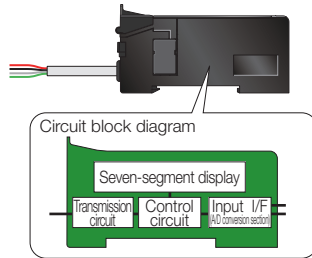

Realizes highly functional compact robot hand

Issues

- To increase functionality of hand part, multiple sensors need to be arranged on the robot hand. A relay box and multiple miniature analog signal wirings concentrated on the robot hand results in a complex mechanism.

When ASLINKAMP analog input module is used

- Slave modules can be installed within the arm by using miniature AnyWireASLINK devices which can be dispersed. Not only binary signals but also analog data can be converted to digital to transmit, realizing easier installation and compact hand.

Issues

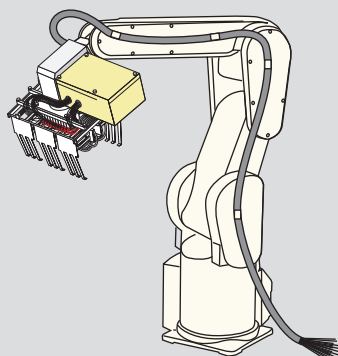

Solution

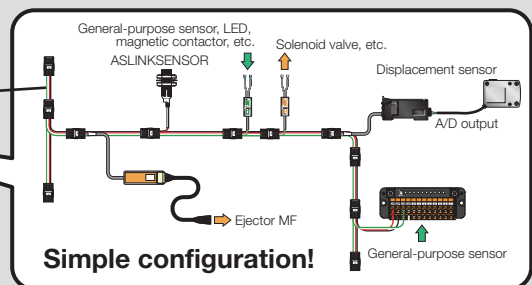
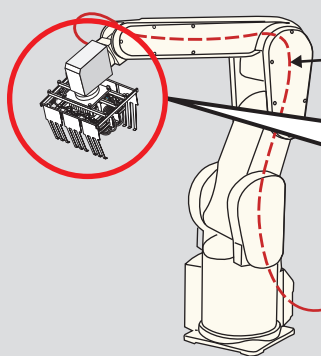

Amplifier integrated type

ASLINKSENSOR

Number of input points: 1, 2 or 16 (1ch) Number of output points: 1

ASLINKSENSOR (photoelectric, proximity, photo interrupter, etc.) can be directly connected to the AnyWireASLINK transmission line. Integration of transmission lines and sensor functions realizes reduced wiring, providing added values such as "visualization", "preventative maintenance", and "intelligence".

**Photo electric sensor (transmission)
Laser sensor (transmission)**

Optical signals are used between the optical transmitter element and optical receiver element.

Circuit block diagram: Transmission circuit, Input I/F (A/D conversion section), Sensor amplifier (amplifying section), Sensor head (optical receiver section).

**Photo electric sensor (regression reflection)
Photo electric sensor (regression reflection)**

Circuit block diagram: Transmission circuit, Input I/F (A/D conversion section), Sensor amplifier (amplifying section), Sensor head (optical transmitter and receiver sections).

Photo electric sensor (diffuse reflection)

Circuit block diagram: Transmission circuit, Input I/F (A/D conversion section), Sensor amplifier (amplifying section), Sensor head (optical transmitter and receiver sections).

Proximity sensor

Magnetic induction signals are used for the detector signals.

Circuit block diagram: Transmission circuit, Input I/F (A/D conversion section), Sensor amplifier (amplifying section), Sensor head (coil).

Photo interrupter

Optical signals are used for the detector signals between the U-shaped section.

Circuit block diagram: Transmission circuit, Input I/F (A/D conversion section), Sensor amplifier (amplifying section), Sensor head (optical transmitter and receiver sections).

Cylinder sensor

Cylinder type (Cylinder is not attached)

(Cylinder sensor)

Pressure sensor

(Pressure sensor)

Measures to prevent mis-detection caused by contamination

Specifying the cause and location of mis-detection caused by contamination on the sensor's detection surface requires time and labor. With ASLINKSENSOR, the programmable controller can monitor the sensing state. The system stop caused by mis-detection can be prevented and the recovery time can be greatly reduced.

Issues

- A workpiece detection proximity sensor is used on a robot which transfers sheet metal from a press. Metal chips, oil and dust are contaminated with the detection surface while using, decreasing sensitivity.

When ASLINKSENSOR is used

- A drop in sensitivity is monitored with the programmable controller. Prevents mis-detection by servicing the sensor, or by adjusting the sensitivity sensor until maintenance.

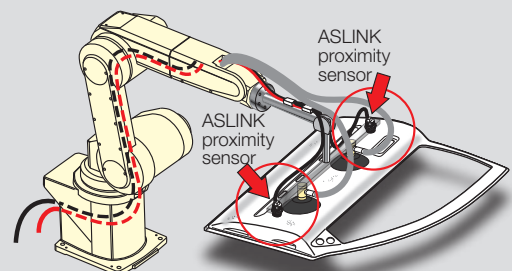
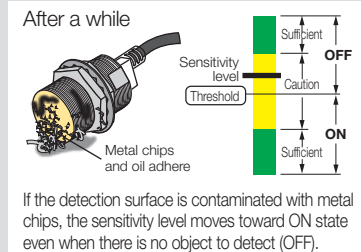
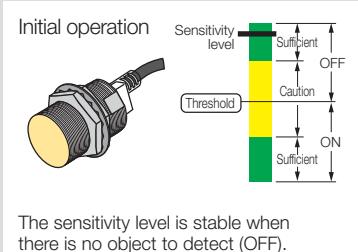

Robust sensors expand applications

Application 1

Spatter resistant (fluorine resin coated product)

Fluorine resin coated sensor allows easier spatter removal in the welding shop.

Durability

Temperature characteristics and water-resistant structure were improved for use in the welding environment. Ensures durability equivalent to the dedicated manufacturer's general-purpose sensor.

Easy connection and "visualization"

Connection or replacement is easily done just by attaching to or removing from the transmission cable. Sensing level change and sensor disconnection can be checked by the programmable controller and GOT (HMI). "Visualization" is achieved! Reduced wiring tasks, prevention of intermittent stops, and reduced maintenance time are realized!

- For positioning and operation in harsh environments where punching press and welding machines operate with metallic fragments scattering
- For motion mechanism check
- For connection check of tool changer

■ Detection object: magnetic metal
 ■ Detection distance example: Iron

M8	0 to 1 mm
M12	0 to 2 mm
M18	0 to 5 mm
M30	0 to 10 mm

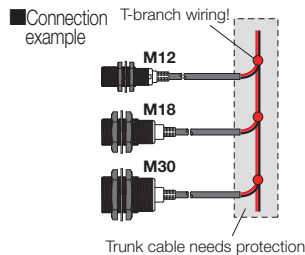

"Visualization" allows maintenance before the system stops!

Simple configuration with "less wiring"!

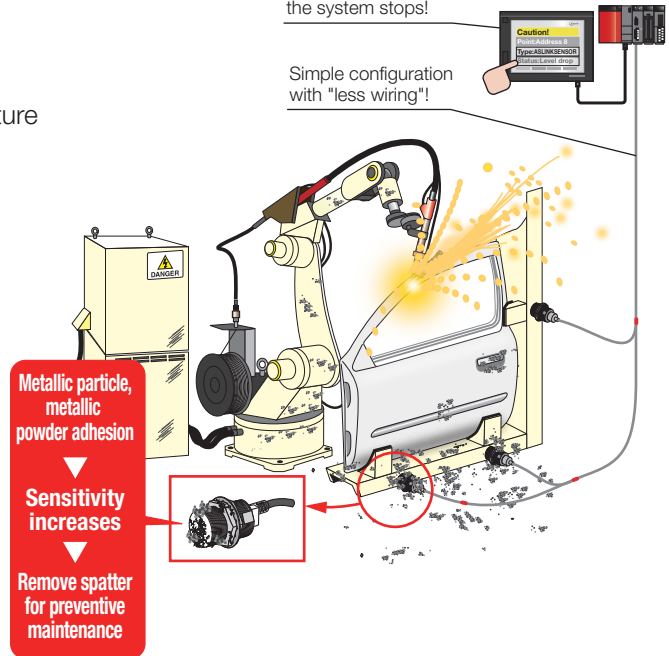

Application 2

IP67 compatible

Closed structure supports applications requiring waterproof.

Waterproof

Protection structure compliant with IP67 enables reduced wiring in harsh environments.

Easy connection and "visualization"

ASLINK products can be connected to the transmission line by push-to-lock connection using waterproof connectors. Sensing level change and sensor disconnection can be detected by the programmable controller. "Visualization"! Reduced wiring tasks, prevention of intermittent stops, and reduced maintenance time are realized!

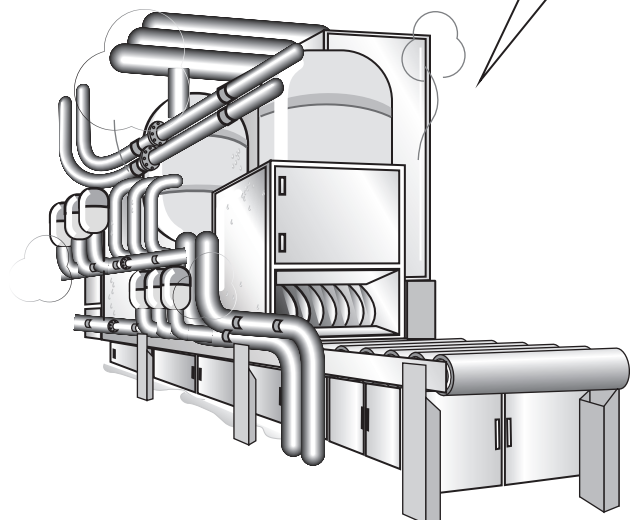
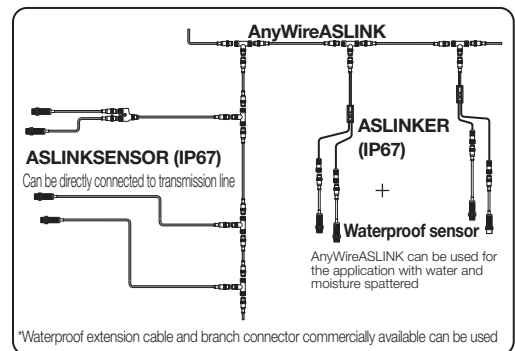

AnyWireASLINK partner product

Electrical screwdriver DLV30/45/70-ASL series **Delvo**



Overview

Delvo is the electric screwdrivers connectable to MELSEC iQ-R/F and MELSEC-Q/L/F Series via wire-saving AnyWireASLINK.

- Electric screwdriver equipped with LED
LED colors are switchable in 7 colors including blue, green, and red via AnyWireASLINK to prevent driver selection errors.
- Cable disconnection detection between the programmable controller and the driver
- DLV7000/7100/7200/8000/8100/8200 series are also supported

System configuration example

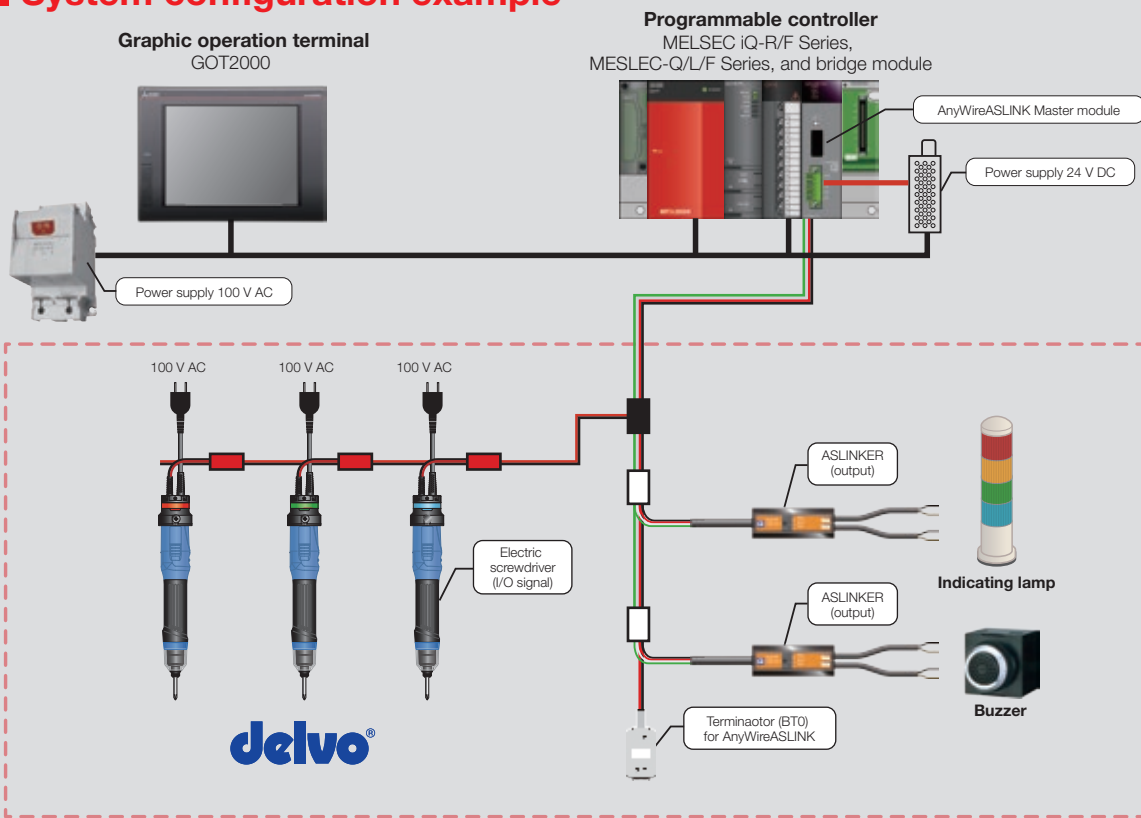

NITTO KHOKI Head Office
9-4, Nakaikagami 2-chome, Ohta-ku, Tokyo 146-8555 Japan
Phone: +81-3-3755-1111 Fax: +81-3-3753-8791 E-mail: overseas@nitto-kohki.co.jp URL: www.nitto-kohki.co.jp/e

Product List

Mitsubishi Electric products

Product name	Model	Outline	Standard/mark		
			CE	UL	KC
AnyWireASLINK master module	RJ51AW12AL	AnyWireASLINK system compatible master module for MELSEC iQ-R Series			
	QJ51AW12AL	AnyWireASLINK system compatible master module for MELSEC-Q Series	●	●	●
	LJ51AW12AL	AnyWireASLINK system compatible master module for MELSEC-L Series			
	FX5-ASL-M	NEW AnyWireASLINK system compatible master module for MELSEC iQ-F Series			
AnyWireASLINK master block	FX3U-128ASL-M	AnyWireASLINK system master block for MELSEC-F Series For FX3U/FX3G Series (FX3S Series is not supported)	●	●	—
CC-Link IE Field—AnyWireASLINK bridge module	NZ2AW1GFAL	CC-Link IE Field—AnyWireASLINK bridge module	●	●	●
CC-Link - AnyWireASLINK bridge module	NZ2AW1C2AL	CC-Link - AnyWireASLINK bridge module CC-Link Ver. 2.0 compatible	●	●	●

Anywire products

ASLINKER

Product name	Model	Type	Points		Rated voltage/current, note	IP67 compatible	Supported configuration		Standard/mark		
			I/P	O/P			2-wire type (non-insulated)	4-wire type (insulated)	CE	UL	KC
SMARTLINKER Cable type	B2N87SB-02D-CC20	NEW NPN	DC 2 points	—	24 V DC, 3.5 mA/point (input)	—	●	—	—	—	—
	B2N87SB-02DS-CC20	NEW PNP	DC 2 points	—	24 V DC, 3.5 mA/point (input)	—	—	●	—	—	—
	BL2LN87SB-02D-CC20	NEW NPN	DC 2 points	—	24 V DC, 3.5 mA/point (input)	—	—	●	—	—	—
	BL2LN87SB-02DS-CC20	NEW PNP	DC 2 points	—	24 V DC, 3.5 mA/point (input)	—	—	—	●	—	—
Cable type	B281SB-02U-CC20	NPN	DC 2 points	—	24 V DC, 3.5 mA/point (input)	—	—	—	●	●	●
	B281SB-02US-CC20	PNP	DC 2 points	—	24 V DC, 3.5 mA/point (input)	—	—	—	●	—	—
	B281XB-02U-CC20	NPN	DC 1 point	Transistor 1 point	24 V DC, 3.5 mA (input), 24 V DC, 100 mA (output)	—	●	—	●	●	●
	B281XB-02US-CC20	PNP	DC 1 point	Transistor 1 point	24 V DC, 3.5 mA (input), 24 V DC, 100 mA (output)	—	—	—	●	—	—
	B281PB-02U-CC20	NPN	—	Transistor 2 points	24 V DC, 100 mA/point (output)	—	—	—	●	●	●
	B281PB-02US-CC20	PNP	—	Transistor 2 points	24 V DC, 100 mA/point (output)	—	—	—	●	—	—
	BL287SB-02F-CC20	NPN	DC 2 points	—	24 V DC, 3.5 mA/point (input)	—	—	—	●	●	●
	BL287SB-02FS-CC20	PNP	DC 2 points	—	24 V DC, 3.5 mA/point (input)	—	—	—	●	—	—
	BL287XB-02F-CC20	NPN	DC 1 point	Transistor 1 point	24 V DC, 3.5 mA (input), 24 V DC, 100 mA (output)	—	—	●	●	●	●
	BL287XB-02FS-CC20	PNP	DC 1 point	Transistor 1 point	24 V DC, 3.5 mA (input), 24 V DC, 100 mA (output)	—	—	—	●	—	—
	BL287PB-02F-CC20	NPN	—	Transistor 2 points	24 V DC, 100 mA/point (output)	—	—	—	●	●	●
	BL287PB-02FS-CC20	PNP	—	Transistor 2 points	24 V DC, 100 mA/point (output)	—	—	—	●	—	—
M12 connector type	B280SB-02U-C1220	NPN	DC 2 points	—	24 V DC, 3.5 mA/point (input)	—	—	—	—	●	●
	B280SB-02US-C1220	PNP	DC 2 points	—	24 V DC, 3.5 mA/point (input)	—	—	—	—	●	—
	B280XB-02U-C1220	NPN	DC 1 point	Transistor 1 point	24 V DC, 3.5 mA (input), 24 V DC, 100 mA (output)	●	●	—	—	●	●
	B280XB-02US-C1220	PNP	DC 1 point	Transistor 1 point	24 V DC, 3.5 mA (input), 24 V DC, 100 mA (output)	—	—	—	—	●	—
M12/M12 cable type	B280PB-02U-C1220	NPN	—	Transistor 2 points	24 V DC, 100 mA/point (output)	—	—	—	—	●	●
	B280PB-02US-C1220	PNP	—	Transistor 2 points	24 V DC, 100 mA/point (output)	—	—	—	—	●	—
	BL287SB-02F-2D220	NPN	DC 2 points	—	24 V DC, 3.5 mA/point (input)	—	—	—	—	—	—
	BL287SB-02FS-2D220	PNP	DC 2 points	—	24 V DC, 3.5 mA/point (input)	—	—	—	—	—	—
	BL287XB-02F-2D220	NPN	DC 1 point	Transistor 1 point	24 V DC, 3.5 mA (input), 24 V DC, 100 mA (output)	●	—	●	—	—	—
M12/M8 cable type	BL287XB-02F-2D220	PNP	DC 1 point	Transistor 1 point	24 V DC, 100 mA/point (output)	—	—	—	—	—	—
	BL287PB-02F-2D220	NPN	—	Transistor 2 points	24 V DC, 100 mA/point (output)	—	—	—	—	—	—
	BL287PB-02FS-2D220	PNP	—	Transistor 2 points	24 V DC, 100 mA/point (output)	—	—	—	—	—	—
	BL287SB-02F-2D820	NPN	DC 2 points	—	24 V DC, 3.5 mA/point (input) M8 (4 poles)	—	—	—	—	—	—
	BL287SB-02FS-2D820	PNP	DC 2 points	—	24 V DC, 3.5 mA/point (input) M8 (4 poles)	—	—	—	—	—	—
	BL287XB-02F-2D820	NPN	DC 1 point	Transistor 1 point	24 V DC, 3.5 mA (input) M8 (4 poles), 24 V DC, 100 mA (output) M8 (4 poles)	●	—	●	—	—	—
Cable type adaptor	ADP-81	—	—	—	2-wire type ASLINKER cable type mounting dedicated adaptor (4 pc. set)	●	—	—	—	—	—
	ADP-87	—	—	—	4-wire type ASLINKER cable type mounting dedicated adaptor (4 pc. set)	—	—	—	—	—	—

ASLINKTERMINAL

Product name	Model	Type	Points		Outline	Supported configuration		Standard/mark		
			I/P	O/P		Rated voltage/current, note	2-wire type (non-insulated)	4-wire type (insulated)	CE	UL
Compact 8-point terminal	BL296SB-08F-20	NPN	DC 8 points	—	24 V DC/4.2 mA/point (input)	—	●	●	●	●
	BL296SB-08FS-20	PNP	DC 8 points	—	24 V DC/4.2 mA/point (input)			●	—	—
	BL296XB-08F-20	NPN	DC 4 points	Transistor 4 points	24 V DC/4.2 mA/point (input), 24 V DC/100 mA/point, 800 mA/common (output)			●	●	●
	BL296XB-08FS-20	PNP	DC 4 points	Transistor 4 points	24 V DC/4.2 mA/point (input), 24 V DC/100 mA/point, 800 mA/common (output)			●	—	—
	BL296PB-08F-20	NPN	—	Transistor 8 points	24 V DC/100 mA/point, 800 mA/common (output)			●	●	●
BL296PB-08FS-20	PNP	—	Transistor 8 points	24 V DC/100 mA/point, 800 mA/common (output)	●	—	—			
Connection cable	BL296-08-CN20	—	—	—	Common, cable length: 0.2 m	—	—	—	—	
	BL296-08-CN50				Common, cable length: 0.5 m					
	BL296-08-CN1K				Common, cable length: 1 m					
Connection terminal (e-CON)	BL296S-08-4	—	8 points	—	Mounted connector (e-CON)	—	—	—	—	
	BL296X-08-4		4 points	4 points						
	BL296P-08-4		—	8 points						
Connection terminal (JST)	BL296S-08-9	—	8 points	—	Mounted connector (JST XH Series)	—	—	—	—	
	BL296X-08-9		4 points	4 points						
	BL296P-08-9		—	8 points						
Connection terminal (Molex)	BL296S-08-10	—	8 points	—	Mounted connector (MOLEX 5045 Series)	—	—	—	—	
	BL296X-08-10		4 points	4 points						
	BL296P-08-10		—	8 points						
Integrated compact 4-point terminal (e-CON)	BL296SB-04F-4A-20	NPN	DC 4 points	—	24 V DC/3.5 mA/point (input)	—	●	—	—	
	BL296SB-04FS-4A-20	PNP	DC 4 points	—	24 V DC/3.5 mA/point (input)					
	BL296XB-04F-4A-20	NPN	DC 2 points	Transistor 2 points	24 V DC, 3.5 mA/point (input), 24 V DC, 100 mA/point, 200 mA/common (output)					
	BL296XB-04FS-4A-20	PNP	DC 2 points	Transistor 2 points	24 V DC, 3.5 mA/point (input), 24 V DC, 100 mA/point, 200 mA/common (output)					
	BL296PB-04F-4A-20	NPN	—	Transistor 4 points	24 V DC, 100 mA/point, 400 mA/common (output)					
BL296PB-04FS-4A-20	PNP	—	Transistor 4 points	24 V DC, 100 mA/point, 400 mA/common (output)						
Integrated compact 8-point terminal (e-CON)	BL296SB-08F-4-20	NPN	DC 8 points	—	24 V DC/3.5 mA/point (input)	—	●	●	—	
	BL296SB-08FS-4-20	PNP	DC 8 points	—	24 V DC/3.5 mA/point (input)					
	BL296XB-08F-4-20	NPN	DC 4 points	Transistor 4 points	24 V DC, 3.5 mA/point (input), 24 V DC, 100 mA/point, 400 mA/common (output)					
	BL296XB-08FS-4-20	PNP	DC 4 points	Transistor 4 points	24 V DC, 3.5 mA/point (input), 24 V DC, 100 mA/point, 400 mA/common (output)					
	BL296PB-08F-4-20	NPN	—	Transistor 8 points	24 V DC, 100 mA/point, 800 mA/common (output)					
BL296PB-08FS-4-20	PNP	—	Transistor 8 points	24 V DC, 100 mA/point, 800 mA/common (output)						
Integrated compact 16-point terminal (e-CON)	BL296SB-16F-4A-20	NPN	DC 16 points	—	24 V DC/3.5 mA/point (input)	—	●	—	—	
	BL296SB-16FS-4A-20	PNP	DC 16 points	—	24 V DC/3.5 mA/point (input)					
	BL296XB-16F-4A-20	NPN	DC 8 points	Transistor 8 points	24 V DC, 3.5 mA/point (input), 24 V DC, 100 mA/point, 800 mA/common (output)					
	BL296XB-16FS-4A-20	PNP	DC 8 points	Transistor 8 points	24 V DC, 3.5 mA/point (input), 24 V DC, 100 mA/point, 800 mA/common (output)					
	BL296PB-16F-4A-20	NPN	—	Transistor 16 points	24 V DC, 100 mA/point, 1A/common					
	BL296PB-16FS-4A-20	PNP	—	Transistor 16 points	24 V DC, 100 mA/point, 1A/common					
Small terminal block type terminal (support 3-wire type I/O signal line)	BL296SB-08F-V50	NPN	DC 8 points	—	24 V DC, 3.5 mA/point (input), screw terminal block	—	●	—	—	
	BL296SB-08FS-V50	PNP	DC 8 points	—	24 V DC, 3.5 mA/point (input), screw terminal block					
	BL296XB-08F-V50	NPN	DC 4 points	Transistor 4 points	24 V DC, 3.5 mA/point (input), 24 V DC, 100 mA/point, 400 mA/common (output), screw terminal block					
	BL296XB-08FS-V50	PNP	DC 4 points	Transistor 4 points	24 V DC, 3.5 mA/point (input), 24 V DC, 100 mA/point, 400 mA/common (output), screw terminal block					
	BL296PB-08F-V50	NPN	—	Transistor 8 points	24 V DC, 100 mA/point, 800 mA/common (output), screw terminal block					
	BL296PB-08FS-V50	PNP	—	Transistor 8 points	24 V DC, 100 mA/point, 800 mA/common (output), screw terminal block					
	BL296SB-16F-V50	NPN	DC 16 points	—	24 V DC, 3.5 mA/point (input), screw terminal block					
	BL296SB-16FS-V50	PNP	DC 16 points	—	24 V DC, 3.5 mA/point (input), screw terminal block					
	BL296XB-16F-V50	NPN	DC 8 points	Transistor 8 points	24 V DC, 3.5 mA/point (input), 24 V DC, 100 mA/point, 800 mA/common (output), screw terminal block					
	BL296XB-16FS-V50	PNP	DC 8 points	Transistor 8 points	24 V DC, 3.5 mA/point (input), 24 V DC, 100 mA/point, 800 mA/common (output), screw terminal block					
	BL296PB-16F-V50	NPN	—	Transistor 16 points	24 V DC, 100 mA/point, 1.6 A/common, screw terminal block					
	BL296PB-16FS-V50	PNP	—	Transistor 16 points	24 V DC, 100 mA/point, 1.6 A/common, screw terminal block					
	BL296SB-08F-3-V50	NPN	DC 8 points	—	24 V DC, 3.5 mA/point (input), Spring type terminal block					
	BL296SB-08FS-3-V50	PNP	DC 8 points	—	24 V DC, 3.5 mA/point (input), Spring type terminal block					
	BL296XB-08F-3-V50	NPN	DC 4 points	Transistor 4 points	24 V DC, 3.5 mA/point (input), 24 V DC, 100 mA/point, 400 mA/common (output), Spring type terminal block					
	BL296XB-08FS-3-V50	PNP	DC 4 points	Transistor 4 points	24 V DC, 3.5 mA/point (input), 24 V DC, 100 mA/point, 400 mA/common (output), Spring type terminal block					
	BL296PB-08F-3-V50	NPN	—	Transistor 8 points	24 V DC, 100 mA/point, 800 mA/common (output), Spring type terminal block					
	BL296PB-08FS-3-V50	PNP	—	Transistor 8 points	24 V DC, 100 mA/point, 800 mA/common (output), Spring type terminal block					
	BL296SB-16F-3-V50	NPN	DC 16 points	—	24 V DC, 3.5 mA/point (input), Spring type terminal block					
	BL296SB-16FS-3-V50	PNP	DC 16 points	—	24 V DC, 3.5 mA/point (input), Spring type terminal block					
	BL296XB-16F-3-V50	NPN	DC 8 points	Transistor 8 points	24 V DC, 3.5 mA/point (input), 24 V DC, 100 mA/point, 800 mA/common (output), Spring type terminal block					
	BL296XB-16FS-3-V50	PNP	DC 8 points	Transistor 8 points	24 V DC, 3.5 mA/point (input), 24 V DC, 100 mA/point, 800 mA/common (output), Spring type terminal block					
	BL296PB-16F-3-V50	NPN	—	Transistor 16 points	24 V DC, 100 mA/point, 1.6 A/common (output), Spring type terminal block					
	BL296PB-16FS-3-V50	PNP	—	Transistor 16 points	24 V DC, 100 mA/point, 1.6 A/common (output), Spring type terminal block					
	BL296SB-08F-11-V50	NPN	DC 8 points	—	24 V DC, 3.5 mA/point (input), EURO terminal block					
	BL296SB-08FS-11-V50	PNP	DC 8 points	—	24 V DC, 3.5 mA/point (input), EURO terminal block					
	BL296XB-08F-11-V50	NPN	DC 4 points	Transistor 4 points	24 V DC, 3.5 mA/point (input), 24 V DC, 100 mA/point, 400 mA/common (output), EURO terminal block					
	BL296XB-08FS-11-V50	PNP	DC 4 points	Transistor 4 points	24 V DC, 3.5 mA/point (input), 24 V DC, 100 mA/point, 400 mA/common (output), EURO terminal block					
	BL296PB-08F-11-V50	NPN	—	Transistor 8 points	24 V DC, 100 mA/point, 800 mA/common (output), EURO terminal block					
	BL296PB-08FS-11-V50	PNP	—	Transistor 8 points	24 V DC, 100 mA/point, 800 mA/common (output), EURO terminal block					
BL296SB-16F-11-V50	NPN	DC 16 points	—	24 V DC, 3.5 mA/point (input), EURO terminal block						
BL296SB-16FS-11-V50	PNP	DC 16 points	—	24 V DC, 3.5 mA/point (input), EURO terminal block						
BL296XB-16F-11-V50	NPN	DC 8 points	Transistor 8 points	24 V DC, 3.5 mA/point (input), 24 V DC, 100 mA/point, 800 mA/common (output), EURO terminal block						
BL296XB-16FS-11-V50	PNP	DC 8 points	Transistor 8 points	24 V DC, 3.5 mA/point (input), 24 V DC, 100 mA/point, 800 mA/common (output), EURO terminal block						
BL296PB-16F-11-V50	NPN	—	Transistor 16 points	24 V DC, 100 mA/point, 1.6 A/common (output), EURO terminal block						
BL296PB-16FS-11-V50	PNP	—	Transistor 16 points	24 V DC, 100 mA/point, 1.6 A/common (output), EURO terminal block						

Product name	Model	Type	Points		Outline	Supported configuration		Standard/mark		
			I/P	O/P		2-wire type (non-insulated)	4-wire type (insulated)	CE	UL	KC
Small terminal block type terminal (compatible with 2-wire type I/O signal line)	BL296SB-08F	NPN	DC 8 points	—	24 V DC, 3.5 mA/point Screw terminal block	—	●	—	—	—
	BL296SB-08FS	PNP	DC 8 points	—						
	BL296XB-08F	NPN	DC 4 points	Transistor 4 points	24 V DC, 3.5 mA/point (input), 24 V DC, 100 mA/point, 400 mA/common (output), Screw terminal block	—	●	—	—	—
	BL296XB-08FS	PNP	DC 4 points	Transistor 4 points						
	BL296PB-08F	NPN	—	Transistor 8 points	24 V DC, 100 mA/point, 800 mA/common Screw terminal block	—	—	—	—	—
	BL296PB-08FS	PNP	—	Transistor 8 points						
	BL296SB-08F-3	NPN	DC 8 points	—	24 V DC, 3.5 mA/point Spring type terminal block	—	●	—	—	—
	BL296SB-08FS-3	PNP	DC 8 points	—						
	BL296XB-08F-3	NPN	DC 4 points	Transistor 4 points	24 V DC, 3.5 mA/point (input), 24 V DC, 100 mA/point, 400 mA/common (output), Spring type terminal block	—	●	—	—	—
	BL296XB-08FS-3	PNP	DC 4 points	Transistor 4 points						
	BL296PB-08F-3	NPN	—	Transistor 8 points	24 V DC, 100 mA/point, 800 mA/common Spring type terminal block	—	—	—	—	—
	BL296PB-08FS-3	PNP	—	Transistor 8 points						
	BL296SB-08F-11	NPN	DC 8 points	—	24 V DC, 3.5 mA/point EURO terminal block	—	●	—	—	—
	BL296SB-08FS-11	PNP	DC 8 points	—						
	BL296XB-08F-11	NPN	DC 4 points	Transistor 4 points	24 V DC, 3.5 mA/point (input), 24 V DC, 100 mA/point, 400 mA/common (output), EURO terminal block	—	●	—	—	—
BL296XB-08FS-11	PNP	DC 4 points	Transistor 4 points							
BL296PB-08F-11	NPN	—	Transistor 8 points	24 V DC, 100 mA/point, 800 mA/common EURO terminal block	—	—	—	—	—	
BL296PB-08FS-11	PNP	—	Transistor 8 points							
Relay terminal (with relay integrated)	BL296PB-08RS	Relay contact	—	Relay 8 points (all point independent)	G2R a contact, 3 A/point, 24 V DC, 200 V AC	●	●	●	●	●
Relay terminal (with no relay integrated)	BL296PB-08RSN				without G2R, G3R relay integrated	—	—	—	—	—
Manifold driver	BL264PB-16F-T5	NPN	—	Transistor 16 points	CKD MN4G-T70-FL series manifold compatible	—	●	—	—	—
	BL264PB-16FS-T5	PNP	—	Transistor 16 points						
Adapter for compact 8-point terminal	ADP-96	—	—	—	DIN rail adapter (4 pcs)	—	—	—	—	—
Adapter for connection terminal	ADP-T96	—	—	—	DIN rail adapter (4 sets)	—	—	—	—	—
Adapter for small terminal block terminal	ADP-108	—	—	—	DIN rail adapter (1 set)	—	—	—	—	—
Adapter for integrated small 16-point terminal	ADP-W96	NEW	—	—	DIN rail adapter (4 sets)	—	—	—	—	—
Power supply distribution module	BL296-04PW4	—	—	—	Power supply only, 4 points e-CON 4P 1 A/common	—	—	—	—	—
	BL296-08PW4	—	—	—	Power supply only, 8 points e-CON 4P 2 A/common	—	—	—	—	—

ASLINKAMP

Product name	Model	Points		Type	Outline	Supported configuration		Standard/mark		
		I/P	O/P			2-wire type (non-insulated)	4-wire type (insulated)	CE	UL	KC
For fiber head	B289SB-01AF-CAM20-V	1 point	—	Master	Red light compatible head: AFT-1/1-1/2/4	●	—	●	●	●
	B289SB-01AF-CAS-V			Slave		—	—	—	—	
	LA-F1011	1 point	—	Master	Red light compatible head: AFT-1/1-1/2/4 with 7-segment indication	—	●	—	—	—
	LB-F1011			Slave		—	—	—	—	
	BA-F116	NEW	1 point	—	Single	Red light compatible head: AFT-1/1-1/2/4, when fiber ø2.2 is used: IP66, when fiber ø1.0 is used: IP40	●	—	—	—
	BA-F116-12	NEW	1 point	—	Single		●*1	—	—	—
	AFT-1	—	—	—	—	Fiber head M3 bending R 20	—	—	—	—
	AFT-1-1	—	—	—	—	Fiber head M3 bending R 20 heat-resistance 100°C	—	—	—	—
	AFT-2	—	—	—	—	Fiber head M3 bending R 25	—	—	—	—
	AFT-4	—	—	—	—	Fiber head M3 bending R 30	—	—	—	—
For photoelectric head	B289SB-01AP-CAM20	1 point	—	Master	Compatible head: general-purpose head	●	—	—	●	●
	B289SB-01AP-CAS			Slave		—	—	—	—	
For proximity head	B289SB-01AK-CAM20	1 point	—	Master	Compatible head: general-purpose head	●	—	—	●	●
	B289SB-01AK-CAS			Slave		—	—	—	—	
Analog input module (with 7 segment display)	LA-A12W	16 points (1ch.)	—	Master	Input range: selectable from 0...10 V, 0...5 V, 1...5 V, 4...20 mA, 0...20 mA Analog value (15 bits) Channel non-isolated with 7-segment indication, supplied wire for transmission connection: 4 core	—	● non-insulated	—	—	—
	LB-A12W			Slave		—	—	—	—	
	LA-A1AW	16 points (1ch.)	—	Master	Input range: selectable from 0...10 V, 0...5 V, 1...5 V, 4...20 mA, 0...20 mA Analog value (15 bits) Channel non-isolated with 7-segment indication, supplied wire for transmission connection: 4 core	—	●	—	—	—
	LB-A1AW			Slave		—	—	—	—	
	LB-S24	NEW	—	—	—	Power supply module for analog input module with 7-segments (100 mA/24 V DC (output))	—	—	—	—

*1. M12 connector

ASLINKSENSOR

Product name	Model	Points		Outline	IP67 rated	2-wire type (non-insulated)	4-wire type (insulated)	Standard/mark			
		I/P	O/P					CE	UL	KC	
Photoelectric sensor	B283SB-01-1KC	1 point	—	Transmission type, optical receiver module, detection distance 5000 mm	—	●	—	—	●	●	
	B283SB-01-1KP	—	1 point	Transmission type, optical transmitter module, detection distance 5000 mm							
	B283SB-PC-SET	1 point	1 point	A set of B283SB-01-1KC and B283SB-01-1KP							
	B283SB-01-1KR-V	1 point	—	Regression reflection type (red LED, detection distance 700 mm)							
	B283SB-01-1KS	1 point	—	Diffuse reflection type, detection distance 450 mm							
	BS-H0117-1KC	1 point	—	Transmission type, optical receiver module, detection distance 5000 mm							
	BS-H0117-1KP	—	1 point	Transmission type, optical transmitter module, detection distance 5000 mm							
	BS-H0117-PC-SET	1 point	1 point	A set of BS-H0117-1KC and BS-H0117-1KP							
	BS-H0217-1K	1 point	—	Regression reflection type (red LED), detection distance 3000 mm							
	BS-H0317-1K	1 point	—	Diffuse reflection type, detection distance selectable 500 mm (long distance) or 100 mm (short distance)							
	BS-H0117G-1KC	NEW	1 point	Transmission type, optical receiver module, detection distance 5 m							
	BS-H0117G-1KP	NEW	—	Transmission type, optical transmitter module, detection distance 5 m							
	BS-H0117G-PC-SET	NEW	1 point	A set of BS-H0117G-1KC and BS-H0117G-1KP							
	BS-H0217G-1K	NEW	1 point	Regression reflection type, detection distance 3 mm							
	BS-H0317G-1K	NEW	1 point	Diffuse reflection type, detection distance 500 mm							
	Laser sensor	BS-L0117-1K	NEW	1 point							Transmission type (laser spot), optical receiver module, detection distance 30 m
BS-L0117-1KP		NEW	—	Transmission type (laser spot), optical transmitter module, detection distance 30 m							
BS-L0117-PC-SET		NEW	1 point	A set of BS-L0117-1K and BS-L0117-1KP							
BS-L0217-1K		NEW	1 point	Regression reflection type (laser spot), detection distance 0.3...10 m							
Proximity sensor	BS-K1117-M08-1K	1 point	—	All screw, M8, detection distance 0...1 mm	●	●	—	—	—	—	
	BS-K1117-M12-1K			All screw, M12, detection distance 0...2 mm							
	BS-K1117-M18-1K			All screw, M18, detection distance 0...5 mm							
	BS-K1117-M30-1K			All screw, M30, detection distance 0...10 mm							
	BS-K1117-M08-3012	NEW	1 point	—							All screw, M8, detection distance 0...1 mm
	BS-K1117-M12-3012	NEW									All screw, M12, detection distance 0...2 mm
BS-K1117-M18-3012	NEW	All screw, M18, detection distance 0...5 mm									
BS-K1117-M30-3012	NEW	All screw, M30, detection distance 0...10 mm									
Spatter resistant type	BS-K1117S-M12-1K	1 point	—	All screw, M12, detection distance 0...2 mm	●	●	—	—	—	—	
	BS-K1117S-M18-1K			All screw, M18, detection distance 0...5 mm							
	BS-K1117S-M30-1K			All screw, M30, detection distance 0...10 mm							
	BS-K1117S-M12-3012			NEW							All screw, M12, detection distance 0...2 mm
Non-shielded type	BS-K1217-M12-1K	1 point	—	All screw, M12, detection distance 0...6.8 mm	●	●	—	—	—	—	
	BS-K1217-M18-1K			All screw, M18, detection distance 0...12 mm							
	BS-K1217-M30-1K			All screw, M30, detection distance 0...20 mm							
	BS-K1217-M08-3012			NEW							All screw, M8, detection distance 0...3.4 mm
Amp-relay type	BM-K1117G-S04-1K	1 point	—	ø4.0 sleeve head, detection distance 0...0.8 mm	●	●	—	—	—	—	
	BM-K1117G-S05-1K			ø5.4 sleeve head, detection distance 0...1 mm							
	BM-K1117G-M04-1K			M4 All screw head, detection distance 0...0.6 mm							
	BM-K1117G-M05-1K			M5 All screw head, detection distance 0...1 mm							
	BM-K1117G-S04-3012			NEW							Amp-relay type, detection distance 0...0.8 mm
	BM-K1117G-S05-3012			NEW							Amp-relay type, detection distance 0...1.0 mm
Full stainless body type	BS-K1117M-M12-1K	1 point	—	All screw M12, detection distance 0...1.6 mm	●	●	—	—	—	—	
	BS-K1117M-M18-1K			All screw M18, detection distance 0...3.8 mm							
	BS-K1117M-M30-1K			All screw M30, detection distance 0...8 mm							
	BS-K1117M-M12-3012			NEW							All screw M12, detection distance 0...1.6 mm
	BS-K1117M-M18-3012			NEW							All screw M18, detection distance 0...3.8 mm
Polyarylate body type	BS-K1118-M12-1K	1 point	—	All screw M12, detection distance 0...2 mm	●	●	—	—	—	—	
	BS-K1118-M18-1K			All screw M18, detection distance 0...5 mm							
	BS-K1118-M30-1K			All screw M30, detection distance 0...10 mm							
	BS-K1118-M12-3012			NEW							All screw M12, detection distance 0...2 mm
	BS-K1118-M18-3012			NEW							All screw M18, detection distance 0...5 mm
Chemical resistant (fluorine resin body) type	BS-K1117C-M12-1K	1 point	—	All screw M12, detection distance 0...2 mm	●	●	—	—	—	—	
	BS-K1117C-M18-1K			All screw M18, detection distance 0...5 mm							
	BS-K1117C-M30-1K			All screw M30, detection distance 0...10 mm							
	BS-K1117C-M12-3012			NEW							All screw M12, detection distance 0...2 mm
	BS-K1117C-M18-3012			NEW							All screw M18, detection distance 0...5 mm
Photo interrupter	B297SB-01-1K40	1 point	—	Standard type	—	●	—	—	●	●	
Cylinder sensor	B285SB-01-1K1	1 point	—	SMC made cylinder, round groove compatible	—	●	—	—	●	●	

Product name	Model	Points		Outline	IP67 rated	Supported configuration		Standard/mark		
		I/P	O/P			2-wire type (non-insulated)	4-wire type (insulated)	CE	UL	KC
Pressure sensor	B284SB-01-1KPP30	1 point	-	Gauge pressure, positive pressure 0...1000 kPa, M5 port (internal thread)	-	●	-	-	-	-
	B284SB-01-1KNP30			Gauge pressure, negative pressure 0...-1000 kPa, M5 port (internal thread)						
	B284SB-01-1KLP30			Gauge pressure, compound pressure -100...100 kPa, M5 port (internal thread)						
	B284SB-01-1KPLP30			Gauge pressure, low positive pressure 0...100 kPa, M5 port (internal thread)						
	B284SB-02-1KPP30	2 points	-	Gauge pressure, positive pressure 0...1000 kPa, M5 port (internal thread)	-	●	-	-	-	-
	B284SB-02-1KNP30			Gauge pressure, negative pressure 0...-1000 kPa, M5 port (internal thread)						
	B284SB-02-1KLP30			Gauge pressure, compound pressure -100...100 kPa, M5 port (internal thread)						
	B284SB-02-1KPLP30			Gauge pressure, low positive pressure 0...100 kPa, M5 port (internal thread)						
	B284SB-J1-1KPP30	16 points (1 ch.)	-	Gauge pressure, positive pressure, 0...1000 kPa, M5 port (internal thread), analog value (10 bit)	-	●	-	-	-	-
	B284SB-J1-1KNP30			Gauge pressure, negative pressure 0...-1000 kPa, M5 port (internal thread), analog value (10 bit)						
B284SB-J1-1KLP30	Gauge pressure, compound pressure -100...100 kPa, M5 port (internal thread), analog value (10 bit)									
B284SB-J1-1KPLP30	Gauge pressure, low positive pressure 0...100 kPa, M5 port (internal thread), analog value (10 bit)									
Reflection plate	AKR-1	-	-	For reflection type photoelectric sensor, reflection surface, 60.9 x 50.9 mm	-	-	-	-	-	-
	AKR-2	-	-	For reflection type photoelectric sensor, reflection surface, 42 x 35 mm	-	-	-	-	-	-
SUS washer for proximity sensor	BS-K-M12-SW	NEW	-	For proximity sensor M12 toothed lock washer (with 1 piece)	-	-	-	-	-	-
	BS-K-M18-SW	NEW	-	For proximity sensor M18 toothed lock washer (with 1 piece)	-	-	-	-	-	-

*1. Standard of AnyWire Corporation.

*2. M12 connector

Related products

Product name	Model	Outline	Supported configuration		Standard/mark		
			2-wire type (non-insulated)	4-wire type (insulated)	CE	UL	KC
ASLINKMONITOR	B287-74DP01-C20	Display for monitoring sensing level (analog raw value)	●	-	-	-	-
	ARW-SP	Sensing level (analog raw value) monitor, parameter setting value monitor, address writer function	-	●	-	-	-
ASLINK filter	ANF-01	Filter for 24 V DC line	-	-	●	-	●
Terminator (for transmission line)	BT0	Transmission waveform rectifying module	●	●	-	-	-
Water resistant terminator (for transmission line)	BT0-12	IP 67 waterproof transmission waveform shaping module, M12 connector connection	●	●	-	-	-
	BT0-C	IP 67 waterproof transmission waveform shaping module, cable connection	●	●	-	-	-
Address writer	ARW-04	Address, parameter write/read tool (far-infrared communication)	-	-	-	-	-
	ARW-D04	NEW Desk type, transmission signal integrated	-	-	-	-	-
Extension cable	ARW-EX-L4L4	NEW Extension transmission cable for ARW-D04, 4-pole link connector-4 pole link connector	-	●	-	-	-
	ARW-EX-L412	NEW Extension transmission cable for ARW-D04, 4-pole link connector-M12 connector	-	●	-	-	-
Address writer remote head	ARW-RH	Optional address writer tool for setting narrow places	-	-	-	-	-
Flat cable (for transmission line)	FK2-125-100	Wire diameter 1.25 sq x 2-core, 100 m coil	●	-	-	-	-
	FK2-075-100	Wire diameter 0.75 sq x 2-core, 100 m coil	-	-	-	-	-
	FK4-125-100	Wire diameter 1.25 sq x 4-core, 100 m coil	-	●	-	-	-
	FK4-075-100	Wire diameter 0.75 sq x 4-core, 100 m coil	-	●	-	-	-
LP connector (for transmission line)	LP2-BR-10P	For wire diameter 1.25 sq x 2-core flat cable, sheath outer diameter ø2.54 mm	●	-	-	-	-
	LP2-BK-10P	For wire diameter 0.75 sq x 2-core flat cable, sheath outer diameter ø2.54 mm	-	-	-	-	-
	LP4-WR-10P	For wire diameter 1.25 sq x 4-core flat cable, sheath outer diameter ø2.54 mm (claw-breaking prevention type)	-	●	-	-	-
	LP4-WH-10P	For wire diameter 0.75 sq x 4-core flat cable, sheath outer diameter ø2.54 mm (claw-breaking prevention type)	-	●	-	-	-
	LP2-YEG-10P	For wire diameter 0.5 sq, 2-core cabtyre cable, sheath outer diameter ø1.8 ... 2.1 mm	●	-	-	-	-
	LP2-PWH-10P	For wire diameter 0.3 sq, 2-core cabtyre cable, sheath outer diameter ø1.4 ... 1.7 mm	-	-	-	-	-
	LP4-OR-10P	For wire diameter 0.75 sq, 4-core cabtyre cable, sheath outer diameter ø2.1 ... 2.4 mm	-	●	-	-	-
	LP4-YE-10P	For wire diameter 0.75 sq, 4-core cabtyre cable, sheath outer diameter ø1.8 ... 2.1 mm	-	●	-	-	-
	LP4-ORG-10P	For wire diameter 0.5 sq, 4-core cabtyre cable, sheath outer diameter ø2.1 ... 2.4 mm	-	●	-	-	-
	LP4-YEG-10P	For wire diameter 0.5 sq, 4-core cabtyre cable, sheath outer diameter ø1.8 ... 2.1 mm	-	●	-	-	-
LE connector (for transmission line)	LE4-WW-10P	For wire diameter 0.3 sq, 4-core cabtyre cable, sheath outer diameter ø1.1 ... 1.4 mm	-	-	-	-	-
	LE4-BR-10P	NEW For 4 core flat cable (size 1.25 sq), coating outer diameter ø2.54 mm-e-CON 4 pin socket conversion, 10 pieces	-	-	-	-	-
	LE4-BR-100P	NEW For 4 core flat cable (size 1.25 sq), coating outer diameter ø2.54 mm-e-CON 4 pin socket conversion, 100 pieces	-	-	-	-	-
T attachment (for transmission line), attachment for T branching * It cannot be plugged or unplugged after connection	TA4-GB-100P	For 4 core flat cable (size 1.25 sq), coating outer diameter ø2.54 mm, for 1.25 sq-1.25 sq branching, 100 pieces	-	●	-	-	-
	TA4-WB-100P	For 4 core flat cable (size 1.25 sq), coating outer diameter ø2.54 mm, for 1.25 sq-0.3 sq branching, 100 pieces	-	●	-	-	-
LP connector pressure welding tool	LP-TOOL	Dedicated tool for LP connector press welding	●	●	-	-	-
Crimping tool for T attachment	TA-TOOL	Crimping tool for T attachment	-	●	-	-	-
Trunk cable (for transmission line)	BL2-1S1P-3K	NEW IP 67 waterproof straight socket M12 /straight plug M12 3 m	●	●	-	-	-
	BL2-1S1P-5K	NEW IP 67 waterproof straight socket M12 /straight plug M12 5 m	●	●	-	-	-
	BL2-1S1P-10K	NEW IP 67 waterproof straight socket M12 /straight plug M12 10 m	●	●	-	-	-
	BL2-0C1S-3K	NEW IP 67 waterproof straight socket M12 / 4-core discrete-wire 3 m	●	●	-	-	-
Branch module (for transmission line)	BL2109-04-22	NEW IP 67 waterproof branch module for M12 connector M12 x 4	●	●	-	-	-
	BL2109-08-22	NEW IP 67 waterproof branch module for M12 connector M12 x 8	●	●	-	-	-
Conversion adapter cable	BL2-RVAS	NEW For MELFA RV Series forearm, standard 1A type	-	-	-	-	-
	BL2-RVAH	NEW For MELFA RV Series forearm, high capacitance 2A type	-	-	-	-	-
	BL2-RVBS	NEW For MELFA RV Series base, standard 1A type	-	-	-	-	-
	BL2-RVBH	NEW For MELFA RV Series base, large capacity 2A type	-	-	-	-	-
EP connector (for connection terminal (e-CON))	EP4-RE-8P	For size 0.14...0.2 sq, coating outer diameter ø0.8...1.0 mm (red)	-	-	-	-	-
	EP4-YE-8P	For size 0.14...0.2 sq, coating outer diameter ø1.0...1.2 mm (yellow)	-	-	-	-	-
	EP4-OR-8P	For size 0.14...0.2 sq, coating outer diameter ø1.2...1.6 mm (orange)	-	-	-	-	-
	EP4-GR-8P	For size 0.3...0.5 sq, coating outer diameter ø1.0...1.2 mm (green)	-	-	-	-	-
	EP4-BL-8P	For size 0.3...0.5 sq, coating outer diameter ø1.2...1.6 mm (blue)	-	-	-	-	-
	EP4-GL-8P	For size 0.3...0.5 sq, coating outer diameter ø1.6...2.0 mm (gray)	-	-	-	-	-
EP connector pressure welding tool	EP-TOOL	Dedicated tool for EP connector press welding	-	-	-	-	-

* For detailed information about wiring and selecting models, please refer to "Digital Link Sensor AnyWireASLINK catalog" published by AnyWire Corporation.

Outer dimensional drawings

<Outer dimensional drawings>

Unit: mm

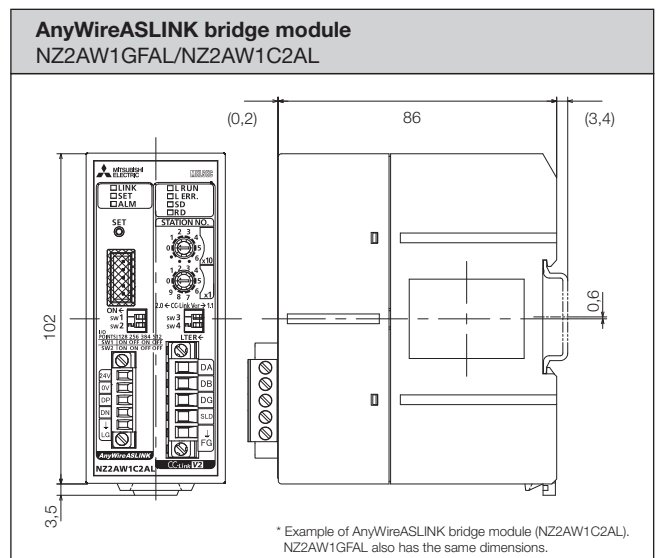
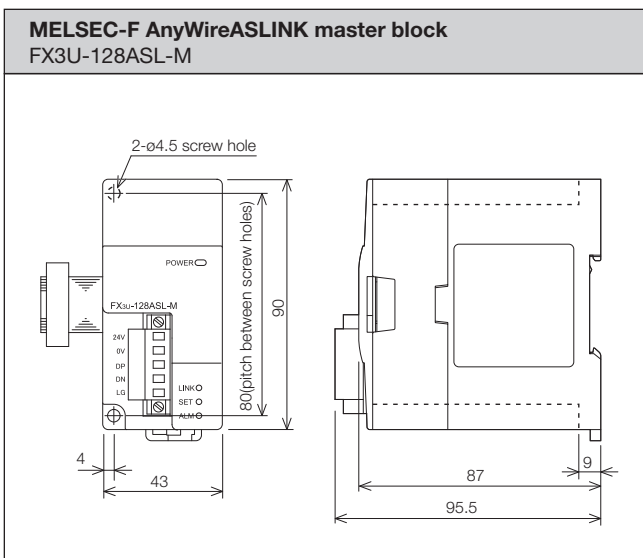
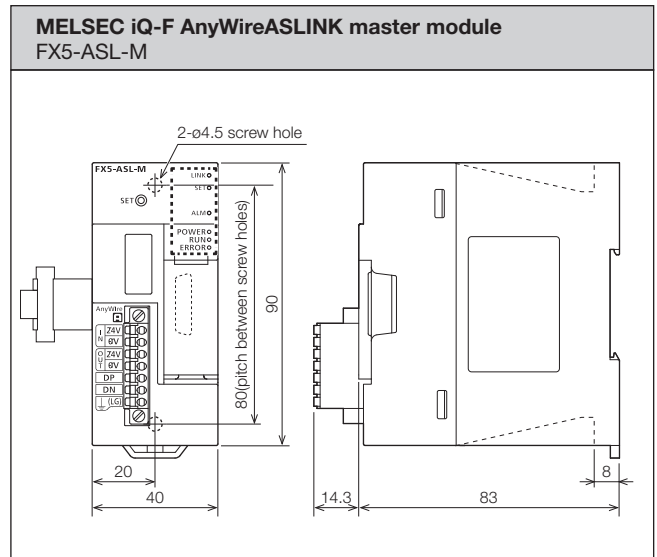
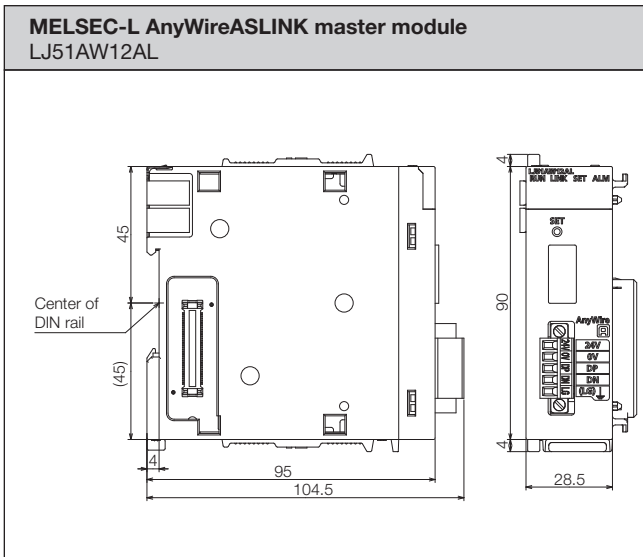
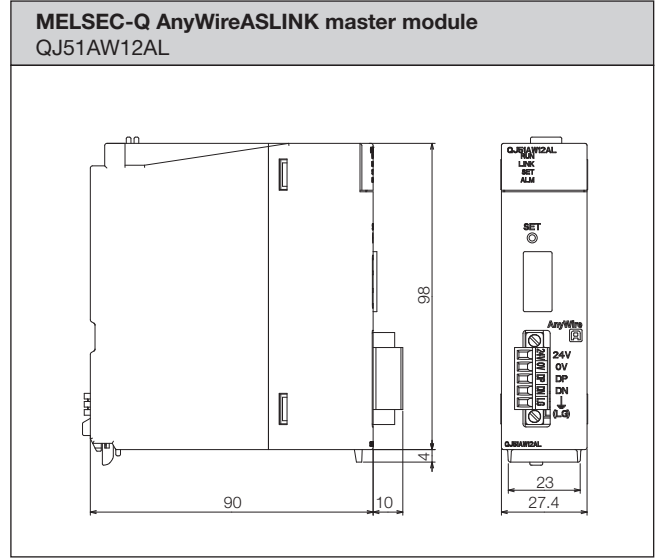
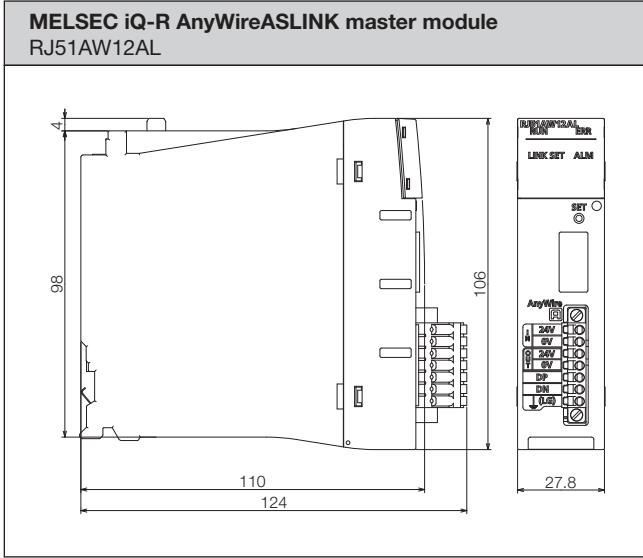

<Outer dimensional drawings>

Unit: mm

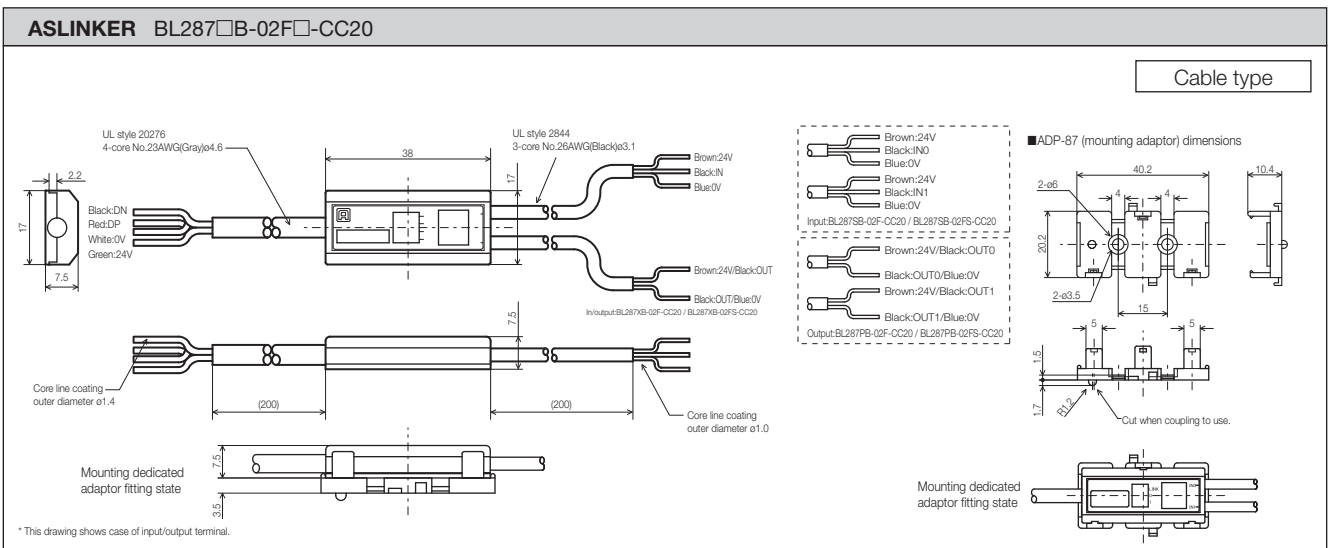
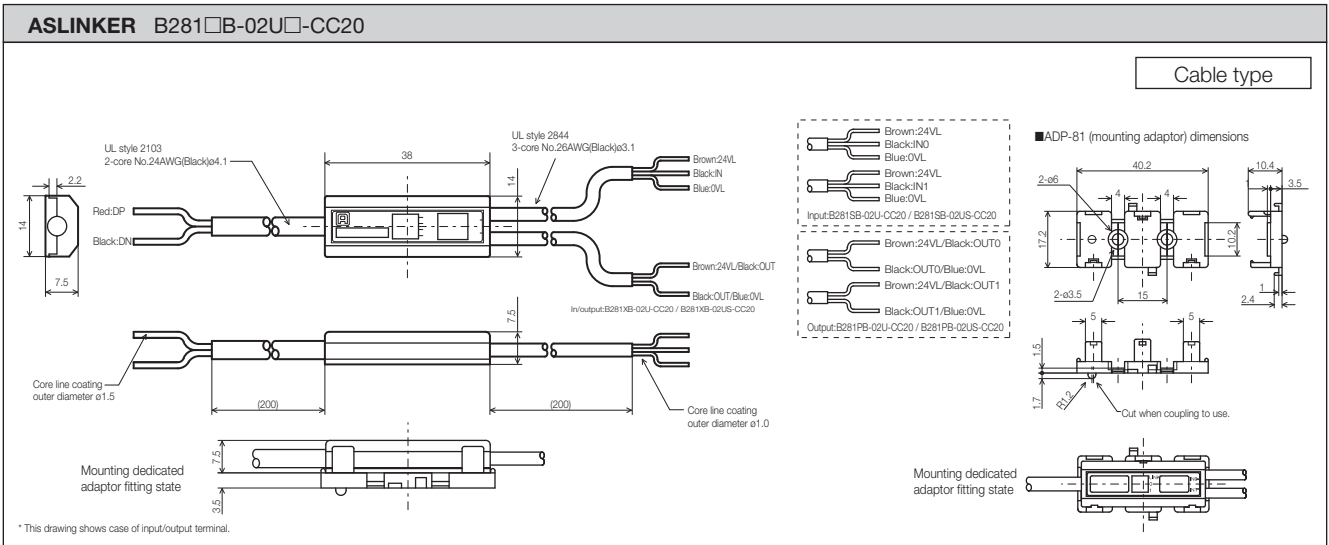
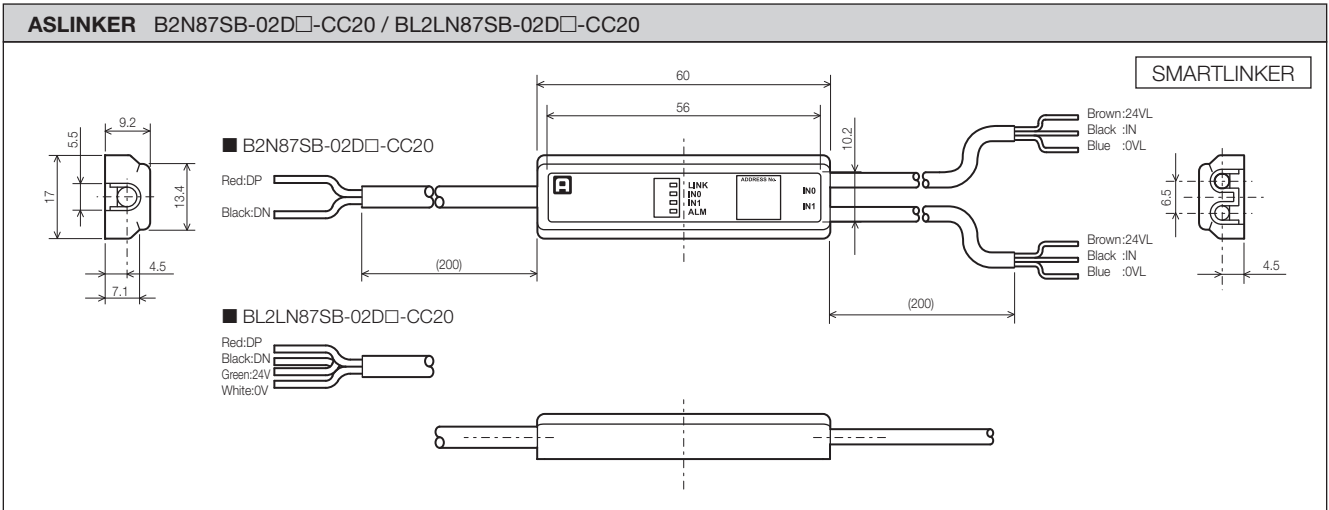

<Outer dimensional drawings>

Unit: mm

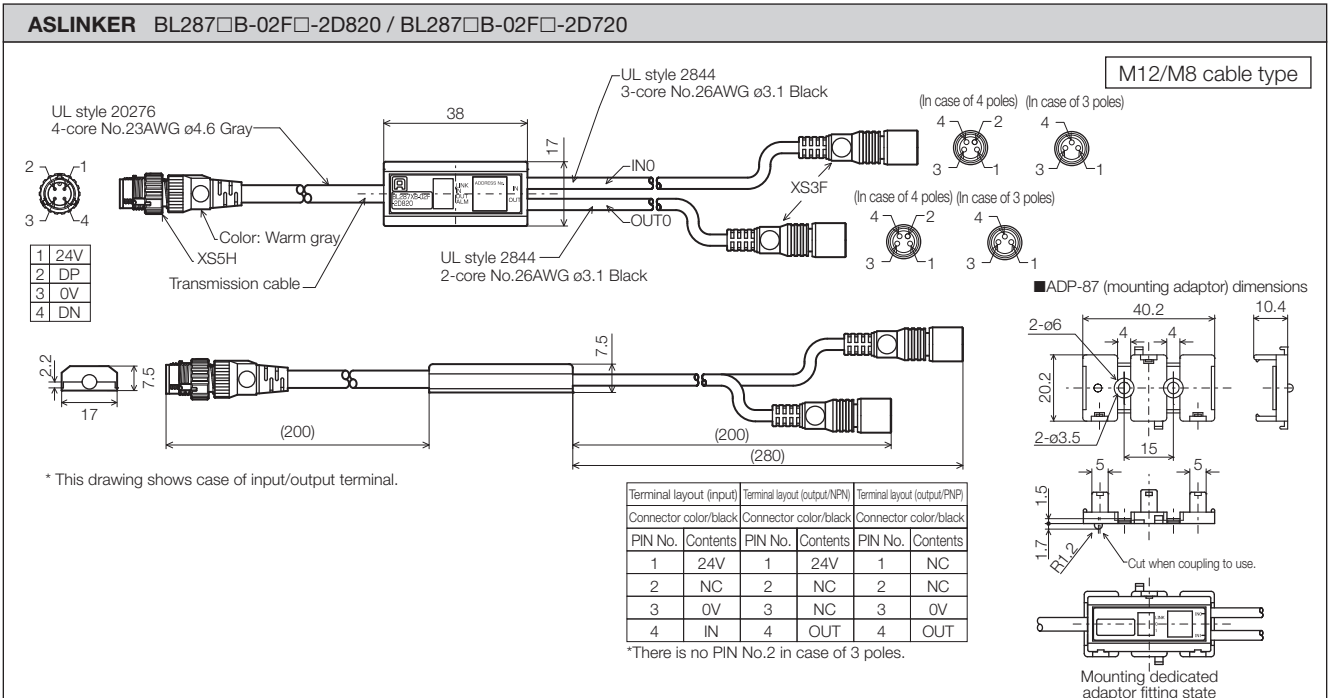
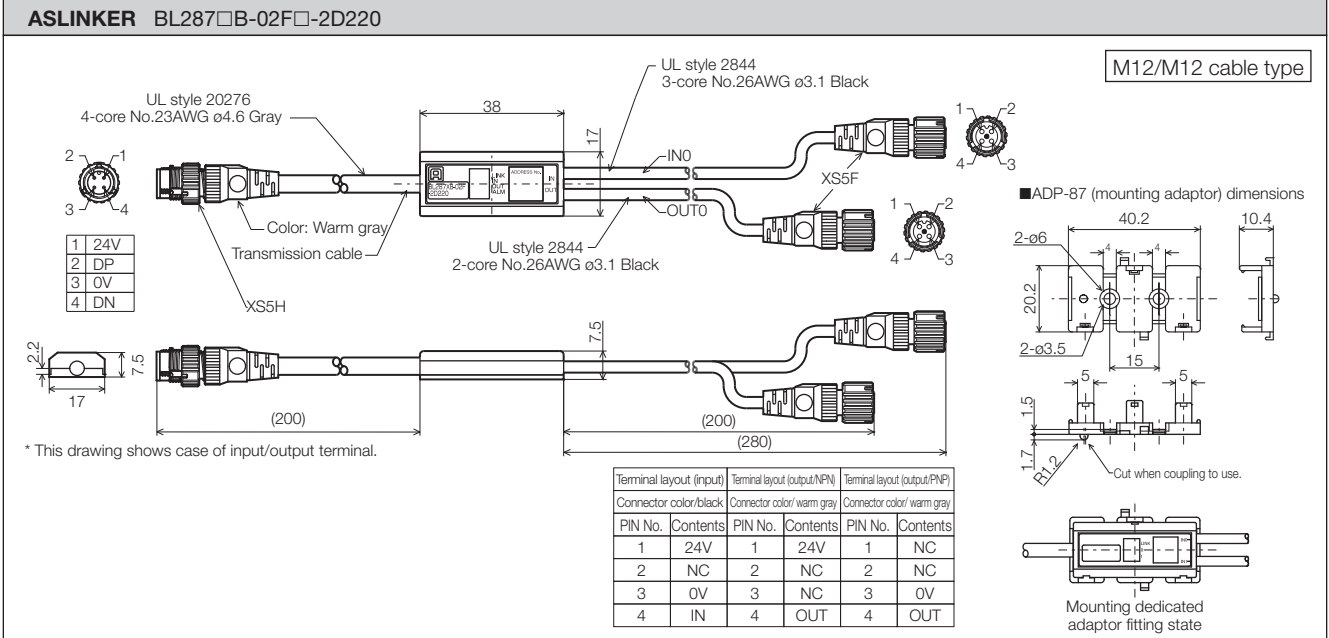
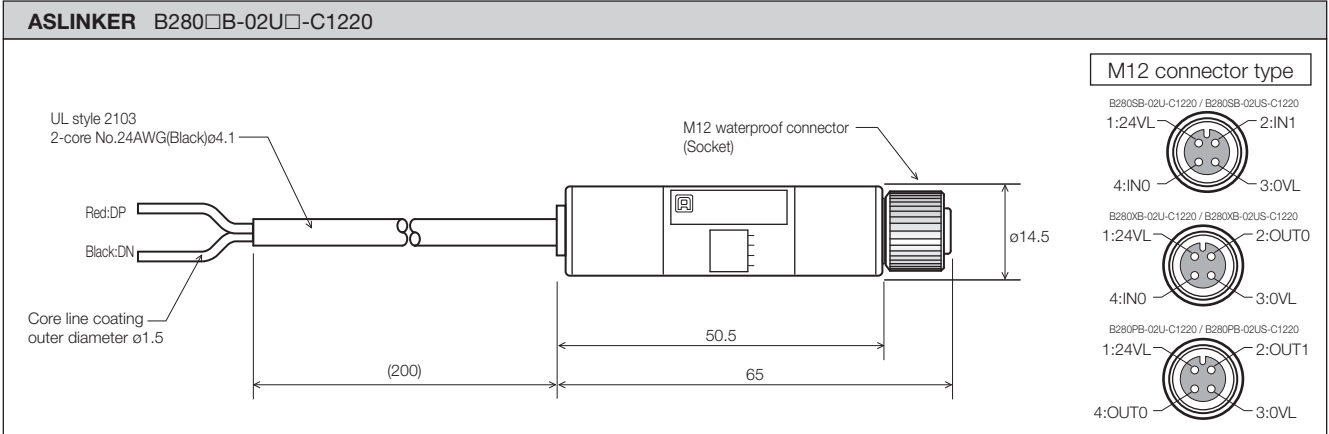

<Outer dimensional drawings>

Unit: mm

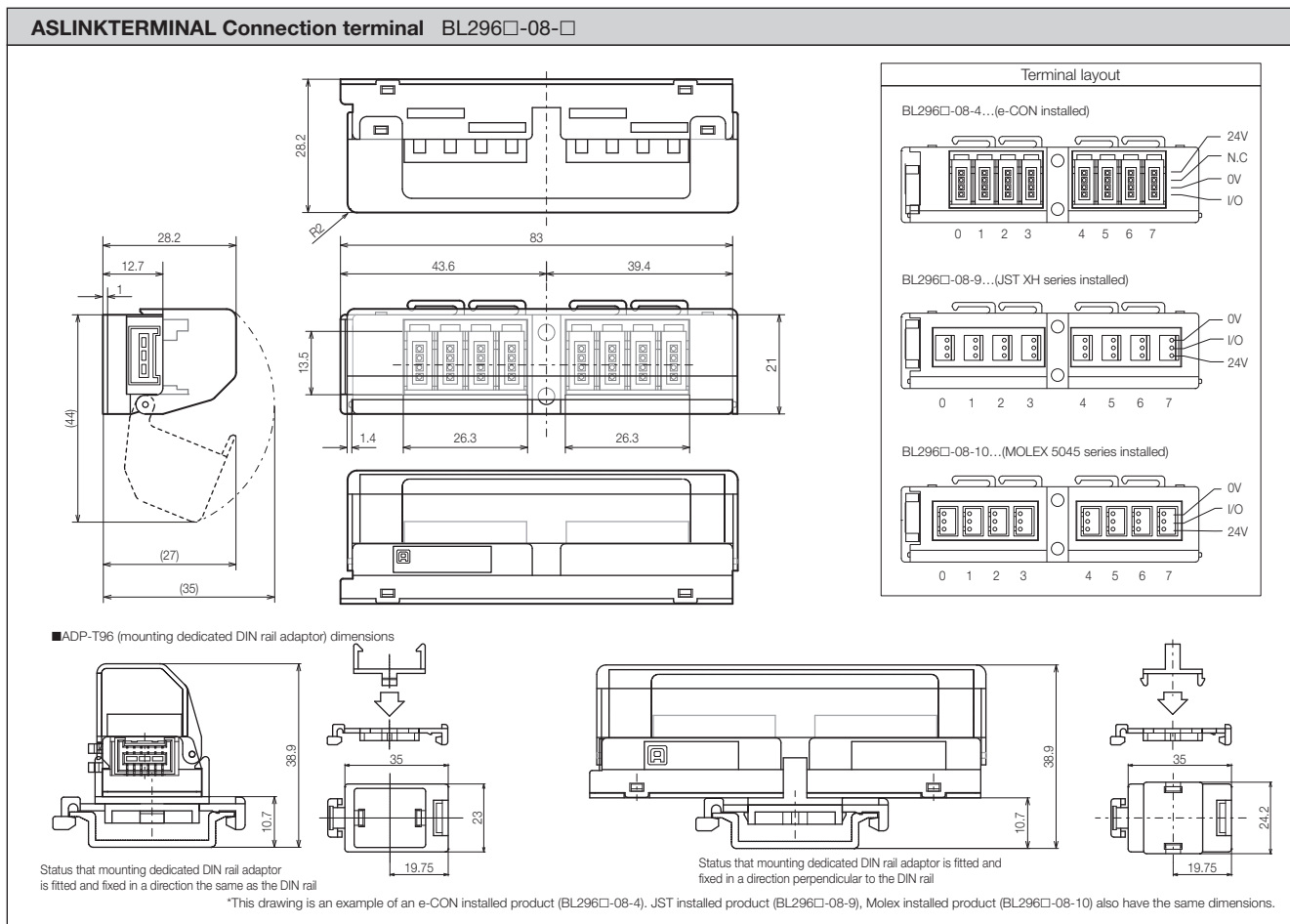
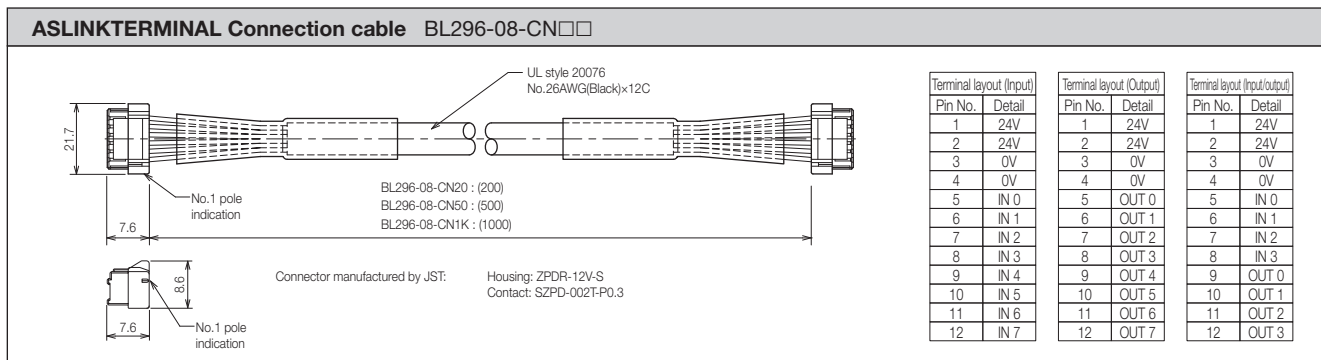
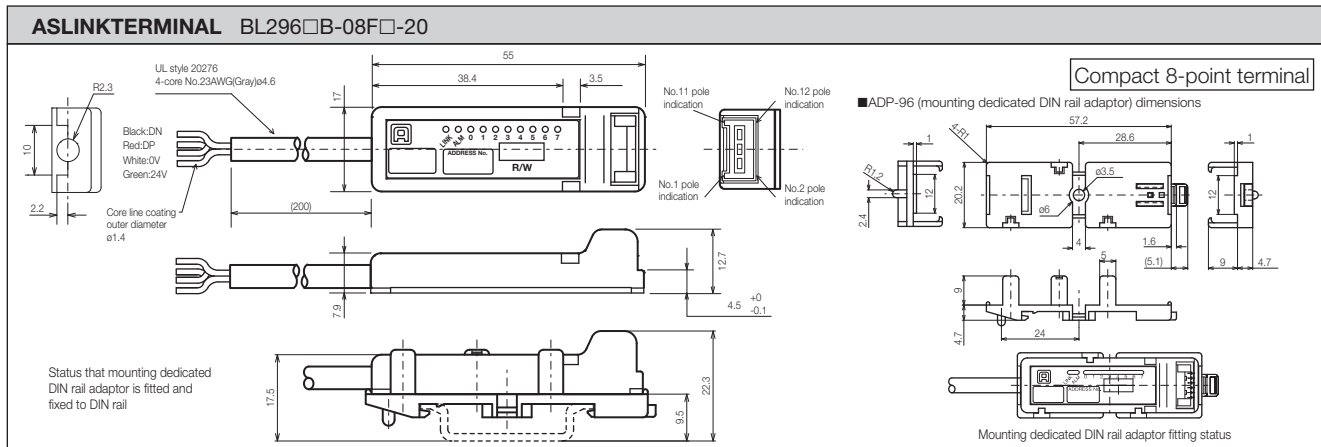

<Outer dimensional drawings>

Unit: mm

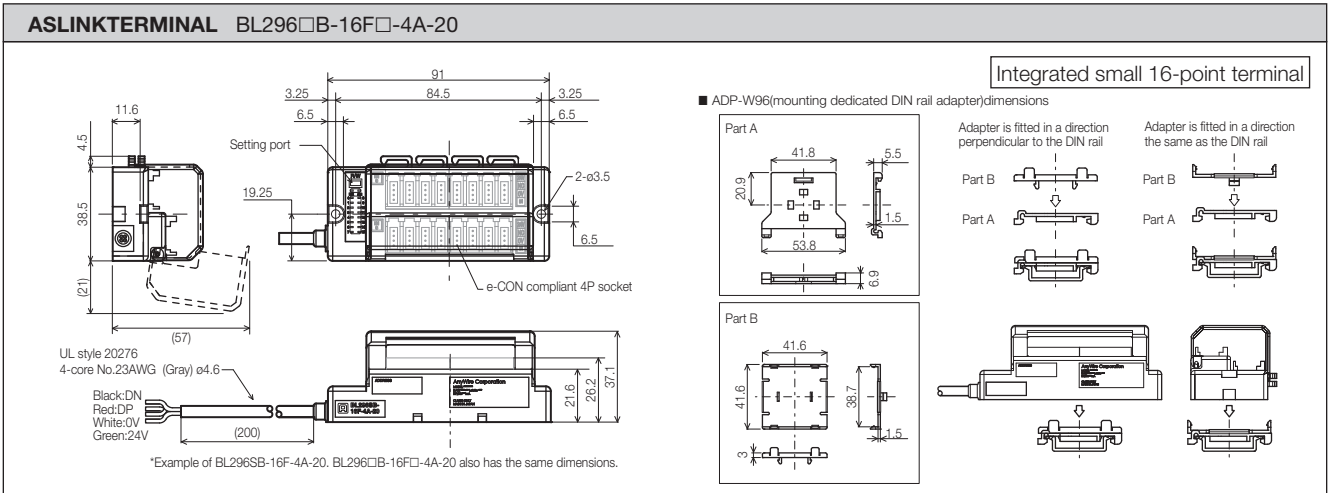
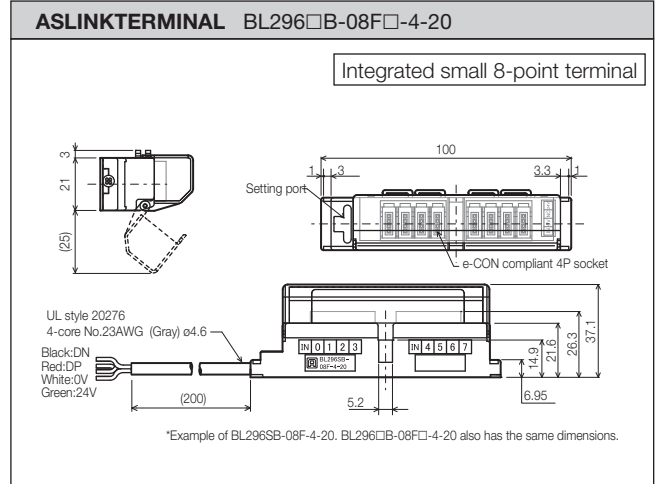
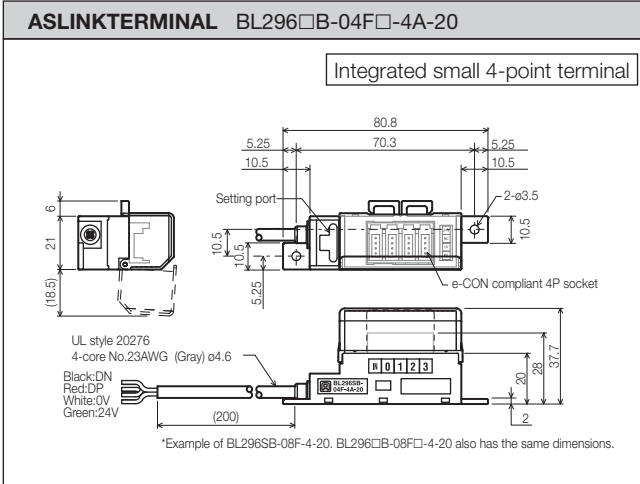

<Outer dimensional drawings>

Unit: mm

ASLINKTERMINAL BL296□B-08F□-V50 / BL296□B-08F□-3-V50 / BL296□B-08F□-11-V50

Small terminal block type terminal (support 3-wire I/O signal line)

■ BL296□B-08F□-V50

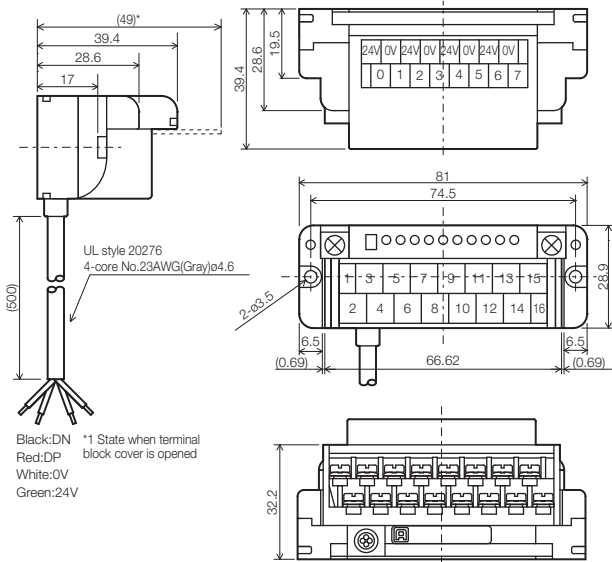

*Example of BL296PB-16F-V50. BL296□B-16F□-V50 also has the same dimensions.

■ BL296□B-08F□-3-V50

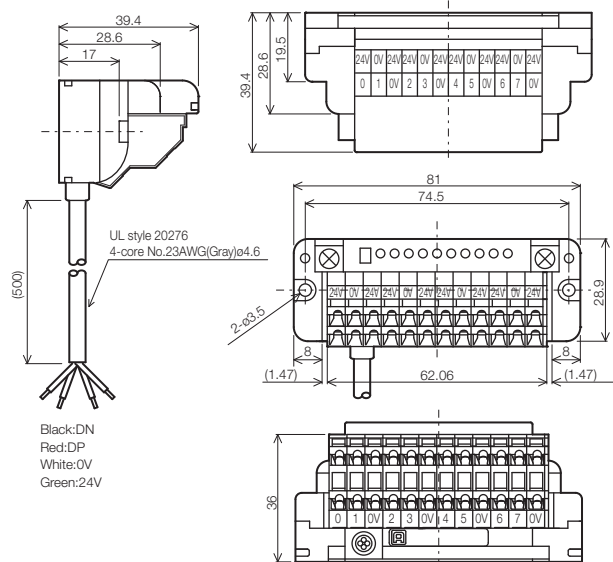

*Example of BL296PB-16F-3-V50. BL296□B-16F□-3-V50 also has the same dimensions.

■ BL296□B-08F□-11-V50

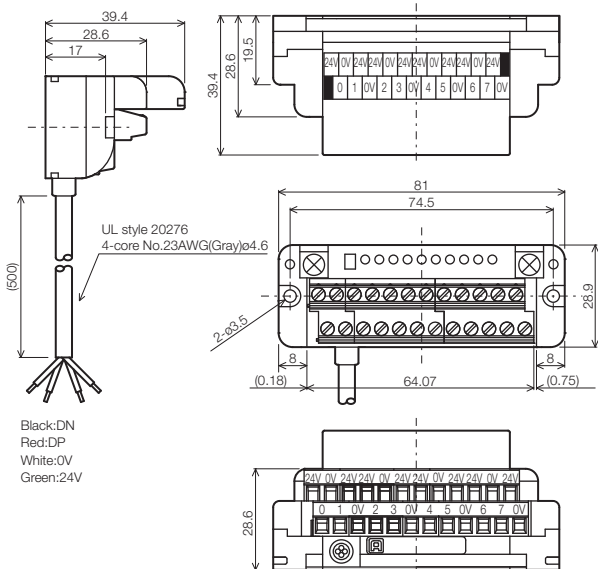

*Example of BL296PB-16F-11-V50. BL296□B-16F□-11-V50 also has the same dimensions.

■ ADP-108 (mounting dedicated DIN rail adaptor) dimensions

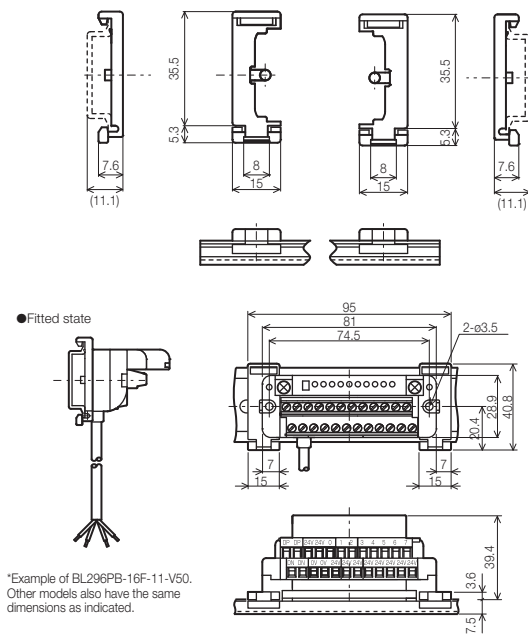

*Example of BL296PB-16F-11-V50. Other models also have the same dimensions as indicated.

<Outer dimensional drawings>

ASLINKTERMINAL BL296□B-16F□-V50 / BL296□B-16F□-3-V50 / BL296□B-16F□-11-V50

Small terminal block type terminal (support 3-wire I/O signal line)

■ BL296□B-16F□-V50

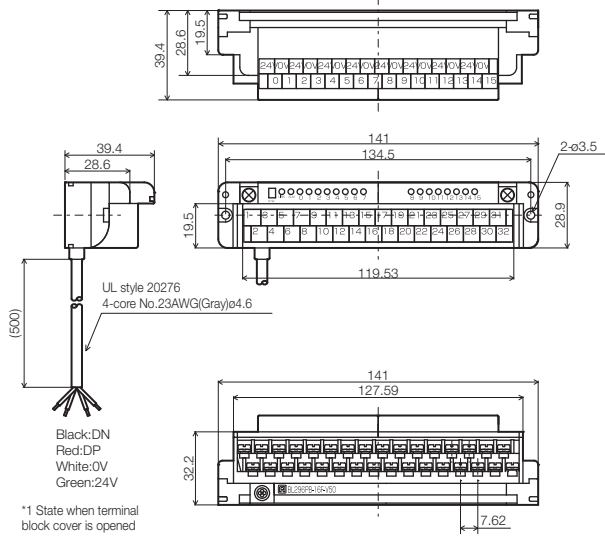

*Example of BL296PB-16F-V50. BL296□B-16F□-V50 also has the same dimensions.

■ BL296□B-16F□-3-V50

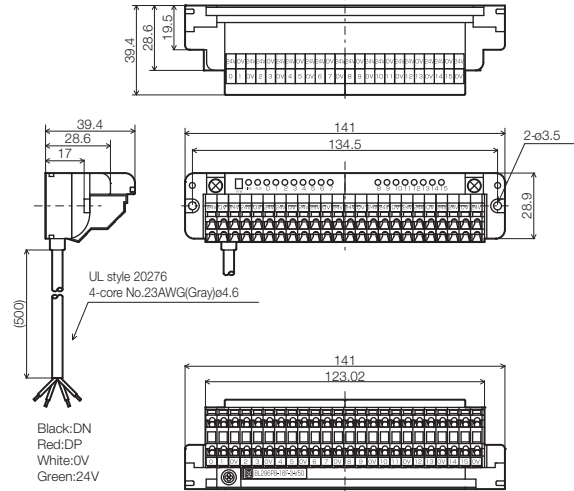

*Example of BL296PB-16F-3-V50. BL296□B-16F□-3-V50 also has the same dimensions.

■ BL296□B-16F□-11-V50

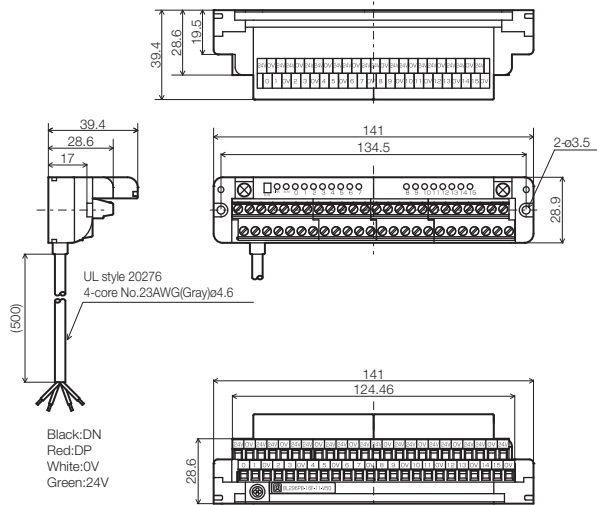

*Example of BL296PB-16F-11-V50. BL296□B-16F□-11-V50 also has the same dimensions.

■ ADP-108 (mounting dedicated DIN rail adaptor) dimensions

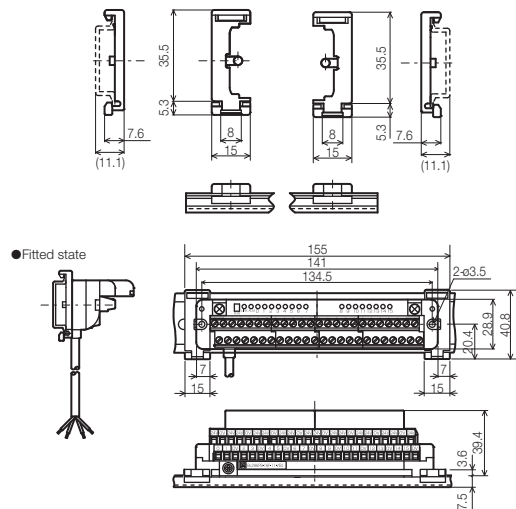

*Example of BL296PB-16F-11-V50. Other models also have the same dimensions as indicated.

<Outer dimensional drawings>

Unit: mm

ASLINKTERMINAL BL296□B-08F□ / BL296□B-08F□-3 / BL296□B-08F□-11

Small terminal block type terminal (support 2-wire I/O signal line)

■ BL296□B-08F□

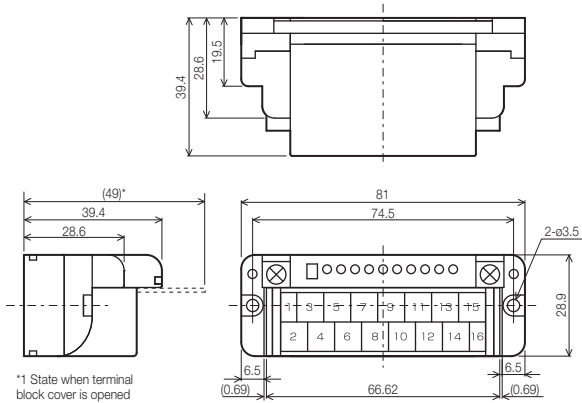

*Example of BL296PB-08F. BL296□B-08F□ also has the same dimensions.

■ BL296□B-08F□-3

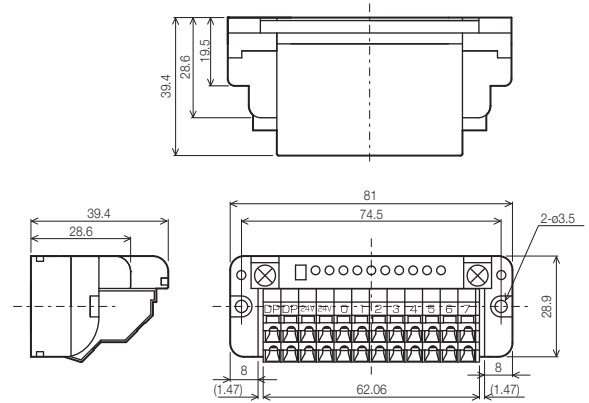

*Example of BL296PB-08F-3. BL296□B-08F□-3 also has the same dimensions.

■ BL296□B-08F□-11

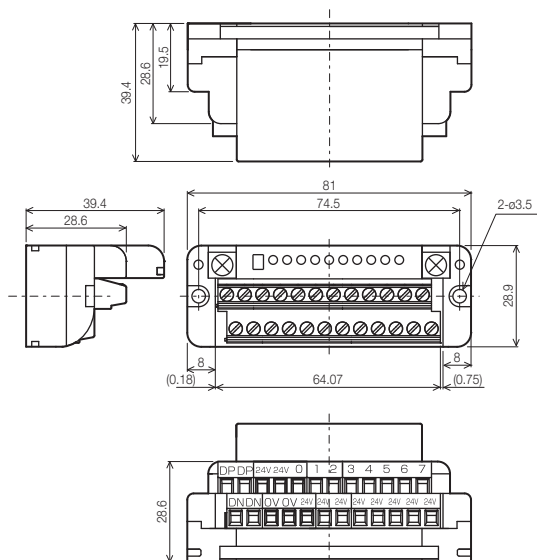

*Example of BL296PB-08F-11. BL296□B-08F□-11 also has the same dimensions.

■ ADP-108 (mounting dedicated DIN rail adaptor) dimensions

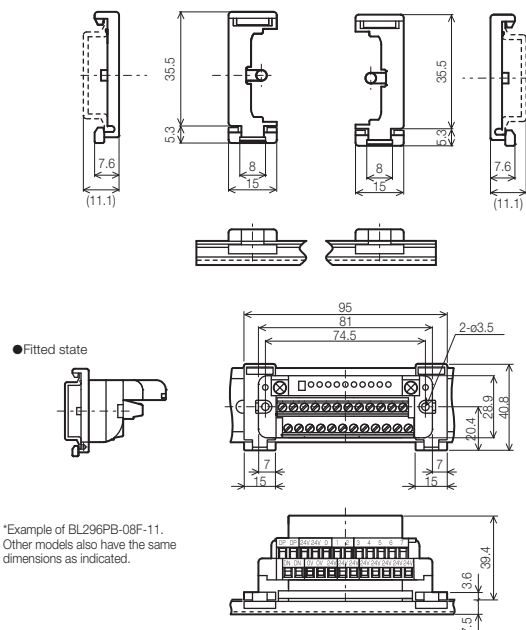

*Example of BL296PB-08F-11. Other models also have the same dimensions as indicated.

<Outer dimensional drawings>

Unit: mm

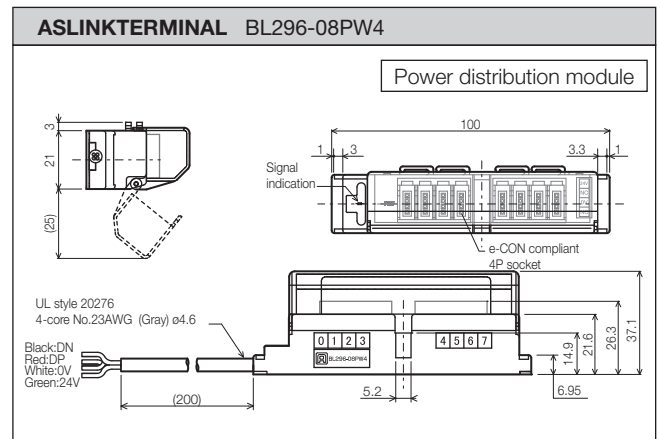
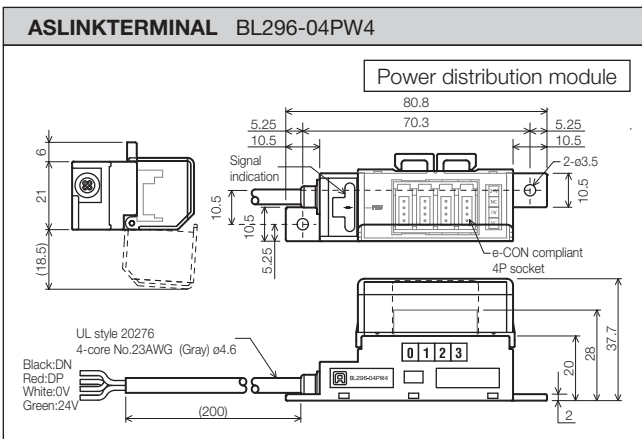
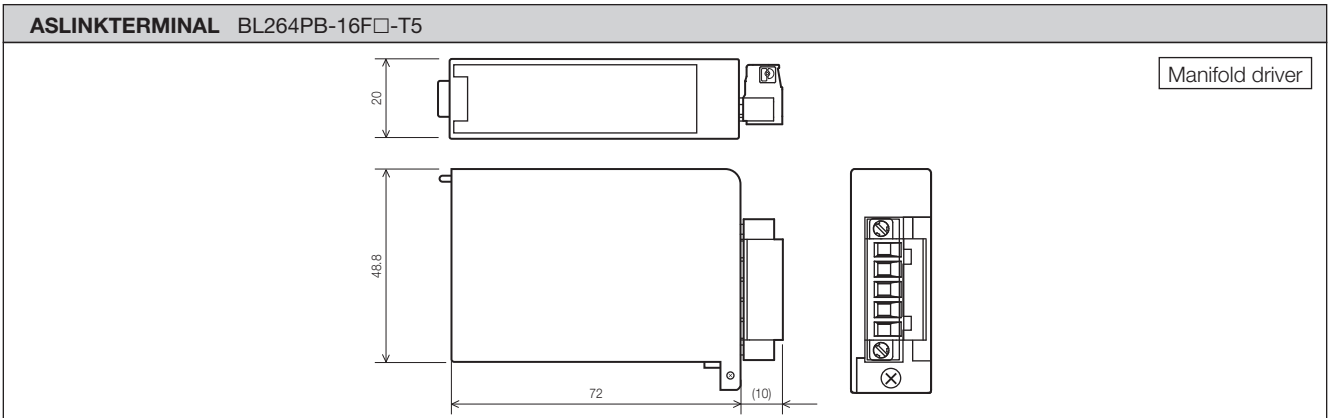
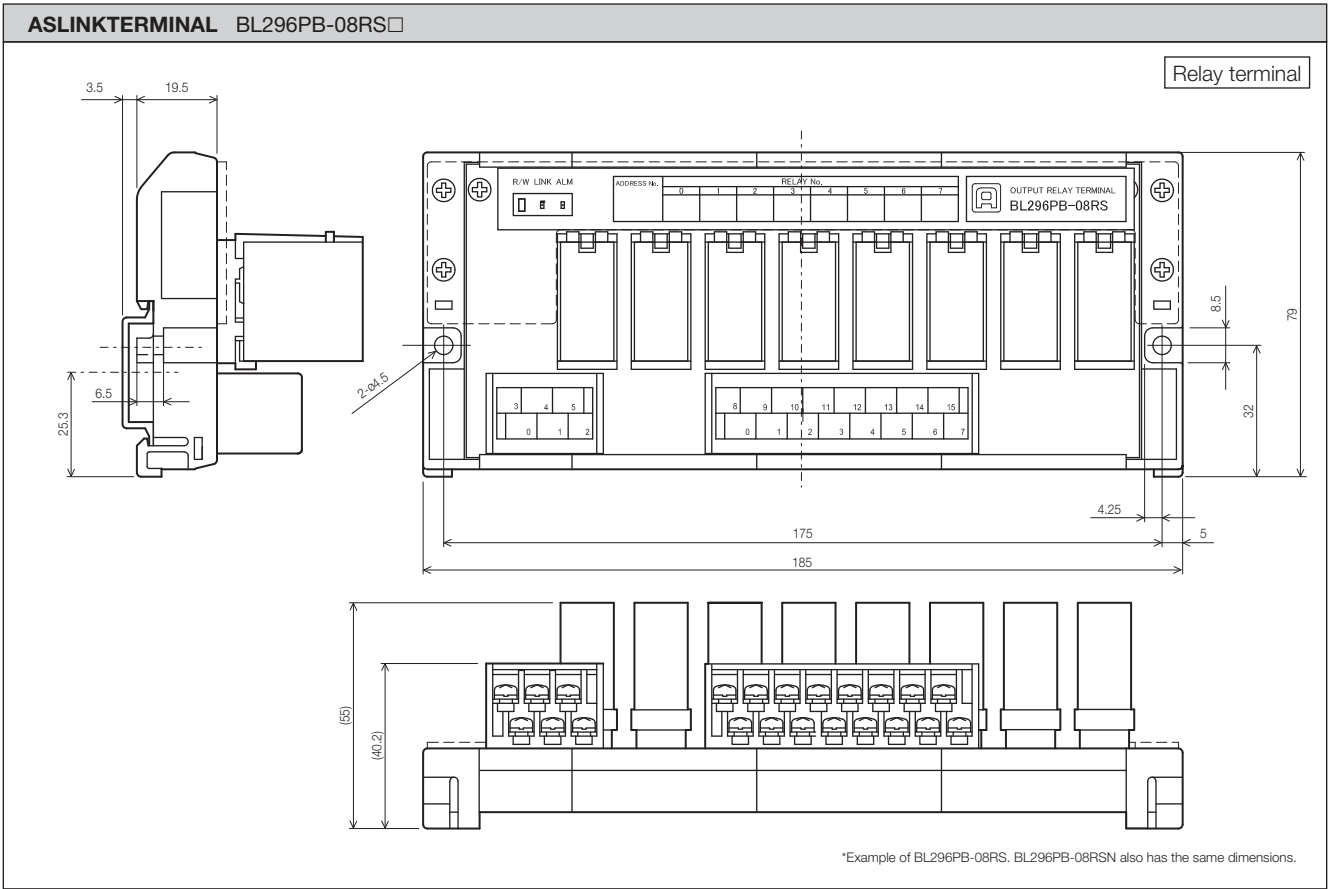

<Outer dimensional drawings>

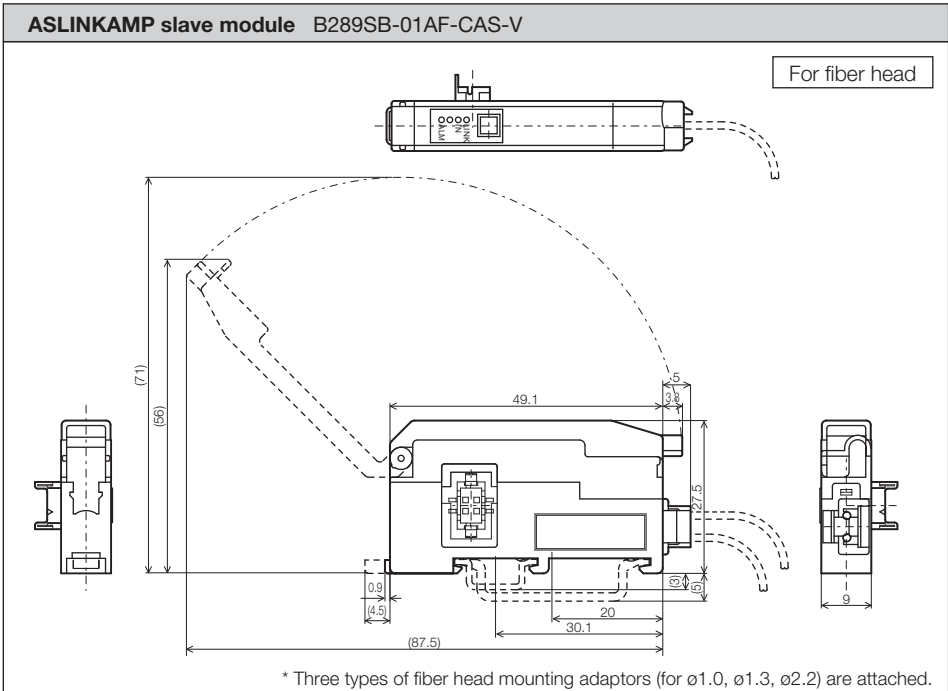
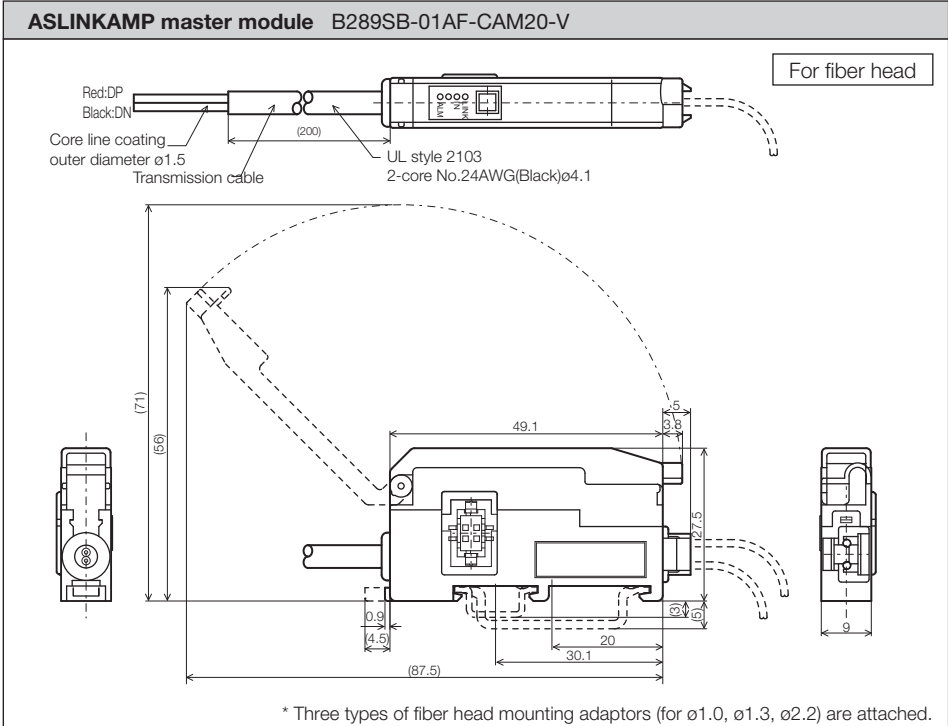

ASLINKAMP additional coupling drawing

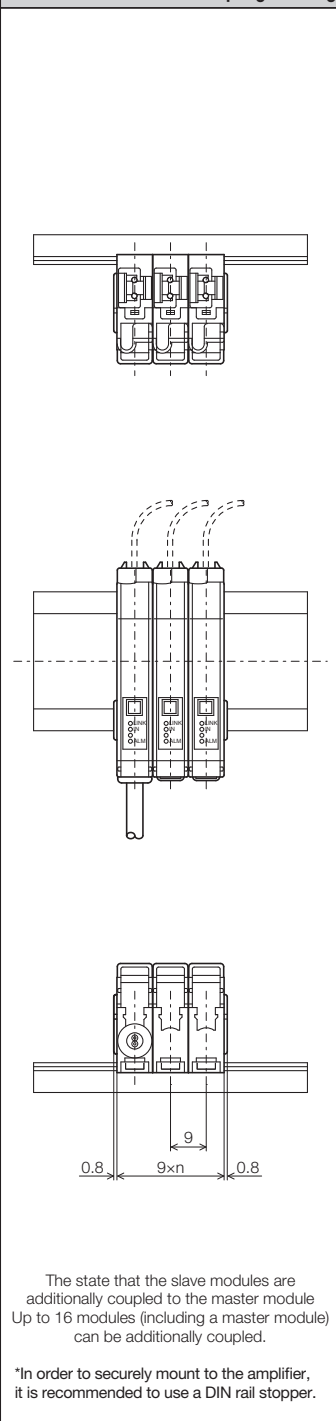

<Outer dimensional drawings>

Unit: mm

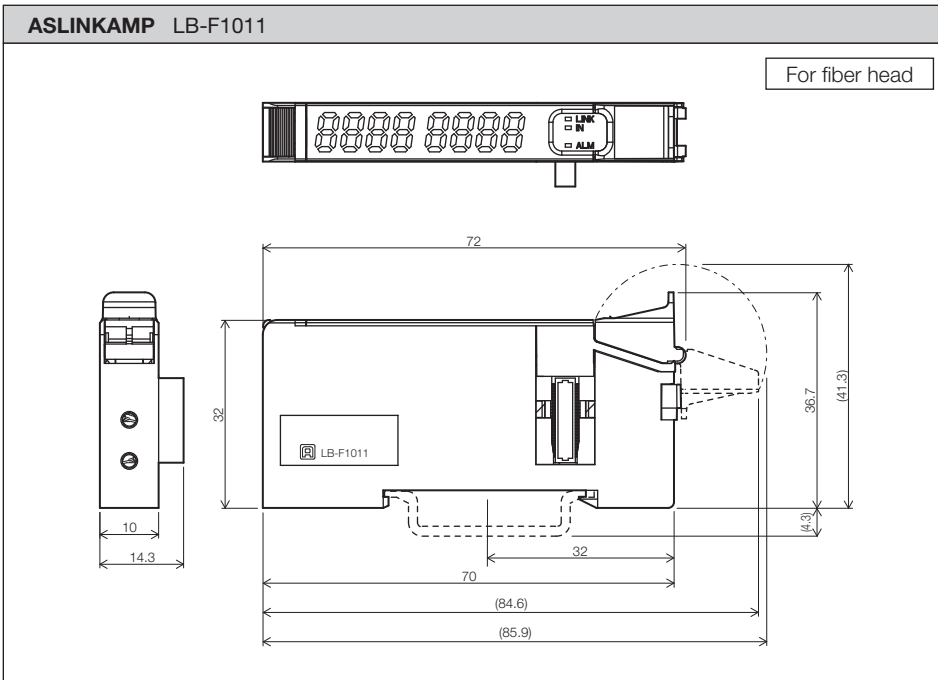
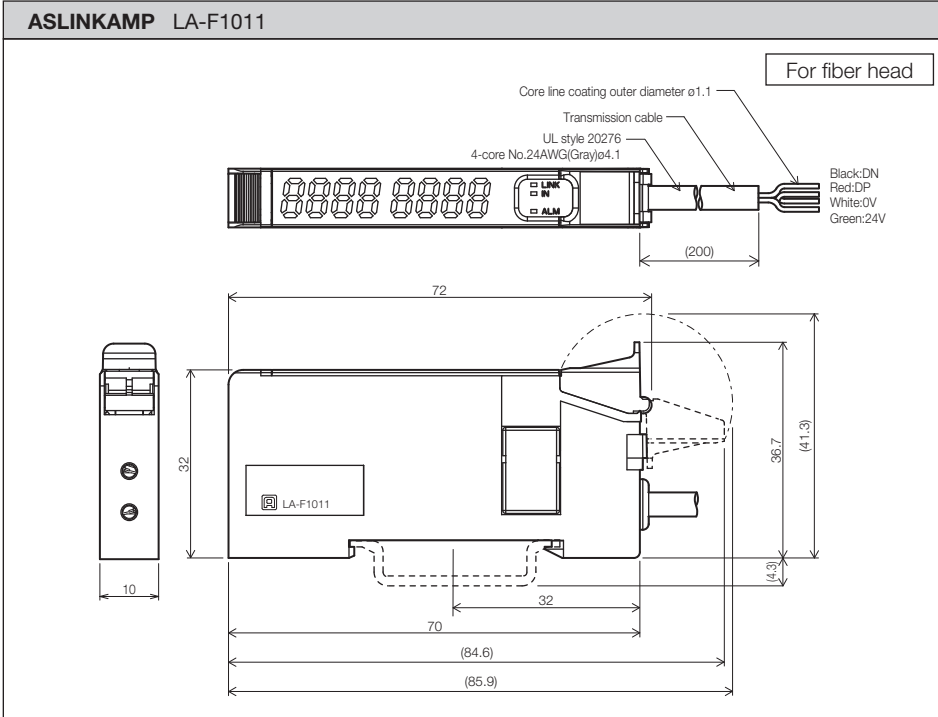

ASLINKAMP additional coupling drawing

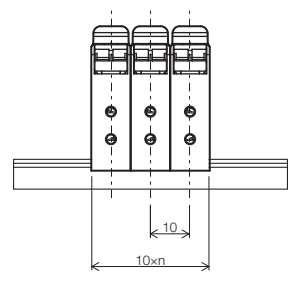
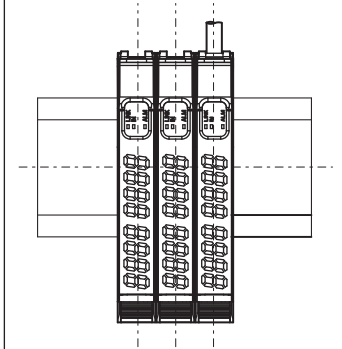

The state that the master module additionally coupled to the slave module Up to 32 modules (including a slave module) can be additionally coupled.

*In order to securely mount modules, it is recommended to use a DIN rail stopper.

<Outer dimensional drawings>

Unit: mm

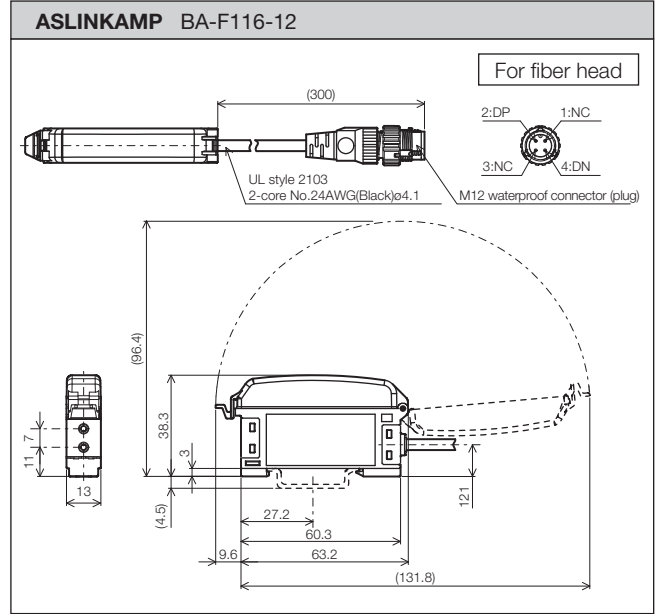
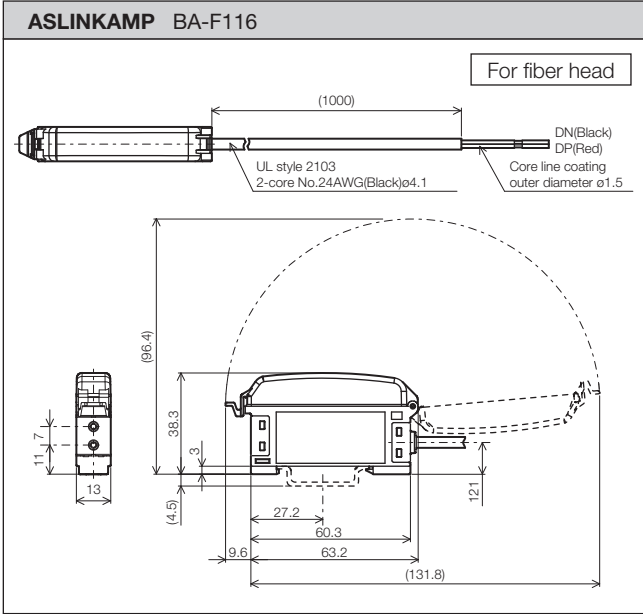

<Outer dimensional drawings>

Unit: mm

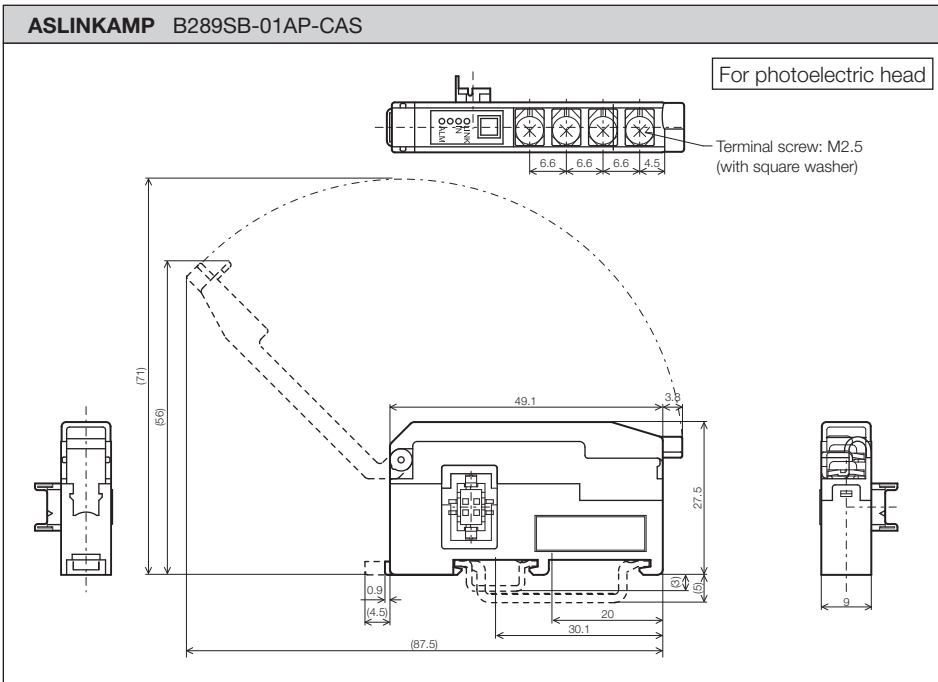
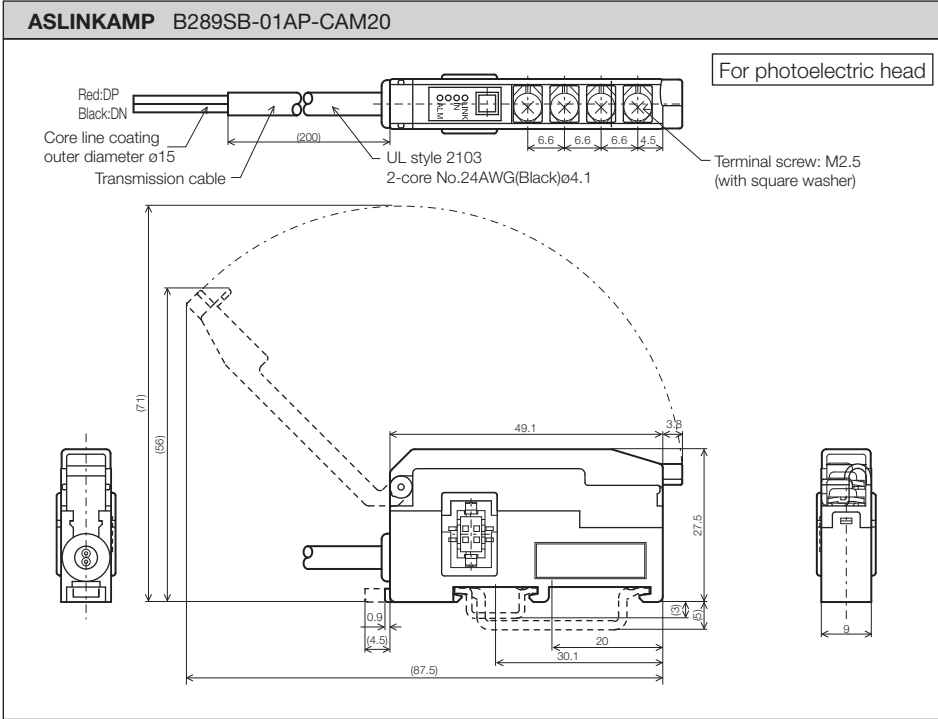

ASLINKAMP additional coupling drawing

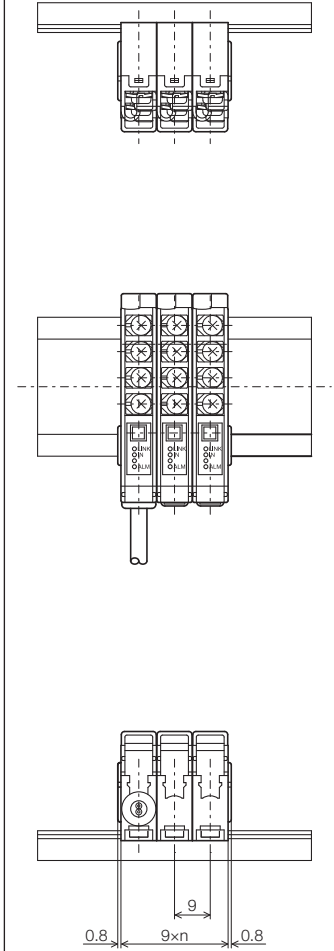

The state that the slave modules additionally coupled to the master module Up to 16 modules (including a master module) can be additionally coupled.

*In order to securely mount to the amplifier, it is recommended to use a DIN rail stopper.

<Outer dimensional drawings>

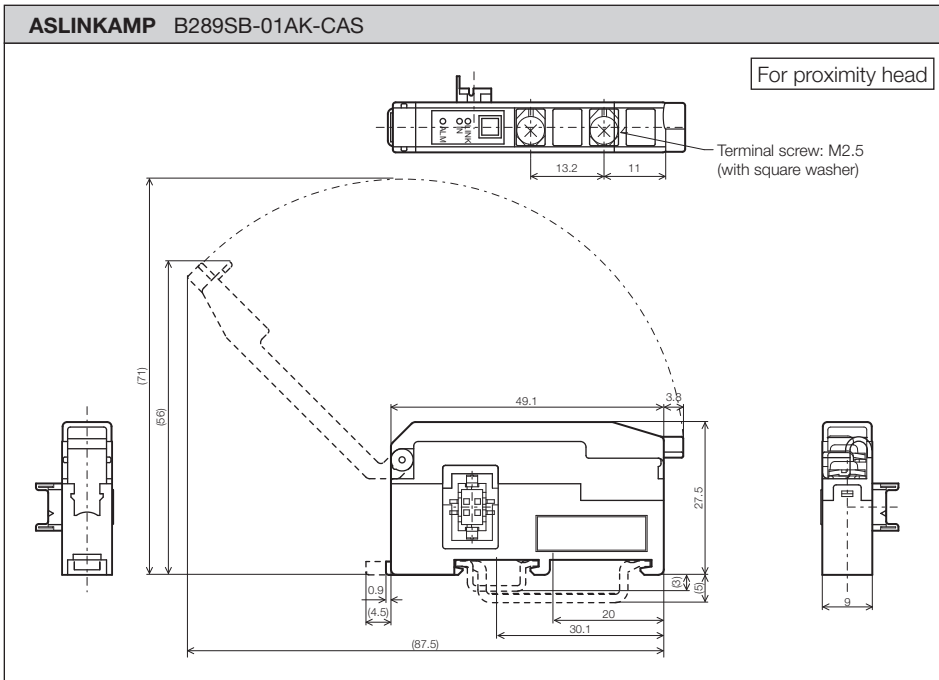
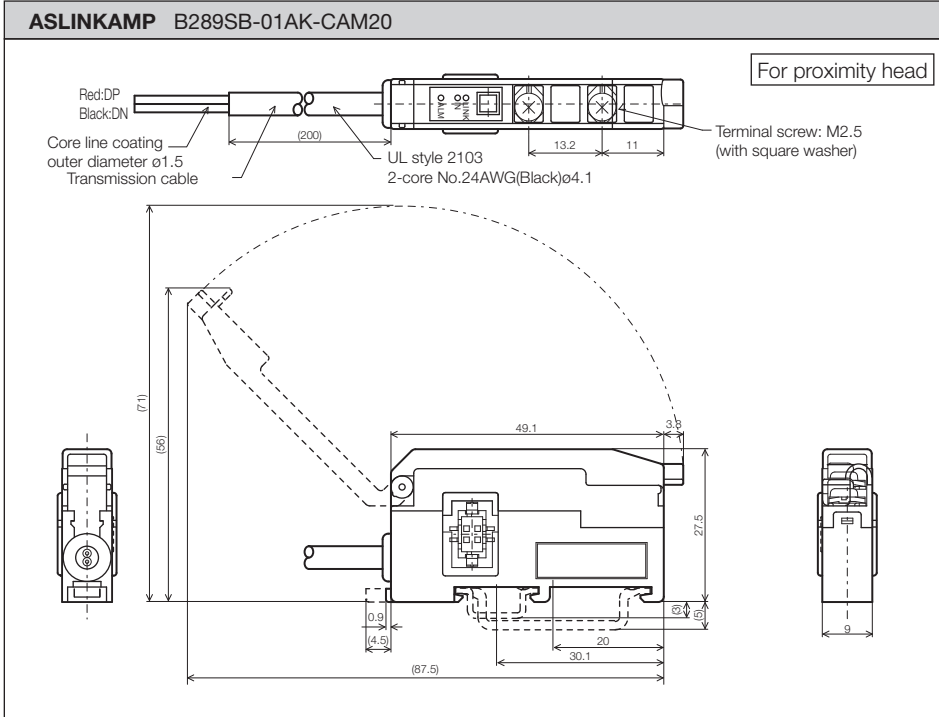

ASLINKAMP additional coupling drawing

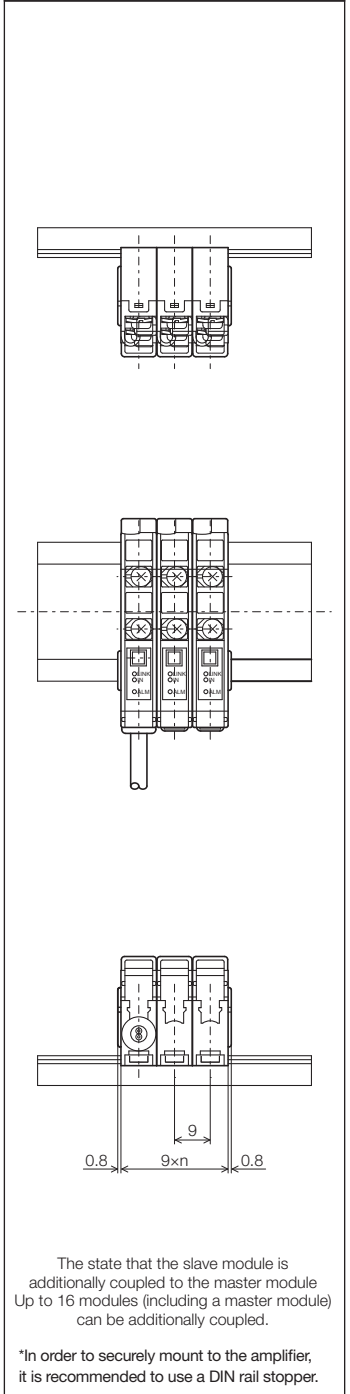

<Outer dimensional drawings>

Unit: mm

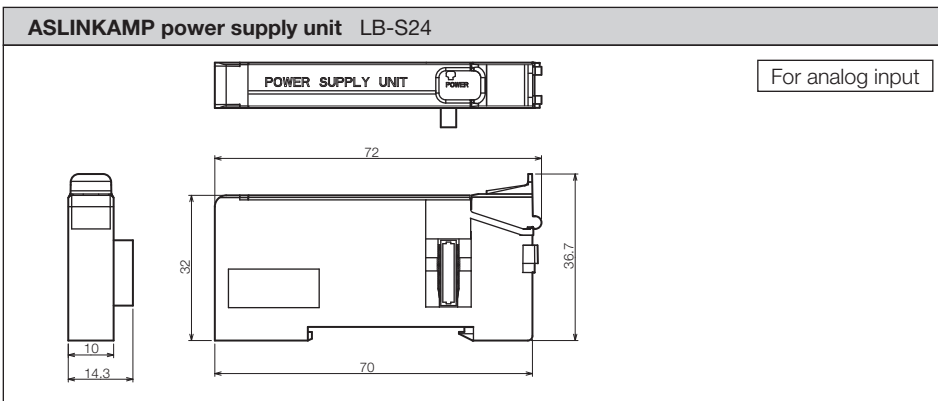
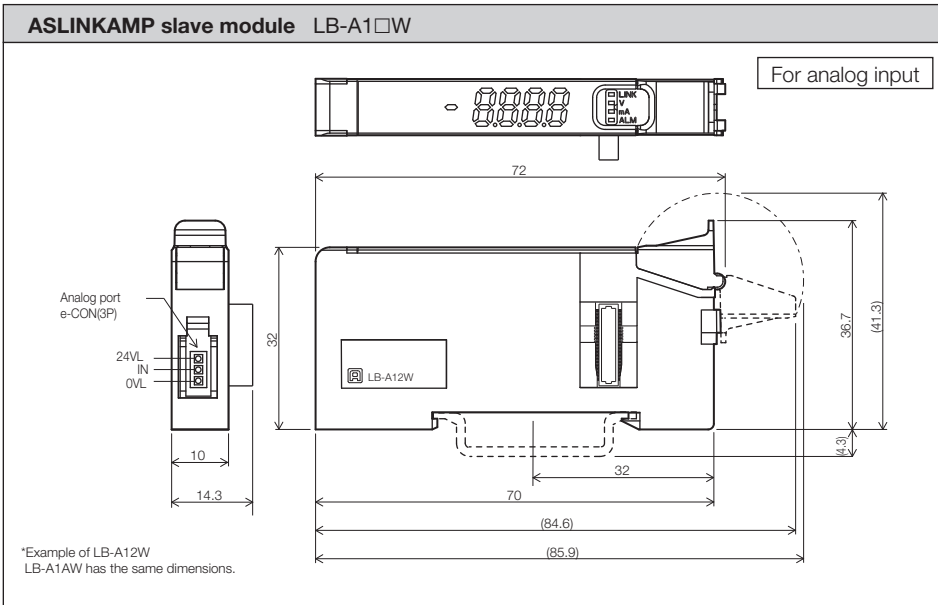
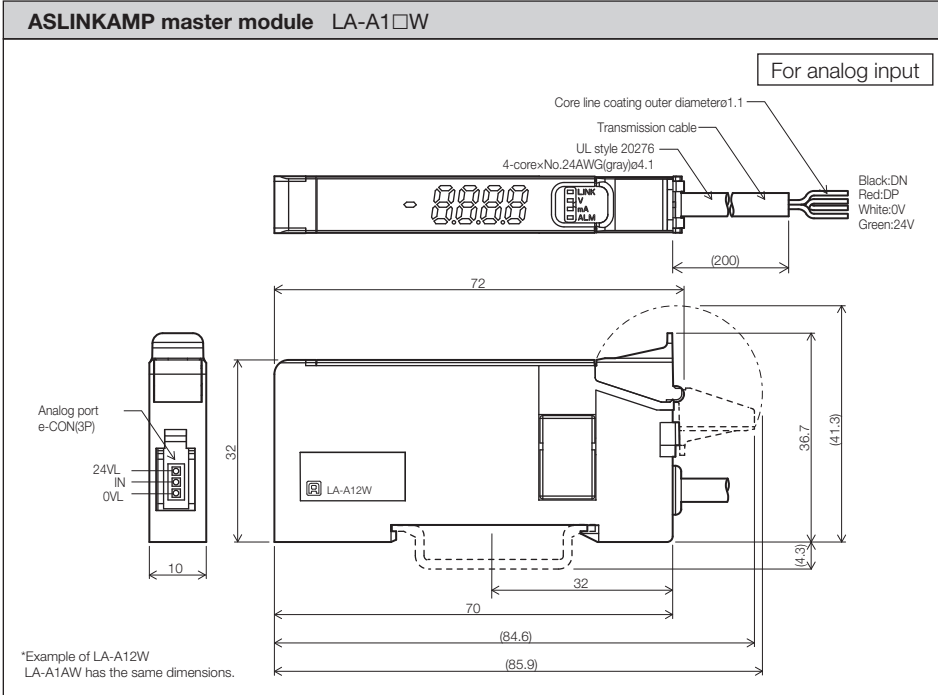

ASLINKAMP additional coupling drawing

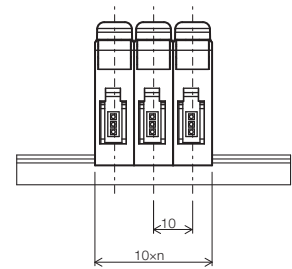
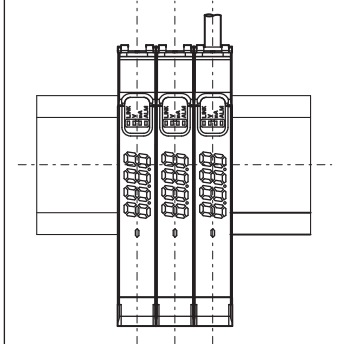

The state that slave modules are additionally coupled to the master module. Up to 16 modules (including a master module) can be additionally coupled.

***In order to securely mount modules, it is recommended to use a DIN rail stopper.**

<Outer dimensional drawings>

Unit: mm

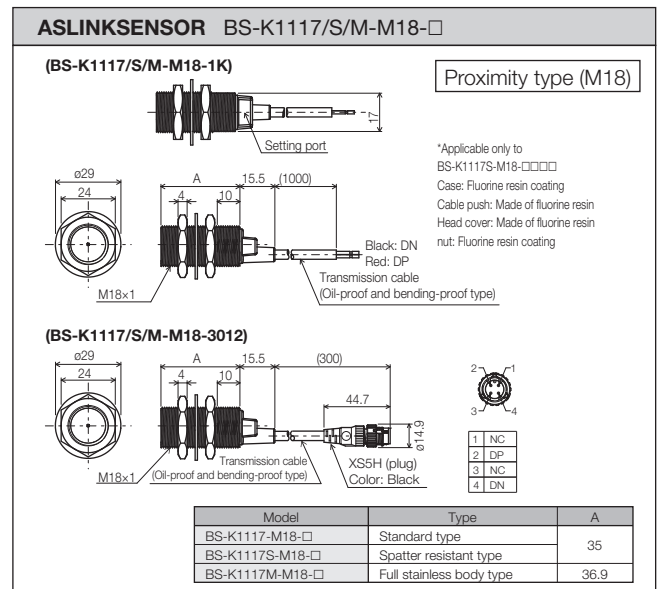
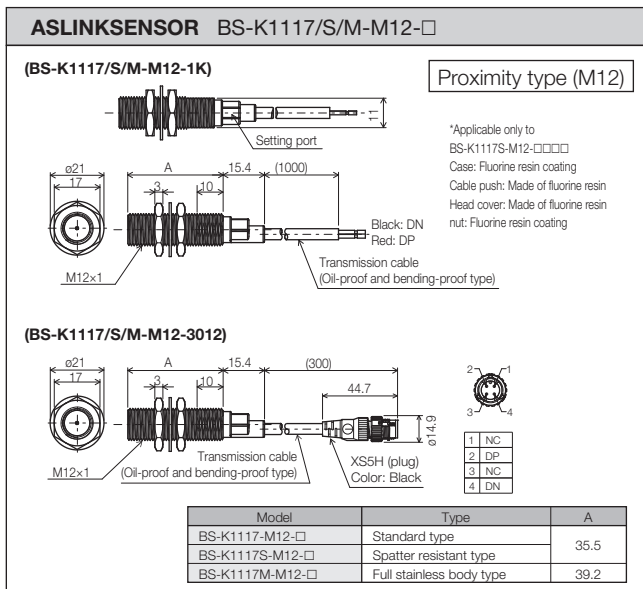
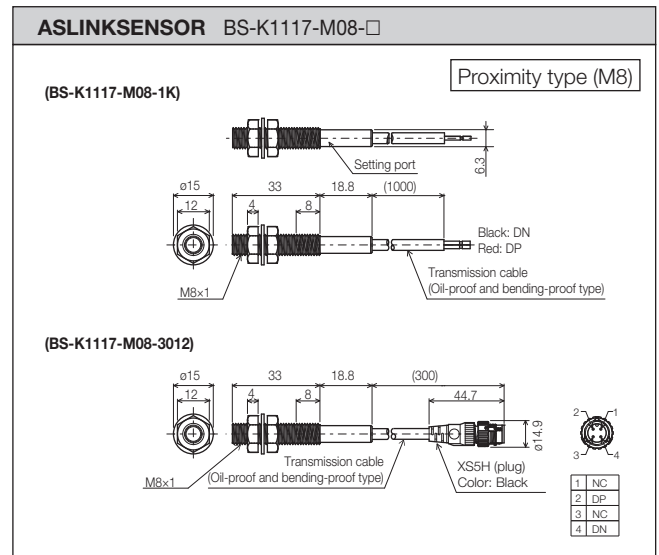
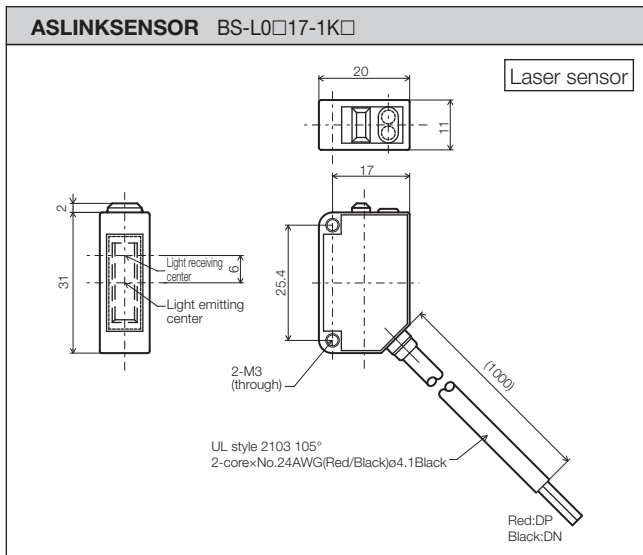
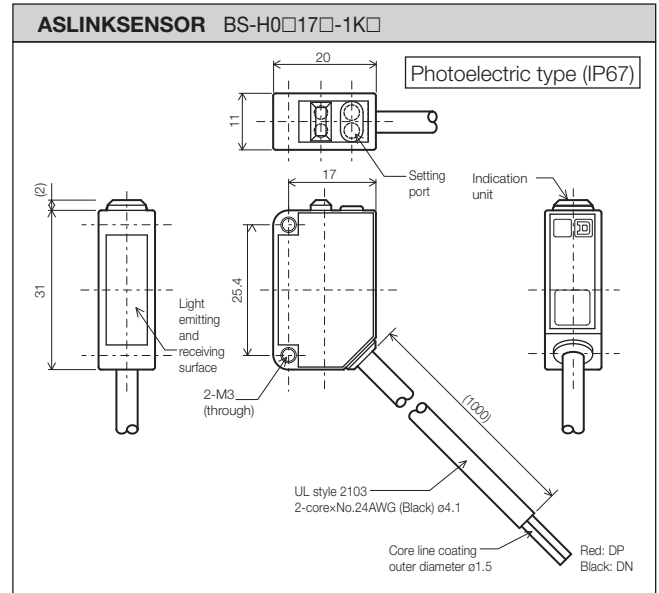
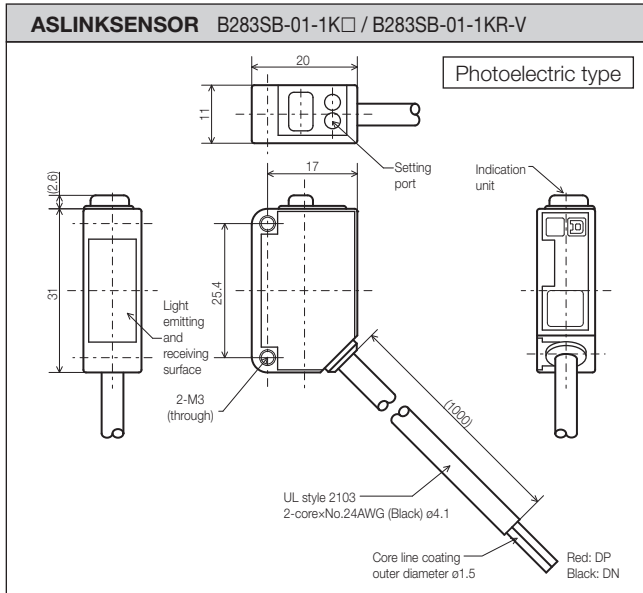

<Outer dimensional drawings>

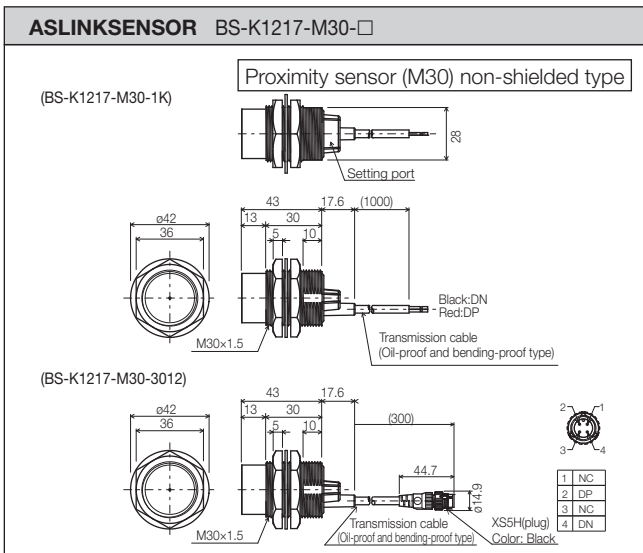
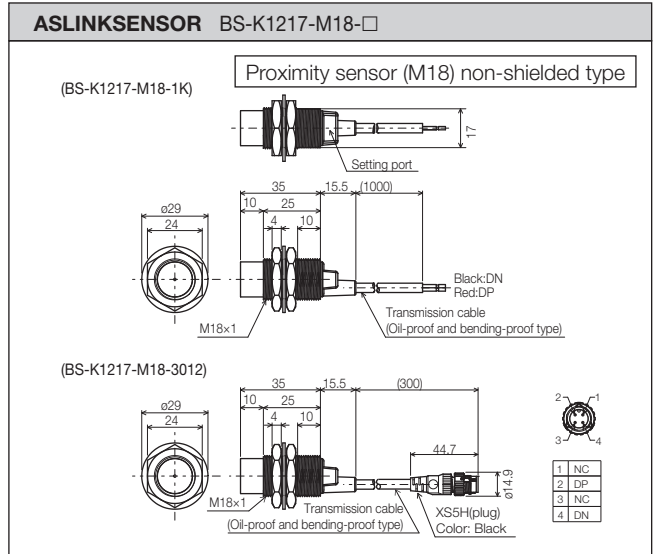
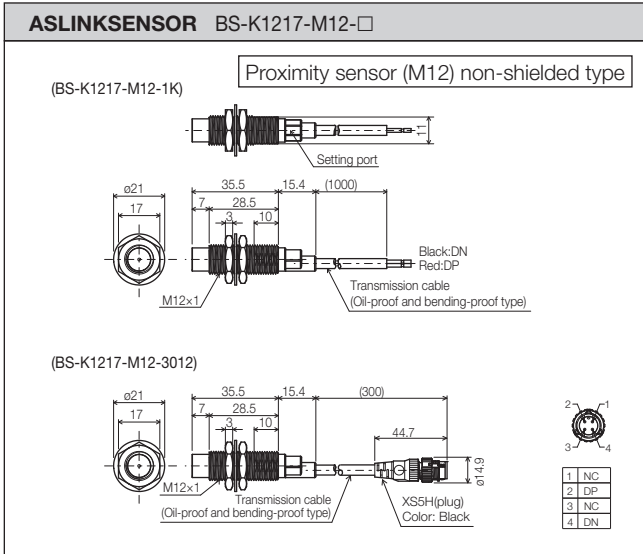
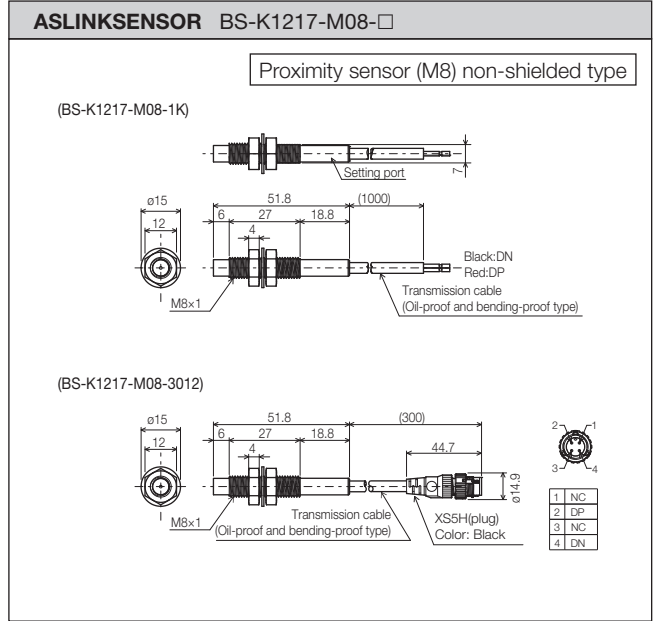
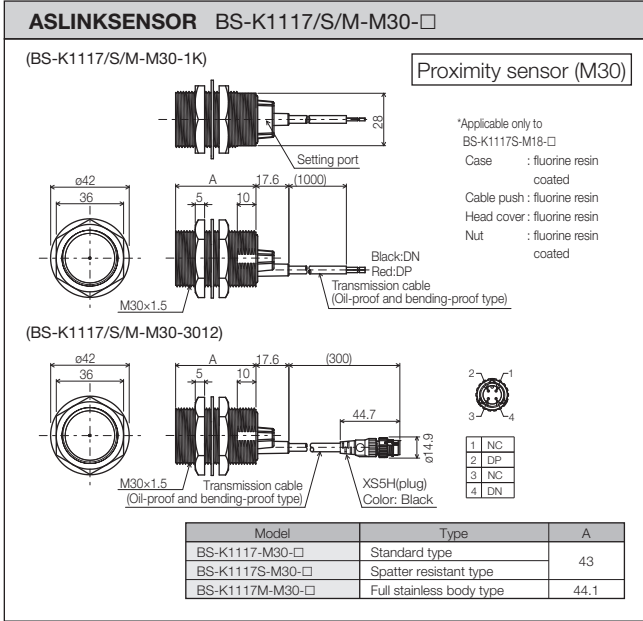

<Outer dimensional drawings>

Unit: mm

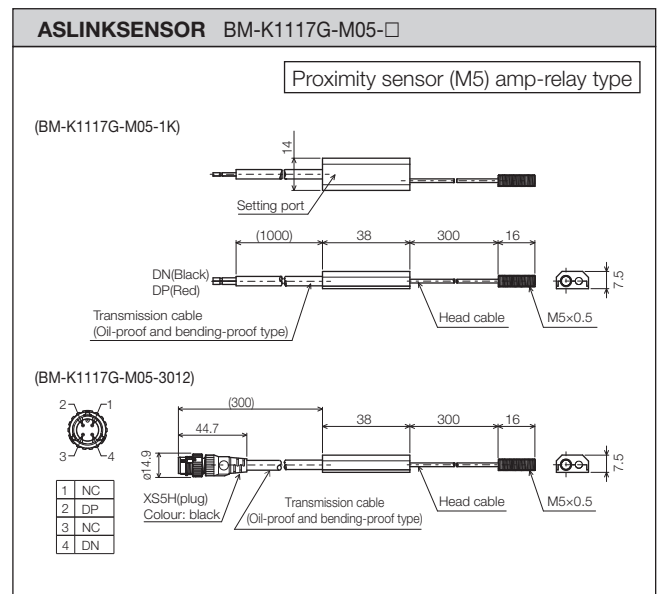
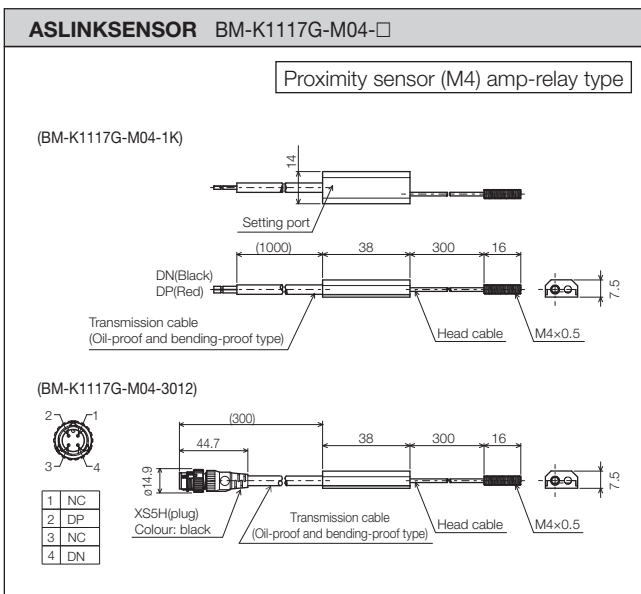
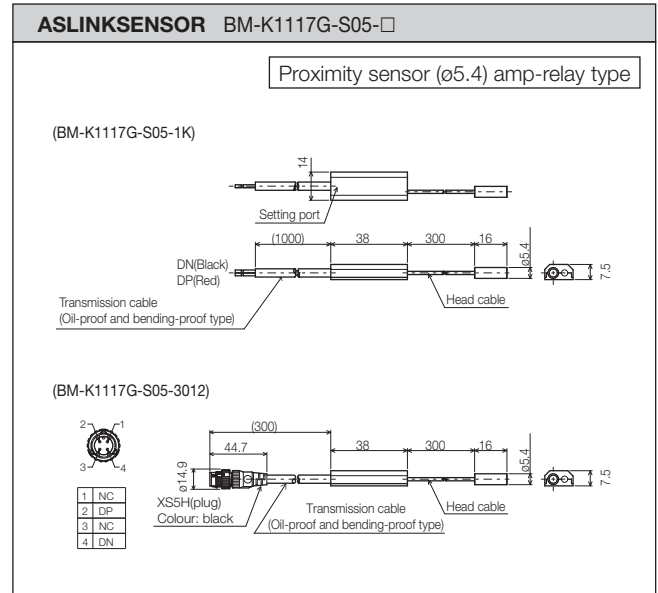
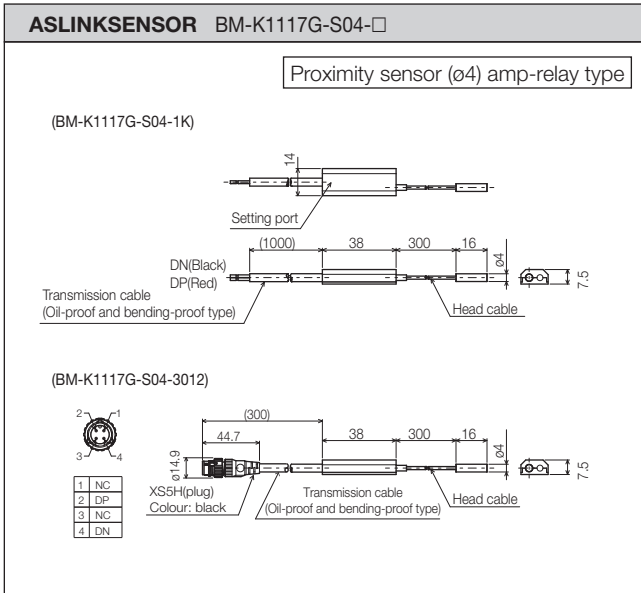

<Outer dimensional drawings>

Unit: mm

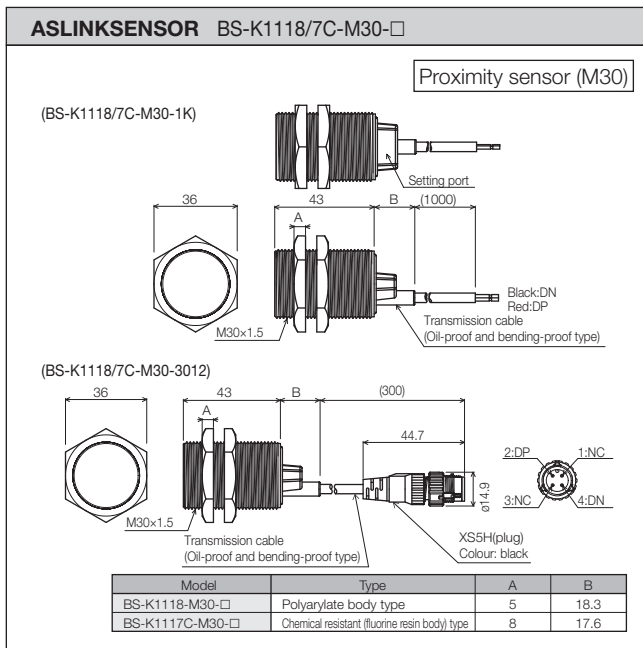
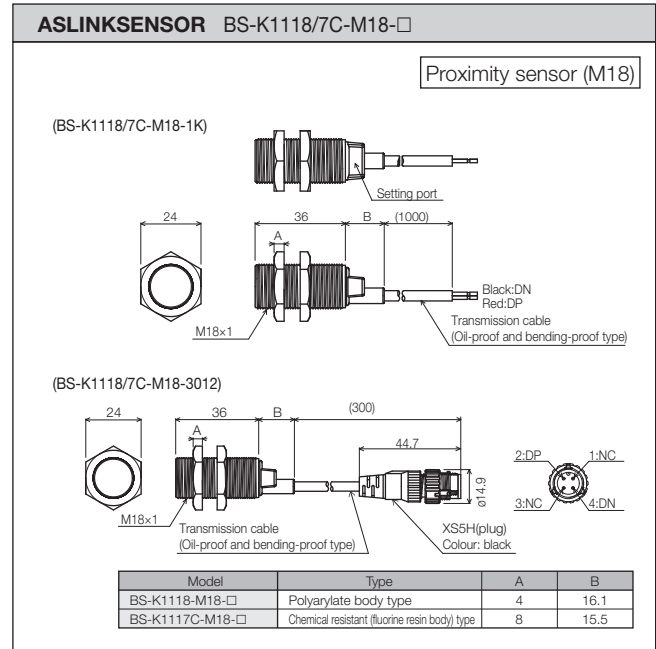
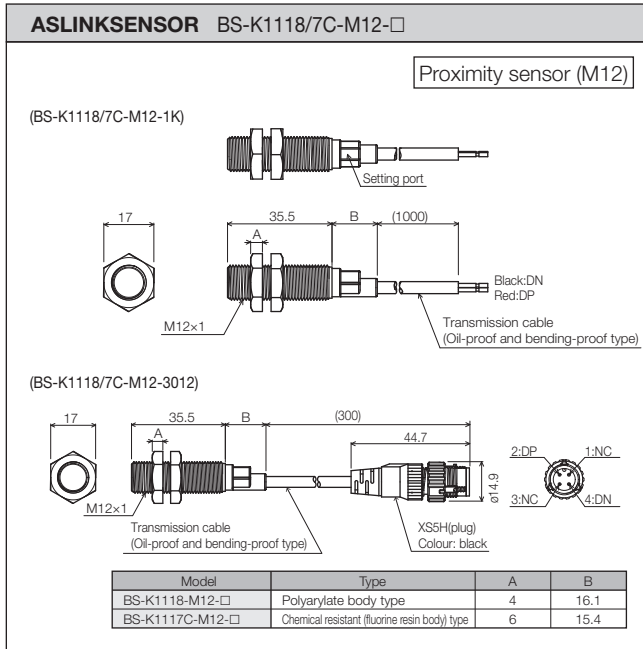

<Outer dimensional drawings>

Unit: mm

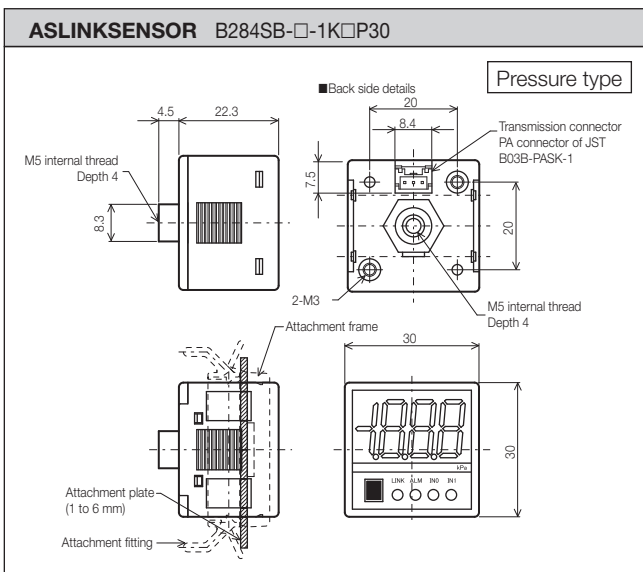
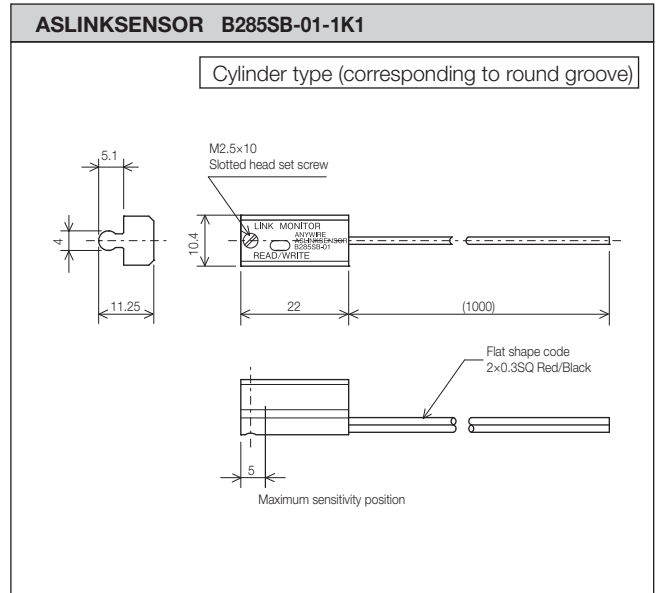
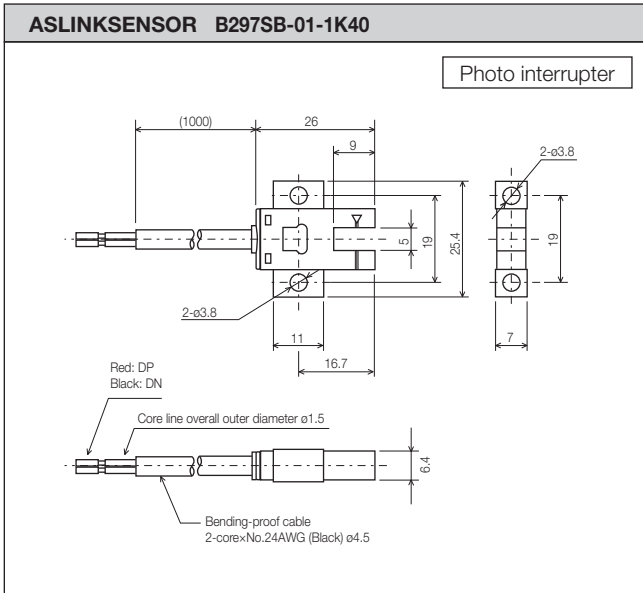

<Outer dimensional drawings>

Unit: mm

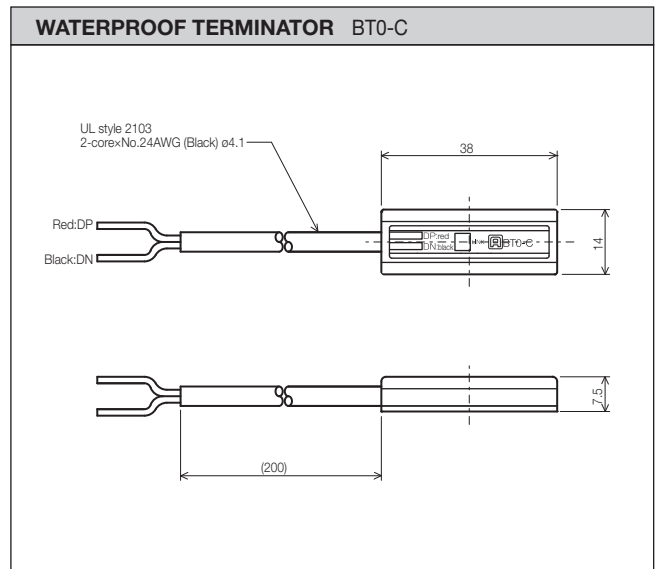
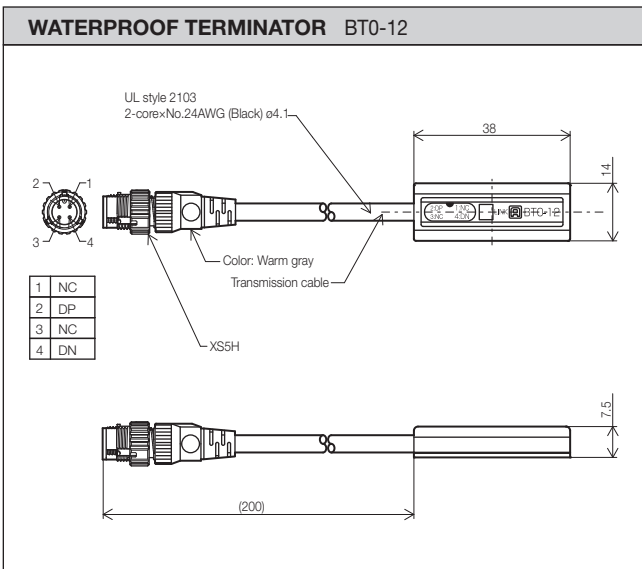
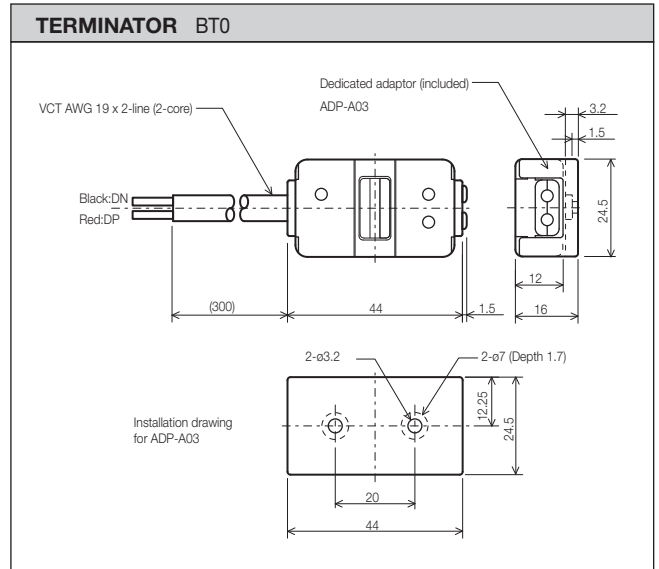
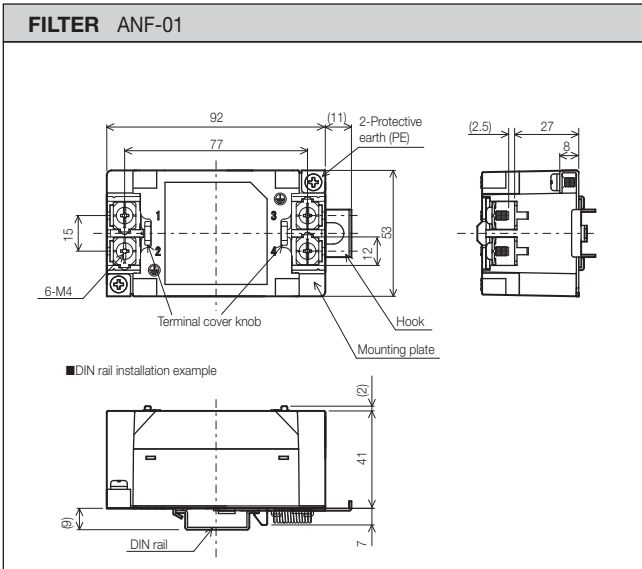
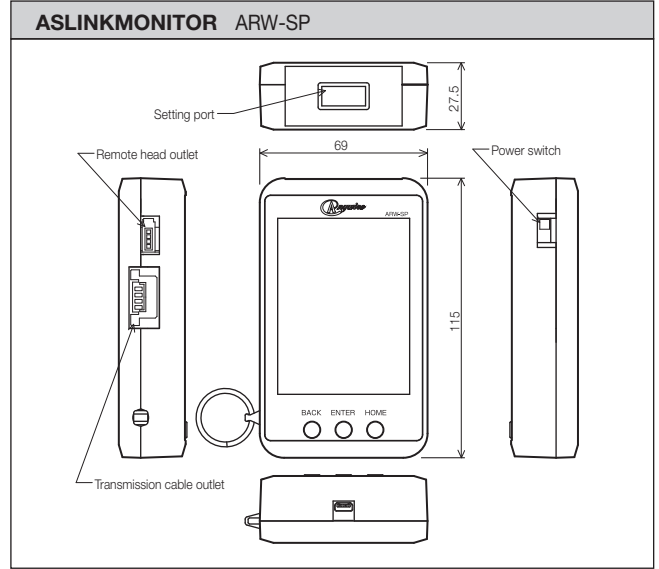
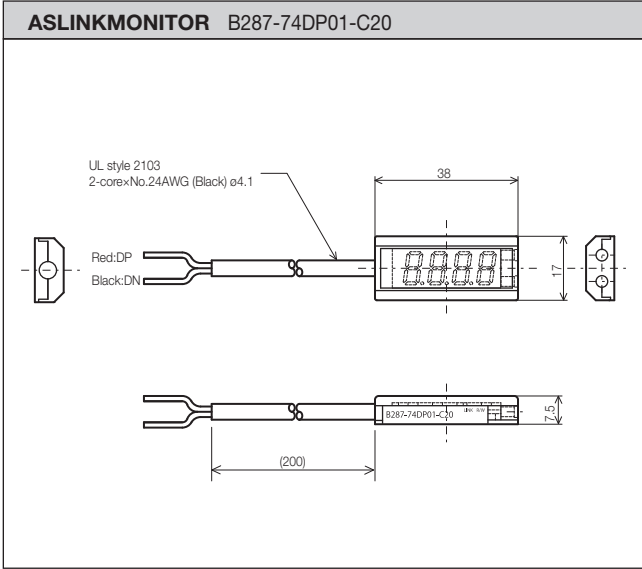

<Outer dimensional drawings>

Unit: mm

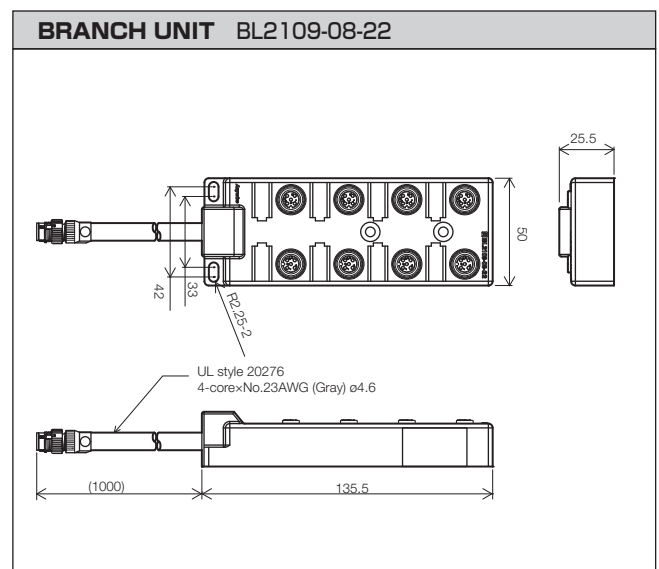
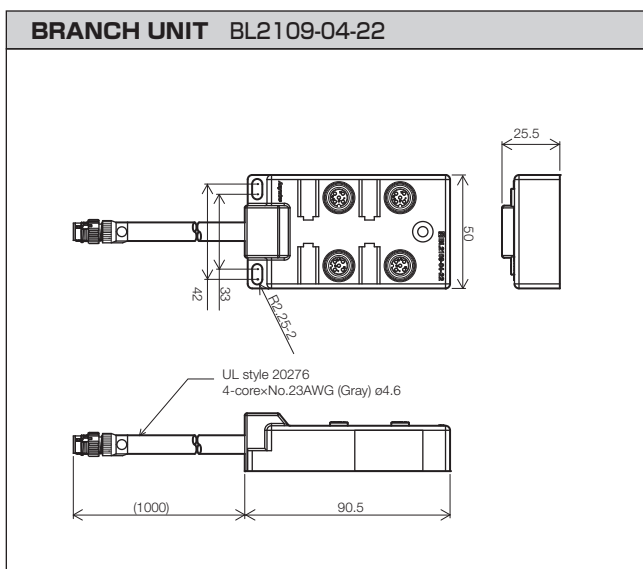
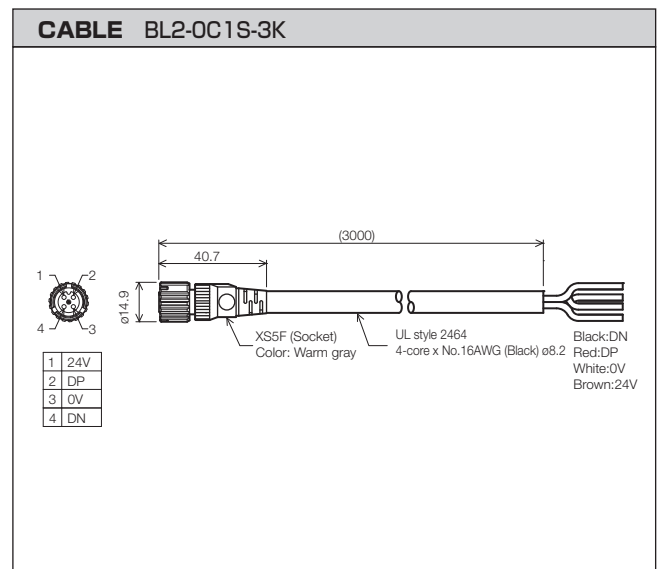
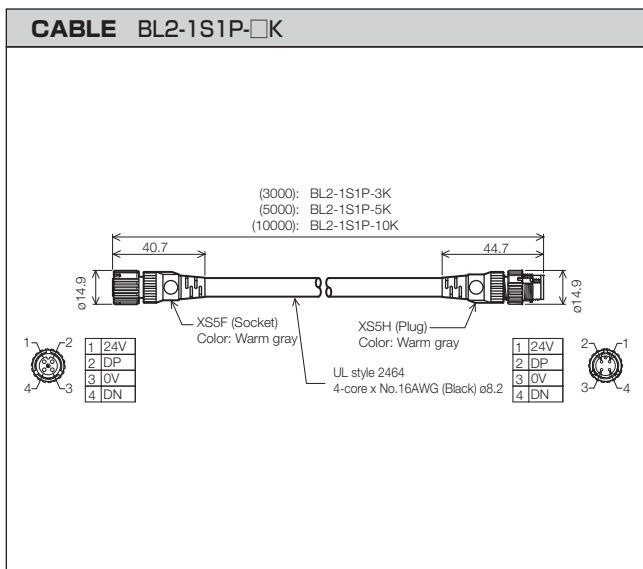
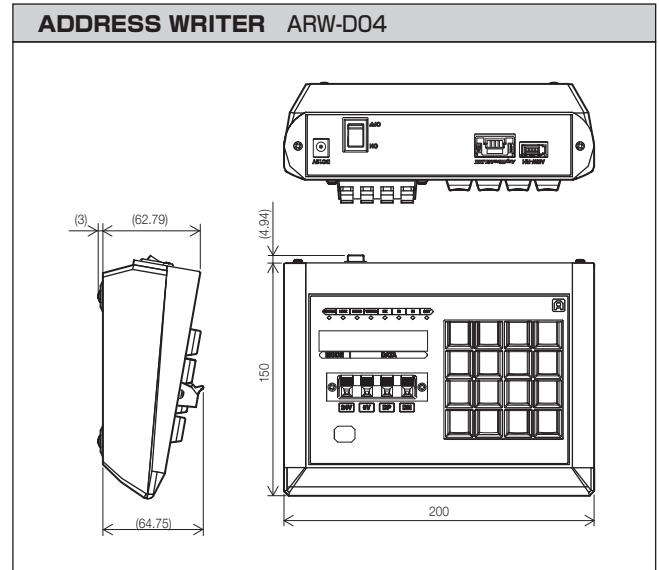
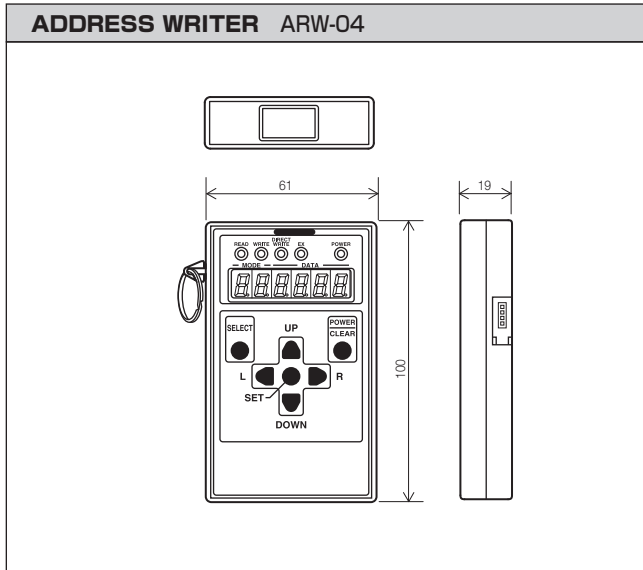

<Outer dimensional drawings>

Unit: mm

Conversion adapter cable BL2-RVAG

Manufacturer: TE Connectivity Ltd.
Model: 1-1903130-6

Fit product
Mitsubishi Electric
Forearm part external wiring set
1F-HB02S-1
For E/F1 connector, E/F2 connector

Pin number	Cable color	Signal name	Lettering on tube marker
A1	-	-	-
A2	-	-	-
A3	-	-	-
A4	-	-	-
A5	Red	DP	Red DP
A6	Black	DN	Black DN
B1	-	-	-
B2	-	-	-
B3	-	-	-
B4	-	-	-
B5	Green	24V	Green 24V
B6	White	0V	White 0V

UL1007-AWG20(0.5sq)
Coating external diameter: ϕ 1.8 to 2.1mm
Compatible LP connector: LP4-YEG-10P(AnyWire type)

Conversion adapter cable BL2-RVAH

Manufacturer: TE Connectivity Ltd.
Model: 1-1903130-6

Fit product
Mitsubishi Electric
Forearm part external wiring set
1F-HB02S-1
For E/F1 connector, E/F2 connector

Pin number	Cable color	Signal name	Lettering on tube marker
A1	Red	DP	Red DP
A2	Black	DN	Black DN
A3	-	-	-
A4	-	-	-
A5	Red	DP	Red DP
A6	Black	DN	Black DN
B1	Green	24V	Green 24V
B2	White	0V	White 0V
B3	-	-	-
B4	-	-	-
B5	Green	24V	Green 24V
B6	White	0V	White 0V

UL1007-AWG20(0.5sq)
Coating external diameter: ϕ 1.8 to 2.1mm
Compatible LP connector: LP4-YEG-10P(AnyWire type)

Conversion adapter cable BL2-RVBS

Manufacturer: TE Connectivity Ltd.
Model: 1-1318115-6

Fit product
Mitsubishi Electric
Base part external wiring set
1F-HA02S-1
For E/F1 connector, E/F2 connector

Pin number	Cable color	Signal name	Lettering on tube marker
A1	-	-	-
A2	-	-	-
A3	-	-	-
A4	-	-	-
A5	Red	DP	Red DP
A6	Black	DN	Black DN
B1	-	-	-
B2	-	-	-
B3	-	-	-
B4	-	-	-
B5	Green	24V	Green 24V
B6	White	0V	White 0V

UL1007-AWG20(0.5sq)
Coating external diameter: ϕ 1.8 to 2.1mm
Compatible LP connector: LP4-YEG-10P(AnyWire type)

Conversion adapter cable BL2-RVBH

Manufacturer: TE Connectivity Ltd.
Model: 1-1318115-6

Fit product
Mitsubishi Electric
Base part external wiring set
1F-HA02S-1
For E/F1 connector, E/F2 connector

Pin number	Cable color	Signal name	Lettering on tube marker
A1	Red	DP	Red DP
A2	Black	DN	Black DN
A3	-	-	-
A4	-	-	-
A5	Red	DP	Red DP
A6	Black	DN	Black DN
B1	Green	24V	Green 24V
B2	White	0V	White 0V
B3	-	-	-
B4	-	-	-
B5	Green	24V	Green 24V
B6	White	0V	White 0V

UL1007-AWG20(0.5sq)
Coating external diameter: ϕ 1.8 to 2.1mm
Compatible LP connector: LP4-YEG-10P(AnyWire type)

■ **Other Anywire product groups** In addition to AnyWireASLINK, a variety of products specialized for applications are available!!

DB A20 series

Overall length MAX. 3 km	Topology free	Max. number of points 1024 points	4-wires (2 transmission cables, 2 power wires)	Transmission speed 125 kHz/31.3 kHz, 7.8 kHz/2 kHz
-----------------------------	------------------	--------------------------------------	--	---

▶ Mitsubishi Electric products



■ AnyWire DB A20
Master module
QJ51AW12D2



■ AnyWire DB A20
Master module
LJ51AW12D2



■ CC-Link-AnyWire DB A20
Bridge module
NZ2AW1C2D2

This series is suitable for medium- to small-scale wire-saving in factories.

The original transmission method allows general-purpose cable to be used with little branching constraints.



A remote I/O, analog, temperature/humidity terminal, and POKA-YOKE terminals are available.

This series also supports trolley and slip rings.



Bitty series

Overall length MAX. 100 m	Topology free	Max. number of points 512 points	2-wires (Power superimposed)	Transmission speed 27.0 kHz
------------------------------	------------------	-------------------------------------	---------------------------------	--------------------------------

▶ Mitsubishi Electric products

■ CC-Link-AnyWire Bitty
Bridge module
NZ2AW1C1BY

■ AnyWire Bitty Series
FX3U-128BTY-M

* For FX3U-128BTY-M, max. number of points is 128 points.

This series is suitable for small-scale wire-saving such as in control panels and systems.

The power is fed superimposed on the transmission line, so sensors and valves, etc., can be controlled and the load power can be supplied just by laying a 2-wire transmission line.

Remote I/O and POKA-YOKE terminals are available.

This series also supports slip rings.

▶ Anywire products 

POKA-YOKE



■ LED display type POKA-YOKE
Terminal pipe rack mounted type
A027XB-02G2-P

This terminal is specialized for (failsafe) applications. The terminal with the rigid case, easy to read display, replaceable lever was designed reflecting opinions from the production site and a variety of size selection is available. Mounting on pipes and flat tables is also supported. This terminal can be controlled from a programmable controller, and is perfect for structuring (failsafe) in the factory.

Mapping

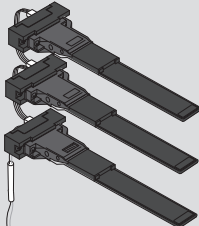

■ Mapping terminal

This terminal is specialized for FPD glass detection. The module integrating infrared detection function and transmission function can be connected in serial to configure a single mapping terminal. A free pitch and number of channels are supported, and the setup can be customized by adding modules.

Related product catalogs

[Mitsubishi Electric product]



iQ Sensor Solution
L(NA)16029



MELSEC iQ-R-Series
iQ-Platform-compatible PAC
L(NA)08298



iQ Platform
Programmable Controller
MELSEC-Q series [QnU]
L(NA)08101



Programmable Controllers
MELSEC-L series
L(NA)08159



MELSEC iQ-F Series
iQ-Platform-compatible PLC
L(NA)08428



PROGRAMMABLE
CONTROLLERS MELSEC-F
FX Family Catalog
HIME-B215



iQ Platform
Graphic Operation Terminal
GOT2000 Series
L(NA)08270

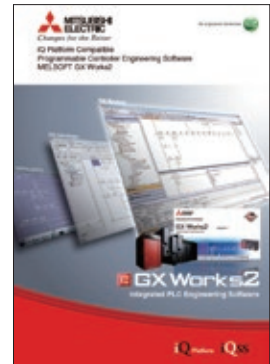

iQ Platform Compatible
Programmable Controller
Engineering Software
MELSOFT GX Works2
L(NA)08122



iQ Platform
Graphic Operation Terminal Screen
Design Software
MELSOFT GT Works3
L(NA)08170

[Anywire product]

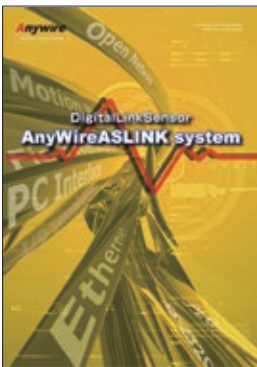

Digital Link Sensor
AnyWireASLINK system

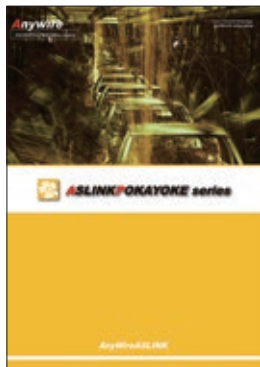

ASLINK POKAYOKE series

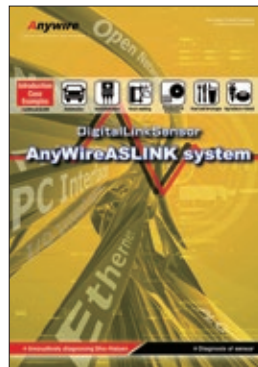

Digital Link Sensor
AnyWireASLINK system
Introduction case examples

Ethernet is a trademark of Xerox Corporation.

All other company names and product names used in this document are trademarks or registered trademarks of their respective companies.

Precautions before use

This publication explains the typical features and functions of the products herein and does not provide restrictions or other information related to usage and module combinations. Before using the products, always read the product user manuals. Mitsubishi Electric will not be held liable for damage caused by factors found not to be the cause of Mitsubishi Electric; opportunity loss or lost profits caused by faults in Mitsubishi Electric products; damage, secondary damage, or accident compensation, whether foreseeable or not, caused by special factors; damage to products other than Mitsubishi Electric products; or any other duties.

For safe use

- To use the products given in this publication properly, always read the relevant manuals before beginning operation.
- The products have been manufactured as general-purpose parts for general industries, and are not designed or manufactured to be incorporated in a device or system used in purposes related to human life.
- Before using the products for special purposes such as nuclear power, electric power, aerospace, medicine or passenger-carrying vehicles, consult with Mitsubishi Electric.
- The products have been manufactured under strict quality control. However, when installing the products where major accidents or losses could occur if the products fail, install appropriate backup or fail-safe functions in the system.

Anywire Corporation

Headquarters

1 Babazusho, Nagaokakyo-shi, Kyoto 617-8550 JAPAN

Contact by mail

info_e@anywire.jp

Contact by website

<http://www.anywire.jp>

MITSUBISHI ELECTRIC CORPORATION

HEAD OFFICE: TOKYO BUILDING, 2-7-3, MARUNOUCHI, CHIYODA-KU, TOKYO 100-8310, JAPAN
NAGOYA WORKS: 1-14, YADA-MINAMI 5, HIGASHI-KU, NAGOYA, JAPAN
