

MITSUBISHI ELECTRIC SERVO SYSTEM CONTROLLER

Migration Guide of Motion Controller [Q170MCPUR ⇒ Q170MSCPUR(-S1)]



● SAFETY PRECAUTIONS ●

(Please read these instructions before using this equipment.)

Before using this product, please read this manual and the relevant manuals introduced in this manual carefully and pay full attention to safety to handle the product correctly.

These precautions apply only to this product. Refer to the Q170MSCPU Users manual for a description of the Motion controller safety precautions.

In this manual, the safety instructions are ranked as "DANGER" and "CAUTION".



Indicates that incorrect handling may cause hazardous conditions, resulting in death or severe injury.



Indicates that incorrect handling may cause hazardous conditions, resulting in medium or slight personal injury or physical damage.

Depending on circumstances, procedures indicated by  CAUTION may also be linked to serious results.

In any case, it is important to follow the directions for usage.

Please save this manual to make it accessible when required and always forward it to the end user.

For Safe Operations

1. Prevention of electric shocks

DANGER

- Never open the front case or terminal covers while the power is ON or the unit is running, as this may lead to electric shocks.
- Never run the unit with the front case or terminal cover removed. The high voltage terminal and charged sections will be exposed and may lead to electric shocks.
- Never open the front case or terminal cover at times other than wiring work or periodic inspections even if the power is OFF. The insides of the Motion controller and servo amplifier are charged and may lead to electric shocks.
- Completely turn off the externally supplied power used in the system before mounting or removing the module, performing wiring work, or inspections. Failing to do so may lead to electric shocks.
- When performing wiring work or inspections, turn the power OFF, wait at least ten minutes, and then check the voltage with a tester, etc. Failing to do so may lead to electric shocks.
- Be sure to ground the Motion controller, servo amplifier and servomotor. (Ground resistance : 100 Ω or less) Do not ground commonly with other devices.
- The wiring work and inspections must be done by a qualified technician.
- Wire the units after installing the Motion controller, servo amplifier and servomotor. Failing to do so may lead to electric shocks or damage.
- Never operate the switches with wet hands, as this may lead to electric shocks.
- Do not damage, apply excessive stress, place heavy things on or sandwich the cables, as this may lead to electric shocks.
- Do not touch the Motion controller, servo amplifier or servomotor terminal blocks while the power is ON, as this may lead to electric shocks.
- Do not touch the built-in power supply, built-in grounding or signal wires of the Motion controller and servo amplifier, as this may lead to electric shocks.

2. For fire prevention

CAUTION

- Install the Motion controller, servo amplifier, servomotor and regenerative resistor on incombustible. Installing them directly or close to combustibles will lead to fire.
- If a fault occurs in the Motion controller or servo amplifier, shut the power OFF at the servo amplifier's power source. If a large current continues to flow, fire may occur.
- When using a regenerative resistor, shut the power OFF with an error signal. The regenerative resistor may abnormally overheat due to a fault in the regenerative transistor, etc., and may lead to fire.
- Always take heat measures such as flame proofing for the inside of the control panel where the servo amplifier or regenerative resistor is installed and for the wires used. Failing to do so may lead to fire.
- Do not damage, apply excessive stress, place heavy things on or sandwich the cables, as this may lead to fire.

3. For injury prevention

CAUTION

- Do not apply a voltage other than that specified in the instruction manual on any terminal. Doing so may lead to destruction or damage.
- Do not mistake the terminal connections, as this may lead to destruction or damage.
- Do not mistake the polarity (+ / -), as this may lead to destruction or damage.
- Do not touch the heat radiating fins of controller or servo amplifier, regenerative resistor and servomotor, etc., while the power is ON and for a short time after the power is turned OFF. In this timing, these parts become very hot and may lead to burns.
- Always turn the power OFF before touching the servomotor shaft or coupled machines, as these parts may lead to injuries.
- Do not go near the machine during test operations or during operations such as teaching. Doing so may lead to injuries.

4. Various precautions

Strictly observe the following precautions.

Mistaken handling of the unit may lead to faults, injuries or electric shocks.

(1) System structure

CAUTION

- Always install a leakage breaker on the Motion controller and servo amplifier power source.
- If installation of an electromagnetic contactor for power shut off during an error, etc., is specified in the instruction manual for the servo amplifier, etc., always install the electromagnetic contactor.
- Install the emergency stop circuit externally so that the operation can be stopped immediately and the power shut off.
- Use the Motion controller, servo amplifier, servomotor and regenerative resistor with the correct combinations listed in the instruction manual. Other combinations may lead to fire or faults.
- Use the Motion controller, base unit and motion module with the correct combinations listed in the instruction manual. Other combinations may lead to faults.
- If safety standards (ex., robot safety rules, etc.,) apply to the system using the Motion controller, servo amplifier and servomotor, make sure that the safety standards are satisfied.
- Construct a safety circuit externally of the Motion controller or servo amplifier if the abnormal operation of the Motion controller or servo amplifier differ from the safety directive operation in the system.
- In systems where coasting of the servomotor will be a problem during the forced stop, emergency stop, servo OFF or power supply OFF, use dynamic brakes.
- Make sure that the system considers the coasting amount even when using dynamic brakes.
- In systems where perpendicular shaft dropping may be a problem during the forced stop, emergency stop, servo OFF or power supply OFF, use both dynamic brakes and electromagnetic brakes.

CAUTION

- The dynamic brakes must be used only on errors that cause the forced stop, emergency stop, or servo OFF. These brakes must not be used for normal braking.
- The brakes (electromagnetic brakes) assembled into the servomotor are for holding applications, and must not be used for normal braking.
- The system must have a mechanical allowance so that the machine itself can stop even if the stroke limits switch is passed through at the max. speed.
- Use wires and cables that have a wire diameter, heat resistance and bending resistance compatible with the system.
- Use wires and cables within the length of the range described in the instruction manual.
- The ratings and characteristics of the parts (other than Motion controller, servo amplifier and servomotor) used in a system must be compatible with the Motion controller, servo amplifier and servomotor.
- Install a cover on the shaft so that the rotary parts of the servomotor are not touched during operation.
- There may be some cases where holding by the electromagnetic brakes is not possible due to the life or mechanical structure (when the ball screw and servomotor are connected with a timing belt, etc.). Install a stopping device to ensure safety on the machine side.
- To maintain the safety of the programmable controller system against unauthorized access from external devices via the network, take appropriate measures. To maintain the safety against unauthorized access via the Internet, take measures such as installing a firewall.

(2) Parameter settings and programming

CAUTION

- Set the parameter values to those that are compatible with the Motion controller, servo amplifier, servomotor and regenerative resistor model and the system application. The protective functions may not function if the settings are incorrect.
- The regenerative resistor model and capacity parameters must be set to values that conform to the operation mode, servo amplifier and servo power supply module. The protective functions may not function if the settings are incorrect.
- Set the mechanical brake output and dynamic brake output validity parameters to values that are compatible with the system application. The protective functions may not function if the settings are incorrect.
- Set the stroke limit input validity parameter to a value that is compatible with the system application. The protective functions may not function if the setting is incorrect.
- Set the servomotor encoder type (increment, absolute position type, etc.) parameter to a value that is compatible with the system application. The protective functions may not function if the setting is incorrect.
- Set the servomotor capacity and type (standard, low-inertia, flat, etc.) parameter to values that are compatible with the system application. The protective functions may not function if the settings are incorrect.

CAUTION

- Set the servo amplifier capacity and type parameters to values that are compatible with the system application. The protective functions may not function if the settings are incorrect.
- Use the program commands for the program with the conditions specified in the instruction manual.
- Set the sequence function program capacity setting, device capacity, latch validity range, I/O assignment setting, and validity of continuous operation during error detection to values that are compatible with the system application. The protective functions may not function if the settings are incorrect.
- Some devices used in the program have fixed applications, so use these with the conditions specified in the instruction manual.
- The input devices and data registers assigned to the link will hold the data previous to when communication is terminated by an error, etc. Thus, an error correspondence interlock program specified in the instruction manual must be used.
- Use the interlock program specified in the intelligent function module's instruction manual for the program corresponding to the intelligent function module.

(3) Transportation and installation

CAUTION

- Transport the product with the correct method according to the mass.
- Use the servomotor suspension bolts only for the transportation of the servomotor. Do not transport the servomotor with machine installed on it.
- Do not stack products past the limit.
- When transporting the Motion controller or servo amplifier, never hold the connected wires or cables.
- When transporting the servomotor, never hold the cables, shaft or detector.
- When transporting the Motion controller or servo amplifier, never hold the front case as it may fall off.
- When transporting, installing or removing the Motion controller or servo amplifier, never hold the edges.
- Install the unit according to the instruction manual in a place where the mass can be withstood.
- Do not get on or place heavy objects on the product.
- Always observe the installation direction.
- Keep the designated clearance between the Motion controller or servo amplifier and control panel inner surface or the Motion controller and servo amplifier, Motion controller or servo amplifier and other devices.
- Do not install or operate Motion controller, servo amplifiers or servomotors that are damaged or that have missing parts.
- Do not block the intake/outtake ports of the Motion controller, servo amplifier and servomotor with cooling fan.
- Do not allow conductive matter such as screw or cutting chips or combustible matter such as oil enter the Motion controller, servo amplifier or servomotor.

⚠ CAUTION

- The Motion controller, servo amplifier and servomotor are precision machines, so do not drop or apply strong impacts on them.
- Securely fix the Motion controller, servo amplifier and servomotor to the machine according to the instruction manual. If the fixing is insufficient, these may come off during operation.
- Always install the servomotor with reduction gears in the designated direction. Failing to do so may lead to oil leaks.
- Store and use the unit in the following environmental conditions.

Environment	Conditions	
	Motion controller/Servo amplifier	Servomotor
Ambient temperature	According to each instruction manual.	0°C to +40°C (With no freezing) (32°F to +104°F)
Ambient humidity	According to each instruction manual.	80% RH or less (With no dew condensation)
Storage temperature	According to each instruction manual.	-20°C to +65°C (-4°F to +149°F)
Atmosphere	Indoors (where not subject to direct sunlight). No corrosive gases, flammable gases, oil mist or dust must exist	
Altitude	According to each instruction manual	
Vibration	According to each instruction manual	

- When coupling with the synchronous encoder or servomotor shaft end, do not apply impact such as by hitting with a hammer. Doing so may lead to detector damage.
- Do not apply a load larger than the tolerable load onto the synchronous encoder and servomotor shaft. Doing so may lead to shaft breakage.
- When not using the module for a long time, disconnect the power line from the Motion controller or servo amplifier.
- Place the Motion controller and servo amplifier in static electricity preventing vinyl bags and store.
- When storing for a long time, please contact with our sales representative.
Also, execute a trial operation.
- When fumigants that contain halogen materials such as fluorine, chlorine, bromine, and iodine are used for disinfecting and protecting wooden packaging from insects, they cause malfunction when entering our products.
Please take necessary precautions to ensure that remaining materials from fumigant do not enter our products, or treat packaging with methods other than fumigation (heat method).
Additionally, disinfect and protect wood from insects before packing products.

(4) Wiring

⚠ CAUTION

- Correctly and securely wire the wires. Reconfirm the connections for mistakes and the terminal screws for tightness after wiring. Failing to do so may lead to run away of the servomotor.
- After wiring, install the protective covers such as the terminal covers to the original positions.
- Do not install a phase advancing capacitor, surge absorber or radio noise filter (option FR-BIF) on the output side of the servo amplifier.
- Correctly connect the output side (terminal U, V, W) and ground. Incorrect connections will lead the servomotor to operate abnormally.
- Do not connect a commercial power supply to the servomotor, as this may lead to trouble.
- Do not mistake the direction of the surge absorbing diode installed on the DC relay for the control signal output of brake signals, etc. Incorrect installation may lead to signals not being output when trouble occurs or the protective functions not functioning.

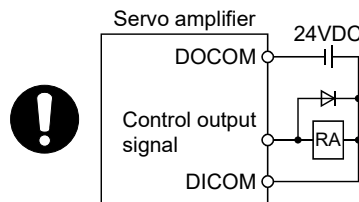

For the sink output interface

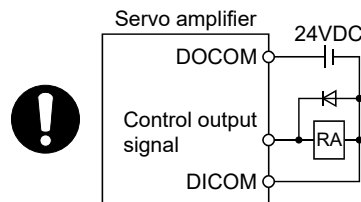

For the source output interface

- Do not connect or disconnect the connection cables between each unit, the encoder cable or PLC expansion cable while the power is ON.
- Securely tighten the cable connector fixing screws and fixing mechanisms. Insufficient fixing may lead to the cables coming off during operation.
- Do not bundle the power line or cables.

(5) Trial operation and adjustment

⚠ CAUTION

- Confirm and adjust the program and each parameter before operation. Unpredictable movements may occur depending on the machine.
- Extreme adjustments and changes may lead to unstable operation, so never make them.
- When using the absolute position system function, on starting up, and when the Motion controller or absolute position motor has been replaced, always perform a home position return.
- Before starting test operation, set the parameter speed limit value to the slowest value, and make sure that operation can be stopped immediately by the forced stop, etc. if a hazardous state occurs.

(6) Usage methods

⚠ CAUTION

- Immediately turn OFF the power if smoke, abnormal sounds or odors are emitted from the Motion controller, servo amplifier or servomotor.
- Always execute a test operation before starting actual operations after the program or parameters have been changed or after maintenance and inspection.
- Do not attempt to disassemble and repair the units excluding a qualified technician whom our company recognized.
- Do not make any modifications to the unit.
- Keep the effect or electromagnetic obstacles to a minimum by installing a noise filter or by using wire shields, etc. Electromagnetic obstacles may affect the electronic devices used near the Motion controller or servo amplifier.
- When using the CE Mark-compliant equipment, refer to the User's manual for the Motion controllers and refer to the corresponding EMC guideline information for the servo amplifiers, inverters and other equipment.
- Use the units with the following conditions.

Item	Conditions
Input power	According to each instruction manual.
Input frequency	According to each instruction manual.
Tolerable momentary power failure	According to each instruction manual.

(7) Corrective actions for errors

⚠ CAUTION

- If an error occurs in the self diagnosis of the Motion controller or servo amplifier, confirm the check details according to the instruction manual, and restore the operation.
- If a dangerous state is predicted in case of a power failure or product failure, use a servomotor with electromagnetic brakes or install a brake mechanism externally.
- Use a double circuit construction so that the electromagnetic brake operation circuit can be operated by emergency stop signals set externally.

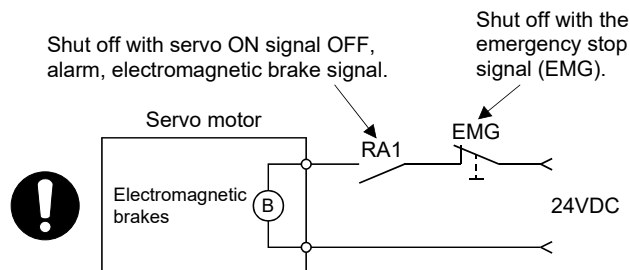

- If an error occurs, remove the cause, secure the safety and then resume operation after alarm release.
- The unit may suddenly resume operation after a power failure is restored, so do not go near the machine. (Design the machine so that personal safety can be ensured even if the machine restarts suddenly.)

(8) Maintenance, inspection and part replacement

CAUTION

- Perform the daily and periodic inspections according to the instruction manual.
- Perform maintenance and inspection after backing up the program and parameters for the Motion controller and servo amplifier.
- Do not place fingers or hands in the clearance when opening or closing any opening.
- Periodically replace consumable parts such as batteries according to the instruction manual.
- Do not touch the lead sections such as ICs or the connector contacts.
- Before touching the module, always touch grounded metal, etc. to discharge static electricity from human body. Failure to do so may cause the module to fail or malfunction.
- Do not directly touch the module's conductive parts and electronic components. Touching them could cause an operation failure or give damage to the module.
- Do not place the Motion controller or servo amplifier on metal that may cause a power leakage or wood, plastic or vinyl that may cause static electricity buildup.
- Do not perform a megger test (insulation resistance measurement) during inspection.
- When replacing the Motion controller or servo amplifier, always set the new module settings correctly.
- When the Motion controller or absolute value motor has been replaced, carry out a home position return operation using one of the following methods, otherwise position displacement could occur.
 - 1) After writing the servo data to the Motion controller using programming software, switch on the power again, then perform a home position return operation.
 - 2) Using the backup function of the programming software, load the data backed up before replacement.
- After maintenance and inspections are completed, confirm that the position detection of the absolute position detector function is correct.
- Do not drop or impact the battery installed to the module.

Doing so may damage the battery, causing battery liquid to leak in the battery. Do not use the dropped or impacted battery, but dispose of it.
- Do not short circuit, charge, overheat, incinerate or disassemble the batteries.
- The electrolytic capacitor will generate gas during a fault, so do not place your face near the Motion controller or servo amplifier.
- The electrolytic capacitor and fan will deteriorate. Periodically replace these to prevent secondary damage from faults. Replacements can be made by our sales representative.
- Lock the control panel and prevent access to those who are not certified to handle or install electric equipment.
- Do not burn or break a module and servo amplifier. Doing so may cause a toxic gas.

(9) About processing of waste

When you discard Motion controller, servo amplifier, a battery (primary battery) and other option articles, please follow the law of each country (area).

CAUTION

- This product is not designed or manufactured to be used in equipment or systems in situations that can affect or endanger human life.
- When considering this product for operation in special applications such as machinery or systems used in passenger transportation, medical, aerospace, atomic power, electric power, or submarine repeating applications, please contact your nearest Mitsubishi Electric sales representative.
- Although this product was manufactured under conditions of strict quality control, you are strongly advised to install safety devices to forestall serious accidents when it is used in facilities where a breakdown in the product is likely to cause a serious accident.

(10) General cautions

- All drawings provided in the instruction manual show the state with the covers and safety partitions removed to explain detailed sections. When operating the product, always return the covers and partitions to the designated positions, and operate according to the instruction manual.

REVISIONS

Print Date	Manual No.	Revision
Dec, 2021	L(NA)03196ENG-A	First edition

This manual confers no industrial property rights or any rights of any other kind, nor does it confer any patent licenses. Mitsubishi Electric Corporation cannot be held responsible for any problems involving industrial property rights which may occur as a result of using the contents noted in this manual.

© 2021 MITSUBISHI ELECTRIC CORPORATION

INTRODUCTION

Please read this manual carefully so that equipment is used to its optimum.

CONTENTS

Safety Precautions	A- 1
Revisions	A-11
Contents	A-12

1. OVERVIEW OF MIGRATION FROM Q170MCPU TO Q170MSCPU(-S1)	1- 1 to 1-16
---	---------------------

1.1 Benefits of Migration	1- 1
1.2 Main Target Models for Migration.....	1- 2
1.3 System Configuration.....	1- 5
1.3.1 System configuration using Q170MCPU before migration.....	1- 5
1.3.2 System configuration using Q170MSCPU(-S1) after migration	1- 6
1.4 Case Study on Migration	1- 7
1.4.1 Whole system migration (recommended)	1- 8
1.4.2 Phased migration	1- 9
1.4.3 Separate repair.....	1-10
1.4.4 Precautions for powering off only a desired servo amplifier	1-12
1.4.5 Configuration when the MR-MV200 optical hub unit is used.....	1-13
1.5 Project Diversion	1-14
1.6 Relevant Documents.....	1-15
1.6.1 Relevant catalogs.....	1-15
1.6.2 Relevant manuals	1-16

2. DETAILS OF MIGRATION FROM Q170MCPU TO Q170MSCPU(-S1)	2- 1 to 2-22
--	---------------------

2.1 Table of Components and Software.....	2- 1
2.1.1 Servo amplifiers and servo motors	2- 2
2.1.2 Operating system software	2- 3
2.1.3 Engineering environment (required).....	2- 3
2.2 Differences Between Q170MCPU TO Q170MSCPU(-S1).....	2- 4
2.3 Project Diversion	2- 9
2.3.1 List of divertible/Not divertible data (SV13/SV22).....	2- 9
2.3.2 Project diversion procedures by engineering environment	2-10

1. OVERVIEW OF MIGRATION FROM Q170MCPU TO Q170MSCPU(-S1)

1.1 Benefits of Migration

Migrating from the existing system using Q170MCPU Motion controllers to a new system using iQ Platform Motion controllers Q170MSCPU(-S1), which support the programs on the Q170MCPU, is recommended. We also recommend migrating servo amplifiers to the MR-J4 series at the same time.

Migrating not only allows the system to run for longer periods, but also has the following advantages.

(1) High-speed operation and high functionality of the Motion controller

The Motion controller Q170MSCPU(-S1) achieves the operation cycle of 0.22 ms/4 axes, enabling a dramatically fast operation.

The controller also achieves further advanced motion control with a wide variety of motion control functions.

→ Increased productivity from higher speeds and functionality of the Motion controller

(2) High-speed communication by SSCNETIII/H 

Speeding up and improving noise tolerance of servo system network communications are achieved by optical communication. A long distance cable of 100 m can be also used.

→ Increased speeds over the entire facility (three-times faster compared to SSCNETIII)

(3) Servo amplifier MR-J4 and servo motor 

The servo amplifier MR-J4 series achieves high performance operation with a variety of functions including one-touch tuning, a 22-bit high resolution encoder (4194304 pulse/rev), and 2.5 kHz speed frequency response. The product line includes multi-axis servo amplifiers that contribute to energy saving, space saving, and reduced wiring of a machine. The MR-J4 series compatible rotary servo motor, HG series enables to output high torque at high speed. Linear servo motors and direct drive motors are also available. Select the motor type according to your application from our extensive product lines.

→ Increase of applications, improved performance, energy saving, downsizing, and reduced wiring of drive systems

(4) Lower maintenance cost

After 5 years of usage, the products will need maintenance, such as replacement of the whole circuit board due to the life of components including electrolytic capacitors and memories.

To use the system the longest possible, an early migration to the latest model is recommended in terms of performance and quality.

→ Increased equipment longevity

1. OVERVIEW OF MIGRATION FROM Q170MCPU TO Q170MSCPU(-S1)

1.2 Main Target Models for Migration

The main target models and operating system software for replacement described in this section are as follows.

If you are using special operating system software or application-specific operating system software, contact your local sales office.

(1) Modules

Product name	Model before migration		Model after migration
Motion controller	Q170MCPU		Q170MSCPU Q170MSCPU-S1
Servo external signals interface module	Q172DLX		← (same as the left)
Manual pulse generator interface module	Q173DPX		← (same as the left)
Manual pulse generator	MR-HDP01		← (same as the left)
SSCNETIII cable ^(Note-1)	MR-J3BUS□M MR-J3BUS□M-A MR-J3BUS□M-B ^(Note-2)		← (same as the left)

(Note-1): "□" indicates the cable length.

(015: 0.15m, 03: 0.3m, 05: 0.5m, 1: 1m, 2: 2m, 3: 3m, 5: 5m, 10: 10m, 20: 20m, 25: 25m, 30: 30m, 40: 40m, 50: 50m)

(Note-2): For a long distance cable of up to 100 m or an ultra-long bending life cable, contact Mitsubishi Electric System & Service Co., Ltd.

OVERSEAS SERVICE SECTION (Email: osb.webmaster@melsc.jp)

(2) Operating system software

Before migration				After migration		
CPU model	OS Type	OS model		CPU model	OS Type	OS model
Q170MCPU	SV13	SW8DNC-SV13QG		Q170MSCPU(-S1)	SV13	SW8DNC-SV13QN
	SV22	SW8DNC-SV22QF			SV22	SW8DNC-SV22QN

(Note): The operating system software (SV22) is installed in Q170MSCPU(-S1) at the time of product purchase.

1. OVERVIEW OF MIGRATION FROM Q170MCPU TO Q170MSCPU(-S1)

(3) Servo amplifiers/Rotary servo motors

Before migration from Q170MCPU				After migration to Q170MSCPU(-S1)		
Servo amplifier		Rotary servo motor		Servo amplifier		Rotary servo motor
MR-J3 series	MR-J3-□B	HF-KP□		MR-J4 series	MR-J4-□B(-RJ)	HG-KR□
	MR-J3W-□B	HF-MP□			MR-J4W2-□B	HG-MR□
	MR-J3-□BS	HF-SP□			MR-J4W3-□B	HG-SR□
	MR-J3-□B-RJ006	HF-JP□				HG-RR□
		HC-LP□				HG-UR□
HC-RP□		HG-JR□				
	HC-UP□					
	HA-LP□					

(4) Servo amplifiers/Linear servo motors



Before migration from Q170MCPU				After migration to Q170MSCPU(-S1)			
Servo amplifier		Linear servo motor		Servo amplifier		Linear servo motor	
MR-J3 series	MR-J3-□B-RJ004	LM-H2□		MR-J4 series	MR-J4-□B(-RJ)	LM-H3□	
		LM-F□				MR-J4W2-□B	LM-F□
		LM-K2□				MR-J4W3-□B	LM-K2□
		LM-U2□					LM-U2□

(5) Servo amplifiers/Direct drive motors

Before migration from Q170MCPU				After migration to Q170MSCPU(-S1)			
Servo amplifier		Direct drive motor		Servo amplifier		Direct drive motor	
MR-J3 series	MR-J3-□B-RJ080W	TM-RFM□		MR-J4 series	MR-J4-□B(-RJ)	TM-RFM□	
							MR-J4W2-□B
							MR-J4W3-□B

1. OVERVIEW OF MIGRATION FROM Q170MCPU TO Q170MSCPU(-S1)

(6) Servo system network

Item		
Communications medium	Optical fiber cable	← (same as the left)
Communications speed	50 Mbps	150 Mbps
Communications cycle	Send	0.22 ms/0.44 ms/0.88 ms
	Receive	0.22 ms/0.44 ms/0.88 ms
Number of control axes	Up to 16 axes/line	← (same as the left)
Transmission distance	[Standard code for inside panel] Up to 3 m between stations Maximum overall distance: 48 m (3 m × 16 axes)	[Standard code for inside panel and standard cable for outside panel] Up to 20 m between stations Maximum overall distance: 320 m (20 m × 16 axes)
	[Standard cable for outside panel] Up to 20 m between stations Maximum overall distance: 320 m (20 m × 16 axes)	
	[Long distance cable] Up to 50 m between stations Maximum overall distance: 800 m (50 m × 16 axes)	
		[Long distance cable] Up to 100 m between stations Maximum overall distance: 1600 m (100 m × 16 axes)

(7) Engineering environment (required)

Product name	Model	Version
MELSOFT MT Works2	SW1DND-MTW2-E	Ver.1.56J or later
MELSOFT GX Works2	SW1DNC-GXW2-E	Ver.1.98C or later
MELSOFT MR Configurator2	SW1DNC-MRC2-E	Ver.1.18U or later

1. OVERVIEW OF MIGRATION FROM Q170MCPU TO Q170MSCPU(-S1)

1.3 System Configuration

1.3.1 System configuration using Q170MCPU before migration

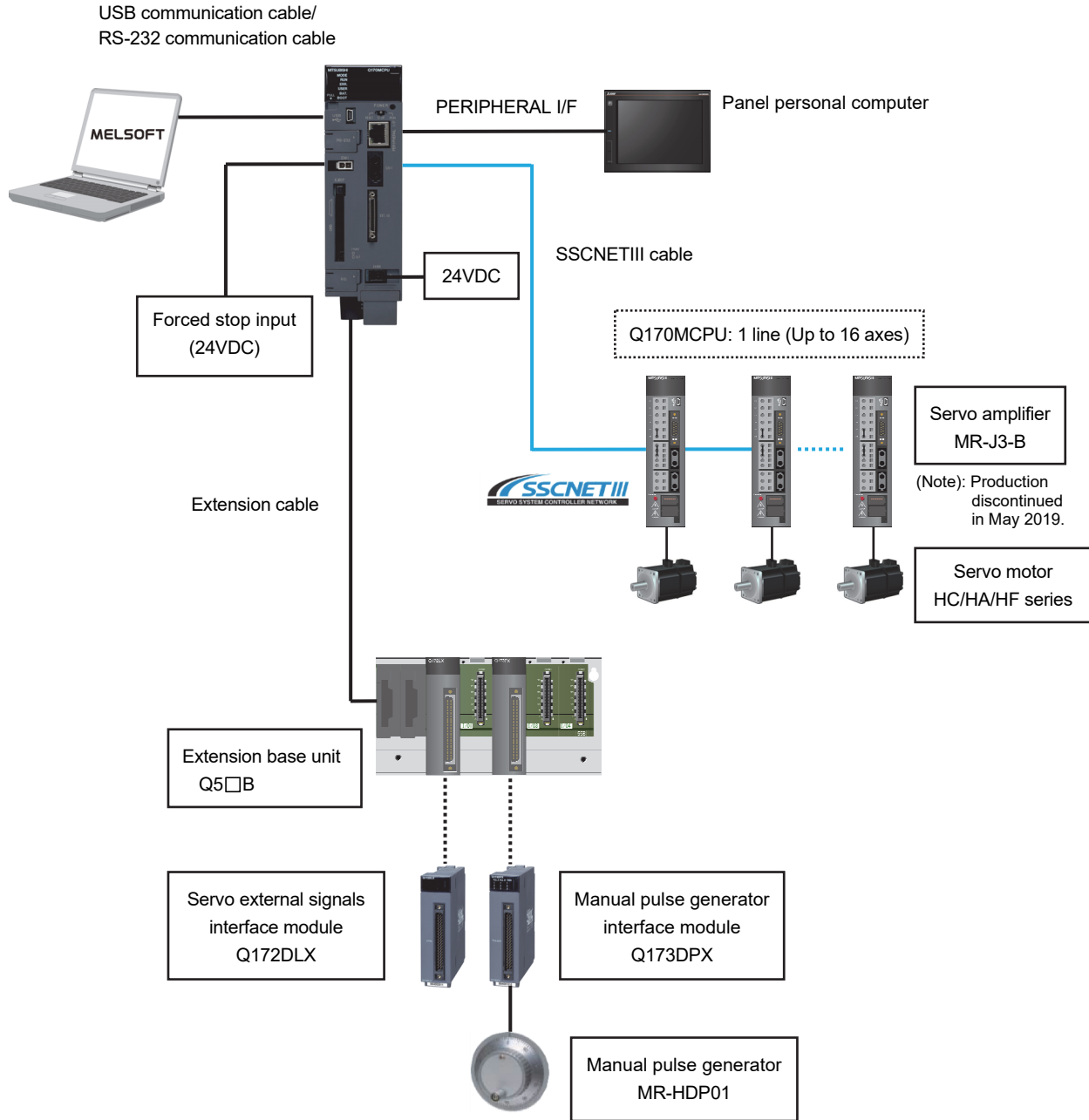

1. OVERVIEW OF MIGRATION FROM Q170MCPUR TO Q170MSCPU(-S1)

1.3.2 System configuration using Q170MSCPU(-S1) after migration

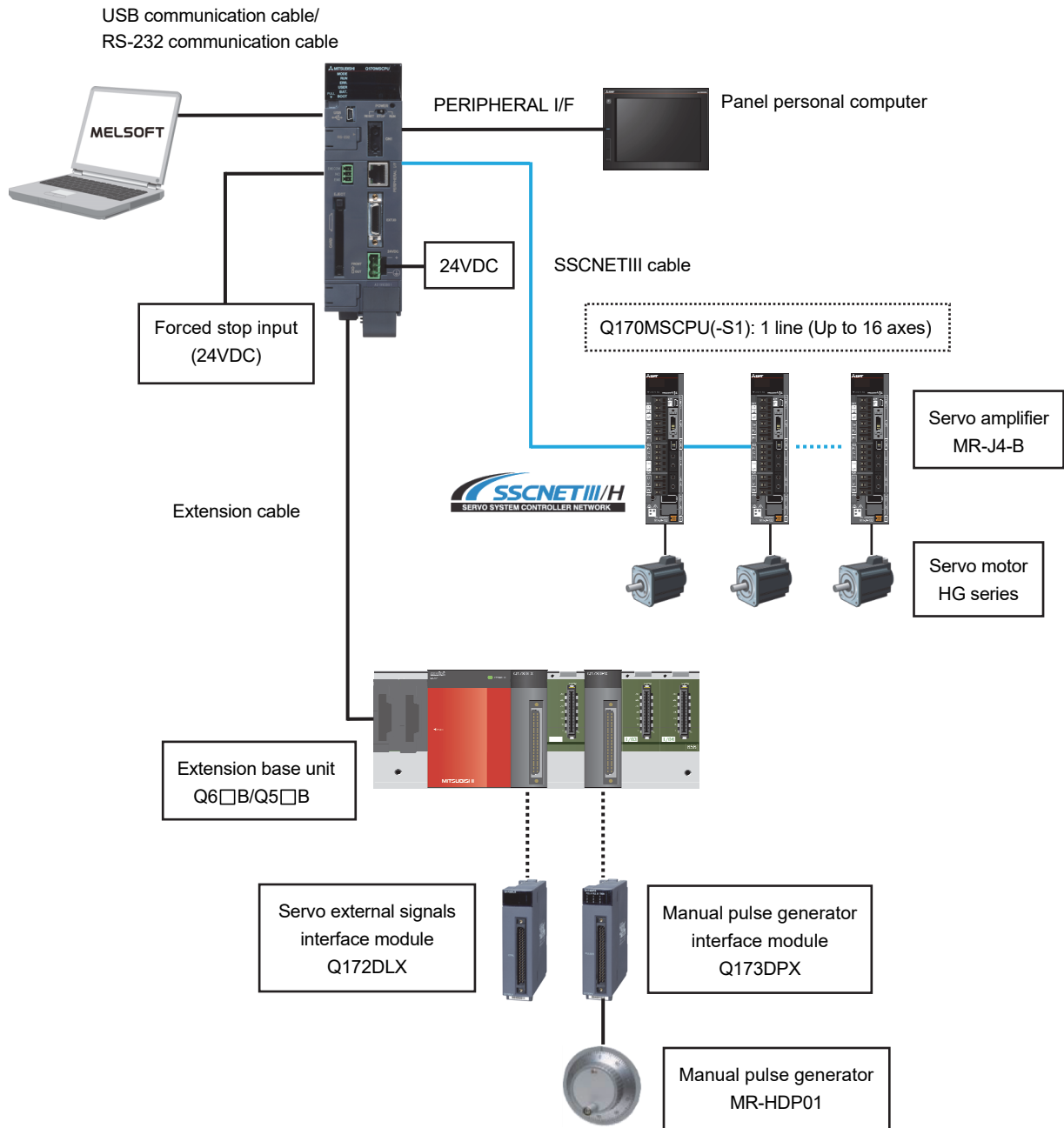

1.4 Case Study on Migration

The following describes a case study for migrating the existing system using Q170MCPUR.

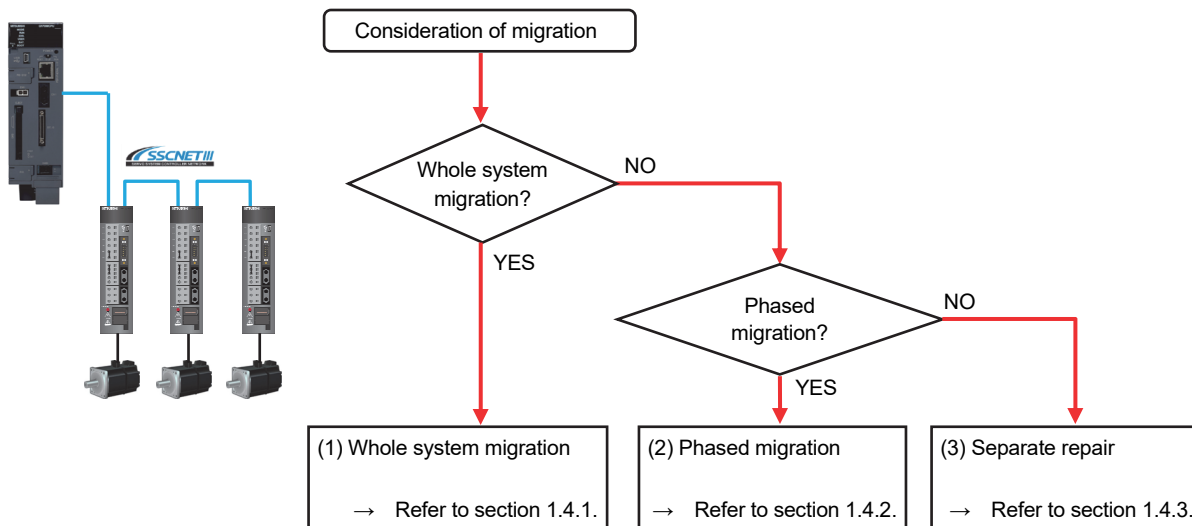

(1) Whole system migration (recommended)

The controller, servo amplifiers, servo motors, and servo system network are replaced simultaneously. Although a large-scale installation is required, the whole system migration allows the system to operate for longer periods. (Refer to section 1.4.1.)

(2) Phased migration (When the whole system migration is difficult due to the installation period and cost.)

The controller is replaced with Q170MSCPU(-S1) in the first phase, and then the MR-J3-B servo amplifiers are gradually replaced with MR-J4-B. (Refer to section 1.4.2.)

(3) Separate repair

This is a replacement method for when the controller, the servo amplifier, or the servo motor malfunctions. (Refer to section 1.4.3.)

1. OVERVIEW OF MIGRATION FROM Q170MCPU TO Q170MSCPU(-S1)

1.4.1 Whole system migration (recommended)

The following shows the system when the whole system migration takes place.

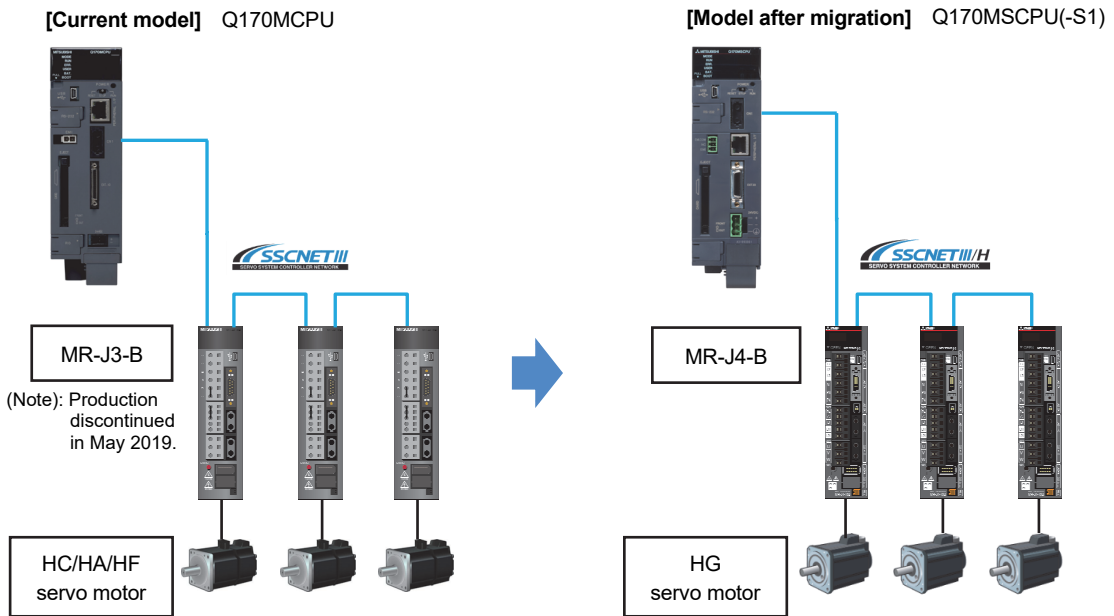

[Changes in the system]

Product name	Model before migration	Model after migration
Motion controller	Q170MCPU	Q170MSCPU(-S1)
Servo amplifier	MR-J3-B	MR-J4-B
Servo motor	HC/HA/HF series	HG series
Internal I/F connector set	Q170MIOCON ^(Note-1)	LD77MHIOCON
Connector for forced stop input cable	Q170DEMICON ^(Note-1)	FK-MCP1.5/3-ST-3.81 ^(Note-2)
24VDC power supply connector set	Q170MPWCON ^(Note-1)	FKC2.5/3-ST-5.08 ^(Note-2)

(Note-1): Packed together with Q170MCPU

(Note-2): Packed together with Q170MSCPU(-S1)

1. OVERVIEW OF MIGRATION FROM Q170MCPU TO Q170MSCPU(-S1)

1.4.2 Phased migration

The following shows the procedure for the phased migration in which the controller is replaced with Q170MSCPU(-S1) in the first phase, and then the MR-J3-B servo amplifiers are gradually replaced with MR-J4-B in the following phases.

[Current model]

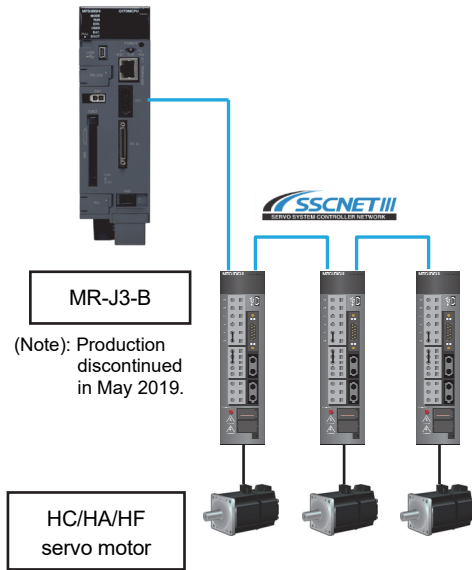

[Replacement - Phase 1]

Replacement of the controller and the external I/F cable

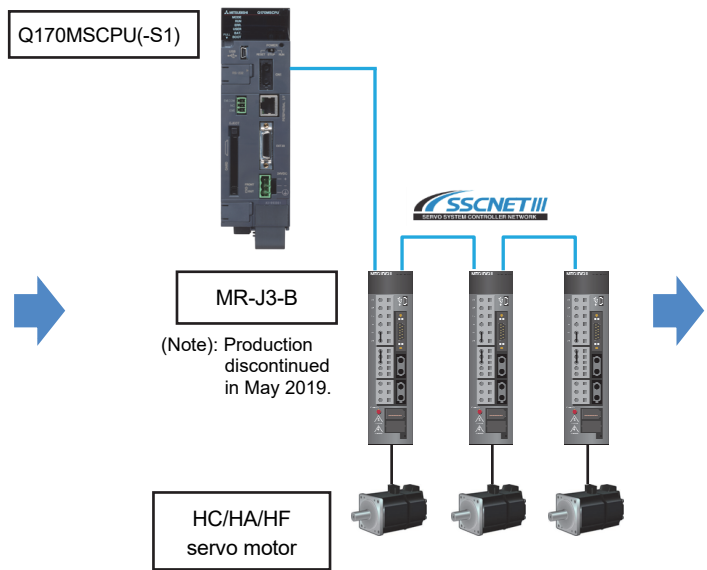

[Replacement - Phase 2]

Servo amplifier and servo motor replacement for only one axis

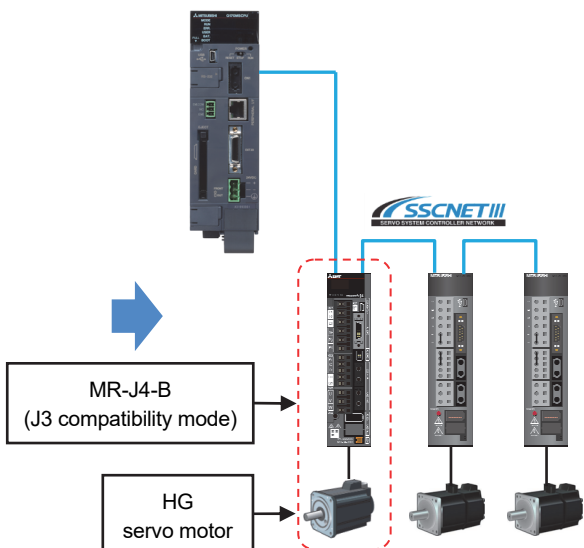

[Replacement - Phase 3]

Servo amplifier and servo motor replacement for all axes, and servo system network replacement

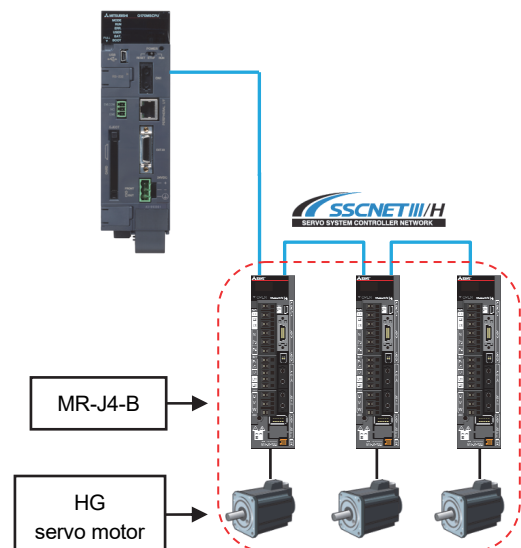

(Note): For replacing the servo amplifier or the servo motor, refer to section "1.4.3 Separate repair".

(Note): For details of the J3 compatibility mode, refer to the "Transition from MELSERVO-J3/J3W Series to J4 Series Handbook".

(Note): When replacing all the servo amplifiers with MR-J4-B, servo system network can be changed from SSCNET III to SSCNET III/H. Change the SSCNET setting to SSCNET III/H, and switch the servo amplifier setting from "J3 compatibility mode" to "J4 mode".

1. OVERVIEW OF MIGRATION FROM Q170MCPU TO Q170MSCPU(-S1)

1.4.3 Separate repair

The following shows the procedure for the separate repair.

(1) When the controller has malfunctioned.

Replace the controller and the external I/F cable.

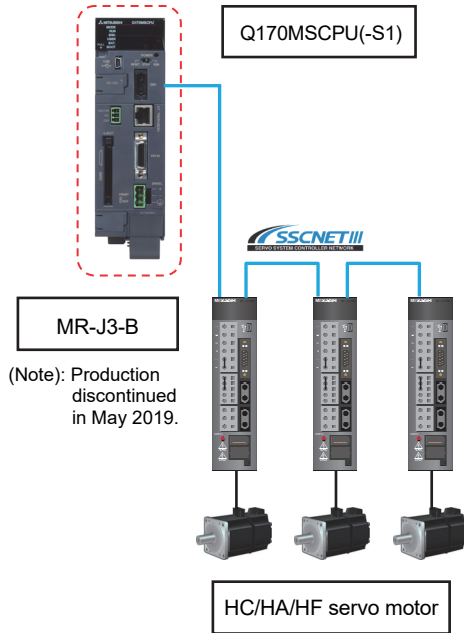

(Notes):

• **MR-J3-B can operate with the replaced controller.**

The existing servo amplifiers and servo motors can be used with the new controller.

(2) When the MR-J3-B servo amplifier has malfunctioned.

Replace only the servo amplifier.

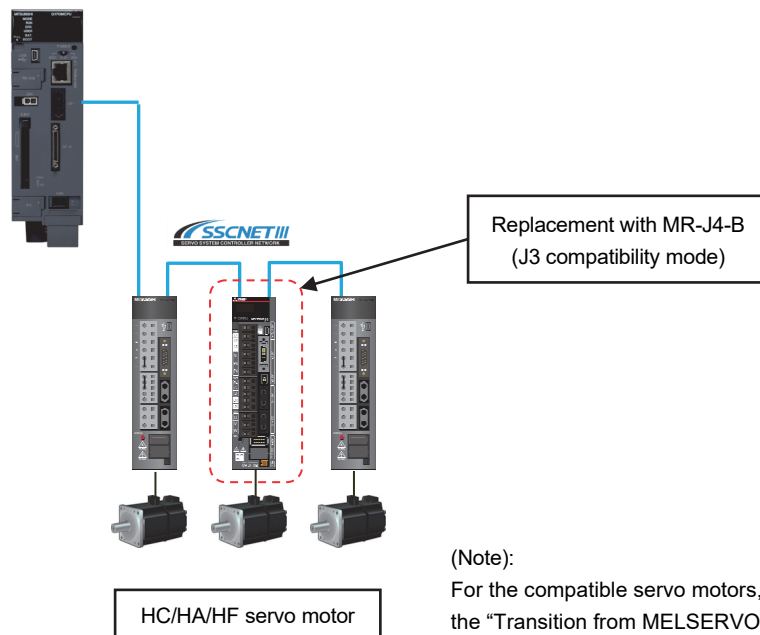

(Note):

For the compatible servo motors, refer to the "Transition from MELSERVO-J3/J3W Series to J4 Series Handbook".

1. OVERVIEW OF MIGRATION FROM Q170MCPU TO Q170MSCPU(-S1)

- (3) When the HC/HA/HF servo motor has malfunctioned
Simultaneously replace the servo amplifier and the malfunctioned servo motor.

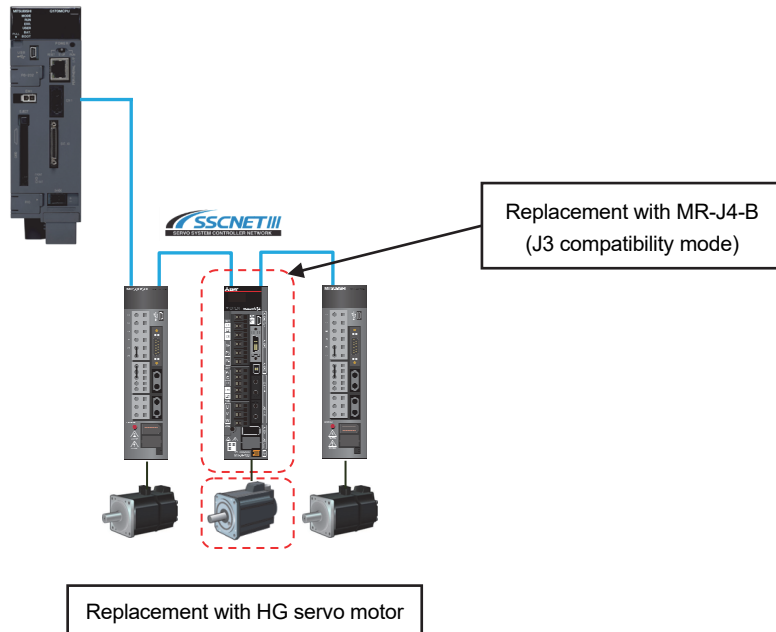

1. OVERVIEW OF MIGRATION FROM Q170MCPUR TO Q170MSCPU(-S1)

1.4.4 Precautions for powering off only a desired servo amplifier

Use the SSCNETIII/H compatible MR-MV200 optical hub unit for powering off only a desired servo amplifier.

Refer to section 1.4.5 for details of the MR-MV200 optical hub unit.

The system with the MR-MV200 is shown below.

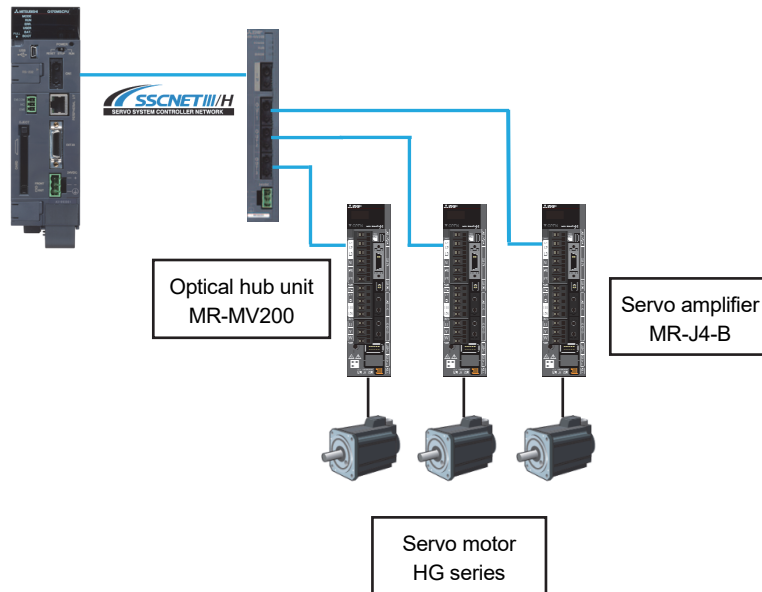

1. OVERVIEW OF MIGRATION FROM Q170MCPU TO Q170MSCPU(-S1)

1.4.5 Configuration when the MR-MV200 optical hub unit is used

The MR-MV200 can branch a single SSCNETIII/H network line in three separate directions (three outputs per one input).

A connection example when using the MR-MV200 and the specifications are shown below.

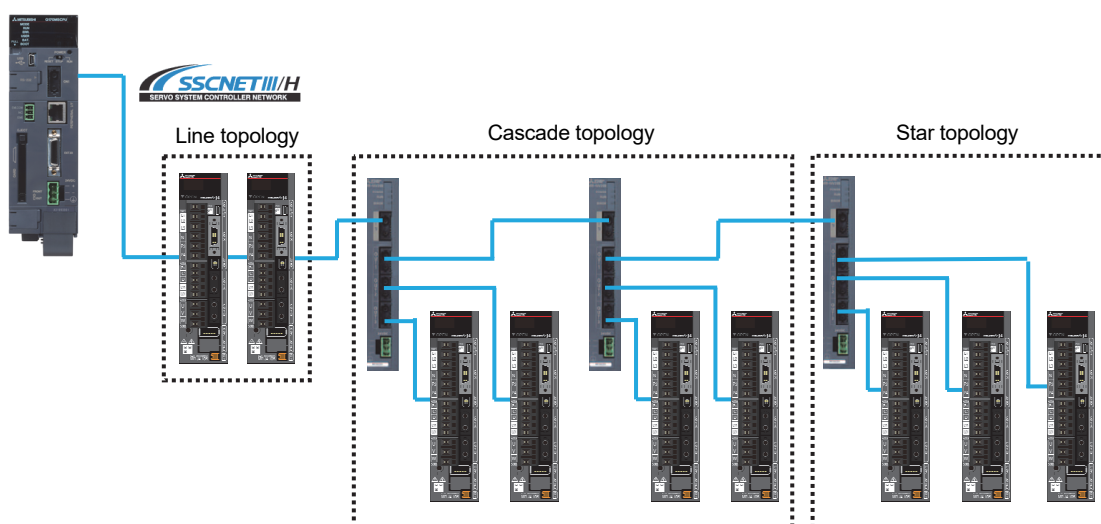

Item	Description
Input voltage [V]	21.6 to 26.4 VDC (24 VDC \pm 10 %)
Consumption current [A]	0.2
Mass [kg]	0.22
Mounting method	Directly mounted to the control panel or with DIN rail
Cable length [m]	Up to 100
Number of optical hub units	Up to 16 units/line
Number of servo amplifiers	Up to 16 axes/line
Exterior dimensions [mm]	168 (H) x 30 (W) x 100 (D)

1. OVERVIEW OF MIGRATION FROM Q170MCPU TO Q170MSCPU(-S1)

1.5 Project Diversion

The following functions can convert the projects of Q170MCPU into those of Q170MSCPU(-S1). When Q170MCPU is replaced with Q170MSCPU, an existing Q03UDCPU project can be used as it is for the new system. However, when Q170MCPU is replaced with Q170MSCPU-S1, the PLC type must be changed to Q06UDHCPU. For the procedure for project diversion, refer to section “2.3.2 Project diversion procedures by engineering environment”.

(1) Motion CPU project

“Project diversion function” and “Change type/OS type function” of MELSOFT MT Works2

“Project diversion function” or “Change type/OS type function”



(2) PLC CPU project

“Change PLC type function” of MELSOFT GX Works2.

“Change PLC Type function”





1. OVERVIEW OF MIGRATION FROM Q170MCPU TO Q170MSCPU(-S1)

1.6 Relevant Documents

Refer to the following relevant documents for the replacement.

1.6.1 Relevant catalogs

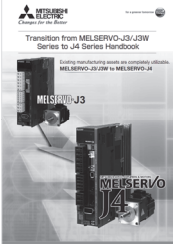
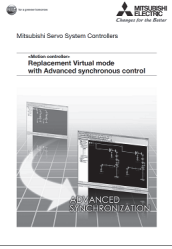
<p>MITSUBISHI ELECTRIC SERVO SYSTEM CONTROLLERS</p>  <p>L(NA)03062</p>	<p>SERVO AMPLIFIERS & MOTORS MELSERVO-J4</p>  <p>L(NA)03058</p>
<p>Transition from MELSERVO-J3/J3W Series to J4 Series Handbook</p>  <p>L(NA)03127</p>	<p>Replacement of Virtual mode with Advanced synchronous control</p>  <p>L(NA)03123</p>

1. OVERVIEW OF MIGRATION FROM Q170MCPUR TO Q170MSCPUR(-S1)

1.6.2 Relevant manuals

(1) Motion controller

Manual title	Manual No.
Q170MSCPUR Motion Controller User's Manual	IB-0300212
Q173D(S)CPU/Q172D(S)CPU Motion Controller Programming Manual (COMMON)	IB-0300134
Q173D(S)CPU/Q172D(S)CPU Motion Controller (SV13/SV22) Programming Manual (Motion SFC)	IB-0300135
Q173D(S)CPU/Q172D(S)CPU Motion Controller (SV13/SV22) Programming Manual (REAL MODE)	IB-0300136
Q173D(S)CPU/Q172D(S)CPU Motion Controller (SV22) Programming Manual (VIRTUAL MODE)	IB-0300137
Q173DSCPUR/Q172DSCPUR Motion Controller (SV22) Programming Manual (Advanced Synchronous Control)	IB-0300198

(2) Servo amplifier

Manual title	Manual No.
MR-J4-_B_(-RJ) SERVO AMPLIFIER INSTRUCTION MANUAL	SH-030106
MR-J4 Servo amplifier Instructions and Cautions for Safe Use of AC Servos	IB-0300175E
MELSERVO-J4 Servo amplifier INSTRUCTION MANUAL TROUBLE SHOOTING	SH-030109ENG
MR-J4W2-_B_/MR-J4W3-_B_/MR-J4W2-0303B6 SERVO AMPLIFIER INSTRUCTION MANUAL	SH-030105

2. DETAILS OF MIGRATION FROM Q170MCPU TO Q170MSCPU(-S1)

2. DETAILS OF MIGRATION FROM Q170MCPU TO Q170MSCPU(-S1)

2.1 Table of Components and Software

Prepare modules, servo amplifiers, operating system software, and an engineering environment according to the following tables in this section.

Product name	Model before migration		Model after migration
Motion controller	Q170MCPU		Q170MSCPU Q170MSCPU-S1
Servo external signals interface module	Q172DLX		← (same as the left)
Manual pulse generator interface module	Q173DPX		← (same as the left)
Manual pulse generator	MR-HDP01		← (same as the left)
SSCNETIII cable ^(Note-1)	MR-J3BUS□M MR-J3BUS□M-A MR-J3BUS□M-B ^(Note-2)		← (same as the left)

(Note-1): "□" indicates the cable length.

(015: 0.15m, 03: 0.3m, 05: 0.5m, 1: 1m, 2: 2m, 3: 3m, 5: 5m, 10: 10m, 20: 20m, 25: 25m, 30: 30m, 40: 40m, 50: 50m)

(Note-2): For a long distance cable of up to 100 m or an ultra-long bending life cable, contact Mitsubishi Electric System & Service Co., Ltd.

OVERSEAS SERVICE SECTION (Email: osb.webmaster@melsc.jp)

2. DETAILS OF MIGRATION FROM Q170MCPU TO Q170MSCPU(-S1)

2.1.1 Servo amplifiers and servo motors

The servo system network is changed from SSCNETIII to SSCNETIII/H.

Select a SSCNETIII/H compatible servo amplifier and a servo motor connectable to the selected servo amplifier.

(1) Servo amplifiers/Rotary servo motors

Before migration from Q170MCPU				After migration to Q170MSCPU(-S1)		
Servo amplifier		Rotary servo motor		Servo amplifier		Rotary servo motor
MR-J3 series	MR-J3-□B	HF-KP□		MR-J4 series	MR-J4-□B(-RJ)	HG-KR□
	MR-J3W-□B	HF-MP□			MR-J4W2-□B	HG-MR□
	MR-J3-□BS	HF-SP□			MR-J4W3-□B	HG-SR□
	MR-J3-□B-RJ006	HF-JP□				HG-RR□
		HC-LP□				HG-UR□
	HC-RP□			HG-JR□		
	HC-UP□					
	HA-LP□					

(2) Servo amplifiers/Linear servo motors



Before migration from Q170MCPU				After migration to Q170MSCPU(-S1)		
Servo amplifier		Linear servo motor		Servo amplifier		Linear servo motor
MR-J3 series	MR-J3-□B-RJ004	LM-H2□		MR-J4 series	MR-J4-□B(-RJ)	LM-H3□
		LM-F□			MR-J4W2-□B	LM-F□
		LM-K2□			MR-J4W3-□B	LM-K2□
		LM-U2□				LM-U2□

(3) Servo amplifiers/Direct drive motors

Before migration from Q170MCPU				After migration to Q170MSCPU(-S1)		
Servo amplifier		Direct drive motor		Servo amplifier		Direct drive motor
MR-J3 series	MR-J3-□B-RJ080W	TM-RFM□		MR-J4 series	MR-J4-□B(-RJ)	TM-RFM□
					MR-J4W2-□B	
					MR-J4W3-□B	

2. DETAILS OF MIGRATION FROM Q170MCPU TO Q170MSCPU(-S1)

[Comparison of servo system network]

Item		
Communications medium	Optical fiber cable	← (same as the left)
Communications speed	50 Mbps	150 Mbps
Communications cycle	Send	0.22 ms/0.44 ms/0.88 ms
	Receive	0.22 ms/0.44 ms/0.88 ms
Number of control axes	Up to 16 axes/line	← (same as the left)
Transmission distance	[Standard code for inside panel] Up to 3 m between stations Maximum overall distance: 48 m (3 m × 16 axes)	[Standard code for inside panel and standard cable for outside panel] Up to 20 m between stations Maximum overall distance: 320 m (20 m × 16 axes)
	[Standard cable for outside panel] Up to 20 m between stations Maximum overall distance: 320 m (20 m × 16 axes)	
	[Long distance cable] Up to 50 m between stations Maximum overall distance: 800 m (50 m × 16 axes)	
		[Long distance cable] Up to 100 m between stations Maximum overall distance: 1600 m (100 m × 16 axes)

2.1.2 Operating system software

Use the operating system software for Q170MSCPU(-S1).

Before migration			After migration		
CPU model	OS Type	OS model	CPU model	OS Type	OS model
Q170MCPU	SV13	SW8DNC-SV13QG	Q170MSCPU(-S1)	SV13	SW8DNC-SV13QN
	SV22	SW8DNC-SV22QF		SV22	SW8DNC-SV22QN

(Note): The operating system software (SV22) is installed in Q170MSCPU(-S1) at the time of product purchase.

2.1.3 Engineering environment (required)

The engineering environment that supports Q170MSCPU(-S1) is as follows.

Product name	Model	Version
MELSOFT MT Works2	SW1DND-MTW2-E	Ver. 1.56J or later
MELSOFT GX Works2	SW1DNC-GXW2-E	Ver. 1.98C or later
MELSOFT MR Configurator2	SW1DNC-MRC2-E	Ver. 1.18U or later

2. DETAILS OF MIGRATION FROM Q170MCPU TO Q170MSCPU(-S1)

2.2 Differences Between Q170MCPU and Q170MSCPU(-S1)

(1) Performance and specifications

(a) Comparison of motion control specifications

▶ An item that requires a setting change at migration.

Models		Q170MCPU	Q170MSCPU	Q170MSCPU-S1	Points for migration
Items					
Number of control axes		Up to 16	Up to 16		-
Operation cycle (default)	SV13	0.44ms/ 1 to 6 axes 0.88ms/ 7 to 16 axes	0.22ms/ 1 to 4 axes 0.44ms/ 5 to 10 axes 0.88ms/11 to 16 axes		▶ If the operation cycle is set as default (automatic), the operation cycle will be changed. Set an operation cycle where necessary because the change in the operation cycle may change program execution timing. (Refer to section 2.2(5).)
	SV22	0.44ms/ 1 to 4 axes 0.88ms/ 5 to 12 axes 1.77ms/ 13 to 16 axes	0.44ms/ 1 to 6 axes 0.88ms/ 7 to 16 axes		
Control methods		Positioning control, Speed control, Speed/position switching control, Fixed-pitch feed, Constant speed control, Position follow-up control, Speed control with fixed position stop, Speed switching control, High-speed oscillation control, Synchronous control (SV22 (Virtual mode switching method))	Positioning control, Speed control, Speed/position switching control, Fixed-pitch feed, Constant speed control, Position follow-up control, Speed switching control, Speed control with fixed position stop, High-speed oscillation control, Speed-torque control, Synchronous control (SV22 (Virtual mode switching method/ Advanced synchronous control method))		-
Number of actual I/O points (PX/PY)		256 points (Internal I/F (Input 4 points, Output 2 points) + I/O module + Intelligent function module)	256 points (Internal I/F (Input 4 points, Output 2 points) + I/O module + Intelligent function module)		The built-in interface in Motion CPU can also be used.
Servo system network		SSCNETIII	SSCNETIII/H or SSCNETIII		-
Digital oscilloscope function		<ul style="list-style-type: none"> • Motion buffering method (Real-time waveform can be displayed) • Sampling data: Word 4CH, Bit 8CH 	<ul style="list-style-type: none"> • Motion buffering method (Real-time waveform can be displayed) • Sampling data: Word 16CH, Bit 16CH 		-
Security function		Protection by password	<ul style="list-style-type: none"> • Protection by password • Software security key 		-

2. DETAILS OF MIGRATION FROM Q170MCPU TO Q170MSCPU(-S1)

(b) Comparison of PLC CPU area control and performance

Models		Q170MCPU	Q170MSCPU	Q170MSCPU-S1
Items		Q03UDCPU or equivalent (20k steps)	Q03UDCPU or equivalent (30k steps)	Q06UDHCPU or equivalent (60ksteps)
PLC CPU area		Q03UDCPU or equivalent (20k steps)	Q03UDCPU or equivalent (30k steps)	Q06UDHCPU or equivalent (60ksteps)
Processing speed (sequence instruction)	LD instruction	0.02μs	0.02μs	0.0095μs
	MOV instruction	0.04μs	0.04μs	0.019μs
	PC MIX value (instruction/μs)	28	28	60
	Floating point addition	0.12μs	0.12μs	0.057μs
Program capacity		20k steps (80k bytes)	30k steps (120k bytes)	60k steps (240k bytes)
Number of I/O points (X/Y)		512 points (Up to 320 points (64 points × 5 modules) is usable with I/O module.)	4096 points	
File register (R, ZR)		98304 points	98304 points	393216 points
Extension base unit	Number of extensions	1 extension (Q52B/Q55B usable)	7 extensions (Up to 64 slots) ^(Note-1) (Q52B/Q55B/Q63B/Q65B/Q68B/Q612B usable)	
	GOT bus connection	<ul style="list-style-type: none"> Extension base unit used: Connection after the extension base unit of stage 1 Extension base unit not used: Direct bus connection to Motion controller 	No restriction	
PLC type when program is made by GX Works2		Q03UDCPU	Q03UDCPU	Q06UDHCPU
Motion dedicated PLC instruction		D(P).DDR D, D(P).DDWR, D(P).SFCS, D(P).SVST, D(P).CHGT, D(P).CHGV, D(P).CHGA, D(P).GINT	D(P).DDR D, D(P).DDWR, D(P).SFCS, D(P).SVST, D(P).CHGT, D(P).CHGT2, D(P).CHGV, D(P).CHGVS ^(Note-2) , D(P).CHGA, D(P).CHGAS ^(Note-2) , D(P).GINT	

(Note-1): Occupies 8 slots of the main base unit as empty slots.

(Note-2): SV22 advanced synchronous control only

2. DETAILS OF MIGRATION FROM Q170MCPU TO Q170MSCPU(-S1)

(2) Exterior dimensions and mass

	Q170MCPU	Q170MSCPU(-S1)
Dimensions		
Exterior dimensions [mm]	178.0[H] × 52.0[W] × 135.0[D]	186.0[H] × 52.0[W] × 135.0[D]
Input current 24VDC [A]	1.36	1.40
Mass [kg]	0.90	0.80

(3) Items that need a review or a change following the servo system network change

Items	Differences		Changes/revisions
	Q170MCPU	Q170MSCPU(-S1)	
System setting/ SSCNET configuration	Q170MCPU: 1 line (Up to 16 axes/line)	Q170MSCPU(-S1): 1 line (Up to 16 axes/line)	Set the servo amplifier's rotary switch and connection according to the SSCNET configuration.
Electronic gear	-	-	Change "Number of pulses per revolution" and "Movement amount per revolution" of the fixed parameters according to the resolution per the connected servo motor revolution.

2. DETAILS OF MIGRATION FROM Q170MCPU TO Q170MSCPU(-S1)

(4) Operating system software

(a) Motion SFC (SV13/SV22)

Items		Differences	
		Q170MCPU	Q170MSCPU(-S1)
Motion SFC program capacity	Code in total (Motion SFC chart + Operation control + Transition)	543k bytes	652k bytes
	Text in total (Operation control + Transition)	484k bytes	668k bytes
Motion SFC program event tasks		Fixed cycle 0.44ms, 0.88ms, 1.77 ms, 3.55 ms, 7.11 ms, 14.2 ms	Fixed cycle 0.22ms, 0.44ms, 0.88ms, 1.77 ms, 3.55 ms, 7.11 ms, 14.2 ms

(b) Virtual mode (SV22)

Items		Differences	
		Q170MCPU	Q170MSCPU(-S1)
Virtual servo motor command in-position range [pulse]		1 to 32767	1 to 2147483647
Cam	Number of pulses per cam shaft revolution [pulse]	1 to 1073741824	1 to 1073741824/ Word device (D, W, #, U□\G)
	Output unit	mm, inch, pulse	mm, inch, pulse, degree

2. DETAILS OF MIGRATION FROM Q170MCPU TO Q170MSCPU(-S1)

(5) Operation cycle

The operation cycle settings of Q170MCPU can be imported to Q170MSCPU(-S1) when the projects of Q170MCPU are diverted to Q170MSCPU(-S1) in MELSOFT MT Works2. (Refer to section 2.3.2(1) for details of project diversion.)

However, if the operation cycle is set as default (automatic), the operation cycle will be changed. Set an operation cycle where necessary by following the table below because the change in the operation cycle may change program execution timing.

[Control axes and operation cycle at default]

Model		Q170MCPU	Q170MSCPU(-S1)
Item			
Number of control axes		Up to 16	Up to 16
Operation cycle (default)	SV13	0.44ms/ 1 to 6 axes 0.88ms/ 7 to 16 axes	0.22ms/ 1 to 4 axes 0.44ms/ 5 to 10 axes 0.88ms/11 to 16 axes
	SV22	0.44ms/ 1 to 4 axes 0.88ms/ 5 to 12 axes 1.77ms/ 13 to 16 axes	0.44ms/ 1 to 6 axes 0.88ms/ 7 to 16 axes

[Settable operation cycle]

Q170MCPU	Q170MSCPU(-S1)
0.44ms	0.22ms
0.88ms	0.44ms
1.77ms	0.88ms
3.55ms	1.77ms
7.11ms	3.55ms
14.2ms	7.11ms
	14.2ms

2. DETAILS OF MIGRATION FROM Q170MCPU TO Q170MSCPU(-S1)

2.3 Project Diversion

2.3.1 List of divertible/not divertible data (SV13/SV22)

Q170MCPU data name	Divertible/not divertible	Remarks
System settings		
Basic settings		
Base setting	○	
Multiple CPU setting	○	
System basic setting	○	
SSCNET setting	○	(Note-1)
System configuration	○	
SSCNET configuration	○	(Note-2)
Optional data monitor	○	
High-speed read data	○	
Mark detection	○	
Servo data settings		
Servo data	○	(Note-3)
Servo parameter	○	(Note-4)
Parameter block	○	
Limit output data	○	
Motion SFC programs		
Motion SFC parameter	○	
Motion SFC program	○	
Servo programs		
K mode allocation	○	SV22 only
Servo program	○	
Mechanical system program	○	SV22 only
Cam data	○	SV22 only
Device memory	○	
Backup data	×	
Communication setting	○	
Label and structure	○	

○: Divertible, ×: Not divertible

(Note-1): Select SSCNETIII or SSCNETIII/H at SSCNET setting.

(Note-2): The existing servo amplifier model is replaced according to the selected communication type (SSCNET) in SSCNET setting. Refer to MELSOFT MT Developer2 Help for servo amplifier replacement.

(Note-3): Review the fixed parameters according to the resolution per servo motor revolution.
(Number of pulses per revolution and movement amount per revolution)

(Note-4): Refer to "MELSOFT MT Developer2 Help" for conversion rules for servo parameters.

2. DETAILS OF MIGRATION FROM Q170MCPU TO Q170MSCPU(-S1)

2.3.2 Project diversion procedures by engineering environment

The following shows the project diversion procedures for Motion CPU.

The contents of this manual are based on the specifications of the engineering environment (MELSOFT GX Works2 Ver.1.198C, MELSOFT MT Works2 Ver.1.155M). Update to the latest version when replacing.

(1) Procedures for PLC CPU projects diversion by MELSOFT GX Works2

(a) Migration to Q170MSCPU

The existing PLC CPU project of Q170MCPU can be used as it is.

(b) Migration to Q170MSCPU-S1

Use the “PLC type change function” of MELSOFT GX Works2.

1) Start MELSOFT GX Works2. Read the project to be diverted.

2) Select “Change PLC Type” in “Project” menu to open “Change PLC Type” screen.

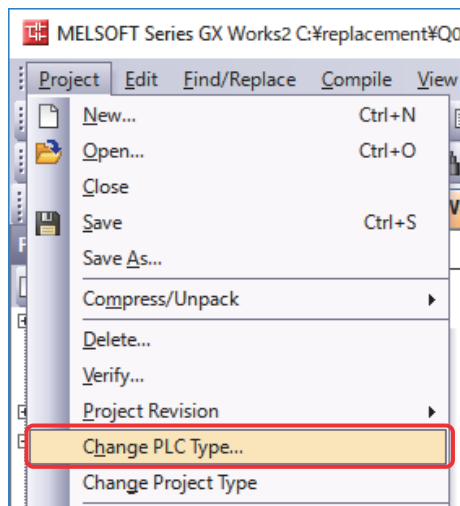

3) Select the replaced PLC CPU (Q06UDH) for “PLC Type”. Click “OK”.

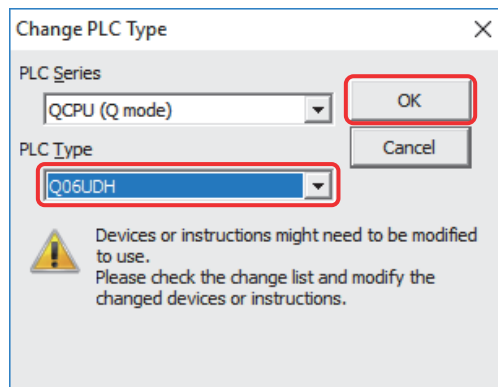

2. DETAILS OF MIGRATION FROM Q170MCPU TO Q170MSCPU(-S1)

4) If the screen below appears during conversion, click "Yes".

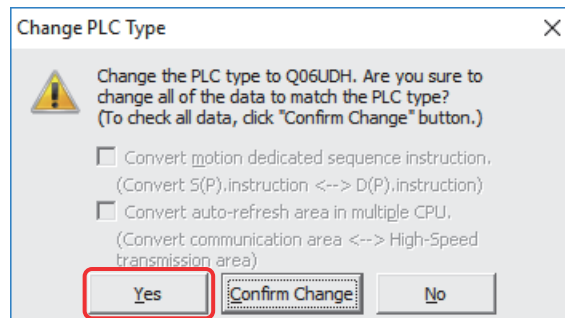

The diversion is completed.

2. DETAILS OF MIGRATION FROM Q170MCPU TO Q170MSCPU(-S1)

(2) Procedures for Motion CPU projects diversion by MELSOFT MT Developer2
Motion CPU projects can be diverted by “Project diversion function” or “Change type/OS type function” of MELSOFT MT Developer2. Even if Motion SFC is not used, these functions can be used for project diversion.

(a) Project diversion function

1) Start MELSOFT MT Developer2. Select [Divert file] - [Divert MT Developer2 Format Project...] from “Project” menu.

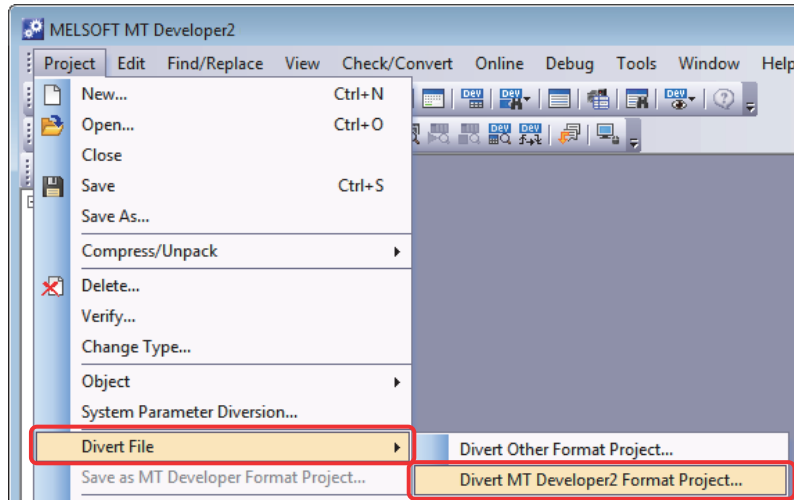

2. DETAILS OF MIGRATION FROM Q170MCPU TO Q170MSCPU(-S1)

2) Click “Browse” on the “Divert MT Developer2 Format Project” screen.

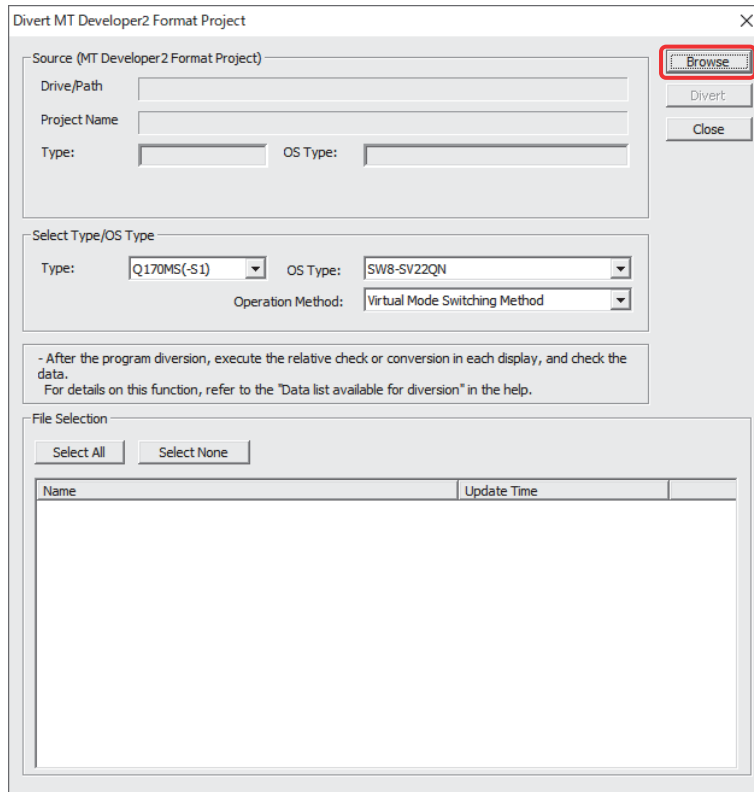

3) Select the project to be diverted on the file selection window. Click [Open] to update the selected project (MT Developer2 Format Project).

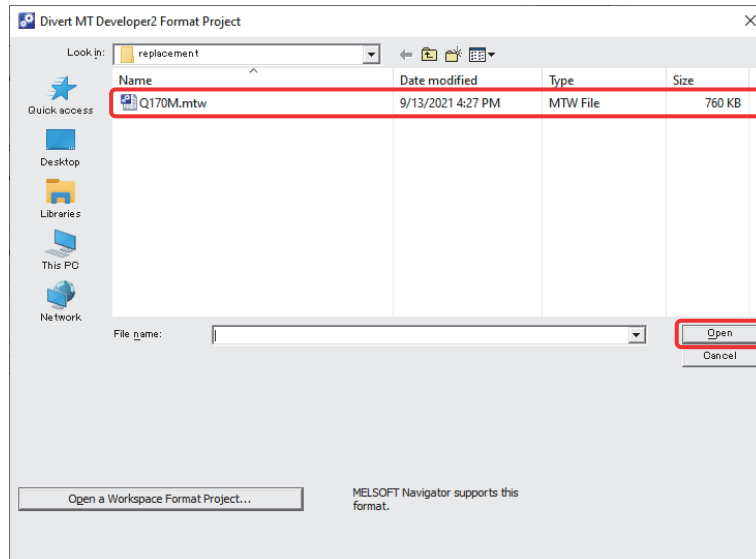

2. DETAILS OF MIGRATION FROM Q170MCPU TO Q170MSCPU(-S1)

4) Select the replaced model for [Select Type/OS Type] (the setting example below: Q170MS(-S1)).

When SV22 is selected for OS type, the "Operation Method" is required to set, however, there is no need to change the original setting because "Virtual Mode Switching Method" is already selected.

(When setting "Advanced synchronous control method", refer to "Replacement of Virtual mode with advanced synchronous control").

Divert MT Developer2 Format Project

Source (MT Developer2 Format Project)

Drive/Path: C:\#replacement#\

Project Name: Q170M

Type: Q170M OS Type: SW8-SV22QF

Select Type/OS Type

Type: Q170MS(-S1) OS Type: SW8-SV22QN

Operation Method: Virtual Mode Switching Method

- After the program diversion, execute the relative check or conversion in each display, and check the data.
For details on this function, refer to the "Data list available for diversion" in the help.

File Selection

Select All Select None

Name	Update Time
<input type="checkbox"/> System Setting/Servo Data Setting	12/24/2019 3:16:11 PM
<input type="checkbox"/> Motion SFC Program/Motion SFC Parameter	12/24/2019 3:16:11 PM
<input type="checkbox"/> Vision System Parameter	12/24/2019 3:16:11 PM
<input type="checkbox"/> Servo Program	12/24/2019 3:16:11 PM
<input type="checkbox"/> Mechanical System Program	12/24/2019 3:16:11 PM
<input type="checkbox"/> Cam Data	12/24/2019 3:16:11 PM
<input type="checkbox"/> Label/Structure	12/24/2019 3:16:11 PM
<input type="checkbox"/> Transfer Setting Information	12/24/2019 3:16:11 PM
<input type="checkbox"/> Device Comment	12/24/2019 3:16:11 PM

2. DETAILS OF MIGRATION FROM Q170MCPU TO Q170MSCPU(-S1)

5) Check the box of the data to be diverted in the "File Selection". Click "Divert".

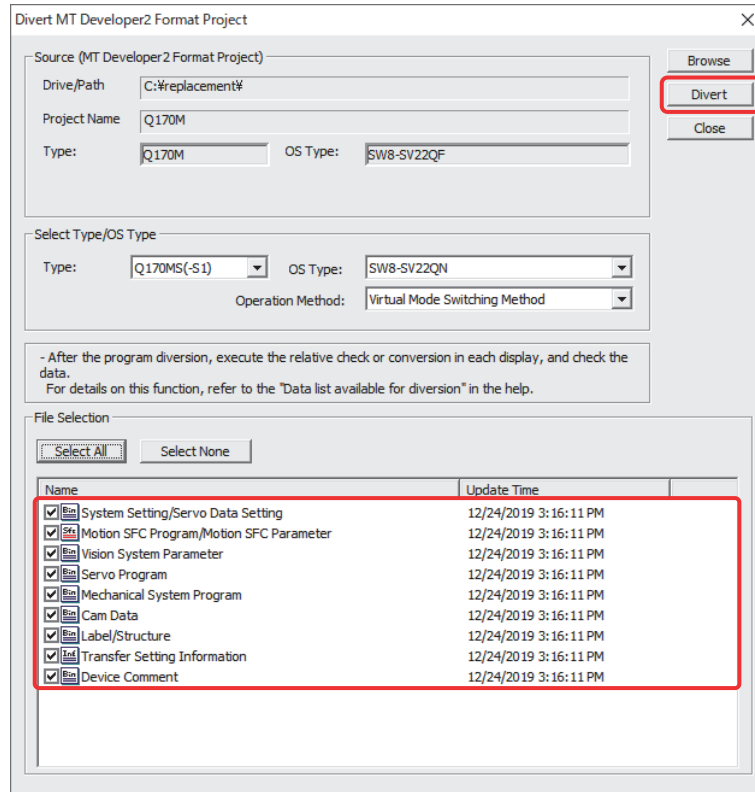

Divert MT Developer2 Format Project

Source (MT Developer2 Format Project)

Drive/Path: C:\replacement#\

Project Name: Q170M

Type: Q170M OS Type: SW8-SV22QF

Select Type/OS Type

Type: Q170MS(-S1) OS Type: SW8-SV22QN

Operation Method: Virtual Mode Switching Method

- After the program diversion, execute the relative check or conversion in each display, and check the data.
For details on this function, refer to the "Data list available for diversion" in the help.

File Selection

Select All Select None

Name	Update Time
<input checked="" type="checkbox"/> System Setting/Servo Data Setting	12/24/2019 3:16:11 PM
<input checked="" type="checkbox"/> Motion SFC Program/Motion SFC Parameter	12/24/2019 3:16:11 PM
<input checked="" type="checkbox"/> Vision System Parameter	12/24/2019 3:16:11 PM
<input checked="" type="checkbox"/> Servo Program	12/24/2019 3:16:11 PM
<input checked="" type="checkbox"/> Mechanical System Program	12/24/2019 3:16:11 PM
<input checked="" type="checkbox"/> Cam Data	12/24/2019 3:16:11 PM
<input checked="" type="checkbox"/> Label/Structure	12/24/2019 3:16:11 PM
<input checked="" type="checkbox"/> Transfer Setting Information	12/24/2019 3:16:11 PM
<input checked="" type="checkbox"/> Device Comment	12/24/2019 3:16:11 PM

2. DETAILS OF MIGRATION FROM Q170MCPU TO Q170MSCPU(-S1)

- 6) When “System Setting/Servo Data Setting” is selected in “File Selection” in 5), execute the series conversion of the servo amplifier. Select the servo amplifiers and the servo motors to be used for the replaced controller (Q170MS(-S1)). Click "OK".

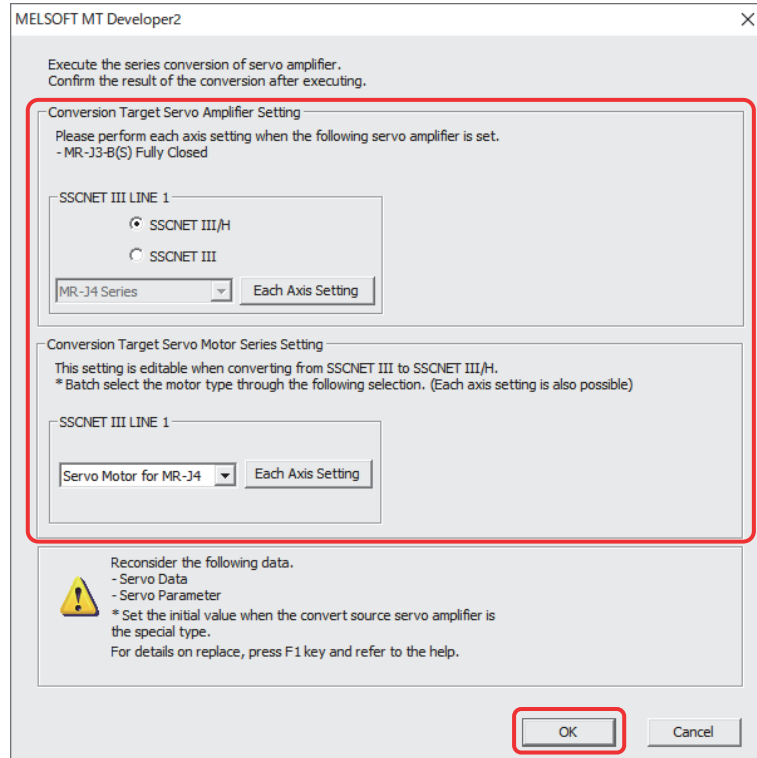

(Note): Refer to “Q170MSCPU Motion Controller User’s Manual” for the servo system networks supported by the replaced servo amplifiers and SSCNETIII compatible devices (SSCNETIII or SSCNETIII/H).

(Note): When servo parameters settings are changed from “MR-J3 series” to “MR-J4 series”, the parameter conversion is carried out based on conversion rules.

Refer to “MELSOFT MT Developer2 Help [Appendix] - [Servo parameter conversion]” for the conversion rules.

- 7) When the project diversion completion message appears, click [OK].

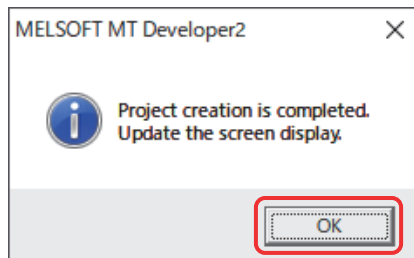

2. DETAILS OF MIGRATION FROM Q170MCPU TO Q170MSCPU(-S1)

The diversion is completed.

If the operation cycle is set as default (automatic), the operation cycle will be changed. Set an operation cycle where necessary because the change in the operation cycle may change the program execution timing. (Refer to section 2.2(5).)

Though the project has been diverted, conversion of Motion SFC programs and servo programs has not finished yet. Make sure to execute [Project Batch Check/Conversion] before writing to the Motion controller.

(b) Change type/OS type change function

- 1) Start MELSOFT MT Developer2. Select [Change Type/OS Type...] in "Project" menu to open "Change Type/OS Type" screen.

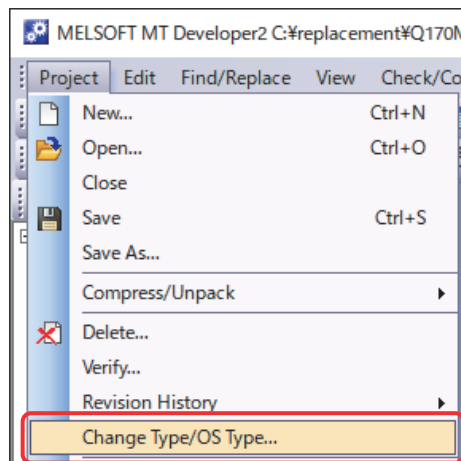

- 2) Select the replaced Motion CPU (Q170MS(-S1)) for "Type" and the new operating system software model for "OS Type". Click "OK".

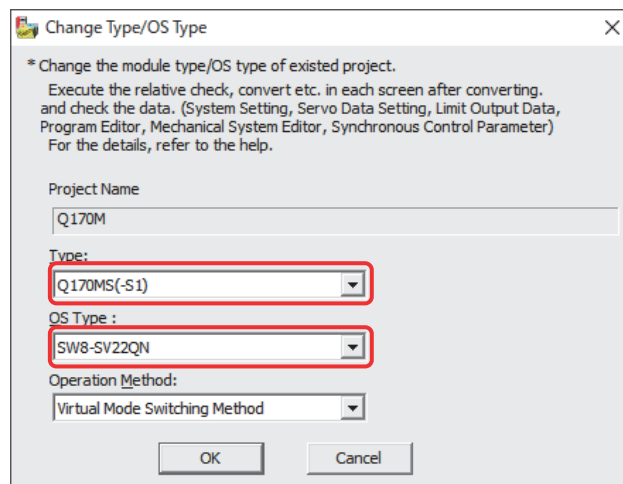

2. DETAILS OF MIGRATION FROM Q170MCPU TO Q170MSCPU(-S1)

- 3) Execute the series conversion of the servo amplifier. Select the servo amplifiers and the servo motors to be used for the replaced controller (Q170MS(-S1)). Click "OK".

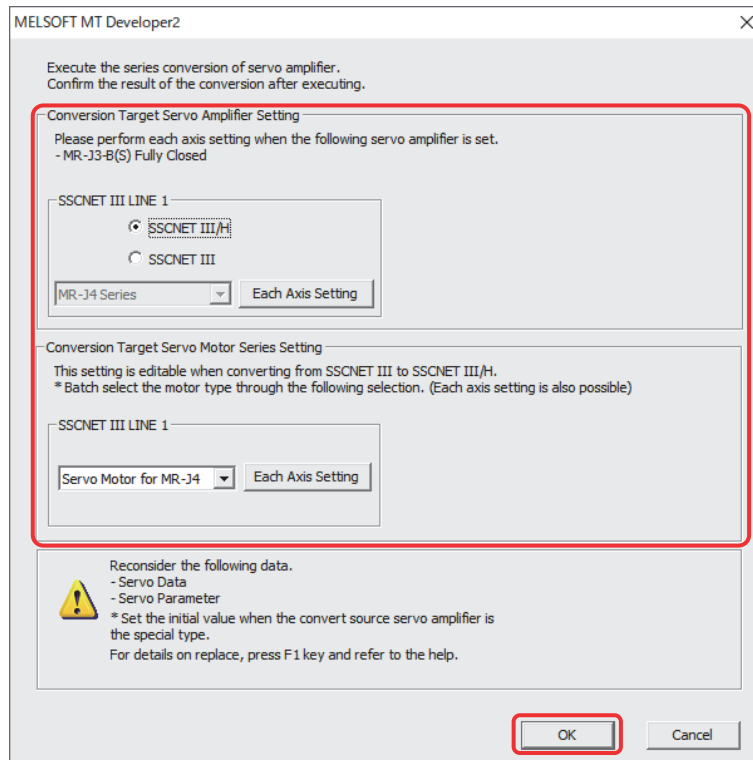

(Note): Refer to "Q170MSCPU Motion Controller User's Manual" for the servo system networks supported by the replaced servo amplifiers and SSCNETIII compatible devices (SSCNETIII or SSCNETIII/H).

(Note): When servo parameters settings are changed from "MR-J3 series" to "MR-J4 series", the parameter conversion is carried out based on conversion rules.

Refer to "MELSOFT MT Developer2 Help [Appendix] - [Servo parameter conversion]" for the conversion rules.

- 4) When the project diversion completion message appears, click [OK].

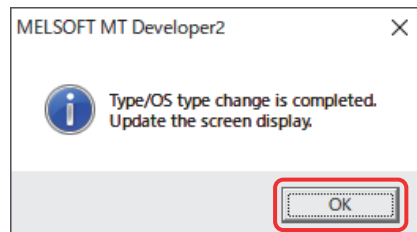

2. DETAILS OF MIGRATION FROM Q170MCPU TO Q170MSCPU(-S1)

The diversion is completed.

If the operation cycle is set as default (automatic), the operation cycle will be changed. Set an fixed operation cycle where necessary because the change in the operation cycle may change the program execution timing. (Refer to section 2.2(5).)

Though the project has been diverted, conversion of Motion SFC programs and servo programs has not finished yet. Make sure to execute [Project Batch Check/Conversion] before writing to the Motion controller.

WARRANTY

Please confirm the following product warranty details before using this product.

1. Gratis Warranty Term and Gratis Warranty Range

If any faults or defects (hereinafter "Failure") found to be the responsibility of Mitsubishi occurs during use of the product within the gratis warranty term, the product shall be repaired at no cost via the sales representative or Mitsubishi Service Company.

However, if repairs are required onsite at domestic or overseas location, expenses to send an engineer will be solely at the customer's discretion. Mitsubishi shall not be held responsible for any re-commissioning, maintenance, or testing on-site that involves replacement of the failed module.

[Gratis Warranty Term]

The gratis warranty term of the product shall be for one year after the date of purchase or delivery to a designated place. Note that after manufacture and shipment from Mitsubishi, the maximum distribution period shall be six (6) months, and the longest gratis warranty term after manufacturing shall be eighteen (18) months. The gratis warranty term of repair parts shall not exceed the gratis warranty term before repairs.

[Gratis Warranty Range]

- (1) The range shall be limited to normal use within the usage state, usage methods and usage environment, etc., which follow the conditions and precautions, etc., given in the instruction manual, user's manual and caution labels on the product.
- (2) Even within the gratis warranty term, repairs shall be charged for in the following cases.
 1. Failure occurring from inappropriate storage or handling, carelessness or negligence by the user. Failure caused by the user's hardware or software design.
 2. Failure caused by unapproved modifications, etc., to the product by the user.
 3. When the Mitsubishi product is assembled into a user's device, Failure that could have been avoided if functions or structures, judged as necessary in the legal safety measures the user's device is subject to or as necessary by industry standards, had been provided.
 4. Failure that could have been avoided if consumable parts (battery, backlight, fuse, etc.) designated in the instruction manual had been correctly serviced or replaced.
 5. Failure caused by external irresistible forces such as fires or abnormal voltages, and Failure caused by force majeure such as earthquakes, lightning, wind and water damage.
 6. Failure caused by reasons unpredictable by scientific technology standards at time of shipment from Mitsubishi.
 7. Any other failure found not to be the responsibility of Mitsubishi or that admitted not to be so by the user.

2. Onerous repair term after discontinuation of production

- (1) Mitsubishi shall accept onerous product repairs for seven (7) years after production of the product is discontinued. Discontinuation of production shall be notified with Mitsubishi Technical Bulletins, etc.
- (2) Product supply (including repair parts) is not available after production is discontinued.

3. Overseas service

Overseas, repairs shall be accepted by Mitsubishi's local overseas FA Center. Note that the repair conditions at each FA Center may differ.

4. Exclusion of loss in opportunity and secondary loss from warranty liability

Regardless of the gratis warranty term, Mitsubishi shall not be liable for compensation to:

- (1) Damages caused by any cause found not to be the responsibility of Mitsubishi.
- (2) Loss in opportunity, lost profits incurred to the user by Failures of Mitsubishi products.
- (3) Special damages and secondary damages whether foreseeable or not, compensation for accidents, and compensation for damages to products other than Mitsubishi products.
- (4) Replacement by the user, maintenance of on-site equipment, start-up test run and other tasks.

5. Changes in product specifications

The specifications given in the catalogs, manuals or technical documents are subject to change without prior notice.

6. Precautions for Choosing the Products

- (1) For the use of our Motion controller, its applications should be those that may not result in a serious damage even if any failure or malfunction occurs in Motion controller, and a backup or fail-safe function should operate on an external system to Motion controller when any failure or malfunction occurs.
- (2) Our Motion controller is designed and manufactured as a general purpose product for use at general industries. Therefore, applications substantially influential on the public interest for such as atomic power plants and other power plants of electric power companies, and also which require a special quality assurance system, including applications for railway companies and government or public offices are not recommended, and we assume no responsibility for any failure caused by these applications when used. In addition, applications which may be substantially influential to human lives or properties for such as airlines, medical treatments, railway service, incineration and fuel systems, man-operated material handling equipment, entertainment machines, safety machines, etc. are not recommended, and we assume no responsibility for any failure caused by these applications when used. We will review the acceptability of the abovementioned applications, if you agree not to require a specific quality for a specific application. Please contact us for consultation.

Microsoft and Windows are either registered trademarks or trademarks of Microsoft Corporation in the United States and/or other countries.

The company names, system names and product names mentioned in this document are either registered trademarks or trademarks of their respective companies.

In some cases, trademark symbols such as '™' or '®' are not specified in this manual.

Migration Guide of Motion Controller [Q170MCPUR ⇒ Q170MSCPUR(-S1)]

Country/Region	Sales office	
USA	Mitsubishi Electric Automation, Inc. 500 Corporate Woods Parkway, Vernon Hills, IL 60061, U.S.A.	Tel : +1-847-478-2100
Mexico	Mitsubishi Electric Automation, Inc. Mexico Branch Boulevard Miguel de Cervantes Saavedra 301, Torre Norte Piso 5, Ampliacion Granada, Miguel Hidalgo, Ciudad de Mexico, Mexico, C.P.11520	Tel : +52-55-3067-7512
Brazil	Mitsubishi Electric do Brasil Comercio e Servicos Ltda. Avenida Adelino Cardana, 293, 21 andar, Bethaville, Barueri SP, Brazil	Tel : +55-11-4689-3000
Germany	Mitsubishi Electric Europe B.V. German Branch Mitsubishi-Electric-Platz 1, 40882 Ratingen, Germany	Tel : +49-2102-486-0
UK	Mitsubishi Electric Europe B.V. UK Branch Travellers Lane, UK-Hatfield, Hertfordshire, AL10 8XB, U.K.	Tel : +44-1707-28-8780
Italy	Mitsubishi Electric Europe B.V. Italian Branch Centro Direzionale Colleoni - Palazzo Sirio, Viale Colleoni 7, 20864 Agrate Brianza (MB), Italy	Tel : +39-039-60531
Spain	Mitsubishi Electric Europe B.V. Spanish Branch Carretera de Rubi, 76-80-Apdo. 420, E-08174 Sant Cugat del Valles (Barcelona), Spain	Tel : +34-935-65-3131
France	Mitsubishi Electric Europe B.V. French Branch 25, Boulevard des Bouvets, 92741 Nanterre Cedex, France	Tel : +33-1-55-68-55-68
Czech Republic	Mitsubishi Electric Europe B.V. Czech Branch, Prague Office Pekarska 621/7, 155 00 Praha 5, Czech Republic	Tel : +420-255-719-200
Poland	Mitsubishi Electric Europe B.V. Polish Branch ul. Krakowska 48, 32-083 Balice, Poland	Tel : +48-12-347-65-00
Russia	Mitsubishi Electric (Russia) LLC St. Petersburg Branch Startovaya street, 8, BC "Aeroplaza", office 607; 196210, St. Petersburg, Russia	Tel : +7-812-449-51-34
Sweden	Mitsubishi Electric Europe B.V. (Scandinavia) Hedvig Mollersgata 6, 223 55 Lund, Sweden	Tel : +46-8-625-10-00
Turkey	Mitsubishi Electric Turkey A.S. Umraniye Branch Serifali Mah. Kale Sok. No:41 34775 Umraniye - Istanbul, Turkey	Tel : +90-216-969-2500
UAE	Mitsubishi Electric Europe B.V. Dubai Branch Dubai Silicon Oasis, P.O.BOX 341241, Dubai, U.A.E.	Tel : +971-4-3724716
South Africa	Adroit Technologies 20 Waterford Office Park, 189 Witkoppen Road, Fourways, South Africa	Tel : +27-11-658-8100
China	Mitsubishi Electric Automation (China) Ltd. Mitsubishi Electric Automation Center, No.1386 Hongqiao Road, Shanghai, China	Tel : +86-21-2322-3030
Taiwan	SETSUYO ENTERPRISE CO., LTD. 6F, No.105, Wugong 3rd Road, Wugu District, New Taipei City 24889, Taiwan	Tel : +886-2-2299-2499
Korea	Mitsubishi Electric Automation Korea Co., Ltd. 7F to 9F, Gangseo Hangang Xi-tower A, 401, Yangcheon-ro, Gangseo-Gu, Seoul 07528, Korea	Tel : +82-2-3660-9529
Singapore	Mitsubishi Electric Asia Pte. Ltd. 307 Alexandra Road, Mitsubishi Electric Building, Singapore 159943	Tel : +65-6473-2486
Thailand	Mitsubishi Electric Factory Automation (Thailand) Co., Ltd. True Digital Park Building Sukhumvit 101 Sukhumvit Road, Bang Chak, Prakanong, Bangkok, Thailand	Tel : +66-2092-8600
Indonesia	PT. Mitsubishi Electric Indonesia Gedung Jaya 8th Floor, JL. MH. Thamrin No.12, Jakarta Pusat 10340, Indonesia	Tel : +62-21-3192-6461
Vietnam	Mitsubishi Electric Vietnam Company Limited 11th & 12th Floor, Viettel Tower B, 285 Cach Mang Thang 8 Street, Ward 12, District 10, Ho Chi Minh City, Vietnam	Tel : +84-28-3910-5945
India	Mitsubishi Electric India Pvt. Ltd. Pune Branch Emerald House, EL-3, J Block, M.I.D.C., Bhosari, Pune - 411026, Maharashtra, India	Tel : +91-20-2710-2000
Australia	Mitsubishi Electric Australia Pty. Ltd. 348 Victoria Road, P.O. Box 11, Rydalmere, N.S.W 2116, Australia	Tel : +61-2-9684-7777

MITSUBISHI ELECTRIC CORPORATION

HEAD OFFICE: TOKYO BUILDING, 2-7-3, MARUNOUCHI, CHIYODA-KU, TOKYO 100-8310, JAPAN
NAGOYA WORKS: 1-14, YADA-MINAMI 5, HIGASHI-KU, NAGOYA, JAPAN