

Numerical Control (CNC)

Connection Manual

M700VW Series

Introduction

This manual covers the items required for installing and connecting the MITSUBISHI CNC M700VW Series. Read this manual thoroughly and understand the product's functions and performance before starting to use.

This manual is written on the assumption that all optional functions are added, but the actually delivered device may not have all functions.

The unit names, cable names and various specifications are subject to change without notice. Please confirm these before placing an order.

Be sure to keep this manual always at hand.





This manual notes a reference chapter as "Chapter: Section: Paragraph".

(Example) For "1.3.1 List of Units":

"System Configuration: List of Configuration: List of Units"

("1.3.1 List of Units" included in "1.3 List of Configuration" of "1 System Configuration")

CAUTION

-  For items described as "Restrictions" or "Usable State" in this manual, the instruction manual issued by the machine tool builder takes precedence over this manual.
-  Items that are not described in this manual must be interpreted as "not possible".
-  This manual is written on the assumption that all optional functions are added. Confirm the specifications issued by the machine tool builder before starting to use.
-  Refer to the Instruction Manual issued by each machine tool builder for details on each machine tool.
-  Some screens and functions may differ depending on each NC system (or version), and some functions may not be possible. Please confirm the specifications before starting to use.

The numerical control unit is configured of the control unit, display unit, operation board (keyboard unit, operation panel I/O unit), servo drive unit, spindle drive unit, power supply unit + driver, servomotor, spindle motor, etc.

In this manual, the following items are generically called "controller".

- Control unit
- Display unit
- Operation board (keyboard unit, operation panel I/O unit)
- Numerical control unit peripheral devices (input/output unit, safety unit)

In this manual, the following items are generically called "drive unit".

- Servo drive unit
- Spindle drive unit
- Power supply unit + driver

In this manual, the following items are generically called "motor".

- Servo motor
- Spindle motor

Refer to the following documents.

M700V/M70V/E70 Series PLC Interface Manual IB-1500920

MDS-D2/DH2 Series Specifications Manual IB-1501124

MDS-D2/DH2 Series Instruction Manual IB-1501127

MDS-DM2 Series Specifications Manual IB-1501136

MDS-DM2 Series Instruction Manual IB-1501139

MDS-DJ Series Specifications Manual IB-1501130



MDS-DJ Series Instruction Manual IB-1501133

Safety Handbook (Original Instructions) IB-1501025

Precautions for Safety





Always read this manual and enclosed documents before installation, operation, maintenance and inspection to ensure correct usage. Thoroughly understand the basics, safety information and precautions of the devices before using.

This manual classifies the safety precautions into "DANGER", "WARNING" and "CAUTION".











 DANGER When the user could be subject to imminent fatalities or serious injuries if handling is mistaken.
 WARNING When the user could be subject to fatalities or serious injuries if handling is mistaken.
 CAUTION When the user could be subject to injuries or the property could be damaged if handling is mistaken.

Note that the items under "  CAUTION" could lead to serious consequences as well depending on the situation. All the items are important and must always be observed.

The following signs indicate prohibition and compulsory.

	<p>This sign indicates prohibited behavior (must not do).</p> <p>For example,  indicates "Keep fire away".</p>
	<p>This sign indicates a thing that is compulsory (must do).</p> <p>For example,  indicates "it must be grounded".</p>

The meaning of each pictorial sign is as follows.

 CAUTION	 CAUTION rotated object	 CAUTION HOT	 Danger Electric shock risk	 Danger explosive
 Prohibited	 Disassembly is prohibited	 KEEP FIRE AWAY	 General instruction	 Earth ground

For Safe Use









Mitsubishi CNC is designed and manufactured solely for applications to machine tools.

Do not use this product in any applications other than those specified as above, especially those which are substantially influential on the public interest or which are expected to have significant influence on human lives or properties.

We will review the acceptability of the abovementioned applications, if the customer agrees not to require a specific quality for a specific application. Please contact us for consultation.

1. Items related to prevention of electric shocks



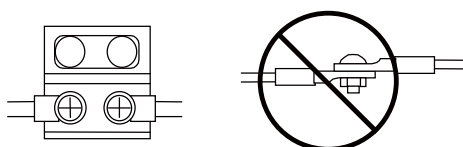

WARNING

-  Do not open or remove the front cover while the power is ON or during operation. The high voltage terminals and charged sections will be exposed, and this could result in electric shocks.
-  Do not remove the front cover even when the power is OFF, except for the wiring works or periodic inspections. The inside of the controller and drive unit are charged, and this could result in electric shocks. Always wait at least 15 minutes after turning the power OFF. Then, check the voltage with a tester, etc., before wiring works, inspections or connecting with peripheral devices. Failure to observe this could result in electric shocks.
-  Earth ground the controller, drive unit and motor according to the local laws. (In Japan, ground the 200V Series input products with Class C or higher protective grounding and the 400V Series input with Class D or higher protective grounding.)
-  All wiring works, maintenance and inspections must be carried out by a qualified technician. Failure to observe this could result in electric shocks. Contact your nearby Service Center or Service Station for replacing parts and servicing.
-  Wire the controller, drive unit and motor after installation. Failure to observe this could result in electric shocks.
-  Do not operate the switches with wet hands. Failure to observe this could result in electric shocks.
-  Do not damage, apply excessive stress, place heavy things on or sandwich the cables. Failure to observe this could result in electric shocks.
-  Insulate the power lead using a fixed terminal block. Failure to observe this could result in electric shocks.



2. Items related to prevention of fire

CAUTION

-  Install the controller, drive unit, motor and regenerative resistor on non-combustible material. Installation directly on or near combustible materials could result in fires.
-  If any malfunction in the unit is observed, shut off the power at the unit's power supply side. Continuous flow of large current could result in fires.
-  Install an appropriate no fuse breaker (NFB) and contactor (MC) on the power input section of the drive unit and configure the sequence that shuts the power off upon drive unit's emergency stop or alarm.
-  When a breaker is shared for multiple power supply units, the breaker may not function upon short-circuit failure in a small capacity unit. Do not share a breaker for multiple units as this is dangerous.
-  Incorrect wiring and connections could cause the devices to damage or burn.

3. Items related to prevention of bodily injury or property damage

DANGER



When transporting or installing a built-in IPM spindle or linear servomotor, be careful so that your hand or property will not be trapped in the motors or other metal objects. Also keep the devices with low magnetic tolerance away from the product.

CAUTION



Do not apply voltages to the connectors or terminals other than voltages indicated in the connection manual for the controller or specifications manual for the drive unit. Failure to observe this could cause bursting, damage, etc.



Incorrect connections could cause the devices to rupture or damage, etc. Always connect the cables to the indicated connectors or terminals.



Incorrect polarity (+ -) could cause the devices to rupture or damage, etc.



Persons wearing medical devices, such as pacemakers, must stay away from this unit. The electromagnetic waves could adversely affect the medical devices.



Fins on the rear of the unit, regenerative resistor and motor, etc., will be hot during operation and for a while after the power has been turned OFF. Do not touch or place the parts and cables, etc. close to these sections. Failure to observe this could result in burns.

























Do not enter the machine's movable range during automatic operation. Keep your hands, feet or face away from the spindle during rotation.

4. General precautions









Always follow the precautions below. Incorrect handling could result in faults, injuries or electric shocks, etc.

(1) Transportation and installation

CAUTION

-  Correctly transport the products according to the mass.
-  Use motor's suspension bolts to transport the motor itself. Do not use it to transport the motor after installation onto the machine.
-  Do not stack the products exceeding the indicated limit.
-  Do not hold the cables, shaft or detector when transporting the motor.
-  Do not transport the controller or drive unit by suspending or holding the connected wires or cables.
-  Do not hold the front cover when transporting the unit, or the front cover could come off, causing the unit to drop.
-  Install on a non-combustible place where the unit's or motor's mass can be withstood according to the instruction manual.
-  The motor does not have a complete water-proof (oil-proof) structure. Do not allow oil or water to contact or enter the motor. Prevent the cutting chips from being accumulated on the motor as they easily soak up oil.
-  When installing the motor facing upwards, take measures on the machine side so that gear oil, etc., will not enter the motor shaft.
-  Do not remove the detector from the motor. (The detector installation screw is treated with sealing.)
-  Do not allow foreign matters, especially, conductive foreign matters such as screws or metal chips, or combustible foreign matters such as oil, to enter the controller, drive unit or motor. Failure to observe this could result in rupture or damage.
-  Do not get on the product or place heavy objects on it.
-  Provide prescribed distance between the controller/drive unit and inner surface of the control panel/other devices.
-  Do not install or operate the controller, drive unit or motor that is damaged or has missing parts.
-  Take care not to cut hands, etc. with the heat radiating fins or metal edges.
-  Do not block the intake/outtake ports of the motor with the cooling fan.
-  Install the controller's display section and operation board section on the spot where cutting oil will not reach.
-  The controller, drive unit and motor are precision devices, so do not drop or apply thumping vibration and strong impacts on them.
-  Hard disk unit is a precision device, so do not drop or apply strong impacts on it.
-  Store and use the units according to the environment conditions indicated in each specifications manual.
-  When disinfectants or insecticides must be used to treat wood packaging materials, always use methods other than fumigation (for example, apply heat treatment at the minimum wood core temperature of 56 °C for a minimum duration of 30 minutes (ISPM No. 15 (2009))).
If products such as units are directly fumigated or packed with fumigated wooden materials, halogen substances (including fluorine, chlorine, bromine and iodine) contained in fumes may contribute to the erosion of the capacitors.
When exporting the products, make sure to comply with the laws and regulations of each country.
-  Do not use the products in conjunction with any components that contain halogenated flame retardants (bromine, etc). Failure to observe this may cause the erosion of the capacitors.
-  Securely fix the motor to the machine. The motor could come off during operation if insecurely fixed.

 **CAUTION**

-  **Always install the motor with reduction gear in the designated direction. Failure to observe this could result in oil leaks.**
-  **Always install a cover, etc., over the shaft so that the rotary section of the motor cannot be touched during motor rotation.**
-  **When installing a coupling to the servomotor shaft end, do not apply impacts by hammering, etc. The detector could be damaged.**
-  **Use a flexible coupling when connecting with a ball screw, etc., and keep the shaft core deviation smaller than the tolerable radial load of the shaft.**
-  **Do not use a rigid coupling as an excessive bending load will be applied on the shaft and could cause the shaft to break.**
-  **Do not apply a load exceeding the tolerable level onto the motor shaft. The shaft or bearing could be damaged.**
-  **Before using this product after a long period of storage, please contact the Mitsubishi Service Station or Service Center.**
-  **Following the UN recommendations, battery units and batteries should be transported based on the international regulations such as those determined by International Civil Aviation Organization (ICAO), International Air Transport Association (IATA), International Maritime Organization (IMO) and U.S. Department of Transportation (DOT).**

(2) Items related to wiring

⚠ CAUTION

- ⚠ Correctly wire this product. Failure to observe this could result in motor runaway, etc.
- ⚠ Do not install a phase advancing capacitor, surge absorber or radio noise filter on the output side of the drive unit.
- ⚠ Correctly connect the output side (terminal U, V, W). The motor will not run properly if incorrectly connected.
- ⚠ Always install an AC reactor per each power supply unit.
- ⚠ Always install an appropriate breaker per each power supply unit. A breaker cannot be shared for multiple power supply units.
- ⚠ Do not directly connect a commercial power supply to the motor. Failure to observe this could result in faults.
- ❗ When using an inductive load such as relays, always connect a diode in parallel to the load as a noise countermeasure.
- ❗ When using a capacitive load such as a lamp, always connect a protective resistor serially to the load to suppress rush currents.
- ⚠ Do not mistake the direction of the surge absorption diode to be installed on the DC relay for the control output signal. If mistaken, the signal will not be output due to fault in the drive unit, and consequently the protective circuit, such as emergency stop, could be disabled.

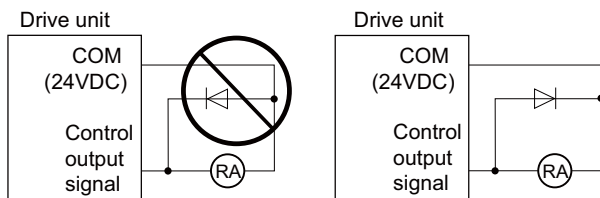

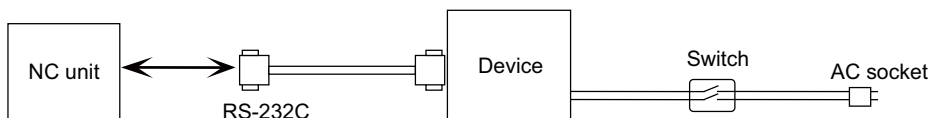

- ⊘ Do not connect or disconnect the cables between units while the power is ON.
- ⚠ Do not connect or disconnect the PCBs while the power is ON.
- ⚠ Do not pull the cables when connecting/disconnecting them.
- ⚠ Securely tighten the cable connector fixing screw or fixing mechanism. The motor could come off during operation if insecurely fixed.
- ⚡ Always treat the shield cables indicated in the Connection Manual with grounding measures such as cable clamps.
- ⚠ Separate the signal wire from the drive line or power line when wiring.
- ⚠ Use wires and cables whose wire diameter, heat resistance level and bending capacity are compatible with the system.
- ⚡ Ground the device according to the requirements of the country where the device is to be used.
- ⚠ Wire the heat radiating fins and wires so that they do not contact.
- ⚠ When using the RS-232C device as a peripheral device, caution must be paid for connector connection/disconnection. Always use a double-OFF type AC power supply switch on the device side, and connect/disconnect the connector with the AC power supply on the device side OFF.

















(3) Adjustments

CAUTION

-  Check and adjust programs and each parameter before starting operation. Failure to observe this could result in unpredictable operations depending on the machine.
-  Do not make drastic adjustments or changes as the operation could become unstable.

(4) Usage

CAUTION

-  Install an external emergency stop circuit so that the operation can be stopped and the power turns OFF immediately when unforeseen situation occurs. A contactor, etc., is required in addition to the shutoff function mounted in the controller.
-  Turn OFF the power immediately if any smoke, abnormal noise or odor is generated from the controller, drive unit or motor.
-  Only a qualified technician may disassemble or repair this product.
-  Do not alter.
-  Use a noise filter, etc. to reduce the effect of electromagnetic disturbances in the case where electromagnetic disturbances could adversely affect the electronic devices used near the drive unit.
-  Use the drive unit, motor and each regenerative resistor with the designated combination. Failure to observe this could result in fires or faults.
-  The combination of the motor and drive unit that can be used is determined. Be sure to check the models of motor and drive unit before test operation.
-  The brakes (electromagnetic brakes) mounted in the servomotor are used for the purpose of holding, and must not be used for normal braking. Also, do not run the motor with the motor brake applied. Motor brake is used for the purpose of holding.
-  For the system running via a timing belt, install a brake on the machine side so that safety can be ensured.
-  Be sure to confirm SERVO OFF (or READY OFF) when applying the electromagnetic brake. Also, be sure to confirm SERVO ON prior to releasing the brake.
-  When using the DC OFF type electromagnetic brake, be sure to install a surge absorber on the brake terminal.
-  Do not connect or disconnect the cannon plug while the electromagnetic brake's power is ON. The cannon plug pins could be damaged by sparks.
-  After changing programs/parameters, or after maintenance/inspection, always carry out a test operation before starting actual operation.
-  Use the power that are complied with the power specification conditions (input voltage, input frequency, tolerable instantaneous power failure time) indicated in each specifications manual.
-  When making detector cables, do not mistake connection. Failure to observe this could result in malfunction, runaway or fire.

(5) Troubleshooting

CAUTION



Use a motor with electromagnetic brakes or establish an external brake mechanism for the purpose of holding; this serves as countermeasures for possible hazardous situation caused by power failure or product fault.



Use a double circuit structure for the electromagnetic brake's operation circuit so that the brakes will activate even when the external emergency stop signal is issued.

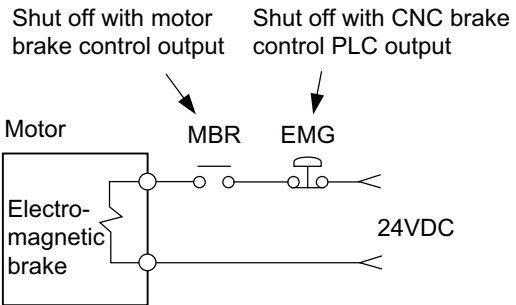

The machine could suddenly restart when the power is restored after an instantaneous power failure, so stay away from the machine. (Design the machine so that the operator safety can be ensured even if the machine restarts.)









To secure the absolute position, do not shut off the servo drive unit's control power supply when its battery voltage drops (warning 9F) in the servo drive unit side.



If the battery voltage drop warning alarm occurs in the controller side, make sure to back up the machining programs, tool data and parameters, etc. with the input/output device before replacing the battery. Depending on the level of voltage drop, memory loss could have happened. In that case, reload all the data backed up before the alarm occurrence.



(6) Maintenance, inspection and part replacement

CAUTION

-  Periodically back up the programs, tool data and parameters to avoid potential data loss. Also, back up those data before maintenance and inspections.
-  When replacing the battery on the controller side, the machining programs, tool data and parameters should be backed up with the input/output device beforehand. In case the memory is damaged in replacing the batteries, reload all the data backed up before replacing the battery.
-  The electrolytic capacitor's capacity will drop due to deterioration. To prevent secondary damage due to capacitor's faults, Mitsubishi recommends the electrolytic capacitor to be replaced approx. every five years even when used in a normal environment. Contact the Service Center or Service Station for replacements.
-  Do not perform a megger test (insulation resistance measurement) during inspection.
-  Do not replace parts or devices while the power is ON.
-  Do not short-circuit, charge, overheat, incinerate or disassemble the battery.
-  There may be a unit filled with substitute Freon in the heat radiating fins of the 37kW or smaller unit. Be careful not to break the heat radiating fins during maintenance or replacement.

(7) Disposal

CAUTION

-  Take the batteries and backlights for LCD, etc., off from the controller, drive unit and motor, and dispose of them as general industrial wastes.
-  Do not alter or disassemble controller, drive unit, or motor.
-  Collect and dispose of the spent batteries and the backlights for LCD according to the local laws.

(8) General precautions

To explain the details, drawings given in the instruction manual, etc., may show the unit with the cover or safety partition removed. When operating the product, always place the cover or partitions back to their original position, and operate as indicated in the instruction manual, etc.

Treatment of waste

The following two laws will apply when disposing of this product. Considerations must be made to each law. The following laws are in effect in Japan. Thus, when using this product overseas, the local laws will have a priority. If necessary, indicate or notify these laws to the final user of the product.

- (1) Requirements for "Law for Promotion of Effective Utilization of Resources"
 - (a) Recycle as much of this product as possible when finished with use.
 - (b) When recycling, often parts are sorted into steel scraps and electric parts, etc., and sold to scrap contractors. Mitsubishi Electric recommends sorting the product and selling the members to appropriate contractors.
- (2) Requirements for "Law for Treatment of Waste and Cleaning"
 - (a) Mitsubishi Electric recommends recycling and selling the product when no longer needed according to item (1) above. The user should make an effort to reduce waste in this manner.
 - (b) When disposing a product that cannot be resold, it shall be treated as a waste product.
 - (c) The treatment of industrial waste must be commissioned to a licensed industrial waste treatment contractor, and appropriate measures, including a manifest control, must be taken.
 - (d) Batteries correspond to "primary batteries", and must be disposed of according to local disposal laws.

Disposal



(Note) This symbol mark is for EU countries only.
This symbol mark is according to the directive 2006/66/EC Article 20 Information for end-users and Annex II.

Your MITSUBISHI ELECTRIC product is designed and manufactured with high quality materials and components which can be recycled and/or reused.

This symbol means that batteries and accumulators, at their end-of-life, should be disposed of separately from your household waste.

If a chemical symbol is printed beneath the symbol shown above, this chemical symbol means that the battery or accumulator contains a heavy metal at a certain concentration. This will be indicated as follows:

Hg: mercury (0.0005%), Cd: cadmium (0.002%), Pb: lead (0.004%)

In the European Union there are separate collection systems for used batteries and accumulators.

Please, dispose of batteries and accumulators correctly at your local community waste collection/recycling centre.

Please, help us to conserve the environment we live in!

Trademarks

MELDAS, MELSEC, EZSocket, EZMotion, iQ Platform, MELSOFT, GOT, CC-Link, CC-Link/LT and CC-Link IE are either trademarks or registered trademarks of Mitsubishi Electric Corporation in Japan and/or other countries.

Ethernet is a registered trademark of Xerox Corporation in the United States and/or other countries.

Microsoft® and Windows® are either trademarks or registered trademarks of Microsoft Corporation in the United States and/or other countries.

CompactFlash and CF are either trademarks or registered trademarks of SanDisk Corporation in the United States and/or other countries.

UNIX is a registered trademark of The Open Group in the United States and/or other countries.

Intel® and Pentium® are either trademarks or registered trademarks of Intel Corporation in the United States and/or other countries.

Other company and product names that appear in this manual are trademarks or registered trademarks of the respective companies.

本製品の取扱いについて

(日本語 /Japanese)

本製品は工業用 (クラス A) 電磁環境適合機器です。販売者あるいは使用者はこの点に注意し、住商業環境以外での使用をお願いいたします。

Handling of our product

(English)

This is a class A product. In a domestic environment this product may cause radio interference in which case the user may be required to take adequate measures.

본 제품의 취급에 대해서

(한국어 /Korean)

이 기기는 업무용 (A 급) 전자파적합기기로서 판매자 또는 사용자는 이 점을 주의하시기 바라며 가정외의 지역에서 사용하는 것을 목적으로 합니다 .

Contents

1 System Configuration	1
1.1 System Basic Configuration Drawing	2
1.2 General Connection Diagram	3
1.2.1 For 10.4-type Display Unit	3
1.2.2 For 15-type Display Unit	4
1.3 List of Configuration	5
1.3.1 List of Units	5
1.3.2 Durable Parts	8
1.3.3 List of Cables	9
2 General Specifications	11
2.1 Environment Conditions	12
2.2 Control Unit	14
2.3 Display Unit	28
2.4 Keyboard Unit	38
2.5 Operation Panel I/O Unit	41
2.6 Hard Disk Unit	55
2.7 Remote I/O Unit	58
2.8 Scan I/O Unit	65
2.9 External Power Supply Unit	76
2.10 Manual Pulse Generator	81
2.11 Synchronous Feed Encoder	83
2.12 Expansion Unit and Expansion Card	84
2.12.1 Expansion unit	84
2.12.2 Expansion card (PROFIBUS-DP)	85
2.12.3 Expansion card (CC-Link)	86
2.13 Expansion I/O Card	88
2.14 Handy Terminal	96
2.15 Optical Communication Repeater Unit (FCU7-EX022)	100
2.16 MITSUBISHI CNC Machine Operation Panel	103
2.16.1 MITSUBISHI CNC Machine Operation Panel A	103
2.16.2 MITSUBISHI CNC Machine Operation Panel B	110
2.17 Exclusive CF Cards for MITSUBISHI CNC	114
2.17.1 Precautions for Use of Commercially Available CF Cards	114
2.18 Precautions for Use of USB devices	115
3 Installation	117
3.1 Heat Radiation Countermeasures	118
3.2 Noise Countermeasures	121
3.2.1 Connection of FG (Frame Ground)	121
3.2.2 Shield Clamping of Cables	122
3.2.3 Connecting Spark Killers	122
3.3 Unit Installation	123
3.3.1 Control Unit	123
3.3.2 Display Unit	124
3.3.3 Keyboard Unit	125
3.3.4 Operation Panel I/O Unit	125
3.3.5 Control Unit Battery	126
3.3.6 Expansion Unit	127
4 Connection	129
4.1 Precautions for Wiring	130
4.1.1 Precautions when Connecting/Disconnecting Cables	130
4.1.2 Precautions for Using Optical Communication Cable	133
4.1.2.1 Optical Communication Cable Outline and Parts	133
4.1.2.2 Precautions for Handling Optical Communication Cable	133
4.1.2.3 Precautions for Laying Optical Communication Cable	134
4.1.3 Precautions for Connecting 24V Power Supply	134

4.1.4 Ferrite Core Installation Method.....	135
4.2 Connection of Control Unit.....	136
4.2.1 Control Unit Connection System Drawing.....	136
4.2.2 Connecting with Power Supply.....	137
4.2.3 Connecting with Emergency Stop Signal.....	138
4.2.4 Connecting with Operation Panel I/O Unit.....	141
4.2.5 Connecting with Drive Unit.....	142
4.2.5.1 Connecting with MDS-D2/DH2 Series.....	143
4.2.5.2 Connecting with MDS-DM2 Series.....	145
4.2.5.3 Connecting with MDS-DJ Series.....	146
4.2.6 Connecting with Auxiliary Axis Servo Drive Unit: MR-J2-CT.....	147
4.2.7 Connecting with RS-232C Device.....	148
4.2.8 Connecting with Skip Signal (Sensor).....	150
4.2.9 Connecting with Synchronous Feed Encoder/ Manual Pulse Generator.....	152
4.2.9.1 Handle Numbers.....	152
4.2.10 Connecting with Safety Observing I/O Device.....	153
4.2.10.1 Connection diagram using SDIO connector.....	153
4.2.10.2 Connection diagram using I/O unit.....	155
4.2.10.3 Connection diagram using the STO-compatible drive system.....	156
4.2.11 Connecting with I/O Devices via Expansion Card.....	157
4.2.11.1 Connecting with I/O Devices via PROFIBUS-DP.....	157
4.2.11.2 Connecting with I/O Devices via CC-Link.....	158
4.3 Connection of Operation Panel I/O Unit.....	161
4.3.1 Operation Panel I/O Unit Connection System Drawing.....	161
4.3.2 Connecting with Power Supply.....	162
4.3.3 Connecting with Emergency Stop Signal.....	163
4.3.4 Connecting with Display Unit.....	164
4.3.5 Connecting with Keyboard Unit.....	165
4.3.6 Connecting with Manual Pulse Generator (MPG).....	166
4.3.6.1 Handle Numbers.....	167
4.3.7 Connecting with Machine Operation Panel.....	168
4.3.7.1 Wiring for 24V Common Input.....	169
4.3.7.2 Wiring for 0V Common Input.....	170
4.3.7.3 Wiring for Sink Type Output (FCU7-DX670/DX770).....	171
4.3.7.4 Wiring for Source Type Output (FCU7-DX671/DX771).....	172
4.4 Connection of Display Unit.....	173
4.4.1 Display Unit Connection System Drawing.....	173
4.4.2 Connecting with Power Supply.....	174
4.4.3 Connecting with Keyboard Unit.....	175
4.4.4 Connecting with Hard Disk Unit.....	176
4.5 Connection of Remote I/O Unit.....	177
4.5.1 Connection and Station No. Setting on Remote I/O Unit.....	177
4.5.2 Station No. Setting when Using Multiple Remote I/O Units.....	179
4.5.3 Connecting FCUA-DX10x/14x Unit with Machine Control Signal.....	183
4.5.4 Connecting FCUA-DX14x Unit with Analog Input/Output Signal.....	185
4.5.5 Connecting FCUA-DX11x Unit with Machine Control Signal.....	186
4.5.6 Connecting FCUA-DX12x Unit with Machine Control Signal.....	188
4.6 Connection of MITSUBISHI CNC Machine Operation Panel.....	190
4.7 Connection of Scan I/O card.....	193
4.8 Connection of Expansion I/O Card.....	194
4.8.1 Connecting with Power Supply.....	194
4.8.2 Connecting with Control Unit/ Operation Panel I/O Unit.....	194
4.8.3 Connecting with Remote I/O Unit.....	195
4.9 Connection of Handy Terminal.....	196
4.10 Turning the Power ON/OFF.....	197
4.11 Connection Example When Not Using Operation Panel I/O Unit.....	199

Appendix 1 Cable.....	201
Appendix 1.1 Cable Wire and Assembly.....	203
Appendix 1.2 CNP2E-1 Cable.....	205
Appendix 1.3 CNP3EZ-2P/CNP3EZ-3P Cable.....	206

Appendix 1.4 CNV22J-K1P / CNV22J-K2P Cable	207
Appendix 1.5 CNV2E-6P/CNV2E-7P Cable	208
Appendix 1.6 CNV2E-8P/CNV2E-9P Cable	209
Appendix 1.7 CNV2E-D Cable	210
Appendix 1.8 CNV2E-HP Cable	211
Appendix 1.9 CNV2E-K1P / CNV2E-K2P Cable	212
Appendix 1.10 DG21 Cable	213
Appendix 1.11 DG22 Cable	214
Appendix 1.12 DG23 Cable	215
Appendix 1.13 DG24 Cable	216
Appendix 1.14 E-TM Terminator Connector	217
Appendix 1.15 F020/F021/F022 Cable	218
Appendix 1.16 F034/F035 Cable	219
Appendix 1.17 F070 Cable	220
Appendix 1.18 F110 Cable	221
Appendix 1.19 F120 Cable	222
Appendix 1.20 F142 Cable	223
Appendix 1.21 F170 Cable	224
Appendix 1.22 FCUA-R030 Cable	225
Appendix 1.23 FCUA-R031 Cable	226
Appendix 1.24 FCUA-R050/R054 Cable	227
Appendix 1.25 FCUA-R211 Cable	228
Appendix 1.26 FCUA-R300/FCUA-R301 Cable	229
Appendix 1.27 G020/G021/G022 Cable	231
Appendix 1.28 G023/G024 Cable	232
Appendix 1.29 G031/G032 Cable	233
Appendix 1.30 G071 Cable	234
Appendix 1.31 G123 Cable	235
Appendix 1.32 G170 Cable	236
Appendix 1.33 G171 Cable	237
Appendix 1.34 G295 Cable	238
Appendix 1.35 G300 Cable	239
Appendix 1.36 G301 Cable	240
Appendix 1.37 G310 Cable	241
Appendix 1.38 G380 Cable	242
Appendix 1.39 G395 Cable	243
Appendix 1.40 G396 Cable	244
Appendix 1.41 G430 Cable	245
Appendix 1.42 G460 Cable	246
Appendix 1.43 MR-BKS1CBL-A1-H / MR-BKS1CBL-A2-H Cable	247
Appendix 1.44 MR-PWS1CBL-A1-H / MR-PWS1CBL-A2-H Cable	248
Appendix 1.45 R-TM Terminator Connector	249
Appendix 1.46 SH21 Cable	250
Appendix 1.47 SH41 Cable	251
Appendix 1.48 List of Cable Connector Sets	252

Appendix 2 EMC Installation Guidelines 255

Appendix 2.1 Introduction	256
Appendix 2.2 EMC Directives	256
Appendix 2.3 EMC Measures	257
Appendix 2.4 Panel Structure	257
Appendix 2.4.1 Measures for Control Panel Body	257
Appendix 2.4.2 Measures for Door	258
Appendix 2.4.3 Measures for Power Supply	258
Appendix 2.5 Measures for Wiring in Panel	259
Appendix 2.5.1 Precautions for Wiring in Panel	259
Appendix 2.5.2 Shield Treatment of Cables	260
Appendix 2.6 EMC Countermeasure Parts	262
Appendix 2.6.1 Shield Clamp Fitting	262
Appendix 2.6.2 Ferrite Core	263
Appendix 2.6.3 Surge Absorber	264

Appendix 2.6.4 Selection of Stabilized Power Supply	266
Appendix 3 Restrictions for Lithium Batteries	267
Appendix 3.1 Restriction for Packing	268
Appendix 3.1.1 Target Products	269
Appendix 3.1.2 Handling by User	270
Appendix 3.1.3 Reference	271
Appendix 3.2 Products information data sheet (ER battery)	272
Appendix 3.3 Issuing Domestic Law of the United States for Primary Lithium Battery Transportation....	274
Appendix 3.3.1 Outline of Regulation	274
Appendix 3.3.2 Target Products	274
Appendix 3.3.3 Handling by User	274
Appendix 3.3.4 Reference	274
Appendix 3.4 Restriction related to EU Battery Directive.....	275
Appendix 3.4.1 Important Notes	275
Appendix 3.4.2 Information for end-user.....	275
Appendix 4 Precautions for Compliance to UL/c-UL Standards	277



System Configuration

1.1 System Basic Configuration Drawing

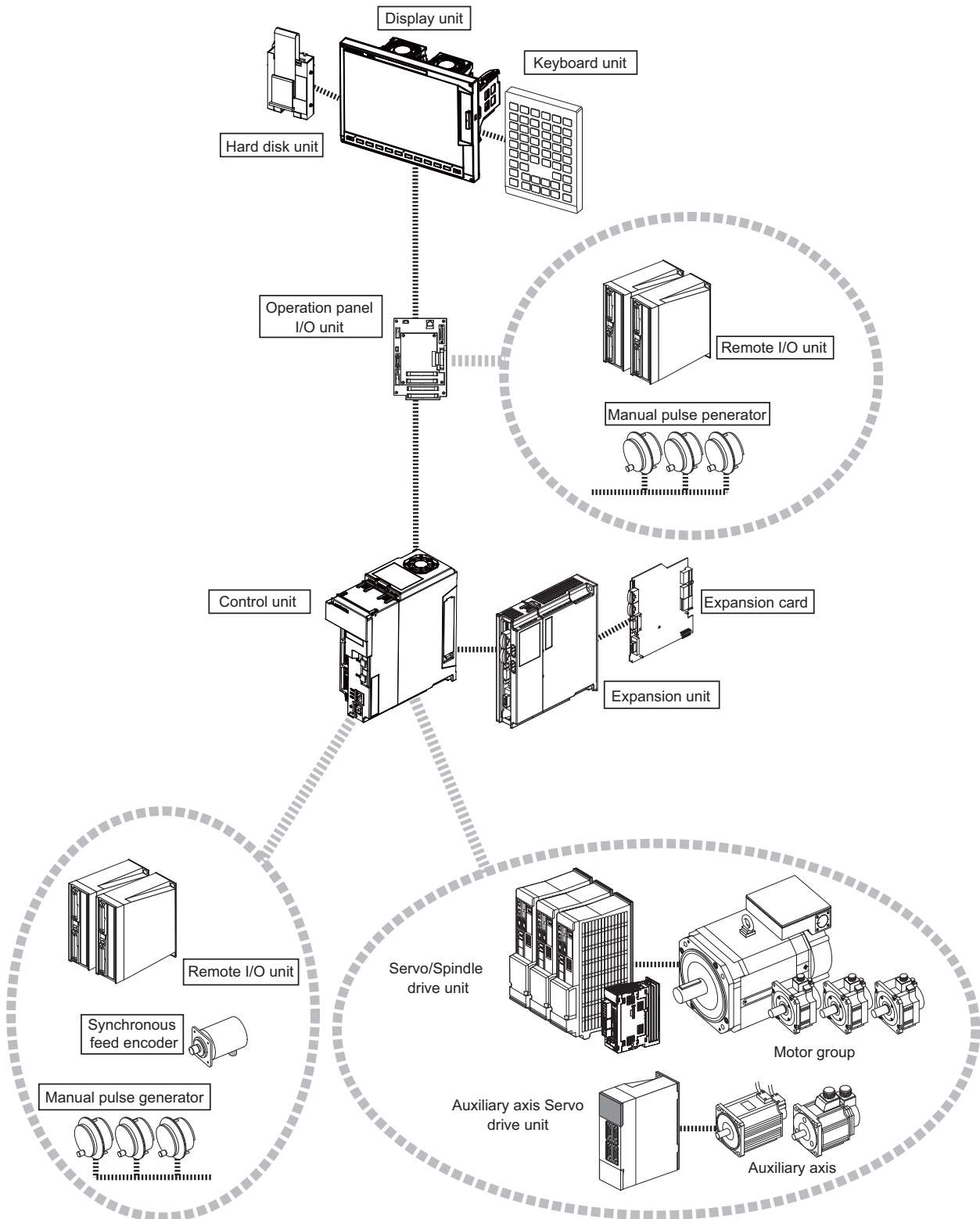

(Note) For the drive unit configuration, refer to the Instruction Manual of the drive unit you use.

1.2 General Connection Diagram

1.2.1 For 10.4-type Display Unit

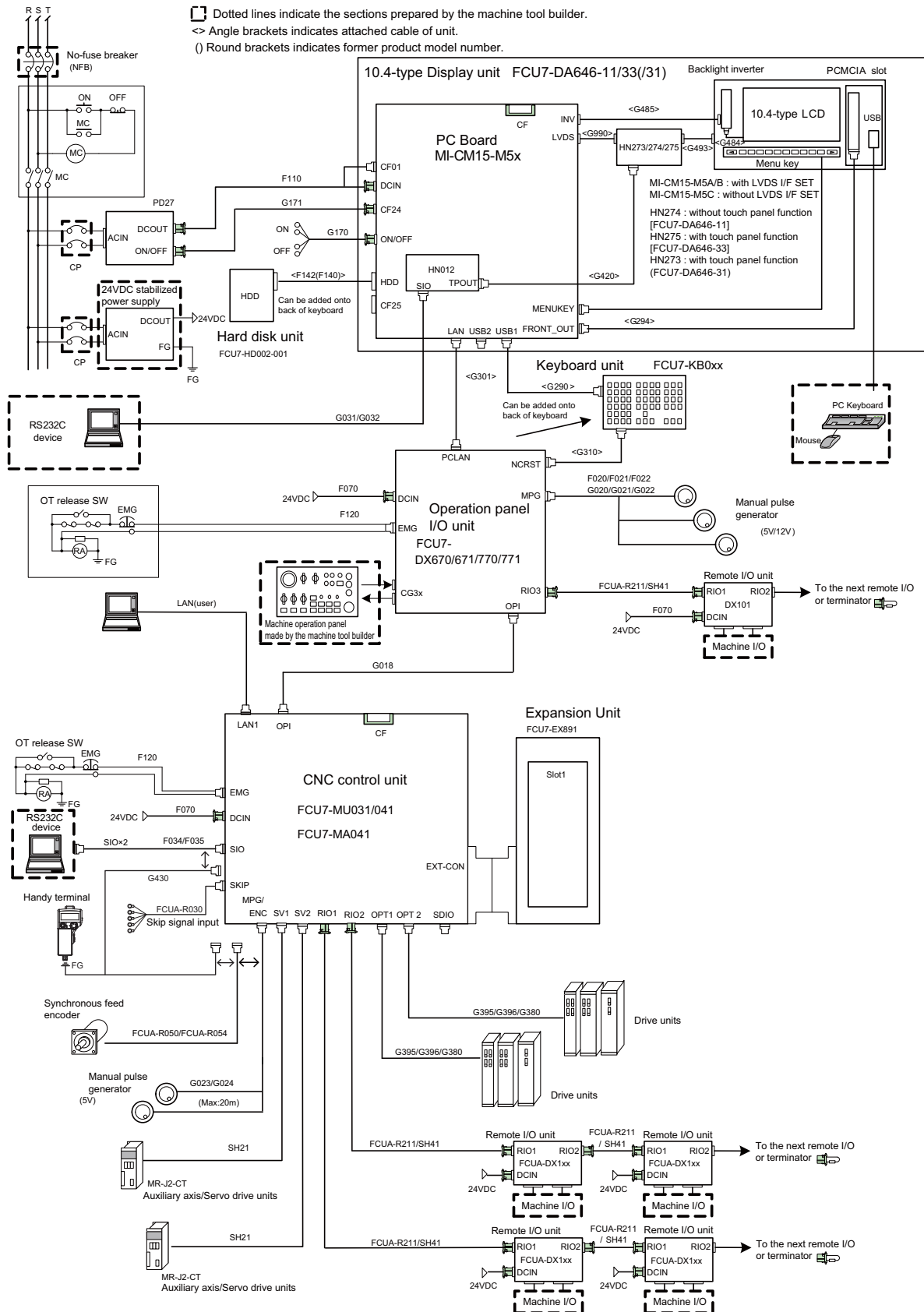

- (Note1) For information on how to connect the drive unit, refer to the drive unit's manual.
- (Note2) For a connection of the MITSUBISHI CNC Machine Operation Panel, refer to "Connection:Connection of MITSUBISHI CNC Machine Operation Panel" to be described.

1.2.2 For 15-type Display Unit

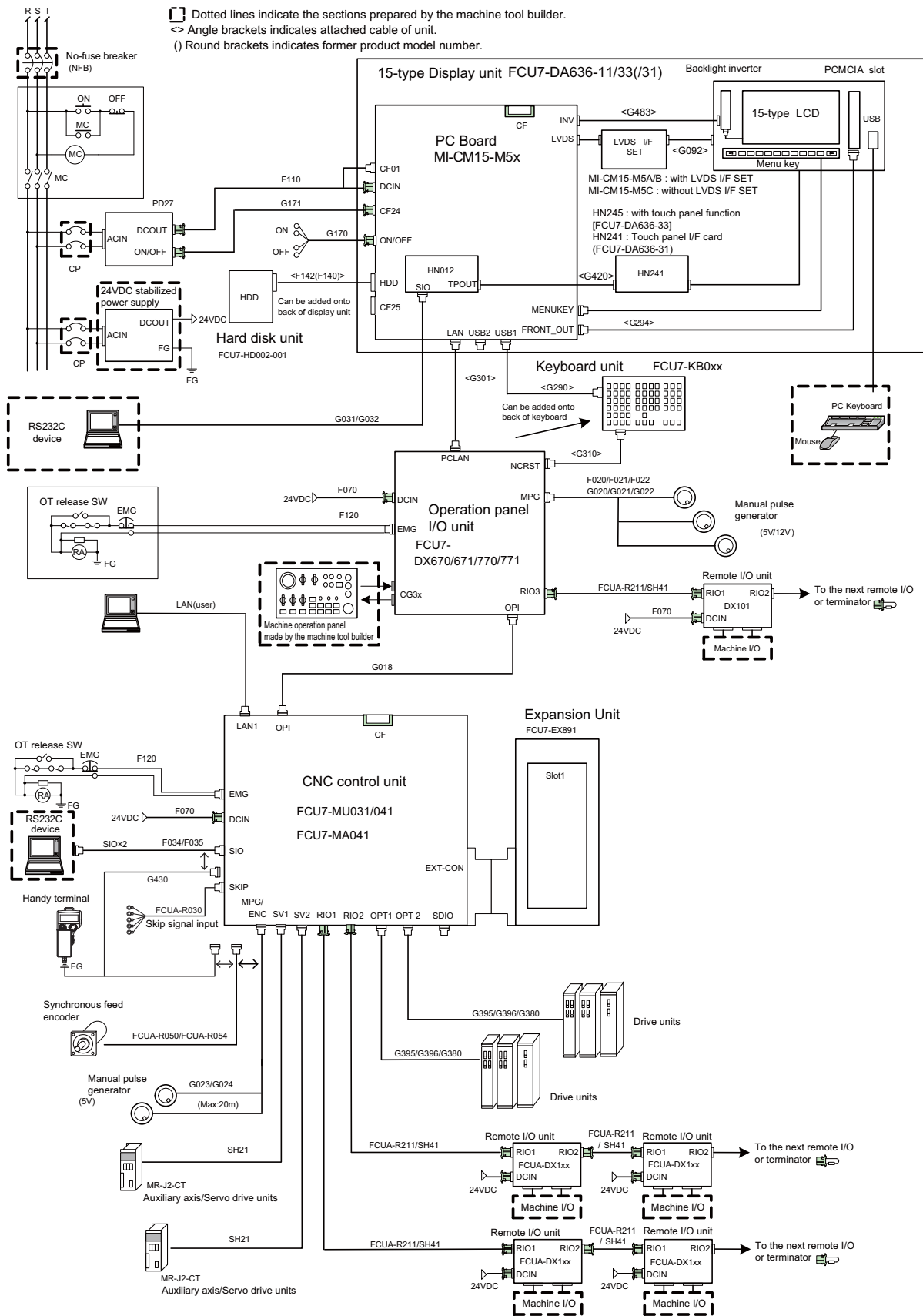

(Note1) For information on how to connect the drive unit, refer to the drive unit's manual.

(Note2) For a connection of the MITSUBISHI CNC Machine Operation Panel, refer to "Connection:Connection of MITSUBISHI CNC Machine Operation Panel" to be described.

1.3 List of Configuration

1.3.1 List of Units

Classification	Type	Components	Remarks
[Control unit]			
NC functions For M720VW	FCU7-MU031	Main control card Base card Power supply card LED card	Export Tarde Control Order and Foreign Exchange Order noncompliant unit
NC functions For M730VW	FCU7-MU041	Main control card Base card Power supply card LED card	Export Tarde Control Order and Foreign Exchange Order noncompliant unit
NC functions For M750VW	FCU7-MA041	Main control card Base card Power supply card LED card	Export Tarde Control Order and Foreign Exchange Order compliant unit
[Display unit]			
10.4-type color TFT (VGA:640*480) Panel computer	FCU7-DA646-11	LCD panel Backlight inverter Menu keys Inverter cable LCD cable Backlight cable	PCMCIA II card I/F is normally equipped with the display unit
10.4-type color TFT touch panel (VGA:640*480) Panel computer	FCU7-DA646-33	LCD panel Backlight inverter Menu keys Inverter cable LCD cable Backlight cable Touch panel	PCMCIA II card I/F is normally equipped with the display unit
15-type color TFT (XGA:1024*768) Panel computer	FCU7-DA636-11	LCD panel Backlight inverter Menu keys Inverter cable LCD cable Backlight cable	PCMCIA II card I/F is normally equipped with the display unit
15-type color TFT touch panel (XGA:1024*768) Panel computer	FCU7-DA636-33	LCD panel Backlight inverter Menu keys Inverter cable LCD cable Backlight cable Touch panel	PCMCIA II card I/F is normally equipped with the display unit
10.4-type color TFT touch panel (VGA:640*480) Panel computer	FCU7-DA646-31	LCD panel Backlight inverter Menu keys Inverter cable LCD cable Backlight cable Touch panel	PCMCIA II card I/F is normally equipped with the display unit (Note) Out of production
15-type color TFT touch panel (XGA:1024*768) Panel computer	FCU7-DA636-31	LCD panel Backlight inverter Menu keys Inverter cable LCD cable Backlight cable Touch panel	PCMCIA II card I/F is normally equipped with the display unit (Note) Out of production
[Keyboard unit]			
Keyboard for 8.4-type display unit Clear keys	FCU7-KB021	Escutcheon, key switch G290 cable	ONG layout (for M system/L system, XYZ)
Keyboard for 10.4-type display unit Clear keys	FCU7-KB041	Escutcheon, key switch G290 cable	ABC layout (for M system/L system)
Keyboard for 10.4-type display unit Clear keys	FCU7-KB045	Escutcheon, key switch G290 cable	Full keyboard (for M system/L system) (in tandem)

1 System Configuration

Classification	Type	Components	Remarks
[Operation panel I/O unit]			
DI 24V/0V common input DO Sink output	FCU7-DX670	Base card Mounting bracket G301 cable G310 cable Terminator (R-TM)	DI: 32-points 24V/0V common type DO: 32-points sink type (output 60mA) Output insulation type Display unit-main body relay I/F MPG:3ch Emergency stop input Remote I/O 1ch (160 points/160 points) Occupied stations DI/DO: Select 1 station from between 1 and 6 MPG: 7,8 (fixed) RIO3 extensible stations: Unselected stations between 1 and 6
DI 24V/0V common input DO Sink output	FCU7-DX770	Base card Add-on card Mounting bracket G301 cable G310 cable Terminator (R-TM)	DI: 64-points 24V/0V common type DO: 64-points sink type (output 60mA) Output insulation type Display unit-main body relay I/F MPG:3ch Emergency stop input Remote I/O 1ch (128 points/128 points) Occupied stations DI/DO: Select 2 stations from between 1 and 6 MPG: 7,8 (fixed) RIO3 extensible stations: Unselected stations between 1 and 6
DI 24V/0V common input DO Source output	FCU7-DX671	Base card Mounting bracket G301 cable G310 cable Terminator (R-TM)	DI: 32-points 24V/0V common type DO: 32-points source type (output 60mA) Output insulation type Display unit-main body relay I/F MPG:3ch Emergency stop input Remote I/O 1ch (160 points/160 points) Occupied stations DI/DO: Select 1 station from between 1 and 6 MPG: 7,8 (fixed) RIO3 extensible stations: Unselected stations between 1 and 6
DI 24V/0V common input DO Source output	FCU7-DX771	Base card Add-on card Mounting bracket G301 cable G310 cable Terminator (R-TM)	DI: 64-points 24V/0V common type DO: 64-points source type (output 60mA) Output insulation type Display unit-main body relay I/F MPG:3ch Emergency stop input Remote I/O 1ch (128 points/128 points) Occupied stations DI/DO: Select 2 stations from between 1 and 6 MPG: 7,8 (fixed) RIO3 extensible stations: Unselected stations between 1 and 6
[Hard Disk Unit]			
External memory device	FCU7-HD002-001	Hard disk Mounting plate, cushioning rubber F142 cable (50cm)	

Classification	Type	Components	Remarks
[Remote I/O unit]			
DI 24V/0V common input DO Sink output	FCUA-DX100	RX311	DI: 32-points 24V/0V common type (photo coupler insulation) DO: 32-points sink type (non-insulation) Number of occupied stations: 1
DI 24V/0V common input DO Sink output	FCUA-DX110	RX311+RX321-1	DI: 64-points 24V/0V common type (photo coupler insulation) DO: 48-points sink type (non-insulation) Number of occupied stations: 2
DI 24V/0V common input DO Sink output AO Analog output	FCUA-DX120	RX311+RX321	DI: 64-points 24V/0V common type (photo coupler insulation) DO: 48-points sink type (non-insulation) AO: 1 point Number of occupied stations: 2
DI 24V/0V common input DO Sink output AI Analog input AO Analog output	FCUA-DX140	RX311+RX341	DI: 32-points 24V/0V common type (photo coupler insulation) DO: 32-points sink type (non-insulation) AI: 4 points AO: 1 point Number of occupied stations: 2
DI 24V/0V common input DO Source output	FCUA-DX101	RX312	DI: 32-points 24V/0V common type (photo coupler insulation) DO: 32-points source type (non-insulation) Number of occupied stations: 1
DI 24V/0V common input DO Source output	FCUA-DX111	RX312+RX322-1	DI: 64-points 24V/0V common type (photo coupler insulation) DO: 48-points source type (non-insulation) Number of occupied stations: 2
DI 24V/0V common input DO Source output AO Analog output	FCUA-DX121	RX312+RX322	DI: 64-points 24V/0V common type (photo coupler insulation) DO: 48-points source type (non-insulation) AO: 1 point Number of occupied stations: 2
DI 24V/0V common input DO Source output AI Analog input AO Analog output	FCUA-DX141	RX312+RX341	DI: 32-points 24V/0V common type (photo coupler insulation) DO: 32-points source type (non-insulation) AI: 4 points AO: 1 point Number of occupied stations: 2
[Scan I/O card]			
Sink type	HR347	HR347	Scan DI/DO = 64 points/64 points DI/DO = 32 points/32 points
Source type	HR357	HR357	Scan DI/DO = 64 points/64 points DI/DO = 32 points/32 points
[External power supply unit]			
External power supply with power supply ON/OFF function	PD25	Power supply card Case set	Input 200VAC Output 24VDC (3A)
External power supply with power supply ON/OFF function	PD27	Power supply card Case set	Input 200 to 400VAC Output 24VDC (8A)
[Manual pulse generator]			
5V Manual pulse generator	UFO-01-2Z9	UFO-01-2Z9 (Produced by NIDEC NEMICON)	Input 5VDC 100pulse/rev
12V Manual pulse generator	HD60C	HD60C	Input 12VDC 25pulse/rev
[Encoder]			
Synchronous feed encoder	OSE1024-3-15-68	OSE1024-3-15-68	Input 5VDC 1024pulse/rev
[Expansion Unit]			
Expansion unit x 1slot	FCU7-EX891	HR891 Mounting plate, case set	One expansion card HN5xx can be mounted additionally.
[Expansion Card]			
PROFIBUS-DP	FCU7-HN578	HN578	PROFIBUS-DP x 1ch
PROFIBUS-DP	FCU7-HN571	HN571	PROFIBUS-DP x 1ch (Note) Out of production (replacement: FCU7- HN578)
CC-Link	FCU7-HN576	HN576	CC-Link x 1ch
CC-Link	FCU7-HN577	HN577	CC-Link x 2ch
[Optical communication repeater unit]			
Optical communication repeater unit	FCU7-EX022	FCU7-EX022	Using up to two units, relay of the total length of up to 90m can be performed.
[MITSUBISHI CNC machine operation panel]			
MITSUBISHI CNC machine operation panel A	FCU7-KB921	Escutcheon, key switch control card	Mitsubishi standard 55 key
MITSUBISHI CNC machine operation panel B	FCU7-KB926	Escutcheon, Switch	

1 System Configuration

Classification	Type	Components	Remarks
[Cable connector sets]			
For ENC,SKIP,SIO,MPG,AO	FCUA-CS000	Connector (10120-3000VE,2pcs), Shell kit (10320-52F0-008,2pcs)	
For RIO	FCUA-CS301	Connector (7940-6500SC,4pcs.), Strain relief (3448-7940,2pcs.)	
For PD25/PD27 ACIN	FCUA-CN200	Connector (2-178128-3), Contact (1-175218-5,3pcs.)	
For PD25/PD27 DCOUT	3-178127-6 1-175218-5	Connector (3-178127-6), Contact (1-175218-5,6pcs.)	
For PD25/PD27 ON/OFF	1-178288-5 1-175218-5	Connector (1-178288-5), Contact (1-175218-5,6pcs.)	
For EMG F120	005057-9403 0016020103	Connector (005057-9403), Contact (0016020103,3pcs.)	
For RIO	FCUA-CN211	Connector (1-178288-3), Contact (1-175218-2,3pcs.)	
For DCIN,F070	FCUA-CN220	Connector (2-178288-3), Contact (1-175218-5,3pcs)	
For DIO	FCUA-CN300	Connector (7940-6500SC,2pcs.)	
MPG cable for I/O unit	CDA-15P HDA-CTH CD-PC-111	Connector(CDA-15P), Housing(HDA-CTH), Contact(CD-PC-111,14pcs)	
[Original manufactured memory card]			
Exclusive CF cards for MITSUBISHI CNC 256MB	FCU7-CF256M	FCU7-CF256M	256MB capacity
Exclusive CF cards for MITSUBISHI CNC 2GB	FCU7-CF002G	FCU7-CF002G	2GB capacity

(Note 1) Operation panel I/O unit can be mounted on the back side of the keyboard unit.

(Note 2) DI: Digital input signals, DO: Digital output signals, AI: Analog input signals, AO: Analog output signals

1.3.2 Durable Parts

Durable parts	Part type
Battery for control unit and display unit	Q6BAT
Backlight for FCU7-DA646-11/31/33(*)	104LHS49
Backlight for FCU7-DA636-11/31/33(*)	AA-L5902174G01
Touch panel protective sheet for FCU7-DA646-31/33	N939B036G51
Touch panel protective sheet for FCU7-DA636-31/33	N939B060G61
Control unit cooling fan	109P0412H731
Display unit cooling fan	MMF-06G24DS-RP2

(*) Contact the Service Center, Service Station, Sales Office or delayer for repairs or part replacement.

1.3.3 List of Cables

Type	Application	Length (m) of cables provided by Mitsubishi	Max. cable length
CNP2E-1-xM	Motor side PLG cable Spindle side accuracy detector TS5690 cable	2, 3, 4, 5, 7, 10, 15, 20, 25, 30	30m
CNP3EZ-2P-xM	Spindle side detector cable OSE-1024 cable	2, 3, 4, 5, 7, 10, 15, 20, 25, 30	30m
CNP3EZ-3P-xM	Spindle side detector cable OSE-1024 cable	2, 3, 4, 5, 7, 10, 15, 20, 25, 30	30m
CNV22J-K1P-0.3M	For HF-KP (Servo) Motor side detector relay cable (motor side) Lead out in direction of motor shaft Compatible with only IP65	0.3	0.3m
CNV22J-K2P-0.3M	For HF-KP (Servo) Motor side detector relay cable (motor side) Lead out in opposite direction of motor shaft Compatible with only IP65	0.3	0.3m
CNV2E-6P-xM	Motor side detector cable (for A51/A74N(/A74)) / Ball screw side detector cable	2, 3, 4, 5, 7, 10, 15, 20, 25, 30	30m
CNV2E-7P-xM	Motor side detector cable (for A51/A74N(/A74)) / Ball screw side detector cable	2, 3, 4, 5, 7, 10, 15, 20, 25, 30	30m
CNV2E-8P-xM	For HF/HF-H, HF-KP (Tool spindle) Motor side detector cable (for A48/ A51/A74N(/A74)) / For HF-KP (Servo) Motor side detector relay cable (Drive unit side)	2, 3, 4, 5, 7, 10, 15, 20, 25, 30	30m
CNV2E-9P-xM	For HF/HF-H, HF-KP (Tool spindle) Motor side detector cable (for A48/ A51/A74N(/A74))	2, 3, 4, 5, 7, 10, 15, 20, 25, 30	30m
CNV2E-D-xM	MDS-B-SD unit cable	2, 3, 4, 5, 7, 10, 15, 20, 25, 30	30m
CNV2E-HP-xM	MDS-B-HR unit cable	2, 3, 4, 5, 7, 10, 15, 20, 25, 30	30m
CNV2E-K1P-xM	For HF-KP (Servo) Motor side detector cable Lead out in direction of motor shaft Compatible with only IP65	2, 3, 5, 7, 10	10m
CNV2E-K2P-xM	For HF-KP (Servo) Motor side detector cable Lead out in opposite direction of motor shaft Compatible with only IP65	2, 3, 5, 7, 10	10m
DG21-xM	Battery cable (For drive unit - battery unit)	0.3, 0.5, 1, 5	5m
DG22-xM	Battery cable (For drive unit - drive unit) (Note) This cable is required to supply the power from the battery unit to multiple drive units.	0.3, 0.5, 1, 2, 3, 5, 7, 10	10m
DG23-xM	Battery cable (For drive unit - battery box) (Note) The battery box side is connected using a bare conductor or a terminal bar.	0.3, 0.5, 1, 2, 3, 5, 7, 10	10m
DG24-xM	5V supply / DO output cable (For drive unit - battery box) (Note) The battery box side is connected using a bare conductor or a terminal bar.	0.3, 0.5, 1, 2, 3, 5, 7, 10	10m
E-TM	Terminator for OPI interface	-	-
F020 LxM	Manual pulse generator cable (12V): 1ch (for connection to operation panel I/O unit)	0.5, 1, 2, 3, 5, 7, 10, 20	50m
F021 LxM	Manual pulse generator cable (12V): 2ch (for connection to operation panel I/O unit)	1, 2	50m
F022 LxM	Manual pulse generator cable (12V): 3ch (for connection to operation panel I/O unit)	1, 2	50m
F034 LxM	RS-232C I/F cable: 1ch (for control unit)	0.5, 1, 2, 3, 5, 8, 10	15m (*)
F035 LxM	RS-232C I/F cable: 2ch (for control unit)	0.5, 1, 2, 3, 5, 8, 10	15m (*)
F070 LxM	24VDC power cable	0.5, 1.5, 3, 5, 8, 10, 15, 20	30m
F110 LxM	24VDC power cable for PD25/PD27	0.5, 1.5, 3, 5, 8, 10, 15	15m
F120 LxM	Emergency stop cable	0.5, 1.5, 3, 5, 8, 10, 15, 20	30m
F142	Cable for hard disk (comes with the hard disk) (Note) F140 is out of production.	0.5	0.5m
F170 LxM	ON/OFF switch cable for PD25/PD27	0.5, 1.5, 3, 5, 8, 10, 15	15m
FCUA-R030-xM	SKIP input cable	3, 7	20m
FCUA-R031-xM	Analog input/output cable (for remote I/O unit)	2, 3, 7	30m
FCUA-R050-xM	Synchronous encoder - control unit (straight, with connector)	5	30m
FCUA-R054-xM	Synchronous encoder - control unit (right angle, with connector)	3, 5, 10, 15, 20	30m
FCUA-R211-xM	Remote I/O (with terminal block) between remote I/O, remote I/O - CNC control unit, remote I/O - Operation panel I/O unit, remote I/O - MITSUBISHI CNC machine operation panel A	0.3, 1, 2, 3, 5, 8, 10, 15, 20	30m (*)

1 System Configuration

Type	Application	Length (m) of cables provided by Mitsubishi	Max. cable length
FCUA-R300	DI/DO cable (one side connector) (for remote I/O unit)	3	50m
FCUA-R301-xM	DI/DO cable (both side connectors) (for remote I/O unit)	1, 2, 3, 5	50m
G018 LxM	Cable between control unit - operation panel I/O unit	1, 2, 3, 5, 7, 10, 15, 20	20m
G020 LxM	Manual pulse generator cable (5V): 1ch (for connection to operation panel I/O unit)	2	20m
G021 LxM	Manual pulse generator cable (5V): 2ch (for connection to operation panel I/O unit)	2	20m
G022 LxM	Manual pulse generator cable (5V): 3ch (for connection to operation panel I/O unit)	2	20m
G023 LxM	Manual pulse generator cable (5V): 1ch (for connection to control unit)	1, 2, 3, 5, 8, 10, 15, 20	20m (*)
G024 LxM	Manual pulse generator cable (5V): 2ch (for connection to control unit)	1, 2, 3, 5, 8, 10, 15, 20	20m (*)
G031 LxM	RS-232C I/F cable: 1ch (for display unit)	0.5, 1, 2, 3, 5, 7, 10, 15	15m (*)
G032 LxM	RS-232C I/F cable: 2ch (for display unit)	0.5, 1, 2, 3, 5, 7, 10, 15	15m (*)
G071 LxM	DC24V relay cable for MITSUBISHI CNC machine operation panel	0.5	0.5m
G123	Terminator for emergency stop interface	-	-
G170 LxM	ON/OFF switch cable (ON/OFF switch - display unit)	0.35, 0.5, 1, 1.5, 2, 3, 5, 10, 15	15m
G171 LxM	Power ON/OFF cable (Display unit - PD25/PD27 power unit)	0.5, 1, 3, 5, 7, 10, 15	15m
G290	USB cable for keyboard (comes with the keyboard unit)	0.7	1m
G295	Cable for EtherNet/IP, PROFIBUS-DP configuration	0.3, 3	5m
G300 LxM	LAN cross cable (Shielded cable is recommended when the length will be 1m or more)	1, 3, 5, 10	10m
G301 LxM	LAN straight cable (Shielded cable is recommended when the length will be 1m or more)	1	1m
G310	Cable for NC reset (comes with the operation I/O unit)	0.08	0.1m
G380 LxM	Optical communication cable For wiring between drive units (outside panel) For optical communication repeater unit	5, 10, 12, 15, 20, 25, 30	30m
G395 LxM	Optical communication cable For wiring between drive units (outside panel) For wiring between NC-drive units	3, 5, 7, 10	10m
G396 LxM	Optical communication cable For wiring between drive units (inside panel)	0.3, 0.5, 1, 2, 3, 5	10m
G430 LxM	Cable for connection to handy terminal	3, 5, 10	10m
G460 LxM	Cable between MITSUBISHI CNC machine operation panel A and MITSUBISHI CNC machine operation panel B	0.5	0.5m
MR-BKS1CBLxM-A1-H	<200V Series> Brake cable for HF-KP Lead out in direction of motor shaft	2, 3, 5, 7, 10	10m
MR-BKS1CBLxM-A2-H	<200V Series> Brake cable for HF-KP Lead out in opposite direction of motor shaft	2, 3, 5, 7, 10	10m
MR-PWS1CBLxM-A1-H	<200V Series> Power cable for HF-KP Lead out in direction of motor shaft	2, 3, 5, 7, 10	10m
MR-PWS1CBLxM-A2-H	<200V Series> Power cable for HF-KP (Note) It can not be used with HF-KP13. Lead out in opposite direction of motor shaft	2, 3, 5, 7, 10	10m
R-TM	Terminator for remote I/O interface	-	-
SH21 LxM	Power supply communication cable Power backup unit communication cable Cable for Auxiliary axis/Servo drive unit	0.35, 0.5, 0.7, 1, 1.5, 2, 2.5, 3, 3.5, 4, 4.5, 5, 6, 7, 8, 9, 10, 15, 20, 30	30m
SH41 LxM	Remote I/O cable between remote I/O, remote I/O - CNC control unit, remote I/O - Operation panel I/O unit, remote I/O - MITSUBISHI CNC machine operation panel A (between remote I/O units in a panel)	0.3, 0.5, 0.7	1m (*)

(Note 1) "x" in type columns indicate cable length (unit: m).

(Note 2) Lengths indicated with an asterisk (*) in the max. cable length column indicate the maximum cable length when connecting via other unit.

General Specifications

2.1 Environment Conditions

Item	Unit name		Control unit	Display unit	Keyboard unit	Operation panel I/O unit	Machine operation panel
	Type		FCU7-MU031/041 FCU7-MA041	FCU7-DA646-x/ 636-x	FCU7-KB021/041/ 045	FCU7-DX670/671/ 770/771	FCU7-KB921/926
General Specifications	Ambient temperature	During operation	0 to 55C°				
		During storage	-20 to 60C°				
	Ambient humidity	Long term	10 to 75% RH (with no dew condensation)				
		Short term	10 to 95% RH (with no dew condensation) (Note 1)				
	Vibration resistance		4.9m/s ² or less (during operation)				
	Shock resistance		29.4m/s ² or less (during operation)				
	Working atmosphere		No corrosive gases, dust or oil mist				
Required power specifications	Power voltage		24VDC ±5% Ripple noise 200mV (P-P)	PD25 or PD27 (AC-24VDC power supply unit)	5VDC (Provided by the display unit)	24VDC ±5% Ripple noise 200mV (P-P)	24VDC ±5% (Note 7)
	Power capacity		2.5A	3A(when using PD25) 8A(when using PD27)	0.5A	0.7A	0.25A (Note 7)
	Instantaneous stop tolerance time		20ms			-	20ms
Others	Heating value	(max)	16W	FCU7-DA646:48W FCU7-DA636:54W	-	Control section: 5.0W (Note 3)	6W
	Mass	(kg)	1.1	FCU7-DA646:4.0 FCU7-DA636:6.0	FCU7-KB021:1.0 FCU7-KB041:1.5 FCU7-KB045:1.6	0.6	FCU7-KB921:1.2 FCU7-KB926:0.5
	Outline dimension	(mm)	76(W) x 168(H) x 155(D)	FCU7-DA646: 260(W) x 220(H) FCU7-DA636: 400(W) x 320(H)	FCU7-KB021: 140(W) x 200(H) FCU7-KB041: 230(W) x 220(H) FCU7-KB045: 290(W) x 160(H)	116(W) x 167(H)	FCU7-KB921: 260(W) x 140(H) FCU7-KB926: 140(W) x 140(H)

Item	Unit name		Remote I/O unit			
	Type		FCUA-DX10x	FCUA-DX11x	FCUA-DX12x	FCUA-DX14x
General Specifications	Ambient temperature	During operation	0 to 55C°			
		During storage	-20 to 60C°			
	Ambient humidity	Long term	10 to 75% RH (with no dew condensation)			
		Short term	10 to 95% RH (with no dew condensation) (Note 1)			
	Vibration resistance		4.9m/s ² or less (during operation)			
	Shock resistance		29.4m/s ² or less (during operation)			
	Working atmosphere		No corrosive gases or dust			
Required power specifications	Input power voltage		24VDC±5% Ripple noise 200mV (P-P)			
	Power capacity		24V 0.7A (Note 4)	24V 1.5A (Note 4)		24V 0.7A (Note 4)
	Instantaneous stop tolerance time		-			
Others	Heating value	(max.)	25W (Note 5)	30W (Note 5)		30W (Note 5)
	Mass		0.5kg	0.6kg	0.6kg	0.6kg

(Note 1) "Short term" means within one month.

(Note 2) For the current value of the I/O circuit, calculate with the number of points used and load.

(Note 3) For the heating value of the I/O circuit, calculate with the number of points used.

(Note 4) Allows only the amount to be consumed by control circuit.

(Note 5) Differs according to the number of machine input operation points and the load and number of points connected to the machine output. The maximum value applies when all points are ON.

(Note 6) MITSUBISHI CNC M700VW Series, which is an open equipment, must be installed within a sealed metal control panel.

(Note 7) FCU7-KB926 does not need 24VDC power supply input.

2.2 Control Unit

Dimension and names of parts

[FCU7-MU031 / FCU7-MU041 / FCU7-MA041]

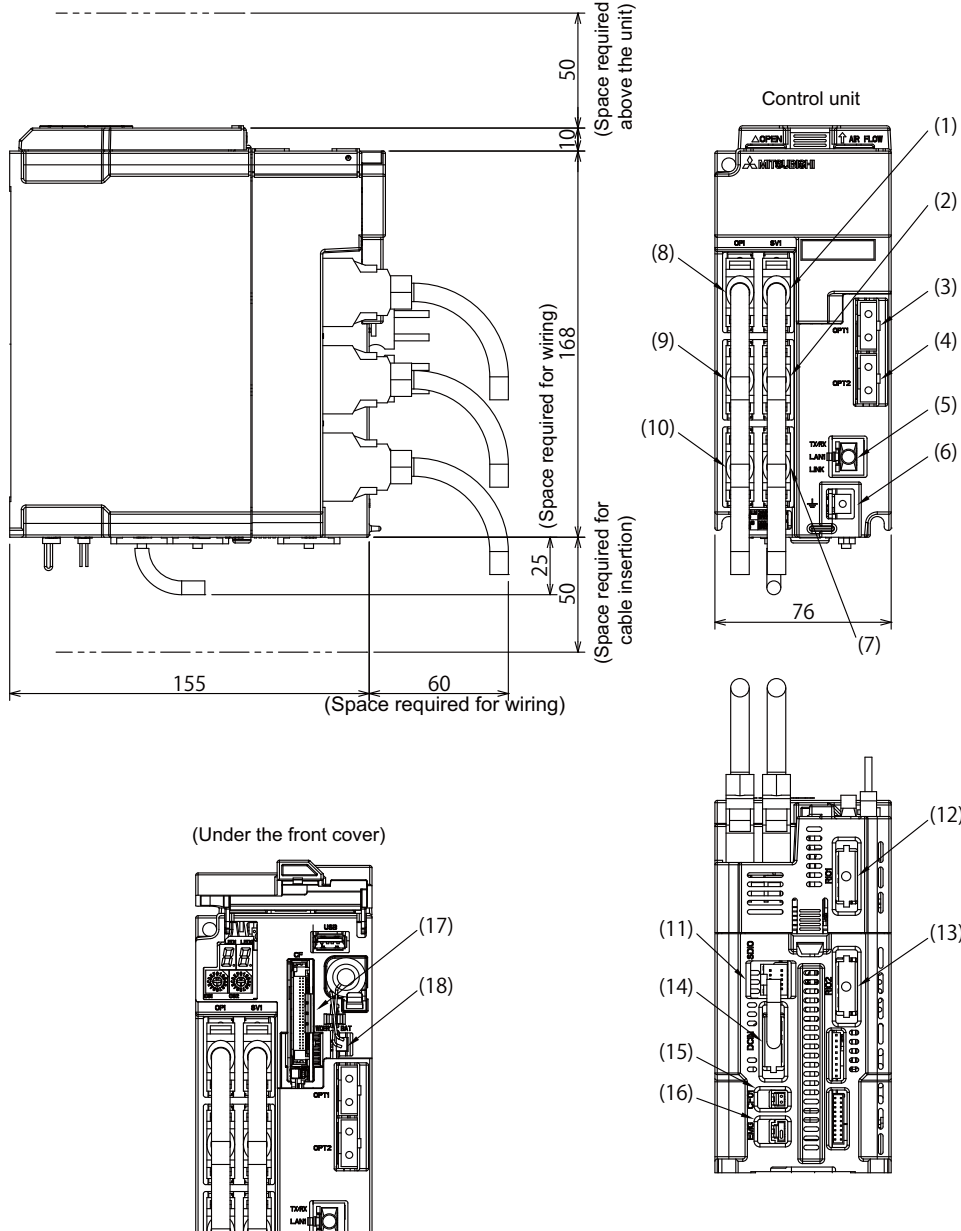

No.	Connector name	Function	No.	Connector name	Function
(1)	SV1	Auxiliary axis communication I/F	(11)	SDIO	Safety observing input/output I/F
(2)	SV2	Auxiliary axis communication I/F	(12)	RIO1	Remote I/O unit I/F
(3)	OPT1	Optical communication I/F	(13)	RIO2	Remote I/O unit I/F
(4)	OPT2	Optical communication I/F	(14)	DCIN	24VDC input
(5)	LAN1	Ethernet I/F	(15)	CF01	Power OFF input
(6)	FG	FG terminal	(16)	EMG	External emergency stop input
(7)	SKIP	Skip input 8ch	(17)	CF	CF card I/F
(8)	OPI	Operation panel I/O unit I/F	(18)	BAT	Battery (Q6BAT) I/F
(9)	SIO	RS-232C communication I/F 2ch			
(10)	ENC	Encoder input 1ch (5V manual pulse generator input 2ch)			

[With expansion unit (FCU7-EX891)]

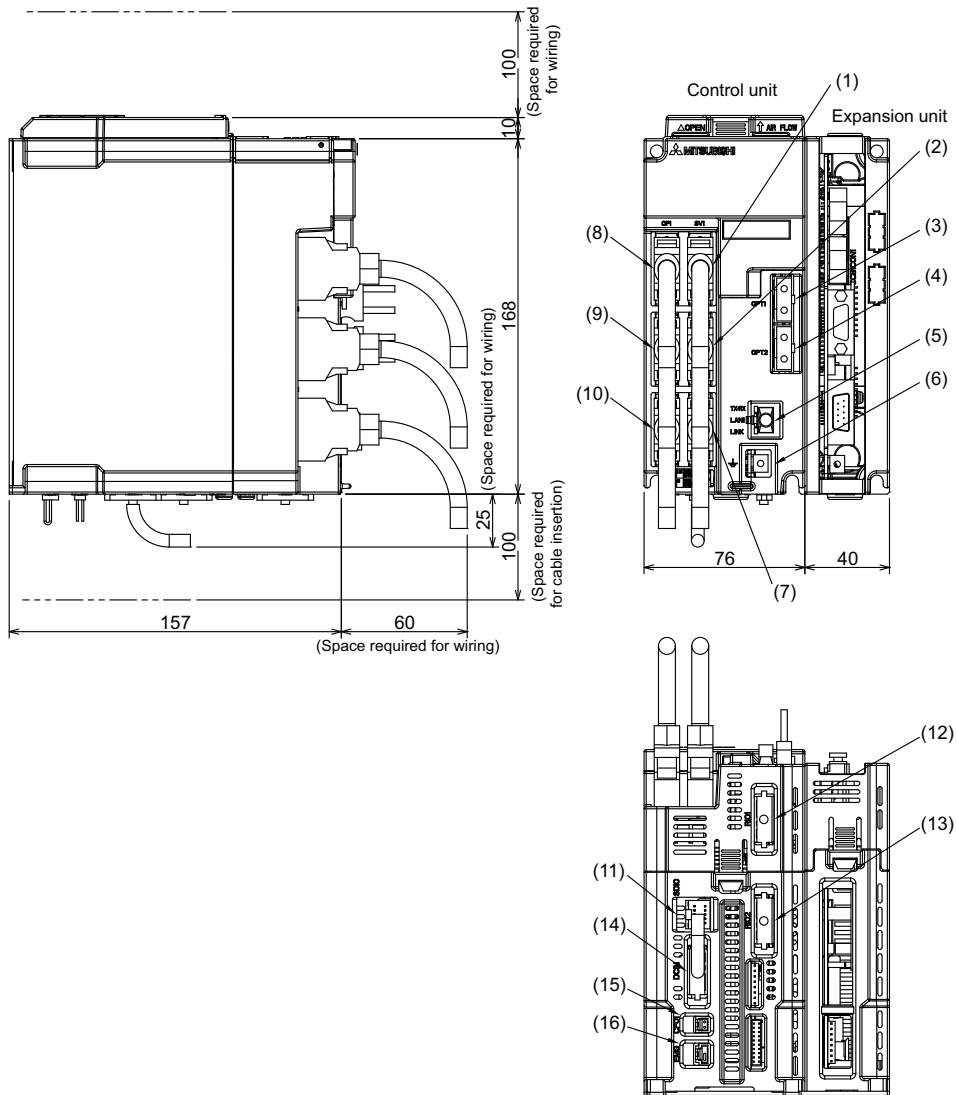

<Installation dimension drawing>

Control unit only

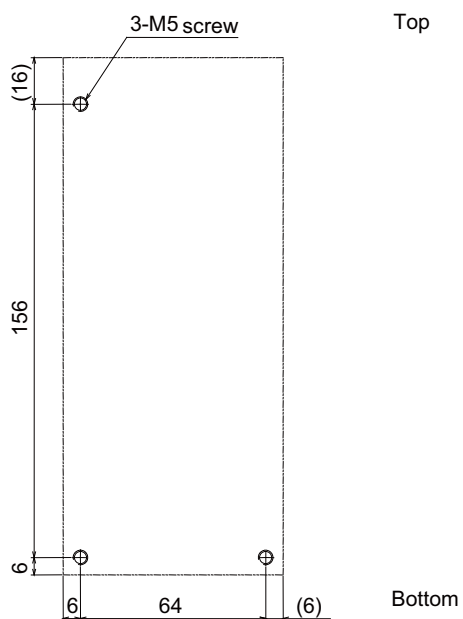

With expansion unit

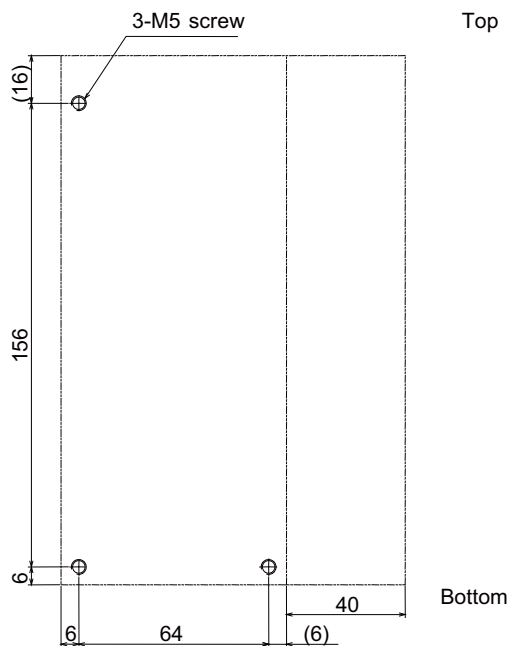

(1) Auxiliary axis communication I/F (SV1)

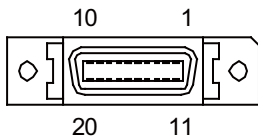

1		GND	11		GND
2	O	SVTXD1	12	O	SVTXD1*
3	I	SVALM1	13	I	SVALM1*
4	I	SVRXD1	14	I	SVRXD1*
5		GND	15		GND
6		NC	16		NC
7	O	SVEMG1	17	O	SVEMG1*
8		NC	18		NC
9		NC	19		NC
10		NC	20		NC

* Connect connector case with FG pattern.

<Cable side connector type>

Plug: 10120-3000VE

Shell: 10320-52F0-008

Recommended manufacturer: 3M

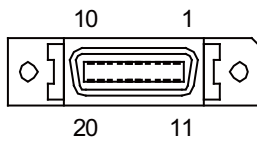
(2) Auxiliary axis communication I/F (SV2)

1		GND	11		GND
2	O	SVTXD2	12	O	SVTXD2*
3	I	SVALM2	13	I	SVALM2*
4	I	SVRXD2	14	I	SVRXD2*
5		GND	15		GND
6		NC	16		NC
7	O	SVEMG1	17	O	SVEMG1*
8		NC	18		NC
9		NC	19		NC
10		NC	20		NC

* Connect connector case with FG pattern.

<Cable side connector type>

Plug: 10120-3000VE

Shell: 10320-52F0-008

Recommended manufacturer: 3M

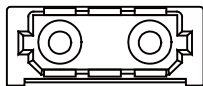
(3) Optical communication I/F (OPT1)**(4) Optical communication I/F (OPT2)****<Cable side connector type>****(PCF type)**

Connector: CF-2D101-S

Recommended manufacturer: Japan Aviation Electronics

(POF type)

Connector: PF-2D101

Recommended manufacturer: Japan Aviation Electronics

(5) Ethernet I/F (LAN1)

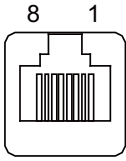

1	○	TD+
2	○	TD-
3		RD+
4		
5		
6		RD-
7		
8		

* Connect connector case with FG pattern.

* Use cross cable (G300) when directly connecting a device such as a personal computer to the unit.

<Cable side connector type>

Connector: 5-569550-3

Recommended manufacturer: Tyco Electronics

(6) FG terminal (FG)

(7) Skip input 8ch (SKIP)

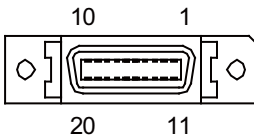

1		COM	11		COM
2		SKIP0	12		SKIP1
3		SKIP2	13		SKIP3
4		NC	14		NC
5		COM	15		COM
6		NC	16		NC
7		SKIP4	17		SKIP5
8		SKIP6	18		SKIP7
9		NC	19		NC
10		NC	20		NC

* Connect connector case with FG pattern.

<Cable side connector type>

Plug: 10120-3000VE

Shell: 10320-52F0-008

Recommended manufacturer: 3M

(a) Skip signal input conditions

Use the input signal within the following condition ranges.

		24V common	0V common
1	Input voltage at external contact ON	6V or less	18V or more, 25.2V or less
2	Input current at external contact ON	6mA or more	
3	Input voltage at external contact OFF	20V or more, 25.2V or less	4V or less
4	Input current at external contact OFF	2mA or less	
5	Input resistance	Approx. 2.2kΩ	
6	Input signal holding time (Ton)	2ms or more	
7	Internal response time	0.08ms or less	
8	Machine side contact capacity	+30V or more, 16mA or more	

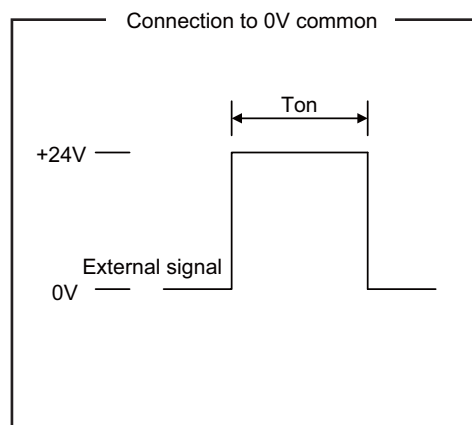
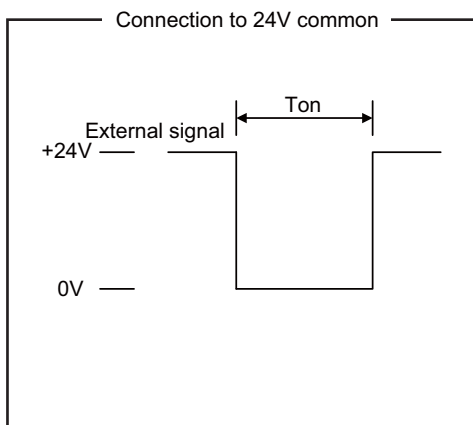

Connection to 24V common

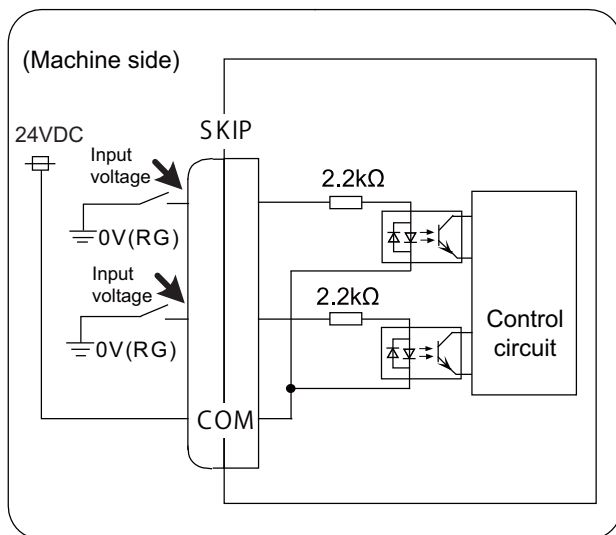

Connection to 0V common

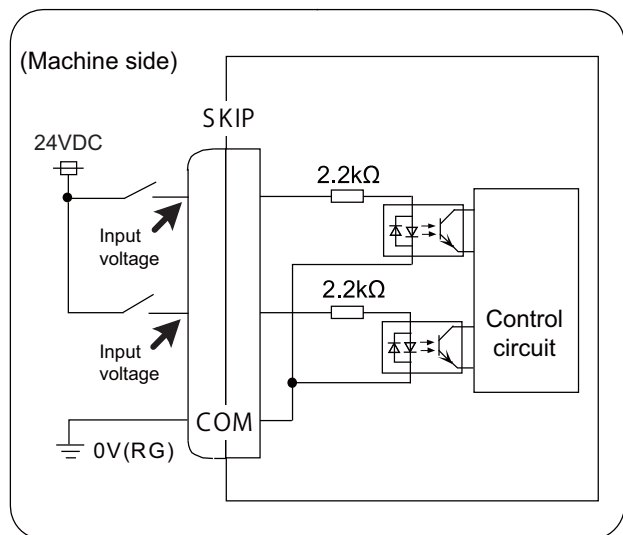

(8) Operation panel I/O unit I/F (OPI)

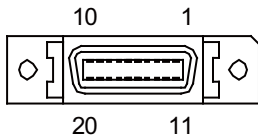

1		GND	11		GND
2		NC	12		NC
3		CMTT	13		CMTR
4		NC	14		NC
5		GND	15		GND
6	O	PHYOUT	16	O	PHYOUT*
7	I	PHYIN	17	I	PHYIN*
8		5V	18		NC
9	O	RTXD3	19	O	RTXD3*
10	I	TMEMG	20	I	TMEMG*

* Connect connector case with FG pattern.

<Cable side connector type>

Plug: 10120-3000VE

Shell: 10320-52F0-008

Recommended manufacturer: 3M

(Note) When not using OPI connector, connect the terminator connector E-TM (optional).

(9) Serial communication (RS-232C) I/F 2ch (SIO)

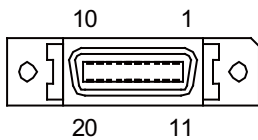

1		0V	11		0V
2	I	RD1(RXD1)	12	O	SD1(TXD1)
3	I	CS1(CTS1)	13	O	RS1(RTS1)
4	O	DR1(DSR1)	14	I	ER1(DTR1)
5		0V	15		0V
6		NC	16		NC
7	I	RD2(RXD2)	17	O	SD2(TXD2)
8	I	CS2(CTS2)	18	O	RS2(RTS2)
9	O	DR2(DSR2)	19	I	ER2(DTR2)
10		NC	20		NC

* Connect connector case with FG pattern.

<Cable side connector type>

Plug: 10120-3000VE

Shell: 10320-52F0-008

Recommended manufacturer: 3M

(10) Encoder input 1ch/ 5V manual pulse generator input 2ch (ENC)

Synchronous feed encoder or 5V manual pulse generator can be connected to this connector.

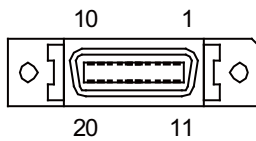

1		0V	11		0V
2	I	ENC1Z	12	I	ENC1Z*
3	I	ENC1B	13	I	ENC1B*
4	I	ENC1A	14	I	ENC1A*
5		0V	15		0V
6	O	5V	16	O	5V
7	I	HA2A	17	I	HA2B
8	I	HA1A	18	I	HA1B
9		NC	19		NC
10	O	5V	20	O	5V

* Connect connector case with FG pattern.

<Cable side connector type>

Plug: 10120-3000VE

Shell: 10320-52F0-008

Recommended manufacturer: 3M

(a) Input for synchronous feed encoder**<Specification of input part>**

Number of pulse phases	Three phases (A phase, B phase, a phase difference 90 degrees, Z phase) (Refer to the waveform below.)	
Signal output of the encoder	Line driver output	
Signal voltage	Input voltage range	0V to 5.25V
	Differential-input voltage VIT+	0.2V to 5.25V
	Differential-input voltage VIT-	-5.25V to -0.2V
Power supply voltage	5VDC±10%	
Current consumption	200mA or less	
Number of pulses per rotation	1024 pulse/rev	
Input frequency (rotation speed)	136kHz or less (8000r/min or less)	
Cable length	50m or less	

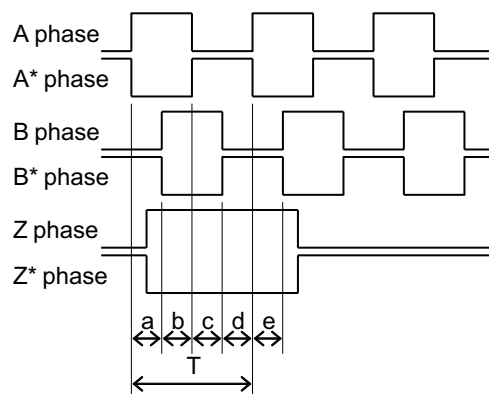

a.b.c.d.e: A phase or B phase rising edge (falling edge) phase difference = $T/4 \pm T/10$

(b) Input for 5V manual pulse generator
 <Specification of input part>

Number of pulse phases	Two phases (A phase, B phase, a phase difference 90 degrees) (Refer to the waveform below.)
Signal output of manual pulse generator	Voltage output, open collector output
Signal voltage	H level 3.5V to 5.25V L level 0V to 0.5V
Power supply voltage	5VDC±10%
Current consumption	100mA or less
Number of pulses per rotation	25 pulse/rev, 100 pulse/rev
Input frequency (rotation speed)	1kHz or less (40r/s or less for 25pulse/rev, 10r/s or less for 100pulse/rev)
Cable length	20m or less

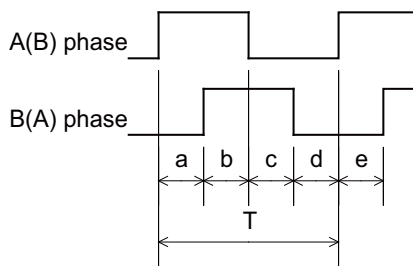

a.b.c.d.e: A phase or B phase rising edge (falling edge) phase difference = $T/4 \pm T/10$
 T: A or B phase cycle

(c) 5V manual pulse generator input/output circuit

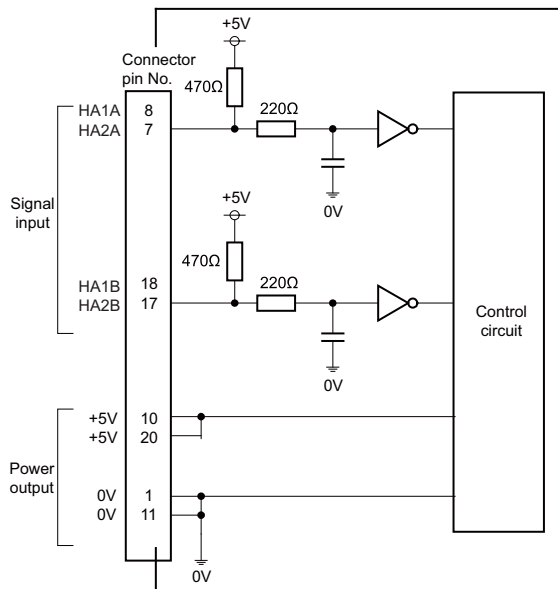

When using the synchronous feed encoder and the manual pulse generator at the same time, connect the manual pulse generator to the operation panel I/O unit or use a distribution cable made by the machine tool builder.

(11) Safety observing input/output I/F (SDIO)

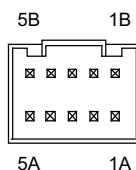

Pin	I/O	Function	Pin	I/O	Function
1A		COMMON terminal	1B		GND(RG)
2A	I	SDI1 (Door 1 switch input)	2B	I	SDI2 (Door 2 switch input)
3A	I	EMGIN1 (Emergency stop input for each part system)	3B	I	EMGIN2 (Emergency stop input for each part system)
4A		24VDC	4B	O	SDO1 (Contactor control output for each part system)
5A	O	SDO2 (Contactor control output for each part system)	5B	O	SDO3 (Contactor control output for each part system)

Pin	Characteristic	Voltage	Current	Description
SDI1 to 2	Input	Refer to the description		Sink input signal: 0V COM: 24V Source input signal: 24V COM: 0V
SDO1 to 3	Output	24V	Max. 60mA	Contactor shutoff signal output (Note) The output voltage/current of the terminals SDO1 to 3 (with 24VDC/60mA) may not be sufficient to directly control the contactor. In such a case, use a relay and the like that operates under 24VDC/60mA between the control unit and the contactor.

<Cable side connector type>

Type: 51353-1000

Contact: 56134-9000

Recommended manufacturer: MOLEX

<Wire material>

Type: UL1061-2464 AWG22

Recommended manufacturer: Oki Electric Cable

Safety standards taken into consideration

- (a) Machinery directive
98/37/EC Machinery directive
- (b) Safety-related parts of control system Part1: General principles for design
EN954-1:1996 Safety of machine - Safety-related parts of control system Part1:
General principles for design
- (c) Safety of machine
EN60204-1/1997 Safety of machine - Electrical equipment of machines; Part 1: General requirements

(12) Remote I/O unit I/F (RIO1)

Up to eight remote I/O stations can be connected.

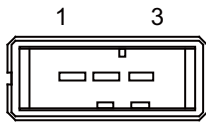

1	I/O	TXRX1
2	I/O	TXRX1*
3		0V

<Cable side connector type>

Connector: 1-178288-3

Contact: 1-175218-2 x3

Recommended manufacturer: Tyco Electronics

(13) Remote I/O unit I/F (RIO2)

Up to eight remote I/O stations can be connected.

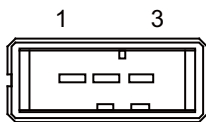

1	I/O	TXRX2
2	I/O	TXRX2*
3		0V

<Cable side connector type>

Connector: 1-178288-3

Contact: 1-175218-2 x3

Recommended manufacturer: Tyco Electronics

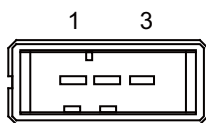
(14) 24VDC input (DCIN)

1	I	+24V
2		0V
3		FG

<Cable side connector type>

Connector: 2-178288-3

Contact: 1-175218-5 x3

Recommended manufacturer: Tyco Electronics

(a) Specifications of power supply

Consider the following characteristics when selecting the stabilized power supply (prepared by machine tool builder). Use a power supply that complies with CE Marking or that follows the safety standards given below.

[Stabilized power supply selection items]

Item		Standard setting
Output	Voltage fluctuation	±5% or less of 24VDC
	Ripple noise	200mV (P-P)
Power capacity		2.5A or more
Output holding time		20ms
Overcurrent protection		Required

[Standards]

Safety Standards: UL1950, CSA C22.2 No. 234 approved, IEC950 compliant

Noise Terminal Voltage: FCC Class A, VCCI-Class A

High Harmonics Current Restrictions: IEC61000-3-2

(Note) 24VDC voltage may drop instantaneously due to rush current at the beginning of 24V power supply to the control unit.

The level of voltage drop depends on the capacity of the power supply. Do not share the power supply with the devices that have alarms to warn the voltage drop.

⚠ CAUTION

- Using a stabilized power supply without overcurrent protection may cause the unit's failure due to miswiring of 24V.

(15) Power OFF input (CF01)

Use this when turning the control unit power OFF with an external source such as an ON/OFF switch.
Supply +24V to ACFAIL when using this connector.



1	I	GND
2	I	ACFAIL

<Cable side connector type>

Connector: 005057-9403
Contact: 0016020103 x2
Recommended manufacturer: MOLEX

(Note) Control unit can be used if this connector is not connected.

(16) External emergency stop input (EMG)

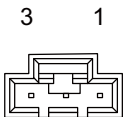

1		FG
2	I	EMG IN
3	O	+24V

<Cable side connector type>

Connector: 005057-9403
Contact: 0016020103 x3
Recommended manufacturer: MOLEX

(Note) Use this when not using the operation panel I/O unit, or when installing an emergency stop switch in the electric cabinet. Connect a terminator (G123 cable) when not using this connector.

(17) CF card I/F (CF)

It is recommended to use CF cards of the original equipment manufactured parts. Mitsubishi is unable to guarantee the machine operation when a commercially available CF card or SD memory card (SD-CF adapter is required) is used. In that case, performance check must be made carefully by machine tool builder. (Refer to "General Specifications: Precautions for Use of Exclusive CF cards for MITSUBISHI CNC: Commercially Available CF cards".)

(18) Battery (Q6BAT) I/F (BAT)

(20) LED

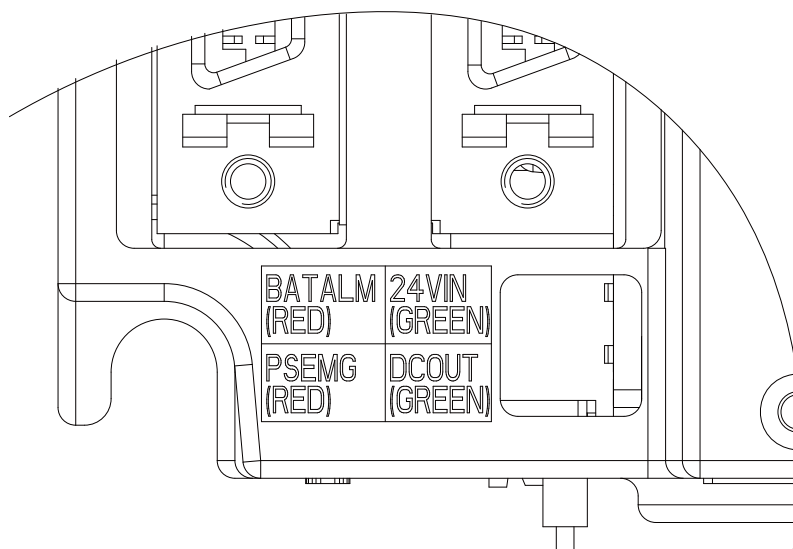

Name	Lamp state	Details
24VIN	Lit (Yellow green)	24V power is being supplied from the external power supply.
	Not lit	24V power is not being supplied from the external power supply. Check the other LEDs for another possible factor (failure) as follows: - Fuse is disconnected near DCIN connector
DCOUT	Lit (Yellow green)	The followings are all successfully output; 5V and 3.3V generated from 24V; 1.2V, 1.3V, 1.5V, and 2.5V on the main control card or base card.
	Not lit	The followings may have caused an error: - No 24V-power supply from the external power supply. - Failure in any of the power output circuits. - Failure in the 3.3V power output circuit. - Failure of LED. - Failure of the logic IC, which helps turn the LED on.
PSEMG	Lit (Red)	The followings may have caused an error: - Pressing the emergency stop switch. - Disconnection of the emergency stop cable. - Disconnection of the G123 cable (when not used).
	Not lit	No emergency stop has occurred. Check the other LEDs for another possible factor (failure) as follows: - Failure in the 3.3V power output circuit. - Failure of LED. - Failure of the logic IC, which helps turn the LED on.
BATALM	Lit (Red)	Battery voltage has dropped to 2.7V or less Otherwise, the battery has not been mounted.
	Not lit	No battery alarm has occurred. Check the other LEDs for another possible factor (failure) as follows: - Failure in the 3.3V power output circuit. - Failure of LED. - Failure of the logic IC, which helps turn the LED on.

2.3 Display Unit

Outline dimension

[FCU7-DA646-11 (10.4-type)]

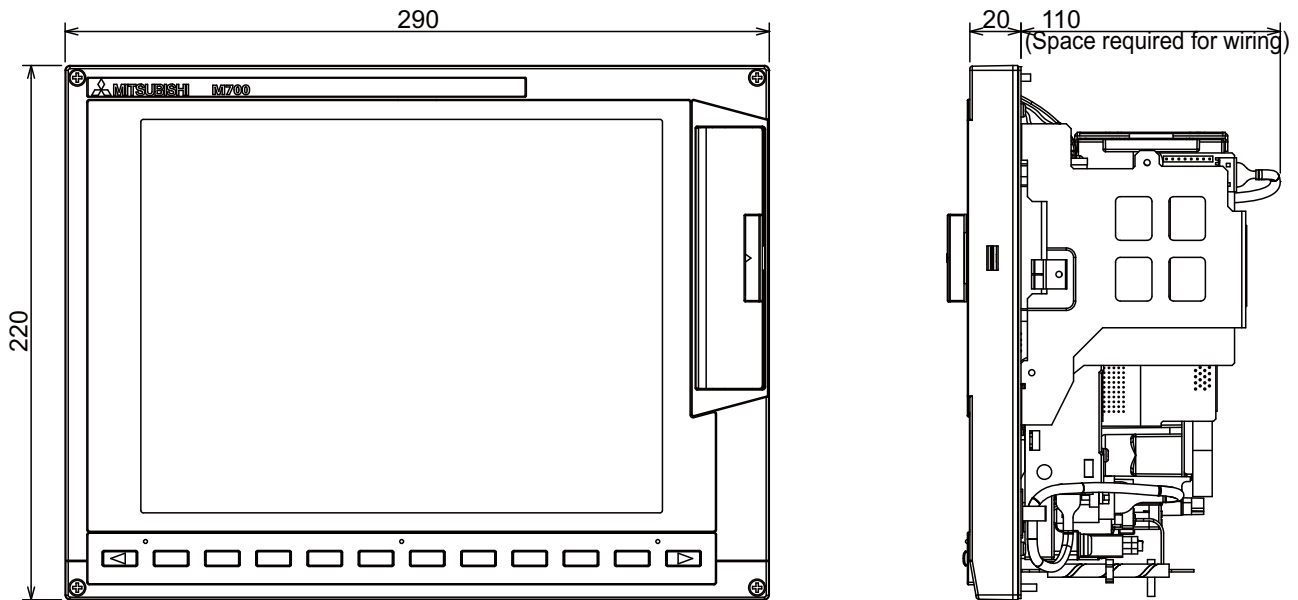

(Note) The space of 30mm or more should be provided above the display unit for inserting and removing the CF card, and a space to replace the cooling fan.

<Panel cut dimension drawing>

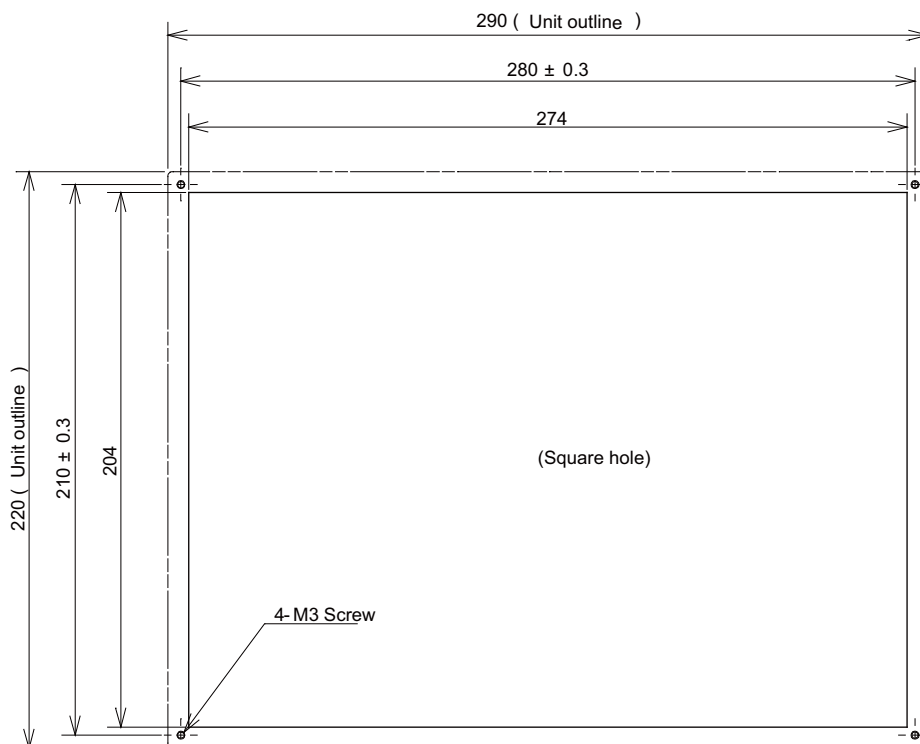

[FCU7-DA646-31/FCU7-DA646-33 (10.4-type with touch panel)]

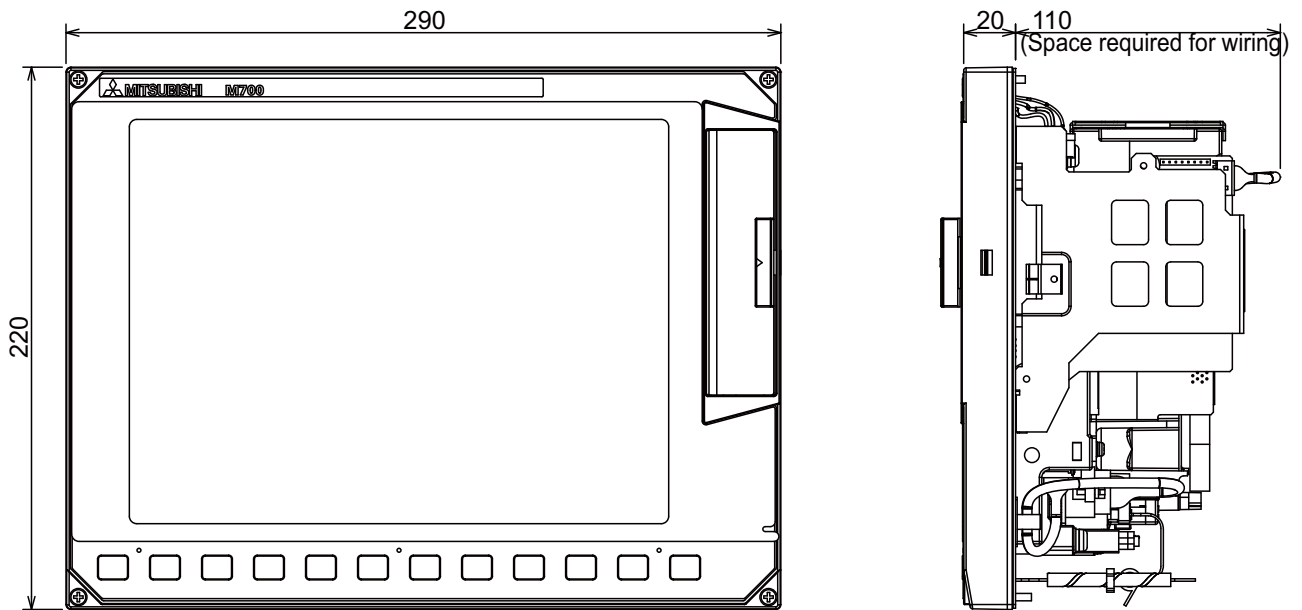

(Note) The space of 30mm or more should be provided above the display unit for inserting and removing the CF card, and a space to replace the cooling fan.

<Panel cut dimension drawing>

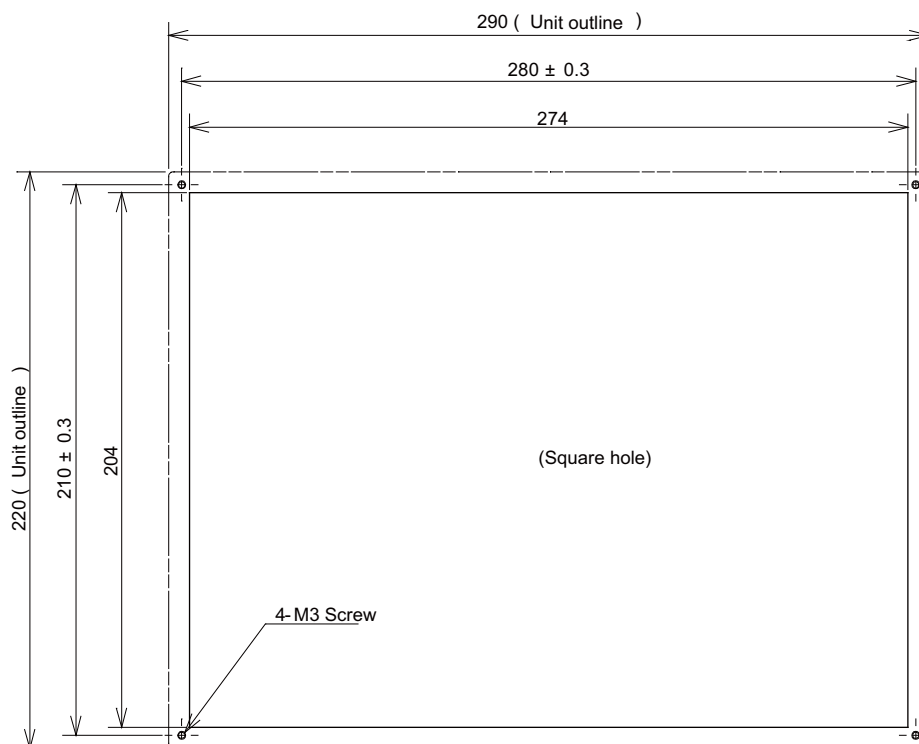

[FCU7-DA636-11 (15-type)]

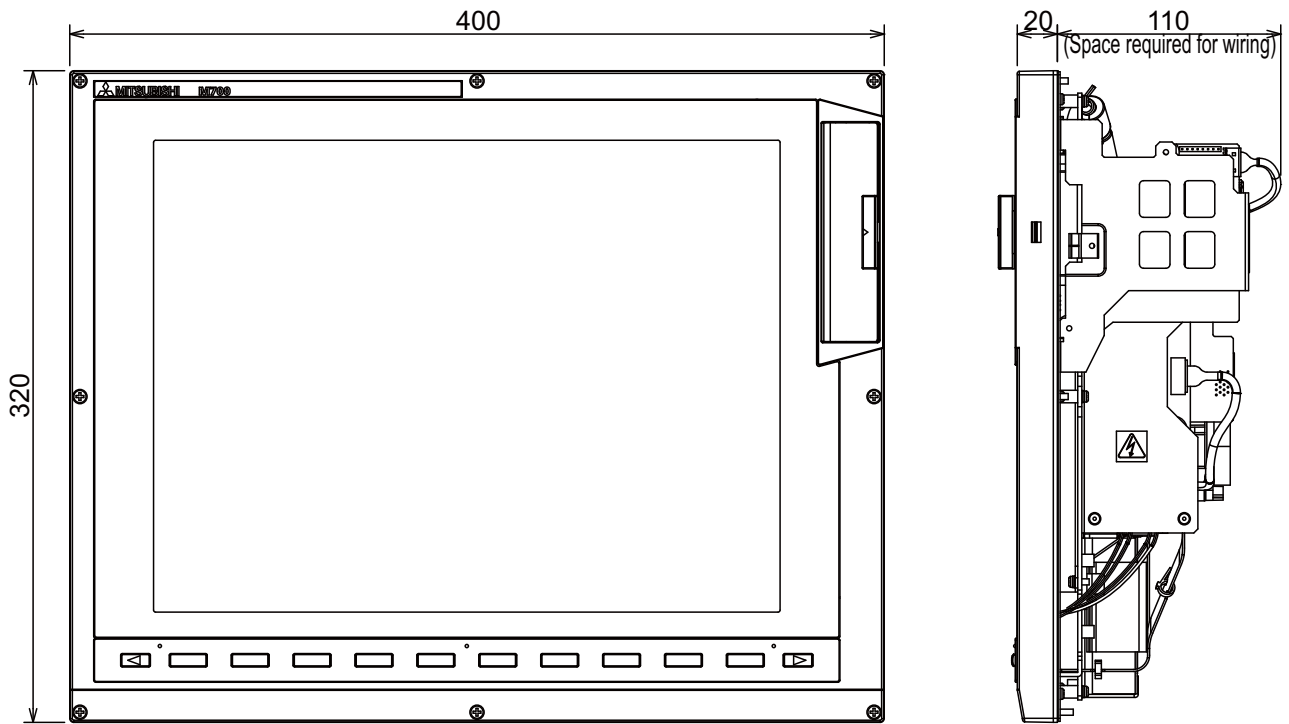

(Note) The space of 30mm or more should be provided above the display unit for inserting and removing the CF card, and a space to replace the cooling fan.

<Panel cut dimension drawing>

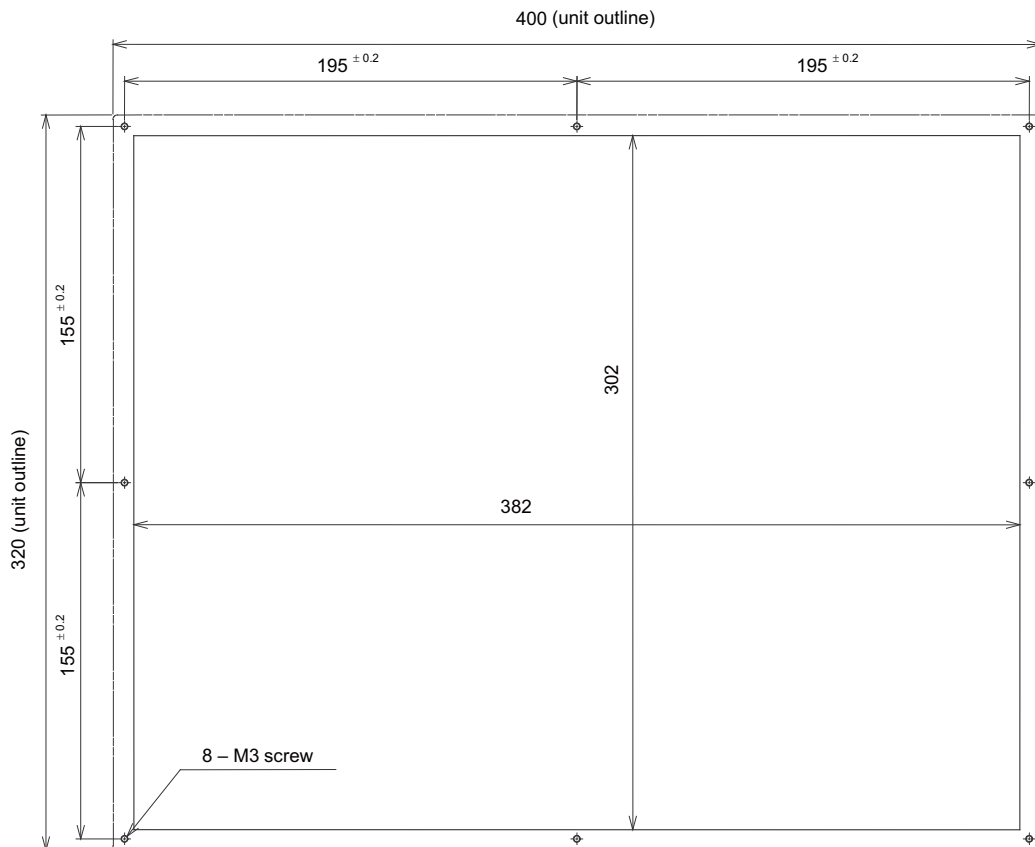

[FCU7-DA636-31/FCU7-DA636-33 (15-type with touch panel)]

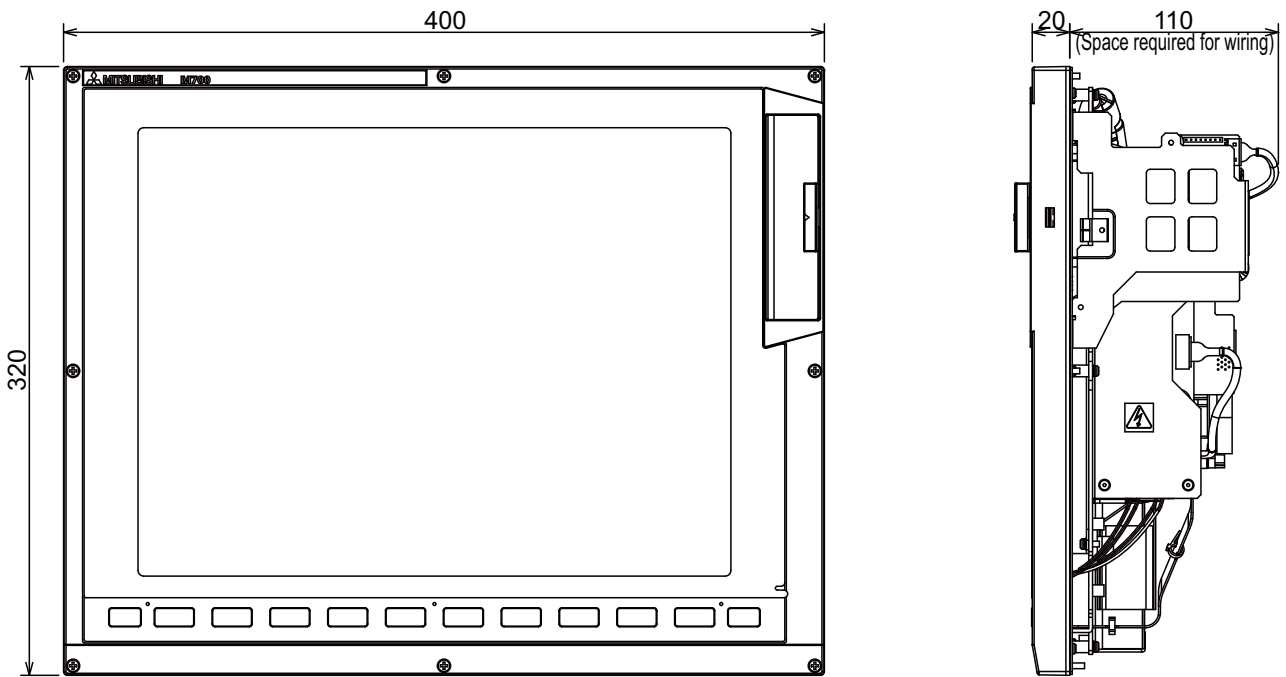

(Note) The space of 30mm or more should be provided above the display unit for inserting and removing the CF card, and a space to replace the cooling fan.

<Panel cut dimension drawing>

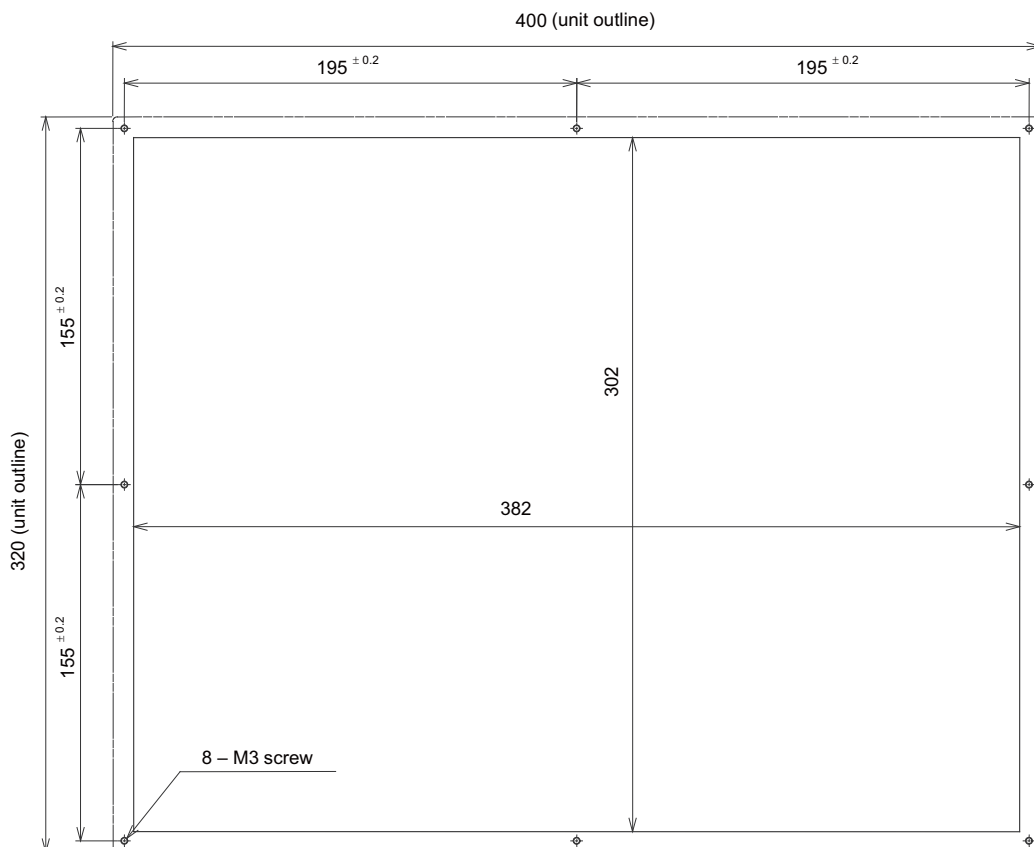

Names of parts

[Unit rear view]

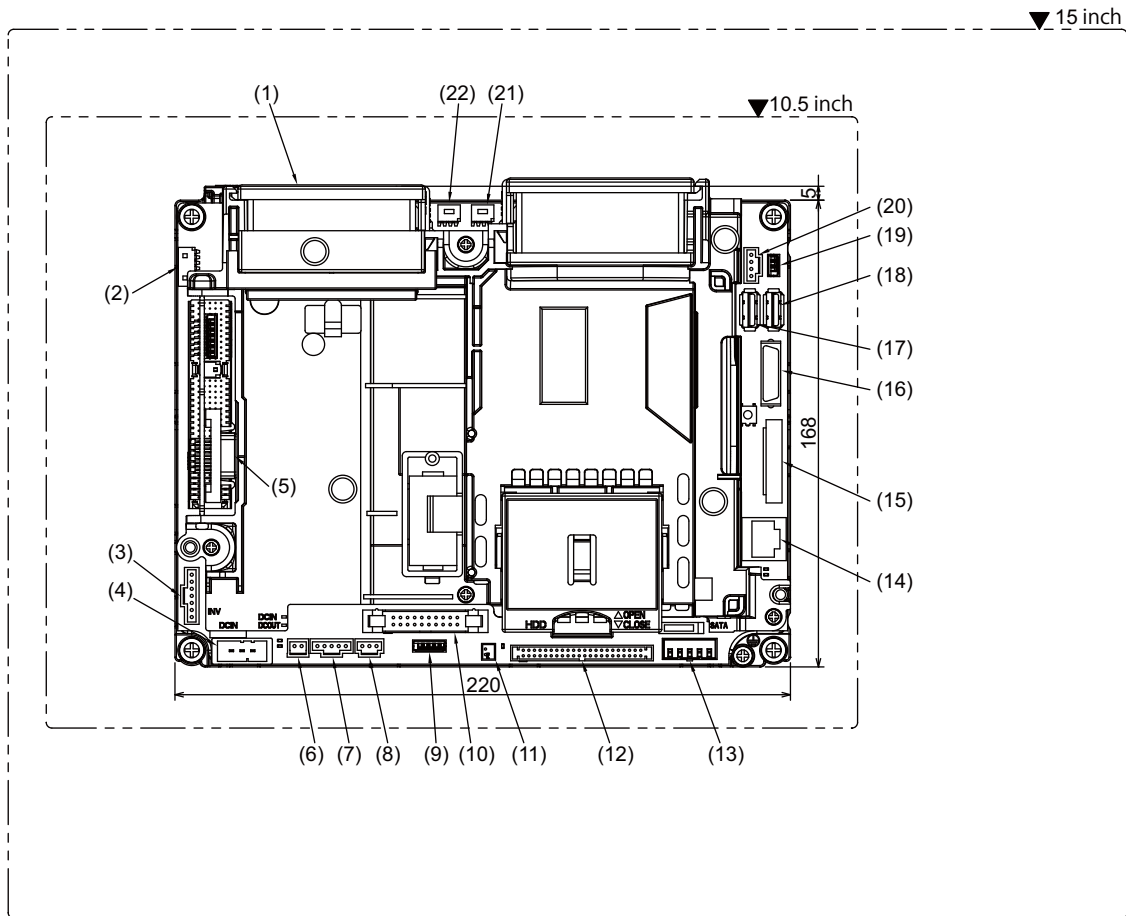

No.	Connector name	Function	No.	Connector name	Function
(1)	CF	(Not used)	(12)	HDD	Hard disk I/F
(2)	FRONT_OUT	Front IC card I/F	(13)	SAVR	(Not used)
(3)	INV	Backlight inverter I/F	(14)	LAN	Ethernet I/F
(4)	DCIN	24VDC input	(15)	LVDS	Display unit signal I/F
(5)	SIOPC	Serial communication (RS-232C) I/F 2ch	(16)	CRT	(Not used)
(6)	CF01	ACFAIL input	(17)	USB1	USB I/F
(7)	CF24	External ON/OFF switch I/F	(18)	USB2	USB I/F
(8)	EMG	External emergency stop input	(19)	FAN3	(Not used)
(9)	USB-FDD	(Not used)	(20)	ON/OFF	PD25/PD27 ON/OFF signal input
(10)	MENUKEY	Menu key I/F	(21)	FAN2	CPU cooling FAN I/F
(11)	BAT	Battery (Q6BAT) I/F	(22)	FAN1	CPU cooling FAN I/F

(1) CF card I/F (CF)

(2) Front IC card I/F (FRONT_OUT)

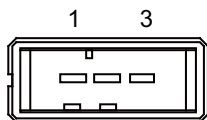
(3) Backlight inverter I/F (INV)**(4) 24VDC input (DCIN)**

1	I	+24V
2		0V
3		FG

<Cable side connector type>

Connector: 2-178288-3

Contact: 1-175218-5 x3

Recommended manufacturer: Tyco Electronics

(a) Specifications of power supply

Consider the following characteristics when selecting the stabilized power supply (prepared by machine tool builder). Use a power supply that complies with CE Marking or that follows the safety standards given below.

[Stabilized power supply selection items]

Item		Standard setting
Output	Voltage fluctuation	±5% or less of 24VDC
	Ripple noise	200mV (P-P)
Power capacity		2.5A or more
Output holding time		20ms
Overcurrent protection		Required

[Standards]

Safety Standards: UL1950, CSA C22.2 No.234 approved, IEC950 compliant

Noise Terminal Voltage: FCC Class A, VCCI-Class A

High Harmonics Current Restrictions: IEC61000-3-2

(Note) 24VDC voltage may drop instantaneously due to rush current at the beginning of 24V power supply to the display unit. The level of voltage drop depends on the capacity of the power supply. Do not share the power supply with the devices that have alarms to warn the voltage drop.

⚠ CAUTION

1. Using a stabilized power supply without overcurrent protection may cause the unit's failure due to miswiring of 24V.

(5) Serial communication (RS-232C) I/F 2ch (SIOPC)

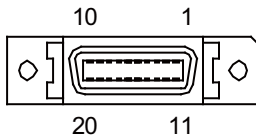

1		0V	11		0V
2	I	RD1(RXD1)	12	O	SD1(TXD1)
3	I	CS1(CTS1)	13	O	RS1(RTS1)
4	I	CD1(DCD1)	14	I	ER1(DTR1)
5		0V	15		0V
6	O	DR1(DSR1)	16	I	RI1(RI1)
7	I	RD2(RXD2)	17	O	SD2(TXD2)
8	I	CS2(CTS2)	18	O	RS2(RTS2)
9	I	CD2(DCD2)	19	I	ER2(DTR2)
10	O	DR2(DSR2)	20	I	RI2(RI2)

* Connect connector case with FG pattern.

<Cable side connector type>

Plug: 10120-3000VE

Shell: 10320-52F0-008

Recommended manufacturer: 3M

(6) ACFAIL input (CF01)



1	I	GND
2	I	ACFAIL

<Cable side connector type>

Connector: 005057-9403

Contact: 0016020103 x2

Recommended manufacturer: MOLEX

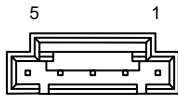
(7) External ON/OFF switch I/F (CF24)

1		NC
2	I	P-OFF
3		LG-OFF
4		LG-ON
5	I	P-ON

* Use this to connect the power supply unit and display unit

<Cable side connector type>

Connector: 51030-0530

Contact: 0016020103 x4

Recommended manufacturer: MOLEX

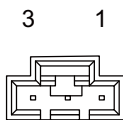
(8) External emergency stop input (EMG)

1		FG
2	I	EMG IN
3	O	+24V

<Cable side connector type>

Connector: 005057-9403

Contact: 0016020103 x3

Recommended manufacturer: MOLEX

(Note) Connect a terminator (G123 cable) when not using.

(9) Not used (USB-FDD)**(10) Menu key I/F (MENUKEY)****(11) Battery (Q6BAT) I/F (BAT)****(12) Hard disk I/F (HDD)****(13) Not used (SAVR)**

(14) Ethernet I/F (LAN)

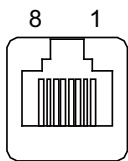

1	○	TD+
2	○	TD-
3	⊥	RD+
4		
5		
6	⊥	RD-
7		
8		

* Connect connector case with FG pattern.

* Use a straight cable (G301) for connection with the operation panel I/O unit.

<Cable side connector type>

Connector: 5-569550-3

Recommended manufacturer: Tyco Electronics

(15) Display unit signal I/F (LVDS)

(16) Not used (CRT)

(17) USB I/F (USB1)

(18) USB I/F (USB2)

When using a commercially available USB memory, performance check must be made by machine tool builder.
5V, max 500mA

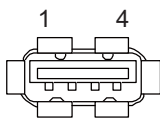

1	○	Vcc
2	I/O	-Data1/2
3	I/O	+Data1/2
4		GND

* Connect connector case with FG pattern.

<Cable side connector type>

Connector: DUSB-APA42-A-C50

Contact: DUSB-PA1-100 (When AWG20 to 24)

Recommended manufacturer: DDK

(19) Not used (FAN3)

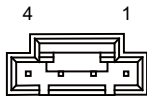
(20) PD25/PD27 ON/OFF signal input (ON/OFF)

1		GND
2	I	PON
3	I	POFF
4		GND

<Cable side connector type>

Connector: 51030-0430

Contact: 0016020103 x4

Recommended manufacturer: MOLEX

(21) CPU cooling FAN I/F (FAN2)**(22) CPU cooling FAN I/F (FAN1)**

24V

2.4 Keyboard Unit

Outline dimension

[FCU7-KB021]

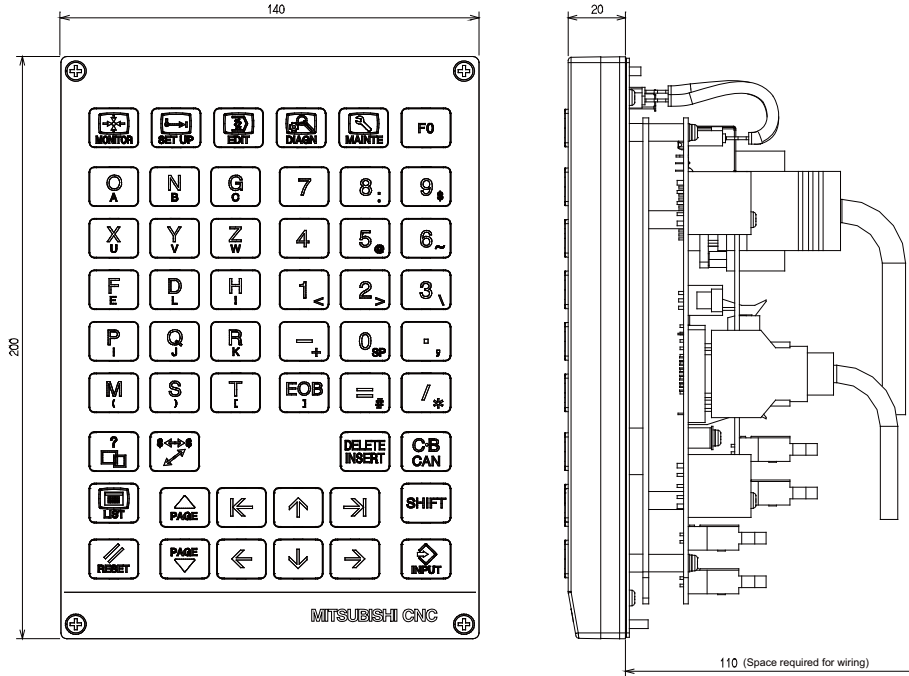

(Note) The above side view shows the state with the operation panel I/O unit mounted.

<Panel cut dimension drawing>

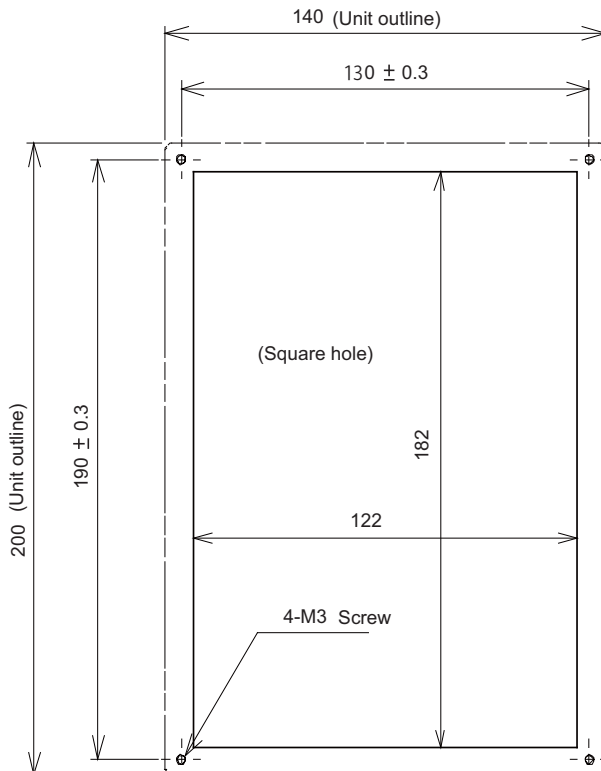

[FCU7-KB041]

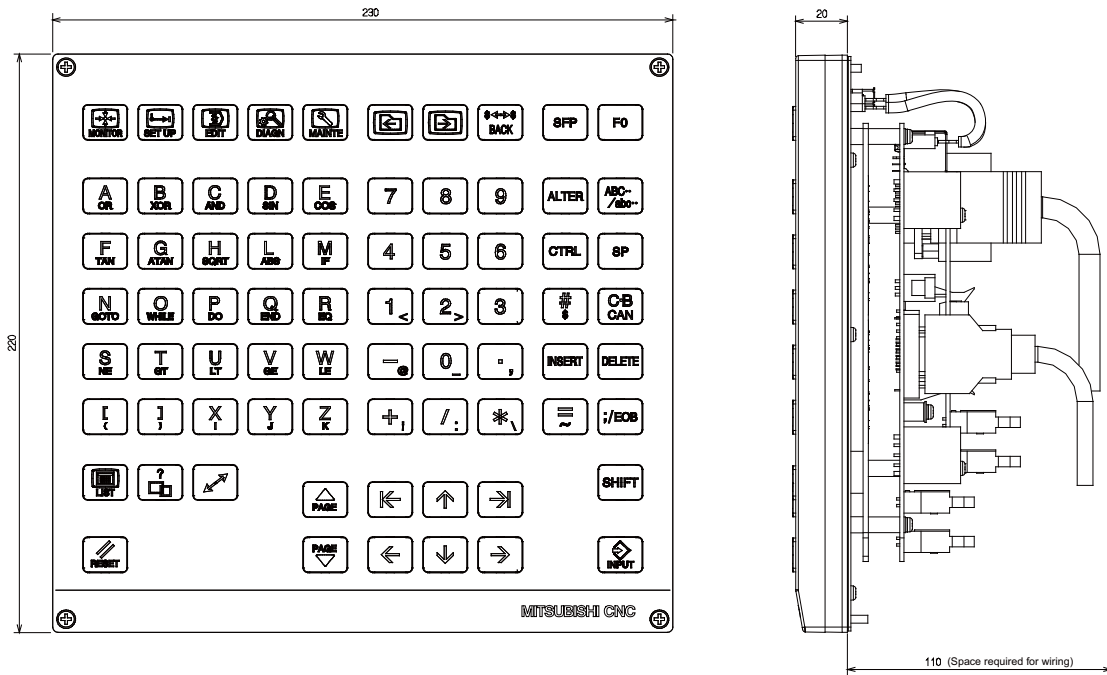

(Note) The above side view shows the state with the operation panel I/O unit mounted.

<Panel cut dimension drawing>

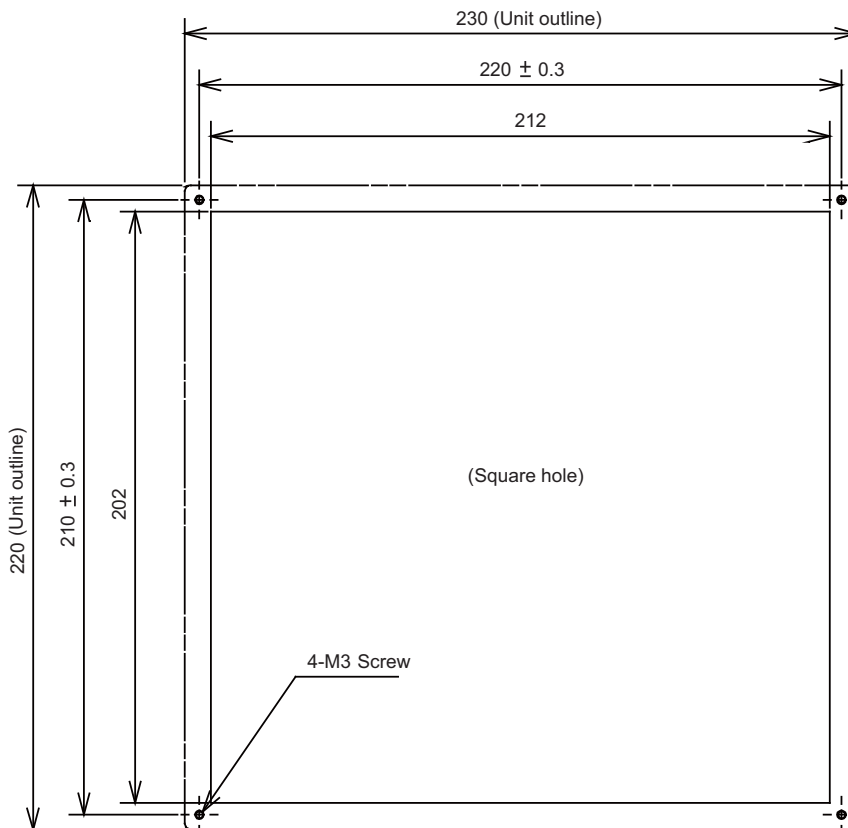

[FCU7-KB045 (Clear keys for 10.4-type/ QWERTY assignment)]

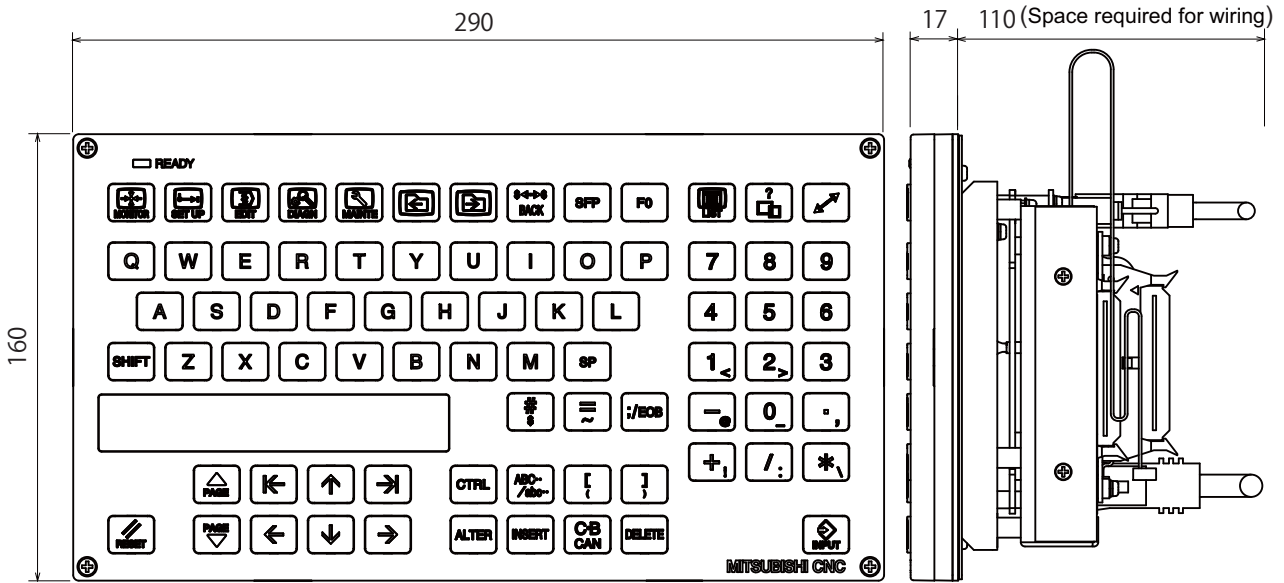

(Note) The above side view shows the state with the operation panel I/O unit mounted.

<Panel cut dimension drawing>

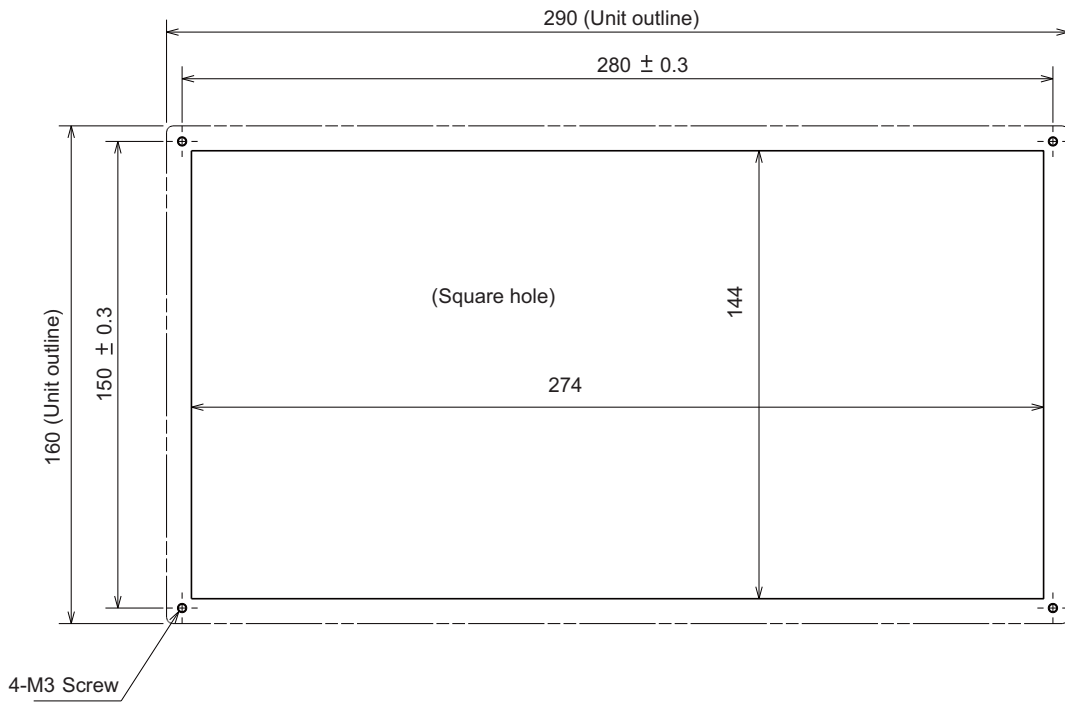

2.5 Operation Panel I/O Unit

Characteristics of operation panel I/O unit are as follows.

- (1) Operation panel (display unit section) and electric cabinet (control unit section) can be wired with one cable (G018). This is effective to simplify the wiring between operation panel and electric cabinet, as well as to reduce the cost of wiring.
G018 cable includes RI03, EMG and LAN.
- (2) Number of DI/DO points that can be mounted on the machine operation panel is 32/32 as standard and 64/64 at the maximum.
Both sink type and source type are available.
- (3) Remote I/O interface --- 1ch
Remote I/O unit, card-sized I/O card, scan I/O card, etc. can be extended up to 5 channels.
Note that the following (a) and (b) will be applied if DI/DO mounted on the operation panel I/O unit is used.
 - (a) When 32 points/32 points are used, up to 5 channels, or 160 points/160 points in total, are available.
 - (b) When 64 points/64 points are used, up to 4 channels, or 128 points/128 points in total, are available.
- (4) Manual pulse generator --- 3ch
5V and 12V manual pulse generators can be connected.
- (5) Emergency stop input --- 1ch
Emergency stop switch installed on the operation panel can be connected.
- (6) LAN communication interface --- 1ch
Display unit can be connected.
- (7) NC reset interface --- 1ch
NC can be reset by DI input. NC reset interface is connected to the keyboard unit.
- (8) Installation on the back side of the keyboard unit is possible.
Allows space saving inside the operation panel.

2 General Specifications

Classification	Type	Components	Remarks
DI 24V/0V common input DO Sink output	FCU7-DX670	Base card Mounting bracket G301 cable G310 cable Terminator (R-TM)	DI: 32-points 24V/0V common type DO: 32-points sink type (output 60mA) Output insulation type Display unit-main body relay I/F MPG:3ch Emergency stop input Remote I/O 1ch (160 points/160 points) Occupied stations DI/DO: Select 1 station from between 1 and 6 MPG: 7,8 (fixed) RIO3 extensible stations: Unselected stations between 1 and 6
DI 24V/0V common input DO Sink output	FCU7-DX770	Base card Add-on card Mounting bracket G301 cable G310 cable Terminator (R-TM)	DI: 64-points 24V/0V common type DO: 64-points sink type (output 60mA) Output insulation type Display unit-main body relay I/F MPG:3ch Emergency stop input Remote I/O 1ch (128 points/128 points) Occupied stations DI/DO: Select 2 stations from between 1 and 6 MPG: 7,8 (fixed) RIO3 extensible stations: Unselected stations between 1 and 6
DI 24V/0V common input DO Source output	FCU7-DX671	Base card Mounting bracket G301 cable G310 cable Terminator (R-TM)	DI: 32-points 24V/0V common type DO: 32-points source type (output 60mA) Output insulation type Display unit-main body relay I/F MPG:3ch Emergency stop input Remote I/O 1ch (160 points/160 points) Occupied stations DI/DO: Select 1 station from between 1 and 6 MPG: 7,8 (fixed) RIO3 extensible stations: Unselected stations between 1 and 6
DI 24V/0V common input DO Source output	FCU7-DX771	Base card Add-on card Mounting bracket G301 cable G310 cable Terminator (R-TM)	DI: 64-points 24V/0V common type DO: 64-points source type (output 60mA) Output insulation type Display unit-main body relay I/F MPG:3ch Emergency stop input Remote I/O 1ch (128 points/128 points) Occupied stations DI/DO: Select 2 stations from between 1 and 6 MPG: 7,8 (fixed) RIO3 extensible stations: Unselected stations between 1 and 6

(Note) Operation panel I/O unit is attached to the back side of the keyboard unit when shipped. (This applies only when purchasing operation panel I/O unit and the keyboard unit together.)

Dimension and names of parts

[FCU7-DX670 / FCU7-DX671]

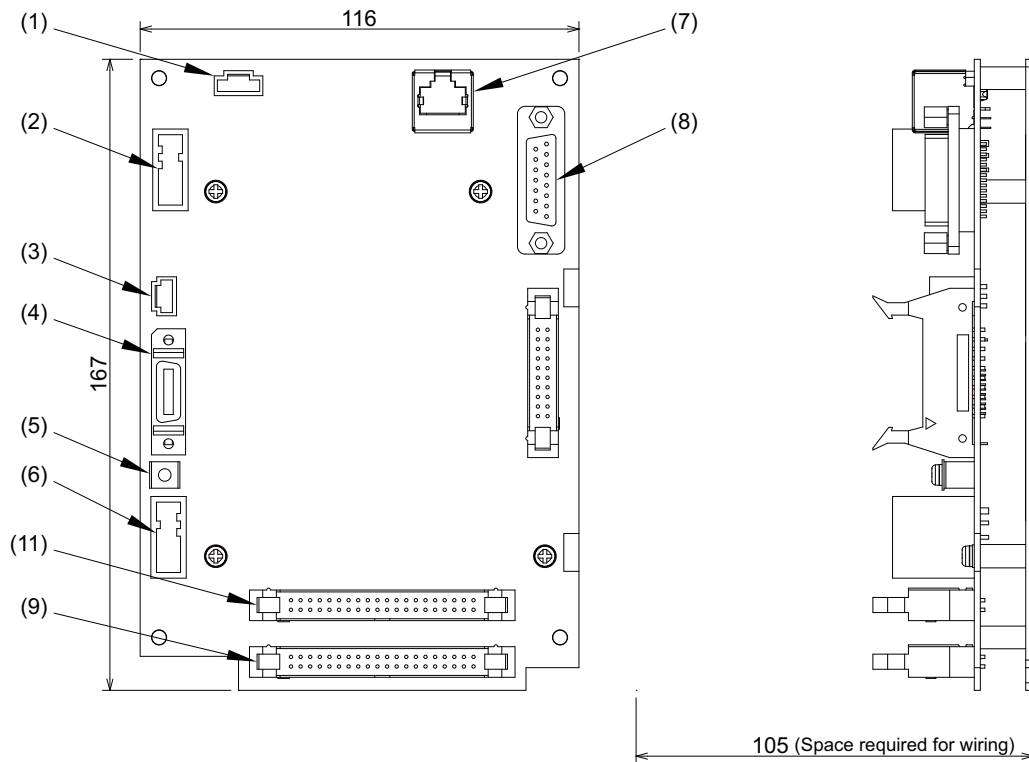

<Dimension drawing for installing on the panel>

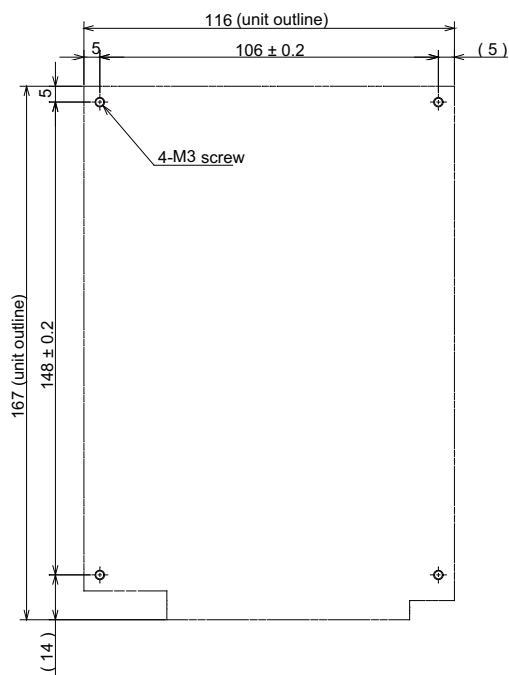

<Installation on the back side of the keyboard>

Operation panel I/O unit can be installed on the back side of the keyboard.

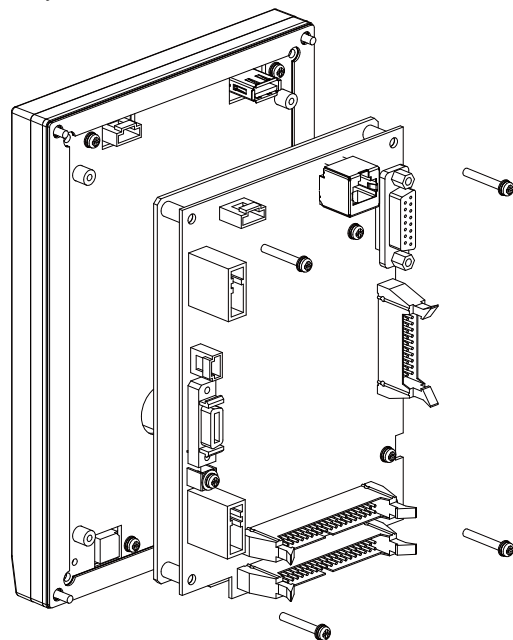

(Note) Use M3x25 screws (with spring washer and plain washer) when mounting the operation panel I/O unit.

[FCU7-DX770 / FCU7-DX771]

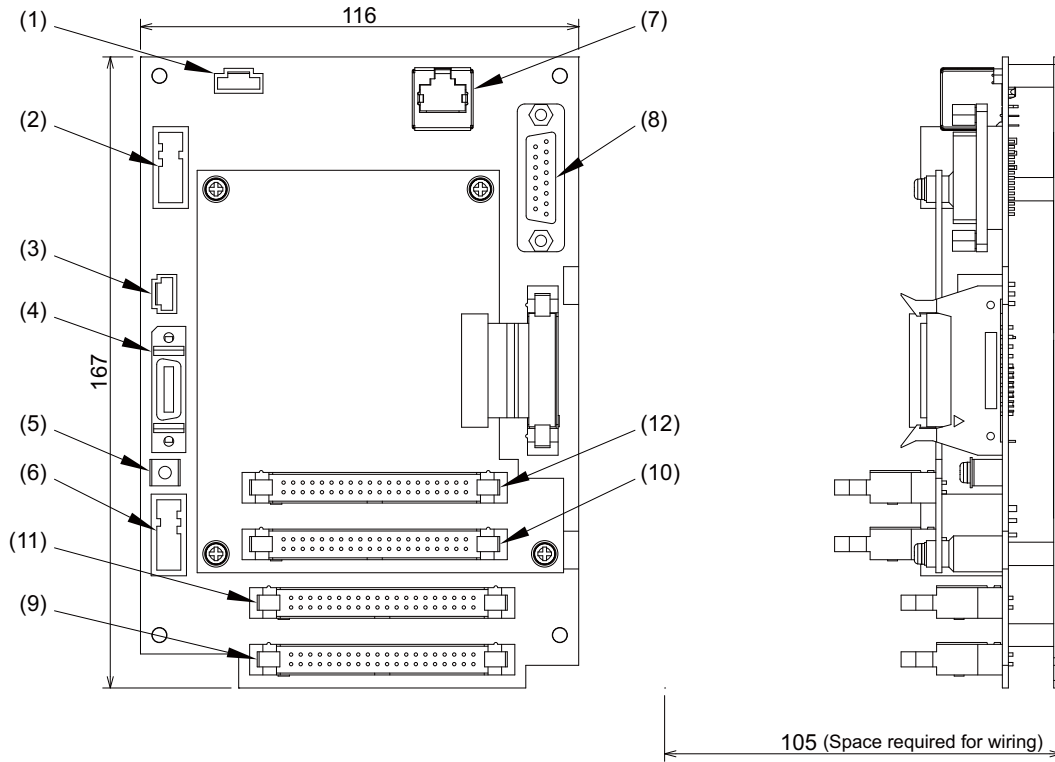

<Dimension drawing for installing on the panel>

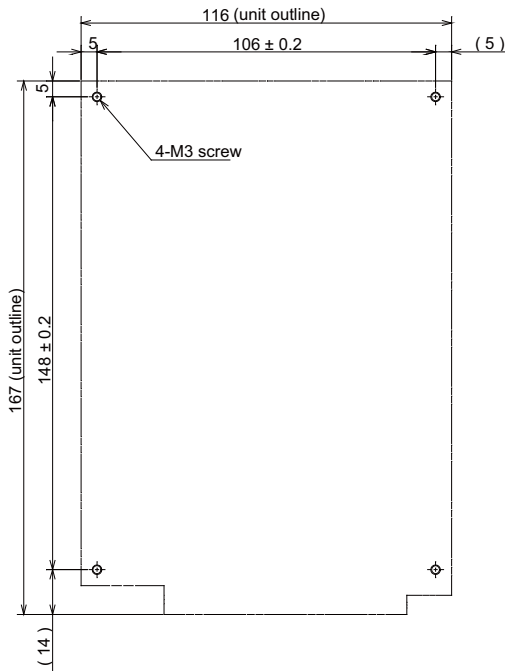

<Installation on the back side of the keyboard>

Operation panel I/O unit can be installed on the back side of the keyboard.

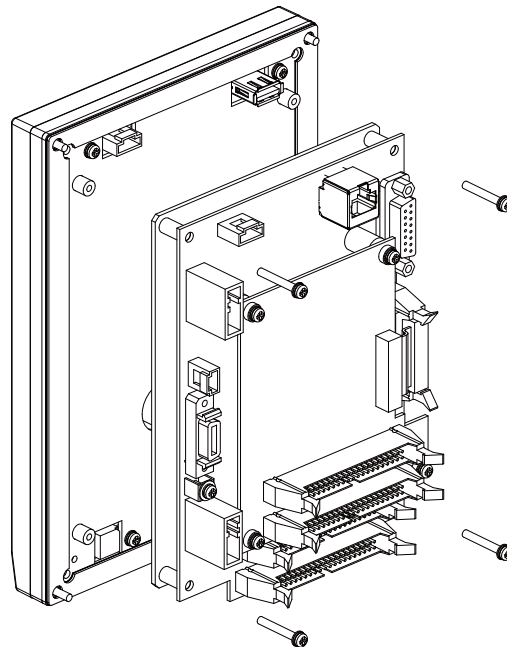

(Note) Use M3x25 screws (with spring washer and plain washer) when mounting the operation panel I/O unit.

No.	Connector name	Function	No.	Connector name	Function
(1)	NCRST	NC keyboard - Control unit Reset I/F	(7)	PCLAN	Ethernet I/F
(2)	DCIN	24VDC input	(8)	MPG	Manual pulse generator input 3ch(5V, 12V)
(3)	EMG	External emergency stop input for operation panel	(9)	CG31	Machine input
(4)	OPI	Control unit I/F	(10)	CG33	Machine input
(5)	FG	RIO3 cable clamp FG	(11)	CG32	Machine output
(6)	RIO3	Remote I/O unit I/F	(12)	CG34	Machine output

(1) NC keyboard - Control unit Reset I/F (NCRST)

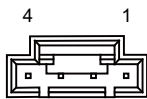

1	I	RSTIN
2		NC
3	O	0V(GND)
4		NC

<Cable side connector type>

Connector: 51030-0430

Contact: 0016020103 x4

Recommended manufacturer: MOLEX

(2) 24VDC input (DCIN)

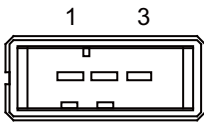

1	I	+24V
2		0V
3		FG

<Cable side connector type>

Connector: 2-178288-3

Contact: 1-175218-5 x3

Recommended manufacturer: Tyco Electronics

(a) Specifications of power supply

Consider the following characteristics when selecting the stabilized power supply (prepared by machine tool builder). Use a power supply that complies with CE Marking or that follows the safety standards given below.

[Stabilized power supply selection items]

Item		Standard setting
Output	Voltage fluctuation	±5% or less of 24VDC
	Ripple noise	200mV (P-P)
Power capacity		2.5A or more
Output holding time		20ms
Overcurrent protection		Required

[Standards]

Safety Standards: UL1950, CSA C22.2 No.234 approved, IEC950 compliant

Noise Terminal Voltage: FCC Class A, VCCI-Class A

High Harmonics Current Restrictions: IEC61000-3-2

(Note) 24VDC voltage may drop instantaneously due to rush current at the beginning of 24V power supply to the operation panel I/O unit. The level of voltage drop depends on the capacity of the power supply. Do not share the power supply with the devices that have alarms to warn the voltage drop.

⚠ CAUTION

1. Using a stabilized power supply without overcurrent protection may cause the unit's failure due to miswiring of 24V.

(3) External emergency stop input for operation panel (EMG)

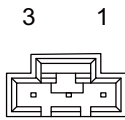

1		FG
2	I	EMG IN
3	O	+24V

* Be sure to connect EMG terminal cable (G123) to the connector when not used.

<Cable side connector type>

Connector: 005057-9403
Contact: 0016020103 x3
Recommended manufacturer: MOLEX

(4) Control unit I/F (OPI)

(5) RIO3 cable clamp FG (FG)

(6) Remote I/O unit I/F (RIO3)

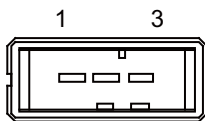

1	I/O	TXRX3
2	I/O	TXRX3*
3		0V(GND)

<Cable side connector type>

Connector: 1-178288-3
Contact: 1-175218-2 x3
Recommended manufacturer: Tyco Electronics

Refer to the following chart for the maximum number of connecting stations and I/O points.

Operation panel I/O unit type	Max. number of stations (RIO3 connection)	Max. number of I/O points (RIO3 connection)
FCU7-DX670	5 stations	160 points/ 160 points
FCU7-DX671	5 stations	160 points/ 160 points
FCU7-DX770	4 stations	128 points/ 128 points
FCU7-DX771	4 stations	128 points/ 128 points

(Note) Refer to the section "General Specifications: Remote I/O Unit" for the number of occupying stations and I/O points of remote I/O units.

(7) Ethernet I/F (PCLAN)

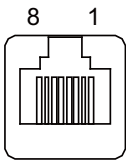

1	○	TD+
2	○	TD-
3	┃	RD+
4		
5		
6	┃	RD-
7		
8		

* Connect connector case with FG pattern.

* Use a straight cable (G301) for connection with the display unit.

<Cable side connector type>

Connector: 5-569550-3

Recommended manufacturer: Tyco Electronics

(8) Manual pulse generator input 3ch (5V,12V) (MPG)

5V manual pulse generator and 12V manual pulse generator can be connected to this connector.
Connect the synchronous feed encoder to the ENC connector of the control unit.

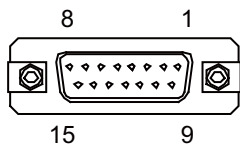

1	┃	HA1A	9		0V
2	┃	HA1B	10	○	+12V
3	┃	HA2A	11		0V
4	┃	HA2B	12	○	+12V
5	┃	HA3A	13		0V
6	┃	HA3B	14	○	+12V
7	○	+5V	15		NC
8	○	+5V			

* Connect connector case with FG pattern.

<Cable side connector type>

Connector: CDA-15P

Contact: CD-PC-111 x11 (5V power supply type) / CD-PC-111 x12 (12V power supply type)

Case: HDA-CTH

Recommended manufacturer: Hirose Electric

<Specification of input part>

	5V manual pulse generator	12V manual pulse generator
Number of pulse phases	Two phases (A phase, B phase, a phase difference 90 degrees) (Refer to the waveform below.)	
Signal output of manual pulse generator	Voltage output, open collector output	Open collector output
Signal voltage	H level 3.5V to 5.25V L level 0V to 0.5V	
Power supply voltage	5VDC±10%	12VDC±10%
Current consumption	100mA or less	
Number of pulses per rotation	25 pulse/rev, 100 pulse/rev	
Input frequency (rotation speed)	1kHz or less (40r/s or less for 25pulse/rev, 10r/s or less for 100pulse/rev)	
Cable length	20m or less	50m or less

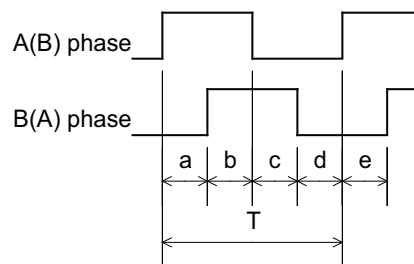

a.b.c.d.e: A phase or B phase rising edge (falling edge) phase difference = $T/4 \pm T/10$
T: A or B phase cycle

<Input/output circuit>

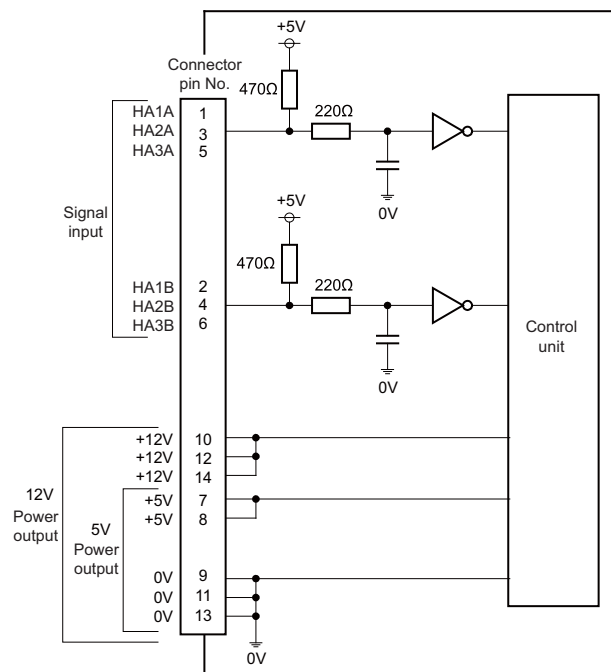

(9) Machine input (CG31)
 Digital input 32 points (1st station)

(10) Machine input (CG33)
 Digital input 32 points (2nd station)

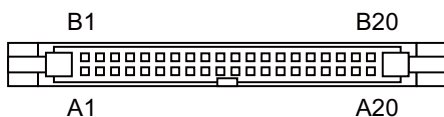

<Cable side connector type>

Connector: 7940-6500SC
 Strain relief: 3448-7940
 Recommended manufacturer: 3M

CG31						CG33					
B			A			B			A		
20	I	X200	20	I	X210	20	I	X220	20	I	X230
19	I	X201	19	I	X211	19	I	X221	19	I	X231
18	I	X202	18	I	X212	18	I	X222	18	I	X232
17	I	X203	17	I	X213	17	I	X223	17	I	X233
16	I	X204	16	I	X214	16	I	X224	16	I	X234
15	I	X205	15	I	X215	15	I	X225	15	I	X235
14	I	X206	14	I	X216	14	I	X226	14	I	X236
13	I	X207	13	I	X217	13	I	X227	13	I	X237
12	I	X208	12	I	X218	12	I	X228	12	I	X238
11	I	X209	11	I	X219	11	I	X229	11	I	X239
10	I	X20A	10	I	X21A	10	I	X22A	10	I	X23A
9	I	X20B	9	I	X21B	9	I	X22B	9	I	X23B
8	I	X20C	8	I	X21C	8	I	X22C	8	I	X23C
7	I	X20D	7	I	X21D	7	I	X22D	7	I	X23D
6	I	X20E	6	I	X21E	6	I	X22E	6	I	X23E
5	I	X20F	5	I	X21F	5	I	X22F	5	I	X23F
4		NC	4		NC	4		NC	4		NC
3		COM	3		COM	3		COM	3		COM
2	I	+24V	2		0V	2	I	+24V	2		0V
1	I	+24V	1		0V	1	I	+24V	1		0V

The input/output assignment differs according to the station No. setting switch. Refer to "PLC Interface Manual" for details.

(a) Outline of digital signal input circuit

Both 24V common and 0V common connections are allowed in the digital signal input circuit.

Follow the wiring diagram below for each type.

Input circuit

24V common

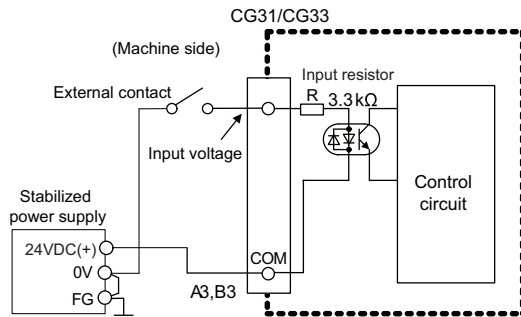

0V common

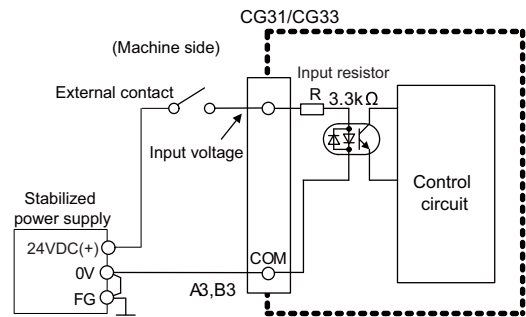

Input conditions

The input signals must be used within the following condition ranges.

		24V common	0V common
1	Input voltage at external contact ON	6V or less	18V or more, 25.2V or less
2	Input current at external contact ON	9mA or more	
3	Input voltage at external contact OFF	20V or more, 25.2V or less	4V or less
4	Input current at external contact OFF	2mA or less	
5	Input resistance	Approx. 3.3kΩ	
6	Tolerable chattering time (T1)	3ms	
7	Input signal holding time (T2)	40ms or more (Note)	
8	Input circuit operation delay time (T3 and T4)	3 to 16ms	
9	Machine side contact capacity	30V or more, 16mA or more	

(Note) Input signal holding time: The guide is 40ms or more. The input signal will not be recognized unless it is held for the ladder processing cycle time or longer.

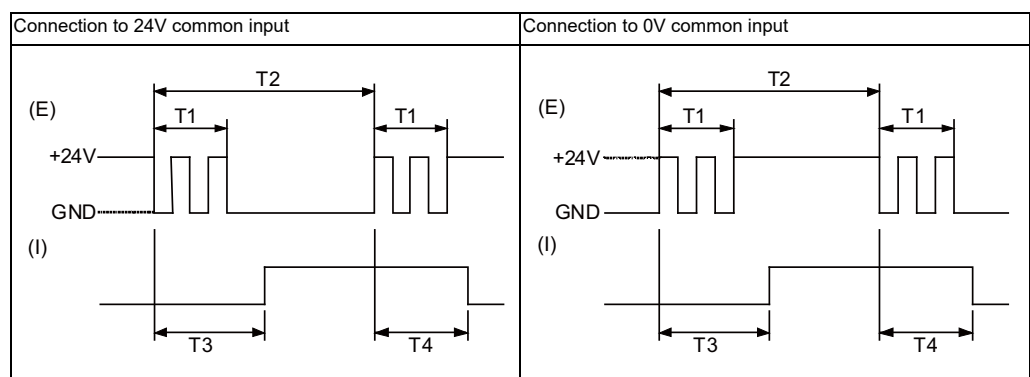

(E) : External signal, (I):Internal signal

(11) Machine output (CG32)

Digital output 32 points (1st station)

(12) Machine output (CG34)

Digital output 32 points (2nd station)

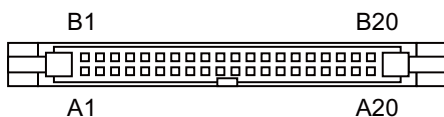

<Cable side connector type>

Connector: 7940-6500SC

Strain relief: 3448-7940

Recommended manufacturer: 3M

CG32						CG34					
B			A			B			A		
20	O	Y200	20	O	Y210	20	O	Y220	20	O	Y230
19	O	Y201	19	O	Y211	19	O	Y221	19	O	Y231
18	O	Y202	18	O	Y212	18	O	Y222	18	O	Y232
17	O	Y203	17	O	Y213	17	O	Y223	17	O	Y233
16	O	Y204	16	O	Y214	16	O	Y224	16	O	Y234
15	O	Y205	15	O	Y215	15	O	Y225	15	O	Y235
14	O	Y206	14	O	Y216	14	O	Y226	14	O	Y236
13	O	Y207	13	O	Y217	13	O	Y227	13	O	Y237
12	O	Y208	12	O	Y218	12	O	Y228	12	O	Y238
11	O	Y209	11	O	Y219	11	O	Y229	11	O	Y239
10	O	Y20A	10	O	Y21A	10	O	Y22A	10	O	Y23A
9	O	Y20B	9	O	Y21B	9	O	Y22B	9	O	Y23B
8	O	Y20C	8	O	Y21C	8	O	Y22C	8	O	Y23C
7	O	Y20D	7	O	Y21D	7	O	Y22D	7	O	Y23D
6	O	Y20E	6	O	Y21E	6	O	Y22E	6	O	Y23E
5	O	Y20F	5	O	Y21F	5	O	Y22F	5	O	Y23F
4		COM	4		COM	4		COM	4		COM
3		COM	3		COM	3		COM	3		COM
2	I	+24V	2		0V	2	I	+24V	2		0V
1	I	+24V	1		0V	1	I	+24V	1		0V

The input/output assignment differs according to the station No. setting switch. Refer to "PLC Interface Manual" for details.

(a) Outline of digital signal output circuit

The digital signal output circuit uses a sink type (DX670/DX770) or source type (DX671/DX771). Use within the specification ranges shown below.

Output circuit

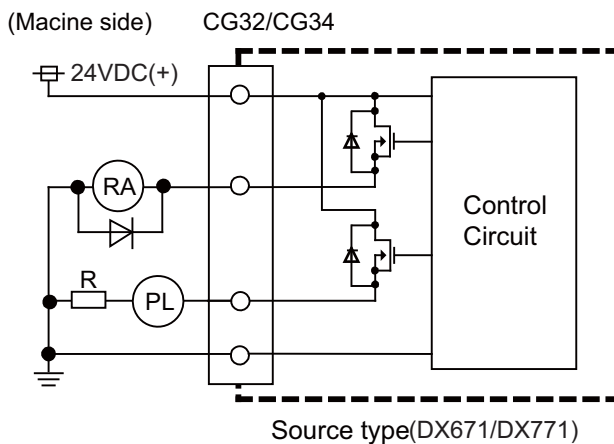
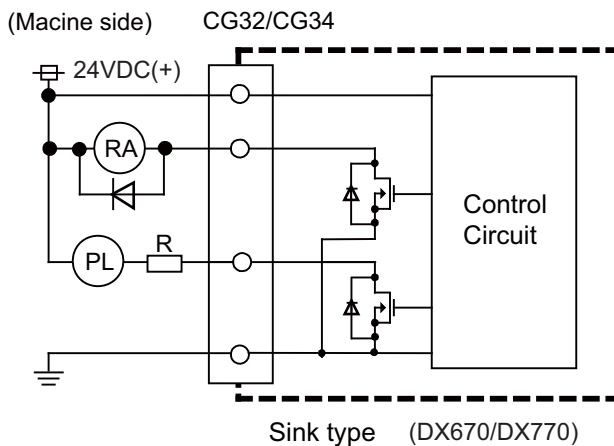

RA : Relay
PL : Pilot lamp

Output conditions

Insulation method	Insulation
Rated load voltage	24VDC
Max. output current	60mA/point
Output delay time	40μs

(Note 1) When using an inductive load such as a relay, always connect a diode (voltage resistance 100V or more, 100mA or more) in parallel to the load.

(Note 2) When using a capacitive load such as a lamp, always connect a protective resistor (R=150Ω) serially to the load to suppress rush currents. (Make sure that the current is less than the above tolerable current including the momentary current.)

CAUTION

1. When using an inductive load such as a relay, always connect a diode in parallel to the load.
2. When using a capacitive load such as a lamp, always connect a protective resistor serially to the load to suppress rush currents.

(13) LED

Name	Function	Color	Status		Details
			Normal	At fault	
24VIN	24VDC input check	Green	Lit	Not lit	Lit when some voltage (V) is applied. (This is not for checking the voltage level.)
PSEMG	Emergency stop switch status	Red	Not lit	Lit	Lit when an emergency stop has occurred.
RIO1 (two-color LED)	ON	Green	Lit	Not lit	Lit during transmission.
	ALM	Red	Not lit	Lit	Lit when no communication has been established for 7.28ms or longer.
RIO2 (two-color LED)	ON	Green	Lit	Not lit	Lit during transmission.
	ALM	Red	Not lit	Lit	Lit when no communication has been established for 7.28ms or longer.
RIO3 (two-color LED)	ON	Green	Lit	Not lit	Lit during transmission.
	ALM	Red	Not lit	Lit	Lit when no communication has been established for 7.28ms or longer.

2.6 Hard Disk Unit

Outline dimension

[FCU7-HD002-001]

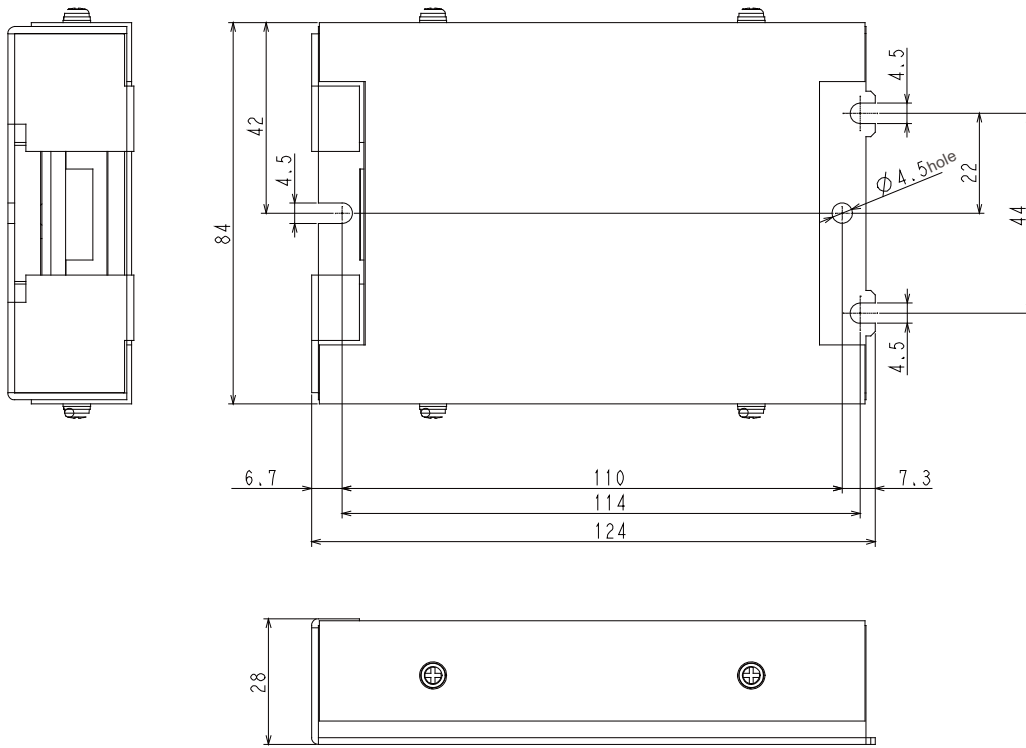

The flat cable F142 is attached.

<Installation dimension drawing>

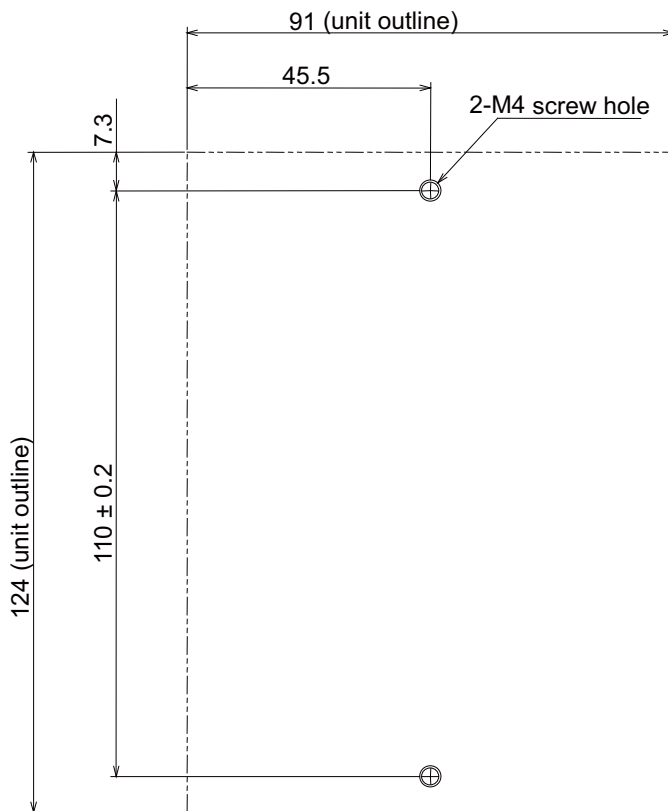

(Note) Mount the hard disk unit so that the cable lead-out side is vertically straight up and the unit does not incline over $\pm 15^\circ$ from the mounting surface.

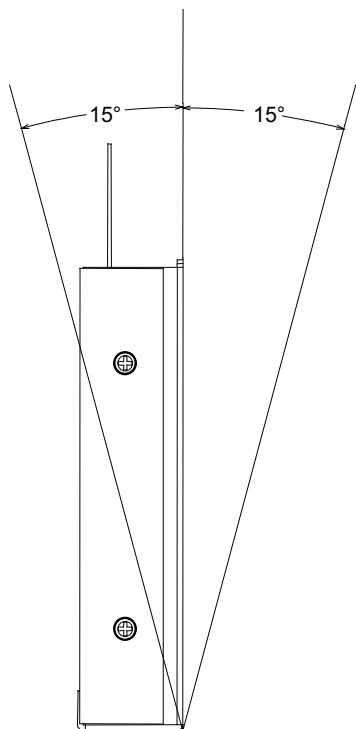

<Installation on the back of the keyboard>

Fix the hard disk unit with three M4 screws as follows to install it on the back of the keyboard unit (FCU7-KB041).

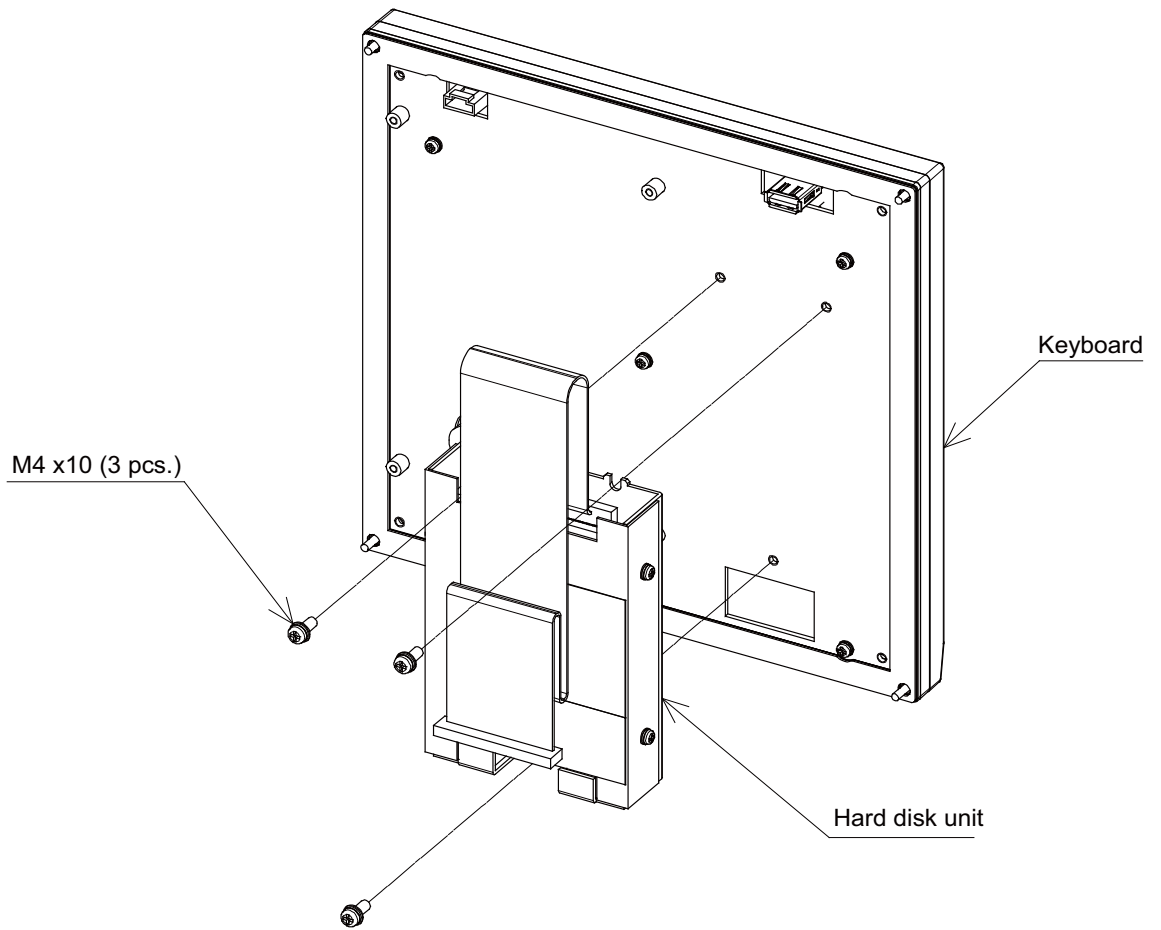

2.7 Remote I/O Unit

The following eight types of signals can be input/output from the remote I/O unit (FCUA-DX1xx) according to the type and No. of contacts. Use serial link connections to connect the unit with the control unit or the operation panel I/O unit. Multiple remote I/O units can be used as long as the total number of occupied stations is eight or less.

Classification	Type	Components	Remarks
DI 24V/0V common input DO Sink output	FCUA-DX100	RX311	DI: 32-points 24V/0V common type (photo coupler insulation) DO: 32-points sink type (non-insulation) Number of occupied stations: 1
DI 24V/0V common input DO Sink output	FCUA-DX110	RX311+RX321-1	DI: 64-points 24V/0V common type (photo coupler insulation) DO: 48-points sink type (non-insulation) Number of occupied stations: 2
DI 24V/0V common input DO Sink output AO Analog output	FCUA-DX120	RX311+RX321	DI: 64-points 24V/0V common type (photo coupler insulation) DO: 48-points sink type (non-insulation) AO: 1 point Number of occupied stations: 2
DI 24V/0V common input DO Sink output AI Analog input AO Analog output	FCUA-DX140	RX311+RX341	DI: 32-points 24V/0V common type (photo coupler insulation) DO: 32-points sink type (non-insulation) AI: 4 points AO: 1 point Number of occupied stations: 2
DI 24V/0V common input DO Source output	FCUA-DX101	RX312	DI: 32-points 24V/0V common type (photo coupler insulation) DO: 32-points source type (non-insulation) Number of occupied stations: 1
DI 24V/0V common input DO Source output	FCUA-DX111	RX312+RX322-1	DI: 64-points 24V/0V common type (photo coupler insulation) DO: 48-points source type (non-insulation) Number of occupied stations: 2
DI 24V/0V common input DO Source output AO Analog output	FCUA-DX121	RX312+RX322	DI: 64-points 24V/0V common type (photo coupler insulation) DO: 48-points source type (non-insulation) AO: 1 point Number of occupied stations: 2
DI 24V/0V common input DO Source output AI Analog input AO Analog output	FCUA-DX141	RX312+RX341	DI: 32-points 24V/0V common type (photo coupler insulation) DO: 32-points source type (non-insulation) AI: 4 points AO: 1 point Number of occupied stations: 2

Dimension and names of parts

[Front view]

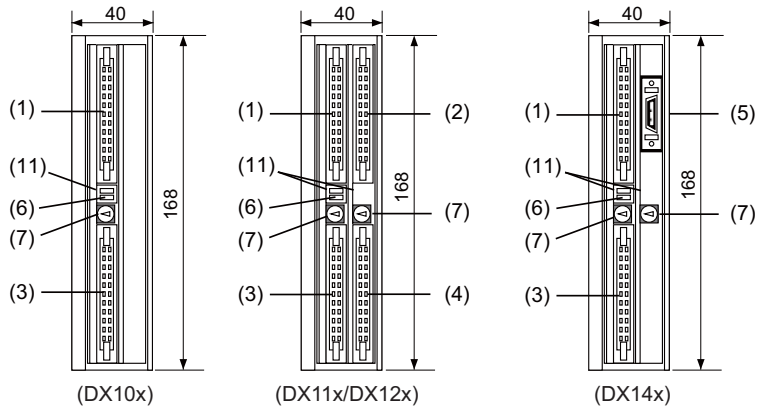

[Bottom view]

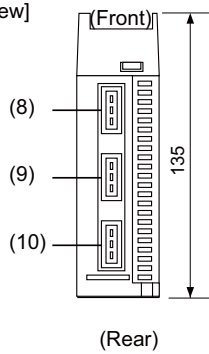

[Side view]

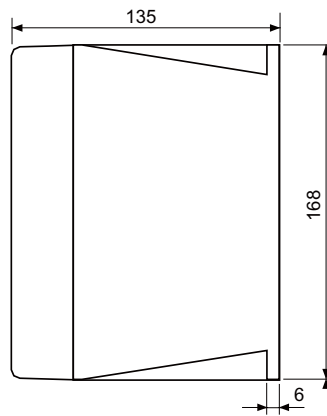

<Installation dimension drawing>

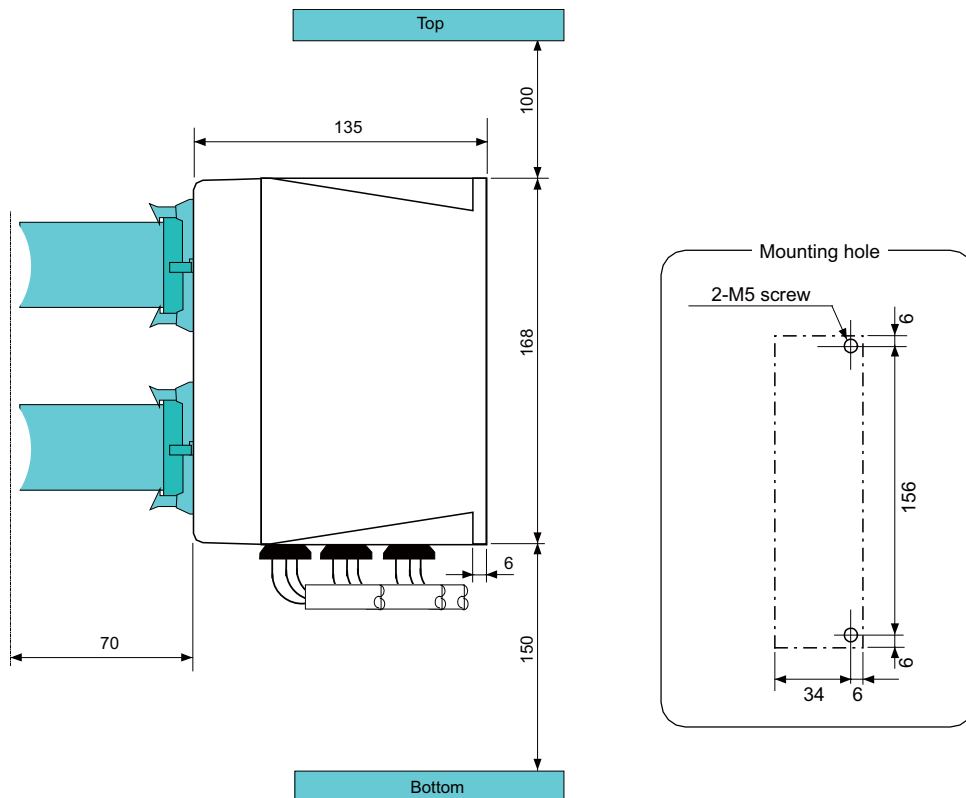

- (1) Machine input (DI-L)
- (2) Machine input (DI-R)

Both 24V common and 0V common connections are allowed in the digital signal input circuit. Follow the wiring diagram below for each type.

Input circuit

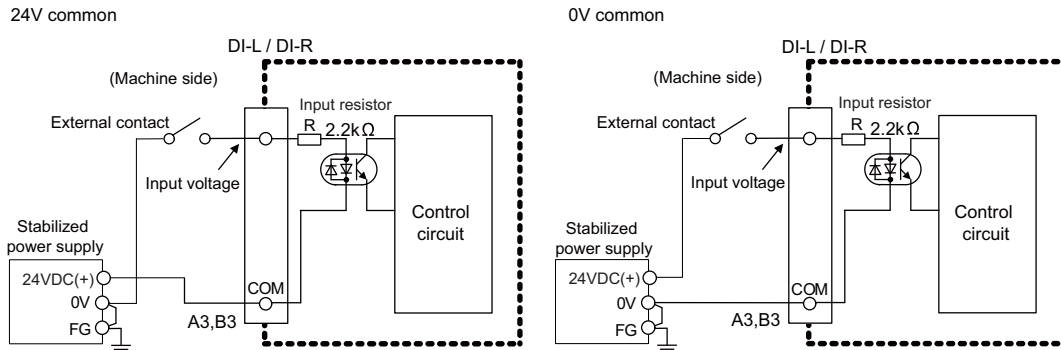

Input conditions

The input signals must be used within the following condition ranges.

		24V common	0V common
1	Input voltage at external contact ON	6V or less	18V or more, 25.2V or less
2	Input current at external contact ON	9mA or more	
3	Input voltage at external contact OFF	20V or more, 25.2V or less	4V or less
4	Input current at external contact OFF	2mA or less	
5	Input resistance	Approx. 2.2kΩ	
6	Tolerable chattering time (T1)	3ms	
7	Input signal holding time (T2)	40ms or more (Note)	
8	input circuit operation delay time (T3 and T4)	3 to 16ms	
9	Machine side contact capacity	30V or more, 16mA or more	

(Note) Input signal holding time: The guide is 40ms or more. The input signal will not be recognized unless it is held for the ladder processing cycle time or longer.

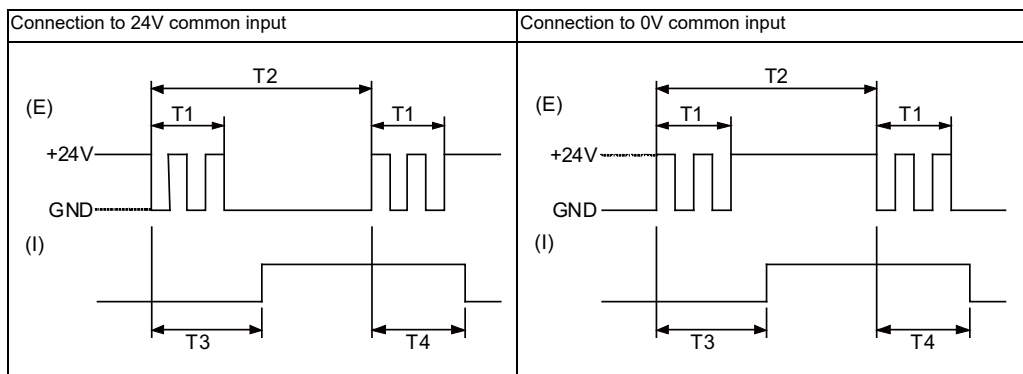

(E) : External signal, (I) : Internal signal

- (3) Machine output (DO-L)
- (4) Machine output (DO-R)

The digital signal output circuit uses a sink type (DX1x0) or source type (DX1x1).
Use within the specification ranges shown below.

Output circuit

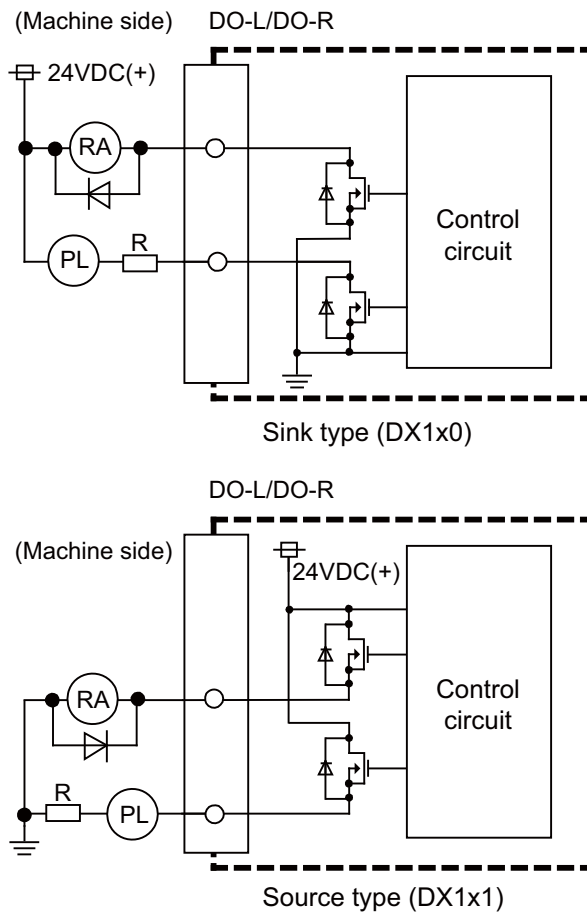

Output conditions

Insulation method	Non-insulation
Rated load voltage	24VDC
Max. output current	60mA/point
Output delay time	40μs

- (Note 1) When using an inductive load such as a relay, always connect a diode (voltage resistance 100V or more, 100mA or more) in parallel to the load.
- (Note 2) When using a capacitive load such as a lamp, always connect a protective resistor (R=150Ω) serially to the load to suppress rush currents. (Make sure that the current is less than the above tolerable current including the momentary current.)

[Analog signal input/output (AIO)]

The analog signal output circuit can be used only for FCUA-DX120/DX121.

Output circuit

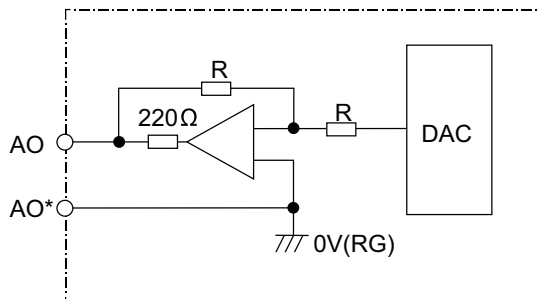

Output conditions

Output voltage	0V to ±10V (±5%)
Resolution	12bit (±10V × n/4096) (Note)
Load conditions	10kΩ load resistance
Output impedance	220Ω

(Note) $n=(2^0 \text{ to } 2^{11})$

⚠ CAUTION

1. When using an inductive load such as a relay, always connect a diode in parallel to the load.
2. When using a capacitive load such as a lamp, always connect a protective resistor serially to the load to suppress rush currents.

(5) Analog signal input/output (AIO)

(a) Outline of analog signal output circuit

The analog signal output circuit can be used only for FCUA-DX140/DX141.

Output circuit

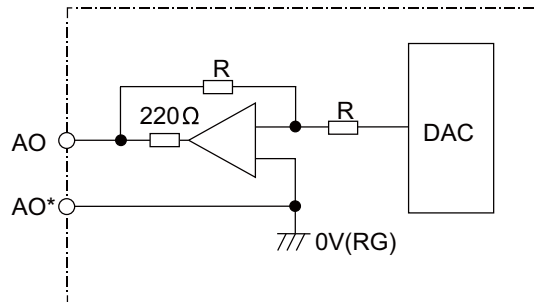

Output conditions

Output voltage	0V to ±10V (±5%)
Resolution	12bit (±10V × n/4096) (Note)
Load conditions	10kΩ load resistance
Output impedance	220Ω

(Note) $n=(2^0 \text{ to } 2^{11})$

(b) Outline of analog signal input circuit

The analog signal input circuit can be used only for FCUA-DX140/DX141.

Input circuit

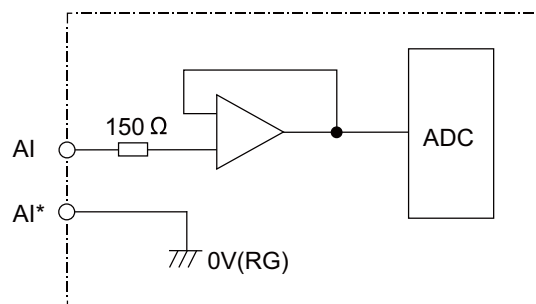

Input conditions

Max. input rating	±15V
Resolution	$ -10 \text{ to } +10\text{V} / 4096 = 4.88\text{mV}$
Precision	Within ±25mV
AD input sampling time	14.2ms(AI0)/ 42.6ms(AI1 to 3)

(6) Transfer speed changeover switch (DS)

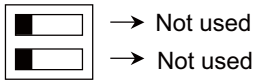

(7) Station No. changeover switch (CS)



(8) Remote I/O unit I/F #1 (RIO1)

(9) Remote I/O unit I/F #2 (RIO2)

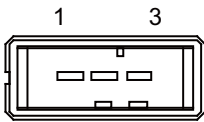

1	I/O	TXRX
2	I/O	TXRX*
3		0V

<Cable side connector type>

Connector: 1-178288-3

Contact: 1-175218-2 x3

Recommended manufacturer: Tyco Electronics

(10) 24VDC input (DCIN)

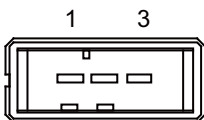

1	I	+24V
2		0V
3		FG

<Cable side connector type>

Connector: 2-178288-3

Contact: 1-175218-5 x3

Recommended manufacturer: Tyco Electronics

(11) LED

Name	Function	At fault	Conditions
POWER Green (UP)	Internal output voltage(5VDC) check	Not lit	(1) Failure of 24VDC input (2) Fuse is disconnected (3) Failure of internal voltage output in I/O unit
ALM Red (DOWN)	RIO communication status check	Lit	(1) Partial disconnection between control unit and remote I/O unit (2) Miswiring of connected remote I/O unit

2.8 Scan I/O Unit

The HR347/357 card is the machine operation panel input/output card. It has a digital input/output and scan input/output, and is connected to the machine operation panel and other devices.

		Item	HR347	HR357
Scan	Input	Number of points	64 points	
		Configuration	8 common × 8 data matrix	
		Rated voltage	5VDC	
		Max. current	80mA/point	
		Input cycle	1.46ms cycle, 11.68ms cycle	
		Input signal holding time	11.68ms or more (*1)	
	Output	Number of points	64 points	
		Configuration	4 common × 8 data + 4 common × 8 data matrix	
		Rated load voltage	5VDC	
		Max. output current	200mA/point	
Output cycle		1.46ms cycle, 5.84ms cycle		
Digital	Input	Number of points	32 points	
		Type	24V common/ 0V common	
		Input voltage at external contact ON	6V or less	18V or more, 25.2V or less
		Input current at external contact ON	2mA or less	9mA or more
		Input voltage at external contact OFF	20V or more, 25.2V or less	4V or less
		Input current at external contact OFF	9mA or more	2mA or less
		Tolerable chattering time	2.2ms or less	
		Input signal holding time	40ms or more	
		Input circuit operation delay time	2.2ms ≤ T3 ≈ T4 ≤ 11ms	
	Machine side contact capacity	30V or more, 16mA or more		
	Output	Number of points	32 points	
		Rated load voltage	24VDC	
		Max. output current	60mA/point	
		Type	Sink	Source

(*1) Input signal holding time: The guide is 11.68ms or more. The input signal will not be recognized unless it is held for the ladder processing cycle time or longer.

Dimension and names of parts

[HR347/ HR357]

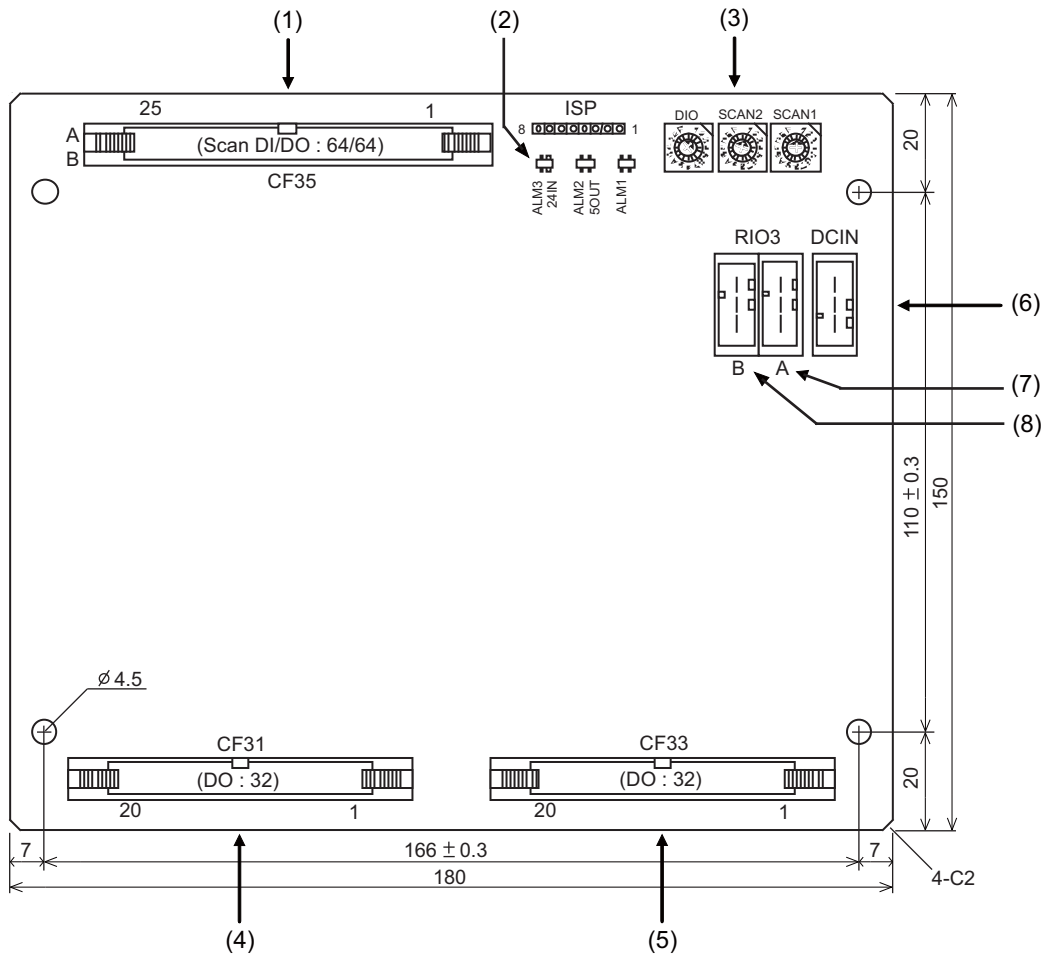

(1) Scan type input/output (CF35)

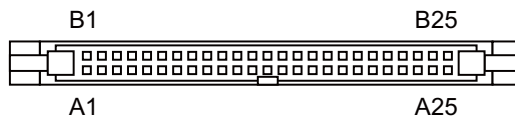

CF35					
		B			A
25		GND	25		GND
24	O	LC3B	24	O	LC3A
23	O	LC2B	23	O	LC2A
22	O	LC1B	22	O	LC1A
21	O	LC0B	21	O	LC0A
20	I	LD7B*	20	I	LD7A*
19	I	LD6B*	19	I	LD6A*
18	I	LD5B*	18	I	LD5A*
17	I	LD4B*	17	I	LD4A*
16	I	LD3B*	16	I	LD3A*
15	I	LD2B*	15	I	LD2A*
14	I	LD1B*	14	I	LD1A*
13	I	LD0B*	13	I	LD0A*
12		GND	12		
11			11		
10			10		
9	O	KYC7*	9	O	KYC6*
8	O	KYC5*	8	O	KYC4*
7	O	KYC3*	7	O	KYC2*
6	O	KYC1*	6	O	KYC0*
5	I	KYD7*	5	I	KYD6*
4	I	KYD5*	4	I	KYD4*
3	I	KYD3*	3	I	KYD2*
2	I	KYD1*	2	I	KYD0*
1			1		GND

(Note) The GND pin is normally unused.
Do not connect the GND pin to the frame ground.

<Cable side connector type>

Connector: 7950-6500SC

Strain relief: 3448-7950

Recommended manufacturer: 3M

LCxA/B	Common signals for scan DO
LDxA/B*	Data signals for scan DO
KYCx*	Common signals for scan DI
KYDx*	Data signals for scan DI

* This is an example when SCAN1 is set to "0", SCAN2 to "1", and DIO to "2".
Refer to "PLC Interface Manual" for details.

(a) Scan input

An example is shown of a scan input circuit manufactured by the machine manufacturer.

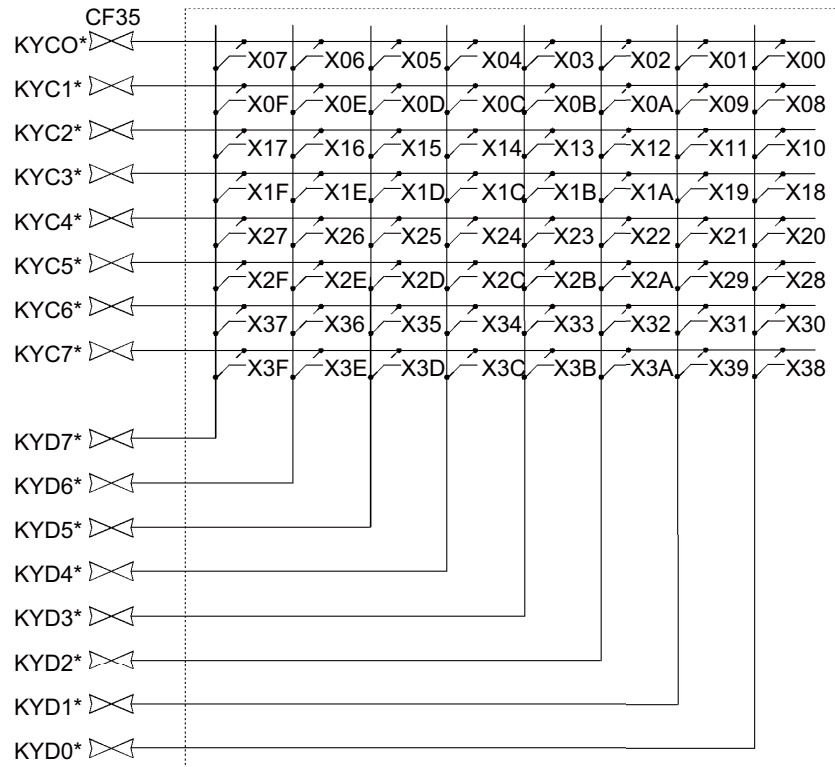

(Note) To scan input, connect a sneak path prevention diode as shown in the following drawing. The unit may not be able to read the correct input signals without a sneak path prevention diode installed.

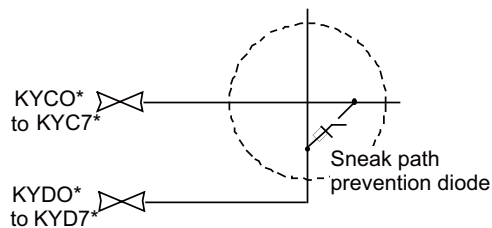

The common signals are changed over with scan input as shown in the following drawing. Key input data can be received when the common signal is LOW. The common signal changeover cycle is 11.68ms, but the input signal will not be recognized unless it is held for the ladder processing cycle time or longer. The scan input is a 5V system.

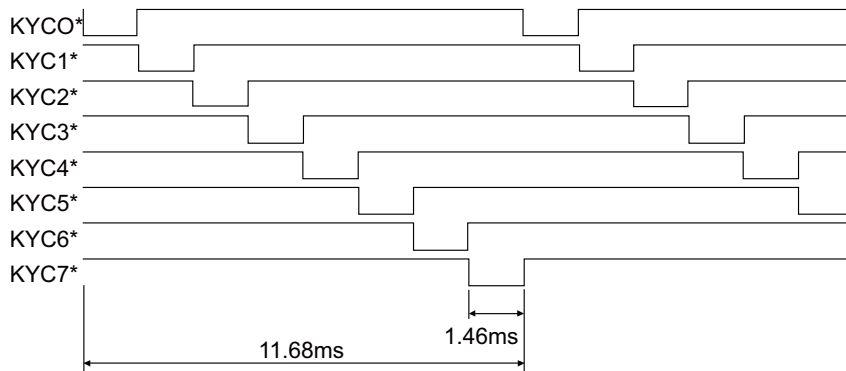

(b) Scan output

An example is shown of a scan output circuit manufactured by the machine manufacturer.

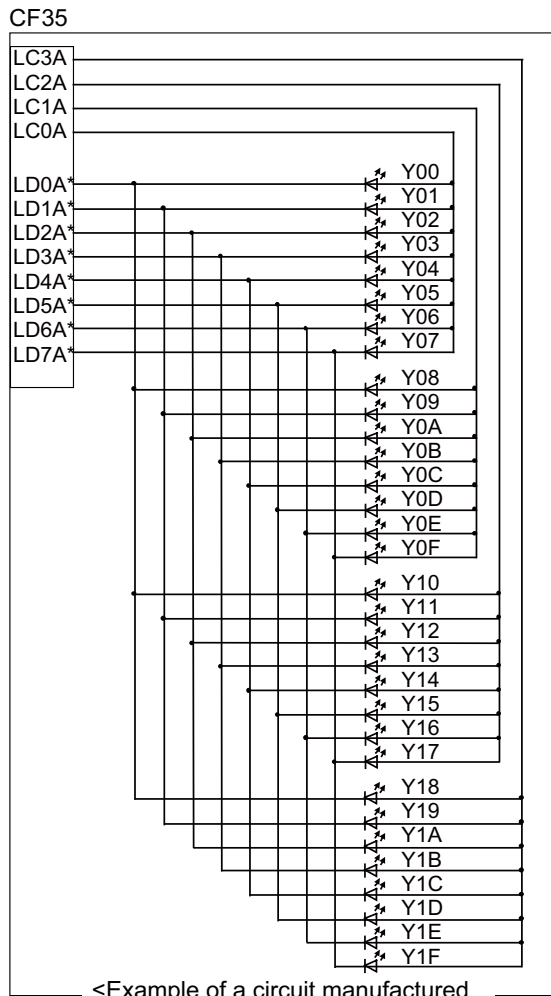

<Example of a circuit manufactured by the machine tool builder>

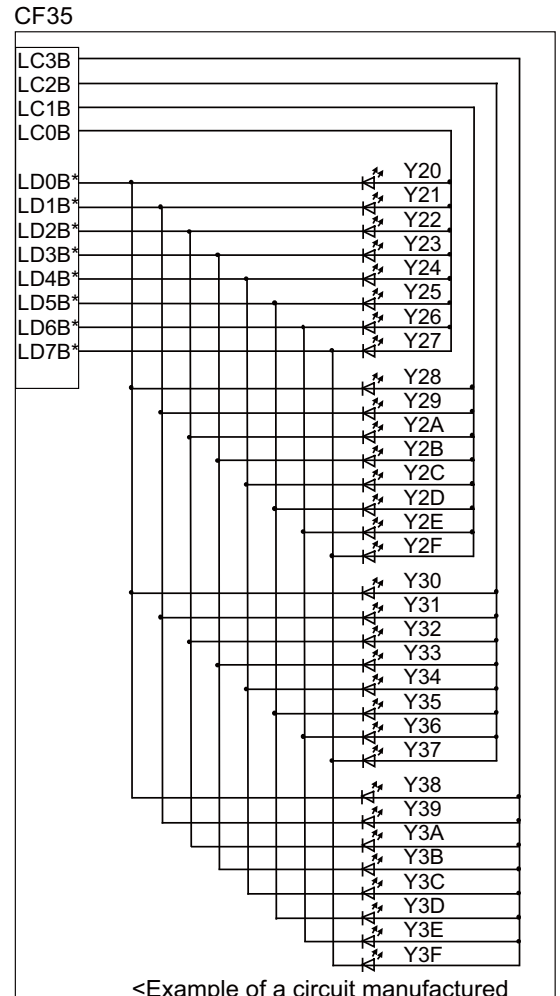

<Example of a circuit manufactured by the machine tool builder>

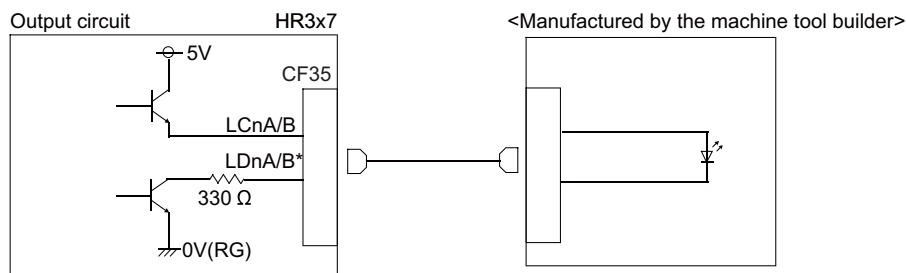

The common signals are changed over with scan output as shown in the following drawing. The LED outputs data, and lights only when the common signal is HIGH. The common signal changes to 4 signals in succession, and light s once every 5.84ms for 1.46ms only. The scan output is a 5V system.

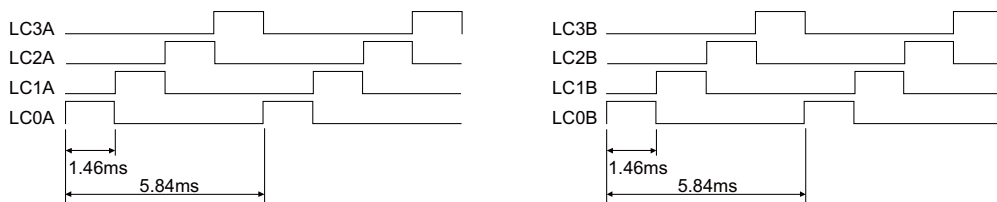

(2) LED

LED	Function	Color	Status		Remedy
			Normal	At fault	
24IN	24VDC input check	Green	Lit	Not lit	24VDC voltage check
5OUT	Internal output voltage check	Green	Lit	Not lit	Contact the MITSUBISHI service dept.
ALM1	Communication error of the station designated by rotary switch "SCAN1"	Red	Not lit	Lit	Check the station No. designation by the rotary switch of the remote I/O unit.
ALM2	Communication error of the station designated by rotary switch "SCAN2"	Red	Not lit	Lit	Check the station No. designation by the rotary switch of the remote I/O unit.
ALM3	Communication error of the station designated by rotary switch "DIO"	Red	Not lit	Lit	Check the station No. designation by the rotary switch of the remote I/O unit.

(3) Rotary switch

Set the address (station No.) assignment in DI/DO: 32/32 point units. Set using SCAN1, SCAN 2 and DIO rotary switches. The assignment address is changed with the rotary switch setting.

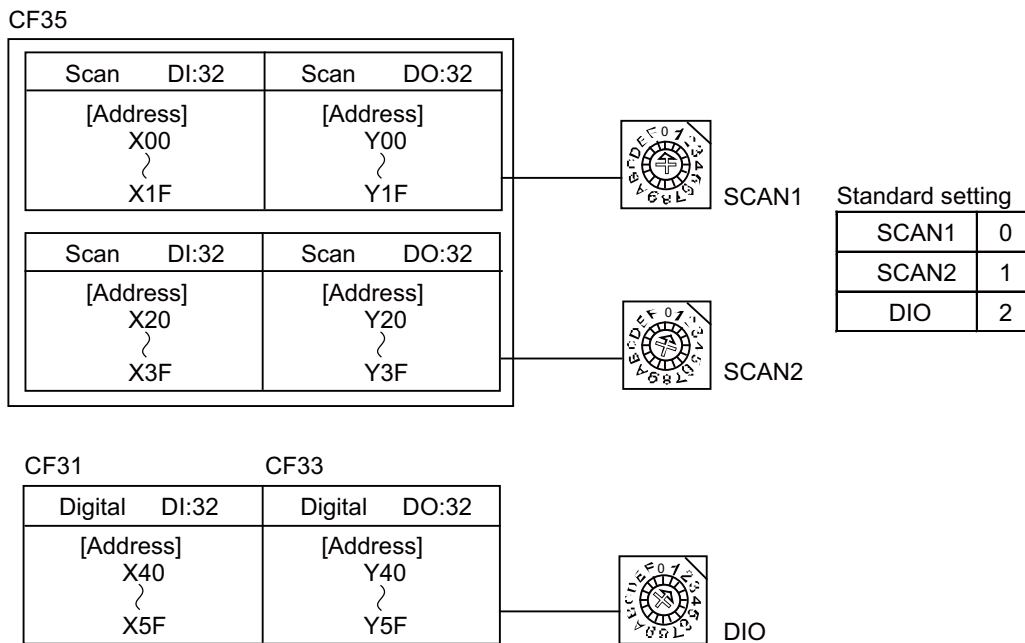

Rotary switch	Description
SCAN1	For scan input/output station No. setting 32points/32points (Normally set to "0")
SCAN2	For scan input/output station No. setting 32points/32points (Normally set to "1")
DIO	For digital input/output station No. setting 32points/32points (Normally set to "2")

(Note) Set each different station Nos. for SCAN1, SCAN2 and DIO. Up to 8 stations can be used in a part system. Set the Nos. from 0 to 7.

(4) Machine input (CF31)
Digital input

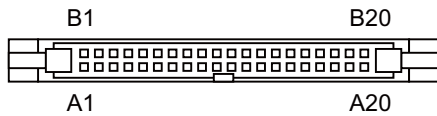

CF31					
		B			A
20	I	X40	20	I	X50
19	I	X41	19	I	X51
18	I	X42	18	I	X52
17	I	X43	17	I	X53
16	I	X44	16	I	X54
15	I	X45	15	I	X55
14	I	X46	14	I	X56
13	I	X47	13	I	X57
12	I	X48	12	I	X58
11	I	X49	11	I	X59
10	I	X4A	10	I	X5A
9	I	X4B	9	I	X5B
8	I	X4C	8	I	X5C
7	I	X4D	7	I	X5D
6	I	X4E	6	I	X5E
5	I	X4F	5	I	X5F
4			4		
3	I	COM	3	I	COM
2	I	24VDC	2		0V(RG)
1	I	24VDC	1		0V(RG)

<Cable side connector type>

Connector: 7940-6500SC
Strain relief: 3448-7940
Recommended manufacturer: 3M

* This is an example when SCAN1 is set to "0", SCAN2 to "1", and DIO to "2".
Refer to "PLC Interface Manual" for details.

Both 24V common and 0V common connections are allowed in the digital signal input circuit.

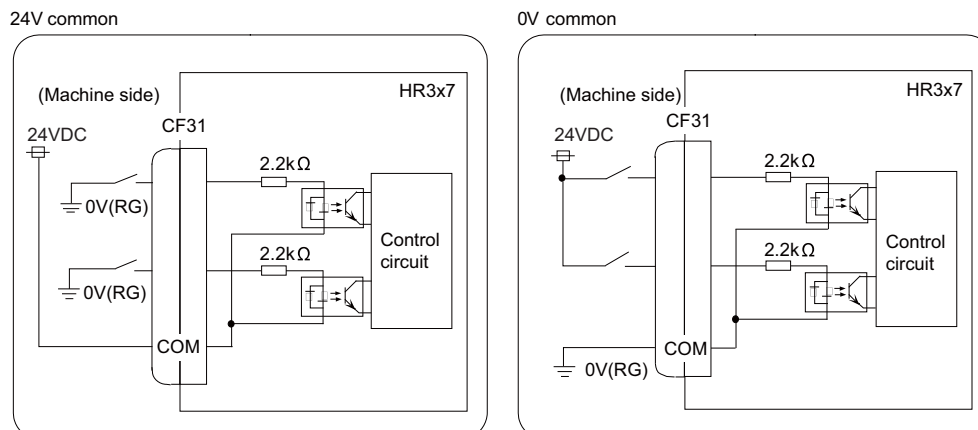

Input conditions

The input signals must be used within the following condition ranges.

		24V common	0V common
1	Input voltage at external contact ON	6V or less	18V or more, 25.2V or less
2	Input current at external contact ON	9mA or more	
3	Input voltage at external contact OFF	20V or more, 25.2V or less	4V or less
4	Input current at external contact OFF	2mA or less	
5	Input resistance	Approx. 2.2kΩ	
6	Tolerable chattering time (T1)	3ms	
7	Input signal holding time (T2)	40ms or more (Note)	
8	Input circuit operation delay time (T3 and T4)	3 to 16ms	
9	Machine side contact capacity	30V or more, 16mA or more	

(Note) Input signal holding time: The guide is 40ms or more. The input signal will not be recognized unless it is held for the ladder processing cycle time or longer.

[Connection to 24V common input]

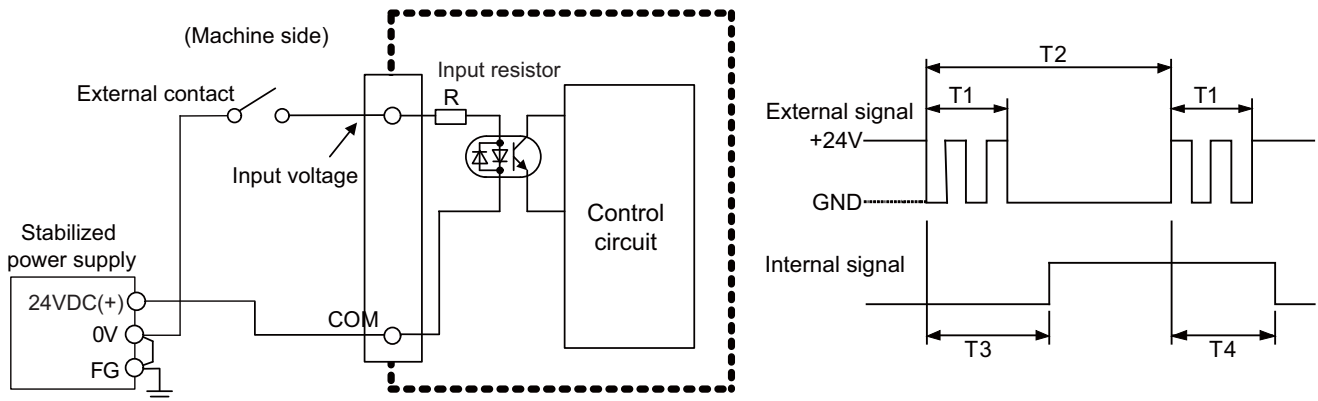

[Connection to 0V common input]

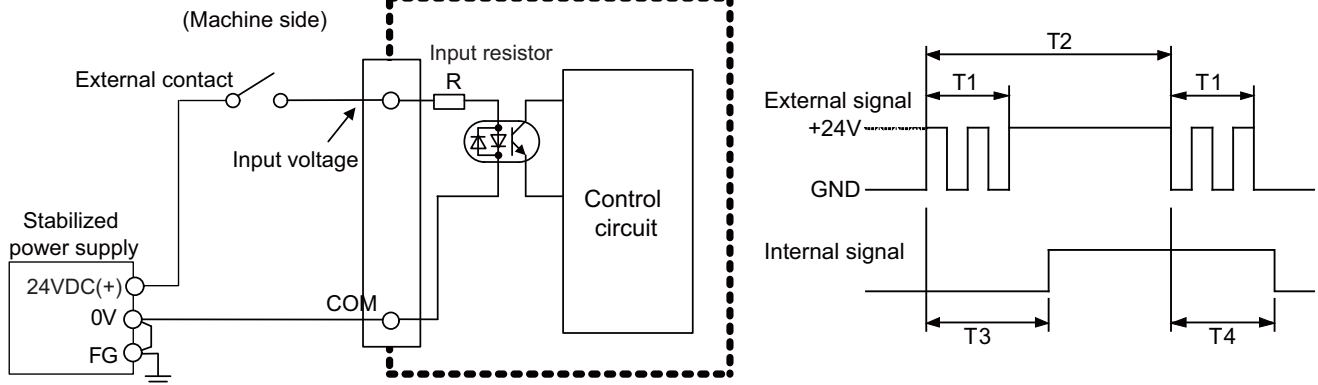

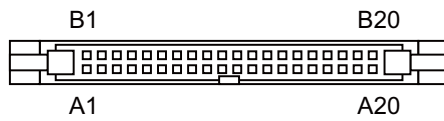
(5) Machine output (CF33)**Digital output**

CF33					
		B			A
20	O	Y40	20	O	Y50
19	O	Y41	19	O	Y51
18	O	Y42	18	O	Y52
17	O	Y43	17	O	Y53
16	O	Y44	16	O	Y54
15	O	Y45	15	O	Y55
14	O	Y46	14	O	Y56
13	O	Y47	13	O	Y57
12	O	Y48	12	O	Y58
11	O	Y49	11	O	Y59
10	O	Y4A	10	O	Y5A
9	O	Y4B	9	O	Y5B
8	O	Y4C	8	O	Y5C
7	O	Y4D	7	O	Y5D
6	O	Y4E	6	O	Y5E
5	O	Y4F	5	O	Y5F
4			4		
3			3		
2	I	24VDC	2		0V(RG)
1	I	24VDC	1		0V(RG)

<Cable side connector type>

Connector: 7940-6500SC

Strain relief: 3448-7940

Recommended manufacturer: 3M

* This is an example when SCAN1 is set to "0", SCAN2 to "1", and DIO to "2".

Refer to "PLC Interface Manual" for details.

The HR357 output circuit is a source type (source output).

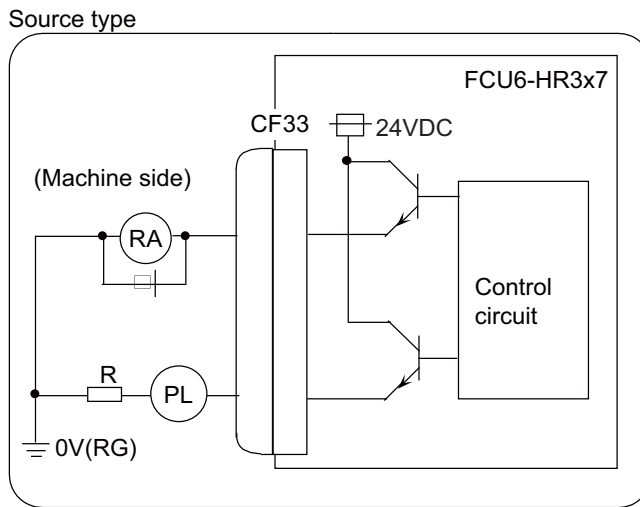

CAUTION

1. Do not apply any voltage to the connector other than that specified in this manual. Failure to observe this could cause bursting, damage, etc.

Output conditions

Insulation method	Non-insulation
Rated load voltage	24VDC
Max. output current	60mA/point
Saturation voltage	1.6V (standard)
Output delay time	40μs

(Note 1) When using an inductive load such as a relay, always connect a diode (voltage resistance 100V or more, 100mA or more) in parallel to the load.

(Note 2) When using a capacitive load such as a lamp, always connect a protective resistor (R=150Ω) serially to the load to suppress rush currents. (Make sure that the current is less than the above tolerable current including the momentary current.)

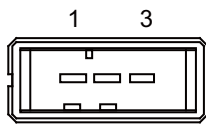
(6) 24VDC input (DCIN)

1	I	+24V
2		0V
3		FG

<Cable side connector type>

Connector: 2-178288-3

Contact: 1-175218-5 x3

Recommended manufacturer: Tyco Electronics

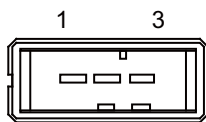
(7) Remote I/O unit I/F (RIO3A)**(8) Remote I/O unit I/F (RIO3B)**

1	I/O	TXRX1
2	I/O	TXRX1*
3		0V

<Cable side connector type>

Connector: 1-178288-3

Contact: 1-175218-2 x3

Recommended manufacturer: Tyco Electronics

2.9 External Power Supply Unit

Item	PD25	PD27
Input power voltage	200V to 230VAC +10%-15% 50/60Hz±1Hz	200V to 480VAC +10%-15% 50/60Hz±3Hz
Output current	3A	8A
Dimension	130mm × 65mm × 230mm	170mm × 65mm × 230mm
Mass	1.5kg	2.5kg
Output holding time	300ms	300ms

(Note 1) PD25/PD27 will not be turned ON by the ON/OFF switch immediately after the power OFF. Wait at least 2 seconds, and then turn the power ON.

(Note 2) The power supply configuration for NC devices depends on the machine. Appropriate circuit protector must be selected by machine builder according to the load of the machine.

(Note 3) PD25/PD27 does not comply with 100VAC.

Dimension and names of parts

[PD25]

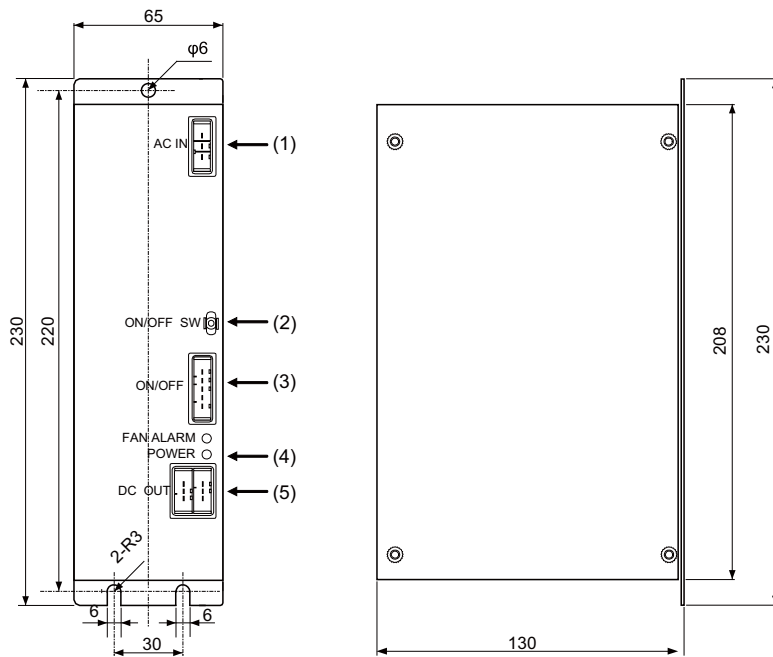

<Mounting direction and clearance>

Mount the external power supply unit vertically and so that it is visible from the front. Provide space for heat dissipation and ventilation.

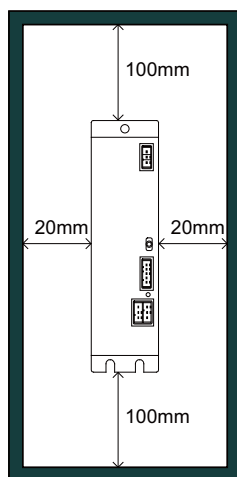

Dimension and names of parts

[PD27]

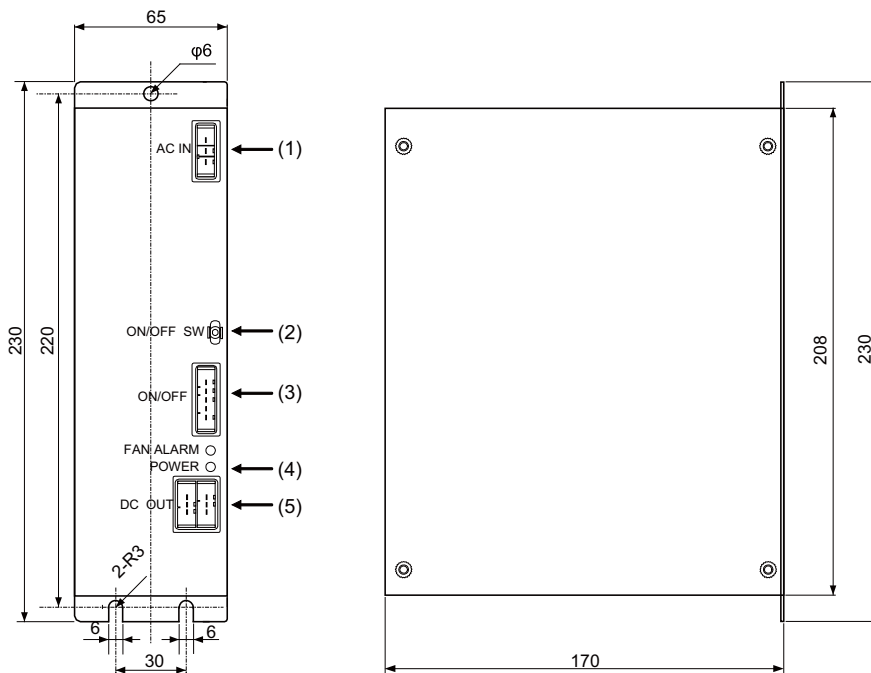

<Mounting direction and clearance>

Mount the external power supply unit vertically and so that it is visible from the front. Provide space for heat dissipation and ventilation.

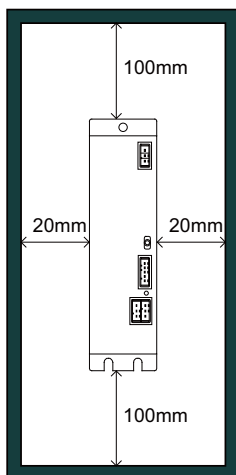

(1) AC power input (ACIN)

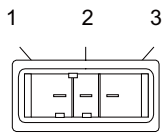

1	I	ACIN N
2	I	ACIN H
3		FG

<Cable side connector type>

Connector: 2-178128-3

Contact: 1-175218-5 × 3

Recommended manufacturer: Tyco Electronics

(2) ON/OFF switch (ON/OFF SW)

Switch ON (upward): 24VDC output
Switch OFF (downward):
24VDC output OFF

(3) ON/OFF input (ON/OFF)

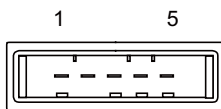

1		NC
2	I	P-OFF
3		0V
4		0V
5	I	P-ON

<Cable side connector type>

Connector: 1-178288-5

Contact: 1-175218-5 × 4

Recommended manufacturer: Tyco Electronics

(4) LED (POWER)

Green light at +24V output

(5) 24VDC output (DCOUT)

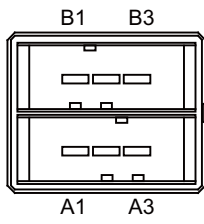

1A	O	ACFAIL	1B	O	+24V
2A		0V	2B		0V
3A		NC	3B		FG

<Cable side connector type>

Connector: 3-178127-6

Contact: 1-175218-5 (for AWG16) × 3, 1-175217-5 (for AWG22) × 2

Recommended manufacturer: Tyco Electronics

2.10 Manual Pulse Generator

[UFO-01-2Z9]

5V Manual Pulse Generator (100 pulse/rev)

<Outline dimension drawing>

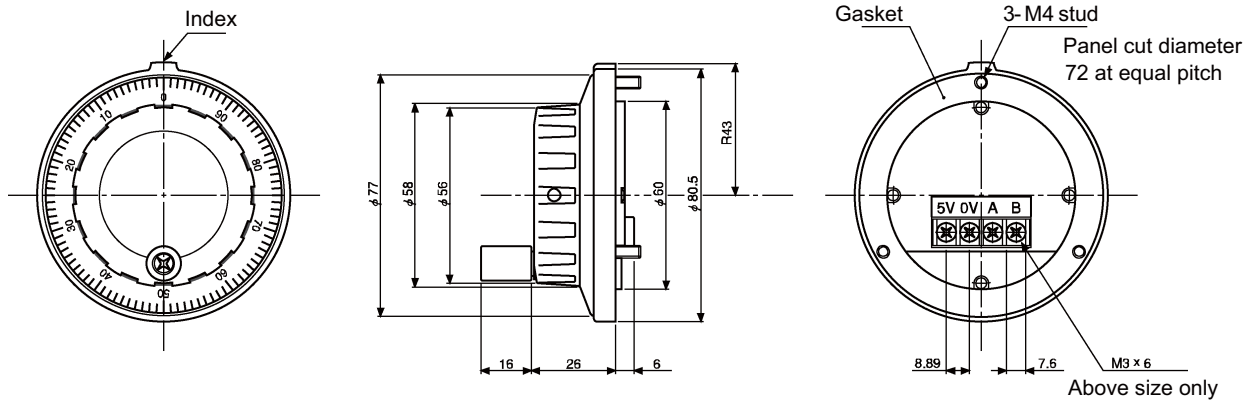

<Panel cut drawing>

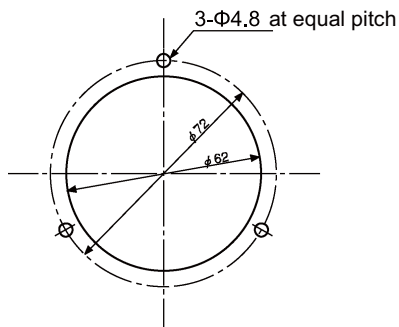

Produced by NIDEC NEMICON CORPORATION

[HD60C]

12V Manual Pulse Generator (25 pulse/rev)

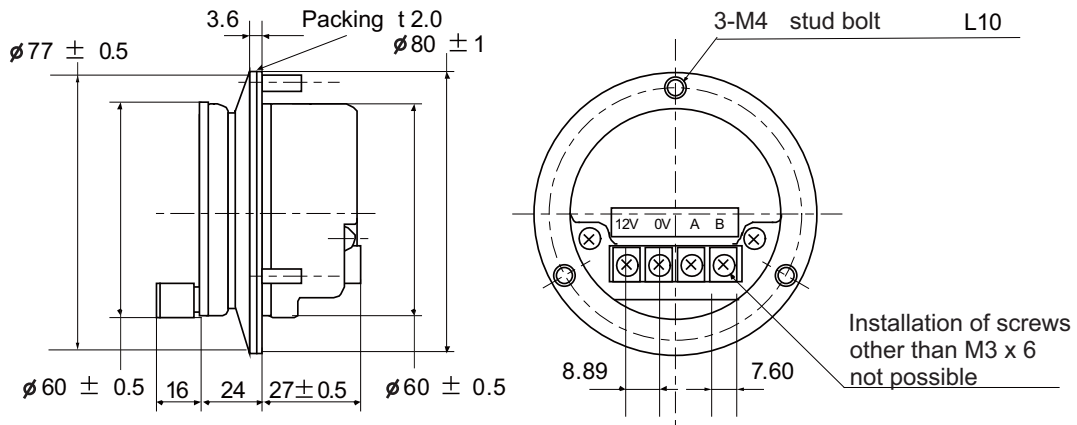

<Panel cut dimension drawing>

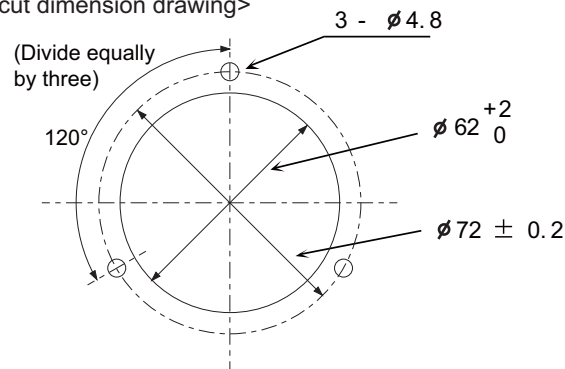

2.11 Synchronous Feed Encoder

Dimension and names of parts

[OSE-1024-3-15-68]

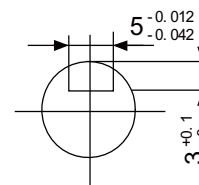
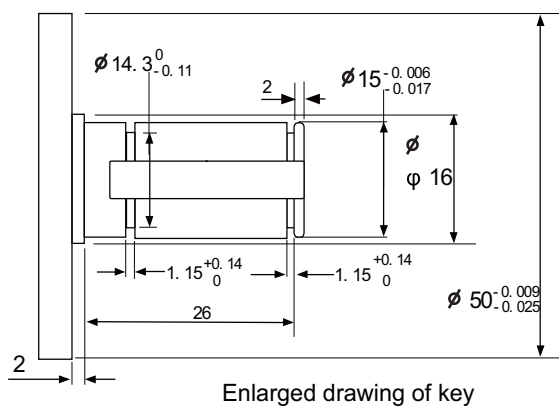
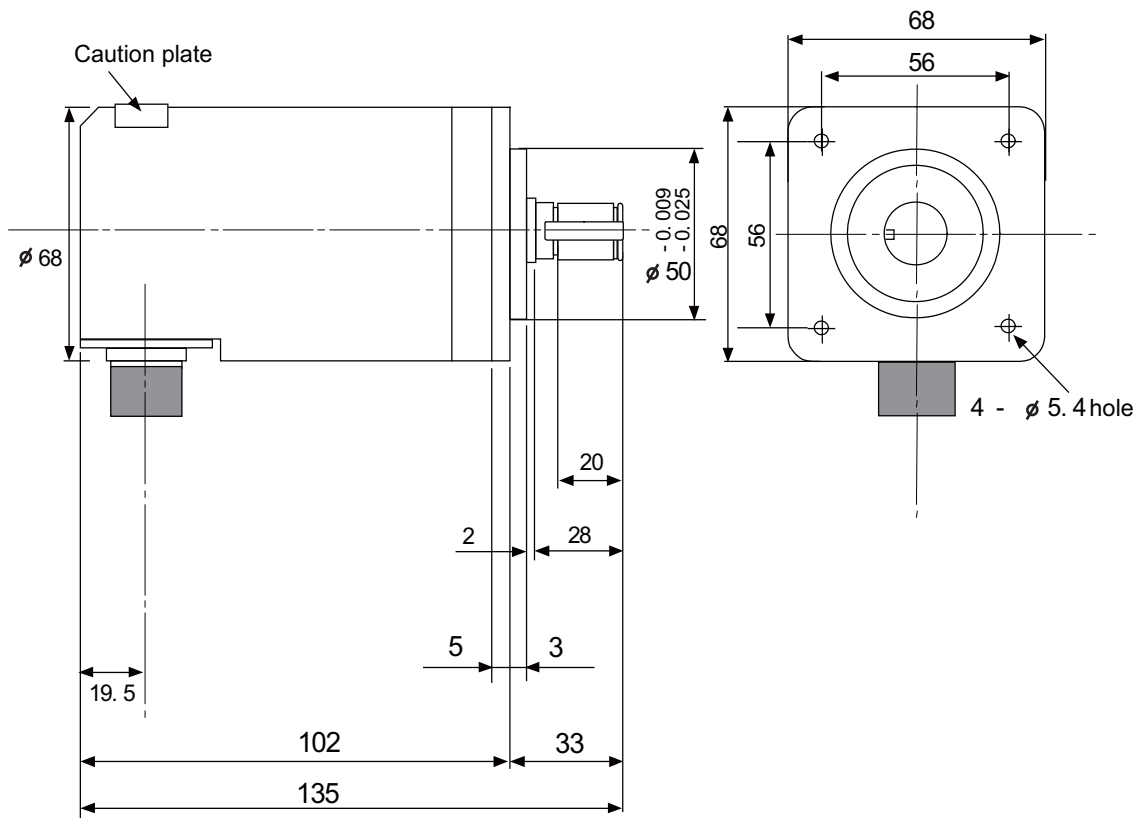

Cross section BB
Valid depth of key groove is 21mm

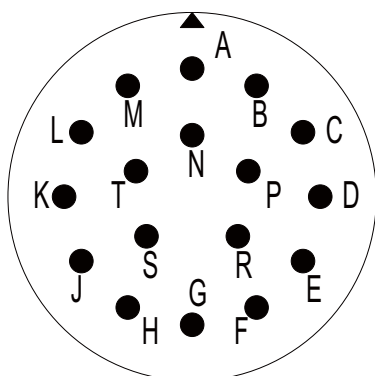

Connector pin assignment

Pin	Function	Pin	Function
A	A phase	K	0V
B	Z phase	L	-
C	B phase	M	-
D	-	N	A phase
E	Case grounding	P	Z phase
F	-	R	B phase
G	-	S	-
H	+5V	T	-
J	-		

2.12 Expansion Unit and Expansion Card

Connecting the I/O device via PROFIBUS-DP or CC-Link requires the corresponding expansion card and the expansion unit FCU7-EX891. Mount the expansion unit on the right side of the control unit, then the expansion card onto the slot of the expansion unit.

2.12.1 Expansion unit

Outline dimension

[FCU7-EX891]

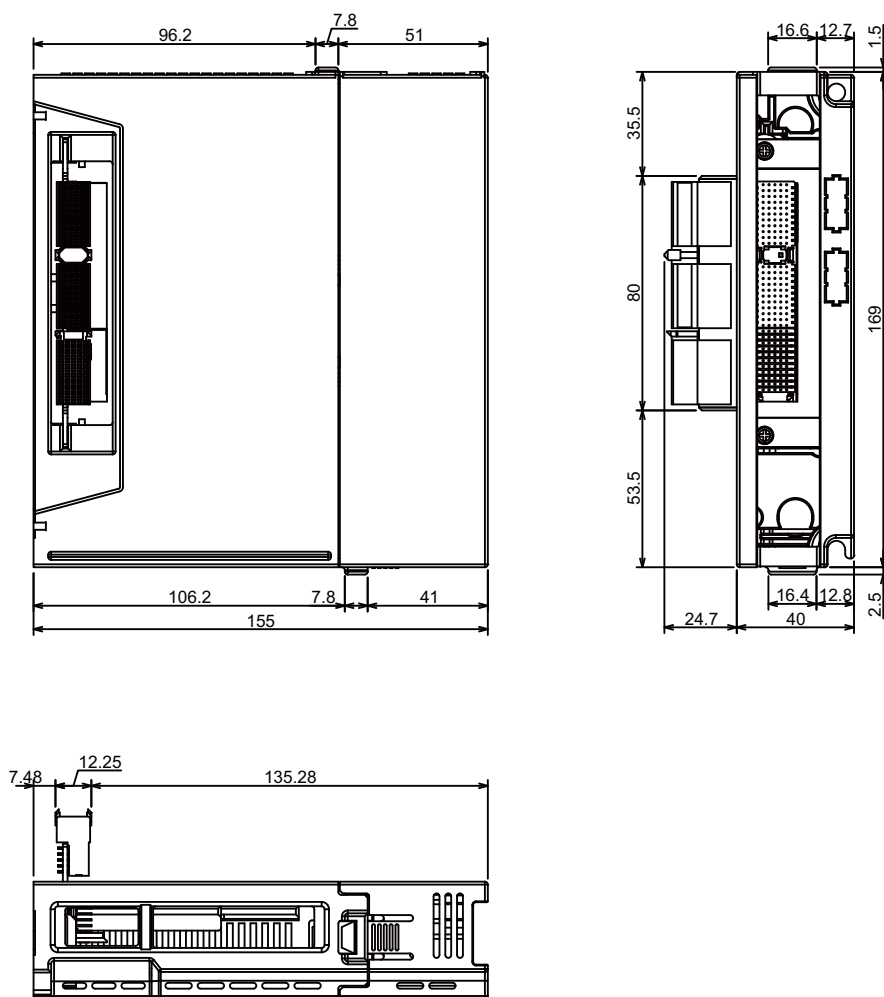

2.12.2 Expansion card (PROFIBUS-DP)

FCU7-HN578/FCU7-HN571 operates as a PROFIBUS-DP master station.

[FCU7-HN578]

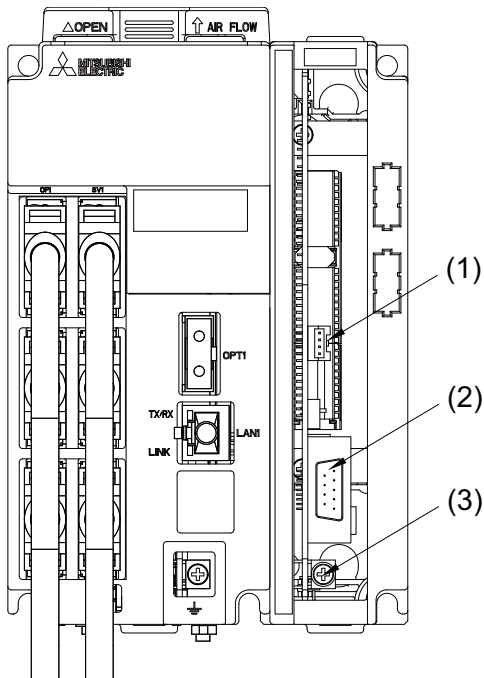

[FCU7-HN571]

(Note) Out of production (replacement: FCU7-HN578)

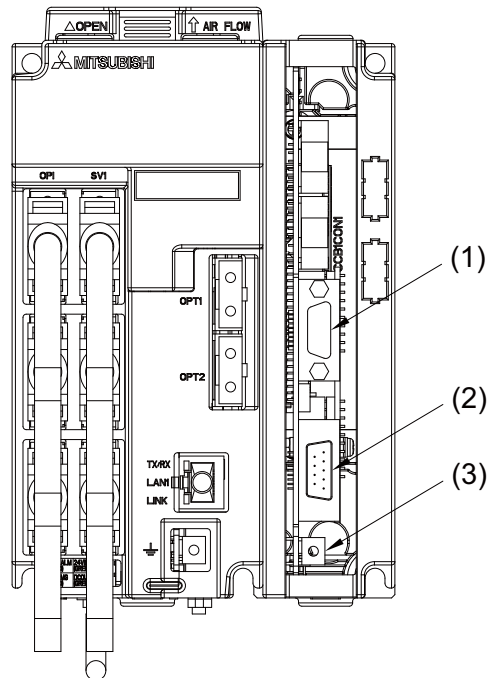

(1) PROFIBUS-DP configuration I/F (CONF)

(2) PROFIBUS-DP communication I/F (NET)

(3) Frame ground (FG)

2.12.3 Expansion card (CC-Link)

FCU7-HN576/FCU7-HN577 operates as a CC-Link (Ver.2) master/local station.

[FCU7-HN576(CC-Link 1ch)]

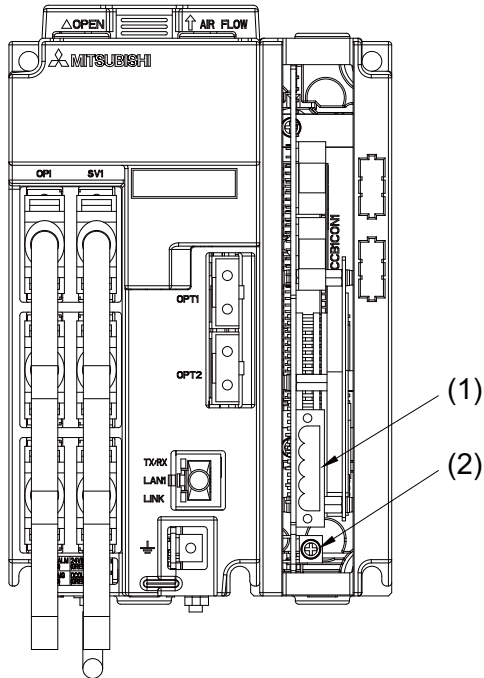

(1) CC-Link communication I/F (CC-LINK)

(2) Frame ground (FG)

[FCU7-HN577(CC-Link 2ch)]

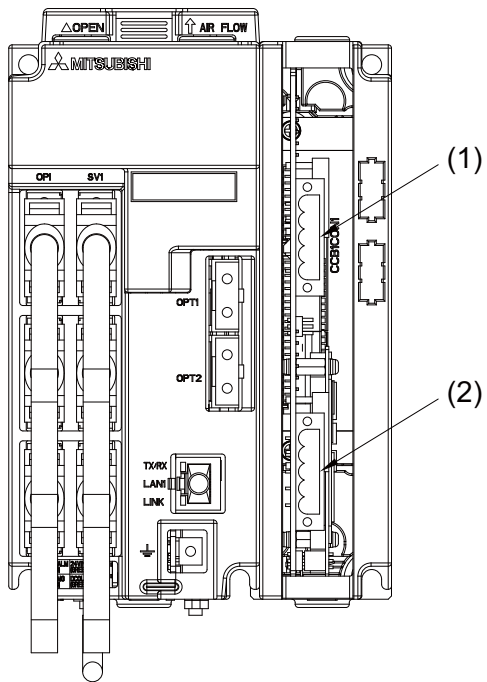

(1) CC-Link communication I/F (CC-LINK1)

(2) CC-Link communication I/F (CC-LINK2)

2.13 Expansion I/O Card

QY231 is a card for machine/ operation board input and output, which is connected to the control unit remote I/O communication (MC link B) or to the operation panel I/O unit remote I/O communication.

Compatible machine control signals	Number of occupied stations
Machine input signal (DI): 64 points (photocoupler insulation) sink/ source shared type Machine output signal (DO): 48 points (non-insulation) source type	2

Outline drawing and names of parts

[QY231]

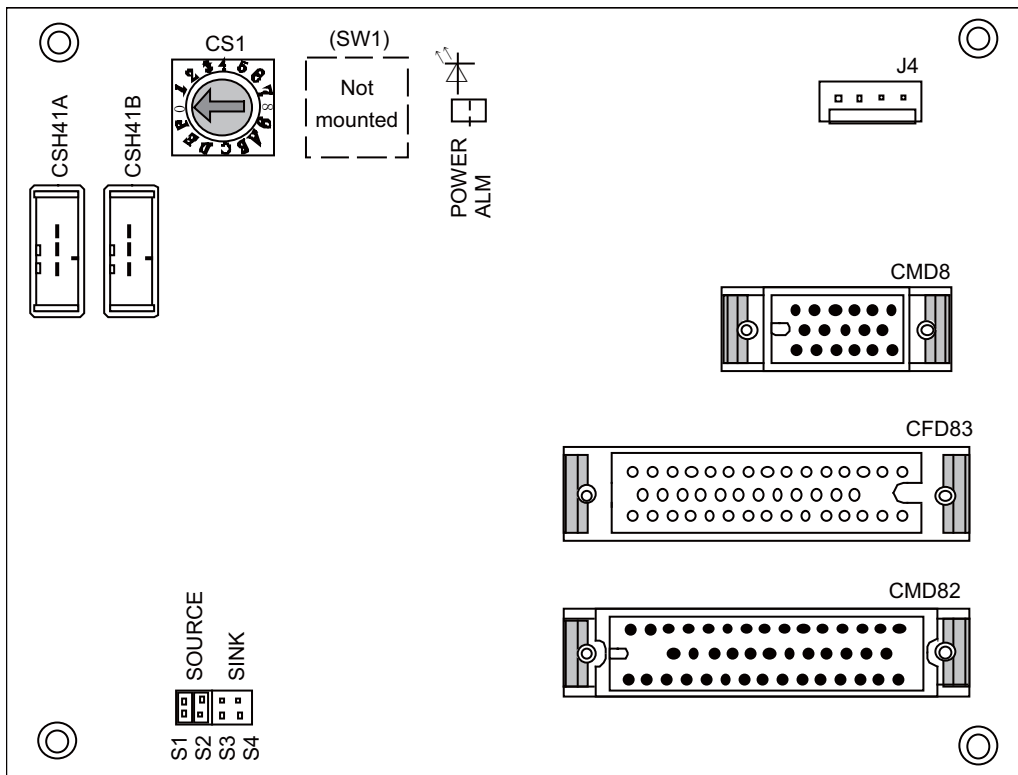

(1) Remote I/O unit I/F (CHS41A)

(2) Remote I/O unit I/F (CHS41B)

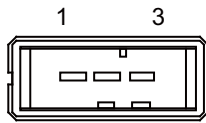

1	I/O	TXRX3
2	I/O	TXRX3*
3		0V(GND)

<Cable side connector type>

Connector: 1-178288-3

Contact: 1-175218-2 x3

Recommended manufacturer: Tyco Electronics

(3) Power input terminal (24VDC) (J4)

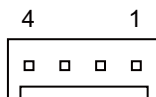

1		0V(RG)
2	I	24VDC
3	I	24VDC
4		0V(RG)

<Cable side connector type>

Connector: 51191-0400

Contact: 50802-8100 x4

Recommended manufacturer: MOLEX

(4) Machine input I/F (CMD81/CMD82)

The followings are a 24V common input circuit corresponding to machine side sink output and a 0V common input circuit corresponding to machine side source output.

24V common

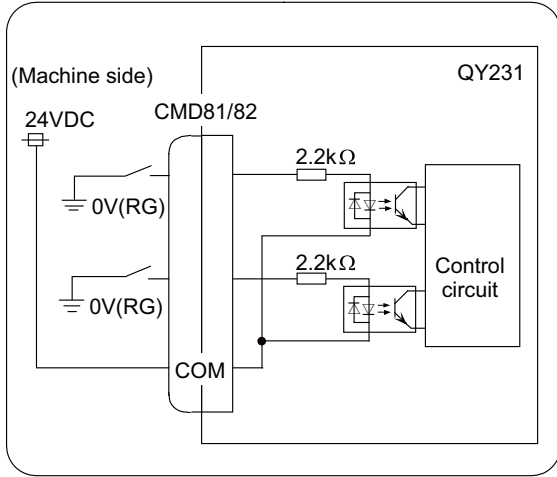

0V common

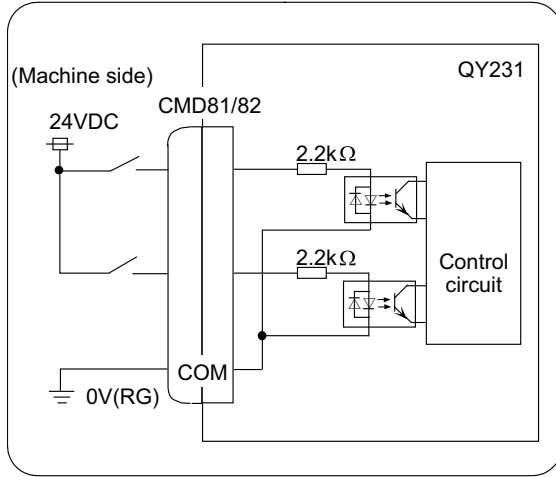

⚠ CAUTION

1. Do not apply any voltage to the connector other than that specified in this manual. Failure to observe this could cause bursting, damage, etc.

Input conditions

The input signals must be used within the following condition ranges.

		24V common	0V common
1	Input voltage at external contact ON	6V or less	18V or more, 25.2V or less
2	Input current at external contact ON	9mA or more	
3	Input voltage at external contact OFF	20V or more, 25.2V or less	4V or less
4	Input current at external contact OFF	2mA or less	
5	Input resistance	Approx. 2.2kΩ	
6	Tolerable chattering time (T1)	3ms	
7	Input signal holding time (T2)	40ms or more (Note)	
8	input circuit operation delay time (T3 and T4)	3 to 16ms	
9	Machine side contact capacity	30V or more, 16mA or more	

(Note) Input signal holding time: The guide is 40ms or more. The input signal will not be recognized unless it is held for the ladder processing cycle time or longer.

[Connection to 24V common input]

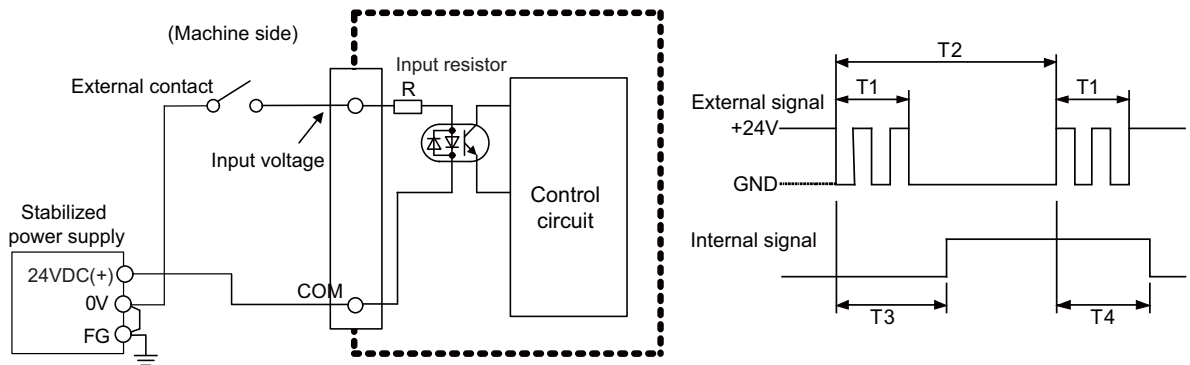

[Connection to 0V common input]

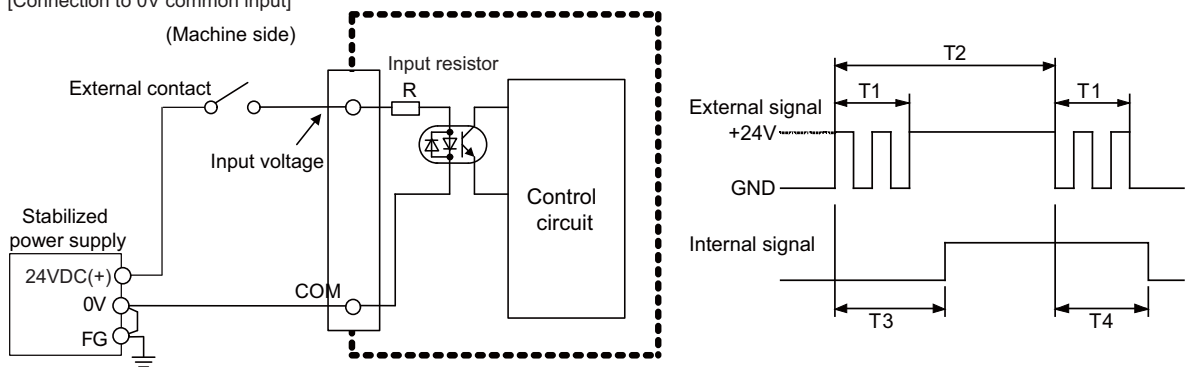

(a) Machine input I/F (CMD81)

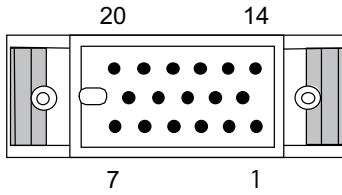

<Cable side connector type>

Connector: MRP20F01

Contact: MRP-F102

Case: MR20W

Recommended manufacturer: HONDA TSUSHIN KOGYO

7	0V(RG)	13		20	24VDC
6		12	X36	19	X37
5	X35	11	X33	18	X34
4	X32	10	X30	17	X31
3	X3F	9	X3D	16	X3E
2	X3C	8	X3A	15	X3B
1	X39			14	X38

(Note) This is an example when CS1 is set to "0". Refer to "PLC Interface Manual" for details.

(b) Machine input I/F (CMD82)

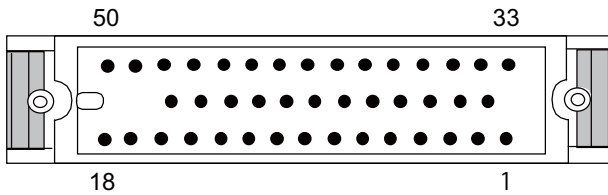

<Cable side connector type>

Connector: MRP50F01

Contact: MRP-F102

Case: MR50W

Recommended manufacturer: HONDA TSUSHIN KOGYO

18	0V(RG)			50	X27
17	X26			49	X25
16	X24	32	X22	48	X23
15	X21	31	X2F	47	X20
14	X2E	30	X2C	46	X2D
13	X2B	29	X29	45	X2A
12	X28	28	X16	44	X17
11	X15	27	X13	43	X14
10	X12	26	X10	42	X11
9	X1F	25	X1B	41	X1E
8	X1D	24	X18	40	X1C
7	X1A	23	X05	39	X19
6	X07	22	X02	38	X06
5	X04	21	X0F	37	X03
4	X01	20	X0C	36	X00
3	X0E	19	X09	35	X0D
2	X0B			34	X0A
1	X08			33	24VDC

(Note) This is an example when CS1 is set to "0". Refer to "PLC Interface Manual" for details.

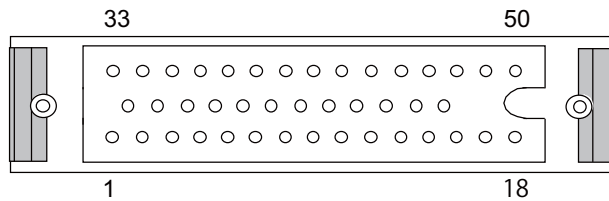
(5) Machine output I/F (CFD83)**<Cable side connector type>**

Connector: MRP50M01

Contact: MRP-M102

Case: MR50W

Recommended manufacturer: HONDA TSUSHIN KOGYO

1	Y08			33	24VDC
2	Y0B			34	Y0A
3	Y0E	19	Y09	35	Y0D
4	Y01	20	Y0C	36	Y00
5	Y04	21	Y0F	37	Y03
6	Y07	22	Y02	38	Y06
7	Y1A	23	Y05	39	Y19
8	Y1D	24	Y18	40	Y1C
9	Y1F	25	Y1B	41	Y1E
10	Y12	26	Y10	42	Y11
11	Y15	27	Y13	43	Y14
12	Y28	28	Y16	44	Y17
13	Y2B	29	Y29	45	Y2A
14	Y2E	30	Y2C	46	Y2D
15	Y21	31	Y2F	47	Y20
16	Y24	32	Y22	48	Y23
17	Y26			49	Y25
18	0V(RG)			50	Y27

(Note) This is an example when CS1 is set to "0". Refer to "PLC Interface Manual" for details.

QY231 employs source type output circuit.

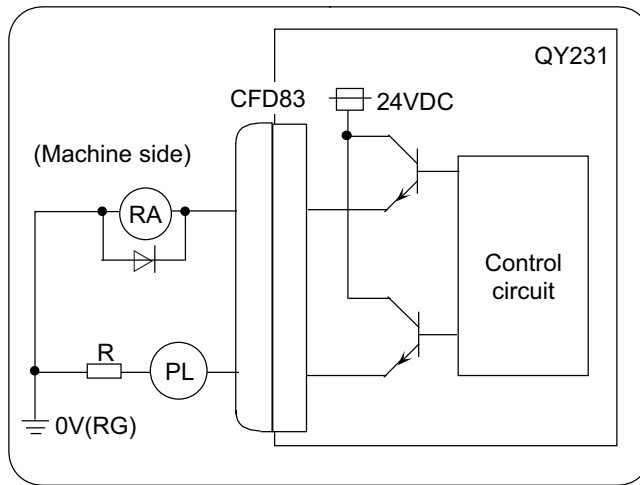

CAUTION

1. Do not apply any voltage to the connector other than that specified in this manual. Failure to observe this could cause bursting, damage, etc.

Output conditions

Insulation method	Non-insulation
Rated load voltage	24VDC
Max. output current	60mA/point
Saturation voltage	1.6V (standard)
Output delay time	40μs

(Note 1) When using an inductive load such as a relay, always connect a diode (voltage resistance 100V or more, 100mA or more) in parallel to the load.

(Note 2) When using a capacitive load such as a lamp, always connect a protective resistor (R=150Ω) serially to the load to suppress rush currents. (Make sure that the current is less than the above tolerable current including the momentary current.)

(7) Rotary switch

Set the address (station No.) assignment in DI/DO: 64/48 point units.

Use the rotary switch CS1 for the setting.

The assignment address is changed with the rotary switch setting.

Setting	Function
0	Remote I/O station 0 and 1 setting
1	Invalid
2	Remote I/O station 2 and 3 setting
3	Invalid
4	Remote I/O station 4 and 5 setting
5	Invalid
6	Remote I/O station 6 and 7 setting
7	Invalid
8 to F	Setting prohibited

(Note) The assignment with X and Y are for reference. When actually making the assignment, add DI/DO assignment No. to the head address assigned to each remote IO unit station No.

(8) Setting switches

Set sink/source type for digital input.

S1 and S2	S3 and S4	Function
ON	OFF	Source input
OFF	ON	Sink input

2.14 Handy Terminal

Item	Unit name		Handy terminal
	Type		HG1T-SB12UH-MK1346-L5
General Specifications	Ambient temperature	During operation	0 to 40 °C
		During storage	-20 to 60 °C
	Ambient humidity		Long term: 10 to 75% RH (with no dew condensation)
			Short term: 10 to 95% RH (with no dew condensation) (Note 1)
	Vibration resistance	During operation	9.8m/s ² [1.0G] or less, 10 to 55Hz
	Shock resistance	During storage	98m/s ² [10.0G] or less
	Working atmosphere		No corrosive gases, dust or oil mist
Power specifications	Power voltage		24VDC±5% Ripple noise 240mV (P-P)
	Current consumption	(max.)	0.2A
	Instantaneous stop tolerance time		24VDC: 4ms or less
Others	Heating value		4W (max.)
	Mass		600g

(Note 1) "Short term" means within one month.

(Note 2) The unit is an IP65F equivalent.

Dimension and names of parts

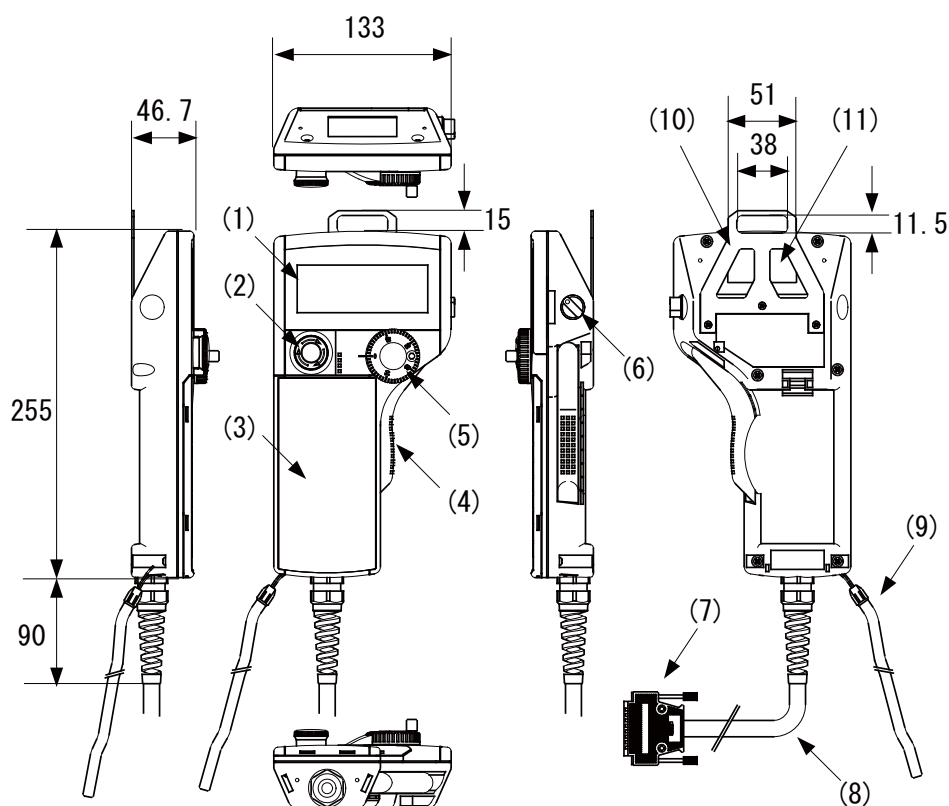

No.	Name	Function/ Specification	No.	Name	Function/ Specification
(1)	LCD	Monochrome display with backlight 192(W) × 64(H) dots	(7)	HOST	Host interface connector (DDK: 17JE-23250-02(D8A6))
(2)	SW1	Emergency stop switch Contact rating/ Contact: 24VDC, 1A Contact configuration: 2b contacts (IDEC Corporation: HA1E-V2S2VR)	(8)	-	Host interface cable (5m)
(3)	-	Membrane switch (Note)	(9)	-	Simplified hand strap (IDEC Corporation: HG9Z-PS1)
(4)	SW2	Enable switch Contact rating/ Contact: 24VDC, 50mA Contact configuration: 3 position contact × 2 (OFF-ON-OFF) (IDEC Corporation: HE3B-M2)	(10)	-	Panel hanging fitting (IDEC Corporation: HG9Z-TK1)
(5)	SW4	Manual pulse generator Output: Open collector 4.7kΩ pull-up resistor is connected. (TOKYO SOKUTEIKIZAI CO., LTD: RE19PH50C16RR)	(11)	-	Serial number plate
(6)	SW6	Selector switch			

(Note) Do not press multiple switches simultaneously: When three or more switches are pressed simultaneously, unpressed switches are also detected as pressed ones.

Signal explanation

HOST terminal No.	HOST connector signal name	Input/ Output	Function/ Name
1	FG	-	Frame ground
2	Reserved	-	Reserved
3	Reserved	-	Reserved
4	Reserved	-	Reserved
5	Reserved	-	Reserved
6	0V	-	Communication signal ground
7	RS(RTS)	O	RS-232C communication signal (Request To Send)
8	CS(CTS)	I	RS-232C communication signal (Clear To Send)
9	SW2_C11	-	Enable switch contact 1 terminal 1
10	SW2_C12	-	Enable switch contact 1 terminal 2
11	SW1_NC11	-	Emergency stop switch contact 1 terminal 1
12	SW1_NC12	-	Emergency stop switch contact 1 terminal 2
13	24VDC(-)	I	24VDC ground
14	SD(TXD)	O	RS-232C communication signal (Send Data)
15	RD(RXD)	I	RS-232C communication signal (Receive Data)
16	HA	O	Manual pulse generator A phase signal
17	HB	O	Manual pulse generator B phase signal
18	SW6_NO1	-	Switchover switch terminal 1
19	SW6_C1	-	Switchover switch terminal 2
20	0V	-	Ground
21	SW2_C21	-	Enable switch contact 2 terminal 1
22	SW2_C22	-	Enable switch contact 2 terminal 2
23	SW1_NC21	-	Emergency stop switch contact 2 terminal 1
24	SW1_NC22	-	Emergency stop switch contact 2 terminal 2
25	24VDC(+)	I	24VDC power supply input

(Note) The input/output goes to/from the handy terminal.

Terminal connections

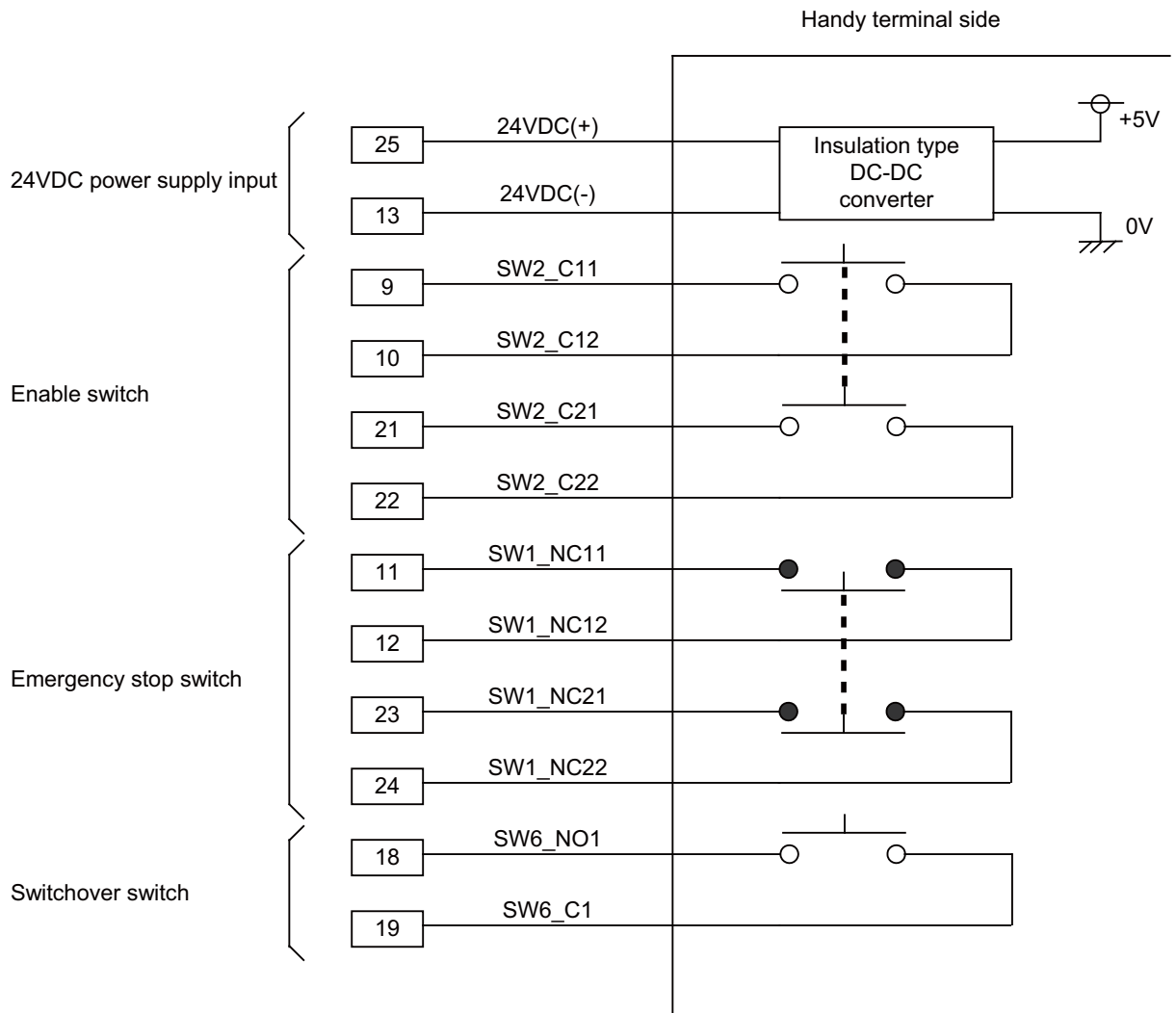

2.15 Optical Communication Repeater Unit (FCU7-EX022)

When the distance of the optical communication cable between NC control unit and drive unit is over 30m, the communication can be performed by relaying the optical signal.

Using up to two units, relay of the total length of up to 90m can be performed.

<Product features>

- (a) When the distance of the optical communication cable between NC control unit and drive unit is over 30m, the communication can be performed by relaying the optical signal.
- (b) The relay between NC control unit and drive unit can be performed for up to two channels.
- (c) If the distance between NC control unit and drive unit is even within 30m, the cable can be divided by the relay in transporting the machine.
- (d) Same mounting dimension as the remote I/O unit (DX unit).

⚠ CAUTION

This unit cannot be used between drive units.

Dimension and Names of parts

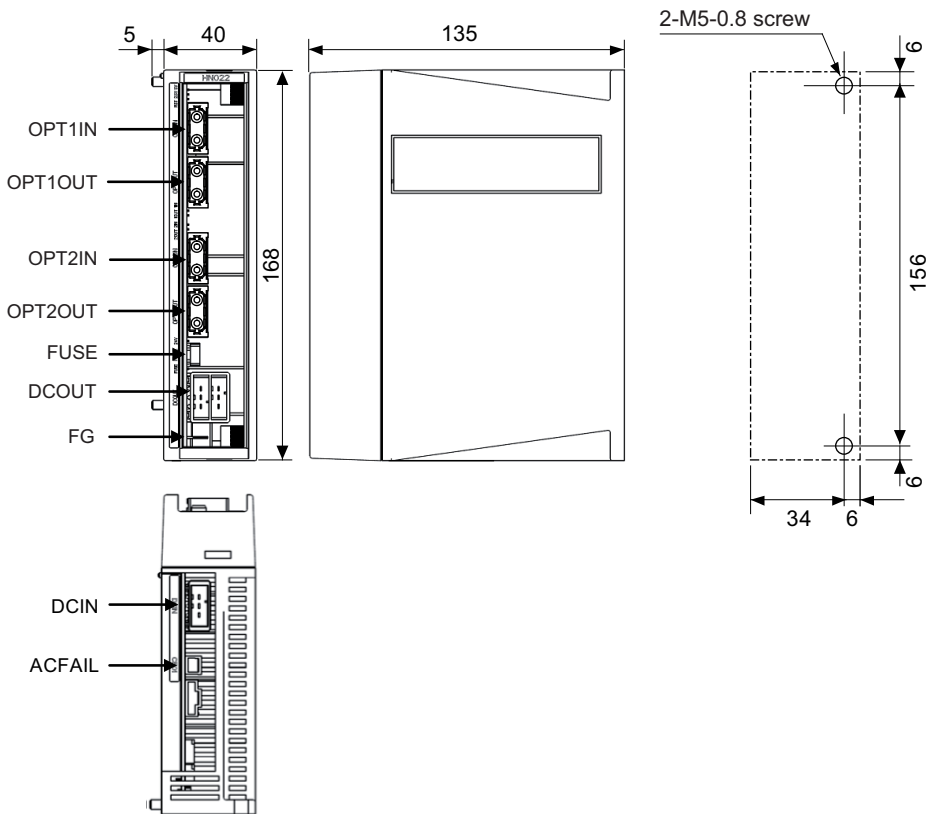

(1) Optical communication I/F (OPT1IN, OPT1OUT, OPT2IN, OPT2OUT)

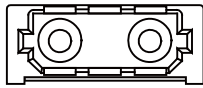

<Cable side connector type>

(PCF type)

Connector : CF-2D101-S

Recommended manufacturer: Japan Aviation Electronics

(POF type)

Connector : PF-2D101

Recommended manufacturer: Japan Aviation Electronics

(2) 24VDC input (DCIN)

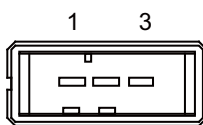

1	I	+24V
2		0V(RG)
3		FG

<PCB side connector type>

Connector: 2-178293-5

Recommended manufacturer: Tyco Electronics

<Cable side connector type>

Connector: 2-178288-3

Contact: 1-175218-5

Recommended manufacturer: Tyco Electronics

(3) 24VDC output (DCOUT)

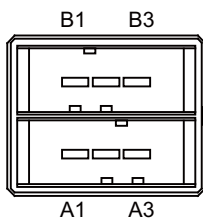

A1	O	ACFAIL	B1	O	+24V
A2		COM	B2		0V(RG)
A3		NC	B3		FG

<PCB side connector type>

Connector : 3-178137-5

Recommended manufacturer: Tyco Electronics

<Cable side connector type>

Connector: 2-178127-6

Contact: 1-175218-5

Recommended manufacturer: Tyco Electronics

(4) Power OFF input (CF01)



1		COM
2	I	ACFAIL

<PCB side connector type>

Connector: 53103-0230

Recommended manufacturer: MOLEX

<Cable side connector type>

connector: 005057-9402

Contact: 0016020103

Recommended manufacturer: MOLEX

(5) FG terminal (FG)

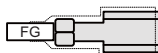

<Cable side faston terminal type name>

Type name : 175022-1(For AWG20-14 250 series)

Recommended manufacturer: Tyco Electronics

Terminal protection tube: 174817-2 (Yellow)

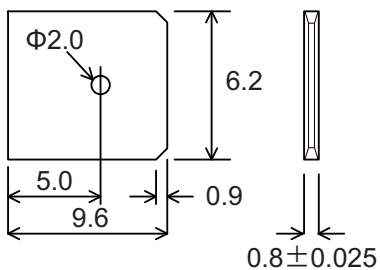

Unit side tab terminal shape

(Note) The faston terminal "175022-1" of the cable side is a simple lock type. Make sure to insert until the simple lock pin is in the Φsecond hole. Firmly press the simple lock release tab when unplugging it.

2.16 MITSUBISHI CNC Machine Operation Panel

2.16.1 MITSUBISHI CNC Machine Operation Panel A

Outline dimension

[FCU7-KB921 (MITSUBISHI CNC machine operation panel A)]

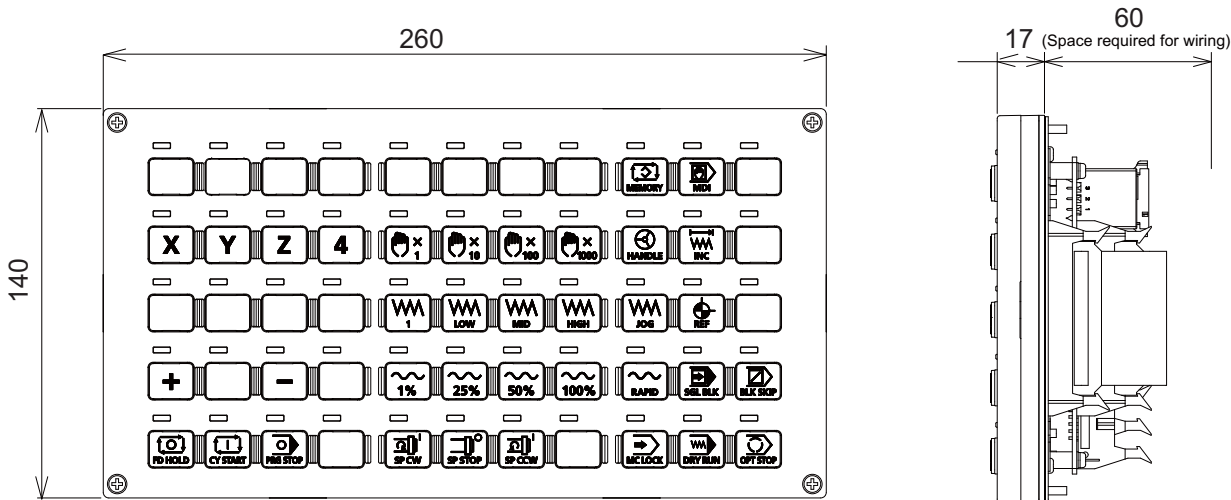

<Panel cut dimension drawing>

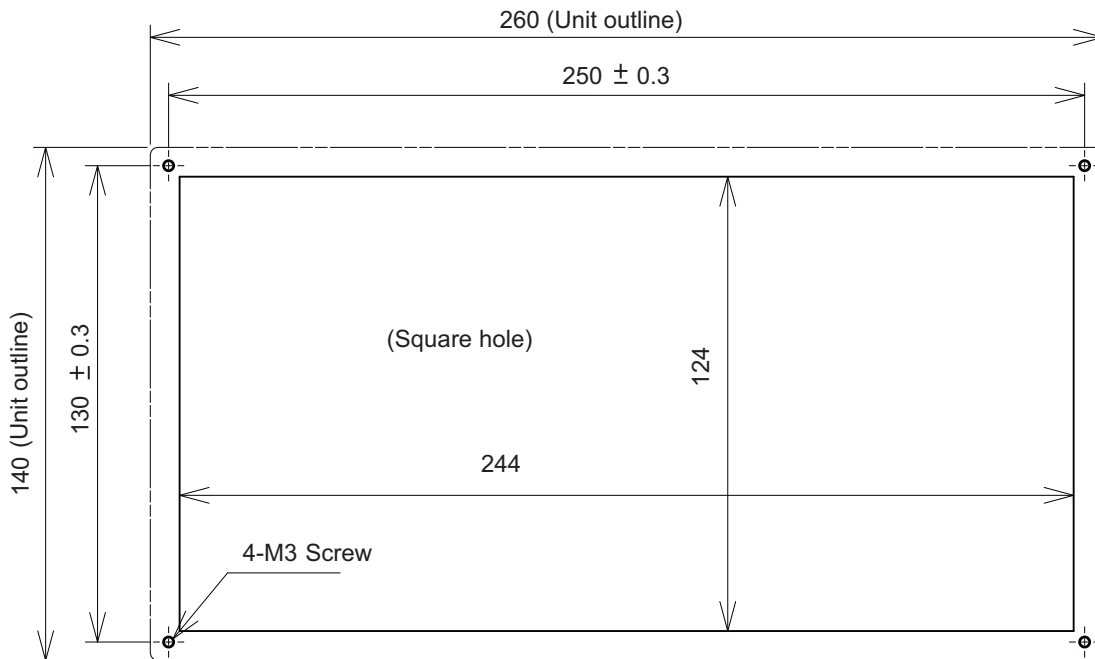

Connector

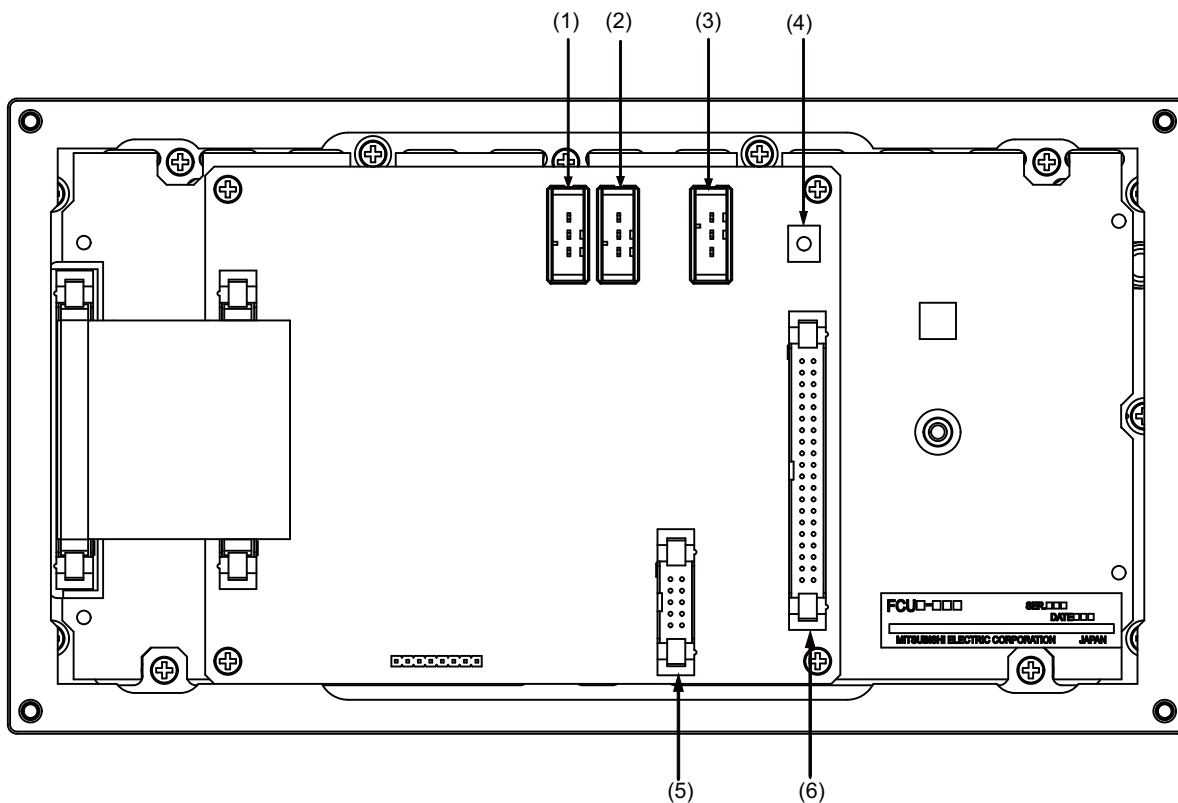

No.	Connector name	Function	No.	Connector name	Function
(1)	DCIN	24VDC input	(4)	FG	FG terminal
(2)	DCOUT	24VDC output	(5)	EXT	Relay wiring
(3)	RIOIN	Remote I/O	(6)	SUBP	Machine operation panel B switch

(1)(2) 24VDC input/output (DCIN/DCOUT)

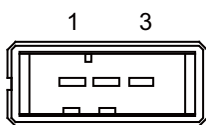

1	I/O	+24V
2	-	0V
3	-	FG

<Cable side connector type>

Connector: 2-178288-3

Contact: 1-175218-5 x3

Recommended manufacturer: Tyco Electronics

(3) Remote I/O connected connector (RIOIN)

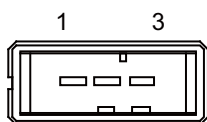

1	I/O	TXRX
2	I/O	TXRX*
3	-	0V

<Cable side connector type>

Connector: 1-178288-3

Contact: 1-175218-2 x3

Recommended manufacturer: Tyco Electronics

(4) FG terminal (FG)

(5) Relay wiring (EXT)

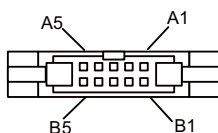

B05	-		A05	-	
B04	O	Relay EMGCOM	A04	O	Relay EMG
B03	O	Relay 6	A03	O	Relay 5
B02	O	Relay 4	A02	O	Relay 3
B01	O	Relay 2	A01	O	Relay 1

<Cable side connector type>

Connector: HIF3BA-10D-2.54C

Contact: HIF3-2428SC

Recommended manufacturer: Hirose Electric

(6) Machine operation panel B switch (SUBP)

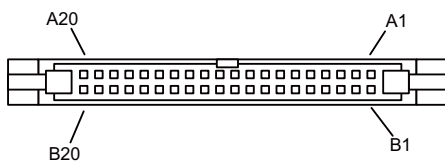

B20	I	Relay EMGCOM	A20	I	Relay EMG
B19	I	Relay 6	A19	I	Relay 5
B18	I	Relay 4	A18	I	Relay 3
B17	I	Relay 2	A17	I	Relay 1
B16	-	0V	A16	I	Spare SW(X75)
B15	-	0V	A15	I	Spare SW(X74)
B14	-	0V	A14	I	Spare SW(X73)
B13	-	0V	A13	I	Selector SW(X72)
B12	-		A12	I	G(X71)
B11	I	F(X6D)	A11	I	E(X6F)
B10	I	D(0V)	A10	I	C(X70)
B09	I	B(X6E)	A09	I	A(X6C)
B08	-		A08	I	G(X6B)
B07	I	F(X67)	A07	I	E(X66)
B06	I	D(0V)	A06	I	C(X6A)
B05	I	B(X68)	A05	I	A(X66)
B04	-		A04	I	G(X65)
B03	I	F(X61)	A03	I	E(X63)
B02	I	D(0V)	A02	I	C(X64)
B01	I	B(X62)	A01	I	A(X60)

<Cable side connector type>

Connector: HIF3BA-40D-2.54C

Contact: HIF3-2428SC

Recommended manufacturer: Hirose Electric

(a) **Wiring of machine operation panel B**
 <Wiring of rotary switch (SUBP)>

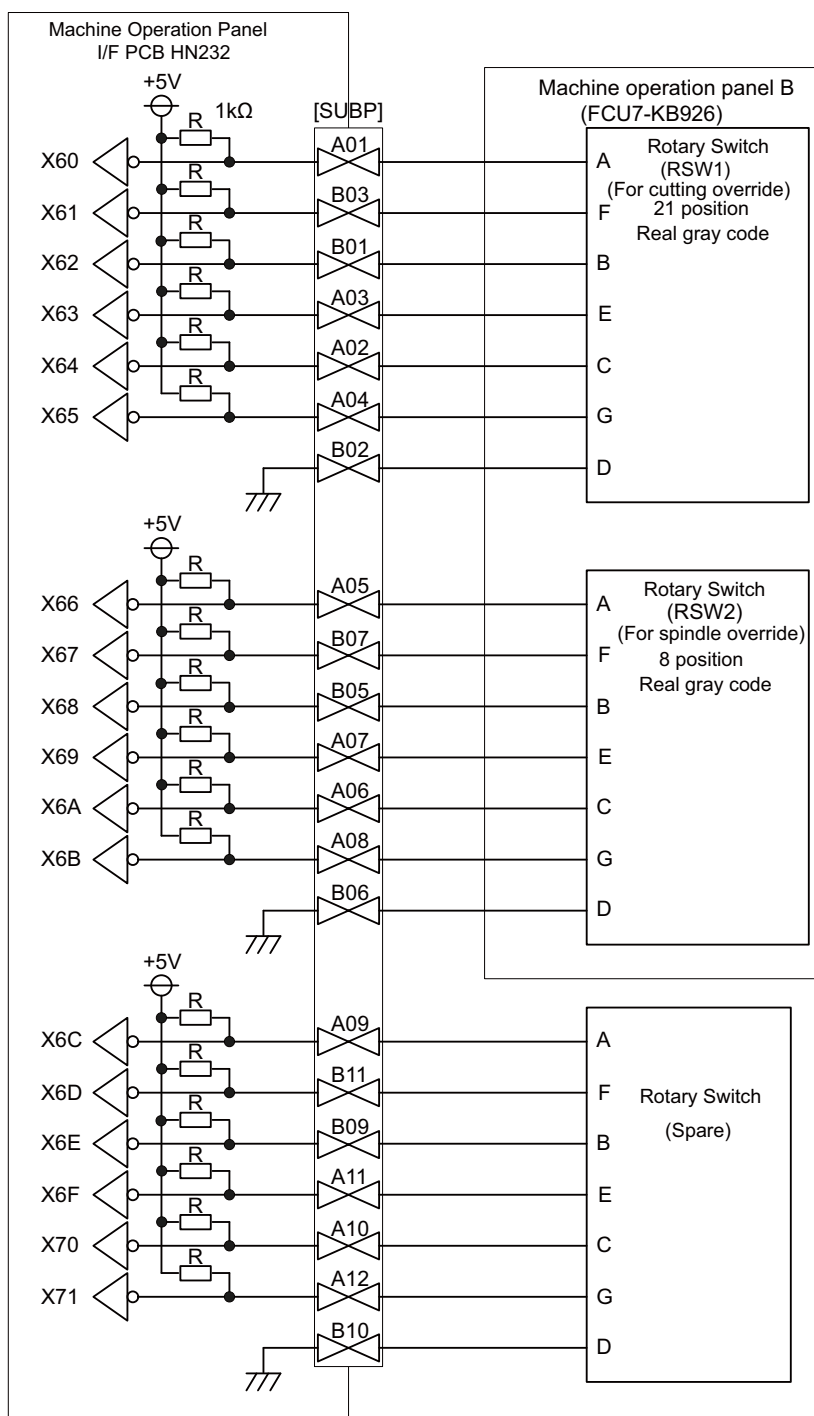

- (Note1) Use the special lead wire with a connector for wiring of rotary switch.
 Lead wire with a connector: ACX011-705 (7 terminals, 0.5m) Fuji Electric
- (Note2) A09 to 12 and B09 to 11 of SUBP are spares, so they do not need wiring.
- (Note3) Select a rotary switch which guarantees 5V/1mA.
- (Note4) Length of cables must be 0.5m or shorter.
- (Note5) The numbers in the above diagram do not indicate the actual device numbers.

<Wiring of other switches (SUBP)>

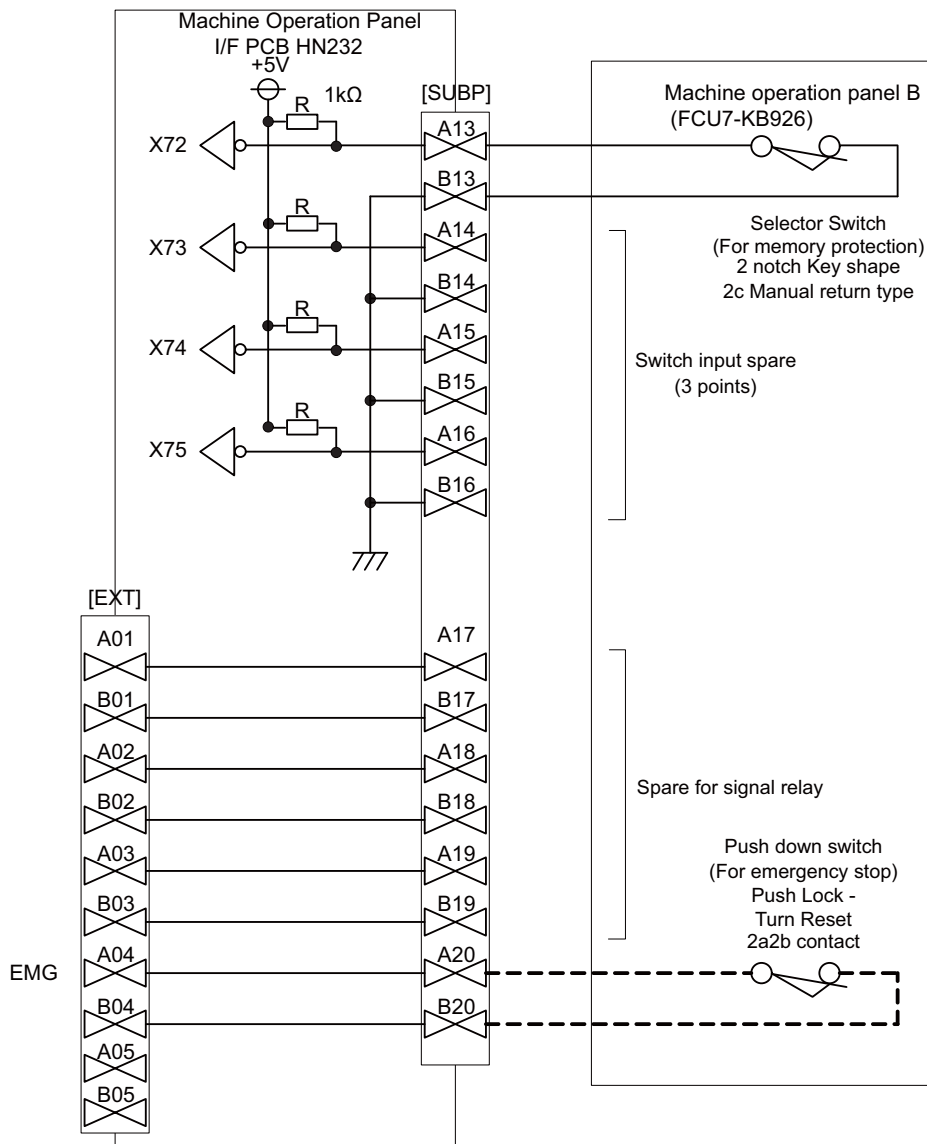

- (Note1) Wirings for selector switches must be directly soldered to terminals or use tab terminals (110 series).
- (Note2) When wiring the emergency stop switch, the crimp terminal must be fastened with thread.
- (Note3) For NCs whose control unit and display unit are integrated, wire the emergency stop switch directly to the EMG connector of the control unit. (Use F120 cable)
And for NCs whose control unit and display are separated, relay it by the machine operation panel I/F PCB HN232.
- (Note4) Select a rotary switch which guarantees 5V/1mA.
- (Note5) Length of cables must be 0.5m or shorter.
- (Note6) The numbers in the above diagram do not indicate the actual device numbers.

<Connection when the selector SW has 3 notches>

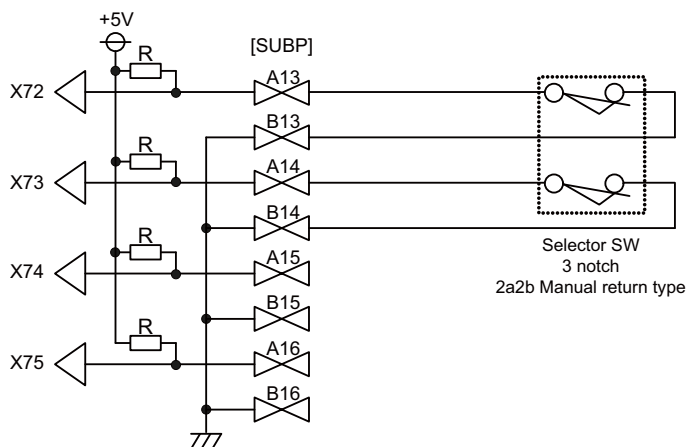

<Connection when relaying wiring to control panel>

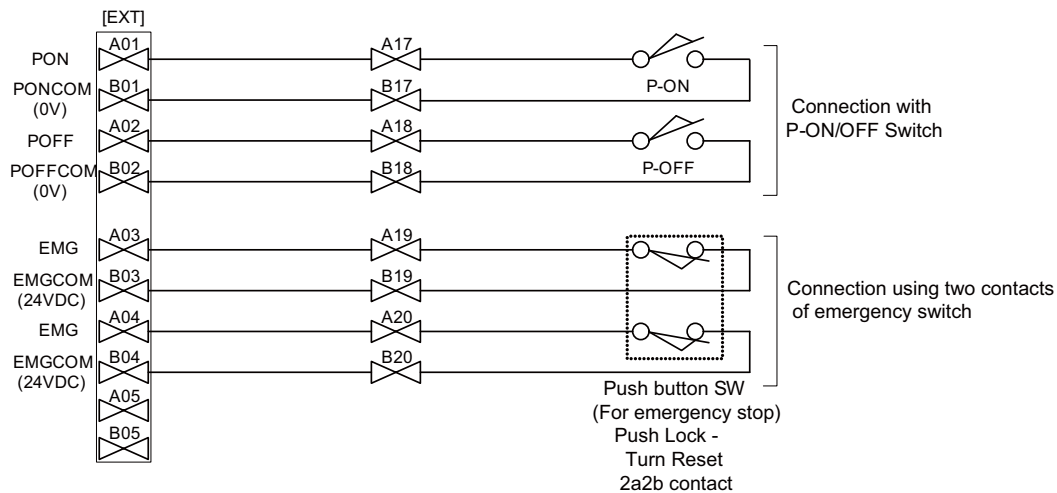

2.16.2 MITSUBISHI CNC Machine Operation Panel B

Outline dimension

[FCU7-KB926 (MITSUBISHI CNC machine operation panel B)]

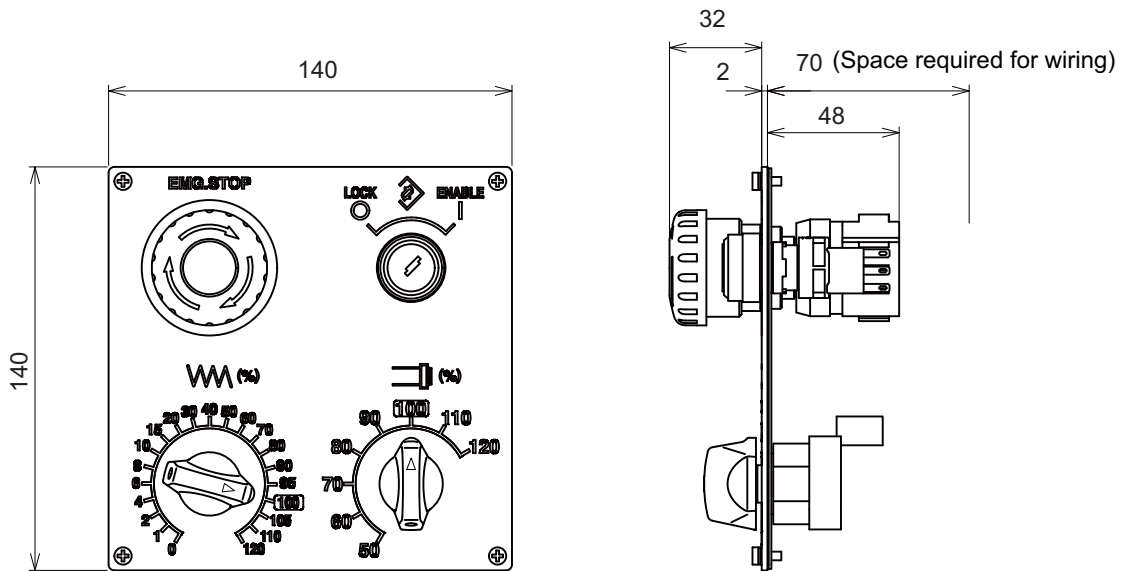

<Panel cut drawing>

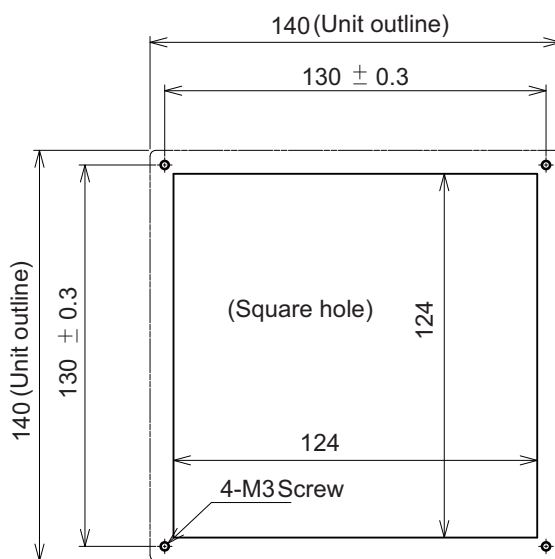

Connector

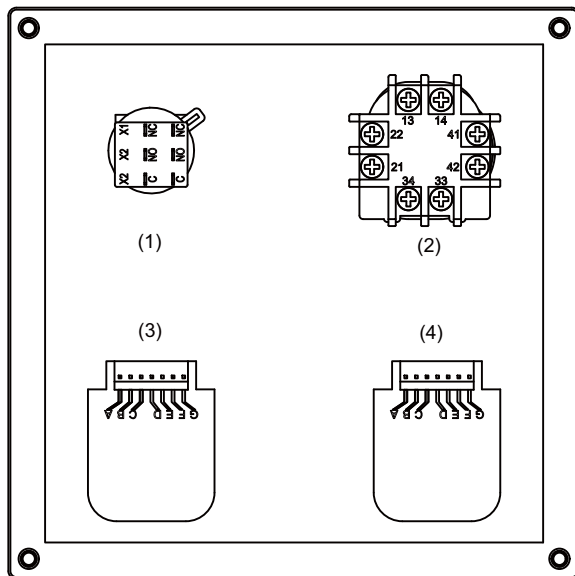

No.	Switch	No.	Switch
(1)	Memory protection switch	(3)	Spindle override (RSW2)
(2)	Emergency stop button	(4)	Cutting override (RSW1)

(1) Memory protection switch

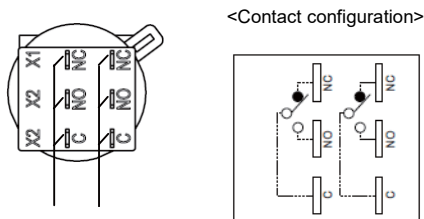

Contact 2 Contact 1

C	-	Contact 1(Common)
NO	O	Contact 1(A contact)
NC	O	Contact 1(B contact)
C	-	Contact 2(Common)
NO	O	Contact 2(A contact)
NC	O	Contact 2(B contact)

<Switch type>

Switch: HA1K-2C2B

Recommended manufacturer: IDEC

Connection: Terminal (#110 type)

(2) Emergency stop button

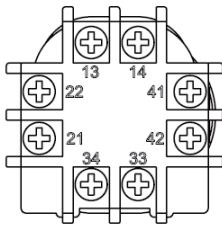

13	O	Contact 1(A contact)
14	O	Contact 1(A contact)
21	O	Contact 2(B contact)
22	O	Contact 2(B contact)
33	O	Contact 3(A contact)
34	O	Contact 3(A contact)
41	O	Contact 4(B contact)
42	O	Contact 4(B contact)

<Switch type>

Switch: XA1E-BV422MR

Recommended manufacturer: IDEC

Connection: Thread terminal (M3)

(3) Spindle override (RSW2)

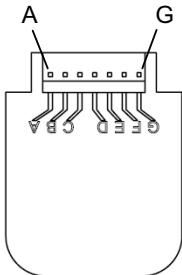

A	O	Output signal 1
B	O	Output signal 3
C	O	Output signal 5
D	-	Common terminal
E	O	Output signal 4
F	O	Output signal 2
G	-	-

<Switch type>

Switch: AC09-GX0/7L3B02

Recommended manufacturer: Fuji Electric

Connection: Connector

<Switch side connector type>

Connector: IL-7P-S3EN2

Recommended manufacturer: Japan Aviation Electronics

<Cable side connector type>

Connector: IL-7S-S3L-(N)

Contact: L-C2-10000

Recommended manufacturer: Japan Aviation Electronics

(4) Cutting override (RSW1)

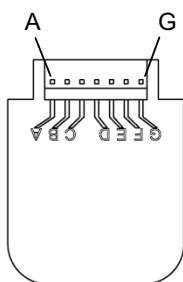

A	O	Output signal 1
B	O	Output signal 3
C	O	Output signal 5
D	-	Common terminal
E	O	Output signal 4
F	O	Output signal 2
G	O	Output signal 6

<Switch type>

Switch: AC09-GY0/20L3B02

Recommended manufacturer: Fuji Electric

Connection: Connector

<Switch side connector type>

Connector: IL-7P-S3EN2

Recommended manufacturer: Japan Aviation Electronics

<Cable side connector type>

Connector: IL-7S-S3L-(N)

Contact: IL-C2-10000

Recommended manufacturer: Japan Aviation Electronics

2.17 Exclusive CF Cards for MITSUBISHI CNC

Item	FCU7-CF256M	FCU7-CF002G
Capacity	256MB	2GB
Operation-guaranteed temperature	-40 °C to +85 °C	
NAND Flash	SLC (Note)	

(Note) SLC stands for Single Level Cell, and it stores one bit data in each memory cell. This provides longer life span and high product reliability in comparison with MLC (Multi Level Cell), which is commonly applied to CF cards.

2.17.1 Precautions for Use of Commercially Available CF Cards

Mitsubishi is unable to guarantee the machine operation when a commercially available CF card or SD memory card (SD-CF adapter is required) is used. In that case, performance check must be made carefully by machine tool builder.

- (1) Commercially available CF cards may not be compatible with MITSUBISHI units or suitable FA environment for temperature- or noise-wise. In case of using it, careful performance check must be required by the machine tool builder.
- (2) When inserting/removing a commercially available CF card, turn the MITSUBISHI device's power OFF to avoid any troubles. If a card must be inserted and removed while the power is ON, make sure to take sufficient time (approx. ten seconds or more) between the insertion and removal.
- (3) Do not pull out the card or turn OFF the power during access to the CF card. Failure to observe this could cause the memory contents to be erased. In case of emergency, always perform backups by having your important data duplicated, etc. as MITSUBISHI will not guarantee the broken or lost data.

2.18 Precautions for Use of USB devices

(1) USB keyboard/ mouse

- (a) MITSUBISHI will not provide performance guarantee and maintenance for commercially available USB keyboards and mice. Commercially available devices may not be compatible with MITSUBISHI units or suitable FA environment for temperature- or noise-wise. In case of using one of them, careful performance check must be required by the machine tool builder.
- (b) Commercially available USB keyboards/ mice are only available when developing applications or during maintenance. They are not designed to be integrated into the unit.
- (c) Commercially available USB keyboards/ mice are susceptible to noise, etc. and may cause a malfunction in the unit that may lead to an accident. Do not use them while the machine is operated.
- (d) The performance of USB devices under plug-and-play is not guaranteed. When inserting/removing USB devices, always turn the MITSUBISHI device's power OFF.
- (e) USB1 on the back of the display unit is used for mounting the MITSUBISHI keyboard unit.

(2) Other USB devices

- (a) MITSUBISHI will not provide performance guarantee and maintenance for commercially available USB printer, USB floppy disk, USB memory, USB hub, USB-CDROM, USB-DVDRAM, and other USB devices. Commercially available devices may not be compatible with MITSUBISHI units or suitable FA environment for temperature- or noise-wise. In the case of using one of them, careful performance check must be required by the machine tool builder, and necessary noise countermeasures, such as executing EMI countermeasures or adding the ferrite cores, must be taken. (Refer to "EMC Installation Guidelines: EMC Countermeasure Parts: Ferrite Core" for recommended ferrite core.)
- (b) Other restrictions are the same as for USB keyboard.

(3) Other precautions on USB

The maximum USB bus power (5VDC) that can be supplied from USB1 or USB2 connector on the back of the display unit is 500mA each. Also, the maximum USB bus power (5VDC) that can be supplied from the front IC card USB connector is 100mA. When connecting a commercially available USB device that requires power exceeding the maximum current, select the one of which power can be supplied from an outside source. However, MITSUBISHI will not provide performance guarantee and maintenance for commercially available USB devices. Commercially available devices may not be compatible with MITSUBISHI units or suitable FA environment for temperature- or noise-wise. In case of using one of them, careful performance check must be required by the machine tool builder.

3

Installation

3.1 Heat Radiation Countermeasures

Please refer to the following method for heat radiation countermeasures.

Example of heat radiation countermeasures

<Hypothetical conditions>

- (1) Average internal temperature of operation panel: $T \leq 55^{\circ}\text{C}$
- (2) Peripheral temperature of operation panel : $T_a \leq 0^{\circ}\text{C}$ to 45°C
- (3) Internal temperature rise value : $\Delta T = T - T_a$ (max) = 10°C

Procedures for heat design and verification

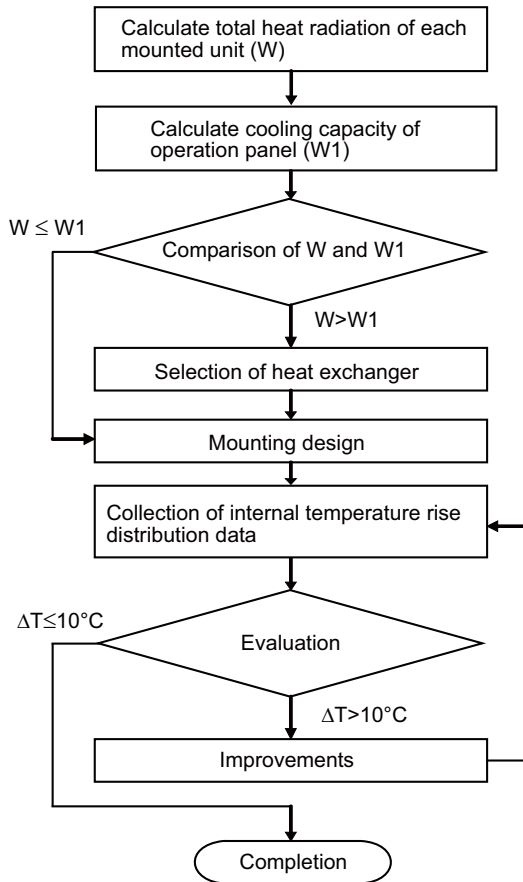

<Supplement>

- (1) Refer to "General Specification" for the heat generated by each unit.
- (2) Enclosed cabinet (thin steel plate) cooling capacity calculation equation

$$W1 = U \times A \times \Delta T$$
 U: $6 \text{ W/m}^2\text{°C}$
 A: Effective heat radiation area (m^2) (Area where heat can be radiated from operation panel)
 ΔT: Internal temperature rise value (10°C)
 (Caution) $8 \text{ W/m}^2\text{°C}$ can be applied only when the operation panel is so small that the internal temperature stays uniform.
- (3) Points of caution for heat radiation countermeasures when designing mounting state
 - Consider convection in operation panel (eliminate heat spots)
 - Collect hot air at suction port of heat exchanger in operation panel.
- (4) Criterion for internal temperature rise distribution data
 - ΔT (average value) $\leq 10^{\circ}\text{C}$
 - ΔTmax (maximum value) $\leq 15^{\circ}\text{C}$
 - R (inconsistency $\Delta T_{\text{max}} - \Delta T_{\text{min}}$) $\leq 6^{\circ}\text{C}$
 - (Evaluate existence of heat spots)

The following shows an example of calculation applied to heat radiation countermeasures for the operation panel when 10.4-type display unit is used. Because heat will accumulate in the upper portions of the unit, install an agitating fan as required.

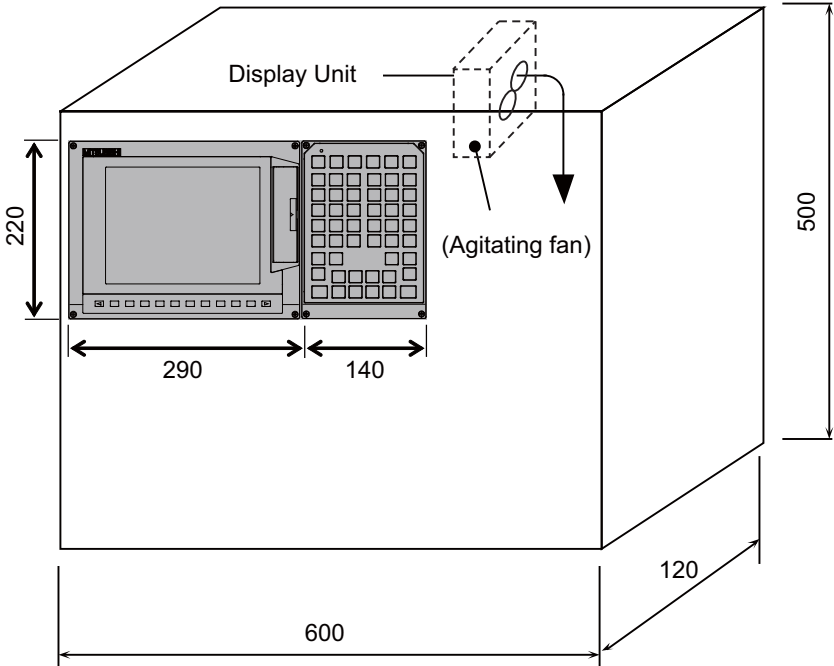

Calculation example of panel internal heating value

(1) Calculation of unit heating value

Heating value (W)

Total heating value of units (W) :

27W (= display unit + operation panel I/O unit)

Total heating value (W) by machine input (D1) :

5.6W (= 24V (total heating value when the 32 points are simultaneously turned ON) × 7.3mA × 32)

... 24V (current consumption per point of the operation panel I/O unit DI) divided by 3.3kΩ ≈ 7.3mA

Total heating value W = 32.6W (27 + 5.6)

(2) Calculation of operation panel cooling capacity

Tolerance value for temperature rise (Δt)

- Panel internal temperature (according to each unit's specification) T ≤ 55C°

- Panel peripheral temperature (according to machine's specification) Ta ≤ 45C°

Tolerance value for internal temperature rise ΔT = 10C° (T - Ta)

Heat radiation area (A)

The surface of the molded unit, which has lower radiation capacity than the metal plate surface, should be excluded for the heat radiation area in principle.

The bottom of the operation panel, which has difficulty in radiating due to the temperature distribution, should also be excluded for the heat radiation area in principle.

Heat radiation area A = 0.71 mm²(≈ 0.6 × 0.12 + 0.6 × 0.5 × 2 - (0.26 + 0.14) × 0.2 + 0.12 × 0.5 × 2)

(Top surface) (Front, rear surface) (Unit surface) (Both sides surface)

Operation panel cooling capacity (W1)

Calculate the cooling capacity to keep the temperature rise in the operation panel less than 10C°.

Cooling capacity W1 = 42.6W (6 × A × ΔT)

(3) Comparison of heating value and operation panel cooling capacity

The operation panel cooling capacity is over the heating value, which presumed no need to install the heat exchanger.

(4) Confirmation with the actual machine

The result of the calculation above is only a rough indication. The actual temperature rise may differ according to the structure of the operation panel.

Be sure to confirm the temperature rise value in the operation panel when the machine is running.

3.2 Noise Countermeasures

3.2.1 Connection of FG (Frame Ground)

The frame should basically be grounded at one ground point.

Connect the control unit's 0V (RG) to the FG on the +24V stabilized power supply.

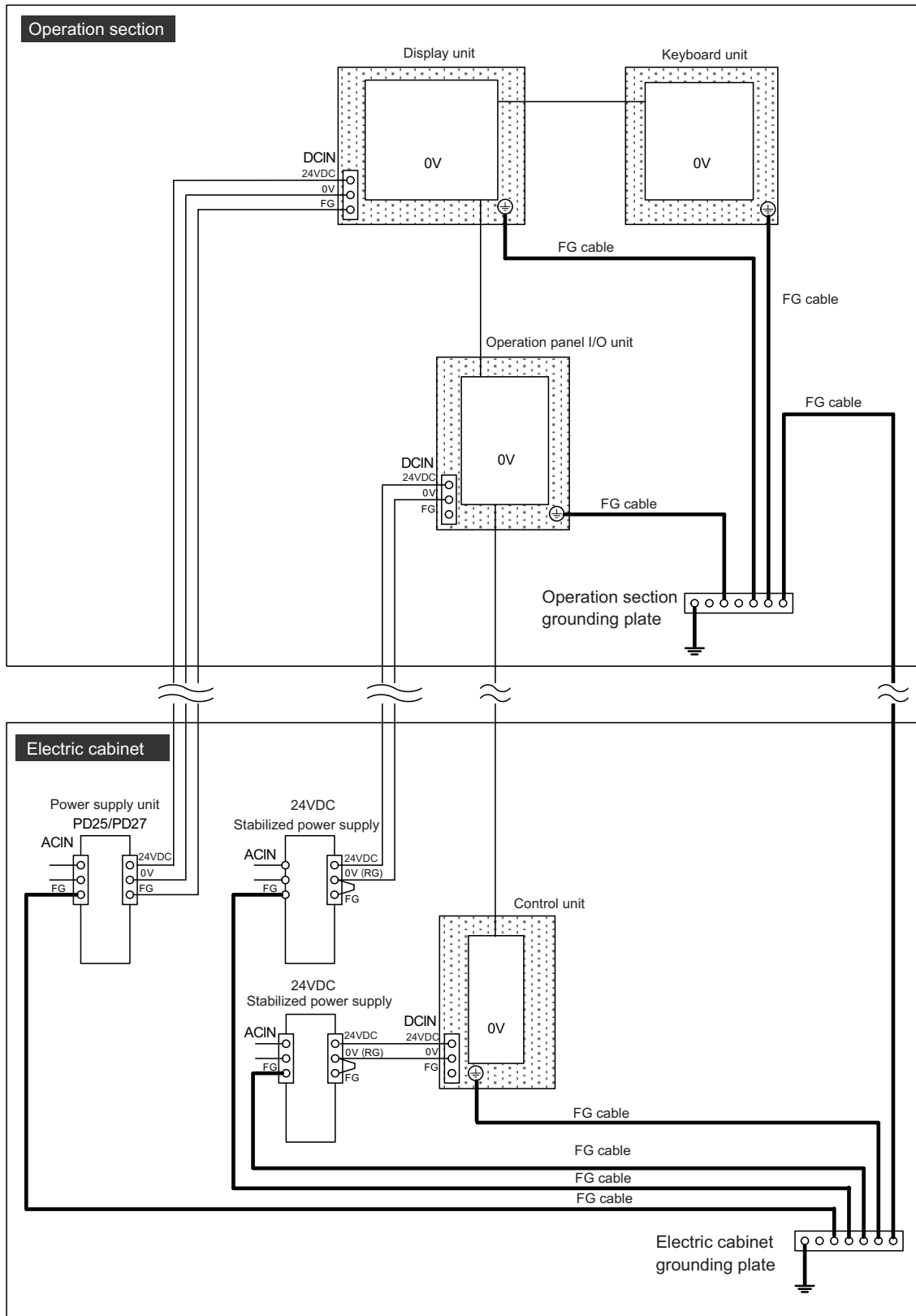

(Note) "24VDC" represents (+) side of 24V stabilized power supply, while "0V(RG)" represents (-) side. "FG" (Frame Ground) corresponds to the general expression "PE" (Protective Earth).

3.2.2 Shield Clamping of Cables

The shield cables connected to the units must be properly connected to the ground with clamp fittings and the like in order to stabilize the system's operation while preventing malfunctioning due to exogenous noise. (Refer to "EMC Installation Guidelines: EMC Countermeasure Parts: Shield Clamp Fitting".)

3.2.3 Connecting Spark Killers

Connect a spark killer on the coil or the contact in parallel for noise countermeasures.

Use spark killers which are 0.33 to 0.1 μ F, 10 to 120 Ω .

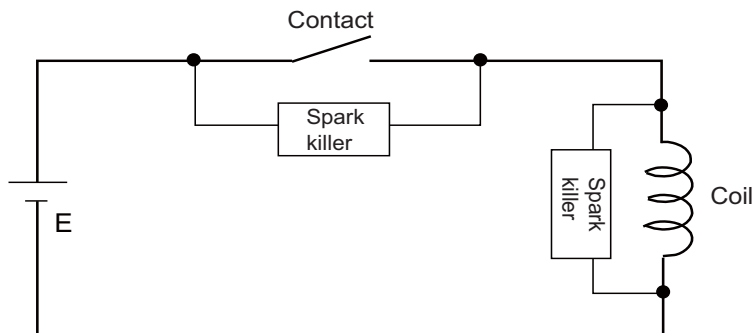

3.3 Unit Installation

3.3.1 Control Unit

Mount the control unit with three fixing screws.

(Note) Refer to "General Specifications: Control Unit" for the installation dimension and the screw hole position.

[FCU7-MU031/ FCU7-MU041/ FCU7-MA041]

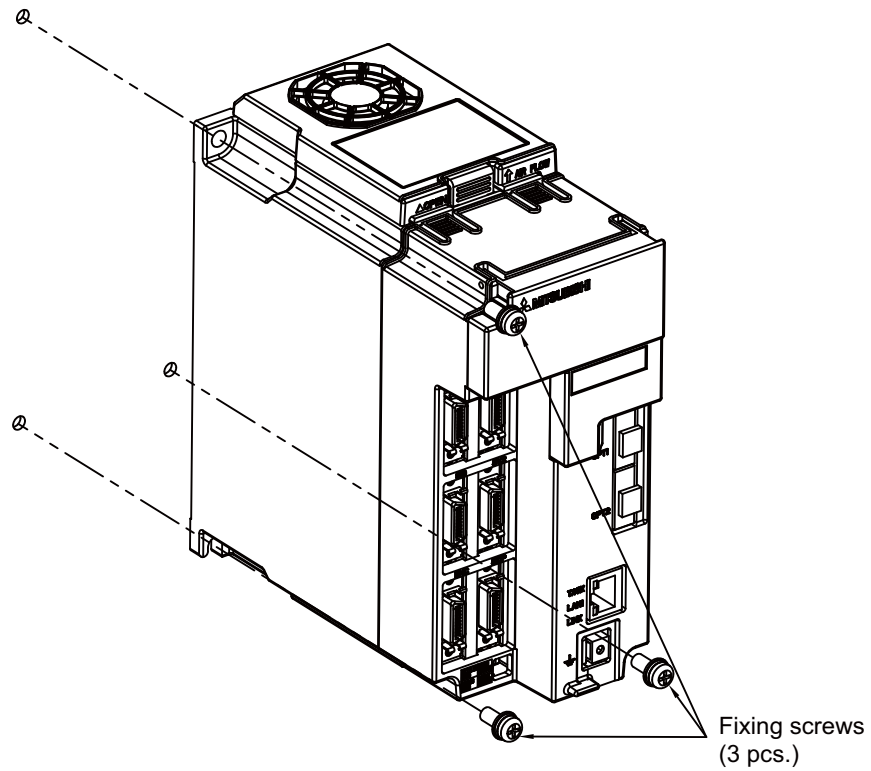

3.3.2 Display Unit

Mount the display unit with eight fixing screws.

(Note) Refer to "General Specifications: Display Unit" for the panel cut dimension drawing and the screw hole position.

[FCU7-DA646-11/31/33 (10.4-type display unit)]

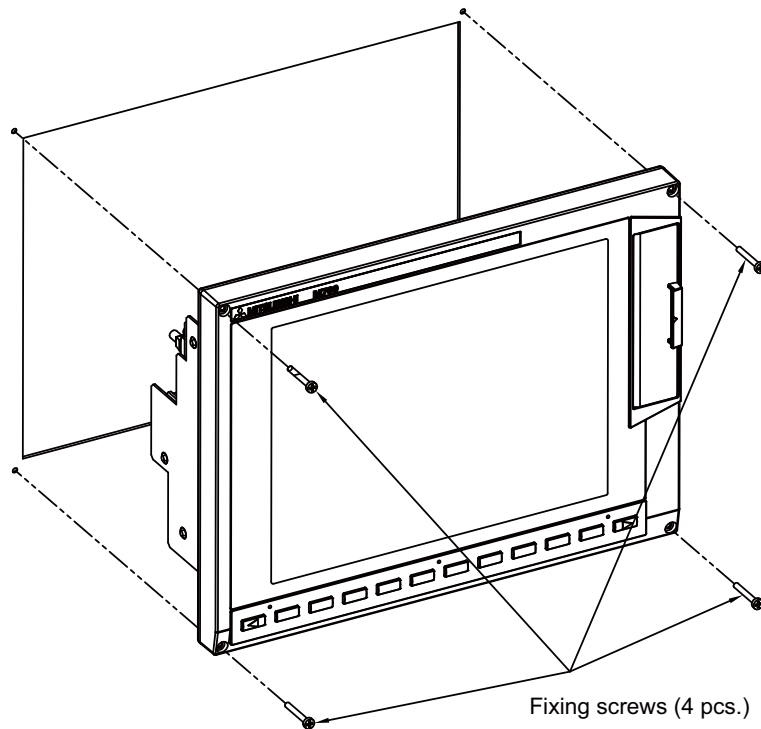

[FCU7-DA636-11/31/33 (15-type display unit)]

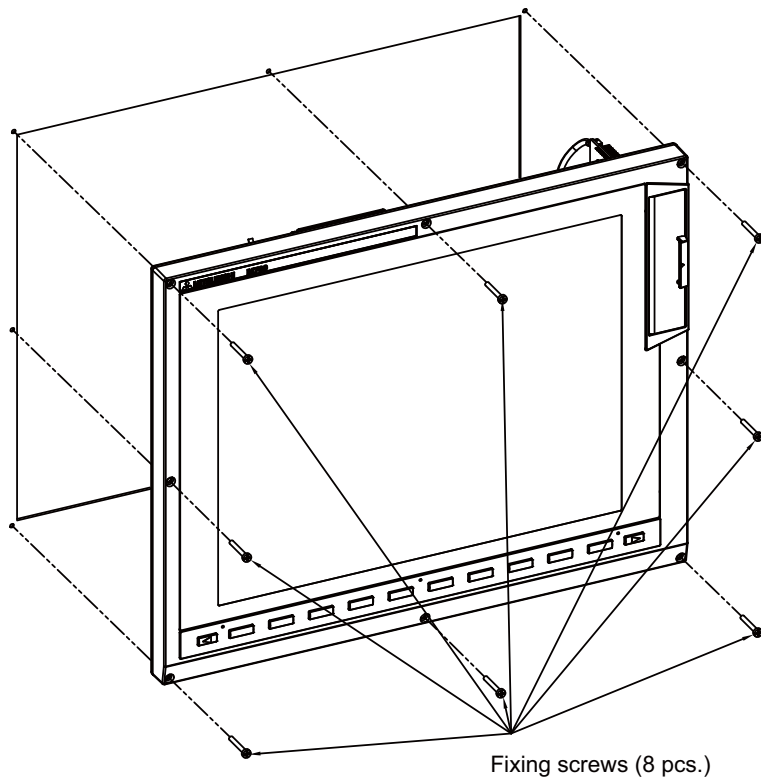

3.3.3 Keyboard Unit

Mount the keyboard unit with four fixing screws.

(Note) Refer to "General Specifications: Keyboard Unit" for the panel cut dimension drawing and the screw hole position.

[FCU7-KB041]

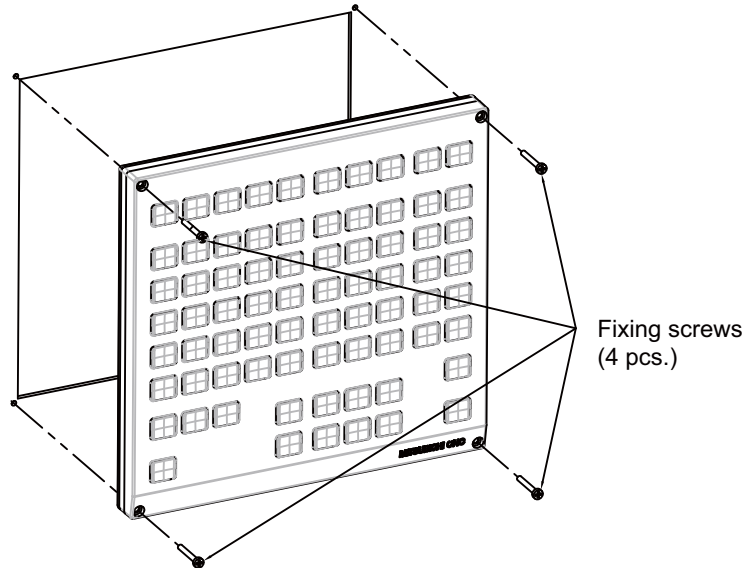

3.3.4 Operation Panel I/O Unit

The operation panel I/O unit can be mounted on the back of the keyboard unit with four fixing screws.

(Note) Refer to "General Specifications: Operation Panel I/O Unit" for the installation dimension and the screw hole position.

[FCU7-DX770/ FCU7-DX771]

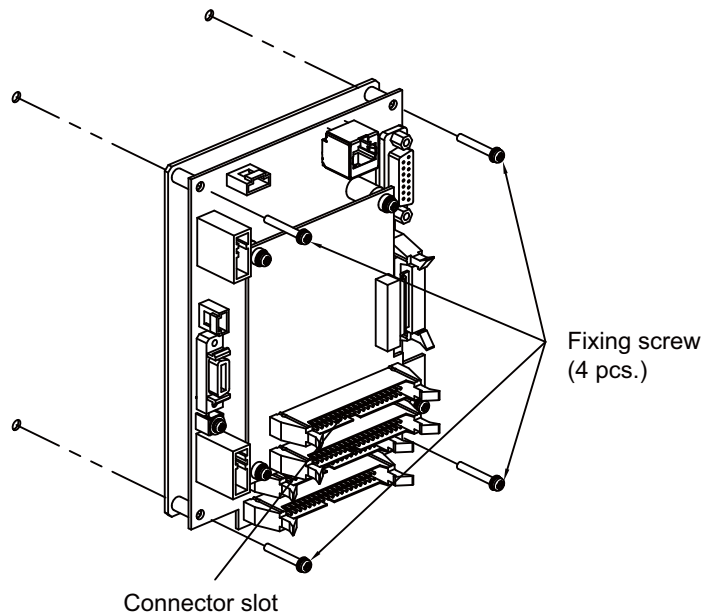

3.3.5 Control Unit Battery

A lithium battery in the control unit battery holder retains parameter settings, machining programs and the like, which requires to be backed up at the power OFF.

Battery	Q6BAT
Battery cumulative data holding time	45,000 hours (At 0 to 45°C. The life will be shorter if the temperature is high.)
Battery life	Approx. 5 years (from date of battery manufacture)

[Installation method]

- (1) Check that the machine power is turned OFF. (If the power is not OFF, turn it OFF.)
- (2) Confirm that the control unit LED, 7-segment display, etc., are all OFF.
- (3) Open the battery cover of the control unit. Pull the right side of the battery cover toward front.
- (4) Fit the new battery into the battery holder.
- (5) Insert the connector connected to the new battery into the BAT connector. Pay attention to the connector orientation: do not insert backwards.
- (6) Close the front cover of the control unit. At this time, confirm that the cover is closed by listening for the "click" sound when the latch catches.

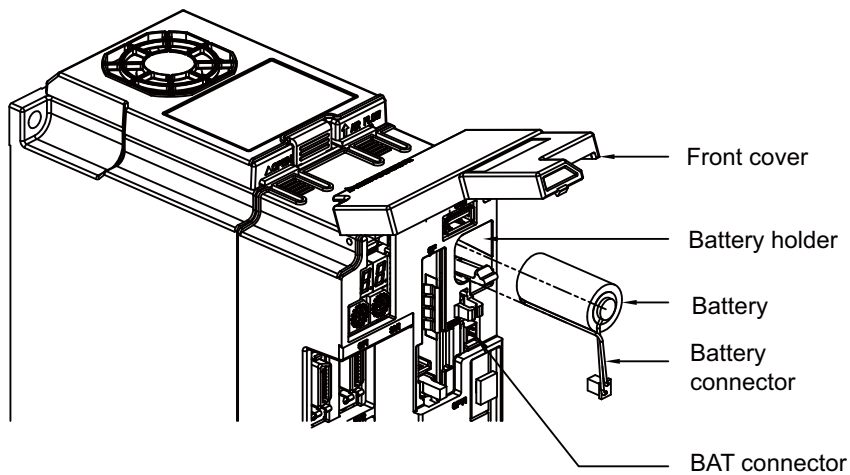

[Precautions for handling battery]

- (1) Do not disassemble the battery.
- (2) Do not place the battery in flames or water.
- (3) Do not pressurize and deform the battery.
- (4) This is a primary battery so do not charge it.

CAUTION

Do not short circuit, charge, overheat, incinerate or disassemble the battery.

3.3.6 Expansion Unit

[Installing the expansion card onto the expansion unit]

- (1) Push the tabs at the top and bottom of the expansion unit to remove the front cover.
- (2) Insert the expansion card onto the expansion unit. Connect the connector from the expansion card to the expansion unit.
- (3) Install the front cover.

[Installing the expansion unit on the control unit]

- (1) Remove the expansion unit connector cover from the side of the control unit.
- (2) Connect the connector from the expansion unit to the control unit.
- (3) Fix the control unit on the back of the expansion unit base metal plate with two flat-head screws (M3x6).



4

Connection

4.1 Precautions for Wiring

4.1.1 Precautions when Connecting/Disconnecting Cables

If the cable is connected/disconnected without turning the power OFF, the normal unit or peripheral devices could be damaged, and risks could be imposed.

Disconnect each cable with the following procedures.

- (a) For the following type of connector, press the tabs with a thumb and forefinger in the direction of the arrow, and pull the connector off.

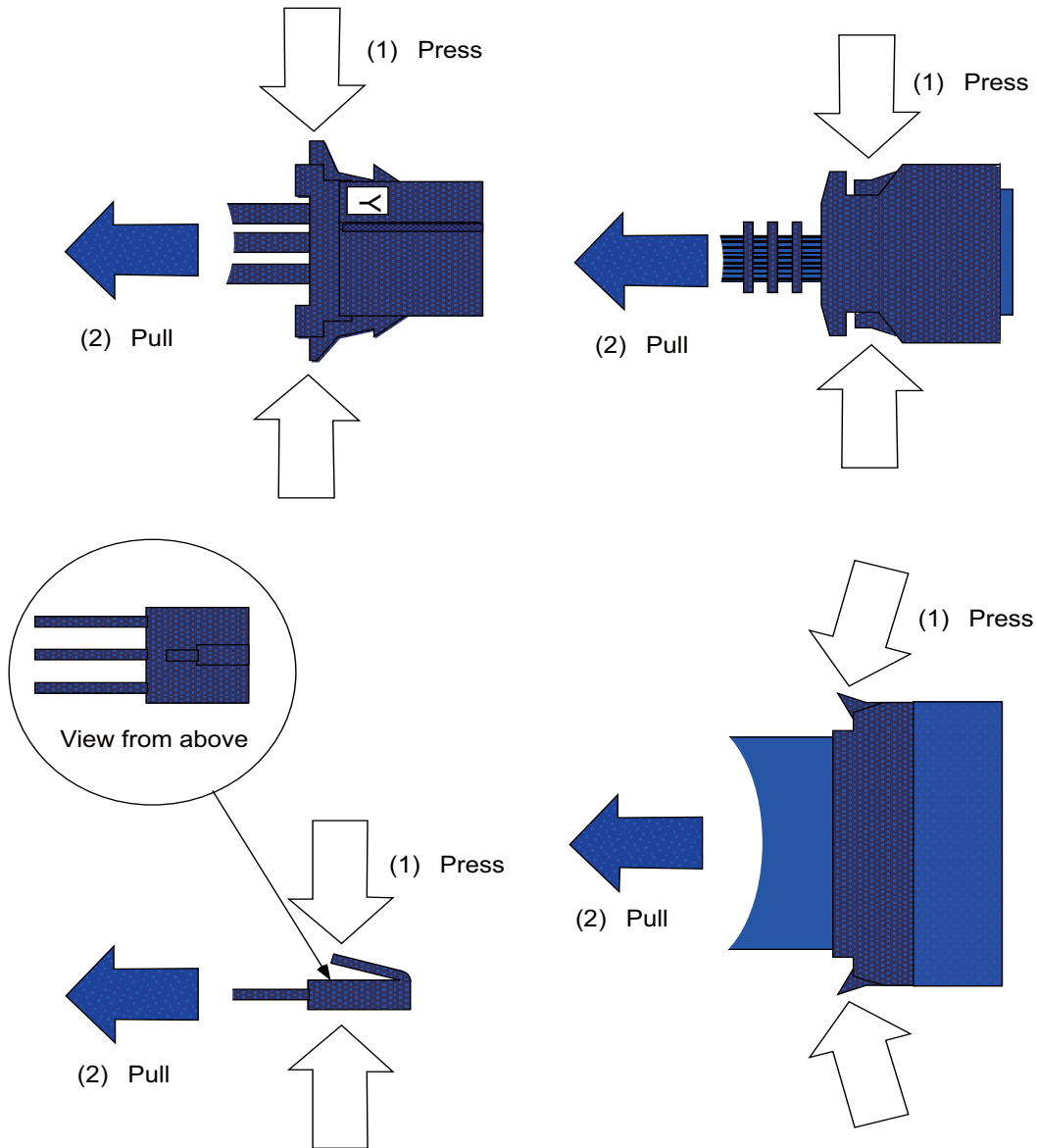

CAUTION

1. Do not connect or disconnect the cables between units while the power is ON.
2. Do not pull the cables when connecting/disconnecting it.

- (b) For a flat cable type connector with latches, open the latches in the directions of the arrows, and pull the connector off.

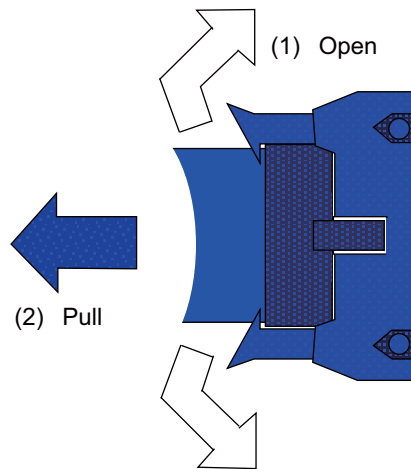

- (c) For a flat cable type connector without latches, hold the connector with a thumb and forefinger, and pull the connector off.

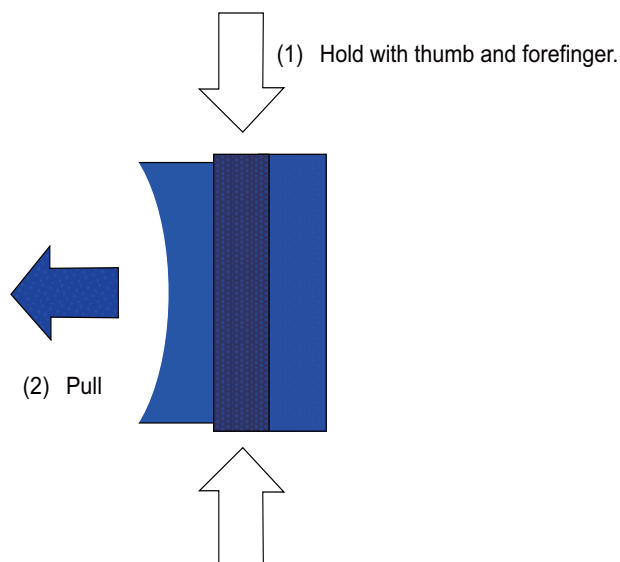

- (d) For the screw fixed type connector, loosen the two fixing screws, and pull the connector off.

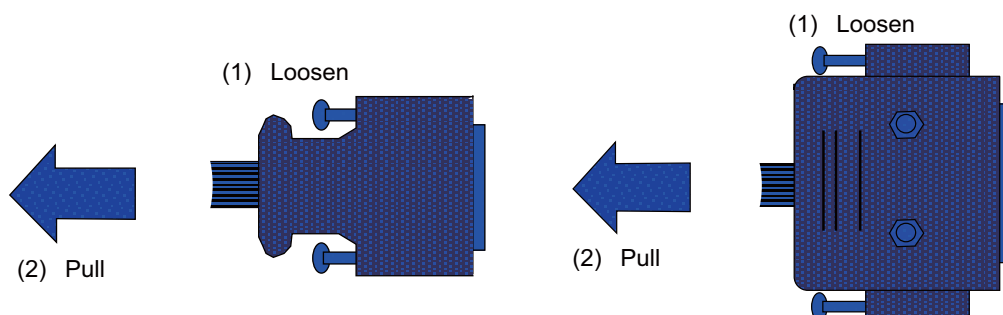

⚠ CAUTION

1. Do not connect or disconnect the cables between units while the power is ON.
2. Do not pull the cables when connecting/disconnecting it.

(e) For the optical cable connector, pull off while holding down the lock button.

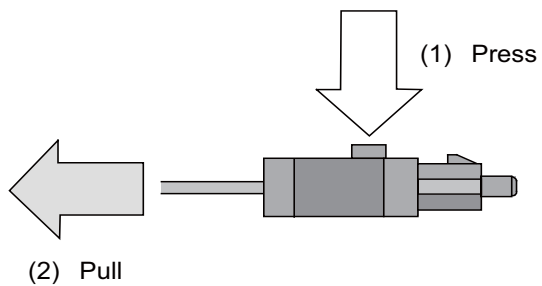

(f) For the Ethernet connector, pull off while holding down the locked latch.

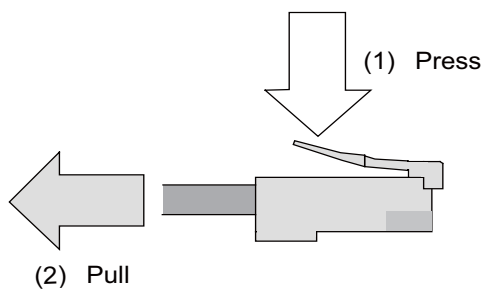

⚠ CAUTION

1. Do not connect or disconnect the cables between units while the power is ON.
2. Do not pull the cables when connecting/disconnecting it.

4.1.2 Precautions for Using Optical Communication Cable

An optical communication cable is used for communication between the control unit and the drive unit. Special precautions, differing from the conventional cable, are required when laying and handling the optical communication cable.

(Note) If the cable you use is not Mitsubishi's, malfunctions resulted from connection problems or aged deterioration are not covered under the warranty.

4.1.2.1 Optical Communication Cable Outline and Parts

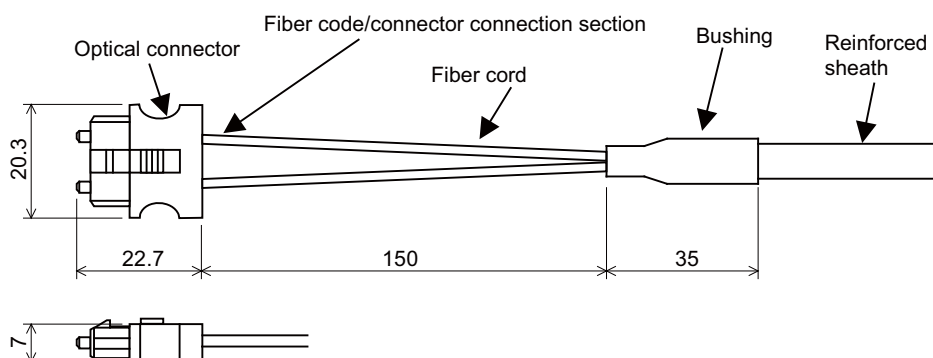

To ensure the system performance and reliability, purchase the optical communication cable from Mitsubishi. A machining drawing is given in "Cable" as reference, but the purchased optical communication cable cannot be cut or connected by the machine tool builder.

4.1.2.2 Precautions for Handling Optical Communication Cable

- (1) A protective cap is attached to the optical module and optical communication cable mounted on the PCB when the system is delivered. Leaving this protective cap unattached could result in connection faults from the adherence of dirt and dust. Do not remove the protective cap when not connecting the cable. If dirty, wipe off lightly with a piece of dry gauze, etc. (Do not use solvents such as alcohol as the optical fiber material could melt.)
- (2) Hold the connector section when connecting or disconnecting the optical connector. Holding the fiber cord will result in force exceeding the tolerable tension on the fiber cord and connector connection section, and could cause the fiber cord to dislocate from the optical connector thereby inhibiting use.
- (3) The optical connector cannot be connected in reversed. Check the connector orientation when connecting the optical communication cable to the optical module. Align the connector lock lever with the lock holes on the PCB's optical module, and press the connector straight in. Confirm that the lock lever connects with the optical module and that a "click" is heard.
- (4) When disconnecting the optical communication cable from the PCB, press the lock release buttons on the lock lever, and pull out the cable while holding the connector section. The connector could be damaged if the cable is pulled without pressing down on the lock release buttons.
- (5) Do not apply excessive force onto the optical communication cable by stepping on it or dropping tools, etc., on it.

4.1.2.3 Precautions for Laying Optical Communication Cable

- (1) Do not apply a force exceeding the cable's tolerable tension. Binding the cables too tight with tie-wraps could result in an increased loss or a disconnection. Use a cushioning material such as a sponge or rubber when bundling the cables and fix so that the cables do not move.
- (2) Do not connect the cables with a radius less than the tolerable bending radius. Excessive stress could be applied near the connector connection section and cause the optical characteristics to drop. The cable bending radius should be 10 times or more than the outer diameter at the reinforced sheath, and 20 times or more than the outer diameter at the fiber cord section.
- (3) Do not apply torsion to the optical communication cable. Laying a twisted cable could cause the optical characteristics to drop.
- (4) When laying the cables in a conduit, avoid applying stress on the fiber cord and connector connection section. Use the tensile end such as a pulling eye or cable grip, etc.
- (5) Fix the reinforced sheath with a cable clamp so that the mass of the optical communication cable is not directly applied on the fiber cord and connector connection section.
- (6) Never bundle the cables with vinyl tape. The plasticizing material in the vinyl tape could cause the POF cable to break.
- (7) Loop the excessive cable with twice or more than the minimum bending radius.

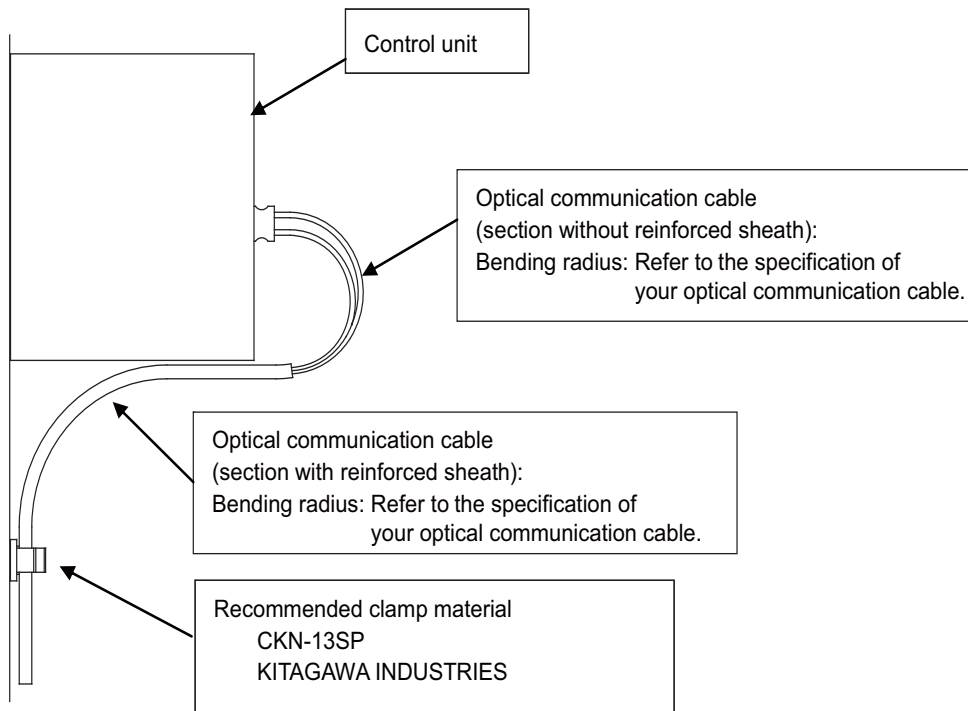

4.1.3 Precautions for Connecting 24V Power Supply

- (1) When 24V power is supplied to the unit (control unit, display unit) under the following conditions, welding may occur on the contacts due to rush current; so be careful.

When 24VDC's ON/OFF are directly controlled by a magnetic switch such as relay AND
 When heat capacity of the contacts for relay, etc. used to control 24VDC's ON/OFF is small.

4.1.4 Ferrite Core Installation Method

(1) The units to which the ferrite core needs to be installed

Ferrite core and the installation manual come with the following units.

Install the ferrite core to the cable listed in (2).

- FCU7-DX670
- FCU7-DX671
- FCU7-DX770
- FCU7-DX771
- FCU7-DA636-xx
- FCU7-DA646-xx

(2) The cables to which the ferrite core needs to be installed

24VDC cable (such as F070)

... For FCU7-DX670/DX671/DX770/DX771

RS-232C cable (such as G031/G032)

... For FCU7-DA636/DA646-xx

(3) Installation manner of ferrite core

- (a) Wrap the cable to the ferrite core once.
- (b) Make sure to fit the case until it clicks.
- (c) Tie the ferrite core and the cable with binding band so that the position of the ferrite core does not move.

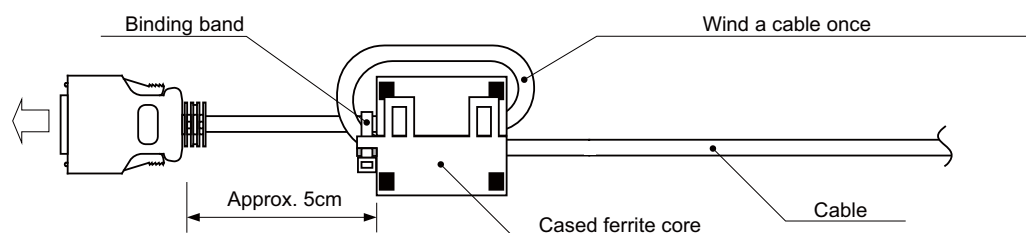

(4) For installing the ferrite core to the unit other than above when it is necessary

Install the ferrite core if the noise countermeasure is necessary to the cable (such as USB cable) with other units.

(Refer to "EMC Installation Guidelines: EMC Countermeasure Parts: Ferrite Core" for recommended ferrite core.)

4.2 Connection of Control Unit

The method for connecting to each unit and device from the control unit is explained in this section.

4.2.1 Control Unit Connection System Drawing

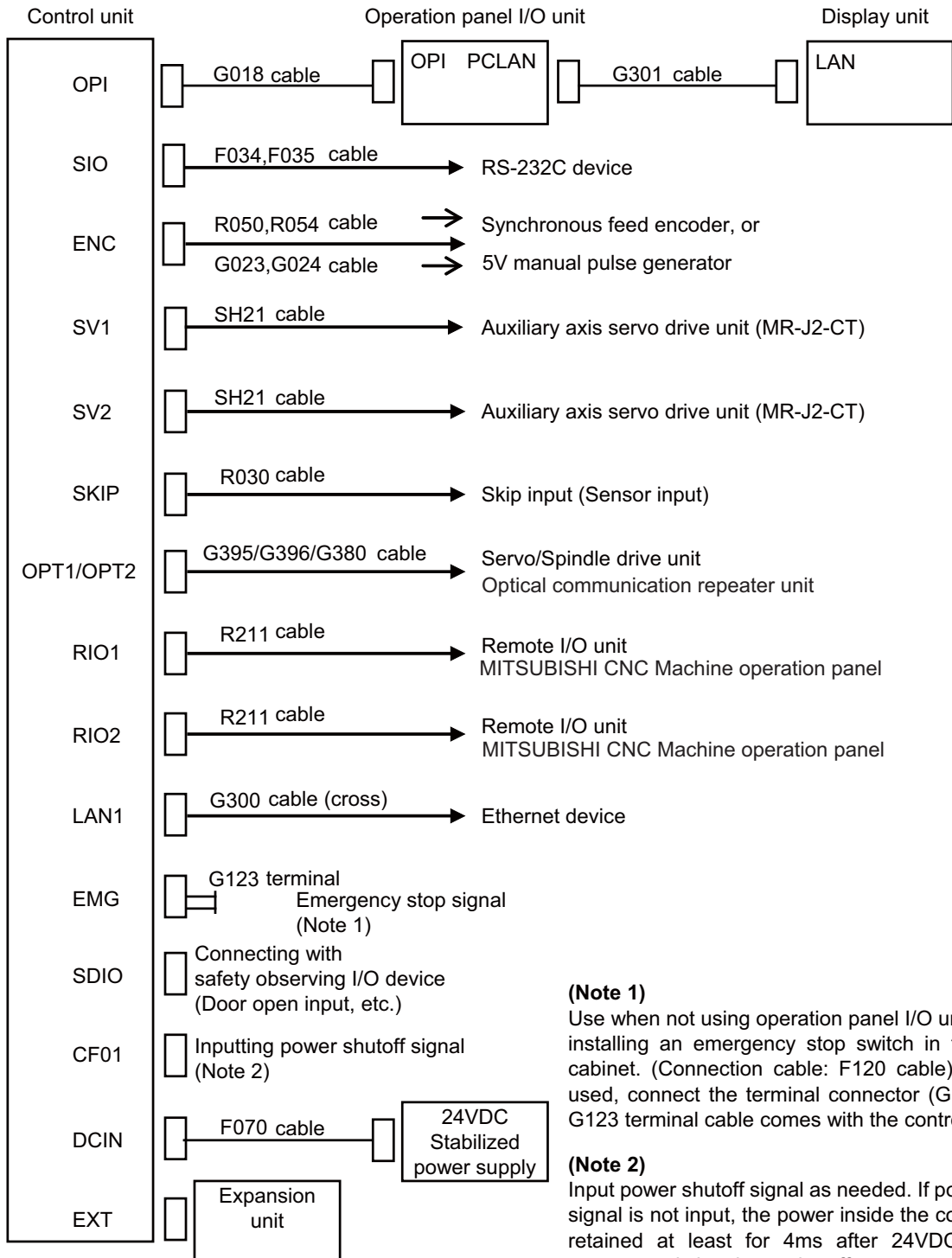

4.2.2 Connecting with Power Supply

Connect a general-purpose 24VDC stabilized power supply or PD25/PD27 power supply unit to the control unit.

(1) When using general-purpose 24VDC stabilized power supply

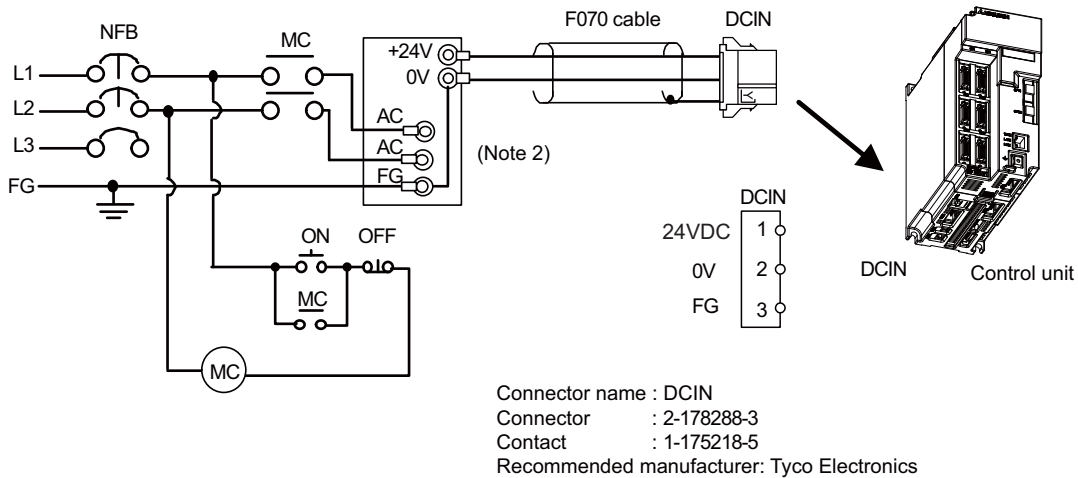

(Note 1) Rush current may occur to lead welding on the contacts, when a magnetic switch such as relay directly controls 24VDC's ON/OFF during 24V power supply to the control unit. Use relay with large heat capacity of contacts to control 24VDC's ON/OFF.

(Note 2) Make a short-circuit between 0V and FG on the terminal to cut noise.

<Related items>

Cable drawing "Cable: F070 Cable"

Connector pin assignment: "General Specifications: Control Unit" (DCIN connector)

(2) When using PD25/PD27 power supply unit

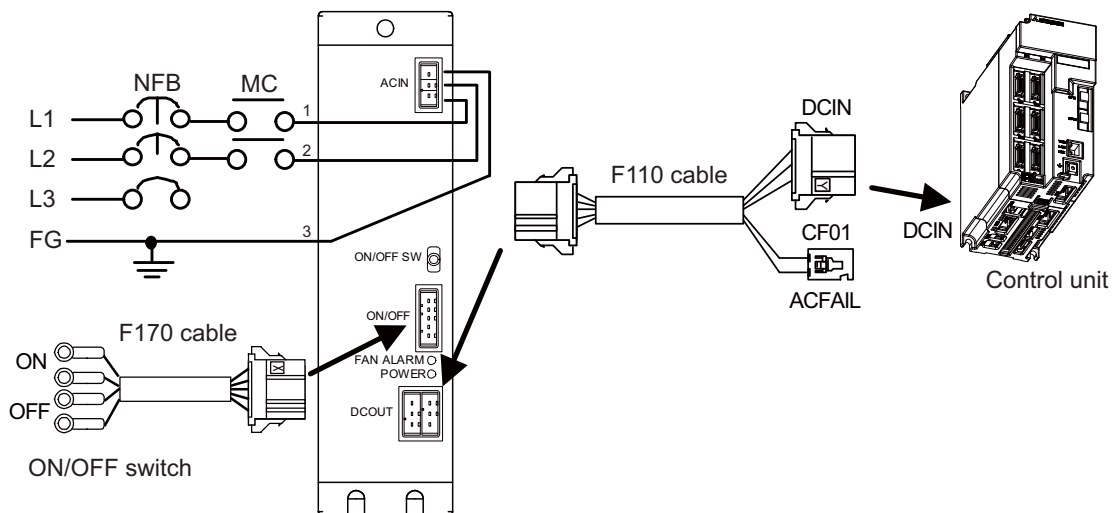

<Related items>

Cable drawing: "Cable: F110 Cable", "Cable: F170 Cable"

Connector pin assignment: "General Specifications: Control Unit" (DCIN connector)

4.2.3 Connecting with Emergency Stop Signal

Connect the emergency stop switch to EMG connector by F120 cable.

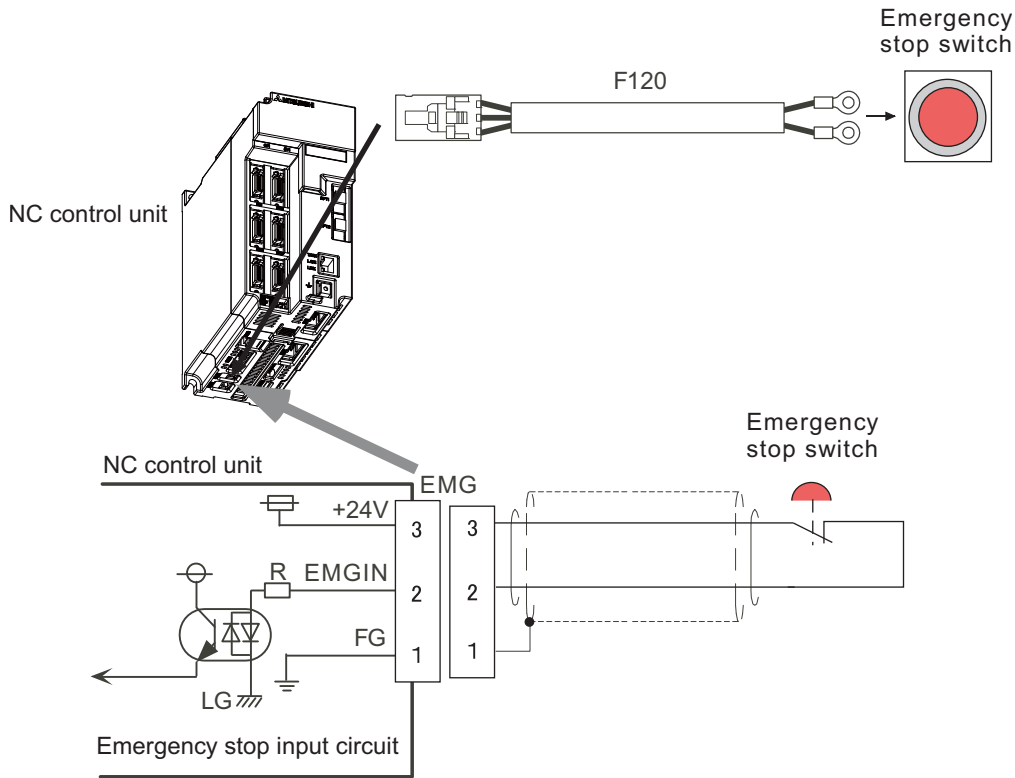

<Related items>

Cable drawing: "Cable: F120 Cable"

<When not using control unit side emergency stop input signal (EMG)>

When not using control unit side emergency stop input signal, such as when operation panel I/O unit side emergency stop input signal (EMG) is used, invalidate the input signal by using terminal cable G123. G123 cable comes with the control unit.

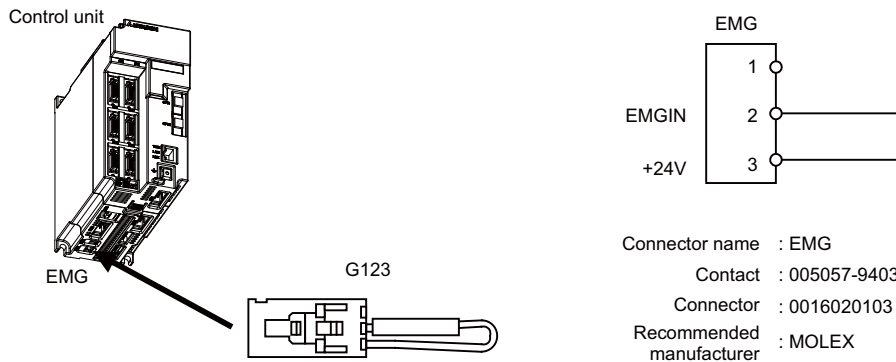

Connector name : EMG
 Contact : 005057-9403
 Connector : 0016020103
 Recommended manufacturer : MOLEX

Besides the emergency stop input from the NC controller, double-protection when an emergency stop occurs can be provided by directly inputting an external emergency stop to the drive unit. Even if the emergency stop is not input from NC for some reason, the contactors can be shut off by the external emergency stop input. Outlines are shown below. For more details, refer to the Instruction Manual of each drive unit.

<Power supply unit (MDS-D2-CV) external emergency stop: Example>

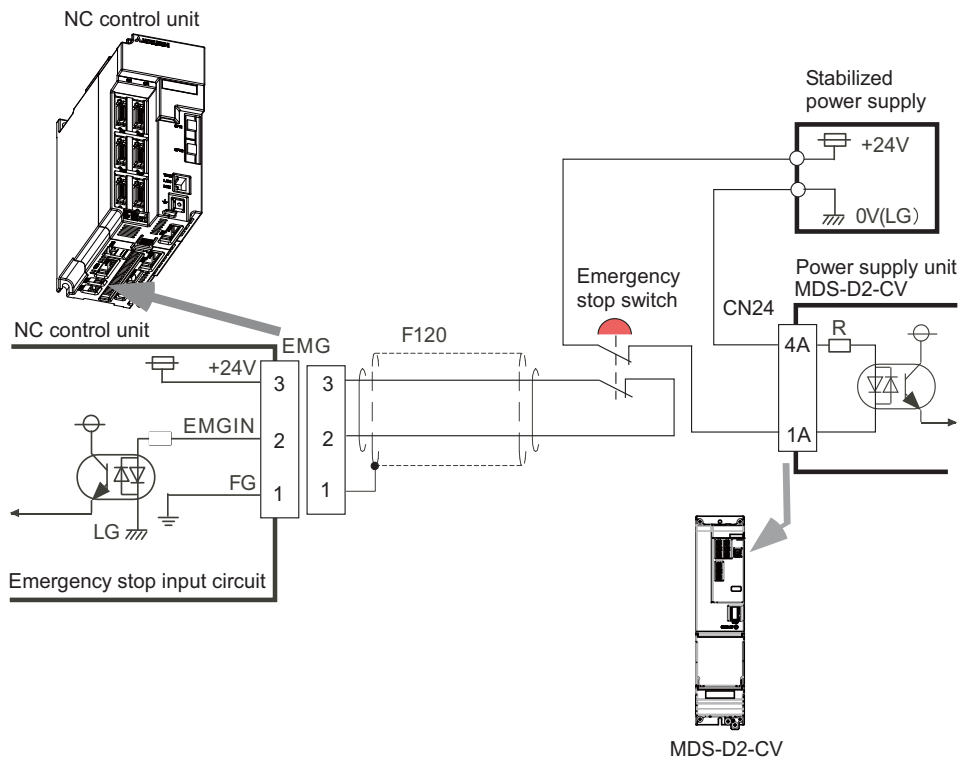

<Drive unit (MDS-DJ-V1) external emergency stop: Example>

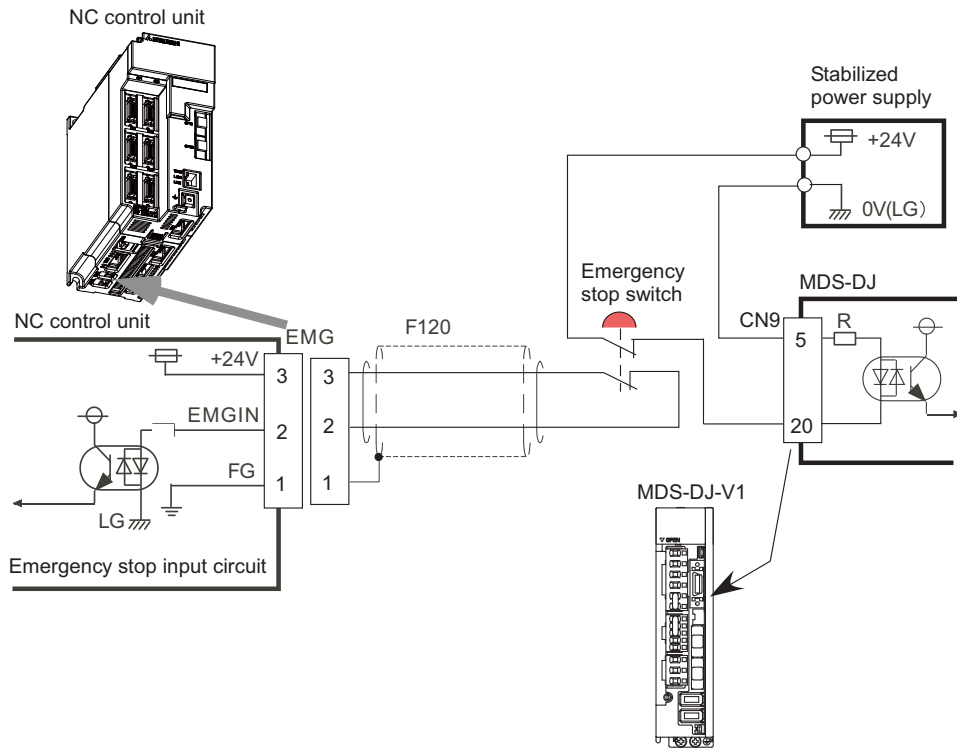

<Caution>

- (1) External emergency stop cannot substitute the emergency stop signal which is input to NC. It is a function which helps the NC emergency stop.
- (2) When duplicating emergency stop input, wire the NC emergency stop input and the power supply unit external emergency stop input from the same emergency stop switch.

4.2.4 Connecting with Operation Panel I/O Unit

Connect the operation panel I/O unit to the connector OPI.

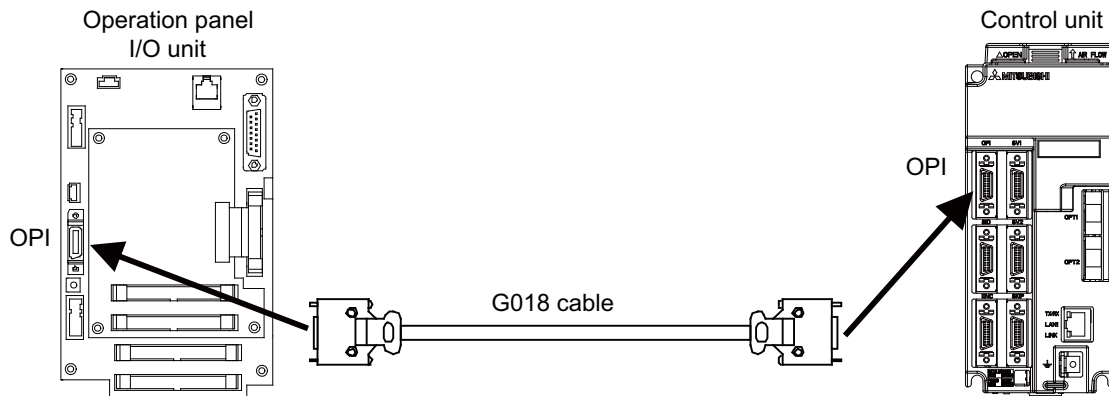

<Related items>

Connector pin assignment: "General Specifications: Control Unit" (OPI connector)

4.2.5 Connecting with Drive Unit

Connect the optical communication cables from the NC to the each drive unit so that they run in a straight line from the NC to the drive unit that is a final axis. Up to 16 axes can be connected per system. Note that the number of connected axes is limited by the NC.

(Note) Refer to "Precautions for Using Optical Communication Cable" when handling and wiring optical communication cable.

Cable application table

Cable	Panel internal wiring		Panel external wiring	
	Under 10m	10 to 30m	10m or less	10 to 30m
G396	○	×	×	×
G395	○	×	○	×
G380	○	○	○	○

(Note) Wiring of over 30m can be applied when relaying the optical signal by optical communication repeater unit. Refer to the specification manual of the drive unit for the details of the optical communication repeater unit.

4.2.5.1 Connecting with MDS-D2/DH2 Series

CAUTION

1. Connect the NC and the drive units by the optical communication cables. The distance between the NC and the final drive unit must be within 30m and the bending radius within 80mm.
2. For the main circuit wiring of the drive unit and power supply unit, the drive unit of 200V series is to be wired with MDS-D2-CV, and the drive unit of 400V series is to be wired with MDS-DH2-CV.
3. A spindle drive unit that controls the high-speed synchronous tapping (OMR-DD control) has to be connected on the farther side from the NC than the subject synchronous tapping control.

POINT

Axis Nos. are determined by the rotary switch for setting the axis No. (Refer to the instruction manual of Drive unit.) The axis No. has no relation to the order for connecting to the NC.

(1) When using one power supply unit

Connect the largest-capacity spindle drive unit to the final axis of the NC communication bus in order to control the power supply unit. The spindle drive unit must be installed adjacent to the power supply unit. In the system with servo only, a servo drive unit for controlling unbalance axis must be installed in the same manner in the same way.

< Connection >

CN1A : CN1B connector on NC or previous stage's drive unit

CN1B : CN1A connector on next stage's drive unit

CN4 : Connector for communication between power supply unit (master side) and drive unit

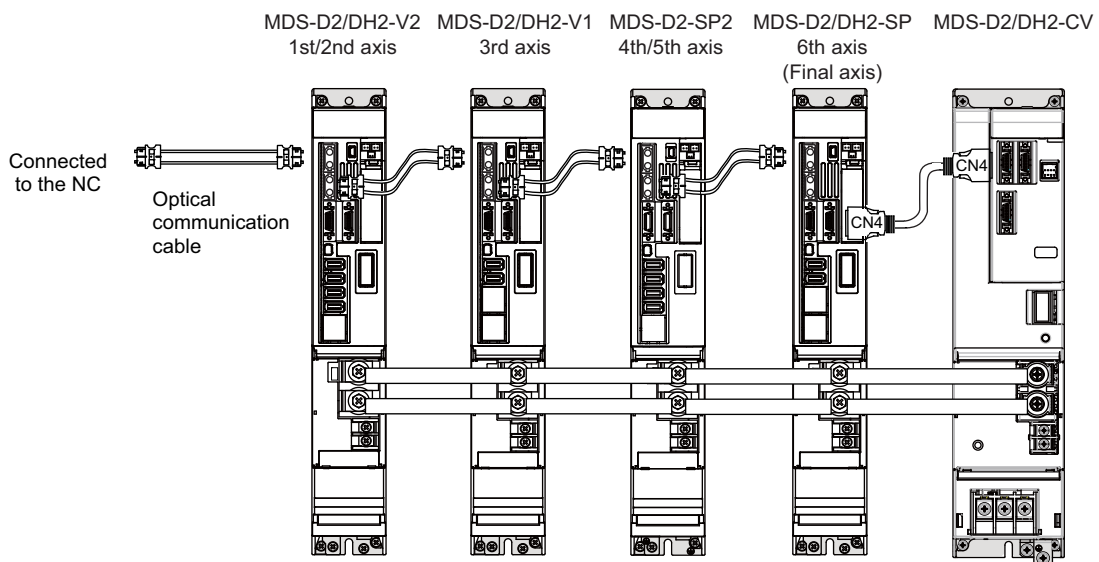

The optical communication cables from the NC to the final drive unit must be within 30m.

Connection when using one power supply unit

(2) When using two or more power supply units within a single NC communication bus system

Two or more power supply units may be required within a single NC communication bus system if the spindle drive unit capacity is large. The drive unit receiving power (L+, L-) from each power supply unit must always have NC communication cable connection at the NC side of each power supply unit. In the NC communication bus connection example below, power supply [1] cannot supply power (L+, L-) to the 5th axis servo drive unit. For basic connection information, refer to "(1) When using one power supply unit".

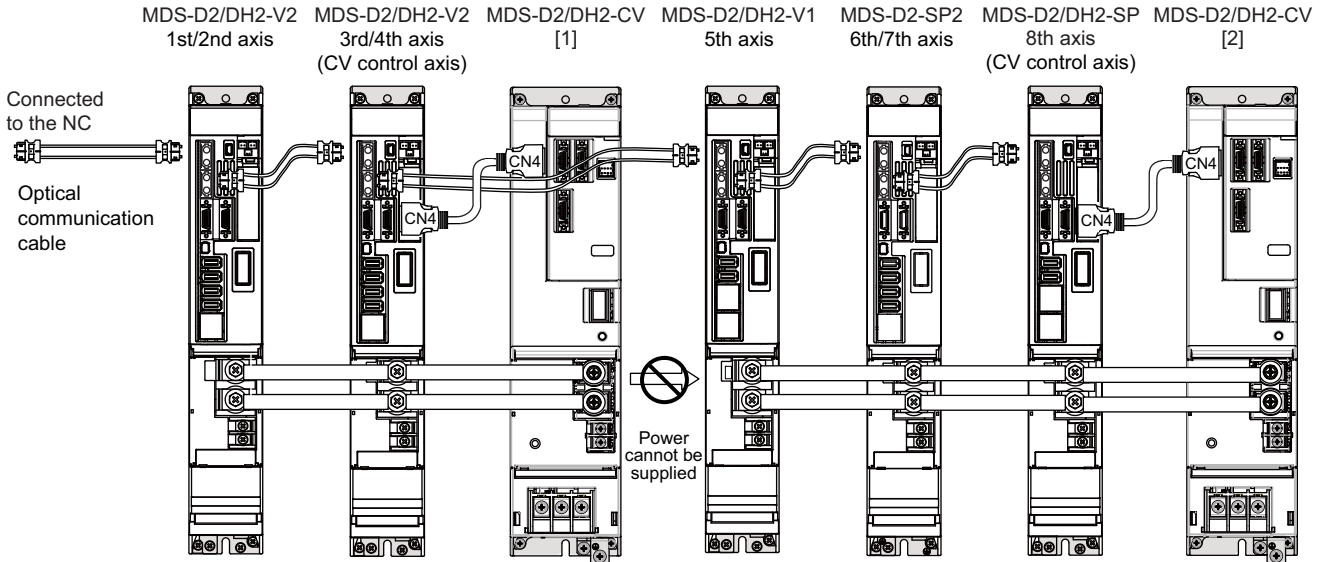

Connections when using two power supply units within a single NC communication bus system

CAUTION

1. The drive unit receiving power (L+, L-) from each power supply unit must always have NC communication bus connection at the NC side of each power supply unit.
2. If two or more power supply units are connected in the drive system, confirm that the units are not connected with each other through the L+ and L- lines before turning ON the power. Also make sure that the total capacity of the drive units connected to the same power supply unit meets the unit's selected capacity.

4.2.5.2 Connecting with MDS-DM2 Series

CAUTION

1. Connect the NC and the drive units by the optical communication cables. The distance between the NC and the final drive unit must be within 30m and the bending radius within 80mm.
2. A spindle drive unit that controls the high-speed synchronous tapping (OMR-DD control) has to be connected on the farther side from the NC than the subject synchronous tapping control.
Thus, if you use an MDS-DM2 unit for servo control of the high-speed synchronous tapping, combinable spindle drive is that of the MDS-DM2 unit only.

(1) When using only MDS-DM2-SPV Series

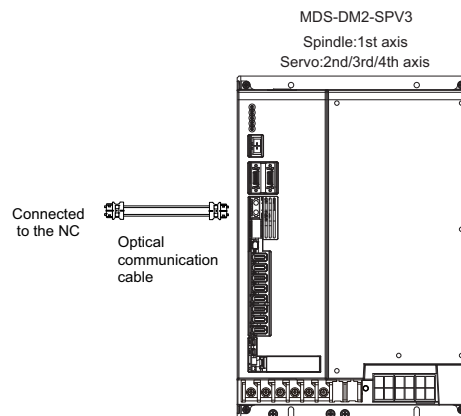

(2) When using the MDS-D2 unit together

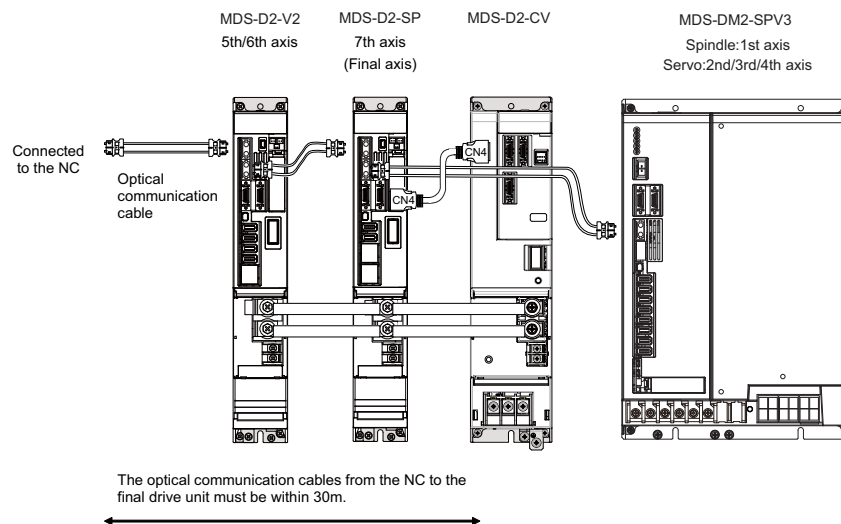

POINT

For MDS-DM2-SPV Series, axis Nos. are fixed as follows.

- 1st axis : spindle
- 2nd axis : servo L axis
- 3rd axis : servo M axis
- 4th axis : servo axis (only MDS-DM2-SPV3)

4.2.5.3 Connecting with MDS-DJ Series

CAUTION

1. Connect the NC and the drive units by the optical communication cables. The distance between the NC and the final drive unit must be within 30m and the bending radius within 80mm.
2. A spindle drive unit that controls the high-speed synchronous tapping (OMR-DD control) has to be connected on the farther side from the NC than the subject synchronous control.

POINT

Axis Nos. are determined by the rotary switch for setting the axis No. (Refer to the instruction manual of drive unit.) The axis No. has no relation to the order for connecting to the NC.

< Connection >

CN1A:CN1B connector on NC or previous stage's drive unit

CN1B:CN1A connector on next stage's drive unit

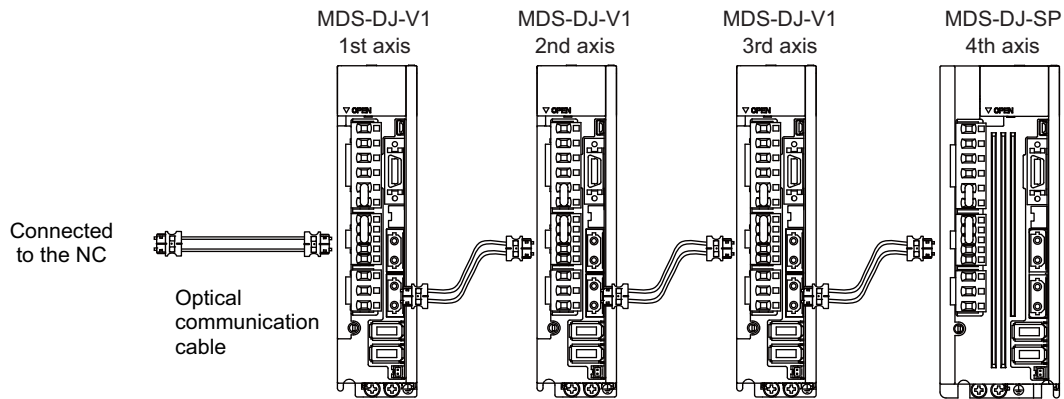

The optical communication cables from the NC to the final drive unit must be within 30m.

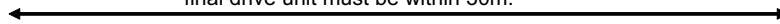

4.2.6 Connecting with Auxiliary Axis Servo Drive Unit: MR-J2-CT

Connect auxiliary axis servo drive unit MR-J2-CT to the connector SV1, SV2.

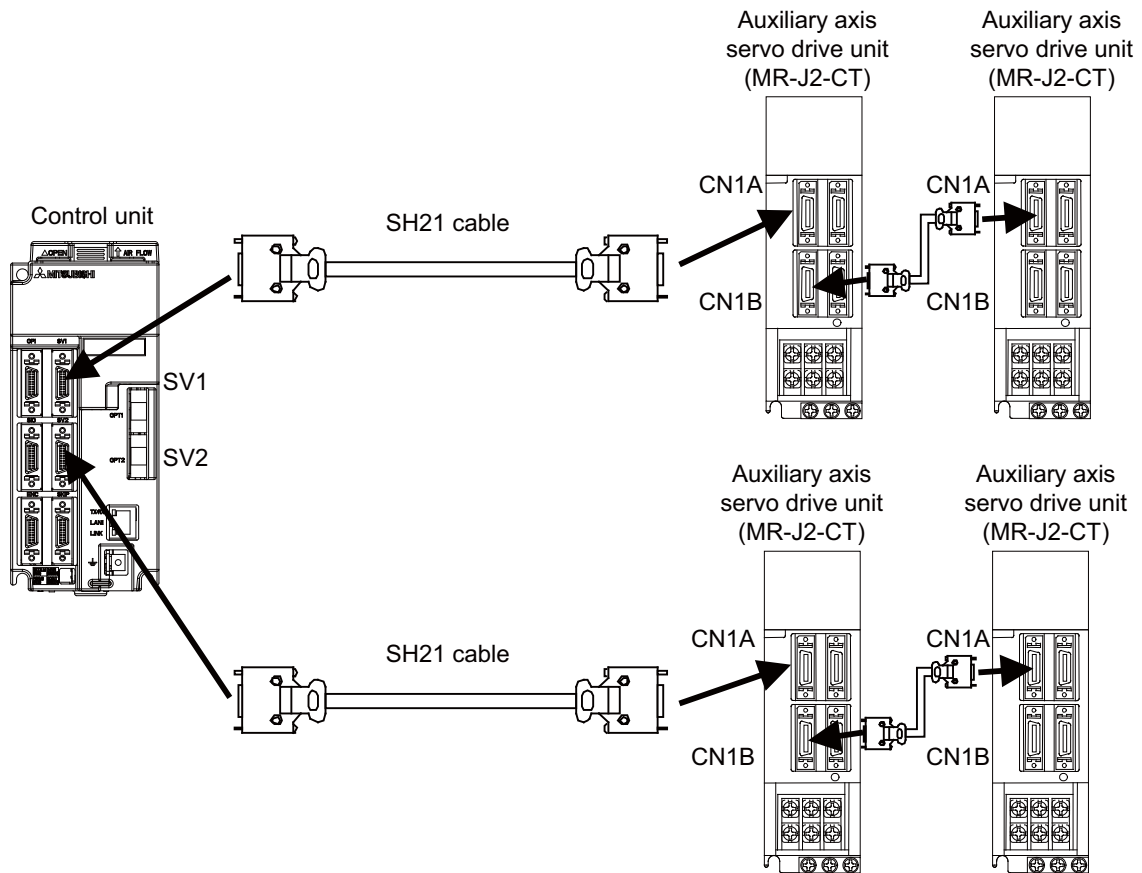

<Related items>

Cable drawing: "Cable: SH21 Cable"

Connector pin assignment: "General Specifications: Control Unit" (SV1 connector, SV2 connector)

4.2.7 Connecting with RS-232C Device

(1) Connect the RS-232C device to the connector SIO.

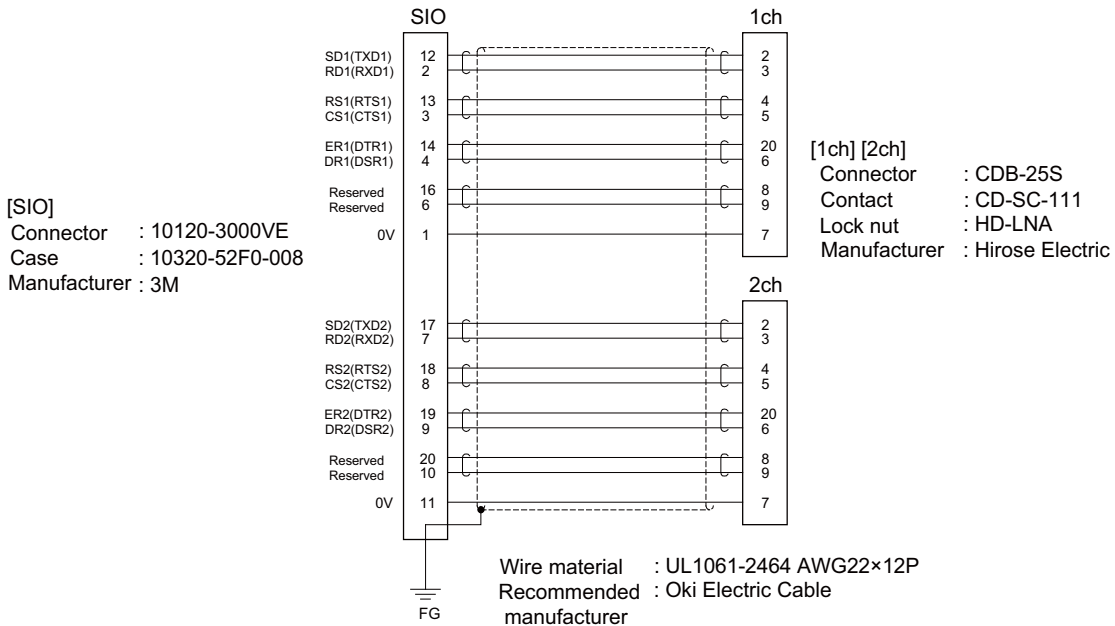
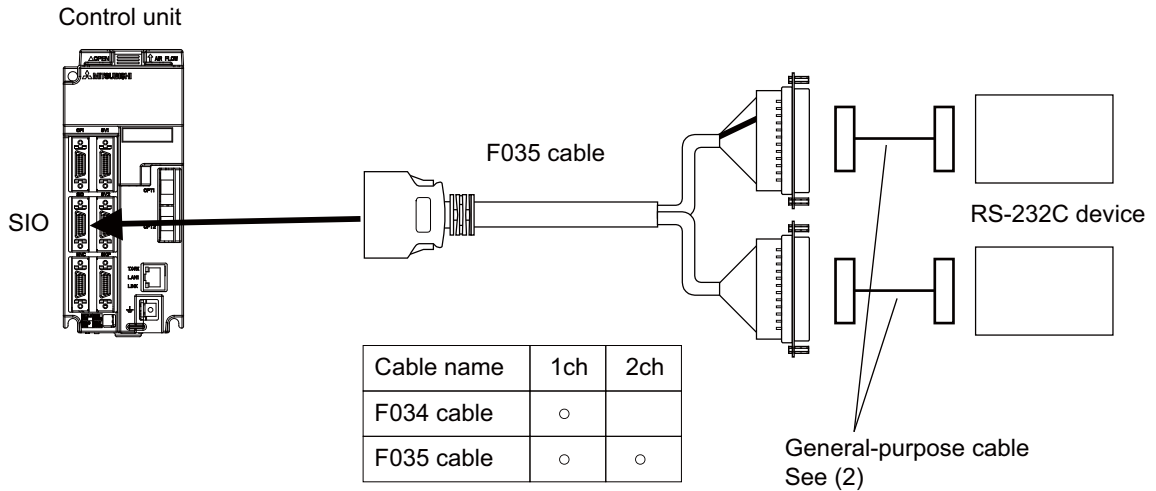

<Related items>

Cable drawing: "Cable: F034/F035 Cable"

Connector pin assignment: "General Specifications: Control Unit" (SIO connector)

(2) Example of wiring connections to the RS-232C device

When connecting to the RS-232C device, refer to the following diagrams and cross the wiring for the transmission signals.

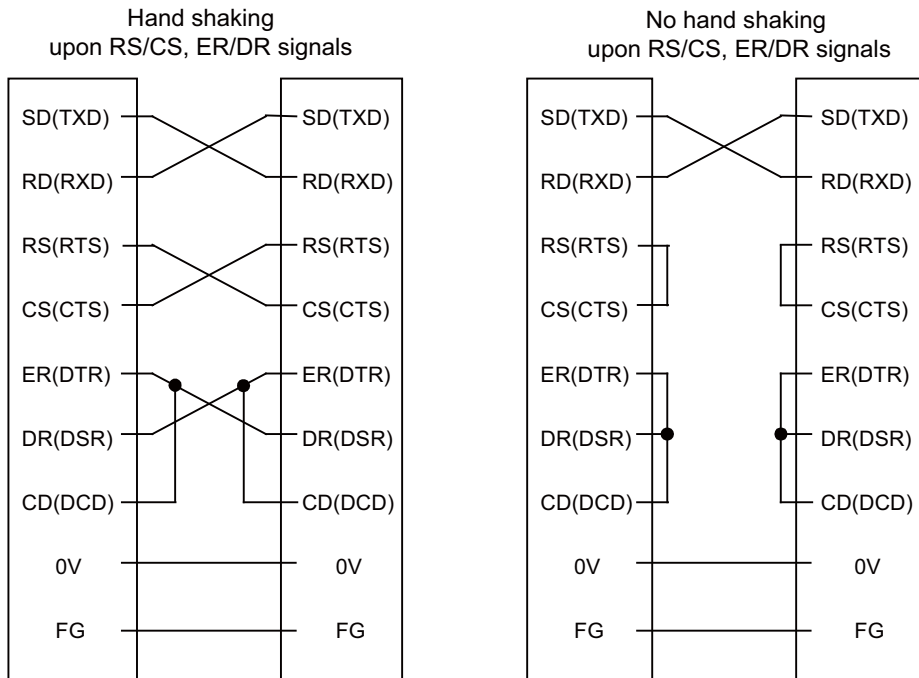

4.2.8 Connecting with Skip Signal (Sensor)

Connect skip signals to the connector SKIP.

Skip signals are used for processing high-speed signals. Always shield the cable.

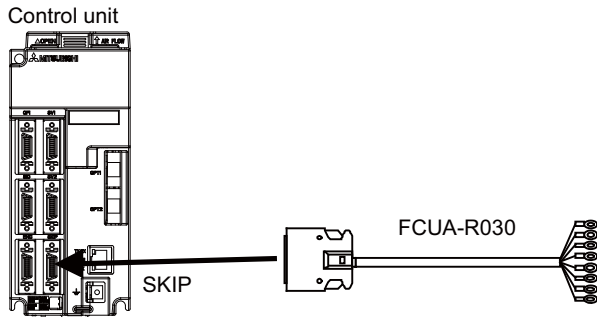

(Note) Connecting the skip signal cable to a wrong connector causes a damage on the control unit when turning ON the skip signal power supply. Confirm the wiring before turning the power ON.

(1) Connection of skip signal cable

<0V connection at COM terminal>

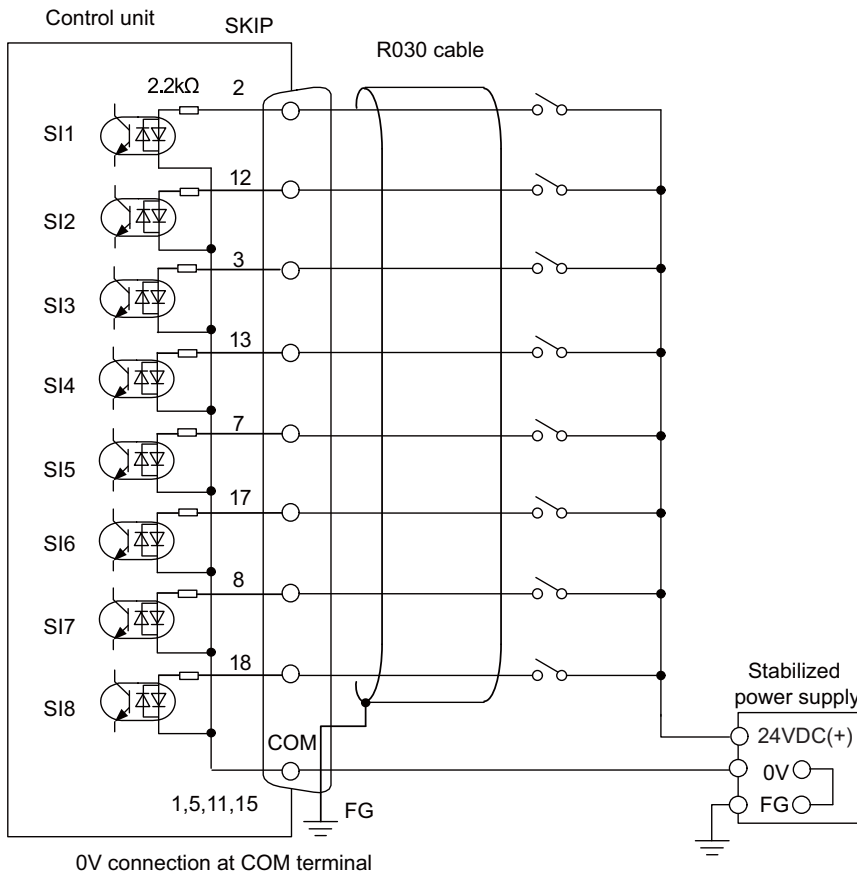

<24V connection at COM terminal>

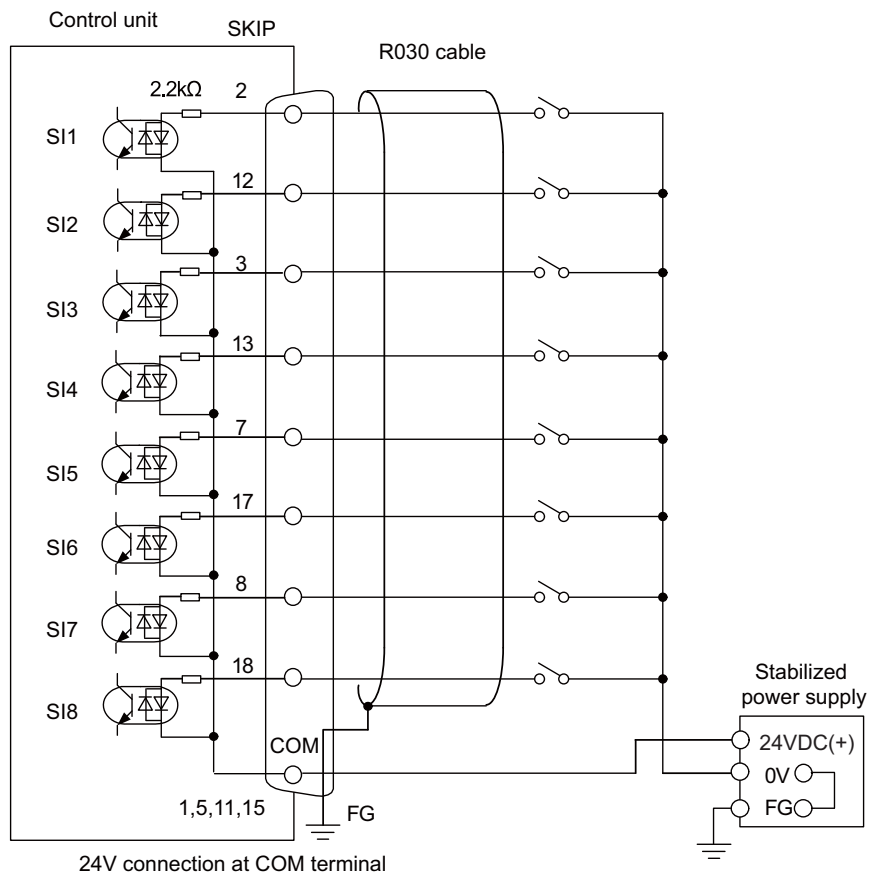

- (Note 1) NC recognizes input signals of 2ms or more as the valid skip signals. If machine contacts (relay, etc.) are used, malfunctions will occur due to chattering. Use semiconductor contacts (transistor, etc.).
- (Note 2) Fold the cable shield over the sheath, and wrap copper foil tape over it. Connect the wound copper foil tape to GND plate of the connector.

<Related items>

Cable drawing: "Cable: FCUA-R930 Cable"

Connector pin assignment: "General Specifications: Control Unit" (SKIP connector)

4.2.9 Connecting with Synchronous Feed Encoder/ Manual Pulse Generator

Synchronous feed encoder (1ch) or 5V power supply type manual pulse generator (2ch) can be connected.

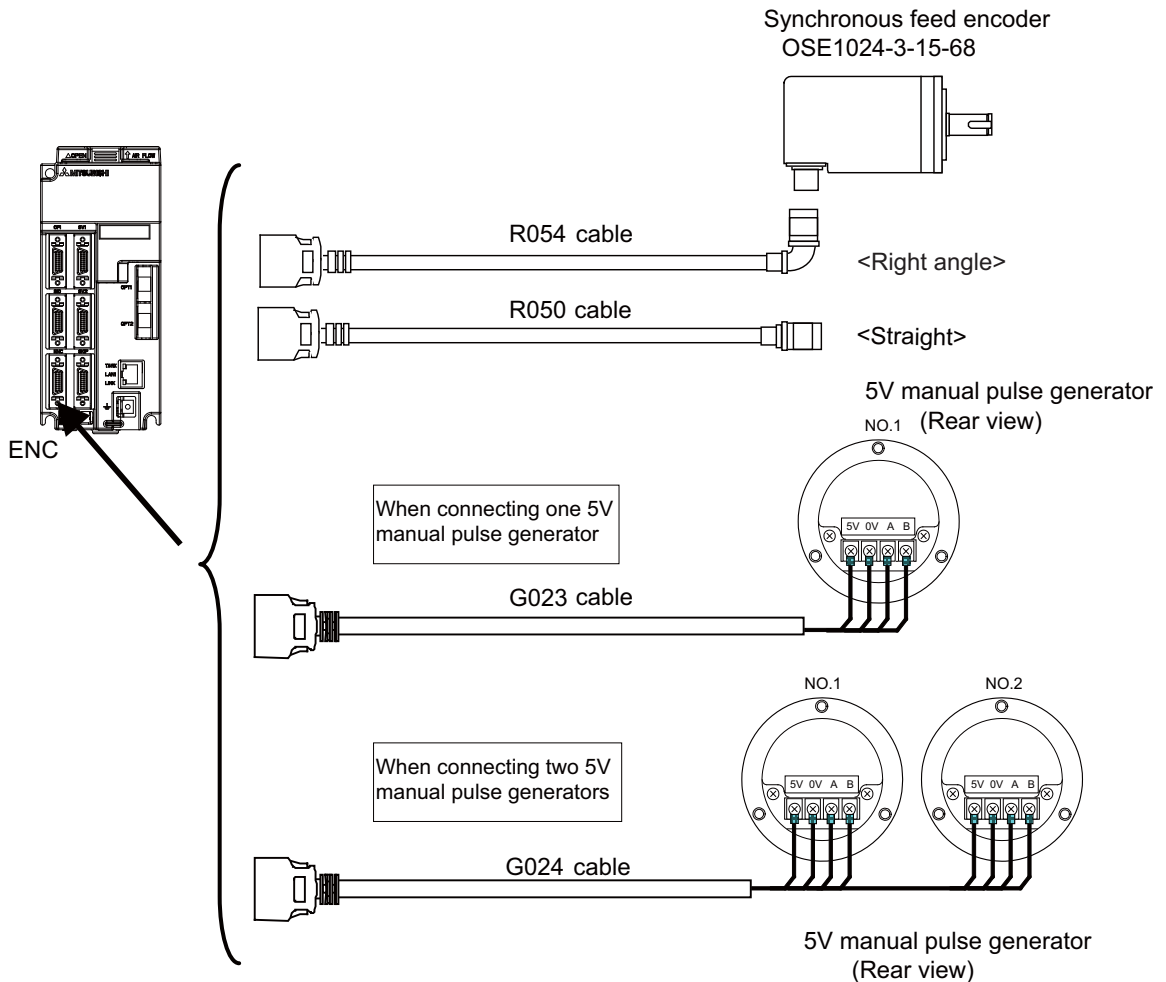

<Related items>

Cable drawing: "Cable: FCUA-R050/R054 Cable" and "Cable: G023/G024 Cable"

Connector pin assignment: "General Specifications: Control Unit" (ENC connector)

When using the synchronous feed encoder and the manual pulse generator at the same time, the cables must be prepared by the machine tool builder.

4.2.9.1 Handle Numbers

Unit configuration decides handle Nos.

"ENC": Connector on control unit "MPG": Connector on operation panel I/O unit

Operation panel I/O unit (FCU7-DX67x/ DX77x)	Function	Connector name	Function
Used	"MPG" 1ch	"MPG" 2ch	"MPG" 3ch
Not used	"ENC" 1ch	"ENC" 2ch	-

(Note) If one handle is only connected to "MPG", the handle connected to "ENC" 1ch will still be treated as the 3rd handle.

4.2.10 Connecting with Safety Observing I/O Device

Safety observing functions follow "IEC61800-5-2/EN61800-5-2", and safety of the functions complies with "ENISO13849-1:2008 (PL d, Category 3)". However, make sure to check the safety of the machine by using "risk assessment".

With this function, the following executions can be realized.

- (1) Open the door without shutting the motor drive power OFF.
- (2) Operate under the safety speed or lower while the door is open.

Refer to the "Safety Handbook (Original Instructions)" (IB-1501025) for the details of the connection with the safety observing I/O devices.

Refer to the instruction manual of the drive unit for the details of the connection with the drive unit.

4.2.10.1 Connection diagram using SDIO connector

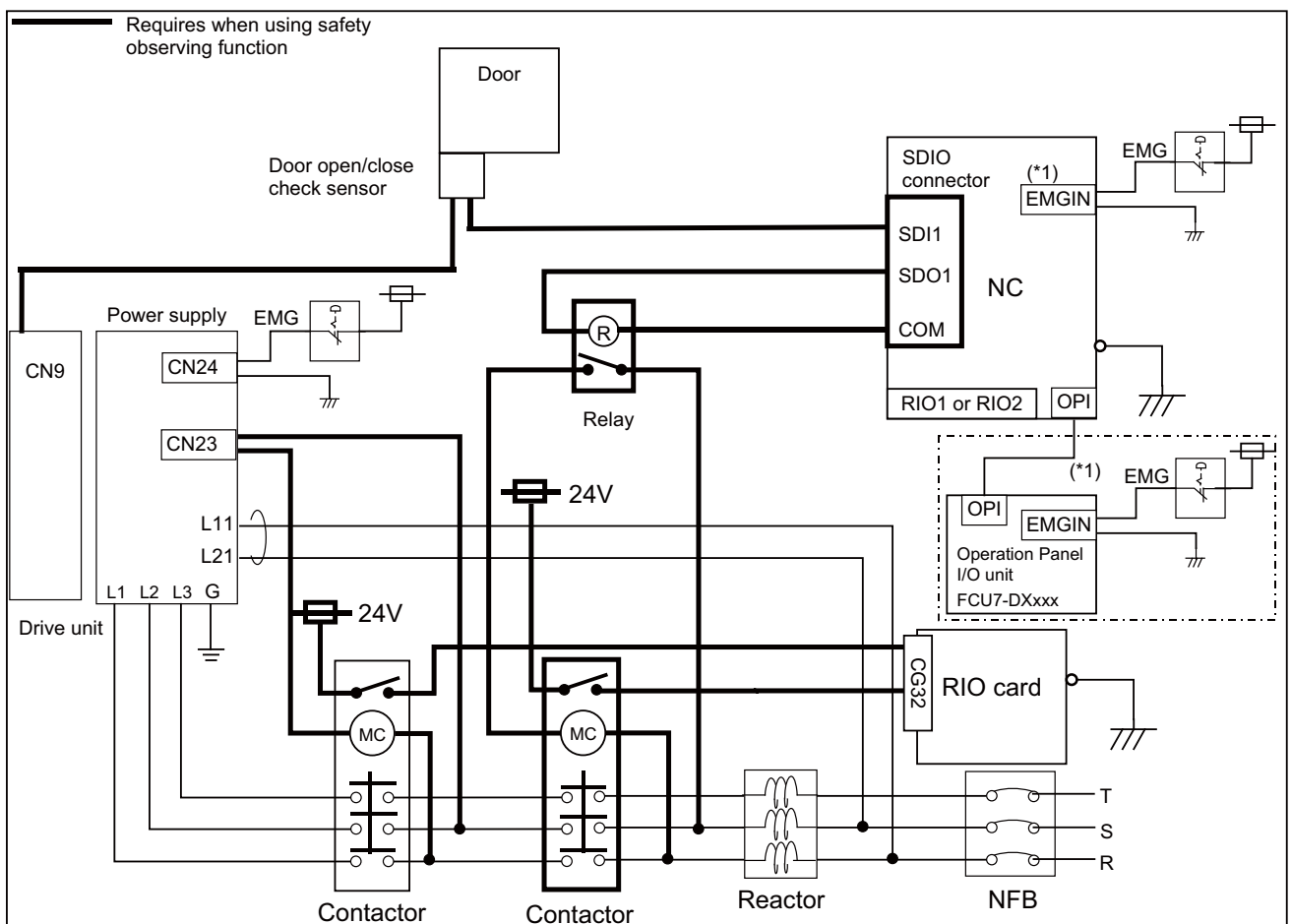

- (*1) NC side emergency stop input is in NC unit body and operation panel I/O unit. Disusing side needs to be ended.

(Note) Cables for the SDIO connector must be manufactured by the machine tool builder.
 [SDIO connector cable]

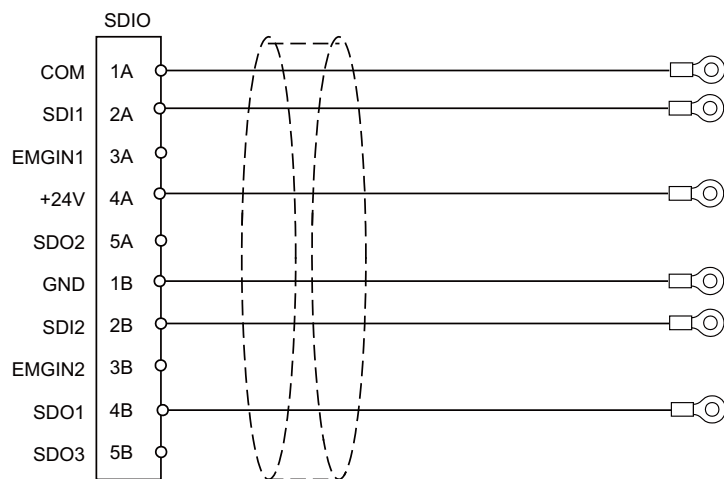
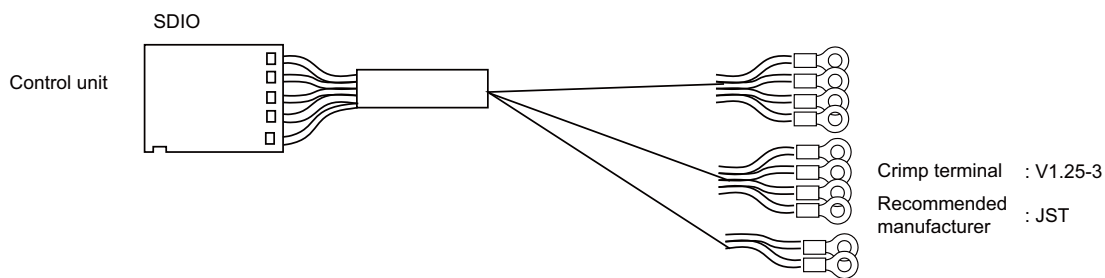

Connector : 51353-1000
 Contact : 56134-9000 x6
 Recommended manufacturer : MOLEX

Wire material : UL1061-2464 AWG22
 Recommended manufacturer : Oki Electric Cable

4.2.10.2 Connection diagram using I/O unit

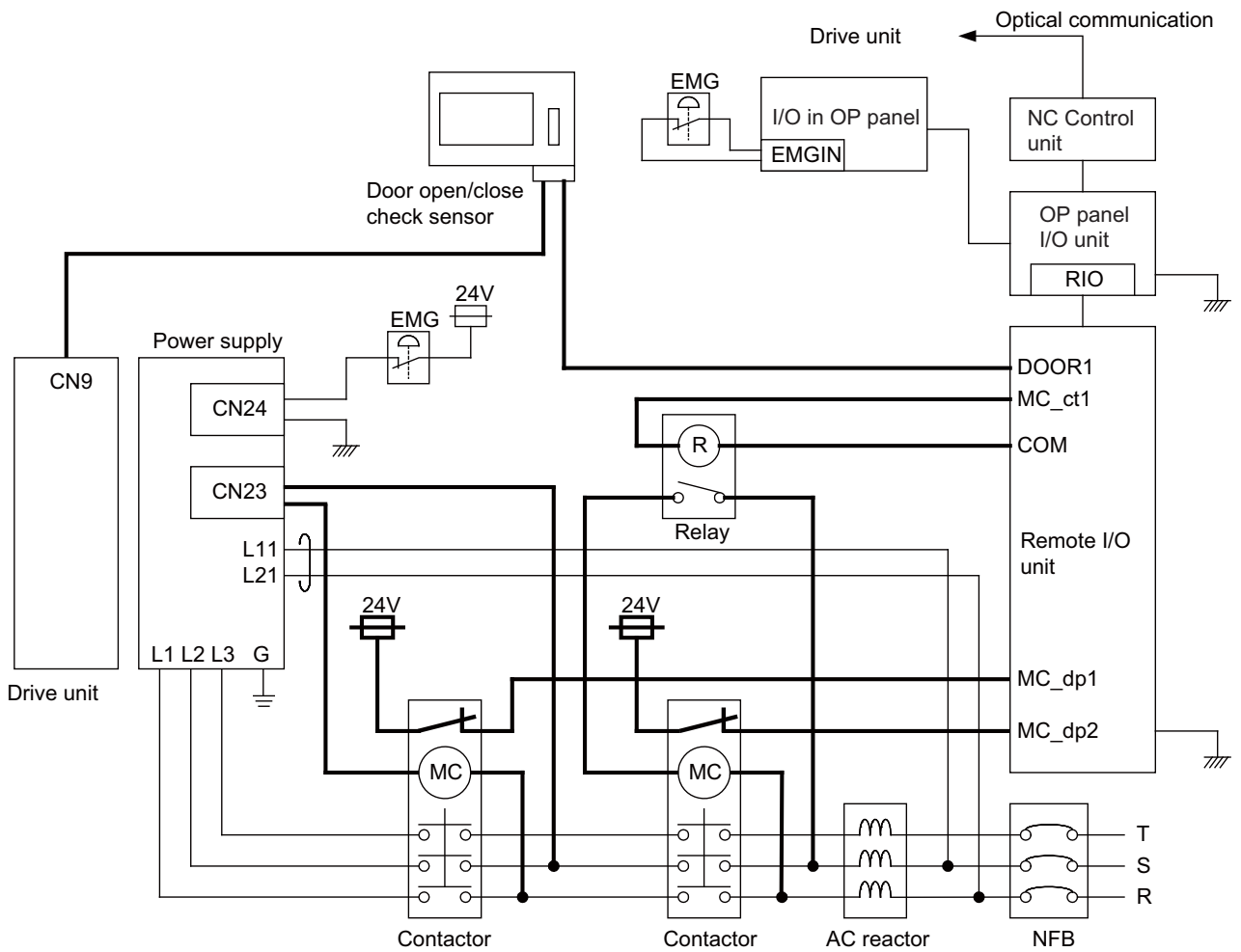

4.2.10.3 Connection diagram using the STO-compatible drive system

STO (Safe Torque Off) is a function to execute the gate shutdown by drive unit's internal circuit.

Two contactors were used for duplex power shutdown. However, the STO function can be substituted for one of the contactors.

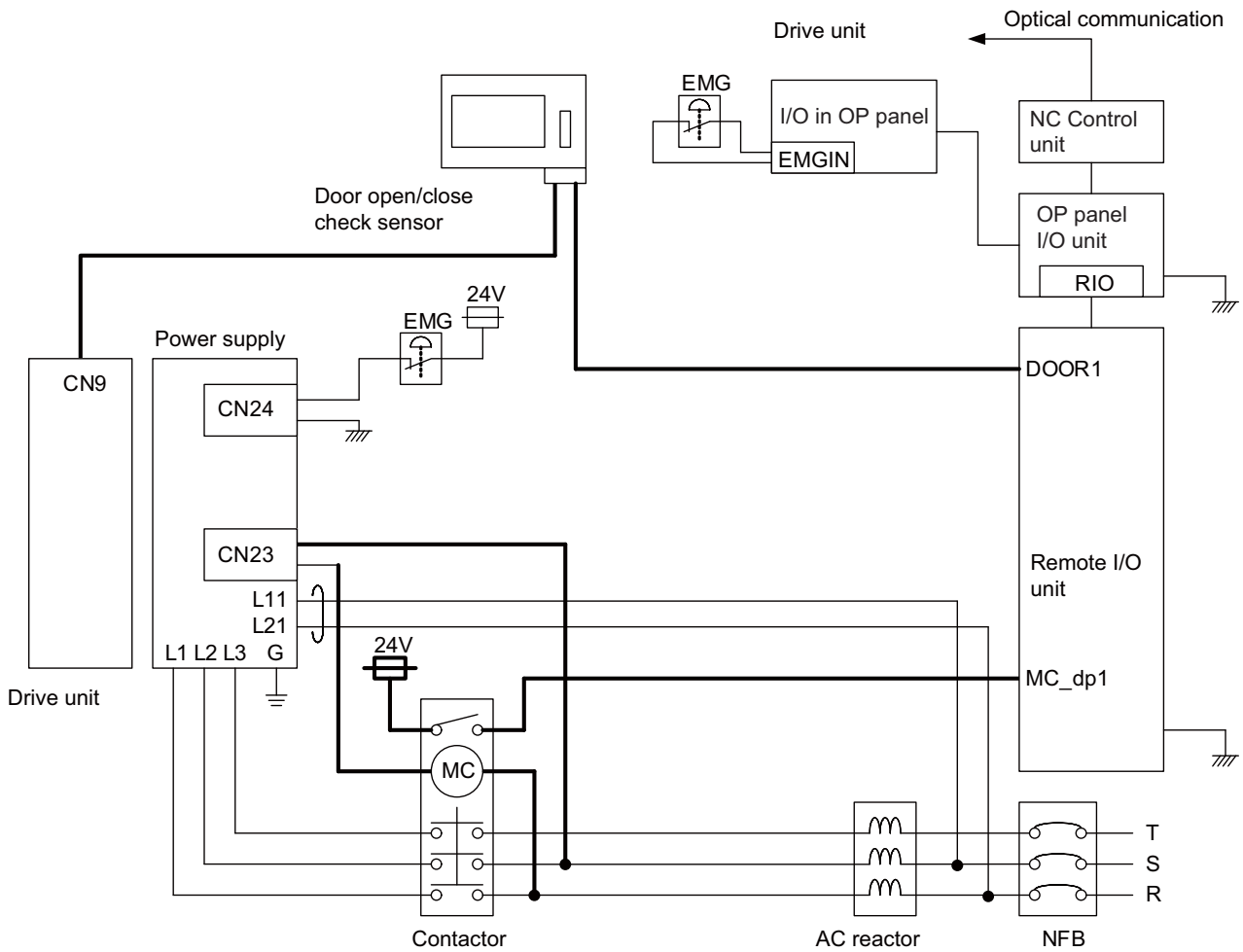

4.2.11 Connecting with I/O Devices via Expansion Card

Expansion unit (FCU7-EX891) and expansion card is required for connecting I/O devices via expansion card. Mount the expansion unit on the right side of the control unit, then the expansion card onto the slot of the expansion unit.

4.2.11.1 Connecting with I/O Devices via PROFIBUS-DP

The expansion card FCU7-HN578/FCU7-HN571 operates as a PROFIBUS-DP master station.

Use dedicated cable for the PROFIBUS-DP and connect to the NET connector.

When installed at the end of the network, turn the terminator slide switch ON. In all the others cases, the switch must be turned OFF.

When setting parameters in the PFOFIBUS-DP unit by using configuration software (parameter setting tool), connect PROFIBUS-DP unit and personal computer (PC/AT compatible) with G295 cable or RS-232C cross cable. At this time, configuration software must be installed in the personal computer.

[Connection of FCU7-HN578]

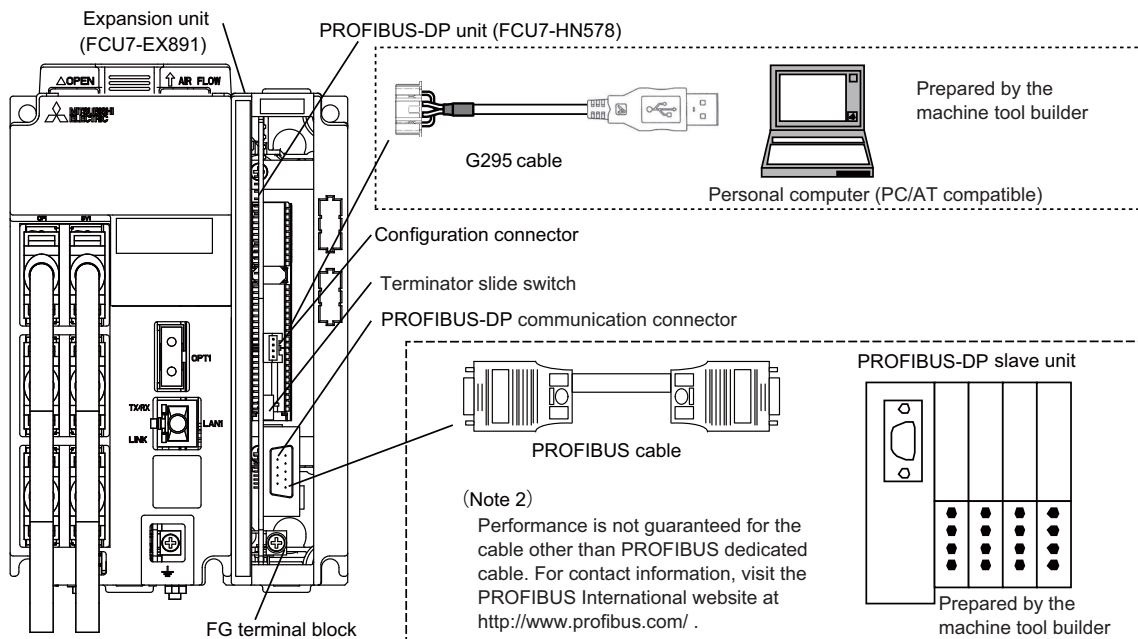

(Note 1) Connect FG wire to the main earth plate of the electric cabinet.

[Connection of FCU7-HN571]

(Note) Out of production (replacement: FCU7-HN578)

Use the RS-232C cross cable to connect with a personal computer (PC/AT compatible). The rest is the same as the FCU7-HN578 connection.

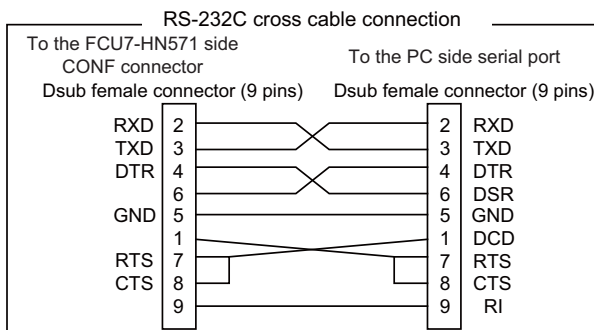

(Note)
There are open pins on FCU7-HN571 side, but connection should be made to all pins to eliminate the cable orientation.

For the inquiries related to configuration software, contact:

Hilscher Gesellschaft für Systemautomation mbH
Rheinstrasse 78
D-65795 Hattersheim Germany
TEL: +49-6190-9907-0 FAX: +49-6190-9907-50

4.2.11.2 Connecting with I/O Devices via CC-Link

The expansion card FCU7-HN576/FCU7-HN577 operates as a CC-Link (Ver.2) master/local station. CC-Link uses the dedicated cable. Connect the cable to the terminal block provided with the CC-Link unit. Make sure to attach the terminator, provided with the CC-Link unit, to the final station unit.

Connection of FCU7-HN576

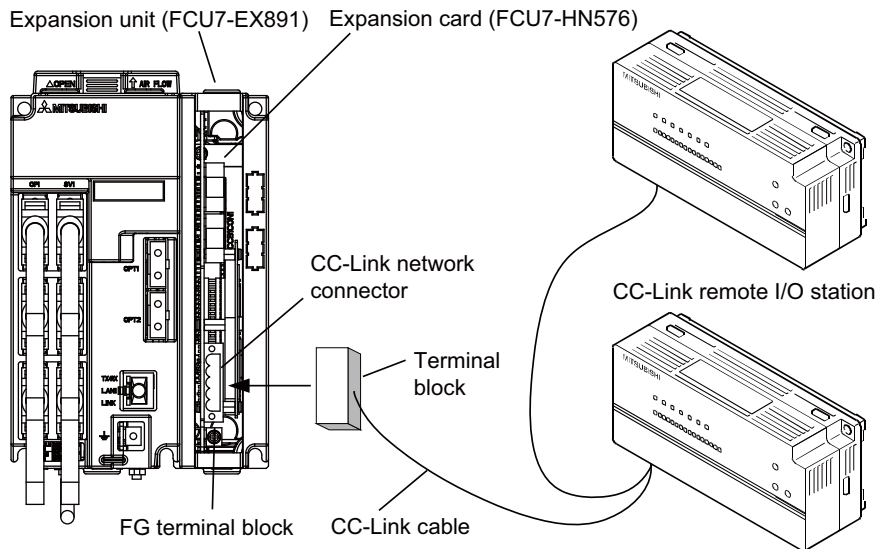

Connection of FCU7-HN577

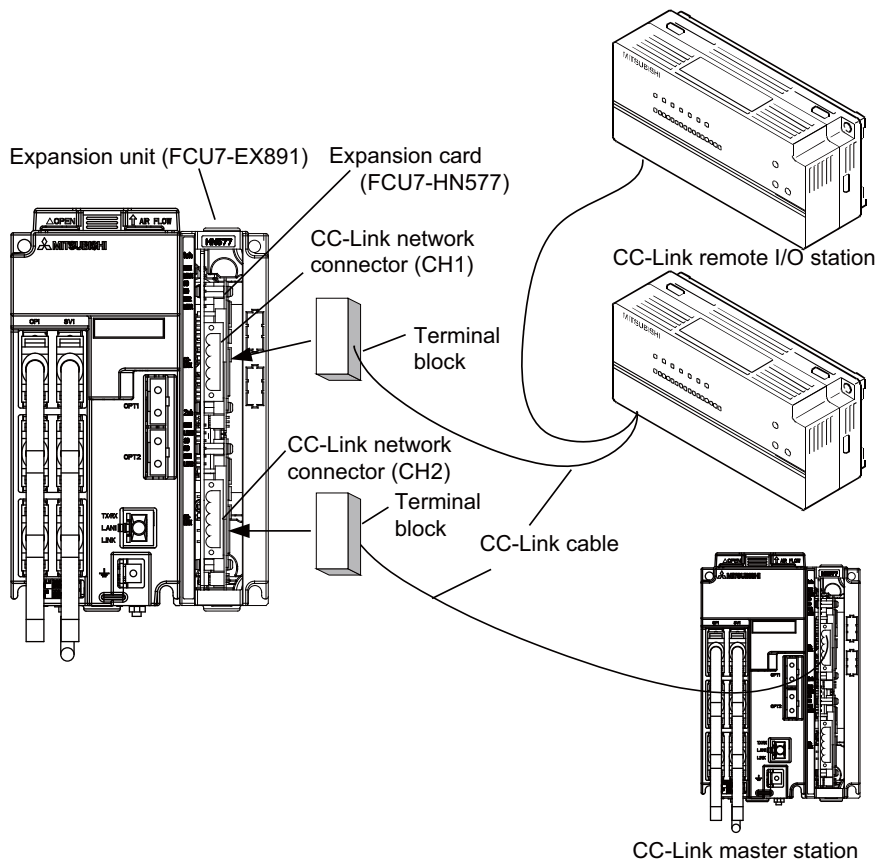

Connection of CC-Link cable

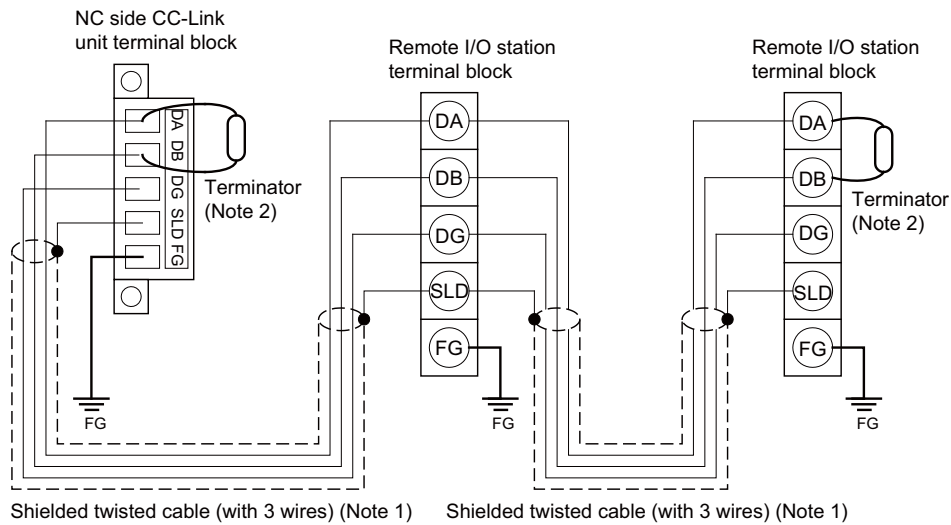

(Note 1) Unless the CC-Link dedicated cable is used, CC-Link system does not guarantee its operation. For the specifications of the CC-Link dedicated cable and the inquiries, see the homepage of the CC-Link Partner Association (<http://www.cc-link.org/>). (Click "Product Information".)

(Note 2) Use the terminator provided with the CC-Link unit. The value of the terminator depends on the cable used: 110 Ω when the CC-Link dedicated cable is used, 130 Ω when the CC-Link dedicated high performance cable is used.

Connection of FG wire

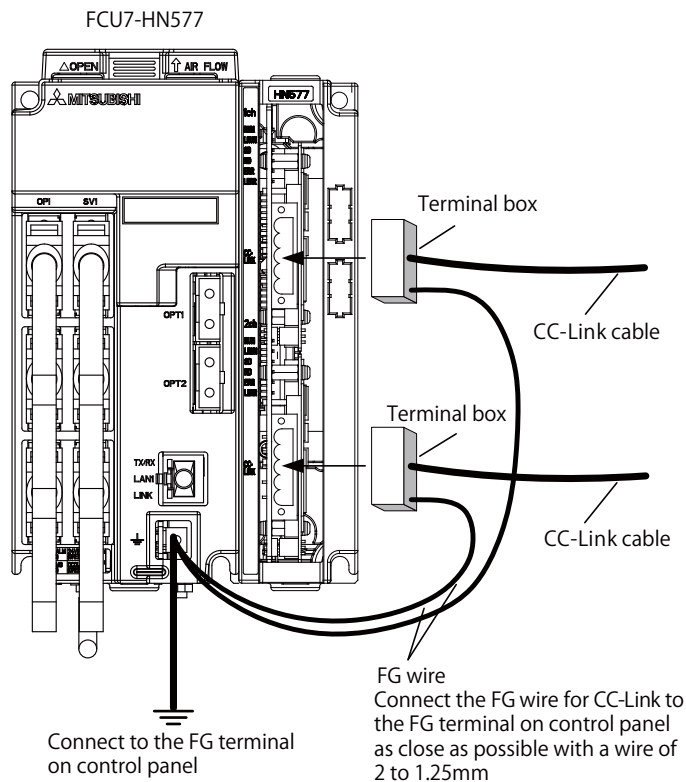

(Note 1) Use the FG terminal on the NC side CC-Link terminal block for the connection to the ground of the electric cabinet.

(Note 2) As FCU7-HN577 does not have its special FG terminal block, use the FG terminal on CC-Link terminal block. When using the FG terminal on CC-Link terminal block, connect it to the ground of the electric cabinet via the special terminal block for FG on the control unit.

Wiring the cables to the CC-Link terminal block

- (1) Remove the sheath of the cable and isolate each internal wire from the shield mesh.
- (2) Remove the shield mesh and the coat of each internal wire. Twist the core wires.

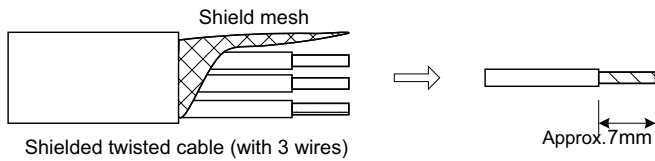

- (3) In the intermediate station, twist together the same wires or the shield meshes of the cables from/to the previous/next station.
- (4) In the final station, process the provided terminator as follows to attach to the station.

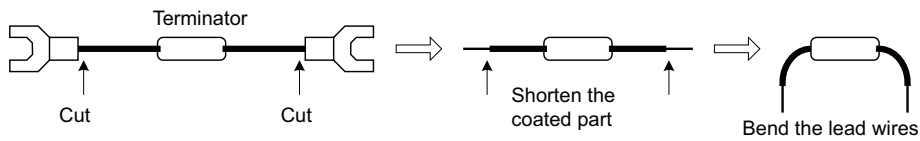

- (5) Insert the core wire into the opening of the terminal block. Hold the wire tight with a flat-blade screwdriver. Check the screws on the terminal are loose enough before inserting the wires into the openings.

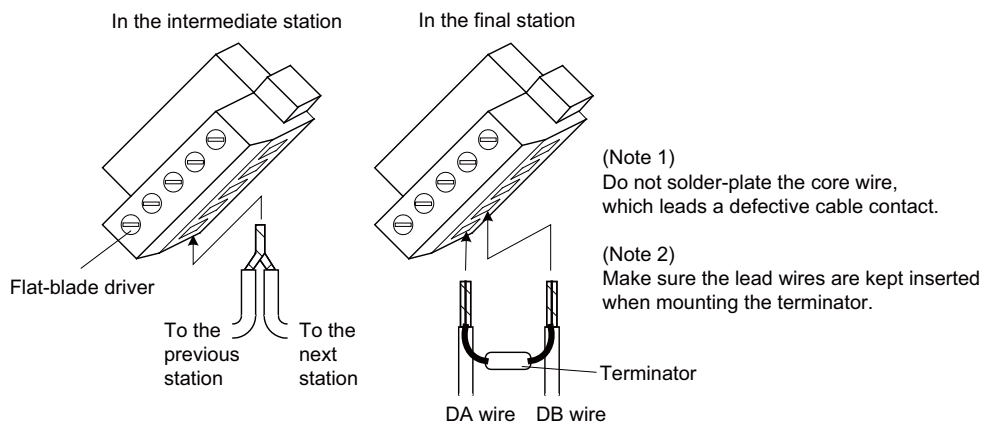

- (6) After wiring cables to the terminal block, Mount the terminal block into the CC-Link connector and fix it with a flat-blade screwdriver.

4.3 Connection of Operation Panel I/O Unit

4.3.1 Operation Panel I/O Unit Connection System Drawing

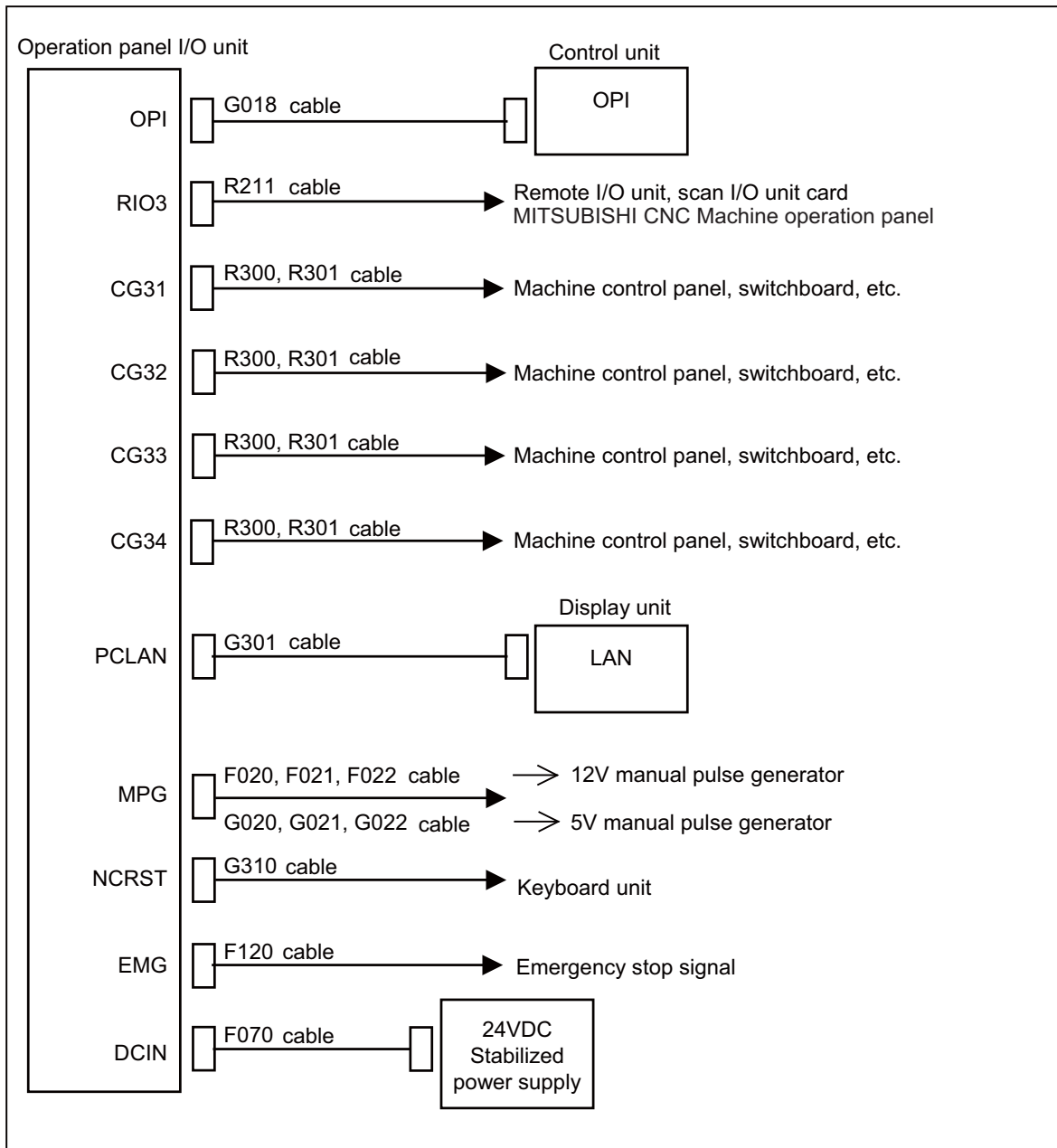

4.3.2 Connecting with Power Supply

Connect 24VDC power supply (general-purpose stabilized power supply) to the operation panel I/O unit.

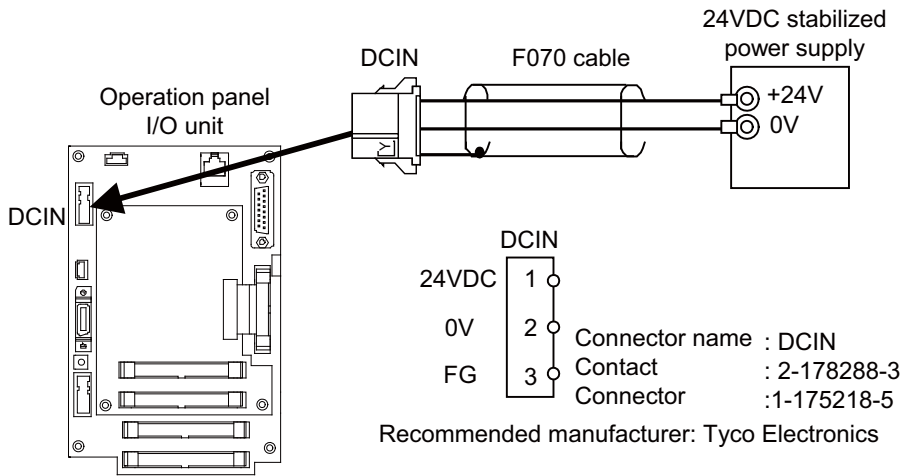

(Note) Install the ferrite core that comes with the operation panel I/O unit on the F070 cable.
Refer to the section "Connection : Precautions for Wiring : Ferrite Core Installation Method" for details.

<Related items>

Cable drawing: "Cable: F070 Cable"

Connector pin assignment: "General Specifications: Operation Panel I/O Unit" (DCIN connector)

4.3.3 Connecting with Emergency Stop Signal

Emergency stop switch is connected to EMG connector by F120 cable.

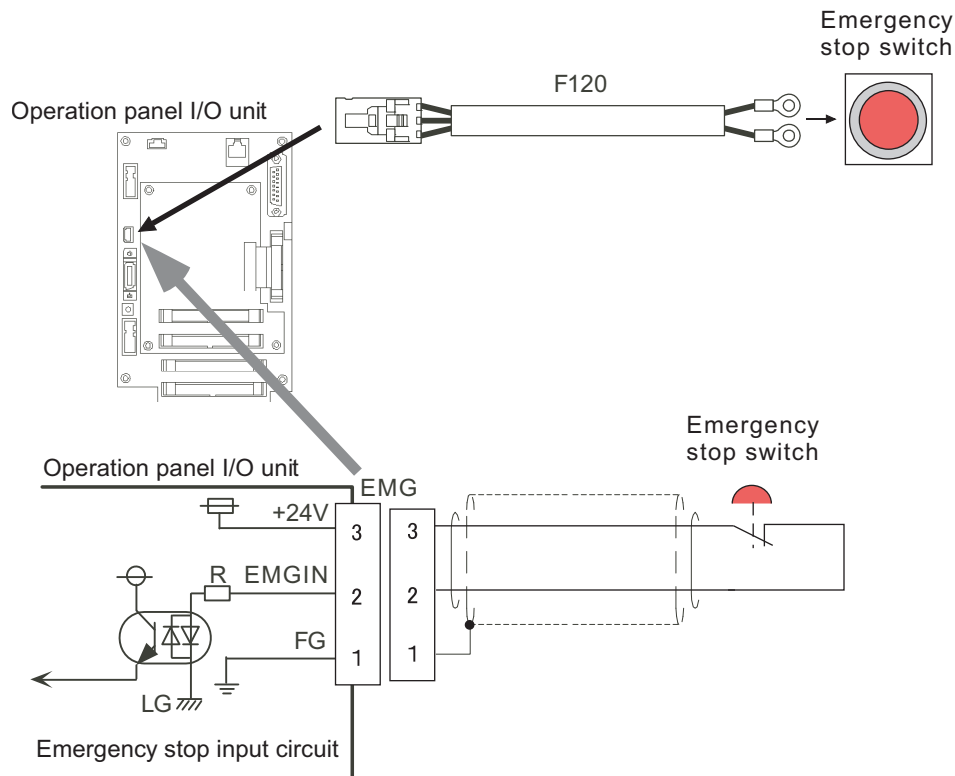

<Related items>

Cable drawing: "Cable: F120 Cable"

<When not using operation panel I/O unit side emergency stop input signal (EMG)>

When not using operation panel I/O unit side emergency stop input signal (EMG), such as when control unit side emergency stop input signal (EMG) is used, invalidate the input signal by using terminal cable G123.

Note that G123 cable does not come with the operation panel I/O unit. (G123 cable comes with the control unit.)

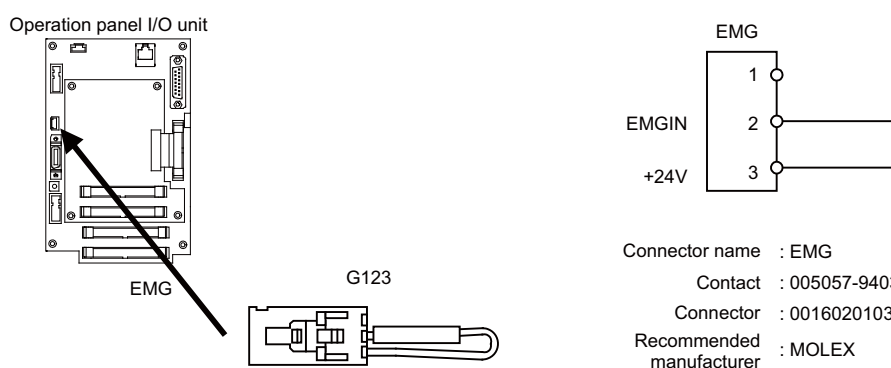

(Note) When installing emergency stop switch at operation panel and electric cabinet each, both emergency stop input signals (EMG), the signal at the operating panel I/O unit side and at the control unit side, can be used.

4.3.4 Connecting with Display Unit

Connect display unit to the connector PCLAN.

G301 cable (1m) comes with the operation panel I/O unit.

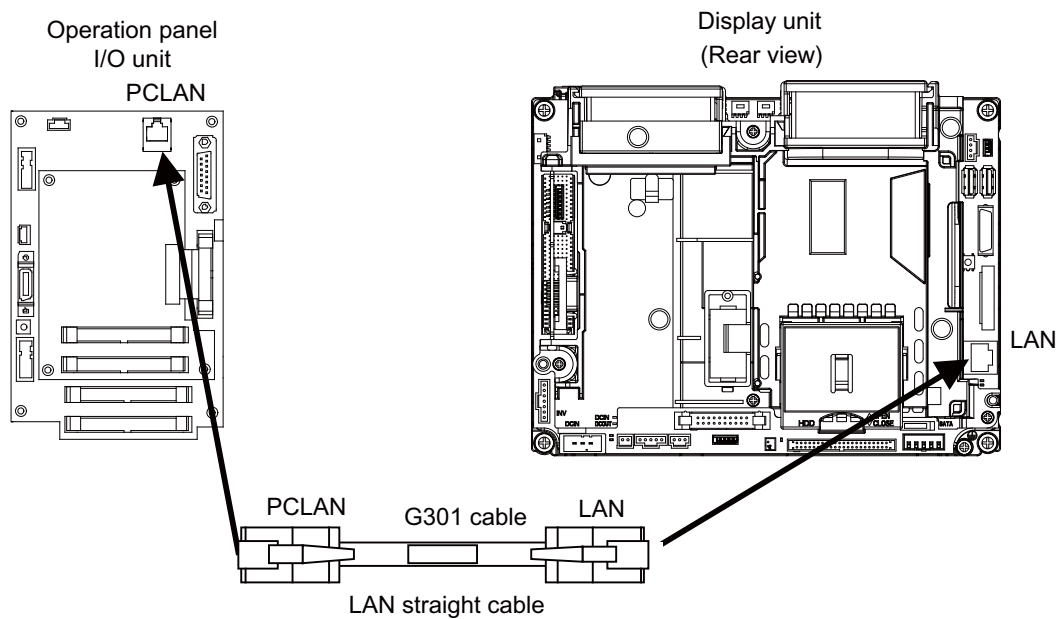

<Related items>

Cable drawing: "Cable: G301 Cable"

Connector pin assignment: "General Specifications: Operation Panel I/O Unit" (PCLAN connector)

4.3.5 Connecting with Keyboard Unit

Connect keyboard unit to the connector NCRST.
G310 cable (0.08m) comes with the operation panel I/O unit.

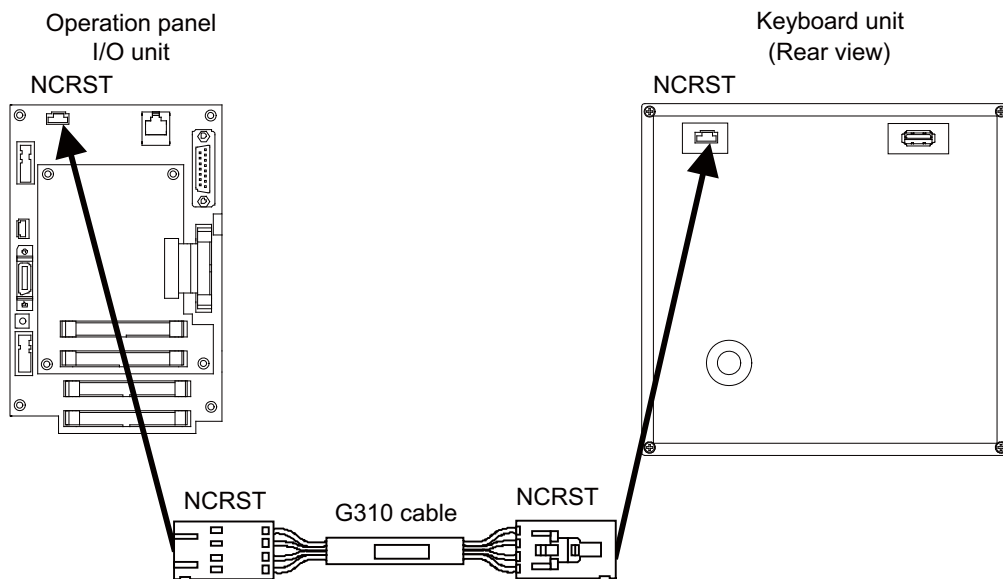

<Related items>

Cable drawing: "Cable: G310 Cable"

Connector pin assignment: "General Specifications: Operation Panel I/O Unit" (NCRST connector)

4.3.6 Connecting with Manual Pulse Generator (MPG)

Both 5V power supply type (UFO-01-2Z9) and 12V power supply type (HD60C) manual pulse generator can be used. Take the maximum cable length, etc. into consideration when selecting.

- (Note) Set one of the following parameters which is suitable for your manual pulse generator.
- 5V manual pulse generator (UFO-01-2Z9) : #1240 set12/bit0 = 1 (100 pulse/rev)
 - 12V manual pulse generator (HD60C) : #1240 set12/bit0 = 0 (25 pulse/rev)

(1) Connecting with 5V manual pulse generator (maximum cable length: 20m)

Connect the 5V manual pulse generator to the connector MPG.

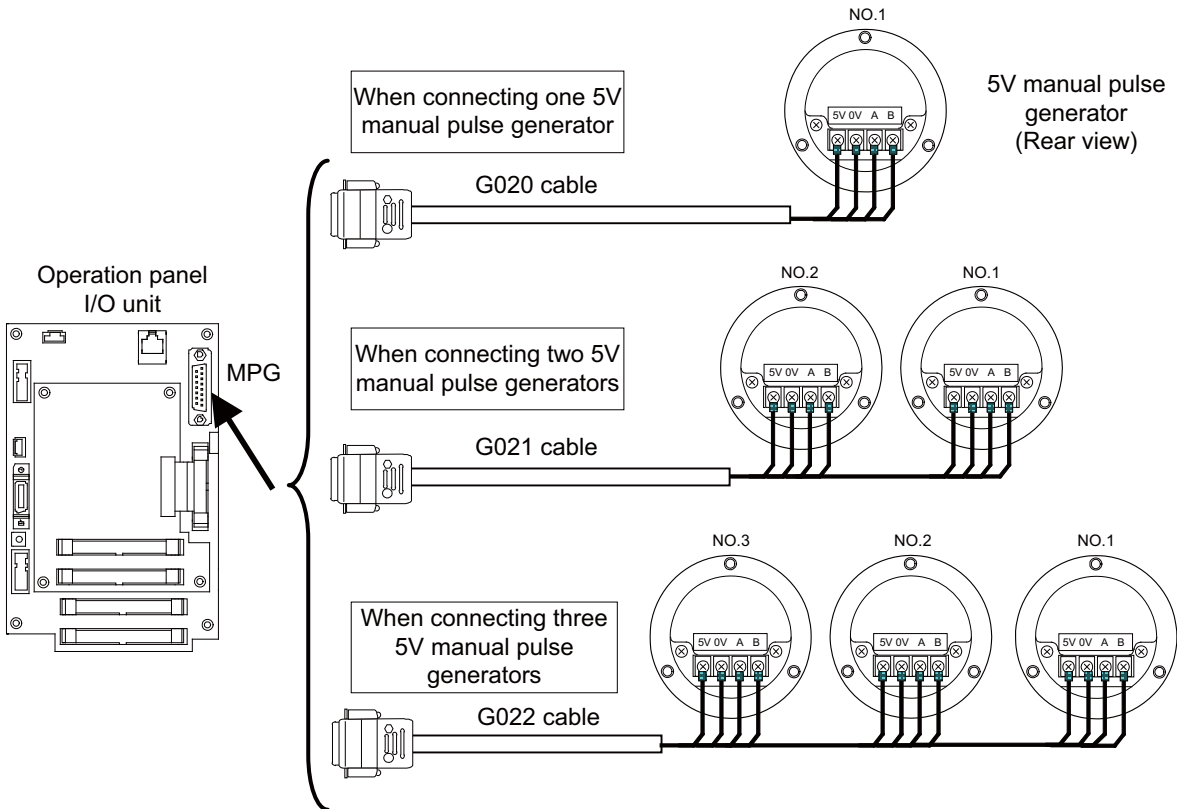

(2) Connecting with 12V manual pulse generator (maximum cable length: 50m)

Connect the 12V manual pulse generator to the connector MPG.

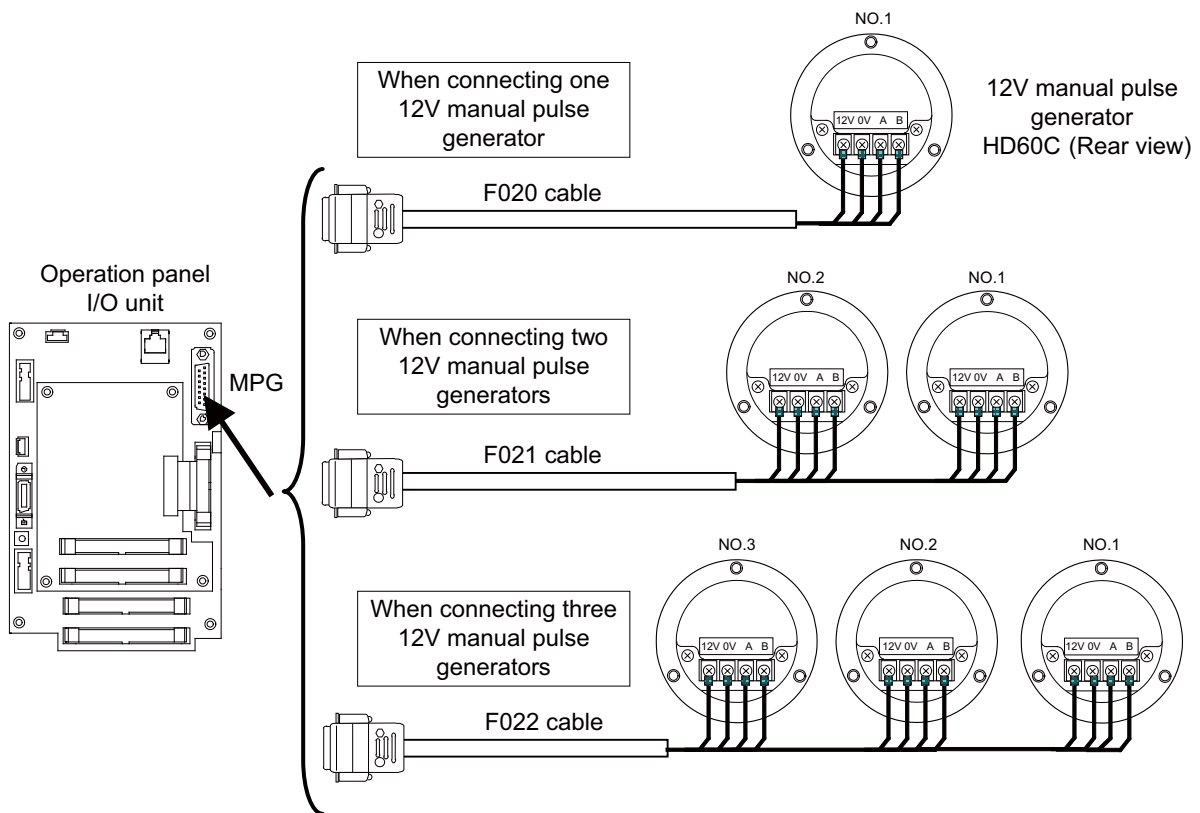

- (Note 1) When selecting a manual pulse generator, make sure that its case and 0V terminal are insulated.
 (Note 2) Select 25pulse/rev or 100pulse/rev on the parameter screen.

<Related items>

Cable drawing: "Cable: F020/F021/F022 Cable"

Connector pin assignment: "General Specifications: Operation Panel I/O Unit" (MPG connector)

4.3.6.1 Handle Numbers

Unit configuration decides handle Nos.

"ENC": Connector on control unit "MPG": Connector on operation panel I/O unit

Operation panel I/O unit (FCU7-DX67x/ DX77x)	1st handle	2nd handle	3rd handle
Used	"MPG" 1ch	"MPG" 2ch	"MPG" 3ch
Not used	"ENC" 1ch	"ENC" 2ch	-

(Note) If one handle is only connected to "MPG", the handle connected to "ENC" 1ch will still be treated as the 3rd handle.

4.3.7 Connecting with Machine Operation Panel

Connect the machine operation panel to the connector CG31, CG32, CG33 or CG34.

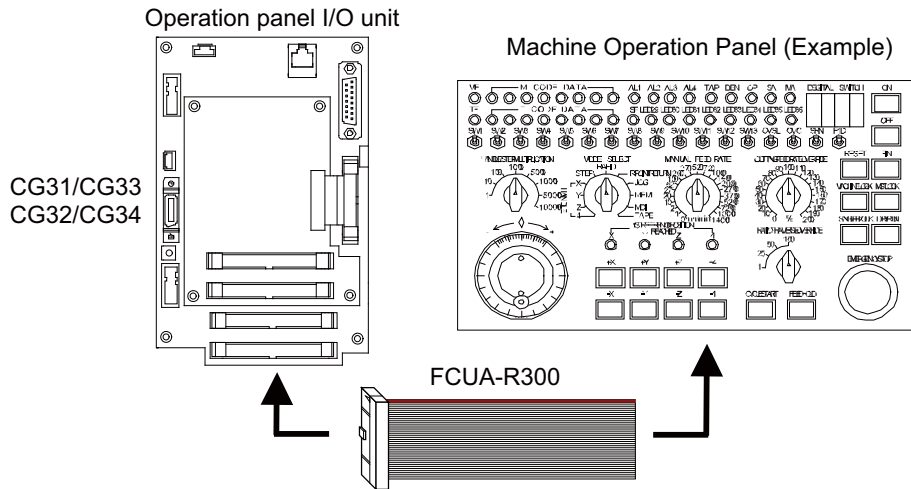

<Related items>

- Cable drawing: "Cable: FCUA-R300/FCUA-R301 Cable"
- Connector pin assignment: "General Specifications: Operation Panel I/O Unit" (CG31/CG32/CG33/CG34 connector)

4.3.7.1 Wiring for 24V Common Input

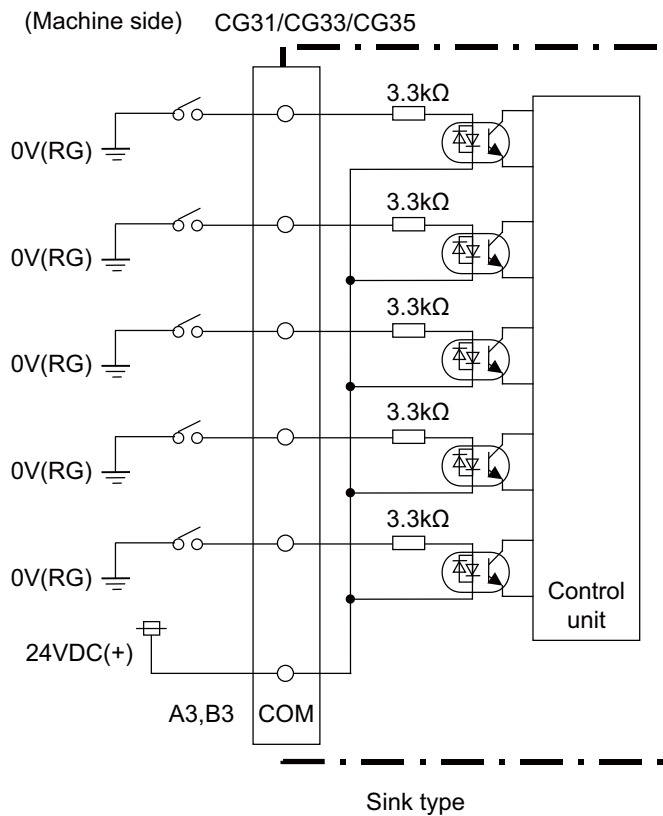

For connection details, refer to the descriptions on machine input connector pin assignment in "(1) Machine input (CG31)", "(2) Machine input (CG33)", and "(3) Machine input (CG35)" under Section "General Specifications: Operation Panel I/O Unit".

4.3.7.2 Wiring for 0V Common Input

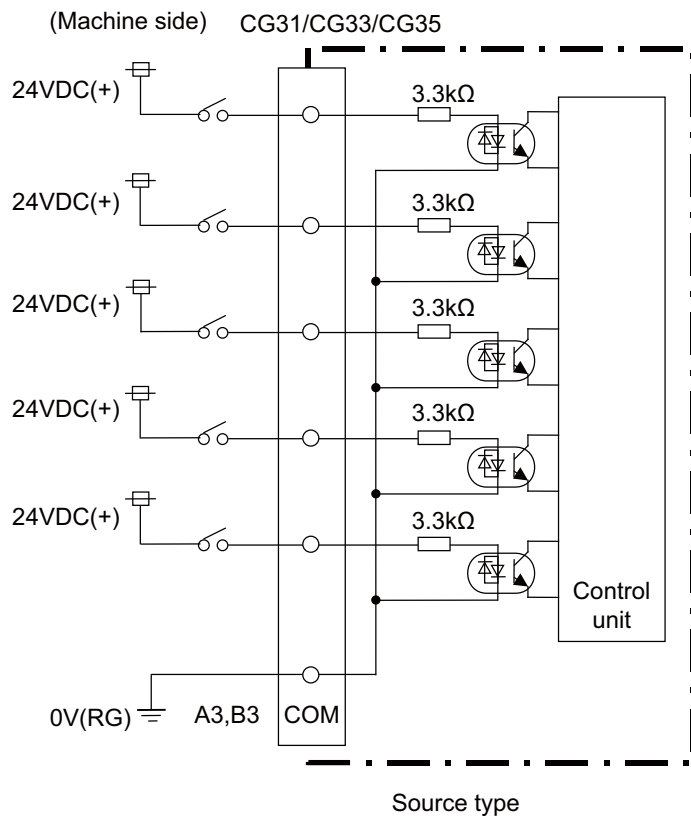

For connection details, refer to the descriptions on machine input connector pin assignment in "(1) Machine input (CG31)", "(2) Machine input (CG33)", and "(3) Machine input (CG35)" under Section "General Specifications: Operation Panel I/O Unit".

4.3.7.3 Wiring for Sink Type Output (FCU7-DX670/DX770)

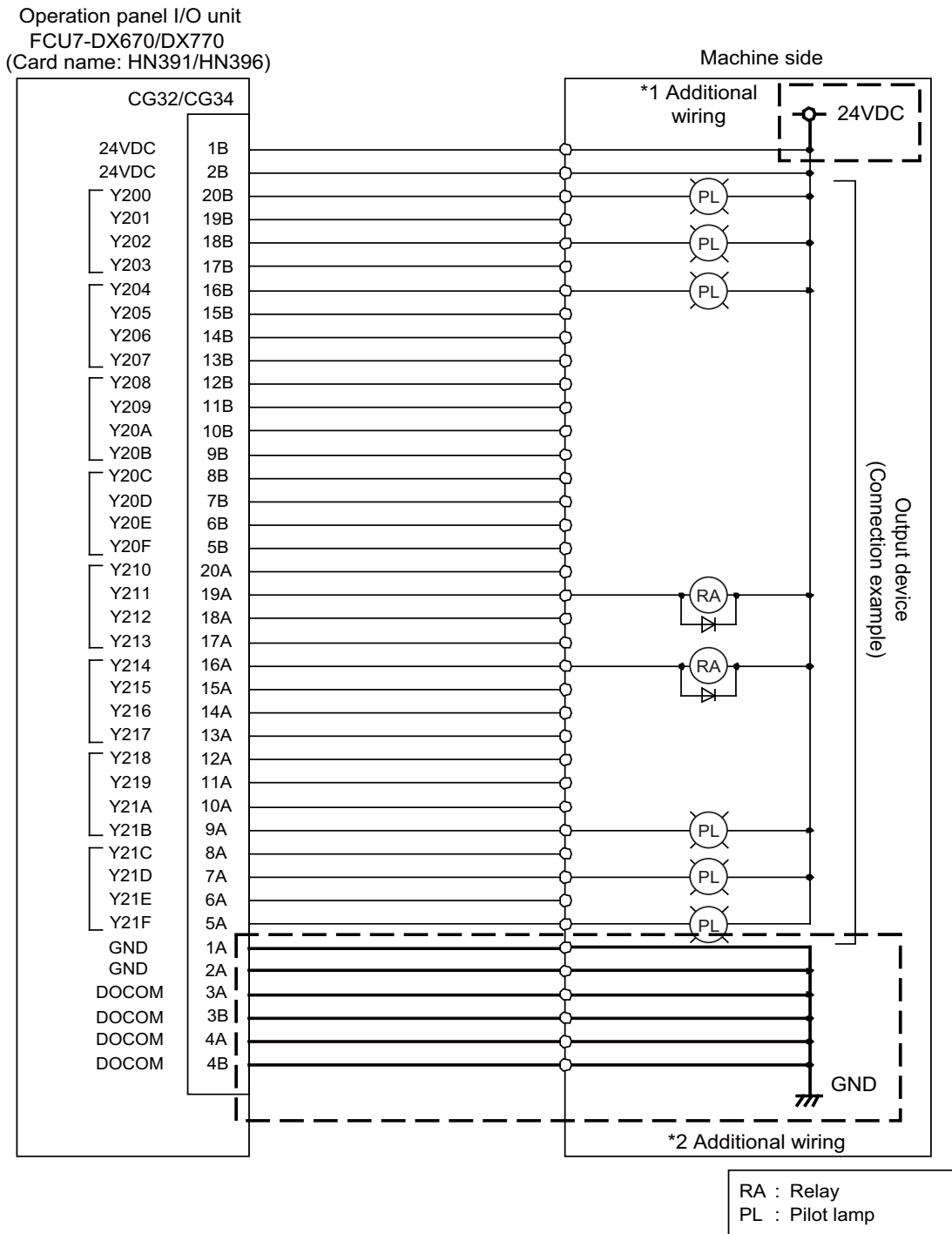

- (Note 1) Connect +24V to the flat connector 1B, 2B (24VDC). (*1)
- (Note 2) Connect 0V (GND) to the flat connector 3A, 3B, 4A, 4B (DOCOM). (*2)
- (Note 3) Connect 0V (GND) to the flat connector 1A, 2A (GND). (*2)
- (Note 4) When large current flows due to small amount of connected load, fuse may be blown out or 24V power supply voltage may drop. In order to secure the appropriate current value, watch the connected load.

4.3.7.4 Wiring for Source Type Output (FCU7-DX671/DX771)

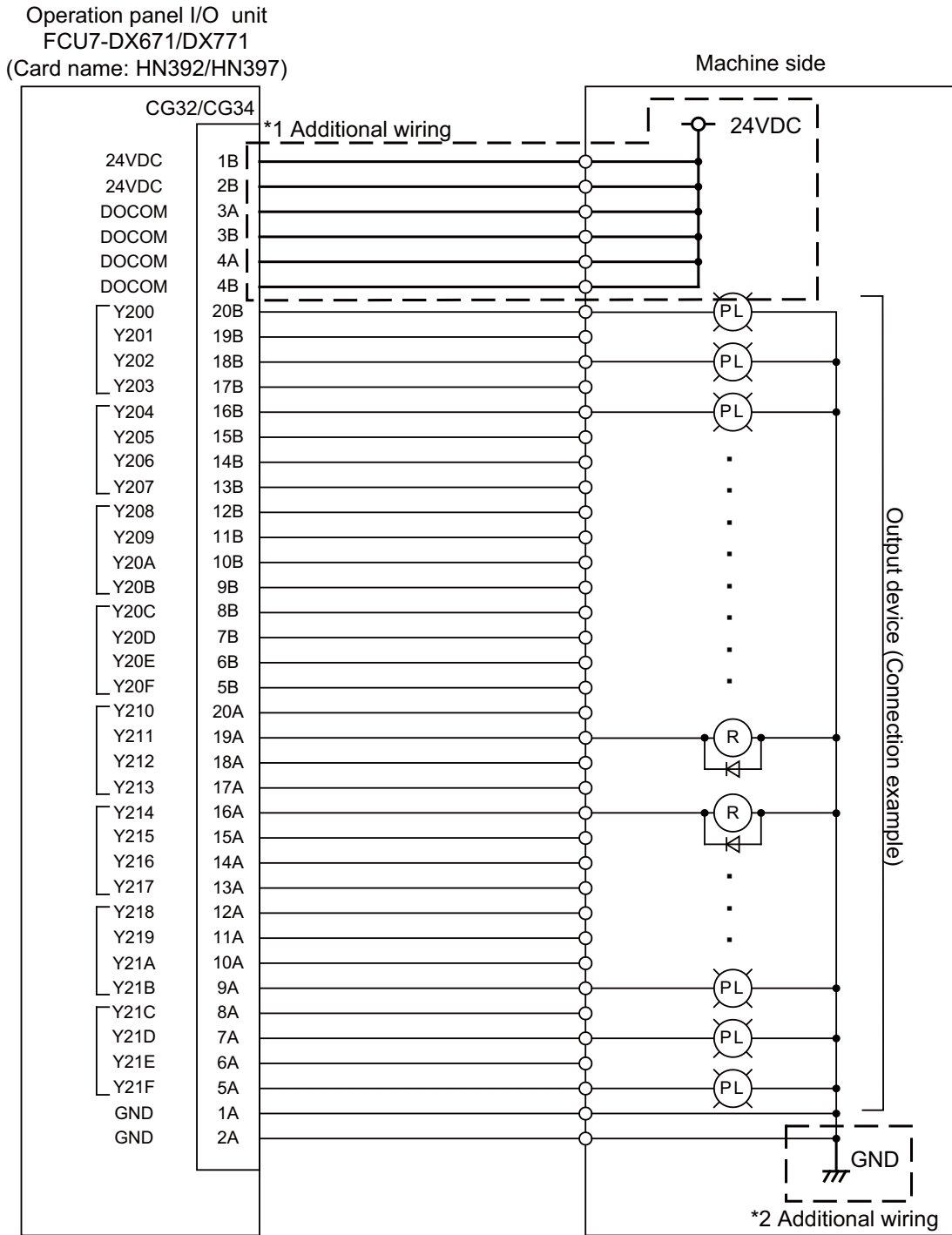

- (Note 1) Connect +24V to the flat connector 1B, 2B (24VDC). (*1)
- (Note 2) Connect +24V to the flat connector 3A, 3B, 4A, 4B (DOCOM). (*1)
- (Note 3) Connect 0V (GND) to the flat connector 1A, 2A (GND). (*2)
- (Note 4) For the power supply connected to DOCOM, consider the power consumption of the output devices.
- (Note 5) When large current flows due to small amount of connected load, fuse may be blown out or 24V power supply voltage may drop. In order to secure the appropriate current value, watch the connected load.

4.4 Connection of Display Unit

The method for connecting to each unit and device from the display unit is briefly explained in this section.

4.4.1 Display Unit Connection System Drawing

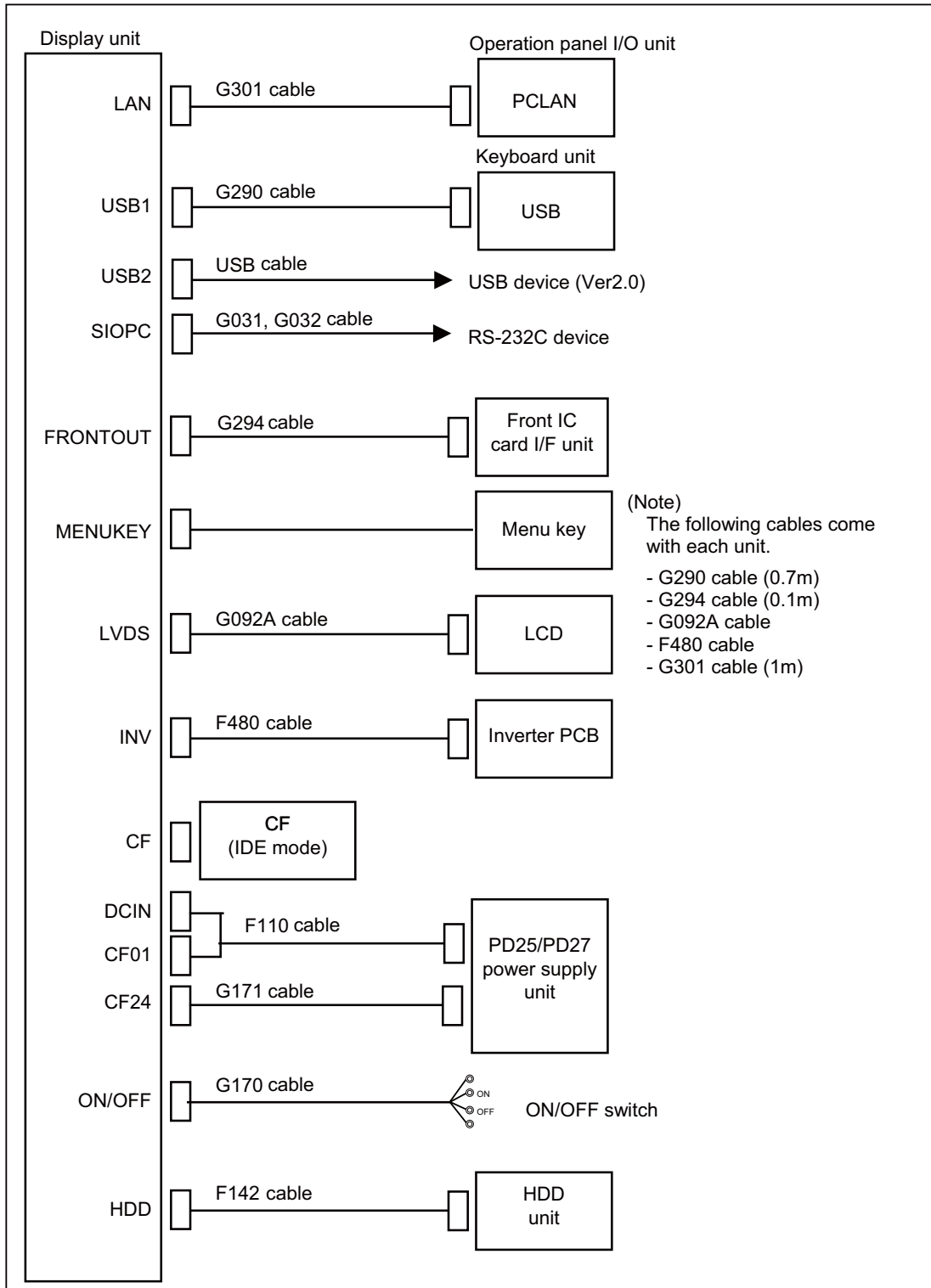

(Note) Refer to "General Specifications: Precautions for Use of USB Devices" for the precautions when connecting commercially available USB devices.

4.4.2 Connecting with Power Supply

Connect PD25/PD27 power supply unit to the display unit.

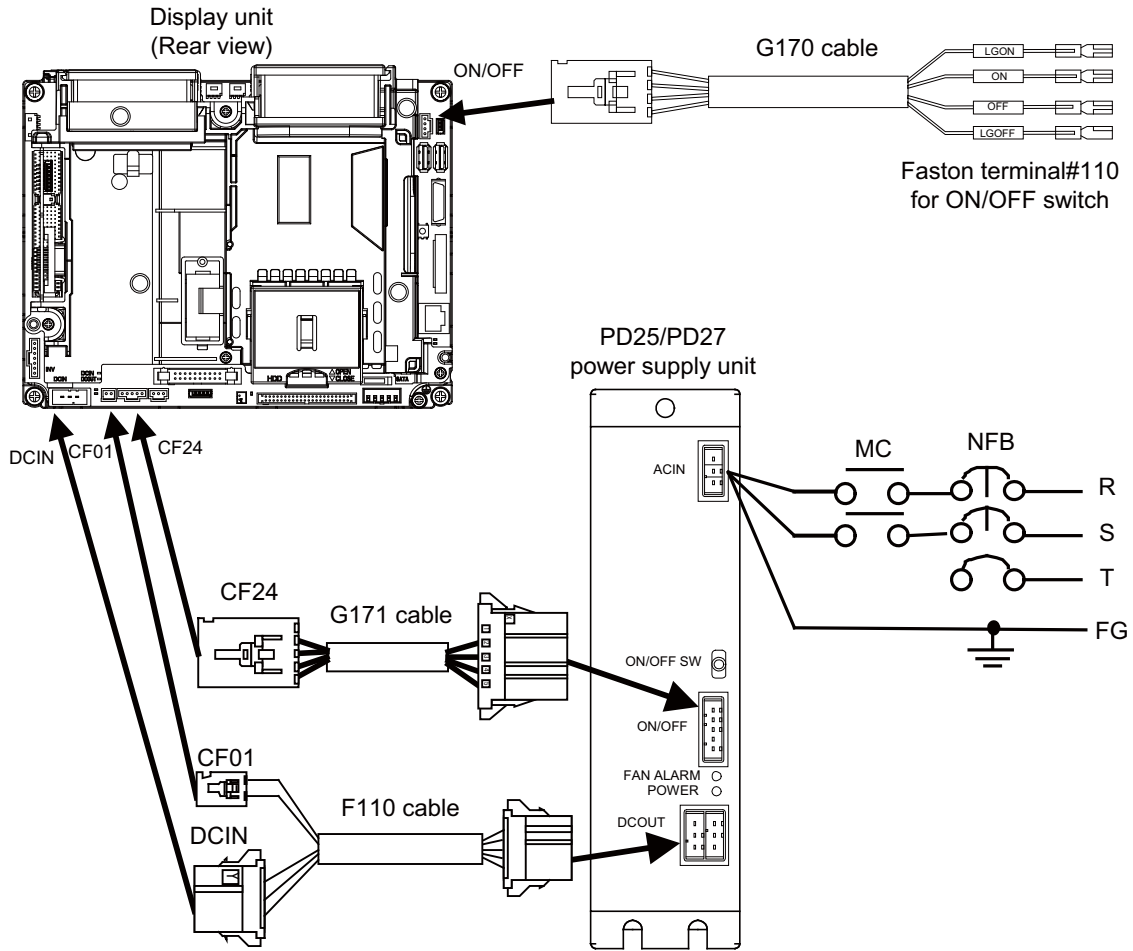

<Related items>

Cable drawing "Cable: F110/G170/G171 Cable"

Connector pin assignment: "General Specifications: Display Unit" (DCIN connector, CF01 connector, CF24 connector)

4.4.3 Connecting with Keyboard Unit

Connect keyboard unit to the connector USB1.
G290 cable (0.7m) comes with the keyboard unit.

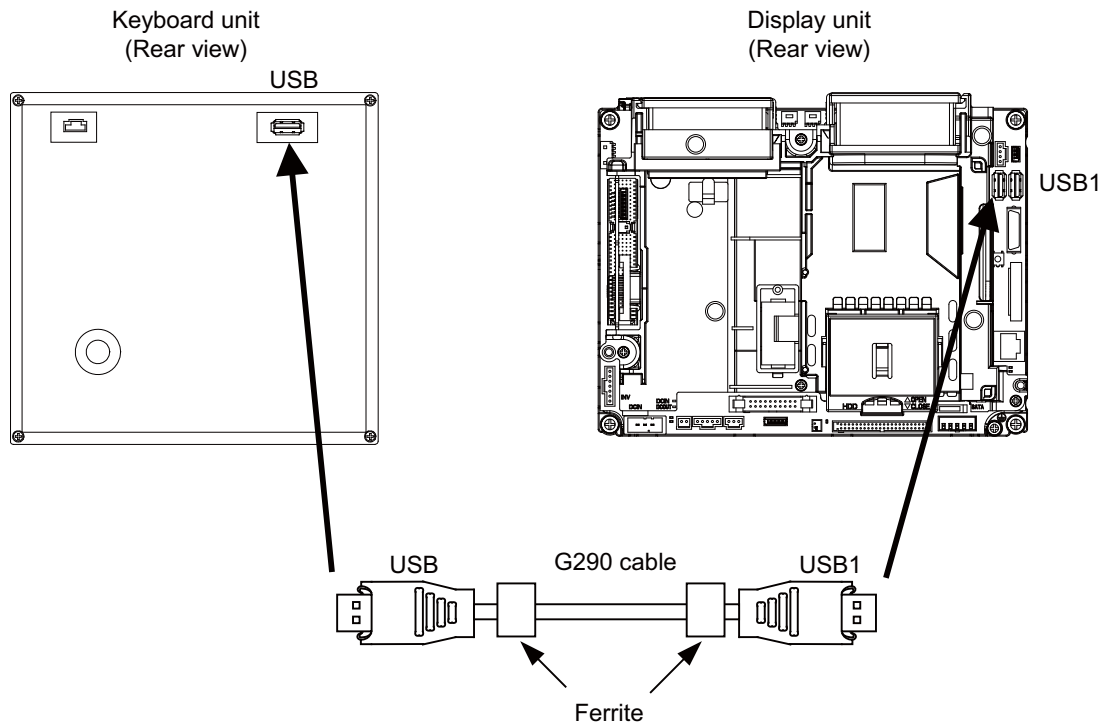

(Note) Do not use commercially available USB cable. Failure to observe could result in malfunction.

<Related items>

Connector pin assignment: "General Specifications: Display Unit" (USB1 connector)

4.4.4 Connecting with Hard Disk Unit

Connect hard disk unit to the connector HDD.

F142 cable comes with the hard disk unit (FCU7-HD002-1).

Hard disk unit can be mounted on the back of the keyboard unit FCU7-KB04x.

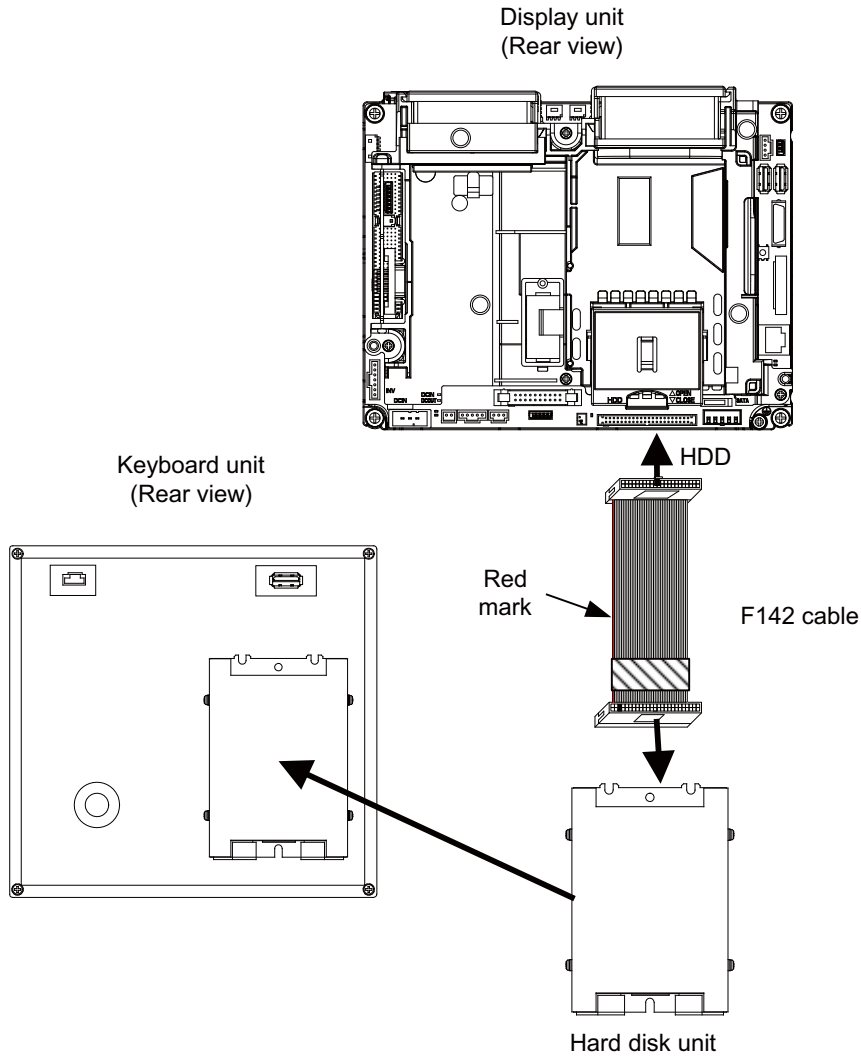

(Note) Do not turn the power OFF during access to the hard disk. Failure to observe this could cause the units to malfunction. In case of emergency, always perform backups by having your important data duplicated, etc. as MITSUBISHI will not guarantee the broken or lost data. Be sure to inform this matter to the end users.

<Related items>

Cable drawing "Cable: F142 Cable"

Connector pin assignment: "General Specifications: Display Unit" (HDD connector)

4.5 Connection of Remote I/O Unit

This chapter describes the connection of the remote I/O unit and machine control signals.

4.5.1 Connection and Station No. Setting on Remote I/O Unit

When connecting directly to the control unit

Control unit
FCU7-MU031/041
FCU7-MA041

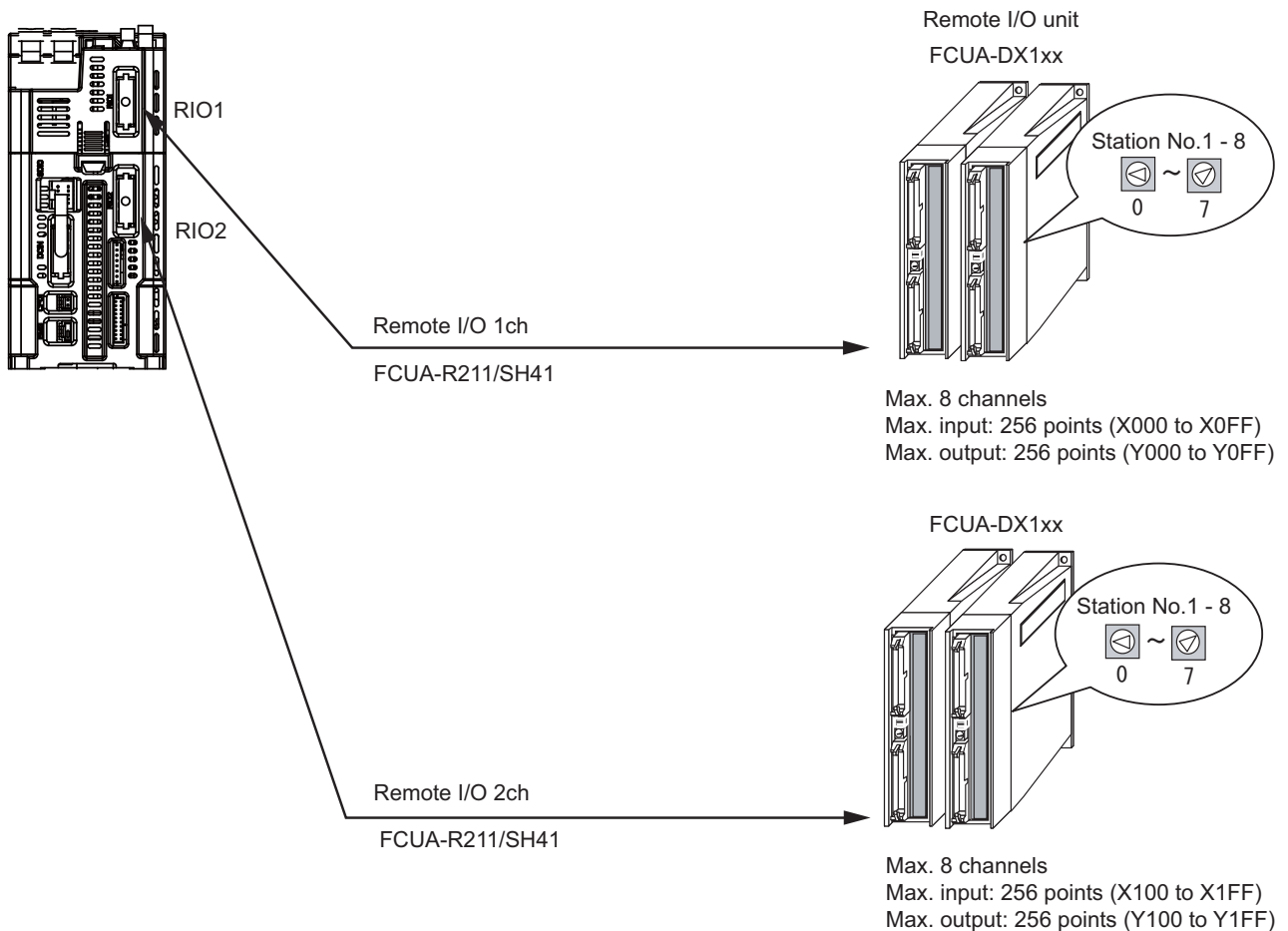

(Note) A remote I/O unit has one or two rotary switch(es) for unit No. setting, which links the device Nos. (with X/Y). The rotary switch setting is as follows, from "0" to "7".

When using MITSUBISHI CNC Machine operation panel, RIO station No. "4" to "6" will be occupied.

Station No.	Rotary switch
1	0
2	1
3	2
4	3
5	4
6	5
7	6
8	7

When connecting to the operation panel I/O unit

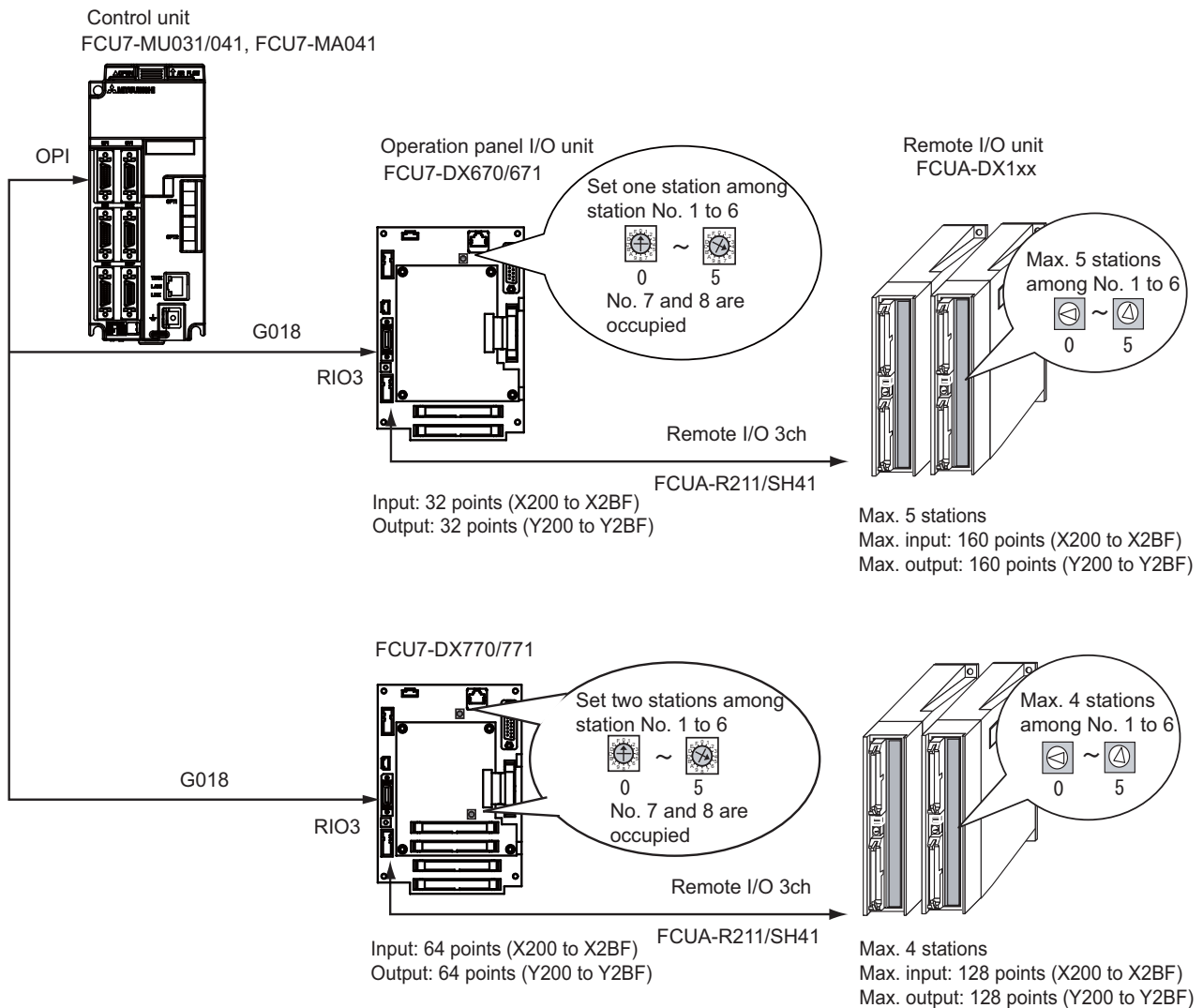

(Note) Operation panel I/O unit occupies one or two stations among station No. 1 to 6. (Station No. 7 and 8 are reserved for manual pulse generator.)
Therefore, RIO3 can use five or four stations from No. 1 to 6.

4.5.2 Station No. Setting when Using Multiple Remote I/O Units

Multiple remote I/O units can be used, as long as the total No. of occupied stations connected with serial links is eight or less. (four/five or less when connected to the operation panel I/O unit).

Unit type	Number of occupied stations
FCUA-DX10x	1
FCUA-DX11x	2
FCUA-DX12x	2
FCUA-DX14x	2

When using multiple remote I/O units, a characteristic station No. must be set for each unit. The FCUA-DX10x unit has one rotary switch, FCUA-DX11x, DX12x and DX14x unit have two. Each of these switches must be set to a characteristic station No. within a range of 0 to 7 (0 to 5 when connected to the operation panel I/O unit).

When connecting directly to the control unit

Setting example 1

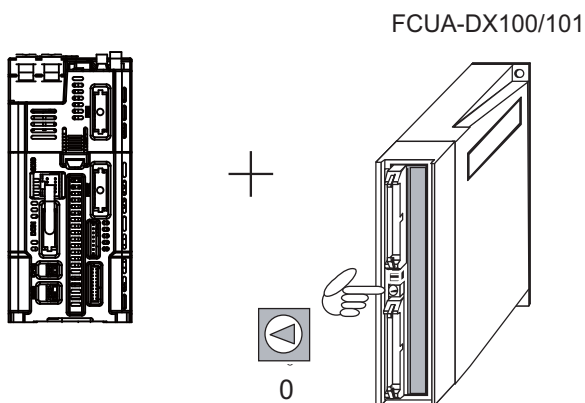

Total number of occupied stations: 1

Setting example 2

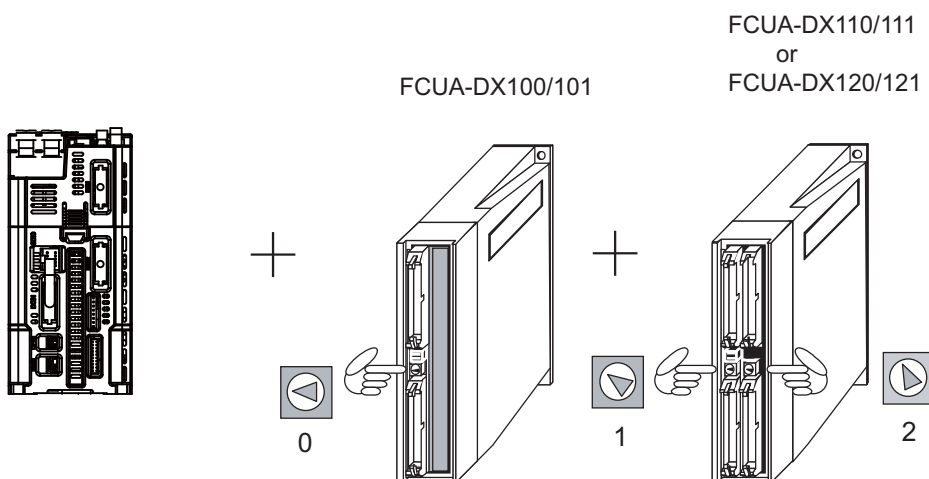

Number of occupied stations: 1

2
Total number of occupied stations: 3

Setting example 3

FCUA-DX110/111
or
FCUA-DX120/121

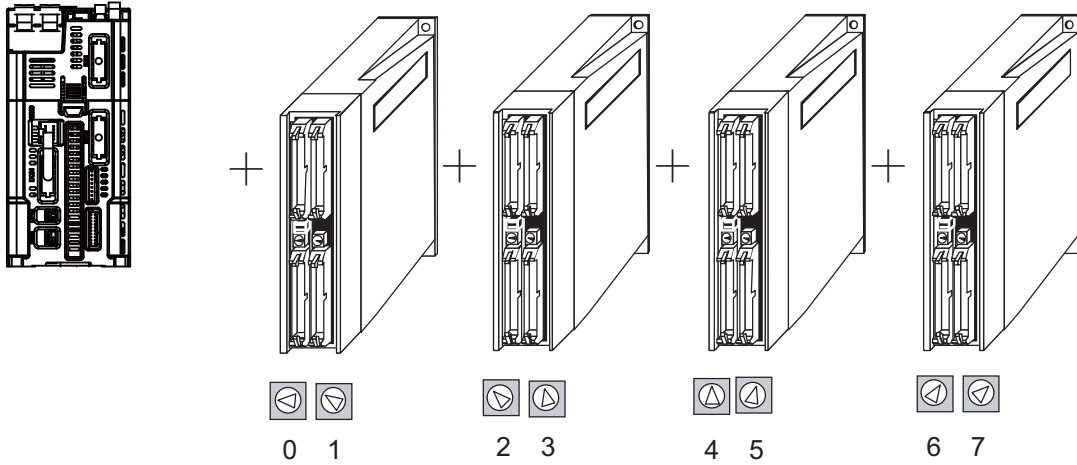

Number of occupied stations: 2

2

2

2

Total number of occupied stations: 8 (Maximum configuration)

When connecting to the operation panel I/O unit

Operation panel I/O unit occupies one or two stations among station No. 1 to 6. (Station No. 7 and 8 are reserved for manual pulse generator.)

Therefore, RIO3 can occupy up to five or four stations, as shown below.

Operation panel I/O unit type	Max. number of stations (RIO3 connection)	Max. number of I/O points (RIO3 connection)	Remote I/O Rotary switch Setting range
FCU7-DX670/671	5 channels	160 points/160 points	0 to 5
FCU7-DX770/771	4 channels	128 points/128 points	0 to 5

Setting example 1

FCU7-DX670/671

FCUA-DX100/101

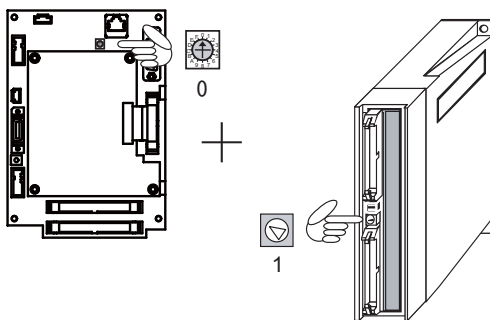

Number of occupied stations: 1

Total number of occupied stations: 1

Setting example 2

FCU7-DX670/671

FCUA-DX100/101

FCUA-DX110/111
or
FCUA-DX120/121

FCUA-DX110/111
or
FCUA-DX120/121

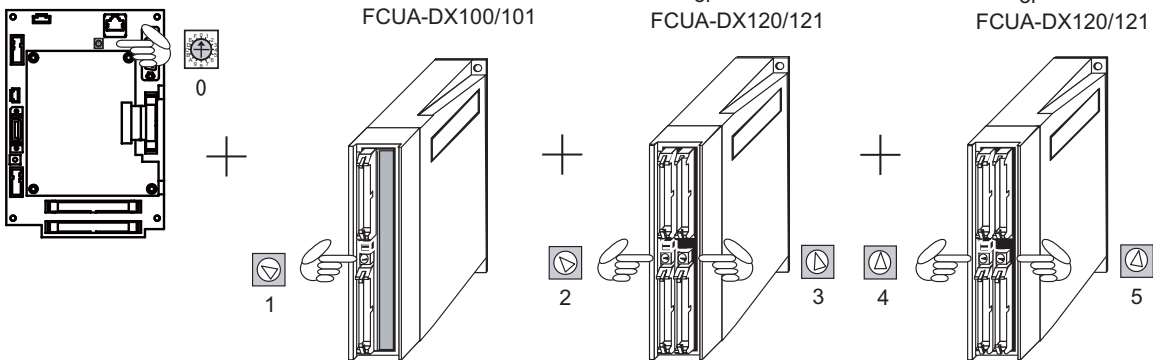

Number of occupied stations: 1

2

2

Total number of occupied stations: 5 (Maximum configuration)

Setting example 3

FCU7-DX770/771

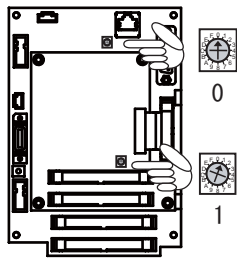

FCUA-DX110/111
or
FCUA-DX120/121

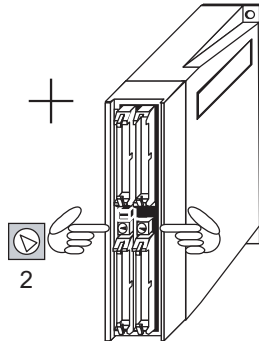

FCUA-DX110/111
or
FCUA-DX120/121

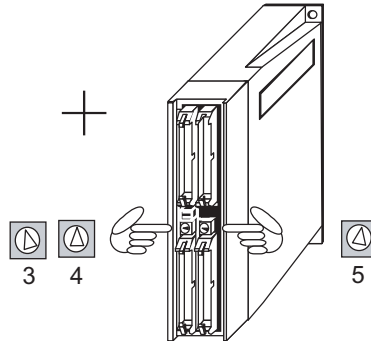

Number of occupied stations: 2

2

Total number of occupied stations: 4 (Maximum configuration)

4.5.3 Connecting FCUA-DX10x/14x Unit with Machine Control Signal

Type of machine input/output signal and number of points	Input	Output
		32 points

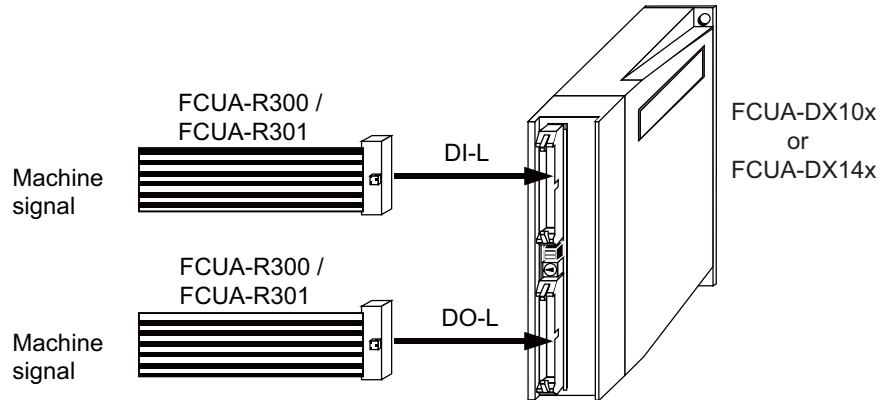

<Outline of connection>

Connection to 24V common (example)

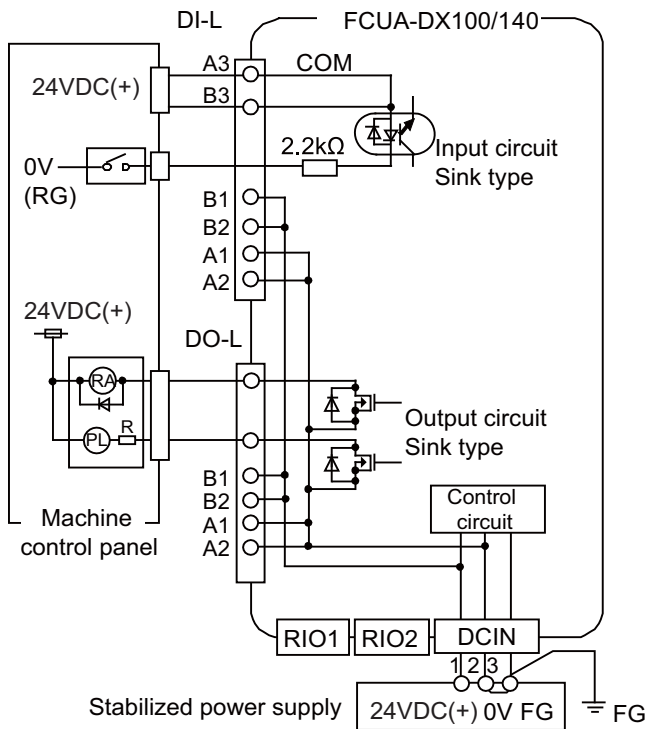

Connection to 0V common (example)

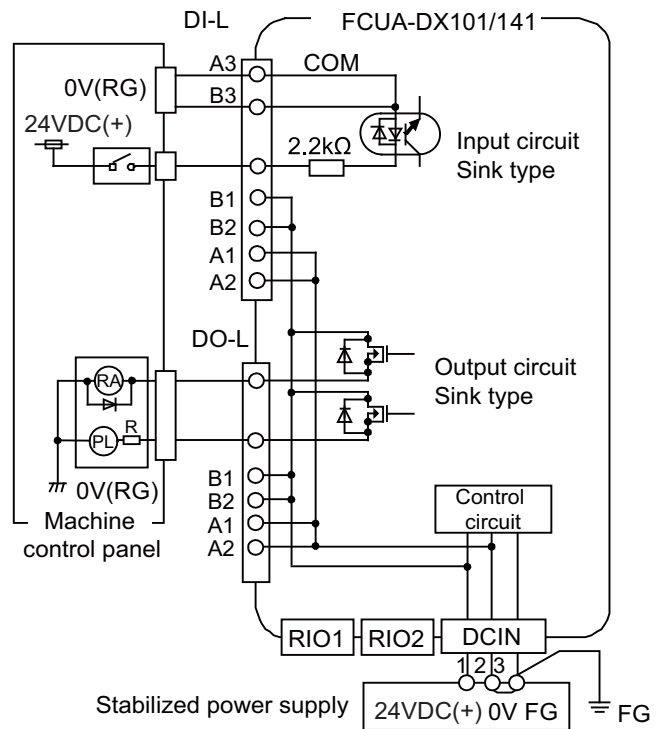

⚠ CAUTION

1. Connect the cable to the designated connector. Incorrect connections could damage the device.
2. Do not connect or disconnect the connection cables between each unit while the power is ON.

<Signal assignment>

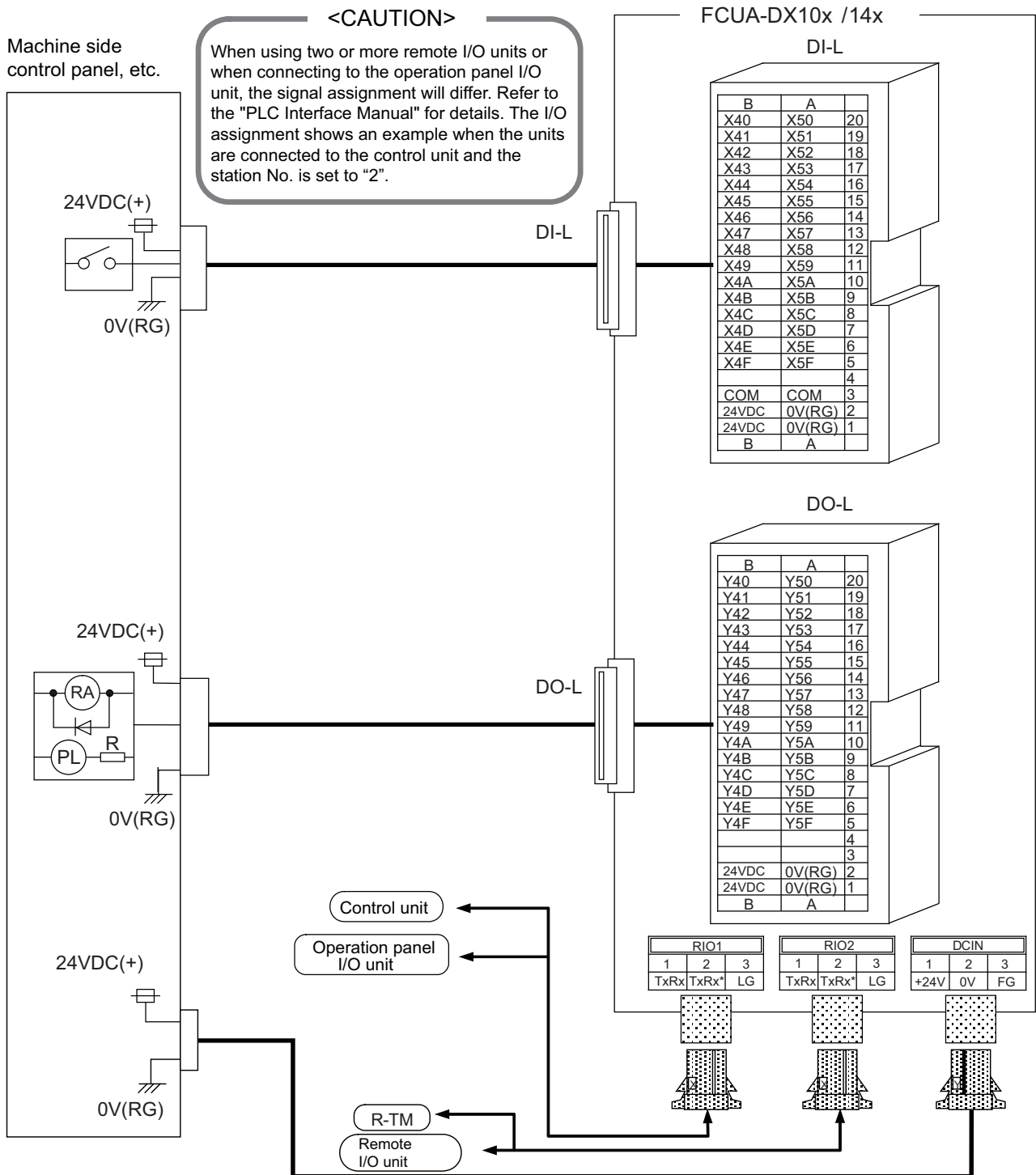

<Adaptive connector>

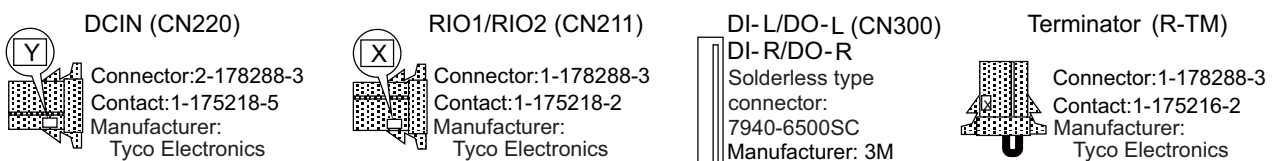

(Note 1) () is the MITSUBISHI original type name.

(Note 2) Refer to "Cable: R-TM Terminator Connector" for the details of R-TM.

4.5.4 Connecting FCUA-DX14x Unit with Analog Input/Output Signal

For the analog input/output signal, connect the FCUA-R031 cable to "AIO". Up to four input points and one output point can be connected for the analog input/output signal. When manufacturing the FCUA-R031 cable, use the FCUA-CS000 connector set (optional, with both ends).

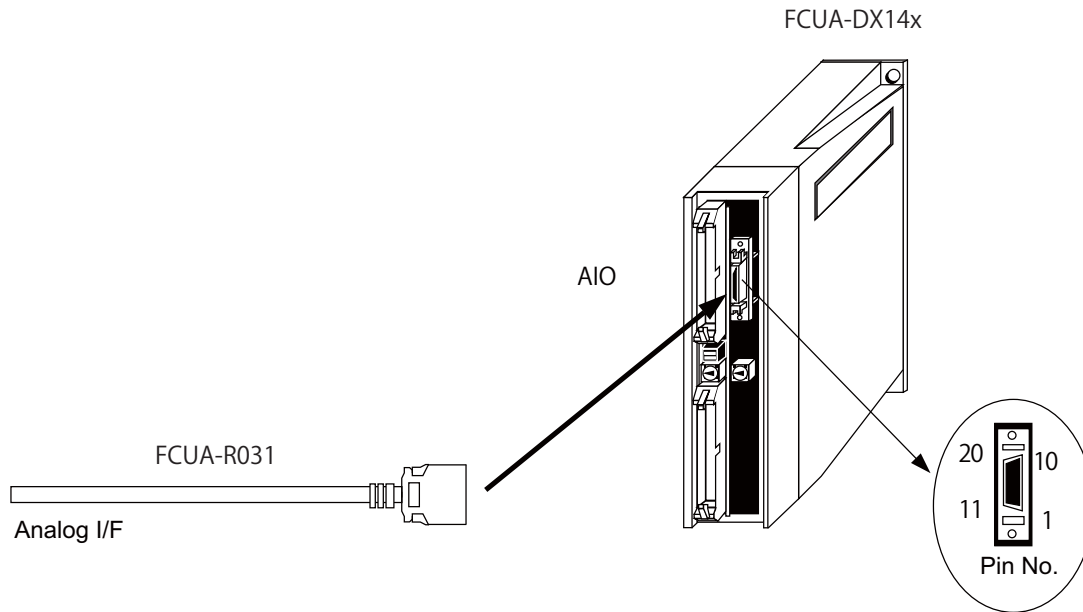

Input/output circuit

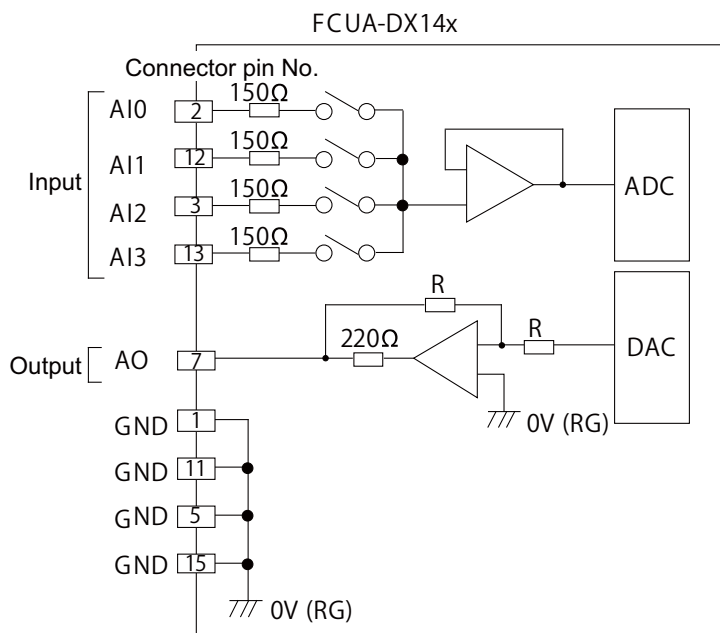

⚠ CAUTION

1. Connect the cable to the designated connector. Incorrect connections could damage the device.
2. Do not connect or disconnect the connection cables between each unit while the power is ON.

4.5.5 Connecting FCUA-DX11x Unit with Machine Control Signal

Type of machine input/output signal and number of points	Input	Output
		64 points

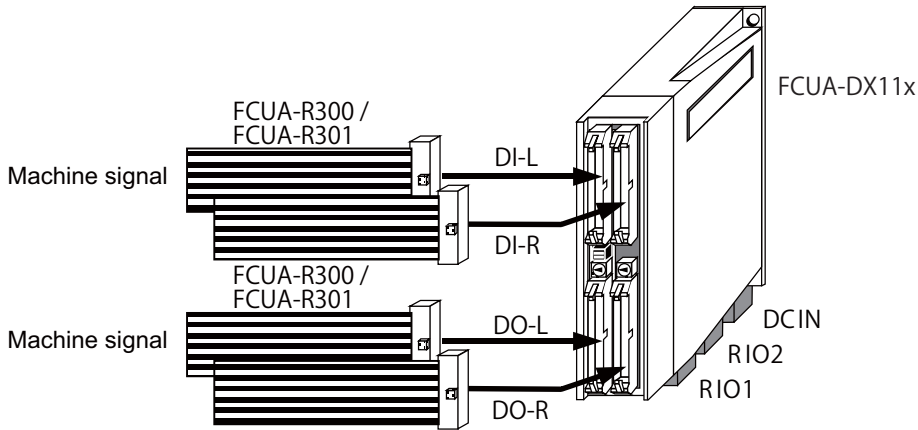

<Outline of connection>

Connection to 24V common (example)

Connection to 0V common (example)

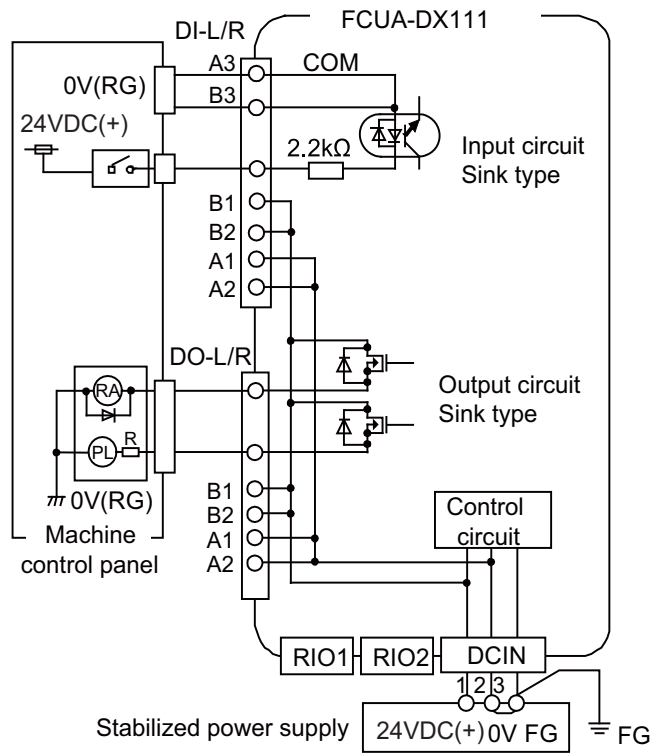
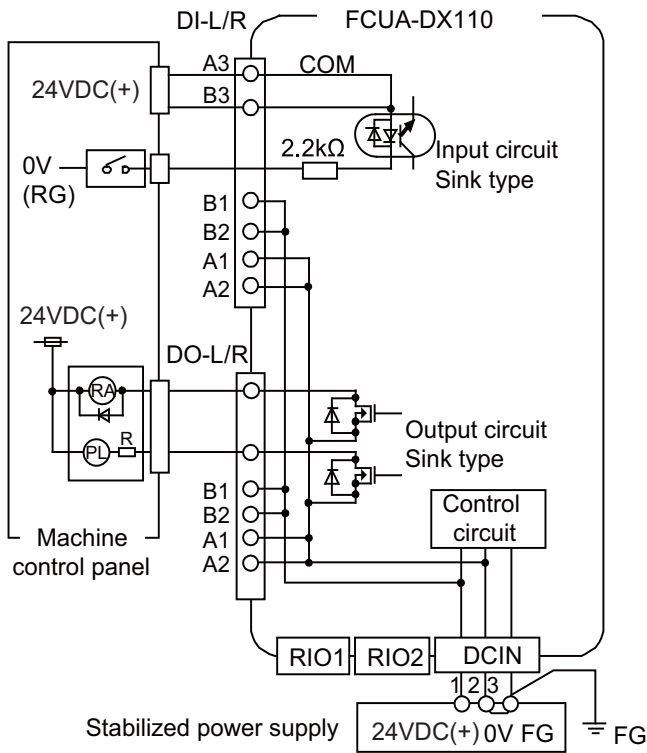

CAUTION

1. Connect the cable to the designated connector. Incorrect connections could damage the device.
2. Do not connect or disconnect the connection cables between each unit while the power is ON.



<Signal assignment>

<CAUTION>

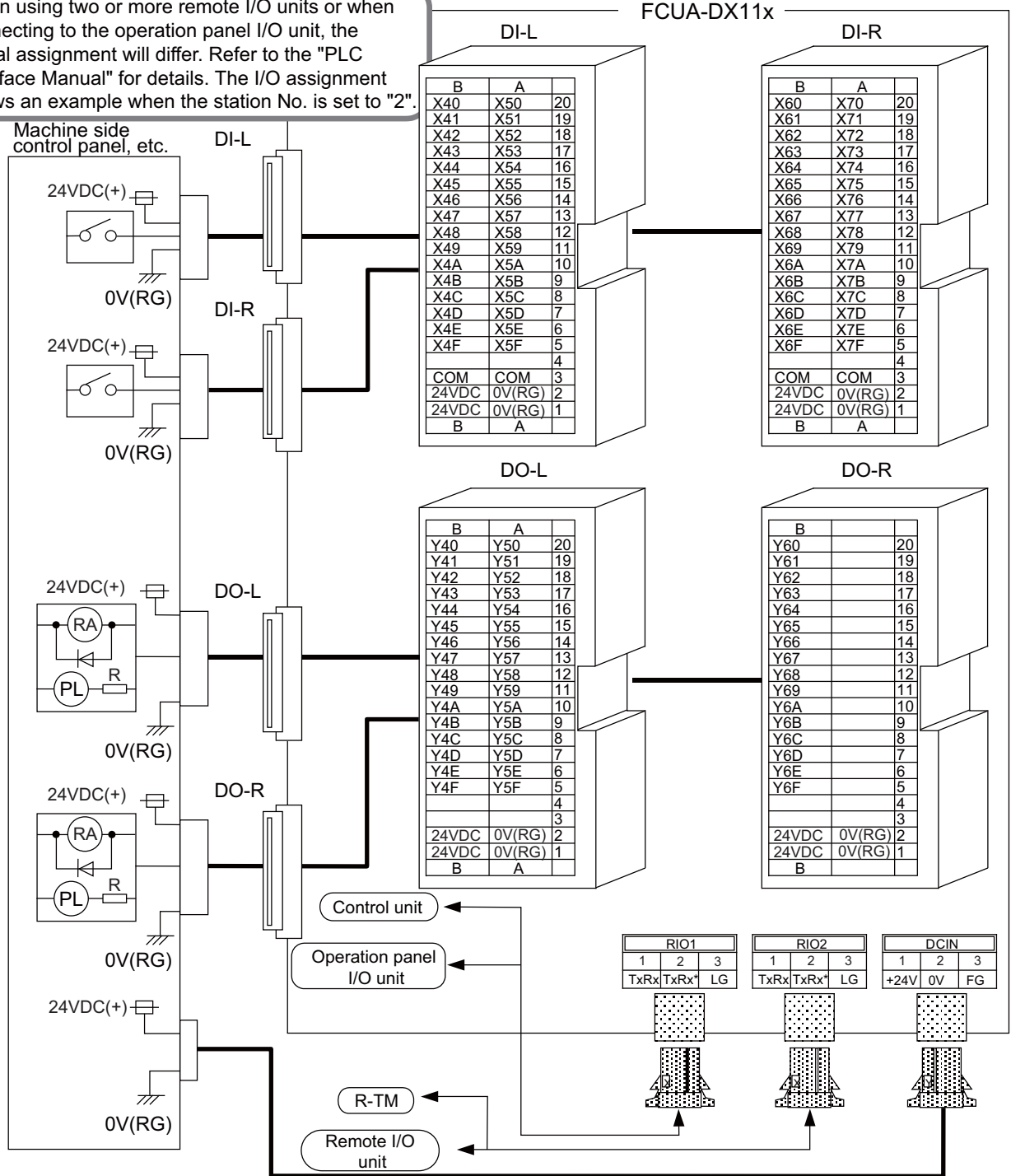
When using two or more remote I/O units or when connecting to the operation panel I/O unit, the signal assignment will differ. Refer to the "PLC Interface Manual" for details. The I/O assignment shows an example when the station No. is set to "2".

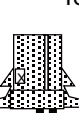

<Adaptive connector>

- 
DCIN (CN220)
 Connector: 2-178288-3
 Contact: 1-175218-5
 Manufacturer: Tyco Electronics
- 
RIO1/RIO2 (CN211)
 Connector: 1-178288-3
 Contact: 1-175218-2
 Manufacturer: Tyco Electronics
- 
DI-L/DO-L (CN300)
DI-R/DO-R
 Solderless type connector:
 7940-6500SC
 Manufacturer: 3M
- 
Terminator (R-TM)
 Connector: 1-178288-3
 Contact: 1-175216-2
 Manufacturer: Tyco Electronics

(Note 1) () is the MITSUBISHI original type name.

(Note 2) Refer to "Cable: R-TM Terminator Connector" for the details of R-TM.

4.5.6 Connecting FCUA-DX12x Unit with Machine Control Signal

Type of machine input/output signal and number of points	Input	Output	Analog output
		64 points	48 points

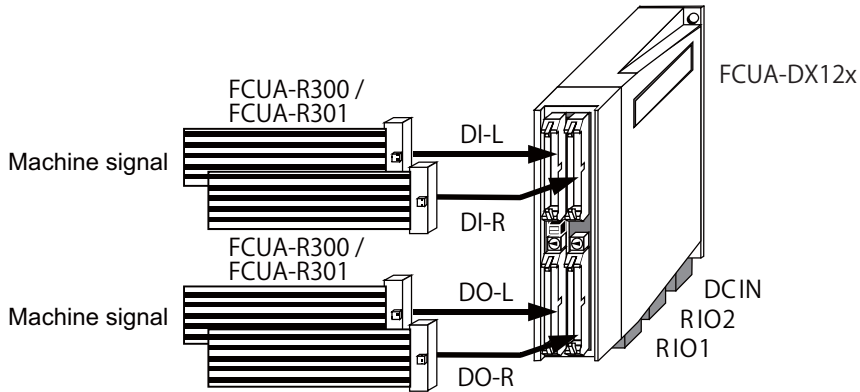

<Outline of connection>

Connection to 24V common (example)

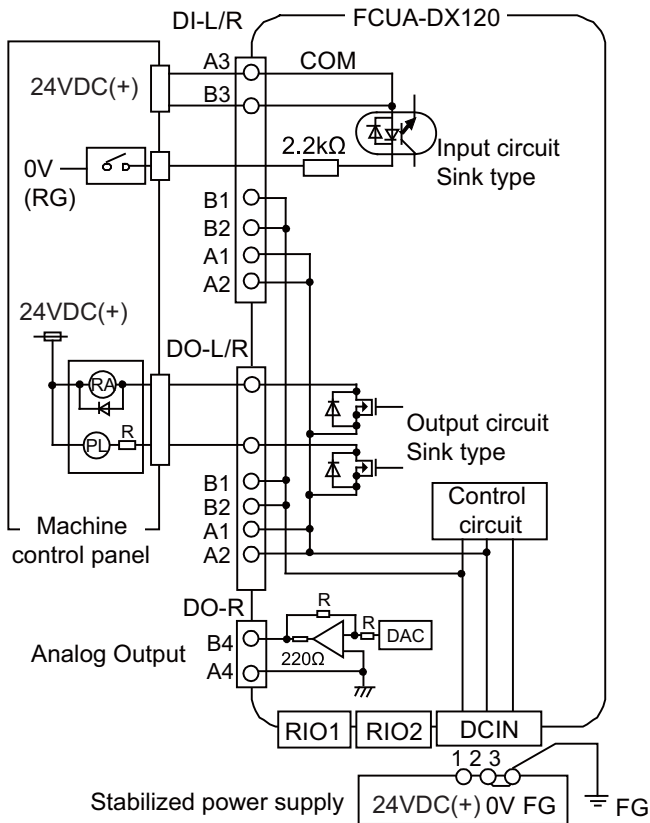

Connection to 0V common (example)

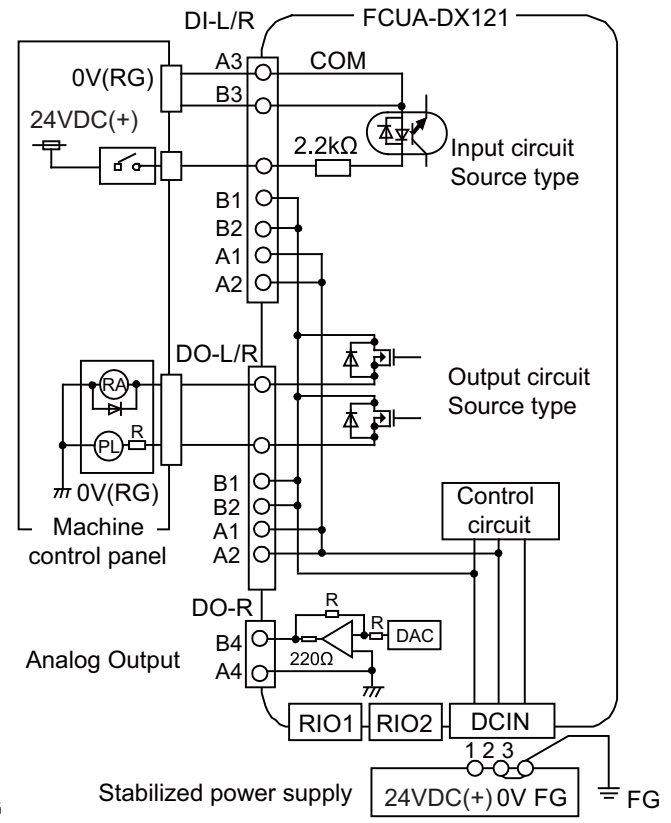

CAUTION

1. Connect the cable to the designated connector. Incorrect connections could damage the device.
2. Do not connect or disconnect the connection cables between each unit while the power is ON.

<Signal assignment>

<CAUTION>
When using two or more remote I/O units or when connecting to the operation panel I/O unit, the signal assignment will differ. Refer to the "PLC Interface Manual" for details. The I/O assignment shows an example when the station No. is set to "2".

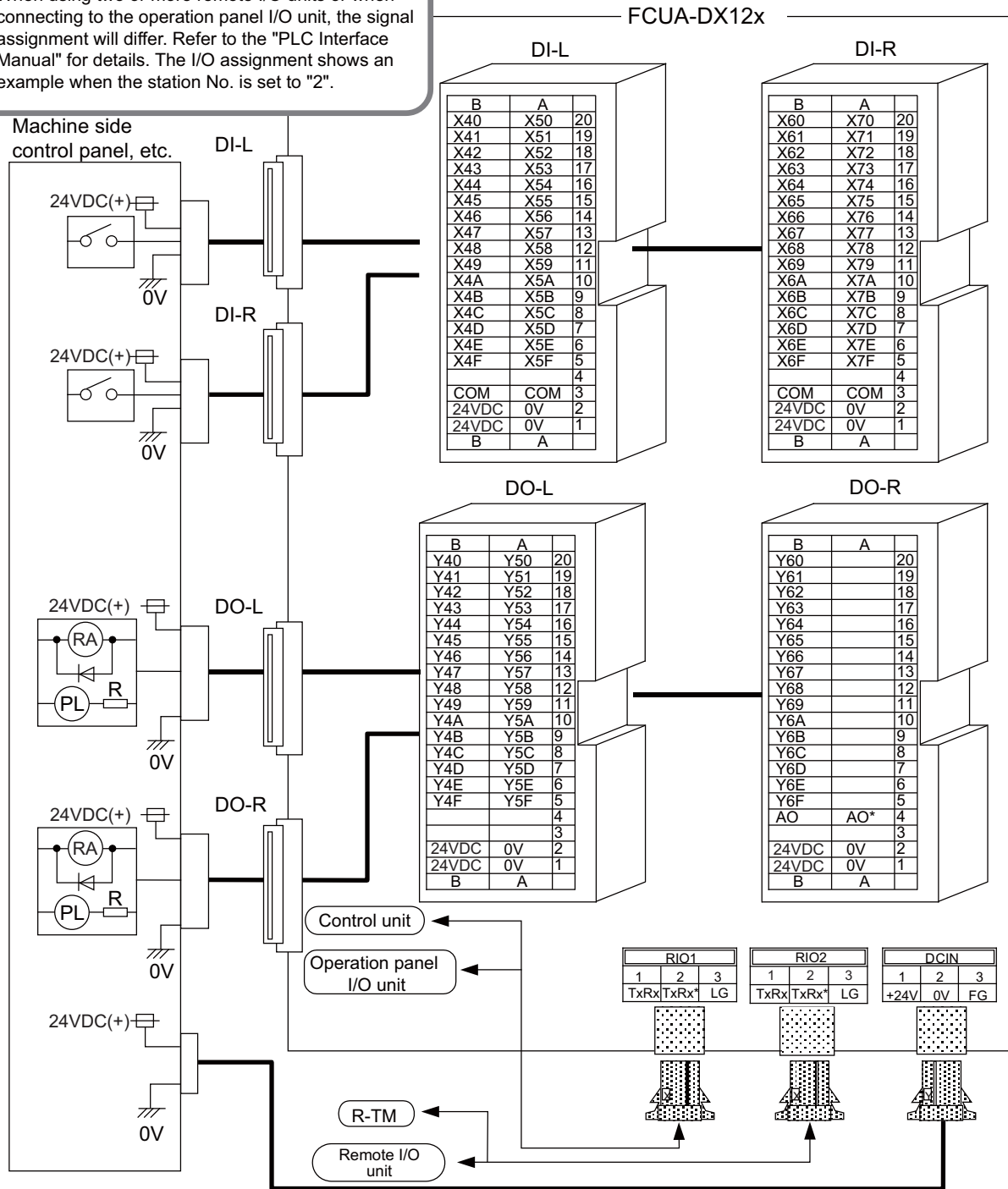

<Adaptive connector>

- | | | | |
|--|---|---|---|
| <p>DCIN (CN220)</p> <p>Connector: 2-178288-3
Contact: 1-175218-5
Manufacturer: Tyco Electronics</p> | <p>RIO1/RIO2 (CN211)</p> <p>Connector: 1-178288-3
Contact: 1-175218-2
Manufacturer: Tyco Electronics</p> | <p>DI-L/DO-L (CN300)
DI-R/DO-R</p> <p>Solderless type connector:
7940-6500SC
Manufacturer: 3M</p> | <p>Terminator (R-TM)</p> <p>Connector: 1-178288-3
Contact: 1-175216-2
Manufacturer: Tyco Electronics</p> |
|--|---|---|---|

(Note 1) () is the MITSUBISHI original type name.

(Note 2) Refer to "Cable: R-TM Terminator Connector" for the details of R-TM.

4.6 Connection of MITSUBISHI CNC Machine Operation Panel

(Note) In this chapter "MITSUBISHI CNC Machine operation panel" is shorten to Machine operation panel. Connect Machine operation panel A to the remote I/O unit I/F of control unit or operation panel I/O unit.

- Machine operation panel A (RIOIN) - cable (FCUA-R211 or SH41) - control unit (RIO1)
- Machine operation panel A (RIOIN) - cable (FCUA-R211 or SH41) - control unit (RIO2)
- Machine operation panel A (RIOIN) - cable (FCUA-R211 or SH41) - operation panel I/O unit (RIO3)

When relaying EMG signal from Machine operation panel A, the following connection is necessary.

- Machine operation panel A (EXT) - cable (F120) - control unit (EMG)

When supplying power to control unit from Machine operation panel A, the following connection is necessary.

- Machine operation panel A (DCOUT) - cable (G071) - operation panel I/O unit (DCIN)

Connect Machine operation panel B to Machine operation panel A as follows.

- Machine operation panel B - cable (G460) - Machine operation panel A (SUBP)

[When connecting to operation panel I/O unit (RIO3)]

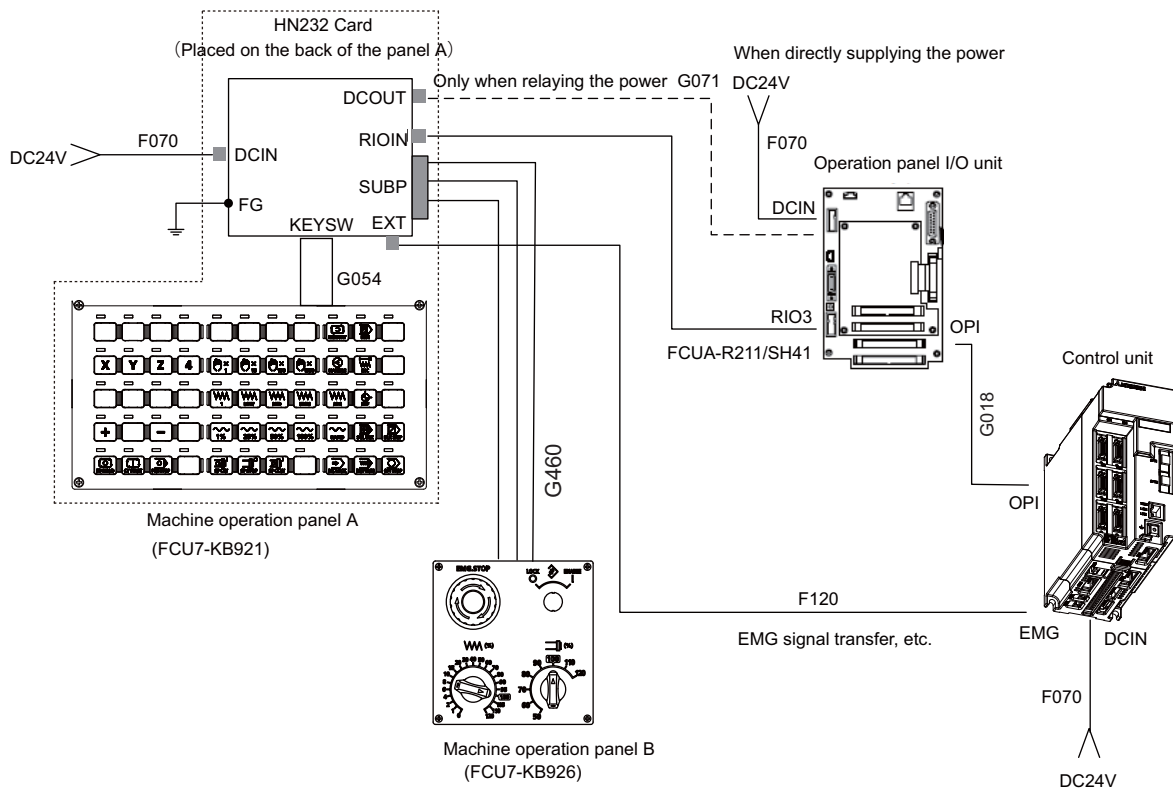

<Related items>

- Cable drawing: "Cable: FCUA-R211 Cable"
- "Cable: SH41 Cable"
- "Cable: F120 Cable"
- "Cable: G460 Cable"

Connector pin assignment: "General Specifications: Operation panel I/O unit" (RIO3 connector/DCIN connector/DCOUT connector/ RIOIN connector/SUBP connector/EXT connector/OPI connector/EMG connector)

<Software Interface>

Machine operation panel occupies RIO station No. 4 to 6. The device numbers for switch and LED on operation panel are fixed as listed below.

The following lists the devices for using the RIO 1st channel.

Station	Device No.			Detail
	RIO1	RIO2	RIO3	
1	X00 ~ X1F/Y00 ~ Y1F	X100 ~ X11F/Y100 ~ Y11F	X200 ~ X21F/Y200 ~ Y21F	
2	X20 ~ X3F/Y20 ~ Y3F	X120 ~ X13F/Y120 ~ Y13F	X220 ~ X23F/Y220 ~ Y23F	
3	X40 ~ X5F/Y40 ~ Y5F	X140 ~ X15F/Y140 ~ Y15F	X240 ~ X25F/Y240 ~ Y25F	
4	X60 ~ X7F/Y60 ~ Y7F	X160 ~ X17F/Y160 ~ Y17F	X260 ~ X27F/Y260 ~ Y27F	Machine operation panel B (Switch)...16 points vacant
5	X80 ~ X9F/Y80 ~ Y9F	X180 ~ X19F/Y180 ~ Y19F	X280 ~ X29F/Y280 ~ Y29F	Machine operation panel A (Key switch/LED)
6	XA0 ~ XBF/YA0 ~ YBF	X1A0 ~ X1BF/Y1A0 ~ Y1BF	X2A0 ~ X2BF/Y2A0 ~ Y2BF	Machine operation panel A (Key switch/LED)
7	XC0 ~ XDF/YC0 ~ YDF	X1C0 ~ X1DF/Y1C0 ~ Y1DF	-	
8	XE0 ~ XFF/YE0 ~ YFF	X1E0 ~ X1FF/Y1E0 ~ Y1FF	-	

Table: Device No. for Machine operation panel

(1) Machine operation panel B (Switch)

Machine operation panel B is equipped with rotary switches (cutting override, spindle override) and a selector switch (memory protection key), and an emergency stop button. Direct wiring connection will be applied to the emergency stop button, and device numbers for other switches are defined as listed below.

(a) Cutting override (6bit)

21 position code list

Setting value	Device No.					
	X60	X61	X62	X63	X64	X65
0	0	0	0	0	0	0
1	1	0	0	0	0	1
2	1	1	0	0	0	0
3	0	1	0	0	0	1
4	0	1	1	0	0	0
5	1	1	1	0	0	1
6	1	0	1	0	0	0
7	0	0	1	0	0	1
8	0	0	1	1	0	0
9	1	0	1	1	0	1
10	1	1	1	1	0	0
11	0	1	1	1	0	1
12	0	1	0	1	0	0
13	1	1	0	1	0	1
14	1	0	0	1	0	0
15	0	0	0	1	0	1
16	0	0	0	1	1	0
17	1	0	0	1	1	1
18	1	1	0	1	1	0
19	0	1	0	1	1	1
20	0	1	1	1	1	0

(b) Spindle override (6bit)

8 position code list

Setting value	Device No.					
	X66	X67	X68	X69	X6A	X6B
0	0	0	0	0	0	Not used
1	0	0	0	0	1	
2	1	1	0	0	0	
3	0	1	0	0	1	
4	0	1	1	0	0	
5	1	1	1	0	1	
6	1	0	1	0	0	
7	0	0	1	0	1	

(c) Memory protection switch (1bit)

Memory protection switch X6C

Spare X6D - X6F

(2) Machine operation panel A (Key switch/LED)

Machine operation panel A is equipped with 55 switches and 55 LEDs.

They are allocated X device and Y device as in the figure below.

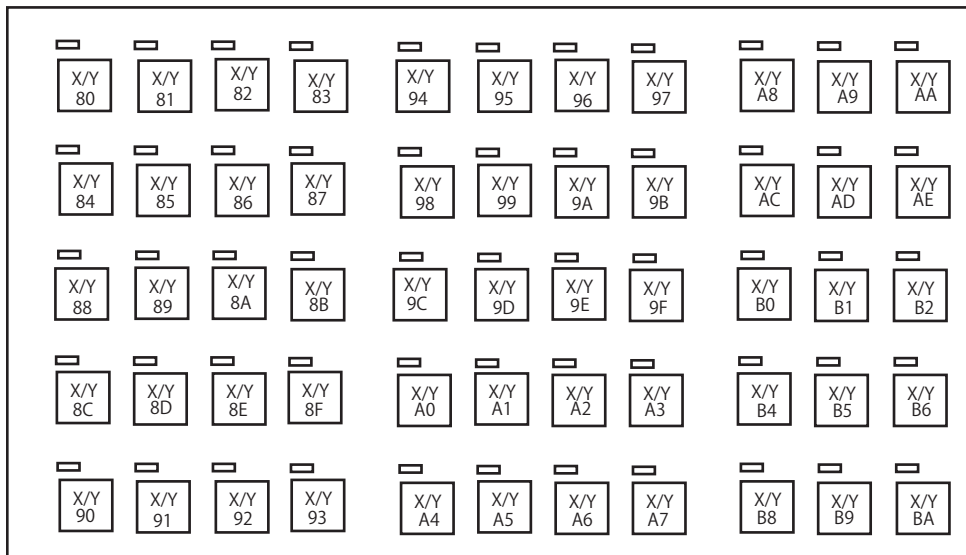

(Note1) If the stations of Machine operation panel and other RIO unit overlap, all the connections of the overlapping RIOs will be invalidated and cannot be used. Stations which do not overlap can be used.

(Note2) Refer to the last page "Table: Device No. for Machine operation panel" for the device No. when connecting to RIO2 and RIO3.

4.7 Connection of Scan I/O card

(1) External power supply (DCIN)

24VDC is required for the HR347/HR357 card operation. Prepare a stabilized power supply that satisfies the following specifications.

Output: 24VDC \pm 5%

Ripple: \pm 5%(P-P)

Rated output current: 2.5A

* The rated output current is the value when using 60mA \times 32 points for the machine output.

Prepare a power supply that satisfies the 24VDC output's total output current and control current (0.5A).

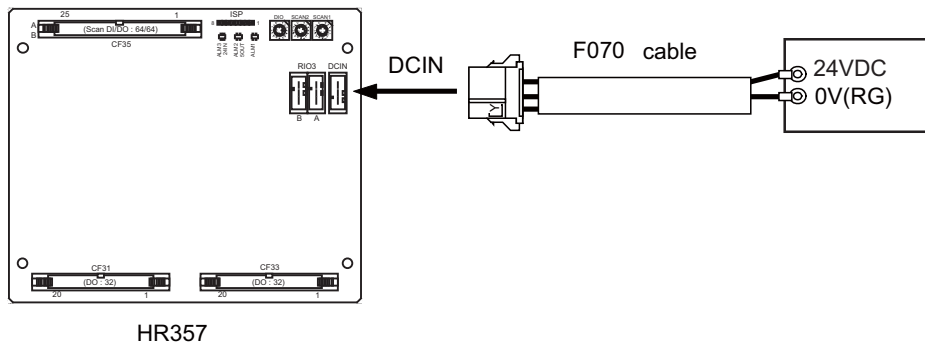

(2) Connecting the remote I/O communication cable (RIO3A/B)

(a) Connection of the RIO3A connector

Connect the RIO3A to the RIO1, RIO2 connector of the control unit or the RIO3 of the operation panel I/O unit.

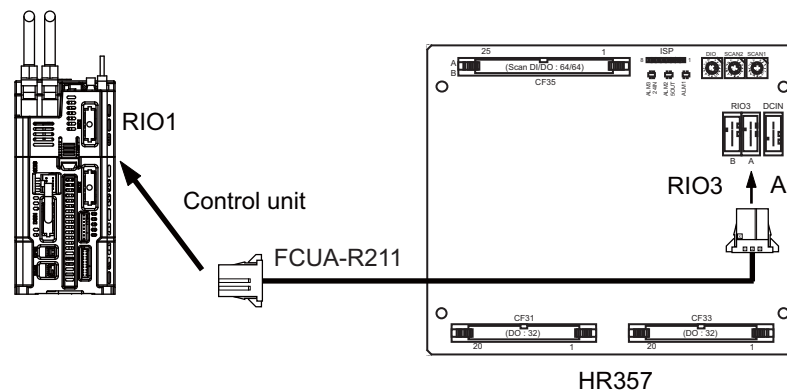

(b) Connection of the RIO3B connector

Multiple remote I/O units can be used, as long as the total No. of occupied stations connected with serial links is less than eight. (Refer to "Connection: Connection of Remote I/O Unit" for details.) HR357 occupies three stations, so the remote I/O units can be connected to the RIO3B in combinations of 5 stations or less. Connect a terminator to the RIO3B when it is not connected to any device.

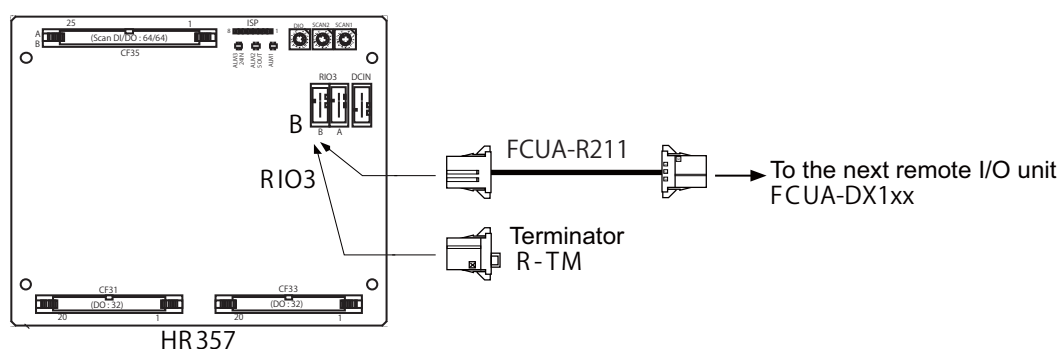

4.8 Connection of Expansion I/O Card

4.8.1 Connecting with Power Supply

24VDC is required for the expansion I/O card operation. Prepare a stabilized power supply that satisfies the following specifications.

Rated output: 24VDC±5%

Ripple: 240mV (P-P)

Rated current: 3.8A

* The rated output current is the value when using 60mA × 48 points for the machine output (DO). Prepare a power supply that satisfies the 24VDC output's total output current.

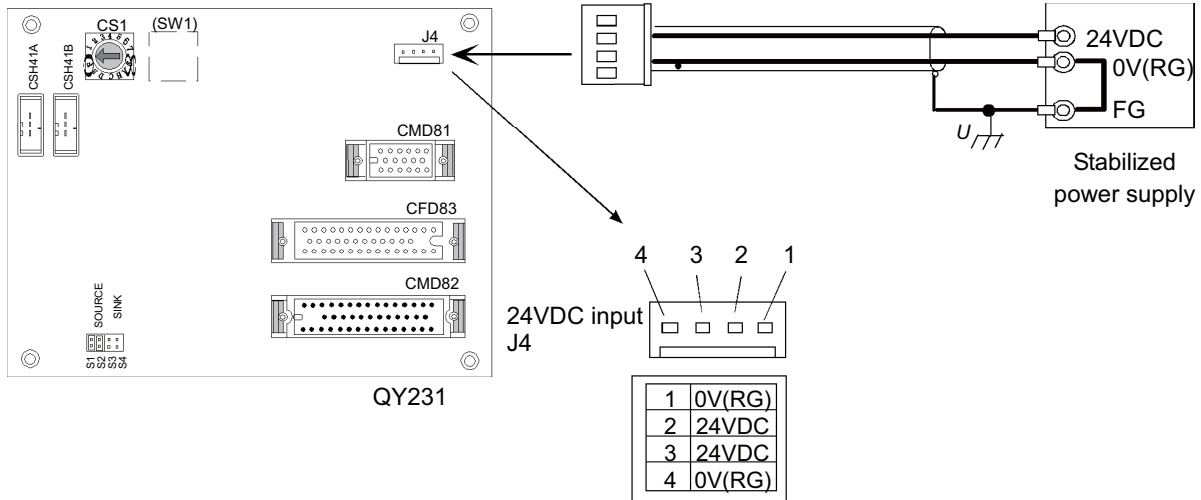

(Note) Cables for the J4 connector must be manufactured by the machine tool builder.

4.8.2 Connecting with Control Unit/ Operation Panel I/O Unit

Connect the CSH41A connector to the RIO1/RIO2 connector of the control unit, or RIO3 connector of the operation panel I/O unit.

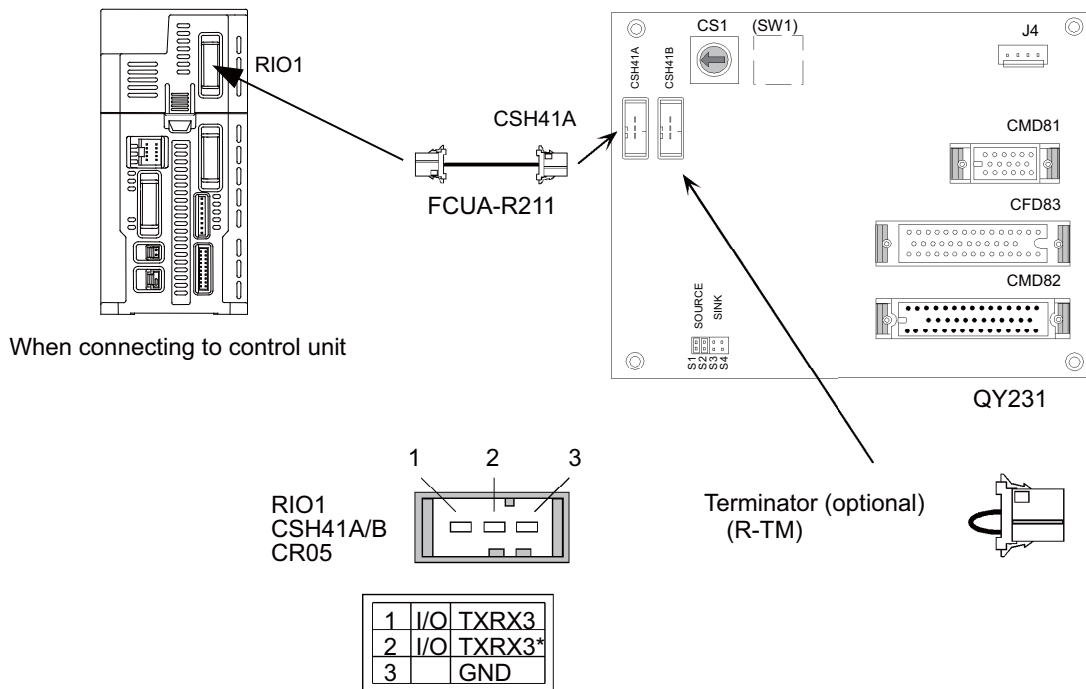

4.8.3 Connecting with Remote I/O Unit

When the remote I/O unit is connected with a serial link, multiple units can be combined and used in a range of eight or less total occupied stations. (Refer to the section "Connection: Connection of Remote I/O Unit" for details.)

QY231 occupies two stations, so the remote I/O units including this card can be connected to RIO1 of the control unit in combinations of 6 stations or less.

Connect a terminator R-TM to the CSH41B when it is not connected to any device.

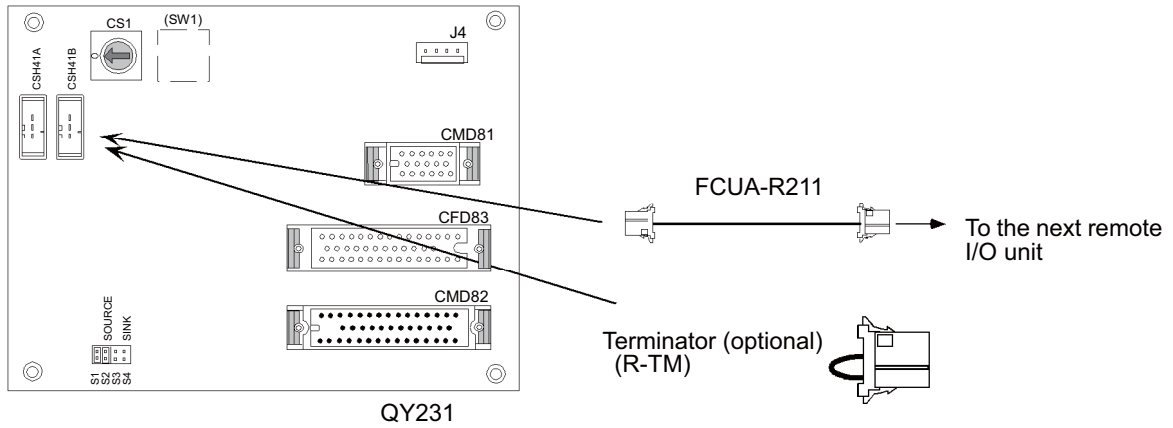

4.9 Connection of Handy Terminal

Connect handy terminal to the control unit connector SIO and ENC.

Connect the emergency stop switch (SW1), enable switch (SW2), selector switch (SW) and 24VDC input to the control panel terminal block.

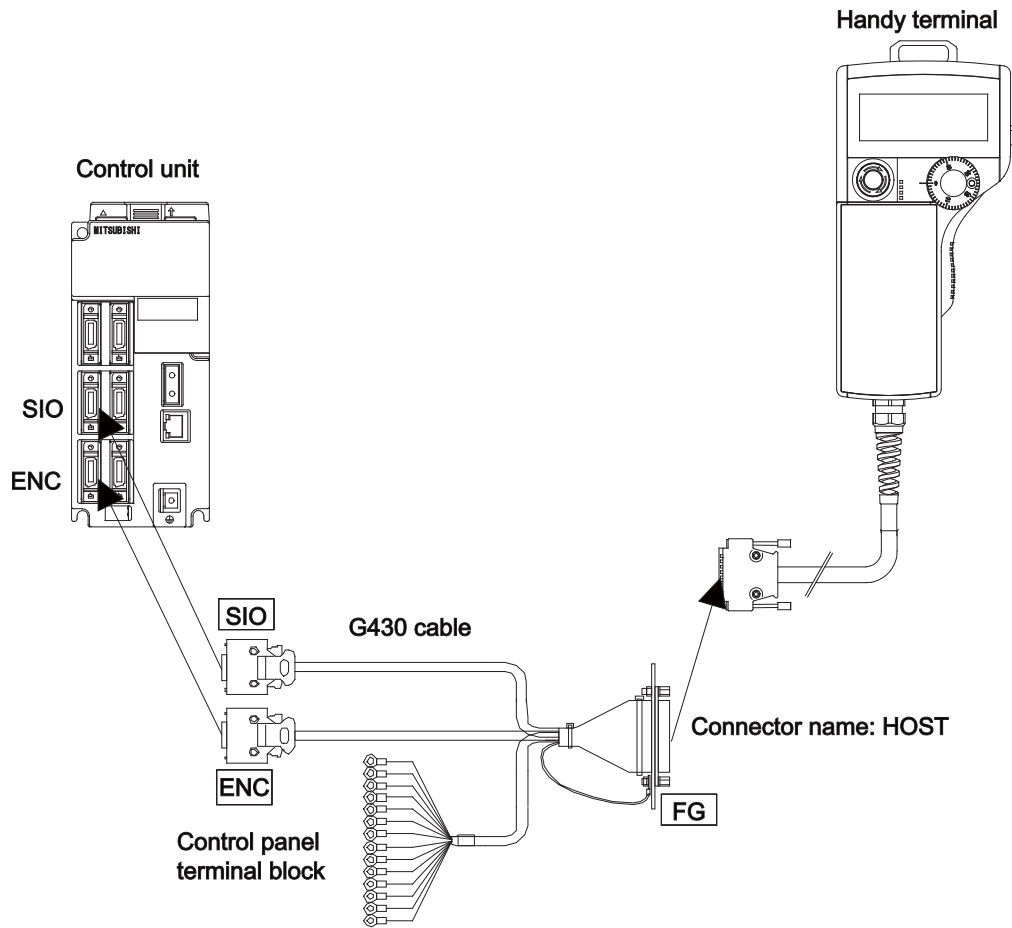

4.10 Turning the Power ON/OFF

To turn the power ON:

Turn ON the switch connected to the display unit.

To turn the power OFF:

Turn OFF the switch connected to the display unit.

→ Power source of the display and control units is turned OFF after the display unit is shutdown.

(1) When the control unit and the display unit share a power supply

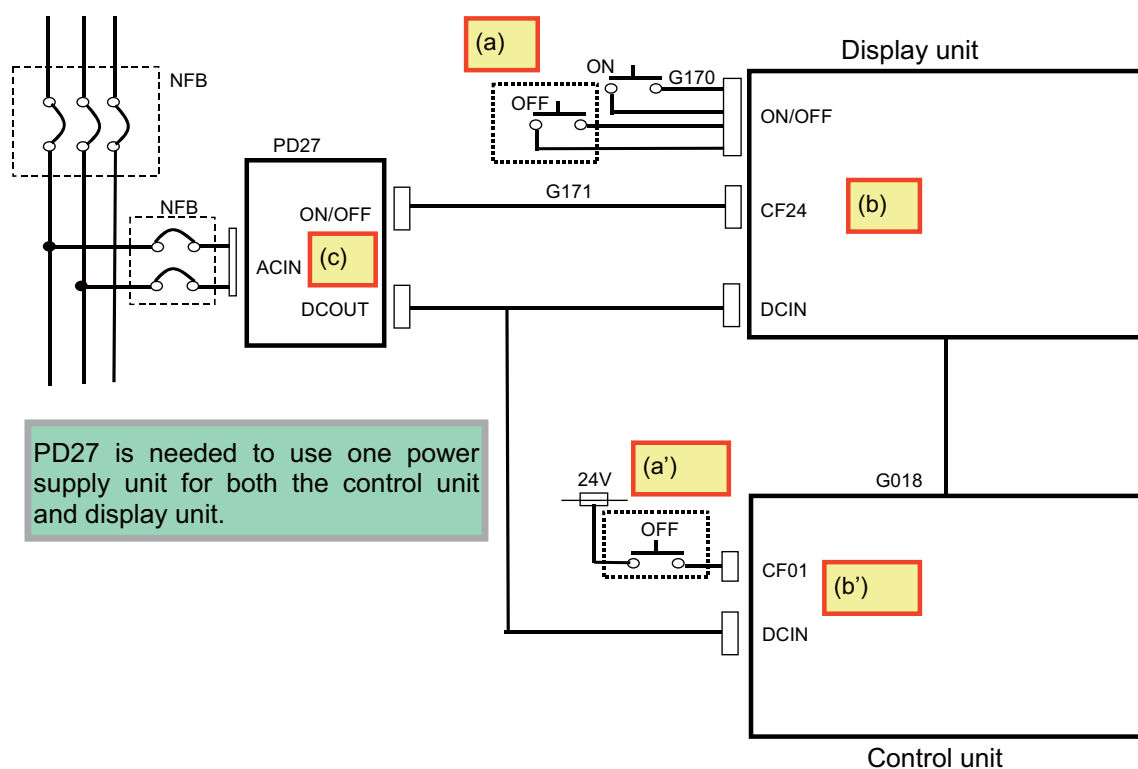

- (a) The switch is turned OFF
- (b) A signal is input from the OFF switch through the G170 cable, which starts a shutdown process. After the completion of the shutdown process, the OFF signal is sent to PD27 through G171 cable.
- (c) PD27 stops outputting the voltage. Both display and control units are turned OFF.
- (a') To stop the NC operations at the same time of switching OFF the display unit (in order to keep the axis position during the shutdown process, for example), send the same OFF signal to the control unit using the switch of 2a contact.
- (b') The OFF switch inputs a signal to CF01, which starts a NC termination process. (including a termination notification to the servo drive unit)

(2) When the control unit and the display unit use each different power supply

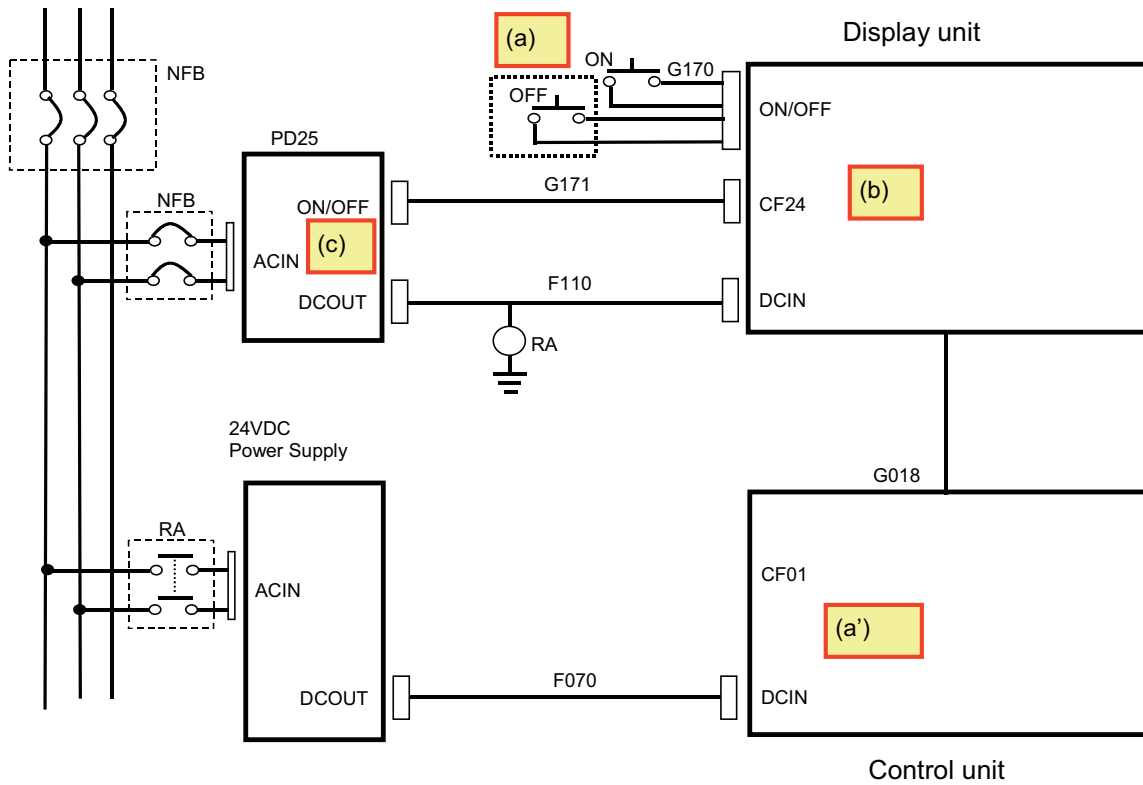

- (a) The switch is turned OFF
- (b) A signal is input from the OFF switch through the G170 cable, which starts a shutdown process. After the completion of the shutdown process, the OFF signal is sent to PD25 through G171 cable.
- (c) PD25 stops outputting the voltage. Relays operate to turn OFF the other power source. Both display and control units are turned OFF.
- (a') To stop the NC operations at the same time of switching OFF the display unit (in order to keep the axis position during the shutdown process, for example), the control unit also needs to be turned OFF.

4.11 Connection Example When Not Using Operation Panel I/O Unit

Connection examples when not using operation panel I/O unit are introduced in this section.

(Note) Operation panel I/O unit is effective to simplify the wiring, etc.

Whether or not to adopt the operation panel I/O unit should be carefully considered at the machine tool builder side.

[Examples when not using operation panel I/O unit]

(Ex.1) When operation area is made by using scan I/O card, etc.

(Ex.2) When electric cabinet (control unit section) and operation panel (display unit section) are placed within the same control panel.

(When the space between control unit and display unit is small, and simplification of wiring between those units is not as significant.)

(Ex.3) When machine operation panel and keyboard unit are not necessary to be installed by using a display unit with touch panel.

The following is a general connection diagram when not using operation I/O unit.
 (Examples when using 10.4-type display unit)

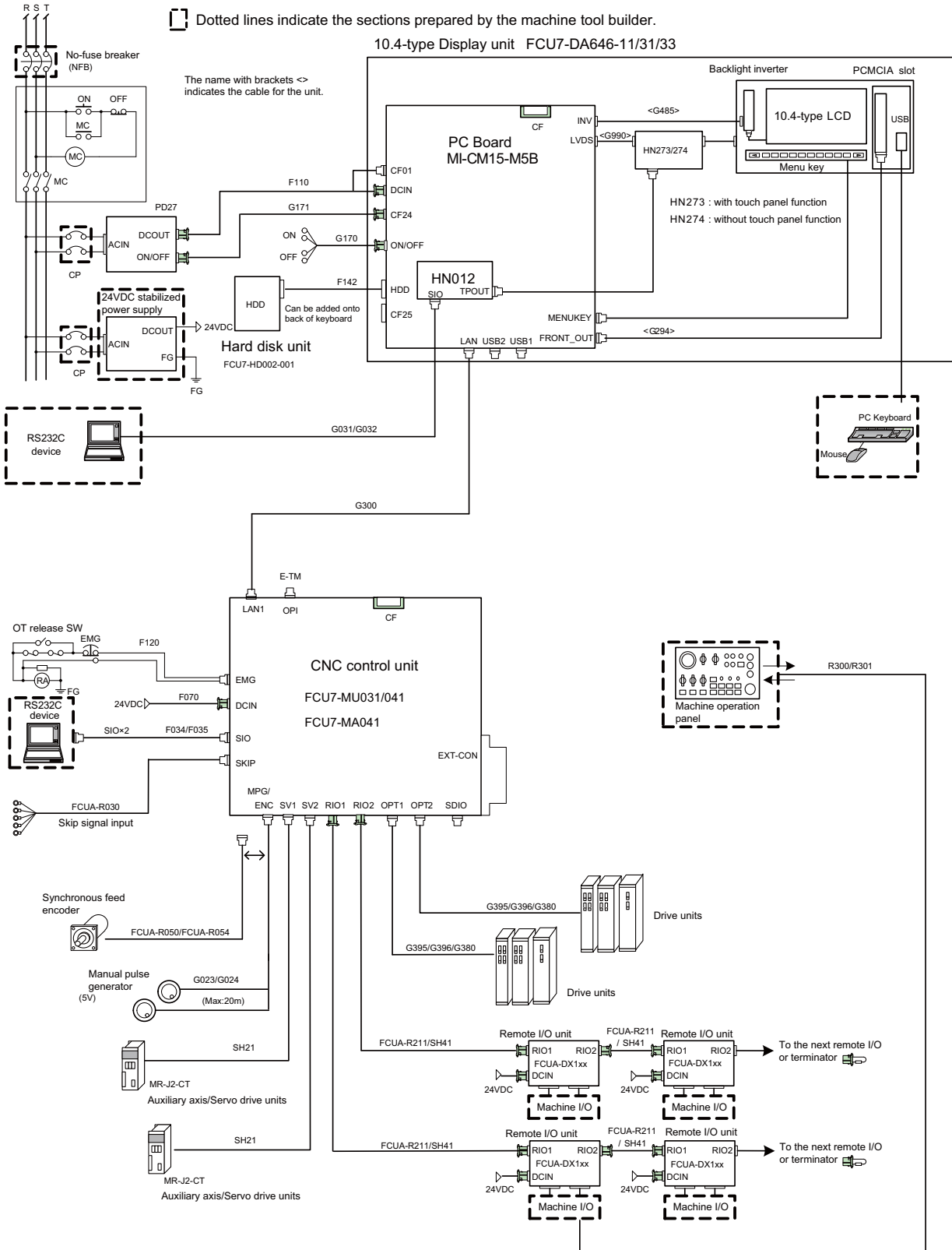

- (Note 1) In this connection example, control unit's LAN connector is occupied for communication with display unit. So, external LAN communication directly from control unit is not possible.
- (Note 2) Always connect terminal connector E-TM (separately sold) to control unit's OPI connector. If not connected, no operation occurs due to emergency stop state.

Appendix 1

Cable

(Note) Symbols for writing cable drawings

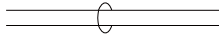
(1)  indicates twisted pair.

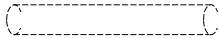
(2)  indicates the shield sheath.

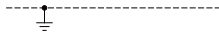
(3)  indicates shield clamping to the grounding plate.

(4) In the cable drawings, the partner of the twisted pair cable is given a priority, so the pin No. of the connectors at both ends are not necessary in number of order.

(5) Equivalent parts can be used for the connector, contact and wire material.

(6) The tolerances of the cables provided by Mitsubishi Electric are as follows:

Cable length (mm)	Tolerances (mm)
600 or shorter	±30
601 to 1000	±50
1001 to 5000	±100
5001 to 10000	±150
10001 to 15000	±200
15001 to 20000	±300

Appendix 1.1 Cable Wire and Assembly

(1) Cable wire

The specifications of the wire used for each cable, and the machining methods are shown in this section. When manufacturing the detector cable and battery connection cable, use the recommended wires shown below or equivalent products.

(a) Heat resistant specifications cable

Wire type (special order part)	Finish outer diameter	Sheath material	No. of pairs	Wire characteristics					Flexibility
				Configura tion	Conductive resistor	Withstand voltage	Insulation resistance	Heat resistance temperatu re	
BD20288 Compound 6-pair shielded cable Specification No. Bangishi-17145 (Note 1)	8.7mm	Heat resistant PVC	2 (0.5mm ²)	100 strands/ 0.08mm	40.7Ω/km or less	500VAC/ 1min	1000MΩ/km or more	105C°	70 × 10 ⁴ times or more at R200
			4 (0.2mm ²)	40 strands/ 0.08mm	103Ω/km or less				

(b) General-purpose heat resistant specifications cable

Wire type (special order part)	Finish outer diameter	Sheath material	No. of pairs	Wire characteristics					Flexibility
				Configurat ion	Conductive resistor	Withstand voltage	Insulation resistance	Heat resistance temperatu re	
BD20032 Compound 6-pair shielded cable Specification No. Bangishi-16903 Revision No. 3 (Note 1)	8.7mm	PVC	2 (0.5mm ²)	100 strands/ 0.08mm	40.7Ω/km or less	500VAC/ 1min	1000MΩ/ km or more	60C°	100 × 10 ⁴ times or more at R200
			4 (0.2mm ²)	40 strands/ 0.08mm	103Ω/km or less				

(Note 1) Bando Electric Wire (Contact: +81-48-461-0561 <http://www.bew.co.jp>)

(Note 2) The Mitsubishi standard cable is the (a) Heat resistant specifications cable. For MDS-C1/CH series, (b) or equivalent is used as the standard cable.

Compound 6-pair cable structure drawing

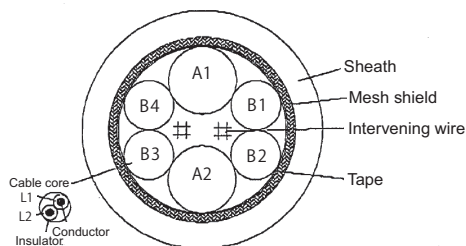

Core identification

Pair No.	Insulator color	
	L1	L2
A1 (0.5mm ²)	Red	White
A2 (0.5mm ²)	Black	White
B1 (0.2mm ²)	Brown	Orange
B2 (0.2mm ²)	Blue	Green
B3 (0.2mm ²)	Purple	White
B4 (0.2mm ²)	Yellow	White

(2) Cable assembly

Assemble the cable with the cable shield wire securely connected to the ground plate of the connector.

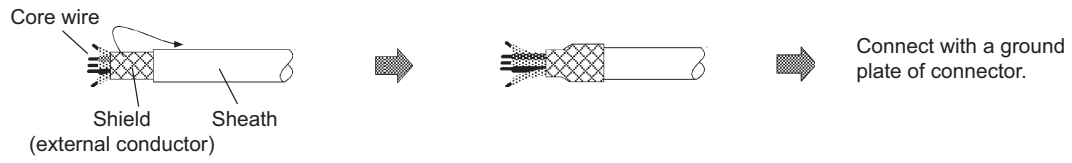

Appendix 1.2 CNP2E-1 Cable

Max. cable length: 30m

Application: Motor side PLG cable

Spindle side accuracy detector

TS5690 cable

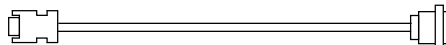

Spindle drive unit side connector

(3M)

Receptacle: 36210-0100PL

Shell kit: 36310-3200-008

(MOLEX)

Connector set: 54599-1019

Spindle motor side connector

(Tyco Electronics)

Connector: 172169-1

Contact: 170363-1(AWG26-22)

170364-1(AWG22-18)

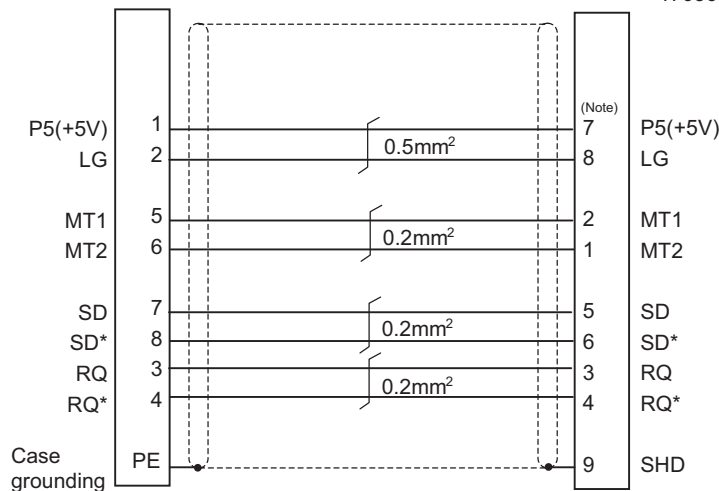

(Note) For the pin "7" or "8", use the contact "170364-1".
For the other pins, use the contact "170363-1".

<Cable connection diagram (for 15m or less)>

Spindle drive unit side connector

(3M)

Receptacle: 36210-0100PL

Shell kit: 36310-3200-008

(MOLEX)

Connector set: 54599-1019

Spindle motor side connector

(Tyco Electronics)

Connector: 172169-1

Contact: 170363-1(AWG26-22)

170364-1(AWG22-18)

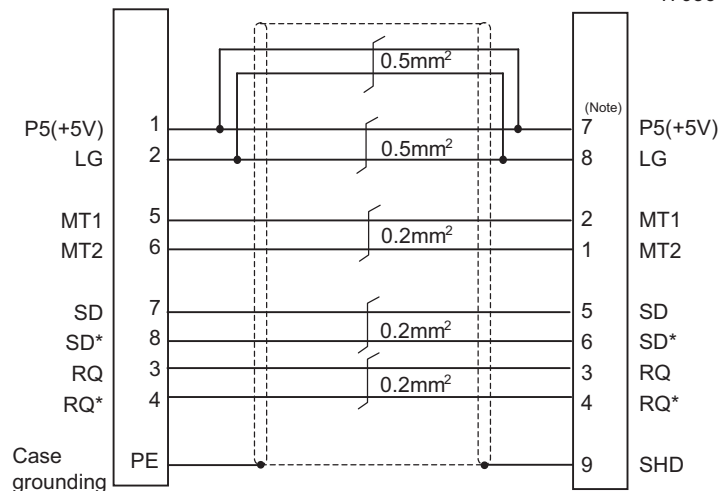

(Note) For the pin "7" or "8", use the contact "170364-1".
For the other pins, use the contact "170363-1".

<Cable connection diagram (for 15m to 30m)>

Appendix 1.3 CNP3EZ-2P/CNP3EZ-3P Cable

Max. cable length: 30m

Application: Spindle side detector cable

OSE-1024 cable

CNP3EZ-2P (Straight)

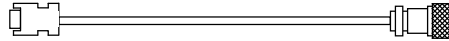

CNP3EZ-3P (Angle)



Spindle drive unit side connector
(3M)
Receptacle: 36210-0100PL
Shell kit: 36310-3200-008
(MOLEX)
Connector set: 54599-1019

Spindle motor side connector
(DDK)
Connector: MS3106A20-29S (D190)
Back shell: CE02-20BS-S (straight)
CE-20BA-S (angle)
Clamp: CE3057-12A-3

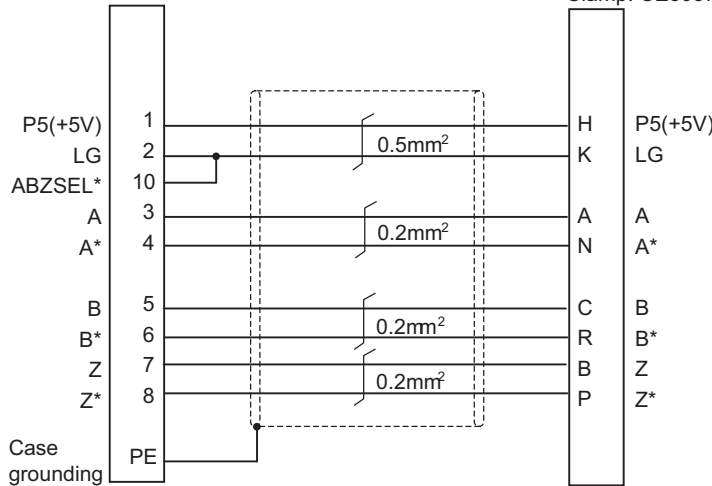

<Cable connection diagram (for 15m or less)>

Spindle drive unit side connector
(3M)
Receptacle: 36210-0100PL
Shell kit: 36310-3200-008
(MOLEX)
Connector set: 54599-1019

Spindle motor side connector
(DDK)
Connector: MS3106A20-29S (D190)
Back shell: CE02-20BS-S (straight)
CE-20BA-S (angle)
Clamp: CE3057-12A-3

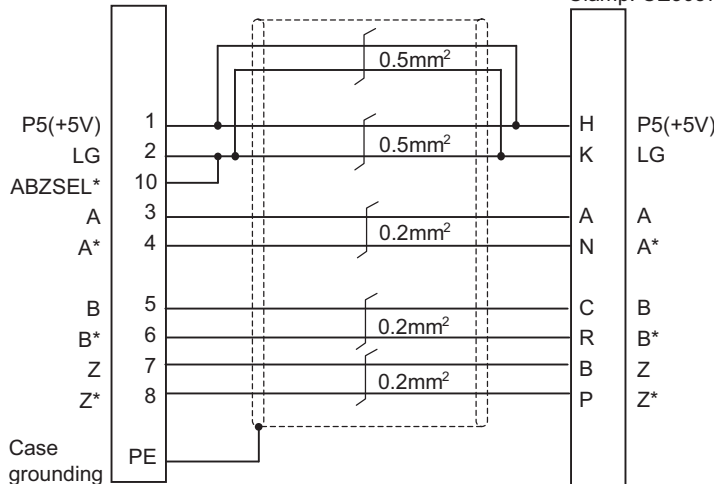

<Cable connection diagram (for 15m to 30m)>

Appendix 1.4 CNV22J-K1P / CNV22J-K2P Cable

Max. cable length: 0.3m

Application: For HF-KP (Servo) Motor side detector relay cable (motor side)

Compatible with only IP65

CNV22J-K1P (load side angle)

CNV22J-K2P (reverse load side angle)

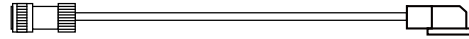

Servo drive unit side connector
 (DDK)
 Plug: CM10-CR10P-M

Servo motor detector/
 Ball screw side detector side connector
 Plug: 1747464-1
 Contact: 1674335-4

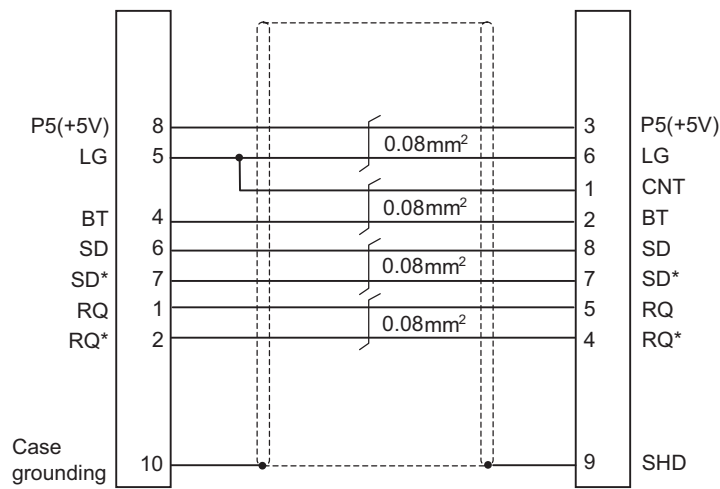

<Cable connection diagram>

Appendix 1.5 CNV2E-6P/CNV2E-7P Cable

Max. cable length: 30m

Application: Motor side detector cable (for A51/A74N(/A74))/ Ball screw side detector cable

CNV2E-6P (Straight)

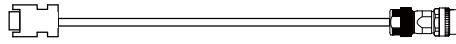

CNV2E-7P (Angle)



Drive unit side connector
(3M)
Receptacle: 36210-0100PL
Shell kit: 36310-3200-008
(MOLEX)
Connector set: 54599-1019

Motor detector/
Ball screw side detector side connector
(DDK)
Plug: CM10-SP10S-M(D6) (Straight)
CM10-AP10S-M(D6) (Angle)
Contact: CM10-#22SC(S1)(D8)

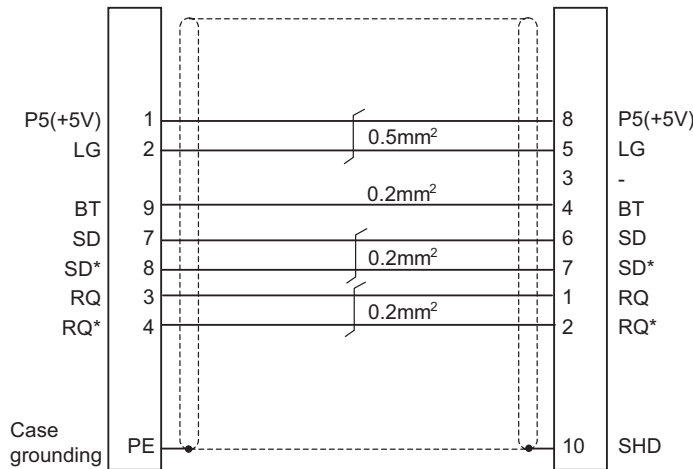

<Cable connection diagram (for 15m or less)>

Drive unit side connector
(3M)
Receptacle: 36210-0100PL
Shell kit: 36310-3200-008
(MOLEX)
Connector set: 54599-1019

Motor detector/
Ball screw side detector side connector
(DDK)
Plug: CM10-SP10S-M(D6) (Straight)
CM10-AP10S-M(D6) (Angle)
Contact: CM10-#22SC(S1)(D8)

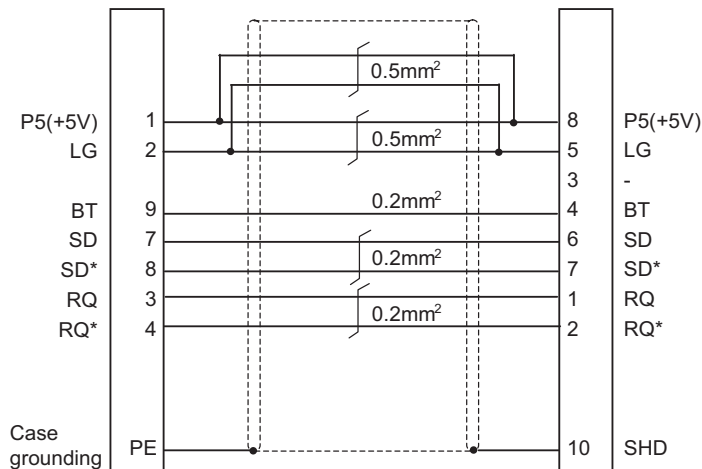

<Cable connection diagram (for 15m to 30m)>

Appendix 1.6 CNV2E-8P/CNV2E-9P Cable

Max. cable length: 30m

Application: For HF/HF-H, HF-KP (Tool spindle) Motor side detector cable (for A48/A51/A74N(/A74)) /

For HF-KP (Servo) Motor side detector relay cable (Drive unit side) (CNV2E-8P)

CNV2E-8P (Straight)

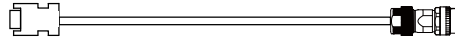

CNV2E-9P (Angle)

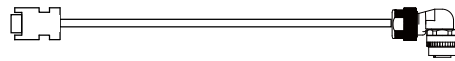

Drive unit side connector
 (3M)
 Receptacle: 36210-0100PL
 Shell kit: 36310-3200-008
 (MOLEX)
 Connector set: 54599-1019

Motor detector/
 Ball screw side detector side connector
 (DDK)
 Plug: CMV1-SP10S-M2 (Straight)
 CMV1-AP10S-M2 (Angle)
 Contact: CMV1-#22ASC-S1

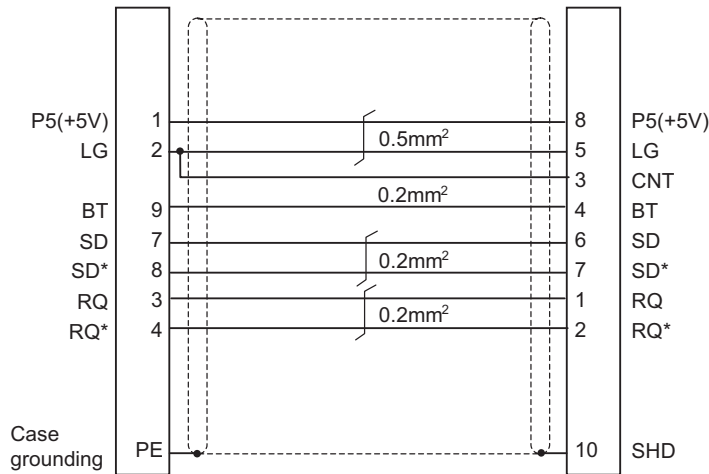

<Cable connection diagram (for 15m or less)>

Drive unit side connector
 (3M)
 Receptacle: 36210-0100PL
 Shell kit: 36310-3200-008
 (MOLEX)
 Connector set: 54599-1019

Motor detector/
 Ball screw side detector side connector
 (DDK)
 Plug: CMV1-SP10S-M2 (Straight)
 CMV1-AP10S-M2 (Angle)
 Contact: CMV1-#22ASC-S1

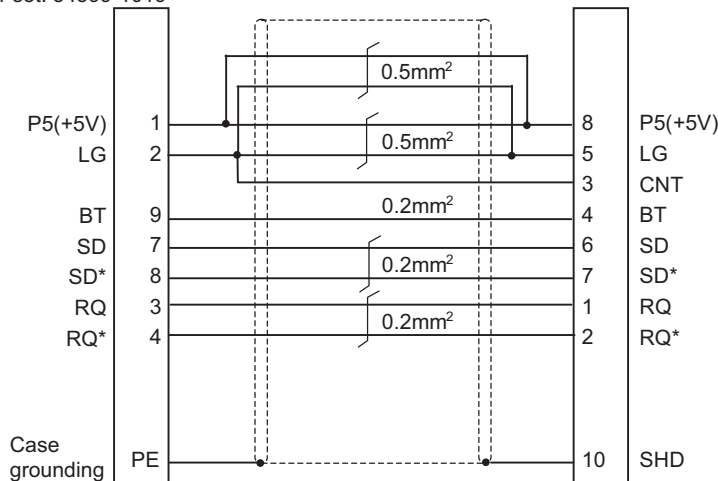

<Cable connection diagram (for 15m to 30m)>

Appendix 1.7 CNV2E-D Cable

Max. cable length: 30m

Application: MDS-B-SD unit cable



Drive unit side connector
(3M)
Receptacle: 36210-0100PL
Shell kit: 36310-3200-008
(MOLEX)
Connector set: 54599-1019

MDS-B-SD unit side connector
(3M)
Connector: 10120-3000VE
Shell kit: 10320-52F0-008

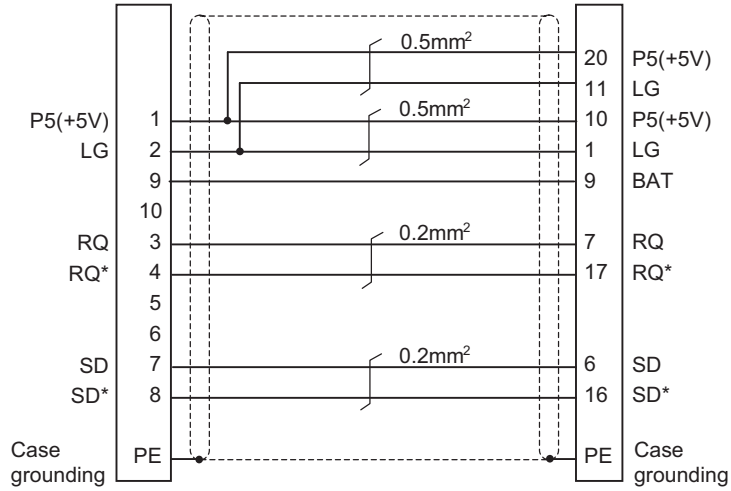

<Cable connection diagram>

Appendix 1.8 CNV2E-HP Cable

Max. cable length: 30m

Application: MDS-B-HR unit cable



Drive unit side connector
(3M)
Receptacle: 36210-0100PL
Shell kit: 36310-3200-008
(MOLEX)
Connector set: 54599-1019

MDS-B-HR unit side connector
(Hirose Electric)
Plug: RM15WTP-8S
Clamp: RM15WTP-CP (10)

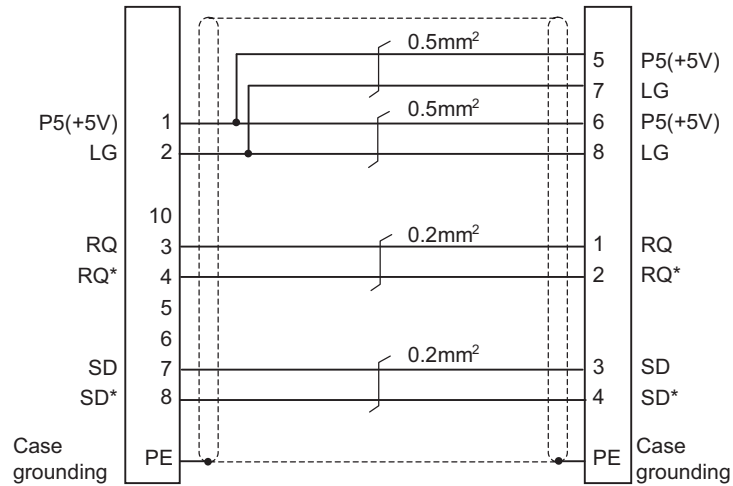

<Cable connection diagram>

Appendix 1.9 CNV2E-K1P / CNV2E-K2P Cable

Max. cable length: 10m

Application: For HF-KP (Servo) Motor side detector cable

Compatible with only IP65

CNV2E-K1P (load side angle)

CNV2E-K2P (reverse load side angle)



Servo drive unit side connector
 (3M)
 Receptacle : 36210-0100PL
 Shell kit : 36310-3200-008
 (MOLEX)
 Connector set : 54599-1019

Servo motor detector connector
 (Tyco Electronics AMP)
 Connector : 1674320-1

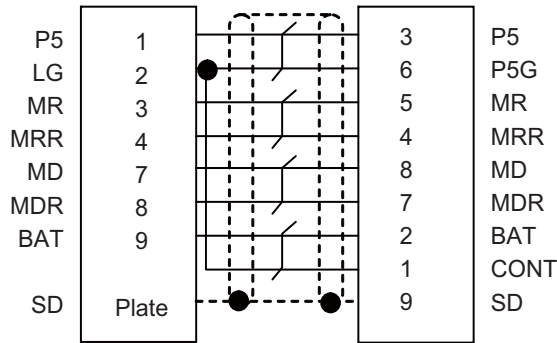

<Cable connection diagram>

Appendix 1.10 DG21 Cable

Max. cable length: 5m

Application: Battery cable (For drive unit - battery unit)

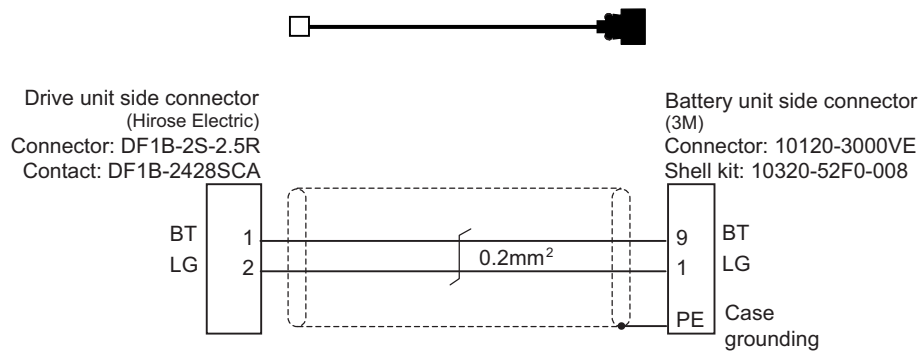

<Cable connection diagram between drive unit and MDS-A-BT/ A6BAT(MR-BAT)(MDS-BTCASE)>

Appendix 1.11 DG22 Cable

Max. cable length: 10m

Application: Battery cable (For drive unit - drive unit)

(Note) This cable is required to supply the power from the battery unit to multiple drive units.

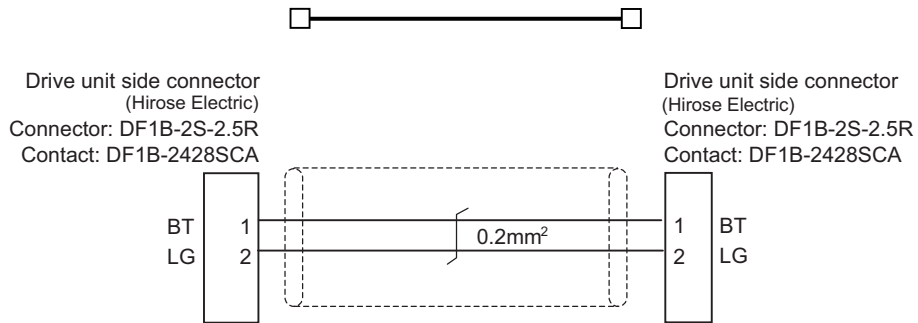

<Cable connection diagram between drive unit and drive unit>

Appendix 1.12 DG23 Cable

Max. cable length: 10m

Application: Battery cable (For drive unit - battery box)

(Note) The battery box side is connected using a bare conductor or a terminal bar.



Drive unit side connector
Connector : DF1B-2S-2.5R
Contact : DF1B-2428SCA

Battery box side

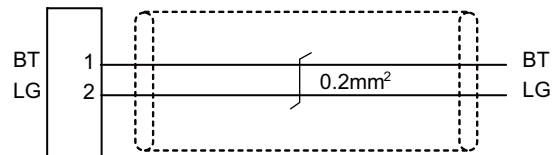

<DG23 cable connection diagram (Connection cable between drive unit and MDS-BTBOX-36)>

Appendix 1.13 DG24 Cable

Max. cable length: 10m

Application: 5V sply/DO output cable (For drive unit - battery box)

(Note) The battery box side is connected using a bare conductor or a terminal bar.

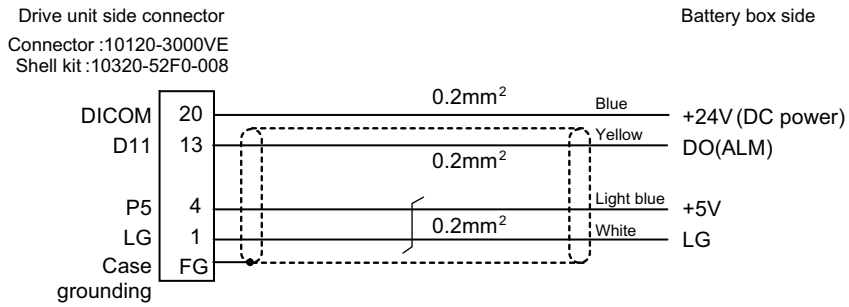
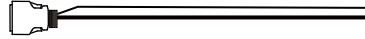

<DG24 cable connection diagram (Connection cable for alarm output between drive unit and MDS-BTBOX-36)>
(For MDS-D2/DH2)

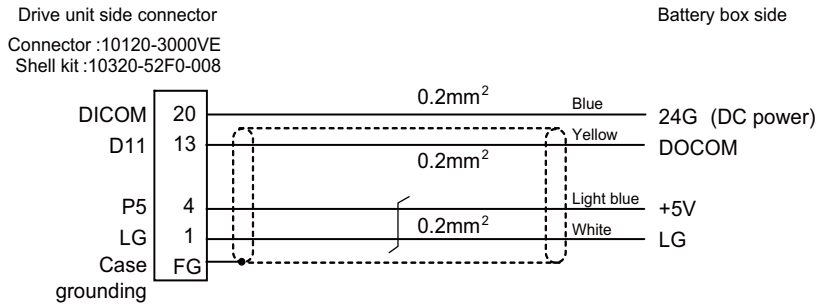

<DG24 cable connection diagram (Connection cable for alarm output between drive unit and MDS-BTBOX-36)>
(For MDS-DM2)

Appendix 1.14 E-TM Terminator Connector

Application: Terminator for OPI interface

E-TM

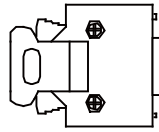

E-TM

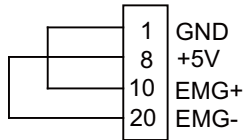

Wire material : UL1007 AWG22

[E-TM]

Plug : 10120-3000VL

Shell : 10320-52F0-008

Recommended manufacturer : 3M

(Note) The cable led-in hole must be closed.

Appendix 1.15 F020/F021/F022 Cable

Max. cable length: 50m

Application: Manual Pulse Generator cable (12V)
(for connection to operation panel I/O unit)

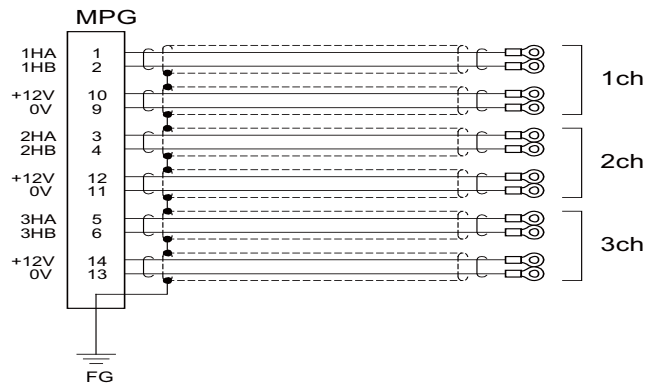
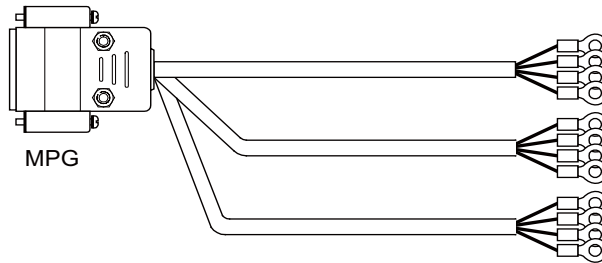

[HANDLE]

Connector: CDA-15P

Contact: CD-PC-111 x 12

Case: HDA-CTH

Recommended manufacturer: Hirose Electric

Wire material: B-22(19)U x 2SJ-1 x 9

Recommended manufacturer:

Sumitomo Electric Industries

[1ch][2ch][3ch]

Crimp terminal: V1.25-3 x 12

Recommended manufacturer: JST

Cable name	1ch	2ch	3ch
F020 cable	○		
F021 cable	○	○	
F022 cable	○	○	○
○ : Usable channel			

(Note) Fold the cable shield over the sheath, and wrap copper foil tape over it. Connect the wound copper foil tape to GND plate of the connector.

Appendix 1.16 F034/F035 Cable

Max. cable length: 15m (the maximum length of the cable when connected to the control unit via other units)

Application: RS232C I/F cable (for control unit)

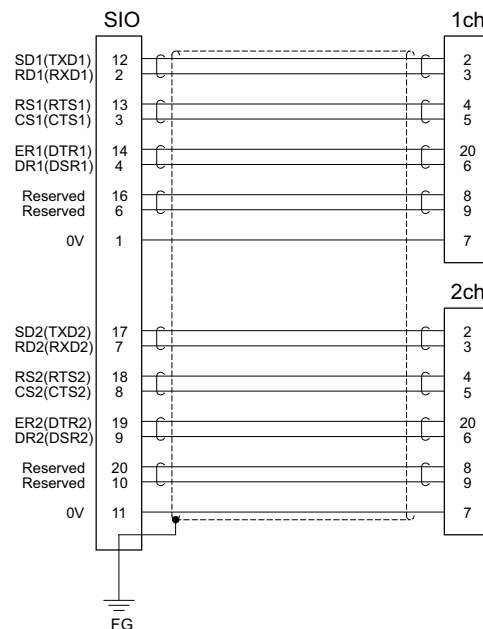
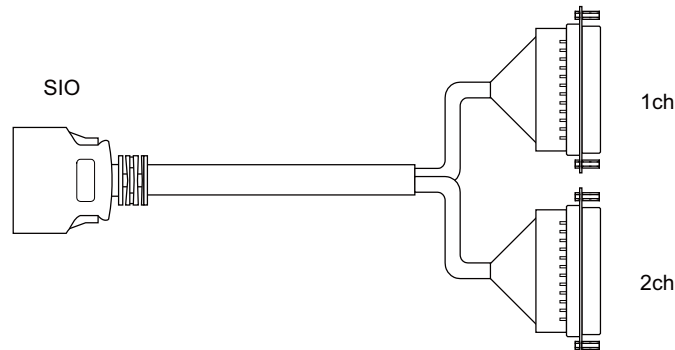

[SIO]
Connector: 10120-3000VE
Case: 10320-52F0-008
Recommended manufacturer: 3M

Wire material: UL1061-2464
AWG24×12P
Recommended manufacturer: Oki
Electric Cable

[1ch][2ch]
Connector: CDB-25S
Contact: CD-SC-111×9
Lock nut: HD-LNA×2
Recommended manufacturer:
Hirose Electric

Cable name	1ch	2ch
F034 cable	○	
F035 cable	○	○
○ : Usable channel		

(Note 1) Fold the cable shield over the sheath, and wrap copper foil tape over it. Connect the wound copper foil tape to GND plate of the connector.

(Note 2) Signal names in parentheses "()" are generally used.

(Note 3) Connect to the serial communication connector of the control unit. Use G031/G032 cable when connecting to the serial communication connector of the display unit.

Appendix 1.17 F070 Cable

Max. cable length: 30m

Application: 24VDC power cable

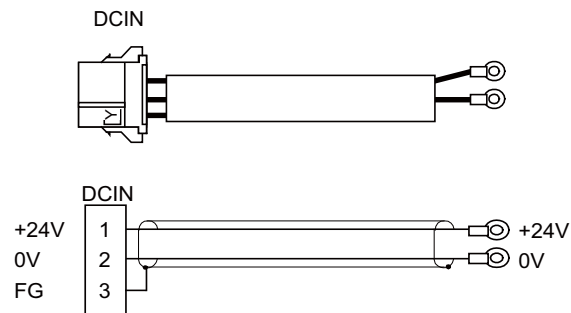

[DCIN]

Connector: 2-178288-3

Contact: 1-175218-5 ×3

Recommended manufacturer: Tyco Electronics

Wire material: B-18(19)U×2SJ-1×9

Recommended manufacturer:

Nikko Electric Wire

Crimp terminal: V1.25-3 or V1.25-4×2

Recommended manufacturer: JST

Appendix 1.18 F110 Cable

Max. cable length: 15m

Application: 24VDC power cable for PD25/PD27

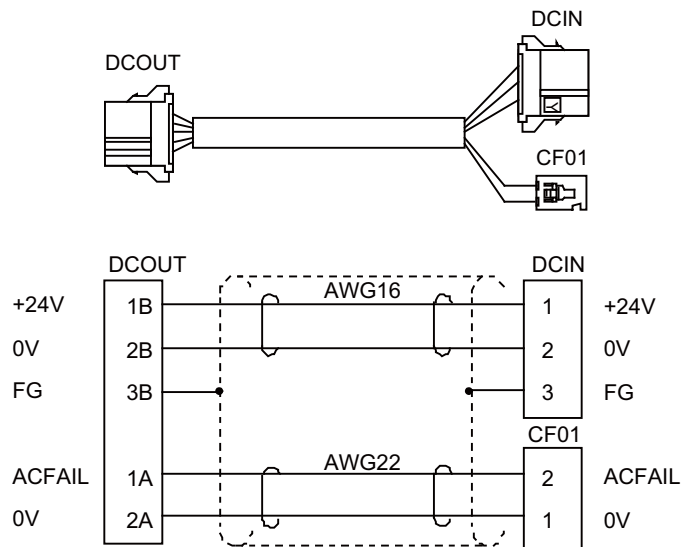

[DCOUT]

Connector: 3-178127-6

Contact:

1-175218-5 (for AWG16) ×3,

1-175217-5 (for AWG22) ×2

Recommended manufacturer:

Tyco Electronics

Wire material:

UL2464 2×22AWG+2×16AWG SS-95138

Recommended manufacturer: DDK

[DCIN]

Connector: 2-178288-3

Contact: 1-175218-5 ×3

Recommended manufacturer:

Tyco Electronics

[CF01]

Connector: 005057-9402

Contact: 0016020103 ×2

Recommended manufacturer:

MOLEX

Appendix 1.19 F120 Cable

Max. cable length: 30m

Application: Emergency stop cable

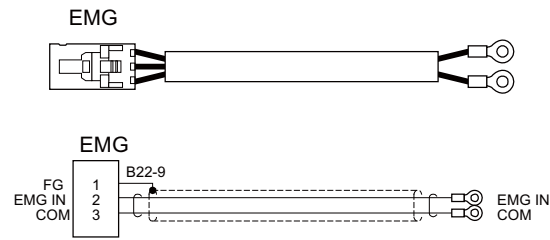

[EMG]

Connector: 005057-9403

Contact: 0016020103 ×3

Recommended manufacturer: MOLEX

Wire material: B-22(19)U×2SJ-1×9

Recommended manufacturer:

Nikko Electric Wire

Crimp terminal: V1.25-3 ×2

Recommended manufacturer: JST

Appendix 1.20 F142 Cable

Max. cable length: 0.5m

Application: Cable for hard disk (comes with the hard disk)

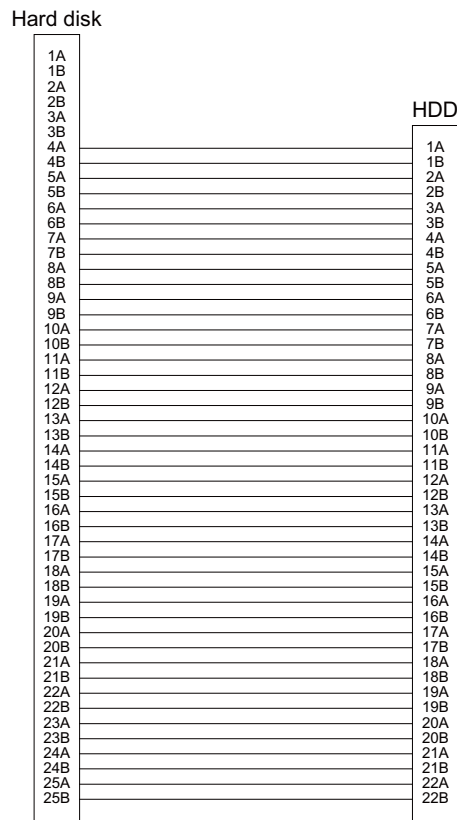
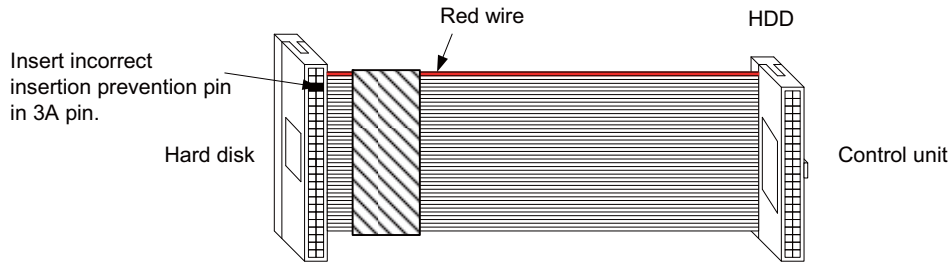

Connector: 89361-150
Recommended manufacturer: BERG

Wire material: UL2651 AWG28

[HDD]
Crimp terminal: FCN-727B044-G/LM-D
Recommended manufacturer:
FUJITSU

Appendix 1.21 F170 Cable

Max. cable length: 15m

Application: ON/OFF switch cable for PD25/PD27

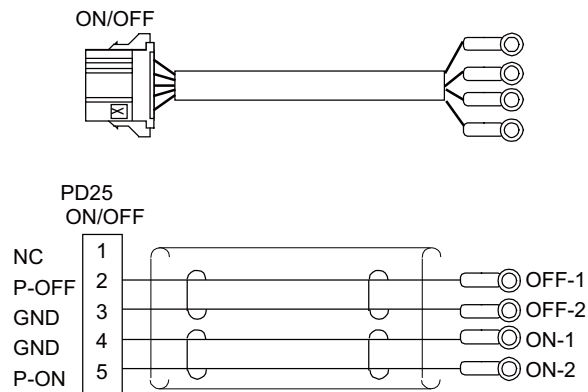

[ON/OFF]

Connector: 1-178288-5

Contact: 1-175218-5

Recommended manufacturer:

Tyco Electronics

Wire material: DPV/VS 3P×0.3mm²

Recommended manufacturer:

Bando Electric Wire

Crimp terminal: V1.25-3 or V1.25-4

Recommended manufacturer: JST

(Note) Select the crimp terminal suitable for the terminal block and switch you use.

Appendix 1.22 FCUA-R030 Cable

Max. cable length: 20m

Application: SKIP input cable

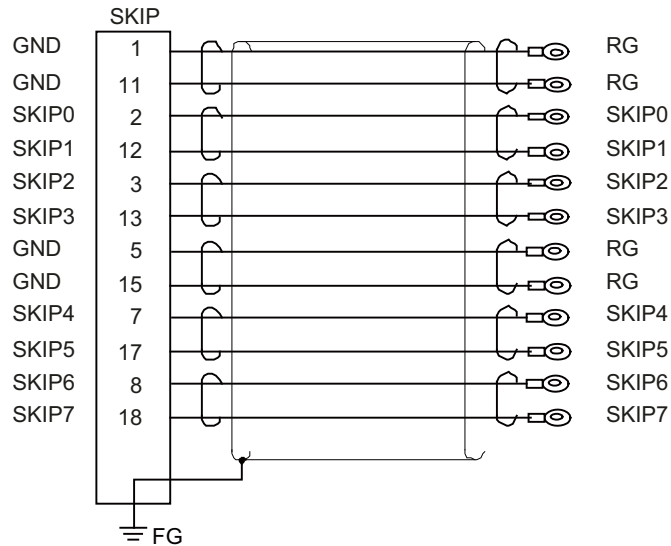
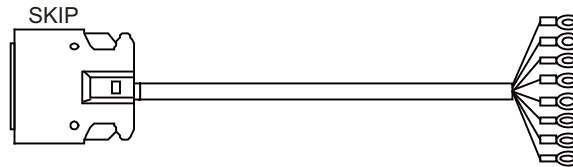

[SKIP]
 Connector: 10120-3000VE
 Case: 10320-52F0-008
 Recommended manufacturer: 3M

Wire material: UL1061-2464
 AWG22×6P
 Recommended manufacturer:
 Oki Electric Cable

Crimp terminal: V1.25-4 ×12
 Recommended manufacturer: JST

(Note) Fold the cable shield over the sheath, and wrap copper foil tape over it. Connect the wound copper foil tape to GND plate of the connector.

Appendix 1.23 FCUA-R031 Cable

Max. cable length: 30m

Application: Analog input/output (for remote I/O unit)

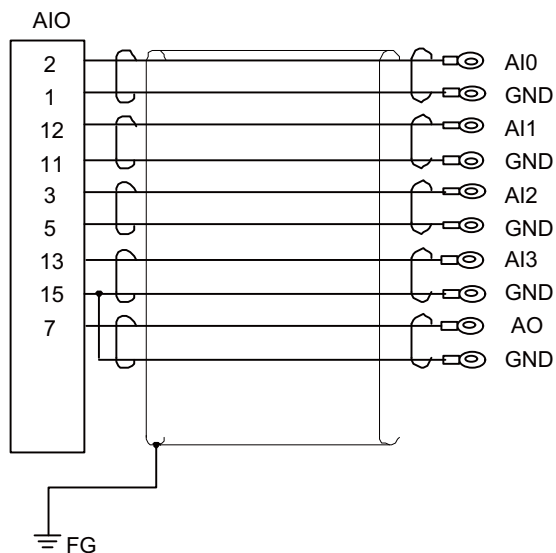
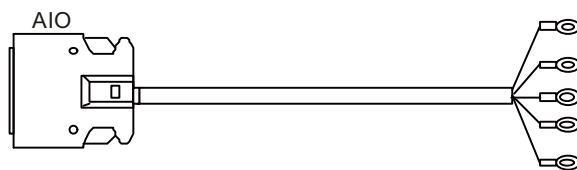

[AIO]
 Connector: 10120-3000VE
 Case: 10320-52F0-008
 Recommended manufacturer: 3M

Wire material: UL1061-2464
 AWG24×6P
 Recommended manufacturer:
 Oki Electric Cable

Crimp terminal: V1.25-3 ×10
 Recommended manufacturer: JST

(Note) Fold the cable shield over the sheath, and wrap copper foil tape over it. Connect the wound copper foil tape to GND plate of the connector.

Appendix 1.24 FCUA-R050/R054 Cable

Max. cable length: 30m

Application: Synchronous encoder - control unit

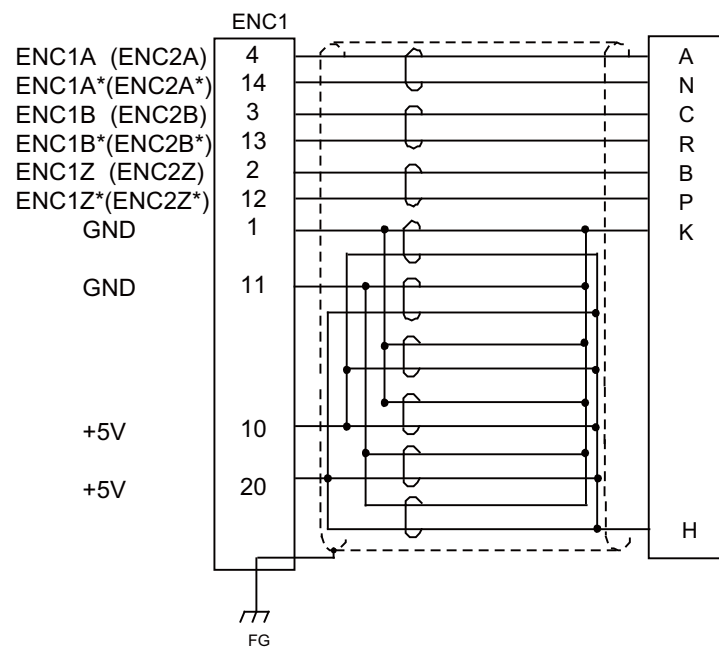
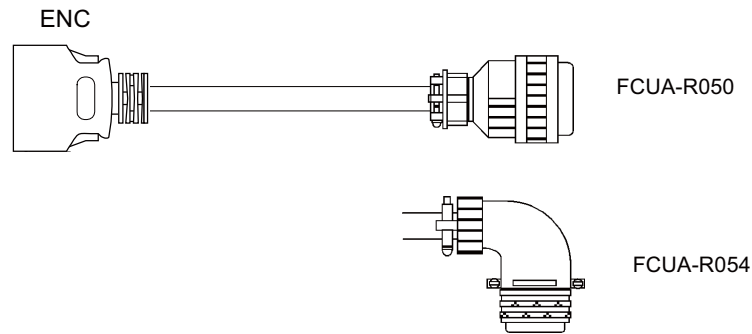

[ENC1]
 Plug: 10120-3000VL
 Shell: 10320-52F0-008
 Recommended manufacturer: 3M

Wire material: UL1061-2464
 AWG24×12P
 Recommended manufacturer:
 Oki Electric Cable

[FCUA-R050 cable]
 Connector: MS3106B20-29S
 Cable clamp: MS3057-12A
 Recommended manufacturer:
 ITT Cannon
 [FCUA-R054 cable]
 Connector: MS3108B20-29S
 Cable clamp: MS3057-12A
 Recommended manufacturer:
 ITT Cannon

(Note) Fold the cable shield over the sheath, and wrap copper foil tape over it. Connect the wound copper foil tape to GND plate of the connector.

Appendix 1.25 FCUA-R211 Cable

Max. cable length: 30m (the maximum length of the cable when connected to the control unit via other units)

Application: Remote I/O (with terminal block)
 between remote I/O,
 remote I/O-CNC control unit,
 remote I/O-Operation panel I/O unit,
 remote I/O-MITSUBISHI CNC machine operation panel A

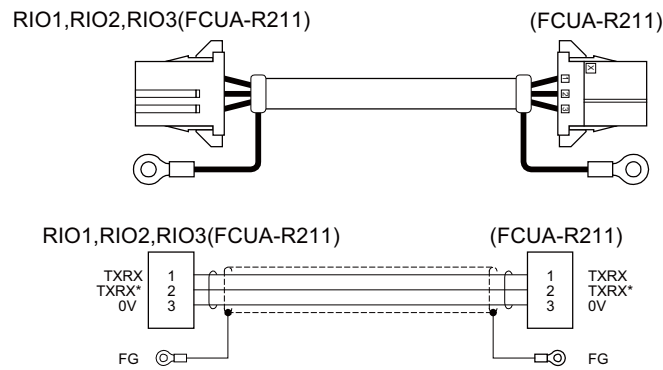

[RIO1, RIO2, RIO3]
 Connector: 1-178288-3
 Contact: 1-175218-2 ×3
 Recommended manufacturer:
 Tyco Electronics

Wire material:
 MVVS 3C×0.5mm² (MIC 3C×0.5mm²)
 Recommended manufacturer: Takeuchi Densen

Connector: 1-178288-3
 Contact: 1-175218-2 ×3
 Recommended manufacturer:
 Tyco Electronics

(Note) Fold the cable shield over the sheath, and wrap copper foil tape over it. Connect the wound copper foil tape to GND plate of the connector.

Appendix 1.26 FCUA-R300/FCUA-R301 Cable

Type: FCUA-R300

Max. cable length: 50m

**Application: DI/DO cable (one side connector)
(for remote I/O unit)**

DI-L/DO-L, DI-R/DO-R

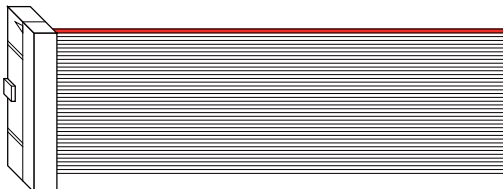

[DI-L/DO-L,DI-R/DO-R]

Connector: 7940-6500SC

Recommended manufacturer: 3M

Wire material: B40-S

Recommended manufacturer:

Oki Electric Cable

Type: FCUA-R301

Max. cable length: 50m

**Application: DI/DO cable (both side connectors)
(for remote I/O unit)**

DI-L/DO-L, DI-R/DO-R



[DI-L/DO-L,DI-R/DO-R]

Connector: 7940-6500SC

Recommended manufacturer: 3M

Wire material: B40-S

Recommended manufacturer:

Oki Electric Cable

Connector: 7940-6500SC

Strain relief: 3448-7940

Recommended manufacturer: 3M

There are two types of cable for the remote I/O unit: FCUA-R300 and FCUA-R301.

The FCUA-R300 cable has one end cut off, and the FCUA-R301 cable is used for connection to the IDEC terminal block BX1F-T40A (Note 1). If a cable longer than 3m is required, use the connector set FCUA-CN300 or FCUA-CS301.

The one-end FCUA-CN300 connector (optional, with one end) includes the DI-L (DI-R) and DO-L (DO-R) connectors. The FCUA-CS301 connector (optional, with both ends) includes the DI-L (DI-R) and DO-L (DO-R) connectors, and two connectors for connection with the terminal block (IDEC).

(Note 1) IDEC I/O terminal BX1F-T40A

Machine control panel,
electric cabinet, etc.

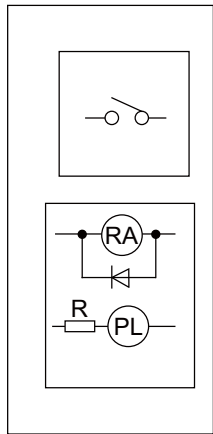

RA : Relay
PL : Pilot lamp

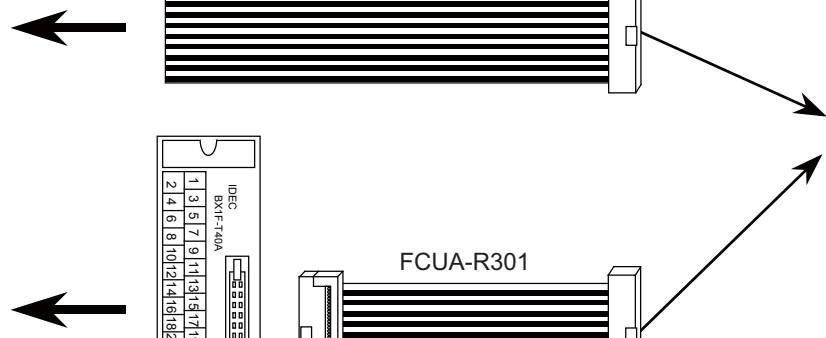
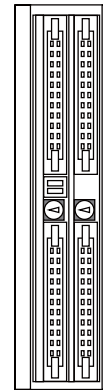
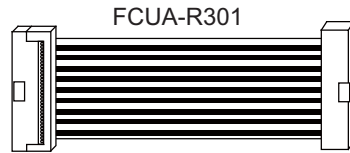
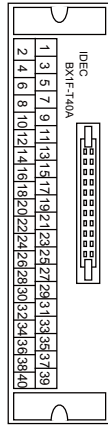
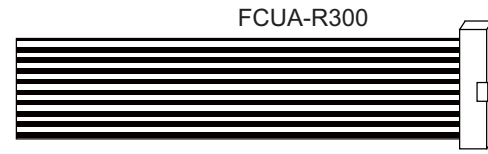

Connector pin correspondence

Terminal block BX1F	FCUA-DX1xx	Terminal block BX1F	FCUA-DX1xx
1	A1	2	B1
3	A2	4	B2
5	A3	6	B3
7	A4	8	B4
9	A5	10	B5
11	A6	12	B6
13	A7	14	B7
15	A8	16	B8
17	A9	18	B9
19	A10	20	B10
21	A11	22	B11
23	A12	24	B12
25	A13	26	B13
27	A14	28	B14
29	A15	30	B15
31	A16	32	B16
33	A17	34	B17
35	A18	36	B18
37	A19	38	B19
39	A20	40	B20

Appendix 1.27 G020/G021/G022 Cable

Max. cable length: 20m

Application: Manual Pulse Generator cable (5V)
 (for connection to operation panel I/O unit)

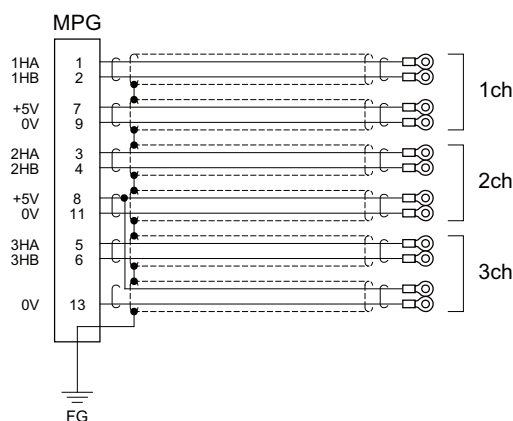
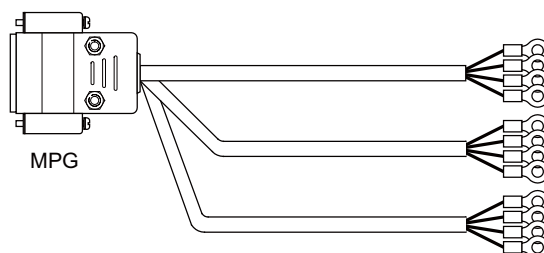

[HANDLE]

Connector: CDA-15P
 Contact: CD-PC-111 x 11
 Case: HDA-CTH
 Recommended manufacturer: Hirose
 Electric

Wire material: B-22(19)U x 2SJ-1 x 9
 Recommended manufacturer:
 Sumitomo Electric Industries

[1ch][2ch][3ch]
 Crimp terminal: V1.25-3 x 12
 Recommended manufacturer: JST

Cable name	1ch	2ch	3ch
G020 cable	○		
G021 cable	○	○	
G022 cable	○	○	○
○ : Usable channel			

(Note) Fold the cable shield over the sheath, and wrap copper foil tape over it. Connect the wound copper foil tape to GND plate of the connector.

Appendix 1.28 G023/G024 Cable

Max. cable length: 20m (the maximum length of the cable when connected to the control unit via other units)

Application: Manual Pulse Generator cable (5V)
(for connection to control unit)

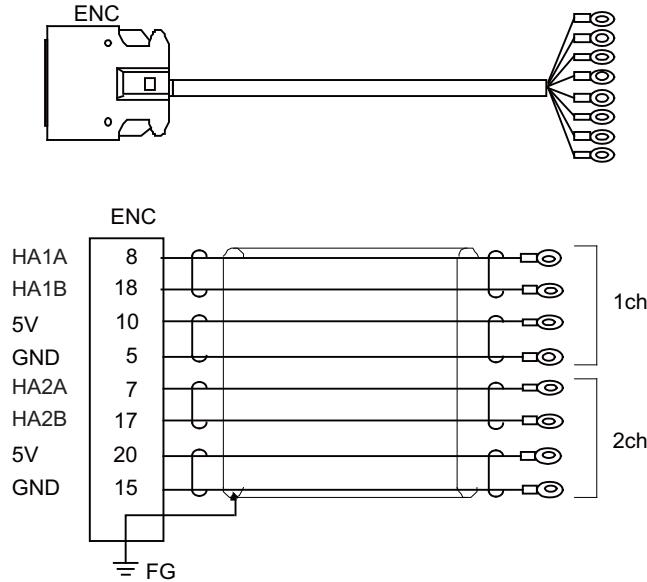

[ENC]

Connector: 10120-3000VE

Case: 10320-52F0-008

Recommended manufacturer: 3M

Wire material:

UL1061-2464 AWG22×6P

Recommended manufacturer:

Oki Electric Cable

[1ch][2ch]

Crimp terminal: V1.25-3 ×8

Recommended manufacturer: JST

Cable name	1ch	2ch
G023 cable	○	
G024 cable	○	○
○ : Usable channel		

(Note) Fold the cable shield over the sheath, and wrap copper foil tape over it. Connect the wound copper foil tape to GND plate of the connector.

Appendix 1.29 G031/G032 Cable

Max. cable length: 15m (the maximum length of the cable when connected to the display unit via other units)

Application: RS232C I/F cable (for display unit)

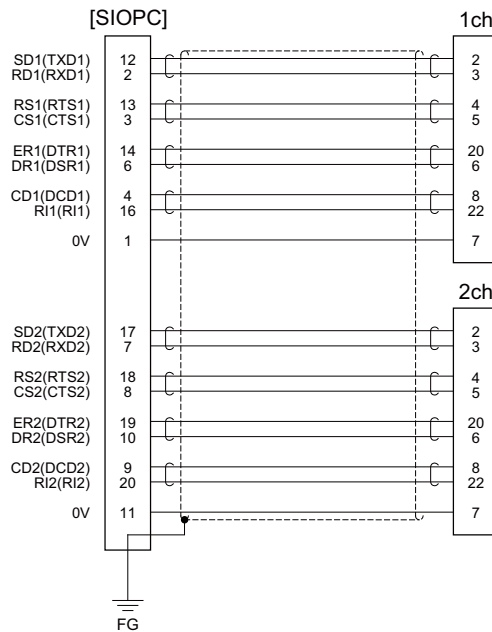
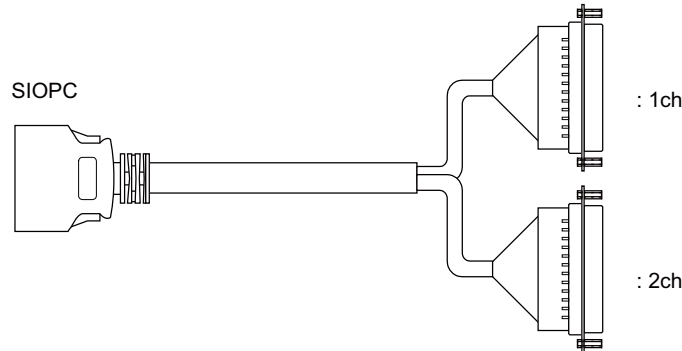

[SIOPC]
Connector: 10120-3000VE
(10120-6000EL)
Case: 10320-52F0-008
(10320-3210-000)
Recommended manufacturer: 3M

Wire material: UL1061-2464
AWG24×12P
Recommended manufacturer: Oki
Electric Cable

[1ch][2ch]
Connector: CDB-25S
Contact: CD-SC-111×9
Lock nut: HD-LNA×2
Recommended manufacturer:
Hirose Electric

Cable name	1ch	2ch
G031 cable	○	
G032 cable	○	○
○ : Usable channel		

(Note 1) Fold the cable shield over the sheath, and wrap copper foil tape over it. Connect the wound copper foil tape to GND plate of the connector.

(Note 2) Signal names in parentheses "()" are generally used.

(Note 3) Connect to the serial communication connector of the display unit. Use F034/F035 cable when connecting to the serial communication connector of the control unit.

Appendix 1.30 G071 Cable

Max. cable length: 0.5m

Application: 24VDC relay cable for MITSUBISHI CNC machine operation panel

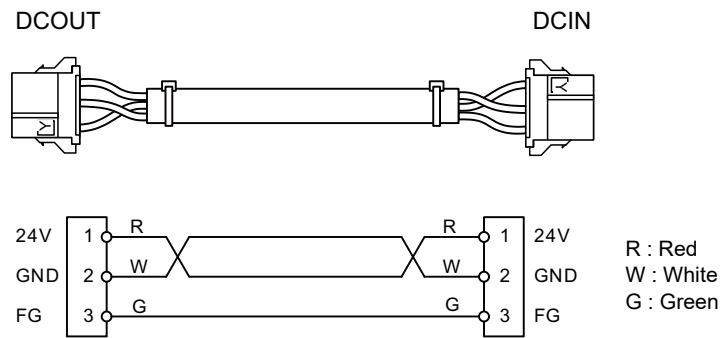

[DCOUT]

Connector: 2-178288-3

Contact: 1-175218-5 x 3

Recommended manufacturer: Tyco Electronics

Wire material: UL1264 AWG16
(Red, White, Green)

[DCIN]

Connector: 2-178288-3

Contact: 1-175218-5 x 3

Recommended manufacturer: Tyco Electronics

(Note) These cables are available only when wired to a same control panel.

Appendix 1.31 G123 Cable

Application: Terminator for emergency stop interface

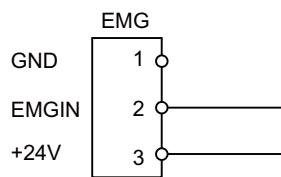
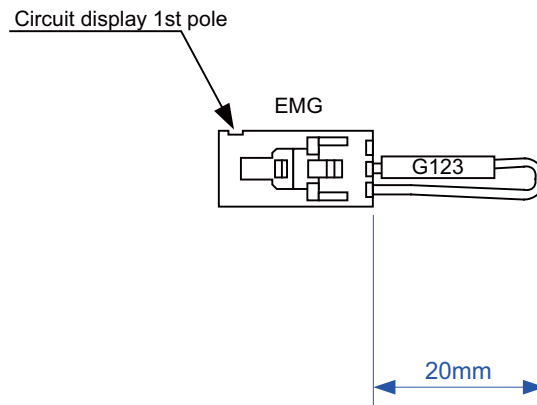

Wire material : B-22(19)U×2SJ-1×9
 Recommended manufacturer : Sumitomo Electric Industries

[EMG]
 Connector : 005057-9403
 Contact : 0016020103 x 2
 Recommended manufacturer : MOLEX

Appendix 1.32 G170 Cable

Max. cable length: 15m

Application: ON/OFF switch cable (ON/OFF switch - display unit)

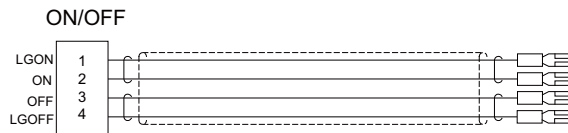
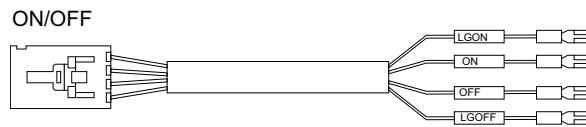

[ON/OFF]

Connector: 51030-0430

Contact: 0016020103 x 4

Recommended manufacturer: MOLEX

Wire material: DPV/VS 4P x 0.2SQ

Recommended manufacturer: Bando

Electric Wire

Faston terminal #110 x 4

Appendix 1.33 G171 Cable

Max. cable length: 15m

Application: Power supply ON/OFF cable (Display unit - PD25/PD27 power unit)

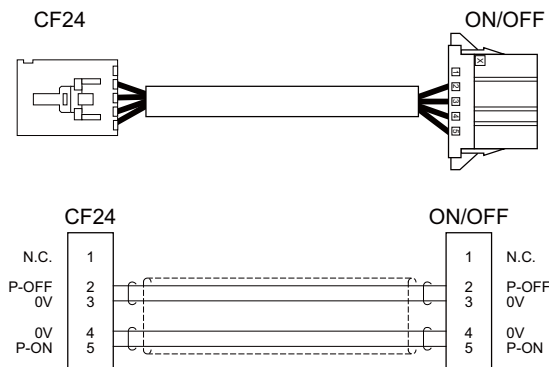

[CF24]

Connector: 51030-0530

Contact: 0016020103 x 4

Recommended manufacturer: MOLEX

Wire material: DPVVS6 6P x 0.2SQ
 Recommended manufacturer: Bando
 Electric Wire

[ON/OFF]

Connector: 1-178288-5

Contact: 1-175218-5 x 4

Recommended manufacturer: Tyco
 Electronics

Appendix 1.34 G295 Cable

Application: Cable for EtherNet/IP, PROFIBUS-DP configuration

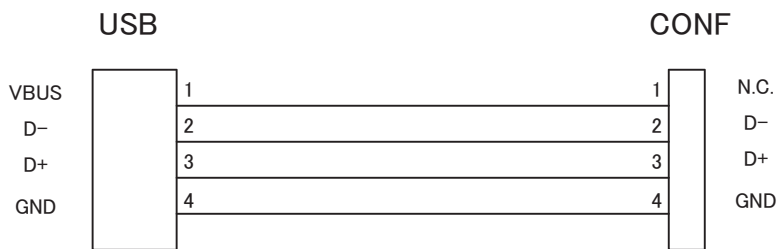
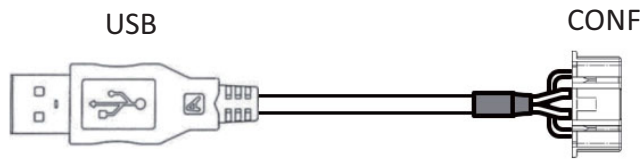

[USB]

Connector/cable: U2C-E □□ BK
 Manufacturer: Elecom

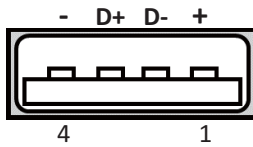

[CONF]

Connector: PAP-04V-S(P)*JST
 Contact: SPHD-002T-P0.5*JST
 Manufacturer: JST

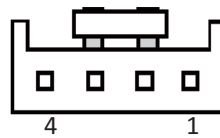

Appendix 1.35 G300 Cable

Max. cable length: 10m

Application: LAN cross cable (Shielded cable is recommended when the length will be 1m or more)

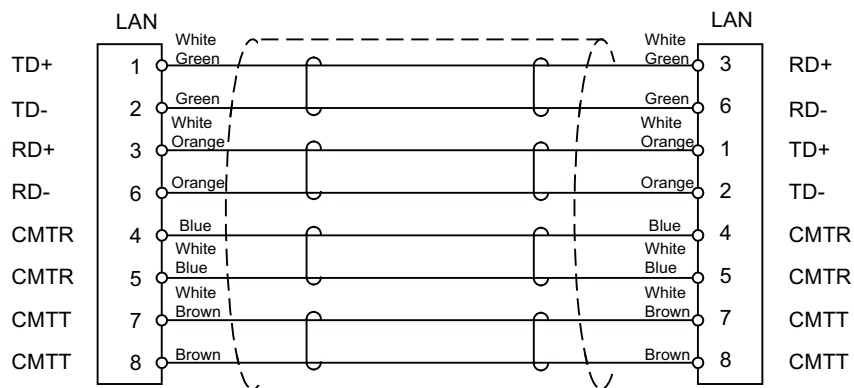
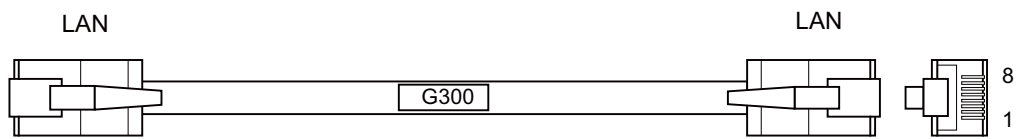

[LAN]

Connector: 5-558530

Recommended manufacturer:

Tyco Electronics

Wire material: LAN category 5 twisted pair x 4P

Appendix 1.36 G301 Cable

Max. cable length: 1m

Application: LAN straight cable (Shielded cable is recommended when the length will be 1m or more)

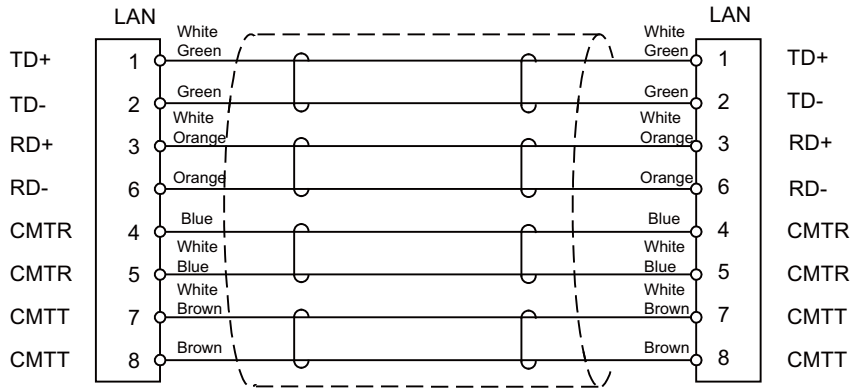
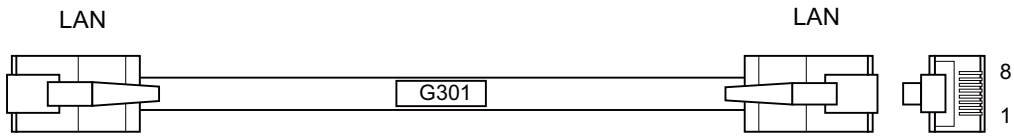

[LAN]

Connector: 5-558530

Recommended manufacturer:

Tyco Electronics

Wire material: LAN category 5 twisted pair x 4P

Appendix 1.37 G310 Cable

Max. cable length: 0.1m

Application: Cable for NC reset (comes with the operation I/O unit)

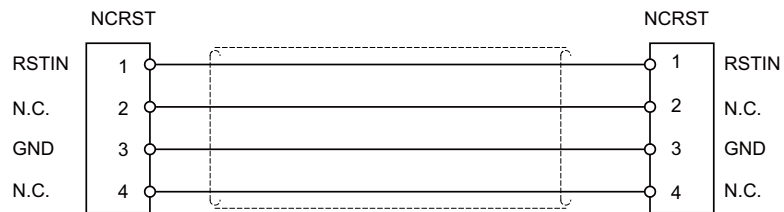
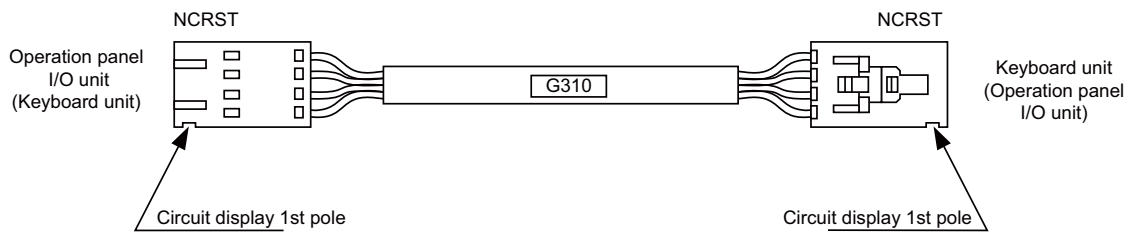

[NCRST]
 Connector: 51030-0430
 Contact: 0016020103 x 4
 Recommended manufacturer: MOLEX

Wire material: UL1061-2464 AWG22
 Recommended manufacturer: Oki
 Electric Cable

[NCRST]
 Connector: 51030-0430
 Contact: 0016020103 x 4
 Recommended manufacturer: MOLEX

Appendix 1.38 G380 Cable

Max. cable length: 30m

Application: Optical communication cable

for wiring between drive units (outside panel)

for optical communication repeater unit

Use when the cable length is 10m or more to 30m or less.

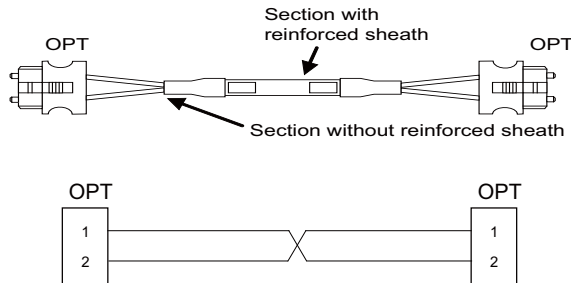

[OPT]

Connector: CF-2D101-S

Recommended manufacturer:
Japan Aviation Electronics

Wire material:

Hard clad type PCF optic cable

Recommended manufacturer:
Oki Electric Cable

Cable	Minimum bending radius: R
2-core cable (section with reinforced sheath)	50mm
2-core cable (section without reinforced sheath)	25mm

- (Note 1) Binding the cables too tight with tie-wraps could result in an increased loss or a disconnection. Use a cushioning material such as a sponge or rubber when bundling the cables and fix so that the cables do not move. Recommended clamp material: CKN-13SP KITAGAWA INDUSTRIES.
- (Note 2) Never bundle the cables with vinyl tape. The plasticizing material in the vinyl tape could cause the PCF cable reinforced sheath to damage.
- (Note 3) Loop the excessive cable with twice or more than the minimum bending radius.

Appendix 1.39 G395 Cable

Max. cable length: 10m

Application: Optical communication cable

for wiring between drive units (outside panel)

for wiring between NC-drive units

Use when wiring outside of the panel with a cable of 10m or less.

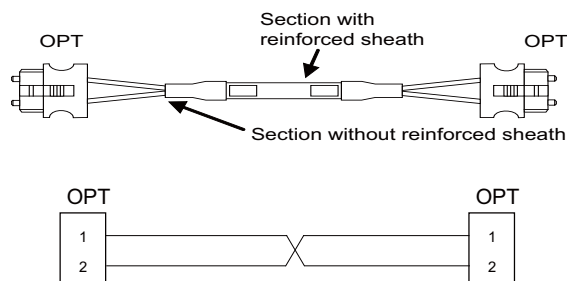

[OPT]

Connector: PF-2D103

Recommended manufacturer:

Japan Aviation Electronics

Wire material: ESCA Premium

Recommended manufacturer:

MITSUBISHI RAYON

Cable	Minimum bending radius: R
2-core cable (section with reinforced sheath)	50mm
2-core cable (section without reinforced sheath)	30mm

- (Note 1) Binding the cables too tight with tie-wraps could result in an increased loss or a disconnection. Use a cushioning material such as a sponge or rubber when bundling the cables and fix so that the cables do not move. Recommended clamp material: CKN-13SP KITAGAWA INDUSTRIES.
- (Note 2) Never bundle the cables with vinyl tape. The plasticizing material in the vinyl tape could cause the POF cable to break.
- (Note 3) Loop the excessive cable with twice or more than the minimum bending radius.

Appendix 1.40 G396 Cable

Max. cable length: 10m

Application: Optical communication cable

for wiring between drive units (inside panel)

Use when wiring in the panel with a cable of 10m or less.

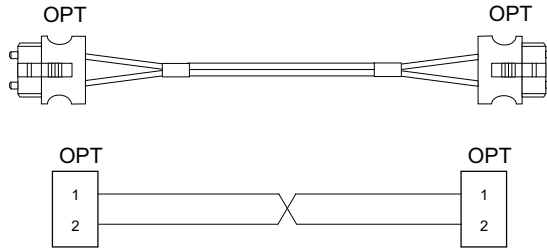

[OPT]

Connector: PF-2D103

Recommended manufacturer:

Japan Aviation Electronics

Wire material: ESCA Premium

Recommended manufacturer:

MITSUBISHI RAYON

Cable	Minimum bending radius: R
2-core parallel cord	30mm

- (Note 1) Binding the cables too tight with tie-wraps could result in an increased loss or a disconnection. Use a cushioning material such as a sponge or rubber when bundling the cables and fix so that the cables do not move. Recommended clamp material: CKN-13SP KITAGAWA INDUSTRIES.
- (Note 2) Never bundle the cables with vinyl tape. The plasticizing material in the vinyl tape could cause the POF cable to break.
- (Note 3) Loop the excessive cable with twice or more than the minimum bending radius.

Appendix 1.41 G430 Cable

Max. cable length: 10m

Application: For connection to handy terminal

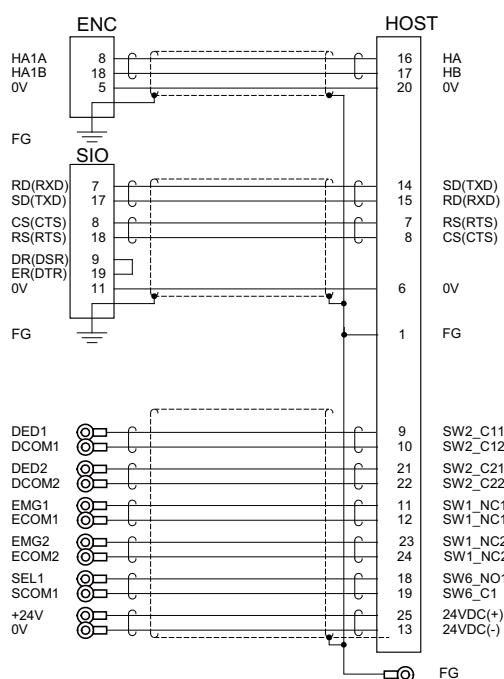
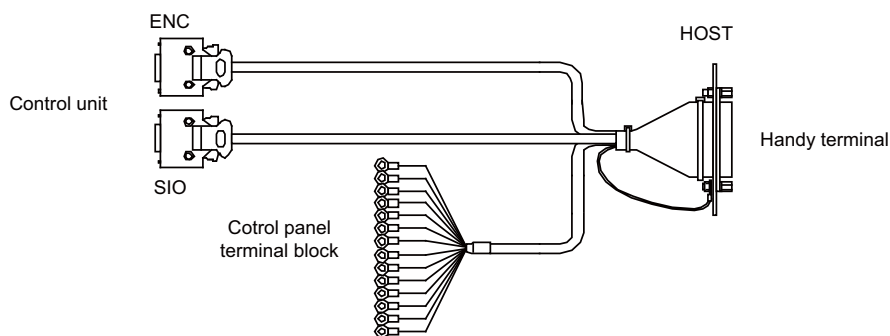

[ENC][SIO]

Plug: 10120-3000VL

Shell: 10320-52F0-008

Recommended manufacturer: 3M

Wire material: UL1061-2464 AWG28 x 3P

Recommended manufacturer: Oki

Electric Cable

[Control panel terminal block]

Crimp terminal: R1.25-3.5

Recommended manufacturer: JST

Wire material: UL1061-2464 AWG24 x 8P

Recommended manufacturer: Oki

Electric Cable

FG terminal

Crimp terminal: V1.25-4

Recommended manufacturer: JST

Wire material: UL1061-2464

AWG18(Green)

Recommended manufacturer: Oki

Electric Cable

[HOST]

Plug: CDB-25S

Contact: CD-SC-221 ×21

Recommended manufacturer: Hirose

Electric

(Note) Fold the cable shield over the sheath, and wrap copper foil tape over it.
Connect the wound copper foil tape to GND plate of the connector.

Appendix 1.42 G460 Cable

Max. cable length: 0.5m

Application: Cable between MITSUBISHI CNC machine operation panel A and MITSUBISHI CNC machine operation panel B

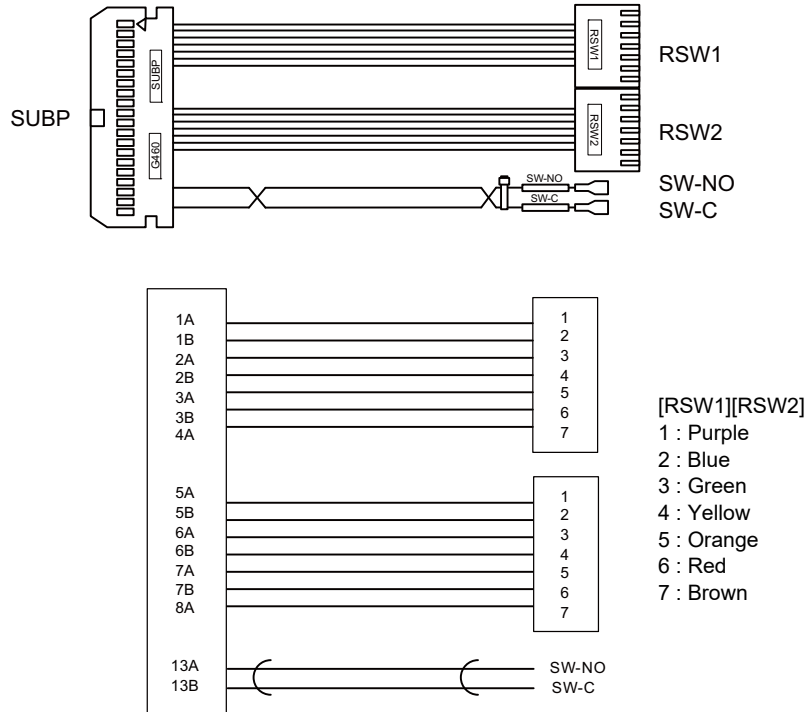

[SUBP]

Connector: HIF3BA-40D-2.54C
 Contact: HIF3-2428SC x 16
 Recommended manufacturer: Hirose Electric

Wire material: UL1007 AWG24
 (Red, Black)

[RSW1][RSW2]

Connector with cable : ACX011-705 x 2
 Contact: 1-175218-5 x 3
 Recommended manufacturer: Fuji Electric

[SW-NO][SW-C]

Connector: STO-01T-110N
 Recommended manufacturer: JST

(Note) Coat the connector [SW-NO][SW-C] with an insulation.

Appendix 1.43 MR-BKS1CBL-A1-H / MR-BKS1CBL-A2-H Cable

Max. cable length: 10m

Application: <200V Series> Brake cable for HF-KP

MR-BKS1CBL-A1-H (load side angle)

MR-BKS1CBL-A2-H (reverse load side angle)



Servo motor brake connector
(Japan Aviation Electronics)

Connector: JN4FT02SJ1

Hood, Socket insulator,
Bushing and Ground nut

Contact: ST-TMH-S-C1B-100(A534G)

Crimp tool: CT160-3TMH5B

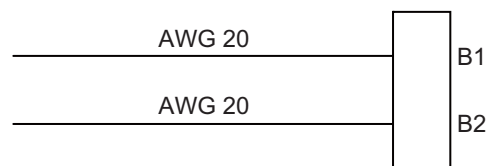

<Cable connection diagram>

Appendix 1.44 MR-PWS1CBL-A1-H / MR-PWS1CBL-A2-H Cable

Max. cable length: 10m

Application: <200V Series> Power cable for HF-KP

MR-PWS1CBL-A1-H (load side angle)

MR-PWS1CBL-A2-H (reverse load side angle)

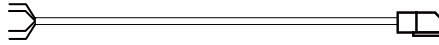

Servo motor power supply connector
(Japan Aviation Electronics)

Connector: JN4FT04SJ1

Hood, Socket insulator,

Bushing and Grand nut

Contact: ST-TMH-S-C1B-100(A534G)

Crimp tool: CT160-3TM5B

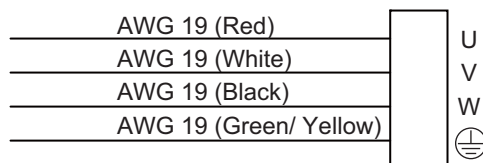

<Cable connection diagram>

Appendix 1.45 R-TM Terminator Connector

Application: Terminator for OPI interface

R-TM

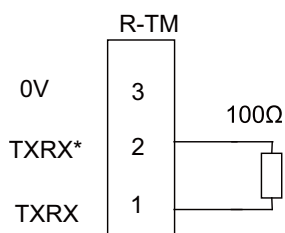
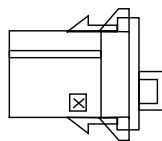

[R-TM]

Connector: 1-178288-3 (X type)

Contact: 1-175216-2 ×2

Recommended manufacturer: Tyco Electronics

Resistor: 100Ω 1/4W

(Note 1) The parts used shall be Mitsubishi recommended parts. Equivalent parts may be used providing they are compatible with the specifications.

(Note 2) Cover the 100Ω terminator with a black insulation tube.

(Note 3) Stamp the connector name "R-TM" in white on the rear of the connector.

Appendix 1.46 SH21 Cable

Max. cable length: 30m

Application: Power supply communication cable

Power backup unit communication cable

Cable for Auxiliary axis/Servo drive units

SV1, SV2

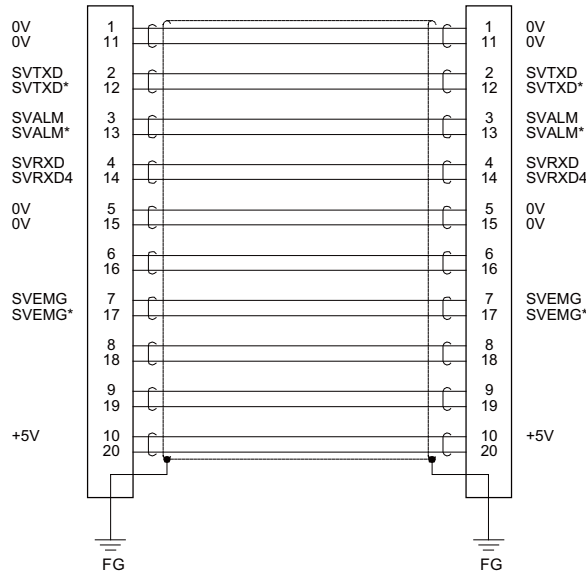
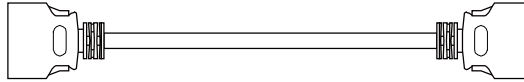

[SV1, SV2]

Plug: 10120-3000VE

Shell: 10320-52F0-008

Recommended manufacturer: 3M

Wire material: UL20276 AWG28×10P

Recommended manufacturer:

Toyokuni Electric Cable

Plug: 10120-3000VE

Shell: 10320-52F0-008

Recommended manufacturer: 3M

(Note) Fold the cable shield over the sheath, and wrap copper foil tape over it. Connect the wound copper foil tape to GND plate of the connector.

Appendix 1.47 SH41 Cable

Max. cable length: 1m (the maximum length of the cable when connected to the control unit via other units)

Application: Remote I/O cable

between remote I/O,

remote I/O-CNC control unit,

remote I/O-Operation panel I/O unit,

remote I/O-MITSUBISHI CNC machine operation panel A

(between remote I/O units in a panel)

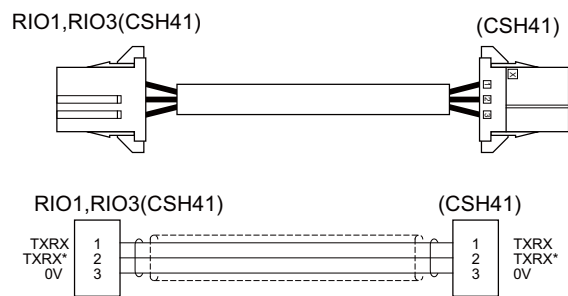

[RIO1, RIO2, RIO3]

Connector: 1-178288-3

Contact: 1-175218-2 ×3

Recommended manufacturer:

Tyco Electronics

Wire material:

MVVS 3C×0.5mm² (MIC 3C×0.5mm²)

Recommended manufacturer: Takeuchi Densen

Connector: 1-178288-3

Contact: 1-175218-2 ×3

Recommended manufacturer:













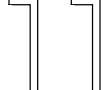

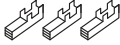

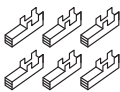
Tyco Electronics

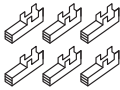

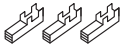
(Note 1) Protect both ends of the cable with insulated bushing.

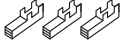
(Note 2) RIO1 and RIO3 can be used commonly.

(Note 3) Use this cable for short applications, such as bridging the remote I/O units in the same panel. Normally use the FCUA-R211 cable with high noise withstand level.

Appendix 1.48 List of Cable Connector Sets

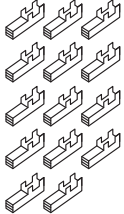
Type	Application	Package contents	
FCUA-CS000	Control unit - General I/O units	Connector (3M) 10120-3000VE x 2pcs. 	Shell kit (3M) 10320-52F0-008 x 2pcs. 
FCUA-CS301	Remote I/O unit - terminal block	Connector (3M) 7940-6500SC x 4pcs. 	Strain relief (3M) 3448-7940 x 2pcs. 
FCUA-CN200	200VAC power supply connector (for power supply unit PD25/PD27)	Connector (Tyco Electronics) 2-178288-3 x 1pc. 	Tin contact (Tyco Electronics) 1-175218-5 x 3 pcs. 
3-178127-6 1-175218-5 x 6 pcs.	24VDC power supply connector for power supply unit (PD25/PD27) (with power OFF detection)	Connector (Tyco Electronics) 3-178127-6 x 1pc. 	Tin contact (Tyco Electronics) 1-175218-5 x 6 pcs. 
1-178288-5 1-175218-5 x 6 pcs.	ON/OFF connector for power supply unit (PD25/PD27)	Connector (Tyco Electronics) 1-178288-5 x 1pc. 	Tin contact (Tyco Electronics) 1-175218-5 x 6 pcs. 
005057-9403 0016020103 x 3 pcs.	Emergency stop connector	Connector (MOLEX) 005057-9403 x 1pc. 	Gold contact (MOLEX) 0016020103 x 3 pcs. 
FCUA-CN211	Remote I/O communication connector	Connector (Tyco Electronics) 1-178288-3 x 1pc. 	Gold contact (Tyco Electronics) 1-175218-2 x 3pcs. 
FCUA-CN220	24VDC power supply connector	Connector (Tyco Electronics) 2-178288-3 x 1pc. 	Tin contact (Tyco Electronics) 1-175218-5 x 3pcs. 
FCUA-CN300	DIO connector	Connector (3M) 7940-6500SC x 2pcs. 	

Type	Application	Package contents	
CDA-15P HDA-CTH CD-PC-111* x 14pcs.	Manual pulse generator input connector	Connector (Hirose Electric) CDA-15P x 1pc. 	Gold contact (Hirose Electric) CD-PC-111 x 14pc. 
		Housing (Hirose Electric) HDA-CTH x 1pc. 	-

Appendix 2

EMC Installation Guidelines

For details of the drive section (servo/spindle drive unit), refer to the "EMC Installation Guidelines" of instruction manuals for each drive unit.

Appendix 2.1 Introduction

EMC Directives became mandatory in EU (European Union) as of January 1, 1996. The subject products must have a CE mark attached indicating that the product complies with the Directives. In United Kingdom, the subject products require the EMC Directives and will need to have a UKCA marking as of January 1, 2023.

As the NC unit is a component designed to control machine tools, it is believed that it is not a direct EMC Directives subject. However, we would like to introduce the following measure plans to back up EMC Directives compliance of the machine tool as the NC unit is a major component of the machine tools.

- (1) **Methods of installation in control/operation panel**
- (2) **Methods of wiring cables to outside of panel**
- (3) **Introduction of members for measures**

Mitsubishi Electric is carrying out tests to confirm the compliance to the EMC Directives under the environment described in this manual. However, the level of the noise will differ according to the equipment type and layout, control panel structure and wiring lead-in, etc.

Thus, we ask that the final noise level be confirmed by the machine manufacturer.

Appendix 2.2 EMC Directives

The EMC Directives largely regulate the following two items.

- Emission Capacity to prevent output of obstructive noise that adversely affects external devices.
- Immunity Capacity to not malfunction due to obstructive noise from external source.

The details of each level are classified in the table below.

It is assumed that the Standards and test details required for a machine tool are the same as these.

Class	Name	Details	CE marking / UKCA marking	
Emission				
	Radiated noise	Restriction of electromagnetic noise radiated through the air	EN61000-6-4 (General industrial machine)	EN55011 (CLASS: A)
	Conductive noise	Restriction of electromagnetic noise discharged from power supply line	EN61800-3 (Motor control unit)	
Immunity				
	Static electricity electrical discharge	(Example) Regulation of withstand level of static electricity electrical discharge accumulated in human body	EN61000-6-2 (General industrial machine) EN61800-3 (Motor control unit)	EN61000-4-2
	Radiation immunity	(Example) Simulation of immunity from digital wireless telephones		EN61000-4-3
	Burst immunity	(Example) Regulation of withstand level of noise from relay or plug and play		EN61000-4-4
	Conductive immunity	(Example) Regulation of withstand level of noise flowed from power supply wires, etc.		EN61000-4-6
	Power supply frequency magnetic field	(Example) Regulation of electromagnetic noise of 50/60Hz power supply frequency		EN61000-4-8
	Power supply dip (fluctuation)	(Example) Regulation of power voltage drop withstand level		EN61000-4-11
	Surge	(Example) Regulation of withstand level of noise caused by lightning		EN61000-4-5

Appendix 2.3 EMC Measures

The main items relating to EMC measures include the following.

- (1) Store the device in a sealed metal panel.
- (2) Ground all conductors that are floating electrically. Decrease the impedance.
- (3) Increase the distance between the drive line and signal wire.
- (4) Shield the cables wired outside of the panel.
- (5) Install a noise filter.

Take care to the following items to suppress the noise radiated outside of the panel.

- (1) Accurately ground the devices.
- (2) Use shielded cables.
- (3) Increase the electrical seal of the panel. Reduce the gaps and holes.

Appendix 2.4 Panel Structure

The design of the panel is a very important factor for the EMC measures, so take the following measures into consideration.

Appendix 2.4.1 Measures for Control Panel Body

- (1) Use metal for all members configuring the panel.
- (2) When joining the metal plate, treat the welded or contacting sections so that the impedance is reduced, and then fix with screws.

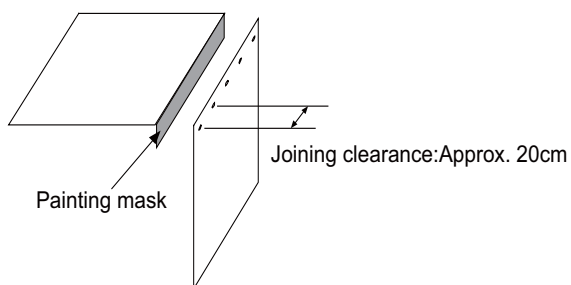

- (3) Note that if the plate warps due to the screw fixing, etc. By creating a clearance, noise could leak from that place.
- (4) Plate (nickel tin) the metal plate surface at the grounding plate, and connect the connections with a low impedance.
- (5) If there is a large opening, such as ventilation holes, make sure to close the hole.

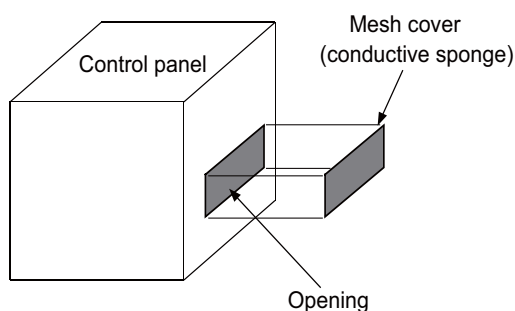

- (Note 1) Using screws to fix the plates that have been painted is the same as an insulated state. Peel the paint and fix the screws.

Appendix 2.4.2 Measures for Door

- (1) Use metal for all members configuring the panel.
- (2) When joining the door, use a gasket to lower the impedance of the contacting sections, or use a structure with a large contact area as shown below.
- (3) The EMI gasket or conductive packing must contact the metal surface uniformly and at the correct position.

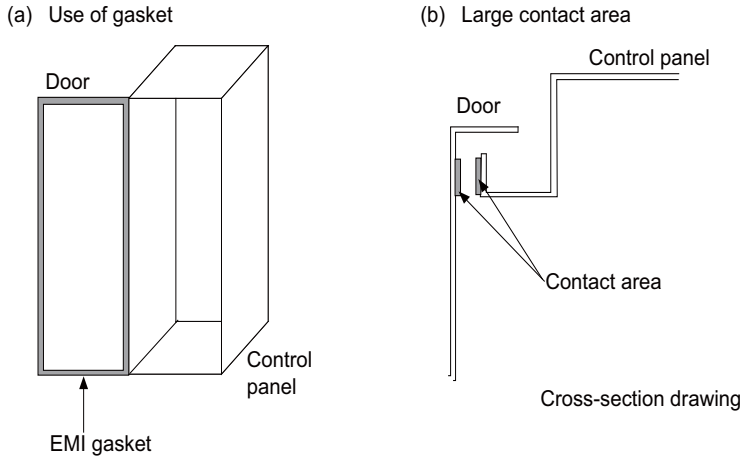

- (Note 1) When not using a gasket, ground the control panel grounding with a grounding wire to lower the door's impedance.
- (Note 2) Using screws to fix the plates that have been painted (attachment of packing) is the same as an insulated state. Peel the paint and fix the screws.

Appendix 2.4.3 Measures for Power Supply

- (1) Shield the power supply section and insert a filter to prevent the noise from flowing in or out. Selection of the noise filter capacity will differ according to the drive unit and devices being used.

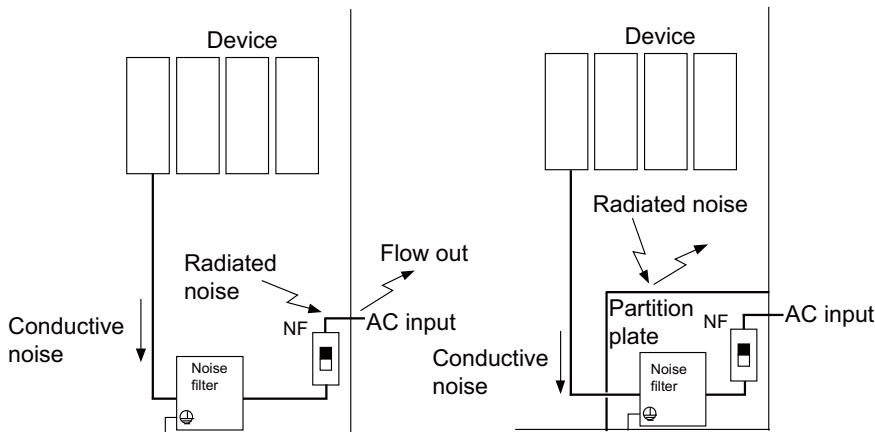

- (Note 1) The conductive noise can be suppressed by inserting a noise filter, but the radiated noise will flow out.
- (Note 2) The conductive and radiated noise can both be suppressed by adding a partition plate to the noise filter.

Appendix 2.5 Measures for Wiring in Panel

Cables act as antennas to propagate unnecessary noise, and thus must be appropriately shielded and treated.

The following measures must be sufficiently considered for the cables (SH21/G018/F012/FCUA-R211) that carry out high-speed communication.

Appendix 2.5.1 Precautions for Wiring in Panel

- (1) If the cables are led unnecessary in the panel, they will pick up noise. Pay attention to the device layout and wire length so that the wiring length is as short as possible.

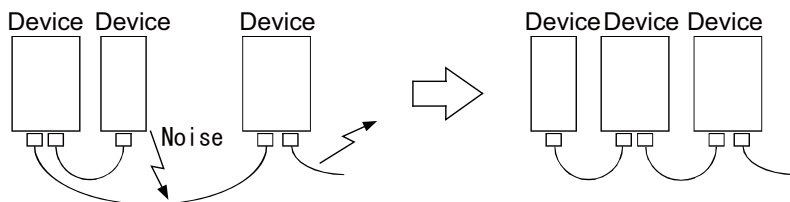

- (2) Always connect the grounding wire to the FG terminal indicated on the device.
- (3) Keep the distance between the drive line and detector cable to the drive section motor as far apart as possible when wiring.
- (4) Do not lead the power supply wire around the panel without using a filter.

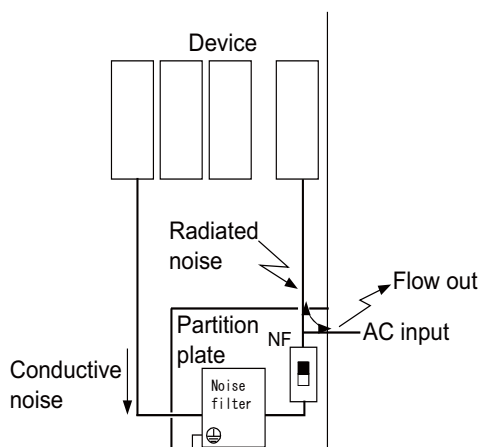

Appendix 2.5.2 Shield Treatment of Cables

Use shielded cables for the cables wired outside the panel.

Use a shield clamp within 10cm of the lead-out port from the panel. (Refer to "EMC Countermeasure Parts: Shield Clamp Fitting".)

(1) DC power supply cable [F110/F070 cable]

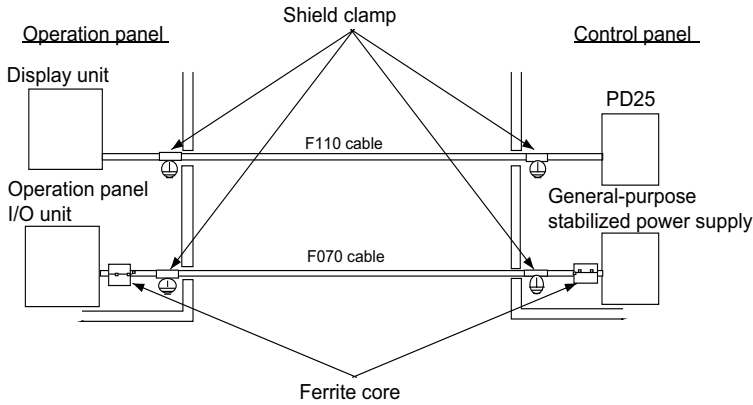

- Use a shield clamp within 10cm from the panel's inlet/outlet.
- When using a ferrite core, install it on both ends of the connected units.
- Always install a ferrite core (Refer to "EMC Countermeasure Parts: Ferrite Core".) on the general-purpose stabilized power supply. The ferrite core may not be required depending on the selected power supply.

(2) Remote I/O cable [FCUA-R211 cable]

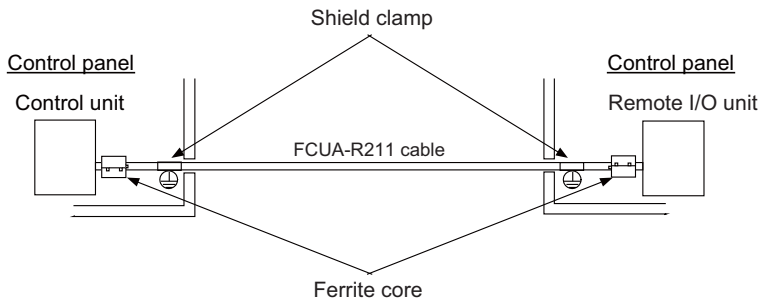

- Use a shield clamp within 10cm from the panel's inlet/outlet.
- When using a ferrite core, install it on both ends of the connected units.

(3) Servo communication cable [SH21 cable]

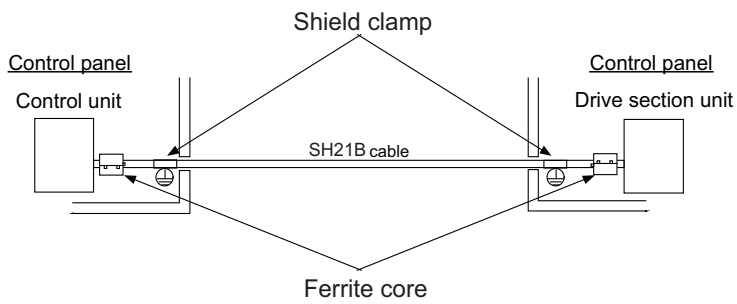

- Use a shield clamp within 10cm from the panel's inlet/outlet.
- When using a ferrite core, install it on both ends of the connected units.

(4) Ethernet cable

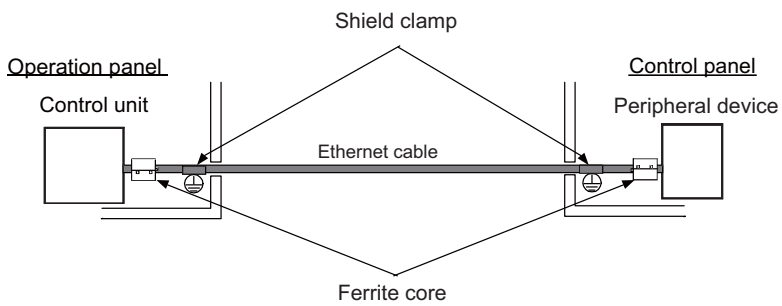

- Use a shielded cable. Use a shield clamp within 10cm from the panel's inlet/outlet.
- When using a ferrite core, install it on both ends of the connected units.

Appendix 2.6 EMC Countermeasure Parts

Appendix 2.6.1 Shield Clamp Fitting

The effect can be improved by directly connecting the cable's shield sheath to the grounding plate as shown below. Install the grounding plate near the outlet (within 10cm) of each panel, and press against the grounding plate with the clamp fitting.

If the cables are thin, several can be bundled and clamped together.

To provide sufficient frame ground, install the grounding plate directly on the cabinet or connect with a grounding wire.

	A	B	C	Enclosed fittings
Ground Plate #D	100	86	30	Clamp fitting A×2
Ground Plate #E	70	56	-	Clamp fitting B×1

	L1 (maximum dimension when it is open)	L2 (reference dimension)
Clamp fitting A	25	(77)
Clamp fitting B	12	(54)

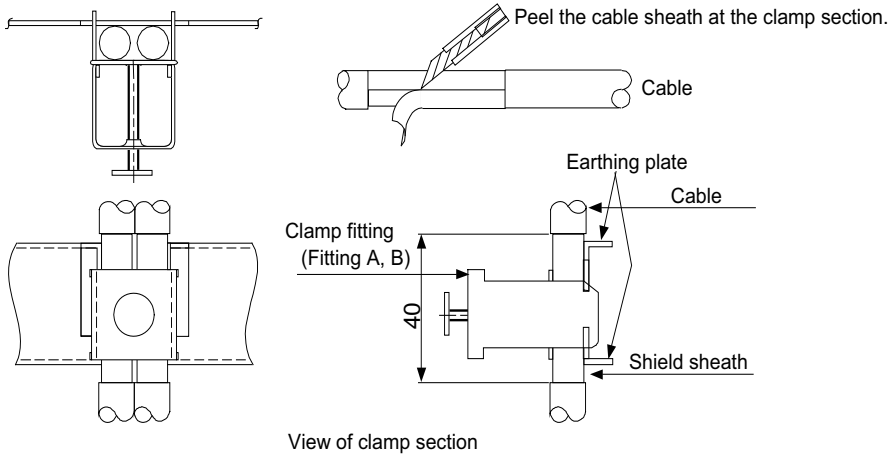

• Outline drawing

Earthing plate

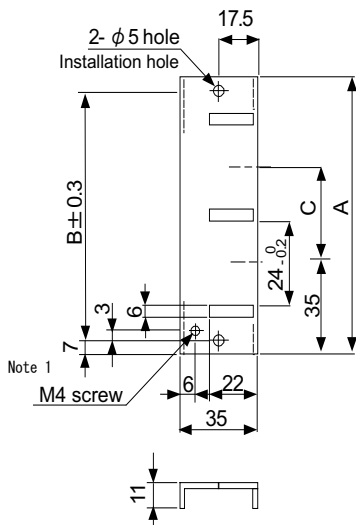

Clamp fitting

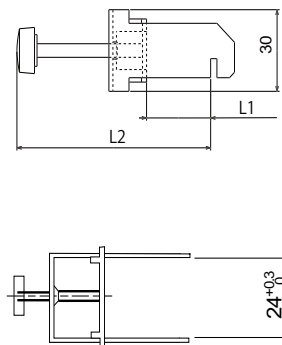

[Unit: mm]

(Note 1) Screw hole for wiring to earthing plate in cabinet.
 (Note 2) The earthing plate thickness is 1.6mm.

Appendix 2.6.2 Ferrite Core

The ferrite core is mounted integrally with the plastic case.

This can be installed with one touch without cutting the interface cable or power supply cable.

This ferrite core is effective against common mode noise, allowing measures against noise without affecting the quality of the signal.

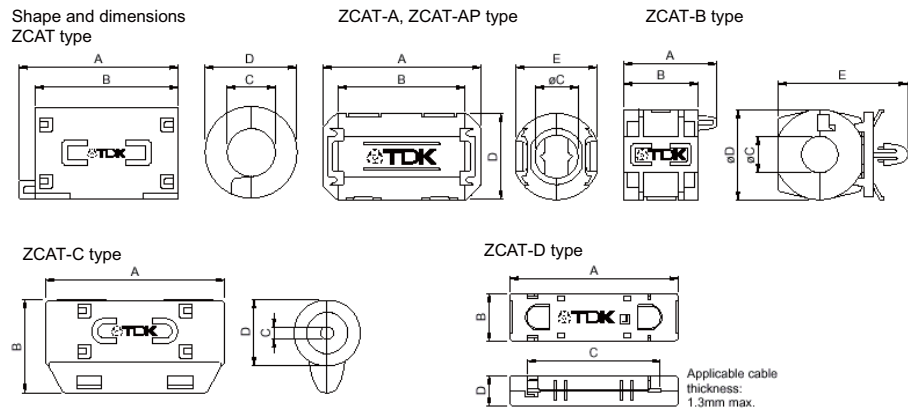

Recommended ferrite core: TDK ZCAT Series

							Unit: mm
Part Name	A	B	φC	φD	E	Applicable cable outer diameter	Mass (g)
ZCAT1518-0730-M(-BK)*1	22±1	18±1	7±1	15±1	-	7max.	6
ZCAT1518-0730(BK)*2	22±1	18±1	7±1	15±1	-	7max.	6
ZCAT2017-0930-M(-BK)	21±1	17±1	9±1	20±1	-	9max.	11
ZCAT2032-0930-M(-BK)*1	36±1	32±1	9±1	19.5±1	-	9max.	22
ZCAT2032-0930(-BK)*2	36±1	32±1	9±1	19.5±1	-	9max.	22
ZCAT2132-1130-M(-BK)*1	36±1	32±1	11±1	20.5±1	-	11max.	22
ZCAT2132-1130(-BK)*2	36±1	32±1	11±1	20.5±1	-	11max.	22
ZCAT3035-1330-M(-BK)*1	39±1	34±1	13±1	30±1	-	13max.	63
ZCAT3035-1330(-BK)*2	39±1	34±1	13±1	30±1	-	13max.	63
ZCAT1525-0430AP-M(-BK)	25±1	20±1	4±1	15±1	11.5±1	2.5 to 4(USB)	7
ZCAT1325-0530A-M(-BK)*1	25±1	20±1	5±1	12.8±1	11.2±1	3 to 5(USB)	7
ZCAT1325-0530A(-BK)	25±1	20±1	5±1	12.8±1	11.2±1	3 to 5(USB)	7
ZCAT1730-0730A-M(-BK)	30±1	23±1	7±1	16.5±1	15±1	4 to 7(USB)	12
ZCAT2035-0930A-M(-BK)*1	35±1	28±1	9±1	19.5±1	17.4±1	6 to 9	22
ZCAT2035-0930A(-BK)	35±1	28±1	9±1	19.5±1	17.4±1	6 to 9	22
ZCAT2235-1030A-M(-BK)	35±1	28±1	10±1	21.5±1	20±1	8 to 10	27
ZCAT2436-1330A-M(-BK)	36±1	29±1	13±1	23.5±1	22±1	10 to 13	29
ZCAT2017-0930B-M(-BK)	21±1	17±1	9±1	20±1	28.5±1	9max.	12
ZCAT2749-0430C-M(-BK)	49±1	27±1	4.5±1	19.5±1	-	4.5max.	26
ZCAT4625-3430D(-BK)	45.5±1	24.5±1	34±1	12±1	-	26 For core flat cable	32
ZCAT4625-3430DT(-BK)*3	45.5±1	24.5±1	34±1	13±1	-	26 For core flat cable	32
ZCAT6819-5230D(-BK)	67.5±1	18.5±1	52±1	16±1	-	40 For core flat cable	58
ZCAT6819-5230DT(-BK)*3	67.5±1	18.5±1	52±1	17±1	-	40 For core flat cable	58

*1 The M stamp is attached.

*2 A fixing band is attached at shipment.

*3 The core is fixed with double-sided tape. (The tape is enclosed with the part.)

● ZCAT-B type: Cabinet fixing type installation hole φ4.8 to 4.9mm, plate thickness 0.5 to 2mm

● ZCAT-AP, ZCAT-C type: Structure that prevents easy opening after case is closed.

Appendix 2.6.3 Surge Absorber

Make sure that the surge does not directly enter the AC line of the general-purpose stabilized power supply (user-prepared) supplying power to the control unit and DIO. Select the following product or equivalent for the surge absorber. Refer to the manufacturer catalog for detailed characteristics, outline and connection methods of the surge absorber.

(1) Part name: RAV-781BYZ-2

Manufacturer: OKAYA ELECTRIC INDUSTRIES

Circuit voltage 50/60Hz Vrms	Max. tolerable circuit voltage	Clamp voltage V±10%	Surge withstand level 8/20µs	Surge electrical discharge start voltage 1.2/50µs	Static capacity	Working temperature range
250V 3φ	300V	783V	2,500A	20kV	75pF	-20 to +70°C

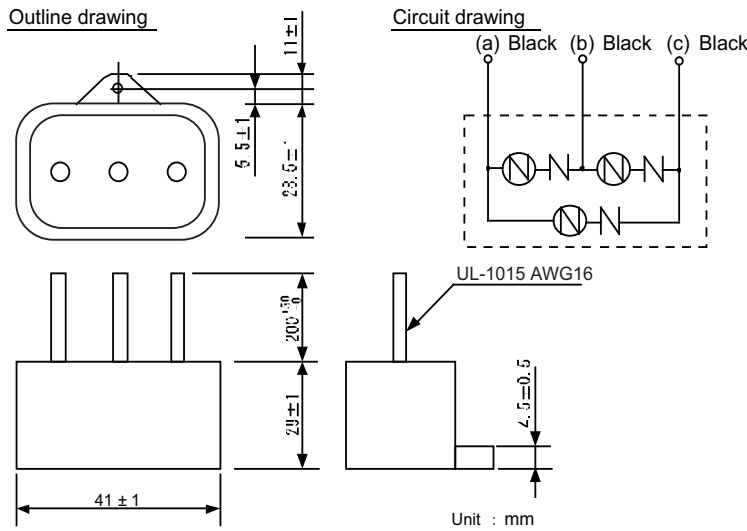

(2) Part name: RAV-781BXZ-4

Manufacturer: OKAYA ELECTRIC INDUSTRIES

Circuit voltage 50/60Hz Vrms	Max. tolerable circuit voltage	Clamp voltage V±10%	Surge withstand level 8/20µs	Surge electrical discharge start voltage 1.2/50µs	Static capacity	Working temperature range
250V 3φ	300V	700V	2,500A	2kV	75pF	-20 to +70°C

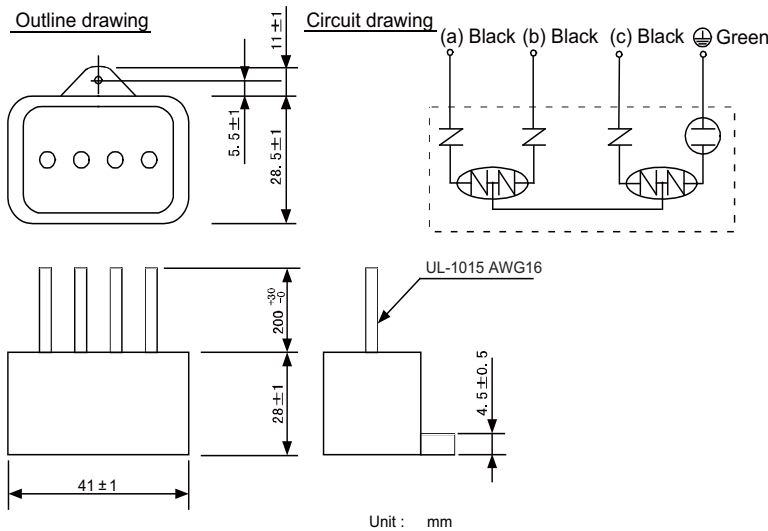

(3) Example of surge absorber installation

An example of installing the surge absorber in the machine control panel is shown below.

A short-circuit fault will occur in the surge absorber if a surge exceeding the tolerance is applied. Thus, install a circuit protection breaker in the stage before the surge absorber. Note that almost no current flows to the surge absorber during normal use, so a breaker installed as the circuit protection for another device can be used for the surge absorber.

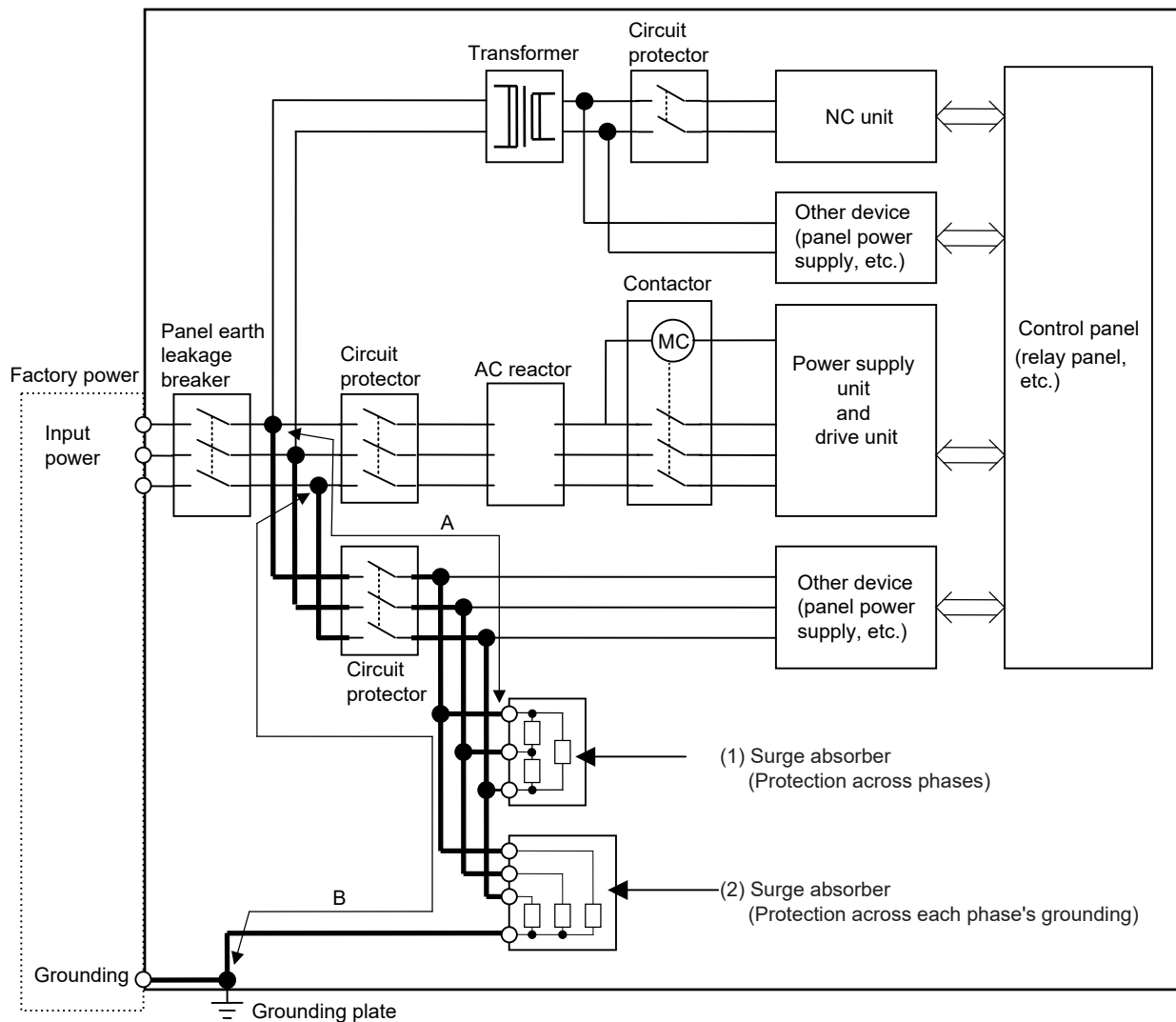

Surge absorber installation

CAUTION

1. The wires from the surge absorber should be connected without extensions.
2. If the surge absorber cannot be installed just with the enclosed wires, keep the wiring length of A and B to 2m or less. If the wires are long, the surge absorber's performance may drop and inhibit protection of the devices in the panel.
3. Surge absorber to be selected varies depending on input power voltage.

Appendix 2.6.4 Selection of Stabilized Power Supply

Consider the following characteristics when selecting the stabilized power supply (prepared by machine manufacturer).
Use a power supply that complies with CE Marking or that follows the safety standards given below.

Stabilized power supply selection items

Item		Standard setting	Remarks
Output	Voltage fluctuation	±5%	±5% or less of 24VDC output
	Ripple noise	120mV (max.)	
	Spike noise	500mV (max.)	
Output current		---	Refer to the maximum current consumption of the unit in use and calculate.
Output holding time		20ms (min)	Instantaneous power failure time (AC side)

Standards

Safety Standards: UL1950, CSA C22.2 No. 234 approved, IEC950 compliant

Noise Terminal Voltage: FCC Class A, VCCI-Class A

High Harmonics Current Restrictions: IEC61000-3-2

Appendix 3

Restrictions for Lithium Batteries

Appendix 3.1 Restriction for Packing

The United Nations Dangerous Goods Regulations "Article 22" became effective from 2003. When transporting lithium batteries with means subject to the UN Regulations, such as by air transport, measures corresponding to the Regulations must be taken.

The UN Regulations classify the batteries as dangerous goods (Class 9) or not dangerous goods according to the lithium metal content. To ensure safety during transportation, lithium batteries (battery unit) directly exported from Mitsubishi are packaged in a dedicated container (UN package) for which safety has been confirmed.

When the customer is transporting these products with means subject to the UN Regulations, such as air transport, the shipper must follow the details explained in this section "Handling by User".

The followings are restrictions for transportation. Each restriction is specified based on the recommendation of the United Nations.

Area	Transportation method	Restriction	Special clause
World	Air	ICAO, IATA	-
World	Marine	IMO	188
United States	All (air, marine, land)	DOT	49 CFR 173.185
Europe	land	RID, ADR	188

Appendix 3.1.1 Target Products

The following Mitsubishi NC products use lithium batteries. If the lithium metal content exceeds 1g for battery cell and 2g for battery, the battery is classified as dangerous good (Class9).

In order to avoid an accidental actuation during the transportation, all lithium battery products incorporated in a machinery or device must be fixed securely and must be shipped with wrapped over the outer package as to prevent damage or short-circuits.

(1) Materials falling under Class 9

Mitsubishi type (Type for arrangement)	Battery type	Lithium metal content	Number of incorporated ER6V batteries	Application (Data backup)	Battery class	Outline dimension drawing
CR23500SE-CJ5	CR23500SE-CJ5	1.52g	-	For NC SRAM (M500)	Battery cell	Refer to "Battery Option" in the specification manual for drive unit you are using for the outline dimension drawing for servo.

(2) Materials not falling under Class 9

Mitsubishi type (Type for arrangement)	Battery type	Lithium metal content	Number of incorporated ER6V batteries	Application (Data backup)	Battery class	Outline dimension drawing
CR2032 (for built-in battery)	CR2032	0.067g	-	For NC SRAM/	Battery cell	Refer to "Battery Option" in the specification manual for drive unit you are using for the outline dimension drawing for servo.
CR2450 (for built-in battery)	CR2450	0.173g	-	For NC SRAM		
ER6, ER6V series (for built-in battery)	ER6, ER6V	0.65g	-	For NC SRAM/ servo detector		
A6BAT(MR-BAT)	ER17330V	0.48g	-	For servo detector		
Q6BAT	Q6BAT	0.57g	-	For NC SRAM		

(Note) If the number of batteries exceeds 24 batteries for the battery cell or 12 batteries for the battery, the dedicated packing (for materials falling under Class 9) is required.

(Example) Rating nameplate for battery units

MITSUBISHI BATTERY UNIT	
TYPE	MDS-A-BT-6 ← Mitsubishi type
OUTPUT DC 3.6 V	
LITHIUM BATTERIES: ER6 x6	Class 9 ← Safety class
(Battery Type: ER6-B6-11)	← Battery manufacturer type
Mercury Content: Less than 1 ppm	
Lithium Metal Content: 3.9 g	← Lithium metal content
MITSUBISHI ELECTRIC CORPORATION JAPAN 	

Appendix 3.1.2 Handling by User

The following technical opinion is solely Mitsubishi's opinion. The shipper must confirm the latest IATA Dangerous Goods Regulations, IMDG Codes and laws and orders of the corresponding export country.

These should be checked by the company commissioned for the actual transportation.

IATA: International Air Transport Association

IMDG Code: A uniform international code for the transport of dangerous goods by seas determined by IMO (International Maritime Organization).

■ **When shipping isolated lithium battery products**

(1) Reshipping in Mitsubishi UN packaging (Class 9)

Mitsubishi packing applies package specifications complying with the UN Packing Instruction. The user only needs to add the following details before shipping. (Consult with the shipping company for details.)

(a) Indication of container usage mark on exterior box (Label with following details recorded.)

- [1] Proper shipping name (Lithium batteries)
- [2] UN NO. (UN3090 for isolated battery, UN3091 for battery incorporated in a device or included)
- [3] Shipper and consignee's address and name

Example of completing form

SHIPPER: Shipper information	CONSIGNEE: Consignee information
PROPER SHIPPING NAME LITHIUM BATTERIES	
UN NO. : UN3090 CLASS: 9 SUBSIDIARY RISK	
PACKING GROUP: II PACKING INST.: 903	

- [4] A care label with a telephone number for additional information (120×110mm)
 (A care label is to be attached on the outer package. Shipping less than or equal to 4 isolated batteries incorporated in machinery does not need care label.)

Lithium battery care label (Air transportation sample)



- (b) Preparation of shipping documents and declaration of dangerous goods
 For information required in description, refer to "Product information data sheet".

(2) When packaged by user

The user must follow UN Regulations when packing, preparing for shipping and preparing the indications, etc.

(a) Packing a lithium battery falling under Class 9

[1] Consult with The Ship Equipment Inspection Society of Japan for details on packaging.

[2] Prepare for shipping as explained in "(1) Reshipping in Mitsubishi UN packaging".

The Ship Equipment Inspection Society of Japan <http://www.hakuyohin.or.jp/english.html>

(b) Packing a lithium battery not falling under Class 9

[1] Cells and batteries are separated so as to prevent short circuits and are stored in a strong outer packaging (12 batteries or less, 24 battery cells or less).

[2] Prepare for the certificates or test results showing compliance to drop test from 1.2m in height.

(The safety test results have been obtained from the battery manufacturer. Consult with Mitsubishi when the safety test results are required.)

[3] Prepare for shipping as explained in "(1) Reshipping in Mitsubishi UN packaging (Class 9)".

■ **When shipping lithium batteries incorporating in a device or machinery**

Dedicated packaging (UN packaging) is not required for batteries incorporated in device or machinery. Yet, make sure to fix the contents securely before the transportation as to prevent damage and short-circuit.

If machinery and devices which incorporates lithium battery is not waterproof, package must be waterproof material.

Check with your shipping company for details on packing and transportation.

Appendix 3.1.3 Reference

Refer to the following materials for details on the regulations and responses.

Guidelines regarding transportation of lithium batteries and lithium ion batteries (Edition 11)..... Battery Association of Japan

Appendix 3.2 Products information data sheet (ER battery)

MSDS system does not cover the product used in enclosed state. The ER battery described in this section applies to that product.

This description is applied to the normal use, and is provided as reference but not as guarantee.

This description is based on the lithium battery's (ER battery) hazardous goods data sheet (Products information data sheet) which MITSUBISHI has researched, and will be applied only to the ER batteries described in the previous section "Restriction for Packing".

(1) Outline of hazard

Principal hazard and effect	Not found.
Specific hazard	As the chemical substance is stored in a sealed metal container, the battery itself is not hazardous. But when the internal lithium metal attaches to human skin, it causes a chemical skin burn. As a reaction of lithium with water, it may ignite or forms flammable hydrogen gas.
Environmental effect	Not found.
Possible state of emergency	Damages or short-circuits may occur due to external mechanical or electrical pressures.

(2) First-aid measure

Inhalation	If a person inhales the vapor of the substance due to the battery damage, move the person immediately to fresh air. If the person feels sick, consult a doctor immediately.
Skin contact	If the content of the battery attaches to human skin, wash off immediately with water and soap. If skin irritation persists, consult a doctor.
Eye contact	In case of contact with eyes due to the battery damage, rinse immediately with a plenty of water for at least 15 minutes and then consult a doctor.
Ingestion	If swallowed, consult a doctor immediately.

(3) Fire-fighting measure

Appropriate fire-extinguisher	Dry sand, dry chemical, graphite powder or carbon dioxide gas
Special fire-fighting measure	Keep the battery away from the fireplace to prevent fire spreading.
Protectors against fire	Fire-protection gloves, eye/face protector (face mask), body/skin protective cloth

(4) Measure for leakage

Environmental precaution	Dispose of them immediately because strong odors are produced when left for a long time.
How to remove	Get them absorbed into dry sand and then collect the sand in an empty container.

(5) Handling and storage

Handling	Cautions for safety handling	Do not peel the external tube or damage it. Do not dispose of the battery in fire or expose it to heat. Do not immerse the battery in water or get it wet. Do not throw the battery. Do not disassemble, modify or transform the battery. Do not short-circuit the battery.
	Storage condition	Avoid direct sunlight, high temperature and high humidity. (Recommended temp. range: +5 to +35C°, humidity: 70%RH or less)
	Material to avoid	Flammable or conductive material (Metal: may cause a short-circuit)

(6) Physical/chemical properties

Appearance	Physical form	Solid
	Shape	Cylinder type
	Smell	Odorless
	pH	Not applicable (insoluble)
	Boiling point/Boiling range, Melting point, Decomposition temperature, Flash point	No information

(7) Stability and reactivity

Stability	Stable under normal handling condition.
Condition to avoid	Do not mix multiple batteries with their terminals uninsulated. This may cause a short-circuit, resulting in heating, bursting or ignition.
Hazardous decomposition products	Irritative or toxic gas is emitted in the case of fire.

(8) Toxicological information

As the chemical substance is stored in a sealed metal container, the battery has no harmfulness. Just for reference, the table below describes the main substance of the battery.

< Lithium metal >

Acute toxicity	No information
Local effect	Corrosive action in case of skin contact

< Thionyl chloride >

Acute toxicity	LC ₅₀ : 500ppm (inhaled administration to rat)
Local effect	The lungs can be damaged by chronic cough, dyspnea and asthma.

< Aluminum chloride >

Acute toxicity	LD ₅₀ : 3700ppm (oral administration to rat)
Local effect	Not found.

< Lithium chloride >

Acute toxicity	LD ₅₀ : 526ppm (oral administration to rat)
Local effect	The central nerves and kidney can be influenced.

< Carbon black >

Acute toxicity	LD ₅₀ : 2,000mg/kg > (rat)
Carcinogenicity	LARC group 2 (suspected of being carcinogenic)

(9) Ecological information

Mobility, Persistence/ Decomposability, Bio-accumulation potential, Ecological toxicity	Not found.
--	------------

(10) Caution for disposal

Dispose of the battery following local laws or regulations.

Pack the battery properly to prevent a short-circuit and avoid contact with water.

Appendix 3.3 Issuing Domestic Law of the United States for Primary Lithium Battery Transportation

Federal Aviation Administration (FAA) and Research and Special Programs Administration (RSPA) announced an additional regulation (interim final rule) for the primary lithium batteries transportation restrictions item in "Federal Register" on Dec.15 2004.

This regulation became effective from Dec.29, 2004. This law is a domestic law of the United States, however it also applies to the domestic flight and international flight departing from or arriving in the United States. Therefore, when transporting lithium batteries to the United State, or within the United State, the shipper must take measures required to transport lithium batteries. Refer to the Federal Register and the code of Federal Regulation ("Reference" from the previous section "Restriction for Packing") for details.

Appendix 3.3.1 Outline of Regulation

- (1) Transporting primary lithium battery by passenger aircraft is forbidden.
 - (a) Excluding primary lithium battery for personal use in a carry-on or checked luggage (Lithium metal content should be not more than 5g for cell and 25g for battery. For details on the lithium metal content, refer to "Transportation Restrictions for Lithium Batteries: Target Products".)
- (2) When transporting primary lithium battery by cargo aircraft, indicate that transportation by passenger aircraft is forbidden on the exterior box.

Appendix 3.3.2 Target Products

All NC products for which the lithium batteries are used are subject to the regulation. (Refer to the table of "Target Products" from the previous section "Restriction for Packing".)

Appendix 3.3.3 Handling by User

The "Target Products" from the previous section "Outline of Regulation" described above is solely Mitsubishi's opinion. The shipper must confirm orders of "Transportation Restrictions for Lithium Batteries: Reference" described below for transportation method corresponding the regulation.

These should be checked by the company commissioned for the actual lithium battery transportation.

(1) Indication of exterior box

When transporting primary lithium battery by cargo aircraft, indicate that transportation by passenger aircraft is forbidden on the exterior box.

Display example

**PRIMARY LITHIUM BATTERIES
FORBIDDEN FOR TRANSPORT ABOARD PASSENGER AIRCRAFT.**

- (a) The character color must be displayed with contrast. (black characters against white background, black characters against yellow background, etc.)
- (b) The height (size) of characters to be displayed is prescribed depending on the packaging mass. (When the total mass is over 30kg: at least 12mm, When the total mass is less than 30kg: at least 6mm)

Appendix 3.3.4 Reference

- (1) Federal Register (Docket No. RSPA-2004-19884 (HM-224E)) PDF format
Search from the following URL.
<https://www.federalregister.gov/>
- (2) 49CFR (Code of Federal Regulation, Title49) (173.185 Lithium batteries and cells.)
Search from the following URL.
<https://www.ecfr.gov/current/title-49>

Appendix 3.4 Restriction related to EU Battery Directive

EU Battery Directive (2006/66/EC) has been enforced since September 26th in 2008. Hereby, battery and machinery incorporating battery marketed in European Union countries must be in compliance with the EU Battery Directive. Lithium battery provided by MITSUBISHI are subjected to this restriction.

Appendix 3.4.1 Important Notes

Follow the instruction bellow as shipping products incorporating MITSUBISHI device.

- (1) When shipping products incorporating MITSUBISHI device any time later than September 26th, 2008, the symbol mark shown as Figure 1 in section "Information for end-user" is required to be attached on the machinery or on the package. Also, the explanation of the symbol must be added.
- (2) Machinery with battery and maintenance battery produced before the EU Battery Directive are also subjected to the restriction. When shipping those products to EU countries later than September 26th, 2008, follow the instruction explained in (1).

Appendix 3.4.2 Information for end-user

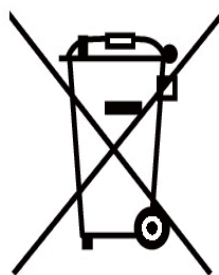

Figure 1

Note: This symbol mark is for EU countries only.

This symbol mark is according to the directive 2006/66/EC Article 20 Information for end-users and Annex II.

Your MITSUBISHI ELECTRIC product is designed and manufactured with high quality materials and components which can be recycled and/or reused. This symbol means that batteries and accumulators, at their end-of-life, should be disposed of separately from your household waste.

If a chemical symbol is printed beneath the symbol shown above, this chemical symbol means that the battery or accumulator contains a heavy metal at a certain concentration. This will be indicated as follows: Hg: mercury (0,0005%), Cd: cadmium (0,002%), Pb: lead (0,004%)

In the European Union there are separate collection systems for used batteries and accumulators. Please, dispose of batteries and accumulators correctly at your local community waste collection/recycling centre.

Please, help us to conserve the environment we live in!

Appendix 4

Precautions for Compliance to UL/c-UL Standards

- (1) Selection of external 24 VDC power supply unit (The unit shall be prepared by the machine tool builder.)
This NC system complies with the UL Standards on the condition that the stabilized power supply unit supplying 24 VDC to each unit meets the requirements for SELV/limited power LPS or Class 2 power supplies and that supply voltage fluctuations do not exceed $\pm 5\%$ of nominal voltage.
The stabilized power supply unit supplying 24 VDC to each unit must comply with the requirements of international standards and national laws/standards required for stabilized power supplies.

- (2) Unit's ambient environment
This NC system complies with the UL Standards on the condition that the unit is used under the environmental conditions described in "Environment Conditions", including the maximum relative humidity of 95% (noncondensing) and the maximum altitude of 1000 m.
To comply with UL Standards, each unit must be designed to be within the environmental conditions described in the "Environment Conditions" section.
The product must be used under environmental conditions of Overvoltage category II or lower and Pollution degree 2 or lower.

Revision History

Date of revision	Manual No.	Revision details
Jan. 2009	IB(NA)1500935-A	First edition created.
Aug. 2010	IB(NA)1500935-B	<p>The following units were added.</p> <ul style="list-style-type: none"> - FCU7-KB045 (Keyboard unit) - FCU7-EX022 (Optical communication repeater unit) - FCU7-KB921/KB926 (MITSUBISHI CNC machine operation panel) <p>The following unit was deleted.</p> <ul style="list-style-type: none"> - FCU7-KB022 (Keyboard unit) <p>The following cables were added.</p> <ul style="list-style-type: none"> - CNV22J-K1P/K2P (Detector extension cable for HF-KP motor) - G071 (DC24V relay cable for MITSUBISHI CNC machine operation panel) - G460 (Cable between MITSUBISHI CNC machine operation panel A and MITSUBISHI CNC machine operation panel B) <p>The following sections were added.</p> <ul style="list-style-type: none"> - 2.15 Optical Communication Repeater Unit - 2.16 MITSUBISHI CNC Machine Operation Panel - 4.2.6 Connecting with Optical Communication Repeater Unit - 4.6 Connecting with MITSUBISHI CNC Machine Operation Panel - 8.8 CNV22J-K1P / CNV22J-K2P cable - 8.27 G071 cable - 8.38 G460 calbe <p>The following section was deleted.</p> <ul style="list-style-type: none"> - 8.18 F320/F321 cable <p>According to the addition and deletion of sections, the following section No. were changed.</p> <ul style="list-style-type: none"> - From "2.15 -2.16" to "2.17 - 2.18" - From "4.2.6 - 4.2.11" to "4.2.7 - 4.2.12" - From "4.6 - 4.10" to "4.7 - 4.11" - Throughout Chapter 8 <p>Explanation about the connection with FCU7-HN577 was added to "4.2.11.2 Connecting with I/O Devices via CC-Link".</p> <p>Mistakes were corrected.</p>
Nov. 2011	IB(NA)1500935-C	<p>"Handling of our product" was added.</p> <p>Following units were added.</p> <ul style="list-style-type: none"> - FCU7-DA646-33, FCU7-DA636-33 (Display unit) <p>Following cables were added.</p> <ul style="list-style-type: none"> - DG23 (Battery cable) - DG24 (5V supply/DO output cable) <p>Following chapters were added.</p> <ul style="list-style-type: none"> - 4.3.7.1 Wiring for Sink Type Input - 4.3.7.2 Wiring for Source Type Input - 8.11 DG23 Cable - 8.12 DG24 Cable <p>Following chapter numbers were changed as the new chapters are added.</p> <ul style="list-style-type: none"> - "4.3.7.1 to 4.3.7.2" were changed to "4.3.7.3 to 4.3.7.4". - "8.11 to 8.44" were changed to "8.13 to 8.46". <p>Mistakes were corrected.</p>

Date of revision	Manual No.	Revision details
Jun. 2013	IB(NA)1500935-D	<p>Corresponded to MDS-D2/DH2, MDS-DJ, MDS-DM2.</p> <ul style="list-style-type: none"> - Corrected contents of 4.2.5.1 to 4.2.5.3. - Revised related explanation, etc. <p>Connector set was added to "1.3.1 List of Units".</p> <p>"(11) LED" was added to "2.7 Remote I/O Unit".</p> <p>Chapter 2.17 was revised and chapter name was changed to "2.17 Exclusive CF Cards for MITSUBISHI CNC".</p> <p>"4.2.9.1 Handle Numbers" and "4.3.6.1 Handle Numbers" were added.</p> <p>"4.2.10 Connecting with Safety Observing I/O Device" was revised and added/changed the following chapters.</p> <ul style="list-style-type: none"> - "4.2.10.2 Connection diagram using I/O unit" - "4.2.10.3 Connection diagram using the STO-compatible drive system" <p>"8.3 CNP3EZ-2P/CNP3EZ-3P Cable" were added.</p> <p>Cable name of F140 was changed to F142.</p> <p>Reviewed application name of cable.</p> <p>Reviewed "8.47 List of Cable Connector Sets" in keeping with connector set added to "1.3.1 List of Units".</p>
Dec. 2013	IB(NA)1500935-E	<p>The construction of chapters and sections were revised.</p> <ul style="list-style-type: none"> - "5 EMC Installation Guidelines" to Appendix 2. - "6 Restrictions for Lithium Batteries" to Appendix 3. - "7 Precautions for Compliance to UL/c-UL Standards" to Appendix 4. - "8 Cable" to Appendix 1. <p>Mistakes were corrected.</p>
Feb. 2014	IB(NA)1500935-F	<p>Following chapters were revised.</p> <ul style="list-style-type: none"> - "1.2.1 For 10.4-type Display Unit" - "4.2.3 Connecting with Emergency Stop Signal" - "Appendix 1.37 G380 Cable" - "Appendix 1.38 G395 Cable" - "Appendix 1.39 G396 Cable" <p>The title of the chapter was revised.</p> <ul style="list-style-type: none"> - "4.2.5 Connecting with Drive Unit" <p>Mistakes were corrected.</p>
Jan. 2024	IB(NA)1500935-G	<ul style="list-style-type: none"> - FCU7-HN571 was discontinued and replaced with FCU7-HN578. <p>Following chapter was added.</p> <ul style="list-style-type: none"> - "Appendix 1.34 G295 Cable" <p>Following chapters were revised.</p> <ul style="list-style-type: none"> - "1.3.1 List of Units" - "2.12.2 Expansion card (PROFIBUS-DP)" - "4.2.11.1 Connecting with I/O Devices via PROFIBUS-DP" - "Appendix 3.1 Restriction for Packing" - "Appendix 3.3 Issuing Domestic Law of the United States for Primary Lithium Battery Transportation" <p>Mistakes were corrected.</p>

Global Service Network

AMERICA

MITSUBISHI ELECTRIC AUTOMATION INC. (AMERICA FA CENTER)

HQ and Central Region Service Center (Chicago)
500 CORPORATE WOODS PARKWAY, VERNON HILLS, ILLINOIS 60061, U.S.A.
TEL: +1-847-478-2500 / FAX: +1-847-478-2650
Minneapolis, MN Service Satellite
Detroit, MI Service Satellite
Grand Rapids, MI Service Satellite
Cleveland, OH Service Satellite
St. Louis, MO Service Satellite
Indianapolis, IN Service Satellite

South/East Region Service Center (Georgia)

1845 SATELLITE BOULEVARD STE. 450, DULUTH, GEORGIA 30097, U.S.A.
TEL: +1-678-258-4529 / FAX: +1-678-258-4519
Charleston, SC Service Satellite
Charlotte, NC Service Satellite
Raleigh, NC Service Satellite
Dallas, TX Service Satellite
Houston, TX Service Satellite
Hartford, CT Service Satellite
Knoxville, TN Service Satellite
Nashville, TN Service Satellite
Huntsville, AL Service Satellite
Pittsburg, PA Service Satellite
Tampa, FL Service Satellite
Miami, FL Service Satellite
Lafayette, LA Service Satellite
Allentown, PA Service Satellite

Western Region Service Center (California)

5900-B KATELLA AVE. - 5900-A KATELLA AVE. CYPRESS, CALIFORNIA 90630, U.S.A.
TEL: +1-714-699-2625 / FAX: +1-847-478-2650
San Francisco, CA Service Satellite
Seattle, WA Service Satellite
Denver, CO Service Satellite

Canada Region Service Center (Toronto)

4299 14TH AVENUE MARKHAM, ONTARIO L3R 0J2, CANADA
TEL: +1-905-475-7728 / FAX: +1-905-475-7935
Edmonton, AB Service Satellite
Montreal, QC Service Satellite

Mexico Region Service Center (Querétaro)

Parque Tecnológico Innovación Querétaro, Lateral Carretera Estatal 431, Km 2+200, Lote 91 Modulos 1 y 2
Hacienda la Machorra, CP 76246, El Marqués, Querétaro, México
TEL: +52-442-153-6050
Monterrey, NL Service Satellite
Mexico City, DF Service Satellite

BRAZIL

MITSUBISHI ELECTRIC DO BRASIL COMÉRCIO E SERVIÇOS LTDA.

Votorantim Office
AV. GISELE CONSTANTINO, 1578, PARQUE BELA VISTA, VOTORANTIM-SP, BRAZIL CEP:18.110-650
TEL: +55-15-3023-9000
Blumenau, Santa Catarina Office

EUROPE

MITSUBISHI ELECTRIC EUROPE B.V.

European Service Headquarters (Dusseldorf, GERMANY)
Mitsubishi-Electric-Platz 1 40882 RATINGEN, GERMANY
TEL: +49-2102-486-5000 / FAX: +49-2102-486-5910

South Germany Service Center (Stuttgart)

SCHELMENWASENSTRASSE 16-20, 70567 STUTTGART, GERMANY
TEL: +49-711-770598-123 / FAX: +49-711-770598-141

France Service Center (Paris)

2 RUE DE L'UNION, 92565 RUEIL-MALMAISON CEDEX, FRANCE
TEL: +33-1-41-02-83-13 / FAX: +33-1-49-01-07-25

France Service Satellite (Lyon)

240, ALLEE JACQUES MONOD 69800 SAINT PRIEST FRANCE
TEL: +33-1-41-02-83-13 / FAX: +33-1-49-01-07-25

Italy Service Center (Milan)

VIA ENERGY PARK 14, VIMERCATE 20871 (MB) ITALY
TEL: +39-039-6053-342 / FAX: +39-039-6053-206

Italy Service Satellite (Padova)

VIA G. SAVELLI, 24 - 35129 PADOVA, ITALY
TEL: +39-039-6053-342 / FAX: +39-039-6053-206

U.K. Service Center

TRAVELLERS LANE, HATFIELD, HERTFORDSHIRE, AL10 8XB, U.K.
TEL: +44-1707-288-780 / FAX: +44-1707-278-695

Spain Service Center

CTRA. RUBI, 76-80 8174 SAINT CUGAT DEL VALLES, BARCELONA, SPAIN
TEL: +34-935-65-2236 / FAX: +34-935-89-1579

Poland Service Center

UL.KRAKOWSKA 50, 32-083 BALICE, POLAND
TEL: +48-12-347-6500 / FAX: +48-12-630-4701

Hungary Service Center

MITSUBISHI ELECTRIC EUROPE B.V. HUNGARIAN BRANCH
BUDAÖRS OFFICE PARK, SZABADSÁG ÚT 117., 2040 BUDAÖRS, HUNGARY
TEL: +36-70-433-2263

Turkey Service Center

MITSUBISHI ELECTRIC TURKEY ELEKTRİK ÜRÜNLERİ A.Ş.
SERIFALI MAHALLESİ KALE SOKAKI NO.41 34775
UMRANIYE, İSTANBUL, TURKEY
TEL: +90-216-969-2500 / FAX: +90-216-661-44-47

Czech Republic Service Center

MITSUBISHI ELECTRIC EUROPE B.V. PRAGUE OFFICE
Pekařská 621/7, 155 00 PRAHA 5, CZECH REPUBLIC
TEL: +420-734-402-587

Sweden Service Center

HAMMARBACKEN 14, P.O.BOX 750 SE-19127, SOLLENTUNA, SWEDEN
TEL: +46-8-6251200 / FAX: +46-8-6251014

Bulgaria Service Center

AKHNATON Ltd. (Service Partner)
4 ANDREJ LJAPCHEV BLVD. POB 21, BG-1756 SOFIA, BULGARIA
TEL: +359-2-8176009 / FAX: +359-2-9744061

Ukraine Service Center (Kiev)

CSC Automation Ltd. (Service Partner)
4 B. YEVHENA SVERSTYUKA STR., 02002 KIEV, UKRAINE
TEL: +380-44-494-3344 / FAX: +380-44-494-3366

South Africa Service Center

Adroit Technologies (Service Partner)
20 WATERFORD OFFICE PARK, WATERFORD DRIVE, CNR OF WITKOPPEN ROAD,
FOURWAYS JOHANNESBURG SOUTH AFRICA
TEL: +27-11-658-8100 / FAX: +27-11-658-8101

ASEAN**MITSUBISHI ELECTRIC ASIA PTE. LTD. (ASEAN FA CENTER)**

Singapore Service Center
307 ALEXANDRA ROAD MITSUBISHI ELECTRIC BUILDING SINGAPORE 159943
TEL: +65-6473-2308 / FAX: +65-6476-7439

PHILIPPINES**MELCO FACTORY AUTOMATION PHILIPPINES INC.**

Head Office
128 LOPEZ RIZAL STREET, BRGY., HIGHWAY HILLS, MANDALUYONG CITY, MM PHILIPPINES 1550
TEL: +63-2-8256-8042 / FAX: +632-8637-2294

Philippines Service Center
KM.23 WEST SERVICE ROAD SSH, CUPANG, MUNTINLUPA CITY, PHILIPPINES
TEL: +63-2-8807-0420 / FAX: +63-2-8842-5202

VIETNAM**MITSUBISHI ELECTRIC VIETNAM CO., LTD.**

Vietnam Ho Chi Minh Service Center
11TH & 12TH FLOOR, VIETTEL TOWER B, 285 CACH MANG THANG 8 STREET, WARD 12, DISTRICT 10, HO CHI MINH CITY, VIETNAM
TEL: +84-28-3910-5945 / FAX: +84-28-3910-5947

Vietnam Hanoi Service Center
14TH FLOOR, CAPITAL TOWER, 109 TRAN HUNG DAO STREET, CUA NAM WARD, HOAN KIEM DISTRICT, HA NOI CITY, VIETNAM
TEL: +84-24-3937-8075 / FAX: +84-24-3937-8076

INDONESIA**PT. MITSUBISHI ELECTRIC INDONESIA**

Indonesia Service Center (Cikarang)
JL. KENARI RAYA BLOK G2-07A, DELTA SILICON 5, LIPPO CIKARANG - BEKASI 17550, INDONESIA
TEL: +62-21-2961-7797 / FAX: +62-21-2961-7794

MALAYSIA**MITSUBISHI ELECTRIC SALES MALAYSIA SDN. BHD.**

Malaysia Service Center (Kuala Lumpur Service Center)
LOT 11, JALAN 219, P.O BOX 1036, 46880 PETALING JAYA, SELANGOR DARUL EHSAN, MALAYSIA
TEL: +60-3-7626-5032

Johor Bahru Service Center
9, Jalan Perjiranan 4/6, Bandar Dato Onn, 81100 Johor.
TEL: 07-3642250 / 2256

Pulau Pinang Service Center
25-G, Pusat Perniagaan Perdana Jaya, Jalan Permatang Rawa, 14000 Bukit Mertajam, Pulau Pinang
TEL: +60-4-510-1838 / Fax: +60-4-510-1835

THAILAND**MITSUBISHI ELECTRIC FACTORY AUTOMATION (THAILAND) CO., LTD.**

Thailand Service Center (Bangkok)
101, TRUE DIGITAL PARK OFFICE, 5TH FLOOR, SUKHUMVIT ROAD, BANGCHAK, PHRA KHANONG, BANGKOK, 10260 THAILAND
TEL: +66-2-092-8600 / FAX: +66-2-043-1231-33

INDIA**MITSUBISHI ELECTRIC INDIA PVT., LTD.**

Service Head office and South India Service Center (Bangalore)
CNC eXPerience Park, PLOT NO. 57/A, PEENYA PHASE 3, PEENYA INDUSTRIAL AREA, BANGALORE 560058, KARNATAKA, INDIA
TEL: +91-80-4655-2121
Chennai Service Satellite
Coimbatore Service Satellite
Hyderabad Service Satellite

North India Service Center (Gurgaon)
PLOT 517, GROUND FLOOR, UDYOG VIHAR PHASE-III, GURUGRAM 122008, HARYANA, INDIA
TEL: +91-124-463-0300
Ludhiana Service Satellite
Panthenagar Service Satellite
Delhi Service Satellite
Jamshedpur Service Satellite
Manesar Service Satellite

West India Service Center (Pune)
ICC-Devi GAURAV TECHNOLOGY PARK, UNIT NO.402, FOURTH FLOOR, NORTH WING, SURVEY NUMBER 191-192 (P), NEXT to INDIAN CARD CLOTHING COMPANY Ltd, OFF. VALLABH NAGAR, PIMPRI, PUNE- 411 018, MAHARASHTRA, INDIA
TEL: +91-20-6819-2274
Kolhapur Service Satellite
Aurangabad Service Satellite
Mumbai Service Satellite

West India Service Center (Ahmedabad)
204-209, 2ND FLOOR, 31FIVE, CORPORATE ROAD PRAHLADNAGAR, AHMEDABAD -380015, GUJARAT, INDIA
TEL: + 91-79-6777-7888
Rajkot Service Satellite

CHINA**MITSUBISHI ELECTRIC AUTOMATION (CHINA) LTD. (CHINA FA CENTER)**

CNC Call Center
TEL: +86-400-921-5130

Shanghai Service Center
NO.1386 HONG QIAO ROAD, CHANG NING QU, SHANGHAI 200336, CHINA
TEL: +86-21-2322-3030 / FAX: +86-21-2322-3000*8422

Qingdao Service Center
Suzhou Service Center
Wuhan Service Center
Ningbo Service Center
Hefei Service Center
Beijing Service Center
Tianjin Service Center
Xian Service Center
Dalian Service Center
Chengdu Service Center

Shenzhen Service Center
LEVEL 8, GALAXY WORLD TOWER B, 1 YABAO ROAD, LONGGANG DISTRICT, SHENZHEN 518129, CHINA
TEL: +86-755-2399-8272 / FAX: +86-755-8229-3686

Dongguan Service Center
Xiamen Service Center

KOREA**MITSUBISHI ELECTRIC AUTOMATION KOREA CO., LTD. (KOREA FA CENTER)**

Korea Seoul Service Center
8F GANGSEO HANGANG XI-TOWER A, 401 YANGCHEON-RO, GANGSEO-GU, SEOUL 07528 KOREA
TEL: +82-2-3660-9631 / FAX: +82-2-3664-8668

Korea Daegu Service Center
2F KT BLDG. 8, HOGUK-RO, BUK-GU, DAEGU 41518, KOREA
TEL: +82-53-382-7401 / FAX: +82-53-382-7412

Korea Changwon Technical Center
#205, 888, CHANGWON-DAERO, SEONGSAN-GU, CHANGWON-SI, GYEONGSANGNAM-DO, 51532, KOREA
TEL: +82-55-261-5559 / FAX: +82-55-261-5558

TAIWAN**MITSUBISHI ELECTRIC TAIWAN CO., LTD. (TAIWAN FA CENTER)**

Taiwan Taichung Service Center
NO. 8-1, GONGYEQU 16TH RD., XITUN DIST., TAICHUNG CITY 40768, TAIWAN
TEL: +886-4-2359-0688 / FAX: +886-4-2359-0689

Taiwan Taipei Service Center
11F, NO.88, SEC.6, ZHONGSHAN N. RD., SHILIN DIST., TAIPEI CITY 11155, TAIWAN
TEL: +886-2-2833-5430 / FAX: +886-2-2833-5433

Taiwan Tainan Service Center
11F-1, NO.30, ZHONGZHENG S. RD., YONGKANG DIST., TAINAN CITY 71067, TAIWAN
TEL: +886-6-252-5030 / FAX: +886-6-252-5031

OCEANIA**MITSUBISHI ELECTRIC AUSTRALIA PTY. LTD.**

Oceania Service Center
348 VICTORIA ROAD, RYDALMERE, N.S.W. 2116 AUSTRALIA
TEL: +61-2-9684-7269/ FAX: +61-2-9684-7245

Notice

Every effort has been made to keep up with software and hardware revisions in the contents described in this manual. However, please understand that in some unavoidable cases simultaneous revision is not possible. Please contact your Mitsubishi Electric dealer with any questions or comments regarding the use of this product.

Duplication Prohibited

This manual may not be reproduced in any form, in part or in whole, without written permission from Mitsubishi Electric Corporation.

COPYRIGHT 2009-2024 MITSUBISHI ELECTRIC CORPORATION
ALL RIGHTS RESERVED

MITSUBISHI ELECTRIC CORPORATION

HEAD OFFICE : TOKYO BLDG.,2-7-3 MARUNOUCHI,CHIYODA-KU,TOKYO 100-8310,JAPAN

MODEL	M700VW Series
MODEL CODE	100-219
Manual No.	IB-1500935