

Numerical Control (CNC)

## **Instruction Manual**

### **NC Designer2**

## Introduction

This instruction manual describes how to use NC Designer2. Incorrect handling may lead to unforeseen accidents, so make sure to read this instruction manual thoroughly before operation to ensure correct usage. NC Designer2 supports the following NC series. Some of the functions are not adapted to the NC Designer2, depending on its series.

Supported models	Abbreviations in this manual
M800VW (Windows-based display unit)	M800V/M80V (Windows-based display unit)
M80VW (Windows-based display unit)	
M800W (Windows-based display unit)	M800/M80 (Windows-based display unit)
M80W (Windows-based display unit)	
M800VW (Windows-less display unit)	M800V/M80V (Windows-less display unit)
M800VS	
M80VW (Windows-less display unit)	
M80V	
M800W (Windows-less display unit)	M800/M80 (Windows-less display unit)
M800S	
M80W (Windows-less display unit)	
M80	
E80	
M700VW	M700VW
M700VS	M700VS/M70V/E70
M70V	
E70	

### Notes on Reading This Manual

- (1) For the specifications of individual machine tools, refer to the manuals issued by the respective machine tool builders. The "restrictions" and "available functions" described by the machine tool builders have precedence over this manual.
- (2) This manual describes as many special operations as possible, but it should be kept in mind that operations not mentioned in this manual cannot be performed.

In this manual, the following abbreviations might be used.

MTB: Machine tool builder

## Notes on Using This Software

### (1) Decimal point

Regardless of the language used on the OS which NC Designer 2 is installed on, "." is used for decimal points.

### (2) Properties in property sheets and property setup dialogs for which a numerical value is entered

(a) "-" or "+" at the start if the numerical value is handled as a number.

(b) When characters (other than numbers and decimal points ".") are included, the sequence of numbers and decimal points from the start are handled as numerical values.

Example: When "0123AB" is entered, it is handled as "123".

When "67@89" is entered, it is handled as "67".

(c) When multiple decimal points "." are included, the second decimal point and the values that follow are ignored.

Example: When "78.9.12" is entered, it is handled as "78.9".

(d) When two-byte numbers are entered, they are handled as a character string and the error message "It is not a numerical value" is displayed. Enter one-byte numbers.

## Precautions for Safety

Always read the specifications issued by the machine tool builder, this manual, related manuals and attached documents before installation, operation, programming, maintenance or inspection to ensure correct use.

Understand this numerical controller, safety items and cautions before using the unit.

This manual ranks the safety precautions into "DANGER", "WARNING" and "CAUTION".



When the user may be subject to imminent fatalities or major injuries if handling is mistaken.



When the user may be subject to fatalities or major injuries if handling is mistaken.







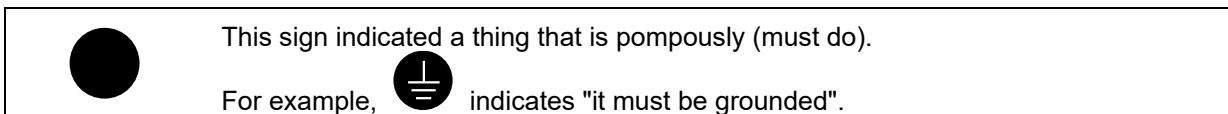
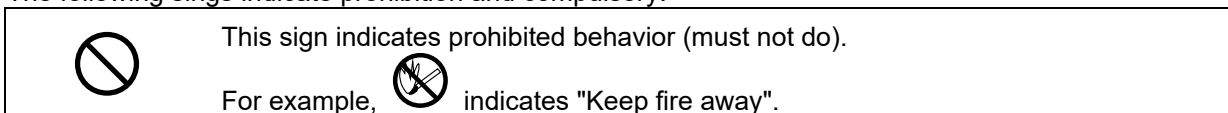





When the user may be subject to injuries or when property damage may occur if handling is mistaken.

The following signs indicate prohibition and compulsory.



The meaning of each pictorial sign is as follows.

 CAUTION	 CAUTION rotated object	 CAUTION HOT	 Danger Electric shock risk	 Danger explosive
 Prohibited	 Disassembly is prohibited	 KEEP FIRE AWAY	 General instruction	 Earth ground



Note that even items ranked as " CAUTION", may lead to major results depending on the situation. In any case, important information that must always be observed is described.

 **DANGER**







Not applicable in this manual.

 **WARNING**

Not applicable in this manual.

 **CAUTION**

**1. Items related to product and manual**

-  If the descriptions relating to the "restrictions" and "allowable conditions" conflict between this manual and the machine tool builder's instruction manual, the latter has priority over the former.
-  The operations to which no reference is made in this manual should be considered impossible.
-  This manual is compiled on the assumption that your machine is provided with all optional functions. Confirm the functions available for your machine before proceeding to operation by referring to the specification issued by the machine tool builder.
-  In some NC system versions, there may be cases that different pictures appear on the screen, the machine operates in a different way on some function is not activated.
-  To protect the availability, integrity and confidentiality of the NC system against cyber-attacks including unauthorized access, denial-of-service (Dos) (\*1) attack, and computer virus from external sources via a network, take security measures such as firewall, VPN, and anti-virus software.  
(\*1) Denial-of-service (Dos) refers to a type of cyber-attack that disrupts services by overloading the system or by exploiting a vulnerability of the system.
-  Mitsubishi Electric assumes no responsibility for any problems caused to the NC system by any type of cyber-attacks including DoS attack, unauthorized access and computer virus.

## Trademarks

MELDAS, MELSEC, EZSocket, EZMotion, iQ Platform, MELSOFT, GOT, CC-Link, CC-Link/LT and CC-Link IE are either trademarks or registered trademarks of Mitsubishi Electric Corporation in Japan and/or other countries.

Ethernet is a registered trademark of Xerox Corporation in the United States and/or other countries.

TRELLIX is a registered trademark or a trademark of Musarubra US LLC or its subsidiaries in the United States and other countries.

Microsoft and Windows are either trademarks or registered trademarks of Microsoft Corporation in the United States and/or other countries.

CompactFlash and CF are either trademarks or registered trademarks of SanDisk Corporation in the United States and/or other countries.

SD Logos are trademarks or registered trademarks of SD-3C, LLC in the United States, other countries or both.

Wind River Systems, Inc., VxWorks and Tornado are either trademarks or registered trademarks of Wind River Systems, Inc. in the United States and/or other countries.

Other company and product names that appear in this manual are trademarks or registered trademarks of the respective companies.

# CONTENTS

1. Outline .....	1
1.1 What Is NC Designer2? .....	1
1.1.1 GUI Design Tool .....	2
1.1.2 What Is the GUI Library? .....	2
1.1.3 Interpreter Method and Compilation Method .....	2
2. Features and Specifications of NC Designer2 .....	3
2.1 Features of NC Designer2 .....	3
2.2 Specifications of NC Designer2 .....	4
2.2.1 Screen Elements of NC Designer2 .....	4
2.2.2 What Is "Project"? .....	5
2.2.3 Operating Environment of NC Designer2 .....	6
2.2.4 Specification List .....	6
2.2.5 Precautions .....	7
2.3 Menu List .....	8
2.3.1 File .....	8
2.3.2 Editing .....	8
2.3.3 View .....	9
2.3.4 Control .....	10
2.3.5 Figure .....	11
2.3.6 Setting .....	11
2.3.7 Layout .....	11
2.3.8 Tool .....	12
2.3.9 Window .....	12
2.3.10 Help .....	12
2.4 Flow of Development Using NC Designer2 .....	13
3. Startup and Termination of NC Designer2 .....	14
3.1 Starting NC Designer2 .....	14
3.2 Exiting From NC Designer2 .....	14
3.3 User Interface .....	15
3.3.1 Function of Each Part of Basic Screen .....	15
3.4 Installing NC Designer2 .....	15
4. Creating a Project .....	16
4.1 Creating a New Project .....	16
4.2 Entering Project Properties .....	18
4.3 Saving the Project .....	19
4.4 Saving the Project as .....	19
4.5 Opening a Project .....	20
4.6 Opening a Recently Used Project .....	20
4.7 Template Function .....	21
4.7.1 Outline .....	21
4.7.2 Dialog specifications .....	22
4.7.3 Operation Specifications .....	23
5. Creating and Saving the Page .....	25
5.1 What Is Page? .....	25
5.2 Creating a New Panel .....	25
5.3 Creating a New Window .....	25
5.4 Entering Panel Properties .....	26
5.5 Entering Window Properties .....	27
5.6 Saving the Panel/Window .....	28
5.7 Save All .....	28
5.8 Opening a Panel/Window .....	29
5.9 Closing the Panel/Window .....	29
5.10 Switching the Editing Window .....	30
5.10.1 Previous Screen .....	30
5.10.2 Next Screen .....	30
5.10.3 Cascade .....	30
5.10.4 Tile .....	31
5.10.5 Arrange Icons .....	31
5.10.6 Switching Locale .....	31
5.10.7 Zoom .....	32
5.10.8 Refresh .....	32
5.10.9 Changing the Theme Color .....	33
5.11 Creating View Frame .....	33
5.11.1 Switching the View Frame .....	35
5.12 Importing a Page .....	36

5.12.1 Operation Screen.....	37
5.12.1.1 Page Import Dialog.....	37
5.12.1.2 Resource Data Name Conversion Table Dialog.....	39
5.12.1.3 Message Log.....	45
5.12.2 Flow of Import Operation.....	46
5.12.3 Selecting the Import Source/Destination.....	48
5.12.4 Deleting a Page in the Import Source.....	50
5.12.5 Changing a Resource Data Name.....	51
5.12.6 Restrictions.....	52
6. Resource.....	53
6.1 Resource.....	53
6.2 Resource Tree.....	53
6.3 Locale.....	54
6.3.1 Creating a New Locale.....	54
6.3.2 Deleting a Locale.....	54
6.3.3 Locale Setup.....	55
6.3.4 Switching the Locale.....	55
6.4 Character Sequence Resource.....	56
6.4.1 Creating a New Character String Resource.....	56
6.4.2 Editing or Creating Character String Resource.....	57
6.4.3 Replacing the Character String Resource.....	57
6.4.4 Deleting Character String Resource.....	57
6.4.5 Importing or Exporting Character String Resource.....	58
6.5 Font Resource.....	62
6.5.1 Creating a New Font Resource.....	62
6.5.2 Deleting Font Resource.....	62
6.5.3 Specifying Font Resource.....	63
6.6 Image Resource.....	64
6.6.1 Creating a New Image Resource.....	64
6.6.2 Deleting an Image Resource.....	64
6.6.3 Specifying an Image File.....	64
6.7 Solid Frame Resource.....	65
6.7.1 Creating a New Solid Frame Resource.....	65
6.7.2 Deleting a Solid Frame Resource.....	65
6.7.3 Specifying a Solid Frame File.....	66
6.8 Filling Pattern Resource.....	67
6.8.1 Editing the Filling Pattern.....	67
6.9 Line Pattern Resource.....	68
6.9.1 Editing the Line Pattern.....	68
6.10 File Name Resource.....	69
6.10.1 Creating a New File Name Resource.....	69
6.10.2 Deleting the File Name Resource.....	69
6.10.3 Specifying the File Name Resource.....	69
6.11 Resource management.....	70
6.11.1 Outline.....	70
6.11.2 Operation Screen.....	71
6.11.2.1 Resource list.....	73
6.11.3 Operation specification.....	75
7. Creating Controls.....	76
7.1 Common Functions of Controls.....	76
7.1.1 Control Name.....	76
7.1.2 Position/Size.....	77
7.1.3 Color/Pattern.....	78
7.1.4 Image.....	78
7.1.5 Text.....	78
7.1.6 Character Attribute.....	79
7.1.7 Scrolling Caption Character String.....	80
7.1.8 Blink.....	81
7.1.9 Solid Frame.....	82
7.1.10 Callback Function.....	82
7.1.11 Event List Dialog Box.....	85
7.1.12 Switch Screen Dialog Box.....	86
7.1.13 Show/Hide.....	86
7.1.14 Input Permission.....	86
7.1.15 Touch Gesture.....	87
7.1.16 Property Setup Dialog.....	88
7.1.16.1 Standard Control.....	89
7.1.16.1.1 [Style] Tab.....	89

7.1.16.1.2 [Text] Tab.....	91
7.1.16.2 NC Control.....	93
7.1.16.2.1 [Style] Tab.....	93
7.1.16.2.2 [Text] Tab.....	94
7.1.16.3 Operation Procedures.....	95
7.1.16.4 Input Assist Function.....	96
7.1.16.4.1 Input Assist Window.....	96
7.1.16.4.2 Operation Procedure.....	97
7.1.16.4.3 Precautions.....	97
7.2 Standard Control.....	98
7.2.1 Basic Control Object (GCBasicControl).....	98
7.2.1.1 Property Settings.....	98
7.2.2 Button Object (GCButton).....	99
7.2.2.1 Property Setup Dialog.....	99
7.2.2.1.1 [Behavior Settings] Tab.....	100
7.2.2.1.2 [Style] Tab.....	101
7.2.2.1.3 [Text] Tab.....	102
7.2.2.1.4 [Extended] Tab.....	103
7.2.2.2 Property Settings.....	104
7.2.3 Text Box Object (GCTextBox).....	107
7.2.3.1 Property Setup Dialog.....	107
7.2.3.1.1 [Display Settings] Tab.....	108
7.2.3.1.2 [Style] Tab.....	109
7.2.3.1.3 [Text] Tab.....	110
7.2.3.1.4 [Input Range] Tab.....	111
7.2.3.1.5 [Extended] Tab.....	112
7.2.3.2 Property Settings.....	113
7.2.3.3 Complements.....	115
7.2.4 Label Object (GCLabel).....	116
7.2.4.1 Property Settings.....	116
7.2.5 List Object (GCList).....	117
7.2.5.1 Property Settings.....	117
7.2.5.2 Complements.....	118
7.2.6 Picture Object (GCPicture).....	119
7.2.6.1 Property Setup Dialog.....	119
7.2.6.1.1 [Style] Tab.....	120
7.2.6.1.2 [Text] Tab.....	121
7.2.6.1.3 [Extended] Tab.....	122
7.2.6.2 Property Settings.....	123
7.2.7 Check Box Object (GCCheckBox).....	125
7.2.7.1 Property Settings.....	125
7.2.8 Radio Button Object (GCRadioButton).....	127
7.2.8.1 Property Settings.....	127
7.2.9 Progress Bar Object (GCProgressBar).....	129
7.2.9.1 Property Settings.....	129
7.2.10 HTML Browser Object (GCHtmlBrowser).....	131
7.2.10.1 Property Setup Dialog.....	131
7.2.10.1.1 [Display/Action] Tab.....	132
7.2.10.1.2 [Style] Tab.....	133
7.2.10.1.3 [Text] Tab.....	134
7.2.10.2 Property Settings.....	135
7.2.10.3 Complements.....	137
7.2.11 Scroll Bar Object (GCScrollBarEx).....	138
7.2.11.1 Property Settings.....	138
7.2.11.2 Complements.....	141
7.2.12 Edit Control Object (GCEdit).....	142
7.2.12.1 Property Settings.....	142
7.2.13 Table Object (GNCTable).....	144
7.2.13.1 Property Settings.....	144
7.2.13.2 Complements.....	146
7.2.14 Input Box Object(GInputBox).....	150
7.2.14.1 Property Setup Dialog.....	150
7.2.14.1.1 [Input/View] Tab.....	151
7.2.14.1.2 [Style] Tab.....	152
7.2.14.1.3 [Text] Tab.....	153
7.2.14.1.4 [Extended] Tab.....	154
7.2.14.2 Property Settings.....	155
7.2.14.3 Complements.....	158

7.2.14.4 Restrictions.....	164
7.2.15 Ten-key object (GsoftKey).....	165
7.2.15.1 Property Setup Dialog.....	166
7.2.15.1.1 [Input/View] Tab.....	167
7.2.15.1.2 [Style] Tab.....	168
7.2.15.1.3 [Text] Tab.....	169
7.2.15.1.4 [Extended] Tab.....	170
7.2.15.2 Property Settings.....	171
7.2.15.3 Complements.....	175
7.2.15.4 Restrictions.....	186
7.3 NC Control Object.....	187
7.3.1 Counter (GNXCounter); Counter Display Part.....	187
7.3.1.1 Property Settings.....	187
7.3.1.2 Complements.....	190
7.3.2 CycleTime (GNXCycleTime); Cycle Time Display Part.....	191
7.3.2.1 Property Settings.....	191
7.3.2.2 Complements.....	192
7.3.3 Feedrate (GNXFeedrate); F Display Part.....	193
7.3.3.1 Property Settings.....	193
7.3.3.2 Complements.....	194
7.3.4 Gmodal M (GNXGModal); M System Modal Display Part.....	195
7.3.4.1 Property Settings.....	195
7.3.4.2 Complements.....	196
7.3.5 Gmodal L (GNXGModal_L); L System Modal Display Part.....	197
7.3.5.1 Property Settings.....	197
7.3.5.2 Complements.....	198
7.3.6 Gmodal Simple (GNXGModalSimple); Simple Modal Display Part.....	199
7.3.6.1 Property Settings.....	199
7.3.6.2 Complements.....	200
7.3.7 LoadMeter (GNXLoadMeter); Load Meter Display Part.....	201
7.3.7.1 Property Settings.....	201
7.3.7.2 Complements.....	203
7.3.8 MSTB (GNXMSTB); MSTB display part.....	204
7.3.8.1 Property Settings.....	204
7.3.8.2 Complements.....	206
7.3.9 ONB (GNONB); ONB Display Part.....	207
7.3.9.1 Property Settings.....	207
7.3.9.2 Complements.....	208
7.3.10 ProgramBuffer (GNXPrgBuff); Program Buffer Display Part.....	209
7.3.10.1 Property Settings.....	209
7.3.10.2 Complements.....	210
7.3.11 SPCommand (GNXSPCommand); S Display Part.....	211
7.3.11.1 Property Settings.....	211
7.3.11.2 Complements.....	212
7.3.12 PLC Button Object (GNCPLCButton).....	213
7.3.12.1 Property Setup Dialog.....	213
7.3.12.1.1 [Device] Tab.....	214
7.3.12.1.2 [Style] Tab.....	216
7.3.12.1.3 [Text] Tab.....	217
7.3.12.1.4 [Extended] Tab.....	218
7.3.12.2 Property Settings.....	219
7.3.12.3 Complements.....	222
7.3.13 PLC Text Box Object (GNCPLCTextBox).....	227
7.3.13.1 Property Setup Dialog.....	227
7.3.13.1.1 [Device] Tab.....	228
7.3.13.1.2 [Style] Tab.....	231
7.3.13.1.3 [Text] Tab.....	232
7.3.13.1.4 [Input Range] Tab.....	233
7.3.13.1.5 [Extended] Tab.....	234
7.3.13.2 Property Settings.....	235
7.3.13.3 Complements.....	237
7.3.14 NC Data Textbox (GNCDataTextBox).....	244
7.3.14.1 Property Setup Dialog.....	244
7.3.14.1.1 [Device] Tab.....	245
7.3.14.1.2 [Style] Tab.....	247
7.3.14.1.3 [Text] Tab.....	248
7.3.14.1.4 [Extended] Tab.....	249
7.3.14.2 Property Settings.....	250

7.3.14.3 Complements .....	252
7.3.15 PLC extension button (GNCPLCEXButton).....	256
7.3.15.1 Property Setup Dialog .....	256
7.3.15.1.1 [Device] Tab.....	257
7.3.15.1.2 [Style] Tab.....	260
7.3.15.1.3 [Text] Tab.....	261
7.3.15.1.4 [Extended] Tab.....	262
7.3.15.1.5 [Dynamic change property (Status 1 - 7)] Tab .....	264
7.3.15.2 Property Settings.....	266
7.3.15.3 Complements .....	273
7.3.16 PLC Message (GNCPLCMessage) .....	281
7.3.16.1 Property Settings.....	281
7.3.16.2 Complements .....	284
7.3.17 Menu (GNXMenu) ; Menu display part.....	287
7.3.17.1 Property Settings.....	287
7.3.17.2 Complements .....	288
7.3.18 Extension Menu (GNCEXMenu); Extension Menu Display Part.....	289
7.3.18.1 Property Setup Dialog .....	289
7.3.18.1.1 [Behavior Settings] Tab.....	290
7.3.18.1.2 [Style/Text] Tab.....	292
7.3.18.2 Property Settings.....	294
7.3.18.3 Complements .....	302
7.3.19 FileInOut (GNXFileTransfer) ; Input/Output Control.....	309
7.3.19.1 Property Settings.....	309
7.3.19.2 Complements .....	310
7.3.20 AlarmMessage (GNXAlarmMessage) ; Alarm Display Part .....	315
7.3.20.1 Property Settings.....	315
7.3.20.2 Complements .....	316
7.3.21 MonitorStatus (GNXMonitorStatus) ; Operation Status Display Part .....	318
7.3.21.1 Property Settings.....	318
7.3.21.2 Complements .....	319
7.3.22 Time (GNXTime) ; Time Display Part.....	320
7.3.22.1 Property Settings.....	320
7.3.22.2 Complements .....	320
7.3.23 Page Change Button (GNCPAGECHANGEButton) .....	321
7.3.23.1 Property Setup Dialog .....	321
7.3.23.1.1 [Behavior Settings] Tab.....	322
7.3.23.1.2 [Style] Tab.....	324
7.3.23.1.3 [Text] Tab.....	325
7.3.23.1.4 [Extended] Tab.....	326
7.3.23.1.5 [Open] Tab.....	328
7.3.23.1.6 [Close] Tab.....	329
7.3.23.2 Property Settings.....	330
7.3.23.3 Complements .....	333
7.3.24 Stacked Graph (GNCStackedGraph).....	344
7.3.24.1 Property Settings.....	344
7.3.24.2 Complements .....	346
7.3.25 Statistics Graph (GNCStatisticsGraph) .....	347
7.3.25.1 Property Settings.....	347
7.3.25.2 Complements .....	348
7.3.26 Alarm List (GNCAAlarmList).....	350
7.3.26.1 Property Setup Dialog .....	350
7.3.26.1.1 [Alarm Settings] Tab.....	351
7.3.26.1.2 [Style] Tab.....	352
7.3.26.1.3 [Text] Tab.....	353
7.3.26.1.4 [Extended] Tab.....	354
7.3.26.2 Property Settings.....	355
7.3.26.3 Complements .....	358
7.3.26.4 Restrictions.....	367
7.3.27 Meter (GNCMeter).....	368
7.3.27.1 Property Setup Dialog .....	369
7.3.27.1.1 [Device/Style] Tab.....	370
7.3.27.1.2 [Extended] Tab.....	374
7.3.27.2 Property Settings.....	375
7.3.27.3 Complements .....	380
7.3.27.4 Precautions .....	381
7.3.27.5 Restrictions.....	381

7.3.28 Trend Graph (GNCTrendGraph).....	382
7.3.28.1 Property Setup Dialog.....	383
7.3.28.1.1 [Data] Tab.....	384
7.3.28.1.2 [Style] Tab.....	387
7.3.28.1.3 [Extended] Tab.....	389
7.3.28.2 Property Settings.....	390
7.3.28.3 Complements.....	394
7.3.28.4 Precautions.....	395
7.3.28.5 Limitations.....	395
8. Parts Library.....	396
8.1 Operation Screen.....	397
8.1.1 Image List Dialogue.....	397
8.2 Operation Procedure.....	398
8.3 Precautions.....	400
9. Figure.....	401
9.1 What Is Figure?.....	401
9.2 Figure Creation Method.....	402
9.2.1 Drawing a New Figure.....	402
9.3 Common Functions of Figure.....	404
9.3.1 Position/Size.....	404
9.3.2 Perimeter Line.....	404
9.3.3 Color/Pattern.....	405
9.4 Figure Settings.....	406
9.4.1 Rectangle.....	406
9.4.2 Circle and Oval.....	406
9.4.3 Line.....	406
9.4.4 Connected Line.....	407
9.4.5 Sector.....	407
9.4.6 Polygon.....	407
9.4.7 Arc.....	408
10. Screen Editing.....	409
10.1 Editing Operation.....	409
10.1.1 Undo.....	409
10.1.2 Redo.....	409
10.1.3 Cut.....	410
10.1.4 Copy.....	410
10.1.5 Paste.....	411
10.1.6 Delete.....	411
10.1.7 Find.....	412
10.1.8 Select All.....	413
10.1.9 Continuous copy.....	414
10.1.9.1 Operation Specifications.....	417
10.1.9.2 Limitations.....	418
10.1.10 Batch Conversion.....	419
10.1.10.1 Operation Procedure.....	419
10.1.11 Copy and Paste between Projects.....	421
10.1.11.1 Operation Procedure.....	421
10.1.11.2 Complements.....	424
10.1.11.3 Restrictions.....	426
10.2 Layout Function.....	427
10.2.1 Size Change.....	427
10.2.2 Move.....	428
10.2.3 Arrangement and Alignment.....	428
10.2.4 Arrange to Uniform Size.....	430
10.2.5 Order.....	431
10.2.6 Fine Adjustment.....	431
10.2.7 Rotation/Flip.....	432
10.2.8 Deformation.....	434
10.2.9 Grouping and Ungrouping.....	436
10.2.10 Grid.....	438
10.3 Control List.....	439
10.3.1 Operation Screen.....	440
10.3.1.1 The list.....	442
10.3.2 Operation Specifications.....	444
10.3.3 Restrictions.....	444
10.4 Focus Setup.....	445
10.5 Error Check.....	448
10.5.1 Error Check Item List.....	449



10.5.2 Result of Error Check.....	450
10.6 Memory Usage Check.....	451
10.6.1 Memory Usage Check Dialog .....	451
10.6.2 Operation Methods .....	453
10.6.3 Check Results.....	454
10.7 Development by Multiple Users.....	455
10.7.1 Option Setting.....	456
10.8 Sub Cursor Setting.....	457
10.8.1 Screen Specifications .....	458
10.8.2 Sub Cursor Setting Screen Displaying Method.....	462
10.8.3 Sub Cursor Setting Procedure.....	465
10.8.3.1 Move the Sub Cursor by Key Input (Arrow Key, TAB Key, Input Key).....	465
10.8.3.2 Set the Input Value to the Target Control .....	467
10.8.3.3 Change the Display Start Position.....	467
10.8.3.4 Transfer a Key to Other Control .....	468
10.8.4 Limitations.....	471
11. Simulation.....	472
11.1 Simulation Function.....	472
11.1.1 Starting Simulation.....	472
11.1.2 Simulation Screen.....	472
11.1.3 Function List .....	473
11.1.4 Quitting Simulation.....	473
11.2 Simulation Tools.....	474
11.3 Message Window.....	475
12. Simulation (NC Trainer2 plus) .....	476
12.1 Simulation (NC Trainer2 plus).....	476
12.2 Operation Procedure.....	477
12.3 Limitations.....	479
13. Generating a Document.....	480
13.1 Document Generation Function .....	480
13.1.1 Generating a Project Information Document.....	480
13.1.2 Generating a Screen Information Document.....	481
13.1.3 Output Image .....	482
14. Project Convert.....	484
14.1 Export for the Project Executing the Interpreter .....	484
14.1.1 Export .....	484
14.1.2 File Configuration.....	486
14.2 Project Convert to the ND2 Format .....	487
15. Source Code Generation.....	488
15.1 Generating Screen Data Source Codes.....	488
15.2 User Code Protection.....	492
16. Features and Configuration of GUI Library .....	494
16.1 Features of GUI Library.....	494
16.2 Configuration of GUI Library.....	495
16.3 Folder Configuration for Data File .....	496
17. Application Execution Method .....	497
17.1 Application Execution Method.....	497
17.1.1 Outline .....	497
17.1.2 Independent/Combinational Execution .....	499
17.2 Interpreter Method.....	500
17.2.1 What Is Interpreter Method? .....	500
17.2.2 Flow of Operation .....	500
17.3 Compilation Method .....	502
17.3.1 What Is Compilation Method?.....	502
17.3.2 Flow of Operation .....	502
17.3.2.1 Preparation for Visual Studio 2017/2019/2022 .....	502
17.3.2.1.1 Visual Studio 2015 Installation .....	503
17.3.2.1.2 Windows SDK 7.1 Download .....	503
17.3.2.1.3 Windows SDK 7.1 Installation .....	503
17.3.2.1.4 Registry Correction .....	507
17.3.2.1.5 MSBuild Props File Correction .....	508
17.3.2.2 Operation Procedures in Visual Studio.....	509
17.3.2.2.1 Operation Procedure with Visual Studio 2010.....	510
17.3.2.2.2 Operation Procedure with Visual Studio 2017.....	514
17.3.2.2.3 Operation Procedure with Visual Studio 2019.....	518
17.3.2.2.4 Operation Procedure with Visual Studio 2022.....	522
17.3.2.3 Operation Procedure with NC Compiler/NC Compiler2.....	527
17.4 Application Window .....	530

17.4.1	What Is Application Window?	530
17.4.2	Launching the Application Window	531
17.4.3	Functions of Application Window	531
17.4.4	Screen Configuration	532
17.4.5	Closing the Application Window	532
17.5	Screen Switching	533
17.5.1	Outline	533
17.5.2	Screen Switching Method	533
17.5.2.1	Changing From the Custom Screen to the Standard Screen (F0 Release)	535
17.5.2.2	Changing the Menu Name While Displaying Custom Screen (Menu Release)	537
17.5.2.3	Closing the Custom Screen (Menu Release)	540
17.5.3	Screen No. Designation Method	541
17.5.4	Panel Switching History	542
17.5.5	Displaying Previously Displayed Custom Screen	543
17.6	Custom Release	546
17.6.1	Outline	546
17.6.2	S/W Configuration	548
17.6.2.1	Necessary Applications	548
17.6.2.2	Necessary Files	549
17.6.3	Development Procedure of Custom Release S/W	551
17.6.4	F0 Release	552
17.6.4.1	Interpreter Method	552
17.6.4.1.1	Config.ini	552
17.6.4.1.2	customdef.ini	554
17.6.4.2	Compilation Method	555
17.6.4.2.1	Config.ini	555
17.6.4.2.2	customdef.ini	556
17.6.4.3	Switching of "Onboard" and "Execution File by F0 Release" by Bit Selection Parameter (#6451 bit0)	557
17.6.5	Menu Release	558
17.6.5.1	Interpreter Method	558
17.6.5.1.1	Config.ini	558
17.6.5.1.2	customdef.ini	558
17.6.5.1.3	Icon Image	564
17.6.5.2	Compilation Method	565
17.6.5.2.1	Config.ini	565
17.6.5.2.2	customdef.ini	565
17.6.5.2.3	Icon Image	565
17.6.5.3	Changing the Arrangement of the Main Menu	566
17.6.5.3.1	customdef.ini	566
17.6.5.4	Focus while the Instance Is Held	568
17.6.5.5	Settings of an Operation Message	569
17.6.6	Screen Part Assignment	570
17.6.6.1	Screen Selection Bar Display Open	571
17.6.6.2	Operation Screen Base Display Open	572
17.6.6.3	Interpreter Method	573
17.6.6.3.1	config.ini	573
17.6.6.3.2	customdef.ini	573
17.6.6.4	Compilation Method	574
17.6.6.4.1	config.ini	574
17.6.6.4.2	customdef.ini	574
17.6.6.5	Caution for Creating Customized Window for Screen Part Assignment	574
17.6.6.5.1	Size and Display Coordinate of Displayed Customized Window	574
17.6.6.5.2	Customized Window Focus/ Available Event	575
17.6.6.5.3	Sample Code (Timer Processing)	576
17.6.6.5.4	Sample Code (Process to Pass the Key to the Standard Screen When Input Is Enabled)	579
17.6.7	Selectable Display Assignment	586
17.6.7.1	Interpreter Method	588
17.6.7.1.1	config.ini	588
17.6.7.1.2	customdef.ini	588
17.6.7.2	Compilation Method	589
17.6.7.2.1	config.ini	589
17.6.7.2.2	customdef.ini	589
17.6.7.3	Caution for Creating Customized Window for Selectable Display Assignment	589
17.6.7.3.1	Size and Display Coordinate of Displayed Customized Window	589
17.6.7.3.2	Customized Window Focus/ Available Event	590

17.6.7.3.3 Sample Code (Switching Axis to Be Displayed with Page Key/ Part System Switch Key).....	591
17.6.7.3.4 Sample Code (Displaying the Next Axis by Touching a Button).....	596
17.6.8 G Code Guidance Release, M Code Guidance Release .....	601
17.6.8.1 Designation of the Guidance File Folder .....	602
17.6.8.1.1 Config.ini .....	602
17.6.8.2 Format of the Guidance File .....	603
17.6.8.2.1 File Name .....	603
17.6.8.2.2 HTML File .....	606
17.6.8.2.3 Precautions .....	608
17.6.9 Limitation of Number of Project Registration.....	609
17.6.9.1 Register Two or More Windows in One Project .....	609
17.6.9.2 Register Two or More Screens in One Project .....	610
17.6.10 About the Switch of Display/Non-display of the Menu by the Parameter .....	611
17.6.11 Adjusting Standard and Customized Screen Size according to Resolution .....	612
17.6.12 Displaying an Original Logo on the Standard Screen .....	613
17.6.13 Parameter .....	614
17.6.13.1 User Parameters .....	614
17.6.13.2 Machine Parameters .....	614
17.6.14 Limitations.....	615
17.7 Custom Release File Setting .....	617
17.7.1 Operation Screen.....	617
17.7.1.1 Custom Screen Configuration Dialog .....	617
17.7.2 Operation Procedure.....	628
17.7.3 Precautions.....	631
17.8 Memory Card Transfer .....	632
17.8.1 Operation screen .....	632
17.8.2 Operation Procedure.....	637
17.9 Home Screen .....	639
17.9.1 Types of MTB's App.....	640
17.9.2 Configuration Settings Files .....	641
17.9.2.1 List of Configuration Settings Files .....	641
17.9.2.2 Storage Location of Applications and Configuration Settings Files .....	642
17.9.2.3 Files Required for Registration .....	642
17.9.3 Fixed Home Screen Display .....	643
17.9.3.1 Interpreter Method.....	643
17.9.3.1.1 Setting Home Screen Config File (HomeScrnCustomConfig.ini) .....	643
17.9.3.1.2 Setting Application Definition File (HomeScrn_oooo.ini) .....	644
17.9.3.1.3 Setting Application Language File (HomeScrn_oooo_△△△.ini) .....	648
17.9.3.2 Compilation Method.....	649
17.9.3.2.1 Setting Home Screen Config File (HomeScrnCustomConfig.ini) .....	649
17.9.3.2.2 Setting Application Definition File (HomeScrn_oooo.ini) .....	649
17.9.3.2.3 Setting Application Language File (HomeScrn_oooo_△△△.ini) .....	649
17.9.3.3 Precaution When Creating Customized Screen with Fixed Home Screen Display.....	649
17.9.3.3.1 Displayable Area on Customized Screen.....	649
17.9.3.3.2 Changing Operation Menu Display .....	650
17.9.3.3.3 Receiving Notification When Operation Menu Is Pressed on Home Screen .....	652
17.9.3.3.4 Notifying Key Input from Application .....	654
17.9.3.4 Caution .....	656
17.9.4 Full-Screen Display.....	657
17.9.4.1 Interpreter Method.....	657
17.9.4.1.1 Setting Home Screen Config File (HomeScrnCustomConfig.ini) .....	657
17.9.4.1.2 Setting Application Definition File (HomeScrn_oooo.ini) .....	658
17.9.4.1.3 Setting Application Language File (HomeScrn_oooo_△△△.ini) .....	658
17.9.4.2 Compilation Method.....	659
17.9.4.2.1 Setting Home Screen Config File (HomeScrnCustomConfig.ini) .....	659
17.9.4.2.2 Setting Application Definition File (HomeScrn_oooo.ini) .....	659
17.9.4.2.3 Setting Application Language File (HomeScrn_oooo_△△△.ini) .....	659
17.9.4.3 Caution .....	659
17.10 S/W Keyboard .....	660
17.10.1 Outline .....	660
17.10.2 Function Specifications .....	661
17.10.3 Programming Method .....	662
17.10.3.1 Open S/W Keyboard Window .....	662
17.10.3.2 Close S/W Keyboard Window .....	663
17.10.3.3 Set S/W Keyboard Position .....	664
17.10.3.3.1 Set the Initial Display Position of the S/W Keyboard Window .....	664

17.10.3.3.2 Change the S/W Keyboard Window Position Arbitrarily While the Window Is Being Displayed .....	665
17.10.3.4 Set the Status of Entry Area of S/W Keyboard Window .....	666
17.10.3.4.1 Display the Entered Characters on the Entry Area of S/W Keyboard Window .....	667
17.10.3.4.2 Process When the [INPUT] Key Is Pressed .....	668
17.10.3.5 Get the Entry Area Status of S/W Keyboard Window .....	669
17.10.3.6 Clear S/W Keyboard Entry Area .....	670
17.10.3.7 Set Character String in S/W Keyboard Entry Area .....	671
17.10.3.8 Get Character String from S/W Keyboard Entry Area .....	672
17.10.3.9 Display S/W Keyboard Window in the Foreground .....	673
17.10.4 Example .....	674
Appendix .....	678
Appendix 1. Error Message List .....	678
Appendix 2. Shortcut Key List .....	684
Appendix 3. About NC Designer2 .....	685
Appendix 4. Pattern List .....	686
Appendix 4.1 Filling Pattern List .....	686
Appendix 4.2 Line Pattern List .....	686
Appendix 5. Default Palette Color .....	687
Appendix 6. Data Type Definitions .....	689
Appendix 7. HTML Tag List .....	697
Appendix 8. Executing File Registration Method .....	699
Appendix 8.1 F0 Release .....	699
Appendix 8.1.1 melAppCtrl.ini .....	699
Appendix 8.1.2 Details of melAppCtrl.ini .....	699
Appendix 8.1.3 Function of Update Cycle Setting .....	705
Appendix 8.2 Menu Release .....	706
Appendix 8.2.1 customdef.ini .....	706
Appendix 8.2.2 Icon Image .....	706
Appendix 8.3 Using a Function Key (Screen Switching Key) in the Custom Screen .....	707
Appendix 8.3.1 Utilization Method 1 by Adding a Definition to melAppCtrl.ini (Only the Meaning of Function Key Can Be Changed with "F0" Key) .....	708
Appendix 8.3.2 Utilization Method 2 by Adding a Definition to melAppCtrl.ini (Changing to a Specific Standard Screen with "F0" Key) .....	709
Appendix 8.3.3 Utilization Method 3 by Adding a Definition to melAppCtrl.ini (Changing to the Specific Standard Screen with "Menu" Key) .....	711
Appendix 8.3.4 The Standard Screen After Changing .....	713
Appendix 8.4 Home Screen .....	714
Appendix 8.4.1 Setting Home Screen Config File (HomeScrnCustomConfig.ini) .....	714
Appendix 8.4.2 Setting Application Definition File (HomeScrn_oooo.ini) .....	714
Appendix 8.4.3 Setting Application Language File (HomeScrn_oooo_△△△.ini) .....	715
Appendix 8.4.4 Precautions .....	715
Appendix 9. HMI Integrated Installer .....	716
Appendix 9.1 Outline .....	716
Appendix 9.2 Configuration .....	717
Appendix 9.3 Screen Configuration .....	718
Appendix 9.4 Operation Methods .....	723
Appendix 9.4.1 Installing the Application .....	723
Appendix 9.5 Details for Functions .....	728
Appendix 9.5.1 Installation Method .....	728
Appendix 9.5.2 About the Memory Card or USB Memory for Upgrade .....	730
Appendix 9.6 Parameter .....	742
Appendix 9.7 Operation/Alarm Messages .....	743
Appendix 9.8 Limitations .....	744
Appendix 9.9 Precautions .....	744
Appendix 10. Installing Custom Data (M700VS/M70V/E70) .....	745
Appendix 11. Installing Custom Data (M800V/M80V/ M800/M80 (Windows-less Display Unit)) .....	748
Appendix 12. Entry Key Code List at KeyPress/KeyRelease .....	752



# 1. Outline

This section describes an outline of NC Designer2.

## 1.1 What Is NC Designer2?

NC Designer2 provides you with a GUI development environment consisting of a GUI design tool for generating the source code of host equipment on the drawn GUI screen and a GUI library that does not depend on specific platforms.

NC Designer2 consists of a GUI design tool, which substantially reduces GUI development work-hours, and a fast and compact graphic library.

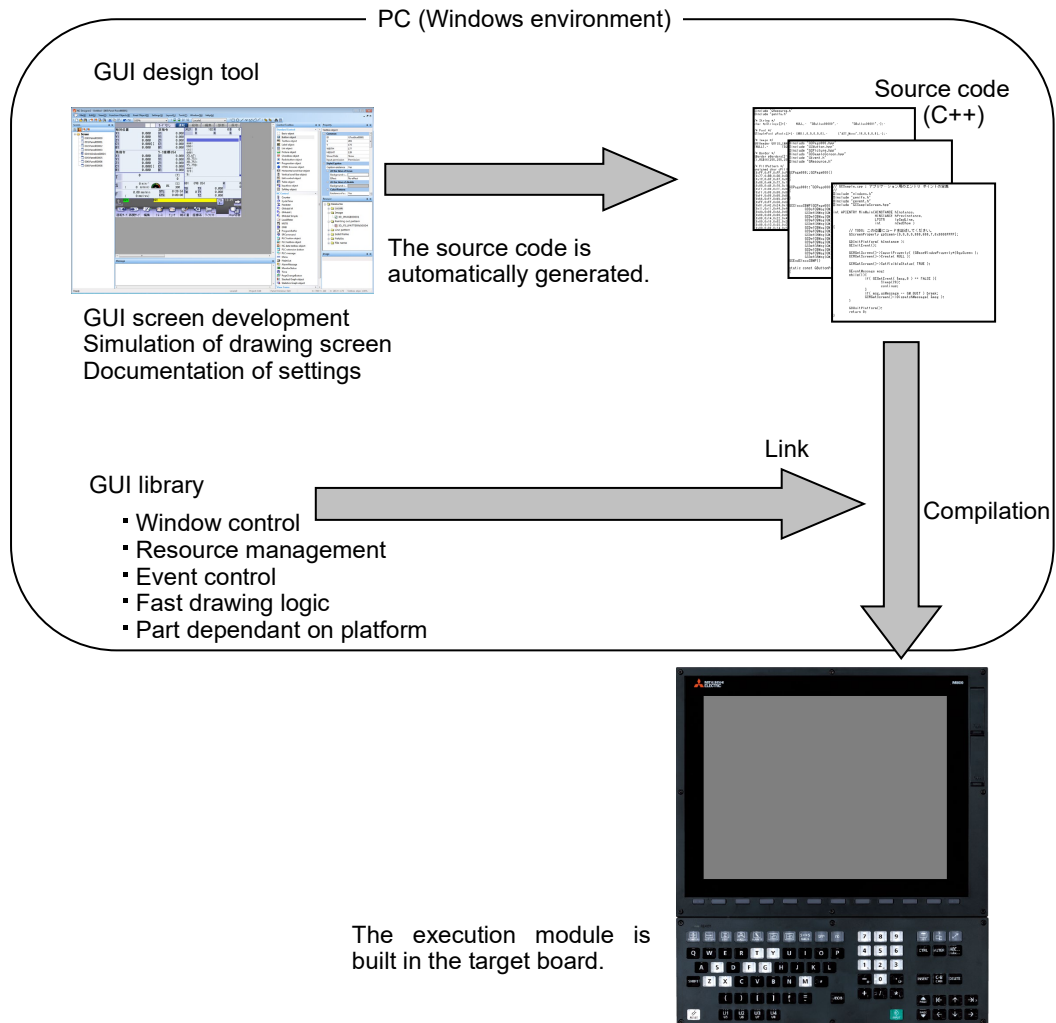

1. Outline

**1.1.1 GUI Design Tool**

With NC Designer2, figures and parts having various functions are laid out on the screen during creation of screen data. Source codes (C++) matching the GUI library are automatically generated according to the created screen data.

NC Designer2 has various functions such as the simulation function for the PC, so that the development process which required many work-hours with conventional development methods are now automated, and re-working after assembly in the actual machine is minimized.

**1.1.2 What Is the GUI Library?**

The GUI library strongly supports development of the graphic user interface.

The GUI library contains functions for mouse and key events and window system, which are indispensable for the configuration of the GUI, as well as the drawing function.

**1.1.3 Interpreter Method and Compilation Method**

The screen development method includes two types: interpreter method (C++ language is not needed) and compilation method (C++ language is needed). The intended purposes etc. of these methods are the table below.

	<b>Interpreter method</b>	<b>Compilation method</b>
Purpose	Development of comparatively simple screen	Development of screen with more complex control operation
Programming	Unnecessary (with Macro function)	C++ language programming
Development (compilation) environment	Unnecessary	The compiler is necessary
Execution speed	Slower than the compilation method	Faster than the interpreter method

## 2. Features and Specifications of NC Designer2

In this section, what can be done with NC designer2 is described for those who operate NC Designer2 for the first time. Specifications and functions are referred to in the description.

### 2.1 Features of NC Designer2

NC Designer2 has the following features.

#### Ultimate GUI development framework applicable to various embedded systems (platforms)

- Automatic generation of source code  
Various source codes are automatically generated from the data created with NC Designer2.
- Possible to load various fonts
- GUI library which does not depend on the platform  
The GUI library allows you to match every platform through repetitive generation.

#### Substantial improvement of GUI development efficiency through embedded system

- Powerful editing functions (cut, copy, paste, rotation, alignment, zoom, etc.)
- Automatic generation of development document  
NC Designer2 automatically creates documents such as the screen list and property data in a file (rich text format).
- Simulation function for PC  
Screens created with NC Designer2 can be simulated.
  - Simple GUI simulation such as screen switching is realized.
  - Using the simulation tool, you can change properties of the GUI part.  
(Modification event history is also supported.)



## 2.2 Specifications of NC Designer2

### 2.2.1 Screen Elements of NC Designer2

The screen elements displayed (that is, created) with NC Designer2 include the followings.

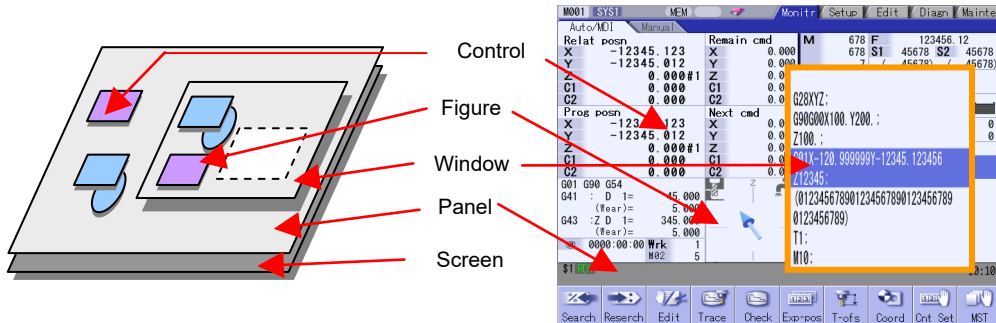

Screen element	Description
Screen	Physical hardware display area. Available only one screen for each system. That is, only one screen for each project.
Page	Screen. The page includes the panel and the window.
Panel	Screen displayed in full size on the screen.
Window	Screen displayed in a window state on the screen.
Object	The object is a screen element arranged on the page. The object includes the control, figure and view frame.
Control	The control is a group of GUI functions including buttons and pictures.
Figure	The figure can be drawn with the basic drawing function of the GUI library. The figure includes rectangles, circles, lines, continuous lines, polygons, sectors and arcs.
View frame	The view frame is a display area in the page having multiple pages. Controls and figures can be arranged on each page of the view frame.

**2.2.2 What Is "Project"?**

With NC Designer2, a group of GUI screens used for a certain application is called a "project". The project mainly consists of a folder of which screen files are stored and a project data file. When a model is selected in the model selection of the wizard creating new projects and a project "Sample" is created, a "Sample" folder and project data file (Note 2) are created.

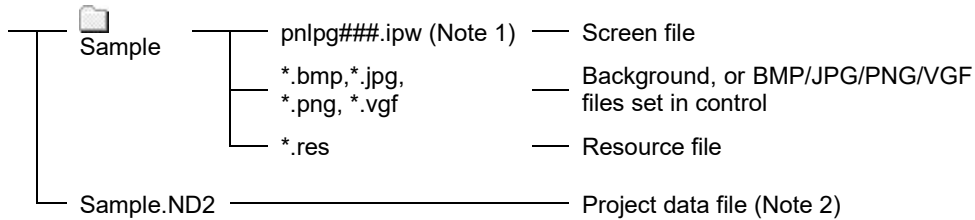

(Note 1): ###: A three-digit hexadecimal value indicating the page number

(Note 2): When "M800V/M80V/M800/M80/E80 Series" is selected, a project with the ND2 file extension, Sample.ND2, is created.

When "M700V/M70V/E70 Series" is selected, a project with the IPP file extension, Sample.IPP, is created.

To open an existing project, select the file having extension ND2.

**IMPORTANT**

- ◆ To move or copy project data to another PC, select both the folder and project data file. Because the project consists of these two pieces of data, the project does not open with only one of them.
- ◆ Settings related to the screen size and display scale are stored in the CONFIG.INI file, that is in a same folder with melhi.exe.

To modify the screen size or the display magnification, adjust the values in the [SCREEN].

```
[SCREEN]
WIDTH = 640
HEIGHT = 480
SCALE = 100
```

### 2.2.3 Operating Environment of NC Designer2

The system environment necessary for the operation of NC Designer2 is shown below.

OS	Windows 10 Windows 11
CPU	Processor with CPU clock 1 GHz or more
HD	400MB or more (excluding the free space necessary for running the OS)
Memory	2GB or more
Screen	Resolution: SVGA (800 × 600) or higher

### 2.2.4 Specification List

Function	Outline
Screen	1 for each project
Panel/window	Max. 256 sheets of panels and windows in total for each project
View frame	Max. 10 frames for each panel or window
Screen size	Horizontal: 1 to 2560 dots Vertical: 1 to 1920 dots
Number of controls that can be created on each page	Max. 512
Number of controls that can be created in each frame	Max. 256. However, the maximum limit of the page (512) may not be exceeded inside the page of the frame.
Number of locales	Max. 32
Background image file	BMP, JPG, PNG or VGF file (Note)
Filling pattern	Up to 38 types can be registered.
Line pattern	Up to 8 types can be registered.

(Note): When controls that designate VGF files are any of the following, they are not displayed on screen editing windows.

- When a width exceeding 2048 pixels is designated.
- When the display start position coordinate is placed on a position that exceeds 2048.

To display the controls on screen editing windows, designate a width of 2048 pixel or less and place the display start position coordinate on the position of 2048 or less.

### 2.2.5 Precautions

#### (1) Touch panel

Take note of the following when displaying a screen created for a display unit that is touch panel compatible.

- Multi-touch is not compatible. Do not touch multiple positions at the same time.
- For M700VW/M700VS/M70V/M70/E70, if two or more positions are touched, the middle point of those is detected.
- For M800VW/M800VS/M80VW/M80V/M800W/M800S/M80W/M80/E80, if two positions are touched, the first position is detected. If three or more positions are touched, no position is detected.

#### (2) Colors on displays

Depending on the specifications of the display, the display color (RGB) set in NC Designer2 may be rounded to an approximate value when being displayed.

#### (3) Windows setting

- When "Make text bigger" (\*1) is changed in the Windows settings during the NC Designer2 operation, restart NC Designer2. If NC Designer2 is used without restart, the screen layout may be broken.

(\*1) "Make text bigger" can be changed on "Settings" - "Ease of Access" - "Display" of Windows10.

## 2.3 Menu List

A list of pull-down menus of NC Designer2 and the usage of each item are described below.

### 2.3.1 File

Item	Function
New Project	Create a new project/copy data.
Open Project	Open an existing project.
Save Project	Overwrite the project being edited.
Save Project As	Save the project being edited, under a new name.
New Panel	Add a new panel to the project being edited.
New Window	Add a new window to the project being edited.
Open Panel/Window	Open the panel/window of the project being edited.
Close Panel/Window	Close the panel/window being edited.
Import Panel/Window	Copy the panel/window of another project to the project being edited.
Save Panel/Window	Save the panel/window being edited.
Save All	Overwrite all the project data being edited.
Source code generation	Convert the created data into source code of various formats.
Project convert	Convert the created data into an interpreter method file. Convert the projects being edited into the ND2 form.
Document generation	Output project and window data into a file (rich text format).
Custom screen configuration	Create a setting file to display the customized screen on an NC display.
Recent Projects	Read and display up to four recently edited projects.
Write to the memory card	Generate the custom data, setting files, etc. in each installer format configuration.
Exit	Exit from NC Designer2.

### 2.3.2 Editing

Item	Function
Undo	Abandon changes and restore the original state.
Redo	Execute the operation canceled with "undo".
Cut	Delete the selected object and copy it in the clipboard.
Copy	Copy the selected object and copy it in the clipboard.
Paste	Paste the object from the clipboard.
Delete	Delete the selected object (without copying it in the clipboard).
Find	Search for a control or caption.
Edit of a caption	Edit the caption of each part directly on the editing screen.
Select All	Select all objects or all controls or figures of the same type on the editing page.
Continuous copy	Copy the selected object by the designated number vertically or horizontally.
Batch conversion	Convert screen designs in a batch. This function is only for M800V/M80V/M800/M80/E80 Series.

### 2.3.3 View

Item	Function
Toolbars	Select the tool bar displayed with NC Designer2.
Resource	Display or hide the resource tree.
Screen tree	Display or hide the screen tree.
Control Toolbox	Display or hide the control toolbox.
Property	Display or hide the properties sheet.
Image	Display or hide the image view.
Message	Display or hide the message window.
Statusbar	Display or hide the status bar.
Switch Locale	Switch the locale being displayed.
Previous Screen	Display the previous page.
Next Screen	Display the next page.
Previous Frame Page	Select the previous view frame.
Next Frame Page	Select the next view frame.
Zoom	Specify the zoom ratio of the page.
Refresh	Redraw the page.
Change theme color	Switch the NC control display by the theme color. This function is only for M800V/M80V/M800/M80/E80 Series.

2.3.4 Control

Item	Function
Basic object	Select to draw the basic control.
Button object	Select to draw a button.
Checkbox object	Select to draw a check box.
Edit control object	Select to draw an edit control.
HTML browser object	Select to draw an HTML browser.
Label object	Select to draw a label.
List object	Select to draw a list.
Picture object	Select to draw a picture.
Progressbar object	Select to draw a progress bar.
Radiobutton object	Select to draw a radio button.
Textbox object	Select to draw a text box.
Vertical scroll bar object	Select to draw a vertical scroll bar.
Horizontal scroll bar object	Select to draw a horizontal scroll bar.
Input box	Select to draw an input box.
Ten-key	Select to draw a ten-key.
NC data text box	Select to draw an NC data textbox.
PLC button	Select to draw a PLC button.
PLC extension button	Select to draw a PLC extension button.
PLC textbox object	Select to draw a PLC textbox.
PLC message	Select to draw a PLC message.
Page change button	Select to draw the page change button.
Stacked graph	Select to draw the stacked graph.
Statistics graph	Select to draw the statistics graph.
Table object	Select to draw a table.
Counter	Select to draw a counter display part.
CycleTime	Select to draw a cycle time display part.
Feedrate	Select to draw a feedrate (F) display part.
GModal M	Select to draw an M system modal display part.
GModal L	Select to draw an L system modal display part.
GModal Simple	Select to draw a simple modal display part.
LoadMeter	Select to draw a load meter display part.
Menu	Select to draw a menu part.
Extension Menu	Select to draw an extension menu part.
MSTB	Select to draw a MSTB part.
ONB	Select to draw an ONB display part.
ProgramBuffer	Select to draw a program buffer display part.
SPCommand	Select to draw a spindle (S) display part.
FileInOut	Select to draw an input/output control part.
AlarmMessage	Select to draw an alarm message display part.
Monitor	Select to draw an operation status display part.
Time	Select to draw a time display part.
Alarm list	Select to draw an alarm list part.
Meter	Select to draw a meter part.
TrendGraph	Select to draw a TrendGraph part.
Frame	Select to draw a view frame.

### 2.3.5 Figure

Item	Outline
Rectangle	Select to draw a rectangle.
Circle&Oval	Select to draw a circle or ellipse.
Straight Line	Select to draw a line.
Poryline	Select to draw a continuous line.
Polygon	Select to draw a polygon.
Sector	Select to draw a sector.
Arc	Select to draw an arc.

### 2.3.6 Setting

Item	Function
Project Properties	Enter the project property settings.
Panel/Window Properties	Enter the panel/window property settings.
Focus setup	Enter the focus destination setting.
Panel macro edit	Edit the macro used in the screen.
Project macro edit	Edit the macro used in the project.

### 2.3.7 Layout

Item	Function
Align/Distribution	Change the alignment or arrangement of selected multiple objects.
Make Same Size	Resize the horizontal or vertical width of selected multiple objects to the smallest or largest object size.
Order	Display the selected object at the far front or far back position.
Nudge	Move the selected object left, right, up or down by a dot or grid.
Rotate/Flip	Rotate the object or create a mirror image of it.
Modify	Deform the polygon or arc.
Group	Group multiple objects. Or cancel a group.
Grid	Enter the grid setting.



**2.3.8 Tool**

<b>Item</b>	<b>Function</b>
Screen Maintenance	Copy or delete the screen.
Error check	Perform an error check of the created data.
Memory Usage Check	Checks if the memory used by all pages and resources of the project being edited, and the total size of the files stored in the desired folders and the files output by interpreter method do not exceed the upper limit of the actual machine. This function is only for M800V/M80V/M800/M80/E80 Series.
Functional Object List	Display a list of controls and jump to the selected control.
Export of a character sequence resource	Export the character string resource in a CSV file.
Import of a character sequence resource	Import the character string in a CSV file into the character string resource.
Test	Perform an action test of the screen.
Open at NC Trainer2 plus	Perform an action test with NC Trainer2 plus.
Options	Customize NC Designer2 operations or specified values.
Resource management	Delete the unnecessary resources being used in a project in a batch.

**2.3.9 Window**

<b>Item</b>	<b>Function</b>
Cascade	Overlap screen editing windows.
Tile	Arrange screen editing windows like tiles.
Arrange Icons	Arrange minimized window icons.

**2.3.10 Help**

<b>Item</b>	<b>Function</b>
About NC Designer2	Display the version of the product.

### 2.4 Flow of Development Using NC Designer2

The flow of GUI development using NC Designer2 is shown below.

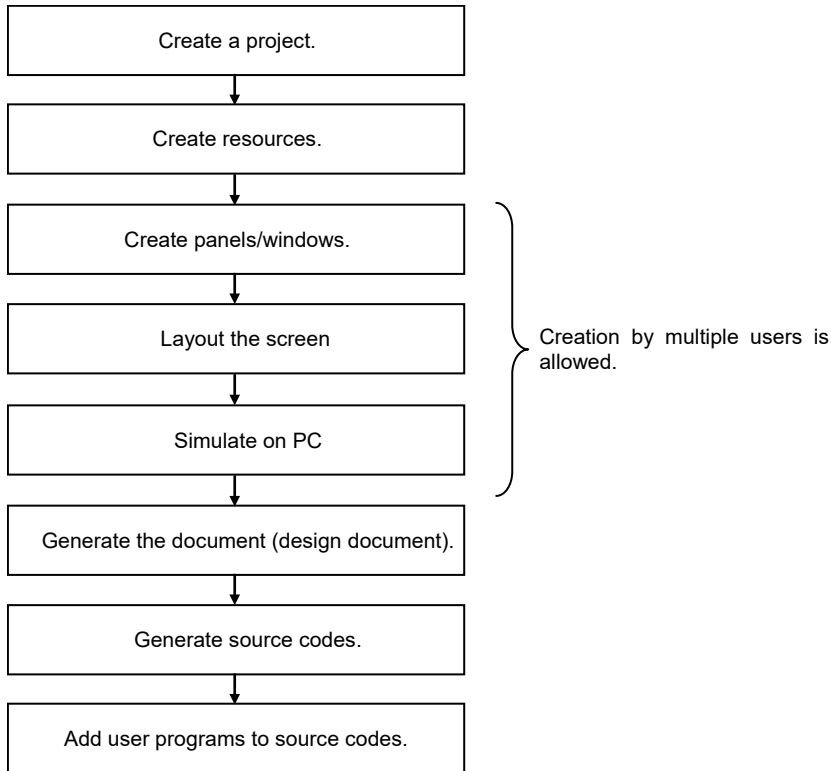

Resources such as the character strings and image data are controlled by a single user because they are common project data. Create the character string of each control and the window title character string in advance as resources. After creating resources, each screen layout can be arranged by multiple users.

After source codes are generated, add the user-specific program to the source code and perform application development.

## 3. Startup and Termination of NC Designer2

The startup and termination methods of NC Designer2 are described in this section. Refer to "3.4 Installing NC Designer2" for how to install NC Designer2.

### 3.1 Starting NC Designer2

To launch NC Designer2, select the start button of Windows, followed by "Programs", → "MELSOFT application", → "NC Designer2" and "NC Designer2". (The displayed names may vary according to the "program folder" designated during installation.)

After NC Designer2 is launched, the main window is displayed. Selected dialogues of the project are displayed according to the setting.

### 3.2 Exiting From NC Designer2

Perform one of the following procedures to exit from NC Designer2.

- Select [Exit] from the [File] menu.
- Click on the  button at the upper right of the main window.
- Double click on the NC Designer2 icon at the upper left of the main window.
- Click on the NC Designer2 icon at the upper left of the main window and select [Close] from the displayed control menu box
- While holding down the [Alt] key, press the [F4] key.

If the open project data has not been saved, a confirmation message is displayed.

### 3.3 User Interface

#### 3.3.1 Function of Each Part of Basic Screen

The configuration of the operation screen of NC Designer2 and the name of each part are described in the following.

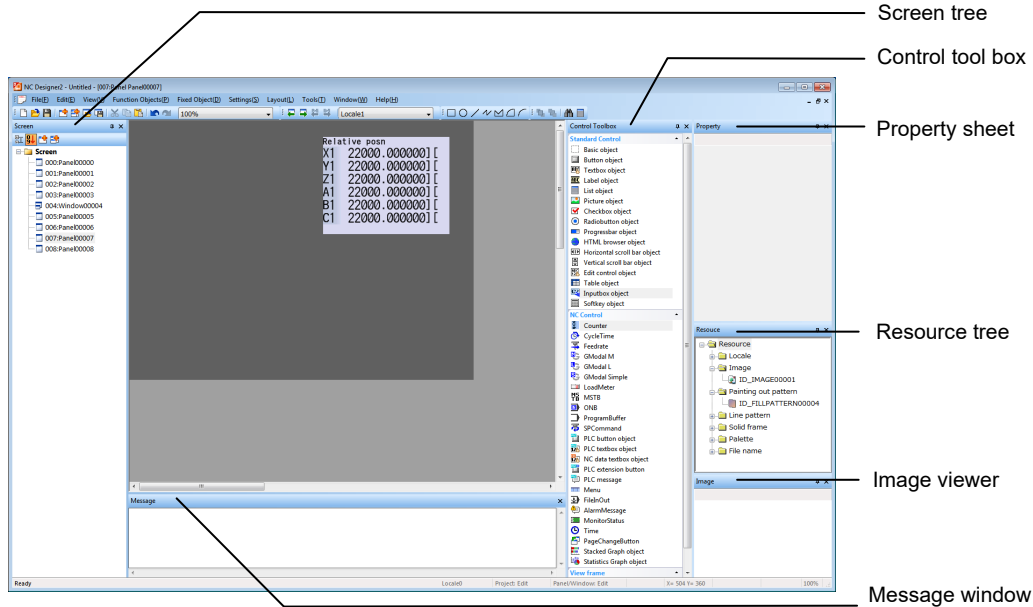

#### Status Bar

The position of the cursor and descriptions about the selected function or control are displayed.

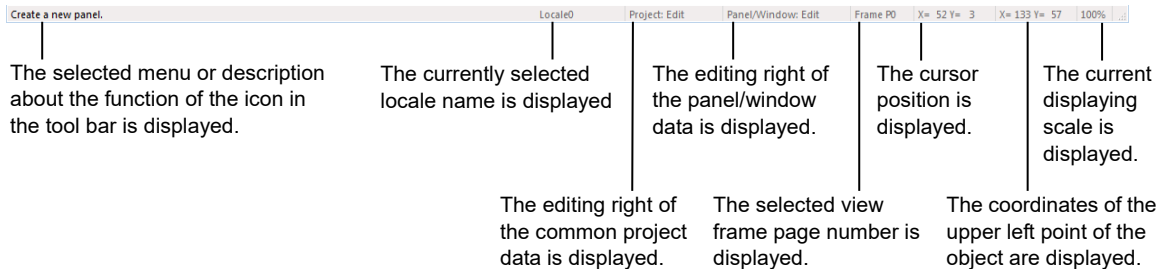

### 3.4 Installing NC Designer2

Double-click NC Designer2.exe to install NC Designer2. Follow the explanations.

(Note 1) If an old version of NC Designer has already been installed, the software will be updated to NC Designer2.

## 4. Creating a Project

Basic operations about the project where various pieces of created data are stored are described in this section.

### 4.1 Creating a New Project

The procedure from creation of a new project to editing of the screen is described.

1. Select [New Project] from the [File] menu or select the [New Project] button in the tool bar.
2. The New Project wizard is displayed. Follow the instructions in the wizard to enter settings about the project.

Project setting NC type selection

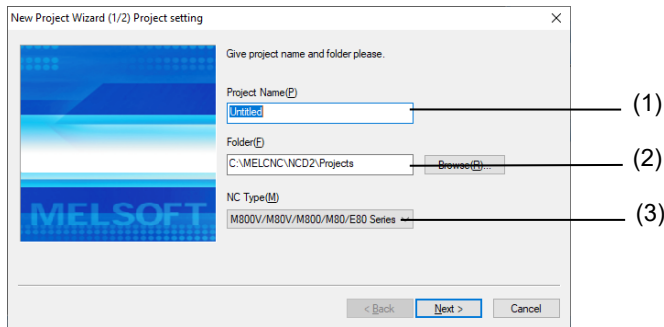

No.	Item	Description
(1)	Project Name	Enter the project name.
(2)	Folder	Designate the folder where the project is stored with a full path.
(3)	NC Type	Select an NC type.

#### NOTE

- ◆ In the compilation method, the following project names cannot be used.
    - The same name as the panel/window name
    - "SampleScreen"
    - The combination of the panel/window name and the view frame name is same as the project name.
- Example
- Project name: TestMonitor
  - Panel/window name: Test
  - View frame name: Monitor

4. Creating a Project

Project property setting

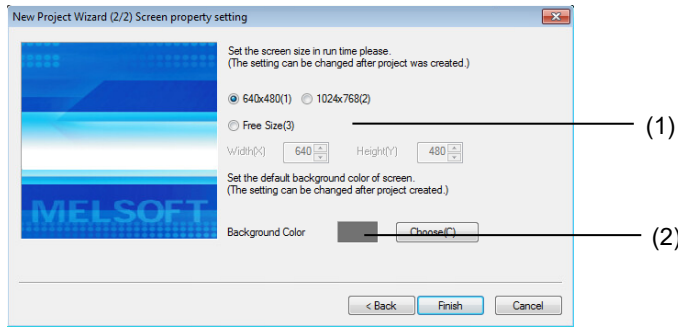

No.	Item	Description
(1)	Page size	Select the default screen size of the page.
(2)	Background Color	Designate the default background color of the page. Click on the Select button and select the desired color in the displayed [Color] dialog box.

3. Click on the [Finish] button to create the project.

**NOTE**

- ◆ After a project is created, the panel of page 0 is automatically created.
- ◆ If a new project is created while another project is being edited, a message urging to save the currently edited project is displayed.
- ◆ Settings related to the screen size and display scale are stored in the CONFIG.INI file, that is in a same folder with melhi.exe.

To modify the screen size or the display magnification, adjust the values in the [SCREEN].

```
[SCREEN]
WIDTH = 640
HEIGHT = 480
SCALE = 100
```

### 4.2 Entering Project Properties

Enter the properties of the project being edited.

1. Select [Project Properties] from the [Setting] menu.
2. Project properties are displayed in the property sheet.
3. Enter each item.

Enter the following items.

Item	Description
Project Title	Enter a comment about the project.
System font	Select the resource ID of the character font displayed in the title bar of the window.
Title bar active color	Specify the color of the title bar of the active window.
Title bar inactive color	Specify the color of the title bar of the inactive window.
System background color	Specify the background color of the button displayed in the title bar of the window.
System foreground color	Specify the foreground color of the button displayed in the title bar of the window.
Window frame	Select the shape of the window frame from the solid frame resource ID.
Unicode Correspondence	Select "Yes" for Unicode character code of each locale.
Execution start screen No.	Specify the page number of the panel displayed first.
Default background color of a screen	Specify the default background color of the panel and window.
Screen width	Designate the screen width in dots (1 to 2560).
Screen height	Designate the screen height in dots (1 to 1920).
Display magnification	Designate the display scale of the application in percent (25 to 800).

The setting is confirmed when it is entered.

The system font and color settings are reflected as shown below.

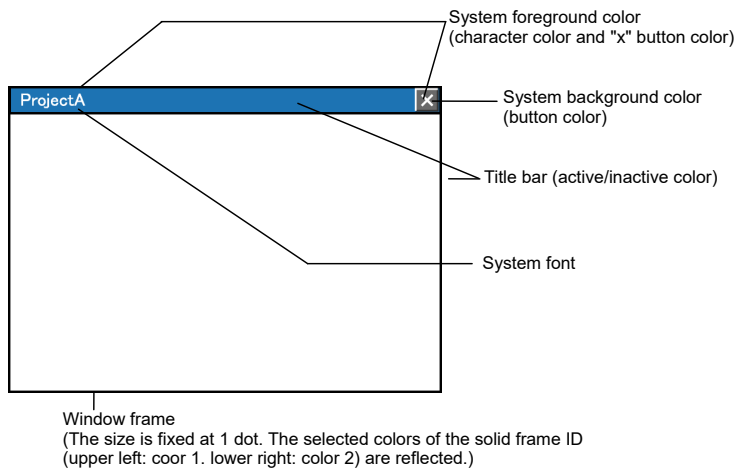

**NOTE**

- ◆ The user who has opened the project to "Edit" common project data can change the project properties.

### 4.3 Saving the Project

The method for saving the project file is described.

1. Select [Save Project] from the [File] menu or select the [Save Project] button in the tool bar.

**NOTE**

- ◆ If the edited project has not been saved, an overwrite confirmation dialog box is displayed when the project is closed.

### 4.4 Saving the Project as ...

Save the project being edited under another file name or at another location.

1. Select [Save Project as ...] from the [File] menu.
2. The [Save Project as] dialog box is displayed.

Designate the destination directory and file name and click on the [Save] button.

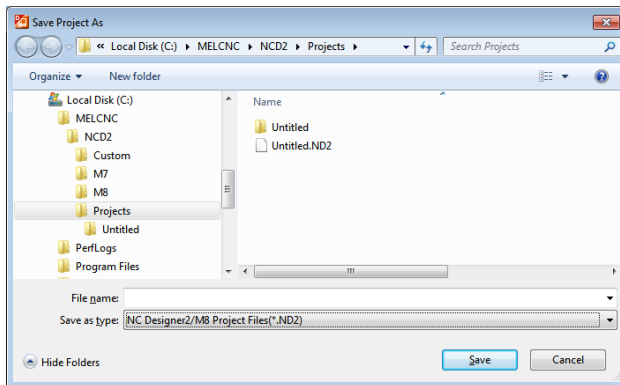

**NOTE**

- ◆ If the project is saved under a new name, all the currently opened files are copied to the directory of the new project.
  - ◆ In the compilation method, the following project names cannot be used.
    - The same name as the panel/window name.
    - "SampleScreen"
    - The combination of the panel/window name and the view frame name is same as the project name.
- Example
- Project name: TestMonitor
  - Panel/window name: Test
  - View frame name: Monitor



## 4.5 Opening a Project

Open an existing project.

1. Select [Open Project] from the [File] menu or select the [Open Project] button in the tool bar.
2. The Open Project dialog box is displayed.

Select a project file (extension: ND2, IPP) and click on the [Open] button.

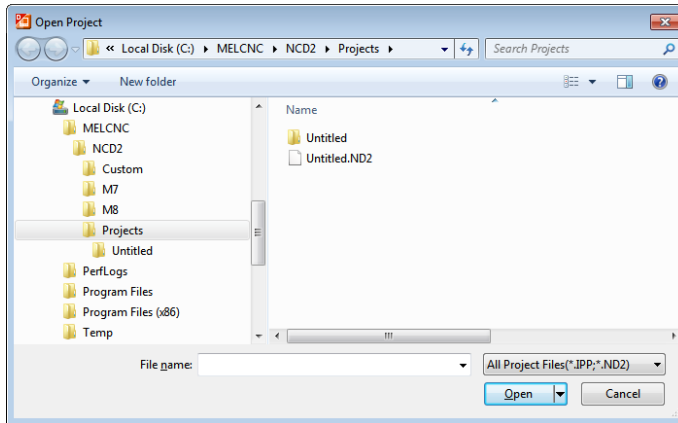

## 4.6 Opening a Recently Used Project

Up to four most recent projects can be opened directly.

1. Select [Recent Projects] from the [File] menu.
2. The recently used projects are displayed with directory.  
Select the desired project.

## 4.7 Template Function

### 4.7.1 Outline

The template function makes screen creation more efficient by allowing the copying of a template project when creating a new project.

The screen image of the template project is displayed on the copy data (project) dialog to make selecting the optimal project easy.

This function is only for M800V/M80V/M800/M80/E80 Series.

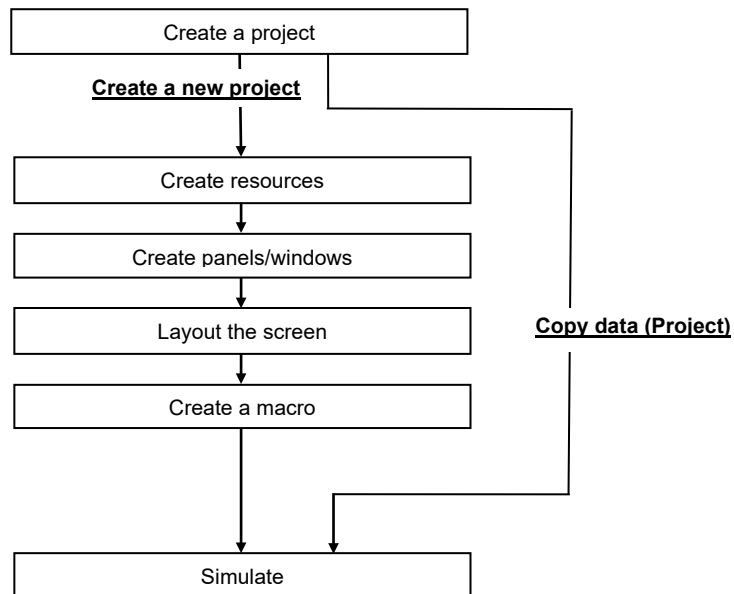

4.7.2 Dialog specifications

On the copy data (project) dialog, the details of the template projects are displayed to help selecting the template project. A new project using the selected template can be created by designating the destination folder to store the project and the project name.

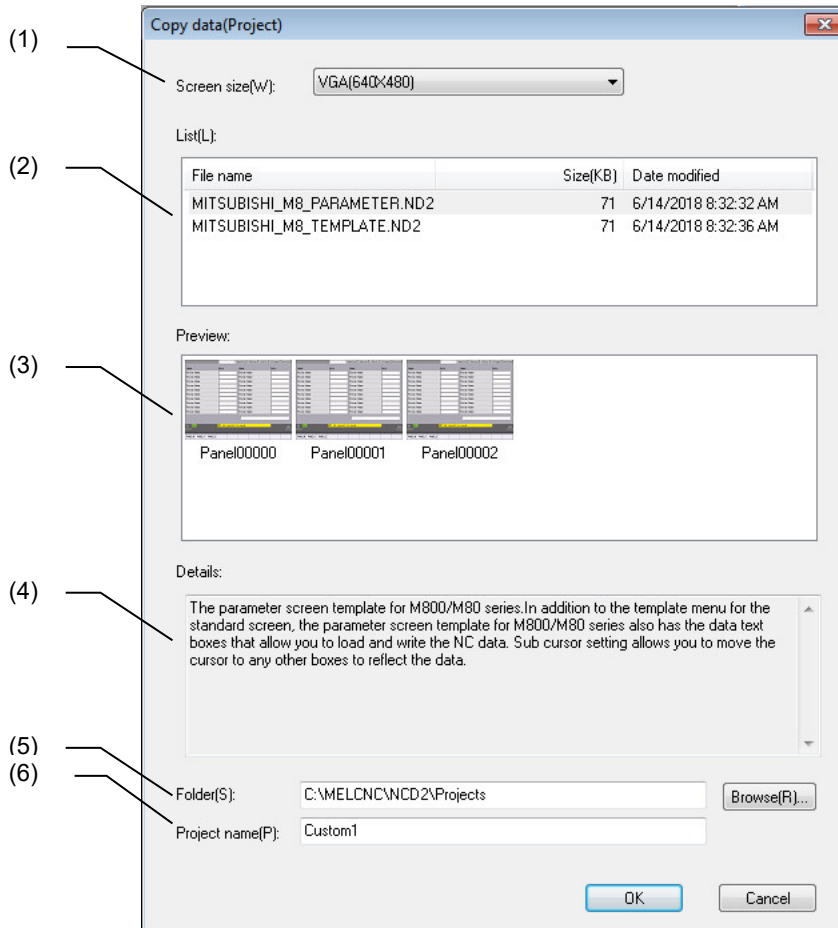

The following items are displayed in this dialog box.

No.	Item	Description
(1)	Screen size	Select the screen size of the template project. The projects with the selected screen size are displayed on the list.
(2)	List	Display the list of the template projects. Display the file name, data size and the date modified.
(3)	Preview	Display the images of the panels/windows set in the template project that is selected on the [List].
(4)	Details	Display the details of the template project that is selected on the [List]
(5)	Folder	Designate the full path of the destination folder for storing the project. The copy data project is saved to the designated path.
(6)	Project name	Specify the project name. (Up to 31 letters)

**NOTE**

◆ An interpreter method macro file and a compilation method source file are imported with the project.

4.7.3 Operation Specifications

Project Select Dialog

1. Start up NC Designer2.
2. The project select dialog box is displayed. (Note)

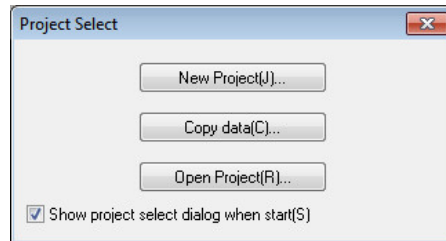

3. Press the [Copy data] button to display the copy data (project) dialog box.

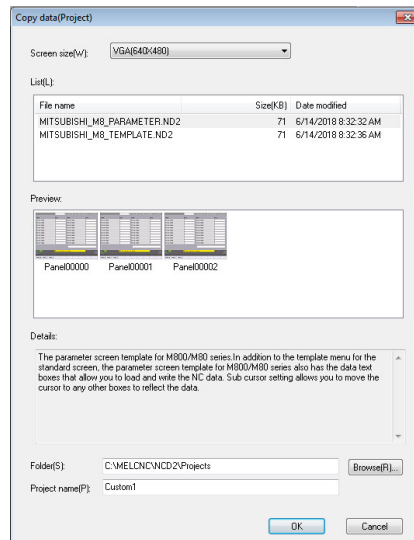

4. After the setting, press the [OK] button.
5. A project is created in the designated folder.

(Note) Project select dialog is displayed only when "Show project select dialog when start" on the option dialog box is checked.

## 4. Creating a Project

## File menu [Copy data (Project)]

1. Start up NC Designer2.
2. Select [New Project]-[Copy data (Project)] from the [File] menu.
3. [Copy data (Project)] dialog box is displayed.

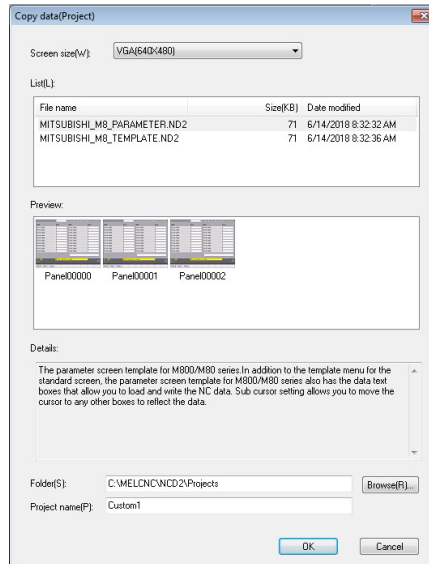

4. After the setting, press the [OK] button.
5. A project is created in the designated folder.

## 5. Creating and Saving the Page

In this section, the page (screen) that can be displayed on the target board and the basic operations available in each page are described.

### 5.1 What Is Page?

The "page" indicates a screen displayed with NC Designer2.

The page includes the following two types.

Item	Description
Panel	Screen displayed in full size on the screen.
Window	Screen displayed in a window state on the screen.

### 5.2 Creating a New Panel

To create a new panel in a project being edited, perform one of the following operations.

- Select [New Panel] from the [File] menu.
- Click [New Panel] button in the tool bar.
- Select [New Panel] in popup menu which is displayed by right-click on the screen tree.
- Click [New Panel] button of the screen tree.

#### **NOTE**

- ◆ After a new panel is created, the smallest page number among unused page numbers is automatically assigned to the new panel.

### 5.3 Creating a New Window

To create a new panel in a project being edited, perform one of the following operations.

- Select [New Window] from the [File] menu.
- Click [New Window] button in the tool bar.
- Select [New Window] in popup menu which is displayed by right-click on the screen tree.
- Click [New Window] button of the screen tree.

#### **NOTE**

- ◆ After a new window is created, the smallest page number among unused page numbers is automatically assigned to the new window.

### 5.4 Entering Panel Properties

Enter the properties of the panel being edited.

1. To view panel properties, perform one of the following operations.

- Select [Panel/Window Properties] from the [Setting] menu.
- Select [Panel/Window Properties] from the popup menu which is displayed by right-click on the panel.
- Select the panel name of the panel that is open on the screen tree.
- Select [Panel/Window Properties] from the popup menu which is displayed by right-click on the panel being edited of the screen tree.

2. Enter each item.

The setting items include the followings.

Item	Description
Panel Title	Enter a one-byte character string to specify the panel title (up to 31 characters). The first character must be a one-byte letter (A to Z or a to z). The second and later characters must be one-byte letters, numbers or underscores (_).
WIDTH	Specify the panel width in dots (1 to 2560).
HEIGHT	Specify the panel height in dots (1 to 1920).
Background Color	Specify the background color.
Background File	Select "Yes" to use the background, or select "No" to refrain from using it.
Background Image	Select the ID of the image resource used for the background. Use the resource tree to register the image resource.
Blink off time	Enter the OFF interval (regular display) of the control blink in ms (100 to 60000).
Blink on time	Enter the ON interval of the control blink in ms (100 to 60000).

The setting is confirmed when entry is finished.

**NOTE**

- ◆ For the blink, refer to "Blink" in Section 7.1 "Common Control Functions".
- ◆ In the compilation method, the following panel names cannot be used.
  - The same name as the project name
  - The same name as the window name
  - "SampleScreen"
  - The combination of the view frame name and the panel name is "SampleScreen".
  - The combination of the view frame name and the panel name is same as the project name.

Example

- Project name: TestMonitor
- Panel name: Test
- View frame name: Monitor

### 5.5 Entering Window Properties

Enter the properties of the window being edited.

1. To view panel properties, perform one of the following operations.

- Select [Panel/Window Properties] from the [Setting] menu.
- Select [Panel/Window Properties] from the popup menu which is displayed by right-click on the window.
- Select the window name of the window that is open on the screen tree.
- Select [Panel/Window Properties] from the popup menu which is displayed by right-click on the panel being edited of the screen tree.

2. Enter each item.

The following items can be entered.

Item	Description
Window Name	Specify the window name (up to 31 characters). The first character must be a one-byte letter (A to Z or a to z). The second and later characters must be one-byte letters, numbers or underscores (_).
X	Specify the X coordinate of the upper left corner of the window in dots (0 to 2559).
Y	Specify the Y coordinate of the upper left corner of the window in dots (0 to 1919).
WIDTH	Specify the panel width in dots (1 to 2560).
HEIGHT	Specify the panel height in dots (1 to 1920).
Background Color	Specify the background color.
Background File	Select "Yes" to use the background image, or select "None" to refrain from using it.
Background Image	Select the ID of the image resource used as a background image. Use the resource tree to register the image resource.
Title	Select the character string displayed in the title bar of the window from the character string resource, or enter a new one.
Existence of a title bar	Select "Yes" to display the window with a title bar, or select "None" to display it without a title bar.
Existence of a close button	Select "Yes" to display a close button in the title bar of the window, or select "None" to refrain from displaying the close button.
Existence of a window frame	Select "Yes" to display the window with the window frame, or select "None" to display the window without the window frame.
Blink off time	Specify the OFF interval (regular display) of the blink of the control in ms (100 to 60000).
Blink on time	Specify the ON interval of the blink of the control in ms (100 to 60000).

The setting is confirmed when entry is finished.

**NOTE**

- ◆ For the blink, refer to "Blink" in Section 7.1 "Common Control Functions".
  - ◆ In the compilation method, the following project names cannot be used.
    - The same name as the project name
    - The same name as the window name
    - "SampleScreen"
    - The combination of the view frame name and the panel name is "SampleScreen".
    - The combination of the view frame name and the panel name is same as the project name.
- Example
- Project name: TestMonitor
  - Panel name: Test
  - View frame name: Monitor
- ◆ The window size includes the title bar size.



## 5.6 Saving the Panel/Window

To save the panel/window being edited, perform one of the following operations.

- Select [Save Panel/Window] from the [File] menu.
- Click the [Save Panel/Window] button on the tool bar.
- Select [Save Panel/Window] from the popup menu which is displayed by right-click on the screen tree.

### **NOTE**

- ◆ The shortcut key for [Save Panel/Window] is [Ctrl] + [S].
- ◆ If the panel/window being edited has not been saved, a confirmation dialog box is displayed when the panel/window is closed. To save, click on the [Yes] button.

## 5.7 Save All

The entire project is saved.

After this procedure, not only the opened page but also the entire project is saved.

1. Select [Save All] from the [File] menu.
2. After the project is saved, a message dialog box is displayed.  
Click on the [OK] button.

### **NOTE**

- ◆ Saving the entire project causes a change in the common project data. Only the user holding the right of editing the common project data can execute the function.

### 5.8 Opening a Panel/Window

To open the panel/window of the current open project, perform one of the following operations.

- Select [Open Panel/Window] from the dialogue.
- Double-click the existing panel/window on the screen tree.
- Select [Open] from the popup menu which is displayed by right-click on the screen tree.

1. Select [Open Panel/Window] from the [File] menu, or select the [Open Panel/Window] button in the tool bar, to display [Open Panel/Window].
2. Select the desired screen and click on the [OK] button.

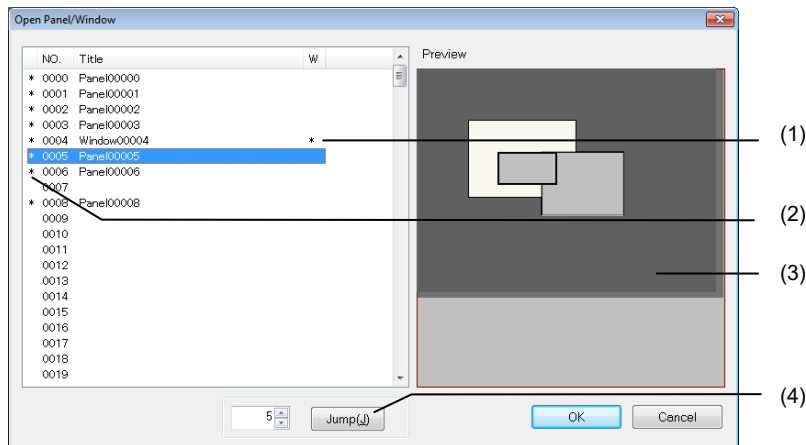

No.	Item	Description
(1)	Window	The window is marked with an asterisk (*).
(2)	Operation state	The page being used is marked with an asterisk (*).
(3)	Preview	A preview of the selected page is displayed.
(4)	Jump	Designate the page number and click on the [Jump] button to jump to the designated page.

3. The selected screen is displayed.

**NOTE**

- ◆ The shortcut key for [Open Panel/Window] is [Ctrl] + [0].
- ◆ If a page with an unused page number is opened, a new panel is created.
- ◆ The number of pages that can be edited simultaneously is 16.

### 5.9 Closing the Panel/Window

To close the open panel /window, perform one of the following operations.

- Select [Close Panel/Window] from the [File] menu.
- Click mark in the top right of the page.
- Select [Close] from the popup menu which is displayed by right-click on the screen tree.

## 5.10 Switching the Editing Window

The method for switching the editing window is described.

### 5.10.1 Previous Screen

The editing window of the previous page number is displayed.

1. Select [Previous Screen] from the [View] menu or select the [Previous Screen] button in the tool bar.

#### **NOTE**

- ◆ The editing window is the screen area created in the editing page (panel or window) units.
- ◆ If there is no panel or editing window one the page earlier than the currently opened panel or window, this function may not be used.
- ◆ An error is caused if a new screen is opened beyond the limit in the number of editing pages.

### 5.10.2 Next Screen

The screen of the next screen page number is displayed.

1. Select [Next Screen] in the [View] menu or select [Next Screen] button in the tool bar.

#### **NOTE**

- ◆ If there is no panel or editing window for the page numbers later than the currently opened panel or window, this function may not be used.
- ◆ An error is caused if a new screen is opened beyond the limit in the number of editing pages.

### 5.10.3 Cascade

The active window is brought to the front.

1. Select [Cascade] from the [Window] menu.

### 5.10.4 Tile

Open page windows are displayed in tiles.

1. Select [Tile] from the [Window] menu.

### 5.10.5 Arrange Icons

Minimized page windows are arranged neatly.

Minimized page windows are arranged from left to right below the application window.

1. Select [Arrange Icons] from the [Window] menu.

**NOTE**

◆ This function may not be used if there is no minimized page window.

### 5.10.6 Switching Locale

When two or more locales are registered, the locale is switched.

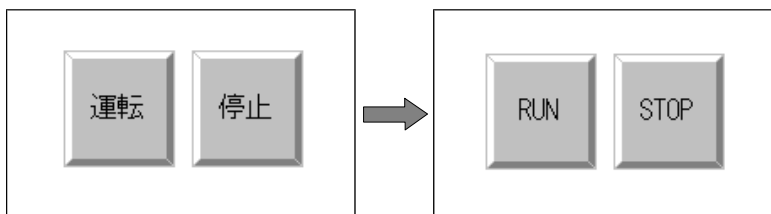

1. Select [Switch Locale] from the [View] menu or select the desired locale in the tool bar.

Or, select the desired locale in the source view, and select "Switch" from the popup menu displayed upon a click of the right mouse button.

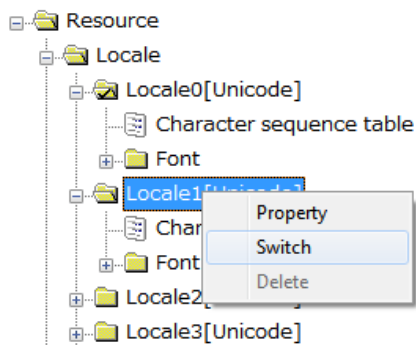

**NOTE**

◆ The currently displayed locale is marked with a check mark in the icon.

**5.10.7 Zoom**

The editing window display is enlarged or reduced.  
 The scale can be selected in the range between 25% and 800%. Or select "fit" to enlarge or reduce according to the current window size.

1. Select [Zoom] from the [View] menu.
2. The [Zoom] dialog box is displayed.

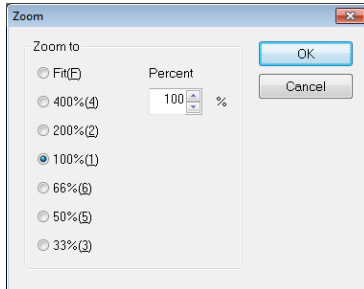

3. Select the scale and click on the [OK] button.
- If [Fit] is selected, the window width fits the width of the editing window.

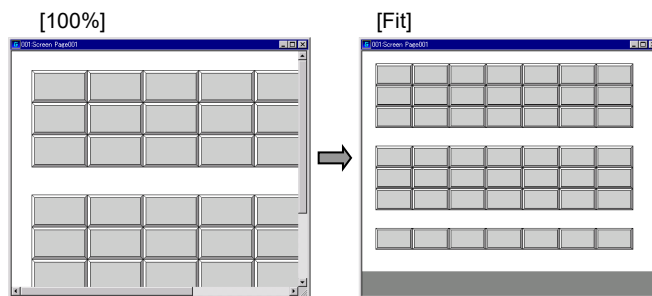

The scale automatically changes so that the window is displayed in the full screen.

**5.10.8 Refresh**

Refresh the screen to erase garbage from the screen or display the current screen again.

1. Select [Refresh] from the [View] menu.

### 5.10.9 Changing the Theme Color

The NC control located on the screen is displayed with the color pattern of the selected theme color. Gray or blue tone can be selected as a theme color.

[For M8V Series]

<Gray tone>



<Blue tone>

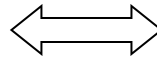

[For M8 Series]

<Gray tone>

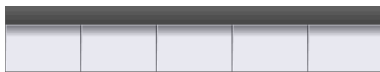

<Blue tone>

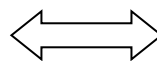
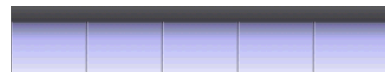

1. Select the theme color to display with the [Change theme color] from the [View] menu.

The screen is displayed with the color pattern of the selected theme color.

**NOTE**

- ◆ If opening the project for M700V/M70V/E70 series, the menu is grayed out.
- ◆ M8V Series or M8 Series can be selected in the "Theme color" property of NC control. Changing between M8V Series and M8 Series is possible by selecting [Batch conversion] from the [Edit] menu. Refer to "10.1.10 Batch Conversion" for details of [Batch conversion].
- ◆ An M8V design will only be correctly displayed with an M800V/M80V Series display. It will not be displayed correctly with an M800/M80/E80 Series display.

### 5.11 Creating View Frame

Use the view frame to switch a part of the displayed page.

The view frame consists of multiple view frame pages. Switch each view frame page according to the variable to switch the displayed image.

The following parts can be arranged in the view frame.

- Controls
- Figures

1. Select [Frame] from the [Control] menu or select the [Frame] button in the control toolbox.

2. The cursor changes to the following shape.



5. Creating and Saving the Page

3. Move the cursor to the starting point of the view frame.
4. Drag the cursor (move the mouse while holding down the left mouse button) to the end point of the display area of the view frame.

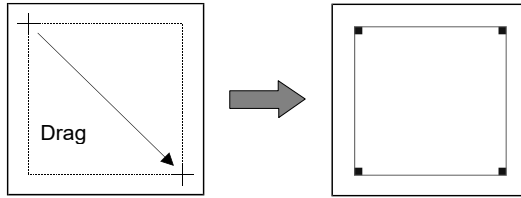

5. Select the view frame. The view frame properties are displayed.
6. Enter each item.

The setting items include the followings.

Item	Description
Frame Name	Specify the view frame name (up to 31 characters). The first character must be a one-byte letter (A to Z or a to z). The second and later characters must be one-byte letters, numbers or underscores ( _ ).
X	0 to 2559
Y	0 to 1919
WIDTH	8 to 2560
HEIGHT	8 to 1920
The number of the maximum frames	Specify the maximum number of frames.
Edit Frame	Designate the frame page No. to be edited.

The setting is confirmed when entry is finished.

**NOTE**

- ◆ The view frame may not be created in another view frame.
  - ◆ The frame of the view frame is highlighted with the reverse color of "Background color" that is specified in properties of panel or window.
  - ◆ In the compilation method, the following project names cannot be used.
    - The combination of panel/window name and the view frame name is "SampleScreen"
    - The combination of the panel/window name and the view frame name is same as the project name.
- Example
- Project name: TestMonitor
  - Panel/window name: Test
  - View frame name: Monitor

Next, the drawing method of each page of the view frame is described.

1. Double click on the view frame area.
2. The editing mode starts in the view frame.
3. Draw using the operation method similar to that of the regular page.
4. Edit other view frame pages.
5. Click on the area outside the view frame of the drawn page to return to the regular drawing mode.

### 5.11.1 Switching the View Frame

The method for switching the view frame page is described.

#### Switching to Previous or Next View Frame Page

Switch to the previous or next view frame page.

1. Select [Previous Frame] or [Next Frame] from the [View] menu or select [Previous Frame] or [Next Frame] button in the tool bar.

#### Switching to an Arbitrary View Frame Page

Display the desired view frame page.

1. Select a view frame and display view frame properties in the property sheet.
2. Designate the desired view frame page to be edited.



## 5.12 Importing a Page

The page import function enables to copy the desired page (panel/window) from another designated project to the currently editing project.

This function brings high productivity by reusing of panel/window for expanding the NC types and functions.

During the page import, the resource data, macro data and C++ source codes are imported in addition to the screen data.

The page of the project created with NC Designer2 under the different version can be also imported.

5. Creating and Saving the Page

5.12.1 Operation Screen

5.12.1.1 Page Import Dialog

The page import dialog enables to import the designated pages (panel/window) from a project of the import source location to the desired pages in the editing project. It is also possible to set whether to import the resource used in the pages.

Dialog Image

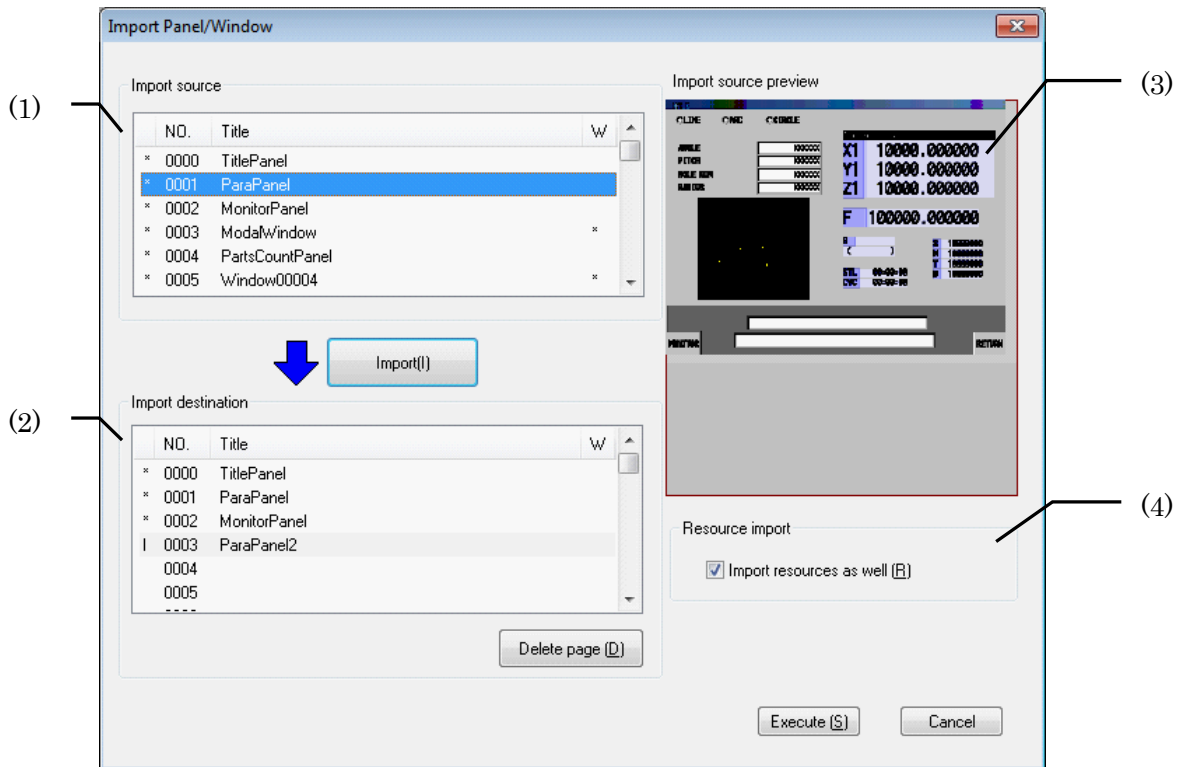

Display Item

The import dialog consists of the following items.

No.	Item	Detail
(1)	The page list of the project in the import source	Displays the page list of the project specified in the import source. "*" appears on the left side of the existing page. "*" appears on the right side of the window page.
(2)	The page list of the project in the import destination	Displays the page list of the currently edited project. "*" appears on the left side of the existing page. "I" appears on the imported page. "*" appears on the right side of the window page.
(3)	Import source preview	Previews the page selected in "The page list of the project in the import source" as in 1.
(4)	Resource import (R)	Sets whether to import the resource used in the page which has import setting.  (Note 1) When [Import resources as well] is checked, the resource is imported, and the desired resource data name can be specified. (Note 2) When [Import resources as well] is not checked, the resource is not imported, and the different control from the import source may displayed.

## Menu

The menus are displayed below.

No.	Item	Detail
(1)	Execute (S)	Saves the setting and closes the dialogue. Starts import.
(2)	Cancel	Cancels the setting and closes the dialogue.
(3)	× button	Cancels the setting and closes the dialogue.
(4)	Import (I)	Configures the import of the page specified in the import source to the page specified in the import destination. (Note 1) Pressing this button does not start import.
(5)	Delete page (D)	This is enabled when the cursor is on the page pointed by "I" in the import destination page list. The page to which import has been configured can be deleted from the project in the import destination.

**NOTE**

- ◆ Even when no pages are available in the page list of the project in the import source or the page list of the project in the import destination, the page numbers 0000 to 0255 are still displayed in the [No.] field.
- ◆ The incorrect pages in the import destination are not displayed in the page list of the project in the import source.

**5.12.1.2 Resource Data Name Conversion Table Dialog**

The [Resource Data Name Conversion Table] dialog appears when import is performed when the [Import resources as well] is checked on the page import dialog. By editing the field in [After Conversion], you can rename the resource data after conversion to your desired name.

Dialog Image

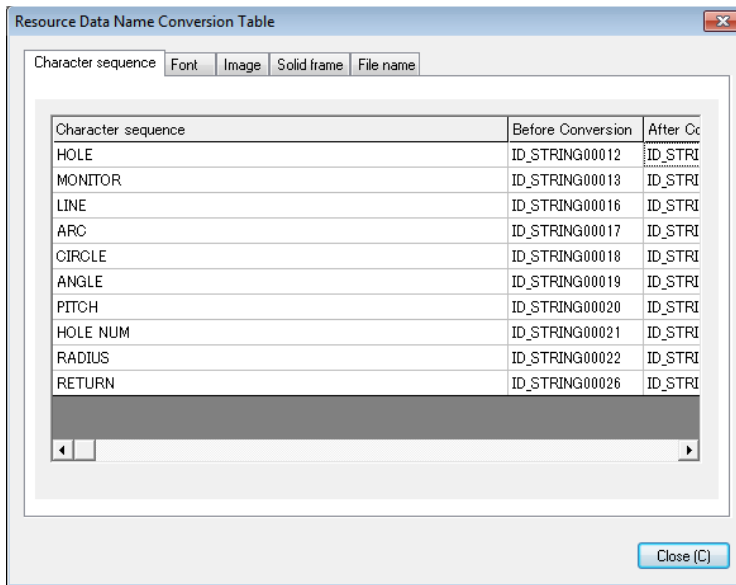

Dialog Configuration

The Resource Data Name Conversion Table dialog consists of the following tabs.

No.	Tab	Description
(1)	Character sequence	Displays a list of the character sequence resources to be imported.
(2)	Font	Displays a list of the font resources to be imported.
(3)	Image	Displays a list of the image resources to be imported.
(4)	Solid frame	Displays a list of the solid frame resources to be imported.
(5)	File name	Displays a list of the file name resources to be imported.

**NOTE**

- ◆ When multiple pages are imported, the list of all resource data to import is displayed.
- ◆ If there is no duplicated resource, even though [Import resource as well] is checked on the page import dialog, this dialog is not displayed. The [Open Panel/Window] dialog appears.

Display Item

The display items of each tab are described below.

(1) [Character sequence] tab

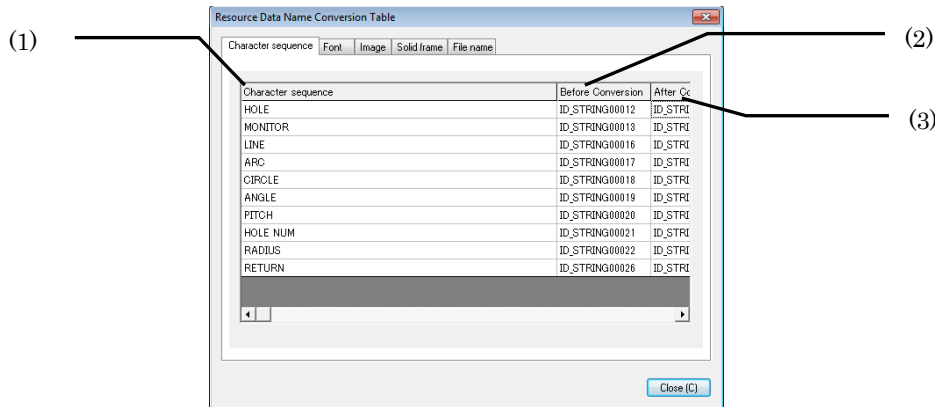

No.	Item	Description
(1)	Character sequence	Displays the character sequence of the selected locale.
(2)	Before Conversion	Displays the resource data name before the conversion
(3)	After Conversion	Displays the resource data name after the conversion.

**NOTE**

- ◆ The resource data name after the conversion is assigned from "ID\_STRINGXXXXX(XXXXX: the total registered resource number plus 1)" in sequence.
- ◆ The character sequence properties of each control which use the character sequence resource are also converted.
- ◆ Only the [After Conversion] field can be edited. Up to 32 characters can be entered as a resource data name. For the usable characters, refer to "6.4.1 Creating a New Character String Resource".
- ◆ If the same character sequence exists in the import source and import destination, it is registered with new resource data name. The character sequence and the resource data name in the import destination are maintained.
- ◆ If the number of locales in the import destination is smaller than the one in the import source, only the character sequence resource of the locales that exist in the import destination is copied. If the number of the locales in the import destination is larger than the one in the import source, the character sequence resource of Local0 is copied and imported for the insufficient locales.

5. Creating and Saving the Page

(2) [Font] tab

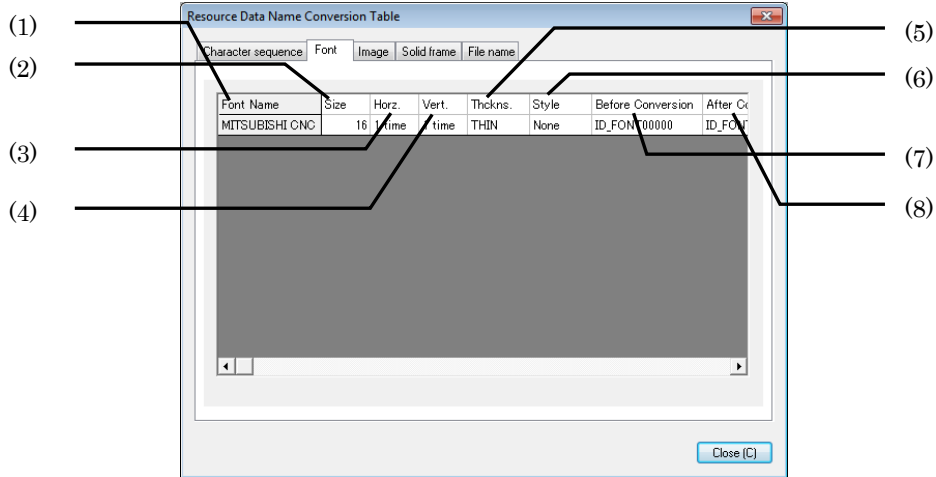

No.	Item	Description
(1)	Font Name	Displays the font name of the selected locale.
(2)	Size	Displays the font size of the selected locale.
(3)	Hoz.	Displays the horizontal zoom of the character size of the selected locale.
(4)	Vert.	Displays the vertical zoom of the character size of the selected locale.
(5)	Thckns.	Displays the character thickness of the selected locale.
(6)	Style	Displays the font style of the selected locale.
(7)	Before Conversion	Displays the resource data before conversion.
(8)	After Conversion	Displays the resource data after conversion.

**NOTE**

- ◆ The resource data name after the conversion is assigned from "ID\_FONTXXXXX(XXXXX: the total registered resource number plus 1)" in sequence.
- ◆ The font properties of each control which use the font resource are also converted.
- ◆ Only the [After Conversion] field can be edited. Up to 32 characters can be entered as a resource data name. For the usable characters, refer to "6.5.3 Specifying Font Resource".
- ◆ If the font resources of the same settings exist in the import source and the import destination, the font resource is not additionally registered. The information of the font resource which was not imported is saved in a log file.
- ◆ If the number of locales in the import destination is smaller than the one in the import source, only the character sequence resource of the locales that exist in the import destination is copied. If the number of the locales in the import destination is larger than the one in the import source, the character sequence resource of Local0 is copied and imported for the insufficient locales.
- ◆ When the font file which does not exist in the import destination (the file saved in the "C:\WINDOWS\Fonts" directory) is imported, the default font name of the import destination is displayed in the resource data name conversion table. The font file is not imported, therefore the dialog that appears after import may be different from the import source.

(3) [Image] tab

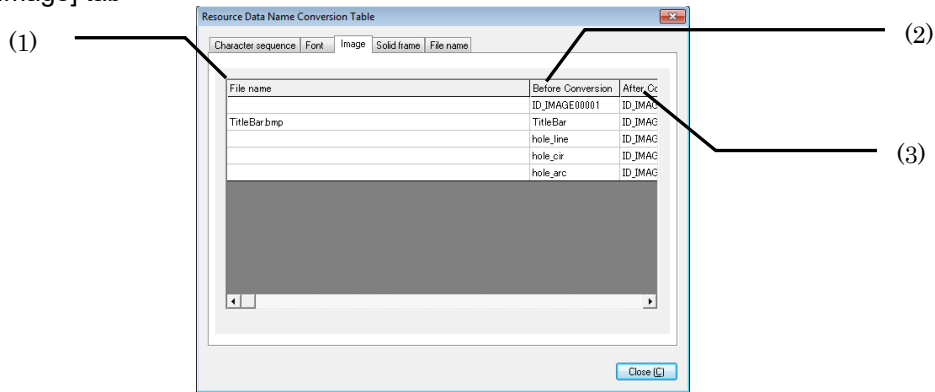

No.	Item	Description
(1)	File name	Displays the file name.
(2)	Before Conversion	Displays the resource data name before the conversion.
(3)	After Conversion	Displays the resource data name after the conversion.

**NOTE**

- ◆ The resource data name after the conversion is assigned from "ID\_IMAGEXXXXX(XXXXX: the total registered resource number plus 1)" in sequence.
- ◆ When import is executed, the file is also imported to the project folder.
- ◆ The image properties of each control which use the image resource are also converted.
- ◆ Only the [After Conversion] field can be edited. Up to 32 characters can be entered as a resource data name. For the usable characters, refer to "6.6.3 Specifying an Image File".
- ◆ If the same image exists in the import source and the import destination, it is registered with new resource data name. The image and the resource data name in the import destination are maintained.
- ◆ When the file does not exist in the import source, the empty file name is displayed but the file is not imported. The information of the image resource which was not imported is saved in a log file.

(4) [Solid frame] tab

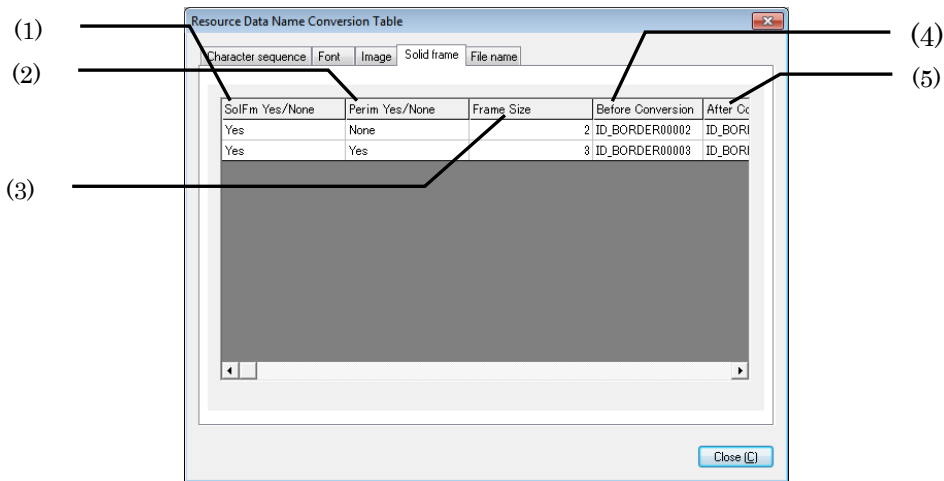

No.	Item	Description
(1)	SolFm Yes/None	Displays existence of a solid frame.
(2)	Perim Yes/None	Displays existence of a Perimeter line
(3)	Frame Size	Displays the frame size.
(4)	Before Conversion	Displays the resource name before conversion.
(5)	After Conversion	Displays the resource name after conversion.

**NOTE**

- ◆ The resource data name after the conversion is assigned from "ID\_BORDERXXXXX(XXXXX: the total registered resource number plus 1)" in sequence.
- ◆ The solid frame properties of each control which use the solid frame resource are also converted.
- ◆ Only the [After Conversion] field can be edited. Up to 32 characters can be entered as a resource data name. For the usable characters, refer to "6.7.3 Specifying a Solid Frame File".
- ◆ If the same solid frame exists in the import source and the import destination, it is registered with new resource data name. The solid frame and the resource data name in the import destination are maintained.



(5) [File name] tab

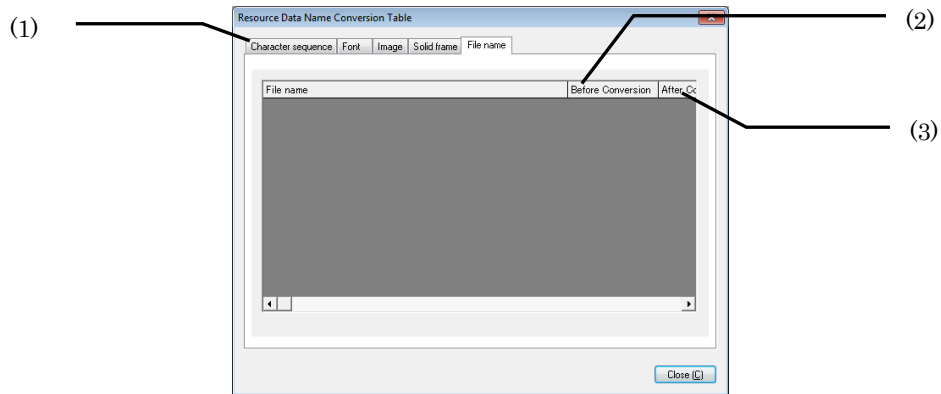

No.	Item	Description
(1)	File name	Displays the file name.
(2)	Before Conversion	Displays the resource data name before conversion.
(3)	After Conversion	Displays the resource data name after conversion.

**NOTE**

- ◆ The resource data name after the conversion is assigned from "ID\_FILEXXXXX(XXXXXX: the total registered resource number plus 1)" in sequence.
- ◆ When import is executed, the file is also imported to the project folder
- ◆ The file name properties of each control which use the file name resource are also converted.
- ◆ Only the [After Conversion] field can be edited. Up to 32 characters can be entered as a resource data name. For the usable characters, refer to "6.10.3 Specifying the File Name Resource".
- ◆ Only the [After Conversion] field can be edited. Up to 32 characters can be entered as a resource data name. For the usable characters, refer to "6.7.3 Specifying a Solid Frame File".
- ◆ If the same solid frame exists in the import source and the import destination, it is registered with new resource data name. The solid frame and the resource data name in the import destination are maintained.
- ◆ When the file does not exist in the import source, the empty file name is displayed but the file is not imported. The information of the image resource which was not imported is saved in a log file.

5. Creating and Saving the Page

5.12.1.3 Message Log

The conversion state of the resource is output to a message log file.

Log File Output Image

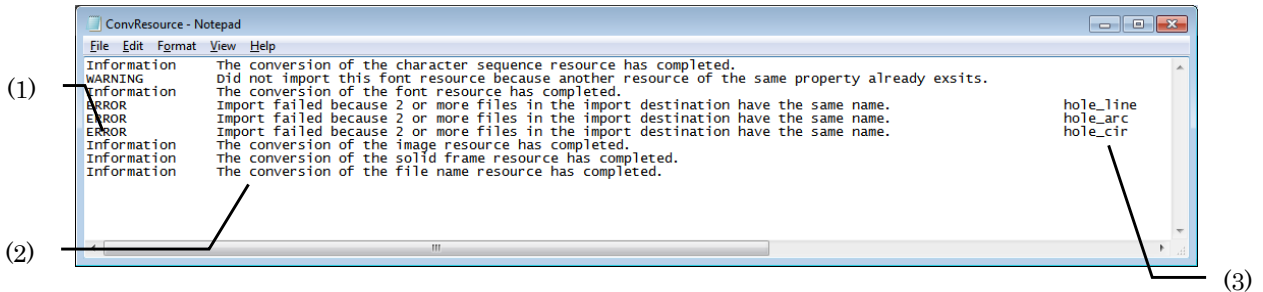

Output Item

A log file is output in the following composition

No.	Item	Description
(1)	Message type	Displays the type of the message. The following three types are mainly used. Information: Each resource has converted WARNING:Not imported ERROR:Unable to import
(2)	Message	Displays messages.
(3)	Resource data name	Displays a resource data name.

Message List

The list of the messages to be output to a log file is described below.

Message
XXX Resource conversion has completed.
XXX:A character sequence, font, image, solid frame or file name.
Did not import this font resource because another resource of the same property already exists.
Import failed because the specified file does not exist in the import source.
Import failed because 2 or more files in the import destination have the same name.

**NOTE**

- ◆ The log file (ConvResource.log) is saved in the folder at the same layer as the project information file (ND2file).
- ◆ When the log file is in the following states, it is unable to write to the file.
  - (1) The file is read-only.
  - (2) Free disk space is insufficient.
  - (3) The project was read from the network area and the file network connection was cut.
- ◆ Pressing the [Close] button on the resource name conversion dialog will display the resource conversion result on a message window.

**5.12.2 Flow of Import Operation**

1. Select [Import Panel/Window] from the [File] menu, or [Page Import] from the popup menu which is displayed by right-click on the screen tree.
2. Specify the project in which contains the page to import, press the [Open] button.

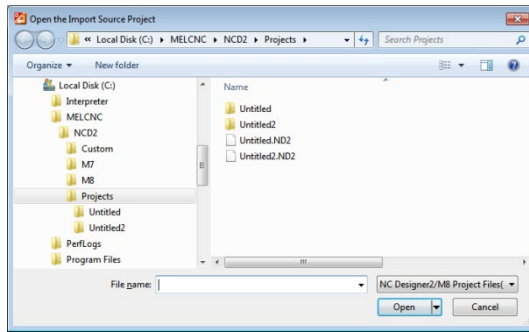

3. The [Import Panel/Window] screen appears.

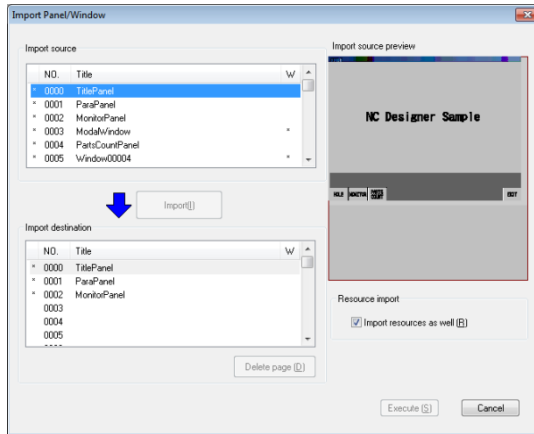

5. Creating and Saving the Page

4. After the setting, press the [Execute] button.

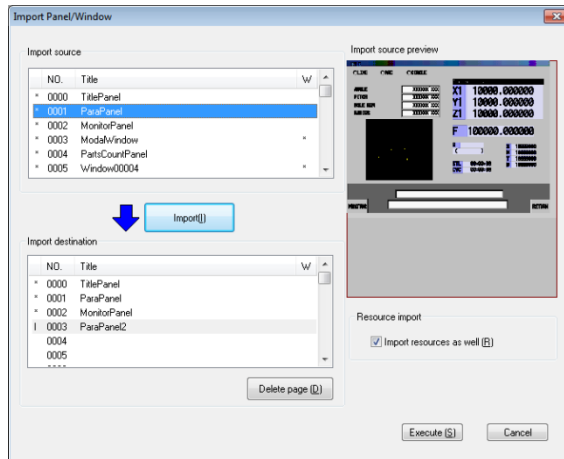

5. The [Open Panel/Window] dialogue appears. Select the panel/window to open, and press the OK button.

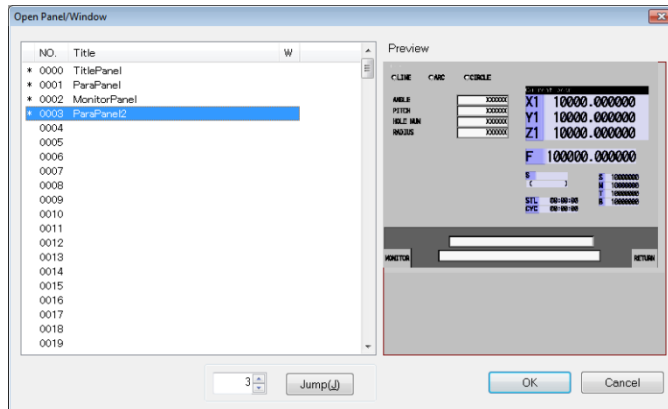

6. The selected panel/window appears.

**NOTE**

- ◆ If the project in the import destination is being referred to, or any one of the panel/window in the project in the import destination is being referred to, [Import Panel/Window] of the [File] menu is grayed out, and it cannot be selected.
- ◆ If the project in the import source is being referred to, or any one of the panel/window in the project in the import source is being referred to, an error dialogue of process execution appears when the project is specified in the "Open Project" dialog, and then the [Open] button is pressed. This disables the import process.

### 5.12.3 Selecting the Import Source/Destination

1. Select the page to import from the page list of the project in the import source.

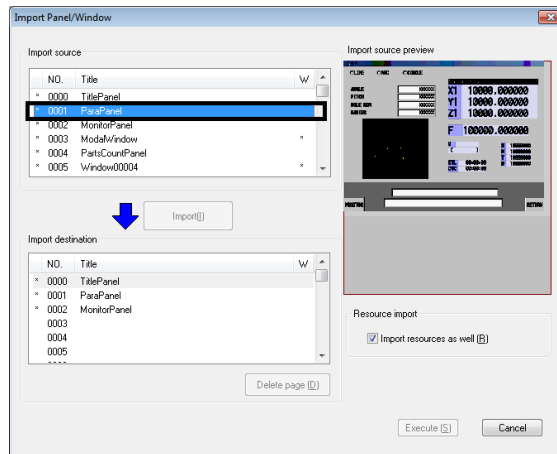

2. Select the location to import from the page list of the project in the import destination.

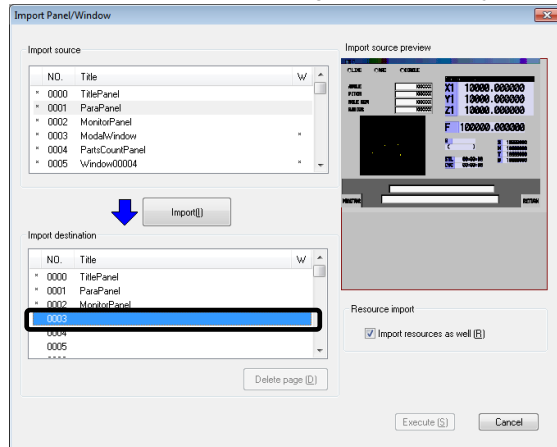

3. Pressing the [Import] button inserts the panel/window name. Repeat the step 1 to step 3 to import multiple pages.

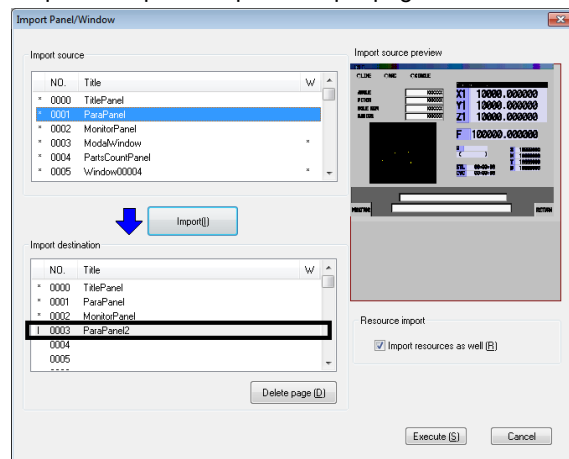

## 5. Creating and Saving the Page

If the page of the same name exists in the import destination, the Title Designation dialog appears. Specify another page name which does not overlap with other pages, then press the OK button.

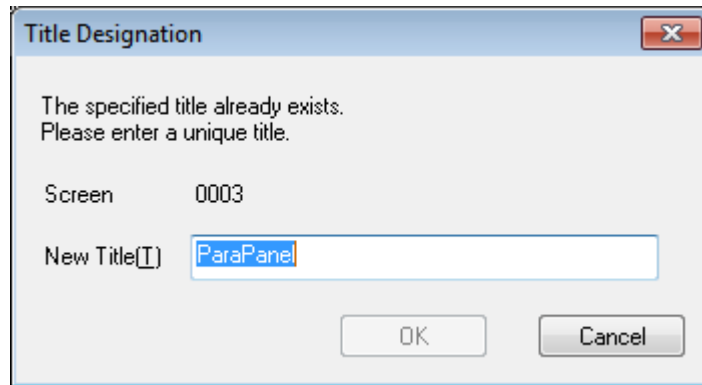

4. Pressing the [Execute] button executes the import for the designated panel/window.

**NOTE**

- ◆ "I" appears on the left end of the page that has the import setting.
- ◆ If the Cancel button is pressed after the page import is set, the import is not executed.
- ◆ The page that has the import setting can be deleted. Follow [Procedure how to delete pages] to delete the added pages.

### 5.12.4 Deleting a Page in the Import Source

1. Click the page to delete in the page list of the project in the import destination.

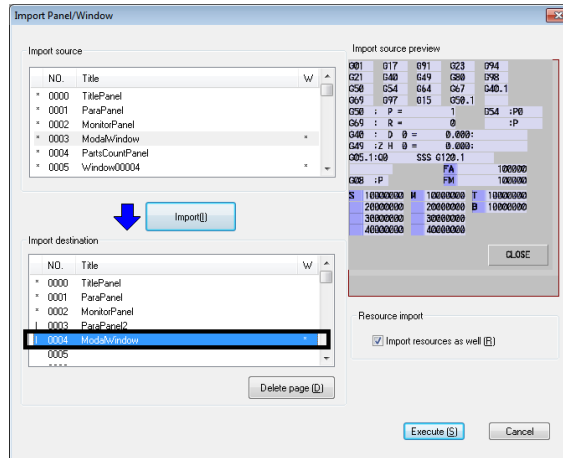

2. Pressing the [Delete page] button deletes the panel/window name.

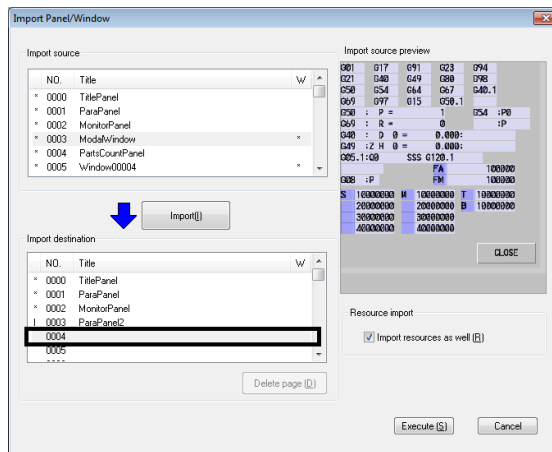

**NOTE**

- ◆ The [Delete page] button is enabled when the cursor is moved to the page that has the import setting (the page marked with "I" appears on the left end).

### 5.12.5 Changing a Resource Data Name

1. Click the position or press the ENTER key to change the resource data name.

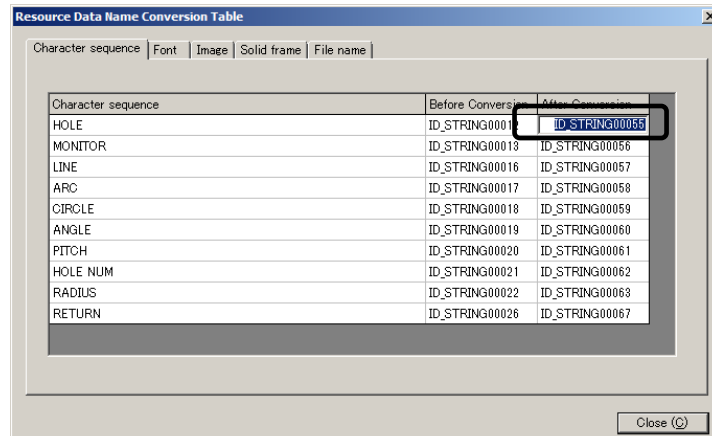

2. Change the resource data name in the [After Conversion] field.

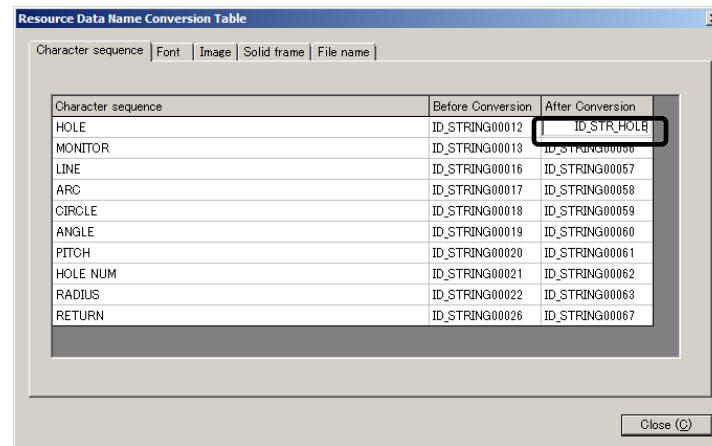

3. Pressing the Enter key changes the data name.

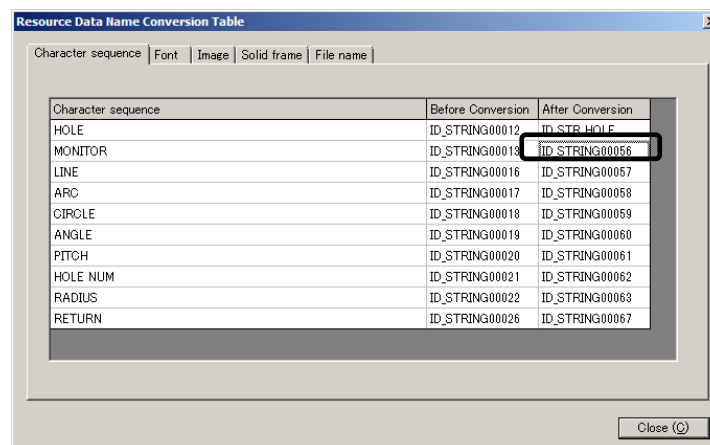



### 5.12.6 Restrictions

1. Painting-out pattern resources and line pattern resources are not imported.
2. The HTML file and PLC message file described in the macro are not imported. The file registered to the file name resource is imported. However, files are not imported in the following cases.
  - 1) When the same file exists in the import source and the import destination.
  - 2) No files exist in the import source.
3. The screen No. and the resource ID used in the macro are not converted.
4. If the screen files that have the same extension but different data formats exist in the import source, the page does not appear in the import source page list.

## 6. Resource

With NC Designer2, the settings and data used commonly in the controls are registered in advance as resources.

This section describes the resource.

### 6.1 Resource

With NC Designer2, the settings and data used commonly in the controls can be registered as resources.

The following data is handled as resources with NC Designer2.

Item	Description
Locale	Character strings used for controls and window title, and font data
Image	Figure data used for background image and picture controls
Painting out pattern	Filling pattern data used for controls and figures
Line pattern	Line pattern data used for figures
Solid frame	External frame specified for controls
File name	File data used for HTML browser controls

#### NOTE

- ◆ When a new resource is created, the resource data name is automatically determined according to the resource type (example: ID\_STRING) and the vacant number of the resource in the project.

When a new character string resource is created, the resource data name is determined as follows.

(Example 1) When the resources from 00001 to 00010 are already registered, the vacant number is 00011.

The character string resource is created with the resource data name "ID\_STRING00011".

(Example 2) When 00007 is the vacant number among the resources from 00001 to 00010, the character string resource is created with the resource name "ID\_STRING00007".

### 6.2 Resource Tree

Resources registered in the currently opened project are displayed. Resources can be added, deleted or the settings of them can be changed.

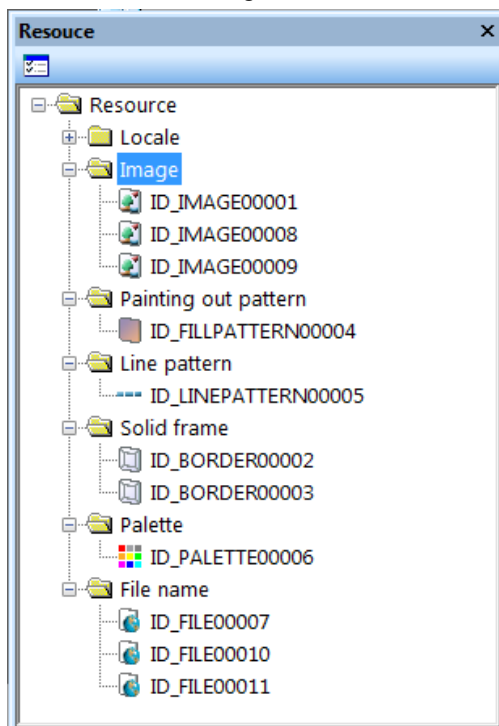

### 6.3 Locale

The set of a character string resource and font resource is called locale.

Up to 32 locales can be registered for each project.

Because two or more locales can be registered for each project, there is no need to divide a project according to the language, but screen data and settings can be handled as an integral group.

#### 6.3.1 Creating a New Locale

1. Move the mouse cursor to "Locale" in the resource tree and click the right mouse button. Select "New locale" from the displayed popup menu.
2. A new locale is registered.

#### 6.3.2 Deleting a Locale

1. Move the mouse cursor to the desired locale name and select "Delete" from the popup menu displayed upon a click of the right mouse button.

### 6.3.3 Locale Setup

1. Double click on the desired locale name or move the mouse cursor to the local name and select "Properties" from the popup menu displayed upon a click of the right mouse button.
2. Locale setting items are displayed in the property sheet.

Item	Description
Locale name	Specify the locale name. The first character of the locale name must be a one-byte letter (A to Z or a to z). The second and later characters must be one-byte letters, numbers or underscores (_). The locale name must be within 16 characters.
Character code	Select the character code of the locale. The "character code" is available only in Unicode.
Language discernment character sequence	Select the language being used.

**NOTE**

- ◆ The locale of all languages has already been registered according to the language specification. Thus, do not change the setting of the locale.

### 6.3.4 Switching the Locale

The displaying locale can be switched on NC Designer2.

1. Move the mouse cursor to the desired locale name and select "Switch" from the popup menu displayed upon a click of the right mouse button.
2. The locale is switched. The currently selected locale is marked with a check mark.

**NOTE**

- ◆ When the lang parameter of NC is switched, the language is automatically switched because the interpreter method and the compilation method (DLL method) synchronize with NC. The compilation method (execution file method) should embed the language switch function in the source code.

## 6.4 Character Sequence Resource

Register the character sequence set in the control.

Up to 5000 character sequence resources can be registered in the character string resource.

### 6.4.1 Creating a New Character String Resource

1. Move the mouse cursor to "Character sequence table" under "Locale" in the resource tree and double click on it or select "Edit" from the popup menu displayed upon a click of the right mouse button.

2. The [character sequence table] is displayed.

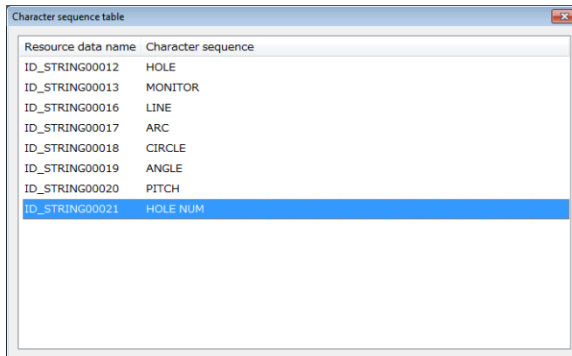

3. To register a new character sequence resource, select an arbitrary resource and select [Create] from the popup menu displayed upon a click of the right mouse button, or double click on the area where no resource is displayed.

The [character sequence property] dialog box is displayed.

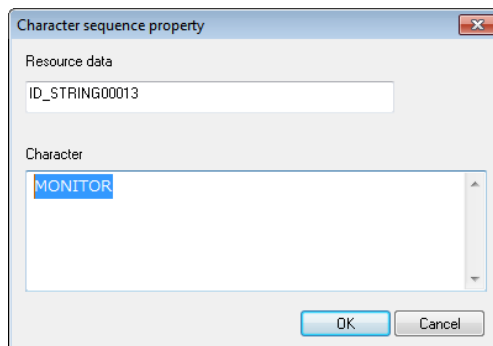

4. Enter the "resource data name" and "character sequence" and click on the [OK] button.

#### NOTE

- ◆ The first character of the resource data name of the character string resource must be a one-byte letter (A to Z or a to z). The second and later characters must be one-byte letters, numbers or underscores (\_). The resource data must be within 32 characters.
- ◆ Up to 256 two-byte characters can be entered as a character string.
- ◆ The character string resource is automatically created in the following case.
  - The character string displayed in the control is entered at control properties setup.
- ◆ If two or more locales are registered and a character string resource is registered to one of those locales, the character string resource data name and character strings are reflected on the character string table of the other locales.
- ◆ During multi-user development, the character string resource is controlled by a single user because it is common project data.

### 6.4.2 Editing or Creating Character String Resource

1. To edit the character string resource, select desired resource data and select [Edit] from the popup menu displayed upon a click of the right mouse button, or double click on the resource data.
2. The [Character String Properties] dialog box is displayed. Change the setting.

### 6.4.3 Replacing the Character String Resource

1. To replace registered character resource data, select the desired resource data and select [Replace] from the popup menu displayed upon a click of the right mouse button.
2. The [Replace] dialog box is displayed.

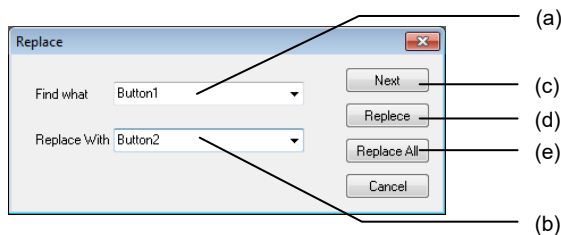

No.	Item	Description
(a)	Find what	Designate the character string to be replaced.
(b)	Replace With	Designate the character string to replace.
(c)	Next	Search for the character string designated in "Find what".
(d)	Replace	Replace the found character string each time a match is found.
(e)	Replace All	Replace all the target character string at once.

**NOTE**

- ◆ The target character string is the one included in the locale being edited.

### 6.4.4 Deleting Character String Resource

1. To delete character string resource, select the desired resource data and select [Delete] from the popup menu displayed upon a click of the right mouse button.

**NOTE**

- ◆ If two or more locales are registered, the character string resource is deleted from the character string table of the other locales, too.

### 6.4.5 Importing or Exporting Character String Resource

Export the character string resource in a text file and edit it with spreadsheet software or the like, then import the result to enter the character string resource at a time.

Exporting Character String Resource

Export the character string resource into a text file.

1. Select [Export Character String Resource] from the [Tool] menu. Or move the cursor to "Locale" in the resource tree and select "Export of a character sequence resource" from the popup menu displayed upon a click of the right mouse button.

2. The [Export of a character sequence resource] dialog box is displayed.

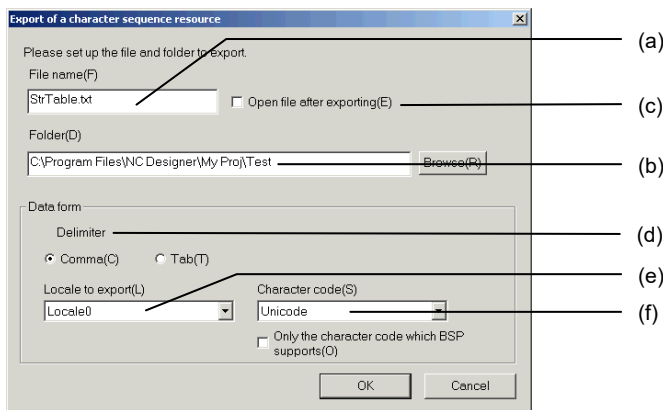

No.	Item	Description
(a)	File name	Designate the export file name (default file name: StrTable.txt).The file name is up to 64 one-byte characters (each two-byte character is equivalent to two characters).
(b)	Folder	Designate the destination of the file. (The maximum number of characters of the folder and file names is 200.)
(c)	Open file after exporting	Place a check mark here to launch the application associated with the extension of the file designated in the "file name" field and open the file. If there is no associated application, Windows opens a dialog to select the application to be launched. Designate the application to be launched.
(d)	Delimiter	Select either comma or tab as a delimiter used in the export file.
(e)	Locale to export	Select the export locale among each locale and "all locales".
(f)	Character code	The character code corresponding to the export file is only the Unicode.

3. Click on the "OK" button to start to export.

**NOTE**  
 ◆ Before exporting the character string resource, save the project ([File] - [Save Project]).

Editing Text File

Use spreadsheet software or text editor to edit the exported text file. The character code name, resource data name of the character string resource, and character string data in the text file can be edited.

1. Use spreadsheet software or text editor to open the exported text file.

If the "Open file after exporting" checkbox is checked when the file is exported, spreadsheet software or the like is launched automatically to load the generated text file.

[CHARSET]	Unicode	
[DATA]	Japanese	English
ID_STRING00000	新規作成	New
ID_STRING00001	開く	Open
ID_STRING00002	閉じる	Close
ID_STRING00003	上書き保存	Save
ID_STRING00004	名前を付けて保存	Save as.
ID_STRING00005	プリンタの設定	Priter setup
ID_STRING00006	印刷プレビュー	Print preview
ID_STRING00007	印刷	Print
ID_STRING00008	終了	Exit

2. Edit the text file.

**NOTE**

- ◆ Do not delete [CHARSET] and [DATA].
  - ◆ The first character of the locale and resource data names must be a one-byte letter (A to Z or a to z). The second and later characters must be letters, numbers or underscores (\_). The locale name must be within 16 characters.
  - ◆ Set the character string registered in the character string resource within 256 two-byte characters.
  - ◆ When editing the text file to be imported, enclose each character string including a comma, tab, line feed and carrier return codes, or double quotation mark in double quotation marks (" "). Specify two repetitive double quotation marks for each double quotation mark.
- Example
- To import [AB, CD], enter [AB, CD].
  - To import [AB" CD], enter [AB"" CD].



Importing Character Sequence Resource

Import the edited text file.

An error check is performed when the file is imported.

1. Select [Import of a character sequence resource] from the [Tool] menu. Or move the mouse cursor to "Locale" in the resource tree, and select "Import of a character sequence resource" from the popup menu displayed upon a click of the right mouse button.
2. The "Import of a character sequence resource" dialog box is displayed.

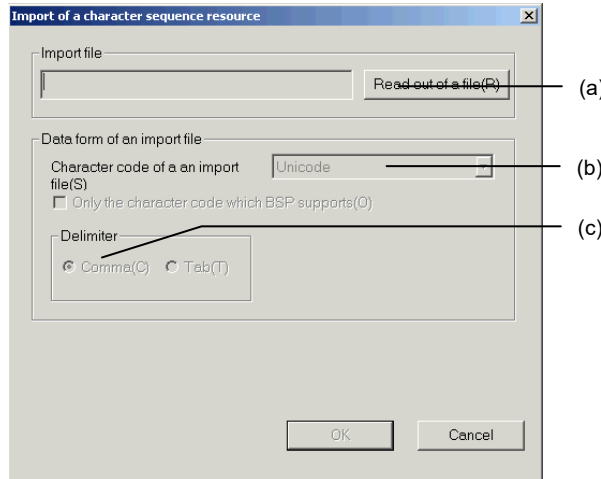

No.	Item	Description
(a)	Import file	Designate the file to be imported. Click on "Read out of a file" and designate the desired file in the displayed file selector. When the designated file can be imported, delimiter is automatically selected. When the file cannot be imported, an error message is displayed. Designate the file after correcting it.
(b)	Data form of an import file	Designate the data format of the file to be imported.
	Character code of an import file	The character code of the file to be imported is only the Unicode.
(c)	Delimiter	Select the delimiter of the file to be imported.

3. Click on the OK button to start to import.

**NOTE**

- ◆ If a duplicate resource data name is found in the importing text file, the duplicate data will overwrite the original data in the application. Check for duplicate resource data name before starting to import.
- ◆ The character string resource can be imported only if the project is opened with the edit flag.
- ◆ If importation is interrupted during importation, the character string data having been imported up to the timing is reflected on the character string resource.

Error Check

If an error is detected during importation, the message view displays an error list.

Message	Remedy
Invalid locale name "XXX" was discovered by the file under import. The information on this column is not imported.	Correct the locale name.
The character sequence with a blank locale name was discovered by the file under import. The information on this column is not imported.	Correct the locale name.
Invalid resource data name "XXX" was discovered by the file which is under import. The information on this line is not imported.	Correct the resource data name.
The column with a blank resource data name was discovered by the file under import. The information on this line is not imported.	Correct the resource data name.
The line to which a locale name overlaps the file under import was discovered. The information on this column is not imported.	Enter an unused locale name.
The character sequence to which length exceeds 256 characters in the file under import was discovered. It is not imported after 256 characters of this character sequence.	Reset the character string registered in the character string resource so that it is within 256 two-byte characters.
Since the number of the maximum registration of a locale name is 32, it is ignored after it.	The number of locale names must be within 32.
Since the number of the maximum registration of the character sequence resource ID is 5000, the character sequence resource after it is disregarded.	The maximum number of registered resources must be within 5000.
In the file under import, since a data key does not exist, a file cannot be imported.	Add a data key ([DATA]) in the imported file.

**NOTE**

- ◆ The first character of the locale and resource data names must be a one-byte letter (A to Z or a to z). The second and later characters must be letters, numbers or underscores (\_).The locale name must be within 16 characters.
- ◆ Show a preview in the [Import Character String] dialog box to display errors in red. Check for errors before starting to import.

## 6.5 Font Resource

Register the font, style and other character attributes to be specified for the control. Up to 5000 font sources can be registered.

### 6.5.1 Creating a New Font Resource

1. Move the mouse cursor to "Font" in the resource tree and select "New font" from the popup menu displayed upon a click of the right mouse button.

2. The new font resource is registered.

(Note) Resource data name is common for all locales. Therefore, a font resource will be registered in all locales if it is created in one locale.

### 6.5.2 Deleting Font Resource

1. Move the mouse cursor to the font resource data name to be deleted, and select "Delete" from the popup menu displayed upon a click of the right mouse button.

(Note) Resource data name is common for all locales. Therefore, a font resource will be deleted from all locales if it is deleted in one locale.

### 6.5.3 Specifying Font Resource

1. Double click on the desired font resource data name or move the mouse cursor to the font resource data name and select "Property" from the popup menu displayed upon a click of the right mouse button.
2. The font resource setting items are displayed in the property sheet.

Item	Description
Resource data name	Specify the resource data name. The first character of the resource data name must be a one-byte letter (A to Z or a to z). The second and later characters must be one-byte letters, numbers or underscores (_). The resource data name must be within 32 characters.
Font name	Specify the font name.
Font size	Specify the font size. The setting is valid if the selected font is a vector font.
Zoom horizontal	Specify the horizontal zoom of the character size. The setting is valid if the selected font is a raster font.
Zoom vertical	Specify the vertical zoom of the character size. The setting is valid if the selected font is a raster font.
Thickness	Select the character thickness among "THIN", "NORMAL" and "BOLD".
Font style	Select the character style among "None" and "Italics".

**NOTE**

- ◆ In M800V/M80V/M800/M80 (Windows-less display unit) and M700VS/M70V/E70, data is displayed in the "MITSUBISHI CNC Gothic" font regardless of the specified font. The font style "Italics" is not available in the "MITSUBISHI CNC Gothic" font except for M800V/M80V/M800/M80 (Windows-based display unit).
- ◆ In M700VW/M700VS/M70V/E70, the size of the displayed font is different from the specified font size. The display size is as follows.

Specified font size	Displayed font size			
	M700VS/M70V/E70	M700VW		M800V/M80V/M800/M80
	All fonts	MITSUBISHI CNC Gothic	Other fonts	All fonts
1 to 13	12	12	Same as the specified size	Same as the specified size
14 to 15		16		
16 to 19	16	24		
20 to 23				
24 to 27	24	32		
28 to 31				
32 to 47	32			
48 to 63	48			
64 to 72	64			

## 6.6 Image Resource

Register image data used for controls or background images.

Registrable image files : BMP, JPG, PNG, and VGF.

Up to 5000 image resources can be registered.

### 6.6.1 Creating a New Image Resource

1. Move the mouse cursor to "Image" in the resource tree and select "New image" from the popup menu displayed upon a click of the right mouse button.
2. The new image resource is registered.

### 6.6.2 Deleting an Image Resource

1. Move the mouse cursor to the desired image resource data name and select "Delete" from the popup menu displayed upon a click of the right mouse button.

### 6.6.3 Specifying an Image File

1. Double click on the desired image resource data name or move the mouse cursor to the image resource data name and select "Property" from the popup menu displayed upon a click of the right mouse button.
2. The image resource setting items are displayed in the property sheet.

Item	Description
Resource data name	Specify the resource data name. The first character of the resource data must be a one-byte letter (A to Z or a to z). The second and later characters must be one-byte letters, numbers or underscores (_). The resource data name must be within 32 characters.
File name (Note)	Specify an image file. Click on the [...] button to display a file selector. Specify an image file from BMP, JPG, PNG, or VGF.

(Note) Select an image resource file with the size of XGA (1024×768) or smaller. If the file size is larger than XGA, the image may not be displayed on the custom screen.

## **6.7 Solid Frame Resource**

Register the solid frame used for controls.

### **6.7.1 Creating a New Solid Frame Resource**

1. Move the mouse cursor to "Solid frame" in the resource tree and select "New solid frame" from the popup menu displayed upon a click of the right mouse button.
2. The new solid frame resource is registered.

### **6.7.2 Deleting a Solid Frame Resource**

1. Move the mouse cursor to the desired solid frame resource data name and select "Delete" from the popup menu displayed upon a click of the right mouse button.

### 6.7.3 Specifying a Solid Frame File

1. Double click on the desired solid frame resource data name or move the cursor to the solid frame resource data name and select "Property" from the popup menu displayed upon a click of the right mouse button.
2. The solid frame resource setting items are displayed in the property sheet.

Item	Description
Resource data name	Specify a resource data name. The first character of the resource data name must be a one-byte letter (A to Z or a to z). The second and later characters must be one-byte letters, numbers or underscores (_). The resource data name must be within 32 characters.
Existence of a solid frame	Select the existence of the solid frame between [Yes] and [None].
Color 1	Specify the color of the upper left side of the solid frame.
Color 2	Specify the color of the lower right side of the solid frame.
Line color	Specify the color of the frame line.
Frame size	Specify the size of the solid frame in dots (1 to 960).

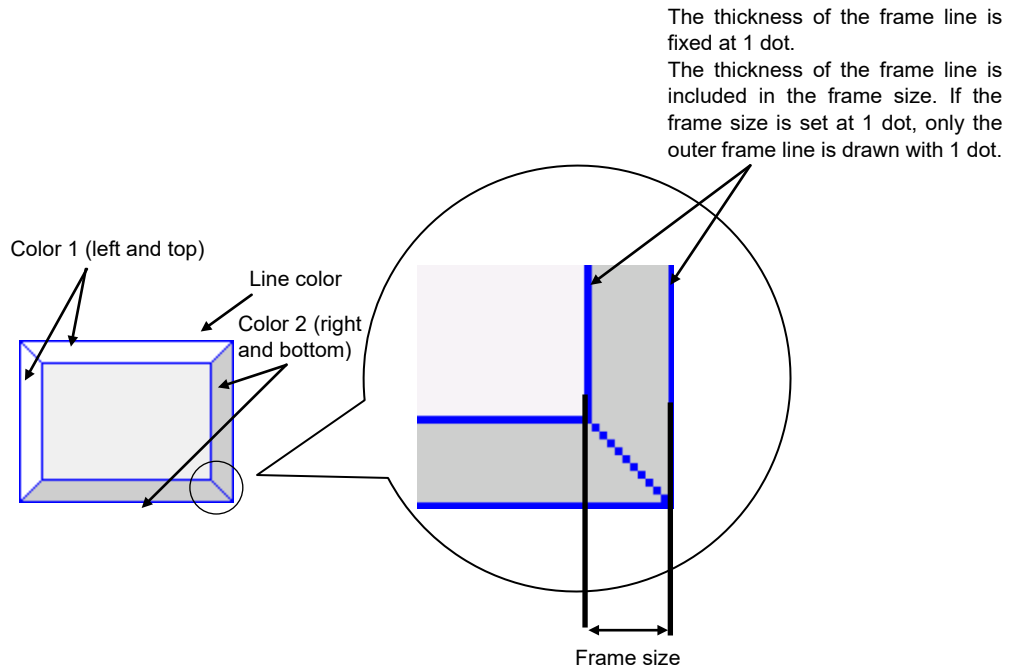

### 6.8 Filling Pattern Resource

Register the filling pattern used for controls and figures.  
 38 filling patterns are provided in the initial state.

#### 6.8.1 Editing the Filling Pattern

1. Move the mouse cursor to the resource data name of "Painting out pattern" in the resource tree and double click on it or select "Edit" from the popup menu displayed upon a click of the right mouse button.
2. The [Pattern Edit] dialog box is displayed. Edit the pattern.

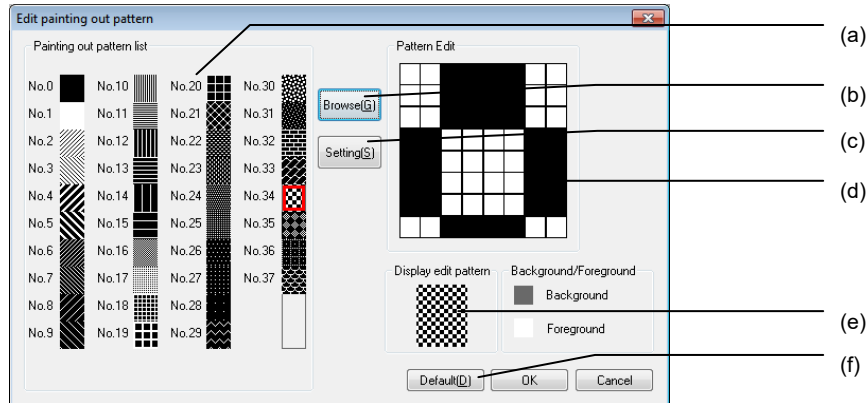

No.	Item	Description
(a)	Painting out pattern list	Select the filling pattern.
(b)	Browse	Copy the currently selected filling pattern to the pattern editing area.
(c)	Setting	Specify the filling pattern being edited in the current pattern edit area to the selected filling pattern list.
(d)	Pattern Edit	Edit the filling pattern in dots. Each time the mouse button is clicked, the foreground and background are switched over.
(e)	Display edit pattern	Display a sample of the edited filling pattern.
(f)	Default	Restore the default filling pattern list.



### 6.9 Line Pattern Resource

Register the line pattern used for figures.  
Eight line patterns are provided in the initial state.

#### 6.9.1 Editing the Line Pattern

1. Move the mouse cursor to the resource data name of "line pattern" in the resource view, and double click on it, or select "Edit" from the popup menu displayed upon a click on the right mouse button.
2. The [Line pattern edit] dialog box is displayed. Edit the pattern.

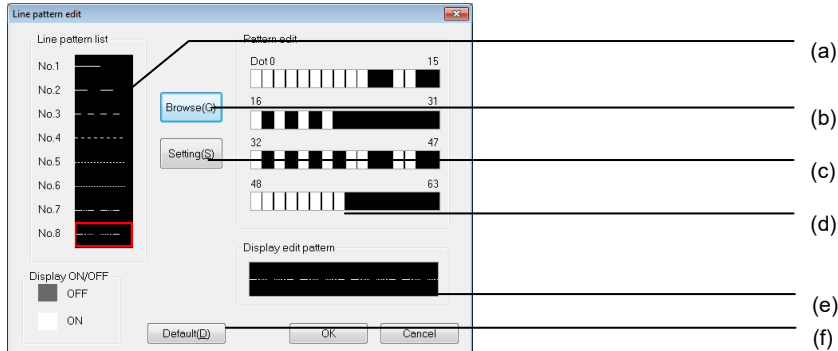

No.	Item	Description
(a)	Line pattern list	Select the line pattern.
(b)	Browse	Copy the currently selected line pattern to the pattern edit area.
(c)	Setting	Specify the line pattern edited in the current pattern editing area to the selected pattern list.
(d)	Pattern edit	Edit the line pattern in dots. Each time the mouse button is clicked, ON and OFF are switched over. The left end, center and right end patterns are displayed, starting at the top.
(e)	Display edit pattern	Display a sample of the line pattern being edited.
(f)	Default	Restore the default line pattern list.

### 6.10 File Name Resource

Register the file name displayed first when the browser control is operated.  
Up to 5000 files can be registered.

#### 6.10.1 Creating a New File Name Resource

1. Move the mouse cursor to "File name" in the resource tree, and select "New File" from the popup menu displayed upon a click of the right mouse button.
  
2. The new file name resource is registered.

#### 6.10.2 Deleting the File Name Resource

1. Move the mouse cursor to the desired file name resource data name, and select "Delete" from the popup menu displayed upon a click of the right mouse button.

#### 6.10.3 Specifying the File Name Resource

1. Double click on the desired file name resource data name, or move the mouse cursor to the file name resource data name, and select "Property" from the popup menu displayed upon a click of the right mouse button.
  
2. The file name resource setting items are displayed in the property sheet.

Item	Description
Resource data name	Specify the resource data name. The first character of the resource data name must be a one-byte letter (A to Z or a to z). The second and later characters must be one-byte letters, numbers or underscores (_). The resource data name must be within 32 characters.
File name	Select the file. Click on the [...] button to display a file selector. Specify the file displayed first.

## **6.11 Resource management**

### **6.11.1 Outline**

The resource management function displays resource data registered to the project being edited in a list, enabling users to select unnecessary resources and delete them in a batch.

With this function, users can delete enlarged resource data and reduce custom data size.

6.11.2 Operation Screen

In the resource management dialog box, users can arbitrarily select resource data to be deleted and delete them.

Resource data registered to the project being edited is displayed in the resource list.

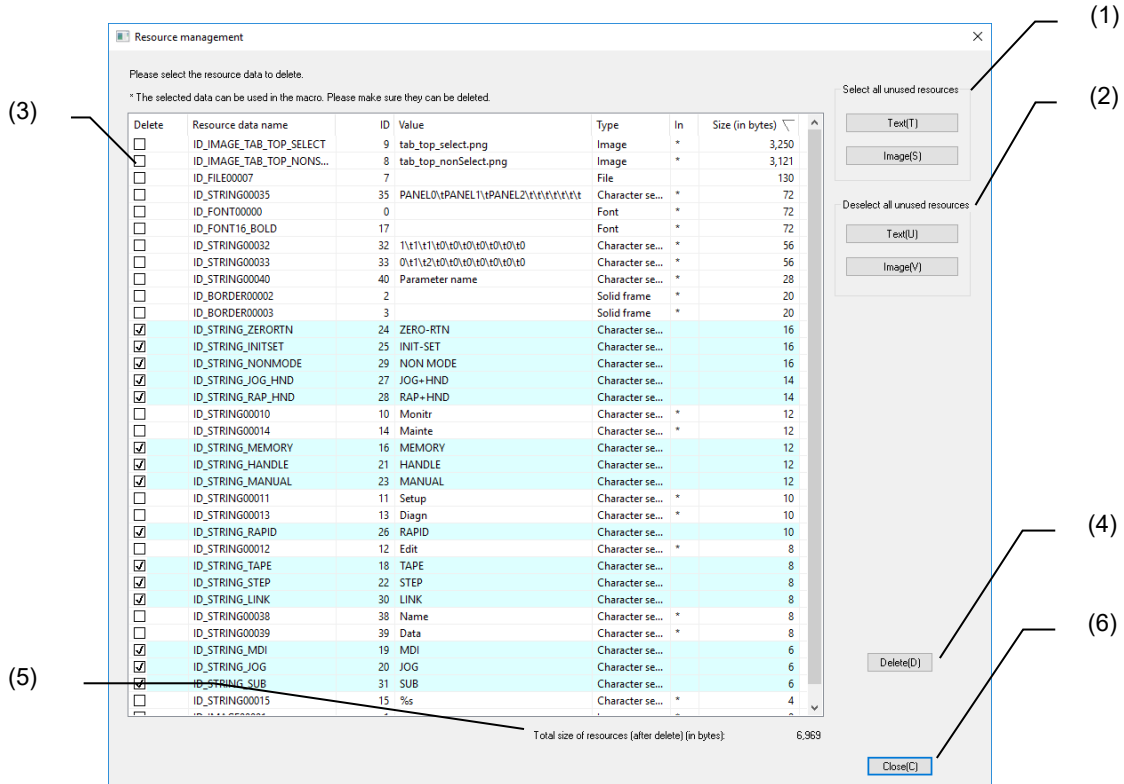

The following items are displayed in this dialog box.

No.	Item	Description
(1)	Select all unused resources	Click on the [Text] / [Image] buttons to check all unused resources whose displayed types are [Text] / [Image].
(2)	Deselect all unused resources	Click on the [Text] / [Image] buttons to uncheck all unused resources whose displayed types are [Text] / [Image].
(3)	Resource list	Displays all resource data registered to the project being edited in a list.  (Note) The painting out pattern, the line pattern and the palette resource are not displayed in the list.
(4)	Delete	Deletes resources whose delete fields in the resource list are checked.
(5)	Total size of resources (after delete) (in bytes)	Displays the total size of the resources (byte) whose delete fields in the resource list are not checked.
(6)	Close	Closes the resource management dialog box.

**NOTE**

- ◆ When you open the resource management dialog box, all unused character sequence resources and image resources are checked.

6.11.2.1 Resource list

The resource data name, the resource ID, the value, the type, the operation state, the size etc. are displayed in the resource list.

Delete	Resource data name	ID	Value	Type	In	Size (in bytes)
<input type="checkbox"/>	ID_IMAGE_TAB_TOP_SELECT	9	tab_top_select.png	Image	*	3,250
<input type="checkbox"/>	ID_IMAGE_TAB_TOP_INPN...	8	tab_top_nonSelect.png	Image	*	3,121
<input type="checkbox"/>	ID_FILE00007	7		File	*	130
<input type="checkbox"/>	ID_STRING00035	35	PANEO\*PANEL1\*PANEL2\*t\*t\*t\*t\*t	Character se...	*	72
<input type="checkbox"/>	ID_FONT00000	0		Font	*	72
<input type="checkbox"/>	ID_FONT06_BOLD	17		Font	*	72
<input type="checkbox"/>	ID_STRING00032	32	1\*t\*1\*t\*0\*t\*0\*t\*0\*t\*0\*t\*0	Character se...	*	56
<input type="checkbox"/>	ID_STRING00033	33	0\*t\*1\*t\*2\*t\*0\*t\*0\*t\*0\*t\*0\*t\*0	Character se...	*	56
<input type="checkbox"/>	ID_STRING00040	40	Parameter name	Character se...	*	28
<input type="checkbox"/>	ID_BORDER00002	2		Solid frame	*	20
<input type="checkbox"/>	ID_BORDER00003	3		Solid frame	*	20
<input checked="" type="checkbox"/>	ID_STRING_ZERO	24	ZERO-RTN	Character se...	*	16
<input checked="" type="checkbox"/>	ID_STRING_INITSET	25	INIT-SET	Character se...	*	16
<input checked="" type="checkbox"/>	ID_STRING_NONMODE	29	NON MODE	Character se...	*	16
<input checked="" type="checkbox"/>	ID_STRING_JOG_HND	27	JOG+HND	Character se...	*	14
<input checked="" type="checkbox"/>	ID_STRING_RAP_HND	28	RAP+HND	Character se...	*	14
<input type="checkbox"/>	ID_STRING00010	10	Monitr	Character se...	*	12
<input type="checkbox"/>	ID_STRING00014	14	Mainte	Character se...	*	12
<input checked="" type="checkbox"/>	ID_STRING_MEMORY	16	MEMORY	Character se...	*	12
<input checked="" type="checkbox"/>	ID_STRING_HANDLE	21	HANDLE	Character se...	*	12
<input checked="" type="checkbox"/>	ID_STRING_MANUAL	23	MANUAL	Character se...	*	12
<input type="checkbox"/>	ID_STRING00011	11	Setup	Character se...	*	10
<input type="checkbox"/>	ID_STRING00013	13	Diagn	Character se...	*	10
<input checked="" type="checkbox"/>	ID_STRING_RAPID	26	RAPID	Character se...	*	10
<input type="checkbox"/>	ID_STRING00012	12	Edit	Character se...	*	8
<input checked="" type="checkbox"/>	ID_STRING_TAPE	18	TAPE	Character se...	*	8
<input checked="" type="checkbox"/>	ID_STRING_STEP	22	STEP	Character se...	*	8
<input checked="" type="checkbox"/>	ID_STRING_LINK	30	LINK	Character se...	*	8
<input type="checkbox"/>	ID_STRING00038	38	Name	Character se...	*	8
<input type="checkbox"/>	ID_STRING00039	39	Data	Character se...	*	8
<input checked="" type="checkbox"/>	ID_STRING_MDI	19	MDI	Character se...	*	6
<input checked="" type="checkbox"/>	ID_STRING_JOG	20	JOG	Character se...	*	6
<input checked="" type="checkbox"/>	ID_STRING_SUB	31	SUB	Character se...	*	6
<input type="checkbox"/>	ID_STRING00015	15	%s	Character se...	*	4

The following items are displayed on the resource list.

No.	Item	Description
(1)	Delete	Check the resource data to be deleted. For checked lines, the entire line is displayed in light blue.
(2)	Resource data name	The resource data name of each resource is displayed.
(3)	ID	The resource ID of each resource is displayed.
(4)	Value	The settings of each resource data is displayed. When unset, an empty file name is displayed.  (1) For character sequence resources, the character sequences of the currently selected locale are displayed. (2) For image resources and file resources, file names are displayed. (3) For font resources and solid frame resources, empty file names are displayed.
(5)	Type	The resource type (character sequence, font, image, solid frame and file) is displayed.
(6)	In use	Displays whether resource data is being used in the properties of controls arranged in the project or not. (Note) When the resource data is being used, "*" is displayed, and when the data is not being used, an empty file name is displayed.  (Note) Only resource data used in properties is displayed. Note that "*" is not displayed when the data is used in the macro.
(7)	Size (in bytes)	Displays the resource sizes (byte).

**NOTE**

- ◆ Because the character sequences of menu 1 to menu 10 registered in the text property of the extension menu are not registered to character sequence resources, they are not displayed in the resource list.

Example:

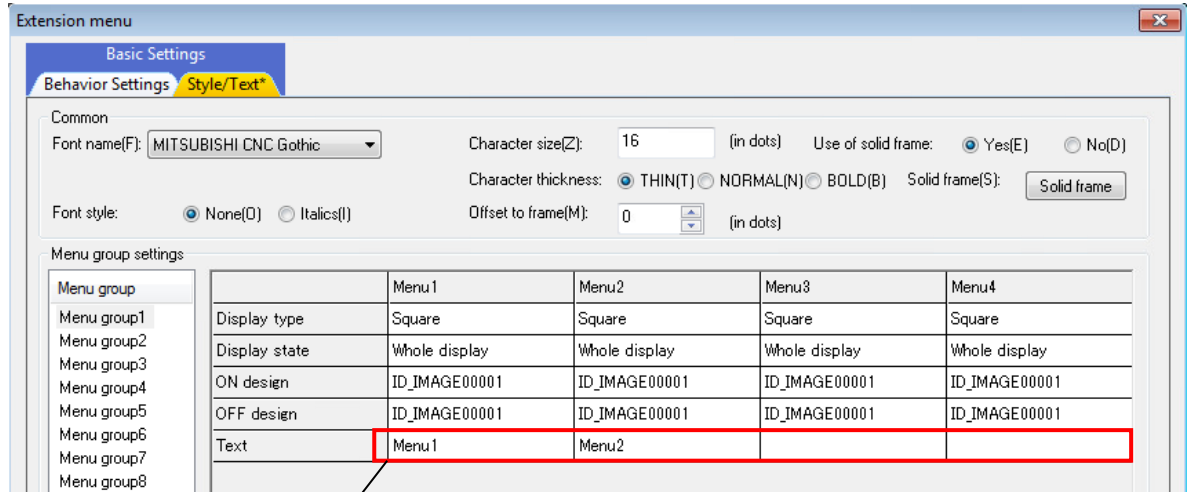

The character sequences "Menu1" and "Menu2" are not displayed in the resource list.  
 The character sequences registered to the text properties "Menu1\tMenu2\t\t\t\t\t\t\t\t" are displayed in the resource list.

- ◆ For font, image, and file name resources, keep at least one resource data.  
 For the solid frame resource, keep at least two resource data.





## 7. Creating Controls

Each control and property settings are described in this section.

The control is an object having the following functions.

- Expression of GUI operation and retention of operation state
- Notification of GUI operation to user program

(Note) Some of the controls or properties are not accepted depending on the models or the versions selected in a new wizard. Several properties have different setting range.

### 7.1 Common Functions of Controls

#### 7.1.1 Control Name

Specify the name of the control

Item	Description
ID	Specify the name of the control. The first character of the control name must be a letter (A to Z or a to z) or underscore (_). The second and later characters must be letters, numbers or underscores (_). The control name must be within 31 characters.

The control name specified here becomes a variable name during source code generation.

The screenshot shows the 'Property' window for a 'Button object'. Under the 'Common' section, the 'ID' property is set to 'GButton00001'. A callout box points to this value and shows the following source code snippet:

```

GCClassCBMP(GCPage000)
GCEndClassCBMP()
Static const ButtonPropertybupProperty[1] =
{
    {GBUTTON,GCPage000::BUTTON00001, 253,
    37, 228, 155, GW_STYLE_CAPTION ...
}
    
```

#### NOTE

- ◆ When a new control is created, the control name is automatically determined according to the part name (example: GButton) and what order the part to be created is located in the page. Even when the existing part is deleted in the page, the number portion (example: 00005) of the control name is not subtracted.
- When a button part is located, the control name is determined as follows.
- (Example 1) When a button part is located on the page where five parts are already located, the control name is "GButton00005".
- (Example 2) When a button part is located where five parts are already located and the 3rd part is deleted, the control name is "GButton00005".
- ◆ Specify the control name while avoiding duplication with other controls in the same page.
  - ◆ If there are duplicate control names, source code generation is not in order. Use the error check function to check for duplication.

7.1.2 Position/Size

Specify the displaying position and size of the control

Item	Description
X	Specify the horizontal position from the upper left of the page/view frame of the control (X coordinate) in dots (0 to 2559).
Y	Specify the vertical position from the upper left of the page/view frame of the control (Y coordinate) in dots (0 to 1919).
WIDTH	Specify the width of the control in dots (8 to 2560).
HEIGHT	Specify the height of the control in dots (8 to 1920).

Position

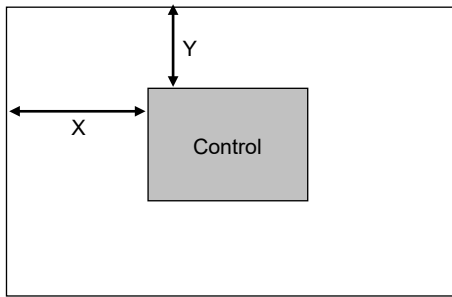

Page/view frame

Size

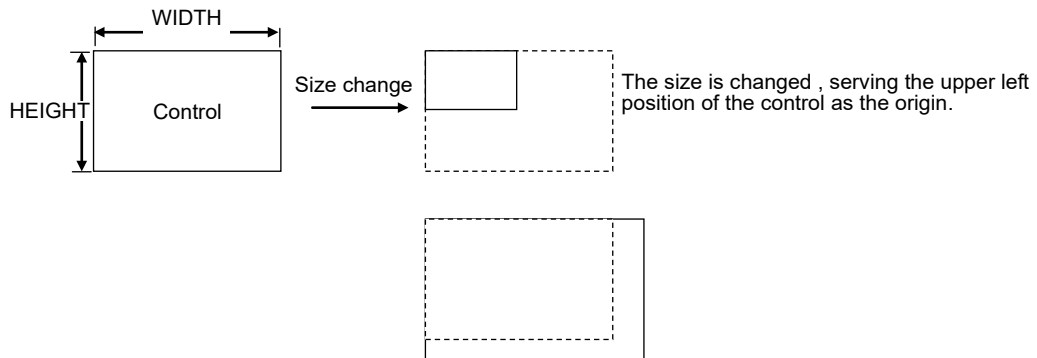

7.1.3 Color/Pattern

Specify the color/pattern of the control

Item	Description
Background color	Specify the background color of the control.
Foreground color	Specify the foreground color (pattern color) of the control.
Pattern	Select the filling pattern among "background", "foreground", "pattern 0" to "pattern 37", and "none".

The relationship among the background color, foreground color and pattern is as shown in the figure below.

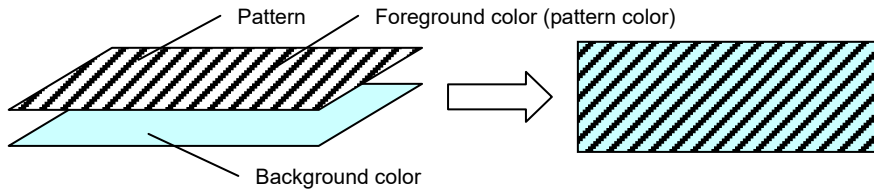

**NOTE**

- ◆ The color or pattern may be specified for each control state for some controls such as the button for which "foreground color at the time of ON", "background color at the time of OFF" and "pattern at the time of focus" may be specified.
- ◆ 38 types of patterns are provided for NC Designer2 in the default state. For the pattern type, refer to Appendix.

7.1.4 Image

Specify the image displayed on the control.

Item	Description
Design	Select the image resource data name to be displayed on the control.

**NOTE**

- ◆ Refer to Section "6. Resource" for the image source.
- ◆ The image may be specified for each control state for some controls such as the button for which "Design at the time of ON", "Design at the time of OFF" and "Design at the time of focus" must be specified.

7.1.5 Text

Specify the caption character string displayed on the control.

Item	Description
Caption existence	Select whether or not the caption is displayed.
Text	Specify the character string displayed on the control. There are the following two methods for the entry of the character string. <ul style="list-style-type: none"> <li>▪ Select from registered character string resources. Click on the ▼ button at the right of the entry area and select one of registered character string resources.</li> <li>▪ Enter a new character string. Click on the entry area and enter a character string directly.</li> </ul>

**NOTE**

- ◆ The new character string is registered as a character string resource.
- ◆ The character string is common data for the project. A single user should enter the new character string.
- ◆ If [Edit Caption] is selected from the [Edit] menu while a control is selected, you can enter the character string directly on the control.

**7.1.6 Character Attribute**

Specify the character attribute of the caption.

Item	Description
Character color	Specify the character color.
Horizontal position	Select the horizontal character position among "Align left", "Center" and "Align right".
Vertical position	Select the vertical character position among "Align top", "Center" and "Align bottom".
Font	Select the ID of the font resource for displaying the caption.
Margin left	Designate the starting position of the caption in dots from the left end of the control (0 to 2560).
Margin right	Designate the starting position of the caption in dots from the right end of the control (0 to 2560).
Margin top	Designate the starting position of the caption in dots from the top of the control (0 to 1920).
Margin bottom	Designate the starting position of the caption in dots from the bottom of the control (0 to 1920).

The relationship between the margin and character string position is as shown below.

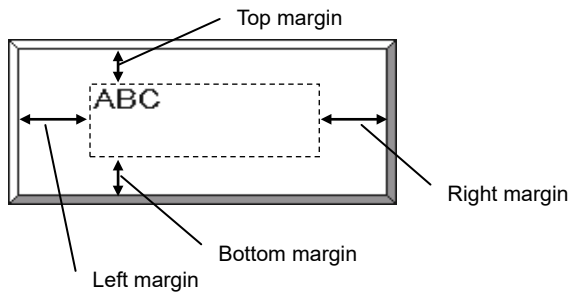

The solid frame is not included in the margin. The rectangle indicated with dot lines indicates the area where the character string is displayed.

**NOTE**

- ◆ Avoid reserving too large a margin. Otherwise the character string may not be displayed completely.

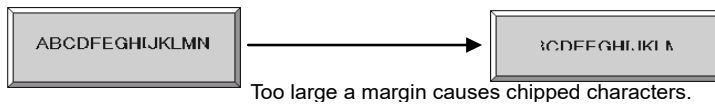

### 7.1.7 Scrolling Caption Character String

Scroll the caption character string displayed at the control.

Item	Description
Scroll	Select the scroll of the caption character string among "Yes", "No" and "When a text sticks out".
The number of times of scrolling	Select the scrolling frequency between "Only 1 time" and "Repeat".
Start delay (ms)	Specify the delay from the start-to-scroll request to the start of scrolling in ms (0 to 60000).
Updating interval (ms)	Specify the scroll refreshment interval in ms (0 to 5000). Specify "0" to refrain from scrolling.
Movement amount (in dots)	Specify the amount of movement in scrolling in dots (0 to 100).
Scroll start position	Select the starting position between "The present position" and "From a right end".

The relationship between the scroll settings and action is as shown below.

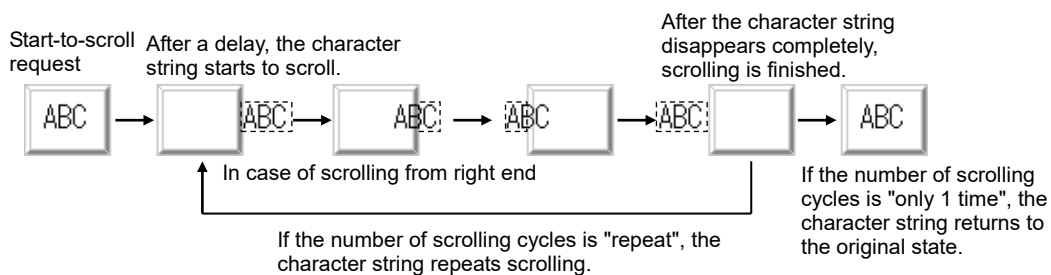

**NOTE**

- ◆ The scrolling direction of the caption character string is from right to left (fixed).
- ◆ If a carriage return is included in the caption character string, the character string scrolls in a single line.



Before scrolling      The character string is in a single line while it scrolls.

- ◆ The caption character string scrolls in the character string display area, allowing for the margins. For the margin, refer to "Character Attribute".

7.1.8 Blink

Blink the caption character string of the control.

Item	Description
Blink	Select whether the character string blinks or not.
The blink method	Select the caption character string blinking method among "Switch Show/Hide character", "A character color is changed", and "A whole color is changed".
The character color/whole color at the time of blink	Specify the blinking character color. The setting is valid if "A character color is changed" or "A whole color is changed" is selected for "The blink method".

If "Switch Show/Hide character" is selected, the caption character string continues to blink.

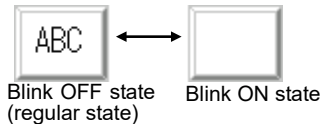

If "A character color is changed" is selected, the character color of the caption character string repeats to change.

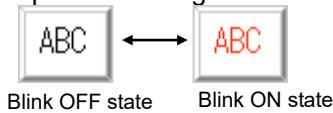

If "A whole color is changed" is selected, the button, label, text box and picture objects change the color of the whole control repeatedly, except for the solid frame. With the check box and radio button objects, the color of the area where the caption character string is displayed changes.

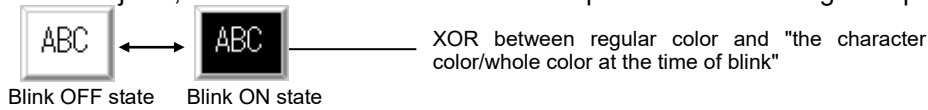

Blink Refreshment Interval

The control for which the blink is specified alternates between the blink OFF and blink ON states. Specify the intervals of both states at [panel/window properties] in the [Settings] menu. For the details on the setting method, refer to Section 5.4 "Entering Panel Properties" and Section 5.5 "Entering Window Properties".

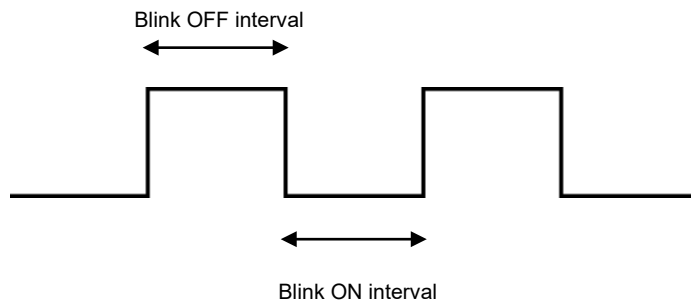

### 7.1.9 Solid Frame

Specify the solid frame of the control.

Item	Description
Use of solid frame	Select the presence of the solid frame between "Yes" and "No".
Solid frame	Select the resource data name of the solid frame resource.

#### NOTE

- ◆ For the solid frame resource, refer to Section 6 "Resource".

### 7.1.10 Callback Function

The callback function is an event-driven function for the user to add the original process in the C++ language. The callback functions are generated by performing [Source Code Generation] when "Yes" is selected in the property sheet of NC Designer2.

Add a process to be executed to the generated functions.

Item	Description
OnKeyPress	This is executed after the key is pressed.
OnKeyRelease	This is executed after the key is released.
OnPress	This is executed after the mouse or another pointing device is pressed.
OnRelease	This is executed after the mouse or another pointing device is released.
OnClick	This is executed after the mouse or another pointing device is clicked. If the pointing device is released on the same control, an event occurs, following OnRelease.
OnDraw	This is executed after the image is drawn.
OnTimer	This is executed after the timer event is called.
OnSetFocus	This is executed after the focus is located.
OnKillFocus	This is executed after the focus moves apart from the control.
OnCreate	This is executed after the page/control is generated.
OnDelete	This is executed before the page/control is deleted.
OnUser	An original process of the user is executed.
OnScroll	This is executed after the scroll bar is clicked on with the mouse or another pointing device.
OnScrollFinish	This is executed after the caption character string has finished scrolling.
OnSelectChange	This is executed when the selection line is changed in the list.
OnChangeString	This is executed after the contents of data area are changed.
OnSubCursorMove	This is executed after the sub cursor position is changed.
OnDrawLineString	This is executed after the character string (per line) is displayed.
OnInit	This is executed after the panel/window is displayed.
OnQuit	This is executed before the panel/window is hidden.
OnEndAnimation	This is executed after "Animation (one time)" or "Animation (reverse one time)" is finished.
PreKeyPress	This is executed before the process to be executed when the key is pressed.
PreChar	This is executed before the process to be executed when a character is input.
OnError	This is executed after it fails to set the input contents in the control specified to reflect the INPUT.
OnUpperLimitOver (Note)	This is executed when the result of accumulation is greater than the upper limit.
OnLowerLimitOver (Note)	This is executed when the result of accumulation is less than the lower limit.

(Note) If an event occurred and its occurrence condition continues, other events do not occur. Note that if the setting of "Upper Limit" or "Lower Limit" is changed, the other continuous conditions are released.

If "yes" is selected at each item, a [...] button is displayed in the setting area.

OnKeyPress	Yes	...
OnKeyRelease	None	
OnPress	None	

Click on the [...] button to display an [Event list] dialog box where details of the action can be specified.

**NOTE**

- ◆ If the character string does not overflow though "When a text sticks out" is selected as a caption character string scrolling method, OnScrollFinish is called immediately without scrolling after the character string starts to scroll. For the caption character string scroll, refer to "Caption Character String Scroll".
- ◆ Whether each callback function can be used or not can be changed for each control by the user.



7. Creating Controls

The following shows callback functions available in each control.

(○: Available; ×: Unavailable)

Control	OnKeyPress	OnKeyRelease	OnPress	OnRelease	OnClick	OnDraw	OnTimer	OnSelfFocus	OnKillFocus	OnCreate	OnDelete	OnUser	OnScrollFinish	OnChangeString	OnSelectChange	OnSubCursorMove	OnScroll	OnDrawLineString	OnInit	OnQuit	OnEndAnimation	PreKey/Press	PreChar	OnError	OnLowerLimitOver	OnUpperLimitOver	
Basic object	○	○	○	○	○	○	○	○	○	○	○	○	○	○	○	○	○	○	○	○	○	○	○	○	○	○	
Button object	○	○	○	○	○	○	○	○	○	○	○	○	○	○	○	○	○	○	○	○	○	○	○	○	○	○	○
Textbox object	○	○	○	○	○	○	○	○	○	○	○	○	○	○	○	○	○	○	○	○	○	○	○	○	○	○	○
Label object	×	×	×	×	×	○	○	○	○	○	○	○	○	○	○	○	○	○	○	○	○	○	○	○	○	○	○
List object	○	○	○	○	○	○	○	○	○	○	○	○	○	○	○	○	○	○	○	○	○	○	○	○	○	○	○
Picture object	×	×	×	×	×	○	○	○	○	○	○	○	○	○	○	○	○	○	○	○	○	○	○	○	○	○	○
Checkbox object	○	○	○	○	○	○	○	○	○	○	○	○	○	○	○	○	○	○	○	○	○	○	○	○	○	○	○
Radiobutton object	○	○	○	○	○	○	○	○	○	○	○	○	○	○	○	○	○	○	○	○	○	○	○	○	○	○	○
Progressbar object	×	×	×	×	×	○	○	○	○	○	○	○	○	○	○	○	○	○	○	○	○	○	○	○	○	○	○
HTML browser object	×	×	×	×	×	×	×	×	×	×	×	×	×	×	×	×	×	×	○	○	○	○	○	○	○	○	○
Horizontal scroll bar object	○	○	○	○	○	○	○	○	○	○	○	○	○	○	○	○	○	○	○	○	○	○	○	○	○	○	○
Vertical scroll bar object	○	○	○	○	○	○	○	○	○	○	○	○	○	○	○	○	○	○	○	○	○	○	○	○	○	○	○
Edit control object	○	○	○	○	○	○	○	○	○	○	○	○	○	○	○	○	○	○	○	○	○	○	○	○	○	○	○
Table object	○	○	○	○	○	○	○	○	○	○	○	○	○	○	○	○	○	○	○	○	○	○	○	○	○	○	○
Input box	○	○	○	○	○	○	○	○	○	○	○	○	○	○	○	○	○	○	○	○	○	○	○	○	○	○	○
Ten-key	○	○	○	○	○	○	○	○	○	○	○	○	○	○	○	○	○	○	○	○	○	○	○	○	○	○	○
Counter	○	○	○	○	○	○	○	○	○	○	○	○	○	○	○	○	○	○	○	○	○	○	○	○	○	○	○
CycleTime	○	○	○	○	○	○	○	○	○	○	○	○	○	○	○	○	○	○	○	○	○	○	○	○	○	○	○
Feedrate	○	○	○	○	○	○	○	○	○	○	○	○	○	○	○	○	○	○	○	○	○	○	○	○	○	○	○
GModal M	○	○	○	○	○	○	○	○	○	○	○	○	○	○	○	○	○	○	○	○	○	○	○	○	○	○	○
GModal L	○	○	○	○	○	○	○	○	○	○	○	○	○	○	○	○	○	○	○	○	○	○	○	○	○	○	○
GModal Simple	○	○	○	○	○	○	○	○	○	○	○	○	○	○	○	○	○	○	○	○	○	○	○	○	○	○	○
LoadMeter	○	○	○	○	○	○	○	○	○	○	○	○	○	○	○	○	○	○	○	○	○	○	○	○	○	○	○
MSTB	○	○	○	○	○	○	○	○	○	○	○	○	○	○	○	○	○	○	○	○	○	○	○	○	○	○	○
ONB	○	○	○	○	○	○	○	○	○	○	○	○	○	○	○	○	○	○	○	○	○	○	○	○	○	○	○
ProgramBuffer	○	○	○	○	○	○	○	○	○	○	○	○	○	○	○	○	○	○	○	○	○	○	○	○	○	○	○
SPCommand	○	○	○	○	○	○	○	○	○	○	○	○	○	○	○	○	○	○	○	○	○	○	○	○	○	○	○
PLC button	○	○	○	○	○	○	○	○	○	○	○	○	○	○	○	○	○	○	○	○	○	○	○	○	○	○	○
PLC textbox object	○	○	○	○	○	○	○	○	○	○	○	○	○	○	○	○	○	○	○	○	○	○	○	○	○	○	○
NC data text box	○	○	○	○	○	○	○	○	○	○	○	○	○	○	○	○	○	○	○	○	○	○	○	○	○	○	○
PLC extension button	○	○	○	○	○	○	○	○	○	○	○	○	○	○	○	○	○	○	○	○	○	○	○	○	○	○	○
PLC message	×	×	×	×	×	○	○	○	○	○	○	○	○	○	○	○	○	○	○	○	○	○	○	○	○	○	○
Menu	○	○	○	○	○	○	○	○	○	○	○	○	○	○	○	○	○	○	○	○	○	○	○	○	○	○	○
Extension Menu	○	○	○	○	○	○	○	○	○	○	○	○	○	○	○	○	○	○	○	○	○	○	○	○	○	○	○
FileInOut	×	×	×	×	×	○	○	○	○	○	○	○	○	○	○	○	○	○	○	○	○	○	○	○	○	○	○
AlarmMessage	×	×	×	×	×	×	×	×	×	×	×	×	×	×	×	×	×	×	×	×	×	×	×	×	×	×	×
MonitorStatus	×	×	○	○	○	○	×	×	×	○	○	○	○	○	○	○	○	○	○	○	○	○	○	○	○	○	○
Time	×	×	×	×	×	×	×	×	×	×	×	×	×	×	×	×	×	×	×	×	×	×	×	×	×	×	×
Page change button	○	○	○	○	○	○	○	○	○	○	○	○	○	○	○	○	○	○	○	○	○	○	○	○	○	○	○
Stacked graph	×	×	×	×	×	○	○	○	○	○	○	○	○	○	○	○	○	○	○	○	○	○	○	○	○	○	○
Statistics graph	×	×	×	×	×	○	○	○	○	○	○	○	○	○	○	○	○	○	○	○	○	○	○	○	○	○	○
Alarm list	○	○	○	○	○	○	○	○	○	○	○	○	○	○	○	○	○	○	○	○	○	○	○	○	○	○	○
Meter	○	○	○	○	○	○	○	○	○	○	○	○	○	○	○	○	○	○	○	○	○	○	○	○	○	○	○
TrendGraph	○	○	○	○	○	○	○	○	○	○	○	○	○	○	○	○	○	○	○	○	○	○	○	○	○	○	○
Frame	×	×	×	×	×	×	×	×	×	×	×	×	×	×	×	×	×	×	×	×	×	×	×	×	×	×	×

7.1.11 Event List Dialog Box

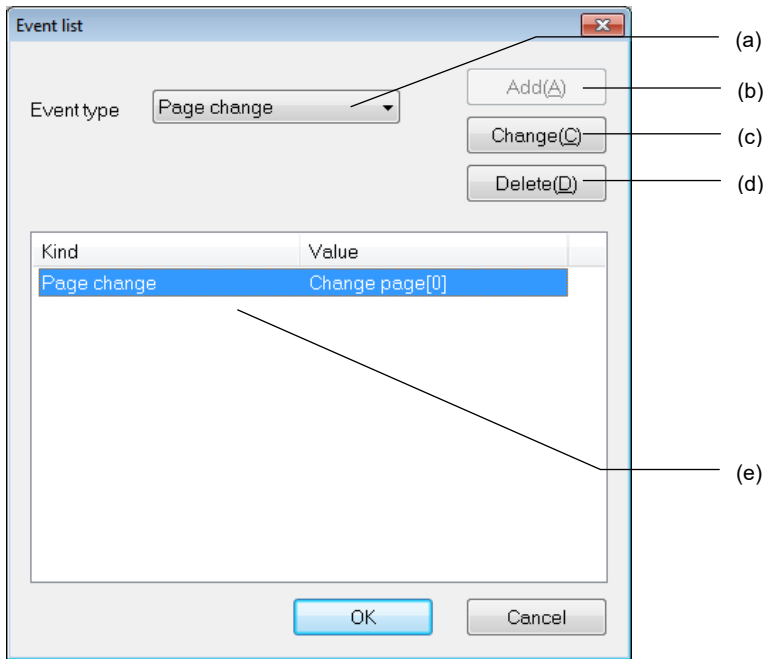

No.	Item	Description
(a)	Event type	Select the event to be added. Only "page change" can be specified.
(b)	Add	Add a selected event. Click on the "Add" button to display the [switch page] dialog box.
(c)	Change	Change the setting of an event selected from the registration list.
(d)	Delete	Delete an event selected from the registration list.
(e)	Entry List	A list of added events is displayed.

**NOTE**

◆ The page (screen) that can be switched with "page switching" is panel only. Switching to the window is not supported.

**7.1.12 Switch Screen Dialog Box**

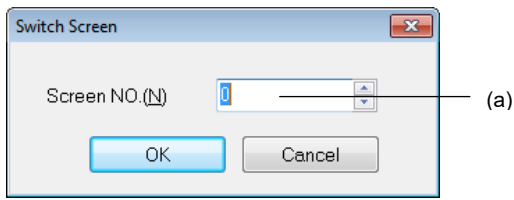

No.	Item	Description
(a)	Screen NO.	Specify the destination page number. Specify the panel page number as the destination.

**NOTE**

- ◆ After the switch screen setting is given, the switch screen process is added automatically in the callback functions during source code generation.

**7.1.13 Show/Hide**

Specify whether the control is displayed or hidden.

Item	Description
Show/Hide	Select whether the control is displayed or hidden.

**7.1.14 Input Permission**

Specify whether entry is permitted or prohibited for the control.

Item	Description
Input permission	Select whether the entry is accepted (permission) or rejected (prohibition).

**NOTE**

- ◆ Select "Hide" for [Show/Hide] and "Permission" for [Input Permission] to create a transparent control object.

### 7.1.15 Touch Gesture

Specify whether to permit or prohibit touch gesture for the control.

This function is only for M800V/M80V/M800/M80/E80 Series.

Item	Description
Touch gesture	Select whether to accept (permission) or reject (prohibition) a touch gesture operation.

#### **NOTE**

- ◆ Touch gesture includes the following operations.
  - Pan (Run your fingertip along the screen)  
The screen is scrolled along your finger motion.
  - Flick (Quickly run your fingertip along the screen)  
The screen is scrolled in the direction of your finger sweep.
- ◆ If you touch three points or more, the operation by the touch gesture is rejected.  
Lift all the fingers off the screen.

**7.1.16 Property Setup Dialog**

Property setup dialog consists of the tabs relating to [Basic Settings] and [Advanced Settings]. Details of each tab will be described in the following sections.

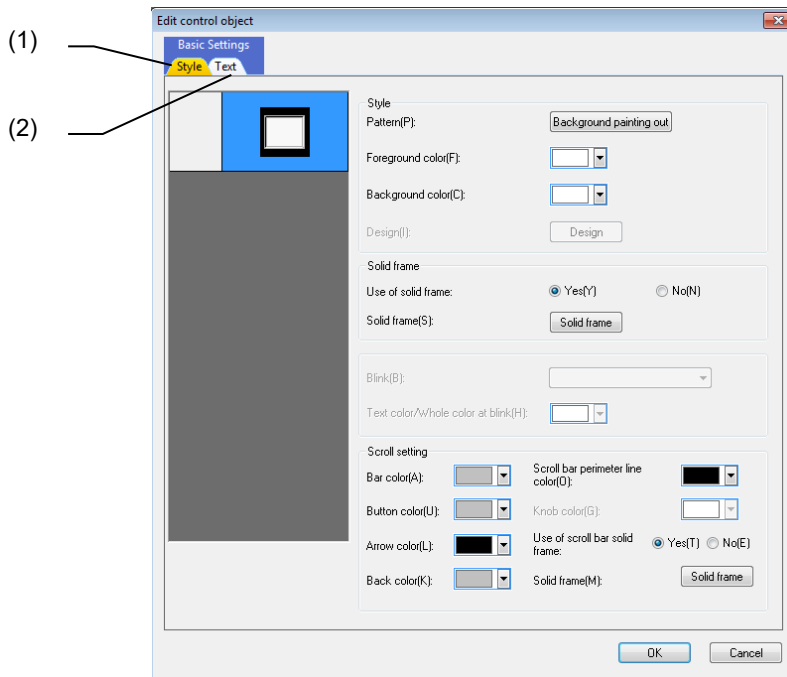

[Basic Settings] consists of the following tabs and tabs for each control.

No.	Tab	Description
(1)	Style	Set or display the background color, solid frame, blink and preview.
(2)	Text	Set or display the font, text, scroll and preview.

[Advanced Settings] consists of a tab to specify the setting for each control.

For specifications of the tab for each control, refer to "7.2 Standard Control" or "7.3 NC Control Object".

7.1.16.1 Standard Control

7.1.16.1.1 [Style] Tab

In [Style] Tab, specify the style, solid frame, blink, and scroll bar.

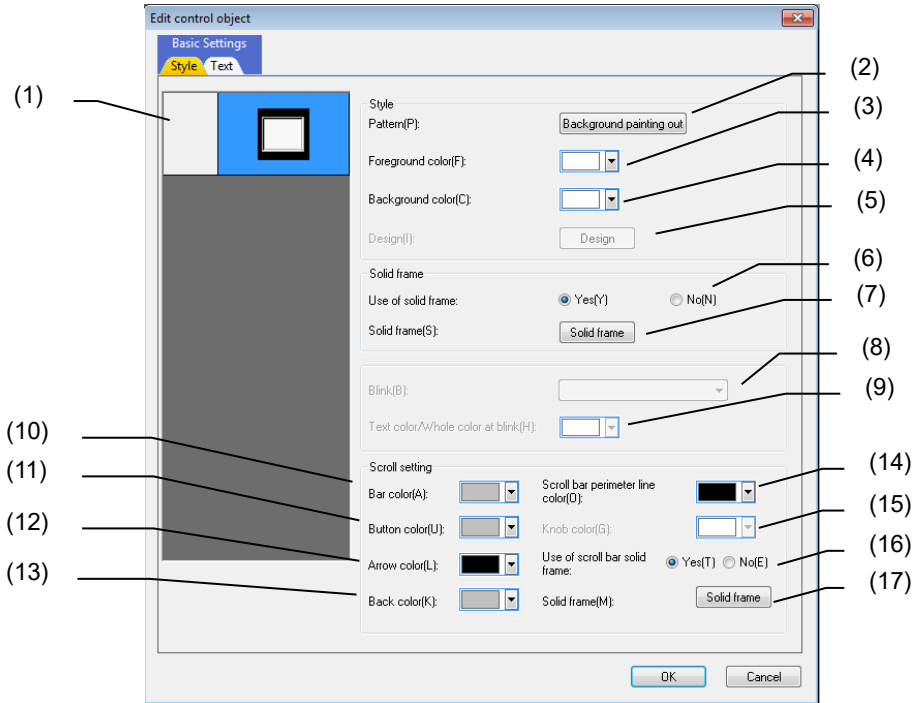

No.	Item	Description
(1)	Control state preview	Select the control state which you want to edit the style.
(2)	Pattern	Select the filling pattern among "Background painting out", "Foreground painting out", "pattern 0" to "pattern 37", and "With no painting out".
(3)	Foreground color	Specify the foreground color.
(4)	Background color	Specify the background color of the state selected in (1) control state preview.
(5)	Design	Select the image. Click on the Design button to display the "Image List" dialog.
(6)	Use of solid frame	Select the presence of the solid frame between "Yes" and "No".
(7)	Solid frame	Specify the solid frame. Click on the Solid frame button to display the "Solid frame Settings" dialog.
(8)	Blink	Select the blink setting among "No", "Switch Show/Hide character", "A character color is changed", and "A whole color is changed".
(9)	Text color/Whole color at blink	Specify the color to be used at blink.
(10)	Bar color	Specify the color of the scroll bar.
(11)	Button color	Specify the button color of the scroll bar.
(12)	Arrow color	Specify the arrow color of the scroll bar.
(13)	Back color	Specify the background color of the scroll bar.
(14)	Scroll bar perimeter line color	Specify the perimeter line color of the scroll bar.
(15)	Knob color	Specify the knob color of the scroll bar.
(16)	Use of scroll bar solid frame	Select the presence of the solid frame of the scroll bar between "Yes" and "No".
(17)	Solid frame	Specify the solid frame of the scroll bar.

**NOTE**

- ◆ "Pattern", "Foreground color", "Background color" and "Design" can be specified for items of the state selected in "control state preview".

Example: The preview of ON, OFF, FOCUS and DISABLE are displayed in button control.

When selecting FOCUS, you can specify the background color at the time of focus.

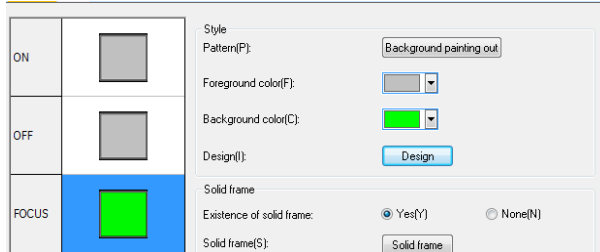

- ◆ The image data registered in the parts library can be selected on the "Image List" dialog.

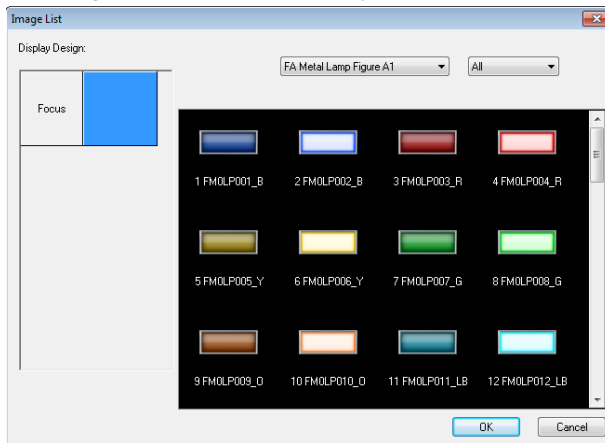

- ◆ When [OK] button is pressed on the property setup dialog, the image specified on the "Image List" dialog is registered as a resource. If there is no resource of the same settings in the existing resources, the image is registered as a new resource. However, if the resource of the same settings exist, the image is not registered. For the property "Design", an ID of existing resource is specified.

- ◆ Detail settings for the solid frame can be specified on the "Solid frame Settings" dialog.

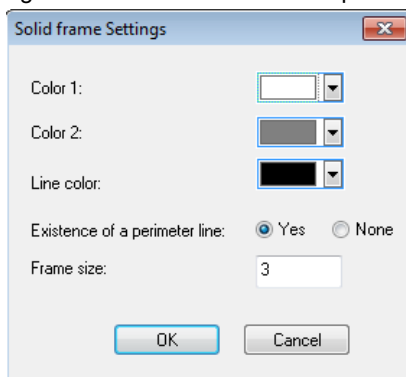

- ◆ When [OK] button is pressed on the property setup dialog, the data specified in "Solid frame Settings" dialog is registered as a resource. If there is no resource of the same settings in the existing resources, the data is registered as a new resource. However, if the resource of the same settings exist, the data is not registered. For the property "Solid frame", an ID of existing resource is specified.

7.1.16.1.2 [Text] Tab

In [Text] tab, specify the font, text, and scroll.

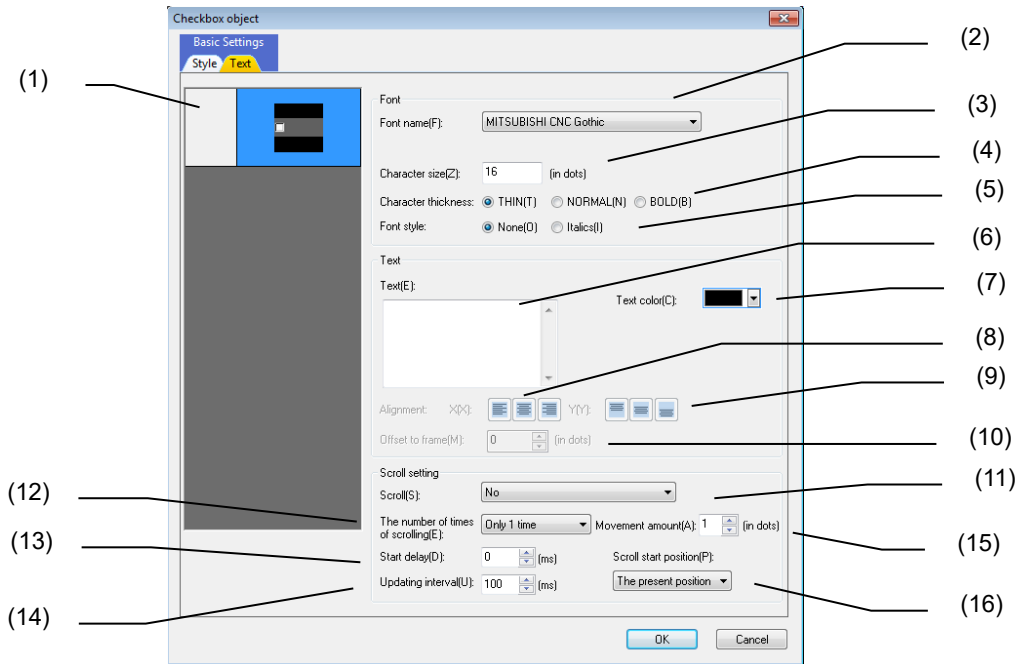

No.	Item	Description
(1)	Control state preview	Specify the control state which you want to edit the text.
(2)	Font name	Specify the font name.  When a font other than "MITSIBISHI CNC Gothic" is selected, the warning message "**Selected font is unavailable for a non-Windows-based display." is displayed in blue characters.
(3)	Character size	Specify the text size.
(4)	Character thickness	Select the text thickness among "THIN", "NORMAL", and "BOLD".
(5)	Font style	Select the font style between "None" and "Italics".
(6)	Text	Specify the displayed character string of the state selected in (1) control state preview.
(7)	Text color	Specify the text color.
(8)	Alignment (X)	Specify horizontal alignment. The buttons are "Align left", "Center", and "Align right" from the left.
(9)	Alignment (Y)	Specify vertical alignment. The buttons are "Align top", "Center", and "Align bottom" from the left.
(10)	Offset to frame	Specify a margin from the frame.  * The specified value is set to the property "Margin left", "Margin right", "Margin top", and "Margin bottom".
(11)	Scroll	Select the scroll setting among "No", "Yes", and "When a text sticks out". (Note)
(12)	The number of times of scrolling	Select the scrolling frequency between "Only 1 time" and "Repeat". (Note)
(13)	Start delay (ms)	Specify the delay from the start of scrolling (0 to 60000). (Note)
(14)	Updating interval (ms)	Specify the scroll refreshment interval (0 to 5000). (Note) Specify "0" to refrain from scrolling.
(15)	Movement amount (in dots)	Specify the amount of movement in scrolling (0 to 100). (Note)
(16)	Scroll start position	Select the starting position between "The present position" and "From a right end". (Note)

(Note) The items relating to the scroll setting are not reflected on the "control state preview".



**NOTE**

- ◆ When [OK] button is pressed on the property setup dialog, the data specified in "Font name", "Text size", "Text thickness", and "Font style" is registered as a resource. If there is no resource of the same settings in the existing resources, the data is registered as a new resource. However, if the resource of the same settings exist, the data is not registered. For the property "Font", an ID of the existing resource is specified.

7.1.16.2 NC Control

7.1.16.2.1 [Style] Tab

In [Style] Tab, specify the color type, foreground color, and background color.

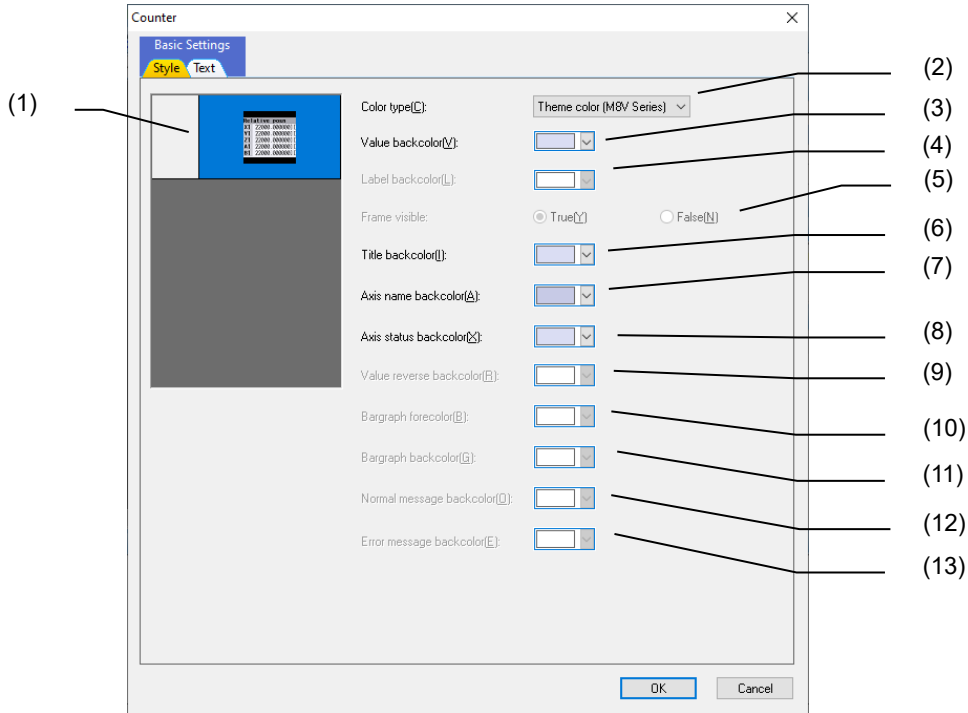

No.	Item	Description
(1)	Control state preview	The control image is drawn with the property value specified in the [Style] tab.
(2)	Color type	Select the color type.  Theme color (M8V Series): The control is displayed in the base color (for M8V Series) designated as the theme color. Theme color (M8 Series): The control is displayed in the base color (for M8 Series) designated as the theme color. Specified color: The control is displayed in the colors specified from (3) to (13). For theme color, refer to "5.10.9 Changing the Theme Color".
(3)	Value bgcolor	Specify the background color of the value part.
(4)	Label bgcolor	Specify the background color of the label part.
(5)	Frame visible	Select the presence of the solid frame between "True" and "False".
(6)	Title bgcolor	Specify the background color of the title part.
(7)	Axis name bgcolor	Specify the background color for the axis name display.
(8)	Axis status bgcolor	Specify the background color for the axis status display.
(9)	Value reverse bgcolor	Specify the background color of the highlighted part.
(10)	Bargraph forecolor	Specify the foreground color of the bar graph area.
(11)	Bargraph bgcolor	Specify the background color of the bar graph area.
(12)	Normal message bgcolor	Specify the background color of the normal message.
(13)	Error message bgcolor	Specify the background color of the error message.

(Note) The items relating to the existing properties for each control can be specified. For the properties which does not exist in the control, the entry is disabled (grayout) and the properties cannot be specified.

7.1.16.2.2 [Text] Tab

In [Text] tab, specify the font type, and text color.

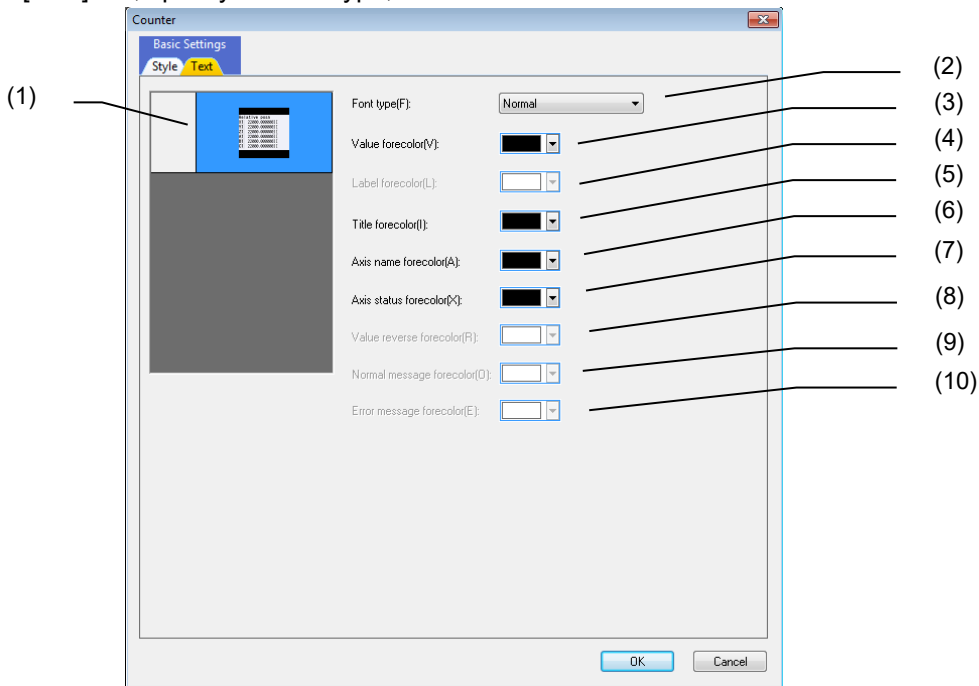

No.	Item	Description
(1)	Control state preview	The control image is drawn with the property value specified in the [Text] tab.
(2)	Font type	Specify the font type.  * The items which can be specified in the font type differ by each control. The selection items of the property "Font Type" are displayed. For SPCCommand (S display part), "Normal", "Middle" and "Big" are displayed as the selection items.
(3)	Value forecolor	Specify the character color of the value.
(4)	Label forecolor	Specify the character color of the label part.
(5)	Title forecolor	Specify the character color of the title part.
(6)	Axis name forecolor	Specify the character color of the axis name.
(7)	Axis status forecolor	Specify the character color of the axis status.
(8)	Value reverse forecolor	Specify the character color of the highlighted part.
(9)	Normal message forecolor	Specify the character color of the normal message.
(10)	Error message forecolor	Specify the character color of the error message.

(Note) The items relating to the existing properties for each control can be specified. For the properties which does not exist in the control, the entry is disabled (grayout).

7.1.16.3 Operation Procedures

Open Property Setup Dialog

1. Double-click the control allocated on the panel or window, or select [Change Property Settings] from the popup menu which is displayed by right-clicking the control.
2. Property setup dialog is displayed.

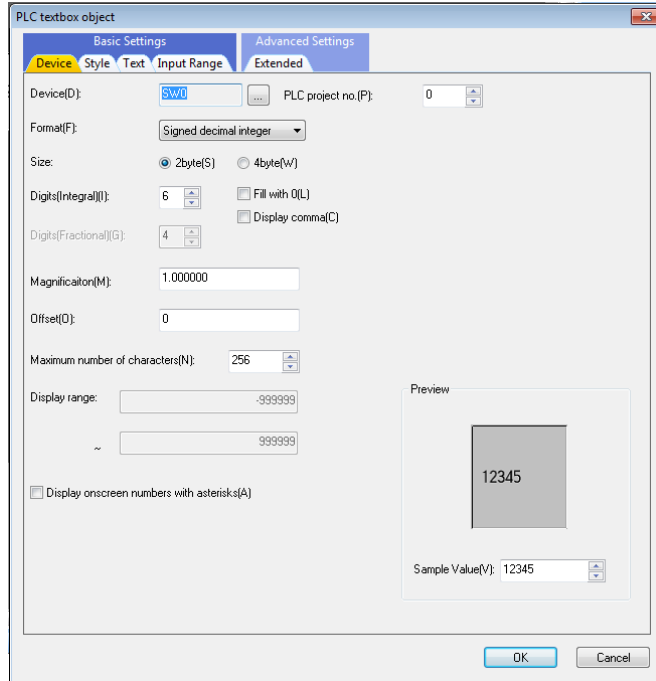

3. After the setting, press the [OK] button.

**NOTE**

- ◆ When you press the [OK] button, the setting data are reflected on each property. When you press the [Cancel] button, the setting data are not reflected on each property.

7.1.16.4 Input Assist Function

This function enables you to search the "Sec/Sub-sec No." of "Custom API library variable" by the keyword input in the NC data input field on the property setup dialog to narrow down the NC data candidates.

This function is only for M800V/M80V/M800/M80/E80 Series.

7.1.16.4.1 Input Assist Window

List of Custom API library variable is displayed on the input assist window.

(1)	(2)	(3)	(4)	(5)	(6)
Sec/ Sub-sec No.	Description	Part sys	Axis	R/W	Data Type
1/1	The number of axes in a part system [...	Y	-	R	T_CHAR
1/2	The number of axes in a part system [...	Y	-	R	T_CHAR
1/100	The number of sets of common variabl...	Y	-	R	T_SHORT
2/1	The number of part systems	-	-	R	T_CHAR
2/2	The total number of NC axes (NC)	-	-	R	T_CHAR
2/3	The total number of control axes (NC+...	-	-	R	T_CHAR
2/4	The number of spindles	-	-	R	T_CHAR
2/5	The number of PLC axes	-	-	R	T_CHAR
2/6	The number of auxiliary axes	-	-	R	T_CHAR
2/7	File system format	-	-	R	
2/8	The number of sets of common variabl...	-	-	R	T_LONG
2/9	Information of the max. number of mac...	-	-	R	T_SHORT
2/10	The number of power supply axes (SV...	-	-	R	T_CHAR
2/100	NC type	-	-	R	T_CHAR
2/101	PLC device allocation type (M6/M7)	-	-	R	T_CHAR
3/1	Tool compensation type	Y	-	R	T_CHAR
3/2	The number of tool compensation sets	Y	-	R	T_SHORT
3/3	The number of workpiece offset sets	Y	-	R	T_CHAR
6/2000	Local variable empty variable	Y	-	R	T_DOUBLE

No.	Item	Description
(1)	Sec/Sub-sec No.	Displays the Sec/Sub-sec No. of the Custom API library variable.
(2)	Description	Displays the description of the Custom API library variable. For the Custom API library variable of M8V Series, display the description with "(M8V)□" (□: one-byte space) added at the head.
(3)	Part sys	Displays whether the Custom API library variable needs part system designation or not.
(4)	Axis	Displays whether the Custom API library variable needs axis designation or not.
(5)	R/W	Displays whether the Custom API library variable can be read/write or not.
(6)	Data Type	Displays the data type of the Custom API library variable.

**NOTE**

- ◆ Up to 20 candidates can be displayed in the input assist window.  
When 21 or more candidates are searched, a vertical scroll bar is displayed and the displayed data can be switched with the PageUp key, PageDown key or the mouse wheel.
- ◆ Up to 1,000 Custom API library variables can be searched.
- ◆ When the input assist window is displayed, some data may not be displayed completely. In that case, change the column width.

7.1.16.4.2 Operation Procedure

Set the Sec/Sub-sec No. to the NC data

1. To display the input assist window, input the keyword in the NC data field on the property setup dialog, or press the "▼" button.

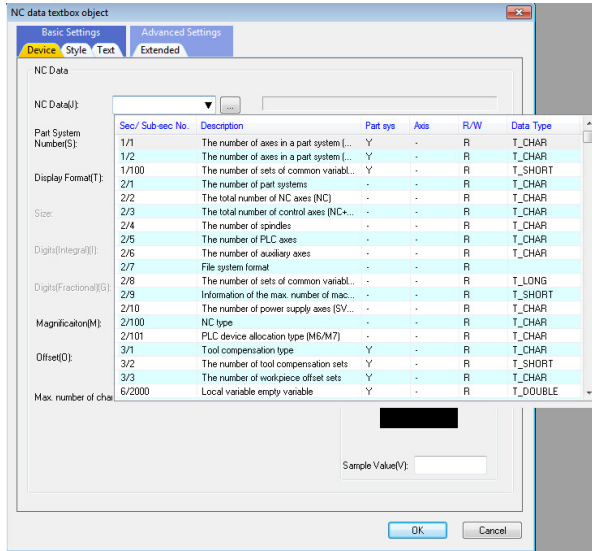

2. Depending on the keyword input in the NC data field, the input assist window display changes with the following conditions.

- The "Sec/Sub-sec No." or "Description" that are relevant to the input keyword. (Uppercase and lowercase characters are not distinguishable. Two-byte characters and one-byte characters are distinguishable.)

3. To set the Sec/Sub-sec No. in the NC data field, perform one of the following operations.

- Click the Custom API variable line to be specified.
- Select the Custom API variable to be specified with the up/down keys on the keyboard and press the Enter key.

**NOTE**

- ◆ "Description" of the Custom API variable corresponding to Sec/Sub-sec No. is displayed on the property setup dialog after setting the NC data on it.
- ◆ Display of the description field of "Part System Number" on the property setup dialog becomes invalid when "Part sys" of Custom API variable corresponding to Sec/Sub-sec No. of the NC data is "-".
- ◆ Display of the description field of "Axis Number" on the property setup dialog becomes invalid when "Axis" of Custom API variable corresponding to Sec/Sub-sec No. of the NC data is "-".
- ◆ NC data field becomes blank when both Section No. and Sub-section No. are "0".

7.1.16.4.3 Precautions

- When there is no "Description" display field, or no "Part System Number" and "Axis" input field such as the Property setup dialog of trend graph control, the "Description" fields etc. are not displayed even if a Custom API variable corresponding to the input NC data exists.

## 7.2 Standard Control

### 7.2.1 Basic Control Object (GCBasicControl)

The basic control object is a control for providing an area where original drawing for the user or process can be performed.

The basic control does not have a specific function and appearance, action and other properties are described by the user after the source is generated.

#### 7.2.1.1 Property Settings

The property settings of the basic control object are divided into the followings.

Control name	:	Specify the control name.
Position/size	:	Specify the position and size of the control.
Callback function	:	Specify the presence of the callback function.
Show/hide	:	Specify whether the control is displayed or hidden.
Input permission	:	Select whether the entry is accepted (permission) or rejected (prohibition).

For properties, refer to "7.1 Common Functions of Controls".

### 7.2.2 Button Object (GCButton)

The button object holds the ON/OFF status internally and the status changes each time it is pressed or released.

Two types of actions can be selected for the button action: momentary and alternate.

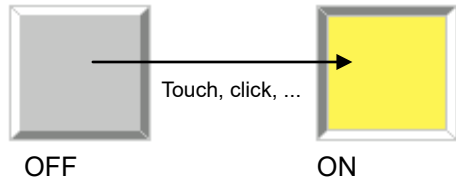

#### 7.2.2.1 Property Setup Dialog

Property setup dialog of button control object consists of the tabs relating to [Basic Settings] and [Advanced Settings]. Details of each tab will be described in the following sections.

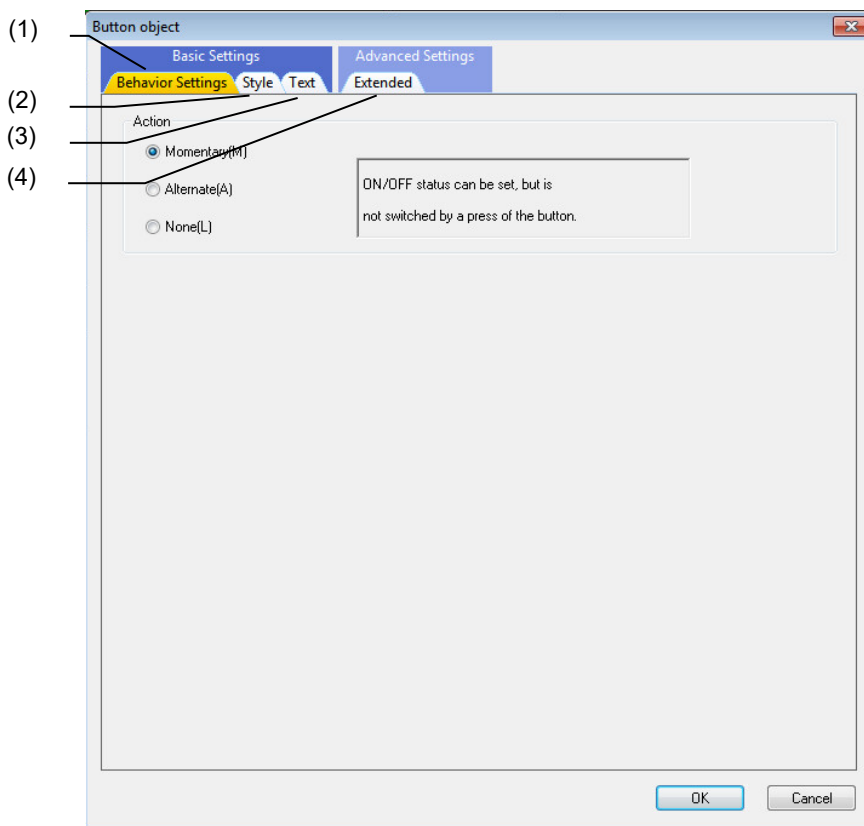

[Basic Settings] consists of the following tabs.

No.	Tab	Description
(1)	Behavior Settings	Specify the action.
(2)	Style	Set or display the background color, solid frame, blink and preview.
(3)	Text	Set or display the font, text, scroll and preview.

[Advanced Settings] consists of the following tab.

No.	Tab	Description
(4)	Extended	Set the item relating to the extended condition for the style.



7.2.2.1.1 [Behavior Settings] Tab

In [Behavior Settings] tab, specify the button action.

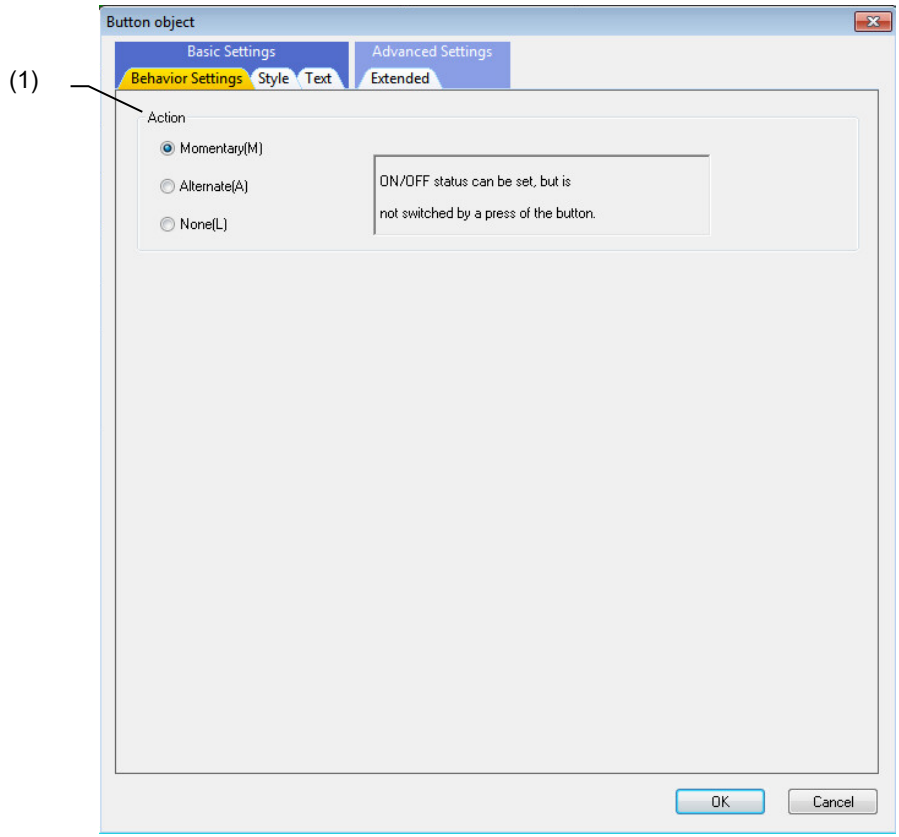

No.	Item	Description
(1)	Action	Select the button action among "None", "Momentary", or "Alternate".

7.2.2.1.2 [Style] Tab

In [Style] tab, specify the background color, solid frame, and blink.

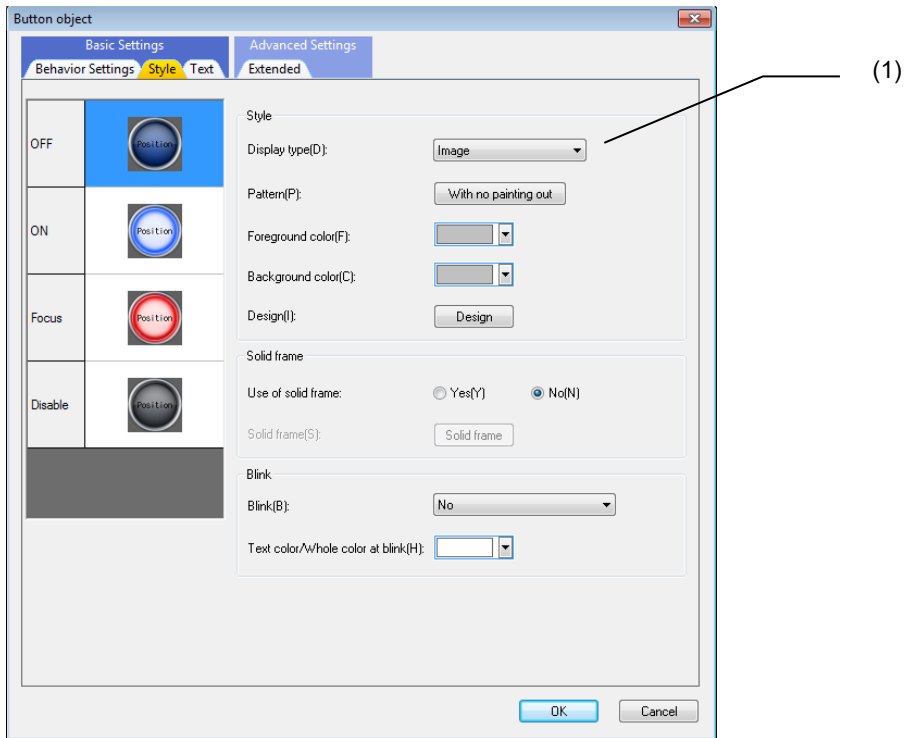

No.	Item	Description
(1)	Display type	Select the display type among "Square", "Circle", and "Image".

For the items other than the above, refer to "7.1.16.1.1 [Style] Tab".

7.2.2.1.3 [Text] Tab

In [Text] tab, specify the font, text, and scroll.

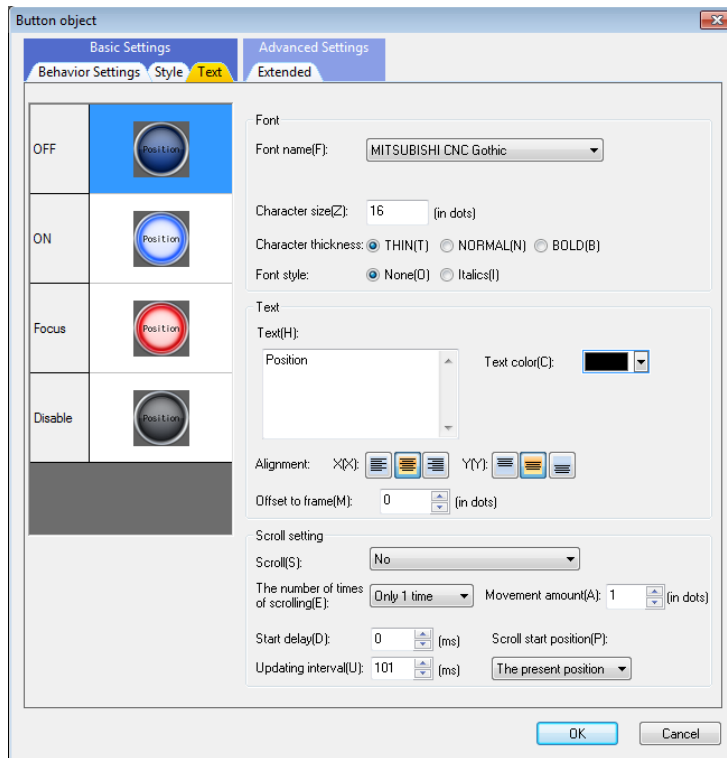

For each item, refer to "7.1.16.1.2 [Text] Tab".

7.2.2.1.4 [Extended] Tab

In [Extended] tab, set whether to provide the background color when the button is selected, and when the button does not work.

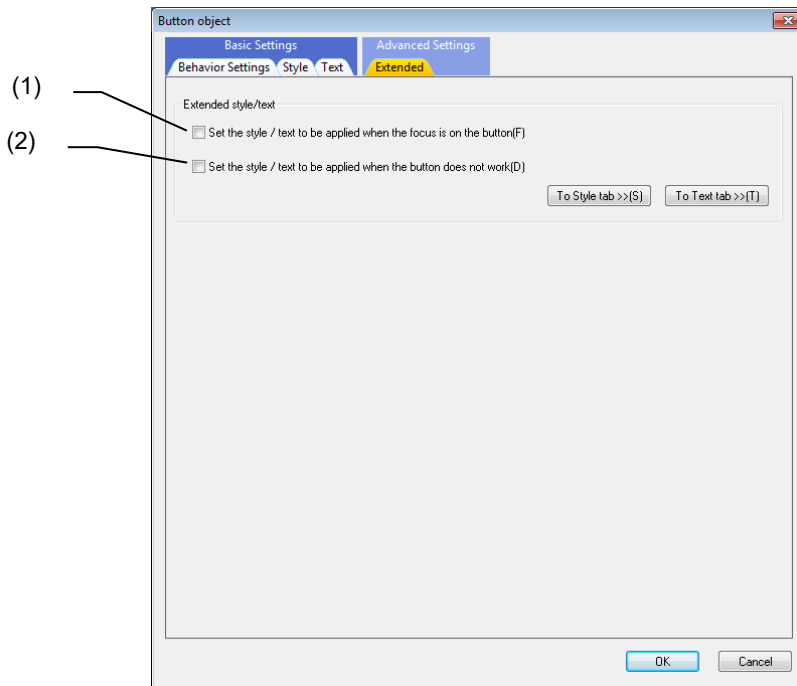

No.	Item	Description
(1)	Set the style / text to be applied when the focus is on the button	When this box is checked, the pattern, foreground color, background color, and design for when the button is selected (Focus) can be specified on the [Style] tab and [Text] tab.
(2)	Set the style / text to be applied when the button does not work	When this box is checked, the pattern, foreground color, background color, and design for when the button does not work (Disable) can be specified on the [Style] tab and [Text] tab.

### 7.2.2.2 Property Settings

The property settings for the button object are divided into followings.



Control name	:	Specify the control name.
Position/size	:	Specify the position and size of the control.
Button type	:	Select the button action.
Display type	:	Select the display type of the button.
Color/pattern	:	Specify the color and pattern of the control.
Image	:	Specify the image of the control.
Caption	:	Specify the caption (character string) displayed on the control.
Character attribute	:	Specify the character attribute of the caption.
Solid frame	:	Specify the solid frame of the control.
Caption character string scroll	:	Specify the scroll of the caption character string.
Blink	:	Specify the blink of the caption character string.
Callback function	:	Specify whether or not the callback functions are provided.
Show/hide	:	Select whether the control is displayed or hidden.
Input permission	:	Select whether the entry is accepted (permission) or rejected (prohibition).

7. Creating Controls

Button Type

Item	Description
Button type	Select the button action among the following three types.
Momentary	The button turns on when it is pressed. It turns off when it is released.
Alternate	The button alternates ON and OFF each time it is pressed.
None	The button does not turn on or off even if it is pressed.

Display Type

Item	Description
Display type	Select the button type among the following three types.
Square	Rectangular button. The button is indicated in the designated color and pattern. 
Circle	Round button. The button is indicated in the designated color and pattern. 
Image	The button is indicated with the designated image resource. 

Color/Pattern

Item	Description
Pattern at the time of ON <sup>*1</sup>	Specify the pattern of the ON button.
Foreground color at the time of ON <sup>*1</sup>	Specify the foreground color of the ON button.
Background color at the time of ON <sup>*1</sup>	Specify the background color of the ON button.
Design at the time of ON <sup>*2</sup>	Specify the image of the ON button.
Pattern at the time of OFF <sup>*1</sup>	Specify the pattern of the OFF button.
Foreground color at the time of OFF <sup>*1</sup>	Specify the foreground color of the OFF button.
Background color at the time of OFF <sup>*1</sup>	Specify the background color of the OFF button.
Design at the time of OFF <sup>*2</sup>	Specify the image of the OFF button.

\*1: The setting is valid if the [Display Type] is "Square" or "Circle".

\*2: The setting is valid if the [Display Type] is "Image".

Image

Item	Description
Effect at the time of focus	Specify whether the color of the button when the focus is located changes or not. Select between "change color" and "no change".
Pattern at the time of focus <sup>*1</sup>	Specify the pattern of the button when the focus is located.
Foreground color at the time of focus <sup>*1</sup>	Specify the foreground color of the button when the focus is located.
Background color at the time of focus <sup>*1</sup>	Specify the background color of the button when the focus is located.
Design at the time of focus <sup>*2</sup>	Specify the image of the button when the focus is located.
Pattern at the time of disable <sup>*1</sup>	Specify the pattern of the button when the entry is disabled.
Foreground color at the time of disable <sup>*1</sup>	Specify the foreground color of the button when the entry is disabled.
Background color at the time of disable <sup>*1</sup>	Specify the background color of the button when the entry is disabled.
Design at the time of disable <sup>*2</sup>	Specify the image of the button when the entry is disabled.

\*1: The setting is valid if the [Display Type] is "Square" or "Circle".

\*2: The setting is valid if the [Display Type] is "Image".

For the other properties, refer to "7.1 Common Functions of Controls".

### 7.2.3 Text Box Object (GCTextBox)

The text box object is a control for the values and character strings to display or enter in the designated rectangle.

For values, character string/binary conversion is made.

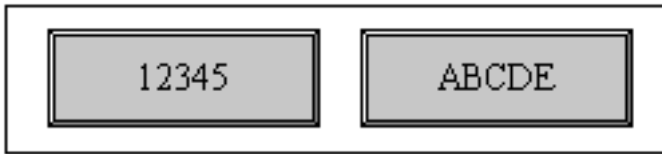

#### 7.2.3.1 Property Setup Dialog

Property setup dialog of text box control consists of the tabs relating to [Basic Settings] and [Advanced Settings]. Details of each tab will be described in the following sections.

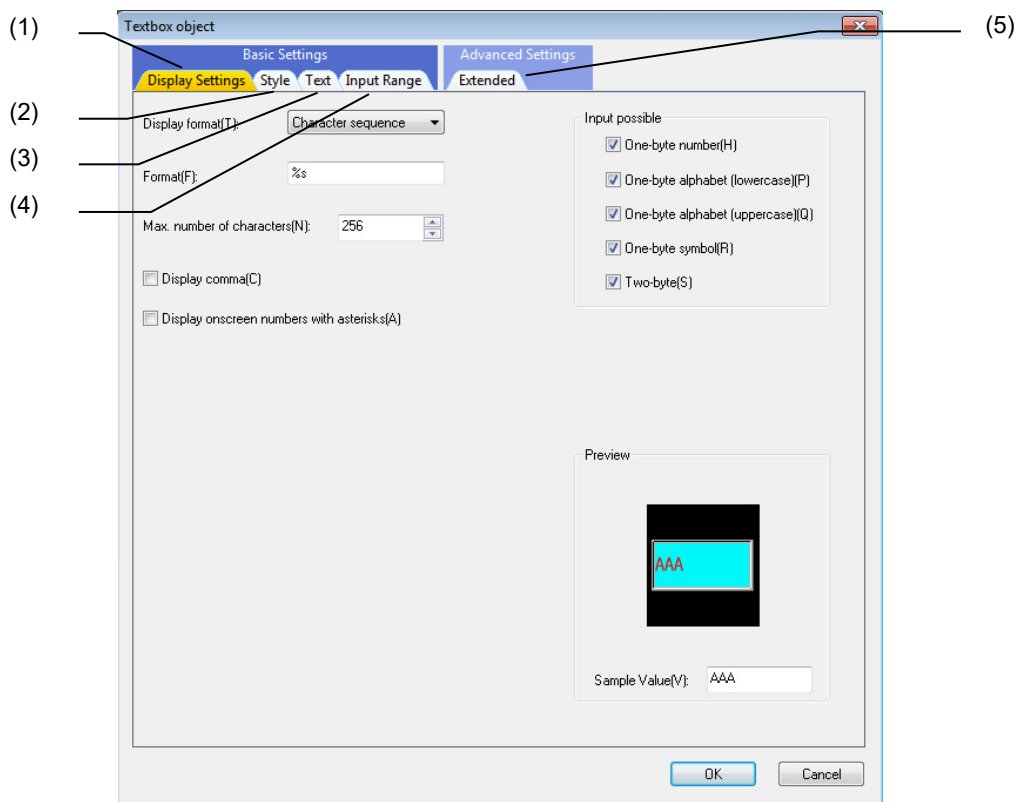

[Basic Settings] consists of the following tabs.

No.	Tab	Description
(1)	Display Settings	Set or display the display format, format, and preview.
(2)	Style	Set or display the background color, solid frame, blink and preview.
(3)	Text	Set or display the font, text, scroll and preview.
(4)	Input Range	Set or display the input range.

[Advanced Settings] consists of the following tab.

No.	Tab	Description
(5)	Extended	Set the item relating to the extended condition for the style.



7.2.3.1.1 [Display Settings] Tab

In [Display Settings] tab, specify the display format, format, etc.

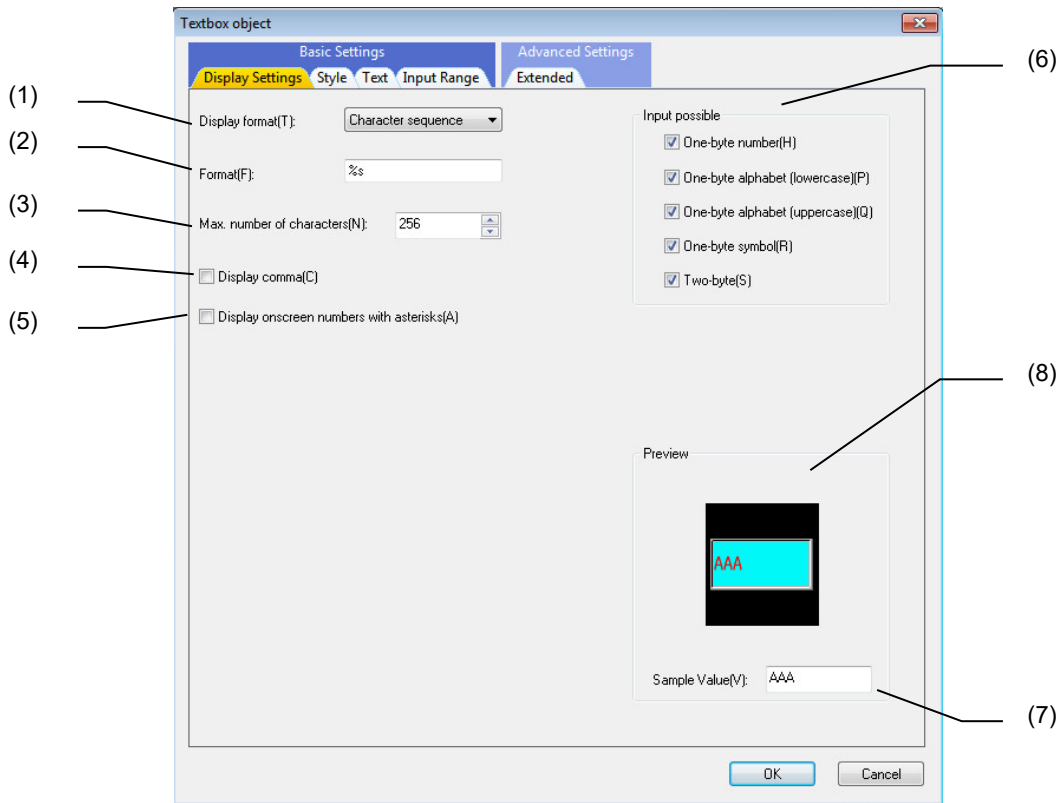

No.	Item	Description
(1)	Display format	Specify the display format. (Character sequence/signed short/unsigned short/signed long/unsigned long/float/double)
(2)	Format	Specify the value-to-character string conversion format.
(3)	Max. number of characters	Specify the maximum number of characters to display.
(4)	Display comma	Check this box to display the value with commas. A comma is inserted after every three digits, if "comma" is set to the display.
(5)	Display onscreen numbers with asterisks	Check this box to display the entered characters by asterisks (*).
(6)	Input possible	For entry in the text box, select whether one-byte numbers, lower case letters, upper case letters, one-byte symbols, and two-byte characters are allowed or not. Check this box to allow the entry.
(7)	Sample Value	Specify the value to be displayed on the preview.
(8)	Preview	Display the "Sample Value" specified in combination with the property "Display format", "Comma" and "Password setting" on the preview.  (Note) When lower case letters, upper case letters, one-byte symbols, or two-byte characters are specified in the "Sample Value", specify "Character sequence" in "Display format".

**NOTE**

- ◆ The following is the combination of "Display format" and "Format".  
Change the setting of "Format" depending on the item specified in "Display format".

Display format	Format
signed short, unsigned short, signed long, unsigned long	%hd, %hu, %ld, %lu
float, double	%f, %lf
Character sequence	%s

**7.2.3.1.2 [Style] Tab**

In [Style] tab, specify the background color, solid frame, and blink.

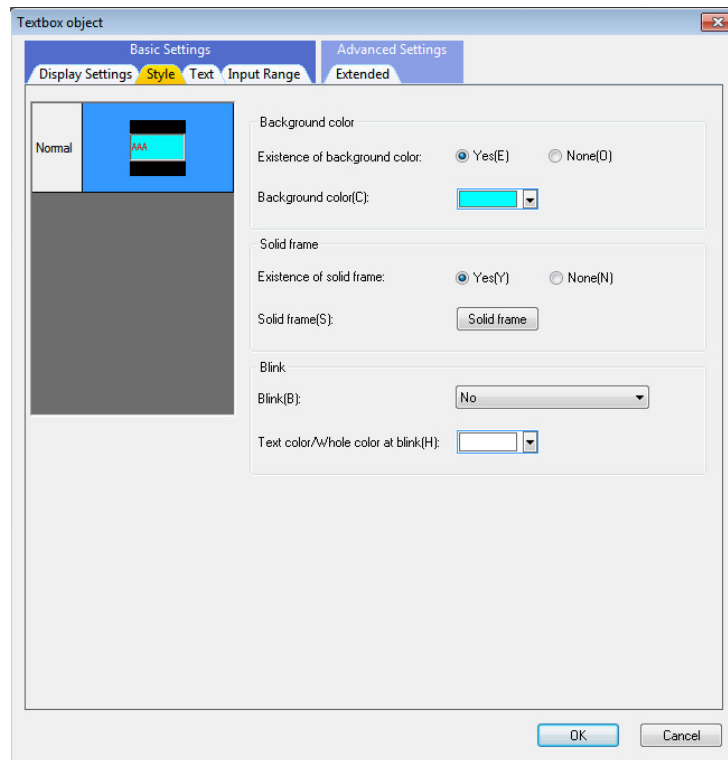

For each item, refer to "7.1.16.1.1 [Style] Tab".

7.2.3.1.3 [Text] Tab

In [Text] tab, specify the font, text, and scroll.

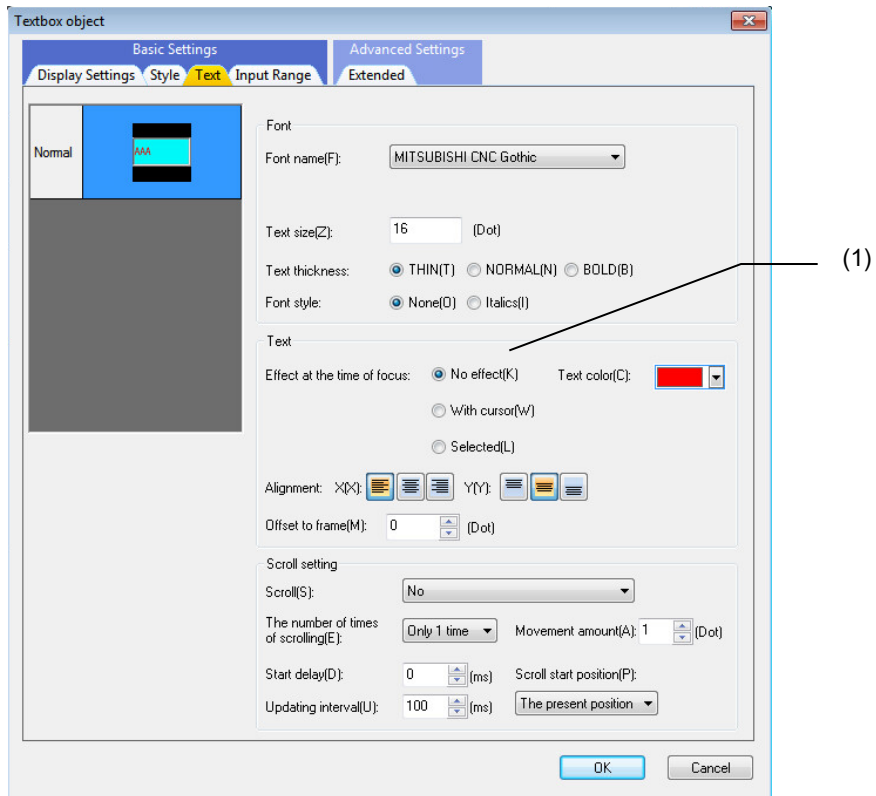

No.	Item	Description
(1)	Effect at the time of focus	Select how the cursor and setting values are displayed at the time of focus. "With cursor": Displays the cursor. "No effect": Does not display the cursor. "Selected": Selects the entire setting value.

For the items other than the above, refer to "7.1.16.1.2 [Text] Tab".

**7.2.3.1.4 [Input Range] Tab**

In [Input Range] tab, specify the input range.

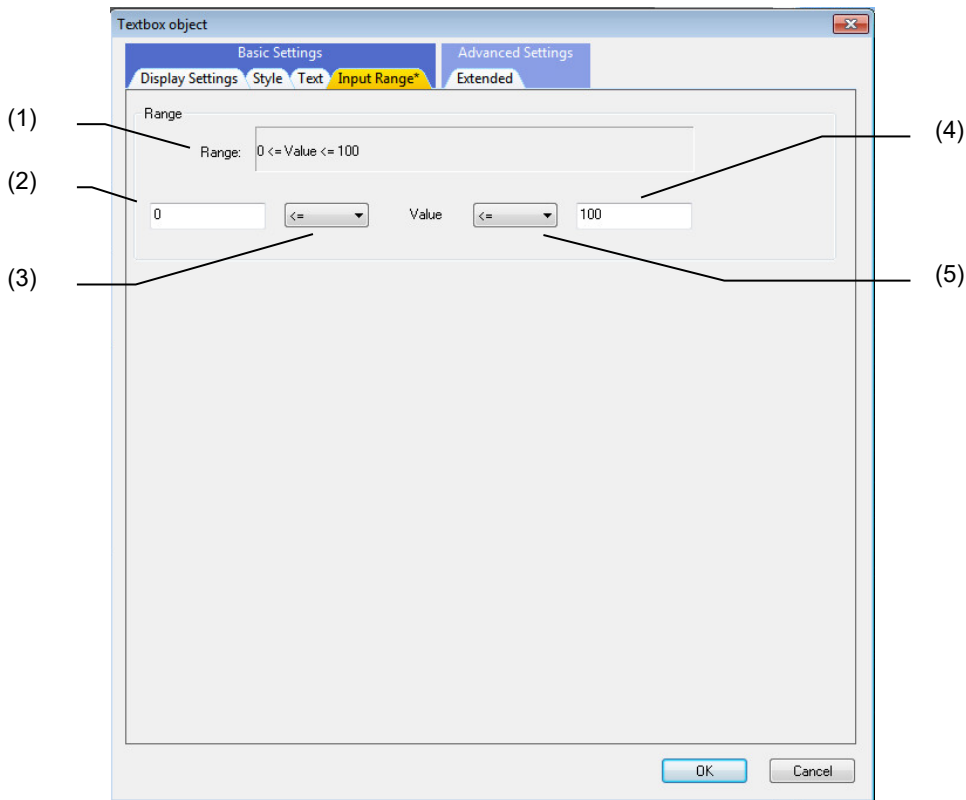

No.	Item	Description
(1)	Range	Display the range.
(2)	Minimum value	Specify the minimum value.
(3)	Comparison operator for minimum value	Select the comparison operator for minimum value between "<=" and "None".
(4)	Maximum value	Specify the maximum value.
(5)	Comparison operator for maximum value	Select the comparison operator for maximum value between "<=" and "None".

7.2.3.1.5 [Extended] Tab

In [Extended] tab, set whether to provide the background color at the time of focus and disable.

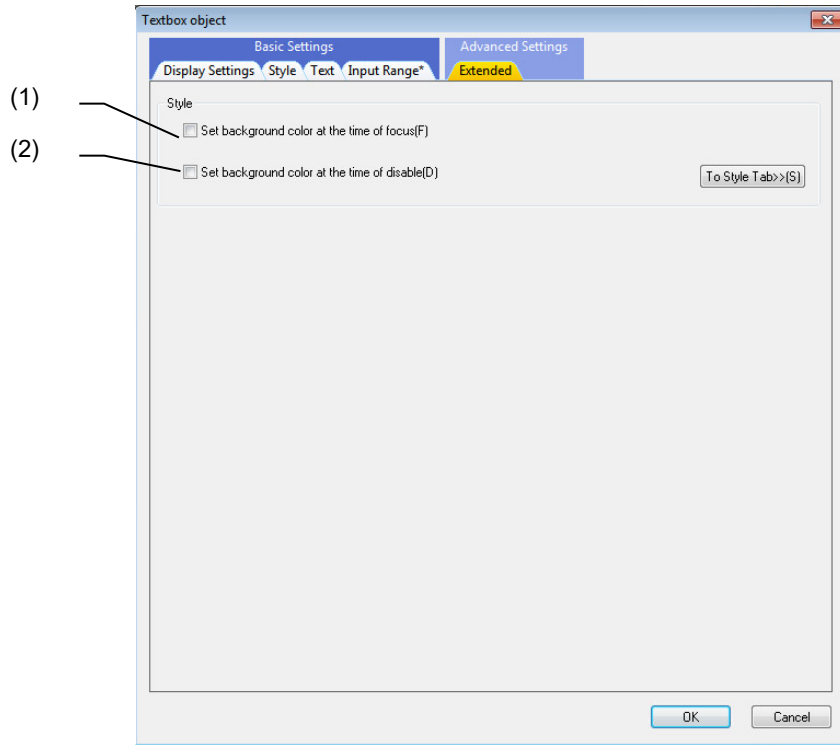

No.	Item	Description
(1)	Set background color at the time of focus	Check this box to specify the background color at the time of focus on [Style] tab.
(2)	Set background color at the time of disable	Check this box to specify the background color at the time of disable on [Style] tab.

**7.2.3.2 Property Settings**

The property settings for the text box object are divided into the followings.

- Control name : Specify the control name.
- Position/size : Specify the position and size of the control.
- Color/pattern : Specify the color and pattern of the control.
- Display type : Select the display type.
- Password : Specify the password.
- Caption : Specify the caption (character string) to be displayed on the control.
- Character attribute : Specify the character attribute of the caption.
- Solid frame : Specify the solid frame of the control.
- Caption character string scroll : Specify the scroll of the caption character string.
- Blink : Specify the blink of the caption character string.
- Callback function : Specify the presence of callback functions.
- Show/hide : Select whether the control is displayed or hidden.
- Input permission : Select whether the entry is accepted (permission) or rejected (prohibition).

Color/Pattern

Item	Description
Use of background color	Select if the background color is provided or not. If "No" is selected, the background is transparent.
Background color	Specify the background color.
Background color at the time of focus	Specify the background color at the time of focus.
Background color at the time of disable	Specify the background color when the entry is disabled.

Display Type/Display Format

Item	Description
Type	Select the displaying and entry type among the following six types.
Character sequence	A character string is displayed or entered.
signed short	A signed short value is displayed or entered.
unsigned short	An unsigned short value is displayed or entered.
signed long	A signed long value is displayed or entered.
unsigned long	An unsigned long value is displayed or entered.
float	A floating point value is displayed or entered.
double	A value of double-precision floating-point is displayed or entered.
Display format (Note)	Specify the value-to-character string conversion type.
Number of the maximum characters	Specify the maximum number of characters to be displayed (1 to 256).
Maximum check	For the value field, select whether to check for the maximum value limit or not.
Maximum	Specify the maximum value for the maximum value check. (-2147483648 to 4294967295).
Minimum check	For the value field, select whether to check for the minimum value limit or not.
Minimum	Specify the minimum value for the minimum value check. (-2147483648 to 4294967295).
Comma	For the value field, select whether to display commas or not.
Half-size number	For entry in the text box, select whether one-byte numbers are allowed or not.
Half-size English small letter	For entry in the text box, select whether one-byte lower case letters are allowed or not.
Half-size English capital letter	For entry in the text box, select whether one-byte upper case letters are allowed or not.
Half-size sign	For entry in the text box, select whether one-byte symbols are allowed or not.
Full size	For entry in the text box, select whether two-byte characters are allowed or not.

(Note) Specify the suitable type specifier for each type. If the combination of type and display format is not suitable, it will not be displayed correctly.

**NOTE**

- ◆ Correspondence table for the combination of the type and the display format

Type	Display format
signed short, unsigned short, signed long, unsigned long	%hd, %hu, %ld, %lu
float, double	%f, %lf

Example) When displaying in hexadecimal notation, specify %X to the display format.

\* Set with the combination above when the type and the display format are set with GCSTextboxSetTextType function or GCSTextboxSetFormatID function.

Password

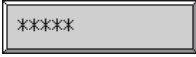
Item	Description
Password setup	Select "Yes" to display entered characters with asterisks (*). 

Character Attribute

Item	Description
Effect at the time of focus	Select how the cursor and setting values are displayed at the time of focus. "With cursor": Displays the cursor. "No effect": Does not display the cursor. "Selected": Selects the entire setting value.

For the other properties, refer to "7.1 Common Functions of Controls".

7.2.3.3 Complements

Operations with Keys

 Key

This key deletes all the characters in the text box.

Press  key.



All the characters in the text box will be deleted and the cursor will move to the initial position (\*1).

(\*1) The initial position is the position which is specified in the property "Horizontal position". When "No effect" is set in the property "Effect at the time of focus", the cursor is not displayed.



### 7.2.4 Label Object (GCLabel)

The label object is a control for displaying a character string inside the designated rectangle.

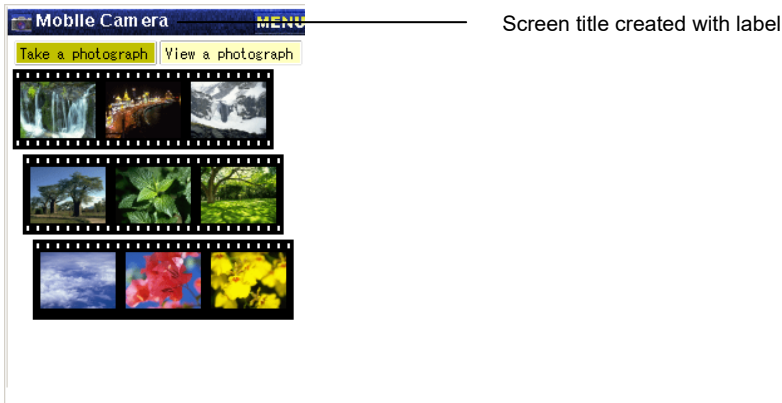

#### 7.2.4.1 Property Settings

The property settings of the label object are divided into the followings.

- Control name : Specify the control name.
- Position/size : Specify the position and size of the control.
- Caption : Specify the caption (character string) displayed on the control.
- Character attribute : Specify the character attribute of the caption.
- Caption character string scroll : Specify the scroll of the caption character string.
- Blink : Specify the blink of the caption character string.
- Callback function : Specify whether or not the callback functions are provided.
- Show/hide : Select whether the control is displayed or hidden.

For properties, refer to "7.1 Common Functions of Controls".

**7.2.5 List Object (GCList)**

The list object is a control for allowing the user to select from a list of several character strings.

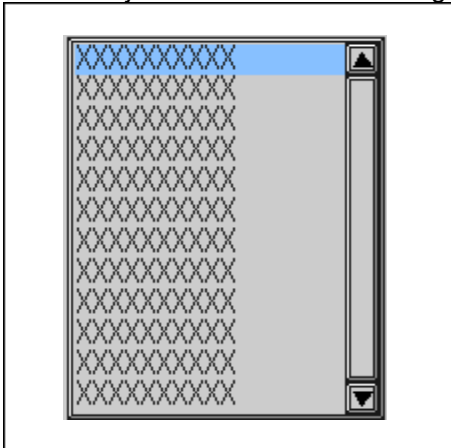

**7.2.5.1 Property Settings**

The property settings of the list object are divided into the followings.

- Control name : Specify the name of the control.
- Position/size : Specify the position and size of the control.
- Color/Pattern : Specify the color and pattern of the control.
- Scroll bar : Specify the color and width of the scroll bar and scroll bar button.
- Selection bar : Specify the color of the selection bar.
- Max. number of lines : Specify the maximum number of lines of character strings shown in the list.
- Character attribute : Specify the character attribute of the caption.
- Solid frame : Specify the solid frame of the control.
- Callback functions : Specify whether or not the callback functions are provided.
- Show/hide : Select whether the control is displayed or hidden.
- Input permission : Select whether the entry is accepted (permission) or rejected (prohibition).
- Operation : Specify the operation of the control.

Color/Pattern

Item	Description
Background color	Specify the background color of the control.
Background color at the time of focus	Specify the background color of the list where the focus is located.
Background color at the time of disable	Specify the background color of the disabled list.

Scroll Bar

Item	Description
Scroll bar color	Specify the color of the scroll bar.
Scroll button color	Specify the color of the scroll button.
Scroll bar width	Specify the width of the scroll bar in dots (16 to 960).

Selection Bar

Item	Description
Select bar color	Specify the color of the selection bar.

The scroll bar and selection bar settings are reflected on the following parts.

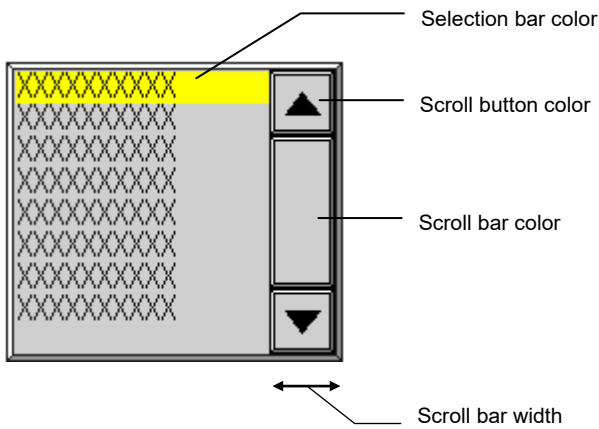

Max. Number of Lines

Item	Description
Number of the maximum lines	Specify the maximum number of lines of character strings displayed in the list (1 to 512).

For the other properties, refer to "7.1 Common Functions of Controls".

7.2.5.2 Complements

Operation specifications

- (1) Pan (Run your fingertip along the screen)  
 The touched line is scrolled along your finger motion (Vertical direction).  
 On the scroll bar, the slider follows your finger motion.
- (2) Flick (Quickly run your fingertip along the screen)  
 The screen is scrolled in the direction of your finger sweep (Vertical direction).

### 7.2.6 Picture Object (GCPicture)

The picture object is a control where the image is switched according to the state of an external device or the internal state of software to notify the user of the state.

The picture supports up to 32 states. Each state has separate appearance.

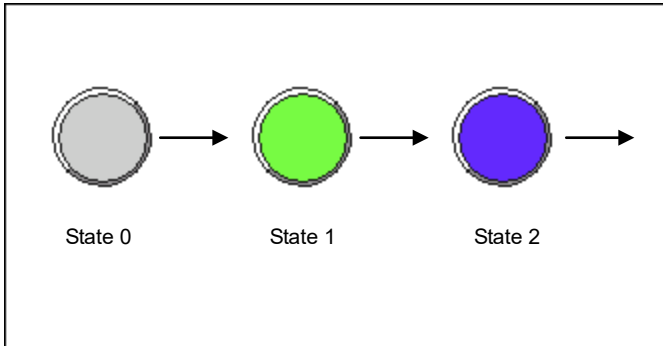

#### 7.2.6.1 Property Setup Dialog

Property setup dialog of picture object consists of the tabs relating to [Basic Settings] and [Advanced Settings]. Details of each tab will be described in the following sections.

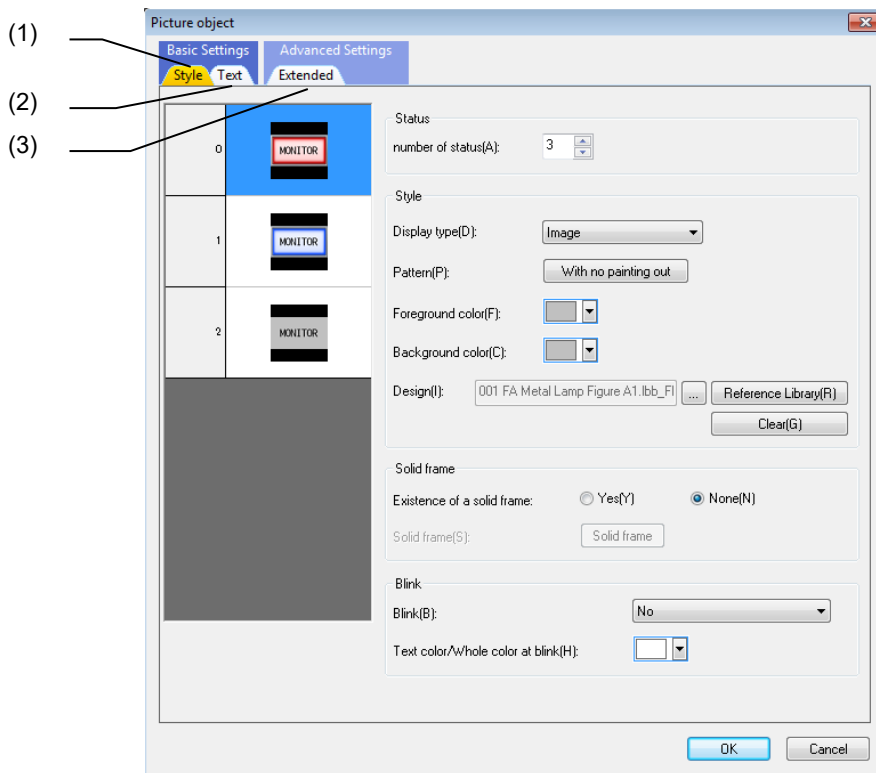

[Basic Settings] consists of the following tabs.

No.	Tab	Description
(1)	Style	Set or display the background color, solid frame, blink, and preview.
(2)	Text	Set or display the font, text, scroll, and preview.

[Advanced Settings] consists of the following tab.

No.	Tab	Description
(3)	Extended	Set the start effect and slide amount.

7.2.6.1.1 [Style] Tab

In [Style] Tab, specify the background color, solid frame, and blink, etc.

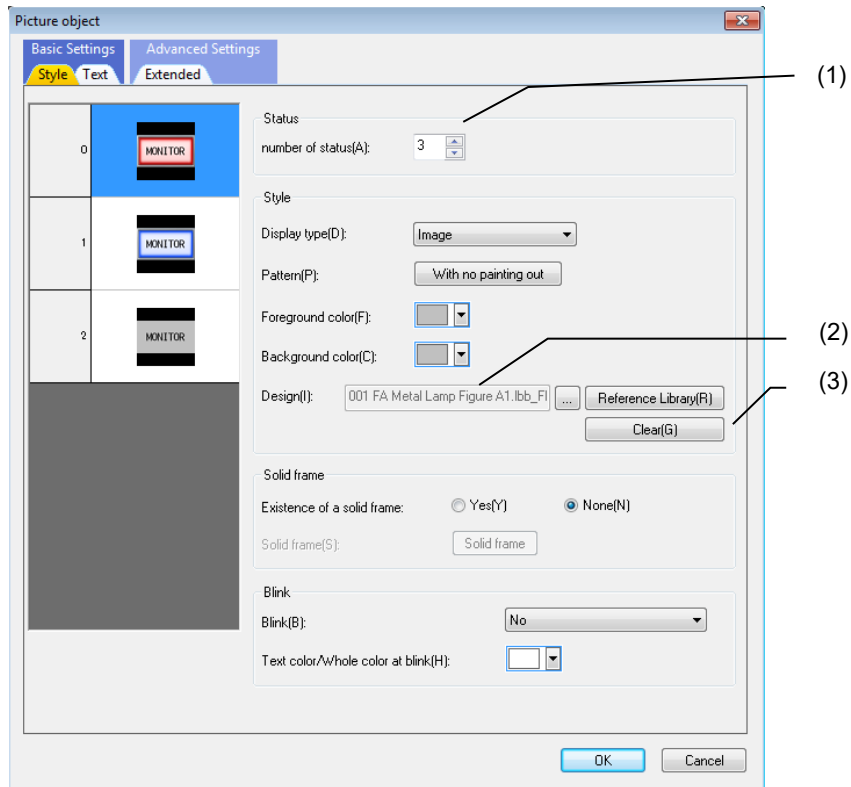

No.	Item	Description
(1)	number of status	Specify the number of states expressed with the picture. (1 to 31)
(2)	Design	Select the image. Click on the [...] button and select the desired image. Click on the "Reference Library" button to display the "Image List" dialog.
(3)	Clear	Clear the design setting.

For the items other than the above, refer to "7.1.16.1.1 [Style] Tab".

7.2.6.1.2 [Text] Tab

In [Text] tab, specify the font, text, and scroll, etc.

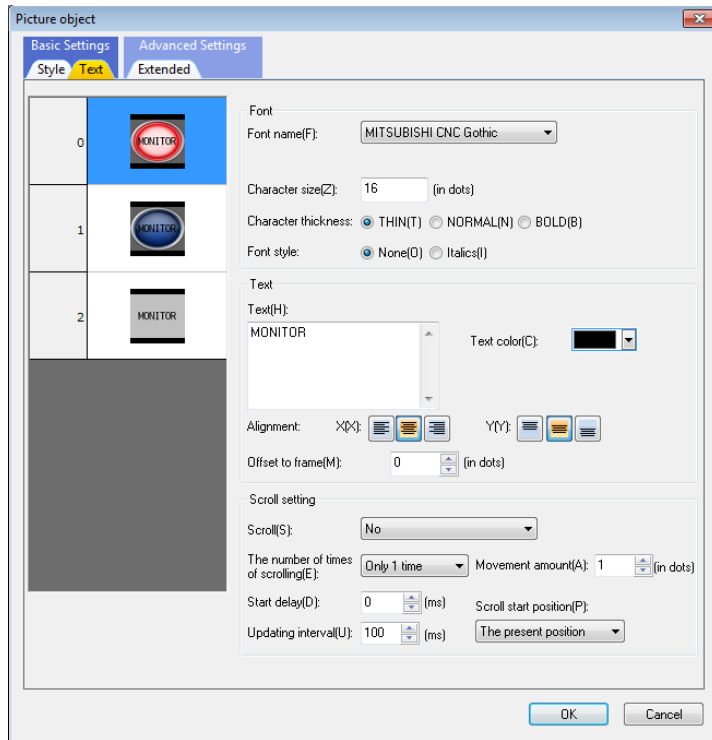

For each item, refer to "7.1.16.1.2 [Text] Tab".

7.2.6.1.3 [Extended] Tab

In [Extended] tab, specify the start effect and slide amount.

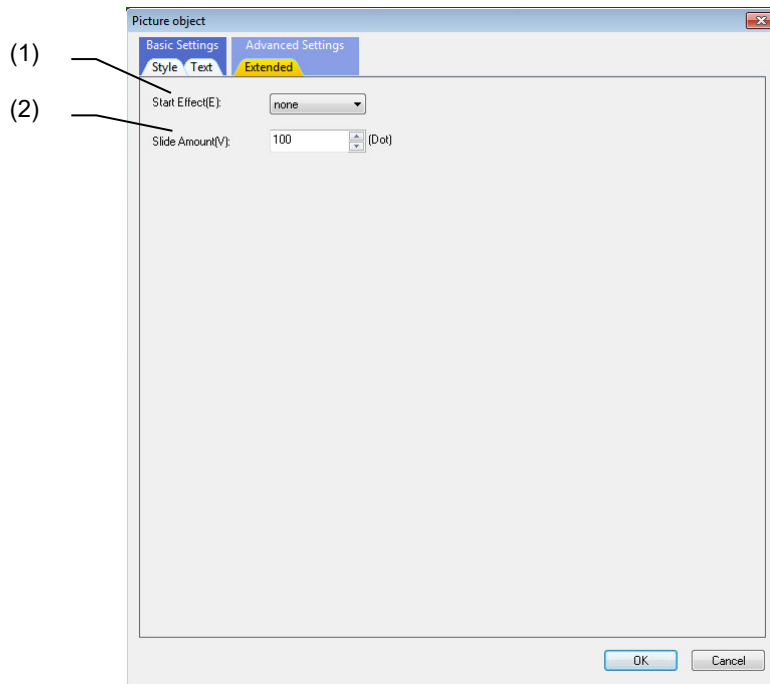

No.	Item	Description
(1)	Start Effect	Set the start effect. (none, Fade In, Slide In, Shake, Zoom In) This setting is available for the images with the property "Pattern" set to "Background painting out".
(2)	Slide Amount	Set a travel amount of images (the distance the top left position of the image moves before and after the travel). (1 to 2000)



**7.2.6.2 Property Settings**

The property settings of the picture object are divided into the followings.

Control name	:	Specify the name of the control.
Position/size	:	Specify the position and size of the control.
Display type	:	Select the display type of the picture.
Number of states	:	Specify the number of states expressed with the picture.
Color/pattern	:	Specify the color and pattern of the control.
Image	:	Specify the image given to the control.
Caption	:	Specify the caption (character string) displayed on the control.
Character attribute	:	Specify the character attribute of the caption.
Solid frame	:	Specify the solid frame of the control.
Caption character string scroll	:	Specify the scroll of the caption character string.
Blink	:	Specify the blink of the caption character string.
Callback function	:	Specify whether or not the callback functions are provided.
Show/hide	:	Select whether the control is displayed or hidden.



Display

Item	Description
Display type	Select the button type among the following three types.
Square	Rectangular button. The button is indicated in the designated color and pattern. 
Circle	Round button. The button is indicated in the designated color and pattern. 
Image	The button is indicated with the designated image resource. 
Start Effect	Set the start effects. (none, Fade In, Slide In, Shake, Zoom In) This setting is available for the images with the property "Pattern" is set to "Background painting out".
Slide Amount	Set a travel amount of images (the distance how far the top left position of the image moves before and after the travel). (1 to 2000)

Number of States

Item	Description
Number of states	Specify the number of states expressed with the picture (1 to 32).

Color/Pattern/Image

Item	Description
State0 to 31 pattern <sup>*1</sup>	Specify the filling pattern of the picture for each state.
State0 to 31 foreground color <sup>*1</sup>	Specify the foreground color (pattern color) of the picture for each state.
State0 to 31 background color <sup>*1</sup>	Specify the background color of the picture for each state.
State0 to 31 Design <sup>*2</sup>	Select the ID of the image resource displayed for the picture for each state.
State0 to 31 Draw type <sup>*3</sup>	Specify the drawing method of pictures in each state. (still picture, Animation(loop), Animation(one time), Animation(reverse loop), Animation(reverse one time))
State0 to 31 Start frame (1 to 10000) <sup>*3</sup>	Specify the start frame in each state.
State0 to 31 End frame (1 to 10000) <sup>*3</sup>	Specify the end frame in each state.
State0 to 31 Play magnification (1 to 10000) <sup>*3</sup>	Specify the playing magnification in each state.

\*1: The setting is valid if the [Display type] is "Square" or "Circle".

\*2: The setting is valid if the [Display type] is "Image".

\*3: This setting is used if the animation file is set to [Design].

For the other properties, refer to "7.1 Common Functions of Controls".

### 7.2.7 Check Box Object (GCCheckBox)

The check box object is a control where the ON/OFF state is held and the ON/OFF state is graphically displayed upon a user-driven state change.

The check box holds the ON/OFF state internally, and the state changes according to events.

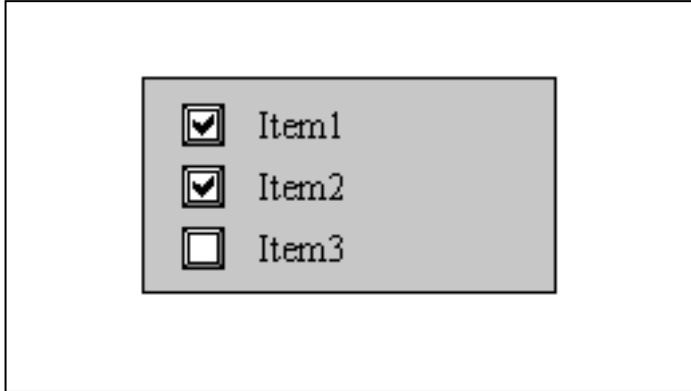

#### 7.2.7.1 Property Settings

The property settings of the check box object are divided into the followings.

Control name	:	Specify the control name.
Position/size	:	Specify the position and size of the control.
Box	:	Specify the color, size and solid frame of the box.
Caption	:	Specify the caption (character string) displayed on the control.
Character attribute	:	Specify the character attribute of the caption.
Focus	:	Specify the displaying method and color of the check box where the focus is located.
Caption character string scroll	:	Specify the scroll of the caption character string.
Blink	:	Specify the caption character string.
Callback function	:	Specify whether or not the callback functions are provided.
Show/hide	:	Select whether the control is displayed or hidden.
Input permission	:	Select whether the entry is accepted (permission) or rejected (prohibition).

Box

Item	Description
Size of box	Specify the box size in dots (8 to 1920). The box is a square.
Use of box frame	Specify presence/absence of the box frame.
Frame of a box	Select the ID of the solid frame resource to be given to the box.
Color of a box	Specify the color of the box.

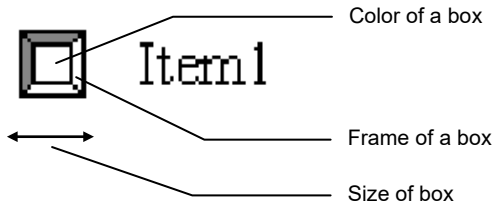

Focus

Item	Description
Effect at the time of focus	Select the displaying method of the check box where the focus is located. (Only "Change color" can be selected with this version.)
Background color at the time of focus	Specify the background color of the check box where the focus is located.
Color of a box at the time of disable	Designate the color of the disabled box.
Character color at the time of disable	Designate the character color of the disabled check box.

For the other properties, refer to "7.1 Common Functions of Controls".

### 7.2.8 Radio Button Object (GCRadioButton)

The radio button object is a control for realizing exclusive selection among a group of multiple radio buttons.

The radio button holds the ON/OFF state internally, and the state changes according to events.

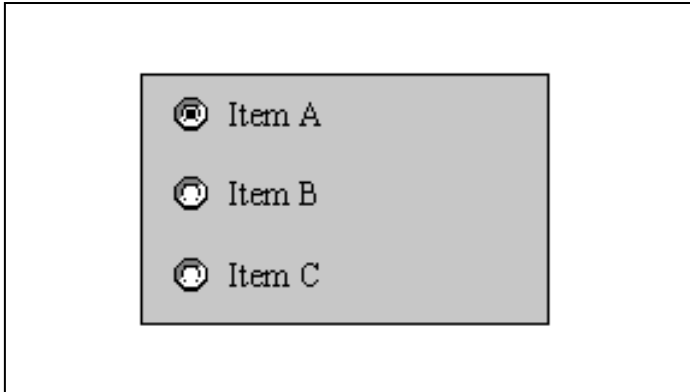

#### 7.2.8.1 Property Settings

The property settings of the radio button object are divided into the followings.

- Control name : Specify the control name.
- Position/size : Specify the position and size of the control.
- Box : Specify the color, size and solid frame of the box.
- Caption : Specify the caption (character string) displayed on the control.
- Character attribute : Specify the character attribute of the caption.
- Focus : Specify the displaying method and color of the radio button where the focus is located.
- Caption character string scroll : Specify the scroll of the caption character string.
- Blink : Specify the blink of the caption character string.
- Callback function : Specify whether or not the callback functions are provided.
- Show/hide : Select whether the control is displayed or hidden.
- Input permission : Select whether the entry is accepted (permission) or rejected (prohibition).

Box

Item	Description
Group NO.	Specify the group number to which the radio button belongs (0 to 32767). Only one radio button among those belonging to the same group number is allowed to be active.
Size of box	Specify the box size in dots (8 to 1920).
Use of box frame	Specify the presence of the box frame.
Frame of a box	Select the ID of the solid frame resource to be given to the box.
Color of a box	Specify the color of the box.

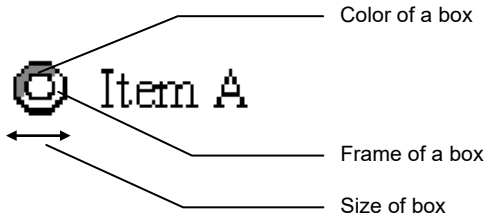

Focus

Item	Description
Effect at the time of focus	Select the displaying method of the radio button where the focus is located (Only "Change color" can be selected with this version.)
Background color at the time of focus	Designate the background color of the radio button where the focus is located.
Color of a box at the time of disable	Designate the color of the disabled box.
Character color at the time of disable	Designate the character color of the disabled radio button.

For the other properties, refer to "7.1 Common Functions of Controls".

### 7.2.9 Progress Bar Object (GCProgressBar)

The progress bar object is a control expressing the progress of a process with the filled amount.

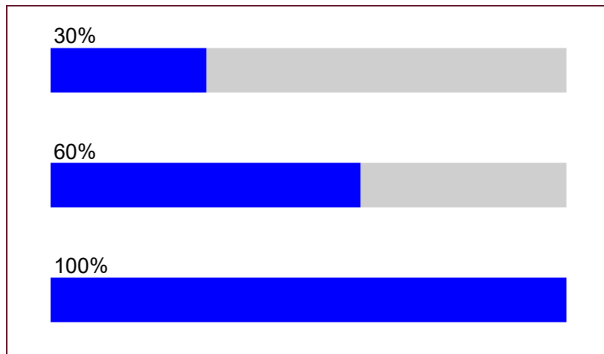

#### 7.2.9.1 Property Settings

The property settings of the progress bar object are divided into the followings.

Control name	:	Specify the control name.
Position/size	:	Specify the position and size of the control.
Color/pattern	:	Specify the color and pattern.
Filling direction	:	Specify the filling direction of the progress bar.
Callback function	:	Specify whether or not the callback functions are provided.
Show/hide	:	Select whether the control is displayed or hidden.

Color/Pattern

Item	Description
Main part background color	Specify the background color of the main body of the progress bar.
Main part foreground color	Specify the foreground color of the main body of the progress bar.
Main part painting out pattern	Specify the filling pattern of the main body of the progress bar.
Bar background color	Specify the background color of the bar.
Bar foreground color	Specify the foreground color of the bar.
Bar painting out pattern	Specify the filling pattern of the bar.

The color settings are reflected in the following way.

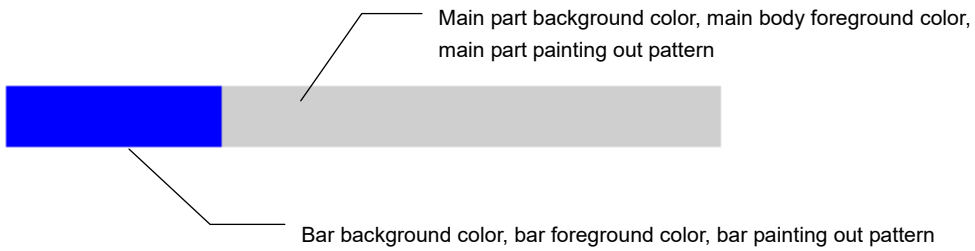

Filling Direction

Item	Description
Direction	Select the direction of progress of the bar among the following options: "From left to right", "From right to left", "From top to bottom" and "From bottom to top".
Minimum	Designate the 0% bar length (-2147483648 to 2147483647).
Maximum	Designate the 100% bar length (-2147483648 to 2147483647).

For the other properties, refer to "7.1 Common Functions of Controls".

### 7.2.10 HTML Browser Object (GCHtmlBrowser)

The HTML browser object is a control displayed on the screen upon interpretation of the data of an HTML file.



#### 7.2.10.1 Property Setup Dialog

Property setup dialog of HTML browser control consists of the tab relating to [Basic Settings]. Details of the tab will be described in the following sections.

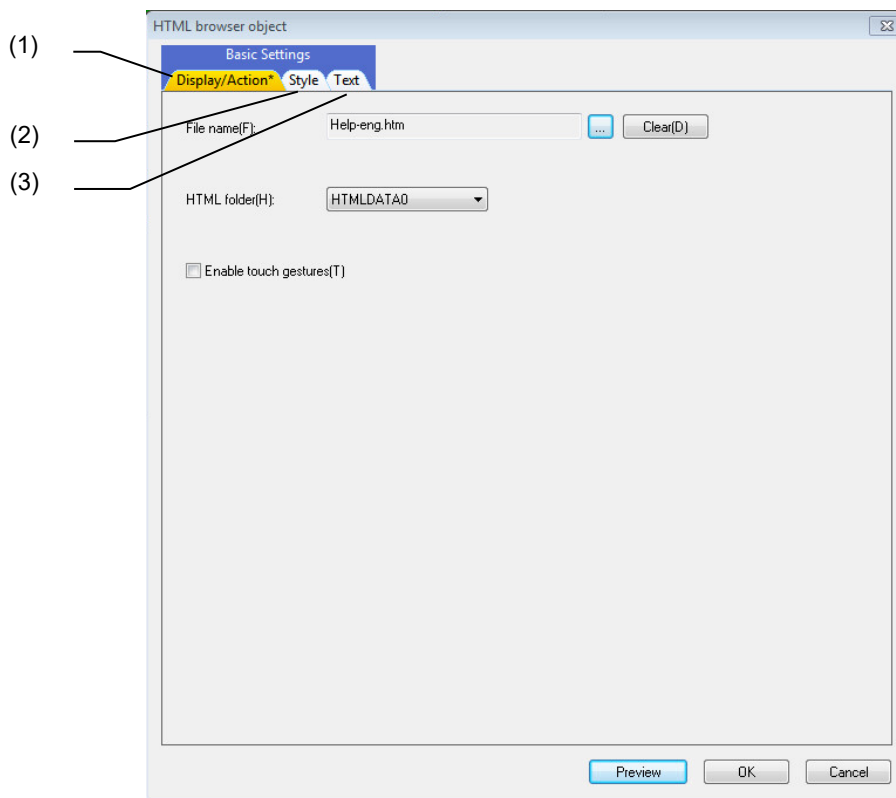

[Basic Settings] consists of the following tabs.

No.	Item	Description
(1)	Display/Action	Specify the file name and HTML folder etc.
(2)	Style	Specify the style of the background color, solid frame, and scroll.
(3)	Text	Specify the font, text color, and the color of links.



7.2.10.1.1 [Display/Action] Tab

In [Display/Action] tab, specify the file name and HTML folder etc.

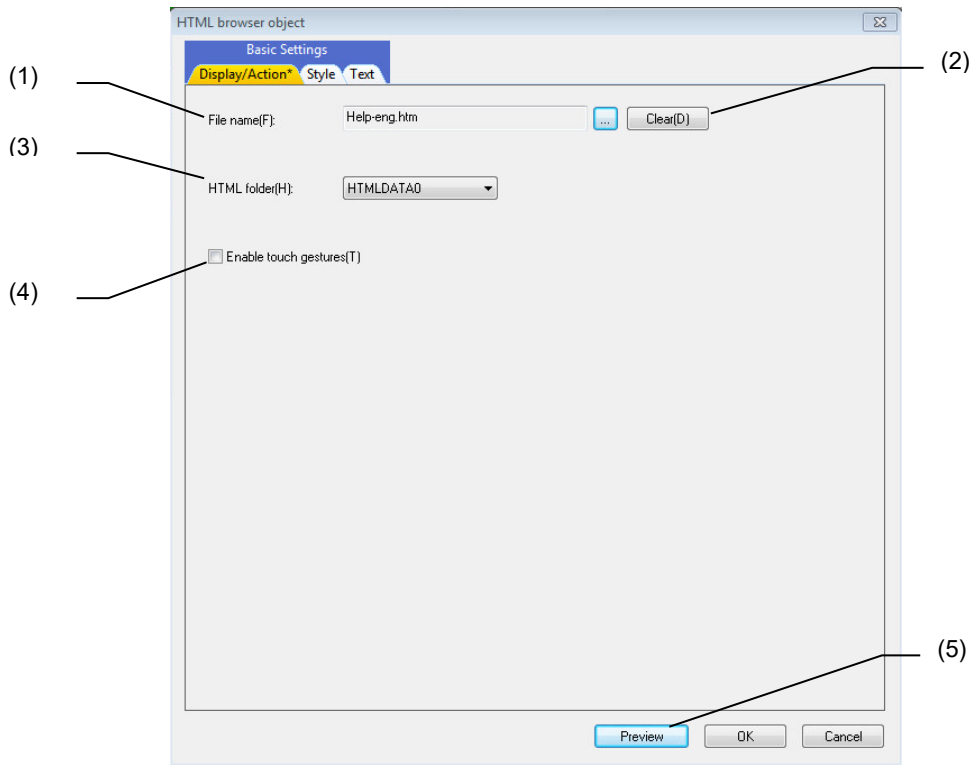

No.	Item	Description
(1)	File name	Specify the HTML file. Click on the "..." button to display the file selection dialog. If the designated file does not exist in the HTML folder, a message "The specified file does not exist" will be displayed.
(2)	Clear	Clear the file name setting.
(3)	HTML folder (Note)	Select the folder that stores the HTML files. Select from HTMLDATA0 to HTMLDATA7
(4)	Enable touch gestures	Check this box to accept a touch gesture operation.
(5)	Preview	Display the window to check the specified property design. Sample data is displayed when the file name is not designated.

(Note) Description of the HTML file designated in file name is displayed on the preview regardless of the HTML folder setting.

7.2.10.1.2 [Style] Tab

In [Style] tab, specify the background color, solid frame, and the scroll setting.

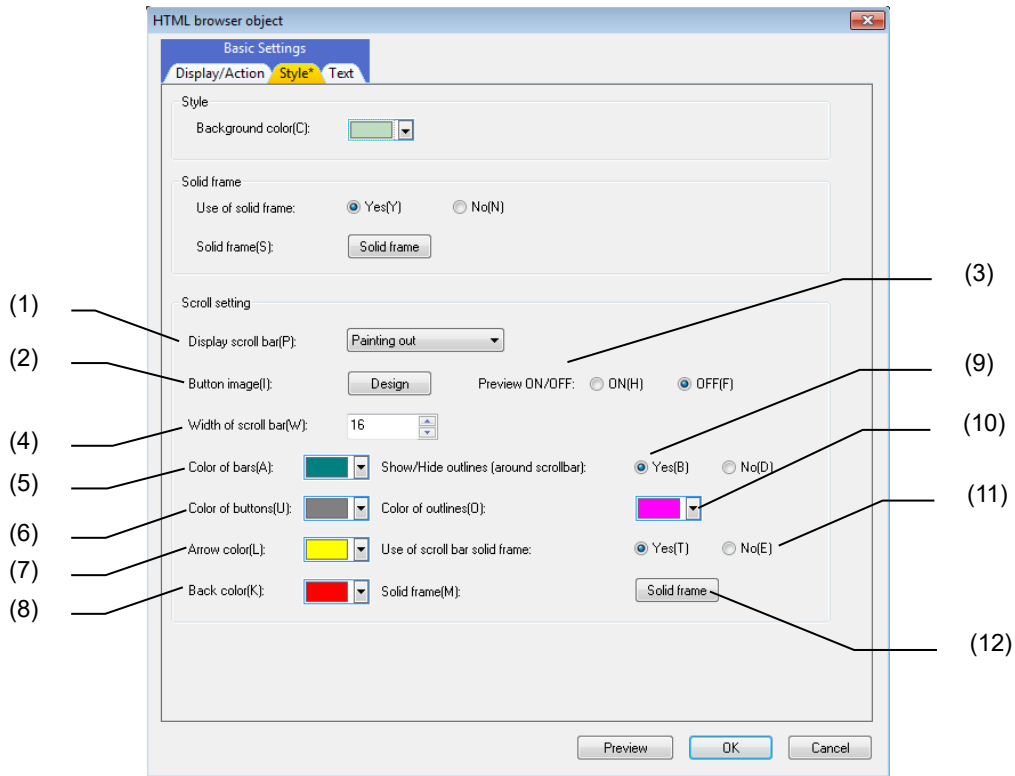

No.	Item	Description
(1)	Display scroll bar	Select the scroll bar display from "Painting out" / "Image" / "With no painting out".
(2)	Button image	Specify the image of the ON/OFF button to display on the scroll button.
(3)	Preview ON/OFF	Select the status to display on the preview between ON and OFF.
(4)	Width of scroll bar	Specify the width of the scroll bar.
(5)	Color of bars	Specify the color of the scroll bars.
(6)	Color of buttons	Specify the color of the scroll buttons.
(7)	Arrow color	Specify the arrow color of the scroll bar.
(8)	Back color	Specify the background color of the scroll bar.
(9)	Show/Hide outlines (around scrollbar)	Specify the presence/absence of the outlines around the scroll bars.
(10)	Color of outlines	Specify the color of the outlines of the scroll bar.
(11)	Use of scroll bar solid frame	Specify the presence/absence of the solid frame of the scroll bar.
(12)	Solid frame	Specify the solid frame of the scroll bar.

For the items other than the above, refer to "7.1.16.1.1 [Style] Tab".

7.2.10.1.3 [Text] Tab

In [Text] tab, specify the text color and color for the links.

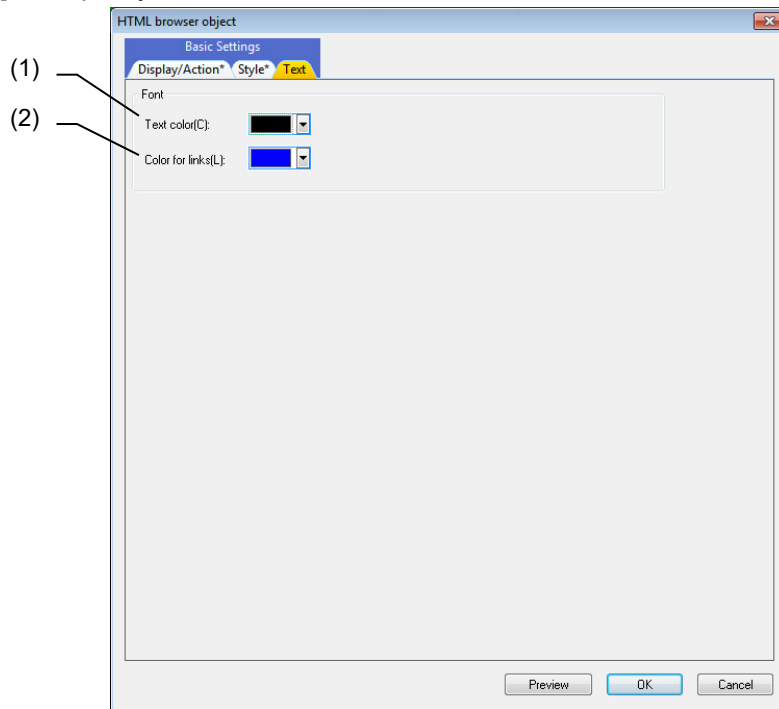

No.	Item	Description
(1)	Text color	Specify the text color. This color is applied when a text color is not specified in the HTML file.
(2)	Color for links	Specify the color of the links. This color is applied when a color of the links is not specified in the HTML file.

**7.2.10.2 Property Settings**

The HTML browser property settings are divided into the followings.

- Control name : Specify the control name.
- Position/size : Specify the position and size of the control.
- Default : Specify the default character color, default background color, and default character attribute applied when they are not specified in the HTML file.
- Solid frame : Specify the solid frame of the control.
- HTML file : Specify the HTML displayed at the control.
- Scroll bar : Specify the color and width of the scroll bar and the color and image of the scroll bar button.
- Show/Hide : Select whether the control is displayed or hidden.
- Input permission : Select whether the entry is accepted (permission) or rejected (prohibition).
- Operation : Specify the operation of the control.

Default

Item	Description
Default character color	Specify the default character color used when it is not specified in the HTML file.
Default background color	Specify the default background color used when it is not specified in the HTML file.
Default link color	Specify the default link color used when it is not specified in the HTML file.
Default font	Specify the default font used when it is not specified in the HTML file.

HTML File

Item	Description
HTML Folder	Select the folder containing an HTML file
HTML File	Select the ID of the HTML file resource as an HTML file displayed first as a control.

**NOTE**

- ◆ To store HTML files in HTML folders, absolute paths have to be defined in the Config.ini file. The relationship between the description in the combo boxes and actual folders is shown below.

< Example of M800V/M80V/M800/M80 (Windows-based display unit) and M700VW >

```
[HTML_BROWSER]
HTMLDATA0=D:/Custom/HTMLDATA0/
HTMLDATA1=D:/Custom/HTMLDATA1/
HTMLDATA2=D:/Custom/HTMLDATA2/
:
HTMLDATA7=D:/Custom/HTMLDATA7/
```

< Example of M800V/M80V/M800/M80 (Windows-less display unit) and M700VS/M70V/E70 >

(For 15-type display units, designate /custom/ instead of /custom15/.)

```
[HTML_BROWSER]
HTMLDATA0=/custom/HTML/
HTMLDATA1=
HTMLDATA2=
:
HTMLDATA7=
```

Scroll Bar

Item	Description
Display scroll bar	Select between "Painting out" and "Image".
Scroll bar color*1	Specify the color of the scroll bar.
Scroll button color*1	Specify the color of the scroll button.
Scroll arrow color*1	Specify the color of the arrow of the scroll bar.
Button1 to 4 design at the time of ON*2	Specify the image displayed at the ON scroll bar.
Button1 to 4 design at the time of OFF*2	Specify the image displayed at the OFF scroll bar.
Use of perimeter line	Select the perimeter line between "Yes" and "No".
Perimeter line color	Specify the color of the perimeter line.
Scroll background color	Specify the background color of the scroll bar.
Scroll width	Specify the width of the scroll bar in dots (16 to 96).

\*1: The setting is valid if "display scroll bar" is "painting out".

\*2: The setting is valid if "display scroll bar" is "image".

The scroll bar settings are reflected on the following parts.

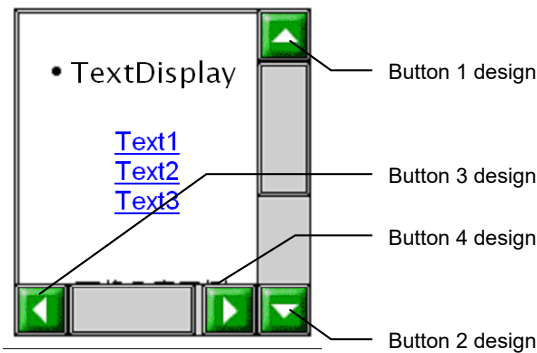
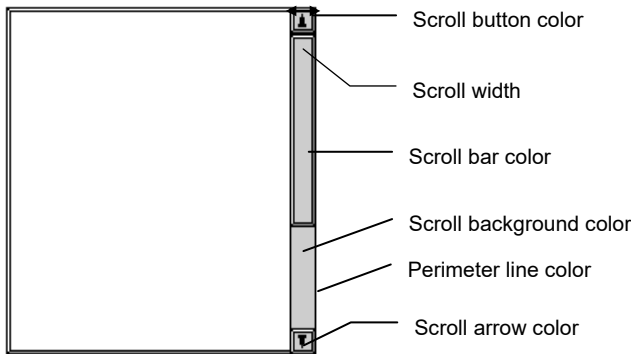

**NOTE**

- ◆ If the displaying area of the HTML file is larger than that of the HTML browser control, the vertical and/or horizontal scroll bar(s) is (are) displayed. If the displaying area of the HTML file is smaller than that of the HTML browser control, the remaining screen area is filled with the background color and no scroll bar is displayed.

For the other properties, refer to "7.1 Common Functions of Controls".

**7.2.10.3 Complements**

Operation specifications

- (1) Pan (Run your fingertip along the screen)  
The screen is scrolled along your finger motion (Vertical, horizontal or diagonal direction).  
On the scroll bar, the slider follows your finger motion and moves in the direction of each bar.
- (2) Flick (Quickly run your fingertip along the screen)  
The screen is scrolled in the direction of your finger sweep (Vertical or horizontal direction).

### 7.2.11 Scroll Bar Object (GCScrollBarEx)

The scroll bar object is a sliding button used to scroll the screen image up/down or left/right. The scroll bar includes two types: vertical scroll bar for vertical movement and horizontal scroll bar for horizontal movement.

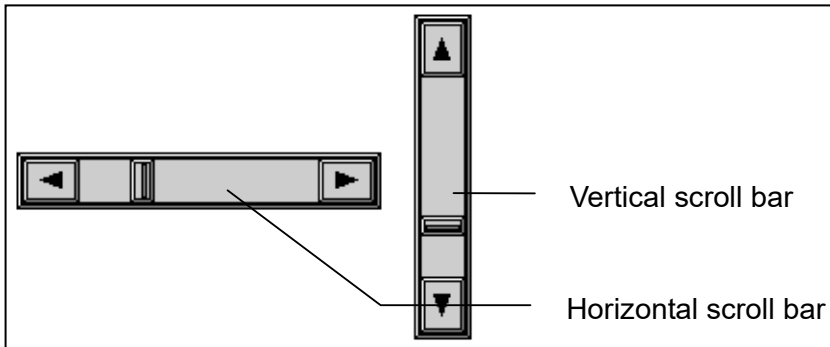

#### 7.2.11.1 Property Settings

The Property settings of the scroll bar are divided into the followings. The same settings are used for both the vertical and horizontal scroll bars.

- Control name : Specify the control name.
- Position/size : Specify the position and size of the control.
- Display type : Select the displaying type of the button.
- Color/image : Specify the color and width of the scroll bar and the color and image of the scroll button.
- Scroll movement : Specify the minimum and maximum values of the scroll bar.
- Knob : Specify the width and color of the knob.
- Solid frame : Specify the solid frame of the control.
- Perimeter line : Specify the perimeter line of the control.
- Perimeter solid frame : Specify the perimeter solid frame of the control.
- Callback function : Specify whether or not the callback functions are provided.
- Show/hide : Select whether the control or bar is displayed or hidden.
- Input permission : Select whether entry is accepted (permission) or rejected (prohibition).
- Operation : Specify the operation of the control.

Display Type

Item	Description
Display type	Select the button type from the following two options.
Painting out	The button is expressed in the designated scroll button and scroll arrow colors.
Image	The button is expressed with the designated image resource.

Color/Image

Item	Description
Scroll bar color <sup>*1</sup>	Specify the color of the scroll bar.
Scroll button color <sup>*1</sup>	Specify the color of the scroll button.
Scroll arrow color <sup>*1</sup>	Specify the color of the scroll button arrow.
Button 1 to 2 design at the time of ON <sup>*2</sup>	Specify the image of the ON button.
Button 1 to 2 design at the time of OFF <sup>*2</sup>	Specify the image of the OFF button.
Scroll background color	Specify the background color of the scroll bar.

\*1: The setting is valid if the [Display type] is "Painting out".

\*2: The setting is valid if the [Display type] is "Image".

The scroll bar settings are reflected on the following parts.

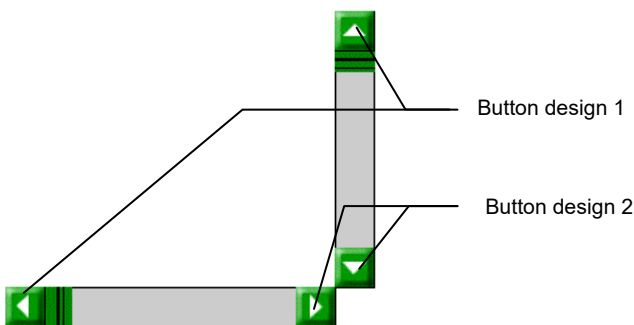
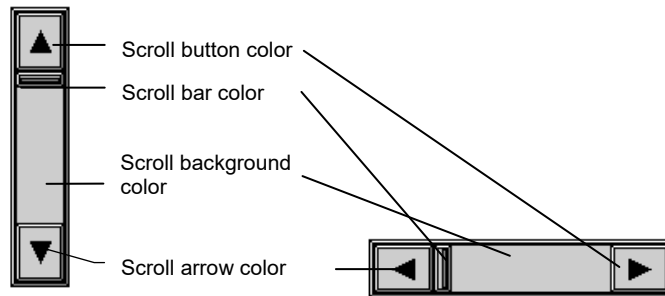



7. Creating Controls

Scroll Movement

Item	Description
Scroll minimum	Specify the minimum value of the movement range of the scroll bar (0 to 32767).
Scroll maximum	Specify the maximum value of the movement range of the scroll bar (0 to 32767).
1 page size	Specify the amount scrolled upon a click of the background color area of the scroll bar (1 to 32767).

Knob

Item	Description
Knob width	Specify the width of the knob (0 to 2560).
Knob color	Specify the color of the knob.

Perimeter Line

Item	Description
Use of perimeter line	Select the presence of the perimeter line of the scroll between "Yes" and "No".
Perimeter line color	Specify the color of the perimeter line.

Perimeter Solid Frame

Item	Description
Use of perimeter line	Select the perimeter solid frame of the whole scroll bar between "Yes" and "No".
Perimeter solid frame	Select the ID of the solid frame resource.

The knob, solid frame, perimeter line, and perimeter solid frame settings are reflected on the following parts.

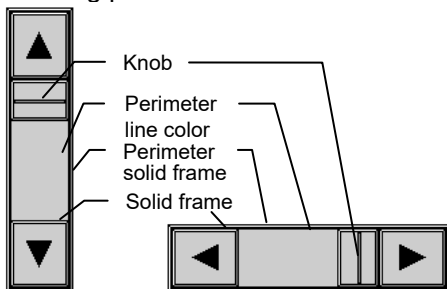

For the other properties, refer to "7.1 Common Functions of Controls".

### 7.2.11.2 Complements

#### Operation specifications

- (1) Pan (Run your fingertip along the screen)  
On the scroll bar, the slider follows your finger motion and moves in the direction of each bar (Vertical or horizontal direction).

### 7.2.12 Edit Control Object (GCEdit)

The edit control object is a control for displaying, inserting or overwriting a character string in the designated rectangle. The cursor is displayed and carriage return can be entered.

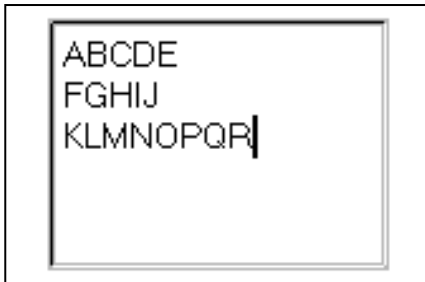

#### 7.2.12.1 Property Settings

The property settings of the edit control object are divided into the followings.

- Control name : Specify the control name.
- Position/size : Specify the position and size of the control.
- Color/pattern : Specify the color and pattern of the control.
- Solid frame : Specify the solid frame of the control.
- Insert/overwrite : Select between the insertion and overwriting of the entered characters.
- Buffer size : Specify the internal buffer size and line buffer size.
- Scroll bar : Specify the color and width of the scroll bar and the color and image of the scroll bar button.
- Character attribute : Specify the character attribute of the displayed character string.
- Callback function : Specify whether or not the callback functions are provided.
- Show/hide : Select whether the control is displayed or hidden.
- Input permission : Select whether the entry is accepted (permission) or rejected (prohibition).

#### Insert/Overwrite

Item	Description
Insert/Overwrite	Select the character entry mode between "Insert" and "Overwrite".

#### Buffer Size

Item	Description
Internal buffer size(KB)	Specify the total buffer size of the displayed character strings in kilo bytes (1 to 5123).
Single line buffer size(B)	Specify the line buffer size in bytes (2 to 2048).

#### NOTE

- ◆ The calculation method of the buffer size is shown below.
  - (Line buffer size) = (1 character (2B)) x (number of characters in line)
  - (Internal buffer size) = ((line buffer size) x (number of lines)) / 1000
- ◆ If characters exceeding the buffer size are entered, characters are stored up to the limit and overflowing characters are abandoned.

Scroll Bar

Item	Description
Display scroll bar	Select the scroll bar between "Painting out" and "Image".
Scroll bar color <sup>*1</sup>	Specify the color of the scroll bar.
Scroll button color <sup>*1</sup>	Specify the color of the scroll button.
Scroll arrow color <sup>*1</sup>	Specify the color of the arrow of the scroll button.
Use of scroll bar solid frame	Select the solid frame of the scroll bar between "Yes" and "No".
Scroll bar solid frame	Select the ID of the solid frame resource of the scroll bar.
Button1 to 4 design at the time of ON <sup>*2</sup>	Specify the image of the ON scroll bar.
Button1 to 4 design at the time of OFF <sup>*2</sup>	Specify the image of the OFF scroll bar.
Use of scroll bar perimeter line	Select the perimeter of the scroll bar between "Yes" and "No".
Scroll bar perimeter line color	Specify the color of the perimeter line of the scroll bar.
Scroll bar background color	Specify the background color of the scroll bar.
Scroll width	Specify the width of the scroll bar in dots (16 to 96).

\*1: The setting is valid if [Display scroll bar] is "Painting out".

\*2: The setting is valid if [Display scroll bar] is "Image".

The scroll bar settings are reflected on the following parts.

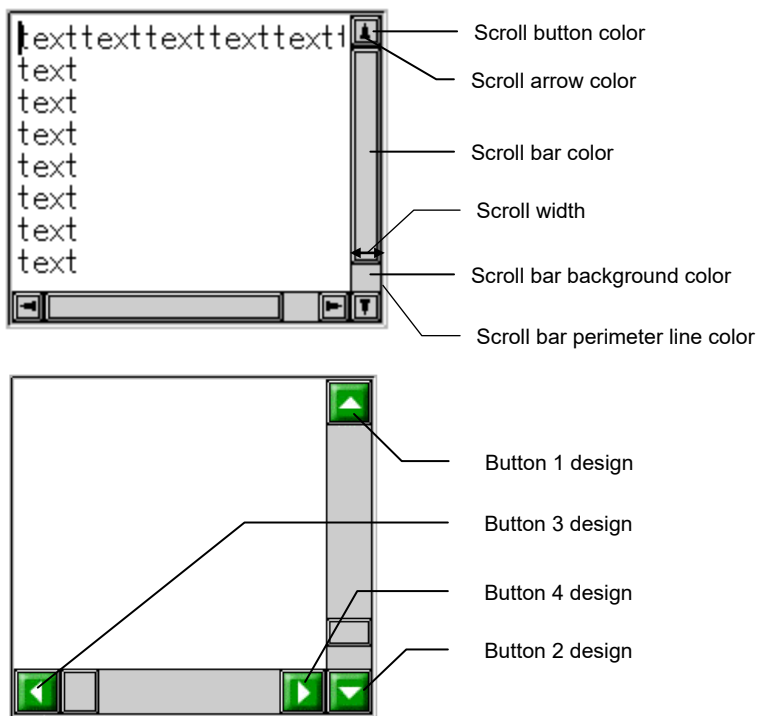

For the other properties, refer to "7.1 Common Functions of Controls"

**7.2.13 Table Object (GNCTable)**

Table control (GNCTable) is a control that uses cells with the number (n) of rows and columns to manage and display the character string data. Each row and column can have its own title.

**7.2.13.1 Property Settings**

The property settings of the table control object are divided into the followings.

- Control name : Specify the control name.
- Position/Size : Specify the position and the size of the control.
- Show/Hide : Specify whether the control is displayed or hidden.
- Input permission : Select whether the entries are accepted (permission) or rejected (prohibition).
- Table : Specify the number of rows/columns and the column width in the control.
- Solid frame : Specify the solid frame of the control.
- Character attribute : Specify the character attribute of captions.
- Sub cursor : Specify whether to show/hide the Sub cursor, as well as its color attribute and default display position.
- Row title : Specify whether to show/hide the row title, as well as its displayed character, color attribute and the space between the rows.
- Column title : Specify whether to show/hide the column title, as well as its displayed character, color attribute and the space between the columns.
- Data area : Specify the solid frame, color attribute and the space between the cells.
- Callback function : Specify whether or not the callback functions are provided.

Table

Item	Description
Number of the rows	Specify the number of rows in the data area. (1 to 20).
Number of the columns	Specify the number of columns in the data area. (1 to 32)
Kind of the columns ratio	Select whether to use percentage or pixel values to specify the width of columns.
Columns ratio	Specify the width of columns according to the type selected in "Kind of the columns ratio". Use "\t" to delimit each value of width.

Sub Cursor

Item	Description
Use of sub cursor	Select the existence of a sub cursor between "Yes" and "No".
Initial row position of the Sub cursor	Specify the Sub cursor's initial position in rows.
Initial column position of the Sub cursor	Specify the Sub cursor's initial position in columns.
Background color of the Sub cursor	Select the background color of the Sub cursor.

7. Creating Controls

Row Title

Item	Description
Show/Hide of the row title	Select whether the row titles are displayed or hidden.
Character sequence of the row title	Input character strings for each row title. Use "\t" to delimit each character string.
Row spacing of the row title	Specify the space between the row title cells in pixels.
Column spacing of the row title	Specify the space between the row title and the data area in pixels.
Background color of the row title	Select the background color of the row title.
Boundary color of the row title	Select the boundary color of the row title cells.
Horizontal character position of the row title	Select "Align left"/"Center"/"Align right" for the horizontal character position in the row title.
Vertical character position of the row title	Select "Align top"/"Center"/"Align bottom" for the vertical character position in the row title.
Use of row title solid frame	Select the existence of the solid frame between "Yes" and "No".
Row title solid frame	Select the ID of the solid frame resource.

Column Title

Item	Description
Show/Hide of the column title	Select whether the column titles are displayed or hidden.
Character sequence of the column title	Input character strings for each column title. Use "\t" to delimit each character string.
Row spacing of the column title	Specify the space between the column title cells in pixels.
Column spacing of the column title	Specify the space between the column title and the data area in pixels.
Background color of the column title	Select the background color of the column title.
Boundary color of the column title	Select the boundary color of the column title cells.
Horizontal character position of column title	Select "Align left"/"Center"/"Align right" for the horizontal display position of characters in the column title.
Vertical character position of the column title	Select "Align top"/"Center"/"Align bottom" for the vertical display position of characters in the column title.
Use of column title solid frame	Select the existence of the solid frame between "Yes" and "No".
Column title solid frame	Select the ID of the solid frame resource.

Data Area

Item	Description
Use of whole data area solid frame	Select the existence of the solid frame for the whole data area between "Yes" and "No".
Whole data area solid frame	Select the resource ID of the solid frame for the whole area.
Row spacing of the data area	Specify the space between the rows in the data area in pixels.
Column spacing of the data area	Specify the space between the columns in the data area in pixels.
Background color of the data area	Select the background color of the data area.
Boundary color of the data area	Select the boundary color of the data area.
Horizontal character position of the data area	Select "Align left"/"Center"/"Align right" for the horizontal character position in the data area.
Vertical character position of the data area	Select "Align top"/"Center"/"Align bottom" for the vertical character position in the data area.
Use of data area solid frame	Select the existence of the solid frame for each cell between "Yes" and "No".
Data area solid frame	Select the resource ID of the solid frame for each cell.

### 7.2.13.2 Complements

**Movement of the Sub Cursor**

The following table shows how the Sub cursor moves in the table control object.

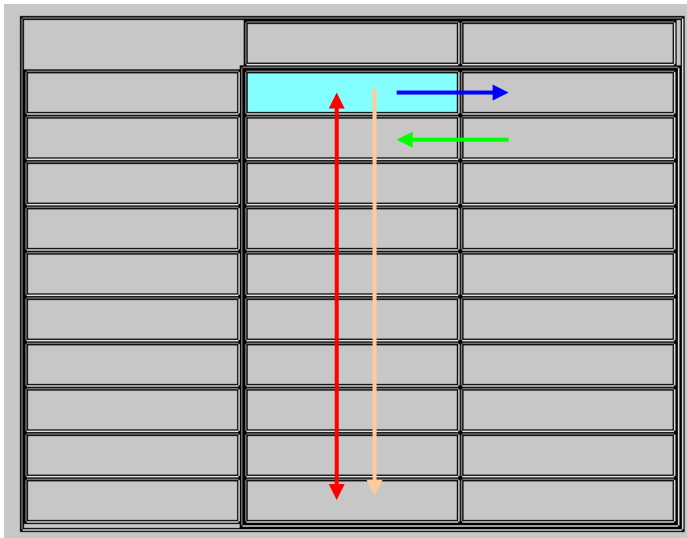

↑ key	↓ key	Tab key	Shift+Tab key	Enter key
Sub cursor moves up in the same column.	Sub cursor moves down in the same column.	Sub cursor moves to the right.	Sub cursor moves to the left.	Sub cursor moves down in the same column.



- Cursor movement when the ↑ or ↓ key is pressed
- Cursor movement when the Tab key is pressed
- Cursor movement when the Shift+Tab keys are pressed
- Cursor movement when the Enter key is pressed

Usage Examples

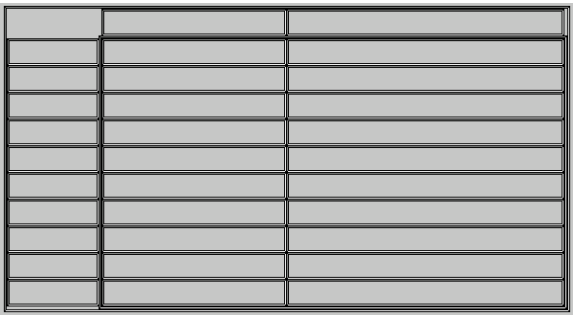
The followings show the initial display of the control object and the screen images when the properties were changed.

Screen	Properties value		Image
1	Number of rows	1	
	Number of columns	1	
	Columns ratio	Blank	
2	Number of rows	10	
	Number of columns	2	
	Columns ratio	1\2\3	
3	Use of row title solid frame	No	
	Use of column title solid frame	No	
	Use of data area solid frame	No	
	Background color of the row title	RGB (220,230,155)	
	Background color of the data area	RGB (255,255,255)	
	Sub Cursor	RGB (0,255,255)	



Screen	Properties value		Image
4	Perimeter solid frame	ID_BORDER0003	
	Whole data area solid frame	ID_BORDER0003	
	Row spacing of the data area	1	
	Column spacing of the data area	1	
5	Character sequence of the row title	“Row title01\t Row title02\t Row title03\t Row title04\t Row title05\t Row title06\t Row title07\t Row title08\t Row title09\t Row title10”	
	Boundary color of the row title	RGB (220,230,155)	
	Horizontal character position of the row title	Align Right	
	Character sequence of the column title	“Column title 01\t Column title 02”	
	Boundary color of the column title	RGB (192,192,192)	
	Horizontal color of the column title	Center	

Remarks

Restrictions

Restrictions for creating a control object are shown below.

- (1) Properties of the control on the on-memory panel or window  
 The setting values in the properties of the control on the on-memory panel or window, after having been changed with public functions, are retained when redisplayed with a screen change.
- (2) Availability of GCSTableGetCellNumFromPoint( ) when the control object has never been displayed  
 If the table control object, allocated on the on-memory panel or window, has never been displayed, an attempt to get a cell No. with GCSTableGetCellNumFromPoint( ) leads an error (GERR\_NCTABLE\_RANGEOVER).
- (3) Setting range of a character string in GCSTableSetCellString( )  
 GCSTableSetCellString( ) can contain only 128 characters to specify a character string for a cell in the data area.
- (4) Data after the number of rows and columns were changed with public functions  
 If the smaller number of rows than displayed is specified in GCSNCTableSetLineCount( ) to change the number of rows, the data (displayed character string and background color) in the rows to be hidden will be cleared.  
 If a control object with 20 rows, for example, is changed to be displayed with 17 rows with GCSNCTableSetLineCount( ), the data that has been set in 18th to 20th rows is all lost after the change. The data will not be restored if the number of rows is set to 20 again with GCSNCTableSetLineCount( ). The same happens when the number of columns is changed with GCSNCTableSetRowCount( ).
- (5) Setting range of the font resource ID with public functions  
 When changing the font with GCSNCTableSetFontID( ), specify a font resource ID for the 2nd argument "usID" from the ones registered as NC Designer2 resource in designing.

Timing of the Display with the Changed Font and the Number of Rows/Columns

The following table shows the time to display the updates for the control object allocated on the panel or window, when the configurations (font, number of rows/columns) are changed with public functions.

Function name	When the control object is displayed	When the control object is hidden (on-memory)
GCSNCTableSetFontID	○	△
GCSNCTableSetLineCount	○	△
GCSNCTableSetRowCount	○	△

- : Updates instantly
- △: Updates when the control object is displayed again
- ×: Execution is not available

### 7.2.14 Input Box Object(GInputBox)

The input box object is a control that displays numerical values and character strings as well as entered keys. It has the same functions as the text box object but differs in the following points.

- Operation function was added.
- The input values can be reflected to another specified control (Specification of a control to reflect the INPUT).

For the specification of a control to reflect the INPUT, refer to GCSInputBoxSetRefrectControl in "5.26 InputBox" of "NC Designer2 Macro Function Manual" (IB-1501500).

In combination with the sub cursor setting, the input value can be set in the control at which the sub cursor is pointed and the control can be moved by the arrow key/TAB key.

For the details of sub cursor settings, refer to "10.7 Sub Cursor Setting".

#### 7.2.14.1 Property Setup Dialog

Property setup dialog consists of the tabs relating to [Basic Settings] and [Advanced Settings]. Details of each tab will be described in the following sections.

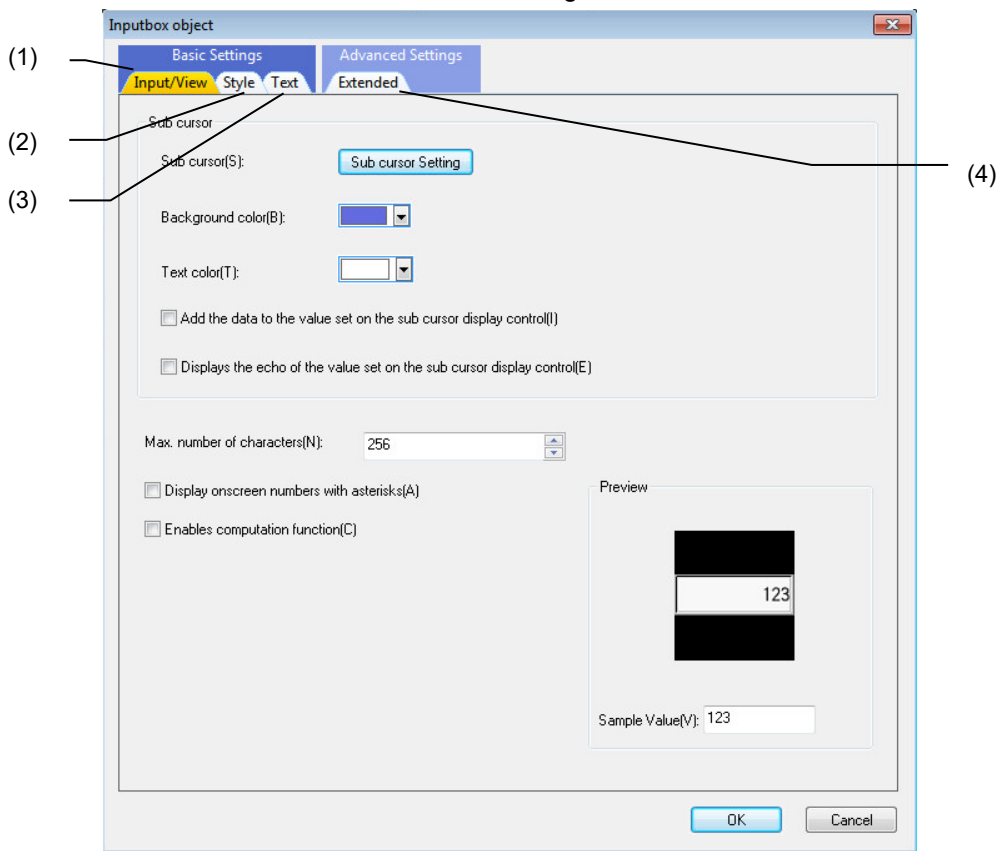

[Basic Settings] consists of the following tabs.

No.	Item	Description
(1)	Input/View	Set or display the sub cursor and preview.
(2)	Style	Set or display the background color, solid frame, and preview.
(3)	Text	Set or display the font, text, cursor, and preview.

[Advanced Settings] consists of the following tab.

No.	Item	Description
(4)	Extended	Set the item relating to the extended condition for the style/text.

7.2.14.1.1 [Input/View] Tab

In [Input/View] tab, specify the sub cursor and the sample value.

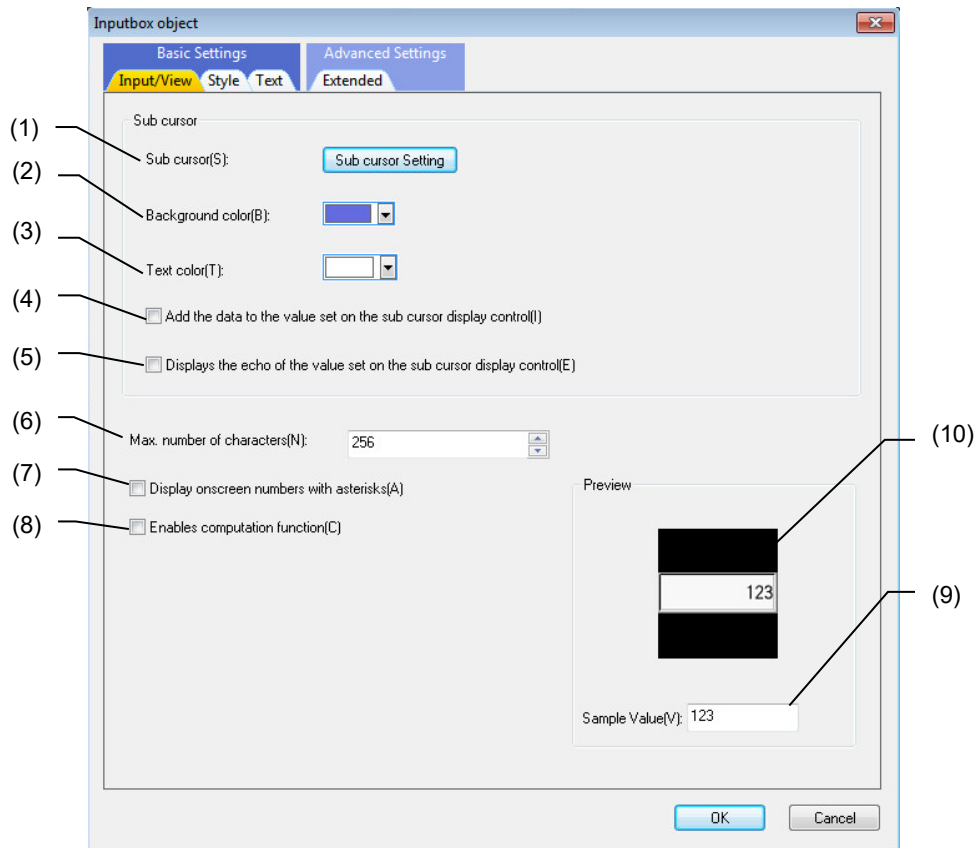

No.	Item	Description
(1)	Sub cursor	Specify the sub cursor. Click on the sub cursor button to display the "Sub cursor Setting" dialog. (Note) The sub cursor button is valid when one of the following controls is arranged either on the input box control which is located on the panel/window or on the view frame - Text box - PLC text box - NC data text box  For the "Sub cursor Setting", refer to "10.7 Sub Cursor Setting"
(2)	Background color	Specify the sub cursor background color.
(3)	Text color	Specify the sub cursor text color.
(4)	Add the data to the value set on the sub cursor display control	Check this box to add the input value to the value of the control which displays the sub cursor when pressing the INPUT key.
(5)	Displays the echo of the value set on the sub cursor display control	Check this box to echo back the value specified on the control which displays the sub cursor to the input box.
(6)	Max. number of characters	Specify the maximum number of the characters to display.
(7)	Display onscreen numbers with asterisks	Check this box to display the input characters with asterisks.
(8)	Enables computation function	Check this box to enable the computation function.
(9)	Sample Value	Specify the value to be displayed on the preview.
(10)	Preview	A preview of the input value is displayed.

7.2.14.1.2 [Style] Tab

In [Style] tab, specify the background color and the solid frame.

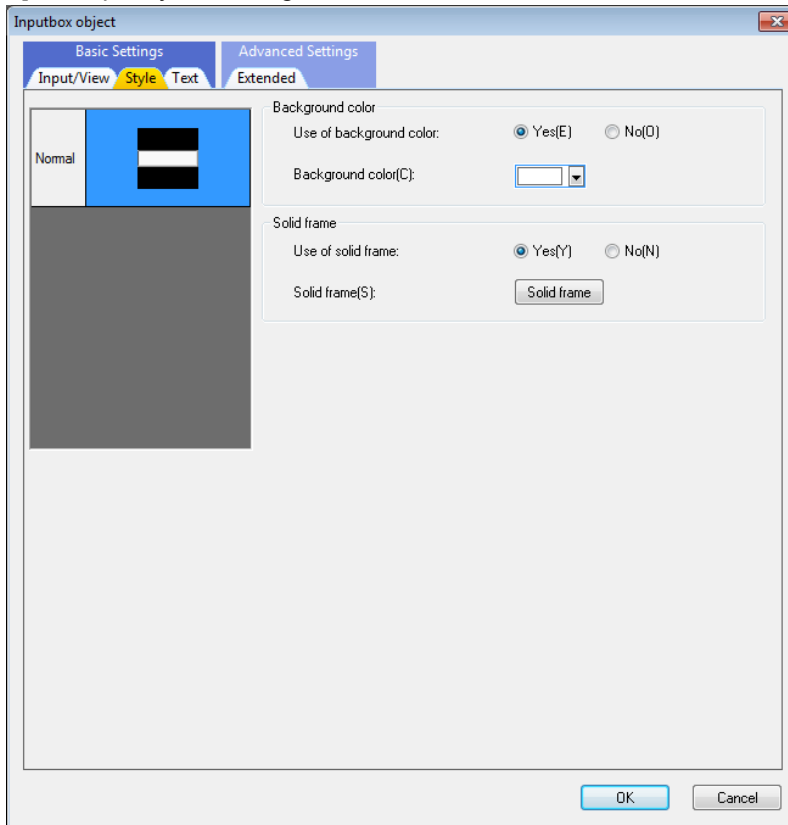

For each item, refer to "7.1.16.1.1 [Style] Tab".

7.2.14.1.3 [Text] Tab

In [Text] tab, specify the font, text, and the cursor.

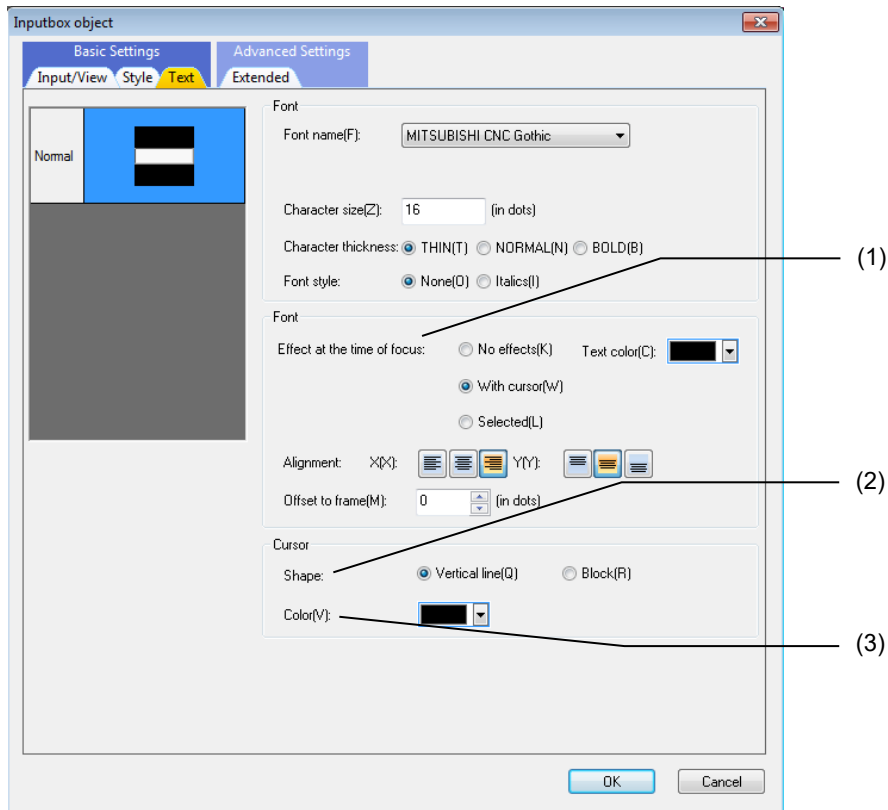

No.	Item	Description
(1)	Effect at the time of focus	Select how the cursor and setting values are displayed at the time of focus. "With cursor": Displays the cursor. "No effects": Does not display the cursor. "Selected": Selects the entire setting value.
(2)	Shape	Select the cursor shape from "Vertical line" or "Block".  (Note) This item is valid when either "With cursor" or "Selected" in "Effect at the time of focus" is selected.
(3)	Color	Specify the cursor color.  (Note) This item is valid when either "With cursor" or "Selected" in "Effect at the time of focus" is selected.

For the items other than the above, refer to "7.1.16.1.2 [Text] Tab".

7.2.14.1.4 [Extended] Tab

In [Extended] tab, set whether to provide the background color at the time of focus and disable.

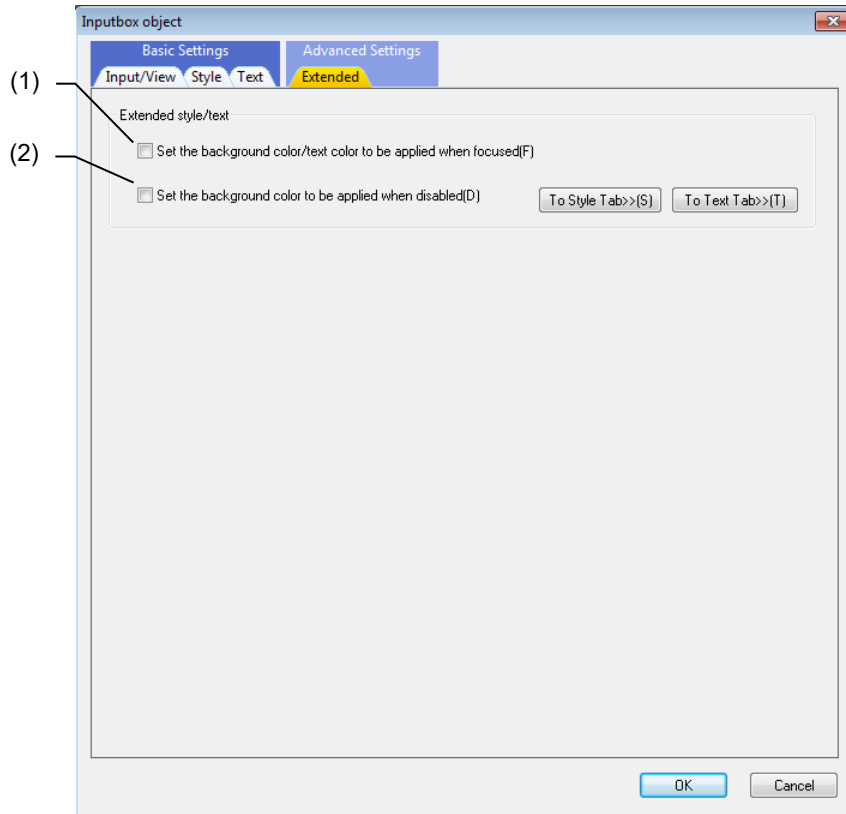

No.	Item	Description
(1)	Set the background color/text color to be applied when focused	Check this box to enable to set the background/text color on the [style] tab/[text] tab when focused.
(2)	Set the background color to be applied when disabled	Check this box to enable to set the background color on the [style] tab at the time of disable.

**7.2.14.2 Property Settings**

The property settings for the input box object are divided into the followings.

Control name	:	Specify the control name.
Position/size	:	Specify the position and size of the control.
Show/hide	:	Select whether the control is displayed or hidden.
Color/pattern	:	Specify the color and pattern of the control.
Display type/ Display format	:	Specify the format of character strings to be displayed in the control.
Password	:	Specify the password.
Character attribute	:	Specify the character attribute of the caption.
Solid frame	:	Specify the solid frame of the control.
Operation function	:	Specify whether or not the operation function is provided.
Echo back	:	Specify whether or not the echo back is provided.
Input method	:	Specify the input method (Absolute/Incremental)
Sub cursor	:	Specify the display color of the sub cursor.
Extended function	:	Specify whether to enable or disable extended functions.
Callback function	:	Specify the presence of callback functions.



7. Creating Controls

Color/pattern

Item	Description
Use of background color	Select whether to provide the background color. If "No" is selected, the background will be transparent.
Background color	Specify the background color.
Character color	Specify the character color.
Background color at the time of focus	Specify the background color of an input box at the time of focus.
Character color at the time of focus	Specify the character color of an input box at the time of focus.
Background color at the time of disable	Specify the background color of an input box when the entry is disabled. When the entry is disabled, entered contents will be cleared.

Display type/Display format

Item	Description
Number of the maximum characters	Specify the maximum number of characters to display. (1 to 256)

Password

Item	Description
Password setup	Select "Yes" to display entered characters with asterisks (*).

Character attribute

Item	Description
Effect at the time of focus	Select how the cursor and setting values are displayed at the time of focus. "With cursor": Displays the cursor. "No effect": Does not display the cursor. "Selected": Selects the entire setting value.
Cursor type	Select the type of cursor from "Vertical line" or "Block", when "Effect at the time of focus" is set as "With cursor" or "Selected".
Cursor color	Specify the color of cursor.

Operation function

Item	Description
Operation function	Select "Yes" or "None" to provide the operation function.

7. Creating Controls

Echo back

Item	Description
Echo back	Select whether to echo back the positional value of the control to which INPUT will be reflected or the sub cursor, from "Yes"/"No". * The control to which INPUT will be reflected can be designated by the function "GCSInputBoxSetRefrectControl".

Input method

Item	Description
Abs/Inc	Specify whether to directly set the input value to the control when entering the INPUT key (absolute), or to add the positional value of the sub cursor or the control to which INPUT will be reflected, to the input value when entering the INPUT key (incremental).

Sub cursor

Item	Description
Sub cursor Background color	Specify the background color of the control where the sub cursor is displayed.
Sub cursor Character color	Specify the character color of the control where the sub cursor is displayed.

Extended function

Item	Description
Extended function (A7) enabled	Specify whether to enable or disable the functions extended in NC Designer2 version A7 or later. When "Enable" is selected, the functions extended in version A7 or later for input box control can be used. When "Disable" is selected, only the functions of version A6 or earlier can be used.

For the other properties, refer to "7.1 Common Functions of Controls".

### 7.2.14.3 Complements

#### Cursor type

The cursor type can be changed between "Vertical line" and "Block" as shown below.

Display example: Cursor type "Vertical line"

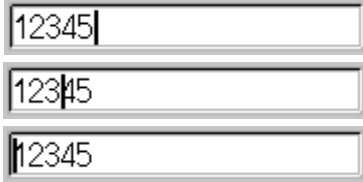

Display example: Cursor type "Block"



Operations with Keys

Types of Keys

The following keys are available for the input box.

Key type	Key	Operation
Data setting keys	A B C D E F G H I J K L M N O P Q R S T U V W X Y Z a b c d e f g h i j k l m n o p q r s t u v w x y z 0 1 2 3 4 5 6 7 8 9 + - / * = . , ; ( ) etc.	Press these keys to set alphabetic characters, numerals and operation symbols, etc.
Data correction keys	INSERT(Data insert key)	When cursor type is "block", the data insertion mode is entered. Press a data setting key to insert a character before the current cursor position. (The overwrite mode is entered when the DELETE, C.B, INPUT, cursor or TAB, etc., key is pressed, or when the screen is changed.)
	DELETE(Data delete key)	Press DELETE to delete a character in the data setting area. - When the cursor is "Vertical line", the character after the cursor position will be deleted. - When the cursor is "Block", the character before the cursor position will be deleted.
	C.B(Cancel key)	Press C.B to cancel the setting in the data setting area.
Cursor keys	↑ ↓	When the sub cursor settings are made, press these keys to move the target control.
	← →	When the sub cursor settings are made, press these keys to move the target control.
	← →	Press these keys to move the cursor one character to the left or right in the data setting area. If a control is set as the destination of these arrow keys (←, →) by the sub cursor settings, the cursor will not move within the data setting area and, instead, will move to the target control.
INPUT key	INPUT	Press INPUT to fix the data in the data setting area and reflect the input value to the control which is specified to reflect the INPUT. When the sub cursor settings are made, the input value will be reflected before the sub cursor moves.
Operation key	SP(Space key)	Inserts a blank.

(Note) If any key other than those listed above is entered, it will be ignored. If [Key transfer control] is set by the sub cursor setting, the focus will move to the target control and transfers the key.

For the sub cursor setting, refer to "10.7 Sub Cursor Setting".

Set the input numerals and alphabetic characters

Input numeric, alphabetical and other keys while the focus is placed on the control to display the character strings.

By specifying a control to reflect the INPUT beforehand, the input data can be reflected to the specified control when pressing the **INPUT** key.

Operation example:

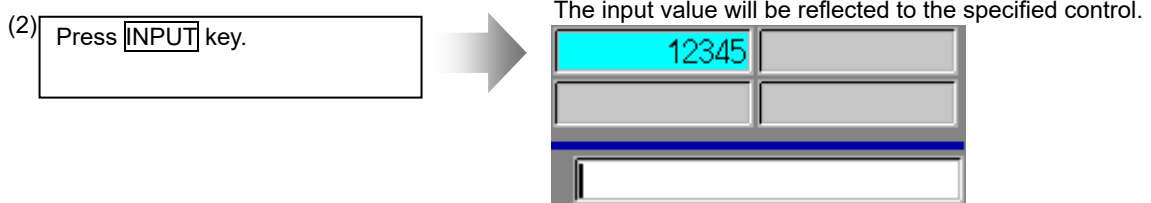
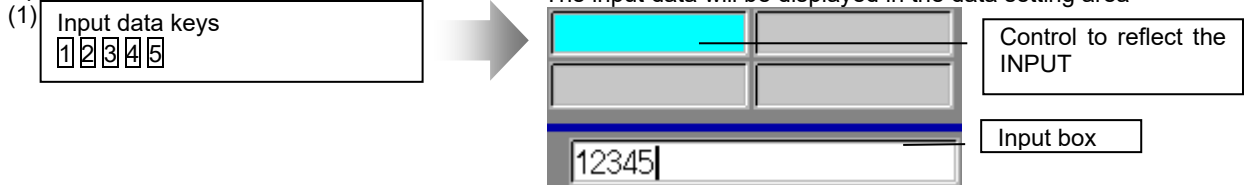

(Note) When reflecting the input data to the specified control is conducted successfully, the data in the data setting area will be cleared. And if it fails, the data will remain displayed in the data setting area.

Operations in the data setting area

Keys will be input to where the cursor is displayed.

When a key is input, the data will be displayed at the current cursor position and the cursor will shift a character to the right.

Numeric keys/Alphabetical keys

Operation example: Cursor type "Vertical line"

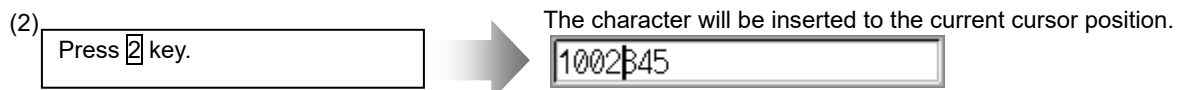
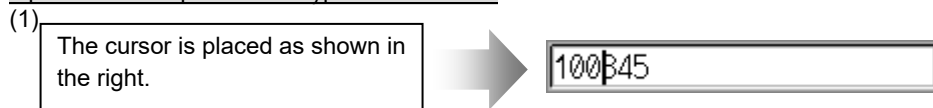

Operation example: Cursor type "Block"

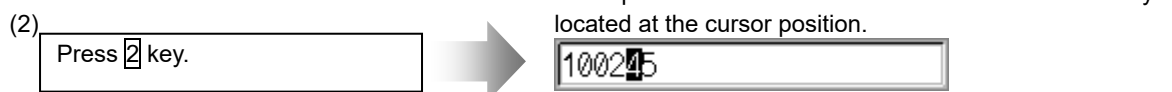
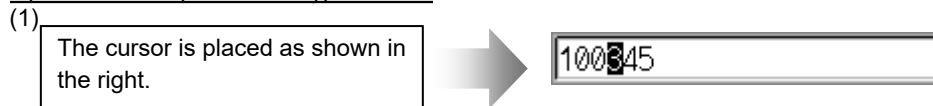

  Key

These keys move the cursor one character to the left or right.

Operation example: Cursor type "Vertical line"

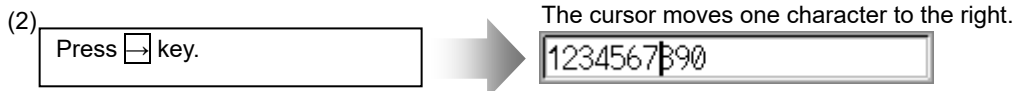
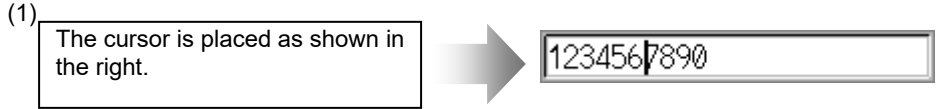

Operation example: Cursor type "Block"

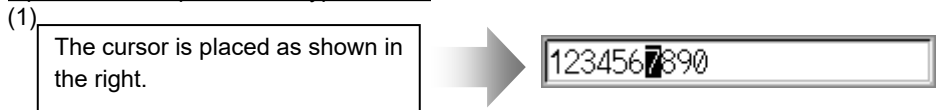

 Key

When cursor type is "block", the data insertion mode is entered. The characters input after the mode is entered will be inserted before the cursor position. When cursor type is "Vertical line", it is always in the data insertion mode, so this key will be ignored.

Operation example:

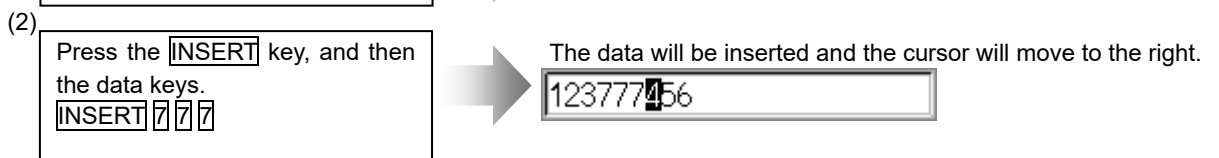
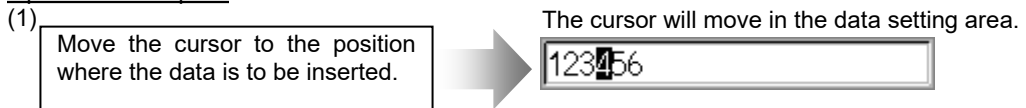



(Note) The overwrite mode is entered when , , , cursor or TAB, etc., keys are pressed, or when the screen is changed.

**DELETE** Key

- (1) When the cursor type is "Vertical line"  
 This key deletes the character to the right of the cursor.

Operation example:

(a) Move the cursor to the position where the data is to be deleted.  The cursor will move in the data setting area.

(b) Press **DELETE** key.  The character after the cursor will be deleted and the cursor will not move.

- (2) When the cursor type is "Block"  
 This key deletes the character to the left of the cursor.

Operation example:

(a) Move the cursor to the data to be deleted.  The cursor will move in the data setting area.

(b) Press **DELETE** key.  The character before the cursor will be deleted and the cursor will not move.

**C.B** Key

This key deletes all the characters in the data setting area.

Operation example:

(1) Press **C.B** key.  All the characters in the data setting area will be deleted and the cursor will move to the far left.

 (Block)

Inputting Operations

In addition to the method of directly inputting numeric data for specific data settings, the method of inputting the operation results using four rules operators and function symbols can be used.

Input method

Input numerical values, function symbols, operators and parentheses ( ) in the data setting area. Press **INPUT** key to display the operation results.

By specifying a control to reflect the INPUT beforehand, the input data can be reflected to the specified control when pressing **INPUT** key again.

Setting examples of operators and functional symbols and the results are as follows.

Examples of operator settings, and results		
Operation	Setting example	Result
Addition	=100+50	150
Subtraction	=100-50	50
Multiplication	=12.3*4	49.2
Division	=100/3	33.3333333
Function	=1.2*(2.5+SQRT(4))	5.4

Function symbols, setting examples and results			
Function	Function symbol	Setting example	Result
Absolute value	ABS	=ABS (50-60)	10
Square root	SQRT	=SQRT (3)	1.7320508
Sine	SIN	=SIN (30)	0.5
Cosine	COS	=COS (15)	0.9659258
Tangent	TAN	=TAN (45)	1
Arc tangent	ATAN	=ATAN (1.3)	52.431408

Operation examples

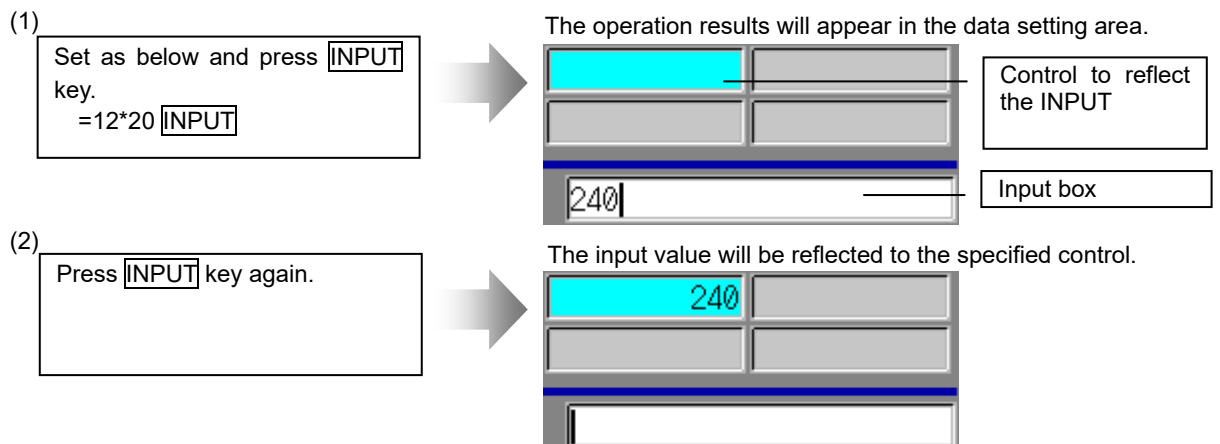

(Note) When reflecting the input data to the specified control is conducted successfully, the data in the data setting area will be cleared. And if it fails, the data will remain displayed in the data setting area.



## Precautions for using arithmetic operators and functions

- Division : An error will occur if the denominator of a division is zero.
- Square root : An error will occur if the value in parentheses ( ) is negative.
- Trigonometric function : The unit of angle  $\theta$  is degree ( $^{\circ}$ ).
- Arc tangent :  $-90 < \text{calculation result} < 90$

## Restrictions

Followings are the restrictions for operation function.

- (1) Always input "=" before any characters.
- (2) Do not use the following characters as the second or the last character.
  - Invalid as second character: \*, /, )
  - Invalid as last character: \*, /, (, +, -
- (3) An error will occur when the number of opening and closing parentheses is not equal.
- (4) The  $360^{\circ}$  limit does not apply on the angle. SIN (500) is interpreted as SIN (140).
- (5) The exponential setting, like "1.23E-4", cannot be used. The operation result is not displayed with exponential.
- (6) It is not possible to set characters exceeding the number of characters which can be input to the data setting area.
- (7) It is not possible to omit "0" before a decimal point, like ".5", when inputting operations.
- (8) The accuracy is guaranteed for the calculation with 15 digits or less. An unintended rounding will occur to calculations with over 15 digits.
  - Ex.1) When the 18th to 20th digits are rounded down.  
(=12345678901234567890\*1 → 12345678901234567000)
  - Ex.2) When the 18th digit is rounded to the positive direction.  
(=123456789012345678\*1 → 123456789012345680)
- (9) Operators and functions which are not mentioned above, such as "ASIN", cannot be used.
- (10) Regardless of the input setting unit and metric system/inch system, the maximum digit number below the decimal point of the operation result is seven.

**7.2.14.4 Restrictions**

- (1) When the control to reflect the INPUT is a text box (when "float" is set in the "Type" property), a value different from the one displayed in the data setting area may be set.
- (2) When a value is input after "0", "0" will be attached at the top of the value.  
The "0" will be cleared only when an arithmetic processing is executed.
- (3) Two-byte characters cannot be entered in the input box.
- (4) When "Yes" is set to the "Echo back" property and the number of characters of the data obtained from the control to which INPUT will be reflected exceeds the number of characters set in the "maximum number of characters" property, the display will be blank. There will be no echo back display.
- (5) When the control to which INPUT will be reflected is a PLC text box with an interlock, data reflection from the input box will fail, and values will not be updated.

**7.2.15 Ten-key object (GsoftKey)**

The ten-key is a control which displays numerical values and character strings as well as input keys. The key buttons within the ten-key control and the keys on the operation board can be used as input keys.

The following operations are also available with the ten-key control.

Operation function

The input values can be reflected to another specified control (Specification of a control to reflect the INPUT).

For the specification of a control to reflect INPUT, refer to GCSSoftKeySetRefrectControl in "5.27 SoftKey" of "NC Designer2 Macro Function Manual" (IB-1501500).

In combination with the sub cursor function, the input value can be set in the control at which the sub cursor is pointed and the control can be moved by the arrow key/TAB key.

For the details of sub cursor setting, refer to "10.7 Sub Cursor Setting".

The ten-key is a control which facilitates input processing to the text box and others by saving the need for using macro description. The SW keyboard is a keyboard window which substitutes the NC keyboard. The following table shows the difference in functions.

	<b>Ten-key</b>	<b>SW keyboard</b>
Purpose	SW keyboard control which can interface with text box, PLC text box, NC data text box.	Simple NC keyboard window
	No macro creation needed for data input processing	Macro creation needed for the data input processing
	Layout can be customized	Layout fixed (Left, center, right)
Function		
Key type	Three (Decimal/Hexadecimal/ALL key)	Two (Ten-key/ALL key)
Abs/Inc	Yes	No
Calculation	Yes	No

**7.2.15.1 Property Setup Dialog**

Property setup dialog of ten-key control consists of the tabs relating to [Basic Settings] and [Advanced Settings]. Details of each tab will be described in the following sections.

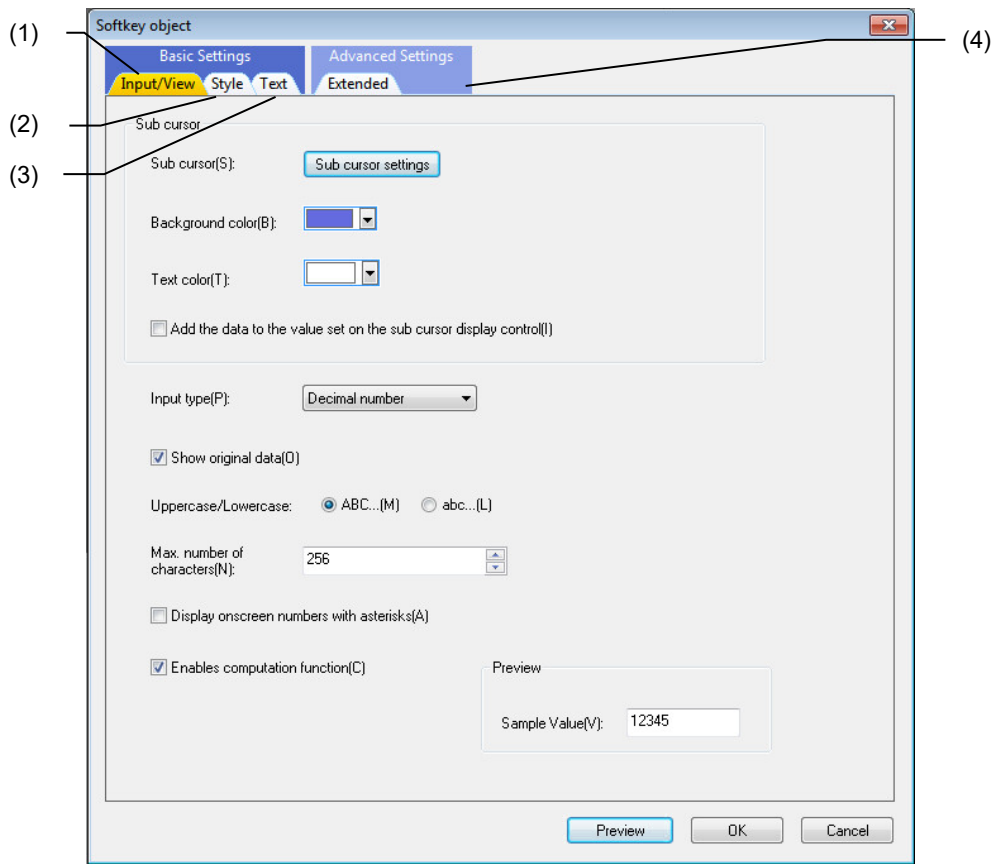

[Basic Settings] consists of the following tabs.

No.	Tab	Description
(1)	Input/View	Set or display the sub cursor and preview.
(2)	Style	Set or display the background color, solid frame, and preview.
(3)	Text	Set or display the text color, cursor, and preview.

[Advanced Settings] consists of the following tab.

No.	Tab	Description
(4)	Extended	Set the item relating to the extended styles and title bar.

7.2.15.1.1 [Input/View] Tab

In [Input/View] Tab, specify the sub cursor and the sample value of the preview.

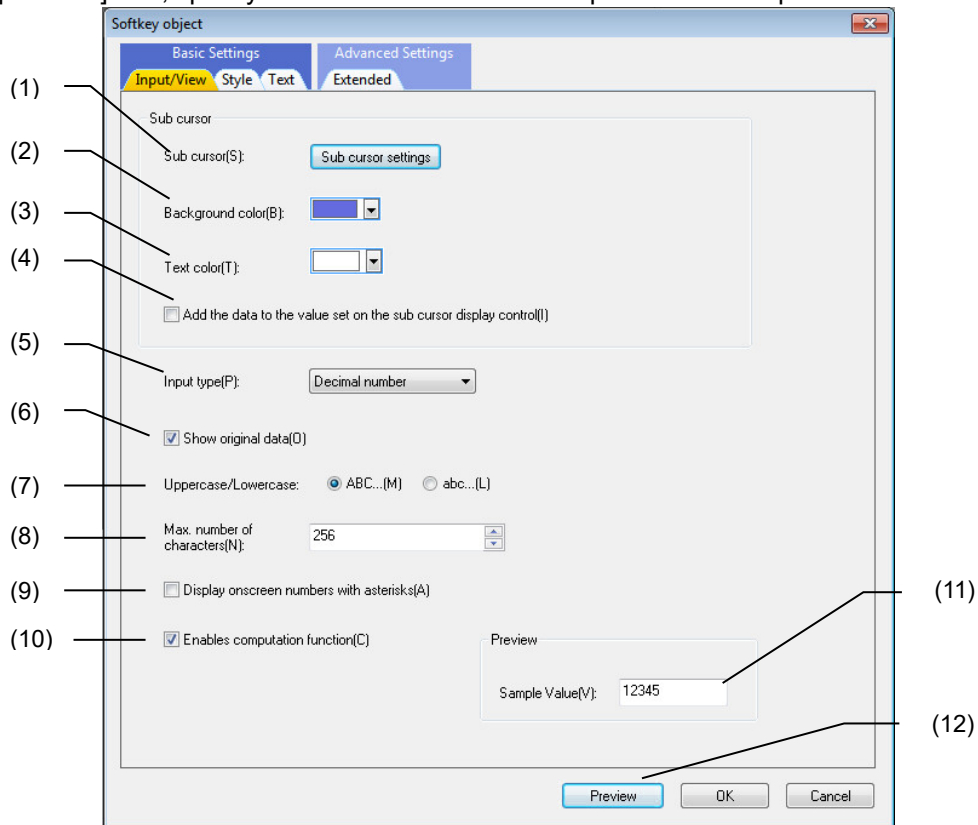

No.	Item	Description
(1)	Sub cursor	Specify the sub cursor. Click on the sub cursor button to display the "Sub cursor Setting" dialog. (Note) The sub cursor button is valid when one of the following controls is arranged either on the ten-key control which is located on the panel/window or on the view frame - Text box - PLC text box - NC data text box  For the "Sub Cursor Setting", refer to "10.7 Sub Cursor Setting".
(2)	Background color	Specify the sub cursor background color.
(3)	Text color	Specify the sub cursor text color.
(4)	Add the data to the value set on the sub cursor display control	Check this box to add the input value to the value of the control which displays the sub cursor when pressing the INPUT key.
(5)	Input type	Select the input type from "Decimal number", "Hexadecimal" or "ALL key type".
(6)	Show original data	Check this box to display the original value part.
(7)	Uppercase/Lowercase	Select the input method to be displayed at the first time from "ABC..."/"abc...". When "abc..." is set, the <span style="border: 1px solid black; padding: 2px;">ABC.../abc...</span> key button on the ten-key control will be highlighted.
(8)	Max. number of characters	Specify the maximum number of the characters to display.
(9)	Display onscreen numbers with asterisks	Check this box to display the input characters with asterisks.
(10)	Enables computation function	Check this box to enable the computation function.
(11)	Sample Value	Specify the value to be displayed on the preview.

No.	Item	Description
(12)	Preview	Display the window to check the specified property design.

**7.2.15.1.2 [Style] Tab**

In [Style] tab, specify the background color and solid frame.

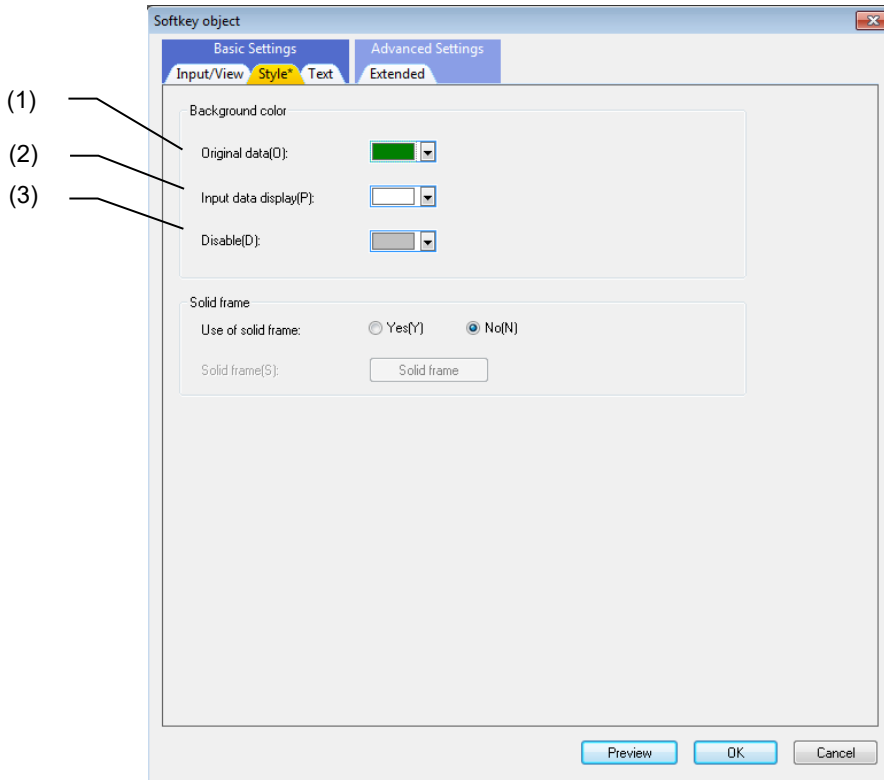

No.	Item	Description
(1)	Original data	Specify the background color of the original value part.
(2)	Input data display	Specify the background color of input data display part.
(3)	Disable	Specify the background color of an input data display part when the entry is allowed but the focus is OFF or the entry is disabled.

For the items other than the above, refer to "7.1.16.1.1 [Style] Tab".

7.2.15.1.3 [Text] Tab

In [Text] tab, specify the text color and cursor.

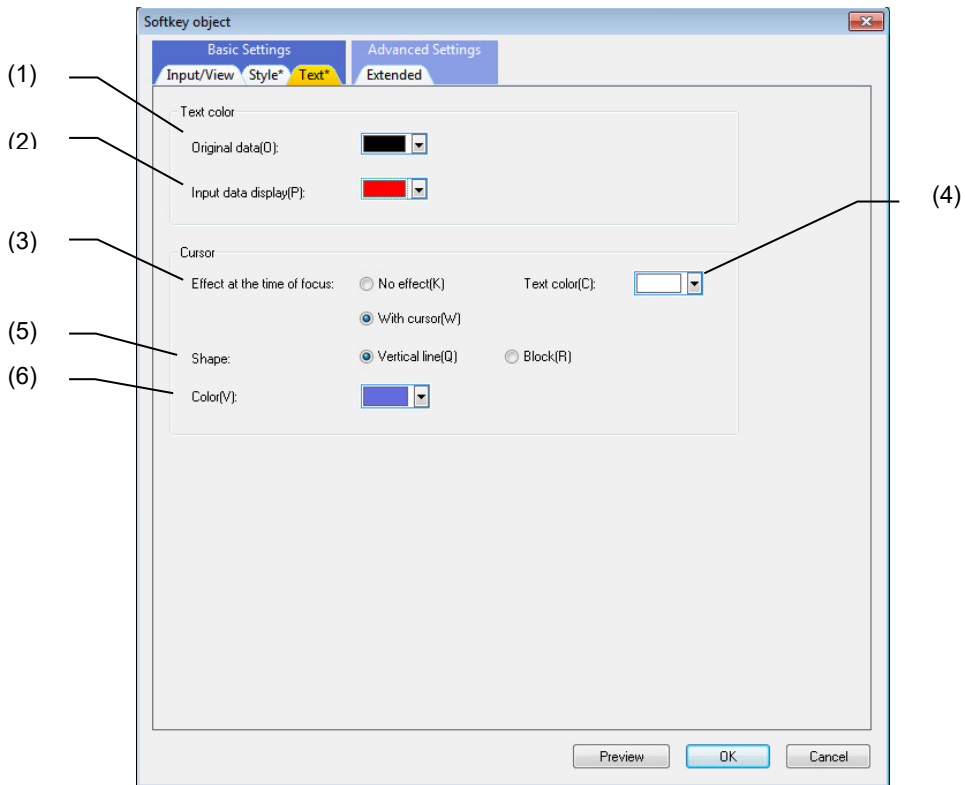

No.	Item	Description
(1)	Original data	Specify the text color of the original value part.
(2)	Input data display	Specify the text color of input data display part.
(3)	Effect at the time of focus	Select the effect at the time of focus among "No effect" or "With cursor".
(4)	Text color	Specify the text color of the cursor position.
(5)	Shape	Select the cursor shape from "Vertical line" or "Block".
(6)	Color	Specify the cursor color.

7.2.15.1.4 [Extended] Tab

In [Extended] tab, specify the extended styles and title bar.

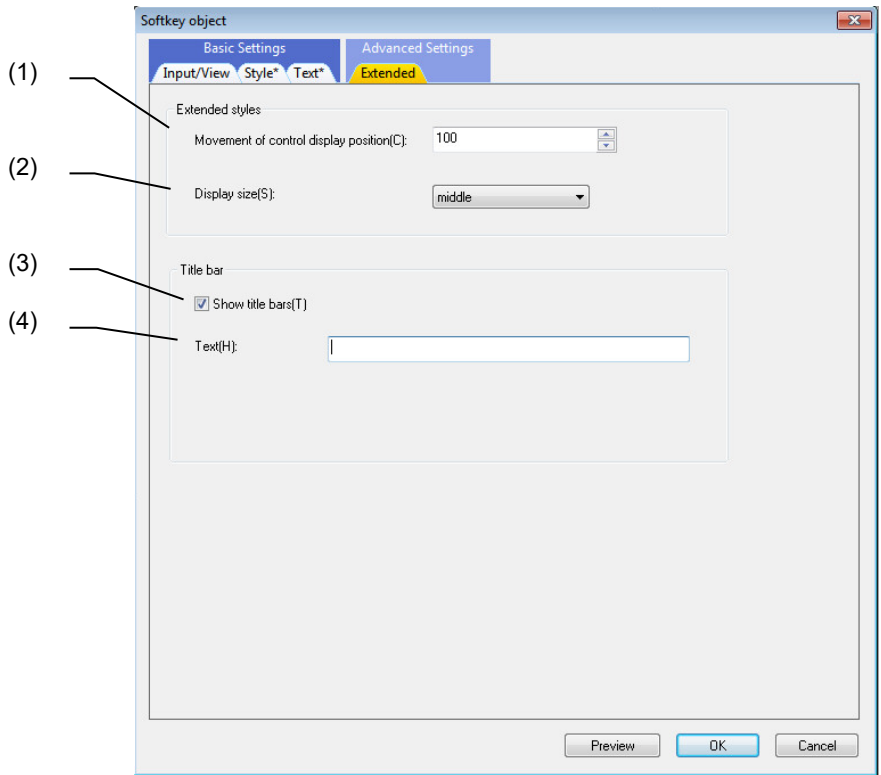

No.	Item	Description
(1)	Movement of control display position	Specify how much the control moves with the position movement button.  <p>Display position movement button</p>
(2)	Display size	Select the display size of the key buttons from "Small" / "middle" / "Horizontal". The selected display size will become valid when the input type is set to "Decimal number" or "Hexadecimal".
(3)	Show title bars	Check this box to display the title bar.
(4)	Text	Specify the character string of the title bar.

**7.2.15.2 Property Settings**

The property settings for the ten-key object are divided into the followings.

- Control name : Specify the control name.
- Position/size : Specify the position and size of the control.
- Show/hide : Select whether the control is displayed or hidden.
- Color/pattern : Specify the color and pattern of the control.
- Display type/Display format : Specify the format of character strings to be displayed in the control.
- Password : Specify the password.
- Character attribute : Specify the character attribute of the caption.
- Solid frame : Specify the solid frame of the control.
- Operation function : Specify whether or not the operation function is provided.
- Input method : Specify the input method (Absolute/Incremental) and the switching over between uppercase and lowercase characters.
- Sub cursor : Specify the display color of the sub cursor.
- Input type : Specify the input type.
- Display type : Specify the display type of buttons.
- Control display position movement amount : Specify the movement amount of the display position.
- Callback function : Specify the presence of callback functions.

Position/Size

Item	Description
X	Specify the horizontal position from the upper left of the page/view frame of the control (X coordinate) in dots (0 to 2559).
Y	Specify the vertical position from the upper left of the page/view frame of the control (Y coordinate) in dots (0 to 1919).
WIDTH (Note)	Specify the width of the control in dots (8 to 2560).
HEIGHT (Note)	Specify the height of the control in dots (8 to 1920).

(Note) If an area smaller than the entire ten-key is specified, the drawings will not be updated correctly while key input can be handled. Make sure that the specified area is as large as the ten-key.



Show/Hide

Item	Description
Show/Hide	Select whether to display the control.
Title bar Show/Hide	Select "Show" to display and "Hide" not to display the title bar.
Title bar Displayed character string (Note)	Specify the character string to be displayed on the title bar. There are two specification methods for character string. - Select from the registered character string resources. - Newly input character strings.
Original value Show/Hide	Select "Show" to display and "Hide" not to display the original value.

(Note) The maximum number of characters for the title name differs depending on the input type and display type. When the title name exceeds the limit, it will overlap with the movement mark Δ. Make sure that the title name does not exceed the maximum number of characters.

	Type	Button (Small)		Button (middle)		Horizontal		ALL key type
		Dec.	Hex.	Dec.	Hex.	Dec.	Hex.	
Max. no. of characters	M800V/M80V/M800 /M80 (Windows-based display unit)	11	11	18	18	34	43	18

\* When characters are input as one-byte characters.



Color/pattern

Item	Description
Original value Background color	Specify the background color of the original value part.
Original value Character color	Specify the character color of the original value part.
Input data display Background color	Specify the background color of input data display part.
Input data display Character color	Specify the character color of input data display part.
Background color at the time of disable	Specify the background color of an input data display part when the entry is allowed but the focus is OFF or the entry is disabled. When the entry is disabled, entered contents will be cleared.

Display type/Display format

Item	Description
Number of the maximum characters	Specify the maximum number of characters to display/set. (1 to 256) Characters exceeding the display range will be displayed by scrolling.

7. Creating Controls

Password

Item	Description
Password setup	Select "Yes" to display entered characters with asterisks (*). Characters will also be displayed with asterisks (*) at original value part.

Character attribute

Item	Description
Cursor Display (Note)	When the entry is allowed at the time of focus, select "With cursor" to display the cursor and "No effect" not to display the cursor.
Cursor type (Note)	Select the cursor type which will be displayed when the entry is allowed at the time of focus, from "Vertical line" or "Block".
Cursor background color (Note)	Specify the background color of the sub cursor.
Cursor character color (Note)	Specify the character color of the sub cursor.

(Note) The settings will be valid only when "ALL key type" is selected for the property item "Input type".

Solid Frame

Item	Description
Control Use of solid frame	Select the presence of the solid frame between "Yes" and "No".
Control Solid frame	Select the ID of the solid frame resource.

Operation function

Item	Description
Operation function (Note)	When the "Input type" is set to "ALL key type", select whether to provide the operation function between "Yes" and "None". When not provided, an operator will be counted as a character. When the "Input type" is set to "Decimal number" or "Hexadecimal", the operation function will always be valid.

(Note) The settings will be valid only when "ALL key type" is selected for the property item "Input type".

Input method

Item	Description
Abs/Inc	Specify whether to directly set the input value to the control when entering the INPUT key (absolute), or to add the positional value of the sub cursor or the control to which INPUT will be reflected, to the input value when entering the INPUT key (incremental). When "Inc" is set, the <b>Inc</b> key button on the ten-key control will be highlighted.
ABC.../abc... (Note)	Select the input method from uppercase/lowercase character. When "abc..." is set, the <b>ABC../abc..</b> key button on the ten-key control will be highlighted and lowercase character will be selected.

(Note) The settings will be valid only when "ALL key type" is selected for the property item "Input type".

7. Creating Controls

Sub cursor

Item	Description
Sub cursor Background color (Note)	Specify the background color of the control where the sub cursor is displayed.
Sub cursor Character color (Note)	Specify the character color of the control where the sub cursor is displayed.

(Note) For the details of sub cursor setting, refer to "10.7 Sub Cursor Setting".

Input type

Item	Description
Input type	Select the input type for the ten-key from Decimal number/Hexadecimal/ALL key type.

Display type

Item	Description
Display type	Select the display type of the key buttons from "Small"/"middle"/"Horizontal". The selected display type will become valid when the input type is set to "Decimal number"/"Hexadecimal".

Control display position movement amount

Item	Description
Control display position movement amount	Specify how much the control moves with the position movement button. If the size of the display after the movement with the position movement button exceeds the size of the panel or the window, the display position of the ten-key control will not change. Also, if the ten-key control is placed inside a frame, it will not move beyond the frame. (1 to 2560)

For the other properties, refer to "7.1 Common Functions of Controls".

### 7.2.15.3 Complements

Screen configuration

Screen image

The input types of the ten-key control are divided into decimal input (normal/horizontal), hexadecimal input (normal/horizontal), and all key type input (normal). Also, two button sizes are available for decimal input/hexadecimal input (normal).

Display image for each input type

The decimal/hexadecimal/all key type input can be switched over by changing the property item "Input type". Images of each input type are shown below.

<Decimal input type>

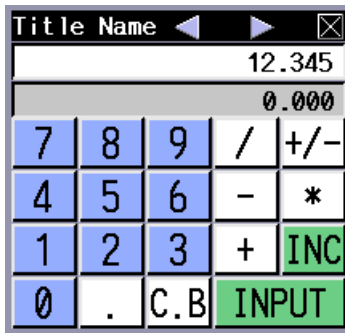

<Hexadecimal input type>

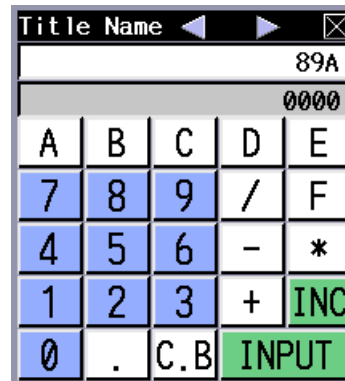

<All key type input>



Content

The configuration of a numerical control keypad is shown below. The title bar and the original value part can be hidden by changing the setting in the property item "Title bar Show/Hide" and "Original value Show/Hide".

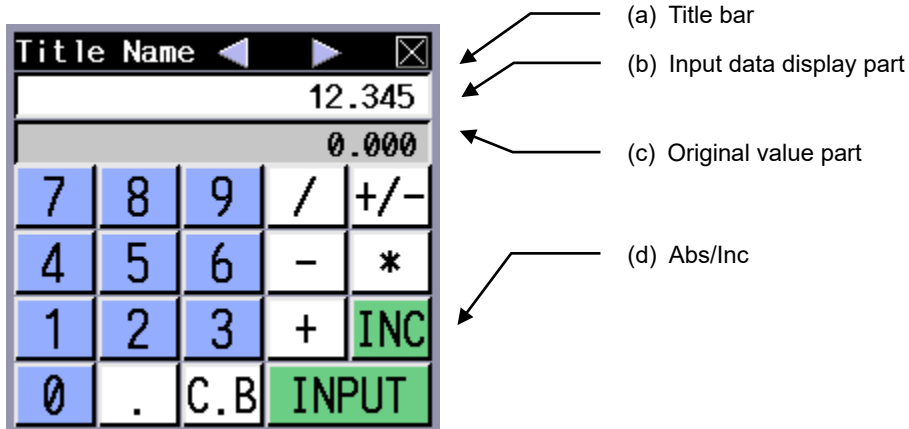

Name	Details
(a) Title bar	Displays the title name, the position movement button, and the close button. Specify the movement amount handled by the position movement button in the property. The title bar can be hidden by the property setting.
(b) Input data display part	Displays the value to be set. Press the [INPUT] key button to set this value to the control specified to reflect the INPUT.
(c) Original value part	Displays the value in the control specified to reflect the INPUT. Original value part can be hidden by the property setting.
(d) Abs/Inc	Change the setting method between absolute and incremental. When the incremental method is selected ([INC] key is highlighted), the value in the input data display part will be added to the value in the control to reflect the INPUT. But when the character string type of the control is "character string", inputting a value to the control will be disabled.

Highlighting the key button

When touched, the keys will be highlighted as below.

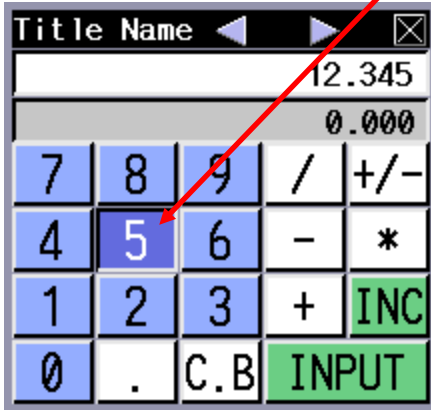

(Note) The position movement button and the close button on the title bar will not be highlighted.

Type of sub cursor

When "With cursor" is selected for the property item "Cursor Display", the type of the cursor will be as follows depending on the property setting "Cursor type".

Display example) Cursor type "Vertical line"



Display example) Cursor type "Block"



Operations with Keys

Buttons on the title bar

The "position movement button" and the "close button" are located on the title bar. The operations of controls with these buttons are explained below. Be aware that, when the title bar is hidden, these buttons cannot be used.

<Position movement button>

Click these buttons to move the ten-key to the direction indicated by the button.

The ten-key will move up and down when the "Input type" is "Decimal number" or "Hexadecimal" and also the "Display type" is "Horizontal". In other cases, it will move to right and left. Set the movement amount in the property item "Position movement".

<Close button>

Click this button to hide the ten-key. When the ten-key is specified as the "input control" in the sub cursor setting, the sub cursor will remain displayed.

The ten-key will reappear if the sub cursor movement is made when the ten-key is hidden. Also, touch the control to which the sub cursor setting is made to display the ten-key at the coordinate set as the "display start position" in the sub cursor setting.

For the details of sub cursor setting, refer to "10.7 Sub Cursor Setting".

Types of key buttons

The operations with key buttons displayed in the ten-key control and with those on the NC keyboard are received.

Keys	Details
[0] to [9], [A] to [Z]	These reflect the input numerals and alphabets to the input data display part.
[.]	This reflects the decimal point to the input data display part.
[+/-]	This highlights the sign of the value in the input data display part.
[+], [-], [*], [/]	These set the four rules operators to the input data display part.
[SP]	This puts a character space to the input data display part.
[C.B]	This clears (blank) the value in the input data display part.
[INPUT]	When an operation is not being performed (when the four rules operators are displayed), this sets the value in the input data display part to the control to reflect the INPUT. When an operation is being performed (when the four rules operators are displayed), this sets the operation result to the input data display part.
[INC]	Change the setting method between absolute and incremental. When the incremental method is selected ([INC] key is highlighted), the value in the input data display part will be added to the value in the control to reflect the INPUT.
[SHIFT]	Press this key to select the characters written in the lower part of each button. Example) Press [SHIFT] and then [G] to input "C".
[ABC.../abc...]	Press this key to switch between uppercase and lowercase alphabets.
Others	The input values will be reflected to the input data display part.

Key type	Key	Operation
<b>Keys related to data input (Keys available for the ten-key control)</b>		
Data setting keys	A B C D E F G H I J K L M N O P Q R S T U V W X Y Z a b c d e f g h i j k l m n o p q r s t u v w x y z 0 1 2 3 4 5 6 7 8 9 + - = * / . ; ( ) etc.	Press these keys to set alphabetic characters, numerals and operation symbols, etc.
Data correction keys	INSERT (Data insert key)	When the type of the cursor is "block", the data insertion mode is entered. Press a data setting key to insert a character before the current cursor position. (The overwrite mode is entered when the DELETE, C.B, INPUT, cursor or TAB, etc., keys are pressed, or when the screen is changed.)
	DELETE (Data delete key)	Press DELETE to delete a character in the data setting area. - When the cursor is "Vertical line", the character after the cursor position will be deleted. - When the cursor is "Block", the character before the cursor position will be deleted.
	C·B (Cancel key)	Press C·B to cancel the setting in the data setting area.
Cursor keys	↑ ↓	When the sub cursor settings are made, press these keys to move the target control. (*)The values in the data setting area will not be cleared even if the sub cursor moves.
	← →	When the sub cursor settings are made, press these keys to move the target control. (*)The values in the data setting area will not be cleared even if the sub cursor moves.
	← →	Press these keys to move the cursor one character to the left or right in the data setting area. If a control is set as the destination of these arrow keys (←, →) by the sub cursor settings, the cursor will not move within the data setting area and, instead, will move between the target controls. (*)The values in the data setting area will not be cleared even if the sub cursor moves.
INPUT key	INPUT	Press INPUT to fix the data in the data setting area and reflect the input value to the control which is specified to reflect the INPUT. When the sub cursor settings are made, the input value will be reflect before the cursor moves to the target control. When operators are displayed in the ten-key display part, the operation result will be displayed in the input part but the input value will not be reflected to the specified control.
Operation key	SP (Space key)	Inserts a blank. (*) If INPUT is entered when only a space is input, the display characters in the control to which the sub cursor setting is made will be cleared.

(Note) If any key other than those listed above is entered, it will be ignored. If [Key transfer control] is set by the sub cursor setting, the focus will move to the set control and transfers the key. For the sub cursor setting, refer to "10.7 Sub Cursor Setting".



Set the input numerals and alphabetic characters

Input numeric, alphabetical and other keys while the focus is placed on the control to display the character strings.

By specifying a control to reflect the INPUT beforehand, the input data can be reflected to the specified control when pressing the **INPUT** key.

Decimal/Hexadecimal input

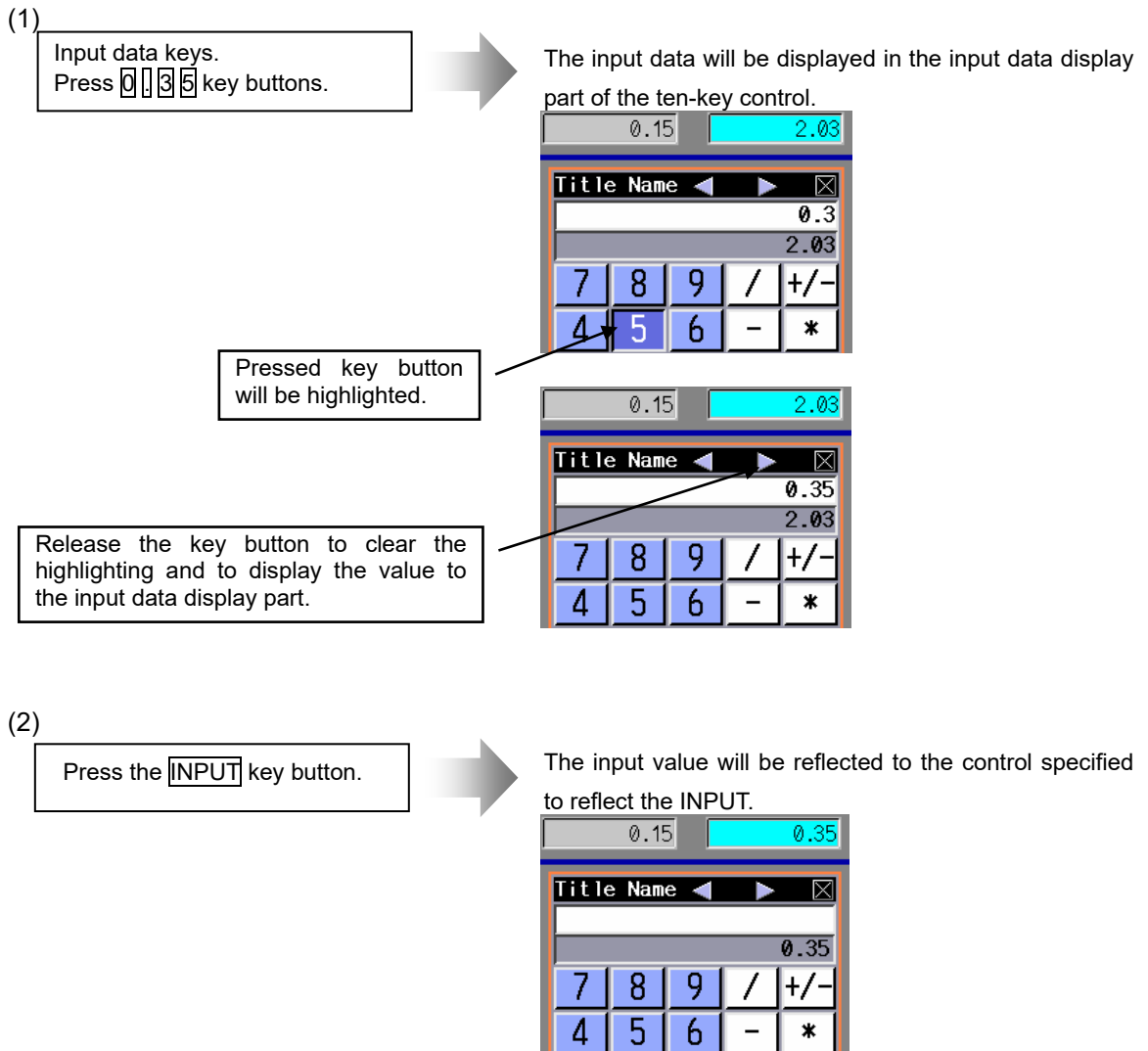

(Note 1) Data will be right-aligned in the input data display part and the original value part.

(Note 2) When the setting succeeds, the content in the input data display part will be cleared and the display of the original value part will be updated.

(Note 3) When the setting fails, neither displayed content in the input data display part nor the original value part will be changed.

(Note 4) When "0" before a decimal point is omitted, like **.****3****5**, ".35" will be displayed in the input data display part. And if the **INPUT** key is pressed, the character string ".35" will be set in the specified control. The setting will fail if the specified control to reflect the INPUT accepts numerals only.

All key type input

- (Note 1) Data will be left-aligned in the input data display part and the original value part.
- (Note 2) When the setting succeeds, the content in the input data display part will be cleared and the display of the original value part will be updated.
- (Note 3) When the setting fails, neither displayed content in the input data display part nor the original value part will be changed.
- (Note 4) When the character string type of the control is "character string", press SP key to insert a blank and then press INPUT key button to clear the content of the control. But if more than one blank are inserted, the blanks will be set in the control.

When data is set to the hexadecimal display control from a decimal input ten-key

The value in the input data display part will be converted to hexadecimal number before being reflected to the control to reflect the INPUT. Likewise, when a value is set to a decimal display control from a hexadecimal input ten-key, the value in the input data display part will be converted to decimal number before being reflected. All key type input can be operated as same as when using a decimal input ten-key.

The input data will be displayed in the input data display part of the ten-key.

The value in the input data display part will be reflected to the control after being converted according to the settings of the control.

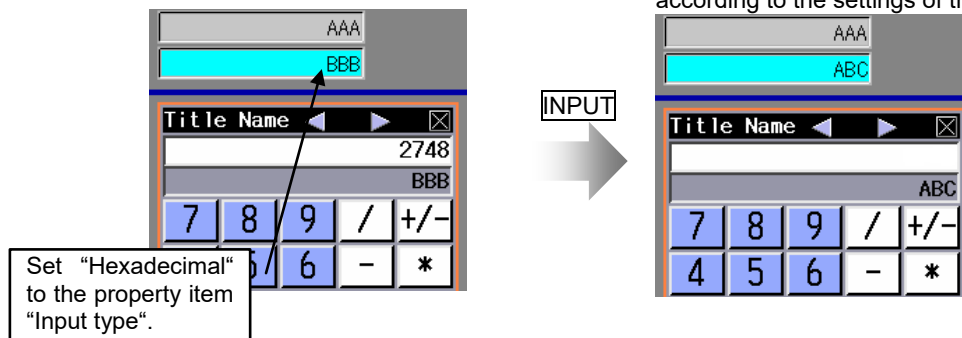

- (Note) The content of the control to which the INPUT is to be reflected will directly be displayed in the original value part regardless of the ten-key input type.  
When the input type is "Decimal number" and the control to reflect the INPUT is a hexadecimal display control, a hexadecimal number will be displayed in the original value part.

When data setting fails

Setting an input data may fail depending on the property setting of the control to reflect the INPUT.

If the data setting fails, the process written in the callback function OnError will be executed.

## Operation in the input data display part

For the all key type input, set the property item "Cursor Display" to "With cursor" to display the cursor in the input data display part.

Key input will be performed to where the cursor is currently displayed.

When a key is input, data will be displayed at the cursor position and the cursor will move a character to the right.

When the cursor is hidden, the data will be overwritten as well as when the cursor type is "Block".



The data will be inserted to the far right when the input type is decimal or hexadecimal.





## Numeric keys/Alphabetical keys

For the details of operation, refer to "7.2.14 Input box(GinputBox)".

 /  key

For the details of operation, refer to "7.2.14 Input box(GinputBox)".

(Note 1) The cursor will not moved during decimal and hexadecimal input. Characters will always be inserted to the far right even using  /  key.

(Note 2) When a control is specified as the destination of sub cursor movement in the sub cursor setting,  /  key operation gives priority to the sub cursor movement between controls. So the  /  key operation will become unable to move the sub cursor within the input data display part.

 key

For the details of operation, refer to "7.2.14 Input box(GinputBox)".



(Note) For the decimal and hexadecimal input, it is always in the data insertion mode, so this key will be ignored.

 key

## (1) All key type input

When the cursor type is "Vertical line", the character after the cursor position will be deleted. When the cursor is "Block", the character before the cursor position will be deleted.

For the details of operation, refer to "7.2.14 Input box(GinputBox)".

(Note) When a control is specified as the destination of sub cursor movement in the sub cursor setting, the sub cursor will not move within the input data display part. So when the cursor type is "Vertical line",  key will become unable to delete data. Use  key to delete characters in the input data display part.

## (2) For the decimal and hexadecimal input, the character at the far right will be deleted.

 key

This key deletes all the characters in the input data display part. When an operator is being displayed, the operator will be cleared, too.

For the details of operation, refer to "7.2.14 Input box(GinputBox)".

Input operation

The ten-key control provides a four rules operation function. The following operation procedure applies also when the input type is set to "ALL key type" and the operation function is set to "Yes".

Operation example

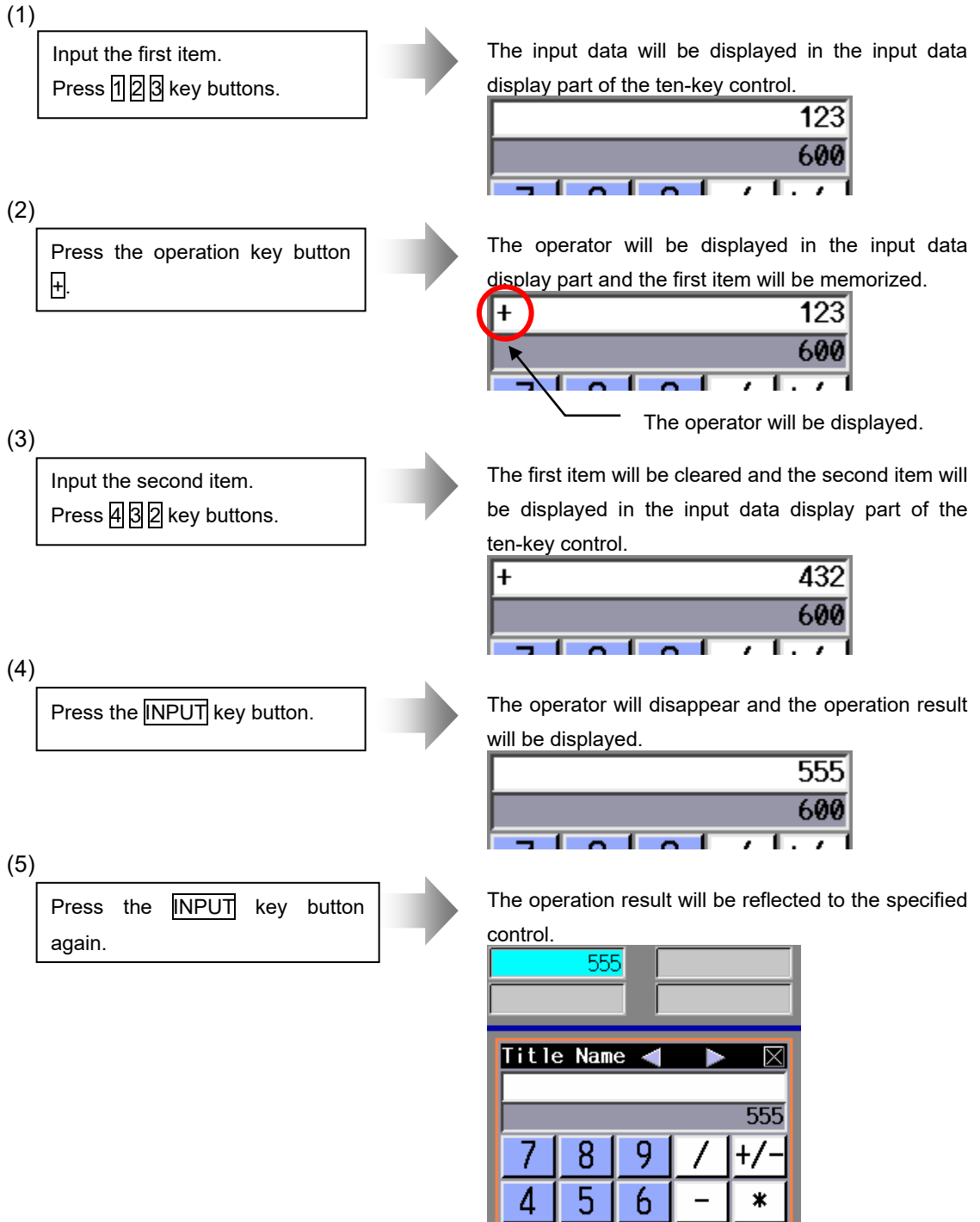

(Note) Press an operator key button after inputting the second item, instead of the **INPUT** key button, to display the operation result and the operator in the input data display part and to continue with another operation.

Example of operation failure

If the operation fails, neither displayed content in the input data display part or the original value part will be updated. But the operator will be cleared and the operator input will be canceled.

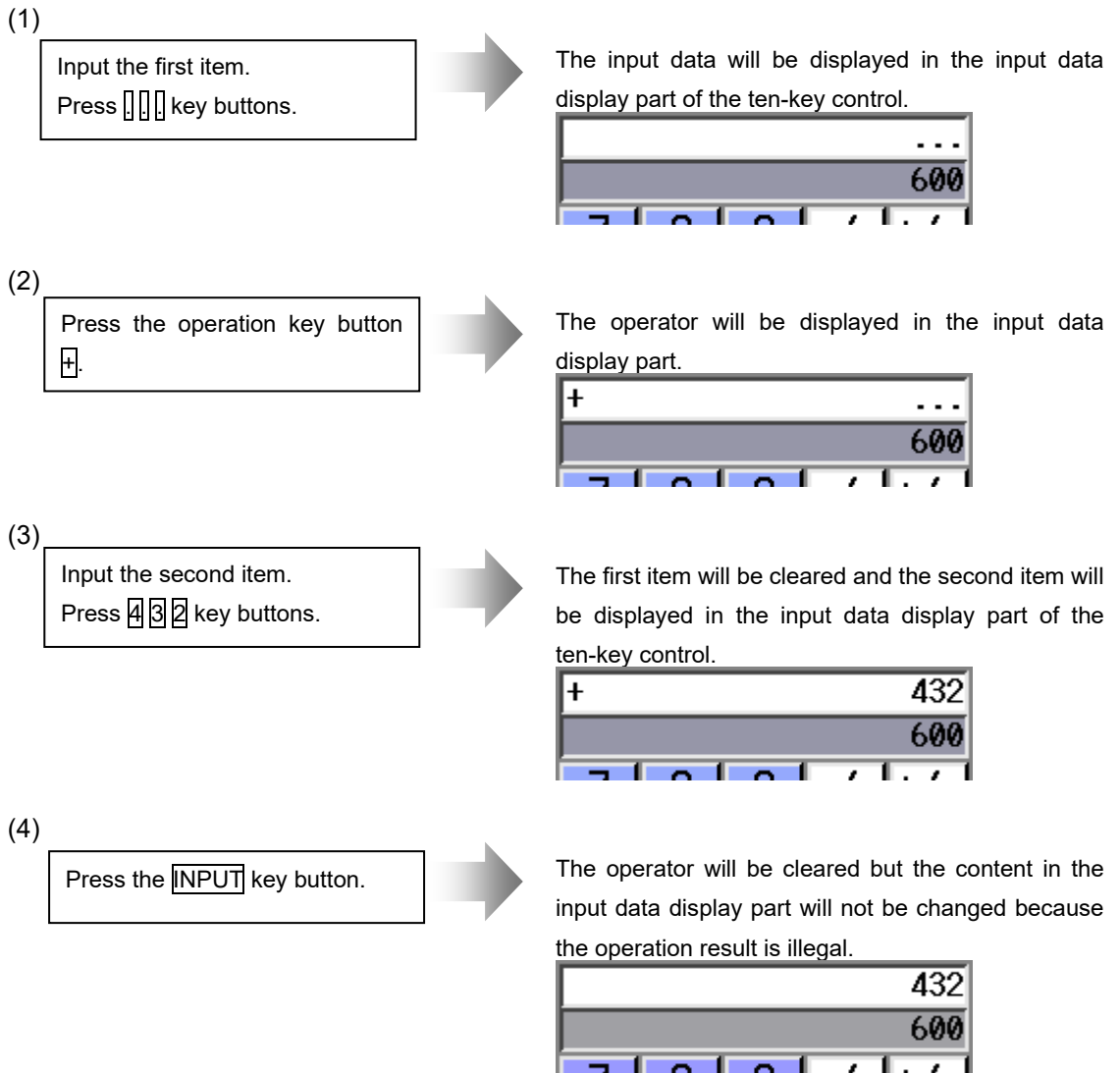

Canceling the operation input

Press the **INPUT** key after inputting the operator to cancel the operator input.

- (1)
 

Input the first item.  
 Press **1****2****3** key buttons.

→

123  
 600
- (2)
 

Press the operation key button **+**.

→

The operator will be displayed in the input data display part.

+ 123  
 600
- (3)
 

Press the **INPUT** key button.

→

The operator will be cleared.

123  
 600
- (4)
 

Press **4** key button.

→

The first item will not be cleared and "4" will be added to the far right.

1234  
 600

The operator display when character string is displayed by scrolling

If a character string exceeding the display range of the input data display part is input, a scroll display will be applied. The characters to be scrolled are those set with the data setting keys and the **+/-** key. When an operator is being displayed, its position is fixed and will not be scrolled.

- (1)
 

Press the operator key button **+** and input as many characters as possible to display.

→

+ 123456789012345678901  
 600
- (2)
 

Press **2** key button.

→

The "1" at the far left will be hidden and "2" will appear at the far right.  
 The operator will not be cleared.

+ 234567890123456789012  
 600

## Precautions for using operators and functions

- (1) An error will occur if the denominator of a division is zero.
- (2) When more than one operator is pressed one after another, the last one will become valid.
- (3) Several decimal points can be displayed at a time, but an operation will be illegal with several decimal points displayed.
- (4) The operation will be illegal when a "0" before a decimal point is omitted, like  $\square \square \square \square$ .
- (5) In the all key type input mode, the operation will be handled in decimal number. Operations in hexadecimal number are illegal.

## Restrictions of operation function

Followings are the limitations of operation function.

- (1) The accuracy is guaranteed for the calculation with 15 digits or less in decimal number. An unintended rounding will occur to calculations with over 15 digits.  
 Ex.1) When the 18th to 20th digits are rounded down.  
 (=12345678901234567890\*1 → 12345678901234567000)  
 Ex.2) When the 18th digit is rounded to the positive direction.  
 (=123456789012345678\*1 → 123456789012345680)  
 The calculation accuracy is the same for switching the sign of values using the  $\square$  key button.
- (2) Regardless of the input setting unit and metric system/inch system, the maximum digit number below the decimal point of the operation result is 7.
- (3) Operation using () cannot be performed.
- (4) Operation using a function symbol not provided in the key buttons cannot be performed.
- (5) Operation will not be performed by pressing "=" key.

## 7.2.15.4 Restrictions

- (1) When the property item "Original value Show/Hide" is set to "Show" and the character string set in the control to reflect the INPUT exceeds the "maximum number of characters" set in the property, the original value part will be blank.
- (2) When a text box is set as the control to reflect the INPUT (when the "type" property is set to "float"), a value different from the one displayed in the input data display part may be set in the text box.
- (3) If the ten-key is moved over a control with a display updating cycle (such as counter and F command), it will not be displayed correctly. Make sure that the layout does not cause any overlapping. Also, hide the title bar to invalidate the movement button operation.
- (4) When a value is input after "0", "0" will be attached at the top of the value. The "0" will be cleared only when an arithmetic processing is executed.
- (5) The hexadecimal input type ten-key cannot handle decimal numbers. A decimal point will not be displayed even by pressing the "." key button.

### 7.3 NC Control Object

#### 7.3.1 Counter (GNXCounter); Counter Display Part

The counter display part can display the current position, workpiece coordinate position, etc.

##### 7.3.1.1 Property Settings

The property settings of the Counter are divided into the followings.

- Control name : Specify the control name.
- Position/Size : Specify the position and the size of the control.
- Part system designation : Specify the part system.
- Character attribute : Specify the character attribute of captions.
- Counter kind : Specify the kind of counter to display.
- Display : Specify the number of axes to display and the presence of space between the rows.
- Axis status : Specify the display of the axis status.
- Title : Specify the display of the title.
- Axis name : Specify the display of the axis name.
- Coordinate : Specify the display of the coordinate.
- Color type : Specify the color type.
- Callback function : Specify whether or not the callback functions are provided.

Part system designation

Item	Description
NumberOfSystems	Specify the part system.

Character Attribute

Item	Description
FontType	Specify the font size and thickness.
Font12:	Font size 12
Font12 Bold:	Font size 12, bold
Font14:	Font size 14
Font14 Bold:	Font size 14, bold
Normal:	Normal size
Normal Bold:	Normal size, bold
Middle:	Middle size
Middle Bold:	Middle size, bold
Font28:	Font size 28
Font28 Bold:	Font size 28, bold
Font32:	Font size 32
Font32 Bold:	Font size 32, bold
Big:	Double height and width
Big Bold:	Double height and width, bold
Font40:	Font size 40
Font40 Bold:	Font size 40, bold
Font48:	Font size 48
Font48 Bold:	Font size 48, bold
Font48 Bold(Type2):	Font size 48, bold(Type2)
Font64:	Font size 64
Font64(Type2):	Font size 64(Type2)
Font64 Bold:	Font size 64, bold



7. Creating Controls

Counter Kind

Item	Description
CounterKind	Specify what kinds of coordinate values to display. Current Position: Current position Work Coordinate Position: Workpiece coordinate position Machine Position: Machine's position Program Position: Program position Program 0 Point: Programmed 0 Point Error Compensation: Error compensation amount Remain Command: Remaining command Manual Interruption Amount: Manual interruption amount Next Command: Next command Restart Position: Restart position Restart Remain Distance: Remaining distance for the restart Tip Wk Coord Position: Tip workpiece coordinate position Distance(Machine Axis Movement): Machine axis movement Pulse(Tool Axis Movement): Tool axis movement Tip Mach Position: Tip machining position Relative Position: Relative position PLC axis: PLC axis position (Note) All the other settings are invalid. However, work installation position, table coordinate position, and inclined surface coordinate position can be specified from GCSCounterSetCounterType function. (Note) If the axis name of a PLC axis is not designated, the axis name for the counter is displayed as "P+axis number"(P1, P2,...).

Display

Item	Description
LineNumber	Specify the number of axes to display. (1 to 16)
LineGapVisibleLineGapVisible	Specify whether the space is provided or not between the rows.

Axis Status

Item	Description
AxisStatusVisible	Specify the presence of the axis status.
AxisStatusType	Select "Normal Type".
DiameterAxisVisible	Specify whether to display the diametrical axis
AxisStatusForeColor	Specify the character color for the axis status display.
AxisStatusBackColor	Specify the background color for the axis status display.

Title

Item	Description
TitleForeColor	Specify the character color of the title.
TitleBackColor	Specify the background color of the title.

Axis name

Item	Description
AxisNameForeColor	Specify the character color for the axis name display.
AxisNameBackColor	Specify the background color for the axis name display.

Coordinate

Item	Description
ValueForeColor	Specify the character color for the coordinate value display.
ValueBackColor	Specify the background color for the coordinate value display.
CharacterNumber	Specify the digit number of the coordinate value. (1 to 18)
PicoUnitVisible	Specify whether to enable the Pico unit.
AxisCross	Specify whether to enable to switch over the display of axes names during mixed synchronization control. 1: Enable 0: Disable

Color Type

Item	Description
ColorType	Select the color type. Theme color (M8V Series): The control is displayed in the base color (for M8V Series) designated as the theme color. Theme color (M8 Series): The control is displayed in the base color (for M8 Series) designated as the theme color. Specified color: The colors set for each property are reflected. For theme color, refer to "5.10.9 Changing the Theme Color".

For the other properties, refer to "7.1 Common Functions of Controls".

7.3.1.2 Complements

Image

The following are the configurations of the counter display parts.

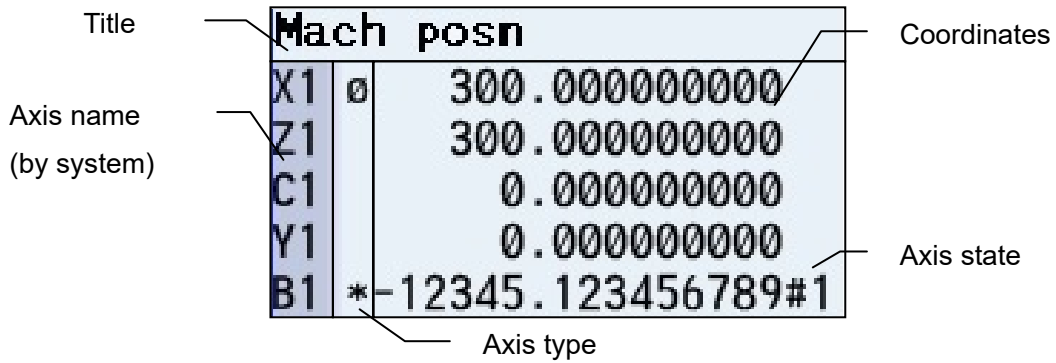

Table 1 Details for the axis states

Type of axis state	Displayed contents	Description
Normal type	No. of reference position #1 to #4	Returned to the reference position corresponding with the reference position number.
	]]	In emergency stop
	MR	Mirror image executed
	><	Axis removed state
	CT	Auxiliary axis selected
Restart type	RP	Thx axis has returned to the restart position.

Table 2 Details for the axis types

Displayed contents	Meaning
*	Non-control axis
φ	Diameter axis
(No indication)	Other axes than those above.

An item is indicated in order from the top of the table 2, if the axis has the several specifications of the list.

**7.3.2 CycleTime (GNXCycleTime); Cycle Time Display Part**

The cycle time display part is used to display the automatic start-up time and the cycle time.

Automatic start-up time (STL) .....	Total accumulated time during the automatic operation, from when the automatic start-up button is pressed in the memory (tape) mode or MDI to when the feed hold stop, block stop or reset button is pressed.
Cycle time (CYC) .....	The automatic operation time from when the automatic start-up button is pressed in the memory (tape) mode or MDI to when the feed hold stop, block stop or reset button is pressed.
Date (DAT) .....	This is preset to "0" by turning the power OFF. The current date set in the NC is displayed. Year: 4 digits, Month: 2 digit, Date: 2 digit (YYYY.MM.DD)
Time (TIM) .....	The current time set in the NC is displayed with the 24-hour system. (HH:MM:SS)
Power-ON time (PON) .....	This displays the total integrated time of the time from NC power ON to OFF. (HH:MM:SS)
Automatic operation time (OP) .....	The total integrated time from NC power ON to OFF. (HH:MM:SS)
External accumulated time1 (EX1) ...	This content differs depending on the PLC sequence. (HH:MM:SS)
External accumulated time2 (EX2) ...	This content differs depending on the PLC sequence. (HH:MM:SS)
Cut time (CUT) .....	The total time of the cutting commands (G1/G2/G3, etc.) given in the memory (tape) mode or MDI mode, from when the automatic start-up button is pressed until a feed hold stop, block stop, or a press of the reset button. (HHHHH:MM:SS) This is preset to "0" by the automatic start-up button or turning the power OFF.

**7.3.2.1 Property Settings**

The property settings of the CycleTime are divided into the followings.

- Control name : Specify the control name.
- Position/Size : Specify the position and the size of the control.
- Part system designation : Specify the part system.
- Character attribute : Specify the character attribute of captions.
- Time type : Specify the time type
- Display : Specify the existence of frame, as well as space between the rows.
- Label : Specify the display of the label.
- Value : Specify the display of the value.
- Color type : Specify the color type.
- Callback function : Specify whether or not the callback functions are provided.

Part system designation

Item	Description
NumberOfSystems	Specify the part system.

Character attribute

Item	Description
FontType	Specify the font size and thickness. Normal: Normal font Normal Bold: Normal bold font Middle: Middle font Big: Font with double height and width

7. Creating Controls

Time type

Item	Description
UpperTimeType	Specify the time type to be displayed at first time.
LowerTimeType	DATE ..... Date TIME ..... Time POWERON ..... Power ON AUTORUN ..... Automatic operation AUTOEXEC ..... Automatic start-up OUTSIDE1 ..... External accumulated time1 OUTSIDE2 ..... External accumulated time2 CYCTIME ..... Cycle time CUTTIME ..... Cut time DEFAULT ..... Default (upper: automatic start / lower: cycle time)

Display

Item	Description
LineGapVisible	Specify whether the space is provided or not between the rows.
FrameVisible	Specify the frame is provided or not.

Label

Item	Description
LabelForeColor	Specify the character color of the label.
LabelBackColor	Specify the background color of the label.

Value

Item	Description
ValueForeColor	Specify the character color of the value.
ValueBackColor	Specify the background color of the value.

Color Type

Item	Description
ColorType	Select the color type. Theme color (M8V Series): The control is displayed in the base color (for M8V Series) designated as the theme color. Theme color (M8 Series): The control is displayed in the base color (for M8 Series) designated as the theme color. Specified color: The colors set for each property are reflected. For theme color, refer to "5.10.9 Changing the Theme Color".

For the other properties, refer to "7.1 Common Functions of Controls".

7.3.2.2 Complements

Screen Specifications

Screen Images

(1) Label			(2) Value (Time)										
a	b	c	1	2	3	4	5	6	7	8	9	0	1
d	e	f	1	2	3	4	5	6	7	8	9	0	1

### 7.3.3 Feedrate (GNXFeedrate); F Display Part

F display part shows the vector direction speed currently being moved in during interpolation feed, the speed of the axis with highest speed during each axis independent feed. This part also shows dwell (code: G04).

Setting the property (speed display type) enables the display of tool tip speed.

#### 7.3.3.1 Property Settings

The property settings of the Feedrate are divided into the followings.

- Control name : Specify the control name.
- Position/Size : Specify the position and the size of the control.
- Part system designation : Specify the part system.
- Character attribute : Specify the character attribute of captions.
- Speed display type : Specify the type of the speed display.
- Display : Specify the frame is provided or not.
- Label : Specify the display of the label.
- Value : Specify the display of the value.
- Color type : Specify the color type.
- Callback function : Specify whether or not the callback functions are provided.

#### Part system designation

Item	Description
NumberOfSystems	Specify the part system.

#### Character Attribute

Item	Description
FontType	Specify the font size and thickness. Font12: Font 12 Font14: Font 14 Normal: Normal font Normal Bold: Normal bold font Font24: Font 24 Middle: Middle font Big: Font with double height and width

#### Speed Display Type

Item	Description
SpeedType	Specify the type of the speed display. Normal: Normal speed display Tool Tip Speed: Tool tip speed display

#### Display

Item	Description
FrameVisible	Specify the frame is provided or not.
AutoNumberChange	Specify whether to enable the automatic adjustment of the number of digit. False: Fixed to 12 digits. True: Automatically adjust the digits number for speed, according to the width.
Label/UnitVisible	Specify whether to display the label and the unit. The unit is acquired from the NC and the speed type is switched among the speed, the dwell, and the circumferential speed according to the unit. True: Enable Label/Enable Unit Label True Unit False: Enable Label/Disable Unit Label False Unit True: Disable Label/Enable Unit False: Disable Label/Disable Unit

7. Creating Controls

Label

Item	Description
LabelForeColor	Specify the character color of the label.
LabelBackColor	Specify the background color of the label.

Value

Item	Description
ValueForeColor	Specify the character color of the value.
ValueBackColor	Specify the background color of the value.

Color Type

Item	Description
ColorType	Select the color type. Theme color (M8V Series): The control is displayed in the base color (for M8V Series) designated as the theme color. Theme color (M8 Series): The control is displayed in the base color (for M8 Series) designated as the theme color. Specified color: The colors set for each property are reflected. For theme color, refer to "5.10.9 Changing the Theme Color".

For the other properties, refer to "7.1 Common Functions of Controls".

7.3.3.2 Complements

Screen Specifications

Screen Images

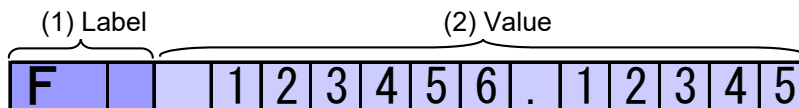

### 7.3.4 Gmodal M (GNXGModal); M System Modal Display Part

The G modal display part is used to show each modal state.

#### 7.3.4.1 Property Settings

The property settings of the Gmodal M are divided into the followings.

- Control name : Specify the control name.
- Position/Size : Specify the position and the size of the control.
- Part system designation : Specify the part system.
- Label : Specify the display of the label.
- Value : Specify the display of the value.
- Display : Specify whether the space is provided or not between the rows and whether to display MSTB.
- Color type : Specify the color type.
- Callback function : Specify whether or not the callback functions are provided.

#### Part system designation

Item	Description
NumberOfSystems	Specify the part system.

#### Label

Item	Description
LabelForeColor	Specify the character color of the label.
LabelBackColor	Specify the background color of the label.

#### Value

Item	Description
ValueForeColor	Specify the character color of the value.
ValueBackColor	Specify the background color of the value.

#### Display

Item	Description
LineGapVisible	Specify whether the space is provided or not between the rows.
MSTBVisible	Specify whether to display MSTB.
DispType	Specify the display type. Vertical type Horizontal type

#### Color Type

Item	Description
ColorType	Select the color type. Theme color (M8V Series): The control is displayed in the base color (for M8V Series) designated as the theme color. Theme color (M8 Series): The control is displayed in the base color (for M8 Series) designated as the theme color. Specified color: The colors set for each property are reflected. For theme color, refer to "5.10.9 Changing the Theme Color".

For the other properties, refer to "7.1 Common Functions of Controls".



7.3.4.2 Complements

Screen Specifications

Screen Images

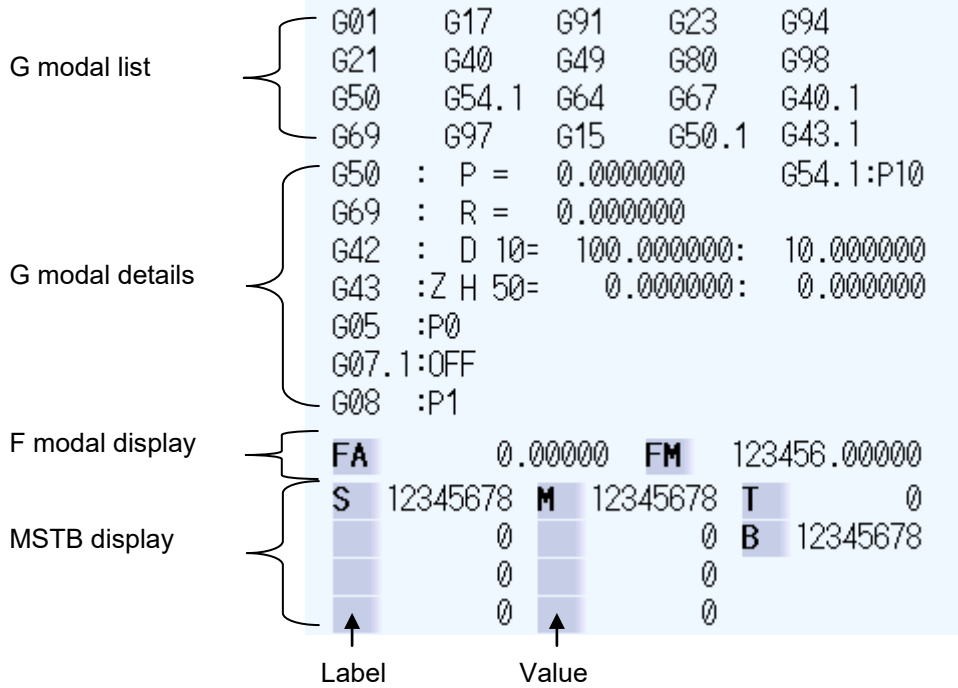

Restrictions

When no M command has been executed, the value in the M display shows "0".

### 7.3.5 Gmodal L (GNXGModal\_L); L System Modal Display Part

The G modal display part (L system) is used to show each modal state.

#### 7.3.5.1 Property Settings

The property settings of the Gmodal L are divided into the followings.

- Control name : Specify the control name.
- Position/Size : Specify the position and the size of the control.
- Part system designation : Specify the part system.
- Label : Specify the display of the label.
- Value : Specify the display of the value.
- Display : Specify whether the space is provided or not between the rows.
- Color type : Specify the color type.
- Callback function : Specify whether or not the callback functions are provided.

#### Part system designation

Item	Description
NumberOfSystems	Specify the part system.

#### Label

Item	Description
LabelForeColor	Specify the character color of the label.
LabelBackColor	Specify the background color of the label.

#### Value

Item	Description
ValueForeColor	Specify the character color of the value.
ValueBackColor	Specify the background color of the value.

#### Display

Item	Description
LineGapVisible	Specify whether the space is provided or not between the rows.
SSpeedMSTBVisible	Specify whether to display the constant surface speed control and the MSTB.
DispType	Specify the display type. Vertical type Horizontal type

#### Color Type

Item	Description
ColorType	Select the color type. Theme color (M8V Series): The control is displayed in the base color (for M8V Series) designated as the theme color. Theme color (M8 Series): The control is displayed in the base color (for M8 Series) designated as the theme color. Specified color: The colors set for each property are reflected. For theme color, refer to "5.10.9 Changing the Theme Color".

For the other properties, refer to "7.1 Common Functions of Controls".

7.3.5.2 Complements

Screen Specifications

Screen Images

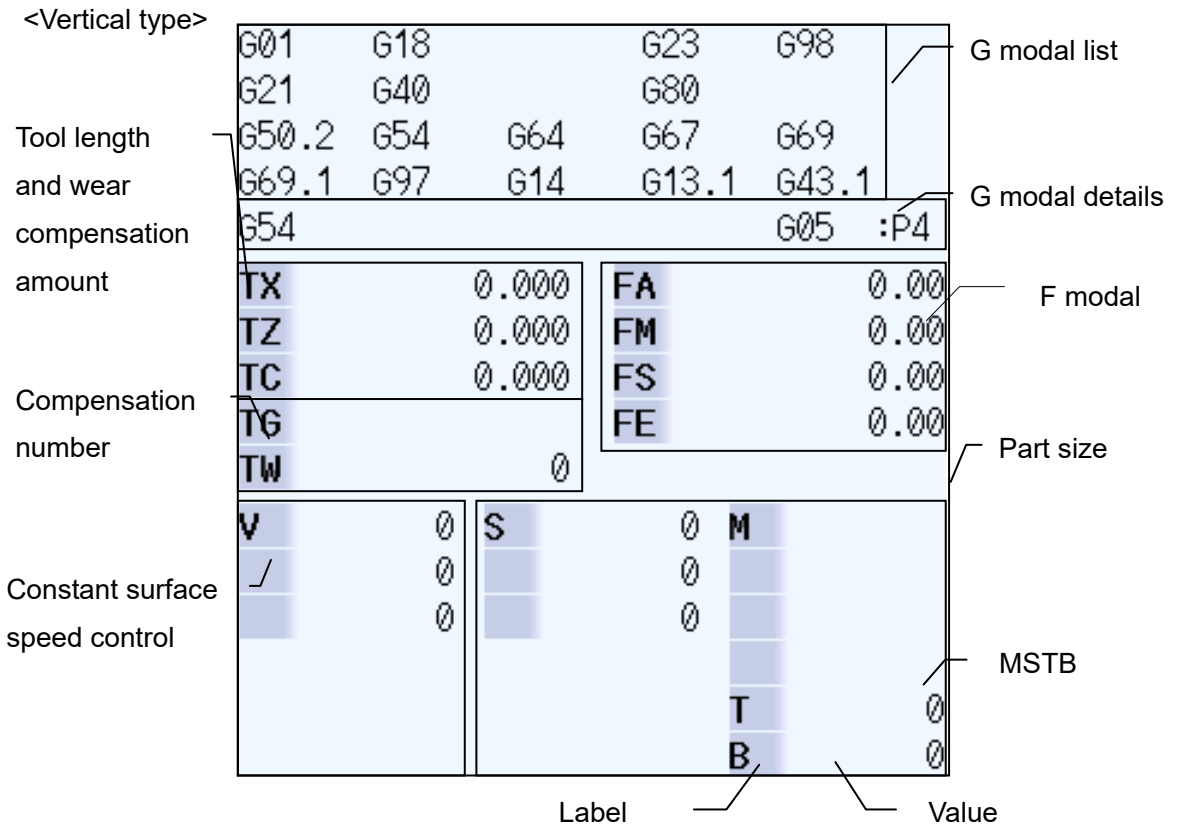

### 7.3.6 Gmodal Simple (GNXGModalSimple); Simple Modal Display Part

The G modal display part (simple) is used to show each modal state.

#### 7.3.6.1 Property Settings

The property settings of the Gmodal Simple are divided into the followings.

- Control name : Specify the control name.
- Position/Size : Specify the position and the size of the control.
- Part system designation : Specify the part system.
- Character attribute : Specify the character attribute of captions.
- Display : Specify whether the space is provided or not between the rows.
- Value : Specify the display of the value.
- Color type : Specify the color type.
- Callback function : Specify whether or not the callback functions are provided.

##### Part system designation

Item	Description
NumberOfSystems	Specify the part system.

##### Character Attribute

Item	Description
FontType	Specify the font size and thickness. Normal Normal font Big Font with double height and width

##### Display

Item	Description
LineGapVisible	Specify whether the space is provided or not between the rows.

##### Value

Item	Description
ValueForeColor	Specify the character color of the value.
ValueBackColor	Specify the background color of the value.

##### Color Type

Item	Description
ColorType	Select the color type. Theme color (M8V Series): The control is displayed in the base color (for M8V Series) designated as the theme color. Theme color (M8 Series): The control is displayed in the base color (for M8 Series) designated as the theme color. Specified color: The colors set for each property are reflected. For theme color, refer to "5.10.9 Changing the Theme Color".

For the other properties, refer to "7.1 Common Functions of Controls".

### 7.3.6.2 Complements

Screen Specifications

Screen Images

<M system>

```
G02.3 G91 G54.1P999
G41 : D999=12345.000000
      (Wear)=12345.000000
G43.4: H999=12345.000000
      (Wear)=12345.000000
```

Value

<L system>

```
G02.3 G99 G54.1P999
TG 123 TX -12.345
TW 123 TZ 12.345
      TY 10.000
```

Label

Value

**7.3.7 LoadMeter (GNXLoadMeter); Load Meter Display Part**

The Load meter display part can display the spindle load and Z axis load in the bar graphs by using user PLC.

(When the load meter is not set by user PLC, these are not displayed on the screen.)

Two load meters are displayed by using four lines (the area of the spindle standby and the load meter) when the spindle standby is not displayed.

One load meter is displayed by using two lines (the area of the spindle standby and the load meter) when the spindle standby is displayed.

**7.3.7.1 Property Settings**

The property settings of the LoadMeter are divided into the followings.

- Control name : Specify the control name.
- Position/Size : Specify the position and the size of the control.
- Part system designation : Specify the part system.
- Label : Specify the display of the label.
- Value : Specify the display of the value.
- Display type : Specify the display of the spindle load and the Z axis load.
- Color type : Specify the color type.
- Callback function : Specify whether or not the callback functions are provided.

Part system designation

Item	Description
NumberOfSystems	Specify the part system.

Label

Item	Description
LabelForeColor	Specify the character color of the label.
LabelBackColor	Specify the background color of the label.

Value

Item	Description
ValueForeColor	Specify the character color of the value.
ValueBackColor	Specify the background color of the value.
CharacterNumber	Specify the size of the Load meter display part. (4 to 50)

## Display Type

Item	Description
DispType	Specify the display of the spindle load and the Z axis load. 0: Displays the spindle load only 1: Displays the Z axis load only 2: Displays the both spindle and Z axis loads

## Color Type

Item	Description
ColorType	Select the color type. Theme color (M8V Series): The control is displayed in the base color (for M8V Series) designated as the theme color. Theme color (M8 Series): The control is displayed in the base color (for M8 Series) designated as the theme color. Specified color: The colors set for each property are reflected. For theme color, refer to "5.10.9 Changing the Theme Color".

For the other properties, refer to "7.1 Common Functions of Controls".

7.3.7.2 Complements

Screen Specifications

Screen Images

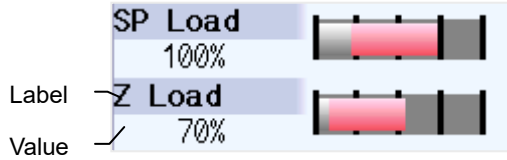

File Registers (R) for the Load Meter Display

		\$1	\$2	\$3	\$4
Load meter 1	For numeral display	R2520	R2720	R2920	R3120
	For bar graph display	R2521	R2721	R2921	R3121
Load meter 2	For numeral display	R2522	R2722	R2922	R3122
	For bar graph display	R2523	R2723	R2923	R3123

(Note) Machines without part system use the display for \$1.

Screen Image of the Load Meter Display Part and the Correspondence of the File Register (R)

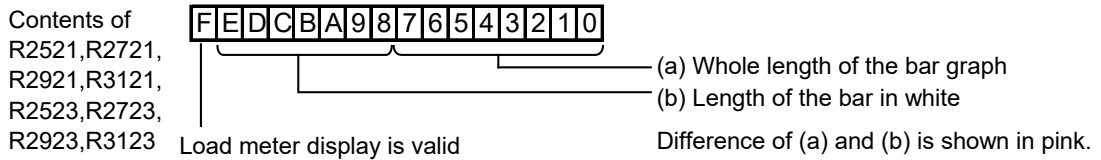
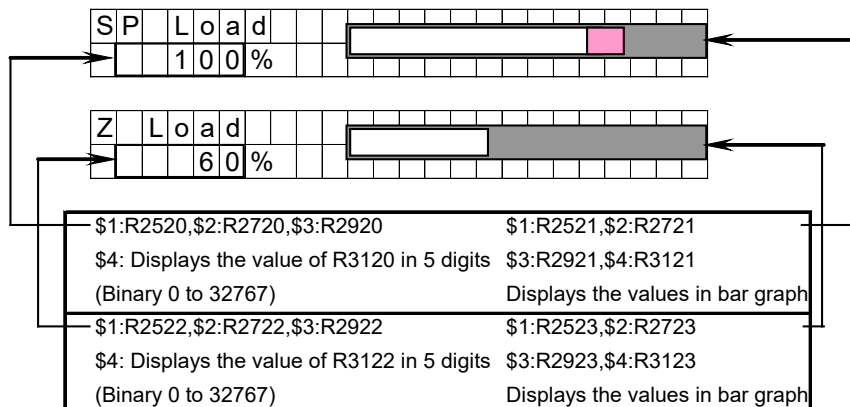

Restrictions

The Load meter display control does not show the scale and its markings, even if they have been set in the ladder program.



**7.3.8 MSTB (GNXMSTB); MSTB display part**

The MSTB display part can display each command of spindle function (S), miscellaneous function (M), tool function (T) and 2nd miscellaneous function (B).

**7.3.8.1 Property Settings**

The property settings of the MSTB are divided into the followings.

- Control name : Specify the control name.
- Position/Size : Specify the position and the size of the control.
- Part system designation : Specify the part system.
- Number of displays : Specify the number of the MSTB commands displayed.
- Character attribute : Specify the character attribute of captions.
- Display type : Select the property setting (in "Number of displays") or the NC parameter setting to give priority when specifying the number of the MSTB commands to display.
- Display : Specify whether to make frame, the space between lines and scroll bar visible and whether to activate the three columns display as well as the number of digits to be displayed.
- Color type : Specify the color type.
- Label : Specify the display of the label.
- Value : Specify the display of the value.
- Callback function : Specify whether or not the callback functions are provided.

Part system designation

Item	Description
NumberOfSystems	Specify the part system.

Number of Displays

Item	Description
S_Number	Specify the number of the S commands displayed (0 to 8).
M_Number	Specify the number of the M commands displayed (0 to 4).
T_Number	Specify the number of the T command displayed (0 or 1).
B_Number	Specify the number of the B command displayed (0 or 1).

Character Attribute

Item	Description
FontType	Specify the font size and thickness. Font12:           Font 12 Font14:           Font 14 Normal:           Normal font Normal Bold:      Normal bold font Middle:           Middle font Big:               Font with double height and width Font40:           Font 40

Display Type

Item	Description
DisplayType	<p>Select the property setting (in "Number of displays") or the NC parameter setting to give priority when specifying the number of the MSTB commands to display.</p> <p>Type0: The number of the MSTB commands displayed is specified by the property setting (in "Number of displays").</p> <p>Type1: The number of the M commands displayed is specified by the parameter "#12005 Mfig (Number of M)". (When the setting value of the parameter "#12005 Mfig (Number of M)" is larger than that of the property settings (in "Number of displays"), the property setting value is applied to the number of the M commands displayed. The number of the other STB commands displayed depends on the property settings (in "Number of displays").</p> <p>Type2: The number of the S commands displayed is specified by the parameter "#1300 ext36 (bit 0) (Multiple spindle control II)". (When the parameter "#1300 ext36 (bit 0) (Multiple spindle control II)" is set to "1", the number of the S commands displayed is also set to "1", regardless of the setting of the parameter "#1039 spinno (Number of spindles)". The number of the other MTB commands displayed depends on the property settings (in "Number of displays"). When the parameter "#1300 ext36 (bit0) (Multiple spindle control II)" is set to "0", the number of the MSTB commands displayed depends on the property settings (in "Number of displays").</p>

Display

Item	Description
LineGapVisible	Specify whether the space is provided or not between the lines.
FrameVisible	Specify the frame is provided or not.
ThreeSequencesType	Specify whether to display the S commands, M commands, and T, B commands in the three columns.
ScrollBarVisible	<p>Specify whether to enable the scroll bar.</p> <p>(Note 1) The scroll bar will not be displayed when the three columns display is valid.</p> <p>(Note 2) When the display digit is 0, the scroll bar will not be displayed.</p> <p>(Note 3) When the display width is narrow, the scroll bar will not be displayed.</p>
LineNumber	<p>Specify the display digit.</p> <p>0: All the lines</p> <p>1 to 12: Only the specified lines</p> <p>(Note) When the three columns display is valid, all the data will be displayed regardless of the display digit.</p>

7. Creating Controls

Color Type

Item	Description
ColorType	Select the color type. Theme color (M8V Series): The control is displayed in the base color (for M8V Series) designated as the theme color. Theme color (M8 Series): The control is displayed in the base color (for M8 Series) designated as the theme color. Specified color: The colors set for each property are reflected. For theme color, refer to "5.10.9 Changing the Theme Color".

Label

Item	Description
LabelForeColor	Specify the character color of the label.
LabelBackColor	Specify the background color of the label.

Value

Item	Description
ValueForeColor	Specify the character color of the value.
ValueBackColor	Specify the background color of the value.

For the other properties, refer to "7.1 Common Functions of Controls".

7.3.8.2 Complements

Screen Specifications

Screen Images

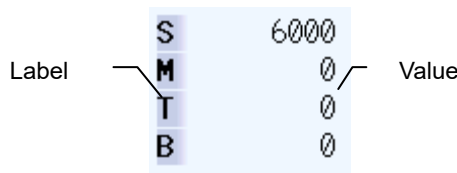

Restrictions

- (1) The macro interruption codes (M96, M97) and subprogram call codes (M98, M99) will not be processed if they are issued.
- (2) When no M command has been executed, the M command value area shows "0".

**7.3.9 ONB (GNONB); ONB Display Part**

The ONB display part displays the program No., sequence No. and block No. currently being executed.

When a subprogram is being executed, the subprogram's program No., sequence No., block No. and percentage display are displayed.

**7.3.9.1 Property Settings**

The property settings of the ONB are divided into the followings.

- Control name : Specify the control name.
- Position/Size : Specify the position and the size of the control.
- Part system designation : Specify the part system.
- Character attribute : Specify the character attribute of captions.
- Display : Specify the presence of frame, as well as space between the lines and columns.
- Label : Specify the display of the label.
- Value : Specify the display of the value.
- Device display : Specify whether or not to display the device.
- Nest level display : Specify whether or not to display the nest level.
- DisplayPercent : Specify whether or not to display the percentage.
- Color type : Specify the color type.
- Callback function : Specify whether or not the callback functions are provided.

Part system designation

Item	Description
NumberOfSystems	Specify the part system.

Character Attribute

Item	Description
FontType	Specify the font size and thickness. Font14: Font 14 Normal: Normal font Font24: Font 24 Middle: Middle font Big: Font with double height and width

Display

Item	Description
DispType	Specify the display type Normal: O number, fixed to 12 digits AutoNumberChange: O number, the digits change automatically. (Note 1) AutoNumberChange(2Lines): O number, the digits change automatically. (2-line display) (Note 2) (Note 1) This is for adjusting automatically the digit number according to the width. A width of 9 digits or more is required. (Note 2) NB number is displayed on the second line. A width of at least 9 digits or more is required.
NnumberDispNum	Specify the number of N number's digits to be displayed. (0 to 12) When it is "0", N number is displayed in 6 digits.
LineGapVisible	Specify whether the space is provided or not between the lines.
SequenceGapS	Specify whether the space is provided or not between the columns.
FrameVisible	Specify the frame is provided or not.

7. Creating Controls

Label

Item	Description
LabelForeColor	Specify the character color of the label.
LabelBackColor	Specify the background color of the label.

Value

Item	Description
ValueForeColor	Specify the character color of the value.
ValueBackColor	Specify the background color of the value.

Device Display

Item	Description
DisplayDeviceName	Specify whether or not to display the device.

Nest Level Display

Item	Description
DisplayNestLevel	Specify whether or not to display the nest level. When the nest level is 10, [*] will be displayed.

DisplayPercent

Item	Description
DisplayPercent	Specify whether or not to display the percentage. True(Normal): Enable to display the percentage. True(Compact): Enable to display the percentage (without margin). False: Disable to display the percentage.

Color Type

Item	Description
ColorType	Select the color type. Theme color (M8V Series): The control is displayed in the base color (for M8V Series) designated as the theme color. Theme color (M8 Series): The control is displayed in the base color (for M8 Series) designated as the theme color. Specified color: The colors set for each property are reflected. For theme color, refer to "5.10.9 Changing the Theme Color".

For the other properties, refer to "7.1 Common Functions of Controls".

7.3.9.2 Complements

Screen Specifications

Screen Images

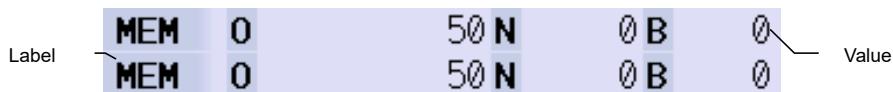

**7.3.10 ProgramBuffer (GNXPrgBuff); Program Buffer Display Part**

The program buffer display part displays the contents of the machining program currently being executed.

The block being executed in the program currently is highlighted.

**7.3.10.1 Property Settings**

The property settings of the ProgramBuffer are divided into the followings.

- Control name : Specify the control name.
- Position/Size : Specify the position and the size of the control.
- Part system designation : Specify the part system.
- Display : Specify the number of lines to display the machining programs, the number of characters in each line, and the presence of space between the lines.
- Value : Specify the display of the value.
- Character attribute : Specify the character attribute of captions.
- Color type : Specify the color type.
- Callback function : Specify whether or not the callback functions are provided.

Part system designation

Item	Description
NumberOfSystems	Specify the part system.

Display

Item	Description
LineNumber	Specify the number of lines to display the programs. (1 to 30)
CharacterNumber (Note)	Specify the number of characters in each line to display the programs. (2 to 80)
LineGapVisible	Specify whether the space between lines and the execution ratio meter are provided. False: Without space between lines or execution ratio meter Gap ON: With a space between lines. Progress ON: With execution ratio meter Progress/Gap ON: With a space between lines and execution ratio meter

(Note) Spaces to separate words are counted as characters.

Value

Item	Description
ValueForeColor	Specify the character color of the usual value area.
ValueBackColor	Specify the background color of the usual value area.
ValueReverseForeColor	Specify the character color of the value area when selected and reversed.
ValueReverseBackColor	Specify the background color of the value area when selected and reversed.

Character attribute

Item	Description
FontType	Specify the font size and thickness. Normal ..... Normal font Normal Bold ..... Normal bold font Middle ..... Middle-sized font

Color Type

Item	Description
ColorType	Select the color type. Theme color (M8V Series): The control is displayed in the base color (for M8V Series) designated as the theme color. Theme color (M8 Series): The control is displayed in the base color (for M8 Series) designated as the theme color. Specified color: The colors set for each property are reflected. For theme color, refer to "5.10.9 Changing the Theme Color".

For the other properties, refer to "7.1 Common Functions of Controls".

7.3.10.2 Complements

Screen Specifications

Screen Images

```

G40 ;
T8 M6 ;
G0 G54 G90 X15. Y0 ;
G43 Z5. H1 ;
G02 I-15 Z-100 F2000 ;
G02 I-15 ;
G01 ;
X25 ;
G02 I-25 ;
G01 X40 ;
    
```

Value

**7.3.11 SPCCommand (GNXSPCommand); S Display Part**

S display part can display the spindle modal (S) and the value of actual spindle rotation speed.

**7.3.11.1 Property Settings**

The property settings of the SPCCommand are divided into the followings.

- Control name : Specify the control name.
- Position/Size : Specify the position and the size of the control.
- Axis designation : Specify the spindle No. to be displayed.
- Number of displays : Specify the number of the S commands displayed.
- Character attribute : Specify the character attribute of captions.
- Label : Specify the display of the label.
- Value : Specify the display of the value.
- Display : Specify whether to activate the three columns display and the number of digits to be displayed.
- Color type : Specify the color type.
- Callback function : Specify whether or not the callback functions are provided.

Axis designation

Item	Description
AxisFlag	Specify the spindle No. to be displayed. - When "0" is set, axes will be displayed in ascending order. - When the number of S display is 1, set one of 1/2/4/8/16/32, then one of 1st spindle(1) to the 6th spindle(32) will be displayed in the spindle No to be displayed. - When the number of S display is more than 1, the spindle No. to be displayed will be decided by a combination of setting values. Set "12" to display the 3rd spindle (4) and the 4th spindle (8). The smaller spindle No. will be displayed first when several setting values are combined. - Even when the spindle No. becomes larger than the number of S display due to combining setting values, the number of spindles to be displayed will not exceed the value designated to the number of S display. When a value out of the setting range is set, it is regarded as the default value (0). - When the No. of a spindle which is not mounted is set, the 1st spindle will be displayed.

Number of Displays

Item	Description
S Number	Specify the number of the S commands displayed. (1 to 8)

Character Attribute

Item	Description
FontType	Specify the font size and thickness. Normal    Normal font Middle    Middle-sized font Big        Font with double height and width



7. Creating Controls

Label

Item	Description
LabelForeColor	Specify the character color of the label.
LabelBackColor	Specify the background color of the label.

Value

Item	Description
ValueForeColor	Specify the character color of the value.
ValueBackColor	Specify the background color of the value.

Display

Item	Description
Line_Number	Specify the number of digits to be displayed.
ThreeSequencesType	Specify whether to activate the three columns display.

Color Type

Item	Description
ColorType	Select the color type. Theme color (M8V Series): The control is displayed in the base color (for M8V Series) designated as the theme color. Theme color (M8 Series): The control is displayed in the base color (for M8 Series) designated as the theme color. Specified color: The colors set for each property are reflected. For theme color, refer to "5.10.9 Changing the Theme Color".

For the other properties, refer to "7.1 Common Functions of Controls".

7.3.11.2 Complements

Screen Specifications

If two or less spindles are set, both the spindle modal and the actual spindle rotation speed (in parentheses) are displayed.

If three or more spindles are set, only the spindle modal is displayed.

Screen Images

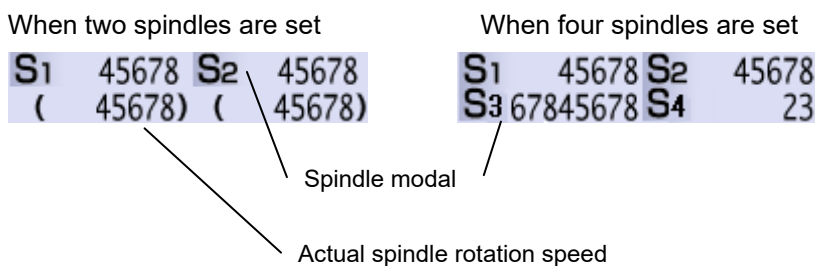

### 7.3.12 PLC Button Object (GNCPLCButton)

The PLC button control enables to read and write data from/to the PLC bit device of NC. It also enables to change the ON/OFF state of the button according to the state of the bit device.

#### 7.3.12.1 Property Setup Dialog

Property setup dialog of PLC button control object consists of the tabs relating to [Basic Settings] and [Advanced Settings]. Details of each tab will be described in the following sections.

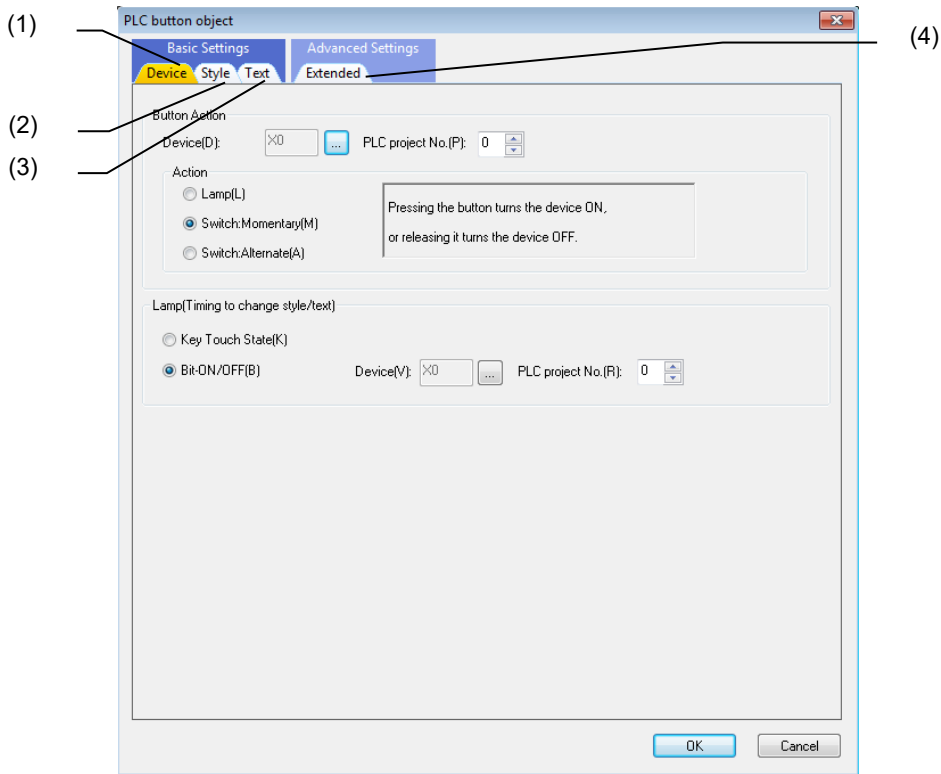

[Basic Settings] consists of the following tabs.

No.	Tab	Description
(1)	Device	Set the button actions and lamp.
(2)	Style	Set or display the background color, solid frame, blink, and preview.
(3)	Text	Set or display the font, text, scroll, and preview.

[Advanced Settings] consists of the following tab.

No.	Tab	Description
(4)	Extended	Set the item relating to the extended condition for the style or text.

7.3.12.1.1 [Device] Tab

In [Device] tab, specify the device and button action.

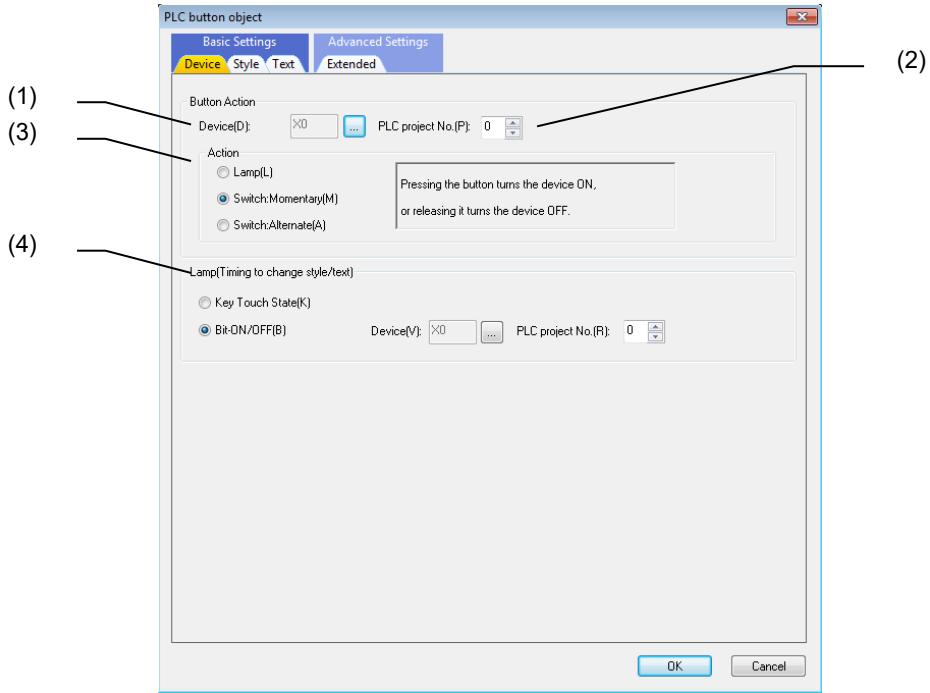

No.	Item	Description
(1)	Device	Specify the address of the PLC device for the read or write operation. Click on the "..." button to display the "PLC Device Setting" dialog.
(2)	PLC project No.	Specify the project number of PLC ladder what PLC device refers. (0 to 6)
(3)	Action	Select the button action among "Lamp", "Switch: Momentary", and "Switch: Alternate".
(4)	Lamp	Specify the timing to change the style or text.  * The button status which can be set in the [Style] tab or the [Text] tab changes depending on the specified contents.

**NOTE**

- ◆ The address of the PLC device can be specified on the "PLC Device Setting".

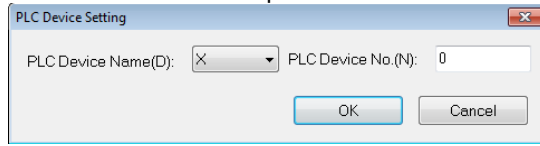

- ◆ **Lamp**  
When "Lamp" is selected in "Action", select between "Do not use the device2" and "To use the device2".

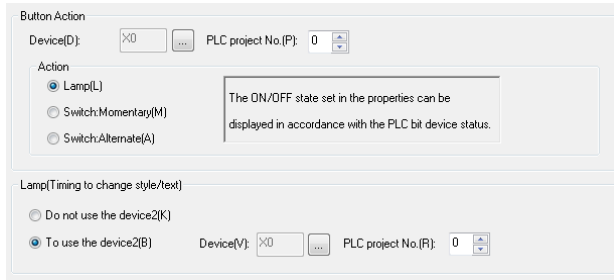

Item	Description
Do not use the device2	Switch the button status (ON or OFF) based on the device setting specified in the button action.
To use the device2	The device2 can be specified. Switch the button status (ON, OFF, ONON, or ONOFF) based on the combination with the device setting specified in the button action. (Note) For device2, specify the device different from the one specified in the button action.

- When "Switch:Momentary" or "Switch:Alternate" is selected in "Action", select between "Key Touch State" and "Bit-ON/OFF".

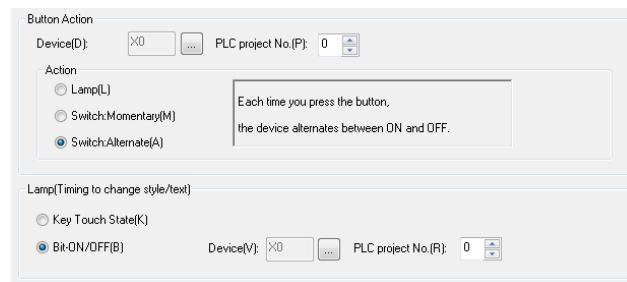
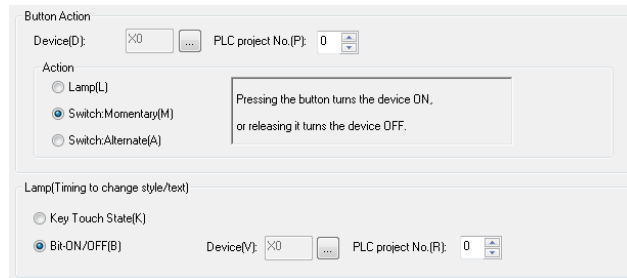

Item	Description
Key Touch State	Switch the button status (ON or OFF) each time the button is pressed or released. When "Switch:Momentary" is selected in "Action", the button turns ON when it is pressed and it turns OFF when it is released. When "Switch:Alternate" is selected, the button alternates ON and OFF each time it is pressed.
Bit-ON/OFF	Switch the button status (ON or OFF) each time the device turns ON or OFF.

7.3.12.1.2 [Style] Tab

In [Style] tab, specify the style, solid frame, and blink.

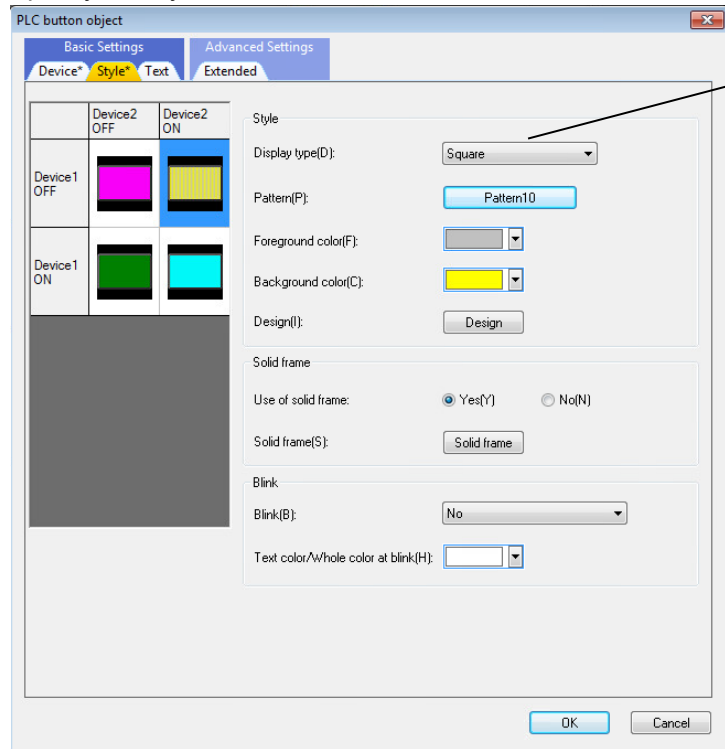

No.	Item	Description
(1)	Display type	Select the display type among "Square", "Circle", and "Image".

For each item, refer to "7.1.16.1.1 [Style] Tab".

7.3.12.1.3 [Text] Tab

In [Text] tab, specify the font, text, and scroll setting.

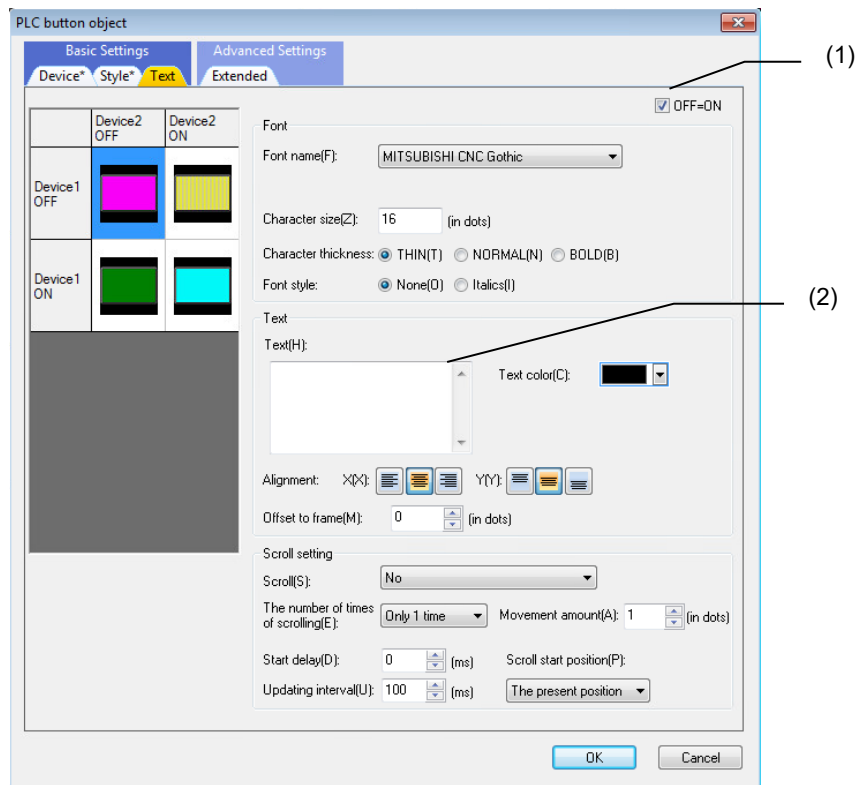

No.	Item	Description
(1)	OFF=ON	When [OFF=ON] is checked, the contents specified in [Text] are specified to all statuses. When [OFF=ON] is not checked, only the [Text] of the status selected in [Control state preview] is specified.
(2)	Text	Specify the display character string. (Note)

(Note) When specifying "Set the style/text to be applied when the focus is on the button" of "7.3.12.1.4 [Extended] Tab", this is disabled. When specifying "Set the style / text to be applied when the button does not work", this is disabled either.

For the items other than the above, refer to "7.1.16.1.2 [Text] Tab".

7.3.12.1.4 [Extended] Tab

In [Extended] tab, set whether to provide the background color when the button is selected.

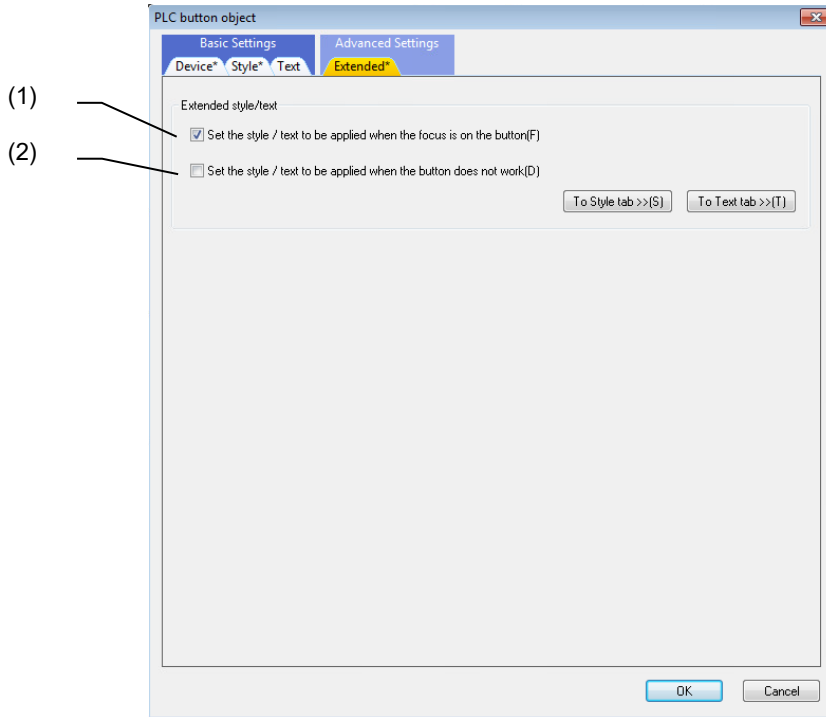

No.	Item	Description
(1)	Set the style / text to be applied when the focus is on the button	When this box is checked, the pattern, foreground color, background color, and design for when the button is selected (Focus) can be specified on the [Style] tab and [Text] tab.
(2)	Set the style / text to be applied when the button does not work	When this box is checked, the pattern, foreground color, background color, and design for when the button does not work (Disable) can be specified on the [Style] tab and [Text] tab.

**7.3.12.2 Property Settings**

The property settings of the PLC button are divided into the followings.

- Control name : Specify the control name.
- Position/Size : Specify the position and the size of the control.
- Show/Hide : Specify whether the control is displayed or hidden.
- Input permission : Select whether the entries are accepted (permission) or rejected (prohibition).
- Ground : Specify the foreground and background.
- Button type : Select the button action.
- Display type : Specify the display type of the button.
- PLC device : Specify the target PLC device.
- Color/Pattern : Specify the color and pattern of the control.
- Image : Specify the image of the control.
- Caption : Specify the caption (character string) displayed on the control.
- Character attribute : Specify the character attribute of captions.
- Solid frame : Specify the solid frame of the control.
- Caption character string scroll : Specify the scroll of the caption character string.
- Blink : Set the blink of the caption character string.
- Update condition : Specify the update condition for drawing.
- Callback function : Specify whether or not the callback functions are provided.

Ground



Item	Description
Ground	Specify the foreground and background. (Usually set to "0".)

Button Type

Item	Description
Button type	Select the button action among the following three types.
Momentary	The button turns ON when pressed, OFF when released.
Alternate	The button alternates ON and OFF each time it is pressed.
None	The button does not turn ON nor OFF when pressed.



Display type

Item	Description
Display type	Select the button type among the following three types.
Square	Rectangular button. The button is indicated in the designated color and pattern. 
Circle	Round button. The button is indicated in the designated color and pattern. 
Image	The button is indicated with the designated image resource. 

PLC Device

Item	Description
PLC device 1	Specify the address of the PLC bit device for the read or write operation.
Action of PLC device 1	Specify the operation to the PLC bit device specified in "PLC device 1". (Read or write)
Project No. of PLC device 1	Specify the project No. of PLC ladder what PLC device 1 refers. (0 to 6)
PLC device 2	Specify the address of the PLC bit device for reading operation.
Project No. of PLC device 2	Specify the project No. of PLC ladder what PLC device 2 refers. (0 to 6)
Action of PLC device 2	Specify the operation to the PLC bit device specified in "PLC device 2". (Read)

Color/Pattern

Item	Description
Pattern at the time of ON*1	Specify the pattern of the ON button.
Foreground color at the time of ON*1	Specify the foreground color of the ON button.
Background color at the time of ON*1	Specify the background color of the ON button.
Design at the time of ON*2	Specify the image of the ON button.
Character sequence at the time of ON	Specify the character string of the ON button.
Pattern at the time of OFF*1	Specify the pattern of the OFF button.
Foreground color at the time of OFF*1	Specify the foreground color of the OFF button.
Background color at the time of OFF*1	Specify the background color of the OFF button.
Design at the time of OFF*2	Specify the image of the OFF button.
Character sequence at the time of OFF	Specify the image of the OFF button.
Pattern at the time of ON ON	Specify the pattern of the ONON button.
Foreground color at the time of ON ON	Specify the foreground color of the ONON button.
Background color at the time of ON ON	Specify the background color of the ONON button.
Design at the time of ON ON	Specify the image of the ONON button.
Character sequence at the time of ON ON	Specify the character string of the ONON button.
Pattern at the time of ON OFF	Specify the pattern of the ONOFF button.
Foreground color at the time of ON OFF	Specify the foreground color of the ONOFF button.
Background color at the time of ON OFF	Specify the background color of the ONOFF button.
Design at the time of ON OFF	Specify the image of the ONOFF button.
Character sequence at the time of ON OFF	Specify the character string of the ONOFF button.

\*1: This setting is valid when the "Display type" is set to "Square or "Circle".

\*2: This setting is valid when the "Display type" is set to "Image".

Image

Item	Description
Effect at the time of focus	Specify whether the color of the button changes or not when the focus is located. Select between "change color" and "no change".
Pattern at the time of focus*1	Specify the pattern of the button when the focus is located.
Foreground color at the time of focus*1	Specify the foreground color of the button when the focus is located.
Background color at the time of focus*1	Specify the background color of the button when the focus is located.
Design at the time of focus*2	Specify the image of the button when the focus is located.
Pattern at the time of disable*1	Specify the pattern of the button when the entry is disabled.
Foreground color at the time of disable*1	Specify the foreground color of the button when the entry is disabled.
Background color at the time of disable*1	Specify the background color of the button when the entry is disabled.
Design at the time of disable*2	Specify the image of the button when the entry is disabled.

\*1: This setting is valid when the "Display type" is set to "Square or "Circle".

\*2: This setting is valid when the "Display type" is set to "Image".

Update condition

Item	Description
Update condition	Select the update condition between "Always" and "At change". "Always" updates the drawing in each cycle. "At change" updates the drawing only when the display is changed.

For the other properties, refer to "7.1 Common Functions of Controls".

7.3.12.3 Complements

PLC Device Read Function

The button can correspond to the state of PLC bit device in the NC and can display the ON/OFF state according to the property settings.

Operation example)



\*4 types of design can be selected for the display according to the two addresses specified.

PLC Device Write Function

The button can write the ON/OFF state into the bit device in the NC specified in the property settings, at the time the button is pressed and its state is changed.

The button has "Momentary"(the button is ON as long as pressed) and "Alternate"(the button alternates ON/OFF when pressed) operation types.

Example of a single operation)

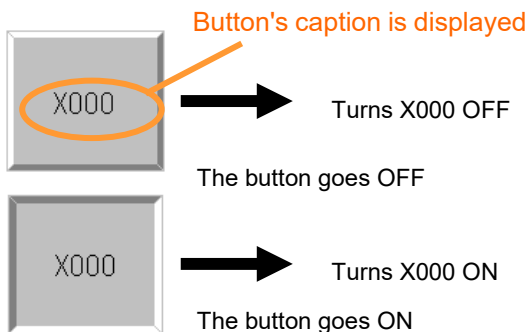

Example of a compounded operation)

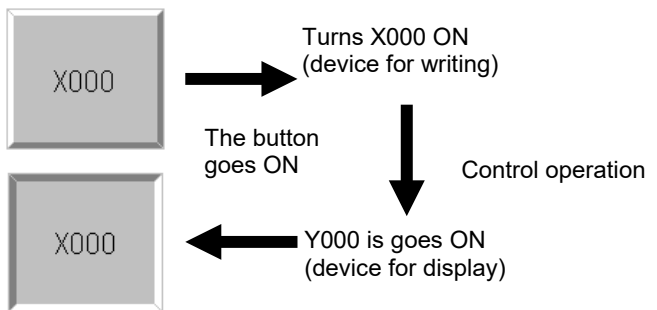

Functional Specifications

Settings of PLC Bit Devices

Up to two PLC devices can be set for the read and write operations.

The PLC device 1 can be set to "None/Read/Write", while PLC device 2 can be set to "None/Read". The PLC device to set should be a bit device.

Item	Specifications	Read	Write
PLC device 1	Reads or writes data from/into the PLC bit device	○	○
PLC device 2	Reads data from the PLC bit device	○	×

Button Action Type

There are the following three types of the button's action when pressed.

Button action	Writing "ON" into the PLC device	Writing "OFF" into the PLC device
Momentary (The button is ON as long as pressed)	Executed when the button is pressed	Executed when the button is released
	Executed when the ENTER key is pressed while the focus is located at the button.	Executed when the ENTER key is released while the focus is located at the button.
Alternate (The button alternates ON/OFF when pressed)	Executed when the OFF-state button is pressed and released.	Executed when the ON-state button is pressed and released.
	Executed when the ENTER key is pressed and released while the focus is located at the OFF-state button.	Executed when the ENTER key is pressed and released while the focus is located at the ON-state button.
	Executed at the fixed interval while the button is ON.	Executed at the fixed interval while the button is OFF.
None (The button does not turn ON/OFF when pressed)	Not executed	Not executed

"Momentary" and "Alternate" have each different time to write data into the PLC device.

(1) Timing of the "Momentary" write

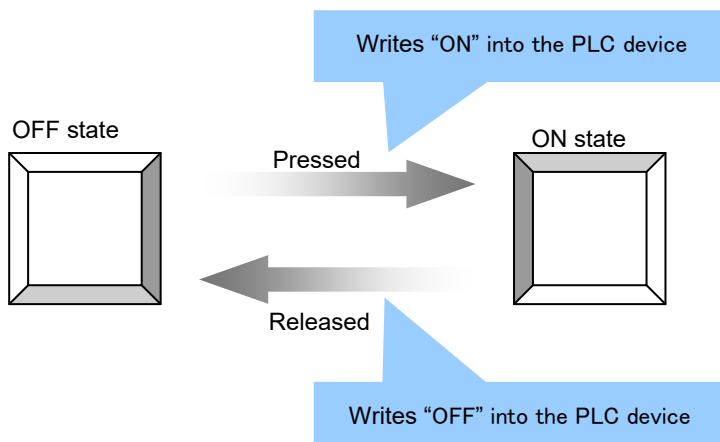

(2) Timing of the "Alternate" write

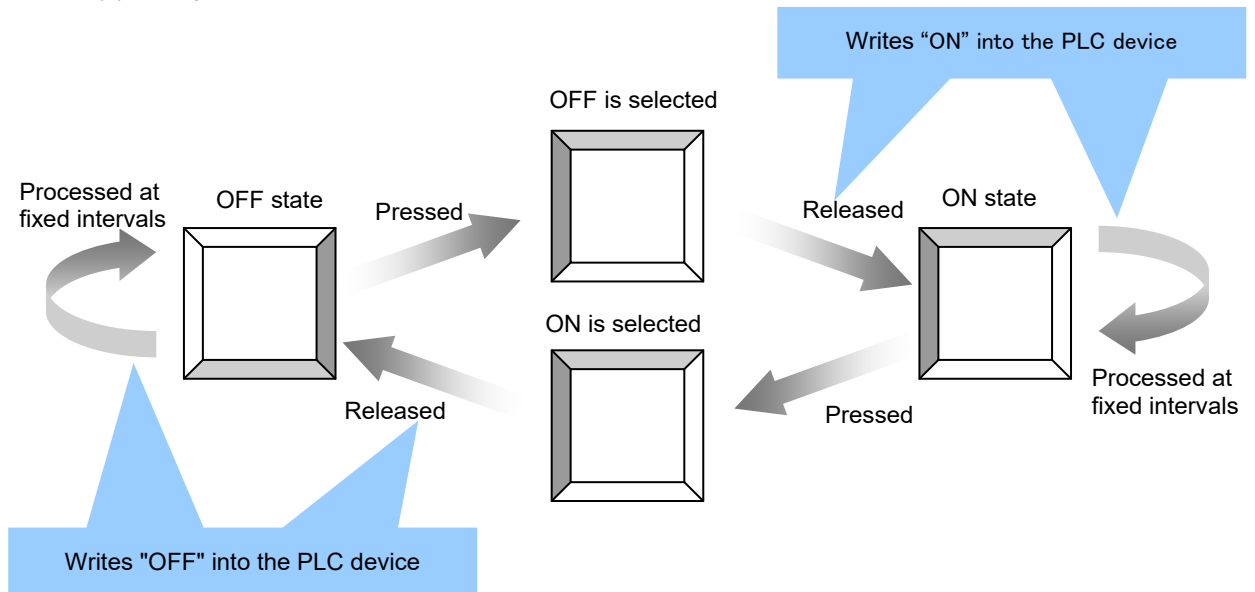

Display Design

The display design of the button can be changed according to its ON/OFF state. The conditions of the display depend on how many PLC devices are set to "read". The following table shows the display design of the button according to the number of devices for "read".

Item	Number of PLC devices for "read"	Specifications
Pattern at the time of ON	0	Displayed while the button is ON
Foreground color at the time of ON	1	Displayed while the PLC device 1 (or 2) is ON
Background color at the time of ON		
Design at the time of ON		
Character sequence at the time of ON	2	Displayed when the PLC device 1 is ON and the PLC device 2 is OFF
Pattern at the time of OFF	0	Displayed while the button is OFF
Foreground color at the time of OFF	1	Displayed while the PLC device 1 (or 2) is OFF
Background color at the time of OFF		
Design at the time of OFF	2	Displayed when the PLC device 1 and 2 are both OFF
Character sequence at the time of OFF		
Pattern at the time of focus	Independent from the number	Displayed when the focus is located at the button and "change color" is set for the "Effect at the time of focus"
Foreground color at the time of focus		
Background color at the time of focus		
Design at the time of focus		
Pattern at the time of disable	Independent from the number	Displayed when the button is disabled
Foreground color at the time of disable		
Background color at the time of disable		
Design at the time of disable		
Character sequence <A> at the time of OFF		
Pattern at the time of ON OFF	2	Displayed when the PLC device 1 is OFF and the PLC device 2 is ON
Foreground at the time of ON OFF		
Background at the time of ON OFF		
Design at the time of ON OFF		
Character string at the time of ON OFF		
Pattern at the time of ON ON	2	Displayed when the PLC device 1 and 2 are both ON
Foreground at the time of ON ON		
Background at the time of ON ON		
Design at the time of t ON ON		
Character string at the time of ON ON		

Ex.)

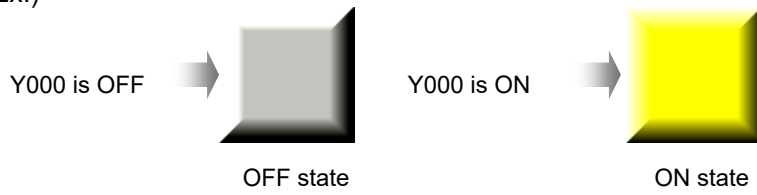

Figure 1. Display of the button when one PLC device is set to "read"

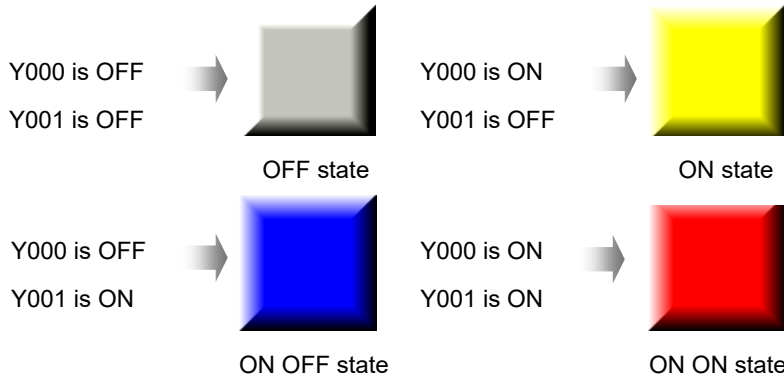

Figure 2. Display of the button when two PLC devices are set to "read"

### 7.3.13 PLC Text Box Object (GNCPLCTextBox)

The PLC text box control enables to read and write data from/to the PLC device of NC.

#### 7.3.13.1 Property Setup Dialog

Property setup dialog of PLC textbox control object consists of the tabs relating to [Basic Settings] and [Advanced Settings]. Details of each tab will be described in the following sections.

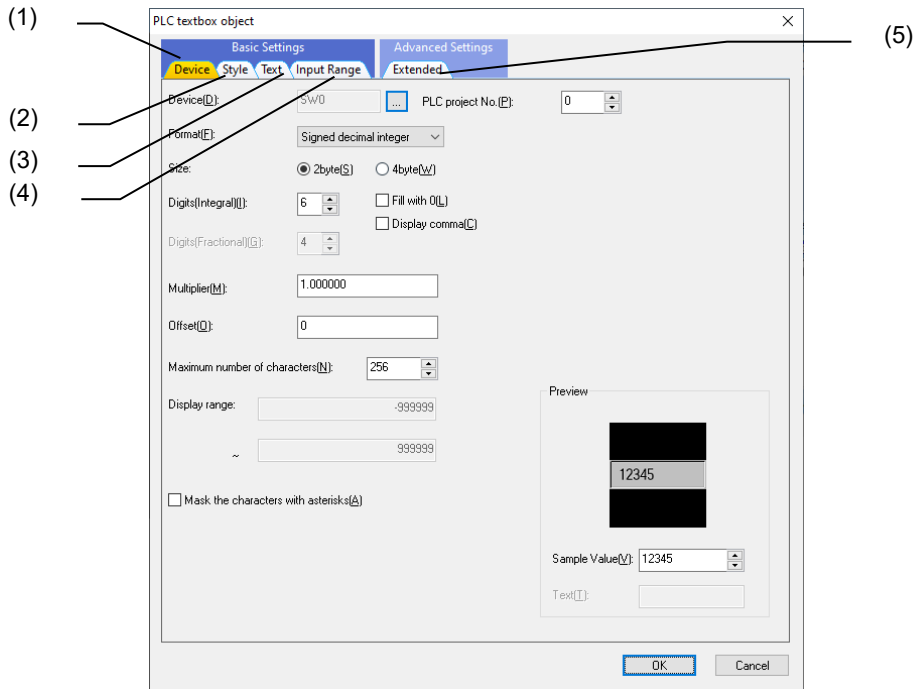

[Basic Settings] consists of the following tabs.

No.	Tab	Description
(1)	Device	Set or display the device, format, and preview.
(2)	Style	Set or display the background color, solid frame, blink, and preview.
(3)	Text	Set or display the font, text, scroll, and preview.
(4)	Input Range	Set or display the input range.

[Advanced Settings] consists of the following tab.

No.	Tab	Description
(5)	Extended	Set the item relating to the extended condition for the style.



7.3.13.1.1 [Device] Tab

In [Device] tab, specify the address of the PLC device and data format for read or write operation.

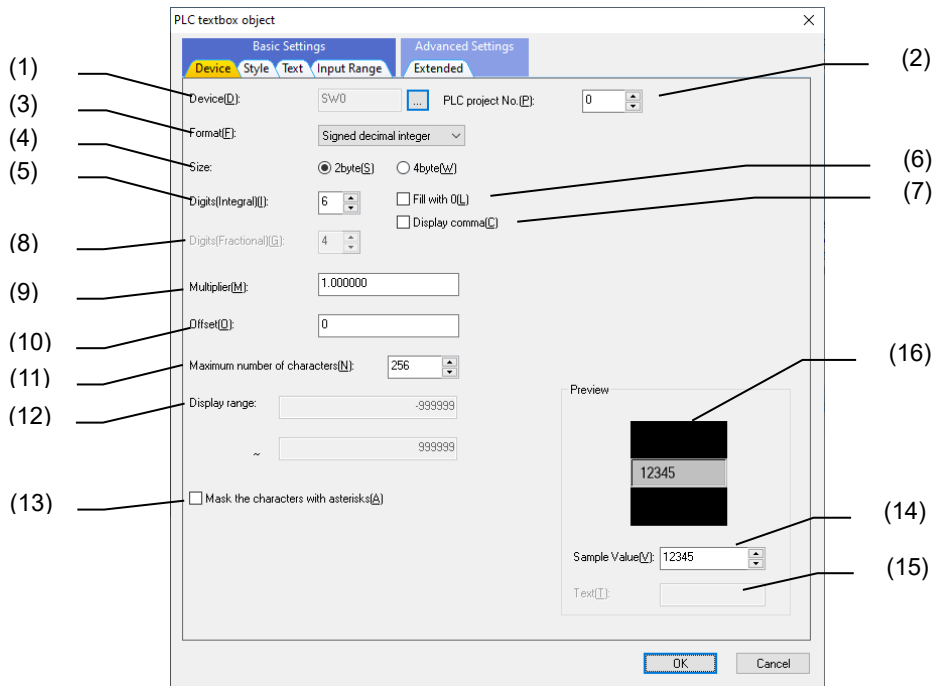

No.	Item	Description
(1)	Device	Specify the address of the PLC device for the read or write operation. Click on the "." button to display the "PLC Device Setting" dialog.
(2)	PLC project no.	Specify the project number of PLC ladder what PLC device refers. (0 to 6)
(3)	Format	Specify the format to display the PLC device value. (Signed decimal integer/ unsigned decimal integer/ Hexadecimal integer/ Real number (float)/ Real number (double) /Character sequence) (Note) "Character sequence" is supported by M800/M80 version F2 or later and M800V/M80V. When a PLC text box with "Character sequence" set for "Format" is placed in a custom screen and executed in M800/M80 version F1 or earlier, "0" will be set to the device and the display will be blank.
(4)	Size	Specify the PLC device size used for reading or writing. When the "Real number (float)" or "Real number (double)" is specified for the property "Format", the radio buttons "2byte" and "4byte" are disabled since the device size is fixed to 4 byte. When "Character sequence" is set for the property "Format", the radio buttons "2byte" and "4byte" are disabled.
(5)	Digits (Integral)	Specify the number of digits in integer part of the value. (0 to 12) When "Character sequence" is set for "Format", this setting is disabled.
(6)	Fill with 0	Check this box to display 0s in the blank digits when the value does not have as many digits as specified. When "Character sequence" is set for "Format", this setting is disabled.

No.	Item	Description
(7)	Display comma	Check this box to display the value with commas. A comma is inserted after every three digits, if "comma" is set to the display. When "Character sequence" is set for "Format", this setting is disabled.
(8)	Digits (Fractional)	Specify the number of digits in decimal part of the value. (0 to 12) *When "Signed decimal integer", "unsigned decimal integer", or "Hexadecimal integer" is specified for the format, this item is disabled. When "Character sequence" is set for "Format", this setting is disabled.
(9)	Magnification	Specify the magnification to the PLC device value to display. (0.000001 to 10000000.000000) When "Character sequence" is set for "Format", this setting is disabled.
(10)	Offset	Specify the offset value added to the PLC device value to display. (-2147483648 to 2147483647) When "Character sequence" is set for "Format", this setting is disabled.
(11)	Maximum number of characters	Specify the maximum number of characters to display. (1 to 256)
(12)	Display range	These are the maximum value and the minimum value which can be displayed on the control. Example 1: When the format is hexadecimal and the number of digits in integer part is 8, the display will be as shown below. Display range:       0 ~ FFFFFFFF Example 2: When "Character sequence" is set for "Format", the display will be as shown below. Display range:       - ~       -
(13)	Mask the characters with asterisks	Entered characters are displayed with asterisks (*).
(14)	Sample Value	Specify the value to be displayed on the preview. When "Character sequence" is set for "Format", this setting is disabled.
(15)	Character sequence	Set the character sequence to be displayed on the preview. When "Format" is set to anything other than "Character sequence", this setting is disabled.

No.	Item	Description
(16)	Preview	<p>Display the value specified in combination with the property "Display format", "The number of integer part digits", "The number of decimal part digits", "Comma", "Zero suppress", "Password", "Magnification", and "Offset" on the preview.</p> <p>When "Character sequence" is set for "Format", the set character string is displayed on the preview.</p> <p>Example 1: Format: hexadecimal The number of integer part digits: 8 Value: A10 → Preview: <b>A10</b></p> <p>Example 2: specify the offset: 200 in example 1 → Preview: <b>AD8</b></p> <p>Example 3: check (13) the display with asterisks in Example (2) → Preview: <b>*****</b></p> <p>Example 4: Format: Character sequence Maximum number of characters: 3 Character sequence: ABC → Preview: <b>ABC</b></p>

**NOTE**

- ◆ The address of the PLC device can be specified on the "PLC Device Setting" dialog.

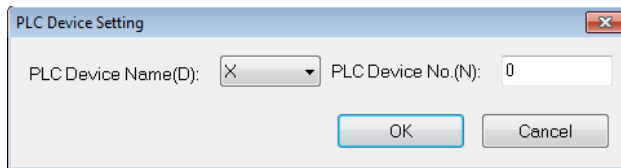

7.3.13.1.2 [Style] Tab

In [Style] tab, specify the background color, solid frame, and blink.

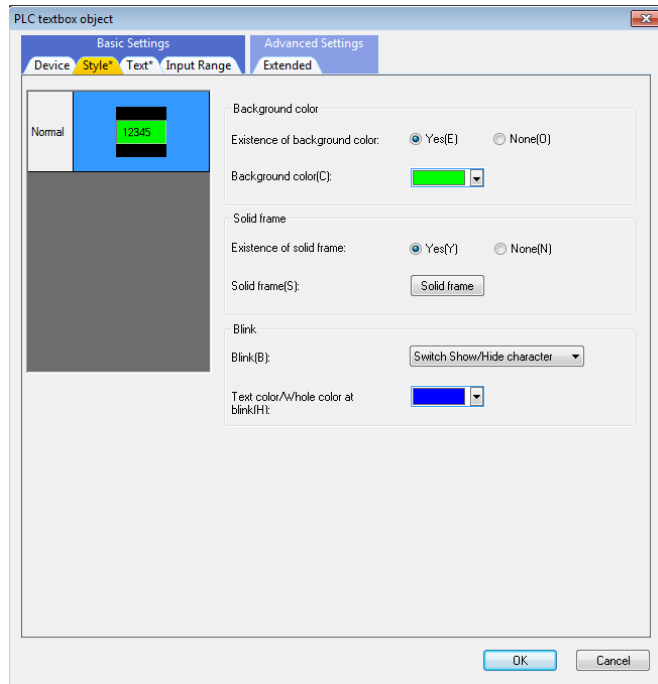

For each item, refer to "7.1.16.1.1 [Style] Tab".

7.3.13.1.3 [Text] Tab

In [Text] tab, specify the font, text, and scroll.

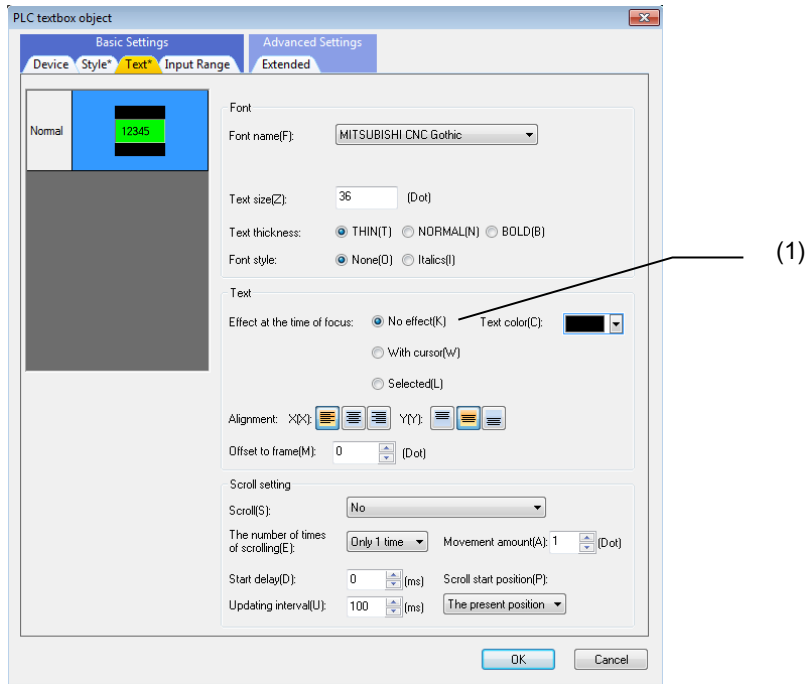

No.	Item	Description
(1)	Effect at the time of focus	Select how the cursor and setting values are displayed at the time of focus. "With cursor": Displays the cursor. "No effect": Does not display the cursor. "Selected": Selects the entire setting value.

For each item, refer to "7.1.16.1.2 [Text] Tab".

7.3.13.1.4 [Input Range] Tab

In [Input Range] tab, specify the input range.

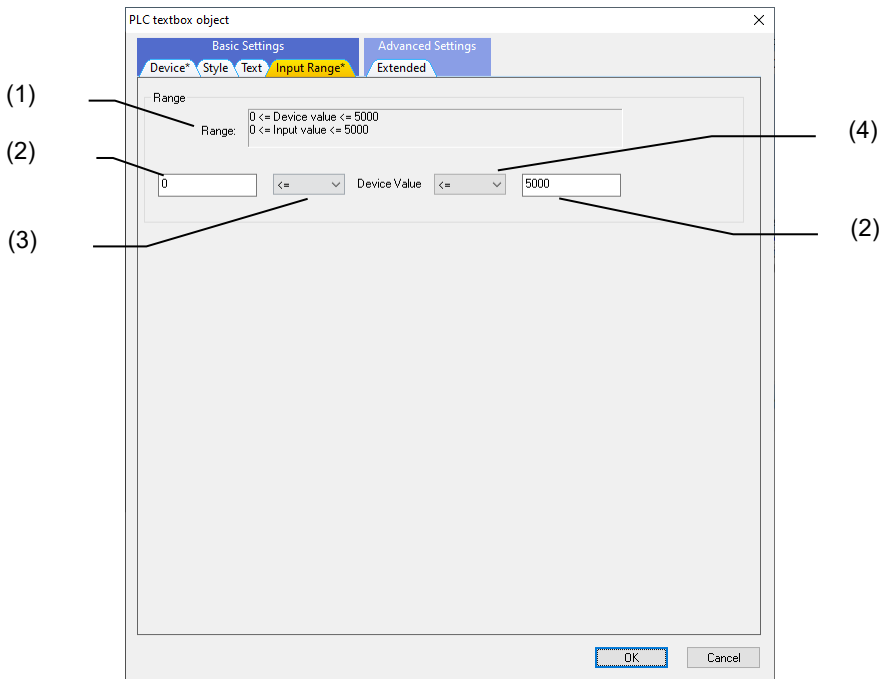

No.	Item	Description
(1)	Range	Displays the range of the value that can be set to the PLC device or PLC text box. "Device value" indicates the setting value of the PLC device. "Input value" indicates the input value of the PLC text box. When "Character sequence" is set for "Format" in the "Device" tab, this setting is disabled.
(2)	Minimum/ maximum value	Specify the minimum/maximum value that can be written to the PLC device. (-2147483648 to 4294967295)
(3)	Comparison operator for minimum value	Select the comparison operator for minimum value between "<=" and "None". When "None" is selected, the input range check of the minimum value will not be performed.
(4)	Comparison operator for maximum value	Select the comparison operator for maximum value between "<=" and "None". When "None" is selected, the input range check of the maximum value will not be performed.

7.3.13.1.5 [Extended] Tab

In [Extended] tab, set whether to provide the background color at the time of focus, disable, and interlock, and set the interlock device and operation.

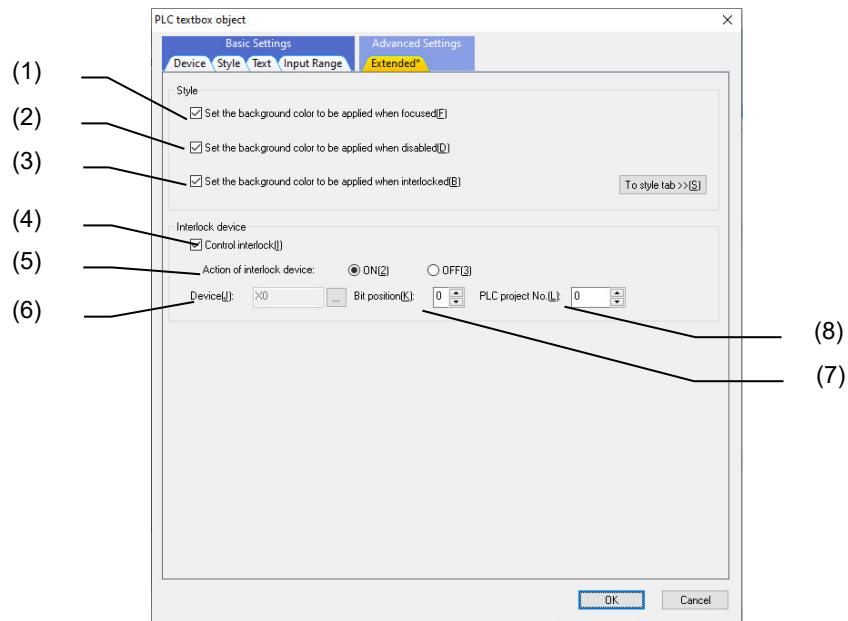

No.	Item	Description
(1)	Set the background color to be applied when focused	Check this box to specify the background color at the time of focus on [Style] tab.
(2)	Set the background color to be applied when disabled	Check this box to specify the background color at the time of disable on [Style] tab.
(3)	Set the background color to be applied when interlocked	Check this box to specify the background color at the time of interlock on [Style] tab.
(4)	Control interlock	Check this box to specify the interlock device and operation.
(5)	Action of interlock device	Select "ON"/"OFF" for the operation of the interlock device. When "ON" is selected, an interlock is executed when the interlock device is ON. When "OFF" is selected, an interlock is executed when the interlock device is OFF.
(6)	Device	Specify the address of the PLC device that interlocks the setting operation to the PLC text box. Clicking the "... " button opens the "PLC Device Setting" dialog.
(7)	Bit position	Specify the bit position of the word device when a word device is specified to the PLC device (interlock device).
(8)	PLC project No.	Specify the PLC ladder project number to which the PLC device (interlock device) refers.

**7.3.13.2 Property Settings**

The property settings of the PLC text box are divided into the followings.

- Control name : Specify the control name.
- Position/Size : Specify the position and the size of the control.
- Show/Hide : Specify whether the control is displayed or hidden.
- Input permission : Select whether the entries are accepted (permission) or rejected (prohibition).
- Ground : Specify the foreground and background.
- Color/Pattern : Specify the color and pattern of the control.
- PLC device : Specify the target PLC device.
- Interlock device : Specify the PLC device that interlocks the setting operation to the control.
- Display type/Display format : Specify the format of the character string displayed on the control.
- Password : Specify the password.
- Caption : Specify the caption (character string) displayed on the control.
- Character attribute : Specify the character attribute of captions.
- Solid frame : Specify the solid frame of the control.
- Caption character string scroll : Specify the scroll of the caption character string.
- Blink : Set the blink of the caption character string.
- Callback function : Specify whether or not the callback functions are provided.

Ground

Item	Description
Ground	Specify the foreground and background. (Usually set to "0".)

Color/Pattern

Item	Description
Use of background color	Select if the background color is provided or not. If "No" is selected, the background is transparent.
Background color	Specify the background color.
Background color at the time of focus	Specify the background color at the time of focus.
Background color at the time of disable	Specify the background color when the entry is disabled.
Background color at the time of interlock	Specify the background color at the time of interlock.

PLC Device

Item	Description
PLC device	Specify the address of the PLC word device for the read or write operation.
PLC device project No. (Note)	Specify the project No. of PLC ladder what PLC device refers. (0 to 6)
Size	Specify the PLC device size used for reading or writing. (2 or 4 byte)
Type	Specify the format to display the PLC device value. (Signed decimal integer/ unsigned decimal integer/ hexadecimal integer/ real number (float)/real number (double)/character sequence)
Magnification	Specify the magnification to the PLC device value to display.
Offset	Specify the offset value added to the PLC device value to display.

(Note) When specifying a device that does not support multi-project and a device with the same device number is used in multiple projects, output will be valid to the device of the project executed last.



Interlock Device

Item	Description
Interlock device	Specify the address of the PLC device that interlocks the setting operation to the PLC text box.
Action of interlock device	Specify the interlock operation. (ON/OFF/No setting)
Interlock device bit position	Specify the bit position of the word device when a word device is specified to the interlock device. (0 to 15)
Interlock device project No.	Specify the project number of the PLC device to which the interlock device refers to in the multi-project function. (0 to 6) (Initial value "0": Default project)

Display Type/Display Format

Item	Description
Number of the maximum characters (Note)	Specify the maximum number of characters to display. (1 to 256)
Maximum check	For the value field, select whether to check for the maximum value limit or not.
Maximum	Specify the maximum value for the maximum value check. (-2147483648 to 4294967295)
Minimum check	For the value field, select whether to check for the minimum value limit or not.
Minimum	Specify the minimum value for the minimum value check. (-2147483648 to 4294967295)
Comma	For the value field, select whether to display commas or not.
The number of integer part digits	Specify the number of digits in integer part of the value. (0 to 12)
The number of decimal part digits	Specify the number of digits in decimal part of the value. (0 to 12)
Zero suppress	Select whether or not to display 0s in the blank digits when the value does not have as many digits as specified.

(Note) For the property "Number of the maximum characters", set the value which satisfies the following relational expression.

"Maximum number of characters" ≥

"Number of digits in integer part" + "Number of digits in decimal part" + 2

("+ 2" is for decimal point and minus sign (-).)

Password

Item	Description
Password setup	Select "Yes" to display entered characters with asterisks (*).  

Character Attribute

Item	Description
Effect at the time of focus	Select how the cursor and setting values are displayed at the time of focus. "With cursor": Displays the cursor. "No effect": Does not display the cursor. "Selected": Selects the entire setting value.

For the other properties, refer to "7.1 Common Functions of Controls".

7.3.13.3 Complements

Functional Specifications

Reading the Value from the PLC Device

PLC device read function allows the value in the specified PLC device to be read at fixed intervals and displayed in the specified numeral/character sequence form. When the value of PLC device exceeds the maximum number of characters, a blank will be displayed.

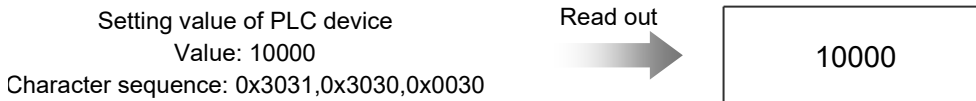

When the property "Display type" is character sequence

Character codes are acquired from a specified PLC device and converted to characters. The number of PLC devices corresponding to the length of the character sequence are read, and the converted characters are connected to be displayed in a text box. When a character code read from the PLC device is not supported, the characters until immediately before the unsupported code are converted and displayed. The characters of the unsupported character code and after are not read.

In the following example, the maximum number of characters is 9, and R1000 to R1004 are the targets to be read.

(\* ) A line feed code is not supported.

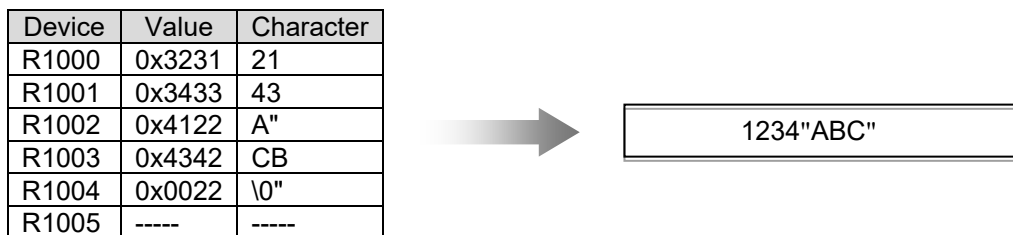

Writing the Value into the PLC Device

PLC device write function allows the value to be written into the PLC device at the time the value has been input and confirmed. The value is "confirmed" when the user presses the ENTER key while inputting the value/character sequence and then the value/character sequence is recognized to be within the setting range of "Type".



When the property "Display type" is character sequence

A character sequence is converted to character code before writing the first character to the lower-side of a PLC device, and the second character to the upper-side of a PLC device. All the input characters are converted and written in consecutive PLC devices.

The following shows the relationship between the length of the character sequence and the maximum number of characters.

"Length of character sequence" > "Maximum number of characters":

The characters up to the maximum number of characters are written, and the characters after are not written.

"Length of character sequence" < "Maximum number of characters":

The characters from the first to the last are written, and a null character (\0) is written at the end.

"Length of character sequence" = "Maximum number of characters":

The characters from the first to the last are written, and a null character (\0) is not written at the end.

When inputting '1234"ABC"', the characters are written into the PLC device as shown below.

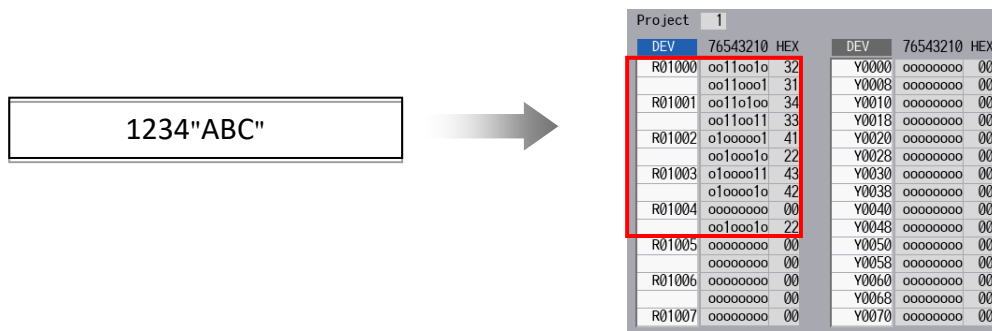

Inputting the Setting Value to be Written into the PLC Device

The followings are the operations required to write the setting value into the PLC device.

(1) Inputting the value

The operation is as same as that of the usual text box control: display the character strings by inputting with keys when the focus is located. Any change of the PLC value does not change the display on the PLC text box control while the value is being input.

(2) Confirming the value

Pressing the ENTER key writes the value into the PLC device. Pressing the ENTER key does not move the focus. The focus is still located at the control.

## Operations with Keys

**C.B** Key

This key deletes all the characters in the PLC text box.

Press **C.B** key.



All the characters in the PLC text box will be deleted and the cursor will move to the initial position (\*1).

(\*1) The initial position is the position which is specified in the property "Horizontal position".  
When "No effect" is set in the property "Effect at the time of focus", the cursor is not displayed.

Display format

Set the display by specifying the type, size, the number of integer part digits, the number of decimal part digits, magnification, offset and comma.

(1) Type

Type	Display range
Signed decimal integer	2 byte: -32768 to 32767      4 byte: -2147483648 to 2147483647
Unsigned decimal integer	2 byte: 0 to 65535      4 byte: 0 to 4294957296
Hexadecimal integer	2 byte: 0 to FFFF      4 byte: 0 to FFFFFFFF
Real number (float)	Valid digit number 7 digits: 3.4E-38 to 3.4E+38
Real number (double)	Valid digit number 15 digits: 1.7E-308 to 1.7E+308
Character sequence	Up to 256 one-byte characters [Supported characters] - Numbers: 0123456789 - Lower-case alphabetic characters: abcdefghijklmnopqrstuvwxyz - Upper-case alphabetic characters: ABCDEFGHIJKLMNOPQRSTUVWXYZ WXYZ - Symbols : !"#\$%&'()*+,-./:;<=>?@[\\]^_`{ }~  (* ) When a character sequence contains an unsupported character, the characters until immediately before the unsupported code are displayed.

(2) Size

Select 2 or 4 byte for the PLC device size used for reading and writing. When the "actual number" is set for the display type, the device size is fixed to 4 byte.

When "Character sequence" is set for "Format", this setting is disabled.

(3) The number of integer part digits

Specify the minimum number of digits displayed in integer part. If the value in integer part has the smaller number of digits than the minimum, spaces are output to the blank digits. Spaces are not output if the value in integer part has the larger number of digits than the minimum.

When "Character sequence" is set for "Format", this setting is disabled.

Display example)

• 1 digit for integer part

0

• 5 digits for integer part

{
{
{
{
{
}
}
}
}
}
0

Spaces in 4 digits

• 5 digits for integer part

1234567

7. Creating Controls

(4) The number of decimal part digits

Specify the number of digits in decimal part to be displayed when the "actual number" is set for the display type. .If the decimal part of the value has the smaller number of digits than specified, "0"s are output to the blank digits. The digit behind the specified digits in decimal part is rounded off to the nearest value.

When "Character sequence" is set for "Format", this setting is disabled.

Display example) Displaying "23.45" in actual number

• 0 digit behind decimal

23

• 1 digit behind decimal

23.5

• 3 digits behind decimal

23.450

The value is rounded off as follows.

Positive value

$0 < X < 0.5$  -> Round-down (to 0)

$0.5 \leq X < 1$  -> Round-up (to 1)

Negative value

$0 > X > -0.5$  -> Round-down (to 0)

$-0.5 \geq X > -1$  -> Round-up (to -1)

(5) Magnification

Specify the magnification to the value, which is read from the PLC device, to display. The specified magnification becomes the divisor for the value, after reduced by the offset amount, to be written into the device. The magnification is available for all types. However, if the value after the magnification exceeds the available number of digits, the display will not be exact.

When "Character sequence" is set for "Format", this setting is disabled.

(6) Offset

Specify the offset value to add to the value, which is read from the PLC device, to display. The magnification, when specified, is carried out to the PLC device value before the offset value is added to. When written into the device, the input value is reduced by the offset value. The offset adjustment is available for all types. However, if the value exceeds the available number of digits after the offset adjustment, the display will not be exact.

When "Character sequence" is set for "Format", this setting is disabled.

(7) Comma

Setting the display with commas is available if the type is set to "decimal integer". A comma is inserted after every three digits, if "comma" is set to the display.

When "Character sequence" is set for "Format", this setting is disabled.

(8) Zero suppress

Zero suppress is used to display "0"s in the blank digits of integer part when the value does not have as many digits as specified. Setting "Yes" outputs spaces to the blank digits in integer part when the value to be displayed does not have as many digits as specified. Setting "No" outputs "0"s to the blank digits of integer part. However, the output which exceeds the maximum number of characters is not performed. When "Character sequence" is set for "Format", this setting is disabled.

Display example) Display the value "1" in integer part with 5 digits

• Zero suppress is set



Spaces in 4 digits

• Zero suppress is not set

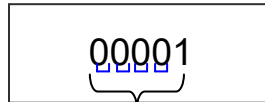

"0"s in 4 digits

(Note 1) When the focus is not located, the number of characters to display is adjusted by the setting of "comma" or "zero suppress".

(Note 2) Commas are not included in the number of characters to display. However, when "Character sequence" is set for "Format", this setting is disabled.

Magnification and Offset

The followings are the process of the magnification and offset adjustment when the value is read and written.

(1) Process to read

The PLC device value, when read, is displayed after the following process:

- 1) Magnification
- 2) Offset adjustment

However, round off to the integer value if the setting type is other numbers than the real number and the displayed number is not integer.

(2) Process to write

The input value (123.4567) is written into the device after the following process:

- 1) Offset adjustment (When offset is 100, the value to be written is 23.4567)
- 2) Magnification (When magnification is 0.001, the value to be written is 23457)

If the value to be written into is not integer, the digit after the decimal point is rounded off.

(Note) Even when the type is double, the value is written to a PLC device as signed long. To display numbers after a decimal point, set a magnification.

When an input value is 123.4567 and magnification is 0.0001, PLC device value will be 1234567, and 123.4567 will be displayed.

When an input value is 123.4567 and magnification is 0.1, PLC device value will be 1235, and 123.5 will be displayed.

Priority of PLC devices

The image displayed by the PLC text box changes in accordance with the states of PLC devices. The priority for reading is shown in the table below. The interlock device is read first, followed by the PLC device.

Priority	PLC device
Higher	Interlock device
Lower	PLC device

Restrictions

- (1) To change the size with GCSNCPLCTextboxSetTextSize(), set the PLC device with GCSNCPLCTextboxSetDevice().

<Interpreter method>

```
LONG Stat;

GCSNCPLCTextboxSetTextSize(10, "GNCPLCTextBox00000", 2);    'Changes the size to 2 bytes.
Real number (float) Stat = GCSNCPLCTextboxSetDevice(10, 'Sets the PLC device. The current
"GNCPLCTextBox00000", "X0");                                device can be set.
```

<Compilation method>

```
short nRet;
GbaseObject *pPanel;
GbaseObject *pChild;

pPanel = GetGBaseObject();
pChild = GCSGetChild(pPanel, GNCPLCTEXTBOX00000);
GCSNCPLCTextboxSetTextSize(pChild, 2);                    //Changes the size to 2 bytes.
nRet = GCSNCPLCTextboxSetDevice(pChild, 'X0');            //Sets the PLC device. The current
                                                         device can be also set.
```

- (2) When the focus is on a PLC text box, the displayed character sequence is not updated because an input operation is being performed. When the focus is not on the PLC text box, the value read from a PLC device is converted to a character sequence and displayed.
- (3) A value within the range that can be entered may not exist due to the magnification, minimum value, or maximum value settings. In that case, when a value outside the range is entered and focus is removed, the entered value that is outside the range will be displayed even when the value of a PLC device is within the range.
- (4) When setting an input range with "real number (float)" or "real number (double)", set a value for boundaries (minimum value, maximum value) that allows for the errors in the floating point of float type or double type.



**7.3.14 NC Data Textbox (GNCDataTextBox)**

The NC data text box is a text box part that enables reading and writing from and to the NC's internal data.

**7.3.14.1 Property Setup Dialog**

Property setup dialog of NC data text box control consists of the tabs relating to [Basic Settings] and [Advanced Settings]. Details of each tab will be described in the following sections.

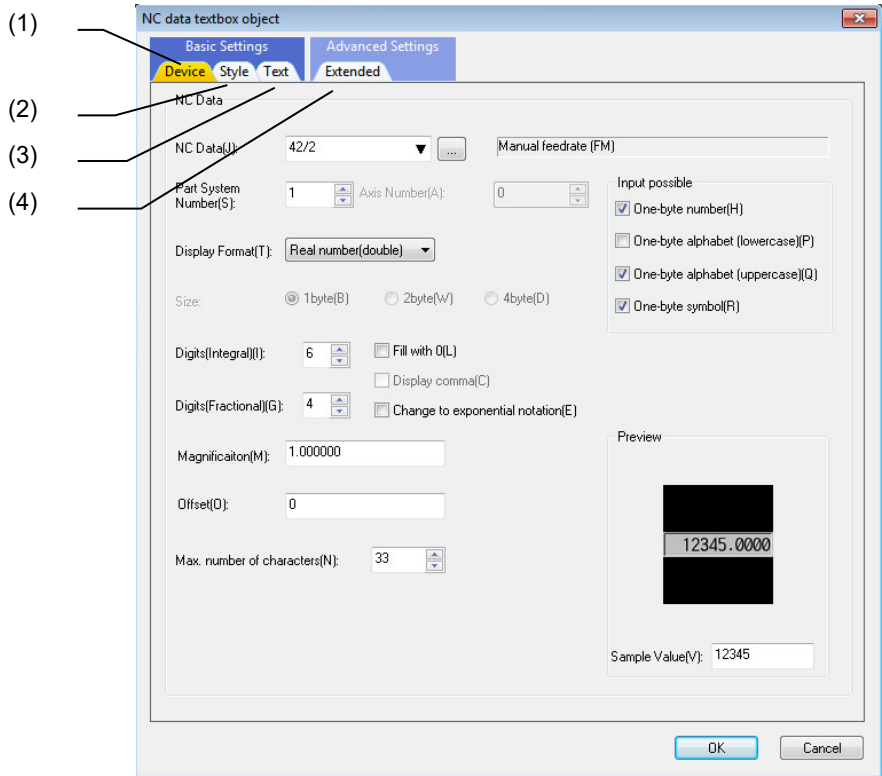

[Basic Settings] consists of the following tabs.

No.	Tab	Description
(1)	Device	Set or display the device, display format, and preview.
(2)	Style	Set or display the background color, solid frame, and preview.
(3)	Text	Set or display the font, text, and preview.

[Advanced Settings] consists of the following tab.

No.	Tab	Description
(4)	Extended	Set the item relating to the extended condition for the style.

7.3.14.1.1 [Device] Tab

In [Device] tab, specify the display format and the number of digits of the NC data to read/write.

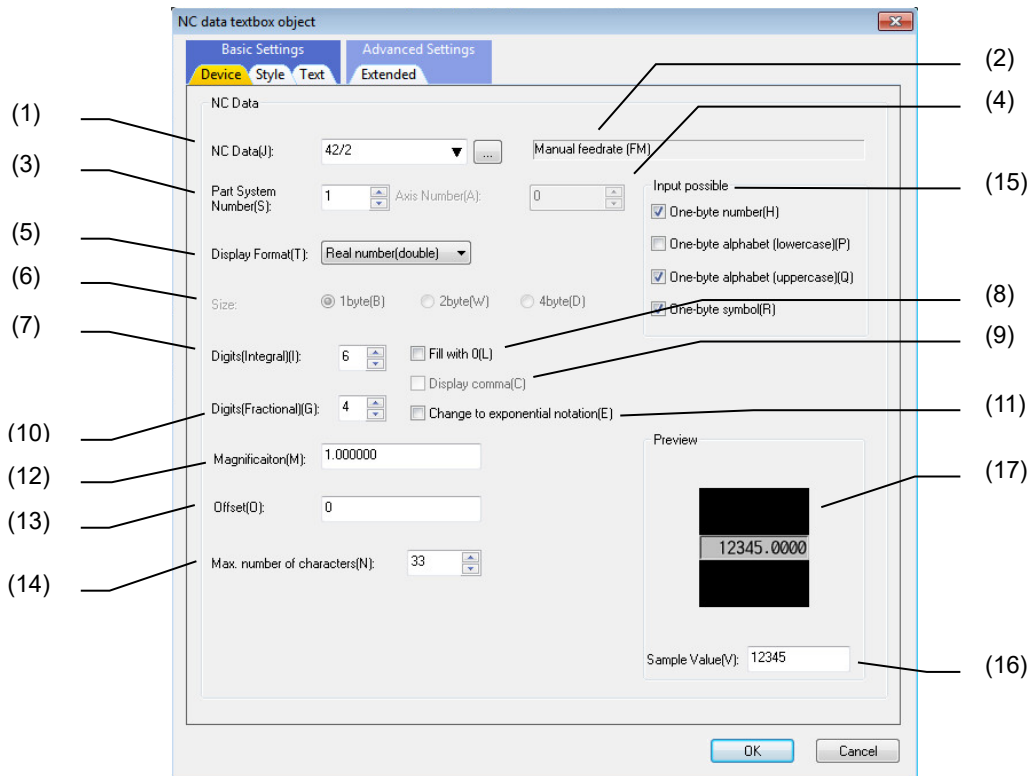

No.	Item	Description
(1)	NC Data	Set the section No./sub-section No. of the NC data to read/write. (* Supported by input assist function.
(2)	Description	Displays the description of the section/sub-section specified in NC Data field. If NC data is not registered in input assist function, the description is displayed as a blank.
(3)	Part System Number	Specify the No. of the part system to which the NC data to read/write belongs.
(4)	Axis Number	Specify the No. of the axis to which the NC data to read/write belongs.
(5)	Display Format	Specify the type of the NC data to read/write. (Character sequence/Binary integer/Signed decimal integer/Unsigned decimal integer/Hexadecimal integer/Real number (double))
(6)	Size	Specify the size of the NC data to read/write. * When "Character sequence" or "Real number (double)" is specified in "Display Format", this is invalid.
(7)	Digits (Integral)	Specify the number of digits in integer part of the value.
(8)	Fill with 0	Check this box to display 0s in the blank digits when the value does not have as many digits as specified.
(9)	Display comma	Check this box to display the value with commas. A comma is inserted after every three digits, if "comma" is set to the display.
(10)	Digits (Fractional)	Specify the number of digits in decimal part of the value. * When other than Real number (double) is specified in "Display Format", this item is disabled.
(11)	Change to exponential notation	Select whether or not to display exponential notation. * When other than Real number (double) is specified in "Display Format", this item is disabled.
(12)	Magnification	Specify the magnification to the NC data value to display. (0.000001 to 10000000.000000)

7. Creating Controls

No.	Item	Description
(13)	Offset	Specify the offset value added to the NC data value to display. (- 2147483648 to 2147483647)
(14)	Max. number of characters	Specify the maximum number of characters to display. (1 to 256)
(15)	Input possible	Select whether one-byte numbers, lower case letters, upper case letters, one-byte symbols, or two-byte characters are allowed or not. Check this box to allow the entry.
(16)	Sample Value	Specify the value to be displayed on the preview.
(17)	Preview	Preview the value specified in combination with the property "Display Format", "Digits (Integral)", "Digits (Fractional)", "Comma", "Zero suppress", "Magnification", and "Offset".  (Note) When "Section Number" is 0, the value cannot be previewed. Specify the value other than 0 for "Section Number".

7.3.14.1.2 [Style] Tab

In [Style] tab, specify the background color and solid frame.

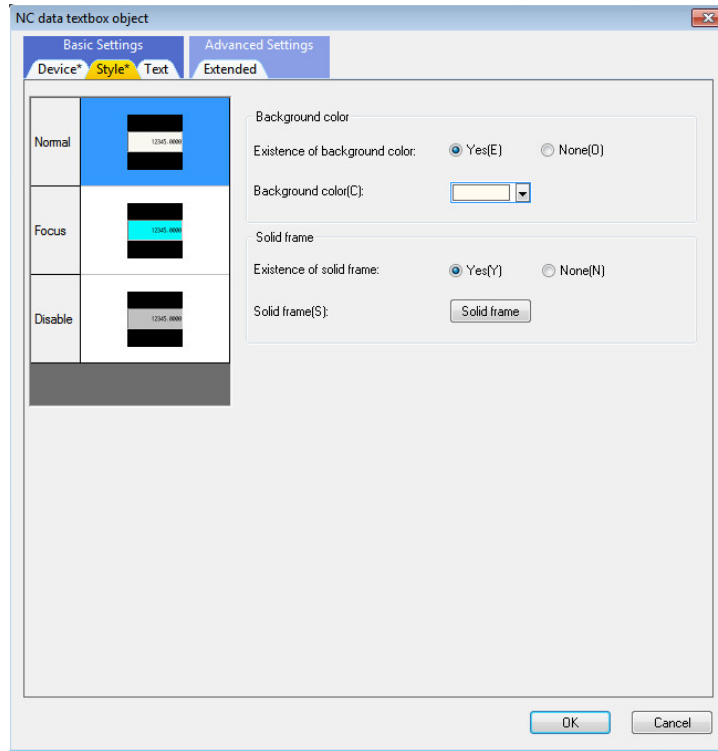

For each item, refer to "7.1.16.1.1 [Style] Tab".

7.3.14.1.3 [Text] Tab

In [Text] tab, specify the font and text.

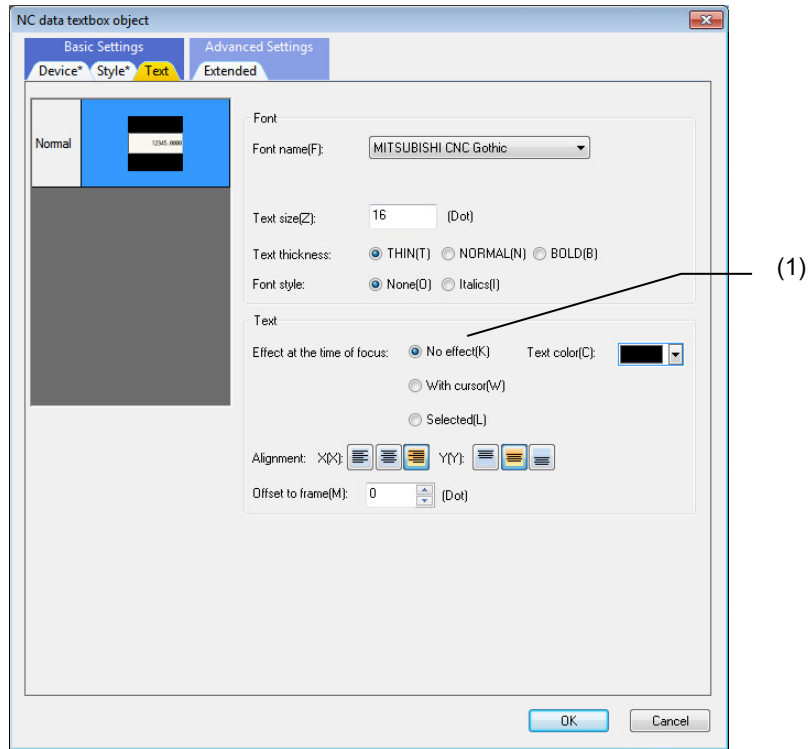

No.	Item	Description
(1)	Effect at the time of focus	Select how the cursor and setting values are displayed at the time of focus. "With cursor": Displays the cursor. "No effect": Does not display the cursor. "Selected": Selects the entire setting value.

For the items other than the above, refer to "7.1.16.1.2 [Text] Tab".

7.3.14.1.4 [Extended] Tab

In [Extended] tab, set whether to provide the background color at the time of focus and disable, and set the display refresh.

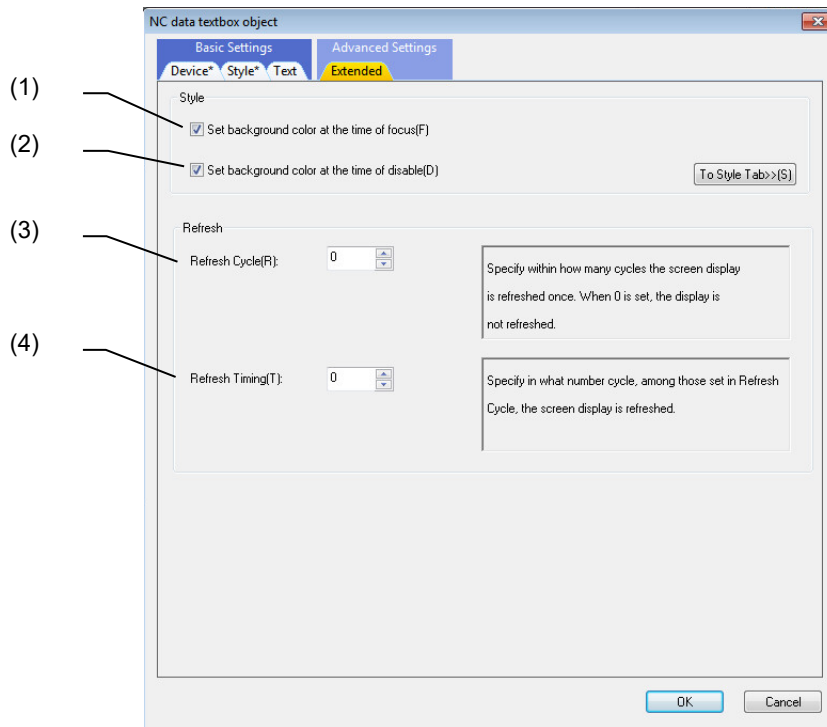

No.	Item	Description
(1)	Set background color at the time of focus	Check this box to specify the background color at the time of focus on [Style] tab.
(2)	Set background color at the time of disable	Check this box to specify the background color at the time of disable on [Style] tab.
(3)	Refresh Cycle	Specify how many cycles the screen display is refreshed once. When 0 is set, the display is not refreshed.
(4)	Refresh Timing	Specify in what number cycle, among those set in Refresh Cycle, the screen display is refreshed.

**7.3.14.2 Property Settings**

The property settings for the NC data text box are divided into the followings.

- Control name : Specify the control name.
- Position/size : Specify the position and the size of the control.
- Show/Hide : Specify whether the control is displayed or hidden.
- Input permission : Select whether the entry is accepted (permission) or rejected (prohibition).
- Part system number : Specify the No. of part system.
- Ground : Specify the foreground and background.
- Color/pattern : Specify the color and pattern of the control.
- NC data : Specify the target NC data.
- Display type/  
display format : Specify the format of the character string displayed on the control.
- Update : Specify the refresh frequency of the NC data display.
- Character attribute : Specify the character attribute of captions.
- Solid frame : Specify the solid frame of the control.
- Callback function : Specify whether or not the callback functions are provided.

Part system number

Item	Description
Part system number	Specify the No. of the part system to which the NC data to read/write belongs (1 to 10).

Ground

Item	Description
Ground	Specify the foreground and background (Usually set to "0").

Color/Pattern

Item	Description
Use of background color	Select if the background color is provided or not. If "No" is selected, the background is transparent.
Background color	Specify the background color.
Background color at the time of focus	Specify the background color at the time of focus.
Background color at the time of disable	Specify the background color when the entry is disabled.

7. Creating Controls

NC Data

Item	Description
Axis number	Specify the No. of the axis to which the NC data to read/write belongs (0 to 32).
AxisCross	Specify the basic part system (0) and the current part system during cross control (1) of the NC data to be read or written.
Number of Section	Set the section No. of the NC data to be read or write (0 to 999).
Number of Sub-section	Set the sub-section No. of the NC data to be read or write (0 to 100000000).
Data Type	Specify the type of the NC data to read/write. (Character sequence, double, signed char, signed short, signed long)
Type	Specify the format to display the NC data value (Character sequence, binary integer, signed decimal integer, unsigned decimal integer, hexadecimal integer, real number(double)).
Magnification	Specify the magnification to the NC data value to display.
Offset	Specify the offset value to be added to the NC data value to display.

Display Type/Display Format

Item	Description
Number of the maximum characters	Specify the maximum number of characters to display. (1 to 256)
Comma	For the value field, select whether to display commas or not.
Half-size number	For entry in the text box, select whether one-byte numbers are allowed or not.
Half-size English small letter	For entry in the text box, select whether one-byte lower case letters are allowed or not.
Half-size English capital letter	For entry in the text box, select whether one-byte upper case letters are allowed or not.
Half-size sign	For entry in the text box, select whether one-byte symbols are allowed or not.
The number of integer part digits	Specify the number of digits in integer part of the value, when the NC data is the real number type or decimal integer type (1 to 12).
The number of decimal part digits	Specify the number of digits in decimal part of the value, when the NC data is the real number type (1 to 10).
Exponential notation	Select whether or not to display exponential notation, when the NC data is the real number type.
Zero suppress	Select whether or not to display 0s in the blank digits when the value does not have as many digits as specified.

Update

Item	Description
RefreshFrequency	Specify the number of times to thin out the timer event processes (0 to 100). When set to "0", the display is not updated at the timer event.
RefreshTiming	The display is refreshed when the counted number of "RefreshFrequency" reaches the number of counts specified with "RefreshTiming" (0 to 99).

Character Attribute

Item	Description
Effect at the time of focus	Select how the cursor and setting values are displayed at the time of focus. "With cursor": Displays the cursor. "No effect": Does not display the cursor. "Selected": Selects the entire setting value.

For the other properties, refer to "7.1 Common Functions of Controls".



7.3.14.3 Complements

Functional Specifications

Reading the Value from NC

NC data read function allows the value in the NC data to be read at fixed intervals and displayed in the specified format.

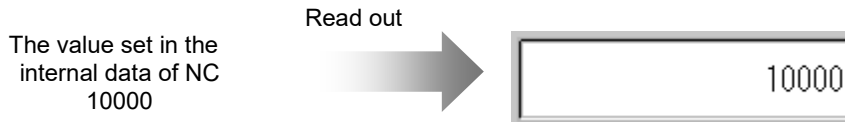

Writing the Value to NC

NC data write function allows the value to be written to the NC at the time the value has been input and confirmed. The value is "confirmed" when the user presses the ENTER key while inputting the value and then the value is recognized to be within the setting range of "Type".

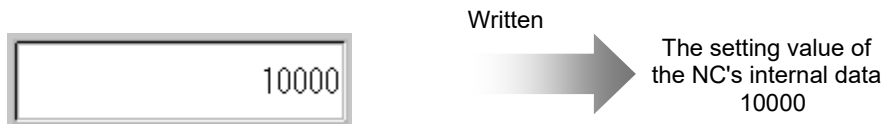

Inputting the Setting Value to be Written to NC

The followings are the operations required to write the setting value to the NC.

(1) Inputting the value

The operation is the same as of the usual text box control: display the character strings by inputting with keys when the focus is located. Any change of the NC's internal data value does not change the display on the NC data text box control while the value is being input.

(2) Confirming the value

Pressing the ENTER key writes the value into the NC. Pressing the ENTER key does not move the focus. The focus is still located at the control.

Operations with Keys

**C.B** Key

This key deletes all the characters in the NC data text box.

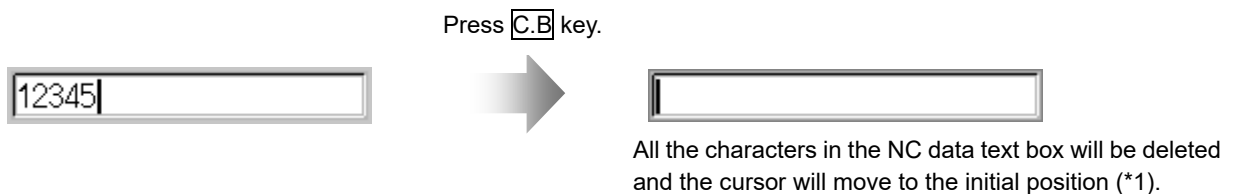

(\*1) The initial position is the position which is specified in the property "Horizontal position". When "No effect" is set in the property "Effect at the time of focus", the cursor is not displayed.

Display Format

Set the display format by specifying the type, data type, the number of integer part digits, the number of decimal part digits, magnification, offset, exponential notation, comma and zero suppress.

(1) Type and data type

The display format is determined as shown below according to the combination of the type and data type. Note that if the character sequence type is selected for the data type, the NC is notified of the number of characters (the maximum number of characters + the number of NULL characters). If the value read from the NC has a larger number of characters than the maximum, it is left blank.

Type	Data type				
	Signed char	Signed short	Signed long	Double	Character sequence
Binary integer	0 or 1 (8bit)	0 or 1 (16bit)	0 or 1 (32bit)		
Hexadecimal integer	00 to FF	0000 to FFFF	00000000 to FFFFFFFF		
Unsigned decimal integer	0 to 255	0 to 65535	0 to 4294967295	Same as on the left	
Signed decimal integer	-128 to 127	-32768 to 32767	-2147483648 to 2147483647	Same as on the left	
Real number (double)	-128.0 to 127.0	-32768.0 to 32767.0	-2147483648.0 to 2147483647.0	-99999999999.999999999 to 99999999999.999999999 (At the exponential notation, the minimum setting unit is 99 digits after the decimal point (1.0E-099).)	-999999999.0 to 999999999.0 (The minimum setting unit is 99 digits after the decimal point (1.0E-099).)
Character sequence					Character sequence

\* To display in the same format as MITSUBISHI standard screen (the standard screen, hereafter), select the "Character sequence" type for Data type, and "Character sequence" for Type.

\* Select "Real number(double)" for Type to input an exponential notation value.

(2) Number of integer part digits/number of decimal part digits

When the type is real number, a real number is displayed with the specified number of integer part digits and the specified number of decimal part digits. When "Yes" is set for the exponential notation, the exponential notation display is enabled.

When "No" is selected, the value after the specified number of decimal part digits is rounded off. However, if the number of the integer part digits of the value read from the NC exceeds the set number of digits, the data displayed is all "".

When "Yes" is set for the exponential notation, and when the value read from the NC is smaller than 1 and is exceeding the specified number of decimal part digits, or when the value is exceeding the specified number of integer part digits, exponential notation is carried out. When a value is displayed with exponential notation, the value is displayed by rounding off, depending on the number of decimal part digits.

If the value read from the NC is within the display range, but is exceeding the maximum number of characters, it is left blank.

When a data in the real number type is displayed, what is displayed is as below (Example: common variable).

Setting value	Data type		
	Double (6.4 digits/no exponential notation)	Double (6.4 digits/exponential notation)	Character sequence type
0.00001	0.0000	1.0000E-05	1.0000E-005
0.00005	0.0000	5.0000E-05	5.0000E-005
0.00015	0.0001	0.0002	0.0002
0.00045	0.0004	0.0004	0.0004
0.00046	0.0004	0.0005	0.0005
0.00054	0.0005	0.0005	0.0005
0.00055	0.0005	0.0006	0.0006
123456.00015	123456.0001	123456.0002	123456.0002
1234567.00000	*****	1.2346E+06	1.2346E+006

When the type is decimal integer, the number of digits specified with the number of integer part digits is displayed. However, if the value read from the NC exceeds the number of integer part digits, the data displayed is all "".

(3) Magnification and offset

When the type is decimal integer or real number, "Magnification" and "Offset" can be reflected on the displayed data. When data is read out from the NC, the magnification is applied to the NC's internal data, and then the offset is added.

When data is written to the NC, the value obtained by subtracting the offset value from the entered value and then divided it with the magnification is written to the NC.

If the result, in which the magnification and offset are reflected, is exceeding the available number of digits, it is not possible to display the correct value.

(4) Exponential notation

When the type is real number, exponential notation is carried out by selecting "Yes" for the exponential notation.

When "Yes" is selected for the exponential notation, and when the value read from the NC is smaller than 1 and is exceeding the specified number of decimal part digits, or when the value is exceeding the specified number of integer part digits, exponential notation is carried out. When a value is displayed with exponential notation, the value is displayed by rounding off, depending on the number of decimal part digits.

When "No" is selected for the exponential notation, the value after the number of decimal part digits is rounded down. Note that if the integer part of the value read from the NC exceeds the number of integer part digits, the data displayed is all "".

(5) Comma

Setting the display with commas is available if the type is set to "decimal integer". A comma is inserted after every three digits, if "comma" is set to the display.

(6) Zero suppress

Zero suppress is used to display "0"s in the blank digits of integer part when the value does not have as many digits as specified. Setting "Yes" outputs spaces to the blank digits in integer part when the value to be displayed does not have as many digits as specified. Setting "No" outputs "0"s to the blank digits of integer part.

Display example) Display the value "1" in integer part with five digits

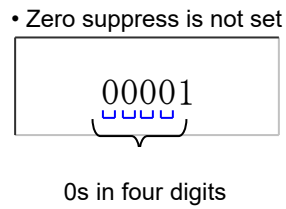
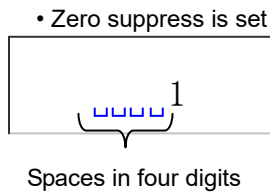

### 7.3.15 PLC extension button (GNCPLEXButton)

PLC extension button is a control part that enables reading and writing from and to the PLC device in NC, and switching the ON/OFF state of a button in accordance with the device condition. This part is equivalent to a PLC button control, but is different from the PLC button in the following points.

- "Actuator" has been added to the button types.
- "Interlock", "Disable" and "Blink" have been added to PLC devices.
- The group designation function has been added.

#### 7.3.15.1 Property Setup Dialog

Property setup dialog of PLC extension button control consists of the tabs relating to [Basic Settings] and [Advanced Settings]. Details of each tab will be described in the following sections.

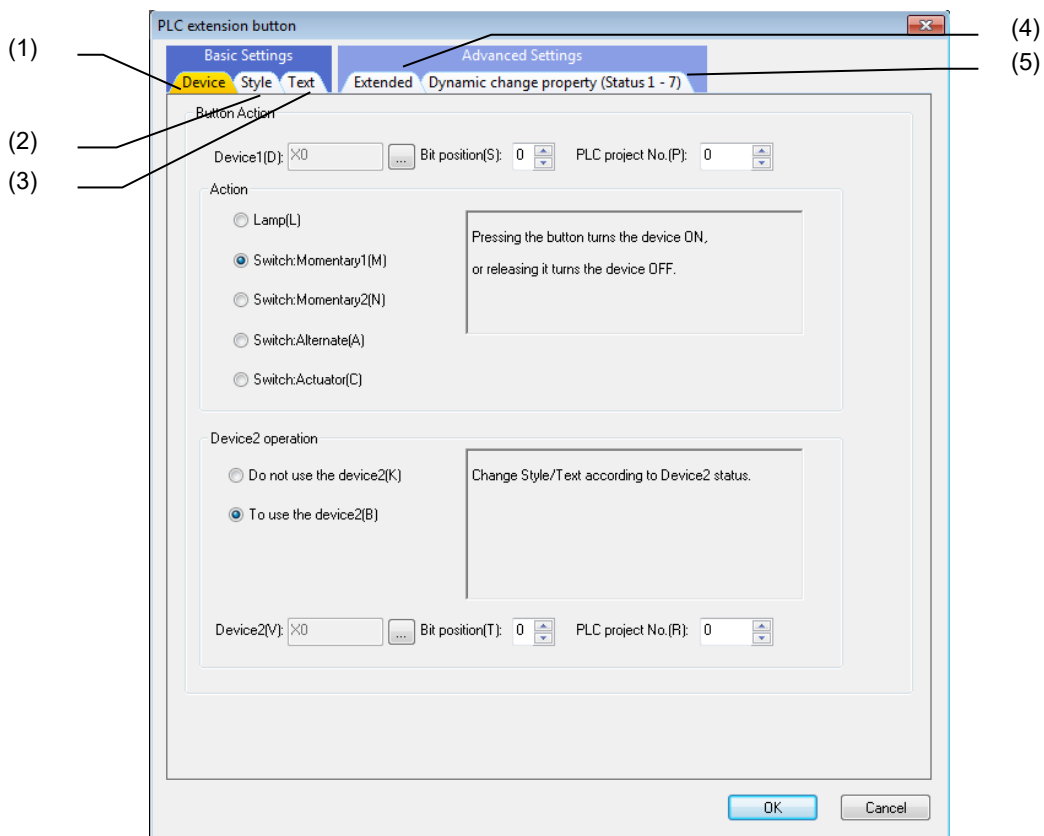

[Basic Settings] consists of the following tabs.

No.	Tab	Description
(1)	Device	Set the button actions.
(2)	Style	Set or display the background color, solid frame, blink, and preview.
(3)	Text	Set or display the font, text, scroll, and preview.

[Advanced Settings] consists of the following tabs.

No.	Tab	Description
(4)	Extended	Set the items relating to the extended condition for the style or text, blink device setting, group, and detail settings of the device.
(5)	Dynamic change property (Status 1 - 7)	Set or display the settings of status change device, and the style, text, solid frame, and preview of each status.

7.3.15.1.1 [Device] Tab

In [Device] tab, specify the device and button action.

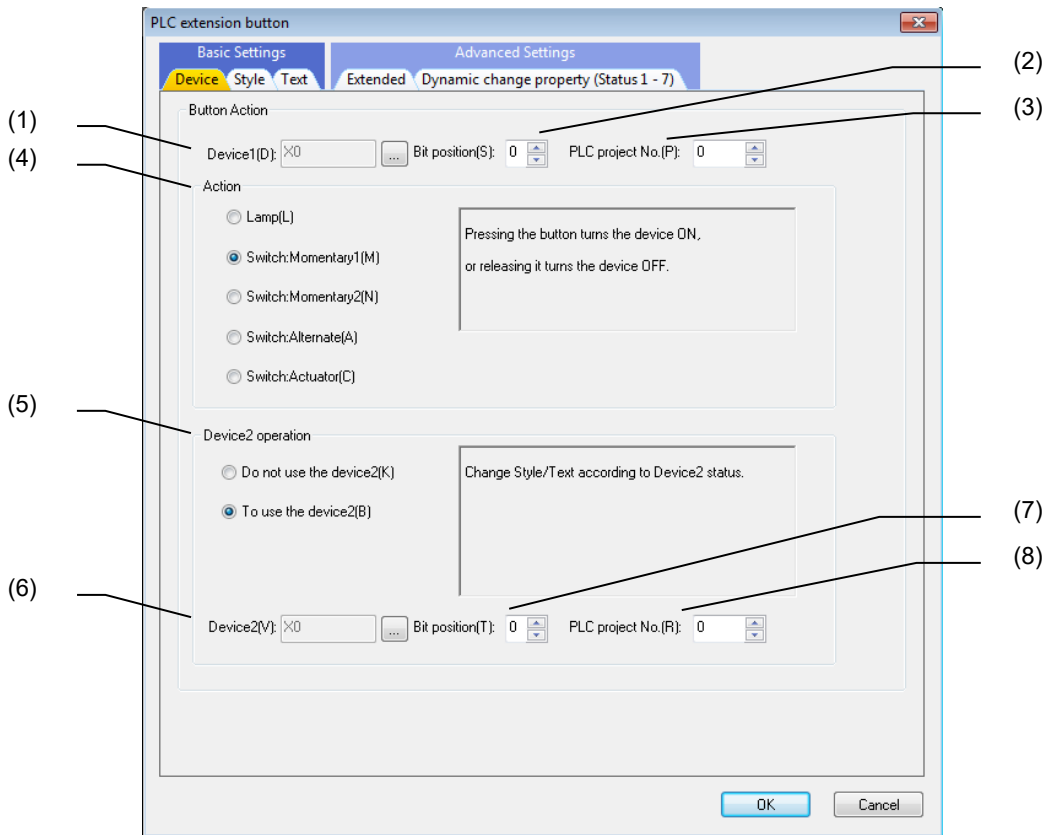

No.	Item	Description
(1)	Device1	Specify the address of the PLC device 1 for the read or write operation. Click on the "..." button to display the "PLC Device Setting" dialog.
(2)	Bit position	Specify the bit position of the word device when the word device is set to PLC device 1.
(3)	PLC project No.	Specify the project number of PLC ladder what PLC device 1 refers. (0 to 6)
(4)	Action	Select the button action from the following. Lamp Switch: Momentary1 Switch: Momentary2 Switch: Alternate Switch: Actuator
(5)	Device2 operation	Specify the action of device 2.  * The button status which can be set in the [Style] tab or the [Text] tab changes depending on the specified contents.
(6)	Device2	Specify the address of the PLC device 2 for the read or write operation. Click on the "..." button to display the "PLC Device Setting" dialog.
(7)	Bit position	Specify the bit position of the word device when the word device is set to PLC device 2.
(8)	PLC project No.	Specify the project No. of PLC ladder what PLC device refers. (0 to 6)

**NOTE**

- ◆ The address of the PLC device can be specified on the "PLC Device Setting" dialog.

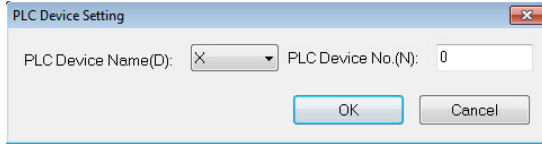

- ◆ **Device2 operation**  
When "Switch:Alternate" is selected in "Action", select the between "Read from Device2" and "Write to Device2".

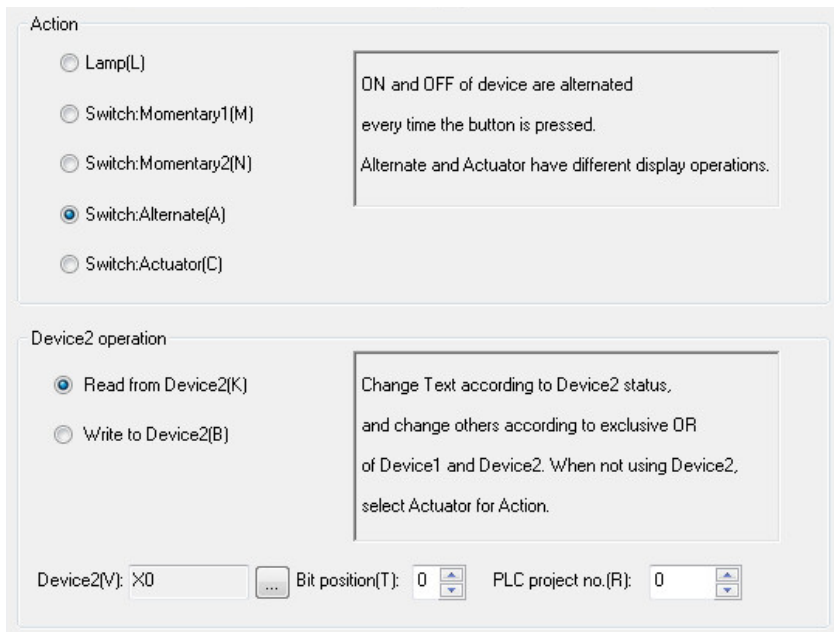

Item	Description
Read from Device2	Switch the characters to display in accordance with the state of the device 2. For the other designs, switch in accordance with the exclusive OR of the device 1 and the device 2.
Write to Device2	The device 2 can be specified. Write the bit-reversal value of the device 1 to the device 2. Switch the style or text in accordance with the state of device 1.

When "Lamp", "Switch:Momentary1", "Switch:Momentary2" or "Switch:Actuator" is selected in "Action", select between "Do not use the device2" and "To use the device2".

Item	Description
Do not use the device2	Switch the button status (ON or OFF) based on the setting of device 1.
To use the device2	<p>The device 2 can be specified.</p> <p>Change the button status based on the combination with the setting of device 1.                      (Note) For device 2, specify the device different from the one specified in the button action.</p> <p>(1) When "Lamp" is selected in "Action"                      Switch the style or text in accordance with the state of device 1. The solid frame is switched in accordance with the state of device 2.</p> <p>(2) When "Switch:Momentary1" is selected in "Action"                      Switch the style or text in accordance with the state of device 2.</p> <p>(3) When "Switch:Momentary2" or "Switch:Actuator" is selected in "Action"                      Switch the style or text in accordance with the state of device 2. The solid frame is switched in accordance with the state of device 1.</p>



7.3.15.1.2 [Style] Tab

In [Style] tab, specify the style, solid frame, and blink.

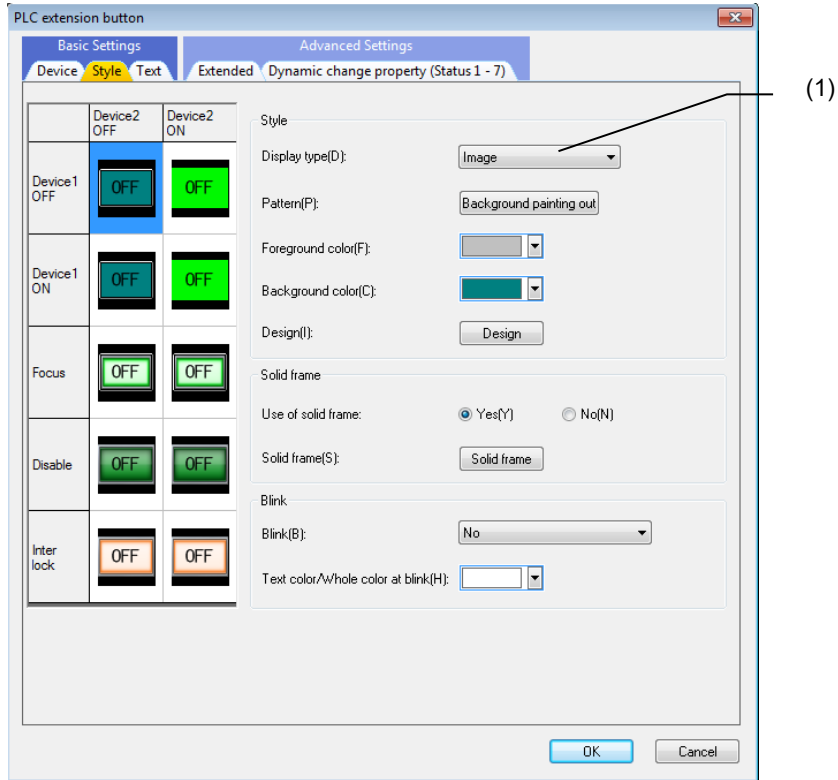

No.	Item	Description
(1)	Display type	Select the display type among "Square", "Circle", and "Image".

For the items other than the above, refer to "7.1.16.1.1 [Style] Tab".

7.3.15.1.3 [Text] Tab

In [Text] tab, specify the font, text, and scroll setting.

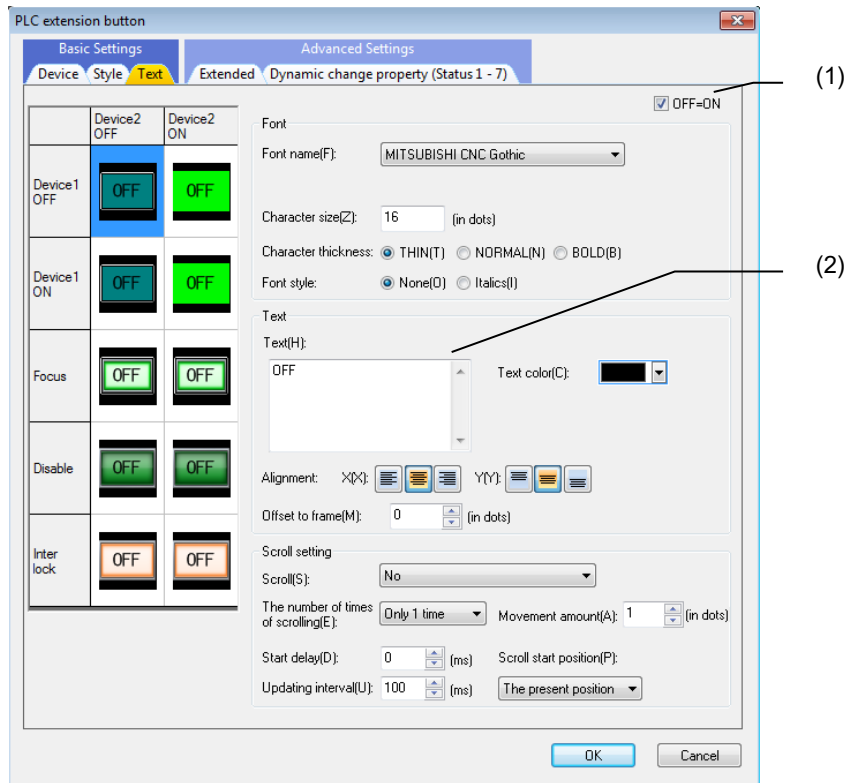

No.	Item	Description
(1)	OFF=ON	When [OFF=ON] is checked, the contents specified in [Text] are specified to all statuses. When [OFF=ON] is not checked, only the [Text] of the status selected in [Control state preview] is specified.
(2)	Text	Specify the display character string. (Note)

(Note) When specifying "To set the style / character of when the button is selected" of "7.3.15.1.4 [Extended] Tab", this is disabled. When specifying "Control ON/OFF of button", this is disabled also.

For the items other than the above, refer to "7.1.16.1.2 [Text] Tab".

7.3.15.1.4 [Extended] Tab

In [Extended] tab, set whether to set the style or character when the button is selected, controlling ON/OFF of button, and the interlock device, etc.

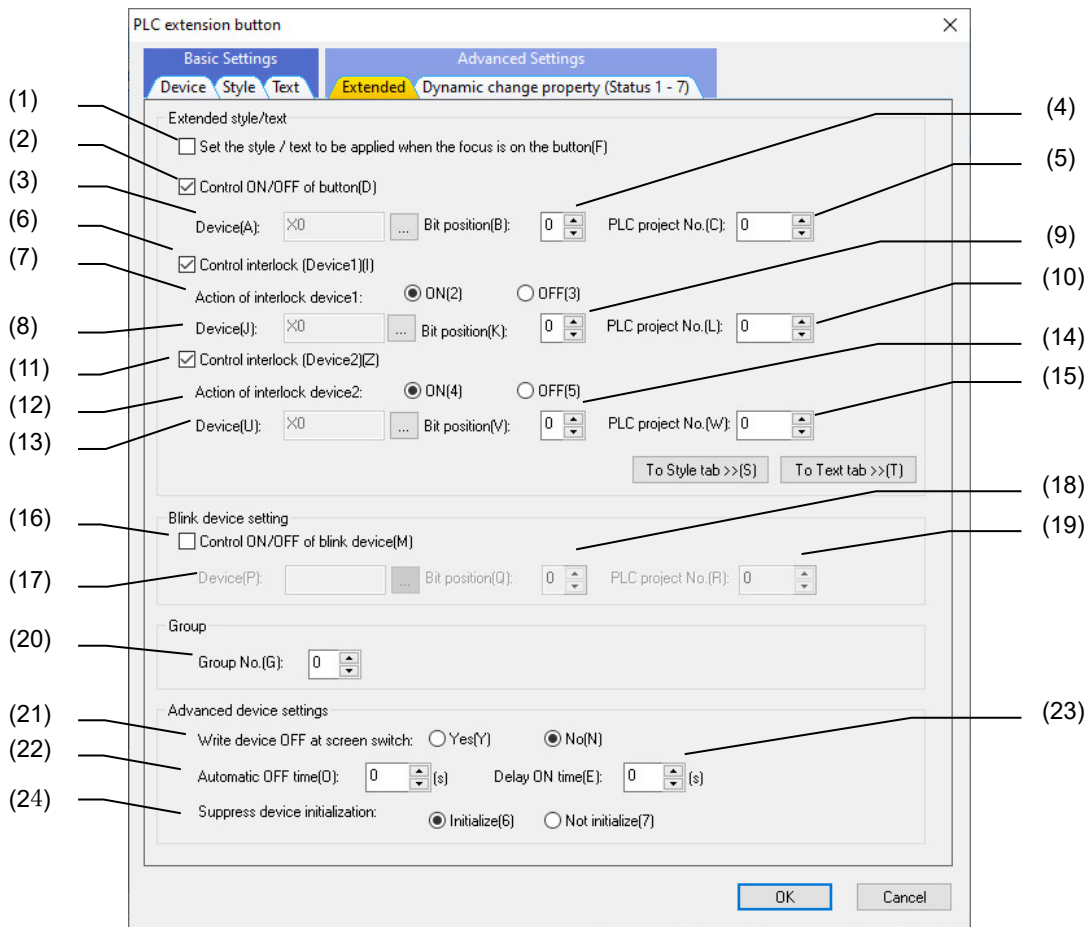

No.	Item	Description
(1)	To set the style / character of when the button is selected	When this is checked, the pattern, foreground color, background color, and design for when the button is selected (Focus) can be specified on the [Style] tab and [Text] tab.
(2)	Control ON/OFF of button	When this is checked, the pattern, foreground color, background color, and design for when the button does not work (Disable) can be specified on the [Style] tab and [Text] tab.
(3)	Device (at the time of disable)	Specify the address of the PLC device for disabling the button action. Click on the "..." button to display the "PLC Device Setting" dialog.
(4)	Bit position (at the time of disable)	Specify the bit position of the word device when the word device is set to PLC device (at the time of disable).
(5)	PLC project No. (at the time of disable)	Specify the project number of PLC ladder what PLC device (at the time of disable) refers.
(6)	Control interlock (Device1)	Check here to specify the operation and the device of the interlock device 1.
(7)	Action of interlock device1	Select the operation of interlock device 1 between "ON" and "OFF".
(8)	Device (interlock 1)	Specify the address of the PLC device for the interlock operation. Click on the "..." button to display the "PLC Device Setting" dialog.
(9)	Bit position (interlock 1)	Specify the bit position of the word device when the word device is set to PLC device (interlock 1).
(10)	PLC project No. (interlock 1)	Specify the project number of PLC ladder what PLC device (interlock 1) refers.
(11)	Control interlock (Device2)	Check here to specify the operation and the device of the interlock device 2.
(12)	Action of interlock device2	Select the operation of interlock device 2 between "ON" and "OFF".

No.	Item	Description													
(13)	Device (interlock 2)	Specify the address of the PLC device for the interlock operation. Click on the "..." button to display the "PLC Device Setting" dialog.													
(14)	Bit position (interlock 2)	Specify the bit position of the word device when the word device is set to PLC device (interlock 2).													
(15)	PLC project No. (interlock 2)	Specify the project number of PLC ladder what PLC device (interlock 2) refers.													
(16)	Control ON/OFF of blink device	Check here to specify the device for controlling the blink display.													
(17)	Device (blink)	Specify the address of the PLC device for controlling the blink display. Click on the "..." button to display the "PLC Device Setting" dialog.													
(18)	Bit position (blink)	Specify the bit position of the word device when the word device is set to PLC device (blink).													
(19)	PLC project No. (blink)	Specify the project number of PLC ladder what PLC device (blink) refers.													
(20)	Group No.	Specify the group number to which the PLC extension button belongs. Only one PLC extension button among those belonging to the same group number is allowed to be active on a screen. When specifying "0", this is disabled. When specifying "Lamp", "Switch:Momentary1", or "Switch:Momentary2" for the action setting in the [Device] tab, this is disabled either.													
(21)	Write device OFF at screen switch	Select whether to write OFF(0) of the target PLC device at screen switching between "Yes" and "No". When specifying any of the following for the action setting in the [Device] tab, this is enabled. - "Switch:Momentary1" - "Switch:Momentary2" - "Switch:Alternate" - "Switch:Actuator"													
(22)	Automatic OFF time	Specify this time to automatically turn OFF the PLC device to be written after the specified time has passed since the button has been pressed. When specifying "0", this is disabled.													
(23)	Delay ON time	Specify this time to turn ON (1) the PLC device for the writing operation by keeping pressing the button. When specifying "0", this is disabled.													
(24)	Suppress device initialization	Select whether to initialize the PLC device when the screen changes to the one where the PLC extension button with this item set is located. When "Initialize" is selected, the initialization target PLC device which meets the property conditions below is initialized to "0". When "Not initialize" is selected, the PLC device is not initialized. <table border="1" data-bbox="710 1370 1460 1612"> <thead> <tr> <th>Action of PLC device 1</th> <th>Button type</th> <th>Action of PLC device 2</th> <th>Initialization target PLC device</th> </tr> </thead> <tbody> <tr> <td rowspan="3">Write</td> <td>Momentary1 Momentary2 (Note 1)</td> <td style="text-align: center;">/</td> <td>PLC device 1</td> </tr> <tr> <td rowspan="2">Alternate Actuator</td> <td>None Read</td> <td>PLC device 1</td> </tr> <tr> <td>Write</td> <td>PLC device 1 PLC device 2</td> </tr> </tbody> </table> <p>(Note 1) When "Momentary1" or "Momentary2" is selected for the button type and "Not initialize" is selected for this item, if the custom screen is closed while the PLC extension button is pressed, the PLC device 1 is not initialized to "0" at the next time of F0 release. In that case, set the property "PLC device OFF" to "Yes".</p>	Action of PLC device 1	Button type	Action of PLC device 2	Initialization target PLC device	Write	Momentary1 Momentary2 (Note 1)	/	PLC device 1	Alternate Actuator	None Read	PLC device 1	Write	PLC device 1 PLC device 2
Action of PLC device 1	Button type	Action of PLC device 2	Initialization target PLC device												
Write	Momentary1 Momentary2 (Note 1)	/	PLC device 1												
	Alternate Actuator	None Read	PLC device 1												
		Write	PLC device 1 PLC device 2												

7.3.15.1.5 [Dynamic change property (Status 1 - 7)] Tab

In [Dynamic change property (Status 1 - 7)] tab, set the settings of status change device, and the style, text, solid frame of each status.

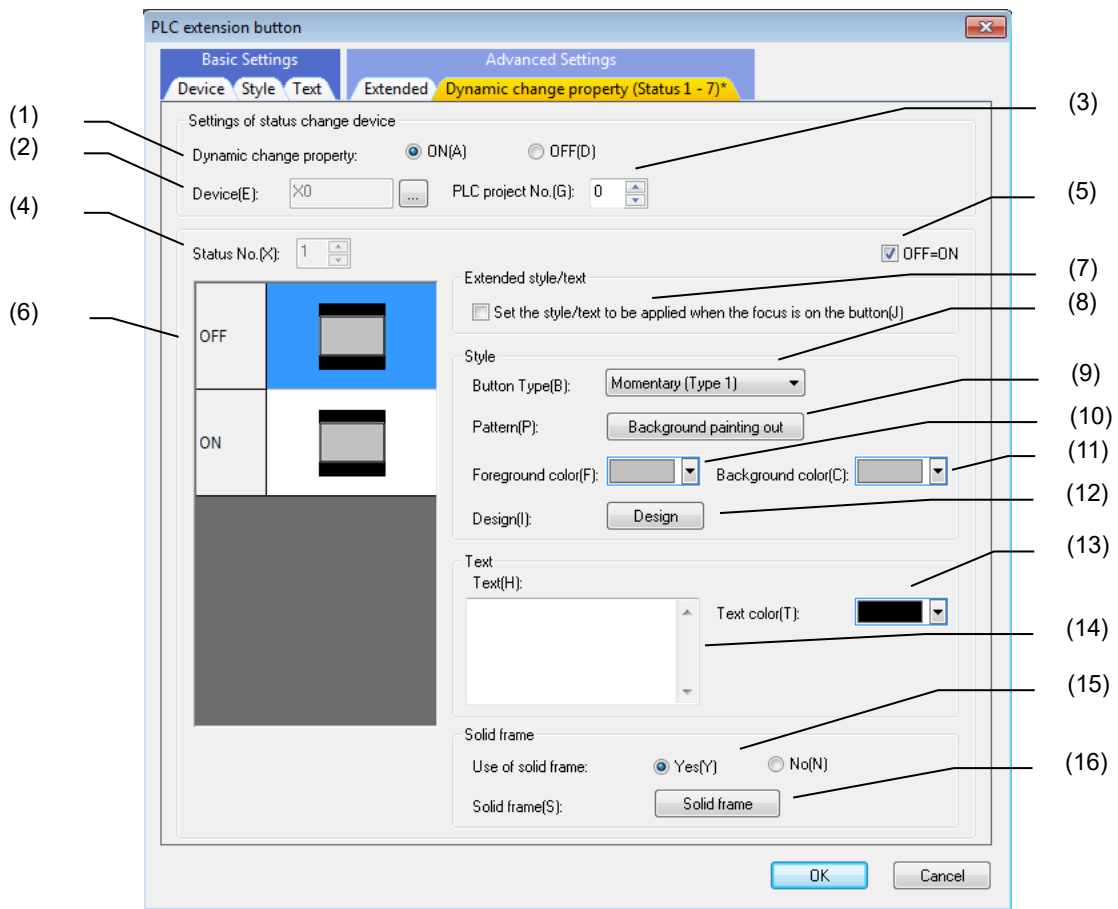

No.	Item	Description
(1)	Dynamic change property	Specify whether to enable dynamic change property function. When "ON" is selected,"(2) Device" to "(16) Solid frame" can be set.
(2)	Device	Specify the address of the PLC device that controls status change. Click the "..." button to open the "PLC Device Setting" dialog box.
(3)	PLC project No.	In the multi-project function, specify the PLC ladder project No. to which the status change device refers.
(4)	Status No.	Specify the number of the status to dynamically switch to. (1 to 7) When switching the status No., the properties of [(5) OFF=ON] to [(16) Solid frame] of each status can be set or displayed.  (Note) When a bit device is set to status change device, the status No. is fixed to 1.
(5)	OFF=ON	When [OFF=ON] is checked, the contents specified in [Text] for OFF are specified to all statuses (ON and Focus). When [OFF=ON] is not checked, only the [Text] of the status selected in [Control status preview] is specified.
(6)	Control status preview	Displays the status (OFF/ON/Focus) of the control for [(4) Status No.]. Select the status (OFF/ON/Focus) of the control that edits style/text/solid frame.
(7)	Set the style/text to be applied when the focus is on the button	When checked, the pattern/foreground color/background color/design/text color when the button is selected (Focus) can be set.
(8)	Button type	Select the button type from "Momentary (Type 1)"/"Momentary (Type 2)"/"Alternate"/"Actuator"/"None".

7. Creating Controls

No.	Item	Description
(9)	Pattern	Select the painting out pattern from "Background painting out"/"Foreground painting out"/"Pattern 0" to "Pattern 37"/"With no painting out".
(10)	Foreground color	Specify the foreground color of the status selected in "(6) Control status preview".
(11)	Background color	Specify the background color of the status selected in "(6) Control status preview".
(12)	Design	Specify the design of the status selected in "(6) Control status preview".
(13)	Text color	Specify the text color of the status selected in "(6) Control status preview".
(14)	Text	Specify the text of the status selected in "(6) Control status preview". (Note) Disabled when Focus is selected.
(15)	Use of solid frame	Specify the use of solid frame of the status selected in "(6) Control status preview". (Note) Disabled when Focus is selected.
(16)	Solid frame	Specify the solid frame of the status selected in "(6) Control status preview". (Note) Disabled when Focus is selected.

### 7.3.15.2 Property Settings

The property settings for the PLC extension button are divided into the followings.

Control name	:	Specify the control name.
Position/size	:	Specify the position and the size of the control.
Show/Hide	:	Specify whether the control is displayed or hidden.
Input permission	:	Select whether the entry is accepted (permission) or rejected (prohibition).
Ground	:	Specify the foreground and background.
Button type	:	Select the button action.
Display type	:	Select the display type of the button.
PLC device	:	Specify the target PLC device.
Color/pattern	:	Specify the color and pattern of the control.
Image	:	Specify the image of the control.
Caption	:	Specify the caption (character string) displayed on the control.
Character attribute	:	Specify the character attribute of captions.
Solid frame	:	Specify the solid frame of the control.
Caption character string scroll	:	Specify the scroll of the caption character string.
Blink	:	Set the blink of the caption character string.
Group	:	Specify the group number.
Dynamic change property	:	Specify the property values which can be switched to depending on whether the dynamic change property function is ON/OFF, the status change device, and the reading values of the status change device. Status 0 is specified in a category other than [Dynamic change property].
Callback function	:	Specify whether or not the callback functions are provided.

7. Creating Controls



Ground

Item	Description
Ground	Specify the foreground (0) and background (1) (Usually set to "0").

Button Type

Item	Description
Button type	Select the button action among the following three types.
Momentary (Type 1)	The button turns ON when it is pressed. It turns OFF when it is released.
Momentary (Type 2)	The display action is different between Type 1 and Type 2.
Alternate	The button alternates ON and OFF each time it is pressed.
Actuator	The display action is different between Alternate and Actuator.
None (Lamp)	The button does not turn ON or OFF even if it is pressed.

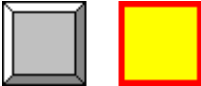
Display Type

Item	Description
Display type	Select the button type among the following three types.
Square	Rectangular button. The button is indicated in the designated color and pattern. 
Circle	Round button. The button is indicated in the designated color and pattern. 
Image	The button is indicated with the designated image resource. 



## PLC Device

Item	Description
PLC device 1	Specify the address of the PLC device for the read or write operation.
Action of PLC device 1	Specify the operation to the PLC device specified in "PLC device 1" (Read, Write or None).
Bit position of PLC device 1	Specify the bit position when the word device is set to PLC device 1 (0 to 15).
PLC device 1 project No.	Specify the project No. of PLC ladder what PLC device 1 refers. (0 to 6)
PLC device 2	Specify the address of the PLC device for the read or write operation.
Action of PLC device 2	Specify the operation to the PLC device specified in "PLC device 2" (Read, Write or None).
Bit position of PLC device 2	Specify the bit position when the word device is set to PLC device 2 (0 to 15).
PLC device 2 project No.	Specify the project No. of PLC ladder what PLC device 2 refers. (0 to 6)
Disable function	Specify whether to enable the function that controls the entry using a PLC device. When "Permission" is selected for Input permission, this setting is enabled.
Disable device	Specify the address of the PLC device for disabling the entry. This setting is enabled when the disable function is valid.
Bit position of disable device	Specify the bit position of the word device when the word device is set to Disable device (0 to 15). This setting is enabled when the disable function is valid.
Disable device project No.	Specify the project No. of PLC ladder what the disable device refers. (0 to 6)
Blink device	Specify the address of the PLC bit/word device for controlling the blink display.
Bit position of blink device	Specify the bit position of the word device when the word device is set to Blink device (0 to 15).
Blink device project No.	Specify the project No. of PLC ladder what the blink device refers. (0 to 6)
Interlock device 1	Specify the address of the PLC device for the interlock operation.
Action of interlock device 1	Specify the type of Interlock 1 (At the time of ON / At the time of OFF/No).
Bit position of interlock device 1	Specify the bit position of the word device when the word device is set to Interlock device 1 (0 to 15).
Interlock device 1 project No.	Specify the project No. of PLC ladder what the interlock device 1 refers. (0 to 6)
Interlock device 2	Specify the address of the PLC device for the interlock operation.
Action of interlock device 2	Specify the type of Interlock 2 (At the time of ON / At the time of OFF/No).
Bit position of interlock device 2	Specify the bit position of the word device when the word device is set to Interlock device 2 (0 to 15).
Interlock device 2 project No.	Specify the project No. of PLC ladder what the interlock device 2 refers. (0 to 6)
PLC device OFF	Select whether to write OFF(0) of the target PLC device at screen switching between "Yes" and "No". This setting is enabled when any of the following is selected for the button type. - "Momentary (Type 1)" - "Momentary (Type 2)" - "Alternate" - "Actuator"
Automatic OFF time*1	Specify this time to automatically turn OFF the PLC device to be written after the specified time has passed since the button has been pressed (0 to 3600 seconds. 0 is invalid).
Delay ON time	Specify this time to turn ON (1) the PLC device for the writing operation by keeping pressing the button (0 to 60 seconds. 0 is invalid).

Item	Description															
Suppress device initialization	<p>Select whether to initialize the PLC device when the screen changes to the one where the PLC extension button with this item set is located. When "Initialize" is selected, the initialization target PLC device which meets the property conditions below is initialized to "0". When "Not initialize" is selected, the PLC device is not initialized.</p> <table border="1" data-bbox="662 380 1447 631"> <thead> <tr> <th data-bbox="662 380 837 459">Action of PLC device 1</th> <th data-bbox="837 380 1101 459">Button type</th> <th data-bbox="1101 380 1268 459">Action of PLC device 2</th> <th data-bbox="1268 380 1447 459">Initialization target PLC device</th> </tr> </thead> <tbody> <tr> <td data-bbox="662 459 837 533" rowspan="2">Write</td> <td data-bbox="837 459 1101 533">Momentary (Type 1) Momentary (Type 2) (Note 1)</td> <td data-bbox="1101 459 1268 533" style="text-align: center;">/</td> <td data-bbox="1268 459 1447 533">PLC device 1</td> </tr> <tr> <td data-bbox="837 533 1101 631">Alternate Actuator</td> <td data-bbox="1101 533 1268 582">None Read</td> <td data-bbox="1268 533 1447 582">PLC device 1</td> </tr> <tr> <td></td> <td></td> <td data-bbox="1101 582 1268 631">Write</td> <td data-bbox="1268 582 1447 631">PLC device 1 PLC device 2</td> </tr> </tbody> </table> <p>(Note 1) When "Momentary (Type 1)" or "Momentary (Type 2)" is selected for the button type and "Not initialize" is selected for this item, if the custom screen is closed while the PLC extension button is pressed, the PLC device 1 is not initialized to "0" at the next time of F0 release. In that case, set the property "PLC device OFF" to "Yes". (Initial value: Initialize)</p>	Action of PLC device 1	Button type	Action of PLC device 2	Initialization target PLC device	Write	Momentary (Type 1) Momentary (Type 2) (Note 1)	/	PLC device 1	Alternate Actuator	None Read	PLC device 1			Write	PLC device 1 PLC device 2
Action of PLC device 1	Button type	Action of PLC device 2	Initialization target PLC device													
Write	Momentary (Type 1) Momentary (Type 2) (Note 1)	/	PLC device 1													
	Alternate Actuator	None Read	PLC device 1													
		Write	PLC device 1 PLC device 2													

- \*1: If the button is kept pressed, the device is automatically turned OFF after the specified time has passed since the button has been pressed.
- \*2: When specifying the device not supporting multi-project and using the device which has the same device number in multiple projects, the output to the device of the project executed last is valid.
- \*3: If "Not initialize" is selected in the property "Suppress device initialization", initialize the PLC device 1 and the PLC device 2 to OFF (0) before the screen changes to the one where the PLC extension button with this item set is located.
- \*4: If "Not initialize" is selected in the property "Suppress device initialization", the PLC device 1 and the PLC device 2 are not written when the screen changes to the one where the PLC extension button with this item set is located. In that case, the time till the screen change is shortened compared to when "Initialize" is selected.

Color/Pattern

Item	Description
Pattern at the time of ON <sup>*1</sup>	Specify the pattern of the ON button.
Foreground color at the time of ON <sup>*1</sup>	Specify the foreground color of the ON button.
Background color at the time of ON <sup>*1</sup>	Specify the background color of the ON button.
Design at the time of ON <sup>*2</sup>	Specify the image of the ON button.
Pattern at the time of OFF <sup>*1</sup>	Specify the pattern of the OFF button.
Foreground at the time of OFF <sup>*1</sup>	Specify the foreground color of the OFF button.
Background at the time of OFF <sup>*1</sup>	Specify the background color of the OFF button.
Design at the time of OFF <sup>*2</sup>	Specify the image of the OFF button.
Pattern at the time of interlock <sup>*1</sup>	Specify the pattern in the interlock state.
Foreground color at the time of interlock <sup>*1</sup>	Specify the foreground color of the button in the interlock state.
Background color at the time of interlock <sup>*1</sup>	Specify the background color of the button in the interlock state.
Design at the time of interlock <sup>*2</sup>	Specify the image to display in the interlock state.

\*1: This setting is valid if [Display Type] is "Square" or "Circle".

\*2: The setting is valid if the [Display Type] is "Image".

Image

Item	Description
Effect at the time of focus	Specify whether the color of the button when the focus is located changes or not. Select between "change color" and "no change".
Pattern at the time of focus <sup>*1</sup>	Specify the pattern of the button when the focus is located.
Foreground color at the time of focus <sup>*1</sup>	Specify the foreground color of the button when the focus is located.
Background color at the time of focus <sup>*1</sup>	Specify the background color of the button when the focus is located.
Design at the time of focus <sup>*2</sup>	Specify the image of the button when the focus is located.
Pattern at the time of disable <sup>*1</sup>	Specify the pattern of the button when the entry is disabled.
Foreground color at the time of disable <sup>*1</sup>	Specify the foreground color of the button when the entry is disabled.
Background color at the time of disable <sup>*1</sup>	Specify the background color of the button when the entry is disabled.
Design at the time of disable <sup>*2</sup>	Specify the image of the button when the entry is disabled.

\*1: This setting is valid if [Display Type] is "Square" or "Circle".

\*2: The setting is valid if the [Display Type] is "Image".

Caption

Item	Description
Character string at the time of ON	Specify the character string to be displayed at the time of ON. The setting is valid if "provided" is selected for the caption existence.
Character string at the time of OFF	Specify the character string to be displayed at the time of OFF. The setting is valid if "provided" is selected for the caption existence.
Character string at the time of interlock	Specify the character string to be displayed in the interlock state. The setting is valid if "provided" is selected for the caption existence.

7. Creating Controls

Character Attribute

Item	Description
Character color at the time of ON	Specify the character color to be displayed at the time of ON.
Character color at the time of OFF	Specify the character color to be displayed at the time of OFF.
Character color at the time of interlock	Specify the character color to be displayed in the interlock state.
Character color at the time of Focus	Specify the character color to be displayed at the time of Focus.

These settings are valid if the [caption] is "provided".

Solid frame

Item	Description
Use of solid frame at the time of ON	Select the presence of the solid frame to be displayed at the time of ON between "Yes" and "No".
Solid frame at the time of ON	Select the ID of the solid frame resource to be displayed at the time of ON.
Use of solid frame at the time of OFF	Select the presence of the solid frame to be displayed at the time of OFF between "Yes" and "No".
Solid frame at the time of OFF	Select the ID of the solid frame resource to be displayed at the time of OFF.
Use of solid frame at the time of interlock	Select the presence of the solid frame to be displayed at the time of interlock between "Yes" and "No".
Solid frame at the time of interlock	Select the ID of the solid frame resource to be displayed at the time of interlock.
Use of solid frame at the time of disable	Select the presence of the solid frame to be displayed at the time of disable between "Yes" and "No".
Solid frame at the time of disable	Select the ID of the solid frame resource to be displayed at the time of disable.

Blink

Blink the caption character string of the control.

Item	Description
Blink	Select the existence of blink from "Yes", "No" or "Blink device".

Group

Item	Description
Group No.	Specify the group number to which the PLC extension button belongs (0 to 100. 0 is invalid). Only one PLC extension button among those belonging to the same group number is allowed to be active on a screen.

Dynamic change property

Dynamically switches properties (show/hide, style/text/solid frame for ON/OFF/Focus) depending on the values obtained from devices.

Switching between eight statuses is possible in dynamic change property. Switch to statuses 1 to 7 in the value of dynamic change property (Status 1 - 7). However, switch to status 0 in the value specified by a category other than [Dynamic change property].

Settings of status change device

Item	Description
ON/OFF	Select ON/OFF for dynamic change property function.
PLC device <sup>*1</sup>	Set the address of the PLC device for status change.
PLC device project No.	In the multi-project function, specify the PLC ladder project No. which refers to the PLC device.

\*1: Bit devices and word devices can be set to the PLC device.

Dynamic change property (Status 1 - 7)

Item	Description
Show/Hide	Select whether the control is shown or hidden. When hidden, the dynamic change property function is disabled. In this case, a macro must be used to change the shown/hidden properties.
Button type	Select the button action among the following five types.
Momentary (Type 1)	The button turns ON when it is pressed. It turns OFF when it is released.
Momentary (Type 2)	The display action is different between Type 1 and Type 2.
Alternate	The button alternates ON and OFF each time it is pressed.
Actuator	The display action is different between Alternate and Actuator.
None (Lamp)	The button does not turn ON or OFF even if it is pressed.
Pattern at the time of ON <sup>*1</sup>	Specify the pattern of the ON button.
Foreground color at the time of ON <sup>*1</sup>	Specify the foreground color of the ON button.
Background color at the time of ON <sup>*1</sup>	Specify the background color of the ON button.
Design at the time of ON <sup>*2</sup>	Specify the image of the ON button.
Character sequence at the time of ON	Specify the character string of the ON button. The setting is valid if "Yes" is selected for the caption existence.
Character color at the time of ON	Specify the character color to be displayed at the time of ON.
Use of solid frame at the time of ON	Select the presence of the solid frame to be displayed at the time of ON between "Yes" and "No".
Solid frame at the time of ON	Select the ID of the solid frame resource to be displayed at the time of ON.
Pattern at the time of OFF <sup>*1</sup>	Specify the pattern of the OFF button.
Foreground color at the time of OFF <sup>*1</sup>	Specify the foreground color of the OFF button.
Background color at the time of OFF <sup>*1</sup>	Specify the background color of the OFF button.
Design at the time of OFF <sup>*2</sup>	Specify the image of the OFF button.
Character sequence at the time of OFF	Specify the character string to be displayed at the time of OFF. The setting is valid if "Yes" is selected for the caption existence.
Character color at the time of OFF	Specify the character color to be displayed at the time of OFF.
Use of solid frame at the time of OFF	Select the presence of the solid frame to be displayed at the time of OFF between "Yes" and "None".
Solid frame at the time of OFF	Select the ID of the solid frame resource to be displayed at the time of OFF.
Effect at the time of focus	Specify whether the color of the button when the focus is located changes or not. Select between "Change color" and "No effect".
Pattern at the time of focus <sup>*1</sup>	Specify the pattern of the focus button.

7. Creating Controls

Item	Description
Foreground color at the time of focus <sup>*1</sup>	Specify the foreground color of the focus button.
Background color at the time of focus <sup>*1</sup>	Specify the background color of the focus button.
Design at the time of focus <sup>*2</sup>	Specify the image of the focus button.
Character color at the time of focus	Specify the character color to be displayed at the time of Focus.

\*1: This setting is valid if [Display Type] is "Square" or "Circle".

\*2: The setting is valid if the [Display Type] is "Image"

For the other properties, refer to "7.1 Common Functions of Controls".

7.3.15.3 Complements

Functional Specifications

PLC Device Setting

Up to two PLC devices can be set for the read and write operations.

The combinations of the operation modes (Read/Write/None) are limited according to the specified button type.

If a combination other than below is selected, the operation is the same as when the input permission is set to "Prohibition".

Item	PLC device	Write	Read	None
Momentary (Type 1)	PLC device 1	○	×	○
	PLC device 2	×	○	×
Momentary (Type 2)	PLC device 1	○	×	×
	PLC device 2	×	○	×
Alternate	PLC device 1	○	×	×
	PLC device 2	○	○	×
Actuator	PLC device 1	○	×	×
	PLC device 2	×	○	×
None (Lamp)	PLC device 1	×	○	×
	PLC device 2	×	○	×

Priority of PLC devices

The image displayed by the PLC extension button changes in accordance with the states of PLC devices.

Each PLC device has a priority level, therefore when a PLC device with a higher priority is active, the state of a PLC device with a lower priority is not referred to.

The priority order of the PLC devices is determined as shown below.

Priority	PLC device
Higher	Disable device
↑	Interlock device 1/Interlock device 2
↓	Blink device
Lower	PLC device 1/PLC device 2

(Note) The status change device overwrites the values of the properties (color/pattern for ON/OFF/Focus) displayed by PLC device 1/PLC device 2 according to the reading values. It has the highest priority, but refers to other PLC devices.

Button Action Type

(1) Momentary (Type 1)

While the button is kept pressed, ON(1) is written to the PLC device specified with PLC device 1 (Write). When the button is released, OFF(0) is written.

The button can correspond to the state of PLC device 2 (Read) and can display the ON/OFF state according to the property settings.

Display action changes as follows according to the ON/OFF of the PLC device 2.

PLC device 2 (Read)	OFF(0)	ON(1)
Color/Pattern	At the time of OFF <sup>*1</sup>	At the time of ON <sup>*1</sup>
Caption/Character attribute	At the time of OFF <sup>*2</sup>	At the time of ON <sup>*2</sup>
Solid frame	At the time of OFF <sup>*3</sup>	At the time of ON <sup>*3</sup>

\*1: Color/Pattern refers to the patterns, foreground colors, background colors and images at the time of ON and OFF.

\*2: Caption/Character attribute refers to the character strings and character colors at the time of ON and OFF.

\*3: Solid frame refers to the solid frames at the time of ON and OFF.

Operation example)

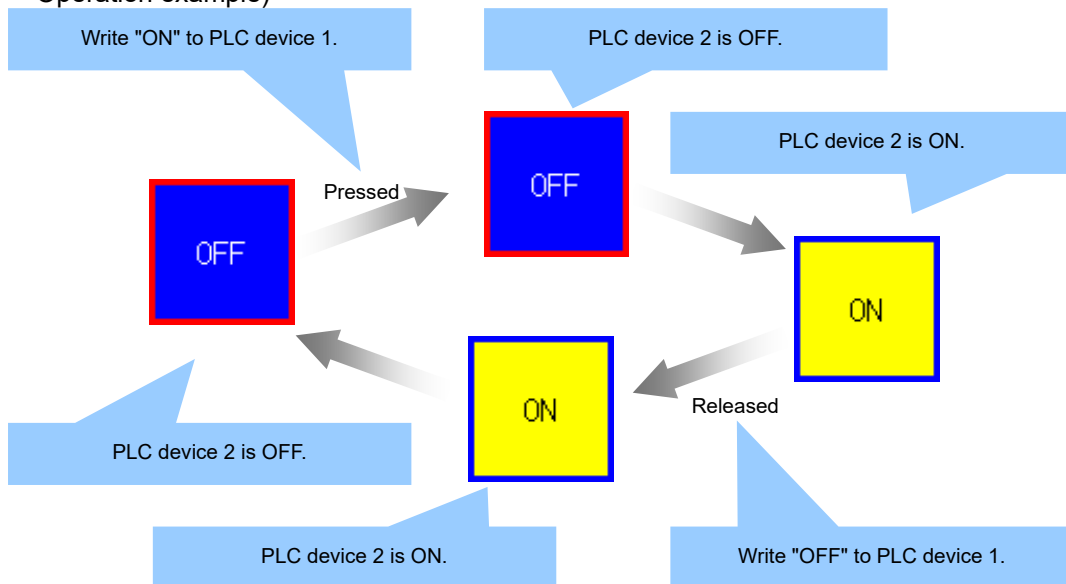

**NOTE**

- ◆ When the action mode of PLC device 1 is set to "None", the states at the time of ON/OFF, which are set in the properties, can also be displayed in line with the state of PLC device 2 (Read).
- ◆ Blink display cannot be controlled with the blink device.
- ◆ The group No. setting is invalid.

(2) Momentary (Type 2)

While the button is kept pressed, ON(1) is written to the PLC device specified with PLC device 1 (Write). When the button is released, OFF(0) is written.

The button can correspond to the combination of PLC device 1 (Write) and PLC device 2 (Read) and can display the ON/OFF state according to the property settings.

Display action changes as follows according to the ON/OFF of PLC device 1 and 2.

PLC device 1 (Write)	OFF(0)		ON(1)	
PLC device 2 (Read)	OFF(0)	ON(1)	OFF(0)	ON(1)
Color/Pattern	At the time of OFF <sup>*1</sup>	At the time of ON <sup>*1</sup>	At the time of OFF <sup>*1</sup>	At the time of ON <sup>*1</sup>
Caption/Character attribute	At the time of OFF <sup>*2</sup>	At the time of ON <sup>*2</sup>	At the time of OFF <sup>*2</sup>	At the time of ON <sup>*2</sup>
Solid frame	At the time of OFF <sup>*3</sup>		At the time of ON <sup>*3</sup>	
Blink device	Enable	Disable	Disable	

\*1: Color/Pattern refers to the patterns, foreground colors, background colors and images at the time of ON and OFF.

\*2: Caption/Character attribute refers to the character strings and character colors at the time of ON and OFF.

\*3: Solid frame refers to the solid frames at the time of ON and OFF.

Operation example)

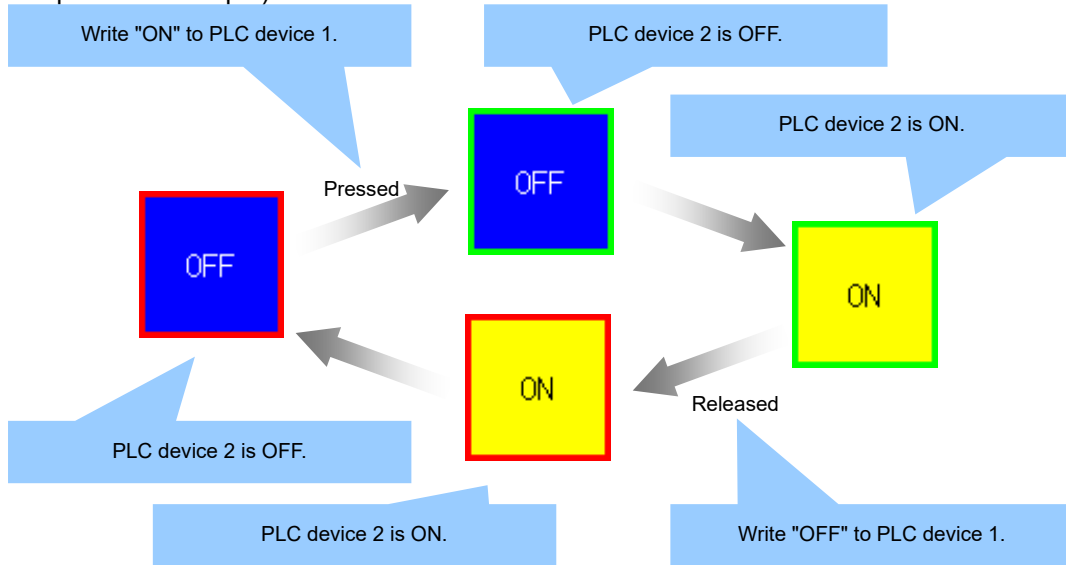

**NOTE**

- ◆ Only when both PLC device 1 and PLC device 2 are OFF, blink display can be controlled with the blink device.
- ◆ The group No. setting is invalid.



(3) Alternate

Each time the button is pressed, ON(1)/OFF(0) of PLC device 1 (Write) is written alternately. When PLC device 1 (Write) is OFF, the button can correspond to the state of PLC device 2 (Read) and can display the ON/OFF state according to the property settings. When PLC device 1 (Write) is ON, the display action is reversed to the above-mentioned operation, except for a character string.

Display action changes as follows according to the ON/OFF of PLC device 1 and 2.

PLC device 1 (Write)	OFF(0)		ON(1)		
	PLC device 2 (Read)	OFF(0)	ON(1)	OFF(0)	ON(1)
Color/Pattern		At the time of *1 OFF	At the time of *1 ON	At the time of *1 ON	At the time *1 of OFF
Character attribute (character color)		At the time of OFF	At the time of ON	At the time of ON	At the time of OFF
Solid frame		At the time of *2 OFF	At the time of *2 ON	At the time of *2 ON	At the time *2 of OFF
Caption (character string)		At the time of OFF	At the time of ON	At the time of OFF	At the time of ON
Blink device		Enable	Disable	Disable	

\*1: Color/Pattern refers to the patterns, foreground colors, background colors and images at the time of ON and OFF.

\*2: Solid frame refers to the solid frames at the time of ON and OFF.

Operation example)

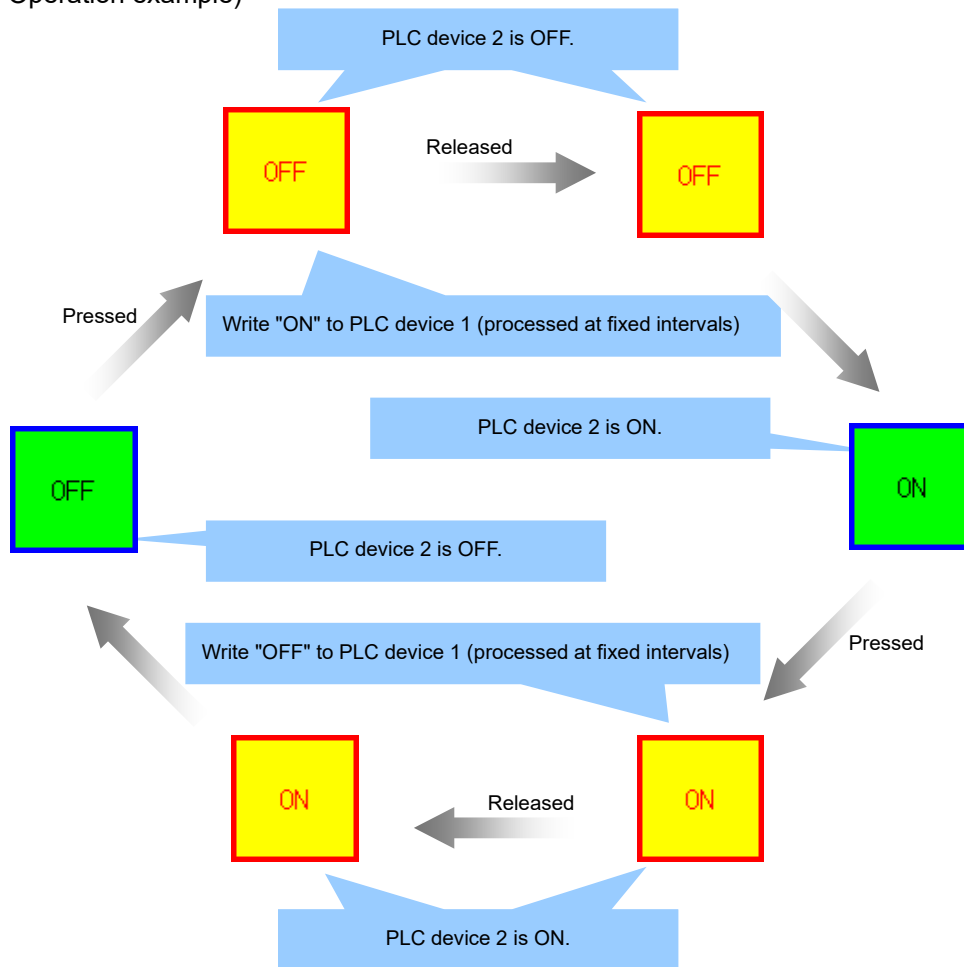

With the alternating button, the action mode of PLC device 2 can be set to "Write".  
 When the action mode of PLC device 2 is set to "Write", ON(1)/OFF(0) of PLC device 2 (Write) is written alternately each time the button is pressed.  
 The button can correspond to the state of PLC device 1 (Write) and can display the ON/OFF state according to the property settings.

Display action changes as follows according to the ON/OFF of PLC device 1.

PLC device 1 (Write)	OFF(0)	ON(1)
Color/Pattern	At the time of OFF <sup>*1</sup>	At the time of ON <sup>*1</sup>
Caption/Character attribute	At the time of OFF <sup>*2</sup>	At the time of ON <sup>*2</sup>
Solid frame	At the time of OFF <sup>*3</sup>	At the time of ON <sup>*3</sup>

\*1: Color/Pattern refers to the patterns, foreground colors, background colors and images at the time of ON and OFF.

\*2: Caption/Character attribute refers to the character strings and character colors at the time of ON and OFF.

\*3: Solid frame refers to the solid frames at the time of ON and OFF.

Operation example)

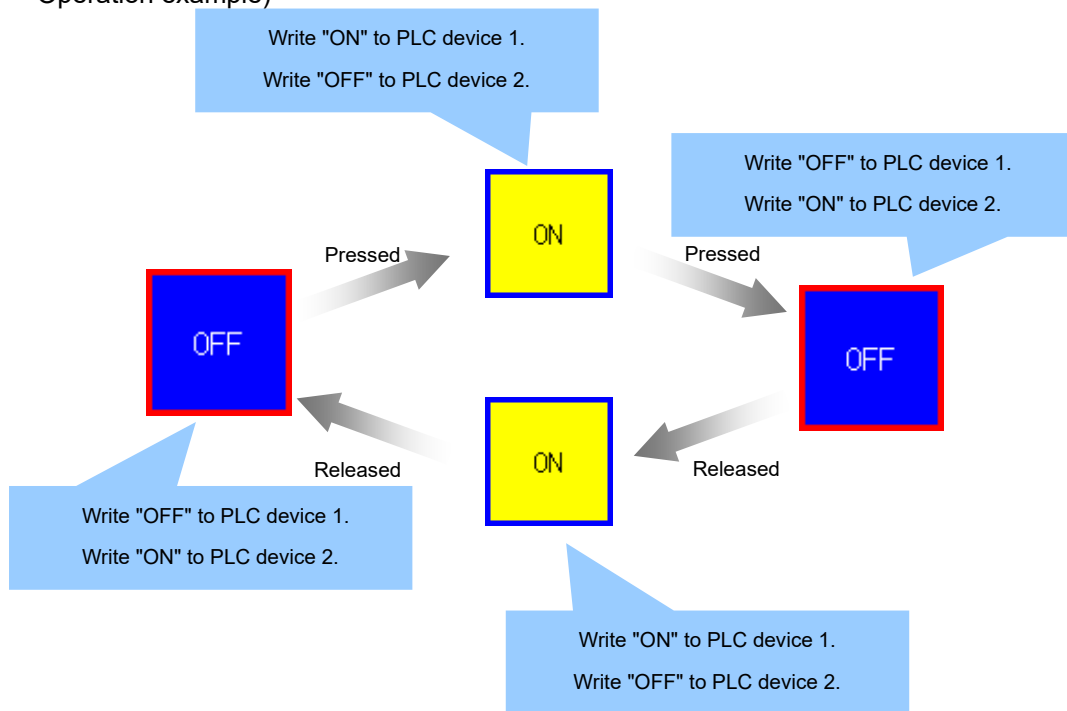

(4) Actuator

Each time the button is pressed, ON(1)/OFF(0) of PLC device 1 (Write) is written alternately. The solid frame corresponds to the state of PLC device 1 (Write) and the items other than the solid frame correspond to the state of PLC device 2 (Read).

Display action changes as follows according to the ON/OFF of PLC device 1 and 2.

PLC device 1 (Write)	OFF(0)		ON(1)	
PLC device 2 (Read)	OFF(0)	ON(1)	OFF(0)	ON(1)
Color/Pattern	At the time of *1 OFF	At the time of *1 ON	At the time of *1 OFF	At the time of *1 ON
Character attribute (character color)	At the time of OFF	At the time of ON	At the time of OFF	At the time of ON
Solid frame	At the time of *2 OFF	At the time of *2 OFF	At the time of *2 ON	At the time of *2 ON
Caption (character string)	At the time of OFF	At the time of ON	At the time of OFF	At the time of ON
Blink device	Enable	Disable	Enable	Disable

\*1: Color/Pattern refers to the patterns, foreground colors, background colors and images at the time of ON and OFF.

\*2: Solid frame refers to the solid frames at the time of ON and OFF.

Operation example)

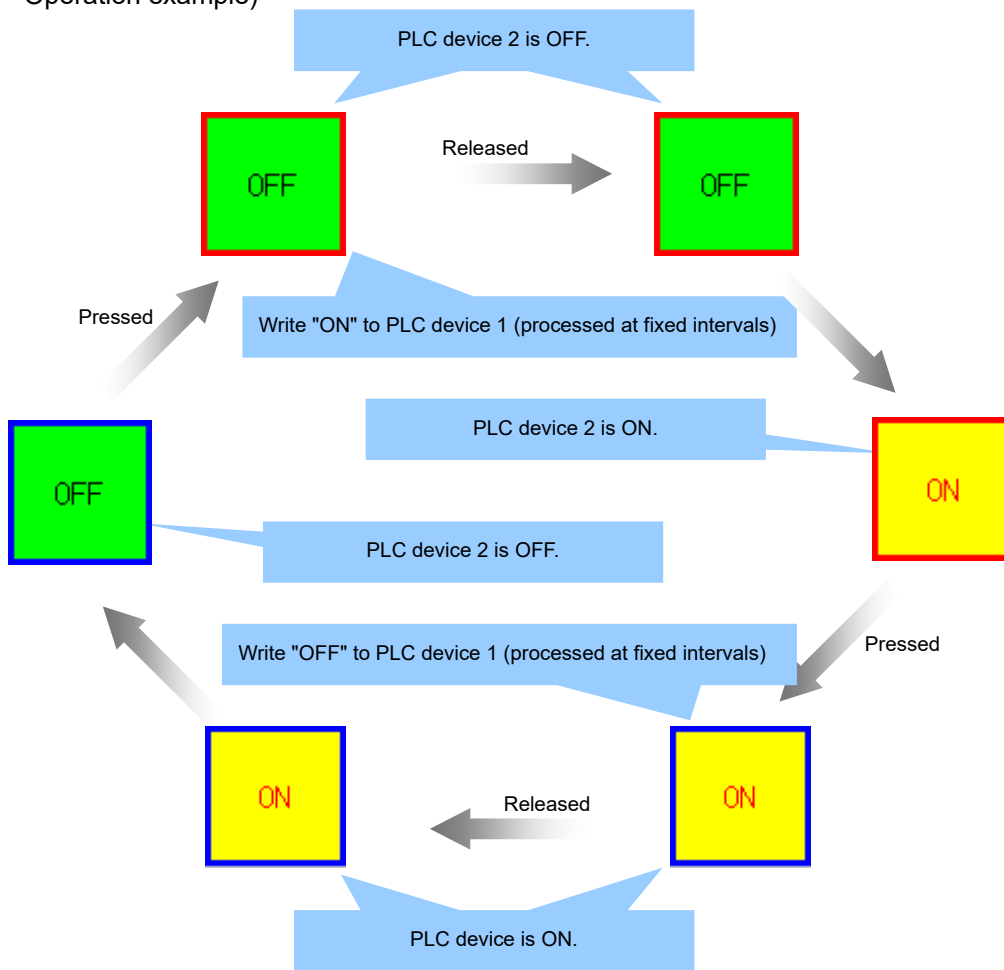

(5) None (Lamp)

Nothing is written to the PLC device, but the display action changes according to the combination of PLC device 1 (Write) and PLC device 2 (Read).

Display action changes as follows according to the ON/OFF of PLC device 1 and 2.

PLC device 1 (Write)	OFF(0)		ON(1)	
PLC device 2 (Read)	OFF(0)	ON(1)	OFF(0)	ON(1)
Color/pattern	At the time of *1 OFF	At the time of *1 OFF	At the time of *1 ON	At the time of *1 ON
Character attribute (character color)	At the time of OFF	At the time of OFF	At the time of ON	At the time of ON
Solid frame	At the time of *2 OFF	At the time of *2 ON	At the time of *2 OFF	At the time of *2 ON
Caption (character string)	At the time of OFF	At the time of OFF	At the time of ON	At the time of ON
Blink device	Enable			

\*1: Color/Pattern refers to the patterns, foreground colors, background colors and images at the time of ON and OFF.

\*2: Solid frame refers to the solid frames at the time of ON and OFF.

Operation example)

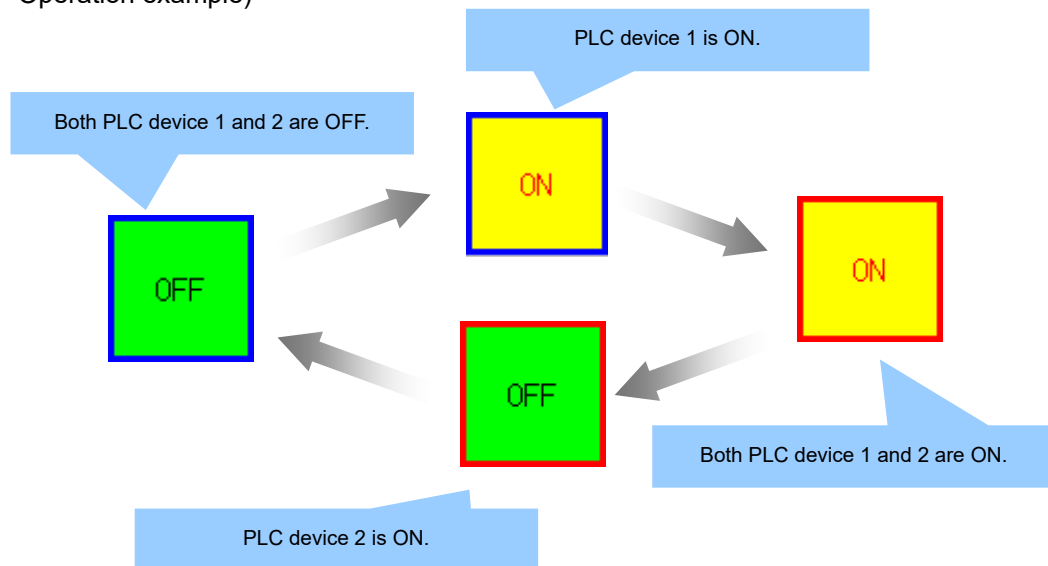

**NOTE**

- ◆ When the action of PLC device 1 is set to a mode other than "Read", PLC device 1 is displayed always in the OFF state.
- ◆ When the action of PLC device 2 is set to a mode other than "Read", PLC device 2 is displayed always in the OFF state.
- ◆ When Disable device is ON with Disable function set to "Enable", the image at the time of disable is displayed.
- ◆ When the settings of Interlock device 1 and 2 are valid, the image at the time of interlock is displayed.
- ◆ The group No. setting is invalid.

Dynamic change property

The value of the status change device is constantly read, and when the reading value is different to the previous reading value, it switches to the status of the value set to the reading value. In each status, properties (show/hide, style/text/solid frame for ON/OFF/Focus) can be set, thus display image patterns increase when combined with [button action type].

The status change device types and valid values are as follows.

Type	Valid values
Bit device	0 to 1
Word device	0 to 7

(Note) Do not specify a value outside the valid value range.

(1) Bit device

Can switch between status 0 and status 1 according to the reading value.

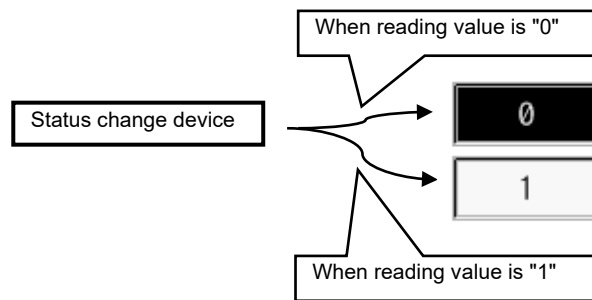

(2) Word device

Can switch to any of status 0 to status 7 according to the reading value.

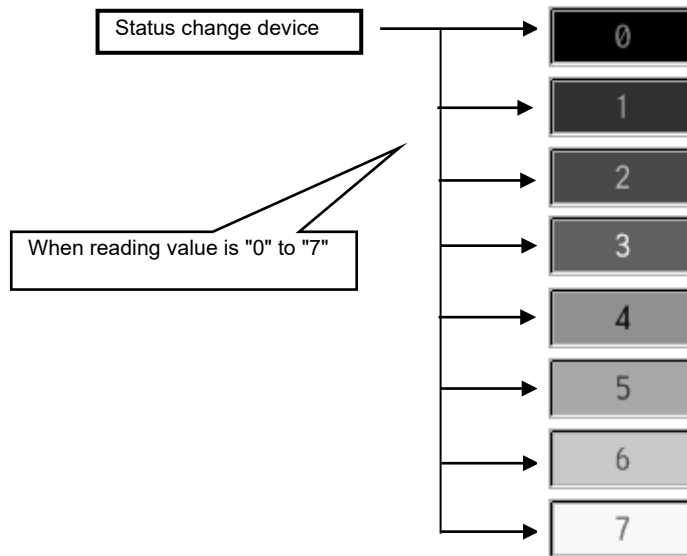

**NOTE**

◆ When the PLC extension button is hidden, the dynamic change property function is disabled. In this case, a macro must be used to change the shown/hidden properties.

**7.3.16 PLC Message (GNCPLCMessage)**

PLC message is a control that displays a message according to the status of PLC device in NC, by obtaining it from the message definition text file (UNICODE text).

**7.3.16.1 Property Settings**

The property settings for the PLC message are divided into the followings.

- Control name : Specify the control name.
- Position/size : Specify the position and size of the control.
- Show/Hide : Specify whether the control is displayed or hidden.
- Ground : Specify the foreground and background.
- Default : Specify the default character color and default background color to be applied when they are not specified in the message definition text file.
- Message file : Specify the message definition text file to be displayed at the control.
- PLC device : Specify the target PLC device.
- Character attribute : Specify the character attribute of captions.
- Caption character string scroll : Specify the scroll of the caption character string.
- Blink : Set the blink of the caption character string.
- Callback function : Specify whether or not the callback functions are provided.

Ground

Item	Description
Ground	Specify the foreground and background (Usually set to "0").

Default

Item	Description
Default character color	Specify the default character color. This color is applied when a character color is not specified in the message definition text file.
Default background color	Specify the default background color. This color is applied when there is no message or when a background color is not specified in the message definition text file.

Message File

Item	Description
Message folder	Select the folder in which the message definition text file is stored.
Message file	Select the message definition text file name from the file resource ID.

**NOTE**

- ◆ To store the message definition text file in the selected message folder, the absolute path has to be defined in the Config.ini file. The relationship between the description in the combo box and the actual folder is shown below.

<Example of M800V/M80V/M800/M80 (Windows-based display unit) and M700VW>

```
[MESS_CONTROL]
MESSDATA0=C:\MESSDATA0\
MESSDATA1=C:\MESSDATA1\
MESSDATA2=C:\MESSDATA2\
:
MESSDATA7=C:\MESSDATA7\
```

<Example of M800V/M80V/M800/M80 (Windows-less display unit) and M700VS/M70V/E70>

```
[MESS_CONTROL]
MESSDATA0=/custom/MESSDATA0/
MESSDATA1=/custom/MESSDATA1/
MESSDATA2=/custom/MESSDATA2/
:
MESSDATA7=/custom/MESSDATA7/
```

- ◆ When the message file size is large, the file consumes the custom release data storage capacity. Therefore, the size of each message file should be 200K byte or less.
- ◆ Up to eight message files are available. When more than one message file is used, the total number of lines in the message files has to be 65535 or less.
- ◆ The file name to be described in the file resource ID has to be 40 or less characters in length (including the extension).

PLC Device

Item	Description
PLC device method	Select the method to display a message between "Bit designation" and "No. designation".
PLC device	Specify the address of the PLC bit device word device for the PLC message display.
Starting bit position	Specify the start position to read the PLC device (0 to 15). This setting is valid when a word device is selected for the PLC device for which "Bit designation" is selected (but not used when a bit device is selected (fixed to zero)). When a word device is selected, a message is displayed according to the state between the starting bit position and the number of bits to use.
Number of bits to use	Specify the number of bits for reading the PLC device. When "Bit designation" is selected, the bit devices between the starting bit position and the number of bits to use are read in the ascending order to display the message (1 to 512). When "No. designation" is selected, specify the number of bits to be handled as numbers (Specify the value from 1 to 16. "16" is specified when a value other than 1 to 16 is set).
Project No. of PLC device	Specify the project No. of PLC ladder. (0 to 6)
Display action	Specify whether to retain the message or delete it when a message to display does not exist after the state of the PLC device has changed. Select between "Keep the display" and "Cancel the display".
Turn back	Select this to display the message in two lines when the message length has exceeded the control's display range. Select between "None" and "Yes".

**NOTE**

◆ Set as shown below according to the PLC device types.

(1) Setting example of "Bit designation"

- To display a message using the bit devices M0 to M10.

PLC device → M0  
Start bit position → 0  
Number of bits used → 11

- To display a message using the word devices R0 (bit 8) to R10 (bit 7).

PLC device → R0  
Start bit position → 8  
Number of bits used → 160

(2) Setting example of "No. designation"

- To display a message using the one byte between M0 and M7.

PLC device → M0  
Start bit position → 0  
Number of bits used → 8

- To display a message using the two bytes between the R0's fourth bit and R1's third bit

PLC device → R0  
Starting bit position → 4  
Number of bits to use → 16

For the other properties, refer to "7.1 Common Functions of Controls".



### 7.3.16.2 Complements

#### Message Definition Text File

To use a PLC message, it is necessary to prepare the message definition text file.  
This file has to be described by UNICODE text.

Up to 65535 lines of message can be included in the file, when one message is regarded as one line.

It is possible to describe messages in more than one language in the message definition text file.  
Use a comma or tab to separate each item.

The following items are described in the message definition text file.

Item	Setting value	Description
Message No.	1 to 65535 (Omissible)	Describe the message No. when "No. designation" is selected for the PLC device method. When the PLC device value corresponds to the message No., the message character string is displayed.  Describe the message No. in a decimal number. When "Bit designation" is selected for the PLC device method, the message No. description is disabled.
Bit position	0 to 511 (Omissible)	Describe the bit position when "Bit designation" is selected for the PLC device method. The bit position is searched in the ascending order within the range starting from the starting bit position and made up of the number of bits to use. When the bit position is matched, the message character string is displayed. Describe the bit position in a decimal number. When "No. designation" is selected for the PLC device method, the bit position description is disabled.
Character color	<ul style="list-style-type: none"> <li>• Color No.: 0 to 255</li> <li>• RGB value in hexadecimal format: 0x000000 to 0xffffffff (Omissible)</li> </ul>	Describe the character color to display a message character string. Specify the character color by one of the following methods. <ul style="list-style-type: none"> <li>• Color No. <sup>*1</sup></li> <li>• RGB hexadecimal format <sup>*2</sup></li> </ul> When the description about the character color is omitted, the message is displayed in a color specified with "Default character color".
Background color	<ul style="list-style-type: none"> <li>• Color No.: 0 to 255</li> <li>• RGB value in hexadecimal format: 0x000000 to 0xffffffff (Omissible)</li> </ul>	Describe the background color to display a message character string. Specify the background color by one of the following methods. <ul style="list-style-type: none"> <li>• Color No. <sup>*1</sup></li> <li>• RGB hexadecimal format <sup>*2</sup></li> </ul> When the description about the background color, the message is displayed with a background color specified with "Default background color".
Message character string	Up to one-byte 256 character (the number of characters per language)	Describe the message character string. Enclose the message with double quotations (""). If you wish to describe a double quotation (") or back slash (\), use "\" or "\". To display the message character string in two lines, describe "\n" at the line feed position (up to 20 lines).

\*1: For the color Nos., refer to "Appendix 5 Default Palette Color".

\*2: "RGB hexadecimal format" specification is supported in M800V/M80V Ver. A3 or later.

Message definition text file is described as below.

(1) Description example for "Bit designation"				
(Message No.),	(Bit position),	(Character color),	(Background color),	Message character string(English, Japanese)
,	0,	0(black),	15(white),	" bit type "," Bit designation "
,	511,	12(red),	2(green),	" \ bit \ \n type"," \ Bit \ \n designation "
(2) Description example for "No. designation"				
(Message No.),	(Bit position),	(Character color),	(Background color),	Message character string (English, Japanese)
1,	,	15(white),	0(black),	" number type "," No. designation "
65535,	,	9(blue),	14(yellow)	" \ number \ \n type "," \ No. \ \n designation "

When specifying character color and background color with RGB value in hexadecimal format, the description is as follows.

Write "Ox" at the start, followed by each two-digit RGB value in hexadecimal format.  
 RGB value specifications range from 00 to ff.  
 Upper-case and lower-case alphabetical characters are not distinguishable in hexadecimal formats.  
 Example: 0x00FF80 R(red)=00, G(green)=FF, B(blue)=80  
 \* Any descriptions that do not comply with the above format will be treated as a color No. specifications.

**NOTE**

◆ To describe messages in more than one language, the messages are described in the following order.

1: English	2: Japanese	3: German	4: French	5: Italian
6: Spanish	7: Chinese (traditional)	8: Korean	9: Portuguese	10: Dutch
11: Swedish	12: Hungarian	13: Polish	14: Chinese (simplified)	15: Russian
16: Turkish	17: Czech	18: Indonesian	19: Vietnamese	

◆ For the unused languages, insert delimiters (commas or tabs) to the omitted languages to align the languages and message positions.  
 To use the message character strings in English, Japanese, French and Portuguese, describe as follows.  
 (Example) 1,,0,15,English,Japanese,,French,,,,,Portuguese

◆ The language to display messages is changed according to "#1043 lang (Select language displayed)" [base common parameter].  
 When a language is switched to the one in which messages are not described, the messages are not displayed.  
 ◆ If a semicolon (;) is described at the top of the line, the line is handled as a comment line.

**7.3.17 Menu (GNXMenu) ; Menu display part**

The menu display is for displaying the menu, the monitor status, and the alarms, or the return button and the switch button, etc.

**7.3.17.1 Property Settings**

The property settings for displaying the menu are divided into the followings.

- Control name : Specify the control name.
- Position/size : Specify the position and size of the control.
- Menu type : Select the menu type.
- Color : Select the color.
- Callback function : Specify whether or not the callback functions are provided.

Menu Type

Item	Description
MenuType	Select the menu type from the following items. The colors set for each property are reflected on Classic. 1StepMenu(VGA)(Classic).....1 step menu for VGA (Classic) 2StepMenu(VGA)(Classic).....2 steps menu for VGA (Classic) 1StepMenu(XGA)(Classic).....1 step menu for XGA (Classic) 2StepMenu(XGA)(Classic).....2 steps menu for XGA (Classic) 1StepMenu(VGA)(M8 Series).....One-row menu for VGA (M8 base color) 2StepMenu(VGA)(M8 Series).....Two-row menu for VGA (M8 base color) 1StepMenu(XGA)(M8 Series).....One-row menu for XGA (M8 base color) 2StepMenu(XGA)(M8 Series).....Two-row menu for XGA (M8 base color) 1StepMenu(VGA)(M8V Series).....1 step menu for VGA (M8V base color) 2StepMenu(VGA)(M8V Series).....2 steps menu for VGA (M8V base color) 1StepMenu(XGA)(M8V Series).....1 step menu for XGA (M8V base color) 2StepMenu(XGA)(M8V Series).....2 steps menu for XGA (M8V base color)
DispType	Specify the display type. Menu..... Displays only the menu (without status display). StatusVisible..... Displays the menu and the status.
Horizontal position	Set the position to display the menu character string (Left-justifying, Centering)

Color

Item	Description
StringForeColor	Set the normal character color.
StringPushedColor	Set the character color when selected.
1StepForeBackColor	Set the normal background color of the one-row menu. (Note)
1StepPushedBackColor	Set the background color of the one-row menu when selected. (Note)
2StepUpperForeBackColor	Set the normal background color of the upper row of the two-row menu. (Note)
2StepUpperPushedBackColor	Set the background color of the upper row of the two-row menu when selected. (Note)
2StepLowerForeBackColor	Set the normal background color of the lower row of the two-row menu. (Note)
2StepLowerPushedBackColor	Set the background color of the lower row of the two-row menu when selected. (Note)

(Note) Enable only when Classic is set to display in Menu Type.

For the other properties, refer to "7.1 Common Functions of Controls".

### 7.3.17.2 Complements

Screen Specifications

Screen Images

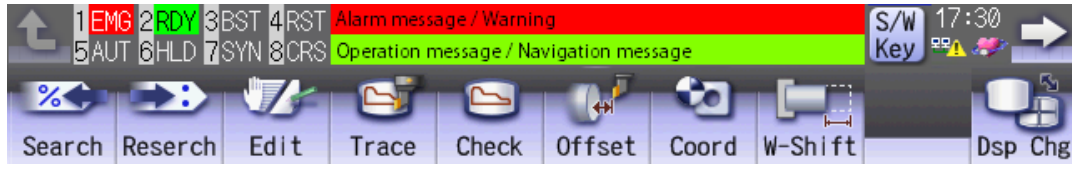

**7.3.18 Extension Menu (GNCEXMenu); Extension Menu Display Part**

With the extension menu display, the following display and operation can be executed by setting the property without programming.

- Switching between the one-row menu and two-row menu display
- Menu display (character strings, design, and background color, etc.)
- Switching between the panel and window
- Writing or reading the PLC device
- Grouping of menu buttons

Up to ten menu groups were retained in the extension menu, and the property of the display or screen change, etc. can be set for each menu group. Switching between the menu groups enables to switch the menu display equivalent to the standard screen.

Extension menu is a control dedicated to M800V/M80V/M800/M80/E80 series.

**7.3.18.1 Property Setup Dialog**

Property setup dialog of the extension menu control consists of the tabs relating to [Basic Settings]. Details of each tab will be described in the following sections.

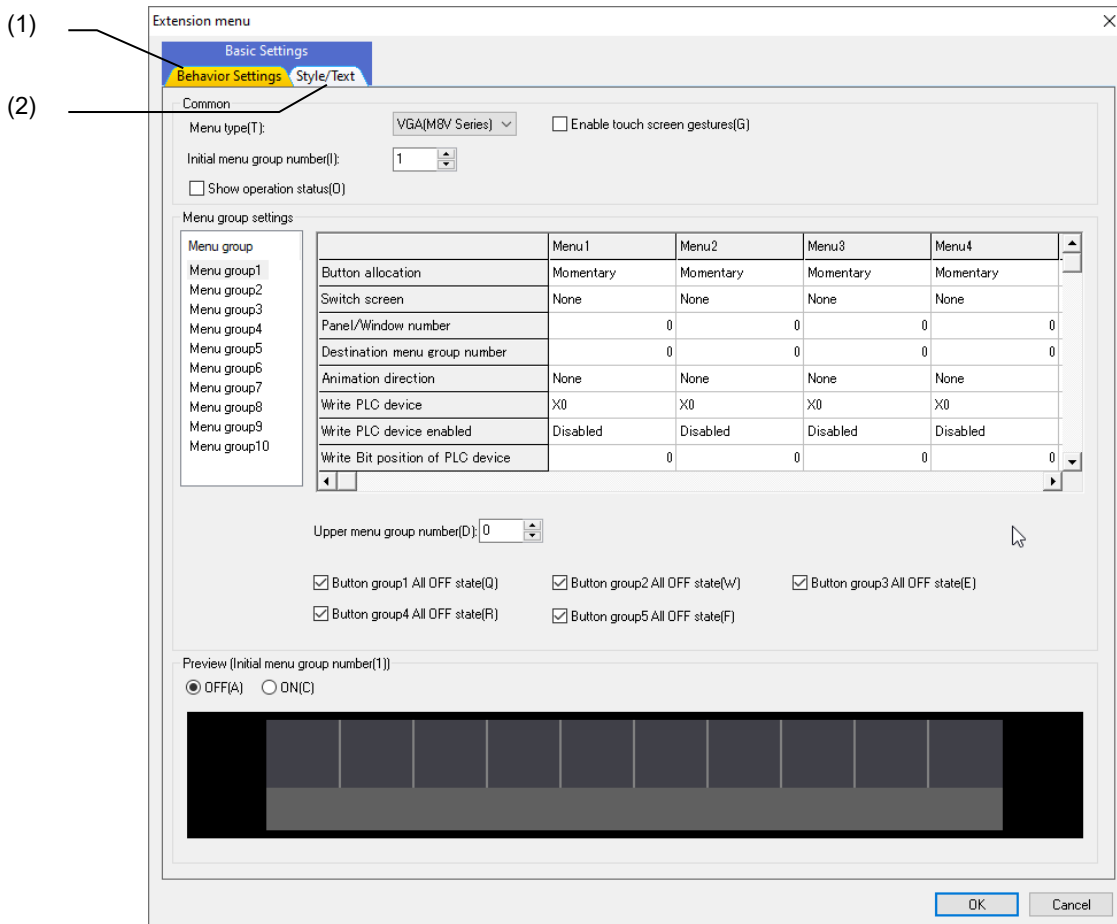

[Basic Settings] consists of the following tabs.

No.	Tab	Description
(1)	Behavior Settings	Set or display the switch screen, animation direction, preview, etc.
(2)	Style/Text	Set or display the font, design, preview, etc.

7.3.18.1.1 [Behavior Settings] Tab

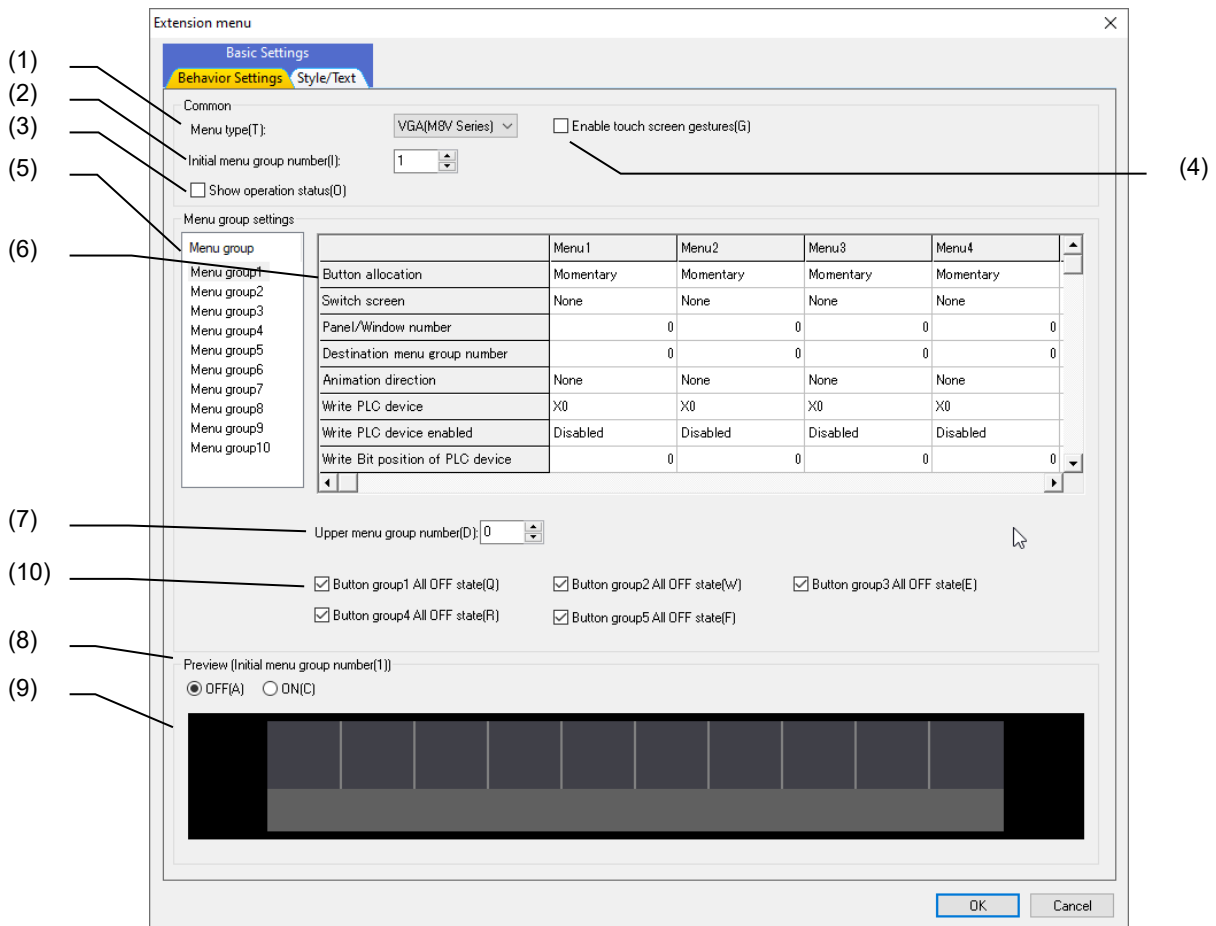

No.	Item	Description
(1)	Menu type	Select the menu type from the following items. VGA(Classic) . . . . . Menu for VGA (Classic) XGA(Classic) . . . . . Menu for XGA (Classic) VGA(M8 Series) . . . . . Menu for VGA (M8 base color) XGA(M8 Series) . . . . . Menu for XGA (M8 base color) VGA(M8V Series) . . . . . Menu for VGA (M8V base color) XGA(M8V Series) . . . . . Menu for XGA (M8V base color) The colors set for each property are reflected on Classic. The base color specified in theme color is displayed on M8 Series and M8V Series. For theme color, refer to "5.10.9 Changing the Theme Color".
(2)	Initial menu group number	Specify the menu group number displayed at the first time. (1 to 10)
(3)	Show operation status	Check this box to display the operation status.
(4)	Enable touch screen gestures	Check this box to enable the touch screen gestures.
(5)	Menu group	Select the menu group number to set the property. Property items of the selected menu group number can be set.
(6)	Menu button settings	Refer to [(1) Menu Button Settings of Menu Group].
(7)	Upper menu group number	Specify the menu group number of the upper row in the two-row display. (0 to 10) When "0" is specified, it switches to a one-row menu. The property of the menu group number selected in [Menu group] can be specified.
(8)	Preview display state	Select the display state of the preview from "ON" and "OFF" states.

7. Creating Controls

No.	Item	Description
(9)	Preview (Initial menu group number (n)) n: The number specified in (2) Initial menu group number	Display the preview of the extension menu control.  The preview of the settings of the menu group number specified in "Initial menu group number" is displayed.
(10)	Button group(n) All OFF state n: Number (1 to 5)	When check boxes are checked, all buttons belonging to the button group can be turned OFF.  The properties of the menu group number selected in [Menu group] can be specified.

(1) Menu Button Settings of Menu Group

The property of the menu group number selected in "menu group number" can be specified.

No.	Item	Description
(1)	Button type	Select the button type from the following. -None -Momentary -Alternate -Button group1 -Button group2 -Button group3 -Button group4 -Button group5
(2)	Switch screen	Select the screen change operation from the following. - None - Switch the panel - Display the window - Close the window - Display the Windows at the time of ON, close the window at the time of OFF - End the Windows at the time of ON, display the window at the time of OFF
(3)	Panel/Window number	Specify the Panel/Window number of the destination screen.
(4)	Destination menu group number	Specify the destination menu group.
(5)	Animation direction	Select the animation direction when moving the menu group from the following. - None - Upward - Downward - Leftward - Rightward
(6)	Write PLC device	Specify the address of the PLC device for the write operation. Click on the "..." button to display the "PLC Device Setting" dialog.
(7)	Write PLC device enabled	Select either "Enabled" or "Disabled" as the state of write PLC device.
(8)	Write Bit position of PLC device	Specify the bit position when a word device (D/R/ZR) is set to write PLC device (0 to 15).
(9)	Write PLC device project No.	Specify the project No. of PLC ladder what write PLC device refers. (0 to 6)
(10)	Read PLC device	Specify the address of the PLC device for the read operation. Click on the "..." button to display the "PLC Device Setting" dialog.
(11)	Read PLC device enabled	Select from "Enabled", "Disabled" or "Same setting as Write PLC device" as the valid state of read PLC device.  When "Same setting as Write PLC device" is specified, data is read based on the settings of properties "write PLC device", "write PLC device enabled", "write Bit position of PLC device", and "write PLC device project No."
(12)	Read Bit position of PLC device	Specify the bit position when a word device (D/R/ZR) is set to read PLC device (0 to 15).
(13)	Read PLC device project No.	Specify the project No. of PLC ladder what read PLC device refers. (0 to 6).



7.3.18.1.2 [Style/Text] Tab

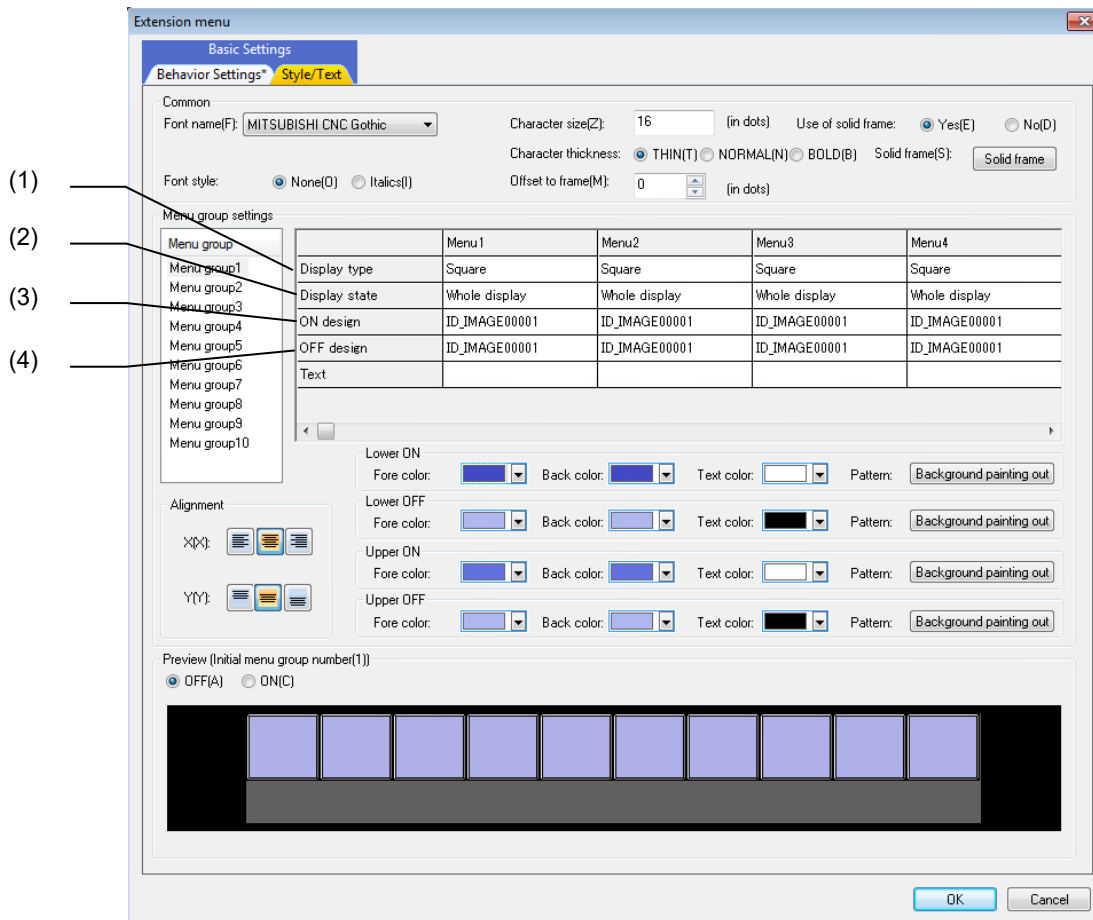

No.	Item	Description
(1)	Display type	Select the display type for each menu button from "Square" or "Image". The property of the menu group number selected in "Menu group" can be set.
(2)	Display state	Select the display state for each menu button from the following. - Hide - Partial display - Whole display - Invalid display  The property of the menu group number selected in "Menu group" can be set.
(3)	ON design	Specify the image resource ID to be displayed at ON.  The property of the menu group number selected in "Menu group" can be set.
(4)	OFF design	Specify the image resource ID to be displayed at OFF.  The property of the menu group number selected in "Menu group" can be set.

For the items other than the above, refer to "7.1.16.1.1 [Style] Tab"/"7.1.16.1.2 [Text] Tab".

**NOTE**

- ◆ "Foreground color", "Background color", "Text color", and "Pattern" cannot be specified when selecting "VGA(M8V Series)", "XGA(M8V Series)", "VGA(M8 Series)", and "XGA(M8 Series)" for "Menu type". The color settings at "ON" and "OFF" are specified by "Screen theme color (#11060)" parameter.
- ◆ When specifying other than "0" for [Upper menu group number] in the [Behavior Settings] tab, the menu is a two-row display. For a two-row display, the design is not drawn. When drawing the design, specify "0" for [Upper menu group number].
- ◆ The background color at ON cannot be checked on the preview when selecting "VGA(M8V Series)", "XGA(M8V Series)", "VGA(M8 Series)", and "XGA(M8 Series)" for "Menu type".

< Background color at ON >



### 7.3.18.2 Property Settings

The property settings for displaying the extension menu are divided into the following.

Control name	:	Specify the control name.
Position/size	:	Specify the position and size of the control.
Show/Hide	:	Specify whether the control is displayed or hidden.
Input permission	:	Select whether the entry is accepted (permission) or rejected (prohibition).
Character attribute	:	Specify the character attribute of the caption.
Solid frame	:	Specify the solid frame of the control.
Menu display	:	Specify the menu type, whether to display the operation status, and the initial display menu group number.
Menu group	:	Specify the following items for each menu group. <ul style="list-style-type: none"> <li>- Display type</li> <li>- Color/pattern/design</li> <li>- Button type</li> <li>- Character strings/attribute</li> <li>- Screen change</li> <li>- Animation direction</li> <li>- PLC device (address/enabled/bit position/project No.)</li> <li>- All OFF state</li> </ul>
Operation	:	Specify the operation of the control.
Callback function	:	Specify whether the callback functions are provided or not.

7. Creating Controls

Character attribute

Item	Description
Font	Select the ID of the font resource for displaying the caption.
Margin left	Designate the starting position of the caption in dots from the left end of the control (0 to 2560).
Margin right	Designate the starting position of the caption in dots from the right end of the control. (0 to 2560).
Margin top *1	Designate the starting position of the caption in dots from the top of the control (0 to 1920).
Margin bottom *1	Designate the starting position of the caption in dots from the bottom of the control (0 to 1920).

\*1: When the upper row of the menu or the button character string is displayed in two lines, the settings of vertical position, margin top and margin bottom are not reflected. The character string is displayed on the center in the vertical direction.

Menu display

Item	Description
Menu type	Select the menu type from the following items. (Initial value:VGA(M8V Series)) VGA(Classic) . . . . . Menu for VGA (Classic) XGA(Classic) . . . . . Menu for XGA (Classic) VGA(M8 Series) . . . . . Menu for VGA (M8 base color) XGA(M8 Series) . . . . . Menu for XGA (M8 base color) VGA(M8V Series) . . . . . Menu for VGA (M8V base color) XGA(M8V Series) . . . . . Menu for XGA (M8V base color) The colors set for each property are reflected on Classic. The base color specified in theme color is displayed on M8 Series and M8V Series. For theme color, refer to "5.10.9 Changing the Theme Color".
Operation Status Visible	Specify whether to display the operation status.
Initial menu group number	Specify the menu group number displayed at the first time when the panel or window with the extension menu is displayed. (1 to 10)

Menu group 1 to 10

Display type

Item	Description
Display type	Specify the display type of the menu position. Use "\t" to delimit each display type of the menu position.  0 or no designation : Square 1 : Image

Color/pattern/design

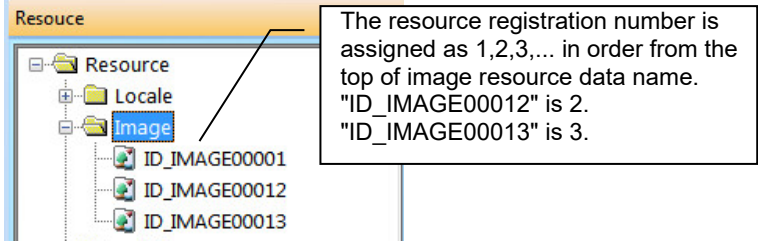
Item	Description
Lower ON pattern*1	Specify the pattern at the time of lower row menu ON.
Lower ON foreground color*1	Specify the foreground color at the time of the lower row menu ON.
Lower ON background color*1	Specify the background color at the time of the lower row menu ON.
ON design*2	Specify the image at the time of the menu ON. (Note 1) The image cannot be specified on the property sheet. Specify it on the property dialog. (Note 2) On the property sheet, a character string consisting of concatenation of the resource registration number for each menu position with "\t" is displayed.
	
Lower ON character color	Set the character color at the time of the lower row menu ON.
Lower OFF pattern*1	Specify the pattern at the time of the lower row menu OFF.
Lower OFF foreground color*1	Specify the foreground color at the time of the lower row menu OFF.
Lower OFF background color*1	Specify the background color at the time of the lower row menu OFF.
OFF design*2	Specify the image at the time of the menu OFF. (Note 1) The image cannot be specified on the property sheet. Specify it on the property dialog. (Note 2) On the property sheet, a character string consisting of concatenation of the resource registration number for each menu position with "\t" is displayed.
Lower OFF character color	Set the character color at the time of lower row menu OFF.
Upper ON pattern*1	Specify the pattern at the time of the upper row menu ON.
Upper ON foreground color*1	Specify the foreground color at the time of the upper row menu ON.
Upper ON background color*1	Specify the background color at the time of the upper row menu ON.
Upper ON character color	Set the character color at the time of the upper row menu ON.
Upper OFF pattern*1	Specify the pattern at the time of the upper row menu OFF.
Upper OFF foreground color*1	Specify the foreground color at the time of the upper row menu OFF.
Upper OFF background color*1	Specify the background color at the time of the upper row menu OFF.
Upper OFF character color	Set the character color at the time of the upper row menu OFF.

\*1: This setting is valid when the [Menu type] is set to [VGA(Classic)] or [XGA(Classic)].

\*2: This setting is valid when the [Display type] is set to "Image".  
The setting is valid when "0" is set to [Upper menu group number].

Button type

Item	Description
Button type	<p>Select the button action among the following eight types. Use "\t" to delimit each button action of the menu position.</p> <p>0 or no designation : None                      1 : Momentary                      2 : Alternate                      3 : Button group1                      4 : Button group2                      5 : Button group3                      6 : Button group4                      7 : Button group5</p>
Momentary	The button turns ON when it is pressed. It turns OFF when it is released.
Alternate	The button alternates ON and OFF each time it is pressed.
None	The button does not turn ON or OFF even if it is pressed.
Button group1 to 5	<p>The button turns ON when it is pressed, and other buttons specified in the same button group turn OFF.</p> <div data-bbox="667 819 1422 1014"> <p>Press C. B turns OFF, and C turns ON.</p> </div> <p>When only one menu button is specified in each button group, the operation is the same as Alternate.</p> <p>(Note) When the property "All OFF state" is prohibited, a menu button that is ON and specified to the button group does not turn OFF if it is pressed.                      When turning OFF all menu buttons specified in the button group, specify "Permission" in the property "All OFF state".</p> <div data-bbox="667 1267 1422 1480"> <p><b>Permission</b></p> <p>Press B that is ON. All A, B, and C turn OFF.</p> </div> <div data-bbox="667 1532 1422 1744"> <p><b>Prohibition</b></p> <p>Press B that is ON. B remains ON.</p> </div>

Character strings/attribute

Item	Description
Character string	Specify the character string to be displayed on each menu position. Use "\t" to delimit each character string of the menu position. Up to 14 characters can be specified as the character string to be entered for each menu position. (Note) "\t" cannot be used because it is used as the separator.
Horizontal position	Select the horizontal character position among "Align left", "Center" and "Align right".
Vertical position *1	Select the vertical character position among "Align top", "Center" and "Align bottom".

\*1: When the upper row of the menu or the button character string is displayed in two lines, the settings of vertical position, margin top and margin bottom are not reflected. The character string is displayed on the center in the vertical direction.

Screen change

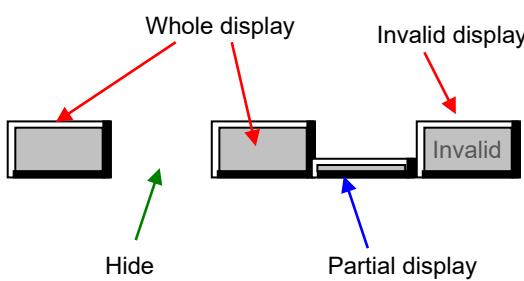
Item	Description
Screen switch operation	Specify the screen change operation for each menu position. Use "\t" to delimit each screen change operation of the menu position.  0 or no designation : None 1 : Change panel 2 : Open window 3 : Close window 4*1 : ON: Open win., OFF: Close win. 5*1 : ON: Close win., OFF: Open win. *1: This setting is valid when the [Button type] is set to [Alternate].
Panel/Window number	Designate the Panel/Window number of the destination screen. Select a number from the following. Use "\t" to delimit each Panel/Window number of the menu position.  0-255 : The page number of the customized screen in the project. "0" is the top page. 1000 : The number of the standard operation screen 2000 : The number of the standard set-up screen 3000 : The number of the standard editing screen 4000 : The number of the standard diagnostic screen 5000 : The number of the standard maintenance screen 6000-9999 : The page number of the customized screen to which the offset number is added.  If the numbers other than the above (including the view frame) or some numbers of non-existent screens are set, the screen will not be switched. Though, the other operations are applied.
Display state	Specify the display status of the menu. Use "\t" to delimit each display status of the menu position.  0 : Hide 1 : Partial display 2 or no designation : Whole display 3 : Invalid display (full display and the character color is gray) display  

7. Creating Controls

Item	Description
Upper menu group number	Specify the menu group number of the upper row in the two-row display. (0 to 10) When "0" is specified, the menu is not displayed on the upper row.
Destination menu group number	<p>Specify the destination menu group. Use "\t" to delimit each destination of the menu position. (0 to 10)</p> <p><u>2\t3\t4\t0\t5\t6\t7\t0\t8\t9\t1\t10\t9</u></p> <p>Menu 1 to 10    Return button (*)    Switch button/Right-flick    Left-flick * This is enabled when the operation status is displayed.)</p> <p>0 or no designation    :    No movement 1 to 10    :    Display the designated group number menu.</p>
Animation direction	<p>Specify the animation direction when moving the menu group. Use "\t" to delimit each animation direction of each menu position.</p> <p>* When the "Destination menu group number" is not specified, the animation is not performed. * When the operation parameter (#8976 Menu animation OFF) is set to 1, the menu animation is not performed.</p> <p>0                        :    None 1                        :    Upward 2                        :    Downward 3                        :    Leftward 4                        :    Rightward</p>



PLC device

Item	Description
Write PLC device	Specify the address of the PLC device for the write operation. Use "\t" to delimit each write PLC device of the menu position. Up to 7 characters can be specified as write PLC device to be specified for each menu position.
Write PLC device enabled	Specify enabled or not to the PLC device specified in write PLC device. Use "\t" to delimit each write PLC device enabled of the menu position.  0: Disabled 1: Enabled
Write Bit position of PLC device	Specify the bit position when a word device is set to write PLC device. (0 to 15) Use "\t" to delimit each write Bit position of PLC device of the menu position.
Write PLC device project No.*1	Specify the project No. of PLC ladder what write PLC device refers. (0 to 6) Use "\t" to delimit each write PLC device project No. of the menu position.
Read PLC device	Specify the address of the PLC device for the read operation. Use "\t" to delimit each read PLC device of the menu position. Up to 7 characters can be specified as read PLC device to be specified for each menu position.
Read PLC device enabled	Select from "Enabled", "Disabled" or "Same setting as Write PLC device" as the valid state of read PLC device. When "Same setting as Write PLC device" is specified, data is read based on the settings of properties "write PLC device", "write PLC device enabled", "write Bit position of PLC device", and "write PLC device project No.".
Read Bit position of PLC device	Specify the bit position when a word device is set to read PLC device. (0 to 15) Use "\t" to delimit each read Bit position of PLC device of the menu position.
Read PLC device project No.*1	Specify the project No. of PLC ladder what read PLC device refers. (0 to 6) Use "\t" to delimit each read PLC device project No. of the menu position.

\*1: When specifying the device not supporting multi-project and using the device which has the same device number in multiple projects, the output to the device of the project executed last is valid.

Button group

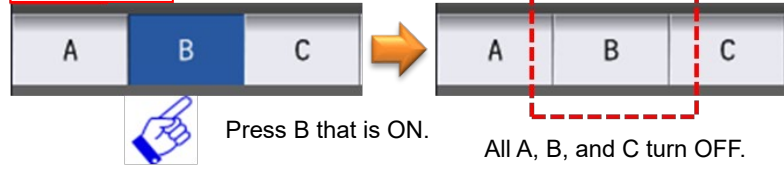
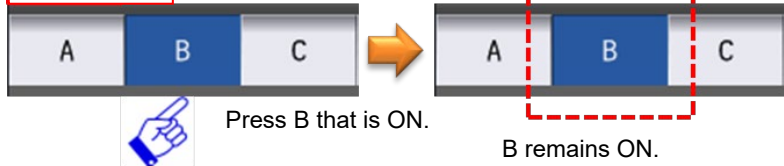
Item	Description
All OFF state	<p data-bbox="657 347 1452 405">Specify whether to permit all menu buttons belonging to the button group to turn OFF or not. Use "\t" to delimit all OFF state of each button group.</p> <p data-bbox="657 432 805 488">0: Permission 1: Prohibition</p> <div data-bbox="657 504 1444 728"> <p data-bbox="667 508 826 555">Permission</p>  </div> <div data-bbox="657 779 1444 996"> <p data-bbox="667 784 826 831">Prohibition</p>  </div>

For the other properties, refer to "7.1 Common Functions of Controls".

7.3.18.3 Complements

Screen configuration

Screen image

■ Menu type: VGA(M8V Series), theme color: gray tone



■ Menu type: VGA(M8V Series), theme color: blue tone

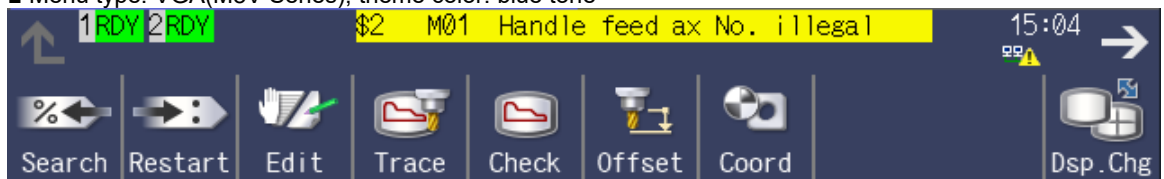

■ Menu type: VGA(M8 Series), theme color: gray tone

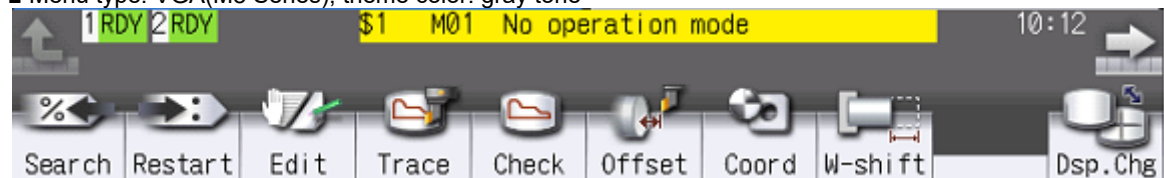

■ Menu type: VGA(M8 Series), theme color: blue tone

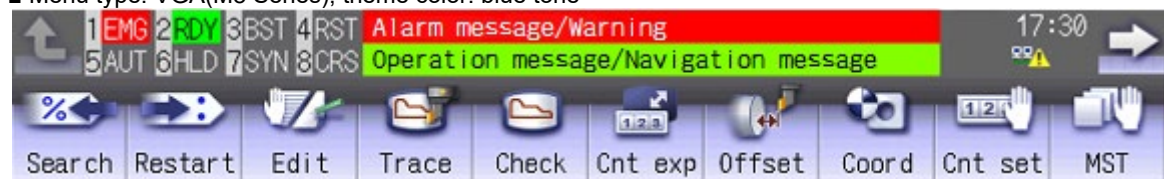

■ Menu type: VGA (Classic)



Operation specifications

- (1) Flick (Quickly run your fingertip along the screen)  
The menu group is moved when "Destination menu group number" is specified for the direction that you swiped your finger.

Example

Menu Design Registration (Image Registered by an User)

To display the icon image created by the user on the menu based on the standard screen, create an image whose background is transparent in PNG format. Register the image in the image resource. The following are the procedures for specifying it to the extension menu.

- (1) Arrange the extension menu on the panel or window.



The extension menu is displayed on the panel.

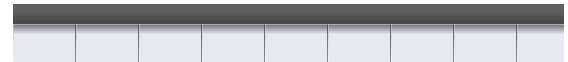

- (2) Select "ON design" of the menu group 1 displayed on the property sheet.



[ON design] is selected.

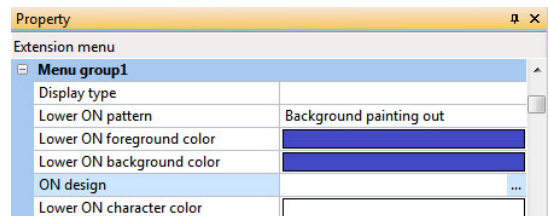

- (3) Press the [...] button.



The property dialog for [ON design] appears.

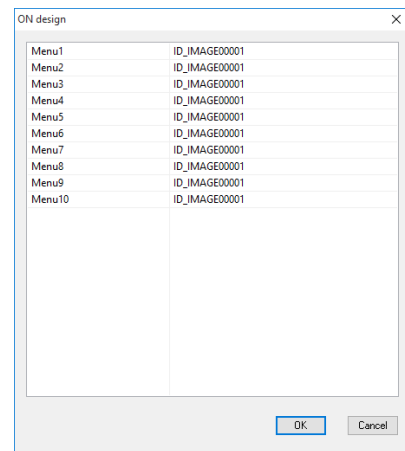

- (4) Select the edit area of menu 1.



The resources registered in the image resource is displayed on the pull-down list.

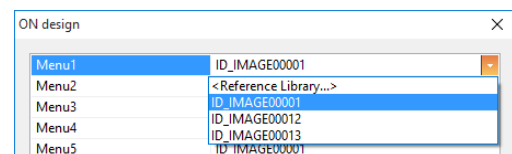



Property Dialog

The property of the extension menu control such as "Character sequence" or "Screenswitch operation" has the property dialog which enables to specify the data for each menu position. The property dialog is displayed by pressing the "..." button displayed when selecting the property to edit on the property sheet.

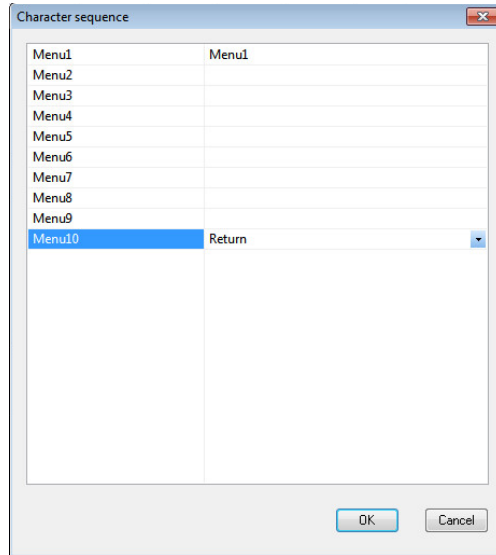

**NOTE**

- ◆ The data specified in the property dialog is concatenated with "\t" and additionally registered as one character string.

Example: "Test" is specified for menu 1, and "Return" is specified for menu 10. Nothing is specified for menu 2 to 9. In this case, the following value is specified on the property sheet.

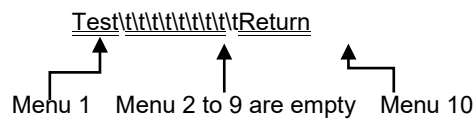

The specified character string is added to the character string resource.

Character sequence table	
Resource data name	Character sequence
ID_STRING00008	Menu1\t
ID_STRING00009	Menu1\tMenu2
ID_STRING00010	Menu1\t\t\t\t\t\t\t\t\t\tReturn

Property "ON design"

1. Paste the extension menu control on the panel.
2. Select [ON design], the property to edit on the property sheet.

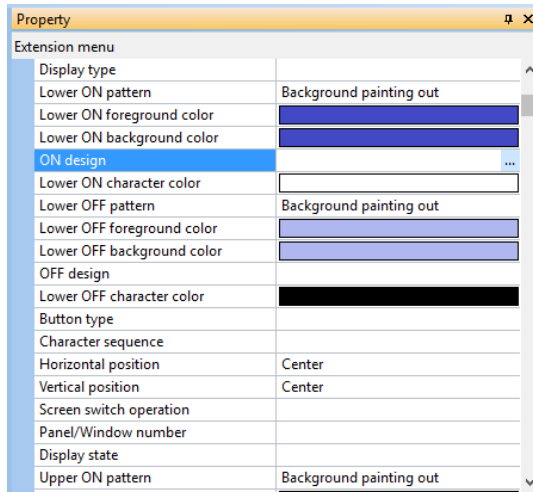

3. The property dialog of the selected property is displayed by pressing the "..." button.

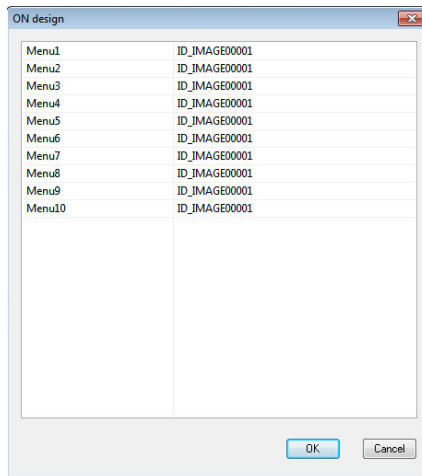

4. Select the edit area of the menu position to specify.

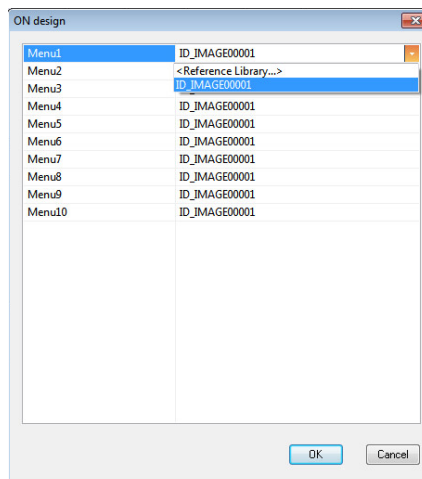





**NOTE**

- ◆ For the properties "ON design" and "OFF design", you cannot edit them on the property sheet.
- ◆ The resource data name specified in the property dialog is concatenated with "\t" with the numbers in order of registration and additionally registered as one character string.

Example: The image is registered to the menu 1 from the parts library. (ID\_IMAGE00012)  
 The image is not registered for ID\_IMAGE00001.

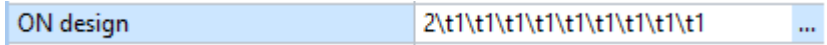

The image is displayed only on the menu 1.

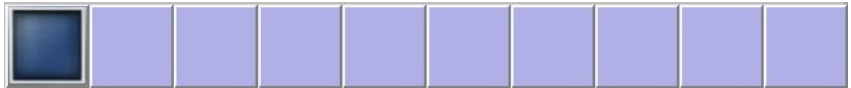

**Precautions**

1. The property items for which the property dialog can be displayed can also be specified on the property sheet. However, you cannot edit "ON design", "OFF design", "write PLC device", and "read PLC device" on the property sheet. Specify them with the property dialog.
2. If a property dialog is opened with the data specified on the property sheet invalid, the initial value is set. Press the cancel button on the property dialog. Original value is displayed on the property sheet.

**Restrictions**

1. When importing the page on which the extension menu control is pasted, change the setting value of the imported page property "ON design" or "OFF design" after importing. Imported resource is registered as a data with a new resource data name in the image resource, therefore specify the design in this dialog again.
2. When the image resource is deleted, the image resource data specified to the property "ON design" or "OFF design" may not be displayed. In this case, create a new image resource again.

**7.3.19 FileInOut (GNXFileTransfer) ; Input/Output Control**

The input/output control part is used to input and output NC files between the NC memory or the NC memory 2 and an external device.

The hard disk built in the NC unit is also handled as an external device.

**7.3.19.1 Property Settings**

The property settings for the input/output control are divided into the followings.

- Control name : Specify the control name.
- Position/size : Specify the position and size of the control.
- Main part area : Specify the color attribute, solid frame and message font type of the main part area.
- Bar graph area : Specify the width and color attribute of the bar graph area, and whether to enable the gradation effect on the area.
- Message area : Specify the color attribute, and whether to display a message on this area.
- Color type : Specify the color type.
- Callback function : Specify whether or not the callback functions are provided.

Main Part Area

Item	Description
MainBackColor	Specify the background color of the input/output control.
FrameVisible	Select whether to use the solid frame. Select between "True" and "False".
FontType	Specify the message font type. Normal..... Normal font Normal Bold..... Normal bold font Middle..... Middle-sized font Big..... Font with double height and width

Bar Graph Area

Item	Description
BarGraphForeColor	Specify the color of the bar graph that is refreshed at the file transfer.
BarGraphBackColor	Specify the color of the bar graph that is drawn at the initial display.
BarGraphWidth	Specify the width of the bar graph area (100 to 1800).
SetBarGradation*1	Specify whether to enable gradation effect when drawing the foreground of the bar graph. Select between "True" and "False".

\*1 Gradation is not supported by M700VS, M70V and E70 Series. Thus, even when "True" is selected, the bar graph is displayed in a plain color.

Message Area

Item	Description
MessageVisible	Switch "True (show)" and "False (hide)" of the message on the control.
NormalMessageFontColor	Specify the normal message character color.
NormalMessageBackColor	Specify the normal message background color.
ErrorMessageFontColor	Specify the error message character color.
ErrorMessageBackColor	Specify the error message background color.

Color Type

Item	Description
ColorType	Select the color type from the following items. Theme color (M8V Series): Display the base color (for M8V Series) designated as the theme color. Theme color (M8 Series): Display the base color (for M8 Series) designated as the theme color. Specified color: The colors set for each property are reflected. For the base color designated as the theme color, refer to "5.10.9 Changing the Theme Color".

For the other properties, refer to "7.1 Common Functions of Controls".

7.3.19.2 Complements

Screen Specifications

Screen Images

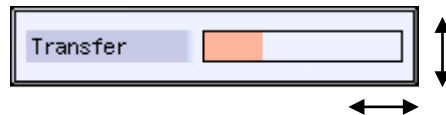
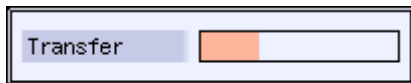

Change the size of the control.

No change is made for the positions of the message area and bar graph area relative to the upper left corner of the control.

List of Available File Paths

A GCS function has to be described to input/output NC files using the input/output control. The file path information is given to the GCS function argument. The list below shows the available file path information.

Device	Device name	Data type	Directory	File name
NC memory	M01:	Machining program	/PRG/USER/ /PRG/FIX/ /PRG/MMACRO/	(Program No.)
		Machining program		
		Fixed cycle program (Note 1)		
		Machine tool builder macro program		
		Parameter	/PRM/	ALL.PRM
Parameter [User, Machine] (text format)				
User PLC	/LAD/	USERPLC.LAD		
NC data	/DAT/	TOOL.OFS TLIFE.TLF  COMMON.VAR SRAM.BIN (Note 2)		
Tool compensation data				
Tool life management data				
Common variable data SRAM data				
NC memory 2	M01:	Machining program	/PRG2/USER/	(Program No.)
		Machining program		
External device - HD - Memory card - DS - USB memory	HD: MEM: M01:/FMEM/ M01:/IC1/ M01:/BMEM/ USB:	To specify a file in the HD device, specify the file under D:/NCFILE. Example) For HD:/ABC/100.PRG: Specify the path D:/NCFILE/ABC/100.PRG. Memory card and DS specification vary depending on the model. Specify the following file name 101 which exists in the memory card. To specify a memory card with M800VW/M800W/M80VW/M80W, "MEM:/101". To specify a memory card with M800VS/M80V/M800S/M80, "M01:/FMEM:/101".		
External device (Direct designation)	C: D:	A direct path designation is possible only for the files in HD (Drive C or D). Example) For C:/WINDOWS/ABC.TXT: Specify the path C:/WINDOWS/ABC.TXT.		

[Precautions when specifying file paths]

(Note 1) To specify a fixed cycle program or machine tool builder macro, the base common parameter "#1166 fixpro (fixed cycle)" must be set.

(Note 2) When transferring an SRAM.BIN file to the NC memory, settings in standard screens in addition to the machine tool builder password must be made in advance. When an SRAM.BIN file is transferred to the NC memory, a "PR" message that recommends the restart of the NC is displayed on the operation screens, etc.

7. Creating Controls

[Precautions relating to file transfer]

- (1) If the transfer destination becomes full during the file transfer, the data transferred up to the point is registered and then an error occurs.
- (2) Up to 223 files can be registered to the root directory of an FD (including the directory).
- (3) Designation of multiple files using a wild card "\*" is not possible. Therefore, if "\*" is included in the file name, an error occurs.
- (4) If the same file name is specified for the transfer source and destination, the file transfer is not carried out, and an error code is returned as the return value.
- (5) If you wish to save a file under the same name as the transfer source file, it is not necessary to give the file name to the transfer destination file path.  
 [File path setting example] When common variables in NC memory is saved in HD  
     Transfer source file path: M01:/DAT/COMMON.VAR  
     Transfer destination file path: D:/NCFILE/  
 To specify a directory as the file information, "/" has to be added at the end of the directory name.
- (6) "/" is used for the paths in the table, but it is also possible to use "\" to specify the path.
- (7) When the file information is specified, the case (uppercase and lowercase) is ignored.
- (8) If the input/output control part is set to "hidden" during transferring, the transfer is interrupted, and when the control part is displayed, the transfer is resumed.
- (9) If the input/output control part is deleted during transferring, the transfer is interrupted. Therefore, do not delete the part during the transfer.
- (10) Do not use two-byte characters in specifying a file path.

Restrictions

Restrictions for creating a control object are shown below.

- (1) Unsupported device  
 RS232C and Ethernet are not supported.
- (2) All file input/output function  
 All file input/output function is not supported
- (3) Deletion of directory  
 When a file is included in a directory to delete, it is not possible to delete the directory.
- (4) Program name  
 There are the following restrictions for the name of the files to be created or transferred in or from NC memory or NC memory 2.
  - (a) Up to 32 characters including the extension
  - (b) The characters available in file name and directory name are one-byte numerals, one-byte uppercase alphabets and the one-byte symbols that can be recognized by Windows.  
 Unavailable characters: \ / : , \* ? " < > | lowercase letters (a to z) and a space
  - (c) Edit lock B and C and Program display lock are effective only on the files in NC memory or NC memory 2 whose names are made up of one-byte numerals.  
 ex) When Edit lock B (8000 to 9999) is active

File name	Characteristics	Change
8000	One-byte numerals only	Disable
8000.PRG	With an extension	Enable
08000	One-byte numerals only. Zero at the head.	Disable
8000A	Characters other than numerals	Enable
- (d) The following files cannot be handled as a file name.
  - The extension is "\$\$\$", "\$\$0", "\$\$1", "\$\$2", "\$\$3", "\$\$4", "\$\$5", "\$\$6", "\$\$7", "\$\$8" or "\$\$9".
  - "0" (the file name is made up of a one-byte zero)
- (5) Up to one input/output control part should be located per screen. Set the screen on which the input/output control part is located so that the instance is not held. Not doing so may cause a memory shortage.

(6) Data protection keys

The erasing and setting of data can be prohibited with data protection keys. The five types of data protection keys are shown below. (The key names vary depending on the machine tool builder. For details refer to the instruction manual supplied by the machine tool builder.)

- (a) KEY1: Protects general tool data and the preset coordinates of the origin
- (b) KEY2: Protects user parameters and common variables
- (c) KEY3: Protects the machining programs of NC memory or NC memory 2
- (d) KEY\_MemC: Protects memory card data
- (e) KEY\_DS: Protects DS data

(a) Protection of tool data (KEY1)

When KEY1 is valid, the operations in Table 1 are prohibited.

Table 1 KEY1 data protection

No.	Operation
1	Tape input/output of tool offset data
2	Input/output of tool compensation amount
3	Input/output of tool registration data
4	Input/output of all tool data
5	Input/output of workpiece coordinate offset amount
6	Input/output of workpiece installation error data
7	Input/output of machining surface data
8	Input of spatial error data (*1)

(\*1) Spatial error data cannot be output regardless of the valid/invalid status of KEY1.

(Note) When the operations in Table 1 are conducted while KEY1 is valid, a "data protect" message appears.

(b) Protection of user parameters and common variables (KEY2)

When KEY2 is valid, the operations in Table 2 are prohibited.

Table 2 KEY2 data protection

No.	Operation
1	Input/output of parameters
2	Input/output of common variables

(Note) When the operations in Table 2 are conducted while KEY2 is valid, a "data protect" message appears.

(c) Protection of machining programs of NC memory or NC memory 2 (KEY3)

When KEY3 is valid, the operations in Table 3 are prohibited.

Table 3 KEY3 data protection

No.	Operation
1	Input/output of machining program memory
2	Erasing of machining programs (one program or all programs)

(Note) When the operations in Table 3 are conducted while KEY3 is valid, a "data protect" message appears.

(d) Protection of memory card data (KEY\_MemC)

When KEY\_MemC is valid, the operations in Table 4 are prohibited.

Table 4 KEY\_MemC data protection

No.	Operation
1	File transfers to the memory card
2	File copying in the memory card
3	File erasing in the memory card
4	File renaming in the memory card
5	Creating/erasing directories in the memory card

(Note) When the operations in Table 4 are conducted while KEY\_MemC is valid, a "data protect" message appears.

(e) Protection of DS data (KEY\_DS)

When KEY\_DS is valid, the operations in Table 5 are prohibited.

Table 5 KEY\_DS data protection

No.	Operation
1	File transfers to the DS
2	File copying in the DS
3	File erasing in the DS
4	File renaming in the DS
5	Creating/erasing directories in the DS

(Note) When the operations in Table 5 are conducted while KEY\_DS is valid, a "data protect" message appears.

**7.3.20 AlarmMessage (GNXAlarmMessage) ; Alarm Display Part**

The alarm display part is used to display the alarm No. and alarm message character string when an alarm occurs.

This part displays NC alarms and PLC alarms, but does not display the stop code.

When more than one alarm occurs at a time, the messages are alternately displayed in a two-second cycle. Up to 60 characters can be included in a message.

**7.3.20.1 Property Settings**

The property settings for the alarm display are divided into the followings.

- Control name : Specify the control name.
- Position/size : Specify the position and size of the control.
- Color : Specify the display color of the control.
- Character attribute : Specify the character attribute of captions.
- Character string display form : Specify the part system to be displayed on the control.
- Update cycle : Specify the update cycle of the alarm display.
- Color type : Specify the color type.

Character Attribute

Item	Description
FontType	Specify the font size and thickness. Normal.....Normal font Normal Bold.....Normal bold font Middle.....Middle-sized font Big.....Font with double height and width

Character String Display Form

Item	Description
DisplayMessage	Specify how to display the character string (0 to 2). 0: Not display the residual when the message is split. 1: Display the residual when the message is split. 2: Dependent on the parameter setting (#11021 PLC mesg disp type) When #11021 is 0: Not display the residual when the message is split. When #11021 is 1: Display the residual when the message is split.

Update cycle

Item	Description
UpdateCycle	Specify the time to update the alarm display(0~2000). (Note) Numbers between 0 and 299 are handled as 2000.

Color Type

Item	Description
ColorType	Select the color type from the following items. Theme color: Display the base color designated as the theme color. Specified color: The colors set for each property are reflected.

For the other properties, refer to "7.1 Common Functions of Controls".



7.3.20.2 Complements

Screen Specifications

Screen Images

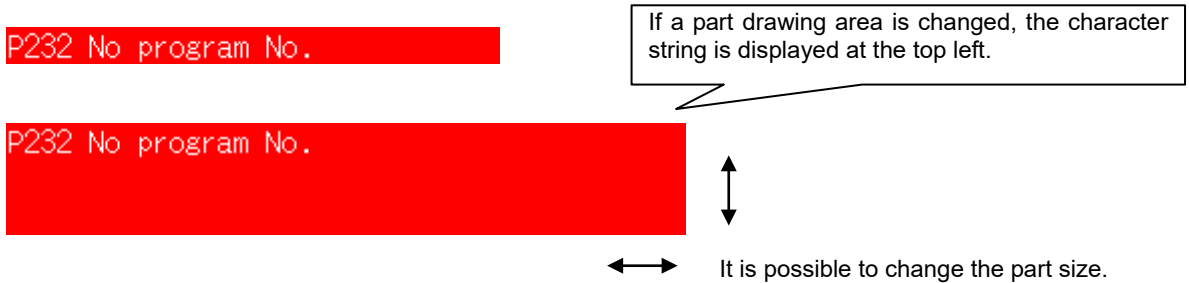

[Message split display (When "1" or "2" is selected for the property "Character string display form")]  
 Up to 60 characters can be included in a message. If the specified part size is too small to display 60 characters at a time, the message to display is split. If the message is split (up to four splits), they are displayed in a two-second cycle, and "... (three characters)" is displayed at the split position.

[Example of split message display] When a part of a specified size can display up to 20 characters

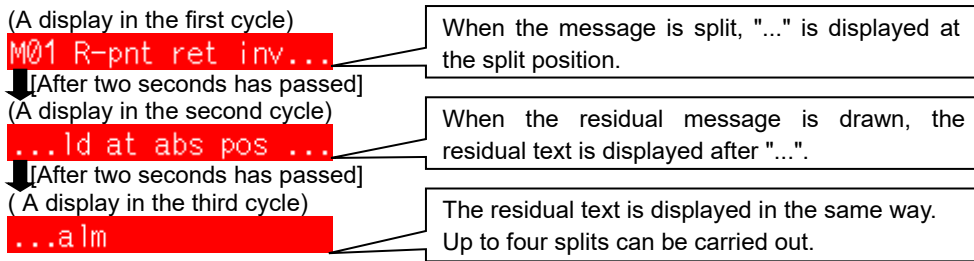

- (Note1) The height of the cell is the same as the height of the font.
- (Note2) Even when the height of the part is extended, the message is displayed in one line. If the specified height of the part is smaller than the font height, the message is not displayed.
- (Note3) The drawing area in a cell (the number of characters to display) is determined depending on the part width. However, if the specified width cannot display the character string of 20 or more characters, the message is not displayed.
- (Note4) For a PLC alarm with a classification No., the message and the classification No. are displayed. When "Not display the residual when the message is split" is selected, only the message is split.
- (Note5) When "2: Dependent on the parameter setting" is selected, up to 40 characters are displayed for a PLC alarm and operator message at a time, even if the control width is extended enough.

[Alarm display for multiple part system control]  
 • The part system name is displayed at the top of the message. The message is displayed in order from \$1.

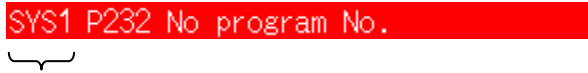

Part system name

List of Alarms

Type	Character	Background	Description	Priority
NC alarm message	White	Red	An operation alarm, program error, MCP alarm, servo alarm or system alarm is displayed.	Higher ↑
NC warning message	Black	Yellow		
PLC alarm message	White	Red	A message such as the details of machine error is displayed by use of user PLC.	↓
Operator message	Black	Yellow	The operator message is displayed by use of user PLC.	
NC alarm message during background check	White	Orange	When a program error occurs during the check, or when the macro alarm message (a message displayed with #3000 variable command) is displayed, the message is displayed.	Lower

(Note 1) When multiple alarms occur simultaneously, up to 10 alarm messages are displayed at 2-second intervals in order of descending priorities (if message text needs to be shortened, the entire text is displayed first, then truncated, before the next message is displayed).

(Note 2) The character color and background color of the messages are fixed to the above, and cannot be changed.

[NC alarm message]

P232 No program No.

[NC warning message]

Y51 Parameter G0tL illegal

[PLC alarm message]

PLC Sample Alarm

[Operator message]

PLC Sample Message

[NC alarm message during background check]

P62 No F command

**7.3.21 MonitorStatus (GNXMonitorStatus) ; Operation Status Display Part**

Operation status is a control that displays the NC operation status. This can display the operation status separately for each part system when multiple part system control is performed.

**7.3.21.1 Property Settings**

The property settings for the operation status display are divided into the followings.

- Control name : Specify the control name.
- Position/size : Specify the position and size of the control.
- Color : Specify the display color of the control.
- Solid frame : Specify the solid frame of the control.
- Character attribute : Specify the character attribute of captions.
- Part system designation : Specify the part system to be displayed on the control.
- Update cycle : Specify the update cycle of the operation status display.
- Color type : Specify the color type.
- Callback function : Specify whether or not the callback functions are provided.

Display type

Item	Description
DispType	Specify the display type. Type1 ····· Part system is displayed after "\$". (Note) Type2 ····· Part system number is displayed without "\$". (Note) If the number of valid part systems is 1, "\$1" is not indicated.

Character attribute

Item	Description
FontType	Specify the font size and thickness. Normal ····· Normal font Normal Bold ····· Normal bold font Middle ····· Middle-sized font Big ····· Font with double height and width
SystemNameColor	Specify the character color of the part system displayed on the control. (Note) When Type 2 is selected to the display type, the character color is fixed to black.

Part system designation

Item	Description
SystemNumber	Specify the No. of the part system to be displayed (0 to 8). When "0" is set, valid part systems are displayed. If the setting is greater than the number of valid part systems, the state of the 1st part system is displayed.

Update Cycle

Item	Description
RefreshFrequency	Specify the number of times to thin out the timer event processes (1 to 100).
RefreshTiming	The display is refreshed when the counted number of "RefreshFrequency" reaches the number of counts specified with "RefreshTiming" (0 to 99).

Color Type

Item	Description
ColorType	Select the color type from the following items. Theme color (M8V Series): Display the base color (for M8V Series) designated as the theme color. Theme color (M8 Series): Display the base color (for M8 Series) designated as the theme color. Specified color: The colors set for each property are reflected. For the base color designated as the theme color, refer to "5.10.9 Changing the Theme Color".

For the other properties, refer to "7.1 Common Functions of Controls".

7.3.21.2 Complements

List of Operation Status

The operation status symbol displayed on the control changes as shown below according to the NC operation state.

Symbol	Operation status	Character color	
		Display type 1	Display type 2
EMG	In emergency stop	Red	White (text) Red (BG)
RST	Resetting NC	White	White
BST	In block stop	White	White
HLD	Operation halted	White	White
SYN	Synchronizing	White	White
CRS	Waiting for cross conversion	White	White
FIN	Waiting for miscellaneous function completion	White	White
AUT	In automatic operation	White	White
RDY	Operation completed state	Green	Black (text) Green (BG)

(Note 1) The character colors for the operation status symbol are fixed as shown above.

(Note 2) "FIN" is displayed when parameter "#1725 cfg25/bit1 (operation status FIN display valid)" is "1".

### 7.3.22 Time (GNXTime) ; Time Display Part

The time display part is used to display the current time.

#### 7.3.22.1 Property Settings

The property settings for the time display part are divided into the followings.

- Control name : Specify the control name.
- Position/size : Specify the position and size of the control.
- Color : Specify the display color of the control.
- Solid frame : Specify the solid frame of the control.
- Character attribute : Specify the character attribute of captions.
- Color type : Specify the color type.

##### Character Attribute

Item	Description
FontType	Specify the font size and thickness. Normal.....Normal font Normal Bold.....Normal bold font Middle.....Middle-sized font Big.....Font with double height and width
ForeColor	Specify the character color.

##### Color Type

Item	Description
ColorType	Select the color type from the following items. Theme color (M8V Series): Display the base color (for M8V Series) designated as the theme color. Theme color (M8 Series): Display the base color (for M8 Series) designated as the theme color. Specified color: The colors set for each property are reflected. For the base color designated as the theme color, refer to "5.10.9 Changing the Theme Color".

For the other properties, refer to "7.1 Common Functions of Controls".

#### 7.3.22.2 Complements

##### Screen Specifications

##### Screen Images

- Without frame

12:34

- With frame

12:34

12:34



If a part drawing area is changed, the character string is displayed at the top left. However, if the specified area is smaller than the character string drawing area, the character string is not displayed.

It is possible to change the part size.

### 7.3.23 Page Change Button (GNCPageChangeButton)

The page change button control is a control to switch screens with key inputs such as menu key, page switch key, etc., or PLC device turned ON.

#### 7.3.23.1 Property Setup Dialog

Property setup dialog of the page change button control consists of the tabs relating to [Basic Settings] and [Advanced Settings]. Details of each tab will be described in the following sections.

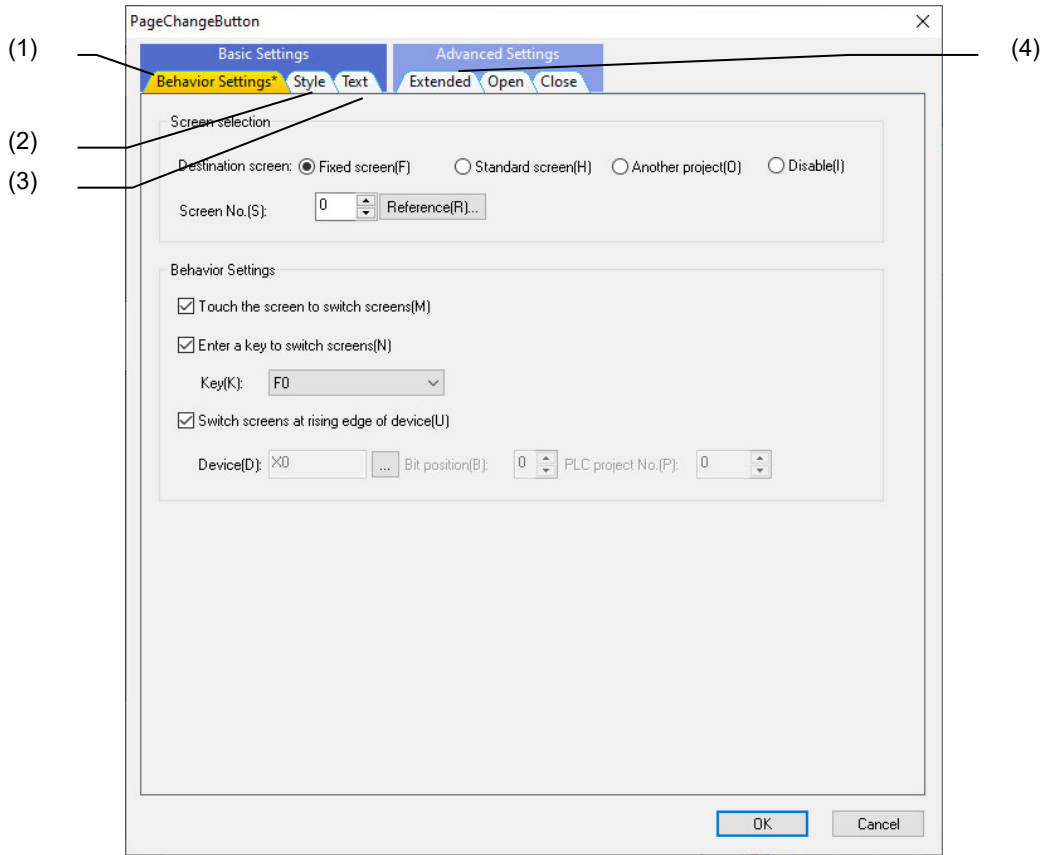

[Basic Settings] consists of the following tabs.

No.	Tab	Description
(1)	Behavior Settings	Specify the switching destination screen and the action.
(2)	Style	Set or display the background color, solid frame, blink and preview.
(3)	Text	Set or display the font, text, scroll and preview.

[Advanced Settings] consists of the following tab.

No.	Tab	Description
(4)	Extended	Set the item relating to the extended condition for the style or text.

7.3.23.1.1 [Behavior Settings] Tab

In [Behavior Settings] tab, specify the switching destination screen and the screen switching action, etc.

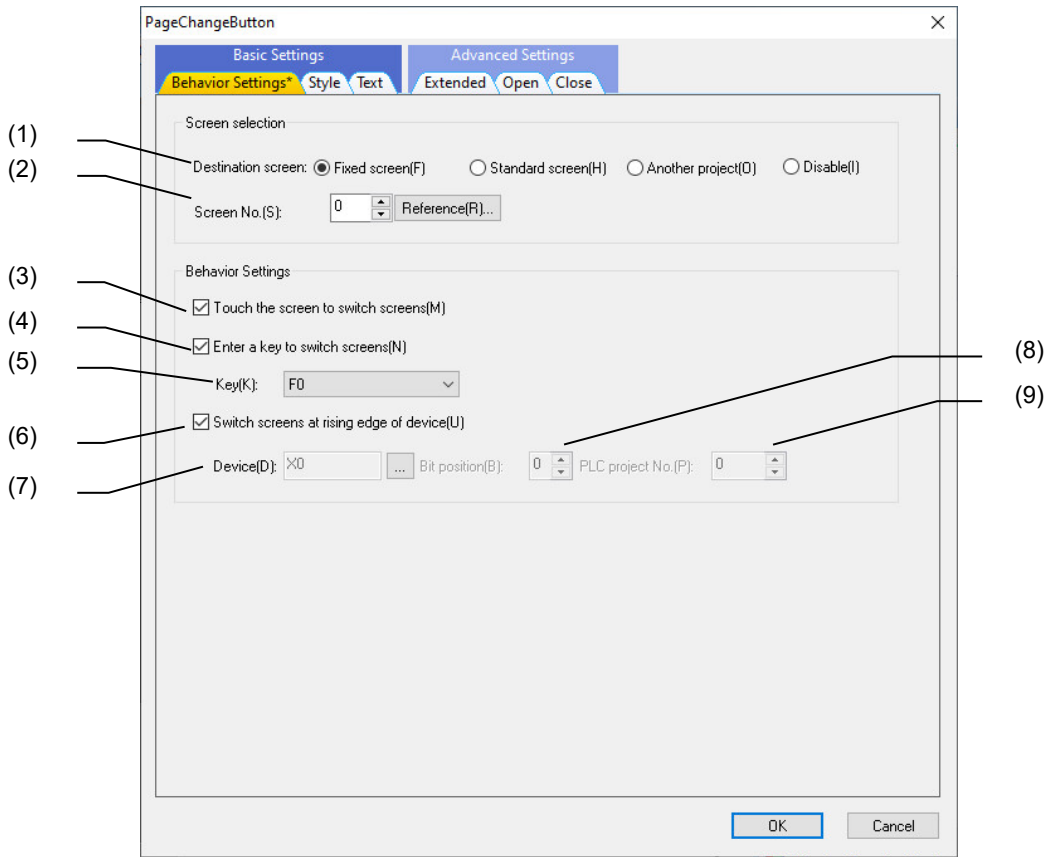

No.	Item	Description
(1)	Destination screen	Select the switching destination screen among "Fixed screen", "Standard screen", "Another project", or "Disable".
(2)	Screen No.	Specify the screen number of the switching destination.
(3)	Touch the screen to switch screens	Check here to switch the screen by touch gestures.
(4)	Enter a key to switch screens	Check here to switch the screen by the key operation.
(5)	Key	Select a key for switching the screen.
(6)	Switch screens at rising edge of device	Check here to switch the screen by starting the device value.
(7)	Device	Specify the address of the PLC device for the screen switching. Click on the "..." button to display the "PLC Device Setting" dialog.
(8)	Bit position	Specify the bit position of the word device when the word device (D/R) is set to the device.
(9)	PLC project no.	Specify the project number of PLC ladder what PLC device refers.

**NOTE**

- ◆ The address of the PLC device can be specified on the "PLC Device Setting".

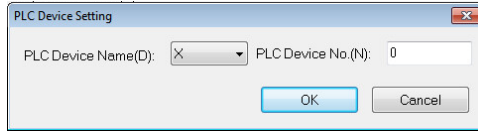

- ◆ The method to input [Screen No.] differs depending on the item selected for [Destination screen].  
When "Fixed screen" is selected for [Destination screen], specify the screen number of the editing project (0 to 255).  
Click on the [Reference] button to display the panel/window list dialog.

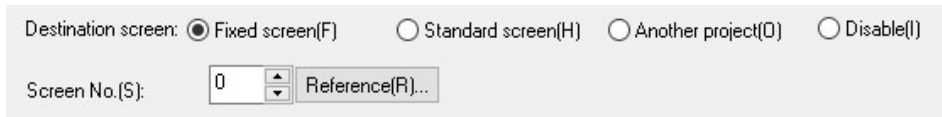

When "Standard screen" is selected for [Destination screen], select the screen among MONITOR screen, SETUP screen, EDIT screen, DIAGN screen, and MAINT screen.

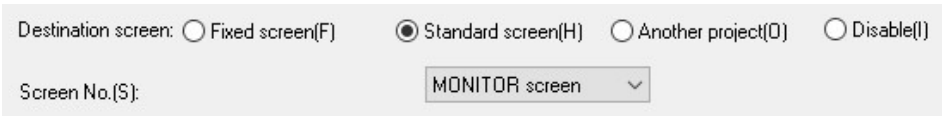

When "Another project" is selected for [Destination screen], specify the screen number of the other project (6000 to 9999).

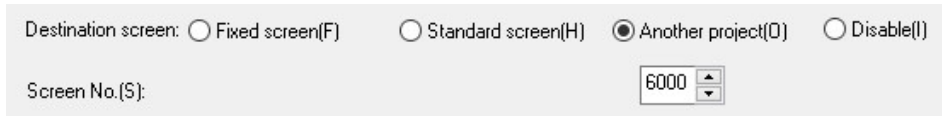

When "Disable" is selected for [Destination screen], the screen change operation is disabled.  
Select "Disable" when using the multiple window batch display function.

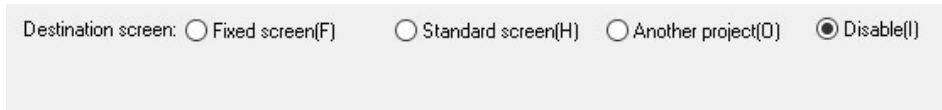



7.3.23.1.2 [Style] Tab

In [Style] tab, specify the style, solid frame, and blink.

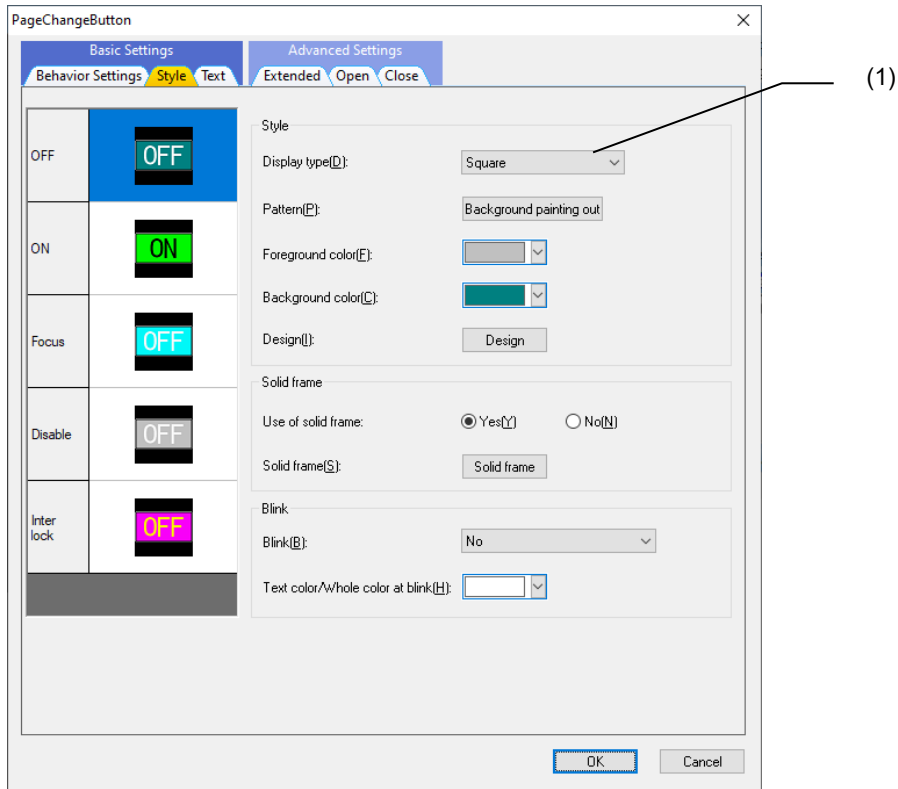

No.	Item	Description
(1)	Display type	Select the display type among "Square", "Circle", and "Image".

For the items other than the above, refer to "7.1.16.1.1 [Style] Tab".

7.3.23.1.3 [Text] Tab

In [Text] tab, specify the font, text, and scroll setting.

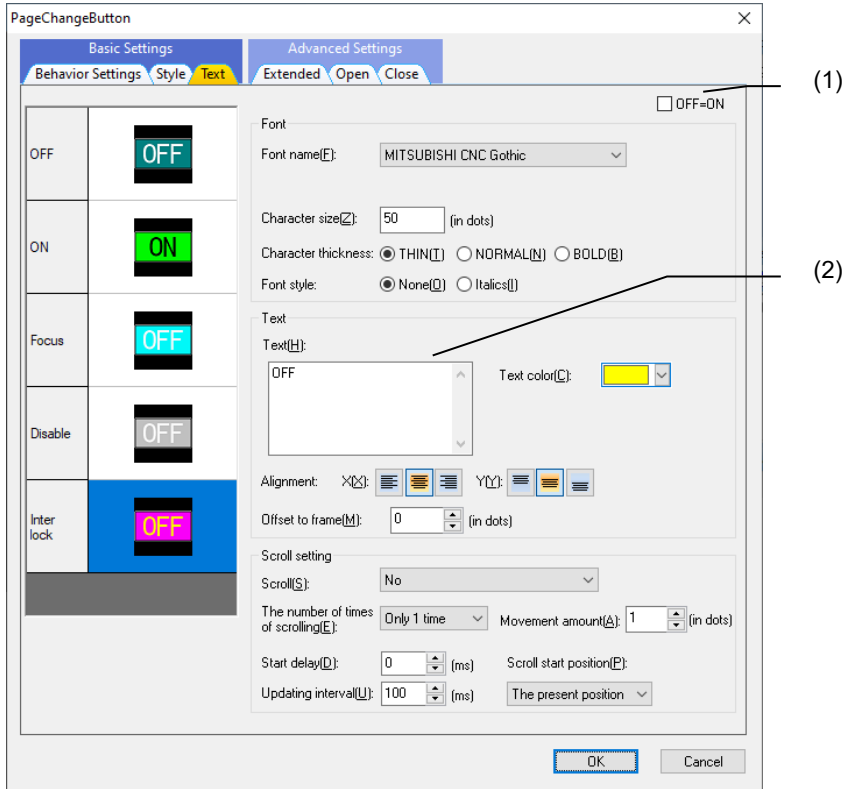

No.	Item	Description
(1)	OFF=ON	When [OFF=ON] is checked, the contents specified in [Text] are specified to all statuses. When [OFF=ON] is not checked, only the [Text] of the status selected in [Control state preview] is specified.
(2)	Text	Specify the display character string. (Note)

(Note) When specifying "Set the style / text to be applied when the focus is on the button" of "7.3.23.1.4 [Extended] Tab", this is disabled. When specifying "Control ON/OFF of button", this is disabled also.

For the items other than the above, refer to "7.1.16.1.2 [Text] Tab".

7.3.23.1.4 [Extended] Tab

In [Extended] tab, set whether to set the style or character when the button is selected, controlling ON/OFF of button, and the interlock device, etc.

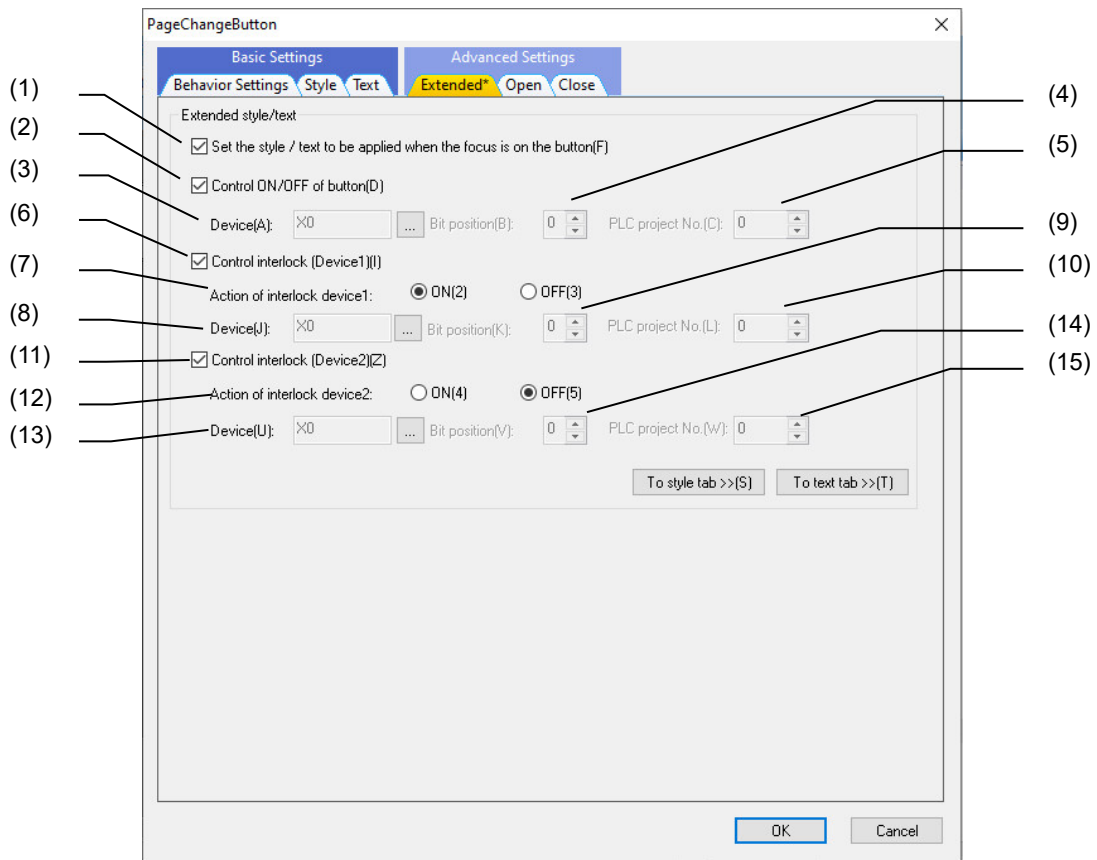

No.	Item	Description
(1)	Set the style / text to be applied when the focus is on the button	When this box is checked, the pattern, foreground color, background color, and design for when the button is selected (Focus) can be specified on the [Style] tab and [Text] tab.
(2)	Control ON/OFF of button	When this box is checked, the pattern, foreground color, background color, design, and solid frame for when the button does not work (Disable) can be specified on the [Style] tab and [Text] tab.
(3)	Device (at the time of disable)	Specify the address of the PLC device for disabling the button action. Click on the "..." button to display the "PLC Device Setting" dialog.
(4)	Bit position (at the time of disable)	Specify the bit position of the word device when the word device is set to PLC device (at the time of disable).
(5)	PLC project No. (at the time of disable)	Specify the project No. of PLC ladder what PLC device (at the time of disable) refers.
(6)	Control interlock (Device1)	Check this box to specify the operation and the device of the interlock device 1. When this is checked, the pattern, foreground color, background color, design, character strings, character colors, and solid frame at the interlock can be specified on the [Style] tab and [Text] tab.
(7)	Action of interlock device1	Select the operation of interlock device 1 between "ON" and "OFF".
(8)	Device (interlock 1)	Specify the address of the PLC device for the interlock operation. Click on the "..." button to display the "PLC Device Setting" dialog.
(9)	Bit position (interlock 1)	Specify the bit position of the word device when the word device is set to PLC device (interlock 1).
(10)	PLC project No. (interlock 1)	Specify the project number of PLC ladder what PLC device (interlock 1) refers.
(11)	Control interlock (Device2)	Check this box to specify the operation and the device of the interlock device 2. When this is checked, the pattern, foreground color, background color, design, character strings, character colors, and solid frame at the interlock can be specified on the [Style] tab and [Text] tab.

<b>No.</b>	<b>Item</b>	<b>Description</b>
(12)	Action of interlock device2	Select the operation of interlock device 2 between "ON" and "OFF".
(13)	Device (interlock 2)	Specify the address of the PLC device for the interlock operation. Click on the "..." button to display the "PLC Device Setting" dialog.
(14)	Bit position (interlock 2)	Specify the bit position of the word device when the word device is set to PLC device (interlock 2).
(15)	PLC project No. (interlock 2)	Specify the project number of PLC ladder what PLC device (interlock 2) refers.

7.3.23.1.5 [Open] Tab

In [Open] tab, specify the screen numbers of multiple windows to simultaneously open.

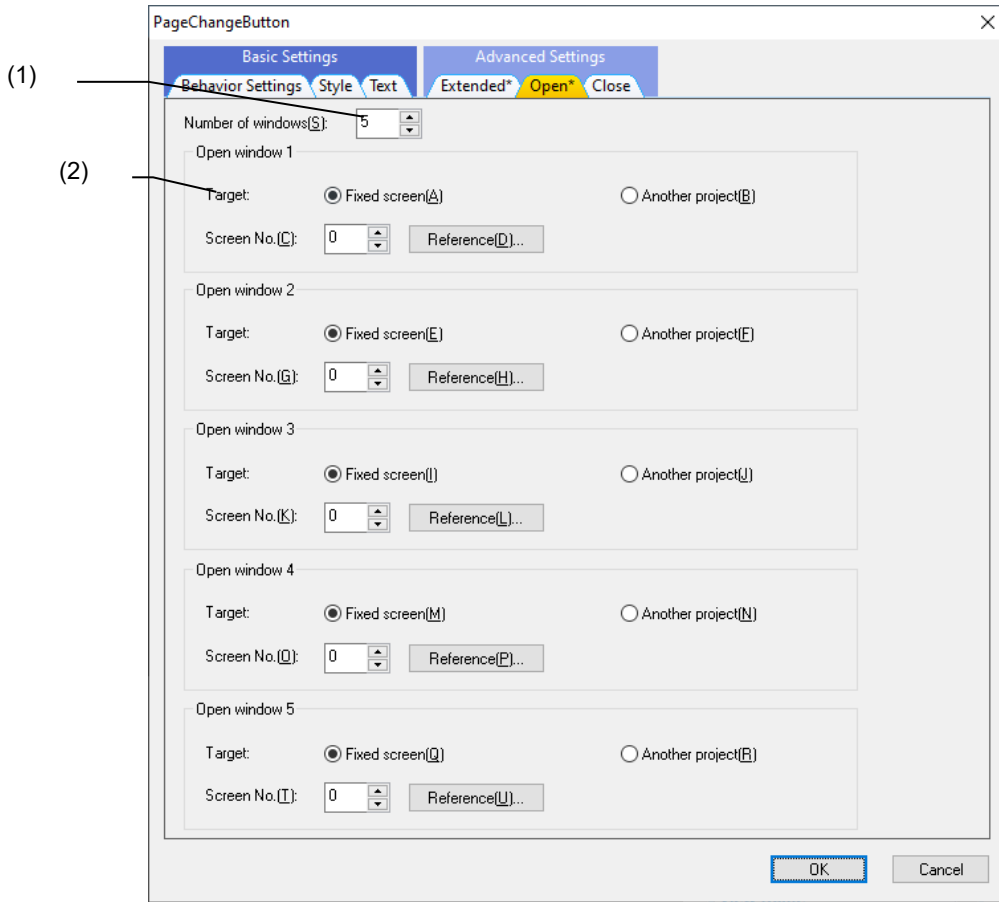

No.	Item	Description
(1)	Number of windows	Specify the number of screens enabled to open. “(2) Open window” switches between enabled and disabled depending on the set number of screens.
(2)	Open window 1 to 5	Specify the windows to open. Windows open in order from “Open window 1”.
	Target	Select “Fixed screen” or “Another project”.
	Screen No.	Specify a screen number.

7.3.23.1.6 [Close] Tab

In [Close] tab, specify the screen numbers of multiple windows to simultaneously close.

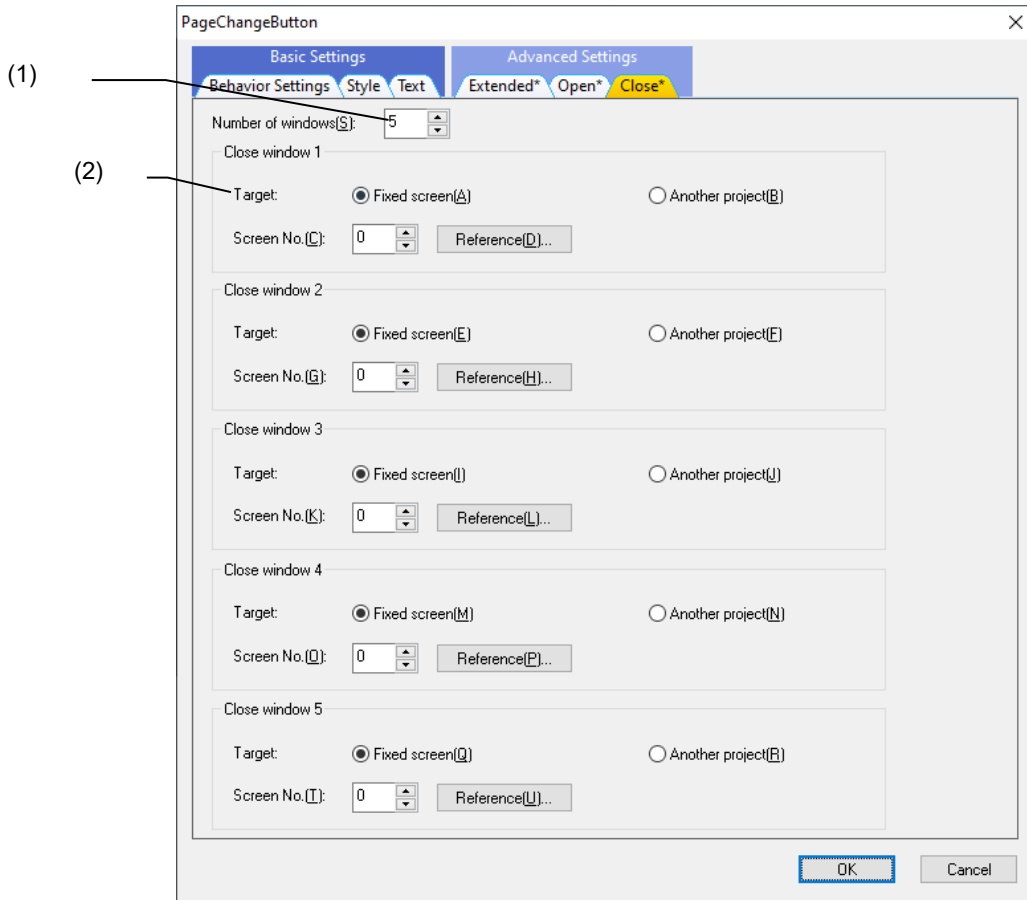

No.	Item	Description
(1)	Number of windows	Specify the number of screens enabled to close. “(2) Close window” switches between enabled and disabled depending on the set number of screens.
(2)	Close window 1 to 5	Specify the windows to close. Windows close in order from “Close window 1”.
	Target	Select “Fixed screen” or “Another project”.
	Screen No.	Specify a screen number.

**7.3.23.2 Property Settings**

The property settings of the page change button are divided into the followings.

- ID : Specify the control name.
- Position/size : Specify the position and size of the control.
- Show/Hide : Specify whether the control is displayed or hidden.
- Input permission : Select whether the entry is accepted (permission) or rejected (prohibition).
- Button type : Select the button action.
- Display type : Select the display type of the button.
- Page change : Specify items regarding the screen switching.
- PLC device : Specify the target PLC device.
- Color/pattern : Specify the color and pattern of the control.
- Image : Specify the image of the control.
- Caption : Specify the caption (character string) displayed on the control.
- Character attribute : Specify the character attribute of the caption.
- Solid frame : Specify the solid frame of the control.
- Caption character sequence : Specify the scroll of the caption character string.
- Blink : Specify the blink of the caption character string.
- Open/Close : Specify the screen numbers of the windows to simultaneously open/close.
- Callback function : Specify whether or not the callback functions are provided.

Button Type

Item	Description
Button type	Select the button action between the following two types.
Momentary	The button turns ON when it is pressed. It turns OFF when it is released.
None <sup>*1</sup>	The button does not turn ON or OFF even if it is pressed.

\*1: The screen is not switched by turning the button ON/OFF (touching the display or pressing the key). It will be switched when the screen switching by the PLC device met the requirement.

Page Change

Item	Description
PageChangeNo (Note 1)	<p>Designate the screen number of the destination screen. Select a number from the following.</p> <p style="margin-left: 40px;">0-255 : The page number of the customized screen in the project. "0" is the top page.</p> <p style="margin-left: 40px;">1000 : The number of the standard operation screen</p> <p style="margin-left: 40px;">2000 : The number of the standard set-up screen</p> <p style="margin-left: 40px;">3000 : The number of the standard editing screen</p> <p style="margin-left: 40px;">4000 : The number of the standard diagnostic screen</p> <p style="margin-left: 40px;">5000 : The number of the standard maintenance screen</p> <p style="margin-left: 40px;">6000-9999 : The page number of the customized screen to which the offset number is added.</p> <p>If the numbers other than the above (including the view frame) or some numbers of non-existent screens are set, the screen will not be switched. Though, the other operations are applied.</p> <p>(Note) Set "999" when using the multiple window batch display function.</p>
FocusMoveToWindow (Note 2)	Specify whether to move the focus on the window when opening the window by the screen switching.
WindowClose (Note 3)	Specify whether to close the window of the original screen by the screen switching.
InputKeyID (Note 4)	<p>Select a key for switching the screen.</p> <p>When a key selected with this item is pressed, the screen designated with the destination screen number will be displayed.</p> <p>* The screen switching with key input will not be performed when "none" is specified.</p>

(Note 1) For the switching to the standard screen, the operation is the same as when the following is pressed on the standard screen: [MONITOR], [SETUP], [EDIT], [DIAGN], or [MAINTE].

(Note 2) When "Close" is specified for the property "WindowClose", the "FocusMoveToWindow" is disabled and the focus is surely moved onto the window. If the panel is the screen switching destination, the focus moves onto the panel regardless the property value.

(Note 3) For a window registered to menu release, the window closes regardless of the "WindowClose" property setting. For F0 release, the window closes in accordance with the "WindowClose" property setting.

(Note 4) Even if you set MONITOR, SETUP, EDIT, DIAGN, or MAINTE, you still need to specify the destination screen No. in the property "PageChangeNo".



PLC Device

Item	Description
PageChange device *1	Specify the address of the PLC device for the screen switching. Switch the screen with starting the designated PLC device.
Action of PageChange device	Specify the operation the PLC device specified in the page change device. Set the value from the following. Read : Read the page change device value turned ON, and switch the screen. None : The screen switching using the PLC device will not be performed.
Bit position of PageChange device	Specify the bit position of the word device when the word device (D/R) is set to the page change device. (0 to 15)
Page change device project No.	Specify the project number of PLC ladder to which the page change device refers. (0 to 6)

\*1: When switching the screen using the page change device, create a ladder that keeps the page change device ON until the page change device turned ON is confirmed by Timer.  
The page change device can be performed only when the button is indicated.

Open/Close

Item	Description
Number of open windows	Specify the number of screens enabled to open. (0-5)
Open window 1 to 5 (*)	Specify the windows to open. Windows open in order from "Open window 1".
Number of close windows	Specify the number of screens enabled to close. (0-5)
Close window 1 to 5 (*)	Specify the windows to close. Windows open in order from "Close window 1".

(\*) The following numbers can be set for screen numbers.  
 0-255 : The page number of the customized screen in the project. "0" is the top page.  
 6000-9999 : The page number of the customized screen to which the offset number is added.  
 If the numbers other than the above (including the view frame), numbers of panel screens, or some numbers of non-existent screens are set, this function will not be executed.

Refer to "7.3.15 PLC extension button (GNCPLCEXButton)" for other properties.

**7.3.23.3 Complements**

Operation Condition

The screen change is carried out by the page change button even when the focus is not on it, depending on the status of key input, touch screen, and the page change device (at turning ON). The following table shows the relations between the page change operation and the status of the page where the page change button is placed.

Screen switching		Page and status		
		Touch screen	Key input	Page change device (Note)
Panel	Active	○	○	○
	Not active	○	×	○
Window	Active	○	○	○
	Not active	○	×	○

(Note) If the page change button is not displayed or placed outside of the panel, pages are not changed by the PageChange device. When the button is displayed even if only partially, the page change will be carried out.

Priority of PLC Devices

The page change button's operation can be limited depending on the state of several PLC devices. Each PLC device has a priority level; therefore the state of a PLC device with a lower priority is not referred to when a PLC device with a higher priority is active. The priority order of the PLC devices is determined as shown below.

Priority	PLC device
High ↓ Low	Disable device
	Interlock device 1/Interlock device 2
	Page change device

Refusing the Screen Switching

When the disable device or the interlock device 1/2 is used, the screen switching will be refused without screen switching operation such as key input, touch, or the status of page change device.

Refusing the screen switching by setting of Disable device (○: screen switching activated  
×: screen switching deactivated)

		Disable functions		
		Enable		Disable
		Disable device ON	Disable device OFF	-
Input	Enabled	×	○	○
	Disabled	×	○	×

Refusing the screen switching by setting of the interlock device (○: screen switching activated  
×: screen switching deactivated)

		Interlock device operations		
		No operation	When ON	When OFF
Device	ON	○	×	○
	OFF	○	○	×

Displaying multiple windows in a batch

Multiple windows specified as close window or open window can open or close in a batch.

Execution order

The windows specified as close window close, and then the windows specified as open window open.

- (1) Windows close in the order of “Close window 1”, “Close window 2”, “Close window 3”, “Close window 4”, “Close window 5”.
- (2) Windows open in the order of “Open window 1”, “Open window 2”, “Open window 3”, “Open window 4”, “Open window 5”.

(Note 1) When a closed window is specified, the function will not be executed.

(Note 2) When an open window is specified, the function will be executed and the open window will be displayed at the front.

Layout (display order)

“Open window 1” is displayed at the back, and “Open window 5” is displayed at the front.

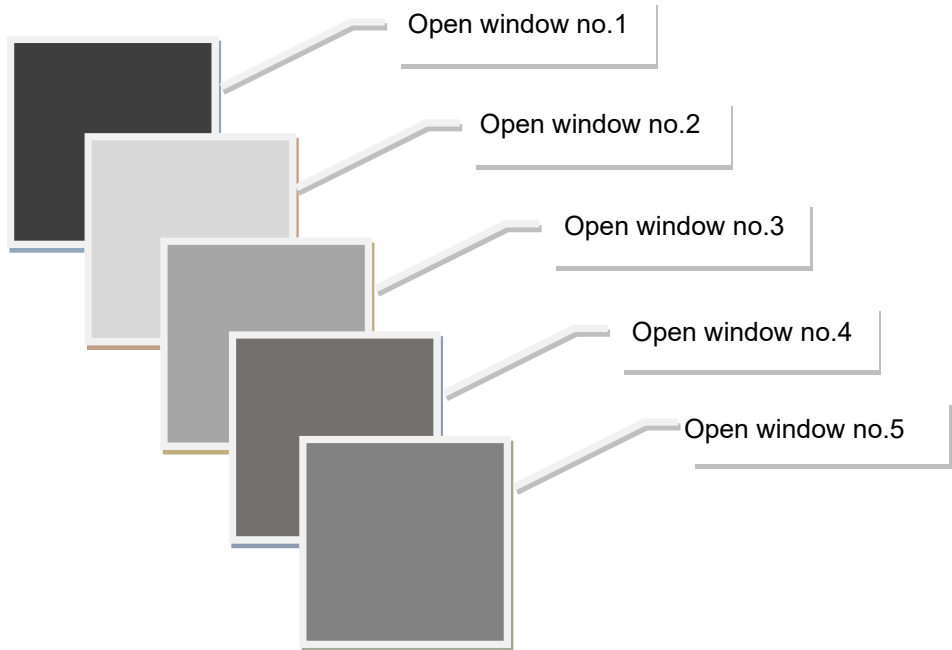

Settings of windows to open

- (1) Set the number of windows to open for "Number of open windows".
- (2) Set the screen numbers of the windows to open for "Open window no.1 to 5".

The number of screens specified for "Number of open windows" will be enabled.  
 Example: When "3" is set for "Number of open windows", Open window no.1 to 3 will be enabled.

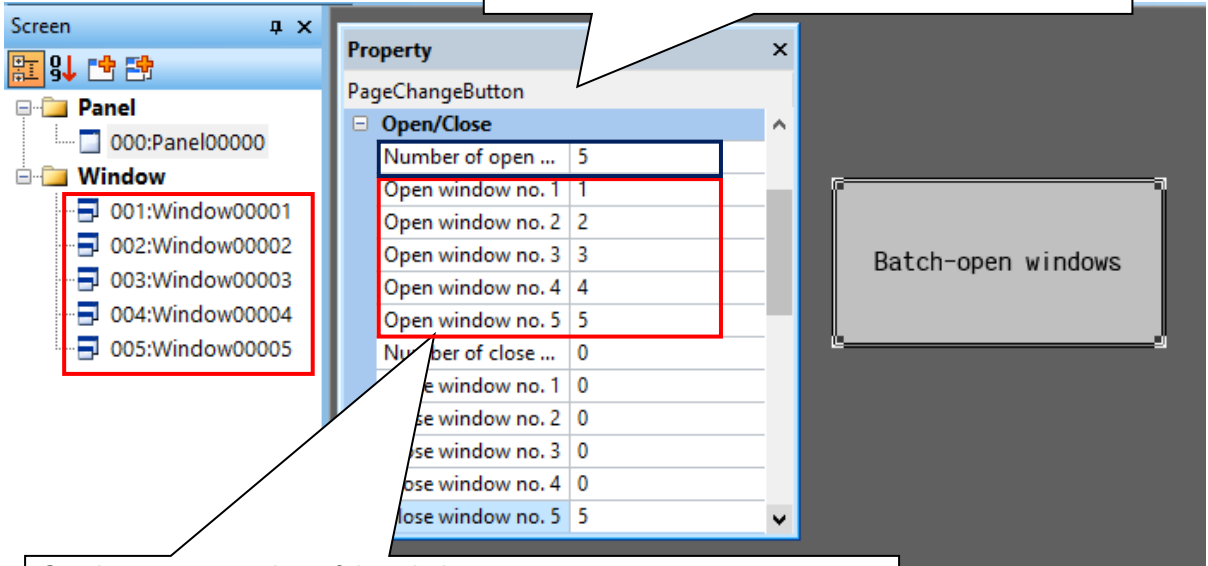

Set the screen number of the window to open.  
 When numbers of panel screens or numbers of non-existent screens are set, this function will not be executed.  
 Specified windows open in order from "Open window no.1".  
 Available screen numbers are as follows.

- Fixed screen: 0 to 255
- Another project: 6000 to 9999

After setting each property, pressing the page change button will open the windows of the specified screen numbers.

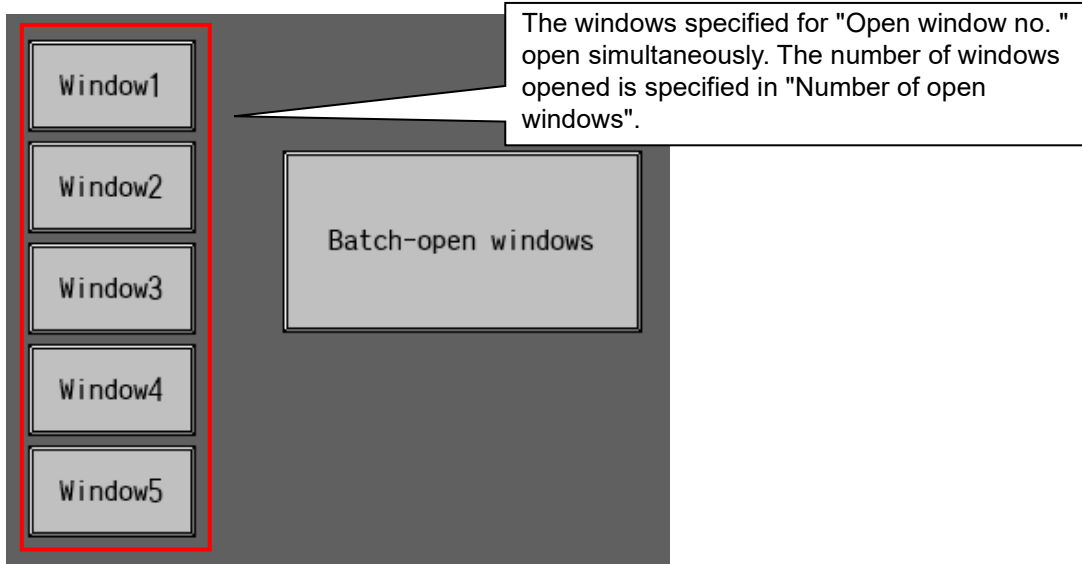

Settings of windows to close

- (1) Set the number of windows (screen numbers) to close for "Number of close windows".
- (2) Set the screen numbers of the windows to close for "Close window no. 1 to 5".

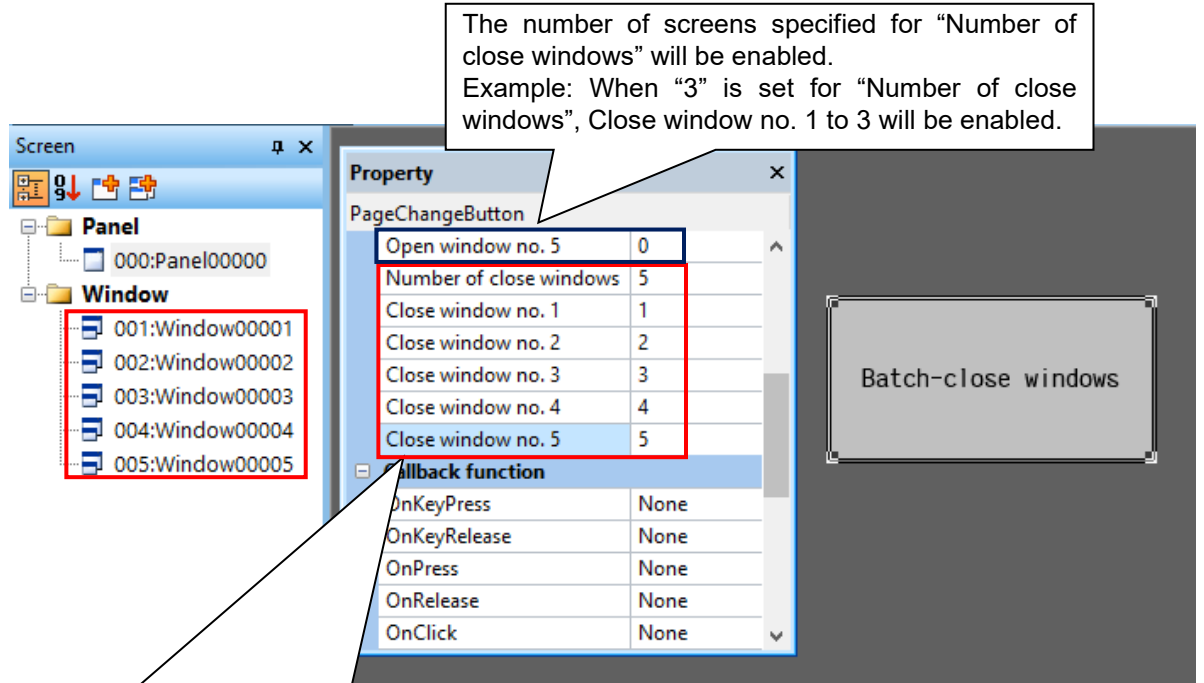

Set the screen number of the window to close.  
 When numbers of panel screens or numbers of non-existent screens are set, this function will not be executed.  
 Specified windows close in order from "Close window no. 1".  
 Available screen numbers are as follows.

- Fixed screen: 0 to 255
- Another project: 6000 to 9999

After setting each property, pressing the page change button will close the windows of the specified screen numbers.

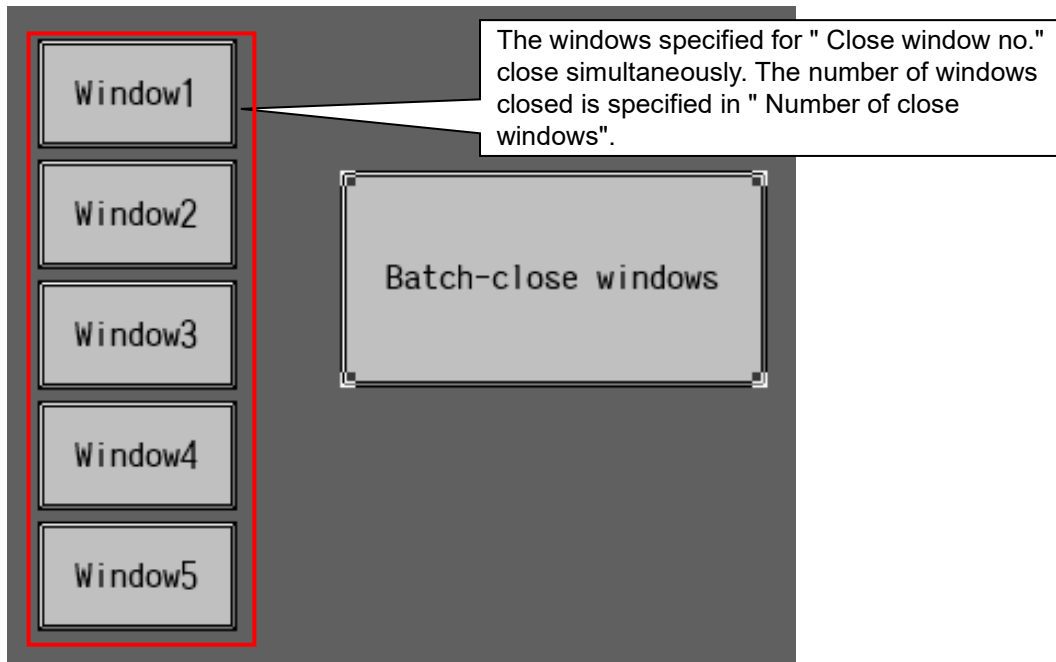



Example of page change/open/close combination

The following table shows the properties of the page change button.

Panel	Item	Property	Value
Panel 1	Page change button 1	PageChangeNo	Screen number of panel 2
		WindowClose	Close
		Open window no.1	Screen number of window 6
		Open window no.2	Screen number of window 7
		Open window no.3	Screen number of window 8
		Open window no.4	Screen number of window 9
		Open window no.5	Screen number of window 10
		Close window no.1	Screen number of window 1
		Close window no.2	Screen number of window 2
		Close window no.3	Screen number of window 3
		Close window no.4	Screen number of window 4
		Close window no.5	Screen number of window 5
Panel 2	Page change button 2	PageChangeNo	Screen number of panel 1
		WindowClose	Close
		Open window no.1	Screen number of window 1
		Open window no.2	Screen number of window 2
		Open window no.3	Screen number of window 3
		Open window no.4	Screen number of window 4
		Open window no.5	Screen number of window 5
		Close window no.1	Screen number of window 6
		Close window no.2	Screen number of window 7
		Close window no.3	Screen number of window 8
		Close window no.4	Screen number of window 9
		Close window no.5	Screen number of window 10

Operation example

- |   |   |  |
|---|---|--|
| <p>(1) Press the page change button 1 in panel 1.</p> | ➔ | Panel 1 closes, and panel 2 opens. Windows 1 to 5 close, and windows 6 to 10 open. |
| <p>(2) Press the page change button 2 in panel 2.</p> | ➔ | Panel 2 closes, and panel 1 opens. Windows 6 to 10 close, and windows 1 to 5 open. |

Examples of other combinations are shown below.

- (1) When placing the page change button in a window and setting the screen number of that window for "Close window no."
  - All the windows specified for Close window no. including the window that the page change button is placed close.
- (2) When setting the same screen number for "Open window no. " and "Close window no. "
  - (1) The windows set for Close window no. close.
  - (2) The windows set for Open window no. open.

\* When an open window is set, the window will close and reopen.

Dynamically executing the multiple window batch display function

- (1) Set “Read” for the property “Action of PageChange device”.
- (2) The device specified for the property “PageChange device” switches from OFF to ON.

When “PageChange device” turns ON while a panel is displayed, the displayed windows will be switched in a batch.

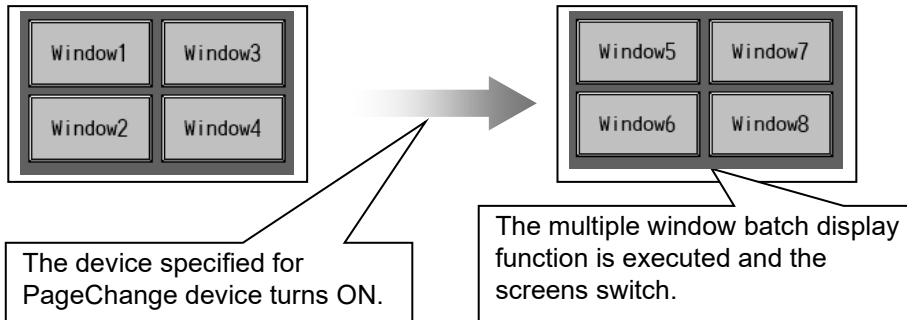

In the case where the specified device is ON when the screen opens, multiple windows will be displayed in a batch.

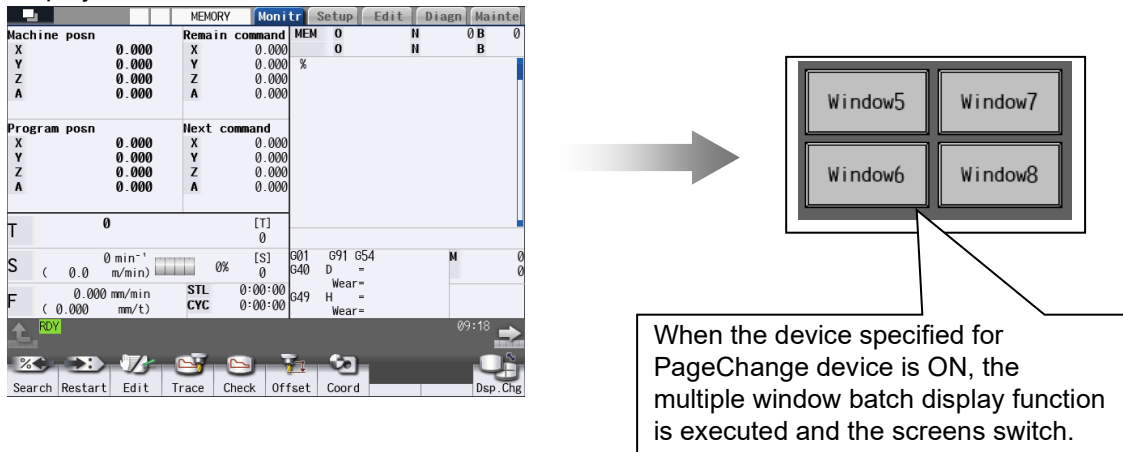

Disabling the existing page change function

By setting the values in the table below for properties, the existing page change function will be disabled.

To use only the multiple window batch display function, set the values in the table below for each property.

Property	Setting value
PageChangeNo	999
InputKeyID	None
FocusMoveToWindow	Not move
WindowClose	Not close

## Restrictions

- (1) In the macro editing, if the OnTimer/OnPress event of the page change button is created, the screen switching is not operated. To execute the screen switching, write the NormalMethod function in the OnTimer/OnPress event of the page change button.
- (2) In the macro editing, if the OnKeyPress event except the page change button is created, the screen switching is operated. When the screen is not to be switched, call the NormalMethod function and return the (1).
- (3) In the compilation method, if the OnKeyPress event is implemented on controls except the page change button, switch "FALSE": passing a key to the page change button or "TRUE": not passing depending on the return value of OnKeyPress. To apply the screen switching after the OnKeyPress event process, set "FALSE" to the return value of the OnKeyPress event.

<Example of the basic control: "Menu 1" is set to "Input key" on the property of the page change button. >

```
long GCPanel00000::GBASICCONTROL00001OnKeyPress(unsigned short usMessage,
long ILParam,long IUParam)
{
    // Input judgement of menu 1 key (F1)
    if (ILParam == GK_F1)
    {
        // Designate "FALSE" to the return value and apply the screen switch
        return FALSE;
    }

    // The screen switch is not applied when it is other keys
    return TRUE;
}
```

- (4) If the focus is on the Edit control object, the screen switching by key input is not operated. Put down the process below to apply the screen switching. The following are examples of the screen switching when F1 key is input.

<Interpreter method>

```
$GEdit00000-OnKeyPress
long _IShiftKey; 'SHIFT key input status
long _IMainKey; 'key input
 IMainKey = LLPARAM;
 IShiftKey = LUPARAM & H1;
if((_IMainKey == 112) && (_IShiftKey == 0)) ' F1 for the operation of the screen switch
button
    Normalmethod(); ' Executes normal method to apply the screen switch
    return(0); 'F1 key is not performed by Edit control but the page change button
Endif
$End
```

<Compilation method>

```
long GCPanel00000::GEDIT00000PreKeyPress (unsigned short usMessage, long
ILParam,long IUParam){
    // F1 for switch process of the page change button
    if(ILParam == GK_F1) {
        // Do not consume the key by Edit control key (implement the page change
button)
        return KEYPRESS_BREAK_FALSE;
    }
    return TRUE;
}
```

- (5) When closing the self screen (window) by operating the page change button allocated on the window, designate a screen number other than that of the self screen (window) for the property "PageChangeNo".
- (6) When you click on the screen group display [MONITOR], [SETUP], [EDIT], [DIAGN] or [MAINTE] on the standard screen while focus is on the page change button for which MONITOR, SETUP, EDIT, DIAGN or MAINTE is set in the property "InputKeyID", the click is handled as the key input of the page change button. The display is switched to the destination screen designated in the property "PageChangeNo".

**7.3.24 Stacked Graph (GNCStackedGraph)**

The stacked graph is a control to read NC data in a determined frequency and stack them to show in the bar graph.

**7.3.24.1 Property Settings**

Property settings for the stacked graph can be categorized as follows:

- Control name : Specify the control name.
- Position/Size : Specify the displaying position and size of the control
- Show/Hide : Specify whether to display the control or not.
- Color/Image : Specify the color and image of the control.
- NC data : Specify the items related to reading the target NC data.
- Graph attribute : Specify the display items: scale (upper limit/lower limit), etc.
- Update : Specify the refresh frequency of the NC data display.
- Callback function : Specify whether the callback functions are provided or not.

NC Data

Item	Description
Number of items	Specify the number of items to show in graph. (1 to 8)
Number of Section	Specify the section number of NC data to read. (0 to 999)
Number of Sub-section	Specify the sub-section number (top number) of NC data to read. (0 to 1000000000)
NumberOfSystems	Specify the part system number (top number) of NC data to read. (1 to 10)
NumberOfAxis	Specify the axis number (top number) of NC data to read. (0 to 32)
Reading method	Specify the method to read NC data. NumberOfAxis/Number of Sub-section/NumberOfSystems
Read offset	Specify the offset. (1 to 1000) Considering the number specified in the reading method as the top number, and designate with the number to be read in the next one.
Data Type	Specify the data type of NC data to read. signed char/unsigned char/signed short/unsigned short/signed long/unsigned long/double

Update

Item	Description
RefreshFrequency	Specify the number of times to thin out the timer event processes. (0 to 100) *The reading is executed only first time when 0 is set.
RefreshTiming	The display is refreshed at the moment the counted number of "RefreshFrequency" reached the number of counts specified with "RefreshTiming". (0 to 99)

Color/Image

Item	Description				
Display Type	Select the background type between the following two types. <table border="1"> <tr> <td>Painting out</td> <td>Display the background in designated pattern.</td> </tr> <tr> <td>Image</td> <td>Display the background in designated image resource.</td> </tr> </table>	Painting out	Display the background in designated pattern.	Image	Display the background in designated image resource.
Painting out	Display the background in designated pattern.				
Image	Display the background in designated image resource.				
Design *1	Specify the image.				
Pattern *2	Specify the painting pattern.				
Foreground color *2	Specify the foreground color.				
Background color *2	Specify the background color.				
Scale color	Specify the scale color.				
Graph pattern 1 to 8 *3	Specify the graph pattern for each item.				
Graph Foreground color 1 to 8 *3	Specify the foreground color of graph for each item.				
Graph Background color 1 to 8 *3	Specify the background color of graph for each item.				
Graph frame color	Specify the frame color of each item of graph.				

\*1: This is enabled when [Image] is set in the display type.

\*2: This is enabled when [Painting out] is set in the display type.

\*3: Graph 1 to 8 are enabled in the range of the number specified in the [Number of items] of NC data property.

Graph Attribute

Item	Description
Display direction	Specify the bar graph direction; vertical or horizontal.
Scale number	Specify the number of scale line. (0 to 101) Set 0 for the setting without scale line. The interval between scales is automatically set depending on the number of scales.
Scale width	Specify the width of scale. (0 to 1000)
Graph frame	Specify the frame enclosing each graph item. (enable/disable)
Scale Min	Specify the minimum value of the graph area. (799999999.0 to -799999999.0)
Scale Max	Specify the maximum value of the graph area. (799999999.0 to -799999999.0)
Lower Limit	Specify the desired value. When the result of accumulation of the graph is less than the set value, OnLowerLimitOver() is called. (799999999.0 to -799999999.0)
Upper Limit	Specify the desired value. When the result of accumulation of the graph is more than the set value, OnLowerLimitOver() is called. (799999999.0 to -799999999.0)
Sort type	Specify the display order of NC data; ascending or descending. If None is selected, displaying in NC designation order.

Refer to "7.1 Common Functions of Controls" for other properties.

7.3.24.2 Complements

Examples of Graphs

The following are NC data, set values of graph attribute, and readout NC data. (The value of NC data read includes minus values.)

Setting items	Value	Data number	Reading value	Back/foreground color of graph	Patterns supported for the following	Sub-section
Number of items	4					
Scale Min	-100					
Scale Max	100	1	50	Violet	[Pattern]	90000
Number of Section	55	2	10	Deep blue	[Pattern]	90001
Number of Sub-section (top)	90000	3	-30	Blue	[Pattern]	90002
Read offset	1	4	20	Green	[Pattern]	90003
Reading method	1					

In order of the readout items, the bar is cumulated up from 0 for a positive value, and cumulated downward from 0 for a negative value. (Horizontal type: left side for the negative value and right side for the positive value)

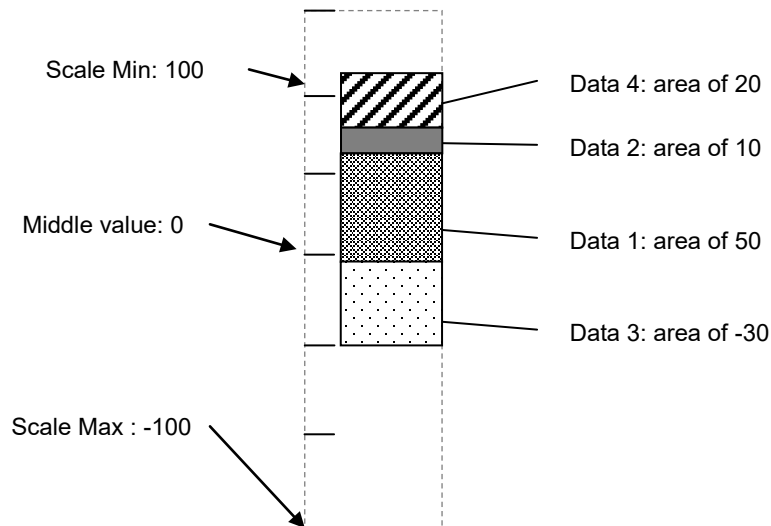

**NOTE**  
 ◆ Graph is drawn in the range of the "Scale Max" and "Scale Min". Modify the setting of the "Scale Max" and the "Scale Min" to draw a graph over their ranges.

Restrictions

- (1) If a program of which the OnTimer() event created in macro editing is executed, the callback function (OnLowerLimitOver/OnUpperLimitOver) is not executed. To create OnTimer() event and read NC data in designated frequency, write the "NormalMethod()" function in the OnTimer() event of macro program.

**7.3.25 Statistics Graph (GNCStatisticsGraph)**

The statistics graph is a control to read NC data in a determined frequency and show them by pie chart or band chart in the ratio to the entirety.

**7.3.25.1 Property Settings**

Property settings for the statistics graph can be categorized as follows:

- Control name : Specify the control name.
- Position/Size : Specify the displaying position and size of the control
- Show/Hide : Specify whether to display the control or not.
- Color/Image : Specify the color and image of the control.
- NC data : Specify the items related to reading the target NC data.
- Graph attribute : Specify the display items: scale (upper limit/lower limit), etc.
- Update : Specify the refresh frequency of the NC data display.
- Callback function : Specify whether the callback functions are provided or not.

Graph Attribute

Items	Descriptions
Graph type	Select "Pie chart" or "Band chart".
Display direction	Specify the band chart direction; vertical or horizontal. This is enabled when "Band chart" is selected for "Graph type" in the properties.

Refer to "7.3.24 Stacked Graph" for other properties.



7.3.25.2 Complements

Examples of Graphs

The following are NC data, set values of graph attribute, and NC data read. (The value of NC data read includes minus values.)

Setting items	Value	Data number	Reading value	Back/foreground color of graph	Patterns supported for the following	Sub-section
Number of items	4	1	50	Violet	[Pattern]	90000
Scale Min	-100	2	10	Deep blue	[Pattern]	90001
Scale Max	100	3	-30	Blue	[Pattern]	90002
Number of Section	55	4	20	Green	[Pattern]	90003
Number of Sub-section (top)	90000					
Read offset	1					
Reading method	1					

The read NC data items are shown in the absolute value.

<Statistics pie chart>

Statistics pie chart is drawn clockwise from 0° in order of the items read.

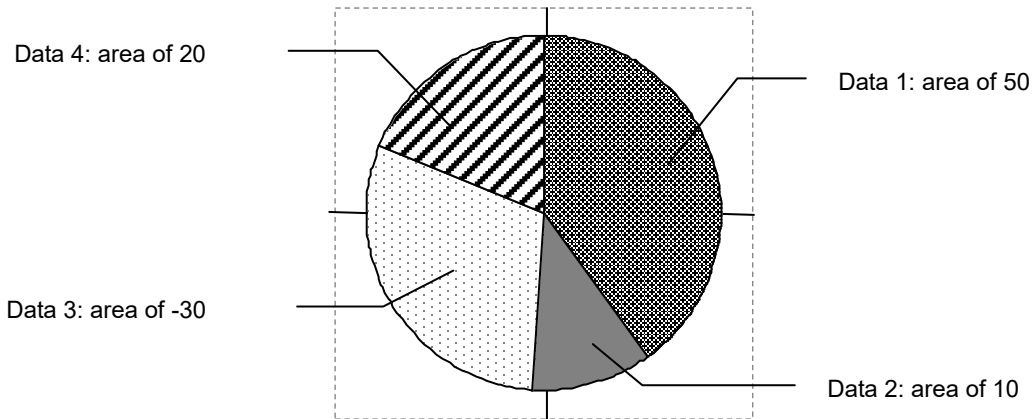

<Statistics band chart>

Statistics band chart is drawn upward from the bottom in order of the items read. (Horizontal type: drawn from left side to right side.)

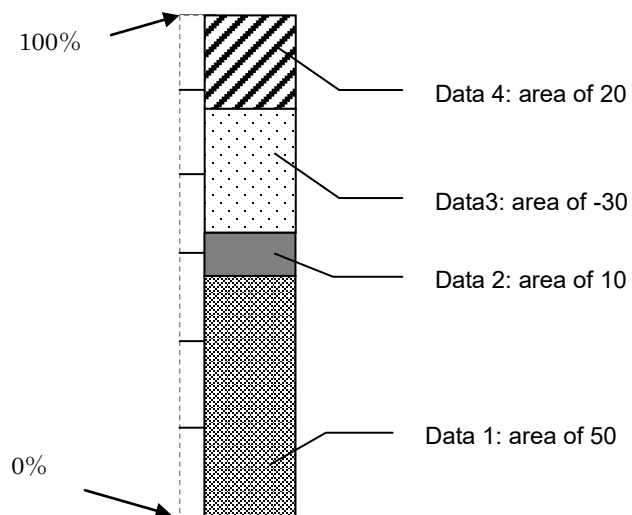

**NOTE**

- ◆ The graph can contain maximum 32 items using functions.  
Set the items using related functions and modify the number of items using the function `GCSNCGraphSetItemNum()`.  
If the number of items is modified to nine or more, specify the background color using the function `"GCSNCGraphSetGraphBackColor()"` and the foreground color using the function `"GCSNCGraphSetGraphForeColor()"` for the ninth item or later.  
This method of modification is enabled while the screen is displayed.

Restrictions

- (1) To create the `OnTimer()` event using macro edit and read NC data in designated frequency, write the `"NormalMethod()"` function in the `OnTimer()` event.

**7.3.26 Alarm List (GNCAAlarmList)**

The alarm list control can display a list of currently occurring alarms on the custom screen. The displayed messages include the NC messages, stop codes, alarm messages, operator messages, etc.  
 A history of alarm information (NC messages and alarm messages) can be displayed also.

**7.3.26.1 Property Setup Dialog**

Property setup dialog of alarm list control consists of the tabs relating to [Basic Settings] and [Advanced Settings]. Details of each tab will be described in the following sections.

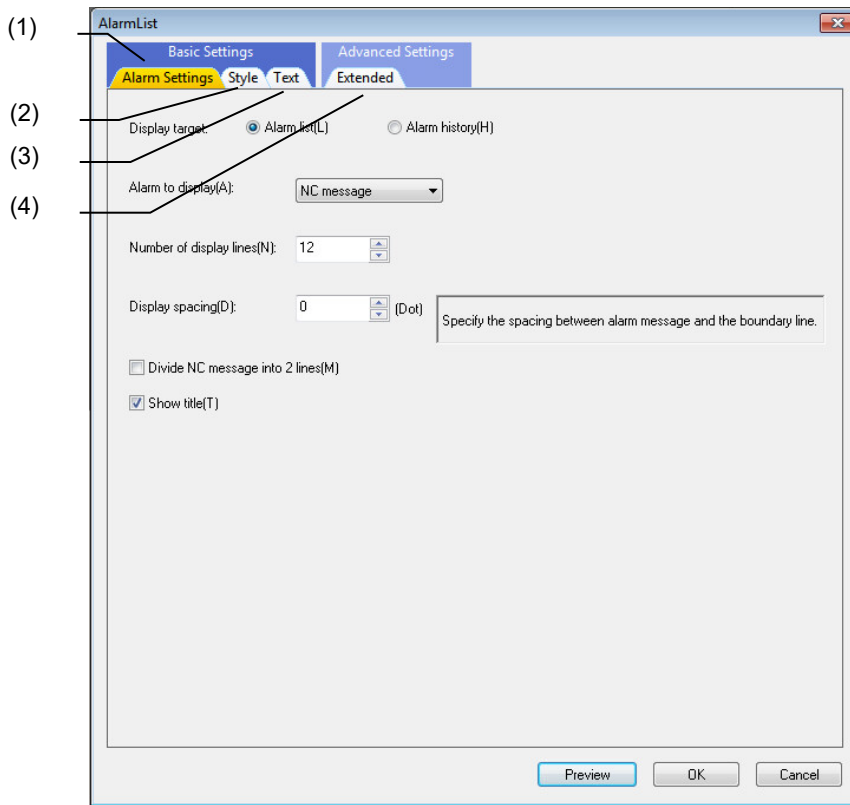

[Basic Settings] consists of the following tabs.

No.	Tab	Description
(1)	Alarm Settings	Set the item relating to the alarm display.
(2)	Style	Set the background color;
(3)	Text	Set the font, and text.

[Advanced Settings] consists of the following tab.

No.	Tab	Description
(4)	Extended	Set the item relating to the message conversion, and operation.

7.3.26.1.1 [Alarm Settings] Tab

In [Alarm Settings] tab, specify the display target of the alarm, the number of the display lines etc.

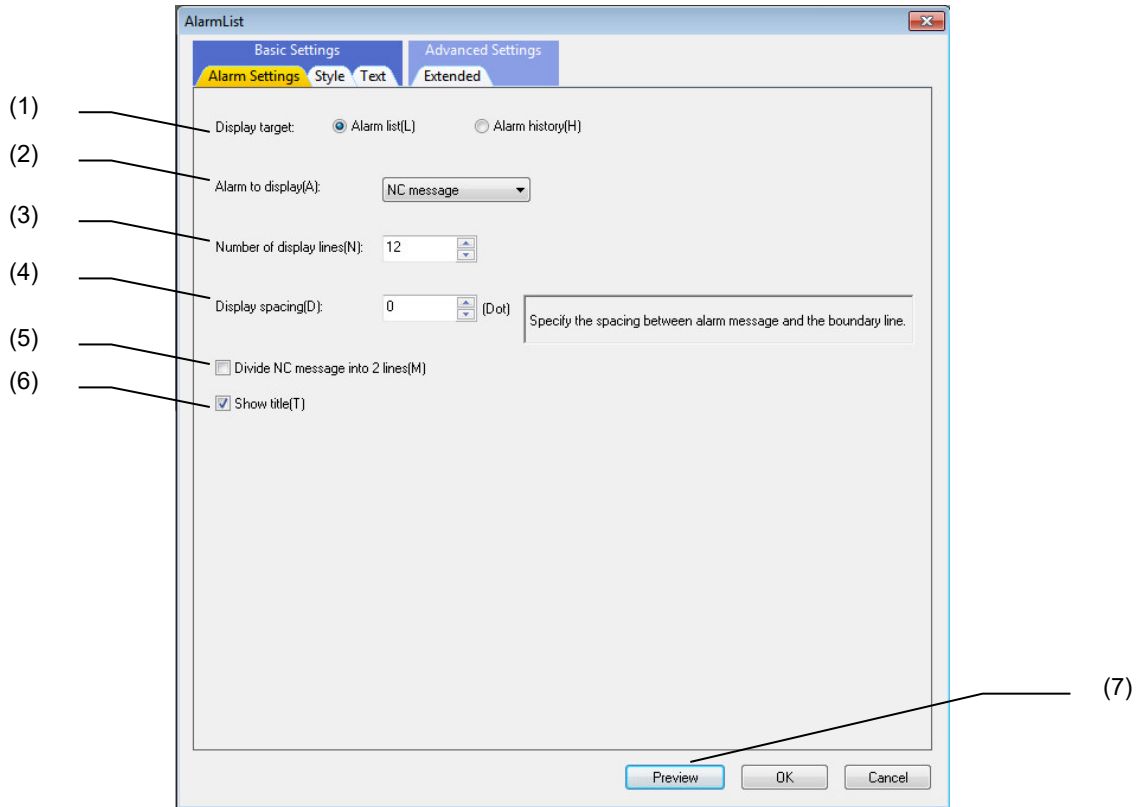

No.	Item	Description
(1)	Display target	Select the display target between "Alarm list" and "Alarm history".
(2)	Alarm to display	Select the alarm type to display among "NC message", "Stop code", "Alarm message" and "Operator message". (Note) This item cannot be set if "Alarm history" is selected for the display target. In this case, the history of NC message and alarm message is displayed.
(3)	Number of display lines	Specify the number of lines to display in one page.
(4)	Display spacing	Specify the spacing between the alarm message and the boundary line.
(5)	Divide NC message into 2 lines	Check this box to divide the NC message into 2 lines.
(6)	Show title	Check this box to show the title part.
(7)	Preview	Display the window to check the specified property design.

**NOTE**

◆ The alarm to display and the page no. are displayed on the title part.

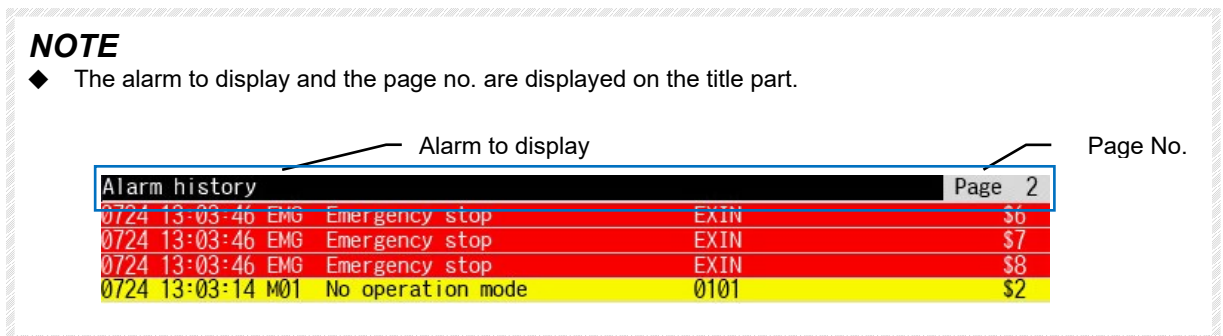

7.3.26.1.2 [Style] Tab

In [Style] tab, specify the background color.

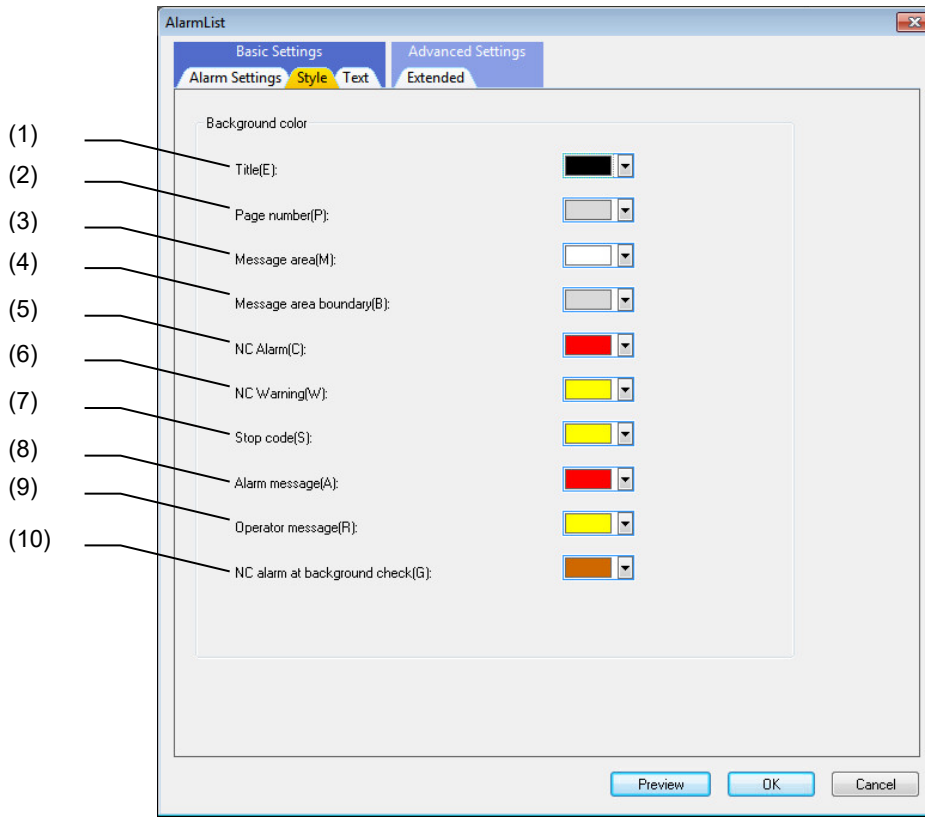

No.	Item	Description
(1)	Title	Specify the background color of the title.
(2)	Page number	Specify the background color of the page number.
(3)	Message area	Specify the background color of the message area.
(4)	Message area boundary	Specify the background color of the message area boundary.
(5)	NC Alarm	Specify the background color of the NC alarm message.
(6)	NC Warning	Specify the background color of the NC warning message.
(7)	Stop code	Specify the background color of the stop code message.
(8)	Alarm message	Specify the background color of the alarm message.
(9)	Operator message	Specify the background color of the operator message.
(10)	NC alarm at background check	Specify the background color of the NC alarm message during the background check.

7.3.26.1.3 [Text] Tab

In [Text] tab, specify the font and the character color.

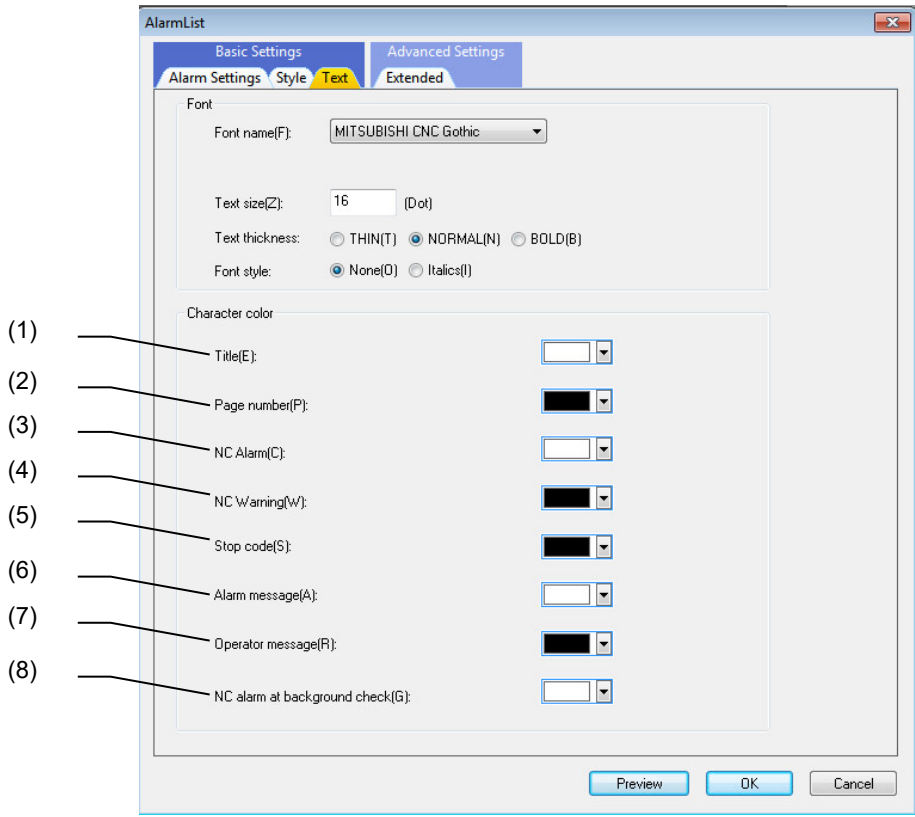

No.	Item	Description
(1)	Title	Specify the character color of the title.
(2)	Page number	Specify the character color of the page number.
(3)	NC Alarm	Specify the character color of the NC alarm message.
(4)	NC Warning	Specify the character color of the NC warning message.
(5)	Stop code	Specify the character color of the stop code message.
(6)	Alarm message	Specify the character color of the alarm message.
(7)	Operator message	Specify the character color of the operator message.
(8)	NC alarm at background check	Specify the character color of the NC alarm message during the background check.

For the items other than the above, refer to "7.1.16.1.2 [Text] Tab".

7.3.26.1.4 [Extended] Tab

In [Extended] tab, specify the message conversion and operation.

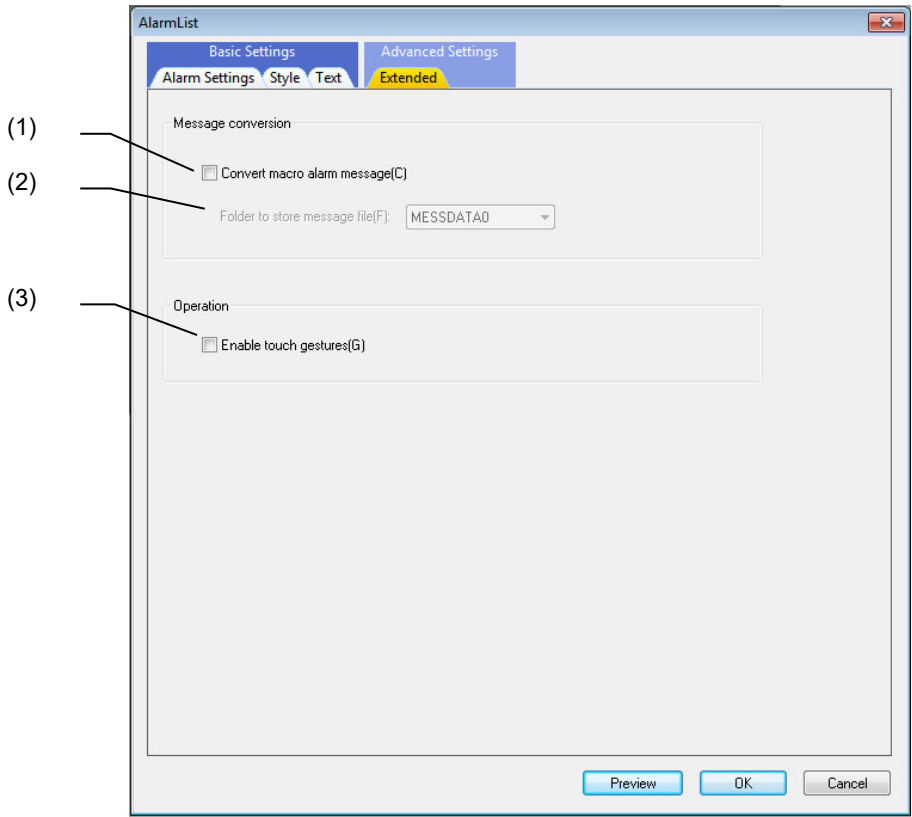

No.	Item	Description
(1)	Convert macro alarm message	Check this box to convert the macro alarm message (NC message of P277). Refer to "7.3.26.3. Complements Message Conversion" for the method of converting macro alarm message.  (Note) Macro alarm message cannot be converted when there is no message definition file. Create a message definition file. Refer to "7.3.26.3. Complements Message Definition File Description Method" for the description method.
(2)	Folder to store message file	Select the folder that stores the message definition file. Select from MESSDATA0 to MESSDATA7.
(3)	Enable touch gestures	Check this box to accept a touch gesture operation.

**7.3.26.2 Property Settings**

Property settings for the alarm list can be categorized as follows:

- Control name : Specify the control name.
- Position/Size : Specify the position and size of the control.
- Show/Hide : Specify whether to display the control or not.
- Font : Specify the font for the character string displayed in the control.
- Display type : Specify the alarm to be displayed on the control.
- Title : Specify items regarding the title.
- Message area : Specify items regarding the message area.
- Operation : Specify the operation of the control.
- Callback function : Specify whether the callback functions are provided or not.

Message File

Item	Descriptions
Message folder	Select the folder in which the message definition file is stored among MESSDATA0 to MESSDATA7. (Initial value: MESSDATA0)

\* For details of the message file, refer to 7.3.26.3 Complements.

Display Type

Item	Descriptions
Display target	Select the display target between Alarm list and Alarm history. (Initial value: Alarm list)
Display type *1	Select the display type among NC message, Stop code, Alarm message, or Operator message. (Initial value: NC message)

\*1 Enabled when Alarm list is selected for the display target.

**NOTE**

◆ When Alarm history is selected for the display target, the history of NC messages and alarm messages is displayed regardless of the display type setting.

Font

Item	Descriptions
Font *1	Select the font resource ID for the character string displayed in the control.

\*1 Row heights of the title, list area, and history area are displayed according to the font size.

The display width of the message is also displayed according to the font size.

When adopting XGA/VGA size, adjust the display by specifying the font size.



Title

Item	Descriptions
Title *1	Select the display of the title between "Yes" and "No". (Initial value: Yes)
Title character color	Specify the title character color to be displayed in title.
Title background color	Specify the title background color.
Page number character color	Specify the page number character color.
Page number background color	Specify the page number background color.

\*1 Title will be displayed as follows depending on the "Title" setting.

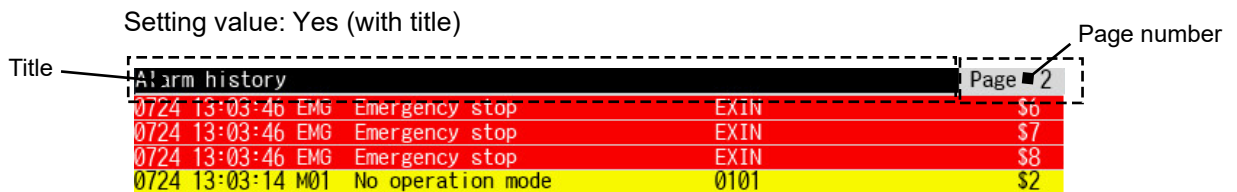

Setting value: No (without title)

0724	13:03:46	EMG	Emergency stop	EXIN	\$6
0724	13:03:46	EMG	Emergency stop	EXIN	\$7
0724	13:03:46	EMG	Emergency stop	EXIN	\$8
0724	13:03:14	M01	No operation mode	0101	\$2

Message Area

Item	Descriptions
Number of display lines *1	Specify the number of display message lines in one page. (0 to 30)
Display spacing *2	Specify the spacing between displayed character string and boundary. (0 to 36)
2-line display	Select whether to display the NC message in two lines. (Initial value: No)
Message conversion	Select either Yes/No the macro alarm message (P277 NC message).(Initial value: No)

\*1 Number of display lines may be less than the setting value depending on the "HEIGHT" setting.

\*2 Display spacing is applied to the lines of message area, but is not applied to title.

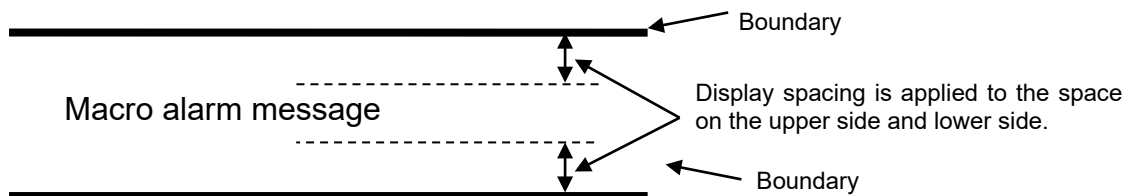

Color

Item	Descriptions
Background color in message area	Select the background color for lines without alarm display in message area.
Boundary color in message area	Specify the color for ruler between the rows.
NC alarm character color	Select the character color for NC message (alarm).
NC alarm background color	Select the background color for NC message (alarm).
NC warning character color	Select the character color for NC message (warning).
NC warning background color	Select the background color for NC message (warning).
Stop code character color	Select the character color for stop code.
Stop code background color	Select the background color for stop code.
Alarm message character color	Select the character color for alarm message.
Alarm message background color	Select the background color for alarm message.
Operator message character color	Select the character color for operator message.
Operator message background color	Select the background color for operator message.
NC alarm character color during background check	Select the character color for NC alarm during background check.
NC alarm background color during background check	Select the background color for NC alarm during background check.

Operation

Item	Descriptions
Touch gesture	Select whether to accept (permit) or reject (prohibit) a touch gesture operation. (Initial value: Prohibition)

**NOTE**

◆ When accepting (permitting) a touch gesture operation, display contents can be scrolled by the following operations.

- Pan (Run your fingertip along the screen)

The touched line is scrolled along your finger motion (Vertical direction).

- Flick (Quickly run your fingertip along the screen)

The screen is scrolled with inertia in the direction of your finger sweep (Vertical direction).

For the other properties, refer to "7.1 Common Functions of Controls".

7.3.26.3 Complements

Alarm List

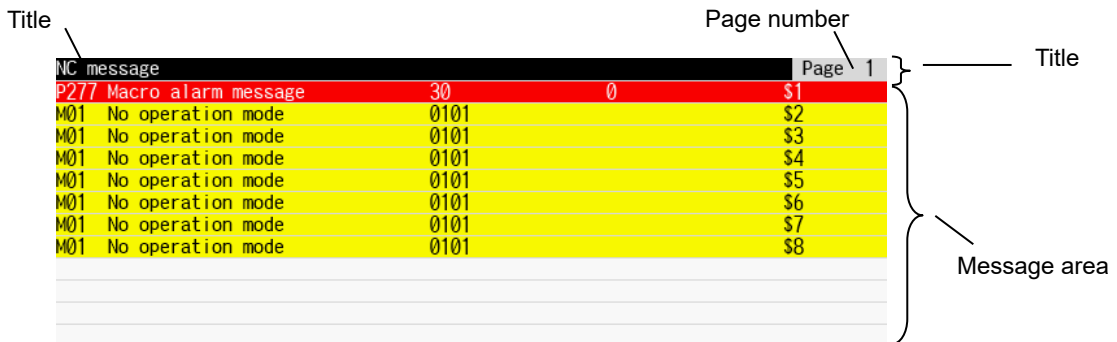

Information displayed in the alarm list is as follows.

Display target	Display type	Displayed contents	Number of display
Alarm list	NC message	An operation alarm, program error, MCP alarm, servo alarm or system alarm is displayed. Messages are displayed in order of priority.	Max. 10
	Stop code	The automatic operation status or stop status during automatic operation are displayed. Messages are displayed in order of priority.	Max. 4
	Alarm message	A message such as the details of machine error is displayed by use of user PLC.	Max. 4
	Operator message	The operator message is displayed by use of user PLC. Macro alarm messages are also displayed in this field.	Max. 4

(1) NC Message

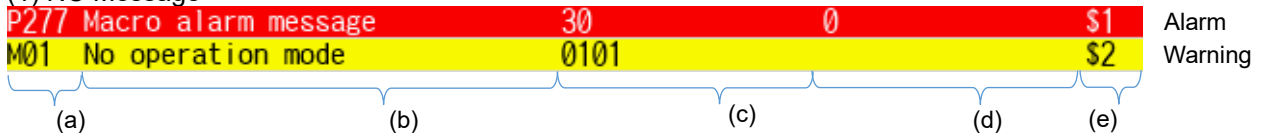

No.	Item	Description
(a)	Alarm class	Alarm class is displayed. 4 one-byte characters
(b)	Alarm message	Alarm message is displayed. 30 one-byte characters (15 two-byte characters)
(c)	Parameter 1	Alarm number, alarm class, and axis name or axis number are displayed. 12 one-byte characters for each item
(d)	Parameter 2	
(e)	Part system	The part system name is displayed. 4 one-byte digits

\* One-byte space is inserted between the items.

(2) Stop code

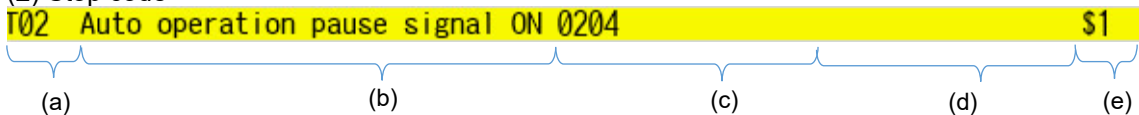

No.	Item	Description
(a)	Alarm class	Alarm class is displayed. 4 one-byte characters
(b)	Alarm message	Alarm message is displayed. 30 one-byte characters (15 two-byte characters)
(c)	Parameter 1	Alarm number, alarm class, and axis name or axis number are displayed. 12 one-byte characters for each item
(d)	Parameter 2	
(e)	Part system	The part system name is displayed. 4 one-byte digits

\* One-byte space is inserted between the items.

7. Creating Controls

(3) Alarm message

- With alarm class display (When #1263 bit2 is OFF)



- Without alarm class display (When #1263 bit2 is ON)

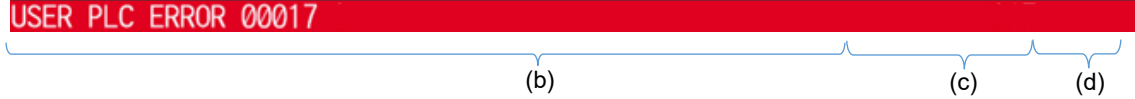

No.	Item	Description
(a)	Alarm class	Alarm class is displayed. 5 one-byte characters
(b)	Alarm message	PLC alarm message is displayed. 46 one-byte characters (23 two-byte characters)
(c)	Parameter	Parameter is displayed. 12 one-byte characters
(d)	Blank	

\* One-byte space is inserted between the items.

(4) Operator message

- With alarm class display (When #1263 bit2 is OFF)

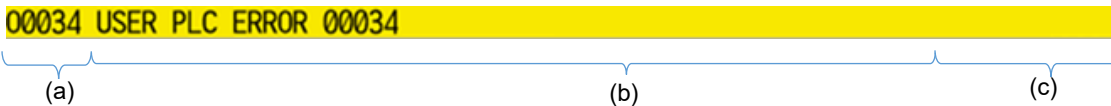

- Without alarm class display (When #1263 bit2 is ON)

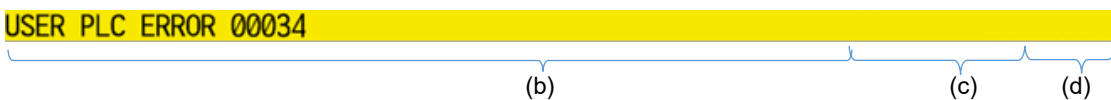

No.	Item	Description
(a)	Alarm class	Alarm class is displayed. 5 one-byte characters
(b)	Alarm message	Operator message is displayed. 60 one-byte characters (30 two-byte characters)
(c)	Parameter	Parameter is displayed. 12 one-byte characters
(d)	Blank	

\* One-byte space is inserted between the items.

Alarm History

The screenshot shows a window titled "Alarm history" with "Page 1" in the top right. The message area contains the following data:

Title				Page number	Title
0724	14:23:52	EMG	Emergency stop	SPIN	\$1
0724	14:23:52	EMG	Emergency stop	SPIN	\$2
0724	14:23:52	M01	No operation mode	0101	\$2
0724	14:23:52	EMG	Emergency stop	SPIN	\$3
0724	14:23:52	M01	No operation mode	0101	\$3
0724	14:23:52	EMG	Emergency stop	SPIN	\$4
0724	14:23:52	M01	No operation mode	0101	\$4

The right side of the window is labeled "Message area".

Information displayed in the alarm history is as follows.

Display target	Displayed contents	Number of display
Alarm history	Alarm information (NC message and alarm message) that occurred is displayed.	Max. 512

(1) NC Message

The screenshot shows an "Alarm Warning" window with the following message: "0724 12:35:25 P277 Macro alarm message 30 0 \$1" and "0724 13:03:14 M01 No operation mode 0101 \$2". Brackets below the message identify fields (a) through (g): (a) Date, (b) Time, (c) Alarm class, (d) Alarm message, (e) Alarm data 1, (f) Alarm data 2, and (g) Part system.

No.	Item	Description
(a)	Date	Date of the alarm occurrence is displayed. 2 one-byte characters for month and date (MMDD)
(b)	Time	Time of the alarm occurrence is displayed. 2 one-byte characters for time:minute:second (HH:NN:SS)
(c)	Alarm class	Alarm class is displayed. 4 one-byte characters
(d)	Alarm message	Alarm message is displayed. 30 one-byte characters (15 two-byte characters)
(e)	Alarm data 1	Alarm number, alarm class, and axis name or axis number are displayed.
(f)	Alarm data 2	
(g)	Part system	The part system name is displayed. 4 one-byte digits

\* One-byte space is inserted between the items.

(2) Alarm message

The screenshot shows an "Alarm message" window with the message: "1018 16:32:00 PLC USER PLC ERROR 256 5". Brackets below the message identify fields (a) through (g): (a) Date, (b) Time, (c) Fixed character string, (d) Alarm message, (e) Message number, (f) Classification number, and (g) (Blank).

No.	Item	Description
(a)	Date	Date of the alarm occurrence is displayed. 2 one-byte characters for month and date (MMDD)
(b)	Time	Time of the alarm occurrence is displayed. 2 one-byte characters for time:minute:second (HH:NN:SS)
(c)	Fixed character string	Fixed to "PLC". 3 digits
(d)	Alarm message	Alarm message is displayed. Up to 30 one-byte characters (15 two-byte characters)
(e)	Message number	0 to 1023, 12 one-byte characters (and space after the character)
(f)	Classification number	-32768 to 32767, 0 is not displayed. 12 one-byte characters (and space after the character)
(g)	(Blank)	4 one-byte digits

\* One-byte space is inserted between the items.

Message Conversion

The alarm message for the macro alarm displayed on the alarm list or alarm history (the NC message of alarm class P277) can be changed to the message for each arbitrary parameter 1 (alarm number) \*1. To convert the message with an alarm list part, prepare a message definition file. For the format, refer to Message Definition File Description Method.

\*1 In the alarm history, alarm data 1 (alarm number)

The following is a conversion example of the macro alarm message occurred while displaying the alarm list.

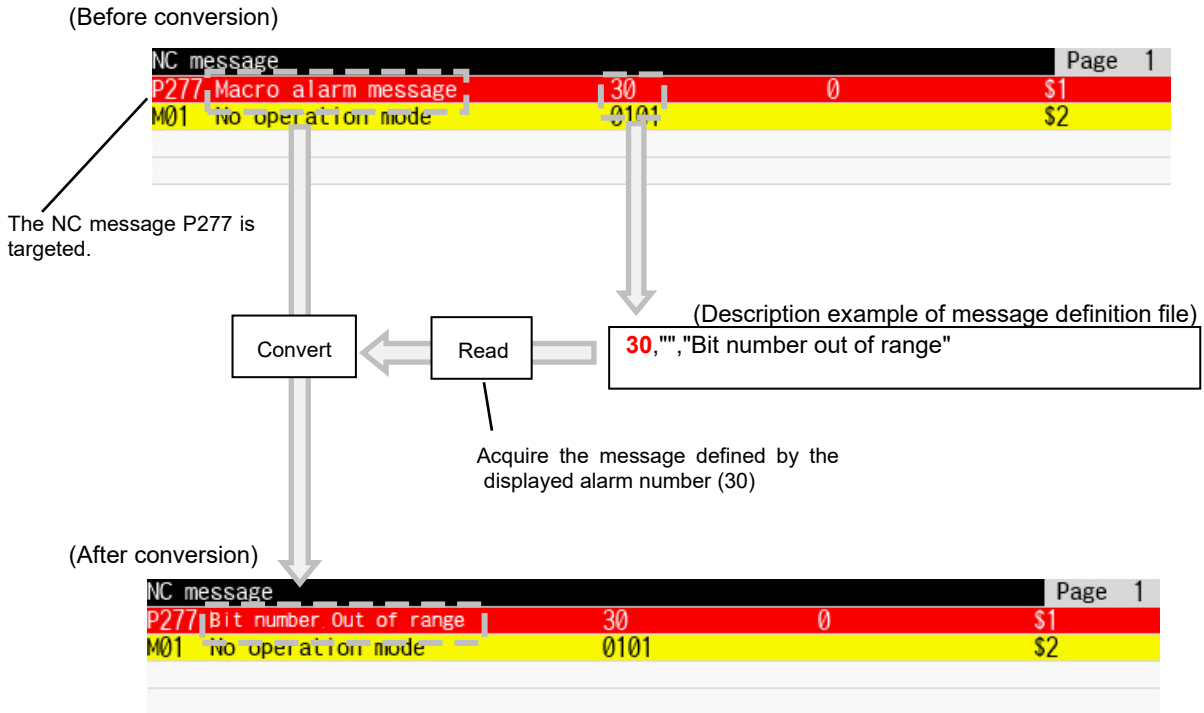

**Message Definition File Description Method**

The message definition file to be used in the alarm list part (MACRO\_ALMSG.TXT) must be described by Unicode (UTF-16: little-endian with BOM) text.

Up to 1000 of message can be included in the file, when one message is regarded as one line.  
 It is possible to describe messages in more than one language in the message definition text file.  
 Use a comma (,) to separate each item.

The following items are described in the message definition file.

Item	Setting value	Description
Alarm number	1 to 9999	Describe the alarm number of the macro alarm message (parameter 1 of the NC message) in a decimal number. When the value exceeds the setting range, the message is not converted.
Message character string	30 one-byte characters per one language (15 two-byte characters)	Describe the message character string. Enclose the message with double quotations (""). If you wish to describe a double quotation (") or back slash (\), use "\" or "\\".

For the unused languages, insert delimiters (commas ,) to the omitted languages to align the languages and message positions.

To use the message character strings in English, Japanese, French and Portuguese, describe as follows.  
 (Example) 1,"english","japanese",,"français",,,,,,"português"

**NOTE**

- ◆ To describe messages in more than one language, the messages are described in the following order.

1: English	2: Japanese	3: German	4: French	5: Italian
6: Spanish	7: Chinese (traditional)	8: Korean	9: Portuguese	10: Dutch
11: Swedish	12: Hungarian	13: Polish	14: Chinese (simplified)	15: Russian
16: Turkish	17: Czech	18: Indonesian	19: Vietnamese	

The language to display messages is changed according to "#1043 lang (Select language displayed)" [base common parameter].

When a language is switched to the one in which messages are not described, the messages are not converted.

- ◆ If a semicolon (;) is described at the top of the line, the line is handled as a comment line.
- ◆ When the message conversion is used for multiple controls, select the same message folder.
- ◆ When the registration exceeds 1000, the messages are not converted.
- ◆ The size of the message definition file should be 100K byte or less.
- ◆ When using the custom release file setting function, store the created message definition file (MACRO\_ALMSG.TXT) in the project folder of the project being edited.

Detailed Display of the Alarm

When the macro process is added, the displayed alarm information is acquired and the related information can be displayed with an HTML browser part, etc.

The following is the example of displaying the HTML file (P277\_120.htm) information with the HTML browser part by acquiring the alarm information and displaying the window while a macro alarm of the NC message (the alarm class is "P277" and the parameter 1 (alarm number) is "120") occurs.

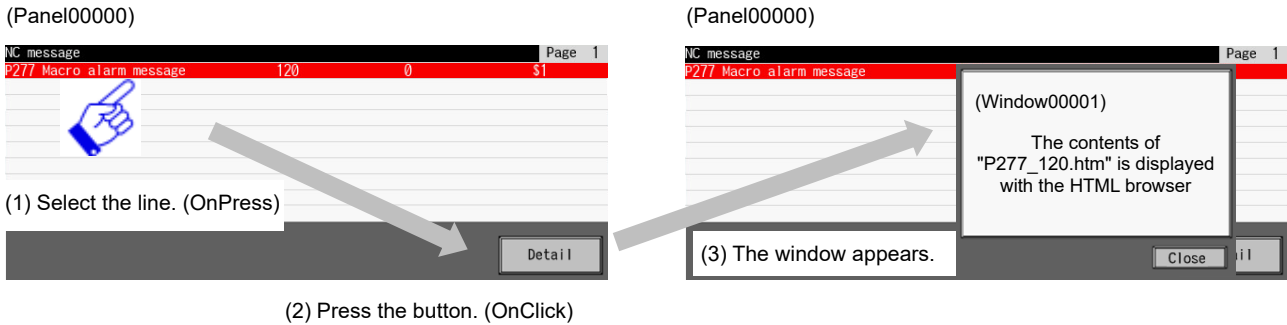

< Interpreter method >

(Panel00000)

```

$GNCAAlarmList00000-OnCreate
    GMEM mem;

    'Create the global memory
    mem = GMEMCreate("ALINFO", 256);
$End

$GNCAAlarmList00000-OnPress
    GMEM mem;
    LONG ISel;
    LONG IReturn;
    STRING strFile;
    STRING strAllInfo(2);

    ' Execute the normal process
    NormalMethod();

    ' Acquire the selected line number
    ISel = GCSNCAAlarmListGetSelectLine(-1, "GNCAAlarmList00000");
    ' Acquire the alarm information of the selected line (alarm class and parameter 1)
    IReturn = GCSNCAAlarmListGetAlarmInfo(-1, "GNCAAlarmList00000", ISel, H5, strAllInfo);

    ' Create HTML file name ("P277_120.htm")
    strcpy(strFile, strAllInfo(0));
    strcat(strFile, "_");
    strcat(strFile, strAllInfo(1));
    strcat(strFile, ".htm");

    ' Select the global memory and specify the HTML file name
    mem = GMEMSelect("ALINFO");
    GMEMSetString(mem, 0, strFile);
$End
    
```



(Panel00000)

```

$GButton00001-OnClick
  @100 = 0;
  ' Display Window00001
  GCSCreateGWindow(1);
$End

$GNCAAlarmList00000-OnDelete
  GMEM mem;

  ' Delete the global memory
  mem = GMEMSelect("ALINFO");
  GMEMDelete(mem);
$End

```

(Window00001)

```

$GBasicControl00002-OnTimer
  STRING strFile;
  GMEM mem;

  if (@100 == 0)
    ' Acquire the HTML file name created from the alarm information
    mem = GMEMSelect("ALINFO");
    strFile = GMEMGetString(mem, 0);

    ' Specify the HTML file name to display on the HTML browser
    GCSThtmlbrowserSetHtmlFileName(-1, "GHtmlBrowser00000", strFile);
    @100 = 1;
  endif
$End

$GButton00001-OnClick
  GCSCloseGWindow(1);
$End

```

**NOTE**

- ◆ To acquire the selected line number at the execution of the OnPress event of the alarm list part, describe "NormalMethod()" function beforehand in the OnPress event of the macro editing.

&lt; Compilation method &gt;

(Panel00000)

```

GTCHAR gstrFile[20] = {0};

long GCPanel00000::GNCALARMLIST00000OnPress(unsigned short usMessage, long ILParam, long IUParam)
{
    short nIndex;
    long lSel;
    long lResult;
    GTCHAR gstrAllInfo[2][20] = {0};
    WSTRINGTYPE wStr[2] = {0};
    GBaseObject *pPanel = GetGBaseObject();
    GBaseObject *pAllList = GCSGetChild(pPanel, GNCALARMLIST00000);

    // Setting of the structure for acquiring the alarm information (setting of the size and the alarm
    // information storage area)
    for (nIndex = 0; nIndex < 2; nIndex++)
    {
        wStr[nIndex].lBuffSize = 20;
        wStr[nIndex].lpszBuff = &gstrAllInfo[nIndex][0];
    }

    // Acquire the selected line number
    lSel = GCSNCAAlarmListGetSelectLine(pAllList);
    // Acquire the alarm information of the selected line (alarm class and parameter 1)
    lResult = GCSNCAAlarmListGetAlarmInfo(pAllList, lSel, 0x00000005, wStr);

    // Create HTML file name ("P277_120.htm")
    _sgtprintf(gstrFile, TEXT("%s_%s.htm"), &gstrAllInfo[0][0], &gstrAllInfo[1][0]);

    return TRUE;
}

long GCPanel00000::GBUTTON00001OnClick(unsigned short usMessage, long ILParam, long IUParam)
{
    // Display Window00001
    GCSCreateGWindow(GCSGetScreen(GetGBaseObject()), 1);
    return TRUE;
}

```

(Window00001)

```

extern GTCHAR gstrFile[20];

long GCWindow00001::GHTMLBROWSER00000OnInit(unsigned short usMessage, long ILParam, long IUParam)
{
    GBaseObject *pPanel = GetGBaseObject();
    GBaseObject *pHtml = GCSGetChild(pPanel, GHTMLBROWSER00000);

    // Specify the HTML file name to be displayed on the HTML browser
    GCShhtmlbrowserSetHtmlFileName(pHtml, gstrFile);
    return TRUE;
}

```

(Window00001)

```
long GCWindow00001::GHTMLBROWSER00000OnInit(unsigned short usMessage, long ILParam, long
IUParam)
{
    GBaseObject *pPanel = GetGBaseObject();
    GBaseObject *pHtml = GCSGetChild(pPanel, GHTMLBROWSER00000);

    // Specify the HTML file name to be displayed on the HTML browser
    GCSThtmlbrowserSetHtmlFileName(pHtml, gstrFile);
    return TRUE;
}
```

### 7.3.26.4 Restrictions

NC alarms (alarms and warnings) and alarm messages recorded on the history are displayed in the alarm history. The following messages are not recorded in the history.

- Operation alarm
  - External interlock axis exists (M01 0004)
  - Cutting override zero (M01 0102)
  - External feed rate zero (M01 0103)
  - Block start interlock (M01 0109)
  - Cutting block start interlock (M01 0110)
  - Rapid traverse override zero (M01 0125)
  - Sp-Sp polygon (G51.2) cut interlock (M01 1033)
- "U50 PLC stopped" before the HMI screen starts up
- Stop code
- Operator message

**7.3.27 Meter (GNCMeter)**

The meter part enables the reading of NC data such as spindle information etc. at specified cycle, and displays it as a meter on the custom screen. This part also gives a visual confirmation of the changes and the status of the values.

"Bar(horizontal)", "Bar(vertical)" or "Sector" can be selected for the shape by property setting. Meter is the control dedicated to M800V/M80V/M800/M80/E80 Series.

< Image >

- Bar(horizontal)



- Bar(vertical)

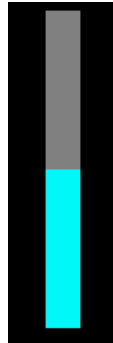

- Sector



7.3.27.1 Property Setup Dialog

Property setup dialog of the meter part consists of the tabs relating to [Basic Settings] and [Advanced Settings]. Details of each tab will be described in the following sections.

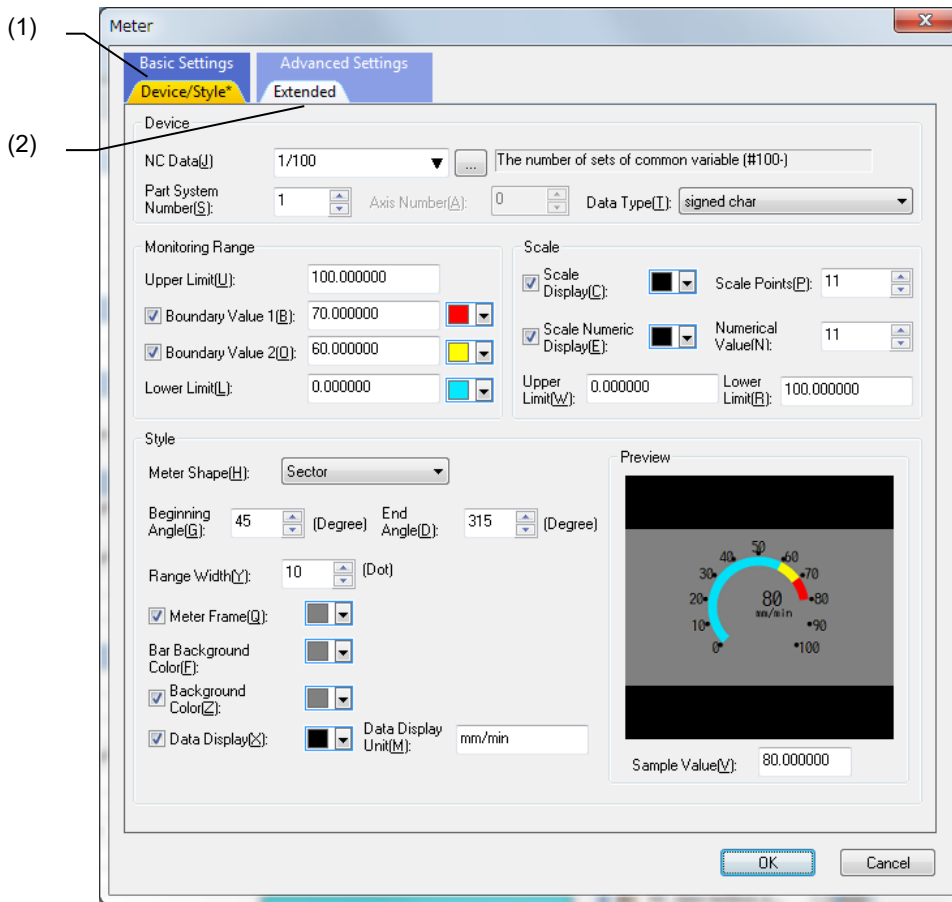

[Basic Settings] consists of the following tab.

No.	Tab	Description
(1)	Device/Style	Set or display the NC data, display design and preview.

[Advanced Settings] consists of the following tab.

No.	Tab	Description
(2)	Extended	Specify the refresh cycle and refresh timing of the data.

7.3.27.1.1 [Device/Style] Tab

In [Device/Style] tab, specify the target NC data, monitoring range, and style etc.

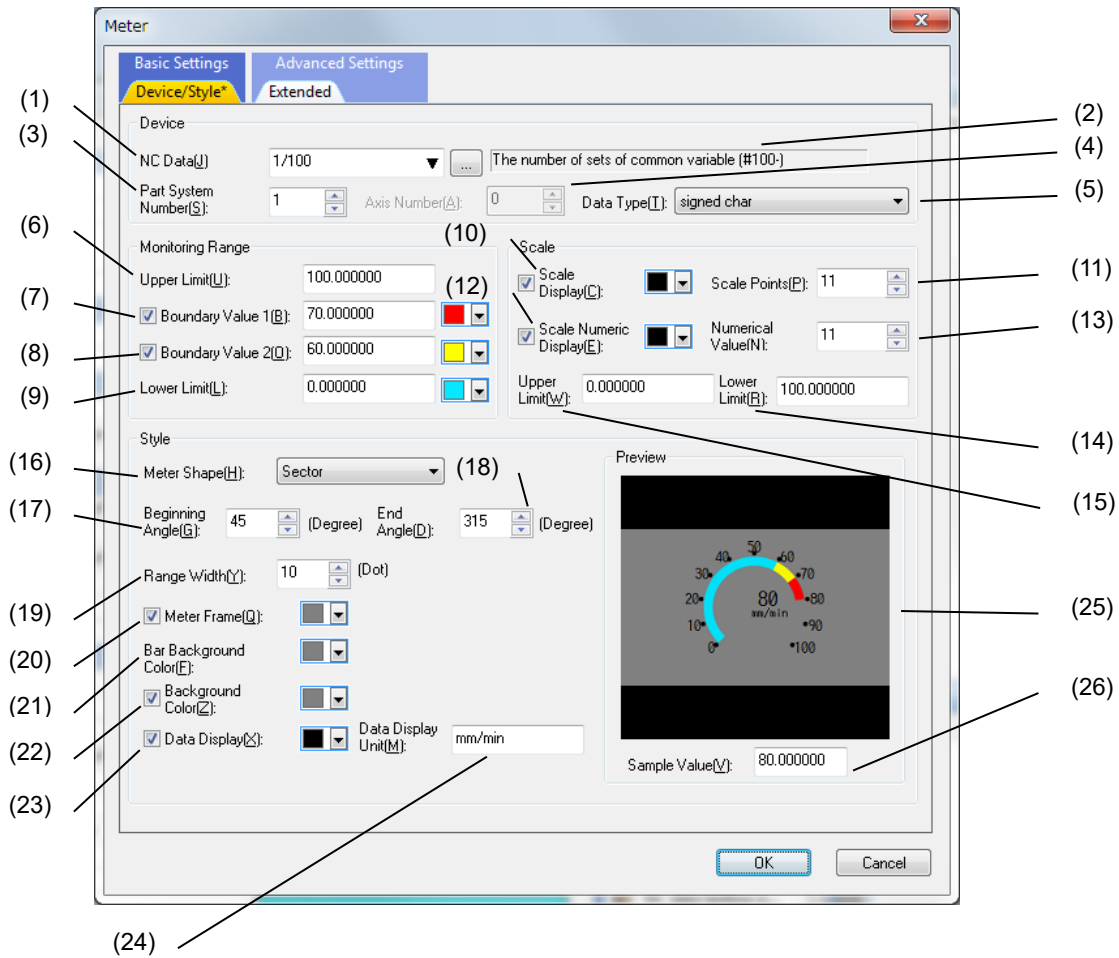

No.	Item	Description
(1)	NC Data	Specify the sec/sub-sec number of the NC data to read. (Section No.: 0 to 999, sub-section No.: 0 to 1000000000)
(2)	Description	Display the description of the sec/sub-sec data corresponding to the NC data candidate.
(3)	Part System Number	Specify the No. of the part system to which the NC data to read belongs. (1 to 10)
(4)	Axis Number	Specify the No. of the axis to which the NC data to read belongs. (0 to 32)
(5)	Data Type	Specify the type of the NC data to read. (signed char, unsigned char, signed short, unsigned short, signed long, unsigned long, double)
(6)	Upper Limit	Specify the upper limit of the data range. (-7999999999.0 to 7999999999.0)
(7)	Boundary Value 1	Check this box to display the upper data area. The color of the boundary value and the upper area can be set. (-7999999999.0 to 7999999999.0)
(8)	Boundary Value 2	Check this box to display the middle data area. The color of the boundary value and the middle area can be set. (-7999999999.0 to 7999999999.0)
(9)	Lower Limit	Specify the lower limit of the data area and the color of the lower area. (-7999999999.0 to 7999999999.0)
(10)	Scale Display	Check this box to display the scale. The color of the scale can be set.
(11)	Scale Points	Specify the number of scale points. (2 to 101)

7. Creating Controls

No.	Item	Description
(12)	Scale Numeric Display	Check this box to display the scale numeric value. The color of the scale numeric value can be set.
(13)	Numerical Value	Specify the number of numerical values displayed on the scale. (2 to 101)
(14)	Lower Limit (scale value)	Specify the lower limit value of the scale numeric value. (-7999999999.0 to 7999999999.0)
(15)	Upper Limit (scale value)	Specify the upper limit value of the scale numeric value. (-7999999999.0 to 7999999999.0)
(16)	Meter Shape	Select the meter shape among "bar(horizontal)"/"bar(vertical)"/"Sector"/"Image".
(17)	Beginning Angle	Specify the beginning angle only when the "Sector" in "Meter Shape" is selected. (0 to 359)
(18)	End Angle	Specify the end angle only when the "Sector" in "Meter Shape" is selected. (0 to 359)
(19)	Range Width	Specify the meter range width only when the "Sector" in "Meter Shape" is selected. (0 to 100)
(20)	Meter Frame	Check this box to display the meter frame. The color of the meter frame can be set.
(21)	Bar Background Color	Specify the background color of the bar.
(22)	Background Color	Check this box to paint out the background. The color of the background can be set.
(23)	Data Display	Check this box to display the NC data on the meter. The data display unit and the color of the data character can be set.
(24)	Data Display Unit	When the "Data Display" box is checked, the data unit to display can be set.
(25)	Preview	Check the design of the specified property.
(26)	Sample Value	Display an arbitrary NC data value while designing. (-7999999999.0 to 7999999999.0)



**NOTE**

- ◆ Press the "..." button beside the NC data field for advanced settings.

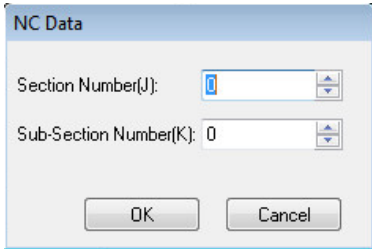

No.	Item	Description
(1)	Section Number	Specify the section number of the NC data to read. (0 to 999)
(2)	Sub-Section Number	Specify the sub-section number of the NC data to read. (0 to 1000000000)

This can also be set with input assist function.  
Refer to "7.1.16.4 Input Assist Function" for details.

- ◆ "Design" and "Data display position" can be selected when "Image" is selected on "Meter Shape".  
When "Design" is clicked, the parts library is displayed and the meter is displayed with the selected image.

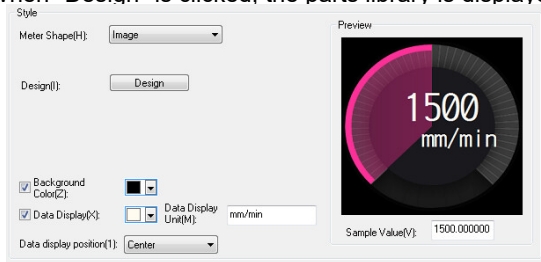

When "Meter Shape" is set to "bar(horizontal)", "bar(vertical)" or "Sector", the meter is displayed with the data set on the monitoring range settings, the style settings and the scale settings.

- ◆ The following can be set on the monitoring range settings  
- Bar(horizontal)

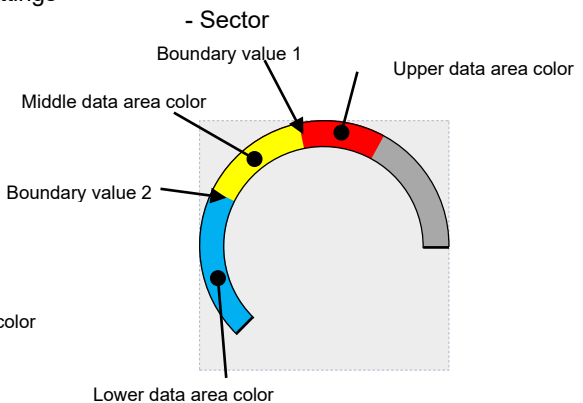
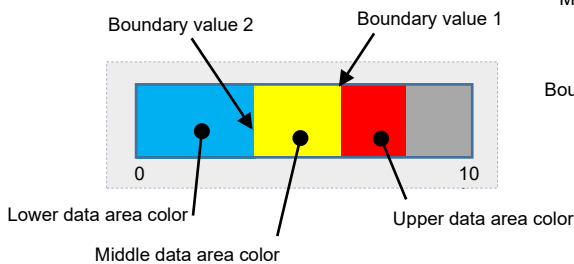

7. Creating Controls

- ◆ The following can be set on the style settings.
  - Bar(horizontal)

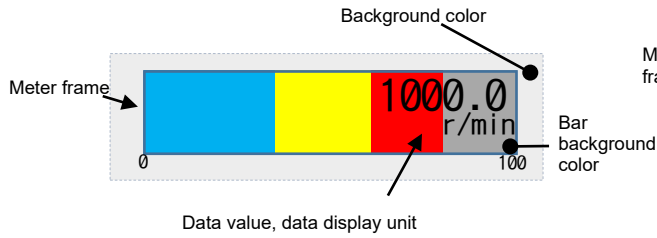

- Sector

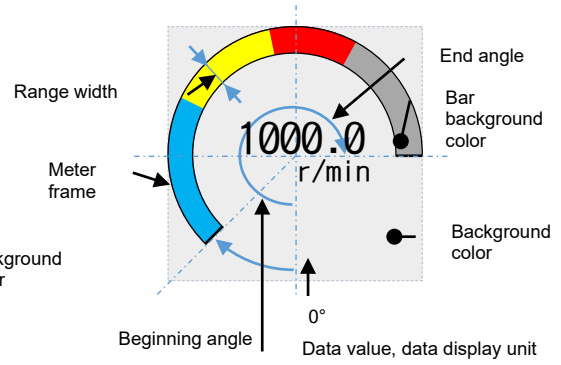

- ◆ The following can be set on the scale settings.

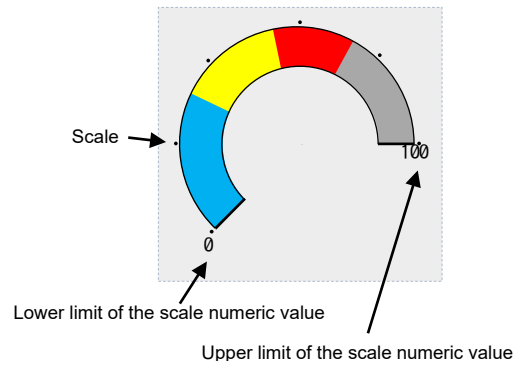
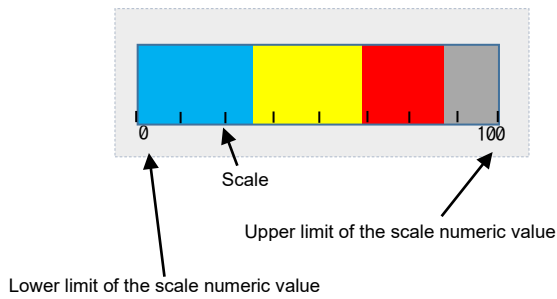

7.3.27.1.2 [Extended] Tab

In [Extended] tab, specify the refresh cycle and refresh timing of the data.

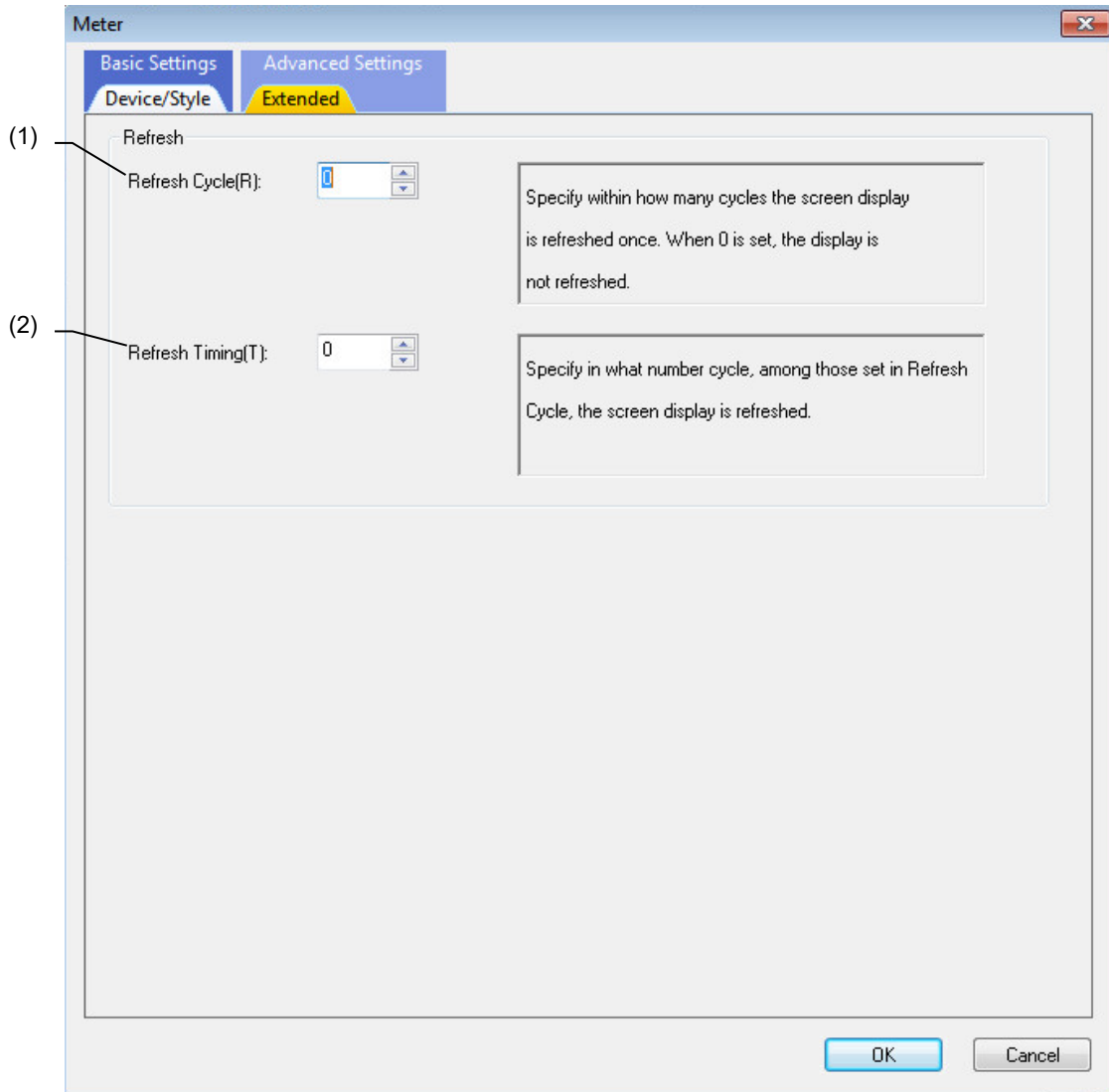

No.	Item	Description
(1)	Refresh Cycle	Specify the number of times to thin out the timer event processes (0 to 100). * The reading is executed only first time when 0 is set.
(2)	Refresh Timing	The display is refreshed at the moment when the counted number of "RefreshFrequency" reaches the number of counts specified with "RefreshTiming" (0 to 99)

**7.3.27.2 Property Settings**

Property settings for the meter part can be categorized as follows.

- Control name : Specify the control name.
- Position/Size : Specify the displaying position and size of the control.
- Address/NC data : Specify the setting relating to the NC data reading.
- Monitoring Range : Specify the input range of NC data, and boundary values.
- Style : Specify items regarding the meter shape and color.
- Scale : Specify items regarding the scale display.
- Data Display : Specify items regarding the display of the NC Data values.
- Refresh : Specify items regarding the refresh cycle of the NC data.
- Callback function : Specify whether the callback functions are provided or not.

Address/NC data

Item	Description
Number of systems	Specify the No. of the part system to which the NC data to read belongs. (1 to 10/initial value: 1)
Number of axis	Specify the No. of the axis to which the NC data to read belongs. (0 to 32/initial value: 0)
Number of section	Specify the section number of the NC data to read. (0 to 999/initial value: 0)
Number of sub-section	Specify the sub-section number of the NC data to read. (0 to 1000000000/initial value: 0)
Data type	Specify the data type of the NC data to read. (signed char, unsigned char, signed short, unsigned short, signed long, unsigned long, double)

Monitoring Range

Item	Description
Presence or absence of boundary value 1	Select the presence of the boundary value of the upper data area. Select from "Yes" and "None". (Initial value: "None")
Boundary value 1	Specify the boundary value of the upper data area. (-7999999999.0 to 7999999999.0/initial value: 70.0)
Presence or absence of boundary value 2	Select the presence of the boundary value of the middle data area. Select from "Yes" and "None". (Initial value: "None")
Boundary value 2	Specify the boundary value of the middle data area. (-7999999999.0 to 7999999999.0/initial value: 60.0)
Lower limit	Specify the lower limit of the data area. (-7999999999.0 to 7999999999.0/initial value: 0.0)
Upper limit	Specify the upper limit of the data area. (-7999999999.0 to 7999999999.0/initial value: 100.0)

(Note) When "Meter Shape" is "Image", the values set on the monitoring range settings are not used.

- Bar(horizontal)

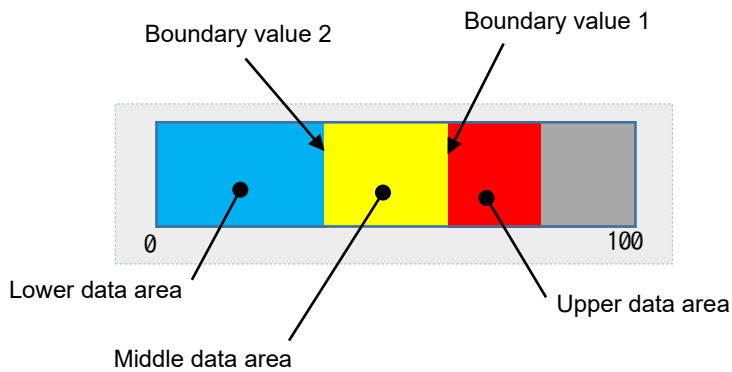

- Sector

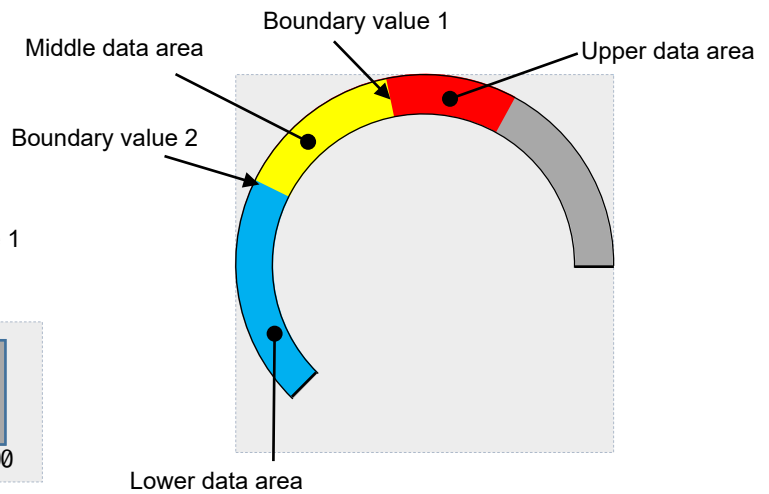

Style

Item	Description
Meter shape	Specify the meter shape. (bar(horizontal), bar(vertical), sector, image/initial value: Sector)
Display type	Select the display type. (Painting out, no painting out/initial value: No painting out)
Presence or absence of meter frame	Select the presence of the meter frame display. Select from "Yes" and "None".(Initial value: "None")
Meter frame color	Specify the meter frame color.
Background color	Specify the background color of the control.
Bar background color	Specify the background color of the bar.
Upper area color	Specify the color of the upper data area.
Middle area color	Specify the color of the middle data area.
Lower area color	Specify the color of the lower data area.
Beginning angle*1	Specify the beginning angle of the meter. (0 to 359/initial value: 45)
End angle*1	Specify the end angle of the meter. (0 to 359/initial value: 315)
Range width*1	Specify the range width of the meter. (0 to 100/initial value: 10)
Design(Animation)*2	Specify the image to display on the control.

\*1 This applies when "Meter Shape" is "Sector". If the "End Angle" is equal or smaller than the "Beginning Angle", an initial value is applied.

\*2 This applies when "Meter Shape" is "Image". Property items (except for "Display Type" and "Background Color") of the monitoring range settings, the style settings and the scale/scale numeric value settings are not used.

- Bar(horizontal)

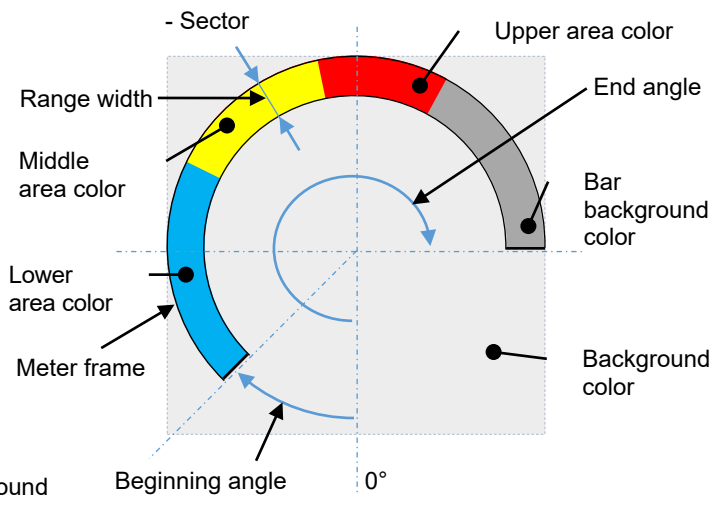
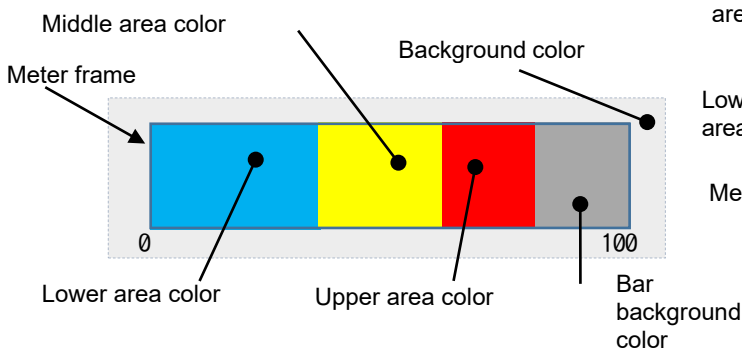

- When meter shape is Image

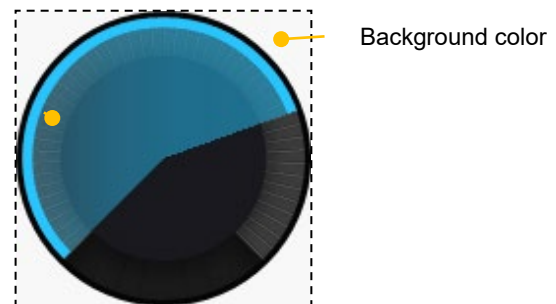
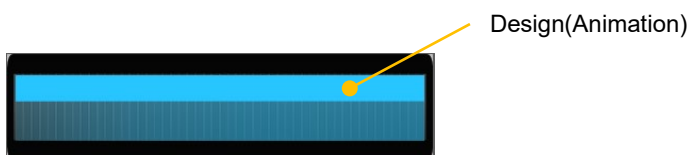

Scale/scale numeric value

Item	Description
Scale display	Select the presence of the scale display. Select from "Yes" and "None". (initial value: "None")
Scale color	Specify the scale color.
Scale points	Specify the number of the scale points. (2 to 101/initial value: 11)
Scale numeric display	Select the presence of the scale numeric display. Select from "Yes" and "None". (initial value: "None")
Numerical color	Specify the numerical value color.
Numerical value	Specify the number of the numerical values displayed on the scale (2 to 101/initial value: 11)
Lower limit	Specify the lower limit value of the scale numeric value. (-7999999999.0 to 7999999999.0/initial value: 0.0)
Upper limit	Specify the upper limit value of the scale numeric value. (-7999999999.0 to 7999999999.0/initial value: 100.0)

(Note) When "Meter Shape" is "Image", the values set on the scale/scale numeric value settings are not used.

- Bar(horizontal)

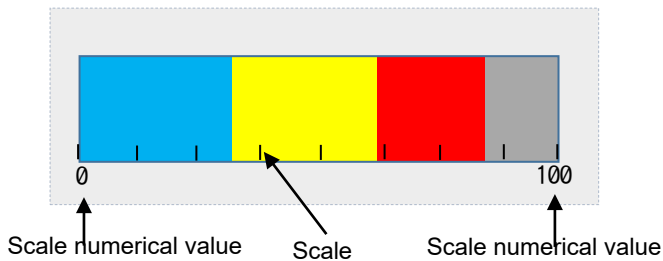

- Sector

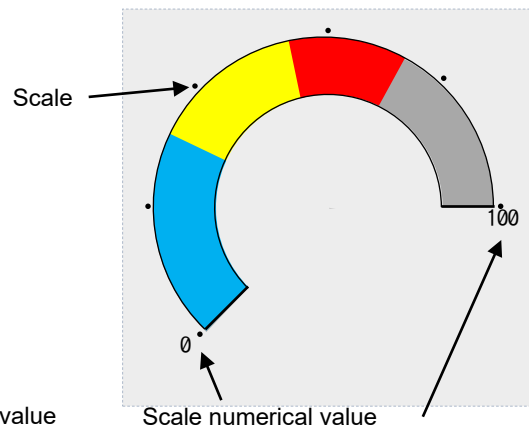

Data Display

Item	Description
Data display*1	Select the presence of the data value display. Select from "Yes" and "None". (initial value: "None")
Data display unit	Specify the data value unit.
Data text color	Specify the color of the data value and unit.
Data display position*2	Select the position to display the data value if "Meter Shape" in the style group is "Image" (Center, Right, Left, Top, Bottom/initial value: Center)
Sample value*3	Display an arbitrary NC data value while designing. (-7999999999.0 to 7999999999.0/initial value: 80.0)

\*1 If "Data Type" is "double", the value is displayed with one decimal place. If "Data Type" is not "double", the value is displayed as an integer. If the NC data value is outside the monitoring range, or if the acquisition of the NC data fails, the data value will be displayed with the number of "\*" equivalent to the digits.

(Example "Data Type" is "double", and upper limit is 100.0: "\*\*\*\*.\*")

\*2 This applies when "Meter Shape" is "Image".

\*3 This value is valid only when designing in NC Designer2.

- Bar(horizontal)

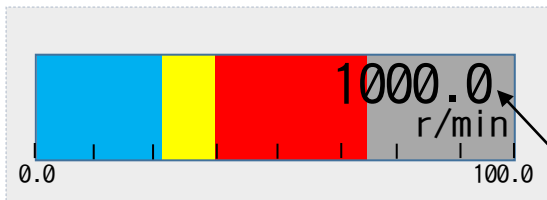

- Sector

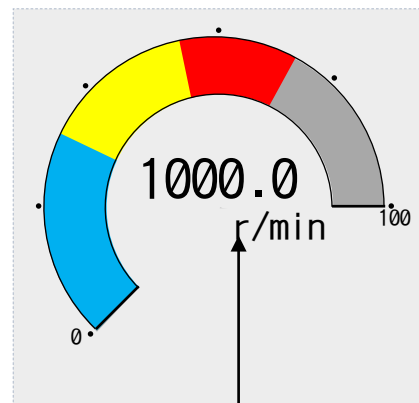

Data value/data display unit

Update

Item	Description
RefreshFrequency	Specify the number of times to thin out the timer event processes. (0 to 100/initial value: 20) *The reading is executed only first time when 0 is set.
RefreshTiming	The display is refreshed at the moment when the counted number of "RefreshFrequency" reaches the number of counts specified with "RefreshTiming". (0 to 99/initial value: 0)

Refer to "7.1 Common Functions of Controls" for other properties.



7.3.27.3 Complements

Example

Set as shown below to display the spindle speed (spindle information) with the meter parts (Sector)

< Example >

Item	Setting value
Number of axis	1
Number of section	34
Number of sub-section	1
Data type	Signed long
Presence of absence of boundary value 1	Yes
Boundary Value 1	500
Presence of absence of boundary value 2	Yes
Boundary value 2	300
Lower limit	0
Upper limit	1000
Meter shape	Sector
Presence of absence of meter frame	None
Scale display	None
Scale numeric display	Yes
Lower limit (Scale numeric value)	0
Upper limit (Scale numeric value)	1000
Data display	Yes
Data display unit	rev/min

< Image when the spindle rotation speed is 700 rev/min >

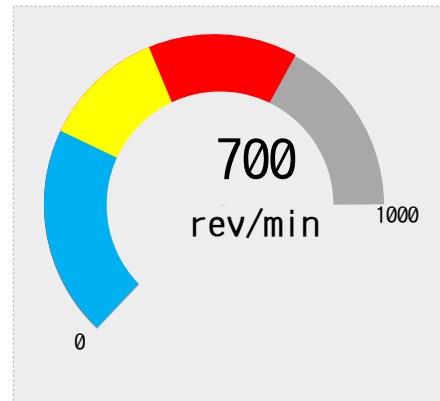

Animation File Display

To change the display according to the value read from the NC, select the image for "Meter Shape" and select the animation file (the file with more than one frame (static image): vgf file) for design(animation).

< Example >

Item	Setting value
Lower limit	0
Upper limit	1000
Meter shape	Image
Design(Animation)	METERBAR020_B

< Example of the display when the data value changes from 0 to 500, and to 1000. >

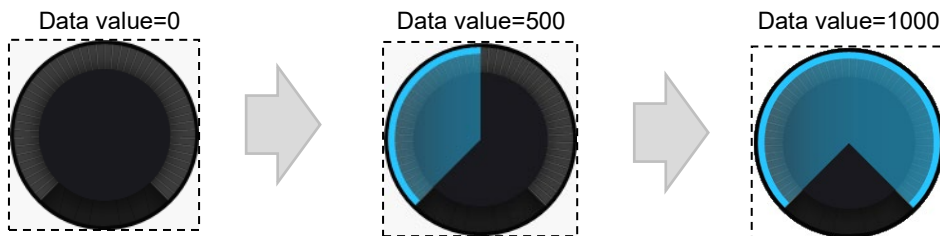

**NOTE**

- ◆ If the data value is lower than the lower limit, the display shows the image of the lower limit. If the data value exceeds the upper limit, the display shows the image of the upper limit.

**7.3.27.4 Precautions**

- Allocating a lot of meter parts may cause a delay of the events such as data acquiring interval, refresh, and the timer of the other controls etc. (Ten is standard about number of meter parts which can be allocated.)
- Meter parts does not display the absolute value. To display the absolute value, change the NC data to absolute values by a ladder etc. before referencing the values.

**7.3.27.5 Restrictions**

- When executing the interpreter method OnTimer() event, the NC data is not read at the frequency specified on refresh. To read the NC data, write the "NormalMethod()" function in the OnTimer() event of macro program.

**7.3.28 Trend Graph (GNCTrendGraph)**

The trend graph part is used to read the NC data such as the spindle information at the designated frequency and display it as a graph.

Aging can be checked by collecting the NC data continuously.

Trend graph is the control dedicated to M800V/M80V/M800/M80/E80 Series.

< Image >

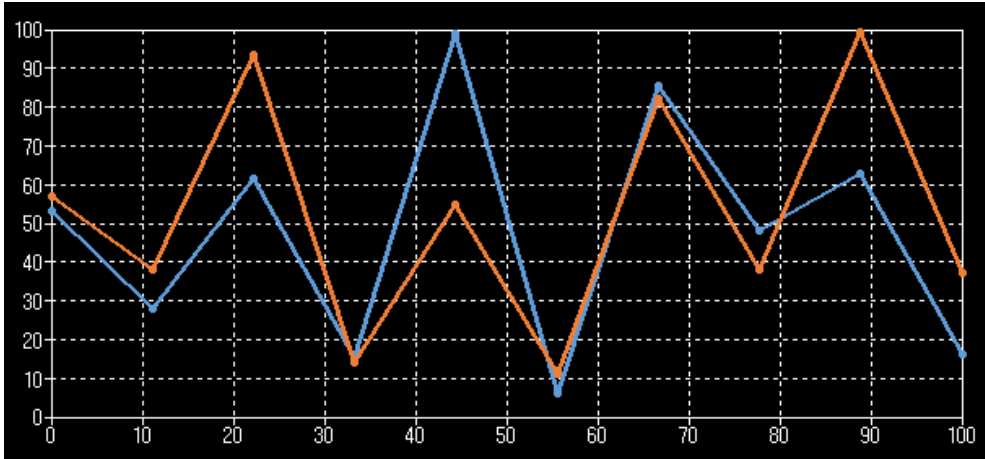

7.3.28.1 Property Setup Dialog

Property setup dialog of trend graph part consists of the tabs relating to [Basic Settings] and [Advanced Settings]. Details of each tab will be described in the following sections.

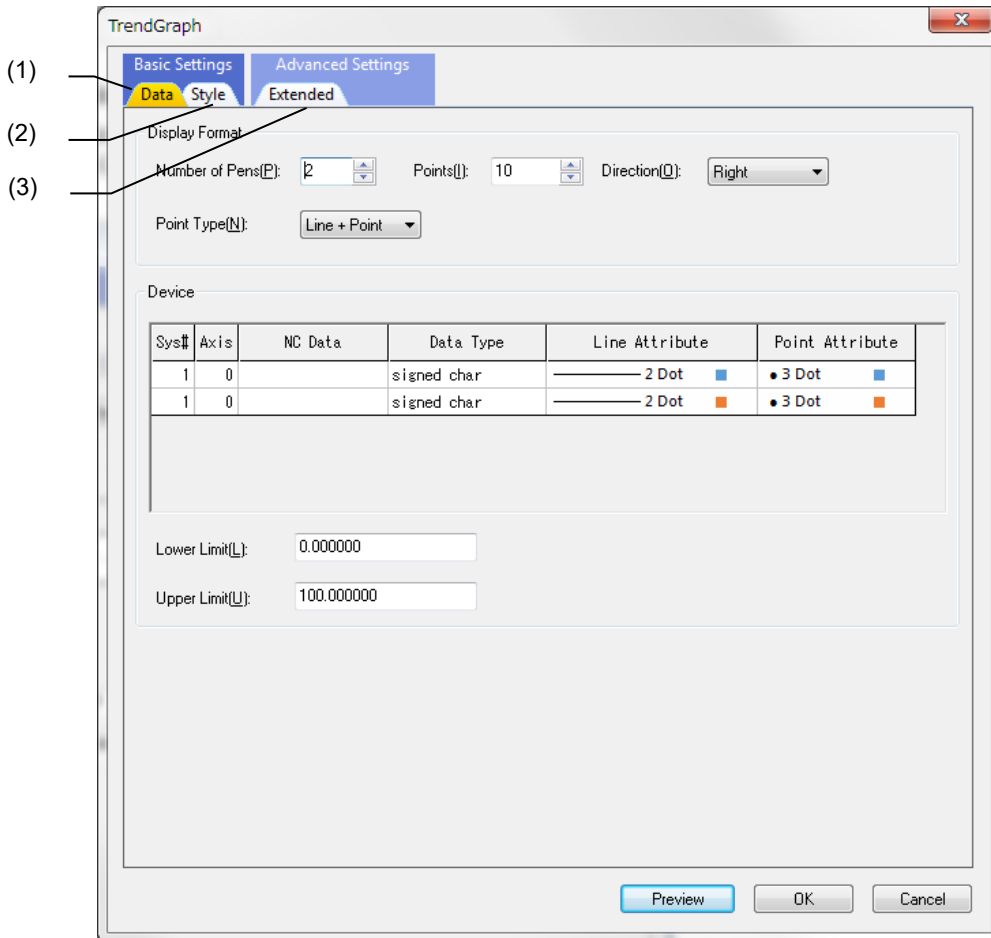

[Basic Settings] consists of the following tabs.

No.	Tab	Description
(1)	Data	Specify the number of pens, points, and the target NC data.
(2)	Style	Specify if the scale is provided or not, the number of scale points, and scale color.

[Advanced Settings] consists of the following tab.

No.	Tab	Description
(3)	Extended	Specify the refresh cycle of the data.

7.3.28.1.1 [Data] Tab

In [Data] Tab, specify the number of pens, points, and the target NC data, etc.

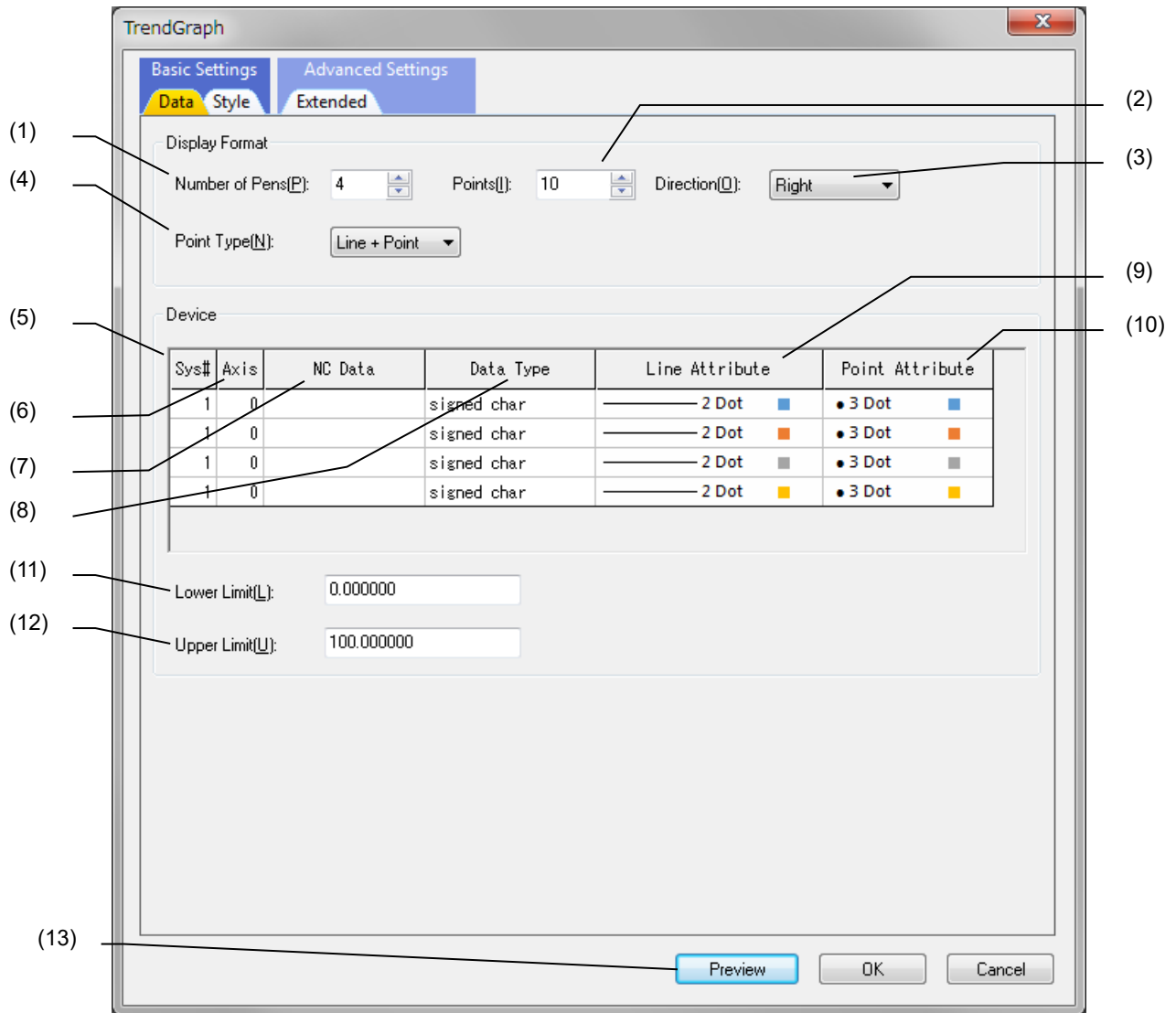

No.	Item	Description
(1)	Number of Pens	Specify the number of pens for the trend graph to display. (1 to 32)
(2)	Points	Specify the number of points to display for one pen of trend graph. (2 to 1024)
(3)	Direction	Select the display direction of the graph. (Right, Left, Top, Bottom)
(4)	Point Type	Select the point type. (Line, Point, Line + Point)
(5)	Sys#	Specify the part system number of NC data to read. When the part system is not specified in the NC data, the part system number cannot be specified. (1 to 10)
(6)	Axis	Specify the axis number of NC data to read. When the axis is not specified in the NC data, the axis number cannot be specified. (0 to 32)
(7)	NC Data	Set the section number/sub-section number of the NC data to read. (Section: 0 to 999, Sub-section: 0 to 1000000000) *Supported by input assist function

## 7. Creating Controls

<b>No.</b>	<b>Item</b>	<b>Description</b>
(8)	Data Type	Specify the type of the NC data to read. (signed char, unsigned char, signed short, unsigned short, signed long, unsigned long, double)
(9)	Line Attribute	Specify the graph line attribute.
(10)	Point Attribute	Specify the graph point attribute.
(11)	Lower Limit	Specify the lower limit of the data. (-7999999999.0 to 7999999999.0)
(12)	Upper Limit	Specify the upper limit of the data. (-7999999999.0 to 7999999999.0)
(13)	Preview	Display the window which the specified property design can be checked.

**NOTE**

- ◆ Section/sub-section of the NC data can be specified by input assist function. Refer to "7.1.16.4 Input Assist Function" for details of input assist function.

When the [...] button next to the NC data is pressed, section/sub-section of the NC data can be specified on the dialog.

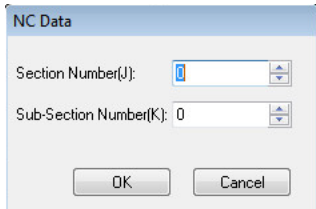

No.	Item	Description
(1)	Section Number	Set the section number of the NC data to read. (0 to 999)
(2)	Sub-Section Number	Set the sub-section number of the NC data to read. (0 to 1000000000)

- ◆ When selecting Line Attribute, details of the line can be specified.

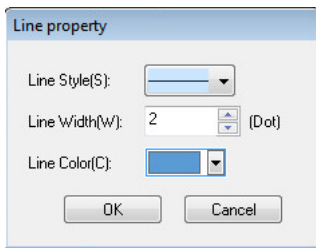

No.	Item	Description
(1)	Line Style	Select the line style. (Solid line, Pattern 1 to 8)
(2)	Line Width	Select the line width. (1 to 7)
(3)	Line Color	Select the line color.

- ◆ When selecting Point Attribute, details of the point can be specified.

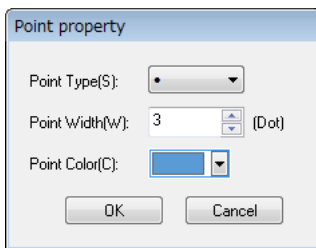

No.	Item	Description
(1)	Point Type	Select the point type. (●, ■, ▲)
(2)	Point Width	Select the point width. (1 to 7)
(3)	Point Color	Select the point color.

7.3.28.1.2 [Style] Tab

In [Style] tab, specify the number of scale points, scale color, background color, etc.

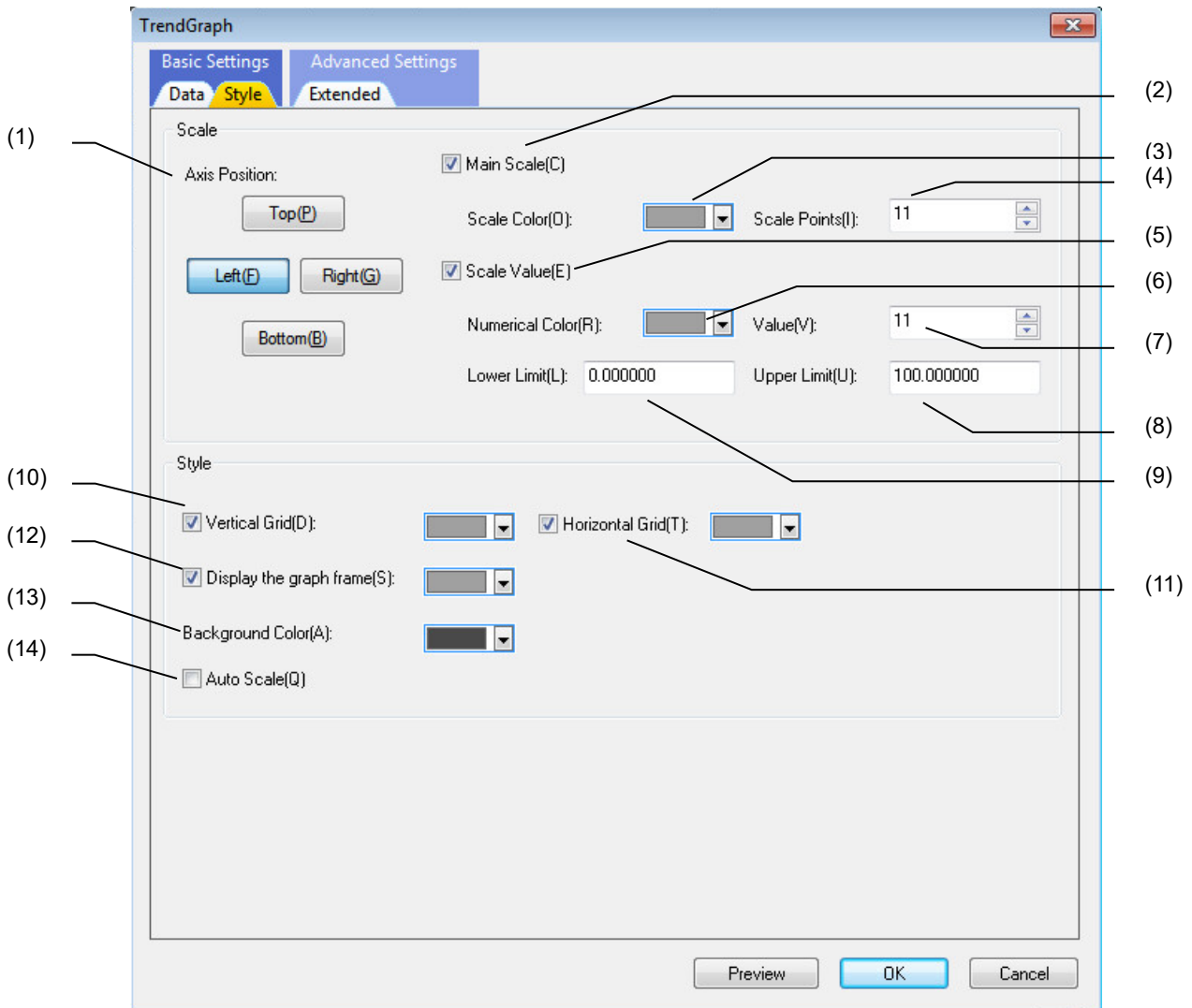

No.	Item	Description
(1)	Axis Position	Select the position to set the scale and the scale numeric value.
(2)	Main Scale	Check this box to display the scale. "Scale Color" and "Scale Points" can be specified.
(3)	Scale Color	Specify the scale line color.
(4)	Scale Points	Specify the number of scale points. (2 to 101)
(5)	Scale Value	Check this box to display the scale value. "Numerical Color", "Value", "Lower Limit", and "Upper Limit" can be specified.
(6)	Numerical Color	Specify the scale value color.
(7)	Value	Specify the number of scale values. (2 to 11)
(8)	Upper Limit	Specify the upper limit of the scale value. (-7999999999.0 to 7999999999.0)
(9)	Lower Limit	Specify the lower limit of the scale value. (-7999999999.0 to 7999999999.0)
(10)	Vertical Grid	Check this box to display the vertical grid. The "vertical grid color" can be specified.
(11)	Horizontal Grid	Check this box to display the horizontal grid. The "horizontal grid color" can be specified.



7. Creating Controls

<b>No.</b>	<b>Item</b>	<b>Description</b>
(12)	Display the graph frame	Check this box to display the graph frame. The "graph frame color" can be specified.
(13)	Background Color	Specify the background color of the graph.
(14)	Auto Scale	Check this box to enable the automatic scale. For the automatic scale, refer to "7.3.28.3. Complements".

7.3.28.1.3 [Extended] Tab

In [Extended] tab, specify the refresh cycle of the data.

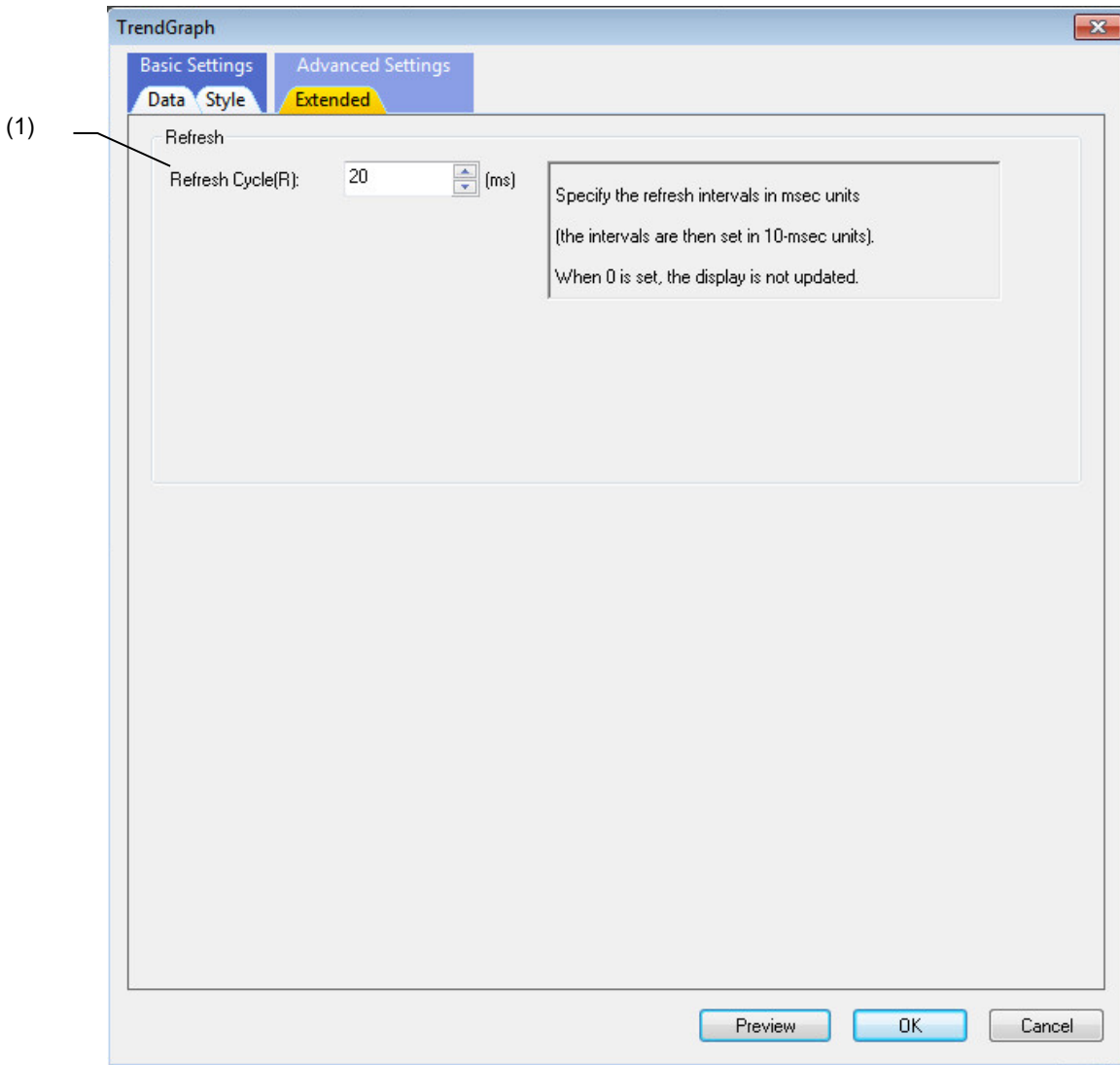

No.	Item	Description
(1)	Refresh Cycle	Specify the refresh cycle.  Specify the value in increments of 10 ms. When the ones digit of the value is specified, it is rounded down.  Example: When "123" is input, the value is 120.  When pressing the spin control, the value increases/decreases by ±10.

**7.3.28.2 Property Settings**

The property settings for the trend graph are divided into the following.

- Control name : Specify the control name.
- Position/Size : Specify the displaying position and size of the control.
- Graph : Specify the items relating to the number of NC data to read and the range.
- Address/NC data : Specify the items relating to the NC data to read.
- Line attribute : Specify the items relating to the graph line.
- Point attribute : Specify the items relating to the graph point.
- Scale : Specify items regarding the scale display.
- Style : Specify the items relating to the graph style.
- Refresh : Specify items relating to the refresh cycle of the NC data.
- Callback function : Specify whether the callback functions are provided or not.

**Graph**

Item	Description
Number of pens	Specify the number of graphs to display on the trend graph (the NC data to read). (1 to 32/Initial value: 2)
Points	Specify the number of points to display on the trend graph (holding points of the NC data to read). (2 to 1024/Initial value: 10)
Point type	Select the type of the line to display on the trend graph. (Line, Point, Line + Point/Initial value: Line + Point)
Display direction	Select the direction of the trend graph. (Right, Left, Top, Bottom/Initial value: Right)
Lower limit	Specify the lower limit of the data which can be displayed on the trend graph. (-7999999999.0 to 7999999999.0/Initial value: 0.0)
Upper limit	Specify the upper limit of the data which can be displayed on the trend graph. (-7999999999.0 to 7999999999.0/Initial value: 100.0)

**Address/NC data**

Item	Description
Number of systems	Specify the No. of the part system to which the NC data to read belongs. (1 to 10/initial value: 1)
Number of axis	Specify the No. of the axis to which the NC data to read belongs. (0 to 32/initial value: 0)
Number of section	Specify the section number of the NC data to read. (0 to 999/initial value: 0)
Number of sub-section	Specify the sub-section number of the NC data to read. (0 to 1000000000/initial value: 0)
Data type	Specify the data type of the NC data to read. (signed char, unsigned char, signed short, unsigned short, signed long, unsigned long, double)

\* Specify the Address/NC data for each graph line.

Line - Point Attribute

Item	Description
Line color	Specify the graph line color.
Line width	Specify the graph line width. (1 to 7/Initial value: 2)
Line type	Specify the graph line type. (Solid line, Pattern 1 to 8/Initial value: Solid line)
Point color	Specify the graph point color.
Point width	Specify the graph point width. (1 to 7/Initial value: 2)
Point type	Specify the graph point type. (●, ■, ▲/Initial value: ●)

\* Specify the line and point attribute for each graph line.

7. Creating Controls

Scale

Item	Description
Scale display *1	Select the display of the scale between "Yes"/"None". (Initial value: None)
Scale color *1	Specify the scale color.
Scale points *1	Specify the number of scales. (2 to 101/Initial value: 11)
Scale numeric display *2	Select the display of the scale value between "Yes"/"None". (Initial value: None)
Numerical color *2	Specify the color of the scale value.
Numerical value *2	Specify the number of the scale values to display. (2 to 11/Initial value: 11)
Lower limit *2	Specify the lower limit of the scale value. (-7999999999.0 to 7999999999.0/Initial value: 0.0)
Upper limit *2	Specify the upper limit of the scale value. (-7999999999.0 to 7999999999.0/Initial value: 100.0)

\*1 The scale is displayed on the top, bottom, left, or right. Specify the scale for each side separately.

\*2 The scale value is displayed on the top, bottom, left, or right. Specify the scale value for each side separately.

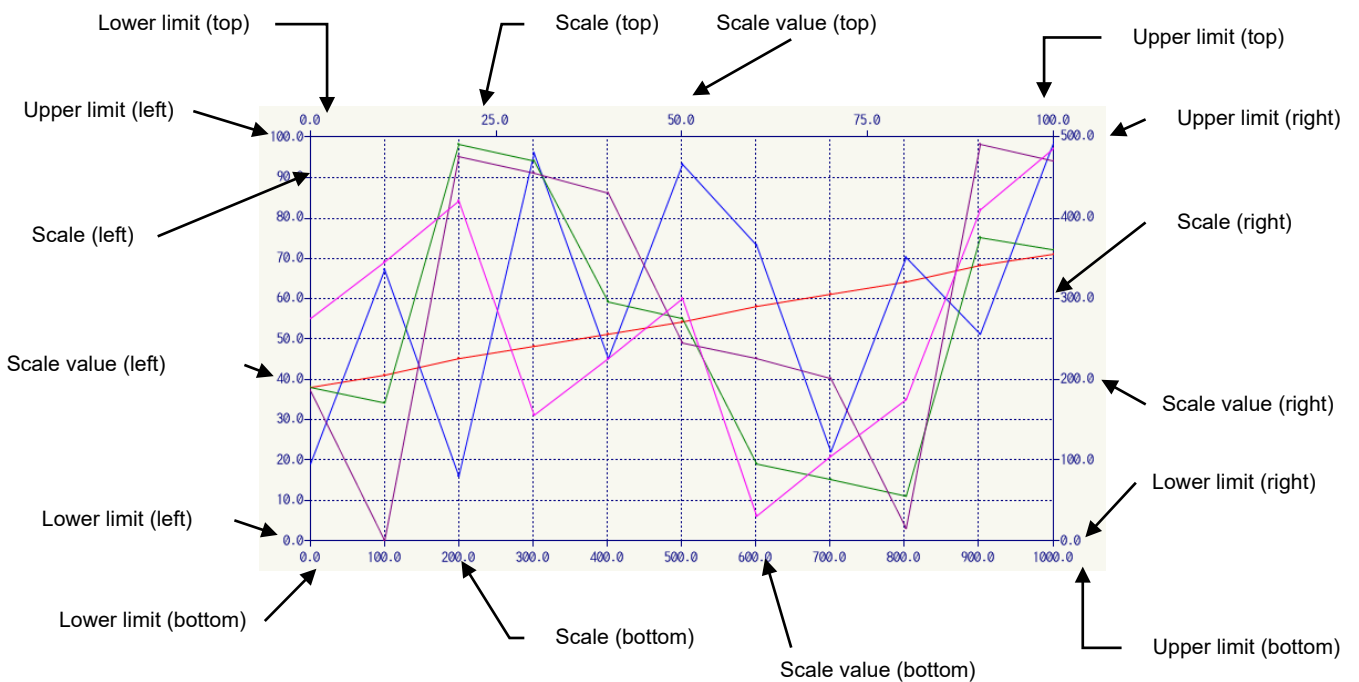

\* The upper limit and the lower limit drawn on the graph do not correspond to the scale value.

Style

Item	Description
Auto scale	Select the automatic scale between "Yes"/"None". (Initial value: None)
Vertical grid line display *1	Select the display of the vertical grid between "Yes"/"None". (Initial value: None)
Vertical grid	Specify the vertical grid color.
Horizontal grid line display *2	Select the display of the horizontal grid between "Yes"/"None". (Initial value: None)
Horizontal grid	Specify the horizontal grid color.
Graph frame	Select the display of the graph frame between "Yes"/"None". (Initial value: None)
Graph frame color	Specify the graph frame color.
Background color	Specify the background color of the graph.

\*1 Broken lines are displayed along the scales of the top or the bottom.

When the scales are displayed on both the top and the bottom, the broken lines are displayed in line with the scales on the bottom.

When the scales are not displayed, grid lines are not displayed even if "Yes" is selected.

\*2 Broken lines are displayed along the scales of the left or the right.

When the scales are displayed on both the left and the right, the broken lines are displayed in line with the scales on the left.

When the scales are not displayed, grid lines are not displayed even if "Yes" is selected.

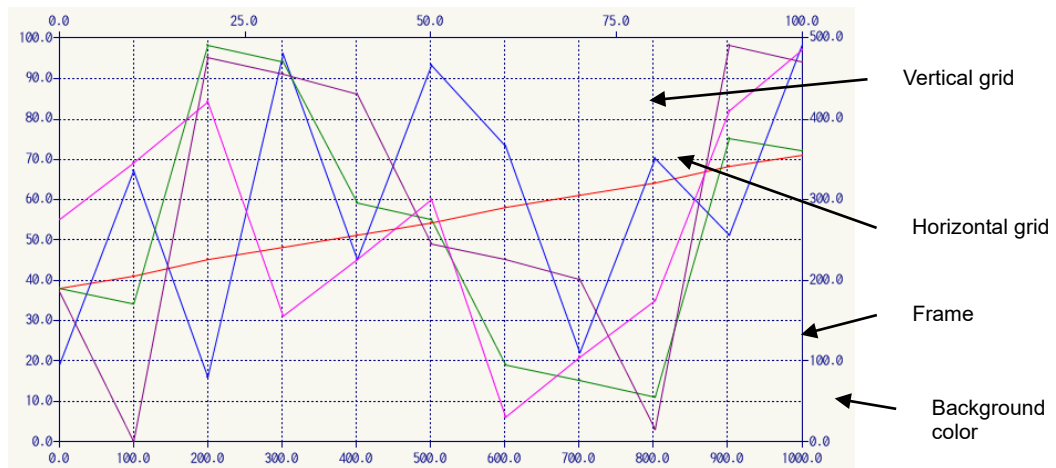

Update

Item	Description
RefreshFrequency	Specify the refresh cycle in 10 ms increments. (0 to 360000/Initial value: 2) When 0 is specified, the graph is not refreshed. (Example: For 10, the graph is refreshed approximately every 100 ms)

Refer to "7.1 Common Functions of Controls" for other properties.

7.3.28.3 Complements

Example

Set as shown below to display the spindle speed with trend graph.

< Example >

Item	Setting value
Number of pens	1
Points	100
Display direction	Right
Point type	Line + Point
Number of systems	1
Axis	1
Number of section	34
Number sub-section	1
Data type	Signed long
Line color	Red
Point color	Red
Scale display (left)	Yes
Scale numeric display (left)	Yes
Lower limit (scale value)	0.0
Upper limit (scale value)	1000.0
Graph frame	Yes

< Image when executed >

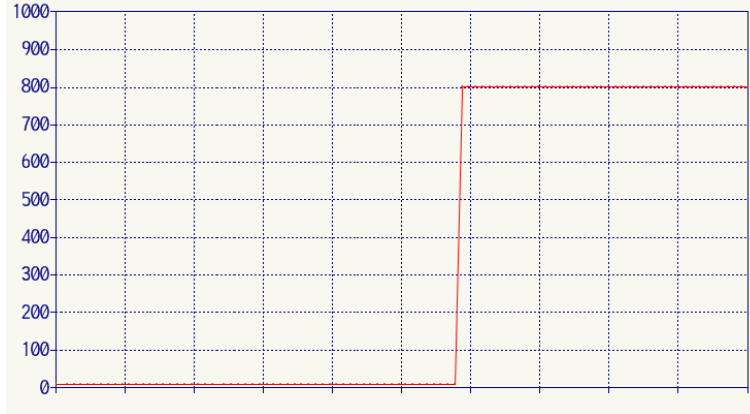

Auto scale

When the data values obtained from the NC exceed the upper and lower limit ranges, they cannot be displayed on the graph.

Auto scale adjusts the upper and lower limit values when such data exists so the data can be displayed on the graph.

Auto scale is enabled by selecting "Yes" for the "Auto scale" property.

< Image >

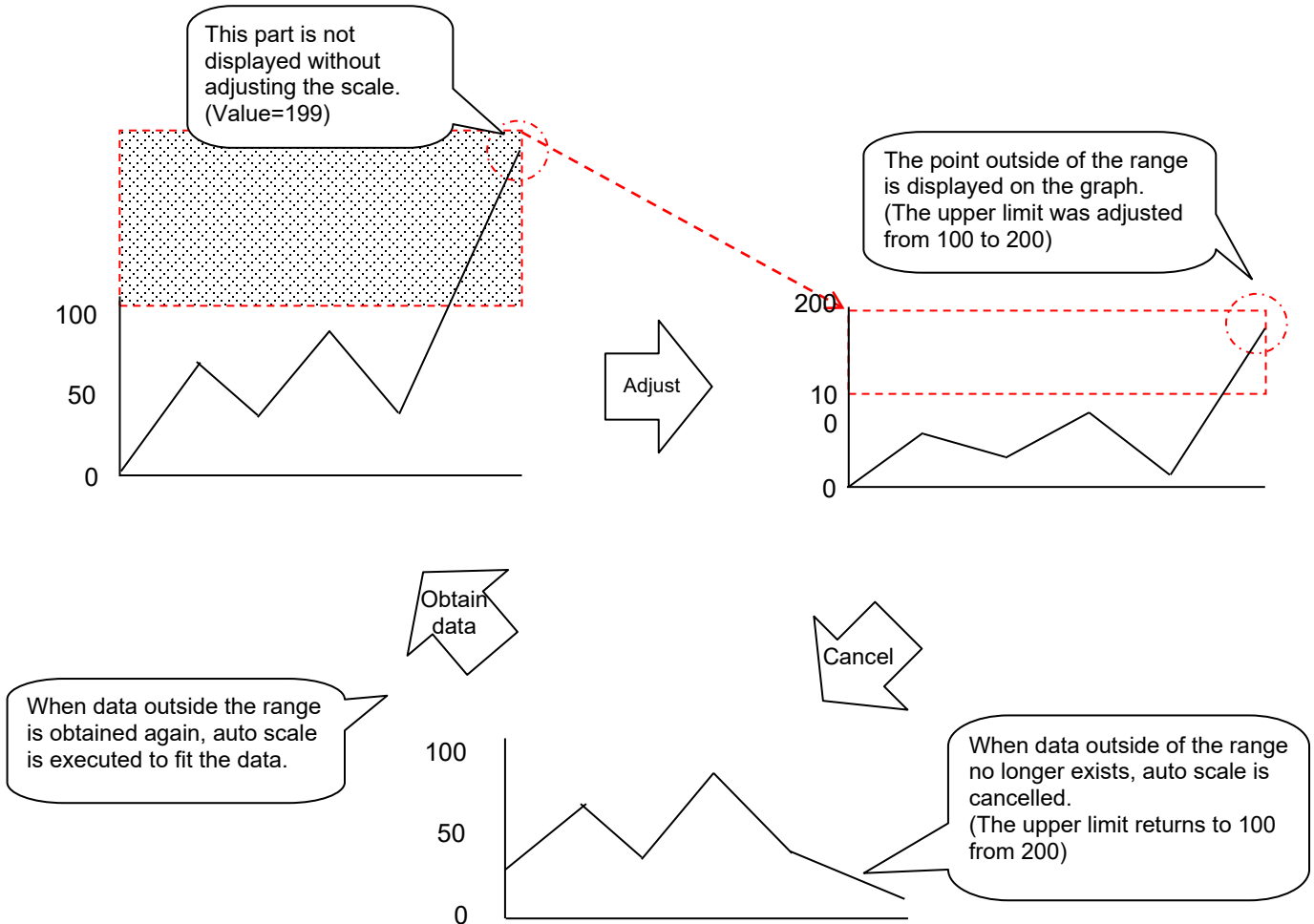

**7.3.28.4 Precautions**

- The data collected from NC is kept while the screen with the part arranged on it is displayed. When the screen is closed, data collection starts over.
- When arranging multiple trend graph parts on one screen, make sure the number of pens is a maximum of 32.

**7.3.28.5 Limitations**

- When the interpreter method OnTimer() event is executed, NC data is not read at the frequency set in refresh cycle. In this case, when reading NC data, a "NormalMethod()" function needs to be written in the OnTimer() event of the macro program.



## 8. Parts Library

In the parts library, the image data which can be set to the design such as the button is registered. To create the screen with excellent design easily, specify the registered data in the parts library to the control.

Parts library is the function dedicated to M800V/M80V/M800/M80/E80 Series.

Arrange the target control on the screen, and then open the Image List dialogue from "Design" property, etc. Select the image and press the [OK] button. The selected image is set to the control design.

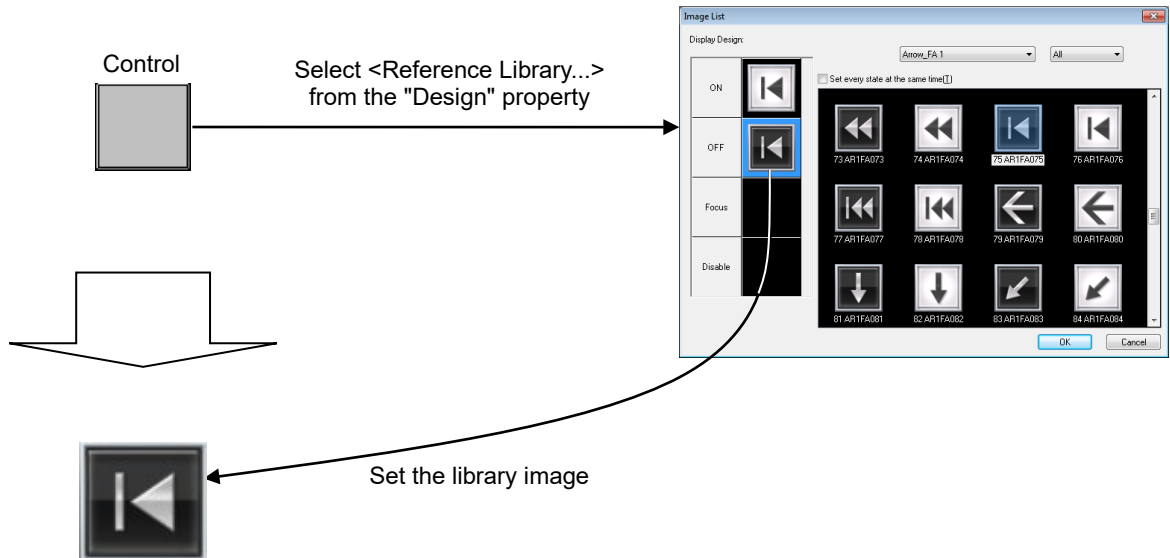

## 8.1 Operation Screen

### 8.1.1 Image List Dialogue

In the Image List dialogue, the design for the control can be set from the image list. In the image list, the images registered in the parts library are displayed.

Dialogue Image

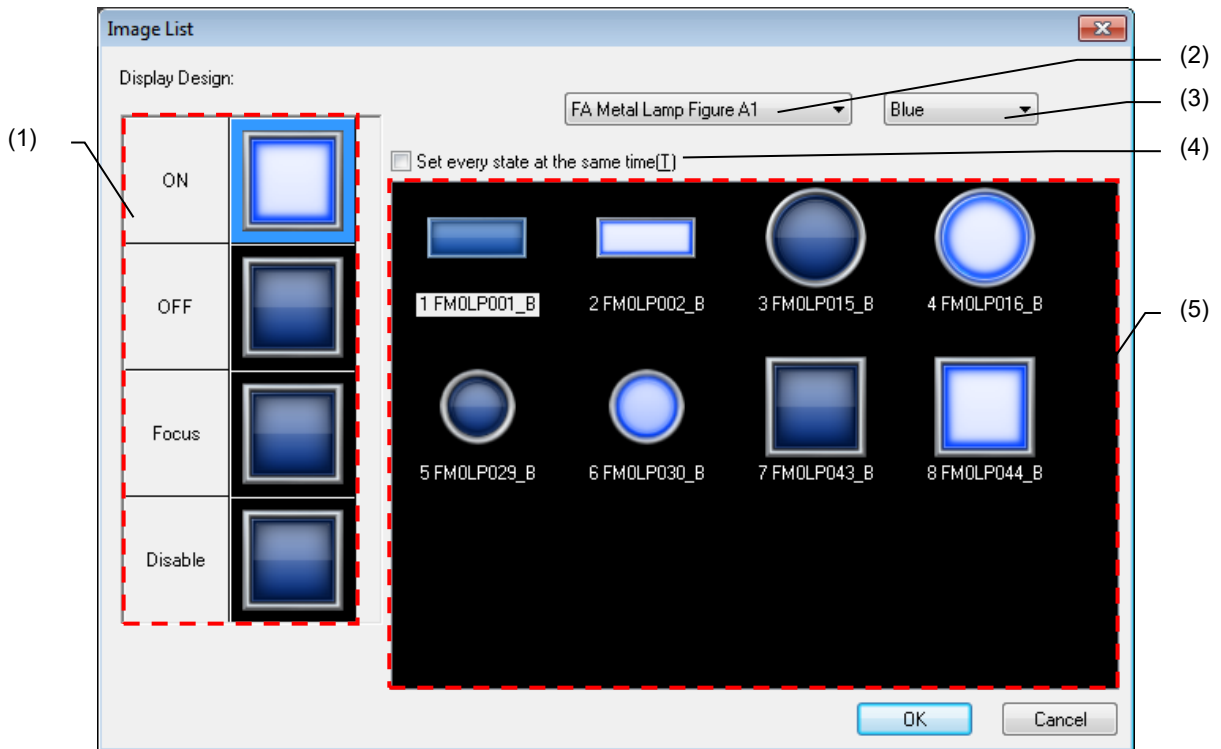

No.	Displayed item	Details
(1)	Display Design	Display the design image in the control.
(2)	Image category	Display the types of the images registered in the library.
(3)	Color pattern selection	Specify the color pattern displayed on the image list.
(4)	Set every state at the same time	When the check box is checked, the selected images are set to the display design of every state.
(5)	Image list	Select the image to set to each state. The selected image is displayed on each state of the item "Display Design".

**NOTE**

- ◆ The display design varies depending on the number of the designs of the state that can be set in the target control.
- ◆ The following are the selectable controls in the parts library.

Type	Control name
Standard control	Button
	List
	Picture
	HTML browser
	Horizontal scroll bar
	Vertical scroll bar
	Edit control
NC control	PLC button
	PLC extension button
	Page change button
	Stacked graph
	Statistics graph
	Extension menu
	Meter

**8.2 Operation Procedure**

To display the Image List dialogue and select the parts library, perform one of the following operations to the control which is compatible with the parts library.

- Select <Reference Library...> from [Design] on the property sheet.
- Select [Change Design] from the popup menu which is displayed by right-clicking the control.
- Press the [Design] button in property setup dialog.

1. Create a control supported by the parts library on the panel or the window.
2. Select the control and then select <Reference Library...> from [Design] on property sheet.

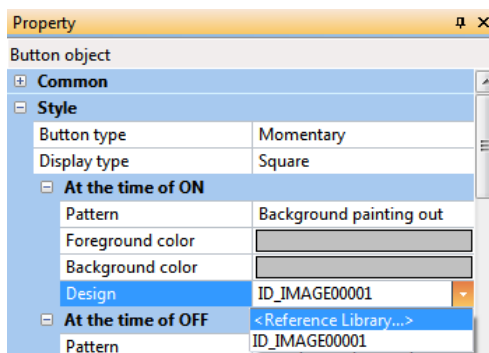

3. Image List dialogue appears.

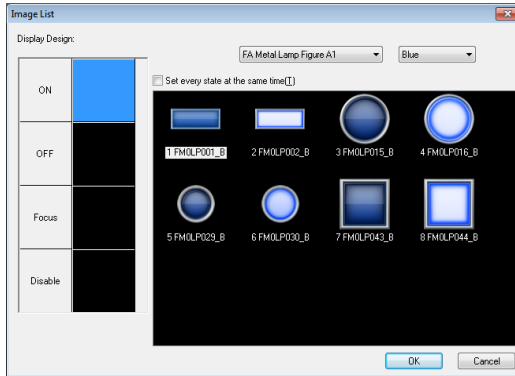

4. When "Red" is selected, the images on the image list are filtered in red tone.

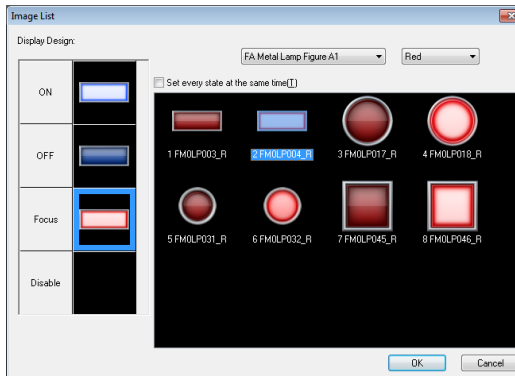

5. Select the design for each state from the image list and press the [OK] button. The images selected to each state are set.

**NOTE**

- ◆ The image set in the parts library is registered in the image resource. The image cannot be set when exceeding the maximum number 5000 that can be registered in the image resource.
- ◆ Color pattern selection can be selected from the following 13 patterns or "All". The images are filtered in the selected color tone on the image list.  
Blue / Red / Yellow / Green / Orange / Cyan / Purple / Pink / Gray / Gold / Silver / Black / White
- ◆ When each state design is changed from the Image List dialogue, the following setting values in the properties are also changed.

Type	Control name	Property			
		Display type	Pattern	Use of solid frame	Shape of meter
Standard control	Button	○	○	○	—
	Picture	○	○	○	—
	Horizontal scroll bar	○	—	×	—
	Vertical scroll bar	○	—	×	—
	List	○	—	×	—
	HTML browser	○	—	×	—
	Edit control	○	—	×	—
NC control	PLC button	○	○	○	—
	PLC extension	○	○	○	—
	Page change	○	○	○	—
	Stacked graph	○	○	—	—
	Statistics graph	○	○	—	—
	Extension menu	×	×	×	—
	Meter	×	—	—	○

(○: Changed / ×: Not changed / —: No function)

### 8.3 Precautions

1. If the editing state of the project common data is set to [Refer], parts library cannot be selected. Set the project [Edit] and open it again.

Refer to the following catalogue for the selectable images on the Image List dialogue.  
(Some images are not supported by NC Designer2 because they are dedicated to GOT2000 Series.)

GOT2000 Series Parts Library Book      L(NA) 08341

Refer to MITSUBISHI ELECTRIC FA Global Website for this book.

MITSUBISHI ELECTRIC FA Global Website: <http://www.mitsubishielectric.com/fa/index.html>

## 9. Figure

This section describes each figure and property settings.

### 9.1 What Is Figure?

Figure is graphic data displayed as a fixed matter. The figure includes the following seven variations.

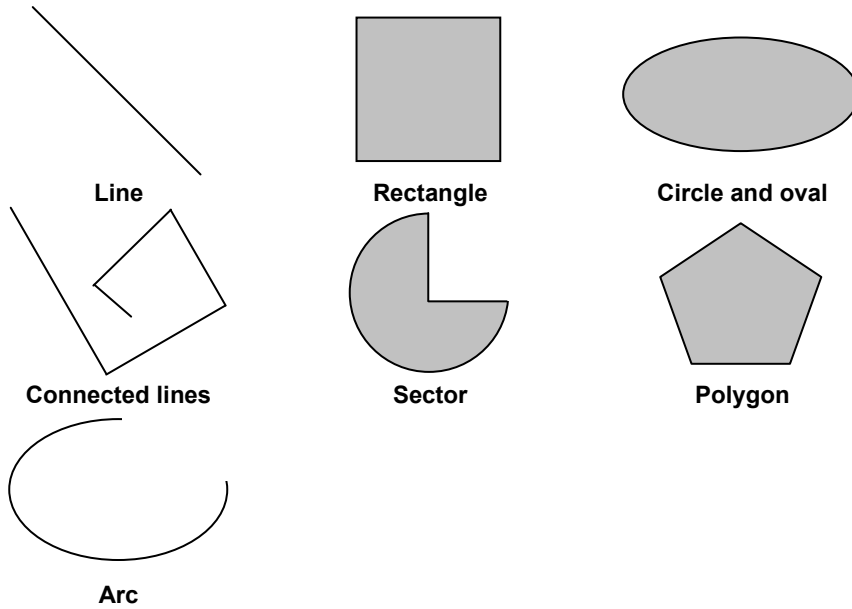

Name	Description
Rectangle	A rectangle is drawn.
Circle&Oval	The inscribed circle of the designated rectangle is drawn.
Straight Line	A line is drawn.
Polyline	Connected lines are drawn.
Polygon	Lines are connected to draw a polygon.
Sector	After a circle is drawn, the angle is designated to draw a sector.
Arc	An arc is drawn.

## 9.2 Figure Creation Method

The method for arranging the figure in the screen and specifying properties is described.

### 9.2.1 Drawing a New Figure

To draw a new figure, open the [Figure] menu, or select the figure tool bar icon.

#### Rectangle, Circle, Oval and Line

1. Move the cursor to the starting point of the rectangle, circle, oval or line.

2. The cursor changes to the shape shown below.



3. Drag the cursor to the end point of the rectangle, circle, oval or line.

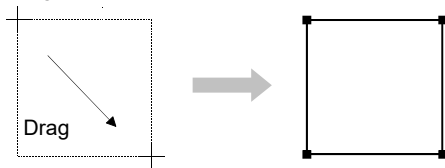

#### Polygon and Connected Lines

1. Move the cursor to the starting point of the polygon or connected lines and click the left mouse button.

2. Move the cursor to the next point and click the left mouse button. Repeat the operation to draw all vertexes of the polygon or connected lines.

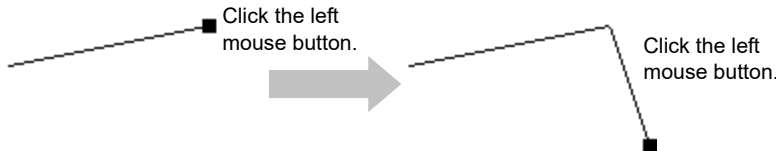

3. Click the right mouse button at the last vertex to exit from the polygon or connected line drawing mode.

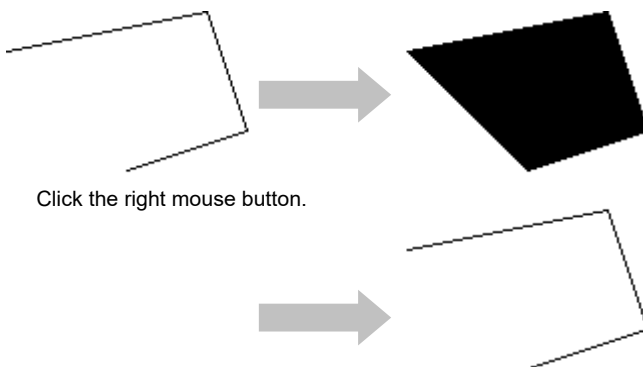

9. Figure

Sector and Arc

1. Move the cursor to the starting point of the sector or arc, and click the left mouse button.
2. Drag to draw a circle or oval.
3. A black box is placed at the 3 o'clock position on the perimeter of the drawn circle or oval.

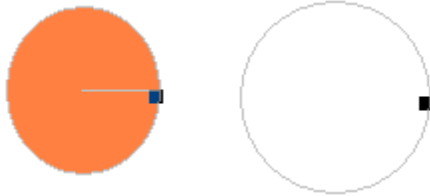

4. Place the cursor at the black box and, after the cursor changes to "+", drag the mouse to the desired position. Dragging should be done within the range of 360°.



5. Click the right mouse button to exit from the sector or arc drawing mode.



**NOTE**

- ◆ Drag while holding down the [Shift] key to create a figure having an equal vertical and horizontal ratio.
- ◆ Drag up/down or left/right while holding down the [Ctrl] key to change the size of the figure evenly up/down or to the left/right.
- ◆ The sector or arc can be set from "Starting point angle·Terminal point angle" in "Property".  
Display example)

When setting start point angle 180°/  
end point angle 90°

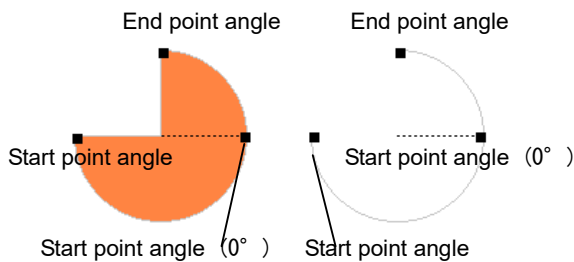

When setting start point angle 90°/  
end point angle 180°

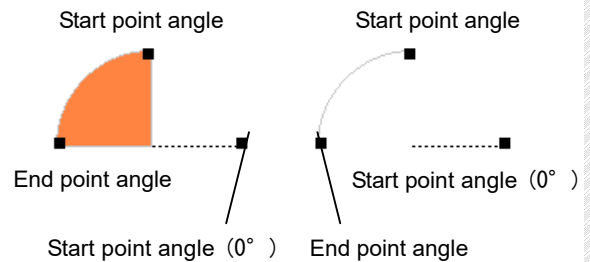

- ◆ Press [Esc] button to exit from the drawing mode.



### 9.3 Common Functions of Figure

#### 9.3.1 Position/Size

Specify the position and size of the control.

Item	Description
Perimeter rectangle X	Specify the horizontal position from the upper left of the page/view frame of the figure (X coordinate) in dots (0 to 2559).
Perimeter rectangle Y	Specify the vertical position from the upper left of the page/view frame of the figure (Y coordinate) in dots (0 to 1919).
Perimeter rectangle WIDTH	Specify the width of the figure in dots (0 to 2560).
Perimeter rectangle HEIGHT	Specify the height of the figure in dots (0 to 1920).

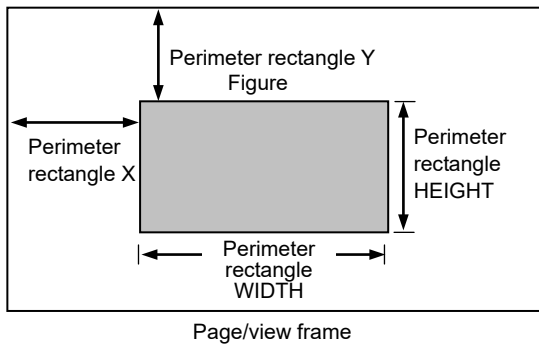

**NOTE**

- ◆ Note that the figure may be arranged outside the page/view frame according to some position and size settings.
- ◆ The size changes, serving the upper left point of the figure as the origin, when the size is changed.
- ◆ For the line, designate the coordinates of the starting and end points.

#### 9.3.2 Perimeter Line

Specify the presence, color and other particulars of the perimeter line.

Item	Description
Perimeter line	Select whether the line is given around the figure or not ("Yes" or "None").
Perimeter line color	Specify the color of the perimeter line.
Perimeter line width	Specify the width of the perimeter line (1 to 20).
The kind of perimeter line	Select the line pattern of the perimeter line among "Solid line", "Pattern 1", ... and "Pattern 8". The line type is valid if the "perimeter line width" is "1".

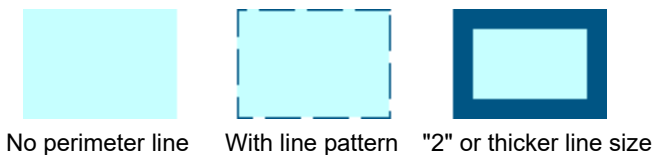

**NOTE**

- ◆ The perimeter line is expressed inside and outside the perimeter. For perimeter line width "2", a single-dot line is drawn both inside and on the perimeter line. For "3", a single-dot line is drawn inside and outside the perimeter line. For "4", a two-dot line is drawn inside the perimeter line and a single-dot line is drawn outside.

9. Figure

**9.3.3 Color/Pattern**

Specify the color and pattern of the figure.

Item	Figure
Painting out foreground color	Specify the background color of the figure.
Painting out background color	Specify the foreground color (pattern color) of the figure.
Painting out pattern	Select the filling pattern among "Background painting out", "Foreground painting out", "Pattern 0" to "Pattern 37", and "With no painting out".

The relationship among the background color, foreground color and pattern is shown in the figure below.

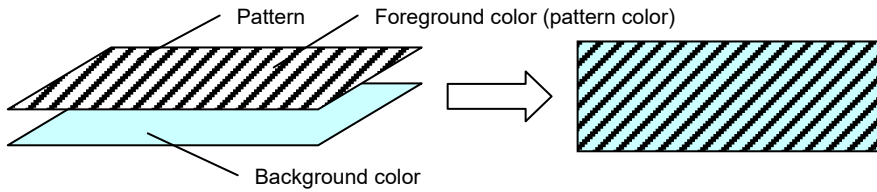

**NOTE**

- ◆ For the displayed patterns, refer to Appendix.

## 9.4 Figure Settings

### 9.4.1 Rectangle

Item	Description
Perimeter rectangle X	Specify the horizontal position of the figure (X coordinate) in dots (0 to 2559).
Perimeter rectangle Y	Specify the vertical position of the figure (Y coordinate) in dots (0 to 1919).
Perimeter rectangle WIDTH	Specify the width of the figure in dots (1 to 2560).
Perimeter rectangle HEIGHT	Specify the height of the figure in dots (1 to 1920).
Perimeter line	Select whether or not to draw the line around the rectangle.
Perimeter line color	Specify the color of the perimeter line.
Perimeter line width	Specify the width of the perimeter line (1 to 20).
The kind of perimeter line	Select the line pattern of the perimeter line among the "Solid line" and "Pattern 1" to "Pattern 8".
Painting out foreground color	Specify the color of the pattern.
Painting out background color	Specify the background color.
Painting out pattern	Select the filling pattern among "Background painting out", "Foreground painting out", "Pattern 0" to "Pattern 37", and "With no painting out".

### 9.4.2 Circle and Oval

Item	Description
Perimeter rectangle X	Specify the horizontal position of the figure (X coordinate) in dots (0 to 2559).
Perimeter rectangle Y	Specify the vertical position of the figure (Y coordinate) in dots (0 to 1919).
Perimeter rectangle WIDTH	Specify the width of the figure in dots (1 to 2560).
Perimeter rectangle HEIGHT	Specify the height of the figure in dots (1 to 1920).
Perimeter line	Select whether or not to give a line around the circle or oval.
Perimeter line color	Specify the color of the perimeter line.
Perimeter line width	Specify the width of the perimeter line (1 to 20).
The kind of perimeter line	Select the line pattern of the perimeter line among the "Solid line" and "Pattern 1" to "Pattern 8".
Painting out foreground color	Specify the color of the pattern.
Painting out background color	Specify the background color.
Painting out pattern	Select the filling pattern among "Background painting out", "Foreground painting out", "Pattern 0" to "Pattern 37", and "With no painting out".

### 9.4.3 Line

Item	Description
Starting point X coordinates	Specify the X coordinate of the starting point in dots (0 to 2559).
Starting point Y coordinates	Specify the Y coordinate of the starting point in dots (0 to 1919).
Terminal point X coordinates	Specify the X coordinate of the end point in dots (0 to 2559).
Terminal point Y coordinates	Specify the Y coordinate of the end point in dots (0 to 1919).
Line color	Specify the line color.
Line width	Specify the width of the line in dots (1 to 20).
The kind of perimeter line	Select the line pattern among the "Solid line" and "Pattern 1" to "Pattern 8".

9. Figure

**9.4.4 Connected Line**

Item	Description
Perimeter rectangle X	Specify the horizontal position of the figure (X coordinate) in dots (0 to 2559).
Perimeter rectangle Y	Specify the vertical position of the figure (Y coordinate) in dots (0 to 1919).
Perimeter rectangle WIDTH	Specify the width of the figure in dots (1 to 2560).
Perimeter rectangle HEIGHT	Specify the height of the figure in dots (1 to 1920).
Line color	Specify the color of the connected lines.
Line width	Specify the width of the connected lines (1 to 20).
The kind of perimeter line	Select the line pattern of connected lines among the "Solid line" and "Pattern 1" to "Pattern 8".

**9.4.5 Sector**

Item	Description
Perimeter rectangle X	Specify the horizontal position (X coordinate) of the figure in dots (0 to 2559).
Perimeter rectangle Y	Specify the vertical position (Y coordinate) of the figure in dots (0 to 1919).
Perimeter rectangle WIDTH	Specify the width of the figure in dots (1 to 2560).
Perimeter rectangle HEIGHT	Specify the height of the figure in dots (1 to 1920).
Starting point angle	Specify the starting angle of the sector in degrees (°) (0 to 359).
Terminal point angle	Specify the end angle of the sector in degrees (°) (0 to 359).
Perimeter line	Select whether or not to give a line around the sector.
Perimeter line color	Specify the color of the perimeter line.
Perimeter line width	Specify the width of the perimeter line (1 to 20).
The kind of perimeter line	Select the line pattern of the perimeter line among "Solid line" and "Pattern 1" to "Pattern 8".
Painting out foreground color	Specify the color of the pattern.
Painting out background color	Specify the background color.
Painting out pattern	Select the filling pattern among the "Background painting out", "Foreground painting out", "Pattern 0" to "Pattern 37" and "With no painting out".

**9.4.6 Polygon**

Item	Description
Perimeter rectangle X	Specify the horizontal position of the figure (X coordinate) in dots (0 to 2559).
Perimeter rectangle Y	Specify the vertical position of the figure (Y coordinate) in dots (0 to 1919).
Perimeter rectangle WIDTH	Specify the width of the figure in dots (1 to 2560).
Perimeter rectangle HEIGHT	Specify the height of the figure in dots (1 to 1920).
Perimeter line	Select whether or not to give a line around the polygon.
Perimeter line color	Specify the color of the perimeter line.
Perimeter line width	Specify the width of the perimeter line (1 to 20).
The kind of perimeter line	Select the line pattern of the perimeter line among the "Solid line" and "Pattern 1" to "Pattern 8".
Painting out foreground color	Specify the color of the pattern.
Painting out background color	Specify the background color.
Painting out pattern	Select the filling pattern among "Background painting out", "Foreground painting out", "Pattern 0" to "Pattern 37" and "With no painting out".

## 9. Figure

## 9.4.7 Arc

Item	Description
Perimeter rectangle X	Specify the horizontal position of the figure (X coordinate) in dots (0 to 2559).
Perimeter rectangle Y	Specify the vertical position of the figure (Y coordinate) in dots (0 to 1919).
Perimeter rectangle WIDTH	Specify the width of the figure in dots (1 to 2560).
Perimeter rectangle HEIGHT	Specify the height of the figure in dots (1 to 1920).
Starting point angle	Specify the starting angle of the arc in degrees ( $^{\circ}$ ) (0 to 359).
Terminal point angle	Specify the end angle of the arc in degrees ( $^{\circ}$ ) (0 to 359).
Line color	Specify the color of the arc.
Line width	Specify the width of the arc (1 to 20).
The kind of perimeter line	Select the line pattern of the arc among the "Solid line" and "Pattern 1" to "Pattern 8".

## 10. Screen Editing

This section describes the screen editing operations of NC Designer2.

### 10.1 Editing Operation

The editing methods of the object arranged in the screen are described.

The object indicates controls and figures arranged in the panel, window or screen.

#### 10.1.1 Undo

Abandon a change and restore the original state before the change. Up to 10 operations can be undone. To undo, there are the following two methods.

- Select [Undo] from the [Edit] menu.
- Select the [Undo] button in the tool bar.

#### **NOTE**

- ◆ The shortcut key corresponding to [Undo] is [Ctrl] + [Z].
- ◆ Note that the following operations cannot be undone with [Undo].
  - Entry of various properties of project, control, etc.
  - Registration, deletion and editing of resource

#### 10.1.2 Redo

Redo the operation undone with "undo".

Up to 10 operations can be redone. (Operations executed earlier than the "undo" record may not be executed.)

1. Select [Redo] from the [Edit] menu, or select the [Redo] button in the tool bar.

To redo further, execute [Redo] again.

#### **NOTE**

- ◆ The shortcut key corresponding to [Redo] is [Ctrl] + [Y].
- ◆ Note that the following operation may not be repeated with [redo].
  - Entry of various properties of project, control, etc.
  - Registration, deletion and editing of resource

### 10.1.3 Cut

Delete the selected object and store it in the clipboard.

1. Select an object.  
To cut multiple objects simultaneously, select all the desired objects to be cut.
2. Select [Cut] from the [Edit] menu, or select the [Cut] button in the tool bar.
3. A confirmation dialog box is displayed. To continue, click on the [Yes] button.

**NOTE**

- ◆ The shortcut key corresponding to [Cut] is [Ctrl] + [X].  
How to select multiple objects  
(1) While holding down the [Shift] key, click the object with the mouse button.

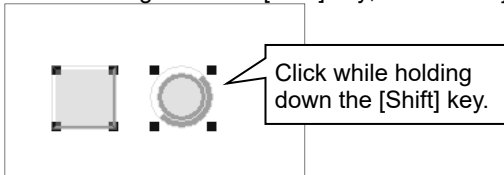

- (2) Enclose the desired objects, using the cursor.

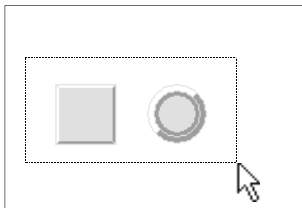

### 10.1.4 Copy

Copy the selected object and save it in the clipboard.

1. Select an object.  
To copy multiple objects simultaneously, select all the desired objects to be copied.

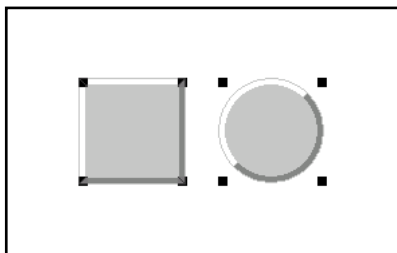

2. Select [Copy] from the [Edit] menu, or select the [Copy] button in the tool bar.

**NOTE**

- ◆ The shortcut key corresponding to [Copy] is [Ctrl] + [C].

### 10.1.5 Paste

Paste the object(s) having been copied or cut and saved in the clipboard. The object is pasted with the same properties as those of the original object.

1. Display the destination screen.
2. Select [Paste] from the [Edit] menu, or select the [Paste] button in the tool bar.

**NOTE**

- ◆ The regular shortcut key corresponding to [Paste] is [Ctrl] + [V].
- ◆ When the control is pasted, the control names are automatically specified.

The automatically assigned control name can be changed later.

### 10.1.6 Delete

Delete the selected object.

1. Select the object to be deleted.  
To delete multiple objects simultaneously, select all the desired objects to be deleted.
2. Select [Delete] from the [Edit] menu.
3. A confirmation dialog box is displayed. To continue deletion, click on the [Yes] button.

**NOTE**

- ◆ The shortcut key corresponding to [Delete] is [Delete].
- ◆ To delete all controls and figures from the screen, use [Select All] in the [Edit] menu.

**IMPORTANT**

- ◆ Different from cutting, deleted controls or figures are not pasted.



**10.1.7 Find**

Search for a control with a specific control name or caption having been set.

1. Select [Find] from the [Edit] menu, or select the [Find] button in the tool bar.
2. The Find dialog box is displayed.

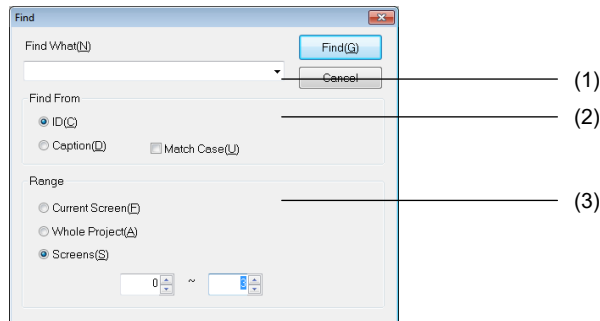

No.	Item	Description
(1)	Search string	Designate the desired control name or caption.
(2)	Target of search	Select either the control name or caption to be searched. Check the "match case" box to search the exact match with the search string.
(3)	Range	Select the search range from the following options.
	Current screen	The current foreground screen is searched.
	Whole project	The whole project is searched.
	Screens	Pages in the designated range are searched.

3. Click on the [Find] button to start to search.
4. When the search is finished, a [Search result list] dialog box is displayed.

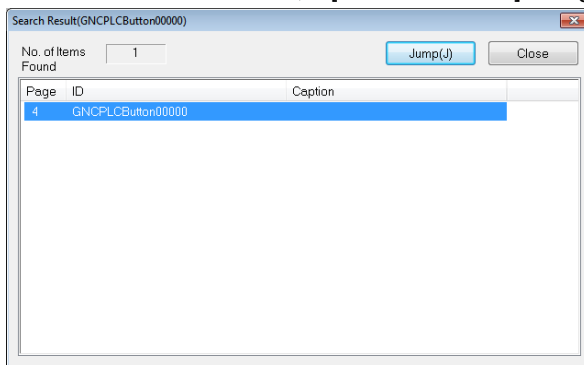

10. Screen Editing

5. Select the control in the search result list and click on the [Jump] button, or double click on the selected line. The screen including the selected control is displayed, and the control blinks in the selected state.

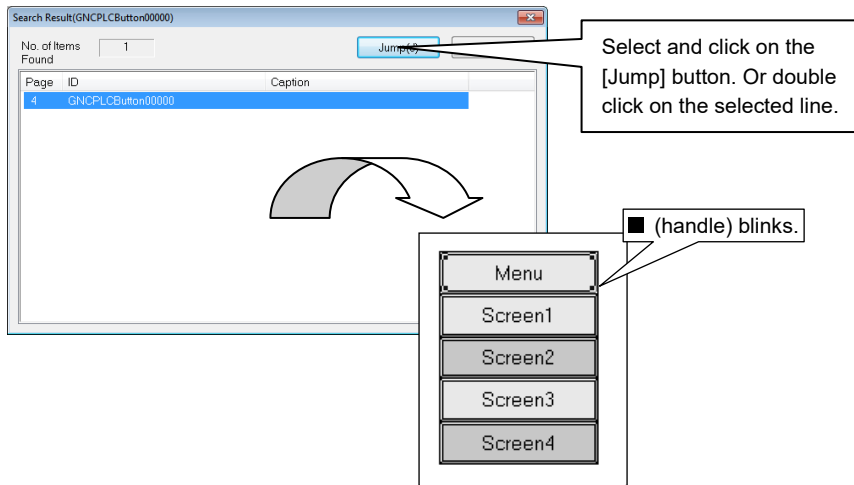

**NOTE**

- ◆ The shortcut key corresponding to [Find] is [Ctrl] + [F].

**10.1.8 Select All**

Use this function to select all objects on the screen or select objects belonging to the same type.

All Objects

Select all objects arranged on the screen.

1. From the [Edit] menu, select [Select All] - [All Objects].

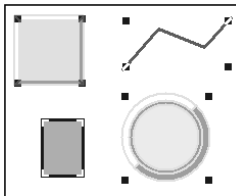

Objects Belonging to Same Type

Select all the objects belonging to the same type as that of the selected object.

1. Select a desired object. From the [Edit] menu, select [Select All] - [Same Object Type.]

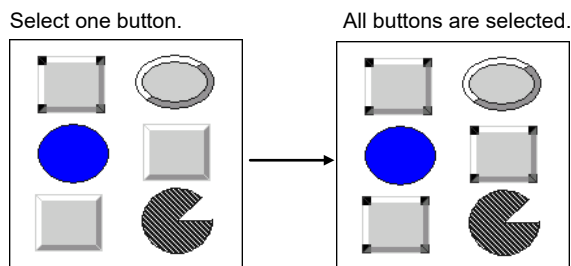

10.1.9 Continuous copy

Specify the all objects after copy, margin, and copy direction to duplicate the selected object. When any of the following properties exists in the selected control, the object is shifted by the number of increments specified by the property values and duplicated.

- Number of systems
- Number of axis
- Number of section
- Number of sub-section
- Number of device

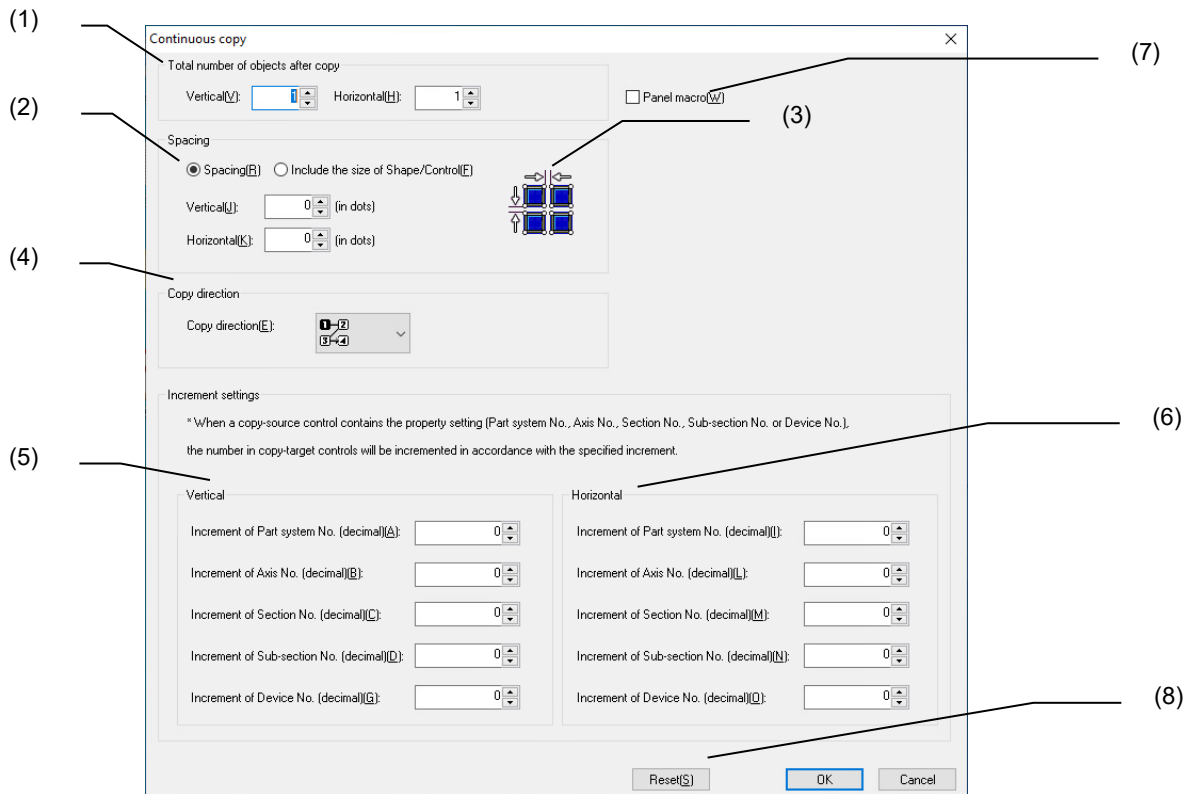

No.	Item	Description
(1)	Total number of objects after copy	Specify the total number of objects after copy.
	Vertical	Specify the number of objects after duplication in the vertical direction. (1 to 32)
	Horizontal	Specify the number of objects after duplication in the horizontal direction. (1 to 32)
(2)	Spacing	Designate the margin placed between the duplicated objects.
	Spacing	Select when specifying the margin between the duplicate source object and the duplicate destination object. (Note 1)
	Include the size of Shape/Control	Select when specifying the margin including the duplicate source object. (Note 1)
	Vertical	Specify the vertical margin for the object duplication. (0 to 999)
	Horizontal	Specify the horizontal margin for the object duplication. (0 to 999)
(3)	Help figure	A figure showing the selected margin and copy direction is displayed.
(4)	Copy direction	Select the copy direction.
		A total of eight directions can be specified. (Note 2)

No.	Item	Description
(5)	Vertical	Specify the number of increments in the vertical direction.
	Increment of Part system No. (decimal)	Specify the number of increments of number of systems. (-7 to 7)
	Increment of Axis No. (decimal)	Specify the number of increments of number of axis. (-31 to 31)
	Increment of Section No. (decimal)	Specify the number of increments of number of section. (-999 to 999)
	Increment of Sub-section No. (decimal)	Specify the number of increments of number of sub-section. (-1000000000 to 1000000000)
(6)	Horizontal	Specify the number of increments in the horizontal direction.
	Increment of Part system No. (decimal)	Specify the number of increments of number of systems. (-7 to 7)
	Increment of Axis No. (decimal)	Specify the number of increments of number of axis. (-31 to 31)
	Increment of Section No. (decimal)	Specify the number of increments of number of section. (-999 to 999)
	Increment of Sub-section No. (decimal)	Specify the number of increments of number of sub-section. (-1000000000 to 1000000000)
(7)	Copy/paste target	Select the copy/paste target.
	Panel macro	Check the box when the panel macro accompanying the selected control is included in the copy/paste target. For the panel macro after the paste, refer to "Screen Macro at the Time of Copy/Paste of Control" of "10.1.11.2 Complements".
(8)	Reset	Specifies the initial values to the data of all items.

(Note 1)

When selecting [Spacing], and duplicating at 8-dot intervals in the horizontal direction:

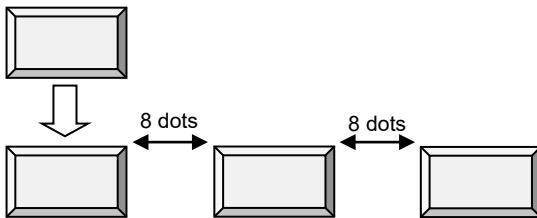

When selecting [Include the size of Shape/Control], and duplicating at 8-dot intervals including the shape/control:

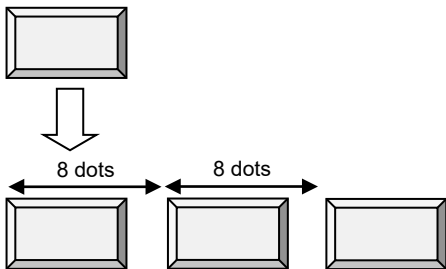

10. Screen Editing

(Note 2)

The following shows the types of copy directions and combo box sequences.

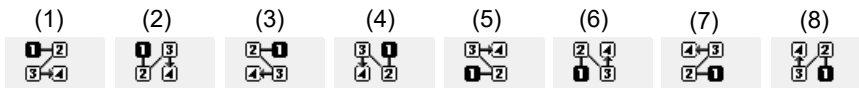

Replace the help figure according to the selected margin and copy direction.

The following are the combinations for "A: Spacing" and "B: Include the size of Shape/Control".

((1) or (2))+A

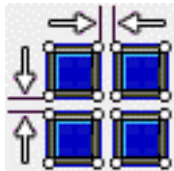

((1) or (2))+B

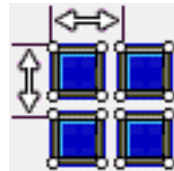

((3) or (4))+A

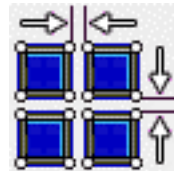

((3) or (4))+B

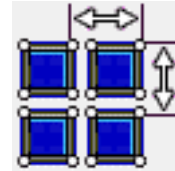

((5) or (6))+A

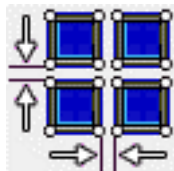

((5) or (6))+B

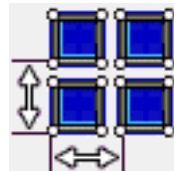

((7) or (8))+A

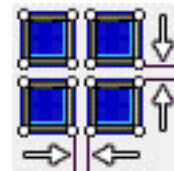

((7) or (8))+B

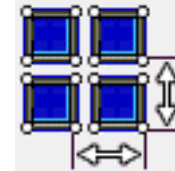

**NOTE**

- ◆ When the all objects after copy for vertical or horizontal is 1, nothing is copied in either direction.
- ◆ When there are no number of systems, number of axis, number of section, number of sub-section, and number of device properties in the control to be duplicated, continuous copy is not affected even if the number of increments for vertical or horizontal are set to 1 or more.
- ◆ Duplication is also possible when figures/controls are grouped or multiple figures/controls are selected.

### 10.1.9.1 Operation Specifications

1. Select the object in the panel/window, and from the [Edit] menu, select [Continuous copy], or click [Continuous copy] from the context menu.
2. The continuous copy dialog box is displayed.

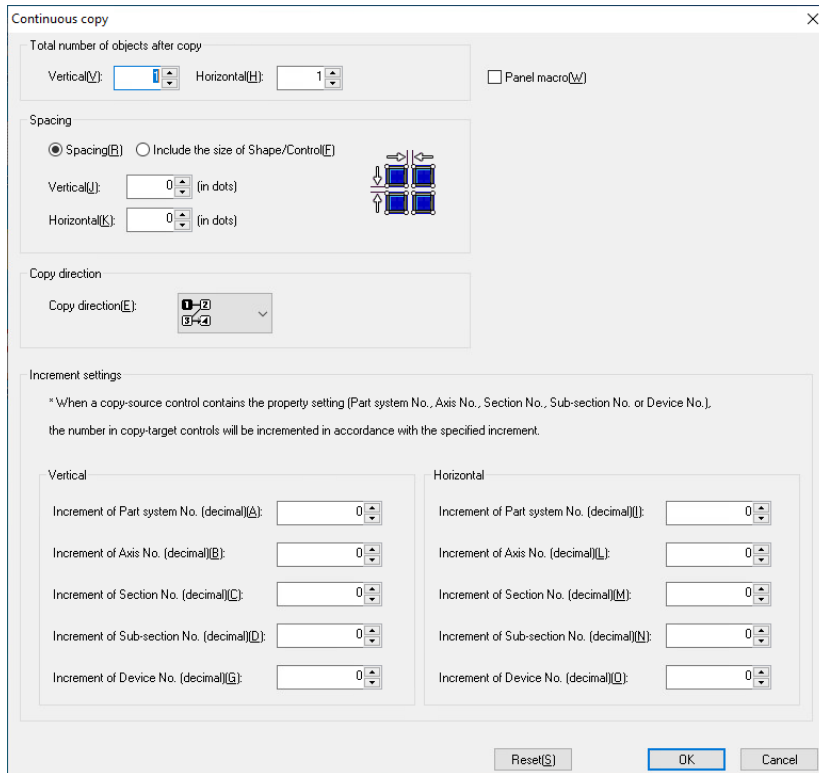

3. Press the [OK] button after setting.  
The selected object is copied.

**10.1.9.2 Limitations**

- (1) When the maximum number of objects for one panel/window (not including in the view frame) is exceeded, up to the maximum number is copied.
- (2) When the objects for one frame exceed 256, up to 256 are copied.
- (3) When the view frames for one panel/window exceed 10, up to 10 are copied.
- (4) When the value of number of systems, number of axis, number of section, number of sub-section, or number of device after incrementing is outside the range, it is copied until the valid range.

Example: When the number of device of the control to be copied is SM2000 (SM: 0 to 2047), and the number of increments is 100, when copying it exceeds SM2047 and thus the control is not copied.

- (5) The maximum copy range is 2560 dots in width, and 1920 dots in height. When copying outside of the maximum copy range, the message "Copy cannot be executed because Object extends out of the view area." is displayed, and the object is not copied.

Example: When a button (A:0, Y:0, WIDTH:100, HEIGHT:100) placed in a panel/window is selected, and the following settings are made in the continuous copy dialog box, the button is copied until the 5th time, then the message "Copy cannot be executed because Object extends out of the view area." is displayed and copying is interrupted.

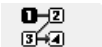
Spacing	Vertical: 500 Horizontal: 500
Total number of objects after copy	Vertical: 5 Horizontal: 6
Copy direction	

**10.1.10 Batch Conversion**

The design of the following controls that are placed on all panels/windows are converted in a batch.

Property	Controls that can be converted in a batch
ColorType	Counter, cycle time, F display, M system modal display, L system modal display, simple modal display, load meter, MSTB, ONB, program buffer, S display, input/output, operation status display, time display
MenuType	Menu
Menu type	Extension menu

When [M8 to M8V design] is selected, controls are converted to M8V base color (M8V Series).  
 When [M8V to M8 design] is selected, controls are converted to M8 base color (M8 Series).  
 Controls with "Specified color" selected in "ColorType" property, and "Classic" selected in "MenuType" and "Menu type" properties will not be converted in a batch.

**10.1.10.1 Operation Procedure**

The following is the procedure for converting from M8 design to M8V design.

1. Select [Batch conversion] - [M8 to M8V design] from the [Edit] menu.  
 When changing from M8V design to M8 design, select [Batch conversion] - [M8V to M8 design].  
 Note that this cannot be selected from the menu when an M7 project is open.

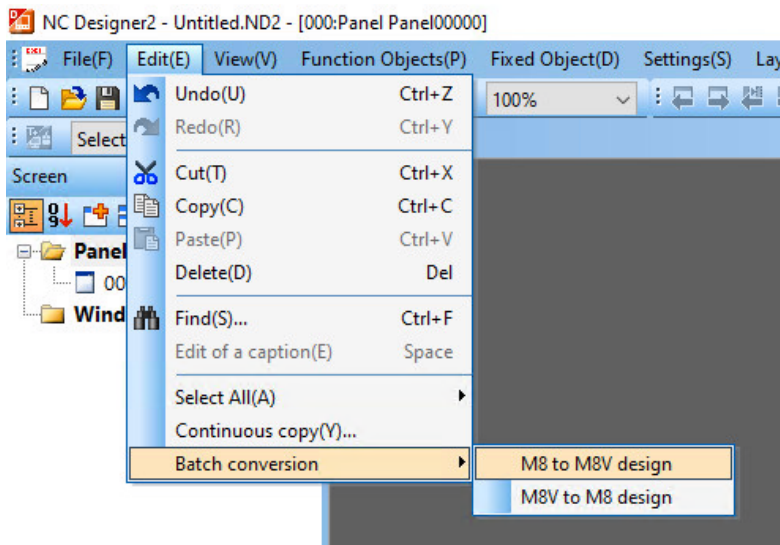



2. A batch conversion to M8V design confirmation dialog appears. (Note)

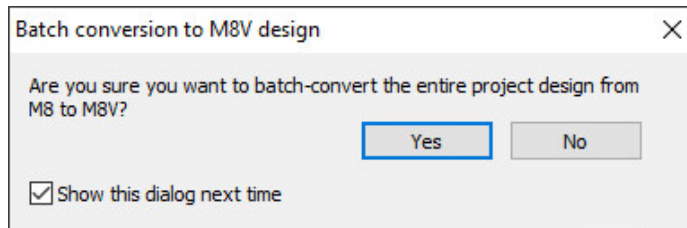

(Note) The batch conversion to M8V design confirmation dialog appears when the "Display a confirmation message before batch design conversion from M8 to M8V" box in the option dialog is checked.

3. Click "Yes" to convert the controls displayed in M8 base color to M8V base color. A completion message appears when conversion is completed.

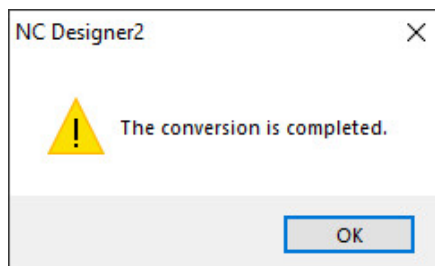

**NOTE**

- ◆ Batch conversion does not support "undo".
- ◆ The M8V design only displays correctly on M800V/M80V displays. It is not displayed correctly on M800/M80/E80 displays.

10. Screen Editing

10.1.11 Copy and Paste between Projects

With copy and paste between projects, the controls and figures can be copied and pasted between different projects. The resources and macro accompanying the control can also be copied and pasted.

Project	Copy and paste
Between M7 projects (IPP format)	○
Between M8 projects (ND2 format)	○
Between M7 project and M8 project	×

○: Available, ×: Not available

10.1.11.1 Operation Procedure

1. Start NC Designer2, and open the copy source project "A".

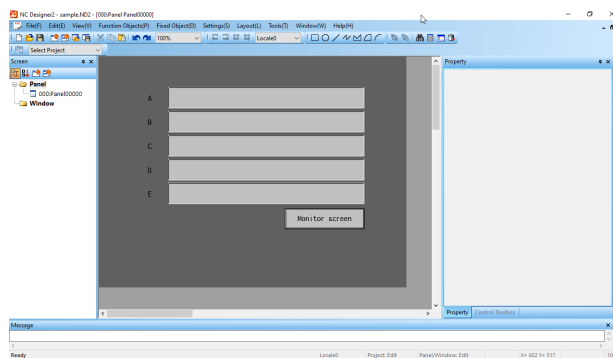

2. Start NC Designer2, and open the copy destination project "B".

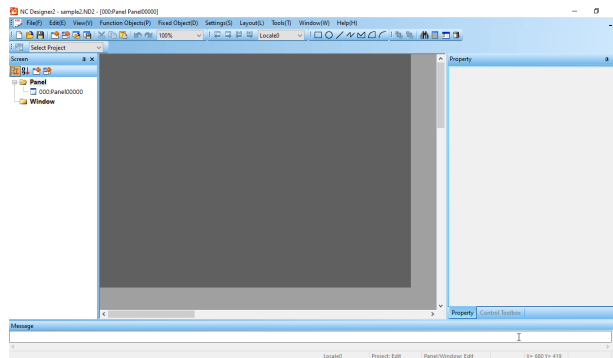

3. Click and select the control located on the project "A" page.

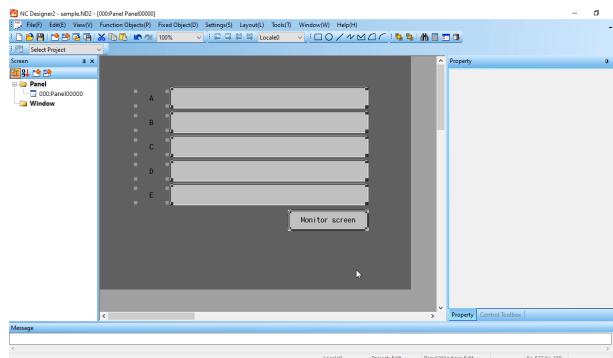

4. While the project "A" control is selected, perform any of the following operations to copy.

- Menu bar [Edit] - [Copy]
- Tool bar [Copy]
- Right-click menu [Copy]
- [Ctrl] + [C] key

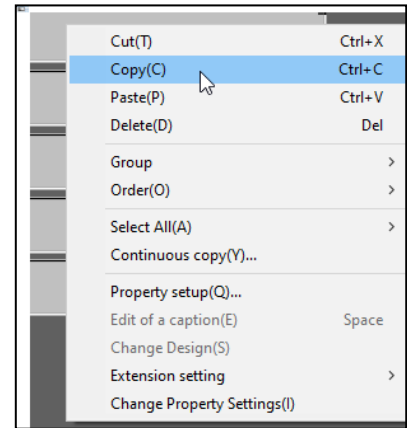
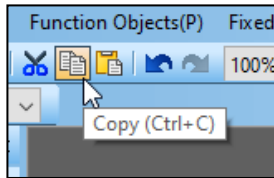
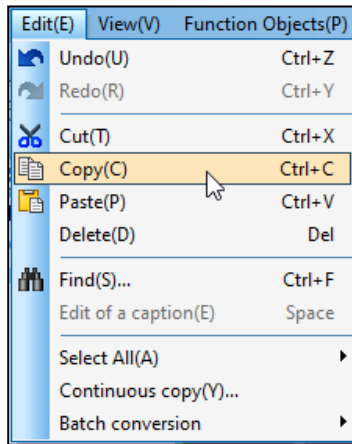

To cut, perform any of the following operations.

- Menu bar [Edit] - [Cut]
- Tool bar [Cut]
- Right-click menu [Cut]
- [Ctrl] + [X] key

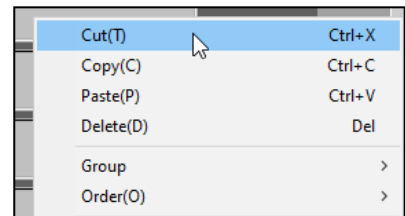
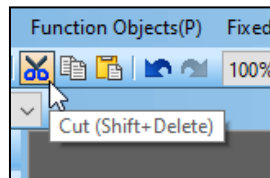
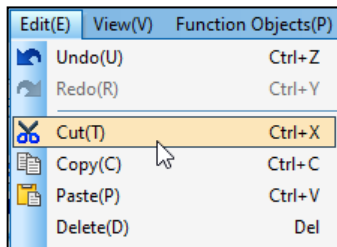

[Paste] in the same project or in another project becomes active after copy or cut is performed.

5. Click (left click or right click) the mouse on the project "B" page.

The clicked position is the upper left position of the control to be pasted.

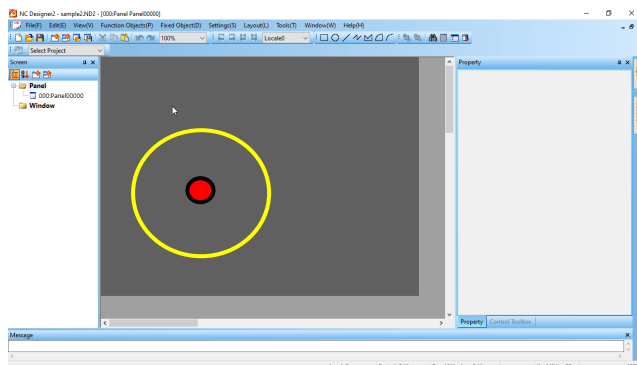

10. Screen Editing

6. Perform any of the following operations to paste on the project "B".

- Menu bar [Edit] - [Paste]
- Tool bar [Paste]
- Right-click menu [Paste]
- [Ctrl] + [V] key

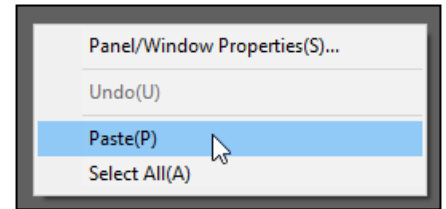
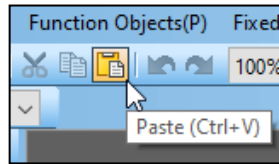
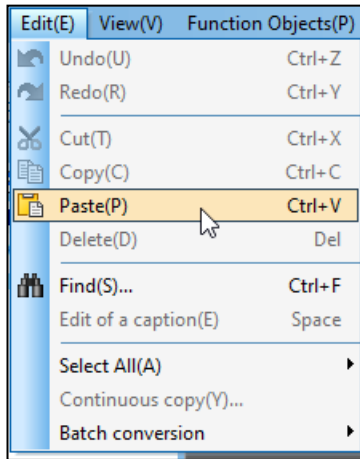

7. The control selected in the project "A" is pasted on the position clicked in the procedure 5.

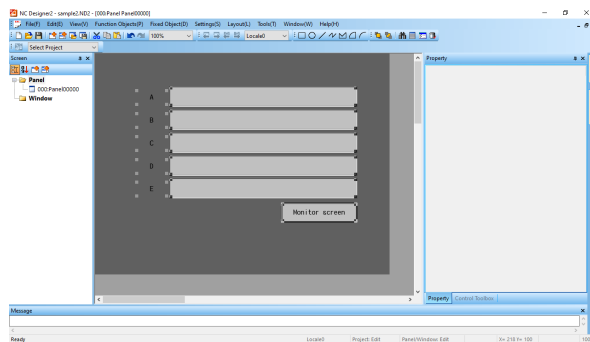

**NOTE**

- ◆ When "Resource data" or "Panel macro" of "Copy/paste target" in the option dialog box is checked, the checked item is included in the copy target items.
- ◆ When copy and paste is performed in the same project, even if "Resource data" in the option dialog box is checked, the checked item is not copied.
- ◆ When "Resource data" in the option dialog box is not checked and copy and paste is performed between different projects, the resource data to which the copy destination control refers is not set.

**10.1.11.2 Complements**

**Control Name of Copy Destination**

When the control is pasted, it is checked whether there is a duplicated control name in the copy destination project.

Duplication check	Control name
Not duplicated	Same as the copy source
Duplicated	Newly created (Note 1)

(Note 1) For the control name which is newly created for the control, refer to "7.1.1 Control Name".

When the control name is changed, the changed contents are displayed on the message window.

(Example) The control name is changed from GButton00002 to GButton00001.

**Resource Data at the Time of Copy/Paste of Control**

When the control is pasted, it is checked whether there is a duplicated resource data name and resource ID in the copy destination project. When there is a duplicated one as a result of the duplication check, the binary comparison is performed between resource data of the copy source and the copy destination.

The following is the resource data value after the duplication check and binary comparison are performed when the control is pasted.

Condition		Result		
Duplication check	Binary comparison	Resource data name	ID	Actual resource data
Not duplicated		Same as the copy source	Same as the copy source	Copied
Duplicated	Matched	Same as the copy destination (Note 1)	Same as the copy destination (Note 2)	Not copied
	Unmatched	Newly created (Note 1) (Note 3)	Newly created (Note 2)	Copied

(Note 1) The resource data name set for the control is automatically changed.

(Note 2) It is necessary to use the corresponding data ID of the copy destination created in the macro program.

(Note 3) For the resource data name which is newly created for the control, refer to "6.1 Resource".

When the resource data name is changed, the changed contents are displayed on the message window.

(Example) The resource data name is changed from ID\_IMAGE00002 to ID\_IMAGE00001.

Screen Macro at the Time of Copy/Paste of Control

When the control is pasted while the copy target contains the screen macro, the header is automatically changed. The copy source information is added to the screen macro.

(Complement) The header of the screen macro (b) consists of control name (a) and event name. For the screen macro function, refer to "NC Designer2 Macro Function Manual" (IB-1501500).

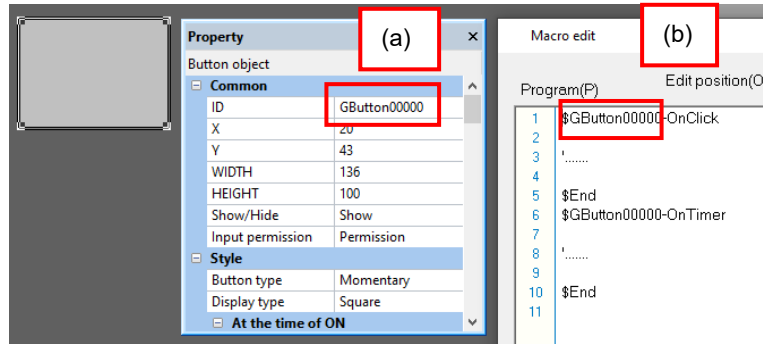

- (1) The control name (b) described in the header is changed to the control name (a) of the copy destination.  
 (Example) When the control is pasted and the control name "GButton00000" is changed to "GButton00001", the header of the macro program is also changed to the copy destination control name "GButton00001".

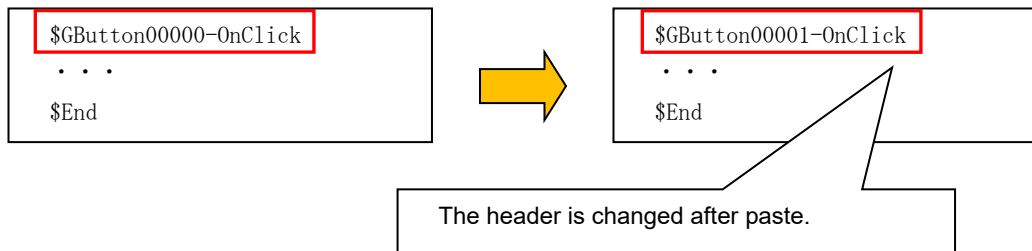

- (2) The copy source information (execution date, project name, panel/window name and control name) is added immediately after the header.  
 (Example) When "GButton00000" of "Panel00000" of "ProjA" is copied and pasted on 2021/7/2, the comment is added as follows.

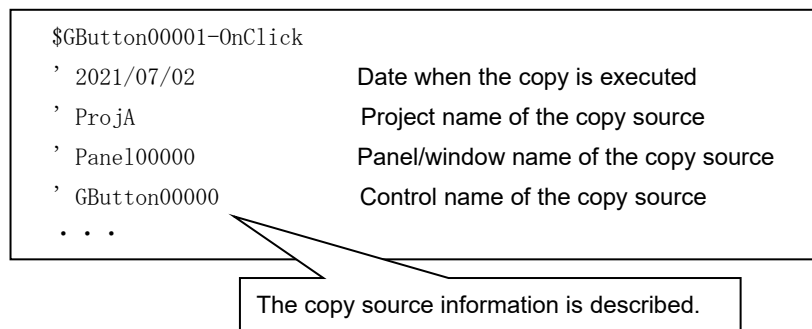

(3) The macro process is copied without any change.

(Example) Even when the control name is changed from "GButton00000" to "GButton00001" at the time of paste, the macro process is copied without any change.

```

$GButton00000-OnClick
GCSButtonSetStringID (-1, "GButton00000" , 0);
GCSButtonSetStringID (-1, "GButton00001" , 1);
GCSButtonSetStringID (-1, "GButton00002" , 2);
$End

```



```

$GButton00001-OnClick
'2021/07/02
'ProjA
'Panel00000
'GButton00000
GCSButtonSetStringID (-1, "GButton00000" , 0);
GCSButtonSetStringID (-1, "GButton00001" , 1);
GCSButtonSetStringID (-1, "GButton00002" , 2);
$End

```

The macro process is copied without any change.

(Note) The control names and resource IDs which are referred to in the macro are not changed. Manually correct the macro program.

### 10.1.11.3 Restrictions

- (1) The sub cursor is not copied between different pages in the same project or between different projects.
- (2) When the upper limits of each data in the copy destination project are exceeded, the paste is not performed. For the upper limits, refer to "2.2.4 Specification List" and "6. Resource".
- (3) The error check of the screen macro in the copy destination project is not performed at the time of copy. Take remedies according to the error messages detected in the "Macro Edit" dialog box.
- (4) There is a possibility that the actual file of the resource data or screen macro does not exist when it is pasted even though it existed when it was copied. In this case, the object is copied when it is pasted; however, non-existing data is not copied. The resource data and the screen macro are not set.
- (5) When the copy source NC Designer2 is closed, the copy information is discarded and can no longer be pasted.
- (6) As for the screen macro, the macro at the time of paste execution is pasted.

## 10.2 Layout Function

The layout function for changing the size and position of the object arranged on the screen is described.

### 10.2.1 Size Change

1. Select the desired object.

2. Move the cursor to the solid box mark at four corners. The cursor shape changes as shown below.

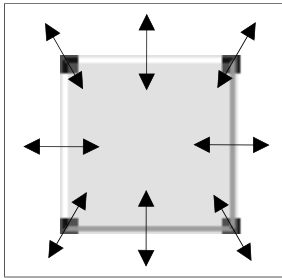

3. Drag in the arrow direction until the object is deformed to the target size.

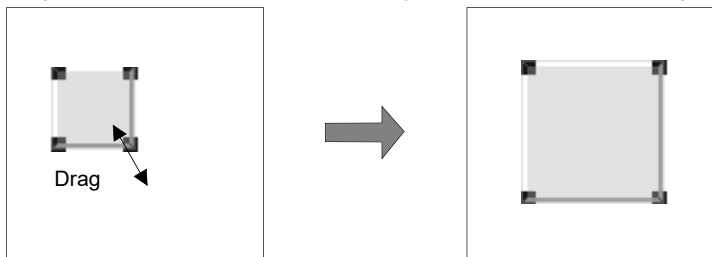

#### **NOTE**

- ◆ Drag while holding down the [Shift] key to change the size while keeping the original aspect ratio.
- ◆ Drag up/down or left/right while holding down the [Ctrl] key to change the size evenly up/down or to left/right.



### 10.2.2 Move

1. Move the cursor to the desired object.

To move multiple objects simultaneously, select all the desired objects to be moved.

2. After the cursor shape changes to the one shown below, drag to the desired position.

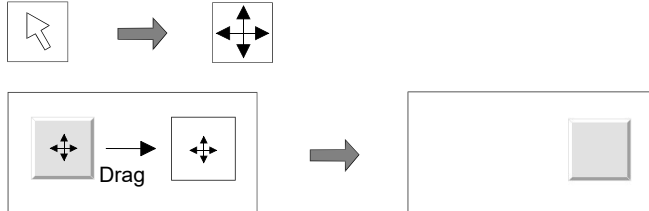

### 10.2.3 Arrangement and Alignment





Align multiple objects up, down, left or right, or at even intervals between up/down/left/right.

Example: Aligning to the highest object

1. Select the objects to be aligned.
2. From the [Layout] menu, select [Align/Distribution] - [Align Top].
3. Align the selected objects along the upper coordinate of the object placed the highest.

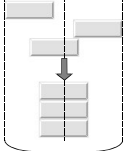
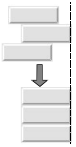

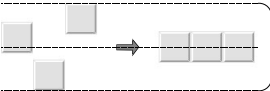
Each function is described below.

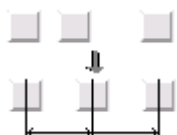
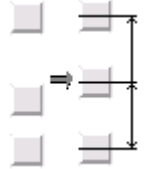
Function	Description
Align Left	 <p>Arrange to the left end.</p>
Center in a Column	 <p>Arrange to the center in the left/right direction.</p>
Align Right	 <p>Arrange to the right end.</p>
Align Top	 <p>Arrange to the top.</p>
Center in a Row	 <p>Arrange to the center in the vertical direction.</p>
Align Bottom	 <p>Arrange to the bottom.</p>
Distribute Horizontally	 <p>Arrange so that the center points are equally distributed.</p>
Distribute Vertically	 <p>Arrange so that the center points are equally distributed.</p>

**10.2.4 Arrange to Uniform Size**



Arrange the width or height of selected multiple objects.

Example: Arranging the size of objects to the narrowest object

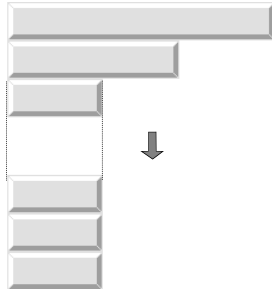
1. Select all the desired objects whose width is to be arranged
2. From the [Layout] menu, select [Make Same Size] - [Smallest Width].

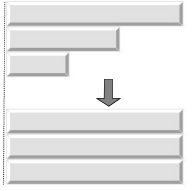

Each function is described below.

Function	Description
Smallest Width	 <p data-bbox="1050 1021 1230 1077">Arrange to the smallest width.</p>
Largest Width	 <p data-bbox="1082 1245 1353 1279">Arrange to the largest width.</p>
Smallest Height	 <p data-bbox="930 1507 1225 1529">Arrange to the smallest height.</p>
Largest Height	 <p data-bbox="930 1727 1209 1749">Arrange to the largest height.</p>

### 10.2.5 Order

Change the order in which overlapped objects are displayed.

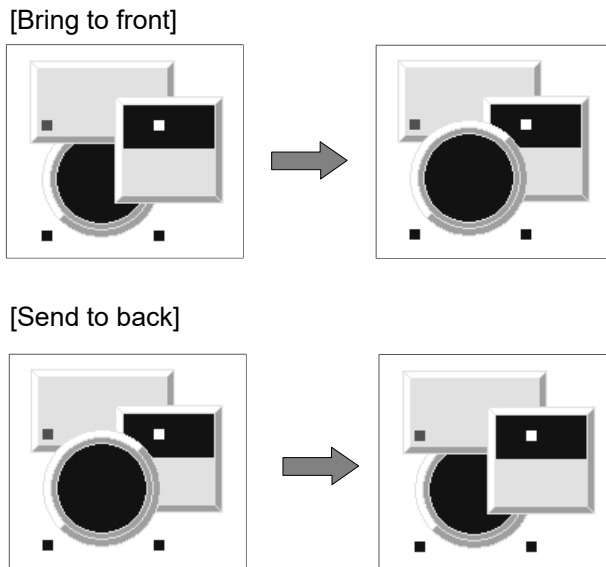

1. Select the desired objects for order change.
2. From the [Layout] menu, select [Order] - [Bring to Front]/[Send to Back] or select [Bring to Front] or [Send to Back] in the tool bar.

### 10.2.6 Fine Adjustment

Move the selected object up/down or left/right by increments of one dot.  
If the grid is valid, the object moves by the set grids.

1. Select the desired object for fine adjustment.
2. From the [Layout] menu, select [Fine Adjustment], and select the desired direction of move.

#### **NOTE**

- ◆ Press the arrow key (→, ←, ↑ or ↓) to obtain the same result.

**10.2.7 Rotation/Flip**

Rotate or flip the object vertically or horizontally. Grouped multiple objects can be rotated or flipped, too.

**Rotate/Flip Around the Rectangle of the Object**

Rotate or flip the object around the rectangle's center coordinate of the object.

1. Select the object to be rotated or flipped.
2. From the [Layout] menu, select [Rotate/Flip] and the direction of rotation or flip.

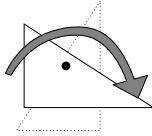
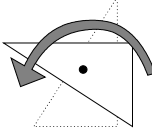
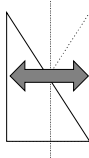
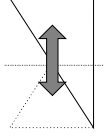
Function	Description
Rotate Right 90 Degrees	
Rotate Left 90 Degrees	
Flip Horizontal	
Flip Vertical	

**NOTE**

- ◆ When grouped objects are rotated or flipped, they rotate or flip around the center of the grouped rectangle.
- ◆ The caption character string does not rotate or flip.

**Rotate or Flip Around the Center of the Page/View Frame**

Rotate or flip the object around the coordinates of the center of the editing page or view frame.

1. Select the object to be rotated or flipped.
2. From the [Layout] menu, select [Rotate/Flip] and select the direction of rotation or flip.

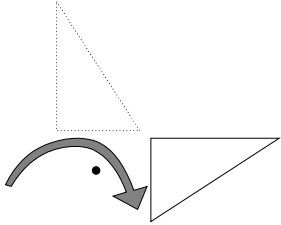
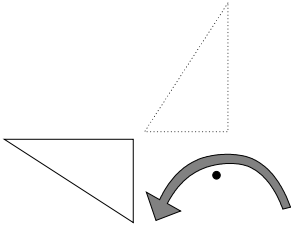
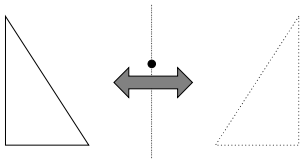
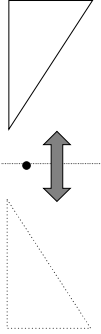
Function	Description
Rotate Right 90 Degrees Around Center of Screen/Frame	
Rotate Left 90 Degrees Around Center of Screen/Frame	
Flip Horizontal Around Center of Screen/Frame	
Flip Vertical Around Center of Screen/Frame	

### 10.2.8 Deformation

Change the position of the vertex of connected lines, polygon, sector or arc, to change its shape. Or some vertexes can be deleted from or added to the connected lines or polygon.

#### Editing the Vertex

1. Select the desired figure.
2. From the [Layout] menu, select [Modify] - [Edit Node].
3. The vertexes of the figure appear.

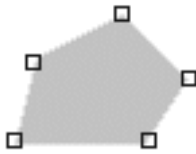

4. Move the cursor to the desired vertex and, after the cursor shape has changed to "+", drag the cursor to the new position.

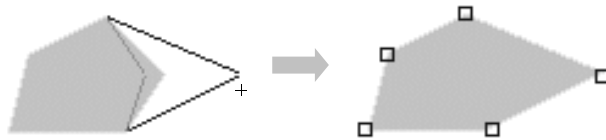

5. Click the right mouse button to exit from the vertex editing mode.

**Adding a Vertex**

1. Select the desired figure.
2. From the [Layout] menu, select [Modify] - [Add Node].
3. The vertexes of the figure appear.
4. Place the cursor on the contour line. The cursor shape changes as shown below.



5. Click the mouse button at the position of the new vertex on the contour line.

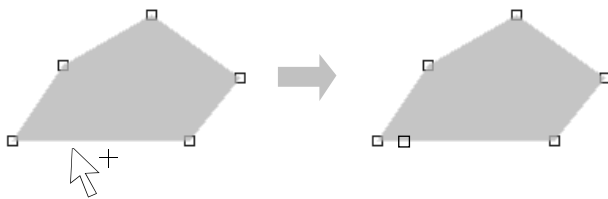

6. Click the right mouse button to exit from the vertex addition mode.

**Deleting a Vertex**

1. Select the desired figure.
2. From the [Layout] menu, select [Modify] - [Delete Node].
3. The vertexes of the figure appear.
4. Move the cursor to the desired vertex. The cursor shape changes as shown below.



5. Click on the desired vertex.

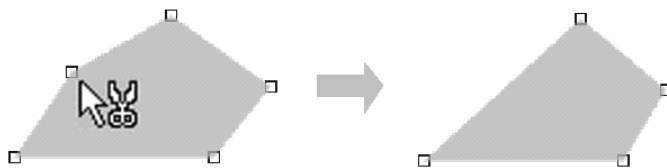

6. Click the right mouse button to exit from the vertex deletion mode.



### 10.2.9 Grouping and Ungrouping

Grouped multiple controls or figures can be edited or operated as if they are a single object. Grouped controls or figures can be grouped with another group or other controls or figures.

#### Grouping

1. Select the desired controls or figures to be grouped.



2. From the [Layout] menu, select [Group] - [Group].



#### **NOTE**

- ◆ The shortcut key corresponding to [Group] is [Ctrl] + [G].
- ◆ The view frame cannot be grouped.

#### Ungrouping

Ungroup to release grouped controls and figures into original objects.

1. Select the desired group to be ungrouped.
2. From the [Layout] menu, select [Group] - [Ungroup].

#### **NOTE**

- ◆ The shortcut key corresponding to [Ungroup] is [Ctrl] + [U].
- ◆ Only one group of objects can be ungrouped at a time.

Property Settings of Grouped Objects

Enter the property settings of each object while they are grouped together.

1. Move the mouse cursor to a grouped object, and select [Property Setting] from the popup menu displayed upon a click of the right mouse button.

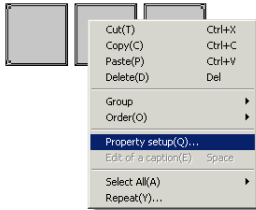

2. The [Object Selection] dialog box is displayed. Select the desired object and click on the [OK] button. Properties of the selected object are displayed in the property sheet.

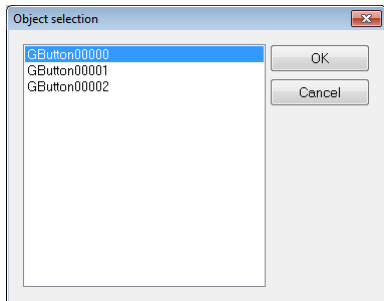

**NOTE**

- ◆ Double click on a desired object in the group while the group is selected, then the properties of the object is displayed in the property sheet.

**10.2.10 Grid**

Specify a grid to be displayed on the panel/window.

1. Select [Grid] in the [Layout] menu.
2. The [Specify Grid] dialog box appears.

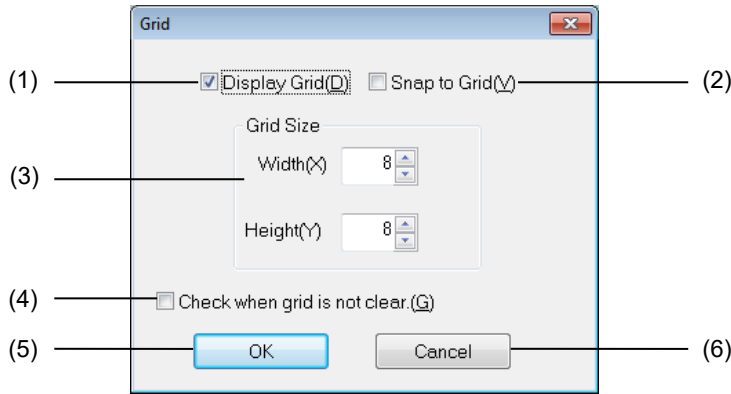

No.	Item	Details
(1)	Display Grid	Check this box to view a grid on the panel/window that is displayed at grid width intervals.
(2)	Snap to Grid	Check this box to move an object at grid width intervals or change its size.
(3)	Grid Size	Specify the grid interval.
	Width (X)	Specify the horizontal interval (1 to 2560). If necessary, you can click the "▲" or "▼" button on the right of the entry field to increase or decrease the numeric value.
	Height (Y)	Specify the vertical interval (1 to 1920). If necessary, you can click the "▲" or "▼" button on the right of the entry field to increase or decrease the numeric value.
(4)	Check when grid is not clear.	If this box is checked while Display Grid is enabled, the grid is displayed in black or white depending on the tone specified for the "Background Color" property, on the panel/window.
(5)	OK button	Click this button to save settings and close the dialog box.
(6)	Cancel button	Click this button to cancel settings and close the dialog box.

3. When the setting process is finished, click the [OK] button.

**NOTE**

- ◆ When an image is specified on the background of the panel/window, the grid may not be clearly visible even if the [Check when grid is not clear.] box is checked.

### **10.3 Control List**

Control information (such as page, ID, type, X, Y, CX, CY, section number, sub-section number, and device) located in the project being edited can be displayed in a list with the control list function. Property data of the device and NC data (section and sub-section) can also be edited on the list. For other control information, the property data can be edited easily by double-clicking on the information on the list and opening the property setup dialog.

10.3.1 Operation Screen

In the control list dialog, the list of controls located in the specified display range and control information are displayed.

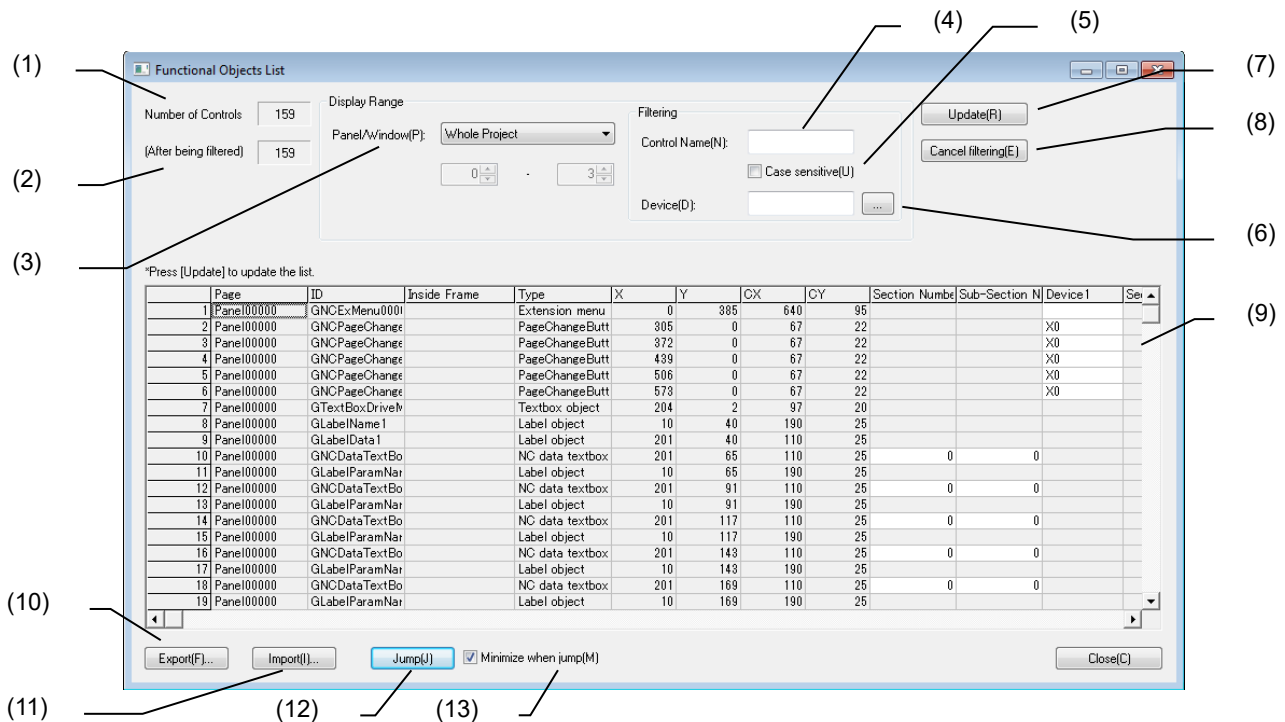

The following items are displayed in this dialog.

No.	Item	Description
(1)	Number of Controls	Display the number of all controls located in the display range specified in [(3) Panel/Window].
(2)	(After being filtered)	Display the number of controls after being filtered with the conditions specified in [(4) Control Name] to [(6) Device].
(3)	Panel/Window	Select the range to display on the list from "Current Screen", "Whole Project", and "Screens".  When selecting "Screens", the setting field of the page number is enabled.
(4)	Control Name	Specify the control name for filtering.
(5)	Case sensitive	When the check box is checked, filtering of the character sequence entered in [(4) Control Name] is case sensitive. When not performing a case sensitive filter, uncheck the check box.
(6)	Device	Specify the device name for filtering.  Click on the "..." button to display the "PLC Device Setting" dialog.
(7)	Update	Update the display of the list.
(8)	Cancel filtering	Release the conditions specified in filtering ([ (4) Control Name] and [(6) Device]).  (Note) The check in [(5) Case sensitive] is not cleared.
(9)	List	Display the list of control information.  Regarding the content, refer to "10.3.1.1 The List".
(10)	Export	Save the control information displayed in [(9) List] in the CSV file format.

10. Screen Editing

No.	Item	Description
(11)	Import	Specify the control information of the CSV file format.  Click on the [Import] button to display the file selection dialog. Specify the CSV file and click on the [OK] button to reflect the content of the file to the control information.
(12)	Jump	Jump to the control selected in the list.
(13)	Minimize when jump	When checked, the control list dialog is minimized when jumping to the control.

**NOTE**

- ◆ When deleting/adding a control, changing property information, etc., click the [Update] button to update the list.
- ◆ Click the [Update] button after filtering with the conditions specified in [(4) Control Name] to [(6) Device] to update the list.
- ◆ When the following description is in a CSV file, an error message is displayed and importation is interrupted. The control information imported before the importation was interrupted is specified.
  - A description containing at least one different page, ID, inside frame, or type
  - A description with a page that does not exist
  - A description with a section number or sub-section number outside the range
  - A description with a device that cannot be specified
- ◆ The first row in a CSV file is a comment. The row number in an error message displayed during an import error includes the comment row.
- ◆ When the control selected in the list has been deleted or the ID has been changed, the error message "Not found" is displayed when clicking on the [Jump] button.
- ◆ With Panel/Window having 16 pages open, if clicking on the [Jump] button, or selecting and double clicking page, ID, inside frame, and type when the Panel/Window selected in the list is not open, the error message "Cannot open any more screens. Close some active screens and try again." is displayed.

10.3.1.1 The list

The control information is displayed in the list. The disabled items (grayout) cannot be edited. Click on the top line (item names) to sort.

Page	ID	Inside Frame	Type	X	Y	CX	CY	Section Number	Sub-Section Number	Device I	Se
1	Panel000000	GNCExMenu0001	Extension menu	0	385	640	95				
2	Panel000000	GNCPageChange	PageChangeButt	305	0	67	22			X0	
3	Panel000000	GNCPageChange	PageChangeButt	372	0	67	22			X0	
4	Panel000000	GNCPageChange	PageChangeButt	439	0	67	22			X0	
5	Panel000000	GNCPageChange	PageChangeButt	506	0	67	22			X0	
6	Panel000000	GNCPageChange	PageChangeButt	573	0	67	22			X0	
7	Panel000000	GTextBoxDrive	Textbox object	204	2	97	20				
8	Panel000000	GLabelName1	Label object	10	40	190	25				
9	Panel000000	GLabelData1	Label object	201	40	110	25				
10	Panel000000	GNCDataTextBo	NC data textbox	201	65	110	25	0	0		
11	Panel000000	GLabelParamNar	Label object	10	65	190	25				
12	Panel000000	GNCDataTextBo	NC data textbox	201	91	110	25	0	0		
13	Panel000000	GLabelParamNar	Label object	10	91	190	25				
14	Panel000000	GNCDataTextBo	NC data textbox	201	117	110	25	0	0		
15	Panel000000	GLabelParamNar	Label object	10	117	190	25				
16	Panel000000	GNCDataTextBo	NC data textbox	201	143	110	25	0	0		
17	Panel000000	GLabelParamNar	Label object	10	143	190	25				
18	Panel000000	GNCDataTextBo	NC data textbox	201	169	110	25	0	0		
19	Panel000000	GLabelParamNar	Label object	10	169	190	25				

The following items are displayed in the list from the left.

No.	Item	Description
(1)	Page	Display the panel/window name of the pages where controls are located.
(2)	ID	Display the control name.
(3)	Inside Frame	Displayed when controls are located in the view frame. Displayed in the format of "inside frame (page number where it is located)".
(4)	Type	Display the types of controls.
(5)	X	Display the horizontal position from the upper left of the page/view frame of the control (X coordinate) in dots.
(6)	Y	Display the vertical position from the upper left of the page/view frame of the control (Y coordinate) in dots.
(7)	CX	Display the width of the control in dots.
(8)	CY	Display the height of the control in dots.
(9)	Section Number	Display the value of the section number property.  (Note) For controls with no section number property, the entry is disabled (grayout).
(10)	Sub-Section Number	Display the value of the sub-section number property.  (Note) For controls with no sub-section number property, the entry is disabled (grayout).
(11)	Device	Display the address of the PLC device.  (Note) For controls with no device property, the entry is disabled (grayout).

**NOTE**

- ◆ For controls displayed in the list that have multiple "section number", "sub-section number", and "device" properties, the maximum number of existing properties are added to the "section number", "sub-section number", and "device" columns.
- ◆ Double-clicking on the page, ID, inside frame, and type opens the property setup dialog for the corresponding control.  
Also, double-clicking X, Y, CX, and CY opens the panel/window that the control is located in front of all other screens, and the control becomes selected. This enables the editing of properties in the property sheet.  
After editing in the property setup dialog and property sheet, click on the [Update] button to update the list.  
The section number, sub-section number, and device can be edited directly on the list by double-clicking on them.



### 10.3.2 Operation Specifications

1. Click on the [Functional Objects List] button in the [Tool] menu.
2. The control list is displayed.

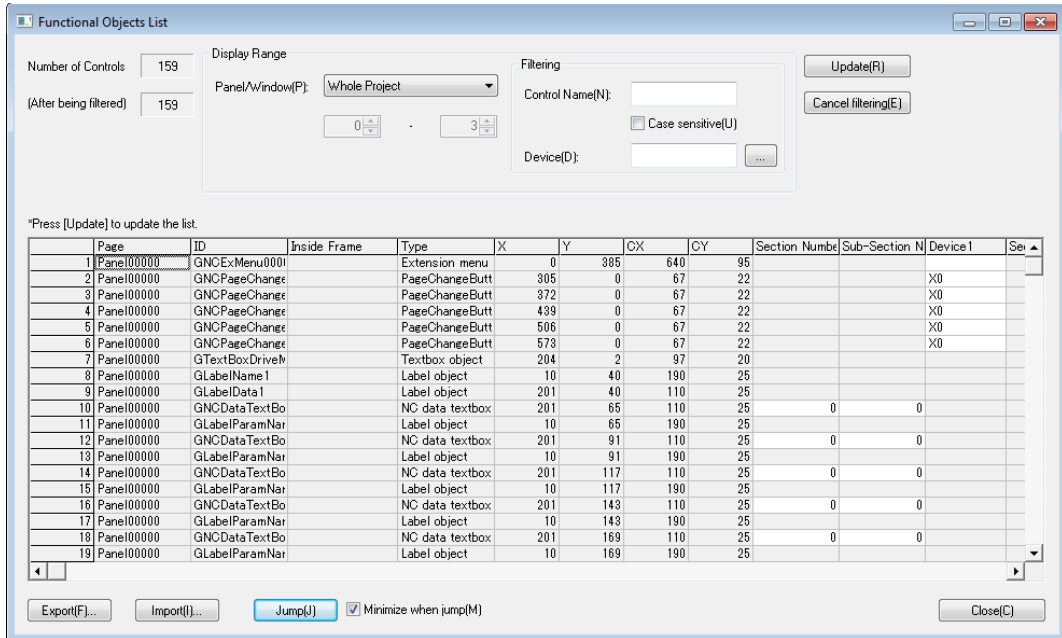

### 10.3.3 Restrictions

- (1) If there are duplicate IDs on the same page, importation, jump, and editing operations etc. are not performed correctly. Use the error check function to check for duplication. For the error check function, refer to "10.5 Error Check".

### 10.4 Focus Setup

With NC Designer2, and the focusing order of each control can be specified.

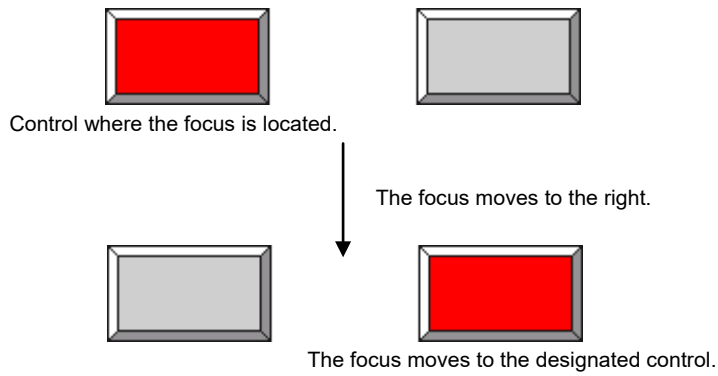

Give the focus setting on each page/frame.

1. Open the desired page/frame.
2. From the [Settings] menu, select [Focus Setup].

3. The [Focus Setup] dialog box is displayed.

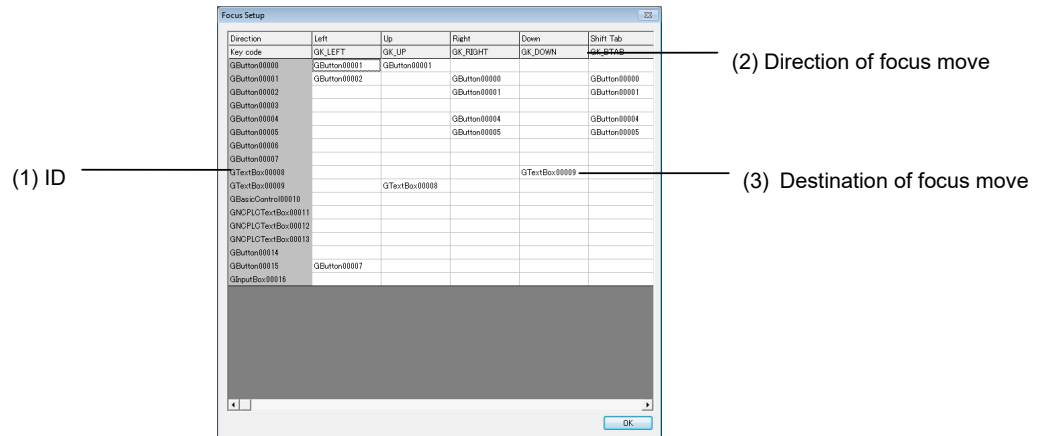

No.	Item	Description
(1)	ID	Display the names of the controls included in the page.
(2)	Direction of focus move	Specify six directions of focus move. Specify the destinations of the focus move after the [GK_LEFT], [GK_UP],[GK_RIGHT], [GK_DOWN], [GK_BTAB] and [GK_TAB] key codes defined in NC Designer2 are received.
(3)	Destination of focus move	Select the control name, which is the destination of the focus move, from the list. Select "NULL" or specify no data to refrain from moving the focus in the direction. To cancel the destination having been entered, select "NULL".

4. After finishing data entry, click on the [OK] button.

**NOTE**

- ◆ While the focus setup is given, control names are displayed at the objects located in the page view.

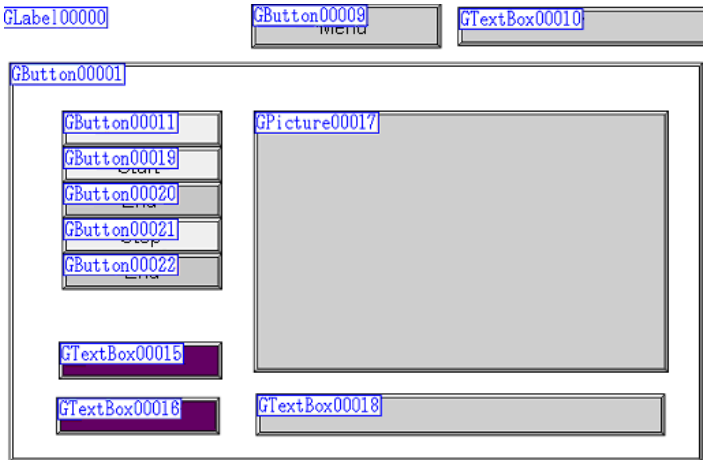

- ◆ Cells are colored in gray for the initial focus which is set from [Input permission] – [Prohibition] in the property of the control or the control with no "Input permission" in the property settings.

HEIGHT	52
Show/Hide	Show
Input permission	Permission
Address	Permission
Ground	Prohibition
PLC device	
PLC device	SW0

→

Direction	Left	Up	Right	Down	Shift Tab
Key code	GK_LEFT	GK_UP	GK_RIGHT	GK_DOWN	GK_BTAB
GButton00000		GButton00001			
GButton00001	GButton00001				
GButton00002			GButton00000		GButton00000
GButton00003			GButton00001		GButton00001
GButton00004			GButton00004		GButton00004
GButton00005			GButton00005		GButton00005
GButton00006					
GButton00007					
GButton00008					
GText00009					
GBasicControl00010					
GNCPLCTextBox00011					
GNCPLCTextBox00012					
GNCPLCTextBox00013					
GButton00014					
GButton00015	GButton00007				
GInputBox00016					
GNCDataTextBox00017					

- ◆ The destination set in the program is given priority over the destination set in [Destination of focus move].

### 10.5 Error Check

1. From the [Tool] menu, select [Error Check].
2. The [Error Check] dialog box is displayed.  
Enter each item and click on the [OK] button.

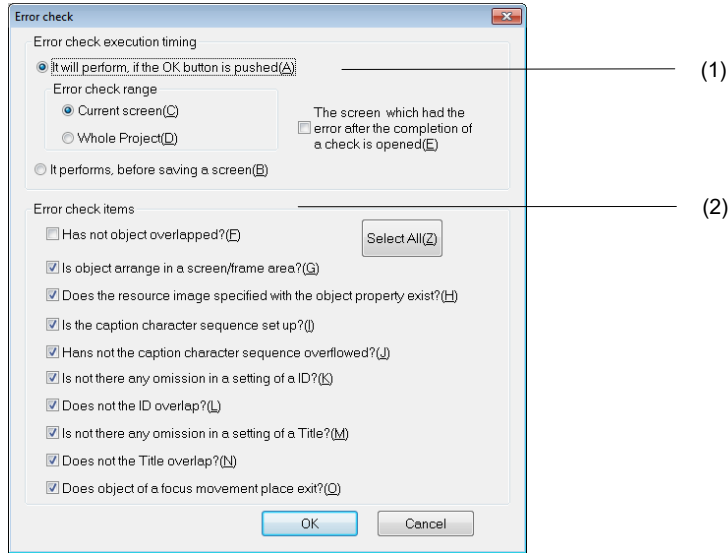

No.	Item	Description
(1)	Error check execution timing	Specify the timing and execution range of the error check.
	It will perform if the OK button is pushed	Execute an error check when the [OK] button is clicked on in the [error check] dialog box. Select the range of execution of the error check between "Current Screen" and "Whole Project".
	It performs before saving a screen	Execute an error check upon screen saving operation before the screen is stored. The error check execution range is only the current screen.
	The screen which had the error after the completion of a check is opened	Check this box to display the error page after error check.
(2)	Error check items	Check the boxes of the desired error check items.

**10.5.1 Error Check Item List**

Item	Description
Has not object overlapped?	Checks if controls/view frames overlap.
Is object arranged in a screen/frame area?	Checks if controls outside the page and controls arranged in the view frame are located outside the view frame.
Does the resource image specified with the object property exist?	Checks if files registered in the image resources specified for controls exist.
Is the caption character sequence set up?	Checks if caption character strings are deleted from the character string resources designated in each control.
Has not the caption character sequence overflowed?	Checks if caption character strings of each locale overflow the character string area of the control.
Is not there any omission in a setting of an ID?	Checks if controls have a control/view frame name.
Does not the ID overlap?	Checks if control/view frame names are duplicated among multiple controls/view frames.
Is not there any omission in a setting of a Title?	Checks if the panels/windows have a panel/window name.
Does not the Title overlap?	Checks if panel/window names are duplicated among multiple panels/windows.
Does object of a focus movement place exist?	Checks if control/view frames specified as a destination of the focus exist.

### 10.5.2 Result of Error Check

The result of the error check is displayed in the message window.

**If No Error Is Detected**

1. The dialog box shown below is displayed after the error check.

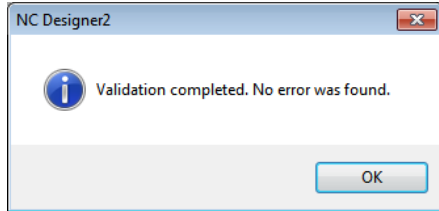

**If an Error Is Found**

1. The result of the error check is displayed in the message view after the error check.

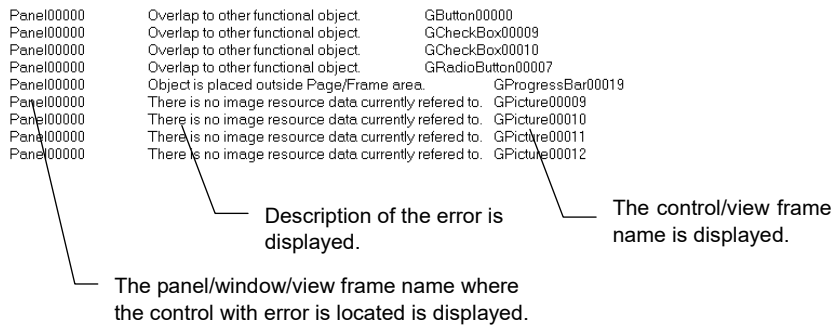

**NOTE**

◆ If 100 or more errors are found, the following message is displayed and the error check is terminated.

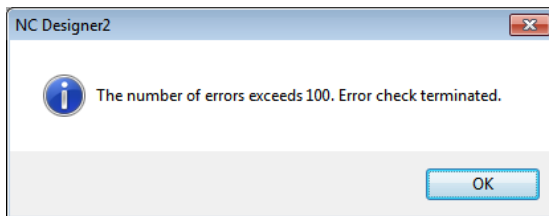

### 10.6 Memory Usage Check

The memory usage check function checks if the memory used by all pages (panels/windows) and the memory used by the resources of the project being edited, and the total size of the files stored in the desired folders and the files output by interpreter method do not exceed the upper limit of the actual machine.

This function is only for M800V/M80V/M800/M80/E80 Series.

#### 10.6.1 Memory Usage Check Dialog

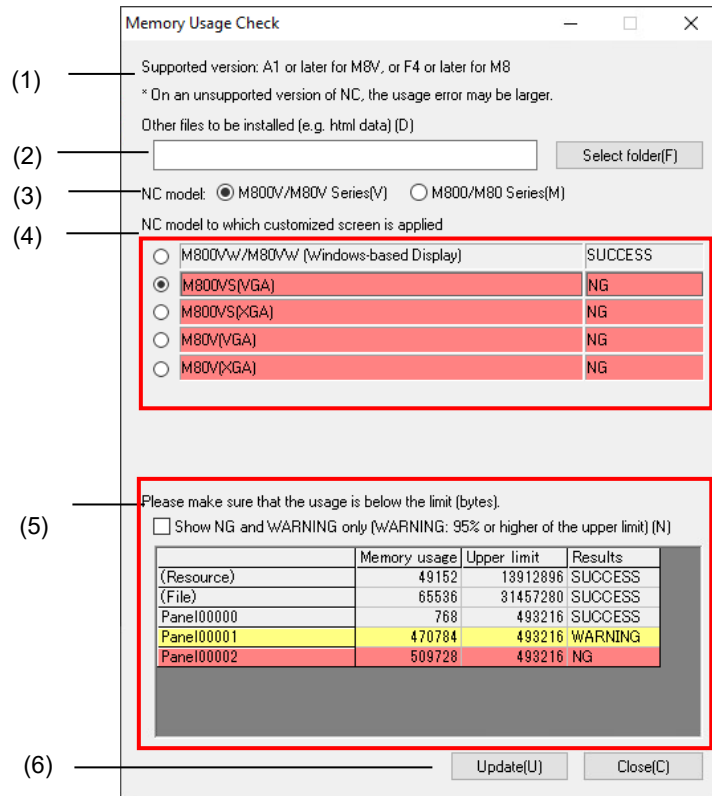

The following items are displayed on this dialog.

No.	Item	Description
(1)	Supported version	Displays the NC versions that this function supports.
(2)	Other files to be installed	Specify the path of files other than the project being edited for which file size is checked. When there are installation files other than the project created in NC Designer2, store these files in a single folder. When this field is empty, a file size check is not conducted.  (Note) Click the "Update" button after specifying the folder. A memory usage check which adds the total size of the files in the specified folder will be executed.
	Select folder	Clicking this button opens the folder selection dialog. The desired folder can be selected.
(3)	NC model	Select the series of the model displaying the custom screens.
(4)	NC model to which customized screen is applied	Displays a list of the models (screen size) for the series selected in "NC model".
	(Radio button)	Select the model (screen size) for checking the memory usage of one page, the memory usage of resources, and the file size.



10. Screen Editing

No.	Item	Description
	Results	<p>Displays the results of the memory usage for each model (screen size).</p> <p>(Note) When the results (NG, WARNING, SUCCESS) of the pages, resources, and files displayed in "List of the upper limit of the usage" are mixed, the result with the highest priority is displayed as the result for each model (screen size). The order of priority for results is "NG", "WARNING", then "SUCCESS". When "NG, "WARNING", and "SUCCESS" are mixed in "List of the upper limit of the usage", "NG" is displayed. When there is only "SUCCESS", "SUCCESS" is displayed.</p>
(5)	<p>List of the upper limit of the usage</p> <p>Show NG and WARNING only</p> <p>Items subject to checking</p> <p>Memory usage</p> <p>Upper limit</p> <p>Results</p>	<p>Displays a list of each of the pages (panels/windows), resources, and files with their memory usage, upper limits, and results.</p> <p>Check this box to display only the rows with "NG" and "WARNING" memory usage results.</p> <p>Displays all the pages, resources, and files of the project being edited.</p> <p>Displays the memory usage of each page, the memory usage of each resource, and the size of files. The file size is the sum of the size of the files for custom screens created by interpreter method and the size of the files stored in the folder specified in "Other files to be installed".</p> <p>Displays the upper limit of memory usage for one page, the upper limit for resources, and the upper limit for file size.</p> <p>Displays the memory usage of one page, the memory usage of resources, and the result for file size.</p>
(6)	Update	<p>Executes memory usage check.</p> <p>A memory usage check is executed once this dialog is opened. Click this button after specifying the path of a desired folder in "Other files to be installed" to execute a memory usage check which adds the total size of the files in the specified folder.</p>

10.6.2 Operation Methods

1. Select [Memory usage check] from the [Tool] menu, or select [Memory usage check] on the tool bar.

2. A project save confirmation dialog opens. (Note)

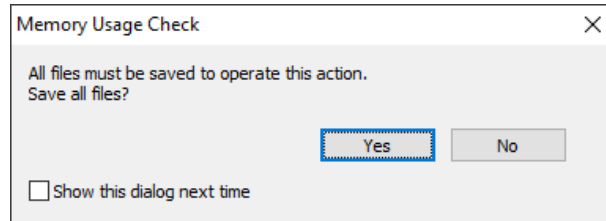

3. Clicking [Yes] saves the project being edited.

After saving the project, the result of the memory usage check is displayed.

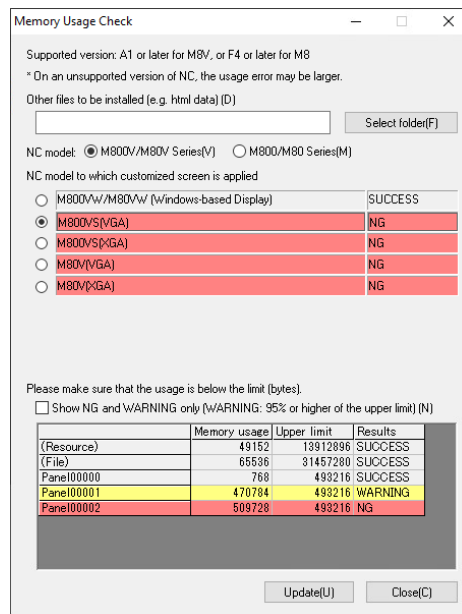

4. When adding files to be subject to checking, select the folder where the files are stored using the "Other files to be installed (e.g. html data) (D)" field or the "Select folder(F)" button, and click the "Update" button.

A message appears when the folder specified in "Other files to be installed" does not exist. Close the message box and enter the correct path in the field.

(Note) The project save confirmation dialog is displayed only when "Show a confirmation message to save the project before executing Memory usage check" on the option dialog is checked.

**NOTE**

- ◆ The project being edited is automatically saved in the following situations regardless of whether "Show a confirmation message to save the project before executing Memory usage check" in the option dialog is checked or not.
  - The "Update" button in the memory usage check dialog is clicked
  - When "Memory usage check" is selected from the [Tool] menu or on the tool bar while the memory usage check dialog is minimized.

**10.6.3 Check Results**

The results of memory usage check are as follows.

Result	Description
SUCCESS	Within the upper limit with significant memory to spare.
WARNING	Within the upper limit with minimal memory to spare.
NG	Exceeding the upper limit.

### 10.7 Development by Multiple Users

To create screens by multiple users using NC Designer2, common project data such as resource data and panel names must be unified for a management purpose. During multi-user development, no screen duplication is allowed among users. (Shown is an example of creation of 30 pages by 3 users.)

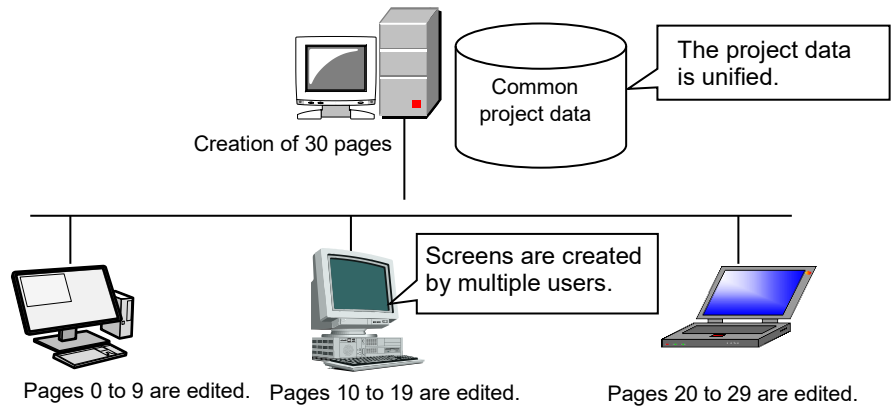

The screen development work is divided into the work that can be distributed to multiple users and the work that must be done by a single user holding the editing right.

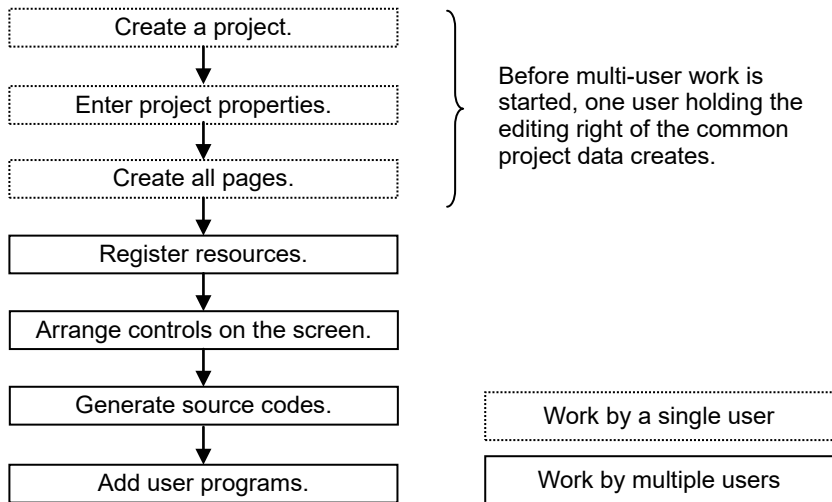

### 10.7.1 Option Setting

The operations and the specified values of NC Designer2 can be customized.

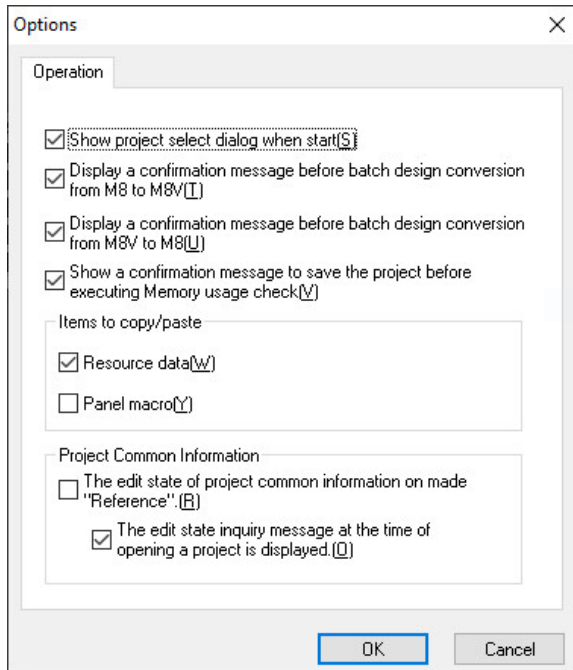

Item	Function
Display the selection dialog for the project when launching	Display the selection dialog for opening/creating a new project when launching NC Designer2.
Display a confirmation message before batch design conversion from M8 to M8V	If it is checked, a M8V batch conversion confirmation message appears before batch conversion.
Display a confirmation message before batch design conversion from M8V to M8	If it is checked, a M8 batch conversion confirmation message appears before batch conversion.
Show a confirmation message to save the project before executing Memory usage check	If it is checked, a project save confirmation message appears before checking memory usage.
Resource data	If it is checked, the resource data accompanying the copy target is also copied. (Note 1)
Screen macro	If it is checked, the screen macro accompanying the copy target is also copied.
Set the editing state of the project common information to "refer"	If it is checked, the panel or the window can be edited, but the project common information cannot be edited.
Display the inquiry message for the editing state when opening the project	If this is checked, the dialog designating the editing state is displayed as opening the project. If other user is using the same project, a confirmation dialog is displayed.

(Note 1) When copy and paste is performed in the same project, the resource data is not copied even if the "Resource data" check box is checked.

(Note 2) When "Resource data" is not checked and copy and paste is performed between different projects, the resource data to which the copy destination control refers is not set.

## 10.8 Sub Cursor Setting

The sub cursor setting enables to reflect the values which has been input in the input controls (input box, ten-key) to the controls where the sub cursor is located, by pressing the INPUT key. The display indicating the destination where the input data is to be reflected is called "sub cursor". The following functions are also available by sub cursor setting.

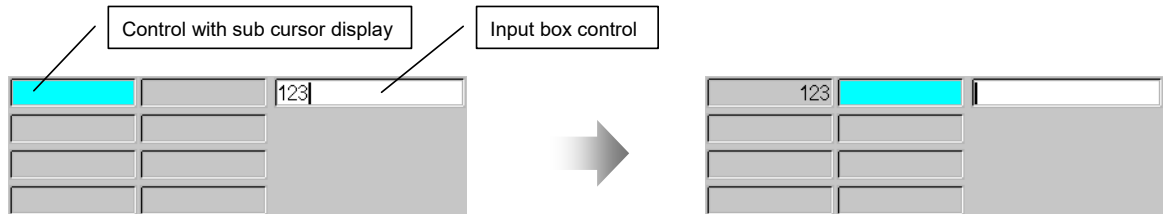

- (1) Displays the sub cursor (Specify the sub cursor position at default)
- (2) Moves the sub cursor with the arrow key/TAB key or a click
- (3) Sets the key transfer control
- (4) Moves the display location of the input area control

The Sub cursor setting dialogue will appear by selecting the pop-up menu [Extension setting]-[Sub cursor setting] which will appear by clicking the right mouse button on an input control.

For the details of the input box, refer to "7.2.14 Input Box Object(GInputBox)".

For the details of the ten-key, refer to "7.2.15 Ten-key object (GSoftKey)".

10.8.1 Screen Specifications

Screen Images

The Sub cursor setting screen is constructed as shown below.

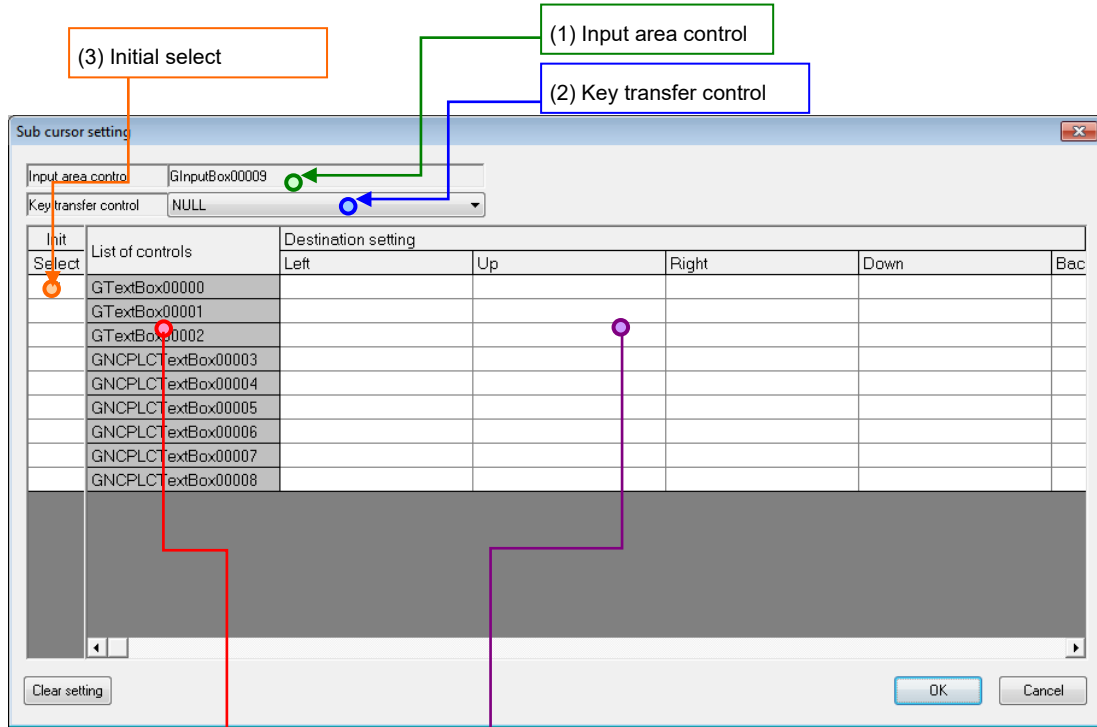

(3) Initial select  
 (4) List of controls  
 (5) Destination setting

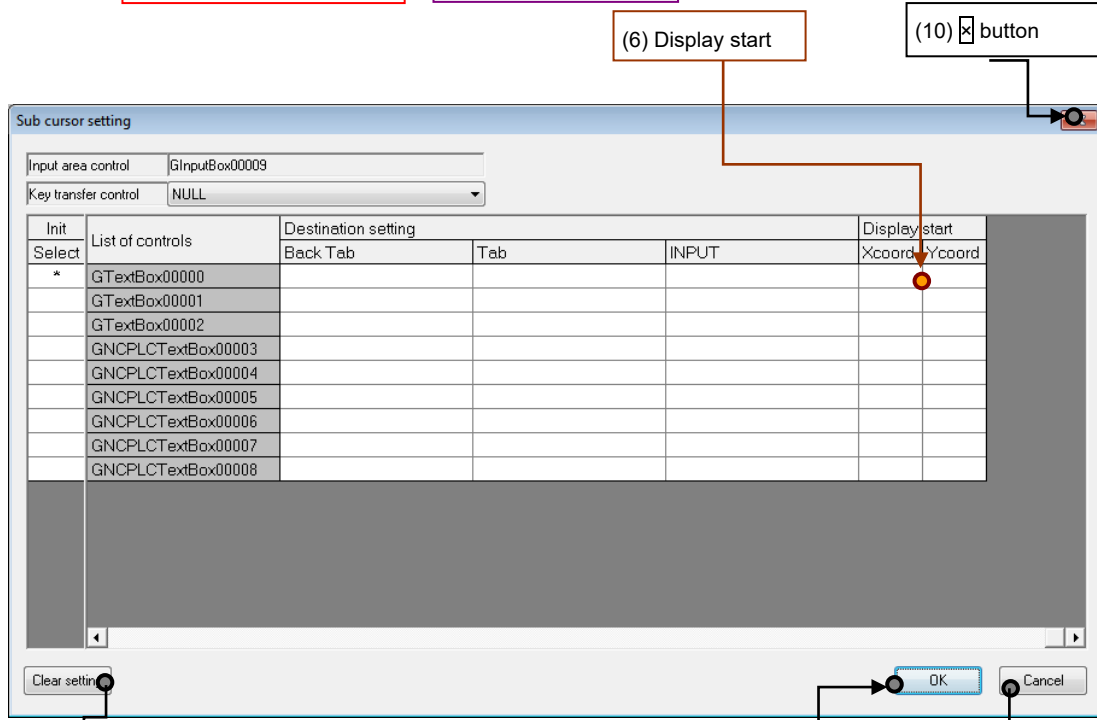

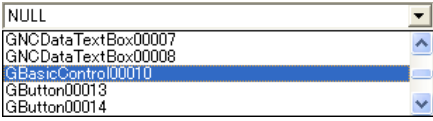

(6) Display start  
 (7) Clear setting button  
 (8) OK button  
 (9) Cancel button  
 (10) Maximize button

Displayed Item

No.	Displayed item	Details
(1)	Input area control	<p>The name of the control to make the "sub cursor setting" will be displayed.</p> <p>(Note 1) Input controls include the input box and the ten-key.</p>
(2)	Key transfer control	<p>Set this when processing keys other than those which are allowed to use in input controls (alphanumeric characters/arrow keys, etc.). When the key transfer control is set, the focus will move to the set key transfer control and key will move in the control. When "NULL" is set, key will move. Select a key transfer control from the list of controls which will appear by clicking the area.</p>  <p>The controls in the list are those located in the page (panel, window)/view frame being edited.</p> <p>(Note 1) Input controls (input box, ten-key) will not be included in the list.</p> <p>(Note 2) For the details of the input box, refer to "7.2.14 Input Box Object(GInputBox)". For the details of the ten-key, refer to "7.2.15 Ten-key object (GSoftKey)".</p>
(3)	Initial select	<p>Specify the control where the sub cursor will be located at first when the focus shifts to an input control.</p> <p>Click a cell to display "*" and the cell will be set as the control where the sub cursor will be located at first.</p> <p>If another cell without "*" is clicked, the "*" in the original cell will be cleared.</p> <p>(Note 1) If the control specified as where the sub cursor is to be located at first is deleted, "*" will appear at the top control of "(4) List of controls" and will be set instead.</p> <p>(Note 2) If any control specified as where the sub cursor is to be located at first is not set after pressing the [Clear setting] button, the top control of "(4) List of controls" will be set as the control.</p>
(4)	List of controls	<p>The list of controls available for sub cursor display in the page (panel, window) or the view frame where the input area control is located, will be displayed.</p> <p>The target controls are the text box, PLC text box, and NC data text box.</p> <p>(Note 1) For the input controls located on a view frame, only the controls located on the view frame will be listed. Also, when the view frame is included on the page and an input control located outside of the view frame is specified, the controls on the view frame will not be listed.</p>

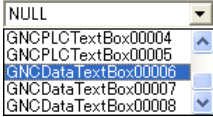

No.	Displayed item	Details
(5)	Destination setting	<p>Set the destination control of sub cursor when an arrow key (←, ↑, →, ↓), a TAB key ( ←, → ), or the INPUT key is pressed. When unset or when "NULL" is set, the sub cursor will not move. Select the destination control from the list of controls which appears by clicking the cell.</p>  <p>The listed controls are the same as "(4) List of controls".            (Note 1) The control cannot be input by copy &amp; paste.            (Note 2) If a control is set as the destination of arrow keys (←, →), the cursor will not move in the input area control by arrow keys (←, →).</p>
(6)	Display start	<p>Set the display position of the input area control for each control where the sub cursor will be displayed. When no setting is made, it will be displayed at where it was pasted on the NC Designer2. Set the display position (from the upper left of the page (panel/window)/view frame) of the input area control in dots. X coordinate setting range: 0 to 2559, Y coordinate setting range: 0 to 1919</p>
(7)	Clear setting button	All the settings ((2),(3),(5),(6)) will be cleared.
(8)	OK button	The dialogue will be closed after saving the settings.
(9)	Cancel button	The dialogue will be closed after discarding the settings.
(10)	 button	The dialogue will be closed after discarding the settings.

**NOTE**

- ◆ The column width of "List of controls", "Key transfer control", "Display start" can be changed.
- ◆ If the display start position (X coordinate/Y coordinate) is out of the setting range or if either of the X/Y coordinate is not set, an error message will appear when [OK] button is clicked.  
For the details of error messages, refer to "Appendix 1. Error Message List".  
If an error occurs, the control name on the List of controls will be displayed in red and the character color or background color of the corresponding area will also turn red.

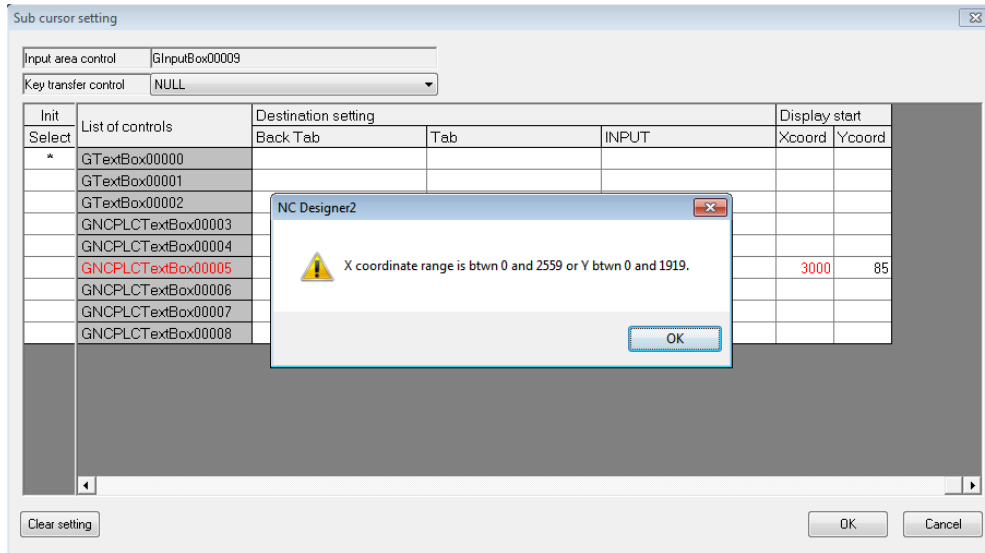

- ◆ If a control which is set to use the sub cursor display is registered in the key transfer control and click [OK] button, the following message will appear.  
The name of the control set in the key transfer control will turn red.

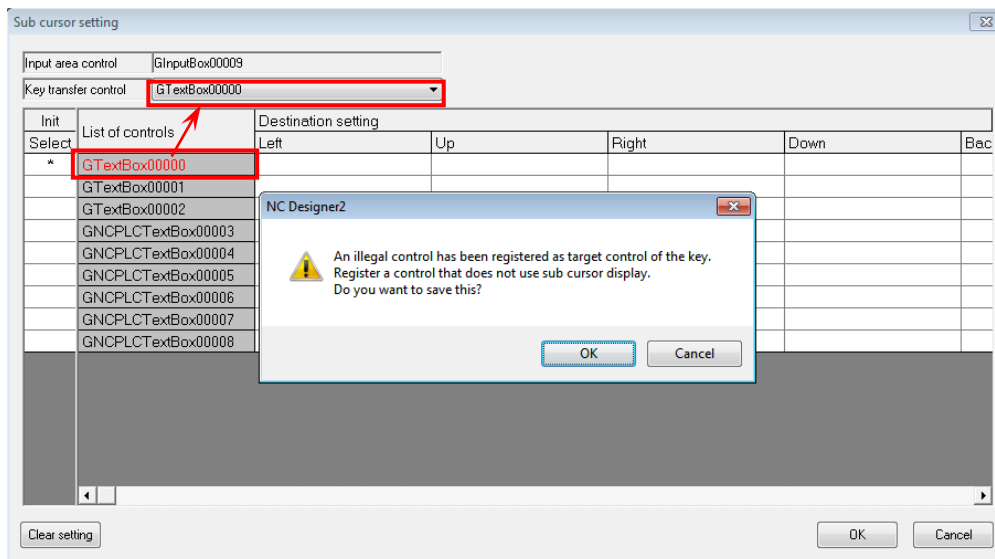

Click the [OK] button to save the setting and close the sub cursor setting screen.

Click the [Cancel] button to close the save confirmation message and return to the sub cursor setting screen.

If a control which is set to use the sub cursor display is registered in the key transfer control as above-mentioned, the key transfer may repeat endlessly.

### 10.8.2 Sub Cursor Setting Screen Displaying Method

How to Call

The sub cursor setting can be made for each input control allocated to each page (panel/window) or view frame.

1. Display the page or frame to make settings.
2. Allocate the control to make sub cursor setting and the input control (Input box).

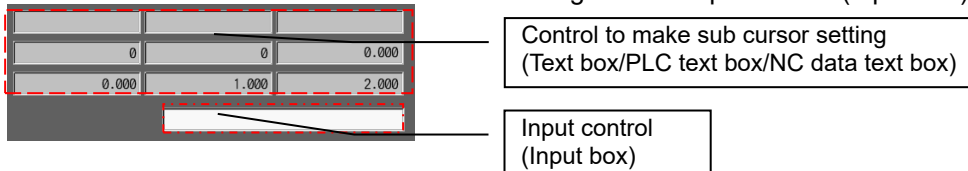

3. Right-click the input control to display the pop-up menu and select [Extension setting] - [Sub cursor setting].

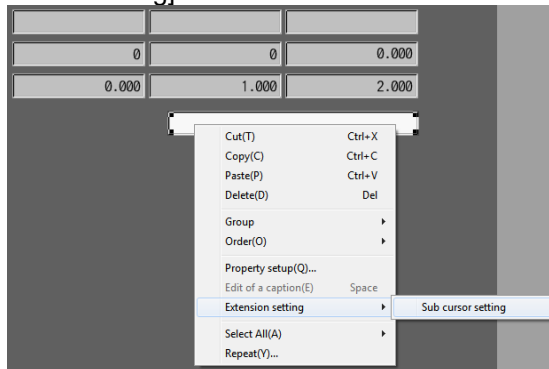

The access can also be made from the menu bar [Settings] - [Extension setting] - [Sub cursor setting].

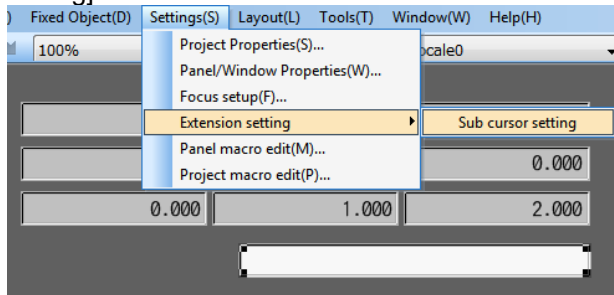

4. [Sub cursor setting] will appear.

Init Select	List of controls	Destination setting				
		Left	Up	Right	Down	Bac
*	GTextBox00000					
	GTextBox00001					
	GTextBox00002					
	GNCPCLTextBox00003					
	GNCPCLTextBox00004					
	GNCPCLTextBox00005					
	GNCPCLTextBox00006					
	GNCPCLTextBox00007					
	GNCPCLTextBox00008					

5. Click [OK] button when settings are completed.

Init Select	List of controls	Destination setting				
		Left	Up	Right	Down	Bac
*	GTextBox00000			GTextBox00001	GNCPCLTextBox00003	
	GTextBox00001	GTextBox00000	GNCPCLTextBox00006	GTextBox00002	GNCPCLTextBox00004	
	GTextBox00002	GTextBox00001	GNCPCLTextBox00007	GNCPCLTextBox00003	GNCPCLTextBox00005	
	GNCPCLTextBox00003	GTextBox00002	GTextBox00000	GNCPCLTextBox00004	GNCPCLTextBox00006	
	GNCPCLTextBox00004	GNCPCLTextBox00003	GTextBox00001	GNCPCLTextBox00005	GNCPCLTextBox00007	
	GNCPCLTextBox00005	GNCPCLTextBox00004	GTextBox00002	GNCPCLTextBox00006	GNCPCLTextBox00008	
	GNCPCLTextBox00006	GNCPCLTextBox00005	GNCPCLTextBox00003	GNCPCLTextBox00007	GTextBox00001	
	GNCPCLTextBox00007	GNCPCLTextBox00006	GNCPCLTextBox00004	GNCPCLTextBox00008	GTextBox00002	
	GNCPCLTextBox00008	GNCPCLTextBox00007	GNCPCLTextBox00005			

**NOTE**

- ◆ During the Sub cursor setting, the objects of page view will display the name of controls.

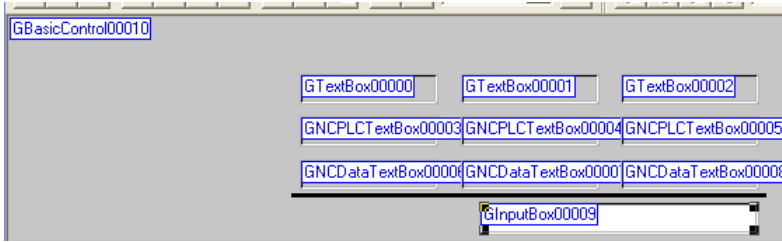

- ◆ When the ten-key is used instead of the input box, the display will be as shown below.

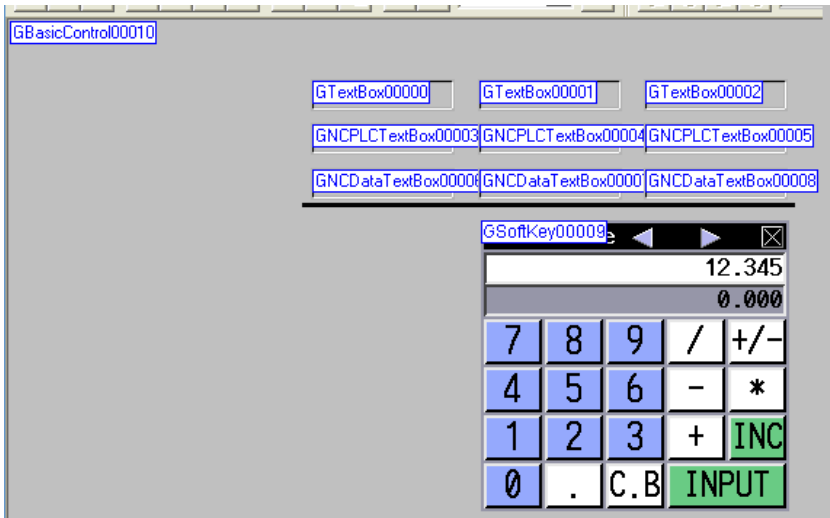

### 10.8.3 Sub Cursor Setting Procedure

Sub cursor setting procedure does not differ between the input box control and the ten-key control. The following explanation uses the input box control.

#### 10.8.3.1 Move the Sub Cursor by Key Input (Arrow Key, TAB Key, Input Key)

With the focus on the input control (input box control), press  $\leftarrow$ ,  $\uparrow$ ,  $\rightarrow$ ,  $\downarrow$ ,  $\leftarrow$ ,  $\rightarrow$ , INPUT key to move the sub cursor.

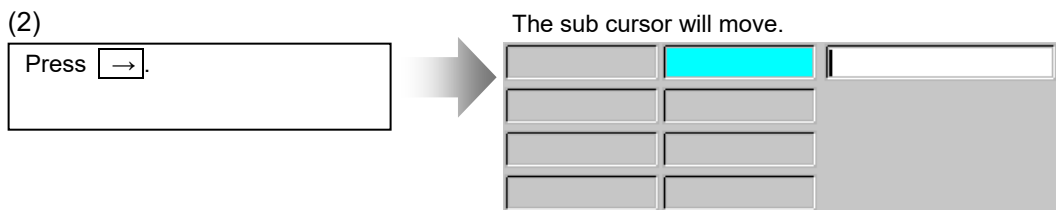
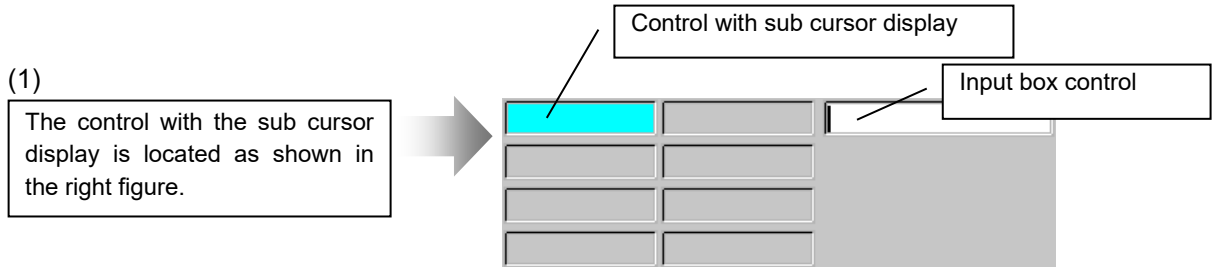

The sub cursor will also move by clicking the control to which the sub cursor setting is made.

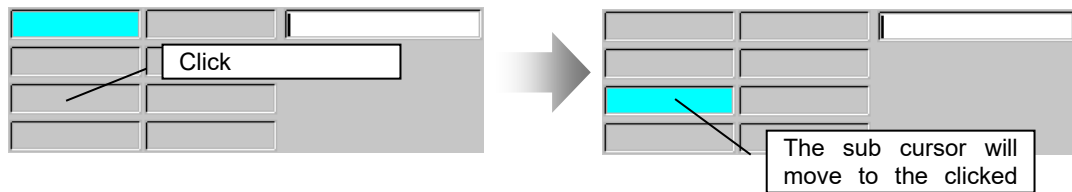

#### NOTE

- ◆ The background color and the character color of the control in which the sub cursor will be displayed depend on the property setting of the input box control; "Sub cursor Background color" and "Sub cursor Character color".
- ◆ The sub cursor will not be displayed until the focus is placed on the input box or the ten-key control.
- ◆ The sub cursor will not move when the destination is not set.
- ◆ The right and left arrow keys ( $\leftarrow$ ,  $\rightarrow$ ) are used to move the cursor within the input destination control. But instead, when the right and left arrow keys ( $\leftarrow$ ,  $\rightarrow$ ) are set to move the sub cursor to the destination control, the cursor will move to the specified control.

## Set the Focus of Input Control

## Interpreter Method

```
$GInputBox00006-OnCreate
  'Set the macro reserved variable flag to 1.
  @100 = 1;
$End
$GInputBox00006-OnTimer
  'When the macro reserved variable flag is 1
  if (@100 == 1)
    'Set the macro reserved variable flag to 0.
    @100 = 0;
    'Set the focus at the input box control.
    GCSCChangeActiveFocus(-1, "GInputBox00006");
  endif
$End
```

## Compilation Method

```
long GCPanel00000::GINPUTBOX00006OnInit(unsigned short usMessage, long ILParam, long IUParam)
{
  GBaseObject *pPanel = NULL;
  GBaseObject *pChild = NULL;
  pPanel = GetGBaseObject();
  pChild = GCSGetChild( pPanel, GINPUTBOX00006 ); // Get the input box control
  if (pChild != NULL) {                          // When it succeeds to get the input box control
    GCSCChangeActiveFocus( pPanel, pChild );     // Set the focus at the input box control
  }
  return TRUE;
}
```

### 10.8.3.2 Set the Input Value to the Target Control

With the focus on the input control (input box control), press the **INPUT** key to set the input value to the control at which the sub cursor is displayed.

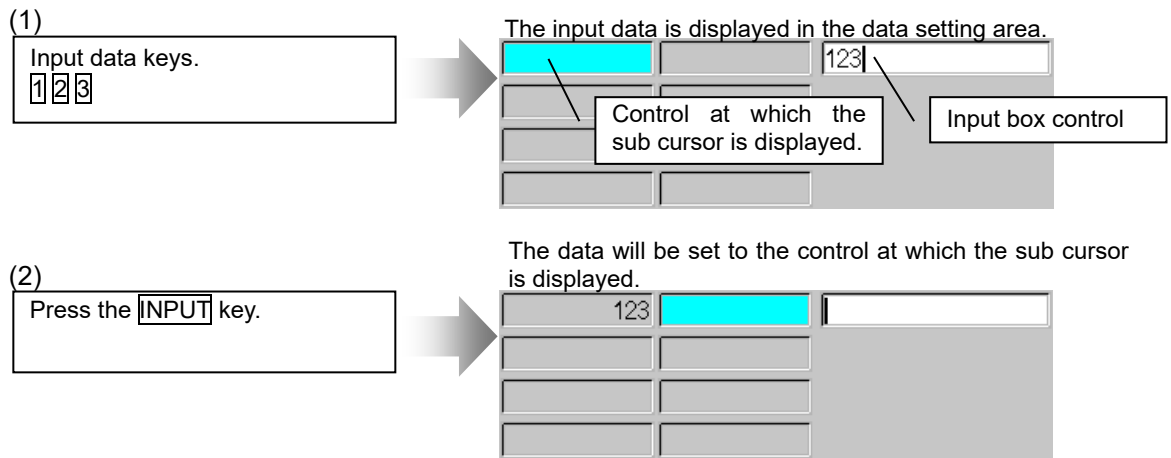

(NOTE) When the setting fails, the content of the input control (input box control) will not be cleared and (even when the destination for the INPUT key is set,) the sub cursor will not move.

### 10.8.3.3 Change the Display Start Position

The display position of input control can be changed for each control with sub cursor display by setting the display position of input control (input box control).

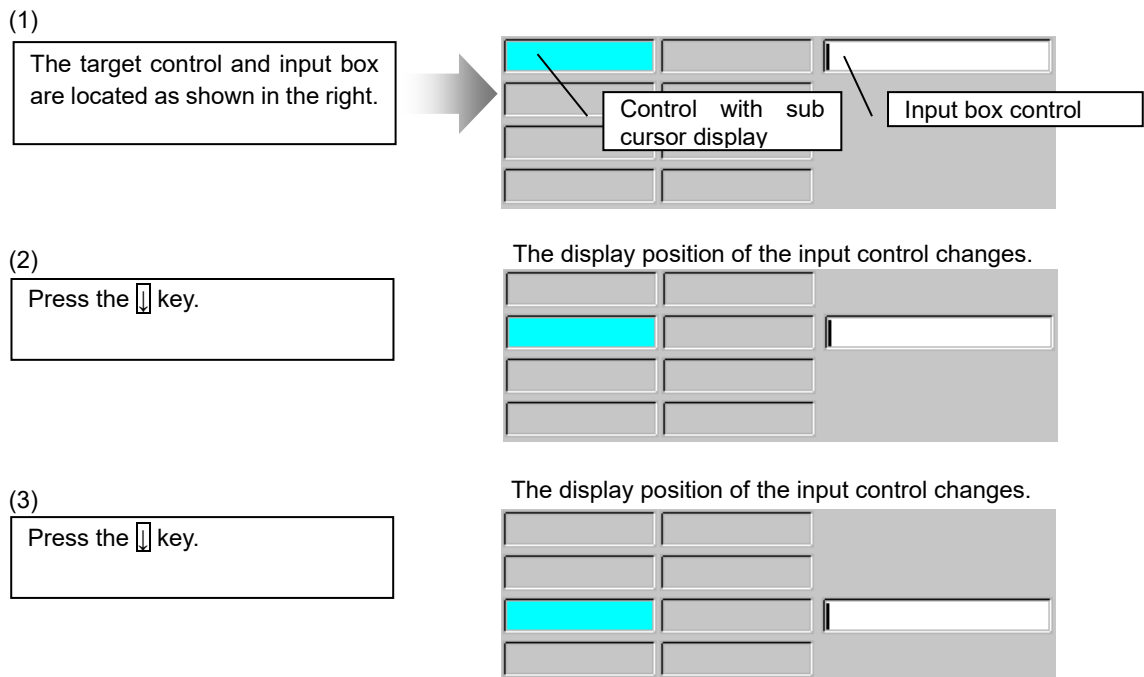



### 10.8.3.4 Transfer a Key to Other Control

Set the key transfer control to use other control to handle the processing of a key other than those available for the input destination control (alphanumeric characters/arrow keys, etc.).

When the key transfer control is set, the focus will move to the transfer destination control and the input key will be transferred.

In the following example, the focus will move to the basic control and the input key will be transferred to the control.

Screen Configuration

The key which cannot be handled by the input box (function key) is transferred to the basic control where the key processing (OnKeyPress) will be carried out.

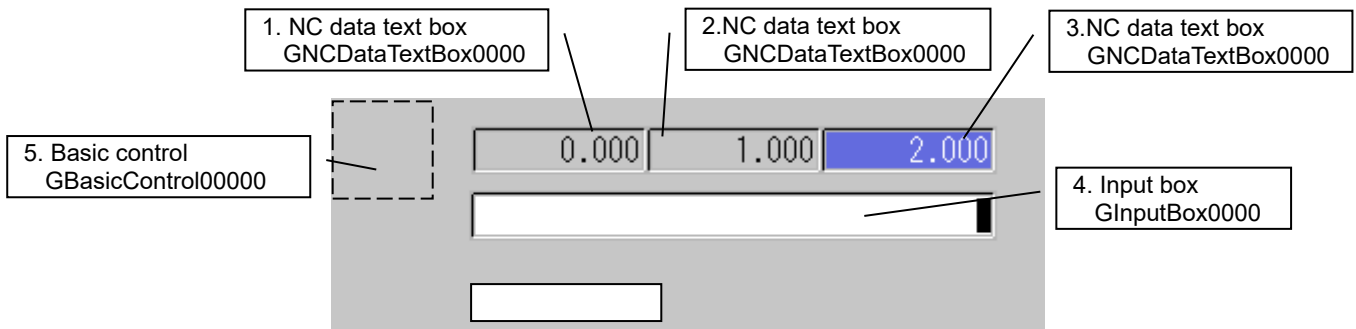

Operation

- (1) The focus is placed at the basic control when the screen opens.
- (2) Mouse-click the NC data text box to display the sub cursor in it and transfer the focus to the input box.
- (3) Press the cursor key (→) to move the sub cursor.
- (4) Press "MONITOR" key (Shift+F1) to go to the Monitor screen.
- (5) Press "SET UP" key (Shift+F2) to go to the Setup screen.
- (6) Press "EDIT" key (Shift+F3) to go to the Edit screen.
- (7) Press "DIAGN" key (Shift+F4) to go to the Diagnosis screen.
- (8) Press "MAINTE" key (Shift+F5) to go to the Maintenance screen.

<Sub cursor setting>

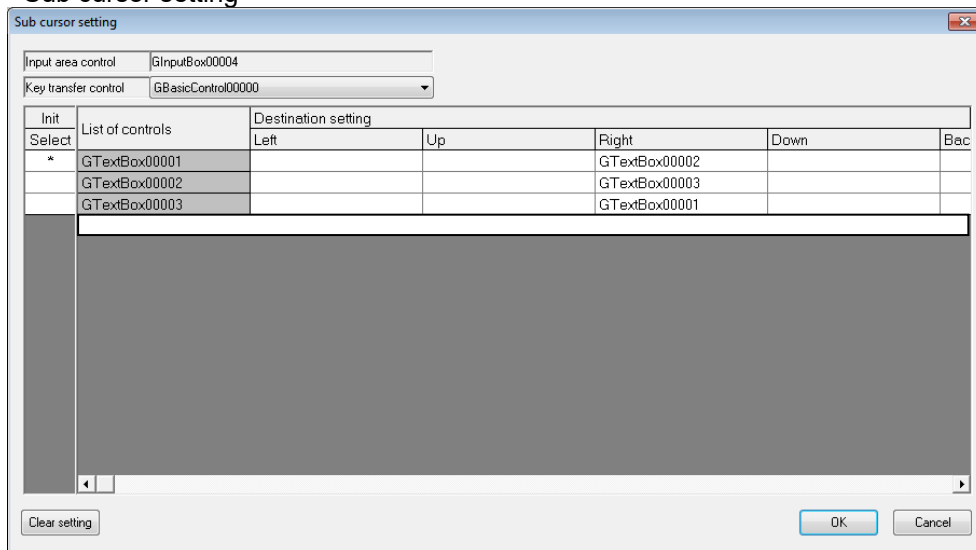

## Source Code

## Interpreter Method

```

$GBasicControl00000-OnCreate
  'Set the macro reserved variable flag to 1.
  @100 = 1;
$End
$GBasicControl00000-OnTimer
  'When the macro reserved variable flag is 1
  if (@100 == 1)
    'Set the macro reserved variable flag to 0.
    @100 = 0;
    'Set the focus at the basic control.
    GCSCChangeActiveFocus(-1, "GBasicControl00000");
  endif
$End

$GBasicControl00000-OnKeyPress
long _IShiftKey; 'Shift key input status
_IShiftKey = LUPARAM & H1;
if((LLPARAM == 112) && (_IShiftKey == 1))
  GCSGShowPanel(1000);
elseif((LLPARAM == 113) && (_IShiftKey == 1))
  GCSGShowPanel(2000);
elseif((LLPARAM == 114) && (_IShiftKey == 1))
  GCSGShowPanel(3000);
elseif((LLPARAM == 115) && (_IShiftKey == 1))
  GCSGShowPanel(4000);
elseif((LLPARAM == 116) && (_IShiftKey == 1))
  GCSGShowPanel(5000);
endif;
$End

```

'When Shift + F1 key code is issued.  
'Changing the screen to Monitor screen.

'When Shift + F2 key code is issued.  
'Changing the screen to Setup screen.

'When Shift + F3 key code is issued.  
'Changing the screen to Edit screen.

'When Shift + F4 key code is issued.  
'Changing the screen to Diagnosis screen.

'When Shift + F5 key code is issued.  
'Changing the screen to Maintenance screen.

## Compilation Method

```

#define KEY_SHIFT  0x01
#define GK_F1      112
#define GK_F2      113
#define GK_F3      114
#define GK_F4      115
#define GK_F5      116

long GCPanel00000::GBASICCONTROL00000OnInit(unsigned short usMessage, long ILParam,
long IUParam)
{
  GBaseObject *pPanel = NULL;
  GBaseObject *pChild = NULL;
  pPanel = GetGBaseObject();
  pChild = GCSGetChild( pPanel, GBASICCONTROL00000); // Get the basic control
  if (pChild != NULL) {                               // When getting the basic control succeeds.
    GCSCheckActiveFocus( pPanel, pChild );           // Set the focus at the basic control.
  }
  return TRUE;
}

long GCPanel00000::GBASICCONTROL00000OnKeyPress (unsigned short usMessage, long
ILParam, long IUParam)
{
  if((IUParam & KEY_SHIFT) == KEY_SHIFT)
  {
    if(ILParam == GK_F1)                             // When Shift + F1 key code is issued.
    {
      // Changing the screen to Monitor screen.
      GESetEvent(GECreateEventMessage(GM_SHOWPANEL,
      GCSGetScreen(GetGBaseObject()), 1000, 0), FALSE);
    }
    else if(ILParam == GK_F2)                         // When Shift + F2 key code is issued.
    {
      // Changing the screen to Setup screen.
      GESetEvent(GECreateEventMessage(GM_SHOWPANEL,
      GCSGetScreen(GetGBaseObject()), 2000, 0), FALSE);
    }
    else if(ILParam == GK_F3)                         // When Shift + F3 key code is issued.
    {
      // Changing the screen to Edit screen.
      GESetEvent(GECreateEventMessage(GM_SHOWPANEL,
      GCSGetScreen(GetGBaseObject()), 3000, 0), FALSE);
    }
    else if(ILParam == GK_F4)                         // When Shift + F4 key code is issued.
    {
      // Changing the screen to Diagnosis screen.
      GESetEvent(GECreateEventMessage(GM_SHOWPANEL,
      GCSGetScreen(GetGBaseObject()), 4000, 0), FALSE);
    }
    else if(ILParam == GK_F5)                         // When Shift + F5 key code is issued.
    {
      // Changing the screen to Maintenance screen.
      GESetEvent(GECreateEventMessage(GM_SHOWPANEL,
      GCSGetScreen(GetGBaseObject()), 5000, 0), FALSE);
    }
  }
}

```

**10.8.4 Limitations**

- (1) If the sub cursor setting is made to the control at which the focus is set, the focus will not move by the key input (cursor key, input key) and the sub cursor will move instead.
- (2) After deleting the control to which the sub cursor display was set, press the [Clear setting] button on the sub cursor setting screen and set the sub cursor display again.
- (3) When a control to which the sub cursor setting is made is registered as the key transfer destination control, the key transfer may be repeated endlessly.
- (4) The value to be reflected is float accuracy, even if a real number (double)/double is set in the property "type" of the PLC text box set the sub-cursor/text box.
- (5) Data to be entered in the input area control must be within the range specified in the range check properties ("Maximum Check", "Minimum Check", and "Type") of the control set in the sub cursor setting. If the input value exceeds this range, it may differ from the value specified for the control set in the sub cursor setting.
- (6) If hexadecimal characters ("%X" or "%x") are specified in the "Display Format" property, of the text box set in the sub cursor setting, the value specified in the entry field is handled as a decimal number.
- (7) If the property "Extended function (A7) enabled" of an input box is set to be enabled, the sub cursor will not move to controls of which "Prohibition" is set for the property "Input permission" even when the control is set for "Destination setting".

The control of which "Permission" is set for the property "Input permission" is searched as the next destination and the sub cursor moves to the control. If the control is not found, the sub cursor will not move.

(Example) When the first display position of the sub cursor is control (1) and the sub cursor is set as follows.

	First selection	Destination setting		Input permission
		←	→	
Control (1)	*	Control (4)	Control (2)	Permission
Control (2)	-	Control (1)	Control (3)	Prohibition
Control (3)	-	Control (2)	Control (4)	Permission
Control (4)	-	Control (3)	Control (1)	Prohibition

Key operation	Sub cursor display	Explanation
←	Control (3)	Searches the destination setting of control (4) since Prohibition is set for control (4).
→	Control (3)	Searches the destination setting of control (2) since Prohibition is set for control (2).

When "Extended function (A7) enabled" is disabled, the sub cursor will move in the same way as a ten-key regardless of the setting of the property "Input permission".

## 11. Simulation

The simulation method is described in this section.

### 11.1 Simulation Function

The simulation function is a function for testing actions of drawn data on NC Designer2. The simulation function allows you to test the state change of controls, page switching, and execution of callback functions, and the following items can be checked.

- Appearance of created panels and windows
- State changes according to value change of control, focus yes/no, show/hide, input permission/prohibition
- Focus move
- Execution timing of callback function displayed in message window
- Panel/window page switching

#### 11.1.1 Starting Simulation

1. Before starting simulation, save the project and screens.
2. From the [Tool] menu, select [Test].
3. Simulation begins. Simulation begins from the first page of panels/windows having been created.

#### NOTE

- ◆ If [Test] is selected from the [Tool] menu without saving the project or window, a dialog box is displayed to urge to save data. Before starting simulation, save data.
- ◆ Only one panel/window can be checked during simulation. Simultaneous view of a panel and a window is impossible.
- ◆ When simulation is started, the locale being edited is displayed.

#### 11.1.2 Simulation Screen

When simulation is executed, a simulation view and simulation tools are displayed. The simulation screen at a startup is the first page of panels/windows having been created.

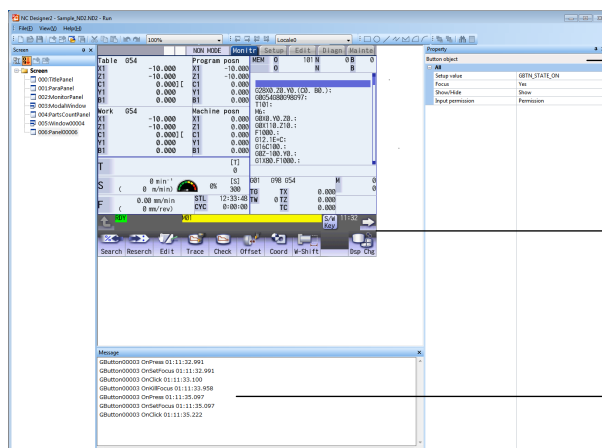

Simulation tool allows you to change the state of the selected control.

The screen being simulated is displayed.

The message window displays the callback execution history.

#### Screen Selection

Select [Open Panel/Window] from the [File] menu and select and display the new screen in the [Open Panel/Window] dialog box.

### 11.1.3 Function List

The following menu functions can be used during simulation.

#### File

Item	Function
Open Panel/Window	Select the panel/window to be displayed.
Quit	Terminate simulation.

#### View

Item	Function
Screen tree	Switch whether the screen tree is displayed or hidden.
Test tools	Select whether the simulation tools are displayed or hidden.
Message Window	Select whether the message window is displayed or hidden.
Switch Locale	Switch the locale to be displayed.
Zoom	Specify the zoom scale of the page.
Change theme color	Switch the NC control display by the theme color. This function is only for M800V/M80V/M800/M80/E80 Series.

#### Help

Item	Function
About NC Designer2	Display the version of NC Designer2.

#### **NOTE**

- ◆ When simulation is started, the screen is displayed at the zoom specified at [Display magnification] in [Project Properties].
- ◆ If the zoom is changed during simulation, the new value is reflected on the [Display magnification] setting in [Project Properties].
- ◆ If [Fit] is selected as a zoom setting, the zoom changes in the range between 25 and 800% to fit the simulation screen size.

### 11.1.4 Quitting Simulation

The simulation screen is terminated.

1. From the [File] menu, select [Quit].

### 11.2 Simulation Tools

Use simulation tools to change values or appearance of controls.

1. Click on a desired control. Settings are displayed at the simulation tool. The settings vary according to the selected control.

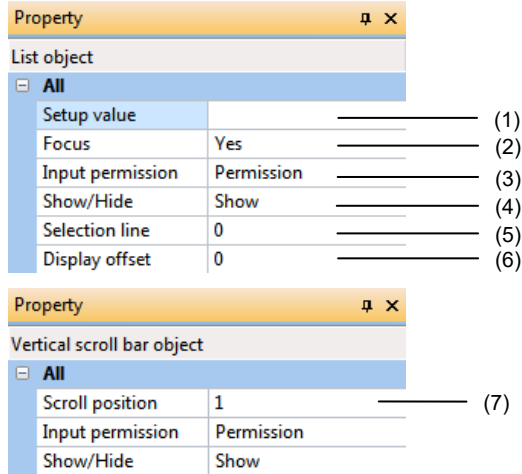

No.	Item	Description
(1)	Setup value	The entered value or character string is reflected on the control.
(2)	Focus	The focus state is displayed.
(3)	Input permission	Input permission and prohibition are switched over. Select prohibition to change to the image of the disabled control.
(4)	Show/Hide	The control is displayed or hidden.
(5)	Selection line	The designated line is selected.
(6)	Display offset	The designated line is displayed at the top.
(7)	Scroll position	Enter a value in the range from the minimum to maximum value of the scroll. The scroll bar moves according to the entered value.

2. Changes in the setting are reflected on the control.

### 11.3 Message Window

The message window shows the execution history of callback functions.

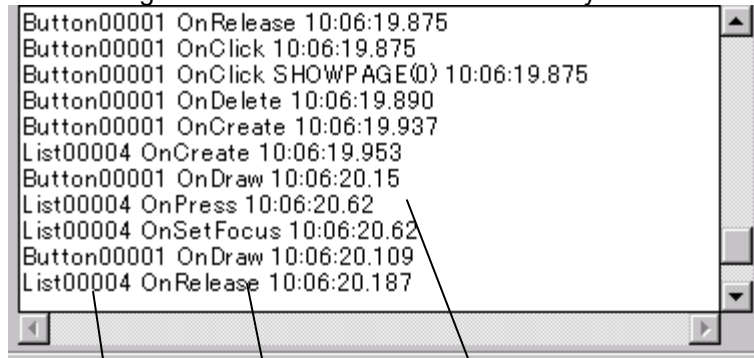

The time of execution of the callback function is displayed.

The executed callback function is displayed.

The control name is displayed.



## 12. Simulation (NC Trainer2 plus)

This section describes how to execute simulation using NC Trainer2 plus.

### 12.1 Simulation (NC Trainer2 plus)

This function enables you to use NC Trainer2 plus to check a custom screen you created with NC Designer2.

When you select an NC Trainer2 plus project from the menu bar or tool bar, NC Trainer2 plus starts automatically and the selected project is opened.

If you perform the key operation set in the Custom screen configuration dialog, the custom screen appears on NC Trainer2 plus.

Simulation (NC Trainer2 plus)	Interpreter version	Compilation version
Each control display	○	○
Action and operation with key or mouse input	○	× (Note)
Action and operation created with a macro program	○	-
Action and operation created with Visual Studio	-	×

○: Can be checked    ×: Cannot be checked    -: Not supported by NC Designer2  
 (Note) Key or mouse input is available in basic operations of each control.

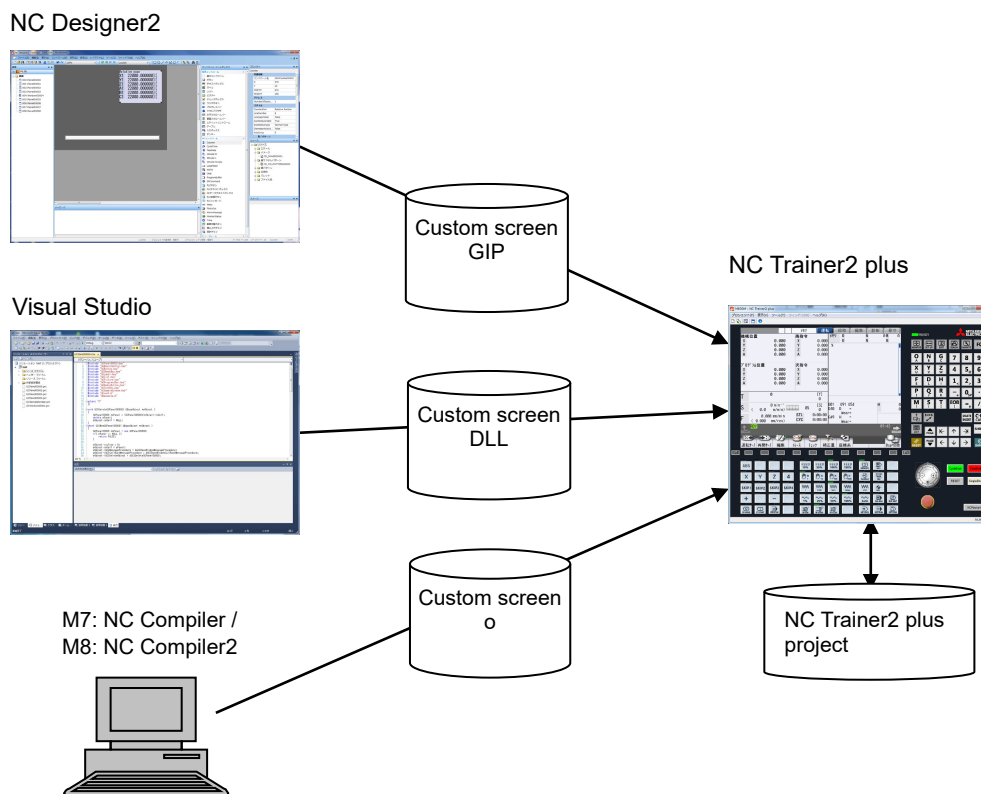

## 12.2 Operation Procedure

### Select NC Trainer2 plus Project

1. Use the pull-down menu of the tool bar or [Open at NC Trainer2 plus] in the [Tool] menu to select an NC Trainer2 plus project for simulation.

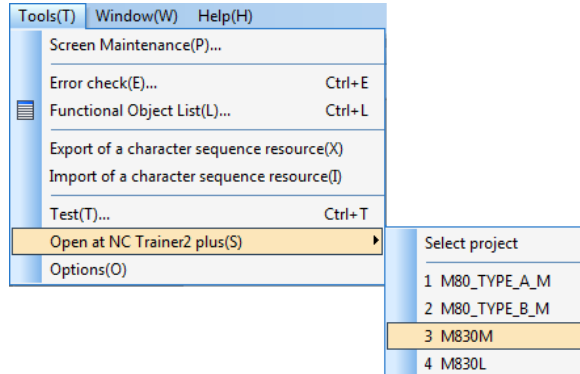

2. NC Trainer2 plus is started.



3. When you perform the key operation set in Custom screen configuration dialog, the created custom screen appears.

### NOTE

- ◆ Up to four latest NC Trainer2 plus projects are displayed.
- ◆ If the simulation is started during the NC Trainer2 plus startup, the message "Is it OK to reboot NC data?" will appear on NC Trainer2 plus. Press the [OK] button to restart the NC and then start the simulation.
- ◆ When the NC Trainer2 plus project name exceeds 20 one-byte characters, the excess characters are replaced with an ellipsis (...).

Select [Select project]

1. Select [Select project] from the pull-down menu of the tool bar or [Open at NC Trainer2 plus] in the [Tools] menu.

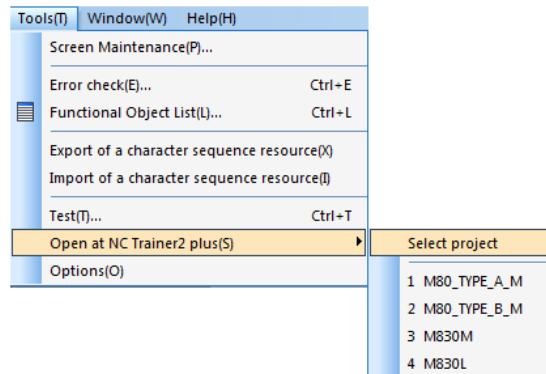

2. NC Trainer2 plus is started and "Open Project" dialog is displayed.

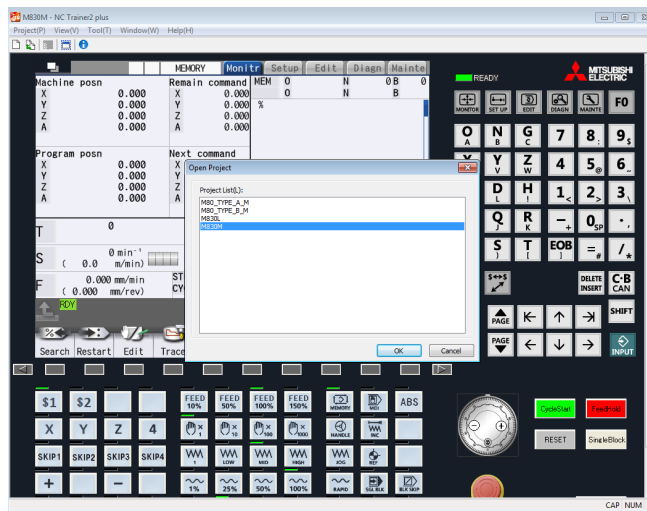

3. Select an NC Trainer2 plus project and then press the [OK] button.
4. The created screen is displayed by inputting the key set in Custom screen configuration dialog.

### 12.3 Limitations

- (1) This function is unavailable when NC Trainer2 plus is not installed. The menu or the icon of the tool bar cannot be selected (grayout).
- (2) NC Trainer2 plus Ver. A4 or later supports this function. Be sure to use NC Trainer2 plus Ver. A4 or later. Otherwise the simulation performance cannot be assured.
- (3) Simulation (NC Trainer2 plus) cannot be executed when there is no NC Trainer2 plus project.
- (4) When editing an NC Designer2 project of "M800V/M80V/M800/M80/E80 Series", only the NC Trainer2 plus projects whose model setting is "M830V", "M80V TypeA", "M80V TypeB", "M830", "M80 TypeA" or "M80 TypeB" are displayed on the menu. When editing an NC Designer2 project of "M700V/M70V/E70 Series", only the projects of "M730V", "M70V TypeA", "M70V TypeB" or "E70" are displayed.
- (5) Operation simulation can be executed only on the interpreter method custom screen. For the compilation method, only the design can be checked.

## 13. Generating a Document

NC Designer2 is provided with a document creation function for outputting project settings and control properties into a rich text format file (hereinafter referred to as RTF file). The document creation function is described in this section.

### 13.1 Document Generation Function

NC Designer2 can output project settings and control properties into an RTF file. The items that can output in the file include the followings.

Data	Description
Project information	Project name, project macro and panel/window name list
Screen information	4 items of each panel/window specified below
Screen hard copy	Hard copy of each panel/window
Object list	List of controls/view frames used in each panel/window
Property setup	Property settings of each control/view frame arranged on each panel/window
Macro	Screen macro specified for each panel/window

#### 13.1.1 Generating a Project Information Document

1. From the [File] menu, select [Document Generation].
2. The [Document generation] dialog box is displayed. Select the [Project information] tab.

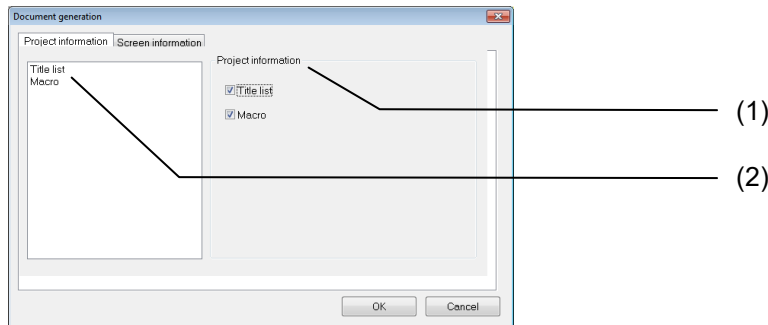

No.	Item	Description
(1)	Output item	Place a check mark on the items to be file-output. The output items include the followings. <ul style="list-style-type: none"> <li>• Panel/window name list</li> <li>• Macro</li> </ul>
(2)	Output item display field	A list of file-output data selected at (1) is displayed.

3. Check the boxes of the data to be file-output.
4. Click on the [OK] button. A [Save As] dialog box is displayed. A file is output after entering the name of the RTF file.

**13.1.2 Generating a Screen Information Document**

1. From the [File] menu, select [Document Generation].
2. The [Document Generation] dialog box is displayed. Select the [Screen Information] tab.

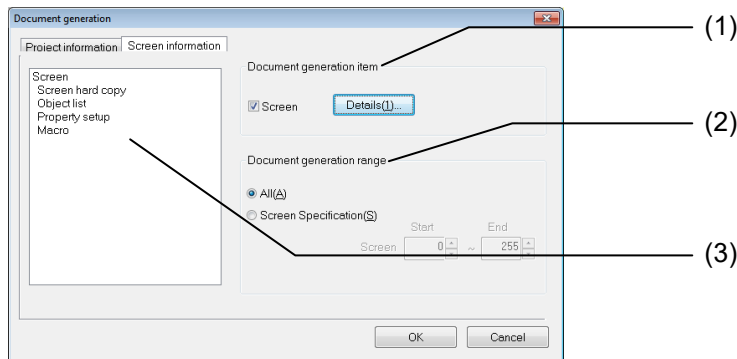

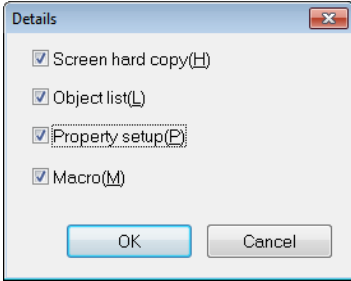
No.	Item	Description				
(1)	Document generation item	<p>Check the boxes for the item included in the output file. Click on the [Details] button and select the items to be file-output in the dialog box shown below.</p>  <p>The items that can be selected include the followings.</p> <ul style="list-style-type: none"> <li>▪ Screen hard copy</li> <li>▪ Object list</li> <li>▪ Property setup</li> <li>▪ Macro</li> </ul>				
(2)	Document generation range	<p>Select the page range of the output file among the following options.</p> <table border="1" style="width: 100%;"> <tr> <td>All</td> <td>Output the data about all panels/windows.</td> </tr> <tr> <td>Screen Specification</td> <td>Output the data of the panels/windows in the designated page range.</td> </tr> </table>	All	Output the data about all panels/windows.	Screen Specification	Output the data of the panels/windows in the designated page range.
All	Output the data about all panels/windows.					
Screen Specification	Output the data of the panels/windows in the designated page range.					
(3)	Output item display field	A list of file-output data selected at (1) is displayed.				

3. Check the boxes of the data to be file-output.
4. Click on the [OK] button. A [Save As] dialog box is displayed.  
A file is output after entering the name of the RTF file.

13. Generating a Document

13.1.3 Output Image

The output images are shown below.

Project Information

```

Project name:test Title:
Panel/Window name list
Page0:Panel100000
Page1:Panel100001
Page2:Window000002
Project macro
$Project-OnCycle
GMEM mem;
mem=GMEMCREATE("memetest",1234);
GMEMsetshort(mem,0,0);
...
    
```

Screen Information

(1) Screen Hard Copy

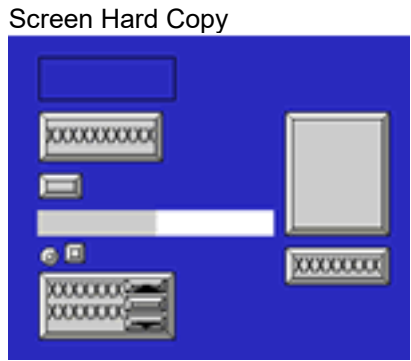

(2) Object List

```

Functional object list
[Button object]
ID=GButton00015
ID=GButton00016
[Label object]
ID=GLabel100017
[Textbox object]
ID=GTextBox01
    
```

## 13. Generating a Document

## (3) Property Setup

```

Property setup
=====
ID=GBasicControl00001
X=114
Y=307
WIDTH=115
HEIGHT=112
Show/Hide=Show
Input permission=Permission
OnKeyPress=None
OnKeyRelease=None
OnPress=None
OnRelease=None
OnClick=None
OnDraw=None
OnTimer=None
OnSetFocus=None
OnKillFocus=None
OnCreate=None
OnDelete=None
OnUser=None
=====

```

## (4) Page Macro

```

Page macro
$DATETIME 2004/08/19 01:47.01
$GBasicControl00001-OnCreate
GMEM mem;
mem_GMEMCREATE("memetest",1234);
GMEMsetshort(mem,0,0);
$End
$GBasicControl00001-OnClick
short a;
GMEM mem;
mem=GMEMselect("memetest");
a=GMEMgetshort(MEM,0);
if(a==0)
    GCSSetString(-1,"GTextBox00001","000");
elseif(a==1)
    GCSSetString(-1,"GTextBox00001","001");
endif
$End

```

## (5) Top of Each Page

The page number and the panel/window name are output at the top.

```
Page number: 0 Panel/Window name:Panel00000
```

**NOTE**

- ◆ If an object list or property setup is output in a file, information about the view frame is also output in the file in addition to the objects.
- ◆ For the screen hard copy, the currently displayed locale data is output in the file.
- ◆ When creating a document in the state that 16 pages of the panels/windows are open, [Screen hard copy] of some of pages may not be output.  
Close the opening panel/window and then create the document in this case.



## 14. Project Convert

The methods for exporting the project created with NC designer2 and also converting them to ND2 are described in this section.

### 14.1 Export for the Project Executing the Interpreter

#### 14.1.1 Export

Export the project to create a project for interpreter execution. Project exportation is also necessary when the macro function is used.

1. From the [File] menu, select [Project convert] - [Export].

A confirmation message is displayed. Press the [OK] button.

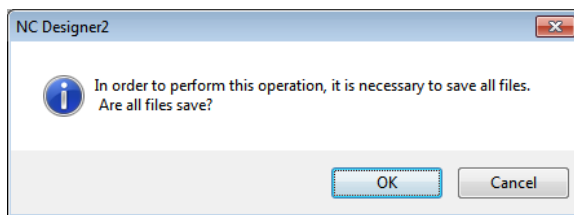

2. An "export" dialog box is displayed. Specify the location and file name of the project to be exported. Press the [Save] button.

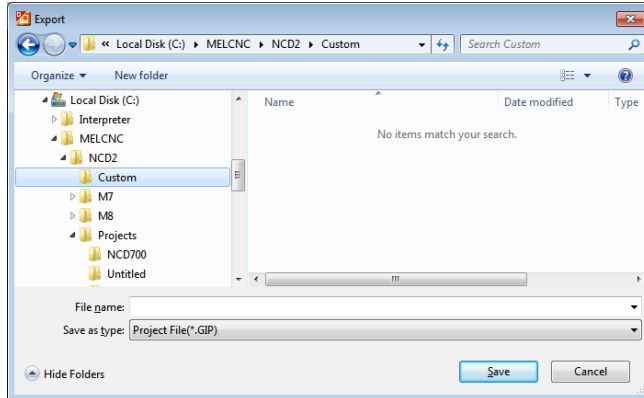

Export has been completed when the following message appears.

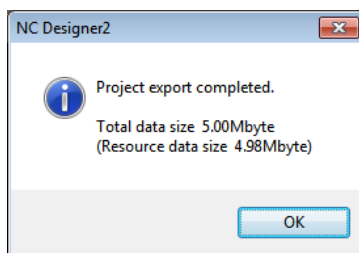

**NOTE**

- ◆ When the resource data exceeds 5Mbyte, exporting is failed and the following message appears.

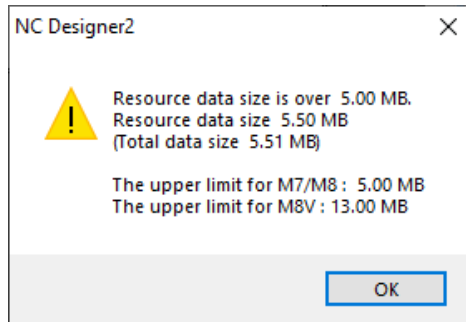

When exporting is failed, delete the registered resources and export the project again.

The maximum size of resource data differs depending on the model. For the maximum size, refer to "NC Designer2 Matching List [Maximum data size]".

- ◆ In NC Designer2 Ver. A7, the operation of macro programs with consecutive positive and negative signs before numbers are correctly executed. Consequently, the operation results for macro programs exported with NC Designer2 Ver. A7 or later and Ver. A6 or earlier may differ. When exporting with different versions of NC Designer2, be sure to confirm that the macro operates as intended.

### 14.1.2 File Configuration

After the project created with NC Designer2 is converted to execute in the interpreter mode, a folder of screen files, resource files and macro folder and a project data file are created. Shown below is the file configuration of an interpreter execution project saved under "Sample".

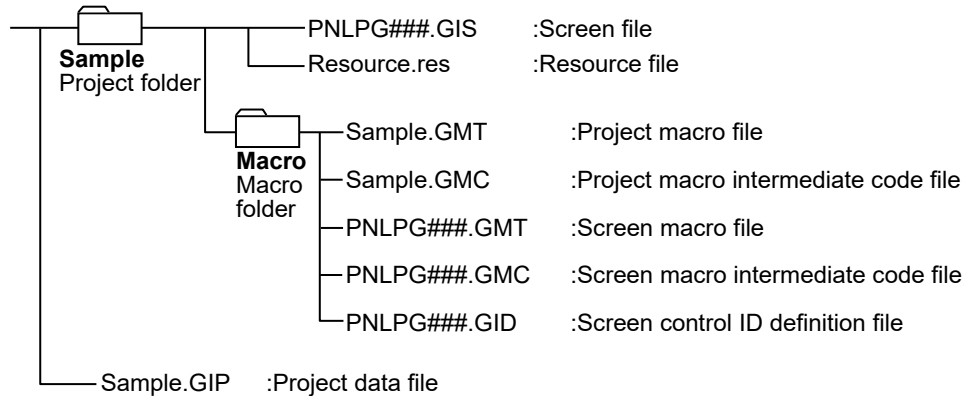

(Note 1) ###: 3-digit hexadecimal value indicating the page number

(Note 2) When "M800V/M80V/M800/M80/E80 Series" is selected in the model selection of the create new project wizard, the screen with GIS extension is created.

When "M700V/M70V/E70 Series" is selected, the screen file with GIW extension is created.

#### NOTE

- ◆ When using the project macro, specify the name of project macro intermediate code file, including the path, in config.ini.  
Refer to 17.6.4.1.1 for details.
- ◆ Only one project can be registered when the project macro is used.  
If more than one project is specified, unintended screen may be displayed.
- ◆ Use the screen macro for drawing screen such as the control operation.

## 14.2 Project Convert to the ND2 Format

A project information file (IPP format) for the M700V/M70V/E70 series that is created with NC Designer2 can be converted to a project information file (ND2 format) for the M800V/M80V/M800/M80/E80 series.

When using a project for the M700V/M70V/E70 series to create a project for the M800V/M80V/M800/M80/E80 series, use a project that has been converted to the appropriate format.

1. Open the IPP project file to be converted.
2. Select [File] - [Project convert] - [ND2] menu. (The [ND2] menu is enabled only when an IPP project file is opened.)

If the file is being edited, the following save confirmation message appears. Click the [OK] button.

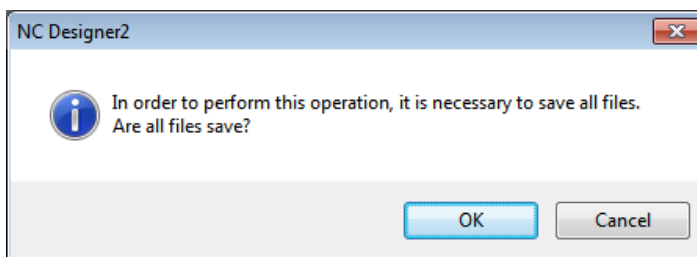

3. The opened panel/window is closed, and the [Save Project As] dialog box is displayed.

Specify the location to save the converted project to and the file name of the project. Press the [Save] button.

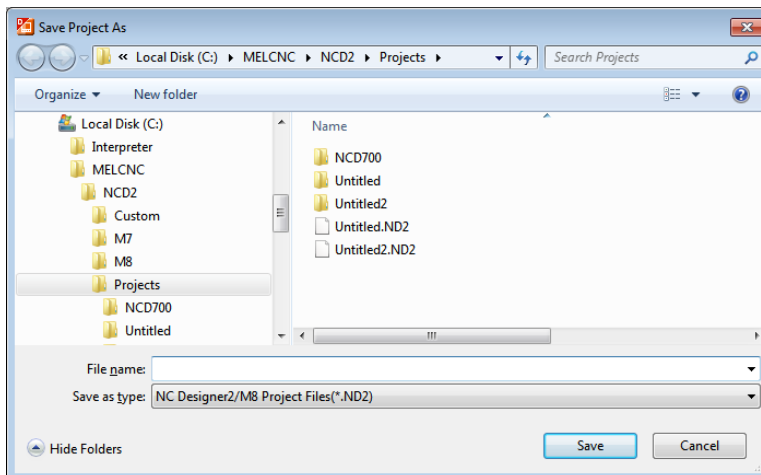

When conversion is completed, a message dialog box containing the words "Project convert is completed. Do you want to open the converted project file?" is displayed.

If you press the [OK] button, the current project is closed, and the converted project is opened. If you press the [Cancel] button, the message dialog box disappears. The converted project retains the resource information before the conversion.

## 15. Source Code Generation

The method for generating source codes from the data created with NC Designer2 is described in this section.

### 15.1 Generating Screen Data Source Codes

With NC Designer2, source codes are generated from the created screen data.

1. Select [Source Code Generation] from the [File] menu.
2. The [Source code generation wizard] is displayed.

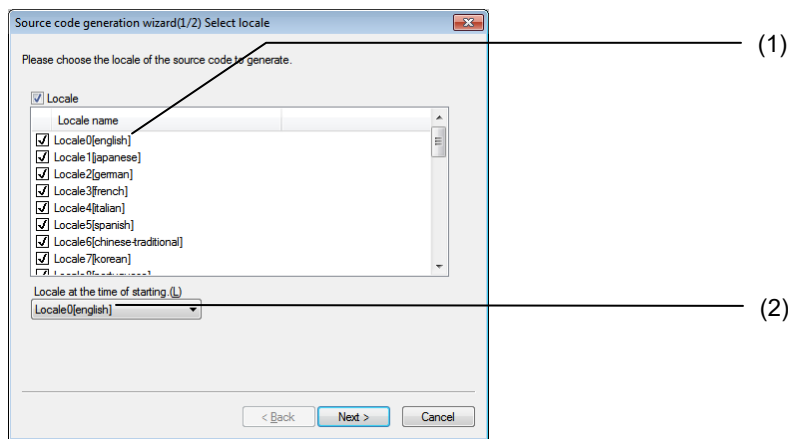

No.	Item	Description
(1)	Locale	Select the locale of the source codes to be generated. All locales are selected initially. After generating the source codes, the locales that were selected previously are selected when opening the source code generation wizard again.
(2)	Locale at the time of starting	Select the initial locale at the time of starting the execution module.

3. After entering the settings, click on [Next].

15. Source Code Generation

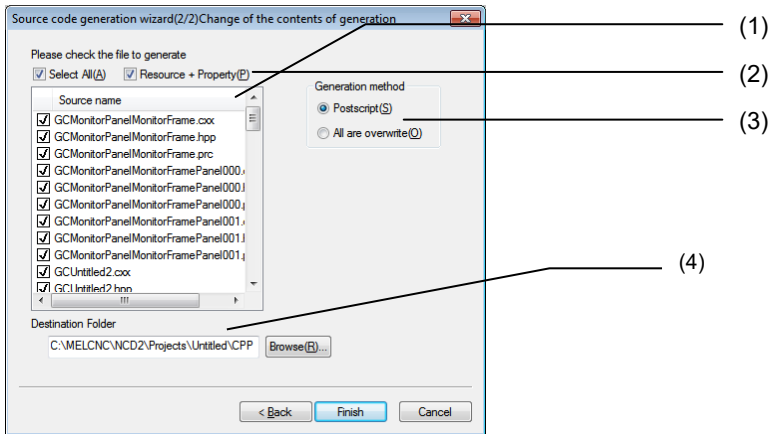

No.	Item	Description
(1)	File list (A)	Select the type of the file to be generated. Select the file and click on the box to alternate between check ON/OFF. To select all files at once, check the box on the title.
(2)	Resource + property selection (P)	Click the button to select only the resource and property files.
(3)	Generation method	Select "Postscript" to add only the data changed after previous source code generation into the source file. Select "overwrite all" to overwrite the entire source file.
(4)	Destination Folder	Designate the folder where the source code is generated.

4. Click on [Finish] to automatically generate source codes.

After generation is finished, a completion notice dialog box is displayed. Click on the [OK] button.

The generated source codes are saved in the folder designated.

15. Source Code Generation

Files created during source code generation include the followings.

File name	Description	User code protection
GCXXX.cxx (XXX: project name)	Application launch-related code file. Screen properties are entered to create screens.	Not protected
GCSampleScreen.cxx	Base screen-related code file. Instance of the resource and the created page are generated.	Protected
GCSampleScreen.hpp		
GCSampleScreen.prc		Not protected
GCXXX.cxx (XXX: window/panel name)	Page-related code file. Controls in each page are generated and callback functions of each control are generated.	Protected
GCXXX.hpp (XXX: window/panel name)		
GCXXX.prc (XXX: window/panel name)		Not protected
GCXXXXYY.cxx (XXX: window/panel name. YYY: view frame name)	View frame-related code file. The view frame is controlled.	Protected
GCXXXXYY.hpp (XXX: window/panel name. YYY: view frame name)		
GCXXXXYY.prc (XXX: window/panel name. YYY: view frame name)		Not protected
GCXXXXYYPanelZZZ.cxx (XXX: window/panel name. YYY: view frame name. ZZZ: view frame page number)	View frame page-related code file. Controls in each page of view frame are generated and callback functions of each control are generated.	Protected
GCXXXXYYPanelZZZ.hpp (XXX: window/panel name. YYY: view frame name. ZZZ: view frame page number)		
GCXXXXYYPanelZZZ.prc (XXX: window/panel name. YYY: view frame name. ZZZ: view frame page number)		Not protected
GResource.c	Resource-related code file.	Not protected
GResource.h		
GLoc_XXX.c (XXX: locale name)		

**NOTE**

- ◆ "User code protection" is a function for protecting the source codes created by the user against overwriting during next source code generation. For details, refer to Section "15.2 User Code Protection".
- ◆ The source code specified as "not protected" in the "user code protection" field is not added even if "add" is selected with the source code generation wizard generation method; it is overwritten, instead.
- ◆ If GCYYY.cxx already exists at the time of source code generation, the part related to callback functions is not overwritten.
- ◆ The screen size and display zoom settings are stored in file CONFIG.INI, that is in the same folder with melhi.exe.  
To modify the screen size or the display magnification, adjust the values in the [SCREEN].  
[SCREEN]  
WIDTH = 640  
HEIGHT = 480  
SCALE = 100
- ◆ The maximum size of resource data differs depending on the model. For the maximum size, refer to "NC Designer2 Matching List [Maximum data size]". The following message appears if the resource data to be output to "GResource.c" exceeds the maximum size at the time of source code generation.  
When the custom screen is not displayed correctly on the NC, reduce the registered resource data.

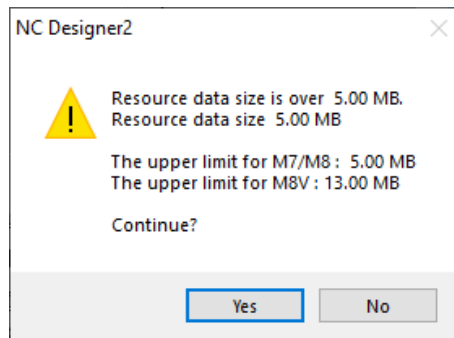

When "Yes" is selected, the source code generation is continued. When "No" is selected, the source code generation is cancelled.



### 15.2 User Code Protection

NC Designer2 automatically encloses the part to be overwritten by NC Designer2 in each created file, with tag codes during source code generation.

The source codes added during the next source code generation can be protected by the user's adding source codes other than at the parts enclosed with tag codes.

Lists of tag codes used for each file are shown below.

Screen header file(GCSampleScreen.hpp)

Tag code	Description
<code>/// //</code> OBJECT_TYPE	Area of definition of object type of panel/window/view frame object created in project is described.
<code>/// //</code> PUBLIC_METHOD	Area where the method (function) created in the screen class is described.
<code>/// //</code> PROTECTED_METHOD	Area where the method (function) created in the screen class is described.

Screen source file(GCSampleScreen.cxx)

Tag code	Description
<code>/// //</code> INITIAL_PANEL	Area where the initial panel is specified.
<code>/// //</code> INITIAL_LOCALE	Area where the initial locale is specified.

Panel header file(GCXXX.hpp)

Tag code	Description
<code>/// //</code> CONTROL_ID	Area where the ID of the control displayed in the panel is described.
<code>/// //</code> PUBLIC_METHOD	Area where the definition of the method (function) created in the panel is described.
<code>/// //</code> CALLBACK_METHOD	Area where the definition of the callback method (function) created in the panel is described.
<code>/// //</code> PROTECTED_METHOD	Area where the definition of the method (function) created in the panel is described.



## 16. Features and Configuration of GUI Library

This section describes an outline of the GUI library.

Refer to "NC Designer Function Reference" (IB-1500109) for the specification details.

### 16.1 Features of GUI Library

The graphical user interface (GUI) library is a C++ language library and it strongly supports GUI development. The GUI library provides you with not only drawing functions but also controlling of the mouse, key and other events as well as other functions indispensable for establishment of the GUI such as the window system, so that the GUI can be created without difficulty.

It is also provided with a GPI (graphic platform interface), which is a mechanism for processes depending on hardware, to make porting to each platform easily. When the GUI library is ported to another platform, GPI processes are created according to the target platform.

### 16.2 Configuration of GUI Library

The basic configuration of the GUI library is shown below.

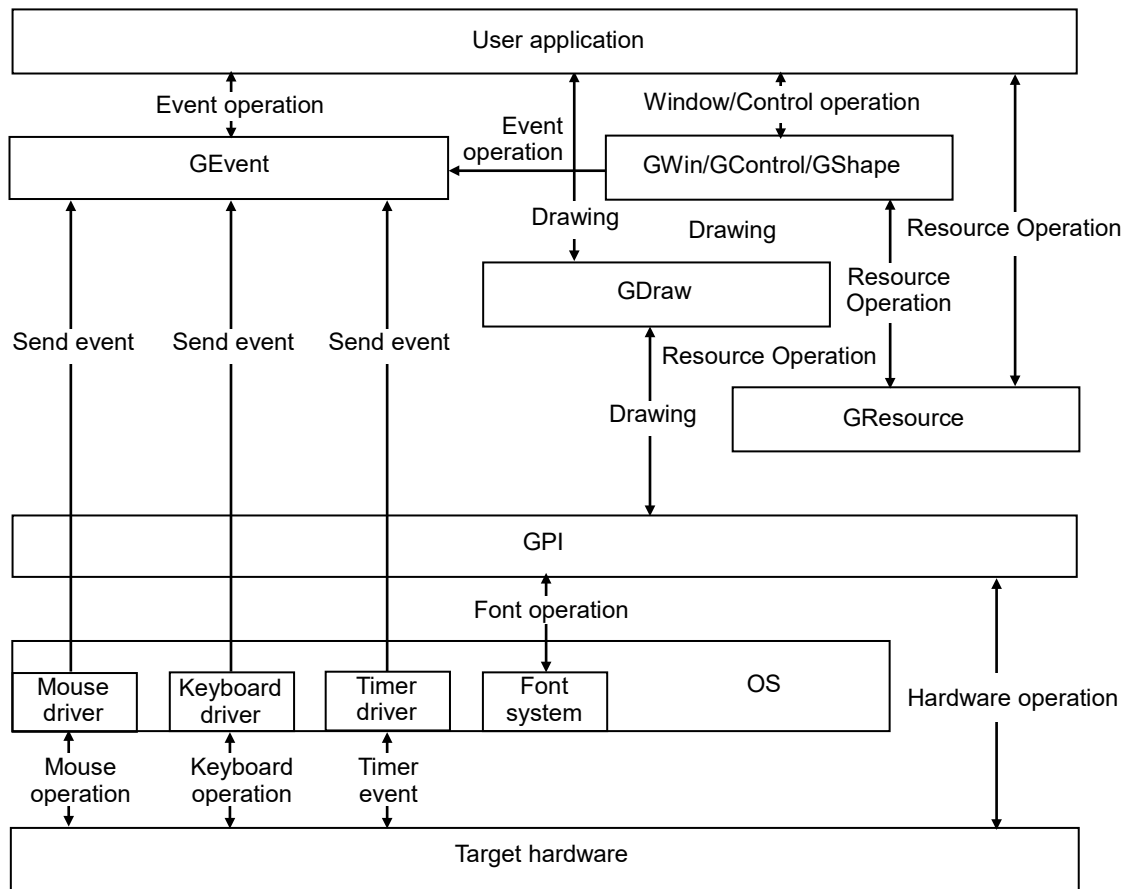

Function name	Description
GDraw	Draws basic figures and characters and specifies coordinates, colors and other drawing environment
GPI	Part dependent on hardware and operating system (drawing to VRAM, font, platform initialization, etc.)
GResource	Handles character strings, solid frames, images and other resources.
GEvent	Controls the mouse, keyboard, timer and other events and window system events such as GWin, GControl and GShape.
GWin/GControl/GShape	Window system

### 16.3 Folder Configuration for Data File

The folder configurations for data file are shown below.

```

NCD2
├─ M7
│  ├─ RUNPARTS
│  ├─ lang
│  ├─ lib
│  │   └─ vc6
│  │       └─ Release_Unicode
│  ├─ include
│  └─ include_VxW
├─ M8
│  ├─ RUNPARTS
│  ├─ lang
│  ├─ lib
│  │   └─ vs2010
│  │       └─ Release
│  ├─ include
│  └─ include_VxW
├─ M8V
│  ├─ RUNPARTS
│  ├─ lang
│  ├─ lib
│  │   └─ vsx
│  │       └─ Release
│  ├─ include
│  └─ include_VxW
├─ Custom
└─ Projects
    
```

Each folder is described below.

Folder name	Description
M7	Folder storing application window for M700V/M70V/E70 Series
M8	Folder storing application window for M800/M80 Series
M8V	Folder storing application window for M800V/M80V Series
lib	Folder storing library files
include	Folder storing GUI library header files
Projects	Folder storing project files
Custom	Folder storing setting files for user update

## 17. Application Execution Method

This section describes the execution method of applications created with NC Designer2.

### 17.1 Application Execution Method

#### 17.1.1 Outline

The execution method of applications created with NC Designer2 includes two types: interpreter and compilation. Either independent or combinational execution is possible.

##### Interpreter Method

With the interpreter method, the project data created with NC Designer2 is converted into an interpreter project for execution. The feature of the interpreter method is that NC Designer2 handles all processes from screen establishment to simple control program creation.

Therefore C++ language programming is unnecessary. While the execution speed is slower than that of the compilation method, GUI applications are developed handily.

Create a project using NC Designer2.

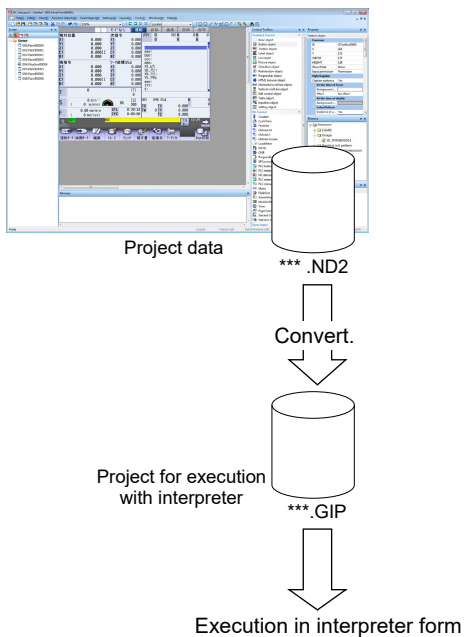

Compilation Method

With the compilation method, a source program is generated from the project data created with NC Designer and it is converted into a module (DLL) for execution. The control program is created in the C++ language and all functions of NC Designer2 are used to realize various control methods. While C++ language programming is necessary, the execution speed is faster than that of the interpreter method and applications having more complex control functions can be developed.

Create a project using NC Designer2.

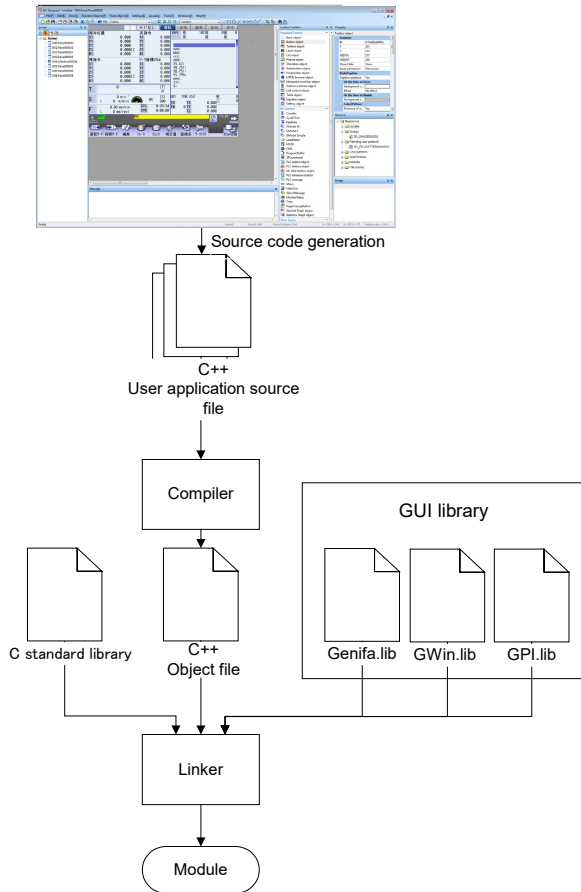

### 17.1.2 Independent/Combinational Execution

You can choose the interpreter method, compilation method and combination of both for the execution of the application. Using combination, you can use the advantages of both methods during application development. For example, screens where frequent specification changes are expected are created with the interpreter method, and complex screens are created with the compilation method.

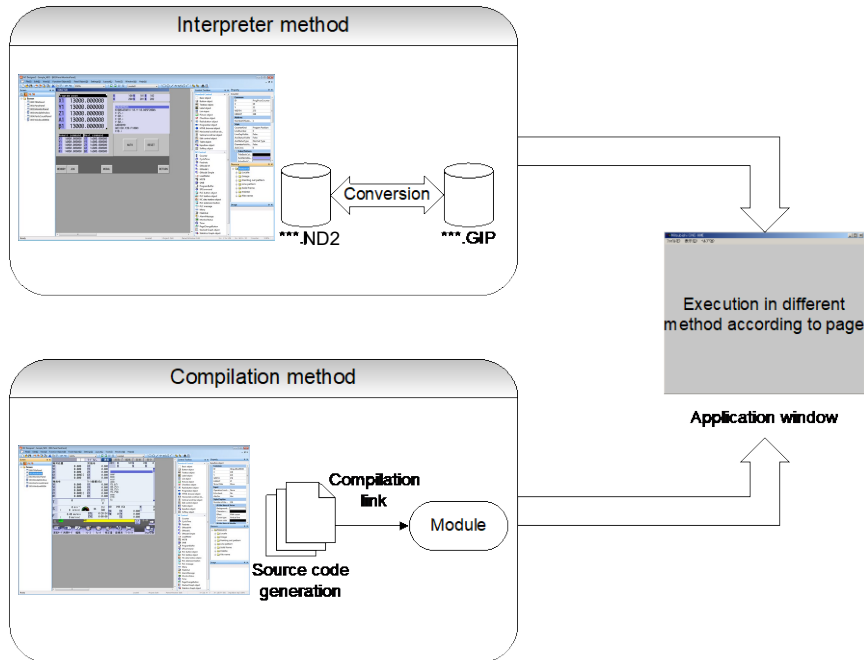



## 17.2 Interpreter Method

### 17.2.1 What Is Interpreter Method?

With the interpreter method, the project data created with NC Designer2 is converted into an interpreter project for execution. The feature of the interpreter method is that NC Designer2 handles all processes from screen establishment to simple control program creation.

Therefore C++ language programming is unnecessary. While the execution speed is slower than that of the compilation method, GUI applications are developed handily.

### 17.2.2 Flow of Operation

The procedure for executing the application in the interpreter method is described here.

1. Create a project with NC Designer2.
2. To add control programs to the project or controls, describe macros. From the [Settings] menu, select [Panel Macro Edit]/[Project Macro Edit]. Edit the macro in the displayed "Macro Edit" dialog box. For details of the macro editing method, refer to "NC Designer2 Macro Function Manual" (IB-1501500).

#### **NOTE**

- ◆ With the interpreter method, callback events do not function. To add screen switching process to controls, use the macro function.

3. Save the project.
4. Convert the project for interpreter execution. From the [File] menu, select [Project convert] - [Export].

For the export, refer to "14.1.1 Export".

17. Application Execution Method

5. Enter various settings related to execution of the application such as the application execution state and project name to be launched. Use the "Config.ini" file for settings. The Config.ini file is in the Custom folder for data file. Use a text editor to open it.

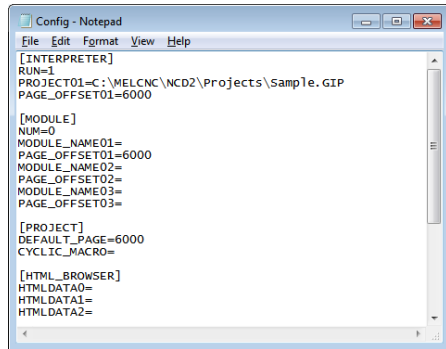

6. Edit the [INTERPRETER] section in the "Config.ini" file as specified below.

Item	Setting	Description
RUN=	1	Specify the number of projects executed with the interpreter method.
PROJECT=	C:\MELCNC\NCD2\Projects \Sample.GIP	Specify the name of the interpreter project including the path.
PAGE_OFFSET=	6000	Specify the screen No. offset value.

7. Edit the [PROJECT] section of the "Config.ini" file as specified below.

Item	Setting	Description
DEFAULT_PAGE=	6000	Specify the screen No. displayed first when the project is launched.

After editing, save and close the file.

8. Double click on "melhmi.exe" to launch it and execute the project in the interpreter mode. "melhmi.exe" is an application window for executing a project and is stored in the folder for data file. For the application window, refer to "17.4.2 Launching the Application Window".

## 17.3 Compilation Method

### 17.3.1 What Is Compilation Method?

With the compilation method, a source program is generated from the project data created with NC Designer2 and it is converted into a module for execution. The control program is created in the C++ language and all functions of NC Designer2 are used to realize various control methods. While C++ language programming is necessary, the execution speed is faster than that of the interpreter method and applications having more complex control functions can be developed.

### 17.3.2 Flow of Operation

The procedure for executing the application in the compilation method is described below.

1. Create a project with NC Designer2.

2. Save the project.

3. Generate source codes.

From the [File] menu, select [Source Code Generation] and follow the displayed "Source code generation wizard" to generate source codes.

For the source code generation method, refer to Section "15 Source Code Generation".

#### 17.3.2.1 Preparation for Visual Studio 2017/2019/2022

When using Visual Studio 2017/2019/2022 to modularize (.dll) source code, the following procedures are required. They are required for M700VW, M800/M80 (Windows-based display unit), but not required for M800V/M80V (Windows-based display unit). (These preparations only need to be conducted once.)

1. Install Visual Studio 2015.

2. Download Windows SDK 7.1.

3. Install Windows SDK 7.1.

4. Correct the registry.

5. 17.3.2.1.4 MSBuild props file correction.

(Note 1) Administrator rights are required for these preparations.

(Note 2) Conducting these preparations changes the developing environment on the PC. Note that this may affect application development on the existing Visual Studio.

The following describes the procedures for preparation on a x64 (AMD64) CPU architecture.

### 17.3.2.1.1 Visual Studio 2015 Installation

If Visual Studio 2015 is not installed, install Visual Studio 2015.

1. Download the installer of Visual Studio 2015 from the Microsoft website.  
(Search for "Visual Studio 2015" on the Microsoft website.)
2. Start the downloaded installer to install Visual Studio 2015.

### 17.3.2.1.2 Windows SDK 7.1 Download

1. Download the Windows SDK 7.1 ISO image from the Microsoft website.  
"Microsoft Windows SDK for Windows 7 and .NET Framework 4 (ISO)"

Download the ISO file that corresponds with the version of Windows used.

For x64(AMD64):GRMSDKX\_EN\_DVD.iso

For x86 :GRMSDK\_EN\_DVD.iso

### 17.3.2.1.3 Windows SDK 7.1 Installation

1. When Microsoft Visual C++ 2010 Redistributable is installed, Windows SDK 7.1 installation fails. Uninstall Microsoft Visual C++ 2010 Redistributable.

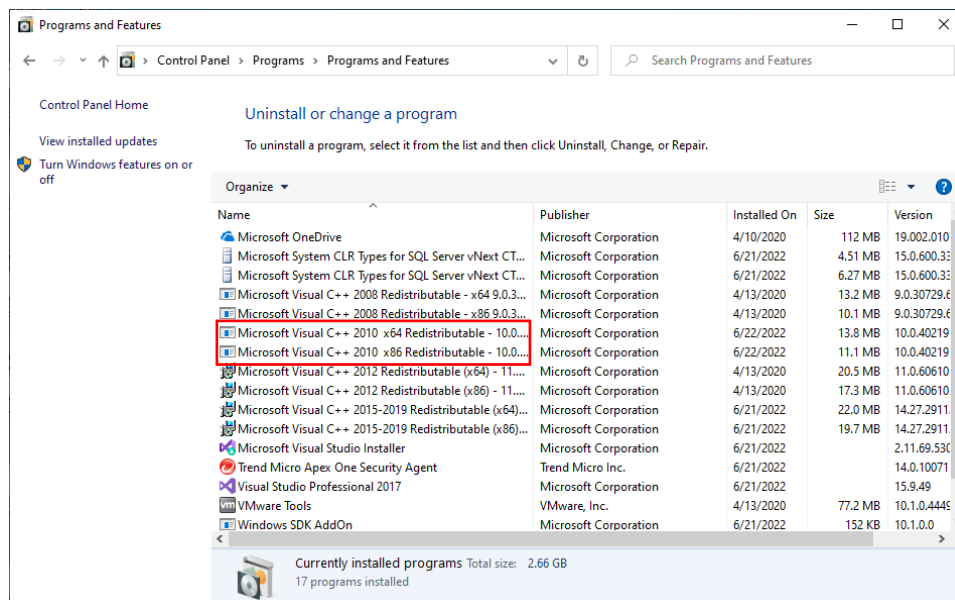

2. Double-clicking GRMSDKX\_EN\_DVD.iso mounts the ISO file. Double-click SDKSetup.exe in the Setup folder.

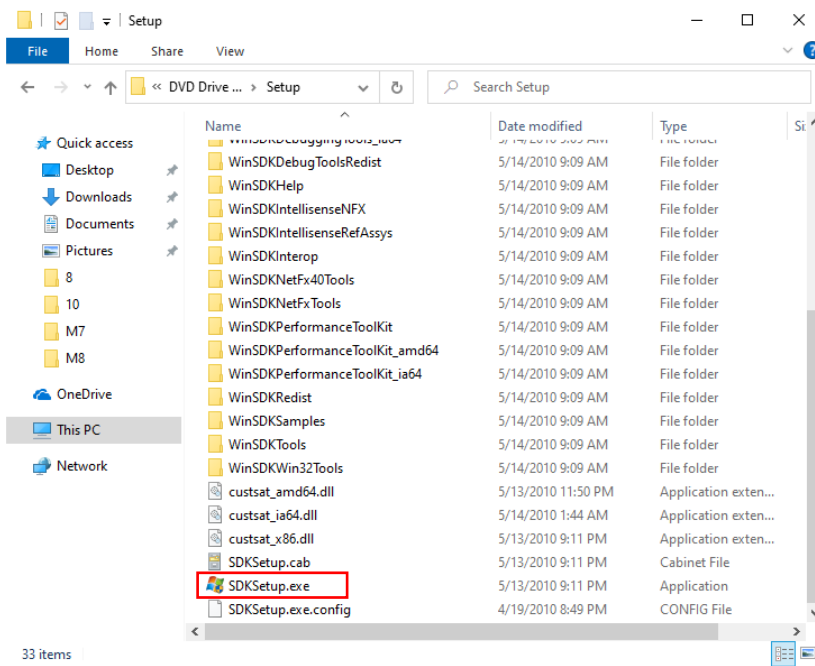

3. When the following dialog appears, wait until the next dialog appears.

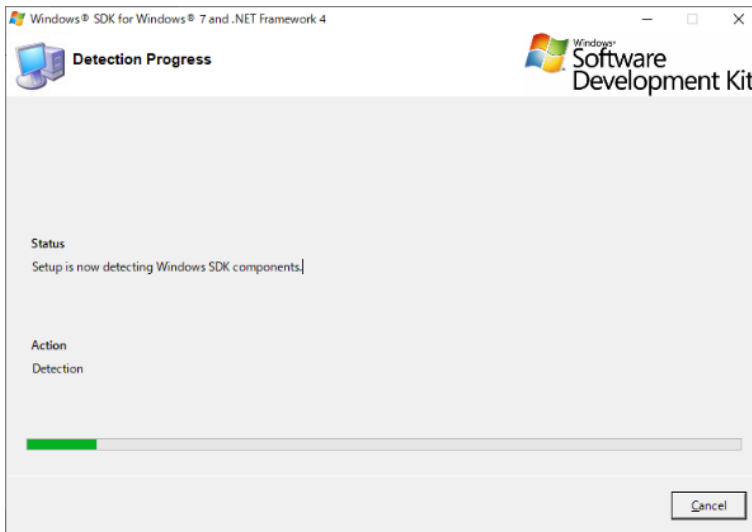

4. Click "Next".

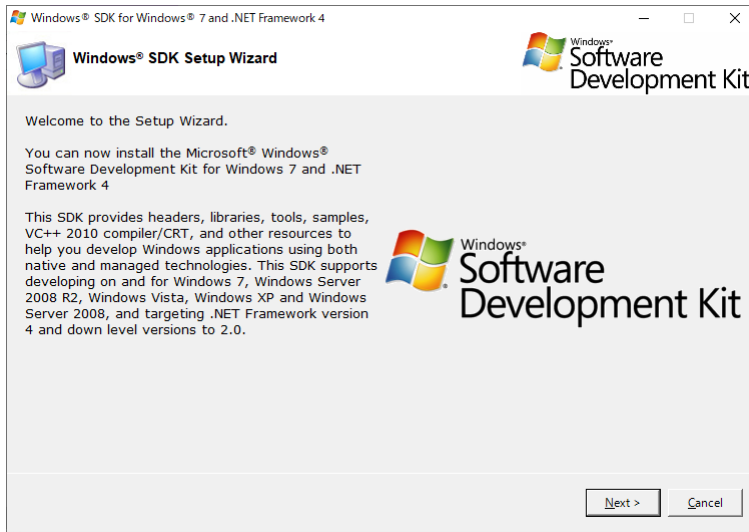

5. Select "I Agree" and click "Next".

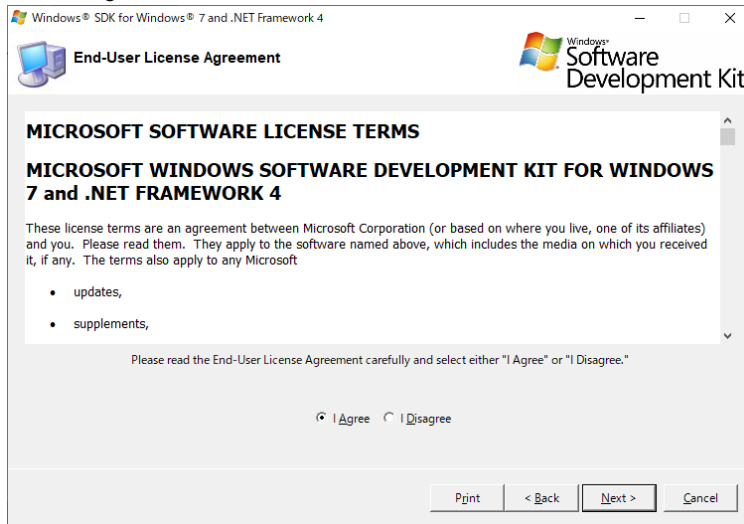

6. Click "Next".

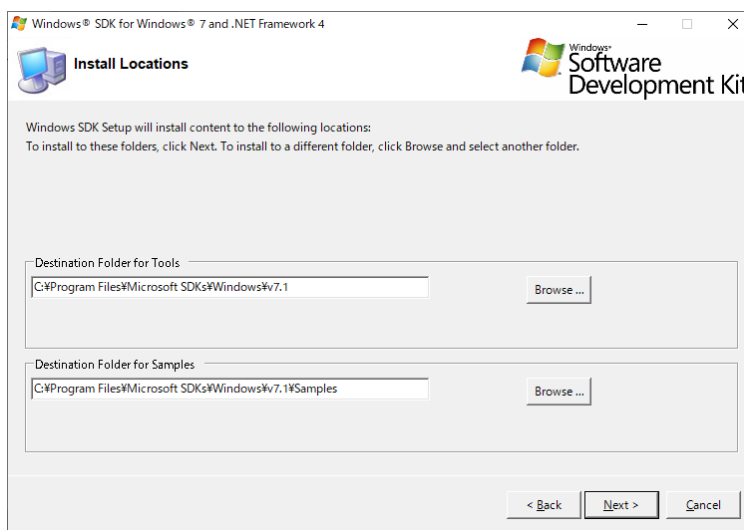

7. Click "Next".

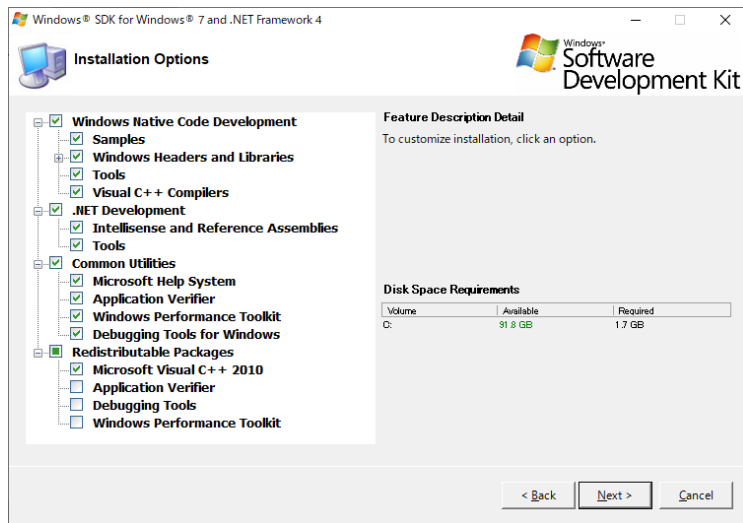

8. Click "Next".

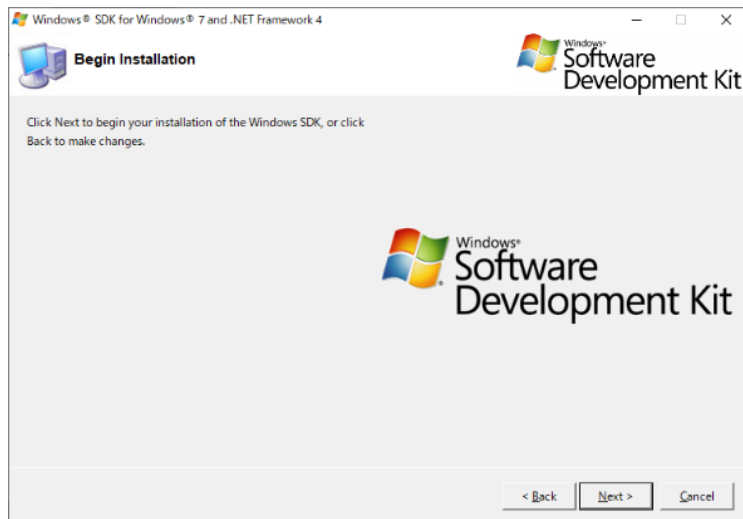

9. Installation begins and the following dialog appears.

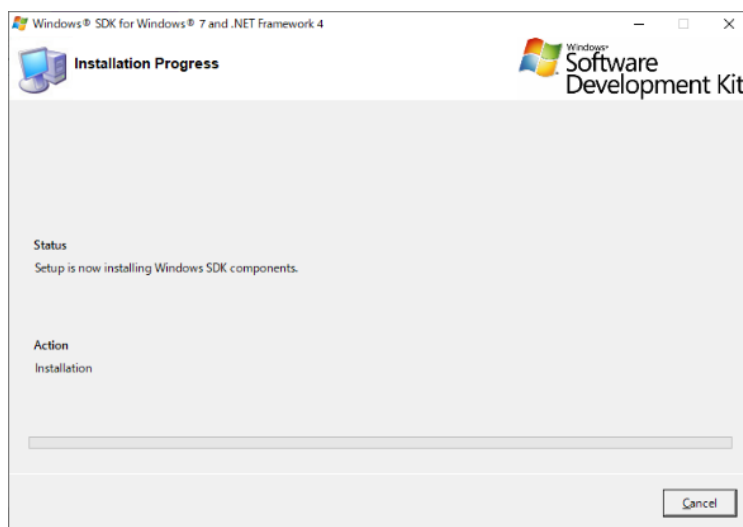

10. Click "Finish" to complete the installation.

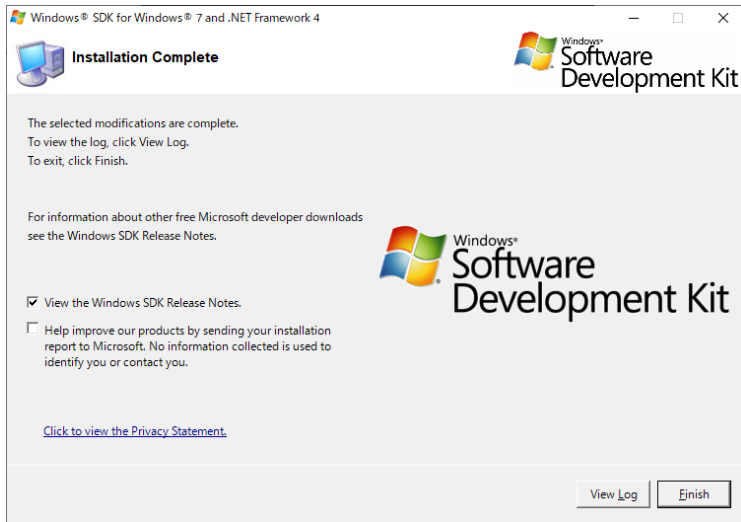

11. When the following dialog appears, click "Cancel".

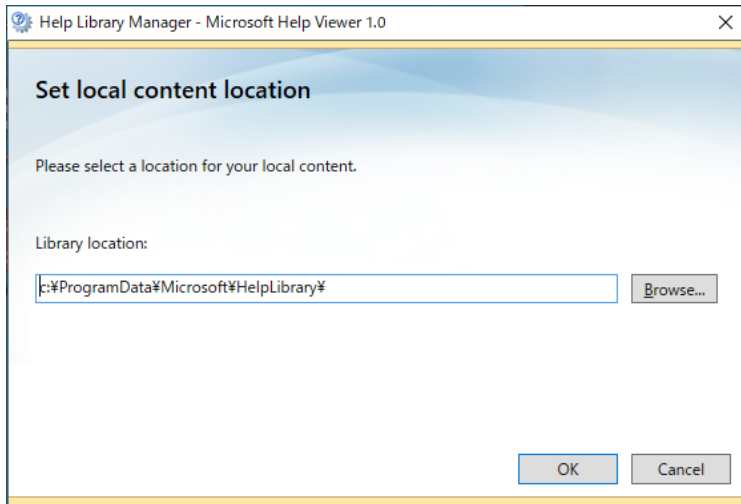

### 17.3.2.1.4 Registry Correction

Add the following values in the registry editor.

Key	HKEY_LOCAL_MACHINE\SOFTWARE\WOW6432Node\Microsoft\VisualStudio\SxS\VS7
Name	10.0
Type	REG_SZ
Data	C:\Program Files (x86)\Microsoft Visual Studio 10.0\

Key (*)	HKEY_LOCAL_MACHINE\SOFTWARE\WOW6432Node\Microsoft\VisualStudio\10.0\Setup\VS
Name	ProductDir
Type	REG_SZ
Data	C:\Program Files (x86)\Microsoft Visual Studio 10.0\

(\*) When the key "VS" does not exist in "HKEY\_LOCAL\_MACHINE\SOFTWARE\WOW6432Node\Microsoft\VisualStudio\10.0\Setup", create a new "VS" key.



17.3.2.1.5 MSBuild Props File Correction

1. Open the following folder in Windows Explorer.

<C:\Program Files (x86)\MSBuild\Microsoft.Cpp\v4.0\Platforms\Win32\PlatformToolsets\v100>

2. Edit Microsoft.Cpp.Win32.v100.props(file extension: .props).

When Windows security does not allow corrections to me made directly, move the file to a location such as the desktop, and return it after editing.

3. Add the line that is underlined below.



[Correction details]

- (a) Copy the contents of line 30 to line 31.

- (b) Correct line 31 as follows. (the red box is the corrected segment)

v7.0A → v7.1

<WindowsSdkDir Condition="'\$(WindowsSdkDir)' == ''">\$(Registry:HKEY\_LOCAL\_MACHINE\SOFTWARE\Wow6432Node\Microsoft\Microsoft SDKs\Windows\v7.0A@InstallationFolder)\WindowsSdkDir



<WindowsSdkDir Condition="'\$(WindowsSdkDir)' == ''">\$(Registry:HKEY\_LOCAL\_MACHINE\SOFTWARE\Wow6432Node\Microsoft\Microsoft SDKs\Windows\v7.1@InstallationFolder)\WindowsSdkDir

When opening the file, the following dialog appears when double-clicking the file in Windows Explorer. Click the "More apps" button and edit the file with an appropriate application.

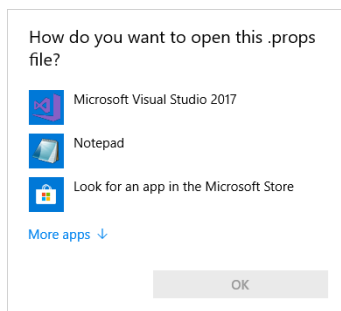

### 17.3.2.2 Operation Procedures in Visual Studio

The following describes the procedures for modularizing (.dll) source code using Visual Studio 2010/2017/2019/2022.

1. Modularize source code according to the procedures of the Visual Studio version being used.

The following are the versions where operation has been confirmed.

Microsoft Visual Studio 2010 Professional Version 10.0.40219.1 SP1 Rel

Microsoft Visual Studio Professional 2017 Version 15.9.29

Microsoft Visual Studio Professional 2019 Version 16.8.0

Microsoft Visual Studio Professional 2022 Version 17.2.5

2. Refer to "17.6 Custom Release" to edit the Config.ini file.

3. Double click on "melhmi.exe" to launch it. The project is executed in the compilation method.

17.3.2.2.1 Operation Procedure with Visual Studio 2010

1. Start up Visual Studio2010 (hereinafter called VS2010) to edit the source code, and compile and link.
2. Create a VS2010 project. From the [File] menu, select [New] - [Project...].  
From "Installed Templates" in "New Project" dialog, select "Win32" from "Visual C++", and enter the solution name and Location. Press the [OK] button.

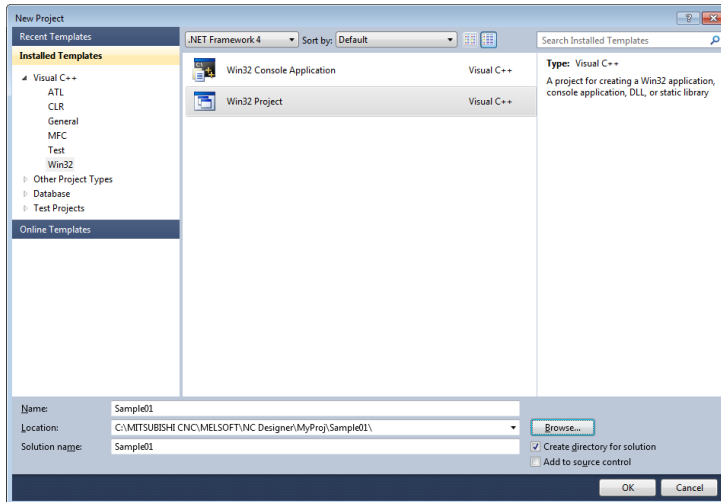

**NOTE**

- ◆ For Visual Studio 2005/2008, a project can be created with the same operation procedure as mentioned above.

3. The dialog box shown below is displayed. Press the [Next] button.

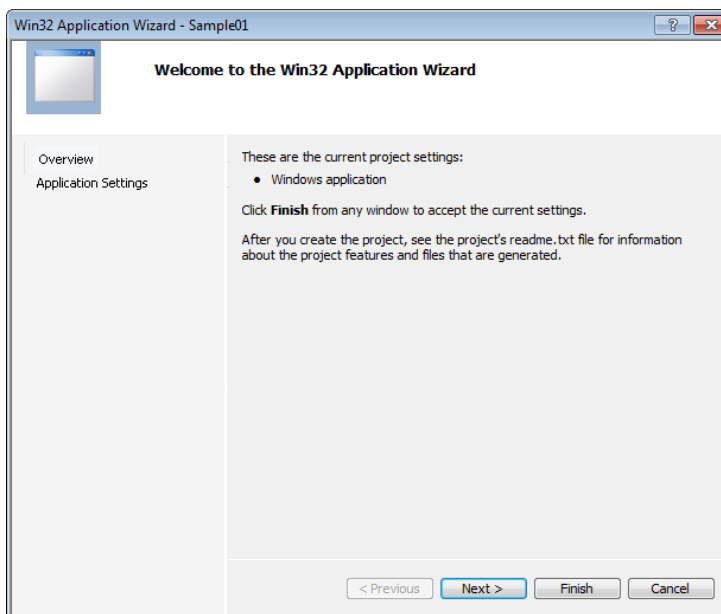

- The dialog box shown below is displayed. Select "DLL" from "Application type" and "Empty project" from "Additional options". Press the [Finish] button.

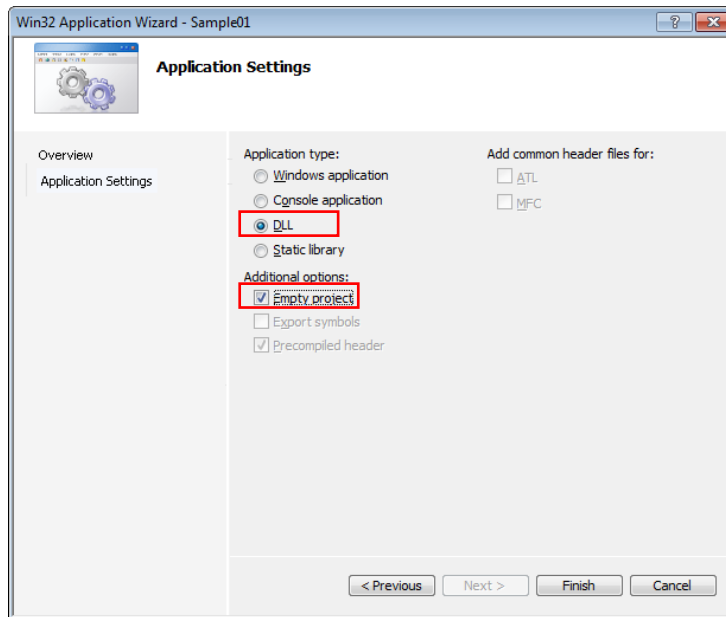

- Add the source file created with NC Designer2 to the project.  
From the [Projects] menu, select [Add Existing Item...] and all files (\*.cxx/ \*.hxx/ \*.prc/ \*.c/ \*.h/ \*.def) generated with NC Designer2.
- From the [Projects] menu, select [Properties] to display "Property Pages" dialog box.  
Select "Configuration Properties" - "General". Select "Use Unicode Character Set" from "Character Set" in "Project Defaults".

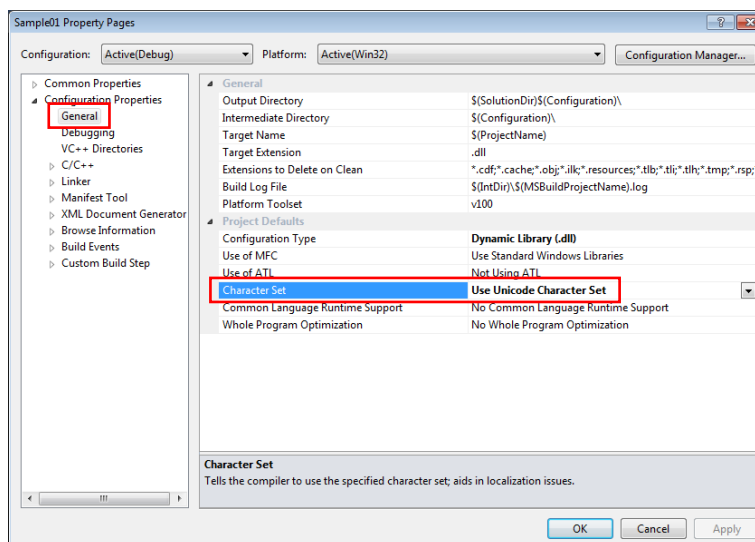

Specify each item as shown below.

Category	Item	Details
Configuration Properties - General	Project Defaults - Character Set	Use Unicode Character set
Configuration Properties - C/C++ - General	Additional Include Directories	For M700V/M70V/E70 Series: C:\MELCNC\NCD2\M7\include For M800V/M80V/M800/M80/E80 Series: M800W/M800S/M80/E80: C:\MELCNC\NCD2\M8\include M800VW/M800VS/M80V: C:\MELCNC\NCD2\M8V\include
Configuration Properties -C/C++ - Preprocessor	Preprocessor Definitions	Delete _MBCS. Add _UNICODE, UNICODE and NC_TYPE_NX.
Configuration Properties -C/C++ -Code Generation	Runtime Library	Multi-thread DLL(/MD)
Configuration Properties -C/C++ - Language	Treat WChar_t As Built in Type	No(/Zc:wchar_t-)
Configuration Properties - Linker - General	Additional Library Directories	For M700V/M70V/E70 Series: C:\MELCNC\NCD2\M7\lib\vc6\Release_Unicode For M800V/M80V/M800/M80/E80 Series: M800W/M800S/M80/E80: C:\MELCNC\NCD2\M8\lib\vs2010\Release M800VW/M800VS/M80V: C:\MELCNC\NCD2\M8V\lib\vsx\Release
Configuration Properties - Linker - Input	Additional Dependencies	gcs.lib;resmng.lib;gcwin.lib;genifa.lib;ncapi32.lib
	Ignore Specific Default Libraries	For M700V/M70V/E70 Series: Libc.lib For M800V/M80V/M800/M80/E80 Series: Libc.lib;Libcmt.lib
	Module Definition File	Specify the path of GPROJECT.def.

**NOTE**

- ◆ Custom API library in NC Designer2 installer is described in "Custom API Library Correspondence List" in this manual. When using the custom API library of the corresponded version or later, change the following two path settings.
  - Configuration Properties - C/C++ - General Additional Include Directories
  - Configuration Properties - Linker - General Additional Library Directories

7. Compile and link.

8. Copy the created library (\*.dll) to the Custom folder for data file. "melhmi.exe" is an application window for executing a project and is stored in the Custom folder for data file.

For the application window, refer to "17.4.2 Launching the Application Window".

- Enter various settings related to execution of the application such as the application execution state and project name to be launched. Use the "Config.ini" file for settings. The Config.ini file is in the Custom folder for data file. Use a text editor to open it.

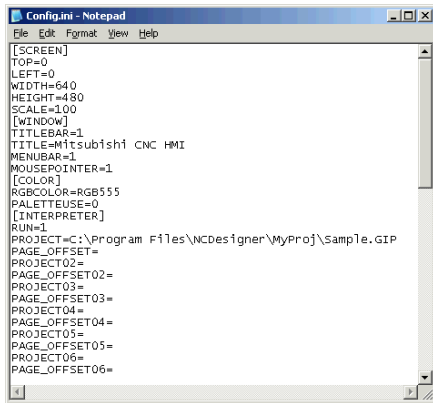

- Edit the [INTERPRETER] section of the "Config.ini" file as shown below.

Item	Setting	Description
RUN=	0	Specify the number of projects executed in the interpreter method. To execute in the compilation method, specify "0".

- Edit the [MODULE] section as shown below.

Item	Setting	Description
NUM=	1	Specify the number of projects executed in the compilation method.
MODULE_NAME01=	Sample.dll	Specify the generated module name.
PAGE_OFFSET01=	6000	Specify the screen No. offset value.

- Edit the [PROJECT] section as shown below.

Item	Setting	Description
DEFAULT_PAGE=	6000	Specify the screen No. displayed first when the project is launched.

After setting, save and close the file.

- Double click on "melhmi.exe" to launch it. The project is executed in the compilation method.

**17.3.2.2.2 Operation Procedure with Visual Studio 2017**

1. Start up Visual Studio 2017.

When using for the first time, refer to "17.3.2.1 Preparation for Visual Studio 2017/2019/2022" for the procedures for the required preparations.

2. Create a new project. From the [File] menu, select [New] - [Project...].

From "Installed" in "New Project" dialog, select "Visual C++" - "Other" - "Empty Project". Specify the Project/Solution name and location and click the [OK] button.

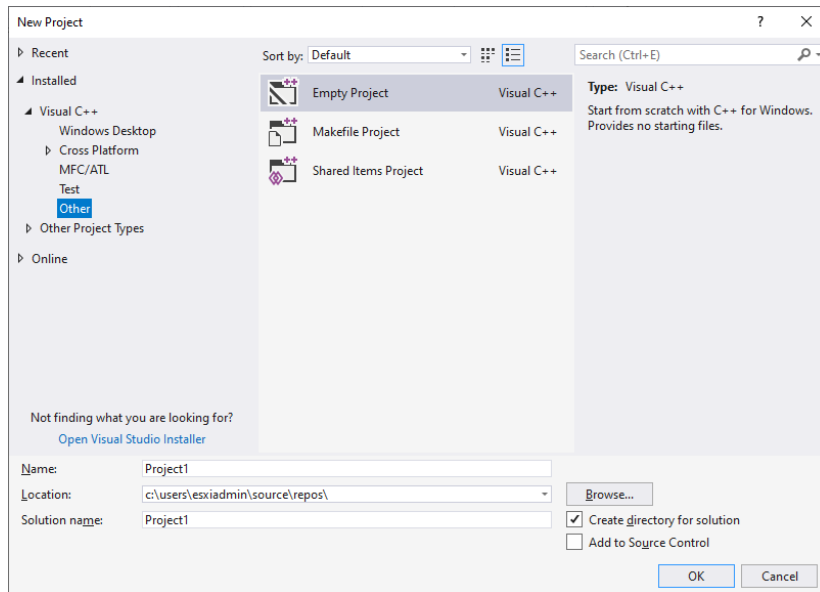

3. Add the source file created with NC Designer2 to the project. From the [Projects] menu, select [Add Existing Item...] and all files (\*.cxx/ \*.hxx/ \*.prc/ \*.c/ \*.h/ \*.def) generated with NC Designer2.

17. Application Execution Method

4. From the [Projects] menu, select [Properties] to display "Property Pages" dialog box.

When "Platform" at the top of the dialog is not "Active(Win32)" select "Win32". Set each item as shown below.

Category	Item	Details
Configuration Properties - General	Project Defaults - Configuration Type	Dynamic Library (.dll)
	Project Defaults - Character Set	Use Unicode Character set
	General - Platform Toolset	For M700V/M70V/E70/M800/M80/E80 Series: Visual Studio 2010 (v100) For M800V/M80V Series: Visual Studio 2017 (v141)

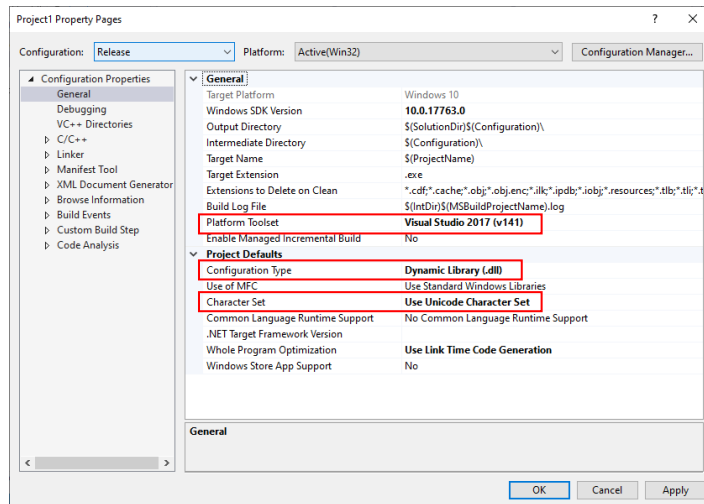

5. Click [Apply]. After clicking [Apply], make sure that "Target Extension" in the "General" section is ".dll".

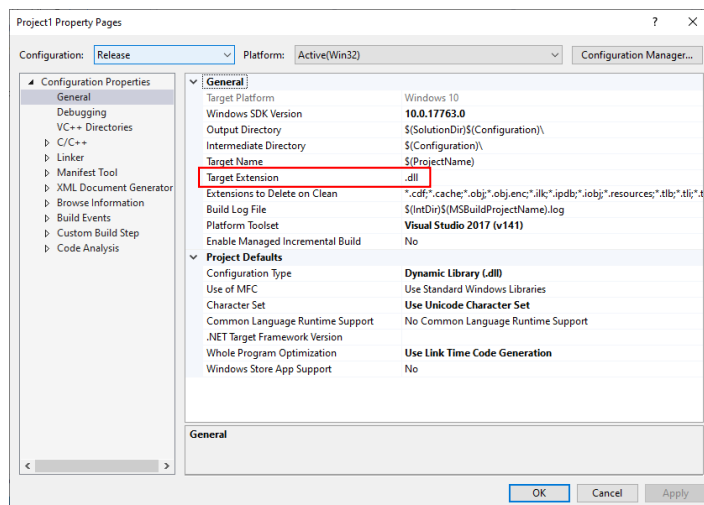



6. Change the settings as follows.

Category	Item	Details
Configuration Properties - C/C++ - General	Additional Include Directories	For M700V/M70V/E70 Series: C:\MELCNC\NCD2\M7\include For M800V/M80V/M800/M80/E80 Series: M800W/M800S/M80/E80: C:\MELCNC\NCD2\M8\include M800VW/M800VS/M80V: C:\MELCNC\NCD2\M8V\include
Configuration Properties -C/C++ - Preprocessor	Preprocessor Definitions	Select "<Edit...>" from the pulldown menu, enter the following in the dialog box that appears, and click OK. _UNICODE;UNICODE;NC_TYPE_NX
Configuration Properties -C/C++ -Code Generation	Runtime Library	Multi-thread DLL(/MD)
Configuration Properties -C/C++ - Language	Treat WChar_t As Built in Type	No(/Zc:wchart_t-)
Configuration Properties -C/C++ -Advanced	Disable the specified warning	For M700V/M70V/E70/M800/M80/E80 Series: 4596 For M800V/M80V Series: 4596;4996
Configuration Properties - Linker - General	Additional Library Directories	For M700V/M70V/E70 Series: C:\MELCNC\NCD2\M7\lib\vc6\Release_Unicode For M800V/M80V/M800/M80/E80 Series: M800W/M800S/M80/E80: C:\MELCNC\NCD2\M8\lib\vs2010\Release M800VW/M800VS/M80V: C:\MELCNC\NCD2\M8V\lib\vsx\Release
Configuration Properties - Linker - Input	Additional Dependencies	Select "<Edit...>" from the pulldown menu, enter the following in the dialog box that appears, and click OK. For M700V/M70V/E70/M800/M80/E80 Series: gcs.lib;resmng.lib;gcwin.lib;genifa.lib;ncapi32.lib;legacy_stdio_definitions.lib For M800V/M80V Series: gcs.lib;resmng.lib;gcwin.lib;genifa.lib;ncapi32.lib;legacy_stdio_definitions.lib
	Ignore Specific Default Libraries	For M700V/M70V/E70 Series: Libc.lib For M800V/M80V/M800/M80/E80 Series: Libc.lib;Libcmt.lib
	Module Definition File	Specify the path of GPROJECT.def.
Configuration Properties - Linker - Advanced	Image Has Safe Exception Handlers	No(/SAFESEH:NO)

**NOTE**

- ◆ Custom API library in NC Designer2 installer is described in "Custom API Library Correspondence List" in this manual. When using the custom API library of the corresponded version or later, change the following two path settings.
  - Configuration Properties - C/C++ - General Additional Include Directories
  - Configuration Properties - Linker - General Additional Library Directories

7. From the [Build] menu, select [Build Solution], and compile and link.

**NOTE**

- ◆ In Visual Studio 2017, the error "E1097 unknown attribute "no\_init\_all" occurs but does not affect compile and link.

8. Copy the created library (\*.dll) and place it in the Custom folder of the folder for data files. "melhmi.exe" is the application window that executes projects which is stored in the folder for data files. For the application window, refer to "17.4.2 Launching the Application Window".

**17.3.2.2.3 Operation Procedure with Visual Studio 2019**

1. Start up Visual Studio 2019.

When using for the first time, refer to "17.3.2.1 Preparation for Visual Studio 2017/2019/2022" for the procedures for the required preparations.

2. Create a new project. Click "Create a new project".

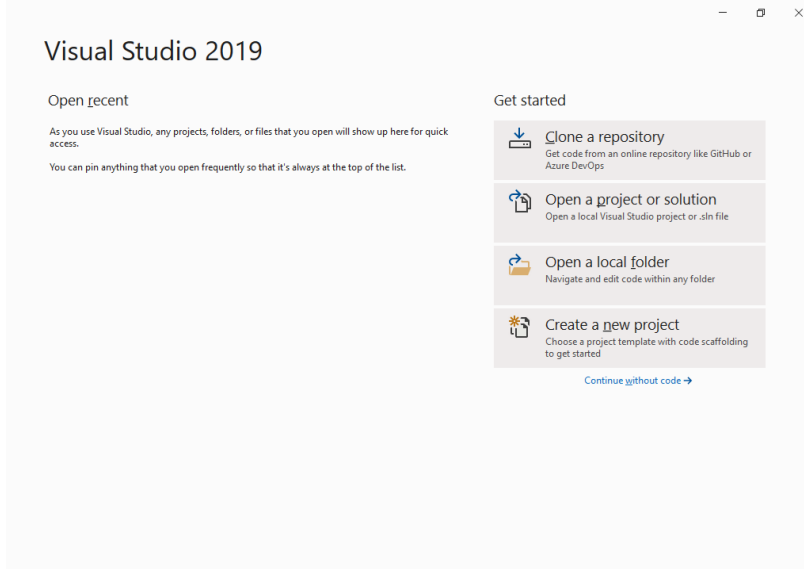

3. From the three pulldown menus, in order from the left, select "C++", "Windows", and "Console". Select "Empty project" from the project templates displayed and click the [Next] button.

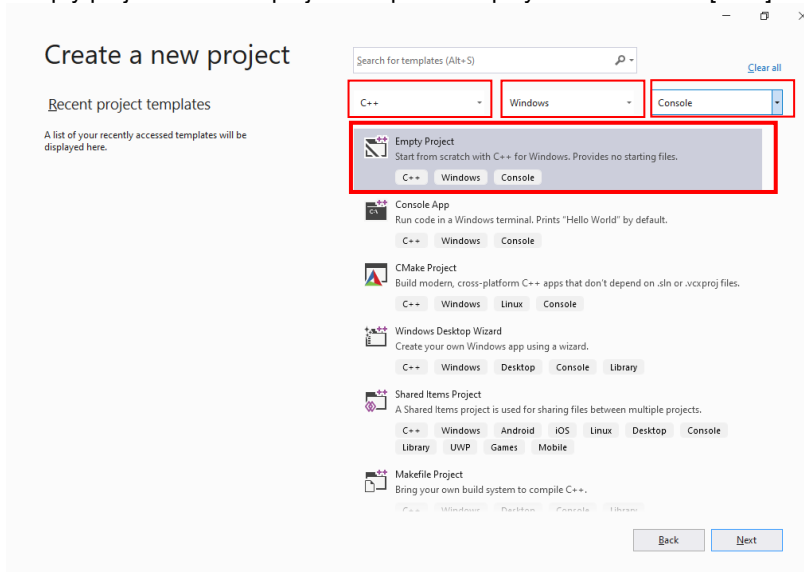

4. Specify the Project/Solution name and location and click the [Create] button.

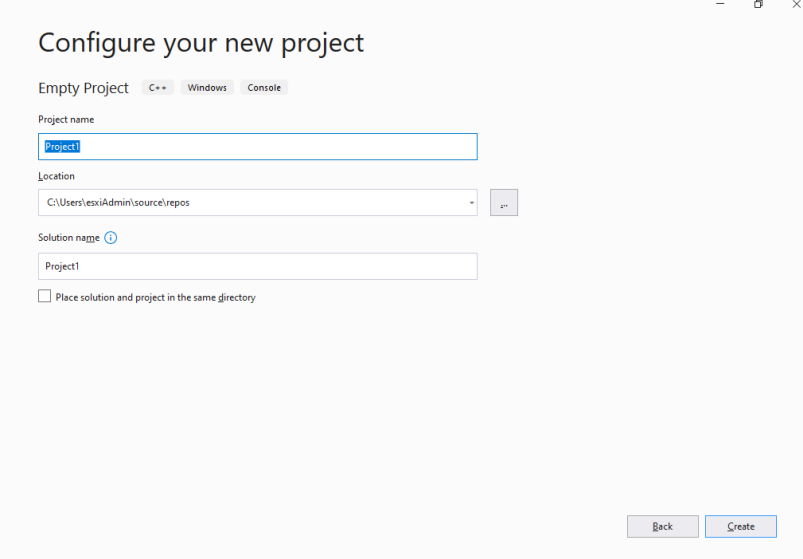

Configure your new project

Empty Project C++ Windows Console

Project name  
Project1

Location  
C:\Users\esxiAdmin\source\repos

Solution name ⓘ  
Project1

Place solution and project in the same directory

Back Create

5. Add the source file created with NC Designer2 to the project. From the [Projects] menu, select [Add Existing Item...] and all files (\*.cxx/ \*.hxx/ \*.prc/ \*.c/ \*.h/ \*.def) generated with NC Designer2.

17. Application Execution Method

6. In solution explorer right-click the project name and select [Properties] to display "Property Pages" dialog box.

When "Platform" at the top of the dialog is not "Active(Win32)" select "Win32".

Set each item as shown below.

Category	Item	Details
Configuration Properties - General	General Properties - Configuration Type	Dynamic Library (.dll)
	General Properties - Platform Toolset	For M700V/M70V/E70/M800/M80/E80 Series: Visual Studio 2010 (v100) For M800V/M80V Series: Visual Studio 2019 (v142)
Configuration Properties -Advanced	Advanced properties - Character Set	Use Unicode Character set

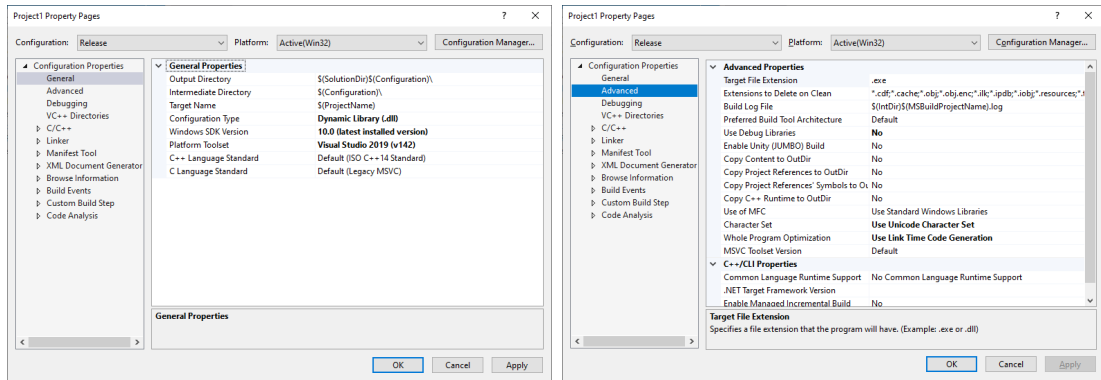

7. Click [Apply]. After clicking [Apply], make sure that "Target File Extension" in the "Advanced Properties" section of "Advanced" is ".dll".

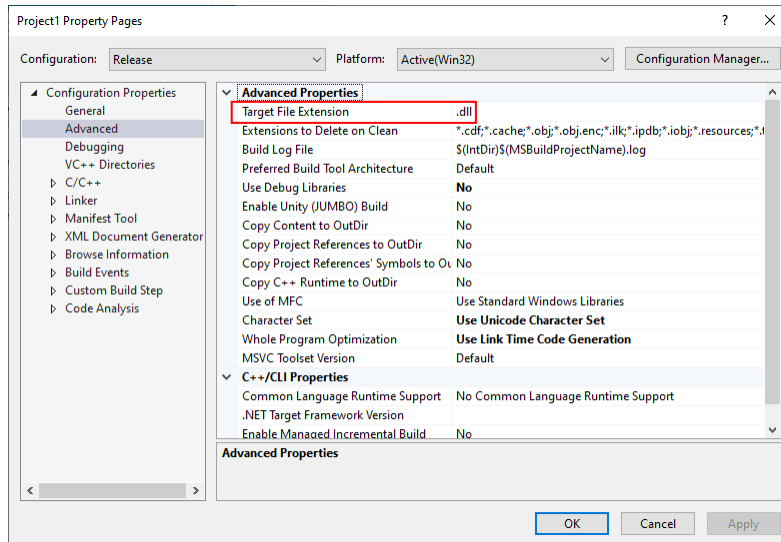

8. Change the settings as follows.

Category	Item	Details
Configuration Properties - C/C++ - General	Additional Include Directories	For M700V/M70V/E70 Series: C:\MELCNC\NCD2\M7\include For M800V/M80V/M800/M80/E80 Series: M800W/M800S/M80/E80: C:\MELCNC\NCD2\M8\include M800VW/M800VS/M80V: C:\MELCNC\NCD2\M8V\include
Configuration Properties -C/C++ - Preprocessor	Preprocessor Definitions	Select "<Edit...>" from the pulldown menu, enter the following in the dialog box that appears, and click OK. _UNICODE;UNICODE;NC_TYPE_NX
Configuration Properties -C/C++ -Code Generation	Runtime Library	Multi-thread DLL(/MD)
Configuration Properties -C/C++ - Language	Treat WChar_t As Built in Type	No(/Zc:wchart_t-)
Configuration Properties -C/C++ -Advanced	Disable the specified warning	For M700V/M70V/E70/M800/M80/E80 Series: 4596 For M800V/M80V Series: 4596;4996
Configuration Properties - Linker - General	Additional Library Directories	For M700V/M70V/E70 Series: C:\MELCNC\NCD2\M7\lib\vc6\Release_Unicode For M800V/M80V/M800/M80/E80 Series: M800W/M800S/M80/E80: C:\MELCNC\NCD2\M8\lib\vs2010\Release M800VW/M800VS/M80V: C:\MELCNC\NCD2\M8V\lib\vsx\Release
Configuration Properties - Linker - Input	Additional Dependencies	Select "<Edit...>" from the pulldown menu, enter the following in the dialog box that appears, and click OK. For M700V/M70V/E70/M800/M80/E80 Series: gcs.lib;resmng.lib;gcwin.lib;genifa.lib;ncapi32.lib;legacy_stdio_definitions.lib For M800V/M80V Series: gcs.lib;resmng.lib;gcwin.lib;genifa.lib;ncapi32.lib;legacy_stdio_definitions.lib
	Ignore Specific Default Libraries	For M700V/M70V/E70 Series: Libc.lib For M800V/M80V/M800/M80/E80 Series: Libc.lib;Libcmt.lib
	Module Definition File	Specify the path of GPROJECT.def.
Configuration Properties - Linker -Advanced	Image Has Safe Exception Handlers	No(/SAFESEH:NO)

**NOTE**

- ◆ Custom API library in NC Designer2 installer is described in "Custom API Library Correspondence List" in this manual. When using the custom API library of the corresponded version or later, change the following two path settings.
  - Configuration Properties - C/C++ - General Additional Include Directories
  - Configuration Properties - Linker - General Additional Library Directories

9. From the [Build] menu, select [Build Solution], and compile and link.

10. Copy the created library (\*.dll) and place it in the Custom folder of the folder for data files. "melhmi.exe" is the application window that executes projects which is stored in the folder for data files. For the application window, refer to "17.4.2 Launching the Application Window".

**17.3.2.2.4 Operation Procedure with Visual Studio 2022**

1. Start up Visual Studio 2022.

When using for the first time, refer to "17.3.2.1 Preparation for Visual Studio 2017/2019/2022" for the procedures for the required preparations.

2. Create a new project. Click "Create a new project".

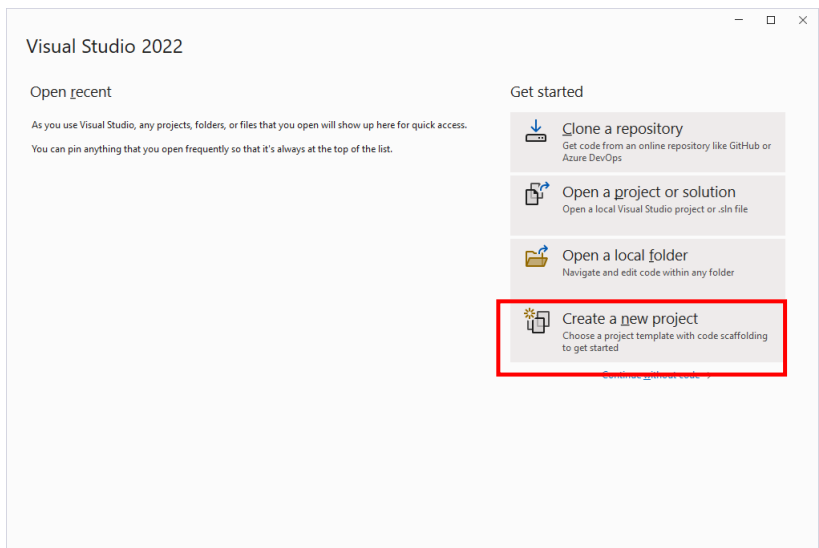

3. From the three pulldown menus, in order from the left, select "C++", "Windows", and "Console". Select "Empty Project" from the project templates displayed and click the [Next] button.

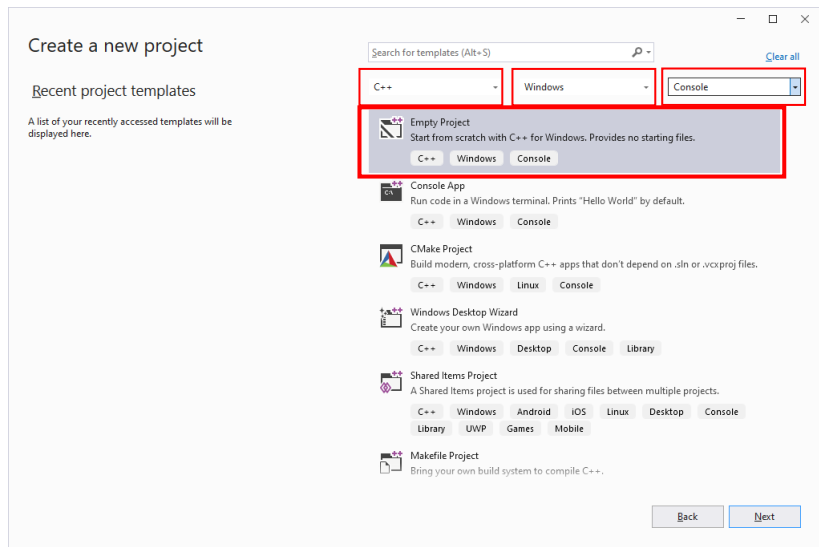

- Specify the Project/Solution names and Location, and click the [Create] button.

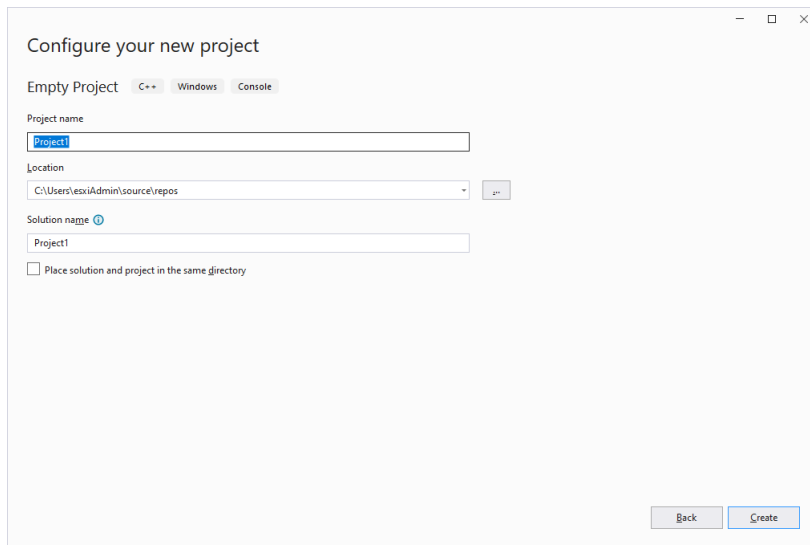

- Add the source file created with NC Designer2 to the project. From the [Projects] menu, select [Add Existing Item...] and all files (\*.cxx/\*.hxx/\*.prc/\*.c/\*.h/\*.def) generated with NC Designer2.
- In solution explorer, right-click the solution and select [Configuration Manager] to display the "Configuration Manager" dialog box.  
Select "x86" in "Active solution platform" at the top of the dialog, and "Win32" in "Platform" of the project.

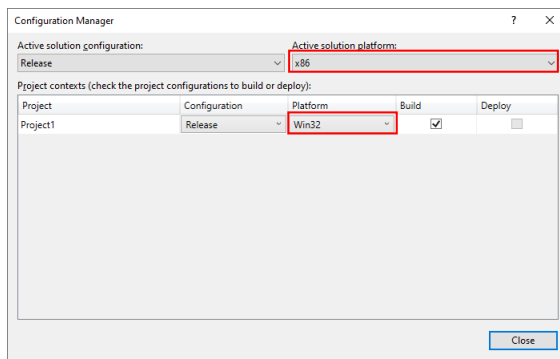



17. Application Execution Method

- In solution explorer, right-click the project name and select [Properties] to display the "Property Pages" dialog box.

Set each item as shown below.

Category	Item	Details
Configuration Properties - General	General Properties - Configuration Type	Dynamic Library (.dll)
	General Properties - Platform Toolset	For M700V/M70V/E70/M800/M80/E80 Series: Visual Studio 2010 (v100) For M800V/M80V Series: Visual Studio 2019 (v142)
Configuration Properties - Advanced	Advanced Properties - Character Set	Use Unicode Character Set

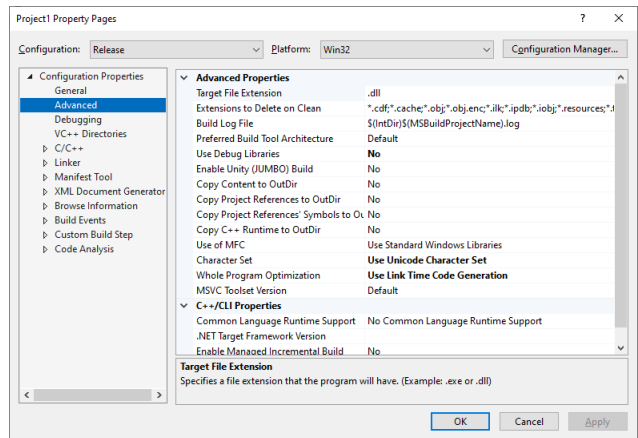
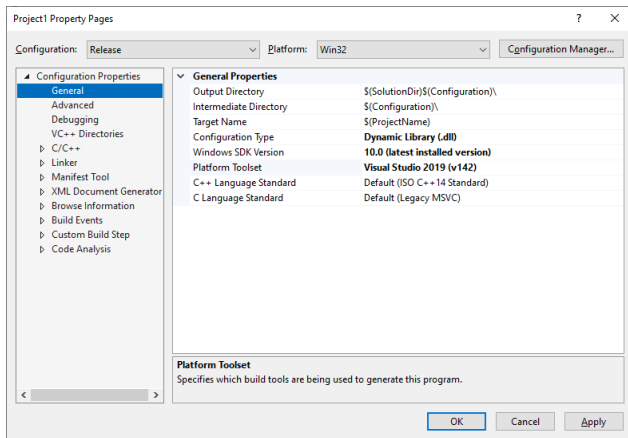

- Click [Apply]. After clicking [Apply], make sure that "Target File Extension" in the "Advanced Properties" section of "Advanced" is ".dll".

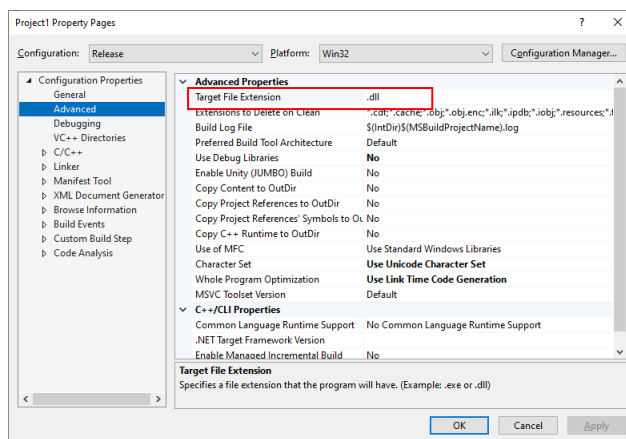

9. Change the settings as follows.

Category	Item	Details
Configuration Properties - C/C++ - General	Additional Include Directories	For M700V/M70V/E70 Series: C:\MELCNC\NCD2\M7\include For M800V/M80V/M800/M80/E80 Series: M800W/M800S/M80/E80: C:\MELCNC\NCD2\M8\include M800VW/M800VS/M80V: C:\MELCNC\NCD2\M8V\include
Configuration Properties - C/C++ - Preprocessor	Preprocessor Definitions	Select "<Edit...>" from the pulldown menu, enter the following in the dialog box that appears, and click [OK]. _UNICODE;UNICODE;NC_TYPE_NX
Configuration Properties - C/C++ - Code Generation	Runtime Library	Multi-thread (/MT)
Configuration Properties - C/C++ - Language	Treat WChar_t As Built in Type	No (/Zc:wchart_t-)
Configuration Properties - C/C++ - Advanced	Disable Specific Warnings	For M700V/M70V/E70/M800/M80/E80 Series: 4596 For M800V/M80V Series: 4596;4996
Configuration Properties - Linker - General	Additional Library Directories	For M700V/M70V/E70 Series: C:\MELCNC\NCD2\M7\lib\vc6\Release_Unicode For M800V/M80V/M800/M80/E80 Series: M800W/M800S/M80/E80: C:\MELCNC\NCD2\M8\lib\vs2010\Release M800VW/M800VS/M80V: C:\MELCNC\NCD2\M8V\lib\vsx\Release
Configuration Properties - Linker - Input	Additional Dependencies	Select "<Edit...>" from the pulldown menu, enter the following in the dialog box that appears, and click [OK]. For M700V/M70V/E70/M800/M80/E80 Series: gcs.lib;resmng.lib;gcwin.lib;genifa.lib;ncapi32.lib For M800V/M80V Series: gcs.lib;resmng.lib;gcwin.lib;genifa.lib;ncapi32.lib;legacy_stdio_definitions.lib
	Ignore Specific Default Libraries	For M700V/M70V/E70 Series: Libc.lib For M800V/M80V/M800/M80/E80 Series: Libc.lib;Libcmt.lib
	Module Definition File	Specify the path of "GPROJECT.def".
Configuration Properties - Linker - Advanced	Image Has Safe Exception Handlers	No (/SAFESEH:NO)

**NOTE**

- ◆ Custom API library in NC Designer2 installer is described in "Custom API Library Correspondence Table" in this manual. When using the custom API library of the supported version or later, change the following two path settings.
  - Configuration Properties - C/C++ - General Additional Include Directories
  - Configuration Properties - Linker - General Additional Library Directories

10. From the [Build] menu, select [Build Solution], and compile and link.
  
11. Copy the created library (\*.dll) and place it in the Custom folder for data files. "melhmi.exe" is the application window that executes projects and is stored in the folder for data files. For the application window, refer to "17.4.2 Launching the Application Window".

17.3.2.3 Operation Procedure with NC Compiler/NC Compiler2

1. Place the Makefile file in the same layer where the CPP folder, in which the source code has been generated, is placed.

The Makefile file sample is included in the SAMPLE MAKEFILE folder of the NC Designer2 software package.

2. Change the Makefile file sample as shown below.

```

# Makefile - Sample programs
#
# DESCRIPTION
# This file contains rules for building
#

# Path of application
APP_PATH =

# Module name
OUTMODL = NCD2_Test.o

# Definition of compiler option
CC = ccmips -EL -mips3 -mno-branch-likely -G 0
CC_OPTIM = -O2 -funroll-loops -fno-strict-aliasing -fforce-addr
CC_COMPILER = -std=c9x -pipe -c -fasm -fno-rtti
CC_DEFINES = -DCPU=$(CPU) -DTOOL=gnule -DMIPSEL -DGCC960 -DVXWORKS54
LOCAL_DEFINE = -D_UNICODE -DUNICODE -DNC_TYPE_NX -DNO_WINDOWS -D_NCDVxWorks -DRW_MULTI_THREAD \
               -D_REENTRANT -D_INTERPRETER_ -DGCC960 -DUNDER_VXW -DNDEBUG

# Path of NC Designer include file
LOCAL_INCLUDE = -I/MELCNC/NCD2/M8/include_VxW -I/MELCNC/NCD2/M8/include

C++_OPTION = -fno-for-scope -fno-builtin -fno-exceptions
CFLAGS = $(CC_OPTIM) \
          $(CC_COMPILER) $(CC_DEFINES) $(ADDED_CFLAGS) $(CC_INCLUDE) \
          $(LOCAL_DEFINE) $(LOCAL_INCLUDE) $(EXTRA_DEFINE) $(EXTRA_INCLUDE)

C++FLAGS = $(CFLAGS) $(C++_OPTION)

.
.
.

# Definition of linker option
LD = ld -mips -EL
LD_PARTIAL_FLAGS = -n -X -r

# Other definitions
RM = vxrm

# Peculiar header file path to the application
EXTRA_INCLUDE = -I$(APP_PATH)/Cpp

# Peculiar constant to application
EXTRA_DEFINE = -DNCDSSample

# Definition of link object
TGT_CPP = $(APP_PATH)/Cpp
TNGSCL = $(TGT_CPP)/GCNCD2_Test.cxx \
         $(TGT_CPP)/GCPanel00000.cxx \
         $(TGT_CPP)/GCWindow00001.cxx \
         $(TGT_CPP)/GCSampleScreen.cxx \
         $(TGT_CPP)/GLoc_Locale0.c \
         $(TGT_CPP)/GLoc_Locale1.c \
         $(TGT_CPP)/GResource.c

.
.
.
    
```

The NC Compiler basic settings are as follows.

Item	Setting value	Description
OUTMODL	***.o	Specify the module name to be generated.
LOCAL_INCLU DE	-I/MELCNC/NCD2/M7/include_VxW -I/MELCNC/NCD2/M7/include	Specify the path of the M7 header definition file.
TGT_CPP	CPP	Define the folder that contains the source file to be compiled.
TNGSCL	c,cxx,cpp file in CPP folder	Specify the source file to be compiled.

The NC Compiler2 basic settings are as follows.

Item	Setting value	Description
OUTMODL	***.o	Specify the module name to be generated.
LOCAL_INCLU DE	-I/MELCNC/NCD2/M8/include_VxW -I/MELCNC/NCD2/M8/include	Specify the path of the M8 header definition file.
	-I/MELCNC/NCD2/M8V/include_VxW -I/MELCNC/NCD2/M8V/include	Specify the path of the M8V header definition file.
TGT_CPP	CPP	Define the folder that contains the source file to be compiled.
TNGSCL	c,cxx,cpp file in CPP folder	Specify the source file to be compiled.

3. Start the command prompt.

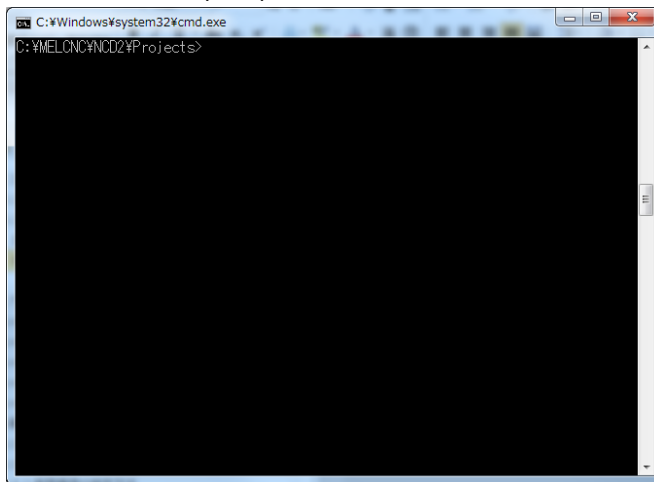

4. Specify the environment variables according to the procedure described in the NC Compiler/NC Compiler2 instruction manual.

5. Move to the folder that contains the Makefile file, then execute "make".

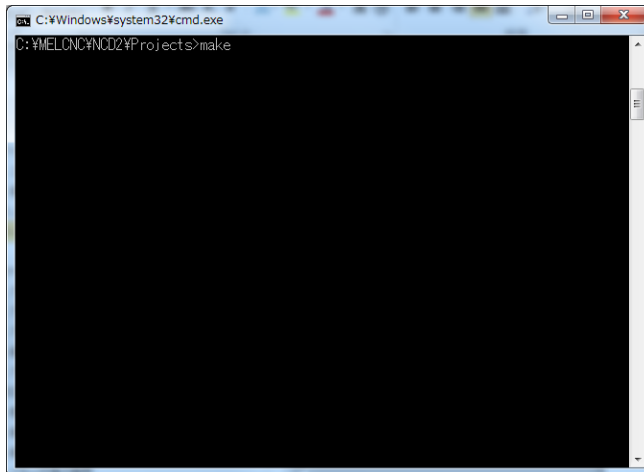

6. When "make" is finished, a module (o file) is generated in the same layer as for C.

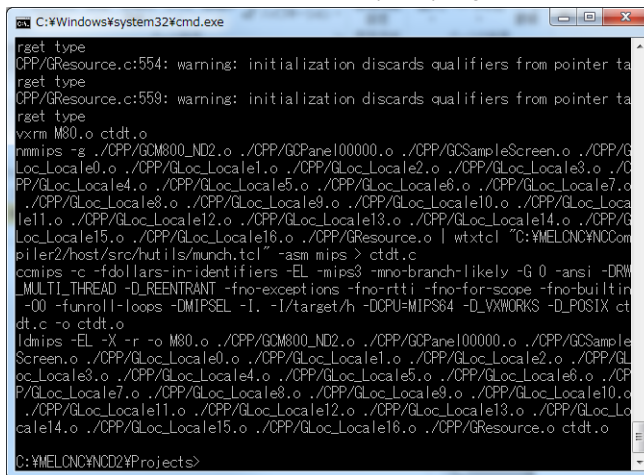

7. Install data in the display unit using SETUP INSTALLER. For information on SETUP INSTALLER, refer to "Appendix 10. Installing Custom Data (M700VS/M70V/E70)" and "Appendix 11. Installing Custom Data (M800V/M80V/M800/M80 (Windows-less display unit))".

## 17.4 Application Window

### 17.4.1 What Is Application Window?

The window displaying the created project is called application window. When executing an application, launch this application window to display panels and windows.

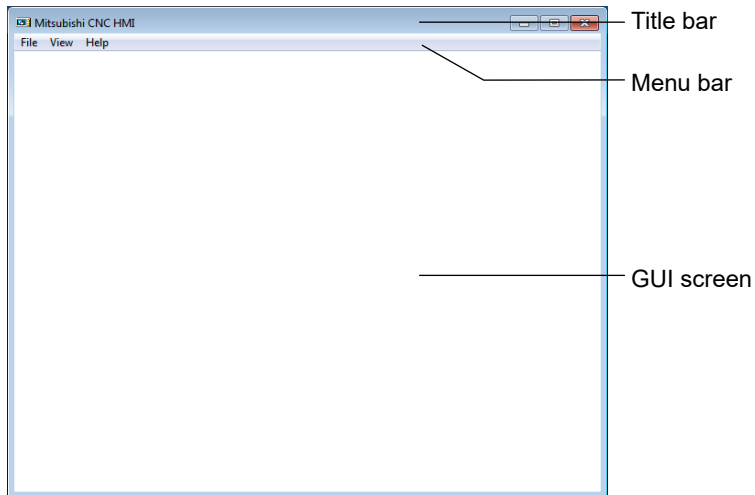

Item	Description
Title bar	The title of the application window is displayed. Specify presence of the title bar and the character string displayed as a title in the Config.ini file.
Menu bar	The menu of the application window is displayed. Presence of the menu bar can be specified in the Config.ini file.
GUI screen	The panels and windows of the created project are displayed and moved in this area.

### 17.4.2 Launching the Application Window

1. Open the folder for data file.

NC Designer2 is installed in the below folders.

For M700V/M70V/E70 Series: C:\MELCNC\NCD2\M7

For M800V/M80V/M800/M80/E80 Series:

M800W/M800S/M80/E80 C:\MELCNC\NCD2\M8

M800W/M800S/M80/E80 C:\MELCNC\NCD2\M8V

2. Double click on "melhmi.exe". After it is launched, the window shown below is displayed.

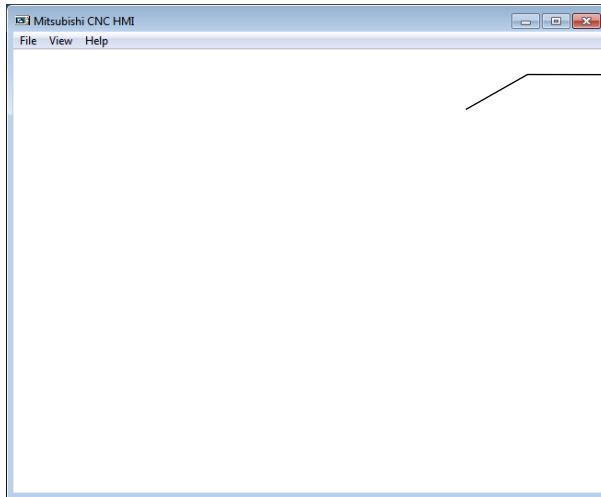

Project screen is displayed.

### 17.4.3 Functions of Application Window

A list of menu items of the application window and application of each item are shown below.

Item		Description
File	Open Project	The project opens. Only the interpreter method project (*.GIP) can be selected.
	Select Screen	Panels/windows open. For details, refer to Section "17.5 Screen Switching".
	Exit	The application window is closed.
View	Title Bar	The title bar is displayed and hidden alternately.
	Menu Bar	The menu bar is displayed and hidden alternately.
Help	About	The version of NC Designer2 is displayed.



### 17.4.4 Screen Configuration

Screen Element

The "page" created with NC Designer2 consists of a "panel" and "windows". (Refer to Section 2.2 "Specifications of NC Designer2".) In the application window, the panel and window can be displayed.

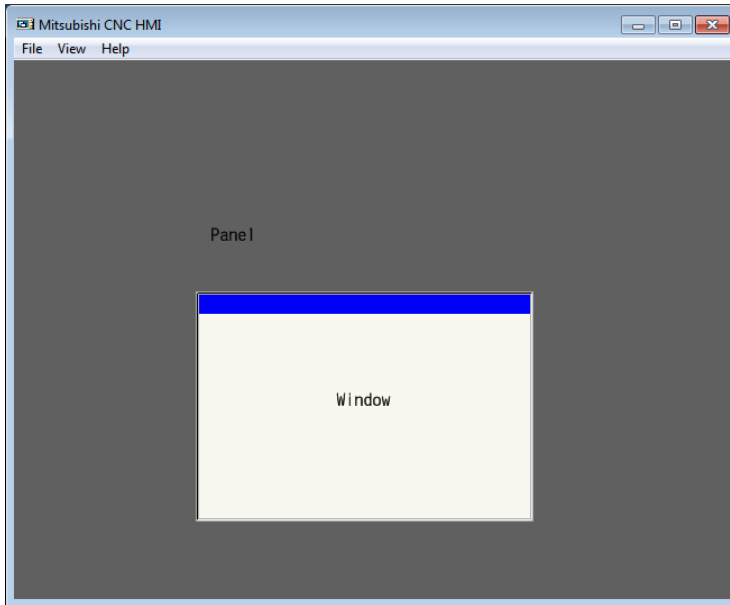

Item	Description
Panel	The panel is displayed in the full screen of the application window. Only one panel is displayed at a time.
Window	The window is displayed in the window state on the application window. Up to 10 windows can be displayed at a time.

Combination of Screen

The panel and window displayed on the application window can be set either in the interpreter or compilation method. Combination of both methods is allowed for the panel and windows, as well.

		Window	
		Interpreter method	Compilation method
Panel	Interpreter method	<input type="radio"/>	<input type="radio"/>
	Compilation method	<input type="radio"/>	<input type="radio"/>

### 17.4.5 Closing the Application Window

To close the application window, perform one of the following operations.

- From the [File] menu, select [Close].
- Click on the button in the title bar.
- Double click on the icon at the left end of the title bar.
- Click on the icon at the left end of the title bar and select [Close] from the displayed control menu box.
- While holding down the [Ctrl] key, press the [F12] key.

## 17.5 Screen Switching

### 17.5.1 Outline

The method for switching the screen (panel and window) displayed on the application window is described here.

### 17.5.2 Screen Switching Method

To switch the screen, there are three methods: use the screen switching dialog box of the application window, specify a screen switch event to the control, or use a macro.

#### Screen Switching Dialog Box

1. Launch the application window.
2. From the [File] menu, select [Open Screen]. The "Screen Selection" dialog box is displayed.
3. Designate a screen No. and press the "OK" button to switch the screen.

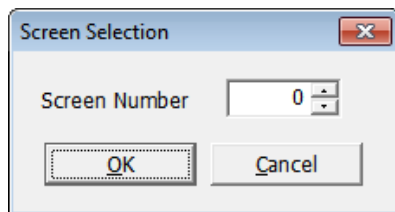

#### Macro

Specify a macro for screen switching to a control to switch the screen.

1. Open a project with NC Designer2 and create a control for setting screen switching. From the [Settings] menu, select [Panel macro edit] to open the "Macro edit" dialog box.
2. Specify the following macro in the created event. Press the [Event creation] button in the "Macro edit" dialog box and use the displayed "Event creation" dialog box to automatically specify the header and footer.

```
$GButton00000-OnClick  
    GCSGShowPanel(XX);  
$End
```

\* XX: Specify the new screen No. with the offset value added.

## Screen Switching Event (compilation method only)

Specify a screen switching event as a callback process of a control to switch the screen.

1. Open a project with NC Designer2 and create a control for setting screen switching event. Open properties of the control and specify "Yes" for the callback to which a screen switching event is to be specified.
2. Generate source codes and specify the following event for the callback created in step 1.

```
GESetEvent(GECreateEventMessage(GM_SHOWPANEL,  
                                GCSGetScreen(GetGBaseObject()), XX, 0), FALSE);
```

\* XX: Specify the new screen No. with the offset value added.

### 17.5.2.1 Changing From the Custom Screen to the Standard Screen (F0 Release)

By mounting the following macro processes in OnKeyPress function of the arranged control part on panel, it is possible to change the custom screen to the standard screen by inputting function key.

The page offset No. and the function key No. of each standard screen are as follows.

<The page offset No. of each standard screen>

Monitor screen offset No. : 1000  
 Setup screen offset No. : 2000  
 Edit screen offset No. : 3000  
 Diagnosis screen offset No. : 4000  
 Maintenance screen offset No. : 5000

<Function key No.>

Function key code for Monitor screen : F1(112) + SHIFT  
 Function key code for Setup screen : F2(113) + SHIFT  
 Function key code for Edit screen : F3(114) + SHIFT  
 Function key code for Diagnosis screen : F4(115) + SHIFT  
 Function key code for Maintenance screen : F5(116) + SHIFT

#### Interpreter Method

##### Macro

```
long _IShiftKey;           'SHIFT key  input status

'The SHIFT key input status is maintained in the 0th bit of LUPARAM.
_IShiftKey = LUPARAM & H1;

if((LLPARAM == 112) && (_IShiftKey == 1))           'Changing the screen to Monitor screen
    GCSGShowPanel(1000);
elseif((LLPARAM == 113) && (_IShiftKey == 1))      'Changing the screen to Setup screen
    GCSGShowPanel(2000);
elseif((LLPARAM == 114) && (_IShiftKey == 1))      'Changing the screen to Edit screen
    GCSGShowPanel(3000);
elseif((LLPARAM == 115) && (_IShiftKey == 1))      'Changing the screen to Diagnosis screen
    GCSGShowPanel(4000);
elseif((LLPARAM == 116) && (_IShiftKey == 1))      'Changing the screen to Maintenance screen
    GCSGShowPanel(5000);
endif;
```

## Compilation Method

## Source Code

```
#define KEY_SHIFT          0x01
#define GK_F1             112
#define GK_F2             113
#define GK_F3             114
#define GK_F4             115
#define GK_F5             116

if((ILParam & KEY_SHIFT) == KEY_SHIFT)
{
    if(ILParam == GK_F1)          //Changing the screen to Monitor screen
    {
        GSEvent(GECreateEventMessage(GM_SHOWPANEL,
        GCSGetScreen(GetGBaseObject()), 1000, 0), FALSE);
    }
    else if(ILParam == GK_F2)    //Changing the screen to Setup screen
    {
        GSEvent(GECreateEventMessage(GM_SHOWPANEL,
        GCSGetScreen(GetGBaseObject()), 2000, 0), FALSE);
    }
    else if(ILParam == GK_F3)    //Changing the screen to Edit screen
    {
        GSEvent(GECreateEventMessage(GM_SHOWPANEL,
        GCSGetScreen(GetGBaseObject()), 3000, 0), FALSE);
    }
    else if(ILParam == GK_F4)    //Changing the screen to Diagnosis screen
    {
        GSEvent(GECreateEventMessage(GM_SHOWPANEL,
        GCSGetScreen(GetGBaseObject()), 4000, 0), FALSE);
    }
    else if(ILParam == GK_F5)    //Changing the screen to Maintenance screen
    {
        GSEvent(GECreateEventMessage(GM_SHOWPANEL,
        GCSGetScreen(GetGBaseObject()), 5000, 0), FALSE);
    }
}
}
```

### 17.5.2.2 Changing the Menu Name While Displaying Custom Screen (Menu Release)

By using the GCSMenuSetMenuButtonLowerName\_all function, the menu name when the custom window (menu registered) is displayed can be changed.

<Screen images>

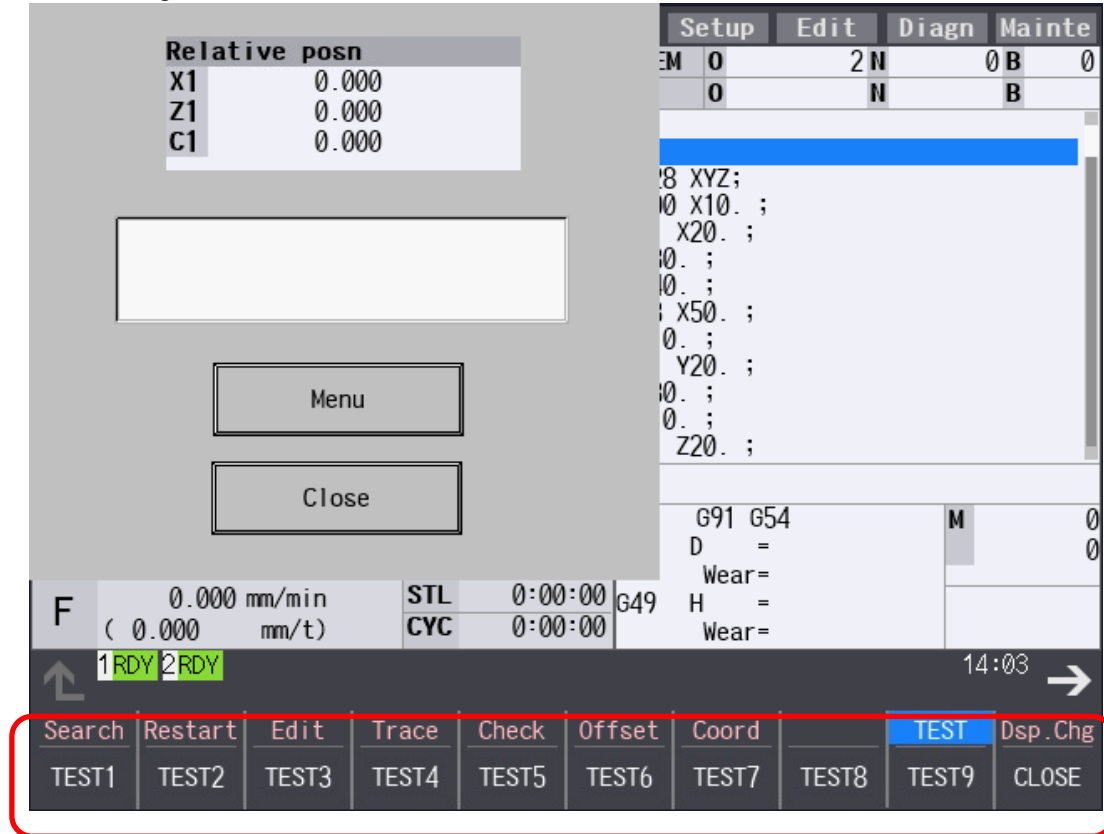

#### Interpreter Method

<GCSMenuSetMenuButtonLowerName\_all function format>  
 1st argument : The page offset No. added custom window  
     Monitor screen : 1000  
     Setup screen : 2000  
     Edit screen : 3000  
     Diagnostic screen : 4000  
     Maintenance screen : 5000  
 2nd argument : 0 fixed  
 3rd argument : 1 fixed  
 4th argument : Character string displayed in menu

#### Macro

```
GCSMenuSetMenuButtonLowerName_all(2000,0,1,
" TEST1, TEST2, TEST3, TEST4, TEST5, TEST6, TEST7, TEST8, TEST9, CLOSE");
```

**(Note 1)** The menu name can be displayed by seven characters a line and two columns, and can be displayed by 14 characters in total.

**(Note 2)** When eight characters or more are set to the menu name, the menu name is automatically displayed by two lines.

## Compilation Method

<GCSSetMenuButtonLowerName\_all function format (when all menu names are changed)>  
1st argument : Menu control part object pointer

It is necessary to acquire the menu control part object by GCSGetChild function beforehand.

When the menu control part object is acquire by GCSGetChild function, the following constant is specified for the 2nd argument of the GCSGetChild function according to the registered screen.

Monitor screen: 59

Setup screen: 38

Edit screen: 15

Diagnostic screen: 34

Maintenance screen: 5

2nd argument : 1 fixed

3rd argument : Character string displayed in menu pointer (10 pointers)

<GCSSetMenuButtonLowerName\_one function format (when one menu name is changed)>  
1st argument : Menu control part object pointer  
2nd argument : 1 fixed  
2nd argument : The menu No. changed menu name  
3rd argument : Character string displayed in menu pointer (1 pointer)

## Source Code

```
char* _psMenuString[10];
long _lParentType = 0;
GBaseObject* _pParent = GCSGetPanel(GCSGetScreen(GetGBaseObject()));
GBaseObject* _pGCNXMenuSub;

//Set the displayed character string
_psMenuString[0] = (char*)&L"TEST1";
_psMenuString[1] = (char*)&L"TEST2";
_psMenuString[2] = (char*)&L"TEST3";
_psMenuString[3] = (char*)&L"TEST4";
_psMenuString[4] = (char*)&L"TEST5";
_psMenuString[5] = (char*)&L"TEST6";
_psMenuString[6] = (char*)&L"TEST7";
_psMenuString[7] = (char*)&L"TEST8";
_psMenuString[8] = (char*)&L"TEST9";
_psMenuString[9] = (char*)&L" CLOSE ";

//Get the menu control part object
//Following XX values specify the following constant: Monitor = 59, Setup = 38, Edit = 15.
_pGCNXMenuSub = (GBaseObject*)GCSGetChild(_pParent, XX);

//Set the menu name
if( _pGCNXMenuSub != 0 )
{
    GCSSetMenuButtonLowerName_all(_pGCNXMenuSub, 1, _psMenuString);
}
}
```

- When only one menu name is changed, specifying it as follows.

```
//Set the menu name second from the left
GCSSetMenuButtonLowerName_one(_pGCNXMenuSub, 1, 2, &_psMenuString[1])
```



**17.5.2.3 Closing the Custom Screen (Menu Release)**

The GCSMenuSendProcessID function is used to close the custom window registered in the menu release. For the operation of an operation message, refer to "17.6.5.5 Settings of an operation message".

**Interpreter Method**

```
<GCSMenuSendProcessID function  format>
  1st argument : The page offset No. added custom window
                Monitor screen : 1000
                Setup screen  : 2000
                Edit screen   : 3000
                Diagnostic screen : 4000
                Maintenance screen : 5000
  2nd argument : 0 fixed
  3rd argument : 0 fixed
```

**Macro**

```
GCSMenuSendProcessID(2000,0,0);
```

**Compilation Method**

Issuing the user event by using GESetEvent function and GECREATEEVENTMESSAGE function closes the custom screen displayed by the menu release.  
The format of each function is as follows.

```
<GESetEvent function  format>
  1st argument : The return value of GECREATEEVENTMESSAGE function
  2nd argument : FALSE fixed

<GECREATEEVENTMESSAGE function  format>
  1st argument : GM_USER fixed
  2nd argument : Panel object pointer (The following refer to the getting method.)
  3rd argument : USNX_PROCESSID fixed
  4th argument : 0 fixed
```

**Source Code**

```
GBaseObject *_gbObj = GCSGetPanel(GCSGetScreen(GetGBaseObject()));
GESetEvent(GECREATEEVENTMESSAGE(GM_USER, _gbObj,
                                USNX_PROCESSID, 0), FALSE);
```

### 17.5.3 Screen No. Designation Method

The screen No. designated for screen switching varies between screen switching in the same project and that across different projects.

Suppose the following two projects.

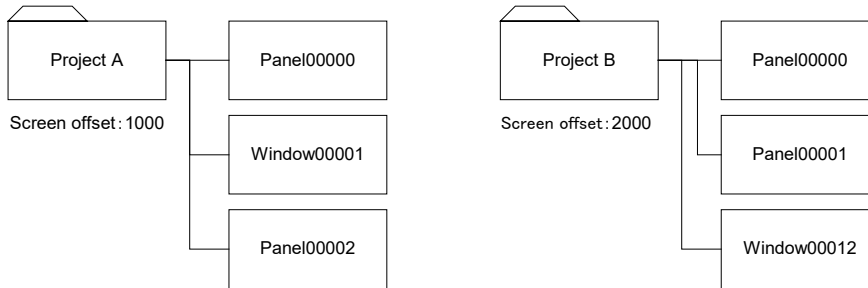

To switch the screen in the same project, designate the screen No. specified in NC Designer2. For example, to switch the screen from "Panel00000" to "Panel00002" in project A, specify screen number "2".

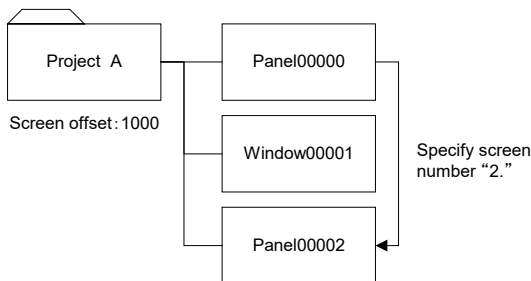

To switch the screen across different projects, designate the sum of the screen number and the screen offset value for each project as a screen number.

To switch the screen from project A to "Window 00012" of project B, specify screen No. "2012".

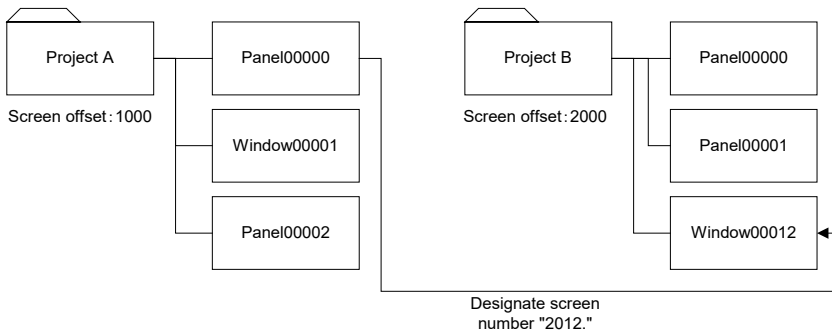

A summary of screen No. examples designated when the screen is switched is shown below.

Project A (screen offset: 1000)

Screen No.	Screen name	Screen switched in same project	Screen switched across different projects
0000	Panel00000	0	1000
0001	Window00001	1	1001
0002	Panel00002	2	1002

Project B (screen offset: 2000)

Screen No.	Screen name	Screen switched in same project	Screen switched across different projects
0000	Panel00000	0	2000
0001	Panel00001	1	2001
0012	Window00012	12	2012

### 17.5.4 Panel Switching History

NC Designer2 stores the history of switched panels when screens are switched between panels. The specifications related to panel switching history are shown below.

Item	Specification
Max. records	32
Storage method	Ring buffer method After the maximum number of records (32) is exceeded, the oldest record is deleted and the new record is saved.

**NOTE**

- ◆ Only panel-to-panel switching is recorded. Window display or view frame switching is not recorded.

Panel Switching Using the History

The panel switching history can be used to restore the display panel or advance it. Use a function or macro to operate.

Item	Function/macro to be used
Restore	Function: GCSPrevPage Macro: GCSPrevPage
Advance	Function: GCSNextPage Macro: GCSNextPage

**NOTE**

- ◆ For the usage of the macro, refer to "NC Designer2 Macro Function Manual" (IB-1501500).

### 17.5.5 Displaying Previously Displayed Custom Screen

If you wish to display a previously displayed custom screen by inputting a function key, you need to define the offset No. (6000 to 7999) of the custom release screen to be held as the previously displayed screen. To define this No., specify the No. using commas as a delimiter in the "PANEL\_HOLDXX" key of the [COFFSET] section in the customdef.ini file.

The examples below are not to hold and hold the screen No. using a function (F0) key.

Example)

config.ini

```
[INTERPRETER]
RUN=1
PROJECT01=D:\custom\TESTPANEL01.GIP
PAGE_OFFSET01=6000

[MODULE]
NUM=1
MODULE_NAME01=D:\custom\TESTPANEL02.dll
PAGE_OFFSET01=7000

(The rest is omitted)
```

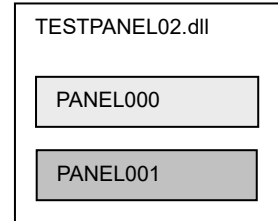
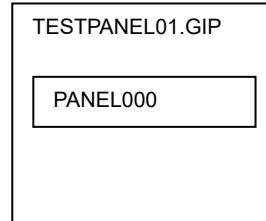

Example 1) Not hold the screen No.

customdef.ini

```
[COFFSET]
FUNC_ID01=1
PANEL_OFFSET01=7000

(The rest is omitted)
```

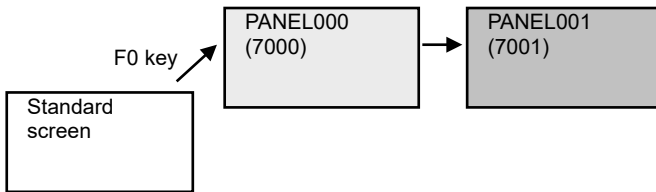

1. When the F0 key is pressed, the screen displays PANEL000.
2. Change the screen from PANEL000 to PANEL001, and then change back to the standard screen.
3. When F0 is pressed again, the screen displays PANEL000.

Example 2) Hold the screen No. within the same project

<Example 2-1>

customdef.ini

```
[COFFSET]
FUNC_ID01=1
PANEL_OFFSET01=7000
PANEL_HOLD01=7000

(The rest is omitted)
```

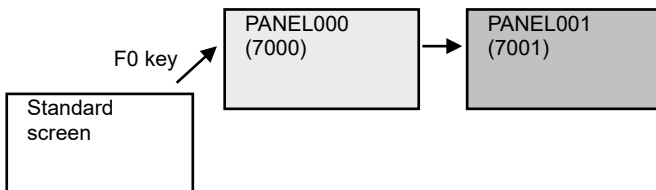

1. When the F0 key is pressed, the screen displays PANEL000.
2. Change the screen from PANEL000 to PANEL001, and then change back to the standard screen.
3. When the F0 key is pressed again, the screen displays **PANEL000**.

<Example 2-2>

customdef.ini

```
[COFFSET]
FUNC_ID01=1
PANEL_OFFSET01=7000
PANEL_HOLD01=7000-7001

(The rest is omitted)
```

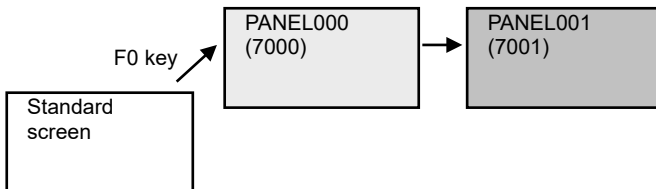

1. When the F0 key is pressed, the screen displays PANEL000.
2. Change the screen from PANEL000 to PANEL001, and then change back to the standard screen.
3. When the F0 key is pressed again, the screen displays **PANEL001**.

Example 3) Hold the screen No. of other project  
customdef.ini

```
[COFFSET]
FUNC_ID01=1
PANEL_OFFSET01=7000
PANEL_HOLD01=7000-7001,6000

(The rest is omitted)
```

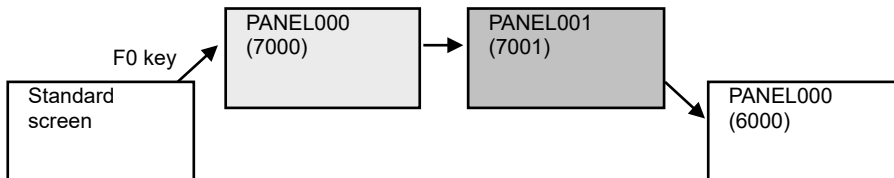

1. When the F0 key is pressed, the screen displays PANEL000(7000).
2. Change the screen from PANEL000(7000) to PANEL001(7001), from PANEL001(7001) to PANEL000(6000), and then change back to the standard screen.
3. When the F0 key is pressed again, the screen displays PANEL000(6000).

When the following macro process is added to the screen change process, the custom screen to be displayed by inputting a function key can be the one that was previously displayed.

#### Interpreter Method

<GCSGetLastPanelNumber function format>

1st argument: Function key (0 to 3)

#### Macro

```
LONG _IPanelNumber = GCSGetLastPanelNumber(0)
GCSGEShowPanel(_IPanelNumber);
```

#### Compilation Method

<GCSGetLastPanelNumber function format>

1st argument: Module screen object pointer (see below for how to get)

2nd argument: Function key (0 to 3)

#### Source Code

```
GBaseObject *_pScreenObj = GCSGetModuleScreen();
long _IPanelNumber = GCSGetLastPanelNumber(_pScreenObj, 0);
GSESetEvent(GECreateEventMessage(GM_SHOWPANEL, GCSGetScreen(GetGBaseObject()),
_IPanelNumber, 0), FALSE);
```

## 17.6 Custom Release

### 17.6.1 Outline

Custom release is a function which allows the user-original window to display as a standard screen or another screen to operation. This function is optional. (For some models such as M80 and M70V, this function is standard.)

Screen customization includes, mainly, F0 assignment, menu assignment, screen part assignment and selectable display assignment:

**F0 release:** Custom release screen (Note 1) can be registered to function keys (F0, SEP, window display, window selection).  
When a function key is pressed, the registered custom release screen will be displayed.  
This type can be registered with "NC Designer2 interpreter method", "NC Designer2 compilation method" and "Executing file registration method" (Note 3).

**Menu release:** Custom release window (Note 2) can be registered in the main menu of the monitor screen, setup screen, edit screen, diagnostic screen, and maintenance screen.  
When the registered menu is pressed, the custom release window will be displayed.  
This type can be registered with "NC Designer2 interpreter method", "NC Designer2 compilation method" and "Executing file registration method" (Note 3).  
Depending on the conditions, display/non-display of the custom menu can be changed.  
Main menu contents of the monitor, setup, edit, diagnostic, and maintenance screen can be rearranged.

**Screen part assignment:** Customized window which is created with "NC Designer2 interpreter method" or "NC Designer2 compilation method" can be displayed as a part of the standard screen.

**Selectable display assignment:** Customized window that is created with "NC Designer2 interpreter method" or "NC Designer2 compilation method" can be displayed on the selectable display area of the monitor screen. In the same way as the selectable display of the standard screen, designated customized window (menu assignment) opens by pressing the input key.

**(Note 1)** An HMI screen originally created with NC Designer2 by the user or an execution file prepared by the user.

(Note that an execution file prepared by the user cannot be used in M800V/M80V/M800/M80 (Windows-less display unit) and M700VS/M70V/E70.)

**(Note 2)** An HMI window originally created with NC Designer2 by the user or an execution file prepared by the user.

(Note that an execution file prepared by the user cannot be used in M800V/M80V/M800/M80 (Windows-less display unit) and M700VS/M70V/E70.)

**(Note 3)** "Executing file registration method" cannot be used in M800V/M80V/M800/M80 (Windows-less display unit) and M700VS/M70V/E70.

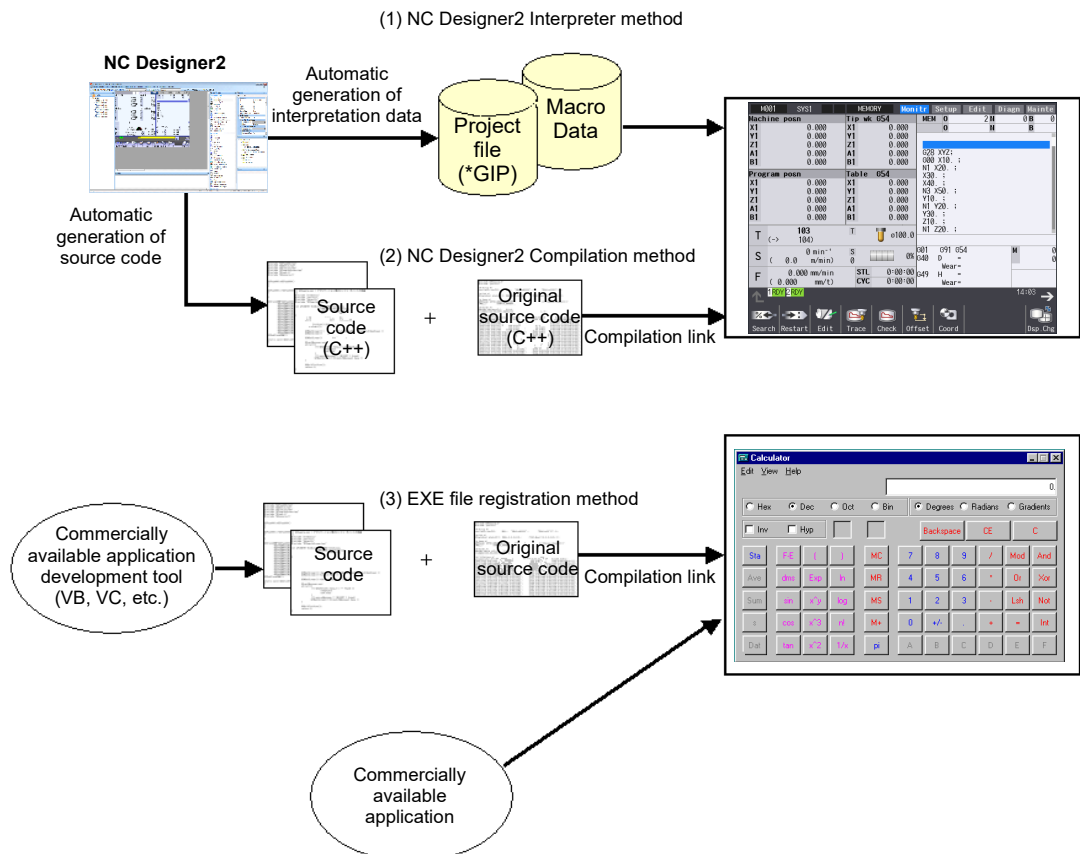

- (1) NC Designer2 interpreter method (GIP method)
 

The interpreter data automatically generated with NC Designer2 can be displayed as an operation screen.

When a simple screen is displayed by using the control that NC Designer2 provides with, this method is suitable.
- (2) NC Designer2 compilation method (DLL method)
 

The DLL is created by editing the source code automatically generated by NC Designer2 and compilation/linking.

The created DLL can be displayed as an operation screen.

When complex processing is executed by using the control that NC Designer2 provides with, this method is suitable.
- (3) Executing file registration method (EXE method)
 

The execution file (EXE file) originally developed can be displayed as an operation screen.

When an original operation screen is created without using the control that NC Designer2 provides with, this method is suitable.

(Note that the executing file registration method cannot be used in M800V/M80V/M800/M80 (Windows-less display unit) and M700VS/M70V/E70.)

Each feature is shown below.

	NC Designer2 interpreter method	NC Designer2 compilation method	Executing file registration method
Creation	◎	○	△
Process speed	△	◎	◎
Flexibility	△	○	◎
Functions	△	○	◎



**17.6.2 S/W Configuration**

**17.6.2.1 Necessary Applications**

The following applications are needed for custom release according to the method.

Release method	NC Designer2	Application
Interpreter method	○	-
Compilation method	○	○ *1
Executing file registration method (M800V/M80V/M800/M80 (Windows-less display unit))	-	△ (Only when the application is developed by using VC++.)
Changed the arrangement of the main menu	-	-

○...Necessary    -...Not necessary    △...Necessary according to the usage

\*1 The following application is needed by the display unit used.

<When using M800V/M80V/M800/M80 (Windows-based display unit) and M700VW>

- Visual Studio C++ compiler for Windows

The following are the versions where operation has been confirmed.

Microsoft Visual Studio 2010 Professional Version 10.0.40219.1 SP1 Rel

Microsoft Visual Studio Professional 2017 Version 15.9.29

Microsoft Visual Studio Professional 2019 Version 16.8.0

Microsoft Visual Studio Professional 2022 Version 17.2.5

<When using M800V/M80V/M800/M80 (Windows-less display unit)>

- NC Compiler2

<When using M700VS/M70V/E70>

- NC Compiler

### 17.6.2.2 Necessary Files

The necessary files are as follows for custom release.

File name	Usage	Storage folder <sup>(Note1)</sup>
Config.ini	This is used when the DLL file and the GIP file are registered as an operation screen.	<ul style="list-style-type: none"> <li>- When using M800V/M80V/M800/M80 (Windows-based display unit) and M700VW D:\Custom\</li> <li>- When using M800V/M80V/M800/M80 (Windows-less display unit) and M700VS/M70V/E70 /custom/</li> </ul>
melAppCtrl.ini	This is used when the execution file is registered as an arbitrary key.	<ul style="list-style-type: none"> <li>- When using M800V/M80V/M800/M80 (Windows-based display unit) and M700VW D:\Custom\</li> <li>- When using M800V/M80V/M800/M80 (Windows-less display unit) and M700VS/M70V/E70 /custom/</li> </ul>
customdef.ini	This is used when the following cases. <ul style="list-style-type: none"> <li>- When the custom release window is added by menu release.</li> <li>- When the custom release window is added by F0 release (Excluding executing file registration method).</li> </ul> <b>(Note)</b> Describe it by Unicode (UTF-16 LE) text.	<ul style="list-style-type: none"> <li>- When using M800V/M80V/M800/M80 (Windows-based display unit) and M700VW D:\Custom\</li> <li>- When using M800V/M80V/M800/M80 (Windows-less display unit) and M700VS/M70V/E70 /custom/</li> </ul>
*.png or *.jpg	This is a picture file of the icon displayed in the main menu at the menu release. Png files are available only for M8V Series. A png file whose background is transparent is recommended.	<ul style="list-style-type: none"> <li>- When using M800V/M80V/M800/M80 (Windows-based display unit) and M700VW D:\Custom\img\</li> <li>- When using M800V/M80V/M800/M80 (Windows-less display unit) and M700VS/M70V/E70 /custom/</li> </ul>
*.DLL	This is custom screen data file created by compilation method.	<ul style="list-style-type: none"> <li>- When using M800V/M80V/M800/M80 (Windows-based display unit) and M700VW D:\Custom\</li> <li>- When using M800V/M80V/M800/M80 (Windows-less display unit) and M700VS/M70V/E70 /custom/</li> </ul>
*.GIP and same name folder	This is custom screen data file created by interpreter method.	<ul style="list-style-type: none"> <li>- When using M800V/M80V/M800/M80 (Windows-based display unit) and M700VW D:\Custom\</li> <li>- When using M800V/M80V/M800/M80 (Windows-less display unit) and M700VS/M70V/E70 /custom/</li> </ul>
*.EXE	This is an execution file registered by the executing file registration method.	<ul style="list-style-type: none"> <li>- When using M800V/M80V/M800/M80 (Windows-based display unit) and M700VW D:\Custom\</li> <li>- When using M800V/M80V/M800/M80 (Windows-less display unit) and M700VS/M70V/E70 /custom/</li> </ul>

**(Note 1)** The storage folder is different according to the display unit used.

**(Note 2)** When M800V/M80V/M800/M80 (Windows-less display unit) and M700VS/M70V/E70 is used as a display unit, this is stored in a folder by using SETUP INSTALLER. For information on SETUP INSTALLER, refer to "Appendix 10. Installing Custom Data (M700VS/M70V/E70)" and "Appendix 11. Installing Custom Data (M800V/M80V/M800/M80 (Windows-less display unit))".

The necessary file of each method is as follows.

Release method	Config.ini	melAppCtrl.ini	customdef.ini	*.png or *.jpg	*.DLL	*.GIP	*.EXE
Interpreter method (F0 release)	○	-	○	-	-	○	-
Compilation method (F0 release)	○	-	○	-	○	-	-
Executing file registration method (F0 release)	-	○	-	-	-	-	○
Interpreter method (Menu release)	○	-	○	○	-	○	-
Compilation method (Menu release)	○	-	○	○	○		-
Executing file registration method (Menu release)	-	-	○	○	-	-	○
Changed the arrangement of the main menu	-	-	○		-	-	-

○...Necessary to prepare or edit

-...Not necessary to prepare or edit

17.6.3 Development Procedure of Custom Release S/W

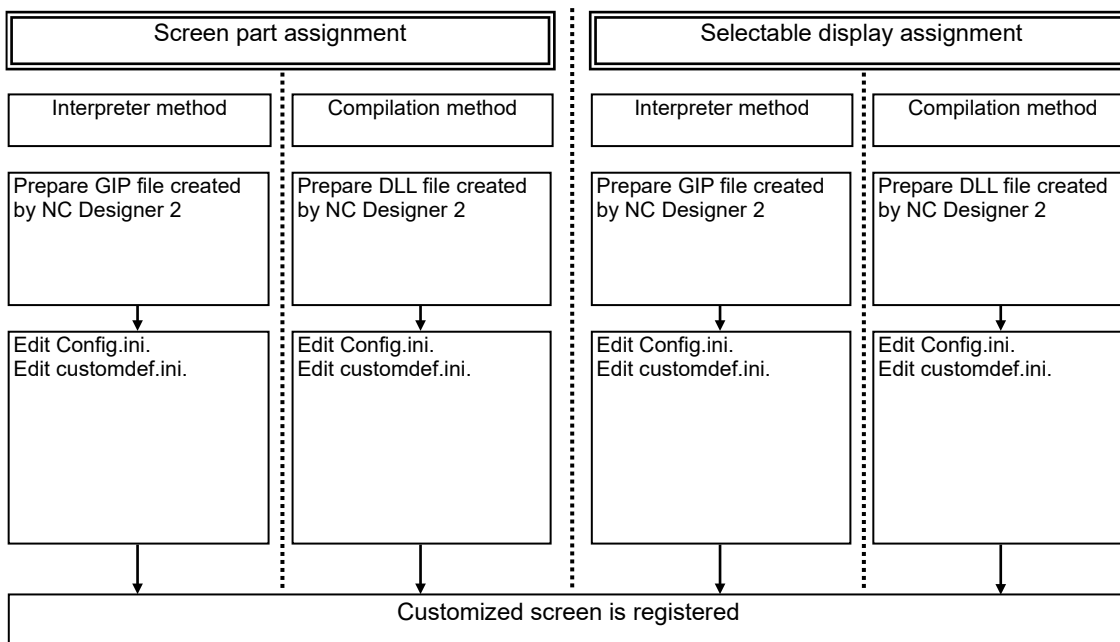
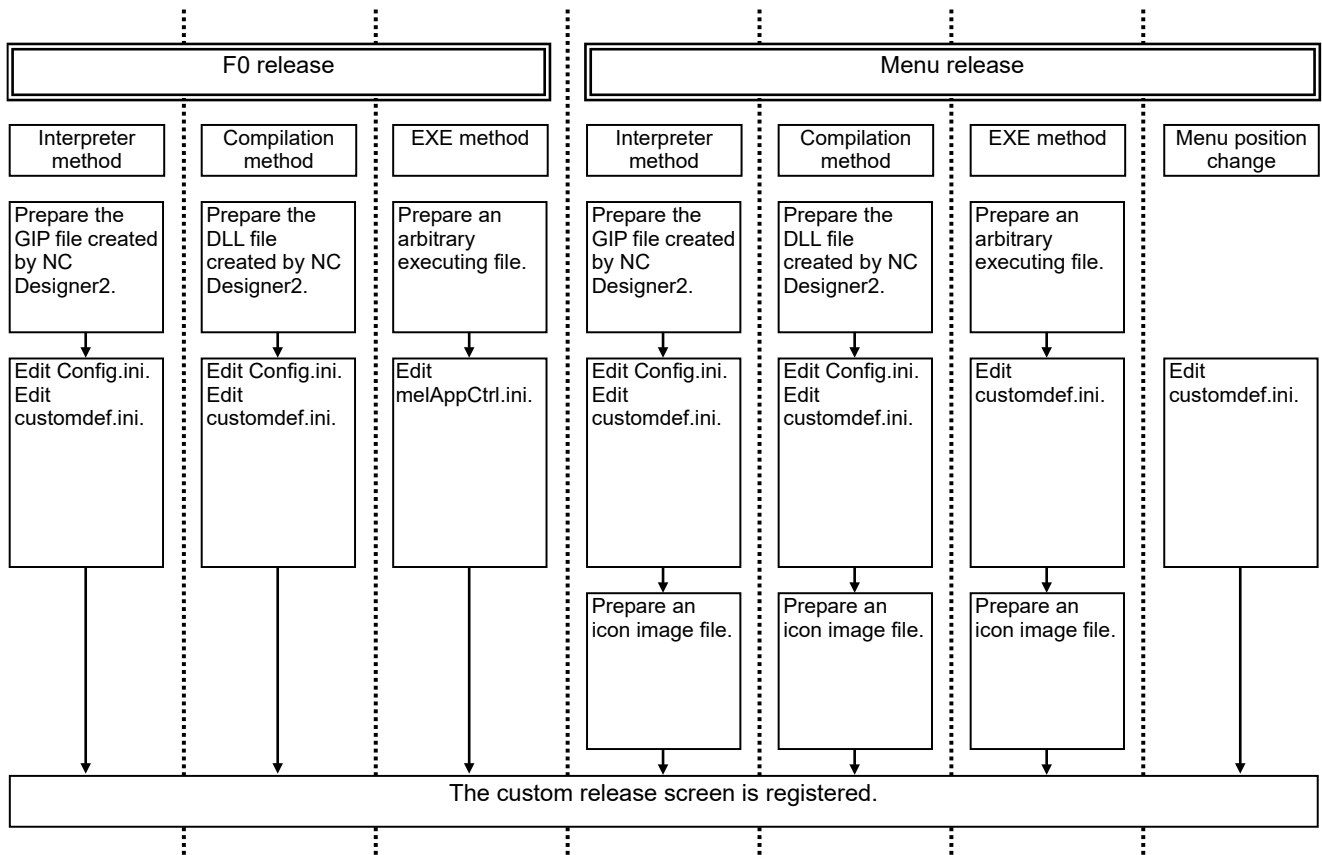

### 17.6.4 F0 Release

In the F0 release, the screen of the custom release created with NC Designer2 or the execution file originally prepared can be registered to the function key.

#### 17.6.4.1 Interpreter Method



To register the interpreter method data to the function key, it is necessary to edit Config.ini and customdef.ini. Use "17.7 Custom Release File Setting" to create them easily. The customdef.ini has to be described by Unicode (UTF-16 LE) text.

##### 17.6.4.1.1 Config.ini

Example of setting

[INTERPRETER]	
RUN=2	;<- Set 2 because PROJECT is registered up to 02.
PROJECT01=PANEL.GIP	;<- When registering the custom release screen
PAGE_OFFSET01=6500	;<- The offset No. is from 6000 to 7000.
PROJECT02=WINDOW.GIP	;<- When registering the custom release window
PAGE_OFFSET02=8000	;<- The setting range of offset No. is from 8000 to 9700.

Edit the following item of the [INTERPRETER] section.

Key name	Details
RUN	<ul style="list-style-type: none"> <li>This sets the number of projects executed by the interpreter method.</li> <li>The number of projects which can be registered is up to ten.</li> <li>Only one project can be registered when the project macro is used.</li> <li>Up to 256 screens and windows can be created for one project.</li> </ul> <p>Setting range : 0 to 10</p>
PROJECTXX (XX = 01 to 10)	<ul style="list-style-type: none"> <li>This sets the GIP file of the startup project by full path.</li> </ul> <p><b>Ex.)</b> &lt;When using M800V/M80V/M800/M80 (Windows-based display unit) and M700VW&gt; PROJECT01=D:\custom\Test.GIP &lt;When using M800V/M80V/M800/M80 (Windows-less display unit) and M700VS/M70V/E70&gt; PROJECT01=/custom/Test.GIP</p> <p><b>(Note 1)</b> Number the end of the key name from 01 sequentially. <b>(Note 2)</b> If the GIP file which does not exist in PROJECT is set, the screen and the window included in the GIP file registered after set cannot be displayed.</p>
PAGE_OFFSETXX (XX = 01 to 10)	<ul style="list-style-type: none"> <li>This is an offset value added to the screen No. in each project. "Screen No. in the project + Offset value" is a screen No. specified when the screen is changed between different projects.</li> <li>Use the offset No. within the following ranges when the custom screen is registered to the function key. Setting range : 6000 to 7700</li> <li>The number of function key which can be registered is four as follows. <ul style="list-style-type: none"> <li>SFP</li> <li>Window display </li> <li>F0</li> <li>Window selection </li> </ul> </li> <li>In assigning customized window to a main menu key as screen part assignment and selectable display assignment, set the offset No. in the following range. Setting range : 8000 to 9700</li> </ul> <p><b>(Note 1)</b> When the screen (window) is created by NC Designer2, number it in order of creation. <b>(Note 2)</b> Do not set the offset No. outside the above-mentioned setting range. <b>(Note 3)</b> Match the No. of the PROJECT key end and the No. of the PAGE_OFFSET key end. <b>(Note 4)</b> Leave space about 256 or more about the first offset No. and the second offset No. when two or more offset Nos. are registered. (Example: The first project : 7000, The second project : 7256, and The third project : 7512.)</p>

Edit the following item of the [PROJECT] section when the project macro is used.

Key name	Details
CYCLIC_MACRO	<ul style="list-style-type: none"> <li>Set the GMC file of the startup project macro by full path.</li> <li>One project macro can be registered.</li> </ul> <p><b>Ex.)</b> &lt; When using M800V/M80V/M800/M80 (Windows-based display unit) and M700VW&gt; CYCLIC_MACRO=D:\custom\Test\Macro\Test.GMC &lt; When using M800V/M80V/M800/M80 (Windows-less display unit) and M700VS/M70V/E70 &gt; CYCLIC_MACRO=/custom/Test/Macro/Test.GMC</p>

17.6.4.1.2 customdef.ini

Example of setting

```

; • When registering the screen (PANEL on NCDesigner2) to the function key
; Set 6500 to the offset No. of F0 key
; The previously displayed screen displays screens that the offset No. is from 6500 to 6999.
[COFFSET]
NUM=1
FUNC_ID01=1
PANEL_OFFSET01=6500
PANEL_HOLD01=6500-6999
    
```

Edit the following item of the [COFFSET] section.

Key name	Details
NUM	<p>This sets the number of registration of F0 release (excluding the executing file registration method).</p> <p>Setting range : 0 to 4 Default : 0</p>
FUNC_IDXX (XX = 01 to 04)	<p>This designates the function key registering the custom release screen.</p> <p>Setting range : 0 to 3 0 : SFP key 1 : F0 key 2 : Window display key 3 : Window selection key</p>
PANEL_OFFSETXX (XX = 01 to 04)	<p>This designates the offset No. of the custom release screen registered to the function key. Designate the offset No. registered in Config.ini.</p> <p>Setting range : 6000 to 7999</p>
PANEL_HOLDXX (XX=01 to 04)	<p>Specify the previously displayed custom screen, if you wish to display it again by inputting a function key. Use this key when a custom release screen is made up of more than one screen (panel), and you wish to display the previously displayed screen again.</p> <p>(Note 1) This key is enabled for NC Designer2 interpreter method or NC Designer2 compilation method. (Note 2) A window cannot be held. (Note 3) Do not include an unnecessary character such as a space in the setting value.</p> <p>Setting range : Maximum number of characters = 64 (Specify the offset No. between 6000 and 7999) Specify the offset No. of the custom screen to be held as a previously displayed screen, using commas as a delimiter. There are two types of methods to specify the offset No., individual designation and range designation. The formats are as follows.</p> <p>Individual designation = (Offset No.),(Offset No.),(Offset No.),... Range designation = (Offset No. – Offset No.),...</p> <p>Default: Not hold Setting example : PANEL_HOLD01=6001,6003,6004-6008,6010,6050</p>

**(Note 1)** When the NUM key is 1 or more, the FUNC\_ID key and PANEL\_OFFSET key are required items and must always be set.

**(Note 2)** When a symbol ";" is at the head of the line, the character string is judged to be a comment.

**(Note 3)** Do not insert the spaces before and behind " = " between the key and the setting value.

### 17.6.4.2 Compilation Method

To register the compilation method data in the function key, it is necessary to edit Config.ini and customdef.ini. Use "17.7 Custom Release File Setting" to create them easily.  
The customdef.ini has to be described by Unicode (UTF-16 LE) text.



#### 17.6.4.2.1 Config.ini

Example of setting

```
[MODULE]
NUM =2 ;<- Set 2 because MODULE_NAME is registered up to 02.
MODULE_NAME01=WINDOWDLL.DLL ;<- When registering the custom release screen
PAGE_OFFSET01=7000 ;<- The setting range of offset No. is from 6000 to 7700.
MODULE_NAME02=PANELDLL.DLL ;<- When registering the custom release window
PAGE_OFFSET02=9000 ;<- The setting range of offset No. is from 8000 to 9700.
```



Edit the following item of the [MODULE] section.

Key name	Details
NUM	<ul style="list-style-type: none"> <li>This sets the number of projects executed by the compilation method.</li> <li>The number of projects which can be registered is up to three.</li> <li>Up to 256 screens and windows can be created for one project.</li> </ul> <p>Setting range : 0 to 3</p>
MODULE_NAMEXX (XX = 01 to 03)	<ul style="list-style-type: none"> <li>For M800V/M80V/M800/M80 (Windows-based display unit) and M700VW, this sets the DLL file of the startup project by full path. <b>Ex.)</b> MODULE_NAME01=D:\custom\Test.DLL</li> <li>For M800V/M80V/M800/M80 (Windows-less display unit) and M700VS/M70V/E70, this sets the project name of NC Designer2. <b>Ex.)</b> MODULE_NAME01=/custom/Test.DLL</li> </ul> <p><b>(Note 1)</b> Number the end of the key name from 01 sequentially. <b>(Note 2)</b> If the file which does not exist in MODULE_NAME is set, the screen and the window included in the file registered after set cannot be displayed.</p>
PAGE_OFFSETXX (XX = 01 to 03)	<ul style="list-style-type: none"> <li>This is an offset value added to the screen No. in each project. "Screen No. in the project + Offset value" is a screen No. specified when the screen is changed between different projects.</li> <li>Use the offset No. within the following ranges when the custom screen is registered to the function key. Setting range : 6000 to 7700</li> <li>The number of function key which can be registered is four as follows. <ul style="list-style-type: none"> <li>SFP</li> <li>F0</li> <li>Window display </li> <li>Window selection </li> </ul> </li> <li>In assigning customized window to a main menu key as screen part assignment and selectable display assignment, set the offset No. in the following range. Setting range : 8000 to 9700</li> </ul> <p><b>(Note 1)</b> When the screen (window) is created by NC Designer2, number it in order of creation. <b>(Note 2)</b> Do not set the offset No. outside the above-mentioned setting range. <b>(Note 3)</b> Match the No. of the MODULE_NAME key end and the No. of the PAGE_OFFSET key end. <b>(Note 4)</b> Leave space about 256 or more about each offset No. when multiple offset Nos. are registered. (Example: The first project: 7000, The second project: 7256, The third project: 7512)</p>

17.6.4.2.2 customdef.ini

Refer to 17.6.4.1.2.

**17.6.4.3 Switching of "Onboard" and "Execution File by F0 Release" by Bit Selection Parameter (#6451 bit0)**

By the bit selection parameter "#6451 bit0 (Onboard ON)", whether to start the onboard or the execution file by the F0 release can be selected with the F0 key. When #6451 bit0 (Onboard ON) is 1, the onboard starts. When #6451 bit0 is 0, the executing file by F0 release starts. However, when the executing file is not registered even if #6451 bit0 (Onboard ON) is 0, the input of F0 key is ignored.

**(Note 1)** Refer to 17.6.4.1 and 17.6.4.2 for registration of the executing file to F0 key.

**(Note 2)** The setting of the executing file registration method is given to priority when both the interpreter/compilation method and the executing file registration method are registered.

**(Note 3)** For M800V/M80V/M800/M80 (Windows-less display unit) and M700VS/M70V/E70, this function is enabled only when the standard screen is displayed.

Refer to Appendix 8. for the executing file registration method.

### 17.6.5 Menu Release

In the menu release, the window of the custom release created with NC Designer2 or the execution file originally prepared can be registered in the main menu of the monitor screen, setup screen, edit screen, diagnostic screen, and maintenance screen.

Main menu contents of the monitor, setup, edit, diagnostic, and maintenance screen can be rearranged.

#### 17.6.5.1 Interpreter Method

To register the interpreter method data to the function key, it is necessary to edit Config.ini and customdef.ini and to prepare the image displayed as the icon. Use "17.7 Custom Release File Setting" to create them easily.

The customdef.ini has to be described by Unicode (UTF-16 LE) text.

##### 17.6.5.1.1 Config.ini

Refer to 17.6.4.1.1.

##### 17.6.5.1.2 customdef.ini

###### Example of setting

```

; • When adding the custom release window
; • Set the custom release window "TEST" to the fourth menu from the left on the first page of the monitor
screen.
; • The panel update processing displaying the window of the custom open is set once every 200ms.
; • When the window is shut, the instance is held.
; • The display existence of the menu is acquired from TESTWIN.DLL.
[CMENU]
NUM=2
SCREEN_TYPE01=0
MENU_POS01=3
WINDOW_OFFSET01=8000
MENU_ENG01=TEST
SUMMARY_ENG01=TEST
MENU_JPN01=SHIKEN
SUMMARY_JPN01=SHIKEN
BG_REFRESH_TIME01=200
INSTANCE_HOLD01=1
MENU_STATE_DLL01=TESTWIN.DLL

; • When adding the executing file
; • Add the menu "calc" to the fifth menu from the left on the first page of the monitor screen,
; When the menu is pressed, "C:\WINDOWS\SYSTEM32\calc.exe" is executed.
; When the execution file starts, the update cycle of a standard screen is set once every 200ms.
SCREEN_TYPE02=0
MENU_POS02=4
WINDOW_OFFSET02=20000
EXECUTE02=C:\WINDOWS\SYSTEM32\calc.exe,calc,
MENU_ENG02=calc
SUMMARY_ENG02=calc
MENU_JPN02=dentaku
BG_REFRESH_TIME01=200
SUMMARY_JPN02=dentaku

```

Edit the following item of the [CMENU] section.

Key name	Details
NUM	<p>Specify the number of custom release registration.</p> <p>Setting range : 0 to 50 Default : 0</p>
SCREEN_TYPEXX (XX = 01 to 50)	<p>Specify the screen where the menu is added.</p> <p>Setting range : 0 to 4 0: Monitor 1: Setup 2: Edit 3: Diagnosis 4: Maintenance</p>
MENU_POSXX (XX = 01 to 50)	<p>Specify the menu position to register.</p> <p>Setting range : 0 to 39 0 to 9 : First page 10 to 19 : Second page 20 to 29 : Third page 30 to 39 : Fourth page (Only monitor screen for M8V)</p> <p>When other menu is registered at the specified menu position, an existing menu becomes invalid. However, when adding a new menu to diagnosis and maintenance, the existing menu can be moved to a vacant position by setting MENU_MOVE to 1. The "maintenance" and "parameter" menus in maintenance are fixed and cannot be customized. They cannot be overwritten or moved by MENU_MOVE.</p>
WINDOW_OFFSETXX (XX = 01 to 50)	<ul style="list-style-type: none"> <li>● For the interpreter method and the compilation method Specify the displayed window No. The setting value is "the offset No. designated for PAGE_OFFSET of Config.ini + the window No. in the project (0 to 255)".  Setting range : 8000 to 9999</li> <li>● For executing file registration method Specify the No. corresponding to the image file name displayed as the icon.  Setting range : 20000 to 20099</li> </ul>

Key name	Details								
EXECUTEXX (XX = 01 to 50)	<p>Designate the started executing file.</p> <p>The starting status of the executing file can be judged by setting the title bar character string and the class name of the window. As a result, a multiple start of the execution file can be controlled.</p> <p>If both the title bar character string and the class names of the window are set, it is judged "The execution file is starting" when each requirement is met at the same time.</p> <p>When the executing file has already started, the focus is set to the corresponding executing file.</p> <p>The details of arguments are as shown below.</p> <table border="1" style="width: 100%; border-collapse: collapse;"> <thead> <tr> <th style="text-align: center;">Argument</th> <th style="text-align: center;">Details</th> </tr> </thead> <tbody> <tr> <td style="vertical-align: top;">1st argument</td> <td>The file name of the starting executing file (including the folder name) Default : Null character</td> </tr> <tr> <td style="vertical-align: top;">2nd argument</td> <td>The title bar character string of window referred to confirm the starting status of the executing file Default : Nothing</td> </tr> <tr> <td style="vertical-align: top;">3rd argument</td> <td>The class name of window referred to confirm the starting status of the executing file Default : Nothing</td> </tr> </tbody> </table> <p>Setting range                      All : Within 200 characters                      File name : Within 100 characters                      Window name, class name : Within 50 characters for each</p> <p>* When two or more executing files corresponding to the condition exist, the executing file found first is operated.                      * It is valid only for the executing file registration method.                      The method is distinguished with the WINDOW_OFFSET key.</p>	Argument	Details	1st argument	The file name of the starting executing file (including the folder name) Default : Null character	2nd argument	The title bar character string of window referred to confirm the starting status of the executing file Default : Nothing	3rd argument	The class name of window referred to confirm the starting status of the executing file Default : Nothing
Argument	Details								
1st argument	The file name of the starting executing file (including the folder name) Default : Null character								
2nd argument	The title bar character string of window referred to confirm the starting status of the executing file Default : Nothing								
3rd argument	The class name of window referred to confirm the starting status of the executing file Default : Nothing								

Key name	Details																				
<p>MENU_YYYYXX (XX = 01 to 50)</p>	<p>Specify character strings for the menu. Describe them within 7 one-byte characters. Set the division of the language to YYY referring to the following.</p> <table border="0"> <tr> <td>ENG : English</td> <td>JPN : Japanese</td> </tr> <tr> <td>DEU : German</td> <td>FRA : French</td> </tr> <tr> <td>ITA : Italian</td> <td>SPA : Spanish</td> </tr> <tr> <td>CHT : Chinese (traditional)</td> <td>KOR : Korean</td> </tr> <tr> <td>POR : Portuguese</td> <td>DUT : Dutch</td> </tr> <tr> <td>SWE : Swedish</td> <td>HUN : Hungarian</td> </tr> <tr> <td>POL : Polish</td> <td>CHS : Chinese (simplified)</td> </tr> <tr> <td>RUS : Russian</td> <td>TUR : Turkish</td> </tr> <tr> <td>CZE : Czech</td> <td>IND : Indonesian</td> </tr> <tr> <td>VIE : Vietnamese</td> <td></td> </tr> </table> <p>When switched to a language to which character strings are not registered, English character strings is displayed by default.</p> <p>Setting range : Within 7 one-byte characters Default : Null character <b>(Note)</b> Adjust the character string display position with space.</p>	ENG : English	JPN : Japanese	DEU : German	FRA : French	ITA : Italian	SPA : Spanish	CHT : Chinese (traditional)	KOR : Korean	POR : Portuguese	DUT : Dutch	SWE : Swedish	HUN : Hungarian	POL : Polish	CHS : Chinese (simplified)	RUS : Russian	TUR : Turkish	CZE : Czech	IND : Indonesian	VIE : Vietnamese	
ENG : English	JPN : Japanese																				
DEU : German	FRA : French																				
ITA : Italian	SPA : Spanish																				
CHT : Chinese (traditional)	KOR : Korean																				
POR : Portuguese	DUT : Dutch																				
SWE : Swedish	HUN : Hungarian																				
POL : Polish	CHS : Chinese (simplified)																				
RUS : Russian	TUR : Turkish																				
CZE : Czech	IND : Indonesian																				
VIE : Vietnamese																					
<p>SUMMARY_YYYYXX (XX = 01 to 50)</p>	<p>Specify character strings for the outline column of the menu list. Describe them within 70 one-byte characters. The setting of YYY is similar to "MENU_YYYYXX". When switched to a language to which character strings are not registered, English character strings is displayed by default.</p> <p>Setting range : Within 70 one-byte characters Default : Null character <b>(Note)</b> Adjust the character string display position with space.</p>																				

Key name	Details
<p>BG_REFRESH_TIMEXX (XX = 01 to 50)</p>	<ul style="list-style-type: none"> <li>● For the interpreter method and the compilation method Specify the update cycle of the panel displayed on the background is set while displaying the window of the custom release. When the custom release window is displayed, the update cycle of the panel is changed to the setting value. When closing, it returns to the origin. It is possible to set "Do not update" or until 0 to 10 seconds by each millisecond unit.</li> </ul> <p>Setting range : -1 to 10000 Default : 0</p> <ul style="list-style-type: none"> <li>-1 : Do not update drawing</li> <li>0 to 100 : Update at the highest cycle of the panel</li> <li>100 to 10000 : Update with setting cycle</li> </ul> <ul style="list-style-type: none"> <li>● For executing file registration method Specify the update cycle of a standard screen when the registered execution file starts. When the executing file is started, the update cycle of a standard screen is changed. When a standard screen moves from the background screen to an active screen, the setting of the update cycle (sleep time) is released. It is possible to set "Do not update", "Do not change" or until 0 to 1 second by each millisecond unit.</li> </ul> <p>Setting range : -1 to 1000 Default : 0</p> <ul style="list-style-type: none"> <li>-1 : Do not update</li> <li>0 : Do not change the update cycle</li> <li>1 to 1000 : Changes to the set update cycle</li> </ul> <p>Out of range : Do not change the update cycle</p>
<p>INSTANCE_HOLDXX (XX = 01 to 50)</p>	<p>Specify whether to hold the instance when the window closes. If the instance is held, the window can be displayed with the closing status when the window will be opened next time. Even if the window is displayed on another screen, the window is displayed with the closing status last time. When the window is opened next time, the focus is placed on the focused control before the window was closed or the window.</p> <p>Setting range : 0 to 1 Default : 0</p> <ul style="list-style-type: none"> <li>0: Do not hold at window close</li> <li>1: Hold at window close</li> </ul> <p>* It is valid only for the interpreter method and the compilation method. The method is distinguished with the WINDOW_OFFSET key.</p>

Key name	Details
<p>MENU_STATE_DLLXX (XX = 01 to 50)</p>	<p>For M800V/M80V/M800/M80 (Windows-based display unit) and M700VW, specify the DLL file defined by the function (MCAAppGetMenuState()) which checks whether to display the menu by full path.  <b>Ex.)</b> &lt;When using M800V/M80V/M800/M80 (Windows-based display unit) and M700VW &gt;                      MENU_STATE_DLL01=D:\custom\Test_MenuState.DLL</p> <p>Setting range : Number of capital letters of file path = 63byte</p> <p>When the DLL file is set, display (TRUE)/non-display (Excluding TRUE) of the menu is switched by the return value of MCAAppGetMenuState() in the DLL. When this item is not set, the menu is unconditionally displayed.</p> <p>Default : Display the menu unconditionally                      * When the set DLL file does not exist or the MCAAppGetMenuState() function is not defined in the set DLL file, the menu is not displayed. When the DLL file path of 63 bytes or more is set, it is judged that the key is invalid, and the menu is displayed.</p> <p>For M800V/M80V/M800/M80 (Windows-less display unit) and M700VS/M70V/E70, specify the name with project name of NC Designer2 following the function (MCAAppGetMenuState()) which checks whether to display the menu.  <b>Ex.)</b> MENU_STATE_DLL01=MCAAppGetMenuStateTest</p>
<p>MENU_MOVE</p>	<p>Specify this to automatically move Mitsubishi's standard menus to vacant space when MTB's menus are added to the position of Mitsubishi's standard menus. (Note 4)                      This setting is valid only on the diagnostic/maintenance screen.</p> <p>Setting range : 0 to 1                      Default : 0</p> <p>0: When MTB's menus are registered in the position of Mitsubishi's standard menus, Mitsubishi's standard menus are not displayed.                      1: When MTB's menus are registered in the position of Mitsubishi's standard menus, Mitsubishi's standard menus are automatically moved to vacant space.</p>

**(Note 1)** When the NUM key is 1 or more, always set to keys without setting default value.

**(Note 2)** When a symbol ";" is at the head of the line, the character string is judged to be a comment.

**(Note 3)** Do not insert the spaces before and behind " = " between the key and the setting value. (For the menu character string and the outline character string, a space can be inserted by the right side of "=" to adjust the position.)

**(Note 4)** Menu positions where menus are not displayed because the option is disabled are treated as vacant spaces. When an option setting is changed from disabled to enabled, and the menu is displayed, the Mitsubishi standard menu allocated to that space moves to another vacant space.



### 17.6.5.1.3 Icon Image

File name and size are shown below.

<png file>

File name : "The values of "WINDOW\_OFFSETXX.png"

Size : 62 x 40

File format : PNG

Create an icon image (PNG) whose background is transparent. As a result, icon image registration for each screen theme color is unnecessary. Png files are available only for M8V Series.

<jpg file>

File name : "The values of WINDOW\_OFFSETXX\_the values of the screen theme color\_OFF.jpg"

Size : 62 x 40

File format : JPEG

By specifying the setting values of base common parameter "#11060 Screen theme color" to the screen theme color value, an icon image to match the screen theme color is displayed.

Store the created image file in the following folder.

Storage folder may differ according to the unit being used.

< When using M800V/M80V/M800/M80 (Windows-based display unit) and M700VW >  
D:\Custom\img\

< When using M800V/M80V/M800/M80 (Windows-less display unit) and M700VS/M70V/E70 >  
/custom/

(Note 1) The image might not be correctly displayed when there is defect in the file name, the size, and the file format.

(Note 2) When M800V/M80V/M800/M80 (Windows-less display unit) and M700VS/M70V/E70 is used as a display unit, the image file is stored in a folder by using SETUP INSTALLER. For information on SETUP INSTALLER, refer to "Appendix 10. Installing Custom Data (M700VS/M70V/E70)" and "Appendix 11. Installing Custom Data (M800V/M80V/M800/M80 (Windows-less display unit))".

(Note 3) When multiple image files exist, file are used in the order of "The values of WINDOW\_OFFSETXX.png", "The values of WINDOW\_OFFSETXX\_the values of the screen theme color\_OFF.jpg", and "The values of WINDOW\_OFFSETXX\_OFF.jpg".

### **17.6.5.2 Compilation Method**

To register the compilation method data to the main key, it is necessary to edit Config.ini and customdef.ini and to prepare the image displayed as the icon. Use "17.7 Custom Release File Setting" to create them easily.

The customdef.ini has to be described by Unicode (UTF-16 LE) text.

#### **17.6.5.2.1 Config.ini**

Refer to 17.6.4.2.1.

#### **17.6.5.2.2 customdef.ini**

Refer to 17.6.5.1.2.

#### **17.6.5.2.3 Icon Image**

Refer to 17.6.5.1.3.

### 17.6.5.3 Changing the Arrangement of the Main Menu

The main menu of the monitor, setup, edit, diagnostic, and maintenance screen can be permuted in easy-to-use the order.

To change the arrangement of the main menu, the customdef.ini must be edited.

The customdef.ini has to be described by Unicode (UTF-16 LE) text.

#### 17.6.5.3.1 customdef.ini

Example of setting

```

; • When changing the position where an existing menu is displayed
[MENU_CHANGE]
NUM=2
; "Edit" is set to the fifth menu of the edit screen.
SCREEN_TYPE01=2
MENU_POS01=4
CHG_SCREEN_ID01=301
; Delete the first menu of the edit screen.
SCREEN_TYPE02=2
MENU_POS02=0
CHG_SCREEN_ID02=0
    
```

Edit the following item of the [MENU\_CHANGE] section.

Key name	Details
NUM	Specify the number of the changing menu position registration.  Setting range : 0 to 90 Default : 0
SCREEN_TYPEXX (XX = 01 to 90)	Specify the screen where the menu is added or changed.  Setting range : 0 to 4 0: Monitor 1: Setup 2: Edit 3: Diagnosis 4: Maintenance
MENU_POSXX (XX = 01 to 90)	Specify the menu position to register.  Setting range : 0 to 39 0 to 9 : First page 10 to 19 : Second page 20 to 29 : Third page 30 to 39 : Fourth page (Only monitor screen for M8V)  When other menu is registered at the specified menu position, an existing menu is invalid.
CHG_SCREEN_IDXX (XX = 01 to 90)	Select the ID No. of the menu to register (refer to supplementation 1) at the menu position set by the above-mentioned from the following. When 0 is set, the menu at the position set by the above-mentioned is invalid.  Setting range : The setting range changes by SCREEN_TYPEXX as follows. SCREEN_TYPEXX : 0    Screen ID : 0,101 to 128 SCREEN_TYPEXX : 1    Screen ID : 0,201 to 220 SCREEN_TYPEXX : 2    Screen ID : 0,301 to 305 SCREEN_TYPEXX : 3    Screen ID : 0,401 to 409 SCREEN_TYPEXX : 4    Screen ID : 0,501 to 503

**(Note 1)** When the NUM key is 1 or more, always set to keys without setting default value.

**(Note 2)** When a symbol ";" is at the head of the line, the character string is judged to be a comment.

**(Note 3)** Do not insert the spaces before and behind " = " between the key and the setting value.

**(Note 4)** The "maintenance" and "parameter" menus in maintenance are fixed.



### 17.6.5.4 Focus while the Instance Is Held

When the instance of the custom release window is held, the focus will stay with the control or the window where the focus was placed when the window was closed last time.

If the initialization while displaying the window is carried out under the specific control, move the focus to that control to execute initialization.

(EXAMPLE)

If the macro is created as follows to perform operations such as the key processing or initialization (character string setting of the menu) with GTextBox0000 control, the focus moves to GButton00001 control when the window is closed by touching GButton00001 control.

As the window is opened again, the key processing and initialization will not be carried out since the focus stays with GButton control.

Thus, move the focus to GTextBox00000 control at GButton00001-OnSetFocus().

• Custom Release Window

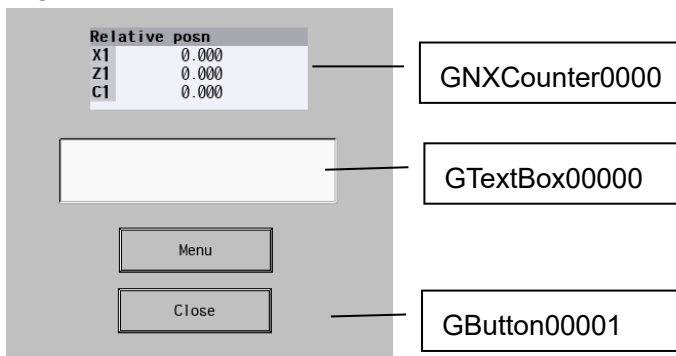

• Menu of Custom Release Window

Search	Restart	Edit	Trace	Check	Offset	Coord		TEST	Dsp.Chg
TEST1	TEST2	TEST3	TEST4	TEST5	TEST6	TEST7	TEST8	TEST9	CLOSE

Macro

```

$GTextBox00000-OnSetFocus
    GCSMenuSetMenuButtonLowerName_all(2000,0,1,
        " TEST1, TEST2, TEST3, TEST4, TEST5, TEST6, TEST7, TEST8, TEST9, CLOSE");
$End
$GTextBox00000-OnKeyPress
    long _IShiftKey; 'SHIFT key input status
    'The SHIFT key input status is maintained in the 0th bit of LUPARAM.
    _IShiftKey = LUPARAM & H1;
    if((LLPARAM == 121) && (_IShiftKey == 0))
        GCSMenuSendProcessID(2000,0,0);
    endif;
$End
$GButton00001-OnClick
    GCSMenuSendProcessID(2000,0,0);
$End
    
```

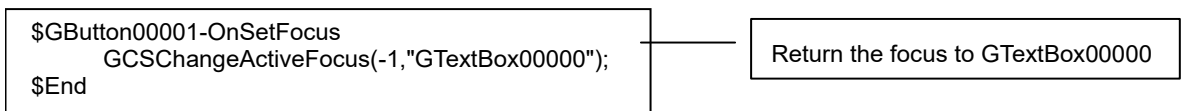

### 17.6.5.5 Settings of an Operation Message

To display the same operation message as a Mitsubishi standard screen at a menu release, use the `GCSMenuSetOpeMessage` function for the interpreter method, and the `GCSSetOpeMessage` function for the compilation method.

\* A sample that displays an operation message in the menu part of the set-up screen is shown below.

#### Interpreter Method

##### GCSMenuSetOpeMessage function format

`GCSMenuSetOpeMessage` (1st argument, 2nd argument, 3rd argument);

1st argument: Screen number (monitor=1000, setup=2000, edit=3000, diagnostic=4000, maintenance=5000)

2nd argument: Control name to display a message

Monitor screen: "GNXMenu00059"

Setup screen: "GNXMenu00038"

Edit screen: "GNXMenu00015"

Diagnostic screen: "GNXMenu00034"

Maintenance screen: "GNXMenu00005"

3rd argument: Operation message

#### Macro

```
GCSMenuSetOpeMessage (2000, "GNXMenu00038", "warning");
```

#### Compilation Method

##### GCSSetOpeMessage function format

`GCSSetOpeMessage` (1st argument, 2nd argument);

1st argument: Operation target object

Acquire the operation target object by using an object number (Monitor screen: 59, Setup screen: 38, Edit screen: 15, Diagnostic screen: 34, Maintenance screen: 5).

2nd argument: Operation message

#### Source Code

```
char pszStringChar[] = "warning\0";
GTCHAR Message[10];
GRCMultiByteToUnicode(GRCLoadNowLanguageStr(), Message, pszStringChar, 10 );
GBaseObject *pParent = GCSGetPanel(GCSGetScreen(GetGBaseObject()));
GBaseObject *pChild = (GBaseObject*)GCSGetChild(pParent, 38);
GCSSetOpeMessage(pChild, (char *)Message);
```

### 17.6.6 Screen Part Assignment

Screen part assignment is a function that enables a customized window which is created with the interpreter method or the compilation method to be displayed as a part of the standard screen. There are 2 types.

- (1) Screen selection bar display open (4 function tabs)
- (2) Operation screen base display open

The customized window which can be displayed with the screen part assignment is for the NC Designer2 window only. Only any one of the above two is enabled for the screen part assignment.

### 17.6.6.1 Screen Selection Bar Display Open

Screen selection bar display open enables to constantly display a customized window which is created with the interpreter method or the compilation method on screen selection bar (4 function tabs) of the standard screen.

The selected function name is shown on the last remaining function tab. Displays of the function tabs are switched according to the definition of the screen part assignment (customdef.ini).

<10.4 type>

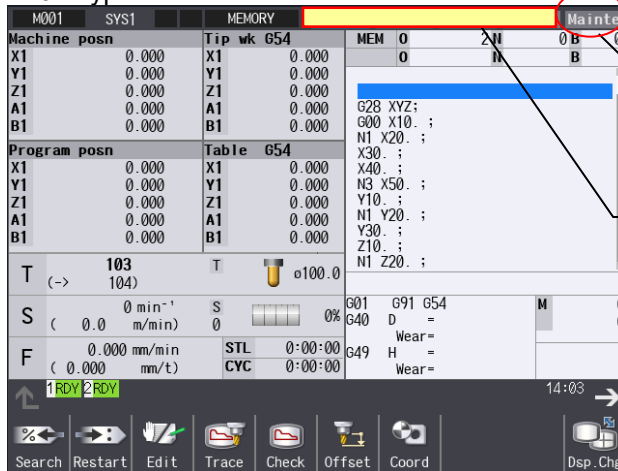

Function tab  
- Displays a name of the selected function

Screen part assignment size  
(W: 266pixel)  
(H: 21pixel)  
(Coordinate: X, Y = 308, 0)

<15 type>

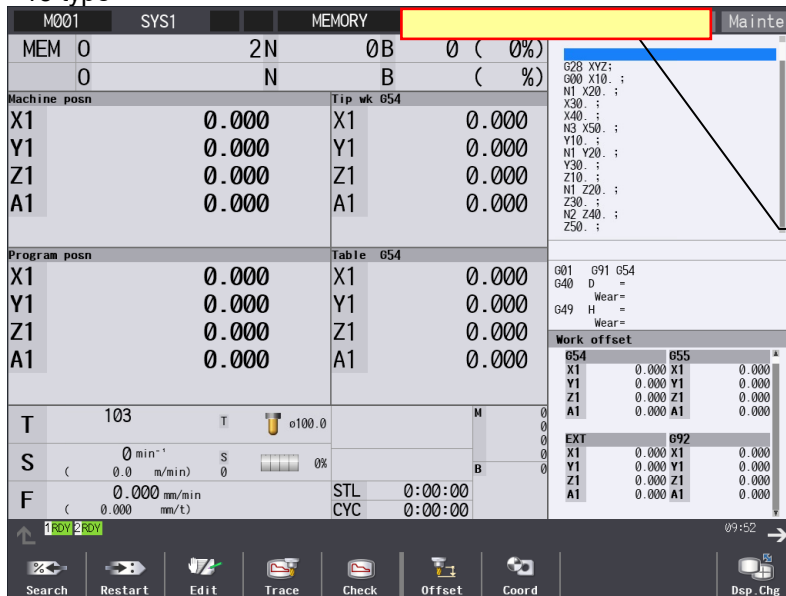

Screen part assignment size  
(W: 393pixel)  
(H: 32 pixel)  
(Coordinate: X, Y=524, 0)

- (Note 1) For points of caution for creating customized window used for screen part assignment, refer to "17.6.6.5 Caution for Creating Customized Window for Screen Part Assignment".
- (Note 2) Customized window that is created with "Execution file registration method" cannot be displayed.
- (Note 3) The screen part assignment area cannot be displayed on PLC onboard and NaviMill/Lathe screens.
- (Note 4) Screen part assignment cannot be used for CNC software tools (NC Monitor2, NC Maintainer).
- (Note 5) Functions cannot be switched by touching function tabs.
- (Note 6) When the screen part assignment is valid, and if I/O window is closed while file transportation, etc. is being carried out on the I/O window in the edit screen, the file operation will be interrupted.



### 17.6.6.2 Operation Screen Base Display Open

Operation screen base display open enables to display a customized window which is created with the interpreter method or the compilation method on the base display of operation screen on the standard screen. Customization window is closed when the screen switches to other functions. It is displayed again when switching back to operation screen. The customization window of the operation screen base display open does not hold instance.

Each menu on operation screen can be used while the customization window is displayed. When the menu is selected, the each menu window of the operation screen is displayed on the front of the customization window and it can be operated.

<8.4type/ 10.4 type>

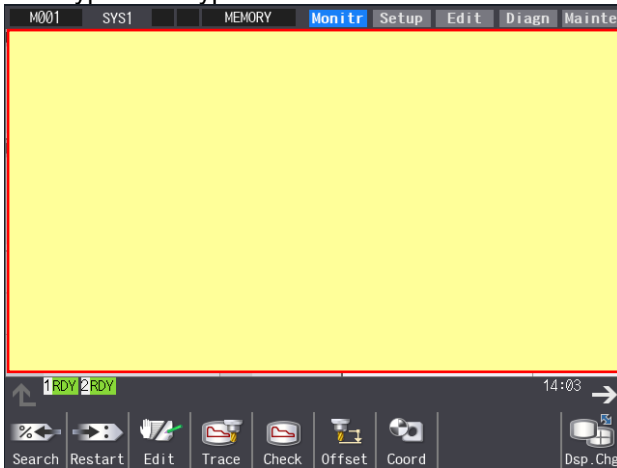

Screen part assignment size  
(W: 640 pixel)  
(H: 363 pixel)  
(Coordinate: X, Y=0, 22)

<15 type>

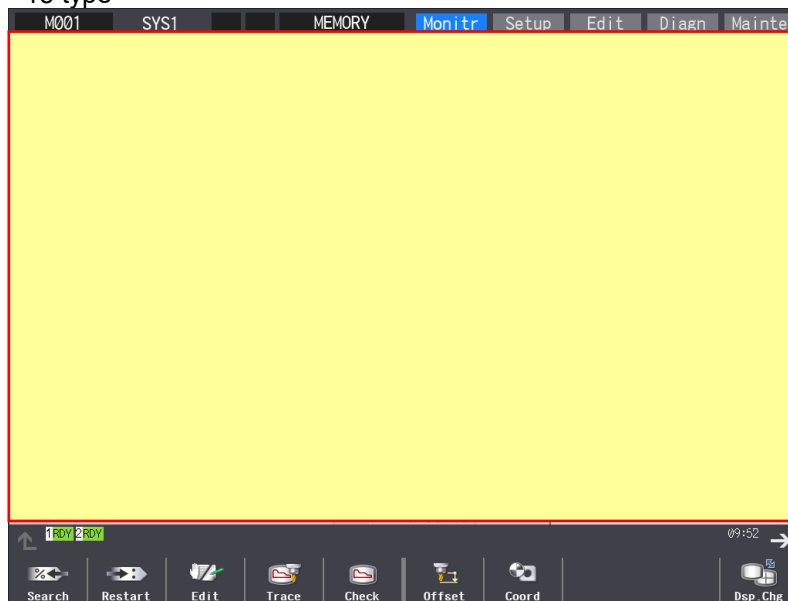

Screen part assignment size  
(W: 1024 pixel)  
(H: 633 pixel)  
(Coordinate: X, Y=0, 33)

- (Note 1) For points of caution for creating customized window used for operation screen base display open, refer to "17.6.6.5 Caution for Creating Customized Window for Screen Part Assignment".
- (Note 2) Customized window that is created with "Execution file registration method" cannot be displayed.
- (Note 3) Operation screen base display open cannot be used for CNC software tools (NC Monitor2, NC Maintainer).
- (Note 4) When the operation screen base display open is valid, and if I/O window is closed while file transportation, etc. is being carried out on the I/O window in the edit screen, the file operation will be interrupted.

### 17.6.6.3 Interpreter Method

In order to display a customized window, created with interpreter method, in the screen part assignment area, "config.ini" or "customdef.ini" must be edited. The "customdef.ini" must be written in the Unicode (UTF-16 LE) text format.

#### 17.6.6.3.1 config.ini

Refer to 17.6.4.1.1.

#### 17.6.6.3.2 customdef.ini

Setting example

```
; • Set the No. of customized window that will be displayed on screen part assignment area.
[CPART]
CPART_OFFSET01=8001
```

Edit the following items in [CPART] section.

Key name	Details
CPART_OFFSETXX (XX=01,10)	<p>Set the offset No. of customized screen which will be displayed on screen part assignment area. (Note 1)</p> <p>To XX, specify the type of screen part assignment.</p> <p>01: the screen selection bar display open</p> <p>10: the operation screen base display open</p> <p>The setting No. will be "Offset No. that is set in PAGE_OFFSET in config.ini + WINDOW No. (0 to 255) in the project". (Note 2)</p> <p>Setting range: 8000 to 9999</p>
CPART_PERMISSION	<p>Set as "input enabled" when the key or touch panel operation is to be enabled in the customized window of the operation screen base display open. (Note 5)</p> <p>As for the screen selection bar display open, this is disabled (No key or touch panel operation) without fail.</p> <p>Setting range: 0/1</p> <p>0: Input disabled (default)</p> <p>1: Input enabled</p>

(Note 1) When there are multiple settings in the [CPART] section, the setting described later will be valid.

(Note 2) When the offset No. (8000 to 9999) of designated window does not exist in the project at selecting the screen selection bar open (CPART\_OFFSET01), the screen selection bar is displayed as one function tab but the customized window will not be displayed.

(Note 3) When a symbol ";" is at the head of the line, the character string is judged as a comment.

(Note 4) Do not insert spaces before and after "=" that is between key and value.

(Note 5) When the input is enabled, the event is received by the customized window of any key. Thus the key event has to be passed from the customized window to the standard screen process when the key to switch the standard screen display (for example, menu key, function key, and the shortcut key which is used on standard screen (M,S,T,X,Y,Z,A,B,C) etc.) is received. The display will not be switched unless the event is passed. (Refer to 17.6.6.5.4.)

**17.6.6.4 Compilation Method**

In order to display customized window which is created with the compilation method on screen part assignment area, "config.ini" and "customdef.ini" must be edited. The "customdef.ini" must be written in the Unicode (UTF-16 LE) text format.

**17.6.6.4.1 config.ini**

Refer to 17.6.4.2.1.

**17.6.6.4.2 customdef.ini**

Refer to 17.6.6.3.2.

**17.6.6.5 Caution for Creating Customized Window for Screen Part Assignment**

**17.6.6.5.1 Size and Display Coordinate of Displayed Customized Window**

Display size and display coordinate of the customized window follows the setting in the panel/window property in NC Designer2. Display size and coordinate is not automatically adjusted to the screen part assignment area. When the property setting is not correctly done, deviation might occur on the display coordinate or the window might be too large for the screen part assignment area. Thus, the setting values must be the values shown below. Also, a total bar, a close button, a window frame, etc. should not be displayed since displaying with those will enlarge the displaying size.

<Property setting (Screen selection bar display open 10.4 type)>

Panel/Window	
Window Name	Window00001
X	308
Y	0
WIDTH	266
HEIGHT	21
Background Color	
Background File	None
Background image	ID_IMAGE00001
Title	
Existence of a title bar	None
Existence of a close button	None
Existence of a window frame	None
Blink off time(ms)	100
Blink on time(ms)	100

Coordinate  
10.4 type: X,Y=308,0  
15 type: X,Y=524,0

Width  
10.4 type: WIDTH=266  
15 type: WIDTH=393

Height  
10.4 type: HEIGHT=21  
15 type: HEIGHT=32

Existence of a title bar: None  
Existence of a close bar: None  
Existence of a window frame: None

### 17.6.6.5.2 Customized Window Focus/ Available Event

Customized window for screen part assignment must be created without being focused. The events input with key operation or touch panel operation will not be received. "OnDraw", "OnTimer", "OnCreate", "OnDelete", "OnInit" and "OnQuit" are only available events for customized window of the screen part assignment.

Therefore, set "None" in the property to avoid using other than those events. Also, "input permission" in the control property should be set to "Prohibition".

However, when "1 (Input enabled)" is specified to "CPART\_PERMISSION" of customdef.ini at the operation screen base display open, the event from the touch panel operation and key input can be received. In this case, it is required to carry out the key processing of standard screen from the customized window so that key operation on the standard screen is possible. (Refer to 17.6.6.5.4)

#### <Event list>

Availability	Event	Details
×	OnKeyPress	Execute after the key is pressed. Key event can be retrieved only when the focus of control parts is active.
×	OnKeyRelease	Execute after the key is released Key event can be retrieved only when the focus of control parts is active.
×	OnPress	Execute after a pointing device such as a mouse is pressed.
×	OnRelease	Execute after a pointing device such as a mouse is released.
×	OnClick	Execute after a pointing device such as a mouse is clicked. When a pointing device is released on the same control, it will be executed after "OnRelease" operation.
○	OnDraw	Execute after drawing is completed
○	OnTimer	Execute after timer event process is called.
×	OnSetFocus	Execute after a control is focused.
×	OnKillFocus	Execute after the focus on a control is released.
○	OnCreate	Execute after page / control is created
○	OnDelete	Execute before page/ control is deleted.
×	OnUser	Execute after process of user's original event is completed.
×	OnScroll	Execute after a scroll bar is clicked by a pointing device such as a mouse.
×	OnScrollFinish	Execute after caption character scroll is completed
×	OnSelectChange	Change a selecting line with a list.
○	OnInit	Execute after "OnCreate" when page/ control is created.
○	OnQuit	Execute before "OnDelete" when page/ control is deleted.

17.6.6.5.3 Sample Code (Timer Processing)

A picture (resource) of the sample code is switched by attaching "picture control" to the customized window with picture control OnTimer.

<Sample Code>

The display of "picture control" is switched by PLC signal. Display "RPN" during rapid traverse, "CUT" during cutting feed and it does not display anything for other states.

(Ex.) Customized window on screen selection bar open



Project Setting Example

(1) Create BMP file for displaying on "picture control" and add it to the resource.

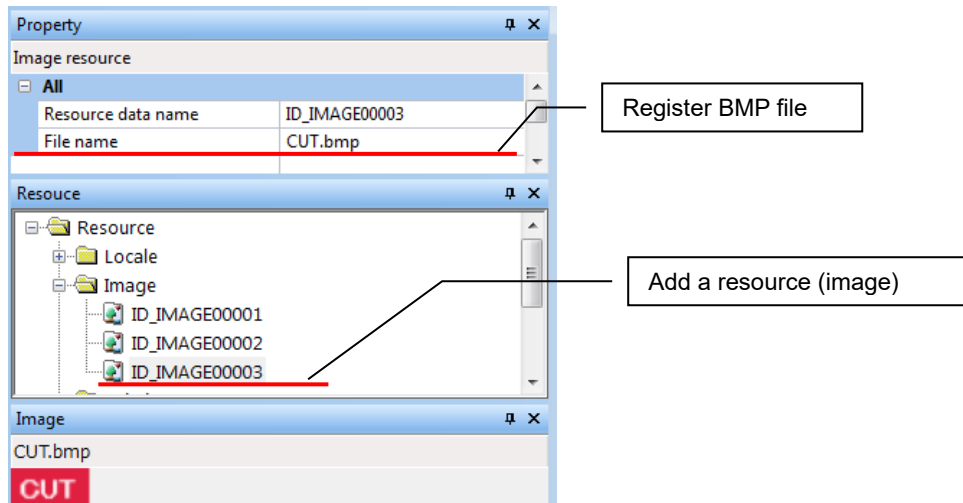

(2) Set the registered resource to the state design of "picture control".

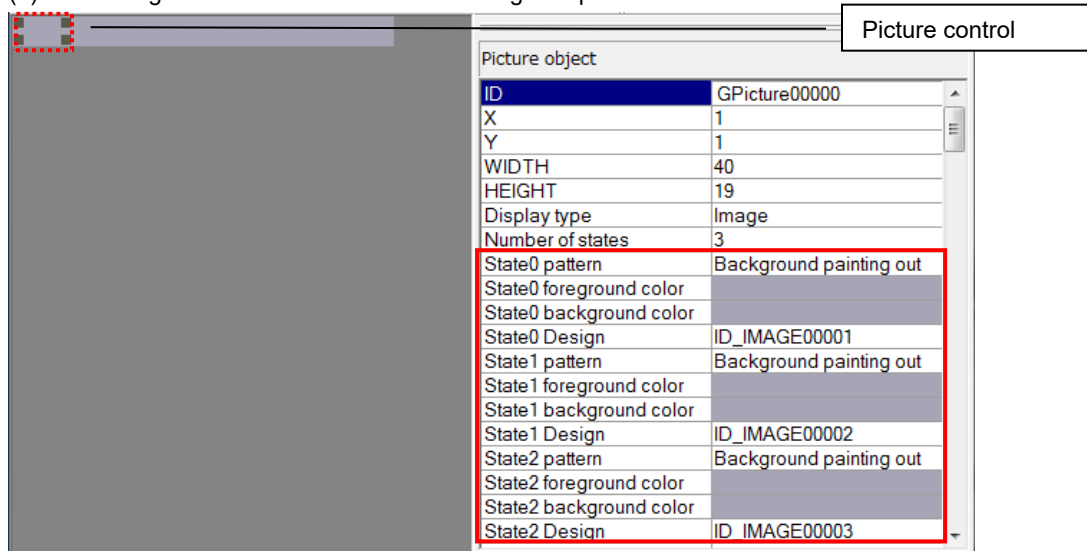

## Interpreter Method

OnTimer macro in "picture control" should be created with "Screen macro edit".

## Macro

```

$GPicture00000-OnTimer
  GMEM gControl ;
  gControl = GMEMCreate("NCCONTROL", 16) ;
  GMEMSetLong(gControl, 0, 1) ; ' Set NC No. to be "1"
  GMEMSetLong(gControl, 4, 0) ; ' Do not designate part system No.
  GMEMSetLong(gControl, 8, 0) ; ' Set to the standard part system
  GMEMSetLong(gControl, 12, H0) ; ' Do not designate axis No.

  GMEM mem ;
  mem = GMEMCreate("TESTMEM", 8) ;
  GMEMSetLong(mem, 0, 0) ;

  LONG Stat;
  Stat = 0;

  'Retrieve $1 rapid traverse state (XC20)
  LONG IRpnVal;
  IRpnVal = 0;
  Stat = GCSNCDDataGetGNCValue(gControl, 53, 3105, 3, mem);
  if(Stat == 1)
    IRpnVal = GMEMGetLong(mem, 0) ;
  endif

  'Retrieve $1 cutting feed state (XC21)
  LONG ICutVal;
  ICutVal = 0;
  Stat = GCSNCDDataGetGNCValue(gControl, 53, 3106, 3, mem);
  if(Stat == 1)
    ICutVal = GMEMGetLong(mem, 0) ;
  endif

  'Switch "picture control" state
  if(IRpnVal == 1)
    GCSPictureSetStatus(-1,"GPicture00000",1);      'Rapid   traverse   (XC20=1)
    state1(display RPN)
  elseif(ICutVal == 1)
    GCSPictureSetStatus(-1,"GPicture00000",2);      'Cutting feed rate (XC21=1): State2
    (Display "CUT")
  else
    GCSPictureSetStatus(-1,"GPicture00000",0);      'Other than rapid traverse/ cutting
    feed states: 0(Display: none)
  Endif

  GMEMDelete(gControl);
  GMEMDelete(mem);
$End

```

## Compilation Method

Source is created by setting "with OnTimer" on the property of "picture control".

Created source code is processed with OnTimer function.

## Source Code

```
#include "melsect.h"
#include "melssect.h"
#include "meltype.h"
#include "ncmcapi.h"
#include "melncapi.h"

long GCWindow00001::GPICTURE00000OnTimer(unsigned short usMessage, long ILParam, long
    IUParam)
{
    DWORD _NCSts = 0;

    // Retrieve $1 rapid traverse state (XC20)
    long _IRpnVal = 0;
    _NCSts = melGetData(NULL, ADR_MACHINE(1), M_SEC_PLC_DEV_BIT,
M_SSEC_PLBIT_X_1SHOT(0xC20),
    0, &_IRpnVal, T_LONG);

    // Retrieve $1 cutting feed state (XC21)
    long _ICutVal = 0;
    _NCSts = melGetData(NULL, ADR_MACHINE(1), M_SEC_PLC_DEV_BIT,
M_SSEC_PLBIT_X_1SHOT(0xC21),
    0, &_ICutVal, T_LONG);



    // Switch "picture control" state
    if(_IRpnVal == 1)
    {
        GCSPictureSetStatus(_pPicture, 1); // Rapid traverse (XC20=1): state1 (Display
"RPN")
    }
    else if(_ICutVal == 1)
    {
        GCSPictureSetStatus(_pPicture, 2); // Cutting feed (XC21=1): State2 (Display
"CUT")
    }
    else
    {
        GCSPictureSetStatus(_pPicture, 0); // Other than rapid traverse/ cutting feed :
State 0 (Display : None)
    }

    return TRUE;
}
```

**17.6.6.5.4 Sample Code (Process to Pass the Key to the Standard Screen When Input Is Enabled)**

Paste the textbox control to customized window. With "OnKeyPress" of the textbox control, the sample code of the processing which passes the key events to standard screen is shown for only the following key.

<Key codes that is required to be passed to standard screen>

Key code	Operation	NC keyboard	Key code	Operation	NC keyboard
SHIFT+F1	Transition to operation screen	MONITOR	F1(112)	Menu 1 selection	Menu key 1
SHIFT+F2	Transition to setup screen	SET UP	F2(113)	Menu 2 selection	Menu key 2
SHIFT+F3	Transition to edit screen	EDIT	F3(114)	Menu 3 selection	Menu key 3
SHIFT+F4	Transition to diagnostics screen	DIAGN	F4(115)	Menu 4 selection	Menu key 4
SHIFT+F5	Transition to maintenance screen	MAINTE	F5(116)	Menu 5 selection	Menu key 5
SHIFT+F9	Custom screen display	SFP	F6(117)	Menu 6 selection	Menu key 6
SHIFT+F10	Custom screen display	F0	F7(118)	Menu 7 selection	Menu key 7
CTRL+F1	Part system switch	\$↔\$	F8(119)	Menu 8 selection	Menu key 8
CTRL+F2	Guidance display	?	F9(120)	Menu 9 selection	Menu key 9
CTRL+F3	Custom screen display	 display	F10(121)	Menu 10 selection	Menu key 10
CTRL+F4	Custom screen display	 switch	F11(122)	Cancel	Menu switch key (left)
CTRL+F8	Menu list display	MENU LIST	F12(123)	Next menu	Menu switch key (right)



<Description of sample code>

The operation specification for the custom screen of sample is as below.

- Character string can be input in textbox control (GTEXTBOX00001).
- Specific key operation on standard screen can be performed.
- Setting value at textbox control (GTEXTBOX00001) is set to textbox control (GTEXTBOX00000), when button control (GBUTTON00002) is clicked.

The following 3 types of processing is implemented in the sample code.

- (1) Using "OnSetFocus" of other controls, move the focus to textbox control (GTEXTBOX00001) for textbox control (GTEXTBOX00001) to always have focus.
- (2) Using "OnKeyPress" of textbox control (GTEXTBOX00001), pass the specific key to the standard screen (KeyPress).
- (3) Using "OnClick" of button control (GBUTTON00002), acquire the value of textbox control (GTEXTBOX00001), and set it to textbox control (GTEXTBOX00000).

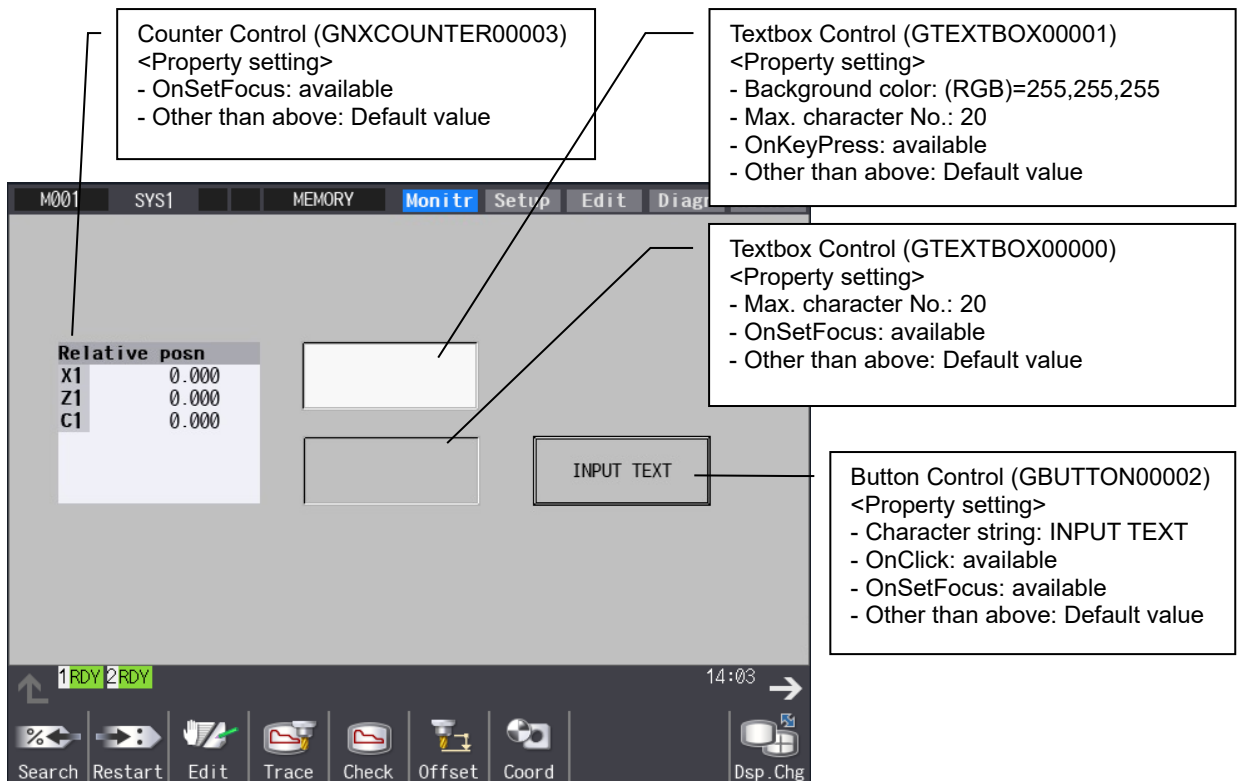

## Interpreter Method

Macro of each control event (OnXXX) should be created with "Screen macro edit".

## Macro

**(1) Processing to move the focus to GTEXTBOX00001 at each control**

```
$GButton00002-OnSetFocus
'Move the focus to GTEXTBOX00001
GCSChangeActiveFocus(-1, "GTextBox00001");
$End
```

```
$GNXCounter00003-OnSetFocus
'Move the focus to GTEXTBOX00001
GCSChangeActiveFocus(-1, "GTextBox00001");
$End
```

```
$GTextBox00000-OnSetFocus
'Move the focus to GTEXTBOX00001
GCSChangeActiveFocus(-1, "GTextBox00001");
$End
```

**(2) Processing to pass the specific key to standard screen (KeyPress)**

```
$GTextBox00001-OnKeyPress
'Set the status of modifier key. (SHIFT,CTRL,ALT)
long _IAttrKey;
_IAttrKey = 0;
if((LUPARAM & H1) != 0)
    _IAttrKey = 1;          'SHIFT valid
elseif((LUPARAM & H2) != 0)
    _IAttrKey = 2;          'CTRL valid
elseif((LUPARAM & H4) != 0)
    _IAttrKey = 3;          'ALT valid
endif;
```

'When the keys below are pressed, KeyPress processing on operation screen panel will be executed.

- ' Menu 1 to 10, Cancel, Next menu
- ' Function (Operation, Setup, Edit, Diagnosis, Maintenance)
- ' Custom screen (F0, SFP)
- ' Part system switchover, Guidance, Custom screen (Win display, Win switchover)
- ' Menu list

```
if(((_IAttrKey == 0) && ((LLPARAM >= 112) && (LLPARAM <= 123))) ||
    ((_IAttrKey == 1) && ((LLPARAM >= 112) && (LLPARAM <= 116))) ||
    ((_IAttrKey == 1) && ((LLPARAM >= 120) && (LLPARAM <= 121))) ||
    ((_IAttrKey == 2) && (LLPARAM >= 112) && (LLPARAM <= 115))) ||
    ((_IAttrKey == 2) && (LLPARAM == 119)))
    'Call for KeyPress on operation screen.
    GCSKeyPress(1000,LLPARAM,LUPARAM);
endif;
$End
```

**(3) Processing to set the value of GTEXTBOX00001 to GTEXTBOX00000 at clicking on button control.**

```
$GButton00002-OnClick  
  STRING _str;  
  'Acquire the value of GTextBox00001.  
  GCSTextboxGetString(-1, "GTextBox00001", _str);  
  'Set the value of GTEXTBOX00000 to GTEXTBOX00001.  
  GCSTextboxSetString(-1, "GTextBox00000", _str);  
$End
```

## Compilation Method

Generate source code and implement the processing to callback function (OnXXX) of each control.

## Source Code

```
#include <windows.h>
```

```
#define KEY_SHIFT    0x01
#define KEY_CTRL     0x02
#define KEY_ALT      0x04
#define GK_F1        112
#define GK_F4        115
#define GK_F5        116
#define GK_F8        119
#define GK_F9        120
#define GK_F10       121
#define GK_F12       123
```

**(1) Processing to move the focus to GTEXTBOX00001 at each control**

```
long GCWindow00003::GBUTTON00002OnSetFocus(unsigned short usMessage, long ILParam,
long IUParam)
```

```
{
    // Move focus to GTEXTBOX00001.
    GBaseObject *pChild = (GBaseObject*)GCSGetChild( GetGBaseObject(),
GTEXTBOX00001 );
    if(pChild != NULL)
    {
        GCSCChangeActiveFocus( GetGBaseObject(), pChild );
    }
    return TRUE;
}
```

```
long GCWindow00003::GNXCOUNTER00003OnSetFocus(unsigned short usMessage, long
ILParam, long IUParam)
```

```
{
    // Move focus to GTEXTBOX00001.
    GBaseObject *pChild = (GBaseObject*)GCSGetChild( GetGBaseObject(),
GTEXTBOX00001 );
    if(pChild != NULL)
    {
        GCSCChangeActiveFocus( GetGBaseObject(), pChild );
    }
    return TRUE;
}
```

```
long GCWindow00003::GTEXTBOX00000OnSetFocus(unsigned short usMessage, long ILParam,
long IUParam)
```

```
{
    // Move focus to GTEXTBOX00001.
    GBaseObject *pChild = (GBaseObject*)GCSGetChild( GetGBaseObject(),
GTEXTBOX00001 );
    if(pChild != NULL)
    {
        GCSCChangeActiveFocus( GetGBaseObject(), pChild );
    }
    return TRUE;
}
```

**(2) Processing to pass the specific key to standard screen (KeyPress)**

```

long GCWindow00003::GTEXTBOX00001OnKeyPress(unsigned short usMessage, long ILParam,
long IUParam)
{
    // Set the status of modifier key. (SHIFT,CTRL,ALT)
    short _sAttrKey = 0;
    if((IUParam & KEY_SHIFT) != 0)
    {
        _sAttrKey = 1;                //SHIFT valid
    }
    else if((IUParam & KEY_CTRL) != 0)
    {
        _sAttrKey = 2;                //CTRL valid
    }
    else if((IUParam & KEY_ALT) != 0)
    {
        _sAttrKey = 3;                //ALT valid
    }

    // When the keys below are pressed, KeyPress processing on operation screen panel will be
    executed.
    //   Menu 1 to 10, Cancel, Next menu
    //   Function (Operation to Maintenance)
    //   Custom screen (F0, SFP)
    //   Part system switchover, Guidance, Custom screen (Win display, Win switchover)
    //   Menu list
    if( ( _sAttrKey == 0) && ((ILParam >= GK_F1) && (ILParam <= GK_F12)) ) ||
        ( _sAttrKey == 1) && ((ILParam >= GK_F1) && (ILParam <= GK_F5)) ) ||
        ( _sAttrKey == 1) && ((ILParam >= GK_F9) && (ILParam <= GK_F10)) ) ||
        ( _sAttrKey == 2) && ((ILParam >= GK_F1) && (ILParam <= GK_F4)) ) ||
        ( _sAttrKey == 2) && (ILParam == GK_F8) ) )
    {
        GBaseObject *_pParent =
(GBaseObject*)GCSGetPanel( GCSGetScreen(GetGBaseObject()) );
        GCSKeyPress( _pParent, ILParam, IUParam);
    }
    return TRUE;
}

```

**(3) Processing to set the value of GTEXTBOX00001 to GTEXTBOX00000 at clicking on button control.**

```
long GCWindow00003::GBUTTON00002OnClick(unsigned short usMessage, long ILParam, long IUParam)
{
    // Acquire the value of GTEXTBOX00001.
    GTCHAR _gtText[20];
    _sgtprintf(_gtText, TEXT(""));
    GBaseObject *pChildText01 = (GBaseObject*)GCSGetChild( GetGBaseObject(),
GTEXTBOX00001 );
    if(pChildText01 != NULL)
    {
        GCSTextboxGetString(pChildText01, _gtText, 20);
    }

    // Set the value of GTEXTBOX00000.
    GBaseObject *pChildText00 = (GBaseObject*)GCSGetChild( GetGBaseObject(),
GTEXTBOX00000 );
    if(pChildText00 != NULL)
    {
        GCSTextboxSetString(pChildText00, _gtText);
    }
    return TRUE;
}
```

### 17.6.7 Selectable Display Assignment

Customized window can be displayed on the selectable display area of the monitor screen. In the same way as the selectable display of the standard screen, designated customized window (menu assignment) is opened by pressing the input key.

<10.4 type>

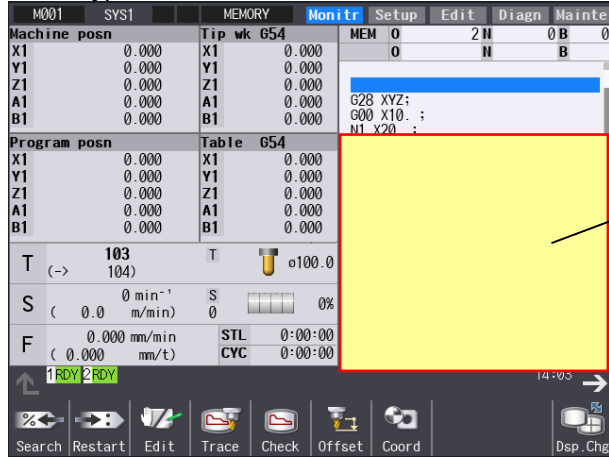

Selectable display assignment area  
(W: 289pixel)  
(H: 238pixel)  
(Coordinate: X, Y=350,145)

↓ Press [INPUT] key.

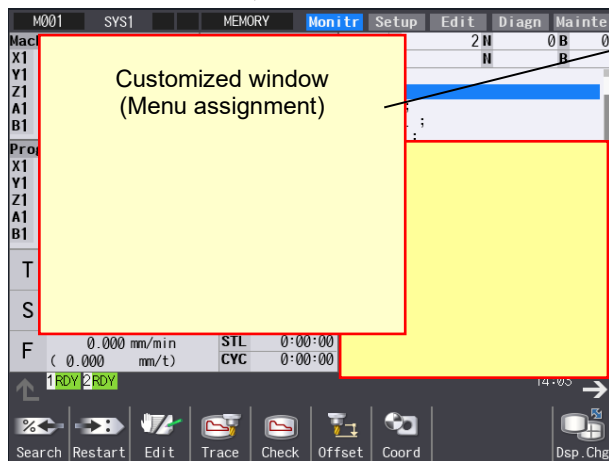

The designated customized window is opened.

<15 type>

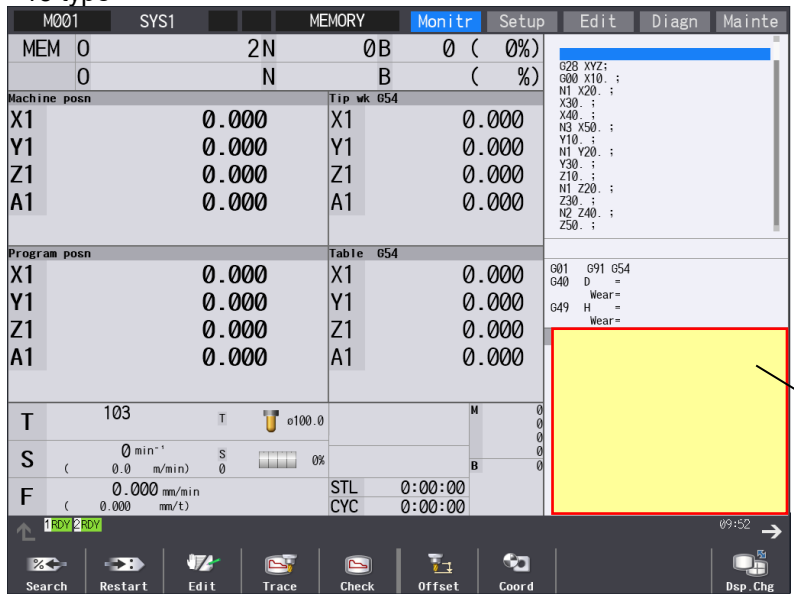

Selectable display assignment area  
(W: 319pixel)  
(H: 244pixel)  
(Coordinate: X, Y=703,421)

- (Note 1) For points of caution for creating customized window used for selectable display assignment, refer to "17.6.7.3 Caution for Creating Customized Window for Selectable Display Assignment".
- (Note 2) Customized window that is created with "EXE file registration method" cannot be displayed.
- (Note 3) The selectable display assignment area cannot be displayed on the simple monitor screen.
- (Note 4) Selectable display assignment cannot be used for CNC software tools (NC Monitor2, NC Maintainer).



**17.6.7.1 Interpreter Method**

In order to display a customized window that is created with interpreter method on the selectable display assignment area, "config.ini" and "customdef.ini" must be edited. The "customdef.ini" must be written in the Unicode (UTF-16 LE) text format.

**17.6.7.1.1 config.ini**

Refer to 17.6.4.1.1.

**17.6.7.1.2 customdef.ini**

Setting example

```

; • Set the No. of customized window to be displayed on the selectable display assignment area.
[CSELECT]
NUM=3
SELECT_OFFSET01=8001
WINDOW_OFFSET01=8002
SELECT_OFFSET02=8501
WINDOW_OFFSET02=8502
SELECT_OFFSET03=9001
WINDOW_OFFSET03=9002
    
```

Edit the following items in [CSELECT] section.

Key name	Details
NUM	Set the number of customized screens to be assigned in the selectable display assignment.  Setting range: 0 to 3 Default: 0
SELECT_OFFSETXX (XX=01~03)  Relation with the setting value of #8940 11 : SELECT_OFFSET01 12 : SELECT_OFFSET02 13 : SELECT_OFFSET03	Set the window No. to be displayed. The setting No. consists of "Offset No. designated in PAGE_OFFSET in config.ini + WINDOW No. in the project (0 to 255)". Even if the window No. set to this key is set to the menu assignment, the window is not opened as menu assignment.  Setting range: 8000 to 9999
WINDOW_OFFSETXX (XX=01~03)	Set the window No. of a customized window (menu assignment) that is opened by pressing input key. The windows to be displayed are only windows that are registered in the menu assignment on monitor screen. The setting No. consists of "Offset No. designated in PAGE_OFFSET in config.ini + WINDOW No. in the project (0 to 255)". However, a customized screen of EXE file registration method cannot be registered.  Setting range: 8000 to 9999

(Note 1) When the NUM key is 1 or more, SELECT\_OFFSET key and WINDOW\_OFFSET key are required to be set.

(Note 2) Do not insert spaces before and after "=" that is between key and value.

(Note 3) Even when moving from the monitor function to another function, instance in the customized window of selectable display is held. Therefore, it affects the memory utilization of customization.

### 17.6.7.2 Compilation Method

In order to display customized window that is created with the compilation method on selectable display assignment area, "config.ini" and "customdef.ini" must be edited. The "customdef.ini" must be written in the Unicode (UTF-16 LE) text format.

#### 17.6.7.2.1 config.ini

Refer to 17.6.4.2.1.

#### 17.6.7.2.2 customdef.ini

Refer to 17.6.7.1.2.

### 17.6.7.3 Caution for Creating Customized Window for Selectable Display Assignment

#### 17.6.7.3.1 Size and Display Coordinate of Displayed Customized Window

Display size and display coordinate of the customized window follow the setting in the panel/window property in NC Designer2. Therefore, the values shown below must be set for the property setting (position and size).

When the property (position and size) is not correctly set, deviation might occur on the display coordinate or the window might be too big for the display range.

<Property setting (10.4 type)>

Property	
Panel/Window	
All	
Window Name	Window00001
X	350
Y	145
WIDTH	289
HEIGHT	238
Background Color	
Background File	Yes
Background image	ID_IMAGE00001
Title	
Use of title bar	No
Use of close button	No
Use of window frame	No
Blink off time(ms)	100
Blink on time(ms)	100

Coordinate  
10.4 type: X, Y=350,145  
15 type: X, Y=703,421

Width  
10.4 type: WIDTH=289  
15 type: WIDTH=319

Height  
10.4 type: HEIGHT=238  
15 type: HEIGHT=244

Existence of a title bar: None  
Existence of a close button: None  
Existence of a window frame: None

**17.6.7.3.2 Customized Window Focus/ Available Event**

Customized window for selectable display assignment must be created without being focused. However, the events such as touch panel operation or key input are received and processed by an active control (BasicControl, etc.). Also, the event of touch panel operation is received and processed by a control that is touched (Refer to 17.6.7.3.4). Set "None" to the property of control so that the events that the availability is marked with "x" in the following table cannot be used.

<Event list>

Availability	Event	Details
○	OnKeyPress	Execute after the key is pressed. An active control receives the key event.
×	OnKeyRelease	Execute after the key is released. Key event can be retrieved only when the focus of control parts is active.
○	OnPress	Execute after a pointing device such as a mouse is pressed.
○	OnRelease	Execute after a pointing device such as a mouse is released.
×	OnClick	Execute after a pointing device such as a mouse is clicked. When a pointing device is released on the same control, it is executed after "OnRelease" operation.
○	OnDraw	Execute after drawing is completed.
○	OnTimer	Execute after timer event process is called.
×	OnSetFocus	Execute after a control is focused.
×	OnKillFocus	Execute after the focus on a control is released.
○	OnCreate	Execute after page / control is created.
○	OnDelete	Execute before page/ control is deleted.
×	OnUser	Execute after process of user's original event is completed.
×	OnScroll	Execute after a scroll bar is clicked by a pointing device such as a mouse.
×	OnScrollFinish	Execute after caption character scroll is completed.
×	OnSelectChange	Change a selecting line with a list.
○	OnInit	Execute after "OnCreate" when page/ control is created.
○	OnQuit	Execute before "OnDelete" when page/ control is deleted.

17.6.7.3.3 Sample Code (Switching Axis to Be Displayed with Page Key/Part System Switch Key)

In the customized window of the selectable display assignment, the display can be switched only by page keys (PAGE, PAGE, ↑, ↓, ←, →, → (right tab), ← (left tab)) and part system switch key.

The following is sample code when switching an axis displayed in CounterControl and switching a part system with page key (PAGE).

<Operation of sample code>

Press page key (PAGE).

Project Setting Example

(1) Paste BasicControl.

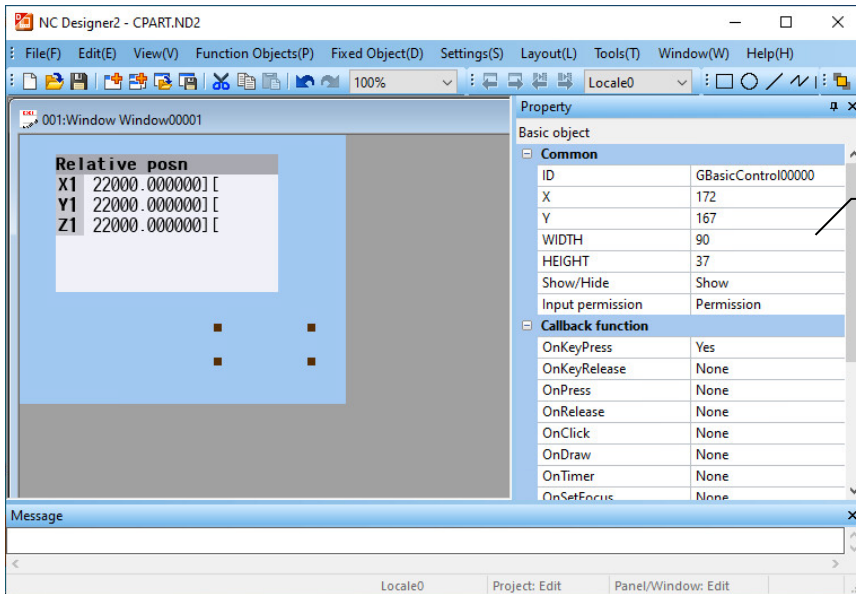

BasicControl  
 <Property setting>  
 X: 172  
 Y: 167  
 WIDTH: 90  
 HEIGHT: 37  
 OnCreate: Yes  
 OnKeyPress: Yes

Other than the above:  
 Default value

(2) Paste CounterControl.

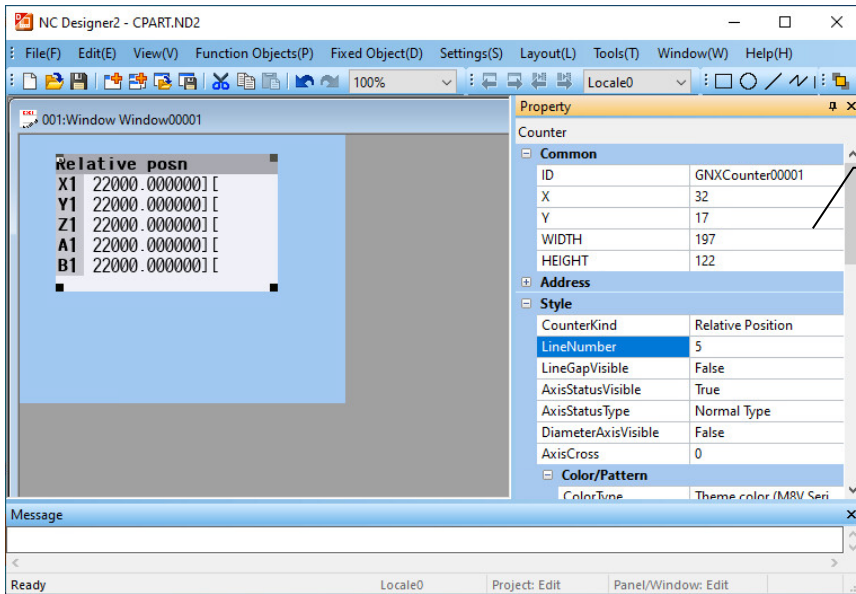

CounterControl  
 <Property setting>  
 X:32  
 Y:17  
 WIDTH:197  
 HEIGHT:122  
 LineNumber:5  
 OnSetFocus: Yes

Other than the above:  
 Default value

## Interpreter Method

The following 2 types of processing are implemented in the sample code.

- (1) Using "OnSetFocus" of other controls, move the focus to BasicControl so that it is always active.
- (2) Switch the display of CounterControl by discriminating the types of keys with "OnKeyPress" of BasicControl.

## Macro

**(1) Processing to move the focus to GBasicControl00000 at each control**

```
$GBasicControl00000-OnCreate
'Move the focus to GBasicControl00000 at generation.
GCSCChangeActiveFocus(-1, "GBasicControl00000");
$End
```

```
$GNXCounter00001-OnSetFocus
'Move the focus to GBasicControl00000.
GCSCChangeActiveFocus(-1, "GBasicControl00000");
$End
```

**(2) Processing to switch an axis to be displayed in GNXCounter00001 when page key (  ) and part system switch key are input**

```
$GBasicControl00000-OnKeyPress
long _IMainKey;
long _ICtrlKey;
_IMainKey = LLPARAM;
_ICtrlKey = LUPARAM & H2;
'Display the next axis when PageDown key is pressed.
if(_IMainKey == 34)
GCSCCounterAxisChange(-1, "GNXCounter00001");
Endif
'Display the second part system when the part system switch key is pressed.
if((_IMainKey == 112) && (_ICtrlKey == 2))
GCSSetSystemNumber(-1, "GNXCounter00001", 2);
Endif
$End
```

## Compilation Method

The following processing is implemented in the sample code.

- (1) Using "OnSetFocus" of other controls, move the focus to BasicControl so that it always has focus.
- (2) Switch the display of CounterControl by discriminating the types of keys with "KeyPress()" of customized window (GCWindow00002).

## Source Code

```
#include <windows.h>
```

```
#define GK_NEXT          34
#define KEY_SHIFT        1
#define KEY_CTRL         2
#define GK_F1           112
```

**(1) Processing to move the focus to GBASICCONTROL00000 at each control**

```
long GCWindow00003::GBASICCONTROL00000OnCreate(unsigned short usMessage, long
ILParam, long IUParam)
{
    // Move the focus to GBASICCONTROL00000.
    GBaseObject *pChild = (GBaseObject*)GCSGetChild( GetGBaseObject(),
GBASICCONTROL00000 );
    if(pChild != NULL)
    {
        GCSCChangeActiveFocus( GetGBaseObject(), pChild );
    }
    return TRUE;
}

long GCWindow00002::GNXCOUNTER00001OnSetFocus(unsigned short usMessage, long
ILParam, long IUParam)
{
    // Move the focus to GBASICCONTROL00000.
    GBaseObject *pChild = (GBaseObject*)GCSGetChild( GetGBaseObject(),
GBASICCONTROL00000 );
    if(pChild != NULL)
    {
        GCSCChangeActiveFocus( GetGBaseObject(), pChild );
    }
    return TRUE;
}
```

**(2) Processing to switch an axis to be displayed in GNXCOUNTER00001 when page key (PAGE) and part system switch key are input**

```
long GCWindow00002::GBASICCONTROL00000OnKeyPress(unsigned short usMessage, long
ILParam, long IUParam)
{
    // Set the status of modifier key. (SHIFT,CTRL,ALT)
    short _sAttrKey = 0;
    if((IUParam & KEY_SHIFT) != 0)
    {
        _sAttrKey = 1;           //SHIFT valid
    }
    else if((IUParam & KEY_CTRL) != 0)
    {
        _sAttrKey = 2;           //CTRL valid
    }

    GBaseObject *_pChild = (GBaseObject*)GetChild(GNXCOUNTER00001);

    if((_sAttrKey == 0) && (ILParam == GK_NEXT))
    {
        // Display the next axis when PageDown key is pressed.
        GCSSetSystemNumber(_pChild, 2);
    }
    if((_sAttrKey == 2) && (ILParam == GK_F1))
    {
        // Display the second part system when part system switch key is pressed.
        GCSSetSystemNumber(_pChild, 2);
    }
    return TRUE;
}
```



17.6.7.3.4 Sample Code (Displaying the Next Axis by Touching a Button)

In the customized window of the selectable display assignment, the display can be switched by touching a button.

The following is sample code when switching an axis to be displayed in CounterControl by touching [Next Ax] button.

<Operation of sample code>

The screenshot shows the 'Monitr' screen with the following data:

Machine posn	Relative posn
X 0.000	X 0.000
Y 0.000	Y 0.000
Z 0.000	Z 0.000
A 0.000	A 0.000
B 0.000	B 0.000
C 0.000	C 0.000

Relative posn window:

X1 0.000
Y1 0.000
Z1 0.000

Code window:

```
G28 XYZ;
G00 X10. ;
N1 X20. ;
```

Buttons: Search, Restart, Edit, Trace, Check, Offset, Coord, Dsp.Chg

↓ Touch [Next Ax] button.

The screenshot shows the 'Monitr' screen after the button touch. The 'Relative posn' window now displays:

A1 0.000
B1 0.000
C1 0.000

The 'Next Ax' button remains visible.

Project Setting Example

(1) Paste BasicControl.

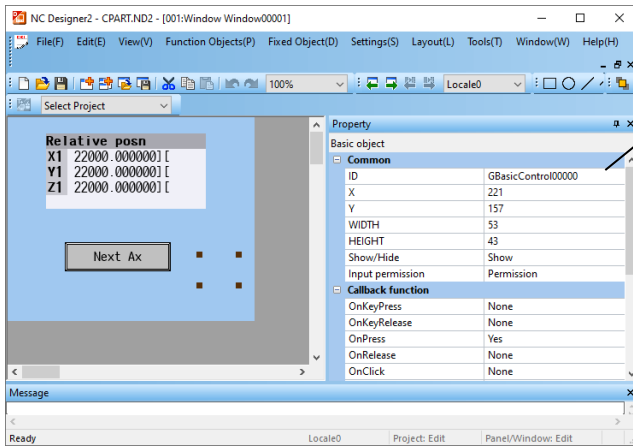

BasicControl  
 <Property setting>  
 X: 221  
 Y: 157  
 WIDTH: 53  
 HEIGHT: 43  
 OnCreate: Yes  
 OnPress: Yes

Other than the above:  
 Default value

(2) Paste CounterControl.

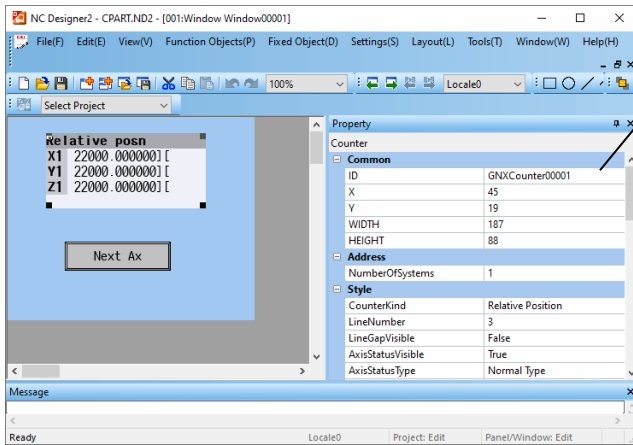

CounterControl  
 <Property setting>  
 X: 45  
 Y: 19  
 WIDTH: 187  
 HEIGHT: 88  
 LineNumber: 3  
 OnSetFocus: Yes

Other than the above:  
 Default value

(3) Paste ButtonControl.

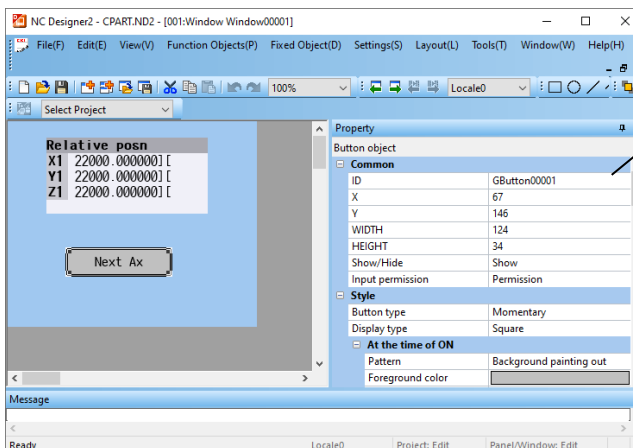

ButtonControl  
 <Property setting>  
 X: 67  
 Y: 146  
 WIDTH: 124  
 HEIGHT: 34  
 Input permission: Prohibition  
 OnSetFocus: Yes

Other than the above:  
 Default value

## Interpreter Method

The following 2 types of processing are implemented in the sample code.

- (1) Using "OnSetFocus" of other controls, move the focus to BasicControl so that it is always active.
- (2) Display the next axis in CounterControl by discriminating the touched position with "OnPress" of BasicControl.

## Macro

**(1) Processing to move the focus to GBasicControl00000 at each control**

```
$GBasicControl00000-OnCreate
'Move the focus to GBasicControl00000 at generation.
GCSCChangeActiveFocus(-1, "GBasicControl00000");
$End
```

```
$GNXCounter00001-OnSetFocus
'Move the focus to GBasicControl00000.
GCSCChangeActiveFocus(-1, "GBasicControl00000");
$End
```

```
$GButton00002-OnSetFocus
'Move the focus to GBasicControl00000.
GCSCChangeActiveFocus(-1, "GBasicControl00000");
$End
```

**(2) Processing to switch an axis to be displayed in GNXCounter00001 when [Next Ax] button is pressed.**

```
$GBasicControl00000-OnPress
'Acquire the position of button control.
GMEM mem;
SHORT _RectXmin;
SHORT _RectXmax;
SHORT _RectYmin;
SHORT _RectYmax;
long _PosX;
long _PosY;
mem = GMEMCreate("TESTMEM", 8);
GCSCGetBounds(-1, "GButton00002", mem);
_RectXmin = GMEMGetShort(mem, 0);
_RectYmin = GMEMGetShort(mem, 2);
_RectXmax = GMEMGetShort(mem, 4);
_RectYmax = GMEMGetShort(mem, 6);

'Acquire the touched position.
_PosX = LUPARAM & H0000FFFF;
_PosY = (LUPARAM & HFFFF0000) >> 16;

'Switch the axis to be displayed in the counter when the button is touched.
if ((_PosX >= _RectXmin) && (_PosX <= _RectXmax) && (_PosY >= _RectYmin) && (_PosY <=
_RectYmax))
  GCSCCounterAxisChange(-1, "GNXCounter00001");
Endif

'Delete the area that the button position was stored.
GMEMDelete(mem);
$End
```

## Compilation Method

The following processing is implemented in the sample code.

- (1) Using "OnSetFocus" of other controls, move the focus to BasicControl so that it is always active.
- (2) Display the next axis in CounterControl by discriminating the touched position with "OnPress" of BasicControl.

## Source Code

```
#include <windows.h>
```

**(1) Processing to move the focus to GBASICCONTROL00000 at each control**

```
long GCWindow00003::GBASICCONTROL00000OnCreate(unsigned short usMessage, long
ILParam, long IUParam)
{
    // Move the focus to GBASICCONTROL00000.
    GBaseObject *pChild = (GBaseObject*)GCSGetChild( GetGBaseObject(),
GBASICCONTROL00000 );
    if(pChild != NULL)
    {
        GCSCChangeActiveFocus( GetGBaseObject(), pChild );
    }
    return TRUE;
}

long GCWindow00003::GNXCOUNTER00001OnSetFocus(unsigned short usMessage, long
ILParam, long IUParam)
{
    // Move the focus to GBASICCONTROL00000.
    GBaseObject *pChild = (GBaseObject*)GCSGetChild( GetGBaseObject(),
GBASICCONTROL00000 );
    if(pChild != NULL)
    {
        GCSCChangeActiveFocus( GetGBaseObject(), pChild );
    }
    return TRUE;
}

long GCWindow00003::GBUTTON00002OnSetFocus(unsigned short usMessage, long ILParam,
long IUParam)
{
    // Move the focus to GBASICCONTROL00000.
    GBaseObject *pChild = (GBaseObject*)GCSGetChild( GetGBaseObject(),
GBASICCONTROL00000 );
    if(pChild != NULL)
    {
        GCSCChangeActiveFocus( GetGBaseObject(), pChild );
    }
    return TRUE;
}
```

**(2) Processing to switch an axis to be displayed in GNXCounter00001 when [Next Ax] button is pressed.**

```
long GCWindow00003::GBASICCONTROL00000OnPress(unsigned short usMessage, long
ILParam, long IUParam)
{
    // Acquire the position of button control.
    GRect _GRect;
    _GRect.nXmin = 0;
    _GRect.nXmax = 0;
    _GRect.nYmin = 0;
    _GRect.nYmax = 0;
    GBaseObject *_pChild = GetChild( GBUTTON00002 );
    short _nX = (short) (IUParam & 0xffff);
    short _nY = (short) ((IUParam & 0xffff0000)>>16);
    if(_pChild != NULL)
    {
        GCSGetBounds( _pChild, &_GRect );

        // Switch the axis to be displayed in the counter when the button is touched.
        if((_nX >= _GRect.nXmin) && (_nX <= _GRect.nXmax) &&
            (_nY >= _GRect.nYmin) && (_nY <= _GRect.nYmax))
        {
            _pChild = GetChild( GNXCOUNTER00001 );
            if(_pChild != NULL)
            {
                GCSAxisChange(_pChild);
            }
        }
    }
    return TRUE;
}
```

### 17.6.8 G Code Guidance Release, M Code Guidance Release

MTB's original G code (G code macro) guidance or M code (M code macro) guidance can be displayed on the G code guidance display area in edit screen. The G code guidance corresponding to the G code macro or the M code guidance corresponding to the M code can be displayed when the MTB creates the guidance file (HTML format) for G code macro or for M code and stores it in a custom folder.

If both the standard G code guidance file and MTB's G code guidance file exist, MTB's G code guidance is displayed.

< 10.4 type >

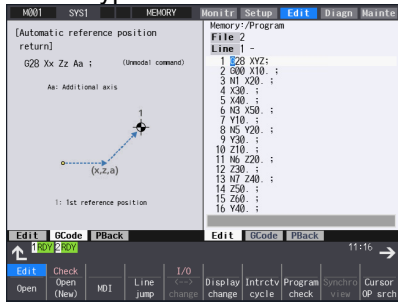

Display the standard G code guidance

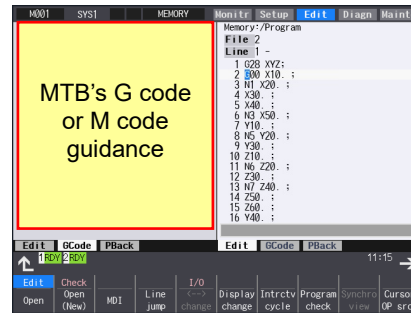
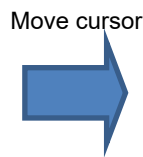

Display the MTB's G code or M code guidance

< 15type Edit 3 screens >

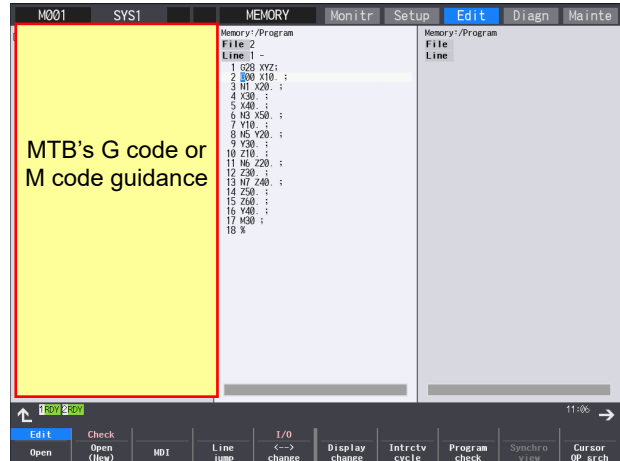

Fig 1 Figure of G code or M code guidance release

(Note 1) Peripheral tools (NC Monitor, NC Maintainer) cannot display the MTB's G code guidance.

**17.6.8.1 Designation of the Guidance File Folder**

To display the guidance file on the G code guidance display area in edit screen, edit config.ini. If there is no MTB's G code in the designated folder, the standard G code guidance is displayed.

**17.6.8.1.1 Config.ini**

Example

```
[HTML_BROWSER]
HTMLDATA_GCODE=D:\custom\gcode_guide\
HTMLDATA_MCODE=D:\custom\mcode_guide\
```

Edit the following items in [HTML\_BROWSER] section.

Key name	Details
HTMLDATA_GCODE	- Designate the folder to store the guidance file. Example) < When using M800V/M80V/M800/M80 (Windows-based display unit) > HTMLDATA_GCODE=D:\custom\gcode_guide\ Designate the folder under :\custom. < When using M800V/M80V/M800/M80 (Windows-less display unit) > HTMLDATA_GCODE=gcode_guide/
HTMLDATA_MCODE	- Designate the folder to store the M code guidance file. Example) < When using M800V/M80V/M800/M80 (Windows-based display unit) > HTMLDATA_MCODE=D:\custom\mcode_guide\ Designate the folder under D:\custom. < When using M800V/M80V/M800/M80 (Windows-less display unit) > HTMLDATA_MCODE=mcode_guide/

(Note 1) When using the figure in the guidance, create the file of the image figure that uses the background color designated by the base common parameter "#11060 Screen theme color" (blue tone/gray tone). Store it in the same folder where the guidance file is.

**17.6.8.2 Format of the Guidance File**

Formats of the guidance file are as follows.

**17.6.8.2.1 File Name**

File names of the format are as follows.

(1) File name of the G code guidance

□g○○○○\_△△△.htm

Table 2 File name settings

Example	Details	Example
□	Select between M system and L system.	M system: "m" L system: "l" *M2 format cannot be designated.
○○○○	Specify with the four digit number following the address G multiplied by 10	G80 : "0800" G180 : "1800" G180.1 : "1801"
△△△	Select the language	eng : English deu: German ita: Italian chi2: Chinese (traditional) por: Portuguese swe: Swedish pol: Polish rus: Russian cze: Czech vie: Vietnamese  jpn: Japanese fra: French spa: Spanish kor: Korean dut: Dutch hun: Hungarian chi1: Chinese (simplified) tur: Turkish ind: Indonesian  * If there is no file for the onscreen language, the file for English is used instead.

(2) File name of the M code guidance

mc○○○○○○○○\_△△△.htm

Table 3 File name settings of the M code guidance

Example	Details	Example
○○○○○○○○	Specify with the eight digit number following the address M.  However, when the corresponding M code guidance file does not exist, the M code guidance of the command value whose last digit is excluded is displayed. When that M code guidance file does not exist either, the M code guidance of the command value whose last two digits are excluded is displayed.	M1 : "00000001" M10 : "00000010" M100 : "00000100" M1000 : "00001000"  <Example of when the M code guidance does not exist> M198: When "00000198" does not exist, the M code guidance of "00000019" is displayed. When "00000019" does not exist, either, the M code guidance of "00000001" is displayed, followed by "00000000".
△△△	Select the language	eng : English deu: German ita: Italian chi2: Chinese (traditional) por: Portuguese swe: Swedish pol: Polish rus: Russian cze: Czech vie: Vietnamese  jpn: Japanese fra: French spa: Spanish kor: Korean dut: Dutch hun: Hungarian chi1: Chinese (simplified) tur: Turkish ind: Indonesian  * If there is no file for the onscreen language, the file for English is used instead.



<Creation example of the M code guidance>

By preparing the M code guidance file as shown below, in addition to the entered M code, a list of proposed M codes can also be displayed while entering an M code.

Table 4 File names and the descriptions of the M code guidance

File name	Description
mc00000000_<language>.htm	Details of "M0" and outlines of all the M codes are described.
mc00000001_<language>.htm	Details of "M1" and outlines of the M codes that start with "M1", such as "M10 to M19, the M100s, the M1000s..." are described.
mc00000010_<language>.htm	Details of "M10" and outlines of the M codes that start with "M10", such as "M100 to M109, the M1000s..." are described.

(1)

Enter "M".



The contents of "mc00000000\_<language>.htm" are displayed in the guidance.

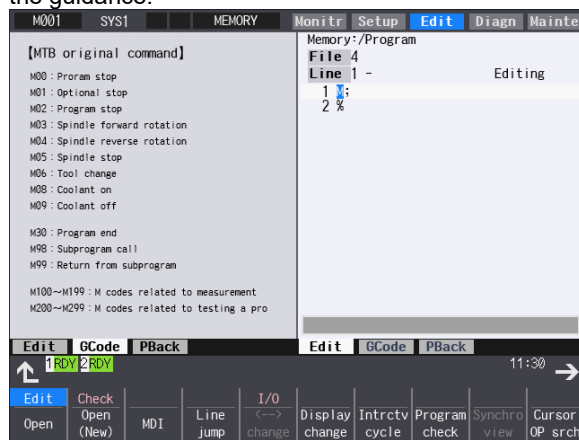

(2)

Enter "M1".



The contents of " mc00000001\_<language>.htm " are displayed in the guidance.

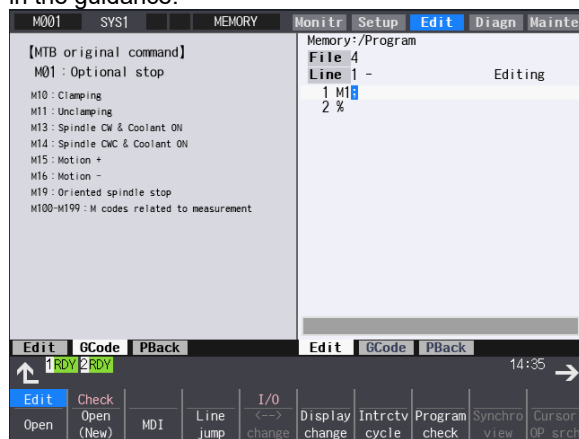

(3)

Enter "0".



The contents of " mc0000010\_<language>.htm " are displayed in the guidance.

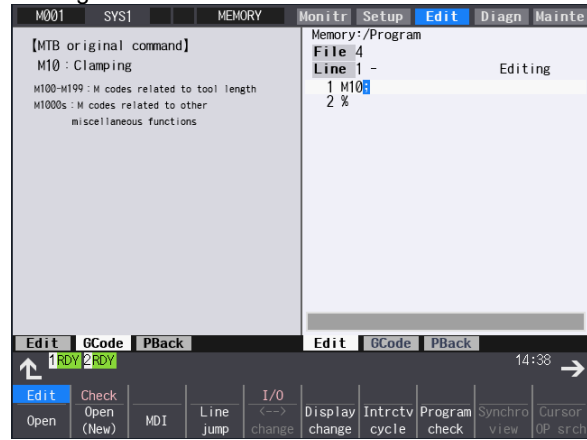

(4)

Enter "0".



Since the guidance of "mc00000100\_<language>.htm" does not exist, the guidance of the input value whose last digit is excluded is displayed. In this case, "mc0000010\_<language>.htm" is displayed.

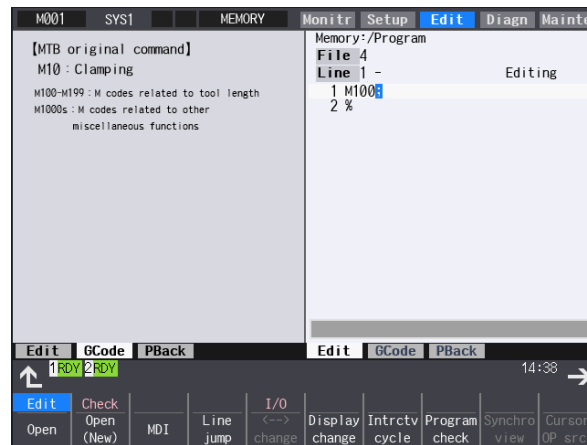

17.6.8.2.2 HTML File

The same tags as HTML browser control can be used. Refer to "Appendix 7. HTML Tag List". The setting of the character code differs depending on the language. Set as follows.

Table 5 Example of setting the character code for each language

Tag	Description	Character code			
charset	Set the character code	English	:windows-1252	Japanese	:Shift_JIS
		German	:windows-1252	French	:windows-1252
		Italian	:windows-1252	Spanish	:windows-1252
		Chinese (traditional)	:big5	Korean	:ks_c_5601-1987
		Portuguese	:windows-1252	Dutch	:windows-1252
		Swedish	:windows-1252	Hungarian	:windows-1250
		Polish	:windows-1250	Chinese (simplified)	:gb2312
		Russian	:windows-1251	Turkish	:cp1254
		Czech	:windows-1250	Indonesian	:windows-1252
		Vietnamese	: windows-1258		

The following is the sample file (mg1010\_jpn.htm) of the G code guidance screen.

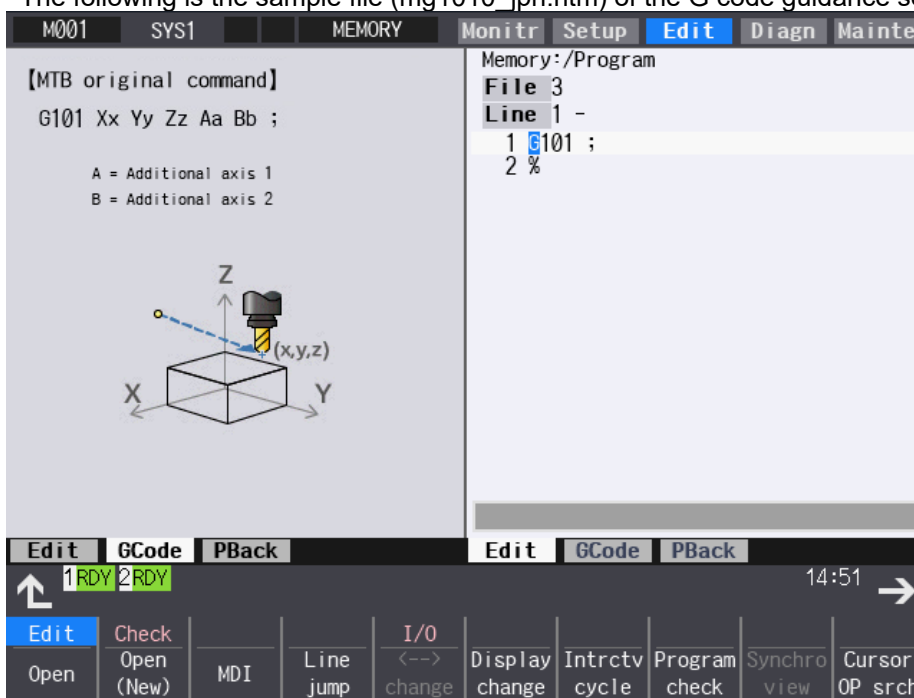

Fig 2 Sample screen of G code guidance release

```

<html>
<head>
<meta content="text/html; charset=Shift_JIS">
</head>

<body>
<font size="3"> [MTB original command] </font><br>
<br>
<font size="3"> G101 Xx Yy Zz Aa Bb ;</font><br>
<br>
<font size="1"> a = Additional axis 1<br>
<font size="1"> b = Additional axis 2<br>
<br>
<br>
<center></center>
</body>
</html>
    
```

Annotations for the HTML code:

- Set the character code (points to `Shift_JIS`)
- Display with the normal font size (points to `[MTB original command]`)
- Display with the small font size (points to `a = Additional axis 1`)
- Designate the image figure position (points to `mg1010.jpg`)
- Designate the file name of the image figure (points to `mg1010.jpg`)

The following is the sample file (mc00000000\_jpn.htm) of the M code guidance screen.

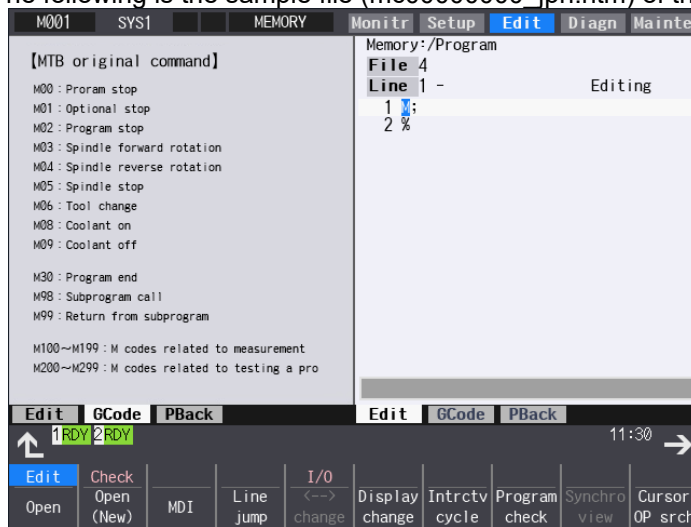

Fig 3 Sample screen of M code guidance release

```

<html>
<head>
<meta content="text/html; charset=Shift_JIS">
</head>

<body>
<font size="3"> [MTB original command] </font><br>
<br>
<font size="1"> M00: Program stop </font><br>
<font size="1"> M01: Optional stop </font><br>
<font size="1"> M02: Program end </font><br>
<font size="1"> M03: Spindle forward rotation </font><br>
<font size="1"> M04: Spindle reverse rotation </font><br>
<font size="1"> M05: Spindle stop </font><br>
<font size="1"> M06: Tool change </font><br>
<font size="1"> M08: Coolant on </font><br>
<font size="1"> M09: Coolant off </font><br>
<br>
<br>
<font size="1"> M30: Program end </font><br>
<font size="1"> M98: Subprogram call </font><br>
<font size="1"> M99: Return from subprogram </font><br>
<br>
<br>
<font size="1"> M100 to M199: M codes related to measurement </font><br>
<font size="1"> M200 to M299: M codes related to testing a program </font><br>
<font size="1"> M300 to M399: M codes related to interrupt operation </font><br>
</body>
</html>
    
```

Set the character code

Display with the normal font size

Display with the small font size

Table 6 Number of characters that can be displayed in a line for each font size

Display screen	Font size	Number of characters that can be displayed in line (one-byte characters)
10.4 type Edit 2 screens 15 type Edit 3 screens	font size="1"	46
	font size="3"	35
	font size="6"	23
15 type Edit 3 screens	font size="1"	59
	font size="3"	39
	font size="6"	29

**17.6.8.2.3 Precautions**

1. The screen cannot be scrolled even if the length of guidance is larger than the display area. Create a guidance file that matches the G code guidance area size.
2. 100K bite is the upper limit of the HTML file size.
3. The supported image format is jpeg only; other image file formats are not displayed.
4. Select the color between "256 Colors (8 bit) " and "24 bitColors". "24 bit Colors" are reduced to 16 bit Colors (RGB565).
5. Adjust the background color of the figure to the base color (blue tone/gray tone) that MTB uses. The following is the RGB value for each base color.

Table 7 RGB value of screen background color by base common parameters "#11060 Screen theme color"

#11060 value	R	G	B
0 (Gray tone)	216 (0xd8)	216 (0xd8)	224 (0xe0)
1 (Blue tone)	219 (0xdb)	221 (0xdd)	244 (0xf4)

6. When using M800V/M80V/M800/M80 (Windows-based display unit), install the G code guidance or M code guidance by using HMI integrated installer. Refer to "Appendix 9. HMI Integrated Installer" for details.
7. When using M800V/M80V/M800/M80 (Windows-less display unit), install the G code guidance or M code guidance by using M80/M800 SETUP INSTALLER. Refer to "Appendix 11. Installing Custom Data (M800V/M80V/M800/M80 (Windows-less Display Unit))".
8. When the cursor is moved to the letter M or after on a G command block that includes the address M (such as G65), the M code guidance is displayed.

### 17.6.9 Limitation of Number of Project Registration

Projects of the interpreter method (GIP file) can be registered up to ten. Projects of the compilation method (DLL file) can be registered up to three.

At this time, correspond as follows so as not to exceed the maximum number.

- Register two or more windows in one project.
- Register two or more screens in one project.

#### 17.6.9.1 Register Two or More Windows in One Project

Two or more windows used by the menu release are registered in one project.

Even if the screen where each window is displayed is different, the windows can be registered.

The example of registering the two windows for menu release in one project is as follows.

Ex.)

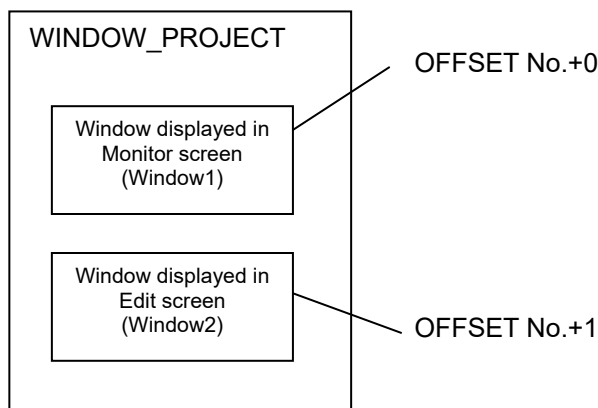

1. Create two windows in one project.  
(The window is number in order of creation: The offset No.+0, the offset No.+1 ... )
2. Create the GIP file or the DLL file from the project created by step 1.
3. Register the file name and offset No. (It is assumed 8000 here.) created by step 2 to Config.ini.
4. Register to display the window offset No. 8000 on Monitor screen and the window offset No. 8001 on Edit screen by [CMENU] section of customdef.ini. (Refer to 17.6.5 for detail of the setting method.)
5. Window1 can be registered on the Monitor screen and Window2 can be registered in the Edit screen.

### 17.6.9.2 Register Two or More Screens in One Project

Two or more screens used by the F0 release are registered in one project. The example of registering the screen for F0 key and the screen for SFP key in one project is as follows.

Ex.)

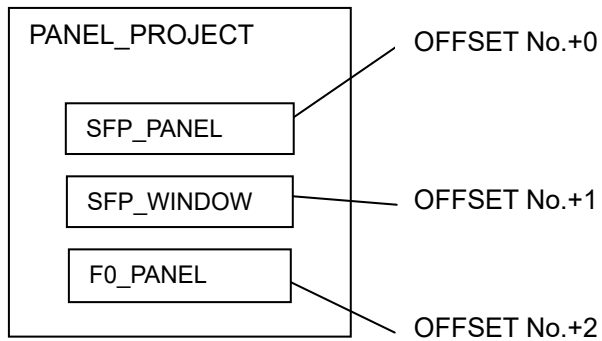

1. Create the screen when the F0 key is pressed and the screen when the SFP key is pressed in one project.  
(In the above example, the panel of F0 is registered as the third screen. )
2. Create the GIP file or the DLL file from the project created by step 1.
3. Register the file name and offset No. (It is assumed 6000 here.) created by step 2 to Config.ini.
4. Register to display the offset No. 6000 at SFP key and the offset No. 6002 at F0 key by [COFFSET] section of customdef.ini. (Refer to 17.6.4 for detail of the setting method.)
5. When the SFP key is pressed, SFP\_PANEL is displayed, and when the F0 key is pressed, F0\_PANEL is displayed.

**17.6.10 About the Switch of Display/Non-display of the Menu by the Parameter**

In this paragraph, the specification of function (MCAppGetMenuState()) which checks display/non-display of the menu is explained.

When display/non-display of the menu is switched by parameter, it is necessary to create the function MCAppGetMenuState() in the DLL designated by the [CMENU] section - "MENU\_STATE\_DLL" key of customdef.ini file and to judge non-display/display.

When the DLL file is specified in the "MENU\_STATE\_DLL" key, the specified DLL file is called, and display/non-display of the menu is switched by the return value. When the DLL file set in key does not exist or the MCAppGetMenuState() function is not defined in the DLL file, the menu is not displayed. When "MENU\_STATE\_DLL" is not set, the menu is unconditionally displayed.

	Function name	MCAppGetMenuState()		
Process	Returns whether to display the menu at the specified position.			
Argument	Type	Data name	I/O	Explanation
	const long	_IScreenType	I	Screen type (0 to 4) 0: Monitor 1: Setup 2: Edit 3: Diagnosis 4: Maintenance
	const long	_IMenuPos	I	Menu position (0 to 39) 0 to 9 : 1st page 10 to 19 : 2nd page 20 to 29 : 3rd page 30 to 39 : 4th page
Return value	long (TRUE : Display/Not TRUE : Non-display)			
Details	Judge the display/non-display of the menu, and set TRUE : Display/Not TRUE : Non-display to the return value.			

**Function model**

```

//*****
//
//      <Function name>          MCAppGetMenuState
//      <Function>              Returns whether to display the menu at the specified position.
//
//      [Argument]
//          const long _IScreenType      (i) Screen type (0 to 4)
//          const long _IMenuPos        (i) Menu position (0 to 39)
//
//      [Return value]
//          long      TRUE                : Menu display
//                  Not TRUE            : Menu non-display
//
//
//*****
long MCAppGetMenuState( const long _IScreenType, const long _IMenuPos )
{
    return TRUE;
}
    
```



### 17.6.11 Adjusting Standard and Customized Screen Size according to Resolution

Although the display size of standard and customized screens is either VGA (640×480) or XGA (1024×768), you can expand or contract the size according to the resolution of the display unit by the Config.ini setting.

This setting is valid only for M800V/M80V/M800/M80 (Windows-based display unit).

- Add "VIEW\_WIDTH=XX (display width)" "VIEW\_HEIGHT=XX (display height)" in the SCREEN section of Config.ini.

Setting example

```
[SCREEN]
VIEW_WIDTH=1280
VIEW_HEIGHT=1024
```

[SCREEN] section

Key name	Description	Setting range
VIEW_WIDTH	Specifies screen width in pixels.	480 to 2048
VIEW_HEIGHT	Specifies screen height in pixels.	320 to 2048

- (Note 1) This function does not work with a model other than M800V/M80V/M800/M80 (Windows-based display unit).
- (Note 2) If either VIEW\_WIDTH or VIEW\_HEIGHT is undefined, the normal display size (width and height of VGA or XGA) is used.
- (Note 3) If you set a value out of setting range, the display appears as a minimum value or maximum value of the setting range.
- (Note 4) When you set VIEW\_WIDTH and VIEW\_HEIGHT to the maximum values, the memory is used around 550MB for the display. In the case that memory cannot be secured, the standard and customized screens are not displayed. Set VIEW\_WIDTH or VIEW\_HEIGHT to the smaller value.
- (Note 5) When you set VIEW\_WIDTH and VIEW\_HEIGHT to a smaller value than the normal display size, the boundaries between screen parts and other thin lines are reduced and may not be displayed.

### 17.6.12 Displaying an Original Logo on the Standard Screen

A logo created by the machine tool builders can be displayed on the upper left of the standard screen. To display the logo, create a logo file (JPG) and install it. If a logo file which is prepared by the machine tool builders exists, unit name (base common parameter #1135 unt\_nm) is not displayed.

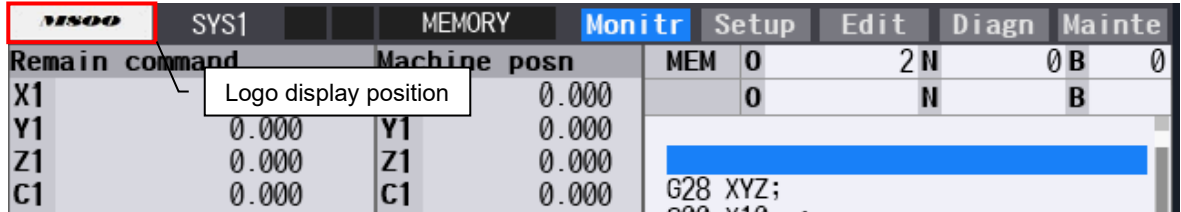

<Logo file specifications>

File name	logo.jpg	
Storage area *1	M800V/M80V/M800/M80 (Windows-based display unit)	D:/custom
	M800V/M80V/M800/M80 (Windows-less display unit)	/Custom/ *1
Size *2	VGA	22×80 pixel
	XGA	32×135 pixel
Number of colors *3	16 bit	

- \*1 For M800V/M80V/M800/M80 (Windows-less display unit), add the prepared logo file to the installer in the same way as the custom screen module (Refer to "Appendix 11. Installing Custom Data (M800V/M80V/M800/M80 (Windows-less display unit))" for details).
- \*2 When the size of the prepared logo file is different from the one specified, the display image may be different from the original because scaling is executed according to the display range.
- \*3 When the prepared logo file is other than 16-bit color file, the display image may be different from the original because the color is converted to 16-bit color.

**17.6.13 Parameter**

The list of the parameter is described in this paragraph.

**17.6.13.1 User Parameters****(1) Operation parameters**

No.	Name	Details	Setting range
#8940	Set select display	Select the screen to be displayed on the selectable display assignment area. 0: Common variable 1: Local variable 2: Workpiece coordinate system offset 3: All spindles' rotation speed 4: Common variables 5: Tool center coordinate display *1 6: Tool compensation amount 7 to 10: (Not used) 11: Customized display 1 *2 12: Customized display 2 *2 13: Customized display 3 *2  *1 Tool center coordinate display is displayed only when any one of 5-axis related options is enabled. *2 Customized display differs depending on a machine tool builder.	0 to 13
#8973	Selectable display	Select whether to enable selectable display on an 8.4- or 10.4-type display terminal. 0: Disable selectable display 1: Enable selectable display. Select what to display using the parameter "#8940 Set select display".	0/1

**(2) Bit selection parameter**

No.	Name	Details	Setting range
#6451 bit0	Onboard on	Switch the onboard ON/OFF. 1 : Onboard ON 0 : Onboard OFF	0/1

**17.6.13.2 Machine Parameters****(1) Base common parameters**

No.	Name	Details	Setting range
#11003 (PR)	APLC valid	Temporarily disable APLC. Normally set "1". 0 : Disable 1 : Enable	0/1
#11060 (PR)	Screen theme color	Select the screen theme colors. This selection affects the colors of the entire screen. 0: Standard colors (gray tone) 1: Blue tone	0/1
#11080 (PR)	HomeScreen display	Select whether to display the home screen. 0: Not display 1: Display (display at power ON) 2: Display (not display at power ON)	0 to 2

### 17.6.14 Limitations

#### Common

- In the interpreter method, the key code flows out only to an active control.
- When the page offset No. of the interpreter method and the compilation method overlaps in Config.ini, the page offset No. of the compilation method is given to priority.  
When the page offset No. overlaps in the interpreter method or the compilation method, the page \* offset No. previously set is given to priority.
- When two or more settings overlap to same function key or menu in customdef.ini, The setting described later is active.
- When two or more settings overlap to same key code in melAppCtrl, either setting is active.
- When the executing file registered by the executing file registration method is not displayed by full-screen, the standard screen is displayed forward to touch the standard screen which operates on the back ground. (The registered execution file is hidden behind the standard screen.)
- When using M800V/M80V/M800/M80 (Windows-less display unit) and M700VS/M70V/E70, switching of onboard / the custom application by bit selection parameter is enabled only when the standard screen is displayed.
- In the M system, the control dedicated to the L system is not available. In the same way, the control dedicated to the M system is not available in the L system. If it is used, key operations may become unavailable on the displayed custom screen.
  - <Control dedicated to L system>
    - L system modal display parts
  - <Control dedicated to M system>
    - M system modal display parts
- When too many controls or screen macros are used in one screen, the custom screen may not be activated. In that case, review the configuration of the custom screen, and reduce the number of controls or the amount of screen macro descriptions.
- The maximum disk space which is available to install custom release and G code guidance release, etc. differs depending on the model. Refer to "NC Designer2 Matching List [Maximum data size]". For M800V/M80V/M800/M80 (Windows-based display unit), up to 48MB is available for a master backup, although it depends on the amount of disk space available.
- When #19701 VNC server control limit is set to "2", input by keyboard operation of the VNC client (pressing enter), and input by software keyboard operation is not available.

#### F0 release

- When the custom release screen or the execution file is registered in the function key where the process exists, the existing process is invalid.
- Two or more screens cannot be registered in one function key by F0 release other than the executing file registration method. Register in another key when two or more screens are displayed.
- When the custom release screen is created by NC Designer2, two is standard about number of windows which can be opened at the same time on panel.
- With the setting to display the home screen (when "#11080 HomeScreen display" is set to other than "0"), window display key is used to switch between the home screen and standard screen.  
Thus, assign the customized screen to another key.

## Menu release

- When the menu is added or deleted in the position where the main menu exists, the existing menu is overwritten. However, in the diagnostic and maintenance screen only, when MTB's menus are added in the position of Mitsubishi's standard menus, Mitsubishi's standard menus can be automatically moved to vacant space.
- The main menu of other screens cannot be set by changing the arrangement of the main menu.  
(Ex. :The main menu of Edit screen cannot be set to Monitor screen.)
- Neither an existing main menu name nor the icon image are changed.
- When the menu of manual operation MST or the counter set is deleted by changing the main menu, the function to display pop-up with the address key is invalid.
- Two or more custom release windows cannot be displayed at the same time.
- Display the 3D check screen and the custom release window at the position where both do not overlap or where 3D screen is completely hidden in the custom release window when these are displayed at the same time.
- When an illegal file path is set in the executing file registration method, the menu is registered, but there is no reaction even if the menu is pressed.
- When the panel renewal is stopped to set BG\_REFRESH\_TIME to -1, the data displayed in the panel is not guaranteed. Take measures to display the registered window by full-screen, etc.
- When the display/non-display of the menu added by conditions is switched, the setting is not active until restarting the standard screen even if the corresponding conditions are changed.
- When "INSTANCE\_HOLD" is set to "1", only instance of the custom window defined by WINDOW\_OFFSET in customdef.ini is stored.
- Even when you close the customized window of EXE file registration method, the menu display of the standard screen is not animated.

## 17.7 Custom Release File Setting

Custom release file setting creates the necessary files such as Config.ini or customdef.ini to display the customized screen on the NC display unit.

### 17.7.1 Operation Screen

#### 17.7.1.1 Custom Screen Configuration Dialog

In the Custom screen configuration dialog, specify the data to output to the setting file. Setting items displayed on the right part are switched depending on the selected item in the tree.

Dialog Image

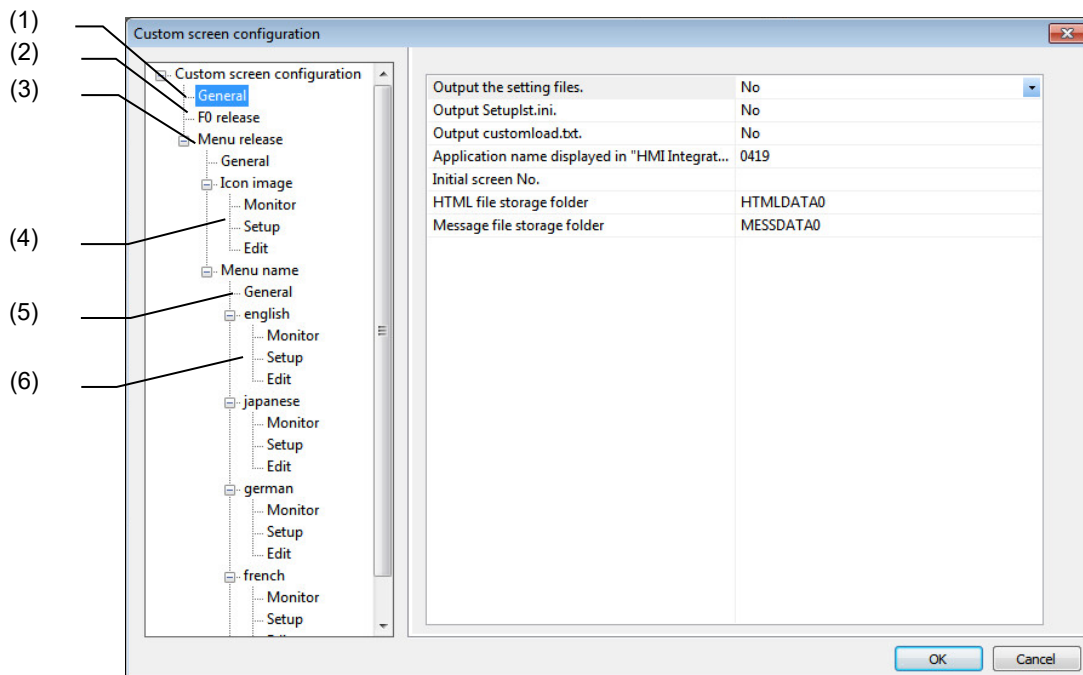

Tree Structure

The following items are displayed in the tree.

No.	Item	Description
(1)	General	Specify the items relating to custom release file setting.
(2)	F0 release	Specify the necessary items for F0 release.
(3)	General under the [Menu release]	Specify the menu position for menu release.
(4)	Standard screen name (Monitor, Setup and Edit) under the [Icon image]	Specify an icon image file to display each menu.
(5)	General under the [Menu name]	Specify the language to specify the menu name.
(6)	Standard screen name (Monitor, Setup and Edit) under the (5)	Specify the menu name to display in each menu position.

Display Item of Each Tree

(1) General

In [General], specify the items relating to custom release file setting. Mainly set whether to output the necessary setting files for executing the custom release.

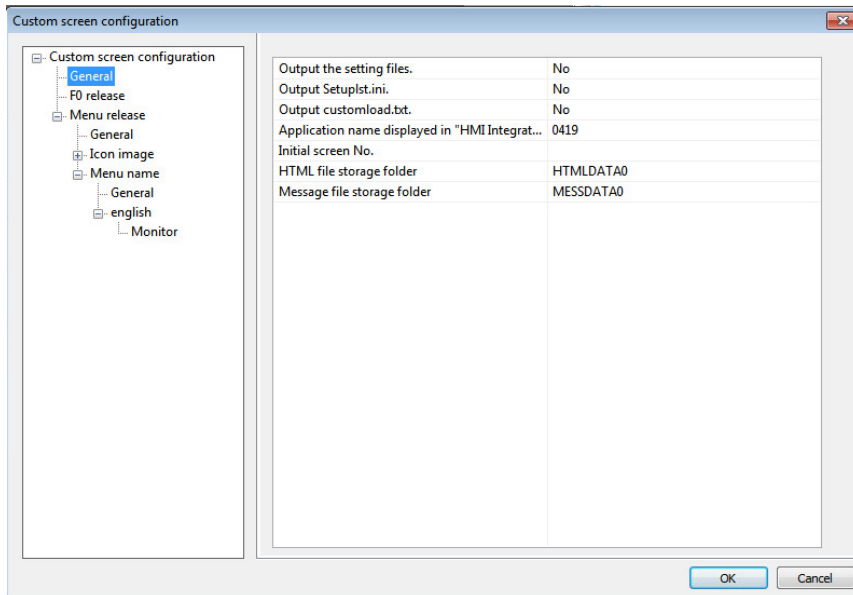

No.	Item	Description
(1)	Output the setting files.	Select whether to output the setting file (Config.ini or customdef.ini) from "Yes" or "No". The default value is "No".
(2)	Output Setuplst.ini.	Select whether to output Setuplst.ini which is required for using HMI Integrated Installer from "Yes" or "No". The default value is "No".
(3)	Output customload.txt.	Select whether to output customload.txt which is required for using "M80/M800 SETUP INSTALLER" or "M70/M700 SETUP INSTALLER" from "Yes" or "No". The default value is "No".
(4)	Application name displayed in "HMI integrated installer"	Specify the name to display in the HMI integrated installer application list. (Note 1) Specify the name within 45 one-byte characters. (Note 2) The default is the name of NC Designer2 project being edited. If the NC Designer2 project name is out of the setting range, "Application01" is set. (Note 3) For the HMI integrated installer, refer to Appendix 9.
(5)	Initial screen No.	Specify the No. of screen to display first when the project is launched. (1000 to 9999) 1000 : Number of standard monitor screen 2000 : Number of standard setup screen 3000 : Number of standard edit screen 4000 : Number of standard diagnosis screen 5000 : Number of standard maintenance screen 6000-9999 : Number of custom screen to which the offset number is added. Leave blank when not registering.
(6)	HTML file storage folder	Designate the folder where the HTML file to output is stored. "HTMLDATA0" to "HTMLDATA2" or "None" can be selected. (Note) The file designated in the property "HTML File" of the HTML browser is created in the designated folder.









No.	Item	Description
(7)	Message file storage folder	Designate the folder where the PLC message file or alarm list message definition file to output is stored. "MESSDATA0" to "MESSDATA7" or "None" can be selected. (Note) The file designated in the property "Message file" of the PLC message is created in the designated folder.

**NOTE**

- ◆ Whether to output the setting files will differ depending on the model or the development method of the screen. Set the each item referring to the following table.

Model	Development method	Config.ini	customdef.ini	Setuplst.ini	customload.txt
M800V/M80V/M800/M80 (Windows-based display unit) and M700VW	Interpreter method	○	○	○	—
	Compilation method	○	○	○	—
M800V/M80V/M800/M80 (Windows-less display unit) and M700VS/M70V/E70	Interpreter method	○	○	—	—
	Compilation method	○	○	—	○

- ◆ The Setuplst.ini is exported to the folder at the same level as other setting files. When using HMI integrated installer, create the folder in the same level as Setuplst.ini and store the module and the setting file of the custom screen. After that, describe the created folder name to the "DIR" key of Setuplst.ini.
- ◆ The folder to store HTML file and the folder for PLC message file are created with the names you designated, and are placed at the same level as Config.ini.

	Project folder
	Project file (GIP file)
	HTMLDATA0
	HTML file (html file)
	MESSDATA0
	Message file (txt file)
	Config.ini
	customdef.ini
	Icon image file



(2) F0 Release

In [F0 release], register the screen created with the panel to the function key. Specify the screen No. registered to offset No. and each function key (SFP, F0, Window display and Window selection).

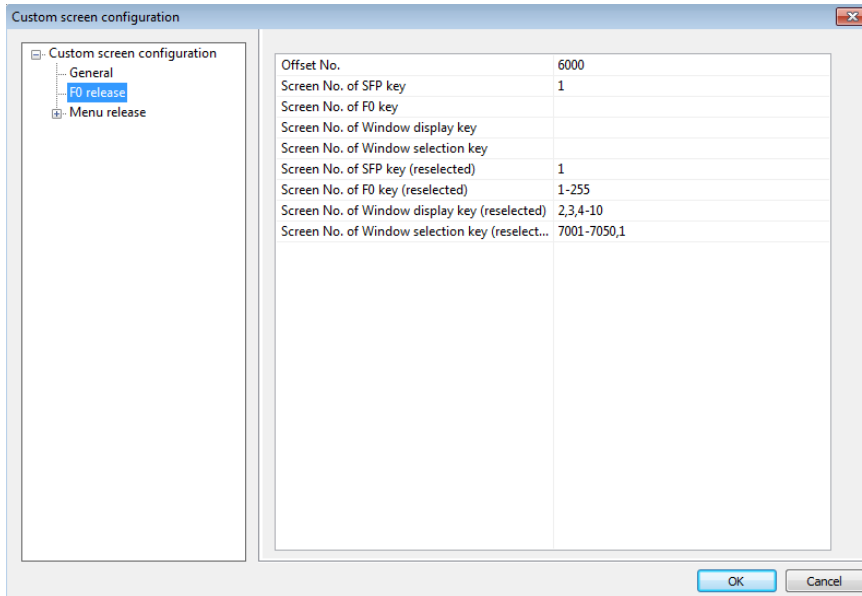

No.	Item	Description
(1)	Offset No.	Specify the offset value added to the created project. (6000 to 7700) The default value is "6000". (Note) Specify the arbitrary No. within setting range even if F0 release is not used.
(2)	Screen No. of SFP key	Specify the screen No. registered to SFP key. (0 to 255) Leave blank when not registering.
(3)	Screen No. of F0 key	Specify the screen No. registered to F0 key. (0 to 255) Leave blank when not registering.
(4)	Screen No. of Window display key	Specify the screen No. registered to Window display key. (0 to 255) Leave blank when not registering.
(5)	Screen No. of Window selection key	Specify the screen No. registered to Window selection key. (0 to 255) Leave blank when not registering.
(6)	Screen No. of SFP key (reselected) (Note)	If you want to reselect a previously displayed screen with the SFP key, select the screen No. Leave blank when not registering. A window cannot be reselected.
(7)	Screen No. of F0 key (reselected) (Note)	If you want to reselect a previously displayed screen with the F0 key, select the screen No. Leave blank when not registering. A window cannot be reselected.
(8)	Screen No. of Window display key (reselected) (Note)	If you want to reselect a previously displayed screen with the Screen display key, select the screen No. Leave blank when not registering. A window cannot be reselected.

No.	Item	Description
(9)	Screen No. of Window selection key (reselected) (Note)	If you want to reselect a previously displayed screen with the Screen selection key, select the screen No. Leave blank when not registering. A window cannot be reselected.

(Note) Following are the setting ranges of the screen No. that is reselected with the press of each function key.

- (1) Up to 64 characters can be specified.
- (2) For a project being edited, 0 to 255 can be set. To reselect another project's screen number, specify the screen number including the offset number.
- (3) The screen numbers to be held can be set with [Individual designation] or [Range designation]. [Individual designation] and [Range designation] can be used together. The following is the example.

[Individual designation] = (Screen No.), (Screen No.), (Screen No.), ...

[Range designation] = (Screen No.-Screen No.), ...

Setting example: 1,3,7504-7508,10,50

**NOTE**

- ◆ The character color of the corresponding screen No. will turn red in the following cases.
  - When the screen No. which is not created in the project is specified
  - When the screen created with the window is specified

Offset No.	6000
Screen No. of SFP key	2
Screen No. of F0 key	3

Note that the character color will not turn red when the compilation method is selected in the Transfer to Memory Card dialog.

If the data is out of the setting range or unspecified, the default value is displayed.

(3) [General] under the [Menu release]

In [Menu release], register the screen created with window to the main menu of the monitor screen, setup screen and edit screen.

Specify the offset No. and the screen No. registered to each menu position. The menu position is added to the tree display immediately after the setting. Up to 50 menus can be registered in the menu release.

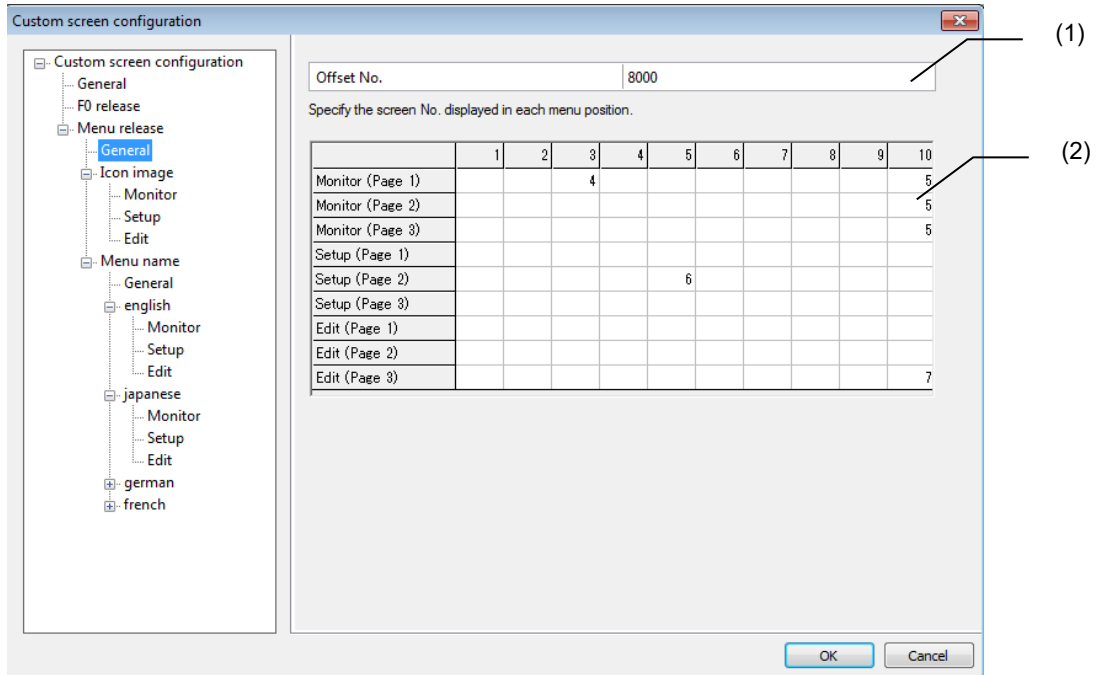

No.	Item	Description
(1)	Offset No.	Specify the offset value added to the created window. (8000 to 9700) The default value is "8000". (Note) Specify the arbitrary No. within setting range if Menu release is not used.
(2)	Main menu of the standard screen	Specify the screen No. of the window registered to the menu position of the standard screen. (0 to 255) Leave blank the menu position that is not registered.

**NOTE**

- ◆ The following tree is displayed under the [Menu release].

```

Menu release
  |__ General
  |__ Icon image
  |  |__ Monitor
  |  |__ Setup
  |  |__ Edit
  |__ Menu name
     |__ General
     |__ Language name (Example: English, Japanese)
        |  |__ Monitor
        |  |__ Setup
        |  |__ Edit
        .
        .
        .
    
```

- ◆ Set both the [General] under the [Menu release] and the [General] under the [Menu name] displayed in a tree for menu release.
- ◆ The character color of the corresponding screen No. will turn red in the following cases.
  - When the screen No. which is not created in the project is specified
  - When the screen created with the panel is specified

Setup (Page 1)				
Setup (Page 2)	254	255	150	151
Setup (Page 3)				9

Note that the character color will not turn red when the compilation method is selected in the Transfer to Memory Card dialog.

(4) [Monitor][Setup][Edit] under the [Icon image]

The image file to be displayed in the menu can be specified in the screen displayed under the [Icon image] ([Monitor][Setup][Edit]) in the tree.

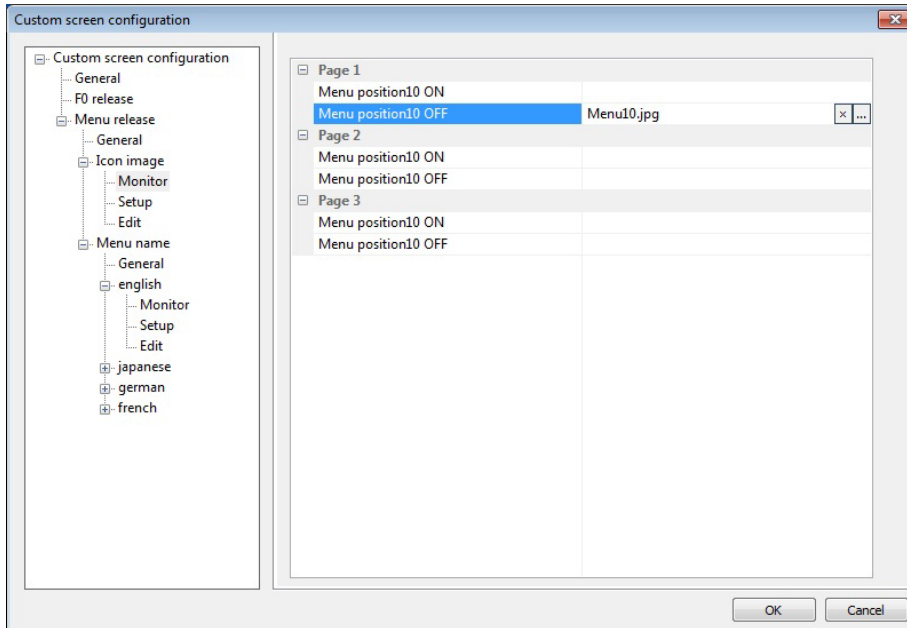

No.	Item	Description
(1)	Menu position10 ON	Specify the file path of the icon image to display for each menu at ON. An arbitrary file name can be specified.
(2)	Menu position10 OFF	Specify the file path of the icon image to display for each menu at OFF. An arbitrary file name can be specified.

**NOTE**

- ◆ Specify the file created 62×40-pixel JPEG format. The image might not be correctly displayed when a defect exists.
- ◆ When the setting file is exported, the file changed to "offset No. + screen No.\_ON.jpg" or "offset No. + screen No.\_OFF.jpg" is copied to the export destination.
- ◆ If the icon image file is not specified when displaying the created screen on the NC display unit, the icon that is registered on the standard screen is displayed.
- ◆ Use the same icon image when the same screen No. window is registered in different menu position.

(5) [General] under the [Menu name]

In [Menu name], specify whether to enable the language for registering the menu. The language name specified to "Enable" is added immediately in the tree. The language name specified to "Disable" is deleted in the tree.

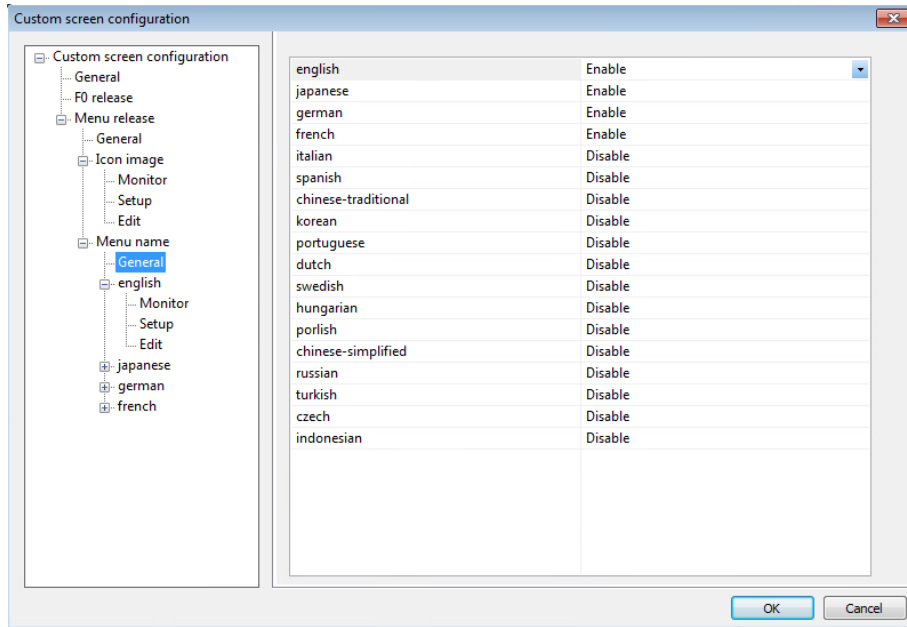

No.	Item	Description
(1)	Language name (18 languages)	Specify whether to enable each language. English is enabled and the other languages are disabled by default.

(6) [Monitor][Setup][Edit] under the each language

The menu names are specified on the screen displayed under the each language in the tree ([Monitor][Setup][Edit]).

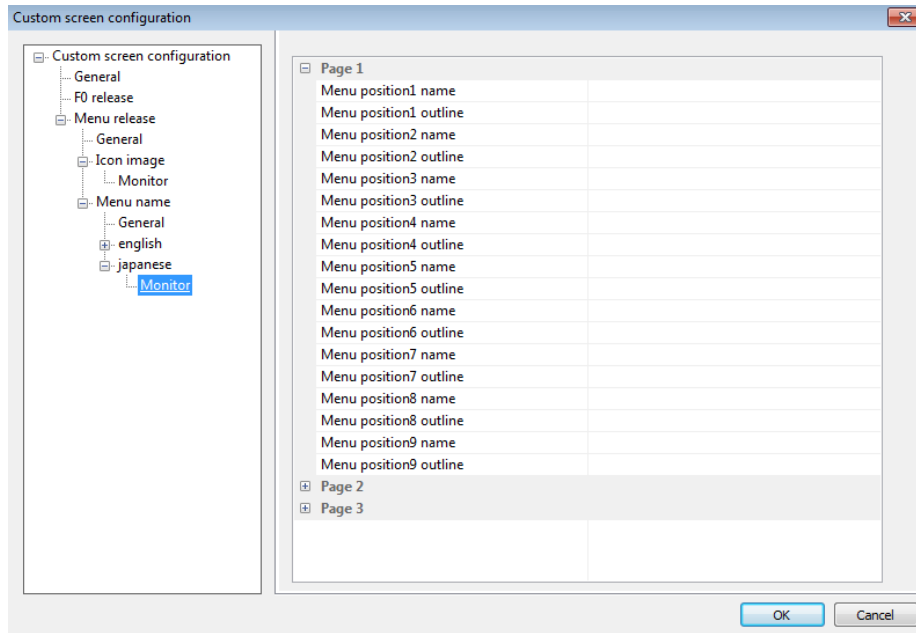

No.	Item	Description
(1)	Menu position (No.) name	Specify the menu name for each menu position. Specify within 7 one-byte characters for VGA and 10 one-byte characters for XGA.
(2)	Menu position (No.) outline	Specify the outline for each menu. Specify within 70 one-byte characters.

**NOTE**

- ◆ The character color of the corresponding screen No. will turn red in the following case.
  - When the screen size is changed by project properties

Page 2	
Menu position4 name	1234567
Menu position4 outline	
Menu position5 name	1234567890
Menu position5 outline	

- ◆ When the compilation method is selected in the Transfer to Memory Card dialog, menu name can be specified with up to 10 one-byte characters. When the install destination NC is VGA, specify within 7 one-byte characters. Note that the whole menu name is not displayed when the name is set with 8 or more characters. When the interpreter method is selected in the Transfer to Memory Card dialog, specify the menu name within 7 one-byte characters for VGA or 10 one-byte characters for XGA.
- ◆ Contents set to the outline of the menu are displayed on the Menu list (list of menus for each screen). The Menu list window is displayed by pressing [MenuList] key  .

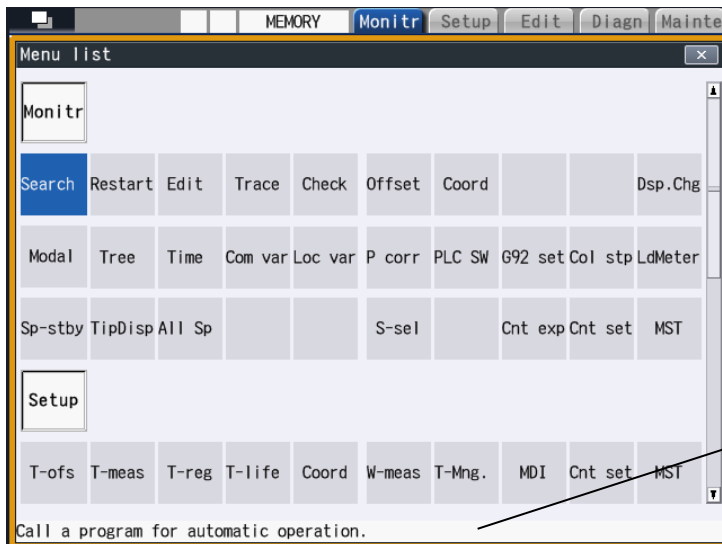

The outline of the menu



### 17.7.2 Operation Procedure

The main operation (custom screen configuration, export for the setting file) is described.

#### Custom Screen Configuration

1. Select [Custom screen configuration] from the [File] menu.

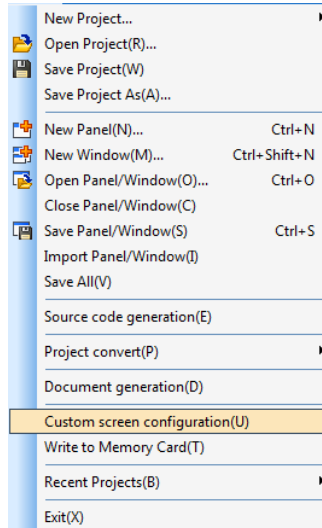

2. Custom screen configuration dialog is displayed.

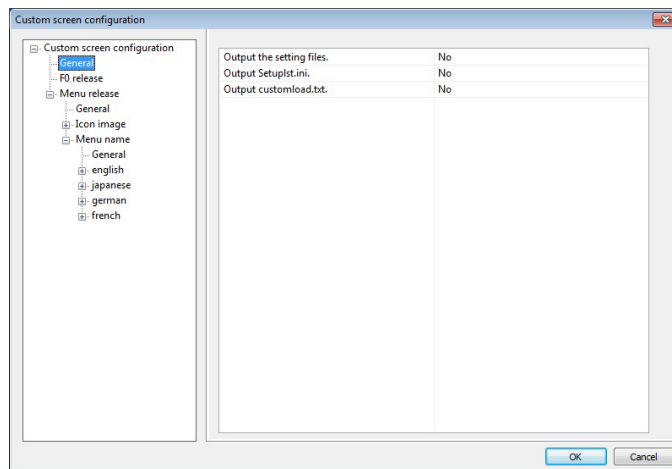

3. After the setting, press the [OK] button.

#### NOTE

- ◆ When exporting the setting file (either Config.ini or customdef.ini), specify "Output the setting files. " to "Yes".

Export for the Setting File (Interpreter Method)

1. Select [Project convert] - [Export] from the [File] menu.

A confirmation message is displayed. Press the [OK] button.

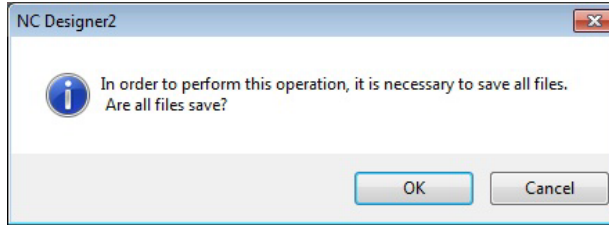

2. An "export" dialog box is displayed. Specify the location and file name of the project to be exported. Press the [Save] button.

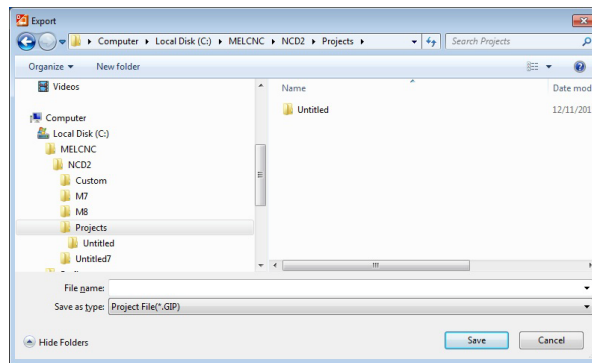

After exportation is successfully finished, a project exportation completion message is displayed. Exportation is finished.

**NOTE**

- ◆ The setting file is exported in the same layer as the GIP file when the macro is generated.
- ◆ When a GIP file or setting file exists in the specified folder, the confirmation message for overwriting is displayed.  
If not overwriting, move these files or change the export destination after canceling the confirmation message for overwriting.

## Export for the Setting File (Compilation Method)

1. Select [Source Code Generation] from the [File] menu.
2. The [Source code generation wizard] is displayed.

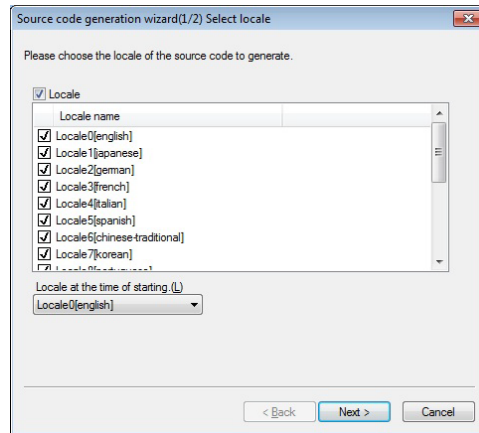

3. After entering the settings, click on [Next].

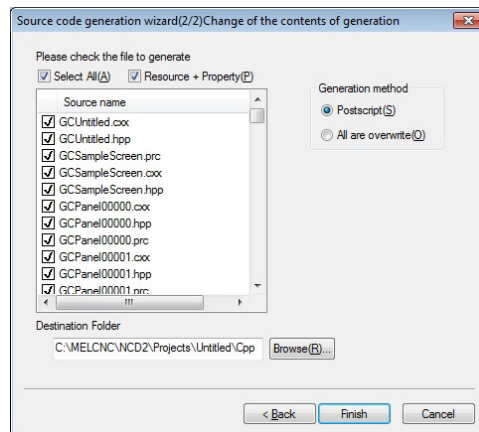

4. Click on [Finish] to automatically generate source codes.  
After generation is finished, a completion notice dialog box is displayed. Click on the [OK] button.  
The generated source codes are saved in the folder designated during project creation.

**NOTE**

- ◆ The setting file is exported in the custom folder created at the same level as the CPP folder during source code generation.
- ◆ Store the custom data created by the compilation method (\*.dll or \*.o file) in the custom folder to which you exported the setting files.
- ◆ "Postscript" or "All are overwrite" can be selected for the source file on [Source code generation wizard]. However, overwriting can only be executed for the setting file. Generate the source code after changing the folder designated or moving the existing setting file because all are overwritten.

### 17.7.3 Precautions

1. When the setting file is exported with compilation method, "project name.dll" is specified to the [MODULE\_NAME] key in the [MODULE] section for the Config.ini file. Create the DLL file with Visual Studio and set the [MODULE\_NAME] key again.
2. To register the customized screen created by multiple projects, edit the setting file in addition.
3. "Application01" is displayed on the HMI integrated installer screen. Edit the [NAME] key in the [APP] section for the Setuplst.ini file to change the display.
4. When installing with the HMI integrated installer, create the folder in the same layer as the Setuplst.ini file and move Config.ini, customdef.ini and the module of the customized screen (the GIP file and folder, the DLL file and the picture file). Specify the created folder name to the [DIR] key in the [APP] section for the Setuplst.ini file.

### 17.8 Memory Card Transfer

Memory card transfer function generates the custom data, setting files, etc. on an SD card (CF card) in each installer format. This function enables you to create custom data in the actual installation format without extra operation, leading to greater ease of operation.

#### 17.8.1 Operation screen

In the Transfer to Memory Card dialog, various settings such as the selection of the Write Data or the Destination Drive can be specified.

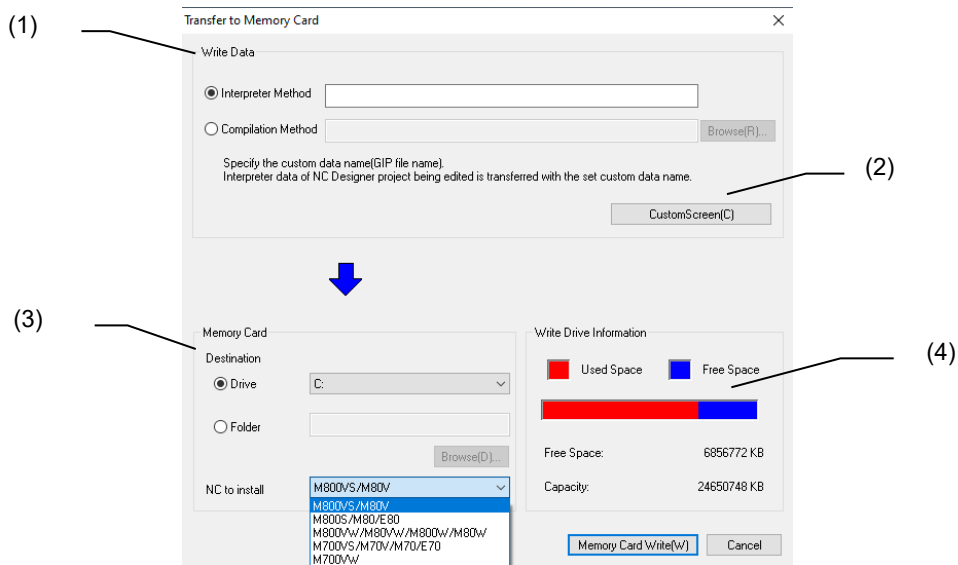

No.	Item	Description
(1)	Write Data	Specify the data to write to the memory card. Specify the custom data of the interpreter or compilation method.
	Interpreter Method	Select the interpreter method custom data. When selected, custom data of the NC Designer2 project being edited is set as the data to write. Set the custom data (*.GIP) name.
	Compilation Method	Select the compilation method custom data. Specify the compilation method custom data (*.dll or *.o file) in the setting file storage folder (custom folder) that is created during the source code generation.
(2)	CustomScreen	Custom screen configuration dialog is displayed. When the interpreter method is selected, the setting file data of the NC Designer2 project being edited project is specified. When the compilation method is selected, the setting file data created during the source code generation is specified.

No.	Item	Description
(3)	Memory Card	Specify the output to the memory card.
	Destination	The destination can be specified from a drive or folder.
	Drive	Select the destination drive. Hard disk, and removable disk are displayed.
	Folder	Specify the destination folder. The folder selection dialog box is displayed by pressing the [Browse] button. Specify any desired folder.
	NC to install	Select the NC model to install.
(4)	Write Drive Information	Memory information of the drive specified as write destination is displayed.

**NOTE**

- ◆ Format the SD card (or CF card) specified as write destination before use.
- ◆ If the custom data name is specified in both the interpreter method and the compilation method, the custom data with enabled radio button is transferred.
- ◆ When the CustomScreen button is pressed in the state that the interpreter method is selected as the data to write, the Custom screen configuration dialog with the data of the NC Designer2 project being edited specified is displayed.  
The settings are reflected on the data of the NC Designer2 project being edited by editing it.  
When the CustomScreen button is pressed in the state that the compilation method is selected, the setting file data in the folder which includes the specified custom data is specified as the Custom screen configuration dialog. The settings are not reflected on the data of the configuration NC Designer2 project being edited by editing it. The change is not reflected on the source data to read (the setting file data of the source code generation destination), either.
- ◆ When the setting file in the same folder as the selected compilation method is out of the data range or is not specified, the initial value is displayed on the Custom screen configuration dialog. Specify the setting again.
- ◆ Installer format differs depending on the NC to install.

NC to install	Installer format
M800V/M80V/M800/M80 (Windows-less display unit)	M80/M800 SETUP INSTALLER
M800V/M80V/M800/M80 (Windows-based display unit)	HMI integrated installer
M700VS/M70V/E70	M70/M700 SETUP INSTALLER
M700VW	HMI integrated installer

- ◆ In HMI integrated installer format, the data to write is created in the following directory configuration.

(1) Interpreter version

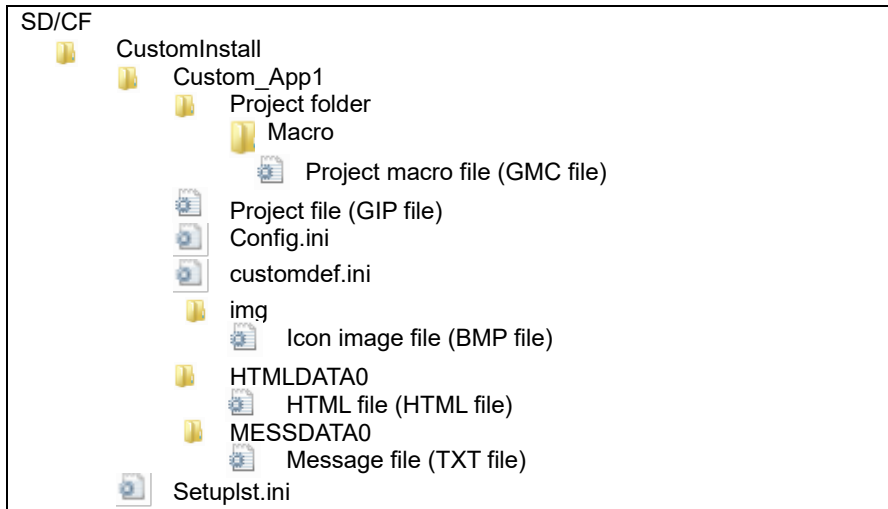

(2) Compilation version

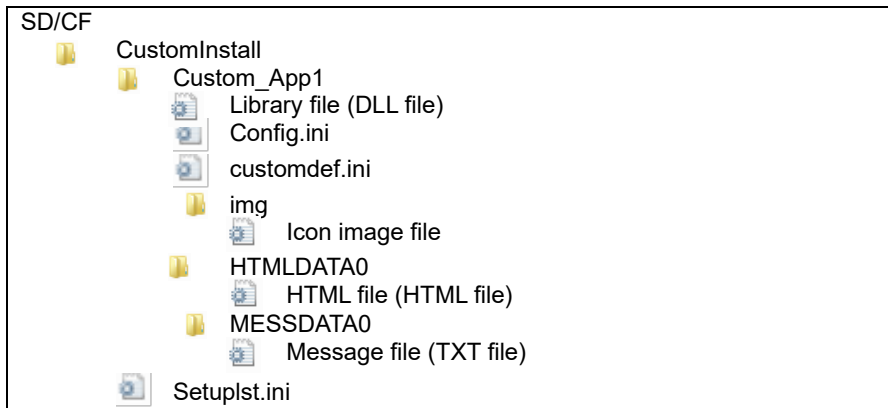

- ◆ For M80/M800 SETUP INSTALLER or M70/M700 SETUP INSTALLER, the data to write is created in the following directory configuration.

(1) Interpreter version

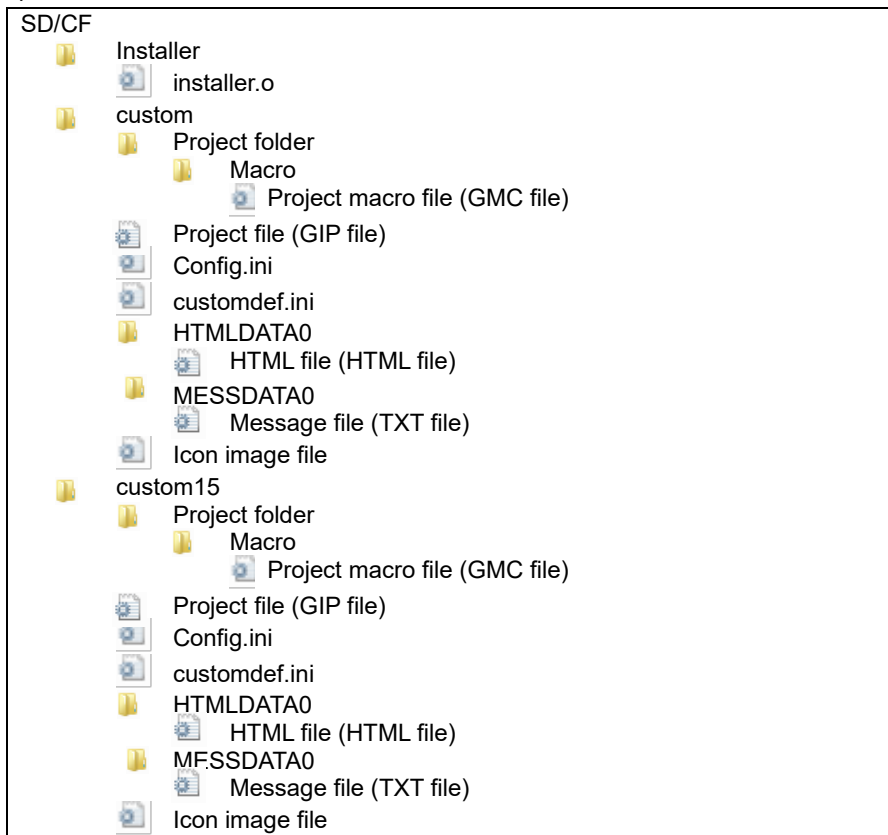



## (2) Compilation version

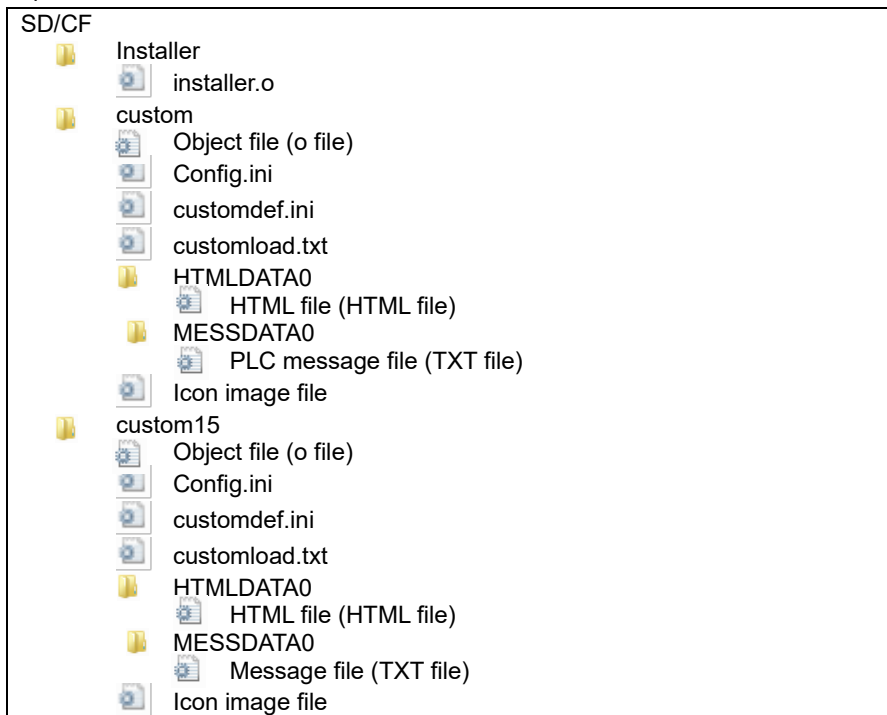

(Note 1) The folder name to be created is switched by the setting of "Screen width" and "Screen height" in project properties.

(Note 2) Data of the custom15 folder is copied to the custom folder in the CNC. When specifying the path name using Config.ini, designate /custom/ instead of /custom15/ even when using 15-type display unit.

- ◆ The file designated in the property "HTML File" of the HTML browser is created in the folder designated in [HTML file storage folder] of the custom release file setting dialog, regardless of the "HTML Folder" setting. The file designated in the property "Message file" of the PLC message is created in the folder designated in [Message file storage folder] of the custom release file setting dialog, regardless of the "Message folder" setting. For the folder which is not designated as [HTML file storage folder] or [Message file storage folder], edit config.ini and create the installation data manually because such folder is not automatically created.

### 17.8.2 Operation Procedure

This section describes the main operation (write to the memory card).

#### Write to the Memory Card

1. Select [Write to Memory Card] from the [File] menu.

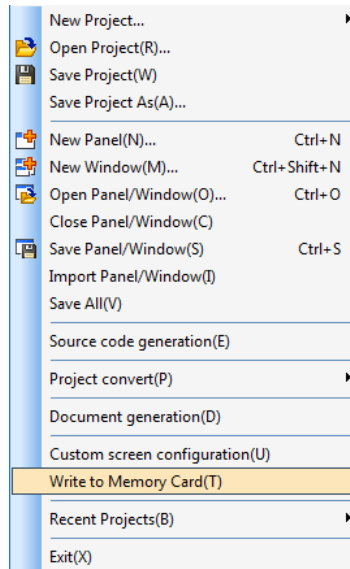

2. Transfer to Memory Card dialog is displayed.

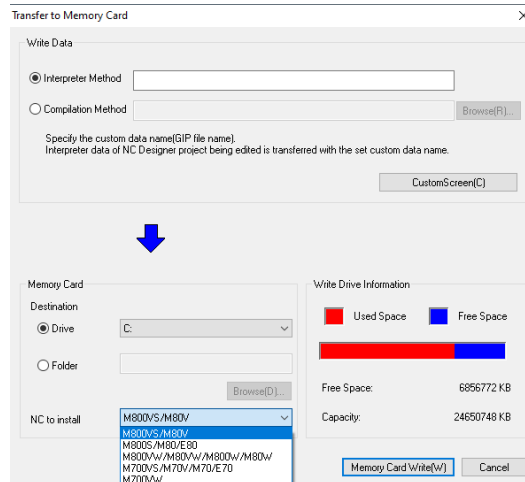

3. After the setting, press the [Memory Card Write] button.
4. After the transfer to the memory card is successfully finished, a completion message is displayed.

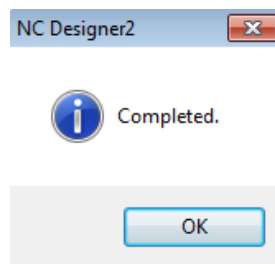

**NOTE**

- ◆ If a project macro file is present for the interpreter method, CYCLIC\_MACRO key is added to the [PROJECT] section of the Config.ini file and output.

## 17.9 Home Screen

This section describes how to set configuration settings files relevant to Home screen.

[Definitions of terms]

Term	Description
ExtApp folder	A folder used to place information about MTB's app (application created by a machine tool builder) to be used on Home screen. Below are path for respective model type: M800V/M80V/M800/M80 (Windows-based display unit): "D:\custom\ExtApp" M800V/M80V/M800/M80 (Windows-less display unit): "MSYS:/Custom/ExtApp"
NC Designer2 interpreter method (GIP method)	The methods for incorporating customized screen in Customization (F0 assignment) function.  For details, refer to "17. Application Execution Method".
NC Designer2 compilation method (DLL method)	
EXE file registration method (EXE method)	

### 17.9.1 Types of MTB's App

Below are types of MTB's app that can be called on Home screen.

#### (1) Fixed Home screen display

MTB's app is displayed in area except the fixed display portions in the upper and right side of Home screen.

You can operate Operation menu and Home button on the fixed display part of Home screen, even if MTB's app is displayed. You do not need to incorporate processing for each application.

This method is compatible with NC Designer2 interpreter method (GIP method)/NC Designer2 compilation method (DLL method).

[Example of the fixed Home screen display]

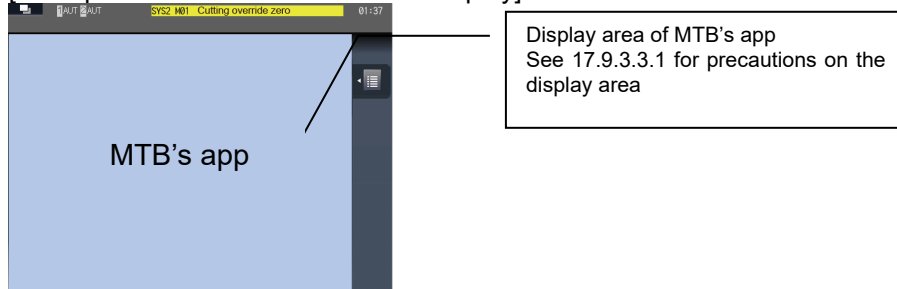

#### (2) Full-screen display

MTB's app is displayed full-screen.

You cannot operate Operation menu or Home button on the fixed display part of Home screen while MTB's app is displayed.

You need to incorporate key operations such as function keys and return to Home screen as well as touch panel operation for each MTB's app.

This method is compatible with NC Designer2 interpreter method (GIP method)/NC Designer2 compilation method (DLL method)/EXE file registration method (EXE method). However, EXE file registration method (EXE method) is only compatible with M800V/M80V/M800/M80 (Windows-based display unit).

[Example of Full-screen display]

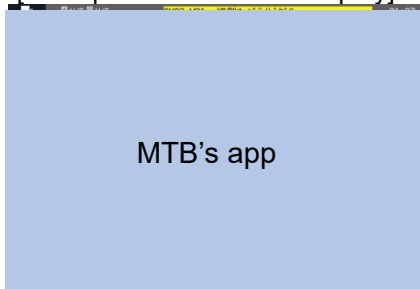

## 17.9.2 Configuration Settings Files

### 17.9.2.1 List of Configuration Settings Files

Configuration settings files	Description																																												
HMI configuration file Config.ini	This file is used to register the created DLL file or GIP file as operation screen. This file is used for both NC Designer2 interpreter method (GIP method) and NC Designer2 compilation method (DLL method) for Customization (F0 assignment) function. For how to create and where to store, refer to "17. Application Execution Method".																																												
Home screen configuration file HomeScrnCustomConfig.ini	By describing the Application definition file to which MTB's app information has been defined, the MTB's app is registered to the list of Application buttons. Store this file in ExtApp folder.																																												
Application definition file HomeScrn_oooo.ini  oooo is application name.	This file is used to define the information (path to MTB's app, invocation argument, menu on operation button, etc.) of MTB's app registered to Home screen. Store this file in any desired folder under ExtApp folder.																																												
Application language file HomeScrn_oooo_△△△.ini  oooo is application name. Specify the same name as in Application definition file. △△△ is language code.	This file is used to define texts (application name displayed under Application button). Prepare this file individually for each language as needed. * The file for English is mandatory. Which file to use is changed according to "#1043 lang". If there is no Application language file for the onscreen language, the file for English is used instead. * Store this file in the same folder as that of Application definition file. *The application names displayed under Application button are fixed to English.  Language types are as follows:																																												
<table border="1" style="width: 100%; border-collapse: collapse;"> <thead> <tr> <th style="background-color: #e0f7fa;">Code</th> <th style="background-color: #e0f7fa;">Language</th> <th style="background-color: #e0f7fa;">Code</th> <th style="background-color: #e0f7fa;">Language</th> </tr> </thead> <tbody> <tr> <td>eng</td> <td>English</td> <td>dut</td> <td>Dutch</td> </tr> <tr> <td>jpn</td> <td>Japanese</td> <td>swe</td> <td>Swedish</td> </tr> <tr> <td>deu</td> <td>German</td> <td>hun</td> <td>Hungarian</td> </tr> <tr> <td>fra</td> <td>French</td> <td>pol</td> <td>Polish</td> </tr> <tr> <td>ita</td> <td>Italian</td> <td>chi1</td> <td>Chinese (simplified)</td> </tr> <tr> <td>spa</td> <td>Spanish</td> <td>rus</td> <td>Russian</td> </tr> <tr> <td>chi2</td> <td>Chinese (traditional)</td> <td>tur</td> <td>Turkish</td> </tr> <tr> <td>kor</td> <td>Korean</td> <td>cze</td> <td>Czech</td> </tr> <tr> <td>por</td> <td>Portuguese</td> <td>ind</td> <td>Indonesian</td> </tr> <tr> <td>vie</td> <td>Vietnamese</td> <td></td> <td></td> </tr> </tbody> </table>		Code	Language	Code	Language	eng	English	dut	Dutch	jpn	Japanese	swe	Swedish	deu	German	hun	Hungarian	fra	French	pol	Polish	ita	Italian	chi1	Chinese (simplified)	spa	Spanish	rus	Russian	chi2	Chinese (traditional)	tur	Turkish	kor	Korean	cze	Czech	por	Portuguese	ind	Indonesian	vie	Vietnamese		
Code	Language	Code	Language																																										
eng	English	dut	Dutch																																										
jpn	Japanese	swe	Swedish																																										
deu	German	hun	Hungarian																																										
fra	French	pol	Polish																																										
ita	Italian	chi1	Chinese (simplified)																																										
spa	Spanish	rus	Russian																																										
chi2	Chinese (traditional)	tur	Turkish																																										
kor	Korean	cze	Czech																																										
por	Portuguese	ind	Indonesian																																										
vie	Vietnamese																																												

**17.9.2.2 Storage Location of Applications and Configuration Settings Files**

Below show the folders in where each configuration settings file is stored.

Release method	Storage folders
Config.ini	[When using M800V/M80V/M800/M80 (Windows-based display unit)] "D:\custom" [When using M800V/M80V/M800/M80 (Windows-less display unit)] "MSYS:/Custom"
HomeScrnCustomConfig.ini	[When using M800V/M80V/M800/M80 (Windows-based display unit)] "D:\custom\ExtApp" [When using M800V/M80V/M800/M80 (Windows-less display unit)] "MSYS:/Custom/ExtApp"
HomeScrn_○○○○.ini	Store this file to path defined in "HomeScrnCustomConfig.ini". *Possible to set in any desired place under D:\custom\ExtApp.
HomeScrn_○○○○_△△△.ini	Store this file in the same place as that of "HomeScrn_○○○○.ini".
○○○○.GIP	[When using M800V/M80V/M800/M80 (Windows-based display unit)] "D:\custom" [When using M800V/M80V/M800/M80 (Windows-less display unit)] "MSYS:/Custom/ExtApp"
○○○○.DLL	[When using M800V/M80V/M800/M80 (Windows-based display unit)] "D:\custom" [When using M800V/M80V/M800/M80 (Windows-less display unit)] *Not available
○○○○.o	[When using M800V/M80V/M800/M80 (Windows-based display unit)] *Not available [When using M800V/M80V/M800/M80 (Windows-less display unit)] "MSYS:/Custom"
○○○○.exe	Store this file to path defined in "HomeScrn_○○○○.ini". *Possible to set in any desired place under D:\custom\ExtApp. *Not available for M800V/M80V/M800/M80 (Windows-less display unit)
○○○○.jpg	Store this file to path defined in "HomeScrn_○○○○.ini". *Possible to set in any desired place under D:\custom\ExtApp.

**17.9.2.3 Files Required for Registration**

Below are the files required for each release method.

Release method	Interpreter method	Compilation method	EXE file registration method
Config.ini	○	○	—
HomeScrnCustomConfig.ini	○	○	○
HomeScrn_○○○○.ini	○	○	○
HomeScrn_○○○○_△△△.ini	○	○	○
○○○○.GIP	○	—	—
○○○○.DLL	—	○	—
○○○○.o	—	○	—
○○○○.exe	—	—	○
○○○○.jpg	○	○	○

○...Need to prepare or edit

—...No need to prepare or edit

### 17.9.3 Fixed Home Screen Display

This section describes how to register an application created by a machine tool builder (referred to as MTB's app) with use of the fixed Home screen display.

#### 17.9.3.1 Interpreter Method

##### 17.9.3.1.1 Setting Home Screen Config File (HomeScrnCustomConfig.ini)

Home screen config file is used to specify a list of Application definition files (HomeScrn\_○○○○.ini) for each MTB's app to be registered to Home screen.

- Section

Section name	Mandatory	Description
COMMON	○	Define application to be registered to Home screen.

- [COMMON] section key

Key name	Mandatory	Description
ITEMnn (nn= 01 to 27)	-	Specify the definition file (Application definition file (*)) of application registered to Home screen. Use either an absolute or relative path to specify the Application definition file name (e.g. HomeScrn_custom_app1.ini). For a relative path, specify a path relative to the folder (ExtApp folder) of this definition file.  * For details of Application definition file, refer to "17.9.3.1.2".  Note) If this key is undefined, neither application button nor sub menus of [Add Application] menu are displayed.  Setting range: Up to 128 characters including the path.

[Setting example]

```
[COMMON]
ITEM01=D:\Custom\ExtApp\HomeScrn_custom_app1.ini           ; <- Define MTB's app 1.
ITEM02=D:\Custom\ExtApp\custom_app2\HomeScrn_custom_app2.ini ; <- Define MTB's app 2.
ITEM04=\custom_app4\HomeScrn_custom_app4.ini             ; <- Define MTB's app 4.
```



**17.9.3.1.2 Setting Application Definition File (HomeScrn\_○○○○.ini)**

Application definition file is used to define the information of extension application registered to Home screen.

Using this definition file, you define the basic information of extension application, Home button operation, Operation menu button operation, etc.

[File contents]

- Section

Section name	Mandatory	Description
COMMON	Yes	Define basic information of the application.
HOME	No	Define this when you want to hide, minimize or terminate the currently displayed application by touching Home button. If this section is undefined, Home button does not work.
SETTING nn (nn=00 to 29)	No	Define the main menu information when Operation menu button is touched. This section is created by the number defined in the SETTINGTOPMENUMOUNT key of [COMMON] section.
Xxx (Arbitrary section name)	No	Define the sub menu information when Operation menu button is touched. Main and sub menus are associated with each other using the SUBMENUSECTIONnn key of [SETTING nn] section. xxx is any desired character string made of up to 32 letters. Available characters are alphanumeric and symbols (space ' ' and underscore '_').

- [COMMON] section key

Key name	Mandatory	Description
NAME	Yes	<p>Specify the character string to be used for the application name displayed under Application button or in the sub menus of [Add Application] menu, using the key described in [LANG] section of Application language file (*).</p> <p>The actually displayed application name is defined in Application language file.</p> <p>* For details of Application language file, refer to "17.9.3.1.3".</p> <p>Note) If this key is undefined, or if application name is unable to be retrieved from the app name key, neither application buttons nor sub menus of [Add Application] menu are displayed.</p> <p>Setting range: Up to 32 characters</p>
TYPE	Yes	<p>Specify the type of MTB's app:</p> <p>0: Fixed Home screen display</p> <p>1: Full-screen display (NC Designer2 interpreter method/ NC Designer2 compilation method)</p> <p>2: Full-screen display (EXE file registration method)</p>
ICONFILENAME	No	<p>Specify the image file (*) to be used as an icon of Application button.</p> <p>Use either an absolute or relative path to specify the image file name (e.g. custom_app1.jpg). For a relative path, specify a path relative to this definition file.</p> <p>*Specify an image file with the size below:</p> <ul style="list-style-type: none"> <li>- XGA: Up to 52 x 52 pixels</li> <li>- VGA: Up to 40 x 40 pixels</li> </ul> <p>*Available format is JPG.</p> <p>Note) If you specify no file, or specified file is nonexistent, the icon of the execution file (MTB's app) defined in the EXECFILENAME key of [COMMON] section is used.</p> <p>Setting range: Up to 128 characters including the path (*1)</p>
PANEL_OFFSET	Yes	<p>Unique offset value allocated to each screen of MTB's app. Specify the offset value defined in HMI configuration file (customdef.ini).</p>
SETTINGTOPMENU UCOUNT	No	<p>Specify the number of main menus to be registered to Operation menu button.</p> <p>Setting range: 0 to 30</p> <p>Default: 0</p> <p>* When set to 0, Operation menu button does not work.</p>

- [HOME] section key

Key name	Mandatory	Description
COMMANDCOUNT	No	<p>Specify the number of COMMANDnn keys in [HOME] section.</p> <p>Setting range: 0 to 29</p> <p>Default: 0</p> <p>* When set to 0, Home button does not work.</p>
COMMANDnn (nn=01 to 30)	No	<p>Specify the argument when calling GCSUser function. (GUSER_FUNC_EXECMENUUEVENT) held by the Panel of onscreen MTB's app.</p> <p>Setting range: Integer values</p>

- [SETTING nn] section

Key name	Mandatory	Description
NAME	Yes	Specify the character string to be used for the main menu name, using the key of Application language file (*). The actually displayed menu name is defined in Application language file.  *For details of Application language file, refer to "17.9.3.1.3".  Note) If this key is undefined, or if menu name is unable to be retrieved from the menu name key, the menu is not displayed.  Setting range: Up to 32 characters
MENU_ID	Yes	Specify the ID used when inquiring menu name/status to Panel.
SUBMENUCOUNT	No (*)	Specify the number of SUBMENUSECTIONnn keys.  Setting range: 0 to 29 Default: 0
SUBMENUSECTIONnn (nn=01 to 30)	No (*)	Define the sub menus to be displayed at a touch of main menu. Specify the sub menu section name (arbitrary section) (*) to associate the sub menus with main menu.  * Available characters for a section name are alphanumeric and symbols (space ' ' and underscore '_').  Setting range: Up to 32 characters
COMMANDCOUNT	No (*)	Specify the number of COMMANDnn keys.  Setting range: 0 to 29 Default: 0
COMMANDnn (nn=01 to 30)	No (*)	Specify the argument when calling GCSUser function. (GUSER_FUNC_EXECMENEUEVENT) held by the Panel of onscreen MTB's app.  Setting range: Integer values

\*Specify either SubMenuCount and SubMenuSectionXX or CommandCount and CommandXX.  
If you define both, SubMenuCount and SubMenuSectionXX have priority.

- [xxx(Arbitrary section)] section

Key name	Mandatory	Description
NAME	Yes	Specify the character string to be used for the sub menu name, using the key of Application language file (*). The actually displayed menu name is defined in Application language file.  * For details of Application language file, refer to "17.9.3.1.3".  Note) If this key is undefined, or if menu name is unable to be retrieved from the menu name key, the menu is not displayed.  Setting range: Up to 32 characters.
MENU_ID	Yes	Specify the ID used when inquiring menu name/status to Panel.
COMMANDCOUNT	No	Specify the number of COMMANDnn keys.  Setting range: 0 to 29 Default: 0
COMMANDnn (nn= 01 to 99)	No	Specify the argument when calling GCSUser function. (GUSER_FUNC_EXECMENEVENT) held by the Panel of onscreen MTB's app  Setting range: Integer values

[Setting example]

[COMMON]	; <- Define basic information of application.
NAME=LANG_APP_NAME	; <- Specify the application name.
ICONFILENAME=D:\Custom\ExtApp\custom_app.jpg	; <- Specify the image to be displayed on Application button.
TYPE=0	; <- Specify the registration type
PANEL_OFFSET=6500	; <- Specify 6500 to the offset number of the panel to be changed
SETTINGTOPMENUCOUNT=2	; <- Specify the number of main menus to display on Operation menu buttons.
[HOME]	; <- Define the operation when Home button is touched.
COMMANDCOUNT=1	; <- COMMANDnn is registered up to 01, thus specify 1.
COMMAND01=0	; <- Call GCSUser of onscreen Panel by specifying argument 0.
[SETTING 01]	; <- Define the 1st main menu (without sub menus).
NAME=LANG_MENU	; <- Specify the menu name.
MENU_ID=1	; <- Specify the ID used when specifying menu name/status to Home screen.
COMMANDCOUNT=1	; <- Command is registered up to 02, thus specify 2.
COMMAND01=1	; <- Call GCSUser of onscreen Panel by specifying argument 1.
[SETTING 02]	; <- Define the 2nd main menu. (with sub menus).
NAME=LANG_FILE	; <- Specify the menu name.
MENU_ID=2	; <- Specify the ID used when specifying menu name/status to Home screen.
SUBMMENUCOUNT=2	; <- SUBMENUSECTION is registered up to 02, thus specify 2.
SUBMENUSECTION01=Setting Copy	; <- Define the sub menu section (arbitrary section name).
SUBMENUSECTION02=Setting Paste	; <- Define the sub menu section (arbitrary section name).
[Setting Copy]	; <- Defined using SUBMENUSECTION01 key of [Setting 02] section.
	; Define arbitrary section (Setting Copy) for sub menu.
NAME=LANG_COPY	; <- Specify the menu name.
MENU_ID=201	; <- Specify the ID used when specifying menu name/status to Home screen.
COMMANDCOUNT=1	; <- COMMAND is registered up to 01, thus specify 1.
COMMAND01=2	; <- Call GCSUser of onscreen Panel by specifying argument 2.
[Setting Paste]	; <- Defined using SUBMENUSECTION02 key of [Setting 02] section.
	; Define arbitrary section (Setting Paste) for sub menu.
NAME=LANG_PASTE	; <- Specify the menu name.
MENU_ID=202	; <- Specify the ID used when specifying menu name/status to Home screen.
COMMANDCOUNT=1	; <- COMMAND is registered up to 01, thus specify 1.
COMMAND01=3	; <- Call GCSUser of onscreen Panel by specifying argument 2.

**17.9.3.1.3 Setting Application Language File (HomeScrnn\_○○○○\_△△△.ini)**

Application language file defines the character string information of the extension application registered to Home screen. Create this file for each language type. Text of this file needs to be written in UNICODE.

[File contents]

- Section

Section name	Mandatory	Description
LANG	Yes	Define the application registered to Home screen.

- [LANG] section key

Key name	Mandatory	Description									
LANG_XXXXX (LANG_XXXXX is any desired string made of up to 32 characters) (*1)	No (*2)	Specify the application name and menu name for each language type. <table border="1" data-bbox="660 651 1441 768"> <thead> <tr> <th>Type</th> <th>Max. data length</th> <th>Available character</th> </tr> </thead> <tbody> <tr> <td>App name</td> <td>8 letters (*2)</td> <td>Alphanumeric, space ( ' ')</td> </tr> <tr> <td>Menu name</td> <td>16 letters (*1)</td> <td>Other than equal (=) and semi-colon (;)</td> </tr> </tbody> </table> <p>*1 A two-byte character is treated as two letters. *2 For the application name, only the English file is referenced, thus if the name is defined for non-English language, it will not be used.</p>	Type	Max. data length	Available character	App name	8 letters (*2)	Alphanumeric, space ( ' ')	Menu name	16 letters (*1)	Other than equal (=) and semi-colon (;)
Type	Max. data length	Available character									
App name	8 letters (*2)	Alphanumeric, space ( ' ')									
Menu name	16 letters (*1)	Other than equal (=) and semi-colon (;)									

\*1 Available characters for arbitrary character string are alphanumeric and underscore (\_).

\*2 The file for English language is mandatory. If the English file has no key, the character string may not be drawn.

If this key is not included in any non-English file, the data defined to the key in English file is used.

[Setting example]

- Application language file for English

Contents of Application language file (HomeScrnn_custom_app1_eng.ini)	
[LANG]	; <- section
LANG_APP_NAME=custom1	; <- a key defined to NAME of [COMMON] section in Application definition file (Note) App name defined in English file is used, thus a name described in non-English file is ignored.
LANG_MENU=MENU	; <- a key defined to NAME of [SETTING 01] section in Application definition file
LANG_FILE=FILE	; <- a key defined to NAME of [SETTING 02] section in Application definition file
LANG_COPY=COPY	; <- a key defined to NAME of [Setting Copy] section in Application definition file
LANG_PASTE=PASTE	; <- a key defined to NAME of [Setting Paste] section in Application definition file

### 17.9.3.2 Compilation Method

#### 17.9.3.2.1 Setting Home Screen Config File (HomeScrnCustomConfig.ini)

Refer to 17.9.3.1.1.

#### 17.9.3.2.2 Setting Application Definition File (HomeScrn\_○○○○.ini)

Refer to 17.9.3.1.2.

#### 17.9.3.2.3 Setting Application Language File (HomeScrn\_○○○○\_△△△.ini)

Refer to 17.9.3.1.3.

### 17.9.3.3 Precaution When Creating Customized Screen with Fixed Home Screen Display

#### 17.9.3.3.1 Displayable Area on Customized Screen

Create a Customized screen as a Panel. The upper side and right end side of the Panel are common display area; thus do not allocate any parts.

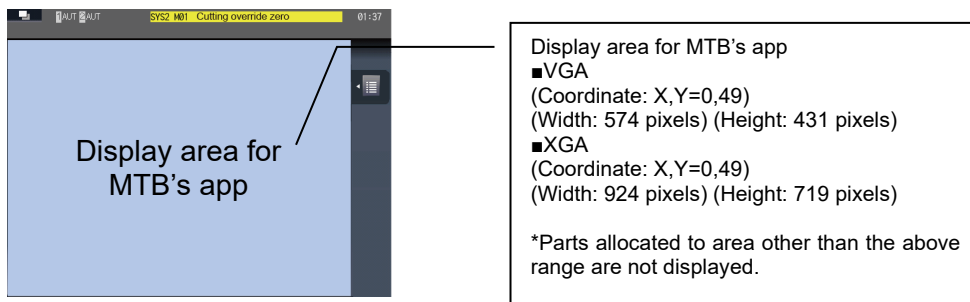

When you create a screen, allocate an application control on a part of NC Designer2 panel, and create an application.

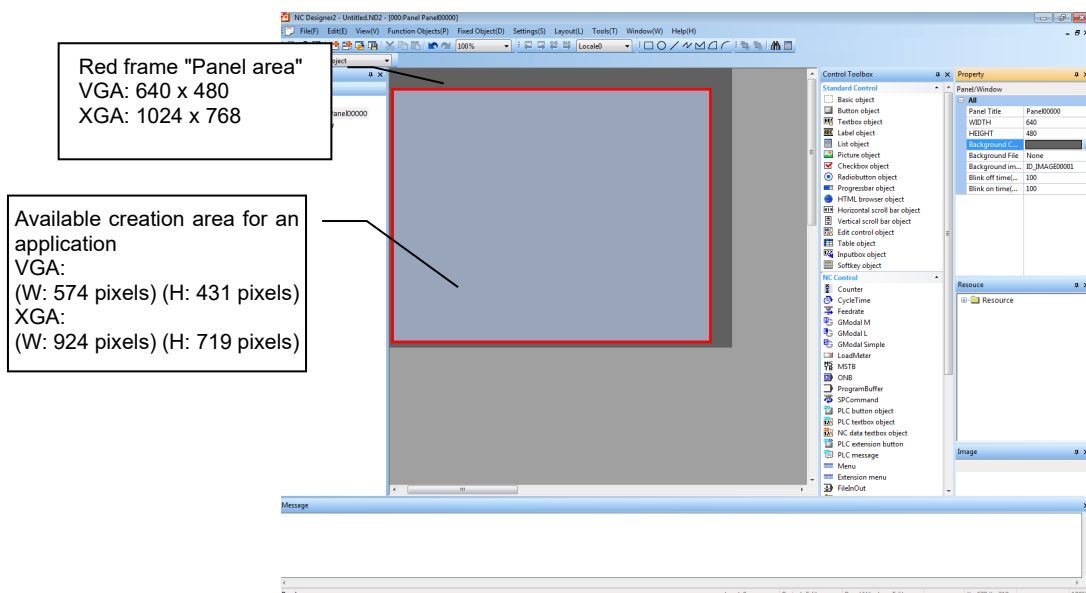

**17.9.3.3.2 Changing Operation Menu Display**

When you change the status of Operation menu button (normal/highlight/invalid/hide), call GCSUser() to Home screen on Customized screen (a screen made by a machine tool builder).

Refer to below program example when you call GCSUser.

Prepare IParam in long form array.

Array number	Description
[0]	The number of Operation menus to be changed (the number of ns)
[n*2]	The information of Operation menu to be changed
The [(n*2)+1]th	Specify the MENU_ID number defined in Application definition file (HomeScrn_oooo.ini).
The [(n*2)+2]th	Status after change (0: normal/1: highlight/2: invalid/3: hide)

n= the number of Operation menus to be changed.

Refer to below table for the argument of GCSUser function.

Array number	Description
The 1st argument	Object to be operated (fixed to 501)
The 2nd argument	Command number to execute (fixed to 0 x 9602)
The 3rd argument	Accompanying information

[Program example: Specify Operation menu status]

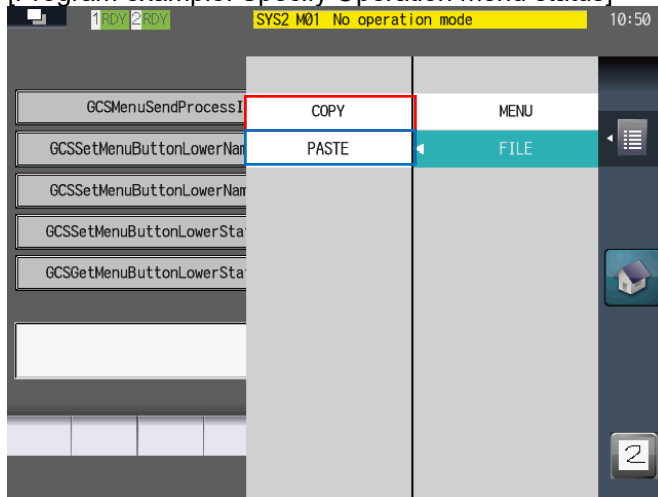

\* Below is a program example to display COPY highlighted and PASTE as invalid of the above screen.

#### (1) Interpreter method

```

GMEM _Param; // Definition
_Param = GMemCreate("MENU_STAT", 20); // Ensure memory (the 2nd argument is
                                     // the number of bytes)
GMemSetLong(_Param, 0, 2); // Specify the number of Operation menus to
                           // change (n=2)

// Highlight sub menu [Copy]
GMemSetLong(_Param, 4, 201); // MENU_ID of sub menu [Copy]
GMemSetLong(_Param, 8, 1); // Specify highlight (1) to the status
                             // after change

// Display sub menu [Paste] as invalid
GMemSetLong(_Param, 12, 202); // MENU_ID MENU_ID of sub menu [Paste]
GMemSetLong(_Param, 16, 2); // Specify invalid (2) to the status after change

// Call GCSUser() function
GCSUser(501, 0x9602, _Param); // GUSER_FUNC_SETMENUSTATE(0x9602)
GMemDelete(_Param); // Memory release
  
```

#### (2) Compilation method

```

long _iParam[(2*2)+1];
 iParam[0] = 2; // Specify the number of Operation menus to change (n=2)

// Highlight sub menu [COPY]
 iParam[1] = 201; // MENU_ID of sub menu [Copy]
 iParam[2] = 1; // Specify highlight (1) to the status after change

// Display sub menu [Paste] as invalid
 iParam[3] = 202; // MENU_ID of sub menu [Paste]
 iParam[4] = 2; // Specify invalid (2) to the status after change

// Call GCSUser() function
GCSUser(GCSGetPanel(GCSGetWindow(GCSGetScreen(GetGBaseObject()), 501 + 1)),
        GUSER_FUNC_SETMENUSTATE, (long) iParam);
  
```



**17.9.3.3.3 Receiving Notification When Operation Menu Is Pressed on Home Screen**

When a setting menu on Home screen is pressed, GCSUser function is used to notify it as a GCSUser event from the Home screen to the customized screen (the screen made by a machine tool builder). The interpreter notifies to OnUser callback function of the control on which focus is set.

Create processing to receive GCSUser events with reference to below program example.

Message ID: GUSER\_FUNC\_EXECMENEUEVENT

Parameter: the value defined to "COMMANDnn" in Application definition file (HomeScrn\_○○○○.ini)

[Program example: Processing when each Operation menu is pressed]

(1) Interpreter method

```

XXXXXXXXXXXXXXXXXXXXXXXXXXXX-OnUser      // XXXXXXXX is a control name
// Processing when each Operation menu is pressed
IF[LLPARAM == GUSER_FUNC_EXECMENEUEVENT]
  // Home button
  IF[LUPARAM==0]                          // MenuID of Home button
  {
    Incorporate a process when Home button is pressed
  }
  // The 1st main menu
  ELSEIF[LLPARAM==1]                      // MenuID of the 1st menu
  {
    Incorporate a process when the 1st main menu is pressed
  }
  // Sub menu [Copy]
  ELSEIF[LLPARAM==2]                      // MenuID of sub menu [Copy]
  {
    Incorporate a process when sub menu [Copy] is pressed
  }
  _IStatus = TRUE;
ENDIF
ENDIF
$END
}

```

## (2) Compilation method

```
long XXXXXXXXXXXX::User( long _ILParam, long _IUParam )
{
    long _IStatus = FALSE;

    switch ( _ILParam )
    {
        // Process when each Operation menu is pressed
        case GUSER_FUNC_EXECMENEUEVENT:
            // Home button
            if ( _IUParam == 0 )
            {
                Incorporate a process when Home button is pressed
            }
            // The 1st main menu
            else if ( _IUParam == 1 )
            {
                Incorporate a process when the 1st main menu is pressed
            }
            // Sub menu [Copy]
            else if ( _IUParam == 2 )
            {
                Incorporate a process when sub menu [Copy] is pressed
            }
            _IStatus = TRUE;
            break;
        default:
            _IStatus = GCPanel::User(_ILParam, _IUParam);
            break;
    }
    return _IStatus;
}
```

**17.9.3.3.4 Notifying Key Input from Application**

When a key to display Operation menu (**LIST** key) is pressed or a key to change to Home screen (**MENU** key [the 10th button from the left]) is pressed, notify the key input from the Customized screen to Home screen so that Operation menu is displayed or screen changes to Home screen. In addition, when a key code shown in below table is notified to Home screen, the Home screen executes the operation described.

Key code	Operation detail
<b>MONITOR</b> key	Display Monitor screen
<b>SET_UP</b> key	Display Setup screen
<b>EDIT</b> key	Display Edit screen
<b>DIAGN</b> key	Display Diagn screen
<b>MAINTE</b> key	Display Mainte screen
<b>SFP</b> key	Display the Customization screen registered.
<b>FO</b> key	Display the Customization screen registered.
Window display key	Display standard screen
<b>LIST</b> key	Display Operation menu
<b>MENU</b> key	Home screen (the 10th button from the left)

Use CSKeyPress function to notify Home screen. Refer to below table for details of CSKeyPress function arguments.

Array number	Description
The 1st argument	Object to be operated (Fixed to 501)
The 2nd argument	Virtual key code
The 3rd argument	Key status

[Program example: Notify Home screen side key input when a key is pressed]

Below is a program example to notify Home screen key codes described the above table.

(1) Interpreter method

```

$XXXXXXXXXXXXXXXXXXXX-KeyPress           // XXXXXXXX is a control name
// Notify Home screen key input
// Omit
IF[(LUPARAM AND 2) <> 0]                 // CTRL key is pressed
IF[LLPARAM==114]                         // Window display key pressed
ELSEIF[LLPARAM==119]                     // LIST key pressed
// Notify Home screen by GCSKeyPress
GCSKeyPress(501,LLPARAM,LUPARAM);
ENDIF
ELSEIF[(LUPARAM AND 1) <> 0]             // SHIFT key is pressed
IF[LLPARAM==112]                         // MONITOR key pressed
ELSEIF[LLPARAM==113]                     // SETUP key pressed
ELSEIF[LLPARAM==114]                     // EDIT key pressed
ELSEIF[LLPARAM==115]                     // DIAGN key pressed
ELSEIF[LLPARAM==116]                     // MAINT key pressed
ELSEIF[LLPARAM==120]                     // SFP key pressed
ELSEIF[LLPARAM==121]                     // F0 key pressed
// Notify Home screen by GCSKeyPress
GCSKeyPress(501,LLPARAM,LUPARAM);
ENDIF
ELSEIF[(LUPARAM AND 7) <> 0]             // SHIFT, ALT or CTRL key is not pressed
IF[LLPARAM==121]                         // The 10th button from MENU key pressed
// Notify Home screen by GCSKeyPress
GCSKeyPress(501,LLPARAM,LUPARAM);
ENDIF
ENDIF
$END

```

## (2) Compilation method

```

long XXXXXXXXXXXX::OnKeyPress (unsigned short usKeyCode, unsigned long ulStatus)
{
// Notify Home screen key input
if (_IStatus == KEY_OK)
{
// Omit
switch(_unType)
case MENUT:
if(usKeyCode == GK_F10) // The 10th button from MENU key pressed
{
GCSKeyPress(GCSGetPanel(GCSGetWindow(GCSGetScreen(GetGBaseObject()),
501 + 1)), usKeyCode, ulStatus);
}
break;
case FUNCT:
if((usKeyCode == GK_F1) || // MONITOR key pressed
(usKeyCode == GK_F2) || // SETUP key pressed
(usKeyCode == GK_F3) || // EDIT key pressed
(usKeyCode == GK_F4) || // DIAGN key pressed
(usKeyCode == GK_F5) || // MAINTE key pressed
(usKeyCode == GK_F9) || // SFP key pressed
(usKeyCode == GK_F10)) // F0 key pressed
{
GCSKeyPress(GCSGetPanel(GCSGetWindow(GCSGetScreen(GetGBaseObject()),
501 + 1)), usKeyCode, ulStatus);
}
// Omit
}
else if(_IStatus == KEY_SP)
{
// Omit
switch(_unType)
case MENUT:
if(usKeyCode == GK_F8) // LIST key pressed
{
GCSKeyPress(GCSGetPanel(GCSGetWindow(GCSGetScreen(GetGBaseObject()),
501 + 1)), usKeyCode, ulStatus);
}
Barek;
Case WINDOWT:
if(usKeyCode == GK_F3) // Window display key pressed
{
GCSKeyPress(GCSGetPanel(GCSGetWindow(GCSGetScreen(GetGBaseObject()),
501 + 1)), usKeyCode, ulStatus);
}
//Omit
}
}

```

**17.9.3.4 Caution**

- In this method only Panel is called from Home screen.  
Regarding changing from one Panel to another Panel and showing Windows, this method only supports the switchover from one Panel to another Panel.  
Operations are not guaranteed when Windows are displayed.
- While Operation menu is displayed, the application side cannot receive key events.
- History while the application screen is displayed is left as details/history of Home screen.

### **17.9.4 Full-Screen Display**

This section describes how to register an application created by a machine tool builder (referred to as MTB'S app) with use of the full-screen display type.

#### **17.9.4.1 Interpreter Method**

##### **17.9.4.1.1 Setting Home Screen Config File (HomeScrnCustomConfig.ini)**

Refer to 17.9.3.1.1.

**17.9.4.1.2 Setting Application Definition File (HomeScrn\_○○○○.ini)**

Application definition file is used to define the information of extension application registered to Home screen. Using this definition file, you define the basic information of extension application, Home button operation, Operation menu button operation, etc.

[File contents]

- Section

Section name	Mandatory	Description
COMMON	Yes	Define basic information of the application.

- [COMMON] section key

Key name	Mandatory	Description
NAME	Yes	Specify the character string to be used for the application name displayed under Application button or in the sub menus of [Add Application] menu, using the key described in [LANG] section of Application language file (*). The actually displayed application name is defined in Application language file.  * For details of Application language file, refer to "17.9.3.1.3".  Note) If this key is undefined, or if application name is unable to be retrieved from the app name key, neither application buttons nor sub menus of [Add Application] menu are displayed.  Setting range: Up to 32 characters
TYPE	Yes	Specify the type of MTB's app: 0: Fixed Home screen display 1: Full-screen display (NC Designer2 interpreter method/NC Designer2 compilation method) 2: Full-screen display (EXE file registration method)
ICONFILENAME	No	Specify the image file (*) to be used as an icon of Application button. Use either an absolute or relative path to specify the image file name (e.g. custom_app1.jpg). For a relative path, specify a path relative to this definition file.  *Specify an image file with the size below: - XGA: Up to 52 x 52 pixels - VGA: Up to 40 x 40 pixels *Available format is JPG.  Note) If you specify no file, or specified file is nonexistent, the icon of the execution file (MTB's app) defined in the EXECFILENAME key of [COMMON] section is used.  Setting range: Up to 128 characters including the path (*1)
PANEL_OFFSET	Yes	Unique offset value allocated to each screen of MTB's app. Specify the offset value defined in HMI configuration file (customdef.ini).

[Setting example]

[COMMON]	; <- Define basic information of application.
NAME=LANG_APP_NAME	; <- Specify the application name.
ICONFILENAME=D:\Custom\ExtApp\custom_app.jpg	; <- Specify the image to be displayed on Application button.
TYPE=1	; <- Specify the registration type
PANEL_OFFSET=6500	; <- Specify 6500 to the offset number of the panel to be changed

**17.9.4.1.3 Setting Application Language File (HomeScrn\_○○○○\_△△△.ini)**

Refer to 17.9.3.1.3.

### **17.9.4.2 Compilation Method**

#### **17.9.4.2.1 Setting Home Screen Config File (HomeScrnCustomConfig.ini)**

Refer to 17.9.3.1.1.

#### **17.9.4.2.2 Setting Application Definition File (HomeScrn\_○○○○.ini)**

Refer to 17.9.3.1.2.

#### **17.9.4.2.3 Setting Application Language File (HomeScrn\_○○○○\_△△△.ini)**

Refer to 17.9.3.1.3.

### **17.9.4.3 Caution**

- In these methods, only Panel is called from Home screen.  
Regarding changing from one Panel to another Panel and showing Windows, these methods support both.
- Panel size to be displayed is only available for full-screen display.



### 17.10 S/W Keyboard

#### 17.10.1 Outline

Custom screen can display the following S/W keyboard window.

This function is adapted to M800V/M80V/M800/M80 (Windows-based display unit),

M800V/M80V/M800/M80 (Windows-less display unit), and M700VS/M70V/E70.

This S/W keyboard window can be laid out on the left end, middle or right end of the screen. When the [ALLKEY] button is pressed, the keyboard is switched between the ten-key and ALL key display.

This section describes how to use the S/W keyboard window on custom screen.

<Ten-key keyboard>

RESET	SFP	F0	
LIST		C.B CAN	DELETE INSERT
+ !	7	8	9
/ :	4 \$	5	6
* \	1 <	2 >	3 #
≈ ~	- @	0 -	. ,
▲ PAGE	←	↑	→
▼ PAGE	←	↓	→
CLOSE	ALLKEY	SHIFT	INPUT

< ALL key keyboard>

RESET	SFP	F0		O A	N B
LIST		C.B CAN	DELETE INSERT	G C	X U
+ !	7	8	9	Y V	Z W
/ :	4 \$	5	6	F E	D L
* \	1 <	2 >	3 #	H I	P I
≈ ~	- @	0 -	. ,	Q J	R K
▲ PAGE	←	↑	→	M (	S )
▼ PAGE	←	↓	→	T [	;/EOB ]
CLOSE	ALLKEY	SHIFT	INPUT	SP	ABC.. /abc..

### 17.10.2 Function Specifications

Defining the following items is required to use the S/W keyboard, as the S/W keyboard window has been created as a window of NC Designer2.

- Monitor screen's offset No. 1000
- S/W keyboard window's page No. 27

By specifying the screen No. as "1027", each of the S/W keyboard functions can be activated.

<Interpreter method>

	Description	Function name	Function No.	Setting
1	Open the S/W keyboard	GCSCreateGWindow()	-	-
2	Close the S/W keyboard	GCSCloseGWindow()	-	-
3	Set the S/W keyboard display position	GCSUser()	4193	0: Ten-key keyboard on the left end 1: Ten-key keyboard on the middle 2: Ten-key keyboard on the right end 3: ALL key keyboard on the left end 4: ALL key keyboard on the middle 5: ALL key keyboard on the right end
4	Set the status of entry area (Enabled/Disabled/Password entry)	GCSUser()	4189	0: Disabled 1: Enabled 2: Password entry
5	Get the status of entry area (Enabled/Disabled/Password entry)	GCSUser()	4194	Entry area's status (0: Disabled 1: Enabled 2: Password entry)
6	Clear the entry area	GCSUser()	4190	0 (fixed)
7	Set a character string to the entry area	GCSUser()	4196	A character string to enter
8	Get a character string from the entry area	GCSUser()	4197	A character string in the entry area of S/W keyboard window
9	Display the S/W keyboard in the foreground	GCSUser()	4195	0 (fixed)

<Compilation method>

	Description	Function name	Event message	Setting
1	Open the S/W keyboard	GCSCreateGWindow()		
2	Close the S/W keyboard	GCSDeleteChild()		
3	Set the S/W keyboard display position	GCSUser()	USNX_CHANGESWK EYPOS	0: Ten-key keyboard on the left end 1: Ten-key keyboard on the middle 2: Ten-key keyboard on the right end 3: ALL key keyboard on the left end 4: ALL key keyboard on the middle 5: ALL key keyboard on the right end
4	Set the status of entry area (Enabled/Disabled/Password entry)	GCSUser()	USNX_SETSWKEYIN PUTACTIVE	0: Disabled 1: Enabled 2: Password entry
5	Get the status of entry area (Enabled/Disabled/Password entry)	GCSUser()	USNX_GETSWKEYIN PUTACTIVE	Entry area's status (0: Disabled 1: Enabled 2: Password entry)
6	Clear the entry area	GCSUser()	USNX_CLEARSWKEY INPUTDATA	0 (fixed)
7	Set a character string to the entry area	GCSUser()	USNX_SETSWKEYIN PUTDATA	A character string to enter
8	Get a character string from the entry area	GCSUser()	USNX_GETSWKEYIN PUTDATA	A character string in the entry area of S/W keyboard window
9	Display the S/W keyboard in the foreground	GCSUser()	USNX_MOVELASTWI NDOW	0 (fixed)

### 17.10.3 Programming Method

#### 17.10.3.1 Open S/W Keyboard Window

To open the S/W keyboard window, you need to set the entry area of the S/W keyboard window to either enabled, disabled or password mode. For how to set, refer to "17.10.3.4 Set the Status of Entry Area of S/W Keyboard Window". The default S/W keyboard is the ten-key type and is displayed on the left end. For how to set the keyboard, refer to "17.10.3.3.1 Set the initial display position of the S/W keyboard window".

#### Example

##### Interpreter Method

( 1 )  
Display the S/W keyboard window when the button control (GButton00000) is pressed  
(Set the entry area of the S/W keyboard window to disabled)

```
$GButton00000-OnClick
  GMEM mem;
  mem = GMEMCreate("TESTMEM", 4);
  GMEMSetLong(mem, 0, 0);
  GCSCreateGWindow (1027);           'Open the S/W keyboard window
  GCSUser (1027, 4189, mem);        'Set the entry area to disabled
  GMEMDelete(mem);
$End
```

##### Compilation Method

Display the S/W keyboard window using the GCSCreateGWindow function.

```
// Open the S/W keyboard window
long _IStatus = GCSCreateGWindow( GCSCGetScreen(GetGBaseObject()),1027 );
if ( _IStatus == TRUE )
{
    // Get the S/W keyboard window object
    GBaseObject *_gpWindowObj = GCSCGetWindow( (GCSCGetScreen(GetGBaseObject())),
        (unsigned short)(1027 + 1) );
    GBaseObject *_gpWinPanelObj = GCSCGetPanel( _gpWindowObj );
    // Set the S/W keyboard entry area to disabled
    long _IStatus = 0;
    GCSUser(_gpWinPanelObj, USNX_SETSWKEYINPUTACTIVE, (long)&_IStatus);
}
```

### 17.10.3.2 Close S/W Keyboard Window

#### Example

##### Interpreter Method

Close the S/W keyboard window when the button control (GButton00000) is pressed.

```
$GButton00000-OnClick  
  GCSCloseGWindow (1027);          'Close S/W keyboard window  
$End
```

##### Compilation Method

Close the S/W keyboard window using the GCSDeleteChild function.

```
GBaseObject *_gcFrameObj;  
_gcFrameObj = GCSGetFrame( GCSGetScreen(GetGBaseObject()) );  
  
GBaseObject *_pFrmChild;  
_pFrmChild = GCSGetChild( _gcFrameObj, (unsigned short)(1027 + 1) );  
if (_pFrmChild != NULL)  
{  
    // Close the S/W keyboard window  
    GCSDeleteChild( _gcFrameObj, _pFrmChild );  
}
```

### 17.10.3.3 Set S/W Keyboard Position

#### 17.10.3.3.1 Set the Initial Display Position of the S/W Keyboard Window

##### Example

##### Interpreter Method

Display the ten-key S/W keyboard window in the screen's middle when the button control (GButton00000) is pressed.

```
$GButton00000-OnClick
```

```
GMEM mem;
```

```
  mem = GMEMCreate("TESTMEM", 4);
```

```
  GMEMSetLong(mem, 0, 1);
```

```
  GCSCreateGWindow (1027);
```

```
  GCSUser (1027, 4193, mem);
```

'Open the S/W keyboard window

'Display the ten-key S/W keyboard window

in the screen's middle.

```
  GCSUser (1027, 4189, 0);
```

'Set the entry area to disabled

```
GMEMDelete(mem);
```

```
$End
```

##### Compilation Method

When the GCSUser function (Function: USNX\_CHANGESWKEYPOS) is used after the GCSCreateGWindow function, the S/W keyboard window can be opened at the specified display position.

```
// Open the S/W keyboard window
long _IStatus = GCSCreateGWindow( GCSGetScreen(GetGBaseObject()),1027 );
if ( _IStatus == TRUE )
{
    // Get the S/W keyboard window object
    GBaseObject *_gpWindowObj = GCSGetWindow( (GCSGetScreen(GetGBaseObject()),
                                                (unsigned short)(1027 + 1) );
    GBaseObject *_gpWinPanelObj = GCSGetPanel( _gpWindowObj );
    // Change the display position of the S/W keyboard
    long _IStatus = 1;
    GCSUser(_gpWinPanelObj, USNX_CHANGESWKEYPOS, (long)&_IStatus );
    // Set the S/W keyboard entry area to disabled
    long _IStatus2 = 0;
    GCSUser(_gpWinPanelObj, USNX_SETSWKEYINPUTACTIVE, (long)&_IStatus2 );
}
```

**17.10.3.3.2 Change the S/W Keyboard Window Position Arbitrarily While the Window Is Being Displayed**

## Example

## Interpreter Method

Display the ten-key S/W keyboard window in the screen's middle when the button control (GButton00000) is pressed.

```
$GButton00000-OnClick
  GMEM mem;
  mem = GMEMCreate("TESTMEM", 4);
  GMEMSetLong(mem, 0, 1);
  GCSUser (1027, 4193, mem); 'Display the ten-key S/W keyboard window in the screen's middle
  GMEMDelete(mem);
$End
```

## Compilation Method

Change the display position of the S/W keyboard window using the GCSUser function (Function: USNX\_CHANGE\_SWKEYPOS).

```
// Get the S/W keyboard window object
GBaseObject *_gpWindowObj = GCSGetWindow( (GCSGetScreen(GetGBaseObject())),
                                           (unsigned short)(1000 + 27 + 1) );
if( _gpWindowObj != NULL )
{
  GBaseObject *_gpWinPanelObj = GCSGetPanel( _gpWindowObj );
  // Change the display position of the S/W keyboard
  long _IStatus = 1;
  GCSUser(_gpWinPanelObj, USNX_CHANGE_SWKEYPOS, (long)&_IStatus);
}
```

### 17.10.3.4 Set the Status of Entry Area of S/W Keyboard Window

The status of the entry area of the S/W keyboard window can be set to disabled, enabled or password mode.

**Disabled** : When a key is input from the S/W keyboard window, the key is passed to the control where the focus is located.

**Enabled** : When a key is input from the S/W keyboard window, the entered key is displayed in the entry area of the S/W keyboard window.  
(Note) If you wish to display an entered key in the entry area of the S/W keyboard window, refer to "17.10.3.4.1 Display the entered characters on the entry area of S/W keyboard window".

**Password display** : When a key is entered from the S/W keyboard window, "\*" is displayed in the entry area of the S/W keyboard window.

#### Example

##### Interpreter Method

Set the entry status of the S/W keyboard window to enabled when the button control (GButton00000) is pressed.

```
$GButton00000-OnClick
  GMEM mem;
  mem = GMEMCreate("TESTMEM", 4);
  GMEMSetLong(mem, 0, 1);
  GCSUser (1027, 4189, mem);          'Set the entry area to enabled
  GMEMDelete(mem);
$End
```

##### Compilation Method

Set the status of the entry area of the S/W keyboard window using the GCSUser function (Function: USNX\_SETSWKEYINPUTACTIVE).

```
// Get the S/W keyboard window object
GBaseObject *_gpWindowObj = GCSGetWindow( (GCSGetScreen(GetGBaseObject())), (unsigned short)(1027 + 1) );
if( _gpWindowObj != NULL )
{
  GBaseObject *_gpWinPanelObj = GCSGetPanel( _gpWindowObj );
  // Set the S/W keyboard entry area to enabled or disabled
  long _IStatus = 1;
  GCSUser( _gpWinPanelObj, USNX_SETSWKEYINPUTACTIVE, (long)& _IStatus);
}
```

**17.10.3.4.1 Display the Entered Characters on the Entry Area of S/W Keyboard Window**

If the entry area of the S/W keyboard window is enabled, an entered key is not displayed in the entry area even when a key is entered from the S/W keyboard window.

However, by adding GCSKeyPress() to the OnKeyPress function of a control placed on a panel, a character string is displayed in the entry area of the S/W keyboard window.

**Example****Interpreter Method**

```
$GTextBox00000-OnKeyPress
  GCSKeyPress(1027, LLPARAM, LUPARAM)    'Pass a key to the S/W keyboard window
endif
```

\* Use the virtual key code (LLPARAM) and key state (LUPARAM) given to KeyPress as the arguments of the GCSKeyPress function.

**Compilation Method**

```
// Get the S/W keyboard window object
GBaseObject *_gpWindowObj = GCSGetWindow( GCSGetScreen(GetGBaseObject())), (unsigned short)(1027 + 1) );
// If the S/W keyboard window object has been gotten (if the S/W keyboard window is displayed)
if(_gpWindowObj != NULL)
{
  GBaseObject *_gpWinPanelObj = GCSGetPanel( _gpWindowObj );
  // Pass a key to the S/W keyboard window
  GCSKeyPress ( _gpWinPanelObj, LLPARAM, LUPARAM);
  // Refresh the S/W keyboard window
  GCSAddRefreshRect( _gpWinPanelObj, NULL, TRUE );
}
```



**17.10.3.4.2 Process When the [INPUT] Key Is Pressed**

If the entry area of the S/W keyboard window is enabled, a value in the entry area is not automatically set in the control placed on a panel even when the [INPUT] key on the keyboard window is pressed. To make this enabled, it is required to get the value using the OnKeyPress function of the control.

By adding the below process to a control placed on a panel, a value in the entry area of the S/W keyboard window can be set.

**Example****Interpreter Method**

```
$GTextBox00000-OnKeyPress
if(LLPARAM == 13)
  GMEM mem;
  STRING strStat;
  mem = GMEMCreate("GETINPUT", 140);
  GCSUser (1027, 4197, mem);           'Get a character string from the entry area
                                      of the S/W keyboard window

  strStat = GMEMGetString(mem,0);
  GCSTextboxSetString(-1,"GTextBox00000",strStat);
  GMEMSetLong(mem, 0, 0);
  GCSUser (1027, 4190, mem);         'Clear the entry area of the S/W keyboard window
  GMEMDelete(mem);
  GCSCheckActiveFocus(-1,"GTextBox00000"); 'Move the focus to GTextBox00000
endif
$End
```

**Compilation Method**

```
if(ILParam == GK_RETURN)
{
  char _szData[256];
  memset( _szData, 0 , sizeof(_szData) );

  // Get the S/W keyboard window object
  GBaseObject *_gpWindowObj = GCSGetWindow( (GCSGetScreen(GetGBaseObject()),
                                             (unsigned short)(1027 + 1) );

  // If the S/W keyboard window object has been gotten (if the S/W keyboard window is displayed)
  if(_gpWindowObj != NULL)
  {
    GBaseObject *_gpWinPanelObj = GCSGetPanel( _gpWindowObj );
    // Get a value from the entry area of the S/W keyboard
    GCSUser( _gpWinPanelObj, USNX_GETSWKEYINPUTDATA, (long) _szData);
  }
}
```

**17.10.3.5 Get the Entry Area Status of S/W Keyboard Window**

## Example

## Interpreter Method

Get the status of the entry area of the S/W keyboard window in Stat when the button control (GButton00000) is pressed.

```
$GButton00000-OnClick
LONG Stat;
GMEM mem;
mem = GMEMCreate("TESTMEM", 4);
GCSUser (1027, 4194, mem);      'Get the status of the entry area of the S/W keyboard window
Stat = GMEMGetLong(mem, 0);
GMEMDelete(mem);
$End
```

## Compilation Method

Get the status of the entry area of the S/W keyboard window using the GCSUser function (Function: USNX\_GETSWKEYINPUTACTIVE).

```
// Get the S/W keyboard window object
GBaseObject *_gpWindowObj = GCSGetWindow( (GCSGetScreen(GetGBaseObject())), (unsigned short)(1027 + 1) );
if( _gpWindowObj != NULL )
{
    GBaseObject *_gpWinPanelObj = GCSGetPanel( _gpWindowObj );
    Long _IStatus = 0;
    // Get the status (enabled or disabled) of the S/W keyboard entry area
    GCSUser( _gpWinPanelObj, USNX_GETSWKEYINPUTACTIVE, (long)&_IStatus );
}
```

### 17.10.3.6 Clear S/W Keyboard Entry Area

#### Example

##### Interpreter Method

Clear the entry area of the S/W keyboard window when the button control (GButton00000) is pressed.

```
$GButton00000-OnClick
  GMEM mem;
  mem = GMEMCreate("TESTMEM", 4);
  GMEMSetLong(mem, 0, 0);
  GCSUser (1027, 4190, mem);          'Clear the entry area of the S/W keyboard window
  GMEMDelete(mem);
$End
```

##### Compilation Method

Clear the entry area of the S/W keyboard window using the GCSUser function (Function: USNX\_CLEARSWKEYINPUTDATA).

```
// Get the S/W keyboard window object
GBaseObject *_gpWindowObj = GCSGetWindow( (GCSGetScreen(GetGBaseObject())),
(unsigned short)(1027 + 1) );
if( _gpWindowObj != NULL )
{
  GBaseObject *_gpWinPanelObj = GCSGetPanel( _gpWindowObj );
  // Clear the entry area of the S/W keyboard
  long _IStatus = 0;
  GCSUser(_gpWinPanelObj, USNX_CLEARSWKEYINPUTDATA, (long)&_IStatus);
}
```

## 17.10.3.7 Set Character String in S/W Keyboard Entry Area

## Example

## Interpreter Method

Set a character string in the entry area of the S/W keyboard window when the button control (GButton00000) is pressed.

```
$GButton00000-OnClicK
  GMEM mem;
  mem = GMEMCreate("TESTMEM", 70);
  GMEMSetString(mem, 0, "abcdef");
  GCSUser (1027, 4196, mem);      'Set a character string in the S/W keyboard window
  mem = GMEMDelete("TESTMEM ");
  GMEMDelete(mem);
$End
```

## Compilation Method

Set a character string in the entry area of the S/W keyboard window using the GCSUser function (Function: USNX\_SETSWKEYINPUTDATA).

```
// Character string to be set
char _szData[256];
memset( _szData, 0 , sizeof(_szData) );
_szData = "ABCDE"

// Get the S/W keyboard window object
GBaseObject *_gpWindowObj = GCSGetWindow( (GCSGetScreen(GetGBaseObject())), (unsigned short)(1027 + 1) );
if(_gpWindowObj != NULL)
{
  GBaseObject *_gpWinPanelObj = GCSGetPanel( _gpWindowObj );
  // Set a character string in the S/W keyboard entry area
  GCSUser( _gpWinPanelObj, USNX_SETSWKEYINPUTDATA, (long)_szData);
}
```

### 17.10.3.8 Get Character String from S/W Keyboard Entry Area

#### Example

##### Interpreter Method

Get a character string from the entry area of the S/W keyboard window when the button control (GButton00000) is pressed.

```
$GButton00000-OnClick
  GMEM mem;
  STRING Data;
  mem = GMEMCreate("TESTMEM", 140);
  GCSUser (1027, 4197, mem);      'Get a character string from the entry area of the S/W
  keyboard window
  Data = GMEMGetString( mem, 0);
  GMEMDelete(mem);
$End
```

##### Compilation Method

Get a character string displayed on the entry area of the S/W keyboard window using the GCSUser (Function: USNX\_GETSWKEYINPUTDATA).

```
char _szData[256];
memset( _szData, 0 , sizeof(_szData) );

// Get the S/W keyboard window object
GBaseObject *_gpWindowObj = GCSTGetWindow( (GCSTGetScreen(GetGBaseObject())), (unsigned short)(1027 + 1) );
// If the S/W keyboard window object has been gotten (if the S/W keyboard window is displayed)
if(_gpWindowObj != NULL)
{
  GBaseObject *_gpWinPanelObj = GCSTGetPanel( _gpWindowObj );
  // Get a value from the entry area of the S/W keyboard
  GCSUser( _gpWinPanelObj, USNX_GETSWKEYINPUTDATA, (long) _szData);
}
```

**17.10.3.9 Display S/W Keyboard Window in the Foreground**

If the display position of the S/W keyboard window is overlapped with that of the other window, the other window is displayed in the foreground when the other window is displayed or touched. In this case, the S/W keyboard window is displayed in the background of the other window. However, the S/W keyboard window is again displayed in the front by adding the following process.

**Example****Interpreter Method**

Display the S/W keyboard window in the foreground when the button control (GButton00000) is pressed

```
$GButton00000-OnClick
  GMEM mem;
  mem = GMEMCreate("TESTMEM", 4);
  GMEMSetLong(mem, 0, 0);
  GCSUser (1027, 4195, mem);          'Display the S/W keyboard window in the foreground
  GMEMDelete(mem);
$End
```

**Compilation Method**

Display the S/W keyboard window in the foreground using the GCSUser function (Function: USNX\_MOVELASTWINDOW).

```
// Get the S/W keyboard window object
GBaseObject *_gpWindowObj = GCSGetWindow( (GCSGetScreen(GetGBaseObject())), (unsigned short)(1027 + 1) );
// If the S/W keyboard window object has been gotten (if the S/W keyboard window is displayed)
if(_gpWindowObj != NULL)
{
  GBaseObject *_gpWinPanelObj = GCSGetPanel( _gpWindowObj );
  // Display S/W keyboard in the foreground when the keyboard is not displayed in the foreground
  long _IStatus = 0;
  GCSUser(_gpWinPanelObj, USNX_MOVELASTWINDOW, (long)&_IStatus);
}
```

17.10.4 Example

Screen Configuration

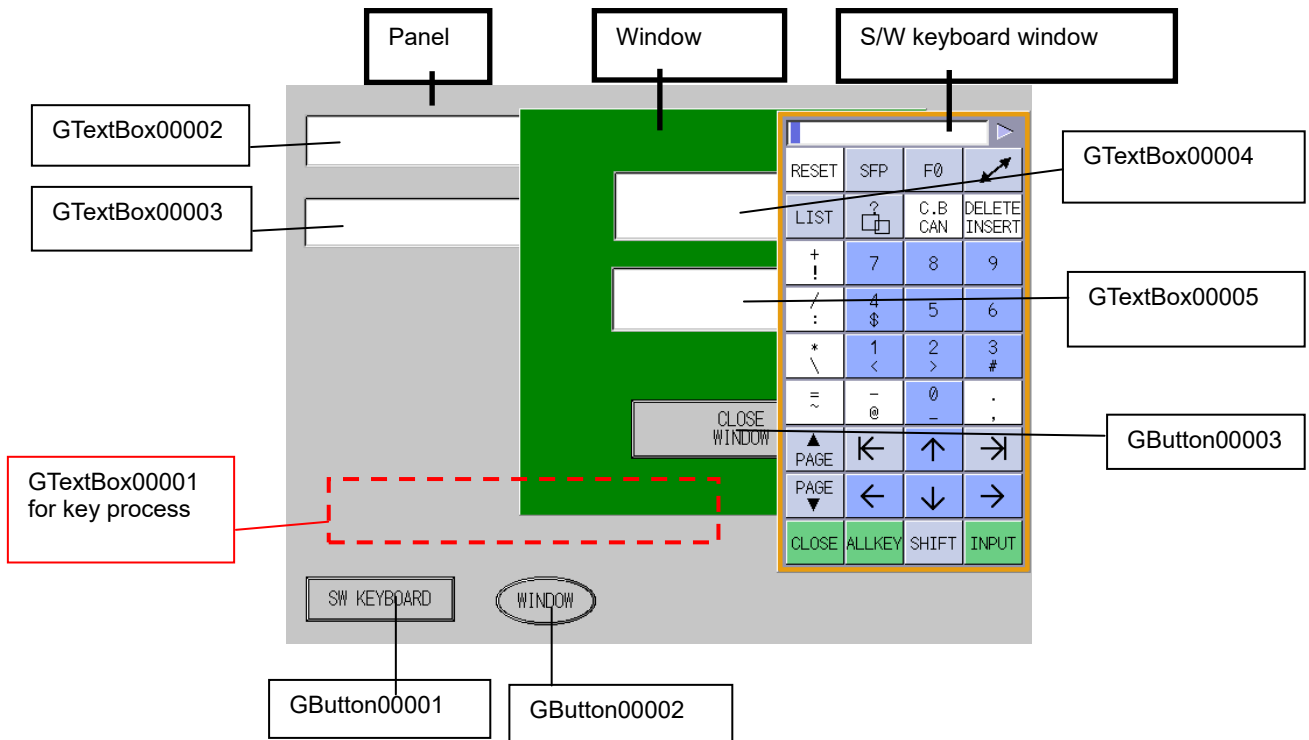

Action

- (1) When GButton00001 on the panel is pressed, the S/W keyboard window is displayed.
- (2) The S/W keyboard window is displayed always in the foreground.
- (3) When GButton00002 on the panel is pressed, the window is displayed.
- (4) When GButton00003 on the window is pressed, the window is closed.
- (5) When a key is entered on the S/W keyboard window while the window is not displayed, the entered character is displayed on the entry areas of both GTextBox00002 and the S/W keyboard window.
- (6) When the [INPUT] key is pressed while the window is not displayed, the character string in the entry area of the S/W keyboard window is displayed on GTextBox00003.
- (7) When a key is entered on the S/W keyboard window while the window is displayed, the entered character is displayed on the entry areas of both GTextBox00004 and the S/W keyboard window.
- (8) When the [INPUT] key is pressed while the window is displayed, the character string in the entry area of the S/W keyboard window is displayed on GTextBox00005.

## Source Code

When a window is opened using F0 release, the focus moves to the window. When a key on the S/W keyboard window is touched, the focus moves to the S/W keyboard window, thus the key is not passed to the window.

To enter the key touched on the S/W keyboard window into a control on a window, create the TextBox control on a panel at first, on which a key process to a control on a window is carried out. The focus should be on the TextBox control created on the panel when the window is displayed. Get the key touched on the S/W keyboard window using the TextBox control for key process, and get the character string on the TextBox control using a control of window.

< Open the S/W keyboard window >

- The control GButton00001 on a panel

When a key on the S/W keyboard window is touched, the entered character is displayed on GTextBox00002, so the focus moves to GTextBox00002.

```
$GButton00001-OnClick
    GCSCreateGWindow(1027);                'Display the S/W keyboard window
    GMEM mem;
    mem = GMEMCreate("TESTMEM", 4);
    GMEMSetLong(mem,0,0);
    GCSUser(1027,4190,mem);                'Clear the entry area
    GMEMSetLong(mem,0,1);
    GCSUser(1027,4189,mem);                'Set the entry area status to enabled
    GMEMDelete(mem);
    GCSCheckActiveFocus(-1,"GTextBox00002"); 'Move the focus to GTextBox00002
$End
```

<Display S/W keyboard in the foreground>

When a window is touched while the S/W keyboard window is being displayed, the focus moves to the touched control, so the window is displayed in the foreground of the S/W keyboard window. Therefore, display the S/W keyboard window in the forefront when the focus moves to each control of window.

```
$GTextBox00005-OnSetFocus
    GMEM mem;
    mem = GMEMCreate("TESTMEM", 4);
    GMEMSetLong(mem,0,0);
    GCSUser(1027,4195,mem);                'Display the S/W keyboard window in the foreground
    GMEMDelete(mem);
$End
```

```
$GTextBox00004-OnSetFocus
    GMEM mem;
    mem = GMEMCreate("TESTMEM", 4);
    GMEMSetLong(mem,0,0);
    GCSUser(1027,4195,mem);                'Display the S/W keyboard window in the foreground
    GMEMDelete(mem);
$End
```



<Open a window>

- The control GButton00002 on a panel

When a window is opened, the opened window is displayed in the foreground. Therefore, display the S/W keyboard window again in the foreground.

Move the focus to the TextBox control for key process.

```
$GButton00002-OnClick
  GCSCreateGWindow(1);
  GMEM mem;
  mem = GMEMCreate("TESTMEM", 4);
  GMEMSetLong(mem,0,0);
  GCSUser(1027,4195,mem);          'Display the S/W keyboard window in the foreground
  GCSUser(1027,4190,mem);          'Clear the entry area
  GMEMDelete(mem);
  GCSCheckActiveFocus(-1,"GTextBox00001");          'Move the focus to GTextBox00001
$End
```

<Close a window>

- GButton00003 control on a window

After the window has been closed, the focus is moved to GTextBox00002.

```
$GButton00003-OnClick
  GCSCloseGWindow(1);
  GCSCheckActiveFocus(0,"GTextBox00002"); 'Move the focus to GTextBox00002
$End
```

<Key process to a control on a panel>

When the [INPUT] key is pressed, a value in the entry area of the S/W keyboard window is set in the GTextBox00003 control on a window.

The entered key is displayed on the entry area of the S/W keyboard window, thus the key is passed to the S/W keyboard window using GCSKeyPress.

```
$GTextBox00002-OnKeyPress
  if(LLPARAM == 13)
  STRING strStat;
  GMEM mem;
  mem = GMEMCreate("TESTMEM", 140);
  GCSUser(1027, 4197, mem);          'Get the character string from the entry area
  strStat = GMEMGetString(mem, 0);
  GCSTextboxSetString(-1,"GTextBox00003",strStat);          'Set a character string in
                                                                GTextBox00003
  GMEMDelete(mem);
  endif;
  GCSKeyPress(1027,LLPARAM, LUPARAM); 'Pass a key to the S/W keyboard window
$End
```

<Enter a key in a window>

- The control GTextBox00001 on a panel (for key process)

A process to be carried out when a key is input to GTextBox00004 is added to the TextBox control for key process.

When the [INPUT] key is pressed, a value in the entry area of the S/W keyboard window is set in the GTextBox00005 control on a window.

In order to display the entered key on the entry area of the S/W keyboard window, the key is passed to the S/W keyboard window using GCSKeyPress.

```
$GTextBox00001-OnKeyPress
```

```
  if(LLPARAM == 13)
```

```
    STRING strStat;
```

```
    GMEM mem;
```

```
    mem = GMEMCreate("TESTMEM", 140);
```

```
    GCSUser(1027, 4197, mem);      'Get the character string from the entry area
```

```
    strStat = GMEMGetString(mem, 0);
```

```
    GCSTextboxSetString(1,"GTextBox00005",strStat);      'Set a character string
                                                         in GTextBox00005
```

```
    GMEMDelete(mem);
```

```
  endif;
```

```
    GCSKeyPress(1027,LLPARAM, LUPARAM);      'Pass a key to the S/W keyboard window
```

```
$End
```

- The control TextBox00004 on a window

Get an entered character string from the TextBox control for key process by use of Timer of TextBox00004.

After getting the character string, move the focus back to the TextBox control for key process.

```
$GTextBox00004-OnTimer
```

```
  STRING strStat;
```

```
  GCSTextboxGetString(0,"GTextBox00001",strStat);      'Get a character string
                                                         to GTextBox00001
```

```
  GCSTextboxSetString(-1,"GTextBox00004",strStat);      'Set a character string
                                                         to GTextBox00004
```

```
  GCSCheckActiveFocus(0,"GTextBox00001");      'Move the focus to GTextBox00001
```

```
$End
```

## Appendix

Reference items for the operation of NC Designer2 are described here. Refer to the description given here when necessary.

### Appendix 1. Error Message List

The error messages displayed with NC Designer2 and remedies are described below.  
(A to Z)

	Message	Cause and remedy
A	A caption character sequence does not exist.	This message is displayed if the selected NC Trainer2 plus project is not present because it has been moved or changed. Select another project.
	An unavailable character string (\t) is included.	This message is displayed when the ENTER key is pressed after inputting the character string \t while inputting the property "Character sequence". Input the characters other than the character string (\t).
	An invalid character is in a locale name. Please set up an effective character.	This message is displayed if a wrong character is designated during registration of the locale. Use letters, numbers or underscores (_) for the locale name.
	An invalid character is included.	This message is displayed if any invalid character is included in the screen number which is reselected with each function key.
	Application name is limited to 45 single-byte characters or less.	This message is displayed if two-byte characters or symbols are specified for "Application name displayed in "HMI integrated installer". Specify the name within 45 single-byte alphanumeric characters.
	As for Panel/Window information, other users are performing read-out or preservation. Please perform ... again after waiting for a while.	This message is displayed if a file has been opened by another user when you read or write the file. (Note)
	As for project common information, other users are performing read-out or preservation. Please perform ... again after waiting for a while.	This message is displayed if a file has been opened by another user when you read or write the file. (Note)
C	Can not create a frame inside a frame.	This message is displayed if a view frame is created inside another view frame. Arrange controls and figures in the view frame.
	Can not create any more frames.	This message is displayed if 10 or more view frames are created in a page. Contain within 10 view frames.
	Can not create any more new screens.	This message is displayed if a new page is created beyond the maximum number of pages at [File] - [New Panel] / [New Window]. Delete unnecessary pages.
	Can not create any more screens.	This message is displayed if a new page is created beyond the maximum number of pages at [Tools] - [Screen Maintenance]. Delete unnecessary pages.
	Can not delete any more nodes.	This message is displayed if the number of vertices of connected lines or a polygon is "3" or fewer at [Layout] - [Modify] - [Delete Node].
	Can not open any more screens. Close other screen to open new screen.	This message is displayed if a new page is opened beyond the number of simultaneously edited pages permitted to NC Designer2. The number of pages that can be edited simultaneously is 16 or fewer. Close unnecessary pages.
	Character string is not set.	The message is displayed if no search string is specified at [Edit] - [Find]. Specify the desired search string in the "Find What" field of the [Find] dialog box.

	Message	Cause and remedy
C	Copy cannot be executed because Axis No. exceeds the limit.	This message is displayed when creating a control with number of axis specified beyond the range. Set the number of axis from 0 to 32.
	Copy cannot be executed because Device No. exceeds the limit.	This message is displayed when creating a control with number of device specified beyond the range. Set the device number within the range.
	Copy cannot be executed because Object extends out of the view area.	This message is displayed when a control outside the screen range (width: 2560, height: 1920) is being created. Adjust the all objects after copy, margin, and copy direction settings in the [Continuous copy] dialog box.
	Copy cannot be executed because Part system No. exceeds the limit.	This message is displayed when creating a control with number of systems specified beyond the range. Set the part system number from 1 to 10.
	Copy cannot be executed because Section No. exceeds the limit.	This message is displayed when creating a control with number of section specified beyond the range. Set the number of section from 0 to 999.
	Copy cannot be executed because Sub-section No. exceeds the limit.	This message is displayed when creating a control with number of sub-section specified beyond the range. Set the number of sub-section from 0 to 1000000000.
	Copy cannot be executed because the total number of objects exceeds the limit.	This message is displayed if the object is created beyond the maximum number of objects that can be created in a single page (incl. that in view frame). Delete unnecessary objects.
	Copy cannot be executed because the number of objects exceeds the limit.	This message is displayed if the object is created beyond the maximum number of objects that can be created in a single page of the page (excl. that in view frame)/view frame Delete unnecessary objects.
	Custom Data name is illegal.	This message is displayed if the custom data name (○○○.GIP) is illegal. Specify the custom data name again.
D	Data is not specified to the setting file. Set the data in the environment setup dialog on the custom screen.	This message is displayed if the custom screen number to display is not specified when pressing the [Memory Card Write] button in Transfer to Memory Card dialog. Specify the screen number to the [F0 release] or [Menu release] menu in the Custom screen configuration dialog.
	Designated custom data of compilation method (*.dill or *.o file) does not exist. Check the setting of custom data.	This message is displayed if the custom data (*.dill or *.o file) designated as the data to write does not exist. Check the setting of custom data again.
	Do you want to quit without saving the property?	This message is displayed when the cancel button is pressed on the property dialog. When the OK button is pressed, the data specified in the property dialog is not reflected on the property sheet.
E	End page No. is out of range. Set a number from 0 to 255.	This message is displayed if the last page No. is specified beyond the range when setting the screen range of a process at [Tools] - [Functional Object List] or the like. Specify the screen page number in the range between 0 and 255.
	End page No. is smaller than the start page No.	This message is displayed if the first page number is larger than the last page No. when setting the screen range of a process at [Tools] - [Functional Object List] or the like. Specify a number smaller than the last page number.
	Error was found in row ○ of column □ in the file to be imported.	"○" in the message indicates the row number (including the comment in the first row), and "□" in the message indicates the column title of the control list. This message is displayed if a description contains at least one different page, ID, inside frame, or type when importing a file using the control list. Check the import file (CSV file) contents.

	Message	Cause and remedy
F	Failed to do this operation because you are not authorized to edit all of the files in this project. Make sure if there are any other peoples editing these files now.	The general editing right is necessary to execute [Save Project], [Save Project As], [Screen Maintenance] and [Source Code Generation] functions. This message is displayed if acquisition of the general right fails. (Note)
	Failed to export project.	This message is displayed if exporting of the project has failed. Check the export destination and retry export.
	Failed to write.	This message is displayed if writing to the memory has failed. Execute write to the memory again.
	File access failed. The following causes are presumed. 1. The destination file or folder is read-only. 2. The destination file or folder is under editing. 3. The available disk space is not enough.	This message is displayed if file access has failed due to any of the three causes on the left. Check the state of the write destination drive, folder and file before executing write to the memory.
	File not found. Check the file name and try again.	This message is displayed when a file with an extension other than the designated extension is specified in the file name of the [Open file] dialog box, and the [Open] button is clicked. Specify a file name with the designated extension.
I	I don't agree with the screen size of this project about the model of selected NC Trainer2 plus project. Select project of the model about which the screen size agrees with 15 type.	This message is displayed if the model of selected project does not support the 15-type display. Select a project of the model which supports the 15-type (M830V, M80V TypeA, M80V TypeB, M830, M80 TypeA, M80 TypeB, or M730V).
	If you don't save the project data, functional object property may break because the project data contains resource data. Do you want to continue?	This message is displayed if the project is terminated without saving the project data after resource data is changed. Execute [File] - [Save Project], [Save Project As] or [Save All] before terminating the project.
	It is not a numerical value.	This message is displayed if other than a value is entered in the value entry area. Enter an integer within the permissible range in the area.
L	Leave at least one file resource.	This message is displayed when all of the file resources are checked in the [Resource management] dialog box. Remove 1 or more checks of the file resources.
	Leave at least one font resource.	This message is displayed when all of the font resources are checked in the [Resource management] dialog box. Remove 1 or more checks of the font resources.
	Leave at least one image resource.	This message is displayed when all of the image resources are checked in the [Resource management] dialog box. Remove 1 or more checks of the image resources.
	Leave at least two solid frame resources.	This message is displayed when all of the solid frame resources are checked, or when only one solid frame resource is unchecked in the [Resource management] dialog box. Remove 2 or more checks of the solid frame resources.
M	Memory for undoing/redoing operation is insufficient. Increase the free memory by closing other screens or exiting other applications etc.	This message is displayed upon memory shortage. Close other screens or terminate other applications to increase the free memory, then execute again.
	Memory is insufficient. Increase the free memory by closing other screens or exiting other applications etc.	This message is displayed upon memory shortage during source code generation. Close unnecessary applications or take other measures to increase the memory and execute source code generation again.
	Memory usage check is in progress.	This message is displayed when is memory usage check being conducted in another NC Designer2 project. Conduct a memory usage check again after a short amount of time.

	Message	Cause and remedy
M	Memory usage check failed.	This message is displayed when there are no access rights to a referenced file, or there is not enough disk space while executing a memory usage check. Check the access rights of the specified folder and the access rights of file in the folder, and check the hard disk free space.
	Menu name is limited to ○ single-byte characters or less.	This message is displayed if the character string set to the menu name of [Custom screen configuration] dialog box exceeds the number of characters. Set the character string within the setting range.
	Menu outline is limited to 70 single-byte characters.	This message is displayed if the menu outline is specified with 71 single-byte characters or more. Specify the outline with up to 70 single-byte characters.
N	NC Trainer2 plus is using. Please select NC Trainer2 plus project again after waiting for a while.	This message is displayed while NC Trainer2 plus is in operation. Execute the simulation again after waiting for a while.
	No items are selected.	This message is displayed if no check item is specified at [Tools] - [Error Check]. Select at least one check item and operate again.
O	Other project exists in this directory. Can not create new one.	This message is displayed if an existing project is designated at [File] - [New Project]. Designate another project name.
P	Please set an alphabetic character (a-z, A-Z) to the head of a locale name.	This message is displayed if a wrong character is used during registration of the locale. Specify a one-byte letter (A to Z or a to z) at the top of the locale name.
R	Reading of a file went wrong during import.	The message is displayed if file reading fails during importation of pages. Make sure the project at the import source can be correctly opened.
	Reading of a file went wrong during import. Processing is interrupted.	The message is displayed if the network is shut off during importation of a character string resource from a network file. Restore network connection and import the character string resource again.
	Reading of a file went wrong. The cause below can be considered. 1. The specified file is editing. 2. Network area was specified to be a reading place and the network connection was cut.	This message is displayed if file reading fails during export of a character string resource or import of pages. Refer to the message and remove the cause, then export the character string resource again, or import the pages.
	Reselected screen No. is limited to 64 single-byte characters.	This message is displayed if the screen number which is reselected with each function key is specified 65 single-byte characters or more. Specify the number with up to 64 single-byte characters.
	Resource data size is over 5.00 MB. Resource data size ○MB (Total data size □MB) The upper limit for M7/M8 : 5.00 MB The upper limit for M8V : 13.00 MB Continue?	This message is displayed if the resource data exceeded the upper limit when the following operations are executed. Reduce the registered resources. - Selecting [Project convert] - [Export] to output project files. - Selecting [Source Code Generation] to generate resource files. - Selecting [Write to Memory Card] and write by "interpreter method". - Saving projects during simulation (NC Trainer2 plus).
S	Select the folder for writing.	This message is displayed if the folder path is not specified when selecting [Folder] for the destination. Press the [Browse] button to designate the destination folder.

	Message	Cause and remedy
S	Since other users are performing the page maintenance, source code generation cannot be performed. Please perform again after waiting for a while.	This message is displayed if screen maintenance is performed by another user when you execute the source code generation. (Note)
	Start page No. is out of range. Set a number from 0 to 255.	This message is displayed if the starting page No. is specified beyond the range when setting the screen range of a process at [Tools] - [Functional Object List] or the like. Specify the screen page number in the range from 0 to 255.
T	The available disk space is not enough.	This message is displayed if available disk space of the designated drive to write is not enough. Change the drive to write or delete other files.
	The delimiter cannot be identified because the data key doesn't exist or is incorrect. Please correct the file.	This message is displayed when the file specified in "Import of a character sequence resource" is a format that cannot be imported. Correct the file.
	The folder specified for "other files" does not exist.	The folder specified to [Other files to be installed (e.g. html data)] in the memory check function does not exist. Specify a path of a folder that exists.
	The following character cannot be used for a file name. \\V:;*?*<>	This message is displayed if a wrong character is designated in the [File Name] at the [Import of a Character Sequence Resource] dialog box. Designate allowable characters for the file name.
	The following character cannot be used for a folder name. \\/:;*?*<>	This message is displayed if a wrong character is designated in the [Folder] at the [Import of a Character Sequence Resource] dialog box. Designate allowable characters for the folder name.
	The input resource data name is already used.	This message is displayed if the registered resource name is already used. Designate another resource data name.
	The model of selected NC Trainer2 plus project is different. In order to simulate, select NC Trainer2 plus project of the same model as this project.	This message is displayed if the model setting is different between the selected NC Trainer2 plus project and the NC Designer2 project being edited. Select the NC Trainer2 plus project of the same model setting as the NC Designer2 project.
	The number of characters of a folder and a file is to sum total %d character.	Contain the sum of the folder name and file name characters within 200 at the [Export of a Character Sequence Resource] dialog box.
	The numerical range is from XXX to XXX.	This message is displayed if an excessive value is entered or the field is left blank at a value entry area. Enter an integer within the permissible range in the area.
	The project already exists. Choose another project name please.	This message is displayed if an existing project is designated at [File] - [New Project]. Designate another project name.
	The project which is going to open cannot be read because of the project edited by NC Designer2 of a version newer than NC Designer2 under execution.	Use NC Designer2 of the version used to create the project.
The registered resources have exceeded the maximum limit of 5000. Change the import settings.	This message is displayed if the resource is created beyond the maximum number of resources that can be registered in one project. Delete unnecessary resources.	
The setting range of X coordinate is between 0 and 2559 and Y coordinate is between 0 and 1919.	This message is displayed if the X coordinate or the Y coordinate is located outside of the setting range when setting the start position of the cursor. Set the coordinates within the setting range.	

	Message	Cause and remedy
T	The specified file name is unusual.	This message is displayed if there is no drive specification for the folder specified at the [New Project Wizard] or [Import of a Character Sequence Resource] dialog box. Designate the folder together with the full path or, to designate a network folder, designate the drive, too.
	The specified locale name is already used.	This message is displayed if the registered locale has been registered. Specify an unused locale name.
	The specified resource data name already exists. Please enter a unique resource data name.	The multiple resource data under the same name cannot exist in one project. Enter the resource data name which does not overlap with the other names.
	The specified title already exists. Please enter a unique title.	The multiple titles under the same name cannot exist in one project. Enter the resource data name which does not overlap with the other names.
	The writing of a file went wrong. The following causes can be considered. 1. The specified file is read-only 2. The free memory of a disk is insufficient. 3. Network area was specified to be a writing place and the network connection was cut.	This message is displayed if file writing fails during exportation of a character string resource. Refer to the message and remove the cause, then export the character string resource again.
	The writing of a property went wrong.	The message is displayed if file reading fails during import of pages. Make sure the file at the import destination is writable.
	The X coordinate is not set.	This message is displayed if the X coordinate has not been set when designating the display start position of the control in which the sub cursor will be displayed. Set the X coordinate.
	The Y coordinate is not set.	This message is displayed if the Y coordinate has not been set when designating the display start position of the control in which the sub cursor will be displayed. Set the Y coordinate.
U	Up to 50 menu items can be set on the screen.	This message is displayed if 51 or more menus are registered on [Menu Release] of [Custom screen configuration] dialog box. Adjust the number of menus to register the screen No.

(Note) If you are not authorized to edit files in a project when you open a project again after NC Designer2 is forced to quit unexpectedly during editing a project, please close NC Designer2 once, make sure that no other users are editing the project and delete ".g2loc" and ".g2edt" files.



## Appendix 2. Shortcut Key List

The shortcut keys that can be used with NC Designer2 are shown below.

Menu	Function	Shortcut key
File	New Panel	Ctrl + N
	Open Panel/Window	Ctrl + O
	New Window	Ctrl + Shift + N
	Save Panel/Window	Ctrl + S
Edit	Undo	Ctrl + Z
	Redo	Ctrl + Y
	Cut	Ctrl + X
	Copy	Ctrl + C
	Paste	Ctrl + V
	Delete	Delete
	Find	Ctrl + F
	Edit of a caption	Space (for control selection only)
	All Objects	Ctrl + A
	Same Object Type	Ctrl + D (for control/ figure selection only)
View	Previous Page	Shift + PageUp
	Next Page	Shift + PageDown
	Previous Frame Page	PageUp (for frame selection only)
	Next Frame Page	PageDown (for frame selection only)
	Refresh	F9
Layout	Up	↑ (for control selection only)
	Down	↓ (for control selection only)
	Left	← (for control selection only)
	Right	→ (for control selection only)
	Group	Ctrl + G (for selection of multiple controls only)
	Ungroup	Ctrl + U (for group selection only)
Tools	Error check	Ctrl + E
	Memory usage check	Ctrl + M
	Functional Object List	Ctrl + L
	Test	Ctrl + T

### **Appendix 3. About NC Designer2**

The version of NC Designer2 is displayed.

1. Select [About NC Designer2] from the [Help] menu.
2. The [About NC Designer2] dialog box is displayed.  
Click on the [OK] button to close the dialog box.

## Appendix 4. Pattern List

### Appendix 4.1 Filling Pattern List

The standard version of NC Designer2 supports the following 38 filling patterns.

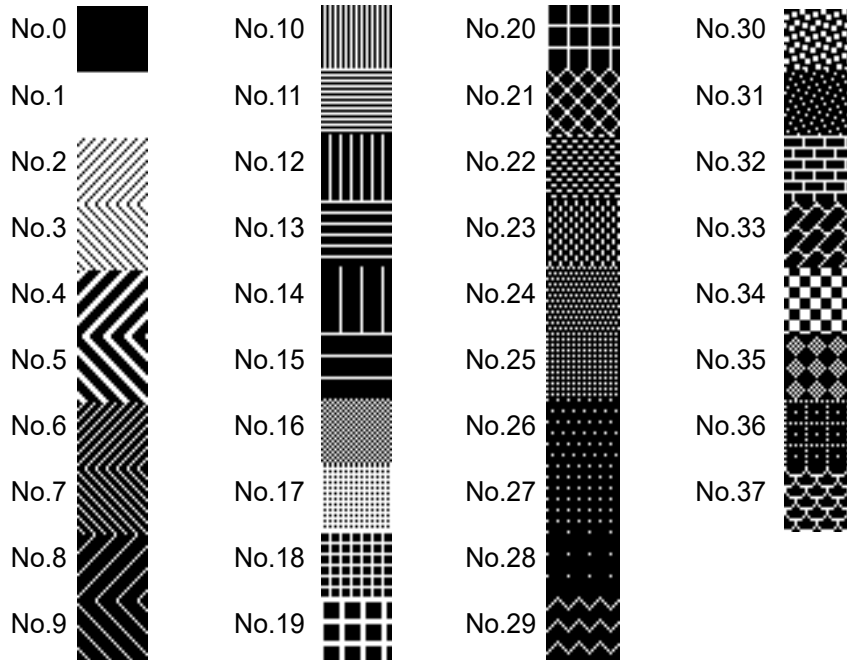

### Appendix 4.2 Line Pattern List

The standard version of NC Designer2 supports the following 9 line patterns.

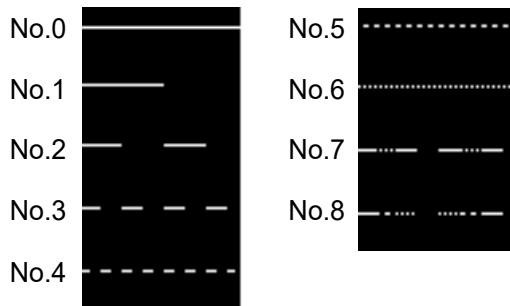

## Appendix 5. Default Palette Color

The standard version of NC Designer2 supports the following palette.

Color No.	RGB	Color No.	RGB	Color No.	RGB	Color No.	RGB
0	(0,0,0)	32	(44,0,0)	64	(0,0,44)	96	(86,255,44)
1	(0,0,128)	33	(86,0,0)	65	(44,0,44)	97	(135,255,44)
2	(0,128,0)	34	(135,0,0)	66	(86,0,44)	98	(192,255,44)
3	(0,128,128)	35	(192,0,0)	67	(135,0,44)	99	(255,255,44)
4	(128,0,0)	36	(0,44,0)	68	(192,0,44)	100	(0,0,86)
5	(128,0,128)	37	(44,44,0)	69	(255,0,44)	101	(44,0,86)
6	(128,128,0)	38	(86,44,0)	70	(0,44,44)	102	(86,0,86)
7	(192,192,192)	39	(135,44,0)	71	(44,44,44)	103	(135,0,86)
8	(128,128,128)	40	(192,44,0)	72	(86,44,44)	104	(192,0,86)
9	(0,0,255)	41	(255,44,0)	73	(135,44,44)	105	(255,0,86)
10	(0,255,0)	42	(0,86,0)	74	(192,44,44)	106	(0,44,86)
11	(0,255,255)	43	(44,86,0)	75	(255,44,44)	107	(44,44,86)
12	(255,0,0)	44	(86,86,0)	76	(0,86,44)	108	(86,44,86)
13	(255,0,255)	45	(135,86,0)	77	(44,86,44)	109	(135,44,86)
14	(255,255,0)	46	(192,86,0)	78	(86,86,44)	110	(192,44,86)
15	(255,255,255)	47	(255,86,0)	79	(135,86,44)	111	(255,44,86)
16	(192,220,192)	48	(0,135,0)	80	(192,86,44)	112	(0,86,86)
17	(166,202,240)	49	(44,135,0)	81	(255,86,44)	113	(44,86,86)
18	(255,251,240)	50	(86,135,0)	82	(0,135,44)	114	(86,86,86)
19	(160,160,164)	51	(135,135,0)	83	(44,135,44)	115	(135,86,86)
20	(32,192,192)	52	(192,135,0)	84	(86,135,44)	116	(192,86,86)
21	(64,192,192)	53	(255,135,0)	85	(135,135,44)	117	(255,86,86)
22	(96,192,192)	54	(0,192,0)	86	(192,135,44)	118	(0,135,86)
23	(128,192,192)	55	(44,192,0)	87	(255,135,44)	119	(44,135,86)
24	(192,32,192)	56	(86,192,0)	88	(0,192,44)	120	(86,135,86)
25	(192,64,192)	57	(135,192,0)	89	(44,192,44)	121	(135,135,86)
26	(192,96,192)	58	(192,192,0)	90	(86,192,44)	122	(192,135,86)
27	(192,128,192)	59	(255,192,0)	91	(135,192,44)	123	(255,135,86)
28	(192,192,32)	60	(44,255,0)	92	(192,192,44)	124	(0,192,86)
29	(192,192,64)	61	(86,255,0)	93	(255,192,44)	125	(44,192,86)
30	(192,192,96)	62	(135,255,0)	94	(0,255,44)	126	(86,192,86)
31	(192,192,128)	63	(192,255,0)	95	(44,255,44)	127	(135,192,86)

Color No.	RGB	Color No.	RGB	Color No.	RGB	Color No.	RGB
128	(192,192,86)	160	(0,192,135)	192	(86,135,192)	224	(44,135,255)
129	(255,192,86)	161	(44,192,135)	193	(135,135,192)	225	(86,135,255)
130	(0,255,86)	162	(86,192,135)	194	(192,135,192)	226	(135,135,255)
131	(44,255,86)	163	(135,192,135)	195	(255,135,192)	227	(192,135,255)
132	(86,255,86)	164	(192,192,135)	196	(0,192,192)	228	(255,135,255)
133	(135,255,86)	165	(255,192,135)	197	(44,192,192)	229	(0,192,255)
134	(192,255,86)	166	(0,255,135)	198	(86,192,192)	230	(44,192,255)
135	(255,255,86)	167	(44,255,135)	199	(135,192,192)	231	(86,192,255)
136	(0,0,135)	168	(86,255,135)	200	(255,192,192)	232	(135,192,255)
137	(44,0,135)	169	(135,255,135)	201	(0,255,192)	233	(192,192,255)
138	(86,0,135)	170	(192,255,135)	202	(44,255,192)	234	(255,192,255)
139	(135,0,135)	171	(255,255,135)	203	(86,255,192)	235	(44,255,255)
140	(192,0,135)	172	(0,0,192)	204	(135,255,192)	236	(86,255,255)
141	(255,0,135)	173	(44,0,192)	205	(192,255,192)	237	(135,255,255)
142	(0,44,135)	174	(86,0,192)	206	(255,255,192)	238	(192,255,255)
143	(44,44,135)	175	(135,0,192)	207	(44,0,255)	239	(24,24,24)
144	(86,44,135)	176	(192,0,192)	208	(86,0,255)	240	(37,37,37)
145	(135,44,135)	177	(255,0,192)	209	(135,0,255)	241	(52,52,52)
146	(192,44,135)	178	(0,44,192)	210	(192,0,255)	242	(68,68,68)
147	(255,44,135)	179	(44,44,192)	211	(0,44,255)	243	(77,77,77)
148	(0,86,135)	180	(86,44,192)	212	(44,44,255)	244	(95,95,95)
149	(44,86,135)	181	(135,44,192)	213	(86,44,255)	245	(105,105,105)
150	(86,86,135)	182	(192,44,192)	214	(135,44,255)	246	(114,114,114)
151	(135,86,135)	183	(255,44,192)	215	(192,44,255)	247	(125,125,125)
152	(192,86,135)	184	(0,86,192)	216	(255,44,255)	248	(146,146,146)
153	(255,86,135)	185	(44,86,192)	217	(0,86,255)	249	(157,157,157)
154	(0,135,135)	186	(86,86,192)	218	(44,86,255)	250	(168,168,168)
155	(44,135,135)	187	(135,86,192)	219	(86,86,255)	251	(180,180,180)
156	(86,135,135)	188	(192,86,192)	220	(135,86,255)	252	(204,204,204)
157	(135,135,135)	189	(255,86,192)	221	(192,86,255)	253	(216,216,216)
158	(192,135,135)	190	(0,135,192)	222	(255,86,255)	254	(229,229,229)
159	(255,135,135)	191	(44,135,192)	223	(0,135,255)	255	(242,242,242)

## Appendix 6. Data Type Definitions

The definitions for various structure data types are given below.

```

#define GColor          long          /* color variable          */
#define HGFONT         GFontHandle* /* 2 font handle         */
#define HGDRAW         GDraw*       /* drawing handle         */

/*****
 * Rectangle structure
 *****/
typedef struct _GRect{
    short      nXmin;          /* upper left X coordinate */
    short      nYmin;          /* upper left Y coordinate */
    short      nXmax;          /* lower right X coordinate */
    short      nYmax;          /* lower right Y coordinate */
}GRect;

/*****
 * Point structure
 *****/
typedef struct _GPoint{
    short      nX;             /* X coordinate            */
    short      nY;             /* Y coordinate            */
}GPoint;

/*****
 * Line structure
 *****/
typedef struct _GLine{
    short      nX1;            /* X coordinate for starting point */
    short      nY1;            /* Y coordinate for starting point */
    short      nX2;            /* X coordinate for ending point   */
    short      nY2;            /* Y coordinate for ending point   */
}GLine;

/*****
 * Polygon structure
 *****/
typedef struct _GPoly{
    short      nNumPoints;     /* number of vertices        */
    GPoint     *pgptPoints;    /* pointer to vertex data    */
    GRect      grBounds;       /* outline rectangle         */
}GPoly;

/*****
 * Brush structure
 *****/
typedef struct _GBrush{
    short      nFillPattern;   /* fill pattern              */
    GColor     gcForeColor;    /* fill foreground color     */
    GColor     gcBackColor;    /* fill background color     */
}GBrush;

/*****
 * Border structure
 *****/
typedef struct _GBorder{
    unsigned char fBorder;     /* 3D border present or absent */
    GColor       gcULColor;    /* upper left border color    */
    GColor       gcLRCor;     /* lower right border color   */
    GColor       gcLineColor; /* line color                 */
    short        nSize;        /* 3D border size            */
}GBorder;

```

```

/*****
 * Caption structure
 *****/
typedef struct _GCaption{
    GColor          gcColor;          /* caption character color */
    unsigned char   ucHPosition;      /* horizontal display position */
    unsigned char   ucVPosition;      /* vertical display position */
    short           nLeftMargin;      /* left margin */
    short           nRightMargin;     /* right margin */
    short           nTopMargin;       /* top margin */
    short           nBottomMargin;    /* bottom margin */
}GCaption;

/*****
 * Cursor structure
 *****/
typedef struct _GCursor{
    unsigned char   ucType;           /* cursor type */
    GColor          gcColor;          /* cursor color */
}GCursor;

/*****
 * Font structure
 *****/
typedef struct _GFontSize{
    short           nAscent;          /* height from baseline to top line */
    short           nDscent;          /* height from baseline to bottom line */
    unsigned short  usWidth;          /* basic character width */
    unsigned short  usHeight;         /* character height */
    unsigned short  usMaxWidth;       /* maximum character width */
}GFontSize;

```

```

/*****
 * Simple font structure
 *****/
typedef struct _GSimpleFont{
    GTCHAR          szFontName[MAX_FONTNAME_LEN+1]; /* font name */
    unsigned char   ucSize;                          /* font size */
    unsigned char   gptXScale;                        /* horizontal scale */
    unsigned char   gptYScale;                        /* vertical scale */
    unsigned char   ucWeight;                         /* thickness */
    unsigned char   ucStyle;                          /* shape */
}GSimpleFont;

typedef struct _GFont{
    short           nID;                               /* font ID */
    GTCHAR          szFontName[MAX_FONTNAME_LEN+1]; /* font name */
    unsigned short  usCharacterSet;                    /* character code */
    short           nFontSizeCount;                   /* number of font sizes */
    GFontSize       *gfsSize;                         /* pointer to font size array */
    short           nFixedWidth;                       /* fixed width font information */
    long            lFontSupport;                      /* forms supported by the font (italics, bold, etc.) */
}GFont;

typedef struct _GFontAttribute{
    unsigned short  usWidth;                           /* character width */
    unsigned short  usHeight;                          /* character height */
    unsigned short  usWeight;                          /* character thickness */
    unsigned short  usItalic;                          /* character italics */
    unsigned short  usOutline;                         /* character border */
    void            *pData;                            /* additional information */
    unsigned char   ucXScale;                          /* horizontal scale */
    unsigned char   ucYScale;                          /* vertical scale */
}GFontAttribute;

typedef struct _GFontPattern{
    GTCHAR          *pcChar;                           /* pointer to character data */
    GTCHAR          *pcNextChar;                       /* pointer to next character data */
    short           nWidth;                             /* width */
    short           nHeight;                            /* height */
    short           nBpp;                               /* number of dots per pixel */
    char            *pcPattern;                        /* pointer to pattern */
    short           nGetSize;                          /* get size flag */
}GFontPattern;

typedef struct _GFontHandle{
    short           nID;                               /* font ID */
    short           nAttributeType;                    /* use either pgfaAttribute or
                                                         * pnAttributeArray as attribute */
    GFontAttribute *pgfaAttribute;                    /* font attribute */
    short           *pnAttributeArray;                 /* font attribute (array) */
}GFontHandle;

```



```

/*****
 * Image data structure
 *****/
typedef struct _GRFHeader{
    short      nType;           /* image type */
    short      nWidth;         /* width */
    short      nHeight;        /* height */
    short      nBpp;           /* number of bits per pixel */
    long       lSize;          /* data size */
    unsigned char *pData;      /* pointer to real data */
}GRFHeader;
typedef struct _GRFHeaderDIB{
    short      nType;           /* image type */
    short      nWidth;         /* width */
    short      nHeight;        /* height */
    short      nBpp;           /* number of bits per pixel */
    long       lSize;          /* data size */
    unsigned char *pData;      /* pointer to real data */
    unsigned char *pPalette;   /* pointer to palette data */
}GRFHeaderDIB;

/* image structure */
typedef struct _GImage{
    GRFHeader      *pImage;     /* pointer to image data structure */
}GImage;

/*****
 * System time structure
 *****/
typedef struct _GSystemTime{
    unsigned long    ulLTime;    /* lower-side 32 bits for system time */
    unsigned long    ulUTime;    /* upper-side 32 bits for system time */
}GSystemTime;

```

```

/*****
 * Drawing environment structure
 *****/
/* GDraw structure */
typedef struct _GDraw{
    GRect          grLocalRect;          /* physical coordinate area */
    GPoint         gptLocalOrigin;      /* position of origin on physical coordinates */
    GRect          grVirtualRect;        /* virtual coordinate area */
    GRect          grClipRect;           /* clipping rectangle */
    GPoint         gptPenPosition;       /* current position */
    GColor         gcPenColor;           /* line color */
    GPoint         gptPenSize;           /* line thickness */
    short          nPenCap;              /* line end shape */
    short          nPenJoin;             /* line contact shape */
    short          nPenDash;             /* line type No. */
    short          nDashOffset;          /* line pattern offset */
    short          nTextMode;            /* text mode */
    GColor         gcForeColor;          /* fill foreground color */
    GColor         gcBackColor;          /* fill background color */
    short          nFillPattern;         /* fill pattern No. */
    short          nDrawCondition;       /* drawing condition */
    short          nDrawingMode;         /* raster operation */
    HGVRAM         hSystemVram;          /* display destination VRAM */
    HGVRAM         hDrawVram;           /* drawing destination VRAM */
    HGFONT         hFont;                /* font */
    void           *vgdftDraw;           /* function table for drawing */
    char           cDashPatterns[NUM_DASH_PATS][DASH_PAT_SIZE];
                                           /* line pattern */
    char           cFillPatterns[NUM_FILL_PATS][FILL_PAT_SIZE];
                                           /* fill pattern */
    GDrawParamPoly gpPoly;               /* polygon drawing parameter */
    GDrawParamWideLine gpwWideLine;     /* wide line drawing parameter */
    GDrawParamOval gpwOval;              /* circle, arc and sector drawing parameter */
    unsigned short usErrorCode;          /* previous error code */
    unsigned char  ucGradationType;      /* gradation type
                                           /* (0: up to down, 1: left to right) */
    GColor         gcGradationColor1;    /* color1 */
    GColor         gcGradationColor2;    /* color2 */
    unsigned short usVertexPos;          /* gradation vertex position (0 to 100) */
    unsigned short usGradationLevel;     /* gradation level (0 to 256) */
    unsigned char  ucColorMode;          /* actual VRAM color
                                           environment information */
    GColor         gcRedMask;            /* direct color R value mask */
    GColor         gcGreenMask;          /* direct color G value mask */
    GColor         gcBlueMask;          /* direct color B value mask */
    char           cRedShift;            /* direct color R value shift value */
    char           cGreenShift;          /* direct color G value shift value */
    char           cBlueShift;          /* direct color B value shift value */
    GColor         gcForeColorOrg;       /* foreground color (original) */
    GColor         gcBackColorOrg;      /* background color (original) */
    GColor         gcPenColorOrg;        /* background color (original) */

    unsigned long  ulExParam;            /* extension parameter */
    short          nExParam;             /* extension parameter
}GDraw;

```

```

/*****
 * Memory management structure
 *****/
typedef struct _GMemory{
    unsigned char    fUseSpace;    /* shows use (0)/not use (1) status for memory space */
    unsigned char    cReserve[3]; /* reserved space (for 4 byte environment adjustment) */
    unsigned long    ulSize;       /* memory space size */
    struct _GMemory  *pvPrevMemorySpace;
                                /* pointer to GMemory in previous memory space */
    struct _GMemory  *pvSmallMemorySpace; /* pointer to space GMemory in small
                                /* memory space */
    struct _GMemory  *pvLargeMemorySpace; /* pointer to space GMemory in large
                                /* memory space */
}GMemory;

typedef struct _GMemorySpaceInformation{
    unsigned char    ucType;        /* memory space type */
    unsigned char    ucPlane;      /* memory space plane No. */
    unsigned char    cReserve[2];  /* reserved space (for 4 byte environment adjustment) */
    char             *pvMemorySpace; /* pointer to memory space allocated by user */
    unsigned long    ulMemorySpaceSize;
                                /* size of memory space allocated by user (multiples of 32) */
    GMemory          *pgmNoUseMemoryTree;
                                /* pointer to unused two-branch memory management */
}GMemorySpaceInformation;

```

```

/*****
 * Control related structures
 *****/
/* Design structure */
typedef struct GDesign{
    GBrush          gbBrush;          /* fill brush          */
    unsigned short  usImageID;       /* image resource ID  */
}GDesign;

/* Focus movement structure */
typedef struct GFocusObject{
    unsigned short  usKeyCode;       /* virtual key code   */
    unsigned short  usType;         /* focus movement method */
    unsigned short  usID;           /* ID of object being moved */
}GFocusObject;

/* Focus movement structure */
typedef struct GFocusInformation{
    unsigned short  usCount;         /* number of focus settings */
    GFocusObject   *pFocusArray;    /* focus setting (array) */
}GFocusInformation;

/* Value structure */
typedef union GValue{
    short          nValue;          /* short value          */
    unsigned short usValue;        /* unsigned short value */
    long           lValue;          /* long value           */
    unsigned long  ulValue;        /* unsigned long value  */
    float          fValue;         /* float value          */
}GValue;

/* GBaseWindow Export/Import structure */
typedef struct GBaseWindowProperty{
    unsigned short  usType;         /* object type          */
    unsigned short  usID;          /* object ID            */
    short          nX;             /* X coordinate         */
    short          nY;             /* Y coordinate         */
    short          nWidth;         /* width                */
    short          nHeight;        /* height               */
    unsigned long  ulStyle;        /* object shape         */
    GFocusInformation *pFocusInfo; /* focus object         */
}GBaseWindowProperty;

```

```

/*****
 * NC data access-related structure
 *****/
/* NC information structure */
typedef struct GNCControl{
    long          lMachine;          /* NC No. */
                                        /* Setting range: 1 to 255 */
    long          lSystem;          /* Part system number */
                                        /* Setting range: 0 to 10 */
    long          lGround;          /* Ground */
                                        /* 0 : Basic part system / Foreground */
                                        /* 1 : Basic part system / Background */
                                        /* 2 : Current part system during cross control / Foreground */
                                        /* 3 : Current part system during cross control / Background */
    unsigned long ulAxis;          /* Axis number */
                                        /* Setting range: 0 to 16 */
}GNCControl;

/* NC data structure */
typedef union GNCValue{
    char          cValue;          /* One-byte integer value */
    unsigned char ucValue;        /* Unsigned one-byte integer value */
    short         nValue;          /* Two-byte integer value */
    unsigned short usValue;       /* Unsigned two-byte integer value */
    long          lValue;          /* Four-byte integer value */
    unsigned long ulValue;        /* Unsigned four-byte integer value */
    double        dValue;          /* Real number value */
}GNCValue;

```

## Appendix 7. HTML Tag List

NC Designer2 supports the following HTML tags.

	Function	Tag name
Document	Document structure definition	<html> - </html>, <head> - </head>, <body> - </body>
TEXT	Title setting	<hxxx> - </hxxx>
	Paragraph setting	<p> - </p>
	Carriage return	 
	Long sentence quotation	<blockquote> - </blockquote>
	Emphasis	<em> - </em>, <strong> - </strong>
	Superscript and subscript designation	<sup> - </sup>, <sub> - </sub>
	Text direction designation	<bdo dir="xxx"> - </bdo>
PAGE	Background color designation	<body bgcolor="xxx"> - </body>
	Background image designation	<body background="xxx" bgsproperties="fixed"> - </body>
	Text color designation	<body text="xxx"> - </body>, <body link="xxx"> - </body>
	Partial text color designation	<font color="xxx"> - </font>
	Title position designation	<hxxx align="yyy"> - </hxxx>
	Paragraph position designation	<p align="xxx"> - </p>
	Designation of position of designated range	<div align="xxx"> - </div>
	Centering	<center> - </center>
	Horizontal ruler display	<hr>, <hr xxx>
	Horizontal ruler color designation	<hr color="xxx">
	Page margin designation	<body xxx> - </body>
FONT	Absolute font size designation	<font size="xxx"> - </font>
	Relative font size designation, pattern 1	<font size="±xxx"> - </font>
	Relative font size designation, pattern 2	<basefont size="xxx">, <font size="±yy"> - </font>
	Font type designation	<font face="xxx,xxx, ···"> - </font>
	Font style designation, pattern 1	<b> - </b>, <i> - </i>, <strike> - </strike>, <s> - </s>, <tt> - </tt>, <u> - </u>
	Font style designation, pattern 2	<big> - </big>, <small> - </small>
	Special character display	& number;, & key word
LIST	Numbered list creation	<ol><li> - </li></ol>
	List mark change	<ul type="xxx"><li> - </li></ul>, <ul><li type="xxx"> - </li></ul>
	Numbered list mark change	<ol type="xxx"><li> - </li></ol>, <ol><li type="xxx"> - </li></ol>
	List starting number change	<ol start="xxx"><li> - </li></ol>
	Serial list number change	<ol><li value="xxx"> - </li></ol>
	Term definition list display	<dl><dt> - </dt><dd> - </dd></dl>, <dl compact><dt> - </dt><dd> - </dd></dl>

	Function	Tag name
LIST	List mark change	<ul type="xxx"><li> - </li></ul>, <ul><li type="xxx"> - </li></ul>
	Numbered list mark change	<ol type="xxx"><li> - </li></ol>, <ol><li type="xxx"> - </li></ol>
IMAGE	Image display	
	Image size designation	
	Designation of arrangement with text	
	Arrangement of text around image	
	Resetting of arrangement around image	<br clear="xxx">
	Image-to-text gap designation	
TABLE	Table creation	<table "xxx"> - </table>, <tr> - </tr>, <td> - </td>
	Table title creation	<th> - </th>
	Designation of table position to text	<table align="xxx"> - </table>
	Resetting of arrangement around table	<br clear="xxx">
	Table size designation	<table width="xxx" height="yyy"> - </table>
	Cell size designation	<th width="xxx" height="yyy"> - </th>, <td width="xxx" height="yyy"> - </td>
	Caption	<caption> - </caption>, <caption align="xxx"> - </caption>
	Vertical cell merge	<th rowspan="xxx"> - </th>, <td rowspan="xxx"> - </td>
	Horizontal cell merge	<th colspan="xxx"> - </th>
LINK	Link creation	<a href="xxx"> - </a>, <a name="xxx"> - </a>

\* "xxx", "yyy" and "zzz" are parameters specified as a tag.

**NOTE**

- ◆ Tags not found in the list are not supported. Unsupported tags are ignored when the file is displayed.
- ◆ The supported image format is jpeg only; other image file formats are not displayed.
- ◆ The upper limit of the HTML file size is 100K bytes.

## Appendix 8. Executing File Registration Method

### Appendix 8.1 F0 Release

To register the executing file data to the function key, it is necessary to edit melAppCtrl.ini. Create the registered executing file by full-screen as much as possible.

#### Appendix 8.1.1 melAppCtrl.ini

Example of setting

```
; When the Shift+F10 key (F0 key) is pressed, the calculator is started.
[Program00]
VirtualKey=VK_F10
KeyData=VK_SHIFT
Command00=Execute,C:\WINDOWS\system32\calc.exe,the calculator,,0,0
```

Refer to Appendix 8.1.2 for details of items.

#### Appendix 8.1.2 Details of melAppCtrl.ini

The configuration file (melAppCtrl.ini) conforms to the description format of the Windows INI file in principle, and the upper bound of the maximum INI file size is 32KByte.

The description format of Windows INI

```
[(Section)]
(Key) = (Value of key)
:
[(Section)]
(Key) = (Value of key)
:
```

Edit the following item of the [GENERAL] section.

Section name	Details	Initial value (when undefined)
GENERAL	Specify general system requirements. A set number of the following "StartUp" section and "Program" section is set.	-

Key name	Details	Initial value (when undefined)
StartUpCount	Specify the set number of the [StartUp] section. Setting range : 0 to 5	0
ProgramCount	Specify the set number of the [Program] section. Setting range : 0 to 10	0
ProgramInvalid	Disable "Command" of the [Program] section. Setting range: 0: "Command" of the [Program] section is executed. 1: "Command" of the [Program] section is not executed and the key is sent to the active application. (Note) When "1" is set, pressing the F0 key does not display the onboard even when "1" (Onboard ON) is selected for the bit selection parameter "#6451 bit0".	0



Edit the following item of the [StartUp] section.

Section name	Details	Initial value (when undefined)
StartUp**	Specify the executing file information when the power supply is turned ON.  To ** of section name, specify the sequential No. (0 to ) until the values in which 1 is subtracted from the [StartUp] key setting value of [General] section.	No setting

Key name	Details	Initial value (when undefined)
CommandCount	Specify the number of executing commands.  Setting range : 0 to 10	1
Command**	Specify the executing commands.  The command is executed in ascending order of the No. set to **. To **, specify the sequential No. (0 to ) until the values in which 1 is subtracted from the [CommandCount] key setting value.  Refer to "Command list" for the command which can be specified.  Setting range : Number of commands of maximum characters = 256 byte	NULL (No commands)

Edit the following item of the [Program] section.

Section name	Details	Initial value (when undefined)
ControlParam	Designate a parameter to control the execution of commands.  Setting range :1(Standard screen), 100 to 199(Custom screen)	1: Standard screen
Program**	Specify the executing file corresponding to the input key.  To ** of section name, specify the sequential No. (0 to ) until the values in which 1 is subtracted from the [Program] key setting value of [General] section.	No setting

Key name	Details	Initial value (when undefined)								
VirtualKey	Specify the key code of operation board to register the execution file.  The key code which can be set is as follows. <table border="1"> <thead> <tr> <th>Key name</th> <th>Virtual key code</th> </tr> </thead> <tbody> <tr> <td>F1 to F12</td> <td>VK_F1 to F12</td> </tr> <tr> <td>'0' to '9'</td> <td>VK_0 to VK_9</td> </tr> <tr> <td>'A' to 'Z'</td> <td>VK_A to VK_Z</td> </tr> </tbody> </table>	Key name	Virtual key code	F1 to F12	VK_F1 to F12	'0' to '9'	VK_0 to VK_9	'A' to 'Z'	VK_A to VK_Z	No setting
Key name	Virtual key code									
F1 to F12	VK_F1 to F12									
'0' to '9'	VK_0 to VK_9									
'A' to 'Z'	VK_A to VK_Z									
KeyData	Specify the Shift/Ctrl/Alt key that combines with above-mentioned "VirtualKey" and is input.  This key can be defined by combining two or more key codes. (In that case, insert a space between the key codes.)  Ex.) The Shift/Ctrl key was pressed at the same time KeyData = VK_SHIFT VK_CONTROL  The key code which can be set is as follows. <table border="1"> <thead> <tr> <th>Key name</th> <th>Virtual key code</th> </tr> </thead> <tbody> <tr> <td>Shift</td> <td>VK_SHIFT</td> </tr> <tr> <td>Ctrl</td> <td>VK_CONTROL</td> </tr> <tr> <td>Alt</td> <td>VK_MENU</td> </tr> </tbody> </table>	Key name	Virtual key code	Shift	VK_SHIFT	Ctrl	VK_CONTROL	Alt	VK_MENU	No setting
Key name	Virtual key code									
Shift	VK_SHIFT									
Ctrl	VK_CONTROL									
Alt	VK_MENU									
CommandCount	Specify the number of executing commands.  Setting range : 1 to 10	1								
Command**	Specify the executing commands.  The command is executed in ascending order of the No. set to **. To **, specify the sequential No. (0 to ) until the values in which 1 is subtracted from the [CommandCount] key setting value.  Refer to "Command list" for the command which can be specified.  Setting range : Number of commands of maximum characters = 256 byte	NULL (No commands)								

Command list

The command set with the "Command\*\*" key is set as a comma-delimited character string (command character string).

Format for command character string is shown below.

(Command name), (1st argument), (2nd argument), (3rd argument)...
---

When the numerical value is set to the argument, the value is processed **as a hexadecimal number when the character of "0x" is added to the head**. Other numerical values are processed as a decimal number.

Command name	Details												
Execute	<p>Start the designated executing file.</p> <p>The starting status of the executing file can be judged by setting the title bar character string and the class name of the window. As a result, a multiple start of the execution file can be controlled.</p> <p>If both the title bar character string and the class names of the window are set, it is judged "The execution file is starting" when each requirement is satisfied at the same time.</p> <p>When the executing file has already started, the focus is set to the corresponding executing file, and the order of displaying the window is changed to most significant. This can be invalidated by the setting of the 4th argument and the 5th argument. )</p> <p>The detail of argument is as shown below.</p> <table border="1"> <thead> <tr> <th>Argument</th> <th>Details</th> </tr> </thead> <tbody> <tr> <td>1st argument</td> <td>The file name of the starting executing file (including the folder name)</td> </tr> <tr> <td>2nd argument</td> <td>The title bar character string of window referred to confirm the starting status of the executing file  Wild-card (*) can be specified in the character string.  When the character string is not specified, it is judged as the unsetting.</td> </tr> <tr> <td>3rd argument</td> <td>The class name of window referred to confirm the starting status of the executing file  Wild-card (*) can be specified in the character string.  When the character string is not specified, it is judged as the unsetting.</td> </tr> <tr> <td>4th argument</td> <td>Presence of focus control  0 : Move focus to the executing file. -1 : Do not control the focus.  When the value is not specified, it is judged the setting value is 0.</td> </tr> <tr> <td>5th argument</td> <td>Presence of window position control  0 : Display the window in most significant. 1 : Display the window in least significant. -1 : Do not control the window position.</td> </tr> </tbody> </table> <p>[Restrictions] When two or more executing files matched to the condition exist, the executing file found first is operated.</p>	Argument	Details	1st argument	The file name of the starting executing file (including the folder name)	2nd argument	The title bar character string of window referred to confirm the starting status of the executing file  Wild-card (*) can be specified in the character string.  When the character string is not specified, it is judged as the unsetting.	3rd argument	The class name of window referred to confirm the starting status of the executing file  Wild-card (*) can be specified in the character string.  When the character string is not specified, it is judged as the unsetting.	4th argument	Presence of focus control  0 : Move focus to the executing file. -1 : Do not control the focus.  When the value is not specified, it is judged the setting value is 0.	5th argument	Presence of window position control  0 : Display the window in most significant. 1 : Display the window in least significant. -1 : Do not control the window position.
Argument	Details												
1st argument	The file name of the starting executing file (including the folder name)												
2nd argument	The title bar character string of window referred to confirm the starting status of the executing file  Wild-card (*) can be specified in the character string.  When the character string is not specified, it is judged as the unsetting.												
3rd argument	The class name of window referred to confirm the starting status of the executing file  Wild-card (*) can be specified in the character string.  When the character string is not specified, it is judged as the unsetting.												
4th argument	Presence of focus control  0 : Move focus to the executing file. -1 : Do not control the focus.  When the value is not specified, it is judged the setting value is 0.												
5th argument	Presence of window position control  0 : Display the window in most significant. 1 : Display the window in least significant. -1 : Do not control the window position.												

Command name	Details						
Sleep	<p>Stop the command execution only at specified time (ms).</p> <p>The detail of argument is as shown below.</p> <table border="1" data-bbox="480 383 1441 445"> <thead> <tr> <th data-bbox="480 383 651 416">Argument</th> <th data-bbox="651 383 1441 416">Details</th> </tr> </thead> <tbody> <tr> <td data-bbox="480 416 651 445">1st argument</td> <td data-bbox="651 416 1441 445">Stop time (ms)</td> </tr> </tbody> </table>	Argument	Details	1st argument	Stop time (ms)		
Argument	Details						
1st argument	Stop time (ms)						
Exit	<p>End the designated executing file.</p> <p>The ending executing file can be selected by setting the title bar character string and the class name of the window.</p> <p>If both the title bar character string and the class names of the window are set, the executing file which satisfies each requirement at the same time is ended.</p> <p>Only when the executing file has already started, the corresponding executing file is ended.</p> <p>The detail of argument is as shown below.</p> <table border="1" data-bbox="480 831 1441 1196"> <thead> <tr> <th data-bbox="480 831 624 864">Argument</th> <th data-bbox="624 831 1441 864">Details</th> </tr> </thead> <tbody> <tr> <td data-bbox="480 864 624 1028">1st argument</td> <td data-bbox="624 864 1441 1028"> <p>The title bar character string of window referred to confirm the starting status of the executing file</p> <p>Wild-card (*) can be specified in the character string.</p> <p>When the character string is not specified, it is judged as the unsetting.</p> </td> </tr> <tr> <td data-bbox="480 1028 624 1196">2nd argument</td> <td data-bbox="624 1028 1441 1196"> <p>The class name of window referred to confirm the starting status of the executing file</p> <p>Wild-card (*) can be specified in the character string.</p> <p>When the character string is not specified, it is judged as the unsetting.</p> </td> </tr> </tbody> </table> <p>[Restrictions] When two or more executing files matched to the condition exist, the executing file found first is operated.</p>	Argument	Details	1st argument	<p>The title bar character string of window referred to confirm the starting status of the executing file</p> <p>Wild-card (*) can be specified in the character string.</p> <p>When the character string is not specified, it is judged as the unsetting.</p>	2nd argument	<p>The class name of window referred to confirm the starting status of the executing file</p> <p>Wild-card (*) can be specified in the character string.</p> <p>When the character string is not specified, it is judged as the unsetting.</p>
Argument	Details						
1st argument	<p>The title bar character string of window referred to confirm the starting status of the executing file</p> <p>Wild-card (*) can be specified in the character string.</p> <p>When the character string is not specified, it is judged as the unsetting.</p>						
2nd argument	<p>The class name of window referred to confirm the starting status of the executing file</p> <p>Wild-card (*) can be specified in the character string.</p> <p>When the character string is not specified, it is judged as the unsetting.</p>						

Command name	Details												
PostMessage	<p>Send the Windows messages to the designated executing file.</p> <p>The executing file sent the Windows messages can be selected by setting the title bar character string and the class name of the window.</p> <p>If both the title bar character string and the class names of the window are set, the Windows messages are sent to the executing file which meets each requirement at the same time.</p> <p>Only when the executing file has already started, the Windows messages specified for the corresponding executing file are sent.</p> <p>The detail of argument is as shown below.</p> <table border="1" style="width: 100%; border-collapse: collapse;"> <thead> <tr> <th style="text-align: center;">Argument</th> <th style="text-align: center;">Details</th> </tr> </thead> <tbody> <tr> <td style="vertical-align: top;">1st argument</td> <td> <p>The title bar character string of window referred to confirm the starting status of the executing file</p> <p>Wild-card (*) can be specified in the character string.</p> <p>When the character string is not specified, it is judged the unsetting.</p> </td> </tr> <tr> <td style="vertical-align: top;">2nd argument</td> <td> <p>The class name of window referred to confirm the starting status of the executing file</p> <p>Wild-card (*) can be specified in the character string.</p> <p>When the character string is not specified, it is judged the unsetting.</p> </td> </tr> <tr> <td style="vertical-align: top;">3rd argument</td> <td>Message ID of sent Windows messages</td> </tr> <tr> <td style="vertical-align: top;">4th argument</td> <td>Argument 1 (wParam) of sent Windows message</td> </tr> <tr> <td style="vertical-align: top;">5th argument</td> <td>Argument 2 (lParam) of sent Windows message</td> </tr> </tbody> </table> <p>[Restrictions] When two or more executing files matched to the condition exist, the executing file found first is operated.</p>	Argument	Details	1st argument	<p>The title bar character string of window referred to confirm the starting status of the executing file</p> <p>Wild-card (*) can be specified in the character string.</p> <p>When the character string is not specified, it is judged the unsetting.</p>	2nd argument	<p>The class name of window referred to confirm the starting status of the executing file</p> <p>Wild-card (*) can be specified in the character string.</p> <p>When the character string is not specified, it is judged the unsetting.</p>	3rd argument	Message ID of sent Windows messages	4th argument	Argument 1 (wParam) of sent Windows message	5th argument	Argument 2 (lParam) of sent Windows message
Argument	Details												
1st argument	<p>The title bar character string of window referred to confirm the starting status of the executing file</p> <p>Wild-card (*) can be specified in the character string.</p> <p>When the character string is not specified, it is judged the unsetting.</p>												
2nd argument	<p>The class name of window referred to confirm the starting status of the executing file</p> <p>Wild-card (*) can be specified in the character string.</p> <p>When the character string is not specified, it is judged the unsetting.</p>												
3rd argument	Message ID of sent Windows messages												
4th argument	Argument 1 (wParam) of sent Windows message												
5th argument	Argument 2 (lParam) of sent Windows message												

**Appendix 8.1.3 Function of Update Cycle Setting**

When the executing file registered by F0 release is started, update cycle of the standard screen which is operated on the background can be set by melAppCtrl.ini. As a result, the time that the starting execution file occupies CPU can be extended.

When a standard screen moves to an active screen, the setting of the update cycle (sleep time) is released.

<The argument of sleep time setting PostMessage>

Argument	Setting value
1st argument	Mitsubishi CNC HMI (fixed)
2nd argument	Mitsubishi CNC HMI Class (fixed)
3rd argument	0x500(fixed)
4th argument	Specify the update cycle time of a standard screen when the custom application is started. When the registered custom application is started, a standard screen is updated at the set update cycle only. It is possible to set "Do not update", "Release setting" or "until 0 to 1 second by each millisecond unit".  Setting rang : -1 to 1000 -1 : Do not update. 0 : Release the setting. 1 to 1000 : Changes to the set update cycle. Out of range : Do not change the update cycle.
5th argument	0 (fixed)

Refer to Appendix 8.1.2 for details of PostMessage.

Setting example of melAppCtrl

```

; The calculator is started when the F0 key is pressed, and the update cycle of a standard screen is set to
500ms.
[Program00]
ControlParam=1
VirtualKey=VK_F10
KeyData=VK_SHIFT
CommandCount=2
Command00=PostMessage,Mitsubishi CNC HMI,Mitsubishi CNC HMI Class,0x500,500,0
Command01=Execute,C:\WINDOWS\SYSTEM32\calc.exe,calculator,,
    
```

← Update at 500ms cycle

**NOTE**

- ◆ When an application is switched by Alt + Tab, the update cycle changing function is not applied.
- ◆ Whether the start of the execution file succeeded is not checked. Even if the start of the executing file is failed, the update cycle of a standard screen is changed.
- ◆ The start time of the registered executing file can be shortened by executing the PostMessage command ahead of the Execute command.
- ◆ The update cycle setting is released by moving the standard screen to the background screen once, and displaying the standard screen on an active screen again. Note that the setting is not released in the display on an active screen.

## **Appendix 8.2 Menu Release**

An arbitrary executing file can be registered in the main menu.

A standard screen can be operated with the executing file started.

To register the executing file registration method data to the main menu, it is necessary to edit Config.ini, and to prepare the icon image and the executing file for registration.

The customdef.ini has to be described by Unicode (UTF-16 LE) text.

Create the registered executing file by full-screen as much as possible.

### **Appendix 8.2.1 customdef.ini**

Refer to 17.6.5.1.2.

### **Appendix 8.2.2 Icon Image**

Refer to 17.6.5.1.3.

### Appendix 8.3 Using a Function Key (Screen Switching Key) in the Custom Screen

The function keys for switching the standard screen, such as [MONITOR], [SETUP], [EDIT], [DIAGN] and [MAINTE], can be used as a screen switching key and operation key in the custom screen for the executing file registration method custom screen.



To use the function keys mentioned above as keys in the custom screen, execute the setting to switch the CotrolParam key in the Program section. There are three specific methods to switch the ControlParam key:

- 1) Utilization method 1 by adding a definition to melAppCtrl.ini (only the meaning of function key can be changed with "F0" key)
- 2) Utilization method 2 by adding a definition to melAppCtrl.ini (changing to a specific standard screen with "F0" key)
- 3) Utilization method 3 by adding a definition to melAppCtrl.ini (changing to the specific standard screen with "Menu" key)

By switching the ControlParam key, the custom screen can receive a function key without a definition in "melAppCtrl.ini". The key allocations are as follows:

Function key	Key that the custom screen receives
MONITOR	SHIFT+F1
SETUP	SHIFT+F2
EDIT	SHIFT+F3
DIAGN	SHIFT+F4
MAINTE	SHIFT+F5

(Complement) The explanations for specific methods for switching the CotrolParam key are based on when the custom screen of the executing file registration method is allocated to "F0" key.

The same applies to SFP key, Screen display key () , and Screen selection key (  ).



**Appendix 8.3.1 Utilization Method 1 by Adding a Definition to melAppCtrl.ini  
(Only the Meaning of Function Key Can Be Changed with "F0" Key)**

The below shows the setting example of melAppCtrl.ini in order that, after displaying the custom screen by pressing "F0", the allocated function keys become transition keys to the standard screen while the custom screen is maintained when "F0" is pressed again.

When "F0" is pressed while the standard screen is displayed, the screen changes to the custom screen and then [MONITOR], [SETUP], [EDIT], [DIAGN] and [MAINTE] become the keys to be used in the custom screen. When "F0" is pressed again, [MONITOR], [SETUP], [EDIT], [DIAGN] and [MAINTE] become transition keys to the standard screen even the custom screen is still valid. After that, it goes back to the standard screen by pressing [MONITOR], [SETUP], [EDIT], [DIAGN] or [MAINTE] key.

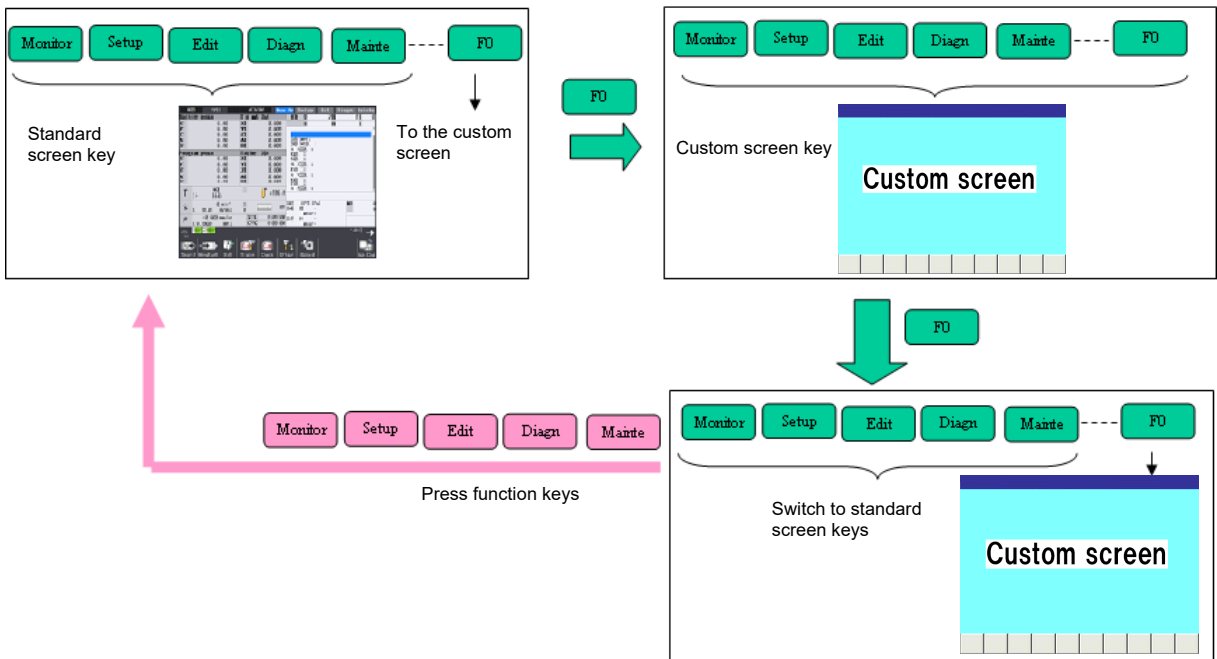

Setting example of "melAppCtrl.ini"

```
[GENERAL]
;Program The number of sections
ProgramCount=2

;Startup the custom screen
[Program00]
ControlParam=1
VirtualKey=VK_F10
KeyData=VK_SHIFT
CommandCount=2
Command00=Execute,d:\Ccustom\custom.exe,Custom Ttitle,Custom Class,0,0
```

Change "ControlParam" to "100"  
Setting range : 100 to 199

```
Command01=PostMessage,Mitsubishi CNC Application Control Task,Mitsubishi CNC Application Control Class,0x400,1,100
```

```
;Change the function keys back to the keys for the standard screen (F0 key)
[Program01]
ControlParam=100
VirtualKey=VK_F10
KeyData=VK_SHIFT
CommandCount=1
```

Change "ControlParam" back to "1".  
\* "1" is the standard screen.

```
Command00=PostMessage,Mitsubishi CNC Application Control Task,Mitsubishi CNC Application Control Class,0x400,1,1
```

### Appendix 8.3.2 Utilization Method 2 by Adding a Definition to melAppCtrl.ini (Changing to a Specific Standard Screen with "F0" Key)

The below shows the setting example of melAppCtrl.ini to change to a specific standard screen by pressing "F0" again after the custom screen is displayed by pressing "F0" key. When "F0" is pressed while the standard screen is displayed, it changes to the custom screen and then [MONITOR], [SETUP], [EDIT], [DIAGN] and [MAINTE] become the keys to be used in the custom screen. When "F0" is pressed again, it changes to a specific standard screen (it is "monitor screen" in this example) and then [MONITOR], [SETUP], [EDIT], [DIAGN] and [MAINTE] become transition keys to the standard screen.

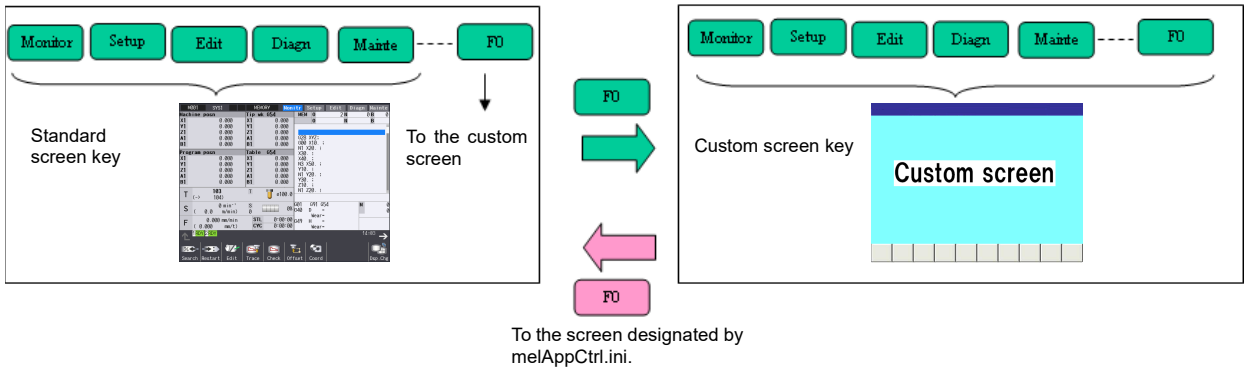

#### Setting example of "melAppCtrl.ini"

```
[GENERAL]
;Program The number of sections
ProgramCount=2

;Startup the custom screen (F0 key)
[Program00]
ControlParam=1
VirtualKey=VK_F10
KeyData=VK_SHIFT
CommandCount=2
Command00=Execute,d:\Ccustom\custom.exe,Custom Ttitle,Custom Class,0,0
Command01=PostMessage,Mitsubishi CNC Application Control Task,Mitsubishi CNC Application Control Class,0x400,1,100

;Change the function keys back to the keys for the standard screen (F0 key)
[Program01]
ControlParam=100
VirtualKey=VK_F10
KeyData=VK_SHIFT
CommandCount=4
Command00=PostMessage,Mitsubishi CNC Application Control Task,Mitsubishi CNC Application Control Class,0x400,1,1
Command01=PostMessage,Mitsubishi CNC HMI,Mitsubishi CNC HMI Class,0x500,0,0
Command02=Execute,c:\ncsys\melhmi.exe,Mitsubishi CNC HMI,Mitsubishi CNC HMI Class,0,0
Command03=PostMessage,Mitsubishi CNC HMI,Mitsubishi CNC HMI Class,0x401,0x70,0x00000001
```

Change "ControlParam" to "100"  
Setting range : 100 to 199

Set ControlParam back to "1".  
\* "1" is the standard screen.

Display the "monitor screen"

## Setting for displaying the screen other than the operation screen

```
//Changes to the setup screen  
Command03=PostMessage,Mitsubishi CNC HMI,Mitsubishi CNC HMI  
Class,0x401,0x71,0x00000001  
//Changes to the edit screen  
Command03=PostMessage,Mitsubishi CNC HMI,Mitsubishi CNC HMI  
Class,0x401,0x72,0x00000001  
//Changes to the diagnosis screen  
Command03=PostMessage,Mitsubishi CNC HMI,Mitsubishi CNC HMI  
Class,0x401,0x73,0x00000001
```

### Appendix 8.3.3 Utilization Method 3 by Adding a Definition to melAppCtrl.ini (Changing to the Specific Standard Screen with "Menu" Key)

The below shows the setting example of melAppCtrl.ini to change to a specific standard screen by pressing "F0" again after the custom screen is displayed by pressing "F0" key, and the sample source.

When "F0" is pressed while the standard screen is displayed, it changes to the custom screen and then [MONITOR], [SETUP], [EDIT], [DIAGN] and [MAINTE] become the keys to be used in the custom screen. When Menu is then pressed, it changes to a specific standard screen (it is "monitor screen" in this example) and then [MONITOR], [SETUP], [EDIT], [DIAGN] and [MAINTE] become transition keys to the standard screen. To use this method, it needs to incorporate the processes of switching the ControlParam key from the menu in the custom screen and of changing to the standard screen into the source code for custom screen application.

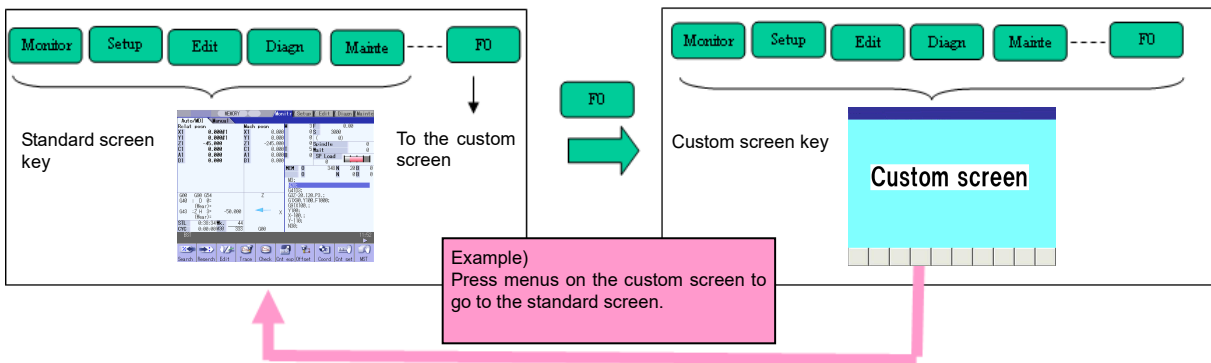

#### Setting example of "melAppCtrl.ini"

```
[GENERAL]
;Program The number of sections
ProgramCount=1

;Startup the custom screen (F0 key)
[Program00]
ControlParam=1
VirtualKey=VK_F10
KeyData=VK_SHIFT
CommandCount=2
Command00=Execute,d:\Ccustom\custom.exe,Custom Ttitle,Custom Class,0,0
Command01=PostMessage,Mitsubishi CNC Application Control Task,Mitsubishi CNC Application Control Class,0x400,1,100
```

Change "ControlParam" to "100"  
Setting range : 100 to 199

Sample source code (processing example of changing to the operation screen from the menu of the custom application)

```
// Return the operation of function keys to the standard screen (return "ControlParam" to "1")
CWnd* _hmiApphwd = FindWindow("Mitsubishi CNC Application Control Class",
"Mitsubishi CNC Application Control Task");
_hmiApphwd->PostMessage(WM_USER, (WPARAM)1, (LPARAM)1);

// Display the standard screen in the most front
CWnd* _hmihwd = FindWindow("Mitsubishi CNC HMI Class","Mitsubishi CNC HMI");
_hmihwd->SetForegroundWindow();

// Display the monitor screen (Monitor) of the standard screen
LPARAM _IKeyStatus = 0;
_IKeyStatus |= 0x00000001;
_hmihwd->PostMessage((WM_USER+0x0001), VK_F1, IKeyStatus);
```

### **Appendix 8.3.4 The Standard Screen After Changing**

When switching to standard screens from custom screens, the screen returns to the screen that had been displayed before switching to custom screens.

If a window was displayed, the window is closed, and the screen which had been displayed before displaying the window is displayed.

All menus return to the main menu, and the menu which was displayed is highlighted.

**Appendix 8.4 Home Screen**

**Appendix 8.4.1 Setting Home Screen Config File (HomeScrnCustomConfig.ini)**

Refer to 17.9.3.1.1.

**Appendix 8.4.2 Setting Application Definition File (HomeScrn\_○○○○.ini)**

Application definition file is used to define the information of extension application registered to Home screen.

Using this definition file, you define the basic information of extension application, Home button operation, Operation menu button operation, etc.

[File contents]

- Section

Section name	Mandatory	Description
COMMON	Yes	Define basic information of the application.
PROGRAM	Yes	Specify the command to execute in accordance with key input.

- [COMMON] section key

Key name	Mandatory	Description
NAME	Yes	Specify the character string to be used for the application name displayed under Application button or in the sub menus of [Add Application] menu, using the key described in [LANG] section of Application language file (*). The actually displayed application name is defined in Application language file. * For details of Application language file, refer to "17.9.3.1.3".  Note) If this key is undefined, or if application name is unable to be retrieved from the app name key, neither application buttons nor sub menus of [Add Application] menu are displayed.  Setting range: Up to 32 characters
TYPE	Yes	Specify the type of MTB's app: 0: Fixed Home screen display 1: Full-screen display (NC Designer2 interpreter method/ NC Designer2 compilation method) 2: Full-screen display (EXE file registration method)
ICONFILENAME	No	Specify the image file (*) to be used as an icon of Application button. Use either an absolute or relative path to specify the image file name (e.g. custom_app1.jpg). For a relative path, specify a path relative to this definition file.  *Specify an image file with the size below: - XGA: Up to 52 x 52 pixels - VGA: Up to 40 x 40 pixels *Available format is JPG.  Note) If you specify no file, or specified file is nonexistent, the icon of the execution file (MTB's app) defined in the EXECFILENAME key of [COMMON] section is used.  Setting range: Up to 128 characters including the path

- [PROGRAM] section key

Key name	Mandatory	Description
COMMANDCOUNT	Yes	Specify the number of commands to execute. Setting range: 1 to 10
COMMANDnn (nn=01 to 10)	Yes	Specify the commands (Execute/Sleep/Exit/PostMessage) to execute. For details of commands, refer to "Appendix 8.1.2 Details of melAppCtrl.ini". Setting range: the maximum command length = 256 bytes

[Setting example]

```
[COMMON]
NAME=LANG_APP_NAM ; <- Define basic information of the application.
ICONFILENAME=D:\Custom\ExtApp\custom_app.jpg ; <- Specify the application name.
TYPE=2 ; <- Specify the image to be displayed on Application button.

[PROGRAM]
COMMANDCOUNT=2 ; <- Specify the registration type.
Command01=PostMessage,Mitsubishi CNC HMI,Mitsubishi CNC HMI Class,0x500,500,0 ; <- Define commands to execute.
Command02=Execute,C:\WINDOWS\SYSTEM32\calc.exe,calculator,, ; <-Specify the number of commands to execute (2 commands in this setting
; <- Renew standard screen at every 500ms.
; <- Start Calculator.
```

### Appendix 8.4.3 Setting Application Language File (HomeScrn\_0000\_ΔΔΔ.ini)

Refer to 17.9.3.1.3.

### Appendix 8.4.4 Precautions

- Panel size to be displayed is only available for full-screen display.



## Appendix 9. HMI Integrated Installer

### Appendix 9.1 Outline

"HMI integrated installer" is a function to install and upgrade "Application of custom release" and "Application of HMI related" with the data in the memory card or USB memory.

For integrated installer, two methods are prepared to install and upgrade the application.

[Methods of installing and upgrading application]

- (1) Method of starting installer (EXE file) for each application prepared beforehand, and installing application  
(Thereafter, this method is described "Installer start method".)
- (2) Method of copying, deleting specified file (directory) with integrated installer, setting registry, and installing application  
(Thereafter, this method is described "File copy method".)

The following are prepared in the memory card or USB memory even if which method is used, and then each application is installed and upgraded:

- Installation environment of each application (EXE file and a file to copy, etc.)
- Setting file which collects information on installation of each application  
(Thereafter, this setting file is described "setup application list".)

### Appendix 9.2 Configuration

The entire configuration of the HMI integrated installer function is as follows.

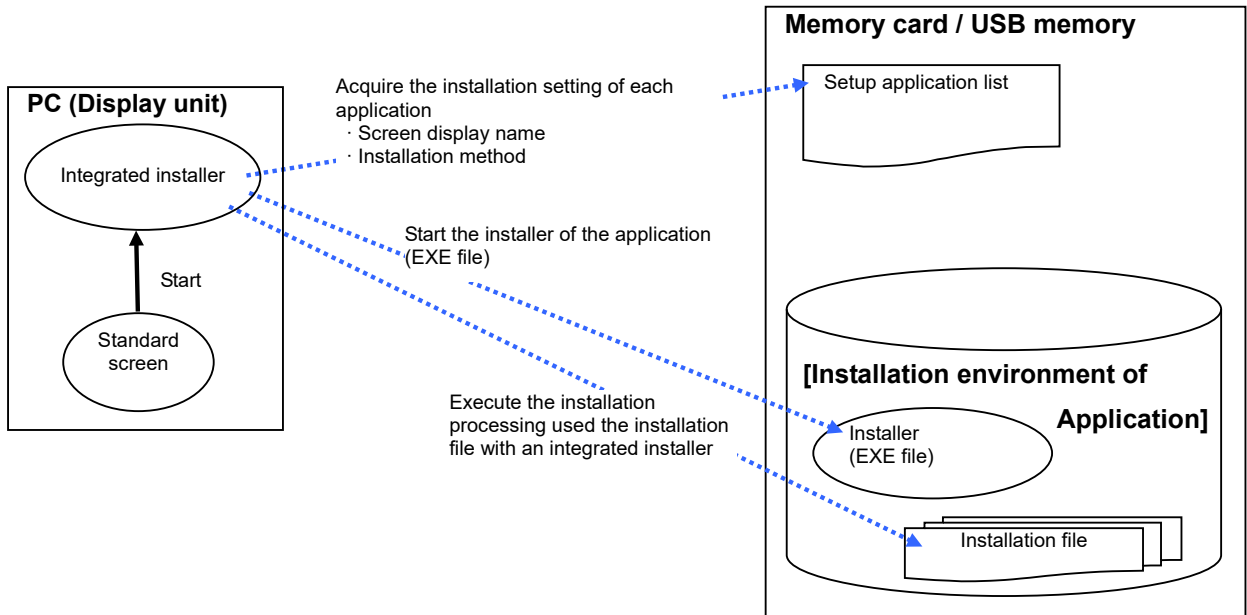

The flow until installation completion of the application is as follows.

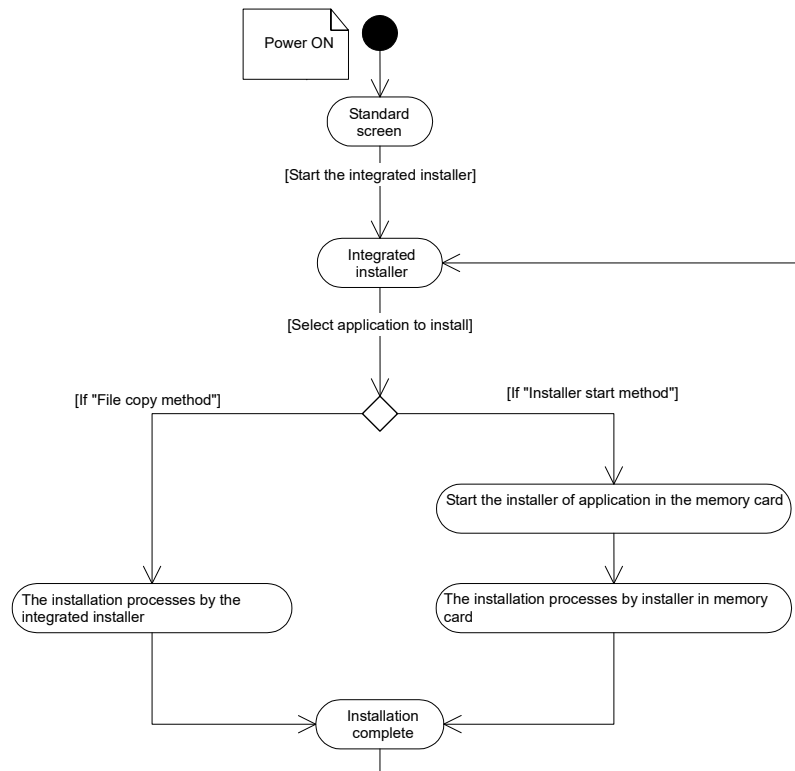





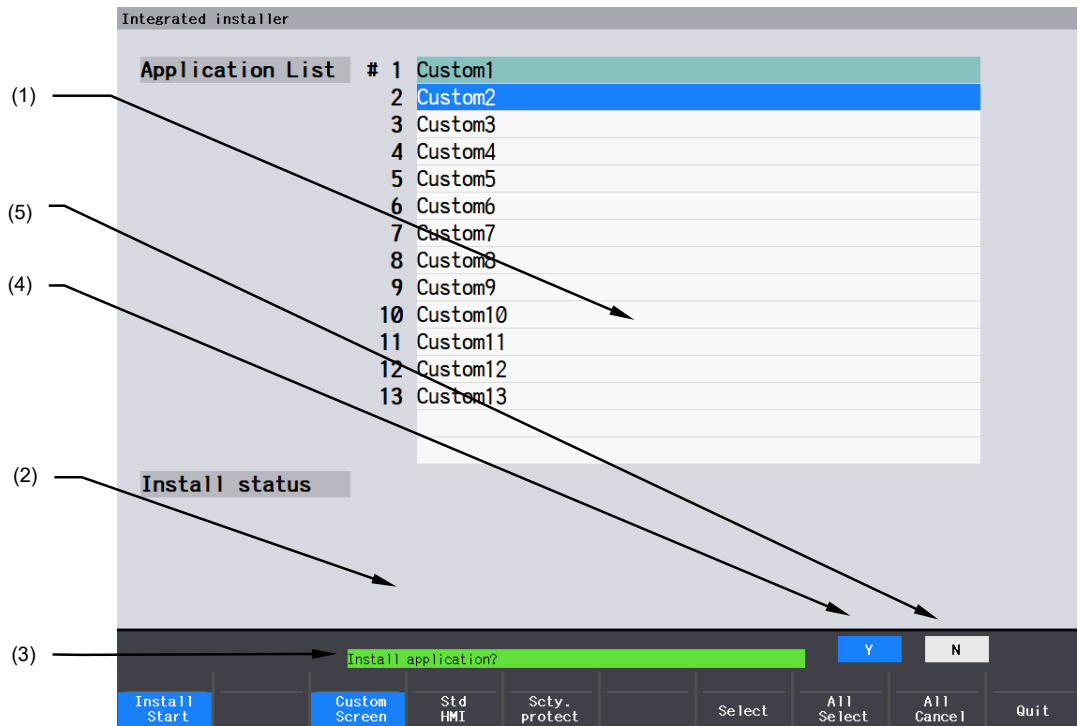

### Appendix 9.3 Screen Configuration





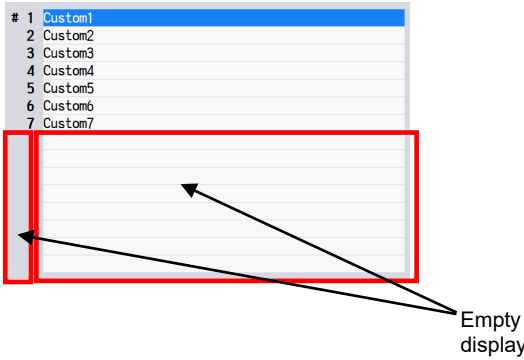

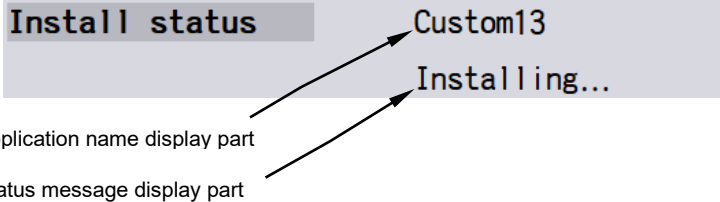
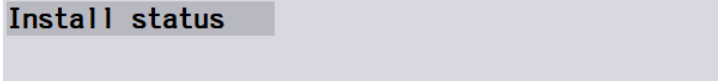
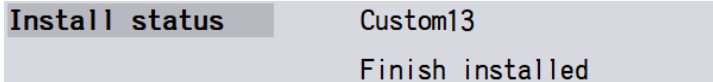
Screen image



Display items

Display item	Details
(1) Application list	<p>This displays the list of the application name which can be installed. The display content of the table changes depending on the selected menu.</p> <p>"Custom screen" menu is selected                      -&gt; "Application of custom release" list which can be installed</p> <p>"Standard HMI" menu is selected                      -&gt; "Application of HMI related" list which can be installed</p> <p>"Application of custom release" is displayed as a default. The name set to "Setup application list" is displayed as application name.</p> <p>The cursor is displayed, and the installed application can be selected. The selected application name is highlighted as follows. Two or more applications can be selected.</p> <p>"Application name which has not been selected"                      # 1 Custom1</p> <p>"Application name which has been selected"                      # 1 Custom1</p> <p>"Application name displaying cursor"                      # 1 Custom1</p> <p>The cursor can be moved by     keys.</p> <p><b>(Note)</b> After the line of the final data display, an empty column is displayed. The line No. is not displayed, too.</p> <p><b>[Example of display (when number of application is 7)]</b></p>  <p>Empty display</p>

Display item	Details
<p>(2) Installation status display part</p>	<p>This displays the installation status of the installing application. Also, an application register message is displayed when it is enabled by pressing the security menu.</p>  <p>Application name display part</p> <p>Status message display part</p> <p><b>[Display examples]</b></p> <p>[Before installation]</p>  <p>[After installation]</p>  <p><u>&lt;When installing&gt;</u>  <b>"Application name display part"</b>          The name of currently installing application is displayed.</p> <p><b>"Status message display part"</b>          The current installation status is displayed as a message. The message "Installing..." is blinked every second while installing the application. When an error will occur during installation, an error message is displayed.</p> <p>(Note) When the installation method is "Installer start method", nothing is displayed in all the display parts (The application installation status is not displayed).</p> <p><u>&lt;When registering application&gt;</u>  <b>"Application name display part"</b>          Nothing is displayed.</p> <p><b>"Status message display part"</b>          The registration status of the application that is permitted to operate while the security function is enabled is displayed as a message. The message "Application registration is in progress" is blinked every second while registering the application. Also, when the application registration is completed, "Application registration is complete" is displayed.</p>
<p>(3) Operation/Power supply restart message display part</p>	<p>This displays the operation messages and the power supply restart messages. The background color is different depending on the kind of the displaying message.</p> <p>"Operation message"</p>  <p>"Power supply restart message"</p> 

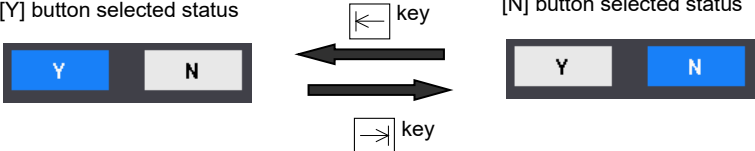
Display item	Details
(4) [Y] button (5) [N] button	<p>There are buttons to decide whether to execute or cancel the operation when a confirmation message is displayed in "Operation/Power supply restart message display part" and then the status is changed to the waiting. The meaning of each button is as follows.</p> <ul style="list-style-type: none"> <li>• [Y] button : Execute the operation</li> <li>• [N] button : Cancel the operation</li> </ul> <p>Usually (the confirmation message is not displayed), each button is "Invalid status", and cannot be selected.</p> <p>"Button invalid status (grayout)"</p>  <p>When the confirmation waiting status, either button is "Selection status", and the other is "Normal status". (The [Y] button turns to "Selection status" when the status is changed to the waiting.)</p> <p>"Button selection status (highlight)"</p>  <p>"Button normal status (normal display)"</p>  <p>The selected button can be switched with the ,  key at the confirmation waiting status.</p> <p>[Y] button selected status  key  key [N] button selected status</p> 

## Menus

<b>Menu</b>	<b>Details</b>
Install Start	This starts the installation of the selected application.
Custom Screen	This displays the "Application of custom release" name which can be installed in the application list.
Std HMI	This displays the "Application of HMI related" name which can be installed in the application list.
Scty protect	This changes the security function status to protect, scans the applications in the display, and starts registering the application that is permitted to operate while the security function is enabled. (Note) This menu is only enabled when an option is set. When an option is not set this menu is disabled and is not displayed. Also, when the security function is enabled, this menu is highlighted, and cannot be operated.
Select	This selects the application at the cursor, and cancels the selection status.
All Select	This selects all applications in the application list.
All Cancel	This cancels the selected status of all applications in the application list.
Quit	This quits the integrated installer. After selected, the end confirmation message is displayed.

## Appendix 9.4 Operation Methods

### Appendix 9.4.1 Installing the Application

(1) The memory card or USB memory where either of installation environment of "Application of custom release" or "Application of HMI related" is stored is prepared, and the memory card is inserted in the memory card interface in front of the display.

(2) Select **Mainte** - **Password input** menu on the Maintenance screen.

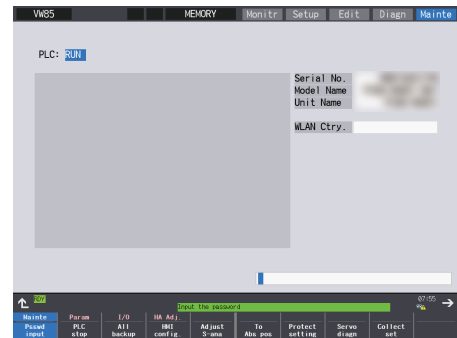

(3) Input the password, and select the **INPUT** key.



The password is set, and the HMI integrated installer can be started.



(4) Select **HMI verup** menu.



The **HMI verup** menu is highlighted, and the message to confirm the stop of PLC is displayed.

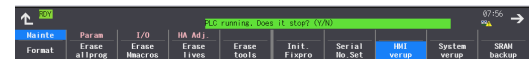



(5) Select the **Y** or **INPUT** key.

After PLC is stopped, HMI integrated installer is started, and then the screen is displayed. When the installation environment of "Application of custom release" in memory card or USB memory, the "Application of custom release" name which can be installed in the application list is displayed.

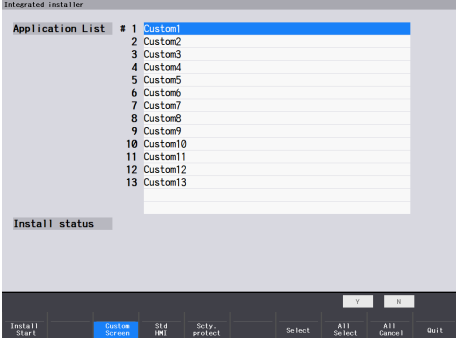

(6) Select one application to install from the displaying application list.

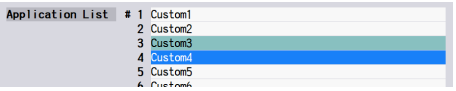

(7) Select **Install start** menu.

The **Install start** menu is highlighted, and a message to confirm installing application is displayed in "Operation/Power supply restart message display part". The [Y] button turns to "Selection status".



**(Note 1)** If any application has not been selected when **Install start** menu is selected, an error message is displayed and the **Install start** menu is unhighlighted.

- (8) Select the **[INPUT]** key.  
Or touch the selection status **[Y]** button.



The installation of the selected application is started. The screen display is different depending on the installation method.

**(Note 1)** When the selection status **[N]** button or the menu is touched, the **[install start]** menu is unhighlighted and the application is not installed.

**(Note 2)** While installing, all menus are invalid menus (grayout), and cannot be selected.

**[Invalid menu display]**



**(Note 3)** All tasks except the related system are quitted immediately before installing the selected application. Quit all unnecessary tasks before an integrated installer starts.



**<<When the application of "File copy method" is selected>>**

The application is installed according to the setting of the setup application list. A current installation situation is displayed in "Installation status display part". The message "Installing..." is blinked every second while installing the application.

**[Example of display 1]**

Application name (registered name) -> TEST Application

<b>Install status</b>	TEST Application
	Installing...

When an error will occur during installing, an application is not installed, and an error message is displayed in "Installation status display part". In that case, quit the integrated installer once, and review the installation environment and the setup application list, etc. in the memory card or USB memory.

**[Example of display 1]**

Application name (registered name) -> Custom 13  
To copy the designated file failed.

<b>Install status</b>	Custom13
	Can't copy file

**[Example of display 2]**

Application name (registered name) -> Test Application  
To delete the designated directory failed.

<b>Install status</b>	Test Application
	Can't delete directory

**(Note 1)** When the installation is interrupted by error, the file installed until interruption does not return to the origin.

**(Note 2)** The message other than "Installing..." displayed while installing is not blinked ("Finish installed" "Can't copy file", etc.).

**<<When the application of "Installer start method" is selected>>**

The installer set to the setup application list is started, and displayed in front of the screen. Install the application according to the guidance displayed on the installer screen.

**[Example of display]**

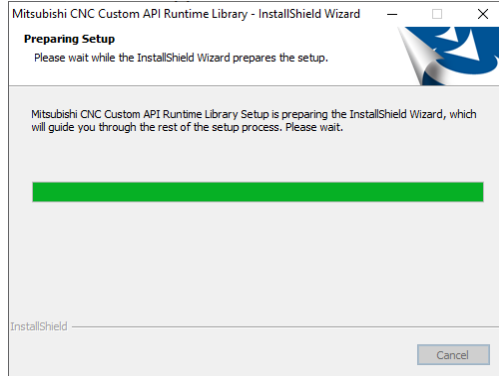

(Note) When no USB keyboard is connected for a 19-type display, the screen keyboard appears.

- (9) The application installation is completed.

**<<When the installation of "File copy method" application is completed>>**

The installation completion message is displayed in "Installation status display part", and the Install start menu highlighting and the selection status of the application are canceled. The power supply-restart message is displayed in "Operation/Power supply restart message display part".

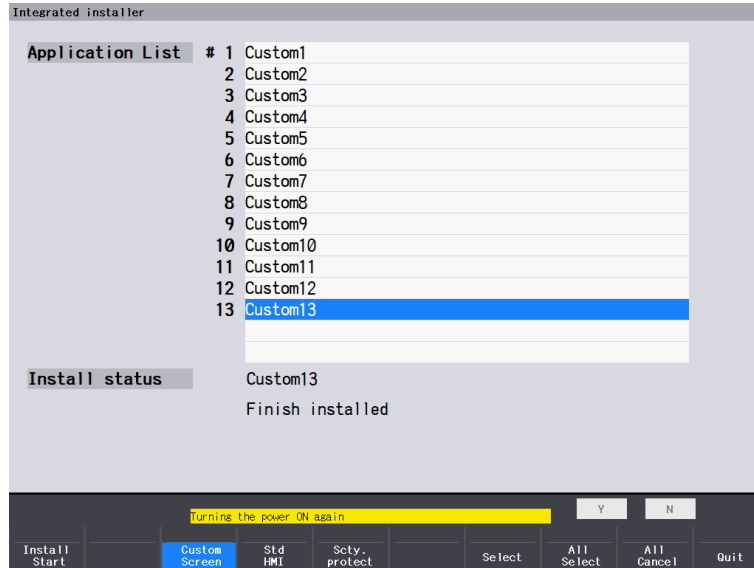

**<<When the installation of "Installer start method" application is completed>>**

When returning to the integrated installer screen after the installation screen was quitted, the Install start menu highlighting and the selection status of the application are canceled. The power supply-restart message is displayed in "Operation/Power supply restart message display part".

(Note 1) For "Installer start method", even if canceling the installation on the started installer screen and then returning to the integrated installer screen, the power supply-restart message is displayed in "Operation/Power supply restart message display part". (When the registered installer is started the power supply-restart message is displayed in "Operation/Power supply restart message display part".)

**Appendix 9.5 Details for Functions**

**Appendix 9.5.1 Installation Method**

For integrated installer, two methods are prepared to install and upgrade the application according to the description of "Appendix 9.1 Outline": "Installer start method" and "File copy method".

Installer start method

The installer for the application (EXE file) prepared beforehand in the memory card or USB memory is started from an integrated installer, and installed by the installer for the application. In this method, the setup application list setting is easy, however, it is necessary to create the installer for the application (EXE file). The process outline of the prepared installer is as follows. Create the created installer file by full-screen as much as possible.

<<The process outline of the installer for the application>>

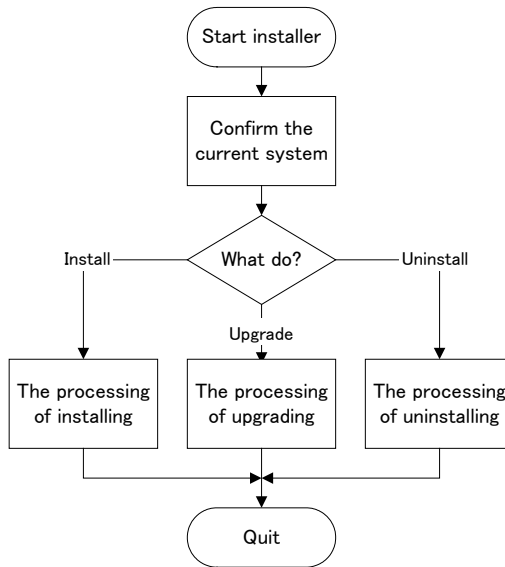

## File copy method

The application is installed by "Installation file" in the memory card or USB memory and an integrated installer.

In this method, it is not necessary to create the installer for the application (EXE file), however, the setup application list setting is complex.

The possible installation processes by an integrated installer are as follows.

<<The possible installation processes>>

- Overwrite the designated file to an arbitrary directory.
- Copy a new file after deleting the file in an arbitrary directory when the designated file exists in an arbitrary directory.
- Overwrite the designated directory to an arbitrary directory.
- Copy a new file after deleting the directory in an arbitrary directory when the designated directory exists in an arbitrary directory.
- Delete the designated file.
- Delete the designated directory.
- Add the registry key to the registry newly.
- Add the new registry entry to the registry key.
- Change the registry entry data.

(Only following three types can be changed and added: "32-bit value (DWORD value)", "Character string value", "Binary value".)

**Appendix 9.5.2 About the Memory Card or USB Memory for Upgrade**

Directory configuration

The directory configuration of the memory card or USB memory for the upgrade is as follows.

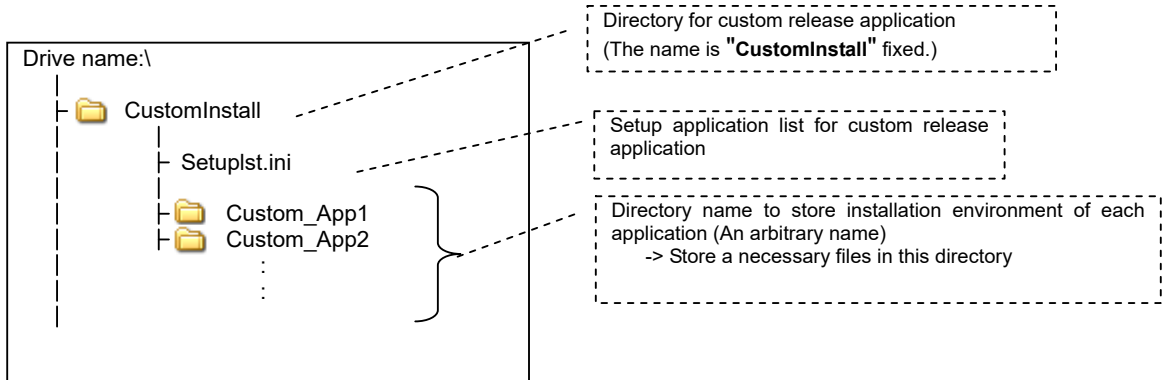

Create for the root directory of the memory card or USB memory as follows:

- Directory for custom release application (directory name : CustomInstall)

Create the followings in the created directory:

- Setup application list (file name : Setuplst.ini)
- Directory to store installation environment of each application

Setup application list (Setup1st.ini)

"Setup application list" is a file to set the installation settings of each application. The integrated installer installs the application according to the setup application list setting.

(1) File name

Setup application list file name is "Setup1st.ini". Do not apply other file name. Apply the same file name to "For application of custom release" and "For application of HMI related".

(2) Description format

Setup application list (Setup1st.ini) conforms to the description format of the Windows INI file as a rule, and the maximum size of the INI file is 32KByte. Apply the same file name to "For application of custom release" and "For application of HMI related".

The description format of Windows INI

```

[[Section]]
(Key) = (Value of key)
:
[[Section]]
(Key) = (Value of key)
:
:
    
```

(3) About each section and key

[APPLIST] Section

<b>Section name</b>	APPLIST
<b>Details</b>	Specify the input password when application is installed and the set number of the [APP] section.
<b>Initial value (when undefined)</b>	No setting

<b>1</b>	<b>Key name</b>	PASSWORD
<b>Details</b>		
Specify the input password when application installation is started.		
<ul style="list-style-type: none"> <li>● Character type which can be set : Only the alphanumeric character</li> <li>● Number of character which can be set : Within 15 one-byte characters</li> </ul>		
<b>Initial value (when undefined)</b>		
No setting		



<b>2</b>	<b>Key name</b>	APPCOUNT
<b>Details</b>		
Specify the number of applications (number of the [APP] section setting) registered in the integrated installer. <ul style="list-style-type: none"> <li>Setting range : 1 to 15 (15 applications or less can be registered.)</li> </ul>		
<b>Initial value (when undefined)</b>		
0		

[APP] Section

<b>Section name</b>	APP**
<b>Details</b>	
Specify the information of each application installation. Specify the sequential No. (1 to 15) to the set value [APPCOUNT] of [APPLIST] section to ** of section name.  <b>(Note 1)</b> Number from 1 sequentially. <b>(Note 2)</b> [APP] section to which larger No. than the value set to [APPCOUNT] key of [APPLIST] section is set is ignored.	
<b>Initial value (when undefined)</b>	
No setting	

<b>1</b>	<b>Key name</b>	NAME
<b>Details</b>		
Specify the name displayed in "Application list". <ul style="list-style-type: none"> <li>Character type which can be set : Only the alphanumeric character</li> <li>Number of character which can be set : Within 45 one-byte characters</li> </ul>		
<b>Initial value (when undefined)</b>		
"Application" + "No. set to [APP] section (** part)"  [Example of display] For example of [APP01] section, "Application01" is displayed in "Application list".  <div style="border: 1px solid gray; padding: 2px; display: inline-block;"> <b>Application List # 1 Application01</b> </div>		

<b>2</b>	<b>Key name</b>	DIR
<b>Details</b>		
Specify the "Directory name to store installation environment" of each application in memory card or USB memory. <ul style="list-style-type: none"> <li>Character type which can be set : Only the alphanumeric character</li> <li>Number of character which can be set : Within 100 one-byte characters</li> </ul> <b>(Note 1)</b> The following directory cannot be selected: the directory name of 100 or more characters, or the directory name used with two-byte character.		
<b>Initial value (when undefined)</b>		
No setting		

<b>3</b>	<b>Key name</b>	INSTALLTYPE
<b>Details</b>		
Specify the application installation method. The key which needs setting is changed depending on this key setting value.		
<ul style="list-style-type: none"> <li>● Setting range : 1 to 2             <ul style="list-style-type: none"> <li>1 : Installer start method</li> <li>2 : File copy method</li> </ul> </li> </ul>		
<b>Initial value (when undefined)</b>		
1 (Installer start method)		

<b>4</b>	<b>Key name</b>	INSTALLER
<b>Details</b>		
Specify the file name (include the extension (.exe)) of the installer (EXE file) which is started when the installation method is "Installer start method ([INSTALLTYPE] key is 1.)".		
<ul style="list-style-type: none"> <li>● Character type which can be set : Only the alphanumeric character</li> <li>● Number of character which can be set : Within 50 one-byte characters</li> </ul>		
<b>(Note 1)</b> Specify the installer (EXE file) which exists in the directory specified with the [DIR] key. The file name of the installer which exists in other directories cannot be specified.		
<b>(Note 2)</b> When the installation method is "File copy method ([INSTALLTYPE] key is 2)", the key is ignored. It is not necessary to set.		
<b>Initial value (when undefined)</b>		
setup.exe		

<b>5</b>	<b>Key name</b>	FILE
<b>Details</b>		
Specify the setting of operation to the file by comma-delimited character when the installation method is "File copy method ([INSTALLTYPE] key is 2)". The format of character string is as follows.		
"The format of character string"		
(Action), (FileName), (ActionDir)		
<b>1</b>	<b>Name</b>	<b>Detail</b>
	Action	<p>Designate the operation to the file (directory) specified by "FileName".</p> <ul style="list-style-type: none"> <li>• Setting range : 1 to 3</li> <li>1 : Overwrite the file (directory) to the copy destination.</li> <li>2 : Copy after the file (directory) to the copy destination is deleted.</li> <li>3 : Delete the file (directory).</li> <li>4 : Add an additional copy of the file (directory) to the copy destination. (Note 1)</li> </ul> <p>(Note 1) Used when adding custom data afterwards. Add an additional copy of the custom file, and add the details of the custom data setting file.</p>
	FileName	<p>Specify the operation file (directory) name designated by "Action".</p> <ul style="list-style-type: none"> <li>• Character type which can be set : Only the alphanumeric character</li> <li>• Number of character which can be set : Within 50 one-byte characters</li> </ul> <p>(Note 1) Specification with wild-card ("*") is also possible.</p> <div style="border: 1px solid black; padding: 5px; margin: 10px 0;"> <p><b>[ "*" + extension ]</b>                  [Setting example] *.txt                  -&gt; All files with "txt" as extension</p> <p><b>[ "*" ]</b>                  -&gt; All files and directory</p> </div> <p>(Note 2) When the file is copied ("Action" is "1" or "2"), specify the file (directory) which exists in the directory specified with the [DIR] key. The file name (directory) which exists in other directories cannot be specified.</p>
	ActionDir	<p>Specify the directory path which relates to the operation designated by "Action".</p> <ul style="list-style-type: none"> <li>• Character type which can be set : Only the alphanumeric character</li> <li>• Number of character which can be set : Within 100 characters</li> </ul> <p>&lt;&lt;When copying the file ("Action" is "1" or "2")&gt;&gt;                  Specify the directory path of the file (directory) to the copy destination specified by "FileName".</p> <p>&lt;&lt;When deleting the file ("Action" is "3")&gt;&gt;                  Specify the directory path in which the file (directory) specified by "FileName" exists.</p> <p>(Note 1) In both cases, the path is set by full path.</p>

<p><b>(Note 1)</b> The number of [FILE] keys which can be set to one [APP**] section is up to 100. All [FILE] keys over 100 are disregarded.</p> <p><b>(Note 2)</b> When the application is installed, the file designated with each [FILE] key is operated by the setup application list sequence.</p> <p><b>(Note 3)</b> When the installation method is "Installer start method ([INSTALLTYPE] key is 1)", all [FILE] key is ignored. It is not necessary to set.</p> <p><b>(Note 4)</b> When the "Action" is "2" or "3" and the deleted file (directory) does not exist, the deletion is not executed. An error will not occur during installation.</p> <p><b>(Note 5)</b> The read-only file cannot be rewritten and deleted.</p>
<p><b>Initial value (when undefined)</b></p>
<p>No setting</p>

<b>6</b>	<b>Key name</b>	REGKEY
<b>Details</b>		
<p>Specify the name of registry key which is created newly when the installation method is "Installer start method ([INSTALLTYPE] key is 2.)". Set the key name including all the parents keys. Specify the separation of each key name "\".</p> <ul style="list-style-type: none"> <li>• Character type which can be set : Only the alphanumeric character</li> <li>• Number of character which can be set : Within 150 one-byte characters (including the parents key name and each key name separation "\")</li> </ul> <p><b>(Note 1)</b> The number of [REGKEY] keys which can be set to one [APP**] section is up to 100. All [REGKEY] keys over 100 are disregarded.</p> <p><b>(Note 2)</b> When the application is installed, the registry key designated with each [REGKEY] key is created by the setup application list sequence.</p> <p><b>(Note 3)</b> When the installation method is "Installer start method ([INSTALLTYPE] key is 1)", all [REGKEY] key is ignored. It is not necessary to set.</p> <p><b>(Note 4)</b> When the set registry key has already existed, nothing is executed. An existing registry key cannot be deleted. An error will not occur during installation.</p>		
<b>Initial value (when undefined)</b>		
<p>No setting</p>		

<b>7</b>	<b>Key name</b>	REGKEYVALUE
<b>Details</b>		
Specify the registry entry set to the registry key by comma-delimited character when the installation method is "File copy method ([INSTALLTYPE] key is 2)". The format of character string is as follows.		
"The format of character string"		
(RegistryKeyName), (ValueName), (ValueType), (Value)		
	<b>Name</b>	<b>Details</b>
1	RegistryKeyName	Specify "Registry key name" which newly sets the registry entry. Set the key name including all the parents keys. Specify the separation of each key name "\". <ul style="list-style-type: none"> <li>● Character type which can be set : Only the alphanumeric character</li> <li>● Number of character which can be set : Within 150 one-byte characters (including the parents key name and each key name separation "\")</li> </ul>
2	ValueName	Specify the name of the registry entry set to registry key designated by "RegistryKeyName". <ul style="list-style-type: none"> <li>● Character type which can be set : Only the alphanumeric character</li> <li>● Number of character which can be set : Within 50 one-byte characters</li> </ul>
3	ValueType	Specify the data type of the registry entry set to registry key designated by "RegistryKeyName". <ul style="list-style-type: none"> <li>● Setting range : 1 to 3  1 : 32-bit value (DWORD value)  2 : Character string value  3 : Binary value</li> </ul>

4	Value	<p>Specify the value of the registry entry set to registry key designated by "RegistryKeyName". The setting range is different depending on the setting value of "ValueType".</p> <p>Setting range [When ValueType = 1 (32-bit value)]</p> <ul style="list-style-type: none"> <li>• Notation : Either decimal or hexadecimal notation</li> </ul> <p>&lt;&lt;Example of setting (when the value is "10000")&gt;&gt; Value=10000 (decimal notation) Value=0x2710 (hexadecimal notation) (Note 1) Add "0x" on the head of the value when the notation is hexadecimal.</p> <p>[When ValueType = 2 (character string value)]</p> <ul style="list-style-type: none"> <li>• Character type which can be set : Only the alphanumeric character</li> <li>• Number of character which can be set : Within 50 one-byte characters</li> </ul> <p>&lt;&lt;Example of setting (when the value is "Custom1")&gt;&gt; Value="Custom1" (Note 2) Enclose the character string with " (double quotation mark).</p> <p>[When ValueType = 3 (binary value)]</p> <ul style="list-style-type: none"> <li>• Character type which can be set : Only the alphanumeric character</li> <li>• Number of character which can be set : Within 50 one-byte characters</li> </ul>
<p><b>(Note 1)</b> The number of [REGKEYVALUE] keys which can be set to one [APP**] section is up to 100. All [REGKEYVALUE] keys over 100 are disregarded.</p> <p><b>(Note 2)</b> When the application is installed, the registry entry designated with each [REGKEYVALUE] key is set by the setup application list sequence.</p> <p><b>(Note 3)</b> When the installation method is "Installer start method ([INSTALLTYPE] key is 1)", all [REGKEYVALUE] key is ignored. It is not necessary to set.</p> <p><b>(Note 4)</b> When the designated registry entry has already existed, the existing registry entry is changed.</p> <p><b>(Note 5)</b> An existing registry entry cannot be deleted.</p>		
<b>Initial value (when undefined)</b>		
No setting		

- (Note 1)** When the application is installed, the installation is operated by the following sequence.
- (1) [FILE] key : (Designated file operation)
  - (2) [REGKEY] key : (Add registry key)
  - (3) [REGKEYVALUE] key : (Add registry entry)

This sequence cannot be changed.

**(Note 2)** The key which needs settings are different depending on the method of installing the application.

Installer start method

	Key name	Comment
1	NAME	
2	DIR	Indispensability
3	INSTALLTYPE	
4	INSTALLER	Indispensability

File copy method

	Key name	Comment
1	NAME	
2	DIR	Indispensability
3	INSTALLTYPE	Indispensability
5	FILE	
6	REGKEY	
7	REGVALUE	

(Note 3) Define the each section key to the setup application list in following the sequence.

[APPLIST] section

	Key name	Comment
1	PASSWORD	
2	APPCOUNT	Indispensability

[APP] section

	Key name	Comment
1	NAME	
2	DIR	Indispensability
3	INSTALLTYPE	Indispensability
4 or later	Any of the following: INSTALLER FILE REGKEY REGKEYVALUE	Indispensability

(4) Example of setting ("For application of custom release")

Setup application list

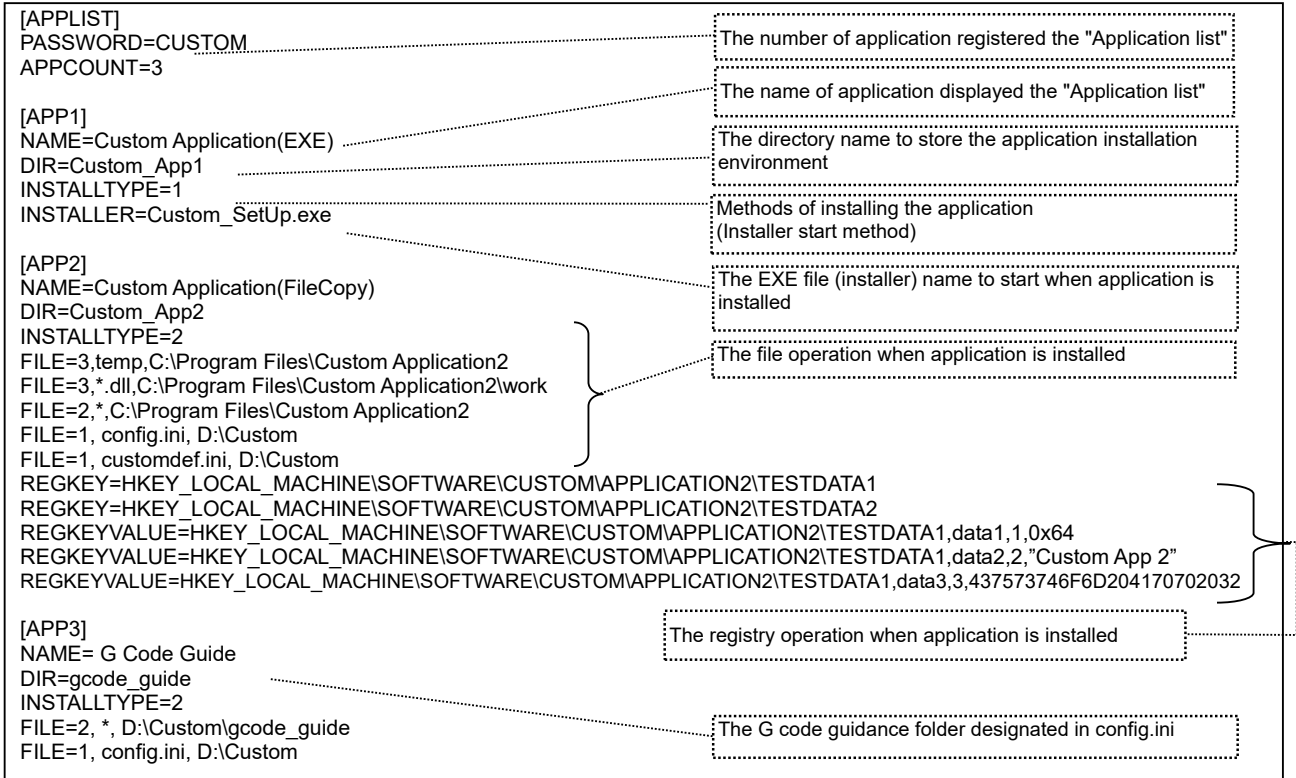

**NOTE**

◆ [APP1] is the installer start method, and [APP2] is the file copy method.



File configuration in memory card

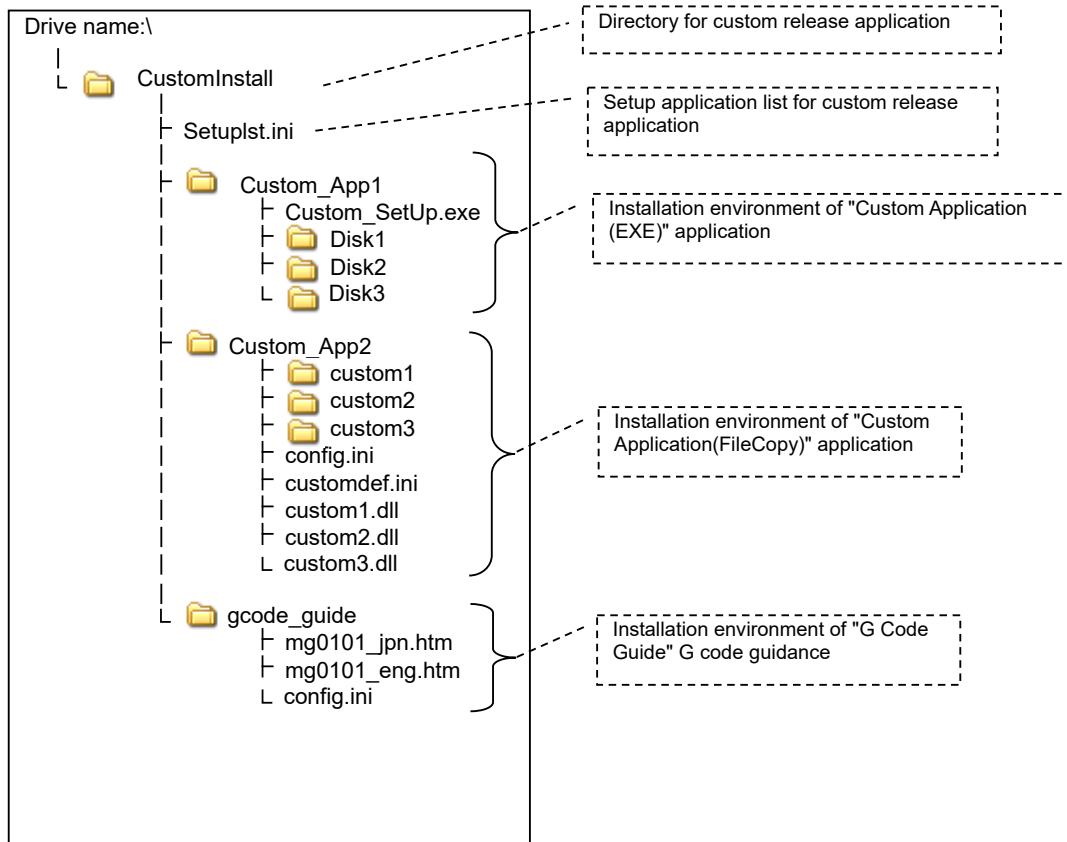

"Application list" when Custom screen menu is selected

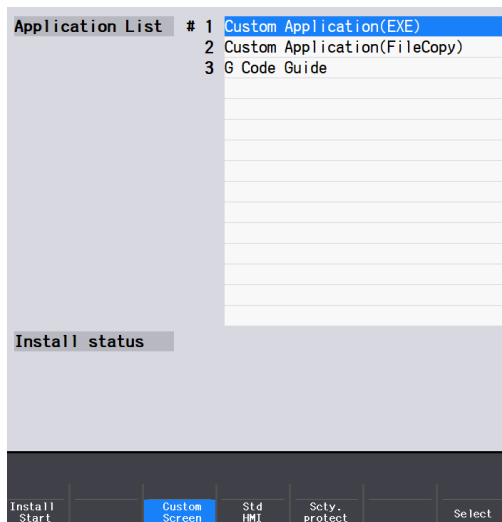

## The flow of each application installation

- "Custom Application (EXE)" application
  - 1) Select "Custom Application (EXE)" from the application list, and select [Install start] menu.
  - 2) The installer (Custom\_SetUp.exe) which exists in the "Custom\_App1" directory (the installation environment of "Custom Application (EXE)" application) is started, and the installer screen is displayed in front of the screen.
  - 3) Install the application according to the guidance displayed on the installer screen.
  - 4) After the installation is completed, the installer screen is quitted, and return to the integrated installer screen.
  
- "Custom Application (FileCopy)" application
  - 1) Select "Custom Application (FileCopy)" from the application list, and select [Install start] menu.
  - 2) Delete the "temp" directory including file if the "temp" directory exists in the "D:\Custom\Custom Application2" directory.
  - 3) Delete the file with ".dll" as extension if the file with ".dll" as extension exists in the "D:\Custom\Custom Application2\work" directory.
  - 4) Copy all files and directories which exist in the "Custom\_App2" directory (the installation environment of "Custom Application (FileCopy)" application) after all files and directories in "D:\Custom\Custom Application2" directory are deleted.
  - 5) Overwrite "config.ini" file which exists in "Custom\_App2" directory (the installation environment of "Custom Application (FileCopy)" application) to "D:\Custom" directory.
  - 6) Overwrite "customdef.ini" file which exists in "Custom\_App2" directory (the installation environment of "Custom Application (FileCopy)" application) to "D:\Custom" directory.
  - 7) Create the "TESTDATA1" key as a subkey of "HKEY\_LOCAL\_MACHINE\SOFTWARE\CUSTOMAPPLICATION2" key to the registry.
  - 8) Create the "TESTDATA2" key as a subkey of "HKEY\_LOCAL\_MACHINE\SOFTWARE\CUSTOMAPPLICATION2" key to the registry.
  - 9) Add the entry (entry name "data1", data type "32-bit value", data "0x00000064") to the key created in "6)".
  - 10) Add the entry (entry name "data2", data type "character string value", data "Custom App 2") to the key created in "6)".
  - 11) Add the entry (entry name "data3", data type "binary value", data "437573746F6D204170702032") to the key created in "6)".
  - 12) The installation is completed.
  
- "G Code Guide" G code guidance
  - 1) Select "G Code Guide" from the application list, and select [Install start] menu.
  - 2) Copy all files and directories which exist in the "gcode guide" directory (the installation environment of "G Code Guide" G code guidance) after all files and directories in "D:\Custom\gcode\_guide" directory are deleted.
  - 3) Overwrite "config.ini" file which exists in "gcode guide" directory (the installation environment of "G Code Guide" G code guidance) to "D:\Custom" directory.
  - 4) The installation is completed.

**Appendix 9.6 Parameter**

The following table shows the related parameters.

[Parameter list]

No.	Name	Detail	Range
#1043	lang (Select language displayed)	Specify the display language. 0: English display 1: Japanese display 11: Display in German 12: Display in French 13: Display in Italian 14: Display in Spanish 15: Display in Chinese (traditional Chinese) 16: Display in Korean 17: Display in Portuguese 18: Display in Dutch 19: Display in Swedish 20: Display in Hungarian 21: Display in Polish 22: Display in Chinese (simplified Chinese) 23: Display in Russian 24: Display in Turkish 25: Display in Czech 31: Display in Indonesian 32: Display in Vietnamese	0 to 1 11 to 25 31 to 32

**NOTE**

- ◆ On the standard screen, start the integrated installer after the related parameters is set.  
The integrated installer cannot set the related parameters.
- ◆ The integrated installer refers the parameter setting value when the integrated installer has started.  
Even if the parameter is changed after starting, the change is invalid.
- ◆ The supported languages depend on the model.

**Appendix 9.7 Operation/Alarm Messages**

The message displayed in each display part is as follows.

[Message list]

<<Operation/Power supply restart message display part>>

Message	Details
<b>Operation message</b>	
Install application?	It is confirmed whether the installation of the application is started. <ul style="list-style-type: none"> <li>• [Y] : Start the installation of the application.</li> <li>• [N] : Do not start the installation of the application.</li> </ul>
Select application to install	An application to install has not been selected from "Application list". Select an application.
Can't install application	The selected application cannot be installed. Confirm the mounting status of the memory card or USB memory and the installation environment in the memory card or USB memory.
Is it OK to change the settings? (Y/N)	It is confirmed whether to start registration of applications that are permitted to operate while the security function is enabled. <ul style="list-style-type: none"> <li>• [Y] : Start registration of the application.</li> <li>• [N] : Do not start registration of the application.</li> </ul>
Quit ?	It is confirmed whether the integrated installer is quitted. <ul style="list-style-type: none"> <li>• [Y] : Quit the integrated installer.</li> <li>• [N] : Do not quit the integrated installer.</li> </ul>
<b>Power supply restart message</b>	
Turning the power ON again	It is necessary to turn the power supply ON again because the application was installed. Turn the power supply ON again.

<<Installation status display part>>

Message	Details
Installing...	The application is installing.
Finish installed	The application installation was completed.
Can't copy file	To copy the specified file failed while installing. Confirm the setting of the setup application list and the installation environment in the memory card.
Can't delete file	To delete the specified file failed while installing. Confirm the setting of the setup application list and the file to delete.
Can't copy directory	To copy the specified directory failed while installing. Confirm the setting of the setup application list and the installation environment in the memory card or USB memory.
Can't delete directory	To delete the specified directory failed while installing. Confirm the setting of the setup application list and the directory to delete.
Can't add registry key	To add the specified registry key failed while installing. Confirm the setting of the setup application list.
Can't add registry entry	The registry entry could not be added to the specified registry key while installing. Confirm the setting of the setup application list.
Can't copy	To copy the specified file or directory failed while installing. Confirm the setting of the setup application list and the installation environment in the memory card or USB memory.
Can't delete	To delete the specified file or directory failed while installing. Confirm the setting of the setup application list and the file/directory to delete.
Application registration is in progress	Registering the application that is permitted to operate while the security function is enabled.
Application registration is complete	Registration of the application that is permitted to operate while the security function is enabled is completed.
Unable to start security protection	When the McAfee® Application Control software is not installed, or when the display is not provided by Mitsubishi, install McAfee® Application Control and confirm the display being used.

### Appendix 9.8 Limitations

- (1) Available languages for the display are "Japanese" and "English" only. If the setting value of base common parameter "#1043 lang (Select language displayed)" is other than "0" or "1", the language displayed is "English".
- (2) When the HMI-related application installer or the data of application of custom release exists in both the memory card and the USB memory, the data in the memory card is installed.  
If the memory card has no data to install, the data in the USB memory is installed.

### Appendix 9.9 Precautions

- When adding an additional copy ("4" in "Action" of [FILE] key) of Setup1st.ini for application of custom release
  - (1) Files (directories) other than custom data setting files (Config.ini, customdef.ini) are overwritten.
  - (2) Custom data setting files (Config.ini, customdef.ini) add contents when there is no duplicated data for all sections. However, when registered information (items within sections such as screen No. offset values, custom screen menu positions, function buttons) is duplicated, an installation error occurs and the data is not installed.  
Refer to 17.6 Custom Release for details of each section.
  - (3) When the number of custom data registrations exceeds the upper limit, an installation error occurs and the data is not installed.

## Appendix 10. Installing Custom Data (M700VS/M70V/E70)

For M700VS/M70V/E70, use M70/M700 SETUP INSTALLER to install the custom screen data. Use a CF card to install.

(1) Data for M70/M700 SETUP INSTALLER

Type	Data	Contents	Remarks
Custom data	Custom screen module	Interpreter data and object data	
	Config.ini	Setting file for the assignment of the custom screen	
	customdef.ini	Setting file for the assignment of the custom screen to a menu or function button on the standard screen.	
	customload.txt	Setting file for registering the object data name and the load order (Note)	
	*.jpg	File for the icon image	

**(Note)** For the module name set in [MODULE\_NAME\*\*] of Config.ini, specify the project name of NC Designer2 excluding the extension (.IPP). For customload.txt, specify the object data name including the extension (.o).

(2) Folder configuration in CF card

Make the following folder configuration in a CF card to store the data for M70/M700 SETUP INSTALLER.

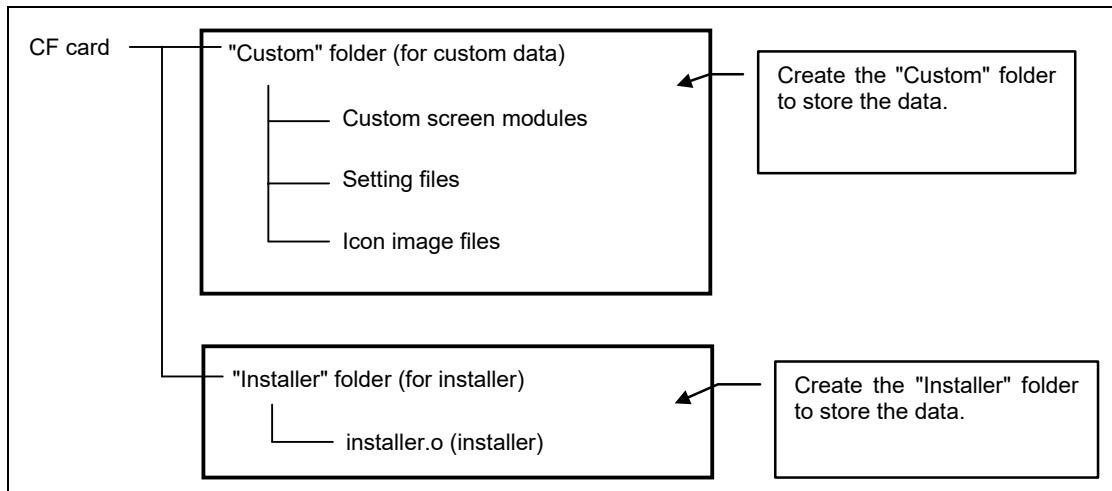

**(Note 1)** installer.o is included in the M70 M700VS SETUP INSTALLER folder of the NC Designer2 software package. Create the "Installer" folder in a CF card to store it.

Starting up M70/M700 SETUP INSTALLER

(1) Insert a CF card for M70/M700 SETUP INSTALLER into the front panel CF.

(2) Turn the power ON while pressing the  menu.

Startup screen appears. A bleep sounds after a while.  
Then the mode selection screen for M70/M700 SETUP INSTALLER appears.



**(Note 1)** Keep pressing the  key until the Mode Select screen appears.

Installing custom data

(1) Press the [Custom Data] menu key on the mode selection screen.

Custom data installation screen appears.

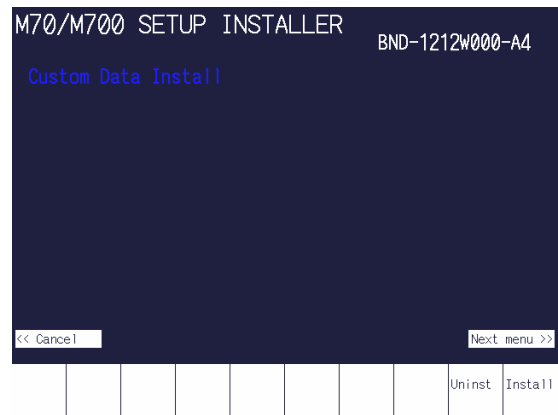

(2) Press the [Install] menu key.

A confirmation message appears.

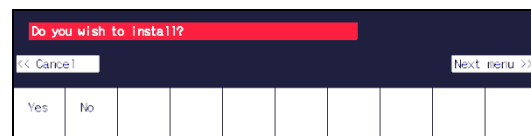

(3) Press the [Yes] menu key.

A message appears after the installation has completed.

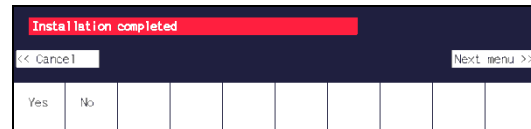

- Pressing the [No] menu key returns to the first menu.
- Do not turn the power OFF during the installation of custom data.



## Appendix 11. Installing Custom Data (M800V/M80V/ M800/M80 (Windows-less Display Unit))

The M800V/M80V/ M800/M80 (Windows-less display unit) installs custom screen data using M80/M800 SETUP INSTALLER.

Data compatible with M80/M800 SETUP INSTALLER is written onto an SD card in the following folder configuration.

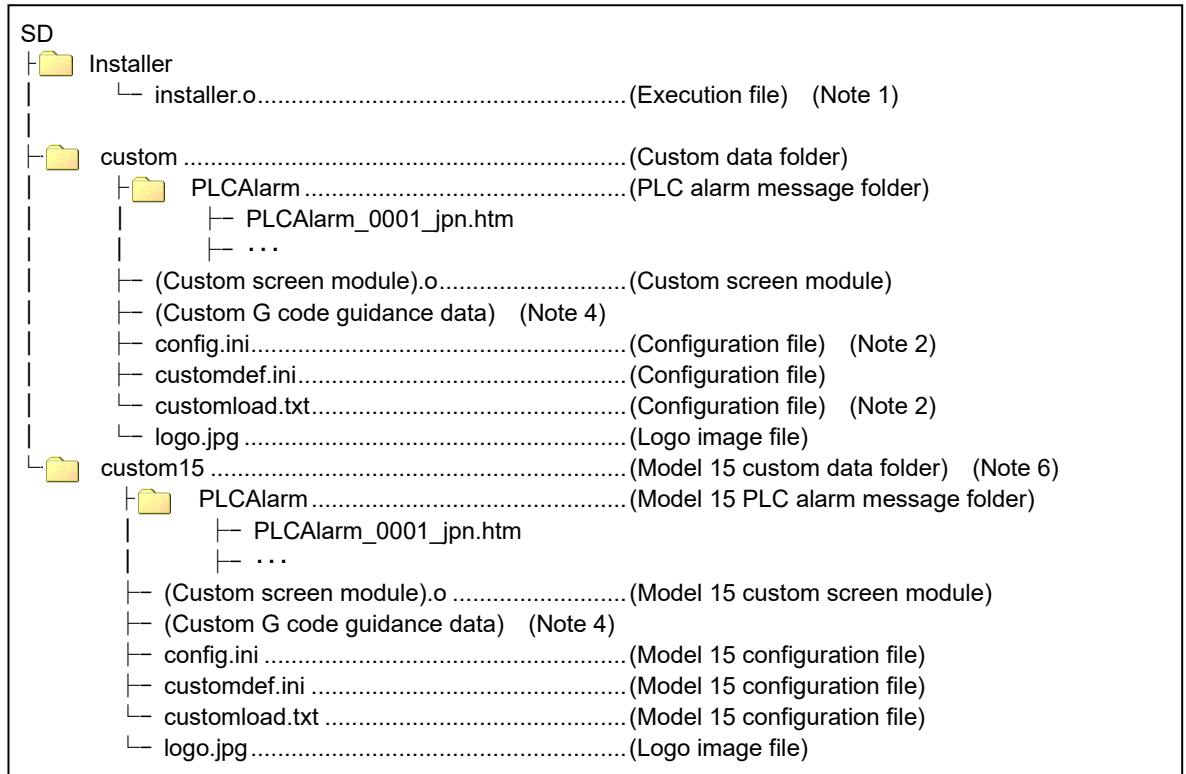

- (Note 1) "installer.o" is included in the M80 M800S SETUP INSTALLER folder of the NC Designer2 software package. Create an Installer folder on an SD card, and store it in the folder.
- (Note 2) For the module name set in [MODULE\_NAME\*\*] of Config.ini, specify the project name of NC Designer2 excluding the extension (.ND2). For customload.txt, specify the object data name including the extension (.o).
- (Note 3) The custom data storage capacity differs depending on the model. Refer to "NC Designer2 Matching List [Maximum data size]". The storage capacity may be different from the data size on installation media because it is calculated on the built-in memory.
- (Note 4) About custom G code guidance data  
- Store the G code guidance data which is created in the G code guidance folder designated in config.ini.
- (Note 5) When GMEMOVER occurs, use the resource management function to delete unnecessary resource data.
- (Note 6) Data of the custom15 folder is copied to the custom folder in the CNC. When specifying the path name using Config.ini, designate /custom/ instead of /custom15/ even when using 15-type display unit.

Launching M80/M800 SETUP INSTALLER

(1) Insert the SD card for the M80/M800 SETUP INSTALLER data, into the SD card interface in the front.

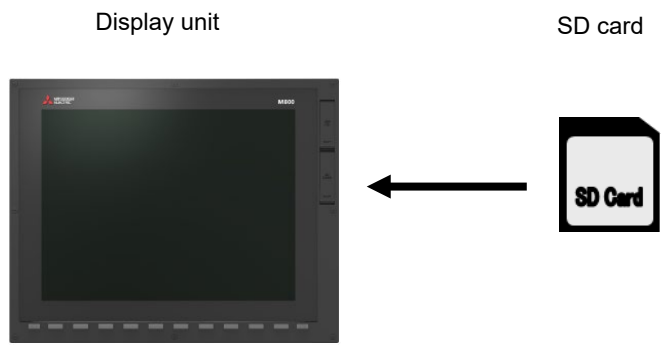

(2) While pressing the [Back] menu key , turn the power on.

Shortly after the startup screen is displayed, the buzzer bleeps, and the M80/M800 SETUP INSTALLER mode selection screen is displayed.

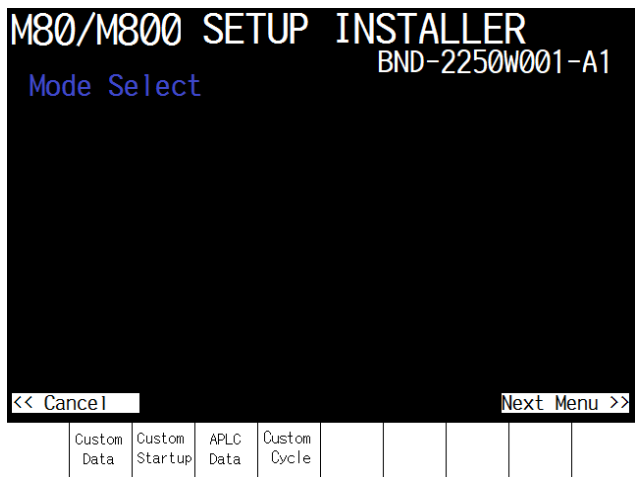

Installing custom data

(1) Press the [Custom Data] menu on the mode selection screen.

The custom data installation screen appears.

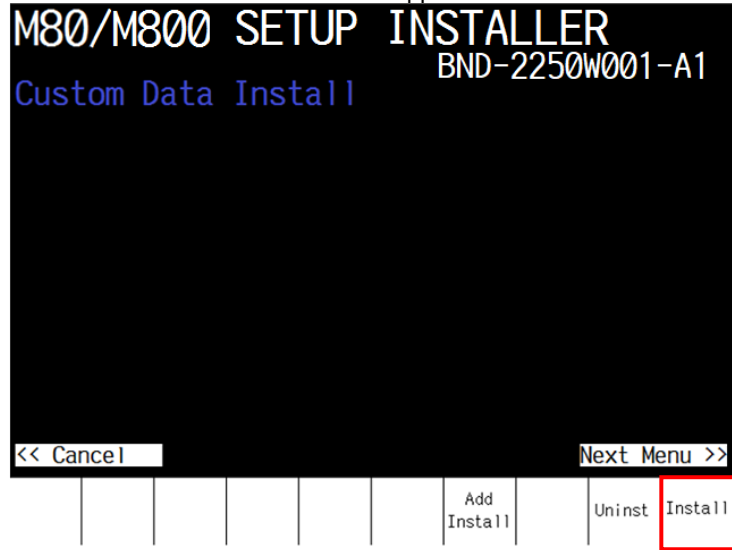

(2) Press the [Install] menu.

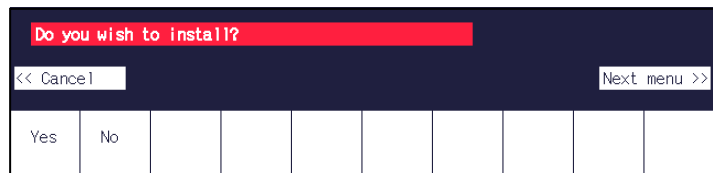

(3) Press the [Yes] menu.

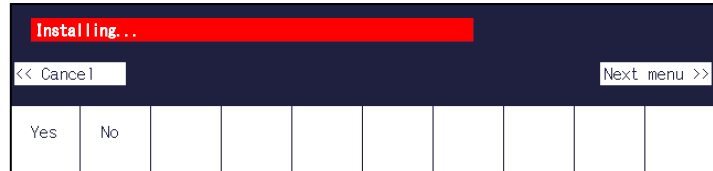

(4) When installation is completed, "Installation completed" appears.

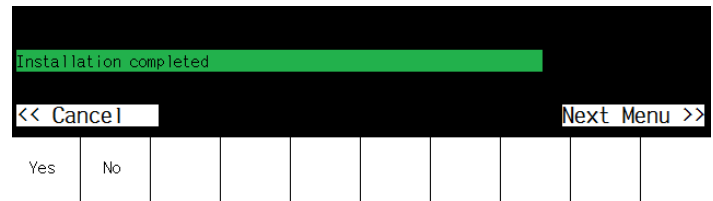

- (Note 1) To uninstall the custom screen, press the [Uninst] menu instead of [Install] menu on the custom data installation screen. Note that uninstallation processing uninstalls the "custom screen", "PLC alarm message", and "logo file".
- (Note 2) The custom data size must be less than the maximum size. If the size exceeds the maximum size, the message "Installation Error. Please check the file size." will appear and the data installation will not be executed. For the maximum size, refer to "NC Designer2 Matching List [Maximum data size]".
- (Note 3) Installation/uninstallation is not carried out even if the [Yes] menu is pressed continuously after installation/uninstallation has been carried out. Press the [Back] menu key  to return to the first screen once.
- (Note 4) Do not turn the power off during installation.

Installing additional custom data

- (1) Press the [Custom Data] menu on the mode selection screen.

The custom data installation screen appears.

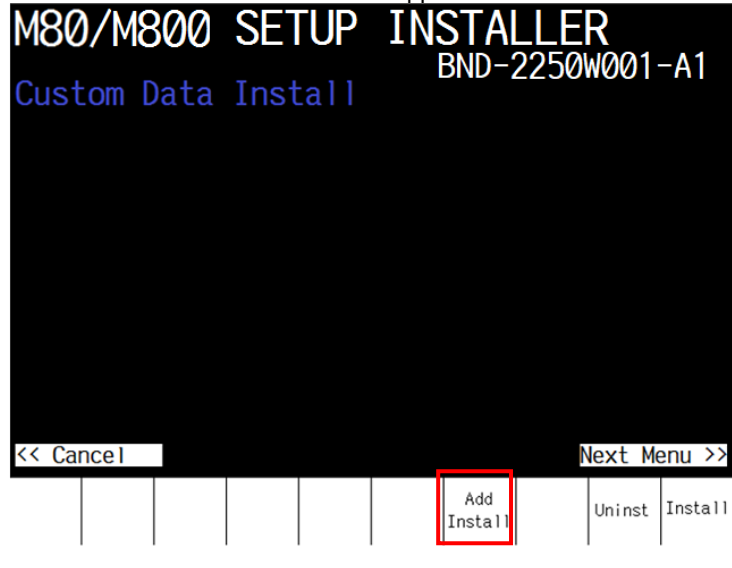

- (2) Press the [Add Install] menu.

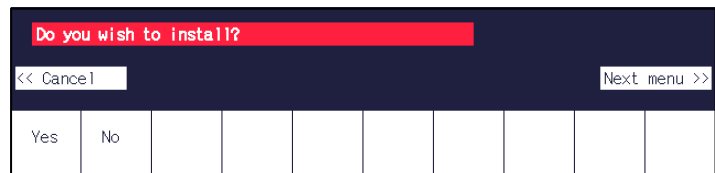

- (3) A confirmation message appears. Press the [Yes] menu.  
(Note) Do not turn the power off during installation.

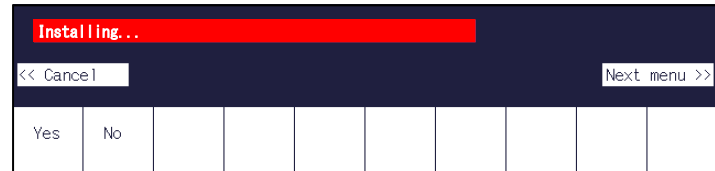

- (4) When installation is completed, "Installation completed" appears.

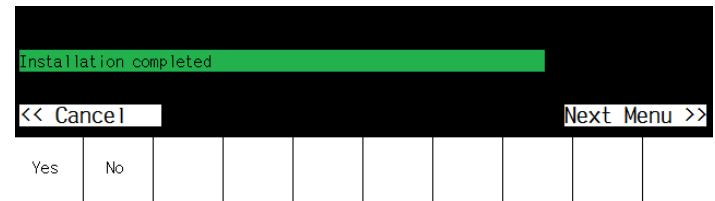

- (Note 1) Files (directories) other than custom data setting files (Config.ini, customdef.ini, customload.txt) are overwritten.
- (Note 2) Custom data setting files (Config.ini, customdef.ini, customload.txt) add contents when there is no duplicated data for all sections. However, when registered information (items within sections such as screen No. offset values, custom screen menu positions, function buttons) is duplicated, the message "Installation error" will appear and the file cannot be installed. Refer to 17.6 Custom Release for details of each section.
- (Note 3) When the number of custom data registrations exceed the upper limit, the message "Installation error" will appear and the file cannot be installed.
- (Note 4) If the total size of custom data exceeds the maximum size, the message "Installation Error. Please check the file size." will appear and the file cannot be installed. For the maximum size, refer to "NC Designer2 Matching List [Maximum data size]".
- (Note 5) Add install is not carried out even if the [Yes] menu is pressed continuously after add install has been carried out. Press the [Back] menu key  to return to the first screen once.

## Appendix 12. Entry Key Code List at KeyPress/KeyRelease

The following is the entry key code list at KeyPress/KeyRelease. The entered main key code and auxiliary key code are stored in LLPARAM and LUPARAM at KeyPress/KeyRelease.

Key entry	LLPARAM	LUPARAM
A	65	-
B	66	-
C	67	-
D	68	-
E	69	-
F	70	-
G	71	-
H	72	-
I	73	-
J	74	-
K	75	-
L	76	-
M	77	-
N	78	-
O	79	-
P	80	-
Q	81	-
R	82	-
S	83	-
T	84	-
U	85	-
V	86	-
W	87	-
X	88	-
Y	89	-
Z	90	-
[	219	-
]	221	-
(	56	BIT0
)	57	BIT0
MONITOR	112	BIT0
SET UP	113	BIT0
Edit	114	BIT0
DIAGN	115	BIT0
MAINTE	116	BIT0
Tab changeover left	120	BIT1
Tab changeover right	121	BIT1
Part system changeover	112	BIT1
SFP	120	BIT0
F0	121	BIT0
LIST	119	BIT1
Window display	114	BIT1
Window changeover	115	BIT1
F1	112	-
F2	113	-
F3	114	-
F4	115	-
F5	116	-
F6	117	-

Key entry	LLPARAM	LUPARAM
0	48	-
1	49	-
2	50	-
3	51	-
4	52	-
5	53	-
6	54	-
7	55	-
8	56	-
9	57	-
-	189	-
+	107	-
/	191	-
*	186	BIT0
.	190	-
@	192	-
_	226	BIT0
,	188	-
!	49	BIT0
:	186	-
\	220	-
<	188	BIT0
>	190	BIT0
PAGE UP	33	-
PAGE DOWN	34	-
←	37	-
↑	38	-
→	39	-
↓	40	-
←	9	BIT0
→	9	-
ALTER	-	-
CTRL	-	-
SHIFT	-	-
SP	32	-
#	51	BIT0
\$	52	BIT0
CB	36	BIT0
CAN	27	-
INS	45	-
DEL	46	-
=	189	BIT0
~	222	BIT0
EOB(:)	187	-
INPUT	13	-
RESET	-	-

Key entry	LLPARAM	LUPARAM
F7	118	-
F8	119	-
F9	120	-
F10	121	-
CANCEL	122	-
Page feed	123	-

Key entry	LLPARAM	LUPARAM

**NOTE**

- ◆ The list above describes the key code that can be entered with ABC array NC keyboard.
- ◆ F1 to 10, cancel, and page feed keys correspond to the buttons at the bottom of the display unit.
- ◆ For LUPARAM, BIT0 is turned ON by entering Shift and BIT1 is turned ON by entering Ctrl.  
 (Note) Shift etc. indicated here are not the key names (buttons) on the NC keyboard, but indicated the ones by the key entry.  
 Ex.) When the MONITOR key is pressed, 112 is stored in LLPARAM and BIT0 for LUPARAM is turned ON.

## NC Matching List [NC Designer2 full-function]

NC Designer2 must be combined with the corresponding version of NC as listed below to provide all its functions.

NC Designer2 Version	Type												
	M700VS	M700VW	M70V	E70	M800W	M800S	M80	M80W	E80	M800VW	M800VS	M80V	M80VW
A0	K4				A0								
A1	K7				A1								
A2	L0				B1								
A3	L6				C4								
A4	L6				C6								
A5	L6				D5								
A6	L6				E5								
A7	L6				F4								
A8	L6				E5						A2		
A9	L6				F9						A4		

## NC Matching List [Additional controls]

NC Designer2 must be combined with the corresponding version of NC as listed below to provide additional controls.

Additional control	Type												
	M700VS	M700VW	M70V	E70	M800W	M800S	M80	M80W	E80	M800VW	M800VS	M80V	M80VW
Page change button					A0	A1	A1	C0	D3	A0			
Stacked graph					A0	A1	A1	C0	D3	A0			
Statistics graph					A0	A1	A1	C0	D3	A0			
Alarm list					C4				D3	A0			
Extension Menu					C6				D3	A0			
Meter					D3						A0		
Trend Graph					D3						A0		

## NC Matching List [Additional functions]

NC Designer2 must be combined with the corresponding version of NC as listed below to provide additional functions.

Additional function	Type											
	M700VS	M700VW	M70V	E70	M800W	M800S	M80	M80W	E80	M800VW	M800VS	M80V
M code guidance release by machine tool builders					F2					A0		





Additional functions/property	Type												
	M700VS	M700VW	M70V	E70	M800W	M800S	M80	M80W	E80	M800VW	M800VS	M80V	M80VW
Extension menu "All OFF state" property "Write PLC device" property "Write PLC device enabled" property "Write Bit position of PLC device" property "Write PLC device project No." property "Read PLC device" property "Read PLC device enabled" property "Read Bit position of PLC device" property "Read PLC device project No." property "Button type" property "Button group1" to "Button group5" All macro functions					E5	E5	E5	E5	E5	A0	A0	A0	A0
PLC extension button "Character color at the time of Focus" property Dynamic change property (Status 1 - 7)					E5	E5	E5	E5	E5	A0	A0	A0	A0
Input box "Extended function (A7) enabled" property					F2	F2	F2	F2	F2	A0	A0	A0	A0
PLC textbox "Format" property "Character sequence"					F2	F2	F2	F2	F2	A0	A0	A0	A0

Additional functions/property	Type												
	M700VS	M700VW	M70V	E70	M800W	M800S	M80	M80W	E80	M800VW	M800VS	M80V	M80VW
Counter CycleTime Feedrate GModal M GModal L GModal Simple LoadMeter Monitor MSTB ONB ProgramBuffer SPCommand Time "ColorType" property "Theme color (M8V Series)"										A0	A0	A0	A0
Menu "MenuType" property "1StepMenu(VGA)(M8V Series)" "2StepMenu(VGA)(M8V Series)" "1StepMenu(XGA)(M8V Series)" "2StepMenu(XGA)(M8V Series)"										A0	A0	A0	A0
Extension menu "Menu type" property "VGA(M8V Series)" "XGA(M8V Series)"										A2	A2	A2	A2
FileInOut "ColorType" property "Theme color (M8V Series)"										A2	A2	A2	A2
PLC textbox "Interlock device" property "Action of interlock device" property "Bit position of interlock device" property "Project No. of interlock device" property										A3	A3	A3	A3
PLC extension button "Suppress device initialization" property										A4	A4	A4	A4

## Custom API Library Correspondence Table

Each NC Designer2 installer includes the following custom API library version.

NC Designer2 version	Custom API library version
A0	A0
A1	A1
A2	A1
A3	C3
A4	C3
A5	D5
A6	E5
A7	F4
A8	A0 (M8V Series)
A9	A0 (M8V Series)

## List of Functions Supported for Each Project [Additional functions]

To use the following additional functions, you need to use a project that supports each function in the latest version of NC Designer2.

Additional functions/property	Type	
	M700V/M70V/E70 Series	M800V/M80V/M800/M80/E80
Change theme color	-	○
Parts library	-	○
Property setup dialog	-	○
Input assist function	-	○
Template function	-	○
Resource management function	○	○
Memory usage check function	-	○
Design batch conversion	-	○
Copy and paste between projects	○	○

○: Supported, -: Not supported

## NC Designer2 Matching List [Additional controls]

Use the NC Designer2 version as listed below to use additional controls.

Additional control	NC Designer2 version
Page change button	A0
Stacked graph	A0
Statistics Graph	A0
Alarm List	A3
Extension menu	A4
Meter	A5
Trend graph	A5

(Note) When the NC Designer2 version is downgraded, the editing of projects with controls that are not supported are not guaranteed.

## NC Designer2 Matching List [Maximum data size]

The maximum data size for each model is as follows.

Model	Maximum data size		
	Custom data	Custom screen module (o file)	Resource data
M8V Series	30 Mbyte	16 Mbyte	13 Mbyte
M8 Series E4 or later	12 Mbyte	6 Mbyte	5 Mbyte
M8 Series E3 or earlier	6 Mbyte	6 Mbyte	2 Mbyte
M7V Series	6 Mbyte	6 Mbyte	5 Mbyte
M7 Series	6 Mbyte	3 Mbyte	2 Mbyte

## Revision History

Date of revision	Manual No.	Revision details
Nov. 2014	IB(NA)1501250-A	First edition created.
May 2015	IB(NA)1501250-B	<ul style="list-style-type: none"> <li>• Corresponded to NC Designer2 Ver.A1.               <ul style="list-style-type: none"> <li>• Line number display was added in Macro Edit Dialog</li> <li>• The functions to operate string in the macro editing were added.</li> <li>• Corresponded to Mitsubishi CNC M800S/M80 Series.</li> </ul> </li>   <li>• The following sections were added.               <ul style="list-style-type: none"> <li>9.2.10 Grid</li> <li>15.3.2.2 Operation Procedure with NC Compiler/NC Compiler2</li> <li>16.7 String Operation Functions</li> <li>Appendix 11 Installing Custom Data (M80/M800S)</li> </ul> </li>   <li>• The following sections were changed.               <ul style="list-style-type: none"> <li>3.3.1 Function of Each Part of Basic Screen                   <ul style="list-style-type: none"> <li>• The menu for the type of selected object was removed from the status bar.</li> </ul> </li> <li>5.1 What Is Page?                   <ul style="list-style-type: none"> <li>• The cursor shape was changed.</li> </ul> </li> <li>6.5.3 Specifying Font Resource                   <ul style="list-style-type: none"> <li>• Notes related to the font specifications for each model were added.</li> </ul> </li> <li>7.3.19.1 Property Settings                   <ul style="list-style-type: none"> <li>• The "Update cycle" property was added.</li> </ul> </li> <li>7.3.19.2 Complements                   <ul style="list-style-type: none"> <li>• The priority order of the alarm message was added.</li> </ul> </li> <li>9.7.4 Limitations                   <ul style="list-style-type: none"> <li>• The limitation for sub cursor setting was added.</li> </ul> </li> <li>15.3.2.1 Operation Procedure with Visual Studio2010                   <ul style="list-style-type: none"> <li>• The settings for VS2010 properties were changed.</li> </ul> </li> <li>15.6.9 Limitations                   <ul style="list-style-type: none"> <li>• The limitations related to Custom Release were added.</li> </ul> </li> <li>16.5 Function Details                   <ul style="list-style-type: none"> <li>• Notes of the following functions were added or changed.                       <ul style="list-style-type: none"> <li>• GCSTextboxSetTextType</li> <li>• GCSTextboxSetFormatID</li> <li>• GCSTextboxSetGValue</li> <li>• GCSTextboxGetGValue</li> </ul> </li> <li>An argument was added to the following function.                       <ul style="list-style-type: none"> <li>• GCSTextboxSetNextMenuButtonState</li> </ul> </li> </ul> </li> </ul> </li>   <li>• Mistakes were corrected.</li> </ul>
Dec. 2015	IB(NA)1501250-C	<ul style="list-style-type: none"> <li>• Corresponded to NC Designer2 Ver.A2.</li> </ul>

(Continue to the next page)

Date of revision	Manual No.	Revision details
		<p style="text-align: right;">(Continued)</p> <ul style="list-style-type: none"> <li>• The following sections were added. <ul style="list-style-type: none"> <li>5.10.9 Changing the Theme Color</li> <li>8. Parts Library</li> <li>16.7 Custom Release File Setting</li> <li>Appendix 12. Entry Key Code List at KeyPress/KeyRelease</li> </ul> </li>   <li>• The following sections were changed. <ul style="list-style-type: none"> <li>2.2.3 Operating Environment of NC Designer2 <ul style="list-style-type: none"> <li>• Windows® 10 was added.</li> </ul> </li> <li>2.3.1 File <ul style="list-style-type: none"> <li>• "Correspondence table for the combination of the type and the display format" was added.</li> </ul> </li> <li>2.3.3 View <ul style="list-style-type: none"> <li>• "Change theme color" was added.</li> </ul> </li> <li>7.2.3.1 Property Settings <ul style="list-style-type: none"> <li>• "Change theme color" was added.</li> </ul> </li> <li>7.2.6.1 Property Settings <ul style="list-style-type: none"> <li>• "Start Effect" was changed.</li> </ul> </li> <li>7.3.1.1/7.3.2.1/7.3.3.1/7.3.4.1/7.3.5.1/7.3.6.1/7.3.7.1/7.3.8.1/7.3.9.1/7.3.10.1/7.3.11.1/7.3.12.1/7.3.13.1/7.3.14.1/7.3.15.1/7.3.16.1/7.3.17.1/7.3.18.1/7.3.19.1/7.3.20.1/7.3.21.1 Property Settings <ul style="list-style-type: none"> <li>• "Color type" was added.</li> </ul> </li> <li>7.3.1.1 Property Settings <ul style="list-style-type: none"> <li>• Descriptions were added to "CounterKind".</li> </ul> </li> <li>7.3.9.1 Property Settings <ul style="list-style-type: none"> <li>• Descriptions were added to "DisplayNestLevel".</li> </ul> </li> <li>7.3.13.2 Complements <ul style="list-style-type: none"> <li>• Descriptions related to the number of characters were added.</li> </ul> </li> <li>7.3.17.1 Property Settings <ul style="list-style-type: none"> <li>• Descriptions were added to "Menu Type".</li> </ul> </li> <li>7.3.19.1 Property Settings <ul style="list-style-type: none"> <li>• "Update cycle" was added.</li> </ul> </li> <li>13.1.1 Export <ul style="list-style-type: none"> <li>• NOTE was added.</li> </ul> </li> <li>14.1 Generating Screen Data Source Codes <ul style="list-style-type: none"> <li>• "Destination Folder" was added.</li> <li>• Descriptions were added to NOTE.</li> </ul> </li> <li>16.2.2 Flow of Operation <ul style="list-style-type: none"> <li>• Detailed descriptions for exporting were deleted.</li> </ul> </li> <li>16.4.2 Launching the Application Window <ul style="list-style-type: none"> <li>• Windows® 10 was added.</li> </ul> </li> <li>16.6.4.1/16.6.5.1 Interpreter Method, 16.6.4.2/16.6.5.2 Compilation Method <ul style="list-style-type: none"> <li>• Descriptions related to custom release file setting were added.</li> </ul> </li> </ul> </li> </ul> <p style="text-align: right;">(Continue to the next page)</p>

Date of revision	Manual No.	Revision details
		<p style="text-align: right;">(Continued)</p> <p>17.4.2 Program Describing Method</p> <ul style="list-style-type: none"> <li>• "Function Argument" was added.</li> </ul> <p>17.4.3 Programming Language</p> <ul style="list-style-type: none"> <li>• Example for error judgment in "Custom API Function" was changed.</li> </ul> <p>17.5 Function Details</p> <ul style="list-style-type: none"> <li>• GCSGetStandardColor was added.</li> <li>• Descriptions of the following functions were added or changed. <ul style="list-style-type: none"> <li>• GCSTMenuSetNextMenuButtonState</li> <li>• GCSCounterSetCounterType</li> <li>• melSetData</li> <li>• melGetData</li> <li>• melGetLumpData</li> <li>• melSelectExecPrg</li> </ul> </li> </ul> <p>Appendix 1. Error Message List</p> <ul style="list-style-type: none"> <li>• Error messages were added.</li> </ul> <p>Appendix 7. HTML Tag List</p> <ul style="list-style-type: none"> <li>• LINK was added.</li> </ul> <p>Appendix 10. Installing Custom Data (M70/M70V/M700VS/E70),</p> <p>Appendix 11. Installing Custom Data (M800S/M80)</p> <ul style="list-style-type: none"> <li>• Notes were added.</li> </ul> <ul style="list-style-type: none"> <li>• Mistakes were corrected.</li> </ul>
Jul. 2017	IB(NA)1501250-D	<ul style="list-style-type: none"> <li>• Corresponded to NC Designer2 Ver.A3.</li> <li>• The following sections were added. <ul style="list-style-type: none"> <li>7.1.15 Touch Gesture</li> <li>7.1.16 Property Setup Dialog</li> <li>7.2.5.2 Complements</li> <li>7.2.10.2 Complements</li> <li>7.2.11.2 Complements</li> <li>7.3.12.1 Property Settings</li> <li>7.3.13.1 Property Settings</li> <li>7.3.25 Alarm List</li> <li>12. Simulation (NC Trainer2 plus)</li> <li>17.6.6 Screen Part Assignment</li> <li>17.6.7 Selectable Display Assignment</li> <li>17.6.10 Adjusting Standard and Customized Screen Size according to Resolution</li> <li>17.6.11 Displaying an Original Logo on the Standard Screen</li> <li>17.6.12.1 User Parameters</li> <li>17.6.12.2 Machine Parameters</li> <li>17.8 Memory Card Transfer</li> <li>17.9 Home screen</li> </ul> </li> </ul> <p style="text-align: right;">(Continue to the next page)</p>



Date of revision	Manual No.	Revision details
		<p style="text-align: right;">(Continued)</p> <p>Appendix 8.4 Home screen  Appendix 9.8 Limitations  NC Matching List  List of Functions Supported for Each Project</p> <ul style="list-style-type: none"> <li>• The following sections were changed. <ul style="list-style-type: none"> <li>Introduction <ul style="list-style-type: none"> <li>• Supported models were added.</li> </ul> </li> <li>6.5.3 Specifying Font Resource <ul style="list-style-type: none"> <li>• NOTE was revised.</li> </ul> </li> <li>6.6.3 Specifying an Image File <ul style="list-style-type: none"> <li>• Note was added.</li> </ul> </li> <li>7.2.5.1/7.2.10.1/7.2.11.1 Property Settings <ul style="list-style-type: none"> <li>• "Operation" setting was added.</li> </ul> </li> <li>7.3.10.1/7.3.13.1/7.3.22.1 Property Settings <ul style="list-style-type: none"> <li>• Note was added.</li> </ul> </li> <li>7.3.10.2 Complements <ul style="list-style-type: none"> <li>• The image was changed.</li> </ul> </li> <li>7.3.22.2 Complements <ul style="list-style-type: none"> <li>• Restrictions were added.</li> </ul> </li> <li>10.7.3.1 Move the Sub Cursor by Key Input (Arrow Key, TAB Key, Input Key)</li> <li>10.7.3.4 Transfer a Key to Other Control <ul style="list-style-type: none"> <li>• The macro example for interpreter method was revised.</li> </ul> </li> <li>15.1 Generating Screen Data Source Codes <ul style="list-style-type: none"> <li>• Remedy for the resource data exceeds 5 Mbytes was added.</li> </ul> </li> <li>17.6.1 Outline</li> <li>17.6.3 Development Procedure of Custom Release S/W</li> <li>17.6.4.1.1 Config.ini</li> <li>17.6.4.1.2 customdef.ini</li> <li>17.6.4.2.1 Config.ini</li> <li>17.6.5.1.2 customdef.ini</li> <li>17.6.5.3.1 customdef.ini</li> <li>17.6.13 Limitations <ul style="list-style-type: none"> <li>• Descriptions related to screen part assignment and selectable display assignment were added.</li> </ul> </li> <li>17.7.1.1 Custom Screen Configuration Dialog <ul style="list-style-type: none"> <li>• The images were changed, display items were added, and NOTES were revised.</li> </ul> </li> <li>17.7.2 Operation Procedure <ul style="list-style-type: none"> <li>• NOTE for the custom data created by the compilation method was added.</li> </ul> </li> <li>17.10.3.1 Open S/W Keyboard Window</li> <li>17.10.3.3.1 Set the Initial Display Position of the S/W Keyboard Window</li> <li>17.10.3.3.2 Change the S/W Keyboard Window Position Arbitrarily While the Window Is Being Displayed</li> </ul> </li> </ul> <p style="text-align: right;">(Continue to the next page)</p>

Date of revision	Manual No.	Revision details
		<p style="text-align: right;">(Continued)</p> <p>17.10.3.6 Clear S/W Keyboard Entry Area</p> <p>17.10.3.9 Display S/W Keyboard Window in the Foreground</p> <ul style="list-style-type: none"> <li>• The example for compilation method was revised.</li> </ul> <p>Appendix 1 Error Message List</p> <ul style="list-style-type: none"> <li>• Error messages were added.</li> </ul> <p>Appendix 8.3.4 The Standard Screen After Changing</p> <ul style="list-style-type: none"> <li>• Items were added to "Setup".</li> </ul> <p>Appendix 9.1 Outline</p> <p>Appendix 9.2 Configuration</p> <p>Appendix 9.5.1 Installation Method</p> <p>Appendix 9.5.2 About the Memory Card or USB Memory for Upgrade</p> <p>Appendix 9.7 Operation/Alarm Messages</p> <ul style="list-style-type: none"> <li>• USB memory was added.</li> </ul> <p>Appendix 9.4.1 Installing the Application</p> <ul style="list-style-type: none"> <li>• USB memory and note were added.</li> </ul> <p>Appendix 9.6 Parameter</p> <ul style="list-style-type: none"> <li>• The display language 2 and 3 were deleted.</li> </ul> <p>Appendix 10 Installing Custom Data (M700VS/M70V/E70)</p> <ul style="list-style-type: none"> <li>• Note was revised.</li> </ul> <p>Appendix 11 Installing Custom Data (M800/M80 (Windows-less display unit))</p> <ul style="list-style-type: none"> <li>• The folder configuration was revised, and note was revised and added.</li> </ul> <ul style="list-style-type: none"> <li>• The following section was deleted. 18. Macro Function</li> </ul> <ul style="list-style-type: none"> <li>• Mistakes were corrected.</li> </ul>
Feb. 2018	IB(NA)1501250-E	<ul style="list-style-type: none"> <li>• Corresponded to NC Designer2 Ver.A4.</li> </ul> <ul style="list-style-type: none"> <li>• The following sections were added. 7.2.3.1 Property Setup Dialog 7.3.14.1 Property Setup Dialog 7.3.15.1 Property Setup Dialog 7.3.18 Extension Menu (GNCEXMenu); Extension Menu Display Part 7.3.23.1 Property Setup Dialog Custom API Library Correspondence Table</li> </ul> <ul style="list-style-type: none"> <li>• The following sections were changed. Precautions for Safety <ul style="list-style-type: none"> <li>• Items in "Caution" were added.</li> </ul> </li> <li>5.5 Entering Window Properties <ul style="list-style-type: none"> <li>• Note contents were revised.</li> </ul> </li> </ul> <p style="text-align: right;">(Continue to the next page)</p>

Date of revision	Manual No.	Revision details
		<p style="text-align: right;">(Continued)</p> <p>5.12.1.2 Resource Data Name Conversion Table Dialog</p> <ul style="list-style-type: none"> <li>• Note contents were revised.</li> </ul> <p>7.3.2 CycleTime (GNXCycleTime); Cycle Time Display Part</p> <ul style="list-style-type: none"> <li>• "Cut time (CUT)" was added.</li> </ul> <p>7.3.26.1 Property Settings</p> <ul style="list-style-type: none"> <li>• "Message file" was added.</li> <li>• "Message conversion" was added to "Message Area".</li> </ul> <p>7.3.26.2 Complements</p> <ul style="list-style-type: none"> <li>• Description related to message conversion was added.</li> </ul> <p>13.1.3 Output Image</p> <ul style="list-style-type: none"> <li>• Note contents were revised.</li> </ul> <p>16. Features and Configuration of GUI Library</p> <ul style="list-style-type: none"> <li>• Reference was added.</li> </ul> <p>17.3.2.1 Operation Procedure with Visual Studio2010</p> <ul style="list-style-type: none"> <li>• Note was added.</li> </ul> <p>17.7.1.1 Custom Screen Configuration Dialog</p> <ul style="list-style-type: none"> <li>• Illustration was revised.</li> <li>• "Message file storage folder" description was revised.</li> </ul> <p>17.8.1 Operation screen</p> <ul style="list-style-type: none"> <li>• Note contents were revised.</li> </ul> <p>Appendix 1 Error Message List</p> <ul style="list-style-type: none"> <li>• Error messages were added.</li> </ul> <p>Appendix 11 Installing Custom Data (M800/M80 (Windows-less Display Unit))</p> <ul style="list-style-type: none"> <li>• Custom data storage capacity was revised.</li> <li>• Illustration was revised.</li> </ul> <p>NC Matching List</p> <ul style="list-style-type: none"> <li>• Items were added.</li> </ul> <ul style="list-style-type: none"> <li>• Mistakes were corrected.</li> </ul>
Oct. 2018	IB(NA)1501250-F	<ul style="list-style-type: none"> <li>• Corresponded to NC Designer2 Ver.A5.</li> <li>• The following sections were added. <ul style="list-style-type: none"> <li>4.7 Template function</li> <li>7.1.16.4 Input assist function</li> <li>7.2.2.1 Property setup dialog</li> <li>7.2.6.1 Property setup dialog</li> <li>7.2.10.1 Property setup dialog</li> <li>7.2.14.1 Property setup dialog</li> <li>7.2.15.1 Property setup dialog</li> <li>7.3.18.1 Property setup dialog</li> <li>7.3.26.1 Property setup dialog</li> <li>7.3.27 Meter</li> </ul> </li> </ul> <p style="text-align: right;">(Continue to the next page)</p>

Date of revision	Manual No.	Revision details
		<p style="text-align: right;">(Continued)</p> <p>7.3.28 Trend Graph</p> <p>17.6.8 G Code Guidance Release</p> <p>NC Designer2 Matching List [Additional controls]</p> <ul style="list-style-type: none"> <li>• The following sections were changed.</li> </ul> <p>Introduction</p> <ul style="list-style-type: none"> <li>• E80 was added to supported models.</li> </ul> <p>2.3.1 File</p> <ul style="list-style-type: none"> <li>• Contents were added to "New Project".</li> <li>• "Write to the memory card" was added.</li> </ul> <p>2.3.4 Control</p> <ul style="list-style-type: none"> <li>• "Extension Menu", "Alarm List", "Meter", "TrendGraph" were added.</li> </ul> <p>2.3.8 Tool</p> <ul style="list-style-type: none"> <li>• "Open at NC Trainer2 plus" was added.</li> </ul> <p>6.4.5 Importing or Exporting Character String Resource</p> <ul style="list-style-type: none"> <li>• Note was revised.</li> </ul> <p>7.3.1.1 Property Settings</p> <ul style="list-style-type: none"> <li>• "FontType" of "Character Attribute" was revised.</li> <li>• Contents were added to "CounterKind" of "Counter Kind".</li> <li>• "CharacterNumber" of "Coordinate" was revised.</li> </ul> <p>7.3.9.1 Property Settings</p> <ul style="list-style-type: none"> <li>• Contents were added to "DispType" of "Display".</li> </ul> <p>7.3.14.1 Property Setup Dialog</p> <ul style="list-style-type: none"> <li>• The image was changed.</li> </ul> <p>7.3.14.1.1 [Device Tab]</p> <ul style="list-style-type: none"> <li>• The image was changed, and items revised.</li> </ul> <p>7.3.18 Extension Menu (GNCEXMenu); Extension Menu Display Part</p> <ul style="list-style-type: none"> <li>• Contents regarding supported models were added.</li> </ul> <p>7.3.18.2 Property Settings</p> <ul style="list-style-type: none"> <li>• "Animation direction" was added to "Menu group".</li> <li>• "Operation" was added.</li> <li>• Contents of "Destination menu group number" were revised.</li> <li>• Contents of "Animation direction" were added.</li> </ul> <p>7.3.18.3 Complements</p> <ul style="list-style-type: none"> <li>• "Operation specifications" was added.</li> </ul> <p>8.1.1 Image List Dialogue</p> <ul style="list-style-type: none"> <li>• Contents were added to Note</li> </ul> <p>8.2 Operation Procedure</p> <ul style="list-style-type: none"> <li>• Operation procedure and Note were revised.</li> </ul> <p>10.7.3.1 Move the Sub Cursor by Key Input (Arrow Key, TAB Key, Input Key)</p> <ul style="list-style-type: none"> <li>• "Compilation method" was revised.</li> </ul> <p>10.7.3.4 Transfer a Key to Other Control</p> <ul style="list-style-type: none"> <li>• "Compilation method" was revised.</li> </ul> <p style="text-align: right;">(Continue to the next page)</p>

Date of revision	Manual No.	Revision details
		<p style="text-align: right;">(Continued)</p> <p>17.1.1 Outline</p> <ul style="list-style-type: none"> <li>• The image of "Interpreter Method" was changed.</li> </ul> <p>17.5.2.2 Changing the Menu Name While Displaying Custom Screen (Menu Release)</p> <ul style="list-style-type: none"> <li>• The contents of "Interpreter Method" and "Compilation Method" were revised.</li> </ul> <p>17.5.2.3 Closing the Custom Screen (Menu Release)</p> <ul style="list-style-type: none"> <li>• The contents of "Interpreter Method" were revised.</li> </ul> <p>17.6.1 Outline</p> <ul style="list-style-type: none"> <li>• Contents were added to "Menu release".</li> </ul> <p>17.6.5 Menu Release</p> <ul style="list-style-type: none"> <li>• Contents were added.</li> </ul> <p>17.6.5.1.2 customdef.ini</p> <ul style="list-style-type: none"> <li>• Contents of "SCREEN_TYPEXX (XX = 01 to 50)" and "MENU_POSXX (XX = 01 to 50)" were revised.</li> <li>• "MENU_MOVE" and a Note were added.</li> </ul> <p>17.6.5.3 Changing the Arrangement of the Main Menu</p> <ul style="list-style-type: none"> <li>• Contents were added.</li> </ul> <p>17.6.5.3.1 customdef.ini</p> <ul style="list-style-type: none"> <li>• Contents of "SCREEN_TYPEXX (XX = 01 to 90)" and "CHG_SCREEN_IDXX (XX = 01 to 90)" were revised.</li> <li>• "Supplementation 1 Screen ID" was added.</li> </ul> <p>17.6.10 About the Switch of Display/Non-display of the Menu by the Parameter</p> <ul style="list-style-type: none"> <li>• Added content to explanation of "MCAAppGetMenuState()".</li> </ul> <p>17.6.11 Adjusting Standard and Customized Screen Size according to Resolution</p> <ul style="list-style-type: none"> <li>• A Note was added.</li> </ul> <p>17.6.14 Limitations</p> <ul style="list-style-type: none"> <li>• "Common" and "Menu release" were revised.</li> </ul> <p>17.9.3.1.3 Setting Application Language File (HomeScr_○○○○_△△△.ini)</p> <ul style="list-style-type: none"> <li>• "Application language file for Japanese" was deleted.</li> </ul> <p>Appendix 8.3.4 The Standard Screen After Changing</p> <ul style="list-style-type: none"> <li>• The contents were revised.</li> </ul> <p>Appendix 9.5.2 About the Memory Card or USB Memory for Upgrade</p> <ul style="list-style-type: none"> <li>• "(4) Example of setting ("For application of custom release")" was revised.</li> </ul> <p>Appendix 11. Installing Custom Data (M800/M80 (Windows-less Display Unit))</p> <ul style="list-style-type: none"> <li>• The contents were revised.</li> <li>• A Note was added.</li> </ul> <p>NC Matching List</p> <ul style="list-style-type: none"> <li>• E80 was added.</li> <li>• Items were deleted.</li> </ul> <ul style="list-style-type: none"> <li>• Mistakes were corrected.</li> </ul>
Sep. 2020	IB(NA)1501250-H	<ul style="list-style-type: none"> <li>• Corresponded to NC Designer2 Ver.A6.</li> </ul> <p style="text-align: right;">(Continue to the next page)</p>

Date of revision	Manual No.	Revision details
		<p style="text-align: right;">(Continued)</p> <ul style="list-style-type: none"> <li>· The following sections were added.</li> <li>Notes on using this software</li> <li>2.2.5 Precautions</li> <li>6.11 Resource management</li> <li>7.3.15.1.5 [Dynamic change property (Status 1 - 7)] Tab</li> <li>10.3.1 Operation Screen</li> <li>10.3.2 Operation Specifications</li> <li>10.3.3 Restrictions</li> <li>Appendix 9.9 Precautions</li> <li>· The following sections were changed.</li> <li>1.1 What Is NC Designer2?</li> <li>2.2.3 Operating Environment of NC Designer2 <ul style="list-style-type: none"> <li>· Details were revised.</li> </ul> </li> <li>2.2.4 Specification List <ul style="list-style-type: none"> <li>· "Outline" in "Number of controls that can be created in each frame"</li> <li>· Note was added to "Background image file"</li> </ul> </li> <li>2.3.8 Tool <ul style="list-style-type: none"> <li>· "Resource management" was added.</li> </ul> </li> <li>4.1 Creating a New Project <ul style="list-style-type: none"> <li>· The images were changed.</li> </ul> </li> <li>5.4 Entering Panel Properties <ul style="list-style-type: none"> <li>· Contents were added.</li> </ul> </li> <li>5.5 Entering Window Properties <ul style="list-style-type: none"> <li>· Contents were added.</li> </ul> </li> <li>6. Resource <ul style="list-style-type: none"> <li>· Section title was changed to "Resource".</li> </ul> </li> <li>6.2 Resource Tree <ul style="list-style-type: none"> <li>· The image was changed.</li> </ul> </li> <li>7.1.7 Scrolling Caption Character String <ul style="list-style-type: none"> <li>· Item was changed.</li> </ul> </li> <li>7.1.9 Solid Frame <ul style="list-style-type: none"> <li>· Item and Description were changed.</li> </ul> </li> <li>7.1.15 Touch Gesture <ul style="list-style-type: none"> <li>· Description was changed.</li> </ul> </li> <li>7.1.16 Property Setup Dialog <ul style="list-style-type: none"> <li>· The image was changed.</li> </ul> </li> <li>7.1.16.1 Standard Control <ul style="list-style-type: none"> <li>· The images were changed.</li> <li>· Items and Descriptions were changed.</li> </ul> </li> <li>7.2.2.1 Property Setup Dialog <ul style="list-style-type: none"> <li>· The images were changed.</li> <li>· Items were changed.</li> </ul> </li> </ul> <p style="text-align: right;">(Continue to the next page)</p>

Date of revision	Manual No.	Revision details
		<p style="text-align: right;">(Continued)</p> <p>7.2.3.2 Property Settings</p> <ul style="list-style-type: none"> <li>• Item and Description were changed.</li> </ul> <p>7.2.6.1 Property Setup Dialog</p> <ul style="list-style-type: none"> <li>• The image was changed.</li> </ul> <p>7.2.6.1.1 [Style] Tab</p> <ul style="list-style-type: none"> <li>• The image was changed.</li> <li>• Item was added.</li> </ul> <p>7.2.6.1.2 [Text] Tab</p> <ul style="list-style-type: none"> <li>• The image was changed.</li> </ul> <p>7.2.6.1.3 [Extended] Tab</p> <ul style="list-style-type: none"> <li>• Description was changed.</li> </ul> <p>7.2.6.2 Property Settings</p> <ul style="list-style-type: none"> <li>• Item and Descriptions were changed.</li> </ul> <p>7.2.7.1 Property Settings</p> <ul style="list-style-type: none"> <li>• Item was changed.</li> </ul> <p>7.2.8.1 Property Settings</p> <ul style="list-style-type: none"> <li>• Item was changed.</li> </ul> <p>7.2.10.1.2 [Style] Tab</p> <ul style="list-style-type: none"> <li>• The image was changed.</li> <li>• Item was changed.</li> </ul> <p>7.2.10.2 Property Settings</p> <ul style="list-style-type: none"> <li>• Item and Description were changed.</li> </ul> <p>7.2.11.1 Property Settings</p> <ul style="list-style-type: none"> <li>• Items and Descriptions were changed.</li> </ul> <p>7.2.12.1 Property Settings</p> <ul style="list-style-type: none"> <li>• Items and Descriptions were changed.</li> </ul> <p>7.2.13.1 Property Settings</p> <ul style="list-style-type: none"> <li>• Items and Descriptions were changed.</li> </ul> <p>7.2.13.2 Complements</p> <ul style="list-style-type: none"> <li>• Properties values were changed.</li> </ul> <p>7.2.14.1 Property Setup Dialog</p> <ul style="list-style-type: none"> <li>• The images were changed.</li> <li>• Items were changed.</li> </ul> <p>7.2.14.2 Property Settings</p> <ul style="list-style-type: none"> <li>• Item and Description were changed.</li> </ul> <p>7.2.15.1.2 [Style] Tab</p> <ul style="list-style-type: none"> <li>• The image was changed.</li> </ul> <p>7.2.15.2 Property Settings</p> <ul style="list-style-type: none"> <li>• Item and Description were changed.</li> </ul> <p>7.3.12.1 Property Setup Dialog</p> <ul style="list-style-type: none"> <li>• The images were changed.</li> <li>• Items were changed.</li> </ul> <p style="text-align: right;">(Continue to the next page)</p>

Date of revision	Manual No.	Revision details
		<p style="text-align: right;">(Continued)</p> <p>7.3.13.2 Property Settings</p> <ul style="list-style-type: none"> <li>• Items and Description were changed.</li> </ul> <p>7.3.14.2 Property Settings</p> <ul style="list-style-type: none"> <li>• Item and Description were changed.</li> </ul> <p>7.3.15.1 Property Setup Dialog</p> <ul style="list-style-type: none"> <li>• The images were changed.</li> <li>• Descriptions related to Dynamic change property (Status 1 - 7) were added.</li> <li>• Item was changed.</li> </ul> <p>7.3.15.2 Property Settings</p> <ul style="list-style-type: none"> <li>• "Dynamic change property" was added.</li> <li>• Item was added to "Character Attribute".</li> <li>• Items and Descriptions were added and changed.</li> </ul> <p>7.3.15.3 Complements</p> <ul style="list-style-type: none"> <li>• Note was added to "Priority of PLC devices".</li> <li>• "Dynamic change property" was added.</li> </ul> <p>7.3.16.2 Complements</p> <ul style="list-style-type: none"> <li>• Content of NOTE was changed.</li> </ul> <p>7.3.18 Extension Menu (GNCEXMenu); Extension Menu Display</p> <ul style="list-style-type: none"> <li>• Contents were added.</li> </ul> <p>7.3.18.1 Property Setup Dialog</p> <ul style="list-style-type: none"> <li>• The image was changed.</li> </ul> <p>7.3.18.1.1 [Behavior Settings] Tab</p> <ul style="list-style-type: none"> <li>• The image was changed.</li> <li>• The items and Descriptions were added and deleted.</li> </ul> <p>7.3.18.1.2 [Style/Text] Tab</p> <ul style="list-style-type: none"> <li>• The image was changed.</li> <li>• Content of NOTE was changed.</li> <li>• Descriptions were changed.</li> </ul> <p>7.3.18.2 Property Settings</p> <ul style="list-style-type: none"> <li>• Items and Descriptions were added and changed.</li> <li>• Contents were revised.</li> </ul> <p>7.3.18.3 Complements</p> <ul style="list-style-type: none"> <li>• "Precautions" was revised.</li> </ul> <p>7.3.23.1.2 [Style] Tab</p> <ul style="list-style-type: none"> <li>• The image was changed.</li> </ul> <p>7.3.23.1.3 [Text] Tab</p> <ul style="list-style-type: none"> <li>• The image was changed.</li> </ul> <p>7.3.23.1.4 [Extended] Tab</p> <ul style="list-style-type: none"> <li>• The image was changed.</li> <li>• Items were changed.</li> </ul> <p>7.3.23.2 Property Settings</p> <ul style="list-style-type: none"> <li>• Item was changed.</li> </ul> <p style="text-align: right;">(Continue to the next page)</p>



Date of revision	Manual No.	Revision details
		<p style="text-align: right;">(Continued)</p> <p>7.3.26 Alarm List (GNCArmList)</p> <ul style="list-style-type: none"> <li>• Section title was changed to "Alarm List (GNCArmList)".</li> </ul> <p>7.3.27 Meter (GNCMeter)</p> <ul style="list-style-type: none"> <li>• Section title was changed to "Meter (GNCMeter)".</li> </ul> <p>7.3.28 Trend Graph (GNCTrendGraph)</p> <ul style="list-style-type: none"> <li>• Section title was changed to "Trend Graph (GNCTrendGraph)".</li> </ul> <p>10.1.9 Repeat</p> <ul style="list-style-type: none"> <li>• The images were changed.</li> <li>• Contents were changed.</li> </ul> <p>10.3 Control List</p> <ul style="list-style-type: none"> <li>• Contents were changed.</li> </ul> <p>11.1.3 Function List</p> <ul style="list-style-type: none"> <li>• Items were added.</li> </ul> <p>15.1 Generating Screen Data Source Codes</p> <ul style="list-style-type: none"> <li>• Description was changed.</li> </ul> <p>17.3.2.1 Operation Procedure with Visual Studio2010</p> <ul style="list-style-type: none"> <li>• Details were revised.</li> </ul> <p>17.4.2 Launching the Application Window</p> <ul style="list-style-type: none"> <li>• Details were revised.</li> </ul> <p>17.6.5.1.2 customdef.ini</p> <ul style="list-style-type: none"> <li>• Details were revised.</li> </ul> <p>17.6.5.3.1 customdef.ini</p> <ul style="list-style-type: none"> <li>• Screen ID was changed.</li> </ul> <p>17.6.8.2.1 File Name/17.6.8.2.2 HTML File</p> <ul style="list-style-type: none"> <li>• Contents were changed.</li> </ul> <p>17.6.14 Limitations</p> <ul style="list-style-type: none"> <li>• Descriptions related to custom release in "Common" were added.</li> </ul> <p>17.7.1.1 Custom Screen Configuration Dialog</p> <p>In the Custom screen configuration dialog, specify</p> <ul style="list-style-type: none"> <li>• The image was changed.</li> <li>• Item was changed.</li> </ul> <p>17.7.2 Operation Procedure</p> <ul style="list-style-type: none"> <li>• The image was changed.</li> </ul> <p>17.8.1 Operation screen</p> <ul style="list-style-type: none"> <li>• The image was changed.</li> <li>• Items were changed.</li> </ul> <p>17.8.2 Operation Procedure</p> <ul style="list-style-type: none"> <li>• The images were changed.</li> </ul> <p>17.9.2.1 List of Configuration Settings Files</p> <ul style="list-style-type: none"> <li>• Contents were changed.</li> </ul> <p>Appendix 1. Error Message List</p> <ul style="list-style-type: none"> <li>• Error messages were added.</li> </ul> <p style="text-align: right;">(Continue to the next page)</p>

Date of revision	Manual No.	Revision details
		<p style="text-align: right;">(Continued)</p> <p>Appendix 9.6 Parameter</p> <ul style="list-style-type: none"> <li>• Contents were changed.</li> </ul> <p>Appendix 9.3 Screen Configuration</p> <ul style="list-style-type: none"> <li>• The image was changed.</li> <li>• Contents were changed.</li> </ul> <p>Appendix 9.5.2 About the Memory Card or USB Memory for Upgrade</p> <ul style="list-style-type: none"> <li>• Contents were changed.</li> </ul> <p>Appendix 9.7 Operation/Alarm Messages</p> <ul style="list-style-type: none"> <li>• Messages were added.</li> </ul> <p>Appendix 11. Installing Custom Data (M800/M80 (Windows-less Display Unit))</p> <ul style="list-style-type: none"> <li>• The images were added and changed.</li> <li>• Contents were added.</li> </ul> <p>NC Matching List</p> <ul style="list-style-type: none"> <li>• Items were added.</li> <li>• Mistakes were corrected.</li> </ul>
Oct. 2021	IB(NA)1501250-J	<ul style="list-style-type: none"> <li>• Corresponded to NC Designer2 Ver.A7.</li> <li>• The following section was added. <ul style="list-style-type: none"> <li>7.3.23.1.5 [Open] Tab</li> <li>7.3.23.1.6 [Close] Tab</li> <li>17.6.5.5 Settings of an Operation Message</li> </ul> </li> <li>• The following sections were changed. <ul style="list-style-type: none"> <li>7.2.10.2 Property Settings <ul style="list-style-type: none"> <li>• Contents were changed.</li> </ul> </li> <li>7.2.14.2 Property Settings <ul style="list-style-type: none"> <li>• Descriptions related to extended function were added.</li> </ul> </li> <li>7.3.13.1 Property Setup Dialog <ul style="list-style-type: none"> <li>• The image was changed.</li> </ul> </li> <li>7.3.13.1.1 [Device] Tab <ul style="list-style-type: none"> <li>• The image was changed.</li> <li>• Contents were changed.</li> </ul> </li> <li>7.3.13.1.4 [Input Range] Tab <ul style="list-style-type: none"> <li>• The image was changed.</li> <li>• Contents were changed.</li> </ul> </li> <li>7.3.13.2 Property Settings <ul style="list-style-type: none"> <li>• Contents were changed.</li> </ul> </li> <li>7.3.13.3 Complements <ul style="list-style-type: none"> <li>• Contents were changed.</li> </ul> </li> <li>7.3.23.1 Property Setup Dialog <ul style="list-style-type: none"> <li>7.3.23.1.1 [Behavior Settings] Tab</li> <li>7.3.23.1.2 [Style] Tab</li> </ul> </li> </ul> </li> </ul> <p style="text-align: right;">(Continue to the next page)</p>

Date of revision	Manual No.	Revision details
		<p style="text-align: right;">(Continued)</p> <p>7.3.23.1.3 [Text] Tab</p> <ul style="list-style-type: none"> <li>• The image was changed.</li> </ul> <p>7.3.23.1.4 [Extended] Tab</p> <ul style="list-style-type: none"> <li>• The image was changed.</li> <li>• Contents were changed.</li> </ul> <p>7.3.23.2 Property Settings</p> <ul style="list-style-type: none"> <li>• The item was added.</li> </ul> <p>7.3.23.3 Complements</p> <ul style="list-style-type: none"> <li>• Contents were changed.</li> </ul> <p>10.7.4 Limitations</p> <ul style="list-style-type: none"> <li>• The item was added.</li> </ul> <p>17.5.2.3 Closing the Custom Screen (Menu Release)</p> <ul style="list-style-type: none"> <li>• Contents were changed.</li> </ul> <p>17.6.8 G Code Guidance Release, M Code Guidance Release</p> <p>17.6.8.1 Designation of the Guidance File Folder</p> <p>17.6.8.2 Format of the Guidance File</p> <ul style="list-style-type: none"> <li>• Descriptions related to M code guidance were added.</li> </ul> <p>17.8.1 Operation screen</p> <ul style="list-style-type: none"> <li>• NOTE was revised.</li> </ul> <p>Appendix 11. Installing Custom Data (M800/M80 (Windows-less Display Unit))</p> <p>NC Matching List</p> <ul style="list-style-type: none"> <li>• Items were added.</li> <li>• Mistakes were corrected.</li> </ul>
Jul. 2022	IB(NA)1501250-K	<ul style="list-style-type: none"> <li>• Corresponded to NC Designer2 Ver.A8.</li> <li>• Corresponded to Mitsubishi Electric CNC M8V Series.</li> <li>• The following sections were added. <ul style="list-style-type: none"> <li>10.1.10 Batch Conversion</li> <li>10.6 Memory Usage Check</li> <li>17.3.2.1 Preparation for Visual Studio 2017/2019 <ul style="list-style-type: none"> <li>17.3.2.1.1 Windows SDK 7.1 Download</li> <li>17.3.2.1.2 Windows SDK 7.1 Installation</li> <li>17.3.2.1.3 Registry Correction</li> <li>17.3.2.1.4 MSBuild Props File Correction</li> </ul> </li> <li>17.3.2.2 Operation Procedure with Visual Studio 2017 <ul style="list-style-type: none"> <li>17.3.2.2.3 Operation Procedure with Visual Studio 2019</li> </ul> </li> </ul> </li> <li>• The following sections were changed. <ul style="list-style-type: none"> <li>1.1.1 GUI Design Tool</li> <li>2.2.2 What Is "Project"?</li> <li>2.2.5 Precautions</li> <li>2.3 Menu List</li> <li>4.1 Creating a New Project</li> <li>4.2 Entering Project Properties</li> </ul> </li> </ul> <p style="text-align: right;">(Continue to the next page)</p>

Date of revision	Manual No.	Revision details
		<p style="text-align: right;">(Continued)</p> <p>4.4 Saving the Project as ...</p> <p>4.7.1 Outline</p> <p>5.2 Creating a New Panel</p> <p>5.3 Creating a New Window</p> <p>5.4 Entering Panel Properties</p> <p>5.5 Entering Window Properties</p> <p>5.6 Saving the Panel/Window</p> <p>5.10.9 Changing the Theme Color</p> <p>5.12.1.2 Resource Data Name Conversion Table Dialog</p> <p>6.4.1 Creating a New Character String Resource</p> <p>6.4.3 Replacing the Character String Resource</p> <p>6.4.5 Importing or Exporting Character String Resource</p> <p>6.5.3 Specifying Font Resource</p> <p>7.1.15 Touch Gesture</p> <p>7.1.16/7.2.2.1/7.2.3.1/7.2.6.1/7.2.10.1/7.2.14.1/7.2.15.1/7.3.12.1/7.3.13.1/ 7.3.14.1/7.3.15.1/7.3.18.1/7.3.23.1/7.3.26.1/7.3.27.1/7.3.28.1</p> <p>Property Setup Dialog</p> <p>7.1.16.2.1 [Style] Tab</p> <p>7.1.16.4 Input Assist Function</p> <p>7.2.2.1.4 [Extended] Tab</p> <p>7.2.3.1.1 [Display Settings] Tab</p> <p>7.2.3.1.3 [Text] Tab</p> <p>7.2.3.1.5 [Extended] Tab</p> <p>7.2.3.2/7.2.10.2/7.2.14.2/7.2.15.2/7.3.1.1/7.3.2.1/7.3.3.1/7.3.4.1/7.3.5.1/7.3.6.1/ 7.3.7.1/7.3.8.1/7.3.9.1/7.3.10.1/7.3.11.1/7.3.13.2/7.3.14.2/7.3.16.1/7.3.17.1/ 7.3.18.2/7.3.19.1/7.3.20.1/7.3.21.1/7.3.22.1/7.3.23.2 Property Settings</p> <p>7.2.10.1.1 [Display/Action] Tab</p> <p>7.2.14.1.1 [Input/View] Tab</p> <p>7.2.14.1.3 [Text] Tab</p> <p>7.2.14.1.4 [Extended] Tab</p> <p>7.2.14.4 Restrictions</p> <p>7.2.15.1.1 [Input/View] Tab</p> <p>7.2.15.1.4 [Extended] Tab</p> <p>7.3.12.1.4 [Extended] Tab</p> <p>7.3.13.1.1 [Device] Tab</p> <p>7.3.13.1.3 [Text] Tab</p> <p>7.3.13.1.5 [Extended] Tab</p> <p>7.3.13.3 Complements</p> <p>7.3.14.1.1 [Device] Tab</p> <p>7.3.14.1.3 [Text] Tab</p> <p>7.3.14.1.4 [Extended] Tab</p> <p>7.3.16.2 Complements</p> <p>7.3.18 Extension Menu (GNCEXMenu); Extension Menu Display Part</p> <p style="text-align: right;">(Continue to the next page)</p>

Date of revision	Manual No.	Revision details
		<p style="text-align: right;">(Continued)</p> <p>7.3.18.1.1 [Behavior Settings] Tab  7.3.18.1.2 [Style/Text] Tab  7.3.18.3 Complements  7.3.19 FileInOut (GNXFileTransfer) ; Input/Output Control  7.3.19.2 Complements  7.3.21.2 Complements  7.3.23.1.4 [Extended] Tab  7.3.26.1.1 [Alarm Settings] Tab  7.3.26.1.4 [Extended] Tab  7.3.26.3 Complements  7.3.27 Meter (GNCMeter)  7.3.27.1.1 [Device/Style] Tab  7.3.28 Trend Graph (GNCTrendGraph)  7.3.28.1.2 [Style] Tab  8. Parts Library  10.1.2 Redo  10.1.7 Find  10.2.10 Grid  10.5 Error Check  10.7.1 Option Setting  10.8.1 Screen Specifications  11.1.1 Starting Simulation  11.1.3 Function List  12.3 Limitations  13.1.1 Generating a Project Information Document  13.1.2 Generating a Screen Information Document  13.1.3 Output Image  14.1.1 Export  14.1.2 File Configuration  14.2 Project Convert to the ND2 Format  15.1 Generating Screen Data Source Codes  16.3 Folder Configuration for Data File  17.2.2 Flow of Operation  17.3.2.2.1 Operation Procedure with Visual Studio 2010  17.3.2.3 Operation Procedure with NC Compiler/NC Compiler2  17.4.2 Launching the Application Window  17.6.1 Outline  17.6.2.1 Necessary Applications  17.6.2.2 Necessary Files  17.6.4.1 Interpreter Method  17.6.4.1.1 Config.ini  17.6.4.1.2 customdef.ini  17.6.4.2 Compilation Method</p> <p style="text-align: right;">(Continue to the next page)</p>

Date of revision	Manual No.	Revision details
		<p style="text-align: right;">(Continued)</p> <p>17.6.4.2.1 Config.ini</p> <p>17.6.4.3 Switching of "Onboard" and "Execution File by F0 Release" by Bit Selection Parameter (#6451 bit0)</p> <p>17.6.5.1 Interpreter Method</p> <p>17.6.5.1.2 customdef.ini</p> <p>17.6.5.1.3 Icon Image</p> <p>17.6.5.2 Compilation Method</p> <p>17.6.5.3 Changing the Arrangement of the Main Menu</p> <p>17.6.5.3.1 customdef.ini</p> <p>17.6.6.3 Interpreter Method</p> <p>17.6.6.4 Compilation Method</p> <p>17.6.7.1 Interpreter Method</p> <p>17.6.7.2 Compilation Method</p> <p>17.6.8.1.1 config.ini</p> <p>17.6.8.2.1 File Name</p> <p>17.6.8.2.2 HTML File</p> <p>17.6.8.2.3 Precautions</p> <p>17.6.10 About the Switch of Display/Non-display of the Menu by the Parameter</p> <p>17.6.11 Adjusting Standard and Customized Screen Size according to Resolution</p> <p>17.6.12 Displaying an Original Logo on the</p> <p>17.6.14 Limitations</p> <p>17.7.1.1 Custom Screen Configuration Dialog</p> <p>17.8.1 Operation screen</p> <p>17.8.2 Operation Procedure</p> <p>17.9 Home Screen</p> <p>17.9.1 Types of MTB's App</p> <p>17.9.2.1 List of Configuration Settings Files</p> <p>17.9.2.2 Storage Location of Applications and Configuration Settings</p> <p>17.10.1 Outline</p> <p>17.10.3 Programming Method</p> <p>17.10.4 Example</p> <p>Appendix 1. Error Message List</p> <p>Appendix 2. Shortcut Key List</p> <p>Appendix 8.1.2 Details of melAppCtrl.ini</p> <p>Appendix 8.2 Menu Release</p> <p>Appendix 9.3 Screen Configuration</p> <p>Appendix 9.4 Operation Methods</p> <p>Appendix 9.5.2 About the Memory Card or USB Memory for Upgrade</p> <p>Appendix 9.6 Parameter</p> <p>Appendix 11. Installing Custom Data (M800V/M80V/ M800/M80 (Windows-less Display Unit))</p> <p>NC Matching List [NC Designer2 full-function]</p> <p>NC Matching List [Additional controls]</p> <p style="text-align: right;">(Continue to the next page)</p>

Date of revision	Manual No.	Revision details
		<p style="text-align: right;">(Continued)</p> <p>NC Matching List [Additional functions]  NC Matching List [Additional functions/property]  Custom API Library Correspondence Table  List of Functions Supported for Each Project [Additional functions]  • Mistakes were corrected.</p>
Mar. 2023	IB(NA)1501250-L	<ul style="list-style-type: none"> <li>• Corresponded to NC Designer2 Ver.A9.</li> <li>• The following sections were added. <ul style="list-style-type: none"> <li>7.2.3.3 Complements</li> <li>10.1.11 Copy and Paste between Projects</li> <li>17.3.2.1.1 Visual Studio 2015 Installation</li> <li>17.3.2.2.4 Operation Procedure with Visual Studio 2022</li> <li>NC Designer2 Matching List [Maximum data size]</li> </ul> </li> <li>• The following sections were changed. <ul style="list-style-type: none"> <li>2.2.3 Operating Environment of NC Designer2 <ul style="list-style-type: none"> <li>• Windows 10 was added.</li> </ul> </li> <li>2.2.5 Precautions <ul style="list-style-type: none"> <li>• The item was added.</li> </ul> </li> <li>6.1 Resource <ul style="list-style-type: none"> <li>• NOTE was added.</li> </ul> </li> <li>7.1.1 Control Name <ul style="list-style-type: none"> <li>• Descriptions were added to NOTE.</li> </ul> </li> <li>7.1.10 Callback Function <ul style="list-style-type: none"> <li>• The following functions were added. <ul style="list-style-type: none"> <li>OnChangeString, OnSubCursorMove, OnDrawLineString, OnInit, OnQuit, OnEndAnimationm, PreKeyPress, PreChar, OnError, OnUpperLimitOver, OnLowerLimitOver</li> </ul> </li> </ul> </li> <li>7.1.16.4.1 Input Assist Window <ul style="list-style-type: none"> <li>• Descriptions were added to "Description".</li> <li>• Descriptions were added to NOTE.</li> </ul> </li> <li>7.3.13.3 Complements <ul style="list-style-type: none"> <li>• "Operations with Keys" was added.</li> </ul> </li> <li>7.3.14.3 Complements <ul style="list-style-type: none"> <li>• "Operations with Keys" was added.</li> </ul> </li> <li>7.3.15.1.4 [Extended] Tab <ul style="list-style-type: none"> <li>• "Write device OFF at screen switch" was changed.</li> <li>• "Suppress device initialization" was added.</li> </ul> </li> <li>7.3.15.2 Property Settings <ul style="list-style-type: none"> <li>• "PLC device OFF" was changed.</li> <li>• "Suppress device initialization" was added.</li> <li>• Notes were added.</li> </ul> </li> </ul> </li> </ul> <p style="text-align: right;">(Continue to the next page)</p>

Date of revision	Manual No.	Revision details
		<p style="text-align: right;">(Continued)</p> <p>7.3.19.2 Complements</p> <ul style="list-style-type: none"> <li>• Contents were changed.</li> </ul> <p>7.3.23.1.1 [Behavior Settings] Tab</p> <ul style="list-style-type: none"> <li>• Descriptions were added to NOTE.</li> </ul> <p>7.3.23.2 Property Settings</p> <ul style="list-style-type: none"> <li>• Notes were added.</li> </ul> <p>7.3.23.3 Complements</p> <ul style="list-style-type: none"> <li>• Notes were deleted.</li> </ul> <p>7.3.27.1.1 [Device/Style] Tab</p> <ul style="list-style-type: none"> <li>• Descriptions were added to NOTE.</li> </ul> <p>7.3.27.2 Property Settings</p> <ul style="list-style-type: none"> <li>• Notes were added.</li> </ul> <p>10.1.9 Continuous copy</p> <ul style="list-style-type: none"> <li>• Screenshot was changed.</li> </ul> <p>10.7.1 Option Setting</p> <ul style="list-style-type: none"> <li>• The images were added.</li> <li>• "Resource data" and "Screen macro" were added.</li> <li>• Notes were added.</li> </ul> <p>14.1.1 Export</p> <ul style="list-style-type: none"> <li>• Descriptions were added to NOTE.</li> </ul> <p>15.1 Generating Screen Data Source Codes</p> <ul style="list-style-type: none"> <li>• Descriptions were added to NOTE.</li> </ul> <p>17.3.2.1 Preparation for Visual Studio 2017/2019</p> <ul style="list-style-type: none"> <li>• Contents were changed.</li> </ul> <p>17.6.5.1.2 customdef.ini</p> <ul style="list-style-type: none"> <li>• Contents were changed.</li> </ul> <p>17.6.5.3.1 customdef.ini</p> <ul style="list-style-type: none"> <li>• Contents were changed.</li> </ul> <p>17.6.7.3.4 Sample Code (Displaying the Next Axis by Touching a Button)</p> <ul style="list-style-type: none"> <li>• Contents were changed.</li> </ul> <p>17.6.10 About the Switch of Display/Non-display of the Menu by the Parameter</p> <ul style="list-style-type: none"> <li>• Contents were changed.</li> </ul> <p>17.6.14 Limitations</p> <ul style="list-style-type: none"> <li>• Contents were changed.</li> </ul> <p>Appendix 11. Installing Custom Data (M800V/M80V/ M800/M80 (Windows-less Display Unit))</p> <ul style="list-style-type: none"> <li>• Contents were changed.</li> </ul> <p>NC Matching List</p> <ul style="list-style-type: none"> <li>• Contents were added.</li> </ul> <p style="text-align: right;">(Continue to the next page)</p>



Date of revision	Manual No.	Revision details
		<p style="text-align: right;">(Continued)</p> <p>7.3.15.1.4/7.3.23.1/7.3.23.1.1/17.5.2.2/17.6.1/17.5.2.2/17.6.1/17.6.5.4/17.6.6.1/  17.6.6.2/17.6.6.5.3/17.6.6.5.4/17.6.7/17.6.7.3.1/17.6.7.3.3/17.6.7.3.4/17.6.8/  17.6.8.2.1/17.6.8.2.2/17.6.12/Appendix 8.3.1/Appendix 8.3.2/Appendix 8.3.3</p> <ul style="list-style-type: none"> <li>• The images were changed.</li> </ul> <p>7.2.13.1/7.2.14.2/7.2.15.2/7.3.12.2/7.3.13.2/7.3.14.2/7.3.15.2/7.3.18.2/7.3.19.1/7.  3.21.1/7.3.24.1/7.3.26.2/7.3.27.2/7.3.28.2</p> <ul style="list-style-type: none"> <li>• The "Callback Function" was deleted.</li> </ul> <p>17.3.2.1/17.3.2.2/17.3.2.2.2/17.3.2.2.3/17.6.2.1</p> <ul style="list-style-type: none"> <li>• Visual Studio 2022 was added.</li> </ul> <ul style="list-style-type: none"> <li>• Mistakes were corrected.</li> </ul>



# Global Service Network

## AMERICA

### **MITSUBISHI ELECTRIC AUTOMATION INC. (AMERICA FA CENTER)**

**Central Region Service Center (Chicago)**  
500 CORPORATE WOODS PARKWAY, VERNON HILLS, ILLINOIS 60061, U.S.A.  
TEL: +1-847-478-2500 / FAX: +1-847-478-2650

**Minneapolis, MN Service Satellite**  
**Detroit, MI Service Satellite**  
**Grand Rapids, MI Service Satellite**  
**Milwaukee, WI Service Satellite**  
**Cleveland, OH Service Satellite**  
**Indianapolis, IN Service Satellite**  
**St. Louis, MO Service Satellite**

### **South/East Region Service Center (Georgia)**

1845 SATELLITE BOULEVARD STE. 450, DULUTH, GEORGIA 30097, U.S.A.  
TEL: +1-678-258-4529 / FAX: +1-678-258-4519

**Charleston, SC Service Satellite**  
**Charlotte, NC Service Satellite**  
**Raleigh, NC Service Satellite**  
**Dallas, TX Service Satellite**  
**Houston, TX Service Satellite**  
**Hartford, CT Service Satellite**  
**Knoxville, TN Service Satellite**  
**Nashville, TN Service Satellite**  
**Baltimore, MD Service Satellite**  
**Pittsburg, PA Service Satellite**  
**Tampa, FL Service Satellite**  
**Syracuse, NY Service Satellite**  
**Orlando, FL Service Satellite**  
**Lafayette, LA Service Satellite**  
**Philadelphia, PA Service Satellite**

### **Western Region Service Center (California)**

5900-B KATELLA AVE. - 5900-A KATELLA AVE. CYPRESS, CALIFORNIA 90630, U.S.A.  
TEL: +1-714-699-2625 / FAX: +1-847-478-2650

**San Jose, CA Service Satellite**  
**Seattle, WA Service Satellite**  
**Denver, CO Service Satellite**

### **Canada Region Service Center (Toronto)**

4299 14TH AVENUE MARKHAM, ONTARIO L3R 0J2, CANADA  
TEL: +1-905-475-7728 / FAX: +1-905-475-7935

**Edmonton, AB Service Satellite**  
**Montreal, QC Service Satellite**

### **Mexico Region Service Center (Querétaro)**

Parque Tecnológico Innovación Querétaro, Lateral Carretera Estatal 431, Km 2+200, Lote 91 Modulos 1 y 2  
Hacienda la Machorra, CP 76246, El Marqués, Querétaro, México  
TEL: +52-442-153-6050

**Monterrey, NL Service Satellite**  
**Mexico City, DF Service Satellite**

## BRAZIL

### **MITSUBISHI ELECTRIC DO BRASIL COMÉRCIO E SERVIÇOS LTDA.**

**Votorantim Office**  
AV. GISELE CONSTANTINO,1578, PARQUE BELA VISTA, VOTORANTIM-SP, BRAZIL CEP:18.110-650  
TEL: +55-15-3023-9000

**Blumenau, Santa Catarina Office**

## EUROPE

### **MITSUBISHI ELECTRIC EUROPE B.V.**

**European Service Headquarters (Dusseldorf, GERMANY)**  
Mitsubishi-Electric-Platz 1 40882 RATINGEN, GERMANY  
TEL: +49-2102-486-5000 / FAX: +49-2102-486-5910

### **South Germany Service Center (Stuttgart)**

SCHELMENWASENSTRASSE 16-20, 70567 STUTTGART, GERMANY  
TEL: + 49-711-770598-0 / FAX: +49-711-770598-141

### **France Service Center (Paris)**

2 RUE DE L'UNION, 92565 RUEIL-MALMAISON CEDEX, FRANCE  
TEL: +33-1-41-02-83-13 / FAX: +33-1-49-01-07-25

### **France Service Satellite (Lyon)**

240, ALLEE JACQUES MONOD 69800 SAINT PRIEST FRANCE  
TEL: +33-1-41-02-83-13 / FAX: +33-1-49-01-07-25

### **Italy Service Center (Milan)**

VIA ENERGY PARK 14, VIMERCATE 20871 (MB) ITALY  
TEL: +39-039-6053-342 / FAX: +39-039-6053-206

### **Italy Service Satellite (Padova)**

VIA G. SAVELLI, 24 - 35129 PADOVA, ITALY  
TEL: +39-039-6053-342 / FAX: +39-039-6053-206

### **U.K. Service Center**

TRAVELLERS LANE, HATFIELD, HERTFORDSHIRE, AL10 8XB, U.K.  
TEL: +44-1707-288-780 / FAX: +44-1707-278-695

### **Spain Service Center**

CTRA. RUBI, 76-80 8174 SAINT CUGAT DEL VALLES, BARCELONA, SPAIN  
TEL: +34-935-65-2236 / FAX: +34-935-89-1579

### **Poland Service Center**

UL.KRAKOWSKA 50, 32-083 BALICE, POLAND  
TEL: +48-12-347-6500 / FAX: +48-12-630-4701

### **Hungary Service Center**

BUDAÖRS OFFICE PARK, SZABADSÁG ÚT 117., 2040 BUDAÖRS, HUNGARY  
TEL: +48-12-347-6500 / FAX: +48-12-630-4701

### **Turkey Service Center**

**MITSUBISHI ELECTRIC TURKEY ELEKTRİK ÜRÜNLERİ A.Ş**  
SERIFALI MAHALLESİ KALE SOKAK. NO.41 34775  
UMRANIYE, ISTANBUL, TURKEY  
TEL: +90-216-969-2500 / FAX: +90-216-661-44-47

### **Czech Republic Service Center**

**AutoCont Control Systems s.r.o (Service Partner)**  
KAFKOVA 1853/3, 702 00 OSTRAVA 2, CZECH REPUBLIC  
TEL: +420-59-5691-185 / FAX: +420-59-5691-199

### **Russia Service Center**

**MITSUBISHI ELECTRIC RUSSIA LLC**  
LETNIKOVSKAYA STREET 2, BLD.1, 5TH 115114 MOSCOW, RUSSIA  
TEL: +7-495-721-2070 / FAX: +7-495-721-2071

### **Sweden Service Center**

HAMMARBACKEN 14, P.O.BOX 750 SE-19127, SOLLENTUNA, SWEDEN  
TEL: +46-8-6251200 / FAX: +46-8-6251014

### **Bulgaria Service Center**

**AKHNATON Ltd. (Service Partner)**  
4 ANDREJ LJAPCHEV BLVD. POB 21, BG-1756 SOFIA, BULGARIA  
TEL: +359-2-8176009 / FAX: +359-2-9744061

### **Ukraine Service Center (Kiev)**

**CSC Automation Ltd. (Service Partner)**  
4 B, YEVHENA SVERSTYUKA STR., 02002 KIEV, UKRAINE  
TEL: +380-44-494-3344 / FAX: +380-44-494-3366

### **Belarus Service Center**

**TECHNIKON Ltd. (Service Partner)**  
NEZAVISIMOSTI PR.177, 220125 MINSK, BELARUS  
TEL: +375-17-393-1177 / FAX: +375-17-393-0081

### **South Africa Service Center**

**Adroit Technologies (Service Partner)**  
20 WATERFORD OFFICE PARK, WATERFORD DRIVE, CNR OF WITKOPPEN ROAD,  
FOURWAYS JOHANNESBURG SOUTH AFRICA  
TEL: +27-11-658-6100 / FAX: +27-11-658-6101

**ASEAN****MITSUBISHI ELECTRIC ASIA PTE. LTD. (ASEAN FA CENTER)**

Singapore Service Center  
307 ALEXANDRA ROAD MITSUBISHI ELECTRIC BUILDING SINGAPORE 159943  
TEL: +65-6473-2308 / FAX: +65-6476-7439

**PHILIPPINES****MELCO FACTORY AUTOMATION PHILIPPINES INC.**

Head Office  
128 LOPEZ RIZAL STREET, BRGY., HIGHWAY HILLS, MANDALUYONG CITY, MM PHILIPPINES 1550  
TEL: +63-2-8256-8042 / FAX: +632-8637-2294

Philippines Service Center  
KM.23 WEST SERVICE ROAD SSH, CUPANG, MUNTINLUPA CITY, PHILIPPINES  
TEL: +63-2-8807-0420 / FAX: +63-2-8842-5202

**VIETNAM****MITSUBISHI ELECTRIC VIETNAM CO., LTD.**

Vietnam Ho Chi Minh Service Center  
11TH & 12TH FLOOR, VIETTEL TOWER B, 285 CACH MANG THANG 8 STREET, WARD 12, DISTRICT 10,  
HO CHI MINH CITY, VIETNAM  
TEL: +84-28-3910-5945 / FAX: +84-28-3910-5947

Vietnam Hanoi Service Center  
14TH FLOOR, CAPITAL TOWER, 109 TRAN HUNG DAO STREET, CUA NAM WARD,  
HOAN KIEM DISTRICT, HA NOI CITY, VIETNAM  
TEL: +84-24-3937-8075 / FAX: +84-24-3937-8076

**INDONESIA****PT. MITSUBISHI ELECTRIC INDONESIA**

Indonesia Service Center (Cikarang)  
JL. KENARI RAYA BLOK G2-07A, DELTA SILICON 5, LIPPO CIKARANG - BEKASI 17550, INDONESIA  
TEL: +62-21-2961-7797 / FAX: +62-21-2961-7794

**MALAYSIA****MITSUBISHI ELECTRIC SALES MALAYSIA SDN. BHD.**

Malaysia Service Center (Kuala Lumpur Service Center)  
LOT 11, JALAN 219, P.O BOX 1036, 46860 PETALING JAYA, SELANGOR DARUL EHSAN, MALAYSIA  
TEL: +60-3-7626-5032  
Johor Bahru Service Satellite  
Pulau Pinang Service Satellite

**THAILAND****MITSUBISHI ELECTRIC FACTORY AUTOMATION (THAILAND) CO., LTD.**

Thailand Service Center (Bangkok)  
101, TRUE DIGITAL PARK OFFICE, 5TH FLOOR, SUKHUMVIT ROAD, BANGCHAK, PHRA KHANONG,  
BANGKOK, 10260 THAILAND  
TEL: +66-2-092-8600 / FAX: +66-2-043-1231-33

**INDIA****MITSUBISHI ELECTRIC INDIA PVT., LTD.**

CNC Technical Center (Bangalore)  
PLOT NO. 56, 4TH MAIN ROAD, PEENYA PHASE 3,  
PEENYA INDUSTRIAL AREA, BANGALORE 560058, KARNATAKA, INDIA  
TEL: +91-80-4655-2121  
Chennai Service Satellite  
Coimbatore Service Satellite  
Hyderabad Service Satellite

North India Service Center (Gurgaon)  
PLOT 517, GROUND FLOOR, UDYOG VIHAR PHASE-III, GURUGRAM 122008, HARYANA, INDIA  
TEL: +91-124-463-0300  
Ludhiana Service Satellite  
Panthenagar Service Satellite  
Delhi Service Satellite  
Jamshedpur Service Satellite  
Manesar Service Satellite

West India Service Center (Pune)  
ICC-Devi GAURAV TECHNOLOGY PARK, UNIT NO.402, FOURTH FLOOR, NORTH WING,  
SURVEY NUMBER 191-192 (P), NEXT to INDIAN CARD CLOTHING COMPANY Ltd,  
OPP. VALLABH NAGAR, PIMPRI, PUNE- 411 018, MAHARASHTRA, INDIA  
TEL: +91-20-6819-2274  
Kolhapur Service Satellite  
Aurangabad Service Satellite  
Mumbai Service Satellite

West India Service Center (Ahmedabad)  
204-209, 2ND FLOOR, 31FIVE, CORPORATE ROAD PRAHLADNAGAR,  
AHMEDABAD -390015, GUJARAT, INDIA  
TEL: + 91-79-6777-7888  
Rajkot Service Satellite

**CHINA****MITSUBISHI ELECTRIC AUTOMATION (CHINA) LTD. (CHINA FA CENTER)**

CNC Call Center  
TEL: +86-400-921-5130

Shanghai Service Center  
NO.1386 HONG QIAO ROAD, CHANG NING QU, SHANGHAI 200336, CHINA  
TEL: +86-21-2322-3030 / FAX: +86-21-2322-3000\*8422

Qingdao Service Center  
Suzhou Service Center  
Wuhan Service Center  
Ningbo Service Center  
Hefei Service Center  
Beijing Service Center  
Tianjin Service Center  
Xian Service Center  
Dalian Service Center  
Chengdu Service Center

Shenzhen Service Center  
LEVEL8, GALAXY WORLD TOWER B, 1 YABAO ROAD, LONGGANG DISTRICT,  
SHENZHEN 518129, CHINA  
TEL: +86-755-2399-8272 / FAX: +86-755-8229-3686

Dongguan Service Center  
Xiamen Service Center

**KOREA****MITSUBISHI ELECTRIC AUTOMATION KOREA CO., LTD. (KOREA FA CENTER)**

Korea Service Center  
8F GANGSEO HANGANG XI-TOWER A, 401 YANGCHEON-RO, GANGSEO-GU,  
SEOUL 07528 KOREA  
TEL: +82-2-3660-9631 / FAX: +82-2-3664-8668  
Korea Daegu Service Satellite

**TAIWAN****MITSUBISHI ELECTRIC TAIWAN CO., LTD. (TAIWAN FA CENTER)**

Taiwan Taichung Service Center  
NO. 8-1, GONGYEQU 16th RD., XITUN DIST., TAICHUNG CITY 40768, TAIWAN  
TEL: +886-4-2359-0688 / FAX: +886-4-2359-0689

Taiwan Taipei Service Center  
11F, NO.88, SEC.6, ZHONGSHAN N. RD., SHILIN DIST., TAIPEI CITY 11155, TAIWAN  
TEL: +886-2-2833-5430 / FAX: +886-2-2833-5433

Taiwan Tainan Service Center  
11F.-1, NO.30, ZHONGZHENG S. RD., YONGKANG DIST., TAINAN CITY 71067, TAIWAN  
TEL: +886-6-252-5030 / FAX: +886-6-252-5031

**OCEANIA****MITSUBISHI ELECTRIC AUSTRALIA PTY. LTD.**

Oceania Service Center  
348 VICTORIA ROAD, RYDALMERE, N.S.W. 2116 AUSTRALIA  
TEL: +61-2-9684-7269 / FAX: +61-2-9684-7245

## **Notice**

Every effort has been made to keep up with software and hardware revisions in the contents described in this manual. However, please understand that in some unavoidable cases simultaneous revision is not possible.

Please contact your Mitsubishi Electric dealer with any questions or comments regarding the use of this product.

## **Duplication Prohibited**

This manual may not be reproduced in any form, in part or in whole, without written permission from Mitsubishi Electric Corporation.

© 2014 - 2023 MITSUBISHI ELECTRIC CORPORATION  
ALL RIGHTS RESERVED.

# MITSUBISHI ELECTRIC CORPORATION

HEAD OFFICE : TOKYO BLDG.,2-7-3 MARUNOUCHI,CHIYODA-KU,TOKYO 100-8310,JAPAN

MODEL	NC Designer2
MODEL CODE	100-404
Manual No.	IB-1501250