



Energy Measuring Unit Programming Manual (CC-Link) For ver.1 remote device station

MODEL

EMU2-HM1-C
EMU2-RD1-C, EMU2-RD3-C
EMU2-RD5-C, EMU2-RD7-C,
EMU2-RD2-C-4W, EMU2-RD4-C-4W

EMU3-DP1-C

EMU4-BD1-MB, EMU4-HD1-MB
EMU4-BM1-MB, EMU4-HM1-MB
EMU4-LG1-MB,
EMU4-A2, EMU4-VA2
EMU4-AX4, EMU4-PX4

- Before operating the instrument, you should first read thoroughly this operation manual for safe operation and optimized performance of the product. Deliver this user's manual to the end user.

CONTENTS

1.	General Description	2
2.	Specification.....	3
3.	Configuration Conditions of CC-Link System.....	4
3.1	Remote net ver.1 mode	4
3.2	Remote net ver.2 mode	5
4.	Programming	7
4.1	Programming Procedure	7
5.	Parameter Settings	8
5.1	Procedure from Parameter Settings to Data Link Startup	8
5.1.1	CPU Parameter Area and Master Module Parameter Memory	8
5.1.2	Procedure for Parameter Settings to Data Link Startup with GX Developer.....	8
5.2	Example of Parameter Settings with GX Developer	9
5.2.1	Master Station Network Parameter Settings.....	9
6.	Communication Between the Master Station and Measuring Unit	13
6.1	Communication Guideline	13
6.2	Initial Communication	14
6.3	Error Communication.....	14
6.4	Normal Communication	15
7.	Remote I/O and Remote Register.....	16
7.1	Remote Input RX, Remote Output RY	16
7.1.1	Remote input RX.....	16
7.1.2	Remote Output RY	21
7.2	Remote Register (RW _r , RW _w)	23
7.2.1	Supported Command	26
7.2.2	Details of Commands.....	27
7.2.3	Data Composition.....	56
7.2.4	Significant digits and Multiplying factor.....	69
7.2.5	About Error Occurrence	92
8.	Abbreviations and Special Terms	93
9.	Program Example	94
9.1	Program Example 1.....	94
9.1.1	Program Content.....	94
9.1.2	Parameter Settings	95
9.1.3	Program example.....	99
9.2	Program Example 2.....	107
9.2.1	Program Content.....	107
9.2.2	Parameter Settings	108
9.2.3	Device Allocation.....	111
9.2.4	Program example.....	114
10.	Test Mode	127
10.1	How to Test.....	127
10.2	Reply Data.....	127

1. General Description

This manual describes the programming methods that should be created by the user for monitoring measurement value of Energy Measuring Unit (called Measuring Unit from here on) with the Control & Communication Link (abbreviated as CC-Link from here on).

In programming, read the following related manuals in addition to this manual.

Table 1.1 Related Manuals

Manual Name	Manual No.
CC-Link System Master/Local Module User's Manual type QJ61BT11	SH-080016 (13JL91)
CC-Link System Master/Local Module User's Manual type QJ61BT11N	SH-080394E (13JR64)
CC-Link System Master/Local Module User's Manual type AJ61BT11/A1SJ61BT11	IB-66721 (13J872)
CC-Link System Master/Local Module User's Manual type AJ61QBT11/A1SJ61QBT11	IB-66722 (13J873)
MELSEC-L CC-Link System Master/Local Module User's Manual	SH-080895ENG (13JZ41)
FX2N-16CCL-M USER'S MANUAL	JY992D93101 (09R710)
FX3U-16CCL-M USER'S MANUAL	JY997D43601 (09R724)
User's Manual for Measuring Unit	Supplied with product or download.

NOTICE

When using Energy Measuring Unit EcoMonitorLight (EMU4-BD1-MB, EMU4-HD1-MB),

EcoMonitorPlus(EMU4-BM1-MB, EMU4-HM1-MB, EMU4-LG1-MB) is necessary CC-Link communication is not available without optional plug-in module.

In this manual, "EMU4-BD1-MB" or "EMU4-HD1-MB" means the main device of EcoMonitorLight with the optional plug-in module (model: EMU4-CM-C) and "EMU4-BM1-MB" or "EMU4-HM1-MB" means the main device of EcoMonitorPlus with the optional plug-in module(model: EMU4-CM-C).

Point						
<p>EMU4-BD1-MB, EMU4-HD1-MB, EMU4-BM1-MB, EMU4-HM1-MB, EMU4-LG1-MB can be setup the version of remote device station by the dip switch of the CC-Link Communication Unit (model: EMU4-CM-C). Use the following as a guideline in setting the remote device station version and set the version.</p> <table border="1"> <thead> <tr> <th>Setup</th> <th>Guideline for selection</th> </tr> </thead> <tbody> <tr> <td>Ver.1remote device station (Ver.1 compatible slave station)</td> <td>Select this when utilizing the conventional program, because of compatibility with Measuring unit previous EMU4.</td> </tr> <tr> <td>Ver.2remote device station (Ver.2 compatible slave station)</td> <td>Select this when configuring a new system or the being newly added to the existing system in combination with the applicable master module.</td> </tr> </tbody> </table> <p>This programming manual is for ver.1 remote device station. For use in the ver.2 remote device station (Ver.2 compatible slave station), refer to the following manual. EMU4 Programing Manual (CC-Link)(For ver.2 remote device station)</p>	Setup	Guideline for selection	Ver.1remote device station (Ver.1 compatible slave station)	Select this when utilizing the conventional program, because of compatibility with Measuring unit previous EMU4.	Ver.2remote device station (Ver.2 compatible slave station)	Select this when configuring a new system or the being newly added to the existing system in combination with the applicable master module.
Setup	Guideline for selection					
Ver.1remote device station (Ver.1 compatible slave station)	Select this when utilizing the conventional program, because of compatibility with Measuring unit previous EMU4.					
Ver.2remote device station (Ver.2 compatible slave station)	Select this when configuring a new system or the being newly added to the existing system in combination with the applicable master module.					

2. Specification

Measuring Unit specification is shown in Table 2.1.

Table 2.1 CC-Link Specification

Item	Specification
CC-Link station type	Remote device station (ver.1 remote device station)
Number of occupied stations	1 station
Maximum number of stations per master station	42 stations (In case of connecting only remote device station occupied by 1 station.)
Transmission speed	156kbps/625kbps/2.5Mbps/5Mbps/10Mbps
Remote I/O (RX, RY)	32 points each
Remote register (RWw, RWr)	4 points each

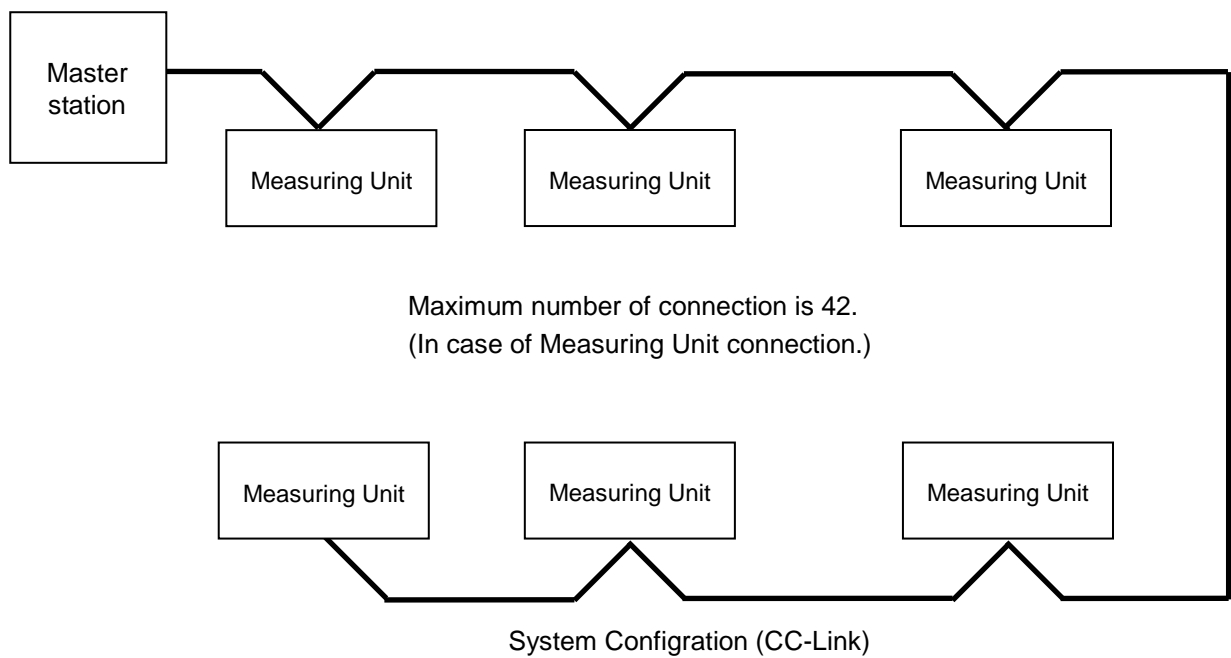

3. Configuration Conditions of CC-Link System

3.1 Remote net ver.1 mode

A total of 64 remote I/O stations, remote device stations, local stations, standby master stations, or intelligent device stations can be connected to a single master station.

However, the following conditions must all be satisfied.

Condition 1	$\{(1 \times a) + (2 \times b) + (3 \times c) + (4 \times d)\} \leq 64$	a: Number of modules occupying 1 station (Measuring Unit is applied) b: Number of modules occupying 2 stations c: Number of modules occupying 3 stations d: Number of modules occupying 4 stations
Condition 2	$\{(16 \times A) + (54 \times B) + (88 \times C)\} \leq 2304$	A: Number of remote I/O stations ≤ 64 B: Number of remote device stations (Measuring Unit is applied) ≤ 42 C: Number of local stations, standby master stations and intelligent device stations ≤ 26

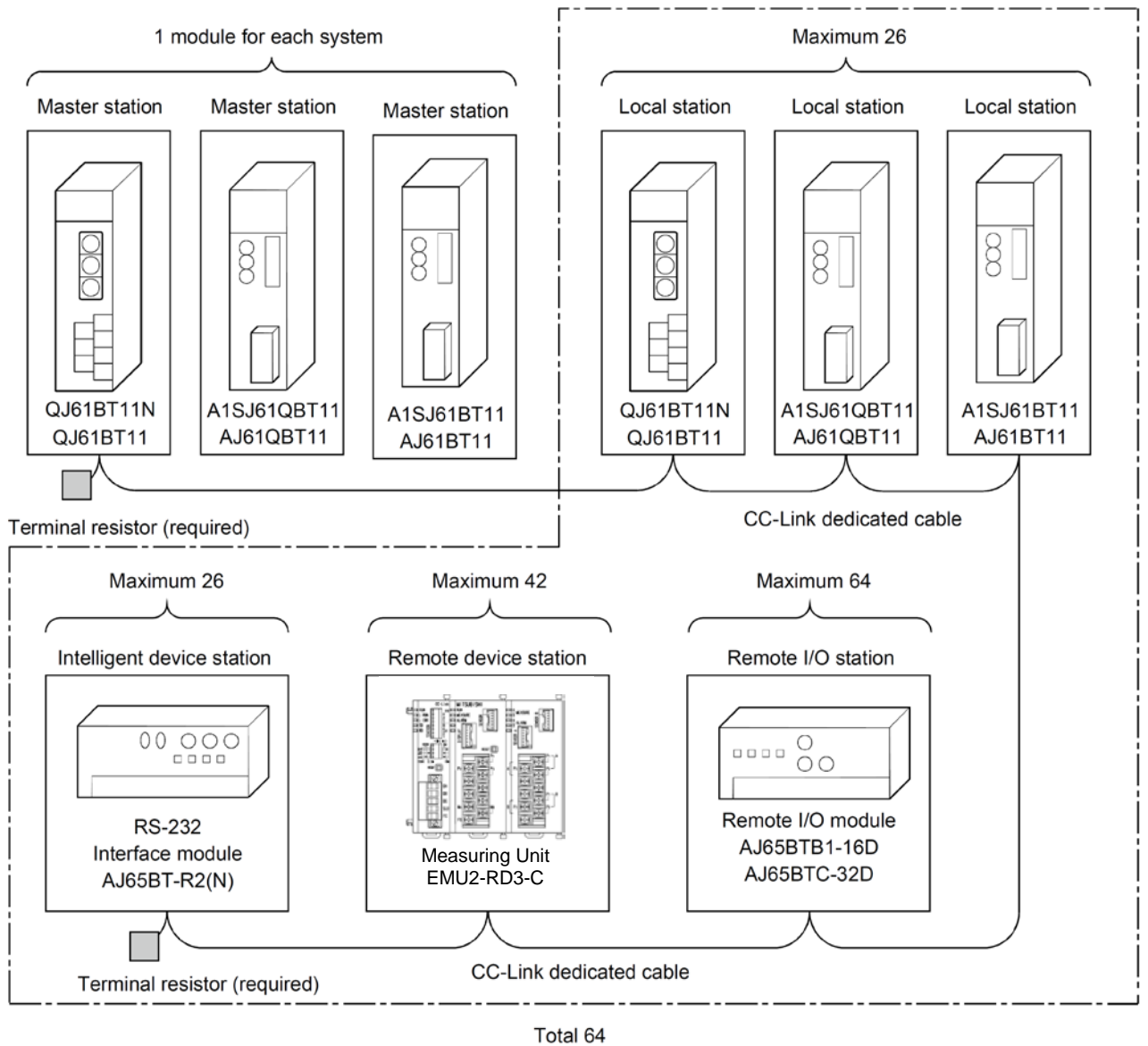

3.2 Remote net ver.2 mode

A total of 64 remote I/O stations, remote device stations, local stations, standby master stations, or intelligent device stations can be connected to a single master station.

However, the following conditions must all be satisfied.

Condition 1	$\{(a+a2+a4+a8) + (b+b2+b4+b8) \times 2 + (c+c2+c4+c8) \times 3 + (d+d2+d4+d8) \times 4\} \leq 64$	<p>a: The total number of ver.1 compatible slave stations that occupy 1 station, and ver.2 compatible slave stations that occupy 1 station which are set to "Single". (Measuring Unit is applied)</p>
Condition 2	$[\{(a \times 32) + (a2 \times 32) + (a4 \times 64) + (a8 \times 128)\} + \{(b \times 64) + (b2 \times 96) + (b4 \times 192) + (b8 \times 384)\} + \{(c \times 96) + (c2 \times 160) + (c4 \times 320) + (c8 \times 640)\} + \{(d \times 128) + (d2 \times 224) + (d4 \times 448) + (d8 \times 896)\}] \leq 8192$	<p>b: The total number of ver.1 compatible slave stations that occupy 2 stations, and ver.2 compatible slave stations that occupy 2 stations which are set to "Single".</p> <p>c: The total number of ver.1 compatible slave stations that occupy 3 stations, and ver.2 compatible slave stations that occupy 3 stations which are set to "Single".</p>
Condition 3	$[\{(a \times 4) + (a2 \times 8) + (a4 \times 16) + (a8 \times 32)\} + \{(b \times 8) + (b2 \times 16) + (b4 \times 32) + (b8 \times 64)\} + \{(c \times 12) + (c2 \times 24) + (c4 \times 48) + (c8 \times 96)\} + \{(d \times 16) + (d2 \times 32) + (d4 \times 64) + (d8 \times 128)\}] \leq 2048$	<p>d: The total number of ver.1 compatible slave stations that occupy 4 stations, and ver.2 compatible slave stations that occupy 4 stations which are set to "Single".</p> <p>a2: The number of ver.2 compatible stations that occupy 1 station which are set to "Double".</p> <p>b2: The number of ver.2 compatible stations that occupy 2 stations which are set to "Double".</p> <p>c2: The number of ver.2 compatible stations that occupy 3 stations which are set to "Double".</p> <p>d2: The number of ver.2 compatible stations that occupy 4 stations which are set to "Double".</p> <p>a4: The number of ver.2 compatible stations that occupy 1 station which are set to "Quadruple".</p> <p>b4: The number of ver.2 compatible stations that occupy 2 stations which are set to "Quadruple".</p> <p>c4: The number of ver.2 compatible stations that occupy 3 stations which are set to "Quadruple".</p> <p>d4: The number of ver.2 compatible stations that occupy 4 stations which are set to "Quadruple".</p> <p>a8: The number of ver.2 compatible stations that occupy 1 station which are set to "Octuple".</p> <p>b8: The number of ver.2 compatible stations that occupy 2 stations which are set to "Octuple".</p> <p>c8: The number of ver.2 compatible stations that occupy 3 stations which are set to "Octuple".</p> <p>d8: The number of ver.2 compatible stations that occupy 4 stations which are set to "Octuple".</p>
Condition 4	$\{(16 \times A) + (54 \times B) + (88 \times C)\} \leq 2304$	<p>A: Number of remote I/O stations ≤ 64</p> <p>B: Number of remote device stations (Measuring Unit is applied) ≤ 42</p> <p>C: Number of local stations, standby master stations and intelligent device stations ≤ 26</p>

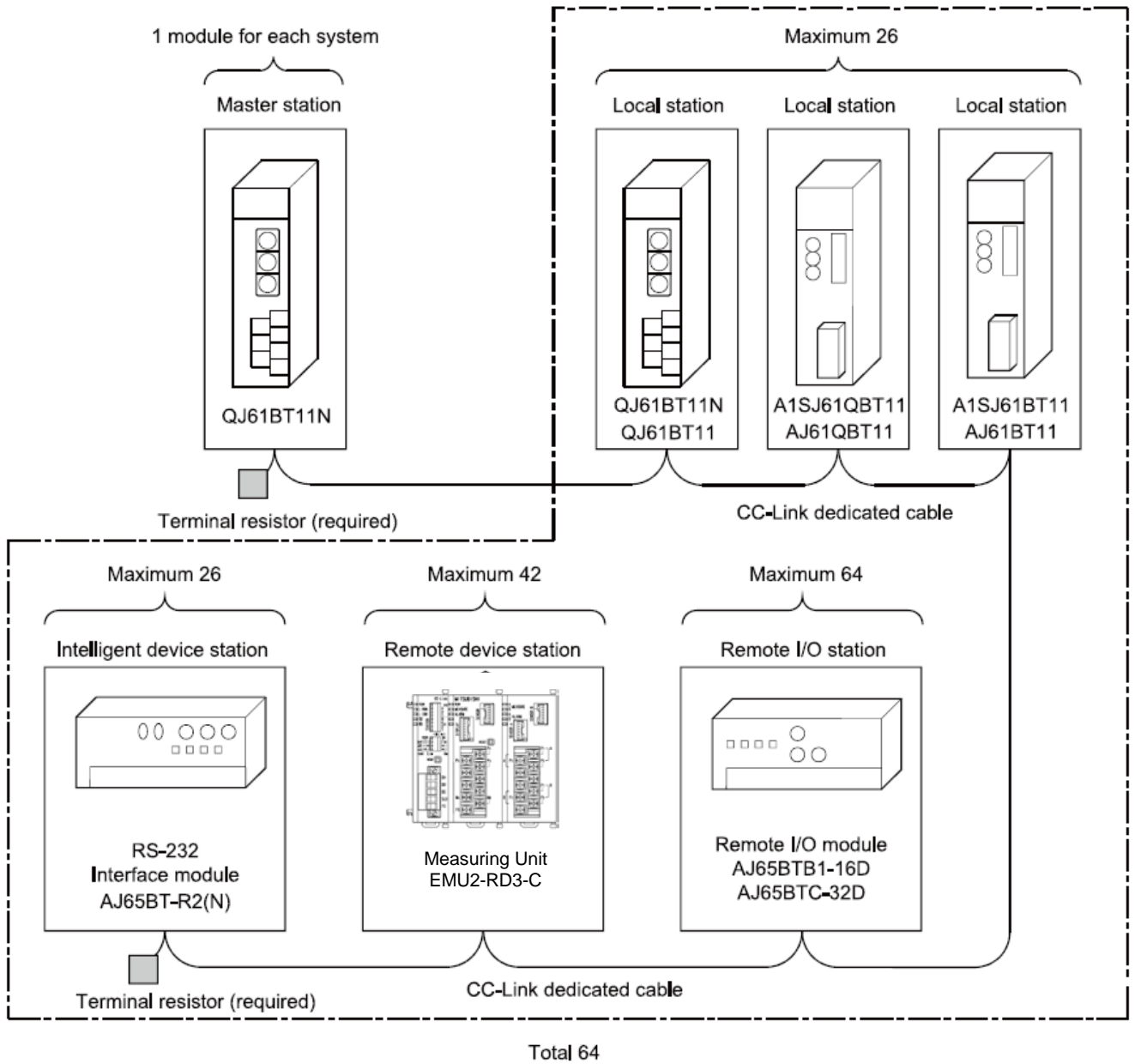

4. Programming

4.1 Programming Procedure

Create a program which executes the "Monitoring of the measurement values" by following the procedure below:

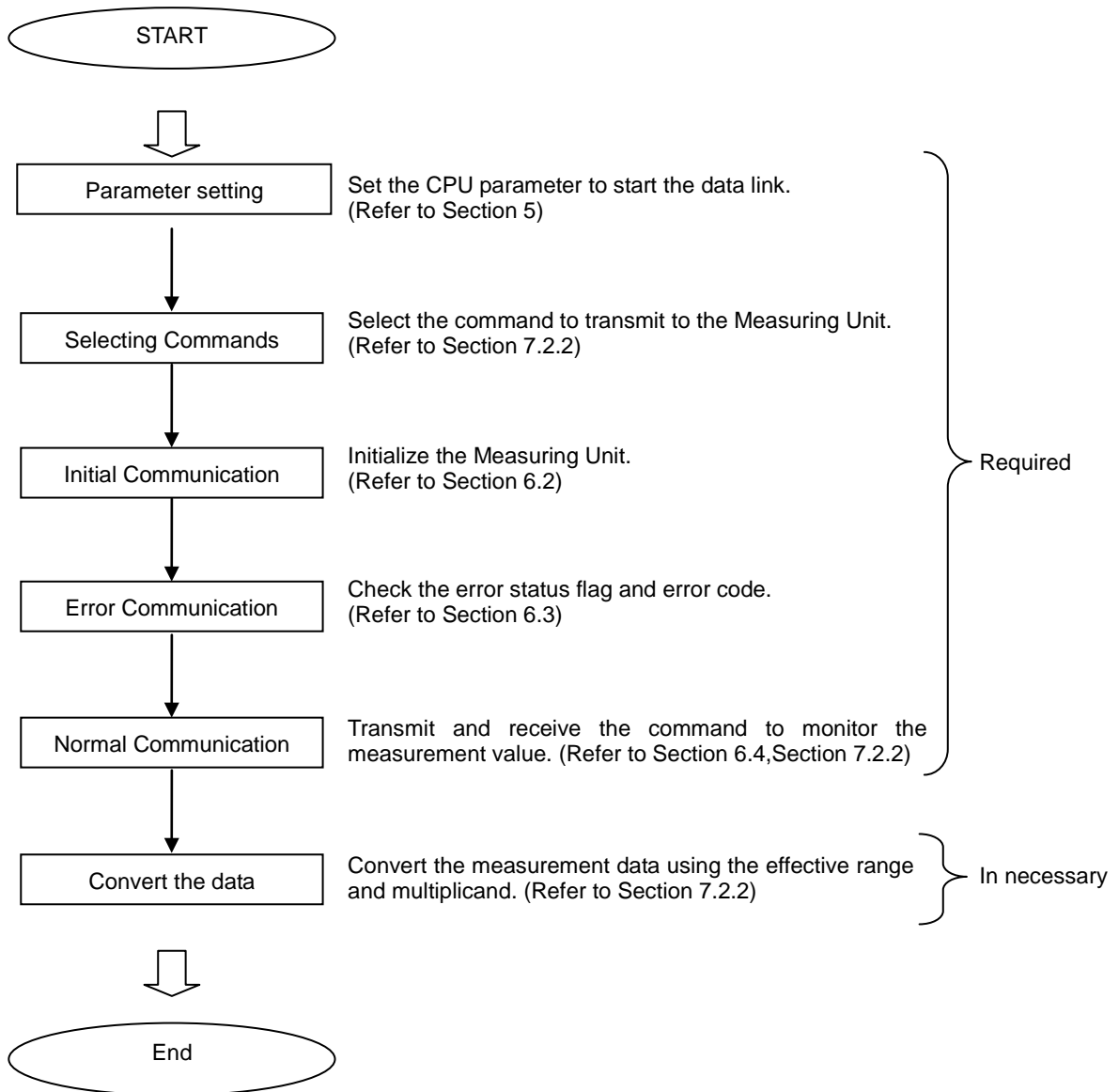

5. Parameter Settings

5.1 Procedure from Parameter Settings to Data Link Startup

The following explains the procedure from setting the parameters to stating the data link.

5.1.1 CPU Parameter Area and Master Module Parameter Memory

(1) CPU Parameter Area

This area is used to set the basic values for controlling the programmable controller system and the network parameters that control the CC-Link system.

(2) Master Station Parameter Memory

This area stores the network parameters for the CC-Link system.

When the module is powered OFF or the programmable controller CPU is reset, the network parameters are erased.

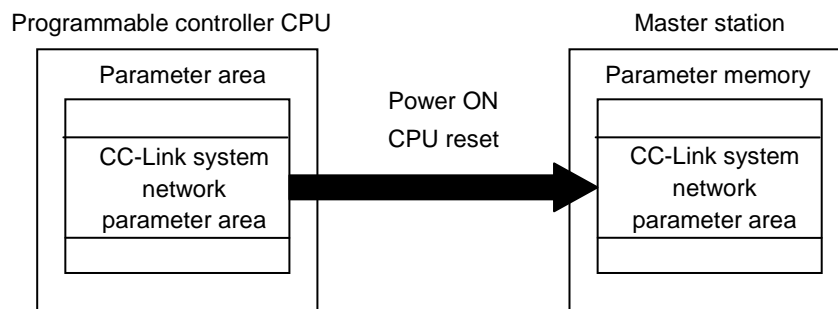

5.1.2 Procedure for Parameter Settings to Data Link Startup with GX Developer

Follow the procedure below for parameter settings to data link startup:

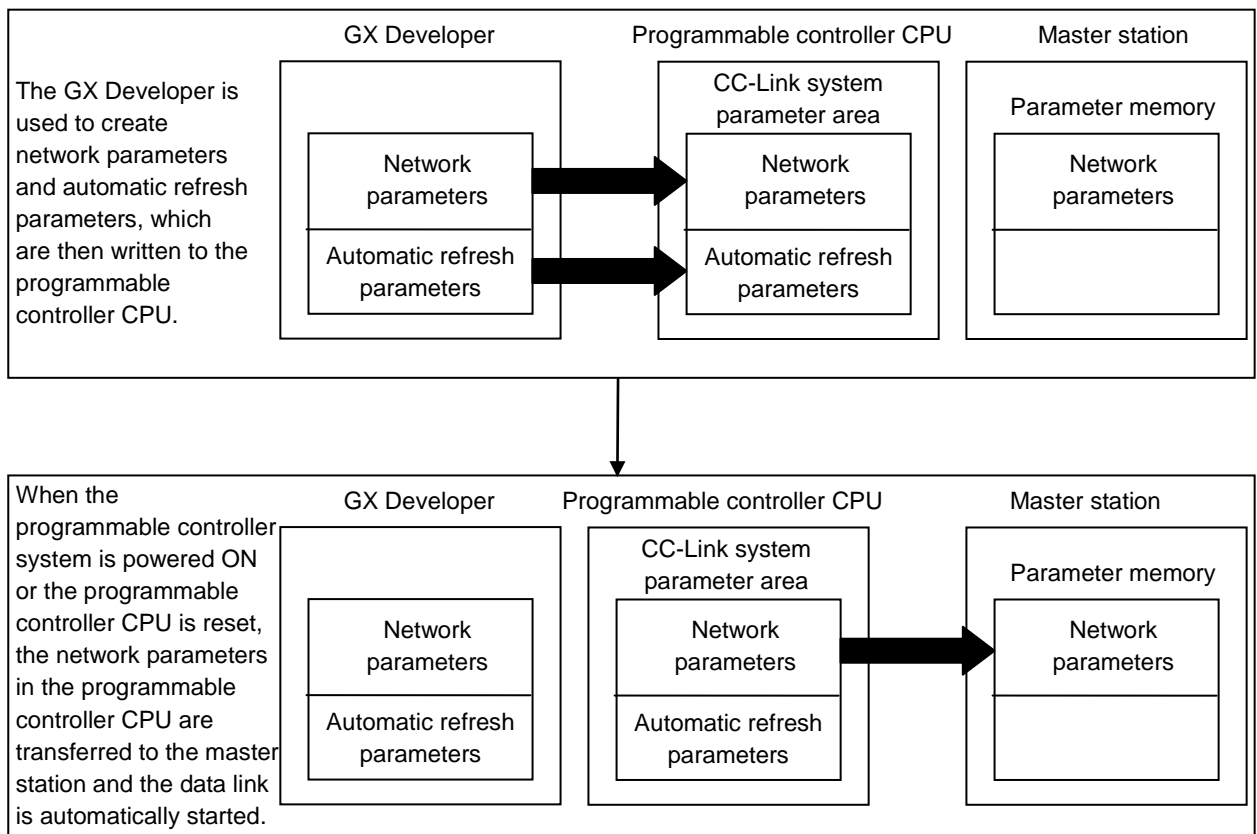

5.2 Example of Parameter Settings with GX Developer

This section explains the parameter settings using the GX Developer. For more details on the GX Developer operation, refer to the GX Developer Operating Manual. The explanations in this section are based on the following example of the system configuration.

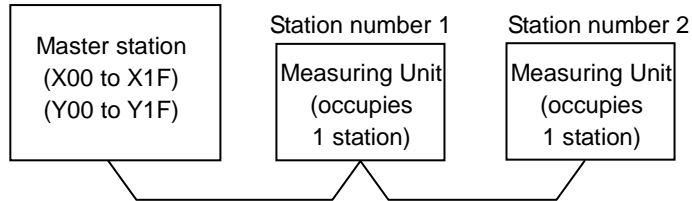

5.2.1 Master Station Network Parameter Settings

- 1) Double-click on the "Network param".
- 2) Double-click on the "CC-Link" on the "Network parameter" screen.
- 3) Set the parameters as required.

The following describes an example of the parameter settings.

The screenshot shows the 'Network parameters Setting the CC-Link list.' dialog box in the MELSOFT GX Developer software. The interface includes a project tree on the left, a network parameter sub-dialog, and a main parameter table. Red boxes and numbers 1, 2, and 3 highlight the steps described in the text.

	1	2
Start I/O No	0000	
Operational setting	Operational settings	
Type	Master station	
Master station data link type	PLC parameter auto start	
Mode	Remote net(Ver.1 mode)	
All connect count	2	
Remote input(RX)	X100	
Remote output(RY)	Y100	
Remote register(RWr)	W300	
Remote register(RWw)	W400	
Ver.2 Remote input(RX)		
Ver.2 Remote output(RY)		
Ver.2 Remote register(RWr)		
Ver.2 Remote register(RWw)		
Special relay(SB)	S80	
Special register(SW)	SW0	
Retry count	3	
Automatic reconnection station count	1	
Stand by master station No.		
PLC down select	Stop	
Scan mode setting	Asynchronous	
Delay information setting	0	
Station information setting	Station information	
Remote device station initial setting	Initial settings	
Interrupt setting	Interrupt settings	

Setting Item	Description	Example for settings	Remarks
No. of boards in module	Set the "No. of boards in module " for which the network parameters are to be set.	1	
Start I/O No	Set the "Start I/O No." for the master station.	0000	Please setup same value of start XY of CC-Link Unit in PC parameter setup
Operational settings	Set the following: ·Parameter name ·Data link err station setting ·Case of CPU Stop setting ·Block data assurance per station	Refer to next page.	Even if the Parameter name is not set, this will not affect the operation of the CC-Link system
Type	Set the station type.	Master station	
Mode	Set the CC-Link mode.	Remote net (Ver.1 mode)	"Remote net ver.2 mode " and "Remote net additional mode" can be also used in case of the QJ61BT11N.
All connect count	Set the total number of connected stations in the CC-Link system including reserved stations.	2 (modules)	
Remote input (RX)	Set the remote input (RX) refresh device.	X100	Device name - Select from X, M, L, B, D, W, R or ZR. Device number - Within the range of the device points that the CPU has.
Remote output (RY)	Set the remote output (RY) refresh device.	Y100	Device name - Select from Y, M, L, B, T, C, ST, D, W, R or ZR. Device number - Within the range of the device points that the CPU has.
Remote register (RW _r)	Set the remote register (RW _r) refresh device.	W300	Device name - Select from M, L, B, D, W, R, or ZR. Device number - Within the range of the device points that the CPU has.
Remote register (RW _w)	Set the remote register (RW _w) refresh device.	W400	Device name - Select from M, L, B, T, C, ST, D, W, R, or ZR. Device number - Within the range of the device points that the CPU has.
Special relay (SB)	Set the link special relay (SB) refresh device.	SB0	Device name - Select from M, L, B, D, W, R, SB or ZR. Device number - Within the range of the device points that the CPU has.
Special register (SW)	Set the link special register (SW) refresh device.	SW0	Device name - Select from M, L, B, D, W, R, SW or ZR. Device number - Within the range of the device points that the CPU has.
Retry count	Set the number of retries for "Retry count", when a communication error occurs.	3	
Automatic reconnection station count	Set the number of modules that can return to system operation by a single link scan.	1	
Standby master station No.	Set the station number for the standby master station	Blank	Blank: No standby master station specified.
PLC down select	Set the data link status for "PLC down select", when a master station programmable controller CPU error occurs.	Stop	
Scan mode setting	Set whether the link scan for the sequence scan is synchronous or asynchronous.	Asynchronous	
Delay information setting	Set for the link scan delay time.	0	
Station information settings	Set the station data.	Refer to 12	

POINT
<p>(1) For the automatic refresh parameter setting, set the start device only. Devices are automatically assigned until the last station number including reserved stations and occupied stations. In the example of the system configuration in this section, the last station number is "2". Therefore, total of remote I/O points is 64 points (32 x 2 = 64) and total of remote register points is 8 points (4 x 2 = 8). If refresh device of remote input (RX) is set to "X100" and that of remote register (RWr) is set to "W300", the end devices will be "X13F" and "W307" respectively.</p> <p>(2) When setting X, Y, B, W, SB and SW as refresh devices, make setting so that they do not overlap with the device numbers used on the other networks, etc.</p>

《Example for Operational settings》

Setting Item	Example for settings	Description	Remarks
Parameter name	"SAMPLE"	Set the Parameter name.	Even if the Parameter name is not set, this will not affect the operation of the CC-Link system
Data link disorder station setting	Clear ("Hold input data" not checked)	Set the input status for the data link error station.	
Case of CPU STOP setting	Refresh ("Clears compulsorily" not checked)	Set the slave station refresh/compulsory clear setting at programmable controller CPU STOP.	
Block data assurance per station	Disable ("Enable setting" not checked)	Set the block guarantee of cyclic data per station.	

《Example for Station information settings》

CC-Link station information. Module 1

Station No.	Station type	Expanded cyclic setting	Exclusive station count	Remote station points	Reserve/invalid station select	Intelligent buffer select(word)		
						Send	Receive	Automatic
1/1	Remote device station	single	Exclusive station 1	32 points	No setting			
2/2	Remote device station	single	Exclusive station 1	32 points	No setting			

Default Check End Cancel

Setting Item	Description	Example for settings	Remarks
Station type	Set the station data.	Remote device station	Set the "remote device station" in case of the Measuring Unit. (If setting of "Mode" is remote net(Ver.2 mode, Set the "Ver.1 Remote device station".)
Number of occupied stations *		Occupies 1 station	Set the "Occupies 1 station" in case of the Measuring Unit.
Remote station points		32 points [when occupies 1 station]	Cannot be changed.
Reserved/invalid station select		No setting	

* "Number of exclusive stations" on the screen is described as "Number of occupied stations" in this manual.

"Exclusive station 1" on the screen is described as "Occupies 1 station" in this manual

6. Communication Between the Master Station and Measuring Unit

6.1 Communication Guideline

There are three communication statuses (Initial Communication, Normal Communication, Error Communication) between the Master station and Measuring Unit.

The following can be performed at normal communication.

- Monitoring of the measurement values such as the current, voltage and energy, etc.
- Setting the set data of the time constant for current demand.

Measuring Unit has a special-purpose command for each measurement items and each setting items. It becomes possible to monitor measurement value or to set the setting value by writing the command into the remote register RWw of the master station.

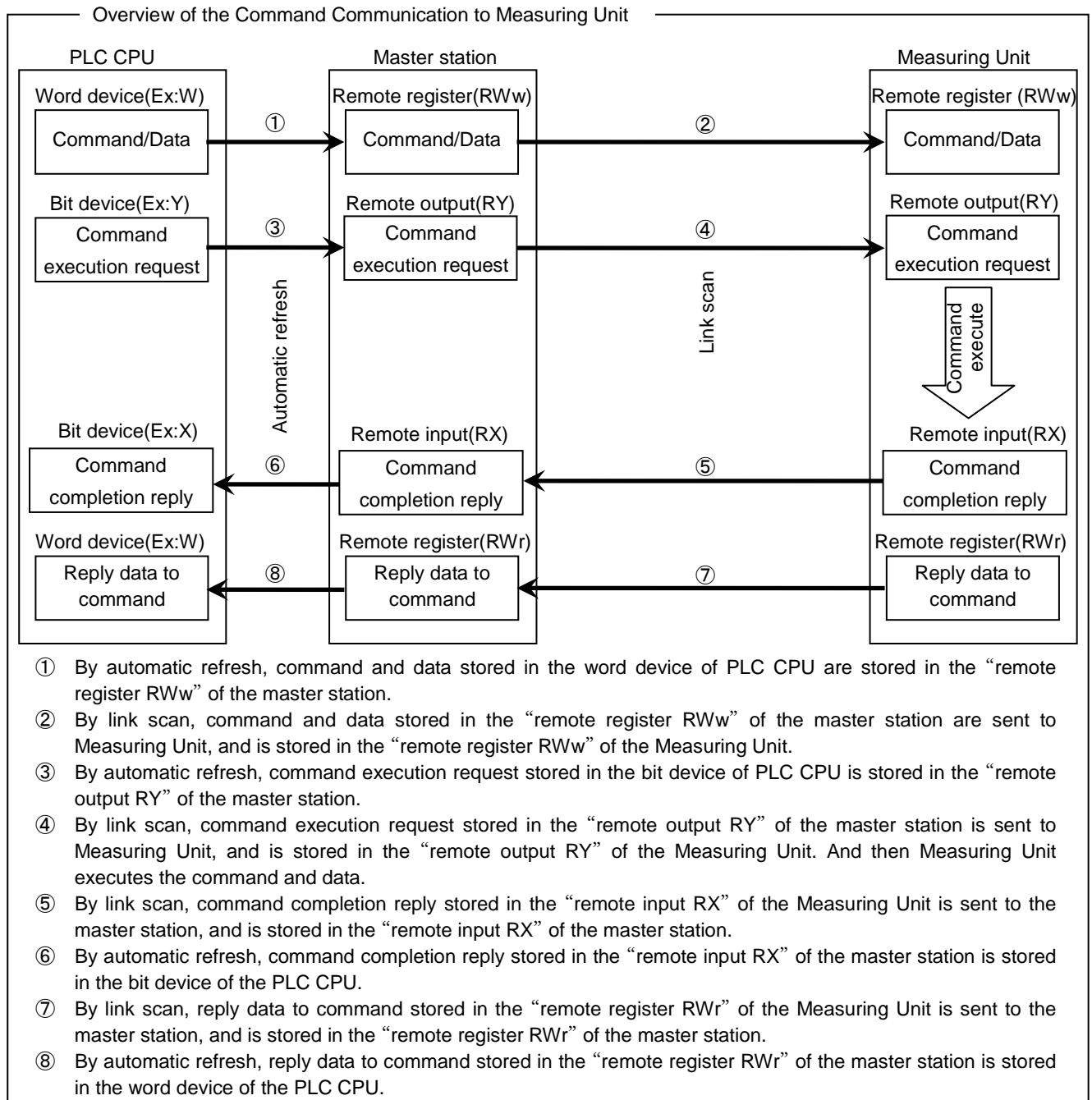

6.2 Initial Communication

Initial communication is performed at the beginning after the power supply is turned on or hardware is reset. Refer to section 7.1 about the remote input RX and the remote output RY.

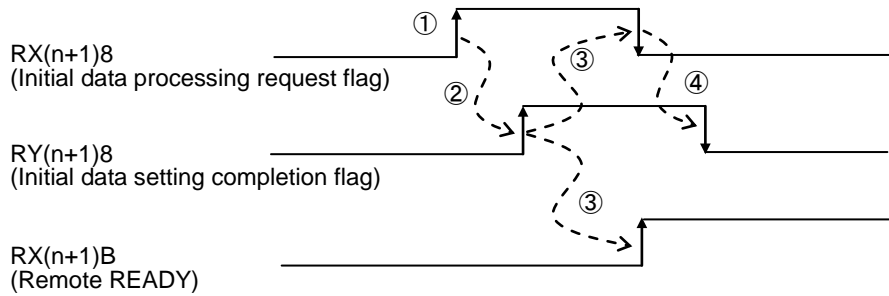

- ① After the power supply is turned on, or hardware is reset, the initial data processing request flag is turned on by Measuring Unit.
- ② After the initial data processing request flag is turned on, turn on the initial data setting completion flag.
- ③ After the initial data setting completion flag is turned on, the initial data processing request flag is turned off and the remote READY is turned on.
- ④ After the initial data processing request flag is turned off, turned off the initial data setting completion flag.

6.3 Error Communication

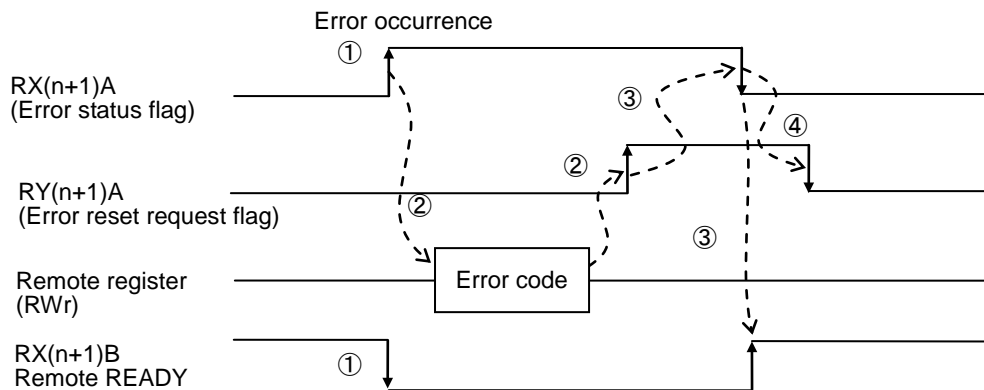

- ① When an error occurs in Measuring Unit, error status flag is turned on and the remote READY is turned off.
- ② When the error status flag is turned on, read the error code from the remote register RWr. Eliminate the cause of the error while referring to the red error code. When resuming communication with Measuring Unit, turn on the error reset request flag.
- ③ After the error reset request flag is turned on, the error status flag is turned off.
- ④ After the error status flag is turned off, turn off the error reset request flag.
- ⑤ After the error reset request flag is turned off, the remote READY is turned on and normal communication is resumed.

Note: Refer to "About Error Occurrence" for error code.

6.4 Normal Communication

After initial data processing is complete, the normally communication is performed to monitor the measurement values and to set the parameters.

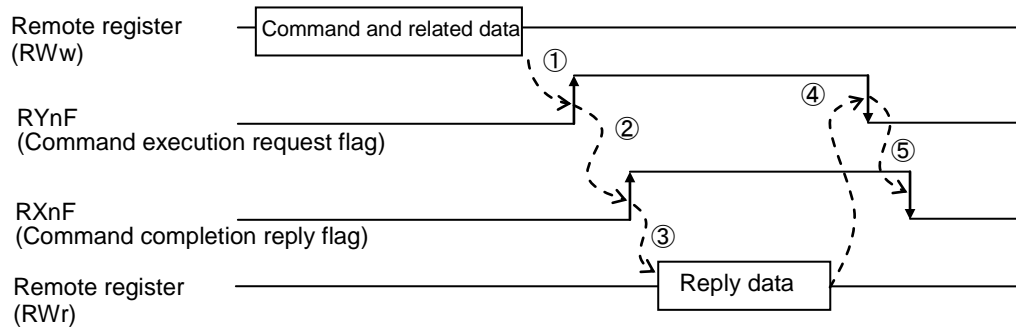

- ① After writing the command and related data into the remote register RWw, turn on the command execution request flag.
- ② After receiving the reply data corresponding to the command, the command completion reply flag turned on.
- ③ After the command completion reply flag is turned on, read the reply data from the remote register RWw.
- ④ After reading the reply data, cancel the command execution request by turning off the command execution request flag.
- ⑤ After the command execution request flag is turned off, the command completion reply flag is turned off.

Note1: When sending commands successively, repeat ① to ⑤ above.

Note2: The command can be sent only when the remote READY is ON.

7. Remote I/O and Remote Register

7.1 Remote Input RX, Remote Output RY

The remote input RX and remote output RY are used to communicate for bit data between the master station and Measuring Unit.

7.1.1 Remote input RX

The allocation of the remote input RX of Measuring Unit is shown in the table below.

Device No.	Signal name	Description		EMU2-*C ⁷	EMU3-DP1-C	Note
		OFF (0)	ON (1)			
RXn0	Reserved	—	—	—	—	
RXn1	Alarm of demand leak current	Non-Alarm state	Alarm state	—	○	Note2
RXn2	Alarm of demand current	Non-Alarm state	Alarm state	○	○	Note2
RXn3	Alarm of demand active power	Non-Alarm state	Alarm state	○	○	Note2
RXn4	Reserved	—	—	—	—	
RXn5	Alarm (total)	Non-Alarm state	Alarm state	○	○	Note2
RXn6	Reserved	—	—	—	—	
RXn7	Reserved	—	—	—	—	
RXn8	Alarm of voltage	Non-Alarm state	Alarm state	○	○	Note2
RXn9	Alarm of operating time ²	Non-Alarm state	Alarm state	—	○	Note2
RXnA	Alarm of operating time ¹	Non-Alarm state	Alarm state	—	○	Note2
RXnB	Alarm of Pulse count ²	Non-Alarm state	Alarm state	—	○	Note2
RXnC	Alarm of Pulse count ¹	Non-Alarm state	Alarm state	—	○	Note2
RXnD	Alarm of power factor	Non-Alarm state	Alarm state	○	○	Note2
RXnE	External input 2	OFF(open)	ON(close)	—	○	Note3
RXnF	Command completion reply flag	No receiving of reply data	Receiving of reply data	○	○	Note1 Note4
RX(n+1)0	Reserved	—	—	—	—	
RX(n+1)1	Reserved	—	—	—	—	
RX(n+1)2	Reserved	—	—	—	—	
RX(n+1)3	Reserved	—	—	—	—	
RX(n+1)4	Reserved	—	—	—	—	
RX(n+1)5	Reserved	—	—	—	—	
RX(n+1)6	Reserved	—	—	—	—	
RX(n+1)7	Reserved	—	—	—	—	
RX(n+1)8	Initial data processing request flag	remote READY ON or error status flag ON	Power supply is turned ON or hardware reset	○	○	Note1
RX(n+1)9	Reserved	—	—	—	—	
RX(n+1)A	Error status flag	Non-Alarm state	Alarm state	○	○	Note1
RX(n+1)B	Remote READY	Command sending not possible	Normally communication status (Command sending possible)	○	○	Note1
RX(n+1)C	Reserved	—	—	—	—	
RX(n+1)D	Reserved	—	—	—	—	
RX(n+1)E	Reserved	—	—	—	—	
RX(n+1)F	Reserved	—	—	—	—	

Note1: For the details, refer to “Communication Between the Master Station and Measuring Unit”.

Note2: The Alarm is output only when it is set in the Measuring Unit.

Note3: External input² is available only when Setting of external input signal of EMU3-DP1-C is setup Contact input.

Note4: Please monitor External input 1 (Group:A0, Channel:31) in data monitor command.

Note5: EMU2-*C is EMU2-HM1-C, EMU2-RD1-C, EMU2-RD3-C, EMU2-RD5-C, EMU2-RD7-C, EMU2-RD2-C-4W or EMU2-RD4-C-4W.

Note6: RX is bit data which is stored the input status of Measuring Unit.

Note7: The “n” in the table is determined by the station number of Measuring Unit.

The allocation of the remote input RX of Measuring Unit is shown in the table below.

Device No.	Signal name	Description		EMU4-BD1 -MB	EMU4-HD1 -MB	Note
		OFF(0)	ON(1)			
RXn0	Alarm of Pulse	Non-Alarm state	Alarm state	—	○	Note 2 Note 3
RXn1	Reserved	—	—	—	—	
RXn2	Alarm of Demand current	Non-Alarm state	Alarm state	—	○	Note 2
RXn3	Alarm of Demand Active power	Non-Alarm state	Alarm state	—	○	Note 2
RXn4	Contact Input	OFF(open)	ON(close)	—	○	Note 4
RXn5	Alarm (total)	Non-Alarm state	Alarm state	—	○	Note 2
RXn6	Reserved	—	—	—	—	
RXn7	Reserved	—	—	—	—	
RXn8	Alarm of Voltage	Non-Alarm state	Alarm state	—	○	Note 2
RXn9	Reserved	—	—	—	—	
RXnA	Reserved	—	—	—	—	
RXnB	Reserved	—	—	—	—	
RXnC	Reserved	—	—	—	—	
RXnD	Alarm of Power factor	Non-Alarm state	Alarm state	—	○	Note 2
RXnE	Reserved	—	—	—	—	
RXnF	Command completion reply flag	No receiving of reply date	Receiving of reply data	○	○	Note 1 Note 5
RX(n+1)0	Reserved	—	—	—	—	
RX(n+1)1	Reserved	—	—	—	—	
RX(n+1)2	Reserved	—	—	—	—	
RX(n+1)3	Reserved	—	—	—	—	
RX(n+1)4	Reserved	—	—	—	—	
RX(n+1)5	Reserved	—	—	—	—	
RX(n+1)6	Reserved	—	—	—	—	
RX(n+1)7	Reserved	—	—	—	—	
RX(n+1)8	Initial data processing request flag	Power OFF, remote READY ON, or error status flag ON	Power supply is turned ON or hardware reset	○	○	Note 1
RX(n+1)9	Reserved	—	—	—	—	
RX(n+1)A	Error status flag	No error occurrence	Error occurrence	○	○	Note 1
RX(n+1)B	Remote READY	Command sending not possible	Normally communication status (Command sending possible)	○	○	Note 1
RX(n+1)C	Reserved	—	—	—	—	
RX(n+1)D	Reserved	—	—	—	—	
RX(n+1)E	Reserved	—	—	—	—	
RX(n+1)F	Reserved	—	—	—	—	

Note1: For the details, refer to “Communication Between the Master Station and Measuring Unit”.

Note2: The Alarm is output only when it is set in the Measuring Unit.

Note3: Alarm of Pulse count is available only when Setting of external input signal of EMU4-HD1-MB is setup Pulse input.

Note4: Contact Input is available only when Setting of external input signal of EMU4-HD1-MB is setup Contact input.

Note5: Please monitor External input 1 (Group:A0, Channel:31) in data monitor command.

Note6: RX is bit data which is stored the input status of Measuring Unit.

Note7: The “n” in the table is determined by the station number of Measuring Unit.

Device No.	Signal name	Description		EMU4-BM1-MB	EMU4-HM1-MB	EMU4-LG1-MB	Note
		OFF(0)	ON(1)				
RXn0	Alarm of Pulse	Non-Alarm state	Alarm state	—	○	—	Note 2 Note 3
RXn1	Reserved	Non-Alarm state	Alarm state	—	—	—	
RXn2	Alarm of Demand current	Non-Alarm state	Alarm state	○	○	—	Note 2
RXn3	Alarm of Demand Active power	Non-Alarm state	Alarm state	○	○	—	Note 2
RXn4	Contact Input	OFF(open)	ON(close)	—	○	—	Note 4
RXn5	Alarm (total)	Non-Alarm state	Alarm state	○	○	—	Note 2
RXn6	Alarm of Current unbalance rate upper limit	Non-Alarm state	Alarm state	○	○	—	Note 2
RXn7	Alarm of Voltage unbalance rate upper limit	Non-Alarm state	Alarm state	○	○	—	Note 2
RXn8	Alarm of Voltage	Non-Alarm state	Alarm state	○	○	—	Note 2
RXn9	Leak current 1-alarm	Non-Alarm state	Alarm state	—	—	○	Note 2
RXnA	Leak current 2-alarm	Non-Alarm state	Alarm state	—	—	○	Note 2
RXnB	Leak current for resistance 1-alarm	Non-Alarm state	Alarm state	—	—	○	Note 2
RXnC	Leak current for resistance 2-alarm	Non-Alarm state	Alarm state	—	—	○	Note 2
RXnD	Alarm of power factor	Non-Alarm state	Alarm state	○	○	—	Note 2
RXnE	Unusable	—	—	—	—	—	
RXnF	Command completion reply flag	No receiving of reply data	Receiving of reply data	○	○	○	Note 1
RX(n+1)0	Reserved	—	—	—	—	—	
RX(n+1)1	Reserved	—	—	—	—	—	
RX(n+1)2	Reserved	—	—	—	—	—	
RX(n+1)3	Reserved	—	—	—	—	—	
RX(n+1)4	Reserved	—	—	—	—	—	
RX(n+1)5	Reserved	—	—	—	—	—	
RX(n+1)6	Reserved	—	—	—	—	—	
RX(n+1)7	Reserved	—	—	—	—	—	
RX(n+1)8	Initial data processing request flag	Power OFF, remote READY ON, or error status flag ON	Power supply is turned ON or hardware reset	○	○	○	Note 1
RX(n+1)9	Reserved	—	—	—	—	—	
RX(n+1)A	Error status flag	No error occurrence	Error occurrence	○	○	○	Note 1
RX(n+1)B	Remote READY	Command sending not possible	Normally communication status (Command sending possible)	○	○	○	Note 1
RX(n+1)C	Reserved	—	—	—	—	—	
RX(n+1)D	Reserved	—	—	—	—	—	
RX(n+1)E	Reserved	—	—	—	—	—	
RX(n+1)F	Reserved	—	—	—	—	—	

Note 1: For the details, refer to "6.Communication Between the Master Station and Measuring Unit"

Note 2: The Alarm is output only when it is set in the Measuring Unit.

Note 3: Alarm of Pulse converted is available only when Setting of external input signal of EMU4-HM1-MB is setup
Pulse input.

Note 4: Contact Input is available only when Setting of external input signal of EMU4-HM1-MB is setup Contact
input.

Note 5: RX is bit data which is stored the input status of Measuring Unit.

Note 6 The "n" in the table is determined by the station number of Measuring Unit.

- (1) Relationships between programmable controller CPU, master module and Measuring Unit(RX)
- 1) The input status of Measuring Unit is stored automatically (for each link scan) in the master station's "remote input RX" buffer memory.
 - 2) The input status stored in the "remote input RX" buffer memory is stored in the CPU device set with the automatic refresh parameters.

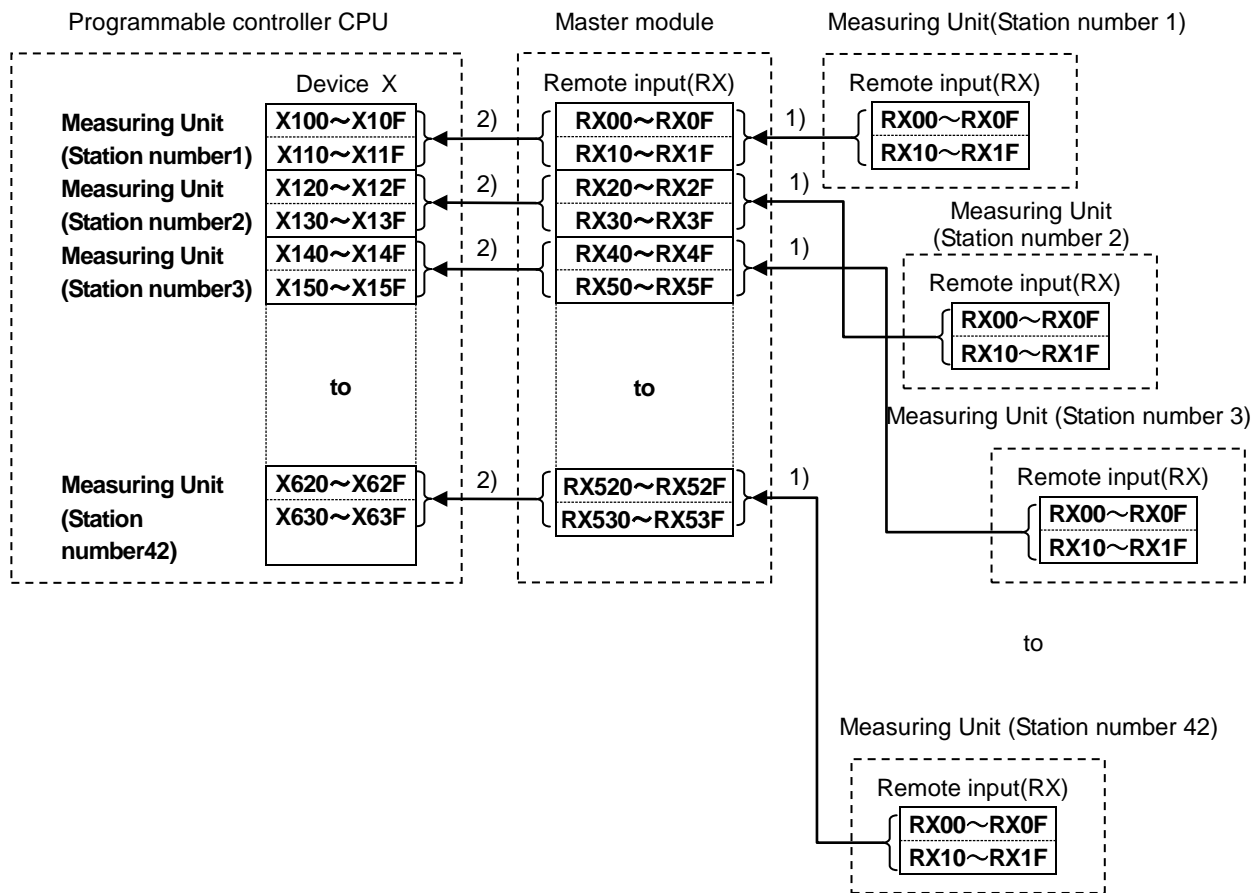

Station number	Device No.	Station number	Device No.	Station number	Device No.
1	X100 ~ X11F	15	X2C0 ~ X2D9	29	X480 ~ X49F
2	X120 ~ X13F	16	X2E0 ~ X2F9	30	X4A0 ~ X4B9
3	X140 ~ X15F	17	X300 ~ X31F	31	X4C0 ~ X4D9
4	X160 ~ X17F	18	X320 ~ X33F	32	X4E0 ~ X4F9
5	X180 ~ X19F	19	X340 ~ X35F	33	X500 ~ X51F
6	X1A0 ~ X1B9	20	X360 ~ X37F	34	X520 ~ X53F
7	X1C0 ~ X1D9	21	X380 ~ X39F	35	X540 ~ X55F
8	X1E0 ~ X1F9	22	X3A0 ~ X3B9	36	X560 ~ X57F
9	X200 ~ X21F	23	X3C0 ~ X3D9	37	X580 ~ X59F
10	X220 ~ X23F	24	X3E0 ~ X3F9	38	X5A0 ~ X5B9
11	X240 ~ X25F	25	X400 ~ X41F	39	X5C0 ~ X5D9
12	X260 ~ X27F	26	X420 ~ X43F	40	X5E0 ~ X5F9
13	X280 ~ X29F	27	X440 ~ X45F	41	X600 ~ X61F
14	X2A0 ~ X2B9	28	X460 ~ X47F	42	X620 ~ X63F

Device No. is determined to "X100~X63F" if refresh device of remote input (RX) is set to "X100".

7.1.2 Remote Output RY

The allocation of the remote output RY of Measuring Unit is shown in the table below.

Device No.	Signal name	Description		Note
		ON(1)→OFF(0)	OFF(0)→ON(1)	
RYn0	Reserved	—	—	
RYn1	Reserved	—	—	
RYn2	Reserved	—	—	
RYn3	Reserved	—	—	
RYn4	Reserved	—	—	
RYn5	Reserved	—	—	
RYn6	Reserved	—	—	
RYn7	Reserved	—	—	
RYn8	Reserved	—	—	
RYn9	Reserved	—	—	
RYnA	Reserved	—	—	
RYnB	Reserved	—	—	
RYnC	Reserved	—	—	
RYnD	Reserved	—	—	
RYnE	Reserved	—	—	
RYnF	Command execution request flag	Cancel command request	Command request	Note 1
RY(n+1)0	Reserved	—	—	
RY(n+1)1	Reserved	—	—	
RY(n+1)2	Reserved	—	—	
RY(n+1)3	Reserved	—	—	
RY(n+1)4	Reserved	—	—	
RY(n+1)5	Reserved	—	—	
RY(n+1)6	Reserved	—	—	
RY(n+1)7	Reserved	—	—	
RY(n+1)8	Initial data setting completion flag	Cancel normal communication request	Normal communication request	Note 1
RY(n+1)9	Reserved	—	—	
RY(n+1)A	Error reset request flag	Cancel error reset request	Error reset request	Note 1
RY(n+1)B	Reserved	—	—	
RY(n+1)C	Reserved	—	—	
RY(n+1)D	Reserved	—	—	
RY(n+1)E	Reserved	—	—	
RY(n+1)F	Reserved	—	—	

Note 1: For the details, refer to “6.Communication Between the Master Station and Measuring Unit”

Note 2: RY is bit device which is sent by the program.

Note 3: The “n” in the table is determined by the station number of Measuring Unit.

Point
Do not read or write to reserved remote registers. If reading or writing is performed, the functions of Measuring Unit is not guaranteed.

- (1) Relationships between programmable controller CPU, master module and Measuring Unit(RY)
- 1) The on/off data of the CPU device set with the automatic refresh parameters is stored in the "remote output RY" buffer memory.
 - 2) Remote output RY is automatically set to on/off (for each link scan) according to the output status stored in the "remote output RY" buffer memory.

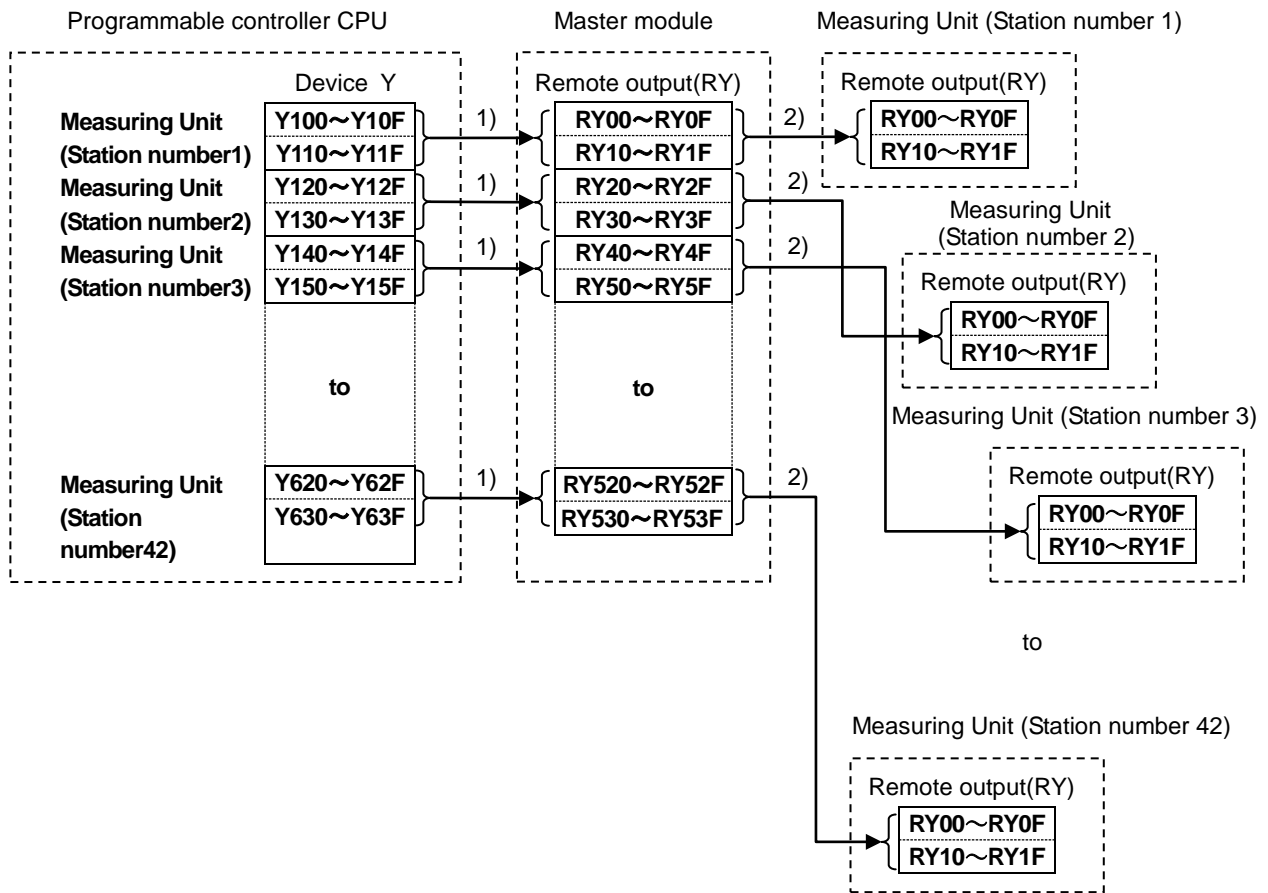

Station number	Device No.	Station number	Device No.	Station number	Device No.
1	Y100 ~ Y11F	15	Y2C0 ~ Y2D9	29	Y480 ~ Y49F
2	Y120 ~ Y13F	16	Y2E0 ~ Y2F9	30	Y4A0 ~ Y4B9
3	Y140 ~ Y15F	17	Y300 ~ Y31F	31	Y4C0 ~ Y4D9
4	Y160 ~ Y17F	18	Y320 ~ Y33F	32	Y4E0 ~ Y4F9
5	Y180 ~ Y19F	19	Y340 ~ Y35F	33	Y500 ~ Y51F
6	Y1A0 ~ Y1B9	20	Y360 ~ Y37F	34	Y520 ~ Y53F
7	Y1C0 ~ Y1D9	21	Y380 ~ Y39F	35	Y540 ~ Y55F
8	Y1E0 ~ Y1F9	22	Y3A0 ~ Y3B9	36	Y560 ~ Y57F
9	Y200 ~ Y21F	23	Y3C0 ~ Y3D9	37	Y580 ~ Y59F
10	Y220 ~ Y23F	24	Y3E0 ~ Y3F9	38	Y5A0 ~ Y5B9
11	Y240 ~ Y25F	25	Y400 ~ Y41F	39	Y5C0 ~ Y5D9
12	Y260 ~ Y27F	26	Y420 ~ Y43F	40	Y5E0 ~ Y5F9
13	Y280 ~ Y29F	27	Y440 ~ Y45F	41	Y600 ~ Y61F
14	Y2A0 ~ Y2B9	28	Y460 ~ Y47F	42	Y620 ~ Y63F

Device No. is determined to "Y100~Y63F" if refresh device of remote output (RY) is set to "Y100".

7.2 Remote Register (RWr, RWw)

The remote register RWr and RWw are used to communicate word data between the master station and Measuring Unit. Because it occupies 1 station, the remote registers RWr and RWw each have 4 words in length. Measuring Unit has the special-purpose commands for each measurement items and setting items. It becomes possible to monitor each measurement values or set each parameters by writing into the remote register RWw of the master station command and the related data allocated to the item you want to monitor or set.

- (1) Relationships between programmable controller CPU, master module and Measuring Unit(RWr)
 - 1) The remote register RWr data of a remote device station is automatically stored in the "remote register Rwr" buffer memory of the master station.
 - 2) The remote register RWr data of Measuring Unit stored in the "remote register RWr" buffer memory is stored in the CPU device set with the automatic refresh parameters.

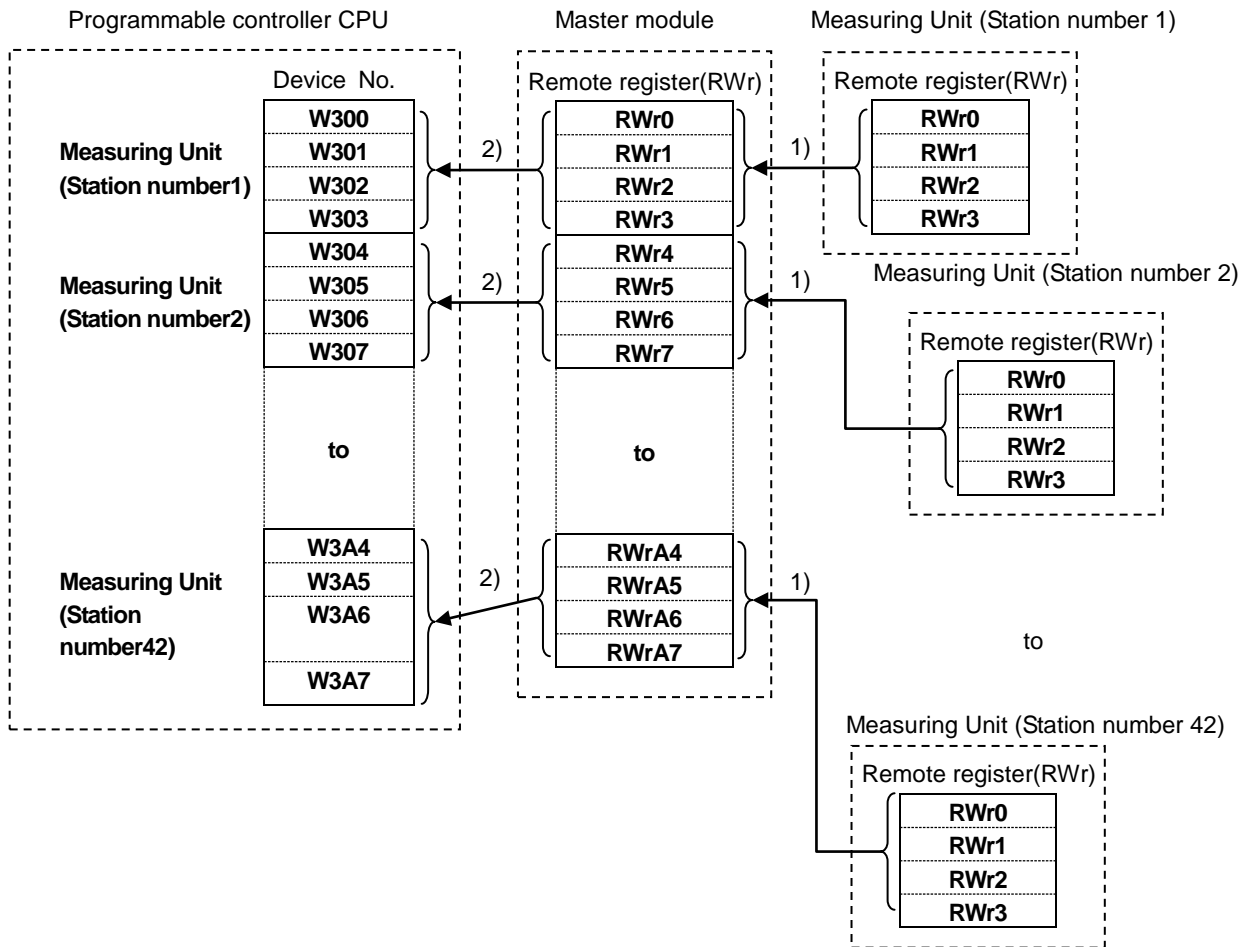

Station number	Device No.	Station number	Device No.	Station number	Device No.
1	W300 ~ W303	15	W338 ~ W33B	29	W370 ~ W373
2	W304 ~ W307	16	W33C ~ W33F	30	W374 ~ W377
3	W308 ~ W30B	17	W340 ~ W343	31	W378 ~ W37B
4	W30C ~ W30F	18	W344 ~ W347	32	W37C ~ W37F
5	W310 ~ W313	19	W348 ~ W34B	33	W380 ~ W383
6	W314 ~ W317	20	W34C ~ W34F	34	W384 ~ W387
7	W318 ~ W31B	21	W350 ~ W353	35	W388 ~ W38B
8	W31C ~ W31F	22	W354 ~ W357	36	W38C ~ W38F
9	W320 ~ W323	23	W358 ~ W35B	37	W390 ~ W393
10	W324 ~ W327	24	W35C ~ W35F	38	W394 ~ W397
11	W328 ~ W32B	25	W360 ~ W363	39	W398 ~ W39B
12	W32C ~ W32F	26	W364 ~ W367	40	W39C ~ W39F
13	W330 ~ W333	27	W368 ~ W36B	41	W3A0 ~ W3A3
14	W334 ~ W337	28	W36C ~ W36F	42	W3A4 ~ W3A7

Device No. is determined to "W300~W3A7" if refresh device of remote register (RW_r) is set to "W300".

- (2) Relationships between programmable controller CPU, master module and Measuring Unit(RWw)
- 1) The transmission data of the CPU device set with the automatic refresh parameters is stored in the "remote register RWw" buffer memory.
 - 2) The data stored in the "remote register RWw" buffer memory is automatically sent to the remote register RWw of each remote device station.

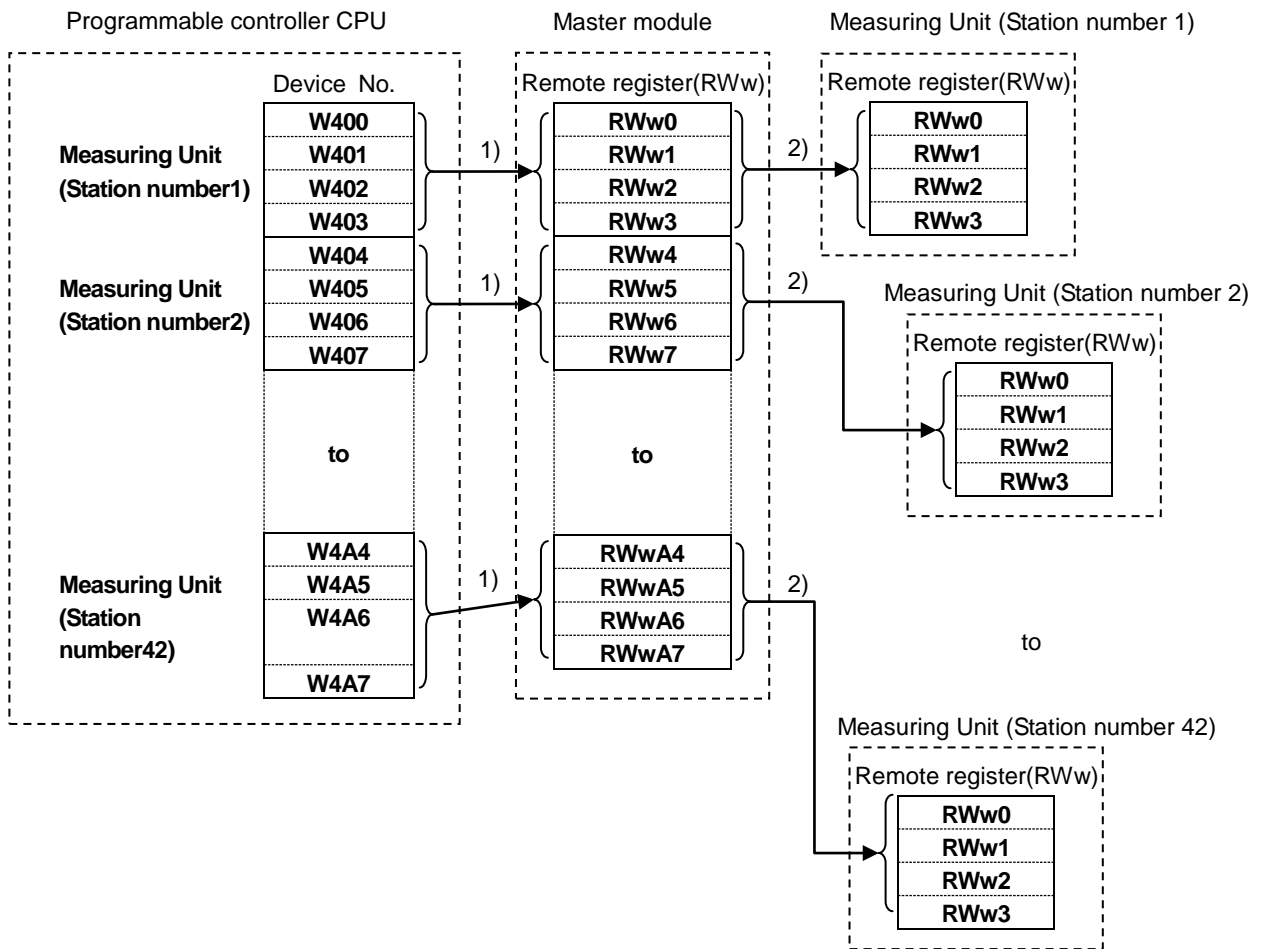

Station number	Device No.	Station number	Device No.	Station number	Device No.
1	W400 ~ W403	15	W438 ~ W43B	29	W470 ~ W473
2	W404 ~ W407	16	W43C ~ W43F	30	W474 ~ W477
3	W408 ~ W40B	17	W440 ~ W443	31	W478 ~ W47B
4	W40C ~ W40F	18	W444 ~ W447	32	W47C ~ W47F
5	W410 ~ W413	19	W448 ~ W44B	33	W480 ~ W483
6	W414 ~ W417	20	W44C ~ W44F	34	W484 ~ W487
7	W418 ~ W41B	21	W450 ~ W453	35	W488 ~ W48B
8	W41C ~ W41F	22	W454 ~ W457	36	W48C ~ W48F
9	W420 ~ W423	23	W458 ~ W45B	37	W490 ~ W493
10	W424 ~ W427	24	W45C ~ W45F	38	W494 ~ W497
11	W428 ~ W42B	25	W460 ~ W463	39	W498 ~ W49B
12	W42C ~ W42F	26	W464 ~ W467	40	W49C ~ W49F
13	W430 ~ W433	27	W468 ~ W46B	41	W4A0 ~ W4A3
14	W434 ~ W437	28	W46C ~ W46F	42	W4A4 ~ W4A7

Device No. is determined to "W400~W4A7" if refresh device of remote register (RWw) is set to "W400".

7.2.1 Supported Command

The commands supported by Measuring Unit are listed in the table below. For the details of each commands, refer to "7.2.2 Details of Commands".

(1) Command

Table 7.1 Supported Commands

Command	Name	Description	Note	page
1H	Data Monitor	For monitoring measurement		27
2H	Data Set	For setting measurement		44

Note) 1: The command can be sent only when the remote READY is ON.

2: The command execution request flag and command completion reply flag are used to send the command and receive replay data. For details of each flag, refer to "6.4 Normal Communication".

3: In case of monitoring the present value and its maximum continuously according to the renewal data timing of Measuring Unit, the maximum may be smaller than the present value.

Table 7.2 Group Channel List for Data Monitor Command (1H) (1/15)

Group (H)	Channel (H)	Note	Data type	Content name			EMU2-HM1-C	EMU2-RD *1	EMU3-DP1-C	EMU4-BD1-MB	EMU4-HD1-MB	Data format				
F0	02		Set-up	Model code			○	○	○	○	○	⑤				
E0	11			Primary current			○	○	○	○	○	④				
E0	12			Primary voltage (L-L)			○	○	○	○	○					
E0	1B	*2		Primary voltage (L-N)			—	—	—	—	○					
E0	1C			Secondary voltage (L-L/L-N)			—	—	—	○	○					
E0	13			Phase & Wiring			○	○	○	○	○	⑤				
E0	16	*5		Time constant for total demand			min	○	○	○	—		—			
02	E0			Time constant for DA			sec	○	○	○	○		○			
08	E0			Time constant for DW			sec	○	○	○	○		○			
12	E0			Time constant for leakage current demand			sec	—	—	○	—		—			
E0	92			5A/Direct				○	○	—	○		○			
E0	8B			Connected phase switch				—	—	○	—		—			
01	01			Measurement	Average current			A	Inst.	○	○	○	○	①		
01	21				Phase 1 current			A	Inst.	○	○	○	○			
01	41	*1	Phase 2 current			A	Inst.	○	○	○	○					
01	61	*1	Phase 3 current			A	Inst.	○	○	○	○					
01	81	*2	Phase N current			A	Inst.	—	○	—	—	○				
02	21		Phase 1 current demand			A	Inst.	○	○	○	○	○				
02	41	*1	Phase 2 current demand			A	Inst.	○	○	○	○	○				
02	61	*1	Phase 3 current demand			A	Inst.	○	○	○	○	○				
02	81	*2	Phase N current demand			A	Inst.	—	○	—	—	○				
02	A1		Maximum rate current demand			A	Inst.	○	○	—	—	—				
02	C5		Average current demand			A	Min.	○	○	○	—	—				
02	A2		Average current demand			A	Max.	○	○	○	—	—				
02	A3		Max. occurrence time		Date and time of above occurrence					—	—	○	—		—	⑥
03	21	*2	Measurement		1-N voltage			V	Inst.	—	○	—	—		○	①
03	41	*2		2-N voltage			V	Inst.	—	○	—	—	○			
03	61	*2		3-N voltage			V	Inst.	—	○	—	—	○			
05	01			Average L-L voltage			V	Inst.	○	○	○	○	○			
05	21			1-2 voltage			V	Inst.	○	○	○	○	○			
05	41	*1		2-3 voltage			V	Inst.	○	○	○	○	○			
05	61	*1		3-1 voltage			V	Inst.	○	○	○	○	○			
05	A2			Average L-L voltage			V	Max.	○	○	○	—	—			
05	A3		Max. occurrence time	Date and time of above occurrence					—	—	○	—	—	⑥		
05	C5		Measurement	Average L-L voltage			V	Min.	○	○	○	—	—	①		
07	01	*3		Active power			kW	Inst. Total	○	○	○	○	○			
08	01	*3		Active power demand			kW	Inst. Total	○	○	○	○	○			
08	02	*3		Active power demand			kW	Max. Total	○	○	○	—	—			
08	03		Max. occurrence time	Date and time of above occurrence					—	—	○	—	—	⑥		
08	05	*3	Measurement	Active power demand			kW	Min. Total	○	○	○	—	—	①		
09	01	*3		Reactive power			kvar	Inst. Total	—	○	○	○	○			
0B	01	*2 *3		Apparent power			kVA	Inst. Total	—	—	—	—	○			
0D	01			Power factor			%	Inst. Total	○	○	○	○	○			
0D	02			Power factor			%	Max. Total	○	○	○	—	—			
0D	05			Power factor			%	Min. Total	○	○	○	—	—			
0F	01			Frequency			Hz	Inst.	—	○	○	○	○			

Inst.: Instantaneous value. Max.: Maximum value. Min.: Minimum value. RMS.: Root-Mean-Square value.

Note: Measurement data correspond as follows according to setting of phase wiring. (Maximum / Minimum data and harmonic data are same.)

Name of channel	Phase wiring			
	3P3W	1P3W(1N3)	1P3W(1N2)	1P2W
1-2 voltage	1-2 voltage	1-N voltage	1-N voltage	Voltage
2-3 voltage	2-3 voltage	2-N voltage	2-N voltage	-
3-1 voltage	3-1 voltage	1-3 voltage	1-3 voltage	-
Phase 1 current	Phase 1 current	Phase 1 current	Phase 1 current	Current
Phase 2 current	Phase 2 current	Phase N current	Phase N current	-
Phase 3 current	Phase 3 current	Phase 3 current	Phase 2 current	-

Table 7.2 Group Channel List for Data Monitor Command (1H) (2/15)

Group (H)	Channel (H)	Note	Data type	Content name			EMU2-HM1-C	EMU2-RD *1	EMU3-DP1-C	EMU4-BD1-MB	EMU4-HD1-MB	Data format		
11	01		Measurement	Leakage current (Harmonic non-inclusion)			mA	Inst.	—	—	○	—	①	
12	01	Leakage current demand (Harmonic non-inclusion)			mA	Inst.	—	—	○	—	—			
12	02	Leakage current demand (Harmonic non-inclusion)			mA	Max.	—	—	○	—	—			
12	03		Max. occurrence time	Date and time of above occurrence					—	—	○	—	—	⑥
13	01		Measurement	Leakage current (Harmonic inclusion)			mA	Inst.	—	—	○	—	①	
14	01	Leakage current demand (Harmonic inclusion)			mA	Inst.	—	—	○	—	—			
14	02	Leakage current demand (Harmonic inclusion)			mA	Max.	—	—	○	—	—			
14	03		Max. occurrence time	Date and time of above occurrence					—	—	○	—	—	⑥
63	21	*6	Measurement	1-2 harmonic voltage			V	RMS. Total	—	○	—	—	○	①
4D	21	*6		1-2 harmonic voltage			V	RMS. 1st	—	○	—	—	○	
4F	21	*6		1-2 harmonic voltage			V	RMS. 3rd	—	○	—	—	○	
51	21	*6		1-2 harmonic voltage			V	RMS. 5th	—	○	—	—	○	
53	21	*6		1-2 harmonic voltage			V	RMS. 7th	—	○	—	—	○	
55	21	*6		1-2 harmonic voltage			V	RMS. 9th	—	○	—	—	○	
57	21	*6		1-2 harmonic voltage			V	RMS. 11th	—	○	—	—	○	
59	21	*6		1-2 harmonic voltage			V	RMS. 13th	—	○	—	—	○	
76	86	*6	Measurement	1-2 voltage THD			%	Inst. Total	—	○	—	—	○	①
76	73	*6		1-2 voltage harmonic distortion			%	Inst. 3rd	—	○	—	—	○	
76	75	*6		1-2 voltage harmonic distortion			%	Inst. 5th	—	○	—	—	○	
76	77	*6		1-2 voltage harmonic distortion			%	Inst. 7th	—	○	—	—	○	
76	79	*6		1-2 voltage harmonic distortion			%	Inst. 9th	—	○	—	—	○	
76	7B	*6		1-2 voltage harmonic distortion			%	Inst. 11th	—	○	—	—	○	
76	7D	*6		1-2 voltage harmonic distortion			%	Inst. 13th	—	○	—	—	○	
63	41	*1 *6	Measurement	2-3 harmonic voltage			V	RMS. Total	—	○	—	—	○	①
4D	41	*1 *6		2-3 harmonic voltage			V	RMS. 1st	—	○	—	—	○	
4F	41	*1 *6		2-3 harmonic voltage			V	RMS. 3rd	—	○	—	—	○	
51	41	*1 *6		2-3 harmonic voltage			V	RMS. 5th	—	○	—	—	○	
53	41	*1 *6		2-3 harmonic voltage			V	RMS. 7th	—	○	—	—	○	
55	41	*1 *6		2-3 harmonic voltage			V	RMS. 9th	—	○	—	—	○	
57	41	*1 *6		2-3 harmonic voltage			V	RMS. 11th	—	○	—	—	○	
59	41	*1 *6		2-3 harmonic voltage			V	RMS. 13th	—	○	—	—	○	
76	9C	*1 *6	Measurement	2-3 voltage THD			%	Inst. Total	—	○	—	—	○	①
76	89	*1 *6		2-3 voltage harmonic distortion			%	Inst. 3rd	—	○	—	—	○	
76	8B	*1 *6		2-3 voltage harmonic distortion			%	Inst. 5th	—	○	—	—	○	
76	8D	*1 *6		2-3 voltage harmonic distortion			%	Inst. 7th	—	○	—	—	○	
76	8F	*1 *6		2-3 voltage harmonic distortion			%	Inst. 9th	—	○	—	—	○	
76	91	*1 *6		2-3 voltage harmonic distortion			%	Inst. 11th	—	○	—	—	○	
76	93	*1 *6		2-3 voltage harmonic distortion			%	Inst. 13th	—	○	—	—	○	

Inst.: Instantaneous value. Max.: Maximum value. Min.: Minimum value. RMS.: Root-Mean-Square value.

Table 7.2 Group Channel List for Data Monitor Command (1H) (3/15)

Group (H)	Channel (H)	Note	Data type	Content name				EMU2-HM1-C	EMU2-RD *1	EMU3-DP1-C	EMU4-BD1-MB	EMU4-HD1-MB	Data format
63	61	*2	Measurement	3-1 harmonic voltage	V	RMS.	Total	—	○	—	—	—	①
4D	61	*2		3-1 harmonic voltage	V	RMS.	1st	—	○	—	—	—	
4F	61	*2		3-1 harmonic voltage	V	RMS.	3rd	—	○	—	—	—	
51	61	*2		3-1 harmonic voltage	V	RMS.	5th	—	○	—	—	—	
53	61	*2		3-1 harmonic voltage	V	RMS.	7th	—	○	—	—	—	
55	61	*2		3-1 harmonic voltage	V	RMS.	9th	—	○	—	—	—	
57	61	*2		3-1 harmonic voltage	V	RMS.	11th	—	○	—	—	—	
59	61	*2		3-1 harmonic voltage	V	RMS.	13th	—	○	—	—	—	
76	B2	*2	Measurement	3-1 voltage THD	%	Inst.	Total	—	○	—	—	—	①
76	9F	*2		3-1 voltage harmonic distortion	%	Inst.	3rd	—	○	—	—	—	
76	A1	*2		3-1 voltage harmonic distortion	%	Inst.	5th	—	○	—	—	—	
76	A3	*2		3-1 voltage harmonic distortion	%	Inst.	7th	—	○	—	—	—	
76	A5	*2		3-1 voltage harmonic distortion	%	Inst.	9th	—	○	—	—	—	
76	A7	*2		3-1 voltage harmonic distortion	%	Inst.	11th	—	○	—	—	—	
76	A9	*2	3-1 voltage harmonic distortion	%	Inst.	13th	—	○	—	—	—		
4B	21	*2	Measurement	1-N harmonic voltage	V	RMS.	Total	—	—	—	—	○	①
35	21	*2		1-N harmonic voltage	V	RMS.	1st	—	—	—	—	○	
37	21	*2		1-N harmonic voltage	V	RMS.	3rd	—	—	—	—	○	
39	21	*2		1-N harmonic voltage	V	RMS.	5th	—	—	—	—	○	
3B	21	*2		1-N harmonic voltage	V	RMS.	7th	—	—	—	—	○	
3D	21	*2		1-N harmonic voltage	V	RMS.	9th	—	—	—	—	○	
3F	21	*2		1-N harmonic voltage	V	RMS.	11th	—	—	—	—	○	
41	21	*2	1-N harmonic voltage	V	RMS.	13th	—	—	—	—	○		
77	86	*2	Measurement	1-N voltage THD	%	Inst.	Total	—	—	—	—	○	①
77	73	*2		1-N voltage harmonic distortion	%	Inst.	3rd	—	—	—	—	○	
77	75	*2		1-N voltage harmonic distortion	%	Inst.	5th	—	—	—	—	○	
77	77	*2		1-N voltage harmonic distortion	%	Inst.	7th	—	—	—	—	○	
77	79	*2		1-N voltage harmonic distortion	%	Inst.	9th	—	—	—	—	○	
77	7B	*2		1-N voltage harmonic distortion	%	Inst.	11th	—	—	—	—	○	
77	7D	*2	1-N voltage harmonic distortion	%	Inst.	13th	—	—	—	—	○		
4B	41	*2	Measurement	2-N harmonic voltage	V	RMS.	Total	—	—	—	—	○	①
35	41	*2		2-N harmonic voltage	V	RMS.	1st	—	—	—	—	○	
37	41	*2		2-N harmonic voltage	V	RMS.	3rd	—	—	—	—	○	
39	41	*2		2-N harmonic voltage	V	RMS.	5th	—	—	—	—	○	
3B	41	*2		2-N harmonic voltage	V	RMS.	7th	—	—	—	—	○	
3D	41	*2		2-N harmonic voltage	V	RMS.	9th	—	—	—	—	○	
3F	41	*2		2-N harmonic voltage	V	RMS.	11th	—	—	—	—	○	
41	41	*2	2-N harmonic voltage	V	RMS.	13th	—	—	—	—	○		
77	9C	*2	Measurement	2-N voltage THD	%	Inst.	Total	—	—	—	—	○	①
77	89	*2		2-N voltage harmonic distortion	%	Inst.	3rd	—	—	—	—	○	
77	8B	*2		2-N voltage harmonic distortion	%	Inst.	5th	—	—	—	—	○	
77	8D	*2		2-N voltage harmonic distortion	%	Inst.	7th	—	—	—	—	○	
77	8F	*2		2-N voltage harmonic distortion	%	Inst.	9th	—	—	—	—	○	
77	91	*2		2-N voltage harmonic distortion	%	Inst.	11th	—	—	—	—	○	
77	93	*2	2-N voltage harmonic distortion	%	Inst.	13th	—	—	—	—	○		
4B	61	*2	Measurement	3-N harmonic voltage	V	RMS.	Total	—	—	—	—	○	①
35	61	*2		3-N harmonic voltage	V	RMS.	1st	—	—	—	—	○	
37	61	*2		3-N harmonic voltage	V	RMS.	3rd	—	—	—	—	○	
39	61	*2		3-N harmonic voltage	V	RMS.	5th	—	—	—	—	○	
3B	61	*2		3-N harmonic voltage	V	RMS.	7th	—	—	—	—	○	
3D	61	*2		3-N harmonic voltage	V	RMS.	9th	—	—	—	—	○	
3F	61	*2		3-N harmonic voltage	V	RMS.	11th	—	—	—	—	○	
41	61	*2	3-N harmonic voltage	V	RMS.	13th	—	—	—	—	○		

Inst.: Instantaneous value. Max.: Maximum value. Min.: Minimum value. RMS.: Root-Mean-Square value.

Table 7.2 Group Channel List for Data Monitor Command (1H) (4/15)

Group (H)	Channel (H)	Note	Data type	Content name			EMU2-HM1-C	EMU2-RD *1	EMU3-DP1-C	EMU4-BD1-MB	EMU4-HD1-MB	Data format	
77	B2	*2	Measurement	3-N voltage THD	%	Inst.	Total	—	—	—	—	○	①
77	9F	*2		3-N voltage harmonic distortion	%	Inst.	3rd	—	—	—	—	○	
77	A1	*2		3-N voltage harmonic distortion	%	Inst.	5th	—	—	—	—	○	
77	A3	*2		3-N voltage harmonic distortion	%	Inst.	7th	—	—	—	—	○	
77	A5	*2		3-N voltage harmonic distortion	%	Inst.	9th	—	—	—	—	○	
77	A7	*2		3-N voltage harmonic distortion	%	Inst.	11th	—	—	—	—	○	
77	A9	*2	3-N voltage harmonic distortion	%	Inst.	13th	—	—	—	—	○		
33	21		Measurement	Phase 1 harmonic current	A	RMS.	Total	—	○	○	—	○	①
1D	21			Phase 1 harmonic current	A	RMS.	1st	—	○	○	—	○	
1F	21			Phase 1 harmonic current	A	RMS.	3rd	—	○	○	—	○	
21	21			Phase 1 harmonic current	A	RMS.	5th	—	○	○	—	○	
23	21			Phase 1 harmonic current	A	RMS.	7th	—	○	○	—	○	
25	21			Phase 1 harmonic current	A	RMS.	9th	—	○	○	—	○	
27	21			Phase 1 harmonic current	A	RMS.	11th	—	○	○	—	○	
29	21			Phase 1 harmonic current	A	RMS.	13th	—	○	○	—	○	
2B	21			Phase 1 harmonic current	A	RMS.	15th	—	—	○	—	—	
2D	21			Phase 1 harmonic current	A	RMS.	17th	—	—	○	—	—	
2F	21		Phase 1 harmonic current	A	RMS.	19th	—	—	○	—	—		
75	86		Measurement	Phase 1 current THD	%	Inst.	Total	—	○	○	—	○	①
75	73			Phase 1 current harmonic distortion	%	Inst.	3rd	—	○	○	—	○	
75	75			Phase 1 current harmonic distortion	%	Inst.	5th	—	○	○	—	○	
75	77			Phase 1 current harmonic distortion	%	Inst.	7th	—	○	○	—	○	
75	79			Phase 1 current harmonic distortion	%	Inst.	9th	—	○	○	—	○	
75	7B			Phase 1 current harmonic distortion	%	Inst.	11th	—	○	○	—	○	
75	7D			Phase 1 current harmonic distortion	%	Inst.	13th	—	○	○	—	○	
75	7F			Phase 1 current harmonic distortion	%	Inst.	15th	—	—	○	—	—	
75	81			Phase 1 current harmonic distortion	%	Inst.	17th	—	—	○	—	—	
75	83		Phase 1 current harmonic distortion	%	Inst.	19th	—	—	○	—	—		
33	41	*2	Measurement	Phase 2 harmonic current	A	RMS.	Total	—	○	—	—	○	①
1D	41	*2		Phase 2 harmonic current	A	RMS.	1st	—	○	—	—	○	
1F	41	*2		Phase 2 harmonic current	A	RMS.	3rd	—	○	—	—	○	
21	41	*2		Phase 2 harmonic current	A	RMS.	5th	—	○	—	—	○	
23	41	*2		Phase 2 harmonic current	A	RMS.	7th	—	○	—	—	○	
25	41	*2		Phase 2 harmonic current	A	RMS.	9th	—	○	—	—	○	
27	41	*2		Phase 2 harmonic current	A	RMS.	11th	—	○	—	—	○	
29	41	*2	Phase 2 harmonic current	A	RMS.	13th	—	○	—	—	○		
75	9C	*2	Measurement	Phase 2 current THD	%	Inst.	Total	—	○	—	—	○	①
75	89	*2		Phase 2 current harmonic distortion	%	Inst.	3rd	—	○	—	—	○	
75	8B	*2		Phase 2 current harmonic distortion	%	Inst.	5th	—	○	—	—	○	
75	8D	*2		Phase 2 current harmonic distortion	%	Inst.	7th	—	○	—	—	○	
75	8F	*2		Phase 2 current harmonic distortion	%	Inst.	9th	—	○	—	—	○	
75	91	*2		Phase 2 current harmonic distortion	%	Inst.	11th	—	○	—	—	○	
75	93	*2	Phase 2 current harmonic distortion	%	Inst.	13th	—	○	—	—	○		
33	61	*1	Measurement	Phase 3 harmonic current	A	RMS.	Total	—	○	○	—	○	①
1D	61	*1		Phase 3 harmonic current	A	RMS.	1st	—	○	○	—	○	
1F	61	*1		Phase 3 harmonic current	A	RMS.	3rd	—	○	○	—	○	
21	61	*1		Phase 3 harmonic current	A	RMS.	5th	—	○	○	—	○	
23	61	*1		Phase 3 harmonic current	A	RMS.	7th	—	○	○	—	○	
25	61	*1		Phase 3 harmonic current	A	RMS.	9th	—	○	○	—	○	
27	61	*1		Phase 3 harmonic current	A	RMS.	11th	—	○	○	—	○	
29	61	*1		Phase 3 harmonic current	A	RMS.	13th	—	○	○	—	○	
2B	61	*1		Phase 3 harmonic current	A	RMS.	15th	—	—	○	—	—	
2D	61	*1		Phase 3 harmonic current	A	RMS.	17th	—	—	○	—	—	
2F	61	*1	Phase 3 harmonic current	A	RMS.	19th	—	—	○	—	—		

Inst.: Instantaneous value. Max.: Maximum value. Min.: Minimum value. RMS.: Root-Mean-Square value.

Table 7.2 Group Channel List for Data Monitor Command (1H) (5/15)

Group (H)	Channel (H)	Note	Data type	Content name			EMU2-HM1-C	EMU2-RD *1	EMU3-DP1-C	EMU4-BD1-MB	EMU4-HD1-MB	Data format		
75	B2	*1	Measurement	Phase 3 current THD	%	Inst. Total	—	○	○	—	○	①		
75	9F	*1		Phase 3 current harmonic distortion	%	Inst. 3rd	—	○	○	—	○			
75	A1	*1		Phase 3 current harmonic distortion	%	Inst. 5th	—	○	○	—	○			
75	A3	*1		Phase 3 current harmonic distortion	%	Inst. 7th	—	○	○	—	○			
75	A5	*1		Phase 3 current harmonic distortion	%	Inst. 9th	—	○	○	—	○			
75	A7	*1		Phase 3 current harmonic distortion	%	Inst. 11th	—	○	○	—	○			
75	A9	*1		Phase 3 current harmonic distortion	%	Inst. 13th	—	○	○	—	○			
75	AB	*1		Phase 3 current harmonic distortion	%	Inst. 15th	—	—	○	—	—			
75	AD	*1		Phase 3 current harmonic distortion	%	Inst. 17th	—	—	○	—	—			
75	AF	*1		Phase 3 current harmonic distortion	%	Inst. 19th	—	—	○	—	—			
33	81	*2	Measurement	Phase N harmonic current	A	RMS. Total	—	—	—	—	○	①		
1D	81	*2		Phase N harmonic current	A	RMS. 1st	—	—	—	—	○			
1F	81	*2		Phase N harmonic current	A	RMS. 3rd	—	—	—	—	○			
21	81	*2		Phase N harmonic current	A	RMS. 5th	—	—	—	—	○			
23	81	*2		Phase N harmonic current	A	RMS. 7th	—	—	—	—	○			
25	81	*2		Phase N harmonic current	A	RMS. 9th	—	—	—	—	○			
27	81	*2		Phase N harmonic current	A	RMS. 11th	—	—	—	—	○			
29	81	*2	Phase N harmonic current	A	RMS. 13th	—	—	—	—	○				
75	C8	*2	Measurement	Phase N current THD	%	Inst. Total	—	—	—	—	○	①		
75	B5	*2		Phase N current harmonic distortion	%	Inst. 3rd	—	—	—	—	○			
75	B7	*2		Phase N current harmonic distortion	%	Inst. 5th	—	—	—	—	○			
75	B9	*2		Phase N current harmonic distortion	%	Inst. 7th	—	—	—	—	○			
75	BB	*2		Phase N current harmonic distortion	%	Inst. 9th	—	—	—	—	○			
75	BD	*2		Phase N current harmonic distortion	%	Inst. 11th	—	—	—	—	○			
75	BF	*2	Phase N current harmonic distortion	%	Inst. 13th	—	—	—	—	○				
80	01		Measurement	Active energy (import)	kWh	count		○	○	○	○	②		
80	63			Active energy (export)	kWh	count		—	—	—	○		○	
81	01			Reactive energy (import lag)	kvar	count		—	○	○	○		○	
80	64			Active energy (import)	kWh	count	expand	○	○	○	○		○	
80	65			Active energy (export)	kWh	count	expand	—	—	—	○		○	
81	66			Reactive energy (import lag)	kvar	count	expand	—	○	○	○		○	
83	01			Pulse count 1	pulse	count		—	—	○	—		○	⑦
84	01			Pulse count 2	pulse	count		—	—	○	—		—	
87	01			Operating time 1	min	count		—	—	○	○		○	
88	01			Operating time 2	min	count		—	—	○	—		—	
8B	01	*7		Active energy during operation 1	kWh	count		—	—	○	—	○	②	
8C	01			Active energy during operation 2	kWh	count		—	—	○	—	—		
E0	03			Date and time				○	○	○	—	—	⑥	
A0	31		Alarm state	Alarm state		Alarm		○	○	○	—	○	③	

Inst.: Instantaneous value. Max.: Maximum value. Min.: Minimum value. RMS.: Root-Mean-Square value.

Table 7.2 Group Channel List for Data Monitor Command (1H) (6/15)

Group (H)	Channel (H)	Note	Data type	Content name	EMU4-BM1-MB	EMU4-HM1-MB	EMU4-A2	EMU4-VA2	Data format	
F0	02		Set-up	Model code	—	○	○	○	○	⑤
E0	11			Primary current	A	○	○	○	○	④
E0	12			Primary voltage (L-L)	V	○	○	○	○	
E0	1B	*2		Primary voltage (L-N)	V	—	○	—	—	
E0	1C			Secondary voltage (L-L/L-N)	V	○	○	○	○	
E0	13			Phase & Wiring	—	○	○	○	○	⑤
E0	21			VT use or non-use	—	○	○	○	○	
02	E0			Time constant for DA	sec	○	○	○	○	
02	E7			Time constant for DA(3side)	sec	○	○	○	○	
08	E0			Time constant for DW	sec	○	○	○	○	
08	E7			Time constant for DW(3side)	sec	○	○	○	○	
E0	92			5A/Direct	—	○	○	○	○	
E0	97			External input	—	—	○	—	—	
E0	98			Contact input	—	—	○	—	—	
E0	99			External output	—	—	○	○	○	
E0	9A			External output circuit	—	—	○	○	○	
83	E6			Unit of pulse output	—	—	○	○	○	
87	E2			Counting operating time	—	○	○	○	○	
8E	E2			Counting operating time(3side)	—	○	○	○	○	
87	E3			Counting method of operating time	—	—	○	—	—	
8E	E3			Counting method of operating time(3side)	—	—	○	—	—	
01	E8			Cut-off setup	%	○	○	○	○	①
01	EA			Cut-off setup(3side)	%	○	○	○	○	
83	E4			Pulse conversion	—	—	○	—	—	⑤
83	E5			Pulse conversion unit	—	—	○	—	—	
80	E4			Electric energy conversion	—	—	○	○	○	①
8A	E4			Electric energy conversion(3side)	—	—	○	○	○	
80	E5			Electric energy conversion unit	—	—	○	○	○	⑤
8A	E5			Electric energy conversion unit(3side)	—	—	○	○	○	
E0	9C			Upper and lower limit alarm extence	—	○	○	○	○	
E0	A6			Upper and lower limit alarm extence(3side)	—	○	○	○	○	
E0	9D			Upper and lower limit alarm element	—	○	○	○	○	①
E0	A7			Upper and lower limit alarm element(3side)	—	○	○	○	○	
E0	9E			Upper and lower limit alarm value	—	○	○	○	○	①
E0	A8			Upper and lower limit alarm value(3side)	—	○	○	○	○	
E0	9F			Alarm delay time	—	○	○	○	○	⑤
E0	A9			Alarm delay time(3side)	—	○	○	○	○	
E0	A0			Alarm reset method	—	○	○	○	○	
E0	AA			Alarm reset method(3side)	—	○	○	○	○	
E0	AB			Simple measuring setup	—	○	○	○	○	①
E0	AC		Power factor setup in simple measuring	—	○	○	○	○		
E0	AD		Power factor setup in simple measuring(3side)	—	○	○	○	○	⑤	
E0	B1		2 circuits measuring	—	○	○	○	○		
01	01		Measurement	Average current	A	Inst.	○	○	○	①
01	21			Phase 1 current	A	Inst.	○	○	○	
01	41	*1		Phase 2 current	A	Inst.	○	○	○	
01	61	*1		Phase 3 current	A	Inst.	○	○	○	
01	81	*2		Phase N current	A	Inst.	—	○	—	
01	1E			Current unbalance rate	%	○	○	○	○	
02	21			Phase 1 current demand	A	Inst.	○	○	○	
02	41	*1		Phase 2 current demand	A	Inst.	○	○	○	
02	61	*1		Phase 3 current demand	A	Inst.	○	○	○	
02	81	*2		Phase N current demand	A	Inst.	—	○	—	

Table 7.2 Group Channel List for Data Monitor Command (1H) (7/15)

Group (H)	Channel (H)	Note	Data type	Content name				EMU4-B M1-MB	EMU4-H M1-MB	EMU4-A2	EMU4-VA2	Data format
03	21	*2	Measurement	1-N voltage	V	Inst.		—	○	—	—	①
03	41	*2		2-N voltage	V	Inst.		—	○	—	—	
03	61	*2		3-N voltage	V	Inst.		—	○	—	—	
03	1E			Voltage unbalance rate	%			○	○	○	○	
05	01			Average L-L voltage	V	Inst.		○	○	○	○	
05	21			1-2 voltage	V	Inst.		○	○	○	○	
05	41	*1		2-3 voltage	V	Inst.		○	○	○	○	
05	61	*1		3-1 voltage	V	Inst.		○	○	○	○	
05	A2			Average L-L voltage	V	Max.		○	○	○	—	
07	01	*3		Measurement	Active power	kW	Inst.		○	○	○	
07	61	*3	Active power(3side)		kW	Inst.		○	○	○	○	
08	01	*3	Active power demand		kW	Inst.		○	○	○	○	
08	61	*3	Active power demand(3side)		kW	Inst.		○	○	○	○	
09	01	*3	Reactive power		kvar	Inst.	Total	○	○	○	○	
09	61	*3	Reactive power(3side)		kvar	Inst.	Total	—	○	○	○	
0B	01	*2 *3	Apparent power		kVA	Inst.	Total	—	○	○	○	
0D	01		Power factor		%	Inst.	Total	○	○	○	○	
0D	61		Power factor(3side)		%	Inst.	Total	○	○	○	○	
0F	01		Frequency		Hz	Inst.		○	○	○	○	
63	21		Measurement	Harmonics total voltage RMS(1-2)	V			—	○	○	○	①
4D	21			Harmonic voltage fundamental(1-2)	V			—	○	○	○	
4F	21			Harmonic voltage 3rd(1-2)	V			—	○	○	○	
51	21			Harmonic voltage 5th(1-2)	V			—	○	○	○	
53	21			Harmonic voltage 7th(1-2)	V			—	○	○	○	
55	21			Harmonic voltage 9th(1-2)	V			—	○	○	○	
57	21			Harmonic voltage 11th(1-2)	V			—	○	○	○	
59	21			Harmonic voltage 13th(1-2)	V			—	○	○	○	
76	86		Measurement	Harmonics total voltage distortion ratio(1-2)	%			—	○	○	○	①
76	73			Harmonics voltage 3rd distortion ratio(1-2)	%			—	○	○	○	
76	75			Harmonics voltage 5th distortion ratio(1-2)	%			—	○	○	○	
76	77			Harmonics voltage 7th distortion ratio(1-2)	%			—	○	○	○	
76	79			Harmonics voltage 9th distortion ratio(1-2)	%			—	○	○	○	
76	7B			Harmonics voltage 11th distortion ratio(1-2)	%			—	○	○	○	
76	7D			Harmonics voltage 13th distortion ratio(1-2)	%			—	○	○	○	
63	41		Measurement	Harmonics total voltage RMS(2-3)	V			—	○	○	○	①
4D	41			Harmonic voltage fundamental(2-3)	V			—	○	○	○	
4F	41			Harmonic voltage 3rd(2-3)	V			—	○	○	○	
51	41			Harmonic voltage 5th(2-3)	V			—	○	○	○	
53	41			Harmonic voltage 7th(2-3)	V			—	○	○	○	
55	41			Harmonic voltage 9th(2-3)	V			—	○	○	○	
57	41			Harmonic voltage 11th(2-3)	V			—	○	○	○	
59	41		Harmonic voltage 13th(2-3)	V			—	○	○	○		
76	9C		Measurement	Harmonics total voltage distortion ratio(2-3)	%			—	○	○	○	①
76	89			Harmonics voltage 3rd distortion ratio(2-3)	%			—	○	○	○	
76	8B			Harmonics voltage 5th distortion ratio(2-3)	%			—	○	○	○	
76	8D			Harmonics voltage 7th distortion ratio(2-3)	%			—	○	○	○	
76	8F			Harmonics voltage 9th distortion ratio(2-3)	%			—	○	○	○	
76	91			Harmonics voltage 11th distortion ratio(2-3)	%			—	○	○	○	
76	93			Harmonics voltage 13th distortion ratio(2-3)	%			—	○	○	○	

Table 7.2 Group Channel List for Data Monitor Command (1H) (8/15)

Group (H)	Channel (H)	Note	Data type	Content name				EMU4-B M1-MB	EMU4-H M1-MB	EMU4-A2	EMU4-VA2	Data format
4B	21		Measurement	Harmonic total voltage RMS(1-N)	V			—	○	○	○	①
35	21	Harmonic voltage fundamental(1-N)		V			—	○	○	○		
37	21	Harmonic voltage 3rd(1-N)		V			—	○	○	○		
39	21	Harmonic voltage 5th(1-N)		V			—	○	○	○		
3B	21	Harmonic voltage 7th(1-N)		V			—	○	○	○		
3D	21	Harmonic voltage 9th(1-N)		V			—	○	○	○		
3F	21	Harmonic voltage 11th(1-N)		V			—	○	○	○		
41	21	Harmonic voltage 13th(1-N)		V			—	○	○	○		
77	86		Measurement	Harmonics total voltage distortion ratio(1-N)	%			—	○	○	○	①
77	73	Harmonics voltage 3rd distortion ratio(1-N)		%			—	○	○	○		
77	75	Harmonics voltage 5th distortion ratio(1-N)		%			—	○	○	○		
77	77	Harmonics voltage 7th distortion ratio(1-N)		%			—	○	○	○		
77	79	Harmonics voltage 9th distortion ratio(1-N)		%			—	○	○	○		
77	7B	Harmonics voltage 11th distortion ratio(1-N)		%			—	○	○	○		
77	7D	Harmonics voltage 13th distortion ratio(1-N)		%			—	○	○	○		
4B	41		Measurement	Harmonics total voltage RMS(2-N)	V			—	○	○	○	①
35	41	Harmonic voltage fundamental(2-N)		V			—	○	○	○		
37	41	Harmonic voltage 3rd(2-N)		V			—	○	○	○		
39	41	Harmonic voltage 5th(2-N)		V			—	○	○	○		
3B	41	Harmonic voltage 7th(2-N)		V			—	○	○	○		
3D	41	Harmonic voltage 9th(2-N)		V			—	○	○	○		
3F	41	Harmonic voltage 11th(2-N)		V			—	○	○	○		
41	41	Harmonic voltage 13th(2-N)		V			—	○	○	○		
77	9C		Measurement	Harmonics total voltage distortion ratio(2-N)	%			—	○	○	○	①
77	89	Harmonics voltage 3rd distortion ratio(2-N)		%			—	○	○	○		
77	8B	Harmonics voltage 5th distortion ratio(2-N)		%			—	○	○	○		
77	8D	Harmonics voltage 7th distortion ratio(2-N)		%			—	○	○	○		
77	8F	Harmonics voltage 9th distortion ratio(2-N)		%			—	○	○	○		
77	91	Harmonics voltage 11th distortion ratio(2-N)		%			—	○	○	○		
77	93	Harmonics voltage 13th distortion ratio(2-N)		%			—	○	○	○		
4B	61		Measurement	Harmonics total voltage RMS(3-N)	V			—	○	○	○	①
35	61	Harmonic voltage fundamental(3-N)		V			—	○	○	○		
37	61	Harmonic voltage 3rd(3-N)		V			—	○	○	○		
39	61	Harmonic voltage 5th(3-N)		V			—	○	○	○		
3B	61	Harmonic voltage 7th(3-N)		V			—	○	○	○		
3D	61	Harmonic voltage 9th(3-N)		V			—	○	○	○		
3F	61	Harmonic voltage 11th(3-N)		V			—	○	○	○		
41	61	Harmonic voltage 13th(3-N)		V			—	○	○	○		
77	B2		Measurement	Harmonics total voltage distortion ratio(3-N)	%			—	○	○	○	①
77	9F	Harmonics voltage 3rd distortion ratio(3-N)		%			—	○	○	○		
77	A1	Harmonics voltage 5th distortion ratio(3-N)		%			—	○	○	○		
77	A3	Harmonics voltage 7th distortion ratio(3-N)		%			—	○	○	○		
77	A5	Harmonics voltage 9th distortion ratio(3-N)		%			—	○	○	○		
77	A7	Harmonics voltage 11th distortion ratio(3-N)		%			—	○	○	○		
77	A9	Harmonics voltage 13th distortion ratio(3-N)		%			—	○	○	○		

Inst.: Instantaneous value. RMS.: Root-Mean-Square value.

Table 7.2 Group Channel List for Data Monitor Command (1H) (9/15)

Group (H)	Channel (H)	Note	Data type	Content name				EMU4-BM1	EMU4-HM1	EMU4-A2	EMU4-VA2	Data format
33	21		Measurement	Phase 1 harmonic current	A	RMS.	Total	—	○	○	○	①
1D	21			Phase 1 harmonic current	A	RMS.	1st	—	○	○	○	
1F	21			Phase 1 harmonic current	A	RMS.	3rd	—	○	○	○	
21	21			Phase 1 harmonic current	A	RMS.	5th	—	○	○	○	
23	21			Phase 1 harmonic current	A	RMS.	7th	—	○	○	○	
25	21			Phase 1 harmonic current	A	RMS.	9th	—	○	○	○	
27	21			Phase 1 harmonic current	A	RMS.	11th	—	○	○	○	
29	21			Phase 1 harmonic current	A	RMS.	13th	—	○	○	○	
75	86			Measurement	Phase 1 current THD	%	Inst.	Total	—	○	○	
75	73		Phase 1 current harmonic distortion		%	Inst.	3rd	—	○	○	○	
75	75		Phase 1 current harmonic distortion		%	Inst.	5th	—	○	○	○	
75	77		Phase 1 current harmonic distortion		%	Inst.	7th	—	○	○	○	
75	79		Phase 1 current harmonic distortion		%	Inst.	9th	—	○	○	○	
75	7B		Phase 1 current harmonic distortion		%	Inst.	11th	—	○	○	○	
75	7D			Phase 1 current harmonic distortion	%	Inst.	13th	—	○	○	○	
33	41	*2	Measurement	Phase 2 harmonic current	A	RMS.	Total	—	○	○	○	①
1D	41	*2		Phase 2 harmonic current	A	RMS.	1st	—	○	○	○	
1F	41	*2		Phase 2 harmonic current	A	RMS.	3rd	—	○	○	○	
21	41	*2		Phase 2 harmonic current	A	RMS.	5th	—	○	○	○	
23	41	*2		Phase 2 harmonic current	A	RMS.	7th	—	○	○	○	
25	41	*2		Phase 2 harmonic current	A	RMS.	9th	—	○	○	○	
27	41	*2		Phase 2 harmonic current	A	RMS.	11th	—	○	○	○	
29	41	*2		Phase 2 harmonic current	A	RMS.	13th	—	○	○	○	
75	9C	*2	Measurement	Phase 2 current THD	%	Inst.	Total	—	○	○	○	①
75	89	*2		Phase 2 current harmonic distortion	%	Inst.	3rd	—	○	○	○	
75	8B	*2		Phase 2 current harmonic distortion	%	Inst.	5th	—	○	○	○	
75	8D	*2		Phase 2 current harmonic distortion	%	Inst.	7th	—	○	○	○	
75	8F	*2		Phase 2 current harmonic distortion	%	Inst.	9th	—	○	○	○	
75	91	*2		Phase 2 current harmonic distortion	%	Inst.	11th	—	○	○	○	
75	93	*2		Phase 2 current harmonic distortion	%	Inst.	13th	—	○	○	○	
33	61	*1	Measurement	Phase 3 harmonic current	A	RMS.	Total	—	○	○	○	①
1D	61	*1		Phase 3 harmonic current	A	RMS.	1st	—	○	○	○	
1F	61	*1		Phase 3 harmonic current	A	RMS.	3rd	—	○	○	○	
21	61	*1		Phase 3 harmonic current	A	RMS.	5th	—	○	○	○	
23	61	*1		Phase 3 harmonic current	A	RMS.	7th	—	○	○	○	
25	61	*1		Phase 3 harmonic current	A	RMS.	9th	—	○	○	○	
27	61	*1		Phase 3 harmonic current	A	RMS.	11th	—	○	○	○	
29	61	*1		Phase 3 harmonic current	A	RMS.	13th	—	○	○	○	
75	B2	*1	Measurement	Phase 3 current harmonic distortion	A	RMS.	Total	—	○	○	○	①
75	9F	*1		Phase 3 current harmonic distortion	A	RMS.	3rd	—	○	○	○	
75	A1	*1		Phase 3 current harmonic distortion	A	RMS.	5th	—	○	○	○	
75	A3	*1		Phase 3 current harmonic distortion	A	RMS.	7th	—	○	○	○	
75	A5	*1		Phase 3 current harmonic distortion	A	RMS.	9th	—	○	○	○	
75	A7	*1		Phase 3 current harmonic distortion	A	RMS.	11th	—	○	○	○	
75	A9	*1		Phase 3 current harmonic distortion	A	RMS.	13th	—	○	○	○	

Inst.: Instantaneous value. RMS.: Root-Mean-Square value.

Table 7.2 Group Channel List for Data Monitor Command (1H) (10/15)

Group (H)	Channel (H)	Note	Data type	Content name			EMU4-BM1	EMU4-HM1	EMU4-A2	EMU4-VA2	Data format
33	81	*2	Measurement	Phase N harmonic current	A	RMS. Total	—	○	○	○	①
1D	81	*2		Phase N harmonic current	A	RMS. 1st	—	○	○	○	
1F	81	*2		Phase N harmonic current	A	RMS. 3rd	—	○	○	○	
21	81	*2		Phase N harmonic current	A	RMS. 5th	—	○	○	○	
23	81	*2		Phase N harmonic current	A	RMS. 7th	—	○	○	○	
25	81	*2		Phase N harmonic current	A	RMS. 9th	—	○	○	○	
27	81	*2		Phase N harmonic current	A	RMS. 11th	—	○	○	○	
29	81	*2		Phase N harmonic current	A	RMS. 13th	—	○	○	○	
75	C8	*2		Measurement	Phase N current THD	%	Inst. Total	—	○	○	
75	B5	*2	Phase N current harmonic distortion		%	Inst. 3rd	—	○	○	○	
75	B7	*2	Phase N current harmonic distortion		%	Inst. 5th	—	○	○	○	
75	B9	*2	Phase N current harmonic distortion		%	Inst. 7th	—	○	○	○	
75	BB	*2	Phase N current harmonic distortion		%	Inst. 9th	—	○	○	○	
75	BD	*2	Phase N current harmonic distortion		%	Inst. 11th	—	○	○	○	
75	BF	*2	Phase N current harmonic distortion		%	Inst. 13th	—	○	○	○	
80	01		Measurement	Active energy (import)	kWh	count	○	○	○	○	②
8A	01			Active energy (import)(3side)	kWh	count	○	○	○	○	
80	63			Active energy (export)	kWh	count	○	○	○	○	
8A	63			Active energy (export)(3side)	kWh	count	○	○	○	○	
81	01			Reactive energy (import lag)	kvarh	count	○	○	○	○	
80	64			Active energy (import)	kWh	count expand	○	○	○	○	
8A	64			Active energy (import)(3side)	kWh	count expand	○	○	○	○	
80	65			Active energy (export)	kWh	count expand	○	○	○	○	
8A	65			Active energy (export)(3side)	kWh	count expand	○	○	○	○	
81	66			Reactive energy (import lag)	kvar	count expand	○	○	○	○	
8B	01	*7		Active energy during operation	kWh	count	—	○	—	—	
8C	01			Active energy during operation(3side)	kWh	count	—	○	—	—	
80	6A			Electric energy conversion			—	○	○	○	
8A	6A			Electric energy conversion(3side)			—	○	○	○	
83	01			Pulse conversion	pulse	count	—	○	—	—	
84	01			Pulse count	pulse	count	—	○	—	—	
87	01			Operating time	hour		—	—	○	○	
88	01		Operating time(3side)	hour		—	—	○	—		
A0	31		Alarm state	Alarm state1	—	Alarm	○	○	○	○	③
A1	35		Alarm state	Alarm state2	—	Alarm	○	○	○	○	

Note

*1: If phase wire system is set to single-phase 2-wire, Out-of-range error occurs.

*2: If phase wire system is set to except three-phase 4-wire, Out-of-range error occurs.

*3: Multiplicand and effective range is fixed for each items according to phase wire system, primary voltage and primary current.(For details, refer to 7.2.2)

*4: Target model are as follows.

EMU2-RD1-C, EMU2-RD3-C, EMU2-RD5-C, EMU2-RD7-C, EMU2-RD2-C-4W, EMU2-RD4-C-4W

*5: Monitor value is "Time constant for DA".

*6: If phase wire system is set to three-phase 4-wire in EMU4-HD1-MB, Out-of-range error occurs.

*7: Monitor value is "Periodic active energy" in EMU4-HD1-MB.

Table 7.2 Group Channel List for Data Monitor Command (1H) (11/15)

Group (H)	Channel (H)	Note	Data type	Content name	EMU4-LG1-MB	Data format	
F0	02		Set-up	Model code	—	○	
E0	13			Phase & Wiring	—	○	
12	E0			Demand alarm: Leak current	sec	○	⑤
E0	AF			Measurement mode	—	○	
7A	81			Differential conversion use/non-use	—	○	
7A	88			Differential conversion value	mA	○	①
11	89			Leak current monitoring element	—	○	⑤
7A	89			lor leak current monitoring element	—	○	
11	86			Leak current lo1- alarm setting value	mA	○	①
11	87			Leak current lo2- alarm setting value	mA	○	
7A	86			lor leak current lo1- alarm setting value	mA	○	
7A	87			lor leak current lo2- alarm setting value	mA	○	
11	8A			lo1-alarm count upper limit	count	○	②
11	8B			lo2-alarm count upper limit	count	○	
7A	8A			lor1-alarm count upper limit	count	○	
7A	8B			lor2-alarm count upper limit	count	○	
E0	9F			Alarm mask time	—	○	⑤
E0	A0			Reset mode	—	○	
E0	B0			Target output of alarm	—	○	
11	01			Measurement	Leak current present value	mA	○
12	01		Demand leak current demand		mA	○	
7A	01		Present leak current for resistance		mA	○	
7B	01		Demand leak current for resistance		mA	○	
7A	82		lor differential conversion value		mA	○	⑦
11	84		lo1-alarm count		count	○	
11	85		lo2-alarm count		count	○	
7A	84		lor1-alarm count		count	○	
7A	85		lor2-alarm count	count	○		
A0	31		Alarm status	Alarm status1	—	○	③
A1	35			Alarm status2	—	○	

Table 7.2 Group Channel List for Data Monitor Command (1H) (12/15)

Group (H)	Channel (H)	Note	Data type	Content name	Unit	EMU4-AX4	Data format
F0	02		Set-up	Model code		○	⑤
65	EB			Conversion rate setting		○	⑤
65	EC			AD Conversion use or non-use setting(Ch1)		○	⑤
67	EC			AD Conversion use or non-use setting(Ch2)		○	
69	EC			AD Conversion use or non-use setting(Ch3)		○	
6B	EC			AD Conversion use or non-use setting(Ch4)		○	
65	E2			Input range setting(Ch1)		○	⑤
67	E2			Input range setting(Ch2)		○	
69	E2			Input range setting(Ch3)		○	
6B	E2			Input range setting(Ch4)		○	
65	ED			Scaling value lower value(Ch1)		○	①
67	ED			Scaling value lower value(Ch2)		○	
69	ED			Scaling value lower value(Ch3)		○	
6B	ED			Scaling value lower value(Ch4)		○	
65	EE			Scaling value upper value(Ch1)		○	①
67	EE			Scaling value upper value(Ch2)		○	
69	EE			Scaling value upper value(Ch3)		○	
6B	EE			Scaling value upper value(Ch4)		○	
65	F0			Scaling unit(Ch1)		○	⑤
67	F0			Scaling unit(Ch2)		○	
69	F0			Scaling unit(Ch3)		○	
6B	F0			Scaling unit(Ch4)		○	
66	EF			Moving average(Ch1)	Times	○	⑤
68	EF			Moving average(Ch2)	Times	○	
6A	EF			Moving average(Ch3)	Times	○	
6C	EF			Moving average(Ch4)	Times	○	
91	E0			Limit A setting(Ch1)		○	①
91	E1			Limit B setting(Ch1)		○	
91	E2			Limit C setting(Ch1)		○	
91	E3			Limit D setting(Ch1)		○	
91	E4			Limit A setting(Ch2)		○	
91	E5			Limit B setting(Ch2)		○	
91	E6			Limit C setting(Ch2)		○	
91	E7			Limit D setting(Ch2)		○	
91	E8			Limit A setting(Ch3)		○	
91	E9			Limit B setting(Ch3)		○	
91	EA			Limit C setting(Ch3)		○	
91	EB			Limit D setting(Ch3)		○	
91	EC			Limit A setting(Ch4)		○	
91	ED			Limit B setting(Ch4)		○	
91	EE			Limit C setting(Ch4)		○	
91	EF			Limit D setting(Ch4)		○	
91	F0		Number over limit monitoring factor (Ch1)		○	⑤	
91	F1		Number over limit monitoring factor (Ch2)		○		
91	F2		Number over limit monitoring factor (Ch3)		○		
91	F3		Number over limit monitoring factor (Ch4)		○		

Table 7.2 Group Channel List for Data Monitor Command (1H) (13/15)

Group (H)	Channel (H)	Note	Data type	Content name	Unit	EMU4-AX4	Data format
E0	99		Set-up	External output setting		○	⑤
E0	9A			External output Channel		○	⑤
E0	B0			External output alarm		○	⑤
E0	9C			Upper limit alarm (Ch1)		○	⑤
E0	A1			Upper limit alarm (Ch2)		○	
E0	A6			Upper limit alarm (Ch3)		○	
E0	B2			Upper limit alarm (Ch4)		○	
E0	9E			Upper limit value (Ch1)		○	①
E0	A3			Upper limit value (Ch2)		○	
E0	A8			Upper limit value (Ch3)		○	
E0	B4			Upper limit value (Ch4)		○	
E0	B7			Lower limit alarm (Ch1)		○	⑤
E0	B9			Lower limit alarm (Ch2)		○	
E0	BB			Lower limit alarm (Ch3)		○	
E0	BD			Lower limit alarm (Ch4)		○	
E0	B8			Lower limit value (Ch1)		○	①
E0	BA			Lower limit value (Ch2)		○	
E0	BC			Lower limit value (Ch3)		○	
E0	BE			Lower limit value (Ch4)		○	
E0	9F			Delay (Ch1)		○	⑤
E0	A4			Delay (Ch2)		○	
E0	A9			Delay (Ch3)		○	
E0	B5			Delay (Ch4)		○	
E0	A0			Alarm reset mode (Ch1)		○	⑤
E0	A5			Alarm reset mode (Ch2)		○	
E0	AA			Alarm reset mode (Ch3)		○	
E0	B6			Alarm reset mode (Ch4)		○	

Table 7.2 Group Channel List for Data Monitor Command (1H) (14/15)

Group (H)	Channel (H)	Note	Data type	Content name	Unit	EMU4-AX4	Data format
65	01		Measurement	AD Conversion value(Ch1)	Digit	○	①
67	01			AD Conversion value(Ch2)	Digit	○	
69	01			AD Conversion value(Ch3)	Digit	○	
6B	01			AD Conversion value(Ch4)	Digit	○	
65	21			Scaling value(Ch1)		○	①
67	21			Scaling value(Ch2)		○	
69	21			Scaling value(Ch3)		○	
6B	21			Scaling value(Ch4)		○	
91	00			Number over limit A(Ch1)	Times	○	②
91	01			Number over limit B(Ch1)	Times	○	
91	02			Number over limit C(Ch1)	Times	○	
91	03			Number over limit D(Ch1)	Times	○	
91	10			Number over limit A(Ch2)	Times	○	
91	11			Number over limit B(Ch2)	Times	○	
91	12			Number over limit C(Ch2)	Times	○	
91	13			Number over limit D(Ch2)	Times	○	
91	20			Number over limit A(Ch3)	Times	○	
91	21			Number over limit B(Ch3)	Times	○	
91	22			Number over limit C(Ch3)	Times	○	
91	23			Number over limit D(Ch3)	Times	○	
91	30		Number over limit A(Ch4)	Times	○		
91	31		Number over limit B(Ch4)	Times	○		
91	32		Number over limit C(Ch4)	Times	○		
91	33		Number over limit D(Ch4)	Times	○		
A0	31		Alarm state	Monitoring alarm state		○	

Table 7.2 Group Channel List for Data Monitor Command (1H) (15/15)

Group (H)	Channel (H)	Note	Data type	Content name	Unit	EMU4-PX4	Data format	
F0	02		Set-up	Model code		○	⑤	
87	E2			Operating time measuring (CH1)		○	⑤	
88	E2			Operating time measuring (CH2)		○		
8D	E2			Operating time measuring (CH3)		○		
8E	E2			Operating time measuring (CH4)		○		
83	E4			Pulse conversion rate(CH1)		○	①	
84	E4			Pulse conversion rate (CH2)		○		
85	E4			Pulse conversion rate (CH3)		○		
86	E4			Pulse conversion rate (CH4)		○		
83	E5			Pulse conversion unit (CH1)		○	⑤	
84	E5			Pulse conversion unit (CH2)		○		
85	E5			Pulse conversion unit (CH3)		○		
86	E5			Pulse conversion unit (CH4)		○		
E0	99			External output setting value		○	⑤	
E0	9A			External output channel		○	⑤	
E0	9C			Upper limit alarm (Ch1)		○	⑤	
E0	A1			Upper limit alarm (Ch2)		○		
E0	A6			Upper limit alarm (Ch3)		○		
E0	B2			Upper limit alarm (Ch4)		○		
E0	9E			Upper limit value (Ch1)	*1	○	②	
E0	A3			Upper limit value (Ch2)	*1	○		
E0	A8			Upper limit value (Ch3)	*1	○		
E0	B4			Upper limit value (Ch4)	*1	○		
E0	97			External input setting (CH1)		○	⑤	
E0	BF			External input setting (CH2)		○		
E0	C0			External input setting (CH3)		○		
E0	C1			External input setting (CH4)		○		
E0	98			Contact input reset mode (CH1)		○	⑤	
E0	C2			Contact input reset mode (CH2)		○		
E0	C3			Contact input reset mode (CH3)		○		
E0	C4			Contact input reset mode (CH4)		○		
83	01			Measurement	Pulse count (CH1)	pulse	○	⑥
84	01				Pulse count (CH2)	pulse	○	
85	01				Pulse count (CH3)	pulse	○	
86	01				Pulse count(CH4)	pulse	○	
83	6A				Pulse conversion value(CH1)	*1	○	②
84	6A				Pulse conversion value (CH2)	*1	○	
85	6A				Pulse conversion value (CH3)	*1	○	
86	6A				Pulse conversion value (CH4)	*1	○	
87	01				Operating time (Ch1)	hour	○	⑥
88	01		Operating time (Ch2)		hour	○		
8D	01		Operating time (Ch3)		hour	○		
8E	01		Operating time (Ch4)		hour	○		
A0	01		Contact input state (Ch1)			○	⑤	
A0	02		Contact input state (Ch2)			○		
A0	03		Contact input state (Ch3)			○		
A0	04		Contact input state (Ch4)			○		
A0	31		Monitoring alarm state			○	③	

*1: Unit is different by the setting of pulse conversion unit.

Please refer to "Group Channel List for Data Set Command (2H)"

Data Set Command (2H)

2H	Data Set	
<ul style="list-style-type: none"> • You can change setting value of measuring unit by PLC. • Writing the number of Group number and Channnel number of data to the memory. • Please refer to Table 7.3 for data group number and data channel number. <p>*After writing the set-up value, about 5 seconds is needed to restart the measurement based on new set-up value.</p>		
Remote register RWw (PLC→Measuring Unit)		Remote register RWr (Measuring Unit→PLC)
b15	b8	b7 b4 b3 b0
m	Group No.	(Unit.No. *1) 2H
m+1	Index number	Channel No.
m+2	Low data	
m+3	High data	
(*1) 0H to 7H is used in the unit No. of Measuring Unit		
b15	b8	b7 b0
n	Channel No.	Group No.
n+1	00H	00H
n+2	00H	00H
n+3	00H	00H

m, n : Address is allocated to the master module by the station number setting.

Table 7.3 Group Channel List for Data Set Command (2H) (1/8)

Hex		Content name	EMU2 *1		EMU3-DP1-C		Data format
Group	Channel		Range	Setting unit	Range	Setting unit	
E0	11	Primary current	(Note1)	—	3CH: 60A 7DH: 125A	—	④
E0	12	Primary voltage	(Note2)	—	(Note5)	—	④
E0	13	Phase Wire system	01H: 1P2W 02H: 1P3W 03H: 3P3W 04H: 3P4W	—	01H: 1P2W 02H: 1P3W 03H: 3P3W	—	⑤
E0	16	Time constant for total demand	(Note3)	—	(Note3)	—	⑤
02	E0	Time constant for DA	(Note3)	Default: 2min (Note3)	(Note3)	Default: 2min (Note3)	⑤
08	E0	Time constant for DW	(Note3)	Default: 2min (Note3)	(Note3)	Default: 2min (Note3)	⑤
12	E0	Time constant for leakage current demand	—	—	(Note3)	Default: 2min (Note3)	⑤
E0	8B	Connected phase switch	—	—	00H: Phase switch disable 01H: Phase switch enable	—	⑤
E0	92	5A input switch	00H: Direct sensor 02H: 5A sensor	—	—	—	⑤
80	01	Active energy	0 to 999999×Multiplicand(Note4)	1×Multiplicand	0 to 999999×Multiplicand (Note4)	1×Multiplicand	②
81	01	Reactive energy (import lag)	0 to 999999×Multiplicand(Note4)	1×Multiplicand	0 to 999999×Multiplicand (Note4)	1×Multiplicand	②
A1	3A	16bit set register	Refer to Table 7.8 Data Format (5/7)	—	Refer to Table 7.8 Data Format (5/7)	—	⑤

Note 1

	EMU2-HM1-C EMU2-RD*1
5A input switch: 00H	50A,100A,250A,400A,600A
5A input switch: 02H	5A,6A,7.5A,8A,10A,12A,15A,20A,25A,30A,40A,50A,60A,75A,80A,100A,120A,150A,200A,250A,300A,400A,500A,600A,750A,800A,1000A,1200A,1500A,1600A,2000A,2500A,3000A,4000A,5000A,6000A,7500A,8000A,10000A,12000A,20000A,25000A,30000A

Note 2

	EMU2-HM1-C	EMU2-RD*1
1P2W/3P3W	110V,220V,440V	110V,220V,440V,690V,1100V,2200V,3300V,6600V,11000V,13200V,13800V,15000V,16500V,22000V,24000V,33000V,66000V,77000V,110000V
1P3W	110V	110V
3P4W(L-L)	—	63.5V/110V,110/190V,120V/208V,220V/380V,240V/415V,254V/440V (Only EMU2-RD*-C-4W)

Note.3

[Group: Channel]	Range	Unit	Note
[E0:16]	0,1,2,3,4,5,6,7,8,9,10,11,12,13,14,15	Minute	[02:E0], [08: E0], [12:E0] is setup same value at once when setup left value in [E0: 16]. Setting value is read when read [E0: 16]. 900 is setup in [02:E0], [08: E0], [12:E0] when setting 15 in [E0: 16]. "0" is read when setting un supported value in [E0: 16].
[02:E0]	0,10,20,30,40,50,60,120,180,240,300,	Second	
[08:E0]	360,420,480,540,600,660,720,780,		
[12:E0]	840,900,1200,1500,1800		

Note 4 : Multiplicand fixed for each items according to phase wire system, primary voltage and primary current.
(For details, refer to 7.2.2)

Note 5

Phase Wire system	Measuring Unit
	EMU3-DP1-C
1P2W	63.5V,100V,110V,120V,173V,190V,208V,220V,240V,254V,380V,415V,440V
1P3W	110V
3P3W	110V,173V,190V,208V,220V,380V,415V,440V

Table 7.3 Group Channel List for Data Set Command (2H) (2/8)

Hex		Content name	EMU4-BD1-MB EMU4-HD1-MB		Data format
Group	Channel		Range	Setting unit	
E0	11	Primary current	5.0A to 6000.0A	(Note1)	④
E0	12	Primary voltage (L-L)	1V to 6600V	(Note2)	④
E0	1B	Primary voltage (L-N)	1V to 6600V (EMU4-HD1-MB 3P4W only)	(Note3)	④
E0	1C	Secondary voltage (L-L/L-N)	1V to 220V	Step 1V	④
E0	13	Phase Wire system	01H: 1P2W 02H: 1P3W 03H: 3P3W 04H: 3P4W (EMU4-HD1-MB only)	—	⑤
02	E0	Time constant for DA	0 to 1800s	Note4	⑤
08	E0	Time constant for DW	0 to 1800s	Note4	⑤
E0	92	5A input switch	00H: Direct sensor 02H: 5A sensor	—	⑤
80	01	Active energy (import)	0 to 999999×Multiplicand (Note5)	Step 1×Multiplicand	②
80	63	Active energy (export)	0 to 999999×Multiplicand (Note5)	Step 1×Multiplicand	②
81	01	Reactive energy (import lag)	0 to 999999×Multiplicand (Note5)	Step 1×Multiplicand	②
A1	3A	16bit set register	Refer to Table 7.8 Data Format (5/7)	—	⑤

Note 1 : Effective value of 5A input switch.

Primary current when setup value is 5A/Direct is 0:Direct Sensor.	50A,100A,250A,400A,600A
Primary current when setup value is 5A/Direct is 0:5A Sensor.	From the most significant digit to 3 digits can be freely setting in the range from 5.0A to 6000.0A. Digits of 4 or more are rounded down to 3 digits. (When less than 10A, to 2 digits.)

Note 2: Effective value of primary voltage(L-L) is follows.

3P3W or 1P2W

From the most significant digit to 3 digits can be freely setting in the range from 1V to 6600V.

(When less than from 1V to 99V, to 2 digits.)

When setup 110V or 220V, Setup is Direct setup (Not use VT) in EMU4-BD1-MB.

When setup 110V, 220V or 440V, Setup is Direct setup (Not use VT) in EMU4-HD1-MB.

1P3W

110V is valid only.

3P4W

From the most significant digit to 3 digits can be freely setting in the range from 1V to 6600V.

(When less than 1V-99V, to 2 digits.)

Set value	Direct voltage	Set value	Direct voltage
110V	63.5/110V	380V	220/380V
173V	100/173V	400V	230/400V
182V	105/182V	415V	240/415V
190V	110/190V	420V	242/420V
199V	115/199V	430V	250/430V
208V	120/208V	440V	254/440V
220V	127/220V	460V	265/460V
346V	200/346V	480V	277/480V

*From the most significant digit to 3 figures can be freely set up in the range.

Note 3 : Setup of phase voltage is only available in 3P4W.

From the most significant digit to 3 digits can be freely setting in the range from 1V to 6600V.

(When less than from 1V to 99V, to 2 digits.)

Setup is Direct setup(Not use VT) when setup in below value.

Set value	Direct voltage
63.5V	63.5/110V
100V	100/173V
105V	105/182V
110V	110/190V
115V	115/199V
120V	120/208V
127V	127/220V
200V	200/346V
220V	220V/380V
230V	230/400V
240V	240/415V
242V	242/420V
250V	250/430V
254V	254/440V
265V	265/460V
277V	277/480V

Note 4 : The set value is the second unit value. (For example of 2 minutes, set as 120 seconds.) About setting range, please refer to each user's manuals.

Note 5 : Multiplicand fixed for each items according to phase wire system, primary voltage and primary current. (For details, refer to 7.2.4 Significant digits and Multiplying factor)

Table 7.3 Group Channel List for Data Set Command (2H) (3/8)

Hex		Content name	EMU4-BM1-MB、EMU4-HM1-MB EMU4-A2、EMU4-VA2		Data format
Group(H)	Channel(H)		Range	Setting unit	
E0	11	Primary current	5.0A to 30000.0A	(Note1)	④
E0	12	Primary voltage (L-L)	1V to 110000V	(Note2)	④
E0	1B	Primary voltage (L-N)	1V to 110000V (EMU4-HM1-MB 3P4W, EMU4-A2 3P4W, EMU4-VA2 3P4W only)	(Note3)	④
E0	1C	Secondary voltage (L-L/L-N)	1V to 220V	Step 1V	④
E0	13	Phase Wire system	01H: 1P2W 02H: 1P3W 03H: 3P3W 04H: 3P4W (EMU4-HM1-MB、 EMU4-A2、EMU4-VA2 only)	—	⑤
E0	21	VT use or non-use	00H:VT non-use, 01H: VT use	—	⑤
02	E0	Time constant for DA	0 to 1800s	Note4	⑤
02	E7	Time constant for DA(3side)			
08	E0	Time constant for DW	0 to 1800s	Note4	⑤
08	E7	Time constant for DW(3side)			
E0	92	5A input switch	00H: Direct sensor 02H: 5A sensor	—	⑤
E0	97	External input	00H:non-use,01H:pulse input,02H:contact input	—	⑤
E0	98	Contact input reset mode	01H:AUTO,02H:HOLD	—	⑤
E0	99	External output	00H:non-use,01H:pulse output,02H:alarm output	—	⑤
E0	A0	External output target circuit	00H:1side,01H:3side	—	⑤
83	E6	The unit of pulse output	00H:0.001,01H:0.01,02H:0.1,03H: 1, 04H:10,05H:100,06H:1000,07H:10 000,08H:100000	—	⑤
87	E2	Operating time	00H:non-use	—	⑤
8E	E2	Operating time(3side)	01H:use		
87	E3	Counting method of operating time(3side)	00H:Current input	—	⑤
8E	E3		01H:Contact input		
01	E8	Cut-off	0.1 to 50.0	Step 0.1	①
01	EA	Cut-off(3side)			
03	E4	Pulse conversion	0.001 to 10000		①
83	E5	Pulse conversion unit	00H:non-use,01H:Wh,02H:kWh, 03H:MWh,04H:J,05H:m2,06H:m3, 07H:l,08H:kl,09H:sec,0AH:min, 0BH:hour,0CH:piece,0DH:set, 0EH:g,0FH:kg,10H:t,11H:¥,12H:\$	—	⑤
80	E4	Electric energy conversion	0.001 to 10000		①
8A	E4	Electric energy conversion(3side)			
80	E5	Electric energy conversion unit	00H:non-use,01H:Wh,02H:kWh, 03H:MWh,04H:J,05H:m2,06H:m3, 07H:l,08H:kl,09H:sec,0AH:min, 0BH:hour,0CH:piece,0DH:set, 0EH:g,0FH:kg,10H:t,11H:¥,12H:\$	—	⑤
8A	E5	Electric energy conversion unit(3side)			
E0	9C	Upper and lower limit alarm extence	00H:non-use 01H:use	—	⑤
E0	A6	Upper and lower limit alarm extence(3side)			
E0	9D	Upper and lower limit alarm element	00H:Current demand upper limit 01H:Current demand lower limit 02H:N phase demand upper limit 03H:Line voltage upper limit 04H:Line voltage lower limit 05H:Phase voltage upper limit 06H:Phase voltage lower limit 07H:Electric power demand upper limit 08H:Electric power demand lower	—	⑤
E0	A7	Upper and lower limit alarm element(3side)			

			limit 09H:Power factor upper limit 0AH:Power factor lower limit 0BH:Pulse converted upper limit 0CH:Current unbalance rate upper limit 0DH:Voltage unbalance rate upper limit		
E0	9E	Upper and lower limit alarm value	Note7	Note7	
E0	A8	Upper and lower limit alarm value(3side)			

Table 7.3 Group Channel List for Data Set Command (2H) (4/8)

Hex		Content name	EMU4-BM1-MB、EMU4-HM1-MB EMU4-A2、EMU4-VA2		Data format
Group(H)	Channel(H)		Range	Setting unit	
E0	9F	Alarm delay time	00H:0,01H:5,02H:10,03H:20,04H:30,	—	⑤
E0	A9	Alarm delay time(3side)	05H:40,06H:50,07H:60,08H:120,09H:180,0AH:240,0BH:300		
E0	A0	Alarm reset method	01H:AUTO	—	⑤
E0	AA	Alarm reset method(3side)	02H:HOLD		
E0	AB	Simple measuring setup	00H: non-use 01H: use	—	⑤
E0	AC	Power factor setup in simple measuring	-0.1 to 100.0 to 0.0%	0.1%	①
E0	AD	Power factor setup in simple measuring (3side)	-0.1 to 100.0 to 0.0%	0.1%	①
E0	B1	2 circuits measuring	00H: non-use 01H: use	—	⑤
80	01	Active energy (import)	0 to 999999×Multiplicand (Note4)	1×Multiplicand	②
8A	01	Active energy (import)(3side)	0 to 999999×Multiplicand (Note4)	1×Multiplicand	②
80	63	Active energy (export)	0 to 999999×Multiplicand (Note4)	1×Multiplicand	②
8A	63	Active energy (export)(3side)	0 to 999999×Multiplicand (Note4)	1×Multiplicand	②
81	01	Reactive energy (import lag)	0 to 999999×Multiplicand (Note4)	1×Multiplicand	②
A1	3A	16bit set register	Refer to Table 7.8 Data Format (5/7)		⑤

Note 1 : Effective value of 5A/Direct setup is follows.

Primary current when setup value is 5A input switch is 0: Direct Sensor	50A,100A,250A,400A,600A
Primary current when setup is 5A input switch is 2 5A Sensor.	From the most significant digit to 3 digits can be freely setting in the range from 5.0A to 6000.0A. Digits of 4 or more are rounded down to 3 digits. (When less than 10A, to 2 digits.)

Note 2 : Effective value of primary voltage(L-L) is follows.

3P3W or 1P2W

From the most significant digit to 3 digits can be freely setting in the range from 1V to 110000V.

(When less than from 1V to 99V, to 2 digits.)

When setup 110V or 220V, setup is use VT in EMU4-BM1-MB.

When setup 110V, 220V or 440V, setup is use VT in EMU4-HM1-MB, EMU4-A2, EMU4-VA2.

1P3W

110V is valid when use EMU4-BM1-MB.

110V and 220V is valid when use EMU4-HM1-MB, EMU4-A2, EMU4-VA2.

3P4W

From the most significant digit to 3 digits can be freely setting in the range from 1V to 110000V.
(When less than 1V-99V, to 2 digits.)

Digits of 4 or more are rounded down to 3 digits.

Note 3 : Phase voltage 3P4W is only setup.

From the most significant digit to 3 digits can be freely setting in the range from 1V to 63500V.
Digits of 4 or more are rounded down to 3 digits.

Note 4 : The set value is the second unit value. (For example of 2 minutes, set as 120 seconds.) About setting range, please refer to each user's manuals.

Note 5 : Setting range is changed by the value of Full load power.

Full load power(kW)		Setting range
	Less than 12	0.001 , 0.01, 0.1, 1
12 or more	Less than 120	0.01 , 0.1, 1, 10
120 or more	Less than 1200	0.1 , 1, 10, 100
1200 or more	Less than 12000	1 , 10, 100, 1000
12000 or more	Less than 120000	10 , 100, 1000, 10000
120000 or more		100 , 1000, 10000, 100000

Full load power is calculated in below.

$$\text{Full load power} = \alpha \times (\text{Primary voltage}) \times (\text{Primary current}) / 1000$$

α : 1 1P2W

: 2 1P3W(Primary voltage is 110V or 220V)

: $\sqrt{3}$ 3P3W

: 3 3P4W(Primary voltage is phase voltage)

Note 6 : From the most significant digit to 4 digits can be freely setting in the range from 0.001 to 10000.

Note 7 : Setup for upper and lower alarm

Setup range is different from target of alarm.

Upper/lower alarm value is needed to setup value.

Target of alarm	Setting range
Current demand upper limit alarm	0~120% of primary current
Current demand lower limit alarm	
Line voltage upper limit alarm Phase voltage upper limit alarm	15/11×0~100% of primary voltage
Line voltage lower limit alarm Phase voltage lower limit alarm	
Electric energy demand upper limit alarm	-120~120% of Full load power
Electric energy demand lower limit alarm	
Power factor upper limit alarm	-5~100~5%
Power factor lower limit alarm	
Pulse conversion upper limit alarm	1~999999.999
Current unbalance rate upper limit alarm	0.01~999.99
Voltage unbalance rate upper limit alarm	

Note 8 : Multiplicand fixed for each items according to phase wire system, primary voltage and primary current.
(For details, refer to 7.2.4 Significant digits and Multiplying factor)

Table 7.3 Group Channel List for Data Set Command (2H) (5/8)

Hex		Content name	EMU4-LG1-MB		Data format
Group(H)	Channel(H)		Range	Setting unit	
E0	13	Phase Wire system	01H: 1P2W, 02H: 1P3W 03H: 3P3W, 04H: 3P4W	—	⑤
E0	AF	Measurement mode	00H:Low SENS, 01H:High SENS	—	⑤
12	E0	Leak current demand time	0 to 1800s	Note1	⑤
7A	81	Differential conversion ON/OFF setting	00H:OFF,01H:ON	—	⑤
7A	88	Differential conversion value	Low SENS:0 to 1000mA High SENS:0 to 100.00mA	Note2	⑤
11	89	lo alarm element	00H:Present value,01H:Demand value	—	⑤
7A	89	lor alarm element	00H:Present value,01H:Demand value 02H: Differential conversion value	—	⑤
11	86	Alarm value (lo1-alarm)	Low SENS:0 to 1000mA High SENS:0 to 100.00mA	Note2	①
11	87	Alarm value (lo2-alarm)	Low SENS:0 to 1000mA High SENS:0 to 100.00mA	Note2	①
7A	86	Alarm value (lor1-alarm)	Low SENS:0 to 1000mA High SENS:0 to 100.00mA	Note2	①
7A	87	Alarm value (lor2-alarm)	Low SENS:0 to 1000mA High SENS:0 to 100.00mA	Note2	①
11	8A	lo1-alarm count upper limit	0 to 999999	1 count step	②
11	8B	lo2-alarm count upper limit			
7A	8A	lor1-alarm count upper limit			
7A	8B	lor2-alarm count upper limit			
E0	B0	Target output of alarm	00H:non-use 01H: lo1-alarm 02H: lo2-alarm 03H: lor1-alarm 04H: lor2-alarm 05H: lo1-alarm count upper limit 06H: lo2-alarm count upper limit 07H: lor1-alarm count upper limit 08H: lor2-alarm count upper limit	—	⑤
E0	9E	Alarm delay time	00H:0, 01H:5, 02H:10, 03H:20, 04H:30, 05H:40, 06H:50, 07H:60, 08H:120, 09H:180, 0AH:240, 0BH:300	—	⑤
E0	9F	Alarm reset method	01H:AUTO, 02H:HOLD	—	⑤
A1	3A	16bit set register	Refer to Table 7.8 Data Format (5/7)	—	⑤

Note 1 : The set value is the second unit value. (For example of 2 minutes, set as 120 seconds.)

Note 2

	Range
Low SENS	0 to 1000mA by 1mA step
High SENS	0 to 100.00mA by 0.01mA step

*From the most significant digit to 3 figures can be freely set up in the range.

Table 7.3 Group Channel List for Data Set Command (2H) (6/8)

Hex		Content name	EMU4-AX4		Data format
Group(H)	Channel(H)		Range	Setting unit	
65	EB	Conversion rate setting	00H: 50ms, 01H: 1ms	—	⑤
65	EC	AD Conversion use or non-use setting (Ch1)	00H: non-use 01H: use	—	⑤
67	EC	AD Conversion use or non-use setting (Ch2)			
69	EC	AD Conversion use or non-use setting (Ch3)			
6B	EC	AD Conversion use or non-use setting (Ch4)			
65	E2	Input range setting (Ch1)	00H: Voltage Input 01H: Current Input	—	⑤
67	E2	Input range setting (Ch2)			
69	E2	Input range setting (Ch3)			
6B	E2	Input range setting (Ch4)			
65	ED	Scaling value lower value (Ch1)	-32767~32767	1 step	①
67	ED	Scaling value lower value (Ch2)			
69	ED	Scaling value lower value (Ch3)			
6B	ED	Scaling value lower value (Ch4)			
65	EE	Scaling value upper value (Ch1)	-32767~32767	1 step	①
67	EE	Scaling value upper value (Ch2)			
69	EE	Scaling value upper value (Ch3)			
6B	EE	Scaling value upper value (Ch4)			
65	F0	Scaling unit (Ch1)	00H: Non, 01H: A, 02H: mA, 03H: kA, 04H: V, 05H: kV, 06H: W, 07H: kW, 08H: MW, 09H: Hz, 0AH: N, 0BH: kN, 0CH: Pa, 0DH: kPa, 0EH: MPa, 0FH: C, 10H: deg, 11H: %	—	⑤
67	F0	Scaling unit (Ch2)			
69	F0	Scaling unit (Ch3)			
6B	F0	Scaling unit (Ch4)			
66	EF	Moving average (Ch1)	1~100 times	1 count step	⑤
68	EF	Moving average (Ch2)			
6A	EF	Moving average (Ch3)			
6C	EF	Moving average (Ch4)			
91	E0	Limit A setting (Ch1)	-32767~32767 Please setting with in the range of Scaling value lower value to Scaling value upper value.	1 step	①
91	E1	Limit B setting (Ch1)			
91	E2	Limit C setting (Ch1)			
91	E3	Limit D setting (Ch1)			
91	E4	Limit A setting (Ch2)			
91	E5	Limit B setting (Ch2)			
91	E6	Limit C setting (Ch2)			
91	E7	Limit D setting (Ch2)			
91	E8	Limit A setting (Ch3)			
91	E9	Limit B setting (Ch3)			
91	EA	Limit C setting (Ch3)			
91	EB	Limit D setting (Ch3)			
91	EC	Limit A setting (Ch4)			
91	ED	Limit B setting (Ch4)			
91	EE	Limit C setting (Ch4)			
91	EF	Limit D setting (Ch4)			
91	F0	Number over limit monitoring factor(CH1)	00H: Integer 01H: Integer (×10) 02H: Integer (×100) 03H: Integer (×1000)	—	⑤
91	F1	Number over limit monitoring factor(CH2)			
91	F2	Number over limit monitoring factor(CH3)			
91	F3	Number over limit monitoring factor(CH4)			

Table 7.3 Group Channel List for Data Set Command (2H) (7/8)

Hex		Content name	EMU4-AX4		Data format
Group(H)	Channel(H)		Range	Setting unit	
E0	99	External output setting value	00H: Non 02H: Alarm output 03H: Contact output		⑤
E0	9A	External output channel	00H: Non, 01H: CH1, 02H: CH2, 03H: CH3, 04H: CH4		⑤
E0	B0	External output alarm	00H: Upper limit alarm or Lower limit alarm 01H: Upper limit alarm 02H: Lower limit alarm		⑤
E0	9C	Upper limit alarm (Ch1)	00H: Off 01H: On		⑤
E0	A1	Upper limit alarm (Ch2)			
E0	A6	Upper limit alarm (Ch3)			
E0	B2	Upper limit alarm (Ch4)			
E0	9E	Upper limit value (Ch1)	-32767~32767		①
E0	A3	Upper limit value (Ch2)	Please setting with in the range of Scaling value lower value to Scaling value upper value.		
E0	A8	Upper limit value (Ch3)			
E0	B4	Upper limit value (Ch4)			
E0	B7	Lower limit alarm (Ch1)	00H: Off 01H: On		⑤
E0	B9	Lower limit alarm (Ch2)			
E0	BB	Lower limit alarm (Ch3)			
E0	BD	Lower limit alarm (Ch4)			
E0	B8	Lower limit value (Ch1)	-32767~32767		①
E0	BA	Lower limit value (Ch2)	Please setting with in the range of Scaling value lower value to Scaling value upper value.		
E0	BC	Lower limit value (Ch3)			
E0	BE	Lower limit value (Ch4)			
E0	9F	Delay (Ch1)	00H: 0sec, 01H: 5sec, 02H: 10sec, 03H: 20 sec, 04H: 30 sec, 05H: 40 sec, 06H: 50 sec, 07H: 60 sec, 08H: 120 sec, 09H: 180 sec, 0AH: 240 sec, 0BH: 300 sec		⑤
E0	A4	Delay (Ch2)			
E0	A9	Delay (Ch3)			
E0	B5	Delay (Ch4)			
E0	A0	Alarm reset mode (Ch1)	01H: Auto 02H: hold		⑤
E0	A5	Alarm reset mode (Ch2)			
E0	AA	Alarm reset mode (Ch3)			
E0	B6	Alarm reset mode (Ch4)			

Table 7.3 Group Channel List for Data Set Command (2H) (8/8)

Hex		Content name	EMU4-PX4		Data format
Group(H)	Group(H)		Range	Setting unit	
87	E2	Operating time measuring (CH1)	00H: Off 01H: On	—	⑤
88	E2	Operating time measuring (CH2)			
8D	E2	Operating time measuring (CH3)			
8E	E2	Operating time measuring (CH4)			
83	E4	Pulse conversion (CH1)	0.001~10000	1xMultiplier	①
84	E4	Pulse conversion (CH2)	Valid for up to four digits. Truncates after five digit.		
85	E4	Pulse conversion (CH3)			
86	E4	Pulse conversion (CH4)			
83	E5	Pulse conversion unit (CH1)	00H: Non, 01H: Wh, 02H: kWh, 03H: MWh, 04H: J, 05H: m ² , 06H: m ³ , 07H: l, 08H: kl, 09H: sec, 0AH: min, 0BH: hour, 0CH: piece, 0DH: set, 0EH: g, 0FH: kg, 10H: t, 11H: ¥, 12H: \$	—	⑤
84	E5	Pulse conversion unit (CH2)			
85	E5	Pulse conversion unit (CH3)			
86	E5	Pulse conversion unit (CH4)			
E0	99	External output setting value	00H: Non 02H: Alarm output 03H: Contact output	—	⑤
E0	9A	External output channel	00H: Non, 01H: CH1, 02H: CH2, 03H: CH3, 04H: CH4	—	⑤
E0	9C	Upper limit alarm (Ch1)	00H: Off 01H: On	—	⑤
E0	A1	Upper limit alarm (Ch2)			
E0	A6	Upper limit alarm (Ch3)			
E0	B2	Upper limit alarm (Ch4)			
E0	9E	Upper limit value (Ch1)	0.001~999999000	1xMultiplier	②
E0	A3	Upper limit value (Ch2)			
E0	A8	Upper limit value (Ch3)			
E0	B4	Upper limit value (Ch4)			
E0	97	External input setting (CH1)	00H: Non 01H: Pulse input 02H: Contact input	—	⑤
E0	BF	External input setting (CH2)			
E0	C0	External input setting (CH3)			
E0	C1	External input setting (CH4)			
E0	98	Contact input reset mode (CH1)	01H: Auto 02H: Hold	—	⑤
E0	C2	Contact input reset mode (CH2)			
E0	C3	Contact input reset mode (CH3)			
E0	C4	Contact input reset mode (CH4)			
83	01	Pulse count (CH1)	0~999999	1 step	⑥
84	01	Pulse count (CH2)			
85	01	Pulse count (CH3)			
86	01	Pulse count (CH4)			
87	01	Operating time (CH1)	0~999999	1 step	⑥
88	01	Operating time (CH2)			
8D	01	Operating time (CH3)			
8E	01	Operating time (CH4)			

7.2.3 Data Composition

Table 7.4 Data Format (1/7)

Data	Data Format ①																																						
<p>Measurement</p> <p>Current, Voltage, Active power, Reactive power, Power factor, Frequency, etc.</p> <p style="border: 1px solid black; padding: 2px; width: fit-content; margin: 10px auto;">Format①</p>	<div style="text-align: center;"> </div> <p>< Multiplicand ></p> <p>Multiplicand is fixed for every item according to settings of primary current, primary voltage, and phase wiring. (Refer to P43.)</p> <table border="1" style="width: 100%; border-collapse: collapse;"> <thead> <tr> <th style="width: 20%;">Index number</th> <th style="width: 30%;">Multiplicand</th> <th style="width: 50%;">Remarks</th> </tr> </thead> <tbody> <tr> <td style="text-align: center;">03H</td> <td style="text-align: center;">$\times 10^3$</td> <td rowspan="7" style="text-align: center; vertical-align: middle;">Actual value = Numerical value \times Multiplicand</td> </tr> <tr> <td style="text-align: center;">02H</td> <td style="text-align: center;">$\times 10^2$</td> </tr> <tr> <td style="text-align: center;">01H</td> <td style="text-align: center;">$\times 10$</td> </tr> <tr> <td style="text-align: center;">00H</td> <td style="text-align: center;">$\times 1$</td> </tr> <tr> <td style="text-align: center;">FFH</td> <td style="text-align: center;">$\times 10^{-1}$</td> </tr> <tr> <td style="text-align: center;">FEH</td> <td style="text-align: center;">$\times 10^{-2}$</td> </tr> <tr> <td style="text-align: center;">FDH</td> <td style="text-align: center;">$\times 10^{-3}$</td> </tr> </tbody> </table> <p>< Example: Active power ></p> <table border="1" style="width: 100%; border-collapse: collapse;"> <thead> <tr> <th style="width: 15%;">Data</th> <th style="width: 15%;">Multiplicand</th> <th style="width: 20%;">Numerical value</th> <th style="width: 50%;">Actual value</th> </tr> </thead> <tbody> <tr> <td style="text-align: center;">FF000000FFH</td> <td style="text-align: center;">FFH $\Rightarrow 10^{-1}$</td> <td style="text-align: center;">000000FFH $\Rightarrow 255$</td> <td style="text-align: center;">$255 \times 10^{-1} = 25.5[\text{kW}]$</td> </tr> <tr> <td style="text-align: center;">00000000FFH</td> <td style="text-align: center;">00H $\Rightarrow 1$</td> <td style="text-align: center;">000000FFH $\Rightarrow 255$</td> <td style="text-align: center;">$255 \times 1 = 255[\text{kW}]$</td> </tr> <tr> <td style="text-align: center;">FFFFFFFF01H</td> <td style="text-align: center;">FFH $\Rightarrow 10^{-1}$</td> <td style="text-align: center;">FFFFFF01H $\Rightarrow -255$</td> <td style="text-align: center;">$-255 \times 10^{-1} = -25.5[\text{kW}]$</td> </tr> <tr> <td style="text-align: center;">00FFFFFF01H</td> <td style="text-align: center;">00H $\Rightarrow 1$</td> <td style="text-align: center;">FFFFFF01H $\Rightarrow -255$</td> <td style="text-align: center;">$-255 \times 1 = -255[\text{kW}]$</td> </tr> </tbody> </table>	Index number	Multiplicand	Remarks	03H	$\times 10^3$	Actual value = Numerical value \times Multiplicand	02H	$\times 10^2$	01H	$\times 10$	00H	$\times 1$	FFH	$\times 10^{-1}$	FEH	$\times 10^{-2}$	FDH	$\times 10^{-3}$	Data	Multiplicand	Numerical value	Actual value	FF000000FFH	FFH $\Rightarrow 10^{-1}$	000000FFH $\Rightarrow 255$	$255 \times 10^{-1} = 25.5[\text{kW}]$	00000000FFH	00H $\Rightarrow 1$	000000FFH $\Rightarrow 255$	$255 \times 1 = 255[\text{kW}]$	FFFFFFFF01H	FFH $\Rightarrow 10^{-1}$	FFFFFF01H $\Rightarrow -255$	$-255 \times 10^{-1} = -25.5[\text{kW}]$	00FFFFFF01H	00H $\Rightarrow 1$	FFFFFF01H $\Rightarrow -255$	$-255 \times 1 = -255[\text{kW}]$
Index number	Multiplicand	Remarks																																					
03H	$\times 10^3$	Actual value = Numerical value \times Multiplicand																																					
02H	$\times 10^2$																																						
01H	$\times 10$																																						
00H	$\times 1$																																						
FFH	$\times 10^{-1}$																																						
FEH	$\times 10^{-2}$																																						
FDH	$\times 10^{-3}$																																						
Data	Multiplicand	Numerical value	Actual value																																				
FF000000FFH	FFH $\Rightarrow 10^{-1}$	000000FFH $\Rightarrow 255$	$255 \times 10^{-1} = 25.5[\text{kW}]$																																				
00000000FFH	00H $\Rightarrow 1$	000000FFH $\Rightarrow 255$	$255 \times 1 = 255[\text{kW}]$																																				
FFFFFFFF01H	FFH $\Rightarrow 10^{-1}$	FFFFFF01H $\Rightarrow -255$	$-255 \times 10^{-1} = -25.5[\text{kW}]$																																				
00FFFFFF01H	00H $\Rightarrow 1$	FFFFFF01H $\Rightarrow -255$	$-255 \times 1 = -255[\text{kW}]$																																				

Table 7.4 Data Format (2/7)

Data	Data Format ②																																				
Measurement Active energy Reactive energy Operating time Periodic power Pulse converted Format②	<div style="text-align: center;"> </div> <p>< Multiplicand > Multiplicand is fixed for every item according to settings of primary current, primary voltage, and phase wiring. (Refer to 7.2.4 Significant digits and Multiplying factor)</p> <table border="1" style="width: 100%; border-collapse: collapse;"> <thead> <tr> <th>Index number</th> <th>Multiplicand</th> <th>Remarks</th> </tr> </thead> <tbody> <tr> <td>04H</td> <td>$\times 10^4$</td> <td rowspan="10" style="vertical-align: middle;">Actual value = Numerical value \times Multiplicand</td> </tr> <tr> <td>03H</td> <td>$\times 10^3$</td> </tr> <tr> <td>02H</td> <td>$\times 10^2$</td> </tr> <tr> <td>01H</td> <td>$\times 10$</td> </tr> <tr> <td>00H</td> <td>$\times 1$</td> </tr> <tr> <td>FFH</td> <td>$\times 10^{-1}$</td> </tr> <tr> <td>FEH</td> <td>$\times 10^{-2}$</td> </tr> <tr> <td>FDH</td> <td>$\times 10^{-3}$</td> </tr> <tr> <td>FCH</td> <td>$\times 10^{-4}$</td> </tr> <tr> <td>FBH</td> <td>$\times 10^{-5}$</td> </tr> </tbody> </table> <p>< Example: Active Energy ></p> <table border="1" style="width: 100%; border-collapse: collapse;"> <thead> <tr> <th>Data</th> <th>Multiplicand</th> <th>Numeric value</th> <th>Actual value</th> </tr> </thead> <tbody> <tr> <td>FF000000FFH</td> <td>FFH$\Rightarrow 10^{-1}$</td> <td>000000FFH$\Rightarrow 255$</td> <td>$255 \times 10^{-1} = 25.5[\text{kWh}]$</td> </tr> <tr> <td>00000000FFH</td> <td>00H$\Rightarrow 1$</td> <td>000000FFH$\Rightarrow 255$</td> <td>$255 \times 1 = 255[\text{kWh}]$</td> </tr> </tbody> </table>	Index number	Multiplicand	Remarks	04H	$\times 10^4$	Actual value = Numerical value \times Multiplicand	03H	$\times 10^3$	02H	$\times 10^2$	01H	$\times 10$	00H	$\times 1$	FFH	$\times 10^{-1}$	FEH	$\times 10^{-2}$	FDH	$\times 10^{-3}$	FCH	$\times 10^{-4}$	FBH	$\times 10^{-5}$	Data	Multiplicand	Numeric value	Actual value	FF000000FFH	FFH $\Rightarrow 10^{-1}$	000000FFH $\Rightarrow 255$	$255 \times 10^{-1} = 25.5[\text{kWh}]$	00000000FFH	00H $\Rightarrow 1$	000000FFH $\Rightarrow 255$	$255 \times 1 = 255[\text{kWh}]$
Index number	Multiplicand	Remarks																																			
04H	$\times 10^4$	Actual value = Numerical value \times Multiplicand																																			
03H	$\times 10^3$																																				
02H	$\times 10^2$																																				
01H	$\times 10$																																				
00H	$\times 1$																																				
FFH	$\times 10^{-1}$																																				
FEH	$\times 10^{-2}$																																				
FDH	$\times 10^{-3}$																																				
FCH	$\times 10^{-4}$																																				
FBH	$\times 10^{-5}$																																				
Data	Multiplicand	Numeric value	Actual value																																		
FF000000FFH	FFH $\Rightarrow 10^{-1}$	000000FFH $\Rightarrow 255$	$255 \times 10^{-1} = 25.5[\text{kWh}]$																																		
00000000FFH	00H $\Rightarrow 1$	000000FFH $\Rightarrow 255$	$255 \times 1 = 255[\text{kWh}]$																																		

Table 7.4 Data Format (3/7)

Data	Data Format ③
<p>Alarm state</p> <div data-bbox="193 293 344 360" style="border: 1px solid black; padding: 5px; width: fit-content; margin-top: 20px;"> Format③ </div>	<p>The diagram illustrates the Data Format ③ for an Alarm state. It consists of three main fields:</p> <ul style="list-style-type: none"> Index number: Located in the upper portion, spanning bits b8 to b15. A fixed value of 00H is indicated for the bits above b8. Low data: A field spanning bits b0 to b7. High data: A field spanning bits b0 to b7. <p>A detailed view of the Alarm state (enclosed in a dashed box) shows the High data field (bits b8 to b15) and the Low data field (bits b0 to b7) as two separate 8-bit data structures.</p> <p>Alarm: Refer to next page.</p>

<The allocation of the alarm state 1 >

Bit	Data			EMU2- *-C	EMU3- DP1-C	EMU4- BD1-MB	EMU4- HD1-MB
	Content	OFF(0)	ON(1)				
b0	Alarm of Pulse	Non-Alarm	Alarm	—	—	—	○
b1	Alarm of Leak Current	Non-Alarm	Alarm	—	○	—	—
b2	Alarm of Demand current	Non-Alarm	Alarm	○	○	—	○
b3	Alarm of Demand Active power	Non-Alarm	Alarm	○	○	—	○
b4	Contact Input	OFF(Open)	ON(Close)	—	—	—	○
b5	Alarm (total)	Non-Alarm	Alarm	○	○	—	○
b6	Reserved	—	—	—	—	—	—
b7	Reserved	—	—	—	—	—	—
b8	Alarm of Voltage	Non-Alarm	Alarm	○	○	—	○
b9	Alarm of Operating Time 2	Non-Alarm	Alarm	—	○	—	—
b10	Alarm of Operating Time 1	Non-Alarm	Alarm	—	○	—	—
b11	Alarm of Pulse 2	Non-Alarm	Alarm	—	○	—	—
b12	Alarm of Pulse 1	Non-Alarm	Alarm	—	○	—	—
b13	Alarm of Power factor	Non-Alarm	Alarm	○	○	—	○
b14	External Input 2	OFF(Open)	ON(Close)	—	○	—	—
b15	External Input 1	OFF(Open)	ON(Close)	—	○	—	—

Note1 : b14-15 (External input 1 and External input 2) is available only when external input signal setup is Contact input in EMU3-DP1-C.

Note2 : b0 (Pulse count) is available only when external input signal setup is Pulse input in EMU4-HD1-MB.

Note3 : b4 (Contact input) is available only when external input signal setup is Contact input in EMU4-HD1-MB.

Bit	Data			EMU4- BM1-MB	EMU4- HM1-MB	EMU4- LG1-MB	EMU4-A2 EMU4-VA2
	Content	OFF(0)	ON(1)				
b0	Alarm of Pulse	Non-Alarm	Alarm	—	○	—	—
b1	Reserved	—	—	—	—	—	—
b2	Alarm of Demand current	Non-Alarm	Alarm	○	○	—	○
b3	Alarm of Demand Active power	Non-Alarm	Alarm	○	○	—	○
b4	Contact Input	OFF(Open)	ON(Close)	—	○	—	—
b5	Alarm (total)	Non-Alarm	Alarm	○	○	—	○
b6	Upper limit current unbalance rate	Non-Alarm	Alarm	○	○	—	○
b7	Upper limit voltage unbalance rate	Non-Alarm	Alarm	○	○	—	○
b8	Alarm of Voltage	Non-Alarm	Alarm	○	○	—	○
b9	Io alarm1	Non-Alarm	Alarm	—	—	○	—
b10	Io alarm2	Non-Alarm	Alarm	—	—	○	—
b11	Ior alarm1	Non-Alarm	Alarm	—	—	○	—
b12	Ior alarm2	Non-Alarm	Alarm	—	—	○	—
b13	Alarm of Power factor	Non-Alarm	Alarm	○	○	—	○
b14	Reserved	—	—	—	—	—	—
b15	Reserved	—	—	—	—	—	—

Note1 : b0 (Pulse converted alarm) is available only when external input signal setup is Pulse input in EMU4-HM1-MB.

Note2 : b0 (Pulse converted alarm) is available both Alarm1 and Alarm2.

Note3 : b4 (Contact input) is available only when external input signal setup is Contact input in MU4-HM1-MB.

Bit	Data			EMU4-AX4	EMU4-PX4
	Content	OFF(0)	ON(1)		
b0	Alarm (Ch1)	Non-Alarm	Alarm	○	○
b1	Alarm (Ch2)	Non-Alarm	Alarm	○	○
b2	Alarm (Ch3)	Non-Alarm	Alarm	○	○
b3	Alarm (Ch4)	Non-Alarm	Alarm	○	○
b4	Contact input(Ch1)	OFF(Open)	ON(Close)	—	○
b5	Alarm (Total)	Non-Alarm	Alarm	○	○
b6	Contact input(Ch2)	OFF(Open)	ON(Close)	—	○
b7	Contact input(Ch3)	OFF(Open)	ON(Close)	—	○
b8	Contact input(Ch4)	OFF(Open)	ON(Close)	—	○
b9	Reserved	—	—	—	—
b10	Reserved	—	—	—	—
b11	Reserved	—	—	—	—
b12	Reserved	—	—	—	—
b13	Reserved	—	—	—	—
b14	Reserved	—	—	—	—
b15	Reserved	—	—	—	—

Note1 : b0 - b3 (Alarm) is upper limit alarm only in using EMU4-PX4.

Note2 : b0 - b3 (Alarm) is available when setting "pulse input" in each external input setup .

Note3 : b4, b6 – b8 (Contact input) is available when setting "contact input" in each external input setup .

<The allocation of the alarm state 2>

Bit	Data			EMU4-BM1-MB	EMU4-HM1-MB	EMU4-LG1-MB	EMU4-A2 EMU4-VA2
	Content	OFF(0)	ON(1)				
b0	Upper limit pulse conversion alarm	Non-Alarm	Alarm	—	○	—	—
b1	Reserved	—	—	—	—	—	—
b2	Upper/ lower demand electric power alarm (3side in 1P2W)	Non-Alarm	Alarm	○	○	—	○
b3	Upper/ lower demand electric power alarm (3side in 1P2W)	Non-Alarm	Alarm	○	○	—	○
b4	Reserved	—	—	—	—	—	—
b5	Upper/lower alarm (Total) (3side in 1P2W)	Non-Alarm	Alarm	○	○	—	○
b6	Reserved	—	—	—	—	—	—
b7	Reserved	—	—	—	—	—	—
b8	Voltage alarm	Non-Alarm	Alarm	○	○	—	○
b9	lo alarm1 Upper limit of alarm occurrence	Non-Alarm	Alarm	—	—	○	—
b10	lo alarm2 Upper limit of alarm occurrence	Non-Alarm	Alarm	—	—	○	—
b11	lor alarm1 Upper limit of alarm occurrence	Non-Alarm	Alarm	—	—	○	—
b12	lor alarm2 Upper limit of alarm occurrence	Non-Alarm	Alarm	—	—	○	—
b13	Upper/lower power factor alarm (3side in 1P2W)	Non-Alarm	Alarm	○	○	—	○
b14	Reserved	—	—	—	—	—	—
b15	Reserved	—	—	—	—	—	—

Note1 : b0 (Pulse converted alarm) is available only when external input signal setup is Pulse input in EMU4-HM1-MB.

Note2 : b0 (Pulse converted alarm) is available both Alarm1 and Alarm2.

Table 7.4 Data Format (4/7)

Data Set-up	Data Format ④																				
<p data-bbox="164 297 336 365">(Primary current Primary voltage)</p> <div data-bbox="193 506 344 573" style="border: 1px solid black; padding: 2px; width: fit-content; margin: 10px auto;">Format④</div>	<div data-bbox="454 280 1420 929" style="border: 1px solid black; padding: 10px;"> <p style="text-align: center;"> Multiplicand: b15, b8, b7, b0 Index number: b8, b7 Low data: b7, b0 High data: b31, b24, b23, b16, b15, b8, b7, b0 </p> <p style="text-align: center;"> Numerical value: 32-bit integer with a sign -2147483648 ~ 2147483647 (80000000H ~ 7FFFFFFFH) </p> </div> <p data-bbox="405 952 582 981">< Multiplicand ></p> <p data-bbox="454 987 1461 1048">Multiplicand is fixed for every item according to settings of primary current, primary voltage, and phase wiring. (Refer to 7.2.4 Significant digits and Multiplying factor)</p> <p data-bbox="427 1115 1185 1176"> Index number = 00H: The actual value is the numeric value. Index number = FFH: The actual value is 10⁻¹ times the numeric value. </p> <p data-bbox="405 1245 906 1274">< Example: Primary current, Primary voltage ></p> <table border="1" data-bbox="427 1274 1445 1635"> <thead> <tr> <th>Set-up value</th> <th>Multiplicand</th> <th>Numeric value</th> <th>Data</th> </tr> </thead> <tbody> <tr> <td>Set-up value = 100.0A (Effective range = one place of decimals)</td> <td>× 10⁻¹ ⇒ FFH</td> <td>1000 ⇒ 03E8H</td> <td>000003E8H</td> </tr> <tr> <td>Set-up value = 400A (Effective range = Integer)</td> <td>× 1 ⇒ 00H</td> <td>400 ⇒ 0190H</td> <td>00000190H</td> </tr> <tr> <td>Set-up value = 110.0V (Effective range = one place of decimals)</td> <td>× 10⁻¹ ⇒ FFH</td> <td>1100 ⇒ 044CH</td> <td>0000044CH</td> </tr> <tr> <td>Set-up value = 3300V (Effective range = Integer)</td> <td>× 1 ⇒ 00H</td> <td>3300 ⇒ 0CE4H</td> <td>00000CE4H</td> </tr> </tbody> </table>	Set-up value	Multiplicand	Numeric value	Data	Set-up value = 100.0A (Effective range = one place of decimals)	× 10 ⁻¹ ⇒ FFH	1000 ⇒ 03E8H	000003E8H	Set-up value = 400A (Effective range = Integer)	× 1 ⇒ 00H	400 ⇒ 0190H	00000190H	Set-up value = 110.0V (Effective range = one place of decimals)	× 10 ⁻¹ ⇒ FFH	1100 ⇒ 044CH	0000044CH	Set-up value = 3300V (Effective range = Integer)	× 1 ⇒ 00H	3300 ⇒ 0CE4H	00000CE4H
Set-up value	Multiplicand	Numeric value	Data																		
Set-up value = 100.0A (Effective range = one place of decimals)	× 10 ⁻¹ ⇒ FFH	1000 ⇒ 03E8H	000003E8H																		
Set-up value = 400A (Effective range = Integer)	× 1 ⇒ 00H	400 ⇒ 0190H	00000190H																		
Set-up value = 110.0V (Effective range = one place of decimals)	× 10 ⁻¹ ⇒ FFH	1100 ⇒ 044CH	0000044CH																		
Set-up value = 3300V (Effective range = Integer)	× 1 ⇒ 00H	3300 ⇒ 0CE4H	00000CE4H																		

Table 7.4 Data Format (5/7)

Data Set-up	Data Format ⑤																																																															
<div style="border: 1px solid black; border-radius: 15px; padding: 5px; width: fit-content;"> Phase wiring Time constant 5A input switch Connected phase switch Model code 16bit set register </div> <div style="border: 1px solid black; border-radius: 15px; padding: 5px; width: fit-content; margin-top: 20px;"> Format⑤ </div>	<div style="text-align: center;"> </div> <p>< Data(Numeric value) ></p> <p>1) Phase wiring</p> <table border="1" style="width: 100%; border-collapse: collapse;"> <thead> <tr> <th style="width: 50%;">Phase wiring</th> <th style="width: 20%;">Data</th> <th style="width: 30%;">Note</th> </tr> </thead> <tbody> <tr> <td>Single phase 2 wire (1P2W)</td> <td style="text-align: center;">00000001H</td> <td rowspan="4" style="vertical-align: middle;">About setting range, please refer to the instrument manual.</td> </tr> <tr> <td>Single phase 3 wire (1P3W)(1N3 display)</td> <td style="text-align: center;">00000002H</td> </tr> <tr> <td>Three phase 3 wire (3P3W)</td> <td style="text-align: center;">00000003H</td> </tr> <tr> <td>Three phase 4 wire (3P4W)</td> <td style="text-align: center;">00000004H</td> </tr> </tbody> </table> <p>2) Time constant for demand</p> <table border="1" style="width: 100%; border-collapse: collapse;"> <thead> <tr> <th style="width: 15%;">Group</th> <th style="width: 15%;">Channel</th> <th style="width: 70%;">Range</th> </tr> </thead> <tbody> <tr> <td style="text-align: center;">E0</td> <td style="text-align: center;">16</td> <td>The range of 0 (=0H) to 15 minutes (=FH) can be set up per minute.</td> </tr> <tr> <td style="text-align: center;">02</td> <td style="text-align: center;">E0</td> <td rowspan="3">The range of 0(= 0H) to 1800 seconds(= 708H)can be set up per seconds.</td> </tr> <tr> <td style="text-align: center;">08</td> <td style="text-align: center;">E0</td> </tr> <tr> <td style="text-align: center;">12</td> <td style="text-align: center;">E0</td> </tr> </tbody> </table> <p>3)5A input switch : Direct sensor = 0 (00H), 5A sensor = 2 (02H) 4)Connected phase switch : Phase switch disable = 0 (00H), Phase switch enable =1 (01H) 5) Model code</p> <table border="1" style="width: 100%; border-collapse: collapse;"> <thead> <tr> <th style="width: 40%;">Model Name</th> <th style="width: 15%;">Data</th> <th style="width: 45%;">Note</th> </tr> </thead> <tbody> <tr><td>EMU2-HM1-C</td><td style="text-align: center;">02H</td><td rowspan="18" style="vertical-align: middle;">b31 to b8 is fixed 0.</td></tr> <tr><td>EMU2-RD1-C</td><td style="text-align: center;">31H</td></tr> <tr><td>EMU2-RD3-C</td><td style="text-align: center;">33H</td></tr> <tr><td>EMU2-RD5-C</td><td style="text-align: center;">35H</td></tr> <tr><td>EMU2-RD7-C</td><td style="text-align: center;">37H</td></tr> <tr><td>EMU2-RD2-C-4W</td><td style="text-align: center;">52H</td></tr> <tr><td>EMU2-RD4-C-4W</td><td style="text-align: center;">54H</td></tr> <tr><td>EMU3-DP1-C</td><td style="text-align: center;">61H</td></tr> <tr><td>EMU4-BD1-MB</td><td style="text-align: center;">01H</td></tr> <tr><td>EMU4-HD1-MB</td><td style="text-align: center;">02H</td></tr> <tr><td>EMU4-BM1-MB</td><td style="text-align: center;">03H</td></tr> <tr><td>EMU4-HM1-MB</td><td style="text-align: center;">04H</td></tr> <tr><td>EMU4-A2</td><td style="text-align: center;">05H</td></tr> <tr><td>EMU4-VA2</td><td style="text-align: center;">06H</td></tr> <tr><td>EMU4-LG1-MB</td><td style="text-align: center;">07H</td></tr> <tr><td>EMU4-AX4</td><td style="text-align: center;">09H</td></tr> <tr><td>EMU4-PX4</td><td style="text-align: center;">0AH</td></tr> </tbody> </table> <p>6)16bit set register Refer to next page.</p>	Phase wiring	Data	Note	Single phase 2 wire (1P2W)	00000001H	About setting range, please refer to the instrument manual.	Single phase 3 wire (1P3W)(1N3 display)	00000002H	Three phase 3 wire (3P3W)	00000003H	Three phase 4 wire (3P4W)	00000004H	Group	Channel	Range	E0	16	The range of 0 (=0H) to 15 minutes (=FH) can be set up per minute.	02	E0	The range of 0(= 0H) to 1800 seconds(= 708H)can be set up per seconds.	08	E0	12	E0	Model Name	Data	Note	EMU2-HM1-C	02H	b31 to b8 is fixed 0.	EMU2-RD1-C	31H	EMU2-RD3-C	33H	EMU2-RD5-C	35H	EMU2-RD7-C	37H	EMU2-RD2-C-4W	52H	EMU2-RD4-C-4W	54H	EMU3-DP1-C	61H	EMU4-BD1-MB	01H	EMU4-HD1-MB	02H	EMU4-BM1-MB	03H	EMU4-HM1-MB	04H	EMU4-A2	05H	EMU4-VA2	06H	EMU4-LG1-MB	07H	EMU4-AX4	09H	EMU4-PX4	0AH
Phase wiring	Data	Note																																																														
Single phase 2 wire (1P2W)	00000001H	About setting range, please refer to the instrument manual.																																																														
Single phase 3 wire (1P3W)(1N3 display)	00000002H																																																															
Three phase 3 wire (3P3W)	00000003H																																																															
Three phase 4 wire (3P4W)	00000004H																																																															
Group	Channel	Range																																																														
E0	16	The range of 0 (=0H) to 15 minutes (=FH) can be set up per minute.																																																														
02	E0	The range of 0(= 0H) to 1800 seconds(= 708H)can be set up per seconds.																																																														
08	E0																																																															
12	E0																																																															
Model Name	Data	Note																																																														
EMU2-HM1-C	02H	b31 to b8 is fixed 0.																																																														
EMU2-RD1-C	31H																																																															
EMU2-RD3-C	33H																																																															
EMU2-RD5-C	35H																																																															
EMU2-RD7-C	37H																																																															
EMU2-RD2-C-4W	52H																																																															
EMU2-RD4-C-4W	54H																																																															
EMU3-DP1-C	61H																																																															
EMU4-BD1-MB	01H																																																															
EMU4-HD1-MB	02H																																																															
EMU4-BM1-MB	03H																																																															
EMU4-HM1-MB	04H																																																															
EMU4-A2	05H																																																															
EMU4-VA2	06H																																																															
EMU4-LG1-MB	07H																																																															
EMU4-AX4	09H																																																															
EMU4-PX4	0AH																																																															

< Details of 16bit set register(1/4) >

Bit	Contents	EMU2- *-C	EMU3- DP1-C	Note
b0	Alarm reset	—	○	
b1	All measurement data reset	○	○	Note1, Note3, Note4
b2	Measurement data reset (except active energy and reactive energy)	○	○	Note2, Note3, Note4
b3	Reserved	—	—	
b4	Reserved	—	—	
b5	Maximum leak current demand reset	—	○	Note3
b6	Maximum active power demand reset	○	—	Note3
	Maximum / Minimum active power demand reset	—	○	
b7	Reserved	—	—	
b8	External input 2 reset	—	○	Note4
	Contact input latch clear	—	—	
b9	External input 1 reset	—	○	Note4
b10	Maximum power factor reset	○	—	Note3
	Maximum / Minimum power factor reset	—	○	
b11	Maximum current demand reset	○	—	Note3
	Maximum / Minimum current demand reset	—	○	
b12	Maximum voltage demand reset	○	—	Note3
	Maximum / Minimum voltage demand reset	—	○	
b13	Maximum over current reset	—	○	
b14	Active energy / Reactive energy reset	○	○	
b15	Reserved	—	—	

Note1: All Max and Min value is reset. Electric Energy and Reactive power (Integrated) is 0kWh (kvarh).

Note2: All Max and Min value is reset. Electric Energy and Reactive power (Integrated) is 0kWh (kvarh).

Note3: All measurement data reset is contained the occurrence time.

Note4: Pulse count is 0pulse , Operating Time is 0min and Electric Energy in Operating Time is 0kWh in EMU3-DP1-C.

< Details of 16bit set register(2/4) >

Bit	Content	EMU4-BD1-MB	EMU4-HD1-MB	EMU4-BM1-BM	EMU4-HM1-MB	EMU4-LG1-MB	EMU4-A2 EMU4-VA2	Note
b0	Alarm reset	—	○	○	○	○	○	
b1	All measurement data reset	○	○	○	○	—	○	Note1
b2	Measurement max/min data reset	—	—	○	○	○	○	
b3	Alarm count reset	—	—	—	—	○	—	
b4	Reserved	—	—	—	—	—	—	
b5	Reserved	—	—	—	—	—	—	
b6	Reserved	—	—	—	—	—	—	
b7	Reserved	—	—	—	—	—	—	
b8	Contact input latch clear	—	○	—	○	—	—	
b9	External input reset	—	○	—	○	—	○	Note2
b10	Reserved	—	—	—	—	—	—	
b11	Reserved	—	—	—	—	—	—	
b12	Reserved	—	—	—	—	—	—	
b13	Reserved	—	—	—	—	—	—	
b14	Active energy / Reactive energy reset	○	○	○	○	—	○	
b15	Reserved	—	—	—	—	—	—	

Note 1: Reset value is showed in below table.

	Integral value
EMU4-BD1-BM	Electric energy, Reactive power, Operating time
EMU4-HD1-BM	Electric energy, Reactive power, Pulse count, Operating time Periodic electric energy, CO2 conversion
EMU4-BM1-MB	Electric energy, Reactive power, Operating time
EMU4-HM1-MB	Electric energy, Reactive power, Pulse count, Pulse conversion, Operating time, Periodic electric energy, Electric energy conversion
EMU4-A2, EMU4-VA2	Electric energy, Reactive power, Operating time, Electric energy conversion

Note 2: Reset value is showed in below table.

	value
EMU4-BD1-BM	Operating time
EMU4-HD1-BM	Electric energy, Reactive power, Pulse count, Operating time Periodic electric energy, CO2 conversion
EMU4-BM1-MB	Operating time
EMU4-HM1-MB	Pulse count, Pulse conversion, Operating time, Periodic electric energy, Electric energy conversion
EMU4-A2, EMU4-VA2	Operating time, Electric energy conversion

< Details of 16bit set register(3/4) >

bit	Set data			EMU4-AX4	Note
	Content	OFF(0)	ON(1)		
b0	Reset alarm	Not clear	Clear it	○	
b1	Reserved	—	—	—	
b2	Reset max and min value	Not clear	Clear it	○	
b3	Reserved	—	—	—	
b4	All CH of number over limit A-D is reset.	Not clear	Clear it	○	
b5	Contact output	OFF(Open)	ON(Close)	○	Note3
b6	Reserved	—	—	—	
b7	Reserved	—	—	—	
b8	Reserved	—	—	—	
b9	Reserved	—	—	—	
b10	Reserved	—	—	—	
b11	Reserved	—	—	—	
b12	Reserved	—	—	—	
b13	Reserved	—	—	—	
b14	Reserved	—	—	—	
b15	Reserved	—	—	—	

< Details of 16bit set register(4/4) >

bit	Set data			EMU4-PX4	Note
	Content	OFF(0)	ON(1)		
b0	Reset alarm	Not reset	Reset	○	
b1	Data reset	Not reset	Reset	○	Note1
b2	Reserved	—	—	—	
b3	Reserved	—	—	—	
b4	Reserved	—	—	—	
b5	Contact output	OFF(Open)	ON(Close)	○	Note3
b6	Reserved	—	—	—	
b7	Reserved	—	—	—	
b8	Clear hold contact input	Not clear	Clear	○	
b9	Reset external input	Not reset	Reset	○	Note2
b10	Reserved	—	—	—	
b11	Reserved	—	—	—	
b12	Reserved	—	—	—	
b13	Reserved	—	—	—	
b14	Reserved	—	—	—	
b15	Reserved	—	—	—	

Note 1: Reset integrate value is showed in below items.

Pulse count, Pulse conversion, Operating time

Note 2: Reset value is showed in below items.

Pulse count, Pulse conversion, Operating time

Note 3: This is only available only when setting external output setting value is contact output.

Table 7.4 Data Format (6/7)

Data	Data Format ⑥																																																																																					
<p>Time data</p> <p>(Time data)</p> <p>Format ⑥</p>	<div style="text-align: center;"> <table border="1" style="margin: auto;"> <tr> <td></td> <td style="text-align: center;">b15</td> <td style="text-align: center;">b8</td> <td style="text-align: center;">b7</td> <td style="text-align: center;">b0</td> </tr> <tr> <td style="text-align: center;">n</td> <td colspan="2" style="text-align: center;">Channel No.</td> <td colspan="2" style="text-align: center;">Group No.</td> </tr> <tr> <td style="text-align: center;">n+1</td> <td colspan="2" style="text-align: center;">Year</td> <td colspan="2" style="text-align: center;">Month</td> </tr> <tr> <td style="text-align: center;">n+2</td> <td colspan="2" style="text-align: center;">Day</td> <td colspan="2" style="text-align: center;">Hour</td> </tr> <tr> <td style="text-align: center;">n+3</td> <td colspan="2" style="text-align: center;">Minute</td> <td colspan="2" style="text-align: center;">Second</td> </tr> </table> </div> <div style="text-align: center;"> <table border="1" style="margin: auto;"> <tr> <td colspan="4" style="text-align: center;">n+1</td> <td colspan="4" style="text-align: center;">n+2</td> <td colspan="4" style="text-align: center;">n+3</td> </tr> <tr> <td style="text-align: center;">b15</td><td style="text-align: center;">b8</td><td style="text-align: center;">b7</td><td style="text-align: center;">b0</td> <td style="text-align: center;">b15</td><td style="text-align: center;">b8</td><td style="text-align: center;">b7</td><td style="text-align: center;">b0</td> <td style="text-align: center;">b15</td><td style="text-align: center;">b8</td><td style="text-align: center;">b7</td><td style="text-align: center;">b0</td> </tr> <tr> <td colspan="2"> </td><td colspan="2"> </td> <td colspan="2"> </td><td colspan="2"> </td> <td colspan="2"> </td><td colspan="2"> </td> </tr> <tr> <td colspan="2" style="text-align: center;">Year (BCD)</td> <td colspan="2" style="text-align: center;">Month (BCD)</td> <td colspan="2" style="text-align: center;">Day (BCD)</td> <td colspan="2" style="text-align: center;">Hour (BCD)</td> <td colspan="2" style="text-align: center;">Minute(BCD)</td> <td colspan="2" style="text-align: center;">Second (BCD)</td> </tr> <tr> <td colspan="2" style="text-align: center;">00~99</td> <td colspan="2" style="text-align: center;">01~12</td> <td colspan="2" style="text-align: center;">01~31</td> <td colspan="2" style="text-align: center;">00~23</td> <td colspan="2" style="text-align: center;">00~59</td> <td colspan="2" style="text-align: center;">00~59</td> </tr> </table> </div> <p><Date data></p> <p>Year data : Last two digits of year (05H indicates 2005.)</p> <p>Month data : Data on month (11H indicates November.)</p> <p>Day data : Data on day (16H indicates the 16th.)</p> <p><Time data></p> <p>Hour data : Data on hour (17H indicates 17 o'clock.)</p> <p>Minute data : Data on minute (15H indicates 15 minutes.)</p> <p>Second data: Data on second (28H indicates 28 minutes.)</p> <p>Note : In case of EMU3-DP1-C, Range of second is 0 fixed.</p>		b15	b8	b7	b0	n	Channel No.		Group No.		n+1	Year		Month		n+2	Day		Hour		n+3	Minute		Second		n+1				n+2				n+3				b15	b8	b7	b0	b15	b8	b7	b0	b15	b8	b7	b0													Year (BCD)		Month (BCD)		Day (BCD)		Hour (BCD)		Minute(BCD)		Second (BCD)		00~99		01~12		01~31		00~23		00~59		00~59	
	b15	b8	b7	b0																																																																																		
n	Channel No.		Group No.																																																																																			
n+1	Year		Month																																																																																			
n+2	Day		Hour																																																																																			
n+3	Minute		Second																																																																																			
n+1				n+2				n+3																																																																														
b15	b8	b7	b0	b15	b8	b7	b0	b15	b8	b7	b0																																																																											
Year (BCD)		Month (BCD)		Day (BCD)		Hour (BCD)		Minute(BCD)		Second (BCD)																																																																												
00~99		01~12		01~31		00~23		00~59		00~59																																																																												

Table 7.4 Data Format (7/7)

Data	Data Format ②												
<p>Measurement</p> <p>(Pulse Operating time)</p> <p>Format⑦</p>	<div style="text-align: center;"> </div> <p>< Multiplicand ></p> <p>Multiplicand is fixed for every item according to settings of primary current, primary voltage, and phase wiring. (Refer to 7.2.4 Significant digits and Multiplying factor)</p> <p>< Example: Measurement value ></p> <table border="1" data-bbox="414 1160 1449 1310"> <thead> <tr> <th>Item</th> <th>Multiplicand</th> <th>Numeric value</th> <th>Actual value</th> </tr> </thead> <tbody> <tr> <td>Pulse</td> <td>00H⇒1</td> <td>000000FFH⇒255</td> <td>255×1 = 255[pulse]</td> </tr> <tr> <td>Operating time</td> <td>00H⇒1</td> <td>0000003CH⇒60</td> <td>60×1 = 60[min]</td> </tr> </tbody> </table>	Item	Multiplicand	Numeric value	Actual value	Pulse	00H⇒1	000000FFH⇒255	255×1 = 255[pulse]	Operating time	00H⇒1	0000003CH⇒60	60×1 = 60[min]
Item	Multiplicand	Numeric value	Actual value										
Pulse	00H⇒1	000000FFH⇒255	255×1 = 255[pulse]										
Operating time	00H⇒1	0000003CH⇒60	60×1 = 60[min]										

7.2.4 Significant digits and Multiplying factor

(1) Electric power and Reactive power data

<EMU2*-C>

Vertical axis: Primary current setting value Horizontal axis: Primary voltage setting value, Phase wire system setting value.

Phase wire system A	V	1P2W					1P3W	3P3W							
		110	220	440	3300	6600	110	110	220	440	3300	6600	11000	22000	33000
5		3digit	3digit	3digit	2digit	2digit	3digit	3digit	3digit	3digit	2digit	2digit	2digit	1digit	1digit
6		3digit	3digit	3digit	2digit	2digit	3digit	3digit	3digit	3digit	2digit	2digit	2digit	1digit	1digit
7.5		3digit	3digit	3digit	2digit	2digit	3digit	3digit	3digit	3digit	2digit	2digit	1digit	1digit	1digit
8		3digit	3digit	3digit	2digit	2digit	3digit	3digit	3digit	3digit	2digit	2digit	1digit	1digit	1digit
10		3digit	3digit	3digit	2digit	2digit	3digit	3digit	3digit	3digit	2digit	2digit	1digit	1digit	1digit
12		3digit	3digit	3digit	2digit	2digit	3digit	3digit	3digit	3digit	2digit	1digit	1digit	1digit	1digit
15		3digit	3digit	3digit	2digit	2digit	3digit	3digit	3digit	3digit	2digit	1digit	1digit	1digit	1digit
20		3digit	3digit	3digit	2digit	1digit	3digit	3digit	3digit	2digit	2digit	1digit	1digit	1digit	1digit
25		3digit	3digit	3digit	2digit	1digit	3digit	3digit	3digit	2digit	1digit	1digit	1digit	1digit	x1
30		3digit	3digit	2digit	2digit	1digit	3digit	3digit	3digit	2digit	1digit	1digit	1digit	1digit	x1
40		3digit	3digit	2digit	1digit	1digit	3digit	3digit	2digit	2digit	1digit	1digit	1digit	x1	x1
50		3digit	3digit	2digit	1digit	1digit	3digit	3digit	2digit	2digit	1digit	1digit	1digit	x1	x1
60		3digit	2digit	2digit	1digit	1digit	2digit	3digit	2digit	2digit	1digit	1digit	1digit	x1	x1
75		3digit	2digit	2digit	1digit	1digit	2digit	2digit	2digit	2digit	1digit	1digit	x1	x1	x1
80		3digit	2digit	2digit	1digit	1digit	2digit	2digit	2digit	2digit	1digit	1digit	x1	x1	x1
100		3digit	2digit	2digit	1digit	1digit	2digit	2digit	2digit	2digit	1digit	1digit	x1	x1	x1
120		2digit	2digit	2digit	1digit	1digit	2digit	2digit	2digit	2digit	1digit	x1	x1	x1	x1
150		2digit	2digit	2digit	1digit	1digit	2digit	2digit	2digit	2digit	1digit	x1	x1	x1	x1
200		2digit	2digit	2digit	1digit	x1	2digit	2digit	2digit	1digit	1digit	x1	x1	x1	x1
250		2digit	2digit	2digit	1digit	x1	2digit	2digit	2digit	1digit	x1	x1	x1	x1	x10
300		2digit	2digit	1digit	1digit	x1	2digit	2digit	2digit	1digit	x1	x1	x1	x1	x10
400		2digit	2digit	1digit	x1	x1	2digit	2digit	1digit	1digit	x1	x1	x1	x10	x10
500		2digit	2digit	1digit	x1	x1	2digit	2digit	1digit	1digit	x1	x1	x1	x10	x10
600		2digit	1digit	1digit	x1	x1	1digit	2digit	1digit	1digit	x1	x1	x1	x10	x10
750		2digit	1digit	1digit	x1	x1	1digit	1digit	1digit	1digit	x1	x1	x10	x10	x10
800		2digit	1digit	1digit	x1	x1	1digit	1digit	1digit	1digit	x1	x1	x10	x10	x10
1000		2digit	1digit	1digit	x1	x1	1digit	1digit	1digit	1digit	x1	x1	x10	x10	x10
1200		1digit	1digit	1digit	x1	x1	1digit	1digit	1digit	1digit	x1	x1	x10	x10	x10
1500		1digit	1digit	1digit	x1	x1	1digit	1digit	1digit	1digit	x1	x10	x10	x10	x10
1600		1digit	1digit	1digit	x1	x1	1digit	1digit	1digit	x1	x1	x10	x10	x10	x10
2000		1digit	1digit	1digit	x1	x10	1digit	1digit	1digit	x1	x1	x10	x10	x10	x10
2500		1digit	1digit	1digit	x1	x10	1digit	1digit	1digit	x1	x10	x10	x10	x10	x100
3000		1digit	1digit	x1	x1	x10	1digit	1digit	1digit	x1	x10	x10	x10	x10	—
4000		1digit	1digit	x1	x10	x10	1digit	1digit	x1	x1	x10	x10	x10	x100	—
5000		1digit	1digit	x1	x10	x10	1digit	1digit	x1	x1	x10	x10	x10	—	—
6000		1digit	x1	x1	x10	x10	x1	1digit	x1	x1	x10	x10	x10	—	—
7500		1digit	x1	x1	x10	x10	x1	x1	x1	x1	x10	x10	x100	—	—
8000		1digit	x1	x1	x10	x10	x1	x1	x1	x1	x10	x10	x100	—	—
10000		1digit	x1	x1	x10	x10	x1	x1	x1	x1	x10	x10	—	—	—
12000		x1	x1	x1	x10	x10	x1	x1	x1	x1	x10	x100	—	—	—
20000		x1	x1	x1	x10	—	x1	x1	x1	x10	x10	—	—	—	—
25000		x1	x1	x1	x10	—	x1	x1	x1	x10	x100	—	—	—	—
30000		x1	x1	x10	—	—	x1	x1	x1	x10	—	—	—	—	—

Phase wire system	3P4W					
	V	63.5 /110	110 /190	120 /208	220 /380	240 /415
A						
5		3digit	3digit	3digit	3digit	3digit
6		3digit	3digit	3digit	3digit	3digit
7.5		3digit	3digit	3digit	3digit	3digit
8		3digit	3digit	3digit	3digit	3digit
10		3digit	3digit	3digit	3digit	3digit
12		3digit	3digit	3digit	3digit	3digit
15		3digit	3digit	3digit	3digit	3digit
20		3digit	3digit	3digit	2digit	2digit
25		3digit	3digit	3digit	2digit	2digit
30		3digit	3digit	3digit	2digit	2digit
40		3digit	2digit	2digit	2digit	2digit
50		3digit	2digit	2digit	2digit	2digit
60		3digit	2digit	2digit	2digit	2digit
75		2digit	2digit	2digit	2digit	2digit
80		2digit	2digit	2digit	2digit	2digit
100		2digit	2digit	2digit	2digit	2digit
120		2digit	2digit	2digit	2digit	2digit
150		2digit	2digit	2digit	2digit	2digit
200		2digit	2digit	2digit	1digit	1digit
250		2digit	2digit	2digit	1digit	1digit
300		2digit	2digit	2digit	1digit	1digit
400		2digit	1digit	1digit	1digit	1digit
500		2digit	1digit	1digit	1digit	1digit
600		2digit	1digit	1digit	1digit	1digit
750		1digit	1digit	1digit	1digit	1digit
800		1digit	1digit	1digit	1digit	1digit
1000		1digit	1digit	1digit	1digit	1digit
1200		1digit	1digit	1digit	1digit	1digit
1500		1digit	1digit	1digit	1digit	1digit
1600		1digit	1digit	1digit	1digit	x1
2000		1digit	1digit	1digit	x1	x1
2500		1digit	1digit	1digit	x1	x1
3000		1digit	1digit	1digit	x1	x1
4000		1digit	x1	x1	x1	x1
5000		1digit	x1	x1	x1	x1
6000		1digit	x1	x1	x1	x1
7500		x1	x1	x1	x1	x1
8000		x1	x1	x1	x1	x1
10000		x1	x1	x1	x1	x1
12000		x1	x1	x1	x1	x1
20000		x1	x1	x1	x10	x10
25000		x1	x1	x1	x10	x10
30000		x1	x1	x1	x10	x10

Note : 3 digit means three decimal places ($\times 10^{-3}$) and 2 digit means two decimal places ($\times 10^{-2}$) and 1 digit means 1 decimal places ($\times 10^{-1}$)

Note : x1 means integer $\times 1$ and x10 means integer $\times 10$.

Note : “-” means out of setting range.

<EMU3-DP1-C>

Vertical axis: Primary current setting value Horizontal axis: Primary voltage setting value, Phase wire system setting value.

Phase wire system	1P2W													1P3W	3P3W									
	V	63.5	100	110	120	173	190	208	220	240	254	380	415	440	110	110	173	190	208	220	380	415	440	
A																								
60		3digit	3digit	3digit	3digit	3digit	3digit	2digit	2digit	2digit	2digit	2digit	2digit	2digit	3digit	3digit	2digit	2digit	2digit	2digit	2digit	2digit	2digit	2digit
125		3digit	2digit	2digit	2digit	2digit	2digit	2digit	2digit	2digit	2digit	2digit	2digit	2digit	2digit	2digit	2digit	2digit	2digit	2digit	2digit	2digit	2digit	2digit

Note : 3 digit means three decimal places ($\times 10^{-3}$) and 2 digit means two decimal places ($\times 10^{-2}$).

< EMU4-BD1-MB, EMU4-HD1-MB >

Vertical axis: Primary current setting value Horizontal axis: Primary voltage setting value, Phase wire system setting value.

Phase Wire system	1P2W								1P3W	3P3W								
	V	110	220	440	690	1100	2200	3300	6600	110	110	220	440	690	1100	2200	3300	6600
A																		
5		3digit	3digit	3digit	3digit	3digit	3digit	2digit	2digit	3digit	3digit	3digit	3digit	3digit	2digit	2digit	2digit	2digit
6		3digit	3digit	3digit	3digit	3digit	2digit	2digit	2digit	3digit	3digit	3digit	3digit	3digit	3digit	2digit	2digit	2digit
7.5		3digit	3digit	3digit	3digit	3digit	2digit	2digit	2digit	3digit	3digit	3digit	3digit	2digit	2digit	2digit	2digit	2digit
8		3digit	3digit	3digit	3digit	3digit	2digit	2digit	2digit	3digit	3digit	3digit	3digit	2digit	2digit	2digit	2digit	2digit
10		3digit	3digit	3digit	3digit	3digit	2digit	2digit	2digit	3digit	3digit	3digit	3digit	2digit	2digit	2digit	2digit	2digit
12		3digit	3digit	3digit	3digit	2digit	2digit	2digit	2digit	3digit	3digit	3digit	3digit	2digit	2digit	2digit	2digit	1digit
15		3digit	3digit	3digit	3digit	2digit	2digit	2digit	2digit	3digit	3digit	3digit	3digit	2digit	2digit	2digit	2digit	1digit
20		3digit	3digit	3digit	2digit	2digit	2digit	2digit	1digit	3digit	3digit	3digit	2digit	2digit	2digit	2digit	2digit	1digit
25		3digit	3digit	3digit	2digit	2digit	2digit	2digit	1digit	3digit	3digit	3digit	2digit	2digit	2digit	2digit	1digit	1digit
30		3digit	3digit	2digit	2digit	2digit	2digit	2digit	1digit	3digit	3digit	3digit	2digit	2digit	2digit	2digit	1digit	1digit
40		3digit	3digit	2digit	2digit	2digit	2digit	1digit	1digit	3digit	3digit	2digit	2digit	2digit	2digit	1digit	1digit	1digit
50		3digit	3digit	2digit	2digit	2digit	2digit	1digit	1digit	3digit	3digit	2digit	2digit	2digit	2digit	1digit	1digit	1digit
60		3digit	2digit	2digit	2digit	2digit	1digit	1digit	1digit	2digit	3digit	2digit	2digit	2digit	2digit	1digit	1digit	1digit
75		3digit	2digit	2digit	2digit	2digit	1digit	1digit	1digit	2digit	2digit	2digit	2digit	2digit	1digit	1digit	1digit	1digit
80		3digit	2digit	2digit	2digit	2digit	1digit	1digit	1digit	2digit	2digit	2digit	2digit	2digit	1digit	1digit	1digit	1digit
100		3digit	2digit	2digit	2digit	2digit	1digit	1digit	1digit	2digit	2digit	2digit	2digit	2digit	1digit	1digit	1digit	1digit
120		2digit	2digit	2digit	2digit	1digit	1digit	1digit	1digit	2digit	2digit	2digit	2digit	1digit	1digit	1digit	1digit	x1
150		2digit	2digit	2digit	2digit	1digit	1digit	1digit	1digit	2digit	2digit	2digit	2digit	1digit	1digit	1digit	1digit	x1
200		2digit	2digit	2digit	1digit	1digit	1digit	1digit	x1	2digit	2digit	2digit	1digit	1digit	1digit	1digit	1digit	x1
250		2digit	2digit	2digit	1digit	1digit	1digit	1digit	x1	2digit	2digit	2digit	1digit	1digit	1digit	1digit	1digit	x1
300		2digit	2digit	1digit	1digit	1digit	1digit	1digit	x1	2digit	2digit	2digit	1digit	1digit	1digit	1digit	1digit	x1
400		2digit	2digit	1digit	1digit	1digit	1digit	x1	x1	2digit	2digit	1digit	1digit	1digit	1digit	1digit	x1	x1
500		2digit	2digit	1digit	1digit	1digit	1digit	x1	x1	2digit	2digit	1digit	1digit	1digit	1digit	1digit	x1	x1
600		2digit	1digit	1digit	1digit	1digit	x1	x1	x1	1digit	2digit	1digit	1digit	1digit	1digit	1digit	x1	x1
750		2digit	1digit	1digit	1digit	1digit	x1	x1	x1	1digit	1digit	1digit	1digit	1digit	x1	x1	x1	x1
800		2digit	1digit	1digit	1digit	1digit	x1	x1	x1	1digit	1digit	1digit	1digit	1digit	x1	x1	x1	x1
1000		2digit	1digit	1digit	1digit	1digit	x1	x1	x1	1digit	1digit	1digit	1digit	1digit	x1	x1	x1	x1
1200		1digit	1digit	1digit	1digit	x1	x1	x1	x1	1digit	1digit	1digit	1digit	x1	x1	x1	x1	x10
1500		1digit	1digit	1digit	1digit	x1	x1	x1	x1	1digit	1digit	1digit	1digit	x1	x1	x1	x1	x10
1600		1digit	1digit	1digit	1digit	x1	x1	x1	x1	1digit	1digit	1digit	x1	x1	x1	x1	x1	x10
2000		1digit	1digit	1digit	x1	x1	x1	x1	x10	1digit	1digit	1digit	x1	x1	x1	x1	x1	x10
2500		1digit	1digit	1digit	x1	x1	x1	x1	x10	1digit	1digit	1digit	x1	x1	x1	x1	x1	x10
3000		1digit	1digit	x1	x1	x1	x1	x1	x10	1digit	1digit	1digit	x1	x1	x1	x1	x1	x10
4000		1digit	1digit	x1	x1	x1	x1	x10	x10	1digit	1digit	x1	x1	x1	x1	x10	x10	x10
5000		1digit	1digit	x1	x1	x1	x1	x10	x10	1digit	1digit	x1	x1	x1	x1	x10	x10	x10
6000		1digit	x1	x1	x1	x1	x10	x10	x10	x1	1digit	x1	x1	x1	x1	x10	x10	x10

Phase Wire system	3P4W																
	V	63.5 110	100 173	105 182	110 190	115 199	120 208	127 220	200 346	220 380	230 400	240 415	242 420	250 430	254 440	265 460	277 480
5	3digit	3digit	3digit	3digit	3digit	3digit	3digit	3digit	3digit	3digit	3digit	3digit	3digit	3digit	3digit	3digit	3digit
6	3digit	3digit	3digit	3digit	3digit	3digit	3digit	3digit	3digit	3digit	3digit	3digit	3digit	3digit	3digit	3digit	3digit
7.5	3digit	3digit	3digit	3digit	3digit	3digit	3digit	3digit	3digit	3digit	3digit	3digit	3digit	3digit	3digit	3digit	3digit
8	3digit	3digit	3digit	3digit	3digit	3digit	3digit	3digit	3digit	3digit	3digit	3digit	3digit	3digit	3digit	3digit	3digit
10	3digit	3digit	3digit	3digit	3digit	3digit	3digit	3digit	3digit	3digit	3digit	3digit	3digit	3digit	3digit	3digit	3digit
12	3digit	3digit	3digit	3digit	3digit	3digit	3digit	3digit	3digit	3digit	3digit	3digit	3digit	3digit	3digit	3digit	3digit
15	3digit	3digit	3digit	3digit	3digit	3digit	3digit	3digit	3digit	3digit	3digit	3digit	3digit	3digit	3digit	3digit	2digit
20	3digit	3digit	3digit	3digit	3digit	3digit	3digit	3digit	2digit	2digit	2digit	2digit	2digit	2digit	2digit	2digit	2digit
25	3digit	3digit	3digit	3digit	3digit	3digit	3digit	3digit	2digit	2digit	2digit	2digit	2digit	2digit	2digit	2digit	2digit
30	3digit	3digit	3digit	3digit	3digit	3digit	3digit	3digit	2digit	2digit	2digit	2digit	2digit	2digit	2digit	2digit	2digit
40	3digit	2digit	2digit	2digit	2digit	2digit	2digit	2digit	2digit	2digit	2digit	2digit	2digit	2digit	2digit	2digit	2digit
50	3digit	2digit	2digit	2digit	2digit	2digit	2digit	2digit	2digit	2digit	2digit	2digit	2digit	2digit	2digit	2digit	2digit
60	3digit	2digit	2digit	2digit	2digit	2digit	2digit	2digit	2digit	2digit	2digit	2digit	2digit	2digit	2digit	2digit	2digit
75	2digit	2digit	2digit	2digit	2digit	2digit	2digit	2digit	2digit	2digit	2digit	2digit	2digit	2digit	2digit	2digit	2digit
80	2digit	2digit	2digit	2digit	2digit	2digit	2digit	2digit	2digit	2digit	2digit	2digit	2digit	2digit	2digit	2digit	2digit
100	2digit	2digit	2digit	2digit	2digit	2digit	2digit	2digit	2digit	2digit	2digit	2digit	2digit	2digit	2digit	2digit	2digit
120	2digit	2digit	2digit	2digit	2digit	2digit	2digit	2digit	2digit	2digit	2digit	2digit	2digit	2digit	2digit	2digit	2digit
150	2digit	2digit	2digit	2digit	2digit	2digit	2digit	2digit	2digit	2digit	2digit	2digit	2digit	2digit	2digit	2digit	1digit
200	2digit	2digit	2digit	2digit	2digit	2digit	2digit	2digit	1digit	1digit	1digit	1digit	1digit	1digit	1digit	1digit	1digit
250	2digit	2digit	2digit	2digit	2digit	2digit	2digit	2digit	1digit	1digit	1digit	1digit	1digit	1digit	1digit	1digit	1digit
300	2digit	2digit	2digit	2digit	2digit	2digit	2digit	2digit	1digit	1digit	1digit	1digit	1digit	1digit	1digit	1digit	1digit
400	2digit	1digit	1digit	1digit	1digit	1digit	1digit	1digit	1digit	1digit	1digit	1digit	1digit	1digit	1digit	1digit	1digit
500	2digit	1digit	1digit	1digit	1digit	1digit	1digit	1digit	1digit	1digit	1digit	1digit	1digit	1digit	1digit	1digit	1digit
600	2digit	1digit	1digit	1digit	1digit	1digit	1digit	1digit	1digit	1digit	1digit	1digit	1digit	1digit	1digit	1digit	1digit
750	1digit	1digit	1digit	1digit	1digit	1digit	1digit	1digit	1digit	1digit	1digit	1digit	1digit	1digit	1digit	1digit	1digit
800	1digit	1digit	1digit	1digit	1digit	1digit	1digit	1digit	1digit	1digit	1digit	1digit	1digit	1digit	1digit	1digit	1digit
1000	1digit	1digit	1digit	1digit	1digit	1digit	1digit	1digit	1digit	1digit	1digit	1digit	1digit	1digit	1digit	1digit	1digit
1200	1digit	1digit	1digit	1digit	1digit	1digit	1digit	1digit	1digit	1digit	1digit	1digit	1digit	1digit	1digit	1digit	1digit
1500	1digit	1digit	1digit	1digit	1digit	1digit	1digit	1digit	1digit	1digit	1digit	1digit	1digit	1digit	1digit	1digit	x1
1600	1digit	1digit	1digit	1digit	1digit	1digit	1digit	1digit	1digit	1digit	1digit	1digit	1digit	x1	x1	x1	x1
2000	1digit	1digit	1digit	1digit	1digit	1digit	1digit	1digit	x1	x1	x1	x1	x1	x1	x1	x1	x1
2500	1digit	1digit	1digit	1digit	1digit	1digit	1digit	1digit	x1	x1	x1	x1	x1	x1	x1	x1	x1
3000	1digit	1digit	1digit	1digit	1digit	1digit	1digit	1digit	x1	x1	x1	x1	x1	x1	x1	x1	x1
4000	1digit	x1	x1	x1	x1	x1	x1	x1	x1	x1	x1	x1	x1	x1	x1	x1	x1
5000	1digit	x1	x1	x1	x1	x1	x1	x1	x1	x1	x1	x1	x1	x1	x1	x1	x1
6000	1digit	x1	x1	x1	x1	x1	x1	x1	x1	x1	x1	x1	x1	x1	x1	x1	x1

Note : Phase wire system : 3P4W is EMU4-HD1-MB only.

Note : 3 digit means three decimal places ($\times 10^{-3}$) and 2 digit means two decimal places ($\times 10^{-2}$) and 1 digit means 1 decimal places ($\times 10^{-1}$)

Note : x1 means integerx1 and x10 means integerx10.

Note : Reply error of out of range of channel according upper table.

Phase Wire system	3P4W															
V	63.5/110	100/173	105/182	110/190	115/199	120/208	127/220	200/346	220/380	230/400	240/415	242/420	250/430	254/440	265/460	277/480
5	3digit	3digit	3digit	3digit	3digit	3digit	3digit	3digit	3digit	3digit	3digit	3digit	3digit	3digit	3digit	3digit
6	3digit	3digit	3digit	3digit	3digit	3digit	3digit	3digit	3digit	3digit	3digit	3digit	3digit	3digit	3digit	3digit
7.5	3digit	3digit	3digit	3digit	3digit	3digit	3digit	3digit	3digit	3digit	3digit	3digit	3digit	3digit	3digit	3digit
8	3digit	3digit	3digit	3digit	3digit	3digit	3digit	3digit	3digit	3digit	3digit	3digit	3digit	3digit	3digit	3digit
10	3digit	3digit	3digit	3digit	3digit	3digit	3digit	3digit	3digit	3digit	3digit	3digit	3digit	3digit	3digit	3digit
12	3digit	3digit	3digit	3digit	3digit	3digit	3digit	3digit	3digit	3digit	3digit	3digit	3digit	3digit	3digit	3digit
15	3digit	3digit	3digit	3digit	3digit	3digit	3digit	3digit	3digit	3digit	3digit	3digit	3digit	3digit	3digit	2digit
20	3digit	3digit	3digit	3digit	3digit	3digit	3digit	2digit	2digit	2digit	2digit	2digit	2digit	2digit	2digit	2digit
25	3digit	3digit	3digit	3digit	3digit	3digit	3digit	2digit	2digit	2digit	2digit	2digit	2digit	2digit	2digit	2digit
30	3digit	3digit	3digit	3digit	3digit	3digit	3digit	2digit	2digit	2digit	2digit	2digit	2digit	2digit	2digit	2digit
40	3digit	2digit	2digit	2digit	2digit	2digit	2digit	2digit	2digit	2digit	2digit	2digit	2digit	2digit	2digit	2digit
50	3digit	2digit	2digit	2digit	2digit	2digit	2digit	2digit	2digit	2digit	2digit	2digit	2digit	2digit	2digit	2digit
60	3digit	2digit	2digit	2digit	2digit	2digit	2digit	2digit	2digit	2digit	2digit	2digit	2digit	2digit	2digit	2digit
75	2digit	2digit	2digit	2digit	2digit	2digit	2digit	2digit	2digit	2digit	2digit	2digit	2digit	2digit	2digit	2digit
80	2digit	2digit	2digit	2digit	2digit	2digit	2digit	2digit	2digit	2digit	2digit	2digit	2digit	2digit	2digit	2digit
100	2digit	2digit	2digit	2digit	2digit	2digit	2digit	2digit	2digit	2digit	2digit	2digit	2digit	2digit	2digit	2digit
120	2digit	2digit	2digit	2digit	2digit	2digit	2digit	2digit	2digit	2digit	2digit	2digit	2digit	2digit	2digit	2digit
150	2digit	2digit	2digit	2digit	2digit	2digit	2digit	2digit	2digit	2digit	2digit	2digit	2digit	2digit	2digit	1digit
200	2digit	2digit	2digit	2digit	2digit	2digit	2digit	1digit	1digit	1digit	1digit	1digit	1digit	1digit	1digit	1digit
250	2digit	2digit	2digit	2digit	2digit	2digit	2digit	1digit	1digit	1digit	1digit	1digit	1digit	1digit	1digit	1digit
300	2digit	2digit	2digit	2digit	2digit	2digit	2digit	1digit	1digit	1digit	1digit	1digit	1digit	1digit	1digit	1digit
400	2digit	1digit	1digit	1digit	1digit	1digit	1digit	1digit	1digit	1digit	1digit	1digit	1digit	1digit	1digit	1digit
500	2digit	1digit	1digit	1digit	1digit	1digit	1digit	1digit	1digit	1digit	1digit	1digit	1digit	1digit	1digit	1digit
600	2digit	1digit	1digit	1digit	1digit	1digit	1digit	1digit	1digit	1digit	1digit	1digit	1digit	1digit	1digit	1digit
750	1digit	1digit	1digit	1digit	1digit	1digit	1digit	1digit	1digit	1digit	1digit	1digit	1digit	1digit	1digit	1digit
800	1digit	1digit	1digit	1digit	1digit	1digit	1digit	1digit	1digit	1digit	1digit	1digit	1digit	1digit	1digit	1digit
1000	1digit	1digit	1digit	1digit	1digit	1digit	1digit	1digit	1digit	1digit	1digit	1digit	1digit	1digit	1digit	1digit
1200	1digit	1digit	1digit	1digit	1digit	1digit	1digit	1digit	1digit	1digit	1digit	1digit	1digit	1digit	1digit	1digit
1500	1digit	1digit	1digit	1digit	1digit	1digit	1digit	1digit	1digit	1digit	1digit	1digit	1digit	1digit	1digit	x1
1600	1digit	1digit	1digit	1digit	1digit	1digit	1digit	1digit	1digit	1digit	1digit	1digit	x1	x1	x1	x1
2000	1digit	1digit	1digit	1digit	1digit	1digit	1digit	x1	x1	x1	x1	x1	x1	x1	x1	x1
2500	1digit	1digit	1digit	1digit	1digit	1digit	1digit	x1	x1	x1	x1	x1	x1	x1	x1	x1
3000	1digit	1digit	1digit	1digit	1digit	1digit	1digit	x1	x1	x1	x1	x1	x1	x1	x1	x1
4000	1digit	x1	x1	x1	x1	x1	x1	x1	x1	x1	x1	x1	x1	x1	x1	x1
5000	1digit	x1	x1	x1	x1	x1	x1	x1	x1	x1	x1	x1	x1	x1	x1	x1
6000	1digit	x1	x1	x1	x1	x1	x1	x1	x1	x1	x1	x1	x1	x1	x1	x1
7500	x1	x1	x1	x1	x1	x1	x1	x1	x1	x1	x1	x1	x1	x1	x1	x1
8000	x1	x1	x1	x1	x1	x1	x1	x1	x1	x1	x1	x1	x1	x1	x1	x1
10000	x1	x1	x1	x1	x1	x1	x1	x1	x1	x1	x1	x1	x1	x1	x1	x1
12000	x1	x1	x1	x1	x1	x1	x1	x1	x1	x1	x1	x1	x1	x1	x1	x1
20000	x1	x1	x1	x1	x1	x1	x1	x10	x10	x10	x10	x10	x10	x10	x10	x10
25000	x1	x1	x1	x1	x1	x1	x1	x10	x10	x10	x10	x10	x10	x10	x10	x10
30000	x1	x1	x1	x1	x1	x1	x1	x10	x10	x10	x10	x10	x10	x10	x10	x10

Note : Phase wire system : 3P4W is EMU4-HM1-MB, EMU4-A2, EMU4-VA2 only.

Note : 3 digit means three decimal places ($\times 10^{-3}$) and 2 digit means two decimal places ($\times 10^{-2}$) and 1 digit means 1 decimal places ($\times 10^{-1}$)

Note : x1 means integerx1 and x10 means integerx10.

Note : Reply error of out of range of channel according upper table.

(2) Current and harmonics current data

< EMU2-*-C and EMU3-DP1-C >

Primary current(A)	EMU2-*-C	EMU3-DP1-C
5	2digit	—
6	2digit	—
7.5	2digit	—
8	2digit	—
10	2digit	—
12	2digit	—
15	2digit	—
20	2digit	—
25	2digit	—
30	2digit	—
40	1digit	—
50	1digit	—
60	1digit	1digit
75	1digit	—
80	1digit	—
100	1digit	—
120	1digit	—
125	—	1digit
150	1digit	—
200	1digit	—
250	1digit	—
300	1digit	—
400	x1	—
500	x1	—
600	x1	—
750	x1	—
800	x1	—
1000	x1	—
1200	x1	—
1500	x1	—
1600	x1	—
2000	x1	—
2500	x1	—
3000	x1	—
4000	x10	—
5000	x10	—
6000	x10	—
7500	x10	—
8000	x10	—
10000	x10	—
12000	x10	—
20000	x10	—
25000	x10	—
30000	x10	—

Note : 3 digit means three decimal places ($\times 10^{-3}$) and 2 digit means two decimal places ($\times 10^{-2}$) and 1 digit means 1 decimal places ($\times 10^{-1}$)

Note : x1 means integerx1 and x10 means integerx10.

Note : “-” means out of setting range.

< EMU4-BD1-MB, EMU4-HD1-MB, EMU4-BM1-MB, EMU4-HM1-MB, EMU4-A2, EMU4-VA2 >

Primary current	EMU4-BD1-MB EMU4-HD1-MB EMU4-BM1-MB EMU4-HM1-MB EMU4-A2 EMU4-VA2
Less than 40A	Decimal 3 digit
40A to 400A	Decimal 2 digit
400A to 4000A	Decimal 2 digit
More than 4000A	Integer

(3) Voltage and harmonics voltage data

< EMU2-*-C and EMU3-DP1-C >

Phase wire system	Primary voltage(V)	EMU2-HM1-C	EMU2-RD1-C EMU2-RD3-C EMU2-RD5-C EMU2-RD7-C	EMU2-RD2-C-4W EMU2-RD4-C-4W	EMU3-DP1-C	
1P2W	63.5	1 digit	1 digit	—	1 digit	
	100	—	—	—	1 digit	
	110	—	—	—	1 digit	
	120	—	—	—	1 digit	
	173	—	—	—	1 digit	
	190	—	—	—	1 digit	
	208	—	—	—	1 digit	
	220	1 digit	1 digit	—	1 digit	
	240	—	—	—	1 digit	
	254	—	—	—	1 digit	
	380	—	—	—	1 digit	
	415	—	—	—	1 digit	
	440	x1	x1	—	x1	
	1P3W	690	—	x1	—	—
		3P3W	1100	—	x1	—
	2200		—	x1	—	—
	3300		—	x10	—	—
	6600		—	x10	—	—
	11000		—	x10	—	—
	13200		—	x10	—	—
	13800		—	x10	—	—
	15000		—	x10	—	—
	16500		—	x10	—	—
22000	—		x10	—	—	
24000	—		x10	—	—	
33000	—		x10	—	—	
66000	—		x10	—	—	
77000	—	x10	—	—		
110000	—	x10	—	—		
3P4W	63.5/110	—	—	1 digit	—	
	110/190	—	—	1 digit	—	
	120/208	—	—	1 digit	—	
	220/380	—	—	1 digit	—	
	240/415	—	—	1 digit	—	
	254/440	—	—	x1	—	

Note : x1 means integerx1 and x10 means integerx10.

< EMU4-BD1-MB, EMU4-HD1-MB >

Primary voltage (Note1)	EMU4-BD1-MB EMU4-HD1-MB
Less than 300V	Decimal 1 digit
More than 300V	Intengerx1

Note1: Primary voltage is phase voltage when phase wire system is 3P4W.

< EMU4-BM1-MB, EMU4-HM1-MB, EMU4-A2, EMU4-VA2 >

Primary voltage (Note1)	EMU4-BM1-MB EMU4-HM1-MB EMU4-A2 EMU4-VA2
Less than 300V	Decimal 1 digit
300V to 3000V	Intengerx1
More than 3000V	Intengerx10

Note1: Primary voltage is phase voltage when phase wire system is 3P4W.

(4) Electric energy, reactive energy and electric energy conversion

<EMU2*-C>

Phase wire system	1P2W					1P3W	3P3W								
	V	110	220	440	3300	6600	110	110	220	440	3300	6600	11000	22000	33000
A															
5		2digit	2digit	2digit	1digit	1digit	2digit	2digit	2digit	2digit	1digit	1digit	1digit	x1	x1
6		2digit	2digit	2digit	1digit	1digit	2digit	2digit	2digit	2digit	1digit	1digit	1digit	x1	x1
7.5		2digit	2digit	2digit	1digit	1digit	2digit	2digit	2digit	2digit	1digit	1digit	x1	x1	x1
8		2digit	2digit	2digit	1digit	1digit	2digit	2digit	2digit	2digit	1digit	1digit	x1	x1	x1
10		2digit	2digit	2digit	1digit	1digit	2digit	2digit	2digit	2digit	1digit	1digit	x1	x1	x1
12		2digit	2digit	2digit	1digit	1digit	2digit	2digit	2digit	2digit	1digit	x1	x1	x1	x1
15		2digit	2digit	2digit	1digit	1digit	2digit	2digit	2digit	2digit	1digit	x1	x1	x1	x1
20		2digit	2digit	2digit	1digit	x1	2digit	2digit	2digit	1digit	1digit	x1	x1	x1	x1
25		2digit	2digit	2digit	1digit	x1	2digit	2digit	2digit	1digit	x1	x1	x1	x1	x10
30		2digit	2digit	1digit	1digit	x1	2digit	2digit	2digit	1digit	x1	x1	x1	x1	x10
40		2digit	2digit	1digit	x1	x1	2digit	2digit	1digit	1digit	x1	x1	x1	x10	x10
50		2digit	2digit	1digit	x1	x1	2digit	2digit	1digit	1digit	x1	x1	x1	x10	x10
60		2digit	1digit	1digit	x1	x1	1digit	2digit	1digit	1digit	x1	x1	x1	x10	x10
75		2digit	1digit	1digit	x1	x1	1digit	1digit	1digit	1digit	x1	x1	x10	x10	x10
80		2digit	1digit	1digit	x1	x1	1digit	1digit	1digit	1digit	x1	x1	x10	x10	x10
100		2digit	1digit	1digit	x1	x1	1digit	1digit	1digit	1digit	x1	x1	x10	x10	x10
120		1digit	1digit	1digit	x1	x1	1digit	1digit	1digit	1digit	x1	x10	x10	x10	x10
150		1digit	1digit	1digit	x1	x1	1digit	1digit	1digit	1digit	x1	x10	x10	x10	x10
200		1digit	1digit	1digit	x1	x10	1digit	1digit	1digit	x1	x1	x10	x10	x10	x10
250		1digit	1digit	1digit	x1	x10	1digit	1digit	1digit	x1	x10	x10	x10	x10	x100
300		1digit	1digit	x1	x1	x10	1digit	1digit	1digit	x1	x10	x10	x10	x10	x100
400		1digit	1digit	x1	x10	x10	1digit	1digit	x1	x1	x10	x10	x10	x100	x100
500		1digit	1digit	x1	x10	x10	1digit	1digit	x1	x1	x10	x10	x10	x100	x100
600		1digit	x1	x1	x10	x10	x1	1digit	x1	x1	x10	x10	x10	x100	x100
750		1digit	x1	x1	x10	x10	x1	x1	x1	x1	x10	x10	x100	x100	x100
800		1digit	x1	x1	x10	x10	x1	x1	x1	x1	x10	x10	x100	x100	x100
1000		1digit	x1	x1	x10	x10	x1	x1	x1	x1	x10	x10	x100	x100	x100
1200		x1	x1	x1	x10	x10	x1	x1	x1	x1	x10	x100	x100	x100	x100
1500		x1	x1	x1	x10	x10	x1	x1	x1	x1	x10	x100	x100	x100	x100
1600		x1	x1	x1	x10	x10	x1	x1	x1	x10	x10	x100	x100	x100	x100
2000		x1	x1	x1	x10	x100	x1	x1	x1	x10	x10	x100	x100	x100	x100
2500		x1	x1	x1	x10	x100	x1	x1	x1	x10	x100	x100	x100	x100	x1000
3000		x1	x1	x10	x10	x100	x1	x1	x1	x10	x100	x100	x100	x100	—
4000		x1	x1	x10	x100	x100	x1	x1	x10	x10	x100	x100	x100	x1000	—
5000		x1	x1	x10	x100	x100	x1	x1	x10	x10	x100	x100	x100	—	—
6000		x1	x10	x10	x100	x100	x10	x1	x10	x10	x100	x100	x100	—	—
7500		x1	x10	x10	x100	x100	x10	x10	x10	x10	x100	x100	x1000	—	—
8000		x1	x10	x10	x100	x100	x10	x10	x10	x10	x100	x100	x1000	—	—
10000		x1	x10	x10	x100	x100	x10	x10	x10	x10	x100	x100	—	—	—
12000		x10	x10	x10	x100	x100	x10	x10	x10	x10	x100	x1000	—	—	—
20000		x10	x10	x10	x100	—	x10	x10	x10	x100	x100	—	—	—	—
25000		x10	x10	x10	x100	—	x10	x10	x10	x100	x1000	—	—	—	—
30000		x10	x10	x100	—	—	x10	x10	x10	x100	—	—	—	—	—

Phase Wire system	3P4W						
	V	63.5 /110	110 /190	120 /208	220 /380	240 /415	254 /440
A							
5		2digit	2digit	2digit	2digit	2digit	2digit
6		2digit	2digit	2digit	2digit	2digit	2digit
7.5		2digit	2digit	2digit	2digit	2digit	2digit
8		2digit	2digit	2digit	2digit	2digit	2digit
10		2digit	2digit	2digit	2digit	2digit	2digit
12		2digit	2digit	2digit	2digit	2digit	2digit
15		2digit	2digit	2digit	2digit	2digit	2digit
20		2digit	2digit	2digit	1digit	1digit	1digit
25		2digit	2digit	2digit	1digit	1digit	1digit
30		2digit	2digit	2digit	1digit	1digit	1digit
40		2digit	1digit	1digit	1digit	1digit	1digit
50		2digit	1digit	1digit	1digit	1digit	1digit
60		2digit	1digit	1digit	1digit	1digit	1digit
75		1digit	1digit	1digit	1digit	1digit	1digit
80		1digit	1digit	1digit	1digit	1digit	1digit
100		1digit	1digit	1digit	1digit	1digit	1digit
120		1digit	1digit	1digit	1digit	1digit	1digit
150		1digit	1digit	1digit	1digit	1digit	1digit
200		1digit	1digit	1digit	x1	x1	x1
250		1digit	1digit	1digit	x1	x1	x1
300		1digit	1digit	1digit	x1	x1	x1
400		1digit	x1	x1	x1	x1	x1
500		1digit	x1	x1	x1	x1	x1
600		1digit	x1	x1	x1	x1	x1
750		x1	x1	x1	x1	x1	x1
800		x1	x1	x1	x1	x1	x1
1000		x1	x1	x1	x1	x1	x1
1200		x1	x1	x1	x1	x1	x1
1500		x1	x1	x1	x1	x1	x1
1600		x1	x1	x1	x1	x1	x10
2000		x1	x1	x1	x10	x10	x10
2500		x1	x1	x1	x10	x10	x10
3000		x1	x1	x1	x10	x10	x10
4000		x1	x10	x10	x10	x10	x10
5000		x1	x10	x10	x10	x10	x10
6000		x1	x10	x10	x10	x10	x10
7500		x10	x10	x10	x10	x10	x10
8000		x10	x10	x10	x10	x10	x10
10000		x10	x10	x10	x10	x10	x10
12000		x10	x10	x10	x10	x10	x10
20000		x10	x10	x10	x100	x100	x100
25000		x10	x10	x10	x100	x100	x100
30000		x10	x10	x10	x100	x100	x100

Note : 2 digit means two decimal places ($\times 10^{-2}$) and 1 digit means 1 decimal places ($\times 10^{-1}$), x1 means integer $\times 1$.

Note : x1 means integer $\times 1$ and x10 means integer $\times 10$.

Note : "-" means out of setting range.

< EMU3-DP1-C >

Phase wire system	1P2W												1P3W	3P3W									
	V	63.5	100	110	120	173	190	208	220	240	254	380	415	440	110	110	173	190	208	220	380	415	440
A																							
60	2digit	2digit	2digit	2digit	2digit	2digit	1digit	1digit	1digit	1digit	1digit	1digit	1digit	2digit	2digit	1digit	1digit	1digit	1digit	1digit	1digit	1digit	1digit
125	2digit	1digit	1digit	1digit	1digit	1digit	1digit	1digit	1digit	1digit	1digit	1digit	1digit	1digit	1digit	1digit	1digit	1digit	1digit	1digit	1digit	1digit	1digit

Note : 2 digit means two decimal places ($\times 10^{-2}$) and 1 digit means 1 decimal places ($\times 10^{-1}$), x1 means integer $\times 1$.

< EMU4-BD1-MB, EMU4-HD1-MB >

Phase wire system	1P2W								1P3W	3P3W								
	V	110	220	440	690	1100	2200	3300	6600	110	110	220	440	690	1100	2200	3300	6600
A																		
5		2digit	2digit	2digit	2digit	2digit	2digit	1digit	1digit	2digit	2digit	2digit	2digit	2digit	2digit	1digit	1digit	1digit
6		2digit	2digit	2digit	2digit	2digit	1digit	1digit	1digit	2digit	2digit	2digit	2digit	2digit	2digit	1digit	1digit	1digit
7.5		2digit	2digit	2digit	2digit	2digit	1digit	1digit	1digit	2digit	2digit	2digit	2digit	2digit	1digit	1digit	1digit	1digit
8		2digit	2digit	2digit	2digit	2digit	1digit	1digit	1digit	2digit	2digit	2digit	2digit	2digit	1digit	1digit	1digit	1digit
10		2digit	2digit	2digit	2digit	2digit	1digit	1digit	1digit	2digit	2digit	2digit	2digit	2digit	1digit	1digit	1digit	1digit
12		2digit	2digit	2digit	2digit	1digit	1digit	1digit	1digit	2digit	2digit	2digit	2digit	1digit	1digit	1digit	1digit	x1
15		2digit	2digit	2digit	2digit	1digit	1digit	1digit	1digit	2digit	2digit	2digit	2digit	1digit	1digit	1digit	1digit	x1
20		2digit	2digit	2digit	1digit	1digit	1digit	1digit	x1	2digit	2digit	2digit	1digit	1digit	1digit	1digit	1digit	x1
25		2digit	2digit	2digit	1digit	1digit	1digit	1digit	x1	2digit	2digit	2digit	1digit	1digit	1digit	1digit	x1	x1
30		2digit	2digit	1digit	1digit	1digit	1digit	1digit	x1	2digit	2digit	2digit	1digit	1digit	1digit	1digit	x1	x1
40		2digit	2digit	1digit	1digit	1digit	1digit	x1	x1	2digit	2digit	1digit	1digit	1digit	1digit	x1	x1	x1
50		2digit	2digit	1digit	1digit	1digit	1digit	x1	x1	2digit	2digit	1digit	1digit	1digit	1digit	x1	x1	x1
60		2digit	1digit	1digit	1digit	1digit	x1	x1	x1	1digit	2digit	1digit	1digit	1digit	1digit	x1	x1	x1
75		2digit	1digit	1digit	1digit	1digit	x1	x1	x1	1digit	1digit	1digit	1digit	1digit	x1	x1	x1	x1
80		2digit	1digit	1digit	1digit	1digit	x1	x1	x1	1digit	1digit	1digit	1digit	1digit	x1	x1	x1	x1
100		2digit	1digit	1digit	1digit	1digit	x1	x1	x1	1digit	1digit	1digit	1digit	1digit	x1	x1	x1	x1
120		1digit	1digit	1digit	1digit	x1	x1	x1	x1	1digit	1digit	1digit	1digit	x1	x1	x1	x1	x10
150		1digit	1digit	1digit	1digit	x1	x1	x1	x1	1digit	1digit	1digit	1digit	x1	x1	x1	x1	x10
200		1digit	1digit	1digit	x1	x1	x1	x1	x10	1digit	1digit	1digit	x1	x1	x1	x1	x1	x10
250		1digit	1digit	1digit	x1	x1	x1	x1	x10	1digit	1digit	1digit	x1	x1	x1	x1	x10	x10
300		1digit	1digit	x1	x1	x1	x1	x1	x10	1digit	1digit	1digit	x1	x1	x1	x1	x10	x10
400		1digit	1digit	x1	x1	x1	x1	x10	x10	1digit	1digit	x1	x1	x1	x1	x10	x10	x10
500		1digit	1digit	x1	x1	x1	x1	x10	x10	1digit	1digit	x1	x1	x1	x1	x10	x10	x10
600		1digit	x1	x1	x1	x1	x10	x10	x10	x1	1digit	x1	x1	x1	x1	x10	x10	x10
750		1digit	x1	x1	x1	x1	x10	x10	x10	x1	x1	x1	x1	x1	x10	x10	x10	x10
800		1digit	x1	x1	x1	x1	x10	x10	x10	x1	x1	x1	x1	x1	x10	x10	x10	x10
1000		1digit	x1	x1	x1	x1	x10	x10	x10	x1	x1	x1	x1	x1	x10	x10	x10	x10
1200		x1	x1	x1	x1	x10	x10	x10	x10	x1	x1	x1	x1	x10	x10	x10	x10	x100
1500		x1	x1	x1	x1	x10	x10	x10	x10	x1	x1	x1	x1	x10	x10	x10	x10	x100
1600		x1	x1	x1	x1	x10	x10	x10	x10	x1	x1	x1	x10	x10	x10	x10	x10	x100
2000		x1	x1	x1	x10	x10	x10	x10	x100	x1	x1	x1	x10	x10	x10	x10	x10	x100
2500		x1	x1	x1	x10	x10	x10	x10	x100	x1	x1	x1	x10	x10	x10	x10	x100	x100
3000		x1	x1	x10	x10	x10	x10	x10	x100	x1	x1	x1	x10	x10	x10	x10	x100	x100
4000		x1	x1	x10	x10	x10	x10	x100	x100	x1	x1	x10	x10	x10	x10	x100	x100	x100
5000		x1	x1	x10	x10	x10	x10	x100	x100	x1	x1	x10	x10	x10	x10	x100	x100	x100
6000		x1	x10	x10	x10	x10	x100	x100	x100	x10	x1	x10	x10	x10	x10	x100	x100	x100

Phase wire system	3P4W																
	V	63.5 110	100 173	105 182	110 190	115 199	120 208	127 220	200 346	220 380	230 400	240 415	242 420	250 430	254 440	265 460	277 480
5	2digit	2digit	2digit	2digit	2digit	2digit	2digit	2digit	2digit	2digit	2digit	2digit	2digit	2digit	2digit	2digit	2digit
6	2digit	2digit	2digit	2digit	2digit	2digit	2digit	2digit	2digit	2digit	2digit	2digit	2digit	2digit	2digit	2digit	2digit
7.5	2digit	2digit	2digit	2digit	2digit	2digit	2digit	2digit	2digit	2digit	2digit	2digit	2digit	2digit	2digit	2digit	2digit
8	2digit	2digit	2digit	2digit	2digit	2digit	2digit	2digit	2digit	2digit	2digit	2digit	2digit	2digit	2digit	2digit	2digit
10	2digit	2digit	2digit	2digit	2digit	2digit	2digit	2digit	2digit	2digit	2digit	2digit	2digit	2digit	2digit	2digit	2digit
12	2digit	2digit	2digit	2digit	2digit	2digit	2digit	2digit	2digit	2digit	2digit	2digit	2digit	2digit	2digit	2digit	2digit
15	2digit	2digit	2digit	2digit	2digit	2digit	2digit	2digit	2digit	2digit	2digit	2digit	2digit	2digit	2digit	2digit	1digit
20	2digit	2digit	2digit	2digit	2digit	2digit	2digit	2digit	1digit	1digit	1digit	1digit	1digit	1digit	1digit	1digit	1digit
25	2digit	2digit	2digit	2digit	2digit	2digit	2digit	2digit	1digit	1digit	1digit	1digit	1digit	1digit	1digit	1digit	1digit
30	2digit	2digit	2digit	2digit	2digit	2digit	2digit	2digit	1digit	1digit	1digit	1digit	1digit	1digit	1digit	1digit	1digit
40	2digit	1digit	1digit	1digit	1digit	1digit	1digit	1digit	1digit	1digit	1digit	1digit	1digit	1digit	1digit	1digit	1digit
50	2digit	1digit	1digit	1digit	1digit	1digit	1digit	1digit	1digit	1digit	1digit	1digit	1digit	1digit	1digit	1digit	1digit
60	2digit	1digit	1digit	1digit	1digit	1digit	1digit	1digit	1digit	1digit	1digit	1digit	1digit	1digit	1digit	1digit	1digit
75	1digit	1digit	1digit	1digit	1digit	1digit	1digit	1digit	1digit	1digit	1digit	1digit	1digit	1digit	1digit	1digit	1digit
80	1digit	1digit	1digit	1digit	1digit	1digit	1digit	1digit	1digit	1digit	1digit	1digit	1digit	1digit	1digit	1digit	1digit
100	1digit	1digit	1digit	1digit	1digit	1digit	1digit	1digit	1digit	1digit	1digit	1digit	1digit	1digit	1digit	1digit	1digit
120	1digit	1digit	1digit	1digit	1digit	1digit	1digit	1digit	1digit	1digit	1digit	1digit	1digit	1digit	1digit	1digit	1digit
150	1digit	1digit	1digit	1digit	1digit	1digit	1digit	1digit	1digit	1digit	1digit	1digit	1digit	1digit	1digit	1digit	x1
200	1digit	1digit	1digit	1digit	1digit	1digit	1digit	1digit	x1	x1	x1	x1	x1	x1	x1	x1	x1
250	1digit	1digit	1digit	1digit	1digit	1digit	1digit	1digit	x1	x1	x1	x1	x1	x1	x1	x1	x1
300	1digit	1digit	1digit	1digit	1digit	1digit	1digit	1digit	x1	x1	x1	x1	x1	x1	x1	x1	x1
400	1digit	x1	x1	x1	x1	x1	x1	x1	x1	x1	x1	x1	x1	x1	x1	x1	x1
500	1digit	x1	x1	x1	x1	x1	x1	x1	x1	x1	x1	x1	x1	x1	x1	x1	x1
600	1digit	x1	x1	x1	x1	x1	x1	x1	x1	x1	x1	x1	x1	x1	x1	x1	x1
750	x1	x1	x1	x1	x1	x1	x1	x1	x1	x1	x1	x1	x1	x1	x1	x1	x1
800	x1	x1	x1	x1	x1	x1	x1	x1	x1	x1	x1	x1	x1	x1	x1	x1	x1
1000	x1	x1	x1	x1	x1	x1	x1	x1	x1	x1	x1	x1	x1	x1	x1	x1	x1
1200	x1	x1	x1	x1	x1	x1	x1	x1	x1	x1	x1	x1	x1	x1	x1	x1	x1
1500	x1	x1	x1	x1	x1	x1	x1	x1	x1	x1	x1	x1	x1	x1	x1	x1	x10
1600	x1	x1	x1	x1	x1	x1	x1	x1	x1	x1	x1	x1	x1	x10	x10	x10	x10
2000	x1	x1	x1	x1	x1	x1	x1	x1	x10	x10	x10	x10	x10	x10	x10	x10	x10
2500	x1	x1	x1	x1	x1	x1	x1	x1	x10	x10	x10	x10	x10	x10	x10	x10	x10
3000	x1	x1	x1	x1	x1	x1	x1	x1	x10	x10	x10	x10	x10	x10	x10	x10	x10
4000	x1	x10	x10	x10	x10	x10	x10	x10	x10	x10	x10	x10	x10	x10	x10	x10	x10
5000	x1	x10	x10	x10	x10	x10	x10	x10	x10	x10	x10	x10	x10	x10	x10	x10	x10
6000	x1	x10	x10	x10	x10	x10	x10	x10	x10	x10	x10	x10	x10	x10	x10	x10	x10

Note : Phase wire system is only EMU4-HD1-MB.

Note : 2 digit means two decimal places ($\times 10^{-2}$) and 1 digit means 1 decimal places ($\times 10^{-1}$)

Note : x1 means integer $\times 1$ and x10 means integer $\times 10$ and x100 means integer $\times 100$.

< EMU4-BM1-MB, EMU4-HM1-MB, EMU4-A2, EMU4-VA2 >

Phase wire system	1P2W																				1P3W		
	V	110	220	440	690	1100	2200	3300	6600	11000	13200	13800	15000	16500	22000	24000	33000	66000	77000	110000	110	220	
A																							
5		2digit	2digit	2digit	2digit	2digit	2digit	1digit	1digit	1digit	1digit	1digit	1digit	1digit	1digit	1digit	x1	x1	x1	x1	x1	2digit	2digit
6		2digit	2digit	2digit	2digit	2digit	1digit	1digit	1digit	1digit	1digit	1digit	1digit	1digit	1digit	x1	x1	x1	x1	x1	x1	2digit	2digit
7.5		2digit	2digit	2digit	2digit	2digit	1digit	1digit	1digit	1digit	1digit	1digit	1digit	1digit	x1	x1	x1	x1	x1	x1	x1	2digit	2digit
8		2digit	2digit	2digit	2digit	2digit	1digit	1digit	1digit	1digit	1digit	1digit	1digit	x1	x1	x1	x1	x1	x1	x1	x1	2digit	2digit
10		2digit	2digit	2digit	2digit	2digit	1digit	1digit	1digit	1digit	x1	x1	x1	x1	x1	x1	x1	x1	x1	x1	x1	2digit	2digit
12		2digit	2digit	2digit	2digit	1digit	1digit	1digit	1digit	x1	x1	x1	x1	x1	x1	x1	x1	x1	x1	x1	x10	2digit	2digit
15		2digit	2digit	2digit	2digit	1digit	1digit	1digit	1digit	x1	x1	x1	x1	x1	x1	x1	x1	x1	x1	x1	x10	2digit	2digit
20		2digit	2digit	2digit	1digit	1digit	1digit	1digit	x1	x1	x1	x1	x1	x1	x1	x1	x1	x10	x10	x10	x10	2digit	2digit
25		2digit	2digit	2digit	1digit	1digit	1digit	1digit	x1	x1	x1	x1	x1	x1	x1	x1	x1	x10	x10	x10	x10	2digit	2digit
30		2digit	2digit	1digit	1digit	1digit	1digit	1digit	x1	x1	x1	x1	x1	x1	x1	x1	x1	x10	x10	x10	x10	2digit	1digit
40		2digit	2digit	1digit	1digit	1digit	1digit	x1	x1	x1	x1	x1	x1	x1	x1	x1	x10	x10	x10	x10	x10	2digit	1digit
50		2digit	2digit	1digit	1digit	1digit	1digit	x1	x1	x1	x1	x1	x1	x1	x1	x10	x10	x10	x10	x10	x10	2digit	1digit
60		2digit	1digit	1digit	1digit	1digit	x1	x1	x1	x1	x1	x1	x1	x1	x10	x10	x10	x10	x10	x10	x10	1digit	1digit
75		2digit	1digit	1digit	1digit	1digit	x1	x1	x1	x1	x1	x1	x1	x10	x10	x10	x10	x10	x10	x10	x10	1digit	1digit
80		2digit	1digit	1digit	1digit	1digit	x1	x1	x1	x1	x1	x1	x10	x10	x10	x10	x10	x10	x10	x10	x10	1digit	1digit
100		2digit	1digit	1digit	1digit	1digit	x1	x1	x1	x1	x10	x10	x10	x10	x10	x10	x10	x10	x10	x10	x10	1digit	1digit
120		1digit	1digit	1digit	1digit	x1	x1	x1	x1	x10	x10	x10	x10	x10	x10	x10	x10	x10	x10	x10	x100	1digit	1digit
150		1digit	1digit	1digit	1digit	x1	x1	x1	x1	x10	x10	x10	x10	x10	x10	x10	x10	x10	x10	x10	x100	1digit	1digit
200		1digit	1digit	1digit	x1	x1	x1	x1	x10	x10	x10	x10	x10	x10	x10	x10	x10	x100	x100	x100	x100	1digit	1digit
250		1digit	1digit	1digit	x1	x1	x1	x1	x10	x10	x10	x10	x10	x10	x10	x10	x10	x100	x100	x100	x100	1digit	1digit
300		1digit	1digit	x1	x1	x1	x1	x1	x10	x10	x10	x10	x10	x10	x10	x10	x10	x100	x100	x100	x100	1digit	x1
400		1digit	1digit	x1	x1	x1	x1	x10	x10	x10	x10	x10	x10	x10	x10	x10	x100	x100	x100	x100	x100	1digit	x1
500		1digit	1digit	x1	x1	x1	x1	x10	x10	x10	x10	x10	x10	x10	x10	x100	x100	x100	x100	x100	x100	1digit	x1
600		1digit	x1	x1	x1	x1	x10	x10	x10	x10	x10	x10	x10	x10	x100	x100	x100	x100	x100	x100	x100	x1	x1
750		1digit	x1	x1	x1	x1	x10	x10	x10	x10	x10	x10	x10	x100	x100	x100	x100	x100	x100	x100	x100	x1	x1
800		1digit	x1	x1	x1	x1	x10	x10	x10	x10	x10	x10	x100	x100	x100	x100	x100	x100	x100	x100	x100	x1	x1
1000		1digit	x1	x1	x1	x1	x10	x10	x10	x10	x100	x100	x100	x100	x100	x100	x100	x100	x100	x100	x100	x1	x1
1200		x1	x1	x1	x1	x10	x10	x10	x10	x100	x100	x100	x100	x100	x100	x100	x100	x100	x100	x1000	x1000	x1	x1
1500		x1	x1	x1	x1	x10	x10	x10	x10	x100	x100	x100	x100	x100	x100	x100	x100	x100	x1000	x1000	x1000	x1	x1
1600		x1	x1	x1	x1	x10	x10	x10	x10	x100	x100	x100	x100	x100	x100	x100	x100	x1000	x1000	x1000	x1000	x1	x1
2000		x1	x1	x1	x10	x10	x10	x10	x100	x100	x100	x100	x100	x100	x100	x100	x100	x1000	x1000	x1000	x1000	x1	x1
2500		x1	x1	x1	x10	x10	x10	x10	x100	x100	x100	x100	x100	x100	x100	x100	x100	x1000	x1000	x1000	x1000	x1	x1
3000		x1	x1	x10	x10	x10	x10	x10	x100	x100	x100	x100	x100	x100	x100	x100	x100	x1000	x1000	x1000	x1000	x1	x10
4000		x1	x1	x10	x10	x10	x10	x100	x100	x100	x100	x100	x100	x100	x100	x100	x1000	x1000	x1000	x1000	x1000	x1	x10
5000		x1	x1	x10	x10	x10	x10	x100	x100	x100	x100	x100	x100	x100	x1000	x1000	x1000	x1000	x1000	x1000	x1000	x1	x10
6000		x1	x10	x10	x10	x10	x100	x100	x100	x100	x100	x100	x100	x1000	x1000	x1000	x1000	x1000	x1000	x1000	x1000	x10	x10
7500		x1	x10	x10	x10	x10	x100	x100	x100	x100	x100	x100	x1000	x1000	x1000	x1000	x1000	x1000	x1000	x1000	x1000	x10	x10
8000		x1	x10	x10	x10	x10	x100	x100	x100	x100	x100	x1000	x1000	x1000	x1000	x1000	x1000	x1000	x1000	x1000	x1000	x10	x10
10000		x1	x10	x10	x10	x10	x100	x100	x100	x1000	x1000	x1000	x1000	x1000	x1000	x1000	x1000	x1000	x1000	x1000	x1000	x10	x10
12000		x10	x10	x10	x10	x100	x100	x100	x1000	x1000	x1000	x1000	x1000	x1000	x1000	x1000	x1000	x1000	x1000	*1	x10	x10	
20000		x10	x10	x10	x100	x100	x100	x1000	x1000	x1000	x1000	x1000	x1000	x1000	x1000	x1000	x1000	*1	*1	*1	*1	x10	x10
25000		x10	x10	x10	x100	x100	x100	x1000	x1000	x1000	x1000	x1000	x1000	x1000	x1000	x1000	x1000	*1	*1	*1	*1	x10	x10
30000		x10	x10	x100	x100	x100	x100	x1000	x1000	x1000	x1000	x1000	x1000	x1000	x1000	x1000	x1000	*1	*1	*1	*1	x10	x100

(*1): Electric energy is x1000, Electric energy conversion is x10000.

Phase wire system	3P3W																			
	V	110	220	440	690	1100	2200	3300	6600	11000	13200	13800	15000	16500	22000	24000	33000	66000	77000	110000
A																				
5	2digit	2digit	2digit	2digit	2digit	1digit	1digit	1digit	1digit	1digit	1digit	x1	x1	x1	x1	x1	x1	x1	x1	x1
6	2digit	2digit	2digit	2digit	2digit	1digit	1digit	1digit	1digit	1digit	x1	x1	x1	x1	x1	x1	x1	x1	x1	x1
7.5	2digit	2digit	2digit	2digit	1digit	1digit	1digit	1digit	1digit	x1	x1	x1	x1	x1	x1	x1	x1	x1	x1	x10
8	2digit	2digit	2digit	2digit	1digit	1digit	1digit	1digit	1digit	x1	x1	x1	x1	x1	x1	x1	x1	x1	x1	x10
10	2digit	2digit	2digit	2digit	1digit	1digit	1digit	1digit	1digit	x1	x1	x1	x1	x1	x1	x1	x1	x1	x10	x10
12	2digit	2digit	2digit	1digit	1digit	1digit	1digit	1digit	x1	x1	x1	x1	x1	x1	x1	x1	x1	x10	x10	x10
15	2digit	2digit	2digit	1digit	1digit	1digit	1digit	1digit	x1	x1	x1	x1	x1	x1	x1	x1	x1	x10	x10	x10
20	2digit	2digit	1digit	1digit	1digit	1digit	1digit	1digit	x1	x1	x1	x1	x1	x1	x1	x1	x1	x10	x10	x10
25	2digit	2digit	1digit	1digit	1digit	1digit	x1	x1	x1	x1	x1	x1	x1	x1	x1	x1	x10	x10	x10	x10
30	2digit	2digit	1digit	1digit	1digit	1digit	x1	x1	x1	x1	x1	x1	x1	x1	x1	x10	x10	x10	x10	x10
40	2digit	1digit	1digit	1digit	1digit	x1	x1	x1	x1	x1	x1	x1	x1	x10	x10	x10	x10	x10	x10	x10
50	2digit	1digit	1digit	1digit	1digit	x1	x1	x1	x1	x1	x1	x10	x10	x10	x10	x10	x10	x10	x10	x10
60	2digit	1digit	1digit	1digit	1digit	x1	x1	x1	x1	x10	x10	x10	x10	x10	x10	x10	x10	x10	x10	x10
75	1digit	1digit	1digit	1digit	x1	x1	x1	x1	x10	x10	x10	x10	x10	x10	x10	x10	x10	x10	x10	x100
80	1digit	1digit	1digit	1digit	x1	x1	x1	x1	x10	x10	x10	x10	x10	x10	x10	x10	x10	x10	x10	x100
100	1digit	1digit	1digit	1digit	x1	x1	x1	x1	x10	x10	x10	x10	x10	x10	x10	x10	x10	x10	x100	x100
120	1digit	1digit	1digit	x1	x1	x1	x1	x10	x10	x10	x10	x10	x10	x10	x10	x10	x10	x100	x100	x100
150	1digit	1digit	1digit	x1	x1	x1	x1	x10	x10	x10	x10	x10	x10	x10	x10	x10	x10	x100	x100	x100
200	1digit	1digit	x1	x1	x1	x1	x1	x10	x10	x10	x10	x10	x10	x10	x10	x10	x10	x100	x100	x100
250	1digit	1digit	x1	x1	x1	x1	x10	x10	x10	x10	x10	x10	x10	x10	x10	x10	x100	x100	x100	x100
300	1digit	1digit	x1	x1	x1	x1	x10	x10	x10	x10	x10	x10	x10	x10	x100	x100	x100	x100	x100	x100
400	1digit	x1	x1	x1	x1	x10	x10	x10	x10	x10	x10	x10	x10	x100	x100	x100	x100	x100	x100	x100
500	1digit	x1	x1	x1	x1	x10	x10	x10	x10	x10	x10	x100	x100	x100	x100	x100	x100	x100	x100	x100
600	1digit	x1	x1	x1	x1	x10	x10	x10	x10	x100	x100	x100	x100	x100	x100	x100	x100	x100	x100	x100
750	x1	x1	x1	x1	x10	x10	x10	x10	x100	x100	x100	x100	x100	x100	x100	x100	x100	x100	x100	x1000
800	x1	x1	x1	x1	x10	x10	x10	x10	x100	x100	x100	x100	x100	x100	x100	x100	x100	x100	x100	x1000
1000	x1	x1	x1	x1	x10	x10	x10	x10	x100	x100	x100	x100	x100	x100	x100	x100	x100	x100	x1000	x1000
1200	x1	x1	x1	x10	x10	x10	x10	x100	x100	x100	x100	x100	x100	x100	x100	x100	x100	x1000	x1000	x1000
1500	x1	x1	x1	x10	x10	x10	x10	x100	x100	x100	x100	x100	x100	x100	x100	x100	x100	x1000	x1000	x1000
1600	x1	x1	x10	x10	x10	x10	x10	x100	x100	x100	x100	x100	x100	x100	x100	x100	x100	x1000	x1000	x1000
2000	x1	x1	x10	x10	x10	x10	x10	x100	x100	x100	x100	x100	x100	x100	x100	x100	x100	x1000	x1000	x1000
2500	x1	x1	x10	x10	x10	x10	x100	x100	x100	x100	x100	x100	x100	x100	x100	x1000	x1000	x1000	x1000	x1000
3000	x1	x1	x10	x10	x10	x10	x100	x100	x100	x100	x100	x100	x100	x100	x1000	x1000	x1000	x1000	x1000	x1000
4000	x1	x10	x10	x10	x10	x100	x100	x100	x100	x100	x100	x100	x100	x1000	x1000	x1000	x1000	x1000	x1000	x1000
5000	x1	x10	x10	x10	x10	x100	x100	x100	x100	x100	x100	x1000	x1000	x1000	x1000	x1000	x1000	x1000	x1000	x1000
6000	x1	x10	x10	x10	x10	x100	x100	x100	x100	x1000	x1000	x1000	x1000	x1000	x1000	x1000	x1000	x1000	x1000	x1000
7500	x10	x10	x10	x10	x100	x100	x100	x100	x1000	x1000	x1000	x1000	x1000	x1000	x1000	x1000	x1000	x1000	x1000	*1
8000	x10	x10	x10	x10	x100	x100	x100	x100	x1000	x1000	x1000	x1000	x1000	x1000	x1000	x1000	x1000	x1000	x1000	*1
10000	x10	x10	x10	x10	x100	x100	x100	x100	x1000	x1000	x1000	x1000	x1000	x1000	x1000	x1000	x1000	x1000	*1	*1
12000	x10	x10	x10	x100	x100	x100	x100	x1000	x1000	x1000	x1000	x1000	x1000	x1000	x1000	x1000	x1000	*1	*1	*1
20000	x10	x10	x100	x100	x100	x100	x100	x1000	x1000	x1000	x1000	x1000	x1000	x1000	x1000	x1000	x1000	*1	*1	*1
25000	x10	x10	x100	x100	x100	x100	x1000	x1000	x1000	x1000	x1000	x1000	x1000	x1000	x1000	x1000	*1	*1	*1	*1
30000	x10	x10	x100	x100	x100	x100	x1000	x1000	x1000	x1000	x1000	x1000	x1000	x1000	x1000	*1	*1	*1	*1	*1

(*1): Electric energy is x1000, Electric energy conversion is x10000.

Phase wire system	3P4W																
	V	63.5 110	100 173	105 182	110 190	115 199	120 208	127 220	200 346	220 380	230 400	240 415	242 420	250 430	254 440	265 460	277 480
5	2digit	2digit	2digit	2digit	2digit	2digit	2digit	2digit	2digit	2digit	2digit	2digit	2digit	2digit	2digit	2digit	2digit
6	2digit	2digit	2digit	2digit	2digit	2digit	2digit	2digit	2digit	2digit	2digit	2digit	2digit	2digit	2digit	2digit	2digit
7.5	2digit	2digit	2digit	2digit	2digit	2digit	2digit	2digit	2digit	2digit	2digit	2digit	2digit	2digit	2digit	2digit	2digit
8	2digit	2digit	2digit	2digit	2digit	2digit	2digit	2digit	2digit	2digit	2digit	2digit	2digit	2digit	2digit	2digit	2digit
10	2digit	2digit	2digit	2digit	2digit	2digit	2digit	2digit	2digit	2digit	2digit	2digit	2digit	2digit	2digit	2digit	2digit
12	2digit	2digit	2digit	2digit	2digit	2digit	2digit	2digit	2digit	2digit	2digit	2digit	2digit	2digit	2digit	2digit	2digit
15	2digit	2digit	2digit	2digit	2digit	2digit	2digit	2digit	2digit	2digit	2digit	2digit	2digit	2digit	2digit	2digit	1digit
20	2digit	2digit	2digit	2digit	2digit	2digit	2digit	2digit	1digit	1digit	1digit	1digit	1digit	1digit	1digit	1digit	1digit
25	2digit	2digit	2digit	2digit	2digit	2digit	2digit	2digit	1digit	1digit	1digit	1digit	1digit	1digit	1digit	1digit	1digit
30	2digit	2digit	2digit	2digit	2digit	2digit	2digit	2digit	1digit	1digit	1digit	1digit	1digit	1digit	1digit	1digit	1digit
40	2digit	1digit	1digit	1digit	1digit	1digit	1digit	1digit	1digit	1digit	1digit	1digit	1digit	1digit	1digit	1digit	1digit
50	2digit	1digit	1digit	1digit	1digit	1digit	1digit	1digit	1digit	1digit	1digit	1digit	1digit	1digit	1digit	1digit	1digit
60	2digit	1digit	1digit	1digit	1digit	1digit	1digit	1digit	1digit	1digit	1digit	1digit	1digit	1digit	1digit	1digit	1digit
75	1digit	1digit	1digit	1digit	1digit	1digit	1digit	1digit	1digit	1digit	1digit	1digit	1digit	1digit	1digit	1digit	1digit
80	1digit	1digit	1digit	1digit	1digit	1digit	1digit	1digit	1digit	1digit	1digit	1digit	1digit	1digit	1digit	1digit	1digit
100	1digit	1digit	1digit	1digit	1digit	1digit	1digit	1digit	1digit	1digit	1digit	1digit	1digit	1digit	1digit	1digit	1digit
120	1digit	1digit	1digit	1digit	1digit	1digit	1digit	1digit	1digit	1digit	1digit	1digit	1digit	1digit	1digit	1digit	1digit
150	1digit	1digit	1digit	1digit	1digit	1digit	1digit	1digit	1digit	1digit	1digit	1digit	1digit	1digit	1digit	1digit	x1
200	1digit	1digit	1digit	1digit	1digit	1digit	1digit	1digit	x1	x1	x1	x1	x1	x1	x1	x1	x1
250	1digit	1digit	1digit	1digit	1digit	1digit	1digit	1digit	x1	x1	x1	x1	x1	x1	x1	x1	x1
300	1digit	1digit	1digit	1digit	1digit	1digit	1digit	1digit	x1	x1	x1	x1	x1	x1	x1	x1	x1
400	1digit	x1	x1	x1	x1	x1	x1	x1	x1	x1	x1	x1	x1	x1	x1	x1	x1
500	1digit	x1	x1	x1	x1	x1	x1	x1	x1	x1	x1	x1	x1	x1	x1	x1	x1
600	1digit	x1	x1	x1	x1	x1	x1	x1	x1	x1	x1	x1	x1	x1	x1	x1	x1
750	x1	x1	x1	x1	x1	x1	x1	x1	x1	x1	x1	x1	x1	x1	x1	x1	x1
800	x1	x1	x1	x1	x1	x1	x1	x1	x1	x1	x1	x1	x1	x1	x1	x1	x1
1000	x1	x1	x1	x1	x1	x1	x1	x1	x1	x1	x1	x1	x1	x1	x1	x1	x1
1200	x1	x1	x1	x1	x1	x1	x1	x1	x1	x1	x1	x1	x1	x1	x1	x1	x1
1500	x1	x1	x1	x1	x1	x1	x1	x1	x1	x1	x1	x1	x1	x1	x1	x1	x10
1600	x1	x1	x1	x1	x1	x1	x1	x1	x1	x1	x1	x1	x1	x10	x10	x10	x10
2000	x1	x1	x1	x1	x1	x1	x1	x1	x10	x10	x10	x10	x10	x10	x10	x10	x10
2500	x1	x1	x1	x1	x1	x1	x1	x1	x10	x10	x10	x10	x10	x10	x10	x10	x10
3000	x1	x1	x1	x1	x1	x1	x1	x1	x10	x10	x10	x10	x10	x10	x10	x10	x10
4000	x1	x10	x10	x10	x10	x10	x10	x10	x10	x10	x10	x10	x10	x10	x10	x10	x10
5000	x1	x10	x10	x10	x10	x10	x10	x10	x10	x10	x10	x10	x10	x10	x10	x10	x10
6000	x1	x10	x10	x10	x10	x10	x10	x10	x10	x10	x10	x10	x10	x10	x10	x10	x10
7500	x10	x10	x10	x10	x10	x10	x10	x10	x10	x10	x10	x10	x10	x10	x10	x10	x10
8000	x10	x10	x10	x10	x10	x10	x10	x10	x10	x10	x10	x10	x10	x10	x10	x10	x10
10000	x10	x10	x10	x10	x10	x10	x10	x10	x10	x10	x10	x10	x10	x10	x10	x10	x10
12000	x10	x10	x10	x10	x10	x10	x10	x10	x10	x10	x10	x10	x10	x10	x10	x10	x10
20000	x10	x10	x10	x10	x10	x10	x10	x10	x100	x100	x100	x100	x100	x100	x100	x100	x100
25000	x10	x10	x10	x10	x10	x10	x10	x10	x100	x100	x100	x100	x100	x100	x100	x100	x100
30000	x10	x10	x10	x10	x10	x10	x10	x10	x100	x100	x100	x100	x100	x100	x100	x100	x100

Note : Phase wire system is only EMU4-HM1-MB, EMU4-A2 and EMU4-VA2.

Note : 2 digit means two decimal places ($\times 10^{-2}$) and 1 digit means 1 decimal places ($\times 10^{-1}$)

Note : x1 means integer $\times 1$ and x10 means integer $\times 10$ and x100 means integer $\times 100$ and x1000 means integer $\times 1000$ and x10000 means integer $\times 10000$.

(5) Pulse conversion data

Pulse converted rate		EMU4-HM1-MB EMU4-PX4
0.001 or more	Less than 0.01	Decimal 3 digit
0.01 or more	Less than 0.1	Decimal 2 digit
0.1 or more	Less than 1	Decimal 1 digit
1 or more	Less than 10	Integer×1
10 or more	Less than 100	Integer×10
100 or more	Less than 1000	Integer×100
1000 or more	Less than 10000	Integer×1000

(6) Leak current data (EMU3-DP1-C)

Data is integer ×1.

< EMU4-LG1-MB >

Mode	EMU4-LG1-MB
Low SENS	Integer×1
High SENS	Decimal 2 digit

(7) Over current (EMU3-DP1-C only)

Data is integer ×1.

(8) Number of times exceeding the limit

Number of times exceeding the Limit	EMU4-AX4
Integer ×1	Integer×1
Integer ×10	Integer×10
Integer ×100	Integer×100
Integer ×1000	Integer×1000

Effective Range and Multiplicand <For EMU4-BD1-MB / EMU4-HD1-MB>

The conditions of multiplying factor by setup of each element are shown below.

Element	Condition	Multiplying factor	
Voltage Harmonics voltage	Primary voltage (Note1)	0V~300V less than	$\times 10^{-1}$
		300V or more	$\times 1$
Current	Primary current	0A~40A less than	$\times 10^{-2}$
Current demand		40A~400A less than	$\times 10^{-1}$
Harmonics current		400A~4000A less than	$\times 1$
Active power Active power demand Reactive power Apparent power	Full load power (Note2)	0kW~12kW less than	$\times 10^{-3}$
		12kW~120kW less than	$\times 10^{-2}$
		120kW~1200kW less than	$\times 10^{-1}$
		1200kW~12000kW less than	$\times 1$
		12000kW~120000kW less than	$\times 10^1$
		120000kW or more	$\times 10^2$
Active energy Reactive energy	Full load power (Note2)	0kW~12kW less than	$\times 10^{-2}$
		12kW~120kW less than	$\times 10^{-1}$
		120kW~1200kW less than	$\times 1$
		1200kW~12000kW less than	$\times 10$
		12000kW~120000kW less than	$\times 10^2$
		120000kW or more	$\times 10^3$
Active energy (extended) Reactive energy (extended)	Full load power (Note2)	0kW~12kW less than	$\times 10^{-5}$
		12kW~120kW less than	$\times 10^{-4}$
		120kW~1200kW less than	$\times 10^{-3}$
		1200kW~12000kW less than	$\times 10^{-2}$
		12000kW~120000kW less than	$\times 10^{-1}$
		120000kW or more	$\times 1$
Frequency	—	—	$\times 10^{-1}$
Power factor	—	—	$\times 10^{-1}$
Harmonics distortion	—	—	$\times 10^{-1}$

Note1: At 3P4W, primary voltage is phase to neutral voltage.

Note2: How to calculate Full load power is the following.

$$\text{Full load power [kW]} = \frac{\alpha \times (\text{Primary voltage}) \times (\text{Primary current})}{1000}$$

- α : 1 at 1P2W
 2 at 1P3W (Primary voltage is 110V)
 $\sqrt{3}$ at 3P3W
 3 at 3P4W (Primary voltage is phase to neutral voltage)

Effective Range and Multiplicand <For EMU4-BM1-MB / EMU4-HM1-MB / EMU4-A2 / EMU4-VA2>

The conditions of multiplying factor by setup of each element are shown below.

Element	Condition	Multiplying factor	
Voltage Harmonics voltage	Primary voltage (Note1)	0V~300V less than	$\times 10^{-1}$
		300V~3000V less than	$\times 1$
		3000V or more	$\times 10$
Current Current demand Harmonics current	Primary current	0A~40A less than	$\times 10^{-2}$
		40A~400A less than	$\times 10^{-1}$
		400A~4000A less than	$\times 1$
		4000A or more	$\times 10$
Active power Active power demand Reactive power Apparent power	Full load power (Note2)	0kW~12kW less than	$\times 10^{-3}$
		12kW~120kW less than	$\times 10^{-2}$
		120kW~1200kW less than	$\times 10^{-1}$
		1200kW~12000kW less than	$\times 1$
		12000kW~120000kW less than	$\times 10^1$
		120000kW or more	$\times 10^2$
Active energy Reactive energy	Full load power (Note2)	0kW~12kW less than	$\times 10^{-2}$
		12kW~120kW less than	$\times 10^{-1}$
		120kW~1200kW less than	$\times 1$
		1200kW~12000kW less than	$\times 10$
		12000kW~120000kW less than	$\times 10^2$
		120000kW or more	$\times 10^3$
Active energy (extended) Reactive energy (extended)	Full load power (Note2)	0kW~12kW less than	$\times 10^{-5}$
		12kW~120kW less than	$\times 10^{-4}$
		120kW~1200kW less than	$\times 10^{-3}$
		1200kW~12000kW less than	$\times 10^{-2}$
		12000kW~120000kW less than	$\times 10^{-1}$
		120000kW or more	$\times 1$
Frequency	—	—	$\times 10^{-1}$
Power factor	—	—	$\times 10^{-1}$
Harmonics distortion	—	—	$\times 10^{-1}$

Note1: At 3P4W, primary voltage is phase to neutral voltage.

Note2: How to calculate Full load power is the following.

$$\text{Full load power [kW]} = \frac{\alpha \times (\text{Primary voltage}) \times (\text{Primary current})}{1000}$$

α : 1 at 1P2W

2 at 1P3W (Primary voltage is 110V)

$\sqrt{3}$ at 3P3W

3 at 3P4W (Primary voltage is phase to neutral voltage)

Effective Range and Multiplicand <For EMU4-LG1-MB>

The conditions of multiplying factor by setup of each element are shown below.

Element	Condition	Multiplying factor
Leak current	Low SENS	$\times 1$
	High SENS	$\times 10^{-2}$

7.2.5 About Error Occurrence

When the command and related data transmitted to Measuring Unit is improper or Measuring Unit is in H/W error, RX(n+1)A (Error status flag) becomes 1(ON), the error code shown in Table 7.11 is returned as reply data.

Table 7.5 Error Code

Error Description	Error Code (Hex.)	EMU2-* -C	EMU3-DP1-C	EMU4-*
Undefined command or Illegal command or packet length	01H	—	○	—
Frequency, voltage harmonic or current harmonic are out of range (Measuring frequency and harmonics needs a voltage input.)	17H	○	—	—
Undefined command or Illegal command or packet length	40H	○	—	○
Invalid group number	41H	○	○	○
Invalid channel number	42H	○	○	○
Measuring Unit is in set-up mode	43H	—	○	○
	44H	○	—	○
Invalid unit number	45H	○	—	○
Invalid data for set-up	51H	○	○	○
H/W error	C0H	—	—	—
Invalid channel number	C1H	—	○	○
Invalid data for set-up	C2H	—	○	○

If an error occurs, the error code is written into the RW_n as shown in the figure below, and RX(n+1)A (error status flag) is turned on (error occurrence) and RX(n+1)B (remote READY) is turned off (normal communication stop). For the error resetting method, refer to “6.3 Error Communication”.

- (1) At the command No. is in range

Remote register RW _n				
	b15	b8	b7	b0
n	Channel No.		Group No.	
n+1	00H		00H	
n+2	00H		Error code	
n+3	00H		00H	

- (2) At the command No. is out of range

Remote register RW _n				
	b15	b8	b7	b0
n	00H		Error code	
n+1	00H		00H	
n+2	00H		00H	
n+3	00H		00H	

8. Abbreviations and Special Terms

Abbreviations and special terms used in this manual are shown below:

Abbreviation and Special Terms	Description
Master station	Station which controls remote stations and local stations. One station is required for one system.
Local station	Station with the CPU which can communicate with master station and other local stations.
Remote I/O station	Remote station which deals with bit information only.
Remote device station	Remote station which deals with bit information and word information.
Remote station	General name for remote I/O station and remote device station. Controlled by a master station.
Intelligent device station	Station that can perform transient transmission.
RX	Remote input
RY	Remote output
RWw	Remote resistor (write area)
RWr	Remote resistor (read area)
Command	Identification code allocated to items to be monitored or set. Measuring Unit uses a special-purpose command that is transmitted to monitor each measurement value or set each parameter.
Demand value	The demand value is an approximate average value during the demand time period. When it is set to 0, each demand present value becomes equivalent to the present value.

9. Program Example

This chapter provides example programs of two types. One is the program to monitor only active energy from a Measuring Unit. Another is the program to monitor the multi-items from two units of Measuring Unit.

- *1. Sample programs are for Q series programmable controller.
- *2. Sample programs are created by using "SW8D5C-GPPW GX Developer".
- *3. The refresh set with the automatic refresh parameters and the refresh executed with the FROM/TO instructions cannot be performed simultaneously.

9.1 Program Example 1

9.1.1 Program Content

This section shows an example the program to monitor only active energy from a Measuring Unit whose station number is 1. This program example is assumed the system configuration in below and the I/O number of the master station is X/Y00 to X/Y 1F.

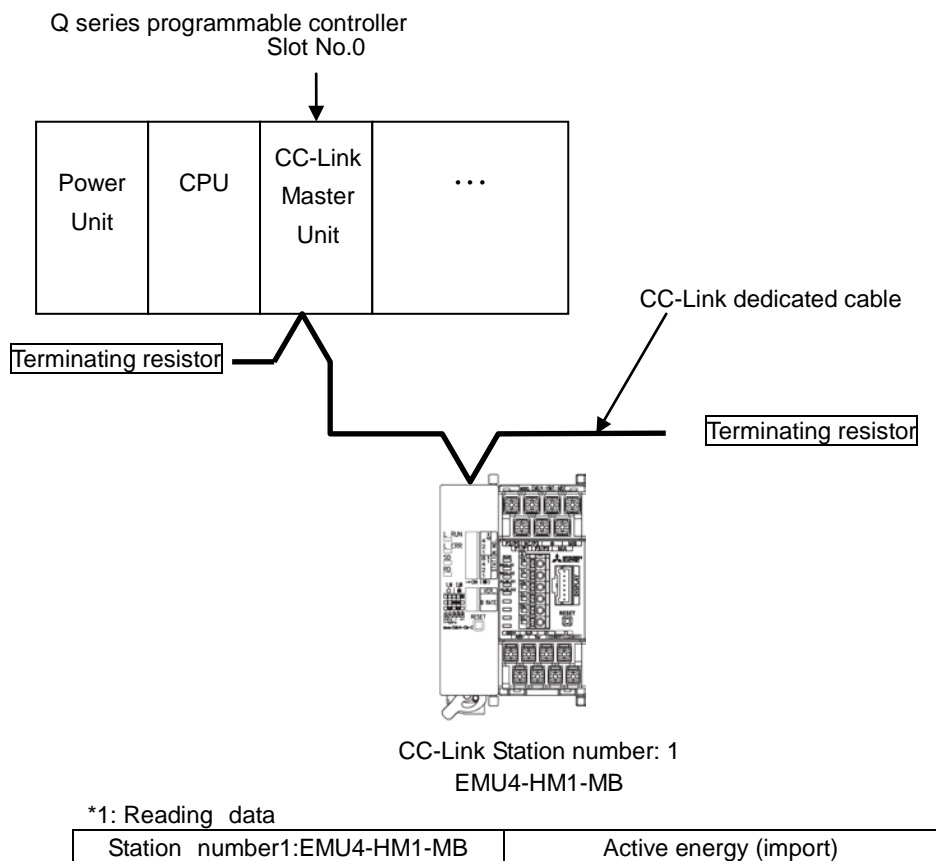

9.1.2 Parameter Settings

Parameter settings are set as following with GX Developer.

(1) Network Parameter Settings and Auto Refresh Parameter Settings

The following is shown CC-Link network parameter settings and auto refresh parameter settings.

The screenshot shows the 'Setting the CC-Link I...' dialog box in MELSOFT GX Developer. The 'No. of boards in module' is set to 1. The table below lists the parameters for two boards (1 and 2).

	1	2
Start I/O No	0000	
Operational setting	Operational settings	
Type	Master station	
Master station data link type	PLC parameter auto start	
Mode	Remote net(Ver.1 mode)	
All connect count	1	
Remote input(RX)	X100	
Remote output(RY)	Y100	
Remote register(RWri)	W300	
Remote register(RWw)	W400	
Ver.2 Remote input(RX)		
Ver.2 Remote output(RY)		
Ver.2 Remote register(RWri)		
Ver.2 Remote register(RWw)		
Special relay(SB)	S80	
Special register(SW)	SW0	
Retry count	3	
Automatic reconnection station count	1	
Stand by master station No.		
PLC down select	Stop	
Scan mode setting	Asynchronous	
Delay information setting	0	
Station information setting	Station information	
Remote device station initial setting	Initial settings	
Interrupt setting	Interrupt settings	

Indispensable settings(No setting / Already set) Set if it is needed(No setting / Alr

Setting item details:

Acknowledge XY assignment Clea

Project

Ready Q02(H) Host station

Setting Item	Description	Example for settings	Remarks
No.of boards in Module	Set the "No. of boards in module" for which the network parameters are to be set.	1	
Start I/O No	Set the "Start I/O No." for the master station	0000	Set the same setting of Start XY in PC parameter setting
Type	Set the station type.	Master station	
Mode	Set the CC-Link mode.	Remote net (Ver.1 mode)	"Remote net ver.2 mode" and "Remote net additional mode" can be also used in case of the QJ61BT11N.
All connect count	Set the total number of connected stations in the CC-Link system including reserved stations	1	
Remote input (RX)	Set the remote input (RX) refresh device.	X100	Device name - Select from X, M, L, B, D, W, R or ZR. Device number - Within the range of the device points that the CPU has.
Remote output (RY)	Set the remote output (RY) refresh device.	Y100	Device name - Select from Y, M, L, B, T, C, ST, D, W, R or ZR. Device number - Within the range of the device points that the CPU has.
Remote register (RWr)	Set the remote register (RWr) refresh device.	W300	Device name - Select from M, L, B, D, W, R, or ZR. Device number - Within the range of the device points that the CPU has.
Remote register (RWw)	Set the remote register (RWw) refresh device.	W400	Device name - Select from M, L, B, T, C, ST, D, W, R, or ZR. Device number - Within the range of the device points that the CPU has.
Special relay (SB)	Set the link special relay (SB) refresh device.	SB0	Device name - Select from M, L, B, D, W, R, SB or ZR. Device number - Within the range of the device points that the CPU has.
Special register (SW)	Set the link special register (SW) refresh device.	SW0	Device name - Select from M, L, B, D, W, R, SW or ZR. Device number - Within the range of the device points that the CPU has.
Retry count	Set the number of retries for "Retry count", when a communication error occurs.	1	
Automatic reconnection station count	Set the number of modules that can return to system operation by a single link scan.	1	
Standby master station No.	Set the station number for the standby master station	Blank	Blank: No standby master station specified.
PLC down select	Set the data link status for "PLC down select", when a master station programmable controller CPU error occurs	Stop	
Scan mode setting	Set whether the link scan for the sequence scan is synchronous or asynchronous	Asynchronous	
Delay information setting	Set for the link scan delay time.	0	50μs

(2) Operational Settings

Operational settings are as follows.

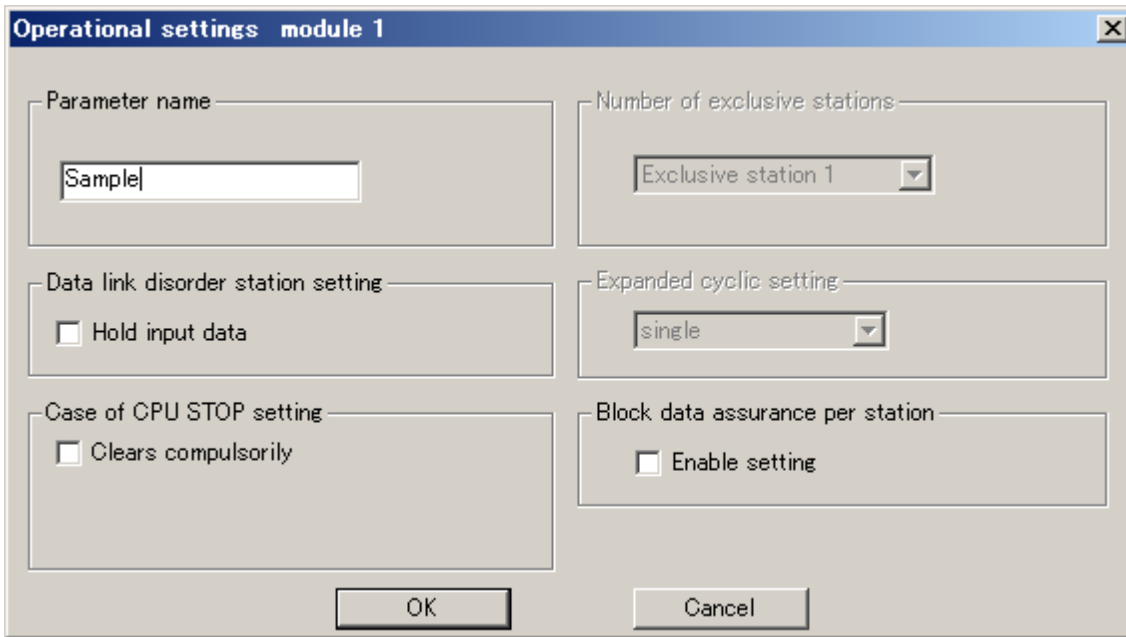

The 'Operational settings module 1' dialog box contains the following settings:

- Parameter name: Sample
- Number of exclusive stations: Exclusive station 1
- Data link disorder station setting: Hold input data
- Expanded cyclic setting: single
- Case of CPU STOP setting: Clears compulsorily
- Block data assurance per station: Enable setting

Buttons: OK, Cancel

(3) Station Information Settings

Station information settings are as follows.

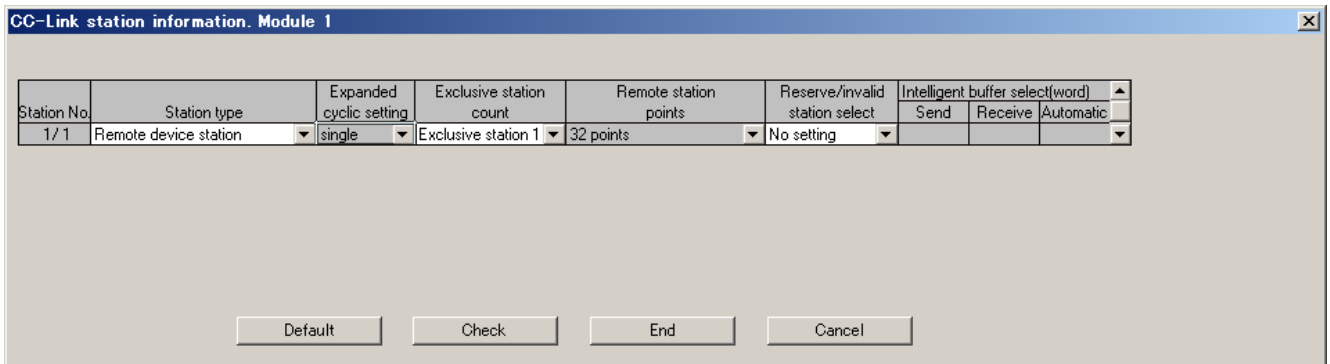

The 'CC-Link station information. Module 1' dialog box displays the following table:

Station No.	Station type	Expanded cyclic setting	Exclusive station count	Remote station points	Reserve/invalid station select	Intelligent buffer select(word)		
						Send	Receive	Automatic
1/1	Remote device station	single	Exclusive station 1	32 points	No setting			

Buttons: Default, Check, End, Cancel

(4) File Register Settings

This program example uses file registers R (ZR). The procedures of file register settings are as follows.

- 1) Double-click "PLC parameter".
- 2) Select "PLC file".
- 3) Select "Use the same file name as the program" or "Use the following file" and set the each item.

In details, refer to the manual for the CPU module used.

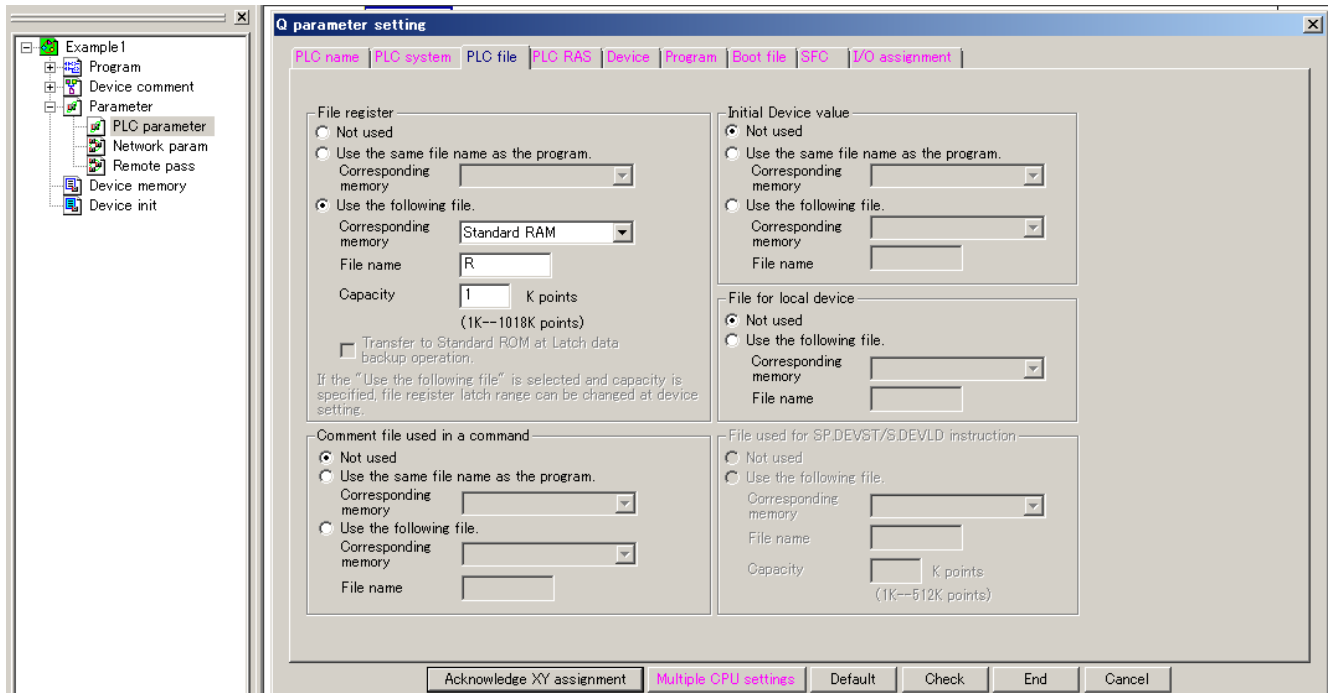

- If you use the CPU module which doesn't have file registers (ex. Q00UJCPU), replace the file register (R) with other device (ex. Data register (D))

9.1.3 Program example

(1) Example of Send Data Setting

This program describes an example of setting commands which are sent to Measuring Unit to devices.

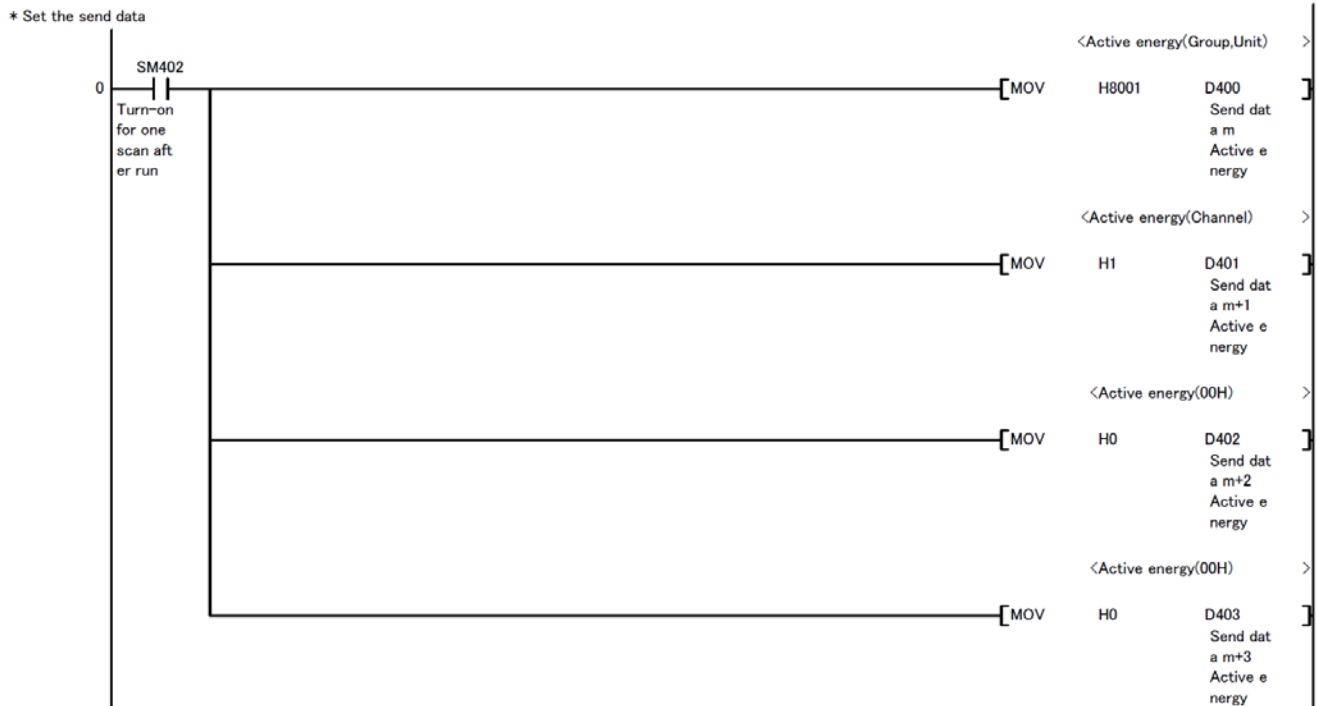

(i) Device Allocation

The following table lists devices used above the example.

Device No.	Setting data	Descriptions	Note
D400	H8011	Send data for monitoring. (Group No. :H80, Unit No.:H1, Command No.: H1)	Group No. changes depending on the data which you want to monitor. Unit No. changes depending on the Measuring Unit. <ul style="list-style-type: none"> Unit No. is H0 when use EMU2-HM1-C, EMU2-RD1-C, EMU3-DP1-C Unit No. is H1 when use EMU4-BD1-MB, EMU4-HD1-MB, EMU4-BM1-MB, EMU4-HM1-MB, EMU4-LG1-MB Unit No. is No. of input circuit (channel No.)when use EcoMonitorPro (multiple measuring) , EMU4-A2,EMU4-VA2.
D401	H1	Send data for monitoring. (Channel No.: H01)	It changes depending on the data which you want to monitor.
D402	H0	Send data for monitoring. (H0 fixed.)	
D403	H0	Send data for monitoring. (H0 fixed.)	

Note: Set the D400 to D403 same as that set device in "(iii) Example of Normal Communication". Depending on the data that you want to monitor, the setting data vary.

The following table lists the examples of setting data.

Command	Descriptions	Device No.	Setting data	Descriptions of setting data.
Data monitor	Phase 1 current	D400	H0111	Group No. :H01, Unit No.:H1, Command No.: H1
		D401	H0021	Channel No.: H21
		D402	H0000	H0 fixed.
		D403	H0000	H0 fixed.
	Total active power	D400	H0711	Group No. :H07, Unit No.:H1, Command No.: H1
		D401	H0001	Channel No.: H01
		D402	H0000	H0 fixed.
Data set	Phase wiring (Set to 3P3W)	D400	HE012	Group No. :HE0, Unit No.:H1, Command No.: H2
		D401	H0013	Index No.: H00, Channel No.: H13
		D402	H0003	Low data
		D403	H0000	High data

For details, refer to "7.2.3.Details of Commands"

(2) Example of Initial

After confirming if data link is normal or not, the initial process is performed only when the connection status is normal.

* Data link confirmation

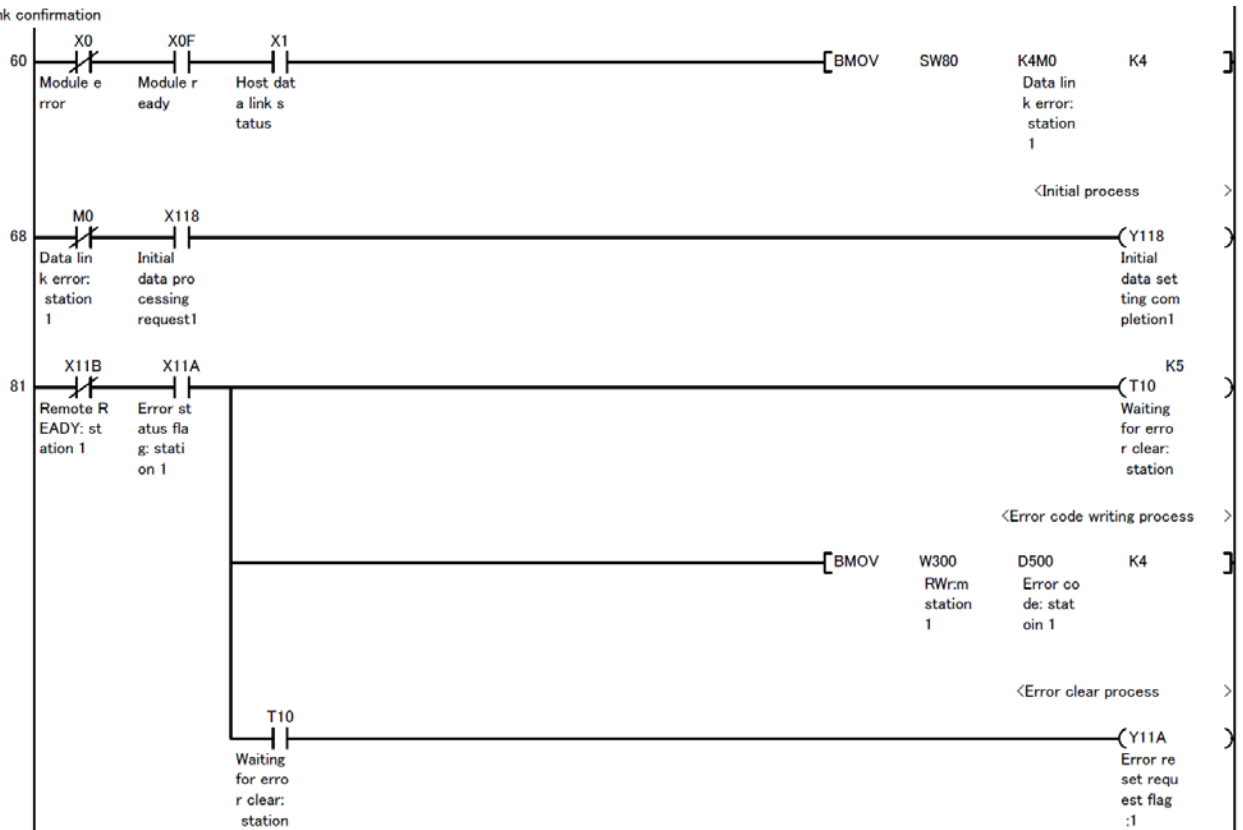

(i) Device Allocation

The following table lists devices used above the example.

Device No.	Descriptions	Note
X0	This signal indicates whether the module is normal or faulty. OFF: Module normal ON: Module error	Depending on the start I/O number of the master/local module, the devices No. vary. <Example> When the start I/O number of the master/local module is 0030: X0→X30 X1→31 X0F→X3F
X1	This signal indicates the data link status of the host station. OFF: Data link stopped ON: During data link	
X0F	This signal indicates whether the module is ready for operation. When the module becomes ready, this signal turns on. This signal turns off under either condition. • An error has been detected in the switch setting of the module. • Module error (Xn0) turns on.	
X118	Remote input (RX) of HM1. Initial data processing request flag.	Depending on the setting of refresh device and the station number of Measuring Unit, the devices No. vary. (In details, refer to "7.1.1 Remote input RX")
X11A	Remote input (RX) of HM1. Error status flag.	
X11B	Remote input (RX) of HM1. Remote READY.	
Y118	Remote output (RY) of HM1. Initial data setting completion flag.	Depending on the setting of refresh device and the station number of Measuring Unit, the devices No. vary. (In details, refer to "7.1.2 Remote Output RY")
Y11A	Remote output (RY) of HM1. Error reset request flag.	
W300 to W303	Remote register (RWr) Receiving data.	Depending on the setting of refresh device and the station number of Measuring Unit, the devices No. vary. (In details, refer to "7.2 Remote Register (RWr, RWw)")
SW80 to SW83	Data link status of each station. OFF: Normal ON: Error	Depending on the setting of refresh device, the devices No. vary.
M0 to M63	Data link status of each station. OFF: Normal ON: Error	Devices in a CPU module. (User selectable)
D500 to D503	Error code receiving data.	Devices in a CPU module. (User selectable) About error code, refer to "7.2.4 About Error Occurrence".
T10	Timer for error canceling wait.	Devices in a CPU module. (User selectable)

(3) Example of Normal Communication

This program describes an example of monitoring of measurement values.

* Data sending and receiving

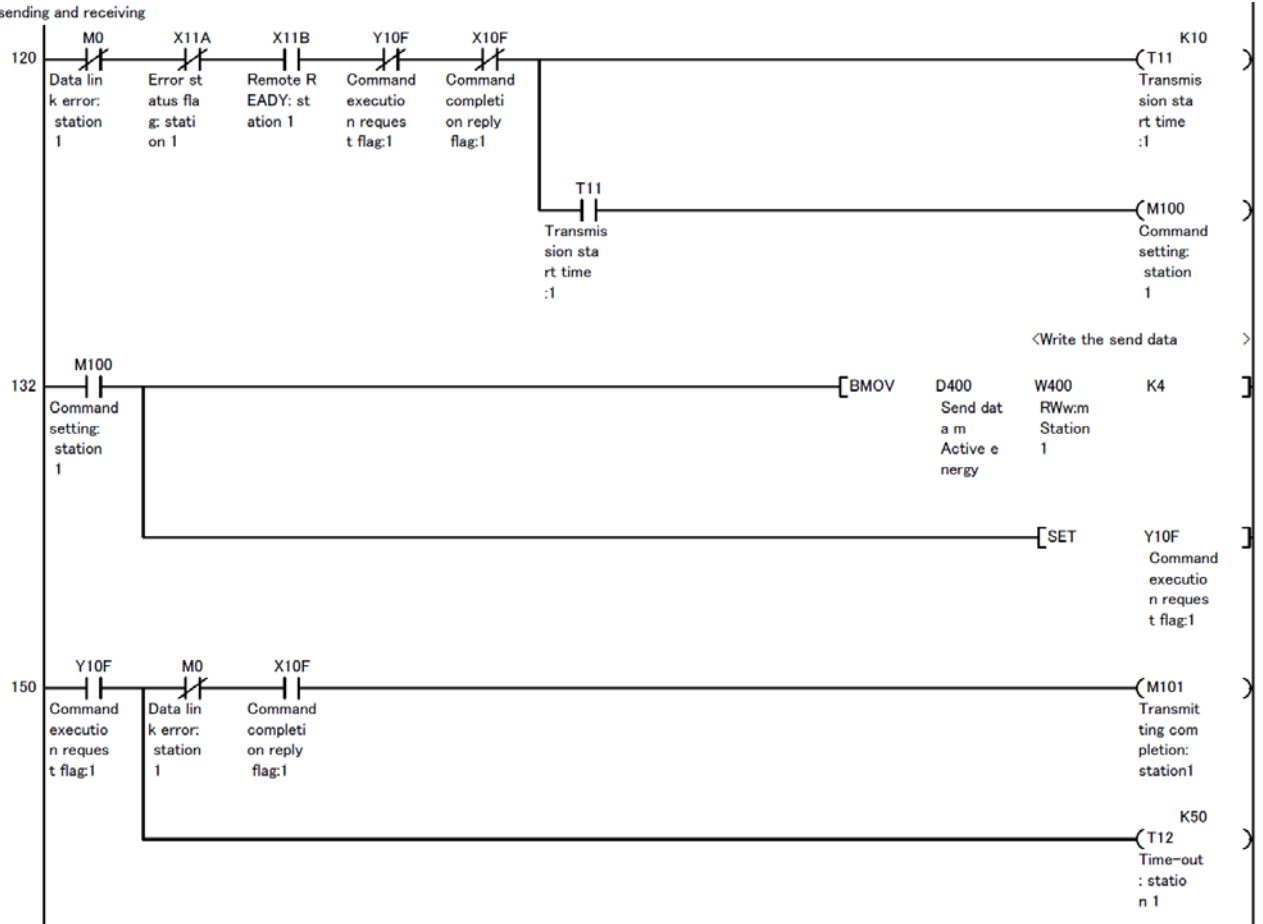

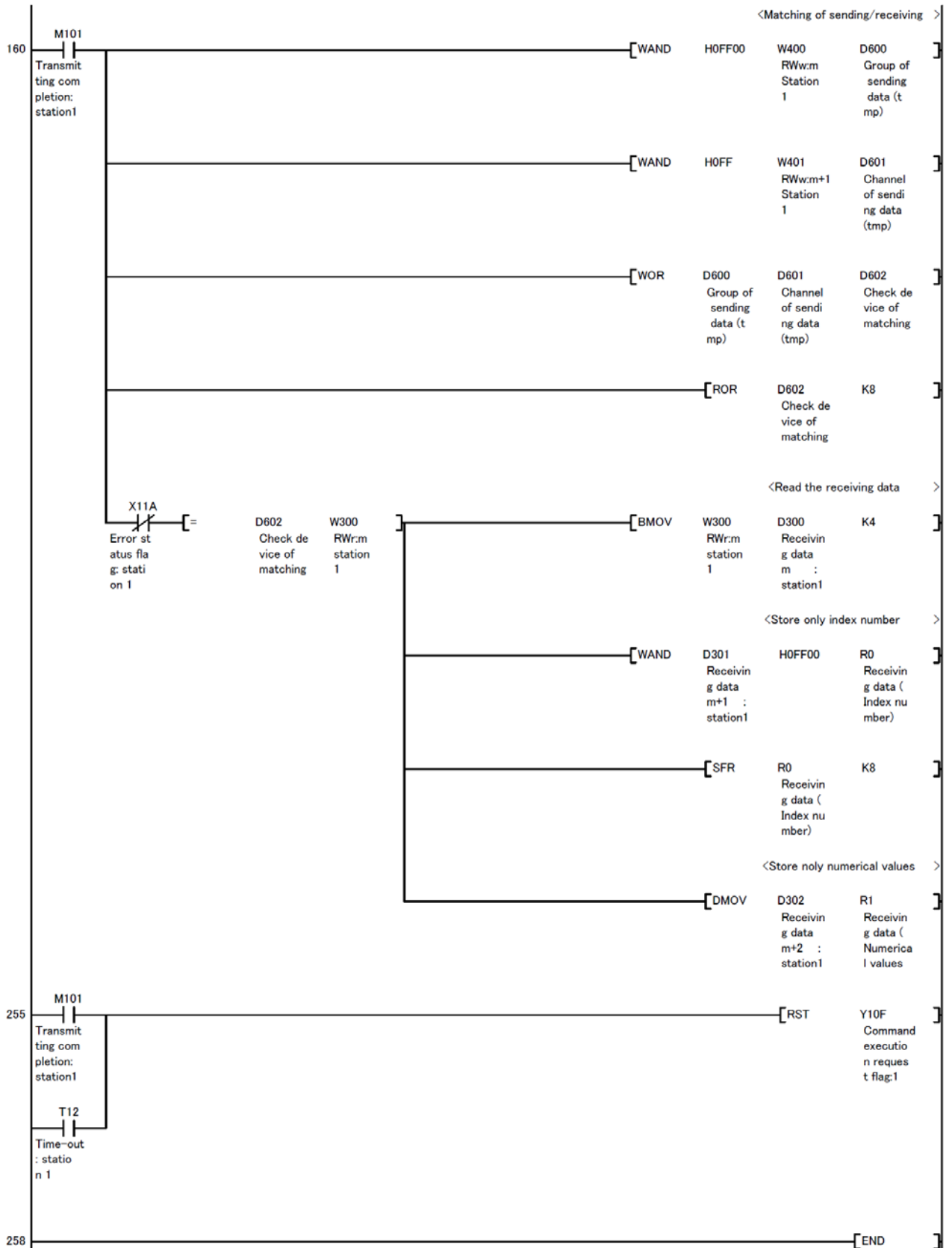

(i) Device Allocation

The following table lists devices used above the example.

Device No.	Descriptions	Note																						
X10F	Remote input (RX) of measuring unit. Command completion reply flag.	Depending on the setting of refresh device and the station number of HM1, the devices No. vary. (In details, refer to "7.1.1 Remote input RX")																						
X11A	Remote input (RX) of measuring unit. Error status flag.																							
X11B	Remote input (RX) of HM1. Remote READY.																							
Y10F	Remote output (RY) of Measuring Unit. Command execution request flag.	Depending on the setting of refresh device and the station number of HM1, the devices No. vary. (In details, refer to "7.1.2 Remote Output RY")																						
W300 to W303	Remote register (RW _r) receiving data	Depending on the setting of refresh device and the station number of HM1, the devices No. vary. (In details, refer to "7.2 Remote Register (RW _r , RW _w)")																						
W400 to W403	Remote register (RW _w) sending data.																							
D300 to D303	Reading device of receiving data	Devices in a CPU module. (User selectable) The following table lists the description.																						
		<table border="1"> <tr> <td>D300</td> <td>Channel No. Group No.</td> </tr> <tr> <td>D301</td> <td>Multiplying factor</td> </tr> <tr> <td>D302</td> <td>Low data</td> </tr> <tr> <td>D303</td> <td>High data</td> </tr> </table>	D300	Channel No. Group No.	D301	Multiplying factor	D302	Low data	D303	High data														
D300	Channel No. Group No.																							
D301	Multiplying factor																							
D302	Low data																							
D303	High data																							
D600 to D602	Checking device for match/mismatch of sending data and receiving data.	Devices in a CPU module. (User selectable)																						
M0	Data link status of station 1.	Devices in a CPU module. (User selectable) Set the same device of data link status which set in "(ii) Example of Initial".																						
M100	Command setting completion flag.	Devices in a CPU module. (User selectable)																						
M101	Transmitting completion flag.	Devices in a CPU module. (User selectable)																						
T11	Transmission starts time.	Devices in a CPU module. (User selectable)																						
T12	Time-out.	Devices in a CPU module. (User selectable)																						
R0	Receiving data (Index number)	Devices in a CPU module. (User selectable) The following table lists the description of index number.																						
		<table border="1"> <thead> <tr> <th>Index number</th> <th>Multiplicand</th> <th>Remarks</th> </tr> </thead> <tbody> <tr> <td>03H</td> <td>$x 10^3$</td> <td rowspan="9">Actual value = Numerical value x Multiplicand</td> </tr> <tr> <td>02H</td> <td>$x 10^2$</td> </tr> <tr> <td>01H</td> <td>$x 10$</td> </tr> <tr> <td>00H</td> <td>$x 1$</td> </tr> <tr> <td>FFH</td> <td>$x 10^{-1}$</td> </tr> <tr> <td>FEH</td> <td>$x 10^{-2}$</td> </tr> <tr> <td>FDH</td> <td>$x 10^{-3}$</td> </tr> <tr> <td>FCH</td> <td>$x 10^{-4}$</td> </tr> <tr> <td>FBH</td> <td>$x 10^{-5}$</td> </tr> </tbody> </table>	Index number	Multiplicand	Remarks	03H	$x 10^3$	Actual value = Numerical value x Multiplicand	02H	$x 10^2$	01H	$x 10$	00H	$x 1$	FFH	$x 10^{-1}$	FEH	$x 10^{-2}$	FDH	$x 10^{-3}$	FCH	$x 10^{-4}$	FBH	$x 10^{-5}$
Index number	Multiplicand	Remarks																						
03H	$x 10^3$	Actual value = Numerical value x Multiplicand																						
02H	$x 10^2$																							
01H	$x 10$																							
00H	$x 1$																							
FFH	$x 10^{-1}$																							
FEH	$x 10^{-2}$																							
FDH	$x 10^{-3}$																							
FCH	$x 10^{-4}$																							
FBH	$x 10^{-5}$																							
		On the basis of the index number, multiply the numerical value by the multiplicand in the host side.																						
R1, R2	Receiving data (numerical value)	Devices in a CPU module. (User selectable) Numerical value is 32-bit integer with a sign. However, the effective numerical value is 0~999999(0H~F423FH). Data changes 999998 → 999999 → 0 → 1																						

Note: In details of index number and numerical value, refer to "7.2.3Details of Commands".

Depending on the sending data (D400 to D403), the receiving data (D300 to D303) vary. The following describes the receiving data in case of example in "(i) Example of Send Data Setting".

Command	Descriptions	Receiving data device No.	Setting data	Stored device No.																	
Data monitor	Phase 1 current	D300	Channel No., Group No.	-																	
		D301	Index number.	R0																	
		D302, D303	Receiving data	R1, R2																	
	Total active power	D300	Channel No., Group No.	-																	
		D301	Index number.	R0																	
		D302, D303	Receiving data	R1, R2																	
	Index number	<p>Depending on the index number (R0), the multiplicand of the measuring data varies. The following table lists the description of index number.</p> <table border="1"> <thead> <tr> <th>Index number</th> <th>Multiplicand</th> <th>Remarks</th> </tr> </thead> <tbody> <tr> <td>02H</td> <td>$x 10^2$</td> <td rowspan="6">Actual value = Numerical value \times Multiplicand</td> </tr> <tr> <td>01H</td> <td>$x10$</td> </tr> <tr> <td>00H</td> <td>$x1$</td> </tr> <tr> <td>FHH</td> <td>$x 10^{-1}$</td> </tr> <tr> <td>FEH</td> <td>$x 10^{-2}$</td> </tr> <tr> <td>FDH</td> <td>$x 10^{-3}$</td> </tr> </tbody> </table> <p>On the basis of the index number, multiply the numerical value by the multiplicand in the host side. In details of index number and numerical value, refer to "7.2.3Details of Commands".</p>				Index number	Multiplicand	Remarks	02H	$x 10^2$	Actual value = Numerical value \times Multiplicand	01H	$x10$	00H	$x1$	FHH	$x 10^{-1}$	FEH	$x 10^{-2}$	FDH	$x 10^{-3}$
	Index number	Multiplicand	Remarks																		
	02H	$x 10^2$	Actual value = Numerical value \times Multiplicand																		
	01H	$x10$																			
00H	$x1$																				
FHH	$x 10^{-1}$																				
FEH	$x 10^{-2}$																				
FDH	$x 10^{-3}$																				
Receiving data	Numerical value is 32-bit integer with a sign. -2147483648~2147483647 (80000000H~7FFFFFFFH)																				

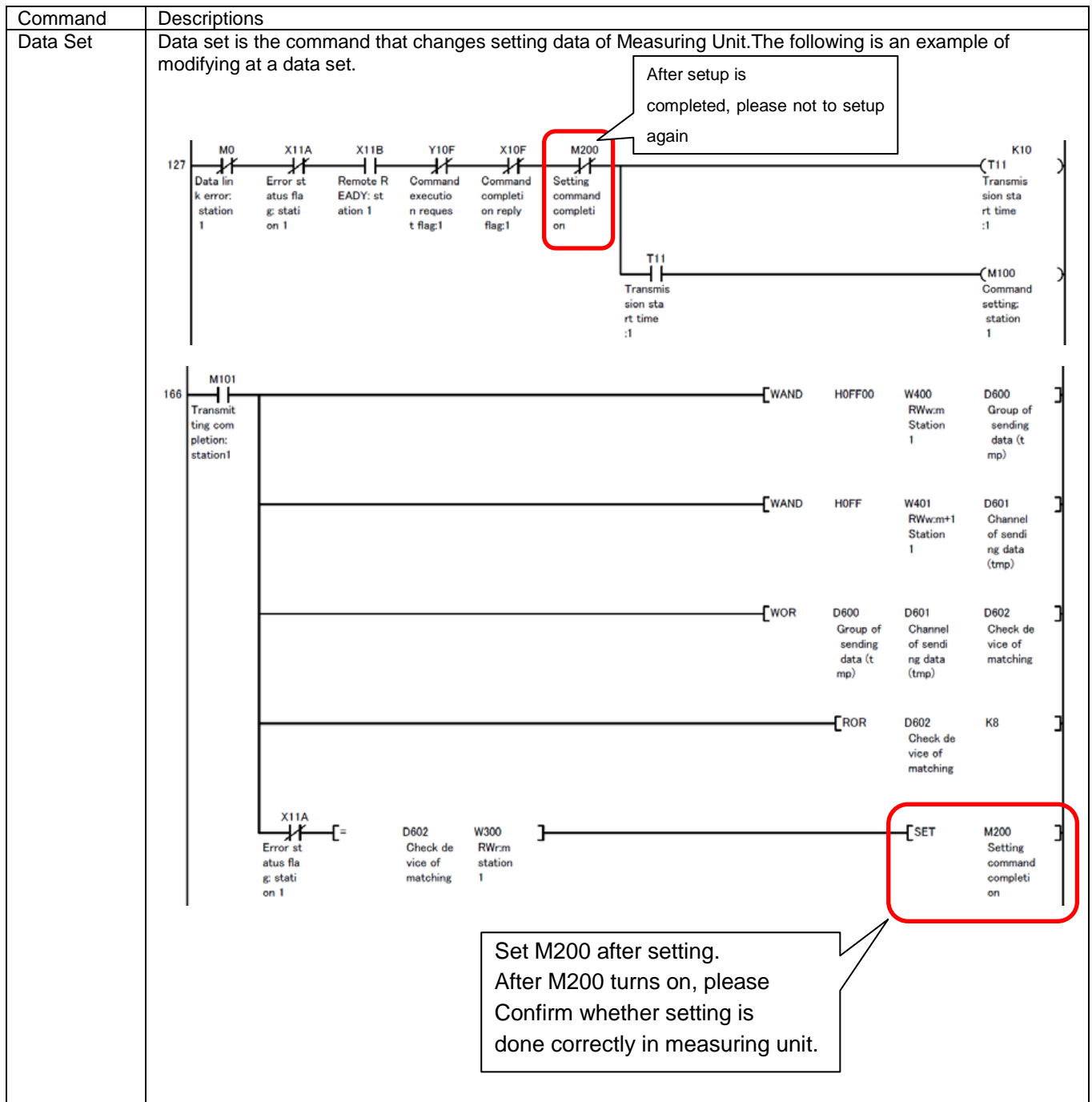

9.2 Program Example 2

9.2.1 Program Content

This section shows an example the program to monitor only active energy from a Measuring Unit whose station number is 1. This program example is assumed the system configuration in below and the I/O number of the master station is X/Y00 to X/Y 1F.

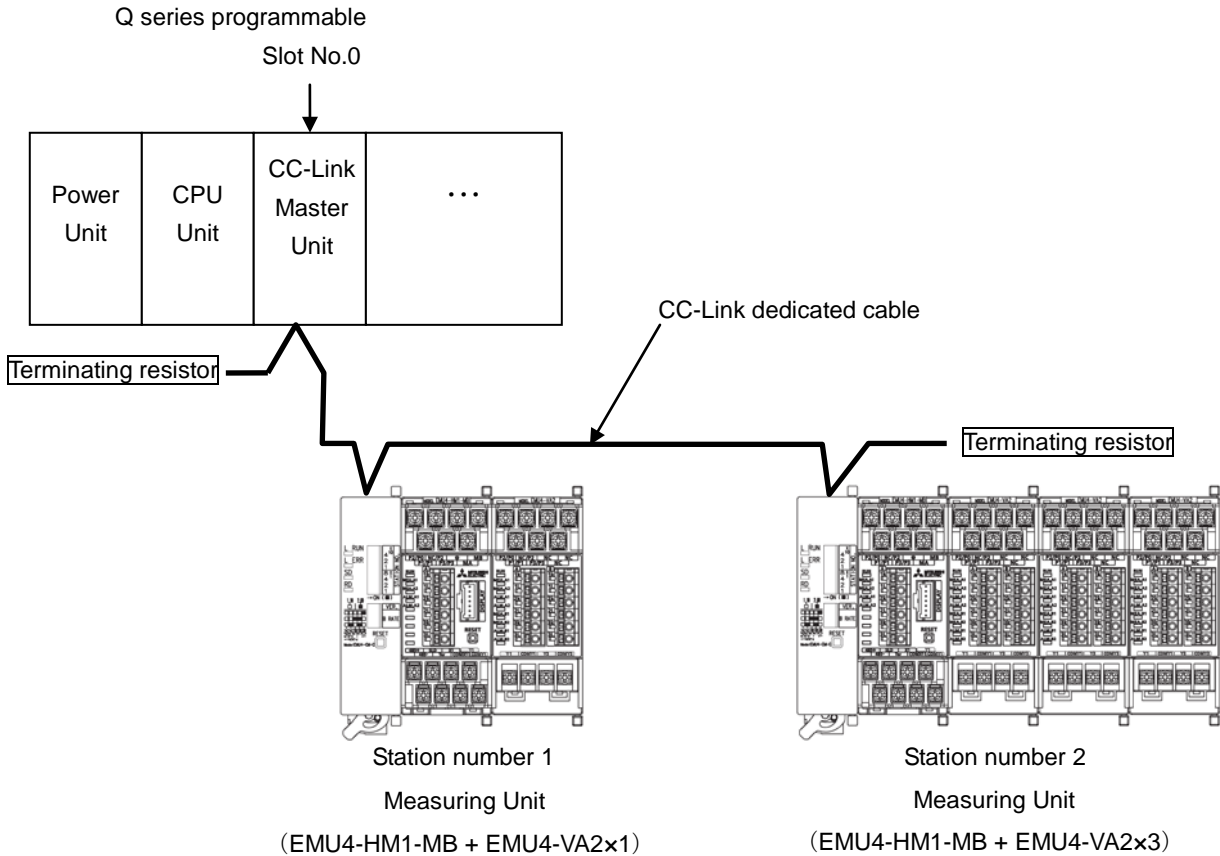

*1: Reading data

Station number	Model	Input circuit number	Reading data
Station number 1	EMU4-HM1-MB	Circuit 1	Phase 1 current, Phase 2 current, Phase 3 current 1-2 voltage, 2-3 voltage, 3-1 voltage Power factor, Total active power, Active energy(import)
	EMU4-VA2	Circuit 2	Phase 1 current, Phase 2 current, Phase 3 current Power factor, Total active power, Active energy(import)
		Circuit 3	Phase 1 current, Phase 2 current, Phase 3 current Total active power, Active energy(import)
Station number 2	EMU4-HM1-MB	Circuit 1	Phase 1 current, Phase 2 current, Phase 3 current
	EMU4-VA2	Circuit 2,3	1-2 voltage, 2-3 voltage, 3-1 voltage
	EMU4-VA2	Circuit 4,5	Power factor, Total active power, Active energy(import)
	EMU4-VA2	Circuit 6,7	*1: Reading data are common in the circuit 1 to 7

9.2.2 Parameter Settings

Parameter settings are set as following with GX Developer.

(1) Network Parameter Settings and Auto Refresh Parameter Settings

The following is shown CC-Link network parameter settings and auto refresh parameter settings.

The screenshot displays the 'Network parameters' window in MELSOFT GX Developer. The window title is 'MELSOFT series GX Developer C:\MELSEC\GPPW\TEST - [Network parameters Setting the CC-Link list.]'. The interface includes a project tree on the left, a 'Network parameter' dialog box, and a main parameter table with columns for board numbers 1 and 2. The table lists various parameters such as Start I/O No, Operational setting, Type, Master station data link type, Mode, All connect count, Remote input/output/register, Ver.2 Remote input/output/register, Special relay/register, Retry count, Automatic reconnection station count, Stand by master station No., PLC down select, Scan mode setting, Delay information setting, Station information setting, Remote device station initial setting, and Interrupt setting. The status bar at the bottom shows 'Ready' and 'Q02(H) Host station'.

	1	2
Start I/O No	0000	
Operational setting	Operational settings	
Type	Master station	
Master station data link type	PLC parameter auto start	
Mode	Remote net(Ver.1 mode)	
All connect count	2	
Remote input(RX)	X100	
Remote output(RY)	Y100	
Remote register(RW/r)	W300	
Remote register(RW/w)	W400	
Ver.2 Remote input(RX)		
Ver.2 Remote output(RY)		
Ver.2 Remote register(RW/r)		
Ver.2 Remote register(RW/w)		
Special relay(SB)	SB0	
Special register(SW)	SW0	
Retry count	1	
Automatic reconnection station count	1	
Stand by master station No.		
PLC down select	Stop	
Scan mode setting	Asynchronous	
Delay information setting	0	
Station information setting	Station information	
Remote device station initial setting	Initial settings	
Interrupt setting	Interrupt settings	

Indispensable settings(No setting / Already set) Set if it is needed(No setting / Alre

(2) Operational Settings

Operational settings are as follows.

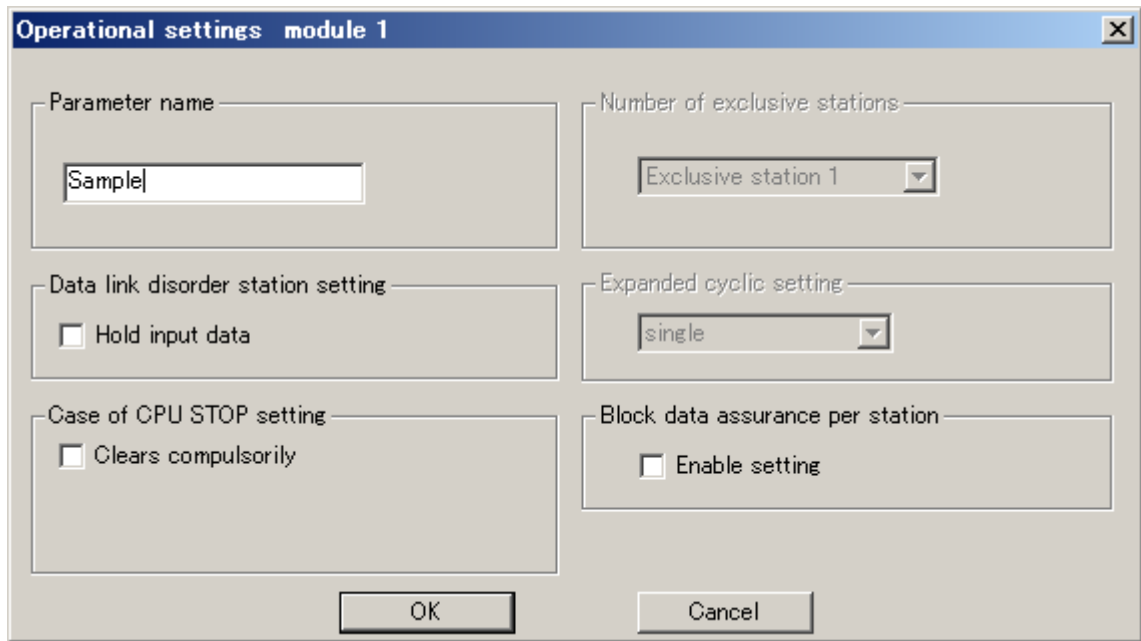

The 'Operational settings module 1' dialog box contains the following fields and controls:

- Parameter name:** Text input field containing 'Sample'.
- Number of exclusive stations:** Dropdown menu set to 'Exclusive station 1'.
- Data link disorder station setting:** Check box for 'Hold input data' (unchecked).
- Expanded cyclic setting:** Dropdown menu set to 'single'.
- Case of CPU STOP setting:** Check box for 'Clears compulsorily' (unchecked).
- Block data assurance per station:** Check box for 'Enable setting' (unchecked).

Buttons: OK, Cancel

(3) Station Information Settings

Station information settings are as follows.

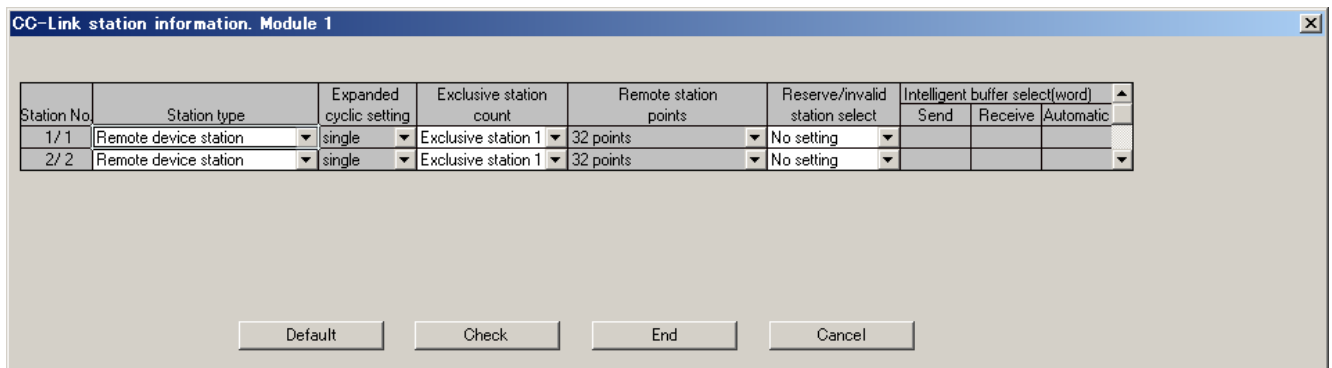

The 'CC-Link station information. Module 1' dialog box displays a table of station settings:

Station No	Station type	Expanded cyclic setting	Exclusive station count	Remote station points	Reserve/invalid station select	Intelligent buffer select(word)		
						Send	Receive	Automatic
1/1	Remote device station	single	Exclusive station 1	32 points	No setting			
2/2	Remote device station	single	Exclusive station 1	32 points	No setting			

Buttons: Default, Check, End, Cancel

(4)File Register Settings

This program example uses file registers (ZR). The procedures of file register settings are as follows.

- 1) Double-click "PLC parameter".
- 2) Select "PLC file".
- 3) Select "Use the same file name as the program" or "Use the following file" and set the each item.

In details, refer to the manual for the CPU module used.

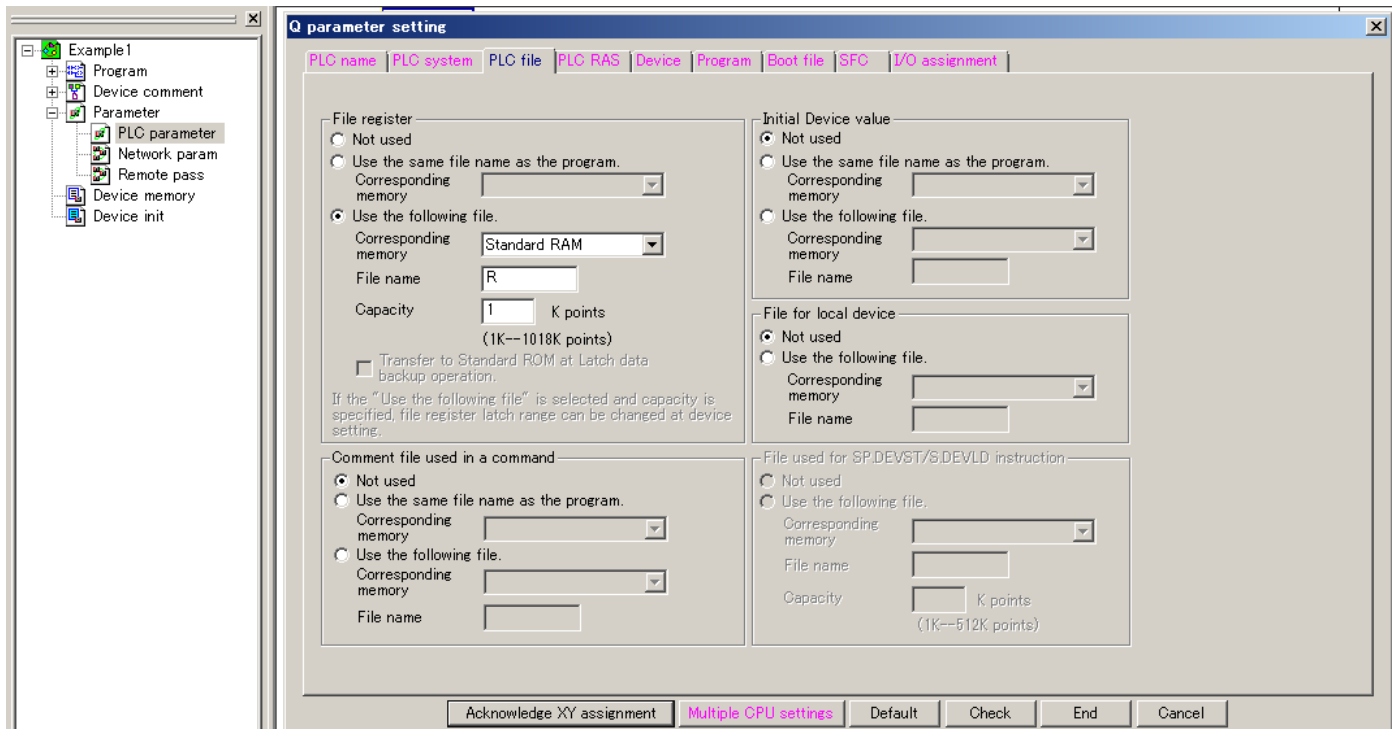

- If you use the CPU module which doesn't have file registers (ex. Q00UJCPU), replace the file register (R) with other device (ex. Data register (D))

9.2.3 Device Allocation

The following table lists devices used above the example.

Items	Descriptions	Device No.	Note
Input/Output signal of CC-Link Unit	Status of CC-Link master station	X0	Device number is changed by the first input/output number of CC-Link unit
	Status of data link of CC-Link master station	X1	
	READY of CC-Link master station	X0F	
Remote input(RX)	Remote input of Station1 (RX00 to RX1F)	X100~X11F	Set X100 to remote input (RX) refresh device.
	Remote input of Station2 (RX20 to RX3F)	X120~X13F	
Remote output(RY)	Remote output Station1 (RY00 to RY1F)	Y100~Y11F	Set Y100 to remote output (RY) refresh device.
	Remote output Station2 (RY20 to RY3F)	Y120~Y13F	
Remote register(RWr)	Remote register Station1 (RWr0 to RWr3)	W300~W303	Set W300 to remote register (RWr) refresh device.
	Remote register Station2 (RWr4 to RWr7)	W304~W307	
Remote register(RWw)	Remote register Station1 (RWw0 to RWw3)	W400~W403	Set W400 to remote register (RWw) refresh device.
	Remote register Station2 (RWw4 to RWw7)	W404~W407	
Link special relay (SB)	Link special relay of master station (SB0 to SB01FF)	SB0~SB01FF	Set SB0 to link special relay (SB) refresh device.
Link special register (SW)	Link special register of master station (SW0 to SW01FF)	SW0~SW01FF	Set SW0 to link special register (SW) refresh device.
Writing sending data	Writing device of sending data of Station1	D300~D303	
	Writing device of sending data of Station2	D304~D307	
Reading receiving data	Reading device of receiving data of Station1	D400~D403	
	Reading device of receiving data of Station1	D404~D407	
Error code	Error code of Station1	D500~D503	
	Error code of Station2	D504~D507	
Checking device	Checking device for match/mismatch of sending data and receiving data of Station1	D600~D602	
	Checking device for match/mismatch of sending data and receiving data of Station2	D604~D606	
Writing Unit No.	Writing device of sending Unit No. data of Station2	D603	
Writing receive data	Writing device of receiving data of Station2	D608~D613	
Data link status	Error status flag of Station1	M0	"ON":Occuring data link error
	Error status flag of Station2	M1	
Command setting	Completion flag of setting for command of Station1	M100	
	Completion flag of setting for command of Station2	M101	
Transmitting completion	Completion flag of transmitting of Station1	M150	
	Completion flag of transmitting of Station2	M151	
Waiting time of error clear	Waiting time for error clear of Station1	T0	
	Waiting time for error clear of Station2	T1	
Time of start transmitting	Time of start transmitting of Station1	T50	
	Time of start transmitting of Station2	T51	
Time out	Time out of Station1	T100	
	Time out of Station2	T101	
Select for receiving data	Index of select the Station	Z0	
	Index of remote I/O for measuring unit	Z2	
	Index of remote register	Z3	
	Index of measuring items	Z4	
	Index of storing receiving data	Z5	

•Measuring module for Station1

Setting number of monitoring items and circuits, monitor setting data in each circuit in sample program of Station1.

Please refer to sample program of Station1 when the data is different from each circuit.

Items	Descriptions		Device No.	Setup	Note	
Number of monitoring items	Please setup number of monitoring items by measuring unit		D0	19		
Number of completed monitoring items	Number of completed monitoring by measuring unit		D1	—		
Sending data	Circuit 1	Current1	Group,Module,Command	D10	H111	Setup the command of monitoring items. Please refer to 7.2.2 Details of Command.
			Channel	D11	H21	
		~				
	Electric Energy	Group,Module,Command	D26	H8011		
		Channel	D27	H1		
	Circuit 2	Current1	Group,Module,Command	D28	H121	
			Channel	D29	H21	
		~				
	Electric Energy	Group,Module,Command	D38	H8021		
		Channel	D39	H1		
	Circuit 3	Current1	Group,Module,Command	D40	H131	
			Channel	D41	H21	
		~				
	Electric Energy	Group,Module,Command	D46	H8031		
		Channel	D47	H1		
Receiving data	Circuit 1	Current1	Multiplying factor	R0	—	Please refer to 7.2.3 Data Composition for Multiplying factor and Numeric data.
			Data	R1, R2	—	
		~				
	Electric Energy	Multiplying factor	R24	—		
		Data	R25, R26	—		
	Circuit 2	Current1	Multiplying factor	R27	—	
			Data	R28, R29	—	
		~				
	Electric Energy	Multiplying factor	R42	—		
		Data	R43, R44	—		
	Circuit 3	Current1	Multiplying factor	R45	—	
			Data	R46, R47	—	
		~				
	Electric Energy	Multiplying factor	R54	—		
		Data	R55, R56	—		

•Measuring module for Station2

Setting number of monitoring items and circuits, monitor setting data in each circuit in sample program of Station2.

Please refer to sample program of Station2 when the data is same in each circuit.

Items	Descriptions		Device No.	Setup	Note
Number of monitoring items	Please setup number of items of measuring unit.		D100	9	
Number of monitoring circuit	Please setup number of circuits of measuring unit		D101	7	
Number of completed monitoring items	Number of completed items by measuring unit		D102	—	
Number of completed monitoring circuit	Number of completed circuits by measuring unit		D103	—	
Sending data	Current1	Group,Module(H0),Command	D110	H101	Setup command of monitoring items. Please refer to 7.2.2 Details of Command. Please set H0 in module number because module number is changed automatically for monitoring.
		Channel	D111	H21	
	Current2	Group,Module(H0),Command	D112	H101	
		Channel	D113	H41	
	Current3	Group,Module(H0),Command	D114	H111	
		Channel	D115	H41	
	Voltage1-2	Group,Module(H0),Command	D116	H101	
		Channel	D117	H21	
	Voltage2-3	Group,Module(H0),Command	D118	H101	
		Channel	D119	H41	
	Voltage3-1	Group,Module(H0),Command	D120	H111	
		Channel	D121	H41	
Power factor	Group,Module(H0),Command	D122	HD01		
	Channel	D123	H1		
Electric Power	Group,Module(H0),Command	D124	H701		
	Channel	D125	H1		
Electric Energy	Group,Module(H0),Command	D126	H8001		
	Channel	D127	H1		
Receiving data	Circuit 1	Current1	Multiplying factor	R100	—
			Data	R101,R102	—
		~			
	Electric Energy	Multiplying factor	R124	—	
		Data	R125, R126	—	
	Circuit 2	Current1	Multiplying factor	R127	—
			Data	R128, R129	—
		~			
	Electric Energy	Multiplying factor	R151	—	
		Data	R152, R153	—	
	Circuit 3	Current1	Multiplying factor	R154	—
			Data	R155, R156	—
		~			
	Electric Energy	Multiplying factor	R178	—	
		Data	R179,R180	—	
	Circuit 4	Current1	Multiplying factor	R181	—
			Data	R182,R183	—
		~			
	Electric Energy	Multiplying factor	R205	—	
		Data	R206,R207	—	
	Circuit 5	Current1	Multiplying factor	R208	—
			Data	R209,R210	—
		~			
	Electric Energy	Multiplying factor	R232	—	
		Data	R233,R234	—	
	Circuit 6	Current1	Multiplying factor	R235	—
			Data	R236,R237	—
		~			
	Electric Energy	Multiplying factor	R259	—	
		Data	R260,R261	—	
Circuit 7	Current1	Multiplying factor	R262	—	
		Data	R263,R264	—	
	~				
Electric Energy	Multiplying factor	R286	—		
	Data	R287,R289	—		

9.2.4 Program Example

*Data clear

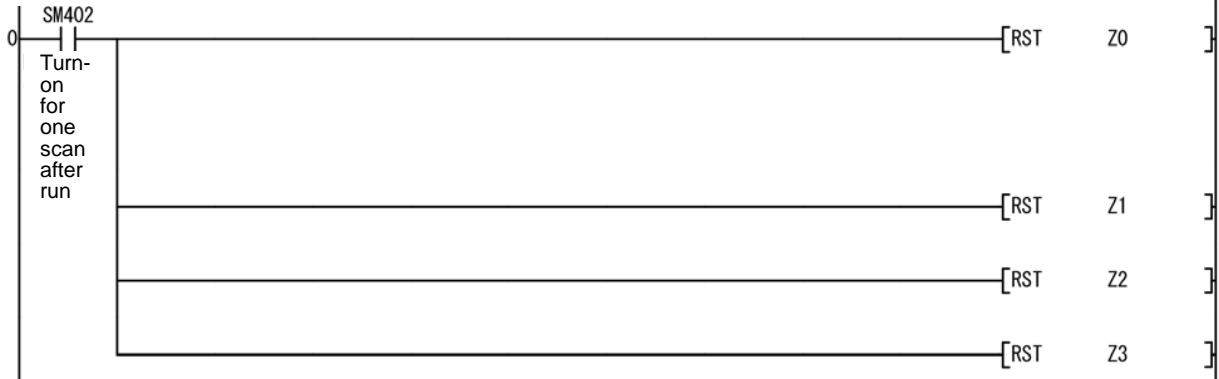

*Set the number of monitoring items

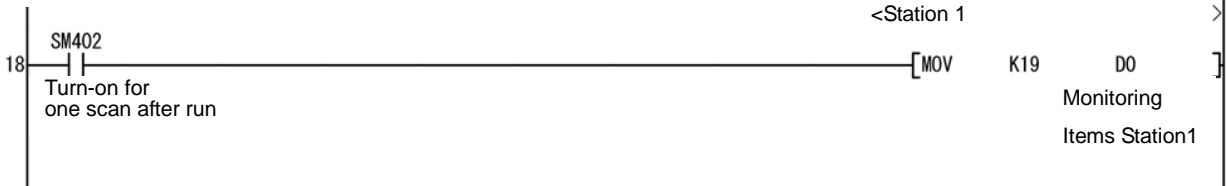

*Set the sending data (circuit1, Station1)

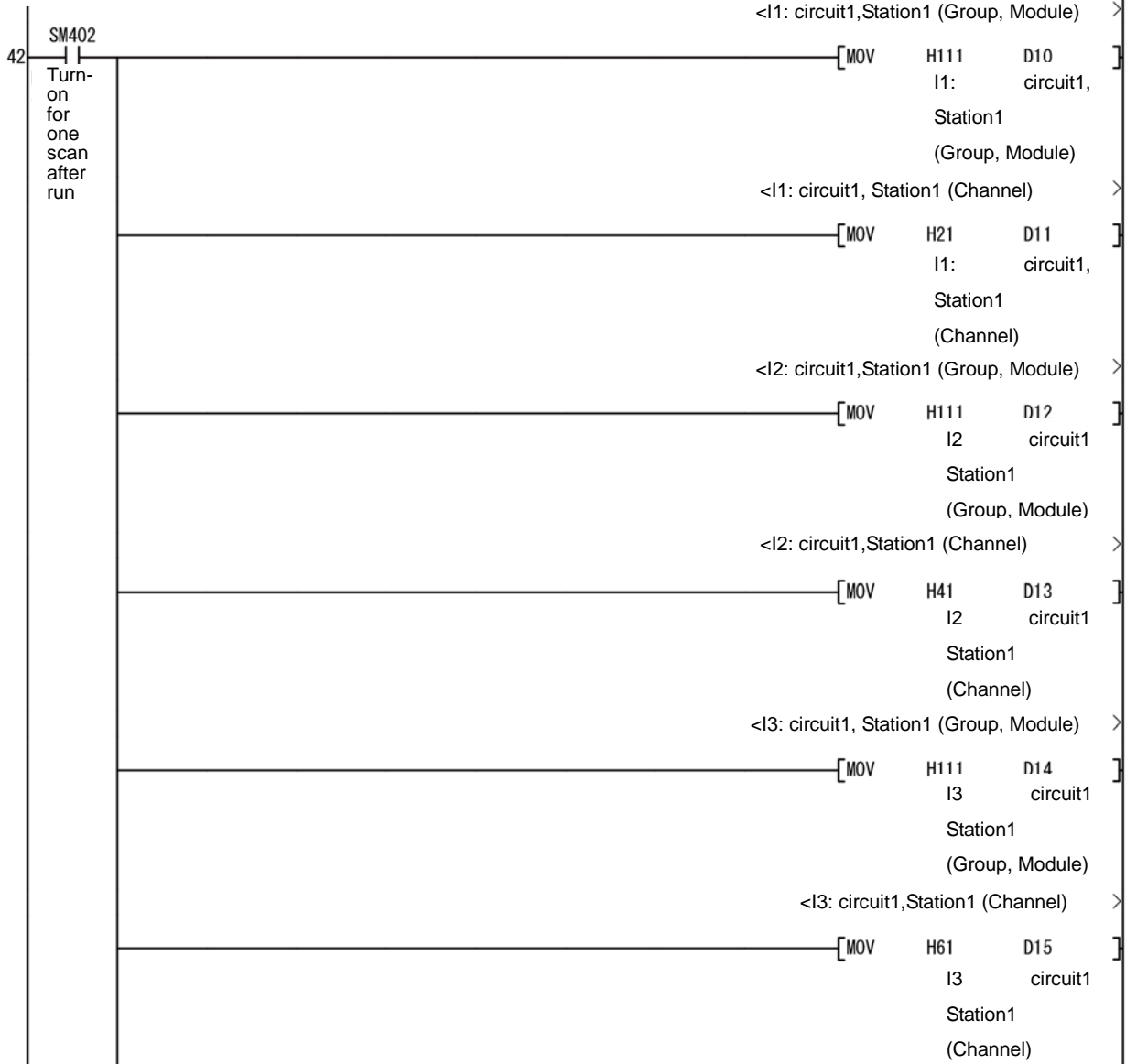

(Continued from the previous page)

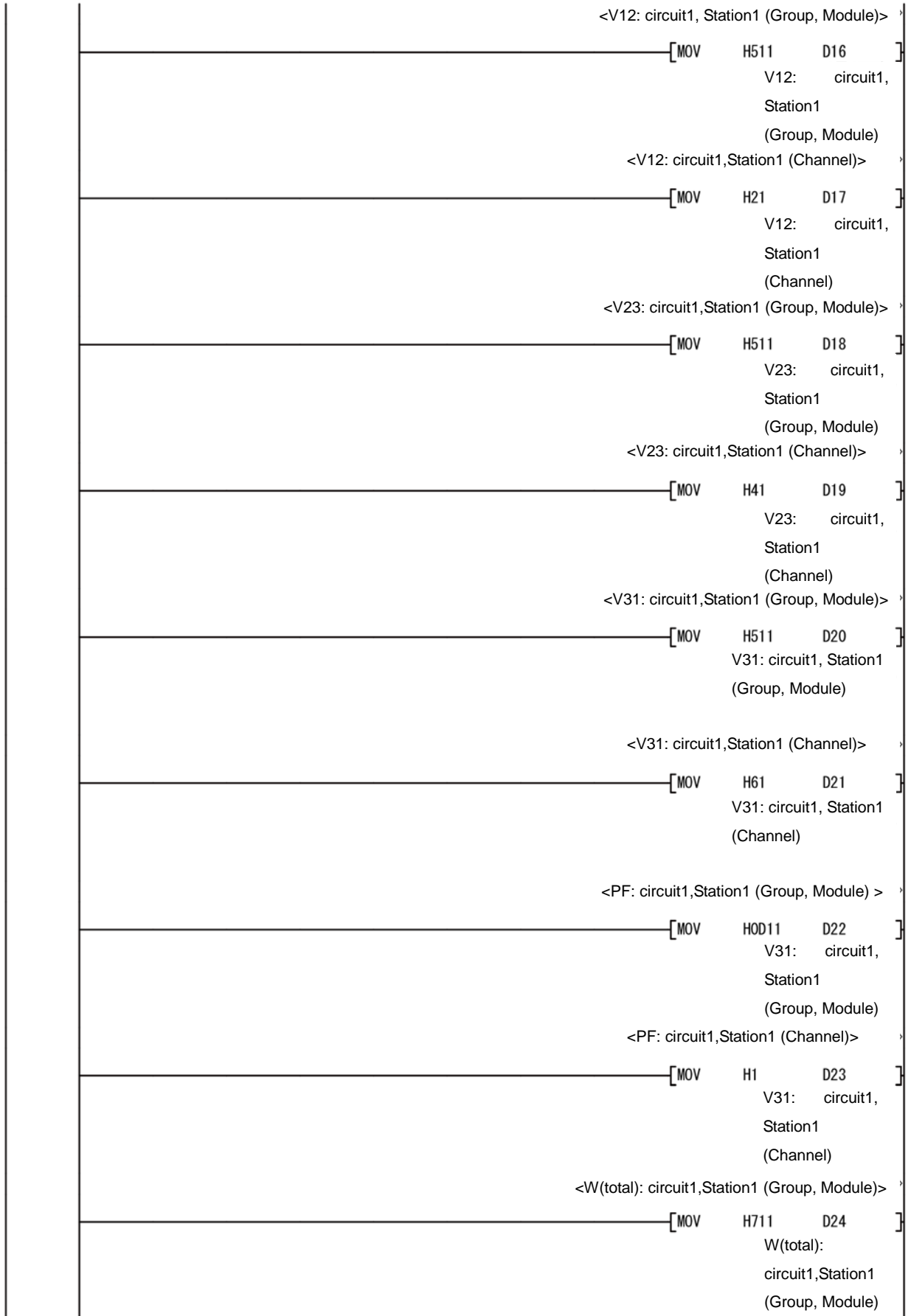

(Continued from the previous page)

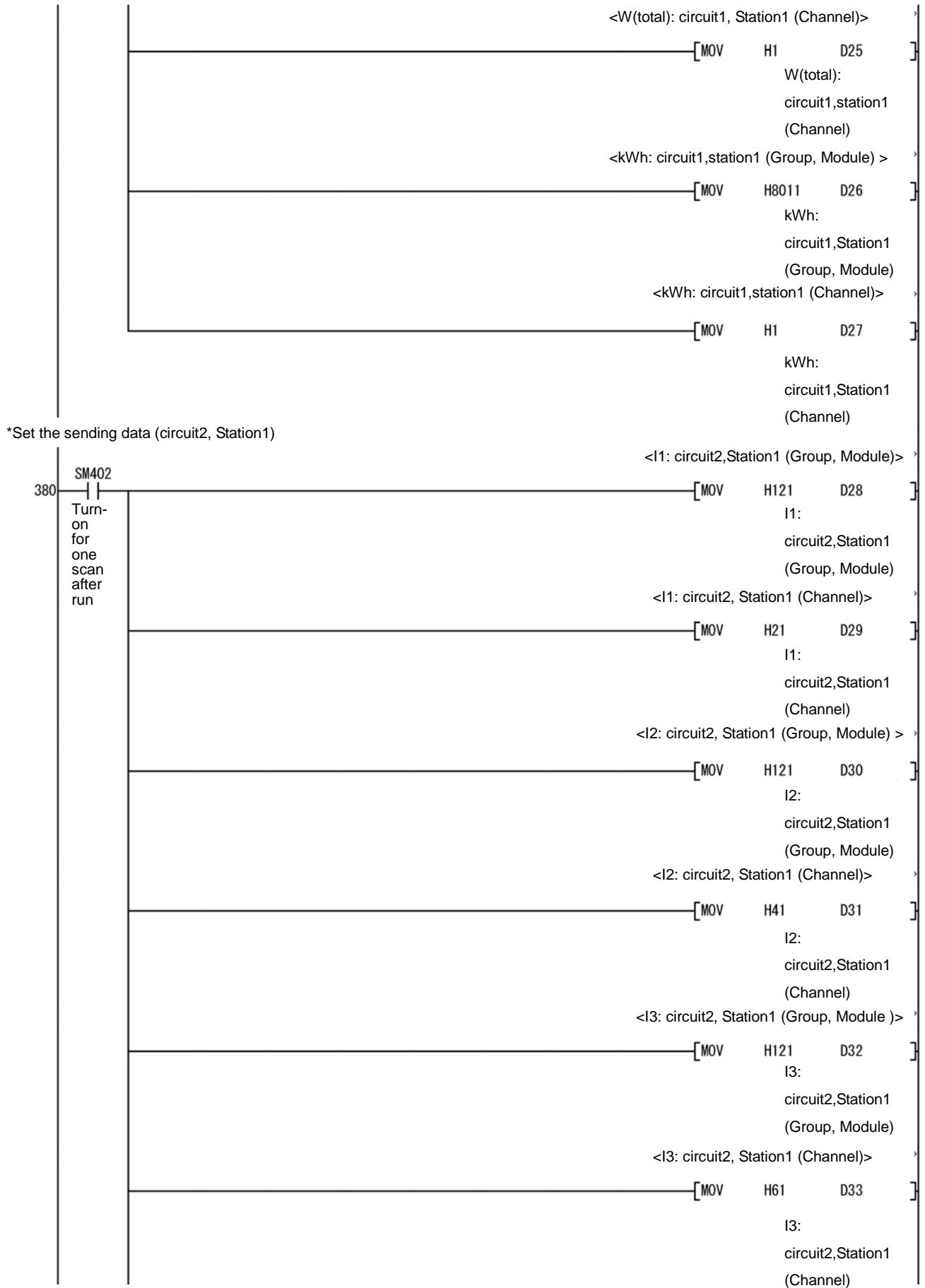

(Continued from the previous page)

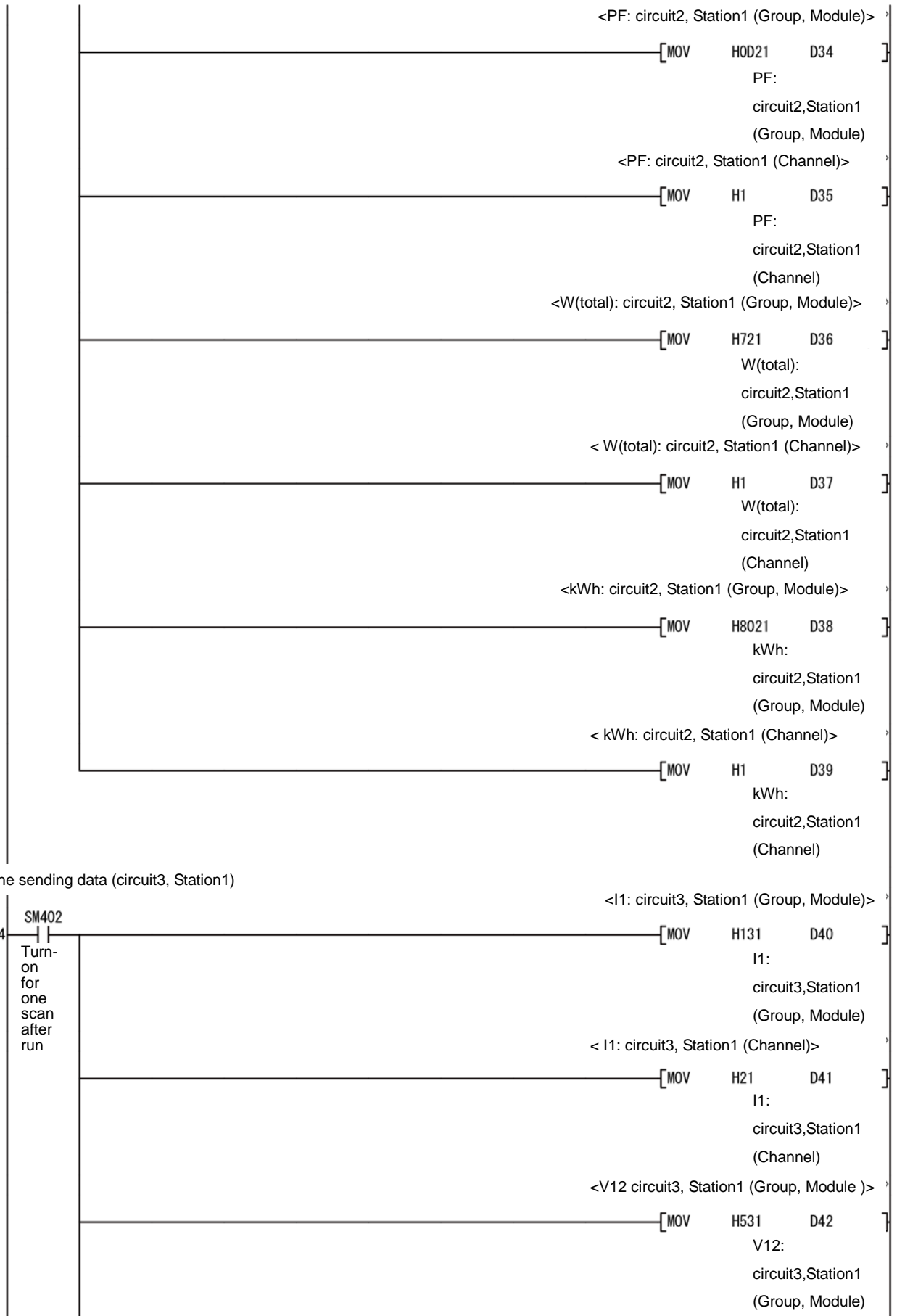

(Continued from the previous page)

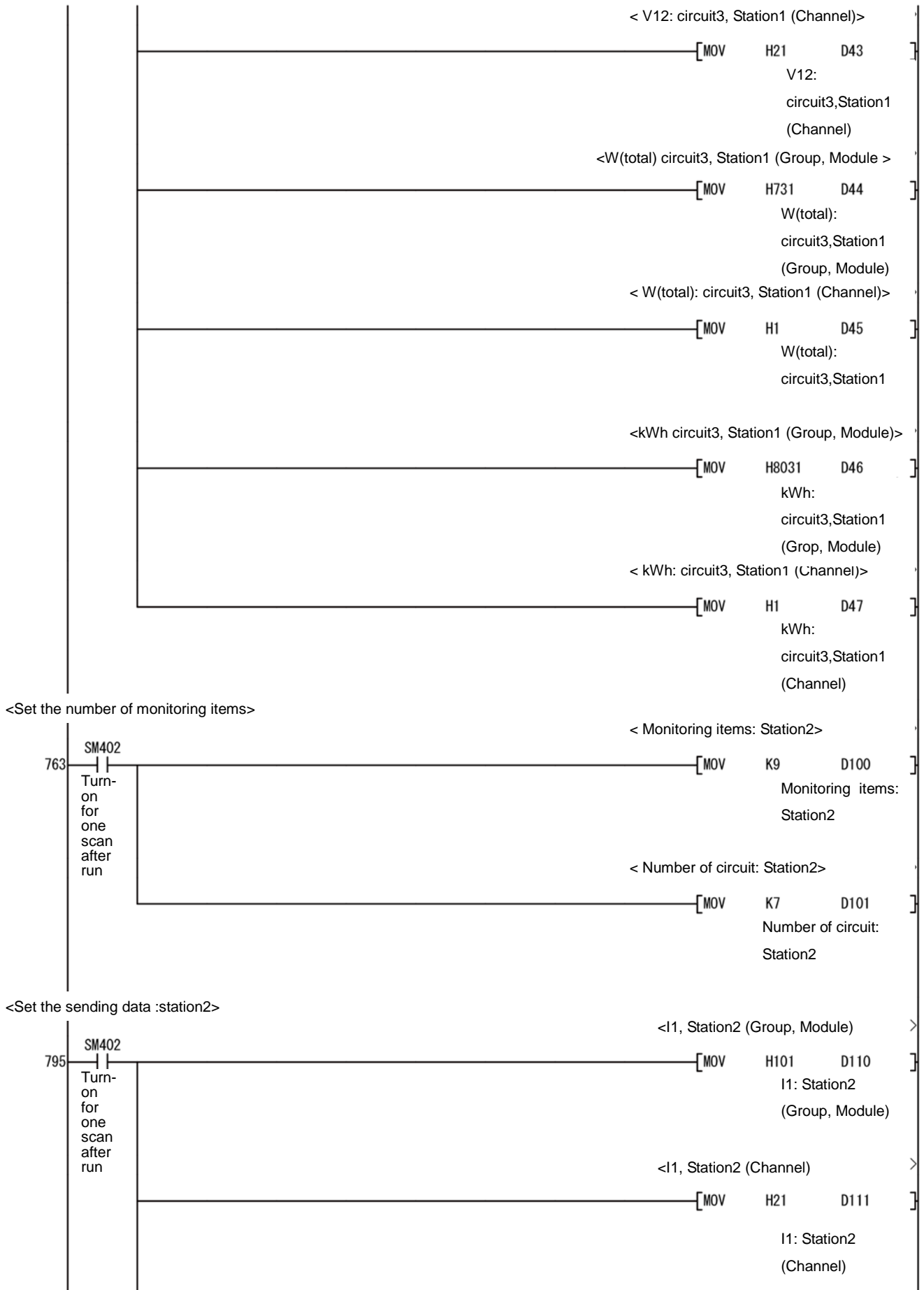

(Continued from the previous page)

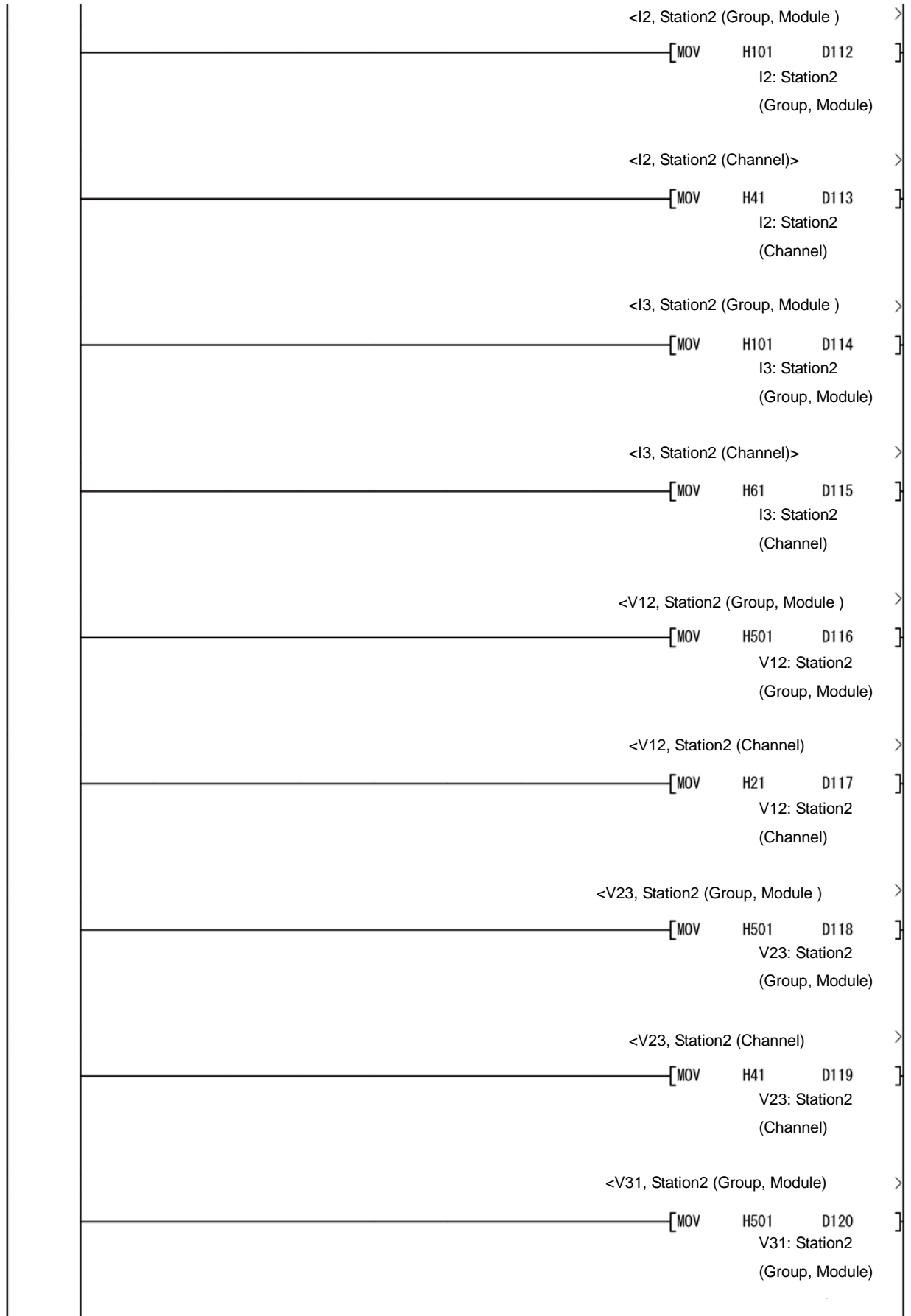

(Continued from the previous page)

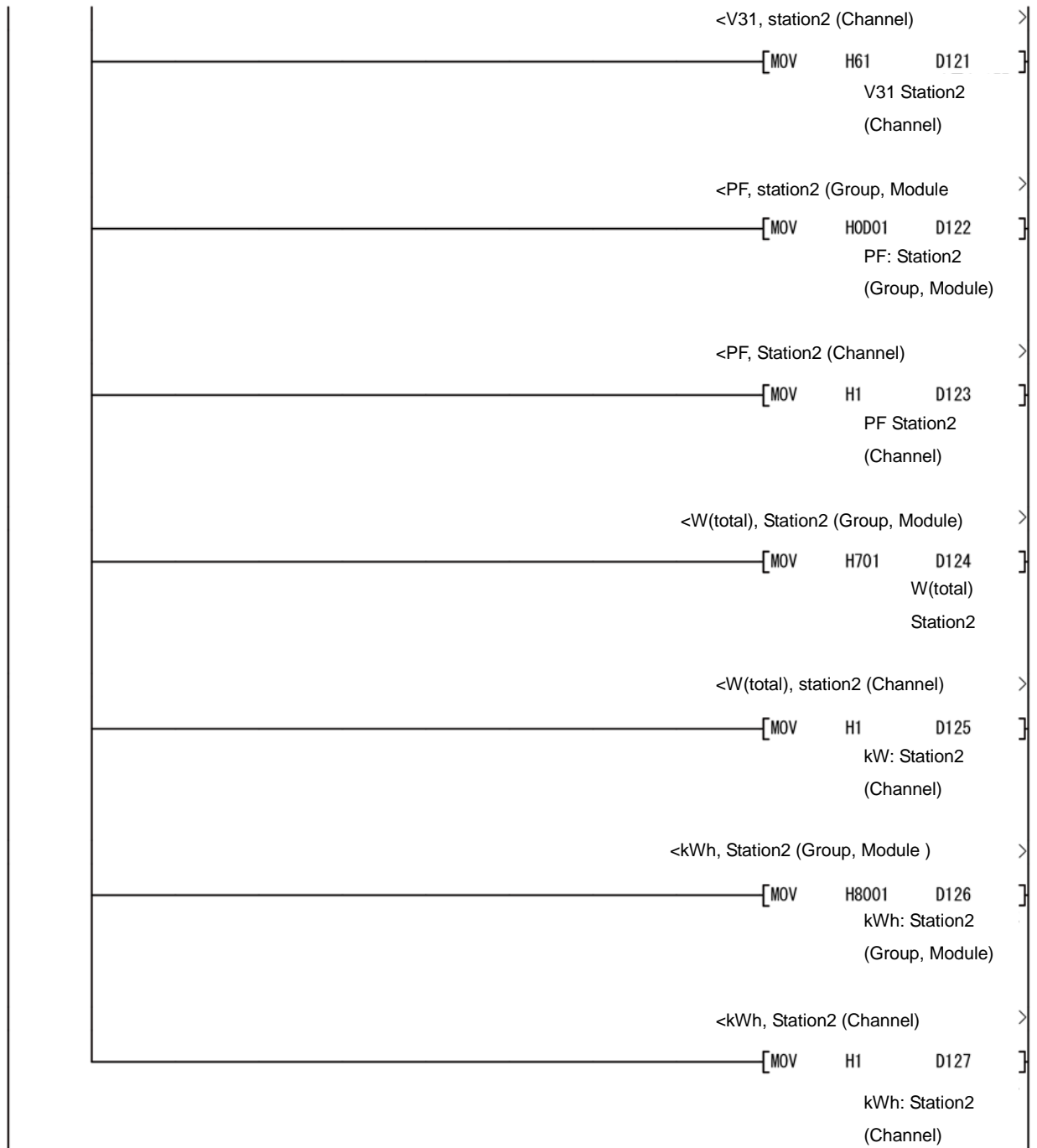

*Data link confirmation

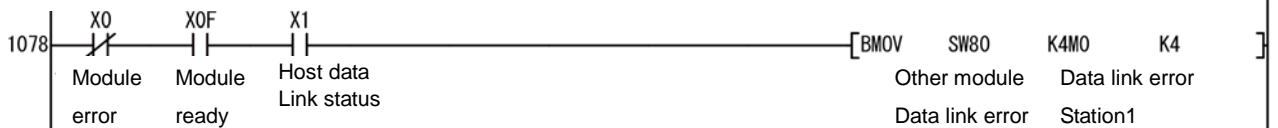

*For station1



(Continued from the previous page)

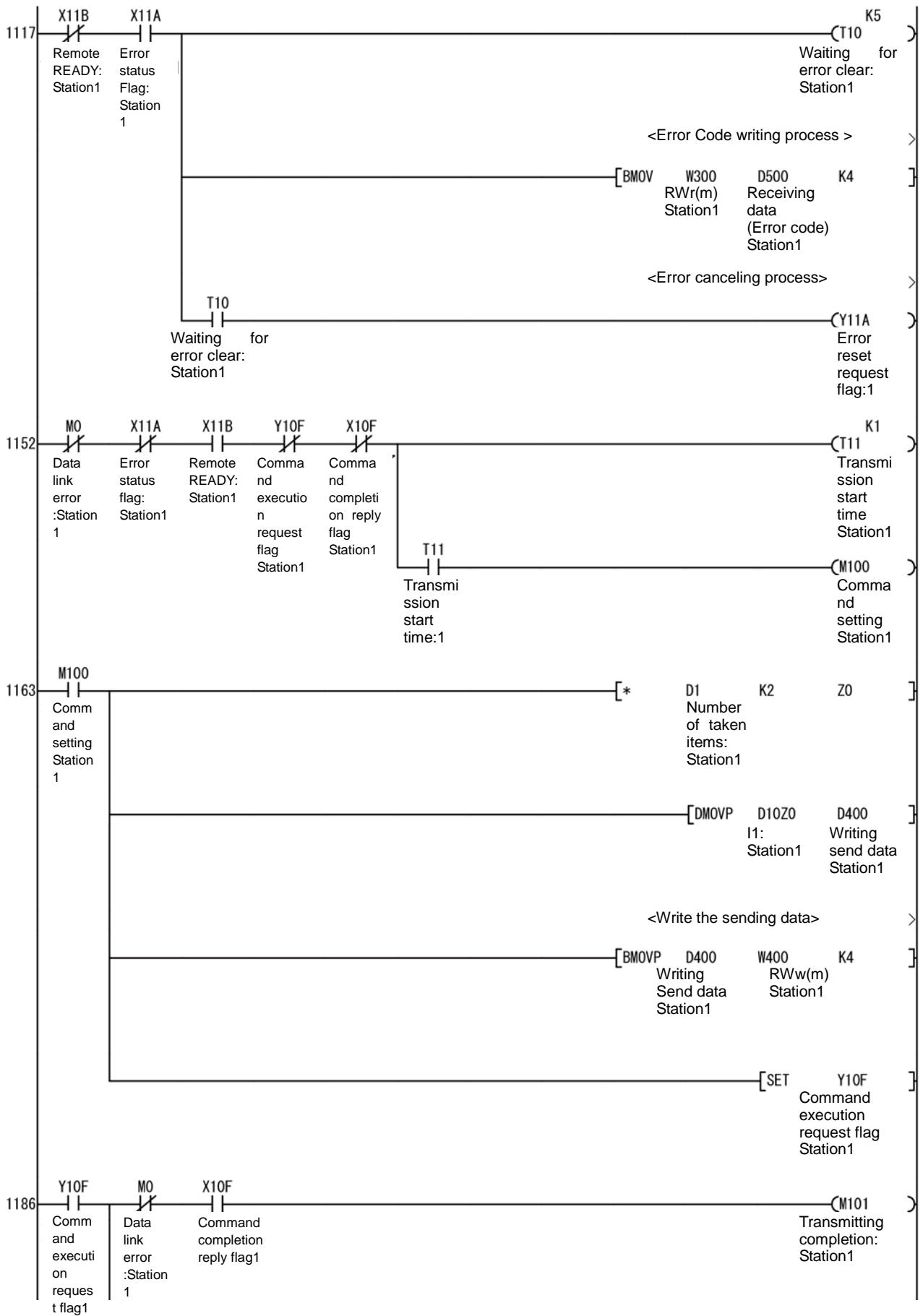

(Continued from the previous page)

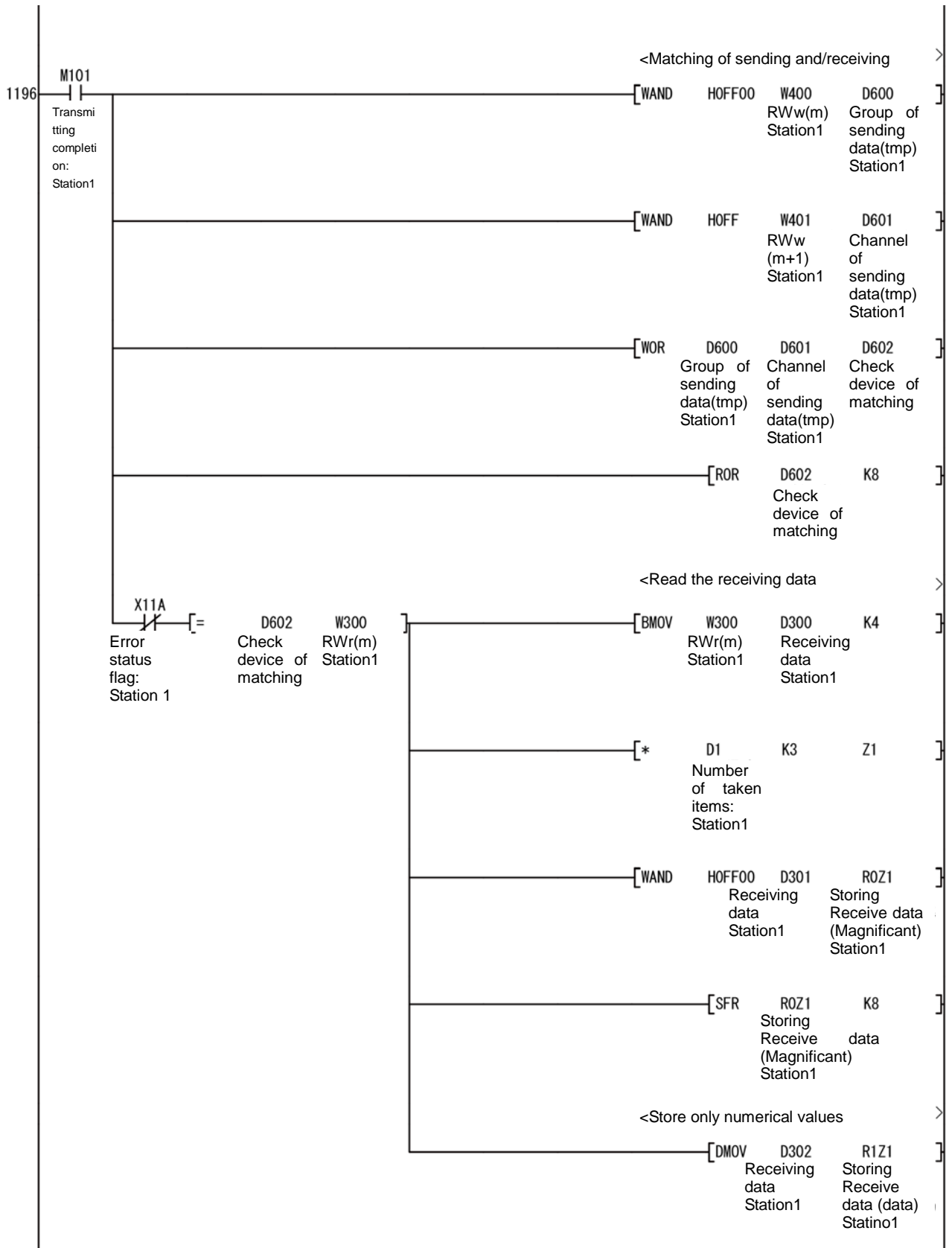

(Continued from the previous page)

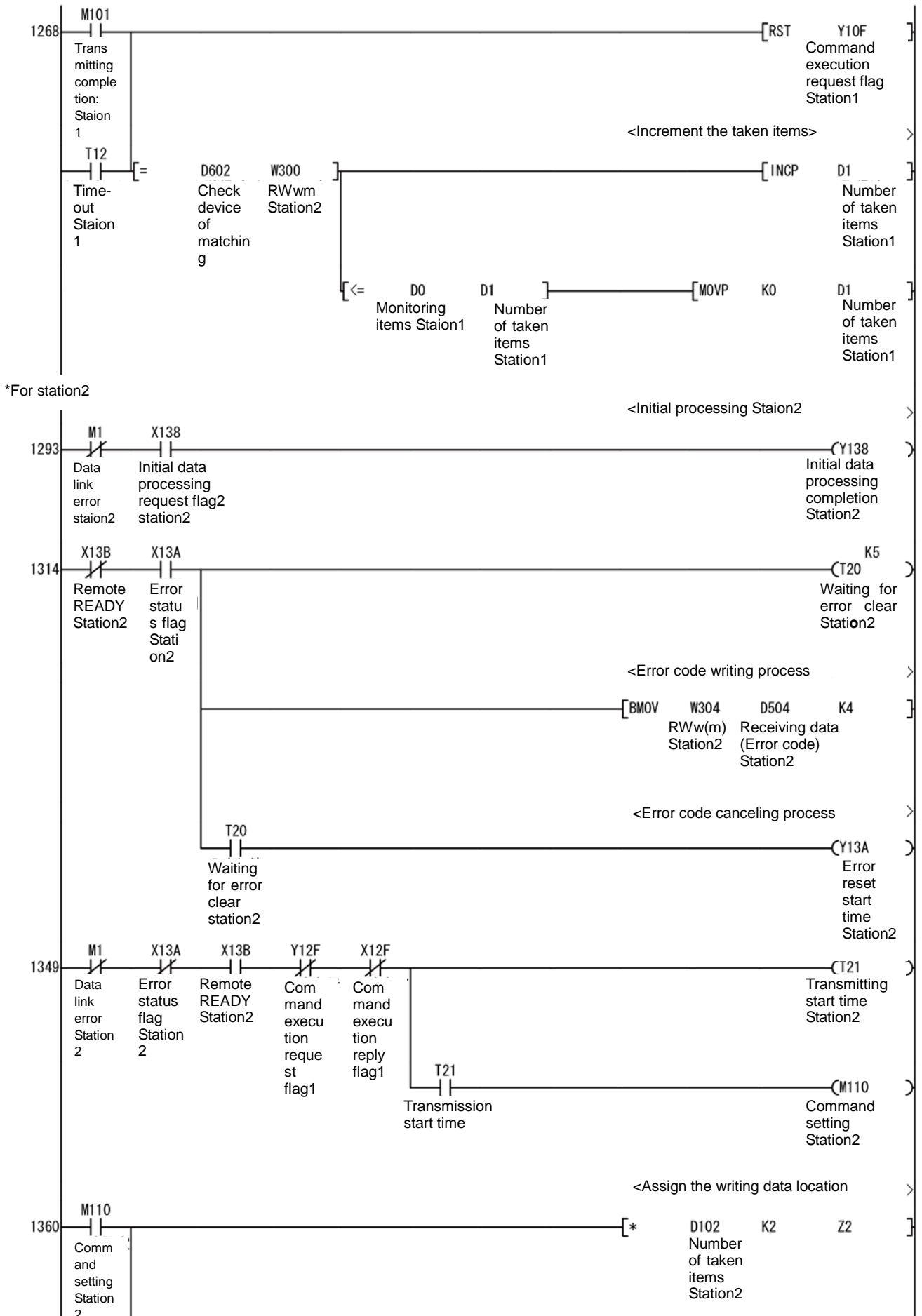

(Continued from the previous page)

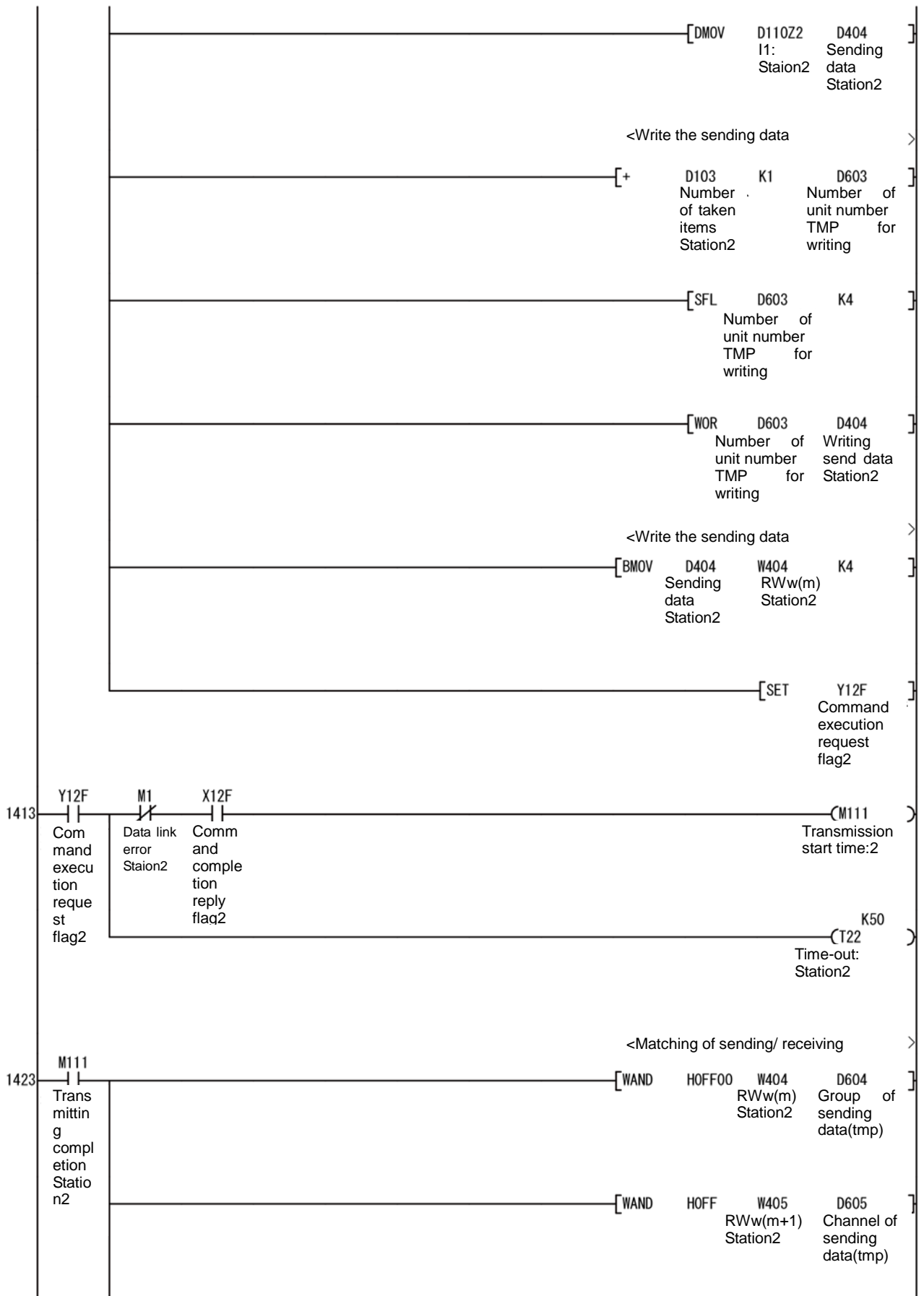

(Continued from the previous page)

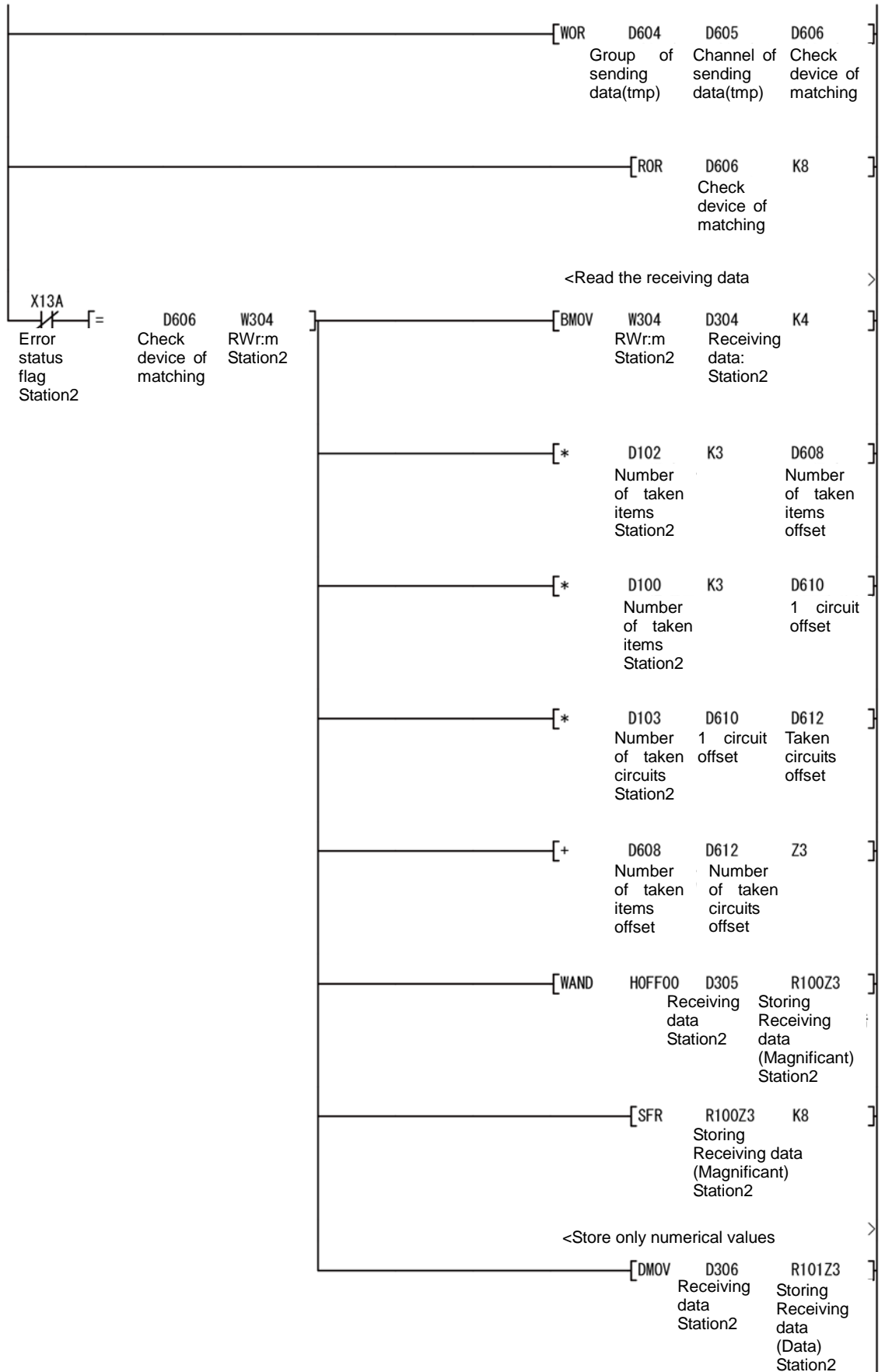

(Continued from the previous page)

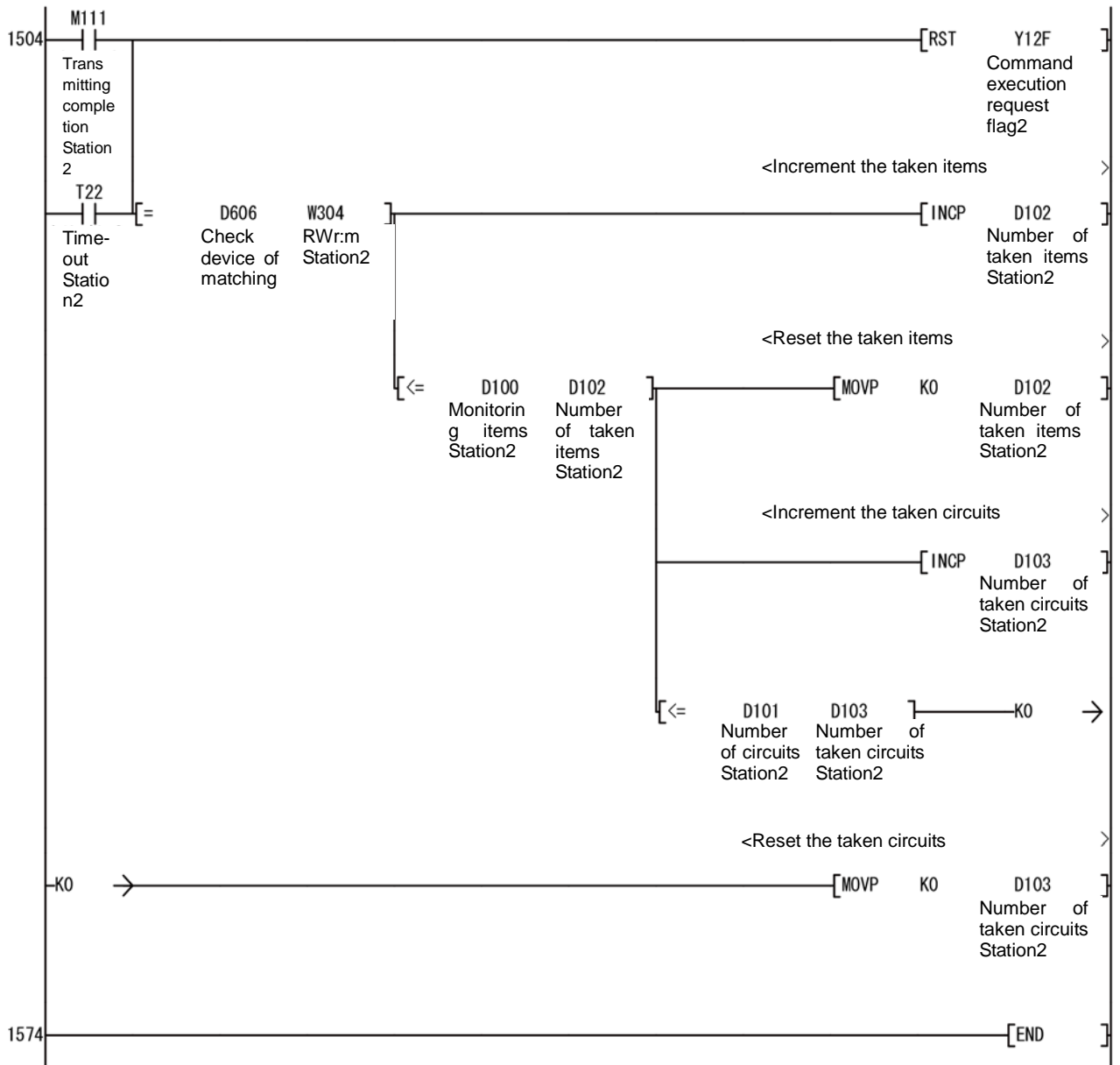

10. Test Mode

Measuring Unit has the test mode which the fixed values are replied even if the voltage and current are not input. It can be used to check the communication to programmable controller.

10.1 How to Test

To do the test, it is necessary to operate the Measuring Unit.

About how to use the test mode, refer to the each instrument manual of Measuring Unit.

10.2 Reply Data

Values displayed on the screen can be monitored. Measurement elements not displayed on the screen are zero (only power factor is 1.000). Therefore, switch the display screen by button operation. (About button operation, refer to the each instrument manual.)

When DI1 to DI3 are used, it is also possible to monitor the digital input status.