



MELHUNT Series

MITSUBISHI GEARED MOTOR
TYPE:GM-S, S2, SP

INSTRUCTION MANUAL

- Before you operate the geared motor, carefully read this manual, and correctly use the motor. Be sure to read the "Safety Precautions" described in this manual to ensure safety during operation.
- After reading, this manual should carefully be kept in a convenient place for the operator's easy reference.
- For product information and technical information about our geared motors, please see the following website.
<https://www.mitsubishielectric.com/fa/>

SAFETY PRECAUTIONS

Carefully operate the Geared Motor. An operation error may cause injury or electric shock.

To ensure operator safety, the safety precautions are ranked as "DANGER" and "CAUTION" In this instruction manual.



When a dangerous situation may occur if handling is mistaken leading to fatal or major injuries.



When a dangerous situation may occur if handling is mistaken leading to medium or minor injuries or physical damage.

Note that some items described as  may lead to major results depending on the situation. In any case, important information that must be observed is described.

DANGER

General

- Before starting use of this Geared Motor always read this manual and the nameplate.

Operation conditions and ambient conditions

- Do not place any object inflammable near the geared motor. Failure to observe this warning may cause fire or explode. If you have to place an organic solvent or explosive powder near the geared motor for some reasons, use the GM-D series explosion-proof geared motor.
- Do not use the geared motor as elevator for human transport. Use of a geared motor for such a purpose is prohibited by the Building Standard Law of Japan.
- If the equipment is to be used with an elevator, be sure to burnish with a safety device to prevent the elevator from accidental falling. Failure to observe this warning may cause physical injury and damage to the equipment.

Wiring

- Be sure to ground the geared motor, and install a circuit breaker for each motor. Without grounding or circuit breaker, you may get an electric or physical injury.
- To wire the geared motor, be sure to observe the technical standards for electric equipment or interior wiring code by the corresponding electric power company.
- Install an optimum motor protector on each motor. Without any protector, the motor may cause a fire at the time of a problem.
- Be sure to supply the specified voltage to the geared motor. If the voltage is too high, a fire may be caused.
- Always follow the connection drawing in the terminal Box or the instruction manual when connecting the power cable.

Operation

- If a load is lifted up, do not release the brake using the manual brake release unit. The load may be dropped
- During inverter operation, be sure to observe the specified frequency range. If the frequency is out of the specified range, the motor may be damaged.
- Failure to observe this warning may cause physical injury and or damage to the equipment.
- Never go near or touch the rotating parts (shaft, etc) during operation, Failure to observe this could lead to entanglement or injuries.
- Operate under the specified rotation speed described in Outline drawings, Specifications, or Catalogue. Otherwise, geared motor may explode or damage.



CAUTION

General

- If the geared motor is equipped with eyebolt or eyeplate, be sure to use eyebolt or eyeplate to lift and transfer a load

Operation conditions and ambient conditions

- Equipments must avoid oil or grease, furnish with protective devices like oil pan, in order to protect from oil leakage caused by failure or lift of the manufactured products.
- Safe guards should be furnished around rotating parts to avoid danger to persons.
- Do not place any-object which may interface with ventilation around the geared motor. Failure to observe this warning may cool air, which may cause burn injury and or fire.

Operation

- To operate the geared motor, observe the allowable loading torque range and the allowable starting frequency range.
- During operation, if the motor generates an abnormal noise, vibrates extremely, or shows abnormal characteristics, be sure to stop the motor, and inspect or overhaul the motor.
- During operation, keep your body away from geared motor. If you touch the geared motor during operation, you may be injured or get burn.
- If the geared motor is equipped with a one-touch manual brake release lever, be sure to lock the brake release lever in the lever holder before starting operation.

Maintenance and modification

- The manufacturer will not warrant and will not be responsible for the product modified or repaired by the user himself.
- Be sure to turn off the power before inspecting or repairing the motor.
- Geared Motor will become quite hot during operation. Take care not to touch the geared motor with your hands or body. Failure to observe this could lead to burns etc.

Disposal

- Treat the motor as general industrial waste when disposing of it.

Contents

1. Product check	4
2. Operation Condition and Ambient Conditions	4
3. Installation and Adjustment	4
4. Connection	5
5. Guidelines for replacing the old geared motor	6
6. Wiring	6
7. Motor Wiring	7
8. Output Shaft Rotational Direction	7
9. Brake Wiring	8
10. Brake(0.1~0.4kW)	10
11. Brake(0.75kW ~2.2kW)	12
12. Dust & Waterproof type	14
13. Operation	16
14. Maintenance and Inspection	16
15. Troubleshooting	17
16. Contact Us	18
17. Labeling(product name) based on the Marking for the Restriction of the Use of Certain Hazardous Substances in Electrical and Electronic Equipment :Geared Motor	19

1. Product Check

When you receive our product(Geared Motor),verify that you have received the correct Product.

- (1) Check that the model number, output, speed, etc, you specified are written on the nameplate.
- (2) Check that product is not damaged during shipment.
- (3) Check the screws and bolts are loose.

2. Operation Condition and Ambient Condition

- (1) Do not place any object inflammable near the geared motor. Failure to observe this warning may case fire or explode
- (2) Do not use the geared motor as elevator for human transport. Use of a geared motor for such a purpose is prohibited by the Building Standard Law .
- (3) If the equipment is to be used with an elevator, be sure to burnish with a safety device to prevent the elevator from accidental falling. Failure to observe this warning may cause physical injury and damage to the equipment.
- (4) When geared motor is rotated from the driven machine, set the safety device on the driven machine not to rotate over the specified geared motor rotation speed. Otherwise, geared motor may explode or damage.

3. Installation and Adjustment

- (1) If the geared motor is equipped with eyebolt or eyeplate ,be sure to use eyebolt or eyeplate to lift and transfer a load.
- (2) In equipments must avoid oil or grease, furnish with protective devices like oil pan, in order to protect from oil leakage caused by failure or lift of the manufactured products.
- (3) Safe guards should be furnished around rotating parts to avoid danger to persons.
- (4) The grease lubrication method is adopted for all the motor models.The grease lubrication type Geared Motors can universal direction. The grease lubricated are filled with grease prior to shipping
- (5) Install the motor at an appropriate place that ensures low humidity and little dust. Check that the ambient temperature is between -15°C and +40°C,and the relative humidity is 90% or less. Check that the motor cannot be frozen at the installation place. In addition, check the motor cooling condition of the installation place. The motor should not be extremely heated.
- (6) Install the motor on a rigid and thermal conductive base using bolts having strength of 8.8 or above. Adjust the flatness of the installation surface to 0.2 mm or less.

4. Connection

- (1) To properly connect the Geared Motor to the machine, reduce the eccentricity between the motor and machine to 0.05mm or less. Use the flexible coupling to easily connect the motor to the machine. (Refer to Fig.1).
- (2) Adjust deflection amount of the chain to 4% of the span(REFER TO Fig.2). If the deflection amount is too large, a great shock may be applied at starting, and the geared motor may be damaged by the shock.
- (3) To prevent damage caused by the overhang load, adjust the positions of the sprocket, gear, pulley, etc. so that the loading position can be closer to the joint of the output shaft and the gear case (refer to Fig.3).
- (4) The tolerance for the holes of the sprocket, coupling, etc. should be H8. Smoothly install the sprocket, coupling etc. using the tap on the output shaft (refer to Fig.4)
- (5) Do not use any hammer for installation. Application of a large force may damage the bearing, gear, etc.

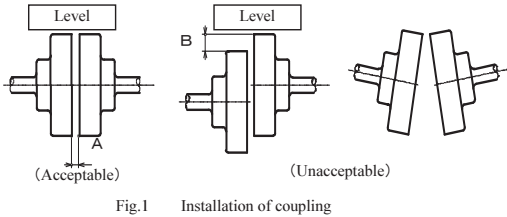

Fig.1 Installation of coupling

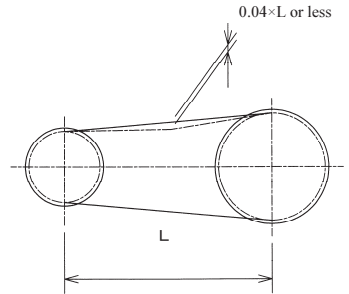

Fig.2 deflection amount of chain

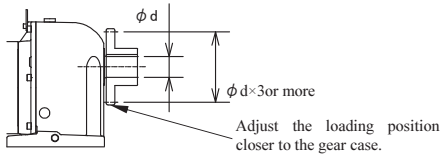

Fig.3 Sprocket position

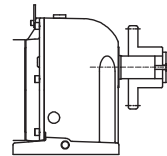

Fig.4 Sprocket installation

5. Guidelines for replacing the old geared motor

When replacement of the old geared motor, please note the following.

- (1) There is mounting compatible, but the total length will be longer. When installation, please check the interference of surrounding devices. Also, consider ventilation for the motor cooling, please keep a distance between the fan cover and the wall, as in Figure 5. Dimensions FC2 is minimum dimensions of the wall-to-fan cover in consideration of ventilation for motor cooling, however, we recommend to set the wall-to-fan distance so that when conducting brake maintenance or etc, the fan cover can be removed.
- (2) Please reconsiders the design of the wiring equipment of the breakers and etc since starting current may increase.
- (3) Since the rotation speed may increase and the power consumption increase, please consider the necessity of countermeasures such as setting the rotational speed of the load machine to the same as previous one by changing the sprocket ratio or the output frequency of the inverter.
- (4) Please reconsider the acceptable number of starts and the acceptable number of starts per hour, since moment of inertia may increase.
- (5) When using non-brake geared motors, period of free-run may be longer. Also, when it comes to brake-in geared motors, especially when simultaneous braking method, brake holding period may be longer. Therefore according to necessity, please adopt separated braking method or Direct current (quick) braking method.

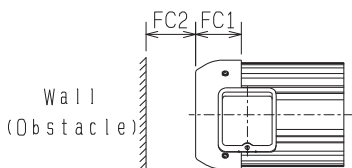

Fig.5 Dimension of the wall-to-fan cover

Output (kW)	FC1(mm)	FC2(mm)
0.75	64(127)	20
1.5	73(145)	40
2.2	83(150)	
3.7	95(170)	
5.5	117(197)	
7.5		

※Dimension in () shows the value with brake

6. Wiring

- (1) Be sure to ground the geared motor, and install a circuit breaker for each motor. Without grounding or circuit breaker, you may get an electric or physical injury.
- (2) To wire the geared motor, use high-quality wiring parts, and be sure to observe the technical standards for electric equipment or interior wire code by the corresponding electric power company. the outline is shown in Table 1. If the wiring distance is long, note that the voltage drop increases.
- (3) Install an protective devices on each motor. Without any protector, the motor may cause a fire at the time of a problem.
- (4) Be sure to supply the specified voltage to the geared motor. If the Voltage is too high, a fire may be caused.

Table 1. Motor Wiring (3-phase induction motor)

※ Ref. Indoor wiring regulations 3705

Motor type	Output (kW)	Minimum wire thickness (mm) (See Note 1)		Maximum wire line length(m) (See Note 2)		Overcurrent breaker (A)(Note3) Full-voltage starting		Over scale ammeter (A)		Minimum grounding wire thickness(mm)	
		200V	400V	200V	400V	200V	400V	200V	400V	200V	400V
		S	0.1, 0.2	1.6	1.6	144	580	15	15	5	5
0.4	1.6		1.6	81	326	15	15	5	5	1.6	1.6
SP	0.75	1.6	1.6	54	217	15	15	5	5	1.6	1.6
	1.5	1.6	1.6	32	130	30	15	10	5	1.6	1.6
	2.2	1.6	1.6	23	94	30	15	10	5	1.6	1.6







Note1: The “minimum wire thickness” is for when three wires are place in a conduit.

Note2: Maximum wire line length is a measure that voltage drop is 2% or less.

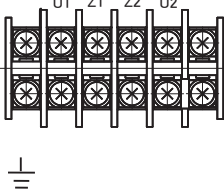
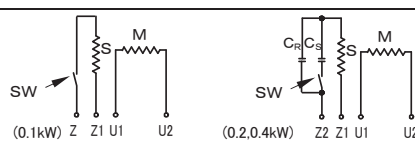
Note3: Overcurrent breaker is for power distribution. Motor breaker for motor protection, please select the ones that conform to the motor rated output.

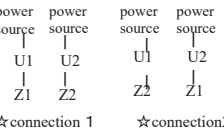
7. Motor Wiring

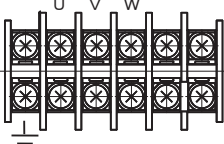
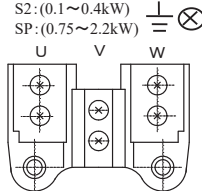
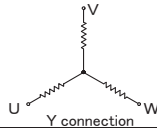
(1) To rotate the 3-phase motor in the opposite direction, exchange the connected terminals between 2 wires (2 of 3wires; R,S, and T). For the Single-phase motor, select connection 1 or 2 from the following table to determine the rotational direction.

Output (kW)	Terminal connection	Wire connection method	Output shaft rotational direction
0.1~0.4 (Single-phase)		<p>Connection diagram</p>  <p>M: Main coil S: Start Coil SW: centrifugal (governor) switch C_n: running capacitor C_s: strating caoacitor</p>	<p>For 2or4 stage of gear units</p>  <p>counterclockwise ★connection 1</p>
		<p>Connection method</p>  <p>★connection 1 ★connection 2</p>	<p>For 2or4 stage of gear units</p>  <p>clockwise</p>
0.1~2.2 (three-phase)	<p>S: (0.1~0.4kW)</p>  <p>S2: (0.1~0.4kW) SP: (0.75~2.2kW)</p> 	<p>Connection method</p>  <p>Y connection</p>	<p>For 2or4 stage of gear units</p> <p>★connection 2</p>  <p>counterclockwise</p>
		<p>Connection method</p> 	

8. Output shaft Rotational Direction

The "output shaft rotational direction" column shown in the following figure shows the rotational direction for the 2 or 4 stage Gear units type. For the 3 stage Gear units type, the output shaft will rotate in the opposite direction.

Output(kW)	Gear ratio	Stage of gear units	Rotation direction (viewed from output shaft end)
0.1	1/3~1/300	2	CounterClockwise
	1/40~1/200	3	Clockwise
	1/270~1/1200	4	CounterClockwise
0.2	1/3~1/30	2	CounterClockwise
	1/40~1/200	3	Clockwise
	1/270~1/1200	4	CounterClockwise
0.4	1/3	3	CounterClockwise
	1/5~1/30	2	CounterClockwise
	1/40~1/200	3	Clockwise
	1/270~1/1200	4	CounterClockwise
0.75	1/3~1/30	2	CounterClockwise
	1/40~1/200	3	Clockwise
	1/270~1/450	4	CounterClockwise
1.5	1/3~1/30	2	CounterClockwise
	1/40~1/200	3	Clockwise
2.2	1/3~1/30	2	CounterClockwise
	1/40~1/100	3	Clockwise

9.Brake Wiring

(1) The brake motion delay time (the time before brake start to operate after turning off the power) depends on brake connection method and load specifications. Select appropriated connection method by considering the functions of machine that attached to motor.

(2) Braking connection method.

Braking wires are connected to simultaneous braking method from factory shipment, for the other braking method, please open the terminal box to change braking connection circuit as shown below.

Table.2 Power supply wiring for motor and Brake

Motor		Connection(factory shipment)	Simultaneous braking method	Separated braking method	Direct current(quick) braking method
INPUT	OUTPUT				
Single Phase	0.1 ~ 0.4 kW				
		<p>Internal wiring</p> <p>(Lower line) (Upper line)</p>	<p>Terminals connection</p> <p>(upper line)</p> <p>Connection bar</p>	<p>Terminal Block</p> <p>(upper line)</p> <p>Connection bar</p>	<p>Terminal Block</p> <p>(upper line)</p> <p>Connection bar</p>
		<p>Motion Delay time</p>	0.2~0.55s	0.1~0.3s	0.01~0.04s
Three Phase	0.1 ~ 2.2 kW				
		<p>Internal wiring</p> <p>For S:0.1~0.4kW</p> <p>(Lower line) (Upper line)</p> <p>Internal wiring</p> <p>For S2:0.2~0.4kW</p> <p>SP:0.75~2.2kW</p> <p>(Lower line) (Upper line)</p>	<p>Terminals connection</p> <p>(upper line)</p> <p>Connection bar</p>	<p>Terminal Block</p> <p>(upper line)</p> <p>Connection bar</p>	<p>Terminal Block</p> <p>(upper line)</p> <p>Connection bar</p>
		<p>Motion Delay time</p>	0.2~0.55s	0.1~0.3s	0.01~0.04s

Notes:

- Speaking sound, generated from brake lining, is not malfunction and does not affect to performance.
- For elevator or high accuracy positioning drive, please use direct current (quick) braking method.
- For simultaneous braking method or direct current (quick) braking method, be sure to connect lead wire (marked with ※) to the terminals U and B2. And, for separated braking method, be sure to disconnect it.
- For separated braking method or direct current (quick) braking method, remove one of the connection bar as shown above.
- For 0.1kW to 2.2kW model, terminal block has 2 lines of terminals (upper and lower line). Be sure to connect power supply wires to upper line terminals. If connect to the lower line, brake will not be released.
- Motion delay time may slightly vary from load specification or from brake torque.

Table.3 Power supply wiring for motor and Brake with inverter drive

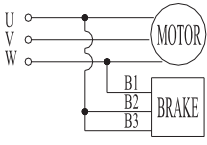
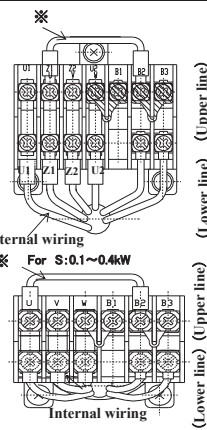
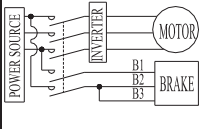
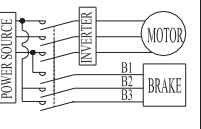
Motor		Connection(factory shipment)	Simultaneous braking method	Separated braking method	Direct current(quick) braking method
INPUT	OUTPUT				
Inverter drive	0.1 ~ 2.2 kW	 <p style="text-align: center;">circuit</p>	 <p style="text-align: center;">Terminals connection</p>		
	Motion Delay time			0.1 ~ 0.3s	0.01 ~ 0.04s

Notes:

- 1) Braking wires are connected as simultaneous braking method from factory shipment. For inverter driving, please open terminal box to change braking connection circuit to those are shown above. And be sure to disconnect lead wire (marked with ※)
- 2) For separated braking method or direct current (quick) braking method, remove the connection bar as shown above.
- 3) Terminal block has 2 lines of terminals (upper and lower line). Be sure to connect power supply wires to upper line terminals. If connect to the lower line, brake will not be released.
- 4) For inverter driving, connect braking wires directly from power source. do not connect through inverter.
- 5) When use inverter drive, at low frequency, the noise may be slightly louder. This noise is not malfunction and does not affect to performance.
- 6) For inverter driving, the power factor improving capacitor cannot be connected to the motor circuit.

Brake usage precautions

1. Connect only brake power without power the motor may deteriorate the motor.
2. If power-factor improving capacitor is attached, be sure to use separated braking method. For inverter driving, the power factor improving capacitor cannot be connected to the motor circuit.
3. To drive the motor with an inverter or to control the input power, please connect the brake to the power source side of the inverter. (Connecting to the output side of the inverter may deteriorate the power source equipment)
4. In the inverter-driving mode, the noise may be slightly louder in the low-frequency zone. However, this type of noise will not deteriorate any motor functions.
5. To operate motor at frequency of 25Hz or less, observe the rate time of 1 hour or 25% ED.
6. To use inverter-driving for 400V class motor, surge voltage from wiring fixed number may occur between the terminal, and this voltage may deteriorate the insulation of the motor. Please use the method below for solution.
 - (1) Insulation strengthening method
Please use 400V class inverter-driving insulation strengthening geared motor.
In Mitsubishi geared motor, insulation strengthening motor are shown below.
- Standard geared motor ---0.1~2.2kW
 - (2) Inverter side surge voltage controlling method
At the secondary side of inverter, please connect the filter for control surge voltage of the motor which decrease within 850V. For Mitsubishi inverter-driving, please connect optional surge voltage controlling filter (FR-ASF-H) at the secondary side of inverter.

10. Brake(0.1~0.4kW)

1) Structure and operation

Fig.6 shows the structure of the brake. The non-excitation braking method (spring-driven braking method) is used for all the models

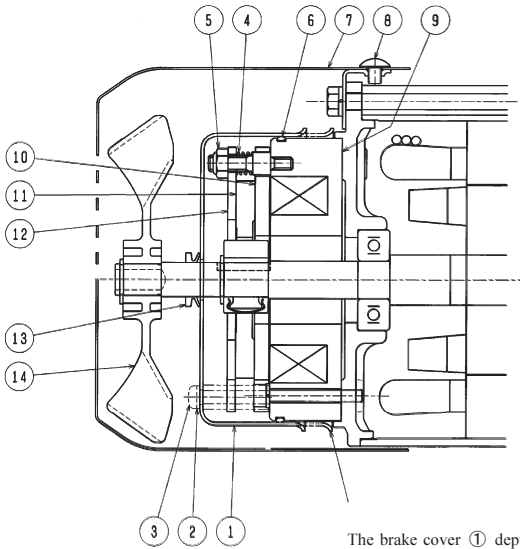

Item	DESCRIPTION
1	Brake cover
2	Seal washer
3	screw
4	spring
5	Hexagon nut
6	O-ring
7	Fan cover
8	Clamp screw
9	Field core
10	Armature
11	Brake lining
12	Side plate
13	End-face V seal (out door type)
14	Fan

The brake cover ① depth size of 0.1kW and 0.2kW differs from 0.4kW.

Fig.6

2) Gap adjustment procedure (Refer to the structural drawing of the brake (Fig.6).

If the brake is abraded due to long use, the gap between the field core and Armature will be larger than the limit gap specified in Table 4. Such a large gap may cause a braking operation error or brake releasing error. For this reason, if the gap is larger than the limit gap, adjust the gap by following the procedure below.

- Step 1** Loosen the fan cover clamp screws (4 screws), and then remove the fan cover.
The fan is fixed by a C-shaped snap ring. Remove the fan and End-face V seal(outdoor type), and then loosen screws (item 3) to remove the brake cover (item 1).
- Step 2** Equally adjust the gap (A) between the field core and Armature to the initial gap (refer to Table 4) by tightening the outer hexagon nut (item 5).
- Step 3** Use the specified thickness gauge (initial thickness gauge) to measure the gap. If the lower limit thickness gauge can be inserted into the gap but the upper limit thickness lower limit thickness gauge cannot be inserted into the gap at any point around the cores, judge that gap is properly adjusted.
- Step 4** Attach the brake cover, and then tighten the screws (item 3) through the seal washers (item 2).

Notes: To adjust the gap, observe the following items.

- Adjust the gap so that the gap difference (difference between the maximum gap and minimum gap) is reduced to 0.05 mm or less.
- Periodically check the gap.
- Be careful not to damage the O-ring (item 6) during adjustment. The waterproofing or soundproofing function may be deteriorated.
- If the thickness of the brake lining is reduced to the limit value specified in Table4, replace the lining.

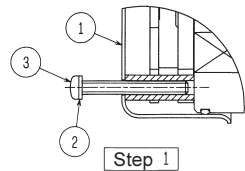

Step 1

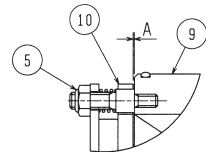

Step 2

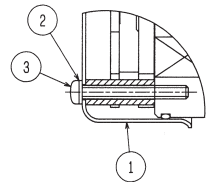

Step 4

3) Brake specifications

Table4 shows the standard specifications for the brake.

Table 4 Standard Specifications for Brake

Brake model	Output (kW)	Number of poles (P)	Brake power supply Voltage(V)	Braking voltage DC(V)	Braking Current (A)	Braking torque (Nm) *Note 1 and 2	Gap(mm)		Lining thickness	
							Initial gap	Limit gap	Initial thickness	Limit thickness
SNB 0.2	0.1,0.2	4	200	90	0.16	1.91	0.15(inserted)-0.25 (not inserted)	0.4	6.0	5.3
			400	180	0.08					
SNB 0.4	0.4	4	200	90	0.18	3.82	0.15(inserted)-0.25 (not inserted)	0.4	5.9	4.9
			400	180	0.09					

Note 1: The braking torque values shown in the above table are the static friction torque values. Dynamic friction torque values will be approximately 80% of the static friction torque values.

Note 2: At starting first operation or after replacing the brake lining, the braking torque may be less than the specified torque. In this case, fit the friction surfaces of the brake by applying the brake several times with a light load

4) Rectifier specifications

Table 5 shows the standard specifications for the rectifier .

Table 5 Standard specifications for Rectifier

Output (kW)	Power supply voltage (V)	Output voltage DC(V)	Control method	Rating	Ambient temperature and humidity	Installation
0.2	200	90	Half wave rectification method	Continuous	15~+40° 90%RH or less	On terminal block
	400	180				
0.4	200	90	Half wave rectification method	Continuous	15~+40° 90%RH or less	On terminal block
	400	180				

5) Manual brake releasing procedure

a) Simplified manual brake releasing

Step 1 Loosen the fan cover clamp screws (4 screws), and then remove the fan cover. After that, remove the fan and End-face V seal.(outdoor type) ; The fan is fixed by a C-shaped snap ring.

Step 2 Loosen the screws (item 3), and then remove the brake cover (item 1). Screw the machine screws into the threaded holes of the side plate. The machine screws will push the Armature to release the brake. At the completion of manual brake releasing, be sure to reset the brake.

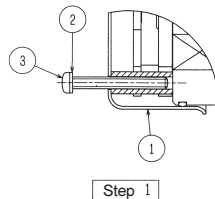

Step 1

Notes: To manually release the brake, observe the following items:

- Be sure to check that the brake is properly released. Basically, reducing the gap to zero will release the brake. To check whether the brake is released, manually turn the motor shaft. If you can turn the shaft, judge that the brake is released.
- If a large tightening force is applied to the simplified manual brake release bolt, the Armature or side plate may be distorted or damaged, and normal operation may not be possible. For this reason, carefully tighten the manual release bolt.
- If the manually released brake is not reset, do not operate the motor. Before starting full-scale operation, be sure to check that the brake functions properly.
- For simplified manual brake releasing, up to 50 times of releasing is allowable.

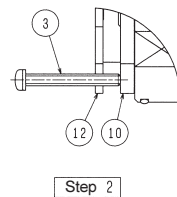

Step 2

b) One-touch manual brake releasing (optional)

• On the top of the fan cover, there is a brake release lever. Turn the lever 90° to release the brake. (Do not turn the lever more than 90°. The brake may not be released.) At the completion of manual brake releasing, be sure to return the lever to the initial position.

• For one-touch manual brake releasing, up to 100 times of releasing is allowable.

The gap adjustment (maintenance) point of one-touch manual brake releasing

【The resolution point at the time of the gap adjustment】

- ① Open a manual lever and exclude combination with the pin of right and left.
- ② Each right and left pulls up pin.
- ③ Please refer to the gap adjustment point for the following work.

【The point to reassemble after the maintenance】

- ① Confirm it so that a D cut parallelism department of the manual lever combination department turns to the slowdown machine side and insert it from a fan cover hole.
- ② Open a manual lever and combined with the pin of right and left.

※ Attention

Of the manual lever please be careful to be able to spread too much.

A wobble occurs in the combination with the pin when I open too much it, and a manual lever is easy to come to come off.

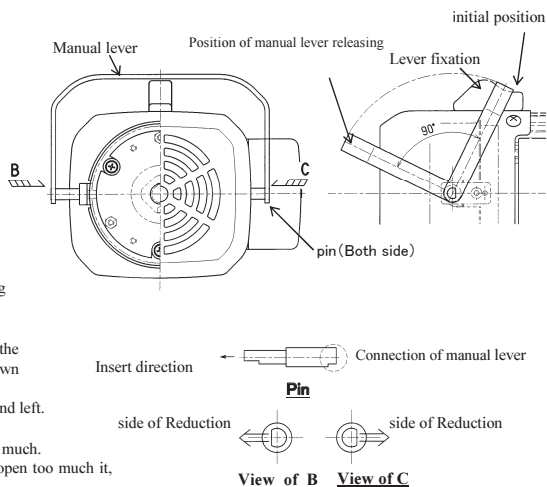

11. Brake(0.75~2.2kW)

1) Structure and operation

Fig. 7 shows the structure of the brake. The non-excitation braking method (spring-driven braking method) is used for all the models

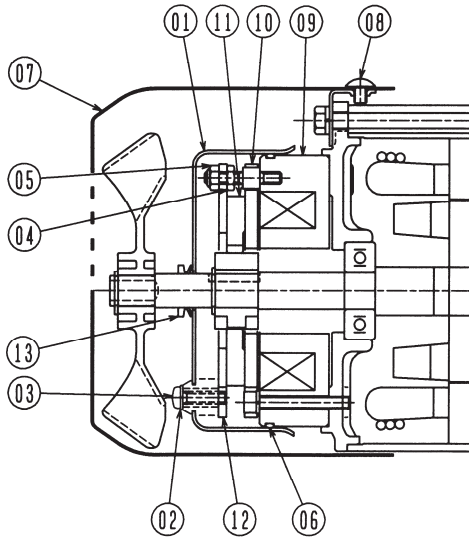

Fig.7

Item	DESCRIPTION
1	Brake cover
2	Flat washer
3	screw
4	Locknut
5	Hexagon nut
6	O-ring
7	Fan cover
8	Clamp screw
9	Field core
10	Armature
11	Brake lining
12	Side plate
13	End-face V seal (Outdoor type)

2) Gap adjustment procedure (Refer to the structural drawing of the brake (Fig.7).

If the brake is abraded due to long use, the gap between the field core and Armature will be larger than the limit gap specified in Table 6. Such a large gap may cause a braking operation error or brake releasing error. For this reason, if the gap is larger than the limit gap, adjust the gap by following the procedure below.

- Step 1** Loosen the fan cover clamp screws (4 screws), and then remove the fan cover. The fan is fixed by hexagon socket head set screws. Remove the fan and End-face V seal(Outdoor type), and then loosen the screws (item 3) to remove the brake cover (item 1).
- Step 2** Inside the brake cover, loosen 3 locknuts(item 4), and then equally adjust the gap(A) between the field core and Armature to the initial gap (refer to Table 6) by tightening the outer hexagon nut(item 5).
- Step 3** Use the specified thickness gauge (initial thickness gauge) to measure the gap. If the lower limit thickness gauge can be inserted into the gap but the upper limit thickness gauge cannot be inserted into the gap at any point around the cores, judge that gap is properly adjusted.
- Step 4** Tighten 3 locknuts(item 4)
- Step 5** Finally check the gap(A) in the same way as step 3.
- Step 6** Attach the brake cover, and then tighten the screws (item 3) through the flat washers (item 2).

Notes: To adjust the gap, observe the following items.

- After adjusting the gap, be sure to tighten all the nuts.
- After tightening the locknuts (item 4) at step 4, the gap may be slightly changed. For this reason, be sure to check the gap at step 5.
- Adjust the gap so that the gap difference (difference between the maximum gap and minimum gap) is reduced to 0.05 mm or less.
- Periodically check the gap.
- Be careful not to damage the O-ring (item 6) during adjustment. The waterproofing or soundproofing function may be deteriorated.
- If the thickness of the brake lining is reduced to the limit value specified in Table6, replace the lining.

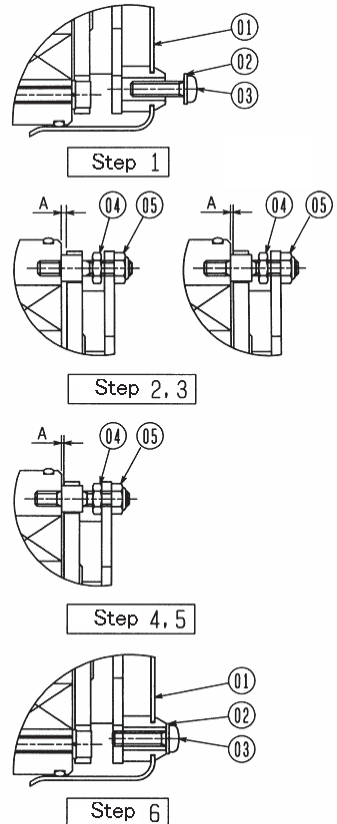

3) Brake specifications

Table 6 shows the standard specifications for the brake.

Table 6 Standard Specifications for Brake

Brake model	Output (kW)	Number of poles (P)	Brake power supply Voltage(V)	Braking voltage DC(V)	Braking Current (A)	Braking torque (Nm) *Note 1 and 2	Gap(mm)		Lining thickness	
							Initial gap	Limit gap	Initial thickness	Limit thickness
SNB 0.8	0.75	4	200	90	0.24	7.16	0.15(inserted)-0.25 (not inserted)	0.5	7.7	6.7
			400	180	0.12					
SNB1.5	1.5	4	200	90	0.25	14.3	0.20(inserted)-0.30 (not inserted)	0.5	10	8.5
			400	180	0.12					
SNB2	2.2	4	200	90	0.37	21.0	0.20(inserted)-0.30 (not inserted)	0.5	10	8.5
			400	180	0.18					

Note 1: The braking torque values shown in the above table are the static friction torque values. Dynamic friction torque values will be approximately 80% of the static friction torque values.

Note2: At starting first operation or after replacing the brake lining, the braking torque may be less than the specified torque. In this case, fit the friction surfaces of the brake by applying the brake several times with a light load

4) Rectifier specifications

Table7 shows the standard specifications for the rectifier .

Table7 Standard specifications for Rectifier

Output (kW)	Power supply voltage (V)	Output voltage DC(V)	Control method	Rating	Ambient temperature and humidity	Installation
0.75	200	90	Half wave rectification method	Continuous	-15~+40℃ 90%RH or less	On terminal block
1.5						
2.2	400	180				

5) Manual brake releasing procedure

a) Simplified manual brake releasing

For this brake releasing method,prepare the brake release bolts shown in Table 8

Step 1 Loosen the fan cover clamp screws (4 screws), and then remove the fan cover. After that, remove the fan and End-face V seal(outdoor type). (The fan is fixed by hexagon socket head setscrews.)

Step 2 Loosen the screws (item 3), and then remove the brake cover (item 1). Screw the machine screws into the threaded holes of the side plate. The machine screws will push the Armature to release the brake. At the completion of manual brake releasing, be sure to reset the brake.

Table 8 Simplified manual brake release bolt

Brake model	Simplified manual brake release bolt
SNB0.8	M4×25
SNB1.5	M6×40
SNB2	

a)Simplified manual brake releasing(pattern 1)

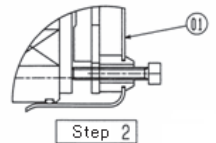
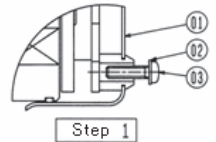

b) One-touch manual brake releasing (optional)

The written contents of one-touch manual brake releasing(optional) are the same as that of 0.1~0.4kW.

Please refer to P11

Notes: To manually release the brake, observe the following items:

- Be sure to check that the brake is properly released. Basically, reducing the gap to zero will release the brake. To check whether the brake is released, manually turn the motor shaft. If you can turn the shaft, judge that the brake is released.
- If a large tightening force is applied to the simplified manual brake release bolt, the Armature or side plate may be distorted or damaged, and normal operation may not be possible. For this reason, carefully tighten the manual release bolt.
- If the manually released brake is not reset, do not operate the motor. Before starting full-scale operation, be sure to check that the brake functions properly.
- For simplified manual brake releasing, up to 50 times of releasing is allowable.

b)Simplified manual brake releasing (pattern 2)

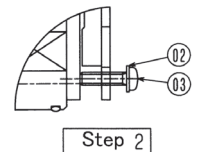
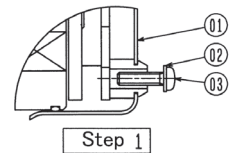

12. Dust & Waterproof type

Please confirm the following notes when waterproof GM uses it.



CAUTION

Labyrinth Plate for output shaft

- Labyrinth Plate that rotates with the shaft is installed in the output shaft. Please do not touch Labyrinth board while rotating.

Washing

- Turn off the power supply when you wash it.
- Do not Wash with steam and hot water. Make the warm water washing the warm water of 80°C or less.
- Do not wash the high pressure.
- Do not rub the surface of painting with the hard one such as metallic brushes. It causes the painting peeling off.

Connecting wires

- The cable must use the water-proof type. Water might go into it.
- Do the installation and tightening Water proof connector surely. Water might go into it.

1. Labyrinth board

- 1) Labyrinth plate is installed in the output shaft. Note the rotation with the shaft.

Refer to a catalog or external dimensional drawing for details.

- 2) Do not add the outside power to Labyrinth plate. It comes in contact with the case and it is likely to damage it.
- 3) Do not bite the foreign body between Labyrinth plate and the case and do not drive in a crowded state.

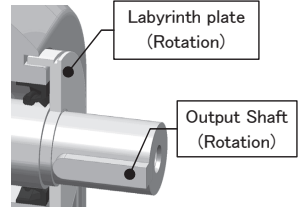

2. Inverter driving

The standard and the range of a low torque are different for the magnetic flux vector control method of 0.1 to 0.4kW.

	magnetic flux vector control	
	Standard type	Waterproof type
0.1 to 0.4kW	3 to 60Hz	20 to 60Hz

3. Wiring work

- 1) The cable for wiring must use the water-proof type.
- 2) It must not be confirmed that packing is installed, when you tighten terminal box cover.
- 3) The terminal box cable taking out part installs Water proof connector OA-W1611-13L (made of ohm electric Ltd.), and note the following.
 - The acceptable electric wire diameter is $\Phi 8.5$ to $\Phi 11.5$.

Water is infiltrated when the electric wire not suited is used, and there is a possibility of electric breakdown.

 - Tighten the Water proof connector surely. (recommended tightening torque 1.2 to 1.5N·m)
 - Paint the seal medicine (Three bond # 1211 etc.) between the entrance of Water proof connector and the cable.

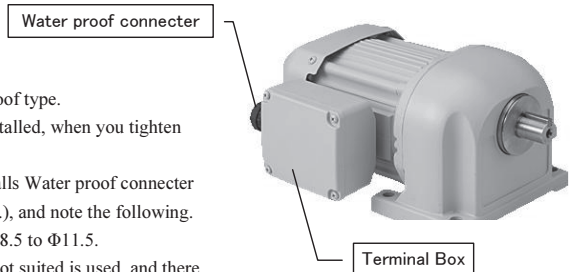

4. Brake gap adjustment

1) Structure and operation

The figure below shows the structure of the brake. The shaft seal structure are different from standard.

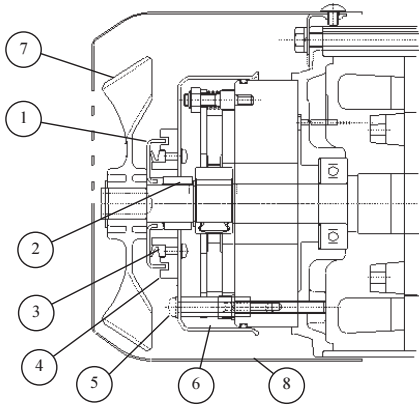

品番	品名
1	Labyrinth Plate
2	Spacer
3	End-face V seal
4	Seal support
5	Pan small screw
6	Brake cover
7	Fan
8	Fan cover

2) Resolution and assembly

The resolution and the assembly when the brake gap is adjusted are the same to standard points.

Parts only for the waterproof type are installed and note the following point.

Refer to the attached paper manual for the gap adjustment points.

【Resolution】

Detach the Fan cover and the fan. Loose the pan small screw. And detach the Brake cover together with Labyrinth Plate and Seal support.

【Assembly】

It is confirmed that Spacer is installed in the shaft and after installing the brake cover, push the Labyrinth Plate until hitting at Spacer.

5. Others

- 1) When starting and stopping, End-face V seal sound might be generated. (There is no problem on the function.)
- 2) It asks for the maintenance of the output shaft and the output shaft oil seal at our factory or our service center.
- 3) Please confirm there is not loosening in Water proof connecter in the periodical inspection.

13. Operation

- If a load is lifted up, do not release the brake using the manual brake release unit. The Load may be dropped.
- During inverter operation, be sure to observe the frequency range specified in the catalogue. If the frequency is out of the specified range, the motor may be damaged.

Before Operation

- (1) Check the bolt tightening condition at each section.
Check that foundation bolts, sprocket bolts, coupling bolts, etc. are tightened properly.
- (2) Check the electric system
Check that the electric system is properly wired, and the terminal box cover is closed. Also check that the breaker capacity and over current protective relay values are properly set.

Operation

- (1) To operate the geared motor, observe the allowable loading torque range and the allowable starting frequency range.
- (2) During operation, if the motor generates an abnormal noise, vibrates extremely, or shows abnormal characteristics, be sure to stop the motor, and inspect or overhaul the motor
- (3) During operation, keep your body away from geared motor. If you touch the geared motor during operation, you may be injured or get burn

other

- (1) At starting, apply a light Load. When the motor speed is increased to the full speed, apply the specified load.
- (2) To stop operation, be sure to turn off the power switch.

14. Maintenance and Inspection

- Do not modify the Geared Motor.
- Be sure to turn off the power before inspecting or repairing the motor.

(1) Daily Inspection

Item	Method	Detail of inspection
Load Current	Ammeter	Within the rated current specified in the nameplate.
Noise	Hearing	Directly check the noise with your ear using a noise detector bar. The motor should not generate any abnormal noise.
Surface temperature	Thermometer	Obtain the motor frame surface temperature rise value by subtracting the ambient temperature value from the motor frame surface temperature value. The temperature rise should be 40°C to 50°C.
Vibration	Vibration meter	Check the vibration of the gear case and frame. The obtained vibration values should be 4.9m/s ² or less.
Lubricant leak	Visual check	Check that no grease or oil leaks from geared motor.
Chain	Visual check	Check that the chain is not extremely defected or too tight. Also check that the chain moves smoothly.

(2) Periodic Inspection

Periodic inspection of the motor and replace the damaged parts while referring to the table below (In case of operating 8 hours a day)

Item	Interval	Detail of inspection	
Grease	Every 4~5year	Replace the grease every 10,000 hours of operation or every 4 or 5 years, whichever is earlier. Grease: NLGI No.000 of Urea Grease with Extreme Pressure manufactured by JX Nippon Oil & Energy Corporation.	
Oil seal	Every 2~3years	If the Lubricant leaks from the seal, replace the oil seal.	
Chain tension	Every 6 months	If the chain is loose, readjust the tension.	
Looseness of Bolts	Every 6 months	If the Bolts are loose, retighten the bolts.	
Bearing	Every 2~3years	If the bearing generates an abnormal noise, replace the bearing.	
Insulation resistance	Every 6 months	Check the insulation resistance using a 500V megger. The insulation resistance should be 1MΩ or more. If the resistance is less than 1MΩ, dry the coil at 90°C or less in an oven	
Brake	Gap adjustment	Every 6 months	Adjust the gap to the initial range.
	Brake lining thickness	Every 1years	If the lining is less than limit thickness, replace the lining.
	O-ring Change	Every 2~3years	Periodically check the o-ring. If the O-ring is damaged, replace the O-ring

Note: Just after replacement of the brake lining, the braking torque may be less than the specified torque. In this case, fit the friction surfaces of the brake by applying the brake several times with a light load.

(3) Others

When oil oozes from set field of motor, if it does not develop, it can be used as it is because there is no problem on a performance. When oil poses a problem, use after wiping off oil. This oil is a grease ingredient applied to very small quantity at the time of the assembly in a factory.

15. Troubleshooting

If the geared motor has a problem, determine the cause and solve the problem while referring to the table below

Problem	Cause	Remedy
Grease leak from Oil seal	Damaged oil seal	Replace the oil seal
Grease leak from cast surface	Blowholes or cracks on cast surface	Replace the cast part.
Grease leak from mating face of gear case, bracket G, etc.	(1)Loose clamp bolt (2)Distorted cast Part	(1)Tighten the clamp bolt. (2)Replace the cast part
Grease leak inside motor	Damaged oil seal	Replace the oil seal. (If the oil leaks to the stator coil, repair the motor at the motor factory.)
Abnormal noise of bearing	Dust or foreign material is in the bearing	Replace the bearing.
Abnormal noise of gear	(1) The gear catches foreign material (2) The gear is abraded due to overload.	(1)Replace the gear, (2)Reduce the load by lowering the current to the rated current value
Other problems	(1)Resonance is caused because the Gearedmotor installation base is not rigid (2) The vibration of machine is transferred to the gearedmotor to cause problem (3) The eccentricity between the machine and the gearedmotor is too large.	(1)Increase the rigidity of the motor installation base. (2)Increase the rigidity of the motor installation base. (3)Readjust the eccentricity to 0.05mm or less.
Non-rotating output shaft	(1)Power source connection error (2)Damaged gear or shaft	(1)Check the power source (2)Check the load
Extreme rise of temperature	(1)Overload operation (2)The starting frequency is too high (3)The ambient temperature is 40°C or above.	(1)Reduce the load by lowering the current to the rated current value (2)Lower the frequency. (3)Ventilate the room to reduce the ambient temperature.
Abnormal noise of motor	(1)Foreign material (2)Damaged bearing (3)Brake gap adjustment error (4)Abraded brake lining (5)Seized brake coil (6)Failure of the rectifier (7)Defective centrifugal(governor) switch	(1)Remove the foreign material. (2)Replace the bearing (3)Adjust the brake gap. (4)Adjust the brake gap, or replace the brake lining. (5)Replace the entire brake unit (6)Replace the rectifier (7)Replace the governor switch
Brake function is not work	(1)Foreign material (2)Life of the lining (3)Unevenly adjusted brake gap (4)Overload (5)The manually released brake is not rest	(1)Remove the foreign material. (2)replace the brake lining (3)Adjust the brake gap (4)Reduce the load by lowering the current to the rated current value (5)Rest the brake to the initial condition

16. Contact us

When you contact us, let us know the following items

- (1) SERIAL No.
 - (2) Model number
 - (3) Output
 - (4) Reduction ratio or speed
 - (5) Part name(see the construction)
 - (6) Quantity
 - (7) Desired delivery date
- (See the nameplate)

【Warranty】

1. Warranty term and scope of warranty

When failure by the responsibility by the side of our company occurs for a product during the term of a warranty, our company will fix a product gratuitously through the store or the service company of our company which purchased. However, when the business trip repair to overseas from domestic is required, or when the business trip repair to the remote place according to a detached island and this is required, I do the cost price which engineer dispatch takes as onerousness.

【Warranty term】

The warranty term for the product shall be 18 months after the date of delivery or 12 month from the product starting operation, whether be shorter. Moreover, the term of warranty of a repair products does not become long more than the term of warranty before repair.

【Scope of warranty】

(1)Inspection

Please inspect your product by yourself. Our service personal, however, can inspect your product at your request with change to you. If a problem is detected by the inspection ,we will discuss with you to determine whether we are responsible for the problem. If we are responsible for the problem, we will repair your product free of charge.

(2)Repair

In the following cases (i , ii , iii ,iv , v ,vi ,vii ,viii and ix) , we will charge the repair expense, parts replacement expense, and traveling expense to you. In the other cases, we will repair your product free of charge.

i)The problem is caused due to inappropriate storage or handling of your product, carelessness, negligence , or operation in inappropriate facility or with inappropriate machine, etc.

ii)The problem is caused because you have modified our product without our approval.

iii)The problem is caused because you have used lubricating oil other than recommendation of our products.

iv)The problem is caused because periodical inspection is not performed.

v)The problem is caused because you have used our product while ignoring the product specifications.

vi)The problem is caused because you have used accepted that the consumable parts (Bearing, oil seal, etc.) specified as the instructions manual etc. Even if it was a normal operating condition were able to protect when performed maintenance and inspection normally.

vii)The problem is caused because natural disasters, such as an external factor by inevitability, such as a fire an unusual voltage, and an earthquake, thunder, and storm and flood damages.

viii)The problem is caused because the reason which was not able to be foreseen with the level of the technology at the time of our company shipment.

ix)Other cases where you are responsible for the problem.

These services are applied only in Japan.The foreign country is unavailable.We appreciate your understanding.

2. Exclusion

Even if a problem of our product causes damage of other manufacturers' machine, etc., we will not compensate any loss caused by the problem of our product or damaged other manufacturers' machines (loss of your company or your customer), even in the warranty period Since it may change without a notice, please give beforehand the specification indicated to a catalog, an instructions manual, or technical data every knowledge.

3. Repair after stopping production

Even if production of the same model is stopped, we will repair your product for 7 years from the date of production stoppage.

However, the parts manufactured by casting and mold have a case where allowed to consider it as the alternative parts which have the same function.

The product supply after production stoppage cannot respond including spare parts.

4. Change of Product specifications

Specifications listed in our catalogs, manuals or technical documents may be changed without notice.

5. Application and use of the Product

(1) For the use of the product, its applications should be those that may not result in a serious damage even if any failure or malfunction occurs in the product, and a backup or fail-safe function should operate on an external system to the product when any failure or malfunction occurs.

(2)The product is designed and manufactured as a general purpose product for use at general industries. Therefore, applications substantially influential on the public interest for such as atomic power plants and other power plants of electric power companies, and also which require a special quality assurance system, including applications for railway companies and government or public offices are not recommended, and we assume no responsibility for any failure caused by these applications when used. In addition, applications which may be substantially influential to human lives or properties for such as airlines, medical treatments, railway service, incineration and fuel systems, man-operated material handling equipment, entertainment machines, safety machines, etc. are not recommended, and we assume no responsibility for any failure caused by these applications when used. We will review the acceptability of the abovementioned applications, if you agree not to require a specific quality for a specific application. Please contact us for consultation.

17. Labeling (product name) based on the Marking for the Restriction of the Use of Certain Hazardous Substances in Electrical and Electronic Equipment: Geared Motor

(1) Marking for the Restriction of the Use of Certain Hazardous Substances in Electrical and Electronic Equipment



This mark indicates the environmental protection use period based on the Administrative Measure on the Restricted Use of Hazardous Substances in Electrical and Electronic Equipment applied to electrical and electronic equipment sold in China. To the extent that this product is used under the instructions on safety and usage, it will not cause any serious impact on the environment, human health, and properties for the indicated number of years from the manufacturing date.

Note:

When disposing of the product after proper use, follow local laws and regulations stipulating how to collect and recycle electrical and electronic devices.

Note: This symbol mark is for China only.

(2) Six hazardous substances, names of parts containing the substances, and the contents

The table below lists the six hazardous substances contained in this equipment, names of parts containing these substances, and the contents.

Names of hazardous substances contained in the equipment and the contents

Part Name	Hazardous Substances					
	Lead (Pb)	Mercury (Hg)	Cadmium (Cd)	Hexavalent chromium (Cr (VI))	Polybrominated biphenyls (PBB)	Polybrominated diphenyl ethers (PBDE)
Structural parts	×	○	○	○	○	○
Stator	○	○	○	○	○	○
Rotor	○	○	○	○	○	○
Brake	×	○	○	○	○	○
Detector	×	○	○	○	○	○

This table is prepared in accordance with the provisions of SJ/T 11364.

○: Indicates that said hazardous substance contained in all of the homogeneous materials for this part is below the limit requirement of GB/T 26572.

×: Indicates that said hazardous substance contained in at least one of the homogeneous materials used for this part is above the limit requirement of GB/T 26572.

(1) 电器电子产品有害物质限制使用标识



根据《电器电子产品有害物质限制使用管理办法》，该标记适用于在中国销售的电器电子产品，其中的数字为产品的环保使用期限。只要遵守本产品在安全和使用方面的注意事项，在自生产日期算起的该年限内，将不会污染环境，也不会给人身和财产带来严重的影响。

(注) 产品正常使用终结废弃时，有关电子电气产品的回收、再利用等要遵守各自自治体的法律法规的要求。

Note: This symbol mark is for China only.

(2) 所含有的6种有害物质的名称, 含有量, 含有部品

本产品中所含有的6种有害物质的名称, 含有量, 含有部品如下表所示。

产品中有害物质的名称及含量

部件名称	有害物质					
	铅 (Pb)	汞 (Hg)	镉 (Cd)	六价铬 (Cr(VI))	多溴联苯 (PBB)	多溴二苯醚 (PBDE)
构造部件	×	○	○	○	○	○
转子	○	○	○	○	○	○
定子	○	○	○	○	○	○
制动器	×	○	○	○	○	○
检测器	×	○	○	○	○	○

本表格依据SJ/T11364的规定编制。

○:表示该有害物质在该部件所有均质材料中的含量均在GB/T 26572规定的限量要求以下。

×:表示该有害物质至少在该部件的某一均质材料中的含量超出GB/T26572规定的限量要求。

Inspection Certificate

Thank you for selecting a Mitsubishi geared motor.
This is to certify that your geared motor has been accepted
by the specified inspection in our factory.

This document was issued in July 2022.

Note that product specifications may be subject to change without prior notice.

MITSUBISHI ELECTRIC FA INDUSTRIAL PRODUCTS CORPORATION