

 **mitsubishi**

**MAGNETIC MOTOR**

**MELIPM SERIES**

**INSTRUCTION MANUAL**

---

Compact & High Efficiency

**MM-CF52 to 352**

# ● Safety Instructions ●

(Always read these instructions before using the equipment.)

Do not attempt to install, operate, maintain or inspect the magnetic motor until you have read through this Instruction Manual, Mitsubishi Magnetic Motor Drive Unit Specifications and Installation Guide, and appended documents carefully and can use the equipment correctly. Do not use the magnetic motor until you have a full knowledge of the equipment, safety information and instructions.

In this Instruction Manual, the safety instruction levels are classified into "WARNING" and "CAUTION".



**WARNING**

Indicates that incorrect handling may cause hazardous conditions, resulting in death or severe injury.



**CAUTION**

Indicates that incorrect handling may cause hazardous conditions, resulting in medium or slight injury to personnel or may cause physical damage.

Note that the  CAUTION level may lead to a serious consequence according to conditions. Always follow the instructions of both levels because they are important to personnel safety.

What must not be done and what must be done are indicated by the following diagrammatic symbols:



Indicates what must not be done. For example, "No Fire" is indicated by .



Indicates what must be done. For example, grounding is indicated by .

In this Instruction Manual, instructions at a lower level than the above, instructions for other functions, and so on are classified into "POINT".

After reading this Instruction Manual, always keep it accessible to the operator.

### 1. To prevent electric shock

 **WARNING**

- Before starting wiring or inspection, switch power off and wait for more than 10 minutes until the charge lamp goes off. Then, confirm the voltage is safe with a voltage tester or like. Not doing so can cause an electric shock.
- Securely connect the drive unit and motor to the earth.
- Any person who is involved in wiring and inspection should be fully competent to do the work.
- Do not attempt to wire the drive unit and motor until they have been installed. Otherwise, you may get an electric shock.
- Operate the switches with dry hand to prevent an electric shock.
- The cables should not be damaged, stressed, loaded, or pinched. Otherwise, you may get an electric shock.

### 2. To prevent fire

 **CAUTION**

- Install the motor on an incombustible material. Installing it directly on or near a combustible can cause a fire.

### 3. To prevent injury

 **CAUTION**

- Only the voltage specified in the Instruction Manual may be applied to each terminal. Otherwise, a burst, damage or like may occur.
- Connect the terminals correctly to prevent a burst, damage or like.
- While power is on or for some time after power-off, do not touch the motor and others since they are hot and you may get burnt.

#### 4. Additional instructions

The following instructions should also be fully noted. Incorrect handling can cause a failure, injury, electric shock or like.

##### (1) Transportation and installation

**⚠ CAUTION**

- Transport the products correctly according to their weights.
- Use the eyebolt of the motor to only transport the motor, and do not use it to transport the motor installed on a machine.
- Stacking in excess of the specified number of products is not allowed.
- Do not carry the motor by the cable or shaft.
- Install the motor in a load-bearing place in accordance with the Instruction Manual.
- Do not climb or stand on the equipment, and do not put heavy objects on the equipment.
- Always install the motor in the specified orientation.
- Do not install or operate the motor which has been damaged or has any parts missing.
- Provide adequate protection to prevent screws, metal pieces and other conductive matter, oil and other combustible matter from entering the motor.
- Do not drop or strike the motor. Isolate it from impact loads.
- Use and store the motor under the following environmental conditions:

Environment	Conditions
	Motor
Ambient temperature	-10°C to +40°C (non-freezing)
Ambient humidity	90%RH or less (non-condensing)
Storage temperature	-20°C to +70°C (non-freezing)
Storage humidity	90%RH or less (non-condensing)
Ambience	Indoors (no direct sunlight), free from corrosive gas, flammable gas, oil mist, dust and dirt.
Altitude	Max. 1000m above sea level
Vibration	X: 9.8m/s <sup>2</sup> , Y: 24.5m/s <sup>2</sup>

- Securely fix the motor to a machine. If fixed insecurely, the motor may come off during operation.
- To ensure personnel safety during operation, always cover the shaft so as not to expose the rotating parts of the motor.
- Do not subject the motor shaft to more than the permissible loads. Doing so can cause the shaft to break.
- When the equipment has been stored for an extended period of time, consult your sales representative.

(2) Wiring

 **CAUTION**

- Wire the equipment correctly and securely. Not doing so can cause the motor to run away.
- Do not install a power capacitor, surge absorber or radio noise filter (FR-BIF option) on the output side of the drive unit.
- Connect the output terminals (U, V, W) correctly. Not doing so can cause the motor to misoperate.
- Do not connect AC power directly to the motor. Doing so can cause a failure.

(3) Test run and adjustment

 **CAUTION**

- Before starting operation, check or adjust the parameter settings. Improper settings may cause some machines to perform unexpected operation.

(4) Usage

 **CAUTION**

- Provide an external emergency stop circuit to ensure that operation can be stopped and power switched off immediately.
- Do not disassemble or repair the equipment.
- Do not modify the equipment.
- Use the motor with the specified drive unit.

(5) Corrective actions

 **CAUTION**

- When a hazardous condition is assumed to take place due to a stop or product failure, use the motor with an external brake mechanism for the purpose of prevention.
- When any alarm has occurred, eliminate its cause, ensure safety, and deactivate the alarm before restarting operation.
- When power is restored after an instantaneous power failure, stay away from the machine because the machine may restart suddenly (design the machine so that it is secured against hazard if restarted).

(6) Disposal

 **CAUTION**

- Dispose of the product as general industrial waste.

# CONTENTS

<b>1. INTRODUCTION</b>	<b>1-1</b>
1.1 Features of the Motor .....	1-1
1.2 Model Definition.....	1-1
<b>2. INSTALLATION</b>	<b>2-1</b>
2.1 Environmental Conditions.....	2-2
2.2 Orientation of Installation .....	2-3
2.3 Transportation .....	2-3
2.4 Precautions for Fitting to Load .....	2-3
2.5 Permissible Loads of the Shaft .....	2-3
2.6 Measures against Oil and Water.....	2-4
<b>3. WIRING</b>	<b>3-1</b>
3.1 Terminal Section Details.....	3-1
<b>4. INSPECTION</b>	<b>4-1</b>
<b>5. SPECIFICATIONS</b>	<b>5-1</b>
5.1 Standard Specifications.....	5-1
5.2 Torque Characteristics .....	5-2
5.3 Special Shaft Motor .....	5-3
<b>6. CHARACTERISTICS</b>	<b>6-1</b>
6.1 Vibration Rank.....	6-1
<b>7. OUTLINE DRAWINGS</b>	<b>7-1</b>

# 1. INTRODUCTION

## 1.1 Features of the Motor

Motor Series	Features	Rated Speed [r/min]	Capacity [kW]	Protective System
MM-CF	Compact, high efficiency, low acoustic noise	2000	0.5 to 3.5	IP44

## 1.2 Model Definition

### (1) Name plate (Rating example)

**MITSUBISHI**  
 MELIPM MOTOR  
 MM-CF52  

---

 INPUT 3AC 192V 2.6A  

---

 OUTPUT 0.5kW  

---

 2000r/min IP44 Cl.F 6.5kg  

---

 SER.No 001 DATE  

---

 MITSUBISHI ELECTRIC  
 MADE IN JAPAN

- ← Model
- ← Input power
- ← Rated output
- ← Rated speed
- ← Serial number

### (2) Model

MM - CF

Rated output

Symbol	Rated output [kW]
5	0.5
10	1.0
15	1.5
20	2.0
35	3.5

Rated speed

Symbol	Speed [r/min]
2	2000

Shaft type

Symbol	Shaft shape
None	Standard (Straight shaft)
K	With keyway

## 2. INSTALLATION

### CAUTION

- Stacking in excess of the specified number of products is not allowed.
- Install the motor on an incombustible material. Installing it directly on or near a combustible can cause a fire.
- Install the motor in a load-bearing place in accordance with this Instruction Manual.
- Do not climb or stand on the equipment, and do not put heavy objects on the equipment. Doing so can cause injury.
- Use the motor within the specified environmental condition range.
- Do not drop or strike the motor. Isolate it from impact loads.
- Do not install or operate the motor which has been damaged or has any parts missing.
- Do not carry the motor by the cable or shaft. Doing so can cause a failure or injury.
- Use the eyebolt of the motor to only transport the motor, and do not use it to transport the motor installed on a machine.
- Securely fix the motor to a machine. If fixed insecurely, the motor may come off during operation.
- Never hit the motor or shaft, especially when coupling the motor to a machine. Doing so can damage the bearings.
- To ensure personnel safety during operation, always cover the shaft so as not to expose the rotating parts of the motor.
- Do not subject the motor shaft to more than the permissible loads. Doing so can cause the shaft to break.
- When the equipment has been stored for an extended period of time, consult your sales representative.



2.1 Environmental Conditions

Environment	Conditions
Ambient temperature	-10°C to +40°C (non-freezing)
Ambient humidity	90%RH or less (non-condensing)
Storage temperature	-20°C to +70°C (non-freezing)
Storage humidity	90%RH or less (non-condensing)
Ambience	Indoors (no direct sunlight), free from corrosive gas, flammable gas, oil mist, dust and dirt.
Altitude	Max. 1000m above sea level
Vibration	X: 9.8m/s <sup>2</sup> , Y: 24.5m/s <sup>2</sup>

Vibration directions are shown below. The above vibration values have been measured in the area where vibration is maximum (normally the opposite-to-load side bracket). When the motor is at a stop, suppress vibration within about half of the permissible values since the bearings are likely to be fretted.

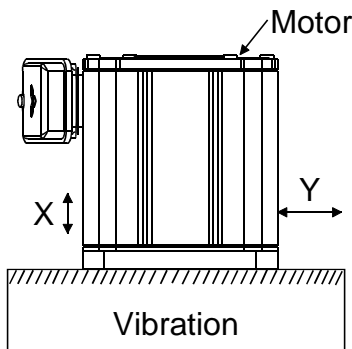

Amplitude in each vibration condition is as follows:

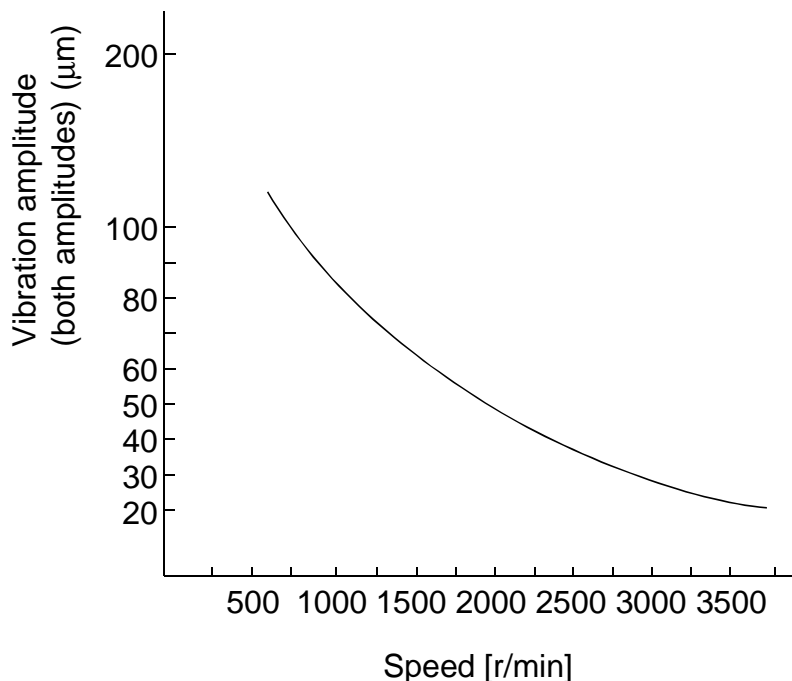

## 2.2 Orientation of Installation

The orientation of installation is given in the following table.

Motor Series	Orientation of Installation	Remarks
MM-CF	Can be installed in any orientation.	When installing the motor horizontally, it is recommended to install it with the cable outlet of the terminal box down.

## 2.3 Transportation

When carrying the motor, hold the motor body and do not support the shaft.

## 2.4 Precautions for Fitting to Load

- (1) When drawing the pulley, use a pulley remover to protect the shaft from impact loads.
- (2) To ensure safety, provide the shaft-mounted pulley and other rotating parts with protective covers and like.
- (3) When mounting the shaft with the pulley, contact us if you need the shaft with threaded end.
- (4) When installing the motor, use spring washers or like and fully tighten bolts so that they do not come loose due to vibration.

## 2.5 Permissible Loads of the Shaft

- (1) Use a flexible coupling and ensure that misalignment is less than the permissible radial load of the shaft.
- (2) When using a pulley, sprocket or timing belt, select it to satisfy the permissible radial load.
- (3) Do not use a rigid coupling since it may apply excessive bending load to the shaft, breaking the shaft.

Motor	L [mm] (Note 1)	Permissible Radial Load [N]	Permissible Thrust Load [N]
MM-CF52 to 152	55	980	490
MM-CF202 to 352	79	2058	980

Note1. See below for the symbol in the table.

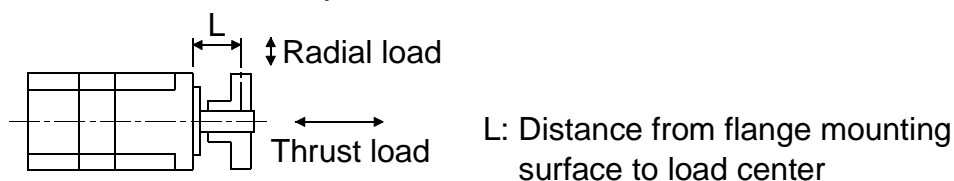

2.6 Measures against Oil and Water

- (1) This motor is not waterproof. Take measures to prevent oil and water from falling onto the motor. Especially, take measures so as not to expose the shaft through portion to oil and water.
- (2) When installing the motor horizontally, install it with the power cable outlet down. Provide a cable trap when installing the motor vertically or diagonally.

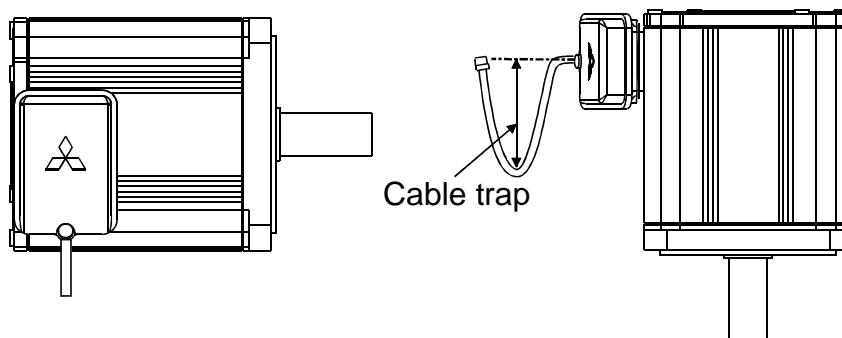

- (3) Do not use the motor with its cable immersed in water.

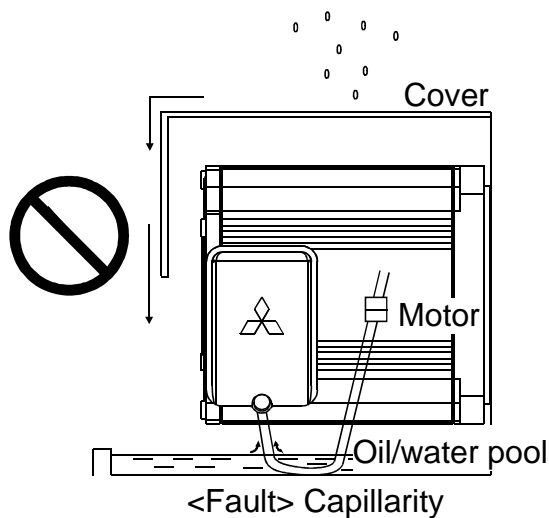

- (4) When installing the motor with its shaft end up, take appropriate action to avoid ingress of oil from the gear box or like into the motor.

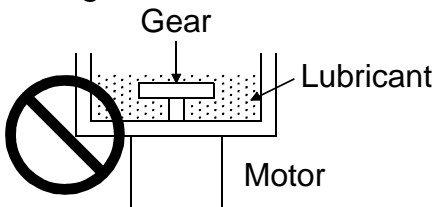

### 3. WIRING

**⚡ WARNING**

- Insulate the connections of the power supply terminals. Not doing so can cause an electric shock.

**⚠ CAUTION**

- Wire the equipment correctly and securely. Not doing so can cause the motor to run away.
- Do not install a power capacitor, surge absorber or radio noise filter (FR-BIF option) on the output side of the drive unit.  
Connect the output terminals (U, V, W) correctly. Not doing so can the motor to misoperate.  
Do not connect AC power directly to the motor. Doing so can cause a failure.

#### 3.1 Terminal Section Details

##### (1) Terminal box details

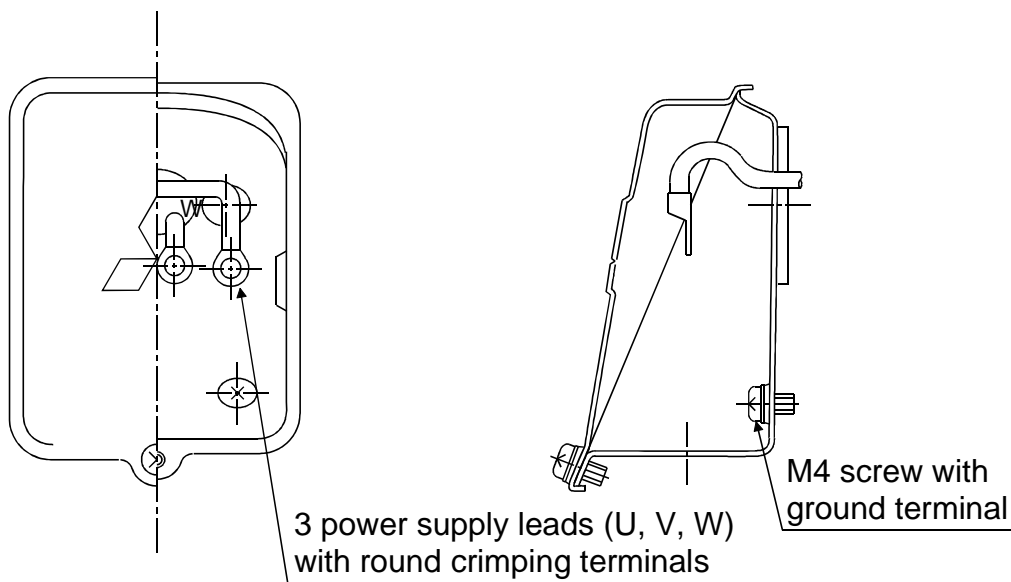

##### (2) Power supply terminal connection method

Wind an insulating tape around the connection three- or four-deep to fully insulate it.

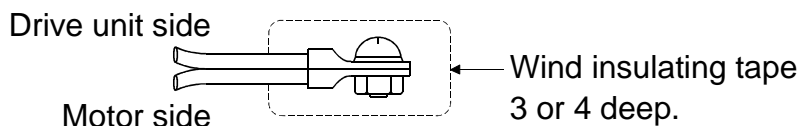

**4. INSPECTION**

 <b>WARNING</b>
<ul style="list-style-type: none"> <li>● Before starting maintenance or inspection, switch power off and wait for more than 10 minutes until the charge lamp goes off. Then, confirm the voltage is safe with a voltage tester or like. Not doing so can cause an electric shock.</li> <li>● Any person who is involved in inspection should be fully competent to do the work. Otherwise, you may get an electric shock. Contact your sales representative for repair and parts replacement.</li> </ul>

<b>POINT</b>
<ul style="list-style-type: none"> <li>• Do not disassemble or repair the equipment on the customer side.</li> </ul>

**(1) Inspection**

It is recommended to perform the following checks periodically.

- (a) Check the bearing and other sections for abnormal noise.
- (b) Check the cable and like for scratches and cracks. Especially in moving applications, check the cable periodically according to the operating conditions.
- (c) Check the load coupling shaft for misalignment.

**(2) Service life**

The parts have the following service life until replacement. However, it varies with the operating method and environmental conditions. If you found any fault, you must change the parts. Contact your sales representative for parts replacement.

Model	Part Name	Life Guideline
MM-CF	Bearing	20,000 to 30,000 hours

(a) Bearings

For the MM-CF, change the bearings after every 20,000 to 30,000 hours of rated-speed and rated-load operation as a guideline. Since the service life depends on the operating circumstances, you must also replace them if you found any abnormal noise or vibration during inspection.

## 5. SPECIFICATIONS

### 5.1 Standard Specifications

Motor		2000r/min Series				
		MM-CF52	MM-CF102	MM-CF152	MM-CF202	MM-CF352
Compatible drive unit	MD-AX520-□□□	0.5K	1.0K	1.5K	2.0K	3.5K
	MD-CX520-□□□					
Continuous characteristics (Note 1)	Rated output [kW]	0.5	1.0	1.5	2.0	3.5
	Rated torque [N•m]	2.39	4.78	7.16	9.55	16.7
Rated speed (Note 1) [r/min]		2000				
Max. speed [r/min]		3000				
Instantaneous permissible speed [r/min]		3450				
Max. torque [N•m]		4.78	9.56	14.32	19.09	33.41
Inertia moment J [ $\times 10^{-4}$ kg•m <sup>2</sup> ]		6.6	13.7	20.0	45.5	85.6
Recommended ratio of load inertia moment to motor shaft inertia moment (Note 2)		100 times max.			50 times max.	
Rated current [A]		1.81	3.70	5.22	7.70	12.5
Insulation rank		Class F				
Structure		Totally-enclosed, self-cooling (protective system: IP44 (Note 3))				
Environmental conditions (Note 4)		As in Section 2.1				
Weight [kg]		5.1	7.2	9.3	13	19

Note 1. When the power supply voltage drops, we cannot guarantee the above output and rated speed.

2. Consult us if the load inertia moment ratio exceeds the above value.

3. This does not apply to the shaft through portion.

4. The motor for use in a place where it is exposed to oil and/or water on a machinery site or like is optional. Please contact us.

5.2 Torque Characteristics

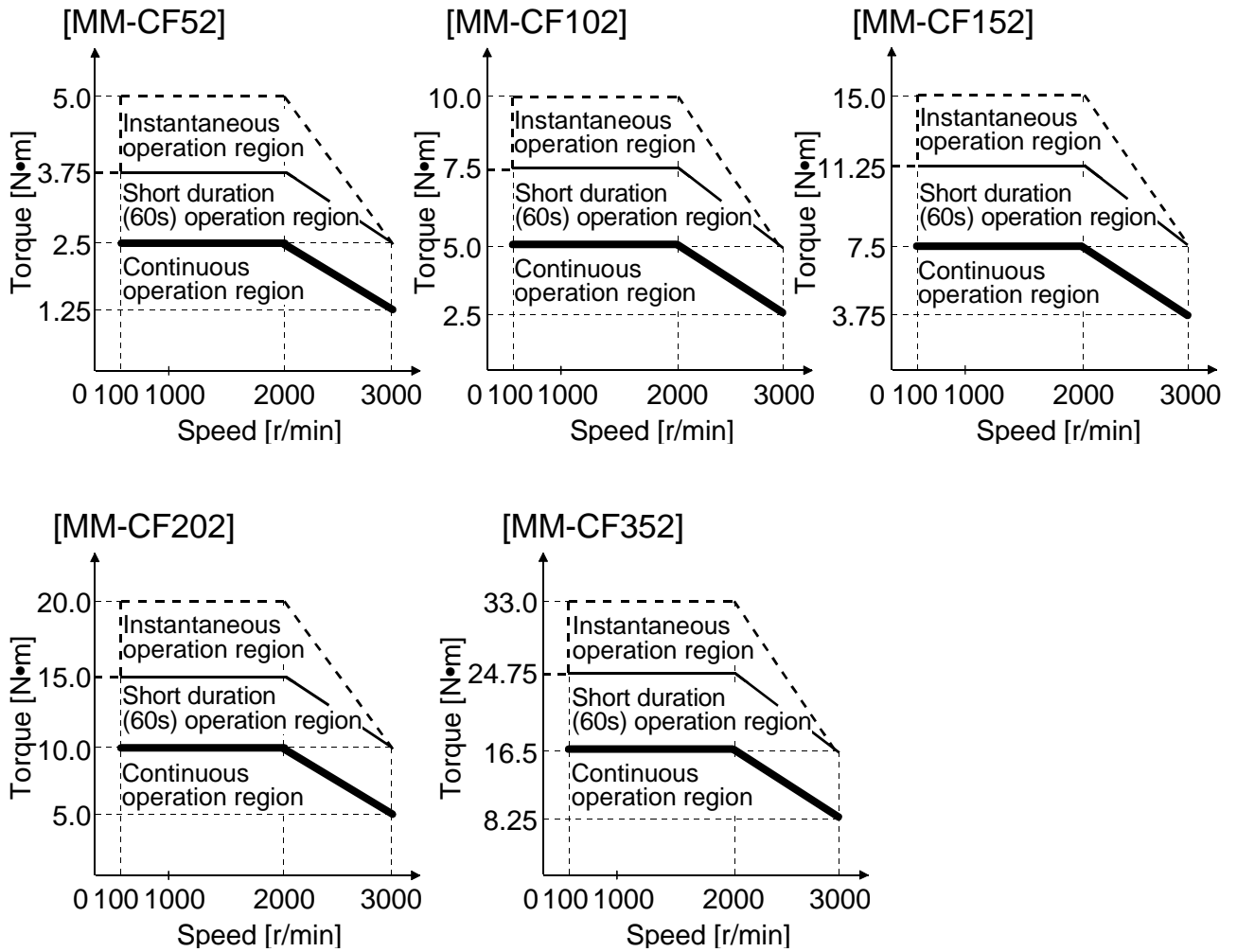

5.3 Special Shaft Motor

A straight shaft without keyway is standard for the motor. However, a keyway shaft is also available. Note that a keyway shaft is not suitable for applications where the motor will be started and stopped frequently. In such applications, use a friction coupling or like since we cannot guarantee the motor against accidents, such as shaft fracture, attributable to a loose key.

(1) With keyway

[Unit: mm]

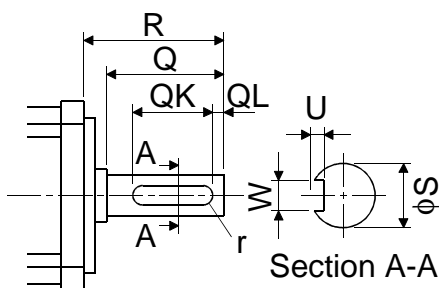

Motor	Variable Dimensions							
	$\phi S$	R	Q	W	QK	QL	U	r
MM-CF52 to 152	24h6	55	50	$8^{0}_{-0.036}$	36	5	$4^{+0.2}_{0}$	4
MM-CF202 to 352	$35^{+0.010}_{0}$	79	-	$10^{0}_{-0.036}$	55	5	$5^{+0.2}_{0}$	5



# 6. CHARACTERISTICS

## 6.1 Vibration Rank

The vibration rank of the motor is V-10 at rated speed. The following diagram shows the motor installation attitude for measurement and the position of measurement.

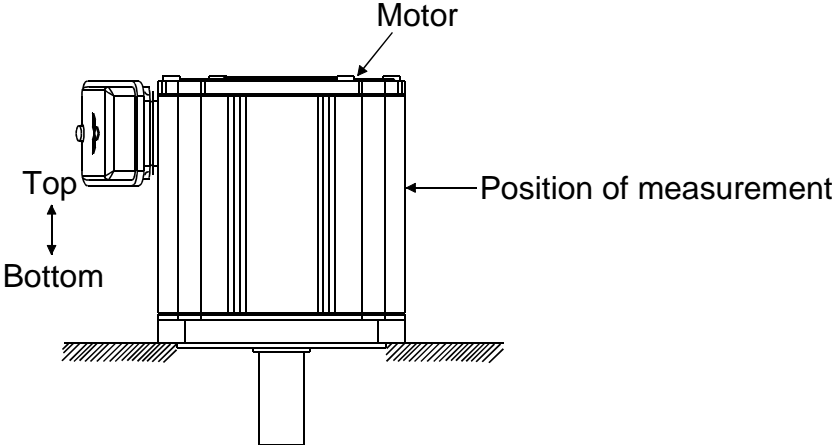

7. OUTLINE DRAWINGS

Model	Output [kW]	Variable Dimensions		Inertia Moment J [ $\times 10^{-4}$ kg·m <sup>2</sup> ]	Weight [kg]
		LL	KB		
MM-CF52	0.5	92	62	6.6	5.1
MM-CF102	1.0	117	87	13.7	7.2
MM-CF152	1.5	142	112	20.0	9.3

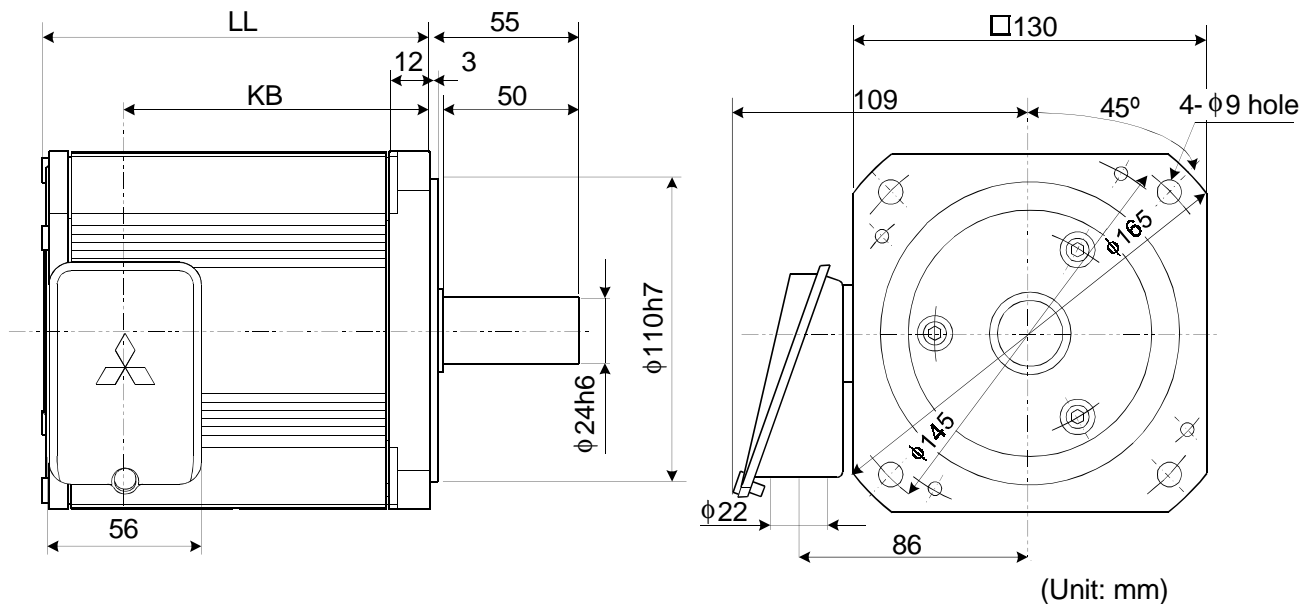

Model	Output [kW]	Variable Dimensions		Inertia Moment J [ $\times 10^{-4}$ kg·m <sup>2</sup> ]	Weight [kg]
		LL	KB		
MM-CF202	2.0	128	77	45.5	13.0
MM-CF352	3.5	170	119	85.6	19.0

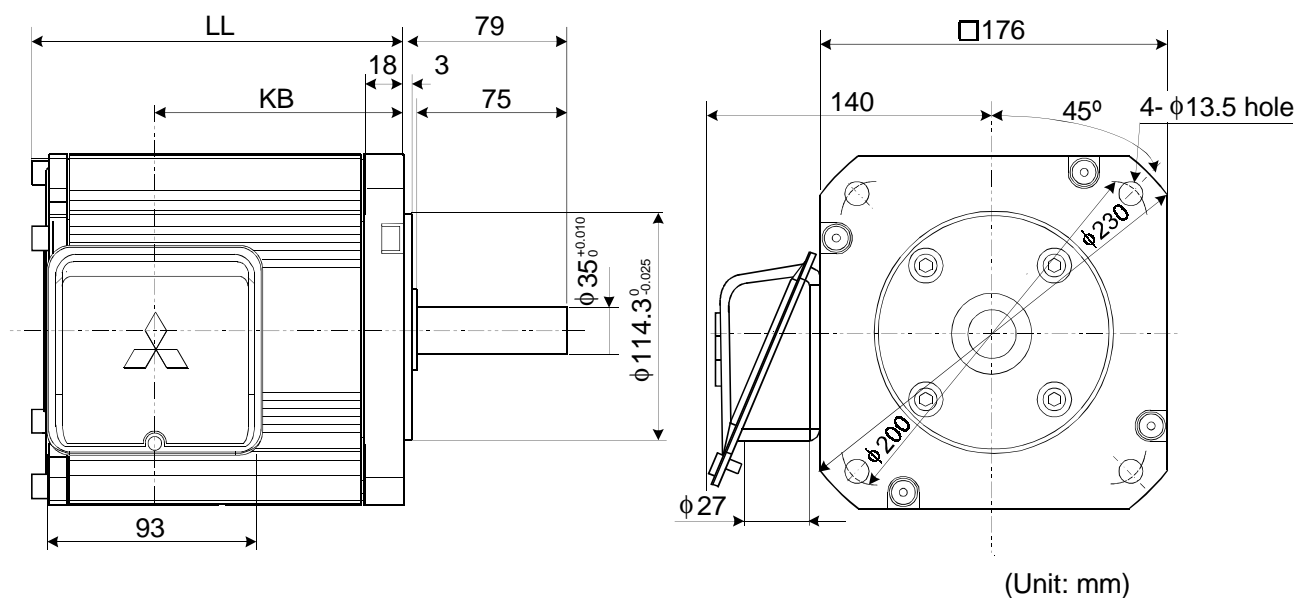

# REVISIONS

\*The manual number is given on the bottom left of the back cover.

Print Date	*Manual Number	Revision
Jan., 2001	IB(NA)-0600054-A	First edition