

**MITSUBISHI
ELECTRIC**



INVERTER FR-E700

INSTRUCTION MANUAL (Applied)

FL remote communication function

FR-E720-0.1KNF to 15KNF FR-E740-0.4KNF to 15KNF

OUTLINE

1

WIRING

2

**PRECAUTIONS FOR
USE OF THE INVERTER**

3

**FL REMOTE
COMMUNICATION FUNCTION**

4

PARAMETERS

5

TROUBLESHOOTING

6

**PRECAUTIONS FOR
MAINTENANCE AND INSPECTION**

7

SPECIFICATIONS

8

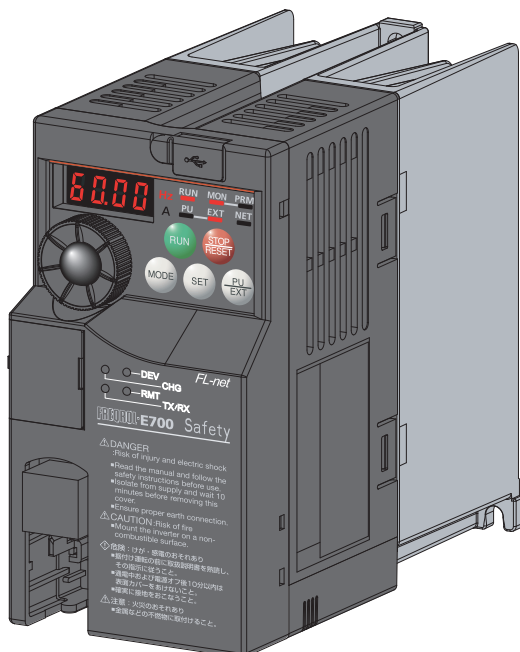

Thank you for choosing this Mitsubishi Inverter.

This Instruction Manual (Applied) provides instructions for advanced use of the FR-E700 series FL remote type inverters. Incorrect handling might cause an unexpected fault. Before using the inverter, always read this Instruction Manual and the Instruction Manual (Basic) [IB-0600397ENG] packed with the product carefully to use the equipment to its optimum performance.

This section is specifically about safety matters

Do not attempt to install, operate, maintain or inspect the inverter until you have read through the Instruction Manual (Basic) and appended documents carefully and can use the equipment correctly. Do not use this product until you have a full knowledge of the equipment, safety information and instructions.

In this Instruction Manual, the safety instruction levels are classified into "WARNING" and "CAUTION".

⚠ WARNING Incorrect handling may cause hazardous conditions, resulting in death or severe injury.

⚠ CAUTION Incorrect handling may cause hazardous conditions, resulting in medium or slight injury, or may cause only material damage.

The **⚠ CAUTION** level may even lead to a serious consequence according to conditions. Both instruction levels must be followed because these are important to personal safety.

1. Electric Shock Prevention

⚠ WARNING

- While power is ON or when the inverter is running, do not open the front cover. Otherwise you may get an electric shock.
- Do not run the inverter with the front cover or wiring cover removed. Otherwise you may access the exposed high-voltage terminals or the charging part of the circuitry and get an electric shock.
- Even if power is OFF, do not remove the front cover except for wiring or periodic inspection. You may accidentally touch the charged inverter circuits and get an electric shock.
- Before wiring or inspection, power must be switched OFF. To confirm that, LED indication of the operation panel must be checked. (It must be OFF.) Any person who is involved in wiring or inspection shall wait for at least 10 minutes after the power supply has been switched OFF and check that there are no residual voltage using a tester or the like. The capacitor is charged with high voltage for some time after power OFF, and it is dangerous.
- This inverter must be earthed (grounded). Earthing (grounding) must conform to the requirements of national and local safety regulations and electrical code (NEC section 250, IEC 536 class 1 and other applicable standards). A neutral-point earthed (grounded) power supply for 400V class inverter in compliance with EN standard must be used.
- Any person who is involved in wiring or inspection of this equipment shall be fully competent to do the work.
- The inverter must be installed before wiring. Otherwise you may get an electric shock or be injured.
- Setting dial and key operations must be performed with dry hands to prevent an electric shock. Otherwise you may get an electric shock.
- Do not subject the cables to scratches, excessive stress, heavy loads or pinching. Otherwise you may get an electric shock.
- Do not change the cooling fan while power is ON. It is dangerous to change the cooling fan while power is ON.
- Do not touch the printed circuit board or handle the cables with wet hands. Otherwise you may get an electric shock.
- When measuring the main circuit capacitor capacity, the DC voltage is applied to the motor for 1s at powering OFF. Never touch the motor terminal, etc. right after powering OFF to prevent an electric shock.

2. Fire Prevention

⚠ CAUTION

- Inverter must be installed on a nonflammable wall without holes (so that nobody touches the inverter heatsink on the rear side, etc.). Mounting it to or near flammable material can cause a fire.
- If the inverter has become faulty, the inverter power must be switched OFF. A continuous flow of large current could cause a fire.
- When using a brake resistor, a sequence that will turn OFF power when a fault signal is output must be configured. Otherwise the brake resistor may overheat due to damage of the brake transistor and possibly cause a fire.
- Do not connect a resistor directly to the DC terminals P/+ and N/-. Doing so could cause a fire.

3. Injury Prevention

CAUTION

- The voltage applied to each terminal must be the ones specified in the Instruction Manual. Otherwise burst, damage, etc. may occur.
- The cables must be connected to the correct terminals. Otherwise burst, damage, etc. may occur.
- Polarity must be correct. Otherwise burst, damage, etc. may occur.
- While power is ON or for some time after power-OFF, do not touch the inverter as they will be extremely hot. Doing so can cause burns.

4. Additional Instructions

Also the following points must be noted to prevent an accidental failure, injury, electric shock, etc.

(1) Transportation and Mounting

CAUTION

- The product must be transported in correct method that corresponds to the weight. Failure to do so may lead to injuries.
- Do not stack the boxes containing inverters higher than the number recommended.
- The product must be installed to the position where withstands the weight of the product according to the information in the Instruction Manual.
- Do not install or operate the inverter if it is damaged or has parts missing.
- When carrying the inverter, do not hold it by the front cover or setting dial; it may fall off or fail.
- Do not stand or rest heavy objects on the product.
- The inverter mounting orientation must be correct.
- Foreign conductive objects must be prevented from entering the inverter. That includes screws and metal fragments or other flammable substance such as oil.
- As the inverter is a precision instrument, do not drop or subject it to impact.
- The inverter must be used under the following environment. Otherwise the inverter may be damaged.

Environment	Surrounding air temperature	-10°C to +50°C (non-freezing)
	Ambient humidity	90%RH or less (non-condensing)
	Storage temperature	-20°C to +65°C *1
	Atmosphere	Indoors (free from corrosive gas, flammable gas, oil mist, dust and dirt)
	Altitude/vibration	Maximum 1,000m above sea level. 5.9m/s ² or less at 10 to 55Hz (directions of X, Y, Z axes)

*1 Temperature applicable for a short time, e.g. in transit.

(2) Wiring

CAUTION

- Do not install a power factor correction capacitor or surge suppressor/capacitor type filter on the inverter output side. These devices on the inverter output side may be overheated or burn out.
- The connection orientation of the output cables U, V, W to the motor affects the rotation direction of the motor.

(3) Trial run

CAUTION

- Before starting operation, each parameter must be confirmed and adjusted. A failure to do so may cause some machines to make unexpected motions.

(4) Usage

WARNING

- Any person must stay away from the equipment when the retry function is set as it will restart suddenly after trip.
- Since pressing  key may not stop output depending on the function setting status, separate circuit and switch that make an emergency stop (power OFF, mechanical brake operation for emergency stop, etc.) must be provided.
- OFF status of the start signal must be confirmed before resetting the inverter fault. Resetting inverter alarm with the start signal ON restarts the motor suddenly.
- The inverter must be used for three-phase induction motors. Connection of any other electrical equipment to the inverter output may damage the equipment.
- Do not modify the equipment.
- Do not perform parts removal which is not instructed in this manual. Doing so may lead to fault or damage of the product.

CAUTION

- The electronic thermal relay function does not guarantee protection of the motor from overheating. It is recommended to install both an external thermal for overheat protection.
- Do not use a magnetic contactor on the inverter input for frequent starting/stopping of the inverter. Otherwise the life of the inverter decreases.
- The effect of electromagnetic interference must be reduced by using a noise filter or by other means. Otherwise nearby electronic equipment may be affected.
- Appropriate measures must be taken to suppress harmonics. Otherwise power supply harmonics from the inverter may heat/damage the power factor correction capacitor and generator.
- When driving a 400V class motor by the inverter, the motor must be an insulation-enhanced motor or measures must be taken to suppress surge voltage. Surge voltage attributable to the wiring constants may occur at the motor terminals, deteriorating the insulation of the motor.
- When parameter clear or all parameter clear is performed, the required parameters must be set again before starting operations because all parameters return to the initial value.
- The inverter can be easily set for high-speed operation. Before changing its setting, the performances of the motor and machine must be fully examined.
- Stop status cannot be hold by the inverter's brake function. In addition to the inverter's brake function, a holding device must be installed to ensure safety.
- Before running an inverter which had been stored for a long period, inspection and test operation must be performed.
- For prevention of damage due to static electricity, nearby metal must be touched before touching this product to eliminate static electricity from your body.

(5) Emergency stop

⚠ CAUTION

- A safety backup such as an emergency brake must be provided to prevent hazardous condition to the machine and equipment in case of inverter failure.
- When the breaker on the inverter input side trips, the wiring must be checked for fault (short circuit), and internal parts of the inverter for a damage, etc. The cause of the trip must be identified and removed before turning ON the power of the breaker.
- When any protective function is activated, appropriate corrective action must be taken, and the inverter must be reset before resuming operation.

(6) Maintenance, inspection and parts replacement

⚠ CAUTION

- Do not carry out a megger (insulation resistance) test on the control circuit of the inverter. It will cause a failure.

(7) Disposal

⚠ CAUTION

- The inverter must be treated as industrial waste.

General instruction

Many of the diagrams and drawings in this Instruction Manual show the inverter without a cover or partially open for explanation. Never operate the inverter in this manner. The cover must be always reinstalled and the instruction in this Instruction Manual must be followed when operating the inverter.

CONTENTS

1	OUTLINE	1
1.1	Product checking and parts identification	2
1.2	Inverter and peripheral devices	3
1.2.1	Peripheral devices	4
1.3	Removal and reinstallation of the cover	5
1.3.1	Front cover	5
1.3.2	Wiring cover	7
1.4	Installation of the inverter and enclosure design	8
1.4.1	Inverter installation environment	8
1.4.2	Cooling system types for inverter enclosure	10
1.4.3	Inverter placement	11
2	WIRING	13
2.1	Wiring	14
2.1.1	Terminal connection diagram	14
2.2	Main circuit terminal specifications	15
2.2.1	Specification of main circuit terminal	15
2.2.2	Terminal arrangement of the main circuit terminal, power supply and the motor wiring	15
2.2.3	Cables and wiring length	17
2.3	Control circuit specifications	20
2.3.1	Control circuit terminal	20
2.3.2	Wiring of control circuit	21
2.3.3	Connecting the 24V external power supply	23
2.3.4	Safety stop function	24
2.4	Connection of stand-alone option unit	25
2.4.1	Connection of a dedicated external brake resistor (MRS type, MYS type, FR-ABR)	25
2.4.2	Connection of the brake unit (FR-BU2)	27
2.4.3	Connection of the DC reactor (FR-HEL)	28
3	PRECAUTIONS FOR USE OF THE INVERTER	29
3.1	EMC and leakage currents	30
3.1.1	Leakage currents and countermeasures	30
3.1.2	EMC measures	32
3.1.3	Power supply harmonics	34
3.1.4	Harmonic suppression guideline in Japan	35

3.2	Installation of power factor improving reactor	37
3.3	Power-OFF and magnetic contactor (MC).....	38
3.4	Inverter-driven 400V class motor	39
3.5	Precautions for use of the inverter.....	40
3.6	Failsafe of the system which uses the inverter	42
4	FL REMOTE COMMUNICATION FUNCTION	45
<hr/>		
4.1	FL remote communication specification.....	46
4.2	Node address setting	46
4.3	Wiring.....	47
4.3.1	Connecting to the network.....	47
4.3.2	Precautions for system configuration	47
4.3.3	Cable specifications.....	47
4.3.4	Connecting the FL-net dedicated cable.....	48
4.4	LED status	49
4.4.1	Device status LED (DEV), remote status LED (RMT)	49
4.4.2	Transmitting (TX)/receiving (RX) LED	49
4.4.3	Communication set status LED (CHG).....	49
4.5	Operation mode setting.....	50
4.5.1	Operation mode basics.....	50
4.5.2	PU operation interlock	51
4.5.3	Operation availability in each operation mode.....	51
4.6	FL remote communication	52
4.6.1	Overview of FL remote communication	52
4.6.2	FL remote data communication types	52
4.7	Cyclic transmission	53
4.7.1	Common memory	54
4.7.2	Output data (master to inverter)	57
4.7.3	Input data (inverter to master)	59
4.8	Message transmission.....	61
4.8.1	Error response at word block read/write.....	61
4.8.2	Word block read/write	62
4.8.3	Network parameter read.....	68
4.8.4	Log data read	69
4.8.5	Log data clear.....	69
4.8.6	Profile read	70
4.8.7	Message loopback.....	71

5.1	Operation panel.....	74
5.1.1	Names and functions of the operation panel	74
5.1.2	Basic operation (factory setting)	75
5.1.3	Changing the parameter setting value.....	76
5.1.4	Setting dial push	77
5.2	Parameter list	78
5.2.1	Parameter list.....	78
5.3	Control mode	92
5.3.1	Changing the control method (Pr. 80, Pr. 81, Pr. 800)	93
5.4	Adjustment of the output torque (current) of the motor.....	94
5.4.1	Manual torque boost (Pr. 0, Pr. 46)	94
5.4.2	Advanced magnetic flux vector control (Pr. 71, Pr. 80, Pr. 81, Pr.89, Pr. 800)	95
5.4.3	General-purpose magnetic flux vector control (Pr. 71, Pr. 80, Pr. 81, Pr. 800)	98
5.4.4	Slip compensation (Pr. 245 to Pr. 247)	100
5.4.5	Stall prevention operation (Pr. 22, Pr. 23, Pr. 48, Pr. 66, Pr. 156, Pr. 157, Pr. 277)	101
5.5	Limiting the output frequency	105
5.5.1	Maximum/minimum frequency (Pr. 1, Pr. 2, Pr. 18).....	105
5.5.2	Avoiding mechanical resonance points (frequency jumps) (Pr. 31 to Pr. 36).....	106
5.6	V/F pattern.....	107
5.6.1	Base frequency, voltage (Pr. 3, Pr. 19, Pr. 47).....	107
5.6.2	Load pattern selection (Pr. 14)	109
5.7	Frequency setting by input signals	111
5.7.1	Operation by multi-speed operation (Pr. 4 to Pr. 6, Pr. 24 to Pr. 27).....	111
5.7.2	Remote setting function (Pr. 59).....	113
5.8	Setting of acceleration/deceleration time and acceleration/ deceleration pattern	116
5.8.1	Setting of the acceleration and deceleration time (Pr. 7, Pr. 8, Pr. 20, Pr. 21, Pr. 44, Pr. 45, Pr. 147)	116
5.8.2	Starting frequency and start-time hold function (Pr. 13, Pr. 571).....	119
5.8.3	Acceleration/deceleration pattern (Pr. 29)	120
5.8.4	Shortest acceleration/deceleration (automatic acceleration/deceleration) (Pr. 61 to Pr. 63, Pr. 292, Pr. 293).....	121
5.9	Selection and protection of a motor	123
5.9.1	Motor overheat protection (Electronic thermal O/L relay) (Pr. 9, Pr. 51)	123
5.9.2	Applied motor (Pr. 71, Pr. 450).....	125
5.9.3	Exhibiting the best performance for the motor (offline auto tuning) (Pr. 71, Pr. 80 to Pr. 84, Pr. 90 to Pr. 94, Pr. 96, Pr. 859)	127

5.10 Motor brake and stop operation.....	135
5.10.1 DC injection brake (Pr. 10 to Pr. 12).....	135
5.10.2 Selection of a regenerative brake (Pr. 30, Pr. 70)	136
5.10.3 Stop selection (Pr. 250)	138
5.10.4 Stop-on contact control function (Pr. 6, Pr. 48, Pr. 270, Pr. 275, Pr. 276)	139
5.11 I/O signal control	141
5.11.1 Operation of start signals (STF, STR signal).....	141
5.11.2 Reset cancel signal (READY signal) and inverter running signal (RUN signal)	142
5.11.3 Second function selection signal (RT signal).....	143
5.11.4 Inverter output shutoff signal (MRS signal, Pr. 17).....	143
5.11.5 Detection of output frequency (SU, FU signal, Pr. 41 to Pr. 43).....	144
5.11.6 Output current detection function (Y12 signal, Y13 signal, Pr. 150 to Pr. 153)	145
5.12 Monitor display and monitor output signal.....	146
5.12.1 Speed display and speed setting (Pr. 37).....	146
5.12.2 Monitor display selection of the operation panel (Pr. 52, Pr. 170, Pr. 171, Pr. 268, Pr. 563, Pr. 564).....	147
5.13 Operation selection at power failure and instantaneous power failure.....	151
5.13.1 Automatic restart after instantaneous power failure/flying start (Pr. 57, Pr. 58, Pr. 96, Pr. 162, Pr. 165, Pr. 298, Pr. 299, Pr. 611)	151
5.13.2 Power-failure deceleration stop function (Pr. 261)	156
5.14 Operation setting at fault occurrence	158
5.14.1 Retry function (Pr. 65, Pr. 67 to Pr. 69)	158
5.14.2 Input/output phase loss protection selection (Pr. 251, Pr. 872).....	160
5.14.3 Earth (ground) fault detection at start (Pr. 249)	160
5.14.4 Display and erasure of communication error occurrence count (Pr. 501)	161
5.15 Energy saving operation.....	162
5.15.1 Optimum excitation control (Pr. 60)	162
5.16 Motor noise, EMI measures, mechanical resonance	163
5.16.1 PWM carrier frequency and soft-PWM control (Pr. 72, Pr. 240).....	163
5.16.2 Speed smoothing control (Pr. 653).....	164
5.17 Misoperation prevention and parameter setting restriction.....	165
5.17.1 Reset selection/PU stop selection (Pr. 75)	165
5.17.2 Parameter write disable selection (Pr. 77).....	166
5.17.3 Reverse rotation prevention selection (Pr. 78)	167
5.17.4 Extended parameter display and user group function (Pr. 160, Pr. 172 to Pr. 174).....	167
5.17.5 Password function (Pr. 296, Pr. 297).....	169
5.18 Special operation and frequency control	171
5.18.1 Jog operation (Pr. 15, Pr. 16)	171

5.18.2	Droop control (Pr. 286, Pr. 287)	173
5.18.3	Regeneration avoidance function (Pr. 665, Pr. 882, Pr. 883, Pr. 885, Pr. 886).....	174
5.19	Useful functions	176
5.19.1	Cooling fan operation selection (Pr. 244)	176
5.19.2	Display of the life of the inverter parts (Pr. 255 to Pr. 259).....	177
5.19.3	Maintenance timer alarm (Pr. 503, Pr. 504).....	180
5.19.4	Free parameter (Pr. 888, Pr. 889)	181
5.20	Setting from the operation panel	182
5.20.1	RUN key rotation direction selection (Pr. 40).....	182
5.20.2	Operation panel frequency setting/key lock operation selection (Pr. 161).....	183
5.20.3	Magnitude of frequency change setting (Pr. 295).....	185
5.21	Parameter clear/ All parameter clear.....	186
5.22	Initial value change list	187
5.23	Check and clear of the faults history	188
6	TROUBLESHOOTING	191
<hr/>		
6.1	Reset method of protective function	192
6.2	List of fault or alarm indications	193
6.3	Causes and corrective actions.....	194
6.4	Correspondences between digital and actual characters	203
6.5	Check first when you have a trouble.....	204
6.5.1	Motor does not start.....	204
6.5.2	Motor or machine is making abnormal acoustic noise.....	205
6.5.3	Inverter generates abnormal noise	205
6.5.4	Motor generates heat abnormally	206
6.5.5	Motor rotates in the opposite direction.....	206
6.5.6	Speed greatly differs from the setting	206
6.5.7	Acceleration/deceleration is not smooth	206
6.5.8	Speed varies during operation.....	207
6.5.9	Operation mode is not changed properly.....	207
6.5.10	Operation panel display is not operating	207
6.5.11	Motor current is too large.....	208
6.5.12	Speed does not accelerate	208
6.5.13	Unable to write parameter setting.....	208
6.5.14	Troubleshooting in FL remote communication.....	209
7	PRECAUTIONS FOR MAINTENANCE AND INSPECTION	211
<hr/>		

7.1 Inspection items..... 212

- 7.1.1 Daily inspection 212
- 7.1.2 Periodic inspection 212
- 7.1.3 Daily and periodic inspection 213
- 7.1.4 Display of the life of the inverter parts 214
- 7.1.5 Checking the inverter and converter modules 214
- 7.1.6 Cleaning 214
- 7.1.7 Replacement of parts 215

7.2 Measurement of main circuit voltages, currents and powers 218

- 7.2.1 Measurement of powers 220
- 7.2.2 Measurement of voltages and use of PT 220
- 7.2.3 Measurement of currents 221
- 7.2.4 Use of CT and transducer 221
- 7.2.5 Measurement of inverter input power factor 221
- 7.2.6 Measurement of converter output voltage (across terminals P and N) 221
- 7.2.7 Insulation resistance test using megger 222
- 7.2.8 Pressure test 222

8 SPECIFICATIONS 223

- 8.1 Rating..... 224**
- 8.2 Common specifications..... 225**
- 8.3 Outline dimension drawings..... 226**

APPENDIX 231

- Appendix 1 Specification change 232**
 - Appendix 1-1 SERIAL number check 232
 - Appendix 1-2 Changed Functions 232
- Appendix 2 Index..... 233**

MEMO

1 OUTLINE

This chapter explains the "OUTLINE" for use of this product. Always read the instructions before using the equipment.

1.1	Product checking and parts identification	2
1.2	Inverter and peripheral devices	3
1.3	Removal and reinstallation of the cover	5
1.4	Installation of the inverter and enclosure design	8

<Abbreviation>
 Inverter Mitsubishi inverter FR-E700 series FL remote type
 FR-E700-NF Mitsubishi inverter FR-E700 series FL remote type
 Pr. Parameter number
 PU operation Operation using the operation panel
 Mitsubishi standard motor SF-JR
 Mitsubishi constant-torque motor ... SF-HRCA

<Trademark>
 Company and product names herein are the trademarks and registered trademarks of their respective owners.

<Mark>

 **REMARKS** :Additional helpful contents and relations with other functions are stated

 **NOTE** :Contents requiring caution or cases when set functions are not activated are stated.

 **POINT** :Useful contents and points are stated.

 **Parameters referred to** : Related parameters are stated.

1

2

3

4

5

6

7

8

1.1 Product checking and parts identification

Unpack the inverter and check the capacity plate on the front cover and the rating plate on the inverter side face to ensure that the product agrees with your order and the inverter is intact.

● Inverter model

FR - E720 - 2.2 KNF

No.	Voltage class
E720	Three-phase 200V class
E740	Three-phase 400V class

Represents the inverter capacity [kW]

Operation panel
(Refer to page 74)

Node address switch
(Refer to page 46)

FL remote communication connector
(Refer to page 48)

Front cover
(Refer to page 5)

Cooling fan
(Refer to page 215)

LED (operation status indication)
(Refer to page 49)

Control circuit terminal block
(Refer to page 20)

Main circuit terminal block
(Refer to page 15)

Combed shaped wiring cover
(Refer to page 7)

Capacity plate *

FR-E720-2.2KNF ← Inverter model

SERIAL : **XXXXXX** ← Serial number

* Location of the capacity plate and the rating plate differs according to the inverter capacity. Refer to the outline dimension drawing. (Refer to page 226)

Example of FR-E720-2.2KNF

Rating plate *

	MITSUBISHI INVERTER
Inverter model	MODEL FR-E720-2.2KNF
Input rating	INPUT : XXXXX
Output rating	OUTPUT : XXXXX
Serial number	SERIAL : _____
	MITSUBISHI ELECTRIC CORPORATION MADE IN JAPAN

PASSED

● Accessory

- Fan cover fixing screws (M3 × 35mm)

These screws are necessary for compliance with the EU Directive (Refer to the Instruction Manual (Basic))

Capacity	Quantity
FR-E720-1.5KNF to 3.7KNF, FR-E740-1.5KNF to 3.7KNF	1
FR-E720-5.5KNF to 15KNF, FR-E740-5.5KNF to 15KNF	2

Harmonic suppression guideline (when inverters are used in Japan)

All models of general-purpose inverters used by specific consumers are covered by "Harmonic suppression guideline for consumers who receive high voltage or special high voltage". (For further details, refer to page 35.)

1.2 Inverter and peripheral devices

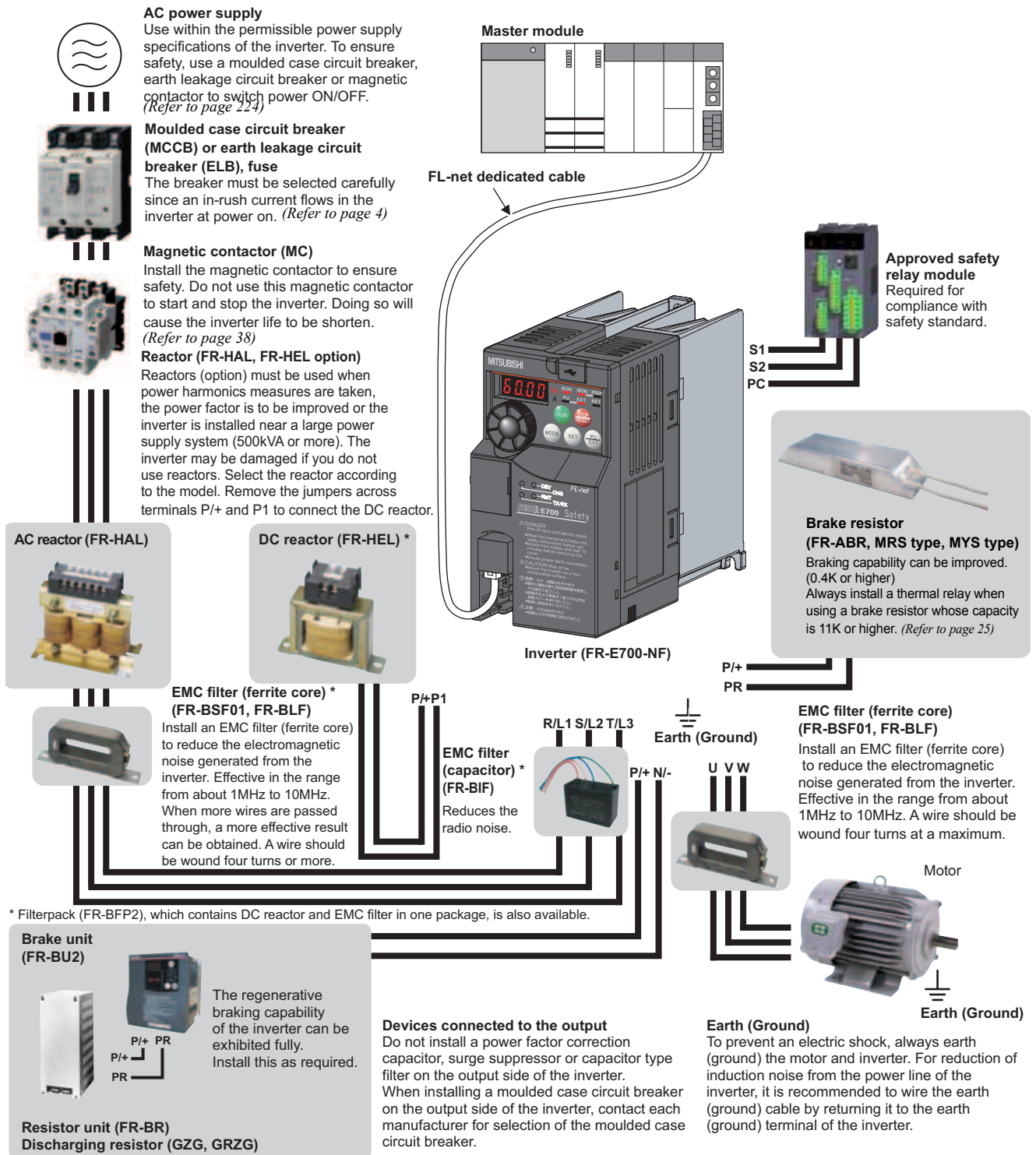

NOTE

- Up to 64 inverters can be connected when using FL remote communication.
- The life of the inverter is influenced by surrounding air temperature. The surrounding air temperature should be as low as possible within the permissible range. This must be noted especially when the inverter is installed in an enclosure. (Refer to page 8)
- Wrong wiring might lead to damage of the inverter. The control signal lines must be kept fully away from the main circuit to protect them from noise. (Refer to page 14)
- Do not install a power factor correction capacitor, surge suppressor or capacitor type filter on the inverter output side. This will cause the inverter to trip or the capacitor and surge suppressor to be damaged. If any of the above devices are connected, immediately remove them.
- Electromagnetic wave interference
The input/output (main circuit) of the inverter includes high frequency components, which may interfere with the communication devices (such as AM radios) used near the inverter. In this case, install options among the capacitor type EMC filter FR-BIF (for use in the input side only), the ferrite core type EMC filter FR-BSF01/FR-BLF, filterpack, and EMC filter to minimize the interference. (Refer to page 32).
- Refer to the instruction manual of each option and peripheral devices for details of peripheral devices.

1.2.1 Peripheral devices

Check the inverter model of the inverter you purchased. Appropriate peripheral devices must be selected according to the capacity. Refer to the following list and prepare appropriate peripheral devices:

Applicable Inverter Model	Motor Output (kW)	Moulded Case Circuit Breaker (MCCB) *1 or Earth Leakage Circuit Breaker (ELB) *2 (NF, NV type)		Magnetic Contactor (MC) *3		Reactor		
		Reactor connection		Reactor connection		FR-HAL	FR-HEL	
		without	with	without	with			
Three-Phase 200V	FR-E720-0.1KNF	0.1	5A	5A	S-N10	S-N10	0.4K *4	0.4K *4
	FR-E720-0.2KNF	0.2	5A	5A	S-N10	S-N10	0.4K *4	0.4K *4
	FR-E720-0.4KNF	0.4	5A	5A	S-N10	S-N10	0.4K	0.4K
	FR-E720-0.75KNF	0.75	10A	10A	S-N10	S-N10	0.75K	0.75K
	FR-E720-1.5KNF	1.5	15A	15A	S-N10	S-N10	1.5K	1.5K
	FR-E720-2.2KNF	2.2	20A	15A	S-N10	S-N10	2.2K	2.2K
	FR-E720-3.7KNF	3.7	30A	30A	S-N20, S-N21	S-N10	3.7K	3.7K
	FR-E720-5.5KNF	5.5	50A	40A	S-N25	S-N20, S-N21	5.5K	5.5K
	FR-E720-7.5KNF	7.5	60A	50A	S-N25	S-N25	7.5K	7.5K
	FR-E720-11KNF	11	75A	75A	S-N35	S-N35	11K	11K
	FR-E720-15KNF	15	125A	100A	S-N50	S-N50	15K	15K
Three-Phase 400V	FR-E740-0.4KNF	0.4	5A	5A	S-N10	S-N10	H0.4K	H0.4K
	FR-E740-0.75KNF	0.75	5A	5A	S-N10	S-N10	H0.75K	H0.75K
	FR-E740-1.5KNF	1.5	10A	10A	S-N10	S-N10	H1.5K	H1.5K
	FR-E740-2.2KNF	2.2	15A	10A	S-N10	S-N10	H2.2K	H2.2K
	FR-E740-3.7KNF	3.7	20A	15A	S-N10	S-N10	H3.7K	H3.7K
	FR-E740-5.5KNF	5.5	30A	20A	S-N20, S-N21	S-N11, S-N12	H5.5K	H5.5K
	FR-E740-7.5KNF	7.5	30A	30A	S-N20, S-N21	S-N20, S-N21	H7.5K	H7.5K
	FR-E740-11KNF	11	50A	40A	S-N20, S-N21	S-N20, S-N21	H11K	H11K
	FR-E740-15KNF	15	60A	50A	S-N25	S-N20, S-N21	H15K	H15K

- *1 •Select an MCCB according to the power supply capacity.
•Install one MCCB per inverter.

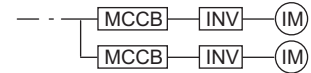

- *2 For the use in the United States or Canada, select a UL and cUL certified fuse with Class T fuse equivalent cut-off speed or faster with the appropriate rating for branch circuit protection. Alternatively, select a UL489 molded case circuit breaker (MCCB).
- *3 Magnetic contactor is selected based on the AC-1 class. The electrical durability of magnetic contactor is 500,000 times. When the magnetic contactor is used for emergency stop during motor driving, the electrical durability is 25 times.
When using the MC for emergency stop during motor driving or using on the motor side during commercial-power supply operation, select the MC with class AC-3 rated current for the motor rated current.
- *4 The power factor may be slightly lower.



NOTE

- When the inverter capacity is larger than the motor capacity, select an MCCB and a magnetic contactor according to the inverter model and cable and reactor according to the motor output.
- When the breaker on the inverter input side trips, check for the wiring fault (short circuit), damage to internal parts of the inverter, etc. Identify the cause of the trip, then remove the cause and power on the breaker.

1.3 Removal and reinstallation of the cover

1.3.1 Front cover

FR-E720-3.7KNF or lower, FR-E740-7.5KNF or lower

●Removal (Example of FR-E720-0.75KNF)

Remove the front cover by pulling it toward you in the direction of arrow.

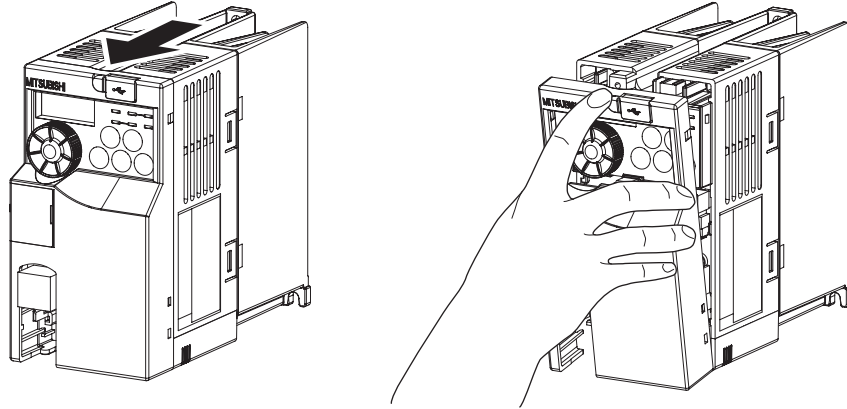

●Reinstallation (Example of FR-E720-0.75KNF)

To reinstall, match the cover to the inverter front and install it straight.

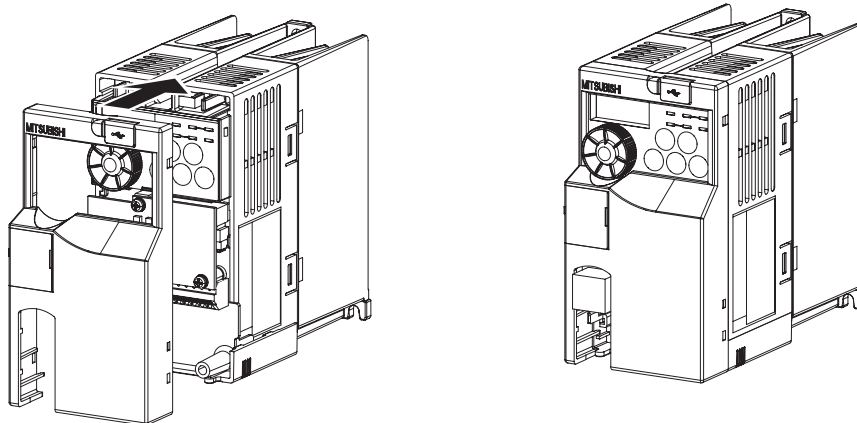

7 Removal and reinstallation of the cover

FR-E720-5.5KNF or higher, FR-E740-11KNF or higher

● Removal (Example of FR-E720-5.5KNF)

- 1) Loosen the installation screws of the front cover 1.
- 2) Remove the front cover 1 by pulling it toward you in the direction of arrow.
- 3) Remove the front cover 2 by pulling it toward you in the direction of arrow.

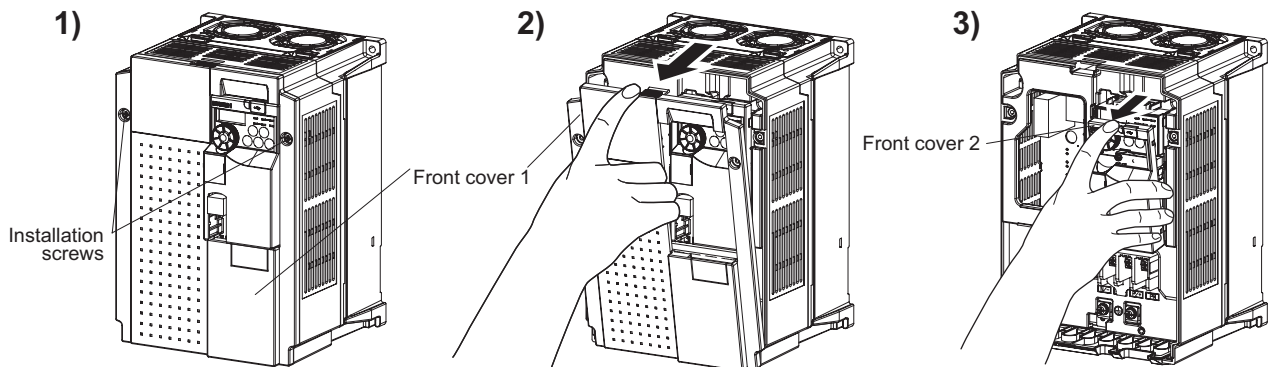

● Reinstallation (Example of FR-E720-5.5KNF)

- 1) Match the front cover 2 to the inverter front and install it straight.
- 2) Insert the two fixed hooks on the lower side of the front cover 1 into the sockets of the inverter.
- 3) Tighten the screw of the front cover 1.

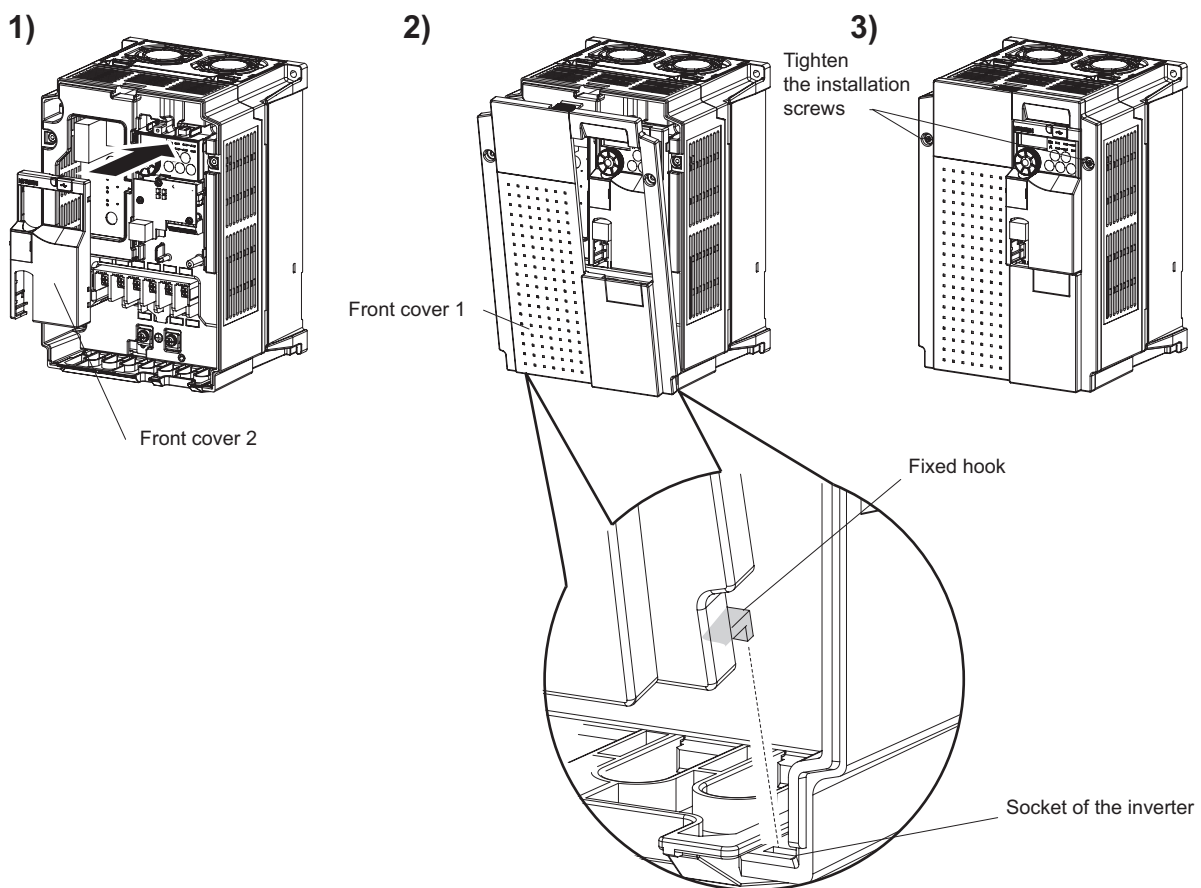

NOTE

- Fully make sure that the front cover has been reinstalled securely.
- The same serial number is printed on the capacity plate of the front cover and the rating plate of the inverter. Since these plates have the same serial numbers, always reinstall the removed cover onto the original inverter.

1.3.2 Wiring cover

●Removal and reinstallation

The cover can be removed easily by pulling it toward you. To reinstall, fit the cover to the inverter along the guides.

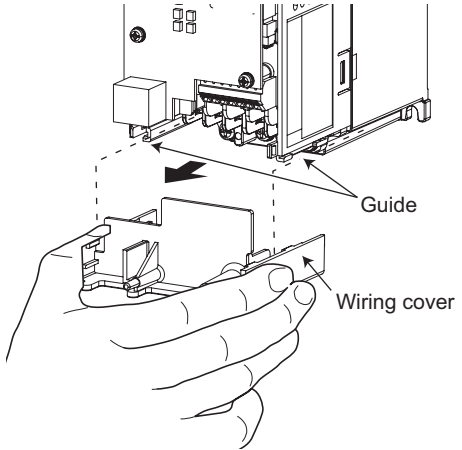
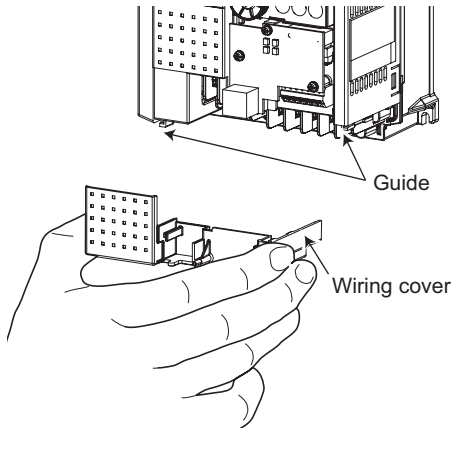
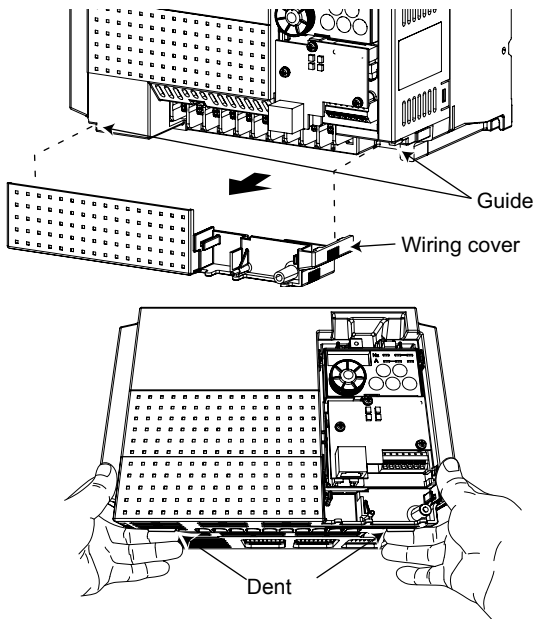
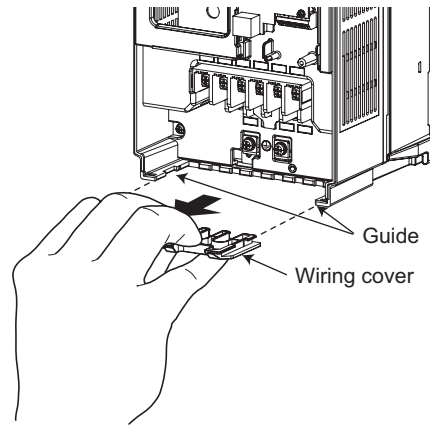
FR-E720-0.1KNF to 0.75KNF	FR-E720-1.5KNF to 3.7KNF FR-E740-0.4KNF to 3.7KNF
 <p data-bbox="319 840 638 862">Example of FR-E720-0.75KNF</p>	 <p data-bbox="989 840 1308 862">Example of FR-E740-3.7KNF</p>
FR-E740-5.5KNF, 7.5KNF	FR-E720-5.5KNF to 15KNF FR-E740-11KNF, 15KNF
 <p data-bbox="159 1579 798 1635">For removal, push the dent on the wiring cover with your finger and pull toward you.</p> <p data-bbox="319 1646 638 1668">Example of FR-E740-5.5KNF</p>	 <p data-bbox="989 1646 1308 1668">Example of FR-E740-11KNF</p>

1.4 Installation of the inverter and enclosure design

When an inverter enclosure is to be designed and manufactured, heat generated by contained equipment, etc., the environment of an operating place, and others must be fully considered to determine the enclosure structure, size and equipment layout. The inverter unit uses many semiconductor devices. To ensure higher reliability and long period of operation, operate the inverter in the ambient environment that completely satisfies the equipment specifications.

1.4.1 Inverter installation environment

As the inverter installation environment should satisfy the standard specifications indicated in the following table, operation in any place that does not meet these conditions not only deteriorates the performance and life of the inverter, but also causes a failure. Refer to the following points and take adequate measures.

Environmental standard specifications of inverter

Item	Description
Surrounding air temperature	-10 to +50°C (non-freezing)
Ambient humidity	90%RH or less (non-condensing)
Atmosphere	Free from corrosive and explosive gases, free from dust and dirt
Maximum altitude	1,000m or less
Vibration	5.9m/s ² or less at 10 to 55Hz (directions of X, Y, Z axes)

(1) Temperature

The permissible surrounding air temperature of the inverter is between -10 and +50°C. Always operate the inverter within this temperature range. Operation outside this range will considerably shorten the service lives of the semiconductors, parts, capacitors and others. Take the following measures so that the surrounding air temperature of the inverter falls within the specified range.

- 1) Measures against high temperature
 - Use a forced ventilation system or similar cooling system. (*Refer to page 10*)
 - Install the panel in an air-conditioned electrical chamber.
 - Block direct sunlight.
 - Provide a shield or similar plate to avoid direct exposure to the radiated heat and wind of a heat source.
 - Ventilate the area around the panel well.
- 2) Measures against low temperature
 - Provide a space heater in the enclosure.
 - Do not power off the inverter. (Keep the start signal of the inverter off.)
- 3) Sudden temperature changes
 - Select an installation place where temperature does not change suddenly.
 - Avoid installing the inverter near the air outlet of an air conditioner.
 - If temperature changes are caused by opening/closing of a door, install the inverter away from the door.

(2) Humidity

Normally operate the inverter within the 45 to 90% range of the ambient humidity. Too high humidity will pose problems of reduced insulation and metal corrosion. On the other hand, too low humidity may produce a spatial electrical breakdown. The insulation distance specified in JEM1103 "Control Equipment Insulator" is defined as humidity 45 to 85%.

- 1) Measures against high humidity
 - Make the panel enclosed, and provide it with a hygroscopic agent.
 - Take dry air into the enclosure from outside.
 - Provide a space heater in the enclosure.
- 2) Measures against low humidity

What is important in fitting or inspection of the unit in this status is to discharge your body (static electricity) beforehand and keep your body from contact with the parts and patterns, besides blowing air of proper humidity into the panel from outside.
- 3) Measures against condensation

Condensation may occur if frequent operation stops change the in-panel temperature suddenly or if the outside-air temperature changes suddenly.

Condensation causes such faults as reduced insulation and corrosion.

 - Take the measures against high humidity in 1).
 - Do not power OFF the inverter. (Keep the start signal of the inverter OFF.)

(3) Dust, dirt, oil mist

Dust and dirt will cause such faults as poor contact of contact points, reduced insulation or reduced cooling effect due to moisture absorption of accumulated dust and dirt, and in-panel temperature rise due to clogged filter. In the atmosphere where conductive powder floats, dust and dirt will cause such faults as malfunction, deteriorated insulation and short circuit in a short time.

Since oil mist will cause similar conditions, it is necessary to take adequate measures.

Countermeasures

- Place in a totally enclosed enclosure.
Take measures if the in-enclosure temperature rises. *(Refer to page 10)*
- Purge air.
Pump clean air from outside to make the in-panel pressure higher than the outside-air pressure.

(4) Corrosive gas, salt damage

If the inverter is exposed to corrosive gas or to salt near a beach, the printed board patterns and parts will corrode or the relays and switches will result in poor contact.

In such places, take the measures given in Section 3.

(5) Explosive, flammable gases

As the inverter is non-explosion proof, it must be contained in an explosion proof enclosure. In places where explosion may be caused by explosive gas, dust or dirt, an enclosure cannot be used unless it structurally complies with the guidelines and has passed the specified tests. This makes the enclosure itself expensive (including the test charges). The best way is to avoid installation in such places and install the inverter in a non-hazardous place.

(6) Highland

Use the inverter at the altitude of within 1000m. If it is used at a higher place, it is likely that thin air will reduce the cooling effect and low air pressure will deteriorate dielectric strength.

(7) Vibration, impact

The vibration resistance of the inverter is up to 5.9m/s^2 at 10 to 55Hz frequency and 1mm amplitude for the directions of X, Y, Z axes. Vibration or impact, if less than the specified value, applied for a long time may make the mechanism loose or cause poor contact to the connectors.

Especially when impact is imposed repeatedly, caution must be taken as the part pins are likely to break.

Countermeasures

- Provide the panel with rubber vibration isolators.
- Strengthen the structure to prevent the panel from resonance.
- Install the panel away from sources of vibration.

1.4.2 Cooling system types for inverter enclosure

From the enclosure that contains the inverter, the heat of the inverter and other equipment (transformers, lamps, resistors, etc.) and the incoming heat such as direct sunlight must be dissipated to keep the in-panel temperature lower than the permissible temperatures of the in-panel equipment including the inverter.

The cooling systems are classified as follows in terms of the cooling calculation method.

- 1) Cooling by natural heat dissipation from the enclosure surface (totally enclosed type)
- 2) Cooling by heat sink (aluminum fin, etc.)
- 3) Cooling by ventilation (forced ventilation type, pipe ventilation type)
- 4) Cooling by heat exchanger or cooler (heat pipe, cooler, etc.)

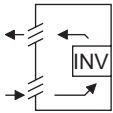
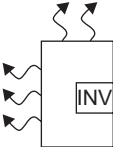
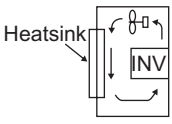
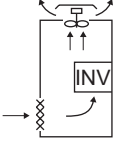
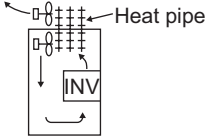
Cooling System		Enclosure Structure	Comment
Natural cooling	Natural ventilation (enclosed, open type)		Low in cost and generally used, but the panel size increases as the inverter capacity increases. For relatively small capacities.
	Natural ventilation (totally enclosed type)		Being a totally enclosed type, the most appropriate for hostile environment having dust, dirt, oil mist, etc. The panel size increases depending on the inverter capacity.
Forced cooling	Fin cooling		Having restrictions on the heatsink mounting position and area, and designed for relative small capacities.
	Forced ventilation		For general indoor installation. Appropriate for panel downsizing and cost reduction, and often used.
	Heat pipe		Totally enclosed type for panel downsizing.

1.4.3 Inverter placement

(1) Installation of the inverter

Enclosure surface mounting

Remove the front cover and wiring cover to fix the inverter to the surface.

- FR-E720-0.1KNF to 0.75KNF
- FR-E720-1.5KNF or higher
- FR-E740-0.4KNF or higher

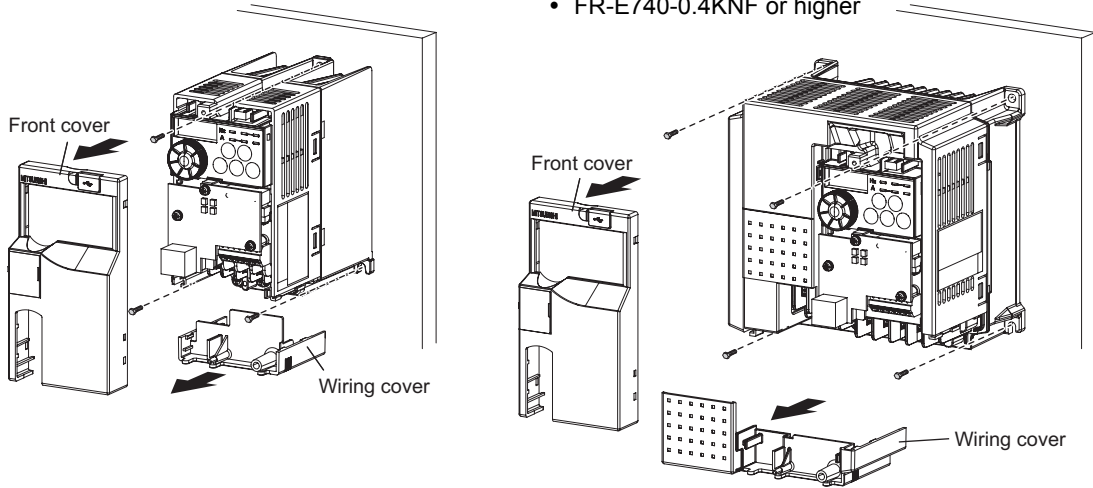

Note

- When encasing multiple inverters, install them in parallel as a cooling measure.
- Install the inverter vertically.
- For heat dissipation and maintenance, take at least the clearances shown in the table below from the inverter to the other devices and to the enclosure surface.

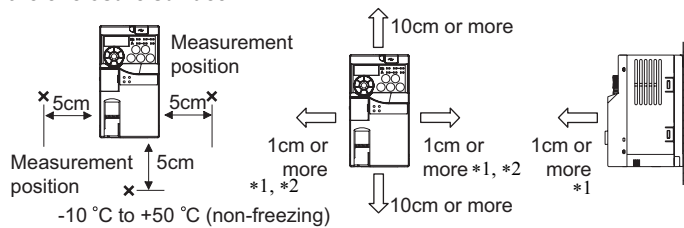

*1 Take 5cm or more clearances for 5.5K or higher.

*2 When using the inverters at the surrounding air temperature of 40°C or less, the inverters can be installed without any clearance between them (0cm clearance).

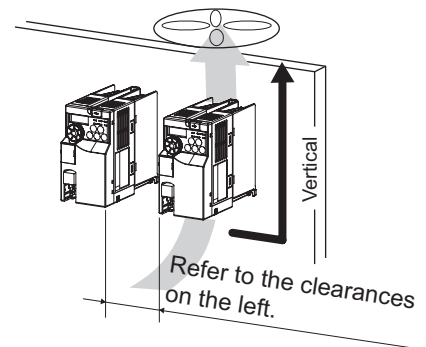

(2) Above inverter

Heat is blown up from inside the inverter by the small fan built in the unit. Any equipment placed above the inverter should be heat resistant.

(3) Arrangement of multiple inverters

When multiple inverters are placed in the same enclosure, generally arrange them horizontally as shown in the right figure (a). When it is inevitable to arrange them vertically to minimize space, take such measures as to provide guides since heat from the bottom inverters can increase the temperatures in the top inverters, causing inverter failures.

When mounting multiple inverters, fully take caution not to make the surrounding air temperature of the inverter higher than the permissible value by providing ventilation and increasing the panel size.

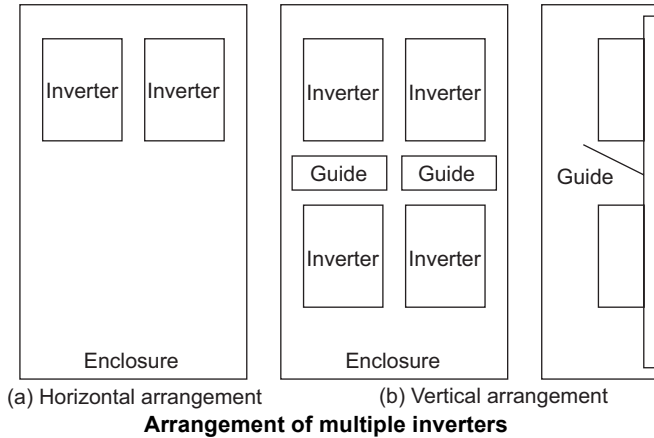

(4) Arrangement of ventilation fan and inverter

Heat generated in the inverter is blown up from the bottom of the unit as warm air by the cooling fan. When installing a ventilation fan for that heat, determine the place of ventilation fan installation after fully considering an air flow. (Air passes through areas of low resistance. Make an airway and airflow plates to expose the inverter to cool air.)

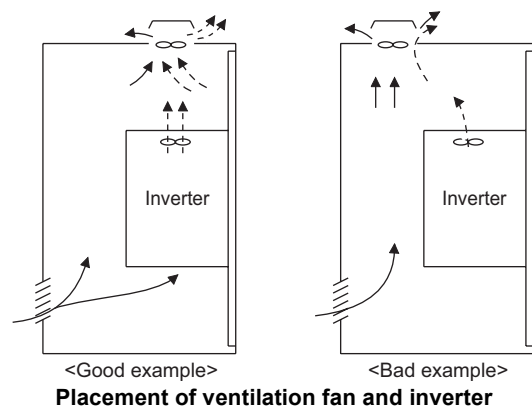

2 WIRING

This chapter describes the basic "WIRING" for use of this product.
Always read the instructions before using the equipment.

2.1	Wiring.....	14
2.2	Main circuit terminal specifications	15
2.3	Control circuit specifications	20
2.4	Connection of stand-alone option unit	25

1

2

3

4

5

6

7

8

2.1 Wiring

2.1.1 Terminal connection diagram

Sink logic

- ⊙ Main circuit terminal
- Control circuit terminal

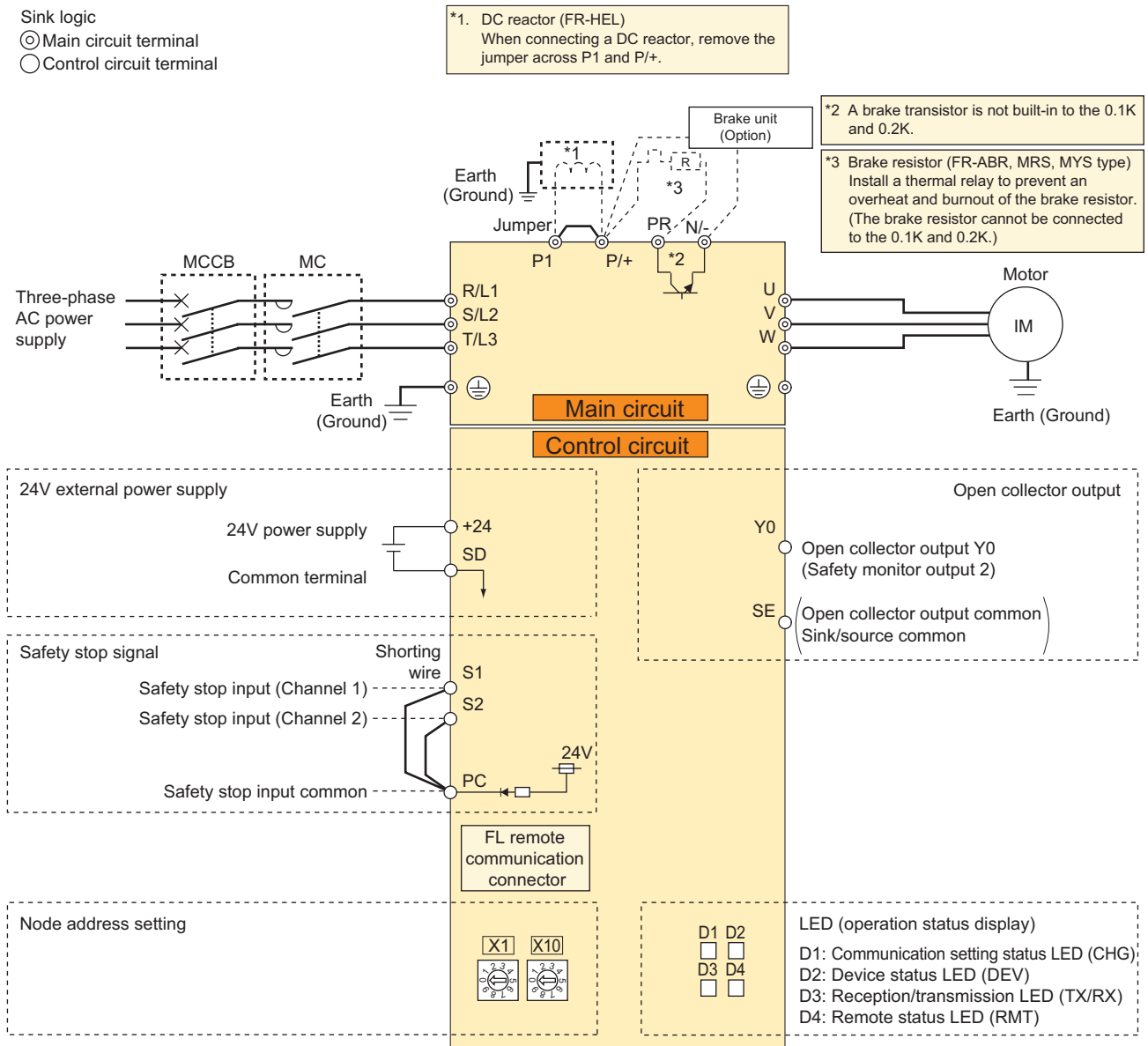

NOTE

- To prevent a malfunction caused by noise, separate the signal cables more than 10cm from the power cables. Also separate the main circuit wire of the input side and the output side.
- After wiring, wire offcuts must not be left in the inverter.
Wire offcuts can cause an alarm, failure or malfunction. Always keep the inverter clean. When drilling mounting holes in an enclosure etc., take care not to allow chips and other foreign matter to enter the inverter.

2.2 Main circuit terminal specifications

2.2.1 Specification of main circuit terminal

Terminal Symbol	Terminal Name	Description
R/L1, S/L2, T/L3	AC power input	Connect to the commercial power supply.
U, V, W	Inverter output	Connect a three-phase squirrel-cage motor.
P/+, PR	Brake resistor connection	Connect a brake resistor (FR-ABR, MRS type, MYS type) across terminals P/+ and PR. (The brake resistor cannot be connected to the 0.1K or 0.2K.)
P/+, N/-	Brake unit connection	Connect the brake unit (FR-BU2).
P/+, P1	DC reactor connection	Remove the jumper across terminals P/+ and P1 and connect a DC reactor.
	Earth (Ground)	For earthing (grounding) the inverter chassis. Must be earthed (grounded).

2.2.2 Terminal arrangement of the main circuit terminal, power supply and the motor wiring

Three-phase 200V class

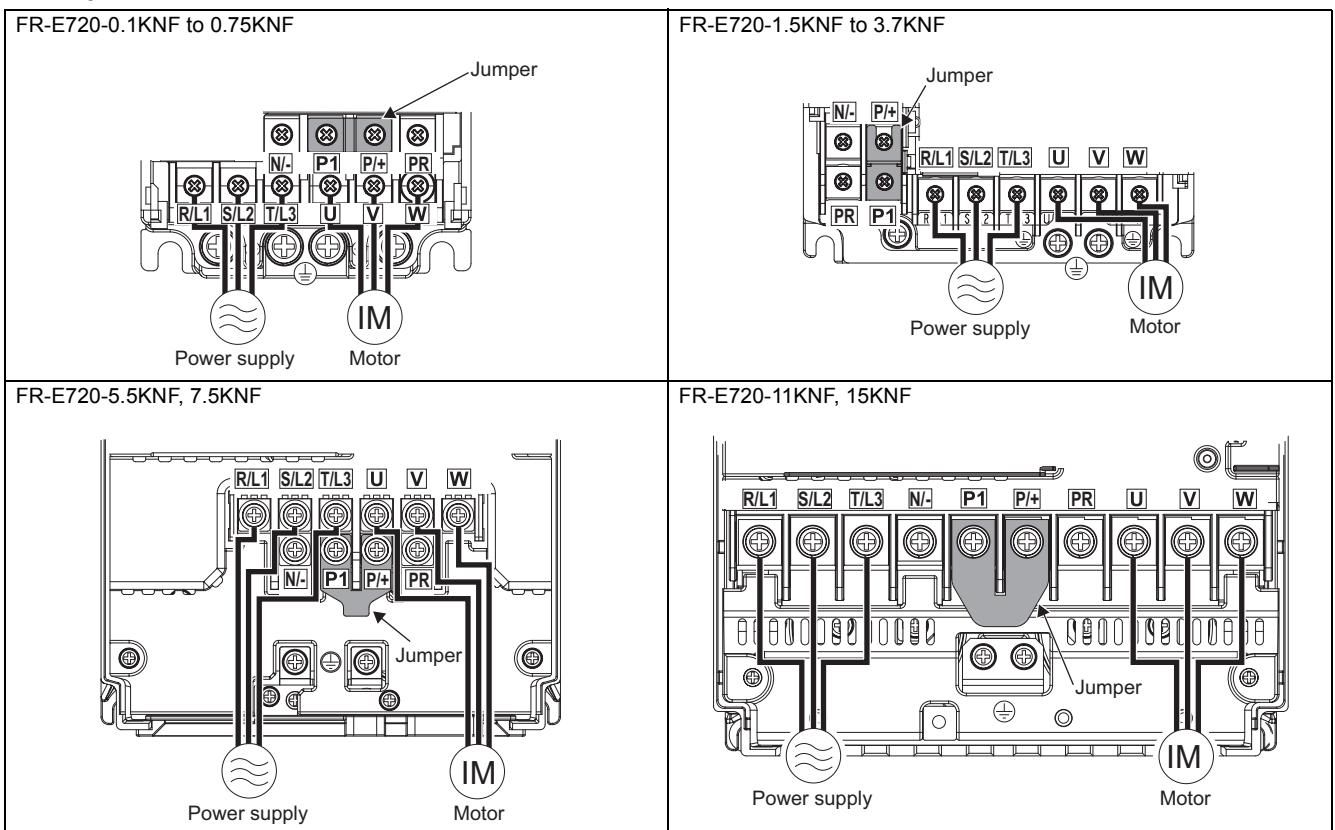

7 Main circuit terminal specifications

Three-phase 400V class

FR-E740-0.4KNF to 3.7KNF

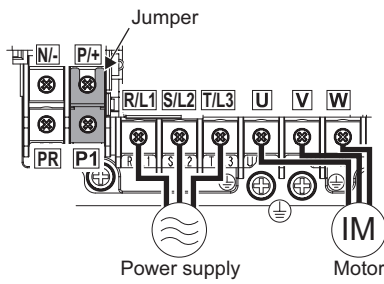

FR-E740-5.5KNF, 7.5KNF

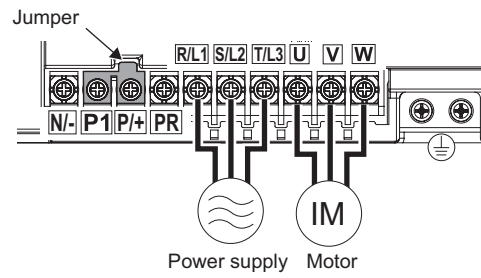

FR-E740-11KNF, 15KNF

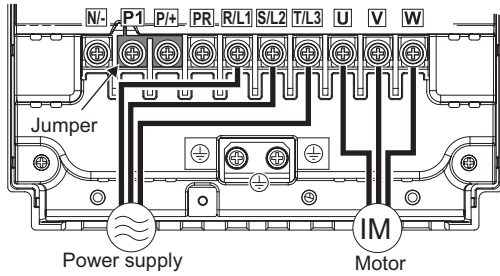

NOTE

- Make sure the power cables are connected to the R/L1, S/L2, T/L3. (Phase need not be matched.) Never connect the power cable to the U, V, W of the inverter. Doing so will damage the inverter.
- Connect the motor to U, V, W. Turning ON the forward rotation switch (signal) at this time rotates the motor counterclockwise when viewed from the load shaft.

2.2.3 Cables and wiring length

(1) Applicable cable size

Select the recommended cable size to ensure that a voltage drop will be 2% or less.

If the wiring distance is long between the inverter and motor, a main circuit cable voltage drop will cause the motor torque to decrease especially at the output of a low frequency.

The following table indicates a selection example for the wiring length of 20m.

Three-phase 200V class (when input power supply is 220V)

Applicable Inverter Model	Terminal Screw Size *4	Tightening Torque N·m	Crimping Terminal		Cable Size							
					HIV Cables, etc. (mm ²) *1			AWG *2		PVC Cables, etc. (mm ²) *3		
					R/L1 S/L2 T/L3	U, V, W	R/L1 S/L2 T/L3	U, V, W	Earthing cable	R/L1 S/L2 T/L3	U, V, W	R/L1 S/L2 T/L3
FR-E720-0.1KNF to 0.75KNF	M3.5	1.2	2-3.5	2-3.5	2	2	2	14	14	2.5	2.5	2.5
FR-E720-1.5KNF, 2.2KNF	M4	1.5	2-4	2-4	2	2	2	14	14	2.5	2.5	2.5
FR-E720-3.7KNF	M4	1.5	5.5-4	5.5-4	3.5	3.5	3.5	12	12	4	4	4
FR-E720-5.5KNF	M5	2.5	5.5-5	5.5-5	5.5	5.5	5.5	10	10	6	6	6
FR-E720-7.5KNF	M5	2.5	14-5	8-5	14	8	5.5	6	8	16	10	6
FR-E720-11KNF	M5	2.5	14-5	14-5	14	14	14	6	6	16	16	16
FR-E720-15KNF	M6(M5)	4.4	22-6	22-6	22	22	14	4	4	25	25	16

Three-phase 400V class (when input power supply is 440V)

Applicable Inverter Model	Terminal Screw Size *4	Tightening Torque N·m	Crimping Terminal		Cable Size							
					HIV Cables, etc. (mm ²) *1			AWG *2		PVC Cables, etc. (mm ²) *3		
					R/L1 S/L2 T/L3	U, V, W	R/L1 S/L2 T/L3	U, V, W	Earthing cable	R/L1 S/L2 T/L3	U, V, W	R/L1 S/L2 T/L3
FR-E740-0.4KNF to 3.7KNF	M4	1.5	2-4	2-4	2	2	2	14	14	2.5	2.5	2.5
FR-E740-5.5KNF	M4	1.5	5.5-4	2-4	3.5	2	3.5	12	14	4	2.5	4
FR-E740-7.5KNF	M4	1.5	5.5-4	5.5-4	3.5	3.5	3.5	12	12	4	4	4
FR-E740-11KNF	M4	1.5	5.5-4	5.5-4	5.5	5.5	8	10	10	6	6	10
FR-E740-15KNF	M5	2.5	8-5	8-5	8	8	8	8	8	10	10	10

- *1 The cable size is that of the cable (HIV cable (600V class 2 vinyl-insulated cable) etc.) with continuous maximum permissible temperature of 75°C. Assumes that the surrounding air temperature is 50°C or less and the wiring distance is 20m or less.
- *2 The recommended cable size is that of the cable (THHW cable) with continuous maximum permissible temperature of 75°C. Assumes that the surrounding air temperature is 40°C or less and the wiring distance is 20m or less. (Selection example for use mainly in the United States.)
- *3 The recommended cable size is that of the cable (PVC cable) with continuous maximum permissible temperature of 70°C. Assumes that the surrounding air temperature is 40°C or less and the wiring distance is 20m or less. (Selection example for use mainly in Europe.)
- *4 The terminal screw size indicates the terminal size for R/L1, S/L2, T/L3, U, V, W, and a screw for earthing (grounding).
A screw for earthing (grounding) of the FR-E720-15KNF is indicated in () .R/L1, S/L2P/N/



NOTE

- Tighten the terminal screw to the specified torque. A screw that has been tighten too loosely can cause a short circuit or malfunction. A screw that has been tighten too tightly can cause a short circuit or malfunction due to the unit breakage.
- Use crimping terminals with insulation sleeve to wire the power supply and motor.

The line voltage drop can be calculated by the following formula:

$$\text{Line voltage drop [V]} = \frac{\sqrt{3} \times \text{wire resistance[m}\Omega\text{/m]} \times \text{wiring distance[m]} \times \text{current[A]}}{1000}$$

Use a larger diameter cable when the wiring distance is long or when it is desired to decrease the voltage drop (torque reduction) in the low speed range.

(2) Earthing (Grounding) precautions

- Always earth (ground) the motor and inverter.

1) Purpose of earthing (grounding)

Generally, an electrical apparatus has an earth (ground) terminal, which must be connected to the ground before use. An electrical circuit is usually insulated by an insulating material and encased. However, it is impossible to manufacture an insulating material that can shut off a leakage current completely, and actually, a slight current flow into the case. The purpose of earthing (grounding) the case of an electrical apparatus is to prevent operator from getting an electric shock from this leakage current when touching it.

To avoid the influence of external noises, this earthing (grounding) is important to audio equipment, sensors, computers and other apparatuses that handle low-level signals or operate very fast.

2) Earthing (grounding) methods and earthing (grounding) work

As described previously, earthing (grounding) is roughly classified into an electrical shock prevention type and a noise-affected malfunction prevention type. Therefore, these two types should be discriminated clearly, and the following work must be done to prevent the leakage current having the inverter's high frequency components from entering the malfunction prevention type earthing (grounding):

(a) If possible, use (I) independent earthing (grounding) in figure below for the inverter. If independent earthing (grounding) is not available, use (II) joint earthing (grounding) in the figure below which the inverter is connected with the other equipment at an earthing (grounding) point. The (III) common earthing (grounding) as in the figure below, which inverter shares a common earth (ground) cable with the other equipment, must be avoided.

A leakage current including many high frequency components flows in the earth (ground) cables of the inverter and inverter-driven motor. Therefore, use the independent earthing (grounding) and separated the earthing (grounding) cable of the inverter from equipments sensitive to EMI.

In a high building, it may be effective to use the EMI prevention type earthing (grounding) connecting to an iron structure frame, and electric shock prevention type earthing (grounding) with the independent earthing (grounding) together.

(b) This inverter must be earthed (grounded). Earthing (Grounding) must conform to the requirements of national and local safety regulations and electrical codes. (NEC section 250, IEC 536 class 1 and other applicable standards).

Use a neutral-point earthed (grounded) power supply for 400V class inverter in compliance with EN standard.

(c) Use the thickest possible earth (ground) cable. The earth (ground) cable should be of not less than the size indicated in the table on the previous *page 17*.

(d) The grounding point should be as near as possible to the inverter, and the ground wire length should be as short as possible.

(e) Run the earth (ground) cable as far away as possible from the I/O wiring of equipment sensitive to noises and run them in parallel in the minimum distance.

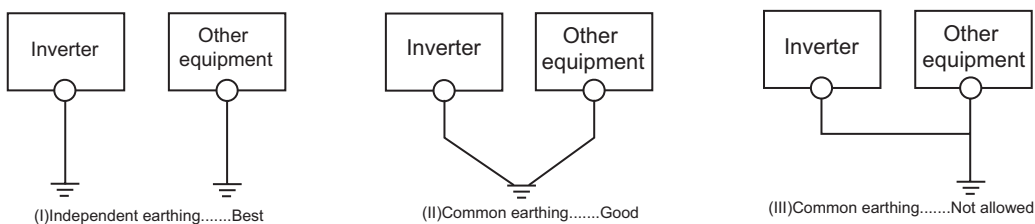

POINT

To be compliant with the EU Directive (Low Voltage Directive),  refer to the Instruction Manual (Basic).

(3) Total wiring length

The overall wiring length for connection of a single motor or multiple motors should be within the value in the table below.

Pr. 72 PWM frequency selection Setting (carrier frequency)		0.1K	0.2K	0.4K	0.75K	1.5K	2.2K	3.7K or Higher
1 (1kHz) or less	200V class	200m	200m	300m	500m	500m	500m	500m
	400V class	-	-	200m	200m	300m	500m	500m
2 to 15 (2kHz to 14.5kHz)	200V class	30m	100m	200m	300m	500m	500m	500m
	400V class	-	-	30m	100m	200m	300m	500m

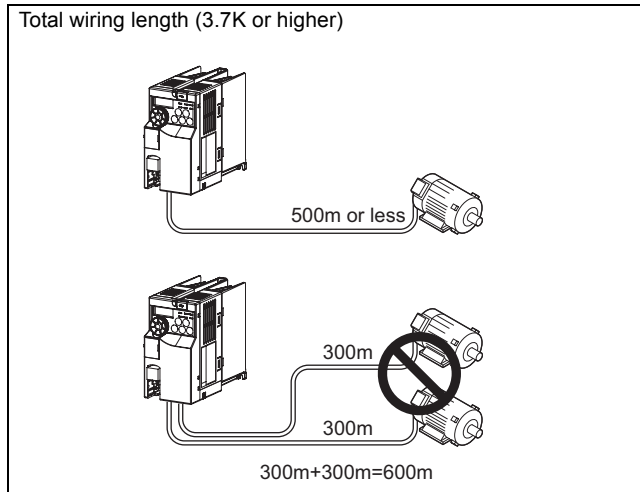

When driving a 400V class motor by the inverter, surge voltages attributable to the wiring constants may occur at the motor terminals, deteriorating the insulation of the motor. In this case, refer to page 39.



NOTE

- Especially for long-distance wiring, the inverter may be affected by a charging current caused by the stray capacitances of the wiring, leading to a malfunction of the overcurrent protective function, fast response current limit function, or stall prevention function or a malfunction or fault of the equipment connected on the inverter output side. If malfunction of fast-response current limit function occurs, disable this function. If malfunction of stall prevention function occurs, increase the stall level. (Refer to page 101 for Pr. 22 Stall prevention operation level and Pr. 156 Stall prevention operation selection)
- Refer to page 163 for details of Pr. 72 PWM frequency selection.
- When using the automatic restart after instantaneous power failure function with wiring length exceeding 100m, select without frequency search (Pr. 162 = "1 (initial value), 11"). (Refer to page 151)

2.3 Control circuit specifications

2.3.1 Control circuit terminal

(1) Input signal

Type	Terminal Symbol	Terminal Name	Description	Rated Specifications	Refer to Page
24V external power supply	+24	24V external power supply	Even when the main circuit power supply is OFF, FL remote communication continues with the input from the 24V external power supply.	Input voltage 23.5 to 26.5VDC Input current 0.7A or less	23
	SD	24V external power supply common terminal	Common terminal for the terminal +24	—	—
Safety stop	S1	Safety stop input (Channel 1)	Terminal S1/S2 are safety stop signals for use with in conjunction with an approved external safety unit. Both terminal S1/S2 must be used in dual channel form. Inverter output is shutoff depending on shorting/opening between S1 and PC, S2 and PC.	Input resistance 4.7kΩ Voltage when contacts are open 21 to 26VDC	24
	S2	Safety stop input (Channel 2)	In the initial status, terminal S1 and S2 are shorted with terminal PC by shorting wire. Remove the shorting wire and connect the safety relay module when using the safety stop function.	When contacts are short-circuited 4 to 6mADC	
	PC	Safety stop input terminal common	Common terminal for safety stop input terminals S1 and S2.	—	—

(2) Output signal

Type	Terminal Symbol	Terminal Name	Description	Rated Specifications	Refer to Page
Open collector	Y0	Open collector output Y0 (safety monitor output 2)	This terminal is switched to Low during the operation with no internal safety circuit fault (E.SAF, E.6, E.7, E.CPU). It is switched to High in operation statuses other than above. (Low indicates that the open collector output transistor is ON (conducts). High indicates that the transistor is OFF (does not conduct).)	Permissible load 24VDC (maximum 27VDC) 0.1A (a voltage drop is 3.4V maximum when the signal is ON)	24
	SE	Open collector output common	Common terminal of terminal Y0.	—	—

(3) Communication

Connector Name	Description	Refer to Page
FL remote communication connector	With the FL remote communication connector, FL remote communication can be performed.	48

2.3.2 Wiring of control circuit

(1) Terminal layout of control circuit terminals

Recommend wire size:
0.3mm² to 0.75mm²

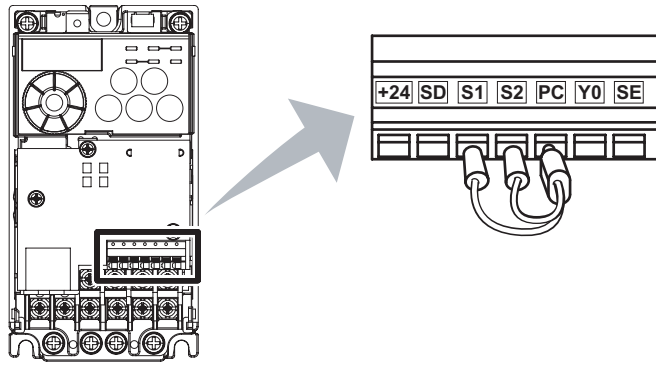

(2) Wiring method

●Wiring

For the control circuit wiring, strip off the sheath of wires, and use them with a blade terminal. For a single wire, strip off the sheath of the wire and apply directly.

Insert the blade terminal or the single wire into a socket of the terminal.

- Strip off the sheath about the length below. If the length of the sheath peeled is too long, a short circuit may occur among neighboring wires. If the length is too short, wires might come off. Wire the stripped wire after twisting it to prevent it from becoming loose. In addition, do not solder it.



- Crimp the blade terminal.

Insert wires to a blade terminal, and check that the wires come out for about 0 to 0.5 mm from a sleeve.

Check the condition of the blade terminal after crimping. Do not use a blade terminal of which the crimping is inappropriate, or the face is damaged.

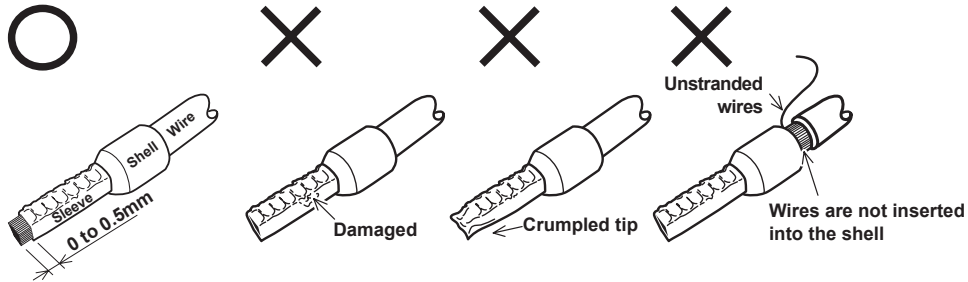

Blade terminals available on the market: (as of Oct. 2008)

●Phoenix Contact Co.,Ltd.

Wire Size (mm ²)	Blade Terminal Model			Blade terminal crimping tool
	with insulation sleeve	without insulation sleeve	for UL wire*	
0.3	AI 0,5-10WH	—	—	CRIMPFOX ZA3
0.5	AI 0,5-10WH	—	AI 0,5-10WH-GB	
0.75	AI 0,75-10GY	A 0,75-10	AI 0,75-10GY-GB	
1	AI 1-10RD	A1-10	AI 1-10RD/1000GB	
1.25, 1.5	AI 1,5-10BK	A1,5-10	—	
0.75 (for two wires)	AI-TWIN 2 x 0,75-10GY	—	—	

*A blade terminal with an insulation sleeve compatible with MTW wire which has a thick wire insulation

●NICHIFU Co.,Ltd.

Wire Size (mm ²)	Blade terminal product number	Insulation product number	Blade terminal crimping tool
0.3 to 0.75	BT 0.75-11	VC 0.75	NH 67

3) Insert the wire into a socket.

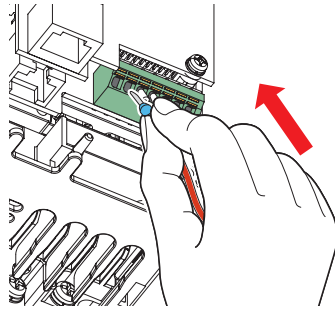

When using a single wire or a stranded wire without a blade terminal, push an open/close button all the way down with a flathead screw driver, and insert the wire.

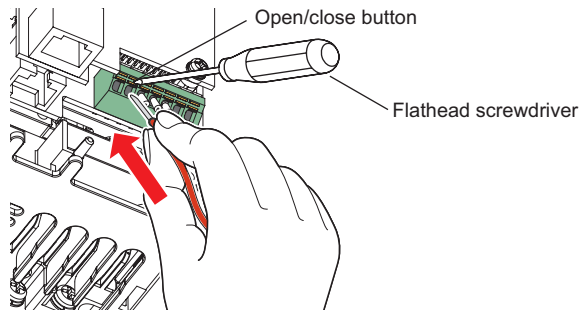

NOTE



- When using a stranded wire without a blade terminal, twist enough to avoid short circuit with a nearby terminals or wires.
- Place the flathead screwdriver vertical to the open/close button. In case the blade tip slips, it may cause to damage of inverter or injury.

●Wire removal

Pull the wire with pushing the open/close button all the way down firmly with a flathead screwdriver.

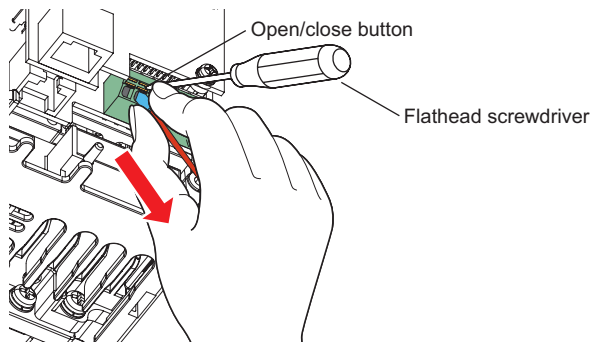

NOTE



- Use a small flathead screwdriver (Tip thickness: 0.4mm/tip width: 2.5mm). If a flathead screwdriver with a narrow tip is used, terminal block may be damaged. Introduced products :(as of Oct. 2008)

Product	Type	Maker
Flathead screwdriver	SZF 0- 0,4 x 2,5	Phoenix Contact Co.,Ltd.

- Place the flathead screwdriver vertical to the open/close button. In case the blade tip slips, it may cause to damage of inverter or injury.

(3) Control circuit common terminals (SD, SE)

Terminals SD and SE are common terminals for I/O signals. (Both common terminals are isolated from each other.) Do not earth them.

Terminal SD is a common terminal for 24V external power supply terminal (+24). The open collector circuit is isolated from the internal control circuit by photocoupler.

Terminal SE is a common terminal for the open collector output terminal (Y0). The contact input circuit is isolated from the internal control circuit by photocoupler.

(4) Wiring instructions

- 1) It is recommended to use the cables of 0.3mm² to 0.75mm² gauge for connection to the control circuit terminals.
- 2) The maximum wiring length should be 30m.
- 3) Do not short across terminals +24 and SD. It may cause a failure to the external power supply.
- 4) Use shielded or twisted cables for connection to the control circuit terminals and run them away from the main and power circuits (including the 200V relay sequence circuit).

2.3.3 Connecting the 24V external power supply

FL remote communication between the master module and the inverter can be continued while the main power circuit is OFF if the 24V external power supply is connected across terminals +24 and SD. When the main circuit power supply is turned ON, the power supply changes from the 24V external power supply to the main circuit power supply.

- (1) Specification of the applied 24V external power supply
 - Input voltage 23.5 to 26.5VDC
 - Input current 0.7A or less
- (2) Operation panel display during the 24V external power supply operation
 - "EV" flickers.

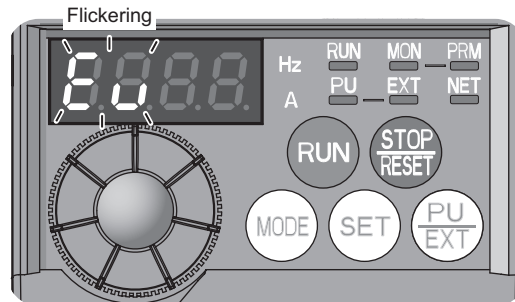

- (3) Function of the 24V external power supply operation
 - When the main power supply is turned ON during the 24V external power supply operation, a reset is performed in the inverter, then the power supply changes to the main circuit power supply. During the reset operation in the inverter, the inverter cannot be controlled through the FL remote communication.
 - The operation stops when the power supply changes to the 24V external power supply from the main circuit power supply regardless of the operating status (in a stop, in running, in automatic restart after instantaneous power failure, in offline (online) tuning, in main circuit capacitor life measurement).
 - All start signals (STF signal, STR signal, and  on the operation panel) are invalid during the 24V external power supply operation.
 - Faults history and parameters can be read and parameters can be written (when the parameter write from the operation panel is enabled) using the operation panel keys.
 - The safety stop function is also valid during the 24V external power supply operation. When the safety stop function is active, however, "SA" is not displayed because "EV" is displayed. The "EV" display has priority over the "SA" display.
 - The following items can be monitored during the 24V external power supply operation. Frequency setting, output current peak value*, converter output voltage peak value*, cumulative energization time, actual operation time*, cumulative power*, and cumulative power 2* (monitor dedicated to the FL remote communication)
 - * The monitored data is not updated after the power supply is changed from the main circuit power supply.
 - (Refer to page 147 for the details of each monitor.)
 - The valid signals when the 24V external power supply is ON are ALM, Safety alarm, Edit, NET, READY and Y95. (Other signals are OFF.)
 - (Refer to page 59 and 60 for the detail of each signal.)
 - The alarms, which have occurred when the main circuit power supply is ON, continue to be output after the power supply is changed to the 24V external power supply. Perform the inverter reset to reset the alarms.
 - The retry function is invalid for all alarms when the 24V external power supply is ON.
 - If the power supply changes from the main circuit power supply to the 24V external power supply while measuring the main circuit capacitor's life in the PU operation mode, the measurement completes after the power supply changes back to the main circuit power supply (Pr.259 = "3").



NOTE

- When the 24V external power supply is input while the main circuit power supply is OFF, the FL remote communication is enabled, but the inverter operation is disabled.
- Inrush current higher than the value described in (1) may flow at a power-ON. Confirm that the power supply and other devices are not affected by the inrush current and the voltage drop caused by it.
- When the wiring length between the external power supply and the inverter is long, the voltage often drops. Select the appropriate wiring size and length to keep the voltage in the rated input voltage range.
- In a serial connection of several inverters, the current increases when it flows through the inverter wiring near the power supply. The increase of the current causes voltage to drop further. When connecting different inverters to different power supplies, use the inverters after confirming that the input voltage of each inverter is within the rated input voltage range.
- "E.SAF" may appear when the start-up time of the 24V power supply is too long in the 24V external power supply operation.

2.3.4 Safety stop function Ver.UP

(1) Description of the function

The terminals related to the safety stop function are shown below.

Terminal Symbol	Description	
S1*1	For input of safety stop channel 1.	Between S1 and PC / S2 and PC Open: In safety stop state. Short: Other than safety stop state.
S2*1	For input of safety stop channel 2.	
PC*1	Common terminal for terminal S1 and S2.	
Y0 (SAFE2 signal)	Outputs when an alarm or failure is detected.	OFF: Internal safety circuit failure.*2 ON : No internal safety circuit failure.*2
SE	Common terminal for open collector outputs (terminal Y0)	

*1 In the initial status, terminal S1 and S2 are shorted with terminal PC by shortening wire. Remove the shortening wire and connect the safety relay module when using the safety stop function.

*2 At an internal safety circuit failure, one of E.SAF, E.6, E.7, and E.CPU is displayed on the operation panel.

Ver.UPSpecifications differ according to the date assembled. Refer to page 232 to check the SERIAL number.

NOTE



- Hold the ON or OFF status for 2ms or longer to input signal to terminal S1 or S2. Signal input shorter than 2ms is not recognized.
- SAFE2 signal can only be used to output an alarm or to prevent restart of an inverter. The signal cannot be used as safety stop input signal to other devices.

(2) Wiring connection diagram

To prevent restart at fault occurrence, connect terminals Y0 (SAFE2 signal) and SE to terminals XS0 and XS1, which are the feedback input terminals of the safety relay module. Terminal Y0 is turned OFF at a fault occurrence.

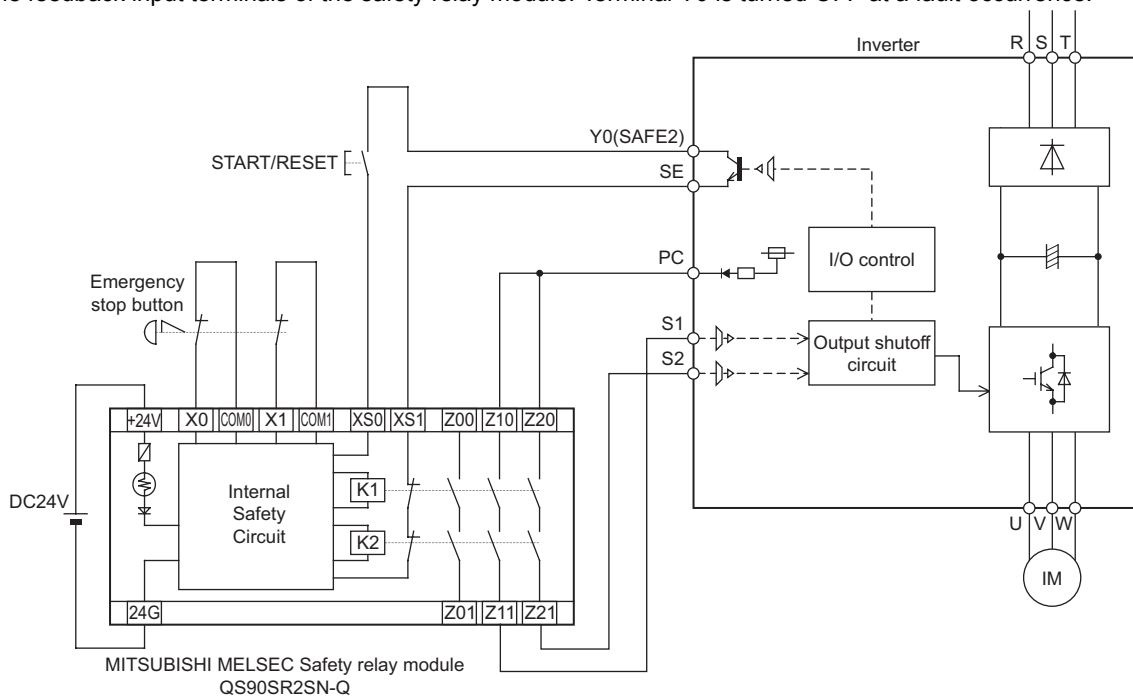

(3) Safety stop function operation

Input power	Input signal		Internal safety circuit*1	Output signal (SAFE2)*3	Operation state
	S1-PC	S2-PC			
OFF	—	—	—	OFF	Output shutoff (Safe state)
ON	Short	Short	No failure	ON	Drive enabled
			Detected	OFF	Output shutoff (Safe state)
	Open	Open	No failure*2	ON	Output shutoff (Safe state)
			Detected	OFF	Output shutoff (Safe state)
			Detected	OFF	Output shutoff (Safe state)
Short	Open	Detected	OFF	Output shutoff (Safe state)	
Open	Short	Detected	OFF	Output shutoff (Safe state)	

*1 At an internal safety circuit failure, one of E.SAF, E.6, E.7, and E.CPU is displayed on the operation panel.

*2 SA is displayed when both of the S1 and S2 signals are in open status and no internal safety circuit failure exists.

*3 ON: Transistor used for an open collector output is conducted.

OFF: Transistor used for an open collector output is not conducted.

For more details, refer to the Safety stop function instruction manual (BCN-A211508-004). (Refer to the front cover of the Instruction Manual (Basic) for how to obtain the manual.)

2.4 Connection of stand-alone option unit

The inverter accepts a variety of stand-alone option units as required.

Incorrect connection will cause inverter damage or accident. Connect and operate the option unit carefully in accordance with the corresponding option unit manual.

2.4.1 Connection of a dedicated external brake resistor (MRS type, MYS type, FR-ABR)

Install a dedicated brake resistor (MRS type, MYS type, FR-ABR) outside when the motor is made to run by the load, quick deceleration is required, etc. Connect a dedicated brake resistor (MRS type, MYS type, FR-ABR) to terminal P/+ and PR.

(For the locations of terminal P/+ and PR, refer to the terminal block layout (page 15).)

Set parameters below.

Connected Brake Resistor	Pr. 30 Regenerative function selection Setting	Pr. 70 Special regenerative brake duty Setting		
MRS type, MYS type	0 (initial value)	—		
MYS type (used at 100% torque / 6%ED)	1	6%	Refer to page 136	
FR-ABR	1	7.5K or lower		10%
		11K or higher		6%

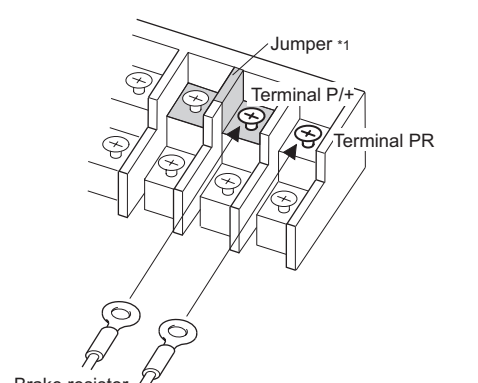
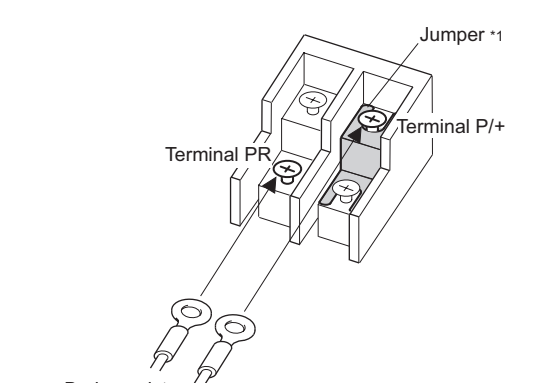
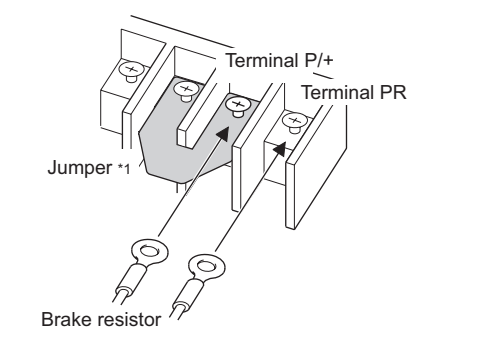
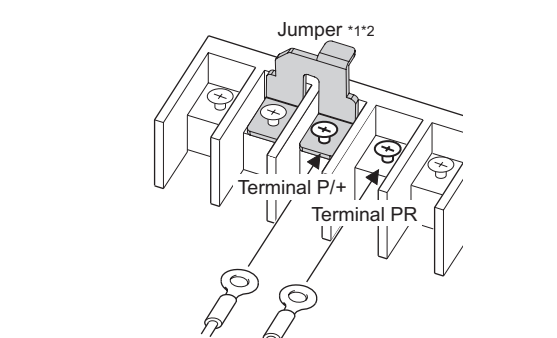
FR-E720-0.4KNF, 0.75KNF	FR-E720-1.5KNF to 3.7KNF FR-E740-0.4KNF to 3.7KNF
Connect the brake resistor across terminals P/+ and PR.	Connect the brake resistor across terminals P/+ and PR.
	
FR-E720-5.5KNF to 15KNF	FR-E740-5.5KNF to 15KNF
Connect the brake resistor across terminals P/+ and PR.	Connect the brake resistor across terminals P/+ and PR.
	

*1 Do not remove the jumper across terminals P/+ and P1 except when connecting a DC reactor.

*2 The shape of jumper differs according to capacities.

7 Connection of stand-alone option unit

- It is recommended to configure a sequence, which shuts off power in the input side of the inverter by the external thermal relay as shown below, to prevent overheat and burnout of the brake resistor (MRS type, MYS type) and high duty brake resistor (FR-ABR) in case the regenerative brake transistor is damaged. (The brake resistor cannot be connected to the 0.1K and 0.2K.)

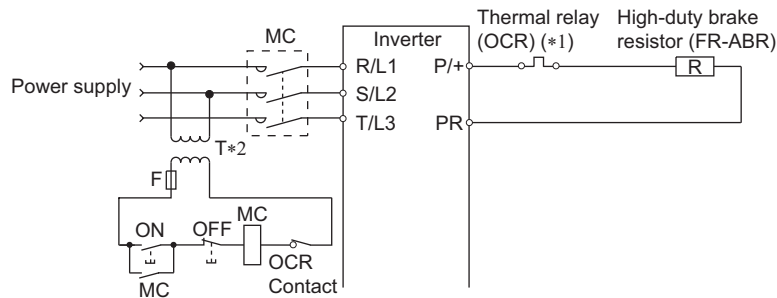

*3 Refer to the table below for the type number of each capacity of thermal relay and the diagram below for the connection.

(Always install a thermal relay when using a brake resistor whose capacity is 11K or higher)

*4 When the power supply is 400V class, install a step-down transformer.

Power Supply Voltage	Brake Resistor	Thermal Relay Type (Mitsubishi product)	Contact Rating
200V	MRS120W200	TH-N20CXHZ-0.7A	110VAC 5A, 220VAC 2A(AC11 class) 110VDC 0.5A, 220VDC 0.25A(DC11class)
	MRS120W100	TH-N20CXHZ-1.3A	
	MRS120W60	TH-N20CXHZ-2.1A	
	MRS120W40	TH-N20CXHZ-3.6A	
	MYS220W50 (two units in parallel)	TH-N20CXHZ-5A	

Power Supply Voltage	High-duty Brake Resistor	Thermal Relay Type (Mitsubishi product)	Contact Rating
200V	FR-ABR-0.4K	TH-N20CXHZ-0.7A	110VAC 5A, 220VAC 2A(AC11 class) 110VDC 0.5A, 220VDC 0.25A(DC11 class)
	FR-ABR-0.75K	TH-N20CXHZ-1.3A	
	FR-ABR-2.2K	TH-N20CXHZ-2.1A	
	FR-ABR-3.7K	TH-N20CXHZ-3.6A	
	FR-ABR-5.5K	TH-N20CXHZ-5A	
	FR-ABR-7.5K	TH-N20CXHZ-6.6A	
	FR-ABR-11K	TH-N20CXHZ-11A	
FR-ABR-15K	TH-N20CXHZ-11A		
400V	FR-ABR-H0.4K	TH-N20CXHZ-0.24A	110VAC 5A, 220VAC 2A(AC11 class) 110VDC 0.5A, 220VDC 0.25A(DC11 class)
	FR-ABR-H0.75K	TH-N20CXHZ-0.35A	
	FR-ABR-H1.5K	TH-N20CXHZ-0.9A	
	FR-ABR-H2.2K	TH-N20CXHZ-1.3A	
	FR-ABR-H3.7K	TH-N20CXHZ-2.1A	
	FR-ABR-H5.5K	TH-N20CXHZ-2.5A	
	FR-ABR-H7.5K	TH-N20CXHZ-3.6A	
	FR-ABR-H11K	TH-N20CXHZ-6.6A	
FR-ABR-H15K	TH-N20CXHZ-6.6A		

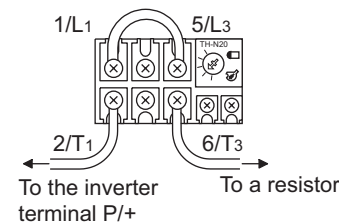

NOTE

- The brake resistor connected should only be the dedicated brake resistor.
- Brake resistor cannot be used with the brake unit, etc.
- Do not use the brake resistor (MRS type, MYS type) with a lead wire extended.
- Do not connect a resistor directly to the terminals P/+ and N/-. This could cause a fire.

2.4.2 Connection of the brake unit (FR-BU2)

Connect the brake unit (FR-BU2(-H)) as shown below to improve the braking capability at deceleration. If the transistors in the brake unit should become faulty, the resistor can be unusually hot. To prevent unusual overheat and fire, install a magnetic contactor on the inverter's input side to configure a circuit so that a current is shut off in case of fault.

(1) Connection example with the GRZG type discharging resistor

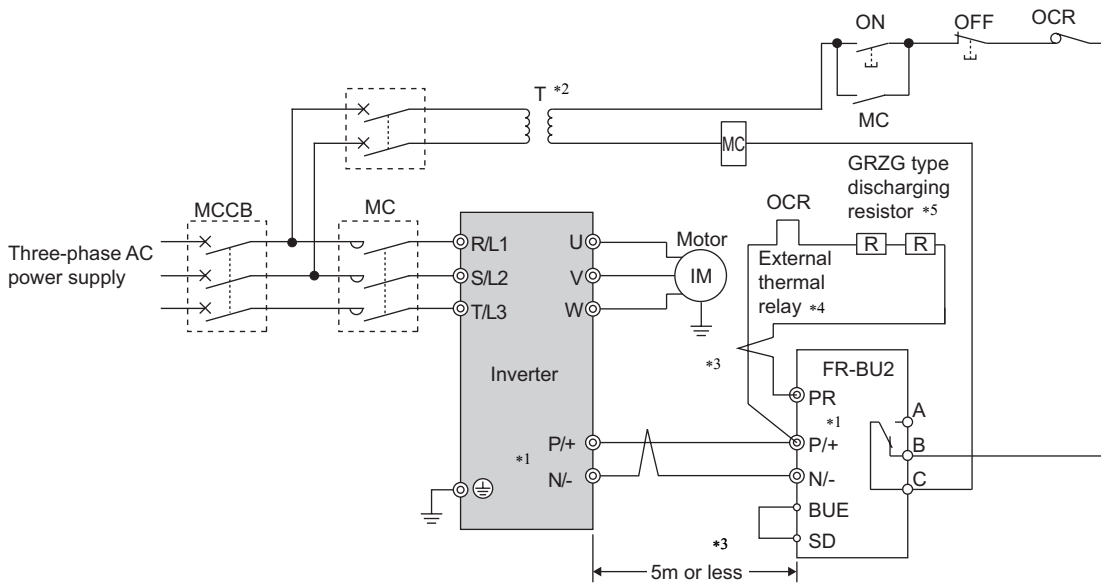

- *1 Connect the inverter terminals (P/+ and N/-) and brake unit (FR-BU2) terminals so that their terminal names match with each other.
(Incorrect connection will damage the inverter and brake unit.)
- *2 When the power supply is 400V class, install a step-down transformer.
- *3 The wiring distance between the inverter, brake unit (FR-BU2) and discharging resistor should be within 5m. Even when the wiring is twisted, the cable length must not exceed 10m.
- *4 It is recommended to install an external thermal relay to prevent overheat of discharging resistors.
- *5 Refer to FR-BU2 manual for connection method of discharging resistor.

<Recommended external thermal relay>

Brake Unit	Discharging Resistor	Recommended External Thermal Relay
FR-BU2-1.5K	GZG 300W-50Ω (one)	TH-N20CXHZ 1.3A
FR-BU2-3.7K	GRZG 200-10Ω (three in series)	TH-N20CXHZ 3.6A
FR-BU2-7.5K	GRZG 300-5Ω (four in series)	TH-N20CXHZ 6.6A
FR-BU2-15K	GRZG 400-2Ω (six in series)	TH-N20CXHZ 11A
FR-BU2-H7.5K	GRZG 200-10Ω (six in series)	TH-N20CXHZ 3.6A
FR-BU2-H15K	GRZG 300-5Ω (eight in series)	TH-N20CXHZ 6.6A

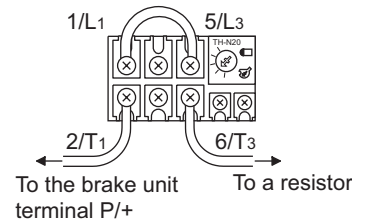

NOTE

- Set "1" in Pr. 0 Brake mode selection of the FR-BU2 to use GRZG type discharging resistor.
- Do not remove the jumper across terminals P/+ and P1 except when connecting a DC reactor.

(2) Connection example with the FR-BR(-H) type resistor

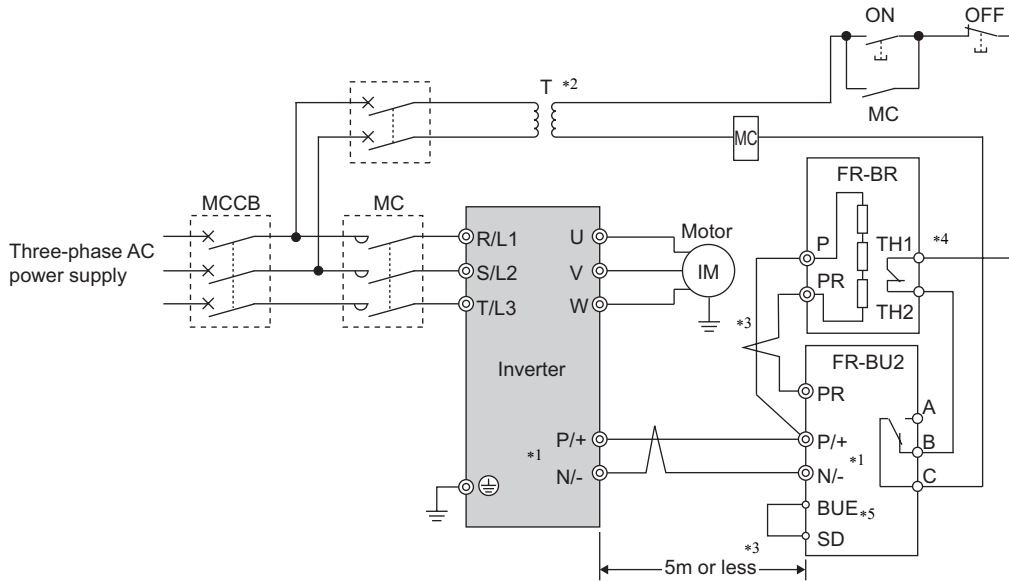

- *1 Connect the inverter terminals (P/+ and N/-) and brake unit (FR-BU2) terminals so that their terminal names match with each other.
(Incorrect connection will damage the inverter and brake unit.)
- *2 When the power supply is 400V class, install a step-down transformer.
- *3 The wiring distance between the inverter, brake unit (FR-BU2) and resistor unit (FR-BR) should be within 5m. Even when the wiring is twisted, the cable length must not exceed 10m.
- *4 Normal: across TH1-TH2...close, Alarm: across TH1-TH2...open
- *5 A jumper is connected across BUE and SD in the initial status.



NOTE

- Do not remove the jumper across terminals P/+ and P1 except when connecting a DC reactor.

2.4.3 Connection of the DC reactor (FR-HEL)

When using the DC reactor (FR-HEL), connect it across terminals P/+ and P1.

In this case, the jumper connected across terminals P/+ and P1 must be removed. Otherwise, the reactor will not exhibit its performance.

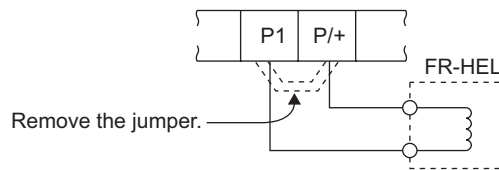

NOTE

- The wiring distance should be within 5m.
- The size of the cables used should be equal to or larger than that of the power supply cables (R/L1, S/L2, T/L3). (Refer to page 17)

3 PRECAUTIONS FOR USE OF THE INVERTER

This chapter explains the "PRECAUTIONS FOR USE OF THE INVERTER" for use of this product.

Always read the instructions before using the equipment.

3.1	EMC and leakage currents	30
3.2	Installation of power factor improving reactor	37
3.3	Power-OFF and magnetic contactor (MC)	38
3.4	Inverter-driven 400V class motor	39
3.5	Precautions for use of the inverter	40
3.6	Failsafe of the system which uses the inverter	42

1

2

3

4

5

6

7

8

3.1 EMC and leakage currents

3.1.1 Leakage currents and countermeasures

Capacitances exist between the inverter I/O cables, other cables and earth and in the motor, through which a leakage current flows. Since its value depends on the static capacitances, carrier frequency, etc., low acoustic noise operation at the increased carrier frequency of the inverter will increase the leakage current. Therefore, take the following measures. Select the earth leakage current breaker according to its rated sensitivity current, independently of the carrier frequency setting.

(1) To-earth (ground) leakage currents

Leakage currents may flow not only into the inverter's own line but also into the other lines through the earth (ground) cable, etc. These leakage currents may operate earth (ground) leakage circuit breakers and earth leakage relays unnecessarily.

●Suppression technique

- If the carrier frequency setting is high, decrease the *Pr. 72 PWM frequency selection* setting. Note that motor noise increases. Selecting *Pr. 240 Soft-PWM operation selection* makes the sound inoffensive.
- By using earth leakage circuit breakers designed for harmonic and surge suppression in the inverter's own line and other line, operation can be performed with the carrier frequency kept high (with low noise).

●To-earth (ground) leakage currents

- Take caution as long wiring will increase the leakage current. Decreasing the carrier frequency of the inverter reduces the leakage current.
- Increasing the motor capacity increases the leakage current. The leakage current of the 400V class is larger than that of the 200V class.

(2) Line-to-line leakage currents

Harmonics of leakage currents flowing in static capacitances between the inverter output cables may operate the external thermal relay unnecessarily. When the wiring length is long (50m or more) for the 400V class small-capacity model (7.5kW or less), the external thermal relay is likely to operate unnecessarily because the ratio of the leakage current to the rated motor current increases.

●Line-to-line leakage current data example (200V class)

Motor Capacity (kW)	Rated Motor Current (A)	Leakage Current (mA) *	
		Wiring length 50m	Wiring length 100m
0.4	1.8	310	500
0.75	3.2	340	530
1.5	5.8	370	560
2.2	8.1	400	590
3.7	12.8	440	630
5.5	19.4	490	680
7.5	25.6	535	725

- Motor: SF-JR 4P
- Carrier frequency: 14.5kHz
- Used wire: 2mm², 4 cores
Cabtyre cable

*The leakage currents of the 400V class are about twice as large.

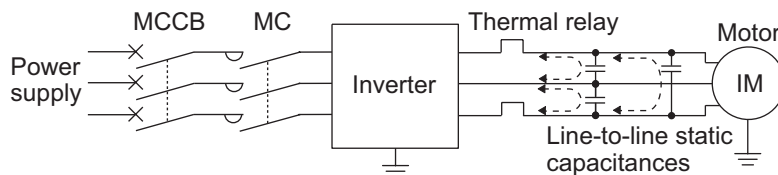

Line-to-line leakage currents path

●Measures

- Use *Pr. 9 Electronic thermal O/L relay*.
- If the carrier frequency setting is high, decrease the *Pr. 72 PWM frequency selection* setting. Note that motor noise increases. Selecting *Pr. 240 Soft-PWM operation selection* makes the sound inoffensive. To ensure that the motor is protected against line-to-line leakage currents, it is recommended to use a temperature sensor to directly detect motor temperature.

●Installation and selection of moulded case circuit breaker

Install a moulded case circuit breaker (MCCB) on the power receiving side to protect the wiring of the inverter input side. Select the MCCB according to the inverter input side power factor (which depends on the power supply voltage, output frequency and load). Especially for a completely electromagnetic MCCB, one of a slightly large capacity must be selected since its operation characteristic varies with harmonic currents. (Check it in the data of the corresponding breaker.) As an earth leakage current breaker, use the Mitsubishi earth leakage current breaker designed for harmonics and surge suppression.

(3) Selection of rated sensitivity current of earth (ground) leakage current breaker

When using the earth leakage current breaker with the inverter circuit, select its rated sensitivity current as follows, independently of the PWM carrier frequency.

- Breaker designed for harmonic and surge suppression

Rated sensitivity current:

$$I_{\Delta n} \geq 10 \times (I_{g1} + I_{gn} + I_{gi} + I_{g2} + I_{gm})$$

- Standard breaker

Rated sensitivity current:

$$I_{\Delta n} \geq 10 \times \{I_{g1} + I_{gn} + I_{gi} + 3 \times (I_{g2} + I_{gm})\}$$

I_{g1}, I_{g2}: Leakage currents in wire path during commercial power supply operation

I_{gn}: Leakage current of inverter input side noise filter

I_{gm}: Leakage current of motor during commercial power supply operation

I_{gi}: Leakage current of inverter unit

Example of leakage current of cable path per 1km during the commercial power supply operation when the CV cable is routed in metal conduit (200V 60Hz)

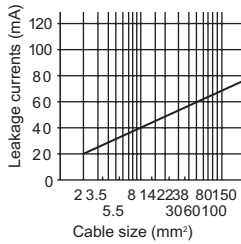

Example of leakage current of three-phase induction motor during the commercial power supply operation (200V 60Hz)

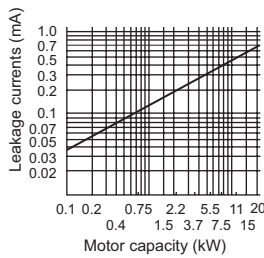

Example of leakage current per 1km during the commercial power supply operation when the CV cable is routed in metal conduit (Three-phase three-wire delta connection 400V60Hz)

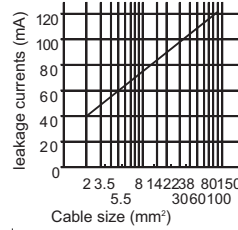

Example of leakage current of three-phase induction motor during the commercial power supply operation (Totally-enclosed fan-cooled type motor 400V60Hz)

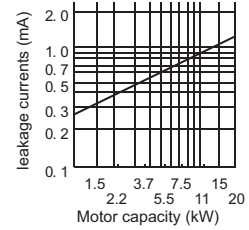

For "Δ" connection, the amount of leakage current is approx. 1/3 of the above value.

<Example>

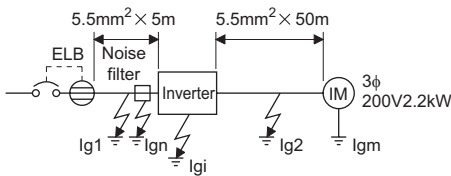

	Breaker Designed for Harmonic and Surge Suppression	Standard Breaker
Leakage current I _{g1} (mA)	$33 \times \frac{5m}{1000m} = 0.17$	
Leakage current I _{gn} (mA)	0 (without noise filter)	
Leakage current I _{gi} (mA)	1	
Leakage current I _{g2} (mA)	$33 \times \frac{50m}{1000m} = 1.65$	
Motor leakage current I _{gm} (mA)		0.18
Total leakage current (mA)	3.00	6.66
Rated sensitivity current (mA) (≥ I _g × 10)	30	100



NOTE

- Install the earth leakage breaker (ELB) on the input side of the inverter.
- In the Δ connection earthed-neutral system, the sensitivity current is blunt against an earth (ground) fault in the inverter output side. Earthing (Grounding) must conform to the requirements of national and local safety regulations and electrical codes. (NEC section 250, IEC 536 class 1 and other applicable standards)
- When the breaker is installed on the output side of the inverter, it may be unnecessarily operated by harmonics even if the effective value is less than the rating.
In this case, do not install the breaker since the eddy current and hysteresis loss will increase, leading to temperature rise.
- General products indicate the following models. BV-C1, BC-V, NVB, NV-L, NV-G2N, NV-G3NA, NV-2F earth leakage relay (except NV-ZHA), NV with AA neutral wire open-phase protection
The other models are designed for harmonic and surge suppressionNV-C/NV-S/MN series, NV30-FA, NV50-FA, BV-C2, earth leakage alarm breaker (NF-Z), NV-ZHA, NV-H

3.1.2 EMC measures

Some electromagnetic noises enter the inverter to malfunction it and others are radiated by the inverter to malfunction peripheral devices. Though the inverter is designed to have high immunity performance, it handles low-level signals, so it requires the following basic techniques. Also, since the inverter chops outputs at high carrier frequency, that could generate electromagnetic noises. If these electromagnetic noises cause peripheral devices to malfunction, EMI measures should be taken to suppress noises. These techniques differ slightly depending on EMI paths.

(1) Basic techniques

- Do not run the power cables (I/O cables) and signal cables of the inverter in parallel with each other and do not bundle them.
- Use twisted shield cables for the detector connecting and control signal cables and connect the sheathes of the shield cables to terminal SD.
- Earth (Ground) the inverter, motor, etc. at one point.

(2) Techniques to reduce electromagnetic noises that enter and malfunction the inverter (Immunity measures)

When devices that generate many electromagnetic noises (which use magnetic contactors, magnetic brakes, many relays, for example) are installed near the inverter and the inverter may be malfunctioned by electromagnetic noises, the following measures must be taken:

- Provide surge suppressors for devices that generate many electromagnetic noises to suppress electromagnetic noises.
- Fit data line filters (page 33) to signal cables.
- Earth (Ground) the shields of the detector connection and control signal cables with cable clamp metal.

(3) Techniques to reduce electromagnetic noises that are radiated by the inverter to malfunction peripheral devices (EMI measures)

Inverter-generated electromagnetic noises are largely classified into those radiated by the cables connected to the inverter and inverter main circuits (I/O), those electromagnetically and electrostatically induced to the signal cables of the peripheral devices close to the main circuit power supply, and those transmitted through the power supply cables.

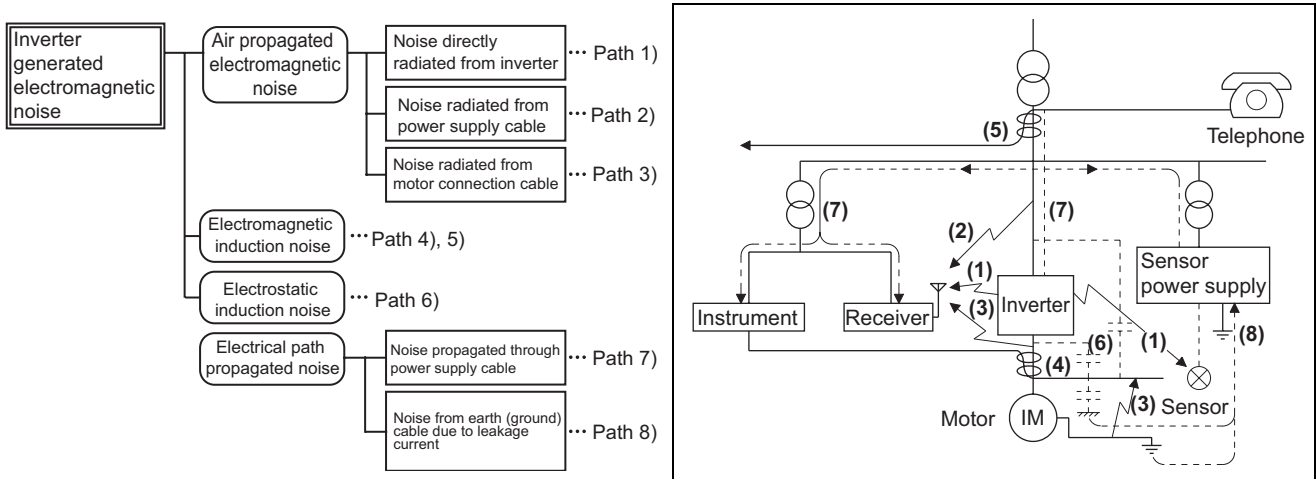

Propagation Path	Measures
(1)(2)(3)	<p>When devices that handle low-level signals and are liable to malfunction due to electromagnetic noises, e.g. instruments, receivers and sensors, are contained in the enclosure that contains the inverter or when their signal cables are run near the inverter, the devices may be malfunctioned by air-propagated electromagnetic noises. The following measures must be taken:</p> <ul style="list-style-type: none"> • Install easily affected devices as far away as possible from the inverter. • Run easily affected signal cables as far away as possible from the inverter and its I/O cables. • Do not run the signal cables and power cables (inverter I/O cables) in parallel with each other and do not bundle them. • Insert common mode filters into I/O and capacitors between the input lines to suppress cable-radiated noises. • Use shield cables as signal cables and power cables and run them in individual metal conduits to produce further effects.
(4)(5)(6)	<p>When the signal cables are run in parallel with or bundled with the power cables, magnetic and static induction noises may be propagated to the signal cables to malfunction the devices and the following measures must be taken:</p> <ul style="list-style-type: none"> • Install easily affected devices as far away as possible from the inverter. • Run easily affected signal cables as far away as possible from the I/O cables of the inverter. • Do not run the signal cables and power cables (inverter I/O cables) in parallel with each other and do not bundle them. • Use shield cables as signal cables and power cables and run them in individual metal conduits to produce further effects.
(7)	<p>When the power supplies of the peripheral devices are connected to the power supply of the inverter in the same line, inverter-generated noises may flow back through the power supply cables to malfunction the devices and the following measures must be taken:</p> <ul style="list-style-type: none"> • Install the common mode filter (FR-BLF, FR-BSF01) to the power cables (output cable) of the inverter.
(8)	<p>When a closed loop circuit is formed by connecting the peripheral device wiring to the inverter, leakage currents may flow through the earth (ground) cable of the inverter to malfunction the device. In such a case, disconnection of the earth (ground) cable of the device may cause the device to operate properly.</p>

●Data line filter

Data line filter is effective as an EMC measure. Provide a data line filter for the detector cable, etc.

●EMC measures

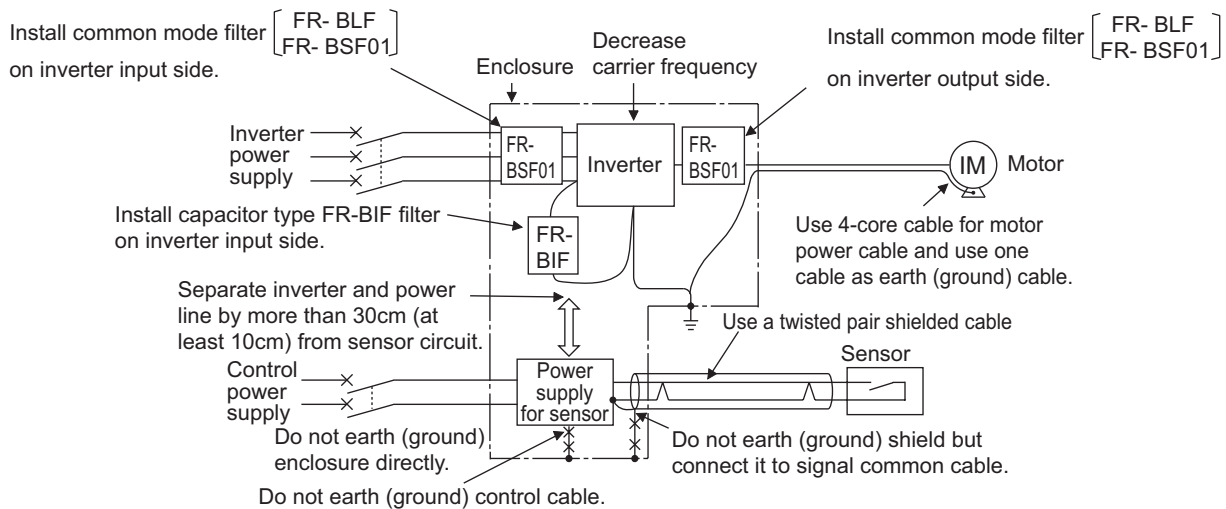

NOTE

• For compliance with the EU EMC directive, please refer the Instruction Manual (Basic).

3.1.3 Power supply harmonics

The inverter may generate power supply harmonics from its converter circuit to affect the power generator, power capacitor etc. Power supply harmonics are different from noise and leakage currents in source, frequency band and transmission path. Take the following countermeasure suppression techniques.

●The differences between harmonics and RF noises are indicated below:

Item	Harmonics	Noise
Frequency	Normally 40th to 50th degrees or less (up to 3kHz or less)	High frequency (several 10kHz to 1GHz order)
Environment	To-electric channel, power impedance	To-space, distance, wiring path
Quantitative understanding	Theoretical calculation possible	Random occurrence, quantitative grasping difficult
Generated amount	Nearly proportional to load capacity	Change with current variation ratio (larger as switching speed increases)
Affected equipment immunity	Specified in standard per equipment	Different depending on maker's equipment specifications
Suppression example	Provide reactor.	Increase distance.

●Suppression technique

The harmonic current generated from the inverter to the input side differs according to various conditions such as the wiring impedance, whether a reactor is used or not, and output frequency and output current on the load side.

For the output frequency and output current, we understand that they should be calculated in the conditions under the rated load at the maximum operating frequency.

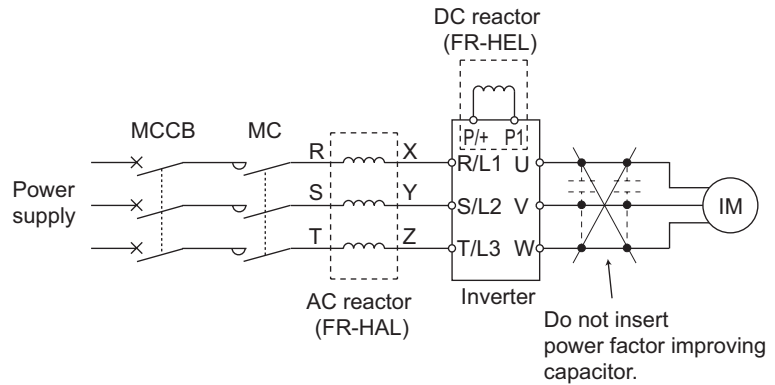

NOTE

The power factor improving capacitor and surge suppressor on the inverter output side may be overheated or damaged by the harmonic components of the inverter output. Also, since an excessive current flows in the inverter to activate overcurrent protection, do not provide a capacitor and surge suppressor on the inverter output side when the motor is driven by the inverter. For power factor improvement, install a reactor on the inverter input side or in the DC circuit.

3.1.4 Harmonic suppression guideline in Japan

Harmonic currents flow from the inverter to a power receiving point via a power transformer. The harmonic suppression guideline was established to protect other consumers from these outgoing harmonic currents.

The three-phase 200V input specifications 3.7kW or less are previously covered by "Harmonic suppression guideline for household appliances and general-purpose products" and other models are covered by "Harmonic suppression guideline for consumers who receive high voltage or special high voltage". However, the transistorized inverter has been excluded from the target products covered by "Harmonic suppression guideline for household appliances and general-purpose products" in January 2004 and "Harmonic suppression guideline for household appliances and general-purpose products" was repealed on September 6, 2004.

All capacity and all models of general-purpose inverter used by specific consumers are covered by "Harmonic suppression guideline for consumers who receive high voltage or special high voltage" (hereinafter referred to as "Guideline for specific consumers").

"Guideline for specific consumers"

This guideline sets forth the maximum values of harmonic currents outgoing from a high-voltage or especially high-voltage consumer who will install, add or renew harmonic generating equipment. If any of the maximum values is exceeded, this guideline requires that consumer to take certain suppression measures.

Table 1 Maximum Values of Outgoing Harmonic Currents per 1kW Contract Power

Received Power Voltage	5th	7th	11th	13th	17th	19th	23rd	Over 23rd
6.6kV	3.5	2.5	1.6	1.3	1.0	0.9	0.76	0.70
22kV	1.8	1.3	0.82	0.69	0.53	0.47	0.39	0.36
33kV	1.2	0.86	0.55	0.46	0.35	0.32	0.26	0.24

(1) Application for specific consumers

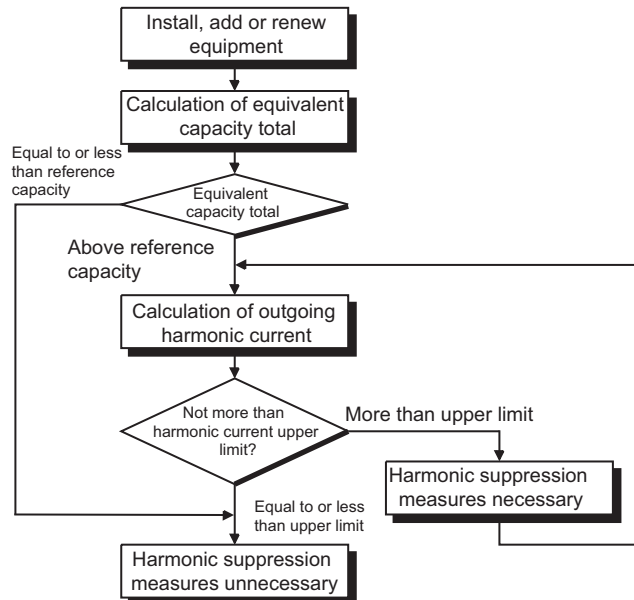

Table 2 Conversion Factors for FR-E700 Series

Class	Circuit Type		Conversion Factor (Ki)
3	Three-phase bridge (Capacitor smoothing)	Without reactor	K31= 3.4
		With reactor (AC side)	K32 = 1.8
		With reactor (DC side)	K33 = 1.8
		With reactors (AC, DC sides)	K34 = 1.4

Table 3 Equivalent Capacity Limits

Received Power Voltage	Reference Capacity
6.6kV	50kVA
22/33 kV	300kVA
66kV or more	2000kVA

Table 4 Harmonic Contents (Values at the fundamental current of 100%)

Reactor	5th	7th	11th	13th	17th	19th	23rd	25th
Not used	65	41	8.5	7.7	4.3	3.1	2.6	1.8
Used (AC side)	38	14.5	7.4	3.4	3.2	1.9	1.7	1.3
Used (DC side)	30	13	8.4	5.0	4.7	3.2	3.0	2.2
Used (AC, DC sides)	28	9.1	7.2	4.1	3.2	2.4	1.6	1.4

1) Calculation of equivalent capacity (P0) of harmonic generating equipment

The "equivalent capacity" is the capacity of a 6-pulse converter converted from the capacity of consumer's harmonic generating equipment and is calculated with the following equation. If the sum of equivalent capacities is higher than the limit in Table 3, harmonics must be calculated with the following procedure:

$$P0 = \sum(Ki \times Pi) \text{ [kVA]}$$

Ki: Conversion factor (refer to Table 2)

Pi: Rated capacity of harmonic generating equipment* [kVA]

i: Number indicating the conversion circuit type

* Rated capacity: Determined by the capacity of the applied motor and found in Table 5. It should be noted that the rated capacity used here is used to calculate generated harmonic amount and is different from the power supply capacity required for actual inverter drive.

2) Calculation of outgoing harmonic current

Outgoing harmonic current = fundamental wave current (value converted from received power voltage) × operation ratio × harmonic content

- Operation ratio: Operation ratio = actual load factor × operation time ratio during 30 minutes
- Harmonic content: Found in Table 4.

Table 5 Rated Capacities and Outgoing Harmonic Currents for Inverter Drive

Applicable Motor (kW)	Rated Current [A]		Fundamental Wave Current Converted from 6.6kV (mA)	Rated Capacity (kVA)	Outgoing Harmonic Current Converted from 6.6kV(mA) (No reactor, 100% operation ratio)							
	200V	400V			5th	7th	11th	13th	17th	19th	23rd	25th
0.4	1.61	0.81	49	0.57	31.85	20.09	4.165	3.773	2.107	1.519	1.274	0.882
0.75	2.74	1.37	83	0.97	53.95	34.03	7.055	6.391	3.569	2.573	2.158	1.494
1.5	5.50	2.75	167	1.95	108.6	68.47	14.20	12.86	7.181	5.177	4.342	3.006
2.2	7.93	3.96	240	2.81	156.0	98.40	20.40	18.48	10.32	7.440	6.240	4.320
3.7	13.0	6.50	394	4.61	257.1	161.5	33.49	30.34	16.94	12.21	10.24	7.092
5.5	19.1	9.55	579	6.77	376.1	237.4	49.22	44.58	24.90	17.95	15.05	10.42
7.5	25.6	12.8	776	9.07	504.4	318.2	65.96	59.75	33.37	24.06	20.18	13.97
11	36.9	18.5	1121	13.1	728.7	459.6	95.29	86.32	48.20	34.75	29.15	20.18
15	49.8	24.9	1509	17.6	980.9	618.7	128.3	116.2	64.89	46.78	39.24	27.16

3) Application of the guideline for specific consumers

If the outgoing harmonic current is higher than the maximum value per 1kW contract power × contract power, a harmonic suppression technique is required.

4) Harmonic suppression techniques

No.	Item	Description
1	Reactor installation (FR-HAL, FR-HEL)	Install an AC reactor (FR-HAL) on the AC side of the inverter or a DC reactor (FR-HEL) on its DC side or both to suppress outgoing harmonic currents.
2	Installation of power factor improving capacitor	When used with a series reactor, the power factor improving capacitor has an effect of absorbing harmonic currents.
3	Transformer multi-phase operation	Use two transformers with a phase angle difference of 30° as in Λ - Δ , Δ - Δ combination to provide an effect corresponding to 12 pulses, reducing low-degree harmonic currents.
4	Passive filter (AC filter)	A capacitor and a reactor are used together to reduce impedances at specific frequencies, producing a great effect of absorbing harmonic currents.
5	Active filter (Active filter)	This filter detects the current of a circuit generating a harmonic current and generates a harmonic current equivalent to a difference between that current and a fundamental wave current to suppress a harmonic current at a detection point, providing a great effect of absorbing harmonic currents.

3.2 Installation of power factor improving reactor

When the inverter is connected near a large-capacity power transformer (500kVA or more) or when a power capacitor is to be switched over, an excessive peak current may flow in the power input circuit, damaging the converter circuit. To prevent this, always install an optional reactor (FR-HAL, FR-HEL).

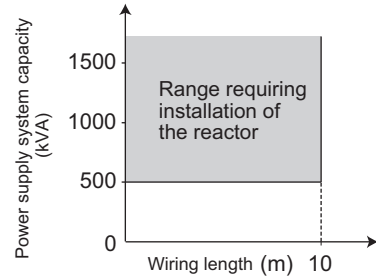
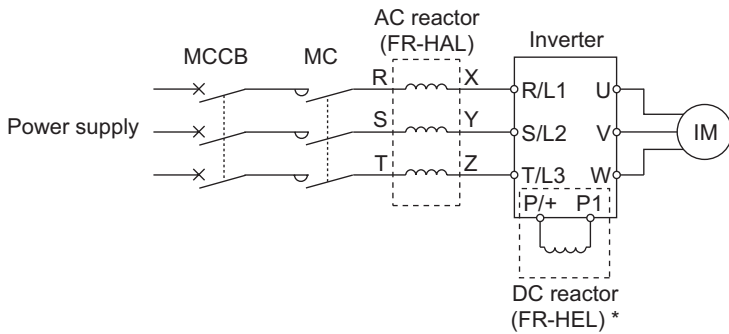

- * When connecting the FR-HEL, remove the jumper across terminals P/+ and P1.
The wiring length between the FR-HEL and inverter should be 5m maximum and minimized.

REMARKS

- Use the same wire size as that of the power supply wire (R/L1, S/L2, T/L3). (Refer to page 17)

3.3 Power-OFF and magnetic contactor (MC)

(1) Inverter input side magnetic contactor (MC)

On the inverter input side, it is recommended to provide an MC for the following purposes.

(Refer to *page 4* for selection.)

- 1) To release the inverter from the power supply when the fault occurs or when the drive is not functioning (e.g. emergency stop operation). For example, MC avoids overheat or burnout of the brake resistor when heat capacity of the resistor is insufficient or brake regenerative transistor is damaged with short while connecting an optional brake resistor.
- 2) To prevent any accident due to an automatic restart at restoration of power after an inverter stop by a power failure
- 3) To separate the inverter from the power supply to ensure safe maintenance and inspection work.

The inverter's input side MC is used for the above purpose, select class JEM1038-AC3 MC for the inverter input side current when making an emergency stop during normal operation.

REMARKS

- Since repeated inrush currents at power ON will shorten the life of the converter circuit (switching life is about 1,000,000 times.), frequent starts and stops of the magnetic contactor must be avoided. Start and stop the inverter by turning ON/OFF the input signal (forward/reverse rotation signal) of the FL remote communication.
- If the main power supply needs to be shut off at an inverter fault, configure a system where the output of an inverter alarm is monitored through FL remote communication, and the magnetic contactor is turned OFF by an programmable controller output.

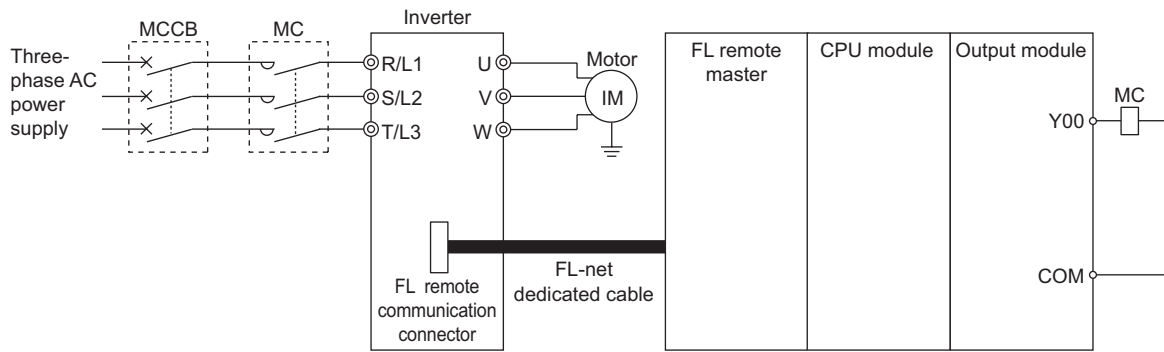

(2) Handling of inverter output side magnetic contactor

Switch the magnetic contactor between the inverter and motor only when both the inverter and motor are at a stop. When the magnetic contactor is turned ON while the inverter is operating, overcurrent protection of the inverter and such will activate. When an MC is provided for switching to the commercial power supply, for example, switch it ON/OFF after the inverter and motor have stopped.

3.4 Inverter-driven 400V class motor

In the PWM type inverter, a surge voltage attributable to wiring constants is generated at the motor terminals. Especially for a 400V class motor, the surge voltage may deteriorate the insulation. When the 400V class motor is driven by the inverter, consider the following measures:

●Measures

It is recommended to take either of the following measures:

(1) Rectifying the motor insulation and limiting the PWM carrier frequency according to the wiring length

For the 400V class motor, use an insulation-enhanced motor.

Specifically,

- 1) Specify the "400V class inverter-driven insulation-enhanced motor".
- 2) For the dedicated motor such as the constant-torque motor and low-vibration motor, use the "inverter-driven, dedicated motor".
- 3) Set *Pr. 72 PWM frequency selection* as indicated below according to the wiring length

	Wiring Length		
	50m or less	50m to 100m	exceeding 100m
<i>Pr. 72 PWM frequency selection</i>	15 (14.5kHz) or less	8 (8kHz) or less	2 (2kHz) or less

(2) Suppressing the surge voltage on the inverter side

Connect the surge voltage suppression filter (FR-ASF-H/FR-BMF-H) on the inverter output side.



NOTE

- For details of *Pr. 72 PWM frequency selection*, refer to page 163.
- For explanation of surge voltage suppression filter (FR-ASF-H/FR-BMF-H), refer to the manual of each option.

3.5 Precautions for use of the inverter

The FR-E700 series is a highly reliable product, but incorrect peripheral circuit making or operation/handling method may shorten the product life or damage the product.

Before starting operation, always recheck the following items.

- (1) **Use crimping terminals with insulation sleeve to wire the power supply and motor.**
- (2) **Application of power to the output terminals (U, V, W) of the inverter will damage the inverter. Never perform such wiring.**
- (3) **After wiring, wire offcuts must not be left in the inverter.**

Wire offcuts can cause an alarm, failure or malfunction. Always keep the inverter clean.

When drilling mounting holes in an enclosure etc., take care not to allow chips and other foreign matter to enter the inverter.
- (4) **Use cables of the size to make a voltage drop 2% or less.**

If the wiring distance is long between the inverter and motor, a main circuit cable voltage drop will cause the motor torque to decrease especially at the output of a low frequency.

Refer to page 17 for the recommended wire sizes.
- (5) **The overall wiring length should be 500m or less.**

Especially for long distance wiring, the fast-response current limit function may decrease or the equipment connected to the secondary side may malfunction or become faulty under the influence of a charging current due to the stray capacity of the wiring. Therefore, note the overall wiring length. (*Refer to page 19*)
- (6) **Electromagnetic wave interference**

The input/output (main circuit) of the inverter includes high frequency components, which may interfere with the communication devices (such as AM radios) used near the inverter. In this case, install the FR-BIF optional capacitor type filter (for use in the input side only) or FR-BSF01 common mode filter to minimize interference.
- (7) **Do not install a power factor correction capacitor, surge suppressor or capacitor type filter on the inverter output side.**

This will cause the inverter to trip or the capacitor and surge suppressor to be damaged. If any of the above devices are connected, immediately remove them.
- (8) **For some short time after the power is switched OFF, a high voltage remains in the smoothing capacitor.**

Before wiring or inspecting inside the inverter, wait 10 minutes or longer after turning OFF the power supply, then confirm that the voltage across the main circuit terminals P/+ and N/- of the inverter is 30VDC or less using a tester, etc. The capacitor is charged with high voltage for some time after power OFF, and it is dangerous.
- (9) **If "EV" is displayed on the operation panel, turn off the 24V external power supply before wiring and inspection.**
- (10) **A short circuit or earth (ground) fault on the inverter output side may damage the inverter modules.**
 - Fully check the insulation resistance of the circuit prior to inverter operation since repeated short circuits caused by peripheral circuit inadequacy or an earth (ground) fault caused by wiring inadequacy or reduced motor insulation resistance may damage the inverter modules.
 - Fully check the to-earth (ground) insulation and phase to phase insulation of the inverter output side before power-on. Especially for an old motor or use in hostile atmosphere, securely check the motor insulation resistance etc.
- (11) **Do not use the inverter input side magnetic contactor to start/stop the inverter.**

Since repeated inrush currents at power ON will shorten the life of the converter circuit (switching life is about 1,000,000 times.), frequent starts and stops of the MC must be avoided. Turn ON/OFF the inverter start controlling terminals (STF, STR) to run/stop the inverter. (*Refer to page 38*)

(12) Across P/+ and PR terminals, connect only an external regenerative brake discharging resistor.

Do not connect a mechanical brake.

The brake resistor cannot be connected to the 0.1K or 0.2K. Leave terminals P/+ and PR open.

Also, never short between these terminals.

(13) Do not apply a voltage higher than the permissible voltage to the inverter I/O signal circuits.

Application of a voltage higher than the permissible voltage to the inverter I/O signal circuits or opposite polarity may damage the I/O devices.

(14) Provide electrical and mechanical interlocks for MC1 and MC2 which are used for bypass operation.

When the wiring is incorrect and if there is a bypass operation circuit as shown right, the inverter will be damaged when the power supply is connected to the inverter U, V, W terminals, due to arcs generated at the time of switch-over or chattering caused by a sequence error.

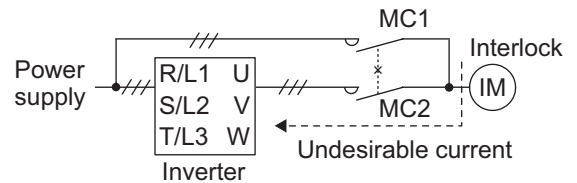

(15) If the machine must not be restarted when power is restored after a power failure, provide a magnetic contactor in the inverter's input side and also make up a sequence which will not switch ON the start signal.

If the start signal (start switch) remains ON after a power failure, the inverter will automatically restart as soon as the power is restored.

(16) Inverter input side magnetic contactor (MC)

On the inverter input side, connect a MC for the following purposes. (Refer to *page 4* for selection.)

- 1) To release the inverter from the power supply when a fault occurs or when the drive is not functioning (e.g. emergency stop operation). For example, MC avoids overheat or burnout of the brake resistor when heat capacity of the resistor is insufficient or brake regenerative transistor is damaged with short while connecting an optional brake resistor.
- 2) To prevent any accident due to an automatic restart at restoration of power after an inverter stop made by a power failure
- 3) To separate the inverter from the power supply to ensure safe maintenance and inspection work.

The inverter's input side MC is used for the above purpose, select class JEM1038-AC3 MC for the inverter input side current when making an emergency stop during normal operation.

(17) Handling of inverter output side magnetic contactor

Switch the magnetic contactor between the inverter and motor only when both the inverter and motor are at a stop. When the magnetic contactor is turned ON while the inverter is operating, overcurrent protection of the inverter and such will activate. When MC is provided for switching to the commercial power supply, for example, switch it ON/OFF after the inverter and motor have stopped.

(18) Instructions for overload operation

When performing operation of frequent start/stop of the inverter, rise/fall in the temperature of the transistor element of the inverter will repeat due to a repeated flow of large current, shortening the life from thermal fatigue. Since thermal fatigue is related to the amount of current, the life can be increased by reducing current at locked condition, starting current, etc. Decreasing current may increase the life. However, decreasing current will result in insufficient torque and the inverter may not start. Therefore, choose the inverter which has enough allowance for current (up to 2 rank larger in capacity).

(19) Make sure that the specifications and rating match the system requirements.

3.6 Failsafe of the system which uses the inverter

When a fault occurs, the inverter trips to output a fault signal. However, a fault output signal may not be output at an inverter fault occurrence when the detection circuit or output circuit fails, etc. Although Mitsubishi assures best quality products, provide an interlock which uses inverter status output signals to prevent accidents such as damage to machine when the inverter fails for some reason and at the same time consider the system configuration where failsafe from outside the inverter, without using the inverter, is enabled even if the inverter fails.

(1) Interlock method which uses the inverter status output signals

By providing interlocks, inverter fault can be detected. For the interlocks, use different status output signals of the inverter (virtual terminals of the FL remote communication) in combinations shown below.

No.	Interlock Method	Check Method	Used Signals	Refer to Page
1)	Inverter protective function operation	Operation check of an alarm contact Circuit error detection by negative logic	Fault output signal (ALM signal)	59
2)	Inverter running status	Check of the reset release signal	Reset release signal (READY signal)	59
3)	Inverter running status	Logic check of the start signal and running signal	Start signal (STF signal, STR signal) Running signal (RUN signal)	57, 59
4)	Inverter running status	Logic check of the start signal and output current	Start signal (STF signal, STR signal) Output current detection signal (Y12 signal)	57, 59

1) Checking by the inverter fault output signal

When the inverter's protective function activates and the inverter trips, the fault output signal (ALM signal) is output. With this signal, you can check if the inverter is operating properly.

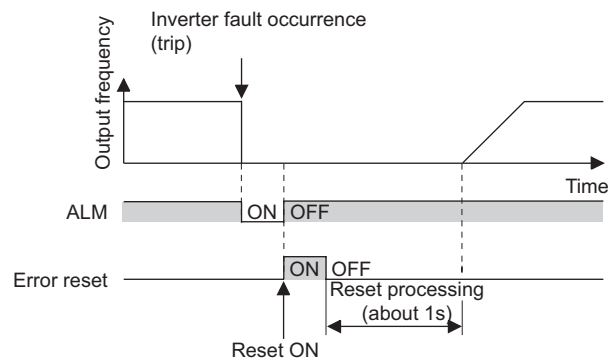

2) Checking the inverter operation status by the reset cancel signal

Reset cancel signal (READY signal) is output when the reset operation of the inverter is cancelled by turning ON the power of the inverter.

Check if the READY signal is output after the reset operation of the inverter is canceled.

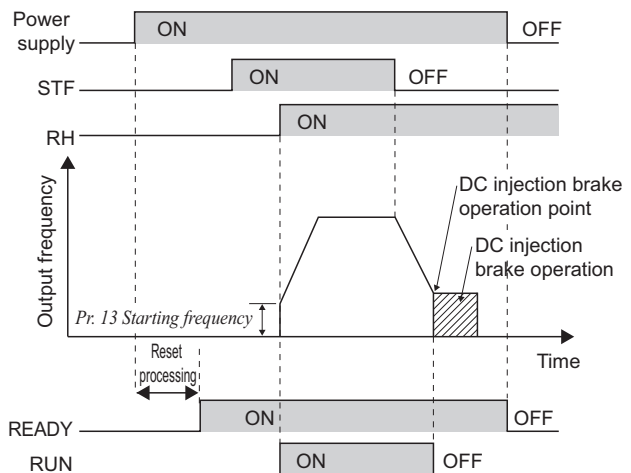

3) Checking the inverter operating status by the start signal input to the inverter and inverter running signal

The inverter running signal (RUN signal) is output when the inverter is running.

Check if RUN signal is output when inputting the start signal to the inverter (forward signal is STF signal and reverse signal is STR signal). For logic check, note that RUN signal is output for the period from the inverter decelerates until output to the motor is stopped, configure a sequence considering the inverter deceleration time.

4)Checking the motor operating status by the start signal input to the inverter and inverter output current detection signal.
 The output current detection signal (Y12 signal) is output when the inverter operates and currents flows in the motor. Check if Y12 signal is output when inputting the start signal to the inverter (forward signal is STF signal and reverse signal is STR signal). Note that the current level at which Y12 signal is output is set to 150% of the inverter rated current in the initial setting, it is necessary to adjust the level to around 20% using no load current of the motor as reference with *Pr.150 Output current detection level*.

For logic check, as same as the inverter running signal (RUN signal), the inverter outputs for the period from the inverter decelerates until output to the motor is stopped, configure a sequence considering the inverter deceleration time.

(2) Backup method outside the inverter

Even if the interlock is provided by the inverter status signal, enough failsafe is not ensured depending on the failure status of the inverter itself. For example, when the inverter CPU fails, even if the interlock is provided using the inverter fault output signal, start signal and RUN signal output, there is a case where a fault output signal is not output and RUN signal is kept output even if an inverter fault occurs.

Provide a speed detector to detect the motor speed and current detector to detect the motor current and consider the backup system such as checking up as below according to the level of importance of the system.

1)Start signal and actual operation check

Check the motor running and motor current while the start signal is input to the inverter by comparing the start signal to the inverter and detected speed of the speed detector or detected current of the current detector. Note that the motor current runs as the motor is running for the period until the motor stops since the inverter starts decelerating even if the start signal turns off. For the logic check, configure a sequence considering the inverter deceleration time. In addition, it is recommended to check the three-phase current when using the current detector.

2)Command speed and actual operation check

Check if there is no gap between the actual speed and commanded speed by comparing the inverter speed command and detected speed of the speed detector.

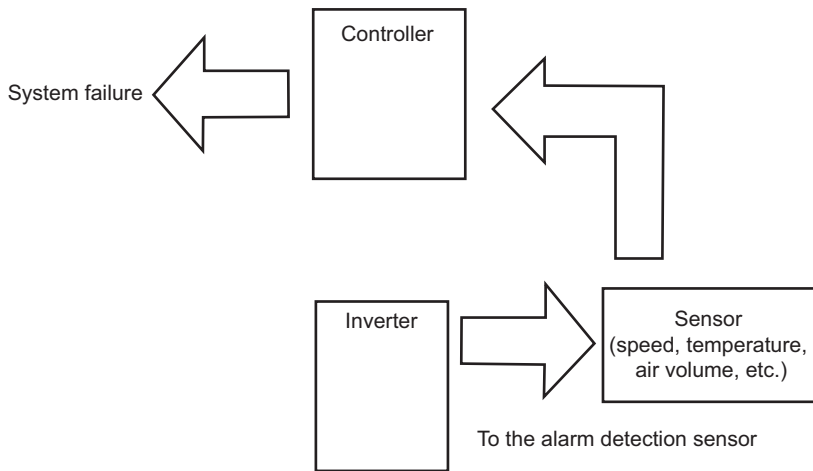

MEMO

4 FL REMOTE COMMUNICATION FUNCTION

This chapter explains the "FL REMOTE COMMUNICATION FUNCTION" for use of this product.

Always read the instructions before using the equipment.

4.1	FL remote communication specification	46
4.2	Node address setting	46
4.3	Wiring	47
4.4	LED status	49
4.5	Operation mode setting.....	50
4.6	FL remote communication	52
4.7	Cyclic transmission	53
4.8	Message transmission	61

1

2

3

4

5

6

7

8

4.1 FL remote communication specification

Type	Built-in to an inverter, RJ-45 connector connection method
Power supply	Supplied from the inverter or the 24V external power supply
Connection cable	FL-net dedicated cable (Refer to page 47)
Maximum number of connectable inverters	64 units maximum
Communication speed	Auto negotiation (auto detection) (10Mbps/100Mbps)
Topology	<ul style="list-style-type: none"> Star (connection with a hub in the center) Star bus (connection with multiple hubs)
Communication distance	<ul style="list-style-type: none"> Between node ↔ hub: 100m maximum (Node indicate master and inverters.) Between hubs: 100m maximum Overall length: 2000m maximum
Electrical interface	Conforms to IEEE802.3u (conforms to CSMA/CD)
Transmission protocol	FL remote
Node address setting	Can be set with node address switch. (Refer to page 46) Reflected to IP address as well. (192.168.250. node address)
I/O points	Input 64 points, output 64 points

4.2 Node address setting

Set the node address between "1 to 64" using node address switches. (Refer to page 2) The setting is applied when the power turns OFF once, then ON again.

Set the arrow (↑) of the corresponding switches to the number to set a desired address.

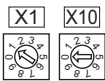
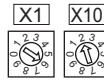

●Setting example

<p>Node address 1: Set the "↑" of X10(SW2) to "0" and the "↑" of X1(SW1) to "1."</p>		<p>Node address 26: Set the "↑" of X10(SW2) to "2" and the "↑" of X1(SW1) to "6."</p>	
--	---	---	---



NOTE

- Always remove the front cover before setting a node address with node address switches. (Refer to page 5 for how to remove the front cover.)
- Set the node address switch to the switch number position correctly. If the switch is set between numbers, normal data communication can not be established.

Good example	Bad example
	
- If the node address switch is set to a value other than "1 to 64", it is invalid due to outside of setting range. In this case, DEV LED is lit red and E.OPT appears on the operation panel. (Refer to page 209)
- You cannot set the same node address to other devices on the network. (Doing so disables proper communication.)
- Set the inverter node address before switching ON the inverter and do not change the setting while power is ON. Otherwise you may get an electric shock.

4.3 Wiring

4.3.1 Connecting to the network

- (1) Be sure to check the following points before connecting the inverter to the network.
 - Check that the correct node address is set. (Refer to page 46)
 - Check that the FL-net dedicated cable is correctly connected to the FL remote communication connector. (Refer to page 48)
- (2) System configuration

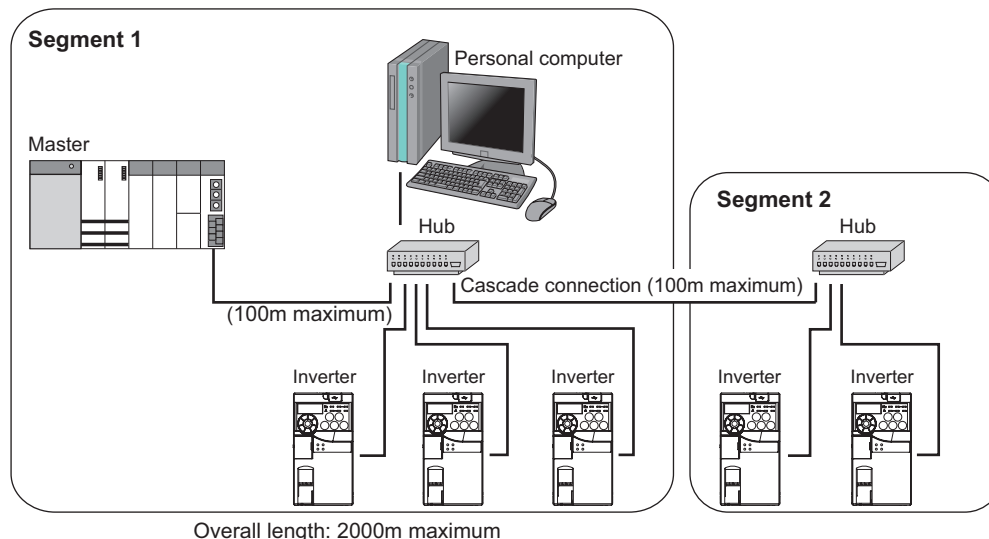

4.3.2 Precautions for system configuration

Enough safety measures are necessary when installing the FL-net dedicated cable and connecting to the FL remote network.

Consult the network provider and network administrator (person in charge of network planning and IP address management) including terminal treatment of connection cable, construction of trunk cable, etc.

We are not responsible for system troubles from connecting to the FL remote network.

4.3.3 Cable specifications

Use the following FL-net dedicated cables.

Cables :TPCC5 or more(Twisted Pair Communication Cable for LAN Category 5)

For the shape, use STP (Shielded Twisted Pair)
(according to the 100BASE-TX(IEEE802.3u) standard)

Maximum wiring length :100m maximum between the hub and the inverter

(according to the 100BASE-TX(IEEE802.3u) standard)



REMARKS

- FL-net dedicated cable...recommended product (as of October 2009)

Model name	Cable length	Manufacturer
FLG-S-000	1m to 100m	Shinwa Co., Ltd.
(Example: when the cable length is 1m) FLG-S-010		

4.3.4 Connecting the FL-net dedicated cable

Connect the FL-net dedicated cable to the FL remote communication connector.

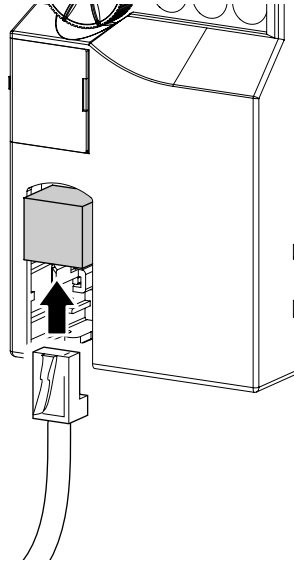

NOTE

- Do not connect the FL-net dedicated cable to the terminal reserved for manufacturer settings.

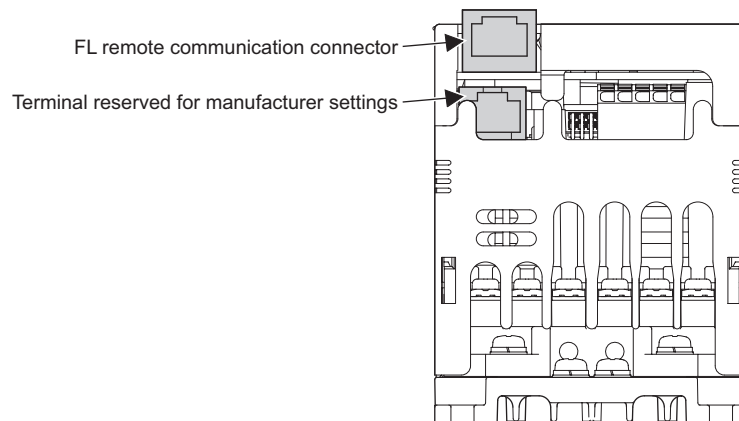

CAUTION

- Do not connect a parameter unit (FR-PU07, etc.) to the FL remote communication connector. Doing so may damage the inverter.
- Take caution not to subject the cables to stress.
- After wiring, wire offcuts must not be left in the inverter. Wire offcuts can cause an alarm, failure or malfunction.

4.4 LED status

Each LED indicates the operating status of the inverter and network according to the indication status.

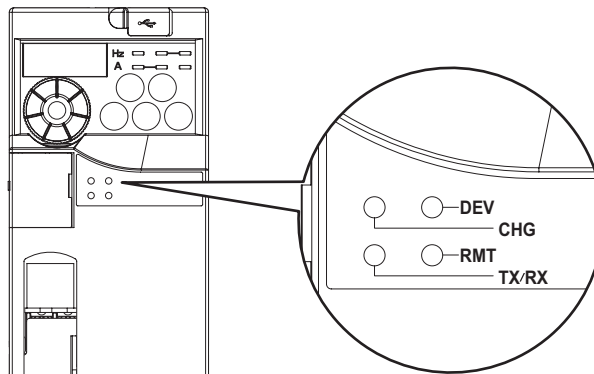

CHG : Communication set status LED
 DEV : Device status LED
 TX/RX : Reception/transmission LED
 RMT : Remote status LED

4.4.1 Device status LED (DEV), remote status LED (RMT)

LED Status		Node Status	Description
DEV	RMT		
<input type="checkbox"/>	<input type="checkbox"/>	Power is OFF	The inverter power is OFF.
<input checked="" type="checkbox"/>	<input type="checkbox"/>	Hardware fault	<ul style="list-style-type: none"> Node address is out of range (other than 1 to 64). The option board is faulty. A contact fault or other failure has occurred in the option connector between the inverter and a communication option.
<input type="checkbox"/>	<input type="checkbox"/>	FL remote network is not connected	Although hardware is normal, it is not connected to the FL remote network.
<input type="checkbox"/>	<input type="checkbox"/>	FL remote network at a remote stop	It is correctly set to connect to the FL remote network and waiting for remote I/O control.
	<input type="checkbox"/>	FL remote network during remote connection processing	Although remote I/O control started, initial processing is in progress.
	<input type="checkbox"/>	Master is not present	When the master is disconnected from FL remote network.
<input type="checkbox"/>	<input type="checkbox"/>	FL remote network during remote operation	During remote I/O control
<input type="checkbox"/>	<input checked="" type="checkbox"/>	Own node is disconnected	When the own node is disconnected from FL remote network.
<input type="checkbox"/>	<input checked="" type="checkbox"/>	Setting error	Although it is connected to the FL remote, setting error is found. (When the slave is not the one the master is expected.)
<input type="checkbox"/>	<input checked="" type="checkbox"/>	Duplicate node	When node address is duplicate with other node address
		Unsupported protocol	Communication is attempted via an unsupported protocol.

:OFF, : red is lit, : green is lit, ↔ :red is flickering, ↔ : green is flickering,

↔ : red and green are alternately flickering

4.4.2 Transmitting (TX)/receiving (RX) LED

LED Status	Node Status	Description
<input type="checkbox"/>	Not transmitting (TX) /not receiving (RX)	
<input type="checkbox"/>	Transmitting (TX)/receiving (RX)	Flickers at high speed during continuous transmitting/receiving

:OFF, : green is lit

4.4.3 Communication set status LED (CHG)

LED Status	Node Status	Description
<input type="checkbox"/>	Communication setting is not changed	
<input checked="" type="checkbox"/> ↔ <input type="checkbox"/>	Communication setting is changed	Red flickers when the setting value actually reflected and of node address switch differ. The setting value of the node address switch is reflected by re-powering ON the inverter in this status, then communication setting status LED turns OFF.

:OFF, ↔ : red is flickering

4.5 Operation mode setting

4.5.1 Operation mode basics

- The operation mode specifies the source of the start command and the frequency command for the inverter.
- Basically, there are following operation modes.
 - Network operation mode (NET operation mode): For inputting a start command and a frequency command through FL remote communication.
 - PU operation mode: For inputting start command and frequency command with the operation panel.
- At power-on, the inverter starts up in the Network operation mode. The operation mode can be switched using  on the operation panel when "1" is set in the X12 signal (Bit11). X12 signal gives a control input command through FL remote communication. (Refer to page 57)
- Confirm the operation mode from the operation panel. (Refer to page 74)

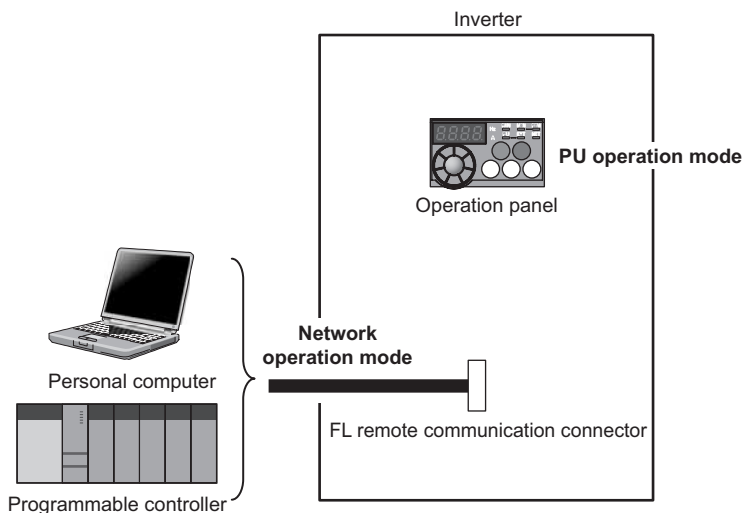

REMARKS

- The stop function (PU stop selection) activated by pressing  of the operation panel is valid even in other than the PU operation mode in the initial setting.
(Refer to Pr. 75 Reset selection/PU stop selection (page 165))

4.5.2 PU operation interlock

- The PU operation interlock function is designed to forcibly change the operation mode to the Network operation mode when the PU operation interlock signal (X12) input turns OFF. This function prevents the operation mode from being accidentally unswitched from the PU operation mode. If the operation mode is left unswitched from the PU operation mode, the inverter does not reply to the commands sent through FL remote communication.

X12 Signal	Function/Operation	
	Operation mode	Parameter write
ON	<ul style="list-style-type: none"> Operation mode (PU, NET) switching enabled Output stop during Network operation 	Parameter write is enabled (depending on Pr. 77 <i>Parameter write selection</i> and each parameter write conditions (Refer to page 78 for the parameter list))
OFF	<ul style="list-style-type: none"> Forcibly switched to Network operation mode Network operation allowed Switching between the PU operation mode is enabled 	Parameter write is disabled (Note that the Pr.297 setting is available when Pr.296 ≠ "9999.")

<Function/operation changed by switching ON-OFF the X12 signal>

Operating Condition		X12 Signal	Operation Mode	Operating Status	Switching to PU Operation Mode
Operation mode	Status				
PU	During stop	ON → OFF *1	Network *2	If Network operation frequency setting and start signal are entered, operation is performed in that status.	Disallowed
	Running	ON → OFF *1			Disallowed
Network	During stop	OFF → ON		During stop	Allowed
		ON → OFF		During operation → output stop	Disallowed
	Running	OFF → ON		Output stop → operation	Disallowed
		ON → OFF			Disallowed

*1 The operation mode switches to the Network operation mode independently of whether the start signal (STF, STR) is ON or OFF. Therefore, the motor is run in Network operation mode when the X12 signal is turned OFF with either of STF and STR ON.

*2 At fault occurrence, pressing  of the operation panel resets the inverter.



NOTE

- If the X12 signal is ON, the operation mode cannot be switched to the PU operation mode when the start signal (STF, STR) is ON.

4.5.3 Operation availability in each operation mode

- Operation availability in each operation mode is shown below. (Monitoring and parameter read can be performed from any operation regardless of operation mode.)

Operation Location	Operation Mode		PU Operation	NET Operation
	Item			
Operation panel	Run command (start)		○	×
	Run command (stop)		○	Δ *3
	Running frequency setting		○	×
	Parameter write		○ *1	×
	Inverter reset		○	×
FL remote communication	Run command (start)		×	○
	Run command (stop)		×	○
	Running frequency setting		×	○
	Parameter write		×	○ *1
	Inverter reset		×	○

○: Enabled, ×: Disabled, Δ: Some are enabled

*1 Some parameters may be write-disabled according to the Pr. 77 *Parameter write selection* setting and operating status. (Refer to page 166)

*2 Some parameters are write-enabled independently of the operation mode and command source presence/absence. When Pr. 77 = 2, write is enabled. (Refer to the parameter list on page 78) Parameter clear is disabled.

*3 Enabled only when stopped by the PU. At a PU stop, PS is displayed on the operation panel. As set in Pr. 75 *Reset selection/PU stop selection*. (Refer to page 165)

4.6 FL remote communication

4.6.1 Overview of FL remote communication

(1) Output from the inverter to the network

Main items to be output from the inverter to the network and their descriptions are explained below.

(○: with function, ×: without function)

Item	Description	Cyclic Transmission	Message Transmission	Refer to Page
Inverter monitor	Monitor various items such as inverter output current and output voltage.	×	○	64
Inverter status	Monitors the output signal of the inverter.	○	○	59, 64
Operation mode read	Reads the operation mode of the inverter.	×	○	63
Output frequency read	Monitors the output frequency of the inverter.	○	○	60, 64
Parameter read	Reads parameter settings of the inverter.	×	○	65
Fault records	Monitors the fault history of the inverter.	×	○	66

REMARKS

- Refer to page 51 for functions controllable from the network in each operation mode.

(2) Input to the inverter from the network

Main items which can be commanded from the network to the inverter and their descriptions are explained below.

(○: with function, ×: without function)

Item	Description	Cyclic Transmission	Message Transmission	Refer to Page
Run command	Sets the control input command such as forward rotation signal (STF) and reverse rotation signal (STR).	○	×	57
Frequency setting	Sets the running frequency of the inverter.	○	×	58
Parameter write	Sets parameters of the inverter.	×	○	65
Fault records all clear	Clears the fault of the inverter.	×	○	66

REMARKS

- Refer to page 51 for functions controllable from the network in each operation mode.

4.6.2 FL remote data communication types

FL remote data communication supports "cyclic transmission" which transmits data periodically (Refer to page 53) and "message transmission" which transmits data non-periodically (Refer to page 61).

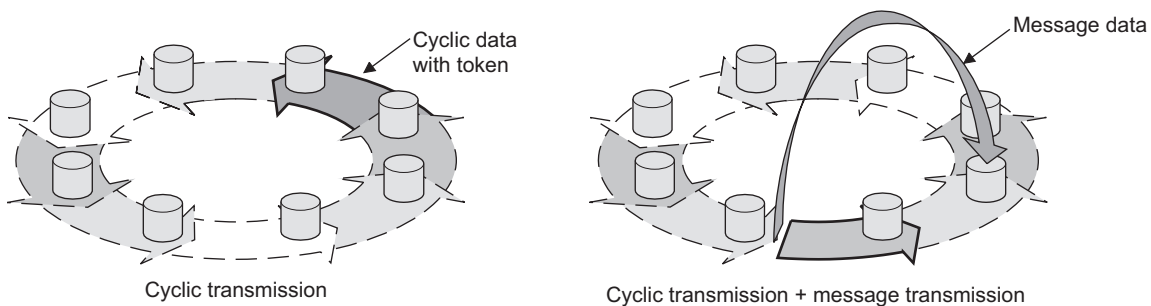

4.7 Cyclic transmission

Cyclic transmission transmits data periodically. Each node shares data through common memory. Data of I/O area is updated periodically by cyclic transmission.

The master controls the inverter by setting run command (control input command, set frequency, etc.) in the output data area.

The inverter sets the inverter status (output frequency, output current, various signals, etc.) in the input data area and sends it to the master.

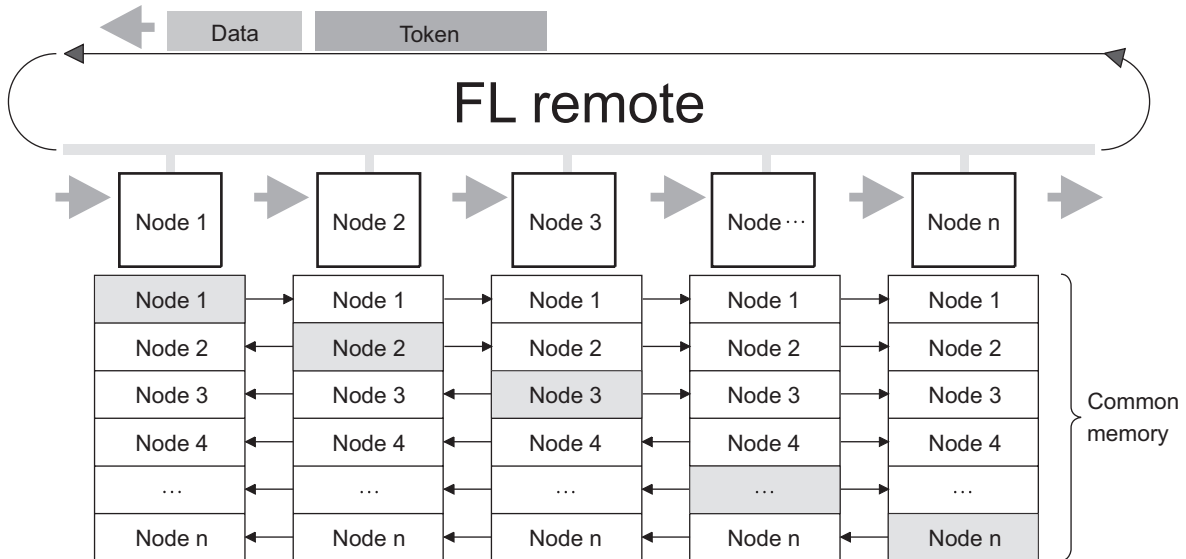

4.7.1 Common memory

Concept of common memory is stated below.

- The common memory is used as a shared memory between nodes which perform cyclic transmission.
- The common memory has two areas which are "common memory area 1" and "common memory area 2".
Common memory area 1 is I/O data area. Common memory area 2 is the control information area.
Two different areas can be assigned to each node.
- When the area each node sends exceed the transmission size (1024 bytes) by one frame, data is transmitted by multiple frames.
- When receiving data which are divided into multiple frames as above, common memory is not updated until all frames sent from one node are received. Synchronism per node unit is guaranteed.
- Entire network has an area of 8k bits (0.5k word) + 8k words = 8.5k words.
The maximum send data capacity per one node is 8.5k words. (Note that one word is 2 bytes.)

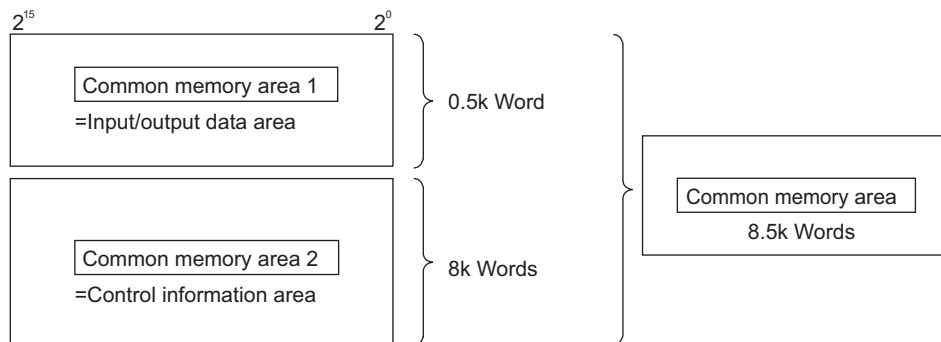

- Among common memory, both common memory area 1 and common memory 2 can be set as a transmission area of one node as desired within the maximum area.
- Each node on FL remote network can share the same data in the whole system by broadcasting data at a constant period. In addition, each node has own transmission area which does not overlap each other to exchange data. (For common memory function, the transmission area assigned to one node is a receive area for other nodes.)

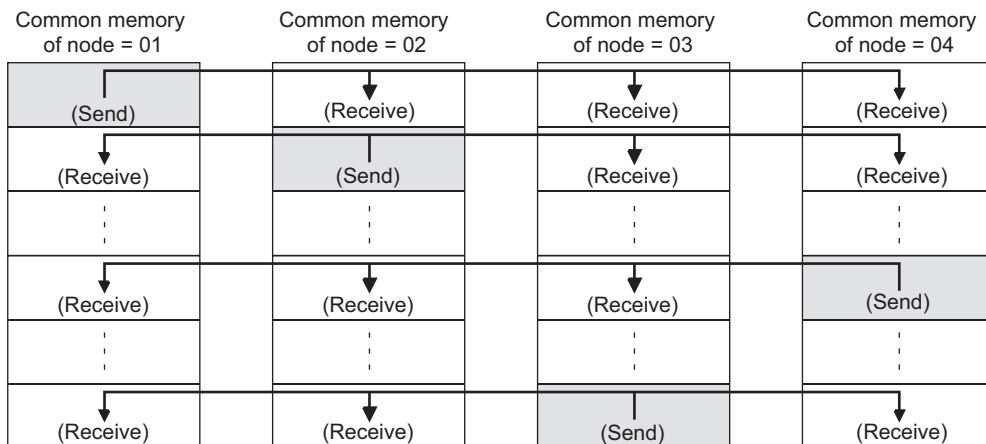

(1) Common memory area 1

	Size	Description	Refer to Page
Input data (Inverter→master)	256 words (512 bytes)	Data to be sent from inverter to master (4 words). The data includes inverter status, output frequency, etc.	59
Output data (Master→inverter)	256 words (512 bytes)	Data to be sent from master to inverter (4 words). The data includes starting command, frequency command, etc.	57

	Virtual address (byte boundary)	Applications		
		Address (word boundary)	Size (word boundary)	Description (Number in parentheses indicates node address)
Input data (Inverter→master)	H00000000	0	4	Input data (#1)
	H00000008	4	4	Input data (#2)
	H00000010	8	4	Input data (#3)
	:			
	H000001F0	248	4	Input data (#63)
	H000001F8	252	4	Input data (#64)
Output data (Master→inverter)	H00000200	256	4	Output data (#1)
	H00000208	260	4	Output data (#2)
	H00000210	264	4	Output data (#3)
	:			
	H000003F0	504	4	Output data (#63)
	H000003F8	508	4	Output data (#64)

* When accessing a message, the access size should be the size stated in the table above.



REMARKS

- When node status is other than "during FL remote network remote operation", all output data is changed to "0". (Refer to page 49 for change of the setting.)
- When transmitting a message, common memory area 1 and 2 are read only. (Refer to page 62)

(2) Common memory area 2

	Size
Control information (inverter→master)	1024 words (2048 bytes)
Control information (master→inverter)	1024 words (2048 bytes)

	Virtual address (byte boundary)	Applications		
		Address (word boundary)	Size (word boundary)	Description (Number in parentheses indicates node address.)
(1) Control information (inverter→master)	H00000400	0	1	Slave status (#)
	H00000402	1	1	Actual status slave type (#1)
	H00000404	2	14	Simple setting check area (#1)
	:			
	H00000BE0	1008	1	Slave status (#64)
	H00000BE2	1009	1	Actual status slave type (#64)
(2) Control information (master→inverter)	H00000BE4	1010	14	Simple setting check area (#64)
	H00000C00	1024	1	Remote control area (#1)
	H00000C02	1025	1	Expected slave type (#1)
	H00000C04	1026	14	Simple setting area (#1)
	:			
	H000013E0	2032	1	Remote control area (#64)
H000013E2	2033	1	Expected slave type (#64)	
H000013E4	2034	14	Simple setting area (#64)	

* When accessing a message, the access size should be the size stated in the table above.



REMARKS

- When sending a message, common memory area 1 and 2 are read only. (Refer to page 62)

(1) Control information (inverter→master)

<Slave status>

Value	Slave status
0	FL remote network is not connected
1	FL remote network remote at a stop
2	FL remote network remote connection processing
3	FL remote network remote operating
4	Master is not present
5	Own node is disconnected
6	Setting error

<Actual slave type>

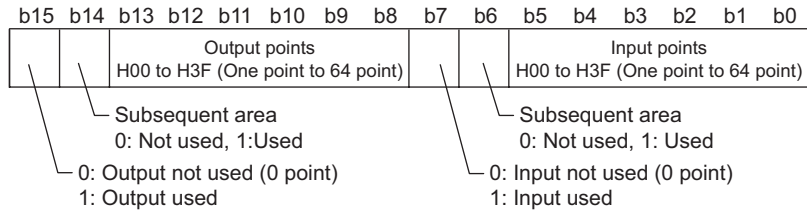

<Simple setting check area>

Not used. (Displays data imported in the simple setting area set from the master.)

(2) Control information (master→inverter)

<Remote control area>

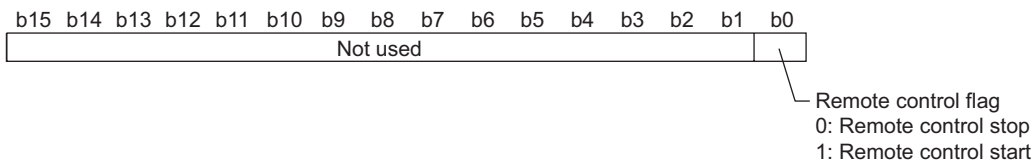

<Expected slave type>

Refer to <Actual slave type>

<Simple setting check area>

Not used

4.7.2 Output data (master to inverter)

[Master output area (master → inverter)]

Word	Address (word boundary) (n: node address)	Applications															
		Bit	15	14	13	12	11	10	9	8	7	6	5	4	3	2	1
0	4(n-1)+256	(1) Control input command															
1	4(n-1)+257	— (not used)															
2	4(n-1)+258	(2) Set frequency (0.01 Hz increments)															
3	4(n-1)+259	— (not used)															

(1) Control input command

Set control input command such as forward and reverse rotation commands.

Bit	Signal	Description			Related Parameters	Refer to Page																
0	STF signal	Forward rotation command	<table border="1"> <thead> <tr> <th>Bit0</th> <th>Bit1</th> <th>Command</th> </tr> </thead> <tbody> <tr> <td>Forward rotation: 0</td> <td>Reverse rotation: 0</td> <td>Stop command</td> </tr> <tr> <td>Forward rotation: 1</td> <td>Reverse rotation: 0</td> <td>Forward rotation command</td> </tr> <tr> <td>Forward rotation: 0</td> <td>Reverse rotation: 1</td> <td>Reverse rotation command</td> </tr> <tr> <td>Forward rotation: 1</td> <td>Reverse rotation: 1</td> <td>Stop command</td> </tr> </tbody> </table>			Bit0	Bit1	Command	Forward rotation: 0	Reverse rotation: 0	Stop command	Forward rotation: 1	Reverse rotation: 0	Forward rotation command	Forward rotation: 0	Reverse rotation: 1	Reverse rotation command	Forward rotation: 1	Reverse rotation: 1	Stop command	—	141
			Bit0	Bit1	Command																	
Forward rotation: 0	Reverse rotation: 0	Stop command																				
Forward rotation: 1	Reverse rotation: 0	Forward rotation command																				
Forward rotation: 0	Reverse rotation: 1	Reverse rotation command																				
Forward rotation: 1	Reverse rotation: 1	Stop command																				
1	STR signal	Reverse rotation command	<table border="1"> <thead> <tr> <th>Bit0</th> <th>Bit1</th> <th>Command</th> </tr> </thead> <tbody> <tr> <td>Forward rotation: 0</td> <td>Reverse rotation: 1</td> <td>Reverse rotation command</td> </tr> <tr> <td>Forward rotation: 1</td> <td>Reverse rotation: 1</td> <td>Stop command</td> </tr> </tbody> </table>			Bit0	Bit1	Command	Forward rotation: 0	Reverse rotation: 1	Reverse rotation command	Forward rotation: 1	Reverse rotation: 1	Stop command								
			Bit0	Bit1	Command																	
Forward rotation: 0	Reverse rotation: 1	Reverse rotation command																				
Forward rotation: 1	Reverse rotation: 1	Stop command																				
2	RL signal	<i>Pr. 59 = 0</i> (initial value)	Low-speed operation command			Pr. 4 to Pr. 6, Pr. 24 to Pr. 27	111															
		<i>Pr. 59 = 1, 2 *1</i>	Remote setting (setting clear)			Pr. 59	113															
		<i>Pr. 270 = 1 *2</i>	Stop-on contact selection 0			Pr. 270, Pr. 275, Pr. 276	139															
3	RM signal	<i>Pr. 59 = 0</i> (initial value)	Middle-speed operation command			Pr. 4 to Pr. 6, Pr. 24 to Pr. 27	111															
		<i>Pr. 59 = 1, 2 *1</i>	Remote setting (deceleration)			Pr. 59	113															
4	RH signal	<i>Pr. 59 = 0</i> (initial value)	High-speed operation command			Pr. 4 to Pr. 6, Pr. 24 to Pr. 27	111															
		<i>Pr. 59 = 1, 2 *1</i>	Remote setting (acceleration)			Pr. 59	113															
5	RT signal	Second function selection	0: second function selection invalid, 1: second function selection valid			Pr. 44 to Pr. 51	143															
		<i>Pr. 270 = 1 *2</i>	Stop-on contact selection 1			Pr. 270, Pr. 275, Pr. 276	139															
6 to 8	— (not used)	Always 0			—	—																
9	MRS signal	Output stop	0: output shut off cancel, 1: output shut off			Pr. 17	143															
10	— (not used)	Always 0			—	—																
11	X12 signal	PU operation interlock			—	51																
		Bit11	Signal Function/Operation																			
			Operation mode	Parameter write																		
0	<ul style="list-style-type: none"> Forcibly switched to Network operation mode Network operation is allowed Switching to the PU operation mode is disabled 	Parameter write is disabled (Note that the <i>Pr.297</i> setting is available when <i>Pr.296</i> ≠ "9999.")																				
1	<ul style="list-style-type: none"> Operation mode (PU, NET) switching is enabled Output stop during Network operation 	Parameter write is enabled (depending on <i>Pr. 77 Parameter write selection</i> and each parameter write conditions)																				
12 to 14	— (not used)	Always 0			—	—																
15	Error reset	Resets the inverter when the setting of Bit15 is changed from 0 to 1 at occurrence of inverter error. Resetting the inverter resets the fault and initializes the inverter status. (FL remote communication remains online.)			—	—																

*1 When *Pr. 59 Remote function selection* = "1" or "2", the functions of the RL, RM and RH signals are changed as given in the table.

*2 When *Pr. 270 Stop-on contact control selection* = "1", functions of RL and RT signals are changed as in the table.



REMARKS

- The values of each bit, "0" and "1," indicate "OFF" and "ON."

(2) Set frequency

The set frequency can be set in 0.01Hz increments.

Bit	Range	Unit
0 to 15	0.00Hz to 400.00Hz	0.01Hz

Example:

If you want to set 120.00Hz, set 12000, which is the value multiplied by 100.



REMARKS

- Regardless of the *Pr.37* setting, the value is always set in frequency (Hz).

4.7.3 Input data (inverter to master)

[Master input area (inverter → master)]

Word	Address (word boundary) (n: node address)	Applications															
		Bit	15	14	13	12	11	10	9	8	7	6	5	4	3	2	1
0	4(n-1)+0	(1) Inverter status monitor															
1	4(n-1)+1	(3) Life/alarm								(2) Alarm code							
2	4(n-1)+2	(4) Output frequency monitor															
3	4(n-1)+3	(5) Output current monitor															

(1) Inverter status monitor

Monitors the output signal of the inverter from the network.

Bit	Signal	Description			Related Parameters	Refer to Page
0	During forward rotation	Bit0	Bit1	Operation	—	—
		Forward rotation: 0	Reverse rotation: 0	During stop		
1	During reverse rotation	Forward rotation: 1	Reverse rotation: 0	During forward rotation	—	—
		Forward rotation: 0	Reverse rotation: 1	During reverse rotation		
		Forward rotation: 1	Reverse rotation: 1	Not used		
2	RUN signal	Inverter running	When the inverter output frequency reaches or exceeds <i>Pr.13 Starting frequency</i> , the value changes to "1".		—	142
3	SU signal	Reached the frequency	When the output frequency reaches the set frequency, the value changes to "1".		Pr.41	144
4	— (not used)	Always 0			—	—
5	OL signal	Overload alarm	While stall prevention function is activated, the value changes to "1".		Pr.22, Pr.23, Pr.66	101
6	FU signal	Output frequency detection	When the output frequency reaches the frequency set in <i>Pr. 42 (Pr. 43 for reverse rotation)</i> , the value changes to "1".		Pr.42, Pr.43	144
7	ALM signal	Fault	When the inverter protective function is activated to stop the output (fault), the value changes to "1".		—	192
8	— (not used)	Always 0			—	—
9	Safety alarm signal	Internal safety circuit fault	When an internal safety circuit fault (E.SAF, E. 6, E. 7, or E.CPU) occurs, the value changes to "1".		—	—
10	Edit signal	Edit enabled	0: Parameter change disabled (X12 signal = "0") 1: Parameter change enabled (X12 signal = "1")		—	—
11	NET signal	0: Command (run command/speed command) can not be given through network 1: Command (run command/speed command) can be given through network		—	—	
12	Y12 signal	Output current detection	When the output current is higher than the <i>Pr.150</i> setting and persists for longer than the time set in <i>Pr.151</i> , the value changes to "1".		Pr.150, Pr.151	145
13	Y13 signal	Zero current detection	When the output current is lower than the <i>Pr.152</i> setting and persists for longer than the time set in <i>Pr.153</i> , the value changes to "1".		Pr.152, Pr.153	145
14	READY signal	Reset cancel	0: inverter resetting/starting after power is turned on 1: Reset canceling		—	142
15	— (not used)	Always 0			—	—

REMARKS

- The values of each bit, "0" and "1," indicate "OFF" and "ON."

(2) Alarm code

Description of an alarm that occurred in the inverter can be read.

Bit	Name	Description
0 to 7	Alarm code	When an alarm (fault) occurs in the inverter, fault code is displayed. (Refer to page 67)

(3) Life/alarm

Whether the control circuit capacitor, main circuit capacitor, cooling fan, and each parts of the inrush current limit circuit have reached the life alarm output level or not can be checked.

Bit	Name	Description
8	Control circuit capacitor life	0: without alarm, 1: with alarm The control circuit capacitor life is calculated from the energization time and temperature according to the operating status, and is counted down from 100%. An alarm is output when the control circuit capacitor life falls below 10%. (The setting value goes back to 0 when the part is replaced.)
9	Main circuit capacitor life	0: without alarm, 1: with alarm On the assumption that the main circuit capacitor capacitance at factory shipment is 100%, the capacitor life is checked every time measurement is made. An alarm is output when the measured value falls below 85%. The life check of the main circuit capacitor can be performed by measuring at the maintenance time, etc. After setting "1" in Pr. 259 Main circuit capacitor life measuring, switch OFF power once, then ON again to check that Pr. 259 = "3" (measuring completion). (The setting value goes back to 0 when the part is replaced.)
10	Cooling fan life	0: without alarm, 1: with alarm This function detects that the cooling fan speed falls 50% or below and outputs an alarm. (The setting value goes back to 0 when the part is replaced.)
11	Inrush current limit circuit life	0: without alarm, 1: with alarm Counts the number of contact (relay, contactor, thyristor) ON times and counts down every 100% (0 times) to 1%/10,000 times. Outputs an alarm when the speed reaches 10% (900000 times). (The setting value goes back to 0 when the part is replaced.)
12	FIN signal (Heatsink overheat pre-alarm)	0: without alarm, 1: with alarm Output when the heatsink temperature reaches about 85% of the heatsink overheat protection providing temperature. (Refer to page 199 for the details.)
13	Alarms	0: without display, 1: with display
14	— (not used)	(Always 0)
15	Y95 signal (maintenance timer)	0: normal, 1: maintenance timer has elapsed When the Pr. 503 Maintenance timer setting has elapsed the time (100h increments) set in Pr.504 Maintenance timer alarm output set time, the value changes to 1. (Turn ON Y95 signal.) When Pr. 504 = "9999", no function is selected. (Refer to page 180 for the details.)



REMARKS

- The values of each bit, "0" and "1," indicate "OFF" and "ON."

(4) Output frequency monitor

The output frequency of the inverter can be monitored in 0.01Hz increments.

Bit	Range	Unit
0 to 15	0.00Hz to 400.00Hz	0.01Hz

Example:

If the monitor value is 120.00Hz, 12000 (the value multiplied by 100) is displayed.



REMARKS

- Regardless of the Pr.37 setting, the value is always displayed in frequency (Hz).

(5) Output current monitor

The output current of the inverter can be monitored in 0.1A increments.

Bit	Range	Unit
0 to 15	0.0A to 3276.7A	0.1A

4.8 Message transmission

Message transmission is a non-periodic data communication method to communicate to a specified node when send request is given.

Basic function of message transmission is as follows.

- (1) When a node receives a token, one frame can be sent before sending cyclic frame.
- (2) The message frame size which can be sent at a time is 1024 bytes at maximum.

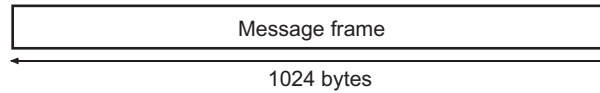

- (3) This method applies algorithm which controls refresh time not exceeding refresh cycle permissible time.
- (4) Two transmission functions are available. One is "one-to-one message transmission" to send to specified nodes, and another is "one-to-n message transmission" to send to all nodes.
- (5)
 - For "one-to-one message transmission", whether the other node has received data correctly or not is checked.
 - For "one-to-n message transmission", response is not given after receipt of a message.

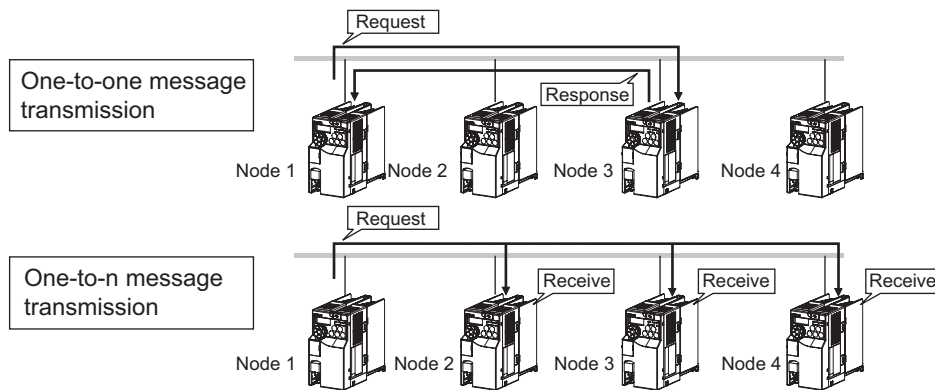

Following functions are provided with a message transmission.

Function	Description	Refer to Page
Word block read/write	Performs data read/write per word unit (one address 16 bit) to the virtual address space (32 bit address space) of other node from the network.	62
Network parameter read	Reads network parameter information of other node from network.	68
Log data read	Reads log information of other node from network.	69
Log data clear	Clears log information (<i>Refer to page 69</i>) of other node from network.	69
Profile read	Reads system parameter of device profile of other node from network.	70
Message loopback	Returns message data received then performs message communication test of device.	71

4.8.1 Error response at word block read/write

Error response may be received when reading/writing the product information of connected Mitsubishi inverter. In such a case, error code is attached to the data portion.

The list of error code is shown below.

Error code	Description	Remarks
H0010	Address error	<ul style="list-style-type: none"> • Odd address was specified. • Accessed address not defined.
H0020	Size error	<ul style="list-style-type: none"> • Write size was other than one word.
H0030	Data error	<ul style="list-style-type: none"> • A value outside the data range was specified. • The range of calibration was too narrow.
H0040	Write disable error	<ul style="list-style-type: none"> • Attempted to write to monitor data. • Attempted to write to a parameter during an operation. • Attempted to write to a write-prohibited parameter.
H0060	During reset	<ul style="list-style-type: none"> • Accessed during inverter reset.

4.8.2 Word block read/write

Performs data read/write per word unit (one address 16 bit unit) to the virtual address space (32 bit address space) of other node from the network.

- Word block read

Item		Data Portion	
Request		Not applicable	
Response	Normal response	Offset	Bit15 to Bit0
		+0	Virtual address space
	:		
	Error response	Offset	Bit15 to Bit0
+0		Error code (Refer to page 61)	

- Word block write

Item		Data Portion	
Request		Offset	Bit15 to Bit0
		+0	Virtual address space
		:	
Response	Normal response	Not applicable	
	Error response	Offset	Bit15 to Bit0
		+0	Error code (Refer to page 61)

(1) Virtual address space of word block read/write

Virtual address (byte boundary)	Applications	Address (word boundary)	Size (word boundary)	Description	Message Access		Refer to Page
					Read	Write	
H00000000	Common memory area 1	0 to 511	512	Input/output data	○	×	55
H00000400	Common memory area 2	0 to 1023	1024	Control information (inverter→master)	○	×	55
H00000C00		1024 to 2047	1024	Control information (master→inverter)	○	×	55
H00001400		2048 to 8191	6144	Control information (blank)	×	×	55
H10000000	Product information	0 to 71	72	Product information	○	×	62
H100000C8		100 to 100	1	Operation mode	○	×	63
H100000DC		110 to 110	1	Inverter status	○	×	64
H100000F0		120 to 121	2	Set frequency	○	×	64
H10000190		200 to 299	100	Inverter monitor	○	×	64
H100007D0		1000 to 1999	1000	Parameter	○	○	65
H10001770		3000 to 3899	900	Fault record	○	○	66

(2) Product information

Reads product information such as the inverter type, inverter capacity, etc.

Virtual address (byte boundary)	Applications			Message Access	
	Address (word boundary)	Size (word boundary)	Description	Read	Write
H10000000	0	50	Manufacturer name: MITSUBISHI ELECTRIC CORPORATION	○	×
H10000064	50	20	Product name: FR-E700	○	×
H1000008C	70	1	Inverter capacity : in 0.1kW increments	○	×

* When accessing a message, the access size should be the size stated in the table above.

<Word block read (manufacturer name)>

Item		Data Portion		
Request		Not applicable		
Response	Normal response	Returns "MITSUBISHI ELECTRIC CORPORATION". The rest are the characters for space.		
		Offset	Bit15 to Bit8	Bit7 to Bit0
		+0	Second character	First character
		+1	Fourth character	Third character
	:			
	+49	Hundredth character	Ninety ninth character	
Error response		Offset	Bit15 to Bit0	
		+0	Error code (Refer to page 61)	

<Word block read (product name)>

Item		Data Portion		
Request		Not applicable		
Response	Normal response	For the 200V class FR-E700, "FR-E720" is returned. The rest are the characters for space.		
		Offset	Bit15 to Bit8	Bit7 to Bit0
		+0	Second character	First character
		+1	Fourth character	Third character
	:			
	+19	Fortieth character	Thirty ninth character	
Error response		Offset	Bit15 to Bit0	
		+0	Error code (Refer to page 61)	

<Word block read (inverter capacity)>

Item		Data Portion			
Request		Not applicable			
Response	Normal response	Inverter capacity is returned.			
		Offset	Bit15 to Bit0	Inverter Capacity	Value
		+0	Inverter Capacity	0.1kW	1
				0.2kW	2
	:				
			15kW	150	
Error response		Offset	Bit15 to Bit0		
		+0	Error code (Refer to page 61)		

(3) Operation mode

Read the operation mode of the inverter from network.

Virtual address (byte boundary)	Applications			Message Access	
	Address (word boundary)	Size (word boundary)	Description	Read	Write
H100000C8	100	1	Operation mode	○	×

* When accessing a message, the access size should be the size stated in the table above.

<Word block read (operation mode)>

Item		Data Portion			
Request		Not applicable			
Response	Normal response	Operation mode is returned.			
		Offset	Bit15 to Bit0	Operation mode	Value
		+0	Operation mode	PU operation	H0001
				PUJOG operation	H0003
			Network operation	H0004	
Error response		Offset	Bit15 to Bit0		
		+0	Error code (Refer to page 61)		

(4) Inverter status

Monitors the output signal of the inverter from network.

Virtual address (byte boundary)	Applications			Message Access	
	Address (word boundary)	Size (word boundary)	Description	Read	Write
H10000DC	110	1	Inverter status	○	×

* When accessing a message, the access size should be the size stated in the table above.

<Word block read (inverter status)>

Item		Data Portion			
Request		Not applicable			
Response	Normal response	Inverter status is returned. (Refer to page 59 for details)			
		<table border="1"> <thead> <tr> <th>Offset</th> <th>Bit15 to Bit0</th> </tr> </thead> <tbody> <tr> <td>+0</td> <td>Inverter status</td> </tr> </tbody> </table>	Offset	Bit15 to Bit0	+0
	Offset	Bit15 to Bit0			
	+0	Inverter status			
Error response	<table border="1"> <thead> <tr> <th>Offset</th> <th>Bit15 to Bit0</th> </tr> </thead> <tbody> <tr> <td>+0</td> <td>Error code (Refer to page 61)</td> </tr> </tbody> </table>	Offset	Bit15 to Bit0	+0	Error code (Refer to page 61)
	Offset	Bit15 to Bit0			
+0	Error code (Refer to page 61)				

(5) Set frequency

Set frequency can be read from RAM or EEPROM in 0.01Hz increments.

Virtual address (byte boundary)	Applications			Message Access	
	Address (word boundary)	Size (word boundary)	Description	Read	Write
H10000F0	120	1	Set frequency (EEPROM/RAM)	○	×
H10000F2	121	1	Set frequency (RAM)	○	×

* When accessing a message, the access size should be the size stated in the table above.

<Word block read (set frequency (EEPROM/RAM))>

<Word block read (set frequency (RAM))>

Item		Data Portion			
Request		Not applicable			
Response	Normal response	Set frequency is returned. H0000 to HFFFF (0.01Hz increments)			
		<table border="1"> <thead> <tr> <th>Offset</th> <th>Bit15 to Bit0</th> </tr> </thead> <tbody> <tr> <td>+0</td> <td>Set frequency</td> </tr> </tbody> </table>	Offset	Bit15 to Bit0	+0
	Offset	Bit15 to Bit0			
	+0	Set frequency			
Error response	<table border="1"> <thead> <tr> <th>Offset</th> <th>Bit15 to Bit0</th> </tr> </thead> <tbody> <tr> <td>+0</td> <td>Error code (Refer to page 61)</td> </tr> </tbody> </table>	Offset	Bit15 to Bit0	+0	Error code (Refer to page 61)
	Offset	Bit15 to Bit0			
+0	Error code (Refer to page 61)				



REMARKS

- Regardless of the Pr.37 setting, the value is always displayed in frequency (Hz).

(6) Inverter monitor

Inverter monitored value can be read.

<Word block read (inverter monitor)>

Item		Data Portion			
Request		Not applicable			
Response	Normal response	Inverter monitor value is returned.			
		<table border="1"> <thead> <tr> <th>Offset</th> <th>Bit15 to Bit0</th> </tr> </thead> <tbody> <tr> <td>+0</td> <td>Inverter monitor value (Refer to page 65)</td> </tr> </tbody> </table>	Offset	Bit15 to Bit0	+0
	Offset	Bit15 to Bit0			
	+0	Inverter monitor value (Refer to page 65)			
Error response	<table border="1"> <thead> <tr> <th>Offset</th> <th>Bit15 to Bit0</th> </tr> </thead> <tbody> <tr> <td>+0</td> <td>Error code (Refer to page 61)</td> </tr> </tbody> </table>	Offset	Bit15 to Bit0	+0	Error code (Refer to page 61)
	Offset	Bit15 to Bit0			
+0	Error code (Refer to page 61)				

Inverter monitor value of each monitor is as in the table below.
 (When accessing a message, the access size should be 2 bytes (1 word).)

Code number	Description	Unit	Code number	Description	Unit
H10000190	Output frequency	0.01Hz	H100001A6	Converter output voltage peak value	0.1V
H10000192	Output current	0.01A	H100001AA	Output power	0.01kW
H10000194	Output voltage	0.1V	H100001AE	Output terminal status *	—
H10000198	Set frequency	0.01Hz	H100001B6	Cumulative energization time	1h
H1000019C	Motor torque	0.1%	H100001BC	Actual operation time	1h
H1000019E	Converter output voltage	0.1V	H100001BE	Motor load factor	0.1%
H100001A0	Regenerative brake duty	0.1%	H100001C0	Cumulative power	1kWh
H100001A2	Electronic thermal relay function load factor	0.1%	H10000208	Motor thermal load factor	0.1%
H100001A4	Output current peak value	0.01A	H1000020A	Inverter thermal load factor	0.1%
			H1000020C	Cumulative power 2	0.01kWh

* Output terminal monitor details
 b15

—	—	—	—	—	—	—	—	—	—	—	ALM signal	FU signal	—	—	—	b0 Terminal Y0
---	---	---	---	---	---	---	---	---	---	---	------------	-----------	---	---	---	-------------------

(7) Parameter

Inverter parameters can be read or written through the network.
 Refer to *the Chapter 5* for details of the parameters.

Virtual address (byte boundary)	Applications			Message Access	
	Address (word boundary)	Size (word boundary)	Description	Read	Write
H100007D0	1000	1	Pr. 0	○	○
H100007D2	1001	1	Pr. 1	○	○
H100007D4	1002	1	Pr. 2	○	○
:					
H10000F9C	1998	1	Pr. 998	○	○
H10000F9E	1999	1	Pr. 999	○	○

* When accessing a message, the access size should be the size stated in the table above.

<Word block read (parameter)>

Item		Data Portion				
Request		Not applicable				
Response	Normal response	Specified parameter values return. <table border="1" style="width: 100%;"> <tr> <th>Offset</th> <th>Bit15 to Bit0</th> </tr> <tr> <td>+0</td> <td>Parameter value</td> </tr> </table>	Offset	Bit15 to Bit0	+0	Parameter value
	Offset	Bit15 to Bit0				
+0	Parameter value					
Error response	<table border="1" style="width: 100%;"> <tr> <th>Offset</th> <th>Bit15 to Bit0</th> </tr> <tr> <td>+0</td> <td>Error code (Refer to page 61)</td> </tr> </table>	Offset	Bit15 to Bit0	+0	Error code (Refer to page 61)	
Offset	Bit15 to Bit0					
+0	Error code (Refer to page 61)					

<Word block write (parameter)>

Item		Data Portion				
Request		Specified parameter values are written. <table border="1" style="width: 100%;"> <tr> <th>Offset</th> <th>Bit15 to Bit0</th> </tr> <tr> <td>+0</td> <td>Parameter value</td> </tr> </table>	Offset	Bit15 to Bit0	+0	Parameter value
Offset	Bit15 to Bit0					
+0	Parameter value					
Response	Normal response	Not applicable				
	Error response	<table border="1" style="width: 100%;"> <tr> <th>Offset</th> <th>Bit15 to Bit0</th> </tr> <tr> <td>+0</td> <td>Error code (Refer to page 61)</td> </tr> </table>	Offset	Bit15 to Bit0	+0	Error code (Refer to page 61)
Offset	Bit15 to Bit0					
+0	Error code (Refer to page 61)					



REMARKS

- Parameter write is available only when "1" is set in the X12 signal (Bit11), which gives a control input command through FL remote communication. (Refer to page 57)
 (Note that the Pr.77 setting cannot be written through FL remote communication.)

(8) Fault record

Fault history can be monitored up to eight past faults occurred in the inverter.

Virtual address (byte boundary)	Applications			Message Access		
	Address (word boundary)	Size (word boundary)	Description	Read	Write	
H10001770	3000	1	Fault record all clear	×	○	
H10001838	3100 to 3899	800	Past eight faults history	○	×	
H10001838	3100	1	Latest faults history	○	×	
H1000183A	3101	3		Fault code	○	×
H10001840	3104	1		Fault display	○	×
H10001842	3105	1		Output frequency at fault occurrence	○	×
H10001844	3106	1		Output current at fault occurrence	○	×
H10001846	3107	1		Output voltage at fault occurrence	○	×
H10001848	3108	2		Energization time at fault occurrence	○	×
H1000184C	3110	90		(blank)	×	×
:			Fault name	○	×	
H10001DB0	3800	1	Past eight faults history	○	×	
H10001DB2	3801	3		Fault code	○	×
H10001DB8	3804	1		Fault display	○	×
H10001DBA	3805	1		Output frequency at fault occurrence	○	×
H10001DBC	3806	1		Output current at fault occurrence	○	×
H10001DBE	3807	1		Output voltage at fault occurrence	○	×
H10001DC0	3808	2		Energization time at fault occurrence	○	×
H10001DC4	3810	90		(blank)	×	×
			Fault name	○	×	

* When accessing a message, the access size should be the size stated in the table above.

<Word block write (fault record all clear)>

Item		Data Portion			
Request		Faults history can be cleared.			
		<table border="1"> <thead> <tr> <th>Offset</th> <th>Bit15 to Bit0</th> </tr> </thead> <tbody> <tr> <td>+0</td> <td>Any *</td> </tr> </tbody> </table>	Offset	Bit15 to Bit0	+0
Offset	Bit15 to Bit0				
+0	Any *				
		* Any value is set.			
Response	Normal response	Not applicable			
	Error response	<table border="1"> <thead> <tr> <th>Offset</th> <th>Bit15 to Bit0</th> </tr> </thead> <tbody> <tr> <td>+0</td> <td>Error code (Refer to page 61)</td> </tr> </tbody> </table>	Offset	Bit15 to Bit0	+0
Offset	Bit15 to Bit0				
+0	Error code (Refer to page 61)				

<Word block read (fault code)>

Item		Data Portion				
Request		Not applicable				
Response	Normal response	Fault code is returned.				
		<table border="1"> <thead> <tr> <th>Offset</th> <th>Bit15 to Bit0</th> </tr> </thead> <tbody> <tr> <td>+0</td> <td>Fault code (Refer to page 67)</td> </tr> </tbody> </table>	Offset	Bit15 to Bit0	+0	Fault code (Refer to page 67)
Offset	Bit15 to Bit0					
+0	Fault code (Refer to page 67)					
	Error response	<table border="1"> <thead> <tr> <th>Offset</th> <th>Bit15 to Bit0</th> </tr> </thead> <tbody> <tr> <td>+0</td> <td>Error code (Refer to page 61)</td> </tr> </tbody> </table>	Offset	Bit15 to Bit0	+0	Error code (Refer to page 61)
Offset	Bit15 to Bit0					
+0	Error code (Refer to page 61)					

<Word block read (alarm display)>

Item		Data Portion												
Request		Not applicable												
Response	Normal response	Alarm display (5 characters) is returned as a character string. (Refer to page 67) The rest one character is space character.												
		<table border="1"> <thead> <tr> <th>Offset</th> <th>Bit15 to Bit8</th> <th>Bit7 to Bit0</th> </tr> </thead> <tbody> <tr> <td>+0</td> <td>Second character</td> <td>First character</td> </tr> <tr> <td>+1</td> <td>Fourth character</td> <td>Third character</td> </tr> <tr> <td>+2</td> <td>Sixth character (space character)</td> <td>Fifth character</td> </tr> </tbody> </table>	Offset	Bit15 to Bit8	Bit7 to Bit0	+0	Second character	First character	+1	Fourth character	Third character	+2	Sixth character (space character)	Fifth character
		Offset	Bit15 to Bit8	Bit7 to Bit0										
	+0	Second character	First character											
+1	Fourth character	Third character												
+2	Sixth character (space character)	Fifth character												
Error response	<table border="1"> <thead> <tr> <th>Offset</th> <th>Bit15 to Bit0</th> </tr> </thead> <tbody> <tr> <td>+0</td> <td>Error code (Refer to page 61)</td> </tr> </tbody> </table>	Offset	Bit15 to Bit0	+0	Error code (Refer to page 61)									
Offset	Bit15 to Bit0													
+0	Error code (Refer to page 61)													

<Word block read (output frequency at fault occurrence (0.01Hz increments), output current (0.01A increments), output voltage (0.1V), energization time (1h increments))>

Item		Data Portion				
Request		Not applicable				
Response	Normal response	Output frequency, output current, output voltage, and energization time at fault occurrence is returned.				
		<table border="1"> <thead> <tr> <th>Offset</th> <th>Bit15 to Bit0</th> </tr> </thead> <tbody> <tr> <td>+0</td> <td>Data at fault occurrence</td> </tr> </tbody> </table>	Offset	Bit15 to Bit0	+0	Data at fault occurrence
		Offset	Bit15 to Bit0			
	+0	Data at fault occurrence				
<table border="1"> <thead> <tr> <th>Offset</th> <th>Bit15 to Bit0</th> </tr> </thead> <tbody> <tr> <td>+0</td> <td>Error code (Refer to page 61)</td> </tr> </tbody> </table>	Offset	Bit15 to Bit0	+0	Error code (Refer to page 61)		
Offset	Bit15 to Bit0					
+0	Error code (Refer to page 61)					
Error response	<table border="1"> <thead> <tr> <th>Offset</th> <th>Bit15 to Bit0</th> </tr> </thead> <tbody> <tr> <td>+0</td> <td>Error code (Refer to page 61)</td> </tr> </tbody> </table>	Offset	Bit15 to Bit0	+0	Error code (Refer to page 61)	
Offset	Bit15 to Bit0					
+0	Error code (Refer to page 61)					

<Word block read (fault name)>

Item		Data Portion															
Request		Not applicable															
Response	Normal response	Fault name is returned in a character string. The rest are space characters. (Refer to page 67)															
		<table border="1"> <thead> <tr> <th>Offset</th> <th>Bit15 to Bit8</th> <th>Bit7 to Bit0</th> </tr> </thead> <tbody> <tr> <td>+0</td> <td>Second character</td> <td>First character</td> </tr> <tr> <td>+1</td> <td>Fourth character</td> <td>Third character</td> </tr> <tr> <td>:</td> <td></td> <td></td> </tr> <tr> <td>+89</td> <td>One hundred eightieth character</td> <td>One hundred seventy-ninth character</td> </tr> </tbody> </table>	Offset	Bit15 to Bit8	Bit7 to Bit0	+0	Second character	First character	+1	Fourth character	Third character	:			+89	One hundred eightieth character	One hundred seventy-ninth character
		Offset	Bit15 to Bit8	Bit7 to Bit0													
		+0	Second character	First character													
		+1	Fourth character	Third character													
	:																
+89	One hundred eightieth character	One hundred seventy-ninth character															
<table border="1"> <thead> <tr> <th>Offset</th> <th>Bit15 to Bit0</th> </tr> </thead> <tbody> <tr> <td>+0</td> <td>Error code (Refer to page 61)</td> </tr> </tbody> </table>	Offset	Bit15 to Bit0	+0	Error code (Refer to page 61)													
Offset	Bit15 to Bit0																
+0	Error code (Refer to page 61)																
Error response	<table border="1"> <thead> <tr> <th>Offset</th> <th>Bit15 to Bit0</th> </tr> </thead> <tbody> <tr> <td>+0</td> <td>Error code (Refer to page 61)</td> </tr> </tbody> </table>	Offset	Bit15 to Bit0	+0	Error code (Refer to page 61)												
Offset	Bit15 to Bit0																
+0	Error code (Refer to page 61)																

●Fault code

Refer to page 194 for details of alarm definitions.

Fault code *	Fault Indication	Fault name
H0000		No alarm
H0010	E.OC1	Overcurrent shut-off during acceleration
H0011	E.OC2	Overcurrent shut-off during constant speed
H0012	E.OC3	Overcurrent shut-off during deceleration or stop
H0020	E.OV1	Regenerative overvoltage shut-off during acceleration
H0021	E.OV2	Regenerative overvoltage shut-off during constant speed
H0022	E.OV3	Regenerative overvoltage shut-off during deceleration or stop
H0030	E.THT	Inverter overload shut-off(electronic thermal relay function)
H0031	E.THM	Motor overload shut-off(electronic thermal relay function)
H0040	E.FIN	Fin overheat
H0052	E.ILF	Input phase failure
H0060	E.OLT	Stall prevention stop
H0070	E.BE	Brake transistor alarm detection
H0080	E.GF	Output side earth(ground) fault overcurrent
H0081	E.LF	Output phase failure
H00A0	E.OPT	Option alarm
H00A1	E.OP1	Communication option alarm
H00B0	E.PE	Parameter storage device alarm
H00B2	E.RET	Retry count excess
H00B3	E.PE2	Parameter storage device alarm
H00C0	E.CPU	CPU error
H00C5	E.IOH	Inrush current limit circuit alarm
H00C9	E.SAF	Safety circuit fault
H00F1	E.1	Option1 alarm
H00F5	E.5	CPU error
H00F6	E.6	
H00F7	E.7	
H00FD	E.13	Internal circuit error

* Alarm code size of cyclic transmission is 1 byte. The last two digits of alarm code are displayed.

4.8.3 Network parameter read

With this function, network parameter information of other node is read from network.

Item		Data Portion				
Request		Not applicable				
Response	Normal response	Offset	Bit15 to Bit8	Bit7 to Bit0	Remarks	
		+0	Second character	First character	Node name Character string of "FR-E700" is stored. In the reset places, space characters are set.	
		+1	Fourth character	Third character		
		+2	Sixth character	Fifth character		
		+3	Eighth character	Seventh character		
		+4	Tenth character	Ninth character		
		+5	Second character	First character	Vender name Character string of "MELCO" is stored. In the reset places, space characters are set.	
		+6	Fourth character	Third character		
		+7	Sixth character	Fifth character		
		+8	Eighth character	Seventh character		
		+9	Tenth character	Ninth character		
		+10	Second character	First character	Manufacturer model name Character string of "FR-A7NF" is stored. In the reset places, space characters are set.	
		+11	Fourth character	Third character		
		+12	Sixth character	Fifth character		
		+13	Eighth character	Seventh character		
		+14	Tenth character	Ninth character		
		+15	First address of area 1			
		+16	Size of area 1			Always 4 words
		+17	First address of area 2			
		+18	Size of area 2			Always 16 words
		+19	(spare)	Token monitoring time out time		Always 10ms
		+20	(spare)	Minimum permissible clearance		Always 1.0ms
		+21	(spare)	Link status		Refer to the description below.
		+22	(spare)	Protocol		Always H80
		+23	Higher-layer status			Refer to the description below.
		+24	Refresh cycle permissible time setting			0 to 65535ms Refresh cycle permissible time (120% value of the time the token circulates one ring) of own node.
		+25	Refresh cycle measured value (present value)			0 to 65535ms Measured value (current value, maximum value, minimum value) of one cycle of own node.
	+26	Refresh cycle measured value (maximum value)				
+27	Refresh cycle measured value (minimum value)					
Error response	Offset	Bit15 to Bit0				
	+0	Error code (Refer to page 61)				

<Link status>

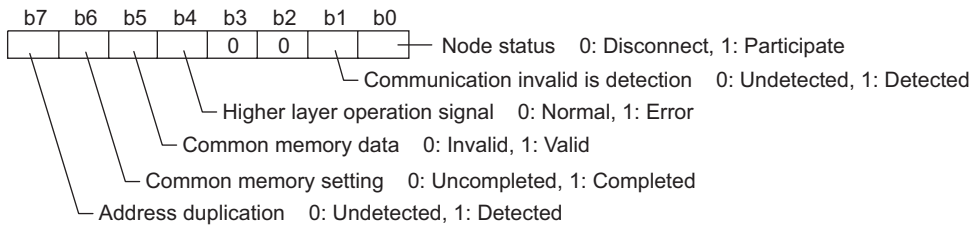

<Higher-layer status>

The inverter periodically creates "higher layer status" based on "slave control status of FL remote" and "inverter status". In addition, the inverter reports the "higher layer status" to the master (FA link layer) periodically.

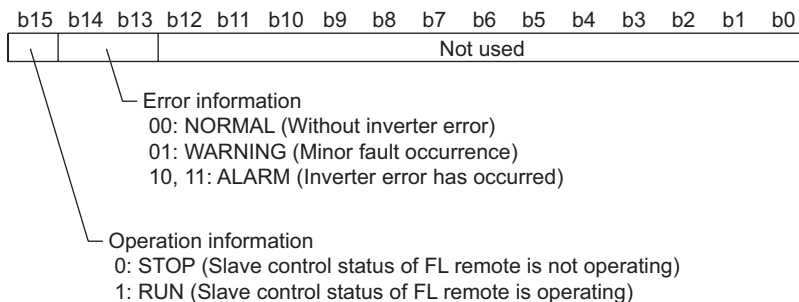

4.8.4 Log data read

With this function, log information of other node is read from network.

Item		Data Portion			
Request		Not applicable			
Response	Normal response	Offset	Bit7 to Bit0	Offset	Bit7 to Bit0
		+0	The number of communication socket transmitting times	+152 to +164	—
		+4	The number of communication socket transmitting error times	+168	The number of message transmission receiving error times
		+8	The number of Ethernet transmitting error times	+172	The number of message sequence version error times
		+12 to +20	—	+176	The number of message sequence retransmitting recognition times
		+24	The number of communication socket receiving times	+180 to +188	—
		+28	The number of communication socket receiving error times	+192	The number of ACK error times
		+32	The number of Ethernet receiving error times	+196	The number of ACK sequence version error times
		+36 to +44	—	+200	The number of ACK sequence number error times
		+48	The number of token transmitting times	+204	The number of ACK node number error times
		+52	The number of cyclic frame transmitting times	+208	The number of ACK TCD error times
		+56	The number of 1:1 message transmitting times	+212 to +236	—
		+60	The number of 1:n message transmitting times	+240	The number of token multiplexing recognition times
		+64, +68	—	+244	The number of token destroyed times
		+72	The number of token receiving times	+248	The number of token reissued times
		+76	The number of cyclic frame receiving times	+252 to +260	—
		+80	The number of 1:1 message receiving times	+264	The number of token hold time out times
		+84	The number of 1:n message receiving times	+268	The number of token monitoring time out times
		+88, +92	—	+272 to +284	—
		+96	The number of cyclic transmission receiving error times	+288	Total operation times
		+100	The number of cyclic address size error times	+292	The number of frame waiting status times
		+104	The number of cyclic CBN error times	+296	Entry time
		+108	The number of cyclic TBN error times	+300	The number of times disconnected
		+112	The number of cyclic BSIZE error times	+304	The number of disconnected times due to skip
		+116 to +140	—	+308	The number of recognition times of other node disconnected
		+144	The number of message transmission retransmitting times	+312 to +332	—
		+148	The number of message transmission retransmitting over times	+336 to +364	List of participation recognized node
		+368 to +508	—		
Error response		Offset	Bit15 to Bit0		
		+0	Error code (Refer to page 61)		

4.8.5 Log data clear

Clears log information (Refer to page 69) of other node from network.

Item		Data Portion	
Request		Not applicable	
Response	Normal response	Not applicable	
	Error response	Offset	Bit15 to Bit0
		+0	Error code (Refer to page 61)

4.8.6 Profile read

With this function, system parameter of device profile of other node is read from network.

Item		Data Portion	
Request		Not applicable	
Response	Normal response	Offset	Bit15 to Bit0
		+0 :	Read data (see the table below for details)
	Error response	Offset	Bit15 to Bit0
		+0	Error code (<i>Refer to page 61</i>)

●SYSPARA

Parameter Name	Name character		Data Type	Parameter description	
	Length	Character		Length	Character
Device profile common specification version	6	"COMVER"	INTEGER	1	1
System parameter recognition character	2	"ID"	PrintableString	7	"SYSPARA"
System parameter change number	3	"REV"	INTEGER	1	0
System parameter change date	7	"REVDATE"	[INTEGER], 2, (0001-9999),	2	(Example) 2009
			[INTEGER], 1, (01-12),	1	(Example) 10
			[INTEGER], 1, (01-31)	1	(Example) 31
Device type	10	"DVCATEGORY"	PrintableString	3	"INV"
Vender name	6	"VENDOR"	PrintableString	10	"MELCO "
Product model name	7	"DVMODEL"	PrintableString	10	"FR-A7NF "

●INVPARA

Parameter Name	Name Character		Data Type	Parameter Description	
	Length	Character		Length	Character
Device specific parameter distinguishing characters	2	"ID"	PrintableString	7	"DEVPARA"
MAC address	10	"MACADDRESS"	INTEGER	6	MAC address (6 bytes) (Example) 08 00 70 46 D0 00
Firmware version (inverter)	7	"INV VER"	PrintableString	5	ROM number (Example) 8214*
Firmware version (option)	7	"OPT VER"	PrintableString	5	ROM number (Example) 8220*

Arrangement of transfer syntax data (coded)

Identifier	Length	Description																																																																					
30	81AA	<table border="1"> <thead> <tr> <th>Identifier</th> <th>Length</th> <th>Description</th> </tr> </thead> <tbody> <tr> <td>30</td> <td>6F</td> <td> <table border="1"> <thead> <tr> <th>Identifier</th> <th>Length</th> <th>Description</th> </tr> </thead> <tbody> <tr><td>13</td><td>06</td><td>"COMVER"</td></tr> <tr><td>02</td><td>01</td><td>1</td></tr> <tr><td>13</td><td>02</td><td>"ID"</td></tr> <tr><td>13</td><td>07</td><td>"SYSPARA"</td></tr> <tr><td>13</td><td>03</td><td>"REV"</td></tr> <tr><td>02</td><td>01</td><td>0</td></tr> <tr><td>13</td><td>07</td><td>"REVDATE"</td></tr> </tbody> </table> </td> </tr> <tr> <td>30</td> <td>0A</td> <td> <table border="1"> <thead> <tr> <th>Identifier</th> <th>Length</th> <th>Description</th> </tr> </thead> <tbody> <tr><td>02</td><td>02</td><td>07D9</td></tr> <tr><td>02</td><td>01</td><td>0A</td></tr> <tr><td>02</td><td>01</td><td>1F</td></tr> </tbody> </table> </td> </tr> <tr> <td></td> <td></td> <td> <table border="1"> <thead> <tr> <th>Identifier</th> <th>Length</th> <th>Description</th> </tr> </thead> <tbody> <tr><td>13</td><td>0A</td><td>"DVCATEGORY"</td></tr> <tr><td>13</td><td>03</td><td>"INV"</td></tr> <tr><td>13</td><td>06</td><td>"VENDOR"</td></tr> <tr><td>13</td><td>0A</td><td>"MELCO "</td></tr> <tr><td>13</td><td>07</td><td>"DVMODEL"</td></tr> <tr><td>13</td><td>0A</td><td>"FR-A7NF "</td></tr> </tbody> </table> </td> </tr> </tbody> </table>	Identifier	Length	Description	30	6F	<table border="1"> <thead> <tr> <th>Identifier</th> <th>Length</th> <th>Description</th> </tr> </thead> <tbody> <tr><td>13</td><td>06</td><td>"COMVER"</td></tr> <tr><td>02</td><td>01</td><td>1</td></tr> <tr><td>13</td><td>02</td><td>"ID"</td></tr> <tr><td>13</td><td>07</td><td>"SYSPARA"</td></tr> <tr><td>13</td><td>03</td><td>"REV"</td></tr> <tr><td>02</td><td>01</td><td>0</td></tr> <tr><td>13</td><td>07</td><td>"REVDATE"</td></tr> </tbody> </table>	Identifier	Length	Description	13	06	"COMVER"	02	01	1	13	02	"ID"	13	07	"SYSPARA"	13	03	"REV"	02	01	0	13	07	"REVDATE"	30	0A	<table border="1"> <thead> <tr> <th>Identifier</th> <th>Length</th> <th>Description</th> </tr> </thead> <tbody> <tr><td>02</td><td>02</td><td>07D9</td></tr> <tr><td>02</td><td>01</td><td>0A</td></tr> <tr><td>02</td><td>01</td><td>1F</td></tr> </tbody> </table>	Identifier	Length	Description	02	02	07D9	02	01	0A	02	01	1F			<table border="1"> <thead> <tr> <th>Identifier</th> <th>Length</th> <th>Description</th> </tr> </thead> <tbody> <tr><td>13</td><td>0A</td><td>"DVCATEGORY"</td></tr> <tr><td>13</td><td>03</td><td>"INV"</td></tr> <tr><td>13</td><td>06</td><td>"VENDOR"</td></tr> <tr><td>13</td><td>0A</td><td>"MELCO "</td></tr> <tr><td>13</td><td>07</td><td>"DVMODEL"</td></tr> <tr><td>13</td><td>0A</td><td>"FR-A7NF "</td></tr> </tbody> </table>	Identifier	Length	Description	13	0A	"DVCATEGORY"	13	03	"INV"	13	06	"VENDOR"	13	0A	"MELCO "	13	07	"DVMODEL"	13	0A	"FR-A7NF "
Identifier	Length	Description																																																																					
30	6F	<table border="1"> <thead> <tr> <th>Identifier</th> <th>Length</th> <th>Description</th> </tr> </thead> <tbody> <tr><td>13</td><td>06</td><td>"COMVER"</td></tr> <tr><td>02</td><td>01</td><td>1</td></tr> <tr><td>13</td><td>02</td><td>"ID"</td></tr> <tr><td>13</td><td>07</td><td>"SYSPARA"</td></tr> <tr><td>13</td><td>03</td><td>"REV"</td></tr> <tr><td>02</td><td>01</td><td>0</td></tr> <tr><td>13</td><td>07</td><td>"REVDATE"</td></tr> </tbody> </table>	Identifier	Length	Description	13	06	"COMVER"	02	01	1	13	02	"ID"	13	07	"SYSPARA"	13	03	"REV"	02	01	0	13	07	"REVDATE"																																													
Identifier	Length	Description																																																																					
13	06	"COMVER"																																																																					
02	01	1																																																																					
13	02	"ID"																																																																					
13	07	"SYSPARA"																																																																					
13	03	"REV"																																																																					
02	01	0																																																																					
13	07	"REVDATE"																																																																					
30	0A	<table border="1"> <thead> <tr> <th>Identifier</th> <th>Length</th> <th>Description</th> </tr> </thead> <tbody> <tr><td>02</td><td>02</td><td>07D9</td></tr> <tr><td>02</td><td>01</td><td>0A</td></tr> <tr><td>02</td><td>01</td><td>1F</td></tr> </tbody> </table>	Identifier	Length	Description	02	02	07D9	02	01	0A	02	01	1F																																																									
Identifier	Length	Description																																																																					
02	02	07D9																																																																					
02	01	0A																																																																					
02	01	1F																																																																					
		<table border="1"> <thead> <tr> <th>Identifier</th> <th>Length</th> <th>Description</th> </tr> </thead> <tbody> <tr><td>13</td><td>0A</td><td>"DVCATEGORY"</td></tr> <tr><td>13</td><td>03</td><td>"INV"</td></tr> <tr><td>13</td><td>06</td><td>"VENDOR"</td></tr> <tr><td>13</td><td>0A</td><td>"MELCO "</td></tr> <tr><td>13</td><td>07</td><td>"DVMODEL"</td></tr> <tr><td>13</td><td>0A</td><td>"FR-A7NF "</td></tr> </tbody> </table>	Identifier	Length	Description	13	0A	"DVCATEGORY"	13	03	"INV"	13	06	"VENDOR"	13	0A	"MELCO "	13	07	"DVMODEL"	13	0A	"FR-A7NF "																																																
Identifier	Length	Description																																																																					
13	0A	"DVCATEGORY"																																																																					
13	03	"INV"																																																																					
13	06	"VENDOR"																																																																					
13	0A	"MELCO "																																																																					
13	07	"DVMODEL"																																																																					
13	0A	"FR-A7NF "																																																																					
		<table border="1"> <thead> <tr> <th>Identifier</th> <th>Length</th> <th>Description</th> </tr> </thead> <tbody> <tr> <td>30</td> <td>39</td> <td> <table border="1"> <thead> <tr> <th>Identifier</th> <th>Length</th> <th>Description</th> </tr> </thead> <tbody> <tr><td>13</td><td>02</td><td>"ID"</td></tr> <tr><td>13</td><td>07</td><td>"DEV PARA"</td></tr> <tr><td>13</td><td>0A</td><td>"MACADDRESS"</td></tr> <tr><td>02</td><td>06</td><td>(6-byte data)</td></tr> <tr><td>13</td><td>07</td><td>"INV VER"</td></tr> <tr><td>13</td><td>05</td><td>(5-byte data)</td></tr> <tr><td>13</td><td>07</td><td>"OPT VER"</td></tr> <tr><td>13</td><td>05</td><td>(5-byte data)</td></tr> </tbody> </table> </td> </tr> </tbody> </table>	Identifier	Length	Description	30	39	<table border="1"> <thead> <tr> <th>Identifier</th> <th>Length</th> <th>Description</th> </tr> </thead> <tbody> <tr><td>13</td><td>02</td><td>"ID"</td></tr> <tr><td>13</td><td>07</td><td>"DEV PARA"</td></tr> <tr><td>13</td><td>0A</td><td>"MACADDRESS"</td></tr> <tr><td>02</td><td>06</td><td>(6-byte data)</td></tr> <tr><td>13</td><td>07</td><td>"INV VER"</td></tr> <tr><td>13</td><td>05</td><td>(5-byte data)</td></tr> <tr><td>13</td><td>07</td><td>"OPT VER"</td></tr> <tr><td>13</td><td>05</td><td>(5-byte data)</td></tr> </tbody> </table>	Identifier	Length	Description	13	02	"ID"	13	07	"DEV PARA"	13	0A	"MACADDRESS"	02	06	(6-byte data)	13	07	"INV VER"	13	05	(5-byte data)	13	07	"OPT VER"	13	05	(5-byte data)																																				
Identifier	Length	Description																																																																					
30	39	<table border="1"> <thead> <tr> <th>Identifier</th> <th>Length</th> <th>Description</th> </tr> </thead> <tbody> <tr><td>13</td><td>02</td><td>"ID"</td></tr> <tr><td>13</td><td>07</td><td>"DEV PARA"</td></tr> <tr><td>13</td><td>0A</td><td>"MACADDRESS"</td></tr> <tr><td>02</td><td>06</td><td>(6-byte data)</td></tr> <tr><td>13</td><td>07</td><td>"INV VER"</td></tr> <tr><td>13</td><td>05</td><td>(5-byte data)</td></tr> <tr><td>13</td><td>07</td><td>"OPT VER"</td></tr> <tr><td>13</td><td>05</td><td>(5-byte data)</td></tr> </tbody> </table>	Identifier	Length	Description	13	02	"ID"	13	07	"DEV PARA"	13	0A	"MACADDRESS"	02	06	(6-byte data)	13	07	"INV VER"	13	05	(5-byte data)	13	07	"OPT VER"	13	05	(5-byte data)																																										
Identifier	Length	Description																																																																					
13	02	"ID"																																																																					
13	07	"DEV PARA"																																																																					
13	0A	"MACADDRESS"																																																																					
02	06	(6-byte data)																																																																					
13	07	"INV VER"																																																																					
13	05	(5-byte data)																																																																					
13	07	"OPT VER"																																																																					
13	05	(5-byte data)																																																																					

* Identifier 13 indicates PrintableString type, identifier 02 indicates INTEGER type.

4.8.7 Message loopback

Perform communication test of device by returning message data received.

Item		Data Portion	
Request		Offset	Bit15 to Bit0
		+0 :	Any data up to 1024 bytes.
Response	Normal response	Offset	Bit15 to Bit0
		+0 :	Same data as request data is sent.

MEMO

5 PARAMETERS

This chapter explains the "PARAMETERS" for use of this product.

Always read the instructions before using the equipment.

The following marks are used to indicate the controls as below.

V/F control

Advanced magnetic flux vector control

General-purpose magnetic flux vector control

(Parameters without any mark are valid for all controls.)

1

2

3

4

5

6

7

8

5.1 Operation panel

5.1.1 Names and functions of the operation panel

The operation panel cannot be removed from the inverter.

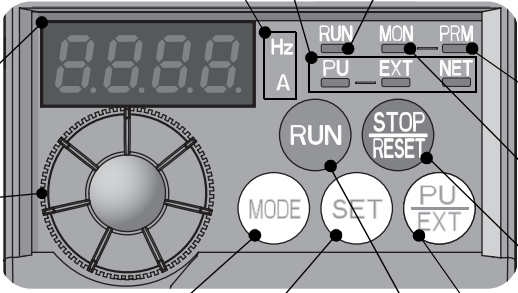

Operation mode indicator
 PU: Lit to indicate PU operation mode.
 EXT: Not lit.
 NET: Lit to indicate Network operation mode.
 (Lit at power-ON at initial setting.)

Unit indicator
 Hz: Lit to indicate frequency.
 (Flickers when the set frequency monitor is displayed.)
 A: Lit to indicate current.
 (Both "Hz" and "A" turn OFF when other than the above is displayed.)

Monitor (4-digit LED)
 Shows the frequency, parameter number, etc.

Setting dial
 (Setting dial: Mitsubishi inverter dial)
 Used to change the frequency setting and parameter settings.
 Press to display the following.

- Displays the set frequency in the monitor mode
- Displays the order in the faults history mode

Mode switchover
 Used to change each setting mode.
 Pressing for a while (2s) can lock operation.
 (Refer to page 183)

Determination of each setting
 If pressed during operation, monitor changes as below:

```

    graph TD
      A[Running frequency] --> B[Output current]
      B --> C[Output voltage]
      C --> A
    
```

Operating status indicator
 Lit or flicker during inverter operation. *

- * Lit: When the forward rotation operation is being performed.
- * Slow flickering (1.4s cycle): When the reverse rotation operation is being performed.
- * Fast flickering (0.2s cycle):

When **RUN** was pressed or the start command was given, but the operation cannot be made.

- When the frequency command is less than the starting frequency.
- When the MRS signal is input.

Parameter setting mode
 Lit to indicate parameter setting mode.

Monitor indicator
 Lit to indicate monitoring mode.

Stop operation
 Used to stop Run command.
 Fault can be reset when protective function is activated (fault).

Operation mode switchover
 Used to switch between the NET and PU operation modes.
 Cancels PU stop also. (Refer to page 165.)

Start command
 The rotation direction can be selected by setting Pr. 40.

5.1.2 Basic operation (factory setting)

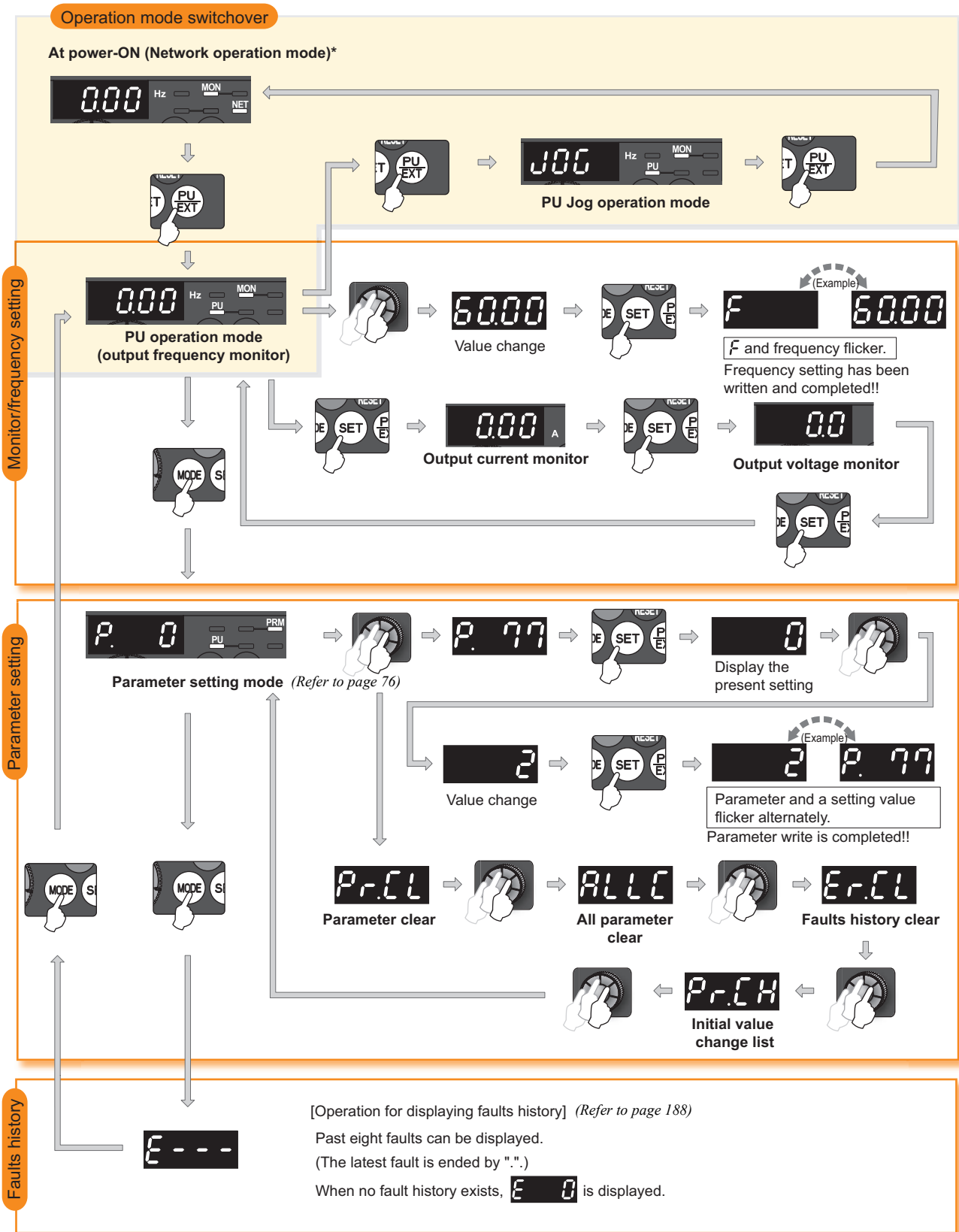

* Switching from the Network operation mode to the PU and PU JOG operation modes using  is available when "1" is set in the X12 signal (Bit11), which gives a control input signal through FL remote communication. (Refer to page 57.)
Setting "0" in the X12 signal (Bit11) forces PU and PU JOG operation modes to change to Network operation mode.

5.1.3 Changing the parameter setting value

Changing example

Change the Pr. 1 Maximum frequency setting.

Operation

1. Screen at power-ON
The inverter starts up in the Network operation mode.
The monitor display appears.
2. Change the X12 signal (Bit11) setting to "1."
X12 signal (Bit11) gives a control input command through FL remote communication.
3. Press to choose the PU operation mode.
4. Press to choose the parameter setting mode.
5. Turn until **P. 1** (Pr. 1) appears.
6. Press to read the currently set value.
"1200"(120.0Hz (initial value)) appears.
7. Turn to change the set value to
"6000" (60.00Hz).
8. Press to set.

Display

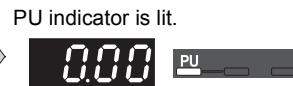

PU indicator is lit.
PRM indicator is lit.
(The parameter number read previously appears.)

Flicker...Parameter setting complete!!

- Turn to read another parameter.
- Press to show the setting again.
- Press twice to show the next parameter.
- Press twice to return the monitor to frequency monitor.

REMARKS

? **Er 1**, **Er 2** or **Er 4** is displayed...Why?

- Er 1** appears Write disable error
- Er 2** appears Write error during operation
- Er 4** appears Mode designation error

(For details, refer to page 194.)

- The number of digits displayed on the operation panel is four. Only the upper four digits of values can be displayed and set. If the values to be displayed have five digits or more including decimal places, the fifth or later numerals can not be displayed nor set.
(Example) For Pr. 1
When 60Hz is set, 60.00 is displayed.
When 120Hz is set, 120.0 is displayed and second decimal place is not displayed nor set.

5.1.4 Setting dial push

Push the setting dial () to display the set frequency* currently set.

* Appears when PU operation mode is selected.

5.2 Parameter list

5.2.1 Parameter list

For simple variable-speed operation of the inverter, the initial setting of the parameters may be used as they are. Set the necessary parameters to meet the load and operational specifications. Parameter setting, change and check are available from the operation panel. For details of parameters, refer to the instruction manual.

REMARKS

- ◎ indicates simple mode parameters. (initially set to extended mode)
- The parameters surrounded by a black border in the table allow its setting to be changed during operation even if "0" (initial value) is set in Pr. 77 Parameter write selection. (Note that the Pr.77 setting cannot be changed through FL remote communication.)

- "O" indicates valid and "x" indicates invalid of "control mode-based correspondence table", "parameter clear", and "all parameter clear".

Function	Parameter	Name	Setting Range	Minimum Setting Increments	Initial Value	Refer to Page	Customer Setting
Basic functions	◎ 0	Torque boost	0 to 30%	0.1%	6/4/3/2% *1	94	
	◎ 1	Maximum frequency	0 to 120Hz	0.01Hz	120Hz	105	
	◎ 2	Minimum frequency	0 to 120Hz	0.01Hz	0Hz	105	
	◎ 3	Base frequency	0 to 400Hz	0.01Hz	60Hz	107	
	◎ 4	Multi-speed setting (high speed)	0 to 400Hz	0.01Hz	60Hz	111	
	◎ 5	Multi-speed setting (middle speed)	0 to 400Hz	0.01Hz	30Hz	111	
	◎ 6	Multi-speed setting (low speed)	0 to 400Hz	0.01Hz	10Hz	111	
	◎ 7	Acceleration time	0 to 3600/360s	0.1/0.01s	5/10/15s *2	116	
	◎ 8	Deceleration time	0 to 3600/360s	0.1/0.01s	5/10/15s *2	116	
DC injection brake	◎ 9	Electronic thermal O/L relay	0 to 500A	0.01A	Rated inverter current	123	
	10	DC injection brake operation frequency	0 to 120Hz	0.01Hz	3Hz	135	
	11	DC injection brake operation time	0 to 10s	0.1s	0.5s	135	
—	12	DC injection brake operation voltage	0 to 30%	0.1%	6/4/2% *3	135	
	13	Starting frequency	0 to 60Hz	0.01Hz	0.5Hz	119	
—	14	Load pattern selection	0 to 3	1	0	109	
	15	Jog frequency	0 to 400Hz	0.01Hz	5Hz	171	
JOG operation	16	Jog acceleration/deceleration time	0 to 3600/360s	0.1/0.01s	0.5s	171	
	17	MRS input selection	0, 2, 4	1	0	143	
—	18	High speed maximum frequency	120 to 400Hz	0.01Hz	120Hz	105	
	19	Base frequency voltage	0 to 1000V, 8888, 9999	0.1V	9999	107	
Acceleration/ deceleration time	20	Acceleration/deceleration reference frequency	1 to 400Hz	0.01Hz	60Hz	116	
	21	Acceleration/deceleration time increments	0, 1	1	0	116	
Stall prevention	22	Stall prevention operation level	0 to 200%	0.1%	150%	101	
	23	Stall prevention operation level compensation factor at double speed	0 to 200%, 9999	0.1%	9999	101	
Multi-speed setting	24	Multi-speed setting (speed 4)	0 to 400Hz, 9999	0.01Hz	9999	111	
	25	Multi-speed setting (speed 5)	0 to 400Hz, 9999	0.01Hz	9999	111	
	26	Multi-speed setting (speed 6)	0 to 400Hz, 9999	0.01Hz	9999	111	
	27	Multi-speed setting (speed 7)	0 to 400Hz, 9999	0.01Hz	9999	111	
—	29	Acceleration/deceleration pattern selection	0, 1, 2	1	0	120	

Parameter	Control Mode-based Correspondence Table			Parameter	
	V/F	AD MFVC	GP MFVC	Clear	All clear
◎ 0	O	x	x	O	O
◎ 1	O	O	O	O	O
◎ 2	O	O	O	O	O
◎ 3	O	x	x	O	O
◎ 4	O	O	O	O	O
◎ 5	O	O	O	O	O
◎ 6	O	O	O	O	O
◎ 7	O	O	O	O	O
◎ 8	O	O	O	O	O
◎ 9	O	O	O	O	O
10	O	O	O	O	O
11	O	O	O	O	O
12	O	O	O	O	O
13	O	O	O	O	O
14	O	x	x	O	O
15	O	O	O	O	O
16	O	O	O	O	O
17	O	O	O	O	O
18	O	O	O	O	O
19	O	x	x	O	O
20	O	O	O	O	O
21	O	O	O	O	O
22	O	O	O	O	O
23	O	O	O	O	O
24	O	O	O	O	O
25	O	O	O	O	O
26	O	O	O	O	O
27	O	O	O	O	O
29	O	O	O	O	O

Function	Parameter	Name	Setting Range	Minimum Setting Increments	Initial Value	Refer to Page	Customer Setting
—	30	Regenerative function selection	0, 1, 2	1	0	136, 151	
Frequency jump	31	Frequency jump 1A	0 to 400Hz, 9999	0.01Hz	9999	106	
	32	Frequency jump 1B	0 to 400Hz, 9999	0.01Hz	9999	106	
	33	Frequency jump 2A	0 to 400Hz, 9999	0.01Hz	9999	106	
	34	Frequency jump 2B	0 to 400Hz, 9999	0.01Hz	9999	106	
	35	Frequency jump 3A	0 to 400Hz, 9999	0.01Hz	9999	106	
	36	Frequency jump 3B	0 to 400Hz, 9999	0.01Hz	9999	106	
—	37	Speed display	0, 0.01 to 9998	0.001	0	146	
—	40	RUN key rotation direction selection	0, 1	1	0	182	
Frequency detection	41	Up-to-frequency sensitivity	0 to 100%	0.1%	10%	144	
	42	Output frequency detection	0 to 400Hz	0.01Hz	6Hz	144	
	43	Output frequency detection for reverse rotation	0 to 400Hz, 9999	0.01Hz	9999	144	
Second functions	44	Second acceleration/deceleration time	0 to 3600/360s	0.1/0.01s	5/10/15s *2	116	
	45	Second deceleration time	0 to 3600/360s, 9999	0.1/0.01s	9999	116	
	46	Second torque boost	0 to 30%, 9999	0.1%	9999	94	
	47	Second V/F (base frequency)	0 to 400Hz, 9999	0.01Hz	9999	107	
	48	Second stall prevention operation current	0 to 200%, 9999	0.1%	9999	101	
	51	Second electronic thermal O/L relay	0 to 500A, 9999	0.01A	9999	123	
—	52	DU/PU main display data selection	0, 5, 7 to 12, 14, 20, 23 to 25, 52 to 57, 61, 62, 100	1	0	147	
—	54	Parameter for manufacturer setting. Do not set.					
—	55						
—	56						
Automatic restart functions	57	Restart coasting time	0, 0.1 to 5s, 9999	0.1s	9999	151	
	58	Restart cushion time	0 to 60s	0.1s	1s	151	
—	59	Remote function selection	0, 1, 2, 3	1	0	113	
—	60	Energy saving control selection	0, 9	1	0	162	
Automatic acceleration /deceleration	61	Reference current	0 to 500A, 9999	0.01A	9999	121	
	62	Reference value at acceleration	0 to 200%, 9999	1%	9999	121	
	63	Reference value at deceleration	0 to 200%, 9999	1%	9999	121	
—	65	Retry selection	0 to 5	1	0	158	
—	66	Stall prevention operation reduction starting frequency	0 to 400Hz	0.01Hz	60Hz	101	
Retry	67	Number of retries at fault occurrence	0 to 10, 101 to 110	1	0	158	
	68	Retry waiting time	0.1 to 360s	0.1s	1s	158	
	69	Retry count display erase	0	1	0	158	
—	70	Special regenerative brake duty	0 to 30%	0.1%	0%	136	
—	71	Applied motor	0, 1, 3 to 6, 13 to 16, 23, 24, 40, 43, 44, 50, 53, 54	1	0	95, 98, 125, 127,	
—	72	PWM frequency selection	0 to 15	1	1	163	
—	73	Parameter for manufacturer setting. Do not set.					
—	74						
—	75	Reset selection/PU stop selection	0 to 3, 14 to 17	1	14	165	
—	77*6	Parameter write selection	0, 1, 2	1	0	166	
—	78	Reverse rotation prevention selection	0, 1, 2	1	0	167	
—	79	Parameter for manufacturer setting. Do not set.					

Parameter	Control Mode-based Correspondence Table			Parameter	
	V/F	AD MFVC	GP MFVC	Clear	All clear
30	○	○	○	○	○
31	○	○	○	○	○
32	○	○	○	○	○
33	○	○	○	○	○
34	○	○	○	○	○
35	○	○	○	○	○
36	○	○	○	○	○
37	○	○	○	○	○
40	○	○	○	○	○
41	○	○	○	○	○
42	○	○	○	○	○
43	○	○	○	○	○
44	○	○	○	○	○
45	○	○	○	○	○
46	○	×	×	○	○
47	○	×	×	○	○
48	○	○	○	○	○
51	○	○	○	○	○
52	○	○	○	○	○
54	Parameter for manufacturer setting. Do not set.				
55					
56					
57	○	○	○	○	○
58	○	○	○	○	○
59	○	○	○	○	○
60	○	×	×	○	○
61	○	○	○	○	○
62	○	○	○	○	○
63	○	○	○	○	○
65	○	○	○	○	○
66	○	○	○	○	○
67	○	○	○	○	○
68	○	○	○	○	○
69	○	○	○	○	○
70	○	○	○	○	○
71	○	○	○	○	○
72	○	○	○	○	○
73	Parameter for manufacturer setting. Do not set.				
74					
75	○	○	○	×	×
77	○	○	○	○	○
78	○	○	○	○	○
79	Parameter for manufacturer setting. Do not set.				

Function	Parameter	Name	Setting Range	Minimum Setting Increments	Initial Value	Refer to Page	Customer Setting
Motor constants	80	Motor capacity	0.1 to 15kW, 9999	0.01kW	9999	93, 95, 98, 127	
	81	Number of motor poles	2, 4, 6, 8, 10, 9999	1	9999	93, 95, 98, 127	
	82	Motor excitation current	0 to 500A (0 to ****), 9999 *5	0.01A (1) *5	9999	127	
	83	Rated motor voltage	0 to 1000V	0.1V	200V/400V *4	127	
	84	Rated motor frequency	10 to 120Hz	0.01Hz	60Hz	127	
	89	Speed control gain (Advanced magnetic flux vector)	0 to 200%, 9999	0.1%	9999	95	
	90	Motor constant (R1)	0 to 50Ω (0 to ****), 9999 *5	0.001Ω (1) *5	9999	127	
	91	Motor constant (R2)	0 to 50Ω (0 to ****), 9999 *5	0.001Ω (1) *5	9999	127	
	92	Motor constant (L1)	0 to 1000mH (0 to 50Ω, 0 to ****), 9999 *5	0.1mH (0.001Ω, 1) *5	9999	127	
	93	Motor constant (L2)	0 to 1000mH (0 to 50Ω, 0 to ****), 9999 *5	0.1mH (0.001Ω, 1) *5	9999	127	
94	Motor constant (X)	0 to 100% (0 to 500Ω, 0 to ****), 9999 *5	0.1% (0.01Ω, 1) *5	9999	127		
96	Auto tuning setting/status	0, 1, 11, 21	1	0	127, 151		
—	117	Parameter for manufacturer setting. Do not set.					
—	118						
—	119						
—	120						
—	121						
—	122						
—	123						
—	124						
—	125						
—	126						
—	127						
—	128						
—	129						
—	130						
—	131						
—	132						
—	133						
—	134						
—	145						
—	146						
—	147	Acceleration/deceleration time switching frequency	0 to 400Hz, 9999	0.01Hz	9999	116	
Current detection	150	Output current detection level	0 to 200%	0.1%	150%	145	
	151	Output current detection signal delay time	0 to 10s	0.1s	0s	145	
	152	Zero current detection level	0 to 200%	0.1%	5%	145	
	153	Zero current detection time	0 to 1s	0.01s	0.5s	145	
	156	Stall prevention operation selection	0 to 31, 100, 101	1	0	101	
—	157	OL signal output timer	0 to 25s, 9999	0.1s	0s	101	
—	Ⓢ 160	User group read selection	0, 1, 9999	1	0	167	
—	161	Frequency setting/key lock operation selection	0, 1, 10, 11	1	0	183	

Parameter	Control Mode-based Correspondence Table			Parameter	
	V/F	AD MFVC	GP MFVC	Clear	All clear
80	×	○	○	○	○
81	×	○	○	○	○
82	×	○	○	×	○
83	×	○	○	○	○
84	×	○	○	○	○
89	×	○	×	×	○
90	○	○	○	×	○
91	×	○	○	×	○
92	×	○	○	×	○
93	×	○	○	×	○
94	×	○	○	×	○
96	○	○	○	×	○
117	Parameter for manufacturer setting. Do not set.				
118					
119					
120					
121					
122					
123					
124					
125					
126					
127					
128					
129					
130					
131					
132					
133					
134					
145					
146					
147	○	○	○	○	○
150	○	○	○	○	○
151	○	○	○	○	○
152	○	○	○	○	○
153	○	○	○	○	○
156	○	○	○	○	○
157	○	○	○	○	○
Ⓢ 160	○	○	○	○	○
161	○	○	○	×	○

Function	Parameter	Name	Setting Range	Minimum Setting Increments	Initial Value	Refer to Page	Customer Setting
Automatic restart functions	162	Automatic restart after instantaneous power failure selection	0, 1, 10, 11	1	1	151	
	165	Stall prevention operation level for restart	0 to 200%	0.1%	150%	151	
—	168	Parameter for manufacturer setting. Do not set.					
—	169	Parameter for manufacturer setting. Do not set.					
Cumulative monitor clear	170	Watt-hour meter clear	0, 10, 9999	1	9999	147	
	171	Operation hour meter clear	0, 9999	1	9999	147	
User group	172	User group registered display/batch clear	9999, (0 to 16)	1	0	167	
	173	User group registration	0 to 999, 9999	1	9999	167	
	174	User group clear	0 to 999, 9999	1	9999	167	
—	178	Parameter for manufacturer setting. Do not set.					
—	179						
—	180						
—	181						
—	182						
—	183						
—	184						
—	190						
—	191						
—	192						
—	232						
—	233						
—	234						
—	235						
—	236						
—	237						
—	238						
—	239						
—	240	Soft-PWM operation selection	0, 1	1	1	163	
—	241	Parameter for manufacturer setting. Do not set.					
—	244	Cooling fan operation selection	0, 1	1	1	176	
Slip compensation	245	Rated slip	0 to 50%, 9999	0.01%	9999	100	
	246	Slip compensation time constant	0.01 to 10s	0.01s	0.5s	100	
	247	Constant-power range slip compensation selection	0, 9999	1	9999	100	
—	249	Earth (ground) fault detection at start	0, 1	1	0	160	
—	250	Stop selection	0 to 100s, 1000 to 1100s, 8888, 9999	0.1s	9999	138	
—	251	Output phase loss protection selection	0, 1	1	1	160	
Life diagnosis	255	Life alarm status display	(0 to 15)	1	0	177	
	256	Inrush current limit circuit life display	(0 to 100%)	1%	100%	177	
	257	Control circuit capacitor life display	(0 to 100%)	1%	100%	177	
	258	Main circuit capacitor life display	(0 to 100%)	1%	100%	177	
	259	Main circuit capacitor life measuring	0, 1 (2, 3, 8, 9)	1	0	177	
Power failure stop	261	Power failure stop selection	0, 1, 2	1	0	156	
	267	Parameter for manufacturer setting. Do not set.					
—	268	Monitor decimal digits selection	0, 1, 9999	1	9999	147	
—	269	Parameter for manufacturer setting. Do not set.					
—	270	Stop-on contact control selection	0, 1	1	0	139	

Parameter	Control Mode-based Correspondence Table			Parameter	
	V/F	AD MFVC	GP MFVC	Clear	All clear
162	○	○	○	○	○
165	○	○	○	○	○
168	Parameter for manufacturer setting. Do not set.				
169	Parameter for manufacturer setting. Do not set.				
170	○	○	○	×	○
171	○	○	○	×	×
172	○	○	○	×	×
173	○	○	○	×	×
174	○	○	○	×	×
178	Parameter for manufacturer setting. Do not set.				
179					
180					
181					
182					
183					
184					
190					
191					
192					
232					
233					
234					
235					
236					
237					
238					
239					
240	○	○	○	○	○
241	Parameter for manufacturer setting. Do not set.				
244	○	○	○	○	○
245	○	×	○	○	○
246	○	×	○	○	○
247	○	×	○	○	○
249	○	○	○	○	○
250	○	○	○	○	○
251	○	○	○	○	○
255	○	○	○	×	×
256	○	○	○	×	×
257	○	○	○	×	×
258	○	○	○	×	×
259	○	○	○	○	○
261	○	○	○	○	○
267	Parameter for manufacturer setting. Do not set.				
268	○	○	○	○	○
269	Parameter for manufacturer setting. Do not set.				
270	×	○	○	○	○

Function	Parameter	Name	Setting Range	Minimum Setting Increments	Initial Value	Refer to Page	Customer Setting
Stop-on contact control	275	Stop-on contact excitation current low-speed multiplying factor	0 to 300%, 9999	0.1%	9999	139	
	276	PWM carrier frequency at stop-on contact	0 to 9, 9999	1	9999	139	
—	277	Stall prevention operation current switchover	0, 1	1	0	101	
—	278	Parameter for manufacturer setting. Do not set.					
—	279						
—	280						
—	281						
—	282						
—	283						
Droop control	286	Droop gain	0 to 100%	0.1%	0%	173	
	287	Droop filter time constant	0 to 1s	0.01s	0.3s	173	
—	292	Automatic acceleration/deceleration	0, 1, 7, 8, 11	1	0	121	
—	293	Acceleration/deceleration separate selection	0 to 2	1	0	121	
—	295	Magnitude of frequency change setting	0, 0.01, 0.1, 1, 10	0.01	0	185	
Password function	296	Password lock level	0 to 6, 99, 100 to 106, 199, 9999	1	9999	169	
	297	Password lock/unlock	(0 to 5), 1000 to 9998, 9999	1	9999	169	
—	298	Frequency search gain	0 to 32767, 9999	1	9999	151	
—	299	Rotation direction detection selection at restarting	0, 1, 9999	1	0	151	
—	338	Parameter for manufacturer setting. Do not set.					
—	339						
—	340						
—	342						
—	343						
Second motor constant	450	Second applied motor	0, 1, 9999	1	9999	125	
	495	Parameter for manufacturer setting. Do not set.					
496							
497							
500							
—	501	Communication error occurrence count display	0	1	0	161	
—	502	Parameter for manufacturer setting. Do not set.					
Maintenance	503	Maintenance timer	0 (1 to 9998)	1	0	180	
	504	Maintenance timer alarm output set time	0 to 9998, 9999	1	9999	180	
—	547	Parameter for manufacturer setting. Do not set.					
—	548						
—	549						
—	550						
—	551						
—	555						
—	556						
—	557						
—	563	Energization time carrying-over times	(0 to 65535)	1	0	147	
—	564	Operating time carrying-over times	(0 to 65535)	1	0	147	
—	571	Holding time at a start	0 to 10s, 9999	0.1s	9999	119	
—	611	Acceleration time at a restart	0 to 3600s, 9999	0.1s	9999	151	

Parameter	Control Mode-based Correspondence Table			Parameter	
	V/F	AD MFVC	GP MFVC	Clear	All clear
275	×	○	○	○	○
276	×	○	○	○	○
277	○	○	○	○	○
278	Parameter for manufacturer setting. Do not set.				
279					
280					
281					
282					
283					
286	×	○	×	○	○
287	×	○	×	○	○
292	○	○	○	○	○
293	○	○	○	○	○
295	○	○	○	○	○
296	○	○	○	×	○
297	○	○	○	×	○
298	○	○	○	×	○
299	○	○	○	○	○
338	Parameter for manufacturer setting. Do not set.				
339					
340					
342					
343					
450	○	○	○	○	○
495	Parameter for manufacturer setting. Do not set.				
496					
497					
500					
501	○	○	○	○	○
502	Parameter for manufacturer setting. Do not set.				
503	○	○	○	×	×
504	○	○	○	×	○
547	Parameter for manufacturer setting. Do not set.				
548					
549					
550					
551					
555					
556					
557					
563	○	○	○	×	×
564	○	○	○	×	×
571	○	○	○	○	○
611	○	○	○	○	○

Function	Parameter	Name	Setting Range	Minimum Setting Increments	Initial Value	Refer to Page	Customer Setting
—	653	Speed smoothing control	0 to 200%	0.1%	0	164	
—	665	Regeneration avoidance frequency gain	0 to 200%	0.1%	100	174	
—	800	Control method selection	20, 30	1	20	93, 95, 98	
—	859	Torque current	0 to 500A (0 to ****) , 9999 *5	0.01A (1) *5	9999	127	
Protective functions	872	Input phase loss protection selection	0, 1	1	1	160	
	882	Regeneration avoidance operation selection	0, 1, 2	1	0	174	
Regeneration avoidance function	883	Regeneration avoidance operation level	300 to 800V	0.1V	400VDC/780VDC *4	174	
	885	Regeneration avoidance compensation frequency limit value	0 to 10Hz, 9999	0.01Hz	6Hz	174	
	886	Regeneration avoidance voltage gain	0 to 200%	0.1%	100%	174	
Free parameter	888	Free parameter 1	0 to 9999	1	9999	181	
	889	Free parameter 2	0 to 9999	1	9999	181	
—	C0	Parameter for manufacturer setting. Do not set.					
—	C2						
—	C3						
—	C4						
—	C5						
—	C6						
—	C7						
—	C22						
—	C23						
—	C24						
—	C25						
—	990						
—	991						
Clear parameters Initial value change list	Pr.CL		Parameter clear	0, 1	1	0	186
	ALLC	All parameter clear	0, 1	1	0	186	
	Er.CL	Faults history clear	0, 1	1	0	188	
	Pr.CH	Initial value change list	—	—	—	187	

*1 Differ according to capacities.
 6%: 0.75K or lower
 4%: 1.5K to 3.7K
 3%: 5.5K, 7.5K
 2%: 11K, 15K

*2 Differ according to capacities.
 5s: 3.7K or lower
 10s: 5.5K, 7.5K
 15s: 11K, 15K

*3 Differ according to capacities.
 6%: 0.1K, 0.2K
 4%: 0.4K to 7.5K
 2%: 11K, 15K

*4 The initial value differs according to the voltage class. (200V class/400V class)

*5 The range differs according to the Pr. 71 setting.

*6 The setting cannot be changed through FL remote communication.

Parameter	Control Mode-based Correspondence Table			Parameter	
	V/F	AD MFVC	GP MFVC	Clear	All clear
653	○	○	○	○	○
665	○	○	○	○	○
800	×	○	○	○	○
859	×	○	○	×	○
872	○	○	○	○	○
882	○	○	○	○	○
883	○	○	○	○	○
885	○	○	○	○	○
886	○	○	○	○	○
888	○	○	○	×	×
889	○	○	○	×	×
C0	Parameter for manufacturer setting. Do not set.				
C2					
C3					
C4					
C5					
C6					
C7					
C22					
C23					
C24					
C25					
990					
991					
Pr.CL		—	—	—	—
ALLC	—	—	—	—	—
Er.CL	—	—	—	—	—
Pr.CH	—	—	—	—	—

5.3	Control mode	92
5.3.1	Changing the control method (Pr. 80, Pr. 81, Pr. 800)	93
5.4	Adjustment of the output torque (current) of the motor	94
5.4.1	Manual torque boost (Pr. 0, Pr. 46)	94
5.4.2	Advanced magnetic flux vector control (Pr. 71, Pr. 80, Pr. 81, Pr.89, Pr. 800)	95
5.4.3	General-purpose magnetic flux vector control (Pr. 71, Pr. 80, Pr. 81, Pr. 800)	98
5.4.4	Slip compensation (Pr. 245 to Pr. 247)	100
5.4.5	Stall prevention operation (Pr. 22, Pr. 23, Pr. 48, Pr. 66, Pr. 156, Pr. 157, Pr. 277)	101
5.5	Limiting the output frequency	105
5.5.1	Maximum/minimum frequency (Pr. 1, Pr. 2, Pr. 18).....	105
5.5.2	Avoiding mechanical resonance points (frequency jumps) (Pr. 31 to Pr. 36).....	106
5.6	V/F pattern	107
5.6.1	Base frequency, voltage (Pr. 3, Pr. 19, Pr. 47).....	107
5.6.2	Load pattern selection (Pr. 14)	109
5.7	Frequency setting by input signals	111
5.7.1	Operation by multi-speed operation (Pr. 4 to Pr. 6, Pr. 24 to Pr. 27).....	111
5.7.2	Remote setting function (Pr. 59).....	113
5.8	Setting of acceleration/deceleration time and acceleration/ deceleration pattern	116
5.8.1	Setting of the acceleration and deceleration time (Pr. 7, Pr. 8, Pr. 20, Pr. 21, Pr. 44, Pr. 45, Pr. 147)	116
5.8.2	Starting frequency and start-time hold function (Pr. 13, Pr. 571).....	119
5.8.3	Acceleration/deceleration pattern (Pr. 29)	120
5.8.4	Shortest acceleration/deceleration (automatic acceleration/deceleration) (Pr. 61 to Pr. 63, Pr. 292, Pr. 293).....	121
5.9	Selection and protection of a motor	123
5.9.1	Motor overheat protection (Electronic thermal O/L relay) (Pr. 9, Pr. 51)	123
5.9.2	Applied motor (Pr. 71, Pr. 450).....	125
5.9.3	Exhibiting the best performance for the motor (offline auto tuning) (Pr. 71, Pr. 80 to Pr. 84, Pr. 90 to Pr. 94, Pr. 96, Pr. 859)	127
5.10	Motor brake and stop operation	135
5.10.1	DC injection brake (Pr. 10 to Pr. 12).....	135
5.10.2	Selection of a regenerative brake (Pr. 30, Pr. 70)	136
5.10.3	Stop selection (Pr. 250)	138
5.10.4	Stop-on contact control function (Pr. 6, Pr. 48, Pr. 270, Pr. 275, Pr. 276)	139
5.11	I/O signal control	141
5.11.1	Operation of start signals (STF, STR signal).....	141
5.11.2	Reset cancel signal (READY signal) and inverter running signal (RUN signal)	142
5.11.3	Second function selection signal (RT signal).....	143
5.11.4	Inverter output shutoff signal (MRS signal, Pr. 17).....	143
5.11.5	Detection of output frequency (SU, FU signal, Pr. 41 to Pr. 43).....	144
5.11.6	Output current detection function (Y12 signal, Y13 signal, Pr. 150 to Pr. 153)	145

5.12 Monitor display and monitor output signal	146
5.12.1 Speed display and speed setting (Pr. 37).....	146
5.12.2 Monitor display selection of the operation panel (Pr. 52, Pr. 170, Pr. 171, Pr. 268, Pr. 563, Pr. 564).....	147
5.13 Operation selection at power failure and instantaneous power failure	151
5.13.1 Automatic restart after instantaneous power failure/flying start (Pr. 57, Pr. 58, Pr. 96, Pr. 162, Pr. 165, Pr. 298, Pr. 299, Pr. 611)	151
5.13.2 Power-failure deceleration stop function (Pr. 261)	156
5.14 Operation setting at fault occurrence	158
5.14.1 Retry function (Pr. 65, Pr. 67 to Pr. 69)	158
5.14.2 Input/output phase loss protection selection (Pr. 251, Pr. 872).....	160
5.14.3 Earth (ground) fault detection at start (Pr. 249)	160
5.14.4 Display and erasure of communication error occurrence count (Pr. 501)	161
5.15 Energy saving operation	162
5.15.1 Optimum excitation control (Pr. 60)	162
5.16 Motor noise, EMI measures, mechanical resonance	163
5.16.1 PWM carrier frequency and soft-PWM control (Pr. 72, Pr. 240).....	163
5.16.2 Speed smoothing control (Pr. 653).....	164
5.17 Misoperation prevention and parameter setting restriction	165
5.17.1 Reset selection/PU stop selection (Pr. 75)	165
5.17.2 Parameter write disable selection (Pr. 77).....	166
5.17.3 Reverse rotation prevention selection (Pr. 78)	167
5.17.4 Extended parameter display and user group function (Pr. 160, Pr. 172 to Pr. 174).....	167
5.17.5 Password function (Pr. 296, Pr. 297).....	169
5.18 Special operation and frequency control	171
5.18.1 Jog operation (Pr. 15, Pr. 16)	171
5.18.2 Droop control (Pr. 286, Pr. 287)	173
5.18.3 Regeneration avoidance function (Pr. 665, Pr. 882, Pr. 883, Pr. 885, Pr. 886).....	174
5.19 Useful functions	176
5.19.1 Cooling fan operation selection (Pr. 244)	176
5.19.2 Display of the life of the inverter parts (Pr. 255 to Pr. 259).....	177
5.19.3 Maintenance timer alarm (Pr. 503, Pr. 504)	180
5.19.4 Free parameter (Pr. 888, Pr. 889)	181
5.20 Setting from the operation panel	182
5.20.1 RUN key rotation direction selection (Pr. 40)	182
5.20.2 Operation panel frequency setting/key lock operation selection (Pr. 161)	183
5.20.3 Magnitude of frequency change setting (Pr. 295).....	185
5.21 Parameter clear/ All parameter clear	186
5.22 Initial value change list	187
5.23 Check and clear of the faults history	188

5.3 Control mode

V/F control (initial setting), Advanced magnetic flux vector control and General-purpose magnetic flux vector control are available with this inverter.

(1) V/F Control

- It controls frequency and voltage so that the ratio of frequency (F) to voltage (V) is constant when changing frequency.

(2) Advanced (General-purpose) magnetic flux vector control

- This control divides the inverter output current into an excitation current and a torque current by vector calculation and makes voltage compensation to flow a motor current which meets the load torque.
- General-purpose magnetic flux vector control is the same function as the FR-E500 series. For other cases, select Advanced magnetic flux vector control.



POINT

If the following conditions are not satisfied, select V/F control since malfunction such as insufficient torque and uneven rotation may occur.

- The motor capacity should be equal to or one rank lower than the inverter capacity. (Note that the capacity should be 0.1kW or higher.)
- Motor to be used is any of Mitsubishi standard motor, high efficiency motor (SF-JR, SF-HR 0.2kW or higher) or Mitsubishi constant-torque motor (SF-JRCA four-pole, SF-HRCA 0.2kW to 15kW). When using a motor other than the above (other manufacturer's motor), perform offline auto tuning without fail.
- Single-motor operation (one motor run by one inverter) should be performed.
- Wiring length from inverter to motor should be within 30m. (Perform offline auto tuning in the state where wiring work is performed when the wiring length exceeds 30m.)

5.3.1 Changing the control method (Pr. 80, Pr. 81, Pr. 800)

Set when selecting the control method for Advanced magnetic flux vector control and General-purpose magnetic flux vector control. The initial value is V/F control.

- Select a control mode using *Pr. 800 Control method selection*.

Parameter Number	Name	Initial Value	Setting Range	Description	
80	Motor capacity	9999	0.1 to 15kW	Set the applied motor capacity.	
			9999	V/F Control	
81	Number of motor poles	9999	2, 4, 6, 8, 10	Set the number of motor poles.	
			9999	V/F Control	
800	Control method selection	20	20	V/F	Advanced magnetic flux vector control *
			30	Control	General-purpose magnetic flux vector control *

* Set a value other than "9999" in *Pr. 80* and *Pr. 81*.

(1) Setting of the motor capacity and the number of motor poles (*Pr. 80, Pr. 81*)

- Motor specifications (motor capacity and number of motor poles) must be set to select Advanced magnetic flux vector control or General-purpose magnetic flux vector control.
- Set the motor capacity (kW) in *Pr. 80 Motor capacity* and set the number of motor poles in *Pr. 81 Number of motor poles*.

(2) Selection of control method









- Select the inverter control method for V/F control, Advanced magnetic flux vector control, and General-purpose magnetic flux vector control.

<i>Pr. 80, 81</i>	<i>Pr. 800 Setting</i>	Control Method
Other than 9999	20 (<i>Pr. 800</i> initial value)	Advanced magnetic flux vector control
	30	General-purpose magnetic flux vector control
9999 (<i>Pr. 80, Pr. 81</i> initial value)	— *	V/F control

* Control method is V/F control regardless of the setting value of *Pr. 800* when "9999" is set in *Pr. 80 Motor capacity* or *Pr. 81 Number of motor poles*.



Parameters referred to

- Advanced magnetic flux vector control  Refer to page 95
- General-purpose magnetic flux vector control  Refer to page 98
- Pr. 450* Second applied motor  Refer to page 125
- Pr. 44* Second acceleration/deceleration time, *Pr. 45* Second deceleration time  Refer to page 116
- Pr. 46* Second torque boost  Refer to page 94
- Pr. 47* Second V/F (base frequency)  Refer to page 107
- Pr. 48* Second stall prevention operation current  Refer to page 101
- Pr. 51* Second electronic thermal O/L relay  Refer to page 123

5.4 Adjustment of the output torque (current) of the motor

Purpose	Parameter that should be Set		Refer to Page
Set starting torque manually	Manual torque boost	Pr. 0, Pr. 46	94
Automatically control output current according to load	Advanced magnetic flux vector control, General-purpose magnetic flux vector control	Pr. 71, Pr. 80, Pr. 81, Pr. 89, Pr. 90, Pr. 450, Pr. 800	95, 98
Compensate for motor slip to secure low-speed torque	Slip compensation (V/F control and General-purpose magnetic flux vector control only)	Pr. 245 to Pr. 247	100
Limit output current to prevent inverter trip	Stall prevention operation	Pr. 22, Pr. 23, Pr. 66, Pr. 156, Pr. 157	101

5.4.1 Manual torque boost (Pr. 0, Pr. 46)

A voltage drop in the low-frequency range can be compensated to improve motor torque reduction in the low-speed range.

- Motor torque in the low-frequency range can be adjusted to the load to increase the starting motor torque.
- Turning the RT signal ON/OFF switches between two start torque boost settings.

Parameter Number	Name	Initial Value		Setting Range	Description
0	Torque boost	0.1K to 0.75K	6%	0 to 30%	Set the output voltage at 0Hz as %.
		1.5K to 3.7K	4%		
		5.5K, 7.5K	3%		
		11K, 15K	2%		
46 *	Second torque boost	9999		0 to 30%	Set the torque boost when the RT signal is ON.
				9999	Without second torque boost

* The above parameters can be set when Pr. 160 User group read selection = "0". (Refer to page 167)

(1) Starting torque adjustment

- On the assumption that Pr. 19 Base frequency voltage is 100%, set the output voltage at 0Hz in % to Pr. 0 (Pr. 46).
- Adjust the parameter little by little (about 0.5%), and check the motor status each time. If the setting is too large, the motor will overheat. The guideline is about 10% at the greatest.

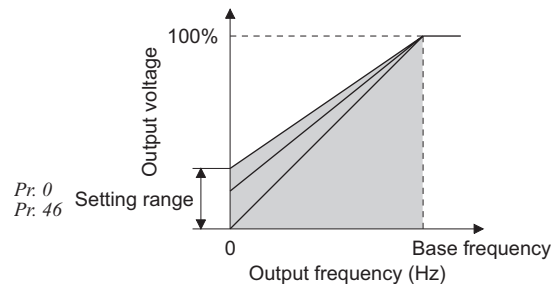

(2) Set two kinds of torque boosts (RT signal, Pr. 46)

- When you want to change torque boost according to applications, switch multiple motors with one inverter, etc., use *Second torque boost*.
- Pr. 46 *Second torque boost* is valid when the RT signal is ON.



REMARKS

- The RT signal acts as the second function selection signal and makes the other second functions valid. (Refer to page 143)





NOTE

- The amount of current flows in the motor may become large according to the conditions such as the motor characteristics, load, acceleration/deceleration time, wiring length, etc., resulting in an overcurrent trip (OL (overcurrent alarm) then E.OC1 (overcurrent trip during acceleration), overload trip (E.THM (motor overload trip), or E.THT (inverter overload trip). (When a fault occurs, release the start command, and decrease the Pr. 0 setting 1% by 1% to reset.) (Refer to page 192.)
- The Pr. 0, Pr. 46 settings are valid only when V/F control is selected.
- When using the inverter dedicated motor (constant-torque motor) with the 5.5K, 7.5K, set torque boost value to 2%. When Pr. 0 = "3%" (initial value), if Pr. 71 value is changed to the setting for use with a constant-torque motor, the Pr. 0 setting changes to 2%.



Parameters referred to

- Pr. 3 Base frequency, Pr. 19 Base frequency voltage  Refer to page 107
- Pr. 71 Applied motor  Refer to page 125

5.4.2 Advanced magnetic flux vector control (Pr. 71, Pr. 80, Pr. 81, Pr.89, Pr. 800)

Advanced magnetic flux vector control can be selected by setting the capacity, poles and type of the motor used in Pr. 80 and Pr. 81.

● **Advanced magnetic flux vector control?**

The low speed torque can be improved by providing voltage compensation to flow a motor current which meets the load torque. Output frequency compensation (slip compensation) is made so that the motor actual speed approximates a speed command value. Effective when load fluctuates drastically, etc.

When the FR-E500 series used for General-purpose magnetic flux vector control was replaced, select General-purpose magnetic flux vector control only when the same operation characteristic is necessary. (Refer to page 98)

Parameter Number	Name	Initial Value	Setting Range	Description
71	Applied motor	0	0,1, 3 to 6, 13 to 16, 23, 24 40, 43, 44 50, 53, 54	By selecting a standard motor or constant-torque motor, thermal characteristic and motor constants of each motor are set.
80	Motor capacity	9999	0.1 to 15kW	Set the applied motor capacity.
			9999	V/F control
81	Number of motor poles	9999	2, 4, 6, 8, 10	Set the number of motor poles.
			9999	V/F control
89	Speed control gain (Advanced magnetic flux vector)	9999	0 to 200%	Motor speed fluctuation due to load fluctuation is adjusted during Advanced magnetic flux vector control. 100% is a referenced value.
			9999	Gain matching with the motor set in Pr.71.
800	Control method selection	20	20	Advanced magnetic flux vector control *
			30	General-purpose magnetic flux vector control * (Refer to page 98)

The above parameters can be set when Pr. 160 User group read selection = "0". (Refer to page 167)

* Set a value other than "9999" in Pr. 80 and Pr. 81.



POINT

If the following conditions are not satisfied, select V/F control since malfunction such as insufficient torque and uneven rotation may occur.

- The motor capacity should be equal to or one rank lower than the inverter capacity. (Note that the capacity should be 0.1kW or higher.)
- Motor to be used is any of Mitsubishi standard motor (SF-JR 0.2kW or higher), high efficiency motor (SF-HR 0.2kW or higher) or Mitsubishi constant-torque motor (SF-JRCA four-pole, SF-HRCA 0.2kW to 15kW). When using a motor other than the above (other manufacturer's motor), perform offline auto tuning without fail.
- Single-motor operation (one motor run by one inverter) should be performed.
- The wiring length from inverter to motor should be within 30m. (Perform offline auto tuning in the state where wiring work is performed when the wiring length exceeds 30m.)

Permissible wiring length between inverter and motor differs according to the inverter capacity and setting value of Pr. 72 PWM frequency selection (carrier frequency). Refer to page 19 for the permissible wiring length.

Adjustment of the output torque (current) of the motor

<Selection method of Advanced magnetic flux vector control>

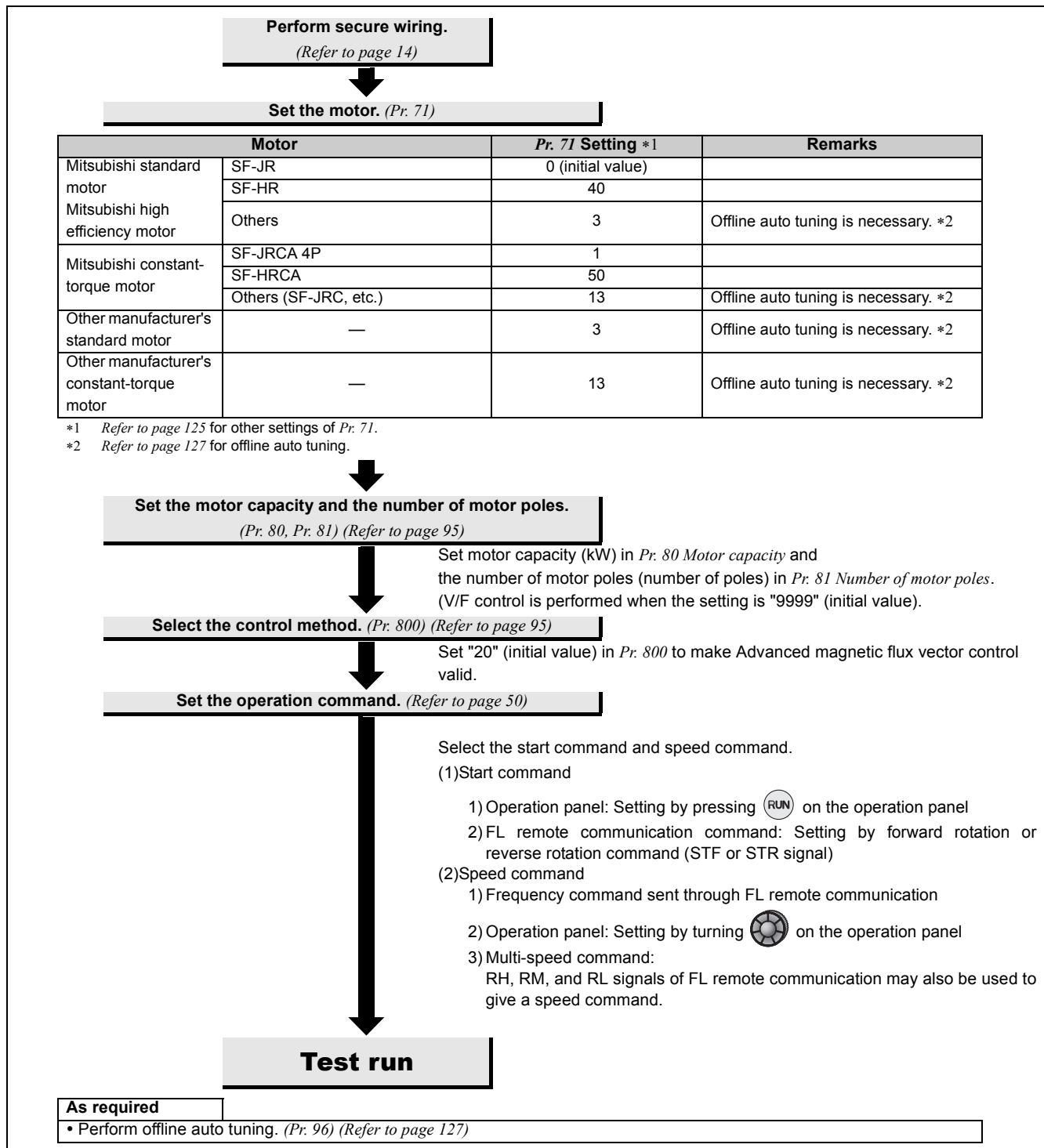

NOTE

- Uneven rotation slightly increases as compared to the V/F control. (It is not suitable for machines such as grinding machine and wrapping machine which requires less uneven rotation at low speed.)
- When a surge voltage suppression filter (FR-ASF-H/FR-BMF-H) is connected between the inverter and motor, output torque may decrease.)

(1) Adjust the motor speed fluctuation at load fluctuation (*Pr. 89 Speed control gain (Advanced magnetic flux vector)*)

The motor speed fluctuation at load fluctuation can be adjusted using *Pr. 89*. (It is useful when the speed command does not match the motor speed after the FR-E500 series inverter is replaced with the FR-E700 series inverter, etc.)

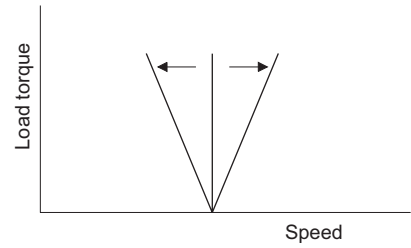

Parameters referred to

Pr. 71, Pr. 450 Applied motor  Refer to page 125

Pr. 800 Control method selection  Refer to page 93

Adjustment of the output torque (current) of the motor

5.4.3 General-purpose magnetic flux vector control (Pr. 71, Pr. 80, Pr. 81, Pr. 800)

General-purpose magnetic flux vector control is the same function as the FR-E500 series.

Select this control when the same operation characteristic is necessary. For other cases, select Advanced magnetic flux vector control. (Refer to page 95)

Parameter Number	Name	Initial Value	Setting Range	Description
71	Applied motor	0	0, 1, 3 to 6, 13 to 16, 23, 24 40, 43, 44 50, 53, 54	By selecting a standard motor or constant-torque motor, thermal characteristic and motor constants of each motor are set.
80	Motor capacity	9999	0.1 to 15kW	Applied motor capacity.
			9999	V/F control
81	Number of motor poles	9999	2, 4, 6, 8, 10	Number of motor poles.
			9999	V/F control
800	Control method selection	20	20	Advanced magnetic flux vector control * (Refer to page 95)
			30	General-purpose magnetic flux vector control *

The above parameters can be set when Pr. 160 User group read selection = "0". (Refer to page 167)

* Set a value other than "9999" in Pr. 80 and Pr. 81.



POINT

If the following conditions are not satisfied, select V/F control since malfunction such as insufficient torque and uneven rotation may occur.

- The motor capacity should be equal to or one rank lower than the inverter capacity. (note that the capacity should be 0.1kW or higher)
- Motor to be used is any of Mitsubishi standard motor (SF-JR 0.2kW or higher), high efficiency motor (SF-JR, SF-HR 0.2kW or higher) or Mitsubishi constant-torque motor (SF-JRCA four-pole, SF-HRCA 0.2kW to 15kW). When using a motor other than the above (other manufacturer's motor), perform offline auto tuning without fail.
- Single-motor operation (one motor run by one inverter) should be performed.
- The wiring length from inverter to motor should be within 30m. (Perform offline auto tuning in the state where wiring work is performed when the wiring length exceeds 30m.)

Permissible wiring length between inverter and motor differs according to the inverter capacity and setting value of Pr. 72 PWM frequency selection (carrier frequency). Refer to page 19 for the permissible wiring length.

<Selection method of General-purpose magnetic flux vector control>

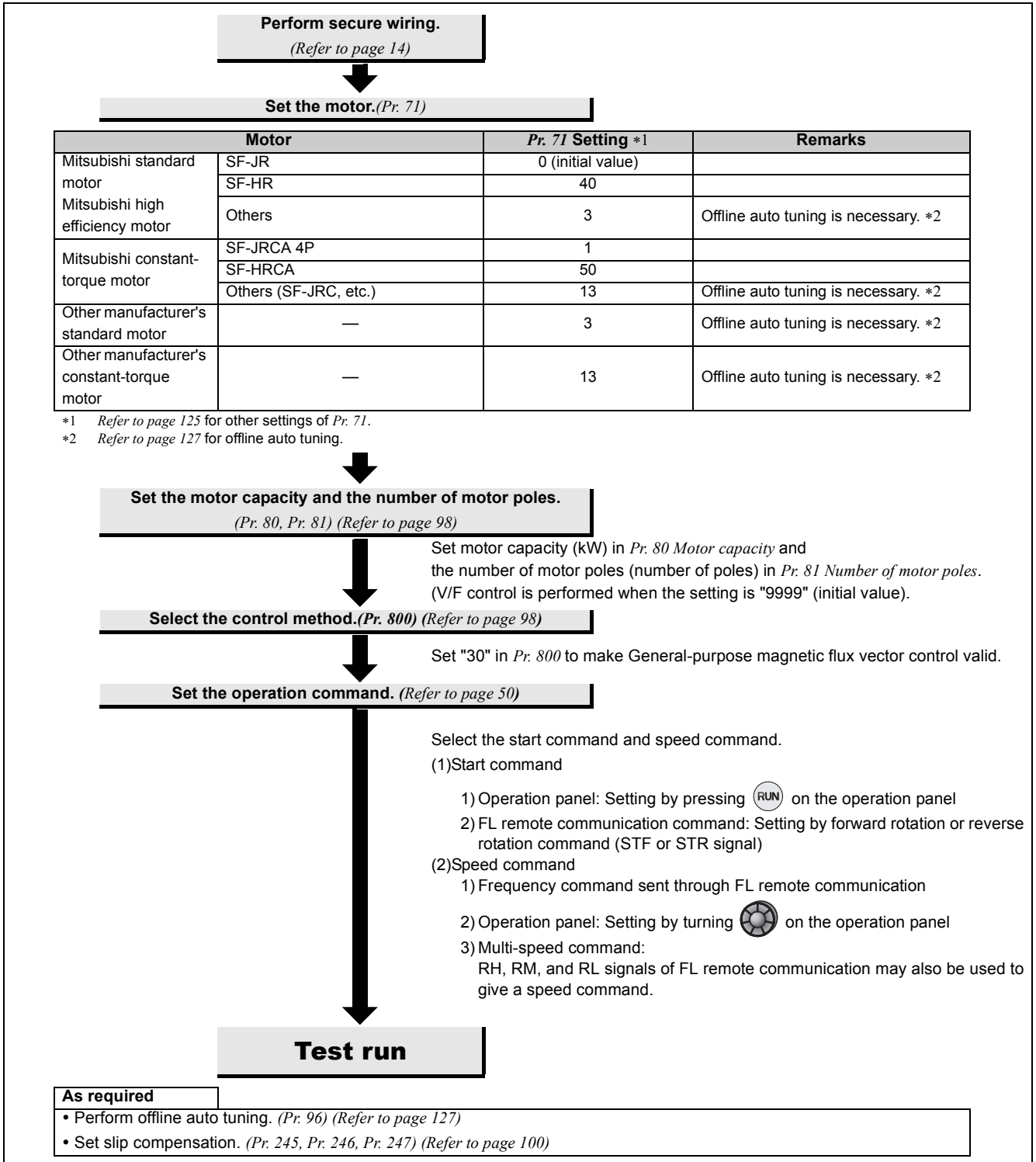

NOTE

- Uneven rotation slightly increases as compared to the V/F control. (It is not suitable for machines such as grinding machine and wrapping machine which requires less uneven rotation at low speed.)
- When a surge voltage suppression filter (FR-ASF-H/FR-BMF-H) is connected between the inverter and motor, output torque may decrease.)



Parameters referred to

- Pr.3 Base frequency, Pr.19 Base frequency voltage Refer to page 107
- Pr.71 Applied motor Refer to page 125
- Pr.77 Parameter write selection Refer to page 166

Adjustment of the output torque (current) of the motor

5.4.4 Slip compensation (Pr. 245 to Pr. 247)

When V/F control or General-purpose magnetic flux vector control is performed, the inverter output current may be used to assume motor slip to keep the motor speed constant.

Parameter Number	Name	Initial Value	Setting Range	Description
245	Rated slip	9999	0.01 to 50%	Rated motor slip.
			0, 9999	No slip compensation
246	Slip compensation time constant	0.5s	0.01 to 10s	Slip compensation response time. When the value is made smaller, response will be faster. However, as load inertia is greater, a regenerative overvoltage fault (E.OV□) is more liable to occur.
247	Constant-power range slip compensation selection	9999	0	Slip compensation is not made in the constant power range (frequency range above the frequency set in Pr. 3)
			9999	Slip compensation is made in the constant power range.

The above parameters can be set when Pr. 160 User group read selection = "0". (Refer to page 167)

- Slip compensation is validated when the motor rated slip calculated by the following formula is set in Pr. 245. Slip compensation is not made when Pr. 245 = "0" or "9999".

$$\text{Rated slip} = \frac{\text{Synchronous speed at base frequency} - \text{rated speed}}{\text{Synchronous speed at base frequency}} \times 100[\%]$$

REMARKS

- When performing slip compensation, the output frequency may become greater than the set frequency. Set the Pr. 1 Maximum frequency value a little higher than the set frequency.
- Slip compensation is always valid when Advanced magnetic flux vector control is selected, the Pr. 245 to Pr. 247 settings are invalid.

Parameters referred to

Pr. 1 Maximum frequency  Refer to page 105

Pr. 3 Base frequency  Refer to page 107

5.4.5 Stall prevention operation (Pr. 22, Pr. 23, Pr. 48, Pr. 66, Pr. 156, Pr. 157, Pr. 277)

This function monitors the output current and automatically changes the output frequency to prevent the inverter from coming to trip due to overcurrent, overvoltage, etc. In addition, simple torque limit which limits the output torque to the predetermined value can be selected.

It can also limit stall prevention and fast-response current limit operation during acceleration/deceleration, driving or regeneration.

● **Stall prevention**

If the output current exceeds the stall prevention operation level, the output frequency of the inverter is automatically varied to reduce the output current.

● **Fast-response current limit**

If the current exceeds the limit value, the output of the inverter is shut off to prevent an overcurrent.

● **Torque limit**

The inverter output frequency is controlled so that the output torque (torque current) will not exceed the stall prevention operation level (motor rated torque is referenced).

Parameter Number	Name	Initial Value	Setting Range	Description
22*	Stall prevention operation level	150%	0	Stall prevention operation invalid
			0.1 to 200%	Set the current value to start the stall prevention operation.
23	Stall prevention operation level compensation factor at double speed	9999	0 to 200%	The stall operation level can be reduced when operating at a high speed above the rated frequency.
			9999	Constant according to Pr. 22.
48	Second stall prevention operation current	9999	0	Stall prevention operation invalid
			0.1 to 200%	Second stall prevention operation level
			9999	Same level as Pr. 22.
66	Stall prevention operation reduction starting frequency	60Hz	0 to 400Hz	Set the frequency at which the stall prevention operation level starts being reduced.
156	Stall prevention operation selection	0	0 to 31, 100, 101	Select whether stall prevention operation and fast-response current limit operation will be performed or not.
157	OL signal output timer	0s	0 to 25s	Output start time of the OL signal output when stall prevention is activated.
			9999	Without the OL signal output
277	Stall prevention operation current switchover	0	0	Output current is the limit level
			1	Output torque (torque current) is the limit level

The above parameters can be set when Pr. 160 User group read selection = "0". (Refer to page 167)

* This parameter allows its setting to be changed during operation in any operation mode even if "0 (initial value) or 1" is set in Pr. 77 Parameter write selection.

(1) Block diagram

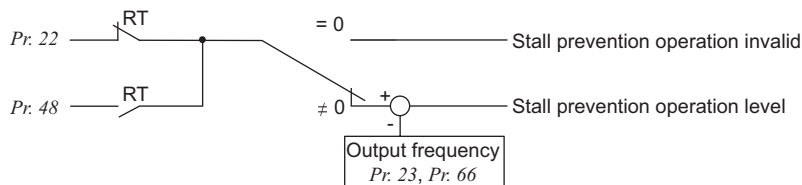

Adjustment of the output torque (current) of the motor

(2) Setting of stall prevention operation level (Pr. 22)

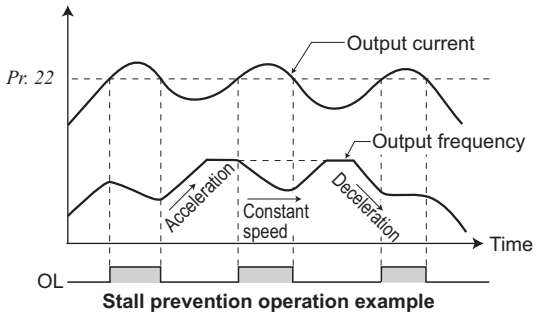

- Set in Pr. 22 the percentage of the output current to the rated inverter current at which stall prevention operation will be performed. Normally set this parameter to 150% (initial value).
- Stall prevention operation stops acceleration (makes deceleration) during acceleration, makes deceleration during constant speed, and stops deceleration (makes acceleration) during deceleration.
- When stall prevention operation is performed, the OL signal is output.



NOTE

- If an overload status lasts long, an inverter trip (e.g. electronic thermal O/L relay (E.THM)) may occur.

(3) A machine protection and load limit by torque limit (Pr. 277)

- When Pr. 277 Stall prevention current switchover = "1", torque limit can be set.
- When output torque (torque current) exceeds the stall prevention operation level, the output frequency is controlled to limit the output torque. For the stall prevention operation level at this time, the motor rated torque is defined as reference.



REMARKS

- When driving multiple motors with one inverter, torque limit does not function properly.
- Since magnetic flux decreases in the constant output range (Pr. 3 Base frequency or more), the inverter operate with lower torque than the stall prevention operation level.
- When torque limit is activated during regeneration, the output frequency is increased up to the maximum frequency.
- Torque limit does not function at 5Hz or less during deceleration.
- Note the following when using torque limit under V/F control.
 - (a) Capacity of the inverter and motor should be the same.
 - (b) Stall prevention operation level (torque limit level) is the rated torque reference of the motor whose capacity is equivalent to the inverter.
 - (c) When Pr. 0 Torque boost setting is large, torque limit is likely to occur in the low speed range.
 - (d) Use the Advanced magnetic flux vector control when more appropriate torque limit is necessary.

(4) Stall prevention operation signal output and output timing adjustment (OL signal, Pr. 157)

- When the output current exceeds the stall prevention operation level and stall prevention is activated, the stall prevention operation signal (OL signal) turns ON for longer than 100ms. When the output current falls to or below the stall prevention operation level, the output signal turns OFF.
- Use Pr. 157 OL signal output timer to set whether the OL signal is output immediately or after a preset period of time.
- This operation is also performed when the regeneration avoidance function or \overline{OL} (overvoltage stall) is executed.

Pr. 157 Setting	Description
0 (initial value)	Output immediately.
0.1 to 25	Output after the set time (s) has elapsed.
9999	Not output.

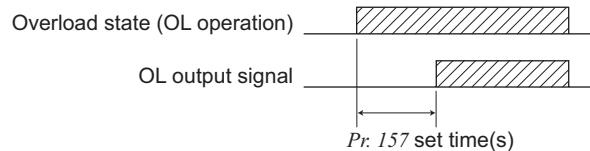

NOTE

- If the frequency has fallen to 1Hz by stall prevention operation and remains for 3s, a fault (E.OLT) appears to trip the inverter output.

(5) Setting of stall prevention operation in high frequency range (Pr. 22, Pr. 23, Pr. 66)

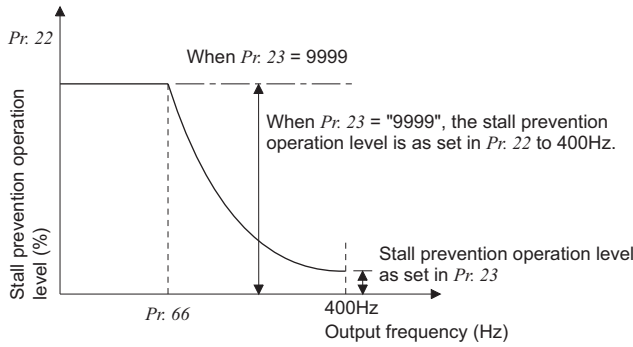

Setting example (Pr. 22 = 150%, Pr. 23 = 100%, Pr. 66 = 60Hz)

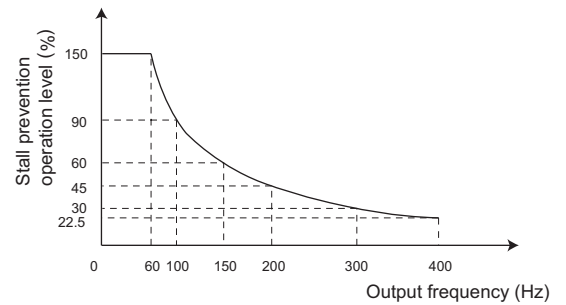

- During high-speed operation above the rated motor frequency, acceleration may not be made because the motor current does not increase. If operation is performed in a high frequency range, the current at motor lockup becomes smaller than the rated output current of the inverter, and the protective function (OL) is not executed even if the motor is at a stop. To improve the operating characteristics of the motor in this case, the stall prevention level can be reduced in the high frequency range. This function is effective for performing operation up to the high-speed range on a centrifugal separator etc. Normally, set 60Hz in Pr. 66 and 100% in Pr. 23.
- Formula for stall prevention operation level

$$\text{Stall prevention operation level in high frequency range (\%)} = A + B \times \left[\frac{\text{Pr. 22} - A}{\text{Pr. 22} - B} \right] \times \left[\frac{\text{Pr. 23} - 100}{100} \right]$$

$$\text{However, } A = \frac{\text{Pr. 66 (Hz)} \times \text{Pr. 22 (\%)}}{\text{Output frequency (Hz)}}, \quad B = \frac{\text{Pr. 66 (Hz)} \times \text{Pr. 22 (\%)}}{400\text{Hz}}$$

- By setting "9999" (initial value) in Pr. 23 Stall prevention operation level compensation factor at double speed, the stall prevention operation level is constant at the Pr. 22 setting up to 400Hz.

(6) Set two types stall prevention operation levels (Pr. 48)

- Turning RT signal ON makes Pr. 48 Second stall prevention operation current valid.



NOTE

- The RT signal acts as the second function selection signal and makes the other second functions valid. (Refer to page 143)

Adjustment of the output torque (current) of the motor

(7) Limit the stall prevention operation and fast-response current limit operation according to the operating status (Pr. 156)

• Refer to the following table and select whether stall prevention operation and fast-response current limit operation will be performed or not and the operation to be performed at OL signal output.

Pr. 156 Setting	Fast-Response Current Limit*4 ○: Activated ●: Not activated	Stall Prevention Operation Selection ○: Activated ●: Not activated			OL Signal Output ○: Operation continued ●: Operation not continued *1	Pr. 156 Setting	Fast-Response Current Limit*4 ○: Activated ●: Not activated	Stall Prevention Operation Selection ○: Activated ●: Not activated			OL Signal Output ○: Operation continued ●: Operation not continued *1		
		Acceleration	Constant speed	Deceleration				Acceleration	Constant speed	Deceleration			
0 (initial value)	○	○	○	○	○	16	○	○	○	○	●		
1	●	○	○	○	○	17	●	○	○	○	●		
2	○	●	○	○	○	18	○	●	○	○	●		
3	●	●	○	○	○	19	●	●	○	○	●		
4	○	○	●	○	○	20	○	○	●	○	●		
5	●	○	●	○	○	21	●	○	●	○	●		
6	○	●	●	○	○	22	○	●	●	○	●		
7	●	●	●	○	○	23	●	●	●	○	●		
8	○	○	○	●	○	24	○	○	○	●	●		
9	●	○	○	●	○	25	●	○	○	●	●		
10	○	●	○	●	○	26	○	●	○	●	●		
11	●	●	○	●	○	27	●	●	○	●	●		
12	○	○	●	●	○	28	○	○	●	●	●		
13	●	○	●	●	○	29	●	○	●	●	●		
14	○	●	●	●	— *2	30	○	●	●	●	— *2		
15	●	●	●	●	— *2	31	●	●	●	●	— *2		
100 *3	Power driving	○	○	○	○	○	101 *3	Power driving	●	○	○	○	○
	Regeneration	●	●	●	●	— *2		Regeneration	●	●	●	●	— *2

*1 When "Operation not continued for OL signal output" is selected, the **E.O.L.T** fault (stopped by stall prevention) is displayed and operation stopped.

*2 Since stall prevention is not activated, OL signal and E.O.L.T are not output.

*3 The settings "100" and "101" allow operations to be performed in the driving and regeneration modes, respectively. The setting "101" disables the fast-response current limit in the driving mode.

*4 OL signal is not output at fast-response current limit operation.



NOTE

- When the load is heavy or the acceleration/deceleration time is short, stall prevention is activated and acceleration/deceleration may not be made according to the preset acceleration/deceleration time. Set Pr. 156 and stall prevention operation level to the optimum values.
- In vertical lift applications, make setting so that the fast-response current limit is not activated. Torque may not be produced, causing a load drop due to gravity.

⚠ CAUTION

⚠ Do not set a small value as the stall prevention operation current. Otherwise, torque generated will reduce.

⚠ Test operation must be performed.

Stall prevention operation during acceleration may increase the acceleration time.

Stall prevention operation performed during constant speed may cause sudden speed changes.

Stall prevention operation during deceleration may increase the deceleration time, increasing the deceleration distance.



Parameters referred to

- Pr. 3 Base frequency Refer to page 107

5.5 Limiting the output frequency

Purpose	Parameter that should be Set		Refer to Page
Set upper limit and lower limit of output frequency	Maximum/minimum frequency	Pr. 1, Pr. 2, Pr. 18	105
Perform operation by avoiding mechanical resonance points	Frequency jump	Pr. 31 to Pr. 36	106

5.5.1 Maximum/minimum frequency (Pr. 1, Pr. 2, Pr. 18)

Motor speed can be limited.

Clamp the upper and lower limits of the output frequency.

Parameter Number	Name	Initial Value	Setting Range	Description
1	Maximum frequency	120Hz	0 to 120Hz	Upper limit of the output frequency.
2	Minimum frequency	0Hz	0 to 120Hz	Lower limit of the output frequency.
18 *	High speed maximum frequency	120Hz	120 to 400Hz	Set when performing the operation at 120Hz or more.

* The above parameters can be set when Pr. 160 User group read selection = "0". (Refer to page 167)

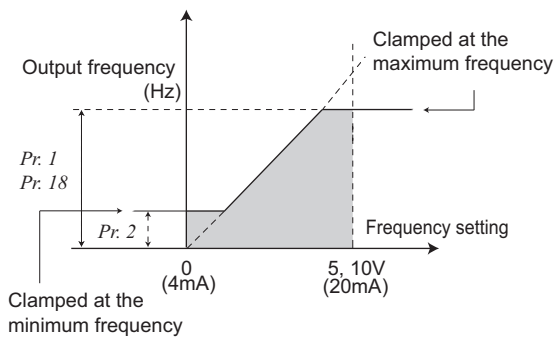

(1) Set maximum frequency

- Use Pr. 1 Maximum frequency to set the maximum frequency. If the value of the frequency command entered is higher than the setting, the output frequency is clamped at the maximum frequency.
- When you want to perform operation above 120Hz, set the upper limit of the output frequency to Pr. 18 High speed maximum frequency. (When Pr. 18 is set, Pr. 1 automatically switches to the frequency of Pr. 18. Also, when Pr. 1 is set, Pr. 18 is automatically changed to the frequency set in Pr. 1.

(2) Set minimum frequency

- Use Pr. 2 Minimum frequency to set the minimum frequency.
- If the set frequency is less than Pr. 2, the output frequency is clamped at Pr. 2 (will not fall below Pr. 2).



REMARKS

- When Pr. 15 Jog frequency is equal to or less than Pr. 2, the Pr. 15 setting has precedence over the Pr. 2 setting.
- When stall prevention is activated to decrease the output frequency, the output frequency may drop to Pr. 2 or below.



CAUTION



Note that when Pr. 2 is set to any value equal to or more than Pr. 13 Starting frequency, simply turning ON the start signal will run the motor at the preset frequency according to the set acceleration time even if the command frequency is not input.



Parameters referred to

- Pr. 13 Starting frequency Refer to page 119
- Pr. 15 Jog frequency Refer to page 171

5.5.2 Avoiding mechanical resonance points (frequency jumps) (Pr. 31 to Pr. 36)

When avoiding resonance arisen from the natural frequency of a mechanical system, use these parameters to jump the resonant frequencies.

Parameter Number	Name	Initial Value	Setting Range	Description
31	Frequency jump 1A	9999	0 to 400Hz, 9999	1A to 1B, 2A to 2B, 3A to 3B is frequency jumps 9999: Function invalid
32	Frequency jump 1B	9999	0 to 400Hz, 9999	
33	Frequency jump 2A	9999	0 to 400Hz, 9999	
34	Frequency jump 2B	9999	0 to 400Hz, 9999	
35	Frequency jump 3A	9999	0 to 400Hz, 9999	
36	Frequency jump 3B	9999	0 to 400Hz, 9999	

The above parameters can be set when Pr. 160 User group read selection = "0". (Refer to page 167)

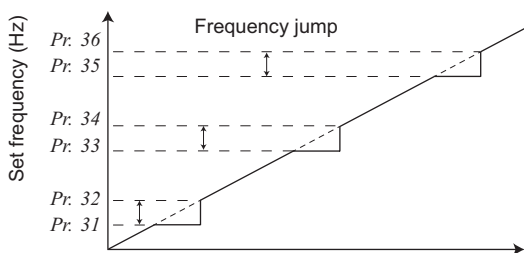

- Up to three areas can be set, with the jump frequencies set to either the top or bottom point of each area.
- The value set to 1A, 2A or 3A is a jump point and operation in the jump zone is performed at these frequencies.

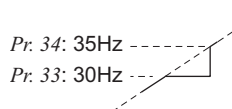

Example 1

To fix the frequency to 30Hz in the range 30Hz to 35Hz, set 35Hz in Pr. 34 and 30Hz in Pr. 33.

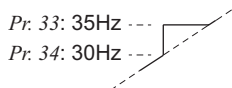

Example 2

To jump the frequency to 35Hz in the range 30Hz to 35Hz, set 35Hz in Pr. 33 and 30Hz in Pr. 34.



NOTE

During acceleration/deceleration, the running frequency within the set area is valid.

5.6 V/F pattern

Purpose	Parameter that should be Set		Refer to Page
Set motor ratings	Base frequency, Base frequency voltage	Pr. 3, Pr. 19, Pr. 47	107
Select a V/F pattern according to applications.	Load pattern selection	Pr. 14	109

5.6.1 Base frequency, voltage (Pr. 3, Pr. 19, Pr. 47)

Used to adjust the inverter outputs (voltage, frequency) to the motor rating.

Parameter Number	Name	Initial Value	Setting Range	Description
3	Base frequency	60Hz	0 to 400Hz	Rated motor frequency. (50Hz/60Hz)
19 *	Base frequency voltage	9999	0 to 1000V	Base voltage.
			8888	95% of power supply voltage
			9999	Same as power supply voltage
47 *	Second V/F (base frequency)	9999	0 to 400Hz	Base frequency when the RT signal is ON.
			9999	Second V/F invalid

* The above parameters can be set when Pr. 160 User group read selection = "0". (Refer to page 167)

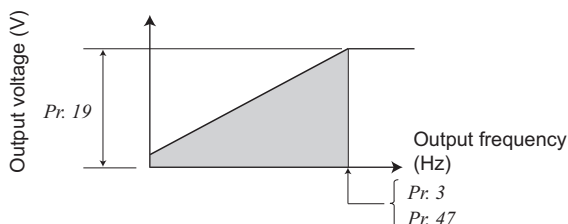

(1) Base frequency setting (Pr. 3)

- When operating a standard motor, generally set the rated frequency of the motor to Pr. 3 Base frequency. When running the motor using commercial power supply-inverter switch-over operation, set Pr. 3 to the same value as the power supply frequency.
- If the frequency given on the motor rating plate is "50Hz" only, always set to "50Hz". Leaving the base frequency unchanged from "60Hz" may make the voltage too low and the torque insufficient. It may result in an inverter trip due to overload. Special care must be taken when "1" (variable torque load) is set in Pr. 14 Load pattern selection .
- When using the Mitsubishi constant-torque motor, set Pr. 3 to 60Hz.

(2) Set two kinds of base frequencies (Pr. 47)

- When you want to change the base frequency when switching two types of motors with one inverter, use the Pr. 47 Second V/F (base frequency).
- Pr. 47 Second V/F (base frequency) is valid when the RT signal is ON.



REMARKS

- The RT signal acts as the second function selection signal and makes the other second functions valid. (Refer to page 143)

(3) Base frequency voltage setting (Pr. 19)

- Use Pr. 19 Base frequency voltage to set the base voltage (e.g. rated motor voltage).
- If the setting is less than the power supply voltage, the maximum output voltage of the inverter is as set in Pr. 19.
- Pr. 19 can be utilized in the following cases.
 - (a) When regeneration is high (e.g. continuous regeneration)

During regeneration, the output voltage becomes higher than the reference and may cause an overcurrent trip (E.OC□) due to an increased motor current.
 - (b) When power supply voltage variation is large

When the power supply voltage exceeds the rated voltage of the motor, speed variation or motor overheating may be caused by excessive torque or increased motor current.







NOTE

- When Advanced magnetic flux vector control or General-purpose magnetic flux vector control is selected, Pr. 3, Pr. 47 and Pr. 19 are invalid and Pr. 83 and Pr. 84 are valid.
Note that Pr. 3 or Pr. 47 value is made valid as inflection points of S-pattern when Pr. 29 Acceleration/deceleration pattern selection = "1" (S-pattern acceleration/deceleration A).



Parameters referred to

- Pr. 14 Load pattern selection  Refer to page 109
- Pr. 29 Acceleration/deceleration pattern selection  Refer to page 120
- Pr. 83 Rated motor voltage, Pr. 84 Rated motor frequency  Refer to page 127
- General-purpose magnetic flux vector control  Refer to page 98
- Advanced magnetic flux vector control  Refer to page 95

5.6.2 Load pattern selection (Pr. 14)

You can select the optimum output characteristic (V/F characteristic) for the application and load characteristics.

Parameter Number	Name	Initial Value	Setting Range	Description
14	Load pattern selection	0	0	For constant-torque load
			1	For variable torque load
			2	For constant-torque elevators (at reverse rotation boost of 0%)
			3	For constant-torque elevators (at forward rotation boost of 0%)

The above parameters can be set when Pr. 160 User group read selection = "0". (Refer to page 167)

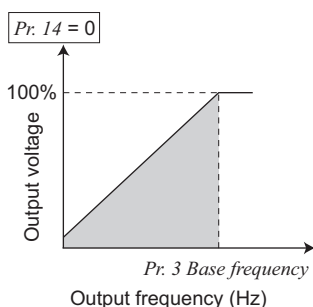

(1) Constant-torque load application (setting "0", initial value)

- At or less than the base frequency, the output voltage varies linearly with the output frequency.
- Set this value when driving the load whose load torque is constant even if the speed varies, e.g. conveyor, cart or roll drive.



POINT

If the load is a fan or pump, select for constant-torque load (setting "0") in any of the following cases.

- When a blower of large inertia moment (J) is accelerated in a short time
- For constant-torque load such as rotary pump or gear pump
- When load torque increases at low speed, e.g. screw pump

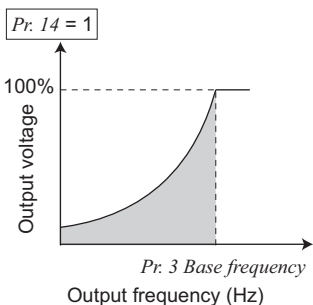

(2) Variable-torque load application (setting "1")

- At or less than the base frequency, the output voltage varies with the output frequency in a square curve.
- Set this value when driving the load whose load torque varies in proportion to the square of the speed, e.g. fan or pump.

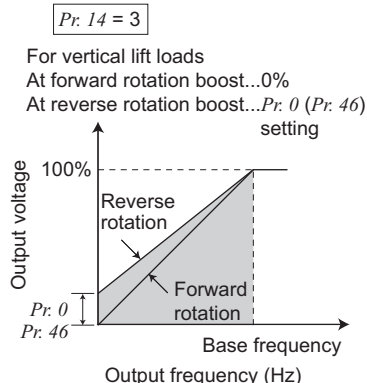
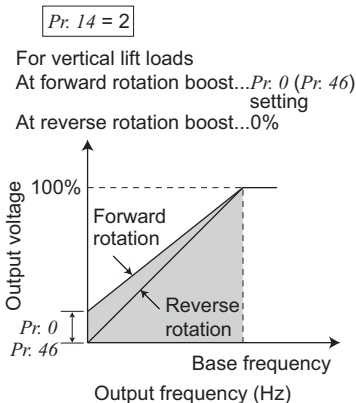

(3) Constant-torque load application (setting "2, 3")

- Set "2" when a vertical lift load is fixed as power driving load at forward rotation and regenerative load at reverse rotation.
- Pr. 0 Torque boost is valid during forward rotation and torque boost is automatically changed to "0%" during reverse rotation. Pr. 46 Second torque boost is valid when the RT signal turns ON.
- Set "3" for an elevated load that is in the driving mode during reverse rotation and in the regenerative load mode during forward rotation according to the load weight, e.g. counterweight system.



REMARKS

- When torque is continuously regenerated as vertical lift load, it is effective to set the rated voltage in *Pr. 19 Base frequency voltage* to prevent trip due to current at regeneration.
- In addition, when the RT signal is ON, the other second functions are also valid.





NOTE

- Load pattern selection does not function under Advanced magnetic flux vector control and General-purpose magnetic flux vector control.



Parameters referred to

Pr. 0, Pr. 46 (Torque boost)  Refer to page 94

Pr. 3 Base frequency  Refer to page 107

General-purpose magnetic flux vector control  Refer to page 98

Advanced magnetic flux vector control  Refer to page 95

5.7 Frequency setting by input signals

Purpose	Parameter that should be Set		Refer to Page
Make frequency setting by combination of input signals	Multi-speed operation	Pr. 4 to Pr. 6, Pr. 24 to Pr. 27	111
Infinitely variable speed setting by input signals	Remote setting function	Pr. 59	113

5.7.1 Operation by multi-speed operation (Pr. 4 to Pr. 6, Pr. 24 to Pr. 27)

Use these parameters to change the speed to pre-set speeds using the RH, RM and RL signals. Speeds can be pre-set using parameters.

A pre-set speed can be selected by simply turning ON/OFF the RH, RM and RL signals.

Parameter Number	Name	Initial Value	Setting Range	Description
4	Multi-speed setting (high speed)	60Hz	0 to 400Hz	Frequency when RH turns ON
5	Multi-speed setting (middle speed)	30Hz	0 to 400Hz	Frequency when RM turns ON
6	Multi-speed setting (low speed)	10Hz	0 to 400Hz	Frequency when RL turns ON
24 *	Multi-speed setting (speed 4)	9999	0 to 400Hz, 9999	Frequency from speed 4 to speed 7 can be set according to the combination of the RH, RM and RL signals. 9999: not selected
25 *	Multi-speed setting (speed 5)	9999	0 to 400Hz, 9999	
26 *	Multi-speed setting (speed 6)	9999	0 to 400Hz, 9999	
27 *	Multi-speed setting (speed 7)	9999	0 to 400Hz, 9999	

The above parameters allow their settings to be changed during operation in any operation mode even if "0" (initial value) is set in Pr. 77 Parameter write selection.

* These parameters can be set when Pr. 160 User group read selection = "0". (Refer to page 167)

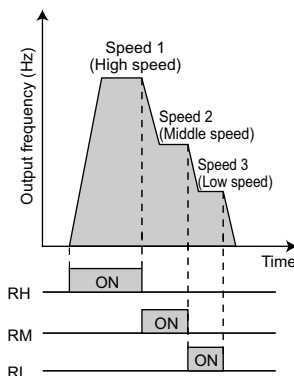

(1) Multi-speed setting for 3 speeds (Pr. 4 to Pr. 6)

- The inverter operates at frequencies set in Pr. 4 when RH signal is ON, Pr. 5 when RM signal is ON and Pr. 6 when RL signal is ON.

REMARKS

- For multi-speed setting, if two or three speeds are simultaneously selected, priority is given to the set frequency of the lower signal. For example, when the RH and RM signals turn ON, the RM signal (Pr. 5) has a higher priority.

(2) Multi-speed setting for 4 or more speeds (Pr. 24 to Pr. 27)

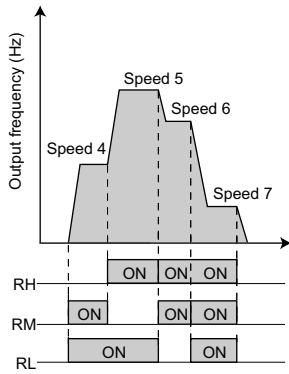

- Frequency from speed 4 to speed 7 can be set according to the combination of the RH, RM and RL signals. Set the running frequencies in Pr. 24 to Pr. 27 (In the initial value setting, speed 4 to speed 7 are invalid).



REMARKS

- Multi-speed setting using parameters is available even during PU operation.
- Pr. 24 to Pr. 27 settings have no priority among them.
- When Pr. 59 Remote function selection \neq "0", multi-speed setting is invalid as RH, RM and RL signals are remote setting signals.



Parameters referred to

Pr. 59 Remote function selection  Refer to page 113

5.7.2 Remote setting function (Pr. 59)

- Continuous variable-speed operation can be performed using acceleration and deceleration signals.
- By simply setting this parameter, you can use the acceleration, deceleration and setting clear functions of the motorized speed setter (FR-FK).

Parameter Number	Name	Initial Value	Setting Range	Description	
				RH, RM, RL signal function	Frequency setting storage function
59	Remote function selection	0	0	Multi-speed setting	—
			1	Remote setting	With
			2	Remote setting	Not used
			3	Remote setting	Not used (Turning STF/STR OFF clears remotely-set frequency.)

The above parameters can be set when Pr. 160 User group read selection = "0". (Refer to page 156)

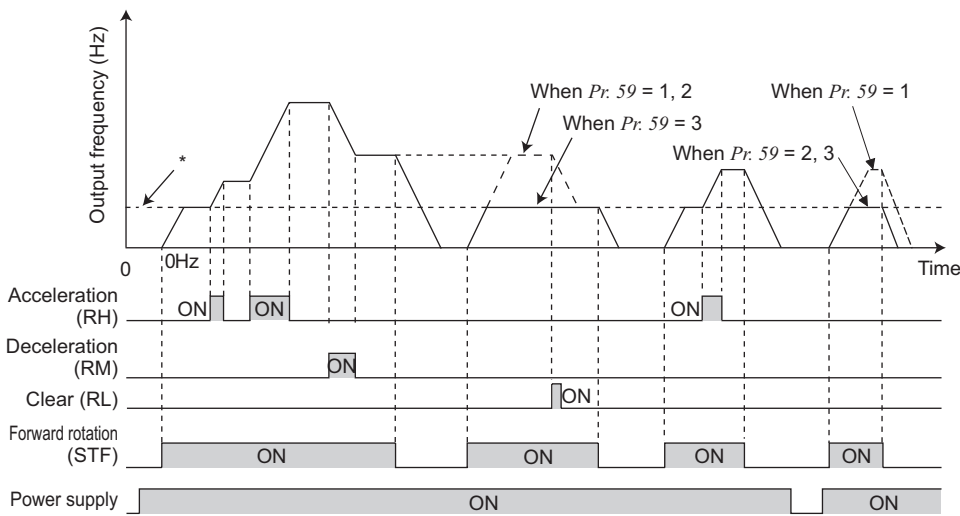

* FL remote communication operation frequency (other than multi-speed) or PU operation frequency

(1) Remote setting function

- Use Pr. 59 to select whether the remote setting function is used or not and whether the frequency setting storage function in the remote setting mode is used or not.
When Pr. 59 is set to any of "1 to 3" (remote setting function valid), the functions of the RH, RM and RL signals are changed to acceleration (RH), deceleration (RM) and clear (RL).
- When using the remote setting function, following frequencies can be compensated to the frequency set by RH and RM operation according to the operation mode.
During FL remote communication operation.....FL remote communication frequency command other than for multi-speed settings
During PU operation.....PU operation frequency

(2) Frequency setting storage

- The frequency setting storage function stores the remotely-set frequency (frequency set by RH/RM operation) into the memory (EEPROM). When power is switched OFF once, then ON, operation is resumed with that output frequency value.
(Pr. 59 = 1)

<Frequency setting storage conditions>

Remote setting frequency is saved in the following timings:

- When the start signal (STF or STR) turns OFF
- Every minute after turning OFF (ON) the RH (acceleration) and RM (deceleration) signals together. (The frequency is overwritten if the latest frequency is different from the previous frequency when comparing the two. The state of the RL signal does not affect writing.)
- When the power supply changes to the 24V external power supply while the start signal (STF or STR) is ON. (When the operation panel indication shows "EV.")



NOTE

- The range of frequency changeable by RH (acceleration) and RM (deceleration) is 0 to maximum frequency (Pr. 1 or Pr. 18 setting). Note that the maximum value of set frequency is (main speed + maximum frequency).

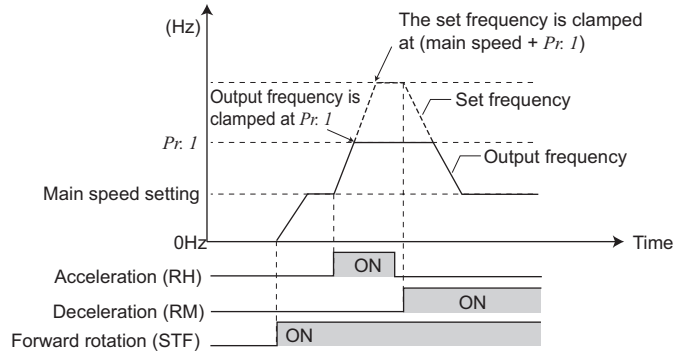

- When the acceleration or deceleration signal switches ON, acceleration/deceleration time is as set in Pr. 44 Second acceleration/deceleration time and Pr. 45 Second deceleration time. Note that when the time set in Pr. 7 or Pr. 8 is longer than the time set in Pr. 44 or Pr. 45, the acceleration/deceleration time is as set in Pr. 7 or Pr. 8. (when RT signal is OFF) When the RT signal is ON, acceleration/deceleration is made in the time set in Pr. 44 and Pr. 45, regardless of the Pr. 7 or Pr. 8 setting.
- Even if the start signal (STF or STR) is OFF, turning ON the acceleration (RH) or deceleration (RM) signal varies the preset frequency.
- When switching the start signal from ON to OFF, or changing frequency by the RH or RM signal frequently, set the frequency setting value storage function (write to EEPROM) invalid (Pr. 59 = "2, 3"). If set valid (Pr. 59 = "1"), frequency is written to EEPROM frequently, this will shorten the life of the EEPROM.

REMARKS

During Jog operation, the remote setting function is invalid.

Setting frequency is "0"

- Even when the remotely-set frequency is cleared by turning ON the RL (clear) signal after turn OFF (ON) of both the RH and RM signals, the inverter operates at the remotely-set frequency stored in the last operation if power is reapplied before one minute has elapsed since turn OFF (ON) of both the RH and RM signals
- When the remotely-set frequency is cleared by turning ON the RL (clear) signal after turn OFF (ON) of both the RH and RM signals, the inverter operates at the frequency in the remotely-set frequency cleared state if power is reapplied after one minute has elapsed since turn OFF (ON) of both the RH and RM signals.

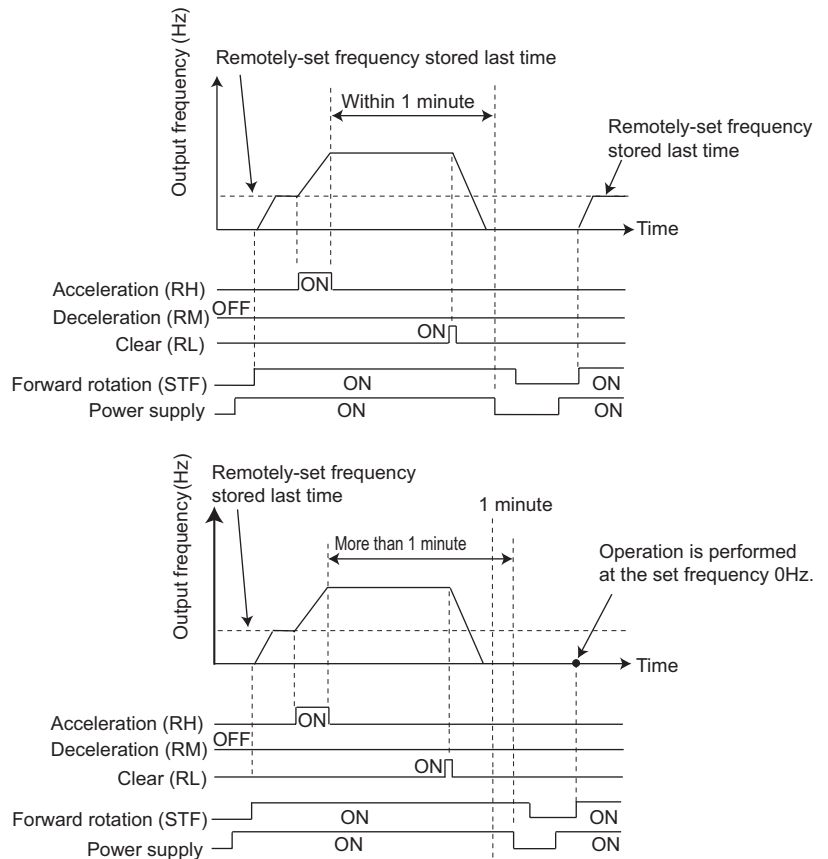

CAUTION
 When selecting this function, re-set the maximum frequency according to the machine.

Parameters referred to

Pr. 1 Maximum frequency, Pr. 18 High speed maximum frequency Refer to page 105
 Pr. 7 Acceleration time, Pr. 8 Deceleration time, Pr. 44 Second acceleration/deceleration time, Pr. 45 Second deceleration time Refer to page 116

5.8 Setting of acceleration/deceleration time and acceleration/ deceleration pattern

Purpose	Parameter that should be Set	Refer to Page
Motor acceleration/deceleration time setting	Acceleration/deceleration times Pr. 7, Pr. 8, Pr. 20, Pr. 21, Pr. 44, Pr. 45, Pr. 147	116
Starting frequency	Starting frequency and start-time hold Pr. 13, Pr. 571	119
Set acceleration/deceleration pattern suitable for application	Acceleration/deceleration pattern Pr. 29	120
Automatically set optimum acceleration/deceleration time	Automatic acceleration/ deceleration Pr. 61 to Pr. 63, Pr. 292	121

5.8.1 Setting of the acceleration and deceleration time (Pr. 7, Pr. 8, Pr. 20, Pr. 21, Pr. 44, Pr. 45, Pr. 147)

Used to set motor acceleration/deceleration time.

Set a larger value for a slower speed increase/decrease or a smaller value for a faster speed increase/decrease.

For the acceleration time at automatic restart after instantaneous power failure, refer to *Pr. 611 Acceleration time at a restart (page 151)*.

Parameter Number	Name	Initial Value	Setting Range	Description	
7	Acceleration time	3.7K or lower	5s	0 to 3600/ 360s *2 Motor acceleration time.	
		5.5K, 7.5K	10s		
		11K, 15K	15s		
8	Deceleration time	3.7K or lower	5s	0 to 3600/ 360s *2 Motor deceleration time.	
		5.5K, 7.5K	10s		
		11K, 15K	15s		
20 *1	Acceleration/ deceleration reference frequency	60Hz	1 to 400Hz	Frequency that will be the basis of acceleration/deceleration time. As acceleration/deceleration time, set the frequency change time from stop to <i>Pr. 20</i> .	
21 *1	Acceleration/ deceleration time increments	0	0	Increments: 0.1s Range: 0 to 3600s	Increments and setting range of acceleration/ deceleration time setting can be changed.
			1	Increments: 0.01s Range: 0 to 360s	
44 *1	Second acceleration/ deceleration time	3.7K or lower	5s	0 to 3600/ 360s *2 Acceleration/deceleration time when the RT signal is ON.	
		5.5K, 7.5K	10s		
		11K, 15K	15s		
45 *1	Second deceleration time	9999	0 to 3600/ 360s *2	Deceleration time when the RT signal is ON.	
			9999	Acceleration time = deceleration time	
147*1	Acceleration/ deceleration time switching frequency	9999	0 to 400Hz	Frequency when automatically switching to the acceleration/deceleration time of <i>Pr. 44</i> and <i>Pr. 45</i> .	
			9999	No function	

*1 The above parameters can be set when *Pr. 160 User group read selection* = "0". (Refer to page 167)

*2 Depends on the *Pr. 21 Acceleration/deceleration time increments* setting. The initial value for the setting range is "0 to 3600s" and the setting increments is "0.1s".

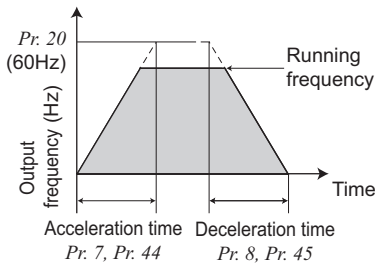

(1) Acceleration time setting (Pr. 7, Pr. 20)

- Use Pr. 7 Acceleration time to set the acceleration time required to reach Pr. 20 Acceleration/deceleration reference frequency from 0Hz.
- Set the acceleration time according to the following formula.

$$\text{Acceleration time setting} = \frac{\text{Pr. 20}}{\text{Maximum operating frequency} - \text{Pr. 13}} \times \text{Acceleration time from a stop to the maximum operating frequency}$$

Example) How to find the setting value for Pr.7 when increasing the output frequency to the maximum frequency of 50Hz in 10s with Pr.20 = "60Hz (initial setting)" and Pr. 13 = "0.5Hz (initial setting)."

$$\text{Pr. 7} = \frac{60\text{Hz}}{50\text{Hz} - 0.5\text{Hz}} \times 10\text{s} \doteq 12.1\text{s}$$

(2) Deceleration time setting (Pr. 8, Pr. 20)

- Use Pr. 8 Deceleration time to set the deceleration time required to reach 0Hz from Pr. 20 Acceleration/deceleration reference frequency.
- Set the deceleration time according to the following expression.

$$\text{Deceleration time setting} = \frac{\text{Pr. 20}}{\text{Maximum operating frequency} - \text{Pr. 10}} \times \text{Deceleration time from the maximum operating frequency to a stop}$$

Example) How to find the setting value for Pr.8 when decreasing the output frequency from the maximum frequency of 50Hz in 10s with Pr.20 = "120Hz" and Pr. 10 = "3Hz (initial setting)."

$$\text{Pr. 8} = \frac{120\text{Hz}}{50\text{Hz} - 3\text{Hz}} \times 10\text{s} \doteq 25.5\text{s}$$

(3) Change the setting range and increments of the acceleration/deceleration time (Pr. 21)

- Use Pr. 21 to set the acceleration/deceleration time and minimum setting range.
 Value "0" (initial value)0 to 3600s (minimum setting increments: 0.1s)
 Value "1"0 to 360s (minimum setting increments: 0.01s)



NOTE

- Changing the Pr. 21 setting changes the acceleration/deceleration time setting (Pr. 7, Pr. 8, Pr. 16, Pr. 44, Pr. 45). (It does not influence the setting of Pr. 611 Acceleration time at a restart.)

<Example>

When Pr. 7 is set to "5.0s" at Pr. 21 setting of "0", and then Pr. 21 is changed to "1", the Pr. 7 setting automatically changes to "0.5s".

Setting of acceleration/deceleration time and acceleration/ deceleration pattern

(4) Set two kinds of acceleration/deceleration times (RT signal, Pr. 44, Pr. 45, Pr. 147)

- Pr. 44 and Pr. 45 are valid when the RT signal is ON, or the output frequency reaches or exceeds the setting of Pr. 147.
- When "9999" is set to Pr. 45, the deceleration time becomes equal to the acceleration time (Pr. 44).
- Acceleration/deceleration time changes when the RT signal turns ON or when the output frequency reaches the Pr.147 setting or higher.

Pr. 147 Setting	Acceleration/Deceleration Time	Description
9999 (initial value)	Pr. 7, Pr. 8	No automatic switching of the acceleration/deceleration time
0.00Hz	Pr. 44, Pr. 45	Second acceleration/deceleration time from a start
0.00Hz ≤ Pr. 147 ≤ Set frequency	Output frequency < Pr. 147: Pr. 7, Pr. 8 Pr. 147 ≤ Output frequency: Pr. 44, Pr. 45	Acceleration/deceleration time automatic switching *
Set frequency < Pr. 147	Pr. 7, Pr. 8	No automatic switching, since output frequency will not reach the switching frequency

* When the RT signal turns on, the acceleration/deceleration time switches to the second acceleration/deceleration time even when the output frequency is not reached to Pr. 147 setting.

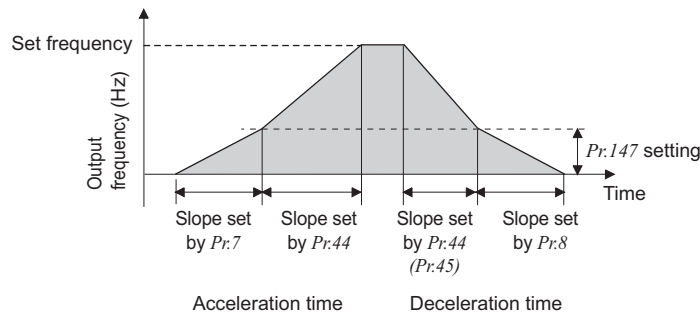

NOTE

- When the acceleration/deceleration pattern is S-pattern acceleration/deceleration A (refer to page 120), the acceleration/ deceleration time is the time required to reach Pr. 3 Base frequency .
- Acceleration/deceleration time formula when the set frequency is the base frequency or higher

$$t = \frac{4}{9} \times \frac{T}{(Pr. 3)^2} \times f^2 + \frac{5}{9} T$$

T: Acceleration/deceleration time setting (s)
f: Set frequency (Hz)

- Guideline for acceleration/deceleration time at the Pr. 3 Base frequency of 60Hz (0Hz to set frequency)

Frequency setting (Hz)	60	120	200	400
Acceleration/ deceleration time (s)				
5	5	12	27	102
15	15	35	82	305



REMARKS

- The RT signal acts as the second function selection signal and makes the other second functions valid. (Refer to page 143)
- When the Pr. 7, Pr. 8, Pr. 44 and Pr. 45 settings are 0.03s or less, the acceleration/deceleration time is 0.04s. At that time, set Pr. 20 to "120Hz" or less.
- Any value can be set to the acceleration/deceleration time but the actual motor acceleration/deceleration time cannot be made shorter than the shortest acceleration/deceleration time determined by the mechanical system J (moment of inertia) and motor torque.



Parameters referred to

Pr. 3 Base frequency Refer to page 107

Pr. 10 DC injection brake operation frequency Refer to page 135

Pr. 29 Acceleration/deceleration pattern selection Refer to page 120

5.8.2 Starting frequency and start-time hold function (Pr. 13, Pr. 571)

You can set the starting frequency and hold the set starting frequency for a certain period of time. Set these functions when you need the starting torque or want to smooth motor drive at a start.

Parameter Number	Name	Initial Value	Setting Range	Description
13	Starting frequency	0.5Hz	0 to 60Hz	Frequency at start can be set in the range 0 to 60Hz. Starting frequency at which the start signal is turned ON.
571	Holding time at a start	9999	0.0 to 10.0s	Holding time of Pr. 13 Starting frequency.
			9999	Holding function at a start is invalid

The above parameters can be set when Pr. 160 User group read selection = "0". (Refer to page 167)

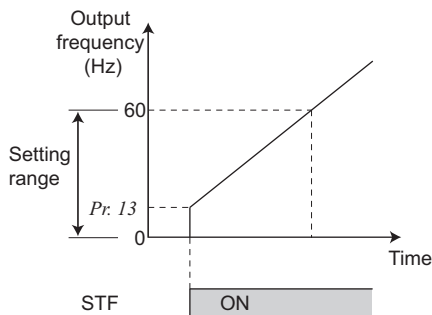

(1) Starting frequency setting (Pr. 13)

- Frequency at start can be set in the range 0 to 60Hz.
- You can set the starting frequency at which the start signal is turned ON.



NOTE

The inverter will not start if the frequency setting signal is less than the value set in Pr. 13. For example, when 5Hz is set in Pr. 13, the motor will not start running until the frequency setting signal reaches 5Hz.

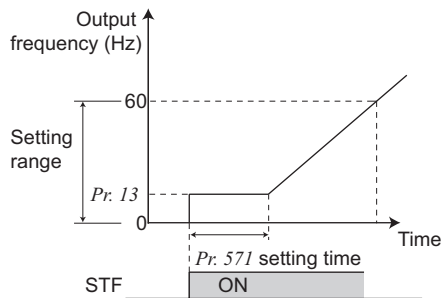

(2) Start-time hold function (Pr. 571)

- This function holds during the period set in Pr. 571 and the output frequency set in Pr. 13 Starting frequency.
- This function performs initial excitation to smooth the motor drive at a start.



REMARKS

When Pr. 13 = "0Hz", the starting frequency is held at 0.01Hz.



NOTE

- When the start signal was turned OFF during start-time hold, deceleration is started at that point.
- At switching between forward rotation and reverse rotation, the starting frequency is valid but the start-time hold function is invalid.



CAUTION

Note that when Pr. 13 is set to any value equal to or lower than Pr. 2 Minimum frequency, simply turning ON the start signal will run the motor at the preset frequency even if the command frequency is not input.



Parameters referred to

Pr. 2 Minimum frequency Refer to page 105

5.8.3 Acceleration/deceleration pattern (Pr. 29)

You can set the acceleration/deceleration pattern suitable for application.

Parameter Number	Name	Initial Value	Setting Range	Description
29	Acceleration/deceleration pattern selection	0	0	Linear acceleration/ deceleration
			1	S-pattern acceleration/deceleration A
			2	S-pattern acceleration/deceleration B

The above parameters can be set when Pr. 160 User group read selection = "0". (Refer to page 167)

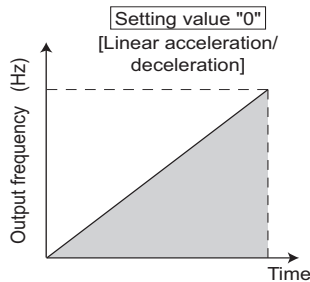

(1) Linear acceleration/deceleration (Pr. 29 = "0", initial value)

- For the inverter operation, the output frequency is made to change linearly (linear acceleration/deceleration) to prevent the motor and inverter from excessive stress to reach the set frequency during acceleration, deceleration, etc. when frequency changes. Linear acceleration/deceleration has a uniform frequency/time slope.

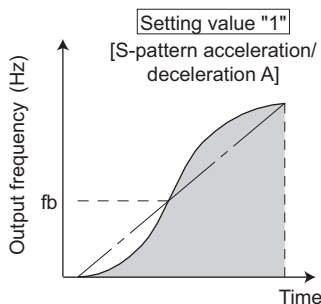

(2) S-pattern acceleration/deceleration A (Pr. 29 = "1")

- For machine tool spindle applications, etc. Used when acceleration/deceleration must be made in a short time to a high-speed range of not lower than the base frequency. In this acceleration/deceleration pattern, Pr. 3 Base frequency (fb) is the inflection point of the S pattern and you can set the acceleration/deceleration time appropriate for motor torque reduction in a constant-power operation range of base frequency (fb) or higher.



NOTE

- As the acceleration/deceleration time of S-pattern acceleration/deceleration A, set the time taken until Pr. 3 Base frequency is reached, not Pr. 20 Acceleration/deceleration reference frequency.

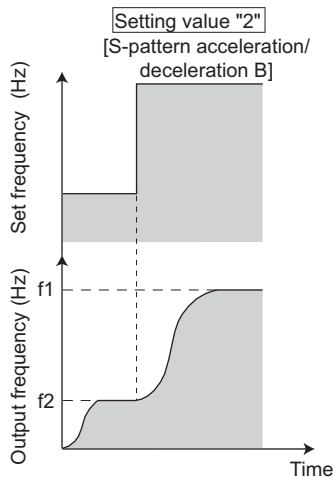

(3) S-pattern acceleration/deceleration B (Pr. 29 = "2")

- For prevention of load shifting in conveyor and other applications. Since acceleration/deceleration is always made in an S shape from current frequency (f2) to target frequency (f1), this function eases shock produced at acceleration/deceleration and is effective for load collapse prevention, etc.



Parameters referred to

Pr. 3 Base frequency Refer to page 107

Pr. 7 Acceleration time, Pr. 8 Deceleration time, Pr. 20 Acceleration/deceleration reference frequency Refer to page 116

5.8.4 Shortest acceleration/deceleration (automatic acceleration/deceleration)
(Pr. 61 to Pr. 63, Pr. 292, Pr. 293)

The inverter operates in the same conditions as when appropriate values are set in each parameter even if acceleration/deceleration time and V/F pattern are not set. This function is useful when you just want to operate, etc. without fine parameter setting.

Parameter Number	Name	Initial Value	Setting Range	Description
61	Reference current	9999	0 to 500A	Set the reference current during shortest acceleration/deceleration.
			9999	Rated inverter output current value is reference
62	Reference value at acceleration	9999	0 to 200%	Set the limit value during shortest acceleration.
			9999	150% is a limit value
63	Reference value at deceleration	9999	0 to 200%	Set the limit value during shortest deceleration.
			9999	150% is a limit value
292	Automatic acceleration/ deceleration	0	0	Normal mode
			1	Shortest acceleration/deceleration (without brake)
			11	Shortest acceleration/deceleration (with brake)
			7, 8	For manufacturer setting. Do not set.
293	Acceleration/deceleration separate selection	0	0	Both acceleration and deceleration are made in the shortest acceleration/deceleration mode
			1	Only acceleration is made in the shortest acceleration/deceleration mode
			2	Only deceleration is made in the shortest acceleration/deceleration mode

The above parameters can be set when Pr. 160 User group read selection = "0". (Refer to page 167)

(1) Shortest acceleration/deceleration mode (Pr. 292 = "1, 11", Pr. 293)

- Set when you want to accelerate/decelerate the motor for the shortest time. It is desired to make acceleration/deceleration in a shorter time for a machine tool etc. but the design values of machine constants are unknown.
- Acceleration/deceleration speed is automatically adjusted at a start of acceleration/deceleration from the value of the setting value of Pr. 7 Acceleration time and Pr. 8 Deceleration time so that acceleration/deceleration is made with the maximum torque the inverter can output. (The setting values of Pr. 7 and Pr. 8 are not changed.)
- Either acceleration or deceleration can be made in the shortest time using Pr. 293 Acceleration/deceleration separate selection. When the setting value is "0" (initial value), both acceleration and deceleration can be made in the shortest time.
- Set "11" when an optional MRS type, MYS type brake resistor, high-duty brake resistor or brake unit is connected. Deceleration time can be further shortened.
- When the shortest/acceleration mode is selected, the stall prevention operation level during acceleration/deceleration from the value of becomes 150% (adjustable using Pr. 61 to Pr. 63). Setting of Pr. 22 Stall prevention operation level is used only during a constant speed operation.
- It is inappropriate to use for the following applications.
 - a) Machine with a large inertia such as a fan (more than 10 times). Since stall prevention operation will be activated for a long time, this type of machine may trip due to motor overloading, etc.
 - b) To perform operation with a constant acceleration/deceleration time.



REMARKS

- Even if automatic acceleration/deceleration mode has been selected, inputting the RT signal (second function selection) during an inverter stop will switch to the normal operation and give priority to the second function selection. Note that RT signal input is invalid even if RT signal is input during operation in the automatic acceleration/deceleration mode.
- Since acceleration/deceleration is made with the stall prevention operation being activated, the acceleration/deceleration speed always varies according to the load conditions.
- Note that when proper values are set in Pr. 7 and Pr. 8, acceleration/deceleration time may be shorter than selecting shortest acceleration/deceleration mode.

Setting of acceleration/deceleration time and acceleration/ deceleration pattern

(2) Adjustment of shortest acceleration/deceleration mode (Pr. 61 to Pr. 63)

•By setting the adjustment parameters Pr. 61 and Pr. 63, the application range can be made wider.

Parameter Number	Name	Setting Range	Description
61	Reference current	0 to 500A	For example, when the motor and inverter are different in capacity, set the rated motor current value. Set reference current (A) of the stall prevention operation level during acceleration/deceleration.
		9999 (initial value)	The rated inverter current is defined as reference.
62 63	Reference value at acceleration	0 to 200%	Set when it is desired to change the reference level of acceleration and deceleration. Set the stall prevention operation level (ratio to the current value of Pr. 61) during acceleration/deceleration.
	Reference value at deceleration		Stall prevention operation level is 150% for the shortest acceleration/ deceleration.



REMARKS

- Since the Pr. 61 to Pr. 63 settings automatically return to the initial value (9999) if the Pr. 292 setting is changed, set Pr. 292 first when you need to set Pr. 61 to Pr. 63.



Parameters referred to

Pr. 0 Torque boost  Refer to page 94

Pr. 7 Acceleration time, Pr. 8 Deceleration time  Refer to page 116

Pr. 22 Stall prevention operation level  Refer to page 101

5.9 Selection and protection of a motor

Purpose	Parameter that should be Set		Refer to Page
Motor protection from overheat	Electronic thermal O/L relay	Pr. 9, Pr. 51	123
Use the constant-torque motor	Applied motor	Pr. 71	125
The motor performance can be maximized for operation in magnetic flux vector control method.	Offline auto tuning	Pr. 71, Pr. 80 to Pr. 84, Pr. 90 to Pr. 94, Pr. 96, Pr. 859	127

5.9.1 Motor overheat protection (Electronic thermal O/L relay) (Pr. 9, Pr. 51)

Set the current of the electronic thermal relay function to protect the motor from overheat. This feature provides the optimum protective characteristics, including reduced motor cooling capability, at low speed.

Parameter Number	Name	Initial Value	Setting Range	Description
9	Electronic thermal O/L relay	Inverter rated current *1	0 to 500A	Set the rated motor current.
51*2	Second electronic thermal O/L relay	9999	0 to 500A	Valid when the RT signal is ON. Set the rated motor current.
			9999	Second electronic thermal O/L relay invalid

*1 The initial value of the 0.75K or lower is set to 85% of the rated inverter current.

*2 The above parameters can be set when Pr. 160 User group read selection = "0". (Refer to page 167)

(1) Electronic thermal O/L relay (Pr. 9)

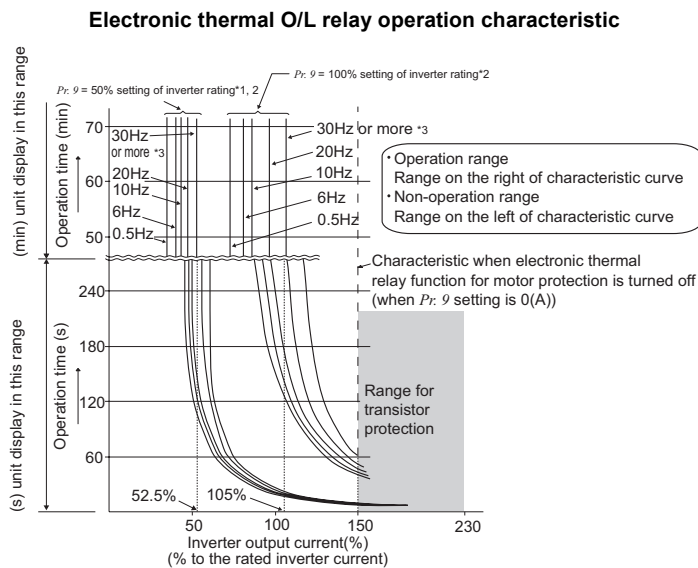

This function detects the overload (overheat) of the motor and trips. (The operation characteristic is shown on the left)

- Set the rated current (A) of the motor in Pr. 9. (If the motor has both 50Hz and 60Hz rating and the Pr. 3 Base frequency is set to 60Hz, set the 1.1 times of the 60Hz rated motor current.)
- Set "0" in Pr. 9 when you do not want to operate the electronic thermal O/L relay, e.g. when using an external thermal relay with the motor. (Note that the output transistor protection of the inverter functions (E.THT).)
- When using a Mitsubishi constant-torque motor
 - 1) Set "1" or "13 to 16", "50", "53", "54" in any of Pr. 71. (This provides a 100% continuous torque characteristic in the low-speed range.
 - 2) Set the rated current of the motor in Pr. 9.

*1 When 50% of the inverter rated output current (current value) is set to Pr. 9

*2 The % value denotes the percentage to the inverter rated output current. It is not the percentage to the motor rated current.

*3 When you set the electronic thermal O/L relay dedicated to the Mitsubishi constant-torque motor, this characteristic curve applies to operation at 6Hz or higher.



NOTE

- Fault by electronic thermal relay function is reset by inverter power reset and reset signal input. Avoid unnecessary reset and power-OFF.
- When multiple motors are operated by a single inverter, protection cannot be provided by the electronic thermal function. Install an external thermal relay to each motor.
- When the difference between the inverter and motor capacities is large and the setting is small, the protective characteristics of the electronic thermal relay function will be deteriorated. In this case, use an external thermal relay.
- A special motor cannot be protected by the electronic thermal relay function.
- The operation time of the transistor protection thermal shortens when the Pr. 72 PWM frequency selection setting increases.
- Electronic thermal relay may not function when 5% or less of inverter rated current is set to electronic thermal relay setting.

(2) Set two different electronic thermal O/L relays (Pr. 51)

Use this function when running two motors of different rated currents individually by a single inverter. (When running two motors together, use external thermal relays.)

- Set the rated current of the second motor to Pr. 51.
- When the RT signal is ON, thermal protection is provided based on the Pr. 51 setting.

Pr. 450 Second applied motor	Pr. 9 Electronic thermal O/L relay	Pr. 51 Second electronic thermal O/L relay	RT = OFF		RT = ON	
			First motor	Second motor	First motor	Second motor
9999	0	9999	×	×	×	×
		0	×	×	×	×
		0.01 to 500	×	Δ	×	○
9999	Other than 0	9999	○	×	○	×
		0	○	×	Δ	×
		0.01 to 500	○	Δ	Δ	○
Other than 9999	0	9999	×	×	×	×
		0	×	×	×	×
		0.01 to 500	×	Δ	×	○
Other than 9999	Other than 0	9999	○	Δ	Δ	○
		0	○	×	Δ	×
		0.01 to 500	○	Δ	Δ	○

- ... Output current value is used to perform integration processing.
- Δ ... Output current is assumed as 0A to perform integration processing. (cooling processing)
- × ... Electronic thermal relay function is not activated.

REMARKS

- The RT signal acts as the second function selection signal and makes the other second functions valid. (Refer to page 143)

(3) Electronic thermal relay function prealarm (TH)

100%: Electronic thermal O/L relay alarm operation value

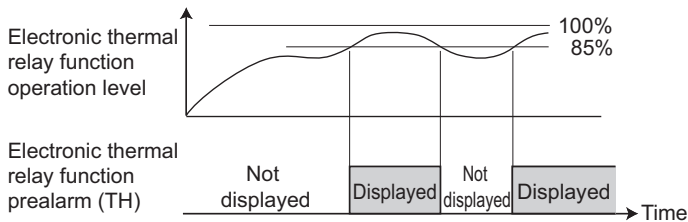

- The electronic thermal relay function prealarm (TH) is displayed when the electronic thermal O/L relay cumulative value reaches 85% of the level set in Pr. 9 or Pr. 51. If it reaches 100% of the Pr. 9 Electronic thermal O/L relay setting, a motor overload trip (E.THM/E.THT) occurs.

Parameters referred to

- Pr. 71 Applied motor Refer to page 125
- Pr. 72 PWM frequency selection Refer to page 163

5.9.2 Applied motor (Pr. 71, Pr. 450)

Setting of the used motor selects the thermal characteristic appropriate for the motor.

Setting is required to use a constant-torque motor. Thermal characteristic of the electronic thermal relay function suitable for the motor is set.

When General-purpose magnetic flux vector or Advanced magnetic flux vector control is selected, the motor constants (SF-JR, SF-HR, SF-JRCA, SF-HRCA, etc.) necessary for control are selected as well.

Parameter Number	Name	Initial Value	Setting Range	Description
71	Applied motor	0	0, 1, 3 to 6, 13 to 16, 23, 24, 40, 43, 44, 50, 53, 54	Selecting the standard motor or constant-torque motor sets the corresponding motor thermal characteristic.
450	Second applied motor	9999	0, 1	Set when using the second motor.
			9999	Second motor is invalid (thermal characteristic of the first motor (Pr. 71))

The above parameters can be set when Pr. 160 User group read selection = "0". (Refer to page 167)

(1) Set the motor to be used

Refer to the following list and set this parameter according to the motor used.

Pr. 71 (Pr. 450) Setting		Thermal Characteristic of the Electronic Thermal Relay Function	Motor (O: Used motor)	
Pr. 71	Pr. 450		Standard (SF-JR, etc.)	Constant-torque (SF-JRCA, etc.)
0 (Pr. 71 initial value)		Thermal characteristics of a standard motor	○	
1		Thermal characteristics of the Mitsubishi constant-torque motor		○
40	—	Thermal characteristic of Mitsubishi high efficiency motor (SF-HR)	○ *1	
50	—	Thermal characteristic of Mitsubishi constant-torque motor (SF-HRCA)		○ *2
3	—	Standard motor	○	
13	—	Constant-torque motor		○
23	—	Mitsubishi standard motor (SF-JR 4P 1.5kW or less)	Select "Offline auto tuning setting"	
43	—	Mitsubishi high efficiency motor (SF-HR)		
53	—	Mitsubishi constant-torque motor (SF-HRCA)		
4	—	Standard motor		
14	—	Constant-torque motor	Auto tuning data can be read, changed, and set.	
24	—	Mitsubishi standard motor (SF-JR 4P 1.5kW or less)		
44	—	Mitsubishi high efficiency motor (SF-HR)		
54	—	Mitsubishi constant-torque motor (SF-HRCA)		
5	—	Standard motor	Star connection	Direct input of motor constants is enabled
15	—	Constant-torque motor		
6	—	Standard motor		
16	—	Constant-torque motor	Delta connection	
—	9999 (initial value)	Without second applied motor		

*1 Motor constants of Mitsubishi high efficiency motor SF-HR.

*2 Motor constants of Mitsubishi constant-torque motor SF-HRCA.



REMARKS

- When performing offline auto tuning, set any of "3, 13, 23, 43, 53" in Pr. 71. (Refer to page 127 for offline auto tuning.)
- For the 5.5K and 7.5K, the Pr. 0 Torque boost and Pr. 12 DC injection brake operation voltage settings are automatically changed according to the Pr. 71 setting as follows.

Automatic Change Parameter	Standard Motor Setting *1	Constant-torque Motor Setting *2
Pr. 0	3%	2%
Pr. 12	4%	2%

*1 Pr. 71 setting: 0, 3 to 6, 23, 24, 40, 43, 44

*2 Pr. 71 setting: 1, 13 to 16, 50, 53, 54



NOTE

- Set the electronic thermal relay function to the thermal characteristic for the constant-torque motor when using a geared motor (GM-S, GM-D, GM-SY, GM-HY2 series) to perform Advanced magnetic flux vector control or General-purpose magnetic-flux vector control.

(2) Use two motors (Pr. 450)

- Set Pr. 450 *Second applied motor* to use two different motors with one inverter.
- When "9999" (initial value) is set, no function is selected.
- When a value other than 9999 is set in Pr. 450, the second motor is valid when the RT signal turns ON.



REMARKS

- The RT signal acts as the second function selection signal and makes the other second functions valid. (Refer to page 143)



CAUTION





**Make sure to set this parameter correctly according to the motor used.
Incorrect setting may cause the motor to overheat and burn.**





Parameters referred to

Pr. 0 Torque boost  Refer to page 94

Pr. 12 DC injection brake operation voltage  Refer to page 135

Pr. 80 Motor capacity, Pr. 81 Number of motor poles  Refer to page 127

Pr. 82 to Pr. 84, Pr. 90 to Pr. 94 (motor constants), Pr. 96 Auto tuning setting/status  Refer to page 127

Pr. 800 Control method selection  Refer to page 93

5.9.3 Exhibiting the best performance for the motor (offline auto tuning)
 (Pr. 71, Pr. 80 to Pr. 84, Pr. 90 to Pr. 94, Pr. 96, Pr. 859)

The motor performance can be maximized with offline auto tuning.

●What is offline auto tuning?

When performing Advanced magnetic flux vector control or General-purpose magnetic flux vector control, the motor can be run with the optimum operating characteristics by automatically measuring the motor constants (offline auto tuning) even when each motor constants differs, other manufacturer's motor is used, or the wiring length is long (30m or more as a reference).

Parameter Number	Name	Initial Value		Setting Range	Description
71	Applied motor	0		0, 1, 3 to 6, 13 to 16, 23, 24, 40, 43, 44, 50, 53, 54	By selecting a standard motor or constant-torque motor, thermal characteristic and motor constants of each motor are set.
80	Motor capacity	9999		0.1 to 15kW	Applied motor capacity.
		9999		9999	V/F control
81	Number of motor poles	9999		2, 4, 6, 8, 10	Number of motor poles.
		9999		9999	V/F control
82	Motor excitation current	9999		0 to 500A	Tuning data (The value measured by offline auto tuning is automatically set.)
		9999		9999	Uses the Mitsubishi motor (SF-JR, SF-HR, SF-JRCA, SF-HRCA) constants.
83	Rated motor voltage	200V class	200V	0 to 1000V	Rated motor voltage (V).
		400V class	400V		
84	Rated motor frequency	60Hz		10 to 120Hz	Rated motor frequency (Hz).
90	Motor constant (R1)	9999		0 to 50Ω, 9999	Tuning data (The value measured by offline auto tuning is automatically set.) 9999: Uses the Mitsubishi motor (SF-JR, SF-HR, SF-JRCA, SF-HRCA) constants.
91	Motor constant (R2)	9999		0 to 50Ω, 9999	
92	Motor constant (L1)	9999		0 to 1000mH, 9999	
93	Motor constant (L2)	9999		0 to 1000mH, 9999	
94	Motor constant (X)	9999		0 to 100%, 9999	
96	Auto tuning setting/status	0		0	Offline auto tuning is not performed
		0		1	For Advanced magnetic flux vector control Offline auto tuning is performed without motor running (all motor constants).
		0		11	For General-purpose magnetic flux vector control Offline auto tuning is performed without motor running. (motor constant (R1) only)
		0		21	Offline auto tuning for V/F control (automatic restart after instantaneous power failure (with frequency search)) (Refer to page 153)
859	Torque current	9999		0 to 500A	Tuning data (The value measured by offline auto tuning is automatically set.)
		9999		9999	Uses the Mitsubishi motor (SF-JR, SF-HR, SF-JRCA, SF-HRCA) constants.

The above parameters can be set when Pr. 160 User group read selection = "0". (Refer to page 167)

- The setting range and increments of *Pr. 82*, *Pr. 90* to *Pr. 94* and *Pr. 859* changes according to the setting value of *Pr. 71* and *Pr. 96*.

Applied Motor		Internal Stored Value *1		Direct Input Value *2		Auto Tuning Measured Value *3	
Parameter Number	Function Name	Setting Range	Setting Increments	Setting Range	Setting Increments	Setting Range	Setting Increments
82	Motor excitation current	0 to 500A, 9999	0.01A	0 to 500A, 9999	0.01A	0 to ****, 9999	1
90	Motor constant (R1)	0 to 50Ω, 9999	0.001Ω	0 to 50Ω, 9999	0.001Ω	0 to ****, 9999	1
91	Motor constant (R2)	0 to 50Ω, 9999	0.001Ω	0 to 50Ω, 9999	0.001Ω	0 to ****, 9999	1
92	Motor constant (L1)	0 to 1000mH, 9999	0.1mH	0 to 50Ω, 9999	0.001Ω	0 to ****, 9999	1
93	Motor constant (L2)	0 to 1000mH, 9999	0.1mH	0 to 50Ω, 9999	0.001Ω	0 to ****, 9999	1
94	Motor constant (X)	0 to 100%, 9999	0.1%	0 to 500Ω, 9999	0.01Ω	0 to ****, 9999	1
859	Torque current	0 to 500A, 9999	0.01A	0 to 500A, 9999	0.01A	0 to ****, 9999	1

*1 When *Pr. 71* = "0, 1, 40 or 50", or setting value of *Pr. 96* read after performing offline auto tuning is not "3, 13, 23".

*2 When *Pr. 71* = "5, 6, 15, or 16"

*3 When *Pr. 71* = "3, 13, 23, 43 or 53" and setting value of *Pr. 96* read after performing offline auto tuning is "3, 13, 23". Or when *Pr. 71* = "4, 14, 24, 44 or 54".



POINT

- This function is valid only when a value other than "9999" is set in *Pr. 80* and *Pr. 81* and Advanced magnetic flux vector control or General-purpose magnetic flux vector control is selected.
- Even when motors (other manufacturer's motor, SF-JRC, etc.) other than Mitsubishi standard motor (SF-JR 0.2kW or higher), high efficiency motor (SF-HR 0.2kW or higher), and Mitsubishi constant-torque motor (SF-JRCA four-pole, SF-HRCA 0.2kW to 15kW) are used or the wiring length is long (30m or more as a reference), using the offline auto tuning function runs the motor with the optimum operating characteristics.
- Tuning is enabled even when a load is connected to the motor.
As the motor may run slightly, fix the motor securely with a mechanical brake or make sure that there will be no problem in safety if the motor runs (caution is required especially in elevator). Note that tuning performance is unaffected even if the motor runs slightly.
- Reading/writing/copy of motor constants tuned by offline auto tuning are enabled.
- The offline auto tuning status can be monitored with the operation panel.
- Do not connect a surge voltage suppression filter (FR-ASF-H/FR-BMF-H) between the inverter and motor.

(1) Before performing offline auto tuning

Check the following before performing offline auto tuning.

- Make sure Advanced magnetic flux vector control or General-purpose magnetic flux vector control (*Pr. 80*, *Pr. 81*) is selected.
- A motor should be connected. Note that the motor should be at a stop at a tuning start.
- The motor capacity should be equal to or one rank lower than the inverter capacity. (note that the capacity should be 0.1kW or more)
- A high-slip motor, high-speed motor and special motor cannot be tuned. (The maximum frequency is 120Hz.)
- As the motor may run slightly, fix the motor securely with a mechanical brake or make sure that there will be no problem in safety if the motor runs (caution is required especially in elevator). Note that tuning performance is unaffected even if the motor runs slightly.
- Offline auto tuning will not be performed properly if it is performed with a surge voltage suppression filter (FR-ASF-H/FR-BMF-H) connected between the inverter and motor. Remove it before starting tuning.

(2) Setting

- 1) Select Advanced magnetic flux vector control (*Refer to page 95*) or General-purpose magnetic flux vector control (*Refer to page 98*).
- 2) Set "1" or "11" in *Pr. 96 Auto tuning setting/status*.
 - When the setting is "1" Tune all motor constants without running the motor.
 When performing Advanced magnetic flux vector control, set "1" to perform tuning.
 It takes approximately 25 to 75s* until tuning is completed.
 (Excitation noise is produced during tuning.)
 *Tuning time differs according to the inverter capacity and motor type.
 - When the setting is "11" Tune motor constants (R1) only without running the motor.
 When performing General-purpose magnetic flux vector control, set "11" to perform tuning.
 It takes approximately 9s until tuning is completed.
- 3) Set the rated motor current (initial value is rated inverter current) in *Pr. 9 Electronic thermal O/L relay*. (*Refer to page 123*)
- 4) Set the rated voltage of motor (initial value is 200V/400V) in *Pr. 83 Rated motor voltage* and rated motor frequency (initial value is 60Hz) in *Pr. 84 Rated motor frequency*.
 (For a Japanese standard motor, etc. which has both 50Hz and 60Hz rated values, use it with an initial value (200V/60Hz or 400V/60Hz).)
- 5) Set *Pr. 71 Applied motor* according to the motor used.

Motor		Pr. 71 Setting *1
Mitsubishi standard motor Mitsubishi high efficiency motor	SF-JR	3
	SF-JR 4P 1.5kW or less	23
	SF-HR	43
	Others	3
Mitsubishi constant-torque motor	SF-JRCA 4P	13
	SF-HRCA	53
	Others (SF-JRC, etc.)	13
Other manufacturer's standard motor	—	3
Other manufacturer's constant-torque motor	—	13



*1 Refer to page 125, for other settings of *Pr. 71*.

(3) Execution of tuning



POINT

Before performing tuning, check the monitor display of the operation panel if the inverter is in the status for tuning. (Refer to 3) below.) When the start command is turned ON under V/F control, the motor starts.







- 1) Set "1" in the X12 signal (Bit11), which gives a control input command through FL remote communication. Then, change the operation mode to the PU operation mode using  on the operation panel.
- 2) Press  on the operation panel. Tuning starts.
(When the Network operation mode is selected and "1" is set in the X12 signal (Bit 11), which gives a control input command through FL remote communication, the inverter output is shutoff. Therefore, inputting a start signal through FL remote communication does not start tuning in this condition.)



NOTE

- To force tuning to end, press  of the operation panel.
- X12 signal is the only valid input/output signal during the offline auto tuning.
Setting "0" in the X12 signal while tuning is being set or performed forces the operation mode to change to Network operation mode.
Use the X12 signal after setting "0" (stop command) in the forward/reverse rotation command (STF/STR signal) to set and perform tuning.
- When executing offline auto tuning, input the run command after switching on the main circuit power (R/L1, S/L2, T/L3) of the inverter.

3) Monitor is displayed on the operation panel during tuning as below.

	Operation Panel Indication	
Pr. 96 setting	1	11
(1) Setting		
(2) Tuning in progress		
(3) Normal end		
(4) Error end (when inverter protective function operation is activated)		



REMARKS

- Reference: Offline auto tuning time (when the initial value is set)

Offline Auto Tuning Setting	Time
Tune all motor constants (Pr. 96 = "1")	Approximately 25 to 75s (Tuning time differs according to the inverter capacity and motor type.)
Tune motor constants (R1) only (Pr. 96 = "11")	Approximately 9s

- The set frequency monitor displayed during the offline auto tuning is 0Hz.

- 4) When offline auto tuning ends, press  on the operation panel. This operation resets the offline auto tuning, and the monitor display of the operation panel returns to normal.
- 5) Set "0" in the X12 signal (Bit11), which gives a control input command through FL remote communication. Then, change the operation mode to Network operation mode.
- 6) If offline auto tuning ended in error (see the table below), motor constants are not set. Perform an inverter reset and restart tuning.

Error Display	Error Cause	Remedy
8	Forced end	Set "1" or "11" in <i>Pr. 96</i> and perform tuning again.
9	Inverter protective function operation	Make setting again.
91	Current limit (stall prevention) function was activated.	Set "1" in <i>Pr. 156</i> .
92	Converter output voltage reached 75% of rated value.	Check for fluctuation of power supply voltage.
93	Calculation error A motor is not connected.	Check the motor wiring and make setting again. Set the rated current of the motor in <i>Pr. 9</i> .

- 7) When tuning is ended forcibly by pressing  during tuning, offline auto tuning does not end properly. (The motor constants have not been set.)
Perform an inverter reset and restart tuning.
- 8) When the rated power specification of the motor is 200/220V(400/440V) 60Hz, set 1.1 times the rated motor current value in *Pr.9 Electronic thermal O/L relay* after tuning is completed.



NOTE

- Do not change the *Pr. 96* setting after completion of tuning (3 or 13). If the *Pr. 96* setting is changed, tuning data is invalid. If the *Pr. 96* setting is changed, tuning must be performed again.
- The motor constants measured once in the offline auto tuning are stored as parameters and their data are held until the offline auto tuning is performed again.
- An instantaneous power failure occurring during tuning will result in a tuning error. After power is restored, the inverter goes into the normal operation mode.
- Any alarm occurring during tuning is handled as in the ordinary mode. Note that if a fault retry has been set, retry is ignored.

 **CAUTION**

 As the motor may run slightly during offline auto tuning, fix the motor securely with a mechanical brake or make sure that there will be no problem in safety if the motor runs. Note that if the motor runs slightly, tuning performance is unaffected.

(4) Utilizing or changing offline auto tuning data for use

The data measured in the offline auto tuning can be read and utilized or changed.

<Operating procedure>

- 1) Set *Pr. 71* according to the motor used.

Motor		<i>Pr. 71</i> Setting *1
Mitsubishi standard motor	SF-JR	4
	SF-JR 4P 1.5kW or less	24
Mitsubishi high efficiency motor	SF-HR	44
	Others	4
Mitsubishi constant-torque motor	SF-JRCA 4P	14
	SF-HRCA	54
	Others (SF-JRC, etc.)	14
Other manufacturer's standard motor	-	4
Other manufacturer's constant-torque motor	-	14

*1 For other settings of *Pr.71*, refer to page 125.

- 2) In the parameter setting mode, read the following parameters and set desired values.

Parameter Number	Name	Setting Range	Setting Increments	Initial Value
82	Motor excitation current	0 to ****, 9999	1	9999
90	Motor constant (R1)	0 to ****, 9999	1	9999
91	Motor constant (R2)	0 to ****, 9999	1	9999
92	Motor constant (L1)	0 to ****, 9999	1	9999
93	Motor constant (L2)	0 to ****, 9999	1	9999
94	Motor constant (X)	0 to ****, 9999	1	9999
859	Torque current	0 to ****, 9999	1	9999



REMARKS

- When "9999" is set in *Pr. 82*, *Pr. 90* to *Pr. 94*, *Pr. 859*, Mitsubishi motor (SF-JR, SF-HR, SF-JRCA, SF-HRCA) constants are used.
- As the motor constants measured in the offline auto tuning have been converted into internal data (****), refer to the following setting example when making setting:

Setting example To slightly increase *Pr. 90* value (5%)

When *Pr. 90* is displayed as "2516",

set 2642 (2516 x 1.05=2641.8) in *Pr. 90*.

(The value displayed has been converted into a value for internal use. Hence, simple addition of a given value to the displayed value has no significance.)

(5) Method to set the motor constants without using the offline auto tuning data

The *Pr. 90* to *Pr. 94* motor constants may either be entered in [Ω] or in [mH]. Before starting operation, confirm which motor constant unit is used.

- To enter the *Pr. 90* to *Pr. 94* motor constants in [Ω]

<Operating procedure>

1) Set *Pr. 71* according to the motor used.

		Star Connection Motor	Delta Connection Motor
Setting	Standard motor	5	6
	Constant-torque motor	15	16

2) In the parameter setting mode, read the following parameters and set desired values.

I_q =torque current, I_{100} =rated current, I_0 =no load current

$$I_q = \sqrt{I_{100}^2 - I_0^2}$$

Parameter Number	Name	Setting Range	Setting Increments	Initial Value
82	Motor excitation current (no load current)	0 to 500A, 9999	0.01A	9999
90	Motor constant (r1)	0 to 50 Ω , 9999	0.001 Ω	9999
91	Motor constant (r2)	0 to 50 Ω , 9999	0.001 Ω	9999
92	Motor constant (x1)	0 to 50 Ω , 9999	0.001 Ω	9999
93	Motor constant (x2)	0 to 50 Ω , 9999	0.001 Ω	9999
94	Motor constant (xm)	0 to 500 Ω , 9999	0.01 Ω	9999
859	Torque current	0 to 500A, 9999	0.01A	9999

3) Refer to the following table and set *Pr. 83* and *Pr. 84*.

Parameter Number	Name	Setting Range	Setting Increments	Initial Value	
83	Rated motor voltage	0 to 1000V	0.1V	200V class	200V
				400V class	400V
84	Rated motor frequency	10 to 120Hz	0.01Hz	60Hz	



REMARKS

- When "9999" is set in *Pr. 82*, *Pr. 90* to *Pr. 94*, *Pr. 859*, Mitsubishi motor (SF-JR, SF-HR, SF-JRCA, SF-HRCA) constants are used.



NOTE

- If "star connection" is mistaken for "delta connection" or vice versa during setting of *Pr. 71*, Advanced magnetic flux vector control and General-purpose magnetic flux vector control cannot be exercised properly.

7 Selection and protection of a motor

● To enter the Pr. 90 to Pr. 94 motor constants in [mH]

<Operating procedure>

1) Set Pr. 71 according to the motor used.

Motor		Pr. 71 Setting *1
Mitsubishi standard motor	SF-JR	0
Mitsubishi high efficiency motor	SF-HR	40
Mitsubishi constant-torque motor	SF-JRCA 4P	1
	SF-HRCA	50

*1 For other settings of Pr. 71, refer to page 125.

2) In the parameter setting mode, read the following parameters and set desired values.

Calculate the Pr. 94 value from the following formula.

$$\text{Pr. 94 setting} = \left(1 - \frac{M^2}{L1 \times L2}\right) \times 100 (\%)$$

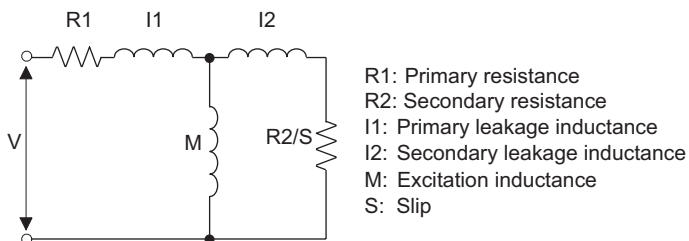

$$L1 = L1 + M: \text{ Primary inductance}$$

$$L2 = L2 + M: \text{ Secondary inductance}$$

Motor equivalent circuit diagram

Parameter Number	Name	Setting Range	Setting Increments	Initial Value
82	Motor excitation current (no load current)	0 to 500A, 9999	0.01A	9999
90	Motor constant (R1)	0 to 50Ω, 9999	0.001Ω	9999
91	Motor constant (R2)	0 to 50Ω, 9999	0.001Ω	9999
92	Motor constant (L1)	0 to 1000mH, 9999	0.1mH	9999
93	Motor constant (L2)	0 to 1000mH, 9999	0.1mH	9999
94	Motor constant (X)	0 to 100%, 9999	0.1%	9999
859	Torque current	0 to 500A, 9999	0.01A	9999

3) Refer to the following table and set Pr. 83 and Pr. 84.

Parameter Number	Name	Setting Range	Setting Increments	Initial Value	
83	Rated motor voltage	0 to 1000V	0.1V	200V class	200V
				400V class	400V
84	Rated Motor Frequency	10 to 120Hz	0.01Hz	60Hz	

REMARKS

- When "9999" is set in Pr. 82, Pr. 90 to Pr. 94, Pr. 859, Mitsubishi motor (SF-JR, SF-HR, SF-JRCA, SF-HRCA) constants are used.



Parameters referred to

Pr. 7 Acceleration time, Pr. 8 Deceleration time Refer to page 116

Pr. 9 Electronic thermal O/L relay Refer to page 123

Pr. 71 Applied motor Refer to page 125

Pr. 80 Motor capacity, Pr. 81 Number of motor poles Refer to page 93

Pr. 156 Stall prevention operation selection Refer to page 101

Pr. 800 Control method selection Refer to page 93

5.10 Motor brake and stop operation

Purpose	Parameter that should be Set		Refer to Page
Motor braking torque adjustment	DC Injection brake	Pr. 10 to Pr. 12	135
Improve the motor braking torque with an option	Selection of a regenerative brake	Pr. 30, Pr. 70	136
Coast the motor to a stop	Selection of motor stopping method	Pr. 250	138
Used to stop the motor with a mechanical brake (vibration restraint at stop-on-contact)	Stop-on-contact control	Pr. 6, Pr. 48, Pr. 270, Pr. 275, Pr. 276	139

5.10.1 DC injection brake (Pr. 10 to Pr. 12)

The DC injection brake can be operated at a motor stop to adjust the stop timing and braking torque. In DC injection brake operation, DC voltage is directly applied to the motor to prevent the motor shaft from rotating. The motor will not return to the original position if the motor shaft rotates due to external force.

Parameter Number	Name	Initial Value	Setting Range	Description
10	DC injection brake operation frequency	3Hz	0 to 120Hz	Operation frequency of the DC injection brake.
11	DC injection brake operation time	0.5s	0	DC injection brake disabled
			0.1 to 10s	Operation time of the DC injection brake.
12	DC injection brake operation voltage	0.1K, 0.2K	6%	DC injection brake voltage (torque). When "0" is set, DC injection brake is disabled.
		0.4K to 7.5K	4%	
		11K, 15K	2%	

The above parameters can be set when Pr. 160 User group read selection = "0". (Refer to page 167)

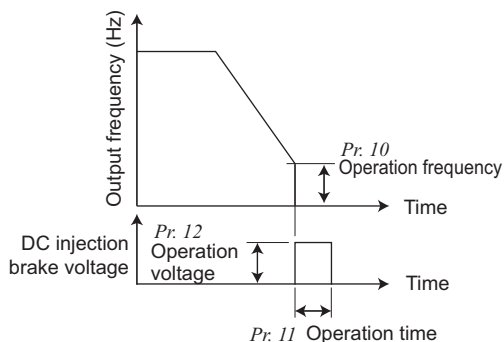

(1) Operation frequency setting (Pr. 10)

- When the frequency at which the DC injection brake will be operated is set to Pr. 10, the DC voltage is applied to the motor upon reaching to the set frequency during deceleration.

(2) Operation time setting (Pr. 11)

- In Pr. 11, set the time of the DC injection brake.
- When the motor does not stop due to large load moment (J), increasing the setting produces an effect.
- When Pr. 11 = "0s", the DC injection brake is disabled. (At a stop, the motor coasts.)

(3) Operation voltage (torque) setting (Pr. 12)

- Use Pr. 12 to set the percentage to the power supply voltage.
- When Pr. 12 = "0%", the DC injection brake is disabled. (At a stop, the motor coasts.)
- When using the constant-torque motor (SF-JRCA) and energy saving motor (SF-HR, SF-HRCA), change the Pr. 12 setting as follows:

Motor	Pr.12 DC injection brake operation voltage Setting	
SF-JRCA	3.7K or lower	4%
	5.5K or higher	2%
SF-HR, SF-HRCA	3.7K or lower	4%
	5.5K, 7.5K	3%
	11K, 15K	2%



REMARKS

- For the 5.5K, 7.5K, when the Pr. 12 setting is the following, changing the Pr. 71 Applied motor setting automatically changes the Pr. 12 setting. Therefore, it is not necessary to change the Pr. 12 setting.
 - When 4% (initial value) is set in Pr. 12
The Pr. 12 setting is automatically changed to 2% if the Pr. 71 value is changed from the value selecting the standard motor (0, 3 to 6, 23, 24, 40, 43, 44) to the value selecting the constant-torque motor (1, 13 to 16, 50, 53, 54).
 - When 2% is set in Pr. 12
The Pr. 12 setting is automatically changed to 4% (initial value) if the Pr. 71 value is changed from the value selecting the constant-torque motor (1, 13 to 16, 50, 53, 54) to the value selecting the standard motor (0, 3 to 6, 23, 24, 40, 43, 44).
- Even if the Pr. 12 setting is increased, braking torque is limited so that the output current is within the rated inverter current.

 **CAUTION**

 **As stop holding torque is not produced, install a mechanical brake.**



Parameters referred to

Pr. 13 Starting frequency  Refer to page 119

Pr. 71 Applied motor  Refer to page 125

5.10.2 Selection of a regenerative brake (Pr. 30, Pr. 70)

- When making frequent starts/stops, use the optional brake resistor (MRS type, MYS type), high-duty brake resistor (FR-ABR) and brake unit (FR-BU2) to increase the regenerative brake duty.

Parameter Number	Name	Initial Value	Setting Range	Description
30	Regenerative function selection	0	0	Inverter without regenerative function Brake resistor (MRS type, MYS type) Brake unit (FR-BU2)
			1	Brake resistor (MYS type) used at 100% torque / 6%ED High-duty brake resistor (FR-ABR)
			2	For manufacturer setting. Do not set.
70	Special regenerative brake duty	0%	0 to 30%	Brake duty (6%) when using the brake resistor (MYS type), Brake duty when using the high-duty brake resistor (FR-ABR)(10%)

The above parameters can be set when Pr. 160 User group read selection = "0". (Refer to page 167)

(1) When using the brake resistor (MRS type, MYS type) and the brake unit (FR-BU2)

- Set Pr. 30 = "0 (initial value)". The Pr. 70 setting is made invalid.

At this time, the regenerative brake duty is as follows.

Model	Regenerative Brake Duty
FR-E720-0.4KNF to 3.7KNF	3%
FR-E720-5.5KNF or higher FR-E740-0.4KNF or higher	2%

(2) When using the brake resistor (MYS type) at 100% torque / 6%ED (FR-E720-3.7KNF only)

- Set "1" in Pr. 30.
- Set "6%" in Pr. 70.

(3) When using the high-duty brake resistor (FR-ABR) (0.4K or higher)

- Set "1" in Pr. 30.
 - Set Pr. 70 as follows.
- | | |
|--------------------|-----|
| 7.5K or lower..... | 10% |
| 11K, 15K..... | 6% |

(4) Regenerative brake duty alarm output

100%: regenerative overvoltage protection operation value

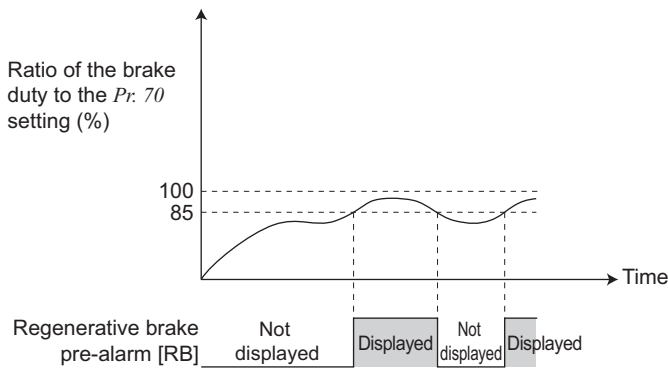

•[RB] appears on the operation panel when 85% of the regenerative brake duty set in *Pr. 70* is reached. If the regenerative brake duty reaches 100% of the *Pr. 70* setting, a regenerative overvoltage (E.OV1 to E.OV3) occurs.

Note that [RB] is not displayed when *Pr. 30* = "0".

 **REMARKS**

- Refer to page 25 to 28 for connecting the brake resistor (MRS type, MYS type), high-duty brake resistor (FR-ABR) and brake unit (FR-BU2).

 **WARNING**

 The value set in *Pr. 70* must not exceed the setting of the brake resistor used. Otherwise, the resistor can overheat.

 **Parameters referred to**

Pr. 57 Restart coasting time  Refer to page 151

5.10.3 Stop selection (Pr. 250)

Used to select the stopping method (deceleration to a stop or coasting) when the start signal turns OFF.

Used to stop the motor with a mechanical brake, etc. together with switching OFF of the start signal.

Parameter Number	Name	Initial Value	Setting Range	Description
250	Stop selection	9999	0 to 100s	The start signal is turned OFF, and the motor coasts to a stop after the specified time period.
			9999	When the start signal is turned OFF, the motor decelerates to stop.
			1000s to 1100s, 8888	For manufacturer setting. Do not set.

The above parameters can be set when Pr. 160 User group read selection = "0". (Refer to page 167)

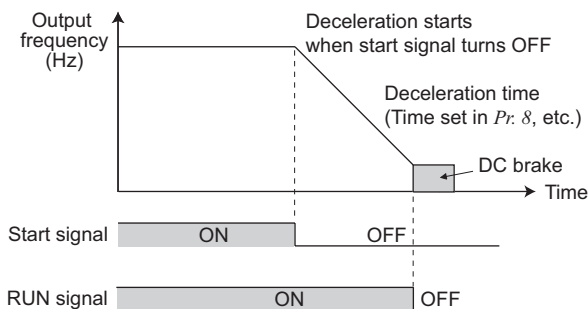

(1) Decelerate the motor to a stop

- Set Pr. 250 to "9999" (initial value) or "8888".
- The motor decelerates to a stop when the start signal (STF/STR) turns OFF.

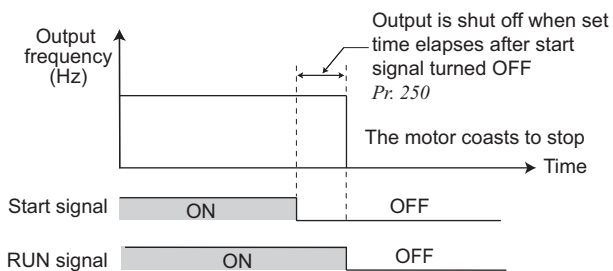

(2) Coast the motor to a stop

- Use Pr. 250 to set the time from when the start signal turns OFF until the output is shut off.
- The output is shut off when the time set in Pr. 250 has elapsed after the start signal had turned OFF. The motor coasts to a stop.
- The RUN signal turns OFF when the output stops.

REMARKS

- Stop selection is invalid when the following functions are activated.
 - Power failure stop function (Pr. 261)
 - PU stop (Pr. 75)
- When setting of Pr. 250 is not 9999, acceleration/deceleration is performed according to the frequency command, until start signal is OFF and output is shutoff.

NOTE

- When the start signal is turned ON again during motor coasting, the motor starts at Pr. 13 Starting frequency.

Parameters referred to

Pr. 7 Acceleration time, Pr. 8 Deceleration time Refer to page 116
Pr. 13 Starting frequency Refer to page 119

5.10.4 Stop-on contact control function (Pr. 6, Pr. 48, Pr. 270, Pr. 275, Pr. 276)



To ensure accurate positioning at the upper limit etc. of a lift, stop-on-contact control causes a mechanical brake to be closed while the motor is developing a holding torque to keep the load in contact with a mechanical stopper etc. This function suppresses vibration which is liable to occur when the load is stopped upon contact in vertical motion applications, ensuring steady precise positioning.

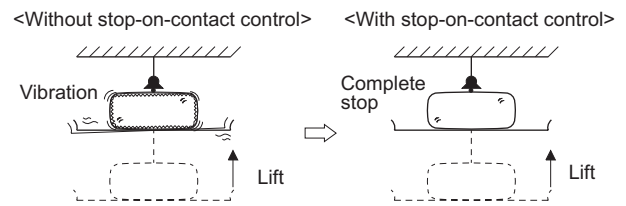

Parameter Number	Name	Initial Value	Setting Range	Description
6	Multi-speed setting (low speed)	10Hz	0 to 400Hz	Sets the output frequency for stop-on-contact control.
48*1	Second stall prevention operation current	9999	0 to 200%	Sets the stall prevention operation level for stall prevention operation level.
			9999	Pr. 22 setting
270*1	Stop-on contact control selection	0	0	Normal operation
			1	Stop-on-contact control
275*1, *2	Stop-on contact excitation current low-speed multiplying factor	9999	0 to 300%	Set the force (holding torque) for stop-on-contact control. Normally set 130% to 180%.
			9999	Without compensation
276*1	PWM carrier frequency at stop-on contact	9999	0 to 9	Sets a PWM carrier frequency for stop-on-contact control.
			9999	As set in Pr. 72 PWM frequency selection.

*1 These parameters can be set when Pr. 160 User group read selection = "0". (Refer to page 167)

*2 These parameters allow their settings to be changed during operation even if "0" (initial value) is set in Pr. 77 Parameter write selection.

(1) Operation example

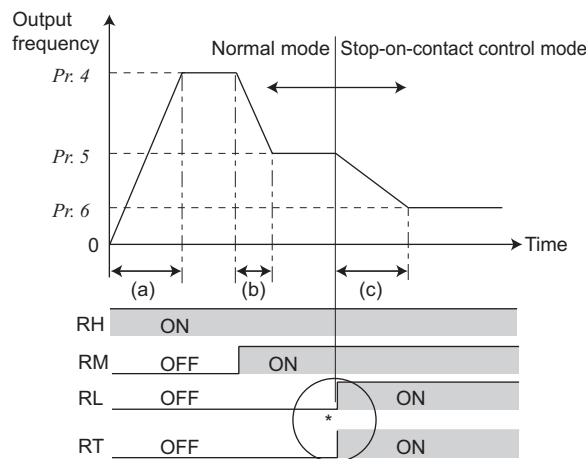

* Goes into stop-on-contact control when both RL and RT switches are ON.
 RL and RT may be switched ON in any order with any time difference.
 (a) Acceleration time (Pr. 7) (b) Deceleration time (Pr. 8)
 (c) Second deceleration time (Pr. 44/Pr. 45)

(2) Set stop-on-contact control

- Make sure that the inverter is in the Network operation mode. (Refer to page 50)
- Select Advanced magnetic flux vector control or General-purpose magnetic flux vector control.
- Set "1" in Pr. 270 Stop-on contact control selection.
- Set output frequency during stop-on-contact control in Pr. 6 Multi-speed setting (low speed). The frequency should be as low as possible (about 2Hz). If it is set to more than 30Hz, the operating frequency will be 30Hz.
- When both the RT and RL signals are switched ON, the inverter starts the stop-on-contact control, in which operation is performed at the frequency set in Pr. 6 independently of the preceding speed.



NOTE

- By increasing the Pr. 275 setting, the low-speed (stop-on-contact) torque increases, but overcurrent fault (E.OCT) may occur or the machine may oscillate in a stop-on-contact state.
- The stop-on-contact function is different from servo-lock function, and if used to stop or hold a load for an extended period, this function can cause the motor to overheat. After a stop, immediately change to a mechanical brake to hold the load.
- Under the following operating conditions, the stop-on-contact function is invalid: PU operation (Pr. 79), Jog operation, remote setting function operation (Pr. 59), automatic acceleration/deceleration operation (Pr. 292)

(3) Function switching of stop-on-contact control selection

Main Functions	Normal Operation (either RL or RT is OFF or both are OFF)	With stop-on-contact Control (both RL and RT are ON)
Output frequency	Multi-speed, setting frequency (Refer to page 58)	Pr. 6 setting
Stall prevention operation level	Pr. 22 setting	Pr. 48 setting (Pr. 22 when Pr. 48 = "9999")
Excitation current low speed scaling factor	—	Only Pr. 275 (0 to 300%) is compensated from normal operation
Carrier frequency	Pr. 72 setting	Pr. 276 setting when output frequency is 3Hz or less (Pr. 72 when Pr. 276 = "9999")
Fast-response current limit	Valid	Invalid

(4) Set frequency when stop-on-contact control (Pr. 270 = 1) is selected

- The following table lists the frequencies set when the input terminals (RH, RM, RL, RT, JOG) are selected together. Bold frame indicates stop-on-contact control is valid.
- Stop-on-contact control is invalid when remote setting function is selected (Pr. 59 = 1 to 3).

Input Signal (○ = ON)				Set Frequency
RH	RM	RL	RT	
○				Pr. 4 Multi-speed setting (high speed)
	○			Pr. 5 Multi-speed setting (middle speed)
		○		Pr. 6 Multi-speed setting (low speed)
			○	Depends on the set frequency. (Refer to page 58)
○	○			Pr. 26 Multi-speed setting (speed 6)
○		○		Pr. 25 Multi-speed setting (speed 5)
○			○	Pr. 4 Multi-speed setting (high speed)
	○	○		Pr. 24 Multi-speed setting (speed 4)
	○		○	Pr. 5 Multi-speed setting (middle speed)
		○	○	Pr. 6 Multi-speed setting (low speed)
	○	○	○	Pr. 6 Multi-speed setting (low speed)
○	○		○	Pr. 26 Multi-speed setting (speed 6)
○	○	○		Pr. 27 Multi-speed setting (speed 7)
○	○	○	○	Pr. 6 Multi-speed setting (low speed)
				Depends on the set frequency. (Refer to page 58)



Parameters referred to

- Pr. 4 to Pr. 6, Pr. 24 to Pr. 27 (multi-speed setting) Refer to page 111
- Pr. 15 Jog frequency Refer to page 171
- Pr. 48 Second stall prevention operation current Refer to page 101
- Pr. 59 Remote function selection Refer to page 113
- Pr. 72 PWM frequency selection Refer to page 163
- Pr. 292 Automatic acceleration/deceleration Refer to page 121

5.11 I/O signal control

Purpose	Parameter that should be Set		Refer to Page
Operation of start signals (STF, STR signal)	—		141
Reset cancellation and inverter run detection	—		142
Second function selection signal (RT signal)	—		143
Setting MRS signal (output shutoff) to NC contact specification	MRS input selection	Pr. 17	143
Detection of output frequency	Up-to-frequency sensitivity Output frequency detection	Pr. 41 to Pr. 43	144
Detection of output current	Output current detection Zero current detection	Pr. 150 to Pr. 153	145

5.11.1 Operation of start signals (STF, STR signal)

- The forward/reverse rotation signals (STF/STR) are used as start and stop signals. Turn ON either of the forward and reverse rotation signals to start the motor in the corresponding direction. Switch both OFF (or both ON) of the start signals during operation to decelerate the inverter to a stop.
- The speed setting signal may either be given by *Pr. 4 to Pr. 6 Multi-speed setting (high, middle, low speeds)*, etc.

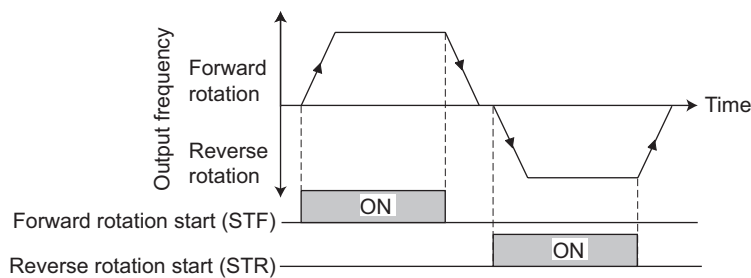



REMARKS

- When *Pr. 250* is set to any of "0 to 100", turning OFF the start command coasts the inverter to a stop. (Refer to page 138)



Parameters referred to

Pr. 4 to Pr. 6 (multi-speed setting)  Refer to page 111

Pr. 250 Stop selection  Refer to page 138

5.11.2 Reset cancel signal (READY signal) and inverter running signal (RUN signal)

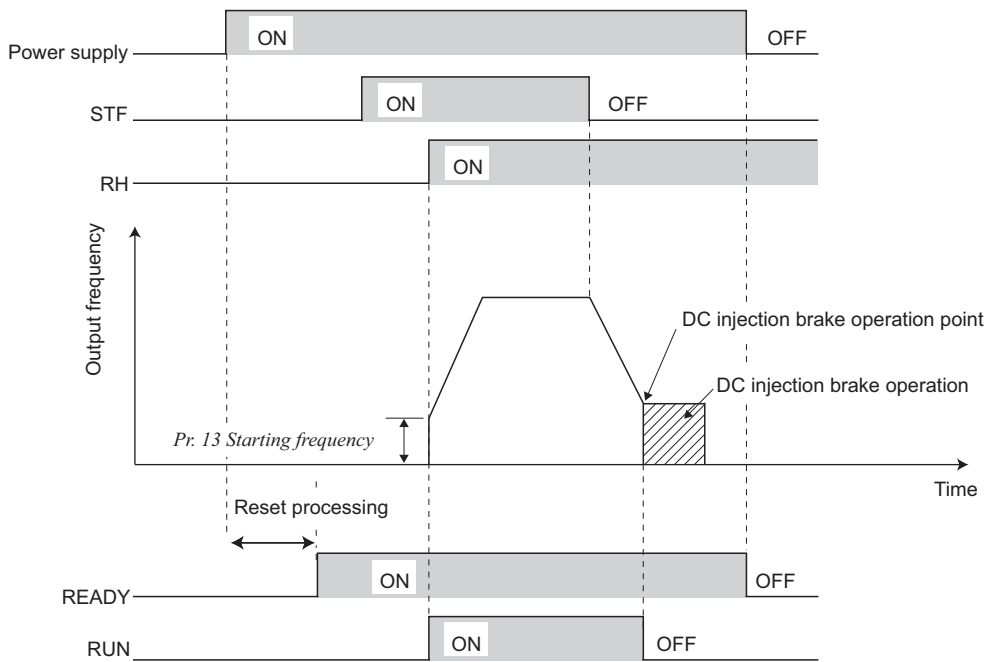

- When the reset operation of the inverter is canceled, reset cancel signal (READY) is output.
- When the output frequency of the inverter rises to or above *Pr. 13 Starting frequency*, the output of the inverter running signal (RUN) is turned ON. During an inverter stop or DC injection brake operation, the output is OFF.

Inverter Status / Output Signal	During Reset Operation	24V External Power Supply (EV Display on the Operation Panel)	Start Signal OFF (During Stop)	Start Signal ON (During Stop)	Start Signal ON (During Operation)	Under DC Injection Brake	Output Shut Off *	Automatic Restart after Instantaneous Power Failure		
								Coasting		Restarting
								Start Signal ON	Start Signal OFF	
READY	OFF	ON	ON	ON	ON	ON	ON	ON	ON	
RUN	OFF	OFF	OFF	OFF	ON	OFF	OFF	OFF	ON	

* When a fault occurs, the MRS signal is ON, or the safety stop function is active.

5.11.3 Second function selection signal (RT signal)

- When the RT signal turns ON, the second function becomes valid.
- The second function has the following applications.
 - (a) Switching between normal use and emergency use
 - (b) Switching between heavy load and light load
 - (c) Changing of acceleration/deceleration time by broken line acceleration/deceleration
 - (d) Switching of characteristic between the main motor and sub motor

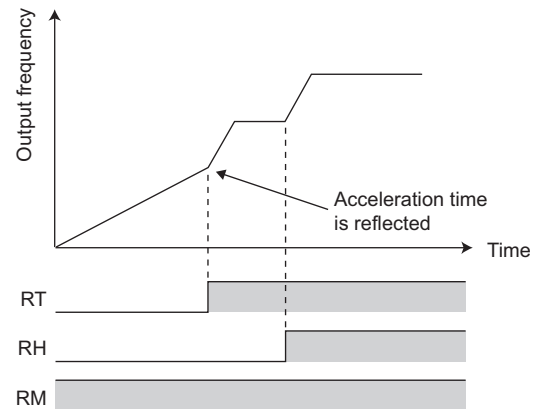

When the RT signal is ON, the following second functions are selected at the same time.

Function	First Function Parameter Number	Second Function Parameter Number	Refer to Page
Torque boost	Pr. 0	Pr. 46	94
Base frequency	Pr. 3	Pr. 47	107
Acceleration time	Pr. 7	Pr. 44	116
Deceleration time	Pr. 8	Pr. 44, Pr. 45	116
Electronic thermal O/L relay	Pr. 9	Pr. 51	123
Stall prevention	Pr. 22	Pr. 48	101
Applied motor	Pr. 71	Pr. 450	125

5.11.4 Inverter output shutoff signal (MRS signal, Pr. 17)

The inverter output can be shut off by the MRS signal. Also, logic for the MRS signal can be selected.

Parameter Number	Name	Initial Value	Setting Range	Description
17	MRS input selection	0	0, 4	Normally open input
			2	Normally closed input (NC contact input specifications)

The above parameters can be set when Pr. 160 User group read selection = "0". (Refer to page 167)

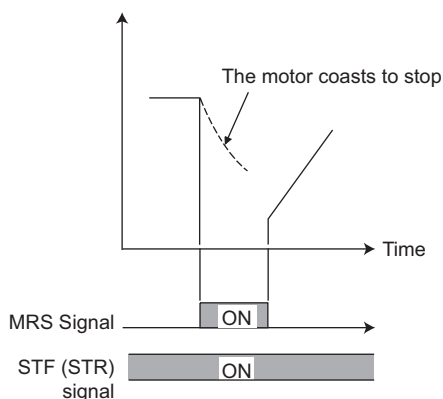

(1) Output shutoff signal (MRS signal)

- Turning ON the output shutoff signal (MRS) during inverter running shuts off the output immediately.
- MRS signal may be used as described below.
 - (a) When mechanical brake (e.g. electromagnetic brake) is used to stop motor
The inverter output is shut off when the mechanical brake operates.
 - (b) To provide interlock to disable operation by the inverter
With the MRS signal ON, the inverter cannot be operated if the start signal is entered into the inverter.
 - (c) Coast the motor to a stop.
When the start signal is turned OFF, the inverter decelerates the motor to a stop in the preset deceleration time, but when the MRS signal is turned ON, the motor coasts to a stop.

(2) MRS signal logic inversion (Pr. 17)

- When Pr. 17 is set to "2", the MRS signal (output stop) can be changed to the normally closed (NC contact) input specification. When the MRS signal turns ON (opens), the inverter shuts off the output.

5.11.5 Detection of output frequency (SU, FU signal, Pr. 41 to Pr. 43)

The inverter's output frequency is detected, and the signals are output through FL remote communication.

Parameter Number	Name	Initial Value	Setting Range	Description
41	Up-to-frequency sensitivity	10%	0 to 100%	Level where the SU signal turns ON.
42	Output frequency detection	6Hz	0 to 400Hz	Frequency where the FU signal turns ON.
43	Output frequency detection for reverse rotation	9999	0 to 400Hz	Frequency where the FU signal turns ON in reverse rotation.
			9999	Same as Pr. 42 setting

The above parameters can be set when Pr. 160 User group read selection = "0". (Refer to page 167)

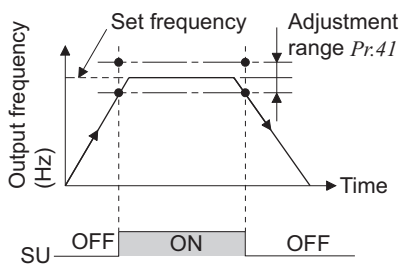

(1) Up-to-frequency sensitivity (SU signal, Pr. 41)

- When the output frequency reaches the set frequency, the up-to-frequency signal (SU) is output.
- The Pr. 41 value can be adjusted within the range 0% to ±100% on the assumption that the set frequency is 100%.
- This parameter can be used to ensure that the running frequency has been reached to provide the operation start signal etc. for related equipment.

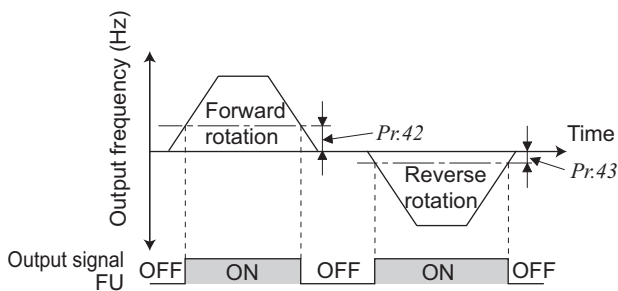

(2) Output frequency detection (FU signal, Pr. 42, Pr. 43)

- The output frequency detection signal (FU) is output when the output frequency reaches or exceeds the Pr. 42 setting.
- This function can be used for electromagnetic brake operation, open signal, etc.
- Frequency detection that is dedicated to reverse operation use can be set by setting detection frequency to Pr. 43. This function is effective for switching the timing of electromagnetic brake operation between forward rotation (rise) and reverse rotation (fall) during vertical lift operation, etc.
- When Pr. 43 ≠ "9999", the Pr. 42 setting is used for forward rotation and the Pr. 43 setting is used for reverse rotation.

REMARKS

- All signals are OFF during DC injection brake.
- The output frequency to be compared with the set frequency is the output frequency before slip compensation is performed.

5.11.6 Output current detection function (Y12 signal, Y13 signal, Pr. 150 to Pr. 153)

The output current is detected while the inverter is running, and the signals are output through FL remote communication.

Parameter Number	Name	Initial Value	Setting Range	Description
150	Output current detection level	150%	0 to 200%	100% is the rated inverter current.
151	Output current detection signal delay time	0s	0 to 10s	Output current detection period. The time from when the output current has risen above the setting until the output current detection signal (Y12) is output.
152	Zero current detection level	5%	0 to 200%	The rated inverter current is assumed to be 100%.
153	Zero current detection time	0.5s	0 to 1s	Period from when the output current drops below the Pr. 152 value until the zero current detection signal (Y13) is output.

The above parameters can be set when Pr. 160 User group read selection = "0". (Refer to page 167)

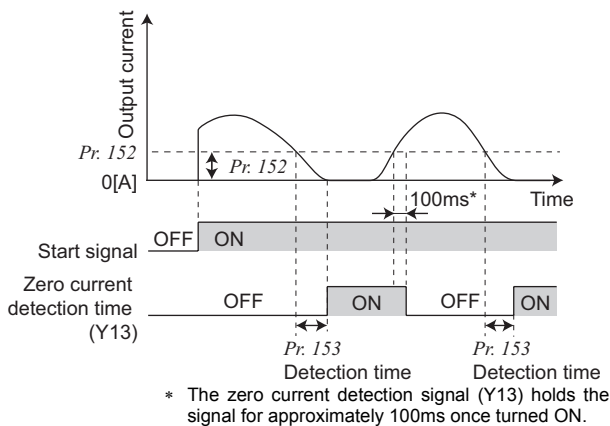
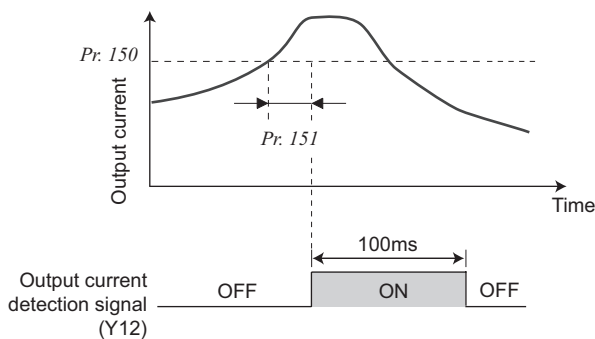

(1) Output current detection (Y12 signal, Pr. 150, Pr. 151)

- The output current detection function can be used for excessive torque detection, etc.
- If the output current remains higher than the Pr.150 setting for longer than the time period set in Pr.151 in the inverter operation using FL remote communication, the output current detection signal (Y12) is output.
- When the Y12 signal turns ON, the ON state is held for approximately 100ms.

(2) Zero current detection (Y13 signal, Pr. 152, Pr. 153)

- If the output current remains lower than the Pr.152 setting for longer than the time period set in Pr.153 in the inverter operation using FL remote communication, the zero current detection signal (Y13) is output.
- When the inverter's output current falls to "0", torque will not be generated. This may cause a drop due to gravity when the inverter is used in vertical lift application. To prevent this, the Y13 signal can be output from the inverter to close the mechanical brake when the output current has fallen to "zero".

REMARKS

- This function is also valid during execution of the offline auto tuning.
- The response time of Y12 and Y13 signals is approximately 0.1s. Note that the response time changes according to the load condition.
- When Pr. 152 = "0", detection is disabled.

CAUTION

- ⚠ The zero current detection level setting should not be too low, and the zero current detection time setting not too long. Otherwise, the detection signal may not be output when torque is not generated at a low output current.
- ⚠ To prevent the machine and equipment from resulting in hazardous conditions detection signal, install a safety backup such as an emergency brake even the zero current detection function is set valid.



Parameters referred to

Offline auto tuning Refer to page 127

5.12 Monitor display and monitor output signal

Purpose	Parameter that should be Set		Refer to Page
Display motor speed Set speed	Speed display and speed setting	Pr. 37	146
Change the monitored item displayed on the operation panel	Operation panel main display data selection Cumulative monitor clear	Pr. 52, Pr. 170, Pr. 171, Pr. 268, Pr. 563, Pr. 564	147

5.12.1 Speed display and speed setting (Pr. 37)

The monitor display and frequency setting of the operation panel can be changed to the machine speed.

Parameter Number	Name	Initial Value	Setting Range	Description
37	Speed display	0	0	Frequency display, setting
			0.01 to 9998*	Machine speed at 60Hz.

The above parameters can be set when Pr. 160 User group read selection = "0". (Refer to page 167)

* The maximum value of the setting range differs according to the Pr. 1 Maximum frequency (Pr. 18 High speed maximum frequency) and it can be calculated from the following formula.

$$\text{Maximum setting value of Pr. 37} < \frac{16777.215 \times 60 \text{ (Hz)}}{\text{Setting value of Pr. 1 (Pr. 18) (Hz)}}$$

Note that the maximum setting value of Pr. 37 is 9998 if the result of the above formula exceeds 9998.

- To display the machine speed, set in Pr. 37 the machine speed for 60Hz operation.
For example, when Pr. 37 = "1000", "1000" is displayed on the output frequency and set frequency monitor when the running frequency is 60Hz. When running frequency is 30Hz, "500" is displayed.

Pr. 37 Setting	Output Frequency Monitor	Set Frequency Monitor	Frequency Setting	Parameter Setting
0 (initial value)	Hz	Hz	Hz	Hz
0.01 to 9998	Machine speed *1	Machine speed *1	Machine speed *1	

*1 Machine speed conversion formulaPr. 37 × frequency/60Hz
*2 Hz is displayed in 0.01Hz increments and machine speed is in 0.001.

NOTE



- Under V/F control, the output frequency of the inverter is displayed in terms of synchronous speed, and therefore, displayed value = actual speed + motor slip. The display changes to the actual speed (estimated value calculated based on the motor slip) when Advanced magnetic flux vector control was selected or slip compensation was valid.
- Since the panel display of the operation panel is 4 digits in length, the monitor value of more than "9999" is displayed "----".
- While the machine speed is displayed on the monitor, values of other parameters related to speed (Pr. 1, etc.) are in frequency increments. Set other parameters (Pr. 1, etc) related to speed in increments of frequency.
- Due to the limitations on the resolution of the set frequency, the indication in the second decimal place may differ from the setting.
- When frequency or set frequency is monitored through FL remote communication, frequency is displayed for monitor description regardless of Pr. 37 setting.

CAUTION

Make sure that the running speed setting is correct.
Otherwise, the motor might run at extremely high speed, damaging the machine.



Parameters referred to

- Pr. 1 Maximum frequency, Pr. 18 High speed maximum frequency Refer to page 105
- Pr. 52 DU/PU main display data selection Refer to page 147
- Pr. 800 Control method selection Refer to page 93

5.12.2 Monitor display selection of the operation panel
(Pr. 52, Pr. 170, Pr. 171, Pr. 268, Pr. 563, Pr. 564)

The monitor to be displayed on the main screen of the operation panel can be selected.

Parameter Number	Name	Initial Value	Setting Range	Description
52 *1	DU/PU main display data selection	0 (output frequency)	0, 5, 7 to 12, 14, 20, 23 to 25, 55, 61, 62, 100 *2	Select the monitor to be displayed on the operation panel. Refer to the following table for monitor description.
170	Watt-hour meter clear	9999	0	Set "0" to clear the watt-hour meter monitor.
			10	Set the maximum value for the monitoring from communication to 9999kWh.
			9999	Set the maximum value for the monitoring from communication to 65535kWh.
171	Operation hour meter clear	9999	0, 9999	Set "0" in the parameter to clear the operation time monitor. Setting 9999 does not clear.
268 *1	Monitor decimal digits selection	9999	0	Displayed as integral value
			1	Displayed in 0.1 increments.
			9999	No function
563	Energization time carrying-over times	0	0 to 65535 (reading only)	The numbers of cumulative energization time monitor exceeded 65535h is displayed. (Reading only)
564	Operating time carrying-over times	0	0 to 65535 (reading only)	The numbers of operation time monitor exceeded 65535h is displayed. (Reading only)

The above parameters can be set when Pr. 160 User group read selection = "0". (Refer to page 167)

*1 This parameter allows its setting to be changed during operation in any operation mode even if "0" (initial value) is set in Pr. 77 Parameter write selection.

*2 The setting values "56 and 57" are for manufacturer setting. Do not set.

(1) Monitored item description list (Pr. 52)

- Set the monitored item to be displayed on the operation panel and parameter unit (FR-PU04/FR-PU07) in Pr. 52 DU/PU main display data selection.
- Refer to the following table and set the monitored item to be displayed.

Monitored Item	Unit	Pr. 52 Setting	Description
Output frequency	0.01Hz	0/100	Displays the inverter output frequency.
Output current	0.01A	0/100	Displays the inverter output current effective value.
Output voltage	0.1V	0/100	Displays the inverter output voltage.
Fault display	—	0/100	Displays 8 past faults individually.
Frequency setting value	0.01Hz	5	Displays the set frequency.
Motor torque	0.1%	7	Displays the motor torque in % on the assumption that the rated motor torque is 100%. (Displays 0% during V/F control)
Converter output voltage	0.1V	8	Displays the DC bus voltage value.
Regenerative brake duty	0.1%	9	Brake duty set in Pr. 30, Pr. 70
Electronic thermal relay function load factor	0.1%	10	Displays the thermal cumulative value on the assumption that the thermal operation level is 100% (Larger thermal between the motor thermal and transistor thermal). *4
Output current peak value	0.01A	11	Holds and displays the peak value of the output power monitor. (Cleared at every start)
Converter output voltage peak value	0.1V	12	Holds and displays the peak value of the DC bus voltage value. (Cleared at every start)
Output power	0.01kW	14	Displays the power on the inverter output side
Cumulative energization time *1	1h	20	Adds up and displays the energization time after inverter shipment. You can check the numbers of the monitor value exceeded 65535h with Pr. 563.
Actual operation time *1, *2	1h	23	Adds up and displays the inverter operation time. You can check the numbers of the monitor value exceeded 65535h with Pr. 564. Can be cleared by Pr. 171. (Refer to page 149)
Motor load factor	0.1%	24	Displays the output current value on the assumption that the inverter rated current value is 100%. Monitor value = output power monitor value/rated inverter current 100 [%]

Monitor display and monitor output signal

Monitored Item	Unit	Pr. 52 Setting	Description
Cumulative power *3	0.01kWh *5	25	Adds up and displays the power amount based on the output power monitor. Can be cleared by Pr. 170. (Refer to page 149)
Inverter output terminal monitor	—	55	Displays the ON/OFF statuses of the inverter output terminals and FL remote communication virtual terminals (FU, ALM signal) on the operation panel. (Refer to page 149 for details)
Motor thermal load factor	0.1%	61	Motor thermal heat cumulative value is displayed. (Motor overload trip (E.THM) at 100%)
Inverter thermal load factor	0.1%	62	Transistor thermal heat cumulative value is displayed. (Inverter overload trip (E.THT) at 100%)
Cumulative power 2	0.01kWh	—	Adds up and displays the power amount based on the output power monitor. (dedicated monitor for FL remote communication) Can be cleared by Pr. 170. (Refer to page 149)

*1 The cumulative energization time and actual operation time are accumulated from 0 to 65535 hours, then cleared, and accumulated again from 0. When the operation panel is used, the time is displayed up to 65.53 (65530h) in the indication of 1h = 0.001, and thereafter, it is added up from 0.

*2 Actual operation time is not accumulated when the cumulative operation time is less than 1h until turning OFF of the power supply.

*3 Since the panel display of the operation panel is 4 digits in length, the monitor value of more than "9999" is displayed "----".

*4 Larger thermal value between the motor thermal and transistor thermal is displayed.

A value other than 0% is displayed if the surrounding air temperature (heatsink temperature) is high even when the inverter is at a stop.

*5 The unit is 1kWh when monitoring through FL remote communication.

REMARKS

- By setting "0" in Pr. 52, the monitoring of output speed to fault display can be selected in sequence by **SET**.
- When the operation panel is used, the displayed units are Hz and A only and the others are not displayed.
- The monitor set in Pr. 52 is displayed in the third monitor position. However, change the output current monitor for the motor load factor.

Initial Value

*The monitor displayed at powering on is the first monitor. Display the monitor you want to display on the first monitor and hold down **SET** for 1s. (To return to the output frequency monitor, hold down **SET** for 1s after displaying the output frequency monitor.)

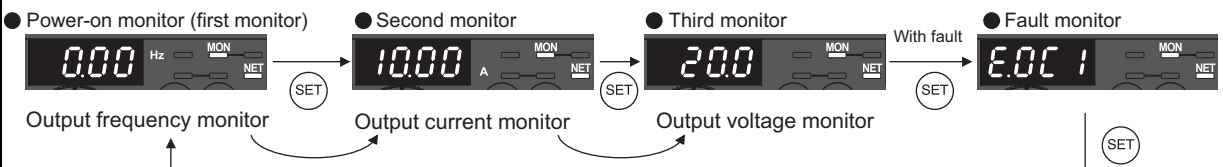

Example) When Pr. 52 is set to "20" (cumulative energization time), the monitor is displayed on the operation panel as described below.

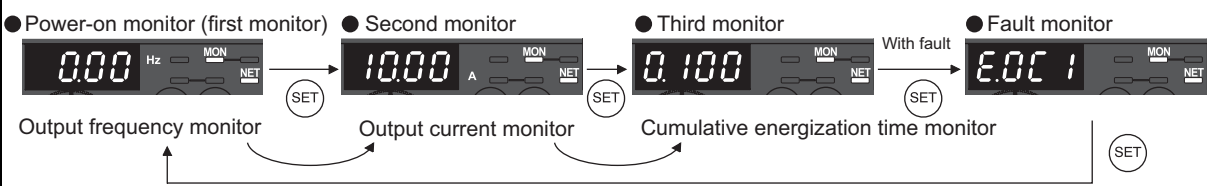

(2) Display set frequency during stop (Pr. 52)

- When "100" is set in Pr. 52, the set frequency and output frequency are displayed during stop and operation respectively. (LED of Hz flickers during stop and is lit during operation.)

	Pr. 52		
	0	100	
	During running/stop	During stop	During running
Output frequency	Output frequency	Set frequency*	Output frequency
Output current	Output current		
Output voltage	Output voltage		
Fault display	Fault display		

* The set frequency displayed indicates the frequency to be output when the start command is ON. Different from the frequency setting displayed when Pr. 52 = "5", the value based on maximum/minimum frequency and frequency jump is displayed.

REMARKS

- During an error, the output frequency at error occurrence appears.
- During MRS signal is ON, the values displayed are the same as during a stop.
- During offline auto tuning, the tuning status monitor has priority.

(3) Operation panel I/O terminal monitor (Pr. 52)

- When Pr.52 = "55," statuses of the output terminals and FL remote communication virtual terminals (FU, ALM signal) are monitored on the operation panel.
- The I/O terminal monitor is displayed on the third monitor.
- The LEDs are ON when a signal is input to terminal Y0 and when the signals FU and ALM are input. The LEDs are OFF when no signal is input to terminal Y0 nor the signals FU and ALM. The center line of the LED is always ON.

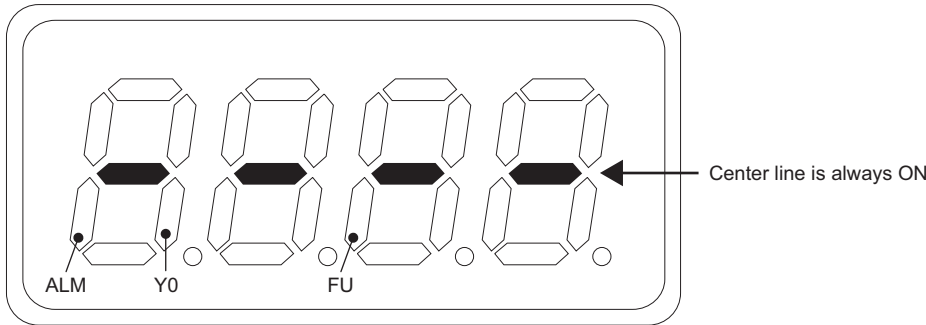

(4) Cumulative power/cumulative power 2 monitor and clear (Pr. 170)

- Monitored values are accumulated in the cumulative power monitor (Pr.52 = "25") or in the cumulative power monitor 2 (dedicated to FL remote communication), and the displayed values are updated every hour.
- The operation panel and FL remote communication display increments and display ranges are as indicated below.

Operation Panel *1		FL remote Communication			
Range	Monitor Unit for Cumulative Power	Range		Monitor Unit for Cumulative Power	Monitor Unit for Cumulative Power 2
		Pr. 170 = 10	Pr. 170 = 9999		
0 to 99.99kWh	0.01kWh	0 to 9999kWh	0 to 65535kWh (initial value)	1kWh	0.01kWh
100.0 to 999.9kWh	0.1kWh				
1000 to 9999kWh	1kWh				

*1 Power is measured in the range of 0 to 9999.99kWh, and displayed in 4 digits. When the monitor value exceeds "99.99", a carry occurs, e.g. "100.0", so the value is displayed in 0.1kWh increments.

- Writing "0" in Pr.170 clears the cumulative power monitor and the cumulative power 2 monitor.

 **REMARKS**

- If "0" is written to Pr. 170 and Pr. 170 is read again, "9999" or "10" is displayed.

(5) Cumulative energization time and actual operation time monitor (Pr. 171, Pr. 563, Pr. 564)

- Cumulative energization time monitor (Pr. 52 = "20") accumulates energization time from shipment of the inverter every one hour.
- On the actual operation time monitor (Pr. 52 = "23"), the inverter running time is added up every hour. (Time is not added up during a stop.)
- If the monitored value exceeds 65535, it is added up from 0. You can check the numbers of cumulative energization time monitor exceeded 65535h with Pr. 563 and the numbers of actual operation time monitor exceeded 65535h with Pr. 564.
- Writing "0" to Pr. 171 clears the cumulative power monitor. (The cumulative time monitor can not be cleared.)

 **REMARKS**

- The cumulative energization time does not increase if the power is ON for less than an hour.
- The actual operation time does not increase if the cumulative running time during power-ON status is less than an hour.
- If "0" is written to Pr. 171 and Pr. 171 is read again, "9999" is always displayed. Setting "9999" does not clear the actual operation time meter.

(6) Selecting the decimal digits for the monitor (*Pr. 268*)

•As the operation panel display is 4 digits long, the decimal places may vary at analog input, etc. The decimal places can be hidden by selecting the decimal digits.

In such a case, the decimal digits can be selected by *Pr. 268*.

<i>Pr. 268</i> Setting	Description
9999 (initial value)	No function
0	For the first or second decimal places (0.1 increments or 0.01 increments) of the monitor, numbers in the first decimal place and smaller are rounded to display an integral value (1 increments). The monitor value smaller than 0.99 is displayed as 0.
1	When 2 decimal places (0.01 increments) are monitored, the 0.01 decimal place is dropped and the monitor displays the first decimal place (0.1 increments). The monitored digits in 1 increments are displayed as they are.



REMARKS

- The number of display digits on the cumulative energization time (*Pr. 52* = "20"), actual operation time (*Pr. 52* = "23"), and cumulative power (*Pr. 52* = "25") does not change.



Parameters referred to

Pr. 30 Regenerative function selection, *Pr. 70* Special regenerative brake duty  Refer to page 136

Pr. 37 Speed display  Refer to page 146

5.13 Operation selection at power failure and instantaneous power failure

Purpose	Parameter that should be Set		Refer to Page
At instantaneous power failure occurrence, restart inverter without stopping motor	Automatic restart operation after instantaneous power failure/flying start	Pr. 57, Pr. 58, Pr. 96, Pr. 162, Pr. 165, Pr. 298, Pr. 299, Pr. 611	151
When undervoltage or a power failure occurs, the inverter can be decelerated to a stop.	Power failure-time deceleration-to-stop function	Pr. 261	156

5.13.1 Automatic restart after instantaneous power failure/flying start (Pr. 57, Pr. 58, Pr. 96, Pr. 162, Pr. 165, Pr. 298, Pr. 299, Pr. 611)

You can restart the inverter without stopping the motor in the following cases:

- When power comes back on after an instantaneous power failure
- When motor is coasting at start

Parameter Number	Name	Initial Value	Setting Range	Description
57	Restart coasting time	9999	0	1.5K or lower....1s 2.2K to 7.5K2s 11K or higher ...3s The above times are coasting time.
			0.1 to 5s	Waiting time for inverter-triggered restart after an instantaneous power failure.
			9999	No restart
58	Restart cushion time	1s	0 to 60s	Voltage starting time at restart.
96	Auto tuning setting/status	0	0	Offline auto tuning is not performed
			1	Advanced magnetic flux vector control Offline auto tuning is performed without motor running (all motor constants) (Refer to page 95)
			11	For General-purpose magnetic flux vector control Offline auto tuning is performed without motor running (motor constants (R1) only) (Refer to page 98)
			21	Offline auto tuning (tuning performed without motor running) for V/F control and automatic restart after instantaneous power failure (with frequency search)
162	Automatic restart after instantaneous power failure selection	1	0	With frequency search
			1	Without frequency search (reduced voltage system)
			10	Frequency search at every start
			11	Reduced voltage at every start
165	Stall prevention operation level for restart	150%	0 to 200%	Considers the rated inverter current as 100% and sets the stall prevention operation level during restart operation.
298	Frequency search gain	9999	0 to 32767	When offline auto tuning is performed under V/F control, frequency search gain necessary for frequency search for automatic restart after instantaneous power failure is set as well as the motor constants (R1).
			9999	Uses the Mitsubishi motor (SF-JR, SF-HR, SF-JRCA, SF-HRCA) constants
299	Rotation direction detection selection at restarting	0	0	Without rotation direction detection
			1	With rotation direction detection
			9999	When Pr. 78 = 0, With rotation direction detection When Pr. 78 = 1, 2 Without rotation direction detection
611	Acceleration time at a restart	9999	0 to 3600s	Acceleration time to reach Pr. 20 Acceleration/deceleration reference frequency at a restart.
			9999	Acceleration time for restart is the normal acceleration time (e.g. Pr. 7)

The above parameters can be set when Pr. 160 User group read selection = "0". (Refer to page 167)

When Pr. 162 = 1, 11 (without frequency search)

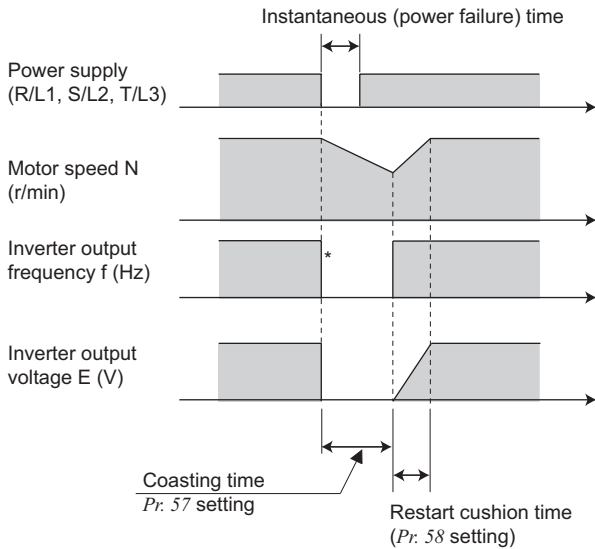

* The output shut off timing differs according to the load condition.

When Pr. 162 = 0, 10 (with frequency search)

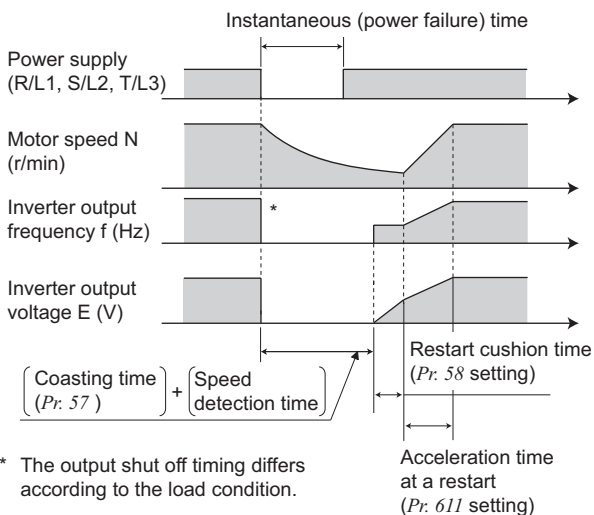

* The output shut off timing differs according to the load condition.

(1) Automatic restart operation selection

(Pr. 162, Pr. 299)

Without frequency search

When Pr. 162 = "1 (initial value)" or "11", automatic restart operation is performed in a reduced voltage system, where the voltage is gradually risen with the output frequency unchanged from prior to an instantaneous power failure independently of the coasting speed of the motor.

REMARKS

- This system stores the output frequency and rotation direction prior to an instantaneous power failure and restart using the stored value. Therefore, if the instantaneous power failure time exceeds 0.2s and the stored value cannot be retained, the inverter starts at Pr. 13 Starting frequency (initial value = 0.5Hz) in the starting direction upon power restoration.

With frequency search

When "0 or 10" is set in Pr. 162, the inverter smoothly starts after detecting the motor speed upon power restoration. (The motor capacity should be equal to or one rank lower than the inverter capacity)

When using the frequency search, perform offline auto tuning.

(Refer to page 127 for Advanced magnetic flux vector control, General-purpose magnetic flux vector control and page 153 for V/F control.)

- During reverse rotation, the inverter can be restarted smoothly as the direction of rotation is detected.
- You can select whether to make rotation direction detection or not with Pr. 299 Rotation direction detection selection at restarting.

When capacities of the motor and inverter differ, set "0" (without rotation direction detection) in Pr. 299.

Pr. 299 Setting	Pr. 78 Setting		
	0	1	2
9999	○	×	×
0 (initial value)	×	×	×
1	○	○	○

○: the rotation direction is detected.

×: the rotation direction is not detected.

REMARKS

- Speed detection time (frequency search) changes according to the motor speed. (maximum 100ms)
- When the inverter capacity is two rank or more larger than the motor capacity, the inverter may not start due to overcurrent trip (E.OC□).
- If two or more motors are connected to one inverter, the function does not operate properly. (The inverter does not start smoothly.)
- When reverse rotation is detected when Pr. 78 = "1" (reverse rotation disabled), the rotation direction is changed to forward rotation after decelerates in reverse rotation when the start command is forward rotation. The inverter will not start when the start command is reverse rotation.

NOTE

- When automatic restart operation after instantaneous power failure is activated while the motor is running at a low speed (less than 10Hz), the motor restarts in the direction prior to instantaneous power failure without detecting the rotation direction (Pr. 299 Rotation direction detection selection at restarting = "1").
- If the frequency search result exceeds the set frequency, the output frequency is limited at the set frequency.
- When the wiring length exceeds 100m, select without frequency search (Pr. 162 = "1, 11").

Restart operation at every start

When Pr. 162 = "10 or 11", automatic restart operation is also performed every start, in addition to the automatic restart after instantaneous power failure. When Pr. 162 = "0", automatic restart operation is performed at the first start after power supply ON, but not performed at the second time or later.

(2) Restart coasting time (Pr. 57)

- Coasting time is the time from when the motor speed is detected until automatic restart control is started.
- Set Pr. 57 to "0" to perform automatic restart operation.
The coasting time is automatically set to the value below. Generally this setting will pose no problems.
1.5K or lower ... 1s
2.2K to 7.5K 2s
11K or higher.... 3s
- Operation may not be performed well depending on the magnitude of the moment of inertia (J) of the load or running frequency. Adjust the coasting time between 0.1s and 5s according to the load specifications.

(3) Restart cushion time (Pr. 58)

- Cushion time is the length of time taken to raise the voltage appropriate to detected motor speed (output frequency prior to instantaneous power failure when Pr. 162 = "1, 11") from 0V.
- Normally the initial value need not be changed for operation, but adjust it according to the magnitude of the moment of inertia (J) of the load or torque.

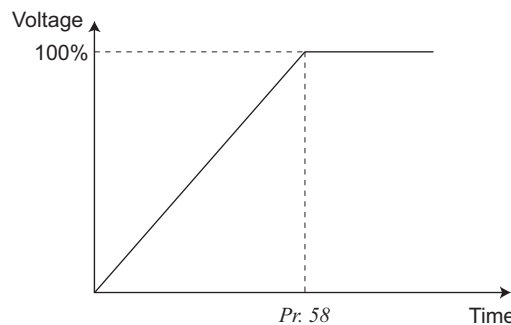

(4) Automatic restart operation adjustment (Pr. 165, Pr. 611)

- Using Pr. 165, you can set the stall prevention operation level at a restart.
- Using Pr. 611, you can set the acceleration time until Pr.20 Acceleration/deceleration reference frequency is reached when automatic restart operation is performed besides the normal acceleration time.

REMARKS

- If the Pr. 21 Acceleration/deceleration time increments is changed, the setting increments of Pr. 611 remain unchanged.

(5) Frequency search gain (Pr. 298), offline auto tuning (Pr. 96)

- When automatic restart after instantaneous power failure operation (with frequency search) is valid at V/F control, perform offline auto tuning.
- Perform offline auto tuning during V/F control in the following order to set Pr. 298 Frequency search gain automatically.
(Refer to page 127 during Advanced magnetic flux vector control and General-purpose magnetic flux vector control.)

●Before performing offline auto tuning

Check the following before performing offline auto tuning.

- The inverter is under V/F control
- A motor should be connected. Note that the motor should be at a stop at a tuning start.
- The motor capacity should be equal to or one rank lower than the inverter capacity. (note that the capacity is 0.1kW or more)
- A high-slip motor, high-speed motor and special motor cannot be tuned. (The maximum frequency is 120Hz.)
- Even if tuning is performed without motor running (Pr. 96 Auto tuning setting/status = "21"), the motor may run slightly. Therefore, fix the motor securely with a mechanical brake, or before tuning, make sure that there will be no problem in safety if the motor runs (caution is required especially in vertical lift applications). Note that tuning performance is unaffected even if the motor runs slightly.
- Offline auto tuning will not be performed properly if it is performed with a surge voltage suppression filter (FR-ASF-H, FR-BMF-H) connected between the inverter and motor. Remove it before starting tuning.

●Setting

- 1) Set "21" in Pr. 96 Auto tuning setting/status.

Tuning is performed without motor running.

It takes approximately 9s * until tuning is completed.

(Excitation noise is produced during tuning.)

*Tuning time differs according to the inverter capacity and motor type.

- 2) Set the rated motor current (initial value is rated inverter current) in Pr. 9 Electronic thermal O/L relay. (Refer to page 123)
- 3) Set Pr. 71 Applied motor according to the motor used.

Motor	Pr. 71 Setting *1	
Mitsubishi standard motor Mitsubishi high efficiency motor	SF-JR	3
	SF-JR 4P 1.5kW or less	23
	SF-HR	43
	Others	3
Mitsubishi constant-torque motor	SF-JRCA 4P	13
	SF-HRCA	53
	Others (SF-JRC, etc.)	13
Other manufacturer's standard motor	—	3
Other manufacturer's constant torque motor	—	13



*1 Refer to page 125 for other settings of Pr. 71.

●Execution of tuning



POINT

Before performing tuning, check the monitor display of the operation panel if the inverter is in the status for tuning. (Refer to 3) below)

- 1) Set "1" in the X12 signal (Bit11), which gives a control input command through FL remote communication. Then, change the operation mode to the PU operation mode using  on the operation panel.
- 2) Press  on the operation panel. Tuning starts.





(When the Network operation mode is selected and "1" is set in the X12 signal (Bit 11), which gives a control input command through FL remote communication, the inverter output is shutoff. Therefore, inputting a start signal through FL remote communication does not start tuning in this condition.)



NOTE

- To force tuning to end, press  of the operation panel.
- X12 signal is the only valid input/output signal during the offline auto tuning. Setting "0" in the X12 signal while tuning is being set or performed changes the operation mode to the Network operation mode forcibly.
- Use the X12 signal after setting "0" (stop command) in the forward/reverse rotation command (STF/STR signal) to set and perform tuning.
- When executing offline auto tuning, input the run command after switching ON the main circuit power (R/L1, S/L2, T/L3) of the inverter.

- 3) Monitor is displayed on the operation panel during tuning as below.

	Operation Panel Indication
Pr. 96 setting	21
(1) Setting	
(2) Tuning in progress	
(3) Normal end	Flickering 
(4) Error end (when inverter protective function operation is activated)	

- Reference: Offline auto tuning time (when the initial value is set)

Offline Auto Tuning Setting	Time
Tune motor constants (R1) only (Pr. 96 = "21")	Approx. 9s (Tuning time differs according to the inverter capacity and motor type.)

- 4) When offline auto tuning ends, press  on the operation panel. This operation resets the offline auto tuning, and the monitor display of the operation panel returns to normal.
- 5) Set "0" in the X12 signal (Bit11), which gives a control input command through FL remote communication. Then, change the operation mode to Network operation mode.
- 6) If offline auto tuning ended in error (see the table below), motor constants are not set. Perform an inverter reset and restart tuning.

Error Display	Error Cause	Remedy
8	Forced end	Set "21" in <i>Pr. 96</i> and perform tuning again.
9	Inverter protective function operation	Make setting again.
91	Current limit (stall prevention) function was activated.	Set "1" in <i>Pr. 156</i> .
92	Converter output voltage reached 75% of rated value.	Check for fluctuation of power supply voltage.
93	Calculation error A motor is not connected.	Check the motor wiring and make setting again. Set the rated current of the motor in <i>Pr. 9</i> .



- 7) When tuning is ended forcibly by pressing  during tuning, offline auto tuning does not end properly. (The motor constants have not been set.)
Perform an inverter reset and restart tuning.
- 8) When the rated power specification on the motor is 200/220V(400/440V) 60Hz, set 1.1 times the rated motor current value in *Pr.9 Electronic thermal O/L relay* after tuning is completed.



NOTE





- Do not change the *Pr. 96* setting after completion of tuning (23). If the *Pr. 96* setting is changed, tuning data is invalid. If the *Pr. 96* setting is changed, tuning must be performed again.
- The motor constants measured once in the offline auto tuning are stored as parameters and their data are held until the offline auto tuning is performed again.
- An instantaneous power failure occurring during tuning will result in a tuning error. After power is restored, the inverter goes into the normal operation mode.
- Any alarm occurring during tuning is handled as in the ordinary mode. Note that if a fault retry has been set, retry is ignored.
- The set frequency monitor displayed during the offline auto tuning is 0Hz.
- Automatic restart operation will also be performed after a reset or when a retry is made by the retry function.

 **CAUTION**

-  When automatic restart after instantaneous power failure has been selected, the motor and machine will start suddenly (after the reset time has elapsed) after occurrence of an instantaneous power failure. Stay away from the motor and machine. When you have selected automatic restart after instantaneous power failure function, apply in easily visible places the CAUTION stickers supplied to the Instruction Manual (Basic).
-  When the start signal is turned OFF or  is pressed during the restart cushion time after instantaneous power failure, deceleration starts after *Pr. 58 Restart cushion time* has elapsed.



Parameters referred to

- Pr. 7 Acceleration time, Pr. 21 Acceleration/deceleration time increments*  Refer to page 116
- Pr. 13 Starting frequency*  Refer to page 119
- Pr. 65, Pr. 67 to Pr. 69 Retry function*  Refer to page 158
- Pr. 71 Applied motor*  Refer to page 125
- Pr. 78 Reverse rotation prevention selection*  Refer to page 167

5.13.2 Power-failure deceleration stop function (Pr. 261)

When a power failure or undervoltage occurs, the inverter can be decelerated to a stop or can be decelerated and re-accelerated to the set frequency.

Parameter Number	Name	Initial Value	Setting Range	Description
261	Power failure stop selection	0	0	Coasts to stop. When undervoltage or power failure occurs, the inverter output is shut off.
			1	When undervoltage or a power failure occurs, the inverter can be decelerated to a stop.
			2	When undervoltage or a power failure occurs, the inverter can be decelerated to a stop. If power is restored during a power failure, the inverter accelerates again.

The above parameters can be set when Pr. 160 User group read selection = "0". (Refer to page 167)

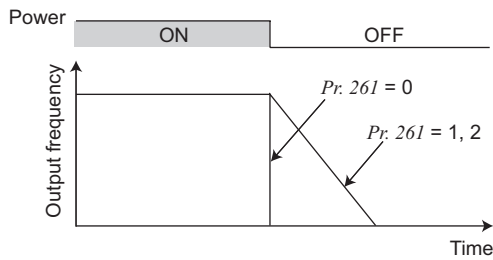

(1) Parameter setting

- When Pr. 261 is set to "1" or "2", the inverter decelerates to a stop if an undervoltage or power failure occurs.

(2) Operation outline of deceleration to stop at power failure

- When undervoltage or power failure has occurred, the output frequency is decreased and controlled so that the converter circuit (DC bus) voltage is constant and decreased to 0Hz to stop.

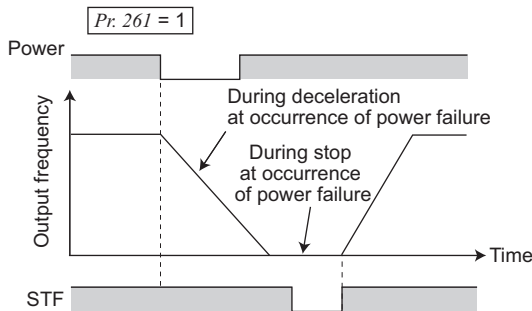

(3) Power failure stop function (Pr. 261 = "1")

- If power is restored during power failure deceleration, deceleration to a stop is continued and the inverter remains stopped. To restart, turn OFF the start signal once, then turn it ON again.

REMARKS

- When automatic restart after instantaneous power failure is selected (Pr. 57 ≠ "9999"), power failure stop function is invalid and automatic restart operation after instantaneous power failure is valid.
- When the power failure deceleration to stop function is active (Pr.261 = "1"), the inverter will not start by turning the power ON while the start signal (STR/STF) is being input through FL remote communication. After switching ON the power, turn OFF the start signal once and then ON again to make a start.

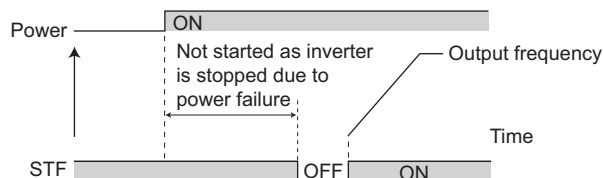

(4) Operation continuation at instantaneous power failure function (Pr. 261 = "2")

- When power is restored during deceleration after a power failure, acceleration is made again up to the set frequency.
- When this function is used in combination with the automatic restart after instantaneous power failure function (Pr. 57 ≠ "9999"), deceleration can be made at a power failure and acceleration can be made again after power restoration.

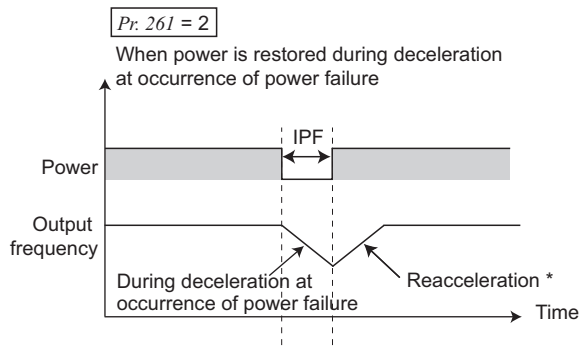

* Acceleration time depends on Pr. 7 (Pr. 44).

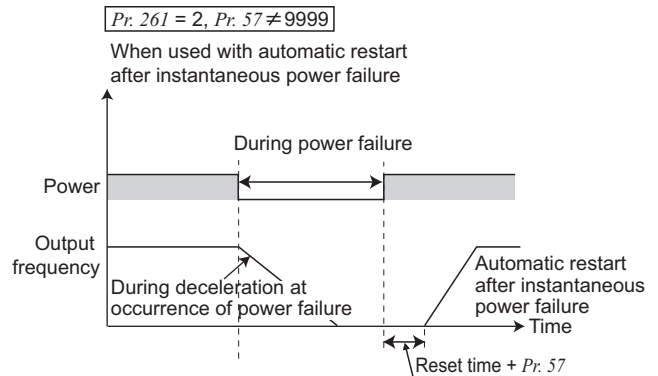

NOTE

- When operation continuation at instantaneous power failure function is used, keep the starting signal (STF/STR) ON even during instantaneous power failure. If the starting signal turns OFF during instantaneous power failure, the inverter decelerates according to the deceleration time setting, causing the motor to coast if enough regenerative energy is not obtained.



REMARKS

- During a stop or trip, the power failure stop selection is not performed.

CAUTION

- Even if the power failure stop function is valid, some loads may cause the inverter to trip and the motor to coast. The motor will coast if enough regenerative energy is not given from the motor to the inverter.



Parameters referred to

Pr. 57 Restart coasting time Refer to page 151

5.14 Operation setting at fault occurrence

Purpose	Parameter that should be Set		Refer to Page
Recover by retry operation at a fault occurrence	Retry operation	Pr. 65, Pr. 67 to Pr. 69	158
Do not output input/output phase failure alarm	Input/output phase failure protection selection	Pr. 251, Pr. 872	160
Detect an earth (ground) fault at start	Earth (ground) fault detection at start	Pr. 249	160
Select the operation at a fault occurrence	Communication error occurrence count display	Pr. 501	161

5.14.1 Retry function (Pr. 65, Pr. 67 to Pr. 69)

If a fault occurs, the inverter resets itself automatically to restart. You can also select the fault for a retry. When you have selected automatic restart after instantaneous power failure (*Pr. 57 Restart coasting time ≠ 9999*), restart operation is performed at the retry operation time which is the same of that of a power failure. (Refer to page 151 for the restart function.)

Parameter Number	Name	Initial Value	Setting Range	Description
65	Retry selection	0	0 to 5	A fault for retry can be selected. (Refer to the next page)
67	Number of retries at fault occurrence	0	0	No retry function
			1 to 10	Set the number of retries at fault occurrence. A fault output is not provided during retry operation.
			101 to 110	Set the number of retries at fault occurrence. (The setting value of minus 100 is the number of retries.) A fault output is provided during retry operation.
68	Retry waiting time	1s	0.1 to 360s	Set the waiting time from when an inverter fault occurs until a retry is made.
69	Retry count display erase	0	0	Clear the number of restarts succeeded by retry.

The above parameters can be set when *Pr. 160 User group read selection = "0"*. (Refer to page 167)

Retry success example

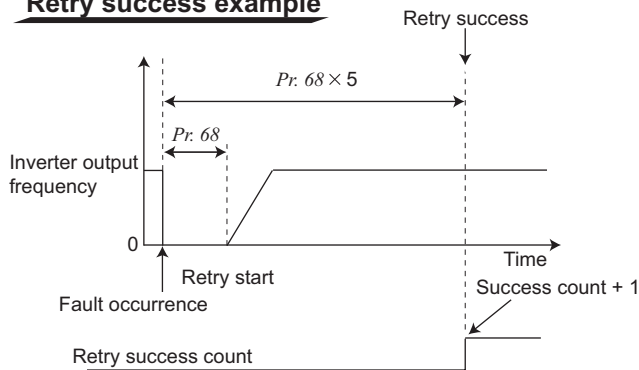

Retry failure example

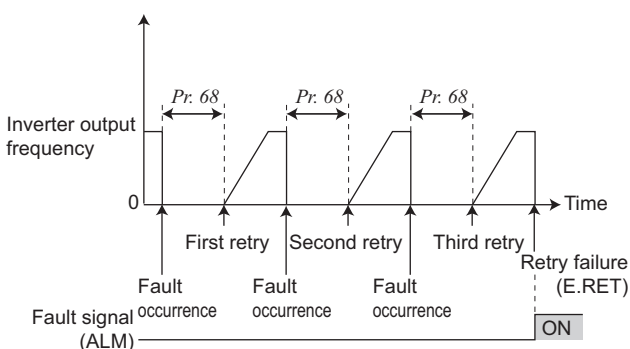

- Retry operation automatically resets a fault and restarts the inverter at the starting frequency when the time set in *Pr. 68* elapses after the inverter is tripped.
- Retry operation is performed by setting *Pr. 67* to any value other than "0". Set the number of retries at fault occurrence in *Pr. 67*.
- When retries fail consecutively more than the number of times set in *Pr. 67*, a retry count excess fault (E.RET) occurs, resulting in inverter trip. (Refer to retry failure example)
- Use *Pr. 68* to set the waiting time from when the inverter trips until a retry is made in the range 0.1 to 360s.
- Reading the *Pr. 69* value provides the cumulative number of successful restart times made by retry. The cumulative count in *Pr. 69* is increased by 1 when a retry is regarded as successful after normal operation continues without faults occurring for more than four times longer than the time set in *Pr. 68* after a retry start. (When retry is successful, cumulative number of retry failure is cleared.)
- Writing "0" to *Pr. 69* clears the cumulative count.

- Using Pr. 65, you can select the fault that will cause a retry to be executed. No retry will be made for the fault not indicated. (Refer to page 194 for the fault description.)
 - indicates the faults selected for retry.

Fault for Retry	Pr. 65 Setting					
	0	1	2	3	4	5
E.OC1	●	●		●	●	●
E.OC2	●	●		●	●	
E.OC3	●	●		●	●	●
E.OV1	●		●	●	●	
E.OV2	●		●	●	●	
E.OV3	●		●	●	●	
E.THM	●					
E.THT	●					

Fault for Retry	Pr. 65 Setting					
	0	1	2	3	4	5
E. BE	●				●	
E. GF	●				●	
E.OLT	●				●	
E.OPT	●				●	
E.OP1	●				●	
E. PE	●				●	
E.ILF	●				●	



NOTE

- The data stored as the error reset for retry is only that of the fault which occurred the first time.
- When an inverter fault is reset by the retry function at the retry time, the accumulated data of the electronic thermal relay function, regeneration brake duty etc. are not cleared. (Different from the power-ON reset.)
- Retry is not performed if E.PE (Parameter storage device fault) occurred at power ON.
- If a fault that is not selected for a retry occurs during retry operation (retry waiting time), the retry operation stops while the fault indication is still displayed.

 **CAUTION**

 When you have selected the retry function, stay away from the motor and machine when the inverter is tripped. They will start suddenly (after the reset time has elapsed) after the inverter trip.
When you have selected the retry function, apply in easily visible places the CAUTION stickers supplied with the Instruction Manual (Basic).



Parameters referred to

Pr. 57 Restart coasting time  Refer to page 151

5.14.2 Input/output phase loss protection selection (Pr. 251, Pr. 872)

You can choose whether to make Input/output phase loss protection valid or invalid.

- Output phase loss protection is a function to stop the inverter output if one of the three phases (U, V, W) on the inverter's output side (load side) is lost.
- Input phase loss protection is a function to stop the inverter output if one of the three phases (R/L1, S/L2, T/L3) on the inverter's input side is lost.

Parameter Number	Name	Initial Value	Setting Range	Description
251	Output phase loss protection selection	1	0	Without output phase loss protection
			1	With output phase loss protection
872	Input phase loss protection selection	1	0	Without input phase loss protection
			1	With input phase loss protection

The above parameters can be set when Pr. 160 User group read selection = "0". (Refer to page 167)

(1) Output phase loss protection selection (Pr. 251)

- If phase loss occurs during inverter running (except for during DC brake operation, or output frequency is 1Hz or less), output phase loss protection (E.LF) activates, and inverter trips.
- When Pr. 251 is set to "0", output phase loss protection (E.LF) becomes invalid.

(2) Input phase loss protection selection (Pr. 872)

- When Pr. 872 is set to "1", input phase loss protection (E.ILF) is provided if a phase loss of one phase among the three phases is detected for 1s continuously.



NOTE

- If an input phase loss continues for a long time, the converter section and capacitor lives of the inverter will be shorter.
- If the load is light or during a stop, lost phase cannot be detected because detection is performed based on the fluctuation of bus voltage. Large unbalanced phase-to-phase voltage of the three-phase power supply may also cause input phase loss protection (E.ILF).
- Phase loss can not be detected during regeneration load operation.

5.14.3 Earth (ground) fault detection at start (Pr. 249)

You can choose whether to make earth (ground) fault detection at start valid or invalid. Earth (Ground) fault detection is executed only right after the start signal is input to the inverter.

Protective function will not activate if an earth (ground) fault occurs during operation.

Parameter Number	Name	Initial Value	Setting Range	Description
249	Earth (ground) fault detection at start	0	0	Without earth (ground) fault detection
			1	With earth (ground) fault detection

The above parameters can be set when Pr. 160 User group read selection = "0". (Refer to page 167)



NOTE

- As detection is executed at start, output is delayed for approx. 20ms every start.
- If an earth (ground) fault is detected while Pr. 249 = "1," the output side earth (ground) fault overcurrent (E.GF) is activated and the inverter trips. (Refer to page 200)
- If the motor capacity is smaller than the inverter capacity of the 5.5K or higher, earth (ground) fault detection may not be provided.

5.15 Energy saving operation

Purpose	Parameter that should be Set		Refer to Page
Energy saving operation	Optimum excitation control	Pr. 60	162

5.15.1 Optimum excitation control (Pr. 60)

Without a fine parameter setting, the inverter automatically performs energy saving operation.
This operation is optimum for fan and pump applications

Parameter Number	Name	Initial Value	Setting Range	Description
60	Energy saving control selection	0	0	Normal operation mode
			9	Optimum excitation control mode

The above parameters can be set when Pr. 160 User group read selection = "0". (Refer to page 167)

- When "9" is set in Pr. 60, the inverter operates in the Optimum excitation control mode.
- The Optimum excitation control mode is a control system which controls excitation current to improve the motor efficiency to maximum and determines output voltage as an energy saving method.



REMARKS

- When the motor capacity is too small as compared to the inverter capacity or two or more motors are connected to one inverter, the energy saving effect is not expected.





NOTE

- When the Optimum excitation control mode is selected, deceleration time may be longer than the setting value. Since overvoltage alarm tends to occur as compared to the constant-torque load characteristics, set a longer deceleration time.
- Optimum excitation control functions only under V/F control. Optimum excitation control does not function under Advanced magnetic flux vector control and General-purpose magnetic flux vector control.
- Optimum excitation control will not be performed during an automatic restart after instantaneous power failure.
- Since output voltage is controlled by Optimum excitation control, output current may slightly increase.



Parameters referred to

Advanced magnetic flux vector control  Refer to page 95
 General-purpose magnetic flux vector control  Refer to page 98
 Pr. 57 Restart coasting time  Refer to page 151

5.16 Motor noise, EMI measures, mechanical resonance

Purpose of Use	Parameter that should be Set		Refer to Page
Reduction of the motor noise Measures against EMI and leakage currents	Carrier frequency and Soft-PWM selection	Pr. 72, Pr. 240	163
Reduce mechanical resonance	Speed smoothing control	Pr. 653	164

5.16.1 PWM carrier frequency and soft-PWM control (Pr. 72, Pr. 240)

You can change the motor sound.

Parameter Number	Name	Initial Value	Setting Range	Description
72 *	PWM frequency selection	1	0 to 15	You can change the PWM carrier frequency. The setting is in [kHz]. Note that 0 indicates 0.7kHz and 15 indicates 14.5kHz.
240 *	Soft-PWM operation selection	1	0	Soft-PWM is invalid
			1	When Pr. 72 = "0 to 5", soft-PWM is valid.

The above parameters can be set when Pr.160 User group read selection = "0". (Refer to page 167)

* The parameters in the table allow its setting to be changed during operation even if "0" (initial value) is set in Pr. 77 Parameter write selection.

(1) PWM carrier frequency changing (Pr. 72)

- You can change the PWM carrier frequency of the inverter.
- Changing the PWM carrier frequency produces an effect on avoiding the resonance frequency of a mechanical system or motor or on EMI measures or on leakage current reduction caused by the PWM switching.

(2) Soft-PWM control (Pr. 240)

- Soft-PWM control is a control method that changes the motor noise from a metallic tone into an unoffending complex tone.



NOTE

- Decreasing the PWM carrier frequency effect on EMI measures and on leakage current reduction, but increases motor noise.
- When PWM carrier frequency is set to 1kHz or less ($Pr.72 \leq 1$), fast response current limit may function prior to stall prevention operation due to increase in ripple currents, resulting in insufficient torque. In such case, set fast-response current limit operation invalid using Pr. 156 Stall prevention operation selection .
- When setting 2kHz or more in Pr. 72 to perform operation in the place where the surrounding air temperature exceeding 40°C, caution should be taken as the rated inverter current should be reduced. (Refer to page 224)



Parameters referred to

Pr. 156 Stall prevention operation selection Refer to page 101

5.16.2 Speed smoothing control (Pr. 653)

Vibration due to mechanical resonance influences the inverter control, causing the output current (torque) unstable. In this case, the output current (torque) fluctuation can be reduced to ease vibration by changing the output frequency.

Parameter Number	Name	Initial Value	Setting Range	Description
653	Speed smoothing control	0	0 to 200%	Increase or decrease the value using 100% as reference to check an effect.

The above parameters can be set when Pr. 160 User group read selection = "0". (Refer to page 167)

(1) Control block diagram

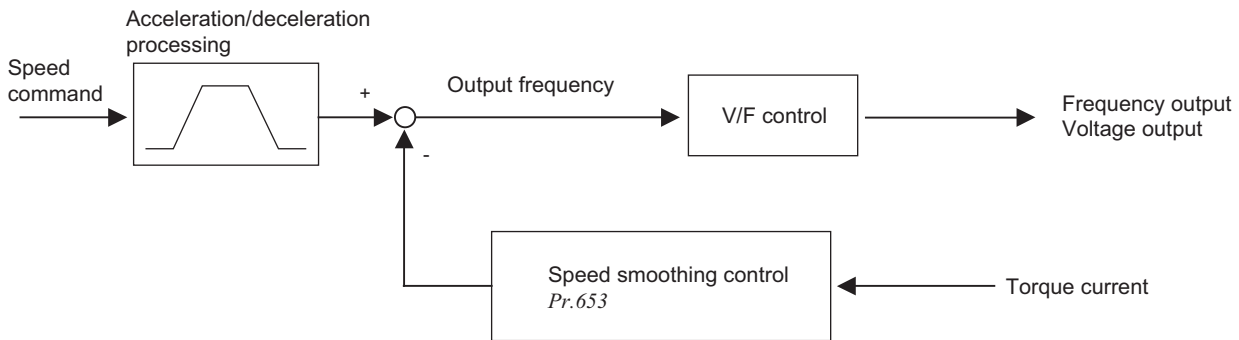

(2) Setting method

If vibration due to mechanical resonance occurs, set 100% in Pr. 653, run the inverter at the frequency which generates maximum vibration and check if the vibration will be reduced or not after several seconds.

If effect is not produced, gradually increase the Pr. 653 setting and check the effect repeatedly until the most effective value is set in Pr. 653.

If vibration becomes large by increasing the Pr. 653 setting, gradually decrease the Pr. 653 setting than 100% to check the effect in a similar manner.



NOTE



Depending on the machine, vibration may not be reduced enough or an effect may not be produced.

5.17 Misoperation prevention and parameter setting restriction

Purpose	Parameter that should be Set		Refer to Page
Stops from operation panel	PU stop selection	Pr. 75	165
Prevention of parameter rewrite	Parameter write disable selection	Pr. 77	166
Prevention of reverse rotation of the motor	Reverse rotation prevention selection	Pr. 78	167
Displays necessary parameters	Display of applied parameters and user group function	Pr. 160, Pr. 172 to Pr. 174	167
Parameter restriction using password	Password function	Pr. 296, Pr. 297	169



5.17.1 Reset selection/PU stop selection (Pr. 75)

The stop function can be selected on the operation panel.

Parameter Number	Name	Initial Value	Setting Range	Description
75	Reset selection/PU stop selection	14	0 to 3	Pressing  decelerates the motor to a stop only in the PU operation mode.
			14 to 17	Pressing  decelerates the motor to a stop in the PU and Network operation modes.





- The above parameters can be set when Pr. 160 User group read selection = "0". (Refer to page 167)
- This parameter allows its setting to be changed during operation in any operation mode even if "0 (initial value) or 1" is set in Pr. 77 Parameter write selection. Also, if (all) parameter clear is executed, this setting will not return to the initial value.

(1) PU stop selection

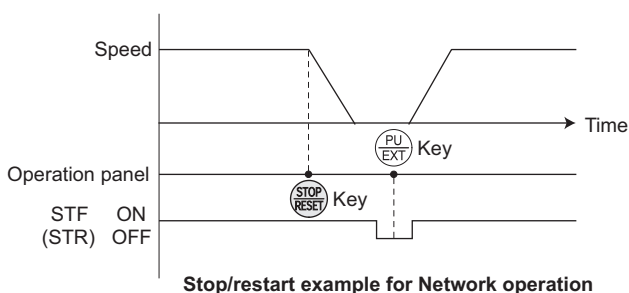
- Setting Pr. 75 = "14 to 17" enables the emergency stop with the  on the operation panel in the PU and Network operation modes.
- When the inverter is stopped by the PU stop function, "PS" (PS) is displayed. A fault output is not provided.
- After the motor is stopped from the PU, it is necessary to perform PU stop (PS) reset to restart. PS reset can be made from the operation panel.
- Cancel the PS indication and restart the operation by resetting the power or by performing an error reset of FL remote communication.
- When Pr. 75 is set to any of "0 to 3", PU stop (PS display) is invalid, deceleration to a stop by  is valid only in the PU operation mode.

(2) How to restart the motor stopped by input from the PU in Network operation mode (PU stop (PS) reset method)



- 1) After completion of deceleration to a stop, switch OFF the STF or STR signal.
- 2) Press  to display  (PS reset)
- 3) Press  to return to .
- 4) Switch ON the STF or STR signal.

REMARKS

- If Pr. 250 Stop selection is set to other than "9999" to select coasting to a stop, the motor will not be coasted to a stop but decelerated to a stop by the PU stop function during FL remote communication operation.

CAUTION

 Do not reset the inverter while the start signal is being input. Otherwise, the motor will start instantly after resetting, leading to potentially hazardous conditions.



Parameters referred to

Pr. 250 Stop selection  Refer to page 138

5.17.2 Parameter write disable selection (Pr. 77)

You can select whether write to various parameters can be performed or not. Use this function to prevent parameter values from being rewritten by misoperation.

Parameter Number	Name	Initial Value	Setting Range	Description
77	Parameter write selection	0	0	Write is enabled only during a stop.
			1	Parameter can not be written.
			2	Parameter write is enabled in any operation mode regardless of operation status.

The above parameters can be set when *Pr. 160 User group read selection* = "0". (Refer to page 167)

Pr. 77 can be set anytime regardless of the operation mode or the operation status. However, it cannot be changed through FL remote communication.

(1) Write parameters only during stop (setting "0" initial value)

- Parameters can be written only during a stop.
- The shaded parameters in the parameter list (page 78) can always be written regardless of the operation mode and operating status. However, *Pr. 72 PWM frequency selection*, *Pr. 240 Soft-PWM operation selection*, and *Pr. 275 Stop-on contact excitation current low-speed multiplying factor* can be written when the inverter is running in the PU operation mode, but cannot be written in the Network operation mode.

(2) Inhibit parameter write (setting "1")

- Parameter write is not enabled.
(Read is enabled.)
- Parameter clear and all parameter clear cannot be performed, either.
- The parameters given on the right can be written if *Pr. 77* = "1". (Note that the *Pr.77* setting cannot be changed through FL remote communication.)

Parameter Number	Name
22	Stall prevention operation level
75	Reset selection/PU stop selection
77	Parameter write selection
160	User group read selection
296	Password lock level
297	Password lock/unlock

(3) Write parameters during operation (setting "2")

- Parameters can always be written.
- The following parameters cannot be written when the inverter is running if *Pr. 77* = "2". Stop the inverter when changing their parameter settings.

Parameter Number	Name
23	Stall prevention operation level compensation factor at double speed
40	RUN key rotation direction selection
48	Second stall prevention operation current
60	Energy saving control selection
61	Reference current
66	Stall prevention operation reduction starting frequency
71	Applied motor
80	Motor capacity
81	Number of motor poles
82	Motor excitation current

Parameter Number	Name
83	Rated motor voltage
84	Rated motor frequency
90 to 94	(Motor constants)
96	Auto tuning setting/status
277	Stall prevention operation current switchover
292	Automatic acceleration/deceleration
293	Acceleration/deceleration separate selection
298	Frequency search gain
450	Second applied motor
800	Control method selection
859	Torque current

5.17.3 Reverse rotation prevention selection (Pr. 78)

This function can prevent reverse rotation fault resulting from the incorrect input of the start signal.

Parameter Number	Name	Initial Value	Setting Range	Description
78	Reverse rotation prevention selection	0	0	Both forward and reverse rotations allowed
			1	Reverse rotation disabled
			2	Forward rotation disabled

The above parameters can be set when Pr. 160 User group read selection = "0". (Refer to page 167)

- Set this parameter when you want to limit the motor rotation to only one direction.
- This parameter setting has higher priority than the  input from the operation panel or the forward/reverse rotation command from the communication.

5.17.4 Extended parameter display and user group function (Pr. 160, Pr. 172 to Pr. 174)

Parameter which can be read from the operation panel can be restricted.

Parameter Number	Name	Initial Value	Setting Range	Description
160 *3, *4	User group read selection	0	9999	Displays only the simple mode parameters
			0	Displays simple mode + extended parameters
			1	Displays the parameters registered in the user group.
172 *1	User group registered display/batch clear	0	(0 to 16)	Displays the number of cases registered as a user group (reading only)
			9999	Batch clear the user group registration
173 *1, *2	User group registration	9999	0 to 999, 9999	Sets the parameter numbers to be registered to the user group
174 *1, *2	User group clear	9999	0 to 999, 9999	Sets the parameter numbers to be cleared from the user group

*1 This parameter can be set when Pr. 160 User group read selection = "0".

*2 The values read from Pr. 173 and Pr. 174 are always "9999".

*3 Pr. 501 can always be read regardless of the Pr. 160 User group read selection setting.

*4 This parameter allows its setting to be changed during operation in any operation mode even if "0 (initial value) or "1" is set in Pr. 77 Parameter write selection.

(1) Display of simple mode parameters and extended parameters (Pr. 160)

- When Pr. 160 = "9999", only the simple mode parameters can be displayed on the operation panel. (Refer to the parameter list, page 78, for the simple mode parameters.)
- In the initial setting (Pr. 160 = "0") status, simple mode parameters and extended parameters can be displayed.



REMARKS

- Every parameter can be read regardless of the Pr.160 setting when reading parameters through FL remote communication.

(2) User group function (Pr. 160, Pr. 172 to Pr. 174)

- The user group function is designed to display only the parameters necessary for setting.
- From among all parameters, 16 parameters maximum can be registered in the user group. When Pr. 160 is set to "1", only the parameters registered to the user group can be accessed. (The parameters not registered in the user group can not be read.)
- To set a parameter in the user group, set its parameter number in Pr. 173.
- To delete a parameter from the user group, set its parameter number to Pr. 174. Set "9999" in Pr. 172 to batch delete parameters registered.

(3) Registration of parameter to user group (Pr. 173)

When registering Pr. 3 to user group

Operation

1. Confirm the operation display and operation mode display.
 - The inverter should be at a stop.
 - Make sure that the inverter is in PU operation mode.
2. Press **(MODE)** to choose the parameter setting mode.
3. Turn **(▲)** to change the set value to "P. 173".
4. Press **(SET)** to display 9999.
5. Turn **(▲)** until Pr. 3 appears.
6. Press **(SET)** to set.
 "P. 173" and "3" are displayed alternately.
 To continue parameter registration, repeat steps 3 to 6.

Display



(MODE) → P. 0 Parameter setting mode

(▲) → P. 173 Displays Pr. 173 User group registration

(SET) → 9999 When Pr. 173 is read, "9999" is displayed

(▲) → 3 Select the parameter number to be registered.

(SET) → 3 P. 173

Flicker...Registration of Pr. 3 to user group completed!!

(4) Deletion of parameter from user group (Pr. 174)

When deleting Pr. 3 from user group

Operation

1. Confirm the operation display and operation mode display.
 - The inverter should be at a stop.
 - The inverter should be in the PU operation mode.
2. Press **(MODE)** to choose the parameter setting mode.
3. Turn **(▲)** until P. 174 appears.
4. Press **(SET)** to display "9999"
5. Turn **(▲)** until Pr. 3 appears.
6. Press **(SET)** to set.
 "P. 174" and "3" are displayed alternately.
 To continue parameter clear, repeat steps 3 to 6.

Display



(MODE) → P. 0 Parameter setting mode

(▲) → P. 174 Displays Pr. 174 User group clear

(SET) → 9999 When Pr. 174 is read, "9999" is displayed

(▲) → 3 Select the parameter number to be registered.

(SET) → 3 P. 174

Flicker...Clear of Pr. 3 to user group completed!!



REMARKS

- Pr. 77 and Pr. 160 can always be read, independently of the user group setting.
- Pr. 77, Pr. 160 and Pr. 172 to Pr. 174 cannot be registered to the user group.
- When Pr. 174 is read, "9999" is always displayed. Although "9999" can be written, no function is available.
- When any value other than "9999" is set to Pr. 172, no function is available.

5.17.5 Password function (Pr. 296, Pr. 297)

Registering a 4-digit password can restrict parameter reading/writing.

Parameter Number	Name	Initial Value	Setting Range	Description
296*1	Password lock level	9999	0 to 6, 99, 100 to 106, 199 *4	Select restriction level of parameter reading/writing when a password is registered.
			9999	No password lock
297*2	Password lock/unlock	9999	1000 to 9998	Register a 4-digit password
			(0 to 5) *3	Displays password unlock error count. (Reading only) (Valid when Pr. 296 = "100" to "106")
			9999 *3	No password lock

Above parameters allow their settings to be changed during operation in any operation mode even if "0 (initial value) or 1" is set in Pr. 77 Parameter write selection.

- *1 The above parameters can be set when Pr. 160 User group read selection = "0".
- *2 When Pr. 296 = "9999" (no password lock), set Pr. 160 = "0" to enable the setting of this parameter. When the password lock is set, this parameter can be set anytime regardless of the Pr. 160 setting.
- *3 The setting value "0 or 9999" can be set to Pr.297 at any time although the setting is invalid (the displayed value does not change).
- *4 Setting Pr.296 = "0 or 100" will cause the Option fault (E.OPT) to occur and the inverter to trip. Do not set these values.

(1) Parameter reading/writing restriction level (Pr. 296)

•Level of reading/writing restriction by PU/NET mode operation command can be selected by Pr. 296.

Pr. 296 Setting	Operation command of the operation panel		Operation command through FL remote communication	
	Read *1	Write *2	Read	Write *2
9999	○	○	○	○
0, 100	Option fault (E.OPT) occurs, and the inverter trips.			
1, 101	○	×	○	×
2, 102	○	×	○	○
3, 103	○	○	○	×
4, 104	×	×	○	×
5, 105	×	×	○	○
6, 106	○	○	○	×
99, 199	Only parameters registered in the user group can be read/written.*3 (For the parameters not registered in the user group, same restriction level as "4, 104" applies.)			

○: enabled, ×: restricted

- *1 If the parameter reading is restricted by the Pr. 160 setting, those parameters are unavailable for reading even when "○" is indicated.
- *2 If the parameter writing is restricted by the Pr. 77 setting, those parameters are unavailable for writing even when "○" is indicated.
- *3 Read/write is enabled only in the simple mode parameters registered in the user group when Pr.160 User group read selection = "9999". Pr.296 and Pr.297 are always read/write enabled whether registered to a user group or not.

(2) Password lock/unlock (Pr.296, Pr.297)

<Lock>

- 1) Set parameter reading/writing restriction level.(Pr. 296 ≠ 9999)

Pr.296 Setting Value	Restriction of Password Unlock Error	Pr.297 Display
1 to 6, 99	No restriction	Always 0
101 to 106, 199	Restricted at fifth error	Displays error count (0 to 5)

* During [Pr. 296 = any of "101 to 106, 199"], if password unlock error has occurred 5 times, correct password will not unlock the restriction. Parameter all clear can unlock the restriction.
(In this case, parameter settings are cleared.)

- 2) Write a four-digit number (1000 to 9998) in Pr. 297 as a password.
(When Pr. 296 = "9999", Pr. 297 cannot be written.)

When password is registered, parameter reading/writing is restricted with the restriction level set in Pr. 296 until unlocking.

REMARKS

- After registering a password, a read value of Pr. 297 is always one of "0" to "5".
- When a password restricted parameter is read/written, **LOCd** is displayed.
- Even if a password is registered, parameters which the inverter itself writes, such as inverter parts life, are overwritten as needed.

<Unlock>

There are two ways of unlocking the password.

- Enter a password in *Pr. 297*.

Unlocked when a password is correct. If a password is incorrect, an error occurs and not unlocked.

During [*Pr. 296* = any of "101 to 106, 199"], if password unlock error has occurred 5 times, correct password will not unlock the restriction. (During password lock)

- Perform all parameter clear.



NOTE

- If the password has been forgotten, perform all parameter clear to unlock the parameter restriction. In that case, other parameters are also cleared.
- All parameter clear cannot be performed during the operation.

(3) Parameter operation during password lock/unlock

Parameter operation		Unlocked		Password registered	Locked
		<i>Pr. 296</i> = 9999 <i>Pr. 297</i> = 9999	<i>Pr. 296</i> ≠ 9999 <i>Pr. 297</i> = 9999	<i>Pr. 296</i> ≠ 9999 <i>Pr. 297</i> = 0 to 4 (Read value)	<i>Pr. 296</i> = 101 to 106, 199 <i>Pr. 297</i> = 5 (Read value)
<i>Pr. 296</i>	Read	○ *1	○	○	○
	Write	○ *1	○ *1	×	×
<i>Pr. 297</i>	Read	○ *1	○	○	○
	Write	×	○	○	○ *3
Performing parameter clear		○	○	×	×
Performing parameter all clear		○	○	○ *2	○ *2

○: enabled, ×: restricted

*1 Reading/writing is unavailable when there is restriction to reading by the *Pr. 160* setting. (Reading is available in NET mode regardless of *Pr. 160* setting.)

*2 Unavailable during the operation.

*3 Correct password will not unlock the restriction.



Parameters referred to

Pr. 77 Parameter write selection Refer to page 166

Pr. 160 Extended function display selection Refer to page 167

5.18 Special operation and frequency control

Purpose	Parameter that should be Set		Refer to Page
Perform jog operation	Jog operation	Pr. 15, Pr. 16	171
Frequency control appropriate for load torque	Droop control	Pr. 286, Pr. 287	173
Avoid overvoltage alarm due to regeneration by automatic adjustment of output frequency	Regeneration avoidance function	Pr. 882, Pr. 883, Pr. 885, Pr. 886	174

5.18.1 Jog operation (Pr. 15, Pr. 16)

You can set the frequency and acceleration/deceleration time for Jog operation. JOG operation can be performed from the operation panel.

This operation can be used for conveyor positioning, test operation, etc.

Parameter Number	Name	Initial Value	Setting Range	Description
15	Jog frequency	5Hz	0 to 400Hz	Frequency for Jog operation.
16	Jog acceleration/deceleration time	0.5s	0 to 3600/ 360s *	Acceleration/deceleration time for Jog operation. As the acceleration/deceleration time, set the time taken to reach the frequency (initial value is 60Hz) set in Pr. 20 Acceleration/deceleration reference frequency. Acceleration/deceleration time can not be set separately.

The above parameters can be set when Pr. 160 User group read selection = "0". (Refer to page 167)

* When the Pr. 21 Acceleration/deceleration time increments setting is "0" (initial value), the setting range is "0 to 3600s" and setting increments is "0.1s". When the setting is "1", the setting range is "0 to 360s" and the setting increments is "0.01s".

(1) Jog operation from the operation panel

•Selects Jog operation mode from the operation panel. Operation is performed only while the start button is pressed.

Operation

- Confirmation of the RUN indicator and operation mode indicator
 - The monitor mode should have been selected.
 - The inverter should be at a stop.
- Change the X12 signal (Bit11) setting to "1." X12 signal (Bit11) gives a control input command through FL remote communication.
- Press **PU EXT** to choose the PU Jog operation mode.
- Press **RUN**.
 - While **RUN** is pressed, the motor rotates.
 - The motor runs at 5Hz. (Pr. 15 initial value)
- Release **RUN**

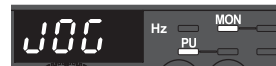

Hold down.



Release



[When changing the frequency of PU Jog operation]

- Press **MODE** to choose the parameter setting mode.
- Turn **▲** until Pr. 15 Jog frequency appears.
- Press **SET** to show the currently set value. (5Hz)
- Turn **▲** to set the value to "10.00". (10Hz)
- Press **SET** to set.



PRM indicator is lit.



(The parameter number read previously appears.)



Flicker...Parameter setting complete!!

- Perform the operations in steps 1 to 5.
The motor rotates at 10Hz.



NOTE

- When Pr. 29 Acceleration/deceleration pattern selection = "1" (S-pattern acceleration/deceleration A), the acceleration/deceleration time is the period of time required to reach Pr. 3 Base frequency.
- The Pr. 15 setting should be equal to or higher than the Pr. 13 Starting frequency.
- During Jog operation, the second acceleration/deceleration via the RT signal cannot be selected. (The other second functions are valid. (Refer to page 227))



Parameters referred to

- Pr. 13 Starting frequency Refer to page 119
- Pr. 20 Acceleration/deceleration reference frequency, Pr. 21 Acceleration/deceleration time increments Refer to page 116
- Pr. 29 Acceleration/deceleration pattern selection Refer to page 120

5.18.2 Droop control (Pr. 286, Pr. 287) **AD MFVC**

This function is designed to balance the load in proportion to the load torque to provide the speed drooping characteristic under Advanced magnetic flux vector control.
 This function is effective for balancing the load when using multiple inverters.

Parameter Number	Name	Initial Value	Setting Range	Description
286	Droop gain	0%	0	Droop control is invalid (Normal operation)
			0.1% to 100%	Droop control is valid Drooping amount at the rated torque as a percentage with respect to the rated motor frequency.
287	Droop filter time constant	0.3s	0 to 1s	Time constant of the filter applied on the torque current.

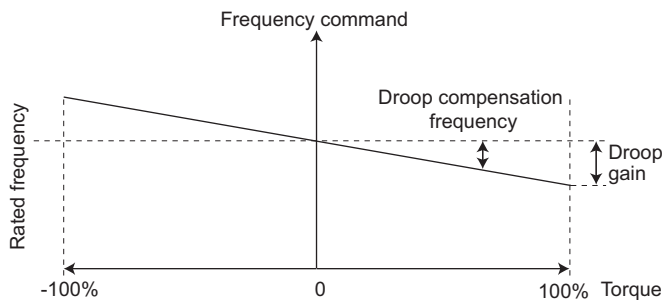

(1) Droop control

- The output frequency is changed according to the magnitude of torque current under Advanced magnetic flux vector control. The drooping amount at the rated torque is set by the droop gain as a percentage using the rated frequency as a reference.
- The maximum droop compensation frequency is 120Hz.

$$\text{Droop compensation frequency} = \frac{\text{Torque current after filtering}}{\text{Rated value of torque current}} \times \frac{\text{Pr. 84 Rated motor frequency} \times \text{Pr. 286 Droop gain}}{100}$$

REMARKS

- Set the droop gain to about the rated slip of the motor.

$$\text{Rated slip} = \frac{\text{Synchronous speed at base frequency} - \text{rated speed}}{\text{Synchronous speed at base frequency}} \times 100[\%]$$

- The maximum value of frequency after droop compensation is either 120Hz or Pr. 1 Maximum frequency, whichever is smaller.



Parameters referred to

Pr. 1 Maximum frequency Refer to page 105

5.18.3 Regeneration avoidance function (Pr. 665, Pr. 882, Pr. 883, Pr. 885, Pr. 886)

This function detects a regeneration status and increases the frequency to avoid the regenerative status.

- Possible to avoid regeneration by automatically increasing the frequency and continue operation if the fan happens to rotate faster than the set speed due to the effect of another fan in the same duct.

Parameter Number	Name	Initial Value	Setting Range	Description
882	Regeneration avoidance operation selection	0	0	Regeneration avoidance function invalid
			1	Regeneration avoidance function is always valid
			2	Regeneration avoidance function is valid only during a constant speed operation
883	Regeneration avoidance operation level	200V class 400 VDC	300 to 800V	Bus voltage level at which regeneration avoidance operates. When the bus voltage level is set to low, overvoltage error will be less apt to occur. However, the actual deceleration time increases. The set value must be higher than the "power supply voltage $\times \sqrt{2}$ ".
		400V class 780 VDC		
885	Regeneration avoidance compensation frequency limit value	6Hz	0 to 10Hz	Limit value of frequency which rises at activation of regeneration avoidance function.
			9999	Frequency limit invalid
886	Regeneration avoidance voltage gain	100%	0 to 200%	Responsiveness at activation of regeneration avoidance. A larger setting will improve responsiveness to the bus voltage change. However, the output frequency could become unstable.
665	Regeneration avoidance frequency gain	100%	0 to 200%	When vibration is not suppressed by decreasing the Pr. 886 setting, set a smaller value in Pr. 665.

The above parameters can be set when Pr. 160 User group read selection = "0". (Refer to page 167)

(1) What is regeneration avoidance function? (Pr. 882, Pr. 883)

- When the regeneration load is large, the DC bus voltage rises and an overvoltage fault (E. OV□) may occur. When this bus voltage rise is detected and the bus voltage level reaches or exceeds Pr. 883, increasing the frequency avoids the regeneration status.
- The regeneration avoidance function is always ON when "1" is set in Pr. 882 and activated only during a constant speed when "2" is set in Pr. 882.

Regeneration avoidance operation example for acceleration

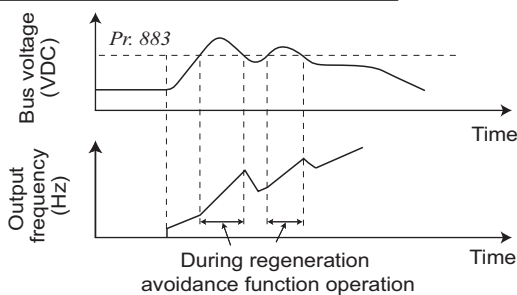

Regeneration avoidance operation example for constant speed

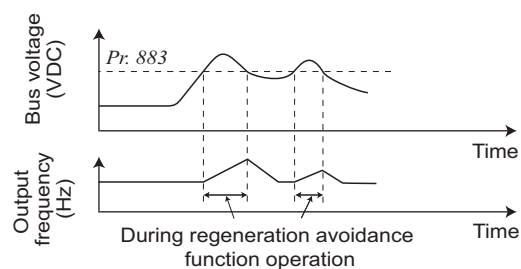

Regeneration avoidance operation example for deceleration

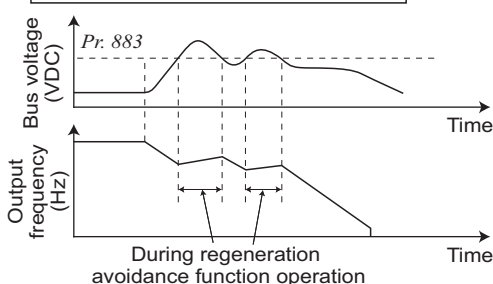

**REMARKS**

- The acceleration/deceleration ramp while the regeneration avoidance function is operating changes depending on the regeneration load.
- The DC bus voltage of the inverter is about $\sqrt{2}$ times as input voltage.
When the input voltage is 220VAC, bus voltage is approximately 311VDC.
When the input voltage is 440VAC, bus voltage is approximately 622VDC.
However, it varies with the input power supply waveform.
- The *Pr. 883* setting should be kept higher than the DC bus voltage level. Otherwise, the regeneration avoidance function is always on even in the non-regeneration status and the frequency increases.
- While overvoltage stall ($\square L$) is activated only during deceleration and stops the output frequency, the regeneration avoidance function is always on (*Pr. 882* = 1) or activated only during a constant speed (*Pr. 882* = 2) and increases the frequency according to the regeneration amount.

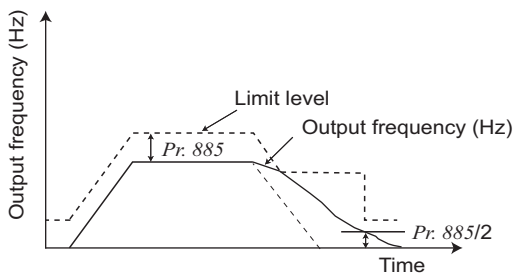
**(2) Limit regeneration avoidance operation frequency (Pr. 885)**

You can limit the output frequency compensated for (increased) by the regeneration avoidance function.

- The frequency is limited to the output frequency (frequency prior to regeneration avoidance operation) + *Pr. 885* Regeneration avoidance compensation frequency limit value during acceleration or constant speed. If the frequency increased by regeneration avoidance function exceeds the limit value during deceleration, the limit value is held until the output frequency falls to 1/2 of *Pr. 885*.
- When the frequency increased by regeneration avoidance function has reached *Pr. 1* Maximum frequency, it is limited to the maximum frequency.
- When *Pr. 885* is set to "9999", regeneration avoidance function operation frequency setting is invalid.

(3) Regeneration avoidance function adjustment (Pr. 665, Pr. 886)

- If the frequency becomes instable during regeneration avoidance operation, decrease the setting of *Pr. 886* Regeneration avoidance voltage gain. Conversely, if sudden regeneration causes an overvoltage alarm, increase the setting.
When vibration is not suppressed by decreasing the *Pr. 886* setting, set a smaller value in *Pr. 665* Regeneration avoidance frequency gain.

**NOTE**

- When regeneration avoidance operation is performed, $\square L$ (overvoltage stall) is displayed and the OL signal is output. Set the operation pattern at an OL signal output using *Pr. 156* Stall prevention operation selection. Set the output timing of the OL signal using *Pr. 157* OL signal output timer.
- When regeneration avoidance operation is performed, stall prevention is also activated.
- The regeneration avoidance function cannot shorten the actual deceleration time taken to stop the motor. The actual deceleration time depends on the regeneration energy consumption capability. When shortening the deceleration time, consider using the regeneration unit (FR-BU2) and brake resistor (MRS type, MYS type and FR-ABR etc.) to consume regeneration energy at constant speed.
- When using the regeneration unit (FR-BU2) and brake resistor (MRS type, MYS type, FR-ABR etc.), set *Pr. 882* to "0 (initial value)" (regeneration avoidance function invalid). When using the regeneration unit, etc. to consume regeneration energy at deceleration, set *Pr. 882* to "2" (regeneration avoidance function valid only at a constant speed).

**Parameters referred to**

Pr. 1 Maximum frequency Refer to page 105

Pr. 8 Deceleration time Refer to page 116

Pr. 22 Stall prevention operation level Refer to page 101

5.19 Useful functions

Purpose	Parameter that should be Set		Refer to Page
Increase cooling fan life	Cooling fan operation selection	Pr. 244	176
To determine the maintenance time of parts	Inverter part life display	Pr. 255 to Pr. 259	177
	Maintenance output function	Pr. 503, Pr. 504	180
Freely available parameter	Free parameter	Pr. 888, Pr. 889	181

5.19.1 Cooling fan operation selection (Pr. 244)

You can control the operation of the cooling fan built in the inverter (FR-E720-1.5KNF or higher, FR-E740-1.5KNF or higher).

Parameter Number	Name	Initial Value	Setting Range	Description
244	Cooling fan operation selection	1	0	Operates in power-ON status. Cooling fan ON/OFF control invalid (the cooling fan is always ON at power ON)
			1	Cooling fan ON/OFF control valid The fan is always ON while the inverter is running. During a stop, the inverter status is monitored and the fan switches ON-OFF according to the temperature.

The above parameters can be set when *Pr.160 User group read selection = "0"*. (Refer to page 167)

- In either of the following cases, fan operation is regarded as faulty and [FN] is shown on the operation panel.
 - Pr. 244 = "0"*
When the fan comes to a stop with power ON.
 - Pr. 244 = "1"*
When the inverter is running and the fan stops during fan ON command.

5.19.2 Display of the life of the inverter parts (Pr. 255 to Pr. 259)

Degrees of deterioration of main circuit capacitor, control circuit capacitor, cooling fan and inrush current limit circuit can be diagnosed by monitor.

When any part has approached the end of its life, an alarm can be output by self diagnosis to prevent a fault.

(Use the life check of this function as a guideline since the life except the main circuit capacitor is calculated theoretically.)

Parameter Number	Name	Initial Value	Setting Range	Description
255	Life alarm status display	0	(0 to 15)	Displays whether the control circuit capacitor, main circuit capacitor, cooling fan, and each parts of the inrush current limit circuit has reached the life alarm output level or not. (Reading only)
256	Inrush current limit circuit life display	100%	(0 to 100%)	Displays the deterioration degree of the inrush current limit circuit. (Reading only)
257	Control circuit capacitor life display	100%	(0 to 100%)	Displays the deterioration degree of the control circuit capacitor. (Reading only)
258	Main circuit capacitor life display	100%	(0 to 100%)	Displays the deterioration degree of the main circuit capacitor. (Reading only) The value measured by Pr. 259 is displayed.
259	Main circuit capacitor life measuring	0	0, 1 (2, 3, 8, 9)	Setting "1" and turning the power supply off starts the measurement of the main circuit capacitor life. When the Pr. 259 value is "3" after powering on again, the measuring is completed. Writes deterioration degree in Pr. 258.

The above parameters can be set when Pr. 160 User group read selection = "0". (Refer to page 167)

**REMARKS**

- Since repeated inrush currents at power ON will shorten the life of the converter circuit, frequent starts and stops of the magnetic contactor must be avoided.

(1) Life alarm display and signal output (Pr. 255)

•Whether any of the control circuit capacitor, main circuit capacitor, cooling fan and inrush current limit circuit has reached the life alarm output level or not can be checked by Pr. 255 Life alarm status display.

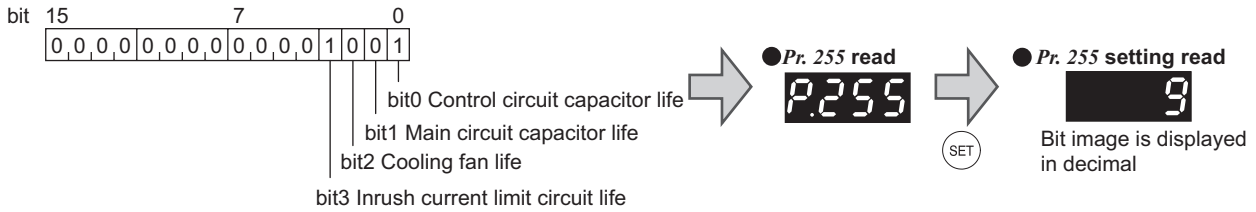

Pr. 255 (decimal)	Bit (binary)	Inrush Current Suppression Circuit Life	Cooling Fan Life	Main Circuit Capacitor Life	Control Circuit Capacitor Life
15	1111	○	○	○	○
14	1110	○	○	○	×
13	1101	○	○	×	○
12	1100	○	○	×	×
11	1011	○	×	○	○
10	1010	○	×	○	×
9	1001	○	×	×	○
8	1000	○	×	×	×
7	0111	×	○	○	○
6	0110	×	○	○	×
5	0101	×	○	×	○
4	0100	×	○	×	×
3	0011	×	×	○	○
2	0010	×	×	○	×
1	0001	×	×	×	○
0	0000	×	×	×	×

○: With warnings, ×: Without warnings

(2) Inrush current limit circuit life display (Pr. 256)

- The life of the inrush current limit circuit (relay, contactor and inrush resistor) is displayed in Pr. 256 .
- The number of contact (relay, contactor, thyristor) ON times is counted, and it is counted down from 100% (0 times) every 1%/10,000 times.
 As soon as 10% (900,000 times) is reached, Pr. 255 bit 3 is turned ON.

(3) Control circuit capacitor life display (Pr. 257)

- The deterioration degree of the control circuit capacitor is displayed in Pr. 257 as a life.
- In the operating status, the control circuit capacitor life is calculated from the energization time and temperature, and is counted down from 100%.
 As soon as the control circuit capacitor life falls below 10%, Pr. 255 bit 0 is turned ON.

(4) Main circuit capacitor life display (Pr. 258, Pr. 259)

- The deterioration degree of the control circuit capacitor is displayed in Pr. 258 as a life.
- On the assumption that the main circuit capacitor capacitance at factory shipment is 100%, the capacitor life is displayed in Pr. 258 every time measurement is made.

When the measured value falls to or below 85%, Pr. 255 bit 1 is turned ON and also an alarm is output to the Y90 signal.

- Measure the capacitor capacity according to the following procedure and check the deterioration level of the capacitor capacity.
 - 1) Check that the motor is connected and at a stop.
 - 2) Set "1" in the X12 signal (Bit11), which gives a control input command through FL remote communication. Then, change the operation mode to the PU operation mode using  on the operation panel.
 - 3) Set "1" (measuring start) in Pr. 259.
 - 4) Switch power OFF. The inverter applies DC voltage to the motor to measure the capacitor capacity while the inverter is OFF.
 - 5) After confirming that the LED of the operation panel is OFF, power ON again. (When using the 24V external power supply, turn ON the power again after "EV" appears.)
 - 6) Check that "3" (measuring completion) is set in Pr. 259, read Pr. 258, and check the deterioration degree of the main circuit capacitor.

Pr. 259	Description	Remarks
0	No measurement	Initial value
1	Measurement start	Measurement starts when the power supply is switched OFF.
2	During measurement	Only displayed and cannot be set
3	Measurement complete	
8	Forced end	
9	Measurement error	

 **REMARKS**

- When the main circuit capacitor life is measured under the following conditions, "forced end" (Pr. 259 = "8") or "measuring error" (Pr. 259 = "9") occurs or it remains in "measuring start" (Pr. 259 = "1"). Therefore, do not measure in such case. In addition, even when "measurement completion" (Pr. 259 = "3") is confirmed under the following conditions, normal measurement can not be done.
 - (a) DC power supply is connected to the terminal P/+ and N/-.
 - (b) The power supply switched ON during measurement.
 - (c) The motor is not connected to the inverter.
 - (d) The motor is running (coasting)
 - (e) The motor capacity is two rank smaller as compared to the inverter capacity.
 - (f) The inverter is tripped or a fault occurred when power is OFF.
 - (g) The inverter output is shut off with the MRS signal.
 - (h) The start command is given while measuring.
 - (i) I/O signals are conducted through FL remote communication and I/O terminals of the control terminal block.
 - (j) The setting value "1" is set in the X12 signal (Bit11), which gives a control input command through FL remote communication, in the Network operation mode.
 - (k) "EV" is displayed on the operation panel (main circuit power supply is OFF, 24V external power supply is ON.)
- Turning the power ON during measuring before LED of the operation panel turns OFF, it may remain in "measuring" (Pr. 259 = "2") status. In such case, carry out operation from step 3.

**POINT**

For accurate life measurement of the main circuit capacitor, wait 3 hours or longer after turning OFF. The temperature left in the main circuit capacitor affects measurement.

**WARNING**

When measuring the main circuit capacitor capacity (Pr. 259 Main circuit capacitor life measuring = "1"), the DC voltage is applied to the motor for 1s at powering OFF. Never touch the motor terminal, etc. right after powering OFF to prevent an electric shock.

(5) Cooling fan life display

- The cooling fan speed of 50% or less is detected, and "FN" is displayed on the operation panel. As an alarm display, Pr. 255 bit2 is turned ON.



REMARKS

- When the inverter is mounted with two or more cooling fans, "FN" is displayed with one or more fans with speed of 50% or less.



NOTE

- For replacement of each part, contact the nearest Mitsubishi FA center.

5.19.3 Maintenance timer alarm (Pr. 503, Pr. 504)

Maintenance timer signal (Y95) is output when the inverter's cumulative energization time reaches the time period set by the parameter during FL remote communication.  (MT) is displayed on the operation panel. This can be used as a guideline for the maintenance time for peripheral devices.

Parameter Number	Name	Initial Value	Setting Range	Description
503	Maintenance timer	0	0 (1 to 9998)	Displays the cumulative energization time of the inverter in 100h increments. (Reading only) Writing the setting of "0" clears the cumulative energization time.
504	Maintenance timer alarm output set time	9999	0 to 9998	Time taken until when the maintenance timer alarm output signal (Y95) is output.
			9999	No function

The above parameters can be set when Pr. 160 User group read selection = "0". (Refer to page 167)

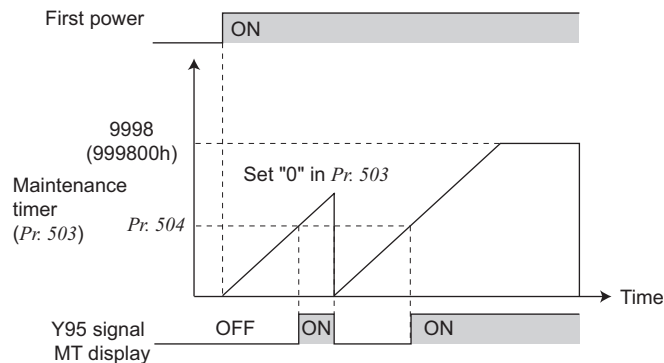

- The cumulative energization time of the inverter is stored into the EEPROM every hour and is displayed in Pr. 503 Maintenance timer in 100h increments. Pr. 503 is clamped at 9998 (999800h).
- When the Pr. 503 value reaches the time set to Pr. 504 Maintenance timer alarm output set time (100h increments), the maintenance timer alarm output signal (Y95) is output.



NOTE

- The cumulative energization time is counted every hour. The energization time of less than 1h is not counted.

5.19.4 Free parameter (Pr. 888, Pr. 889)

You can input any number within the setting range 0 to 9999.

For example, the number can be used:

- As a unit number when multiple units are used.
- As a pattern number for each operation application when multiple units are used.
- As the year and month of introduction or inspection.

Parameter Number	Name	Initial Value	Setting Range	Description
888	Free parameter 1	9999	0 to 9999	Any values can be set. Data is held even if the inverter power is turned OFF.
889	Free parameter 2	9999	0 to 9999	

The above parameters can be set when *Pr. 160 User group read selection* = "0". (Refer to page 167)

The above parameters allow their settings to be changed during operation in any operation mode even if "0" (initial value) is set in *Pr.77 Parameter write selection*.



REMARKS

Pr. 888 and Pr. 889 do not influence the inverter operation.

5.20 Setting from the operation panel

Purpose	Parameter that should be Set		Refer to Page
Selection of rotation direction by  of the operation panel	RUN key rotation direction selection	Pr. 40	182
Use the setting dial of the operation panel like a potentiometer for frequency setting. Key lock of operation panel	Operation panel operation selection	Pr. 161	183
Change the magnitude of change of frequency setting by the setting dial of the operation panel	Magnitude of frequency change setting	Pr. 295	185

5.20.1 RUN key rotation direction selection (Pr. 40)

Used to choose the direction of rotation by operating  of the operation panel.

Parameter Number	Name	Initial Value	Setting Range	Description
40	RUN key rotation direction selection	0	0	Forward rotation
			1	Reverse rotation

The above parameter can be set when Pr. 160 User group read selection = "0". (Refer to page 167)

5.20.2 Operation panel frequency setting/key lock operation selection (Pr. 161)



















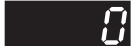

The setting dial of the operation panel can be used for setting like a potentiometer.
The key operation of the operation panel can be disabled.

Parameter Number	Name	Initial Value	Setting Range	Description	
161	Frequency setting/key lock operation selection	0	0	Setting dial frequency setting	Key lock invalid
			1	Setting dial potentiometer	
			10	Setting dial frequency setting	Key lock valid
			11	Setting dial potentiometer	

The above parameters can be set when Pr. 160 User group read selection = "0". (Refer to page 167)

(1) Using the setting dial like a potentiometer to set the frequency.

Operation example Changing the frequency from 0Hz to 60Hz during operation

Operation	Display
1. Screen at power-ON The inverter starts up in the Network operation mode. The monitor display appears.	
2. Change the X12 signal (Bit11) setting to "1." X12 signal (Bit11) gives a control input command through FL remote communication.	
3. Press  to choose the PU operation mode.	PU indicator is lit. 
4. Press  to choose the parameter setting mode.	PRM indicator is lit.  (The parameter number read previously appears.)
5. Turn  until P. 161 (Pr. 161) appears.	
6. Press  to read the currently set value. "0" (initial value) appears.	
7. Turn  to change it to the set value "1".	
8. Press  to set.	
9. Mode/monitor check Press  twice to choose the monitor/frequency monitor.	Flicker Parameter setting complete!! 
10. Press  to start the inverter.	
11. Turn  until "60.00" appears. The flickering frequency is the set frequency. You need not press  .	The frequency flickers for about 5s. 



REMARKS



- If the display changes from flickering "60.00" to "0.00", the setting of *Pr. 161 Frequency setting/key lock operation selection* may not be "1".
- Independently of whether the inverter is running or at a stop, the frequency can be set by simply turning the dial.
- When the frequency is changed, it will be stored in EEPROM as the set frequency after 10s.



NOTE

- When setting frequency by turning the setting dial, the frequency goes up to the set value of *Pr.1 Maximum frequency* (initial value: 120Hz). Adjust *Pr.1 Maximum frequency* setting according to the application.

(2) Disable the setting dial and key operation of the operation panel (Press [MODE] long (2s))

- Operation using the setting dial and key of the operation panel can be invalid to prevent parameter change, and unexpected start or frequency setting.
- Set "10 or 11" in *Pr. 161*, then press  for 2s to make the setting dial and key operation invalid.
- When the setting dial and key operation are invalid, *HOLD* appears on the operation panel. If dial or key operation is attempted while dial and key operation are invalid, *HOLD* appears. (When dial or key is not touched for 2s, monitor display appears.)
- To make the setting dial and key operation valid again, press  for 2s.



REMARKS

- Even if the setting dial and key operation are disabled, the monitor display and  are valid.



NOTE

- Release the operation lock to release the PU stop by key operation.

5.20.3 Magnitude of frequency change setting (Pr. 295)

When setting the set frequency with the setting dial, frequency changes in 0.01Hz increments in the initial status. Setting this parameter increases the magnitude of frequency which changes according to the rotated amount of the setting dial, improving operability.

Parameter Number	Name	Initial Value	Setting Range	Description
295	Magnitude of frequency change setting	0	0	Function invalid
			0.01	The minimum varying width when the set frequency is changed by the setting dial can be set.
			0.10	
			1.00	
			10.00	

The above parameters can be set when Pr. 160 User group read selection = "0". (Refer to page 167)

This parameter allows its setting to be changed during operation in any operation mode even if "0" (initial value) is set in Pr. 77 Parameter write selection.

(1) Basic operation

When a value other than "0" is set in Pr. 295, the minimum varying width when the set frequency is changed by the setting dial can be set.

For example, when "1.00Hz" is set in Pr. 295, one click (one dial gauge) of the setting dial changes the frequency in increments of 1.00Hz→2.00Hz→3.00Hz.

When Pr. 295 = "1"

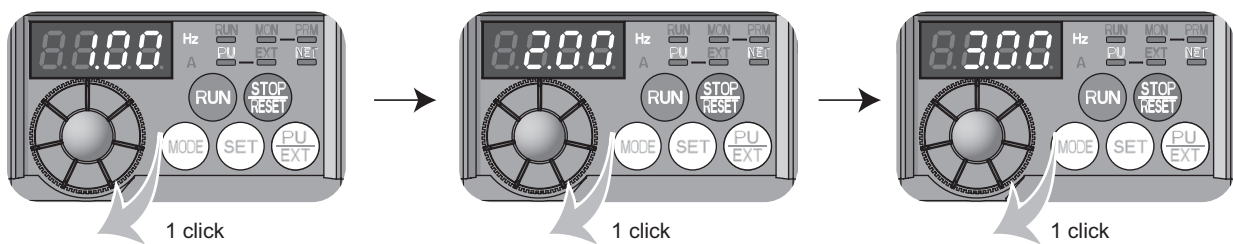

*One rotation of the setting dial equals to 24 clicks (24 dial gauges).

REMARKS

- When machine speed display is selected with Pr. 37, the minimum increments of the magnitude of change is determined by Pr.295 as well. Note that the setting value may differ as speed setting changes the set machine speed and converts it to the speed display again.
- When the set frequency (speed) is 100 or more, frequency is displayed in 0.1 increments. Therefore, the minimum varying width is 0.1 even when Pr. 295 < 0.1.
- When the machine speed setting is 1000 or more, frequency is displayed in 1 increments. Therefore, the minimum varying width is 1 even when Pr. 295 < 1.

NOTE

- For Pr. 295, unit is not displayed.
- This parameter is valid only in the set frequency mode. When other frequency-related parameters are set, it is not activated.
- When 10 is set, frequency setting changes in 10Hz increments. Note the excess speed. (in potentiometer mode)

5.21 Parameter clear/ All parameter clear



POINT

- Set "1" in Pr.CL Parameter clear or ALLC all parameter clear to initialize all parameters. (Parameters are not cleared when "1" is set in Pr. 77 Parameter write selection.)
- Refer to the extended parameter list on page 78 for parameters cleared with this operation.

Operation

1. Screen at power-ON
The inverter starts up in the Network operation mode. The monitor display appears.
2. Change the X12 signal (Bit11) setting to "1."
X12 signal (Bit11) gives a control input command through FL remote communication.
3. Press **PU EXT** to choose the PU operation mode.
4. Press **MODE** to choose the parameter setting mode.
5. Turn **▲** until *Pr.CL (ALLC)* appears.
6. Press **SET** to read the currently set value.
"0"(initial value) appears.
7. Turn **▲** to change it to the set value "1".
8. Press **SET** to set.

Display



PU indicator is lit.



PRM indicator is lit.

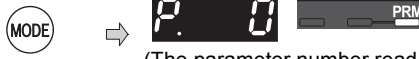

(The parameter number read previously appears.)

Parameter clear

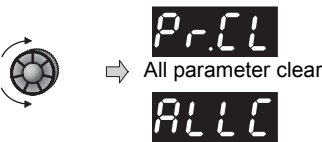

All parameter clear

6. Press **SET** to read the currently set value.
"0"(initial value) appears.



7. Turn **▲** to change it to the set value "1".



8. Press **SET** to set.



Parameter clear

All parameter clear

Flicker ... Parameter setting complete!!

- Turn **▲** to read another parameter.
- Press **SET** to show the setting again.
- Press **SET** twice to show the next parameter.

Setting	Description
0	Not executed.
1	Set parameters back to the initial values. Refer to the parameter list on page 78 for availability of parameter clear and all parameter clear.



REMARKS

? **1** and **E-4** are displayed alternately ... Why?

The inverter is not in the PU operation mode. Carry out operation from step 2 again.

5.22 Initial value change list

Displays and sets the parameters changed from the initial value.

Operation	Display
1. Screen at power-ON The inverter starts up in the Network operation mode. The monitor display appears.	
2. Change the X12 signal (Bit11) setting to "1." X12 signal (Bit11) gives a control input command through FL remote communication.	
3. Press to choose the PU operation mode.	PU indicator is lit.
4. Press to choose the parameter setting mode.	PRM indicator is lit. (The parameter number read previously appears.)
5. Turn until <i>P.r.CH</i> appears.	
6. Pressing changes to the initial value change list screen.	
7. Turning displays the parameter number changed.	
• Press to read the currently set value.	
Turn and press to change the setting (refer to step 6 and 7 on page 76)	
• Turn to read another parameter.	
• The display returns to <i>P. ---</i> after all parameters are displayed.	
8. Pressing in <i>P. ---</i> status returns to the parameter setting mode.	
• Turning sets other parameters.	
• Pressing displays the change list again.	

* It may take several seconds for creating the initial value change list. "P. ---" flickers while creating the list.

Flicker Parameter setting complete!!



NOTE

- Only simple mode parameter is displayed when simple mode is set (Pr. 160 = 9999)
- Only user group is displayed when user group is set (Pr. 160 = "1").
- Pr. 160 is displayed independently of whether the setting value is changed or not.
- When parameter setting is changed after creating the initial value change list, the setting will be reflected to the initial value change list next time.



Parameters referred to

Pr. 160 User group read selection Refer to page 167

5.23 Check and clear of the faults history

(1) Check for the faults history

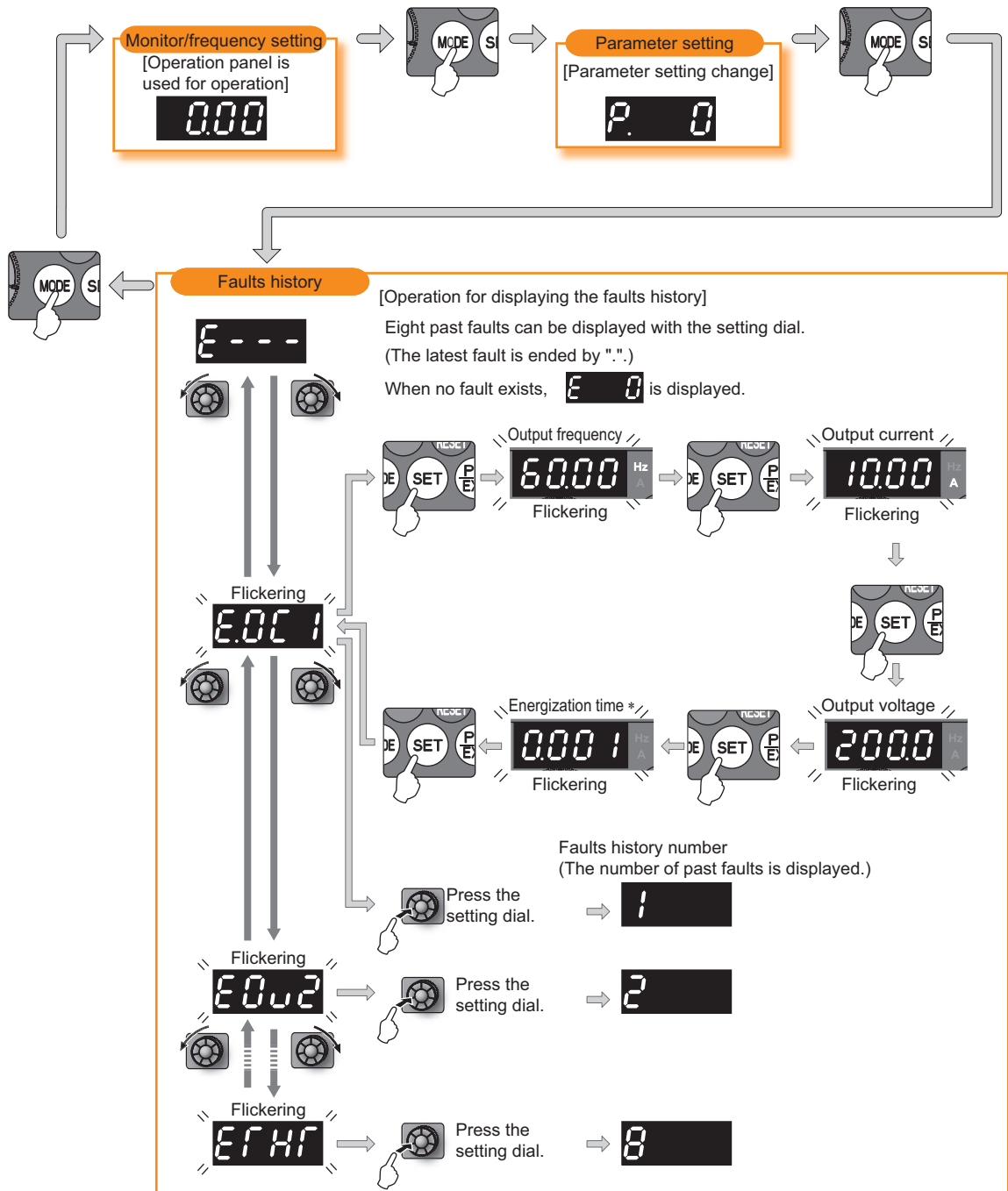

* The cumulative energization time and actual operation time are accumulated from 0 to 65535 hours, then cleared, and accumulated again from 0. When the operation panel is used, the time is displayed up to 65.53 (65530h) in the indication of 1h = 0.001, and thereafter, it is added up from 0.





(2) Clearing procedure





POINT

- Set "1" in *Er.CL* Fault history clear to clear the faults history.

Operation

1. Screen at power-ON
The monitor display appears.
2. Press  to choose the parameter setting mode.
3. Turn  until *Er.CL* (faults history clear) appears.
4. Press  to read the currently set value. "0" (initial value) appears.
5. Turn  to change it to the set value "1".
6. Press  to set.

- Turn  to read another parameter.
- Press  to show the setting again.
- Press  twice to show the next parameter.



Parameters referred to

Pr. 77 Parameter write selection  Refer to page 166

Display



PRM indicator is lit.



(The parameter number read previously appears.)



Flicker...Faults history clear complete!!

MEMO

6 TROUBLESHOOTING

This chapter provides the "TROUBLESHOOTING" of this product.
Always read the instructions before using the equipment.

6.1	Reset method of protective function	192
6.2	List of fault or alarm indications	193
6.3	Causes and corrective actions	194
6.4	Correspondences between digital and actual characters	203
6.5	Check first when you have a trouble	204

1

2

3

4

5

6

7

8

Reset method of protective function

When a fault occurs in the inverter, the inverter trips and the display on the operation panel automatically changes to a fault or alarm indication shown on *page 193*.

If the fault does not correspond to any of the following faults or if you have any other problem, please contact your sales representative.

- Retention of fault output signal... When the magnetic contactor (MC) provided on the input side of the inverter is opened when a fault occurs, the inverter's control power will be lost and the fault output will not be held.
- Fault or alarm indication When a fault or alarm occurs, the operation panel display automatically switches to the fault or alarm indication.
- Resetting method When a fault occurs, the inverter output is kept stopped. Unless reset, therefore, the inverter cannot restart. (*Refer to page 192*)
- When any fault occurs, take the appropriate corrective action, then reset the inverter, and resume operation. Not doing so may lead to the inverter fault and damage.

Inverter fault or alarm indications are roughly categorized as below.

- (1) Error message
A message regarding operational fault and setting fault by the operation panel is displayed. The inverter does not trip.
- (2) Warning
The inverter does not trip even when a warning is displayed. However, failure to take appropriate measures will lead to a fault.
- (3) Alarm
The inverter does not trip.
- (4) Fault
When a fault occurs, the inverter trips, and the ALM signal is also output.

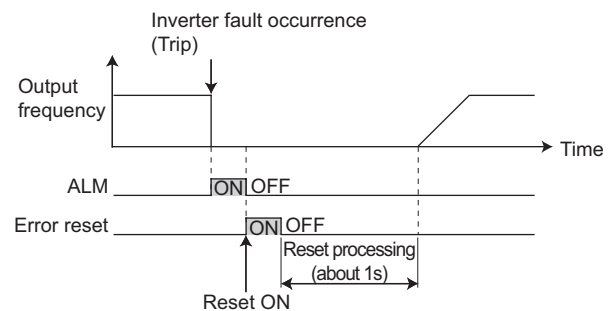

REMARKS

- Past eight faults can be displayed using the setting dial.

6.1 Reset method of protective function

(1) Resetting the inverter

The inverter can be reset by performing any of the following operations. Note that the internal thermal integrated value of the electronic thermal relay function and the number of retries are cleared (erased) by resetting the inverter. Inverter recovers about 1s after the reset is released.

Operation 1: Using the operation panel, press  to reset the inverter.

(This may only be performed when a fault occurs. (*Refer to page 197* for fault.))

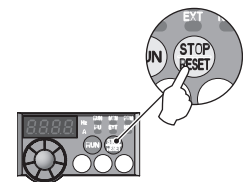

Operation 2: Change the error reset signal setting of FL remote communication from "0" to "1."
(This may only be performed when a fault occurs. (*Refer to page 197* for fault.))

Operation 3: Switch OFF the power once, then switch it ON again after the indication of the operation panel turns OFF.

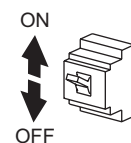

REMARKS

- Use the operation 1 or 2 to reset when using the 24V external power supply.

NOTE

- OFF status of the start signal must be confirmed before resetting the inverter fault. Resetting inverter fault with the start signal ON restarts the motor suddenly.

6.2 List of fault or alarm indications



Operation Panel Indication		Name	Refer to Page	
Error message	E---	E---	Faults history	188
	HOLD	HOLD	Operation panel lock	194
	LOCd	LOCd	Password locked	194
	Er1 / Er2 / Er4	Er1 / Er2 / Er4	Parameter write error	194
	Err.	Err.	Inverter reset	194
	Warning	OL	OL	Stall prevention (overcurrent)
oL		oL	Stall prevention (overvoltage)	195
rb		RB	Regenerative brake prealarm	196
TH		TH	Electronic thermal relay function prealarm	196
PS		PS	PU stop	195
MT		MT	Maintenance signal output	196
UV		UV	Undervoltage	196
SA		SA	Safety stop	196
EV		EV	24V external power supply operation	197
Alarm	Fn	FN	Fan alarm	197
Fault	E.OC1	E.OC1	Overcurrent trip during acceleration	197
	E.OC2	E.OC2	Overcurrent trip during constant speed	197
	E.OC3	E.OC3	Overcurrent trip during deceleration or stop	198
	E.OV1	E.OV1	Regenerative overvoltage trip during acceleration	198
	E.OV2	E.OV2	Regenerative overvoltage trip during constant speed	198
	E.OV3	E.OV3	Regenerative overvoltage trip during deceleration or stop	198
	E.THT	E.THT	Inverter overload trip (electronic thermal relay function)	199
	E.THM	E.THM	Motor overload trip (electronic thermal relay function)	199
	E.FIN	E.FIN	Heatsink overheat	199

Operation Panel Indication		Name	Refer to Page
E.ILF	E.ILF	Input phase loss	199
E.OLT	E.OLT	Stall prevention stop	200
E. bE	E. BE	Brake transistor alarm detection	200
E. GF	E.GF	Output side earth (ground) fault overcurrent at start	200
E. LF	E.LF	Output phase loss	200
E.OPT	E.OPT	Option fault	201
E.OP1	E.OP1	Communication option fault	200
E. 1	E. 1	Option fault	201
E. PE	E.PE	Parameter storage device fault	201
E.PE2	E.PE2	Internal board fault	201
E.rET	E.RET	Retry count excess	201
E. 5 / E. 6 / E. 7 / E.CPU	E. 5 / E. 6 / E. 7 / E.CPU	CPU fault	202
E.IOH	E.IOH	Inrush current limit circuit fault	202
E. 13	E.13	Internal circuit fault	202
E.SAF	E.SAF	Safety circuit fault	202

6.3 Causes and corrective actions

(1) Error message

A message regarding operational troubles is displayed. Output is not shutoff.

Operation panel indication	HOLD	HOLD
Name	Operation panel lock	
Description	Operation lock mode is set. Operation other than  is invalid. (Refer to page 184)	
Check point	—	
Corrective action	Press  for 2s to release lock.	

Operation panel indication	LOCd	LOCd
Name	Password locked	
Description	Password function is active. Display and setting of parameter is restricted.	
Check point	—	
Corrective action	Enter the password in Pr. 297 Password lock/unlock to unlock the password function before operating. (Refer to page 169).	

Operation panel indication	Er1	Er1
Name	Write disable error	
Description	<ul style="list-style-type: none"> You attempted to make parameter setting when Pr. 77 Parameter write selection has been set to disable parameter write. Frequency jump setting range overlapped. 	
Check point	<ul style="list-style-type: none"> Check the setting of Pr. 77 Parameter write selection. (Refer to page 166). Check the settings of Pr. 31 to Pr. 36 (frequency jump). (Refer to page 106) 	

Operation panel indication	Er2	Er2
Name	Write error during operation	
Description	When parameter write was performed during operation with a value other than "2" (writing is enabled independently of operation status in any operation mode) is set in Pr. 77 and the STF (STR) is ON.	
Check point	<ul style="list-style-type: none"> Check the Pr. 77 setting. (Refer to page 166). Check that the inverter is not operating. 	
Corrective action	<ul style="list-style-type: none"> Set "2" in Pr. 77. After stopping operation, make parameter setting. 	

Operation panel indication	Er4	Er4
Name	Mode designation error	
Description	Appears if a parameter setting is attempted in the NET operation mode with Pr. 77 ≠ "2."	
Check point	<ul style="list-style-type: none"> Check that operation mode is PU operation mode. Check the Pr. 77 setting. (Refer to page 166). 	
Corrective action	<ul style="list-style-type: none"> After setting the operation mode to the "PU operation mode", make parameter setting. (Refer to page 212) After setting Pr. 77 = "2", make parameter setting. 	



Operation panel indication	Err.	Err.
Name	Inverter reset	
Description	<ul style="list-style-type: none"> Appears when a reset command is executed by an error reset of FL remote communication and  on the operation panel. Appears at power-OFF. 	
Corrective action	<ul style="list-style-type: none"> Turn OFF the reset command 	

(2) Warning

When a warning occurs, the output is not shut off.

Operation panel indication	OL	OL
Name	Stall prevention (overcurrent)	
Description	During acceleration	When the output current (output torque when <i>Pr. 277 Stall prevention current switchover = "1"</i>) of the inverter exceeds the stall prevention operation level (<i>Pr. 22 Stall prevention operation level, etc.</i>), this function stops the increase in frequency until the overload current decreases to prevent the inverter from resulting in overcurrent trip. When the overload current has reduced below stall prevention operation level, this function increases the frequency again.
	During constant-speed operation	When the output current (output torque when <i>Pr. 277 Stall prevention current switchover = "1"</i>) of the inverter exceeds the stall prevention operation level (<i>Pr. 22 Stall prevention operation level, etc.</i>), this function reduces frequency until the overload current decreases to prevent the inverter from resulting in overcurrent trip. When the overload current has reduced below stall prevention operation level, this function increases the frequency up to the set value.
	During deceleration	When the output current (output torque when <i>Pr. 277 Stall prevention current switchover = "1"</i>) of the inverter exceeds the stall prevention operation level (<i>Pr. 22 Stall prevention operation level, etc.</i>), this function stops the decrease in frequency until the overload current decreases to prevent the inverter from resulting in overcurrent trip. When the overload current has decreased below stall prevention operation level, this function decreases the frequency again.
Check point	<ul style="list-style-type: none"> • Check that the <i>Pr. 0 Torque boost</i> setting is not too large. • Check that the <i>Pr. 7 Acceleration time</i> and <i>Pr. 8 Deceleration time</i> settings are not too small. • Check that the load is not too heavy. • Are there any failure in peripheral devices? • Check that the <i>Pr. 13 Starting frequency</i> is not too large. • Check that the <i>Pr. 22 Stall prevention operation level</i> is appropriate 	
Corrective action	<ul style="list-style-type: none"> • Increase or decrease the <i>Pr. 0 Torque boost</i> setting 1% by 1% and check the motor status. (<i>Refer to page 94</i>) • Set a larger value in <i>Pr. 7 Acceleration time</i> and <i>Pr. 8 Deceleration time</i>. (<i>Refer to page 116</i>) • Reduce the load weight. • Try Advanced magnetic flux vector control and General-purpose magnetic flux vector control. • Change the <i>Pr. 14 Load pattern selection</i> setting. • Set stall prevention operation current in <i>Pr. 22 Stall prevention operation level</i>. (The initial value is 150%.) The acceleration/deceleration time may change. Increase the stall prevention operation level with <i>Pr. 22 Stall prevention operation level</i>, or disable stall prevention with <i>Pr. 156 Stall prevention operation selection</i>. (Operation at OL occurrence can be selected using <i>Pr. 156</i>.) 	

Operation panel indication	oL	oL
Name	Stall prevention (overvoltage)	
Description	During deceleration	<ul style="list-style-type: none"> • If the regenerative energy of the motor becomes excessive to exceed the regenerative energy consumption capability, this function stops the decrease in frequency to prevent overvoltage trip. As soon as the regenerative energy has reduced, deceleration resumes.
		<ul style="list-style-type: none"> • If the regenerative energy of the motor becomes excessive when regeneration avoidance function is selected (<i>Pr. 882 =1</i>), this function increases the speed to prevent overvoltage trip. (<i>Refer to page 174</i>).
Check point	<ul style="list-style-type: none"> • Check for sudden speed reduction. • Check that regeneration avoidance function (<i>Pr. 882, Pr. 883, Pr. 885, Pr. 886</i>) is used. (<i>Refer to page 174</i>). 	
Corrective action	The deceleration time may change. Increase the deceleration time using <i>Pr. 8 Deceleration time</i> .	

Operation panel indication	PS	PS
Name	PU stop	
Description	Stop with  on the operation panel is selected in <i>Pr. 75 Reset selection/PU stop selection</i> . (For <i>Pr. 75 refer to page 165</i> .)	
Check point	Check for a stop made by pressing  of the operation panel.	
Corrective action	Turn the start signal OFF and release with  .	

Causes and corrective actions

Operation panel indication	RB	rb
Name	Regenerative brake prealarm	
Description	Appears if the regenerative brake duty reaches or exceeds 85% of the <i>Pr. 70 Special regenerative brake duty</i> value. When the setting of <i>Pr. 70 Special regenerative brake duty</i> is the initial value (<i>Pr. 70</i> = "0"), this warning does not occur. If the regenerative brake duty reaches 100%, a regenerative overvoltage (E. OV_) occurs.	
Check point	<ul style="list-style-type: none"> Check that the brake resistor duty is not high. Check that the <i>Pr. 30 Regenerative function selection</i> and <i>Pr. 70 Special regenerative brake duty</i> settings are correct. 	
Corrective action	<ul style="list-style-type: none"> Increase the deceleration time. Check that the <i>Pr. 30 Regenerative function selection</i> and <i>Pr. 70 Special regenerative brake duty</i> settings. 	

Operation panel indication	TH	TH
Name	Electronic thermal relay function prealarm	
Description	Appears if the cumulative value of the <i>Pr. 9 Electronic thermal O/L relay</i> reaches or exceeds 85% of the preset level. If it reaches 100% of the <i>Pr. 9 Electronic thermal O/L relay</i> setting, a motor overload trip (E. THM) occurs.	
Check point	<ul style="list-style-type: none"> Check for large load or sudden acceleration. Is the <i>Pr. 9 Electronic thermal O/L relay</i> setting is appropriate? (Refer to page 123) 	
Corrective action	<ul style="list-style-type: none"> Reduce the load and frequency of operation. Set an appropriate value in <i>Pr. 9 Electronic thermal O/L relay</i>. (Refer to page 123) 	

Operation panel indication	MT	MT
Name	Maintenance signal output	
Description	Indicates that the cumulative energization time of the inverter has reached a given time. When the setting of <i>Pr. 504 Maintenance timer alarm output set time</i> is the initial value (<i>Pr. 504</i> = "9999"), this warning does not occur.	
Check point	The <i>Pr. 503 Maintenance timer</i> setting is larger than the <i>Pr. 504 Maintenance timer alarm output set time</i> setting. (Refer to page 180).	
Corrective action	Setting "0" in <i>Pr. 503 Maintenance timer</i> erases the signal.	

Operation panel indication	UV	UV
Name	Undervoltage	
Description	If the power supply voltage of the inverter decreases, the control circuit will not perform normal functions. In addition, the motor torque will be insufficient and/or heat generation will increase. To prevent this, if the power supply voltage decreases below about 115VAC (about 230VAC for 400V class, about 58VAC for 100V class), this function stops the inverter output and displays UV. An alarm is reset when the voltage returns to normal.	
Check point	Check that the power supply voltage is normal.	
Corrective action	Check the power supply system equipment such as power supply.	

Operation panel indication	SA	SA
Name	Safety stop	
Description	Appears when safety stop function is activated (during output shutoff). (Refer to page 24)	
Check point	If the indication appears when safety stop function is not used, check that shorting wires between S1 and PC, S2 and PC are connected.	
Corrective action	<ul style="list-style-type: none"> When not using the safety stop function, short across terminals S1 and PC and across S2 and PC with shorting wire for the inverter to run. If SA is indicated when across S1 and PC and across S2 and PC are both shorted while using the safety stop function (drive enabled), internal failure might be the cause. Check the wiring of terminals S1, S2 and PC and contact your sales representative if the wiring has no fault. 	

Operation panel indication	EV	E_U
Name	24V external power supply operation	
Description	Flickers when the main circuit power supply is OFF and the 24V external power is being supplied.	
Check point	<ul style="list-style-type: none"> • Check if the 24V external power is supplied. • Check if the (main circuit) power supply for the inverter is ON. Check if the voltage is low. • Check if the jumper between terminal P/+ and P1 is removed. 	
Corrective action	<ul style="list-style-type: none"> • Turn ON the power supply for the inverter (main circuit). • If E_U appears by turning ON the power supply of the inverter (main circuit) while the external 24V power is supplied, check the power supply (for the main circuit). • Check if the jumper is installed securely between the terminal P/+ and P1. 	

(3) Alarm

When an alarm occurs, the output is not shut off.

Operation panel indication	FN	F_n
Name	Fan alarm	
Description	For the inverter that contains a cooling fan, F_n appears on the operation panel when the cooling fan stops due to an alarm or different operation from the setting of <i>Pr. 244 Cooling fan operation selection</i> .	
Check point	Check the cooling fan for an alarm.	
Corrective action	Check for fan alarm. Please contact your sales representative.	

(4) Fault

When a fault occurs, the inverter trips and a fault signal is output.

Operation panel indication	E.OC1	$E.OC 1$
Name	Overcurrent trip during acceleration	
Description	When the inverter output current reaches or exceeds approximately 230% of the rated current during acceleration, the protective circuit is activated and the inverter trips.	
Check point	<ul style="list-style-type: none"> • Check for sudden acceleration. • Check that the downward acceleration time is not long for lifts. • Check for output short-circuit/ground fault. • Check that the <i>Pr. 3 Base frequency</i> setting is not 60Hz when the motor rated frequency is 50Hz. • Check if the stall prevention operation level is set too high. • Check if the fast-response current limit operation is disabled. • Check that regeneration is not performed frequently. (Check that the output voltage becomes larger than the V/F reference value at regeneration and overcurrent occurs due to the high voltage.) 	
Corrective action	<ul style="list-style-type: none"> • Increase the acceleration time. (Shorten the downward acceleration time for lifts.) • When "E.OC1" is always lit at starting, disconnect the motor once and start the inverter. If "E.OC1" is still lit, contact your sales representative. • Check the wiring to make sure that output short circuit/ground fault does not occur. • Set 50Hz in <i>Pr. 3 Base frequency</i>. (Refer to page 107) • Lower the setting of stall prevention operation level. (Refer to page 101). • Activate the fast-response current limit operation. • Set base voltage (rated voltage of the motor, etc.) in <i>Pr. 19 Base frequency voltage</i>. (Refer to page 107) 	

Operation panel indication	E.OC2	$E.OC 2$
Name	Overcurrent trip during constant speed	
Description	When the inverter output current reaches or exceeds approximately 230% of the rated current during constant speed operation, the protective circuit is activated and the inverter trips.	
Check point	<ul style="list-style-type: none"> • Check for sudden load change. • Check for output short-circuit/ground fault. • Check if the stall prevention operation level is set too high. • Check if the fast-response current limit operation is disabled. 	
Corrective action	<ul style="list-style-type: none"> • Keep load stable. • Check the wiring to make sure that output short circuit/ground fault does not occur. • Lower the setting of stall prevention operation level. (Refer to page 101). • Activate the fast-response current limit operation. 	

7 Causes and corrective actions

Operation panel indication	E.OC3	E.OC3
Name	Overcurrent trip during deceleration or stop	
Description	When the inverter output current reaches or exceeds approximately 230% of the rated inverter current during deceleration (other than acceleration or constant speed), the protective circuit is activated and the inverter trips.	
Check point	<ul style="list-style-type: none"> • Check for sudden speed reduction. • Check for output short-circuit/ground fault. • Check for too fast operation of the motor's mechanical brake. • Check if the stall prevention operation level is set too high. • Check if the fast-response current limit operation is disabled. 	
Corrective action	<ul style="list-style-type: none"> • Increase the deceleration time. • Check the wiring to make sure that output short circuit/ground fault does not occur. • Check the mechanical brake operation. • Lower the setting of stall prevention operation level. (Refer to page 101). • Activate the fast-response current limit operation. 	

Operation panel indication	E.OV1	E.OV1
Name	Regenerative overvoltage trip during acceleration	
Description	If regenerative energy causes the inverter's internal main circuit DC voltage to reach or exceed the specified value, the protective circuit is activated and the inverter trips. The circuit may also be activated by a surge voltage produced in the power supply system.	
Check point	<ul style="list-style-type: none"> • Check for too slow acceleration. (e.g. during downward acceleration in vertical lift load) • Check that the setting of Pr. 22 Stall prevention operation level is not too small. 	
Corrective action	<ul style="list-style-type: none"> • Decrease the acceleration time. • Check that regeneration avoidance function (Pr. 882, Pr. 883, Pr. 885, Pr. 886) is used. (Refer to page 174). • Set the Pr.22 Stall prevention operation level correctly. 	

Operation panel indication	E.OV2	E.OV2
Name	Regenerative overvoltage trip during constant speed	
Description	If regenerative energy causes the inverter's internal main circuit DC voltage to reach or exceed the specified value, the protective circuit is activated to stop the inverter output. The circuit may also be activated by a surge voltage produced in the power supply system.	
Check point	<ul style="list-style-type: none"> • Check for sudden load change. • Check that the setting of Pr. 22 Stall prevention operation level is not too small. 	
Corrective action	<ul style="list-style-type: none"> • Keep load stable. • Check that regeneration avoidance function (Pr. 882, Pr. 883, Pr. 885, Pr. 886) is used. (Refer to page 174). • Use the brake resistor, brake unit or power regeneration common converter (FR-CV) as required. • Set the Pr.22 Stall prevention operation level correctly. 	

Operation panel indication	E.OV3	E.OV3
Name	Regenerative overvoltage trip during deceleration or stop	
Description	If regenerative energy causes the inverter's internal main circuit DC voltage to reach or exceed the specified value, the protective circuit is activated to stop the inverter output. The circuit may also be activated by a surge voltage produced in the power supply system.	
Check point	Check for sudden speed reduction.	
Corrective action	<ul style="list-style-type: none"> • Increase the deceleration time. (Set the deceleration time which matches the moment of inertia of the load) • Longer the brake cycle. • Use regeneration avoidance function (Pr. 882, Pr. 883, Pr. 885, Pr. 886). (Refer to page 174). • Use the brake resistor, brake unit or power regeneration common converter (FR-CV) as required. 	

Operation panel indication	E.THT	E.THT
Name	Inverter overload trip (electronic thermal relay function)	
Description	If the temperature of the output transistor element exceeds the protection level under the condition that a current not less than the rated inverter current flows and overcurrent trip does not occur (230% or less), the electronic thermal relay activates to stop the inverter output. (Overload capacity 150% 60s, 200% 3s)	
Check point	<ul style="list-style-type: none"> • Check that acceleration/deceleration time is not too short. • Check that torque boost setting is not too large (small). • Check that load pattern selection setting is appropriate for the load pattern of the using machine. • Check the motor for use under overload. • Check for too high surrounding air temperature. 	
Corrective action	<ul style="list-style-type: none"> • Increase acceleration/deceleration time. • Adjust the torque boost setting. • Set the load pattern selection setting according to the load pattern of the using machine. • Reduce the load weight. • Set the surrounding air temperature to within the specifications. 	

Operation panel indication	E.THM	E.THM
Name	Motor overload trip (electronic thermal relay function) *1	
Description	The electronic thermal relay function in the inverter detects motor overheat due to overload or reduced cooling capability during constant-speed operation and pre-alarm (TH display) is output when the integrated value reaches 85% of the Pr. 9 <i>Electronic thermal O/L relay</i> setting and the protection circuit is activated to stop the inverter output when the integrated value reaches the specified value. When running a special motor such as a multi-pole motor or multiple motors, provide a thermal relay on the inverter output side since such motor(s) cannot be protected by the electronic thermal relay function.	
Check point	<ul style="list-style-type: none"> • Check the motor for use under overload. • Check that the setting of Pr. 71 <i>Applied motor</i> for motor selection is correct. (Refer to page 125). • Check that stall prevention operation setting is correct. 	
Corrective action	<ul style="list-style-type: none"> • Reduce the load weight. • For a constant-torque motor, set the constant-torque motor in Pr. 71 <i>Applied motor</i>. • Check that stall prevention operation setting is correct. (Refer to page 101). 	

*1 Resetting the inverter initializes the internal thermal integrated data of the electronic thermal relay function.

Operation panel indication	E.FIN	E.FIN
Name	Heatsink overheat	
Description	If the heatsink overheats, the temperature sensor is actuated and the inverter trips. FIN signal is output through FL remote communication when the temperature rises to 85% of the heatsink overheat protection temperature. (Refer to page 60)	
Check point	<ul style="list-style-type: none"> • Check for too high surrounding air temperature. • Check for heatsink clogging. • Check that the cooling fan is not stopped (Check that F_n is not displayed on the operation panel). 	
Corrective action	<ul style="list-style-type: none"> • Set the surrounding air temperature to within the specifications. • Clean the heatsink. • Replace the cooling fan. 	

Operation panel indication	E.ILF	E.ILF
Name	Input phase loss	
Description	Inverter trips when function valid setting (=1) is selected in Pr. 872 <i>Input phase loss protection selection</i> and one phase of the three phase power input is lost. (Refer to page 160). It may function if phase-to-phase voltage of the three-phase power input becomes largely unbalanced.	
Check point	<ul style="list-style-type: none"> • Check for a break in the cable for the three-phase power supply input. • Check that phase-to-phase voltage of the three-phase power input is not largely unbalanced. 	
Corrective action	<ul style="list-style-type: none"> • Wire the cables properly. • Repair a break portion in the cable. • Check the Pr. 872 <i>Input phase loss protection selection</i> setting. • Set Pr. 872 = "0" (without input phase loss protection) when three-phase input voltage is largely unbalanced. 	

7 Causes and corrective actions

Operation panel indication	E.OLT	E.OLT
Name	Stall prevention stop stop	
Description	If the output frequency has fallen to 1Hz by stall prevention operation and remains for 3s, a fault (E.OLT) appears and trips the inverter. OL appears while stall prevention is being activated. E.OLT may not occur if stall prevention (OL) is activated during output phase loss.	
Check point	<ul style="list-style-type: none"> • Check the motor for use under overload. (Refer to page 102). 	
Corrective action	<ul style="list-style-type: none"> • Reduce the load weight. (Check the Pr. 22 Stall prevention operation level setting.) 	

Operation panel indication	E.BE	E. bE
Name	Brake transistor alarm detection	
Description	When a brake transistor alarm has occurred due to the large regenerative energy from the motor etc., the brake transistor alarm is detected and the inverter trips. <u>In this case, the inverter must be powered OFF immediately.</u>	
Check point	<ul style="list-style-type: none"> • Reduce the load inertia. • Check that the frequency of using the brake is proper. 	
Corrective action	Replace the inverter.	

Operation panel indication	E.GF	E. GF
Name	Output side earth (ground) fault overcurrent at start	
Description	The inverter trips if an earth (ground) fault overcurrent flows at start due to an earth (ground) fault that occurred on the inverter's output side (load side). Whether this protective function is used or not is set with Pr. 249 Earth (ground) fault detection at start. When the setting of Pr. 249 Earth (ground) fault detection at start is the initial value (Pr. 249 = "0"), this warning does not occur.	
Check point	Check for a ground fault in the motor and connection cable.	
Corrective action	Remedy the ground fault portion.	

Operation panel indication	E.LF	E. LF
Name	Output phase loss	
Description	If one of the three phases (U, V, W) on the inverter's output side (load side) is lost during inverter operation (except during DC injection brake operation and when output frequency is under 1Hz), inverter stops the output. Whether the protective function is used or not is set with Pr. 251 Output phase loss protection selection.	
Check point	<ul style="list-style-type: none"> • Check the wiring. (Check that the motor is normal.) • Check that the capacity of the motor used is not smaller than that of the inverter. 	
Corrective action	<ul style="list-style-type: none"> • Wire the cables properly. • Check the Pr. 251 Output phase loss protection selection setting. 	

Operation panel indication	E.OP1	E.OP 1
Name	Communication option fault	
Description	Inverter output is stopped when a fault occurs on the communication line of FL remote communication.	
Check point	<ul style="list-style-type: none"> • Check if the inverter's LED shows any fault. • Check if the FL-net dedicated cable has a break. • Check if the length of the FL-net dedicated cable is within the specified range. 	
Corrective action	<ul style="list-style-type: none"> • Refer to "Troubleshooting in FL remote communication" on page 209, and take corrective actions for the fault. • Check the connection of the FL-net dedicated cable. • Check that each FL-net dedicated cable length between nodes is within the specified range. (Refer to page 46). 	

Operation Panel Indication	E.OPT	E.OPT
Name	Option fault	
Description	<ul style="list-style-type: none"> • Appears when a node address is set out of the setting range (other than 1 to 64). Also appears when the node address is set improperly. • Appears when <i>Pr.296 Password lock level</i> = "0 or 100." 	
Check point	<ul style="list-style-type: none"> • Check if the node address is set within the range of 1 to 64. • Check if the node address switch is set between numbers. • Check if "0 or 100" is set in <i>Pr. 296</i>. 	
Corrective action	<ul style="list-style-type: none"> • Set the node address within the range of 1 to 64. (<i>Refer to page 46</i>). • Set the node address switch to the switch number position correctly. (<i>Refer to page 46</i>). • Set <i>Pr.296</i> ≠ "0 or 100" for the password lock. • If the problem still persists after taking the above measure, please contact your sales representative. 	

Operation panel indication	E. 1	E. 1
Name	Option fault	
Description	<ul style="list-style-type: none"> • Inverter output is stopped if there is excess electrical noise around the inverter or in other conditions. • Appears when the setting of the master is incorrect. 	
Check point	<ul style="list-style-type: none"> • Check for excess electrical noises around the inverter. • Check if a protocol other than FL remote protocol is selected. Also check if the number of words in the transmission/receive area is set to "0." 	
Corrective action	<ul style="list-style-type: none"> • Take measures against noises if there are devices producing excess electrical noises around the inverter. • Select FL remote protocol. Set an appropriate number of words for the transmission/receive area. (<i>Refer to page 54</i> for the setting for the transmission/receive area.) • If the problem still persists after taking the above measure, please contact your sales representative. 	

Operation panel indication	E.PE	E. PE
Name	Parameter storage device fault (control circuit board)	
Description	Stops the inverter output if fault occurred in the parameter stored. (EEPROM fault)	
Check point	Check for too many number of parameter write times.	
Corrective action	Please contact your sales representative.	

Operation Panel Indication	E.PE2	EPE2
Name	Internal board fault	
Description	When a combination of control board and main circuit board is wrong, the inverter is tripped.	
Check point	—	
Corrective action	Please contact your sales representative. (For parts replacement, consult the nearest Mitsubishi FA Center.)	

Operation panel indication	E.RET	E.r ET
Name	Retry count excess	
Description	<p>If operation cannot be resumed properly within the number of retries set, this function trips the inverter.</p> <p>The indication is available only when <i>Pr. 67 Number of retries at fault occurrence</i> is set.</p> <p>When the initial value (<i>Pr. 67</i> = "0") is set, this protective function is not available.</p>	
Check point	Find the cause of fault occurrence.	
Corrective action	Eliminate the cause of the error preceding this error indication.	

Causes and corrective actions

Operation panel indication	E. 5	E. 5
	E. 6	E. 6
	E. 7	E. 7
	E.CPU	E.CPU
Name	CPU fault	
Description	Stops the inverter output if the communication fault of the built-in CPU occurs.	
Check point	<ul style="list-style-type: none"> • Check for devices producing excess electrical noises around the inverter. • Check if the terminals PC and SD are shorted. (E.6/ E.7) 	
Corrective action	<ul style="list-style-type: none"> • Take measures against noises if there are devices producing excess electrical noises around the inverter. • Check the connection between terminals PC and SD. (E.6/ E.7) • Please contact your sales representative. 	

Operation panel indication	E.IOH	E. IOH
Name	Inrush current limit circuit fault	
Description	Stops the inverter output when the resistor of inrush current limit circuit overheated. The inrush current limit circuit fault	
Check point	Check that frequent power ON/OFF is not repeated.	
Corrective action	Configure a circuit where frequent power ON/OFF is not repeated. If the problem still persists after taking the above measure, please contact your sales representative.	

Operation panel indication	E.13	E. 13
Name	Internal circuit fault	
Description	Stop the inverter output when an internal circuit fault occurred.	
Corrective action	Please contact your sales representative.	

Operation panel indication	E.SAF	E.SAF
Name	Safety circuit fault	
Description	Appears when safety circuit is malfunctioning. Appears when one of the lines between S1 and PC, or between S2 and PC is opened. May appear when the start-up time of the 24V power supply is too long in the 24V external power supply operation.	
Check point	<ul style="list-style-type: none"> • If the indication appears when safety stop function is not used, check if shorting wires between S1 and PC, S2 and PC are connected. • If the indication appears when safety stop function is used, check that the safety relay module or the connection has no fault. • Check if the start up time of the 24V external power supply is 500ms or longer. 	
Corrective action	<ul style="list-style-type: none"> • When not using the safety stop function, short across terminals S1 and PC and across S2 and PC with shorting wire. (Refer to page 24). • When using the safety stop function, check that wiring of terminal S1, S2 and PC is correct and the safety stop input signal source such as safety relay module is operating properly. Refer to the Safety stop function instruction manual (BCN-A211508-004) for the details. Refer the front cover of the Instruction Manual (Basic) for how to obtain the manual. • Set the start up time of the 24V external power supply within 500ms. 	



NOTE

- If faults other than the above appear, contact your sales representative.

6.4 Correspondences between digital and actual characters

There are the following correspondences between the actual alphanumeric characters and the digital characters displayed on the operation panel:

Actual	Digital
0	0
1	1
2	2
3	3
4	4
5	5
6	6
7	7
8	8
9	9

Actual	Digital
A	A
B	b
C	C
D	d
E	E
F	F
G	G
H	H
I	I
J	J
L	L

Actual	Digital
M	m
N	n
O	O
o	o
P	P
S	S
T	T
U	U
V	V
r	r
-	-

6.5 Check first when you have a trouble



POINT

- If the cause is still unknown after every check, it is recommended to initialize the parameters (initial value) then set the required parameter values and check again.

6.5.1 Motor does not start

Check points	Possible Cause	Countermeasures	Refer to page
Main Circuit	Appropriate power supply voltage is not applied. (Operation panel display is not provided.)	Power ON a moulded case circuit breaker (MCCB), an earth leakage circuit breaker (ELB), or a magnetic contactor (MC). Check for the decreased input voltage, input phase loss, and wiring.	—
	Motor is not connected properly.	Check the wiring between the inverter and the motor.	15
	The jumper across P/+ and P1 is disconnected.	Securely fit a jumper across P/+ and P1. When using a DC reactor (FR-HEL), remove the jumper across P/+ and P1, and then connect the DC reactor.	28
Input Signal	Start signal is not input.	Check the start command source, and input a start signal. PU operation mode: RUN Network operation mode: STF/STR signal	57, 74
	Both the forward and reverse rotation start signals (STF, STR) are input simultaneously.	Turn ON only one of the forward and reverse rotation start signals (STF or STR). If STF and STR signals are turned ON simultaneously in the initial setting, a stop command is given.	20
	Frequency command is zero. (RUN LED on the operation panel is flickering.)	Enter a frequency command.	58
	Output stop signal (MRS) or error reset is ON. (RUN LED on the operation panel flickers while MRS signal or error reset is ON.)	Turn MRS signal or error reset OFF. Inverter starts the operation with a given start command and a frequency command after turning OFF MRS signal or error reset. Before turning OFF, ensure the safety.	57
	Shorting wires across S1 and PC and across S2 and PC are disconnected even though the safety stop function is not being used.	When not using the safety stop function, short across terminals S1 and PC and across S2 and PC with shorting wire.	24
	was pressed. (Operation panel indication is PS (PS).)	During the Network operation mode, check the method of restarting from a input stop from the operation panel.	195
Parameter Setting	Pr. 0 Torque boost setting is improper when V/F control is used.	Increase Pr. 0 setting by 0.5% increments while observing the rotation of a motor. If that makes no difference, decrease the setting.	94
	Pr. 78 Reverse rotation prevention selection is set.	Check the Pr. 78 setting. Set Pr. 78 when you want to limit the motor rotation to only one direction.	167
	Pr. 13 Starting frequency setting is greater than the running frequency.	Set running frequency higher than Pr. 13. The inverter does not start if the frequency setting signal is less than the value set in Pr. 13.	119
	Frequency settings of various running frequency (such as multi-speed operation) are zero. Especially, Pr. 1 Maximum frequency is zero.	Set the frequency command according to the application. Set Pr. 1 higher than the actual frequency used.	105
	Pr. 15 Jog frequency setting is lower than the Pr. 13 Starting frequency setting during the JOG operation.	Set Pr. 15 Jog frequency higher than Pr. 13 Starting frequency.	171

Check points	Possible Cause	Countermeasures	Refer to page
Parameter Setting	Inverter decelerated to a stop when power failure deceleration stop function is selected.	When power is restored, ensure the safety, and turn OFF the start signal once, then turn ON again to restart. Inverter restarts when Pr. 261="2".	156
	Performing auto tuning.	When offline auto tuning ends, press  of the operation panel. For the Network operation, turn OFF the start signal (STF or STR). This operation resets the offline auto tuning, and the operation panel monitor display returns to the normal. (Without this operation, next operation cannot be started.)	127
Load	Load is too heavy.	Reduce the load.	—
	Shaft is locked.	Inspect the machine (motor).	—
Others	Operation panel display shows an error (e.g. E.OC1).	When any fault occurs, take an appropriate corrective action, then reset the inverter, and resume the operation.	193

6.5.2 Motor or machine is making abnormal acoustic noise

Check points	Possible Cause	Countermeasures	Refer to page
Parameter Setting	No carrier frequency noises (metallic noises) are generated.	In the initial setting, Pr. 240 <i>Soft-PWM operation selection</i> is enabled to change motor noise to an unoffending complex tone. Therefore, no carrier frequency noises (metallic noises) are generated. Set Pr. 240 = "0" to disable this function.	163
	Resonance occurs. (output frequency)	Set Pr. 31 to Pr. 36 (<i>Frequency jump</i>). When it is desired to avoid resonance attributable to the natural frequency of a mechanical system, these parameters allow resonant frequencies to be jumped.	106
	Resonance occurs. (carrier frequency)	Change Pr. 72 <i>PWM frequency selection</i> setting. Changing the PWM carrier frequency produces an effect on avoiding the resonance frequency of a mechanical system or a motor.	163
	Auto tuning is not performed under Advanced magnetic flux vector control or General-purpose magnetic flux vector control.	Perform offline auto tuning.	127
Others	Mechanical looseness	Adjust machine/equipment so that there is no mechanical looseness.	—
Motor	Operating with output phase loss	Check the motor wiring.	—
	Contact the motor manufacturer.		

6.5.3 Inverter generates abnormal noise

Check points	Possible Cause	Countermeasures	Refer to page
Fan	Fan cover was not correctly installed when a cooling fan was replaced.	Install a fan cover correctly.	216

6.5.4 Motor generates heat abnormally

Check points	Possible Cause	Countermeasures	Refer to page
Motor	Motor fan is not working (Dust is accumulated.)	Clean the motor fan. Improve the environment.	—
	Phase to phase insulation of the motor is insufficient.	Check the insulation of the motor.	—
Main Circuit	The inverter output voltage (U, V, W) are unbalanced.	Check the output voltage of the inverter. Check the insulation of the motor.	213
Parameter Setting	The <i>Pr. 71 Applied motor</i> setting is wrong.	Check the <i>Pr. 71 Applied motor</i> setting.	125
—	Motor current is large.	Refer to "6.5.11 Motor current is too large"	208

6.5.5 Motor rotates in the opposite direction

Check points	Possible Cause	Countermeasures	Refer to page
Main Circuit	Phase sequence of output terminals U, V and W is incorrect.	Connect phase sequence of the output cables (terminal U, V, W) to the motor correctly	15
Parameter Setting	<i>Pr. 40 RUN key rotation direction selection</i> setting is incorrect.	Check the <i>Pr. 40</i> setting.	182

6.5.6 Speed greatly differs from the setting

Check points	Possible Cause	Countermeasures	Refer to page
Parameter Setting	<i>Pr. 1, Pr. 2, Pr. 18</i> settings are improper.	Check the settings of <i>Pr. 1 Maximum frequency, Pr. 2 Minimum frequency, Pr. 18 High speed maximum frequency.</i>	105
	<i>Pr. 31 to Pr. 36 (frequency jump)</i> settings are improper.	Narrow down the range of frequency jump.	106
Load	Stall prevention function is activated due to a heavy load.	Reduce the load weight.	—
Parameter Setting		Set <i>Pr. 22 Stall prevention operation level</i> higher according to the load. (Setting <i>Pr. 22</i> too large may result in frequent overcurrent trip (E.OC□).)	101
Motor		Check the capacities of the inverter and the motor.	—

6.5.7 Acceleration/deceleration is not smooth

Check points	Possible Cause	Countermeasures	Refer to page
Parameter Setting	The base frequency does not match the motor characteristics.	For V/F control, set <i>Pr. 3 Base frequency and Pr. 47 Second V/F (base frequency).</i>	107
		For Advanced magnetic flux vector control or General-purpose magnetic flux vector control, set <i>Pr. 84 Rated motor frequency.</i>	127
	Stall prevention function is activated due to a heavy load.	Reduce the load weight.	—
		Set <i>Pr. 22 Stall prevention operation level</i> higher according to the load. (Setting <i>Pr. 22</i> too large may result in frequent overcurrent trip (E.OC□).)	101
		Check the capacities of the inverter and the motor.	—
	Acceleration/deceleration time is too short.	Increase acceleration/deceleration time.	116
	Torque boost (<i>Pr. 0, Pr. 46</i>) setting is improper under V/F control, so the stall prevention function is activated.	Increase/decrease <i>Pr. 0 Torque boost</i> setting value by 0.5% increments to the setting.	94
Regeneration avoidance operation is performed	If the frequency becomes unstable during regeneration avoidance operation, decrease the setting of <i>Pr. 886 Regeneration avoidance voltage gain.</i>	174	

6.5.8 Speed varies during operation

When Advanced magnetic flux vector control or the slip compensation is selected, the output frequency varies between 0 and 2Hz as load fluctuates. This is a normal operation and not a fault.

Check points	Possible Cause	Countermeasures	Refer to page
Load	Load varies during an operation.	Select Advanced magnetic flux vector control or General-purpose magnetic flux vector control.	95
Input signal	Frequency setting signal is varying.	Check the frequency setting signal.	—
Parameter Setting	<i>Pr. 80 Motor capacity</i> and <i>Pr. 81 Number of motor poles</i> setting is improper for the capacities of the inverter and the motor for Advanced magnetic flux vector control or General-purpose magnetic flux vector control.	Check the <i>Pr. 80 Motor capacity</i> and <i>Pr. 81 Number of motor poles</i> setting.	95
	Fluctuation of power supply voltage is too large.	Change the <i>Pr. 19 Base frequency voltage</i> setting (about 3%) under V/F control.	107
	Hunting occurs by the generated vibration, for example, when structural rigidity at load side is insufficient.	Disable automatic control functions, such as energy saving operation, fast-response current limit function, regeneration avoidance function, Advanced magnetic flux vector control, General-purpose magnetic flux vector control, and stall prevention. Adjust so that the control gain decreases and the level of safety increases. Change <i>Pr. 72 PWM frequency selection</i> setting.	— 163
Others	Wiring length exceeds 30m when Advanced magnetic flux vector control or General-purpose magnetic flux vector control is performed.	Perform offline auto tuning.	127
	Wiring length is too long for V/F control, and a voltage drop occurs.	Adjust <i>Pr. 0 Torque boost</i> by increasing with 0.5% increments for low-speed operation. Change to Advanced magnetic flux vector control or General-purpose magnetic flux vector control.	94 95

6.5.9 Operation mode is not changed properly

Check points	Possible Cause	Countermeasures	Refer to page
Input signal	Start signal (STF or STR) is ON.	Check that the STF and STR signals are OFF. When either is ON, the operation mode cannot be changed.	57, 74
	"0" is set in the X12 signal (Bit11), which gives a control input command through FL remote communication.	Set "1" in the X12 signal (Bit11), which gives a control input command through FL remote communication.	57
Others	FL-net dedicated cable is not installed properly. (The cable has contact faults and breaks.)	Install the FL-net dedicated cable properly.	48

6.5.10 Operation panel display is not operating

Check points	Possible Cause	Countermeasures	Refer to page
Main Circuit	Wiring or installation is improper.	Check for the wiring and the installation.	14
		Make sure that the connector is fitted securely across terminal P/+ and P1.	
Main Circuit Control Circuit	Power is not input.	Input the power.	14

6.5.11 Motor current is too large

Check points	Possible Cause	Countermeasures	Refer to page
Parameter Setting	Torque boost (Pr. 0, Pr. 46) setting is improper under V/F control, so the stall prevention function is activated.	Increase/decrease Pr. 0 Torque boost setting value by 0.5% increments to the setting.	94
	V/F pattern is improper when V/F control is performed. (Pr. 3, Pr. 14, Pr. 19)	Set rated frequency of the motor to Pr. 3 Base frequency. Use Pr. 19 Base frequency voltage to set the base voltage (e.g. rated motor voltage).	107
		Change Pr. 14 Load pattern selection according to the load characteristic.	109
	Stall prevention function is activated due to a heavy load.	Reduce the load weight.	—
		Set Pr. 22 Stall prevention operation level higher according to the load. (Setting Pr. 22 too large may result in frequent overcurrent trip (E.OC□).)	101
	Auto tuning is not performed under Advanced magnetic flux vector control or General-purpose magnetic flux vector control.	Check the capacities of the inverter and the motor.	—
	Perform offline auto tuning.	127	

6.5.12 Speed does not accelerate

Check points	Possible Cause	Countermeasures	Refer to page
Parameter Setting	Pr. 1, Pr. 2, Pr. 18 settings are improper.	Check the settings of Pr. 1 Maximum frequency and Pr. 2 Minimum frequency. If you want to run the motor at 120Hz or higher, set Pr. 18 High speed maximum frequency.	105
	Torque boost (Pr. 0, Pr. 46) setting is improper under V/F control, so the stall prevention function is activated.	Increase/decrease Pr. 0 Torque boost setting value by 0.5% increments so that stall prevention does not occur.	94
	V/F pattern is improper when V/F control is performed. (Pr. 3, Pr. 14, Pr. 19)	Set rated frequency of the motor to Pr. 3 Base frequency. Use Pr. 19 Base frequency voltage to set the base voltage (e.g. rated motor voltage).	107
		Change Pr. 14 Load pattern selection according to the load characteristic.	109
	Stall prevention function is activated due to a heavy load.	Reduce the load weight.	—
		Set Pr. 22 Stall prevention operation level higher according to the load. (Setting Pr. 22 too large may result in frequent overcurrent trip (E.OC□).)	101
Auto tuning is not performed under Advanced magnetic flux vector control or General-purpose magnetic flux vector control.	Check the capacities of the inverter and the motor.	—	
	Perform offline auto tuning.	127	
Main Circuit	Brake resistor is connected between terminal P/+ and P1 or between terminal P1 and PR by mistake.	Connect an optional brake transistor (MRS type, MYS type, FR-ABR) between terminal P/+ and PR.	25

6.5.13 Unable to write parameter setting

Check points	Possible Cause	Countermeasures	Refer to page
Input signal	Operation is being performed (signal STF or STR is ON).	Stop the operation. When Pr. 77 = "0" (initial value), write is enabled only during a stop.	166
	"0" is set in the X12 signal (Bit11), which gives a control input command through FL remote communication.	Set "1" in the X12 signal (Bit11), which gives a control input command through FL remote communication.	57
Parameter Setting	You are attempting to set a parameter from the operation panel while in Network operation mode.	Choose the PU operation mode. Or, set Pr. 77 = "2" to enable parameter write regardless of the operation mode.	166
	Parameter is disabled by the Pr. 77 Parameter write selection setting.	Check Pr. 77 Parameter write selection setting.	166
	Key lock is activated by the Pr. 161 Frequency setting/key lock operation selection setting.	Check Pr. 161 Frequency setting/key lock operation selection setting.	183

6.5.14 Troubleshooting in FL remote communication

If a fault occurs and the inverter fails to operate properly, locate the cause of the fault and take proper corrective action by referring to the troubleshooting below. If the corresponding information is not found in the table, the inverter has problem, or the component parts are damaged, contact your sales representative.

Display		Possible Causes	Check Point	Countermeasure
Operation panel of inverter	Operation status LED (Refer to page 49)			
E.1	DEV <input type="checkbox"/>	The firmware has an internal fault.	—	Please contact your sales representative.
	RMT <input type="checkbox"/>	Incorrect setting to the master	Check if a protocol other than FL remote protocol is selected. Also check if the number of words in the transmission/receive area is set to "0."	Select the FL remote protocol. Set an appropriate number of words for the transmission/receive area. (Refer to page 54 for the setting of the transmission/receive area.)
	DEV <input checked="" type="checkbox"/>	The FL remote communication circuit in the inverter is faulty.	—	Please contact your sales representative.
E.OPT	DEV <input checked="" type="checkbox"/>	Node address is out of range (other than 1 to 64).	Check that the node address setting is within the range (1 to 64).	Set the node address within the range (1 to 64) (Refer to page 46)
	RMT <input type="checkbox"/>	Node address is not correctly set.	Check that the node address switch is not set between numbers.	Set the node address switch to the number position correctly. (Refer to page 46)
		The FL remote communication circuit in the inverter is faulty.	—	Please contact your sales representative.
E.OP1	DEV <input type="checkbox"/>	The inverter is not participated in FL remote network and communication between the inverter and switching hub is disconnected.	Check that no break in the cable between the inverter and switching hub.	Make sure to connect the cable between the inverter and switching hub.
	RMT <input type="checkbox"/>	After the inverter participated in FL remote network, communication between the inverter and switching hub is disconnected.		
0.00	DEV <input type="checkbox"/>	FL remote network communication is not established.	Check that node address setting of the inverter and slave station setting of the master are the same.	Set the node address of the inverter and slave station of the master to the same setting.
	RMT <input type="checkbox"/>	Unsupported protocol	A protocol other than FL remote is selected.	Use the master that has the FL remote setting.

:OFF, : red is lit, : green is lit, ↔ :red is flickering

MEMO

7 PRECAUTIONS FOR MAINTENANCE AND INSPECTION

This chapter provides the "PRECAUTIONS FOR MAINTENANCE AND INSPECTION" of this product.
Always read the instructions before using the equipment.

7.1	Inspection items.....	212
7.2	Measurement of main circuit voltages, currents and powers .	218

1

2

3

4

5

6

7

8

The inverter is a static unit mainly consisting of semiconductor devices. Daily inspection must be performed to prevent any fault from occurring due to the adverse effects of the operating environment, such as temperature, humidity, dust, dirt and vibration, changes in the parts with time, service life, and other factors.

●Precautions for maintenance and inspection

When accessing the inverter for inspection, wait for at least 10 minutes after the power supply has been switched OFF, and then make sure that the voltage across the main circuit terminals P/+ and N/- of the inverter is not more than 30VDC using a tester, etc. The capacitor is charged with high voltage for some time after power OFF, and it is dangerous.

If "EV" is displayed on the operation panel, turn off the 24V external power supply before inspection.

7.1 Inspection items

7.1.1 Daily inspection

Basically, check for the following faults during operation.

- (1) Motor operation fault
- (2) Improper installation environment
- (3) Cooling system fault
- (4) Abnormal vibration, abnormal noise
- (5) Abnormal overheat, discoloration

7.1.2 Periodic inspection

Check the areas inaccessible during operation and requiring periodic inspection.

For a periodic inspection, contact your sales representative.

- (1) Check for cooling system fault.....Clean the air filter, etc.
- (2) Tightening check and retightening.....The screws and bolts may become loose due to vibration, temperature changes, etc. Check and tighten them.
Tighten them according to the specified tightening torque (*Refer to page 17*).
- (3) Check the conductors and insulating materials for corrosion and damage.
- (4) Measure insulation resistance.
- (5) Check and change the cooling fan and relay.

When using the safety stop function, periodic inspection is required to confirm that safety function of the safety system operates correctly.

(For more details, refer to the *Safety stop function instruction manual (BCN-A211508-004)*). (*Refer to the front cover of the Instruction Manual (Basic) for how to obtain the manual.*)

7.1.3 Daily and periodic inspection

Area of Inspection	Inspection Item	Description	Interval		Corrective Action at Alarm Occurrence	Customer's Check	
			Daily	Periodic *2			
General	Surrounding environment	Check the surrounding air temperature, humidity, dirt, corrosive gas, oil mist, etc.	○		Improve environment		
	Overall unit	Check for unusual vibration and noise.	○		Check alarm location and retighten		
	Power supply voltage	Check that the main circuit voltages are normal.*1	○		Inspect the power supply		
Main circuit	General	(1) Check with megger (across main circuit terminals and earth (ground) terminal). (2) Check for loose screws and bolts. (3) Check for overheat traces on the parts. (4) Check for stain		○ ○ ○ ○	Contact the manufacturer Retighten Contact the manufacturer Clean		
	Conductors, cables	(1) Check conductors for distortion. (2) Check cable sheaths for breakage and deterioration (crack, discoloration, etc.)		○ ○	Contact the manufacturer Contact the manufacturer		
	Terminal block	Check for damage.		○	Stop the device and contact the manufacturer.		
	Smoothing aluminum electrolytic capacitor	(1) Check for liquid leakage. (2) Check for safety valve projection and bulge. (3) Visual check and judge by the life check of the main circuit capacitor (Refer to page 214)		○ ○ ○	Contact the manufacturer Contact the manufacturer		
	Relay	Check that the operation is normal and no chatter is heard.		○	Contact the manufacturer		
Control circuit, Protective circuit	Operation check	(1) Check that the output voltages across phases with the inverter operated alone is balanced (2) Check that no fault is found in protective and display circuits in a sequence protective operation test.		○ ○	Contact the manufacturer Contact the manufacturer		
	Parts check	Overall	(1) Check for unusual odor and discoloration. (2) Check for serious rust development		○ ○	Stop the device and contact the manufacturer. Contact the manufacturer	
		Aluminum electrolytic capacitor	(1) Check for liquid leakage in a capacitor and deformation trace (2) Visual check and judge by the life check of the main circuit capacitor (Refer to page 214)		○ ○	Contact the manufacturer	
Cooling system	Cooling fan	(1) Check for unusual vibration and noise. (2) Check for loose screws and bolts (3) Check for stain	○	○ ○ ○	Replace the fan Fix with the fan cover fixing screws Clean		
	Heatsink	(1) Check for clogging (2) Check for stain		○ ○	Clean Clean		
Display	Indication	(1) Check that display is normal. (2) Check for stain	○	○	Contact the manufacturer Clean		
	Meter	Check that reading is normal	○		Stop the device and contact the manufacturer.		
Load motor	Operation check	Check for vibration and abnormal increase in operation noise	○		Stop the device and contact the manufacturer.		

*1 It is recommended to install a device to monitor voltage for checking the power supply voltage to the inverter.

*2 One to two years of periodic inspection cycle is recommended. However, it differs according to the installation environment. For a periodic inspection, contact your sales representative.

7.1.4 Display of the life of the inverter parts

The self-diagnostic alarm is output when the life span of the control circuit capacitor, cooling fan and each parts of the inrush current limit circuit is near its end. It gives an indication of replacement time.

The life alarm output can be used as a guideline for life judgment.

Parts	Judgment Level
Main circuit capacitor	85% of the initial capacity
Control circuit capacitor	Estimated remaining life 10%
Inrush current limit circuit	Estimated remaining life 10% (Power on: 100,000 times left)
Cooling fan	Less than 50% of the predetermined speed



POINT

Refer to page 177 to perform the life check of the inverter parts.

7.1.5 Checking the inverter and converter modules

<Preparation>

- (1) Disconnect the external power supply cables (R/L1, S/L2, T/L3) and motor cables (U, V, W).
- (2) Prepare a tester. (Use 100Ω range.)

<Checking method>

Change the polarity of the tester alternately at the inverter terminals R/L1, S/L2, T/L3, U, V, W, P/+ and N/-, and check for electric continuity.



NOTE

1. Before measurement, check that the smoothing capacitor is discharged.
2. At the time of electric discontinuity, the measured value is almost ∞ . When there is an instantaneous continuity, due to the smoothing capacitor, the tester may not indicate ∞ . At the time of electric continuity, the measured value is several to several tens-of ohms depending on the module type, circuit tester type, etc. If all measured values are almost the same, the modules are without fault.

<Module device numbers and terminals to be checked>

		Tester Polarity		Measured Value		Tester Polarity		Measured Value
		+	-			+	-	
Converter module	D1	R/L1	+	Discontinuity	D4	R/L1	-	Continuity
		+	R/L1	Continuity		-	R/L1	Discontinuity
	D2	S/L2	+	Discontinuity	D5	S/L2	-	Continuity
		+	S/L2	Continuity		-	S/L2	Discontinuity
	D3	T/L3	+	Discontinuity	D6	T/L3	-	Continuity
		+	T/L3	Continuity		-	T/L3	Discontinuity
Inverter module	TR1	U	+	Discontinuity	TR4	U	-	Continuity
		+	U	Continuity		-	U	Discontinuity
	TR3	V	+	Discontinuity	TR6	V	-	Continuity
		+	V	Continuity		-	V	Discontinuity
	TR5	W	+	Discontinuity	TR2	W	-	Continuity
		+	W	Continuity		-	W	Discontinuity

(Assumes the use of an analog meter.)

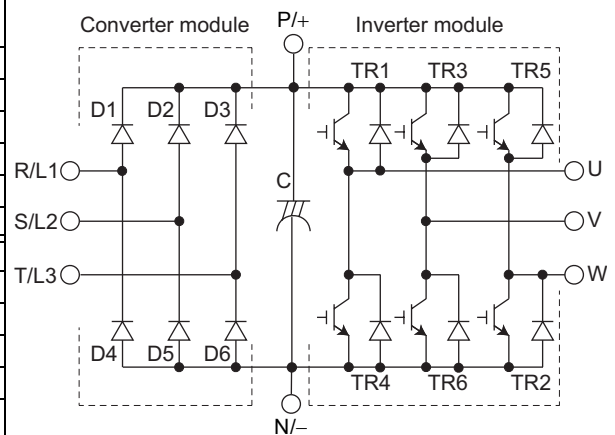

7.1.6 Cleaning

Always run the inverter in a clean status.

When cleaning the inverter, gently wipe dirty areas with a soft cloth immersed in neutral detergent or ethanol.



NOTE

Do not use solvent, such as acetone, benzene, toluene and alcohol, as they will cause the inverter surface paint to peel off. The display, etc. of the operation panel are vulnerable to detergent and alcohol. Therefore, avoid using them for cleaning.

7.1.7 Replacement of parts

The inverter consists of many electronic parts such as semiconductor devices.

The following parts may deteriorate with age because of their structures or physical characteristics, leading to reduced performance or fault of the inverter. For preventive maintenance, the parts must be replaced periodically.

Use the life check function as a guidance of parts replacement.

Part Name	Estimated lifespan *1	Description
Cooling fan	10 years	Replace (as required)
Main circuit smoothing capacitor	10 years *2	Replace (as required)
On-board smoothing capacitor	10 years *2	Replace the board (as required)
Relays	—	as required

*1 Estimated lifespan for when the yearly average surrounding air temperature is 40°C (without corrosive gas, flammable gas, oil mist, dust and dirt etc.)

*2 Output current: 80% of the inverter rated current



NOTE

For parts replacement, contact the nearest Mitsubishi FA Center.

(1) Cooling fan

The replacement interval of the cooling fan used for cooling the parts generating heat such as the main circuit semiconductor is greatly affected by the surrounding air temperature. When unusual noise and/or vibration is noticed during inspection, the cooling fan must be replaced immediately.

●Removal

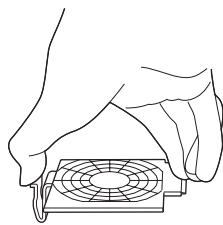
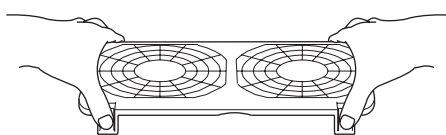
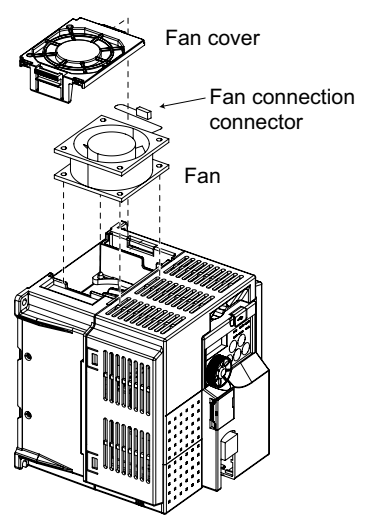
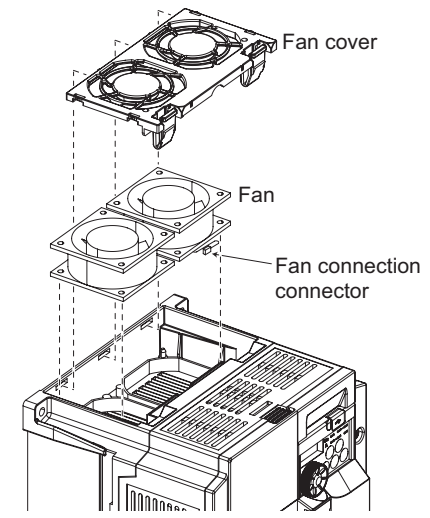
- 1) Push the hooks from above and remove the fan cover.
 - 3.7K or lower 
 - 5.5K or higher 
- 2) Disconnect the fan connectors.
- 3) Remove the fan.
 - 3.7K or lower 
 - 5.5K or higher 

Example for FR-E740-3.7KNF Example for FR-E740-5.5KNF

●Reinstallation

- 1) After confirming the orientation of the fan, reinstall the fan so that the arrow on the left of "AIR FLOW" faces up.

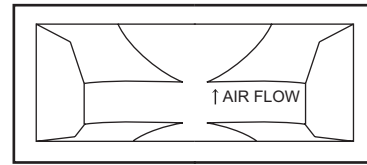

<Fan side face>

- 2) Reconnect the fan connectors.
- 3) When wiring, avoid the cables being caught by the fan.

3.7K or lower

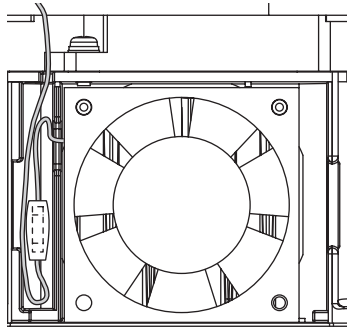

5.5K or higher

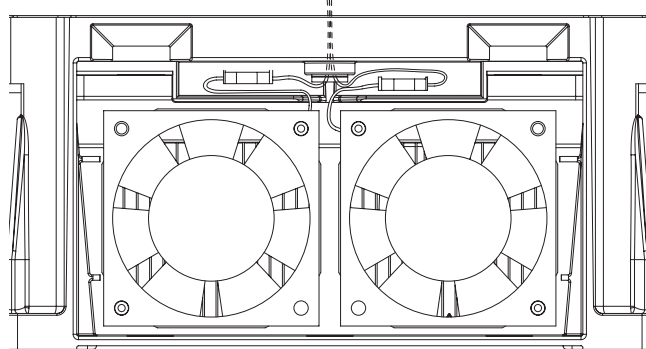

- 4) Reinstall the fan cover.

3.7K or lower

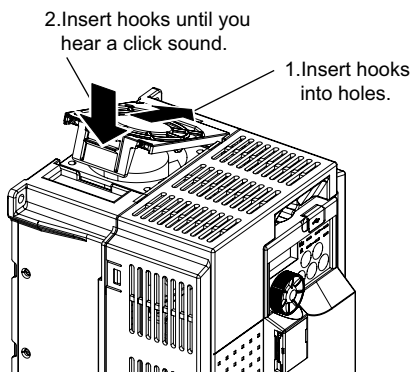

Example for FR-E740-3.7KNF

5.5K or higher

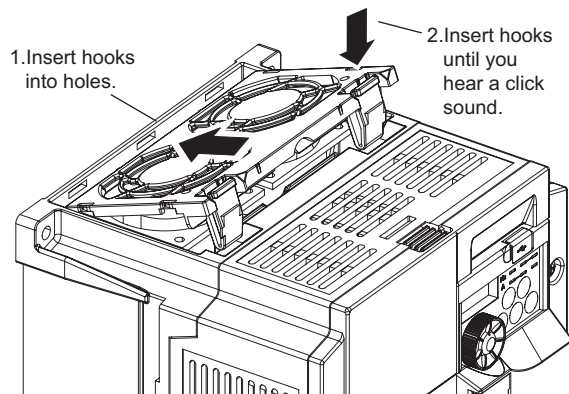

Example for FR-E740-5.5KNF



NOTE

- Installing the fan in the opposite of air flow direction can cause the inverter life to be shorter.
- Prevent the cable from being caught when installing a fan.
- Switch the power OFF before replacing fans. Since the inverter circuits are charged with voltage even after power OFF, replace fans only when the inverter cover is on the inverter to prevent an electric shock accident.

(2) Smoothing capacitors

A large-capacity aluminum electrolytic capacitor is used for smoothing in the main circuit DC section, and an aluminum electrolytic capacitor is used for stabilizing the control power in the control circuit. Their characteristics are deteriorated by the adverse effects of ripple currents, etc. The replacement intervals greatly vary with the surrounding air temperature and operating conditions. When the inverter is operated in air-conditioned, normal environment conditions, replace the capacitors about every 10 years.

When a certain period of time has elapsed, the capacitors will deteriorate more rapidly. Check the capacitors at least every year (less than six months if the life will be expired soon).

The appearance criteria for inspection are as follows:

- 1) Case: Check the side and bottom faces for expansion
- 2) Sealing plate: Check for remarkable warp and extreme crack.
- 3) Check for external crack, discoloration, liquid leakage, etc. Judge that the capacitor has reached its life when the measured capacitance of the capacitor reduced below 80% of the rating.



POINT

Refer to page 177 to perform the life check of the main circuit capacitor.

(3) Relays

To prevent a contact fault, etc., relays must be replaced according to the cumulative number of switching times (switching life).

7.2 Measurement of main circuit voltages, currents and powers

Since the voltages and currents on the inverter power supply and output sides include harmonics, measurement data depends on the instruments used and circuits measured.

When instruments for commercial frequency are used for measurement, measure the following circuits with the instruments given on the next page.

- When installing meters etc. on the inverter output side

When the inverter-to-motor wiring length is large, especially in the 400V class, small-capacity models, the meters and CTs may generate heat due to line-to-line leakage current. Therefore, choose the equipment which has enough allowance for the current rating.

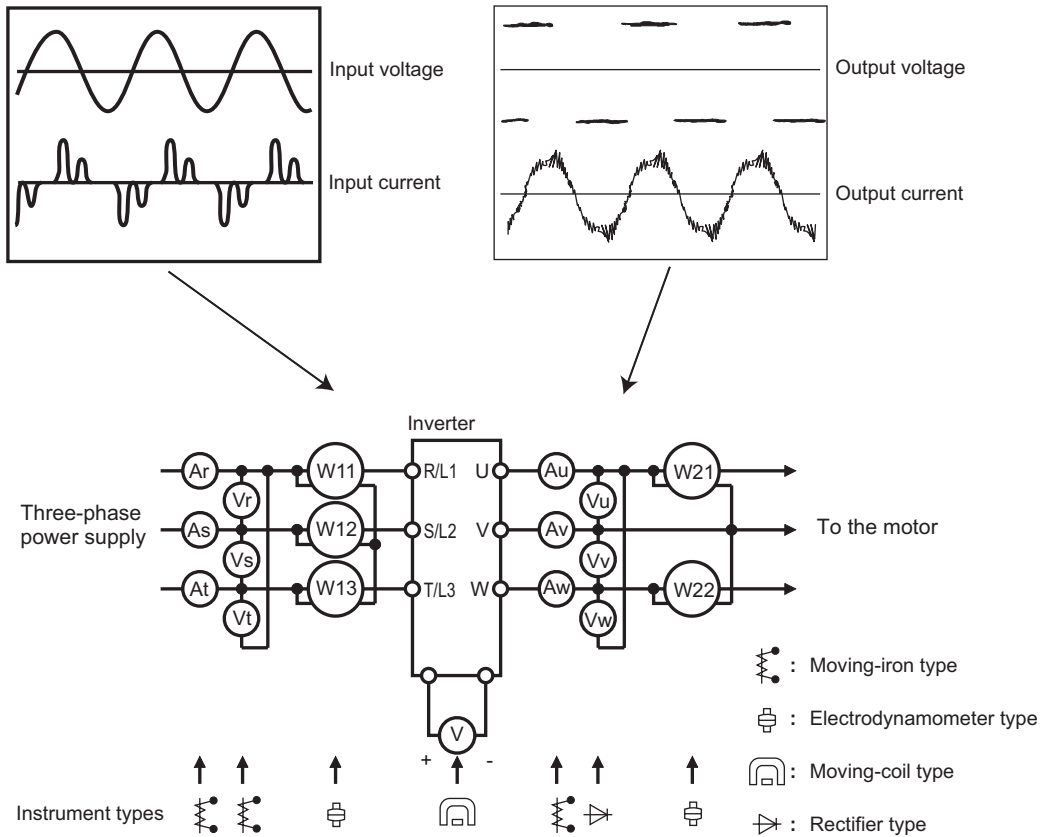

Examples of Measuring Points and Instruments

Measuring Points and Instruments

Item	Measuring Point	Measuring Instrument	Remarks (Reference Measured Value)
Power supply voltage V1	Across R/L1 and S/L2 S/L2 and T/L3 T/L3 and R/L1	Moving-iron type AC voltmeter *3	Commercial power supply Within permissible AC voltage fluctuation (<i>Refer to page 224</i>)
Power supply side current I1	R/L1, S/L2, T/L3 line current	Moving-iron type AC ammeter *3	
Power supply side power P1	R/L1, S/L2, T/L3 and R/L1 and S/L2, S/L2 and T/L3, T/L3 and R/L1	Digital power meter (designed for inverter) or electrodynamic type single- phase wattmeter	P1=W11+W12+W13 (3-wattmeter method)
Power supply side power factor Pf1	Calculate after measuring power supply voltage, power supply side current and power supply side power. $Pf_1 = \frac{P_1}{\sqrt{3}V_1 \times I_1} \times 100 \%$		
Output side voltage V2	Across U and V, V and W and W and U	Rectifier type AC voltage meter *1 *3 (moving-iron type cannot measure)	Difference between the phases is within 1% of the maximum output voltage.
Output side current I2	U, V and W line currents	Moving-iron type AC ammeter *2 *3	Difference between the phases is 10% or lower of the rated inverter current.
Output side power P2	U, V, W and U and V, V and W	Digital power meter (designed for inverter) or electrodynamic type single- phase wattmeter	P2 = W21 + W22 2-wattmeter method (or 3-wattmeter method)
Output side power factor Pf2	Calculate in similar manner to power supply side power factor. $Pf_2 = \frac{P_2}{\sqrt{3}V_2 \times I_2} \times 100 \%$		
Converter output	Across P/+ and N/-	Moving-coil type (such as tester)	Inverter LED display is lit. 1.35 × V1 380V maximum during regeneration for 200V class 760V maximum during regeneration for 400V class

- *1 Use an FFT to measure the output voltage accurately. An FA tester or general measuring instrument cannot measure accurately.
- *2 When the carrier frequency exceeds 5kHz, do not use this instrument since using it may increase eddy-current losses produced in metal parts inside the instrument, leading to burnout. In this case, use an approximate-effective value type.
- *3 A digital power meter (designed for inverter) can also be used to measure.

7.2.1 Measurement of powers

Use digital power meters (for inverter) for the both of inverter input and output side. Alternatively, measure using electrodynamic type single-phase wattmeters for the both of inverter input and output side in two-wattmeter or three-wattmeter method. As the current is liable to be imbalanced especially in the input side, it is recommended to use the three-wattmeter method.

Examples of process value differences produced by different measuring meters are shown below.

An error will be produced by difference between measuring instruments, e.g. power calculation type and two- or three-wattmeter type three-phase wattmeter. When a CT is used in the current measuring side or when the meter contains a PT on the voltage measurement side, an error will also be produced due to the frequency characteristics of the CT and PT.

[Measurement conditions]

Constant-torque (100%) load, note that 60Hz or more should be constantly output 3.7kW, 4-pole motor, value indicated in 3-wattmeter method is 100%.

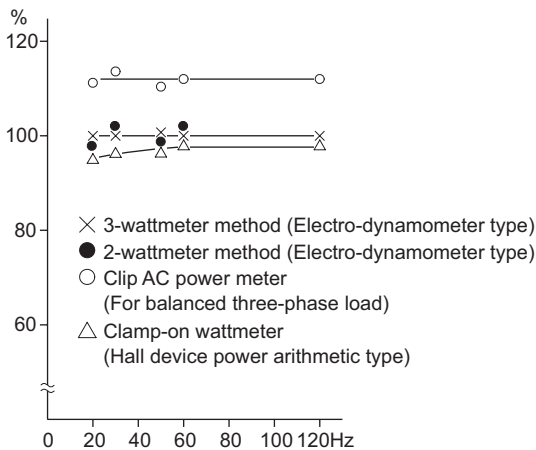

Example of Measuring Inverter Input Power

[Measurement conditions]

Constant-torque (100%) load, note that 60Hz or more should be constantly output 3.7kW, 4-pole motor, value indicated in 3-wattmeter method is 100%.

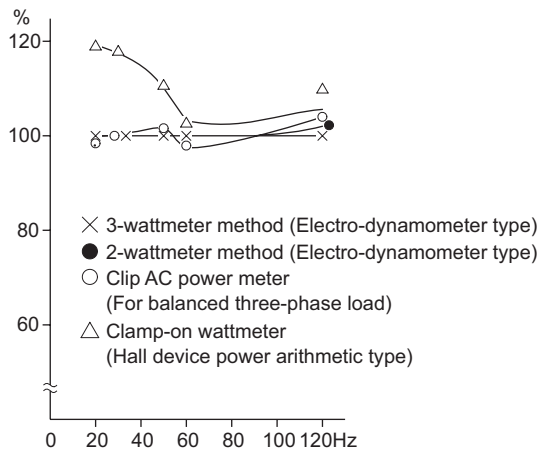

Example of Measuring Inverter Output Power

7.2.2 Measurement of voltages and use of PT

(1) Inverter input side

As the input side voltage has a sine wave and it is extremely small in distortion, accurate measurement can be made with an ordinary AC meter.

(2) Inverter output side

Since the output side voltage has a PWM-controlled rectangular wave, always use a rectifier type voltmeter. A needle type tester can not be used to measure the output side voltage as it indicates a value much greater than the actual value. A moving-iron type meter indicates an effective value which includes harmonics and therefore the value is larger than that of the fundamental wave. The value monitored on the operation panel is the inverter-controlled voltage itself. Hence, that value is accurate and it is recommended to monitor values using the operation panel.

(3) PT

No PT can be used in the output side of the inverter. Use a direct-reading meter. (A PT can be used in the input side of the inverter.)

7.2.3 Measurement of currents

Use a moving-iron type meter on both the input and output sides of the inverter. However, if the carrier frequency exceeds 5kHz, do not use that meter since an overcurrent losses produced in the internal metal parts of the meter will increase and the meter may burn out. In this case, use an approximate-effective value type.

Since current on the inverter input side tends to be unbalanced, measurement of three phases is recommended. Correct value can not be obtained by measuring only one or two phases. On the other hand, the unbalanced ratio of each phase of the output side current should be within 10%.

When a clamp ammeter is used, always use an effective value detection type. A mean value detection type produces a large error and may indicate an extremely smaller value than the actual value. The value monitored on the operation panel is accurate if the output frequency varies, and it is recommended to monitor values (provide analog output) using the operation panel.

Examples of process value differences produced by different measuring meters are shown below.

[Measurement conditions]

Value indicated by moving-iron type ammeter is 100%.

[Measurement conditions]

Value indicated by moving-iron type ammeter is 100%.

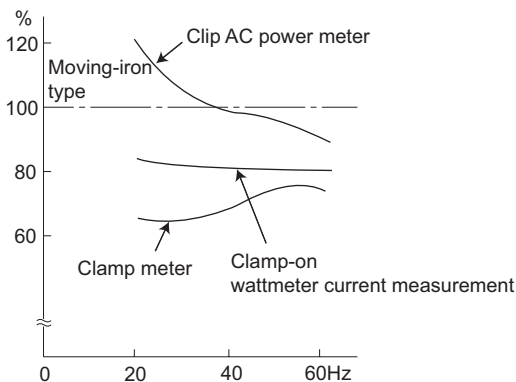

Example of measuring inverter input current

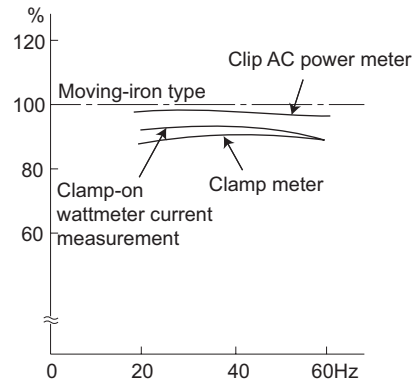

Example of measuring inverter output current

7.2.4 Use of CT and transducer

A CT may be used in both the input and output sides of the inverter, but the one used should have the largest possible VA ability because an error will increase if the frequency gets lower.

When using a transducer, use the effective value calculation type which is immune to harmonics.

7.2.5 Measurement of inverter input power factor

Calculate using effective power and apparent power. A power-factor meter can not indicate an exact value.

$$\begin{aligned} \text{Total power factor of the inverter} &= \frac{\text{Effective power}}{\text{Apparent power}} \\ &= \frac{\text{3-phase input power found by 3-wattmeter method}}{\sqrt{3} \times V (\text{power supply voltage}) \times I (\text{input current effective value})} \end{aligned}$$

7.2.6 Measurement of converter output voltage (across terminals P and N)

The output voltage of the converter is developed across terminals P and N and can be measured with a moving-coil type meter (tester). Although the voltage varies according to the power supply voltage, approximately 270VDC to 300VDC (540VDC to 600VDC for the 400V class) is output when no load is connected and voltage decreases during driving load operation.

When energy is regenerated from the motor during deceleration, for example, the converter output voltage rises to nearly 400VDC to 450VDC (800VDC to 900VDC for the 400V class) maximum.

7.2.7 Insulation resistance test using megger

- For the inverter, conduct the insulation resistance test on the main circuit only as shown below and do not perform the test on the control circuit. (Use a 500VDC megger.)

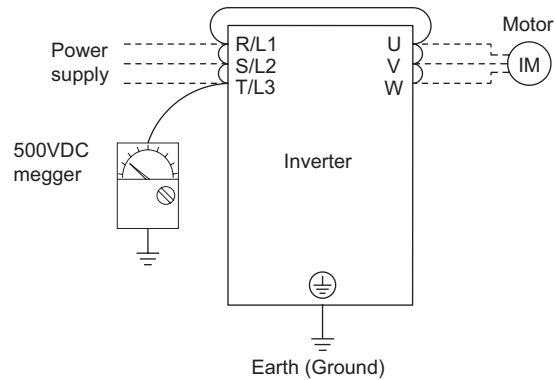

NOTE

- Before performing the insulation resistance test on the external circuit, disconnect the cables from all terminals of the inverter so that the test voltage is not applied to the inverter.
- For the electric continuity test of the control circuit, use a tester (high resistance range) and do not use the megger or buzzer.

7.2.8 Pressure test

Do not conduct a pressure test. Deterioration may occur.



8 SPECIFICATIONS

This chapter provides the "SPECIFICATIONS" of this product.
Always read the instructions before using the equipment.

8.1	Rating.....	224
8.2	Common specifications	225
8.3	Outline dimension drawings.....	226

1

2

3

4

5

6

7

8

8.1 Rating

● Three-phase 200V power supply

Model FR-E720-□KNF		0.1	0.2	0.4	0.75	1.5	2.2	3.7	5.5	7.5	11	15
Applicable motor capacity (kW) *1		0.1	0.2	0.4	0.75	1.5	2.2	3.7	5.5	7.5	11	15
Output	Rated capacity (kVA) *2	0.3	0.6	1.2	2.0	3.2	4.4	7.0	9.5	13.1	18.7	23.9
	Rated current (A) *7	0.8 (0.8)	1.5 (1.4)	3 (2.5)	5 (4.1)	8 (7)	11 (10)	17.5 (16.5)	24 (23)	33 (31)	47 (44)	60 (57)
	Overload current rating *3	150% 60s, 200% 3s (inverse-time characteristics)										
	Voltage *4	Three-phase 200 to 240V										
	Regenerative braking torque *5	150%			100%		50%		20%			
Power supply	Rated input AC (DC) voltage/frequency	Three-phase 200 to 240V 50Hz/60Hz (283 to 339VDC *8)										
	Permissible AC (DC) voltage fluctuation	170 to 264V 50Hz/60Hz (240 to 373VDC *8)										
	Permissible frequency fluctuation	±5%										
	Power supply capacity (kVA) *6	0.4	0.8	1.5	2.5	4.5	5.5	9	12	17	20	28
Protective structure (JEM1030)		Open type (IP00)										
Cooling system		Self-cooling					Forced air cooling					
Approximate mass (kg)		0.5	0.5	0.7	1.0	1.4	1.4	1.7	4.3	4.3	6.5	6.5

● Three-phase 400V power supply

Model FR-E740-□KNF		0.4	0.75	1.5	2.2	3.7	5.5	7.5	11	15	
Applicable motor capacity (kW)*1		0.4	0.75	1.5	2.2	3.7	5.5	7.5	11	15	
Output	Rated capacity (kVA)*2	1.2	2.0	3.0	4.6	7.2	9.1	13.0	17.5	23.0	
	Rated current (A)*7	1.6 (1.4)	2.6 (2.2)	4.0 (3.8)	6.0 (5.4)	9.5 (8.7)	12	17	23	30	
	Overload current rating*3	150% 60s, 200% 3s (inverse-time characteristics)									
	Voltage*4	Three-phase 380 to 480V									
	Regenerative braking torque *5	100%			50%		20%				
Power supply	Rated input voltage/frequency	Three-phase 380 to 480V 50Hz/60Hz									
	Permissible AC voltage fluctuation	325 to 528V 50Hz/60Hz									
	Permissible frequency fluctuation	±5%									
	Power supply capacity (kVA)*6	1.5	2.5	4.5	5.5	9.5	12	17	20	28	
Protective structure (JEM1030)		Open type (IP00)									
Cooling system		Self-cooling				Forced air cooling					
Approximate mass (kg)		1.4	1.4	1.9	1.9	1.9	3.2	3.2	6.0	6.0	

- *1 The applicable motor capacity indicated is the maximum capacity applicable for use of the Mitsubishi 4-pole standard motor.
- *2 The rated output capacity indicated assumes that the output voltage is 230V for three-phase 200V class and 440V for three-phase 400V class.
- *3 The % value of the overload current rating indicated is the ratio of the overload current to the inverter's rated output current. For repeated duty, allow time for the inverter and motor to return to or below the temperatures under 100% load.
- *4 The maximum output voltage does not exceed the power supply voltage. The maximum output voltage can be changed within the setting range. However, the pulse voltage value of the inverter output side voltage remains unchanged at about $\sqrt{2}$ that of the power supply.
- *5 The braking torque indicated is a short-duration average torque (which varies with motor loss) when the motor alone is decelerated from 60Hz in the shortest time and is not a continuous regenerative torque. When the motor is decelerated from the frequency higher than the base frequency, the average deceleration torque will reduce. Since the inverter does not contain a brake resistor, use the optional brake resistor when regenerative energy is large. A brake unit (FR-BU2) may also be used. (Option brake resistor cannot be used for 0.1K and 0.2K.)
- *6 The power supply capacity varies with the value of the power supply side inverter impedance (including those of the input reactor and cables).
- *7 Setting 2kHz or more in Pr. 72 PWM frequency selection to perform low acoustic noise operation in the surrounding air temperature exceeding 40°C, the rated output current is the value in parenthesis.
- *8
 - Connect DC power supply to terminal P/+ and N/-. Connect the plus side of the power supply to terminal P/+ and minus side to terminal N/-.
 - Since the voltage between P/+ and N/- may increase due to the regeneration energy from the motor and exceeds 415V temporarily, select the DC power supply which can withstand the voltage/energy during regeneration. If using the power supply which can not withstand voltage/energy during regeneration, insert diodes in series for reverse current prevention.
 - Although the FR-E700 series has the built-in inrush current limit circuit, select the DC power supply considering the inrush current at powering ON as the inrush current four times of the rated inverter flows at powering ON.
 - Since the power supply capacity depends on the output impedance of the power, select the power supply capacity which has enough allowance according to the AC power supply system capacity.

8.2 Common specifications

Control specifications	Control method	Soft-PWM control/high carrier frequency PWM control (V/F control, Advanced magnetic flux vector control, General-purpose magnetic flux vector control, Optimum excitation control are available)
	Output frequency range	0.2 to 400Hz
	Frequency setting resolution (Digital input)	0.01Hz
	Frequency accuracy (Digital input)	Within 0.01% of the set output frequency
	Voltage/frequency characteristics	Base frequency can be set from 0 to 400Hz, Constant-torque/variable torque pattern can be selected
	Starting torque	200% or more (at 0.5Hz)...when Advanced magnetic flux vector control is set (3.7K or lower)
	Torque boost	Manual torque boost
	Acceleration/deceleration time setting	0.01 to 360s, 0.1 to 3600s (acceleration and deceleration can be set individually), linear or S-pattern acceleration/ deceleration modes are available.
	DC injection brake	Operation frequency (0 to 120Hz), operation time (0 to 10s), operation voltage (0 to 30%) can be changed.
Stall prevention operation level	Operation current level can be set (0 to 200% adjustable), whether to use the function or not can be selected.	
Operation specifications	Frequency setting signal (Digital input)	Signals are entered from the operation panel or through FL remote communication. Frequency setting increments can be set.
	Start signal	Forward and reverse rotation can be selected.
	Operational functions	Maximum/minimum frequency setting, frequency jump operation, automatic restart after instantaneous power failure operation, forward/reverse rotation prevention, remote setting, second function, multi-speed operation, stop-on contact control, droop control, regeneration avoidance, slip compensation, operation mode selection, offline auto tuning function
	Safety stop function*2	Safety shutoff signal can be input from terminals S1 and S2. (compliant with EN ISO 13849-1 Category 3 / PLd EN62061 / IEC61508 SIL2)
	Output signal Open collector output (One terminal)	Safety monitor output 2 (Fixed)
Indication on the operation panel	Operating status	The following operating status can be displayed: output frequency, motor current (steady), output voltage, frequency setting, cumulative energization time, actual operation time, motor torque, converter output voltage, regenerative brake duty, electronic thermal relay function load factor, output current peak value, converter output voltage peak value, motor load factor, inverter output terminal monitor, output power, cumulative power, motor thermal load factor, and inverter thermal load factor.
	Fault record	Fault record is displayed when a fault occurs. Past 8 fault records (output voltage/current/frequency/cumulative energization time right before the fault occurs) are stored.
Protective/warning function	Protective functions	Overcurrent during acceleration, overcurrent during constant speed, overcurrent during deceleration, overvoltage during acceleration, overvoltage during constant speed, overvoltage during deceleration, inverter protection thermal operation, motor protection thermal operation, heatsink overheat, input phase failure, stall prevention stop, output side earth (ground) fault overcurrent at start*4, output short circuit, output phase failure, option fault, parameter error, retry count excess *4, CPU fault, brake transistor alarm, inrush resistance overheat, communication error, safety circuit fault
	Warning functions	Fan alarm*2, overcurrent stall prevention, overvoltage stall prevention, PU stop, parameter write error, regenerative brake prealarm *4, electronic thermal relay function prealarm, maintenance output *4, undervoltage, operation panel lock, password locked*4, inverter reset, safety stop, 24V external power supply operation
Environment	Surrounding air temperature	-10°C to +50°C (non-freezing) *3
	Ambient humidity	90%RH or less (non-condensing)
	Storage temperature*1	-20°C to +65°C
	Atmosphere	Indoors (without corrosive gas, flammable gas, oil mist, dust and dirt etc.)
	Altitude/vibration	Maximum 1000m above sea level, 5.9m/s ² or less at 10 to 55Hz (directions of X, Y, Z axes)

*1 Temperatures applicable for a short time, e.g. in transit.

*2 As the FR-E720-0.1KNF to 0.75KNF, FR-E740-0.4KNF and 0.75KNF are not provided with the cooling fan, this alarm is not available.

*3 When using the inverters at the surrounding air temperature of 40°C or less, the inverters can be installed closely attached (0cm clearance).

*4 This protective function is not available in the initial status.

8.3 Outline dimension drawings

●FR-E720-0.1KNF to 0.75KNF

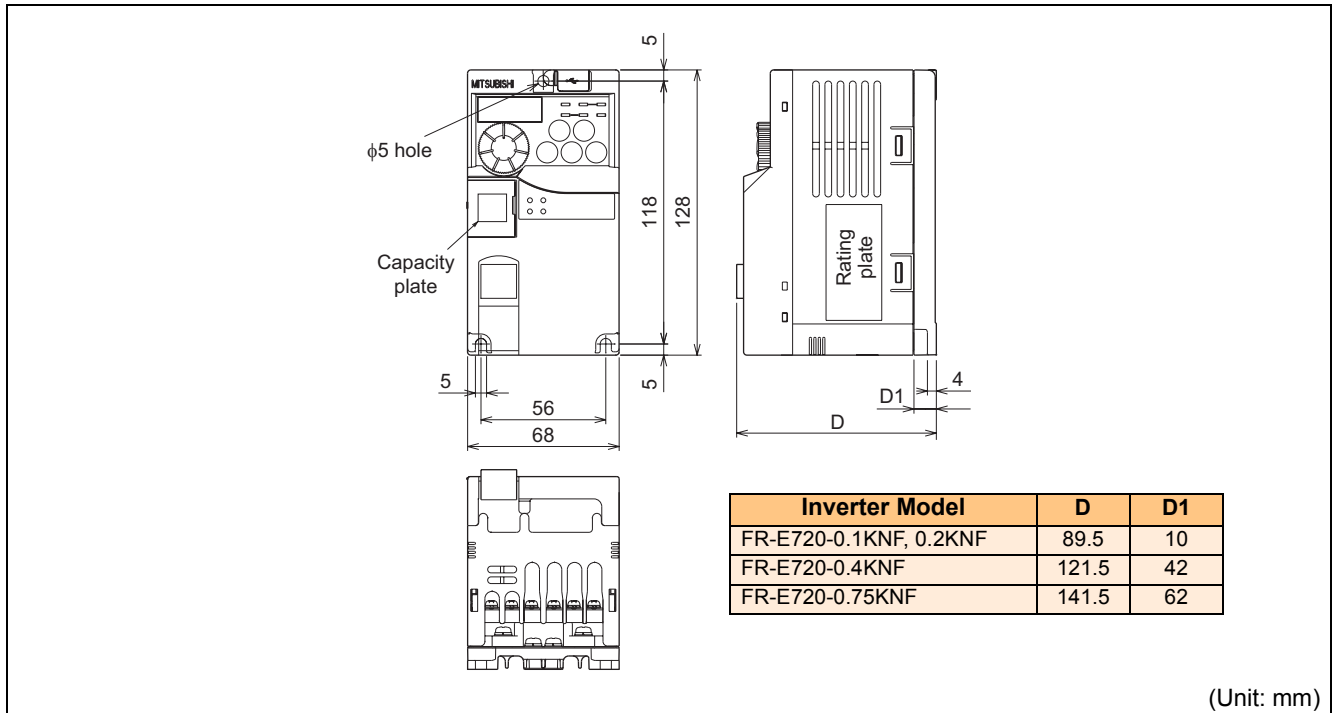

(Unit: mm)

●FR-E720-1.5KNF, 2.2KNF

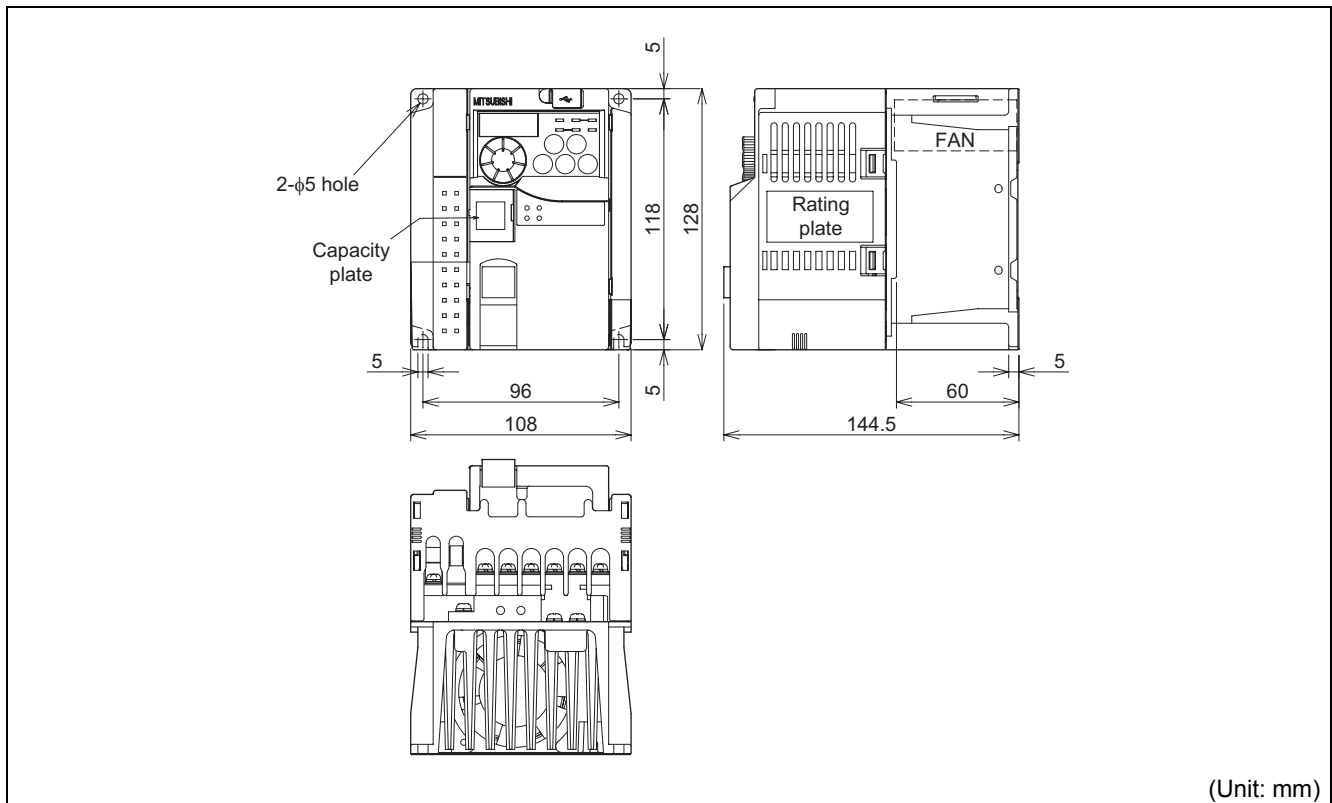

(Unit: mm)

●FR-E720-3.7KNF

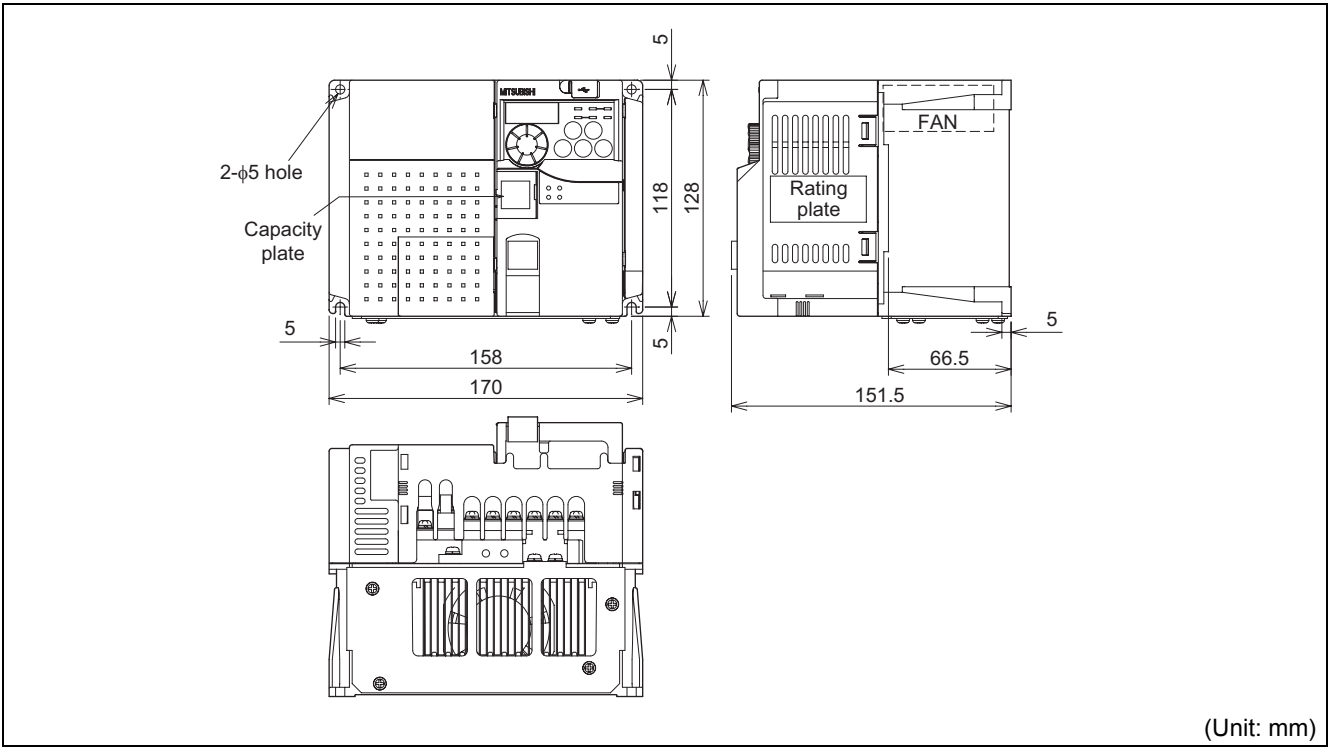

●FR-E720-5.5KNF to 15KNF

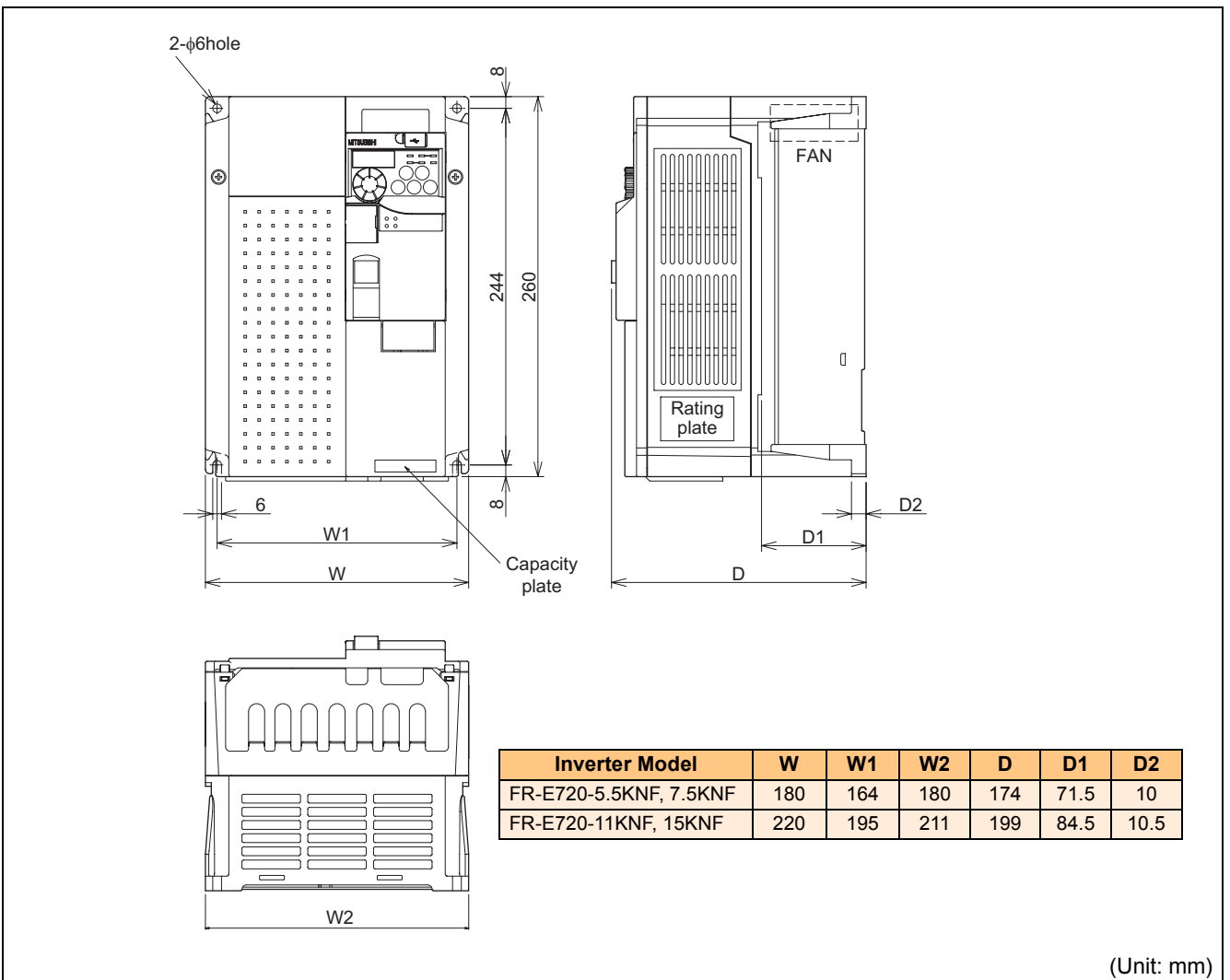

Outline dimension drawings

●FR-E740-0.4KNF to 3.7KNF

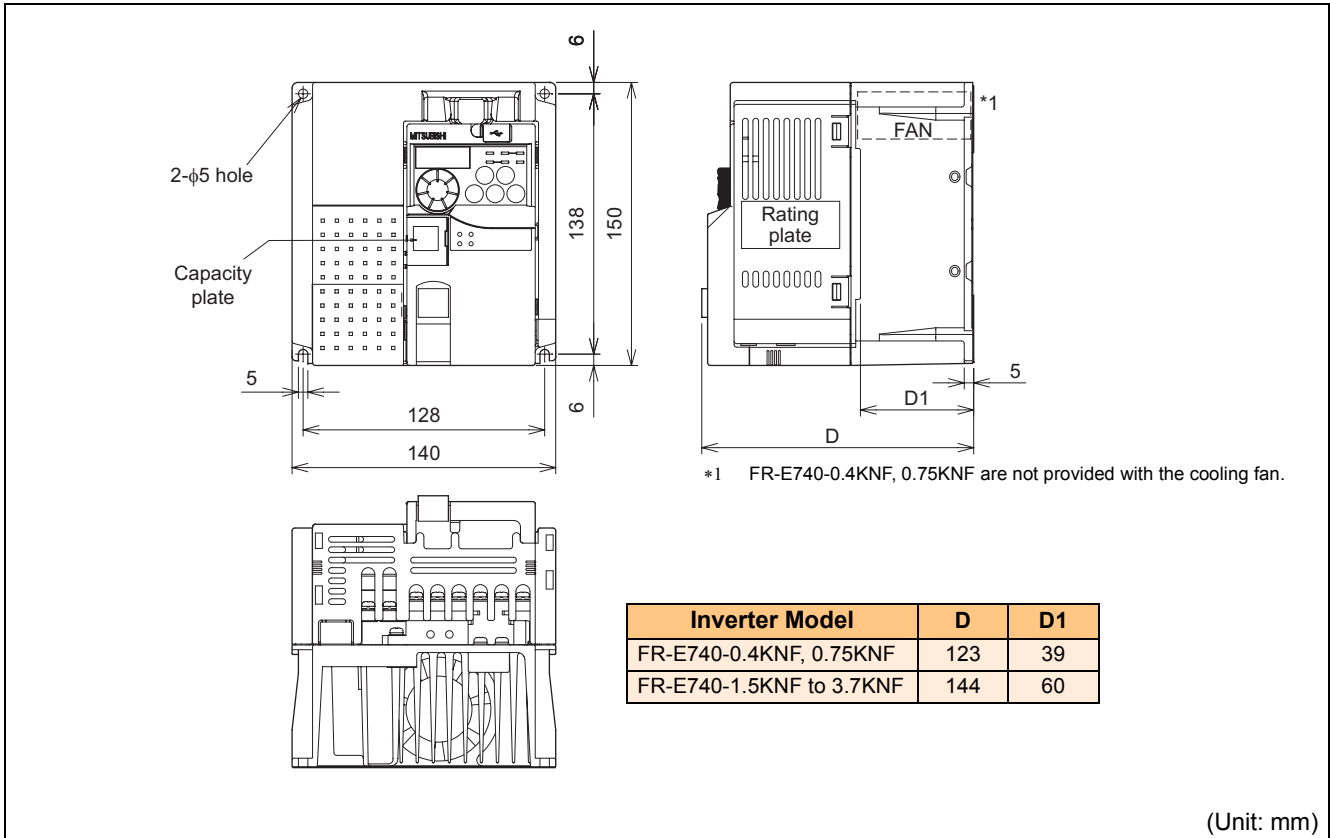

●FR-E740-5.5KNF, 7.5KNF

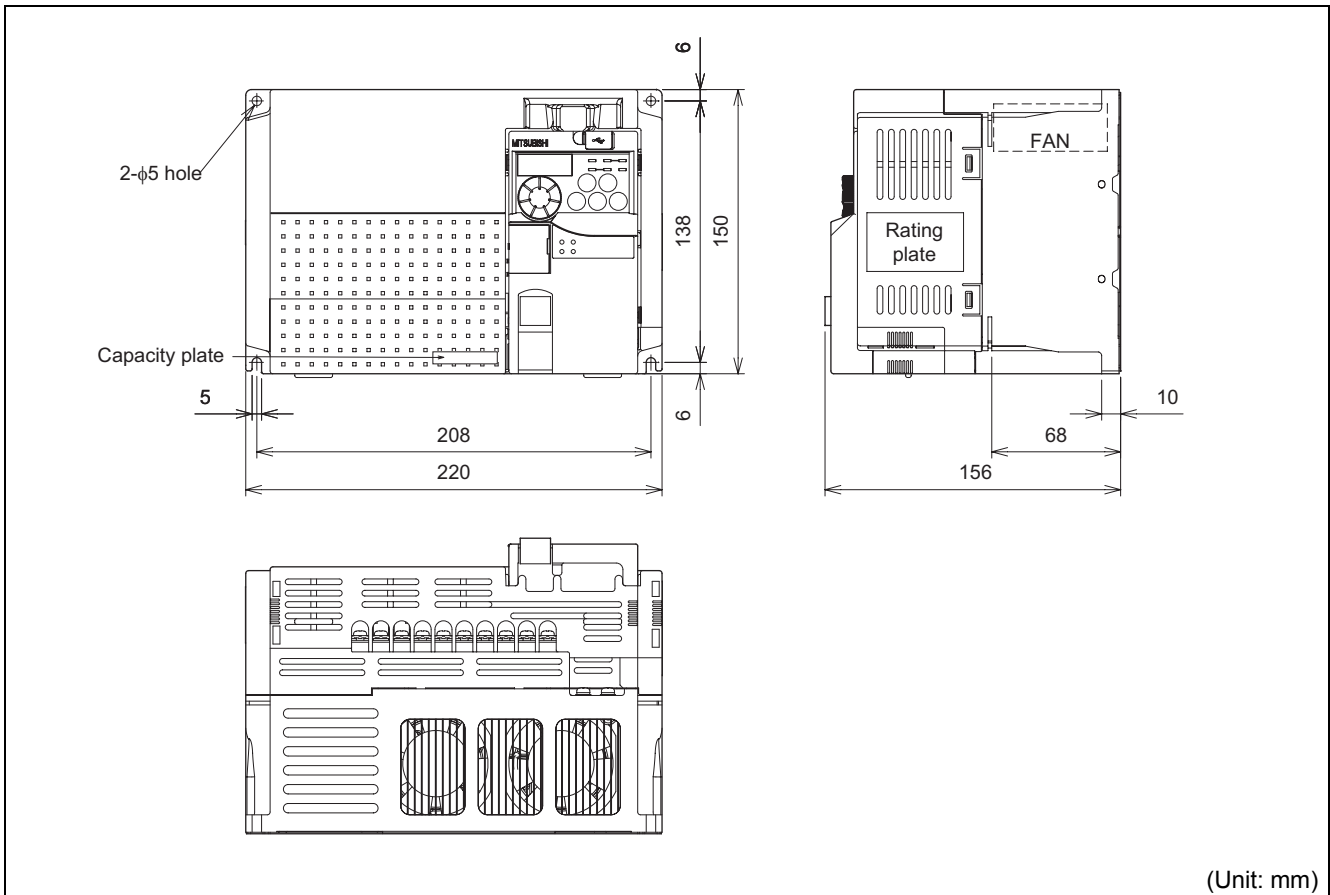

●FR-E740-11KNF, 15KNF

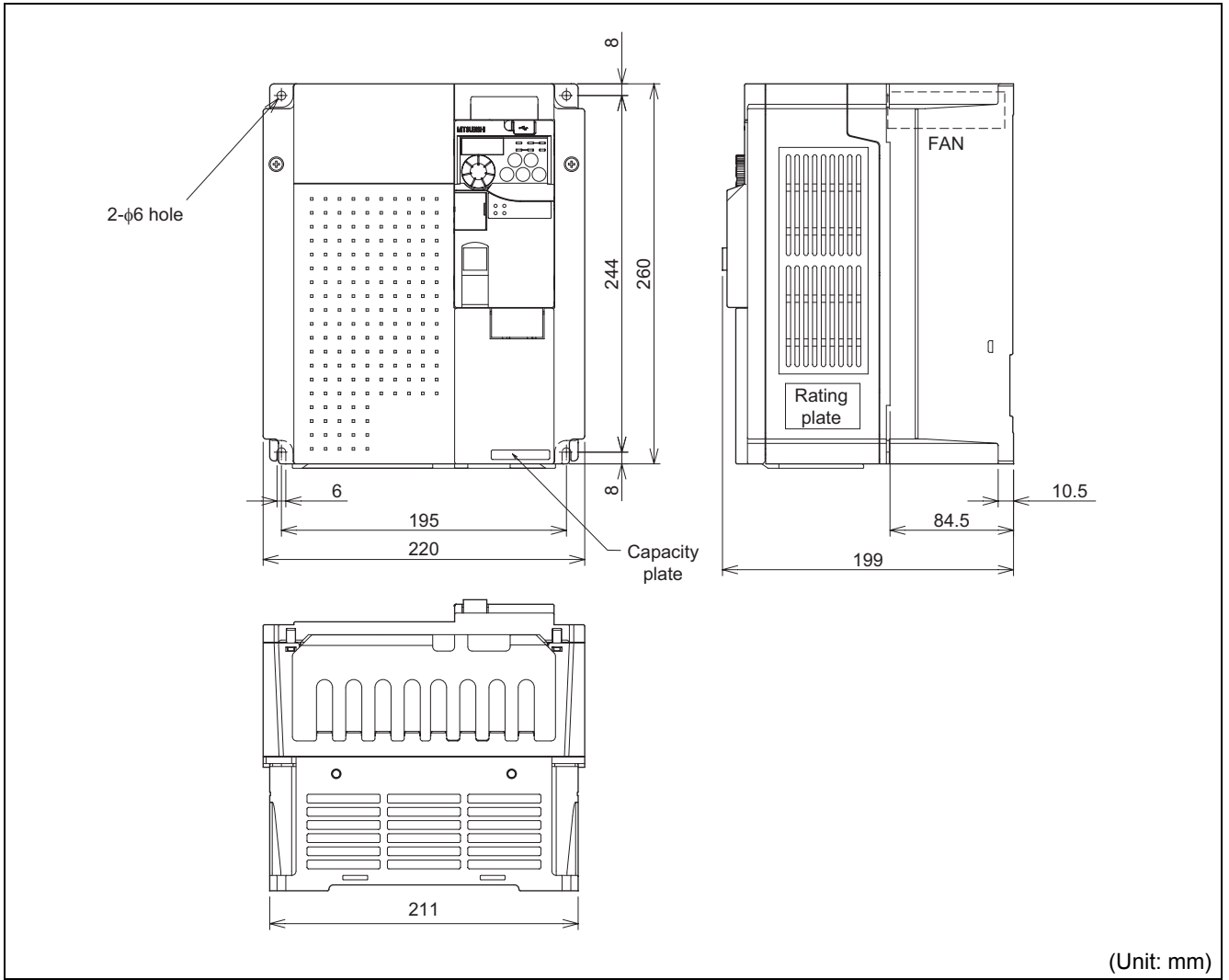

MEMO

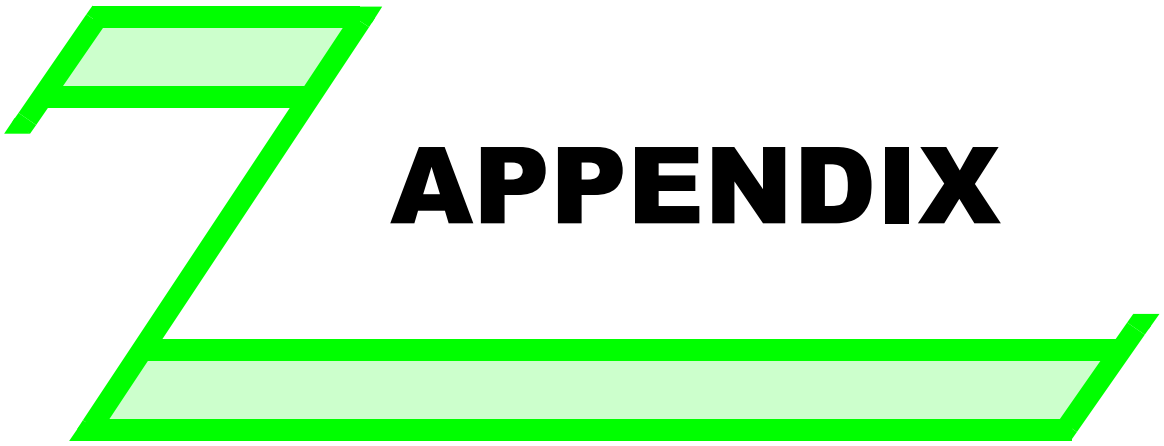
A large, stylized number '3' graphic. The top horizontal bar is light green with a dark green outline. The middle diagonal bar is dark green. The bottom horizontal bar is light green with a dark green outline.

APPENDIX

**This chapter provides the "APPENDIX" of this product.
Always read the instructions before using the equipment.**

Appendix 1 Specification change

Appendix 1-1 SERIAL number check

Check the SERIAL number indicated on the inverter rating plate or package. (*Refer to page 2*)

Rating plate example

□	○	○	○○○○○○
Symbol	Year	Month	Control number
SERIAL (Serial No.)			

The SERIAL consists of one symbol, two characters indicating production year and month, and six characters indicating control number.

The last digit of the production year is indicated as the Year, and the Month is indicated by 1 to 9, X (October), Y (November), and Z (December).

Appendix 1-2 Changed Functions

(1) Operating conditions for SAFE2 signal

The changes apply to the December 2010 production or later. (*Refer to page 24*)

- The operating conditions (E.6, E.7, and E.CPU) are added for the SAFE2 signal, which are used in the safety stop function.

Appendix 2 Index

Numeric

- 24V external power supply operation (EV)..... 197
- 7-speed selection (combination of RL, RM, RH)..... 111

A

- Acceleration time, deceleration time setting (Pr. 7, Pr. 8, Pr. 20, Pr. 21, Pr. 44, Pr. 45)..... 116
- Acceleration/deceleration pattern (Pr. 29)..... 120
- Actual operation time..... 147
- Advanced magnetic flux control (Pr. 71, Pr. 80, Pr. 81, Pr. 89, Pr. 800)..... 95
- Applied motor (Pr. 71, Pr. 450)..... 125
- Automatic restart after instantaneous power failure/flying start (Pr. 57, Pr. 58, Pr. 96, Pr. 162, Pr. 165, Pr. 298, Pr. 299, Pr. 611)..... 151
- Avoiding mechanical resonance points (frequency jumps) (Pr. 31 to Pr. 36)..... 106

B

- Base frequency, voltage (Pr. 3, Pr. 19, Pr. 47)..... 107
- Basic operation (factory setting)..... 75
- Brake transistor alarm detection (E.BE)..... 200

C

- Cable specifications..... 47
- Cables and wiring length..... 17
- Changing the control method (Pr. 80, Pr. 81, Pr. 800)..... 93
- Changing the parameter setting value..... 76
- Checking the inverter and converter modules..... 214
- Cleaning..... 214
- Common memory..... 54
- Communication option fault (E.OP1)..... 200
- Communication set status LED (CHG)..... 49
- Connecting the 24V external power supply..... 23
- Connecting the FL-net dedicated cable..... 48
- Connecting to the network..... 47
- Connection of a DC reactor (FR-HEL)..... 28
- Connection of a dedicated external brake resistor..... 25
- Connection of the brake unit (FR-BU2)..... 27
- Control circuit terminal..... 20
- Converter output voltage..... 147
- Converter output voltage peak value..... 147
- Cooling fan operation selection (Pr. 244)..... 176
- Cooling system types for inverter enclosure..... 10
- CPU error (E.5, E.6, E. 7, E.CPU)..... 202
- Cumulative energization time..... 147
- Cumulative power..... 147
- Cyclic transmission..... 53

D

- Daily and periodic inspection..... 213
- Daily inspection..... 212
- DC injection brake (Pr. 10 to Pr. 12)..... 135
- Detection of output frequency (SU, FU signal, Pr. 41 to Pr. 43)..... 144
- Device status LED (DEV), remote status LED (RMT)..... 49
- Display and erasure of communication error occurrence count (Pr. 501)..... 161

- Display of the life of the inverter parts (Pr. 255 to Pr. 259)..... 214
- Droop control (Pr. 286 to Pr. 287)..... 173
- During forward rotation..... 59
- During reverse rotation..... 59

E

- Earth (ground) fault detection at start (Pr. 249)..... 160
- Edit enabled (Edit signal)..... 59
- Electronic thermal O/L relay pre-alarm (TH)..... 123, 196
- Electronic thermal relay function load factor..... 147
- EMC measures..... 32
- Error reset..... 57
- Error response at word block read/write..... 61
- Exhibiting the best performance for the motor (offline auto tuning) (Pr. 71, Pr. 80 to Pr. 84, Pr. 90 to Pr. 94, Pr. 96, Pr. 859)..... 127
- Extended parameter display and user group function (Pr. 160, Pr. 172 to Pr. 174)..... 167

F

- Fan alarm (FN)..... 176, 197
- Fault (ALM signal)..... 59
- Fault or alarm indication..... 147, 188
- Faults history (E.--)..... 188
- Fin overheat (E.FIN)..... 199
- FL remote communication specification..... 46
- FL remote data communication types..... 52
- Forward rotation command (STF signal)..... 57
- Free parameter (Pr. 888, Pr. 889)..... 181
- Frequency setting value..... 147
- Front cover..... 5

G

- General-purpose magnetic flux vector control (Pr. 71, Pr. 80, Pr. 81, Pr. 800)..... 98

H

- Harmonic suppression guideline in Japan..... 35
- Heatsink overheat pre-alarm (FIN signal)..... 199
- High-speed operation command (RH signal)..... 57, 111

I

- Input data (inverter to master)..... 59
- Input phase loss (E.ILF)..... 160, 199
- Input/output phase loss protection selection (Pr. 251, Pr. 872)..... 160
- Inrush current limit circuit fault (E.IOH)..... 202
- Internal board fault(E.PE2)..... 201
- Internal circuit fault (E.13)..... 202
- Inverter installation environment..... 8
- Inverter output shutoff signal (MRS signal, Pr. 17)..... 143
- Inverter output terminal monitor..... 147, 149
- Inverter overload trip (electronic thermal relay function) (E.THT)..... 123, 199
- Inverter placement..... 11
- Inverter reset (Err.)..... 192, 194
- Inverter reset (RES signal)..... 192
- Inverter running (RUN signal)..... 59, 142

Inverter thermal load factor	147
------------------------------------	-----

J

Jog operation (Pr.15, Pr.16)	171
------------------------------------	-----

L

Leakage currents and countermeasures	30
LED status	49
Load pattern selection (Pr. 14)	109
Log data clear	69
Log data read	69
Low-speed operation command (RL signal)	57, 111

M

Magnitude of frequency change setting (Pr. 295)	185
Maintenance signal output (MT)	180, 196
Maintenance timer alarm (Pr. 503, Pr. 504)	180
Maintenance timer signal (Y95 signal)	180
Manual torque boost (Pr. 0, Pr. 46)	94
Maximum/minimum frequency (Pr. 1, Pr. 2, Pr. 18)	105
Measurement of converter output voltage (across terminals P and N)	221
Measurement of currents	221
Measurement of inverter input power factor	221
Measurement of powers	220
Measurement of voltages and use of PT	220
Message loopback	71
Message transmission	61
Middle-speed operation command (RM signal)	57, 111
Monitor display selection of the operation panel (Pr. 52, Pr. 170, Pr. 171, Pr. 268, Pr. 563, Pr. 564)	147
Motor load factor	147
Motor overheat protection (Electronic thermal O/L relay) (Pr. 9, Pr. 51)	123
Motor overload trip (electronic thermal relay function) (E.THM)	123, 199
Motor thermal load factor	147
Motor torque	147

N

Names and functions of the operation panel	74
NET signal	59
Network parameter read	68
Node address setting	46

O

Operation availability in each operation mode	51
Operation by multi-speed operation (Pr. 4 to Pr. 6, Pr. 24 to Pr. 27)	111
Operation mode basics	50
Operation mode setting	50
Operation of start signals (STF, STR signal)	141
Operation panel frequency setting/key lock operation selection (Pr. 161)	183
Operation panel lock (HOLD)	183, 194
Optimum excitation control (Pr. 60)	162
Option fault (E.1)	201
Option fault (E.OPT)	201
Output current	147
Output current detection (Y12 signal)	59, 145
Output current detection function (Y12 signal, Y13 signal, Pr.	

150 to Pr. 153)	145
Output current peak value	147
Output data (master to inverter)	57
Output frequency	147
Output frequency detection (FU signal)	59, 144
Output phase loss (E.LF)	160, 200
Output power	147
Output side earth (ground) fault overcurrent at start (E.GF)	160, 200
Output stop (MRS signal)	57, 143
Output voltage	147
Overcurrent trip during acceleration (E.OC1)	197
Overcurrent trip during constant speed (E.OC2)	197
Overcurrent trip during deceleration or stop (E.OC3)	198
Overload alarm (OL signal)	59, 101
Overview of the FL remote communication function	52

P

Parameter list	78
Parameter storage device fault (control circuit board) (E.PE)	201
Parameter write disable selection (Pr. 77)	166
Parameter write error (Er1, Er2, Er4)	194
Password function	169
Password locked (LOCd)	194
Periodic inspection	212
Peripheral devices	4
Power supply harmonics	34
Power-failure deceleration stop function (Pr. 261)	156
Precautions for system configuration	47
Pressure test	222
Profile read	70
PU operation interlock	51
PU operation interlock (X12 signal)	57
PU stop (PS)	165, 195
PWM carrier frequency and soft-PWM control (Pr. 72, Pr. 240)	163

R

Reached the frequency (SU signal)	59, 144
Regeneration avoidance function (Pr. 665, Pr. 882, Pr. 883, Pr. 885, Pr. 886)	174
Regenerative brake duty	136, 147
Regenerative brake prealarm (RB)	136, 196
Regenerative overvoltage trip during acceleration (E.OV1)	174, 198
Regenerative overvoltage trip during constant speed (E.OV2)	174, 198
Regenerative overvoltage trip during deceleration or stop (E.OV3)	174, 198
Remote setting (RH, RM, RL signal)	57, 113
Remote setting function (Pr. 59)	113
Replacement of parts	215
Reset cancel (READY signal)	59, 142
Reset cancel signal (READY signal) and inverter running signal (RUN signal)	142
Reset selection/PU stop selection (Pr. 75)	165
Retry count excess (E.RET)	201
Reverse rotation command (STR signal)	57
Reverse rotation prevention selection (Pr. 78)	167
RUN key rotation direction selection (Pr. 40)	182

S

Safety circuit fault (E.SAF)	24, 202
Safety circuit fault (Safety alarm signal).....	59
Safety stop (SA).....	24, 196
Safety stop function.....	24
Second function selection (RT signal).....	57, 143
Second function selection signal (RT signal)	143
Selection of a regenerative brake (Pr. 30, Pr. 70).....	136
Setting dial push.....	77
Shortest acceleration/deceleration (automatic acceleration/ deceleration) (Pr. 61 to Pr. 63, Pr. 292, Pr. 293).....	121
Slip compensation (Pr. 245 to Pr. 247)	100
Specification of main circuit terminal	15
Speed display and speed setting (Pr. 37).....	146
Speed smoothing control (Pr. 653).....	164
Stall prevention (overcurrent) (OL)	101, 195
Stall prevention (overvoltage) (oL).....	174, 195
Stall prevention operation (Pr. 22, Pr. 23, Pr. 48, Pr. 66, Pr. 156, Pr. 157, Pr. 277).....	101
Stall prevention stop (E.OLT).....	101, 200
Starting frequency and start-time hold function (Pr. 13, Pr. 571).....	119
Stop selection (Pr. 250).....	138
Stop-on contact control function (Pr. 6, Pr. 48, Pr. 270, Pr. 275, Pr. 276).....	139
Stop-on contact selection 0 (RL signal)	57, 139
Stop-on contact selection 1 (RT signal).....	57, 139

T

Terminal arrangement of the main circuit terminal, power supply and the motor wiring	15
Terminal connection diagram.....	14
Transmitting (TX)/receiving (RX) LED.....	49

U

Undervoltage (UV).....	196
Use of CT and transducer	221

W

Wiring cover.....	7
Wiring of control circuit.....	21
Word block read/write	62

Z

Zero current detection (Y13 signal).....	59, 145
--	---------

REVISIONS

*The manual number is given on the bottom left of the back cover.

Print Date	*Manual Number	Revision
Feb. 2011	IB(NA)-0600398ENG-A	First edition

 **For Maximum Safety**

- Mitsubishi inverters are not designed or manufactured to be used in equipment or systems in situations that can affect or endanger human life.
- When considering this product for operation in special applications such as machinery or systems used in passenger transportation, medical, aerospace, atomic power, electric power, or submarine repeating applications, please contact your nearest Mitsubishi sales representative.
- Although this product was manufactured under conditions of strict quality control, you are strongly advised to install safety devices to prevent serious accidents when it is used in facilities where breakdowns of the product are likely to cause a serious accident.
- Please do not use this product for loads other than three-phase induction motors.

mitsubishi electric corporation

HEAD OFFICE: TOKYO BUILDING 2-7-3, MARUNOUCHI, CHIYODA-KU, TOKYO 100-8310, JAPAN