

# INVERTER FR-F700P

## INSTRUCTION MANUAL (BASIC)

**FR-F720P-0.75K to 110K**  
**FR-F740P-0.75K to 560K**

Thank you for choosing this Mitsubishi Inverter.  
This Instruction Manual (Basic) is intended for users who "just want to run the inverter".

|          |  |            |
|----------|--|------------|
| <b>1</b> | <b>OUTLINE .....</b>                                   | <b>1</b>   |
| <b>2</b> | <b>INSTALLATION AND WIRING .....</b>                   | <b>3</b>   |
| <b>3</b> | <b>DRIVING THE IPM MOTOR &lt;IPM&gt; .....</b>         | <b>40</b>  |
| <b>4</b> | <b>DRIVING THE MOTOR .....</b>                         | <b>45</b>  |
| <b>5</b> | <b>ADJUSTMENT .....</b>                                | <b>70</b>  |
| <b>6</b> | <b>TROUBLESHOOTING .....</b>                           | <b>115</b> |
| <b>7</b> | <b>PRECAUTIONS FOR MAINTENANCE AND INSPECTION.....</b> | <b>140</b> |
| <b>8</b> | <b>SPECIFICATIONS.....</b>                             | <b>149</b> |

 **For the customers intending to use IPM motors ..... 40**

This inverter is set for a general-purpose motor in the initial settings.  
For use with an IPM motor, refer to page 40.

 **To obtain the Instruction Manual (Applied)**

If you are going to utilize functions and performance, refer to the *Instruction Manual (Applied)* [IB-0600412ENG].  
The *Instruction Manual (Applied)* is separately available from where you purchased the inverter or your Mitsubishi sales representative.

The PDF version of this manual is also available for download at "Mitsubishi Electric FA site," the Mitsubishi Electric FA network service on the world wide web (URL: <http://www.MitsubishiElectric.co.jp/fa/>)

**1**

**2**

**3**

**4**

**5**

**6**

**7**

**8**

This Instruction Manual (Basic) provides handling information and precautions for use of the equipment. Please forward this Instruction Manual (Basic) to the end user.

**This section is specifically about safety matters**

Do not attempt to install, operate, maintain or inspect the inverter until you have read through this Instruction Manual (Basic) and appended documents carefully and can use the equipment correctly. Do not use the inverter until you have a full knowledge of the equipment, safety information and instructions. In this Instruction Manual (Basic), the safety instruction levels are classified into "WARNING" and "CAUTION".

**⚠ WARNING** Incorrect handling may cause hazardous conditions, resulting in death or severe injury.

**⚠ CAUTION** Incorrect handling may cause hazardous conditions, resulting in medium or slight injury, or may cause only material damage.

The **⚠ CAUTION** level may even lead to a serious consequence according to conditions. Both instruction levels must be followed because these are important to personal safety.

**1. Electric Shock Prevention**

**⚠ WARNING**

- While the inverter power is ON, do not open the front cover or the wiring cover. Do not run the inverter with the front cover or the wiring cover removed. Otherwise you may access the exposed high voltage terminals or the charging part of the circuitry and get an electric shock.
- Even if power is OFF, do not remove the front cover except for wiring or periodic inspection. You may accidentally touch the charged inverter circuits and get an electric shock.
- Before wiring, inspection or switching EMC filter ON/OFF connector, power must be switched OFF. To confirm that, LED indication of the operation panel must be checked. (It must be OFF.) Any person who is involved in wiring, inspection or switching EMC filter ON/OFF connector shall wait for at least 10 minutes after the power supply has been switched OFF and check that there are no residual voltage using a tester or the like. The capacitor is charged with high voltage for some time after power OFF, and it is dangerous.
- This inverter must be earthed (grounded). Earthing (grounding) must conform to the requirements of national and local safety regulations and electrical code (NEC section 250, IEC 536 class 1 and other applicable standards). A neutral-point earthed (grounded) power supply for 400V class inverter in compliance with EN standard must be used.
- Any person who is involved in wiring or inspection of this equipment shall be fully competent to do the work.
- The inverter must be installed before wiring. Otherwise you may get an electric shock or be injured.
- Setting dial and key operations must be performed with dry hands to prevent an electric shock. Otherwise you may get an electric shock.
- Do not subject the cables to scratches, excessive stress, heavy loads or pinching. Otherwise you may get an electric shock.
- Do not replace the cooling fan while power is ON. It is dangerous to replace the cooling fan while power is ON.
- Do not touch the printed circuit board or handle the cables with wet hands. Otherwise you may get an electric shock.
- When measuring the main circuit capacitor capacity (*Pr. 259 Main circuit capacitor life measuring = "1"*), the DC voltage is applied to the motor for 1s at powering OFF. Never touch the motor terminal, etc. right after powering OFF to prevent an electric shock.
- IPM motor is a synchronous motor with high-performance magnets embedded in the rotor. Motor terminals hold high-voltage while the motor is running even after the inverter power is turned OFF. Before wiring or inspection, the motor must be confirmed to be stopped. When the motor is driven by the load in applications such as fan and blower, a low-voltage manual contactor must be connected at the inverter's output side, and wiring and inspection must be performed while the contactor is open. Otherwise you may get an electric shock.

**2. Fire Prevention** **⚠ CAUTION**

- Inverter must be installed on a nonflammable wall without holes (so that nobody touches the inverter heatsink on the rear side, etc.). Mounting it to or near flammable material can cause a fire.
- If the inverter has become faulty, the inverter power must be switched OFF. A continuous flow of large current could cause a fire.
- Do not connect a resistor directly to the DC terminals P/+ and N/-. Doing so could cause a fire.
- Daily and periodic inspections must be performed as instructed in the Instruction Manual. If the product is used without receiving any inspection, it may cause a burst, break, or fire.

**3. Injury Prevention** **⚠ CAUTION**

- The voltage applied to each terminal must be the ones specified in the Instruction Manual. Otherwise burst, damage, etc. may occur.
- The cables must be connected to the correct terminals. Otherwise burst, damage, etc. may occur.
- Polarity must be correct. Otherwise burst, damage, etc. may occur.
- While power is ON or for some time after power-OFF, do not touch the inverter since the inverter will be extremely hot. Doing so can cause burns.

**4. Additional Instructions**

Also the following points must be noted to prevent an accidental failure, injury, electric shock, etc.

**(1) Transportation and installation**

**⚠ CAUTION**

- The product must be transported in correct method that corresponds to the weight. Failure to do so may lead to injuries.
- Do not stack the boxes containing inverters higher than the number recommended.
- The product must be installed to the position where withstands the weight of the product according to the information in the Instruction Manual.
- Do not install or operate the inverter if it is damaged or has parts missing. This can result in breakdowns.
- When carrying the inverter, do not hold it by the front cover or setting dial; it may fall off or fail.
- Do not stand or rest heavy objects on the product.
- The inverter mounting orientation must be correct.
- Foreign conductive objects must be prevented from entering the inverter. That includes screws and metal fragments or other flammable substance such as oil.
- As the inverter is a precision instrument, do not drop or subject it to impact.
- The inverter must be used under the following environment: Otherwise the inverter may be damaged.

|             |                             |   |
|-------------|-----------------------------|---|
| Environment | Surrounding air temperature | -10°C to +50°C (non-freezing)   |
|             | Ambient humidity            | 90% RH or less (non-condensing)   |
|             | Storage temperature         | -20°C to +65°C *1   |
|             | Atmosphere                  | Indoors (free from corrosive gas, flammable gas, oil mist, dust and dirt)   |
|             | Altitude, vibration         | Maximum 1000m above sea level for standard operation. 5.9m/s <sup>2</sup> *2 or less at 10 to 55Hz (directions of X, Y, Z axes) |

\*1 Temperature applicable for a short time, e.g. in transit.

\*2 2.9m/s<sup>2</sup> or less for the 185K or higher.

- If halogen-based materials (fluorine, chlorine, bromine, iodine, etc.) infiltrate into a Mitsubishi product, the product will be damaged. Halogen-based materials are often included in fumigant, which is used to sterilize or disinfest wooden packages. When packaging, prevent residual fumigant components from being infiltrated into Mitsubishi products, or use an alternative sterilization or disinfection method (heat disinfection, etc.) for packaging. Sterilization or disinfection of wooden package should also be performed before packaging the product.

**(2) Wiring****⚠ CAUTION**

- Do not install a power factor correction capacitor, surge suppressor or capacitor type filter on the inverter output side. These devices on the inverter output side may be overheated or burn out.
- The connection orientation of the output cables U, V, W to the motor affects the rotation direction of the motor.
- IPM motor terminals (U, V, W) hold high-voltage while the IPM motor is running even after the power is turned OFF. Before wiring, the IPM motor must be confirmed to be stopped. Otherwise you may get an electric shock.
- Never connect an IPM motor to the commercial power supply. Applying the commercial power supply to input terminals (U,V, W) of an IPM motor will burn the IPM motor. The IPM motor must be connected with the output terminals (U, V, W) of the inverter.

**(3) Test operation and adjustment****⚠ CAUTION**

- Before starting operation, each parameter must be confirmed and adjusted. A failure to do so may cause some machines to make unexpected motions.

**(4) Operation****⚠ WARNING**

- The IPM motor capacity must be same with the inverter capacity. (The 0.75K inverter can be used with a one-rank lower MM-EF motor.)
- Do not use multiple IPM motors with one inverter.
- Any person must stay away from the equipment when the retry function is set as it will restart suddenly after trip.
- Since pressing  key may not stop output depending on the function setting status, separate circuit and switch that make an emergency stop (power OFF, mechanical brake operation for emergency stop, etc.) must be provided.
- OFF status of the start signal must be confirmed before resetting the inverter fault. Resetting inverter alarm with the start signal ON restarts the motor suddenly.
- Do not use an IPM motor in an application where a motor is driven by its load and runs at a speed higher than the maximum motor speed.
- A dedicated IPM motor must be used under IPM motor control. Do not use a synchronous motor, induction motor, or synchronous induction motor under IPM motor control.
- The inverter must be used for three-phase induction motors or the dedicated IPM motor. Connection of any other electrical equipment to the inverter output may damage the equipment.
- Do not modify the equipment.
- Do not perform parts removal which is not instructed in this manual. Doing so may lead to fault or damage of the inverter.

**⚠ CAUTION**

- The electronic thermal relay function does not guarantee protection of the motor from overheating. It is recommended to install both an external thermal and PTC thermistor for overheat protection.
- Do not use a magnetic contactor on the inverter input for frequent starting/stopping of the inverter. Otherwise the life of the inverter decreases.
- The effect of electromagnetic interference must be reduced by using a noise filter or by other means. Otherwise nearby electronic equipment may be affected.
- Appropriate measures must be taken to suppress harmonics. Otherwise power supply harmonics from the inverter may heat/damage the power factor correction capacitor and generator.
- When driving a 400V class motor by the inverter, the motor must be an insulation-enhanced motor or measures must be taken to suppress surge voltage. Surge voltage attributable to the wiring constants may occur at the motor terminals, deteriorating the insulation of the motor.
- When parameter clear or all parameter clear is performed, the required parameters must be set again before starting operations because all parameters return to the initial value.
- The inverter can be easily set for high-speed operation. Before changing its setting, the performances of the motor and machine must be fully examined.
- Stop status cannot be hold by the inverter's brake function. In addition to the inverter's brake function, a holding device must be installed to ensure safety.
- Before running an inverter which had been stored for a long period, inspection and test operation must be performed.
- Static electricity in your body must be discharged before you touch the product. Otherwise the product may be damaged.
- Do not connect an IPM motor under the general-purpose motor control settings (initial settings). Do not use a general-purpose motor under the IPM motor control settings. Doing so will cause a failure.
- In the system with an IPM motor, the inverter power must be turned ON before closing the contacts of the contactor at the output side.

**(5) Emergency stop ⚠ CAUTION**

- A safety backup such as an emergency brake must be provided to prevent hazardous condition to the machine and equipment in case of inverter failure.
- When the breaker on the inverter input side trips, the wiring must be checked for fault (short circuit), and internal parts of the inverter for a damage, etc. The cause of the trip must be identified and removed before turning ON the power of the breaker.
- When any protective function is activated, appropriate corrective action must be taken, and the inverter must be reset before resuming operation.

**(6) Maintenance, inspection and parts replacement****⚠ CAUTION**

- Do not carry out a megger (insulation resistance) test on the control circuit of the inverter. It will cause a failure.

**(7) Disposing of the inverter****⚠ CAUTION**

- The inverter must be treated as industrial waste.

**General instructions**

Many of the diagrams and drawings in this Instruction Manual (Basic) show the inverter without a cover or partially open for explanation. Never operate the inverter in this manner. The cover must be always reinstalled and the instruction in this Instruction Manual (Basic) must be followed when operating the inverter. For more details on a dedicated IPM motor, refer to the Instruction Manual of the dedicated IPM motor.

# — CONTENTS —

|          |   |           |
|----------|---|-----------|
| <b>1</b> | <b>OUTLINE</b>  | <b>1</b>  |
| 1.1      | Product checking and parts identification .....   | 1         |
| 1.2      | Step of operation .....   | 2         |
| <b>2</b> | <b>INSTALLATION AND WIRING</b>  | <b>3</b>  |
| 2.1      | Peripheral devices .....  | 4         |
| 2.2      | Method of removal and reinstallation of the front cover .....   | 6         |
| 2.3      | Installation of the inverter and instructions .....   | 8         |
| 2.4      | Wiring .....  | 9         |
| 2.4.1    | Terminal connection diagram .....   | 9         |
| 2.4.2    | EMC filter .....  | 10        |
| 2.4.3    | Specification of main circuit terminal .....  | 11        |
| 2.4.4    | Terminal arrangement of the main circuit terminal, power supply and the motor wiring .....            | 11        |
| 2.4.5    | Control circuit terminals .....   | 19        |
| 2.4.6    | Changing the control logic .....  | 22        |
| 2.4.7    | Wiring of control circuit .....   | 24        |
| 2.4.8    | Mounting the operation panel (FR-DU07) or the parameter unit (FR-PU07) on the enclosure surface ..... | 25        |
| 2.4.9    | RS-485 terminal block .....   | 26        |
| 2.4.10   | Communication operation .....   | 26        |
| 2.5      | Connection of stand-alone option units .....  | 27        |
| 2.5.1    | Connection of the brake unit (FR-BU2) .....   | 27        |
| 2.5.2    | Connection of the brake unit (FR-BU/MT-BU5) .....   | 29        |
| 2.5.3    | Connection of the brake unit (BU type) .....  | 31        |
| 2.5.4    | Connection of the high power factor converter (FR-HC2) .....  | 32        |
| 2.5.5    | Connection of the power regeneration common converter (FR-CV) .....                                   | 33        |
| 2.5.6    | Connection of the power regeneration converter (MT-RC) .....  | 34        |
| 2.5.7    | Connection of the power factor improving DC reactor (FR-HEL) .....                                    | 35        |
| 2.6      | Power-OFF and magnetic contactor (MC) .....   | 36        |
| 2.7      | Precautions for use of the inverter .....   | 37        |
| 2.8      | Failsafe of the system which uses the inverter .....  | 39        |
| <b>3</b> | <b>DRIVING THE IPM MOTOR &lt;IPM&gt;</b>  | <b>40</b> |
| 3.1      | Setting procedure of IPM motor control <IPM> .....  | 40        |
| 3.2      | Initializing the parameters required to drive an IPM motor (Pr.998) <IPM> .....                       | 42        |
| <b>4</b> | <b>DRIVING THE MOTOR</b>  | <b>45</b> |
| 4.1      | Operation panel (FR-DU07) .....   | 45        |
| 4.1.1    | Component of the operation panel (FR-DU07) .....  | 45        |
| 4.1.2    | Basic operation (factory setting) .....   | 46        |

|       |  |    |
|-------|--|----|
| 4.1.3 | Easy operation mode setting (easy setting mode).....   | 47 |
| 4.1.4 | Operation lock (Press [MODE] for an extended time (2s)) .....  | 48 |
| 4.1.5 | Monitoring of output current and output voltage .....  | 49 |
| 4.1.6 | First priority monitor .....   | 49 |
| 4.1.7 | Displaying the set frequency.....  | 49 |
| 4.1.8 | Changing the parameter setting value.....  | 50 |
| 4.2   | Overheat protection of the motor by the inverter (Pr. 9).....  | 51 |
| 4.3   | When the rated motor frequency is 50Hz (Pr. 3)<V/F><S MFVC>.....   | 52 |
| 4.4   | Start/stop from the operation panel (PU operation mode) .....  | 53 |
| 4.4.1 | Setting the set frequency to operate (example: performing operation at 30Hz) .....   | 53 |
| 4.4.2 | Using the setting dial like a potentiometer at the operation .....   | 55 |
| 4.4.3 | Setting the frequency by switches (multi-speed setting for 3 speeds).....  | 56 |
| 4.4.4 | Setting the frequency by analog input (voltage input).....   | 58 |
| 4.4.5 | Setting the frequency by analog input (current input).....   | 59 |
| 4.5   | Start/stop using terminals (External operation) .....  | 60 |
| 4.5.1 | Setting the frequency by the operation panel (Pr. 79 = 3).....   | 60 |
| 4.5.2 | Switching between the automatic operation and the manual operation<br>(operation by the multi-speed setting and the operation panel) (Pr.79=3) ..... | 62 |
| 4.5.3 | Setting the frequency by switches (multi-speed setting for 3 speeds) (Pr.4 to Pr.6) .....  | 64 |
| 4.5.4 | Setting the frequency by analog input (voltage input).....   | 66 |
| 4.5.5 | Changing the output frequency (60Hz, initial value) at the maximum voltage<br>input (5V, initial value) .....  | 67 |
| 4.5.6 | Setting the frequency by analog input (current input).....   | 68 |
| 4.5.7 | Changing the output frequency (60Hz, initial value) at the maximum current input<br>(at 20mA, initial value) .....                                   | 69 |

---

## 5 ADJUSTMENT

---

**70**

|        |  |    |
|--------|--|----|
| 5.1    | Simple mode parameter list.....  | 70 |
| 5.2    | Increasing the starting torque (Pr. 0) <V/F> .....                         | 72 |
| 5.3    | Limiting the maximum and minimum output frequency (Pr. 1, Pr. 2).....      | 73 |
| 5.4    | Changing acceleration and deceleration time (Pr. 7, Pr. 8) .....           | 74 |
| 5.5    | Energy saving operation for fans and pumps (Pr.14, Pr.60) <V/F>.....       | 75 |
| 5.5.1  | Load pattern selection (Pr. 14) .....                                      | 75 |
| 5.5.2  | Energy saving control (Pr.60) .....  | 75 |
| 5.6    | Selection of the start command and frequency command sources (Pr. 79)..... | 77 |
| 5.7    | Parameter clear, all parameter clear .....                                 | 78 |
| 5.8    | Parameter copy and parameter verification .....                            | 79 |
| 5.8.1  | Parameter copy .....   | 79 |
| 5.8.2  | Parameter verification.....  | 80 |
| 5.9    | Initial value change list .....  | 81 |
| 5.10   | Parameter list .....   | 82 |
| 5.10.1 | List of parameters classified by the purpose .....                         | 82 |
| 5.10.2 | Display of the extended parameters .....                                   | 85 |
| 5.10.3 | Parameter list.....  | 86 |

---



---

## **6 TROUBLESHOOTING 115**

---



---

|        |  |     |
|--------|--|-----|
| 6.1    | Reset method of protective function.....                   | 115 |
| 6.2    | List of fault or alarm display.....                        | 116 |
| 6.3    | Causes and corrective actions .....                        | 117 |
| 6.4    | Correspondences between digital and actual characters..... | 130 |
| 6.5    | Check and clear of the faults history .....                | 131 |
| 6.6    | Check first when you have a trouble .....                  | 133 |
| 6.6.1  | Motor does not start.....                                  | 133 |
| 6.6.2  | Motor or machine is making abnormal acoustic noise.....    | 135 |
| 6.6.3  | Inverter generates abnormal noise.....                     | 135 |
| 6.6.4  | Motor generates heat abnormally.....                       | 135 |
| 6.6.5  | Motor rotates in the opposite direction .....              | 136 |
| 6.6.6  | Speed greatly differs from the setting.....                | 136 |
| 6.6.7  | Acceleration/deceleration is not smooth.....               | 136 |
| 6.6.8  | Speed varies during operation.....                         | 137 |
| 6.6.9  | Operation mode is not changed properly .....               | 137 |
| 6.6.10 | Operation panel (FR-DU07) display is not operating.....    | 138 |
| 6.6.11 | Motor current is too large.....                            | 138 |
| 6.6.12 | Speed does not accelerate.....                             | 139 |
| 6.6.13 | Unable to write parameter setting.....                     | 139 |
| 6.6.14 | Power lamp is not lit .....                                | 139 |

---



---

## **7 PRECAUTIONS FOR MAINTENANCE AND INSPECTION 140**

---



---

|       |   |     |
|-------|---|-----|
| 7.1   | Inspection item .....                           | 140 |
| 7.1.1 | Daily inspection .....                          | 140 |
| 7.1.2 | Periodic inspection .....                       | 140 |
| 7.1.3 | Daily and periodic inspection.....              | 141 |
| 7.1.4 | Display of the life of the inverter parts ..... | 142 |
| 7.1.5 | Cleaning .....                                  | 144 |
| 7.1.6 | Replacement of parts .....                      | 144 |
| 7.1.7 | Inverter replacement.....                       | 148 |

---



---

## **8 SPECIFICATIONS 149**

---



---

|       |   |     |
|-------|---|-----|
| 8.1   | Rating .....  | 149 |
| 8.2   | Common specifications .....   | 151 |
| 8.3   | Outline dimension drawings.....   | 153 |
| 8.3.1 | Inverter outline dimension drawings.....  | 153 |
| 8.4   | Specification of premium high-efficiency IPM motor<br>[MM-EFS (1500r/min) series].....  | 162 |
| 8.5   | Specification of premium high-efficiency IPM motor<br>[MM-THE4 (1500r/min) series]..... | 163 |
| 8.6   | Specification of high-efficiency IPM motor<br>[MM-EF (1800r/min) series].....           | 164 |

|       |  |     |
|-------|--|-----|
| 8.7   | Heatsink protrusion attachment procedure .....             | 165 |
| 8.7.1 | When using a heatsink protrusion attachment (FR-A7CN)..... | 165 |
| 8.7.2 | Protrusion of heatsink of the FR-F740P-185K or higher..... | 165 |

## APPENDICES



167

|              |   |     |
|--------------|---|-----|
| Appendix 1   | For customers who are replacing the conventional model with this inverter ..... | 167 |
| Appendix 1-1 | Replacement of the FR-F500 series .....   | 167 |
| Appendix 1-2 | Replacement of the FR-A100 <EXCELENT> series .....                              | 168 |
| Appendix 2   | Instructions for compliance with the EU Directives .....                        | 169 |
| Appendix 3   | Instructions for UL and cUL compliance .....                                    | 171 |

### <Abbreviations>

DU: Operation panel (FR-DU07)  
 PU: Operation panel(FR-DU07) and parameter unit (FR-PU04/FR-PU07)  
 Inverter: Mitsubishi inverter FR-F700P series  
 FR-F700P: Mitsubishi inverter FR-F700P series  
 Pr.: Parameter Number (Number assigned to function)  
 PU operation: Operation using the PU (FR-DU07/FR-PU04/FR-PU07)  
 External operation: Operation using the control circuit signals  
 Combined operation: Combined operation using the PU (FR-DU07/FR-PU04/FR-PU07) and external operation  
 General-purpose motor: Three-phase induction motor  
 Standard motor: SF-JR  
 Constant-torque motor: SF-HRCA  
 Dedicated IPM motor: High-efficiency IPM motor MM-EF (1800r/min specification)  
 Premium high-efficiency IPM motor MM-EFS (1500r/min specification)

The following marks are used to indicate the controls as below.  
 (Parameters without any mark are valid for all controls.)

| Mark  | Control method                      | Applied motor (control)  |
|---|-------------------------------------|--|
|  | V/F control                         | Three-phase induction motor<br>(general-purpose motor control) |
|  | Simple magnetic flux vector control |  |
|  | IPM motor control                   | Dedicated IPM motor<br>(IPM motor control)                     |

### <Trademarks>

LONWORKS® is registered trademarks of Echelon Corporation in the U.S.A. and other countries.  
 Company and product names herein are the trademarks and registered trademarks of their respective owners.

### <Notes on descriptions in this Instruction Manual>

Connection diagrams in this Instruction Manual appear with the control logic of the input terminals as sink logic, unless otherwise specified. (For the control logic, refer to page 22.)

### Harmonic suppression guideline

All models of General-purpose inverters used by specific consumers are covered by "Harmonic suppression guideline for consumers who receive high voltage or special high voltage". (📖 For further details, refer to Chapter 3 of the Instruction Manual (Applied) .)

# 1 OUTLINE

## 1.1 Product checking and parts identification

Unpack the inverter and check the capacity plate on the front cover and the rating plate on the inverter side face to ensure that the product agrees with your order and the inverter is intact.

### • Inverter Model

FR - **F720P** - **5.5** K

| Symbol | Voltage Class          | Represents inverter capacity (kW) |
|--------|------------------------|-----------------------------------|
| F720P  | Three-phase 200V class |                                   |
| F740P  | Three-phase 400V class |                                   |

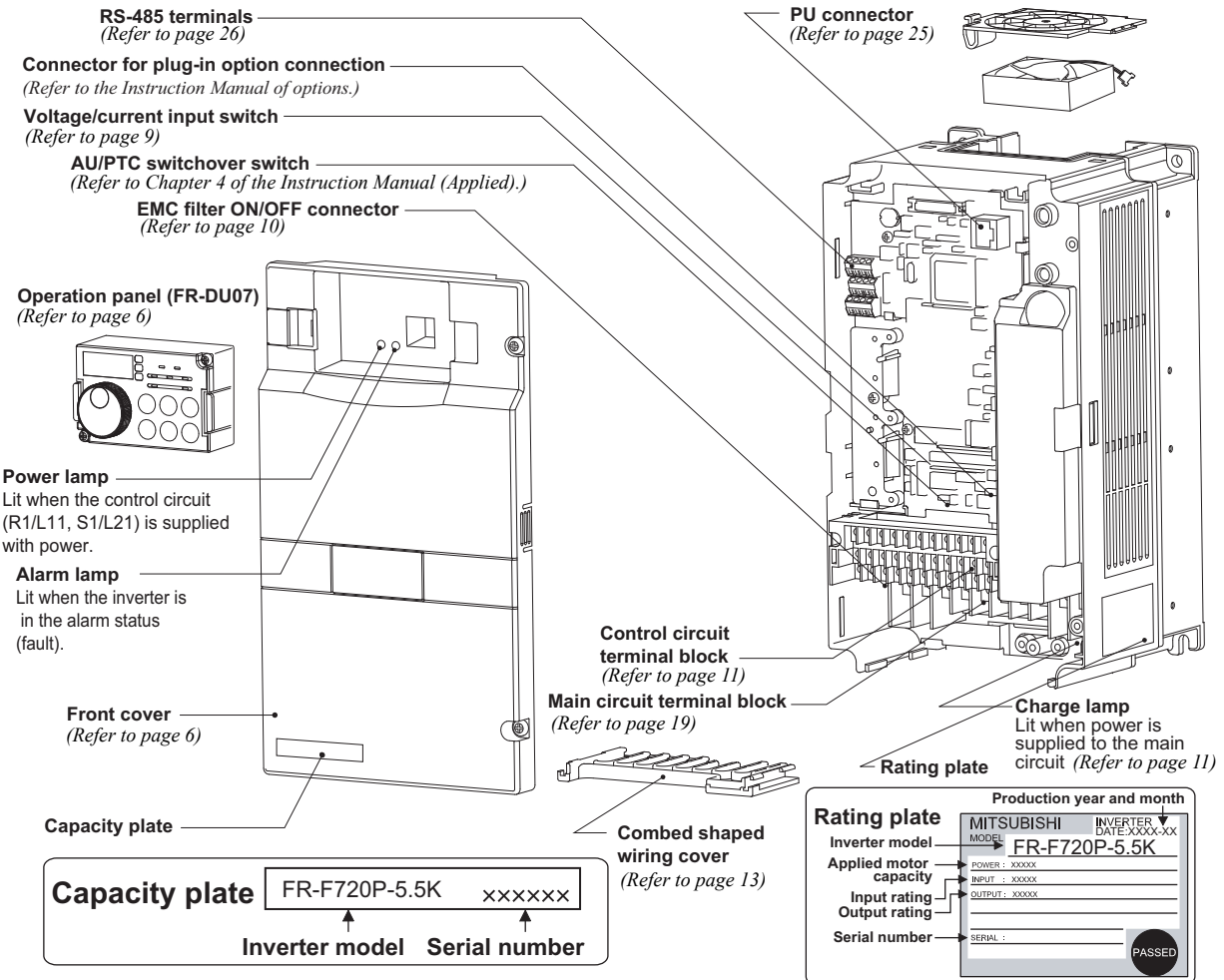

### • Accessory

- Fan cover fixing screws (30K or lower)  
(Refer to page 169)

|      | Capacity      | Screw Size (mm) | Quantity |
|------|---------------|-----------------|----------|
| 200V | 2.2K to 5.5K  | M3 × 35         | 1        |
|      | 7.5K to 15K   | M4 × 40         | 2        |
|      | 18.5K to 30K  | M4 × 50         | 1        |
| 400V | 3.7K, 5.5K    | M3 × 35         | 1        |
|      | 7.5K to 18.5K | M4 × 40         | 2        |
|      | 22K, 30K      | M4 × 50         | 1        |

- DC reactor supplied (75K or higher)
- Eyebolt for hanging the inverter (37K to 315K)

| Capacity     | Eyebolt Size | Quantity |
|--------------|--------------|----------|
| 37K          | M8           | 2        |
| 45K to 160K  | M10          | 2        |
| 185K to 315K | M12          | 2        |



### REMARKS

- For removal and reinstallation of covers, refer to page 6.

### • SERIAL number check

Rating plate example



The SERIAL consists of one symbol, two characters indicating production year and month, and six characters indicating control number. The last digit of the production year is indicated as the Year, and the Month is indicated by 1 to 9, X (October), Y (November), or Z (December).





## 1.2 Step of operation

The inverter needs frequency command and start command. Frequency command (set frequency) determines the rotation speed of the motor. Turning ON the start command starts the motor to rotate. Refer to the flow chart below to perform setting.

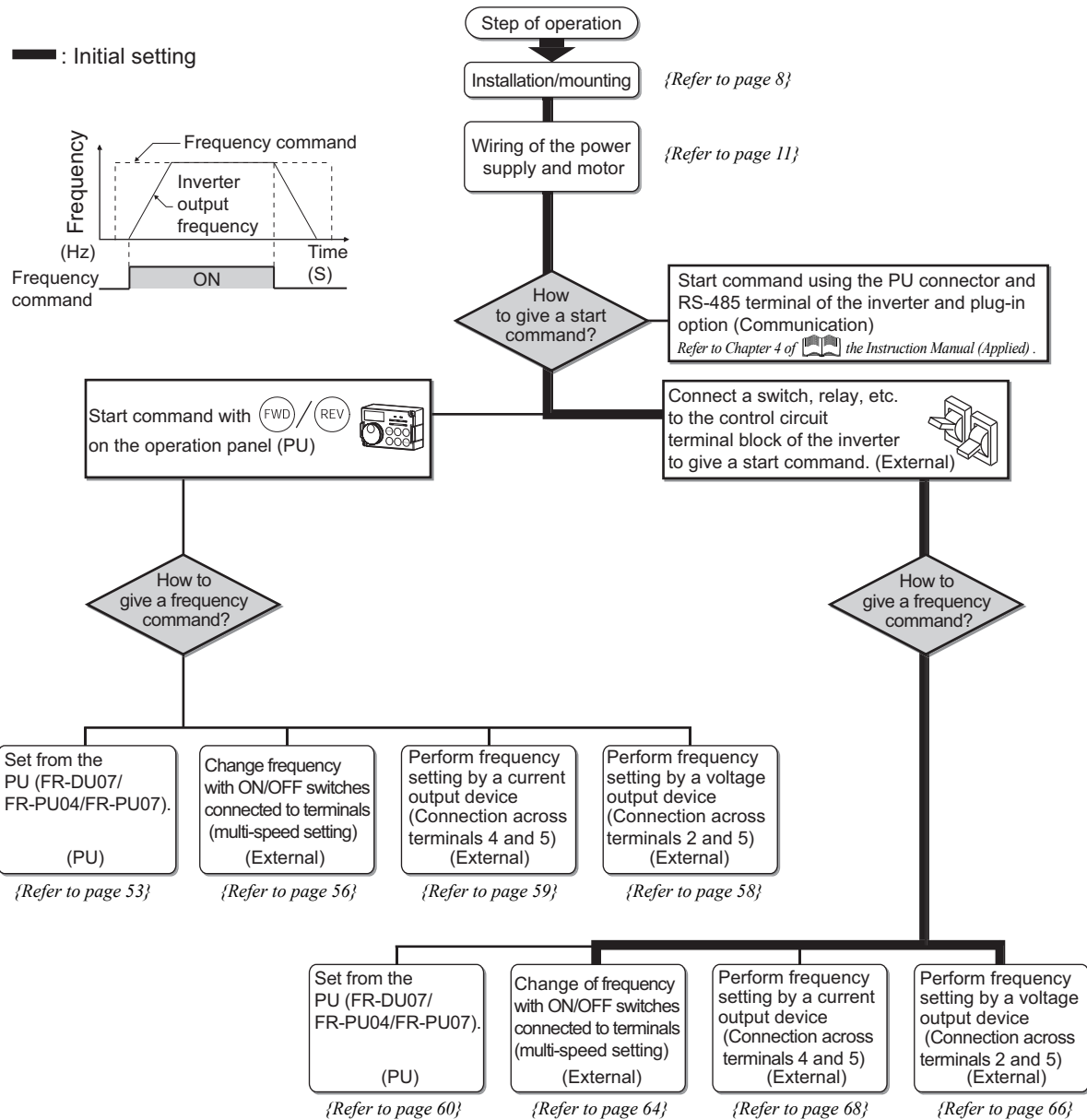

### CAUTION

Check the following points before powering ON the inverter.

- Check that the inverter is installed correctly in a correct place. (Refer to page 8)
- Check that wiring is correct. (Refer to page 9)
- Check that no load is connected to the motor.



- When protecting the motor from overheat by the inverter, set Pr.9 Electronic thermal O/L relay (Refer to page 51)
- To drive a general-purpose motor with the rated motor frequency of 50Hz, set Pr.3 Base frequency (Refer to page 52)

# 2 INSTALLATION AND WIRING

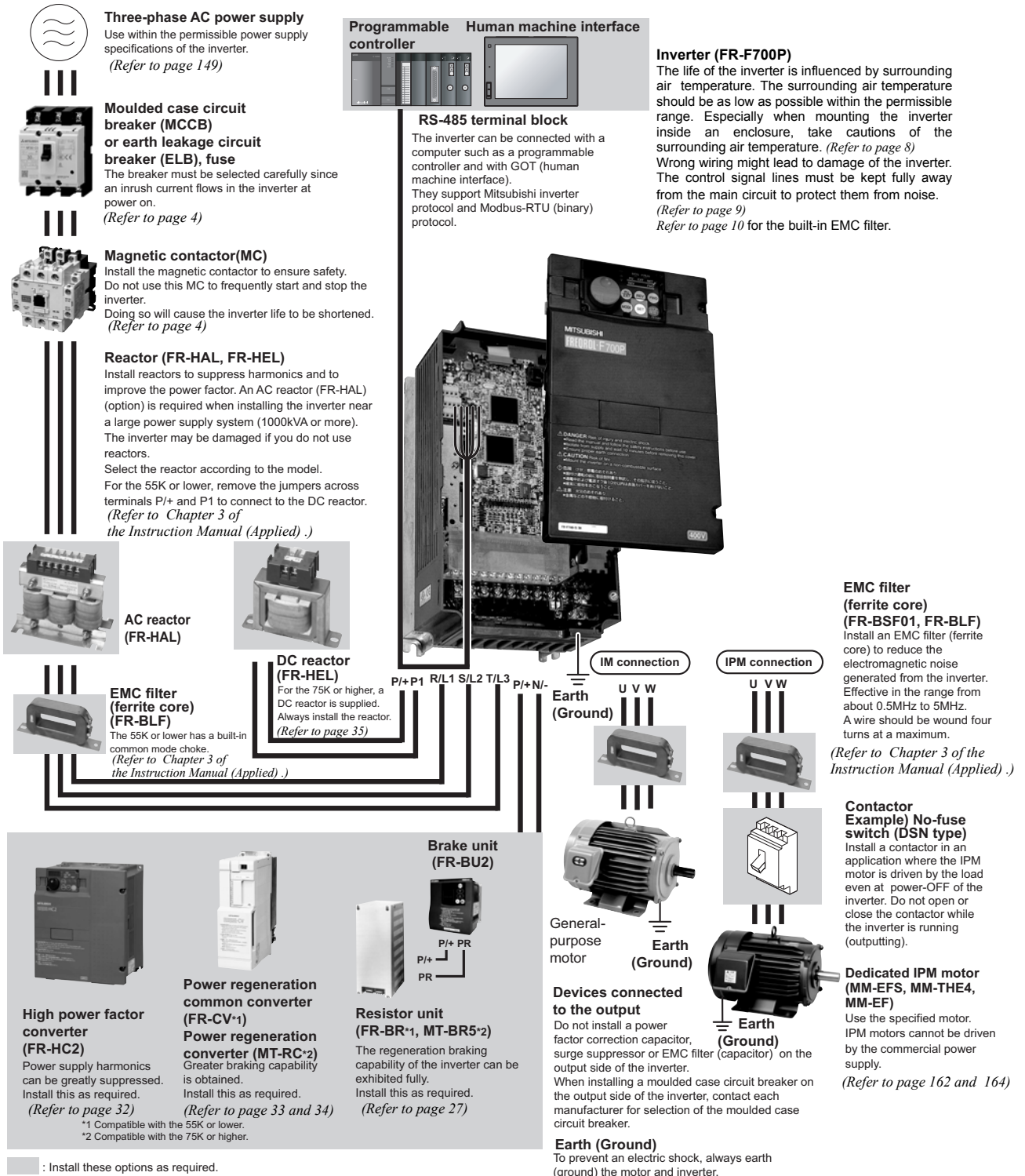

- Do not install a power factor correction capacitor, surge suppressor or capacitor type filter on the inverter output side. This will cause the inverter to trip or the capacitor, and surge suppressor to be damaged. If any of the above devices are connected, immediately remove them.
- Electromagnetic wave interference  
The input/output (main circuit) of the inverter includes high frequency components, which may interfere with the communication devices (such as AM radios) used near the inverter. In this case, set the EMC filter valid to minimize interference.  
(Refer to Chapter 2 of the Instruction Manual (Applied).)
- Refer to the instruction manual of each option and peripheral devices for details of peripheral devices.
- An IPM motor cannot be driven by the commercial power supply.
- An IPM motor is a motor with permanent magnets embedded inside. High-voltage is generated at the motor terminals while the motor is running even after the inverter power is turned OFF. Before closing the contactor at the output side, make sure that the inverter power is ON and the motor is stopped.



## 2.1 Peripheral devices

Check the inverter model of the inverter you purchased. Appropriate peripheral devices must be selected according to the capacity. Refer to the following list and prepare appropriate peripheral devices:

### 200V class

| Motor Output (kW)<br>*1 | Applicable Inverter Model | Moulded Case Circuit Breaker (MCCB) *2 or Earth Leakage Circuit Breaker (ELB) (NF or NV type) |      | Input Side Magnetic Contactor*3 |              |
|-------------------------|---------------------------|---|------|---------------------------------|--------------|
|                         |                           | Power factor improving (AC or DC) reactor   |      |                                 |              |
|                         |                           | Without   | With | Without                         | With         |
| 0.75                    | FR-F720P-0.75K            | 10A   | 10A  | S-N10                           | S-N10        |
| 1.5                     | FR-F720P-1.5K             | 15A   | 15A  | S-N10                           | S-N10        |
| 2.2                     | FR-F720P-2.2K             | 20A   | 15A  | S-N10                           | S-N10        |
| 3.7                     | FR-F720P-3.7K             | 30A   | 30A  | S-N20, S-N21                    | S-N10        |
| 5.5                     | FR-F720P-5.5K             | 50A   | 40A  | S-N25                           | S-N20, S-N21 |
| 7.5                     | FR-F720P-7.5K             | 60A   | 50A  | S-N25                           | S-N25        |
| 11                      | FR-F720P-11K              | 75A   | 75A  | S-N35                           | S-N35        |
| 15                      | FR-F720P-15K              | 125A  | 100A | S-N50                           | S-N50        |
| 18.5                    | FR-F720P-18.5K            | 150A  | 125A | S-N65                           | S-N50        |
| 22                      | FR-F720P-22K              | 175A  | 150A | S-N80                           | S-N65        |
| 30                      | FR-F720P-30K              | 225A  | 175A | S-N95                           | S-N80        |
| 37                      | FR-F720P-37K              | 250A  | 225A | S-N150                          | S-N125       |
| 45                      | FR-F720P-45K              | 300A  | 300A | S-N180                          | S-N150       |
| 55                      | FR-F720P-55K              | 400A  | 350A | S-N220                          | S-N180       |
| 75                      | FR-F720P-75K              | —   | 400A | —                               | S-N300       |
| 90                      | FR-F720P-90K              | —   | 400A | —                               | S-N300       |
| 110                     | FR-F720P-110K             | —   | 500A | —                               | S-N400       |

\*1 Assumes the use of a dedicated IPM motor or a Mitsubishi 4-pole standard motor with the power supply voltage of 200VAC 50Hz.

\*2 Select the MCCB according to the power supply capacity.

Install one MCCB per inverter.

For using commercial-power supply operation, select a breaker with capacity which allows the motor to be directly power supplied.

For installation in the United States or Canada, select a fuse in accordance with UL, cUL, the National Electrical Code and any applicable local codes, or use UL 489 Molded Case Circuit Breaker (MCCB).

(Refer to page 171.)

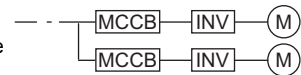

\*3 Magnetic contactor is selected based on the AC-1 class. The electrical durability of magnetic contactor is 500,000 times. When the magnetic contactor is used for emergency stop during motor driving, the electrical durability is 25 times.

If using an MC for emergency stop during motor driving, select an MC regarding the inverter input side current as JEM1038-AC-3 class rated current. When using an MC on the inverter output side for commercial-power supply operation switching using a general-purpose motor, select an MC regarding the rated motor current as JEM1038-AC-3 class rated current.

### CAUTION

- When the inverter capacity is larger than the motor capacity, select an MCCB and a magnetic contactor according to the inverter model, and select cable and reactor according to the motor output.
- When the breaker on the inverter primary side trips, check for the wiring fault (short circuit), damage to internal parts of the inverter, etc. Identify the cause of the trip, then remove the cause and power ON the breaker.

## 400V class

| Motor Output (kW)<br>*1 | Applicable Inverter Model | Moulded Case Circuit Breaker (MCCB) *2<br>or Earth Leakage Circuit Breaker (ELB)<br>(NF or NV type) |       | Input Side Magnetic Contactor*3 |                        |
|-------------------------|---------------------------|---|-------|---------------------------------|------------------------|
|                         |                           | Power factor improving (AC or DC) reactor   |       |                                 |                        |
|                         |                           | Without   | With  | Without                         | With                   |
| 0.75                    | FR-F740P-0.75K            | 5A  | 5A    | S-N10                           | S-N10                  |
| 1.5                     | FR-F740P-1.5K             | 10A   | 10A   | S-N10                           | S-N10                  |
| 2.2                     | FR-F740P-2.2K             | 10A   | 10A   | S-N10                           | S-N10                  |
| 3.7                     | FR-F740P-3.7K             | 20A   | 15A   | S-N10                           | S-N10                  |
| 5.5                     | FR-F740P-5.5K             | 30A   | 20A   | S-N20, S-N21                    | S-N11, S-N12           |
| 7.5                     | FR-F740P-7.5K             | 30A   | 30A   | S-N20, S-N21                    | S-N20, S-N21           |
| 11                      | FR-F740P-11K              | 50A   | 40A   | S-N20, S-N21                    | S-N20, S-N21           |
| 15                      | FR-F740P-15K              | 60A   | 50A   | S-N25                           | S-N20, S-N21           |
| 18.5                    | FR-F740P-18.5K            | 75A   | 60A   | S-N25                           | S-N25                  |
| 22                      | FR-F740P-22K              | 100A  | 75A   | S-N35                           | S-N25                  |
| 30                      | FR-F740P-30K              | 125A  | 100A  | S-N50                           | S-N50                  |
| 37                      | FR-F740P-37K              | 150A  | 125A  | S-N65                           | S-N50                  |
| 45                      | FR-F740P-45K              | 175A  | 150A  | S-N80                           | S-N65                  |
| 55                      | FR-F740P-55K              | 200A  | 175A  | S-N80                           | S-N80                  |
| 75                      | FR-F740P-75K              | —   | 225A  | —                               | S-N95                  |
| 90                      | FR-F740P-90K              | —   | 225A  | —                               | S-N150                 |
| 110                     | FR-F740P-110K             | —   | 225A  | —                               | S-N180                 |
| 132                     | FR-F740P-132K             | —   | 400A  | —                               | S-N220                 |
| 150                     | FR-F740P-160K             | —   | 400A  | —                               | S-N300                 |
| 160                     | FR-F740P-160K             | —   | 400A  | —                               | S-N300                 |
| 185                     | FR-F740P-185K             | —   | 400A  | —                               | S-N300                 |
| 220                     | FR-F740P-220K             | —   | 500A  | —                               | S-N400                 |
| 250                     | FR-F740P-250K             | —   | 600A  | —                               | S-N600                 |
| 280                     | FR-F740P-280K             | —   | 600A  | —                               | S-N600                 |
| 315                     | FR-F740P-315K             | —   | 700A  | —                               | S-N600                 |
| 355                     | FR-F740P-355K             | —   | 800A  | —                               | S-N600                 |
| 400                     | FR-F740P-400K             | —   | 900A  | —                               | S-N800                 |
| 450                     | FR-F740P-450K             | —   | 1000A | —                               | 1000A<br>Rated product |
| 500                     | FR-F740P-500K             | —   | 1200A | —                               | 1000A<br>Rated product |
| 560                     | FR-F740P-560K             | —   | 1500A | —                               | 1200A<br>Rated product |

\*1 Assumes the use of a dedicated IPM motor or a Mitsubishi 4-pole standard motor with the power supply voltage of 400VAC 50Hz.

\*2 Select the MCCB according to the power supply capacity.

Install one MCCB per inverter.

For using commercial-power supply operation, select a breaker with capacity which allows the motor to be directly power supplied.

For installation in the United States or Canada, select a fuse in accordance with UL, cUL, the National Electrical Code and any applicable local codes, or use UL 489 Molded Case Circuit Breaker (MCCB). (Refer to page 171.)

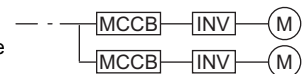

\*3 Magnetic contactor is selected based on the AC-1 class. The electrical durability of magnetic contactor is 500,000 times. When the magnetic contactor is used for emergency stop during motor driving, the electrical durability is 25 times.

If using an MC for emergency stop during motor driving, select an MC regarding the inverter input side current as JEM1038-AC-3 class rated current. When using an MC on the inverter output side for commercial-power supply operation switching using a general-purpose motor, select an MC regarding the rated motor current as JEM1038-AC-3 class rated current.

**CAUTION**

- When the inverter capacity is larger than the motor capacity, select an MCCB and a magnetic contactor according to the inverter model, and select cable and reactor according to the motor output.
- When the breaker on the inverter primary side trips, check for the wiring fault (short circuit), damage to internal parts of the inverter, etc. Identify the cause of the trip, then remove the cause and power ON the breaker.



## 2.2 Method of removal and reinstallation of the front cover

### •Removal of the operation panel

1) Loosen the two screws on the operation panel.  
(These screws cannot be removed.)

2) Push the left and right hooks of the operation panel and pull the operation panel toward you to remove.

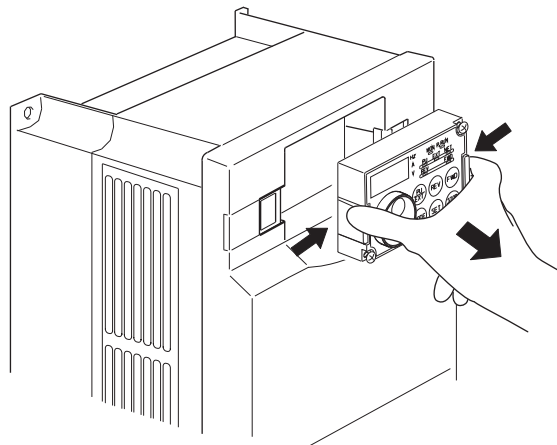
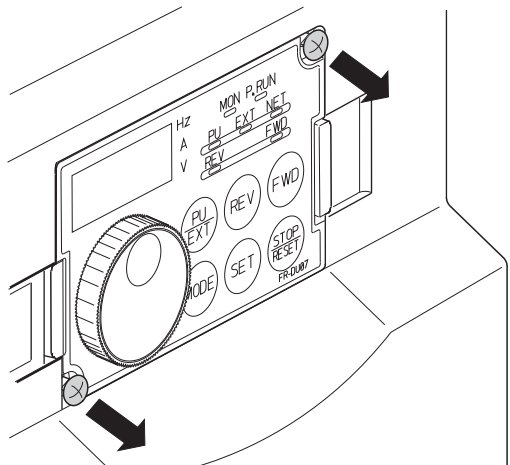

When reinstalling the operation panel, insert it straight to reinstall securely and tighten the fixed screws of the operation panel. (Tightening torque: 0.40N·m to 0.45N·m)

### 30K or lower

#### •Removal

1) Loosen the installation screws of the front cover.

2) Pull the front cover toward you to remove by pushing an installation hook using left fixed hooks as supports.

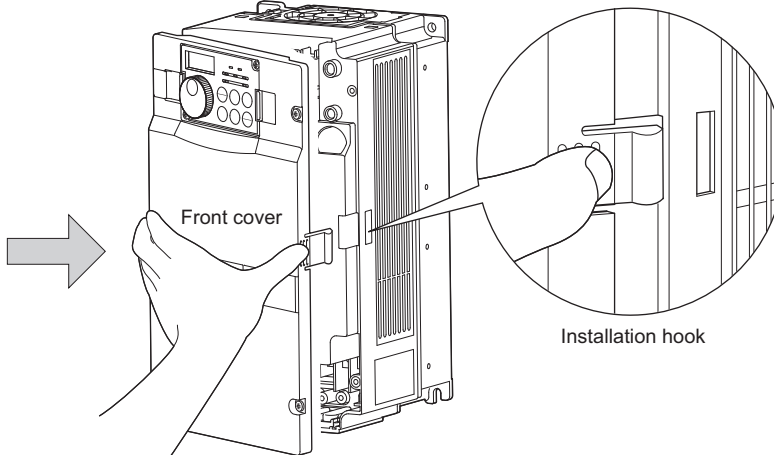
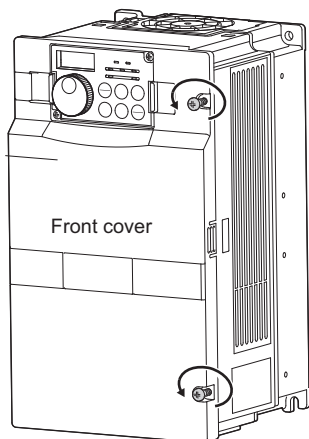

#### •Reinstallation

1) Insert the two fixed hooks on the left side of the front cover into the sockets of the inverter.

2) Using the fixed hooks as supports, securely press the front cover against the inverter.  
(Although installation can be done with the operation panel mounted, make sure that a connector is securely fixed.)

3) Tighten the installation screws and fix the front cover.

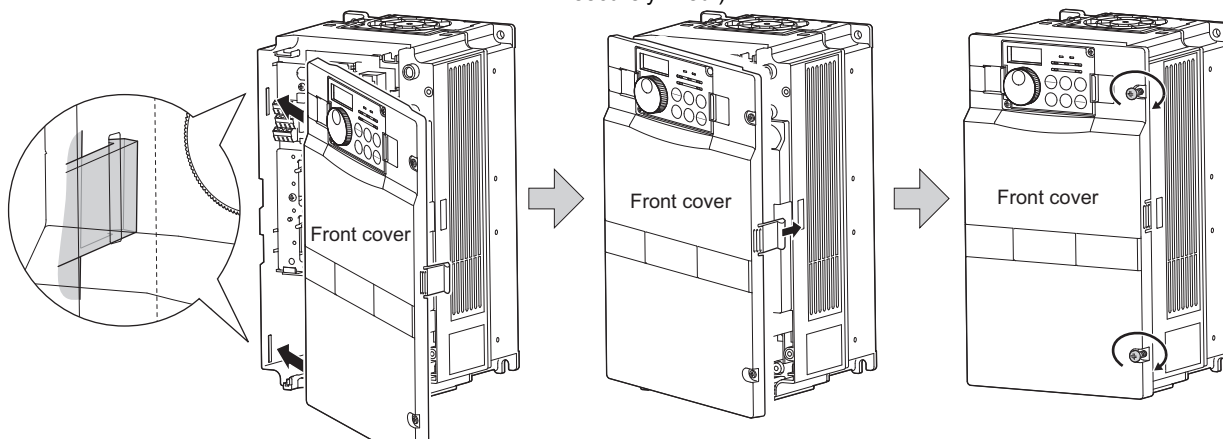

**37K or higher**

**•Removal**

- 1) Remove installation screws on the front cover 1 to remove the front cover 1.
- 2) Loosen the installation screws of the front cover 2.
- 3) Pull the front cover 2 toward you to remove by pushing an installation hook on the right side using left fixed hooks as supports.

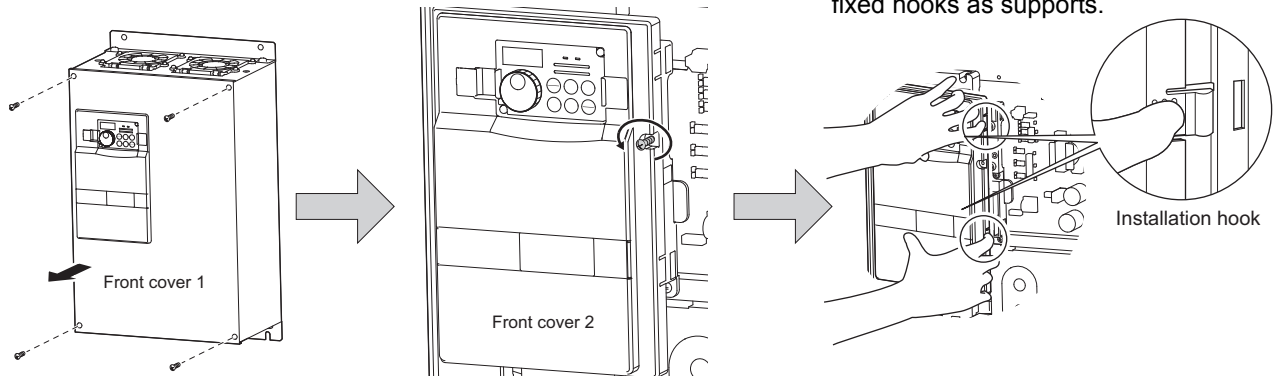

**•Reinstallation**

- 1) Insert the two fixed hooks on the left side of the front cover 2 into the sockets of the inverter.
- 2) Using the fixed hooks as supports, securely press the front cover 2 against the inverter. (Although installation can be done with the operation panel mounted, make sure that a connector is securely fixed.)

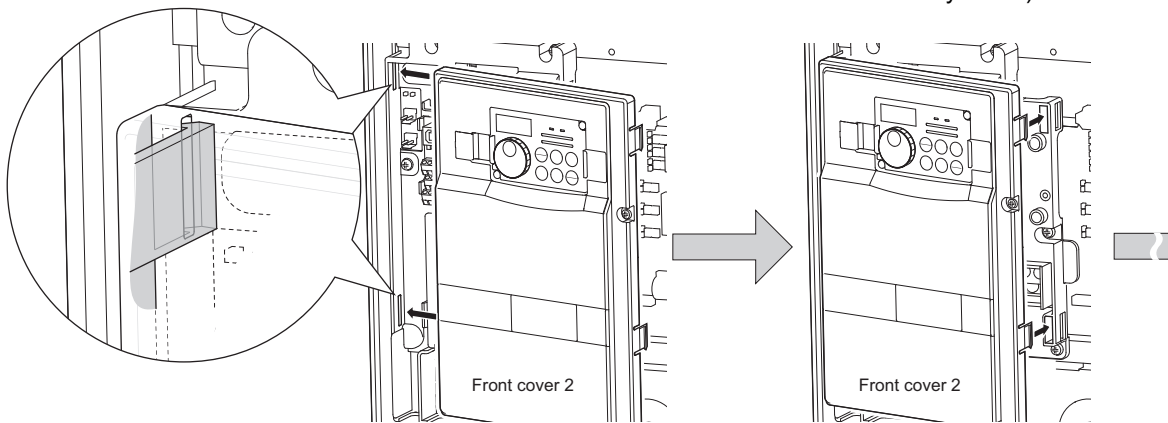

- 3) Fix the front cover 2 with the installation screws.
- 4) Fix the front cover 1 with the installation screws.

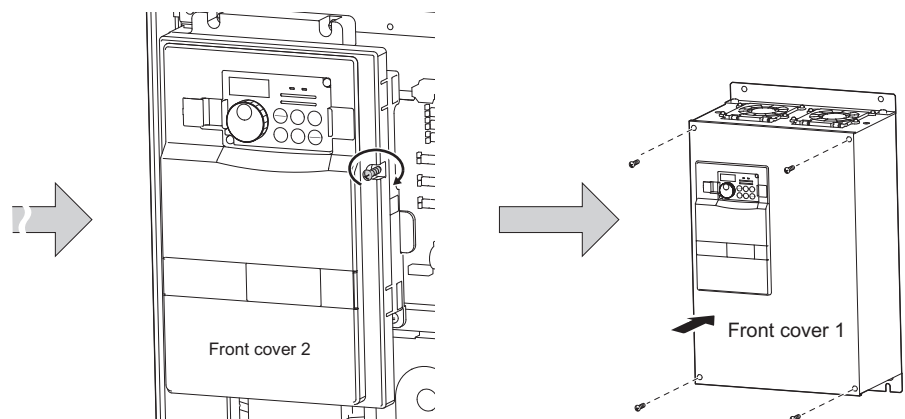

**REMARKS**

- For the FR-F740P-185K or higher, the front cover 1 is separated into two parts.

**CAUTION**

- Fully make sure that the front cover has been reinstalled securely. Always tighten the installation screws of the front cover.
- The same serial number is printed on the capacity plate of the front cover and the rating plate of the inverter. Before reinstalling the front cover, check the serial numbers to ensure that the cover removed is reinstalled to the inverter from where it was removed.

## 2.3 Installation of the inverter and instructions

### • Installation of the Inverter

Installation on the enclosure  
0.75K to 30K

37K or higher

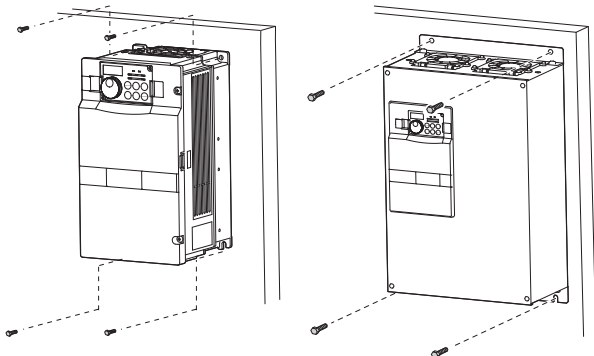

Fix six points for the FR-F740P-185K to 400K and fix eight points for the FR-F740P-450K to 560K.

### CAUTION

- When encasing multiple inverters, install them in parallel as a cooling measure.
- Install the inverter vertically.

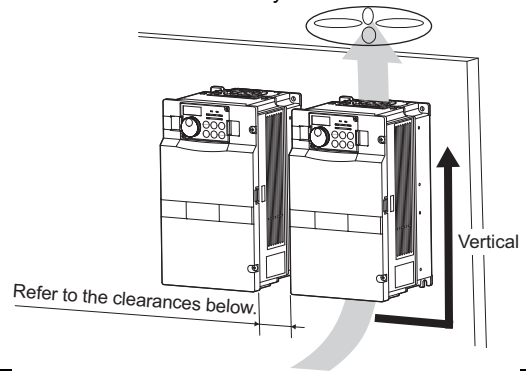

### • Install the inverter under the following conditions.

Surrounding air temperature and humidity

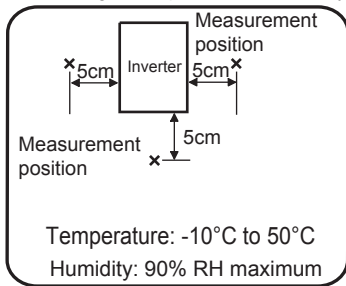

Leave enough clearances as a cooling measure.

Clearances (front)

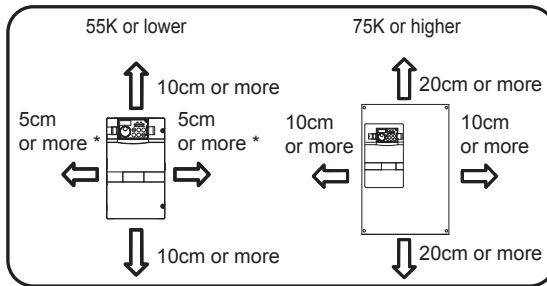

\*1cm or more for 3.7K or lower

Clearances (side)

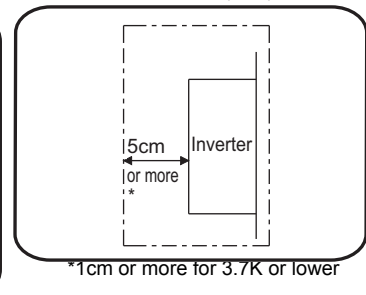

### REMARKS

- For replacing the cooling fan of the FR-F740P-185K or higher, 30cm of space is necessary in front of the inverter. Refer to page 145 for fan replacement.
- The inverter consists of precision mechanical and electronic parts. Never install or handle it in any of the following conditions as doing so could cause an operation fault or failure.

|  |  |   |                                      |
|--|--|---|--------------------------------------|
| <br>Direct sunlight  | <br>Vibration (5.9m/s <sup>2</sup> * or more at 10 to 55Hz (directions of X, Y, Z axes))<br>* 2.9m/s <sup>2</sup> or more for the 185K or higher | <br>High temperature, high humidity                           | <br>Horizontal placement             |
| <br>Vertical mounting (When installing two or more inverters, install them in parallel.) | <br>Transportation by holding the front cover  | <br>Oil mist, flammable gas, corrosive gas, fluff, dust, etc. | <br>Mounting to combustible material |

## 2.4 Wiring

### 2.4.1 Terminal connection diagram

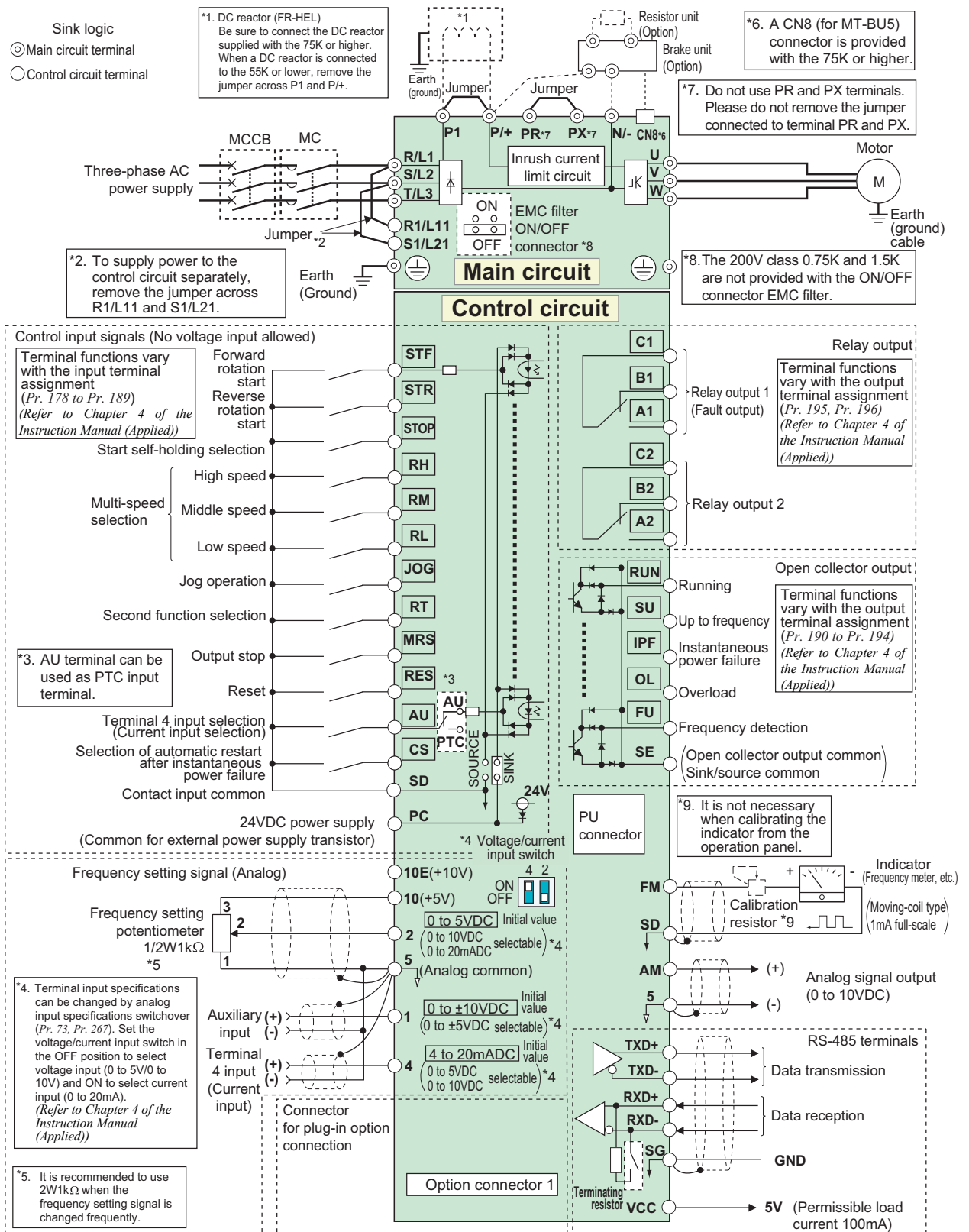

#### CAUTION

- To prevent a malfunction due to noise, keep the signal cables more than 10cm away from the power cables. Also separate the main circuit wire of the input side and the output side.
- After wiring, wire offcuts must not be left in the inverter. Wire offcuts can cause an alarm, failure or malfunction. Always keep the inverter clean.
- When drilling mounting holes in an enclosure etc. take care not to allow chips and other foreign matter to enter the inverter.
- Set the voltage/current input switch correctly. Operation with a wrong setting may cause a fault, failure or malfunction.





### 2.4.2 EMC filter

This inverter is equipped with a built-in EMC filter (capacitive filter) and common mode choke. The EMC filter is effective for reduction of air-propagated noise on the input side of the inverter. The EMC filter is factory-set to disable (OFF). To enable it, fit the EMC filter ON/OFF connector to the ON position. The input side common mode choke, built-in the 55K or lower inverter, is always valid regardless of ON/OFF of the EMC filter ON/OFF connector.

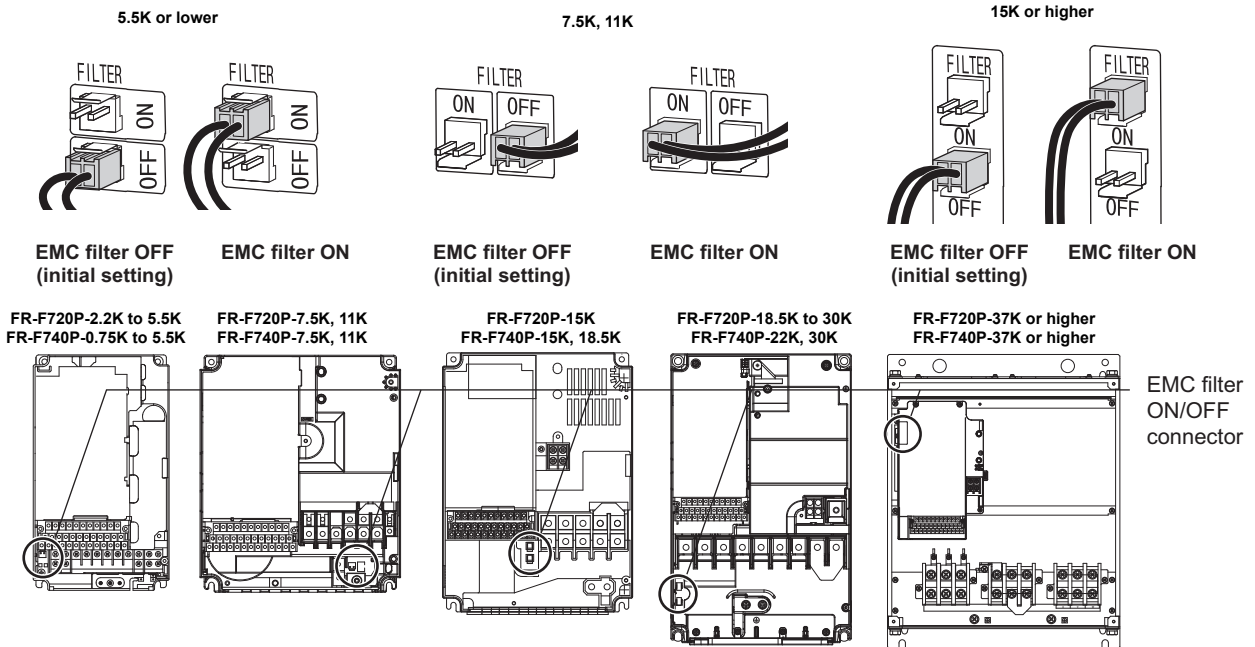

The FR-F720P-0.75K and 1.5K are not provided with the EMC filter ON/OFF connector. (Always ON)

**<How to disconnect the connector>**

- (1) Before removing a front cover, check to make sure that the indication of the inverter operation panel is OFF, wait for at least 10 minutes after the power supply has been switched OFF, and check that there are no residual voltage using a tester or the like. (For the front cover removal method, refer to *page 6*.)
- (2) When disconnecting the connector, push the fixing tab and pull the connector straight without pulling the cable or forcibly pulling the connector with the tab fixed. When installing the connector, also engage the fixing tab securely. If it is difficult to disconnect the connector, use a pair of long-nose pliers, etc.

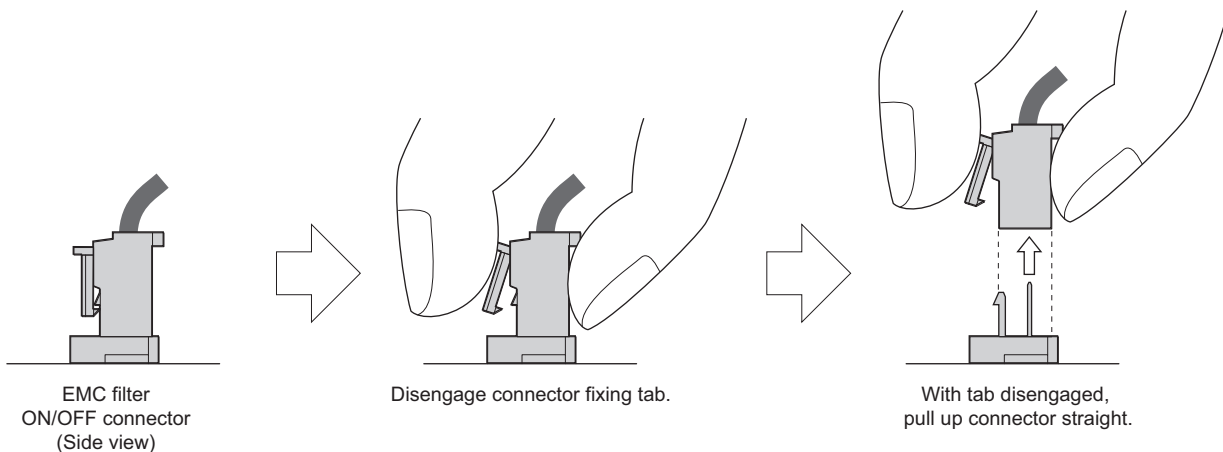

**CAUTION**

- Fit the connector to either ON or OFF.
- Enabling (turning ON) the EMC filter increases leakage current. (Refer to Chapter 3 of the Instruction Manual (Applied))

**⚠ WARNING**

⚠ While power is ON or when the inverter is running, do not open the front cover. Otherwise you may get an electric shock.

### 2.4.3 Specification of main circuit terminal

| Terminal Symbol  | Terminal Name                    | Description  | Refer to Page |              |       |               |            |      |      |      |            |      |      |      |    |
|------------------|----------------------------------|--|---------------|--------------|-------|---------------|------------|------|------|------|------------|------|------|------|----|
| R/L1, S/L2, T/L3 | AC power input                   | Connect to the commercial power supply. Keep these terminals open when using the high power factor converter (FR-HC2) or power regeneration common converter (FR-CV).  | 11            |              |       |               |            |      |      |      |            |      |      |      |    |
| U, V, W          | Inverter output                  | Connect a three-phase squirrel-cage motor or dedicated IPM motor.  | 11            |              |       |               |            |      |      |      |            |      |      |      |    |
| R1/L11, S1/L21   | Power supply for control circuit | <p>Connected to the AC power supply terminals R/L1 and S/L2. To retain the fault display and fault output or when using the high power factor converter (FR-HC2) or power regeneration common converter (FR-CV), remove the jumpers from terminals R/L1 and R1/L11, and S/L2 and S1/L21, and apply external power to these terminals. The power capacity necessary when separate power is supplied from R1/L11 and S1/L21 differs according to the inverter capacity.</p> <table border="1"> <thead> <tr> <th></th> <th>15K or lower</th> <th>18.5K</th> <th>22K or higher</th> </tr> </thead> <tbody> <tr> <td>200V class</td> <td>60VA</td> <td>80VA</td> <td>80VA</td> </tr> <tr> <td>400V class</td> <td>60VA</td> <td>60VA</td> <td>80VA</td> </tr> </tbody> </table> |               | 15K or lower | 18.5K | 22K or higher | 200V class | 60VA | 80VA | 80VA | 400V class | 60VA | 60VA | 80VA | 17 |
|                  | 15K or lower                     | 18.5K  | 22K or higher |              |       |               |            |      |      |      |            |      |      |      |    |
| 200V class       | 60VA                             | 80VA   | 80VA          |              |       |               |            |      |      |      |            |      |      |      |    |
| 400V class       | 60VA                             | 60VA   | 80VA          |              |       |               |            |      |      |      |            |      |      |      |    |
| P/+, N/-         | Brake unit connection            | Connect the brake unit (FR-BU2, FR-BU, BU and MT-BU5), power regeneration common converter (FR-CV), high power factor converter (FR-HC2) or power regeneration converter (MT-RC).  | 27            |              |       |               |            |      |      |      |            |      |      |      |    |
| P/+, P1          | DC reactor connection            | <p>For the 55K or lower, remove the jumper across terminals P/+ and P1, and connect the DC reactor (FR-HEL). (Be sure to connect the DC reactor supplied with the 75K or higher.)</p> <p>When a DC reactor is not connected, the jumper across terminals P/+ and P1 should not be removed.</p>   | 35            |              |       |               |            |      |      |      |            |      |      |      |    |
| PR, PX           |                                  | Please do not remove or use terminals PR and PX or the jumper connected.   | —             |              |       |               |            |      |      |      |            |      |      |      |    |
|                  | Earth (ground)                   | For earthing (grounding) the inverter chassis. Must be earthed (grounded).   | 16            |              |       |               |            |      |      |      |            |      |      |      |    |

### 2.4.4 Terminal arrangement of the main circuit terminal, power supply and the motor wiring

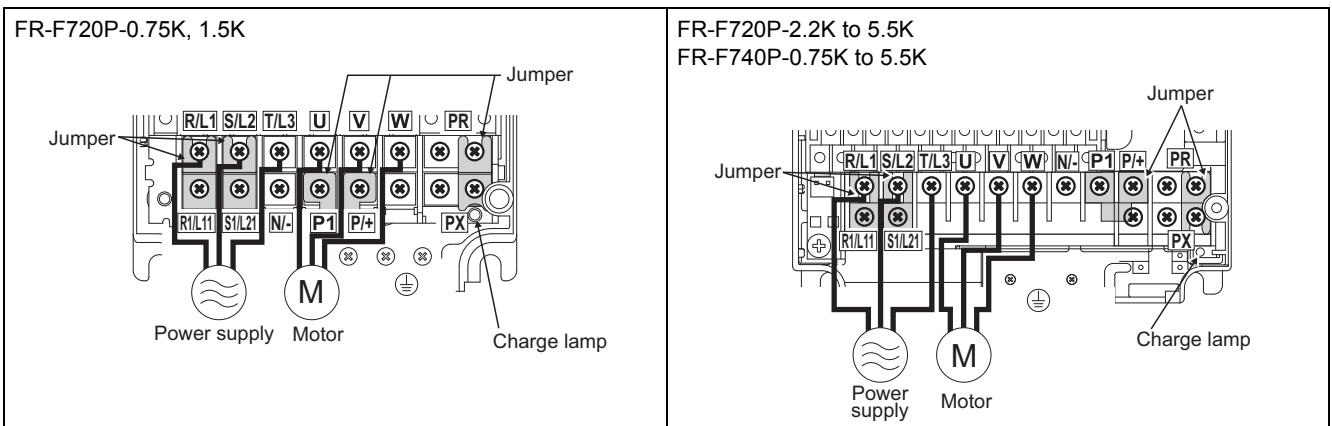



FR-F720P-7.5K, 11K  
FR-F740P-7.5K, 11K

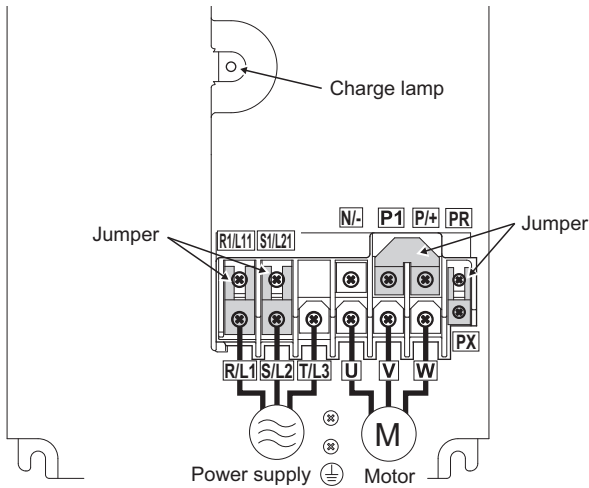

FR-F720P-15K  
FR-F740P-15K, 18.5K

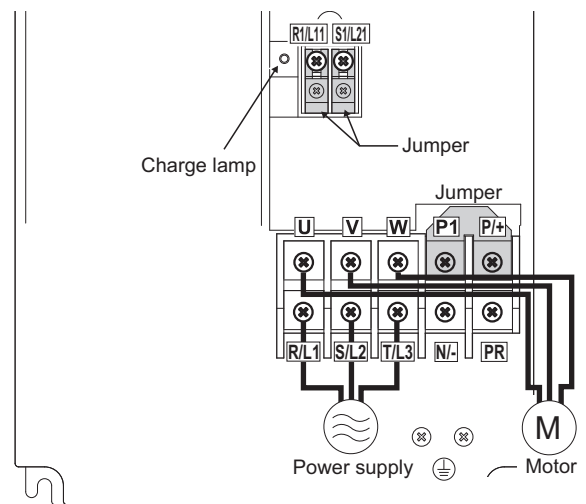

FR-F720P-18.5K to 30K  
FR-F740P-22K, 30K

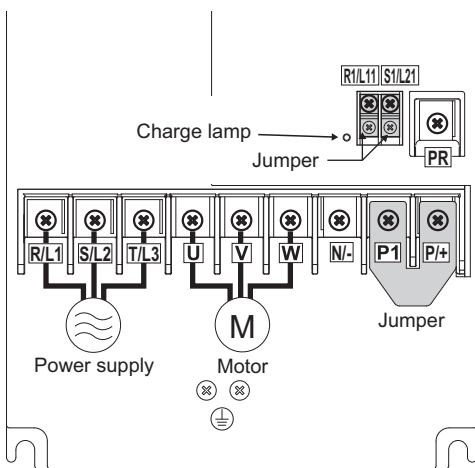

FR-F720P-37K to 55K  
FR-F740P-37K to 55K

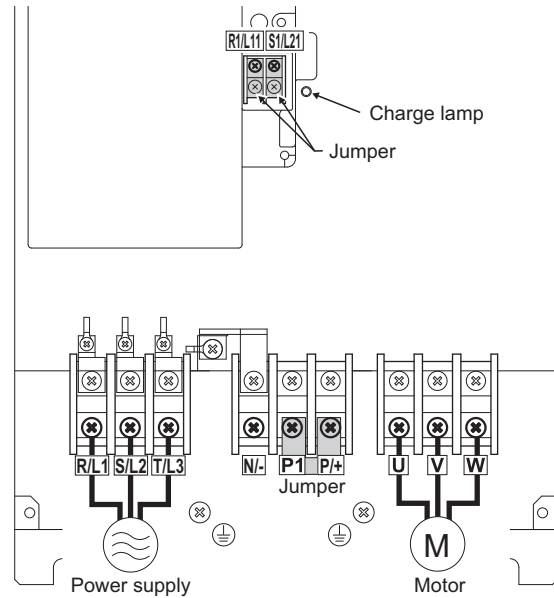

FR-F740P-75K to 110K

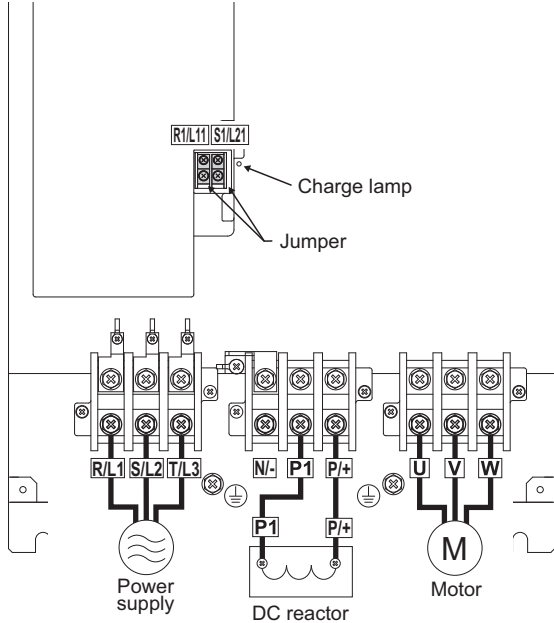

FR-F720P-75K to 110K  
FR-F740P-132K to 220K

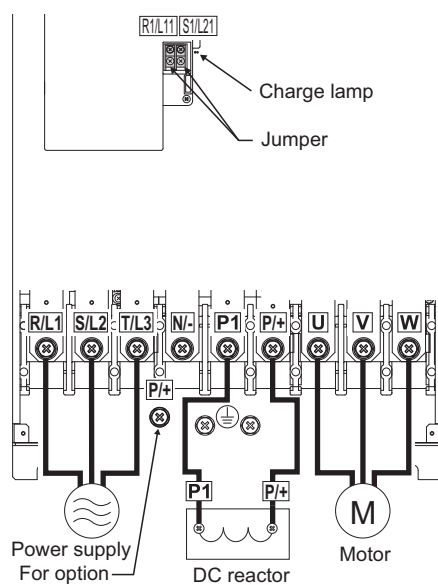

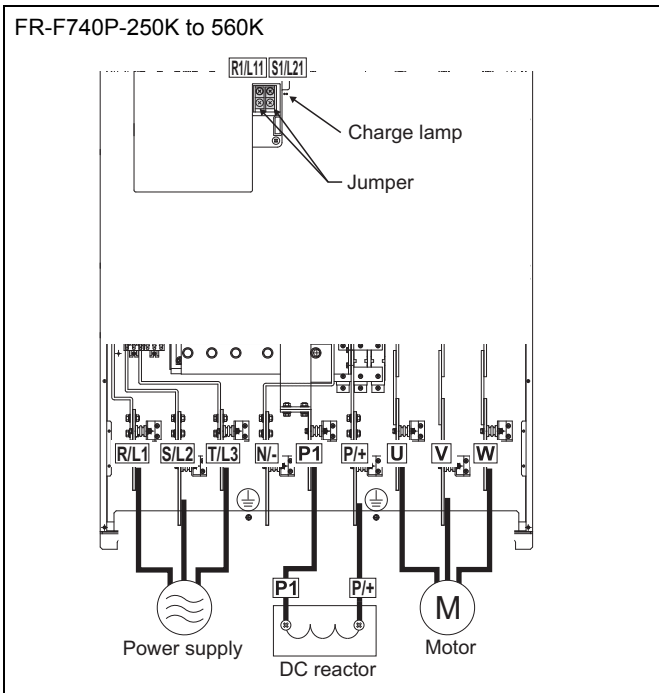

### CAUTION

- The power supply cables must be connected to R/L1, S/L2, T/L3. (Phase sequence needs not to be matched.) Never connect the power cable to the U, V, W of the inverter. Doing so will damage the inverter.
- Connect the motor to U, V, W. At this time, turning ON the forward rotation switch (signal) rotates the motor in the counterclockwise direction when viewed from the motor shaft.
- When wiring the inverter main circuit conductor of the 250K or higher, tighten a nut from the right side of the conductor. When wiring two wires, place wires on both sides of the conductor. (Refer to the drawing below.) For wiring, use bolts (nuts) provided with the inverter.

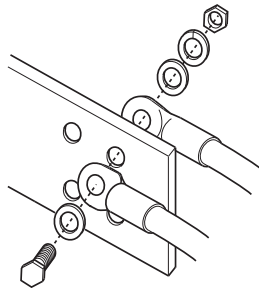

- Handling of the wiring cover  
(FR-F720P-18.5K, 22K, FR-F740P-22K, 30K)  
For the hook of the wiring cover, cut off the necessary parts using a pair of long-nose pliers etc.

### CAUTION

Cut off the same number of lugs as wires. If parts where no wire is put through has been cut off (10mm or more), protective structure (JEM1030) becomes an open type (IP00).

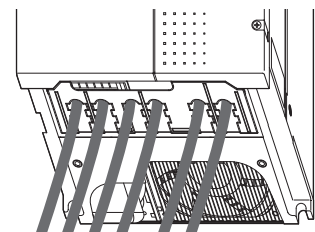
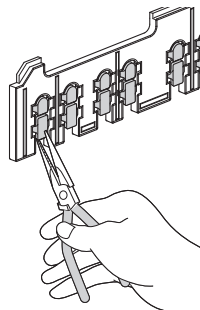



## (1) Cable size and other specifications of the main circuit terminals and the earthing terminal

Select the recommended cable size to ensure that a voltage drop will be 2% or less.

If the wiring distance is long between the inverter and motor, a main circuit cable voltage drop will cause the motor torque to decrease especially at the output of a low frequency.

The following table indicates a selection example for the wiring length of 20m.

### 200V class (when input power supply is 220V)

| Applicable Inverter Model | Terminal Screw Size *4 | Tightening Torque N·m | Crimping Terminal |         | Cable Size                      |         |          |                            |                  |         |                                 |         |                            |
|---------------------------|------------------------|-----------------------|-------------------|---------|---------------------------------|---------|----------|----------------------------|------------------|---------|---------------------------------|---------|----------------------------|
|                           |                        |                       |                   |         | HIV, etc. (mm <sup>2</sup> ) *1 |         |          |                            | AWG/MCM *2       |         | PVC, etc. (mm <sup>2</sup> ) *3 |         |                            |
|                           |                        |                       | R/L1, S/L2, T/L3  | U, V, W | R/L1, S/L2, T/L3                | U, V, W | P/+ , P1 | Earthing (grounding) cable | R/L1, S/L2, T/L3 | U, V, W | R/L1, S/L2, T/L3                | U, V, W | Earthing (grounding) cable |
| FR-F720P-0.75K to 2.2K    | M4                     | 1.5                   | 2-4               | 2-4     | 2                               | 2       | 2        | 2                          | 14               | 14      | 2.5                             | 2.5     | 2.5                        |
| FR-F720P-3.7K             | M4                     | 1.5                   | 5.5-4             | 5.5-4   | 3.5                             | 3.5     | 3.5      | 3.5                        | 12               | 12      | 4                               | 4       | 4                          |
| FR-F720P-5.5K             | M4                     | 1.5                   | 5.5-4             | 5.5-4   | 5.5                             | 5.5     | 5.5      | 5.5                        | 10               | 10      | 6                               | 6       | 6                          |
| FR-F720P-7.5K             | M5                     | 2.5                   | 14-5              | 8-5     | 14                              | 8       | 14       | 5.5                        | 6                | 8       | 16                              | 10      | 16                         |
| FR-F720P-11K              | M5                     | 2.5                   | 14-5              | 14-5    | 14                              | 14      | 14       | 8                          | 6                | 6       | 16                              | 16      | 16                         |
| FR-F720P-15K              | M5                     | 2.5                   | 22-5              | 22-5    | 22                              | 22      | 22       | 14                         | 4                | 6 (*5)  | 25                              | 25      | 16                         |
| FR-F720P-18.5K            | M6                     | 4.4                   | 38-6              | 38-6    | 38                              | 38      | 38       | 14                         | 2                | 2       | 35                              | 35      | 25                         |
| FR-F720P-22K              | M8 (M6)                | 7.8                   | 38-8              | 38-8    | 38                              | 38      | 38       | 22                         | 2                | 2       | 35                              | 35      | 25                         |
| FR-F720P-30K              | M8 (M6)                | 7.8                   | 60-8              | 60-8    | 60                              | 60      | 60       | 22                         | 1/0              | 1/0     | 50                              | 50      | 25                         |
| FR-F720P-37K              | M8 (M6)                | 7.8                   | 80-8              | 80-8    | 80                              | 80      | 80       | 22                         | 3/0              | 3/0     | 70                              | 70      | 35                         |
| FR-F720P-45K              | M10 (M8)               | 14.7                  | 100-10            | 100-10  | 100                             | 100     | 100      | 38                         | 4/0              | 4/0     | 95                              | 95      | 50                         |
| FR-F720P-55K              | M10 (M8)               | 14.7                  | 100-10            | 100-10  | 100                             | 100     | 100      | 38                         | 4/0              | 4/0     | 95                              | 95      | 50                         |
| FR-F720P-75K              | M12 (M10)              | 24.5                  | 150-12            | 150-12  | 125                             | 125     | 150      | 38                         | 250              | 250     | —                               | —       | —                          |
| FR-F720P-90K              | M12 (M10)              | 24.5                  | 150-12            | 150-12  | 150                             | 150     | 2×100    | 38                         | 2×4/0            | 2×4/0   | —                               | —       | —                          |
| FR-F720P-110K             | M12 (M10)              | 24.5                  | 100-12            | 100-12  | 2×100                           | 2×100   | 2×100    | 60                         | 2×4/0            | 2×4/0   | —                               | —       | —                          |

\*1 The cable size is that of the cable (HIV cable (600V class 2 vinyl-insulated cable) etc.) with continuous maximum permissible temperature of 75°C. Assumes that the surrounding air temperature is 50°C or less and the wiring distance is 20m or less.

\*2 The recommended cable size is that of the cable (THHW cable) with continuous maximum permissible temperature of 75°C. Assumes that the surrounding air temperature is 40°C or less and the wiring distance is 20m or less.  
(Selection example for use mainly in the United States.)

\*3 For the 15K or lower, the recommended cable size is that of the cable (PVC cable) with continuous maximum permissible temperature of 70°C. Assumes that the surrounding air temperature is 40°C or less and the wiring distance is 20m or less.  
For the 18.5K or higher, the recommended cable size is that of the cable (XLPE cable) with continuous maximum permissible temperature of 90°C. Assumes that the surrounding air temperature is 40°C or less and wiring is performed in an enclosure.  
(Selection example for use mainly in Europe.)

\*4 The terminal screw size indicates the terminal size for R/L1, S/L2, T/L3, U, V, W, and a screw for earthing (grounding).  
A screw for earthing (grounding) of the 22K or higher is indicated in parentheses.

\*5 When connecting the option unit to P/+, P1, N/-, use THHN cables for the option and terminals R/L1, S/L2, T/L3, U, V, W.

**400V class (when input power supply is 440V)**

| Applicable Inverter Model | Terminal Screw Size *4 | Tightening Torque N·m | Crimping (Compression) Terminal |         | Cable Size                      |         |         |                            |                  |         |                                 |         |                            |
|---------------------------|------------------------|-----------------------|---------------------------------|---------|---------------------------------|---------|---------|----------------------------|------------------|---------|---------------------------------|---------|----------------------------|
|                           |                        |                       |                                 |         | HIV, etc. (mm <sup>2</sup> ) *1 |         |         |                            | AWG/MCM *2       |         | PVC, etc. (mm <sup>2</sup> ) *3 |         |                            |
|                           |                        |                       | R/L1, S/L2, T/L3                | U, V, W | R/L1, S/L2, T/L3                | U, V, W | P/+, P1 | Earthing (grounding) cable | R/L1, S/L2, T/L3 | U, V, W | R/L1, S/L2, T/L3                | U, V, W | Earthing (grounding) cable |
| FR-F740P-0.75K to 3.7K    | M4                     | 1.5                   | 2-4                             | 2-4     | 2                               | 2       | 2       | 2                          | 14               | 14      | 2.5                             | 2.5     | 2.5                        |
| FR-F740P-5.5K             | M4                     | 1.5                   | 2-4                             | 2-4     | 2                               | 2       | 3.5     | 3.5                        | 12               | 14      | 2.5                             | 2.5     | 4                          |
| FR-F740P-7.5K             | M4                     | 1.5                   | 5.5-4                           | 5.5-4   | 3.5                             | 3.5     | 3.5     | 3.5                        | 12               | 12      | 4                               | 4       | 4                          |
| FR-F740P-11K              | M4                     | 1.5                   | 5.5-4                           | 5.5-4   | 5.5                             | 5.5     | 5.5     | 5.5                        | 10               | 10      | 6                               | 6       | 10                         |
| FR-F740P-15K              | M5                     | 2.5                   | 8-5                             | 8-5     | 8                               | 8       | 8       | 5.5                        | 8                | 8       | 10                              | 10      | 10                         |
| FR-F740P-18.5K            | M5                     | 2.5                   | 14-5                            | 8-5     | 14                              | 8       | 14      | 8                          | 6                | 8       | 16                              | 10      | 16                         |
| FR-F740P-22K              | M6                     | 4.4                   | 14-6                            | 14-6    | 14                              | 14      | 22      | 14                         | 6                | 6       | 16                              | 16      | 16                         |
| FR-F740P-30K              | M6                     | 4.4                   | 22-6                            | 22-6    | 22                              | 22      | 22      | 14                         | 4                | 4       | 25                              | 25      | 16                         |
| FR-F740P-37K              | M6                     | 4.4                   | 22-6                            | 22-6    | 22                              | 22      | 22      | 14                         | 4                | 4       | 25                              | 25      | 16                         |
| FR-F740P-45K              | M8                     | 7.8                   | 38-8                            | 38-8    | 38                              | 38      | 38      | 22                         | 1                | 2       | 50                              | 50      | 25                         |
| FR-F740P-55K              | M8                     | 7.8                   | 60-8                            | 60-8    | 60                              | 60      | 60      | 22                         | 1/0              | 1/0     | 50                              | 50      | 25                         |
| FR-F740P-75K              | M8 (M10)               | 7.8                   | 60-8                            | 60-8    | 60                              | 60      | 60      | 22                         | 1/0              | 1/0     | 50                              | 50      | 25                         |
| FR-F740P-90K              | M10                    | 14.7                  | 60-10                           | 60-10   | 60                              | 60      | 80      | 22                         | 3/0              | 3/0     | 50                              | 50      | 25                         |
| FR-F740P-110K             | M10                    | 14.7                  | 80-10                           | 80-10   | 80                              | 80      | 100     | 22                         | 3/0              | 3/0     | 70                              | 70      | 35                         |
| FR-F740P-132K             | M10 (M12)              | 14.7                  | 100-10                          | 100-10  | 100                             | 100     | 100     | 38                         | 4/0              | 4/0     | 95                              | 95      | 50                         |
| FR-F740P-160K             | M10 (M12)              | 14.7                  | 150-10                          | 150-10  | 125                             | 125     | 150     | 38                         | 250              | 250     | 120                             | 120     | 70                         |
| FR-F740P-185K             | M12 (M10)              | 24.5                  | 150-12                          | 150-12  | 150                             | 150     | 2×100   | 38                         | 300              | 300     | 150                             | 150     | 95                         |
| FR-F740P-220K             | M12 (M10)              | 24.5                  | 100-12                          | 100-12  | 2×100                           | 2×100   | 2×100   | 60                         | 2×4/0            | 2×4/0   | 2×95                            | 2×95    | 95                         |
| FR-F740P-250K             | M12 (M10)              | 46                    | 100-12                          | 100-12  | 2×100                           | 2×100   | 2×125   | 60                         | 2×4/0            | 2×4/0   | 2×95                            | 2×95    | 95                         |
| FR-F740P-280K             | M12 (M10)              | 46                    | 150-12                          | 150-12  | 2×125                           | 2×125   | 2×125   | 60                         | 2×250            | 2×250   | 2×120                           | 2×120   | 120                        |
| FR-F740P-315K             | M12 (M10)              | 46                    | 150-12                          | 150-12  | 2×150                           | 2×150   | 2×150   | 60                         | 2×300            | 2×300   | 2×150                           | 2×150   | 150                        |
| FR-F740P-355K             | M12 (M10)              | 46                    | 200-12                          | 200-12  | 2×200                           | 2×200   | 2×200   | 100                        | 2×350            | 2×350   | 2×185                           | 2×185   | 2×95                       |
| FR-F740P-400K             | M12 (M10)              | 46                    | C2-200                          | C2-200  | 2×200                           | 2×200   | 2×200   | 100                        | 2×400            | 2×400   | 2×185                           | 2×185   | 2×95                       |
| FR-F740P-450K             | M12 (M10)              | 46                    | C2-250                          | C2-250  | 2×250                           | 2×250   | 2×250   | 100                        | 2×500            | 2×500   | 2×240                           | 2×240   | 2×120                      |
| FR-F740P-500K             | M12 (M10)              | 46                    | C2-250                          | C2-250  | 2×250                           | 2×250   | 3×200   | 2×100                      | 2×500            | 2×500   | 2×240                           | 2×240   | 2×120                      |
| FR-F740P-560K             | M12 (M10)              | 46                    | C2-200                          | C2-200  | 3×200                           | 3×200   | 3×200   | 2×100                      | 3×350            | 3×350   | 3×185                           | 3×185   | 2×150                      |

\*1 For the 55K or lower, the recommended cable size is that of the cable (e.g. HIV cable (600V class 2 vinyl-insulated cable)) with continuous maximum permissible temperature of 75°C. Assumes that the surrounding air temperature is 50°C or less and the wiring distance is 20m or less.

For the 75K or higher, the recommended cable size is that of the cable (e.g. LMFC (heat resistant flexible cross-linked polyethylene insulated cable)) with continuous maximum permissible temperature of 90°C. Assumes that the surrounding air temperature is 50°C or less and wiring is performed in an enclosure.

\*2 For the 45K or lower, the recommended cable size is that of the cable (THHW cable) with continuous maximum permissible temperature of 75°C. Assumes that the surrounding air temperature is 40°C or less and the wiring distance is 20m or less.

For the 55K or higher, the recommended cable size is that of the cable (THHN cable) with continuous maximum permissible temperature of 90°C. Assumes that the surrounding air temperature is 40°C or less and wiring is performed in an enclosure. (Selection example for use mainly in the United States.)

\*3 For the 45K or lower, the recommended cable size is that of the cable (PVC cable) with continuous maximum permissible temperature of 70°C. Assumes that the surrounding air temperature is 40°C or less and the wiring distance is 20m or less.

For the 55K or higher, the recommended cable size is that of the cable (XLPE cable) with continuous maximum permissible temperature of 90°C. Assumes that the surrounding air temperature is 40°C or less and wiring is performed in an enclosure. (Selection example for use mainly in the Europe.)

\*4 The terminal screw size indicates the terminal size for R/L1, S/L2, T/L3, U, V, W, and a screw for earthing (grounding).

The screw size of the terminals P/+, N/-, and P1 in 75K is indicated in parentheses.

The screw size of the option connecting terminal P/+ in 132K and 160K is indicated in parentheses.

A screw for earthing (grounding) of the 185K or higher is indicated in parentheses.

The line voltage drop can be calculated by the following formula:

$$\text{Line voltage drop [V]} = \frac{\sqrt{3} \times \text{wire resistance [m}\Omega\text{/m]} \times \text{wiring distance [m]} \times \text{current [A]}}{1000}$$

Use a larger diameter cable when the wiring distance is long or when it is desired to decrease the voltage drop (torque reduction) in the low speed range.

**CAUTION**

- Tighten the terminal screw to the specified torque.  
A screw that has been tighten too loosely can cause a short circuit or malfunction.  
A screw that has been tighten too tightly can cause a short circuit or malfunction due to the unit breakage.
- Use crimping terminals with insulation sleeve to wire the power supply and motor.



**(2) Notes on earthing (grounding)**

- Leakage currents flow in the inverter. To prevent an electric shock, the inverter and motor must be earthed (grounded). This inverter must be earthed (grounded). Earthing (Grounding) must conform to the requirements of national and local safety regulations and electrical codes. (NEC section 250, IEC 536 class 1 and other applicable standards)  
A neutral-point earthed (grounded) power supply for 400V class inverter in compliance with EN standard must be used.
- Use the dedicated earth (ground) terminal to earth (ground) the inverter.  
(Do not use the screw in the casing, chassis, etc.)
- Use the thickest possible earth (ground) cable. Use the cable whose size is equal to or greater than that indicated in *page 14* and minimize the cable length. The earthing (grounding) point should be as close as possible to the inverter.



**To be compliant with the EU Directive (Low Voltage Directive), earth (ground) the inverter according to the instructions on page 169.**

**(3) Total wiring length**

**●Under general-purpose motor control**

Connect one or more general-purpose motors within the total wiring length shown in the following table.

| <i>Pr. 72 PWM frequency selection</i> Setting (carrier frequency) | 0.75K | 1.5K | 2.2K or Higher |
|---|-------|------|----------------|
| 2 (2kHz) or lower   | 300m  | 500m | 500m           |
| 3 (3kHz) or higher  | 200m  | 300m | 500m           |

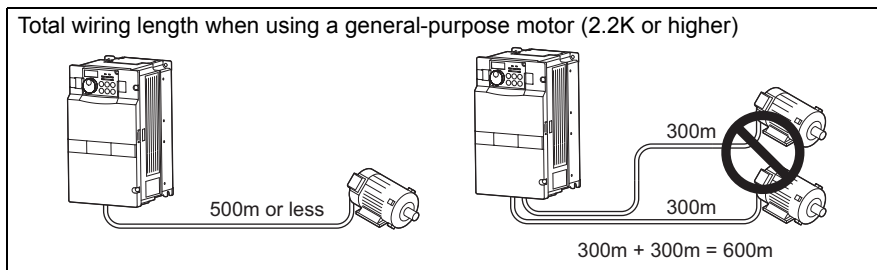

**REMARKS**

When driving a 400V class motor by the inverter, surge voltages attributable to the wiring constants may occur at the motor terminals, deteriorating the insulation of the motor. Take the following measures 1) or 2) in this case.

**●Under general-purpose motor control**

- Use a "400V class inverter-driven insulation-enhanced motor" and set frequency in *Pr. 72 PWM frequency selection* according to wiring length.

| <i>Pr. 72 PWM frequency selection</i> | Wiring Length         |                   |                   |
|---------------------------------------|-----------------------|-------------------|-------------------|
|                                       | 50m or less           | 50m to 100m       | exceeding 100m    |
|                                       | 15 (14.5kHz) or lower | 9 (9kHz) or lower | 4 (4kHz) or lower |

- Connect the surge voltage suppression filter (FR-ASF-H/FR-BMF-H) to the 55K or lower and the sine wave filter (MT-BSL/BSC) to the 75K or higher on the inverter output side.

Refer to *Chapter 3 of the Instruction Manual (Applied)* for the detail.

**●Under IPM motor control**

Use the following length of cable or shorter when connecting an IPM motor.

| Voltage class | Cable type       | <i>Pr. 72 setting</i> (carrier frequency) | 0.75K | 1.5K | 2.2K or higher |
|---------------|------------------|---|-------|------|----------------|
| 200V          | Unshielded cable | 0 (2kHz) to 15 (14kHz)                    | 100m  | 100m | 100m           |
|               |                  | 5 (2kHz) or lower                         | 75m   | 100m | 100m           |
|               | Shielded cable   | 6 (6kHz) or higher                        | 50m   | 75m  | 100m           |
| 400V          | Unshielded cable | 5 (2kHz) or lower                         | 100m  | 100m | 100m           |
|               |                  | 6 to 9 (6kHz)                             | 50m   | 50m  | 100m           |
|               |                  | 10 (10kHz) or higher                      | 50m   | 50m  | 50m            |
|               | Shielded cable   | 5 (2kHz) or lower                         | 75m   | 100m | 100m           |
|               |                  | 6 to 9 (6kHz)                             | 50m   | 50m  | 100m           |
|               |                  | 10 (10kHz) or higher                      | 50m   | 50m  | 50m            |

Use one dedicated IPM motor for one inverter. Multiple IPM motors cannot be connected to an inverter.

**CAUTION**

- Especially for long-distance wiring, the inverter may be affected by a charging current caused by the stray capacitances of the wiring, leading to a malfunction of the overcurrent protective function or fast response current limit function or a malfunction or fault of the equipment connected on the inverter output side. If fast-response current limit function malfunctions, disable this function. (For Pr.156 Stall prevention operation selection, refer to Chapter 4 of the Instruction Manual (Applied).)
- For details of Pr. 72 PWM frequency selection, refer to Chapter 4 of the Instruction Manual (Applied). (When using an optional sine wave filter (MT-BSL/BSC) for the 75K or higher, set "25" in Pr.72 (2.5kHz). (Sine wave filter can be only used with a general-purpose motor.)
- The surge voltage suppression filter (FR-ASF-H/FR-BMF-H) option and sine wave filter (MT-BSL/BSC) cannot be used under IPM motor control, so do not connect them.
- For explanation of surge voltage suppression filter (FR-ASF-H/FR-BMF-H) and sine wave filter (MT-BSL/BSC), refer to the manual of each option.

**(4) Cable size of the control circuit power supply (terminal R1/L11, S1/L21)**

- Terminal screw size: M4
- Cable size: 0.75mm<sup>2</sup> to 2mm<sup>2</sup>
- Tightening torque: 1.5N·m

**(5) When connecting the control circuit and the main circuit separately to the power supply**

<Connection diagram>

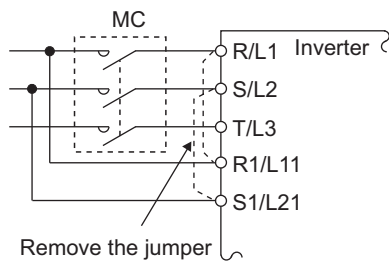

When fault occurs, opening of the electromagnetic contactor (MC) on the inverter power supply side results in power loss in the control circuit, disabling the fault output signal retention. Terminals R1/L11 and S1/L21 are provided for when retention of a fault signal is required. In this case, connect the power supply terminals R1/L11 and S1/L21 of the control circuit to the primary side of the MC.

Do not connect the power cable to incorrect terminals. Doing so may damage the inverter.

**• FR-F720P-0.75K to 5.5K, FR-F740P-0.75K to 5.5K**

- 1) Loosen the upper screws.
- 2) Remove the lower screws.
- 3) Remove the jumper
- 4) Connect the separate power supply cable for the control circuit to the lower terminals (R1/L11, S1/L21).

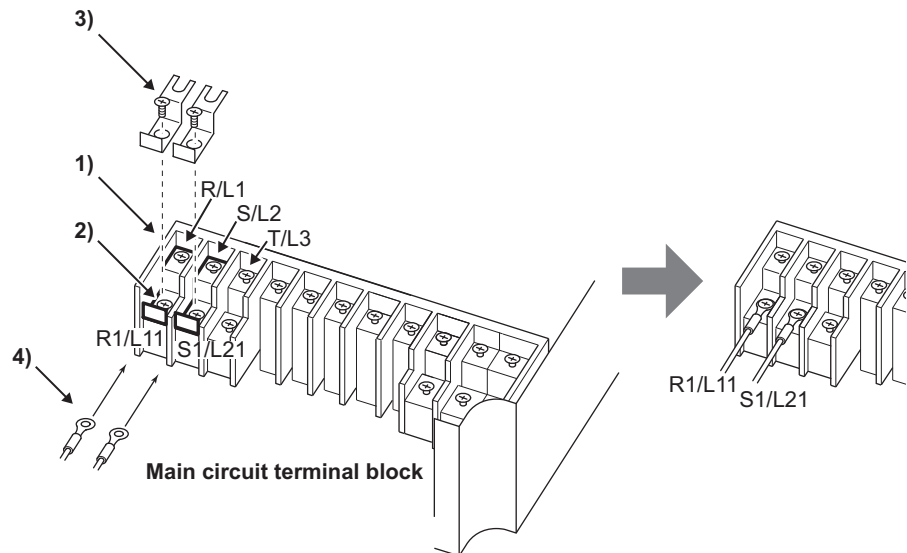





• **FR-F720P-7.5K, 11K, FR-F740P-7.5K, 11K**

- 1) Remove the upper screws.
- 2) Remove the lower screws.
- 3) Remove the jumper.
- 4) Connect the separate power supply cable for the control circuit to the upper terminals (R1/L11, S1/L21).

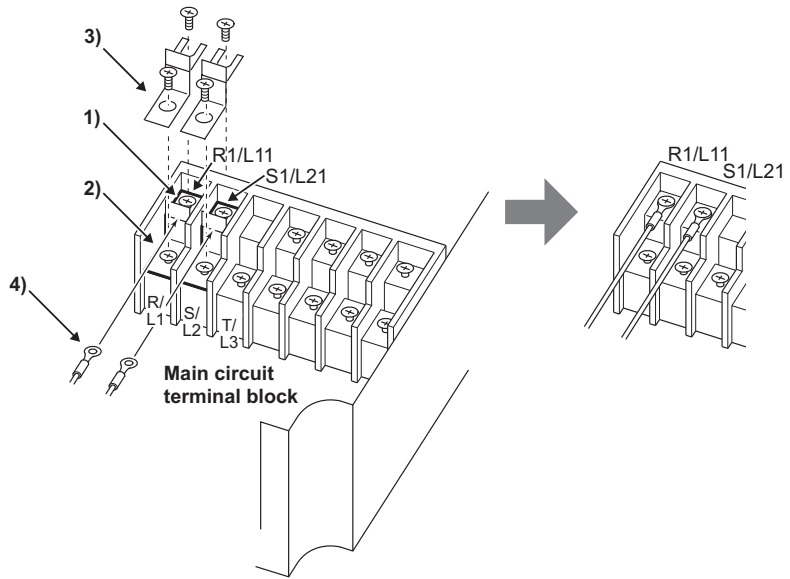

• **FR-F720P-15K, FR-F740P-15K or higher**

- 1) Remove the upper screws.
- 2) Remove the lower screws.
- 3) Pull the jumper toward you to remove.
- 4) Connect the separate power supply cable for the control circuit to the upper terminals (R1/L11, S1/L21).

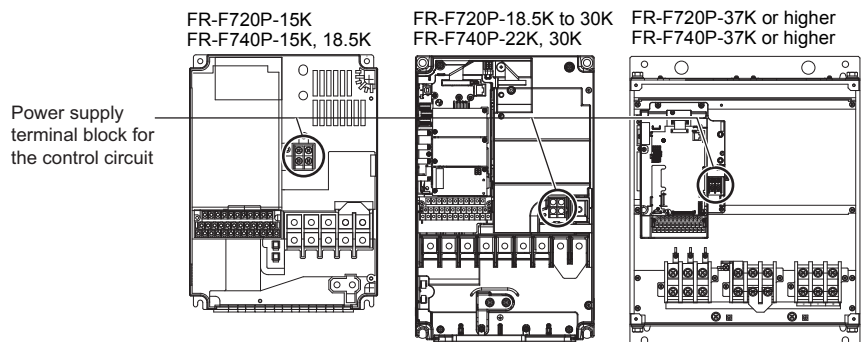
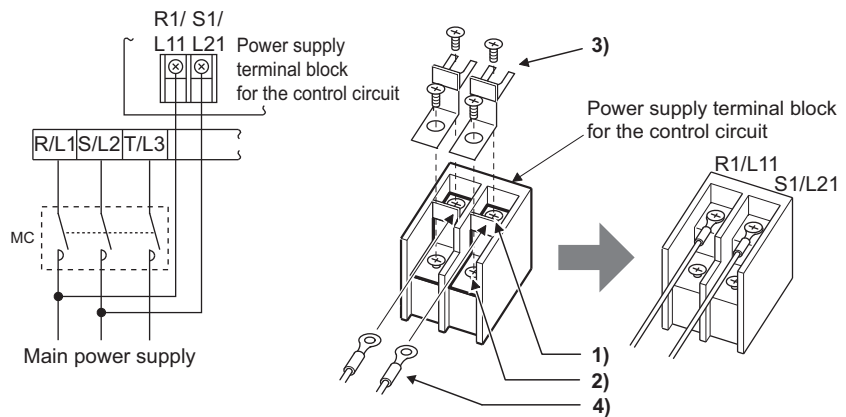

**CAUTION**

- Be sure to use the inverter with the jumpers across terminals R/L1 and R1/L11, and S/L2 and S1/L21 removed when supplying power from other sources. The inverter may be damaged if you do not remove the jumper.
- The voltage should be the same as that of the main control circuit when the control circuit power is supplied from other than the primary side of the MC.
- The power capacity necessary when separate power is supplied from R1/L11 and S1/L21 differs according to the inverter capacity.

|            | 15K or lower | 18.5K | 22K or higher |
|------------|--------------|-------|---------------|
| 200V class | 60VA         | 80VA  | 80VA          |
| 400V class | 60VA         | 60VA  | 80VA          |

- If the main circuit power is switched OFF (for 0.1s or more) then ON again, the inverter resets and a fault output will not be held.

## 2.4.5 Control circuit terminals

 indicates that terminal functions can be selected using Pr. 178 to Pr. 196 (I/O terminal function selection) (Refer to Chapter 4 of the Instruction Manual (Applied).)

### (1) Input signals

| Type                      | Terminal Symbol                                     | Terminal Name   | Description  |   | Rated Specifications  | Refer to Page |   |
|---------------------------|---|---|--|---|---|---------------|---|
| Contact input             | STF   | Forward rotation start  | Turn ON the STF signal to start forward rotation and turn it OFF to stop.  | When the STF and STR signals are turned ON simultaneously, the stop command is given. | Input resistance 4.7kΩ<br>Voltage at opening 21 to 27VDC<br>Current at short-circuited 4 to 6mADC | 60            |   |
|                           | STR   | Reverse rotation start  | Turn ON the STR signal to start reverse rotation and turn it OFF to stop.  |   |   |               |   |
|                           | STOP  | Start self-holding selection  | Turn ON the STOP signal to self-hold the start signal.   |   |   | *2            |   |
|                           | RH, RM, RL  | Multi-speed selection   | Multi-speed can be selected according to the combination of RH, RM and RL signals.   |   |   | 64            |   |
|                           | JOG   | Jog mode selection  | Turn ON the JOG signal to select Jog operation (initial setting) and turn ON the start signal (STF or STR) to start Jog operation.   |   |   | *2            |   |
|                           | RT  | Second function selection   | Turn ON the RT signal to select second function. When the second function such as "second torque boost" and "second V/F (base frequency)" are set, turning ON the RT signal selects these functions.   |   |   | *2            |   |
|                           | MRS   | Output stop   | Turn ON the MRS signal (20ms or more) to stop the inverter output. Use to shut off the inverter output when stopping the motor by electromagnetic brake.   |   |   | *2            |   |
|                           | RES   | Reset   | Use to reset fault output provided when fault occurs. Turn ON the RES signal for more than 0.1s, then turn it OFF. In the initial status, reset is set always-enabled. By setting Pr.75, reset can be set enabled only at fault occurrence. Inverter recovers about 1s after the reset is released.  |   |   | 115           |   |
|                           | AU  | Terminal 4 input selection  | Terminal 4 is valid only when the AU signal is turned ON. (The frequency setting signal can be set between 0 and 20mADC.) Turning the AU signal ON makes terminal 2 (voltage input) invalid.   |   |   | 68            |   |
|                           |   | PTC input   | AU terminal is used as PTC input terminal (thermal protection of the motor). When using it as PTC input terminal, set the AU/PTC switch to PTC.  |   |   | *2            |   |
|                           | CS  | Selection of automatic restart after instantaneous power failure  | When the CS signal is left ON, the inverter restarts automatically at power restoration. Note that restart setting is necessary for this operation. In the initial setting, a restart is disabled.<br><i>(Refer to  Pr. 57 Restart coasting time in Chapter 4 of the Instruction Manual (Applied).)</i> |   |   | *2            |   |
|                           | SD  | Contact input common (sink) (initial setting)   | Common terminal for contact input terminal (sink logic) and terminal FM.   |   |   | —             | — |
|                           |   | External transistor common (source)   | Connect this terminal to the power supply common terminal of a transistor output (open collector output) device, such as a programmable controller, in the source logic to avoid malfunction by undesirable currents.  |   |   |               |   |
| 24VDC power supply common |   | Common output terminal for 24VDC 0.1A power supply (PC terminal). Isolated from terminals 5 and SE.   |  |   |   |               |   |
| PC                        | External transistor common (sink) (initial setting) | Connect this terminal to the power supply common terminal of a transistor output (open collector output) device, such as a programmable controller, in the sink logic to avoid malfunction by undesirable currents. |  | Power supply voltage range 19.2 to 28.8VDC<br>Permissible load current 100mA          | 23  |               |   |
|                           | Contact input common (source)                       | Common terminal for contact input terminal (source logic).  |  |   |   |               |   |
|                           | 24VDC power supply                                  | Can be used as 24VDC 0.1A power supply.   |  |   |   |               |   |



| Type              | Terminal Symbol | Terminal Name                  | Description   | Rated Specifications   | Refer to Page |
|-------------------|-----------------|--------------------------------|---|--|---------------|
| Frequency setting | 10E             | Frequency setting power supply | When connecting the frequency setting potentiometer at an initial status, connect it to terminal 10. Change the input specifications of terminal 2 when connecting it to terminal 10E. (Refer to Pr. 73 Analog input selection in Chapter 4 of  the Instruction Manual (Applied).)  | 10VDC<br>Permissible load current 10mA   | *2            |
|                   | 10              |                                |   | 5VDC<br>Permissible load current 10mA  | 58, 66        |
|                   | 2               | Frequency setting (voltage)    | Inputting 0 to 5VDC (or 0 to 10V, 0 to 20mA) provides the maximum output frequency at 5V (10V, 20mA) and makes input and output proportional. Use Pr. 73 to switch from among input 0 to 5VDC (initial setting), 0 to 10VDC, and 0 to 20mA. Set the voltage/current input switch in the ON position to select current input (0 to 20mA). <sup>*1</sup>  | Voltage input:<br>Input resistance 10kΩ ± 1kΩ<br>Maximum permissible voltage 20VDC<br>Current input:<br>Input resistance 245Ω ± 5Ω<br>Maximum permissible current 30mA | 58, 66        |
|                   | 4               | Frequency setting (current)    | Inputting 4 to 20mADC (or 0 to 5V, 0 to 10V) provides the maximum output frequency at 20mA (5V, 10V) makes input and output proportional. This input signal is valid only when the AU signal is ON (terminal 2 input is invalid). Use Pr. 267 to switch from among input 4 to 20mA (initial setting), 0 to 5VDC, and 0 to 10VDC. Set the voltage/current input switch in the OFF position to select voltage input (0 to 5V/0 to 10V). <sup>*1</sup><br><br>(Refer to Chapter 4 of  the Instruction Manual (Applied).) | <p>Voltage/current input switch</p> <p>Switch 1—<br/>Switch 2—</p>   | 59, 68        |
|                   | 1               | Frequency setting auxiliary    | Inputting 0 to ±5 VDC or 0 to ±10VDC adds this signal to terminal 2 or 4 frequency setting signal. Use Pr.73 to switch between the input 0 to ±5VDC and 0 to ±10VDC (initial setting).  | Input resistance 10kΩ ± 1kΩ<br>Maximum permissible voltage ± 20VDC   | *2            |
|                   | 5               | Frequency setting common       | Common terminal for frequency setting signal (terminal 2, 1 or 4) and analog output terminal AM. Do not earth (ground).   | —  | —             |

\*1 Set Pr. 73, Pr. 267, and a voltage/current input switch correctly, then input an analog signal in accordance with the setting. Applying a voltage signal with voltage/current input switch ON (current input is selected) or a current signal with switch OFF (voltage input is selected) could cause component damage of the inverter or analog circuit of signal output devices.

\*2 Refer to Chapter 4 of the Instruction Manual (Applied).

## (2) Output signals

| Type           | Terminal Symbol | Terminal Name                 | Description  | Rated Specifications  | Refer to Page   |   |
|----------------|-----------------|-------------------------------|--|---|---|---|
| Relay          | A1, B1, C1      | Relay output 1 (Fault output) | 1 changeover contact output indicates that the inverter's protective function has activated and the output stopped.<br>Fault: No conduction between B and C (conduction between A and C)<br>Normal: Conduction between B and C (No conduction between A and C) | Contact capacity 230VAC 0.3A (Power factor=0.4)<br>30VDC 0.3A   | *   |   |
|                | A2, B2, C2      | Relay output 2                | 1 changeover contact output  |   | *   |   |
| Open collector | RUN             | Inverter running              | Switched low when the inverter output frequency is equal to or higher than the starting frequency (initial value 0.5Hz). Switched high during stop or DC injection brake operation.  | Permissible load 24VDC (27VDC maximum) 0.1A (A voltage drop is 3.4V maximum when the signal is ON.)<br><br>Low is when the open collector output transistor is ON (conducts).<br>High is when the transistor is OFF (does not conduct). | *   |   |
|                | SU              | Up to frequency               | Switched low when the output frequency reaches within the range of $\pm 10\%$ (initial value) of the set frequency. Switched high during acceleration/deceleration and at a stop.  |   | Alarm code (4 bits) output  | * |
|                | OL              | Overload warning              | Switched low when stall prevention is activated by the stall prevention function. Switched high when stall prevention is cancelled.  |   |   | * |
|                | IPF             | Instantaneous power failure   | Switched low when an instantaneous power failure and under voltage protections are activated.  |   |   | * |
|                | FU              | Frequency detection           | Switched low when the inverter output frequency is equal to or higher than the preset detected frequency and high when less than the preset detected frequency.  |   |   | * |
|                | SE              | Open collector output common  | Common terminal for terminals RUN, SU, OL, IPF, FU   |   | —   | — |
| Pulse          | FM              | For meter                     | Select one e.g. output frequency from monitor items. (Not output during inverter reset.)<br>The output signal is proportional to the magnitude of the corresponding monitoring item.   | Output item:<br>Output frequency (initial setting)  | Permissible load current 2mA<br>1440 pulses/s at full scale   | * |
| Analog         | AM              | Analog signal output          | To set a full-scale value for monitoring the output frequency and the output current, set Pr.55 and Pr.56.*  | Output item:<br>Output frequency (initial setting)  | Output signal 0 to 10VDC<br>Permissible load current 1mA (load impedance 10k $\Omega$ or more)<br>Resolution 8 bits | * |

\* Refer to Chapter 4 of  the Instruction Manual (Applied).

## (3) Communication

| Type   | Terminal Symbol  | Terminal Name                      | Description   | Refer to Page   |
|--------|------------------|------------------------------------|---|---|
| RS-485 | —                | PU connector                       | With the PU connector, communication can be established through RS-485. (for connection on a 1:1 basis only)<br>Conforming standard : EIA-485 (RS-485)<br>Transmission format : Multidrop link<br>Communication speed : 4800 to 38400bps<br>Overall length : 500m | 25  |
|        | RS-485 terminals | TXD+<br>TXD-<br>RXD+<br>RXD-<br>SG | Inverter transmission terminal<br>Inverter reception terminal<br>Earth (Ground)   | With the RS-485 terminals, communication can be established through RS-485.<br>Conforming standard : EIA-485 (RS-485)<br>Transmission format : Multidrop link<br>Communication speed : 300 to 38400bps<br>Overall length : 500m |



### 2.4.6 Changing the control logic

The input signals are set to sink logic (SINK) when shipped from the factory.

To change the control logic, the jumper connector on the back of the control circuit terminal block must be moved to the other position.

(The output signals may be used in either the sink or source logic independently of the jumper connector position.)

1) Loosen the two installation screws in both ends of the control circuit terminal block. (These screws cannot be removed.)

Pull down the terminal block from behind the control circuit terminals.

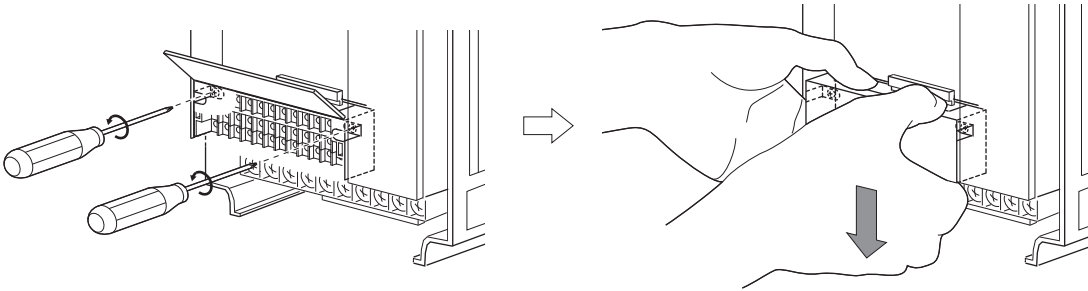

2) Change the jumper connector set to the sink logic (SINK) on the rear panel of the control circuit terminal block to source logic (SOURCE).

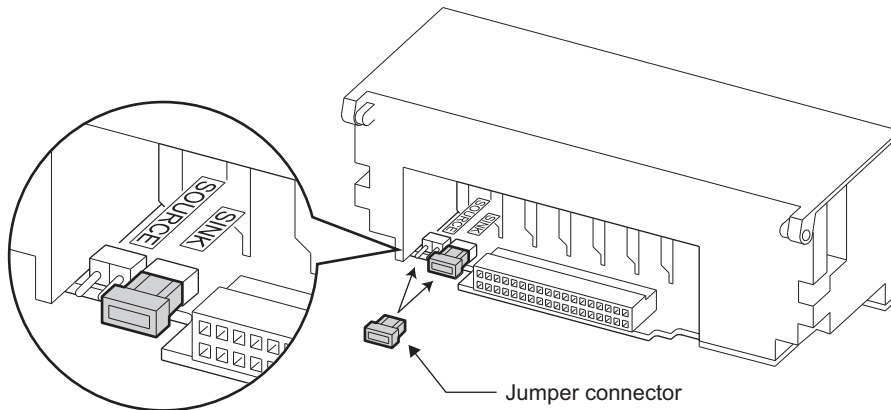

3) Using care not to bend the pins of the inverter's control circuit connector, reinstall the control circuit terminal block and fix it with the mounting screws.

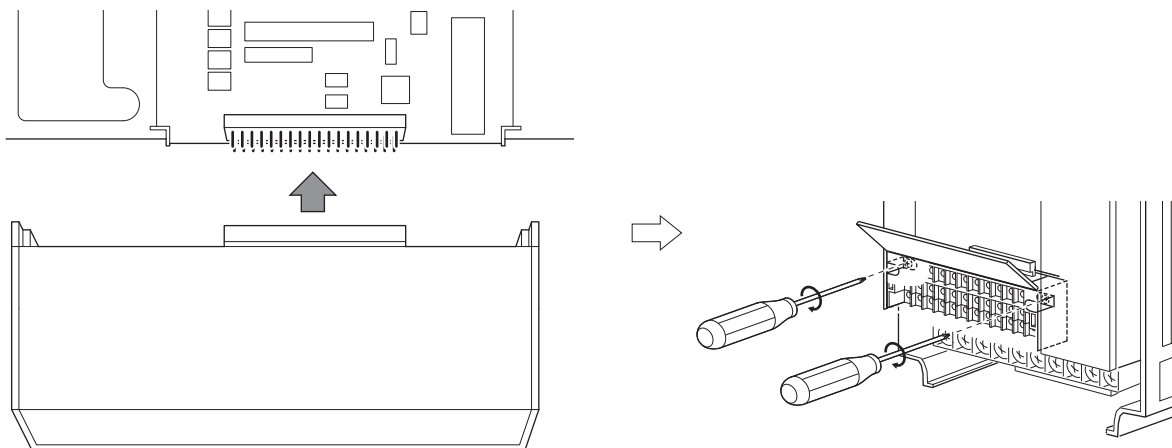

**CAUTION**

- Make sure that the control circuit connector is fitted correctly.
- While power is on, never disconnect the control circuit terminal block.

#### 4) Sink logic and source logic

- In sink logic, a signal switches ON when a current flows from the corresponding signal input terminal. Terminal SD is common to the contact input signals. Terminal SE is common to the open collector output signals.
- In source logic, a signal switches ON when a current flows into the corresponding signal input terminal. Terminal PC is common to the contact input signals. Terminal SE is common to the open collector output signals.

● Current flow concerning the input/output signal when sink logic is selected

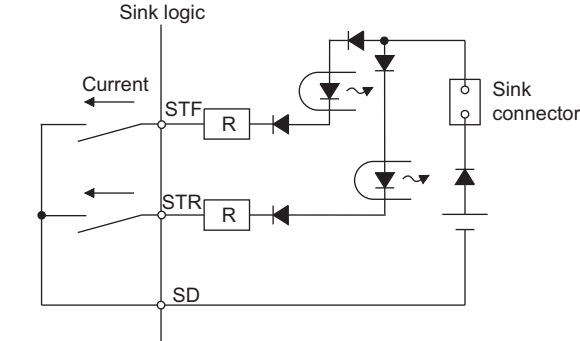

● Current flow concerning the input/output signal when source logic is selected

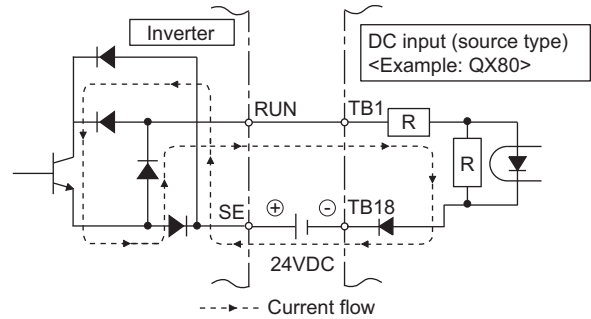
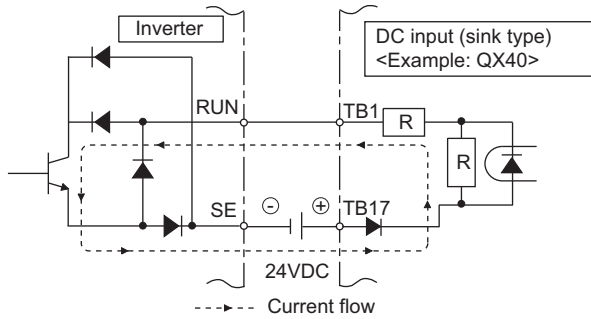
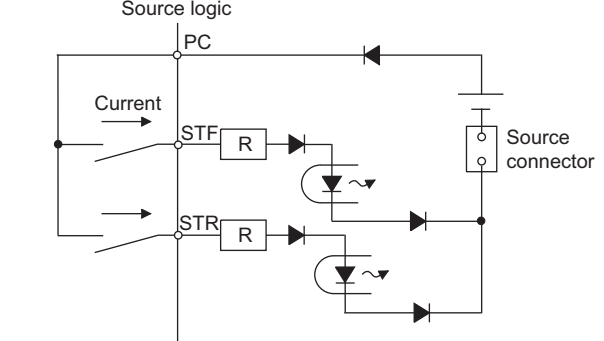

● When using an external power supply for transistor output

· Sink logic type

Use terminal PC as a common terminal, and perform wiring as shown below. (Do not connect terminal SD of the inverter with terminal 0V of the external power supply. When using terminals PC and SD as a 24VDC power supply, do not install a power supply in parallel in the outside of the inverter. Doing so may cause a malfunction due to undesirable current.)

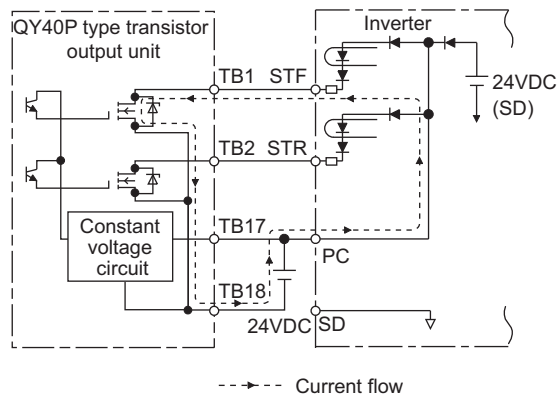

· Source logic type

Use terminal SD as a common terminal, and perform wiring as shown below. (Do not connect terminal PC of the inverter with terminal +24V of the external power supply. When using terminals PC and SD as a 24VDC power supply, do not install an external power supply in parallel with the inverter. Doing so may cause a malfunction in the inverter due to undesirable currents.)

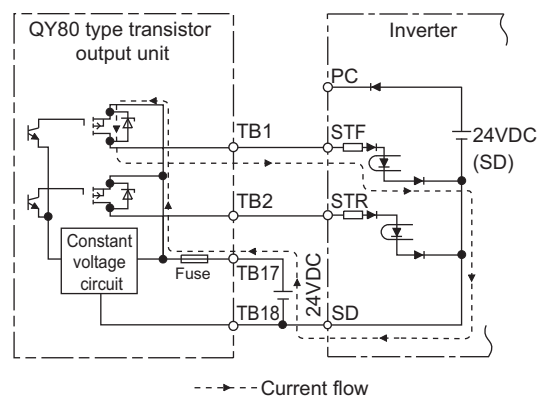



## 2.4.7 Wiring of control circuit

### (1) Control circuit terminal layout

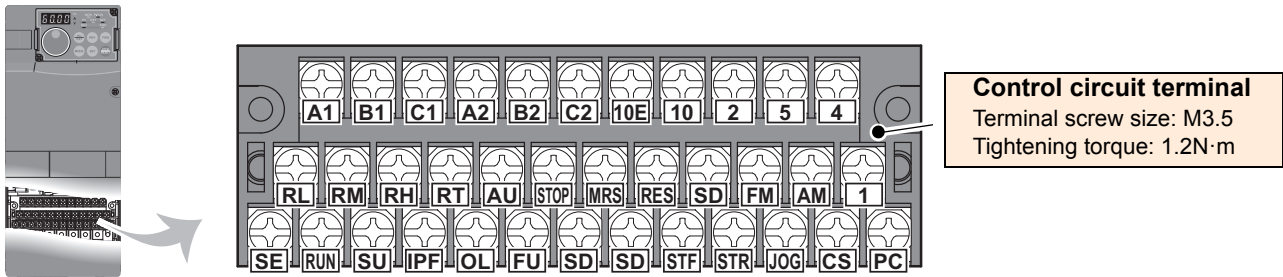

### (2) Common terminals of the control circuit (SD 5, SE)

- Terminals SD, 5, and SE are all common terminals (0V) for I/O signals and are isolated from each other. Do not earth(ground) these terminals. Avoid connecting the terminal SD and 5 and the terminal SE and 5.
- Terminal SD is a common terminal for the contact input terminals (STF, STR, STOP, RH, RM, RL, JOG, RT, MRS, RES, AU, CS) and the pulse train output terminal (FM). The open collector circuit is isolated from the internal control circuit by photocoupler.
- Terminal 5 is a common terminal for frequency setting signal (terminal 2, 1 or 4) and analog output terminal AM. It should be protected from external noise using a shielded or twisted cable.
- Terminal SE is a common terminal for the open collector output terminal (RUN, SU, OL, IPF, FU). The contact input circuit is isolated from the internal control circuit by photocoupler.

### (3) Signal inputs by contactless switches

The contacted input terminals of the inverter (STF, STR, STOP, RH, RM, RL, JOG, RT, MRS, RES, AU, CS) can be controlled using a transistor instead of a contacted switch as shown on the right.

External signal input using transistor

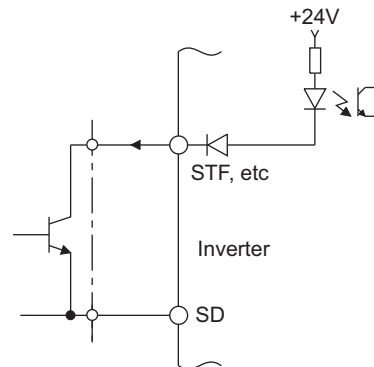

### (4) Wiring instructions

- It is recommended to use the cables of 0.75mm<sup>2</sup> gauge for connection to the control circuit terminals. If the cable gauge used is 1.25mm<sup>2</sup> or more, the front cover may be lifted when there are many cables running or the cables are run improperly, resulting in an operation panel contact fault.
- The maximum wiring length should be 30m (200m for terminal FM).
- When using contact inputs, use two or more parallel micro-signal contacts or twin contacts to prevent a contact faults since the control circuit input signals are micro-currents.

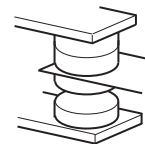

Micro signal contacts

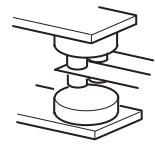

Twin contacts

- To suppress EMI, use shielded or twisted cables for the control circuit terminals and run them away from the main and power circuits (including the 200V relay sequence circuit). For the cables connected to the control circuit terminals, connect their shields to the common terminal of the connected control circuit terminal. When connecting external power supply to the terminal PC, however, connect the shield of the power supply cable to the negative side of the external power supply. Do not directly earth (ground) the shield to the enclosure, etc.
- Always apply a voltage to the fault output terminals (A, B, C) via a relay coil, lamp, etc.

### ● Wiring of the control circuit of the 75K or higher

For wiring of the control circuit of the 75K or higher, separate away from wiring of the main circuit.  
Make cuts in rubber bush of the inverter side and lead wires.

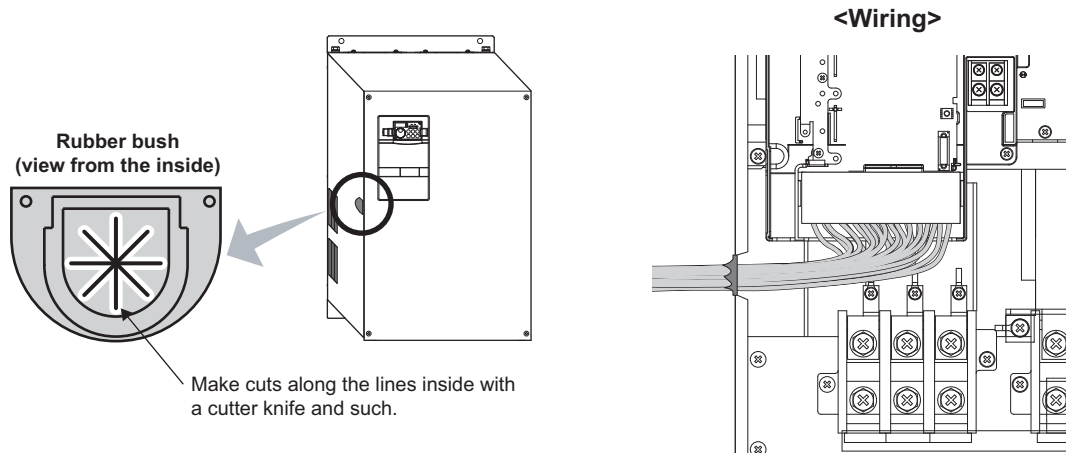

### 2.4.8 Mounting the operation panel (FR-DU07) or the parameter unit (FR-PU07) on the enclosure surface

Having an operation panel or a parameter unit on the enclosure surface is convenient.

With a connection cable, you can mount the operation panel (FR-DU07) or the parameter unit (FR-PU07) to the enclosure surface, and connect it to the inverter.

Use the option FR-CB2□□, or connectors and cables available on the market.

(For mounting the operation panel (FR-DU07), the optional connector (FR-ADP) is required.)

Securely insert one end of connection cable until the stoppers are fixed.

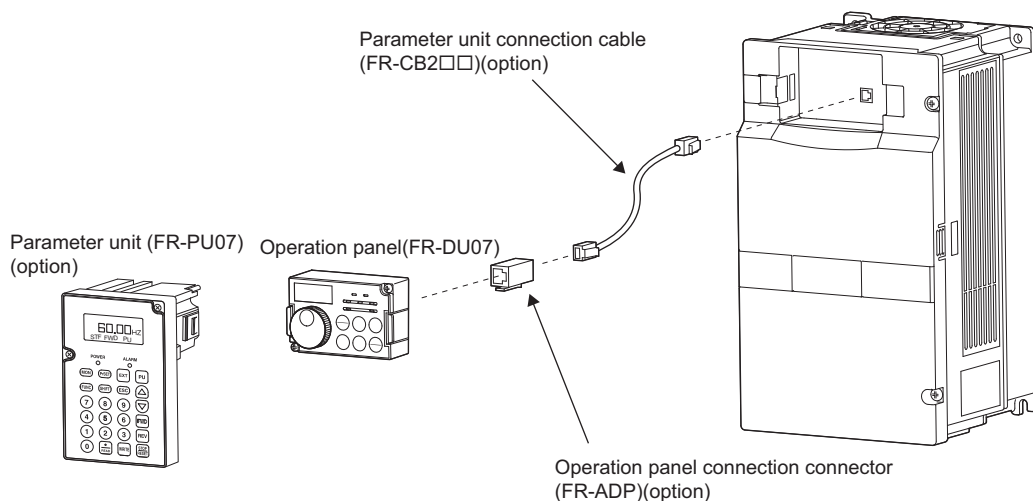

#### CAUTION

Do not connect the cable to a LAN port of a personal computer, to a fax modem socket, or to a telephone connector. Doing so may damage the inverter and the connected device due to the differences in the electric specifications.

#### REMARKS

- Refer to *page 6* for the removal of the operation panel.
- Overall wiring length when the operation panel is connected: 20m
- Parameter unit connection cables can be also fabricated with the communication connectors and communication cables listed in *Chapter 4 of the Instruction Manual (Applied)*.





### 2.4.9 RS-485 terminal block

- Conforming standard: EIA-485(RS-485)
- Transmission format: Multidrop link
- Communication speed: MAX 38400bps
- Overall length: 500m
- Connection cable: Twisted pair cable (4 pairs)

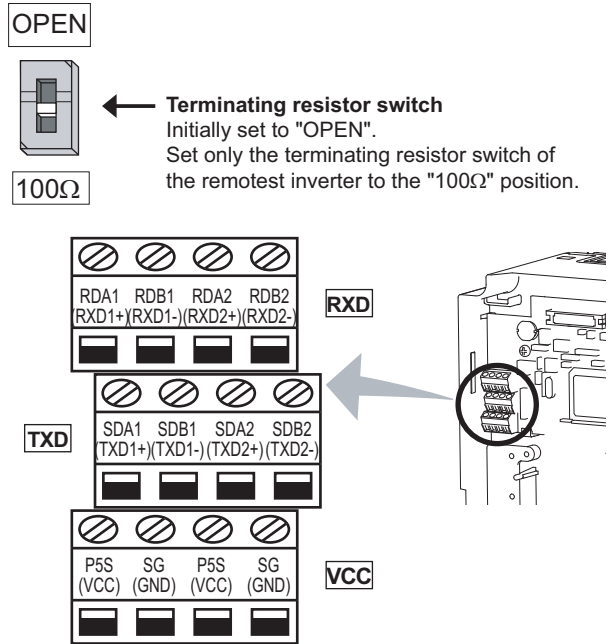

### 2.4.10 Communication operation

Using the PU connector or RS-485 terminal, you can perform communication operation from a personal computer etc. When the PU connector is connected with a personal, FA or other computer by a communication cable, a user program can run and monitor the inverter or read and write to parameters.

For the Mitsubishi inverter protocol (computer link operation), communication can be performed with the PU connector and RS-485 terminal.

For the Modbus-RTU protocol, communication can be performed with the RS-485 terminal.

For further details, refer to Chapter 4 of the Instruction Manual (Applied).

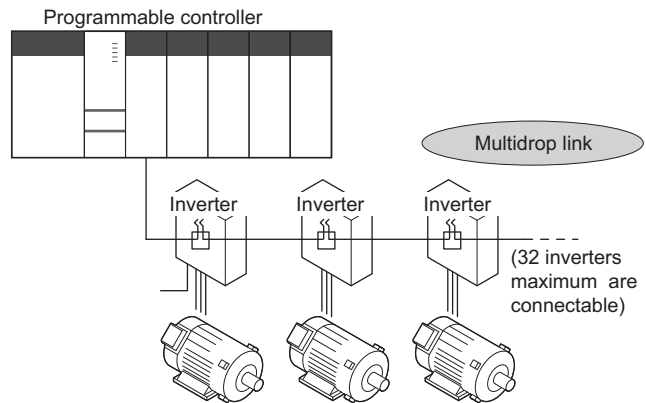

## 2.5 Connection of stand-alone option units

The inverter accepts a variety of stand-alone option units as required.

Incorrect connection will cause inverter damage or accident. Connect and operate the option unit carefully in accordance with the corresponding option unit manual.

### 2.5.1 Connection of the brake unit (FR-BU2)

Connect the brake unit (FR-BU2) as shown below to improve the braking capability at deceleration.

#### (1) Connection example with the GRZG type discharging resistor

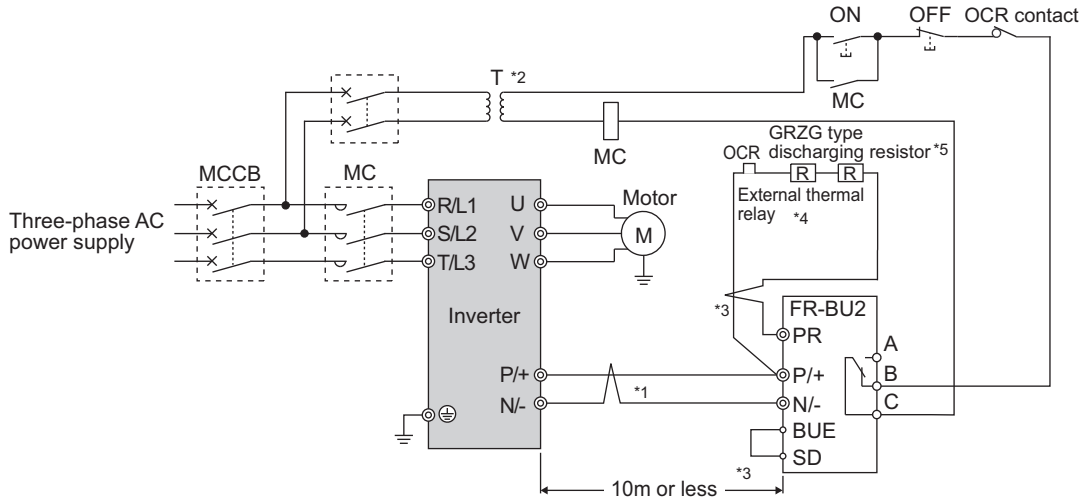

- \*1 Connect the inverter terminals (P/+, N/-) and brake unit (FR-BU2) terminals so that their terminal names match with each other. (Incorrect connection will damage the inverter and brake unit.)
- \*2 When the power supply is 400V class, install a stepdown transformer.
- \*3 Keep a wiring distance of within 5m between the inverter, brake unit (FR-BU2) and discharging resistor. Even when the wiring is twisted, the cable length must not exceed 10m. When twisting, twist at least 5 times per meter. The brake unit may be damaged if cables are not twisted when the wiring length is 5m or more or the wiring length exceeds 10m or more even if cables are twisted.
- \*4 It is recommended to install an external thermal relay to prevent overheat of discharging resistors.
- \*5 Refer to FR-BU2 manual for connection method of discharging resistor.

#### <Recommended external thermal relay>

| Brake Unit   | Discharging Resistor           | Recommended External Thermal Relay |
|--------------|--------------------------------|------------------------------------|
| FR-BU2-1.5K  | GZG 300W-50Ω (one)             | TH-N20CXHZ 1.3A                    |
| FR-BU2-3.7K  | GRZG 200-10Ω (three in series) | TH-N20CXHZ 3.6A                    |
| FR-BU2-7.5K  | GRZG 300-5Ω (four in series)   | TH-N20CXHZ 6.6A                    |
| FR-BU2-15K   | GRZG 400-2Ω (six in series)    | TH-N20CXHZ 11A                     |
| FR-BU2-H7.5K | GRZG 200-10Ω (six in series)   | TH-N20CXHZ 3.6A                    |
| FR-BU2-H15K  | GRZG 300-5Ω (eight in series)  | TH-N20CXHZ 6.6A                    |
| FR-BU2-H30K  | GRZG 400-2Ω (twelve in series) | TH-N20CXHZ 11A                     |

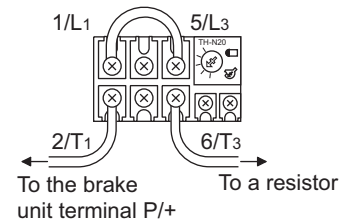

#### CAUTION

- Set "1" in Pr. 0 Brake mode selection of the FR-BU2 to use GRZG type discharging resistor.
- Do not remove the jumper across terminal P/+ and P1 except when connecting a DC reactor (FR-HEL).

(2) FR-BR-(H) connection example with resistor unit

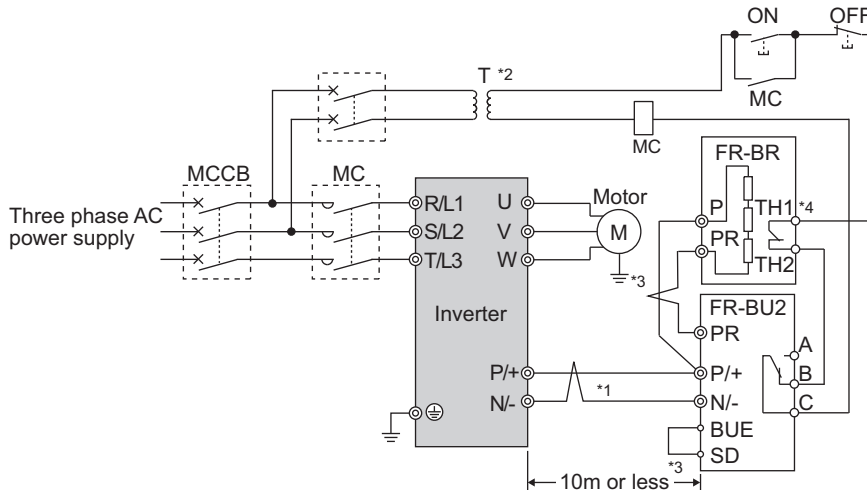

- \*1 Connect the inverter terminals (P/+, N/-) and brake unit (FR-BU2) terminals so that their terminal names match with each other. (Incorrect connection will damage the inverter and brake unit.)
- \*2 When the power supply is 400V class, install a stepdown transformer.
- \*3 The wiring distance between the inverter, brake unit (FR-BU) and resistor unit (FR-BR) should be within 5m. Even when the wiring is twisted, the cable length must not exceed 10m.
- \*4 The contact between TH1 and TH2 is closed in the normal status and is open at a fault.

**CAUTION**

Do not remove the jumper across terminal P/+ and P1 except when connecting a DC reactor (FR-HEL).

(3) Connection example with MT-BR5 type resistor unit

After making sure that the wiring is correct, set the following parameters:

- Pr. 30 Regenerative function selection = "1"
- Pr. 70 Special regenerative brake duty = "0 (initial value)"

Set Pr. 0 Brake mode selection = "2" in the brake unit FR-BU2.

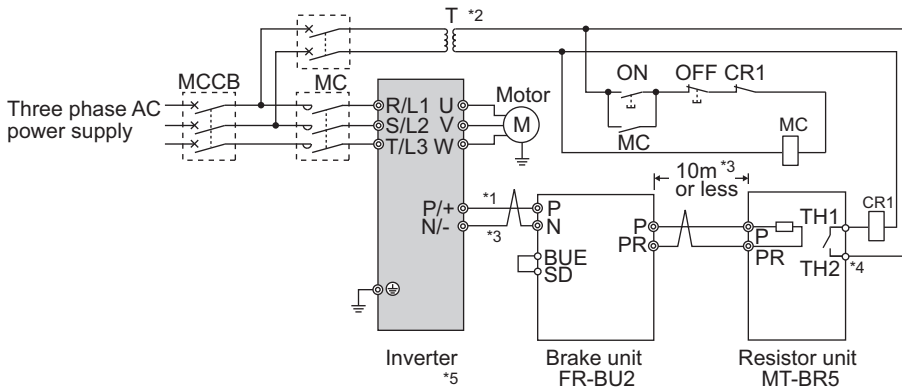

- \*1 Connect the inverter terminals (P/+, N/-) and brake unit (FR-BU2) terminals so that their terminal names match with each other. (Incorrect connection will damage the inverter and brake unit.)
- \*2 When the power supply is 400V class, install a stepdown transformer.
- \*3 The wiring distance between the inverter, brake unit (FR-BU2) and resistor unit (MT-BR5) should be within 5m. If twisted wires are used, the distance should be within 10m.
- \*4 The contact between TH1 and TH2 is open in the normal status and is closed at a fault.
- \*5 CN8 connector used with the MT-BU5 type brake unit is not used.

**CAUTION**

The stall prevention (overvoltage), oL, does not occur while Pr. 30 Regenerative function selection = "1" and Pr. 70 Special regenerative brake duty = "0% (initial setting)."

◆ Parameters referred to ◆

Pr.30 Regenerative function selection Refer to Chapter 4 of the Instruction Manual (Applied)  
 Pr.70 Special regenerative brake duty Refer to Chapter 4 of the Instruction Manual (Applied)

## 2.5.2 Connection of the brake unit (FR-BU/MT-BU5)

When connecting the brake unit (FR-BU(H)/MT-BU5) to improve the brake capability at deceleration, make connection as shown below.

(1) Connection with the FR-BU (55K or lower)

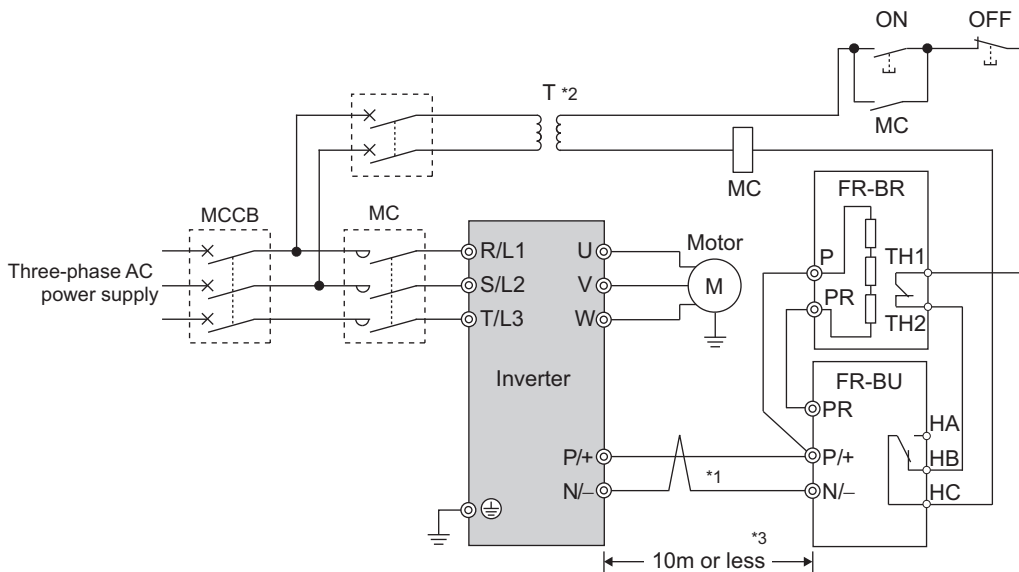

- \*1 Connect the inverter terminals (P/+, N/-) and brake unit (FR-BU (H)) terminals so that their terminal signals match with each other. (Incorrect connection will damage the inverter.)
- \*2 When the power supply is 400V class, install a stepdown transformer.
- \*3 The wiring distance between the inverter, brake unit (FR-BU) and resistor unit (FR-BR) should be within 5m. If twisted wires are used, the distance should be within 10m.

### CAUTION

- If the transistors in the brake unit should become faulty, the resistor can be unusually hot, causing a fire. Therefore, install a magnetic contactor on the inverter's input side to configure a circuit so that a current is shut off in case of fault.
- Do not remove the jumper across terminal P/+ and P1 except when connecting a DC reactor (FR-HEL).

## (2) Connection with the MT-BU5 (75K or higher)

After making sure that the wiring is correct, set the following parameters:

- Pr. 30 Regenerative function selection = "1"
- Pr. 70 Special regenerative brake duty = "10%"

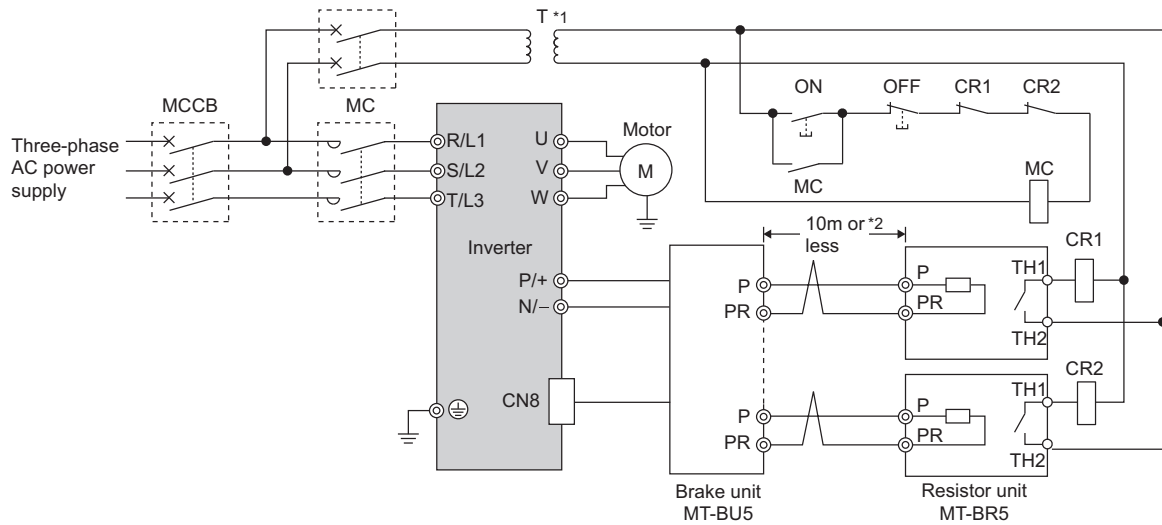

- \*1 When the power supply is 400V class, install a stepdown transformer.
- \*2 The wiring length between the resistor unit and brake resistor should be 10m maximum when wires are twisted and 5m maximum when wires are not twisted.

### CAUTION

- Install the brake unit in a place where a cooling air reaches the brake unit heatsink and within a distance of the cable supplied with the brake unit reaches the inverter.
- For wiring of the brake unit and inverter, use an accessory cable supplied with the brake unit. Connect the main circuit cable to the inverter terminals P/+ and N/- and connect the control circuit cable to the CN8 connector inside by making cuts in the rubber bush at the top of the inverter for leading the cable.
- The brake unit which uses multiple resistor units has terminals equal to the number of resistor units. Connect one resistor unit to one pair of terminal (P, PR).

### <Inserting the CN8 connector>

Make cuts in rubber bush of the upper portion of the inverter and lead a cable.

- 1) Make cuts in the rubber bush for leading the CN8 connector cable with a nipper or cutter knife.

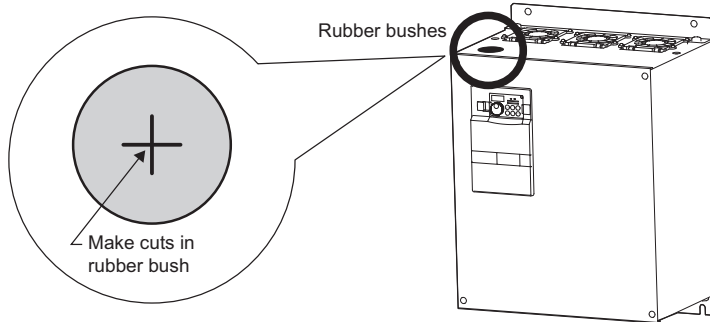

- 2) Insert a connector on the MT-BU5 side through a rubber bush to connect to a connector on the inverter side.

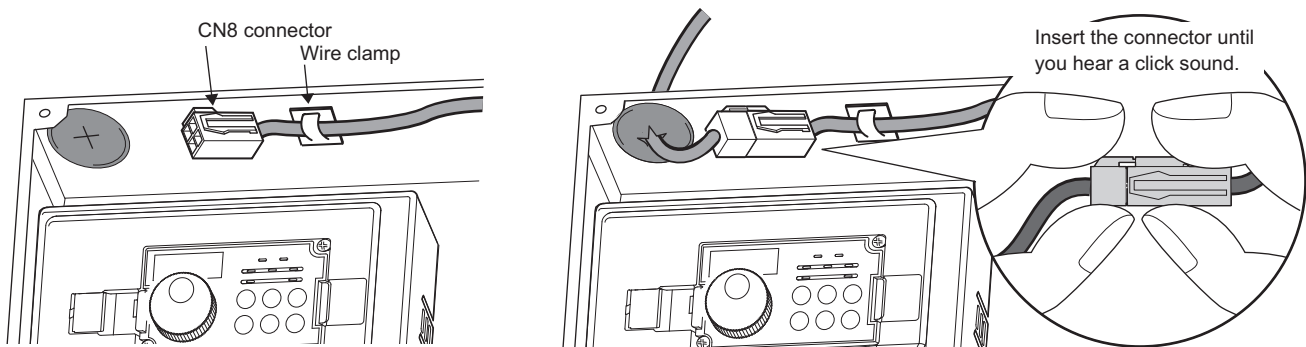

### CAUTION

Clamp the CN8 connector cable on the inverter side with a wire clamp securely.

### ◆ Parameters referred to ◆

- Pr.30 Regenerative function selection Refer to Chapter 4 of the Instruction Manual (Applied)
- Pr.70 Special regenerative brake duty Refer to Chapter 4 of the Instruction Manual (Applied)

### 2.5.3 Connection of the brake unit (BU type)

Connect the brake unit (BU type) correctly as shown below. Incorrect connection will damage the inverter. Remove the jumper across terminals HB and PC and terminals TB and HC of the brake unit and fit it across terminals PC and TB.

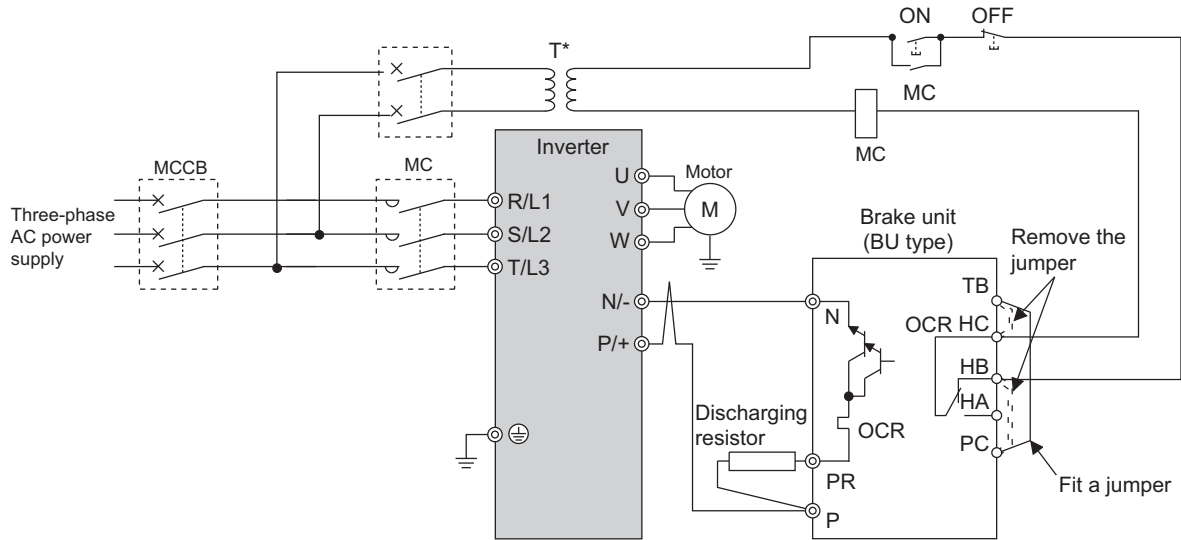

\* When the power supply is 400V class, install a stepdown transformer.

#### CAUTION

- The wiring distance between the inverter, brake unit and discharging resistor should be within 2m. If twisted wires are used, the distance should be within 5m.
- If the transistors in the brake unit should become faulty, the resistor can be unusually hot, causing a fire. Therefore, install a magnetic contactor on the inverter's power supply side to shut off a current in case of fault.
- Do not remove the jumper across terminal P/+ and P1 except when connecting a DC reactor (FR-HEL).

### 2.5.4 Connection of the high power factor converter (FR-HC2)

When connecting the high power factor converter (FR-HC2) to suppress power harmonics, perform wiring securely as shown below. Incorrect connection will damage the high power factor converter and the inverter. Perform the wiring securely, and set *Pr.19 Base frequency voltage* (under V/F control) = "rated motor voltage" and *Pr.30 Regenerative function selection* = "2".

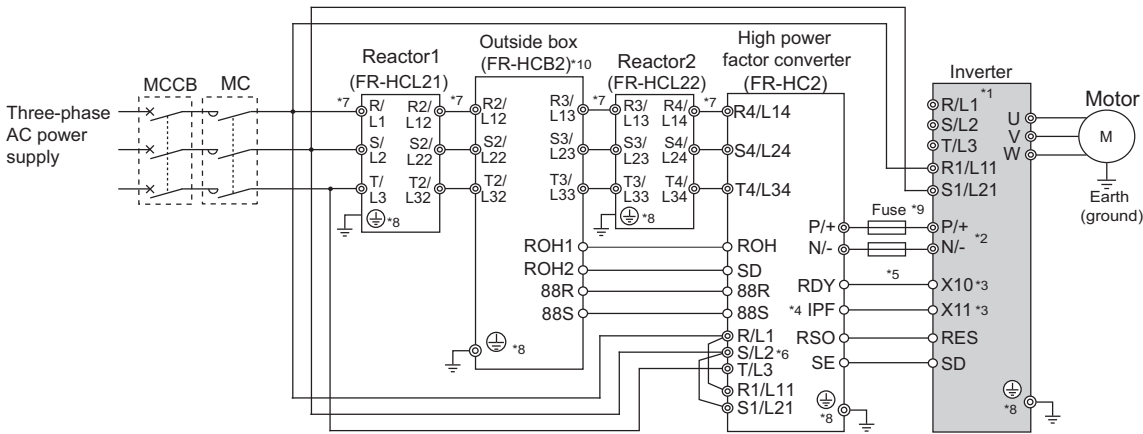

- \*1 Remove the jumpers between terminals R/L1 and R1/L11 as well as between S/L2 and S1/L21, and connect the power supply for the control circuit to across terminals R1/L11 and S1/L21. Do not connect anything to power input terminals (R/L1, S/L2, T/L3). Incorrect connection will damage the inverter. (E.OPT (option fault) will occur. (Refer to page 126.))
- \*2 Do not install an MCCB for the terminals P/+ and N/- (between terminals P and P/+ or between N and N/-). Connecting the opposite polarity of terminals N/- and P/+ will damage the inverter.
- \*3 Assign the X10 (X11) signal to a terminal using any of the *Pr. 178 to Pr. 189 (input terminal function selection)*. (Refer to page 103) For RS-485 or any other communication where the start command is only transmitted once, use the X11 signal to save the operation mode at the time of an instantaneous power failure.
- \*4 Assign the IPF signal to an FR-HC2 terminal. (Refer to the Instruction Manual of FR-HC2.)
- \*5 Be sure to connect terminal RDY of the FR-HC2 to the X10 signal or MRS signal assigned terminal of the inverter, and connect terminal SE of the FR-HC2 to terminal SD of the inverter. Without proper connecting, FR-HC2 will be damaged.
- \*6 Always connect terminals R/L1, S/L2, and T/L3 of the FR-HC2 to the power supply. Operating the inverter without connecting them will damage the FR-HC2.
- \*7 Do not install an MCCB or MC between the reactor 1 terminals (R/L1, S/L2, T/L3) and the FR-HC2 terminals (R4/L14, S4/L24, T4/L34). It will not operate properly.
- \*8 Securely perform grounding (earthing) by using the grounding (earthing) terminal.
- \*9 Installation of a fuse is recommended. (Refer to the Instruction Manual of FR-HC2.)
- \*10 Outside box is not available for 280K or higher. Connect filter capacitors, inrush current limit resistors, and magnetic contactors. (Refer to the Instruction Manual of FR-HC2.)

#### CAUTION

- The voltage phases of terminals R/L1, S/L2, and T/L3 and the voltage phases of terminals R4/L14, S4/L24, and T4/L34 must be matched.
- Match the control logic (sink logic / source logic) of the high power factor converter and the inverter. (Refer to 2.4.6 Changing the control logic)
- Do not connect a DC reactor (FR-HEL) to the inverter when FR-HC2 is connected.

#### ◆ Parameters referred to ◆

*Pr.30 Regenerative function selection*  Refer to Chapter 4 of the Instruction Manual (Applied)

## 2.5.5 Connection of the power regeneration common converter (FR-CV)

When connecting the power regeneration common converter (FR-CV) (55K or lower), make connection so that the inverter terminals (P/+, N/-) and the terminal symbols of the power regeneration common converter (FR-CV) are the same.

After making sure that the wiring is correct, set "2" in Pr. 30 Regenerative function selection.

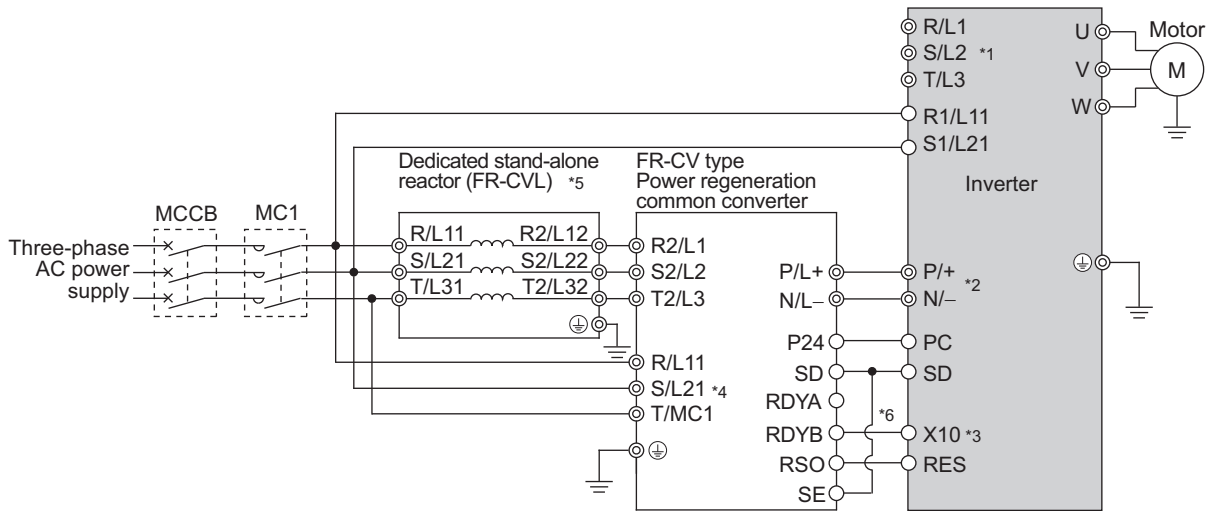

- \*1 Remove the jumpers across terminals R/L1 and R1/L11 and terminals S/L2 and S1/L21 of the inverter, and connect the control circuit power supply across terminals R1/L11 and S1/L21. Do not connect anything to the power input terminals R/L1, S/L2, T/L3. Incorrect connection will damage the inverter. (E.OPT (option fault) will occur. (Refer to page 126.))
- \*2 Do not insert the MCCB between the terminals P/+ and N/- (between P/L+ and P/+, between N/L- and N/-). Opposite polarity of terminals N/-, P/+ will damage the inverter.
- \*3 Assign the terminal for X10 signal using any of Pr. 178 to Pr. 189 (input terminal function selection). (Refer to page 103.)
- \*4 Be sure to connect the power supply and terminals R/L11, S/L21, T/MC1. Operating the inverter without connecting them will damage the power regeneration common converter.
- \*5 Be sure to connect terminal RDYB of the FR-CV to the X10 signal or MRS signal assigned terminal of the inverter, and connect terminal SE of the FR-CV to terminal SD of the inverter. Without proper connecting, FR-CV will be damaged.

### CAUTION

- The voltage phases of terminals R/L11, S/L21, T/MC1 and terminals R2/L1, S2/L2, T2/L3 must be matched.
- Use sink logic (initial setting) when the FR-CV is connected. The FR-CV cannot be connected when source logic is selected.
- Do not connect a DC reactor (FR-HEL) to the inverter when FR-CV is connected.

### ◆ Parameters referred to ◆

Pr.30 Regenerative function selection Refer to Chapter 4 of the Instruction Manual (Applied)



### 2.5.6 Connection of the power regeneration converter (MT-RC)

When connecting a power regeneration converter (MT-RC) (75K or higher), perform wiring securely as shown below. Incorrect connection will damage the regeneration converter and inverter. After connecting securely, set "1" in Pr. 30 Regenerative function selection and "0" in Pr. 70 Special regenerative brake duty.

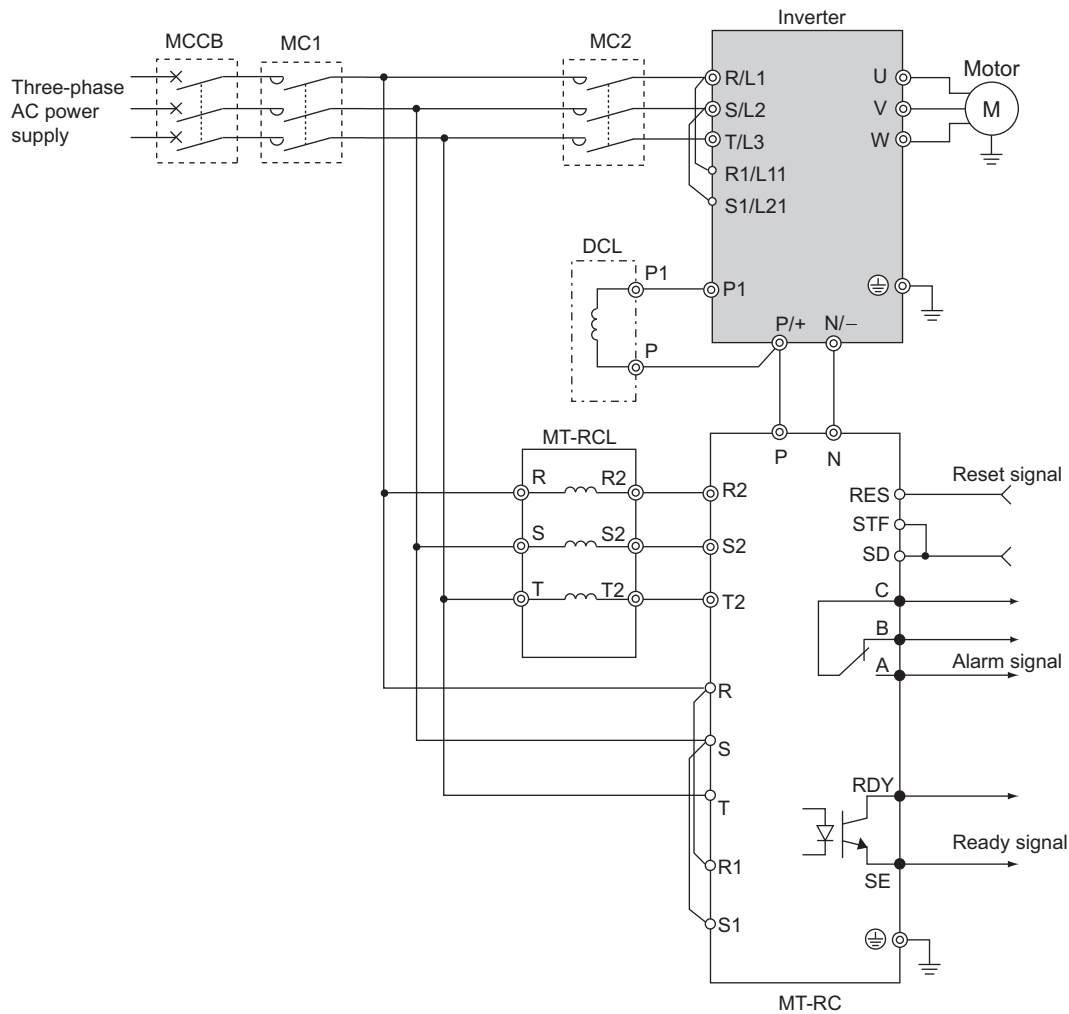

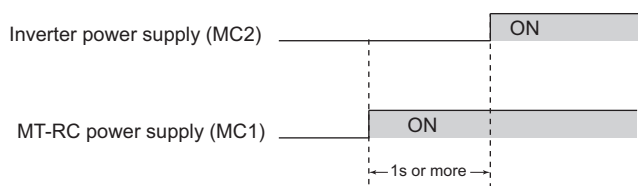

#### CAUTION

- When using the FR-F700P series together with the MT-RC, install a magnetic contactor (MC) at the input side of the inverter so that power is supplied to the inverter after 1s or more has elapsed after powering ON the MT-RC. When power is supplied to the inverter prior to the MT-RC, the inverter and the MT-RC may be damaged or the MCCB may trip or be damaged.
- Refer to the MT-RC manual for precautions for connecting the power coordination reactor and others.



#### ◆ Parameters referred to ◆

Pr.30 Regenerative function selection  Refer to Chapter 4 of the Instruction Manual (Applied)  
 Pr.70 Special regenerative brake duty  Refer to Chapter 4 of the Instruction Manual (Applied)

### 2.5.7 Connection of the power factor improving DC reactor (FR-HEL)

- (1) Keep the surrounding air temperature within the permissible range (-10°C to +50°C). Keep enough clearance around the reactor because it heats up. (Take 10cm or more clearance on top and bottom and 5cm or more on left and right regardless of the installation direction.)

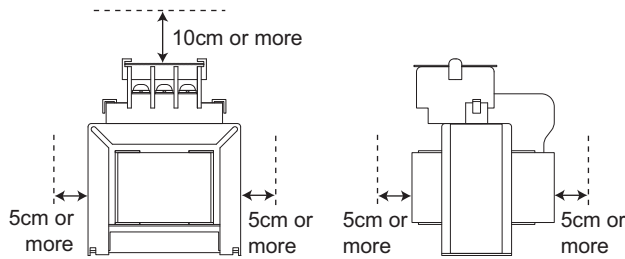

- (2) When using the DC reactor (FR-HEL), connect it between terminals P1 and P/+. For the 55K or lower, the jumper connected across terminals P1 and P/+ must be removed. Otherwise, the reactor will not exhibit its performance. For the 75K or higher, a DC reactor is supplied. Always install the reactor.

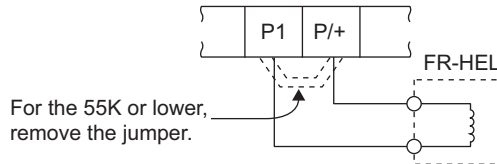

- (3) The DC reactor (FR-HEL) is electrically connected to the enclosure through mounting screws when the DC reactor is securely mounted to the enclosure. If the DC reactor is not earthed (grounded) securely enough, an earthing (grounding) cable may be used. When you are using an earthing (grounding) cable with a 55K or lower capacity inverter, wire the cable to the installation hole where varnish is removed. (Refer to the *Instruction Manual of FR-HEL*.) For 75K or higher, use an earth (ground) terminal to perform earthing (grounding). (Refer to page 153)

**CAUTION**

- The wiring distance should be within 5m.
- The size of the cables used should be equal to or larger than that of the power supply cables (R/L1, S/L2, T/L3) and the earthing (grounding) cable. (Refer to page 14)
- Do not connect a DC reactor (FR-HEL) to the inverter when FR-HC2 or FR-CV is connected.



## 2.6 Power-OFF and magnetic contactor (MC)

### (1) Inverter input side magnetic contactor (MC)

On the inverter input side, it is recommended to provide an MC for the following purposes.  
(Refer to page 4 for selection.)

- 1) To release the inverter from the power supply when the fault occurs or when the drive is not functioning (e.g. emergency stop operation).
- 2) To prevent any accident due to an automatic restart at restoration of power after an inverter stop made by a power failure
- 3) To separate the inverter from the power supply to ensure safe maintenance and inspection work

If using an MC for emergency stop during operation, select an MC regarding the inverter input side current as JEM1038-AC-3 class rated current.

#### REMARKS

Since repeated inrush current at power ON will shorten the life of the converter circuit (switching life is 1,000,000 times (about 500,000 times for the 200V class 37K or higher)), frequent starts/stops must be avoided. Turn ON/OFF the inverter start controlling terminals (STF, STR) to run/stop the inverter.

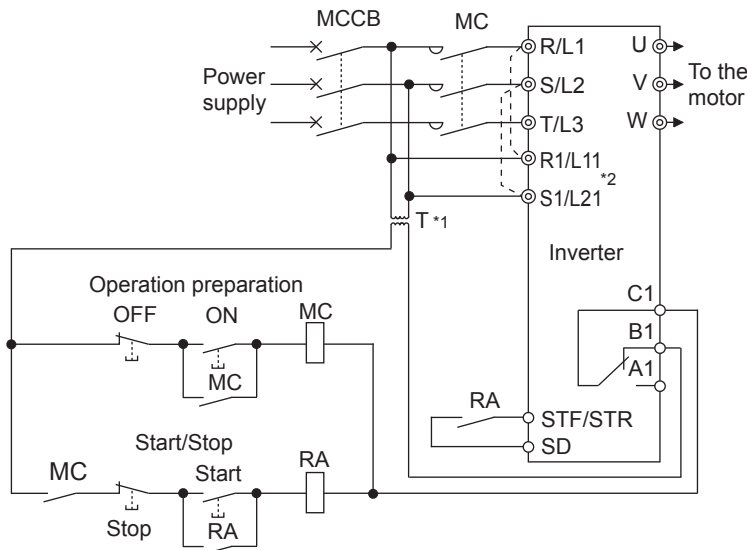

#### • Inverter start/stop circuit example

As shown on the left, always use the start signal (ON or OFF of STF (STR) signal) to make a start or stop.

- \*1 When the power supply is 400V class, install a step-down transformer.
- \*2 Connect the power supply terminals R1/L11, S1/L21 of the control circuit to the primary side of the MC to hold an alarm signal when the inverter's protective circuit is activated. At this time, remove jumpers across terminals R/L1 and R1/L11, and S/L2 and S1/L21. (Refer to page 17 for removal of the jumper.)

### (2) Handling of the inverter output side magnetic contactor

Switch the magnetic contactor between the inverter and general-purpose motor only when both the inverter and motor are at a stop. When the magnetic contactor is turned ON while the inverter is operating, overcurrent protection of the inverter and such will activate. When using a magnetic contactor to switch to a commercial power supply while using a general-purpose motor, it is recommended to use the electronic bypass function Pr. 135 to Pr. 139. (Refer to Chapter 4 of the Instruction Manual (Applied)).

#### CAUTION

IPM motor is a synchronous motor with high-performance magnets embedded in the rotor. Motor terminals hold high-voltage while the motor is running even after the inverter power is turned OFF. Before wiring or inspection, the motor must be confirmed to be stopped. When the motor is driven by the load in applications such as fan and blower, a low-voltage manual contactor must be connected at the inverter's output side, and wiring and inspection must be performed while the contactor is open. Otherwise you may get an electric shock.

## 2.7 Precautions for use of the inverter

The FR-F700P series is a highly reliable product, but using incorrect peripheral circuits or incorrect operation/handling methods may shorten the product life or damage the product. Before starting operation, always recheck the following items.

- (1) **Use crimping terminals with insulation sleeve to wire the power supply and motor.**
- (2) **Application of power to the output terminals (U, V, W) of the inverter will damage the inverter. Never perform such wiring.**
- (3) **After wiring, wire offcuts must not be left in the inverter.**  
Wire offcuts can cause an alarm, failure or malfunction. Always keep the inverter clean. When drilling mounting holes in an enclosure etc., take care not to allow chips and other foreign matter to enter the inverter.
- (4) **Use cables of the appropriate size to make a voltage drop of 2% or less.**  
If the wiring distance is long between the inverter and motor, a main circuit cable voltage drop will cause the motor torque to decrease especially at the output of a low frequency.  
Refer to *page 14* for the recommended cable sizes.
- (5) **The total wiring length should be within the prescribed length.**  
Especially for long distance wiring, the fast-response current limit function may decrease, or the equipment connected to the output side may malfunction. This is caused by a charging current due to the stray capacity of the wiring. Therefore, note the overall wiring length. (*Refer to page 16*)
- (6) **Electromagnetic wave interference**  
The input/output (main circuit) of the inverter includes high frequency components, which may interfere with the communication devices (such as AM radios) used near the inverter. In this case, set the EMC filter valid to minimize interference. (*Refer to page 10*)
- (7) **Do not install a power factor correction capacitor, surge suppressor or capacitor type filter on the inverter output side.**  
This will cause the inverter to trip or the capacitor and surge suppressor to be damaged. If any of the above devices are installed, immediately remove it.
- (8) **For some short time after the power is switched OFF, a high voltage remains in the smoothing capacitor.**  
When accessing the inverter for inspection, wait for at least 10 minutes after the power supply has been switched OFF, and then make sure that the voltage across the main circuit terminals P/+ and N/- of the inverter is no more than 30VDC using a tester, etc.
- (9) **A short circuit or earth (ground) fault on the inverter output side may damage the inverter modules.**
  - Fully check the insulation resistance of the circuit prior to inverter operation since repeated short circuits caused by peripheral circuit inadequacy or an earth (ground) fault caused by wiring inadequacy or reduced motor insulation resistance may damage the inverter modules.
  - Fully check the to-earth (ground) insulation and phase to phase insulation of the inverter output side before power-ON. Especially for an old motor or use in a hostile atmosphere, securely check the motor insulation resistance etc.
- (10) **Do not use the inverter input side magnetic contactor to start/stop the inverter.**  
Since repeated inrush currents at power ON will shorten the life of the converter circuit (switching life is about 1,000,000 times (For the 200V class 37K or higher, switching life is about 500,000)), frequent starts and stops of the MC must be avoided.  
Always use the start signal (ON/OFF of STF and STR signals) to start/stop the inverter. (*Refer to page 9*)
- (11) **Do not apply a voltage higher than the permissible voltage to the inverter I/O signal circuits.**  
Application of a voltage higher than the permissible voltage to the inverter I/O signal circuits or opposite polarity may damage the I/O devices. Especially check the wiring to prevent the speed setting potentiometer from being connected incorrectly to short terminals 10E and 5.
- (12) **When driving a general-purpose motor, provide electrical and mechanical interlocks for MC1 and MC2 which are used for bypass operation.**  
When the wiring is incorrect or if there is an electronic bypass circuit as shown on the right, the inverter will be damaged when the power supply when it is connected to the inverter U, V, W terminals due to arcs generated at the time of switch-over or chattering caused by a sequence error.

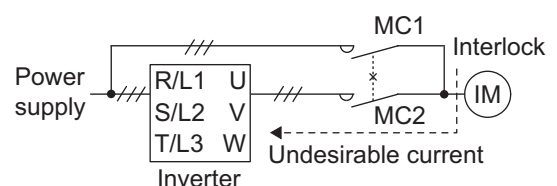

**(13) If the machine must not be restarted when power is restored after a power failure, provide a magnetic contactor in the inverter's input side and also make up a sequence which will not switch on the start signal.**

If the start signal (start switch) remains on after a power failure, the inverter will automatically restart as soon as the power is restored.

**(14) Inverter input side magnetic contactor (MC)**

On the inverter input side, connect an MC for the following purposes. (Refer to page 4 for selection.)

- 1) To release the inverter from the power supply when a fault occurs or when the drive is not functioning (e.g. emergency stop operation).
  - 2) To prevent any accident due to an automatic restart at restoration of power after an inverter stop made by a power failure
  - 3) To separate the inverter from the power supply to ensure safe maintenance and inspection work.
- If using an MC for emergency stop during operation, select an MC regarding the inverter input side current as JEM1038-AC-3 class rated current.

**(15) Handling of inverter output side magnetic contactor**

Switch the magnetic contactor between the inverter and motor only when both the inverter and motor are at a stop. When the magnetic contactor is turned ON while the inverter is operating, overcurrent protection of the inverter and such will activate. When MC is provided for switching to the commercial power supply, for example, switch it ON/OFF after the inverter and motor have stopped.

IPM motor is a synchronous motor with high-performance magnets embedded in the rotor. Motor terminals hold high-voltage while the motor is running even after the inverter power is turned OFF. Before wiring or inspection, the motor must be confirmed to be stopped. When the motor is driven by the load in applications such as fan and blower, a low-voltage manual contactor must be connected at the inverter's output side, and wiring and inspection must be performed while the contactor is open. Otherwise you may get an electric shock.

**(16) Countermeasures against inverter-generated EMI**

If electromagnetic noise generated from the inverter causes frequency setting signal to fluctuate and motor rotation speed to be unstable when changing motor speed with analog signal, the following countermeasures are effective.

- Do not run the signal cables and power cables (inverter I/O cables) in parallel with each other and do not bundle them.
- Run signal cables as far away as possible from power cables (inverter I/O cables).
- Use shield cables as signal cables.
- Install a ferrite core on the signal cable (Example: ZCAT3035-1330 TDK).

**(17) Instructions for overload operation**

When performing an operation of frequent start/stop of the inverter, increase/decrease in the temperature of the transistor element of the inverter may repeat due to a continuous flow of large current, shortening the life from thermal fatigue. Since thermal fatigue is related to the amount of current, the life can be increased by reducing bound current, starting current, etc. Decreasing current may increase the life. However, decreasing current will result in insufficient torque and the motor may not start. A counter action for this is to raise the permissible current level by increasing the inverter capacity (up to 2 ranks) when using a general-purpose motor, and by increasing the inverter and IPM motor capacities when using an IPM motor.

**(18) Make sure that the specifications and rating match the system requirements.**



## 2.8 Failsafe of the system which uses the inverter

When a fault occurs, the inverter trips to output a fault signal. However, a fault output signal may not be output at an inverter fault occurrence when the detection circuit or output circuit fails, etc. Although Mitsubishi assures best quality products, provide an interlock which uses inverter status output signals to prevent accidents such as damage to machine when the inverter fails for some reason and at the same time consider the system configuration where failsafe from outside the inverter, without using the inverter, is enabled even if the inverter fails.

(1) Interlock method which uses the inverter status output signals

By combining the inverter status output signals to provide an interlock as shown below, an inverter alarm can be detected.

| No. | Interlock Method                       | Check Method   | Used Signals  | Refer to Page  |
|-----|--|--|---|--|
| 1)  | Inverter protective function operation | Operation check of an alarm contact<br>Circuit error detection by negative logic | Fault output signal<br>ALM signal   | Refer to Chapter 4 of the Instruction Manual (Applied) |
| 2)  | Inverter running status                | Operation ready signal checks  | Operation ready signal (RY signal)  | Refer to Chapter 4 of the Instruction Manual (Applied) |
| 3)  | Inverter running status                | Logic check of the start signal and running signal                               | Start signal (STF signal, STR signal)<br>Running signal (RUN signal)                | Refer to Chapter 4 of the Instruction Manual (Applied) |
| 4)  | Inverter running status                | Logic check of the start signal and output current                               | Start signal (STF signal, STR signal)<br>Output current detection signal Y12 signal | Refer to Chapter 4 of the Instruction Manual (Applied) |

(2) Backup method outside the inverter

Even if the interlock is provided by the inverter status signal, enough failsafe is not ensured depending on the failure status of the inverter itself. For example, when the inverter CPU fails, even if the interlock is provided using the inverter fault signal, start signal and RUN signal, there is a case where a fault signal is not output and RUN signal is kept output even if an inverter fault occurs.

Provide a speed detector to detect the motor speed and current detector to detect the motor current and consider the backup system such as checking up as below according to the level of importance of the system.

1) Start signal and actual operation check

Check the motor running and motor current while the start signal is input to the inverter by comparing the start signal to the inverter and detected speed of the speed detector or detected current of the current detector. Note that the motor current runs as the motor is running for the period until the motor stops since the inverter starts decelerating even if the start signal turns off. For the logic check, configure a sequence considering the inverter deceleration time. In addition, it is recommended to check the three-phase current when using the current detector.

2) Command speed and actual operation check

Check if there is no gap between the actual speed and commanded speed by comparing the inverter speed command and detected speed of the speed detector.

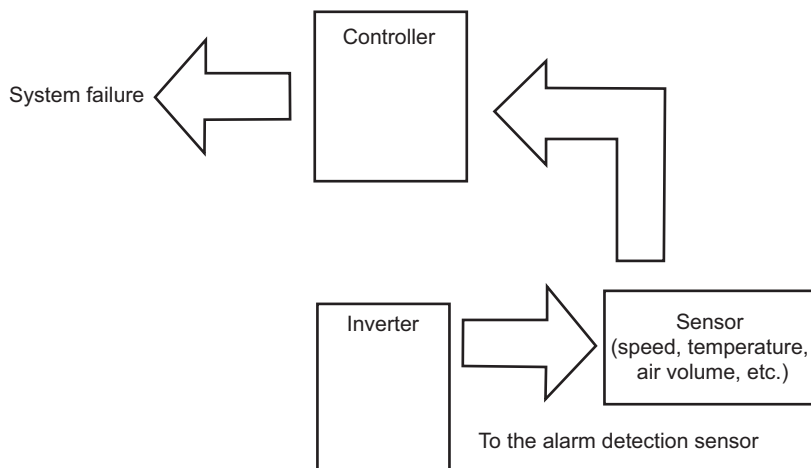

## 3 DRIVING THE IPM MOTOR IPM

Highly efficient motor control and highly accurate motor speed control can be performed by using the inverter with an IPM motor. The motor speed is detected by the output voltage and current of the inverter. It does not require a speed detector such as an encoder. The inverter drives the IPM motor with the least required current when a load is applied in order to achieve the highest motor efficiency.

### POINT

The following conditions must be met to perform IPM motor control.

- For the motor model, a dedicated IPM motor (MM-EFS model, MM-THE4 model, or MM-EF model) must be used.
- The motor capacity must be equivalent to the inverter capacity. (The 0.75K inverter can be used with the 0.4kW MM-EF.)
- Single-motor operation (one motor run by one inverter) must be performed.
- The overall wiring length with the motor must be within the specified value. (Refer to page 16)

### 3.1 Setting procedure of IPM motor control IPM

- This inverter is set for a general-purpose motor in the initial setting. Follow the following procedure to change the setting for the IPM motor control.

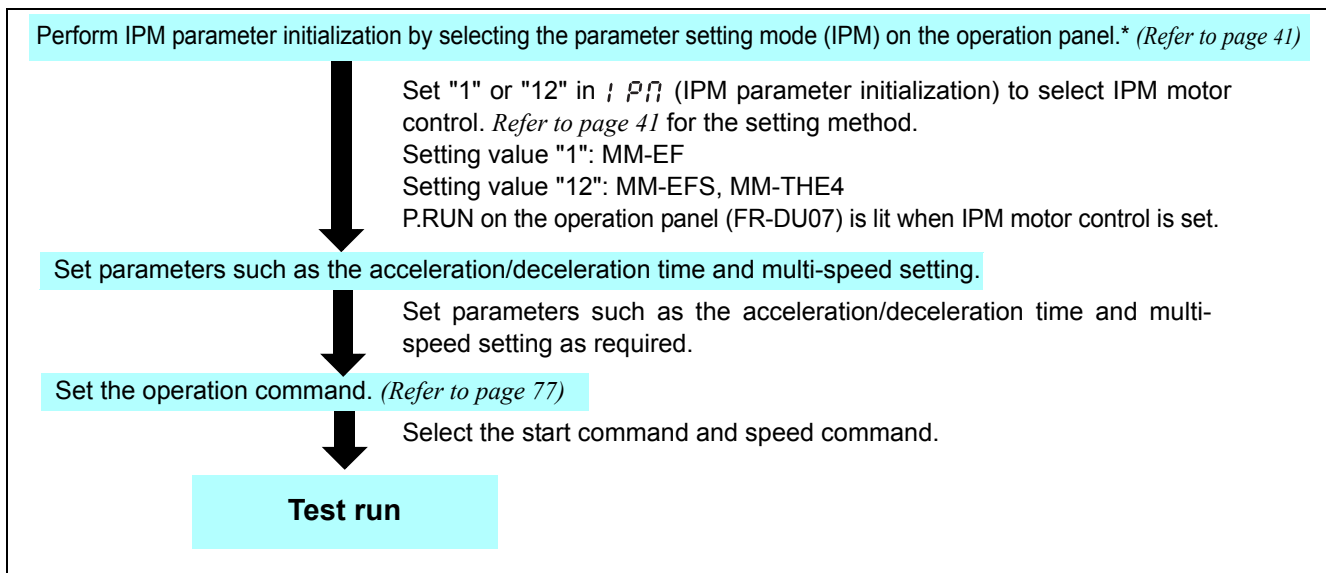

\* IPM parameter initialization is performed by setting Pr. 998 IPM parameter initialization or by selecting  $\text{P}\text{r}\text{99}$  (IPM parameter initialization) on the operation panel. To change to the IPM motor control, perform IPM parameter initialization at first. If parameter initialization is performed after setting other parameters, some of those parameters will be initialized too. (Refer to page 42 for the parameters that are initialized.)

### REMARKS

- "Er1" appears if IPM parameter initialization is performed while Pr.72 = "25."
- To use a 0.4kW MM-EF, set Pr.80 Motor capacity = "0.4" before setting IPM parameter initialization.
- IPM motor control can also be selected with Pr. 80 Motor capacity and Pr. 998 IPM parameter initialization. (Refer to page 42)

### CAUTION

- For the setting range of a speed command under dedicated IPM motor (MM-EFS/MM-THE4 1500r/min specification, MM-EF 1800r/min specification) controls, refer to the output frequency range in Chapter 8.2 Common specifications (Refer to page 151).
- The selectable carrier frequencies under IPM motor control are 2k, 6k, 10k, and 14kHz. (Only 2k and 6kHz are selectable for 75K or higher.)
- Constant-speed operation cannot be performed in the low-speed range lower than 150r/min (MM-EFS, MM-THE4 1500r/min specification) or 180r/min (MM-EF 1800r/min specification). Generally, speed control can be performed in the range that satisfies the ratio, 1:10.
- During IPM motor control, the RUN signal is output about 100ms after turning ON the start command (STF, STR). The delay is due to the magnetic pole detection.
- The following operations and controls are disabled during IPM motor control: adjustable 5 points V/F, bypass sequence, energy saving operation, Optimum excitation control, and speed smoothing.
- The option surge voltage suppression filter (FR-ASF-H/FR-BMF-H) and sine wave filter (MT-BSL/BSC) cannot be used under IPM motor control, so do not connect them.
- When parameter copy is performed from an FR-F700P series inverter, which is set to use MM-EFS or MM-THE4 under IPM motor control, check that IPM motor control is selected on the operation panel (P.RUN is lit) after the copy. When parameters are copied to an FR-F700P series inverter, which is not compatible with MM-EFS or MM-THE4, Simple magnetic flux vector control is selected instead of IPM motor control.



**(1) IPM motor control setting by selecting the parameter setting mode on the operation panel ( ; Pn )**

**POINT**

The parameters required to drive an IPM motor are automatically changed as a batch. (Refer to page 42.)

**Operation example**

Initialize the parameter setting for a premium high-efficiency IPM motor (MM-EFS, MM-THE4) by selecting the parameter setting mode on the operation panel.

| Operation  | Display   |
|--|---|
| 1. Screen at power-ON<br>The monitor display appears.  |   |
| 2. Parameter setting mode<br>Press (MODE) to choose the parameter setting mode.                        | (The parameter number read previously appears.) |
| 3. Selecting the parameter<br>Turn ( ) until ; Pn (IPM parameter initialization) appears.              |   |
| 4. Displaying the setting<br>Press (SET) to read the currently set value. "0" (initial value) appears. |   |
| 5. Selecting the setting<br>Turn ( ) to change it to the set value "12".                               |   |
| 6. Parameter setting<br>Press (SET) to set.  |   |

Flicker ... Parameter setting complete!!  
P.RUN indicator is lit.

- Turn ( ) to read another parameter.
- Press (SET) to show the setting again.
- Press (SET) twice to show the automatic parameter setting (AUTO).

| Setting | Description  |
|---------|--|
| 0       | Parameter settings for a general-purpose motor   |
| 1       | Parameter settings for a high-efficiency IPM motor MM-EF (rotations per minute)                      |
| 12      | Parameter settings for a premium high-efficiency IPM motor MM-EFS and MM-THE4 (rotations per minute) |
| 22, 32  | For manufacturer setting. (Do not set.)  |

**REMARKS**

- Performing IPM parameter initialization by selecting the parameter setting mode on the operation panel automatically changes the Pr. 998 IPM parameter initialization setting.
- The parameter initialization sets the same capacity as the inverter capacity to Pr. 80 Motor capacity. To use a 0.4kW MM-EF, set Pr. 80 Motor capacity = "0.4" before performing IPM parameter initialization by selecting the parameter setting mode on the operation panel.
- The IPM parameter setting is displayed as "1, 12" in the parameter setting mode even if Pr.998 IPM parameter initialization = "101, 112."

**(2) IPM motor control display and IPM motor control signal**

P.RUN on the operation panel (FR-DU07) is lit and the IPM motor control signal (IPM) is output during IPM motor control. For the terminal to output the IPM motor control signal, assign the function by setting "57 (positive logic)" or "157 (negative logic)" to any of Pr.190 to Pr.196 (Output terminal function selection).



### 3.2 Initializing the parameters required to drive an IPM motor (Pr.998) IPM

- By performing IPM parameter initialization, IPM motor control is selected and the parameters, which are required to drive an IPM motor, are changed. Initial settings and setting ranges of the parameters are adjusted automatically to drive an IPM motor.
- Initialization is performed by setting *Pr.998 IPM parameter initialization* or by choosing the mode on the operation panel.

| Parameter Number | Name                         | Initial value | Setting range    | Description  |   |
|------------------|------------------------------|---------------|------------------|--|---|
| 998 *            | IPM parameter initialization | 0             | 0                | Parameter settings for a general-purpose motor (frequency)   | Initial parameter settings required to drive a general-purpose motor are set. |
|                  |                              |               | 1                | Parameter settings for a high-efficiency IPM motor MM-EF (rotations per minute)                      | Initial parameter settings required to drive an IPM motor are set.            |
|                  |                              |               | 12               | Parameter settings for a premium high-efficiency IPM motor MM-EFS and MM-THE4 (rotations per minute) |   |
|                  |                              |               | 101              | Parameter settings for a high-efficiency IPM motor MM-EF (frequency)                                 |   |
|                  |                              |               | 112              | Parameter settings for a premium high-efficiency IPM motor MM-EFS and MM-THE4 (frequency)            |   |
|                  |                              |               | 22, 32, 122, 132 | For manufacturer setting. (Do not set.)  |   |

\* This parameter allows its setting to be changed in any operation mode even if "0 (initial value)" is set in *Pr. 77 Parameter write selection*.

#### (1) IPM parameter initialization (Pr.998)

- To use a 0.4kW MM-EF, set *Pr. 80 Motor capacity* = "0.4" before performing IPM parameter initialization. By performing IPM parameter initialization, initial settings required to drive an IPM motor can be set in parameters.
- When *Pr. 998* = "1 or 12," the monitor is displayed and the frequency is set using the motor rotations per minute. To use frequency to display or set, set *Pr. 998* = "101 or 112."
- Set *Pr. 998* = "0" to change the parameter settings from the settings required to drive an IPM motor to the settings required to drive a general-purpose motor.

| Pr.998 Setting    | Description  | Operation after selecting the parameter setting mode on the operation panel |
|-------------------|--|---|
| 0 (initial value) | Parameter settings for a general-purpose motor (frequency)   | <i>IPM</i> (IPM) ⇒ Write "0"  |
| 1                 | Parameter settings for a high-efficiency IPM motor MM-EF (rotations per minute)                      | <i>IPM</i> (IPM) ⇒ Write "1"  |
| 12                | Parameter settings for a premium high-efficiency IPM motor MM-EFS and MM-THE4 (rotations per minute) | <i>IPM</i> (IPM) ⇒ Write "12"   |
| 101               | Parameter settings for a high-efficiency IPM motor MM-EF (frequency)                                 | Invalid   |
| 112               | Parameter settings for a premium high-efficiency IPM motor MM-EFS and MM-THE4 (frequency)            | Invalid   |

#### REMARKS

- Make sure to set *Pr. 998* before setting other parameters. If the *Pr. 998* setting is changed after setting other parameters, some of those parameters will be initialized too. (Refer to "(2) IPM parameter initialization list" for the parameters that are initialized.)
- To change back to the parameter settings required to drive a general-purpose motor, perform parameter clear or all parameter clear.
- If the setting of *Pr. 998 IPM parameter initialization* is changed from "1, 12 (rotations per minute)" to "101, 112 (frequency)," or from "101, 112" to "1, 12," all the target parameters are initialized.  
The purpose of *Pr. 998* is not to change the display units. Use *Pr. 144 Speed setting switchover* to change the display units between rotations per minute and frequency. *Pr. 144* enables switching of display units between rotations per minute and frequency without initializing the parameter settings.  
Example) Changing the *Pr. 144* setting between "6" and "106" switches the display units between frequency and rotations per minute.

## (2) IPM parameter initialization list

By selecting IPM motor control from the parameter setting mode or with *Pr.998 IPM parameter initialization*, the parameter settings in the following table change to the settings required to drive an IPM motor. The changed settings differ according to the IPM motor specification (capacity). Refer to the IPM motor specification list shown below. Performing parameter clear or all parameter clear sets back the parameter settings to the settings required to drive a general-purpose motor.

| Parameter | Name  | Setting                 |   |                                      | Setting increments |             |
|-----------|---|-------------------------|---|--------------------------------------|--------------------|-------------|
|           |   | General-purpose motor   | IPM motor (rotations per minute)  | IPM motor (frequency)                | 1, 12              | 0, 101, 112 |
|           | <i>Pr.998</i>   | 0 (Initial setting)     | 1 (MM-EF), 12 (MM-EFS, MM-THE4)   | 101 (MM-EF), 112 (MM-EFS, MM-THE4)   |                    |             |
| 1         | Maximum frequency   | 120/60Hz *3             | Maximum motor rotations per minute  | Maximum motor frequency              | 1r/min             | 0.01Hz      |
| 4         | Multi-speed setting (high speed)                              | 60Hz                    | Rated motor rotations per minute  | Rated motor frequency                | 1r/min             | 0.01Hz      |
| 9         | Electronic thermal O/L relay                                  | Rated inverter current  | Rated motor current   |                                      | 0.01A/0.1A *3      |             |
| 13        | Starting frequency  | 0.5Hz                   | Minimum rotations per minute  | Minimum frequency                    | 1r/min             | 0.01Hz      |
| 15        | Jog frequency   | 5Hz                     | Minimum rotations per minute  | Minimum frequency                    | 1r/min             | 0.01Hz      |
| 18        | High speed maximum frequency                                  | 120/60Hz *3             | Maximum motor rotations per minute  | Maximum motor frequency              | 1r/min             | 0.01Hz      |
| 20        | Acceleration/deceleration reference frequency                 | 60Hz                    | Rated motor rotations per minute  | Rated motor frequency                | 1r/min             | 0.01Hz      |
| 22        | Stall prevention operation level                              | 120%                    | Short-time motor torque   |                                      | 0.1%               |             |
| 37        | Speed display   | 0                       | 0   |                                      | 1                  |             |
| 55        | Frequency monitoring reference                                | 60Hz                    | Rated motor rotations per minute  | Rated motor frequency                | 1r/min             | 0.01Hz      |
| 56        | Current monitoring reference                                  | Rated inverter current  | Rated motor current   |                                      | 0.01A/0.1A *3      |             |
| 71        | Applied motor   | 0                       | 120 (when <i>Pr.998</i> = "1" or "101")<br>210 (when <i>Pr.998</i> = "12" or "112") |                                      | 1                  |             |
| 80        | Motor capacity  | 9999                    | Inverter capacity *2  |                                      | 0.01kW/0.1kW *3    |             |
| 125 (903) | Terminal 2 frequency setting gain frequency                   | 60Hz                    | Rated motor rotations per minute  | Rated motor frequency                | 1r/min             | 0.01Hz      |
| 126 (905) | Terminal 4 frequency setting gain frequency                   | 60Hz                    | Rated motor rotations per minute  | Rated motor frequency                | 1r/min             | 0.01Hz      |
| 144       | Speed setting switchover                                      | 4                       | Number of motor poles + 100   | Number of motor poles                | 1                  |             |
| 240       | Soft-PWM operation selection                                  | 1                       | 0   |                                      | 1                  |             |
| 260       | PWM frequency automatic switchover                            | 1                       | 1   |                                      | 1                  |             |
| 263       | Subtraction starting frequency                                | 60Hz                    | Rated motor rotations per minute  | Rated motor frequency                | 1r/min             | 0.01Hz      |
| 266       | Power failure deceleration time switchover frequency          | 60Hz                    | Rated motor rotations per minute  | Rated motor frequency                | 1r/min             | 0.01Hz      |
| 374       | Overspeed detection level                                     | 9999                    | Maximum motor rotations per minute × 105%   | Maximum motor frequency × 105%       | 1r/min             | 0.01Hz      |
| 390 *1    | % setting reference frequency                                 | 60Hz                    | Rated motor frequency   |                                      | 0.01Hz             |             |
| 505       | Speed setting reference                                       | 60Hz                    | Rated motor frequency   |                                      | 0.01Hz             |             |
| 557       | Current average value monitor signal output reference current | Rated inverter current  | Rated motor current   |                                      | 0.01A/0.1A *3      |             |
| 870       | Speed detection hysteresis                                    | 0Hz                     | Speed detection hysteresis rotations per minute                                     | Speed detection hysteresis frequency | 1r/min             | 0.01Hz      |
| 885       | Regeneration avoidance compensation frequency limit value     | 6Hz                     | Minimum rotations per minute  | Minimum frequency                    | 1r/min             | 0.01Hz      |
| 893       | Energy saving monitor reference (motor capacity)              | Rated inverter capacity | Motor capacity ( <i>Pr. 80</i> )  |                                      | 0.01kW/0.1kW *3    |             |

\*1 This parameter can be set when FR-A7NL is mounted.

\*2 When *Pr.80 Motor capacity* ≠ "9999," the *Pr.80 Motor capacity* setting is not changed by IPM parameter initialization. IPM parameter initialization is performed by setting *Pr.998 IPM parameter initialization* or the parameter setting mode on the operation panel.

\*3 Initial values differ according to the inverter capacity. (55K or lower/75K or higher)

### REMARKS

If IPM parameter initialization is performed in rotations per minute (*Pr.998* = "1" or "12"), the frequency-related parameters not listed in the table and the monitored items are also set and displayed in rotations per minute.

Initializing the parameters required to drive  
an IPM motor (Pr.998) <IPM>



[IPM motor specification list]

|   | <b>MM-EF<br/>(30kW or<br/>lower)</b> | <b>MM-EF<br/>(37kW to<br/>75kW)</b> | <b>MM-EF<br/>(90kW or<br/>higher)</b> | <b>MM-EFS<br/>(15kW or<br/>lower)</b> | <b>MM-EFS<br/>(18.5kW to<br/>55kW)</b> | <b>MM-THE4<br/>(75kW to<br/>160kW)</b> |
|---|--------------------------------------|-------------------------------------|---------------------------------------|---------------------------------------|--|--|
| Rated motor frequency<br>(rotations per minute)                   | 90Hz<br>(1800r/min)                  | 120Hz<br>(1800r/min)                | 120Hz<br>(1800r/min)                  | 75Hz<br>(1500r/min)                   | 100Hz<br>(1500r/min)                   | 75Hz<br>(1500r/min)                    |
| Maximum motor frequency<br>(rotations per minute)                 | 135Hz<br>(2700r/min)                 | 180Hz<br>(2700r/min)                | 160Hz<br>(2400r/min)                  | 112.5Hz<br>(2250r/min)                | 150Hz<br>(2250r/min)                   | 90Hz<br>(1800r/min)                    |
| Number of motor poles   | 6                                    | 8                                   | 8                                     | 6                                     | 8                                      | 6                                      |
| Short-time motor torque   | 120%                                 | 120%                                | 120%                                  | 120%                                  | 120%                                   | 120%                                   |
| Minimum frequency<br>(rotations per minute)                       | 9Hz<br>(180r/min)                    | 12Hz<br>(180r/min)                  | 12Hz<br>(180r/min)                    | 7.5Hz<br>(150r/min)                   | 10Hz<br>(150r/min)                     | 7.5Hz<br>(150r/min)                    |
| Speed detection hysteresis<br>frequency (rotations per<br>minute) | 0.5Hz<br>(10r/min)                   | 0.5Hz<br>(8r/min)                   | 0.5Hz<br>(8r/min)                     | 0.5Hz<br>(10r/min)                    | 0.5Hz<br>(8r/min)                      | 0.5Hz<br>(10r/min)                     |

# 4 DRIVING THE MOTOR

## 4.1 Operation panel (FR-DU07)

### 4.1.1 Component of the operation panel (FR-DU07)

To mount the operation panel (FR-DU07) on the enclosure surface, refer to page 25.

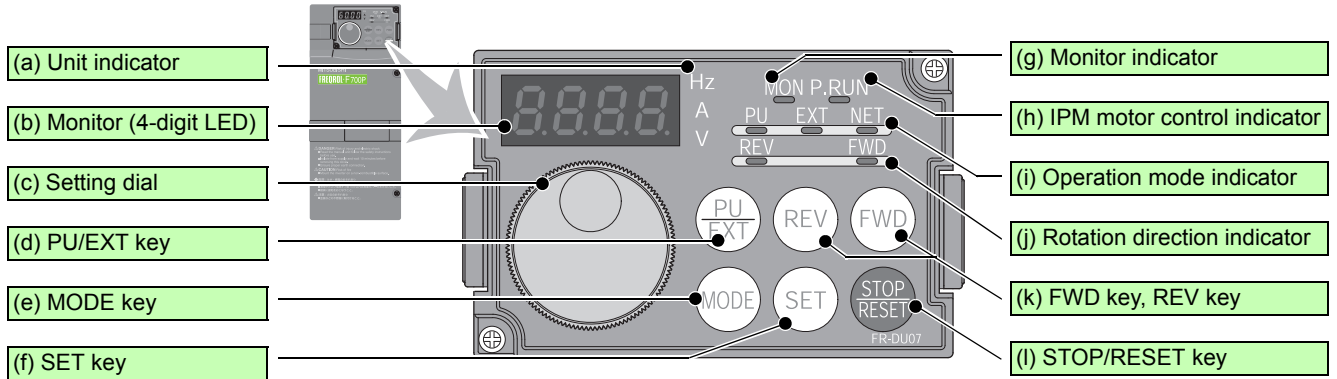

| No. | Component | Name                         | Description  |
|-----|-----------|------------------------------|--|
| (a) |           | Unit indicator               | Hz: Lit to indicate frequency. (Flickers when the set frequency monitor is displayed.)<br>A: Lit to indicate current.<br>V: Lit to indicate voltage.   |
| (b) |           | Monitor (4-digit LED)        | Shows the frequency, parameter number, etc.<br>(To monitor the output power, set frequency and other items, set Pr.52.)  |
| (c) |           | Setting dial                 | The dial of the Mitsubishi inverters. The setting dial is used to change the frequency and parameter settings.<br>Press the setting dial to perform the following operations: <ul style="list-style-type: none"> <li>To display a set frequency in the monitor mode</li> <li>To display the present setting during calibration</li> <li>To display a fault history number in the faults history mode</li> </ul>  |
| (d) |           | PU/EXT key                   | Used to switch between the PU and External operation modes.<br>To use the External operation mode (operation using a separately connected frequency setting potentiometer and start signal), press this key to light up the EXT indicator.<br>(Press  simultaneously (0.5s), or change the Pr.79 setting to change to the combined operation mode. )<br>PU: PU operation mode<br>EXT: External operation mode<br>Used to cancel the PU stop also.  |
| (e) |           | MODE key                     | Used to switch among different setting modes.<br>Pressing  simultaneously changes the operation mode.<br>Holding this key for 2 seconds locks the operation. The key lock is invalid when Pr.161 = "0 (initial setting)." (Refer to page 103.)   |
| (f) |           | SET key                      | Used to enter a setting.<br>If pressed during the operation, monitored item changes as the following: <div style="display: flex; align-items: center; gap: 10px;"> <div style="border: 1px solid black; padding: 2px;">Output frequency</div> <div>→</div> <div style="border: 1px solid black; padding: 2px;">Output current</div> <div>→</div> <div style="border: 1px solid black; padding: 2px;">Output voltage*</div> </div> <p>* Energy saving monitor is displayed when the energy saving monitor is set with Pr. 52.</p> |
| (g) |           | Monitor indicator            | Lit to indicate the monitor mode.  |
| (h) |           | IPM motor control indicator  | Lit to indicate IPM motor control.<br>Flickers to indicate IPM motor test operation.   |
| (i) |           | Operation mode indicator     | PU: Lit to indicate the PU operation mode.<br>EXT: Lit to indicate the External operation mode. (EXT is lit at power-ON in the initial setting.)<br>NET: Lit to indicate the Network operation mode.<br>PU and EXT: Lit to indicate EXT/PU combined operation mode 1 and 2   |
| (j) |           | Rotation direction indicator | FWD: Lit to indicate the forward rotation.<br>REV: Lit to indicate the reverse rotation.<br>Lit: When the forward/reverse operation is being performed.<br>Flickers: When the frequency command is not given even if the forward/reverse command is given.<br>When the frequency command is lower than the starting frequency.<br>When the MRS signal is being input.  |
| (k) |           | FWD key, REV key             | FWD key: Used to give a start command in forward rotation.<br>REV key: Used to give a start command in reverse rotation.   |
| (l) |           | STOP/RESET key               | Used to stop operation commands.<br>Used to reset a fault when the protective function (fault) is activated.   |



### 4.1.2 Basic operation (factory setting)

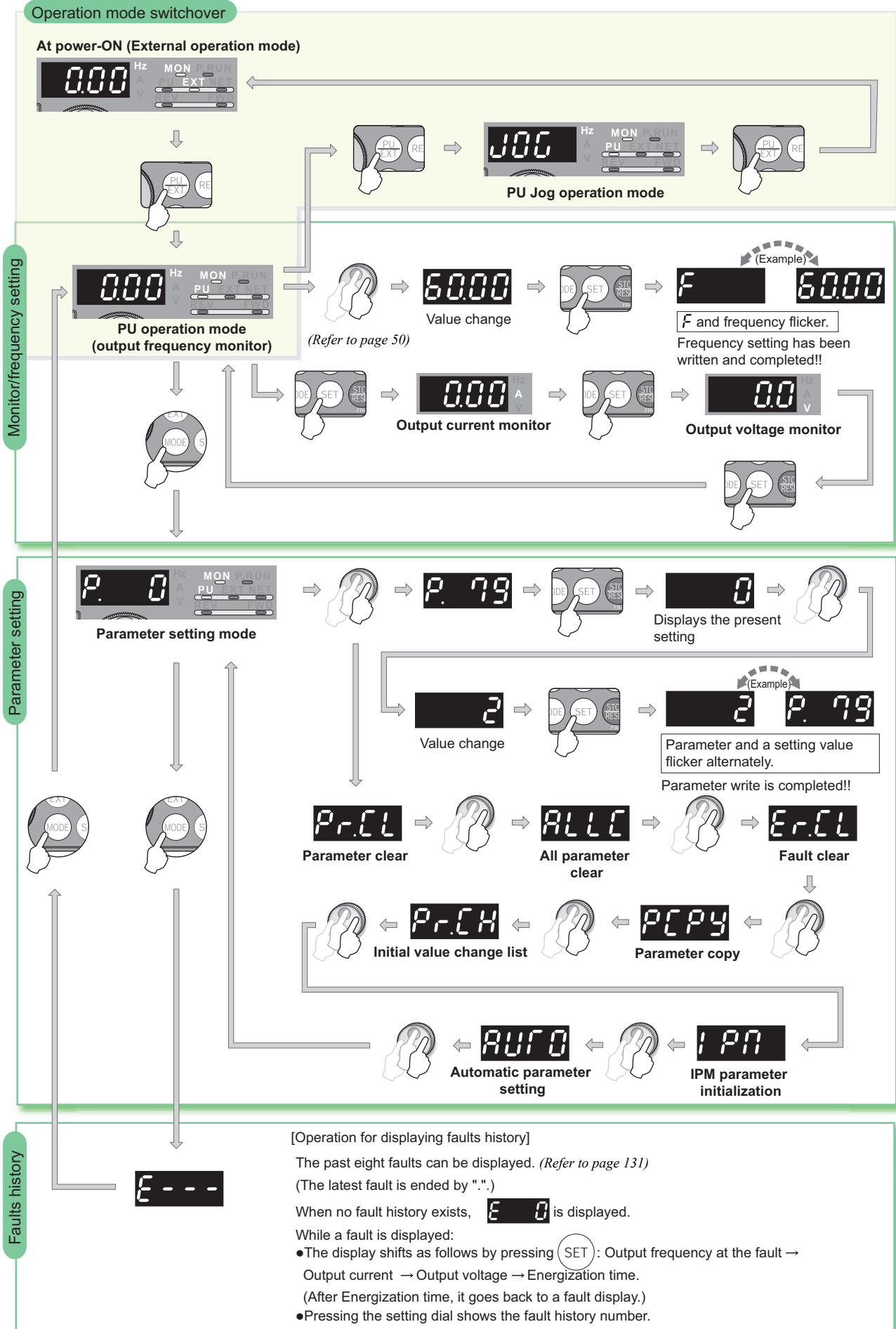

### 4.1.3 Easy operation mode setting (easy setting mode)

Setting of Pr. 79 Operation mode selection according to combination of the start command and speed command can be easily made.

#### Operation example

Start command by the external signal (STF/STR), frequency command by

- Operation**
- Screen at power-ON  
The monitor display appears.
  - Press and for 0.5s.
  - Turn until 79-3 appears.  
(Refer to the table below for other settings)
- Display**
- 
- 
- 

| Operation Panel Indication | Operation Method    |                      |
|----------------------------|---------------------|----------------------|
|                            | Start command       | Frequency command    |
| <br>Flickering             |                     | *                    |
| <br>Flickering             | External (STF, STR) | Analog voltage input |
| <br>Flickering             | External (STF, STR) | *                    |
| <br>Flickering             |                     | Analog voltage input |

\* To use as a potentiometer, refer to page 55.

- Press to set.



**Flicker ... Parameter setting complete!!**  
 ⇒ The monitor display appears after 3s.



#### REMARKS

- ? Er 1 is displayed ... Why?  
 Pr. 79 is not registered in user group with "1" in Pr. 160 User group read selection.
- ? Er 2 is displayed ... Why?  
 Setting cannot be changed during operation. Turn the start command ( or , STF or STR) OFF.
- If is pressed before pressing , the easy setting mode is terminated and the display goes back to the monitor display. If the easy setting mode is terminated while Pr. 79 = "0 (initial setting)", the operation mode switches between the PU operation mode and the External operation mode. Check the operation mode.
- Reset can be made with .
- The priorities of the frequency commands when Pr. 79 = "3" are "Multi-speed operation (RL/RM/RH/REX) > PID control (X14) > terminal 4 analog input (AU) > digital input from the operation panel".



### 4.1.4 Operation lock (Press [MODE] for an extended time (2s))

Operation using the setting dial and key of the operation panel can be invalid to prevent parameter change, and unexpected start or frequency setting.

- Set "10 or 11" in Pr. 161, then press for 2s to make the setting dial and key operation invalid.
- When the setting dial and key operation are invalid, **HOLD** appears on the operation panel.

If dial and key operation is attempted while dial and key operation are invalid, **HOLD** appears. (When dial or key is not touched for 2s, the monitor display appears.)

- To make the setting dial and key operation valid again, press for 2s.

**POINT**

Set "10 or 11" (key lock valid) in Pr.161 Frequency setting/key lock operation selection.

| Operation  | Display   |
|--|---|
| 1. Screen at power-ON<br>The monitor display appears.  |   |
| 2. Press  to choose the PU operation mode.   | PU indicator is lit.<br>                        |
| 3. Press  to choose the parameter setting mode.  | (The parameter number read previously appears.) |
| 4. Turn  until P. 160 (Pr. 160) appears.   |   |
| 5. Press  to read the currently set value.<br>"9999" (initial value) appears.                    |   |
| 6. Turn  to change it to the setting value of "0".   |   |
| 7. Press  to set.  | <b>Flicker ... Parameter setting complete!!</b> |
| 8. Change Pr. 161 to the setting value of "10" in the similar manner.<br>(Refer to step 4 to 7.) | <b>Flicker ... Parameter setting complete!!</b> |
| 9. Press  for 2s to show the key lock.   | <br>Press for 2s.                               |

**Functions valid even in the operation lock status**

Stop and reset with .









**CAUTION**

Release the operation lock to release the PU stop by key operation.

### 4.1.5 Monitoring of output current and output voltage

#### POINT

Monitor display of output frequency, output current and output voltage can be changed by pushing  during monitoring mode.

| Operation  |   | Display   |
|--|---|---|
| 1. Press  during operation to choose the output frequency monitor   |   |  |
| 2. Independently of whether the inverter is running in any operation mode or at a stop, the output current monitor appears by pressing  . |  → |  |
| 3. Press  to show the output voltage monitor.   |  → |  |

#### REMARKS

- Monitored item can be changed from output voltage to other items such as output power and set frequency by setting Pr.52. Refer to Chapter 4 of  the Instruction Manual (Applied).

### 4.1.6 First priority monitor

Hold down  for 1s to set monitor description to be appeared first in the monitor mode.

(To return to the output frequency monitor, hold down  for 1s after displaying the output frequency monitor.)

### 4.1.7 Displaying the set frequency

Press the setting dial (  ) in the PU operation mode or in the External/PU combined operation mode 1 (Pr. 79 = "3") to show the set frequency.





### 4.1.8 Changing the parameter setting value

**Changing example** Change the *Pr. 1 Maximum frequency* .

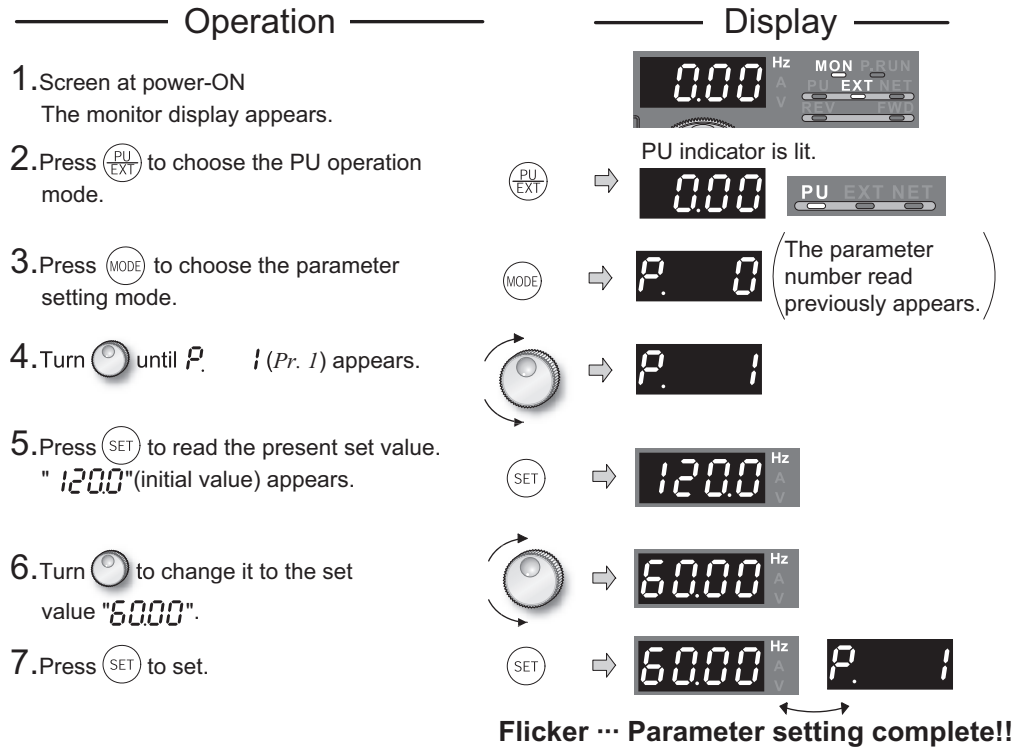

- Turn **▲/▼** to read another parameter.
- Press **SET** to show the setting again.
- Press **SET** twice to show the next parameter.
- Press **MODE** twice to return the monitor to frequency monitor.

#### ? **Er 1** to **Er 4** appear ... Why?

- Er 1** appears. ....Write disable error
- Er 2** appears. ....Write error during operation
- Er 3** appears. ....Calibration error
- Er 4** appears. ....Mode designation error

For details refer to *page 117*.

#### REMARKS

- The number of digits displayed on the operation panel (FR-DU07) is four. Only the upper four digits of values can be displayed and set. If the values to be displayed have five digits or more including decimal places, the fifth or later numerals cannot be displayed nor set.

(Example) When *Pr.1*

When 60Hz is set, 60.00 is displayed.

When 120Hz is set, 120.0 is displayed. The second decimal places cannot be displayed nor set.

#### POINT

When *Pr.77 Parameter write selection* = "0 (initial setting)," the parameter setting change is only available while the inverter is stopped under the PU operation mode.  
To enable the parameter setting change while the inverter is running or under the operation mode other than PU operation mode, change the *Pr.77* setting.

## 4.2 Overheat protection of the motor by the inverter (Pr. 9)

Set the rated motor current in Pr. 9 Electronic thermal O/L relay to protect the motor from overheat.

| Parameter Number | Name                         | Initial Value                | Setting Range *2 |            | Description                  |
|------------------|------------------------------|------------------------------|------------------|------------|------------------------------|
| 9                | Electronic thermal O/L relay | Rated inverter current *1 *3 | 55K or lower     | 0 to 500A  | Set the rated motor current. |
|                  |                              |                              | 75K or higher    | 0 to 3600A |                              |

\*1 Refer to page 149 for the rated inverter current value.

\*2 The minimum setting increments are 0.01A for the 55K or lower and 0.1A for the 75K or higher.

\*3 Performing IPM parameter initialization changes the settings. (Refer to page 42)

**Changing example** Change the Pr. 9 Electronic thermal O/L relay setting to 2.0A according to the rated motor current. (FR-F740P-0.75K)

**Operation**

1. Screen at power-ON  
The monitor display appears.
2. Press to choose the PU operation mode.
3. Press to choose the parameter setting mode.
4. Turn until "P. 9" (Pr. 9 Electronic thermal O/L relay) appears.
5. Press to show the present set value. (2.1A for FR-740P-0.75K)
6. Turn to change the set value to "2.00". (2.0A)
7. Press to set.

**Display**

PU indicator is lit.

The parameter number read previously appears.

Refer to page 149 for initial value of the rated inverter current.

**Flicker ... Parameter setting complete!!**

- By turning , you can read another parameter.
- Press to show the setting again.
- Press twice to show the next parameter.

### CAUTION

- Internal accumulated heat value of the electronic thermal relay function is reset by inverter power reset and reset signal input. Avoid unnecessary reset and power-OFF.
- When using multiple motors with one inverter, or using a multi-pole motor or a specialized motor, provide an external thermal relay (OCR) between the inverter and motor. And for the setting of the thermal relay, add the line-to-line leakage current (refer to Chapter 3 of the Instruction Manual (Applied)) to the current value on the motor rating plate. For low-speed operation where the cooling capability of the motor reduces, it is recommended to use a thermal protector or thermistor-incorporated motor.
- When the difference between the inverter and motor capacities is large and the setting is small, the protective characteristics of the electronic thermal relay function will be deteriorated. In this case, use an external thermal relay.
- PTC thermistor output built-in the motor can be input to the PTC signal (AU terminal). For details, refer to Chapter 4 of the Instruction Manual (Applied).











### 4.3 When the rated motor frequency is 50Hz (Pr. 3) V/F S.MFVC

First, check the motor rating plate. If a frequency given on the rating plate is "50Hz" only, always set *Pr. 3 Base frequency* to "50Hz". If it remains at "60Hz", the voltage may become too low and torque shortage occurs, resulting in an overload trip. It may result in an inverter trip (E.OC□) due to overload.

| Parameter Number | Name           | Initial Value | Setting Range | Description   |
|------------------|----------------|---------------|---------------|---|
| 3                | Base frequency | 60Hz          | 0 to 400Hz    | Set the frequency when the rated motor torque is generated. |

Changing example Change *Pr. 3 Base frequency* to 50Hz according to the rated motor frequency.

| Operation   | Display   |
|---|---|
| <p>1. Screen at power-ON<br/>The monitor display appears.</p>   |   |
| <p>2. Press <span style="border: 1px solid black; border-radius: 50%; padding: 2px;">PU<br/>EXT</span> to choose the PU operation mode.</p>   | <p>PU indicator is lit.</p>                           |
| <p>3. Press <span style="border: 1px solid black; border-radius: 50%; padding: 2px;">MODE</span> to choose the parameter setting mode.</p>    | <p>The parameter number read previously appears.</p>  |
| <p>4. Turn  until <i>Pr. 3 Base frequency</i> appears.</p>   |   |
| <p>5. Press <span style="border: 1px solid black; border-radius: 50%; padding: 2px;">SET</span> to show the present set value. (60Hz)</p>     |    |
| <p>6. Turn  to change the set value to "50.00". (50Hz)</p> |   |
| <p>7. Press <span style="border: 1px solid black; border-radius: 50%; padding: 2px;">SET</span> to set.</p>                                   |   |

**Flicker ... Parameter setting complete!!**

- By turning , you can read another parameter.
- Press SET to show the setting again.
- Press SET twice to show the next parameter.

## 4.4 Start/stop from the operation panel (PU operation mode)

### POINT

From where is the frequency command given?

- Operation at the frequency set in the frequency setting mode of the operation panel →Refer to 4.4.1 (Refer to page 53)
- Operation using the setting dial as the potentiometer →Refer to 4.4.2 (Refer to page 55)
- Change of frequency with ON/OFF switches connected to terminals →Refer to 4.4.3 (Refer to page 56)
- Frequency setting using voltage input signal →Refer to 4.4.4 (Refer to page 58)
- Frequency setting using current input signal →Refer to 4.4.5 (Refer to page 59)

### 4.4.1 Setting the set frequency to operate (example: performing operation at 30Hz)

### POINT

Use the operation panel (FR-DU07) to give both of frequency and start commands in PU operation.

Operation panel (FR-DU07)

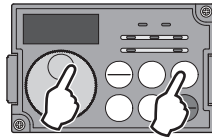

Operation example Performing operation at 30Hz.

#### Operation

#### 1. Screen at power-ON

The monitor display appears.

#### 2. Operation mode setting

Press to choose the PU operation mode.

#### 3. Running frequency setting

Turn to show the frequency "30.00" (30.00Hz) you want to set.

The frequency flickers for about 5s.

While the value is flickering, press to set the frequency.

(If you do not press , the value flickers for about 5s and the display then returns to "0.00" (0.00Hz). At this time, return to "Step 3" and set the frequency again. After the value flickered for about 3s, the display returns to "0.00" (monitor display).

#### 4. Start → acceleration → constant speed

Press or to start running.

The frequency on the display increases in the Pr. 7 Acceleration time, and "30.00" (30.00Hz) appears.

To change the set frequency, perform the operation in above step 3. (Starting from the previously set frequency.)

#### 5. Deceleration → Stop

Press to stop.

The frequency on the display decreases in the Pr. 8 Deceleration time, and the motor stops rotating with "0.00" (0.00Hz) displayed.

#### Display



PU indicator is lit.







Flicker ... Frequency setting complete!!



↓ After 3s, the monitor display appears.





- ? Operation cannot be performed at the set frequency ... Why?
  - ☞ Did you carry out step 4 within 5s after step 3? (Did you press  within 5s after turning  ?)
- ? The frequency does not change by turning  ... Why?
  - ☞ Check to see if the operation mode selected is the External operation mode. (Press  to change to the PU operation mode.)
- ? Operation does not change to the PU operation mode ... Why?
  - ☞ Check that "0" (initial value) is set in *Pr. 79 Operation mode selection*.
  - ☞ Check that the start command is not on.
- ? Change acceleration time ☞ *Pr. 7 (Refer to page 74)*
- ? Change deceleration time ☞ *Pr. 8 (Refer to page 74)*
- ? For example, limit the motor speed to 60Hz maximum. ☞ Set "60Hz" in *Pr. 1. (Refer to page 73)*

**REMARKS**

- Press  to show the set frequency. 
-  can also be used like a potentiometer to perform operation. (*Refer to page 55*)























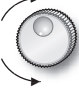







## 4.4.2 Using the setting dial like a potentiometer at the operation

### POINT

Set "0" (extended mode parameter valid) in *Pr. 160 User group read selection*.

Set "1" (setting dial potentiometer mode) in *Pr. 161 Frequency setting/key lock operation selection*.

**Operation example** Change the frequency from 0Hz to 60Hz during operation

| Operation   | Display   |
|---|---|
| <p>1. Screen at power-ON<br/>The monitor display appears.</p>   |   |
| <p>2. Operation mode setting<br/>Press  to choose the PU operation mode.</p>   | <p>PU indicator is lit.</p>   |
| <p>3. Press  to choose the parameter setting mode.</p>   | <p> →  (The parameter number read previously appears.)</p>   |
| <p>4. Turn  until <i>P. 160</i> (<i>Pr. 160</i>) appears.</p>  | <p> → </p>   |
| <p>5. Press  to read the present set value.<br/>"9999" (initial value) appears.</p>  | <p> → </p>   |
| <p>6. Turn  to change it to the setting value of "0".</p>   | <p> → </p>   |
| <p>7. Press  to set.</p>   | <p> → </p> <p style="text-align: center;">↔</p> <p><b>Flicker ... Parameter setting complete!!</b></p> |
| <p>8. Change <i>Pr. 161</i> to the setting value of "1" in the similar manner. (Refer to step 4 to 7.)</p>  | <p> → </p> <p style="text-align: center;">↔</p> <p><b>Flicker ... Parameter setting complete!!</b></p> |
| <p>9. Mode/monitor check<br/>Press  twice to choose monitor/frequency monitor.</p>   | <p> → </p>   |
| <p>10. Start<br/>Press  (or ) to start the inverter.</p>  | <p> → </p>   |
| <p>11. Turn  until "60.00" appears.<br/>The flickering frequency is the set frequency.<br/>You need not press .</p> | <p> → </p> <p style="text-align: center;">The frequency flickers for about 5s.</p>                     |

### REMARKS

- If flickering "60.00" turns to "0.0", the *Pr. 161 Frequency setting/key lock operation selection* setting may not be "1".
- Independently of whether the inverter is running or at a stop, the frequency can be set by simply turning .

### CAUTION

- When using the setting dial, the frequency goes up to the set value of *Pr. 1 Maximum frequency* (In the initial setting, it is 120Hz (55K or lower) or 60Hz (75K or higher) under general-purpose motor control, and it is the maximum motor speed (frequency) under IPM motor control.)  
Adjust *Pr. 1 Maximum frequency* setting according to the application.



### 4.4.3 Setting the frequency by switches (multi-speed setting for 3 speeds)

**POINT**

- Use **FWD** or **REV** on the operation panel (FR-DU07) to give a start command.
- Switch ON the RH, RM, or RL signal to give a frequency command. (Three-speed setting)
- Set "4" (External/PU combination operation mode 2) in Pr. 79 Operation mode selection.

[Connection diagram]

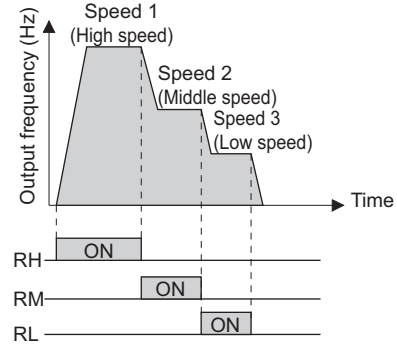
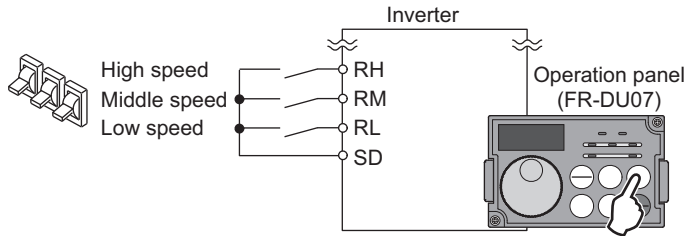

Operation example Operate in low-speed (10Hz)

**Operation**

**Display**

1. Screen at power-ON.

The monitor display appears.



2. Operation mode setting

Set "4" in Pr. 79.

[PU] indicator and [EXT] indicator are lit.

(To change the set value, refer to page 47)



3. Start

Turn ON the low-speed switch (RL).

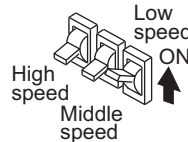

4. Acceleration → constant speed

Press **FWD** or **REV** to start.

The frequency on the display increases in the Pr. 7 Acceleration time, and "10.00" (10.00Hz) appears.



5. Deceleration

Press **STOP/RESET** to stop.

The frequency on the display decreases in the Pr. 8 Deceleration time, and the motor stops rotating with "0.00" (0.00Hz) displayed.



6. Stop

Turn OFF the low-speed switch (RL).

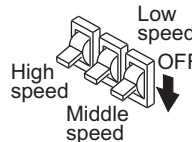



- ? 60Hz for the RH, 30Hz for the RM and 10Hz for the RL are not output when they are turned ON ... Why?
- ☞ Check for the setting of *Pr. 4*, *Pr. 5*, and *Pr. 6* once again.
  - ☞ Check for the setting of *Pr. 1 Maximum frequency* and *Pr. 2 Minimum frequency* once again. (Refer to page 73.)
  - ☞ Check that *Pr. 180 RL terminal function selection* = "0", *Pr. 181 RM terminal function selection* = "1", *Pr. 182 RH terminal function selection* = "2", and *Pr. 59 Remote function selection* = "0". (all are initial values)
- ? [FWD (or REV)] lamp is not lit ... Why?
- ☞ Check that wiring is correct. Check the wiring once again.
  - ☞ Check for the *Pr. 79* setting once again. (*Pr. 79* must be set to "4".) (Refer to page 77.)
- ? Change the frequency of the terminal RL, RM, and RH. ... How?
- ☞ Refer to page 64 to change the running frequency at each terminal in *Pr. 4 Multi-speed setting (high speed)*, *Pr. 5 Multi-speed setting (middle speed)*, and *Pr. 6 Multi-speed setting (low speed)*.

**REMARKS**

- Initial value of terminal RH, RM, and RL are 60Hz, 30Hz, and 10Hz. (To change, set *Pr. 4*, *Pr. 5*, and *Pr. 6*.)
- In the initial setting, when two or more of multi-speed settings are simultaneously selected, priority is given to the set frequency of the lower signal. For example, when RH and RM signals turn ON, RM signal (*Pr. 5*) has a higher priority.
- Maximum of 15-speed operation can be performed. (Refer to Chapter 4 of  the Instruction Manual (Applied).)





### 4.4.4 Setting the frequency by analog input (voltage input)

**POINT**

- Use **FWD** or **REV** on the operation panel (FR-DU07) to give a start command.
- Use the potentiometer (by connecting terminal 2 and 5) to give a frequency command.
- Set "4" (External/PU combination operation mode 2) in *Pr. 79 Operation mode selection*.

[Connection diagram]  
 (The inverter supplies 5V of power to the frequency setting potentiometer.(Terminal 10))

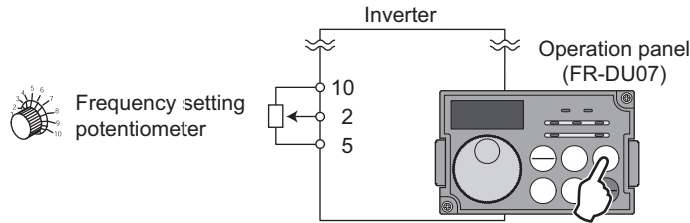

**Operation example** Performing operation at 60Hz.

**Operation**

**Display**

1. Screen at power-ON

The monitor display appears.



2. Operation mode setting

Set "4" in *Pr. 79*.

[PU] indicator and [EXT] indicator are lit.

(To change the set value, refer to page 47)



3. Start

Press **FWD** or **REV**.

[FWD] or [REV] is flickering as no frequency command is given.



Flickering

4. Acceleration → constant speed

Turn the potentiometer (frequency setting potentiometer) clockwise slowly to full.

The frequency value on the display increases according to *Pr. 7*

*Acceleration time* until "60.00"(60Hz) is displayed.



5. Deceleration

Turn the potentiometer (frequency setting potentiometer) counter-clockwise slowly to full. The frequency on the display decreases in the *Pr. 8 Deceleration time*, and the motor stops rotating with

"0.00" (0.00Hz) displayed.

[FWD] indicator or [REV] indicator flickers.



Flickering



6. Stop

Press **STOP/RESET**.



[FWD] indicator or [REV] indicator turns OFF.

? Change the frequency (60Hz) of the maximum value of potentiometer (at 5V)

☞ Adjust the frequency in *Pr. 125 Terminal 2 frequency setting gain frequency*. (Refer to page 67.)

? Change the frequency (0Hz) of the minimum value of potentiometer (at 0V)

☞ Adjust the frequency in *calibration parameter C2 Terminal 2 frequency setting bias frequency*. (Refer to Chapter 4 of the Instruction Manual (Applied).)

### 4.4.5 Setting the frequency by analog input (current input)

**POINT**

- Use **FWD** or **REV** on the operation panel (FR-DU07) to give a start command.
- Use the current signal source (4 to 20mA) (by connecting terminal 4 and 5) to give a frequency command.
- Switch ON the AU signal.
- Set "4" (External/PU combination operation mode 2) in *Pr. 79 Operation mode selection*.

[Connection diagram]

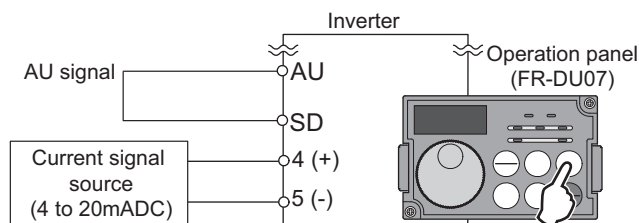

**Operation example** Performing operation at 60Hz.

**Operation**

**Display**

1. Screen at power-ON

The monitor display appears.



2. Operation mode setting

Set "4" in *Pr. 79*.

[PU] indicator and [EXT] indicator are lit.

(To change the set value, refer to page 47)



3. Start

Check that the terminal 4 input selection signal (AU) is ON.

Press **FWD** or **REV**



Flickering

[FWD] or [REV] is flickering as no frequency command is given.

4. Acceleration → constant speed

Perform 20mA input.

The frequency on the display increases in the *Pr. 7 Acceleration time*, and "60.00" (60.00Hz) appears.

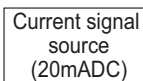

5. Deceleration

Input 4mA or less.

The frequency on the display decreases in the *Pr. 8 Deceleration time*, and the motor stops rotating with "0.00" (0.00Hz) displayed. [FWD] indicator or [EXT] indicator flickers.

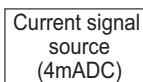

Flickering



6. Stop

Press **STOP/RESET**



[FWD] indicator or [REV] indicator turns OFF.

**REMARKS**

*Pr. 184 AU terminal function selection* must be set to "4" (AU signal) (initial value). (Refer to Chapter 4 of the Instruction Manual (Applied).)

? Change the frequency (60Hz) at the maximum current input (at 20mA, initial value)

Adjust the frequency in *Pr. 126 Terminal 4 frequency setting gain frequency*. (Refer to page 69.)

? Change the frequency (0Hz) at the minimum current input (at 4mA, initial value)

Adjust the frequency in *calibration parameter C5 Terminal 4 frequency setting bias frequency*. (Refer to Chapter 4 of the Instruction Manual (Applied).)



## 4.5 Start/stop using terminals (External operation)

**POINT**

From where is the frequency command given?

- Operation at the frequency set in the frequency setting mode of the operation panel → Refer to 4.5.1 (Refer to page 60)
- Give a frequency command by switch (multi-speed setting) → Refer to 4.5.3 (Refer to page 64)
- Perform frequency setting using voltage input signal → Refer to 4.5.4 (Refer to page 66)
- Perform frequency setting using current input signal → Refer to 4.5.6 (Refer to page 68)

### 4.5.1 Setting the frequency by the operation panel (Pr. 79 = 3)

**POINT**

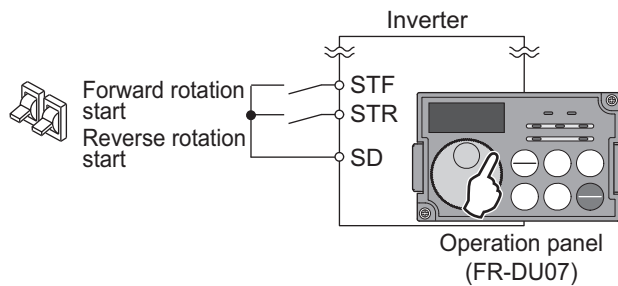

- Switch ON the STF (STR) signal to give a start command.
- Use (  ) on the operation panel (FR-DU07) to give a frequency command.
- Set "3" (External/PU combination operation mode 1) in Pr. 79 Operation mode selection.

[Connection diagram]



Operation example Performing operation at 30Hz.

**Operation**

1. Screen at power-ON  
The monitor display appears.
2. Operation mode setting  
Set "3" in Pr.79.  
[PU] indicator and [EXT] indicator are lit.  
(To change the set value, refer to page 47)
3. Running frequency setting  
Turn  to show the selected frequency, "30.00"  
(30.00Hz). The frequency flickers for about 5s.
4. While the value is flickering, press  to set the frequency.  
  
(If you do not press , the value flickers for about 5s and the display then returns to "0.00" (display) Hz. At this time, return to "Step 8" and set the frequency again.)  
After about 3s of flickering of the value, the display goes back to "0.00" (monitor display).

**Display**



Flicker ... Frequency setting complete!!  
After 3s, the monitor display appears.





Operation

Display

5. Start → acceleration → constant speed

Turn ON the start switch (STF or STR).

The frequency on the display increases in the Pr.7

Acceleration time setting, and "30.00" (30.00Hz) appears.

[FWD] indicator is lit during forward rotation, and [REV] indicator is lit during reverse rotation.



**CAUTION**

When both of STF and STR signals are turned ON, the motor cannot start. If both are turned ON while the motor is running, the motor decelerates to a stop.

6. To change the set frequency, perform the operation in above steps 3 and 4. (Starting from the previously set frequency.)

7. Deceleration → Stop

Turn OFF the start switch (STF or STR).



The frequency on the display decreases in the Pr. 8

Deceleration time, and the motor stops rotating with "0.00" (0.00Hz) displayed.



**REMARKS**

- Pr. 178 STF terminal function selection must be set to "60" (or Pr. 179 STR terminal function selection must be set to "61"). (All are initial values)
- When Pr. 79 Operation mode selection is set to "3", multi-speed operation (refer to page 64) is also valid.

? When the inverter is stopped by  of the operation panel (FR-DU07),  and  are displayed alternately.

1. Turn the start switch (STF or STR) OFF.
2. The display can be reset by .

? When the setting dial is used as a potentiometer.

1. Set Pr.160 User group read selection = "0"(Extended mode parameters valid).
2. Set Pr.161 Frequency setting/key lock operation selection = "1" (setting dial potentiometer). (Refer to page 55.)



### 4.5.2 Switching between the automatic operation and the manual operation (operation by the multi-speed setting and the operation panel) (Pr.79=3)

**POINT**

- Use terminal STF (STR) to give a start command.
- Use terminal RH, RM, and RL to set a frequency (automatic operation) in the normal operation.
- Use the operation panel (FR-DU07) (  ) to set a frequency manually (manual operation) during maintenance, etc.
- Set "3" (External/PU combined operation mode 1) in Pr.79.
- The priority for the frequency setting is "multi-speed setting > operation panel."

[Connection diagram]

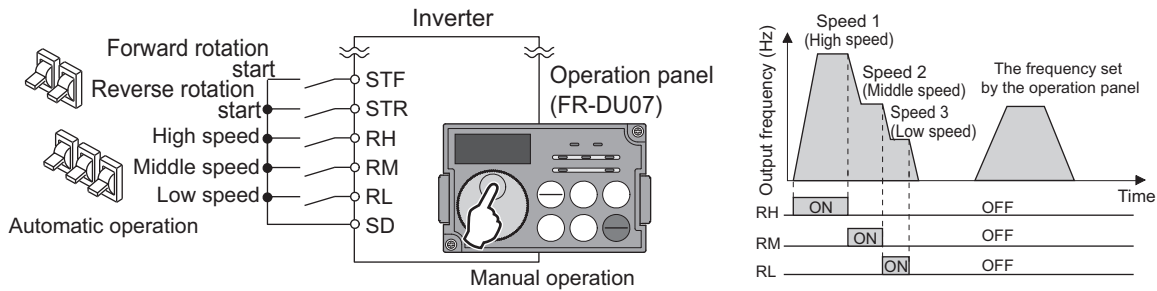

**Operation example**

Operate at the high-speed (60Hz) (automatic operation) in the normal operation. Operate at 30Hz (manual operation) using the operation panel for an adjustment.

**Operation**

- Screen at power-ON**  
The monitor display appears.
- Operation mode setting**  
Set "3" in Pr.79.  
[PU] indicator and [EXT] indicator are lit.  
(To change the set value, refer to page 47.)
- Frequency setting for the automatic operation**  
Turn ON the high-speed switch (RH).
- Start → acceleration → constant speed**  
Turn ON the start switch (STF or STR).  
The frequency on the display increases in the Pr. 7 Acceleration time setting, and "60.00" (60.00Hz) appears.  
[FWD] indicator is lit during the forward rotation and [REV] indicator is lit during the reverse rotation.
  - If RM has been turned ON, 30Hz is displayed. If RL has been turned ON, 10Hz is displayed.

**Display**

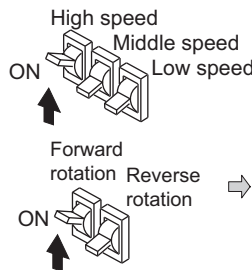

**CAUTION**

When both of STF and STR signals are turned ON, the motor cannot start.  
If both are turned ON while the motor is running, the motor decelerates to a stop.

- Deceleration → stop**  
Turn OFF the start switch (STF or STR).  
The frequency on the display decreases in the Pr. 8 Deceleration time setting, and the motor stops rotating with "0.00" (0.00Hz) displayed.  
[FWD] or [REV] indicator turns OFF.

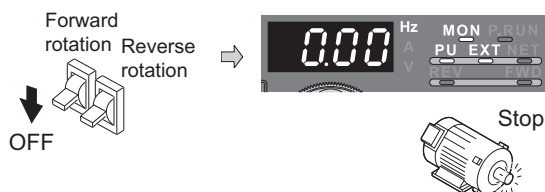



Operation

Display

6. Cancelling the automatic operation

Turn OFF the high-speed switch (RH).

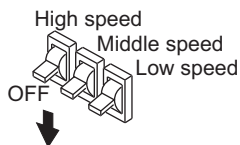

7. Frequency setting in the manual operation

Turn to show the selected frequency, "30.00" (30.00Hz). The frequency flickers for about 5s.



While the value is flickering, press to set the frequency.



(If you do not press , the value flickers for about 5s and the display then returns to "0.00" (0.00Hz in the monitor display). In that case, turn again and set the frequency.)

Flicker... Frequency setting complete!!  
After 3s, the monitor display appears.

The value flickers for about 3s and the display then returns to "0.00" (monitor display).



8. Start → acceleration → constant speed

Turn ON the start switch (STF or STR).

The frequency on the display increases in the Pr. 7 Acceleration time setting, and "30.00" (30.00Hz) appears.

[FWD] indicator is lit during the forward rotation and [REV] indicator is lit during the reverse rotation.

To change the set frequency, perform the operation in above "Step 7"(starting from the previously set frequency).

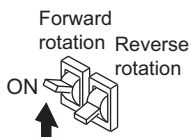

9. Deceleration → stop

Turn OFF the start switch (STF or STR).

The frequency on the display decreases in the Pr. 8 Deceleration time setting, and the motor stops rotating with "0.00" (0.00Hz) displayed.

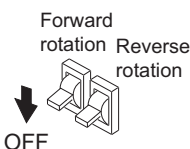

REMARKS

- Pr. 178 STF terminal function selection must be set to "60" (or Pr. 179 STR terminal function selection must be set to "61"). (All are initial values.)
- External analog current input (4 to 20mA) can be used to set a frequency instead of the three-speed setting. Turn ON the terminal 4 input selection signal (AU) to use the analog current input.

? When the inverter is stopped by of the operation panel (FR-DU07), ↔ are displayed alternately.

1. Turn OFF the start switch (STF or STR).

2. The display can be reset by .



### 4.5.3 Setting the frequency by switches (multi-speed setting for 3 speeds) (Pr.4 to Pr.6)

**POINT**

- Switch ON the STF (STR) signal to give a start command.
- Switch ON the RH, RM, or RL signal to give a frequency command.
- [EXT] must be lit. (When [PU] is lit, switch it to [EXT] with  $\frac{PU}{EXT}$ .)
- The initial values of the terminals RH, RM, and RL are 60Hz, 30Hz, and 10Hz. (Use Pr. 4, Pr. 5 and Pr. 6 to change.)
- Operation at 7-speed can be performed by turning two (or three) terminals simultaneously. (Refer to Chapter 4 of the Instruction Manual (Applied).)

[Connection diagram]

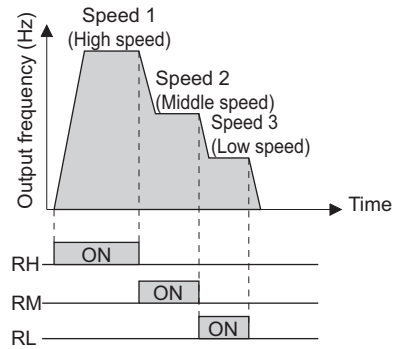
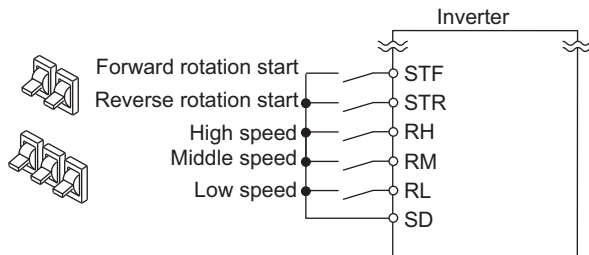

**Changing example** Operation at high speed (60Hz).

**Operation**

1. Screen at power-ON

The monitor display appears.

2. Start

Turn ON the high-speed switch (RH).

3. Acceleration → constant speed

Turn ON the start switch (STF or STR). The frequency on the display increases in the Pr. 7 Acceleration time, and "60.00" (60.00Hz) appears.

[FWD] indicator is lit during forward rotation, and [REV] indicator is lit during reverse rotation.

- When RM is turned ON, 30Hz is displayed. When RL is turned ON, 10Hz is displayed.

**CAUTION**

When both of STF and STR signals are turned ON, the motor cannot start.

If both are turned ON while the motor is running, the motor decelerates to a stop.

4. Deceleration

Turn OFF the start switch (STF or STR).

The frequency on the display decreases in the Pr. 8 Deceleration time, and the motor stops rotating with "0.00" (0.00Hz) displayed.

[FWD] indicator or [REV] indicator turns OFF.

5. Stop

Turn OFF the high-speed switch (RH).

**Display**





? [EXT] is not lit even when  is pressed ... Why?

 Switchover of the operation mode with  is valid when *Pr. 79* = "0" (initial value).

? 60Hz, 30Hz and 10Hz are not output from RH, RM and RL respectively when they are turned ON. ... Why?

 Check for the setting of *Pr. 4*, *Pr. 5*, and *Pr. 6* once again.

 Check for the setting of *Pr. 1 Maximum frequency* and *Pr. 2 Minimum frequency* once again. (Refer to page 73)

 Check for the *Pr. 79* setting once again. (*Pr. 79* must be set to "0" or "2".) (Refer to page 77)



 Check that *Pr. 180 RL terminal function selection* = "0", *Pr. 181 RM terminal function selection* = "1", *Pr. 182 RH terminal function selection* = "2" and *Pr. 59 Remote function selection* = "0". (all are initial values)

? [FWD (or REV)] is not lit. ... Why?



 Check that wiring is correct. Check it again.

 Check that "60" is set in *Pr. 178 STF terminal function selection* (or "61" is set in *Pr. 179 STR terminal function selection*)?  
(all are initial values)

? How is the frequency setting from 4 to 7 speed ?

 In the initial setting, when two or more of multi-speed settings are simultaneously selected, priority is given to the set frequency of the lower signal. For example, when RH and RM signals turn ON, the RM signal (*Pr. 5*) has a higher priority. By setting *Pr. 24* to *Pr. 27* (multi-speed setting), up to 7- speed can be set by combinations of RH, RM, and RL signals. Refer to Chapter 4 of  the Instruction Manual (Applied).

? Perform multi-speed operation more than 8 speed. ... How?

 Use the REX signal to perform the operation. Maximum of 15-speed operation can be performed.  
Refer to Chapter 4 of  the Instruction Manual (Applied).

#### REMARKS

- External operation is fixed by setting "2" (External operation mode) in *Pr. 79 Operation mode selection* when you do not want to take time pressing  or when you want to use the current start command and frequency command. (Refer to page 77)





### 4.5.4 Setting the frequency by analog input (voltage input)

**POINT**

- Switch ON the STF (STR) signal to give a start command.
- Use the potentiometer (by connecting terminal 2 and 5 (voltage input)) to give a frequency command.

[Connection diagram]

(The inverter supplies 5V of power to frequency setting potentiometer. (Terminal 10))

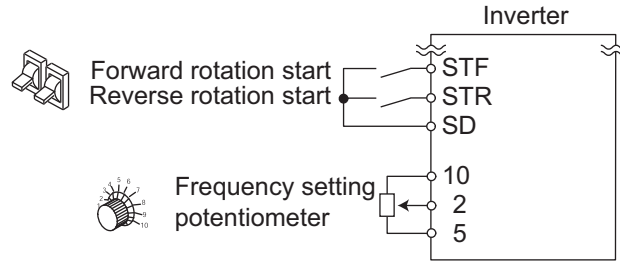

Operation example Performing operation at 60Hz.

**Operation**

1. Screen at power-ON

The monitor display appears.

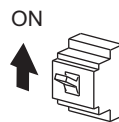

2. Start

Turn the start switch (STF or STR) ON.  
[FWD] or [REV] is flickering as no frequency command is given.

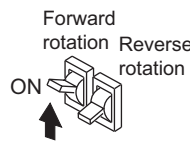

Flickering

**CAUTION**

When both of STF and STR signals are turned ON, the motor cannot start.  
If both are turned ON while the motor is running, the motor decelerates to a stop.

3. Acceleration → constant speed

Turn the potentiometer (frequency setting potentiometer) clockwise slowly to full.  
The frequency on the display increases in the *Pr. 7 Acceleration time*, and "60.00" (60.00Hz) appears. [FWD] indicator is lit during forward rotation, and [REV] indicator is lit during reverse rotation.



4. Deceleration

Turn the potentiometer (frequency setting potentiometer) counterclockwise slowly to full.  
The frequency on the display decreases in the *Pr. 8 Deceleration time*, and the motor stops rotating with "0.00" (0.00Hz) displayed. [FWD] indicator or [EXT] indicator flickers.



Flickering



5. Stop

Turn the start switch (STF or STR) OFF.  
[FWD] indicator or [REV] indicator turns OFF.

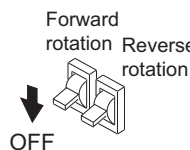

**REMARKS**

*Pr. 178 STF terminal function selection* must be set to "60" (or *Pr. 179 STR terminal function selection* must be set to "61").  
(All are initial values.)



? The motor will not rotate ... Why?

☞ Check that [EXT] is lit.  
[EXT] is valid when Pr. 79 = "0" (initial value).

Use to lit [EXT].

☞ Check that wiring is correct. Check once again.

? Change the frequency (0Hz) of the minimum value of potentiometer (at 0V)

☞ Adjust the frequency in calibration parameter C2 Terminal 2 frequency setting bias frequency. (Refer to

Chapter 4 of the Instruction Manual (Applied).)



When you want to compensate frequency setting, use terminal 1.  
For details, refer to Chapter 4 of the Instruction Manual (Applied).

### 4.5.5 Changing the output frequency (60Hz, initial value) at the maximum voltage input (5V, initial value)

#### <How to change the maximum frequency>

##### Changing example

When you use the 0 to 5VDC input to change frequency at 5V from 60Hz (initial value) to 50Hz, set "50Hz" in Pr. 125.

#### Operation

1. Turn until P. 125 (Pr. 125) appears.

2. Press to show the present set value.  
" 6000 " (60.00Hz)

3. Turn to change the set value  
to "5000". (50.00Hz)

4. Press to set.

5. Mode/monitor check

Press twice to choose the monitor/frequency monitor.

6. To check the setting, turn the start switch (STF or STR) ON  
and input 5V (turn the potentiometer clockwise slowly to full.)  
(Refer to 4.5.4 steps 2 to 5)

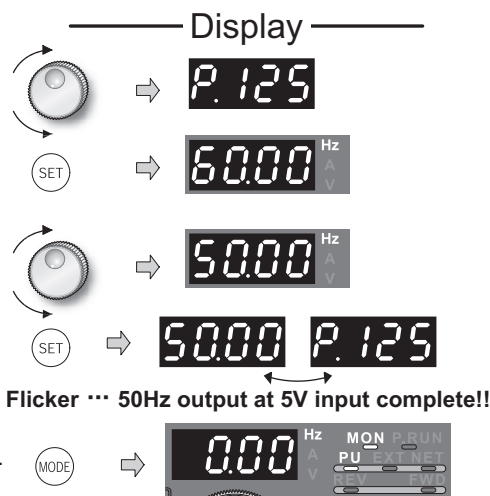

? The monitor on the operation panel or the frequency meter (indicator) connected across terminals FM and SD does not indicate exactly 50Hz... Why?

☞ The indicated value can be adjusted by the calibration parameter C4 Terminal 2 frequency setting gain (Refer to Chapter 4 of the Instruction Manual (Applied).)

☞ The frequency meter (indicator) connected across terminals FM and SD can be adjusted by the calibration parameter C0 FM terminal calibration.

(Refer to Chapter 4 of the Instruction Manual (Applied).)

? Set frequency at 0V using calibration parameter C2.

(Refer to Chapter 4 of the Instruction Manual (Applied).)

? How can I operate at a frequency higher than 120Hz.

☞ Additionally set Pr.18 High speed maximum frequency.

(Refer to Chapter 4 of the Instruction Manual (Applied).)

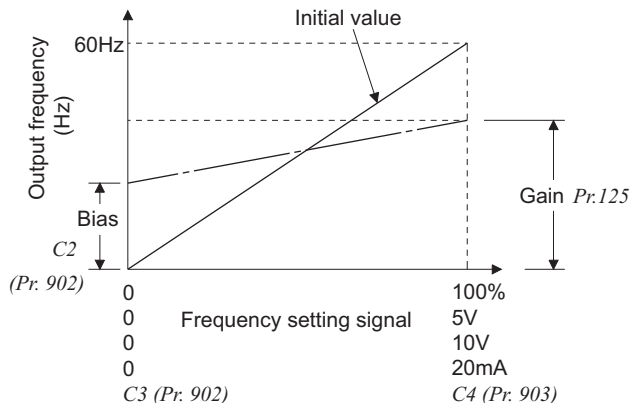

#### REMARKS

As other adjustment methods of frequency setting voltage gain, there are methods to adjust with a voltage applied across terminals 2 or 5 and adjust at any point without a voltage applied.

(Refer to Chapter 4 of the Instruction Manual (Applied).)



### 4.5.6 Setting the frequency by analog input (current input)

**POINT**

- Switch ON the STF (STR) signal to give a start command.
- Switch ON the AU signal.
- Set "2" (External operation mode) in Pr. 79 Operation mode selection.

[Connection diagram]

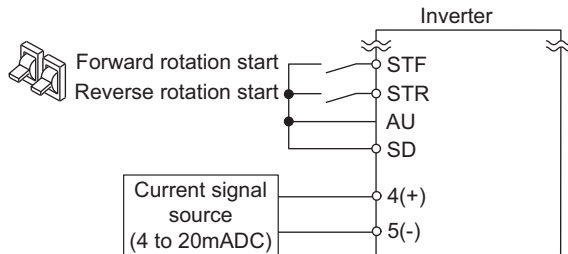

Operation example Performing operation at 60Hz.

**Operation**

**Display**

1. Screen at power-ON

The monitor display appears.

ON

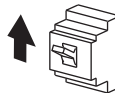

2. Start

Check that the terminal 4 input selection signal (AU) is ON.  
Turn the start switch (STF or STR) ON.  
[FWD] or [REV] is flickering as no frequency

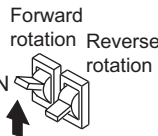

Flickering

**CAUTION**

When both of STF and STR signals are turned ON, the motor cannot start.  
If both are turned ON while the motor is running, the motor decelerates to a stop.

3. Acceleration → constant speed

Perform 20mA input.  
The frequency on the display increases in the Pr.7 Acceleration time, and "60.00" (60.00Hz) appears.  
[FWD] indicator is lit during forward rotation, and [REV] indicator is lit during reverse rotation.

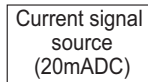

4. Deceleration

Input 4mA or less.  
The frequency on the display decreases in the Pr. 8 Deceleration time setting, and the motor stops rotating with "0.00" (0.00Hz) displayed.  
[FWD] indicator or [EXT] indicator flickers.

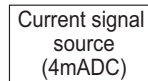

Flickering



5. Stop

Turn the start switch (STF or STR) OFF.  
[FWD] indicator or [REV] indicator turns OFF.

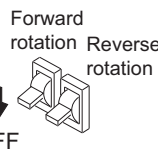

OFF

**REMARKS**

Pr. 184 AU terminal function selection must be set to "4" (AU signal) (initial value). (Refer to Chapter 4 of the Instruction Manual (Applied).)



? The motor will not rotate ... Why?

☞ Check that [EXT] is lit.  
[EXT] is valid when Pr. 79 = "0" (initial value).

Use to lit [EXT].

☞ Check that the AU signal is ON.  
Turn the AU signal ON.

☞ Check that wiring is correct. Check it again.

? Change the frequency (0Hz) of the minimum value of potentiometer (at 4mA)

☞ Adjust the frequency in calibration parameter C5 Terminal 4 frequency setting bias frequency.

(Refer to Chapter 4 of the Instruction Manual (Applied).)

### 4.5.7 Changing the output frequency (60Hz, initial value) at the maximum current input (at 20mA, initial value)

#### <How to change the maximum frequency>

**Changing example** When you use the 4 to 20mA input and want to change the frequency at 20mA from 60Hz (initial value) to 50Hz, set "50Hz" in Pr. 126.

| Operation  | Display   |
|--|---|
| 1. Turn  until P. 126 (Pr. 126) appears.   |   |
| 2. Press  to show the present set value.<br>"6000"(60.00Hz)  |   |
| 3. Turn  to change the set value to "5000".<br>(50.00Hz)   |   |
| 4. Press  to set the value.  |   |
| 5. Mode/monitor check<br>Press  twice to choose the monitor/frequency monitor.                               |   |
| 6. To check the setting, turn the start switch (STF or STR) on and input 20mA. (Refer to 4.5.6 steps 2 to 5) | <b>Flicker ... 50Hz output at 20mA input complete!!</b> |

? The frequency meter (indicator) connected across terminals FM and SD does not indicate exactly 50Hz ... Why?

☞ The indicated value can be adjusted by the calibration parameter C7 Terminal 4 frequency setting gain (Refer to Chapter 4 of the Instruction Manual (Applied).)

☞ The frequency meter (indicator) connected across terminals FM and SD can be adjusted by the calibration parameter C0 FM terminal calibration.

(Refer to Chapter 4 of the Instruction Manual (Applied).)

? Set frequency at 4mA using calibration parameter C5.

(Refer to Chapter 4 of the Instruction Manual (Applied).)

? How can I operate at a frequency higher than 120Hz.

☞ Additionally set Pr.18 High speed maximum frequency.

(Refer to Chapter 4 of the Instruction Manual (Applied).)

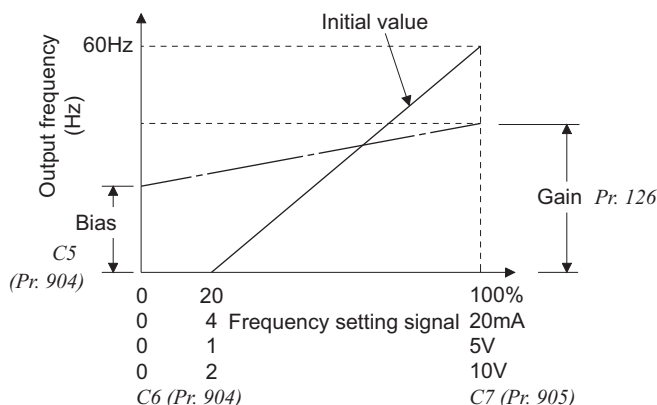

#### REMARKS

As other adjustment methods of frequency setting voltage gain, there are methods to adjust with a voltage applied across terminals 4 and 5 or adjust at any point without a voltage applied.

(Refer to Chapter 4 of the Instruction Manual (Applied) for the setting method of calibration parameter C7.)

# 5 ADJUSTMENT





## 5.1 Simple mode parameter list

For simple variable-speed operation of the inverter, the initial setting of the parameters may be used as they are. Set the necessary parameters to meet the load and operational specifications. Parameter setting, change and check can be made from the operation panel (FR-DU07). For details of parameters, refer to *Chapter 4 of  the Instruction Manual (Applied).*

### POINT

Only simple mode parameters are displayed by the initial setting of *Pr. 160 User group read selection*. Set *Pr. 160 User group read selection* as required. (Refer to page 50 for parameter change.)

| Pr. 160                 | Description  |
|-------------------------|--|
| 9999<br>(Initial Value) | Only the simple mode parameters can be displayed.                  |
| 0                       | Simple mode and extended mode parameters can be displayed.         |
| 1                       | Only the parameters registered in the user group can be displayed. |

| Parameter Number  | Name  | Increments       | Initial Value                | Range                      | Applications   | Refer to |
|---|---|------------------|------------------------------|----------------------------|--|----------|
| 0<br>  | Torque boost                                | 0.1%             | 6/4/3/2/<br>1.5/1%<br>*1     | 0 to 30%                   | Set to increase a starting torque or when the motor with a load will not rotate, resulting in an alarm [OL] and a trip [OC1] | 72       |
| 1   | Maximum frequency                           | 0.01Hz           | 120/<br>60Hz *2,<br>*3       | 0 to 120Hz                 | Set when the maximum output frequency need to be limited.  | 73       |
| 2   | Minimum frequency                           | 0.01Hz           | 0Hz                          | 0 to 120Hz                 | Set when the minimum output frequency need to be limited.  |          |
| 3<br><br> | Base frequency                              | 0.01Hz           | 60Hz                         | 0 to 400Hz                 | Set when the rated motor frequency is 50Hz. Check the motor rating plate.  | 52       |
| 4   | Multi-speed setting (high speed)            | 0.01Hz           | 60Hz *3                      | 0 to 400Hz                 | Set when changing the preset speed in the parameter with a terminal.   | 64       |
| 5   | Multi-speed setting (middle speed)          | 0.01Hz           | 30Hz                         | 0 to 400Hz                 |  |          |
| 6   | Multi-speed setting (low speed)             | 0.01Hz           | 10Hz                         | 0 to 400Hz                 |  |          |
| 7   | Acceleration time                           | 0.1s             | 5/15s *4                     | 0 to 3600s                 | Acceleration/deceleration time can be set.   | 74       |
| 8   | Deceleration time                           | 0.1s             | 10/30s *4                    | 0 to 3600s                 |  |          |
| 9   | Electronic thermal O/L relay                | 0.01/<br>0.1A *5 | Rated inverter current<br>*3 | 0 to 500/<br>0 to 3600A *5 | Protect the motor from overheat by the inverter. Set the rated motor current.  | 51       |
| 60<br>   | Energy saving control selection             | 1                | 0                            | 0, 4, 9                    | The inverter output voltage is minimized when using for fan and pump applications.   | 75       |
| 79  | Operation mode selection                    | 1                | 0                            | 0, 1, 2, 3, 4, 6, 7        | Select the start command location and frequency setting location.  | 77       |
| 125   | Terminal 2 frequency setting gain frequency | 0.01Hz           | 60Hz *3                      | 0 to 400Hz                 | Frequency for the maximum value of the potentiometer (at 5V) can be changed.   | 67       |
| 126   | Terminal 4 frequency setting gain frequency | 0.01Hz           | 60Hz *3                      | 0 to 400Hz                 | Frequency at 20mA input can be changed.  | 69       |
| 160   | User group read selection                   | 1                | 9999                         | 0, 1, 9999                 | Make extended parameters valid   | —        |



| Parameter Number | Name                         | Increments | Initial Value | Range                        | Applications  | Refer to |
|------------------|------------------------------|------------|---------------|------------------------------|---|----------|
| 998              | IPM parameter initialization | 1          | 0             | 0, 1, 12, 101, 112           | By performing IPM parameter initialization, IPM motor control is selected and the parameters, which are required to drive an IPM motor, are changed.  | 42       |
|                  |                              |            |               | 22, 32, 122, 132             | For manufacturer setting. (Do not set.)   |          |
| 999              | Automatic parameter setting  | 1          | 9999          | 10, 11, 20, 21, 30, 31, 9999 | Parameter settings are changed as a batch. Those include communication parameter settings for a Mitsubishi human machine interface (GOT) connection, rated frequency settings of 50Hz/60Hz, and acceleration/ deceleration time increment settings. | 114      |

\*1 Initial values differ according to the inverter capacity. (0.75K/1.5K to 3.7K/5.5K, 7.5K/11K to 37K/45K, 55K/75K or higher)

\*2 Initial values differ according to the inverter capacity. (55K or lower/75K or higher)

\*3 Performing IPM parameter initialization changes the settings. (Refer to page 42)

\*4 Initial values differ according to the inverter capacity. (7.5K or lower/11K or higher)

\*5 Setting increments and setting range differ according to the inverter capacity. (55K or lower/75K or higher)



## 5.2 Increasing the starting torque (Pr. 0) V/F

Set this parameter when "the motor with a load will not rotate", "an alarm [OL] is output, resulting in an inverter trip due to [OC1], etc.

| Parameter Number | Name         | Initial Value |      | Setting Range | Description  |
|------------------|--------------|---------------|------|---------------|--|
| 0                | Torque boost | 0.75K         | 6%   | 0 to 30%      | Motor torque in the low-frequency range can be adjusted to the load to increase the starting motor torque. |
|                  |              | 1.5K to 3.7K  | 4%   |               |  |
|                  |              | 5.5K, 7.5K    | 3%   |               |  |
|                  |              | 11K to 37K    | 2%   |               |  |
|                  |              | 45K, 55K      | 1.5% |               |  |
|                  |              | 75K or higher | 1%   |               |  |

**Changing example** When the motor with a load will not rotate, increase the Pr. 0 value 1% by 1% unit by looking at the motor movement. (The guideline is for about 10% change at the greatest.)

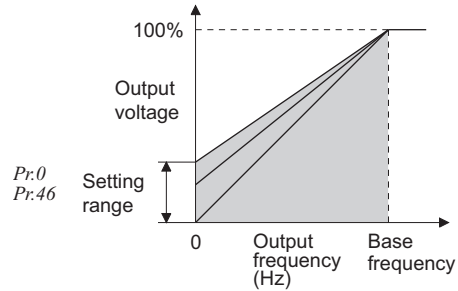

### Operation

#### 1. Screen at power-ON

The monitor display appears.

### Display



#### 2. Operation mode setting

Press PU  
EXT to choose the PU operation mode.



PU indicator is lit.



#### 3. Press MODE to choose the parameter setting mode.



P. 0 (The parameter number read previously appears.)

#### 4. Turn ◀ ▶ until P. 0 (Pr. 0) appears.



#### 5. Press SET to read the present set value. "6.0" (initial value is 6% for the 0.75K) appears.



6.0 (The initial value differs according to the capacity.)

#### 6. Turn ◀ ▶ to change it to the set value "7.0".



#### 7. Press SET to set.



**Flicker ... Parameter setting complete!!**

- By turning ◀ ▶, you can read another parameter.
- Press SET to show the setting again.
- Press SET twice to show the next parameter.

### REMARKS

- Setting Pr.0 too high may cause the motor to overheat, resulting in an overcurrent trip (OL (overcurrent alarm) then E.OC1 (Overcurrent trip during acceleration)), thermal trip (E.THM (Motor overload trip), and E.THT (Inverter overload trip)). When a fault (E.OC1) occurs, release the start command, and decrease the Pr. 0 value 1% by 1% to reset. (Refer to page 121.)

### POINT

If the inverter still does not operate properly after taking the above measures, set Pr. 80 Motor capacity and select the Simple magnetic flux vector control [extended mode]. (Refer to Chapter 4 of the Instruction Manual (Applied).)

## 5.3 Limiting the maximum and minimum output frequency (Pr. 1, Pr. 2)

| Parameter Number | Name              | Initial Value |        | Setting Range | Description                                  |
|------------------|-------------------|---------------|--------|---------------|--|
| 1                | Maximum frequency | 55K or lower  | 120Hz* | 0 to 120Hz    | Set the upper limit of the output frequency. |
|                  |                   | 75K or higher | 60Hz*  |               |  |
| 2                | Minimum frequency | 0Hz           |        | 0 to 120Hz    | Set the lower limit of the output frequency. |

\* Performing IPM parameter initialization changes the settings. (Refer to page 42)

**Changing example** Limit the frequency set by the potentiometer, etc. to 60Hz maximum.  
(Set "60"Hz in Pr. 1 Maximum frequency.)

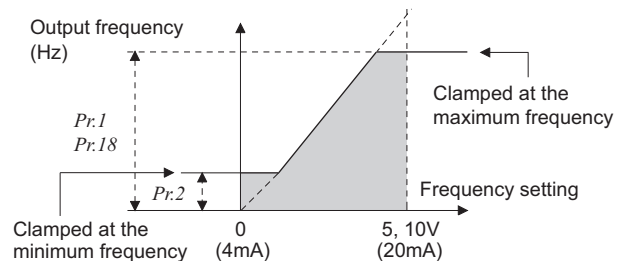

### Operation

1. Screen at power-ON  
The monitor display appears.
2. Operation mode setting  
Press **PU/EXT** to choose the PU operation mode.
3. Press **MODE** to choose the parameter setting mode.
4. Turn **⌚** until **P. 1** (Pr. 1) appears.
5. Press **SET** to read the present set value.  
"1200"(initial value) appears.
6. Turn **⌚** to change it to the set value "6000".
7. Press **SET** to set.

### Display

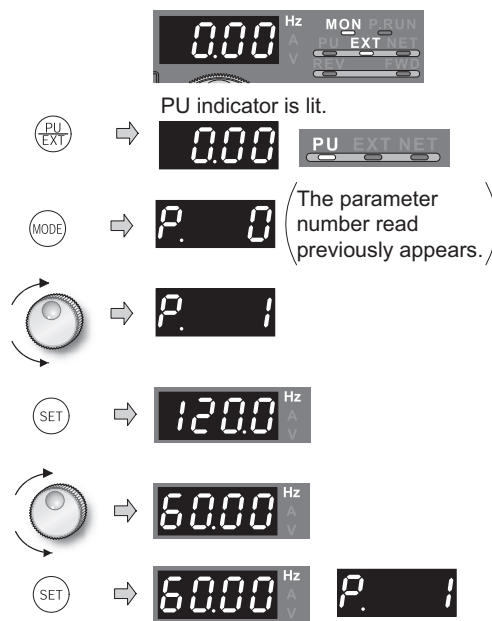

**Flicker ... Parameter setting complete!!**

- By turning **⌚**, you can read another parameter.
- Press **SET** to show the setting again.
- Press **SET** twice to show the next parameter.

### REMARKS

- The output frequency is clamped by the Pr. 2 setting even if the set frequency is lower than the Pr. 2 setting (The frequency will not decrease to the Pr. 2 setting.)  
Note that Pr. 15 Jog frequency has higher priority than the minimum frequency.
- When the Pr. 1 setting is changed, frequency higher than the Pr. 1 setting cannot be set by **⌚**.
- When performing a high speed operation at 120Hz or more, setting of Pr. 18 High speed maximum frequency is necessary. Even if a value higher than the maximum frequency (refer to page 44) is set in Pr.18 under IPM motor control, the high speed maximum frequency is limited to the maximum motor frequency. (Refer to Chapter 4 of *the Instruction Manual (Applied)*.)

## ⚠ CAUTION

⚠ If the Pr. 2 setting is higher than the Pr. 13 Starting frequency value, note that the motor will run at the set frequency according to the acceleration time setting by merely switching the start signal ON, without entry of the command frequency.





## 5.4 Changing acceleration and deceleration time (Pr. 7, Pr. 8)

Set in Pr. 7 Acceleration time a larger value for a slower speed increase and a smaller value for a faster speed increase.  
Set in Pr. 8 Deceleration time a larger value for a slower speed decrease and a smaller value for a faster speed decrease.

| Parameter Number | Name              | Initial Value |     | Setting Range        | Description                      |
|------------------|-------------------|---------------|-----|----------------------|----------------------------------|
| 7                | Acceleration time | 7.5K or lower | 5s  | 0 to 3600/<br>360s * | Set the motor acceleration time. |
|                  |                   | 11K or higher | 15s |                      |                                  |
| 8                | Deceleration time | 7.5K or lower | 10s | 0 to 3600/<br>360s * | Set the motor deceleration time. |
|                  |                   | 11K or higher | 30s |                      |                                  |

\* Depends on the Pr. 21 Acceleration/deceleration time increments setting. The initial value for the setting range is "0 to 3600s" and setting increments is "0.1s".

**Changing example** Change the Pr. 7 Acceleration time setting from "5s" to "10s".

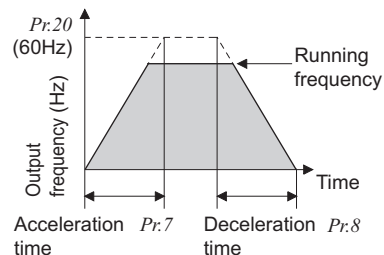

### Operation

- Screen at power-ON  
The monitor display appears.
- Operation mode setting  
Press **PU/EXT** to choose the PU operation mode.
- Press **MODE** to choose the parameter setting mode.
- Turn **▲** until **P. 7** (Pr. 7) appears.
- Press **SET** to read the present set value.  
"5.0"(initial value) appears.
- Turn **▲** to change it to the set value "10.0".
- Press **SET** to set.

### Display

**Flicker ... Parameter setting complete!!**

- By turning **▲**, you can read another parameter.
- Press **SET** to show the setting again.
- Press **SET** twice to show the next parameter.

### POINT

If torque is required in the low-speed range (less than 10% of the rated motor frequency (on page 43)) under IPM motor control, set the Pr.791 Acceleration time in low-speed range and Pr.792 Deceleration time in low-speed range settings higher than the Pr.7 and Pr.8 settings so that the mild acceleration/deceleration is performed only in the low-speed range. (Refer to the Instruction Manual (Applied) for Pr.791 and Pr.792)

## 5.5 Energy saving operation for fans and pumps (Pr.14, Pr.60)

V/F

Set the following functions to perform energy saving operation for fans and pumps.

### 5.5.1 Load pattern selection (Pr. 14) V/F

Select the optimum output characteristic (V/F characteristic) that is suitable for the application and load characteristics.

| Parameter Number | Name                   | Initial Value | Setting Range | Description              |
|------------------|------------------------|---------------|---------------|--------------------------|
| 14               | Load pattern selection | 1             | 0             | For constant torque load |
|                  |                        |               | 1             | For variable-torque load |

The above parameters can be set when Pr.160 User group read selection = "0." (Refer to page 70)

- Set Pr.14 Load pattern selection = "1 (for variable-torque load) (initial value)."
- When the output frequency is equal to or less than the base frequency, the output voltage changes by its square in proportion to the output frequency. Use this setting to drive a load whose load torque changes in proportion to the square of the speed, such as a fan and a pump.

Pr.14 = 1

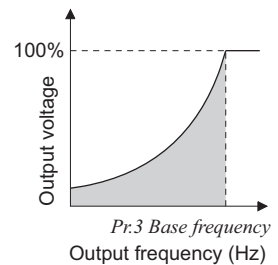

#### CAUTION

- Load pattern selection is available only under V/F control. Load pattern selection is not available under Simple magnetic flux vector control and IPM motor control.

### 5.5.2 Energy saving control (Pr.60) V/F

Without a detailed parameter setting, the inverter can automatically perform energy saving operation.

This operation is appropriate for fan and pump applications.

Use Optimum excitation control when connecting one motor to one inverter. Use Energy saving operation when connecting several motors to one inverter.

| Parameter Number | Name                            | Initial Value | Setting Range | Remarks                    |
|------------------|---------------------------------|---------------|---------------|----------------------------|
| 60               | Energy saving control selection | 0             | 0             | Normal operation           |
|                  |                                 |               | 4             | Energy saving operation    |
|                  |                                 |               | 9             | Optimum excitation control |

#### (1) Energy saving operation (setting "4")

- When "4" is set in Pr. 60, the inverter performs the energy saving operation.
- In the energy saving operation, the inverter automatically controls the output voltage to minimize the inverter output voltage during a constant operation.

#### REMARKS

- For applications where a large load torque is applied to or machines repeat frequent acceleration/deceleration, an energy saving effect is not expected.

#### (2) Optimum excitation control (setting "9")

- When "9" is set in Pr. 60, the inverter performs the Optimum excitation control.
- The Optimum excitation control is a control method which controls excitation current to improve the motor efficiency to maximum and determines output voltage as an energy saving method.

#### REMARKS

- When the motor capacity is too small as compared to the inverter capacity or two or more motors are connected to one inverter, the energy saving effect is not expected.



**CAUTION**

- When the energy saving operation and Optimum excitation control are selected, deceleration time may be longer than the setting value. Since overvoltage alarm tends to occur as compared to the constant-torque load characteristics, set a longer deceleration time.
- The energy saving operation and Optimum excitation control are available only under V/F control. Energy saving operation and Optimum excitation control are not available under Simple magnetic flux vector control and IPM motor control. (For Simple magnetic flux vector control, refer to Chapter 4 of the Instruction Manual (Applied).)

**POINT**

To check the energy saving effect, refer to Chapter 4 of the Instruction Manual (Applied) and check the energy saving effect monitor.

**Changing example** Set "9" (Optimum excitation control) in Pr. 60 Energy saving control selection.

**Operation**

**Display**

1. Screen at power-ON

The monitor display appears.



2. Operation mode setting

Press to choose the PU operation mode.

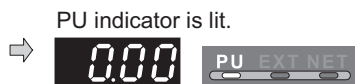

3. Press to choose the parameter setting mode.

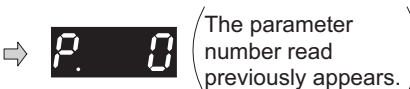

4. Turn until P. 60 (Pr. 60) appears.



5. Press to read the present set value. "0" (initial value) appears.



6. Turn to change it to the set value "9".



7. Press to set.



**Flicker ... Parameter setting complete!!**

8. Perform normal operation.

When you want to check the energy saving effect, refer to Chapter 4 of the Instruction Manual (Applied) to check the energy saving effect monitor.

- By turning , you can read another parameter.
- Press to show the setting again.
- Press twice to show the next parameter.

















## 5.6 Selection of the start command and frequency command sources (Pr. 79)

Select the start command source and frequency command source.

### POINT

Setting value "1" to "4" can be changed in the easy setting mode. (Refer to page 47)

| Parameter Number | Name                     | Initial Value | Setting Range |
|------------------|--------------------------|---------------|---------------|
| 79               | Operation mode selection | 0             | 0 to 4, 6, 7  |

| Pr.79 Setting | Description  |   |   | LED Indication<br>☐: OFF<br>☐: ON   | Refer to                                      |
|---------------|--|---|---|---|---|
| 0             | External/PU switchover mode (press  to switch between the PU and External operation mode.)<br>At power ON, the inverter is in the External operation mode.                  |   |   | PU operation mode<br><br>External operation mode<br><br>NET operation mode<br>       | Chapter 4 of the Instruction Manual (Applied) |
| 1             | <b>Operation mode</b>  | <b>Frequency command</b>  | <b>Start command</b>  | PU operation mode<br>  | Chapter 4 of the Instruction Manual (Applied) |
|               | PU operation mode (fixed)  | Setting by the operation panel (FR-DU07) and PU (FR-PU04/FR-PU07)   | Input by  and  on PU (FR-DU07/FR-PU04/FR-PU07)     |   |   |
| 2             | External operation mode (fixed)<br>The operation can be performed by switching between the External and NET operation modes.   | External signal input (from terminal 2, 4, and 1, JOG, multi-speed selection, etc.)   | External signal input (from terminal STF and STR)   | External operation mode<br><br>NET operation mode<br>   | Chapter 4 of the Instruction Manual (Applied) |
| 3             | External/PU combined operation mode 1  | PU (FR-DU07/FR-PU04/FR-PU07) setting or external signal input (multi-speed setting, across terminals 4 and 5 (valid when AU signal turns ON)). *1 | External signal input (from terminal STF and STR)   | External/PU combined operation mode<br>  | Chapter 4 of the Instruction Manual (Applied) |
| 4             | External/PU combined operation mode 2  | External signal input (Terminal 2, 4, 1, JOG, multi-speed selection, etc.)  | Input by  and  on PU (FR-DU07/FR-PU04/FR-PU07) |   | Chapter 4 of the Instruction Manual (Applied) |
| 6             | Switchover mode<br>Switch among PU operation, External operating, and NET operation while keeping the same operating status.   |   |   | PU operation mode<br><br>External operation mode<br><br>NET operation mode<br> | Chapter 4 of the Instruction Manual (Applied) |
| 7             | External operation mode (PU operation interlock)<br>X12 signal ON *2<br>Operation mode can be switched to the PU operation mode. (output stop during external operation)<br>X12 signal OFF *2<br>Operation mode cannot be switched to the PU operation mode. |   |   | External operation mode<br><br>NET operation mode<br>   | Chapter 4 of the Instruction Manual (Applied) |

\*1 The priorities of the frequency commands when Pr. 79 = "3" are "Multi-speed operation (RL/RM/RH/REX) > PID control (X14) > terminal 4 analog input (AU) > digital input from the operation panel".

\*2 For the terminal used for the X12 signal (PU operation interlock signal) input, set "12" in Pr. 178 to Pr. 189 (input terminal function selection) to assign functions. For Pr. 178 to Pr. 189, refer to Chapter 4 of  the Instruction Manual (Applied).  
When the X12 signal is not assigned, function of the MRS signal switches from MRS (output stop) to PU operation interlock signal.

### REMARKS

If switching of the operation mode is invalid even though Pr.79 is set, refer to page 137.

## 5.7 Parameter clear, all parameter clear

### POINT

- Set "1" in Pr: CL parameter clear, ALLC All parameter clear to initialize parameters. (Parameters are not cleared when "1" is set in Pr: 77 Parameter write selection.)
- Refer to the parameter list on page 86 for the parameters to be cleared with this operation.

### Operation

#### 1. Screen at power-ON

The monitor display appears.

#### 2. Operation mode setting

Press  to choose the PU operation mode.

#### 3. Press to choose the parameter setting mode.

#### 4. Turn until "Pr.CL", "ALLC" appears.

#### 5. Press to read the currently set value. "0" (initial value) appears.

#### 6. Turn to change it to the setting value "1".

#### 7. Press to set.

### Display



PU indicator is lit.

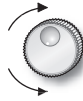
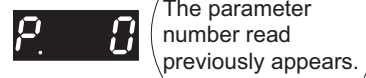

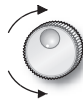

Parameter clear All parameter clear





Parameter clear All parameter clear



Flicker ... Parameter setting complete!!

- Turn  to read another parameter.
- Press  to show the setting again.
- Press  twice to show the next parameter.

?  and  are displayed alternately ... Why?

 The inverter is not in the PU operation mode.

1. Press .

 is lit and the monitor (4-digit LED) displays "0" (Pr: 79 = "0" (initial value)).

2. Carry out operation from step 6 again.

### REMARKS

- Stop the inverter first. Writing error occurs if parameter clear is attempted while the inverter is running.

## 5.8 Parameter copy and parameter verification

| PCPY Setting | Description   |
|--------------|---|
| 0            | Cancel  |
| 1            | Copy the source parameters to the operation panel.                                |
| 2            | Write the parameters copied to the operation panel into the destination inverter. |
| 3            | Verify parameters in the inverter and operation panel. (Refer to page 80.)        |

### REMARKS

- When the copy destination inverter is not the FR-F700(P) series or parameter copy write is performed after parameter copy read is stopped, "model error (r E 4)" is displayed.
- Refer to the parameter list on page 86 and later for availability of parameter copy.
- When the power is turned OFF or an operation panel is disconnected, etc. during parameter copy write, perform write again or check the values by parameter verification.
- Initial settings of certain parameters are different for different capacities, so some parameter settings may be automatically changed when parameter copy is performed from a different-capacity inverter. After performing a parameter copy from a different-capacity inverter, check the parameter settings. Especially under IPM motor control, check the Pr.80 Motor capacity setting before starting the operation. (Refer to the parameter list (page 86) for the parameters with different initial settings for different capacities.)
- If parameters are copied from an older inverter to a newer inverter that has additional parameters, out-of-range setting values may be written in some parameters. In that case, those parameters operate as they were set to initial values.

### 5.8.1 Parameter copy

Parameter settings can be copied to multiple inverters.

————— Operation —————

1. Connect the operation panel to the copy source inverter.
2. Press **MODE** to choose the parameter setting mode.
3. Turn **▲** until **PCPY** (parameter copy) appears.
4. Press **SET** to read the present set value. "0" (initial value) appears.
5. Turn **▲** to change it to the setting value "1".
6. Press **SET** to copy the source parameters to the operation panel.

————— Display —————



1. **MODE** → P. 0 (The parameter number read previously appears)

2. **▲** → PCPY

3. **SET** → 0

4. **▲** → 1

5. **SET** → 1 (The frequency flickers for about 30s)

About 30s later → 1 PCPY

**Flicker ... Parameter copy complete!!**

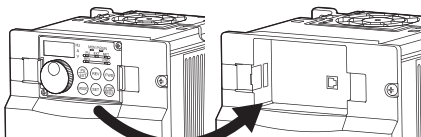

6. **▲** → 2

7. **SET** → 2 (The frequency flickers for about 30s)

8. → 2 PCPY

**Flicker ... Parameter copy complete!!**

7. Connect the operation panel to the copy destination inverter.
8. After performing steps 2 to 5, turn **▲** to change it to "2".
9. Press **SET** to write the parameters copied to the operation panel to the destination inverter.
  - Connect it during a stop.
10. When copy is completed, "2" and "PCPY" flicker.
11. After writing the parameter values to the copy destination inverter, always reset the inverter, e.g. switch power OFF once, before starting operation.

————— Display —————



1. **MODE** → P. 0 (The parameter number read previously appears)

2. **▲** → PCPY

3. **SET** → 0

4. **▲** → 1

5. **SET** → 1 (The frequency flickers for about 30s)

About 30s later → 1 PCPY

**Flicker ... Parameter copy complete!!**

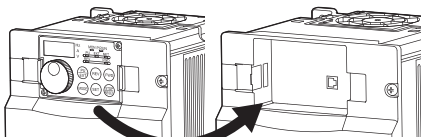

6. **▲** → 2

7. **SET** → 2 (The frequency flickers for about 30s)

8. → 2 PCPY

**Flicker ... Parameter copy complete!!**

- ?  $r-E1$  appears...Why? Parameter read error. Perform operation from step 3 again.
- ?  $r-E2$  appears...Why? Parameter write error. Perform operation from step 8 again.

? **CP** and **000** flicker alternately

Appears when parameters are copied between the inverter of 55K or lower and 75K or higher.

1. Set "0" in *Pr. 160 User group read selection*.
2. Set the following setting (initial value) in *Pr. 989 Parameter copy alarm release*.

| <i>Pr. 989 Setting</i> | 55K or lower | 75K or higher |
|------------------------|--------------|---------------|
|                        | 10           | 100           |

3. Reset *Pr. 9, Pr. 30, Pr. 51, Pr. 52, Pr. 54, Pr. 56, Pr. 57, Pr. 70, Pr. 72, Pr. 80, Pr. 90, Pr. 158, Pr. 190 to Pr. 196, Pr. 557, Pr. 893*.

### 5.8.2 Parameter verification

Whether same parameter values are set in other inverters or not can be checked.

| Operation  | Display   |
|--|---|
| 1. Move the operation panel to the inverter to be verified.                              |   |
| 2. Screen at power-ON<br>The monitor display appears.                                    |   |
| 3. Operation mode setting<br>Press  to choose the PU operation mode.                     | PU indicator is lit.<br>                        |
| 4. Press  to choose the parameter setting mode.  | (The parameter number read previously appears.) |
| 5. Turn  until <i>PCPY</i> (parameter copy) appears.                                     |   |
| 6. Press  to read the present set value.<br>"0"(initial value) appears.                  |   |
| 7. Turn  to change it to the set value<br>"3"(parameter copy verification mode).         |   |
| 8. Press  to read the parameter setting of the verified inverter to the operation panel. | The frequency flickers for about 30s            |
| · If different parameters exist, different parameter numbers and $r-E3$ flicker.         |   |
| · Hold down  to verify.  | Flickering                                      |
| 9. If there is no difference, <i>PCPY</i> and 3 flicker to complete verification.        |   |

**Flicker ... Parameter verification complete!!**

?  $r-E3$  flickers ... Why?

Set frequencies, etc. may be different. Check set frequencies.

## 5.9 Initial value change list

Displays and sets the parameters changed from the initial value.

### Operation

#### 1. Screen at power-ON

The monitor display appears.

#### 2. Operation mode setting

Press  to choose the PU operation mode.

#### 3. Press to choose the parameter setting mode.

#### 4. Turn until *P.r.CH* appears.

#### 5. Pressing changes to the initial value change list screen.

#### 6. Turning displays the parameter number changed.

• Press  to read the present set value.

Turn  and press  to change the setting.  
(Refer to step 6 and 7 on page 50.)

• Turn  to read another parameter.

• The display returns to *P.---* after all parameters are displayed.

#### 7. Pressing in *P.---* status returns to the parameter setting mode.

• Turning  sets other parameters.

• Pressing  displays the change list again.

### Display



PU indicator is lit.



PRM indicator is lit.



(The parameter number read previously appears.)



Flicker ... Frequency setting complete!!



### REMARKS

- Calibration parameters (*C0 (Pr. 900) to C7 (Pr. 905), C42 (Pr. 934) to C45 (Pr. 935)*) are not displayed even they are changed from the initial settings.
- Only simple mode parameter is displayed when simple mode is set (*Pr. 160 = 9999* (initial value)).
- Only user group is displayed when user group is set (*Pr. 160 = "1"*).
- *Pr. 160* is displayed independently of whether the setting value is changed or not.





## 5.10 Parameter list

### 5.10.1 List of parameters classified by the purpose

Set the parameters according to the operating conditions.

The following list indicates purpose of use and corresponding parameters.

| Purpose of Use                                     | Function (Parameter Number)  | Page |
|--|--|------|
| Acceleration/deceleration time/pattern adjustment  | — Acceleration/deceleration patterns and backlash measures (Pr.29, Pr.140 to Pr.143)                                     | 90   |
|  | — Acceleration/deceleration time setting (Pr.7, Pr.8, Pr.20, Pr.21, Pr.44, Pr.45, Pr.147, Pr.791, Pr.792)                | 87   |
|  | — Regenerative avoidance operation (Pr.665, Pr.882 to Pr.886)  | 111  |
|  | — Starting frequency (Pr.13, Pr.571)   | 88   |
| Adjusting the output torque (current) of the motor | — Manual torque boost (Pr.0, Pr.46)  | 86   |
|  | — Simple magnetic flux vector control (Pr.90)  | 97   |
|  | — Simple magnetic flux vector control and IPM motor control (Pr.80)  | 97   |
|  | — Slip compensation (Pr.245 to Pr.247)   | 105  |
|  | — Stall prevention (Pr.22, Pr.23, Pr.48, Pr.49, Pr.66, Pr.148, Pr.149, Pr.154, Pr.156, Pr.157)                           | 89   |
| Communication operation and command source         | — Selection of the NET operation mode command source (Pr.550)  | 107  |
|  | — Selection of the PU operation mode command source (Pr.551)   | 107  |
| Communication operation and setting                | — Control of parameter write by communication (Pr.342)   | 107  |
|  | — Control of parameter write by communication (Pr.342)   | 98   |
|  | — Initial setting of RS-485 communication (Pr.117 to Pr.124, Pr.551)   | 98   |
|  | — Initial setting of RS-485 communication (Pr.331 to Pr.339, Pr.341 to Pr.343, Pr.502, Pr.539, Pr.549 to Pr.551, Pr.779) | 107  |
| Detection of output frequency and current          | — Detection of output current (Y12 signal) and zero current (Y13 signal) (Pr.150 to Pr.153, Pr.166, Pr.167)              | 102  |
|  | — Detection of output frequency (SU, FU, and FU2 signals) (Pr.41 to Pr.43, Pr.50, Pr.870)                                | 91   |
| Energy saving operation                            | — Energy saving control selection (Pr.60)  | 94   |
| Frequency setting by analog input                  | — Analog input selection, override function, analog input compensation (Pr.73, Pr.242, Pr.243, Pr.252, Pr.253, Pr.267)   | 95   |
|  | — Bias and gain for the frequency setting voltage (current) (Pr.125, Pr.126, Pr.241, C2(Pr.902) to C7(Pr.905))           | 99   |
|  | — Noise elimination at the analog input (Pr.74)  | 96   |
| Frequency setting with terminals (contact input)   | — Compensation of multi speed and remote setting inputs (Pr.28)  | 89   |
|  | — Jog operation (Pr.15, Pr.16)   | 88   |
|  | — Multi-speed setting operation (Pr.4 to Pr.6, Pr.24 to Pr.27, Pr.232 to Pr.239)   | 86   |



|  |   |     |
|--|---|-----|
| Frequency setting with terminals (contact input)                     | — Remote setting function (Pr.59)   | 94  |
| Function assignment of external terminal and control                 | — Condition selection for the second functions activation (RT signal) (Pr.155)  | 102 |
|  | — Function assignment of input terminals (Pr.178 to Pr.189)   | 103 |
|  | — Function assignment of output terminals (Pr.190 to Pr.196)  | 104 |
|  | — Logic selection of the output stop signal (MRS) (Pr.17)   | 88  |
|  | — Pulse train output of output power (Y79 signal) (Pr.799)  | 110 |
|  | — Remote output function (REM signal) (Pr.495 to Pr.497)  | 109 |
|  | — Start signal selection (Pr.250)   | 105 |
| IPM motor control  | — Control method selection (Pr.800)   | 110 |
|  | — IPM parameter initialization (Pr.998)   | 114 |
|  | — Proportional gain setting for speed loops (Pr.820, Pr.821)  | 110 |
| Limiting the output frequency  | — Avoiding the mechanic resonance points (frequency jump) (Pr.31 to Pr.36, Pr.552)  | 91  |
|  | — Maximum/minimum frequency (Pr.1, Pr.2, Pr.18)   | 86  |
| Misoperation prevention and parameter setting restriction            | — Displaying necessary parameters only (user group) (Pr.160, Pr.172 to Pr.174)  | 102 |
|  | — Password function (Pr.296, Pr.297)  | 107 |
|  | — Prevention of parameter rewrite (Pr.77)   | 96  |
|  | — Reset selection and disconnected PU detection (Pr.75)   | 96  |
|  | — Reverse motor rotation prevention (Pr.78)   | 96  |
| Monitor display and monitor output signal                            | — Adjustment of terminal FM and AM (calibration) (C0(Pr.900), C1(Pr.901))   | 113 |
|  | — Changing DU/PU monitored items and clearing cumulative monitors (Pr.52, Pr.170, Pr.171, Pr.268, Pr.563, Pr.564, Pr.891) | 92  |
|  | — Changing the monitored item to be output from terminal FM/AM (Pr.54 to Pr.56, Pr.158, Pr.867)                           | 92  |
|  | — Speed display and speed setting (Pr.37, Pr.144, Pr.505)   | 91  |
| Motor brake and stop operation                                       | — Coast to stop at the specified frequency or lower (Pr.522)  | 109 |
|  | — DC injection brake (Pr.10 to Pr.12)   | 88  |
|  | — Decelerate the motor to a stop at instantaneous power failure (Pr.261 to Pr.266)  | 106 |
|  | — Motor stop method and start signal selection (Pr.250)   | 105 |
|  | — Regeneration unit selection (Pr.30, Pr.70)  | 90  |
| Motor noise suppression and measures against EMC and leakage current | — Carrier frequency and Soft-PWM selection (Pr.72, Pr.240, Pr.260)  | 95  |
|  | — Reducing mechanic resonance (speed smoothing control) (Pr.653, Pr.654)  | 110 |
| Operation selection at power failure and instantaneous power failure | — Automatic restart after instantaneous power failure/flying start (Pr.57, Pr.58, Pr.162 to Pr.165, Pr.299, Pr.611)       | 93  |



|  |  |     |
|--|--|-----|
| Operation selection at power failure and instantaneous power failure | — Decelerate the motor to a stop at instantaneous power failure (Pr.261 to Pr.266)   | 106 |
| Operation setting at fault occurrence                                | — Input phase failure protection selection (Pr.251, Pr.872)  | 105 |
|  | — Output function of fault code (Pr.76)  | 96  |
|  | — Overspeed detection level (Pr.374)   | 109 |
|  | — Regenerative avoidance operation (Pr.665, Pr.882 to Pr.886)  | 111 |
|  | — Retry at fault occurrence (Pr.65, Pr.67 to Pr.69)  | 94  |
| Selection and protection of a motor                                  | — Motor protection from overheat (electronic thermal relay function) (Pr.9, Pr.51)   | 87  |
|  | — Motor selection (general-purpose motor, IPM motor) (Pr.71)   | 94  |
| Selection of operation mode and command source                       | — Operation command source and speed command source during communication operation (Pr.338, Pr.339)  | 107 |
|  | — Operation mode at power-ON (Pr.79, Pr.340)   | 96  |
|  | — Operation mode selection (Pr.79)   | 96  |
| Setting of the parameter unit and operation panel                    | — Buzzer control of the operation panel (Pr.990)   | 113 |
|  | — Operation selection of the operation panel (Pr.161)  | 103 |
|  | — Parameter unit language switchover (Pr.145)  | 101 |
|  | — PU contrast adjustment (Pr.991)  | 113 |
| Special operation and frequency control                              | — PID control (Pr.127 to Pr.134, Pr.553, Pr.554, Pr.575 to Pr.577, C42(Pr.934) to C45(Pr.935))   | 99  |
|  | — Switching between the inverter and the bypass operation (Pr.135 to Pr.139, Pr.159)   | 101 |
| Useful function (energy saving operation)                            | — Energy saving monitor (Pr.891 to Pr.899)   | 112 |
| Useful functions   | — Automatic parameter setting (Pr.999)   | 114 |
|  | — Current average value monitor signal (Pr.555 to Pr.557)  | 109 |
|  | — Fault initiation (Pr.997)  | 113 |
|  | — Free parameter (Pr.888, Pr.889)  | 111 |
|  | — Lifespan extension of the cooling fan (Pr.244)   | 105 |
|  | — Maintenance of parts (Pr.503, Pr.504)  | 109 |
|  | — Parameter clear, parameter copy, initial value change list, and automatic parameter setting (Pr.CL, ALLC, Er.CL, PCPY, Pr.CH, IPM, AUTO) | 114 |
|  | — Parameter copy alarm release (Pr.989)  | 113 |
|  | — To display life of inverter parts (Pr.255 to Pr.259)   | 106 |
| V/F pattern setting  | — Adjustable 5 points V/F (Pr.71, Pr.100 to Pr.109)  | 97  |
|  | — Base frequency and voltage (Pr.3, Pr.19, Pr.47)  | 86  |
|  | — V/F pattern suitable for the application (Pr.14)   | 88  |

### 5.10.2 Display of the extended parameters

| Operation   | Display                  |
|---|--------------------------|
| 1. Screen at power-ON<br>The monitor display appears.                                   |                          |
| 2. Operation mode setting<br>Press <b>PU/EXT</b> to choose the PU operation mode.       | PU indicator is lit.<br> |
| 3. Press <b>MODE</b> to choose the parameter setting mode.                              |                          |
| 4. Turn <b>▲/▼</b> until <b>P. 160 (Pr. 160)</b> appears.                               |                          |
| 5. Press <b>SET</b> to read the currently set value.<br>"9999" (initial value) appears. |                          |
| 6. Turn <b>▲/▼</b> to change it to the set value "0".                                   |                          |
| 7. Press <b>SET</b> to set.   |                          |

**Flicker ... Parameter setting complete!!**

- By turning **▲/▼**, you can read another parameter.
- Press **SET** to show the setting again.
- Press **SET** twice to show the next parameter.

After parameter setting is completed, press **MODE** once to show the fault history and press **MODE** twice to return to the monitor display. To change settings of other parameters, perform the operation in above steps 3 to 7.

#### REMARKS

If the setting has not been changed, the value does not flicker and the next parameter number appears.





| Pr. 160                 | Description  |
|-------------------------|--|
| 9999<br>(Initial Value) | Only the simple mode parameters can be displayed.                  |
| 0                       | Simple mode and extended mode parameters can be displayed.         |
| 1                       | Only the parameters registered in the user group can be displayed. |







### 5.10.3 Parameter list

⊙ indicates simple mode parameters.

| Parameter<br>Related parameters  | Name                                      | Increments | Initial Value          | Range            | Description   | Parameter copy              | Parameter clear | All parameter clear |
|--|---|------------|------------------------|------------------|---|-----------------------------|-----------------|---------------------|
|  |   |            |                        |                  |   | ⊙ : enabled<br>× : disabled |                 |                     |
| <b>Adjusting the output torque (current) of the motor — Manual torque boost (Pr.0, Pr.46)</b>  |   |            |                        |                  |   |                             |                 |                     |
| 0⊙   | Torque boost                              | 0.1%       | 6/4/3/2/<br>1.5/1% *   | 0 to 30%         | Set the output voltage at 0Hz as %.   | ⊙                           | ⊙               | ⊙                   |
| 46   | Second torque boost                       | 0.1%       | 9999                   | 0 to 30%         | Set the torque boost when the RT signal is on.  | ⊙                           | ⊙               | ⊙                   |
|  |   |            |                        | 9999             | Without second torque boost   |                             |                 |                     |
| * Initial values differ according to the inverter capacity. (0.75K / 1.5K to 3.7K / 5.5K, 7.5K / 11K to 37K / 45K, 55K / 75K or higher)  |   |            |                        |                  |   |                             |                 |                     |
| <b>Limiting the output frequency — Maximum/minimum frequency (Pr.1, Pr.2, Pr.18)</b>   |   |            |                        |                  |   |                             |                 |                     |
| 1⊙   | Maximum frequency                         | 0.01Hz     | 120/<br>60Hz *1,<br>*2 | 0 to 120Hz       | Set the upper limit of the output frequency.  | ⊙                           | ⊙               | ⊙                   |
| 2⊙   | Minimum frequency                         | 0.01Hz     | 0Hz                    | 0 to 120Hz       | Set the lower limit of the output frequency.  | ⊙                           | ⊙               | ⊙                   |
| 18   | High speed maximum frequency              | 0.01Hz     | 120/<br>60Hz *1,<br>*2 | 120 to 400Hz     | Set when performing the operation at 120Hz or more.   | ⊙                           | ⊙               | ⊙                   |
|  |   |            |                        | *3               |   |                             |                 |                     |
| *1 The setting depends on the inverter capacity. (55K or lower/75K or higher)<br>*2 Performing IPM parameter initialization changes the settings. (Refer to page 42)<br>*3 Even if a value higher than the maximum frequency (refer to page 43) is set in Pr.18 under IPM motor control, the high speed maximum frequency is limited to the maximum motor frequency. |   |            |                        |                  |   |                             |                 |                     |
| <b>V/F pattern setting — Base frequency and voltage (Pr.3, Pr.19, Pr.47)</b>   |   |            |                        |                  |   | <br>                        |                 |                     |
| 3⊙   | Base frequency                            | 0.01Hz     | 60Hz                   | 0 to 400Hz       | Set the frequency when the rated motor torque is generated. (50Hz/60Hz)   | ⊙                           | ⊙               | ⊙                   |
| 19   | Base frequency voltage                    | 0.1V       | 9999                   | 0 to 1000V       | Set the base voltage.   | ⊙                           | ⊙               | ⊙                   |
|  |   |            |                        | 8888             | 95% of power supply voltage   |                             |                 |                     |
|  |   |            |                        | 9999             | Same as power supply voltage  |                             |                 |                     |
| 47   | Second V/F (base frequency)               | 0.01Hz     | 9999                   | 0 to 400Hz       | Set the base frequency when the RT signal is ON.  | ⊙                           | ⊙               | ⊙                   |
|  |   |            |                        | 9999             | Second V/F is invalid   |                             |                 |                     |
| <b>Frequency setting with terminals (contact input) — Multi-speed setting operation (Pr.4 to Pr.6, Pr.24 to Pr.27, Pr.232 to Pr.239)</b>   |   |            |                        |                  |   |                             |                 |                     |
| 4⊙   | Multi-speed setting (high speed)          | 0.01Hz     | 60Hz *                 | 0 to 400Hz       | Set frequency when the RT signal is ON.   | ⊙                           | ⊙               | ⊙                   |
| 5⊙   | Multi-speed setting (middle speed)        | 0.01Hz     | 30Hz                   | 0 to 400Hz       | Set frequency when the RM signal is ON.   | ⊙                           | ⊙               | ⊙                   |
| 6⊙   | Multi-speed setting (low speed)           | 0.01Hz     | 10Hz                   | 0 to 400Hz       | Set frequency when the RL signal is ON.   | ⊙                           | ⊙               | ⊙                   |
| 24 to 27   | Multi-speed setting (4 speed to 7 speed)  | 0.01Hz     | 9999                   | 0 to 400Hz, 9999 | Frequency from 4 speed to 15 speed can be set according to the combination of the RH, RM, RL and REX signals.<br>9999: not selected | ⊙                           | ⊙               | ⊙                   |
| 232 to 239   | Multi-speed setting (8 speed to 15 speed) | 0.01Hz     | 9999                   | 0 to 400Hz, 9999 |   |                             |                 |                     |
| * Performing IPM parameter initialization changes the settings. (Refer to page 42)   |   |            |                        |                  |   |                             |                 |                     |

| Parameter  | Name  | Increments       | Initial Value                   | Range                       | Description  | Parameter copy  | Parameter clear | All parameter clear |   |
|--|---|------------------|---------------------------------|-----------------------------|--|---|-----------------|---------------------|---|
|  |   |                  |                                 |                             |  | ○ : enabled<br>× : disabled   |                 |                     |   |
| <b>Acceleration/deceleration time/pattern adjustment — Acceleration/deceleration time setting (Pr.7, Pr.8, Pr.20, Pr.21, Pr.44, Pr.45, Pr.147, Pr.791, Pr.792)</b>               |   |                  |                                 |                             |  |   |                 |                     |   |
| 7◎   | Acceleration time   | 0.1/<br>0.01s    | 5s/15s *1                       | 0 to 3600/<br>360s          | Set the motor acceleration time.   | ○   | ○               | ○                   |   |
| 8◎   | Deceleration time   | 0.1/<br>0.01s    | 10s/30s<br>*1                   | 0 to 3600/<br>360s          | Set the motor deceleration time.   | ○   | ○               | ○                   |   |
| 20   | Acceleration/<br>deceleration<br>reference frequency      | 0.01Hz           | 60Hz *2                         | 1 to 400Hz                  | Set the frequency referenced as acceleration/<br>deceleration time. Set the frequency change<br>time from stop to Pr. 20 for acceleration/<br>deceleration time. | ○   | ○               | ○                   |   |
| 21   | Acceleration/<br>deceleration time<br>increments          | 1                | 0                               | 0                           | Increments: 0.1s<br>Range: 0 to 3600s  | Increments and setting<br>range of acceleration/<br>deceleration time<br>setting can be<br>changed. | ○               | ○                   | ○ |
|  |   |                  |                                 | 1                           | Increments: 0.01s<br>Range: 0 to 360s  |   |                 |                     |   |
| 44   | Second acceleration/<br>deceleration time                 | 0.1/<br>0.01s    | 5s                              | 0 to 3600/<br>360s          | Set the acceleration/deceleration time when<br>the RT signal is ON.  | ○   | ○               | ○                   |   |
| 45   | Second deceleration<br>time                               | 0.1/<br>0.01s    | 9999                            | 0 to 3600/<br>360s          | Set the deceleration time when the RT signal is<br>ON.   | ○   | ○               | ○                   |   |
|  |   |                  |                                 | 9999                        | Acceleration time = deceleration time  |   |                 |                     |   |
| 147  | Acceleration/<br>deceleration time<br>switching frequency | 0.01Hz           | 9999                            | 0 to 400Hz                  | Frequency when automatically switching to<br>the acceleration/deceleration time of Pr. 44<br>and Pr. 45.   | ○   | ○               | ○                   |   |
|  |   |                  |                                 | 9999                        | No function  |   |                 |                     |   |
| 791<br>   | Acceleration time in<br>low-speed range                   | 0.1/<br>0.01s    | 9999                            | 0 to 3600/<br>360s          | Acceleration time in the low-speed range<br>(less than 10% of the rated motor<br>frequency) is set.  | ○   | ○               | ○                   |   |
|  |   |                  |                                 | 9999                        | The acceleration time set in Pr.7 is applied.<br>(When the second function is enabled, the<br>setting is applied.)   |   |                 |                     |   |
| 792<br>   | Deceleration time in<br>low-speed range                   | 0.1/<br>0.01s    | 9999                            | 0 to 3600/<br>360s          | Deceleration time in the low-speed range<br>(less than 10% of the rated motor<br>frequency) is set.  | ○   | ○               | ○                   |   |
|  |   |                  |                                 | 9999                        | The deceleration time set in Pr.8 is applied.<br>(When the second function is enabled, the<br>setting is applied.)   |   |                 |                     |   |
| *1 Initial values differ according to the inverter capacity. (7.5K or lower/11K or higher)   |   |                  |                                 |                             |  |   |                 |                     |   |
| *2 Performing IPM parameter initialization changes the settings. (Refer to page 42)  |   |                  |                                 |                             |  |   |                 |                     |   |
| <b>Selection and protection of a motor — Motor protection from overheat (electronic thermal relay function) (Pr.9, Pr.51)</b>  |   |                  |                                 |                             |  |   |                 |                     |   |
| 9◎   | Electronic thermal O/<br>L relay                          | 0.01/<br>0.1A *1 | Rated<br>inverter<br>current *2 | 0 to 500/<br>0 to 3600A *1  | Set the rated motor current.   | ○   | ○               | ○                   |   |
| 51<br><br> | Second electronic<br>thermal O/L relay                    | 0.01/<br>0.1A *1 | 9999                            | 0 to 500A/<br>0 to 3600A *1 | Valid when the RT signal is ON.<br>Set the rated motor current.  | ○   | ○               | ○                   |   |
|  |   |                  |                                 | 9999                        | Second electronic thermal O/L relay invalid  |   |                 |                     |   |
| *1 The setting depends on the inverter capacity (55K or lower/75k or higher)   |   |                  |                                 |                             |  |   |                 |                     |   |
| *2 Performing IPM parameter initialization changes the settings. (Refer to page 42)  |   |                  |                                 |                             |  |   |                 |                     |   |



| Parameter  | Name                                   | Increments | Initial Value | Range  | Description  | Parameter copy              | Parameter clear | All parameter clear |
|--|--|------------|---------------|--|--|-----------------------------|-----------------|---------------------|
|  |  |            |               |  |  | O : enabled<br>× : disabled |                 |                     |
| <b>Motor brake and stop operation — DC injection brake (Pr.10 to Pr.12)</b>  |  |            |               |  |  |                             |                 |                     |
| 10   | DC injection brake operation frequency | 0.01Hz     | 3Hz           | 0 to 120Hz*1   | Set the operation frequency of the DC injection brake.   | ○                           | ○               | ○                   |
|  |  |            |               | 9999   | Operate when the output frequency becomes less than or equal to <i>Pr.13 Starting frequency</i> .  |                             |                 |                     |
| 11   | DC injection brake operation time      | 0.1s       | 0.5s          | 0  | DC injection brake disabled  | ○                           | ○               | ○                   |
|  |  |            |               | 0.1 to 10s   | Set the operation time of the DC injection brake.  |                             |                 |                     |
| 12<br><br> | DC injection brake operation voltage   | 0.1%       | 4/2/1%*2      | 0  | DC injection brake disabled  | ○                           | ○               | ○                   |
|  |  |            |               | 0.1 to 30%   | Set the DC injection brake voltage (torque).   |                             |                 |                     |
| *1 Under IPM motor control, the frequency is fixed at 0Hz even if <i>Pr.11</i> ≠ "0."  |  |            |               |  |  |                             |                 |                     |
| *2 Initial values differ according to the inverter capacity. (7.5K or lower/11K to 55K/75K or higher)  |  |            |               |  |  |                             |                 |                     |
| <b>Acceleration/deceleration time/pattern adjustment — Starting frequency (Pr.13, Pr.571)</b>  |  |            |               |  |  |                             |                 |                     |
| 13   | Starting frequency                     | 0.01Hz     | 0.5Hz *       | 0 to 60Hz  | Starting frequency can be set. If the set frequency is set higher than the start frequency under IPM motor control, the output starts at 0.01Hz.   | ○                           | ○               | ○                   |
|  |  |            |               | 571<br><br> | 0.0 to 10.0s   |                             |                 |                     |
|  | Holding time at a start                | 0.1s       | 9999          | 9999   | Holding function at a start is invalid   | ○                           | ○               | ○                   |
| * Performing IPM parameter initialization changes the settings. (Refer to page 42)   |  |            |               |  |  |                             |                 |                     |
| <b>V/F pattern setting — V/F pattern suitable for the application (Pr.14) </b>          |  |            |               |  |  |                             |                 |                     |
| 14   | Load pattern selection                 | 1          | 1             | 0  | For constant-torque load   | ○                           | ○               | ○                   |
|  |  |            |               | 1  | For reduced-torque load  |                             |                 |                     |
| <b>Frequency setting with terminals (contact input) — Jog operation (Pr.15, Pr.16)</b>   |  |            |               |  |  |                             |                 |                     |
| 15   | Jog frequency *                        | 0.01Hz     | 5Hz *         | 0 to 400Hz   | Set the frequency for jog operation.   | ○                           | ○               | ○                   |
| 16   | Jog acceleration/ deceleration time    | 0.1/ 0.01s | 0.5s          | 0 to 3600/ 360s  | Set the acceleration/deceleration time for jog operation. Set the time taken to reach the frequency set in <i>Pr.20 Acceleration/deceleration reference frequency</i> for acceleration/deceleration time. (Initial value is 60Hz *)<br>In addition, acceleration/deceleration time cannot be set separately. | ○                           | ○               | ○                   |
| * Performing IPM parameter initialization changes the settings. (Refer to page 42)   |  |            |               |  |  |                             |                 |                     |
| <b>Function assignment of external terminal and control — Logic selection of the output stop signal (MRS) (Pr.17)</b>  |  |            |               |  |  |                             |                 |                     |
| 17   | MRS input selection                    | 1          | 0             | 0  | Open input always  | ○                           | ○               | ○                   |
|  |  |            |               | 2  | Normally closed input (NC contact input specifications)  |                             |                 |                     |
|  |  |            |               | 4  | External terminal: Normally closed input (NC contact input specifications)<br>Communication: Normally open input   |                             |                 |                     |
| 18   | Refer to <i>Pr.1 and Pr.2</i> .        |            |               |  |  |                             |                 |                     |
| 19   | Refer to <i>Pr.3</i> .                 |            |               |  |  |                             |                 |                     |
| 20, 21   | Refer to <i>Pr.7 and Pr.8</i> .        |            |               |  |  |                             |                 |                     |



| Parameter  | Name   | Increments | Initial Value | Range             | Description   | Parameter copy              | Parameter clear | All parameter clear |
|--|--|------------|---------------|-------------------|---|-----------------------------|-----------------|---------------------|
|  |  |            |               |                   |   | O : enabled<br>x : disabled |                 |                     |
| <b>Adjusting the output torque (current) of the motor — Stall prevention (Pr.22, Pr.23, Pr.48, Pr.49, Pr.66, Pr.148, Pr.149, Pr.154, Pr.156, Pr.157)</b> |  |            |               |                   |   |                             |                 |                     |
| 22   | Stall prevention operation level                                     | 0.1%       | 120% *        | 0                 | Stall prevention operation selection becomes invalid.   | ○                           | ○               | ○                   |
|  |  |            |               | 0.1 to 150%       | Set the current value at which stall prevention operation is started.   |                             |                 |                     |
|  |  |            |               | 9999              | Analog variable   |                             |                 |                     |
| 23<br><br>   | Stall prevention operation level compensation factor at double speed | 0.1%       | 9999          | 0 to 200%         | The stall operation level can be reduced when operating at a high speed above the rated frequency.                      | ○                           | ○               | ○                   |
|  |  |            |               | 9999              | Constant according to Pr. 22  |                             |                 |                     |
| 48   | Second stall prevention operation current                            | 0.1%       | 120%          | 0                 | Second stall prevention operation invalid   | ○                           | ○               | ○                   |
|  |  |            |               | 0.1 to 150%       | The stall prevention operation level can be set.  |                             |                 |                     |
| 49   | Second stall prevention operation frequency                          | 0.01Hz     | 0Hz           | 0                 | Second stall prevention operation invalid   | ○                           | ○               | ○                   |
|  |  |            |               | 0.01 to 400Hz     | Set the frequency at which stall prevention operation of Pr. 48 is started.   |                             |                 |                     |
|  |  |            |               | 9999              | Pr. 48 is valid when the RT signal is ON.   |                             |                 |                     |
| 66<br><br>   | Stall prevention operation reduction starting frequency              | 0.01Hz     | 60Hz          | 0 to 400Hz        | Set the frequency at which the stall operation level starts being reduced.  | ○                           | ○               | ○                   |
| 148  | Stall prevention level at 0V input                                   | 0.1%       | 120%          | 0 to 150%         | Stall prevention operation level can be changed by the analog signal input to terminal 1.                               | ○                           | ○               | ○                   |
| 149  | Stall prevention level at 10V input                                  | 0.1%       | 150%          | 0 to 150%         |   | ○                           | ○               | ○                   |
| 154<br><br>  | Voltage reduction selection during stall prevention operation        | 1          | 1             | 0                 | With output voltage reduction   | ○                           | ○               | ○                   |
|  |  |            |               | 1                 | Without output voltage reduction  |                             |                 |                     |
|  |  |            |               | 10                | With output voltage reduction   | ○                           | ○               | ○                   |
|  |  |            |               | 11                | Without output voltage reduction  | ○                           | ○               | ○                   |
| 156  | Stall prevention operation selection                                 | 1          | 0             | 0 to 31, 100, 101 | Pr. 156 allows you to select whether to use stall prevention or not according to the acceleration/ deceleration status. | ○                           | ○               | ○                   |
| 157  | OL signal output timer   | 0.1s       | 0s            | 0 to 25s          | Set the output start time of the OL signal output when stall prevention is activated.                                   | ○                           | ○               | ○                   |
|  |  |            |               | 9999              | Without the OL signal output  |                             |                 |                     |
| * Performing IPM parameter initialization changes the settings. (Refer to page 42)   |  |            |               |                   |   |                             |                 |                     |
| 24 to 27   | Refer to Pr. 4 to Pr. 6.   |            |               |                   |   |                             |                 |                     |
| <b>Frequency setting with terminals (contact input) — Compensation of multi speed and remote setting inputs (Pr.28)</b>                                  |  |            |               |                   |   |                             |                 |                     |
| 28   | Multi-speed input compensation selection                             | 1          | 0             | 0                 | Without compensation  | ○                           | ○               | ○                   |
|  |  |            |               | 1                 | With compensation   |                             |                 |                     |





| Parameter   | Name   | Increments | Initial Value | Range      | Description  | Parameter copy              | Parameter clear | All parameter clear |  |
|---|--|------------|---------------|------------|--|-----------------------------|-----------------|---------------------|--|
|   |  |            |               |            |  | O : enabled<br>× : disabled |                 |                     |  |
| <b>Acceleration/deceleration time/pattern adjustment — Acceleration/deceleration patterns and backlash measures (Pr.29, Pr.140 to Pr.143)</b>   |  |            |               |            |  |                             |                 |                     |  |
| 29  | Acceleration/<br>deceleration pattern<br>selection | 1          | 0             | 0          | Linear acceleration/ deceleration  | ○                           | ○               | ○                   |  |
|   |  |            |               | 1          | S-pattern acceleration/deceleration A  |                             |                 |                     |  |
|   |  |            |               | 2          | S-pattern acceleration/deceleration B  |                             |                 |                     |  |
|   |  |            |               | 3          | Backlash measures  |                             |                 |                     |  |
|   |  |            |               | 6          | Variable-torque acceleration/deceleration<br> |                             |                 |                     |  |
| 140   | Backlash acceleration<br>stopping frequency        | 0.01Hz     | 1Hz           | 0 to 400Hz | Set the stopping frequency and time for<br>backlash measures.<br>Valid when <i>Pr.29</i> = "3"                                 | ○                           | ○               | ○                   |  |
| 141   | Backlash acceleration<br>stopping time             | 0.1s       | 0.5s          | 0 to 360s  |  | ○                           | ○               | ○                   |  |
| 142   | Backlash deceleration<br>stopping frequency        | 0.01Hz     | 1Hz           | 0 to 400Hz |  | ○                           | ○               | ○                   |  |
| 143   | Backlash deceleration<br>stopping time             | 0.1s       | 0.5s          | 0 to 360s  |  | ○                           | ○               | ○                   |  |
| <b>Motor brake and stop operation — Regeneration unit selection (Pr.30, Pr.70)</b>  |  |            |               |            |  |                             |                 |                     |  |
| 30  | Regenerative function<br>selection                 | 1          | 0             | 0          | Inverter without regenerative function, brake unit (FR-BU2 *2, FR-BU, BU)  | ○                           | ○               | ○                   |  |
|   |  |            |               | 1 *1       | Brake unit (FR-BU2 *3, MT-BU5), power regeneration converter (MT-RC)   |                             |                 |                     |  |
|   |  |            |               | 2          | High power factor converter (FR-HC2), power regeneration common converter (FR-CV)  |                             |                 |                     |  |
|   |  |            |               | 10         | Inverter without regenerative function, brake unit (FR-BU2 *2, FR-BU, BU)  |                             |                 |                     | DC feeding mode 1<br>(operated by DC feeding only)             |
|   |  |            |               | 11 *1      | Brake unit (FR-BU2 *3, MT-BU5), power regeneration converter (MT-RC)   |                             |                 |                     |  |
|   |  |            |               | 20         | Inverter without regenerative function, brake unit (FR-BU2 *2, FR-BU, BU)  |                             |                 |                     | DC feeding mode 2<br>(operated by switching between AC and DC) |
|   |  |            |               | 21 *1      | Brake unit (FR-BU2 *3, MT-BU5), power regeneration converter (MT-RC)   |                             |                 |                     |  |
| 70  | Special regenerative brake duty                    | 0.1%       | 0%            | 0 to 10%   | Set this parameter when a brake unit or power regeneration converter is used. (Setting can be made for the 75K or higher.)     | ○                           | ○               | ○                   |  |
| <p>*1 <i>Pr.30</i> can be set to "1, 11, or 21" for 75K or higher.<br/>                 *2 Used in combination with GZG, GRZG, or FR-BR.<br/>                 *3 Used in combination with MT-BR5.</p> |  |            |               |            |  |                             |                 |                     |  |



| Parameter  | Name  | Increments | Initial Value | Range                                      | Description  | Parameter copy            | Parameter clear | All parameter clear |
|--|---|------------|---------------|--|--|---------------------------|-----------------|---------------------|
|  |   |            |               |  |  | ○: enabled<br>×: disabled |                 |                     |
| <b>Limiting the output frequency — Avoiding the mechanic resonance points (frequency jump) (Pr.31 to Pr.36, Pr.552)</b>                    |   |            |               |  |  |                           |                 |                     |
| 31   | Frequency jump 1A                               | 0.01Hz     | 9999          | 0 to 400Hz, 9999                           | 1A to 1B, 2A to 2B, 3A to 3B is frequency jumps (3-point jump)<br>9999: Function invalid   | ○                         | ○               | ○                   |
| 32   | Frequency jump 1B                               | 0.01Hz     | 9999          | 0 to 400Hz, 9999                           |  | ○                         | ○               | ○                   |
| 33   | Frequency jump 2A                               | 0.01Hz     | 9999          | 0 to 400Hz, 9999                           |  | ○                         | ○               | ○                   |
| 34   | Frequency jump 2B                               | 0.01Hz     | 9999          | 0 to 400Hz, 9999                           |  | ○                         | ○               | ○                   |
| 35   | Frequency jump 3A                               | 0.01Hz     | 9999          | 0 to 400Hz, 9999                           |  | ○                         | ○               | ○                   |
| 36   | Frequency jump 3B                               | 0.01Hz     | 9999          | 0 to 400Hz, 9999                           |  | ○                         | ○               | ○                   |
| 552  | Frequency jump range                            | 0.01Hz     | 9999          | 0 to 30Hz                                  | A total of six jump ranges can be set by setting the common jump range for the frequencies set in Pr.31 to Pr.36. (6-point jump) | ○                         | ○               | ○                   |
|  |   |            |               | 9999                                       | 3-point jump   |                           |                 |                     |
| <b>Monitor display and monitor output signal — Speed display and speed setting (Pr.37, Pr.144, Pr.505)</b>                                 |   |            |               |  |  |                           |                 |                     |
| 37   | Speed display                                   | 1          | 0 *1          | 0  | Frequency display, setting   | ○                         | ○               | ○                   |
|  |   |            |               | 1 to 9998                                  | Set the machine speed of Pr. 505.  |                           |                 |                     |
| 144  | Speed setting switchover                        | 1          | 4 *2          | 0, 2, 4, 6, 8, 10, 102, 104, 106, 108, 110 | Set the number of motor poles when displaying the motor speed.   | ○                         | ○               | ○                   |
| 505  | Speed setting reference                         | 0.01Hz     | 60Hz *2       | 1 to 120Hz                                 | Set the frequency that will be the basis of machine speed display.   | ○                         | ○               | ○                   |
| *1 Performing IPM parameter initialization sets back the settings to the initial settings. (Refer to page 42)                              |   |            |               |  |  |                           |                 |                     |
| *2 Performing IPM parameter initialization changes the settings. (Refer to page 42)  |   |            |               |  |  |                           |                 |                     |
| <b>Detection of output frequency and current — Detection of output frequency (SU, FU, and FU2 signals) (Pr.41 to Pr.43, Pr.50, Pr.870)</b> |   |            |               |  |  |                           |                 |                     |
| 41   | Up-to-frequency sensitivity                     | 0.1%       | 10%           | 0 to 100%                                  | Set the level where the SU signal turns ON.  | ○                         | ○               | ○                   |
| 42   | Output frequency detection                      | 0.01Hz     | 6Hz           | 0 to 400Hz                                 | Set the frequency where the FU signal turns ON.  | ○                         | ○               | ○                   |
| 43   | Output frequency detection for reverse rotation | 0.01Hz     | 9999          | 0 to 400Hz                                 | Set the frequency where the FU signal turns ON in reverse rotation.  | ○                         | ○               | ○                   |
|  |   |            |               | 9999                                       | Same as Pr.42 setting  |                           |                 |                     |
| 50   | Second output frequency detection               | 0.01Hz     | 30Hz          | 0 to 400Hz                                 | Set the frequency where the FU2 signal turns ON.   | ○                         | ○               | ○                   |
| 870  | Speed detection hysteresis                      | 0.01Hz     | 0Hz *         | 0 to 5Hz                                   | The hysteresis range for the detected frequency is set.  | ○                         | ○               | ○                   |
| * Performing IPM parameter initialization changes the settings. (Refer to page 42)   |   |            |               |  |  |                           |                 |                     |
| 44, 45   | Refer to Pr. 7 and Pr. 8.                       |            |               |  |  |                           |                 |                     |
| 46   | Refer to Pr. 0.                                 |            |               |  |  |                           |                 |                     |
| 47   | Refer to Pr. 3.                                 |            |               |  |  |                           |                 |                     |
| 48, 49   | Refer to Pr. 22 and Pr. 23.                     |            |               |  |  |                           |                 |                     |
| 50   | Refer to Pr. 41 to Pr. 43.                      |            |               |  |  |                           |                 |                     |
| 51   | Refer to Pr. 9.                                 |            |               |  |  |                           |                 |                     |



| Parameter | Name | Increments | Initial Value | Range | Description | Parameter copy              | Parameter clear | All parameter clear |
|-----------|------|------------|---------------|-------|-------------|-----------------------------|-----------------|---------------------|
|           |      |            |               |       |             | O : enabled<br>× : disabled |                 |                     |

**Monitor display and monitor output signal — Changing DU/PU monitored items and clearing cumulative monitors (Pr.52, Pr.170, Pr.171, Pr.268, Pr.563, Pr.564, Pr.891)**

|     |  |   |      |  |   |   |   |   |
|-----|--|---|------|--|---|---|---|---|
| 52  | DU/PU main display data selection            | 1 | 0    | 0, 5, 6, 8 to 14, 17, 20, 23 to 25, 50 to 57, 100* | Select the monitor to be displayed on the operation panel and parameter unit. The setting value of "9" is available only for the 75K or higher. | O | O | O |
| 170 | Watt-hour meter clear                        | 1 | 9999 | 0  | Set "0" to clear the watt-hour meter monitor.   | O | × | O |
|     |  |   |      | 10   | Set the maximum value when monitoring from communication to 0 to 9999kWh.   |   |   |   |
|     |  |   |      | 9999   | Set the maximum value when monitoring from communication to 0 to 65535kWh.  |   |   |   |
| 171 | Operation hour meter clear                   | 1 | 9999 | 0, 9999  | Set "0" to clear the operation time monitor. Setting "9999" has no effect.  | × | × | × |
| 268 | Monitor decimal digits selection             | 1 | 9999 | 0  | Displays the monitor as integral value.   | O | O | O |
|     |  |   |      | 1  | Displays the monitor in increments of 0.1.  |   |   |   |
|     |  |   |      | 9999   | No fixed decimal position   |   |   |   |
| 563 | Energization time carrying-over times        | 1 | 0    | (0 to 65535)                                       | The numbers of cumulative energization time monitor exceeded 65535h is displayed. Reading only  | × | × | × |
| 564 | Operating time carrying-over times           | 1 | 0    | (0 to 65535)                                       | The numbers of operation time monitor exceeded 65535h is displayed. Reading only  | × | × | × |
| 891 | Cumulative power monitor digit shifted times | 1 | 9999 | 0 to 4   | Set the number of times to shift the cumulative power monitor digit. Clamps the monitor value at maximum.                                       | O | O | O |
|     |  |   |      | 9999   | No shift<br>Clears the monitor value when it exceeds the maximum value.   |   |   |   |

\* On the unit I/O terminal monitor (Pr. 52 = "55"), the upper LEDs denote the input terminal states and the lower the output terminal states.

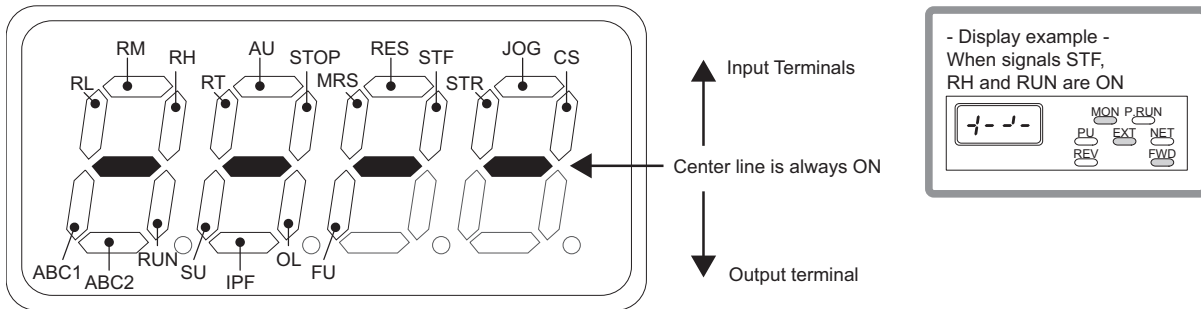

**Monitor display and monitor output signal — Changing the monitored item to be output from terminal FM/AM (Pr.54 to Pr.56, Pr.158, Pr.867)**

|     |                                |              |                           |   |   |   |   |   |
|-----|--------------------------------|--------------|---------------------------|---|---|---|---|---|
| 54  | FM terminal function selection | 1            | 1                         | 1 to 3, 5, 6, 8 to 14, 17, 21, 24, 50, 52, 53 | Select the monitor output to terminal FM. The setting value of "9" is available only for the 75K or higher. | O | O | O |
| 55  | Frequency monitoring reference | 0.01Hz       | 60Hz *2                   | 0 to 400Hz                                    | Set the full-scale value to output the output frequency monitor value to terminal FM and AM.                | O | O | O |
| 56  | Current monitoring reference   | 0.01/0.1A *1 | Rated inverter current *2 | 0 to 500/0 to 3600A *1                        | Set the full-scale value to output the output current monitor value to terminal FM and AM.                  | O | O | O |
| 158 | AM terminal function selection | 1            | 1                         | 1 to 3, 5, 6, 8 to 14, 17, 21, 24, 50, 52, 53 | Select the monitor output to terminal AM. The setting value of "9" is available only for the 75K or higher. | O | O | O |
| 867 | AM output filter               | 0.01s        | 0.01s                     | 0 to 5s                                       | Set the output filter of terminal AM.   | O | O | O |

\*1 The setting depends on the inverter capacity (55K or lower/75K or higher)

\*2 Performing IPM parameter initialization changes the settings. (Refer to page 42)



| Parameter   | Name  | Increments | Initial Value | Range                      | Description  | Parameter copy   | Parameter clear | All parameter clear |   |
|---|---|------------|---------------|----------------------------|--|--|-----------------|---------------------|---|
|   |   |            |               |                            |  | ○ : enabled<br>× : disabled  |                 |                     |   |
| <b>Operation selection at power failure and instantaneous power failure — Automatic restart after instantaneous power failure/flying start (Pr.57, Pr.58, Pr.162 to Pr.165, Pr.299, Pr.611)</b> |   |            |               |                            |  |  |                 |                     |   |
| 57  | Restart coasting time   | 0.1s       | 9999          | 0                          | <b>V/F control, Simple magnetic flux vector control</b><br>The coasting time is as follows:<br>1.5K or lower.....0.5s,<br>2.2K to 7.5K .....1.0s,<br>11K to 55K .....3.0s,<br>75K or higher ....5.0s | <b>IPM motor control</b><br>No coasting time                                   | ○               | ○                   | ○ |
|   |   |            |               | 0.1 to 5s/<br>0.1 to 30s * | Set the waiting time for inverter-triggered restart after an instantaneous power failure.  |  | ○               | ○                   | ○ |
|   |   |            |               | 9999                       | No restart   |  | ○               | ○                   | ○ |
| 58  | Restart cushion time  | 0.1s       | 1s            | 0 to 60s                   | Set a voltage starting time at restart.  |  | ○               | ○                   | ○ |
| 162   | Automatic restart after instantaneous power failure selection | 1          | 0             | 0                          | <b>V/F control, Simple magnetic flux vector control</b><br>Frequency search only performed at the first start  | <b>IPM motor control</b><br>Frequency search only performed at the first start | ○               | ○                   | ○ |
|   |   |            |               | 1                          | Reduced voltage start only performed at the first start (no frequency search)  |  | ○               | ○                   | ○ |
|   |   |            |               | 10                         | Frequency search at every start  |  | ○               | ○                   | ○ |
|   |   |            |               | 11                         | Reduced voltage at every start (no frequency search)   |  | ○               | ○                   | ○ |
| 163   | First cushion time for restart                                | 0.1s       | 0s            | 0 to 20s                   | Set a voltage starting time at restart. Consider according to the magnitude of load (moment of inertia/torque).  |  | ○               | ○                   | ○ |
| 164   | First cushion voltage for restart                             | 0.1%       | 0%            | 0 to 100%                  |  |  | ○               | ○                   | ○ |
| 165   | Stall prevention operation level for restart                  | 0.1%       | 120%          | 0 to 150%                  | Consider the rated inverter current as 100% and set the stall prevention operation level during restart operation.   |  | ○               | ○                   | ○ |
| 299   | Rotation direction detection selection at restarting          | 1          | 9999          | 0                          | Without rotation direction detection   |  | ○               | ○                   | ○ |
|   |   |            |               | 1                          | With rotation direction detection  |  | ○               | ○                   | ○ |
|   |   |            |               | 9999                       | When Pr. 78 = "0", the rotation direction is detected.<br>When Pr. 78 = "1", "2", the rotation direction is not detected.  |  | ○               | ○                   | ○ |
| 611   | Acceleration time at a restart                                | 0.1s       | 5/15s *       | 0 to 3600s                 | Set the acceleration time to reach the Pr. 20 Acceleration/deceleration reference frequency at a restart.  |  | ○               | ○                   | ○ |
|   |   |            |               | 9999                       | Acceleration time for restart is the normal acceleration time (e.g. Pr. 7).  |  | ○               | ○                   | ○ |

\* The setting depends on the inverter capacity (55K or lower/75k or higher)



| Parameter   | Name  | Increments | Initial Value | Range      | Description   | Parameter copy  | Parameter clear | All parameter clear |   |
|---|---|------------|---------------|------------|---|---|-----------------|---------------------|---|
|   |   |            |               |            |   | O : enabled<br>× : disabled                             |                 |                     |   |
| <b>Frequency setting with terminals (contact input) — Remote setting function (Pr.59)</b>                       |   |            |               |            |   |   |                 |                     |   |
| 59  | Remote function selection                                     | 1          | 0             |            | <b>RH, RM, RL signal function</b>   | <b>Frequency setting storage function</b>               | ○               | ○                   | ○ |
|   |   |            |               | 0          | Multi-speed setting   | —   |                 |                     |   |
|   |   |            |               | 1          | Remote setting  | Used  |                 |                     |   |
|   |   |            |               | 2          |   | Not used  |                 |                     |   |
|   |   |            |               | 3          |   | No (Turning STF/STR OFF clears remotely-set frequency.) |                 |                     |   |
|   |   |            |               | 11         | Remote setting (These setting values enable deceleration to the frequency lower than the set frequency.)  | Used  |                 |                     |   |
|   |   |            |               | 12         |   | Not used  |                 |                     |   |
| 13  | Not used (Turning STF/STR OFF clears remotely-set frequency.) |            |               |            |   |   |                 |                     |   |
| <b>Energy saving operation — Energy saving control selection (Pr.60)</b> <span style="float: right;">V/F</span> |   |            |               |            |   |   |                 |                     |   |
| 60 <sup>Ⓞ</sup>   | Energy saving control selection                               | 1          | 0             | 0          | Normal operation mode   | ○   | ○               | ○                   |   |
|   |   |            |               | 4          | Energy saving operation mode  |   |                 |                     |   |
|   |   |            |               | 9          | Optimum excitation control mode   |   |                 |                     |   |
| <b>Operation setting at fault occurrence — Retry at fault occurrence (Pr.65, Pr.67 to Pr.69)</b>                |   |            |               |            |   |   |                 |                     |   |
| 65  | Retry selection   | 1          | 0             | 0 to 5     | A fault for retry can be selected.  | ○   | ○               | ○                   |   |
| 67  | Number of retries at fault occurrence                         | 1          | 0             | 0          | No retry function   | ○   | ○               | ○                   |   |
|   |   |            |               | 1 to 10    | Set the number of retries at fault occurrence. A fault output is not provided during retry operation.   |   |                 |                     |   |
|   |   |            |               | 101 to 110 | Set the number of retries at fault occurrence. (The setting value - 100 is the number of retries.) A fault output is provided during retry operation. |   |                 |                     |   |
| 68  | Retry waiting time  | 0.1s       | 1s            | 0 to 10s   | Set the waiting time from when an inverter fault occurs until a retry is made.  | ○   | ○               | ○                   |   |
| 69  | Retry count display erase                                     | 1          | 0             | 0          | Clear the number of restarts succeeded by retry.  | ○   | ○               | ○                   |   |
| 66  | Refer to Pr.22 and Pr.23.                                     |            |               |            |   |   |                 |                     |   |
| 67 to 69  | Refer to Pr.65.   |            |               |            |   |   |                 |                     |   |
| 70  | Refer to Pr.30.   |            |               |            |   |   |                 |                     |   |
| <b>Selection and protection of a motor — Motor selection (general-purpose motor, IPM motor) (Pr.71)</b>         |   |            |               |            |   |   |                 |                     |   |
| 71  | Applied motor   | 1          | 0             | 0          | Thermal characteristics of a standard motor   | ○   | ○               | ○                   |   |
|   |   |            |               | 1          | Thermal characteristics of the Mitsubishi constant-torque motor   |   |                 |                     |   |
|   |   |            |               | 2          | Thermal characteristic of standard motor Adjustable 5 points V/F  |   |                 |                     |   |
|   |   |            |               | 20         | Mitsubishi standard motor (SF-JR 4P 1.5kW or less)  |   |                 |                     |   |
|   |   |            |               | 120        | High-efficiency IPM motor MM-EF   |   |                 |                     |   |
|   |   |            |               | 210        | Premium high-efficiency IPM motor MM-EFS and MM-THE4  |   |                 |                     |   |
|   |   |            |               | 2010, 2110 | For manufacturer setting. (Do not set.)   |   |                 |                     |   |
| * Performing IPM parameter initialization changes the settings. (Refer to page 42)                              |   |            |               |            |   |   |                 |                     |   |



| Parameter  | Name  | Increments | Initial Value | Range                     | Description  | Parameter copy              | Parameter clear | All parameter clear |
|--|---|------------|---------------|---------------------------|--|-----------------------------|-----------------|---------------------|
|  |   |            |               |                           |  | O : enabled<br>× : disabled |                 |                     |
| <b>Motor noise suppression and measures against EMC and leakage current — Carrier frequency and Soft-PWM selection (Pr.72, Pr.240, Pr.260)</b>   |   |            |               |                           |  |                             |                 |                     |
| 72   | PWM frequency selection                           | 1          | 2             | 0 to 15/<br>0 to 6, 25 *1 | <ul style="list-style-type: none"> <li>•V/F control, Simple magnetic flux vector control<br/>PWM carrier frequency can be changed. The setting is displayed in [kHz]. Note that 0 indicates 0.7kHz, 15 indicates 14.5kHz and 25 indicates 2.5kHz.</li> <li>•IPM motor control<br/>0 to 5 : 2kHz<br/>6 to 9 : 6kHz<br/>10 to 13 : 10kHz<br/>14, 15 : 14kHz<br/><i>Pr.72</i> cannot be set to "25" under IPM motor control.</li> </ul>                           | ○                           | ○               | ○                   |
| 240  | Soft-PWM operation selection                      | 1          | 1 *2          | 0                         | Soft-PWM invalid   | ○                           | ○               | ○                   |
|  |   |            |               | 1                         | When <i>Pr. 72</i> = "0 to 5" ("0 to 4" for the 75K or higher), Soft-PWM is valid.   |                             |                 |                     |
| 260  | PWM frequency automatic switchover                | 1          | 1 *3          | 0                         | PWM carrier frequency is constant independently of load.<br>Under the following controls, perform continuous operation at less than 85% of the rated inverter current. <ul style="list-style-type: none"> <li>•V/F control, Simple magnetic flux vector control<br/>When the carrier frequency setting is 3kHz or higher (<i>Pr.72</i> ≥ 3)</li> <li>•IPM motor control<br/>When the carrier frequency setting is 6kHz or higher (<i>Pr.72</i> ≥ 6)</li> </ul> | ○                           | ○               | ○                   |
|  |   |            |               | 1                         | Decreases PWM carrier frequency automatically when load increases.   |                             |                 |                     |
| *1 The setting depends on the inverter capacity (55K or lower/75k or higher)<br>*2 Performing IPM parameter initialization changes the settings. (Refer to page 42)<br>*3 Performing IPM parameter initialization sets back the settings to the initial settings. (Refer to page 42) |   |            |               |                           |  |                             |                 |                     |
| <b>Frequency setting by analog input — Analog input selection, override function, analog input compensation (Pr.73, Pr.242, Pr.243, Pr.252, Pr.253, Pr.267)</b>  |   |            |               |                           |  |                             |                 |                     |
| 73   | Analog input selection                            | 1          | 1             | 0 to 7,<br>10 to 17       | You can select the input specifications of terminal 2 (0 to 5V, 0 to 10V, 0 to 20mA) and input specifications of terminal 1 (0 to ±5V, 0 to ±10V). Override and reversible operation can be selected. To change the terminal 2 to the voltage input specification (0 to 5V/ 0 to 10V), turn OFF(initial status) the voltage/current input switch. To change it to the current input(0 to 20mA), turn ON the voltage/current input switch.                      | ○                           | ×               | ○                   |
| 242  | Terminal 1 added compensation amount (terminal 2) | 0.1%       | 100%          | 0 to 100%                 | Set the ratio of added compensation amount when terminal 2 is the main speed.  | ○                           | ○               | ○                   |
| 243  | Terminal 1 added compensation amount (terminal 4) | 0.1%       | 75%           | 0 to 100%                 | Set the ratio of added compensation amount when terminal 4 is the main speed.  | ○                           | ○               | ○                   |
| 252  | Override bias                                     | 0.1%       | 50%           | 0 to 200%                 | Set the bias side compensation value of override function.   | ○                           | ○               | ○                   |
| 253  | Override gain                                     | 0.1%       | 150%          | 0 to 200%                 | Set the gain side compensation value of override function.   | ○                           | ○               | ○                   |
| 267  | Terminal 4 input selection                        | 1          | 0             | 0                         | Terminal 4 input 4 to 20mA   | ○                           | ×               | ○                   |
|  |   |            |               | 1                         | Terminal 4 input 0 to 5V   |                             |                 |                     |
|  |   |            |               | 2                         | Terminal 4 input 0 to 10V  |                             |                 |                     |



| Parameter<br>Related parameters  | Name  | Increments | Initial Value | Range            | Description  | Parameter copy              | Parameter clear | All parameter clear |
|--|---|------------|---------------|------------------|--|-----------------------------|-----------------|---------------------|
|  |   |            |               |                  |  | O : enabled<br>× : disabled |                 |                     |
| <b>Frequency setting by analog input — Noise elimination at the analog input (Pr.74)</b>                                 |   |            |               |                  |  |                             |                 |                     |
| 74   | Input filter time constant                                  | 1          | 1             | 0 to 8           | The primary delay filter time constant for the analog input can be set. A larger setting results in slower response.   | O                           | O               | O                   |
| <b>Misoperation prevention and parameter setting restriction — Reset selection and disconnected PU detection (Pr.75)</b> |   |            |               |                  |  |                             |                 |                     |
| 75   | Reset selection/disconnected PU detection/PU stop selection | 1          | 14            | 0 to 3, 14 to 17 | You can select the reset input acceptance, disconnected PU (FR-DU07/FR-PU04/FR-PU07) connector detection function and PU stop function. For the initial value, reset always enabled, without disconnected PU detection, and with PU stop function are set.                                       | O                           | ×               | ×                   |
| <b>Operation setting at fault occurrence — Output function of fault code (Pr.76)</b>                                     |   |            |               |                  |  |                             |                 |                     |
| 76   | Fault code output selection                                 | 1          | 0             | 0                | Without fault code output  | O                           | O               | O                   |
|  |   |            |               | 1                | With fault code output   |                             |                 |                     |
|  |   |            |               | 2                | Fault code output at fault occurrence only   |                             |                 |                     |
| <b>Misoperation prevention and parameter setting restriction — Prevention of parameter rewrite (Pr.77)</b>               |   |            |               |                  |  |                             |                 |                     |
| 77   | Parameter write selection                                   | 1          | 0             | 0                | Write is enabled only during a stop  | O                           | O               | O                   |
|  |   |            |               | 1                | Parameter write is disabled.   |                             |                 |                     |
|  |   |            |               | 2                | Parameter write is enabled in any operation mode regardless of operating status.   |                             |                 |                     |
| <b>Misoperation prevention and parameter setting restriction — Reverse motor rotation prevention (Pr.78)</b>             |   |            |               |                  |  |                             |                 |                     |
| 78   | Reverse rotation prevention selection                       | 1          | 0             | 0                | Both forward and reverse rotations allowed   | O                           | O               | O                   |
|  |   |            |               | 1                | Reverse rotation disallowed  |                             |                 |                     |
|  |   |            |               | 2                | Forward rotation disallowed  |                             |                 |                     |
| <b>Selection of operation mode and command source — Operation mode selection (Pr.79)</b>                                 |   |            |               |                  |  |                             |                 |                     |
| <b>Selection of operation mode and command source — Operation mode at power-ON (Pr.79, Pr.340)</b>                       |   |            |               |                  |  |                             |                 |                     |
| 79 <sup>Ⓞ</sup>  | Operation mode selection                                    | 1          | 0             | 0                | External/PU switchover mode  | O                           | O               | O                   |
|  |   |            |               | 1                | Fixed to PU operation mode   |                             |                 |                     |
|  |   |            |               | 2                | Fixed to External operation mode   |                             |                 |                     |
|  |   |            |               | 3                | External/PU combined operation mode 1  |                             |                 |                     |
|  |   |            |               | 4                | External/PU combined operation mode 2  |                             |                 |                     |
|  |   |            |               | 6                | Switchover mode  |                             |                 |                     |
|  |   |            |               | 7                | External operation mode (PU operation interlock)   |                             |                 |                     |
| 340  | Communication startup mode selection                        | 1          | 0             | 0                | As set in Pr.79.   | O                           | O               | O                   |
|  |   |            |               | 1, 2             | Started in the Network operation mode. When the setting is "2", it will resume the pre-instantaneous power failure operation mode after an instantaneous power failure occurs.   |                             |                 |                     |
|  |   |            |               | 10, 12           | Started in the Network operation mode. Operation mode can be changed between the PU operation mode and Network operation mode from the operation panel. When the setting is "12", it will resume the pre-instantaneous power failure operation mode after an instantaneous power failure occurs. |                             |                 |                     |



| Parameter   | Name                           | Increments          | Initial Value | Range                        | Description  | Parameter copy            | Parameter clear | All parameter clear |
|---|--------------------------------|---------------------|---------------|------------------------------|--|---------------------------|-----------------|---------------------|
|   |                                |                     |               |                              |  | O: enabled<br>×: disabled |                 |                     |
| <b>Adjusting the output torque (current) of the motor — Simple magnetic flux vector control and IPM motor control (Pr.80)</b> |                                |                     |               |                              |  | <br>                      |                 |                     |
| 80  | Motor capacity                 | 0.01kW/<br>0.1kW *1 | 9999 *2       | 0.4 to 55/<br>0 to 3600kW *1 | To select the Simple magnetic flux vector control and IPM motor control, set the capacity of the motor used. | ○                         | ○               | ○                   |
|   |                                |                     |               | 9999                         |  |                           |                 |                     |
| *1 The setting depends on the inverter capacity (55K or lower/75k or higher)  |                                |                     |               |                              |  |                           |                 |                     |
| *2 Performing IPM parameter initialization changes the settings. (Refer to page 42)   |                                |                     |               |                              |  |                           |                 |                     |
| <b>Adjusting the output torque (current) of the motor — Simple magnetic flux vector control (Pr.90)</b>                       |                                |                     |               |                              |  |                           |                 |                     |
| 90  | Motor constant (R1)            | 0.001Ω/<br>0.01mΩ * | 9999          | 0 to 50Ω/<br>0 to 400mΩ *    | Used to set the motor primary resistance value. (Normally setting is not necessary.)                         | ○                         | ×               | ○                   |
|   |                                |                     |               | 9999                         |  |                           |                 |                     |
| * The setting depends on the inverter capacity (55K or lower/75k or higher)   |                                |                     |               |                              |  |                           |                 |                     |
| <b>V/F pattern setting — Adjustable 5 points V/F (Pr.71, Pr.100 to Pr.109)</b>  |                                |                     |               |                              |  |                           |                 |                     |
| 100   | V/F1(first frequency)          | 0.01Hz              | 9999          | 0 to 400Hz,<br>9999          | Set each points (frequency, voltage) of V/F pattern.<br>9999: No V/F setting                                 | ○                         | ○               | ○                   |
| 101   | V/F1(first frequency voltage)  | 0.1V                | 0V            | 0 to 1000V                   |  | ○                         | ○               | ○                   |
| 102   | V/F2(second frequency)         | 0.01Hz              | 9999          | 0 to 400Hz,<br>9999          |  | ○                         | ○               | ○                   |
| 103   | V/F2(second frequency voltage) | 0.1V                | 0V            | 0 to 1000V                   |  | ○                         | ○               | ○                   |
| 104   | V/F3(third frequency)          | 0.01Hz              | 9999          | 0 to 400Hz,<br>9999          |  | ○                         | ○               | ○                   |
| 105   | V/F3(third frequency voltage)  | 0.1V                | 0V            | 0 to 1000V                   |  | ○                         | ○               | ○                   |
| 106   | V/F4(fourth frequency)         | 0.01Hz              | 9999          | 0 to 400Hz,<br>9999          |  | ○                         | ○               | ○                   |
| 107   | V/F4(fourth frequency voltage) | 0.1V                | 0V            | 0 to 1000V                   |  | ○                         | ○               | ○                   |
| 108   | V/F5(fifth frequency)          | 0.01Hz              | 9999          | 0 to 400Hz,<br>9999          |  | ○                         | ○               | ○                   |
| 109   | V/F5(fifth frequency voltage)  | 0.1V                | 0V            | 0 to 1000V                   |  | ○                         | ○               | ○                   |
| 71  | Refer to page 94.              |                     |               |                              |  |                           |                 |                     |





| Parameter   | Name                                       | Increments | Initial Value | Range            | Description  | Parameter copy               | Parameter clear | All parameter clear |   |
|---|--|------------|---------------|------------------|--|------------------------------|-----------------|---------------------|---|
|   |  |            |               |                  |  | O : enabled<br>× : disabled  |                 |                     |   |
| <b>Communication operation and setting — Initial setting of RS-485 communication (Pr.117 to Pr.124, Pr.551)</b> |  |            |               |                  |  |                              |                 |                     |   |
| <b>Communication operation and setting — Control of parameter write by communication (Pr.342)</b>               |  |            |               |                  |  |                              |                 |                     |   |
| 117   | PU communication station number            | 1          | 0             | 0 to 31          | Specify the inverter station number. Set the inverter station numbers when two or more inverters are connected to one personal computer.                               | ○                            | ○               | ○                   |   |
| 118   | PU communication speed                     | 1          | 192           | 48, 96, 192, 384 | Set the communication speed. The setting value × 100 equals the communication speed. For example, the communication speed is 19200bps when the setting value is "192". | ○                            | ○               | ○                   |   |
| 119   | PU communication stop bit length           | 1          | 1             | 0                | <b>Stop bit length</b><br>1 bit  | <b>data length</b><br>8 bits | ○               | ○                   | ○ |
|   |  |            |               | 1                | 2 bits   | 8 bits                       |                 |                     |   |
|   |  |            |               | 10               | 1 bit  | 7 bits                       |                 |                     |   |
|   |  |            |               | 11               | 2 bits   | 7 bits                       |                 |                     |   |
| 120   | PU communication parity check              | 1          | 2             | 0                | Without parity check   |                              | ○               | ○                   | ○ |
|   |  |            |               | 1                | With odd parity check  |                              |                 |                     |   |
|   |  |            |               | 2                | With even parity check   |                              |                 |                     |   |
| 121   | Number of PU communication retries         | 1          | 1             | 0 to 10          | Set the permissible number of retries at occurrence of a data receive error. If the number of consecutive errors exceeds the permissible value, the inverter trips.    |                              | ○               | ○                   | ○ |
|   |  |            |               | 9999             | If a communication error occurs, the inverter will not come to trip.   |                              |                 |                     |   |
| 122   | PU communication check time interval       | 0.1s       | 9999          | 0                | No PU connector communication  |                              | ○               | ○                   | ○ |
|   |  |            |               | 0.1 to 999.8s    | Set the communication check time interval. If a no-communication state persists for longer than the permissible time, the inverter trips.                              |                              |                 |                     |   |
|   |  |            |               | 9999             | No communication check   |                              |                 |                     |   |
| 123   | PU communication waiting time setting      | 1          | 9999          | 0 to 150ms       | Set the waiting time between data transmission to the inverter and response.   |                              | ○               | ○                   | ○ |
|   |  |            |               | 9999             | Set with communication data.   |                              |                 |                     |   |
| 124   | PU communication CR/LF selection           | 1          | 1             | 0                | Without CR/LF  |                              | ○               | ○                   | ○ |
|   |  |            |               | 1                | With CR  |                              |                 |                     |   |
|   |  |            |               | 2                | With CR/LF   |                              |                 |                     |   |
| 342   | Communication EEPROM write selection       | 1          | 0             | 0                | Parameter values written by communication are written to the EEPROM and RAM.   |                              | ○               | ○                   | ○ |
|   |  |            |               | 1                | Parameter values written by communication are written to the RAM.  |                              |                 |                     |   |
| 551   | PU mode operation command source selection | 1          | 2             | 1                | Select the RS-485 terminals as the PU operation mode control source.   |                              | ○               | ○                   | ○ |
|   |  |            |               | 2                | Select the PU connector as the PU operation mode control source.   |                              |                 |                     |   |





| Parameter   | Name  | Increments  | Initial Value | Range        | Description   | Parameter copy              | Parameter clear | All parameter clear |  |
|---|---|---|---------------|--------------|---|-----------------------------|-----------------|---------------------|--|
|   |   |   |               |              |   | O : enabled<br>x : disabled |                 |                     |  |
| <b>Frequency setting by analog input — Bias and gain for the frequency setting voltage (current) (Pr.125, Pr.126, Pr.241, C2(Pr.902) to C7(Pr.905))</b>                                 |   |   |               |              |   |                             |                 |                     |  |
| 125 <sup>Ⓞ</sup>  | Terminal 2 frequency setting gain frequency | 0.01Hz  | 60Hz*         | 0 to 400Hz   | Set the frequency of terminal 2 input gain (maximum).   | ○                           | ×               | ○                   |  |
| 126 <sup>Ⓞ</sup>  | Terminal 4 frequency setting gain frequency | 0.01Hz  | 60Hz*         | 0 to 400Hz   | Set the frequency of terminal 4 input gain (maximum).   | ○                           | ×               | ○                   |  |
| 241   | Analog input display unit switchover        | 1   | 0             | 0            | Displayed in %  | ○                           | ○               | ○                   |  |
|   |   |   |               | 1            | Displayed in V/mA   |                             |                 |                     | Select the unit for analog input display.                              |
| C2 (902)  | Terminal 2 frequency setting bias frequency | 0.01Hz  | 0Hz           | 0 to 400Hz   | Set the frequency on the bias side of terminal 2 input.   | ○                           | ×               | ○                   |  |
| C3 (902)  | Terminal 2 frequency setting bias           | 0.1%  | 0%            | 0 to 300%    | Set the converted % of the bias side voltage (current) of terminal 2 input.   | ○                           | ×               | ○                   |  |
| C4 (903)  | Terminal 2 frequency setting gain           | 0.1%  | 100%          | 0 to 300%    | Set the converted % of the gain side voltage of terminal 2 input.   | ○                           | ×               | ○                   |  |
| C5 (904)  | Terminal 4 frequency setting bias frequency | 0.01Hz  | 0Hz           | 0 to 400Hz   | Set the frequency on the bias side of terminal 4 input.   | ○                           | ×               | ○                   |  |
| C6 (904)  | Terminal 4 frequency setting bias           | 0.1%  | 20%           | 0 to 300%    | Set the converted % of the bias side current (voltage) of terminal 4 input.   | ○                           | ×               | ○                   |  |
| C7 (905)  | Terminal 4 frequency setting gain           | 0.1%  | 100%          | 0 to 300%    | Set the converted % of the gain side current (voltage) of terminal 4 input.   | ○                           | ×               | ○                   |  |
| * Performing IPM parameter initialization changes the settings. (Refer to page 42)<br>The parameter number in parentheses is the one for use with the parameter unit (FR-PU04/FR-PU07). |   |   |               |              |   |                             |                 |                     |  |
| <b>Special operation and frequency control — PID control (Pr.127 to Pr.134, Pr.553, Pr.554, Pr.575 to Pr.577, C42(Pr.934) to C45(Pr.935))</b>   |   |   |               |              |   |                             |                 |                     |  |
| 127   | PID control automatic switchover frequency  | 0.01Hz  | 9999          | 0 to 400Hz   | Set the frequency at which the control is automatically changed to PID control.   | ○                           | ○               | ○                   |  |
|   |   |   |               | 9999         | Without PID automatic switchover function   |                             |                 |                     |  |
| 128   | PID action selection                        | 1   | 10            | 10, 110      | PID reverse action  | ○                           | ○               | ○                   |  |
|   |   |   |               | 11, 111      | PID forward action  |                             |                 |                     | Deviation value signal (terminal 1)                                    |
|   |   |   |               | 20, 120      | PID reverse action  |                             |                 |                     | Measured value input (terminal 4)<br>Set value (terminal 2 or Pr. 133) |
|   |   |   |               | 21, 121      | PID forward action  |                             |                 |                     |  |
|   |   |   |               | 50           | PID reverse action  |                             |                 |                     | Deviation value signal input (LONWORKS, CC-Link communication)         |
|   |   |   |               | 51           | PID forward action  |                             |                 |                     |  |
| 60  | PID reverse action                          | Measured value, set value input (LONWORKS, CC-Link communication) |               |              |   |                             |                 |                     |  |
| 61  | PID forward action                          |   |               |              |   |                             |                 |                     |  |
| 129   | PID proportional band                       | 0.1%  | 100%          | 0.1 to 1000% | If the proportional band is narrow (parameter setting is small), the manipulated variable varies greatly with a slight change of the measured value. Hence, as the proportional band narrows, the response sensitivity (gain) improves but the stability deteriorates, e.g. hunting occurs.<br>Gain K = 1/proportional band | ○                           | ○               | ○                   |  |
|   |   |   |               | 9999         | No proportional control   |                             |                 |                     |  |



| Parameter    | Name                                | Increments | Initial Value | Range            | Description  | Parameter copy              | Parameter clear | All parameter clear |
|--------------|-------------------------------------|------------|---------------|------------------|--|-----------------------------|-----------------|---------------------|
|              |                                     |            |               |                  |  | O : enabled<br>× : disabled |                 |                     |
| 130          | PID integral time                   | 0.1s       | 1s            | 0.1 to 3600s     | When deviation step is input, time (Ti) is the time required for integral (I) action to provide the same manipulated variable as the proportional (P) action. As the integral time decreases, the set point is reached earlier but hunting occurs more easily. | ○                           | ○               | ○                   |
|              |                                     |            |               | 9999             | No integral control.   |                             |                 |                     |
| 131          | PID upper limit                     | 0.1%       | 9999          | 0 to 100%        | Set the upper limit value. If the feedback value exceeds the setting, the FUP signal is output. The maximum input (20mA/5V/10V) of the measured value (terminal 4) is equivalent to 100%.  | ○                           | ○               | ○                   |
|              |                                     |            |               | 9999             | No function  |                             |                 |                     |
| 132          | PID lower limit                     | 0.1%       | 9999          | 0 to 100%        | Set the lower limit value. If the measured value falls below the setting range, the FDN signal is output. The maximum input (20mA/5V/10V) of the measured value (terminal 4) is equivalent to 100%.  | ○                           | ○               | ○                   |
|              |                                     |            |               | 9999             | No function  |                             |                 |                     |
| 133          | PID action set point                | 0.01%      | 9999          | 0 to 100%        | Used to set the set point for PID control.   | ○                           | ○               | ○                   |
|              |                                     |            |               | 9999             | Terminal 2 input voltage is the set point.   |                             |                 |                     |
| 134          | PID differential time               | 0.01s      | 9999          | 0.01 to 10.00s   | For deviation lamp input, time (Td) required for providing only the manipulated variable for the proportional (P) action. As the differential time increases, greater response is made to a deviation change.  | ○                           | ○               | ○                   |
|              |                                     |            |               | 9999             | No differential control.   |                             |                 |                     |
| 553          | PID deviation limit                 | 0.1%       | 9999          | 0 to 100.0%      | Y48 signal is output when the absolute value of deviation amount exceeds the deviation limit value.  | ○                           | ○               | ○                   |
|              |                                     |            |               | 9999             | No function  |                             |                 |                     |
| 554          | PID signal operation selection      | 1          | 0             | 0 to 3, 10 to 13 | Select the operation to be performed at the detection of upper, lower, and deviation limit for the measured value input. The operation for PID output suspension function can be selected.   | ○                           | ○               | ○                   |
| 575          | Output interruption detection time  | 0.1s       | 1s            | 0 to 3600s       | If the output frequency after PID operation remains lower than the Pr: 576 setting for longer than the time set in Pr: 575, the inverter stops operation.  | ○                           | ○               | ○                   |
|              |                                     |            |               | 9999             | Without output interruption function   |                             |                 |                     |
| 576          | Output interruption detection level | 0.01Hz     | 0Hz           | 0 to 400Hz       | Set the frequency at which the output interruption processing is performed.  | ○                           | ○               | ○                   |
| 577          | Output interruption cancel level    | 0.1%       | 1000%         | 900 to 1100%     | Set the level (Pr:577 - 1000%) to release the PID output interruption function.  | ○                           | ○               | ○                   |
| C42<br>(934) | PID display bias coefficient        | 0.01       | 9999          | 0 to 500.00      | Set the coefficient on bias side (minimum) of terminal 4 input.  | ○                           | ×               | ○                   |
|              |                                     |            |               | 9999             | Displayed in %.  |                             |                 |                     |
| C43<br>(934) | PID display bias analog value       | 0.1%       | 20%           | 0 to 300.0%      | Set the converted % on bias side (minimum) current /voltage of terminal 4 input.   | ○                           | ×               | ○                   |
| C44<br>(935) | PID display gain coefficient        | 0.01       | 9999          | 0 to 500.00      | Set the coefficient on gain side (maximum) of the terminal 4 input.  | ○                           | ×               | ○                   |
|              |                                     |            |               | 9999             | Displayed in %.  |                             |                 |                     |
| C45<br>(935) | PID display gain analog value       | 0.1%       | 100%          | 0 to 300.0%      | Set the converted % on gain side (maximum) of current/voltage of terminal 4 input.   | ○                           | ×               | ○                   |

The parameter number in parentheses is the one for use with the parameter unit (FR-PU04/FR-PU07).

| Parameter   | Name   | Increments | Initial Value | Range                                | Description  | Parameter copy  | Parameter clear                  | All parameter clear              |
|---|--|------------|---------------|--------------------------------------|--|---|----------------------------------|----------------------------------|
|   |  |            |               |                                      |  | O: enabled<br>×: disabled   |                                  |                                  |
| <b>Special operation and frequency control — Switching between the inverter and the bypass operation (Pr.135 to Pr.139, Pr.159)</b> |  |            |               |                                      |  |   |                                  |                                  |
| 135   | Electronic bypass sequence selection                                   | 1          | 0             | 0<br>1                               | Without electronic bypass sequence<br>With electronic bypass sequence  | <input type="radio"/>   | <input type="radio"/>            | <input type="radio"/>            |
| 136   | MC switchover interlock time   | 0.1s       | 1s            | 0 to 100s                            | Set the operation interlock time of MC2 and MC3.   | <input type="radio"/>   | <input type="radio"/>            | <input type="radio"/>            |
| 137   | Start waiting time   | 0.1s       | 0.5s          | 0 to 100s                            | Set the time slightly longer (0.3 to 0.5s or so) than the time from when the ON signal enters MC3 until it actually turns ON.  | <input type="radio"/>   | <input type="radio"/>            | <input type="radio"/>            |
| 138   | Bypass selection at a fault  | 1          | 0             | 0<br>1                               | Inverter output is stopped (motor coast) at inverter fault.<br>Operation is automatically switched to bypass operation at inverter fault (Not switched when an external thermal relay operation (E.OHT) or CPU fault (E.CPU) occurs)   | <input type="radio"/>   | <input type="radio"/>            | <input type="radio"/>            |
| 139   | Automatic switchover frequency from inverter to bypass operation       | 0.01Hz     | 9999          | 0 to 60Hz<br>9999                    | Set the frequency to switch inverter operation to bypass operation.<br>Without automatic switchover  | <input type="radio"/>   | <input type="radio"/>            | <input type="radio"/>            |
| 159   | Automatic switchover frequency range from bypass to inverter operation | 0.01Hz     | 9999          | 0 to 10Hz<br>9999                    | Valid during automatic switchover operation (Pr.139 ≠ 9999)<br>When the frequency command decreases below (Pr.139 - Pr.159) after operation is switched from inverter operation to bypass operation, the inverter automatically switches operation to inverter operation and operates at the frequency of frequency command.<br>When the inverter start command (STF/STR) is turned OFF, operation is switched to inverter operation also.<br>Valid during automatic switchover operation (Pr.139 ≠ 9999)<br>When the inverter start command (STF/STR) is turned OFF after operation is switched from inverter operation to bypass operation, operation is switched to inverter operation and the motor decelerates to stop. | <input type="radio"/>   | <input type="radio"/>            | <input type="radio"/>            |
| 140 to 143  | Refer to Pr.29.  |            |               |                                      |  |   |                                  |                                  |
| 144   | Refer to Pr.37.  |            |               |                                      |  |   |                                  |                                  |
| <b>Setting of the parameter unit and operation panel — Parameter unit language switchover (Pr.145)</b>                              |  |            |               |                                      |  |   |                                  |                                  |
| 145   | PU display language selection  | 1          | 0             | 0<br>1<br>2<br>3<br>4<br>5<br>6<br>7 | Japanese<br>English<br>Germany<br>French<br>Spanish<br>Italian<br>Swedish<br>Finnish   | <input type="radio"/>   | <input checked="" type="radio"/> | <input checked="" type="radio"/> |
| 147   | Refer to Pr.7 and Pr.8.  |            |               |                                      |  |   |                                  |                                  |
| 148,149   | Refer to Pr.22 and Pr.23.  |            |               |                                      |  |   |                                  |                                  |



| Parameter  | Name  | Increments | Initial Value | Range          | Description   | Parameter copy              | Parameter clear | All parameter clear |
|--|---|------------|---------------|----------------|---|-----------------------------|-----------------|---------------------|
|  |   |            |               |                |   | O : enabled<br>× : disabled |                 |                     |
| <b>Detection of output frequency and current — Detection of output current (Y12 signal) and zero current (Y13 signal) (Pr.150 to Pr.153, Pr.166, Pr.167)</b> |   |            |               |                |   |                             |                 |                     |
| 150  | Output current detection level                  | 0.1%       | 120%          | 0 to 150%      | Set the output current detection level. 100% is the rated inverter current.   | ○                           | ○               | ○                   |
| 151  | Output current detection signal delay time      | 0.1s       | 0s            | 0 to 10s       | Set the output current detection period. Set the time from when the output current has risen above the setting until the output current detection signal (Y12) is output. | ○                           | ○               | ○                   |
| 152  | Zero current detection level                    | 0.1%       | 5%            | 0 to 150%      | Set the zero current detection level. Suppose that the rated inverter current is 100%.  | ○                           | ○               | ○                   |
| 153  | Zero current detection time                     | 0.01s      | 0.5s          | 0 to 10s       | Set this parameter to define the period from when the output current drops below the <i>Pr.152</i> value until the zero current detection signal (Y13) is output.         | ○                           | ○               | ○                   |
| 166  | Output current detection signal retention time  | 0.1s       | 0.1s          | 0 to 10s       | Set the retention time when the Y12 signal is ON.   | ○                           | ○               | ○                   |
|  |   |            |               | 9999           | The Y12 signal ON status is retained. The signal is turned OFF at the next start.   |                             |                 |                     |
| 167  | Output current detection operation selection    | 1          | 0             |                | <b>Y12 Signal - ON</b>  | <b>Y13 Signal - ON</b>      | ○               | ○                   |
|  |   |            |               | 0              | Operation continued   | Operation continued         |                 |                     |
|  |   |            |               | 1              | Trip (E.CDO)  | Operation continued         |                 |                     |
|  |   |            |               | 10             | Operation continued   | Trip (E.CDO)                |                 |                     |
|  |   |            |               | 11             | Trip (E.CDO)  | Trip (E.CDO)                |                 |                     |
| 154  | Refer to <i>Pr.22</i> and <i>Pr.23</i> .        |            |               |                |   |                             |                 |                     |
| <b>Function assignment of external terminal and control — Condition selection for the second functions activation (RT signal) (Pr.155)</b>                   |   |            |               |                |   |                             |                 |                     |
| 155  | RT signal function validity condition selection | 1          | 0             | 0              | Second function is immediately valid with ON of the RT signal.  | ○                           | ○               | ○                   |
|  |   |            |               | 10             | Second function is valid only during the RT signal is ON and constant speed operation. (Invalid during acceleration/deceleration)   |                             |                 |                     |
| 156, 157   | Refer to <i>Pr.22</i> and <i>Pr.23</i> .        |            |               |                |   |                             |                 |                     |
| 158  | Refer to <i>Pr.54</i> to <i>Pr.56</i> .         |            |               |                |   |                             |                 |                     |
| 159  | Refer to <i>Pr.135</i> to <i>Pr.139</i> .       |            |               |                |   |                             |                 |                     |
| <b>Misoperation prevention and parameter setting restriction — Displaying necessary parameters only (user group) (Pr.160, Pr.172 to Pr.174)</b>              |   |            |               |                |   |                             |                 |                     |
| 160 <sup>Ⓞ</sup>   | User group read selection                       | 1          | 9999          | 9999           | Only the simple mode parameters can be displayed.   | ○                           | ○               | ○                   |
|  |   |            |               | 1              | Only the parameters registered in the user group can be displayed.  |                             |                 |                     |
|  |   |            |               | 0              | Simple mode and extended mode parameters can be displayed.  |                             |                 |                     |
| 172  | User group registered display/batch clear       | 1          | 0             | (0 to 16)      | Displays the number of cases registered as a user group (reading only).   | ○                           | ×               | ×                   |
|  |   |            |               | 9999           | Batch clear the user group registration   |                             |                 |                     |
| 173  | User group registration                         | 1          | 9999          | 0 to 999, 9999 | Set the parameter numbers to be registered to the user group. Read value is always "9999".  | ×                           | ×               | ×                   |
| 174  | User group clear                                | 1          | 9999          | 0 to 999, 9999 | Set the parameter numbers to be cleared from the user group. Read value is always "9999".   | ×                           | ×               | ×                   |



| Parameter   | Name  | Increments | Initial Value | Range  | Description  | Parameter copy            | Parameter clear | All parameter clear |
|---|---|------------|---------------|--|--|---------------------------|-----------------|---------------------|
|   |   |            |               |  |  | ○: enabled<br>×: disabled |                 |                     |
| <b>Setting of the parameter unit and operation panel — Operation selection of the operation panel (Pr.161)</b>          |   |            |               |  |  |                           |                 |                     |
| 161   | Frequency setting/key lock operation selection  | 1          | 0             | 0  | Setting dial frequency setting   | ○                         | ×               | ○                   |
|   |   |            |               | 1  | Setting dial potentiometer   |                           |                 |                     |
|   |   |            |               | 10   | Setting dial frequency setting   | ○                         | ×               | ○                   |
|   |   |            |               | 11   | Setting dial potentiometer   |                           |                 |                     |
| 162 to 165  | Refer to <i>Pr.57 and Pr.58</i> .               |            |               |  |  |                           |                 |                     |
| 166, 167  | Refer to <i>Pr.150 to Pr.153</i> .              |            |               |  |  |                           |                 |                     |
| 168, 169  | Parameter for manufacturer setting. Do not set. |            |               |  |  |                           |                 |                     |
| 170, 171  | Refer to <i>Pr.52</i> .                         |            |               |  |  |                           |                 |                     |
| 172 to 174  | Refer to <i>Pr.160</i> .                        |            |               |  |  |                           |                 |                     |
| <b>Function assignment of external terminal and control — Function assignment of input terminals (Pr.178 to Pr.189)</b> |   |            |               |  |  |                           |                 |                     |
| 178   | STF terminal function selection                 | 1          | 60            | 0 to 8, 10 to 12, 14, 16, 24, 25, 60, 62, 64 to 67, 70 to 72, 9999 | 0: Low-speed operation command (RL)<br>1: Middle-speed operation command (RM)<br>2: High-speed operation command (RH)<br>3: Second function selection (RT)<br>4: Terminal 4 input selection (AU)<br>5: Jog operation selection (JOG)<br>6: Selection of automatic restart after instantaneous power failure, flying start (CS)<br>7: External thermal relay input (OH)<br>8: 15-speed selection (combination with three speeds RL, RM, RH) (REX) | ○                         | ×               | ○                   |
| 179   | STR terminal function selection                 | 1          | 61            | 0 to 8, 10 to 12, 14, 16, 24, 25, 61, 62, 64 to 67, 70 to 72, 9999 | 10: Inverter run enable signal (FR-HC2/FR-CV connection) (X10)<br>11: FR-HC2 connection, instantaneous power failure detection (X11)<br>12: PU operation external interlock (X12)<br>14: PID control valid terminal (X14)<br>16: PU/External operation switchover (X16)<br>24: Output stop (MRS)<br>25: Start self-holding selection (STOP)  | ○                         | ×               | ○                   |
| 180   | RL terminal function selection                  | 1          | 0             | 0 to 8, 10 to 12, 14, 16, 24, 25, 62, 64 to 67, 70 to 72, 9999     | 60: Forward rotation command (STF) (assigned to STF terminal ( <i>Pr.178</i> ) only)   | ○                         | ×               | ○                   |
| 181   | RM terminal function selection                  | 1          | 1             |  | 61: Reverse rotation command (STR) (assigned to STR terminal ( <i>Pr.179</i> ) only)   | ○                         | ×               | ○                   |
| 182   | RH terminal function selection                  | 1          | 2             |  | 62: Inverter reset (RES)   | ○                         | ×               | ○                   |
| 183   | RT terminal function selection                  | 1          | 3             |  | 63: PTC thermistor input (PTC) (assigned to AU terminal ( <i>Pr.184</i> ) only)  | ○                         | ×               | ○                   |
| 184   | AU terminal function selection                  | 1          | 4             |  | 64: PID forward/reverse action switchover (X64)  | ○                         | ×               | ○                   |
| 185   | JOG terminal function selection                 | 1          | 5             | 0 to 8, 10 to 12, 14, 16, 24, 25, 62, 64 to 67, 70 to 72, 9999     | 65: PU/NET operation switchover (X65)  | ○                         | ×               | ○                   |
| 186   | CS terminal function selection                  | 1          | 6             |  | 66: External/NET operation switchover (X66)  | ○                         | ×               | ○                   |
| 187   | MRS terminal function selection                 | 1          | 24            |  | 67: Command source switchover (X67)  | ○                         | ×               | ○                   |
| 188   | STOP terminal function selection                | 1          | 25            |  | 70: DC feeding operation permission (X70)<br>71: DC feeding cancel (X71)<br>72: PID integral value reset (X72)   | ○                         | ×               | ○                   |
| 189   | RES terminal function selection                 | 1          | 62            |  | 9999: No function  | ○                         | ×               | ○                   |



| Parameter  | Name                             | Increments | Initial Value | Range   | Description   | Parameter copy              | Parameter clear | All parameter clear |
|--|----------------------------------|------------|---------------|---|---|-----------------------------|-----------------|---------------------|
|  |                                  |            |               |   |   | O : enabled<br>× : disabled |                 |                     |
| <b>Function assignment of external terminal and control — Function assignment of output terminals (Pr.190 to Pr.196)</b> |                                  |            |               |   |   |                             |                 |                     |
| 190  | RUN terminal function selection  | 1          | 0             |   | 0, 100: Inverter running (RUN)<br>1, 101: Up to frequency (SU)<br>2, 102: Instantaneous power failure/ undervoltage (IPF)<br>3, 103: Overload warning (OL)<br>4, 104: Output frequency detection (FU)<br>5, 105: Second output frequency detection (FU2)  | ○                           | ×               | ○                   |
| 191  | SU terminal function selection   | 1          | 1             | 0 to 5, 7, 8, 10 to 19, 25, 26, 45 to 48, 57, 64, 67, 70, 79, 85, 90 to 96, 98, 99,   | 7, 107: Regenerative brake pre-alarm (RBP) (Only for the 75K or higher)<br>8, 108: Electronic thermal O/L relay pre-alarm (THP)<br>10, 110: PU operation mode (PU)<br>11, 111: Inverter operation ready (RY)<br>12, 112: Output current detection (Y12)<br>13, 113: Zero current detection (Y13)<br>14, 114: PID lower limit (FDN)<br>15, 115: PID upper limit (FUP)  | ○                           | ×               | ○                   |
| 192  | IPF terminal function selection  | 1          | 2             | 100 to 105, 107, 108, 110 to 116, 125, 126, 145 to 148,   | 16, 116: PID forward/reverse rotation output (RL)<br>17, —: Electronic bypass MC1 (MC1) *<br>18, —: Electronic bypass MC2 (MC2) *<br>19, —: Electronic bypass MC3 (MC3) *<br>25, 125: Fan fault output (FAN)<br>26, 126: Heatsink overheat pre-alarm (FIN)<br>45, 145: Inverter running and start command is ON(RUN3)<br>46, 146: During deceleration at occurrence of power failure (retained until release) (Y46)             | ○                           | ×               | ○                   |
| 193  | OL terminal function selection   | 1          | 3             | 157, 164, 167, 170, 179, 185, 190 to 196, 198, 199, 9999  | 47, 147: During PID control activated (PID)<br>48, 148: PID deviation limit (Y48)<br>57, 157: IPM motor control (IPM)<br>64, 164: During retry (Y64)<br>67, 167: During power failure (Y67)<br>70, 170: PID output interruption (SLEEP)<br>79, 179: Pulse train output of output power (Y79)  | ○                           | ×               | ○                   |
| 194  | FU terminal function selection   | 1          | 4             |   | 92, 192: Energy saving average value updated timing (Y92)<br>93, 193: Current average monitor signal (Y93)<br>94, 194: Fault output 2 (ALM2)<br>95, 195: Maintenance timer signal (Y95)<br>96, 196: Remote output (REM)<br>98, 198: Alarm output (LF)<br>99, 199: Fault output (ALM)<br>9999: No function   | ○                           | ×               | ○                   |
| 195  | ABC1 terminal function selection | 1          | 99            | 0 to 5, 7, 8, 10 to 19, 25, 26, 45 to 48, 57, 64, 67, 70, 79, 85, 90, 91, 94 to 96, 98, 99, 100 to 105, 107, 108, 110 to 116, 125, 126, 145 to 148, | 85, 185: DC current feeding (Y85)<br>90, 190: Life alarm (Y90)<br>91, 191: Fault output 3 (power-OFF signal) (Y91)<br>92, 192: Energy saving average value updated timing (Y92)<br>93, 193: Current average monitor signal (Y93)<br>94, 194: Fault output 2 (ALM2)<br>95, 195: Maintenance timer signal (Y95)<br>96, 196: Remote output (REM)<br>98, 198: Alarm output (LF)<br>99, 199: Fault output (ALM)<br>9999: No function | ○                           | ×               | ○                   |
| 196  | ABC2 terminal function selection | 1          | 9999          | 157, 164, 167, 170, 179, 185, 190, 191, 194 to 196, 198, 199, 9999  | 0 to 99: Positive logic, 100 to 199: Negative logic<br>* Available under V/F control and Simple magnetic flux vector control  | ○                           | ×               | ○                   |
| 232 to 239   | Refer to Pr.4 to Pr.6.           |            |               |   |   |                             |                 |                     |
| 240  | Refer to Pr.72.                  |            |               |   |   |                             |                 |                     |
| 241  | Refer to Pr.125 and Pr.126.      |            |               |   |   |                             |                 |                     |
| 242, 243   | Refer to Pr.73.                  |            |               |   |   |                             |                 |                     |



| Parameter<br>Related parameters  | Name   | Increments | Initial Value | Range         | Description  | Parameter copy              | Parameter clear | All parameter clear |
|--|--|------------|---------------|---------------|--|-----------------------------|-----------------|---------------------|
|  |  |            |               |               |  | ○ : enabled<br>× : disabled |                 |                     |
| <b>Useful functions — Lifespan extension of the cooling fan (Pr.244)</b>                                 |  |            |               |               |  |                             |                 |                     |
| 244  | Cooling fan operation selection                  | 1          | 1             | 0             | Operates at power ON<br>Cooling fan ON/OFF control invalid (The cooling fan is always ON at power ON)  | ○                           | ○               | ○                   |
|  |  |            |               | 1             | Cooling fan ON/OFF control valid<br>The fan is normally on during inverter operation. The fan switches ON/OFF according to the temperature during a stop of the inverter whose status is monitored.            |                             |                 |                     |
| <b>Adjusting the output torque (current) of the motor — Slip compensation (Pr.245 to Pr.247)</b>         |  |            |               |               |  |                             |                 |                     |
|  |  |            |               |               |  | <br>                        |                 |                     |
| 245  | Rated slip                                       | 0.01%      | 9999          | 0 to 50%      | Used to set the rated motor slip.  | ○                           | ○               | ○                   |
|  |  |            |               | 9999          | No slip compensation   |                             |                 |                     |
| 246  | Slip compensation time constant                  | 0.01s      | 0.5s          | 0.01 to 10s   | Used to set the response time of slip compensation. When the value is smaller, response will be faster. However, as load inertia is greater, a regenerative overvoltage (E.OV□) error is more liable to occur. | ○                           | ○               | ○                   |
| 247  | Constant-power range slip compensation selection | 1          | 9999          | 0             | Slip compensation is not made in the constant power range (frequency range above the frequency set in Pr.3)  | ○                           | ○               | ○                   |
|  |  |            |               | 9999          | Slip compensation is made in the constant power range.   |                             |                 |                     |
| <b>Motor brake and stop operation — Motor stop method and start signal selection (Pr.250)</b>            |  |            |               |               |  |                             |                 |                     |
| <b>Function assignment of external terminal and control — Start signal selection (Pr.250)</b>            |  |            |               |               |  |                             |                 |                     |
| 250  | Stop selection                                   | 0.1s       | 9999          | 0 to 100s     | The motor is coasted to a stop when the preset time elapses after the start signal is turned OFF.  | ○                           | ○               | ○                   |
|  |  |            |               | 1000 to 1100s | When 1000s to 1100s is set (Pr. 250 setting-1000)s later, the motor coasts to stop.  |                             |                 |                     |
|  |  |            |               | 9999          | When the start signal is turned OFF, the motor decelerates to stop.  |                             |                 |                     |
|  |  |            |               | 8888          |  |                             |                 |                     |
| <b>Operation setting at fault occurrence — Input phase failure protection selection (Pr.251, Pr.872)</b> |  |            |               |               |  |                             |                 |                     |
| 251  | Output phase loss protection selection           | 1          | 1             | 0             | Without output phase loss protection   | ○                           | ○               | ○                   |
|  |  |            |               | 1             | With output phase loss protection  |                             |                 |                     |
| 872  | Input phase loss protection selection            | 1          | 0             | 0             | Without input phase loss protection  | ○                           | ○               | ○                   |
|  |  |            |               | 1             | With input phase loss protection   |                             |                 |                     |
| 252, 253   | Refer to Pr.73.                                  |            |               |               |  |                             |                 |                     |





| Parameter  | Name                                       | Increments        | Initial Value                               | Range          | Description  | Parameter copy   | Parameter clear                                      | All parameter clear |   |   |
|--|--|-------------------|---|----------------|--|--|--|---------------------|---|---|
|  |  |                   |   |                |  | O : enabled<br>× : disabled                            |  |                     |   |   |
| <b>Useful functions — To display life of inverter parts (Pr.255 to Pr.259)</b>   |  |                   |   |                |  |  |  |                     |   |   |
| 255  | Life alarm status display                  | 1                 | 0   | (0 to 15)      | Displays whether the control circuit capacitor, main circuit capacitor, cooling fan, and each parts of the inrush current limit circuit has reached the life alarm output level or not.                                | ×  | ×  | ×                   |   |   |
| 256  | Inrush current limit circuit life display  | 1%                | 100%  | (0 to 100%)    | Displays the deterioration degree of the inrush current limit circuit. Reading only  | ×  | ×  | ×                   |   |   |
| 257  | Control circuit capacitor life display     | 1%                | 100%  | (0 to 100%)    | Displays the deterioration degree of the control circuit capacitor. Reading only   | ×  | ×  | ×                   |   |   |
| 258  | Main circuit capacitor life display        | 1%                | 100%  | (0 to 100%)    | Displays the deterioration degree of the main circuit capacitor. Reading only<br>The value measured by <i>Pr. 259</i> is displayed.  | ×  | ×  | ×                   |   |   |
| 259  | Main circuit capacitor life measuring      | 1                 | 0   | 0, 1           | Start measuring the main circuit capacitor life. Switch the power supply ON again and check the <i>Pr. 259</i> setting. Measurement is complete if the setting is "3". Set the deterioration degree in <i>Pr.258</i> . | ○  | ○  | ○                   |   |   |
| 260  | Refer to <i>Pr.72</i> .                    |                   |   |                |  |  |  |                     |   |   |
| <b>Motor brake and stop operation — Decelerate the motor to a stop at instantaneous power failure (Pr.261 to Pr.266)</b>                                       |  |                   |   |                |  |  |  |                     |   |   |
| <b>Operation selection at power failure and instantaneous power failure — Decelerate the motor to a stop at instantaneous power failure (Pr.261 to Pr.266)</b> |  |                   |   |                |  |  |  |                     |   |   |
| 261  | Power failure stop selection               | 1                 | 0   |                | Operation at undervoltage or power failure   | At power restoration during power failure deceleration | Deceleration time to a stop                          | ○                   | ○ | ○ |
|  |  |                   |   | 0              | Coasts to a stop   | Coasts to a stop                                       | -  |                     |   |   |
|  |  |                   |   | 1              | Decelerates to a stop  | Decelerates to a stop                                  | Depends on <i>Pr. 262</i> to <i>Pr. 266</i> settings |                     |   |   |
|  |  |                   |   | 2              | Decelerates to a stop  | Accelerates again                                      | Depends on <i>Pr. 262</i> to <i>Pr. 266</i> settings |                     |   |   |
|  |  |                   |   | 21             | Decelerates to a stop  | Decelerates to a stop                                  | Automatically adjusts the deceleration time          |                     |   |   |
| 22   | Decelerates to a stop                      | Accelerates again | Automatically adjusts the deceleration time |                |  |  |  |                     |   |   |
| 262  | Subtracted frequency at deceleration start | 0.01Hz            | 3Hz   | 0 to 20Hz      | Normally operation can be performed with the initial value unchanged. But adjust the frequency according to the magnitude of the load specifications (moment of inertia, torque).                                      |  |  | ○                   | ○ | ○ |
| 263  | Subtraction starting frequency             | 0.01Hz            | 60Hz *                                      | 0 to 400Hz     | When output frequency $\geq$ <i>Pr.263</i><br>Decelerate from the speed obtained from (output frequency - <i>Pr.262</i> ).<br>When output frequency $<$ <i>Pr.263</i><br>Decelerate from output frequency              |  |  | ○                   | ○ | ○ |
|  |  |                   |   | 9999           | Decelerate from the speed obtained from (output frequency - <i>Pr.262</i> ).   |  |  | ○                   | ○ | ○ |
| 264  | Power-failure deceleration time 1          | 0.1/0.01s         | 5s  | 0 to 3600/360s | Set a deceleration slope down to the frequency set in <i>Pr.266</i> .  |  |  | ○                   | ○ | ○ |
| 265  | Power-failure deceleration time 2          | 0.1/0.01s         | 9999  | 0 to 3600/360s | Set a deceleration slope below the frequency set in <i>Pr.266</i> .  |  |  | ○                   | ○ | ○ |
|  |  |                   |   | 9999           | Same slope as in <i>Pr.264</i>   |  |  |                     |   |   |





| Parameter   | Name   | Increments | Initial Value | Range                          | Description  | Parameter copy            | Parameter clear | All parameter clear |
|---|--|------------|---------------|--------------------------------|--|---------------------------|-----------------|---------------------|
|   |  |            |               |                                |  | O: enabled<br>×: disabled |                 |                     |
| 266   | Power failure deceleration time switchover frequency | 0.01Hz     | 60Hz *        | 0 to 400Hz                     | Set the frequency at which the deceleration slope is switched from the Pr.264 setting to the Pr.265 setting.   | ○                         | ○               | ○                   |
| * Performing IPM parameter initialization changes the settings. (Refer to page 42)  |  |            |               |                                |  |                           |                 |                     |
| 267   | Refer to Pr.73.                                      |            |               |                                |  |                           |                 |                     |
| 268   | Refer to Pr.52.                                      |            |               |                                |  |                           |                 |                     |
| 269   | Parameter for manufacturer setting. Do not set.      |            |               |                                |  |                           |                 |                     |
| <b>Misoperation prevention and parameter setting restriction — Password function (Pr.296, Pr.297)</b>   |  |            |               |                                |  |                           |                 |                     |
| 296   | Password lock level                                  | 1          | 9999          | 0 to 6, 99, 100 to 106, 199    | Select restriction level of parameter reading/writing when a password is registered.   | ○                         | ×               | ○                   |
|   |  |            |               | 9999                           | No password lock   |                           |                 |                     |
| 297   | Password lock/unlock                                 | 1          | 9999          | 1000 to 9998                   | Register a 4-digit password  | ○                         | ×               | ○                   |
|   |  |            |               | (0 to 5)*                      | Displays password unlock error count. (Reading only) (Valid when Pr. 296 = "100" to "106")   |                           |                 |                     |
|   |  |            |               | 9999 *                         | No password lock   |                           |                 |                     |
| * Pr.297 can be set anytime as Pr.297 = "0 or 9999." However, the setting is invalid (the displayed value does not change).   |  |            |               |                                |  |                           |                 |                     |
| 299   | Refer to Pr.57, Pr. 58.                              |            |               |                                |  |                           |                 |                     |
| <b>Communication operation and setting — Initial setting of RS-485 communication (Pr.331 to Pr.339, Pr.341 to Pr.343, Pr.502, Pr.539, Pr.549 to Pr.551, Pr.779)</b> |  |            |               |                                |  |                           |                 |                     |
| <b>Selection of operation mode and command source — Operation command source and speed command source during communication operation (Pr.338, Pr.339)</b>           |  |            |               |                                |  |                           |                 |                     |
| <b>Communication operation and setting — Control of parameter write by communication (Pr.342)</b>   |  |            |               |                                |  |                           |                 |                     |
| <b>Communication operation and command source — Selection of the NET operation mode command source (Pr.550)</b>   |  |            |               |                                |  |                           |                 |                     |
| <b>Communication operation and command source — Selection of the PU operation mode command source (Pr.551)</b>  |  |            |               |                                |  |                           |                 |                     |
| 331   | RS-485 communication station number                  | 1          | 0             | 0 to 31 (0 to 247)             | Set the inverter station number. (same specifications as Pr.117) When "1" (Modbus-RTU protocol) is set in Pr.551, the setting range within parentheses is applied. | ○                         | ○               | ○                   |
| 332   | RS-485 communication speed                           | 1          | 96            | 3, 6, 12, 24, 48, 96, 192, 384 | Used to select the communication speed. (same specifications as Pr.118)  | ○                         | ○               | ○                   |
| 333   | RS-485 communication stop bit length                 | 1          | 1             | 0, 1, 10, 11                   | Select stop bit length and data length. (same specifications as Pr.119)  | ○                         | ○               | ○                   |
| 334   | RS-485 communication parity check selection          | 1          | 2             | 0, 1, 2                        | Select the parity check specifications. (same specifications as Pr.120)  | ○                         | ○               | ○                   |
| 335   | RS-485 communication retry count                     | 1          | 1             | 0 to 10, 9999                  | Set the permissible number of retries at occurrence of a data receive error. (same specifications as Pr.121)   | ○                         | ○               | ○                   |
| 336   | RS-485 communication check time interval             | 0.1s       | 0s            | 0                              | RS-485 communication can be made, but the inverter trips in the NET operation mode.  | ○                         | ○               | ○                   |
|   |  |            |               | 0.1 to 999.8s                  | Set the communication check time interval. (same specifications as Pr.122)   |                           |                 |                     |
|   |  |            |               | 9999                           | No communication check   |                           |                 |                     |



| Parameter | Name   | Increments | Initial Value  | Range             | Description  | Parameter copy   | Parameter clear   | All parameter clear |   |   |   |
|-----------|--|------------|----------------|-------------------|--|--|-------------------|---------------------|---|---|---|
|           |  |            |                |                   |  | O : enabled<br>× : disabled  |                   |                     |   |   |   |
| 337       | RS-485 communication waiting time setting      | 1          | 9999           | 0 to 150ms, 9999  | Set the waiting time between data transmission to the inverter and response. (same specifications as <i>Pr.123</i> )   | ○  | ○                 | ○                   |   |   |   |
| 338       | Communication operation command source         | 1          | 0              | 0                 | Operation command source communication   | ○  | ○                 | ○                   |   |   |   |
|           |  |            |                | 1                 | Operation command source external  |  |                   |                     |   |   |   |
| 339       | Communication speed command source             | 1          | 0              | 0                 | Frequency command source communication   | ○  | ○                 | ○                   |   |   |   |
|           |  |            |                | 1                 | Frequency command source external  |  |                   |                     |   |   |   |
|           |  |            |                | 2                 | Frequency command source external (When there is no external input, the frequency command via communication is valid, and the external command from terminal 2 or 1 is invalid.) |  |                   |                     |   |   |   |
| 341       | RS-485 communication CR/LF selection           | 1          | 1              | 0, 1, 2           | Select presence/absence of CR/LF. (same specifications as <i>Pr.124</i> )  | ○  | ○                 | ○                   |   |   |   |
| 342       | Communication EEPROM write selection           | 1          | 0              | 0                 | Parameter values written by communication are written to the EEPROM and RAM.   | ○  | ○                 | ○                   |   |   |   |
|           |  |            |                | 1                 | Parameter values written by communication are written to the RAM.  |  |                   |                     |   |   |   |
| 343       | Communication error count                      | 1          | 0              | (read only)       | Displays the number of communication errors during Modbus-RTU communication. Read only. Displayed only when Modbus-RTU protocol is selected.                                     | ×  | ×                 | ×                   |   |   |   |
| 502       | Stop mode selection at communication error     | 1          | 0              |                   | At error occurrence  | Indication   | Fault output      | At error removal    | ○ | ○ | ○ |
|           |  |            |                | 0                 | Coasts to stop   | E.SER  | Output            | Stops (E.SER)       |   |   |   |
|           |  |            |                | 1                 | Decelerates to stop  | E.SER after stop   | Output after stop | Stops (E.SER)       |   |   |   |
|           |  |            |                | 2                 | Decelerates to stop  | E.SER after stop   | Without output    | Restarts            |   |   |   |
| 3         | Continues running at <i>Pr. 779</i>            | —          | Without output | Operates normally |  |  |                   |                     |   |   |   |
| 539       | Modbus-RTU communication check time interval   | 0.1s       | 9999           | 0                 | Modbus-RTU communication can be made, but the inverter trips in the NET operation mode.  |  | ○                 | ○                   | ○ |   |   |
|           |  |            |                | 0.1 to 999.8s     | Set the interval of communication check time. (same specifications as <i>Pr. 122</i> )   |  |                   |                     |   |   |   |
|           |  |            |                | 9999              | No communication check (signal loss detection) is made)  |  |                   |                     |   |   |   |
| 549       | Protocol selection                             | 1          | 0              | 0                 | Mitsubishi inverter (computer link) protocol   | After setting change, reset (switch power OFF, then ON) the inverter. applied after a reset. | ○                 | ○                   | ○ |   |   |
|           |  |            |                | 1                 | Modbus-RTU protocol  |  |                   |                     |   |   |   |
| 550       | NET mode operation command source selection    | 1          | 9999           | 0                 | Communication option valid   |  | ○                 | ○                   | ○ |   |   |
|           |  |            |                | 1                 | Inverter RS-485 terminal valid   |  |                   |                     |   |   |   |
|           |  |            |                | 9999              | Automatic recognition of the communication option Normally, the RS-485 terminals are valid. Communication option is valid when the communication option is mounted.              |  |                   |                     |   |   |   |
| 551       | PU mode operation command source selection     | 1          | 2              | 1                 | Select the RS-485 terminals as the PU operation mode control source.   |  | ○                 | ○                   | ○ |   |   |
|           |  |            |                | 2                 | Select the PU connector as the PU operation mode control source.   |  |                   |                     |   |   |   |
| 779       | Operation frequency during communication error | 0.01Hz     | 9999           | 0 to 400Hz        | Motor runs at the specified frequency at a communication error.  |  | ○                 | ○                   | ○ |   |   |
|           |  |            |                | 9999              | Motor runs at the frequency used before the communication error.   |  |                   |                     |   |   |   |

| Parameter  | Name   | Increments  | Initial Value            | Range                 | Description   | Parameter copy              | Parameter clear | All parameter clear |
|--|--|-------------|--------------------------|-----------------------|---|-----------------------------|-----------------|---------------------|
|  |  |             |                          |                       |   | O : enabled<br>× : disabled |                 |                     |
| 340  | Refer to Pr.79.  |             |                          |                       |   |                             |                 |                     |
| <b>Operation setting at fault occurrence — Overspeed detection level (Pr.374)</b>                                    |  |             |                          |                       |   |                             |                 |                     |
| 374  | Overspeed detection level                                      | 0.01Hz      | 9999                     | 0 to 400Hz            | When the motor speed exceeds the speed set in Pr. 374 under IPM motor control, overspeed (E.OS) occurs, and the inverter outputs are stopped.   | ○                           | ○               | ○                   |
|  |  |             |                          | 9999                  |   |                             |                 |                     |
| <b>Function assignment of external terminal and control — Remote output function (REM signal) (Pr.495 to Pr.497)</b> |  |             |                          |                       |   |                             |                 |                     |
| 495  | Remote output selection  | 1           | 0                        | 0                     | Remote output data clear at powering OFF  | ○                           | ○               | ○                   |
|  |  |             |                          | 1                     | Remote output data held at powering OFF   |                             |                 |                     |
|  |  |             |                          | 10                    | Remote output data clear at powering OFF  |                             |                 |                     |
|  |  |             |                          | 11                    | Remote output data held at powering OFF   |                             |                 |                     |
| 496  | Remote output data 1   | 1           | 0                        | 0 to 4095             | Output terminal can be switched ON and OFF.   | ×                           | ×               | ×                   |
| 497  | Remote output data 2   | 1           | 0                        | 0 to 4095             |   | ×                           | ×               | ×                   |
| 502  | Refer to Pr.331 to Pr.339, Pr.341 to Pr.343.                   |             |                          |                       |   |                             |                 |                     |
| <b>Useful functions — Maintenance of parts (Pr.503, Pr.504)</b>  |  |             |                          |                       |   |                             |                 |                     |
| 503  | Maintenance timer  | 1           | 0                        | 0 (1 to 9998)         | Displays the cumulative energization time of the inverter in 100h increments. When Pr.503 = "1 to 9998", writing the setting value of "0" clears the cumulative energization time. (Writing is disabled when Pr.503 = "0".) | ×                           | ×               | ×                   |
| 504  | Maintenance timer alarm output set time                        | 1           | 9999                     | 0 to 9998             | Set the time taken until when the maintenance timer alarm output signal (Y95) is output.  | ○                           | ×               | ○                   |
|  |  |             |                          | 9999                  | No function   |                             |                 |                     |
| 505  | Refer to Pr.37.  |             |                          |                       |   |                             |                 |                     |
| <b>Motor brake and stop operation — Coast to stop at the specified frequency or lower (Pr.522)</b>                   |  |             |                          |                       |   |                             |                 |                     |
| 522  | Output stop frequency  | 0.01Hz      | 9999                     | 0 to 400Hz            | Set the frequency to start coasting to a stop (output shutoff).   | ○                           | ○               | ○                   |
|  |  |             |                          | 9999                  | No function   |                             |                 |                     |
| 539, 549, 550  | Refer to Pr.331 to Pr.339, Pr.341 to Pr.343.                   |             |                          |                       |   |                             |                 |                     |
| 551  | Refer to Pr.117 to Pr.124, Pr.331 to Pr.339, Pr.341 to Pr.343. |             |                          |                       |   |                             |                 |                     |
| 552  | Refer to Pr.31 to Pr.36  |             |                          |                       |   |                             |                 |                     |
| 553, 554   | Refer to Pr.127 to Pr.134.                                     |             |                          |                       |   |                             |                 |                     |
| <b>Useful functions — Current average value monitor signal (Pr.555 to Pr.557)</b>                                    |  |             |                          |                       |   |                             |                 |                     |
| 555  | Current average time   | 0.1s        | 1s                       | 0.1 to 1.0s           | Set the time taken to average the current during start pulse output (1s).   | ○                           | ○               | ○                   |
| 556  | Data output mask time  | 0.1s        | 0s                       | 0.0 to 20.0s          | Set the time for not obtaining (mask) transient state data.   | ○                           | ○               | ○                   |
| 557  | Current average value monitor signal output reference current  | 0.01/0.1A*1 | Rated inverter current*2 | 0 to 500/0 to 3600A*1 | Set the reference (100%) for outputting the signal of the current average value.  | ○                           | ○               | ○                   |
| *1 Setting increments and setting range differ according to the inverter capacity. (55K or lower/75K or higher)      |  |             |                          |                       |   |                             |                 |                     |
| *2 Performing IPM parameter initialization changes the settings. (Refer to page 42)                                  |  |             |                          |                       |   |                             |                 |                     |



| Parameter<br>Related parameters  | Name   | Increments | Initial Value | Range                                | Description  | Parameter copy   | Parameter clear       | All parameter clear   |
|--|--|------------|---------------|--------------------------------------|--|--|-----------------------|-----------------------|
|  |  |            |               |                                      |  | O : enabled<br>× : disabled  |                       |                       |
| 563, 564   | Refer to Pr.52.                              |            |               |                                      |  |  |                       |                       |
| 571  | Refer to Pr.13.                              |            |               |                                      |  |  |                       |                       |
| 575 to 577   | Refer to Pr.127 to Pr.134.                   |            |               |                                      |  |  |                       |                       |
| 611  | Refer to Pr.57 and Pr.58.                    |            |               |                                      |  |  |                       |                       |
| <b>Motor noise suppression and measures against EMC and leakage current — Reducing mechanic resonance (speed smoothing control) (Pr.653, Pr.654)</b> |  |            |               |                                      |  | <br> |                       |                       |
| 653  | Speed smoothing control                      | 0.1%       | 0%            | 0 to 200%                            | The torque fluctuation is reduced to reduce vibration due to mechanical resonance.   | <input type="radio"/>  | <input type="radio"/> | <input type="radio"/> |
| 654  | Speed smoothing cutoff frequency             | 0.01Hz     | 20Hz          | 0 to 120Hz                           | Set the minimum value for the torque variation cycle (frequency).  | <input type="radio"/>  | <input type="radio"/> | <input type="radio"/> |
| 665  | Refer to Pr.882 to Pr.886.                   |            |               |                                      |  |  |                       |                       |
| 779  | Refer to Pr.331 to Pr.339, Pr.341 to Pr.343. |            |               |                                      |  |  |                       |                       |
| 791, 792   | Refer to Pr.7 and Pr.8.                      |            |               |                                      |  |  |                       |                       |
| <b>Function assignment of external terminal and control — Pulse train output of output power (Y79 signal) (Pr.799)</b>                               |  |            |               |                                      |  |  |                       |                       |
| 799  | Pulse increment setting for output power     | 0.1kWh     | 1kWh          | 0.1kWh, 1kWh, 10kWh, 100kWh, 1000kWh | Pulse train output of output power (Y79) is output in pulses at every output current (kWh) that is specified.  | <input type="radio"/>  | <input type="radio"/> | <input type="radio"/> |
| <b>IPM motor control — Control method selection (Pr.800)</b>   |  |            |               |                                      |  |   |                       |                       |
| 800  | Control method selection                     | 1          | 20            | 9                                    | IPM motor test operation (Motor is not driven even if it is connected.)  | <input type="radio"/>  | <input type="radio"/> | <input type="radio"/> |
|  |  |            |               | 20                                   | Normal operation (Motor can be driven.)  |  |                       |                       |
| <b>IPM motor control — Proportional gain setting for speed loops (Pr.820, Pr.821)</b>  |  |            |               |                                      |  |   |                       |                       |
| 820  | Speed control P gain 1                       | 1%         | 25%           | 0 to 1000%                           | The proportional gain during speed control is set. (Setting this parameter higher improves the trackability for speed command changes. It also reduces the speed fluctuation due to a load fluctuation.) | <input type="radio"/>  | <input type="radio"/> | <input type="radio"/> |
| 821  | Speed control integral time 1                | 0.001s     | 0.333s        | 0 to 20s                             | The integral time during speed control is set. (Setting this parameter lower shortens the return time to the original speed when the speed fluctuates due to external forces. )                          | <input type="radio"/>  | <input type="radio"/> | <input type="radio"/> |
| 867  | Refer to Pr.54 to Pr.56.                     |            |               |                                      |  |  |                       |                       |
| 870  | Refer to Pr.41 to Pr.43.                     |            |               |                                      |  |  |                       |                       |
| 872  | Refer to Pr.251.                             |            |               |                                      |  |  |                       |                       |



| Parameter  | Name   | Increments | Initial Value    | Range       | Description   | Parameter copy              | Parameter clear | All parameter clear |
|--|--|------------|------------------|-------------|---|-----------------------------|-----------------|---------------------|
|  |  |            |                  |             |   | O : enabled<br>× : disabled |                 |                     |
| <b>Operation setting at fault occurrence — Regenerative avoidance operation (Pr.665, Pr.882 to Pr.886)</b>             |  |            |                  |             |   |                             |                 |                     |
| <b>Acceleration/deceleration time/pattern adjustment — Regenerative avoidance operation (Pr.665, Pr.882 to Pr.886)</b> |  |            |                  |             |   |                             |                 |                     |
| 882  | Regeneration avoidance operation selection                   | 1          | 0                | 0           | Regeneration avoidance function invalid   | ○                           | ○               | ○                   |
|  |  |            |                  | 1           | Regeneration avoidance function is always valid   |                             |                 |                     |
|  |  |            |                  | 2           | Regeneration avoidance function is valid only during a constant speed operation   |                             |                 |                     |
| 883  | Regeneration avoidance operation level                       | 0.1V       | DC380V / 760V *1 | 300 to 800V | Set the bus voltage level at which regeneration avoidance operates. When the bus voltage level is set to low, overvoltage error will be less apt to occur. However, the actual deceleration time increases. The set value must be higher than the power supply voltage $\times \sqrt{2}$ .                    | ○                           | ○               | ○                   |
| 884  | Regeneration avoidance at deceleration detection sensitivity | 1          | 0                | 0 to 5      | Set sensitivity to detect the bus voltage change.<br>1 (Low) → 5 (High)   | ○                           | ○               | ○                   |
| 885  | Regeneration avoidance compensation frequency limit value    | 0.01Hz     | 6Hz *2           | 0 to 30Hz   | Set the limit value of frequency which rises at activation of regeneration avoidance function.  | ○                           | ○               | ○                   |
|  |  |            |                  | 9999        | Frequency limit invalid   |                             |                 |                     |
| 886  | Regeneration avoidance voltage gain                          | 0.1%       | 100%             | 0 to 200%   | Adjust responsiveness at activation of regeneration avoidance. Setting a larger value in Pr.886 will improve responsiveness to the bus voltage change. However, the output frequency could become unstable. When vibration is not suppressed by decreasing the Pr.886 setting, set a smaller value in Pr.665. | ○                           | ○               | ○                   |
| 665  | Regeneration avoidance frequency gain                        | 0.1%       | 100%             | 0 to 200%   |   | ○                           | ○               | ○                   |
| *1 The initial value differs according to the voltage level. (200V / 400V)   |  |            |                  |             |   |                             |                 |                     |
| *2 Performing IPM parameter initialization changes the settings. (Refer to page 42)                                    |  |            |                  |             |   |                             |                 |                     |
| <b>Useful functions — Free parameter (Pr.888, Pr.889)</b>  |  |            |                  |             |   |                             |                 |                     |
| 888  | Free parameter 1   | 1          | 9999             | 0 to 9999   | Parameters you can use for your own purposes.   | ○                           | ×               | ×                   |
| 889  | Free parameter 2   | 1          | 9999             | 0 to 9999   | Used for maintenance, management, etc. by setting a unique number to each inverter when multiple inverters are used.  | ○                           | ×               | ×                   |



| Parameter   | Name   | Increments       | Initial Value           | Range                       | Description  | Parameter copy              | Parameter clear | All parameter clear |
|---|--|------------------|-------------------------|-----------------------------|--|-----------------------------|-----------------|---------------------|
|   |  |                  |                         |                             |  | O : enabled<br>× : disabled |                 |                     |
| <b>Useful function (energy saving operation) — Energy saving monitor (Pr.891 to Pr.899)</b> |  |                  |                         |                             |  |                             |                 |                     |
| 891   | Cumulative power monitor digit shifted times               | 1                | 9999                    | 0 to 4                      | Set the number of times to shift the cumulative power monitor digit. Clamps the monitor value at maximum.  | ○                           | ○               | ○                   |
|   |  |                  |                         | 9999                        | No shift<br>Clears the monitor value when it exceeds the maximum value.  |                             |                 |                     |
| 892   | Load factor  | 0.1%             | 100%                    | 30 to 150%                  | Set the load factor for commercial power-supply operation. This value is used to calculate the power consumption estimated value during commercial power supply operation. | ○                           | ○               | ○                   |
| 893   | Energy saving monitor reference (motor capacity)           | 0.01/<br>0.1kW * | Rated inverter capacity | 0.1 to 55/<br>0 to 3600kW * | Set the motor capacity (pump capacity). Set when calculating power saving rate, power saving rate average value, commercial power supply operation power.                  | ○                           | ○               | ○                   |
| 894   | Control selection during commercial power-supply operation | 1                | 0                       | 0                           | Discharge damper control (fan)   | ○                           | ○               | ○                   |
|   |  |                  |                         | 1                           | Inlet damper control (fan)   |                             |                 |                     |
|   |  |                  |                         | 2                           | Valve control (pump)   |                             |                 |                     |
|   |  |                  |                         | 3                           | Commercial power-supply drive (fixed value)  |                             |                 |                     |
| 895   | Power saving rate reference value                          | 1                | 9999                    | 0                           | Consider the value during commercial power-supply operation as 100%  | ○                           | ○               | ○                   |
|   |  |                  |                         | 1                           | Consider the Pr.893 setting as 100%.   |                             |                 |                     |
|   |  |                  |                         | 9999                        | No function  |                             |                 |                     |
| 896   | Power unit cost  | 0.01             | 9999                    | 0 to 500                    | Set the power unit cost. Displays the power saving rate on the energy saving monitor   | ○                           | ○               | ○                   |
|   |  |                  |                         | 9999                        | No function  |                             |                 |                     |
| 897   | Power saving monitor average time                          | 1h               | 9999                    | 0                           | Average for 30 minutes   | ○                           | ○               | ○                   |
|   |  |                  |                         | 1 to 1000h                  | Average for the set time   |                             |                 |                     |
|   |  |                  |                         | 9999                        | No function  |                             |                 |                     |
| 898   | Power saving cumulative monitor clear                      | 1                | 9999                    | 0                           | Cumulative monitor value clear   | ○                           | ×               | ○                   |
|   |  |                  |                         | 1                           | Cumulative monitor value hold  |                             |                 |                     |
|   |  |                  |                         | 10                          | Cumulative monitor continue (communication data upper limit 9999)  |                             |                 |                     |
|   |  |                  |                         | 9999                        | Cumulative monitor continue (communication data upper limit 65535)   |                             |                 |                     |
| 899   | Operation time rate (estimated value)                      | 0.1%             | 9999                    | 0 to 100%                   | Use for calculation of annual power saving amount. Set the annual operation ratio (consider 365 days × 24h as 100%).   | ○                           | ○               | ○                   |
|   |  |                  |                         | 9999                        | No function  |                             |                 |                     |
| * The setting depends on the inverter capacity (55K or lower/75k or higher)                 |  |                  |                         |                             |  |                             |                 |                     |



| Parameter<br>Related parameters  | Name                                | Increments | Initial Value | Range   | Description  | Parameter copy              | Parameter clear | All parameter clear |
|--|-------------------------------------|------------|---------------|---|--|-----------------------------|-----------------|---------------------|
|  |                                     |            |               |   |  | ○ : enabled<br>× : disabled |                 |                     |
| <b>Monitor display and monitor output signal — Adjustment of terminal FM and AM (calibration) (C0(Pr.900), C1(Pr.901))</b> |                                     |            |               |   |  |                             |                 |                     |
| C0 (900)   | FM terminal calibration             | —          | —             | —   | Calibrate the scale of the meter connected to terminal FM.   | ○                           | ×               | ○                   |
| C1 (901)   | AM terminal calibration             | —          | —             | —   | Calibrate the scale of the analog meter connected to terminal AM.  | ○                           | ×               | ○                   |
| C2 (902) to C7 (905)   | Refer to <i>Pr.125 and Pr.126</i> . |            |               |   |  |                             |                 |                     |
| C42 (934) to C45 (935)   | Refer to <i>Pr.127 to Pr.134</i> .  |            |               |   |  |                             |                 |                     |
| The parameter number in parentheses is the one for use with the parameter unit (FR-PU04/FR-PU07).                          |                                     |            |               |   |  |                             |                 |                     |
| <b>Useful functions — Parameter copy alarm release (Pr.989)</b>  |                                     |            |               |   |  |                             |                 |                     |
| 989  | Parameter copy alarm release        | 1          | 10/100 *      | 10/100 *  | Parameters for alarm release at parameter copy   | ○                           | ×               | ○                   |
| * The setting depends on the inverter capacity (55K or lower/75k or higher)  |                                     |            |               |   |  |                             |                 |                     |
| <b>Setting of the parameter unit and operation panel — Buzzer control of the operation panel (Pr.990)</b>                  |                                     |            |               |   |  |                             |                 |                     |
| 990  | PU buzzer control                   | 1          | 1             | 0   | Without buzzer   | ○                           | ○               | ○                   |
|  |                                     |            |               | 1   | With buzzer  |                             |                 |                     |
| <b>Setting of the parameter unit and operation panel — PU contrast adjustment (Pr.991)</b>                                 |                                     |            |               |   |  |                             |                 |                     |
| 991  | PU contrast adjustment              | 1          | 58            | 0 to 63   | Contrast adjustment of the LCD of the parameter unit (FR-PU04/FR-PU07) can be performed.<br>0 (Light) → 63 (Dark)  | ○                           | ×               | ○                   |
| <b>Useful functions — Fault initiation (Pr.997)</b>  |                                     |            |               |   |  |                             |                 |                     |
| 997  | Fault initiation                    | 1          | 9999          | 16 to 18, 32 to 34, 48, 49, 64, 80 to 82, 96, 97, 112, 128, 129, 144, 145, 160, 161, 176 to 179, 192 to 194, 196 to 199, 208, 230, 241, 245 to 247, 253 | The setting range is same with the one for fault data codes of the inverter (which can be read through communication). ( <i>Refer to page 116</i> )<br>Written data is not stored in EEPROM. | ○                           | ○               | ○                   |
|  |                                     |            |               | 9999  | This setting does not initiate a fault. (The read value is always "9999.")   |                             |                 |                     |





| Parameter  | Name                         | Increments | Initial Value | Range            | Description  | Parameter copy              | Parameter clear | All parameter clear |
|--|------------------------------|------------|---------------|------------------|--|-----------------------------|-----------------|---------------------|
|  |                              |            |               |                  |  | O : enabled<br>× : disabled |                 |                     |
| <b>IPM motor control — IPM parameter initialization (Pr.998)</b>   |                              |            |               |                  |  |                             |                 |                     |
| 998 <sup>Ⓞ</sup>   | IPM parameter initialization | 1          | 0             | 0                | Parameter settings for a general-purpose motor (frequency)   | ○                           | ○               | ○                   |
|  |                              |            |               | 1                | Parameter settings for a high-efficiency IPM motor MM-EF (rotations per minute)  |                             |                 |                     |
|  |                              |            |               | 12               | Parameter settings for a premium high-efficiency IPM motor MM-EFS and MM-THE4 (rotations per minute)   |                             |                 |                     |
|  |                              |            |               | 101              | Parameter settings for a high-efficiency IPM motor MM-EF (frequency)   |                             |                 |                     |
|  |                              |            |               | 112              | Parameter settings for a premium high-efficiency IPM motor MM-EFS and MM-THE4 (frequency)  |                             |                 |                     |
|  |                              |            |               | 22, 32, 122, 132 | For manufacturer setting. (Do not set.)  |                             |                 |                     |
| <b>Useful functions — Automatic parameter setting (Pr.999)</b>   |                              |            |               |                  |  |                             |                 |                     |
| 999 <sup>Ⓞ</sup>   | Automatic parameter setting  | 1          | 9999          | 10               | GOT initial setting (PU connector)   | ×                           | ×               | ×                   |
|  |                              |            |               | 11               | GOT initial setting (RS-485 terminals)   |                             |                 |                     |
|  |                              |            |               | 20               | Rated frequency is 50Hz  |                             |                 |                     |
|  |                              |            |               | 21               | Rated frequency is 60Hz  |                             |                 |                     |
|  |                              |            |               | 30               | Acceleration/deceleration time (0.1s increment)  |                             |                 |                     |
|  |                              |            |               | 31               | Acceleration/deceleration time (0.01s increment)   |                             |                 |                     |
|  |                              |            |               | 9999             | No action (The read value is always "9999.")   |                             |                 |                     |
| <b>Useful functions — Parameter clear, parameter copy, initial value change list, and automatic parameter setting (Pr.CL, ALLC, Er.CL, PCPY, Pr.CH, IPM, AUTO)</b> |                              |            |               |                  |  |                             |                 |                     |
| Pr.CL  | Parameter clear              | 1          | 0             | 0, 1             | Setting "1" returns all parameters except calibration parameters to the initial values.  |                             |                 |                     |
| ALLC   | All parameter clear          | 1          | 0             | 0, 1             | Setting "1" returns all parameters to the initial values.  |                             |                 |                     |
| Er.CL  | Faults history clear         | 1          | 0             | 0, 1             | Setting "1" will clear eight past faults.  |                             |                 |                     |
| PCPY   | Parameter copy               | 1          | 0             | 0                | Cancel   |                             |                 |                     |
|  |                              |            |               | 1                | Read the source parameters to the operation panel.   |                             |                 |                     |
|  |                              |            |               | 2                | Write the parameters copied to the operation panel to the destination inverter.  |                             |                 |                     |
|  |                              |            |               | 3                | Verify parameters in the inverter and operation panel.   |                             |                 |                     |
| Pr.CH  | Initial value change list    | —          | —             | —                | Changed parameters (changed from the initial settings) are displayed or set.   |                             |                 |                     |
| IPM  | IPM parameter initialization | 1          | 0             | 0, 1, 12         | When "1 or 12" is set, the parameters required to drive an IPM motor are automatically changed as a batch.   |                             |                 |                     |
|  |                              |            |               | 22, 32           | For manufacturer setting. (Do not set.)  |                             |                 |                     |
| AUTO   | Automatic parameter setting  | —          | —             | —                | Parameter settings are changed as a batch. Those include communication parameter settings for a GOT connection, rated frequency settings of 50Hz/60Hz, and acceleration/ deceleration time increment settings. |                             |                 |                     |

# 6 TROUBLESHOOTING

When a fault occurs in the inverter, the inverter trips and the PU display automatically changes to one of the following fault or alarm indications.

If the fault does not correspond to any of the following faults or if you have any other problem, please contact your sales representative or distributor.

- Retention of fault output signal.....When the magnetic contactor (MC) provided on the input side of the inverter is opened when a fault occurs, the inverter's control power will be lost and the fault output will not be held.
- Fault or alarm indication .....When a fault or alarm occurs, the operation panel display automatically switches to the fault or alarm indication
- Resetting method .....When a fault occurs, the inverter output is kept stopped. Unless reset, therefore, the inverter cannot restart. (Refer to page 115.)
- When any fault occurs, take the appropriate corrective action, then reset the inverter, and resume operation. Not doing so may lead to the inverter fault and damage.

Inverter fault or alarm indications are roughly categorized as below.

- (1) Error message  
A message regarding operational fault and setting fault by the operation panel (FR-DU07) and parameter unit (FR-PU04/FR-PU07) is displayed. The inverter does not trip.
- (2) Warning  
The inverter does not trip even when a warning is displayed. However, failure to take appropriate measures will lead to a fault.
- (3) Alarm  
The inverter does not trip. You can also output an alarm signal by making parameter setting.
- (4) Fault  
When a fault occurs, the inverter trips and a fault signal is output.

**REMARKS**

• Past eight faults can be displayed using the setting dial. (Refer to page 131 for the operation.)

## 6.1 Reset method of protective function

The inverter can be reset by performing any of the following operations. Note that the internal accumulated heat value of the electronic thermal relay function and the number of retries are cleared (erased) by resetting the inverter. Inverter recovers about 1s after the reset is released.

Operation 1:..... Using the operation panel, press  to reset the inverter.  
(This may only be performed when a fault occurs. (Refer to page 121 for fault.))

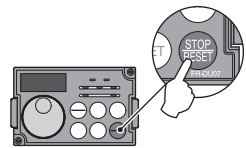

Operation 2:..... Switch power OFF once. After the indicator of the operation panel turns OFF, switch it ON again.

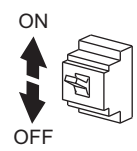

Operation 3:..... Turn ON the reset signal (RES) for more than 0.1s. (If the RES signal is kept ON, "Err." appears (flickers) to indicate that the inverter is in a reset status.)

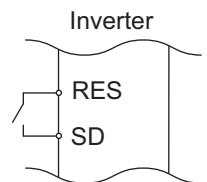

**CAUTION**

• OFF status of the start signal must be confirmed before resetting the inverter fault. Resetting inverter fault with the start signal ON restarts the motor suddenly.



## 6.2 List of fault or alarm display

| Operation Panel Indication |            | Name     | Fault data code  | Refer to page |
|----------------------------|------------|----------|--|---------------|
| Error message              | E---       | E---     | Faults history   | — 131         |
|                            | HOLD       | HOLD     | Operation panel lock                                       | — 117         |
|                            | LOCd       | LOCD     | Password locked  | — 117         |
|                            | Er1 to Er4 | Er1 to 4 | Parameter write error                                      | — 117         |
|                            | rE1 to rE4 | rE1 to 4 | Copy operation error                                       | — 118         |
|                            | Err.       | Err.     | Error  | — 118         |
| Warning                    | OL         | OL       | Stall prevention (overcurrent)                             | — 119         |
|                            | oL         | oL       | Stall prevention (overvoltage)                             | — 119         |
|                            | rb         | RB       | Regenerative brake pre-alarm                               | — 120         |
|                            | TH         | TH       | Electronic thermal relay function pre-alarm                | — 120         |
|                            | PS         | PS       | PU stop  | — 119         |
|                            | MT         | MT       | Maintenance signal output                                  | — 120         |
|                            | CP         | CP       | Parameter copy   | — 120         |
| Alarm                      | Fn         | FN       | Fan alarm  | — 120         |
| Fault                      | E.OC1      | E.OC1    | Overcurrent trip during acceleration                       | 16 (H10) 121  |
|                            | E.OC2      | E.OC2    | Overcurrent trip during constant speed                     | 17 (H11) 121  |
|                            | E.OC3      | E.OC3    | Overcurrent trip during deceleration or stop               | 18 (H12) 122  |
|                            | E.OV1      | E.OV1    | Regenerative overvoltage trip during acceleration          | 32 (H20) 122  |
|                            | E.OV2      | E.OV2    | Regenerative overvoltage trip during constant speed        | 33 (H21) 122  |
|                            | E.OV3      | E.OV3    | Regenerative overvoltage trip during deceleration or stop  | 34 (H22) 123  |
|                            | E.THT      | E.THT    | Inverter overload trip (electronic thermal relay function) | 48 (H30) 123  |
|                            | E.THM      | E.THM    | Motor overload trip (electronic thermal relay function)    | 49 (H31) 123  |
|                            | E.FIN      | E.FIN    | Heatsink overheat  | 64 (H40) 124  |
|                            | E.IPF      | E.IPF    | Instantaneous power failure                                | 80 (H50) 124  |
|                            | E.BE       | E.BE     | Brake transistor alarm detection/internal circuit fault    | 112 (H70) 124 |
|                            | E.UVT      | E.UVT    | Undervoltage   | 81 (H51) 124  |
|                            | E.ILF*     | E.ILF*   | Input phase loss   | 82 (H52) 125  |
|                            | E.OLT      | E.OLT    | Stall prevention stop                                      | 96 (H60) 125  |



| Operation Panel Indication |               | Name   | Fault data code | Refer to page |
|----------------------------|---------------|--|-----------------|---------------|
| E.SOT                      | E.SOT*<br>IPM | Loss of synchronism detection                | 97 (H61)        | 125           |
| E.GF                       | E.GF          | Output side earth (ground) fault overcurrent | 128 (H80)       | 125           |
| E.LF                       | E.LF          | Output phase loss                            | 129 (H81)       | 125           |
| E.OHT                      | E.OHT         | External thermal relay operation             | 144 (H90)       | 126           |
| E.PTC                      | E.PTC*        | PTC thermistor operation                     | 145 (H91)       | 126           |
| E.OPT                      | E.OPT         | Option fault                                 | 160 (HA0)       | 126           |
| E.OP1                      | E.OP1         | Communication option fault                   | 161 (HA1)       | 126           |
| E.1                        | E.1           | Option fault                                 | 241 (HF1)       | 127           |
| E.PE                       | E.PE          | Parameter storage device fault               | 176 (HB0)       | 127           |
| E.PUE                      | E.PUE         | PU disconnection                             | 177 (HB1)       | 127           |
| E.RET                      | E.RET         | Retry count excess                           | 178 (HB2)       | 127           |
| E.PE2                      | E.PE2*        | Parameter storage device fault               | 179 (HB3)       | 127           |
| E.5                        | E.5           | CPU fault                                    | 245 (HF5)       | 128           |
| E.6                        | E.6           |  | 246 (HF6)       |               |
| E.7                        | E.7           |  | 247 (HF7)       |               |
| E.CPU                      | E.CPU         |  | 192 (HC0)       |               |
| E.CTE                      | E.CTE         | RS-485 terminal power supply short circuit   | 193 (HC1)       | 128           |
| E.P24                      | E.P24         | 24VDC power output short circuit             | 194 (HC2)       | 128           |
| E.CDO                      | E.CDO*        | Output current detection value exceeded      | 196 (HC4)       | 128           |
| E.IOH*                     | E.IOH*        | Inrush current limit circuit fault           | 197 (HC5)       | 128           |
| E.SER*                     | E.SER*        | Communication fault (inverter)               | 198 (HC6)       | 129           |
| E.AIE                      | E.AIE*        | Analog input fault                           | 199 (HC7)       | 129           |
| E.OS                       | E.OS<br>IPM   | Overspeed occurrence                         | 208 (HD0)       | 129           |
| E.PID                      | E.PID*        | PID signal fault                             | 230 (HE6)       | 129           |
| E.13                       | E.13          | Internal circuit fault                       | 253 (HFD)       | 129           |

If faults other than the above appear, contact your sales representative.  
 \* If an error occurs when using FR-PU04, "Fault 14" is displayed on FR-PU04.



## 6.3 Causes and corrective actions

### (1) Error Message

A message regarding operational troubles is displayed. Output is not shut off.

|                                   |  |             |
|-----------------------------------|--|-------------|
| <b>Operation Panel Indication</b> | <b>HOLD</b>  | <b>HOLD</b> |
| <b>Name</b>                       | Operation panel lock   |             |
| <b>Description</b>                | Operation lock mode is set. Operation other than  is invalid. (Refer to page 48.) |             |
| <b>Check point</b>                | —  |             |
| <b>Corrective action</b>          | Press  for 2s to release lock.  |             |

|                                   |   |             |
|-----------------------------------|---|-------------|
| <b>Operation panel indication</b> | <b>LOCD</b>   | <b>LOCD</b> |
| <b>Name</b>                       | Password locked   |             |
| <b>Description</b>                | Password function is active. Display and setting of parameter is restricted.  |             |
| <b>Check point</b>                | —   |             |
| <b>Corrective action</b>          | Enter the password in Pr. 297 Password lock/unlock to unlock the password function before operating. (  Refer to Chapter 4 of the Instruction Manual (Applied)). |             |

|                                   |  |             |
|-----------------------------------|--|-------------|
| <b>Operation Panel Indication</b> | <b>Er1</b>   | <b>Er 1</b> |
| <b>Name</b>                       | Write disable error  |             |
| <b>Description</b>                | <ul style="list-style-type: none"> <li>You attempted to make parameter setting when Pr. 77 Parameter write selection has been set to disable parameter writing.</li> <li>Frequency jump setting range overlapped.</li> <li>Adjustable 5 points V/F settings overlapped.</li> <li>The PU and inverter cannot make normal communication.</li> <li>Appears if IPM parameter initialization is attempted in the parameter setting mode while Pr.72 = "25."</li> </ul>  |             |
| <b>Check point</b>                | <ul style="list-style-type: none"> <li>Check the setting of Pr. 77 Parameter write selection ( Refer to Chapter 4 of the Instruction Manual (Applied).)</li> <li>Check the settings of Pr. 31 to 36 and Pr.552 (frequency jump). ( Refer to Chapter 4 of the Instruction Manual (Applied).)</li> <li>Check the settings of Pr. 100 to Pr. 109 (Adjustable 5 points V/F). ( Refer to Chapter 4 of the Instruction Manual (Applied).)</li> <li>Check the connection of the PU and inverter.</li> <li>Check the Pr.72 PWM frequency selection setting. A sine wave filter cannot be used under IPM motor control.</li> </ul> |             |

|                                   |  |             |
|-----------------------------------|--|-------------|
| <b>Operation Panel Indication</b> | <b>Er2</b>   | <b>Er 2</b> |
| <b>Name</b>                       | Write error during operation   |             |
| <b>Description</b>                | When parameter writing was performed during operation with a value other than "2" (writing is enabled independently of operating status in any operation mode) is set in Pr. 77 and the STF (STR) is ON.   |             |
| <b>Check point</b>                | <ul style="list-style-type: none"> <li>Check the Pr. 77 setting. ( Refer to Chapter 4 of the Instruction Manual (Applied).)</li> <li>Check that the inverter is not operating.</li> </ul> |             |
| <b>Corrective action</b>          | <ul style="list-style-type: none"> <li>Set "2" in Pr. 77.</li> <li>After stopping the operation, make parameter setting.</li> </ul>  |             |

|                                   |   |             |
|-----------------------------------|---|-------------|
| <b>Operation Panel Indication</b> | <b>Er3</b>  | <b>Er 3</b> |
| <b>Name</b>                       | Calibration error   |             |
| <b>Description</b>                | Analog input bias and gain calibration values are too close.  |             |
| <b>Check point</b>                | Check the settings of C3, C4, C6 and C7 (calibration functions). (  Refer to Chapter 4 of the Instruction Manual (Applied).) |             |



|                                   |   |            |
|-----------------------------------|---|------------|
| <b>Operation Panel Indication</b> | <b>Er4</b>  | <b>Er4</b> |
| <b>Name</b>                       | Mode designation error  |            |
| <b>Description</b>                | <ul style="list-style-type: none"> <li>You attempted to make parameter setting in the NET operation mode when Pr. 77 is not "2".</li> <li>If a parameter write was performed when the command source is not at the operation panel (FR-DU07).</li> </ul>  |            |
| <b>Check point</b>                | <ul style="list-style-type: none"> <li>Check that operation mode is "PU operation mode".</li> <li>Check the Pr. 77 setting. (Refer to Chapter 4 of the Instruction Manual (Applied).)</li> <li>Check the Pr. 551 setting.</li> </ul>  |            |
| <b>Corrective action</b>          | <ul style="list-style-type: none"> <li>After setting the operation mode to the "PU operation mode", make parameter setting. (Refer to page 77.)</li> <li>After setting "2" in Pr. 77, make parameter setting.</li> <li>Set Pr.551 = "2 (initial setting)". (Refer to Chapter 4 of the Instruction Manual (Applied).)</li> </ul> |            |

|                                   |   |            |
|-----------------------------------|---|------------|
| <b>Operation Panel Indication</b> | <b>rE1</b>  | <b>rE1</b> |
| <b>Name</b>                       | Parameter read error  |            |
| <b>Description</b>                | An error occurred in the EEPROM on the operation panel side during parameter copy reading.  |            |
| <b>Check point</b>                | —   |            |
| <b>Corrective action</b>          | <ul style="list-style-type: none"> <li>Make parameter copy again. (Refer to page 79.)</li> <li>Check for an operation panel (FR-DU07) failure. Please contact your sales representative.</li> </ul> |            |

|                                   |   |            |
|-----------------------------------|---|------------|
| <b>Operation Panel Indication</b> | <b>rE2</b>  | <b>rE2</b> |
| <b>Name</b>                       | Parameter write error   |            |
| <b>Description</b>                | <ul style="list-style-type: none"> <li>You attempted to perform parameter copy write during operation.</li> <li>An error occurred in the EEPROM on the operation panel side during parameter copy writing.</li> </ul>             |            |
| <b>Check point</b>                | Is the FWD or REV LED of the operation panel (FR-DU07) lit or flickering?   |            |
| <b>Corrective action</b>          | <ul style="list-style-type: none"> <li>After stopping the operation, make parameter copy again. (Refer to page 79.)</li> <li>Check for an operation panel (FR-DU07) failure. Please contact your sales representative.</li> </ul> |            |

|                                   |  |            |
|-----------------------------------|--|------------|
| <b>Operation Panel Indication</b> | <b>rE3</b>   | <b>rE3</b> |
| <b>Name</b>                       | Parameter verification error   |            |
| <b>Description</b>                | <ul style="list-style-type: none"> <li>Data on the operation panel side and inverter side are different.</li> <li>An error occurred in the EEPROM on the operation panel side during parameter verification.</li> </ul>  |            |
| <b>Check point</b>                | Check for the parameter setting of the source inverter and inverter to be verified.  |            |
| <b>Corrective action</b>          | <ul style="list-style-type: none"> <li>Press  to continue verification.</li> <li>Make parameter verification again. (Refer to page 80.)</li> <li>Check for an operation panel (FR-DU07) failure. Please contact your sales representative.</li> </ul> |            |

|                                   |   |            |
|-----------------------------------|---|------------|
| <b>Operation Panel Indication</b> | <b>rE4</b>  | <b>rE4</b> |
| <b>Name</b>                       | Model error   |            |
| <b>Description</b>                | <ul style="list-style-type: none"> <li>A different model was used for parameter writing and verification during parameter copy.</li> <li>When parameter copy write is stopped after parameter copy read is stopped.</li> </ul>    |            |
| <b>Check point</b>                | <ul style="list-style-type: none"> <li>Check that the verified inverter is the same model.</li> <li>Check that the power is not turned OFF or an operation panel is not disconnected, etc. during parameter copy read.</li> </ul> |            |
| <b>Corrective action</b>          | <ul style="list-style-type: none"> <li>Use the same model (FR-F700(P) series) for parameter copy and verification.</li> <li>Perform parameter copy read again.</li> </ul>   |            |

|                                   |   |             |
|-----------------------------------|---|-------------|
| <b>Operation Panel Indication</b> | <b>Err.</b>   | <b>Err.</b> |
| <b>Description</b>                | <ul style="list-style-type: none"> <li>The RES signal is ON.</li> <li>The PU and inverter cannot make normal communication (contact fault of the connector).</li> <li>When the voltage drops in the inverter's input side.</li> <li>While the control circuit power (R1/L11, S1/L21) and the main circuit power (R/L1, S/L2, T/L3) are connected to separate power sources, the error may appear when turning ON the main circuit. This is not a fault though.</li> </ul> |             |
| <b>Corrective action</b>          | <ul style="list-style-type: none"> <li>Turn OFF the RES signal.</li> <li>Check the connection of PU and the inverter.</li> <li>Check the voltage on the inverter's input side.</li> </ul>   |             |

## (2) Warning

When the protective function is activated, the output is not shut off.

| Operation Panel Indication | OL   |  | FR-PU04<br>FR-PU07 | OL |
|----------------------------|--|--|--------------------|----|
| <b>Name</b>                | Stall prevention (overcurrent)   |  |                    |    |
| <b>Description</b>         | During acceleration  | When the output current of the inverter exceeds the stall prevention operation level ( <i>Pr. 22 Stall prevention operation level</i> , etc.), this function stops the increase in frequency until the overload current decreases to prevent the inverter from resulting in overcurrent trip. When the overload current has decreased below stall prevention operation level, this function increases the frequency again. |                    |    |
|                            | During constant speed operation  | When the output current of the inverter exceeds the stall prevention operation level ( <i>Pr. 22 Stall prevention operation level</i> , etc.), this function lowers the frequency until the overload current decreases to prevent overcurrent trip. When the overload current has decreased below stall prevention operation level, this function increases the frequency up to the set value.                             |                    |    |
|                            | During deceleration  | When the output current of the inverter exceeds the stall prevention operation level ( <i>Pr. 22 Stall prevention operation level</i> , etc.), this function stops the decrease in frequency until the overload current decreases to prevent the inverter from resulting in overcurrent trip. When the overload current has decreased below stall prevention operation level, this function decreases the frequency again. |                    |    |
| <b>Check point</b>         | <ul style="list-style-type: none"> <li>· Check that the <i>Pr. 0 Torque boost</i> setting is not too large. (V/F control)</li> <li>· Check that the <i>Pr. 7 Acceleration time</i> and <i>Pr. 8 Deceleration time</i> settings are not too small.</li> <li>· Check that the load is not too heavy.</li> <li>· Are there any failure in peripheral devices?</li> <li>· Check that the <i>Pr. 13 Starting frequency</i> is not too large. (V/F control, Simple magnetic flux vector control)</li> <li>· Check that the <i>Pr. 22 Stall prevention operation level</i> is appropriate.</li> <li>· Check if the operation was performed without connecting a motor under IPM motor control.</li> </ul>   |  |                    |    |
| <b>Corrective action</b>   | <ul style="list-style-type: none"> <li>· Increase or decrease the <i>Pr. 0 Torque boost</i> value by 1% and check the motor status. (V/F control) (<i>Refer to page 72.</i>)</li> <li>· Set a larger value in <i>Pr. 7 Acceleration time</i> and <i>Pr. 8 Deceleration time</i>. (<i>Refer to page 74.</i>)</li> <li>· Reduce the load weight. Try Simple magnetic flux vector control (<i>Pr. 80</i>).</li> <li>· Check the peripheral devices</li> <li>· Adjust the <i>Pr.13</i> setting. Change the <i>Pr. 14 Load pattern selection</i> setting. (V/F control)</li> <li>· Set stall prevention operation current in <i>Pr. 22 Stall prevention operation level</i>. (The initial value is 120%.) The acceleration/deceleration time may change. Increase the stall prevention operation level with <i>Pr. 22 Stall prevention operation level</i>, or disable stall prevention with <i>Pr. 156 Stall prevention operation selection</i>. (Use <i>Pr. 156</i> to set either operation continued or not at OL operation.)</li> <li>· Check the connection of the IPM motor.</li> </ul> |  |                    |    |

| Operation Panel Indication | oL   |   | FR-PU04<br>FR-PU07 | oL |
|----------------------------|--|---|--------------------|----|
| <b>Name</b>                | Stall prevention (overcurrent)   |   |                    |    |
| <b>Description</b>         | During deceleration  | <ul style="list-style-type: none"> <li>· If the regenerative energy of the motor becomes excessive and exceeds the regenerative energy consumption capability, this function stops the decrease in frequency to prevent overvoltage trip. As soon as the regenerative energy has decreased, deceleration resumes.</li> <li>· If the regenerative energy of the motor becomes excessive when regeneration avoidance function is selected (<i>Pr. 882 = 1</i>), this function increases the speed to prevent overvoltage trip. ( <i>Refer to Chapter 4 of the Instruction Manual (Applied).</i>)</li> </ul> |                    |    |
|                            |  | <ul style="list-style-type: none"> <li>· Check for sudden speed reduction.</li> <li>· Regeneration avoidance function (<i>Pr. 882 to Pr. 886</i>) is being used? ( <i>Refer to Chapter 4 of the Instruction Manual (Applied).</i>)</li> </ul>   |                    |    |
| <b>Check point</b>         |  |   |                    |    |
| <b>Corrective action</b>   | The deceleration time may change.<br>Increase the deceleration time using <i>Pr. 8 Deceleration time</i> . |   |                    |    |

| Operation Panel Indication | PS  |  | FR-PU04<br>FR-PU07 | PS |
|----------------------------|---|--|--------------------|----|
| <b>Name</b>                | PU stop   |  |                    |    |
| <b>Description</b>         | Stop with  of PU is set in <i>Pr. 75 Reset selection/disconnected PU detection/PU stop selection</i> . ( For <i>Pr. 75</i> , refer to <i>Chapter 4 of the Instruction Manual (Applied)</i> .) |  |                    |    |
| <b>Check point</b>         | Check for a stop made by pressing  of the operation panel.  |  |                    |    |
| <b>Corrective action</b>   | Turn the start signal OFF and release with .  |  |                    |    |



|                            |  |           |                    |    |
|----------------------------|--|-----------|--------------------|----|
| Operation Panel Indication | RB   | <i>rb</i> | FR-PU04<br>FR-PU07 | RB |
| Name                       | Regenerative brake pre-alarm   |           |                    |    |
| Description                | Appears if the regenerative brake duty reaches or exceeds 85% of the <i>Pr. 70 Special regenerative brake duty</i> value. For the 11K or higher, when the setting of <i>Pr. 70 Special regenerative brake duty</i> is the initial value ( <i>Pr. 70 = "0"</i> ), this protective function is not available. If the regenerative brake duty reaches 100%, a regenerative overvoltage (E. OV_) occurs.<br>The RBP signal can be simultaneously output with the [RB] display. For the terminal used for the RBP signal output, assign the function by setting "7" (positive logic) or "107" (negative logic) in any of <i>Pr. 190 to Pr. 196 (output terminal function selection)</i> . (Refer to Chapter 4 of the Instruction Manual (Applied))<br>Appears only for the 75K or higher. |           |                    |    |
| Check point                | <ul style="list-style-type: none"> <li>Check that the brake resistor duty is not high.</li> <li>Check that the <i>Pr. 30 Regenerative function selection</i> and <i>Pr. 70 Special regenerative brake duty</i> values are correct.</li> </ul>  |           |                    |    |
| Corrective action          | <ul style="list-style-type: none"> <li>Increase the deceleration time.</li> <li>Check the <i>Pr. 30 Regenerative function selection</i> and <i>Pr. 70 Special regenerative brake duty</i> values.</li> </ul>   |           |                    |    |

|                            |   |           |                    |    |
|----------------------------|---|-----------|--------------------|----|
| Operation Panel Indication | TH  | <i>TH</i> | FR-PU04<br>FR-PU07 | TH |
| Name                       | Electronic thermal relay function pre-alarm   |           |                    |    |
| Description                | Appears if the cumulative value of the <i>Pr. 9 Electronic thermal O/L relay</i> reaches or exceeds 85% of the preset level. If it reaches 100% of the <i>Pr. 9 Electronic thermal O/L relay</i> setting, a motor overload trip (E. THM) occurs.<br>The THP signal can be simultaneously output with the [TH] display. For the terminal used for the THP signal output, assign the function by setting "8" (positive logic) or "108" (negative logic) in any of <i>Pr. 190 to Pr. 196 (output terminal function selection)</i> . (Refer to Chapter 4 of the Instruction Manual (Applied)) |           |                    |    |
| Check point                | <ul style="list-style-type: none"> <li>Check for large load or sudden acceleration.</li> <li>Is the <i>Pr. 9 Electronic thermal O/L relay</i> setting is appropriate? (Refer to page 51.)</li> </ul>  |           |                    |    |
| Corrective action          | <ul style="list-style-type: none"> <li>Reduce the load weight or the number of operation times.</li> <li>Set an appropriate value in <i>Pr. 9 Electronic thermal O/L relay</i>. (Refer to page 51.)</li> </ul>  |           |                    |    |

|                            |   |           |                    |    |
|----------------------------|---|-----------|--------------------|----|
| Operation Panel Indication | MT  | <i>MT</i> | FR-PU04<br>FR-PU07 | MT |
| Name                       | Maintenance signal output   |           |                    |    |
| Description                | Indicates that the cumulative energization time of the inverter has reached a given time.<br>When the setting of <i>Pr. 504 Maintenance timer alarm output set time</i> is the initial value ( <i>Pr. 504 = "9999"</i> ), this protective function does not function. |           |                    |    |
| Check point                | The <i>Pr. 503 Maintenance timer</i> setting is larger than the <i>Pr. 504 Maintenance timer alarm output set time</i> setting. (Refer to Chapter 4 of the Instruction Manual (Applied).)   |           |                    |    |
| Corrective action          | Setting "0" in <i>Pr. 503 Maintenance timer</i> erases the signal.  |           |                    |    |

|                            |   |           |                    |    |
|----------------------------|---|-----------|--------------------|----|
| Operation Panel Indication | CP  | <i>CP</i> | FR-PU04<br>FR-PU07 | CP |
| Name                       | Parameter copy  |           |                    |    |
| Description                | Appears when parameters are copied between models with capacities of 55K or lower and 75K or higher.  |           |                    |    |
| Check point                | Resetting of <i>Pr.9, Pr.30, Pr.51, Pr.52, Pr.54, Pr.56, Pr.57, Pr.70, Pr.72, Pr.80, Pr.90, Pr.158, Pr.190 to Pr.196, Pr.557 and Pr.893</i> is necessary. |           |                    |    |
| Corrective action          | Set the initial value in <i>Pr. 989 Parameter copy alarm release</i> .  |           |                    |    |



(3) Alarm



When an alarm occurs, the output is not shut off. You can also output an alarm signal by making parameter setting. (Set "98" in any of *Pr. 190 to Pr. 196 (output terminal function selection)*). (Refer to Chapter 4 of the Instruction Manual (Applied).)

|                            |   |                      |                    |    |
|----------------------------|---|----------------------|--------------------|----|
| Operation Panel Indication | FN  | <i>F<sub>n</sub></i> | FR-PU04<br>FR-PU07 | FN |
| Name                       | Fan alarm   |                      |                    |    |
| Description                | For the inverter that contains a cooling fan, <i>F<sub>n</sub></i> appears on the operation panel when the cooling fan stops due to a fault or different operation from the setting of <i>Pr. 244 Cooling fan operation selection</i> . |                      |                    |    |
| Check point                | Check the cooling fan for an alarm.   |                      |                    |    |
| Corrective action          | Check for fan failure. Please contact your sales representative.  |                      |                    |    |

## (4) Fault

When a fault occurs, the inverter trips and a fault signal is output.

| Operation Panel Indication | E.OC1   | <i>E.OC1</i> | FR-PU04<br>FR-PU07 | OC During Acc |
|----------------------------|---|--------------|--------------------|---------------|
| <b>Name</b>                | Overcurrent trip during acceleration  |              |                    |               |
| <b>Description</b>         | When the inverter output current reaches or exceeds approximately 170% of the rated current during acceleration, the protective circuit is activated to stop the inverter output.   |              |                    |               |
| <b>Check point</b>         | <ul style="list-style-type: none"> <li>· Check for sudden acceleration.</li> <li>· Check that the downward acceleration time is not long in vertical lift application.</li> <li>· Check for output short circuit.</li> <li>· Check that the <i>Pr. 3 Base frequency</i> setting is not 60Hz when the rated motor frequency is 50Hz.(V/F control, Simple magnetic flux vector control)</li> <li>· Check if the stall prevention operation level is set too high.</li> <li>· Check if the fast-response current limit operation is disabled. (V/F control, Simple magnetic flux vector control)</li> <li>· Check that the regeneration is not performed frequently. (Check that the output voltage becomes larger than the V/F reference voltage at regeneration and overcurrent occurs due to the high voltage.) (V/F control, Simple magnetic flux vector control)</li> <li>· Check that the inverter capacity matches with the motor capacity. (IPM motor control)</li> <li>· Check if a start command is given to the inverter while the motor is coasting. (IPM motor control)</li> </ul>  |              |                    |               |
| <b>Corrective action</b>   | <ul style="list-style-type: none"> <li>· Increase the acceleration time. (Shorten the downward acceleration time in vertical lift application.)</li> <li>· When "E.OC1" is always lit at starting, disconnect the motor once and start the inverter. If "E.OC1" is still lit, contact your sales representative.</li> <li>· Check the wiring to make sure that output short circuit does not occur.</li> <li>· Set the <i>Pr. 3 Base frequency</i> to 50Hz. (V/F control, Simple magnetic flux vector control) (<i>Refer to page 52.</i>)</li> <li>· Lower the setting of stall prevention operation level. ( <i>Refer to Chapter 4 of the Instruction Manual (Applied).</i>)</li> <li>· Activate the fast-response current limit operation. (V/F control, Simple magnetic flux vector control)</li> <li>· Set base voltage (rated voltage of the motor, etc.) in <i>Pr. 19 Base frequency voltage</i>.(V/F control, Simple magnetic flux vector control) ( <i>Refer to Chapter 4 of the Instruction Manual (Applied).</i>)</li> <li>· Choose inverter and motor capacities that match. (IPM motor control)</li> <li>· Input a start command after the motor stops. Alternatively, set the automatic restart after instantaneous power failure/flying start function. (IPM motor control) ( <i>Refer to Chapter 4 of the Instruction Manual (Applied).</i>)</li> </ul> |              |                    |               |

| Operation Panel Indication | E.OC2   | <i>E.OC2</i> | FR-PU04<br>FR-PU07 | Stedy Spd OC |
|----------------------------|---|--------------|--------------------|--------------|
| <b>Name</b>                | Overcurrent trip during constant speed  |              |                    |              |
| <b>Description</b>         | When the inverter output current reaches or exceeds approximately 170% of the rated current during constant speed operation, the protective circuit is activated to stop the inverter output.   |              |                    |              |
| <b>Check point</b>         | <ul style="list-style-type: none"> <li>· Check for sudden load change.</li> <li>· Check for output short circuit.</li> <li>· Check if the stall prevention operation level is set too high</li> <li>· Check if the fast-response current limit operation is disabled. (V/F control, Simple magnetic flux vector control)</li> <li>· Check that the inverter capacity matches with the motor capacity. (IPM motor control)</li> <li>· Check if a start command is given to the inverter while the motor is coasting. (IPM motor control)</li> </ul>  |              |                    |              |
| <b>Corrective action</b>   | <ul style="list-style-type: none"> <li>· Keep load stable.</li> <li>· Check the wiring to avoid output short circuit.</li> <li>· Lower the setting of stall prevention operation level ( <i>Refer to Chapter 4 of the Instruction Manual (Applied).</i>)</li> <li>· Activate the fast-response current limit operation. (V/F control, Simple magnetic flux vector control)</li> <li>· Choose inverter and motor capacities that match. (IPM motor control)</li> <li>· Input a start command after the motor stops. Alternatively, set the automatic restart after instantaneous power failure/flying start function. (IPM motor control) ( <i>Refer to Chapter 4 of the Instruction Manual (Applied).</i>)</li> </ul> |              |                    |              |





| Operation Panel Indication | E.OC3  | <b>E.Oc3</b> | FR-PU04<br>FR-PU07 | OC During Dec |
|----------------------------|--|--------------|--------------------|---------------|
| <b>Name</b>                | Overcurrent trip during deceleration or stop   |              |                    |               |
| <b>Description</b>         | When the inverter output current reaches or exceeds approximately 170% of the rated inverter current during deceleration (other than acceleration or constant speed), the protective circuit is activated to stop the inverter output.   |              |                    |               |
| <b>Check point</b>         | <ul style="list-style-type: none"> <li>· Check for sudden speed reduction.</li> <li>· Check for output short circuit.</li> <li>· Check for too fast operation of the motor's mechanical brake.</li> <li>· Check if the stall prevention operation level is set too high</li> <li>· Check if the fast-response current limit operation is disabled. (V/F control, Simple magnetic flux vector control)</li> <li>· Check that the inverter capacity matches with the motor capacity. (IPM motor control)</li> <li>· Check if a start command is given to the inverter while the motor is coasting. (IPM motor control)</li> </ul>  |              |                    |               |
| <b>Corrective action</b>   | <ul style="list-style-type: none"> <li>· Increase the deceleration time.</li> <li>· Check the wiring to avoid output short circuit.</li> <li>· Check the mechanical brake operation.</li> <li>· Lower the setting of stall prevention operation level (Refer to Chapter 4 of the Instruction Manual (Applied).)</li> <li>· Activate the fast-response current limit operation. (V/F control, Simple magnetic flux vector control)</li> <li>· Choose inverter and motor capacities that match. (IPM motor control)</li> <li>· Input a start command after the motor stops. Alternatively, set the automatic restart after instantaneous power failure/flying start function. (IPM motor control) (Refer to Chapter 4 of the Instruction Manual (Applied).)</li> </ul> |              |                    |               |

| Operation Panel Indication | E.OV1  | <b>E.Ov1</b> | FR-PU04<br>FR-PU07 | OV During Acc |
|----------------------------|--|--------------|--------------------|---------------|
| <b>Name</b>                | Regenerative overvoltage trip during acceleration  |              |                    |               |
| <b>Description</b>         | If regenerative energy causes the inverter's internal main circuit DC voltage to reach or exceed the specified value, the protective circuit is activated to stop the inverter output. The circuit may also be activated by a surge voltage produced in the power supply system.   |              |                    |               |
| <b>Check point</b>         | <ul style="list-style-type: none"> <li>· Check for too slow acceleration. (e.g. during descending acceleration with lifting load)</li> <li>· Check if Pr.22 Stall prevention operation level is set too low like the no-load current.</li> <li>· Check if the stall prevention operation is frequently activated in an application with a large load inertia.</li> </ul>   |              |                    |               |
| <b>Corrective action</b>   | <ul style="list-style-type: none"> <li>· Decrease the acceleration time.</li> <li>· Use regeneration avoidance function (Pr. 882 to Pr. 886). (Refer to Chapter 4 of the Instruction Manual (Applied).)</li> <li>· Set a value larger than the no load current in Pr. 22 Stall prevention operation level.</li> <li>· Set Pr.154 Voltage reduction selection during stall prevention operation = "10 or 11". (Refer to Chapter 4 of the Instruction Manual (Applied))</li> </ul> |              |                    |               |

| Operation Panel Indication | E.OV2  | <b>E.Ov2</b> | FR-PU04<br>FR-PU07 | Stedy Spd OV |
|----------------------------|--|--------------|--------------------|--------------|
| <b>Name</b>                | Regenerative overvoltage trip during constant speed  |              |                    |              |
| <b>Description</b>         | If regenerative energy causes the inverter's internal main circuit DC voltage to reach or exceed the specified value, the protective circuit is activated to stop the inverter output. The circuit may also be activated by a surge voltage produced in the power supply system.   |              |                    |              |
| <b>Check point</b>         | <ul style="list-style-type: none"> <li>· Check for sudden load change.</li> <li>· Check if Pr.22 Stall prevention operation level is set too low like the no-load current.</li> <li>· Check if the stall prevention operation is frequently activated in an application with a large load inertia.</li> </ul>  |              |                    |              |
| <b>Corrective action</b>   | <ul style="list-style-type: none"> <li>· Keep load stable.</li> <li>· Use regeneration avoidance function (Pr. 882 to Pr. 886). (Refer to Chapter 4 of the Instruction Manual (Applied).)</li> <li>· Use the brake unit or power regeneration common converter (FR-CV) as required.</li> <li>· Set a value larger than the no load current in Pr. 22 Stall prevention operation level.</li> <li>· Set Pr.154 Voltage reduction selection during stall prevention operation = "10 or 11". (Refer to Chapter 4 of the Instruction Manual (Applied))</li> </ul> |              |                    |              |

|                                   |  |      |                    |               |
|-----------------------------------|--|------|--------------------|---------------|
| <b>Operation Panel Indication</b> | E.OV3  | EOV3 | FR-PU04<br>FR-PU07 | OV During Dec |
| <b>Name</b>                       | Regenerative overvoltage trip during deceleration or stop  |      |                    |               |
| <b>Description</b>                | If regenerative energy causes the inverter's internal main circuit DC voltage to reach or exceed the specified value, the protective circuit is activated to stop the inverter output. The circuit may also be activated by a surge voltage produced in the power supply system.   |      |                    |               |
| <b>Check point</b>                | <ul style="list-style-type: none"> <li>· Check for sudden speed reduction.</li> <li>· Check if the stall prevention operation is frequently activated in an application with a large load inertia.</li> </ul>  |      |                    |               |
| <b>Corrective action</b>          | <ul style="list-style-type: none"> <li>· Increase the deceleration time. (Set the deceleration time which matches the moment of inertia of the load)</li> <li>· Longer the brake cycle.</li> <li>· Use regeneration avoidance function (Pr. 882 to Pr. 886). (Refer to Chapter 4 of the Instruction Manual (Applied).)</li> <li>· Use the brake unit or power regeneration common converter (FR-CV) as required.</li> <li>· Set Pr.154 Voltage reduction selection during stall prevention operation = "10 or 11". (Refer to Chapter 4 of the Instruction Manual (Applied))</li> </ul> |      |                    |               |

|                                   |   |      |                    |               |
|-----------------------------------|---|------|--------------------|---------------|
| <b>Operation Panel Indication</b> | E.THT   | ETHT | FR-PU04<br>FR-PU07 | Inv. Overload |
| <b>Name</b>                       | Inverter overload trip (electronic thermal O/L relay function) *  |      |                    |               |
| <b>Description</b>                | If a current not less than 120% of the rated output current flows and overcurrent trip does not occur (170% or less), the electronic thermal relay activates to stop the inverter output in order to protect the output transistors. (Overload capacity 120% 60s inverse-time characteristic)   |      |                    |               |
| <b>Check point</b>                | <ul style="list-style-type: none"> <li>· Check that acceleration/deceleration time is not too short.</li> <li>· Check that Pr. 0 Torque boost setting is not too large (small). (V/F control)</li> <li>· Check that Pr. 14 Load pattern selection setting is appropriate for the load pattern of the using machine. (V/F control)</li> <li>· Check the motor for use under overload.</li> </ul> |      |                    |               |
| <b>Corrective action</b>          | <ul style="list-style-type: none"> <li>· Increase acceleration/deceleration time.</li> <li>· Adjust the Pr. 0 Torque boost setting. (V/F control)</li> <li>· Set the Pr. 14 Load pattern selection setting according to the load pattern of the using machine. (V/F control)</li> <li>· Reduce the load weight.</li> </ul>  |      |                    |               |

\* Resetting the inverter initializes the internal accumulated heat value of the electronic thermal relay function.

|                                   |   |      |                    |               |
|-----------------------------------|---|------|--------------------|---------------|
| <b>Operation Panel Indication</b> | E.THM   | ETHM | FR-PU04<br>FR-PU07 | Motor Ovrload |
| <b>Name</b>                       | Motor overload trip (electronic thermal O/L relay function) *   |      |                    |               |
| <b>Description</b>                | The electronic thermal relay function in the inverter detects motor overheat due to overload or reduced cooling capability during low-speed operation and pre-alarm (TH display) is output when the integrated value reaches 85% of the Pr. 9 Electronic thermal O/L relay setting and the protection circuit is activated to stop the inverter output when the integrated value reaches the specified value. When running a special motor such as a multi-pole motor or multiple motors, provide a thermal relay on the inverter output side since such motor(s) cannot be protected by the electronic thermal relay function. |      |                    |               |
| <b>Check point</b>                | <ul style="list-style-type: none"> <li>· Check the motor for use under overload.</li> <li>· Check that the setting of Pr. 71 Applied motor for motor selection is correct. (V/F control, Simple magnetic flux vector control) (Refer to Chapter 4 of the Instruction Manual (Applied).)</li> <li>· Check that stall prevention operation setting is correct.</li> </ul>   |      |                    |               |
| <b>Corrective action</b>          | <ul style="list-style-type: none"> <li>· Reduce the load weight.</li> <li>· For a constant-torque motor, set the constant-torque motor in Pr. 71 Applied motor. (V/F control, Simple magnetic flux vector control)</li> <li>· Check that stall prevention operation setting is correct. (Refer to Chapter 4 of the Instruction Manual (Applied).)</li> </ul>  |      |                    |               |

\* Resetting the inverter initializes the internal accumulated heat value of the electronic thermal relay function.



|                            |   |              |                    |               |
|----------------------------|---|--------------|--------------------|---------------|
| Operation Panel Indication | E.FIN   | <i>E.FIN</i> | FR-PU04<br>FR-PU07 | H/Sink O/Temp |
| Name                       | Heatsink overheat   |              |                    |               |
| Description                | If the heatsink overheats, the temperature sensor is actuated to stop the inverter output. The FIN signal can be output when the temperature becomes approximately 85% of the heatsink overheat protection operation temperature. For the terminal used for the FIN signal output, assign the function by setting "26" (positive logic) or "126" (negative logic) in any of Pr. 190 to Pr. 196 (output terminal function selection). (Refer to Chapter 4 of the Instruction Manual (Applied)) |              |                    |               |
| Check point                | <ul style="list-style-type: none"> <li>Check for too high surrounding air temperature.</li> <li>Check for heatsink clogging.</li> <li>Check that the cooling fan is stopped. (Check that <i>F<sub>in</sub></i> is displayed on the operation panel.)</li> </ul>   |              |                    |               |
| Corrective action          | <ul style="list-style-type: none"> <li>Set the surrounding air temperature to within the specifications.</li> <li>Clean the heatsink.</li> <li>Replace the cooling fan.</li> </ul>  |              |                    |               |

|                            |   |              |                    |                 |
|----------------------------|---|--------------|--------------------|-----------------|
| Operation Panel Indication | E.IPF   | <i>E.IPF</i> | FR-PU04<br>FR-PU07 | Inst. Pwr. Loss |
| Name                       | Instantaneous power failure   |              |                    |                 |
| Description                | If a power failure occurs for longer than 15ms (this also applies to inverter input shut-off), the instantaneous power failure protective function is activated to trip the inverter in order to prevent the control circuit from malfunctioning. If a power failure persists for longer than 100ms, the fault output is not provided, and the inverter restarts if the start signal is ON upon power restoration. (The inverter continues operating if an instantaneous power failure is within 15ms.) In some operating status (load magnitude, acceleration/ deceleration time setting, etc.), overcurrent or other protection may be activated upon power restoration. When instantaneous power failure protection is activated, the IPF signal is output. (Refer to Chapter 4 of the Instruction Manual (Applied)) |              |                    |                 |
| Check point                | Find the cause of instantaneous power failure occurrence.   |              |                    |                 |
| Corrective action          | <ul style="list-style-type: none"> <li>Remedy the instantaneous power failure.</li> <li>Prepare a backup power supply for instantaneous power failure.</li> <li>Set the function of automatic restart after instantaneous power failure (Pr. 57). (Refer to Chapter 4 of the Instruction Manual (Applied).)</li> </ul>  |              |                    |                 |

|                            |  |              |                    |                |
|----------------------------|--|--------------|--------------------|----------------|
| Operation Panel Indication | E.BE   | <i>E. BE</i> | FR-PU04<br>FR-PU07 | Br. Cct. Fault |
| Name                       | Brake transistor alarm detection/internal circuit fault  |              |                    |                |
| Description                | This function stops the inverter output if a fault occurs in the brake circuit, e.g. damaged brake transistors when using functions of the 75K or higher. <u>In this case, the inverter must be powered OFF immediately.</u> For the 55K or lower, it appears when an internal circuit error occurred. |              |                    |                |
| Check point                | <ul style="list-style-type: none"> <li>Reduce the load inertia.</li> <li>Check that the frequency of using the brake is proper.</li> <li>Check that the brake resistor selected is correct.</li> </ul>   |              |                    |                |
| Corrective action          | For the 75K or higher, when the protective function is activated even if the above measures are taken, replace the brake unit with a new one. For the 55K or lower, replace the inverter.  |              |                    |                |

|                            |   |              |                    |               |
|----------------------------|---|--------------|--------------------|---------------|
| Operation Panel Indication | E.UVT   | <i>E.UVT</i> | FR-PU04<br>FR-PU07 | Under Voltage |
| Name                       | Undervoltage  |              |                    |               |
| Description                | If the power supply voltage of the inverter decreases, the control circuit will not perform normal functions. In addition, the motor torque will be insufficient and/or heat generation will increase. To prevent this, if the power supply voltage decreases below about 150V (300VAC for the 400V class), this function stops the inverter output. When a jumper is not connected across P/+ and P1, the undervoltage protective function is activated. When undervoltage protection is activated, the IPF signal is output. (Refer to Chapter 4 of the Instruction Manual (Applied)) |              |                    |               |
| Check point                | <ul style="list-style-type: none"> <li>Check for start of large-capacity motor.</li> <li>Check that a jumper or DC reactor is connected across terminals P/+ and P1.</li> </ul>   |              |                    |               |
| Corrective action          | <ul style="list-style-type: none"> <li>Check the power supply system equipment such as the power supply.</li> <li>Connect a jumper or DC reactor across terminals P/+ and P1.</li> <li>If the problem still persists after taking the above measure, please contact your sales representative.</li> </ul>   |              |                    |               |

|                            |   |         |         |                  |
|----------------------------|---|---------|---------|------------------|
| Operation Panel Indication | E.ILF   | E I L F | FR-PU04 | Fault 14         |
|                            |   |         | FR-PU07 | Input phase loss |
| Name                       | Input phase loss  |         |         |                  |
| Description                | This fault is output when function valid setting (=1) is set in Pr. 872 Input phase loss protection selection and one phase of the three phase power input is lost.<br>When the setting of Pr. 872 Input phase loss protection selection is the initial value (Pr. 872 = "0"), this fault does not occur. (Refer to Chapter 4 of the Instruction Manual (Applied).) |         |         |                  |
| Check point                | Check for a break in the cable for the three-phase power supply input.  |         |         |                  |
| Corrective action          | <ul style="list-style-type: none"> <li>· Wire the cables properly.</li> <li>· Repair a break portion in the cable.</li> <li>· Check the Pr. 872 Input phase loss protection selection setting.</li> </ul>   |         |         |                  |

|                            |  |         |         |                |
|----------------------------|--|---------|---------|----------------|
| Operation Panel Indication | E.OLT  | E O L T | FR-PU04 | Still Prev STP |
|                            |  |         | FR-PU07 |                |
| Name                       | Stall prevention stop  |         |         |                |
| Description                | If the frequency has fallen to 0.5Hz(1.5Hz under IPM motor control) by stall prevention operation and remains for 3s, a fault (E.OLT) appears and trips the inverter. OL appears while stall prevention is being activated.  |         |         |                |
| Check point                | <ul style="list-style-type: none"> <li>· Check the motor for use under overload. (Refer to Chapter 4 of the Instruction Manual (Applied).)</li> <li>· Check that a motor is connected during IPM motor control. (IPM motor control)</li> <li>· Check for insufficient torque in the low-speed range under IPM motor control.</li> </ul>  |         |         |                |
| Corrective action          | <ul style="list-style-type: none"> <li>· Reduce the load weight.</li> <li>· Check the connection of the IPM motor. (IPM motor control)</li> <li>· Set the IPM motor test operation. (Refer to Chapter 4 of the Instruction Manual (Applied))</li> <li>· Under IPM motor control, set the longer acceleration/deceleration time in the low-speed range in Pr.791 and Pr.792.</li> </ul> |         |         |                |

|                            |   |         |         |                |
|----------------------------|---|---------|---------|----------------|
| Operation Panel Indication | E.SOT   | E S O T | FR-PU04 | Fault 14       |
|                            |   |         | FR-PU07 | Motor step out |
| Name                       | Loss of synchronism detection   |         |         |                |
| Description                | Stops the output when the operation is not synchronized. (This function is only available under IPM motor control.)   |         |         |                |
| Check point                | <ul style="list-style-type: none"> <li>· Check that the IPM motor is not driven overloaded.</li> <li>· Check if a start command is given to the inverter while the IPM motor is coasting.</li> <li>· Check if a motor other than the IPM motor (MM-EFS series, MM-THE4 series, or MM-EF series) is driven.</li> </ul>   |         |         |                |
| Corrective action          | <ul style="list-style-type: none"> <li>· Set the acceleration time longer.</li> <li>· Reduce the load.</li> <li>· If the inverter restarts during coasting, set Pr.57 Restart coasting time ≠ "9999," and select the automatic restart after instantaneous power failure.</li> <li>· Drive the IPM motor (MM-EFS series, MM-THE4 series, or MM-EF series).</li> </ul> |         |         |                |

|                            |   |         |         |              |
|----------------------------|---|---------|---------|--------------|
| Operation Panel Indication | E.GF  | E . G F | FR-PU04 | Ground Fault |
|                            |   |         | FR-PU07 |              |
| Name                       | Output side earth (ground) fault overcurrent  |         |         |              |
| Description                | This function stops the inverter output if an earth (ground) fault overcurrent flows due to an earth (ground) fault that occurred on the inverter's output (load) side. |         |         |              |
| Check point                | Check for an earth (ground) fault in the motor and connection cable.  |         |         |              |
| Corrective action          | Remedy the earth (ground) fault portion.  |         |         |              |

|                            |  |         |         |       |
|----------------------------|--|---------|---------|-------|
| Operation Panel Indication | E.LF   | E . L F | FR-PU04 | E. LF |
|                            |  |         | FR-PU07 |       |
| Name                       | Output phase loss  |         |         |       |
| Description                | This function stops the inverter output if one of the three phases (U, V, W) on the inverter's output side (load side) is lost.  |         |         |       |
| Check point                | <ul style="list-style-type: none"> <li>· Check the wiring (Check that the motor is normal.)</li> <li>· Check that the capacity of the motor used is not smaller than that of the inverter.</li> <li>· Check if a start command is given to the inverter while the motor is coasting. (IPM motor control)</li> </ul>  |         |         |       |
| Corrective action          | <ul style="list-style-type: none"> <li>· Wire the cables properly.</li> <li>· Choose inverter and motor capacities that match.</li> <li>· Input a start command after the motor stops. Alternatively, use automatic restart after instantaneous power failure/flying start function. (IPM motor control) (Refer to Chapter 4 of the Instruction Manual (Applied))</li> </ul> |         |         |       |



|                                   |  |              |                                  |                 |
|-----------------------------------|--|--------------|----------------------------------|-----------------|
| <b>Operation Panel Indication</b> | <b>E.OHT</b>   | <b>E.OHT</b> | <b>FR-PU04</b><br><b>FR-PU07</b> | <b>OH Fault</b> |
| <b>Name</b>                       | External thermal relay operation   |              |                                  |                 |
| <b>Description</b>                | If the external thermal relay provided for motor overheat protection, or the internally mounted temperature relay in the motor, etc. switches ON (contacts open), the inverter output is stopped. This function is available when "7" (OH signal) is set to any of Pr. 178 to Pr. 189 (input terminal function selection).<br>When the initial value (without OH signal assigned) is set, this protective function is not available. |              |                                  |                 |
| <b>Check point</b>                | <ul style="list-style-type: none"> <li>Check for motor overheating.</li> <li>Check that the value of 7 (OH signal) is set correctly in any of Pr. 178 to Pr. 189 (input terminal function selection).</li> </ul>   |              |                                  |                 |
| <b>Corrective action</b>          | <ul style="list-style-type: none"> <li>Reduce the load and operating duty.</li> <li>Even if the relay contacts are reset automatically, the inverter will not restart unless it is reset.</li> </ul>   |              |                                  |                 |

|                                   |  |              |                                  |   |
|-----------------------------------|--|--------------|----------------------------------|---|
| <b>Operation Panel Indication</b> | <b>E.PTC</b>   | <b>E.PTC</b> | <b>FR-PU04</b><br><b>FR-PU07</b> | <b>Fault 14</b><br><b>PTC activated</b> |
| <b>Name</b>                       | PTC thermistor operation   |              |                                  |   |
| <b>Description</b>                | Trips when the motor overheat status is detected for 10s or more by the external PTC thermistor input connected to the terminal AU.<br>This fault is available when "63" is set in Pr. 184 AU terminal function selection and AU/PTC switchover switch is set in PTC side. When the initial value (Pr. 184 = "4") is set, this protective function is not available. |              |                                  |   |
| <b>Check point</b>                | <ul style="list-style-type: none"> <li>Check the connection between the PTC thermistor switch and thermal relay protector.</li> <li>Check the motor for operation under overload.</li> <li>Is valid setting (= 63) selected in Pr. 184 AU terminal function selection? (Refer to Chapter 4 of the Instruction Manual (Applied).)</li> </ul>                          |              |                                  |   |
| <b>Corrective action</b>          | Reduce the load weight.  |              |                                  |   |

|                                   |   |              |                                  |                     |
|-----------------------------------|---|--------------|----------------------------------|---------------------|
| <b>Operation Panel Indication</b> | <b>E.OPT</b>  | <b>E.OPT</b> | <b>FR-PU04</b><br><b>FR-PU07</b> | <b>Option Fault</b> |
| <b>Name</b>                       | Option fault  |              |                                  |                     |
| <b>Description</b>                | <ul style="list-style-type: none"> <li>Appears when the AC power supply is connected to the terminal R/L1, S/L2, T/L3 accidentally when a high power factor converter is connected.</li> <li>Appears when the switch for the manufacturer setting of the plug-in option is changed.</li> <li>Appears when a communication option is connected while Pr. 296 Password lock level = "0 or 100."</li> </ul>  |              |                                  |                     |
| <b>Check point</b>                | <ul style="list-style-type: none"> <li>Check that the AC power supply is not connected to the terminal R/L1, S/L2, T/L3 when a high power factor converter (FR-HC2) or power regeneration common converter (FR-CV) is connected.</li> <li>Check if password lock is activated by setting Pr. 296 = "0, 100"</li> </ul>  |              |                                  |                     |
| <b>Corrective action</b>          | <ul style="list-style-type: none"> <li>Check the parameter (Pr. 30) setting and wiring.</li> <li>The inverter may be damaged if the AC power supply is connected to the terminal R/L1, S/L2, T/L3 when a high power factor converter is connected. Please contact your sales representative.</li> <li>Return the switch for the manufacturer setting of the plug-in option to the initial status. (Refer to Chapter 4 of the Instruction Manual (Applied).)</li> <li>To apply the password lock when installing a communication option, set Pr.296 ≠ "0,100". (Refer to Chapter 4 of the Instruction Manual (Applied).)</li> <li>If the problem still persists after taking the above measure, please contact your sales representative.</li> </ul> |              |                                  |                     |

|                                   |   |              |                                  |                       |
|-----------------------------------|---|--------------|----------------------------------|-----------------------|
| <b>Operation Panel Indication</b> | <b>E.OP1</b>  | <b>E.OP1</b> | <b>FR-PU04</b><br><b>FR-PU07</b> | <b>Option 1 Fault</b> |
| <b>Name</b>                       | Communication option fault  |              |                                  |                       |
| <b>Description</b>                | Stops the inverter output when a communication line fault occurs in the communication option.   |              |                                  |                       |
| <b>Check point</b>                | <ul style="list-style-type: none"> <li>Check for a wrong option function setting and operation.</li> <li>Check that the plug-in option is plugged into the connector securely.</li> <li>Check for a break in the communication cable.</li> <li>Check that the terminating resistor is fitted properly.</li> </ul> |              |                                  |                       |
| <b>Corrective action</b>          | <ul style="list-style-type: none"> <li>Check the option function setting, etc.</li> <li>Connect the plug-in option securely.</li> <li>Check the connection of communication cable.</li> </ul>   |              |                                  |                       |

|                            |  |      |                    |         |
|----------------------------|--|------|--------------------|---------|
| Operation Panel Indication | E. 1   | E. 1 | FR-PU04<br>FR-PU07 | Fault 1 |
| Name                       | Option fault   |      |                    |         |
| Description                | Stops the inverter output if a contact fault or the like of the connector between the inverter and communication option occurs.<br>Appears when the switch for the manufacturer setting of the plug-in option is changed.  |      |                    |         |
| Check point                | <ul style="list-style-type: none"> <li>· Check that the plug-in option is plugged into the connector securely.</li> <li>· Check for excess electrical noises around the inverter.</li> </ul>   |      |                    |         |
| Corrective action          | <ul style="list-style-type: none"> <li>· Connect the plug-in option securely.</li> <li>· Take measures against noises if there are devices producing excess electrical noises around the inverter.</li> </ul> If the problem still persists after taking the above measure, please contact your sales representative or distributor.<br><ul style="list-style-type: none"> <li>· Return the switch position for the manufacturer setting of the plug-in option to the initial status. (  Refer to instruction manual of each option)</li> </ul> |      |                    |         |

|                            |   |       |                    |               |
|----------------------------|---|-------|--------------------|---------------|
| Operation Panel Indication | E.PE  | E. PE | FR-PU04<br>FR-PU07 | Corrupt Memry |
| Name                       | Parameter storage device fault (control circuit board)  |       |                    |               |
| Description                | Trips when a fault occurred in the parameter stored. (EEPROM failure)   |       |                    |               |
| Check point                | Check for too many number of parameter write times.   |       |                    |               |
| Corrective action          | Please contact your sales representative.<br>When performing parameter write frequently for communication purposes, set "1" in Pr. 342 to enable RAM write. Note that powering OFF returns the inverter to the status before RAM write. |       |                    |               |

|                            |   |      |                    |                              |
|----------------------------|---|------|--------------------|------------------------------|
| Operation Panel Indication | E.PE2   | EPE2 | FR-PU04<br>FR-PU07 | Fault 14<br>PR storage alarm |
| Name                       | Parameter storage device fault (main circuit board)                   |      |                    |                              |
| Description                | Trips when a fault occurred in the parameter stored. (EEPROM failure) |      |                    |                              |
| Check point                | _____   |      |                    |                              |
| Corrective action          | Please contact your sales representative.                             |      |                    |                              |

|                            |   |      |                    |              |
|----------------------------|---|------|--------------------|--------------|
| Operation Panel Indication | E.PUE   | EPUE | FR-PU04<br>FR-PU07 | PU Leave Out |
| Name                       | PU disconnection  |      |                    |              |
| Description                | <ul style="list-style-type: none"> <li>· This function stops the inverter output if communication between the inverter and PU is suspended, e.g. the operation panel and parameter unit is disconnected, when "2", "3", "16" or "17" was set in Pr. 75 Reset selection/disconnected PU detection/PU stop selection. This protective function is not available in the initial setting (Pr. 75 = "14").</li> <li>· This function stops the inverter output when communication errors occurred consecutively for more than permissible number of retries when a value other than "9999" is set in Pr. 121 Number of PU communication retries during the RS-485 communication with the PU connector.</li> <li>· This function stops the inverter output if communication is broken for the period of time set in Pr. 122 PU communication check time interval during the RS-485 communication with the PU connector.</li> </ul> |      |                    |              |
| Check point                | <ul style="list-style-type: none"> <li>· Check that the FR-DU07 or parameter unit (FR-PU04/FR-PU07) is fitted tightly.</li> <li>· Check the Pr. 75 setting.</li> </ul>  |      |                    |              |
| Corrective action          | Fit the FR-DU07 or parameter unit (FR-PU04/FR-PU07) securely.   |      |                    |              |

|                            |  |       |                    |               |
|----------------------------|--|-------|--------------------|---------------|
| Operation Panel Indication | E.RET  | E.rEr | FR-PU04<br>FR-PU07 | Retry No Over |
| Name                       | Retry count excess   |       |                    |               |
| Description                | If operation cannot be resumed properly within the number of retries set, this function trips the inverter. This function is available only when Pr. 67 Number of retries at fault occurrence is set. When the initial value (Pr. 67 = "0") is set, this protective function is not available. |       |                    |               |
| Check point                | Find the cause of fault occurrence.  |       |                    |               |
| Corrective action          | Eliminate the cause of the fault preceding this error indication.  |       |                    |               |



|                            |  |       |                    |           |
|----------------------------|--|-------|--------------------|-----------|
| Operation Panel Indication | E. 5   | E. 5  | FR-PU04<br>FR-PU07 | Fault 5   |
|                            | E. 6   | E. 6  |                    | Fault 6   |
|                            | E. 7   | E. 7  |                    | Fault 7   |
|                            | E.CPU  | E.CPU |                    | CPU Fault |
| Name                       | CPU fault  |       |                    |           |
| Description                | Stops the inverter output if the communication fault of the built-in CPU occurs.   |       |                    |           |
| Check point                | Check for devices producing excess electrical noises around the inverter.  |       |                    |           |
| Corrective action          | <ul style="list-style-type: none"> <li>Take measures against noises if there are devices producing excess electrical noises around the inverter.</li> <li>Please contact your sales representative.</li> </ul> |       |                    |           |

|                            |   |       |         |       |
|----------------------------|---|-------|---------|-------|
| Operation Panel Indication | E.CTE   | E.CTE | FR-PU04 | ———   |
|                            |   |       | FR-PU07 | E.CTE |
| Name                       | RS-485 terminal power supply short circuit  |       |         |       |
| Description                | When the internal power supply for RS-485 terminals are shorted, this function shuts off the power output. At this time, communication from the RS-485 terminals cannot be made. To reset, enter the RES signal or switch power OFF, then ON again. |       |         |       |
| Check point                | <ul style="list-style-type: none"> <li>Check that the RS-485 terminals are connected correctly.</li> </ul>  |       |         |       |
| Corrective action          | <ul style="list-style-type: none"> <li>Check the connection of the RS-485 terminals</li> </ul>  |       |         |       |

|                            |  |       |         |       |
|----------------------------|--|-------|---------|-------|
| Operation Panel Indication | E.P24  | E.P24 | FR-PU04 | E.P24 |
|                            |  |       | FR-PU07 |       |
| Name                       | 24VDC power output short circuit   |       |         |       |
| Description                | When the 24VDC power output from the PC terminal is shorted, this function shuts off the power output. At this time, all external contact inputs switch OFF. The inverter cannot be reset by entering the RES signal. To reset it, use the operation panel or switch power OFF, then ON again. |       |         |       |
| Check point                | <ul style="list-style-type: none"> <li>Check for a short circuit in the PC terminal output.</li> </ul>   |       |         |       |
| Corrective action          | <ul style="list-style-type: none"> <li>Remedy the earth (ground) fault portion.</li> </ul>   |       |         |       |

|                            |  |       |         |                 |
|----------------------------|--|-------|---------|-----------------|
| Operation Panel Indication | E.CDO  | E.CDO | FR-PU04 | Fault 14        |
|                            |  |       | FR-PU07 | OC detect level |
| Name                       | Output current detection value exceeded  |       |         |                 |
| Description                | This function stops the inverter output when the output current exceeds the setting of <i>Pr.150 Output current detection level</i> , or the output current falls below the setting of <i>Pr.152 Zero current detection level</i> . This function is active when <i>Pr. 167 Output current detection operation selection</i> is set to "1, 10, 11". When the initial value ( <i>Pr. 167 = "0"</i> ) is set, this fault does not occur. |       |         |                 |
| Check point                | Check the settings of <i>Pr. 150 Output current detection level</i> , <i>Pr. 151 Output current detection signal delay time</i> , <i>Pr. 152 Zero current detection level</i> , <i>Pr. 153 Zero current detection time</i> , <i>Pr. 166 Output current detection signal retention time</i> , <i>Pr. 167 Output current detection operation selection</i> . (Refer to Chapter 4 of the Instruction Manual (Applied).)                   |       |         |                 |

|                            |  |       |         |                 |
|----------------------------|--|-------|---------|-----------------|
| Operation Panel Indication | E.IOH  | E IOH | FR-PU04 | Fault 14        |
|                            |  |       | FR-PU07 | Inrush overheat |
| Name                       | Inrush current limit circuit fault   |       |         |                 |
| Description                | Trips when the resistor of the inrush current limit circuit overheats. The inrush current limit circuit fault  |       |         |                 |
| Check point                | <ul style="list-style-type: none"> <li>Check that frequent power ON/OFF is not repeated.</li> <li>Check that no meltdown is found in the input side fuse (5A) in the power supply circuit of the inrush current suppression circuit contactor (FR-F740P-132K or higher) or no fault is found in the power supply circuit of the contactor.</li> <li>Check that the power supply circuit of inrush current limit circuit contactor is not damaged.</li> </ul> |       |         |                 |
| Corrective action          | Configure a circuit where frequent power ON/OFF is not repeated. If the problem still persists after taking the above measure, please contact your sales representative.   |       |         |                 |

|                            |   |       |         |                |
|----------------------------|---|-------|---------|----------------|
| Operation Panel Indication | E.SER   | E.SEr | FR-PU04 | Fault 14       |
|                            |   |       | FR-PU07 | VFD Comm error |
| Name                       | Communication fault (inverter)  |       |         |                |
| Description                | This function stops the inverter output when communication error occurs consecutively for more than permissible retry count when a value other than "9999" is set in <i>Pr. 335 RS-485 communication retry count</i> during RS-485 communication from the RS-485 terminals. This function also stops the inverter output if communication is broken for the period of time set in <i>Pr. 336 RS-485 communication check time interval</i> . |       |         |                |
| Check point                | Check the RS-485 terminal wiring.   |       |         |                |
| Corrective action          | Perform wiring of the RS-485 terminals properly.  |       |         |                |

|                            |  |       |         |                 |
|----------------------------|--|-------|---------|-----------------|
| Operation Panel Indication | E.AIE  | E.AIE | FR-PU04 | Fault 14        |
|                            |  |       | FR-PU07 | Analog in error |
| Name                       | Analog input fault   |       |         |                 |
| Description                | Stops the inverter output when a 30mA or higher current or a 7.5V or higher voltage is input to terminal 2 while the current input is selected by <i>Pr.73 Analog input selection</i> , or to terminal 4 while the current input is selected by <i>Pr.267 Terminal 4 input selection</i> . |       |         |                 |
| Check point                | Check the setting of <i>Pr. 73 Analog input selection</i> and <i>Pr. 267 Terminal 4 input selection</i> . (Refer to Chapter 4 of the Instruction Manual (Applied).)  |       |         |                 |
| Corrective action          | Either give a frequency command by current input or set <i>Pr. 73 Analog input selection</i> or <i>Pr. 267 Terminal 4 input selection</i> to voltage input.  |       |         |                 |

|                            |  |       |         |      |
|----------------------------|--|-------|---------|------|
| Operation Panel Indication | E.OS<br>IPM  | E. OS | FR-PU04 | E.OS |
|                            |  |       | FR-PU07 |      |
| Name                       | Overspeed occurrence   |       |         |      |
| Description                | Stops the inverter outputs when the motor speed exceeds the <i>Pr. 374 Overspeed detection level</i> under IPM motor control. This protective function is available while the IPM motor control is selected. |       |         |      |
| Check point                | · Check that the <i>Pr. 374 Overspeed detection level</i> value is correct.  |       |         |      |
| Corrective action          | · Set the <i>Pr. 374 Overspeed detection level</i> value correctly.  |       |         |      |

|                            |  |       |         |                           |
|----------------------------|--|-------|---------|---------------------------|
| Operation Panel Indication | E.PID  | E.PId | FR-PU04 | Fault 14                  |
|                            |  |       | FR-PU07 | Fault<br>PID Signal Error |
| Name                       | PID signal fault   |       |         |                           |
| Description                | If any of PID upper limit (FUP), PID lower limit (FDN), and PID deviation limit (Y48) turns ON during PID control, inverter shuts off the output. This function is active under the following parameter settings: <i>Pr.554 PID signal operation selection</i> ≠ "0,10", <i>Pr.131 PID upper limit</i> ≠ "9999", <i>Pr.132 PID lower limit</i> ≠ "9999", and <i>Pr.553 PID deviation limit</i> ≠ "9999". This protective function is not active in the initial setting ( <i>Pr.554</i> = "0", <i>Pr.131</i> = "9999", <i>Pr.132</i> = "9999", <i>Pr.553</i> = "9999"). |       |         |                           |
| Check Point                | · Check if the measured PID value is greater than the upper limit ( <i>Pr.131</i> ) or smaller than the lower limit ( <i>Pr.132</i> ).<br>· Check if the absolute PID deviation value is greater than the limit value ( <i>Pr.553</i> ).   |       |         |                           |
| Corrective Action          | Make correct settings for <i>Pr.131 PID upper limit</i> , <i>Pr.132 PID lower limit</i> , <i>Pr.553 PID deviation limit</i> . (Refer to Chapter 4 of the Instruction Manual (Applied))   |       |         |                           |

|                            |  |       |         |          |
|----------------------------|--|-------|---------|----------|
| Operation Panel Indication | E.13   | E. 13 | FR-PU04 | Fault 13 |
|                            |  |       | FR-PU07 |          |
| Name                       | Internal circuit fault                         |       |         |          |
| Description                | Trips when an internal circuit error occurred. |       |         |          |
| Corrective action          | Please contact your sales representative.      |       |         |          |

### CAUTION

- If protective functions of E.ILF, E.SOT, E.PTC, E.PE2, E.CDO, E.IOH, E.SER, E.AIE, E.PID are activated when using the FR-PU04, "Fault 14" appears.  
Also when the faults history is checked on the FR-PU04, the display is "E.14".
- If faults other than the above appear, contact your sales representative.





## 6.4 Correspondences between digital and actual characters

There are the following correspondences between the actual alphanumeric characters and the digital characters displayed on the operation panel.

| Actual | Digital |
|--------|---------|
| 0      | 0       |
| 1      | 1       |
| 2      | 2       |
| 3      | 3       |
| 4      | 4       |
| 5      | 5       |
| 6      | 6       |
| 7      | 7       |
| 8      | 8       |
| 9      | 9       |

| Actual | Digital |
|--------|---------|
| A      | A       |
| B      | b       |
| C      | C       |
| D      | d       |
| E      | E       |
| F      | F       |
| G      | G       |
| H      | H       |
| I      | I       |
| J      | J       |
| L      | L       |

| Actual | Digital |
|--------|---------|
| M      | m       |
| N      | n       |
| O      | O       |
| o      | o       |
| P      | P       |
| S      | S       |
| T      | T       |
| U      | U       |
| V      | v       |
| r      | r       |
| -      | -       |

## 6.5 Check and clear of the faults history

### (1) Check for the faults history

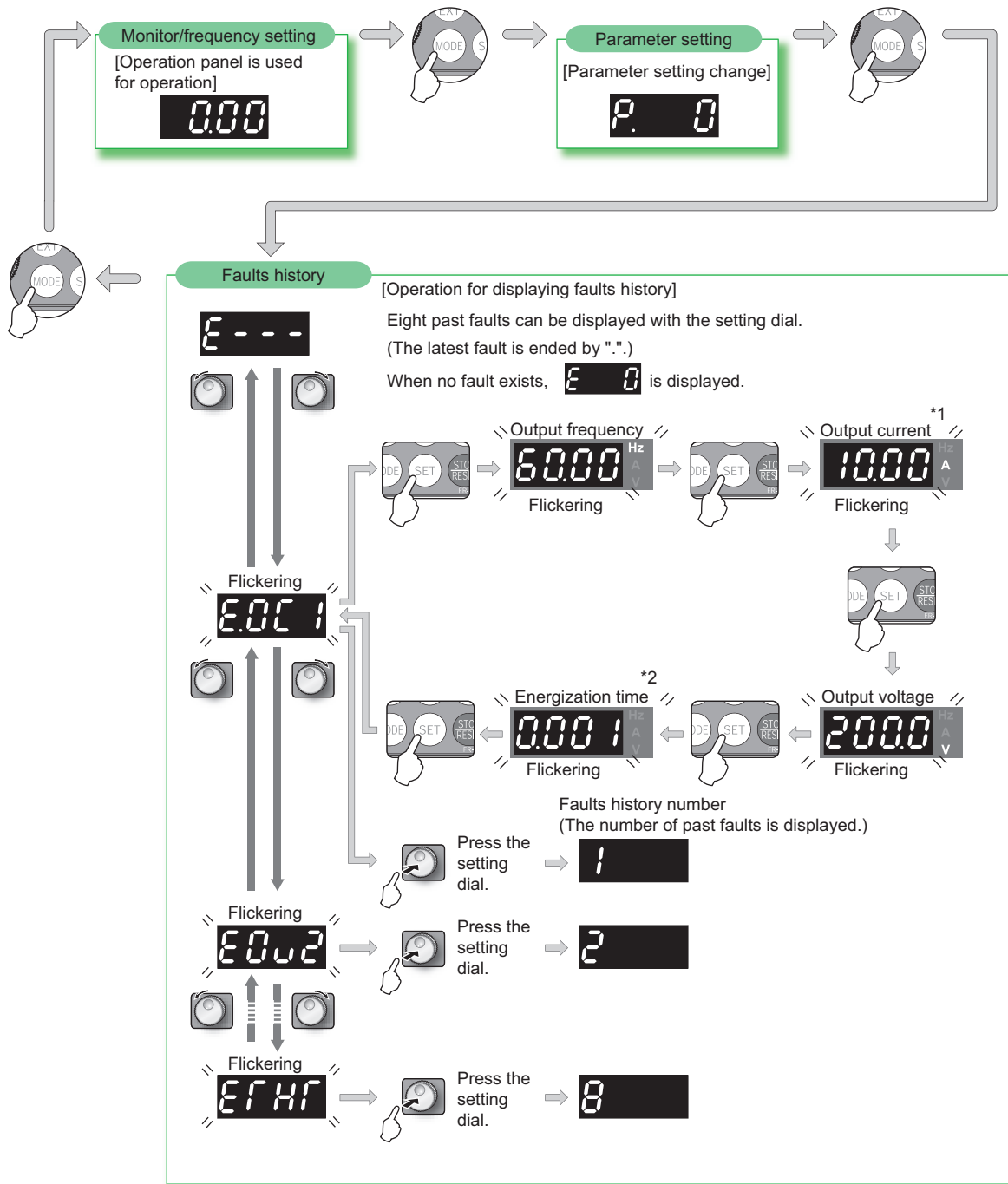

\*1 When an overcurrent trip occurs by an instant overcurrent, the monitored current value saved in the faults history may be lower than the actual current that has flowed.

\*2 The cumulative energization time and actual operation time are accumulated from 0 to 65535 hours, then cleared, and accumulated again from 0. When the operation panel (FR-DU07) is used, the time is displayed up to 65.53 (65530h) in the indication of 1h = 0.001, and thereafter, it is added up from 0.



**(2) Clearing procedure**

**POINT**

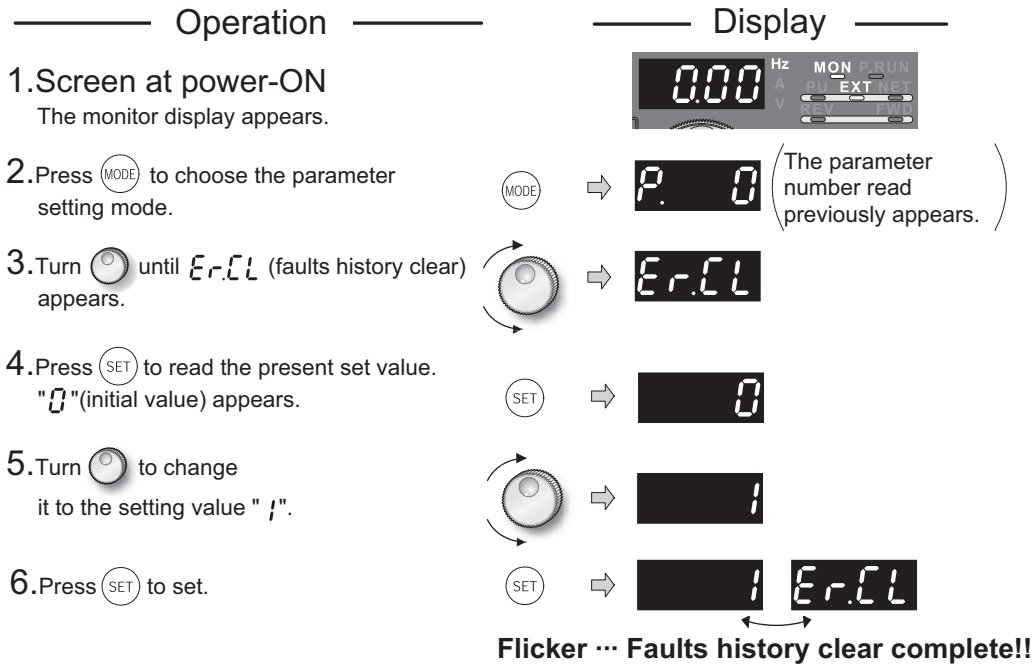
· The faults history can be cleared by setting "1" in *Er.CL* Faults history clear.



**Flicker ... Faults history clear complete!!**



- Press  to read another parameter.
- Press  to show the setting again.
- Press  twice to show the next parameter.



## 6.6 Check first when you have a trouble

### POINT

- If the cause of malfunction is still unknown after performing applicable checks, initialization of parameter settings is recommended. Reset the parameter settings and set the required parameters again, then perform the checks again.
- Where  is indicated in the "Refer to page" column, refer to the *Instruction Manual (Applied)*.

### 6.6.1 Motor does not start

| Check points | Possible Cause  | Countermeasures   | Refer to page   |
|--------------|---|---|---|
| Main Circuit | Appropriate power supply voltage is not applied.<br>(Operation panel display is not provided.)  | Power ON a moulded case circuit breaker (MCCB), an earth leakage circuit breaker (ELB), or a magnetic contactor (MC).   | —   |
|              |   | Check for the decreased input voltage, input phase loss, and wiring.  |   |
|              |   | If only the control power is ON when using a separate power source for the control circuit, turn ON the main circuit power.   | 17  |
|              | Motor is not connected properly.  | Check the wiring between the inverter and the motor. If the electronic bypass function is active, check the wiring of the magnetic contactor connected between the inverter and the motor. (V/F control, Simple magnetic flux vector control) | 11  |
|              | The jumper across P/+ and P1 is disconnected. (55K or lower)  | Securely fit a jumper across P/+ and P1. When using a DC reactor (FR-HEL), remove the jumper across P/+ and P1, and then connect the DC reactor.  | 11  |
| Input Signal | Start signal is not input.  | Check the start command source, and input a start signal.<br>PU operation mode: <br>External operation mode : STF/STR signal                             | 2   |
|              | Both the forward and reverse rotation start signals (STF, STR) are input simultaneously.  | Turn ON only one of the forward and reverse rotation start signals (STF or STR).<br>If STF and STR signals are turned ON simultaneously in the initial setting, a stop command is given.  | 19  |
|              | Frequency command is zero.<br>(FWD or REV LED on the operation panel is flickering.)  | Check the frequency command source and enter a frequency command.   | 2   |
|              | AU signal is not ON when terminal 4 is used for frequency setting.<br>(FWD or REV LED on the operation panel is flickering.)  | Turn ON the AU signal.<br>Turning ON the AU signal activates terminal 4 input.  | 19  |
|              | Output stop signal (MRS) or reset signal (RES) is ON.<br>(FWD or REV LED on the operation panel is flickering.)   | Turn MRS or RES signal OFF.<br>Inverter starts the operation with a given start command and a frequency command after turning OFF MRS or RES signal.<br>Before turning OFF, ensure the safety.  |  |
|              | CS signal is OFF when automatic restart after instantaneous power failure function is selected (Pr. 57 ≠ "9999").<br>(FWD or REV LED on the operation panel is flickering.) | Turn ON the CS signal.<br>Restart operation is enabled when restart after instantaneous power signal (CS) is ON.  |  |
|              | Jumper connector of sink - source is wrongly selected.<br>(FWD or REV LED on the operation panel is flickering.)  | Check that the control logic switchover jumper connector is correctly installed.<br>If it is not installed correctly, input signal is not recognized.   | 22  |
|              | Voltage/current input switch is not correctly set for analog input signal (0 to 5V/0 to 10V, 4 to 20mA).<br>(FWD or REV LED on the operation panel is flickering.)          | Set Pr. 73, Pr. 267, and a voltage/current input switch correctly, then input an analog signal in accordance with the setting.  | 19  |

| Check points  | Possible Cause   | Countermeasures   | Refer to page |
|---|--|---|---------------|
| Input Signal  |  was pressed.<br>(Operation panel indication is $P5$ (PS).)   | During the External operation mode, check the method of restarting from a  input stop from PU.   | 119           |
|   | Two-wire or three-wire type connection is wrong.   | Check the connection.<br>Connect STOP signal when three-wire type is used.  | 105           |
| Parameter Setting   | <i>Pr. 0 Torque boost</i> setting is improper when V/F control is used.  | Increase <i>Pr. 0</i> setting by 0.5% increments while observing the rotation of a motor.<br>If that makes no difference, decrease the setting.   | 72            |
|   | <i>Pr. 78 Reverse rotation prevention selection</i> is set.  | Check the <i>Pr. 78</i> setting.<br>Set <i>Pr. 78</i> when you want to limit the motor rotation to only one direction.  | 96            |
|   | <i>Pr. 79 Operation mode selection</i> setting is wrong.   | Select the operation mode which corresponds with input methods of start command and frequency command.  | 2             |
|   | Bias and gain ( <i>calibration parameter C2 to C7</i> ) settings are improper.   | Check the bias and gain ( <i>calibration parameter C2 to C7</i> ) settings.   | 99            |
|   | <i>Pr. 13 Starting frequency</i> setting is greater than the running frequency.  | Set running frequency higher than <i>Pr. 13</i> .<br>The inverter does not start if the frequency setting signal is less than the value set in <i>Pr. 13</i> .  | 88            |
|   | Frequency settings of various running frequency (such as multi-speed operation) are zero.<br>Especially, <i>Pr. 1 Maximum frequency</i> is zero.   | Set the frequency command according to the application.<br>Set <i>Pr. 1</i> higher than the actual frequency used.  | 73            |
|   | <i>Pr. 15 Jog frequency</i> setting is lower than <i>Pr. 13 Starting frequency</i> .   | Set <i>Pr. 15 Jog frequency</i> higher than <i>Pr. 13 Starting frequency</i> .  | 88            |
|   | Operation mode and a writing device do not match.  | Check <i>Pr. 79, Pr. 338, Pr. 339, Pr. 550, Pr. 551</i> , and select an operation mode suitable for the purpose.  | 77, 108       |
|   | Start signal operation selection is set by the <i>Pr. 250 Stop selection</i>   | Check <i>Pr. 250</i> setting and connection of STF and STR signals.   | 105           |
|   | The motor is decelerated to a stop when power failure deceleration stop function is selected.  | When power is restored, ensure the safety, and turn OFF the start signal once, then turn ON again to restart.<br>The motor restarts when <i>Pr. 261</i> ="2, 22".   | 106           |
|   | Automatic restart after instantaneous power failure function or power failure stop function is activated.<br>(Performing overload operation during input phase loss may cause voltage insufficiency, and that may result in detection of power failure.) | <ul style="list-style-type: none"> <li>Set <i>Pr. 872 Input phase loss protection selection</i> = "1" (input phase failure protection active).</li> <li>Disable the automatic restart after instantaneous power failure function and power failure stop function.</li> <li>Reduce the load.</li> <li>Increase the acceleration time if the automatic restart after instantaneous power failure function or power failure stop function occurred during acceleration.</li> </ul> | 93, 106       |
| DC feeding mode 1 or mode 2 is not selected in <i>Pr.30 Regenerative function selection</i> even though the DC is fed through terminal P and N. | Set the DC feeding mode in <i>Pr.30 Regenerative function selection</i> .  | 88  |               |
| IPM motor test operation is selected under IPM motor control.   | Set "20" in <i>Pr.800 Control method selection</i> .   | 110   |               |
| Load  | Load is too heavy.   | Reduce the load.  | —             |
|   | Shaft is locked.   | Inspect the machine (motor).  | —             |

### 6.6.2 Motor or machine is making abnormal acoustic noise

When operating the inverter with the carrier frequency of 3kHz (6kHz during IPM motor control) or more set in *Pr. 72*, the carrier frequency will automatically decrease if the output current of the inverter exceeds the value in parentheses of the rated output current on *page 149*. This may cause the motor noise to increase. But it is not a fault.

| Check points             | Possible Cause   | Countermeasures  | Refer to page   |
|--------------------------|--|--|---|
| <b>Input signal</b>      | Disturbance due to EMI when frequency command is given from analog input (terminal 1, 2, 4). | Take countermeasures against EMI.  |  |
| <b>Parameter Setting</b> |  | Increase the <i>Pr. 74 Input filter time constant</i> if steady operation cannot be performed due to EMI.  | 96  |
| <b>Parameter Setting</b> | No carrier frequency noises (metallic noises) are generated.                                 | In the initial setting, <i>Pr. 240 Soft-PWM operation selection</i> is enabled to change motor noise to an unoffending complex tone. Therefore, no carrier frequency noises (metallic noises) are generated.<br>Set <i>Pr. 240</i> = "0" to disable this function.                                     | 95  |
|                          | Resonance occurs. (output frequency)   | Set <i>Pr. 31 to Pr. 36 and Pr.552 (Frequency jump)</i> .<br>When it is desired to avoid resonance attributable to the natural frequency of a mechanical system, these parameters allow resonant frequencies to be jumped.   | 91  |
|                          | Resonance occurs. (carrier frequency)  | Change <i>Pr. 72 PWM frequency selection</i> setting.<br>Changing the PWM carrier frequency produces an effect on avoiding the resonance frequency of a mechanical system or a motor.  | 95  |
|                          | Gain adjustment during PID control is insufficient.  | To stabilize the measured value, change the proportional band ( <i>Pr. 129</i> ) to a larger value, the integral time ( <i>Pr. 130</i> ) to a slightly longer time, and the differential time ( <i>Pr. 134</i> ) to a slightly shorter time.<br>Check the calibration of set point and measured value. | 99  |
| <b>Others</b>            | Mechanical looseness   | Adjust machine/equipment so that there is no mechanical looseness.   | —   |
|                          | Contact the motor manufacturer.  |  |   |
| <b>Motor</b>             | Operating with output phase loss   | Check the motor wiring.  | —   |

### 6.6.3 Inverter generates abnormal noise

| Check points | Possible Cause   | Countermeasures                  | Refer to page |
|--------------|--|----------------------------------|---------------|
| <b>Fan</b>   | Fan cover was not correctly installed when a cooling fan was replaced. | Install the fan cover correctly. | 145           |

### 6.6.4 Motor generates heat abnormally

| Check points             | Possible Cause   | Countermeasures   | Refer to page |
|--------------------------|--|---|---------------|
| <b>Motor</b>             | Motor fan is not working (Dust is accumulated.)  | Clean the motor fan.<br>Improve the environment.  | —             |
|                          | Phase to phase insulation of the motor is insufficient.  | Check the insulation of the motor.  | —             |
| <b>Main Circuit</b>      | The inverter output voltage (U, V, W) are unbalanced.  | Check the output voltage of the inverter.<br>Check the insulation of the motor.                   | 141           |
| <b>Parameter Setting</b> | The <i>Pr. 71 Applied motor</i> setting is wrong. (V/F control, Simple magnetic flux vector control) | Check the <i>Pr. 71 Applied motor</i> setting. (V/F control, Simple magnetic flux vector control) | 94            |
| —                        | Motor current is large.  | Refer to "6.6.11 Motor current is too large"  | 138           |

### 6.6.5 Motor rotates in the opposite direction

| Check points        | Possible Cause  | Countermeasures   | Refer to page   |
|---------------------|---|---|---|
| <b>Main Circuit</b> | Phase sequence of output terminals U, V and W is incorrect.   | Connect phase sequence of the output cables (terminal U, V, W) to the motor correctly | 11  |
| <b>Input signal</b> | The start signals (forward rotation, reverse rotation) are connected improperly.  | Check the wiring. (STF: forward rotation, STR: reverse rotation)                      | 19  |
|                     | The polarity of the frequency command is negative during the polarity reversible operation set by Pr: 73 <i>Analog input selection.</i> | Check the polarity of the frequency command.  |  |



### 6.6.6 Speed greatly differs from the setting

| Check points             | Possible Cause  | Countermeasures  | Refer to page   |
|--------------------------|---|--|---|
| <b>Input signal</b>      | Frequency setting signal is incorrectly input.                              | Measure the input signal level.  | —   |
|                          | The input signal lines are affected by external EMI.                        | Take countermeasures against EMI such as using shielded wires for input signal lines.  |  |
| <b>Parameter Setting</b> | Pr. 1, Pr. 2, Pr. 18, calibration parameter C2 to C7 settings are improper. | Check the settings of Pr. 1 <i>Maximum frequency</i> , Pr. 2 <i>Minimum frequency</i> , Pr. 18 <i>High speed maximum frequency</i> .                         | 86  |
|                          |   | Check the calibration parameter C2 to C7 settings.   | 99  |
|                          |   | During IPM motor control, maximum frequency is limited to the maximum motor speed (frequency) of the IPM motor.  | 162,<br>164   |
|                          | Pr. 31 to Pr. 36 ( <i>frequency jump</i> ) settings are improper.           | Narrow down the range of frequency jump.   | 91  |
| <b>Load</b>              | Stall prevention function is activated due to a heavy load.                 | Reduce the load weight.  | —   |
| <b>Parameter Setting</b> |   | Set Pr. 22 <i>Stall prevention operation level</i> higher according to the load. (Setting Pr. 22 too large may result in frequent overcurrent trip (E.OC□).) | 89  |
| <b>Motor</b>             |   | Check the capacities of the inverter and the motor.  | —   |



### 6.6.7 Acceleration/deceleration is not smooth

| Check points             | Possible Cause  | Countermeasures  | Refer to page |
|--------------------------|---|--|---------------|
| <b>Parameter Setting</b> | Acceleration/deceleration time is too short.  | Increase acceleration/deceleration time.   | 74            |
|                          | Torque boost (Pr. 0, Pr. 46) setting is improper under V/F control, so the stall prevention function is activated.    | Increase/decrease Pr. 0 <i>Torque boost</i> setting value by 0.5% increments to the setting.   | 72            |
|                          | The base frequency does not match the motor characteristics under V/F control or Simple magnetic flux vector control. | Set Pr. 3 <i>Base frequency</i> and Pr. 47 <i>Second V/F (base frequency)</i> .  | 86            |
|                          | Regeneration avoidance operation is performed   | If the frequency becomes unstable during regeneration avoidance operation, decrease the setting of Pr: 886 <i>Regeneration avoidance voltage gain</i> .      | 111           |
| <b>Load</b>              | Stall prevention function is activated due to a heavy load.   | Reduce the load weight.  | —             |
| <b>Parameter Setting</b> |   | Set Pr. 22 <i>Stall prevention operation level</i> higher according to the load. (Setting Pr. 22 too large may result in frequent overcurrent trip (E.OC□).) | 89            |
| <b>Motor</b>             |   | Check the capacities of the inverter and the motor.  | —             |

### 6.6.8 Speed varies during operation

| Check points  | Possible Cause  | Countermeasures   | Refer to page  |
|---|---|---|--|
| Load  | Load varies during an operation. (V/F control)  | Select Simple magnetic flux vector control  | 97,<br> |
| Input signal  | Frequency setting signal is varying.  | Check the frequency setting signal.   | —  |
|   | The frequency setting signal is affected by EMI.  | Set filter to the analog input terminal using <i>Pr. 74 Input filter time constant</i> .  | 96   |
|   |   | Take countermeasures against EMI, such as using shielded wires for input signal lines.  |         |
|   | Malfunction is occurring due to the undesirable current generated when the transistor output unit is connected.   | Use terminal PC (terminal SD when source logic) as a common terminal to prevent a malfunction caused by undesirable current.  | 23   |
| Multi-speed command signal is chattering.             | Take countermeasures to suppress chattering.  | —   |  |
| Parameter Setting                                     | Fluctuation of power supply voltage is too large.   | Change the <i>Pr. 19 Base frequency voltage</i> setting (about 3%) under V/F control.   | 86   |
|   | The <i>Pr.80 Motor capacity</i> setting is inappropriate for the inverter and motor capacities under Simple magnetic flux vector control and IPM motor control. | Check the <i>Pr. 80 Motor capacity</i> setting.   | 97   |
|   | Wiring length is too long for V/F control, and a voltage drop occurs.   | Adjust <i>Pr. 0 Torque boost</i> by increasing with 0.5% increments for low-speed operation.  | 72   |
|   |   | Change to Simple magnetic flux vector control.  | 97   |
|   | Hunting occurs by the generated vibration, for example, when structural rigidity at load side is insufficient.  | Disable automatic control functions, such as energy saving operation, fast-response current limit function, regeneration avoidance function, Simple magnetic flux vector control and stall prevention.<br>For PID control, set smaller values to <i>Pr.129 PID proportional band</i> and <i>Pr.130 PID integral time</i> .<br>Lower the control gain, and adjust to increase the stability. | —  |
| Change <i>Pr. 72 PWM frequency selection</i> setting. |   | 95  |  |

### 6.6.9 Operation mode is not changed properly

| Check points      | Possible Cause                     | Countermeasures  | Refer to page  |
|-------------------|------------------------------------|--|--|
| Input signal      | Start signal (STF or STR) is ON.   | Check that the STF and STR signals are OFF.<br>When either is ON, the operation mode cannot be changed.  | 77   |
| Parameter Setting | <i>Pr. 79</i> setting is improper. | When <i>Pr. 79 Operation mode selection</i> setting is "0" (initial value), the inverter is placed in the External operation mode at input power ON. To switch to the PU operation mode, press  on the operation panel (press  when the parameter unit (FR-PU04/FR-PU07) is used) .<br>At other settings (1 to 4, 6, 7), the operation mode is limited accordingly. | 77   |
|                   |                                    | Operation mode and a writing device do not correspond.   | Check <i>Pr. 79, Pr. 338, Pr. 339, Pr. 550, Pr. 551</i> , and select an operation mode suitable for the purpose. |





### 6.6.10 Operation panel (FR-DU07) display is not operating

| Check points                         | Possible Cause   | Countermeasures  | Refer to page |
|--------------------------------------|--|--|---------------|
| <b>Main Circuit, Control Circuit</b> | Power is not input.  | Input the power.   | 9             |
| <b>Front cover</b>                   | Operation panel is not properly connected to the inverter. | Check if the inverter front cover is installed securely. The inverter cover may not fit properly when using wires whose size are 1.25mm <sup>2</sup> or larger, or when using many wires, and this could cause a contact fault of the operation panel. | 6             |

### 6.6.11 Motor current is too large

| Check points             | Possible Cause   | Countermeasures   | Refer to page |
|--------------------------|--|---|---------------|
| <b>Parameter Setting</b> | Torque boost ( <i>Pr. 0, Pr. 46</i> ) setting is improper under V/F control, so the stall prevention function is activated.    | Increase/decrease <i>Pr. 0 Torque boost</i> setting value by 0.5% increments to the setting.  | 72            |
|                          | V/F pattern is improper when V/F control or Simple magnetic flux vector control is performed. ( <i>Pr. 3, Pr. 14, Pr. 19</i> ) | Set rated frequency of the motor to <i>Pr. 3 Base frequency</i> . (V/F control, Simple magnetic flux vector control)<br>Use <i>Pr. 19 Base frequency voltage</i> to set the base voltage (e.g. rated motor voltage). (V/F control, Simple magnetic flux vector control) | 86            |
|                          |  | Change <i>Pr. 14 Load pattern selection</i> according to the load characteristic. (V/F control)   | 88            |
|                          | Stall prevention function is activated due to a heavy load.  | Reduce the load weight.   | —             |
|                          |  | Set <i>Pr. 22 Stall prevention operation level</i> higher according to the load. (Setting <i>Pr. 22</i> too large may result in frequent overcurrent trip (E.OC□).)<br>Check the capacities of the inverter and the motor.  | 89<br>—       |

### 6.6.12 Speed does not accelerate

| Check points      | Possible Cause  | Countermeasures  | Refer to page   |
|-------------------|---|--|---|
| Input signal      | Start command and frequency command are chattering.   | Check if the start command and the frequency command are correct.  | —   |
|                   | The wiring length used for analog frequency command is too long, and it is causing a voltage (current) drop.          | Perform analog input bias/gain calibration.  |  |
|                   | Input signal lines are affected by external EMI.  | Take countermeasures against EMI, such as using shielded wires for input signal lines.   |  |
| Parameter Setting | Pr. 1, Pr. 2, Pr. 18, calibration parameter C2 to C7 settings are improper.   | Check the settings of Pr. 1 Maximum frequency and Pr. 2 Minimum frequency. If you want to run the motor at 120Hz or higher, set Pr. 18 High speed maximum frequency.   | 86  |
|                   |   | Check the calibration parameter C2 to C7 settings.   | 99  |
|                   |   | During IPM motor control, maximum frequency is limited to the maximum motor speed (frequency) of the IPM motor.  | 162, 164  |
|                   | The maximum voltage (current) input value is not set during the external operation. (Pr.125, Pr.126, Pr.18)           | Check the Pr.125 Terminal 2 frequency setting gain frequency and Pr.126 Terminal 4 frequency setting gain frequency settings. To operate at 120Hz or higher, set Pr.18 High speed maximum frequency.   | 59  |
|                   | Torque boost (Pr. 0, Pr. 46) setting is improper under V/F control, so the stall prevention function is activated.    | Increase/decrease Pr. 0 Torque boost setting value by 0.5% increments so that stall prevention does not occur.   | 72  |
|                   | V/F pattern is improper when V/F control or Simple magnetic flux vector control is performed. (Pr. 3, Pr. 14, Pr. 19) | Set rated frequency of the motor to Pr. 3 Base frequency. (V/F control, Simple magnetic flux vector control)<br>Use Pr. 19 Base frequency voltage to set the base voltage (e.g. rated motor voltage). (V/F control, Simple magnetic flux vector control) | 86  |
|                   |   | Change Pr. 14 Load pattern selection according to the load characteristic. (V/F control)   | 88  |
|                   | Stall prevention function is activated due to a heavy load.   | Reduce the load weight.  | —   |
|                   |   | Set Pr. 22 Stall prevention operation level higher according to the load. (Setting Pr. 22 too large may result in frequent overcurrent trip (E.O.C□).)   | 89  |
|                   | Check the capacities of the inverter and the motor.   | —  |   |
|                   | During PID control, output frequency is automatically controlled to make measured value = set point.                  |   |   |

### 6.6.13 Unable to write parameter setting

| Check points      | Possible Cause  | Countermeasures   | Refer to page |
|-------------------|---|---|---------------|
| Input signal      | Operation is being performed (signal STF or STR is ON).   | Stop the operation.<br>When Pr. 77 = "0" (initial value), write is enabled only during a stop.  | 96            |
| Parameter Setting | You are attempting to set the parameter in the External operation mode.   | Choose the PU operation mode.<br>Or, set Pr. 77 = "2" to enable parameter write regardless of the operation mode.                     | 96            |
|                   | Parameter is disabled by the Pr. 77 Parameter write selection setting.  | Check Pr. 77 Parameter write selection setting.   | 96            |
|                   | Key lock is activated by the Pr. 161 Frequency setting/key lock operation selection setting.  | Check Pr. 161 Frequency setting/key lock operation selection setting.   | 103           |
|                   | Operation mode and a writing device do not correspond.  | Check Pr. 79, Pr. 338, Pr. 339, Pr. 550, Pr. 551, and select an operation mode suitable for the purpose.                              | 77, 108       |
|                   | Attempted to set "25" in Pr.72 PWM frequency selection under IPM motor control. Attempted to perform IPM motor control while Pr.72 ="25." | Pr.72 cannot be set to "25" during the IPM motor control. (The sine wave filter (MT-BSL/BSC) cannot be used under IPM motor control.) | 95            |

### 6.6.14 Power lamp is not lit

| Check points                  | Possible Cause                      | Countermeasures   | Refer to page |
|-------------------------------|-------------------------------------|---|---------------|
| Main Circuit, Control Circuit | Wiring or installation is improper. | Check for the wiring and the installation.<br>Power lamp is lit when power supply is input to the control circuit (R1/L11, S1/L21). | 11            |

---

---

## 7 PRECAUTIONS FOR MAINTENANCE AND INSPECTION

---

---

The inverter is a static unit mainly consisting of semiconductor devices. Daily inspection must be performed to prevent any fault from occurring due to the adverse effects of the operating environment, such as temperature, humidity, dust, dirt and vibration, changes in the parts with time, service life, and other factors.

### • Precautions for maintenance and inspection

For some short time after the power is switched OFF, a high voltage remains in the smoothing capacitor. When accessing the inverter for inspection, wait for at least 10 minutes after the power supply has been switched OFF, and then make sure that the voltage across the main circuit terminals P/+ and N/- of the inverter is not more than 30VDC using a tester, etc.

---

### 7.1 Inspection item

---

#### 7.1.1 Daily inspection

Basically, check for the following faults during operation.

- (1) Motor operation fault
- (2) Improper installation environment
- (3) Cooling system fault
- (4) Unusual vibration and noise
- (5) Unusual overheat and discoloration

#### 7.1.2 Periodic inspection

Check the areas inaccessible during operation and requiring periodic inspection.

Consult us for periodic inspection.

- 1) Check for cooling system fault ..... Clean the air filter, etc.
- 2) Tightening check and retightening ..... The screws and bolts may become loose due to vibration, temperature changes, etc.  
Tighten them according to the specified tightening torque.  
*(Refer to page 14, 15.)*
- 3) Check the conductors and insulating materials for corrosion and damage.
- 4) Measure insulation resistance.
- 5) Check and change the cooling fan and relay.

### 7.1.3 Daily and periodic inspection

| Area of Inspection                 | Inspection Item                           | Inspection Item   | Interval   |                        | Corrective Action at Alarm Occurrence  | Customer's Check  |  |
|------------------------------------|---|---|--|------------------------|--|---|--|
|                                    |   |   | Daily  | Periodic <sup>*2</sup> |  |   |  |
| General                            | Surrounding environment                   | Check the surrounding air temperature, humidity, dirt, corrosive gas, oil mist, etc   | ○  |                        | Improve environment  |   |  |
|                                    | Overall unit                              | Check for unusual vibration and noise   | ○  |                        | Check alarm location and retighten   |   |  |
|                                    |   | Check for dirt, oil, and other foreign material. <sup>*3</sup>  | ○  |                        | Clean  |   |  |
|                                    | Power supply voltage                      | Check that the main circuit voltages and control voltages are normal <sup>*1</sup>  | ○  |                        | Inspect the power supply   |   |  |
| Main circuit                       | General                                   | (1)Check with megger (across main circuit terminals and earth (ground) terminal).<br>(2)Check for loose screws and bolts.<br>(3)Check for overheat traces on parts.<br>(4)Check for stains                  |  | ○                      | Contact the manufacturer<br>○ Retighten<br>○ Contact the manufacturer<br>○ Clean |   |  |
|                                    | Conductors, cables                        | (1)Check conductors for distortion.<br>(2)Check cable sheaths for breakage and deterioration (crack, discoloration, etc.)   |  | ○                      | Contact the manufacturer<br>○ Contact the manufacturer                           |   |  |
|                                    | Transformer/reactor                       | Check for unusual odors and abnormal increase in whining sound.   | ○  |                        | Stop the device and contact the manufacturer.                                    |   |  |
|                                    | Terminal block                            | Check for damage.   |  | ○                      | Stop the device and contact the manufacturer.                                    |   |  |
|                                    | Smoothing aluminum electrolytic capacitor | (1)Check for liquid leakage.<br>(2)Check for safety valve projection and bulge.<br>(3)Visual check and judge by the life check of the main circuit capacitor (Refer to page 142)                            |  | ○                      | Contact the manufacturer<br>○ Contact the manufacturer<br>○                      |   |  |
|                                    | Relay/contactator                         | Check that the operation is normal and no chatter is heard.   |  | ○                      | Contact the manufacturer   |   |  |
| Control circuit protective circuit | Operation check                           | (1)Check that the output voltages across phases with the inverter operated alone is balanced<br>(2)Check that no fault is found in protective and display circuits in a sequence protective operation test. |  | ○                      | Contact the manufacturer<br>○ Contact the manufacturer                           |   |  |
|                                    | Parts check                               | Overall   | (1)Check for unusual odors and discoloration.<br>(2)Check for serious rust development   |                        | ○<br>○   | Stop the device and contact the manufacturer.<br>Contact the manufacturer |  |
|                                    |   | Aluminum electrolytic capacitor   | (1)Check for liquid leakage in a capacitor and deformation trace<br>(2)Visual check and judge by the life check of the control circuit capacitor. (Refer to page 142.) |                        | ○<br>○   | Contact the manufacturer  |  |
| Cooling system                     | Cooling fan                               | (1)Check for unusual vibration and noise.<br>(2)Check for loose screws and bolts<br>(3)Check for stains   | ○  |                        | Replace the fan<br>Fix with the fan cover fixing screws<br>Clean                 |   |  |
|                                    | Heatsink                                  | (1)Check for clogging<br>(2)Check for stains  |  | ○<br>○                 | Clean<br>Clean   |   |  |
| Display                            | Indication                                | (1)Check that display is normal.<br>(2)Check for stains   | ○  |                        | Contact the manufacturer<br>Clean  |   |  |
|                                    | Meter                                     | Check that reading is normal  | ○  |                        | Stop the device and contact the manufacturer.                                    |   |  |
| Load motor                         | Operation check                           | Check for vibration and abnormal increase in operation noise  | ○  |                        | Stop the device and contact the manufacturer.                                    |   |  |

\*1 It is recommended to install a device to monitor voltage for checking the power supply voltage to the inverter.

\*2 One to two years of periodic inspection cycle is recommended. However, it differs according to the installation environment. Consult us for periodic inspection.

\*3 Oil component of the heat dissipation grease used inside the inverter may leak out. The oil component, however, is not flammable, corrosive, nor conductive and is not harmful to humans. Wipe off such oil component with a cloth, etc.

#### CAUTION

Continuous use of a leaked, deformed, or degraded smoothing aluminum electrolytic capacitor (as shown in the table above) may lead to a burst, breakage or fire. Replace such capacitor without delay.



### 7.1.4 Display of the life of the inverter parts

The self-diagnostic alarm is output when the life span of the control circuit capacitor, cooling fan, each parts of the inrush current limit circuit is near its end. It gives an indication of replacement time .

The life alarm output can be used as a guideline for life judgement.

| Parts                        | Judgement level   |
|------------------------------|---|
| Main circuit capacitor       | 85% of the initial capacity                                 |
| Control circuit capacitor    | Estimated 10% life remaining                                |
| Inrush current limit circuit | Estimated 10% life remaining (Power ON: 100,000 times left) |
| Cooling fan                  | Less than 50% of the predetermined speed                    |

For the life check of the main circuit capacitor, the alarm signal (Y90) will not be output if a measuring method of (2) is not performed. (Refer to page 143.)

#### (1) Display of the life alarm

- Pr. 255 Life alarm status display can be used to confirm that the control circuit capacitor, main circuit capacitor, cooling fan, and each parts of the inrush current limit circuit has reached the life alarm output level.

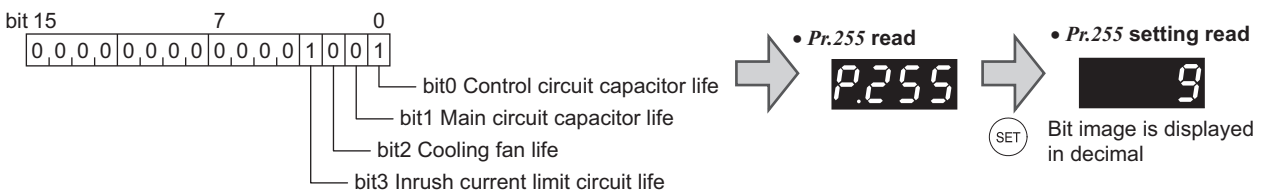

| Pr. 255 (decimal) | Bit (binary) | Inrush Current Limit Circuit Life | Cooling Fan Life | Main Circuit Capacitor Life | Control Circuit Capacitor Life |
|-------------------|--------------|-----------------------------------|------------------|-----------------------------|--------------------------------|
| 15                | 1111         | ○                                 | ○                | ○                           | ○                              |
| 14                | 1110         | ○                                 | ○                | ○                           | ×                              |
| 13                | 1101         | ○                                 | ○                | ×                           | ○                              |
| 12                | 1100         | ○                                 | ○                | ×                           | ×                              |
| 11                | 1011         | ○                                 | ×                | ○                           | ○                              |
| 10                | 1010         | ○                                 | ×                | ○                           | ×                              |
| 9                 | 1001         | ○                                 | ×                | ×                           | ○                              |
| 8                 | 1000         | ○                                 | ×                | ×                           | ×                              |
| 7                 | 0111         | ×                                 | ○                | ○                           | ○                              |
| 6                 | 0110         | ×                                 | ○                | ○                           | ×                              |
| 5                 | 0101         | ×                                 | ○                | ×                           | ○                              |
| 4                 | 0100         | ×                                 | ○                | ×                           | ×                              |
| 3                 | 0011         | ×                                 | ×                | ○                           | ○                              |
| 2                 | 0010         | ×                                 | ×                | ○                           | ×                              |
| 1                 | 0001         | ×                                 | ×                | ×                           | ○                              |
| 0                 | 0000         | ×                                 | ×                | ×                           | ×                              |

○: with alarm, ×: without alarm

**POINT**

Life check of the main circuit capacitor needs to be done by Pr. 259. (Refer to page 143.)

**(2) Measuring method of life of the main circuit capacitor**

- If the value of capacitor capacity measured before shipment is considered as 100%, Pr. 255 bit1 is turned ON when the measured value falls below 85%.
- Measure the capacitor capacity according to the following procedure and check the deterioration level of the capacitor capacity.
  - 1) Check that the motor is connected and at a stop.
  - 2) Set "1" (measuring start) in Pr. 259
  - 3) Switch power OFF. The inverter applies DC voltage to the motor to measure the capacitor capacity when the inverter turns OFF.
  - 4) After confirming that the LED of the operation panel is OFF, power ON again.
  - 5) Check that "3" (measuring completion) is set in Pr. 259, then read Pr. 258 and check the life of the main circuit capacitor.

**REMARKS**

- When the main circuit capacitor life is measured under the following conditions, "forced end" (Pr. 259 = "8") or "measuring error" (Pr. 259 = "9") occurs or it remains in "measuring start" (Pr. 259 = "1").  
When measuring, avoid the following conditions to perform. In addition, even when "measurement completion" (Pr. 259 = "3") is confirmed under the following conditions, normal measurement cannot be done.
  - (a)FR-HC2, MT-HC, FR-CV, MT-RC or sine wave filter is connected.
  - (b)Terminal R1/L11, S1/L21 or DC power supply is connected to the terminals P/+ and N/-.
  - (c)Switch power ON during measuring.
  - (d)The motor is not connected to the inverter.
  - (e)The motor is running.(The motor is coasting.)
  - (f)The motor capacity is two rank smaller as compared to the inverter capacity.
  - (g)The inverter is at an alarm stop or an alarm occurred while power is OFF.
  - (h)The inverter output is shut off with the MRS signal.
  - (i)The start command is given while measuring.
- Operating environment:Surrounding air temperature (annual average 40°C (free from corrosive gas, flammable gas, oil mist, dust and dirt))  
Output current (80% of the rated inverter current)

**POINT**

For the accurate life measuring of the main circuit capacitor, perform after more than 3h passed since the turn OFF of the power as it is affected by the capacitor temperature.

**⚠ WARNING**

- ⚠ When measuring the main circuit capacitor capacity (Pr. 259 Main circuit capacitor life measuring = "1"), the DC voltage is applied to the motor for 1s at powering OFF. Never touch the motor terminal, etc. right after powering OFF to prevent an electric shock.



### 7.1.5 Cleaning

Always run the inverter in a clean status.

When cleaning the inverter, gently wipe dirty areas with a soft cloth immersed in neutral detergent or ethanol.

---

**CAUTION**

---

Do not use solvent, such as acetone, benzene, toluene and alcohol, as they will cause the inverter surface paint to peel off.

The display, etc. of the operation panel (FR-DU07) and parameter unit (FR-PU04/FR-PU07) are vulnerable to detergent and alcohol. Therefore, avoid using them for cleaning.

---

### 7.1.6 Replacement of parts

The inverter consists of many electronic parts such as semiconductor devices.

The following parts may deteriorate with age because of their structures or physical characteristics, leading to reduced performance or fault of the inverter. For preventive maintenance, the parts must be replaced periodically.

Use the life check function as a guidance of parts replacement.

| Part Name                        | Estimated lifespan *1 | Description                     |
|----------------------------------|-----------------------|---------------------------------|
| Cooling fan                      | 10 years              | Replace (as required)           |
| Main circuit smoothing capacitor | 10 years *2           | Replace (as required)           |
| On-board smoothing capacitor     | 10 years *2           | Replace the board (as required) |
| Relays                           | –                     | as required                     |
| Fuse (185K or higher)            | 10 years              | Replace the fuse (as required)  |

\*1 Estimated lifespan for when the yearly average surrounding air temperature is 40°C  
(without corrosive gas, flammable gas, oil mist, dust and dirt etc)

\*2 Output current : 80% of the rated inverter current

---

**CAUTION**

---

For parts replacement, consult the nearest Mitsubishi FA Center.

---

## (1) Cooling fan

The replacement interval of the cooling fan used for cooling the parts generating heat such as the main circuit semiconductor is greatly affected by the surrounding air temperature. When unusual noise and/or vibration is noticed during inspection, the cooling fan must be replaced immediately.

- Removal (FR-F720P-2.2K to 110K, FR-F740P-3.7K to 160K)

1) Push the hooks from above and remove the fan cover.

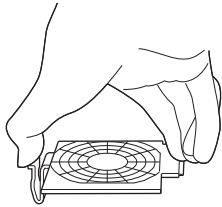

FR-F720P-2.2K to 5.5K  
FR-F740P-3.7K, 5.5K

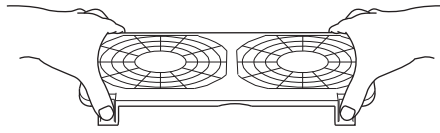

FR-F720P-7.5K to 30K  
FR-F740P-7.5K to 30K

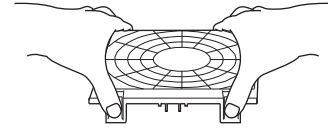

FR-F720P-37K or higher  
FR-F740P-37K to 160K

2) Disconnect the fan connectors.

3) Remove the fan.

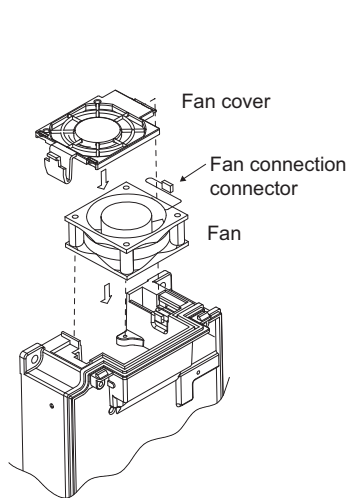

FR-F720P-2.2K to 5.5K  
FR-F740P-3.7K, 5.5K

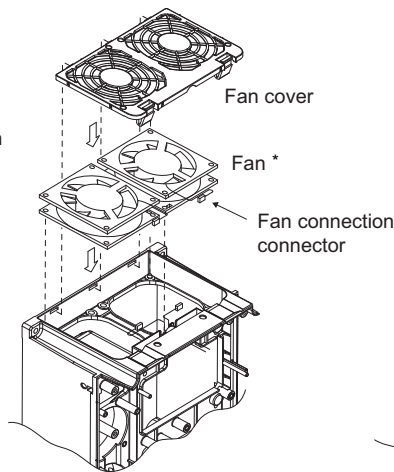

FR-F720P-7.5K to 30K  
FR-F740P-7.5K to 30K

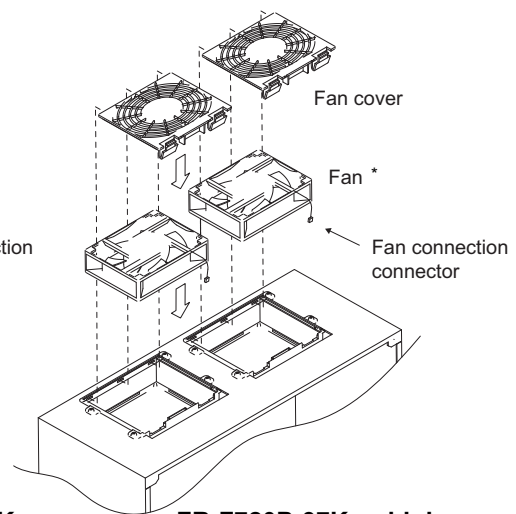

FR-F720P-37K or higher  
FR-F740P-37K to 160K

\* The number of cooling fans differs according to the inverter capacity.





• Reinstallation (FR-F720P-2.2K to 110K, FR-F740P-3.7K to 160K)

1) After confirming the orientation of the fan, reinstall the fan so that the arrow on the left of "AIR FLOW" faces up.

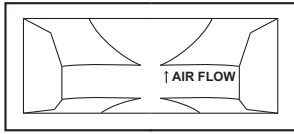

<Fan side face>

2) Reconnect the fan connectors.

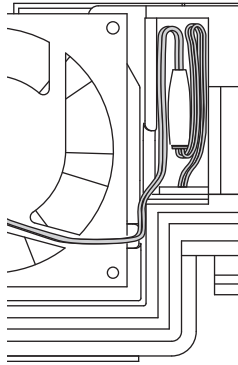

FR-F720P-2.2K to 5.5K  
FR-F740P-3.7K, 5.5K

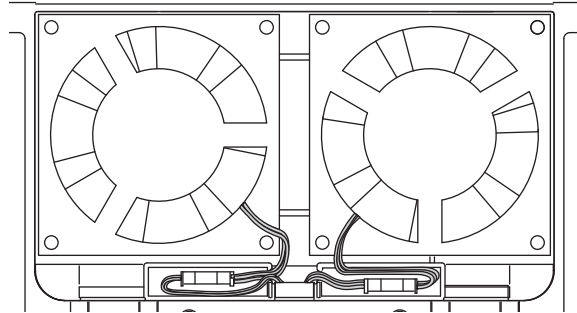

FR-F720P-7.5K to 15K  
FR-F740P-7.5K to 18.5K

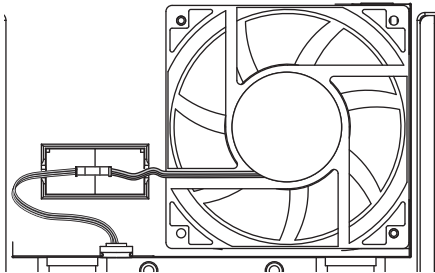

FR-F720P-18.5K, 22K  
FR-F740P-22K, 30K

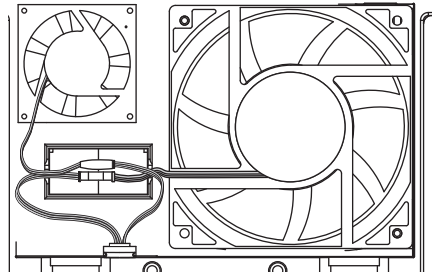

FR-F720P-30K

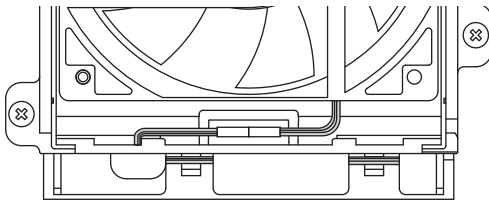

FR-F720P-37K to 110K  
FR-F740P-37K to 160K

3) Reinstall the fan cover.

2. Insert hooks until you hear a click sound.

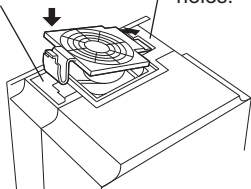

FR-F720P-2.2K to 5.5K  
FR-F740P-3.7K, 5.5K

1. Insert hooks into holes.

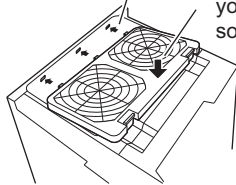

FR-F720P-7.5K to 30K  
FR-F740P-7.5K to 30K

2. Insert hooks until you hear a click sound.

1. Insert hooks into holes.

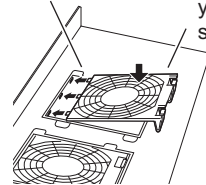

FR-F720P-37K or higher  
FR-F740P-37K to 160K

2. Insert hooks until you hear a click sound.

**CAUTION**

- Installing the fan in the opposite of air flow direction can cause the inverter life to be shorter.
- When installing the fan, use care to prevent wires from being caught between the inverter and fan.
- Switch the power OFF before replacing fans. Since the inverter circuits are charged with voltage even after power OFF, replace fans only when the inverter cover is on the inverter to prevent an electric shock accident.

• Removal (FR-F740P-185K or higher)

- 1) Remove a fan cover.
- 2) After removing a fan connector, remove a fan block.
- 3) Remove a fan. (Make sure to remove the fan cable from the clamp of the fan block beforehand.)

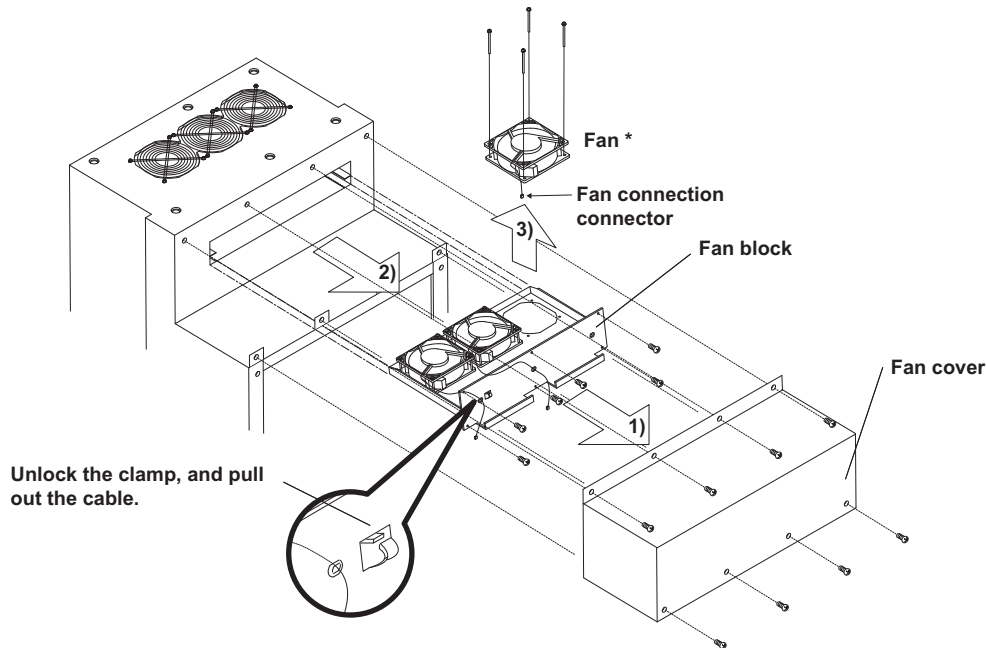

\* The number of cooling fans differs according to the inverter capacity.

• Reinstallation (FR-F740P-185K or higher)

- 1) After confirming the orientation of the fan, reinstall the fan so that the arrow on the left of "AIR FLOW" faces up.

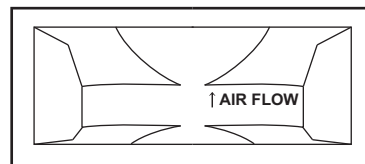

<Fan side face>

- 2) Install fans referring to the above figure.

**CAUTION**

- Installing the fan in the opposite of air flow direction can cause the inverter life to be shorter.
- When installing the fan, use care to prevent wires from being caught between the inverter and fan.
- Switch the power OFF before replacing fans. Since the inverter circuits are charged with voltage even after power OFF, replace fans only when the inverter cover is on the inverter to prevent an electric shock accident.

(2) Replacement procedure of the cooling fan when using a heatsink protrusion attachment (FR-A7CN)

When replacing a cooling fan, remove a top cover of the heatsink protrusion attachment and perform replacement. After replacing the cooling fan, replace the top cover in the original position.

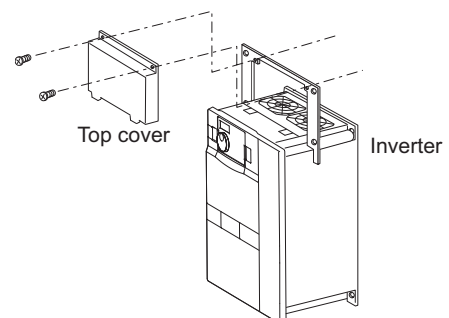



### (3) Smoothing capacitors

A large-capacity aluminum electrolytic capacitor is used for smoothing in the main circuit DC section, and an aluminum electrolytic capacitor is used for stabilizing the control power in the control circuit. Their characteristics are deteriorated by the adverse effects of ripple currents, etc.

The replacement intervals greatly vary with the surrounding air temperature and operating conditions. When the inverter is operated in air-conditioned, normal environment conditions, replace the capacitors about every 10 years.

The appearance criteria for inspection are as follows:

- 1) Case: Check the side and bottom faces for expansion
- 2) Sealing plate: Check for remarkable warp and extreme crack.
- 3) Check for external crack, discoloration, fluid leakage, etc. Judge that the capacitor has reached its life when the measured capacitance of the capacitor reduced below 80% of the rating.



Refer to page 144 to perform the life check of the main circuit capacitor.

### (4) Relays

To prevent a contact fault, etc., relays must be replaced according to the cumulative number of switching times (switching life).

### (5) Fuse inside the inverter (185K or higher)

A fuse is used inside the inverter. Surrounding air temperature and operating condition affect the life of fuses. When the inverter is used in a normal air-conditioned environment, replace its fuse after about 10 years.

### 7.1.7 Inverter replacement

The inverter can be replaced with the control circuit wiring kept connected. Before replacement, remove the wiring cover of the inverter.

- 1) Loosen the two installation screws in both ends of the control circuit terminal block. (These screws cannot be removed.)  
Pull down the terminal block from behind the control circuit terminals.

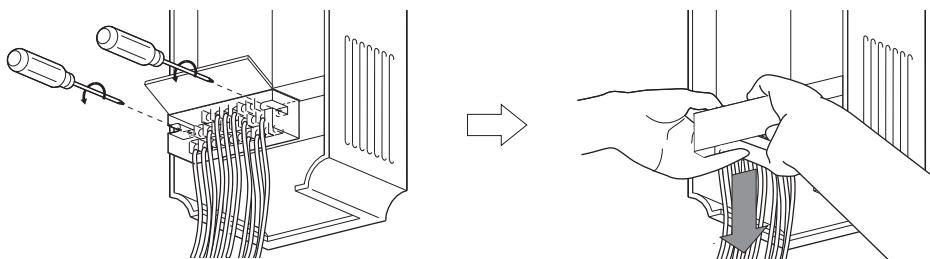

- 2) Using care not to bend the pins of the inverter's control circuit connector, reinstall the control circuit terminal block and fix it with the mounting screws.

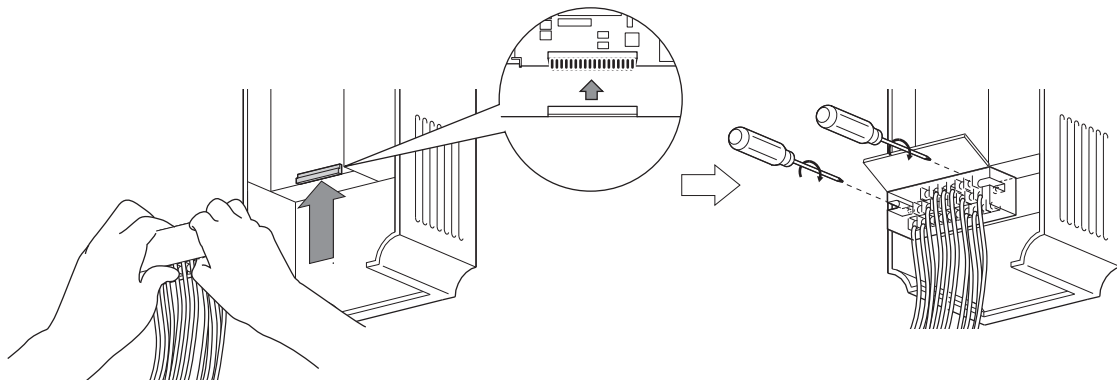

#### CAUTION

Before starting inverter replacement, switch power OFF, wait for at least 10 minutes, and then check the voltage with a tester and such to ensure safety.

# 8 SPECIFICATIONS

## 8.1 Rating

### •200V class

| Type FR-F720P-□□K                             |  | 0.75   | 1.5          | 2.2          | 3.7          | 5.5        | 7.5                | 11         | 15         | 18.5         | 22         | 30               | 37           | 45           | 55           | 75           | 90           | 110          |   |
|---|--|--|--------------|--------------|--------------|------------|--------------------|------------|------------|--------------|------------|------------------|--------------|--------------|--------------|--------------|--------------|--------------|---|
| Applicable motor capacity (kW) <sup>*1</sup>  |  | 0.75   | 1.5          | 2.2          | 3.7          | 5.5        | 7.5                | 11         | 15         | 18.5         | 22         | 30               | 37           | 45           | 55           | 75           | 90           | 110          |   |
| Output  | Rated capacity (kVA) <sup>*2</sup>                     | 1.6  | 2.7          | 3.7          | 5.8          | 8.8        | 11.8               | 17.1       | 22.1       | 27           | 32         | 43               | 53           | 65           | 81           | 110          | 132          | 165          |   |
|   | Rated current (A) <sup>*3</sup>                        | 4.2<br>(3.6)   | 7.0<br>(6.0) | 9.6<br>(8.2) | 15.2<br>(13) | 23<br>(20) | 31<br>(26)         | 45<br>(38) | 58<br>(49) | 70.5<br>(60) | 85<br>(72) | 114<br>(97)      | 140<br>(119) | 170<br>(145) | 212<br>(180) | 288<br>(244) | 346<br>(294) | 432<br>(367) |   |
|   | Overload current rating <sup>*4</sup>                  | 120% for 60s, 150% for 3s (inverse-time characteristics) |              |              |              |            |                    |            |            |              |            |                  |              |              |              |              |              |              |   |
|   | Rated voltage <sup>*5</sup>                            | Three-phase 200 to 240V                                  |              |              |              |            |                    |            |            |              |            |                  |              |              |              |              |              |              |   |
| Power supply                                  | Rated input AC voltage/<br>frequency                   | Three-phase 200 to 220V 50Hz, 200 to 240V 60Hz           |              |              |              |            |                    |            |            |              |            |                  |              |              |              |              |              |              |   |
|   | Permissible AC voltage<br>fluctuation                  | 170 to 242V 50Hz, 170 to 264V 60Hz                       |              |              |              |            |                    |            |            |              |            |                  |              |              |              |              |              |              |   |
|   | Permissible frequency<br>fluctuation                   | ±5%  |              |              |              |            |                    |            |            |              |            |                  |              |              |              |              |              |              |   |
|   | Power supply<br>system capacity<br>(kVA) <sup>*6</sup> | Without<br>DC reactor                                    | 2.1          | 4.0          | 4.8          | 8.0        | 11.5               | 16         | 20         | 27           | 32         | 41               | 52           | 65           | 79           | 99           | —            | —            | — |
|   | With DC<br>reactor                                     | 1.2  | 2.6          | 3.3          | 5.0          | 8.1        | 10                 | 16         | 19         | 24           | 31         | 41               | 50           | 61           | 74           | 110          | 132          | 165          |   |
| Protective structure (JEM 1030) <sup>*8</sup> |  | Enclosed type (IP20) <sup>*7</sup>                       |              |              |              |            |                    |            |            |              |            | Open type (IP00) |              |              |              |              |              |              |   |
| Cooling system                                |  | Self-cooling   |              |              |              |            | Forced air cooling |            |            |              |            |                  |              |              |              |              |              |              |   |
| Approx. mass (kg)                             |  | 1.8  | 2.2          | 3.5          | 3.5          | 3.5        | 6.5                | 6.5        | 7.8        | 13           | 13         | 14               | 23           | 35           | 35           | 67           | 70           | 70           |   |

\*1 The applicable motor capacity indicated is the maximum capacity applicable for use of the Mitsubishi 4-pole standard motor. To use a dedicated IPM motor, refer to page 162, 164.

\*2 The rated output capacity indicated assumes that the output voltage is 220V.

\*3 When operating the inverter with the carrier frequency set to 3kHz or more, the carrier frequency automatically decreases if the inverter output current exceeds the value in parentheses of the rated current. This may cause the motor noise to increase.

\*4 The % value of the overload current rating indicated is the ratio of the overload current to the inverter's rated output current. For repeated duty, allow time for the inverter and motor to return to or below the temperatures under 100% load.

\*5 The maximum output voltage does not exceed the power supply voltage. The maximum output voltage can be changed within the setting range. However, the pulse voltage value of the inverter output side voltage remains unchanged at about  $\sqrt{2}$  that of the power supply.

\*6 The power supply capacity varies with the value of the power supply side inverter impedance (including those of the input reactor and cables).

\*7 When the hook of the inverter front cover is cut off for installation of the plug-in option, protective structure of the inverter changes to an open type (IP00).

\*8 FR-DU07: IP40 (except for the PU connector)



•400V class

| Type FR-F740P-□□K                             |  | 0.75   | 1.5          | 2.2          | 3.7          | 5.5           | 7.5                | 11         | 15         | 18.5       | 22         | 30         | 37               | 45         | 55          |    |
|---|--|--|--------------|--------------|--------------|---------------|--------------------|------------|------------|------------|------------|------------|------------------|------------|-------------|----|
| Applicable motor capacity (kW) <sup>*1</sup>  |  | 0.75   | 1.5          | 2.2          | 3.7          | 5.5           | 7.5                | 11         | 15         | 18.5       | 22         | 30         | 37               | 45         | 55          |    |
| Output  | Rated capacity (kVA) <sup>*2</sup>                     | 1.6  | 2.7          | 3.7          | 5.8          | 8.8           | 12.2               | 17.5       | 22.1       | 26.7       | 32.8       | 43.4       | 53.3             | 64.8       | 80.8        |    |
|   | Rated current (A) <sup>*3</sup>                        | 2.1<br>(1.8)                                     | 3.5<br>(3.0) | 4.8<br>(4.1) | 7.6<br>(6.4) | 11.5<br>(9.8) | 16<br>(13)         | 23<br>(19) | 29<br>(24) | 35<br>(30) | 43<br>(36) | 57<br>(48) | 70<br>(60)       | 85<br>(72) | 106<br>(90) |    |
|   | Overload current rating <sup>*4</sup>                  | 120% 60s, 150% 3s (inverse-time characteristics) |              |              |              |               |                    |            |            |            |            |            |                  |            |             |    |
|   | Rated voltage <sup>*5</sup>                            | Three-phase 380 to 480V                          |              |              |              |               |                    |            |            |            |            |            |                  |            |             |    |
| Power supply                                  | Rated input AC voltage/<br>frequency                   | Three-phase 380 to 480V 50Hz/60Hz                |              |              |              |               |                    |            |            |            |            |            |                  |            |             |    |
|   | Permissible AC voltage<br>fluctuation                  | 323 to 528V 50Hz/60Hz                            |              |              |              |               |                    |            |            |            |            |            |                  |            |             |    |
|   | Permissible frequency<br>fluctuation                   | ±5%  |              |              |              |               |                    |            |            |            |            |            |                  |            |             |    |
|   | Power supply<br>system capacity<br>(kVA) <sup>*6</sup> | Without<br>DC reactor                            | 2.1          | 4.0          | 4.8          | 8.0           | 11.5               | 16         | 20         | 27         | 32         | 41         | 52               | 65         | 79          | 99 |
|   | With DC<br>reactor                                     | 1.2  | 2.6          | 3.3          | 5.0          | 8.1           | 10                 | 16         | 19         | 24         | 31         | 41         | 50               | 61         | 74          |    |
| Protective structure (JEM 1030) <sup>*8</sup> |  | Enclosed type (IP20) <sup>*7</sup>               |              |              |              |               |                    |            |            |            |            |            | Open type (IP00) |            |             |    |
| Cooling system                                |  | Self-cooling                                     |              |              |              |               | Forced air cooling |            |            |            |            |            |                  |            |             |    |
| Approx. mass (kg)                             |  | 3.5  | 3.5          | 3.5          | 3.5          | 3.5           | 6.5                | 6.5        | 7.5        | 7.5        | 13         | 13         | 23               | 35         | 35          |    |

| Type FR-F740P-□□K                             |  | 75   | 90           | 110          | 132          | 160          | 185          | 220          | 250          | 280          | 315          | 355          | 400          | 450          | 500          | 560           |
|---|--|--|--------------|--------------|--------------|--------------|--------------|--------------|--------------|--------------|--------------|--------------|--------------|--------------|--------------|---------------|
| Applicable motor capacity (kW) <sup>*1</sup>  |  | 75   | 90           | 110          | 132          | 160          | 185          | 220          | 250          | 280          | 315          | 355          | 400          | 450          | 500          | 560           |
| Output  | Rated capacity (kVA) <sup>*2</sup>                     | 110  | 137          | 165          | 198          | 247          | 275          | 329          | 366          | 416          | 464          | 520          | 586          | 659          | 733          | 833           |
|   | Rated current (A) <sup>*3</sup>                        | 144<br>(122)                                     | 180<br>(153) | 216<br>(183) | 260<br>(221) | 325<br>(276) | 361<br>(306) | 432<br>(367) | 481<br>(408) | 547<br>(464) | 610<br>(518) | 683<br>(580) | 770<br>(654) | 866<br>(736) | 962<br>(817) | 1094<br>(929) |
|   | Overload current rating <sup>*4</sup>                  | 120% 60s, 150% 3s (inverse-time characteristics) |              |              |              |              |              |              |              |              |              |              |              |              |              |               |
|   | Rated voltage <sup>*5</sup>                            | Three-phase 380 to 480V                          |              |              |              |              |              |              |              |              |              |              |              |              |              |               |
| Power supply                                  | Rated input AC voltage/<br>frequency                   | Three-phase 380 to 480V 50Hz/60Hz                |              |              |              |              |              |              |              |              |              |              |              |              |              |               |
|   | Permissible AC voltage<br>fluctuation                  | 323 to 528V 50Hz/60Hz                            |              |              |              |              |              |              |              |              |              |              |              |              |              |               |
|   | Permissible frequency<br>fluctuation                   | ±5%  |              |              |              |              |              |              |              |              |              |              |              |              |              |               |
|   | Power supply<br>system capacity<br>(kVA) <sup>*6</sup> | Without<br>DC reactor                            | —            | —            | —            | —            | —            | —            | —            | —            | —            | —            | —            | —            | —            | —             |
|   | With DC<br>reactor                                     | 110  | 137          | 165          | 198          | 247          | 275          | 329          | 366          | 416          | 464          | 520          | 586          | 659          | 733          | 833           |
| Protective structure (JEM 1030) <sup>*8</sup> |  | Open type (IP00)                                 |              |              |              |              |              |              |              |              |              |              |              |              |              |               |
| Cooling system                                |  | Forced air cooling                               |              |              |              |              |              |              |              |              |              |              |              |              |              |               |
| Approx. mass (kg)                             |  | 37   | 50           | 57           | 67           | 72           | 110          | 110          | 175          | 175          | 175          | 260          | 260          | 370          | 370          | 370           |

\*1 The applicable motor capacity indicated is the maximum capacity applicable for use of the Mitsubishi 4-pole standard motor. To use a dedicated IPM motor, refer to page 162, 164.

\*2 The rated output capacity indicated assumes that the output voltage is 440V.

\*3 When operating the inverter with the carrier frequency set to 3kHz or more, the carrier frequency automatically decreases if the inverter output current exceeds the value in parentheses of the rated current. This may cause the motor noise to increase.

\*4 The % value of the overload current rating indicated is the ratio of the overload current to the inverter's rated output current. For repeated duty, allow time for the inverter and motor to return to or below the temperatures under 100% load.

\*5 The maximum output voltage does not exceed the power supply voltage. The maximum output voltage can be changed within the setting range. However, the pulse voltage value of the inverter output side voltage remains unchanged at about  $\sqrt{2}$  that of the power supply.

\*6 The power supply capacity varies with the value of the power supply side inverter impedance (including those of the input reactor and cables).

\*7 When the hook of the inverter front cover is cut off for installation of the plug-in option, protective structure of the inverter changes to an open type (IP00).

\*8 FR-DU07: IP40 (except for the PU connector)



## 8.2 Common specifications

|  |   |  |   |
|--|---|--|---|
| Control specifications                 | Control method  |  | High carrier frequency PWM control (V/F control)/Optimum excitation control/Simple magnetic flux vector control/IPM motor control   |
|  | Output frequency range  |  | 0.5 to 400Hz  |
|  | Frequency setting resolution  | Analog input   | 0.015Hz/60Hz (terminal 2 and 4: 0 to 10V/12-bit)<br>0.03Hz/60Hz (terminal 2 and 4: 0 to 5V/11bit, 0 to 20mA/approx.11-bit, terminal 1: 0 to ±10V/12-bit)<br>0.06Hz/60Hz (terminal 1: 0 to ±5V/11-bit)   |
|  |   | Digital input  | 0.01Hz  |
|  | Frequency accuracy  | Analog input   | Within ±0.2% of the maximum output frequency (25°C ±10°C)   |
|  |   | Digital input  | Within 0.01% of the set output frequency  |
|  | Speed control range   |  | 1:10 under V/F control, 1:15 under Simple magnetic flux vector control, 1:10 under IPM motor control  |
|  | Voltage/frequency characteristics   |  | Base frequency can be set from 0 to 400Hz. Constant-torque/variable-torque pattern or adjustable 5 points V/F can be selected.  |
|  | Starting torque   | General-purpose motor control  | Under Simple magnetic flux vector control and slip compensation: 120% (at 3Hz)  |
|  |   | IPM motor control  | 50%   |
| Acceleration/deceleration time setting |   | 0 to 3600s (acceleration and deceleration can be set individually), linear or S-pattern acceleration/deceleration modes are available.   |   |
| DC injection brake                     |   | General-purpose motor control: Operation frequency (0 to 120Hz), operation time (0 to 10s), operation voltage (0 to 30%) can be changed. |   |
| Stall prevention operation level       |   | Operation current level can be set (0 to 150% variable). Whether to use the function or not can be set.                                  |   |
| Operation specifications               | Frequency setting signal  | Analog input   | Terminal 2 and 4: 0 to 10V, 0 to 5V, and 4 to 20mA are available.<br>Terminal 1: -10 to +10V and -5 to 5V are available.  |
|  |   | Digital input  | 4-digit BCD or 16-bit binary using the setting dial of the operation panel or parameter unit (when used with the option FR-A7AX)  |
|  | Start signal  |  | Forward and reverse rotation or start signal automatic self-holding input (3-wire input) can be selected.   |
|  | Input signals (twelve terminals)  |  | The following signals can be assigned to <i>Pr. 178 to Pr.189 (input terminal function selection)</i> : multi-speed selection, remote setting, second function selection, terminal 4 input selection, JOG operation selection, automatic restart after instantaneous power failure/flying start, external thermal relay input, inverter run enable signal (FR-HC2/FR-CV connection), FR-HC2 connection (instantaneous power failure detection), PU operation external interlock signal, PID control enable terminal, PU-External operation switchover, output stop, start self-holding selection, forward rotation command, reverse rotation command, inverter reset, PTC thermistor input, PID forward/reverse action switchover, PU/NET operation switchover, External/NET operation switchover, command source switchover, DC feeding operation permission, DC feeding cancel, and PID integral value reset.   |
|  | Operational functions   |  | Maximum and minimum frequency settings, frequency jump operation, external thermal relay input selection, polarity reversible operation, automatic restart after instantaneous power failure operation, original operation continuation at an instantaneous power failure, electronic bypass operation, forward/reverse rotation prevention, remote setting, second and third function, multi-speed setting, regenerative avoidance, slip compensation, operation mode selection, PID control, and computer link operation (RS-485)   |
|  | Output signal<br>Open collector output (five terminals)<br>Relay output (two terminals)                 |  | The following signals can be assigned to <i>Pr.190 to Pr.196 (output terminal function selection)</i> : inverter running, up to frequency, instantaneous power failure/undervoltage, overload warning, output frequency detection, second output frequency detection, regenerative brake prealarm <sup>*1</sup> , electronic thermal relay function pre-alarm, PU operation mode, inverter operation ready, output current detection, zero current detection, PID lower limit, PID upper limit, PID forward/reverse rotation output, electronic bypass MC1 <sup>*2</sup> , electronic bypass MC2 <sup>*2</sup> , electronic bypass MC3 <sup>*2</sup> , fan fault output, heatsink overheat pre-alarm, inverter running start command is ON, during deceleration at occurrence of power failure, during PID control activated, PID deviation limit, IPM motor control <sup>*6</sup> , during retry, PID output interruption, pulse train output of output power, DC feeding, life alarm, fault output 3 (power-off signal), energy saving average value updated timing, current average value monitor, fault output 2, maintenance timer alarm, remote output, alarm output, and fault output. Fault code of the inverter can be output (4-bit) from the open collector. |
|  | Operating status  |  |   |
|  | When used with the FR-A7AY, FR-A7AR (option)  |  | In addition to above, the following signals can be assigned to <i>Pr.313 to Pr.319 (extension output terminal function selection)</i> : control circuit capacitor life, main circuit capacitor life, cooling fan life, and inrush current limit circuit life. (Only positive logic can be set to the extension terminals of FR-A7AR.)   |
|  | For meter<br>Pulse train output (Max. 2.4kHz: one terminal)<br>Analog output (Max. 10VDC: one terminal) |  | The following signals can be assigned to <i>Pr.54 FM terminal function selection (pulse train output) and Pr. 158 AM terminal function selection (analog output)</i> : output frequency, motor current (steady or peak value), output voltage, frequency setting value, running speed, converter output voltage (steady or peak value), electronic thermal relay load factor, input power, output power, load meter, reference voltage output, motor load factor, energy saving effect, regenerative brake duty <sup>*1</sup> , PID set point, and PID measured value.  |
|  | Indication  | Operation panel (FR-DU07)  | Operating status  |
| Fault record                           |   |  | Fault record is displayed when a fault occurs. Past 8 fault records (output voltage/current/frequency/cumulative energization time right before the fault occurs) are stored.   |
| Parameter unit (FR-PU07)               |   | Interactive guidance   | Function (help) for operation guide and troubleshooting <sup>*4</sup>   |



|                                 |                                   |  |
|---------------------------------|-----------------------------------|--|
| Protective/<br>warning function | Protective function               | Overcurrent during acceleration, overcurrent during constant speed, overcurrent during deceleration/stop, overvoltage during acceleration, overvoltage during constant speed, overvoltage during deceleration/stop, inverter protection thermal operation, motor protection thermal operation, heatsink overheat, instantaneous power failure occurrence, undervoltage, input phase loss <sup>*5</sup> , stall prevention stop, output side earth (ground) fault overcurrent, output short circuit, output phase loss, external thermal relay operation <sup>*5</sup> , PTC thermistor operation <sup>*5</sup> , option fault, parameter error, PU disconnection <sup>*5</sup> , retry count excess <sup>*5</sup> , CPU fault, operation panel power supply short circuit, 24VDC power output short circuit, output current detection value excess <sup>*5</sup> , inrush current limit circuit fault, communication fault (inverter), analog input fault, PID signal fault <sup>*5</sup> , internal circuit fault (15V power supply), brake transistor alarm detection <sup>*1</sup> , loss of synchronism detection <sup>*6</sup> , overspeed occurrence <sup>*5*6</sup> . |
|                                 | Warning function                  | Fan alarm, overcurrent stall prevention, overvoltage stall prevention, regenerative brake prealarm <sup>*5</sup> , electronic thermal relay function prealarm, PU stop, maintenance timer alarm <sup>*3*5</sup> , parameter write error, copy operation error, operation panel lock, parameter copy warning, password locked <sup>*5</sup>   |
| Environment                     | Surrounding air temperature       | -10°C to +50°C (non-freezing)  |
|                                 | Ambient humidity                  | 90% RH or less (non-condensing)  |
|                                 | Storage temperature <sup>*7</sup> | -20°C to 65°C  |
|                                 | Atmosphere                        | Indoors (without corrosive gas, flammable gas, oil mist, dust and dirt etc.)   |
|                                 | Altitude/vibration                | Maximum 1000m above sea level, 5.9m/s <sup>2</sup> or less <sup>*8</sup> at 10 to 55Hz (directions of X, Y, Z axes)  |

\*1 This function is only available for 75K or higher.

\*2 This function is only available under general-purpose motor control.

\*3 This can be displayed only on the operation panel (FR-DU07).

\*4 This can be displayed only on the option parameter unit (FR-PU07).

\*5 This protective function is not available in the initial status.

\*6 This function is available only when an IPM motor is connected.

\*7 Temperature applicable for a short time, e.g. in transit.

\*8 2.9m/s<sup>2</sup> or less for 185K or higher.



### 8.3 Outline dimension drawings

#### 8.3.1 Inverter outline dimension drawings

- FR-F720P-0.75K, 1.5K

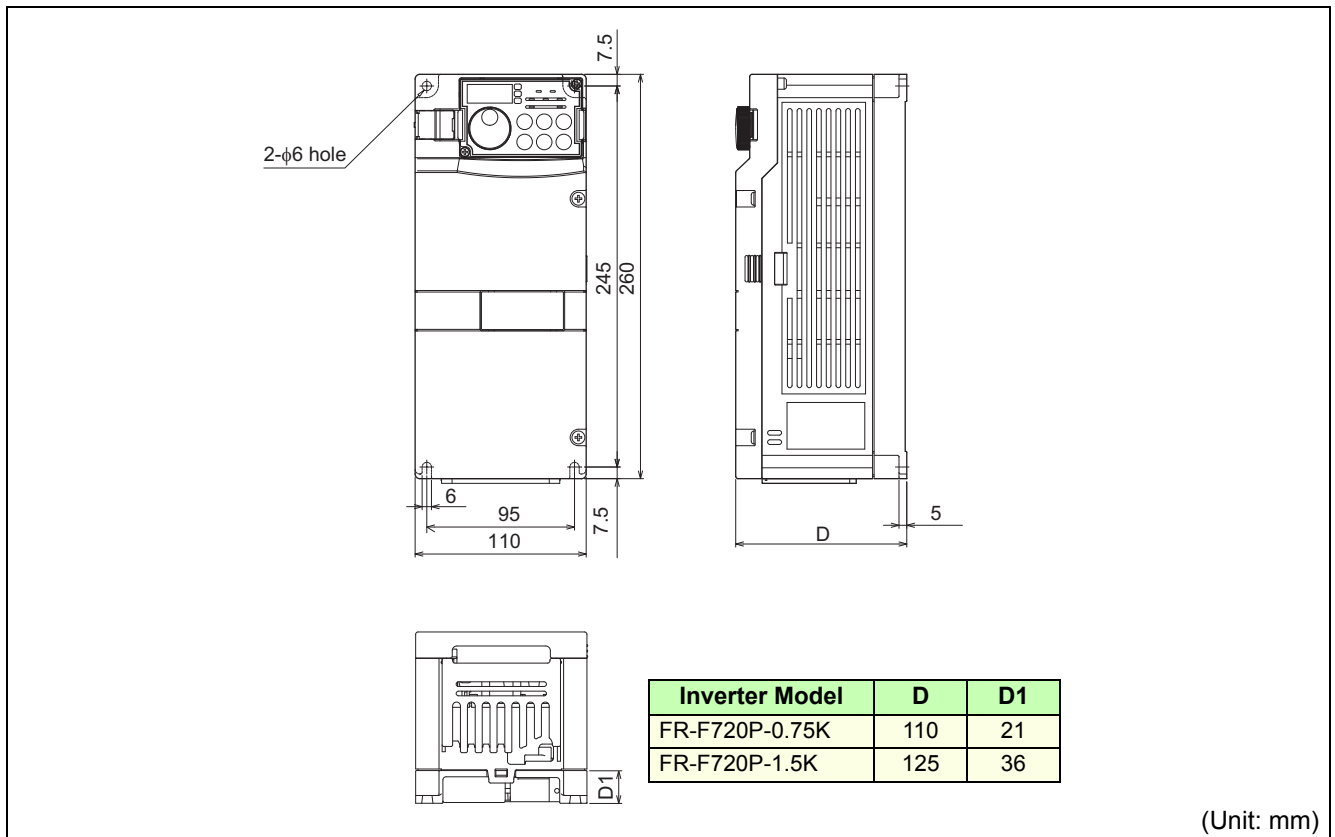

- FR-F720P-2.2K, 3.7K, 5.5K
- FR-F740P-0.75K, 1.5K, 2.2K, 3.7K, 5.5K

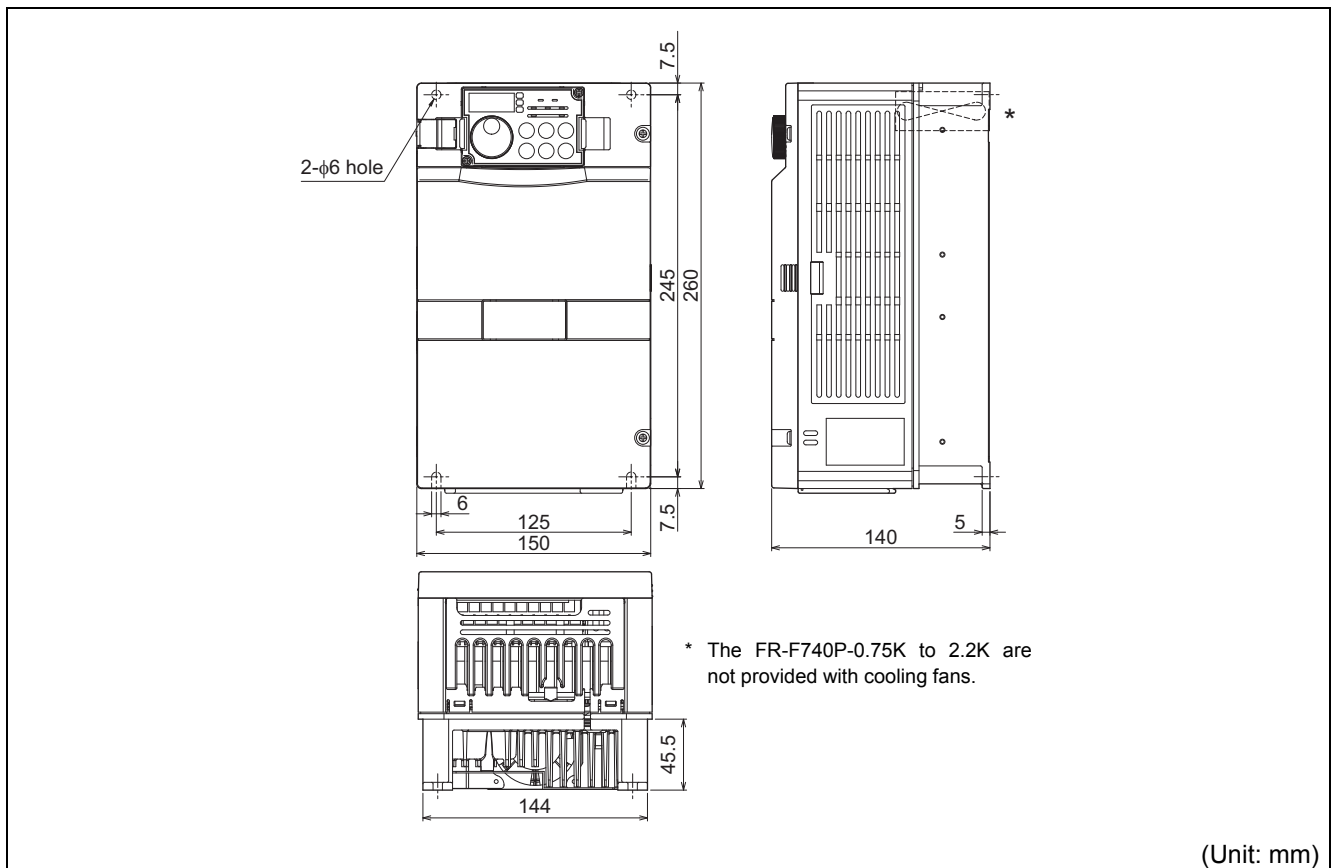





- FR-F720P-7.5K, 11K, 15K
- FR-F740P-7.5K, 11K, 15K, 18.5K

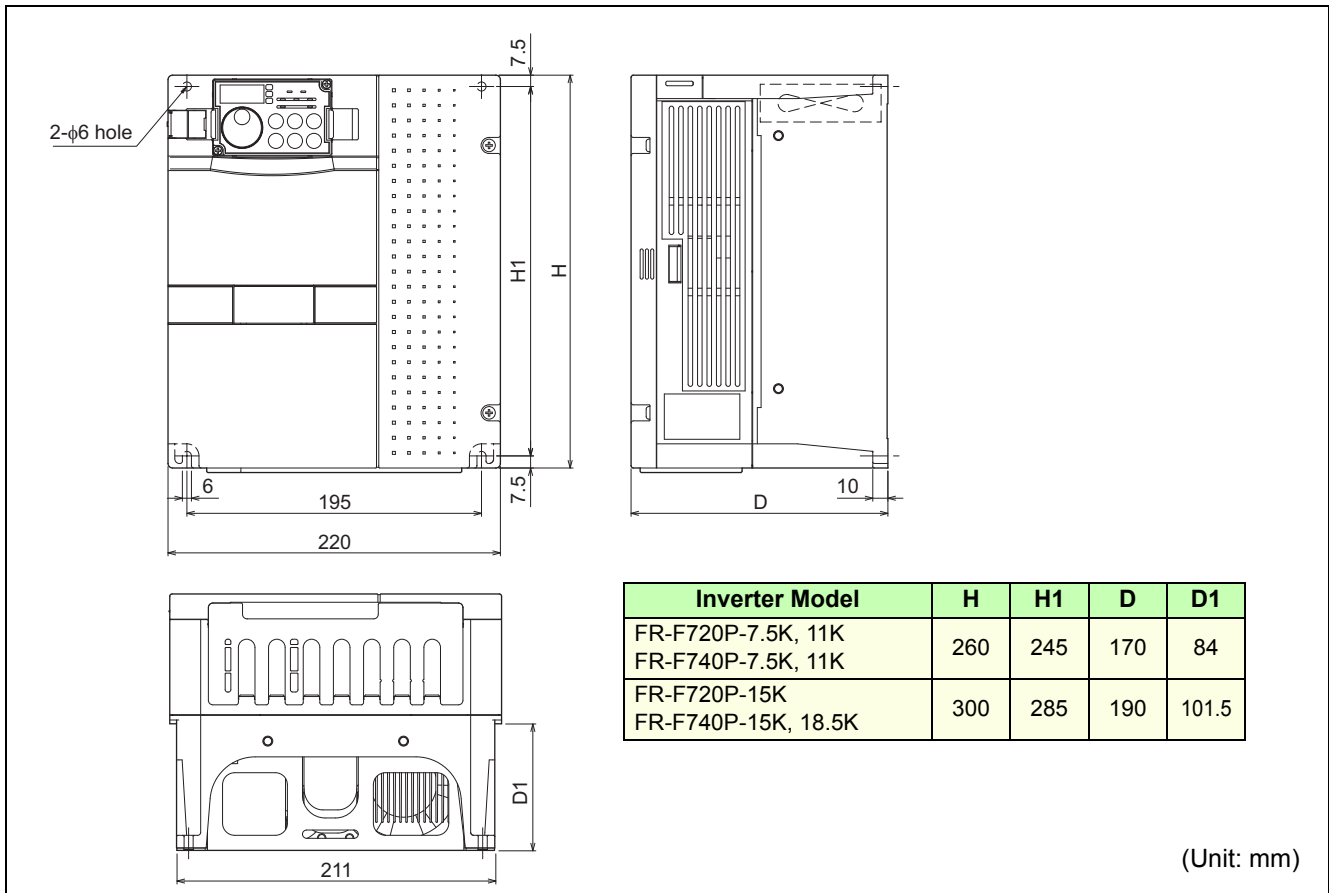

- FR-F720P-18.5K, 22K, 30K
- FR-F740P-22K, 30K

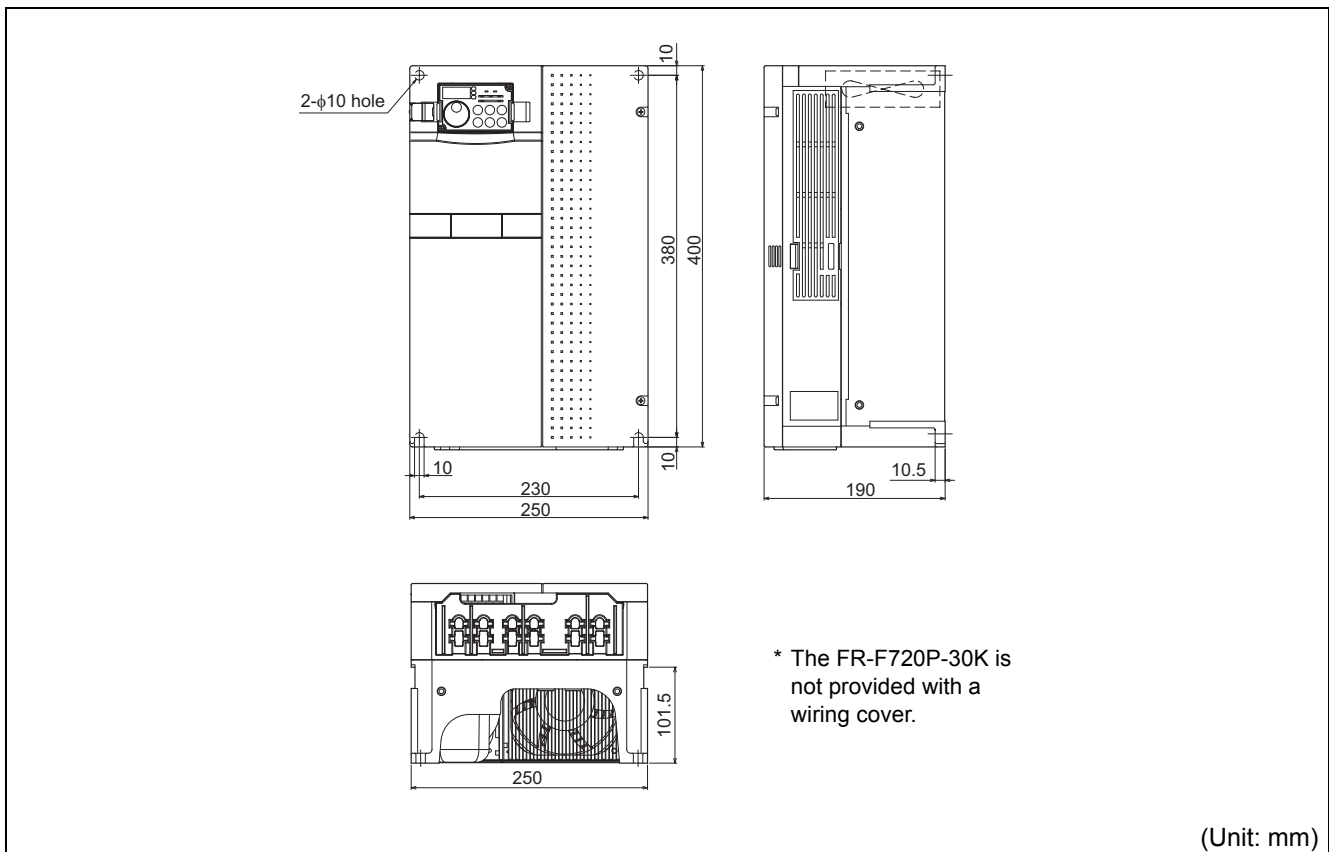

- FR-F720P-37K, 45K, 55K
- FR-F740P-37K, 45K, 55K

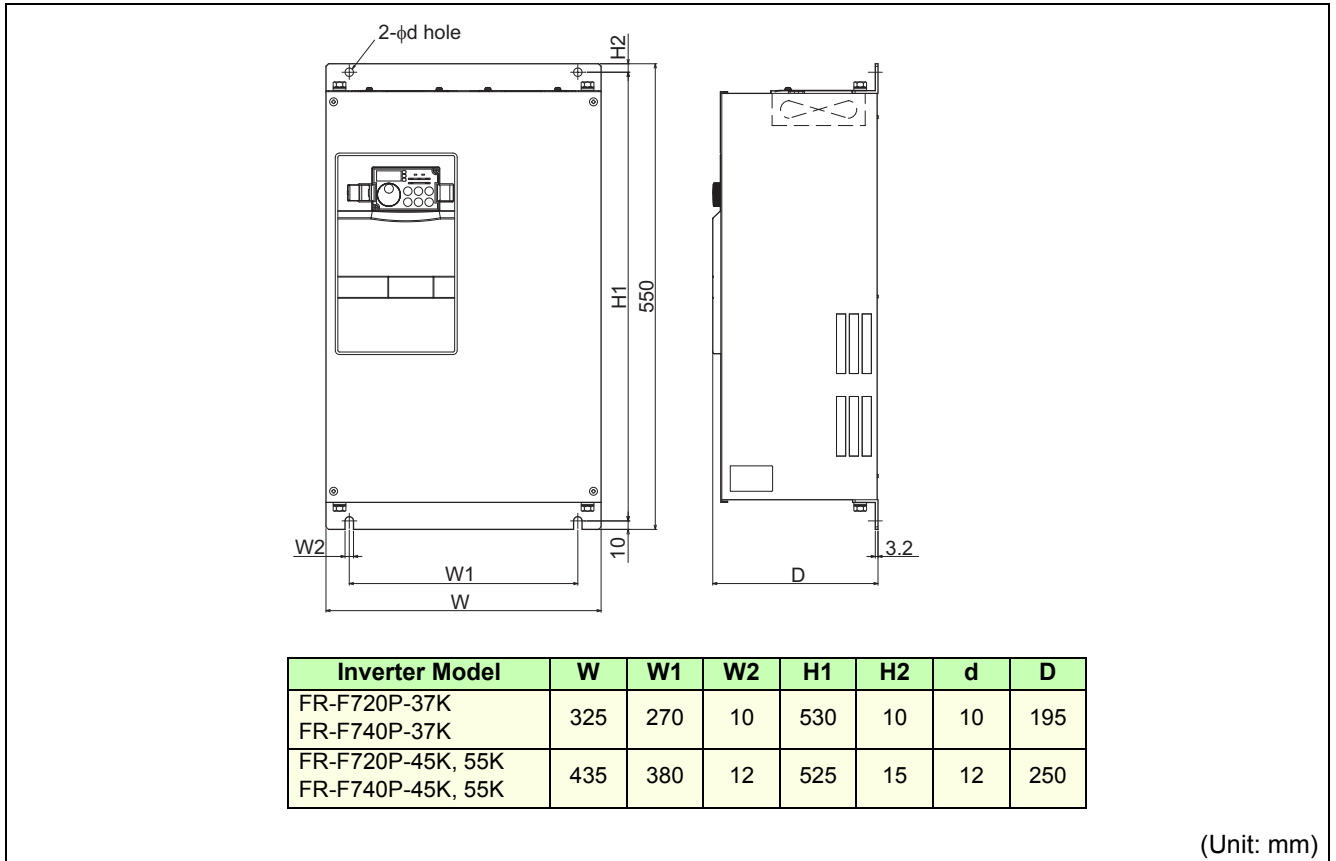

- FR-F740P-75K, 90K

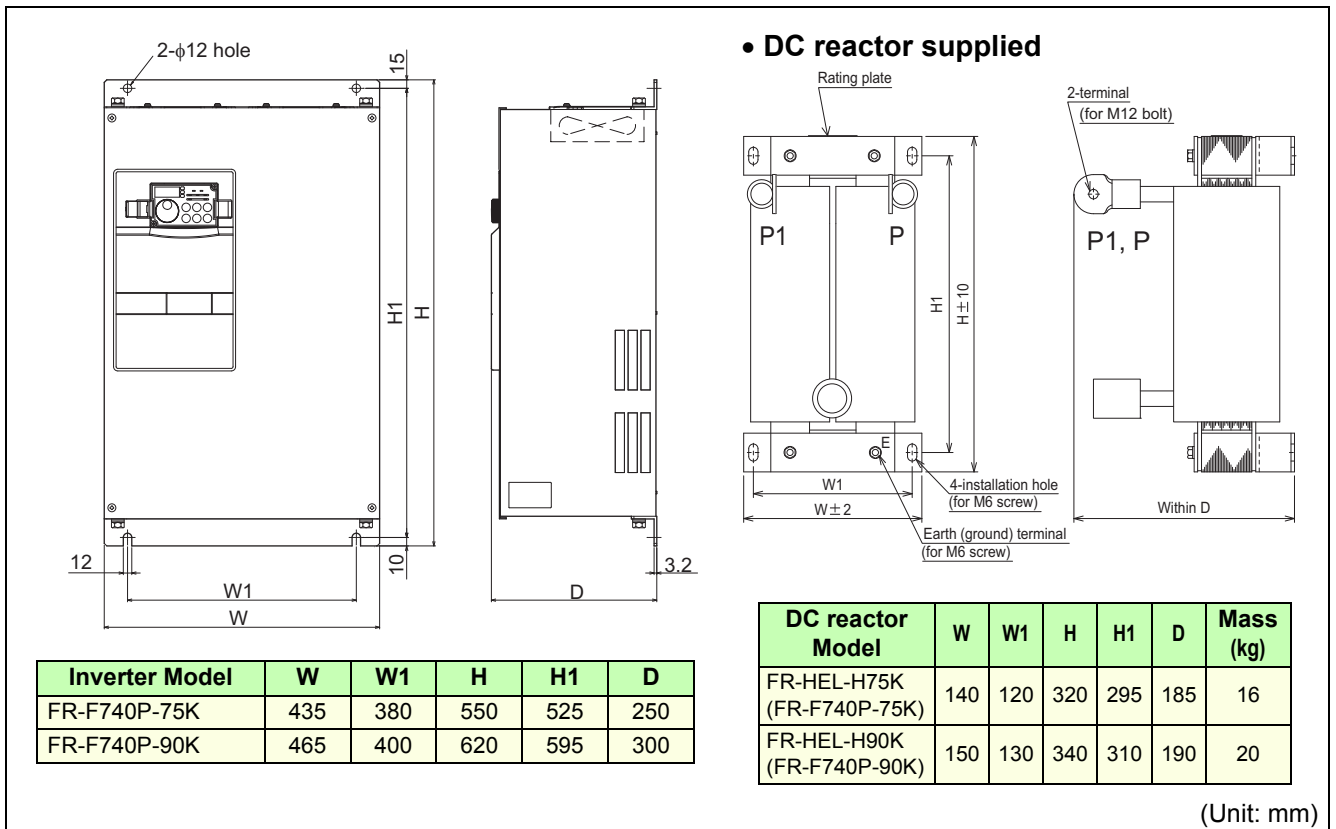



• FR-F740P-110K

**DC reactor supplied**

| DC reactor Model            | Mass (kg) |
|-----------------------------|-----------|
| FR-HEL-H110K(FR-F740P-110K) | 22        |

(Unit: mm)

• FR-F720P-75K, 90K, 110K  
• FR-F740P-132K, 160K

**DC reactor supplied**

| DC reactor Model            | W   | W1  | H   | H1  | D   | S  | Mass (kg) |
|-----------------------------|-----|-----|-----|-----|-----|----|-----------|
| FR-HEL-75K(FR-F720P-75K)    | 150 | 130 | 340 | 310 | 190 | M6 | 17        |
| FR-HEL-90K(FR-F720P-90K)    | 150 | 130 | 340 | 310 | 200 | M6 | 19        |
| FR-HEL-110K(FR-F720P-110K)  | 175 | 150 | 400 | 365 | 200 | M8 | 20        |
| FR-HEL-H132K(FR-F740P-132K) | 175 | 150 | 405 | 370 | 200 | M8 | 26        |
| FR-HEL-H160K(FR-F740P-160K) | 175 | 150 | 405 | 370 | 205 | M8 | 28        |

(Unit: mm)

• FR-F740P-185K, 220K

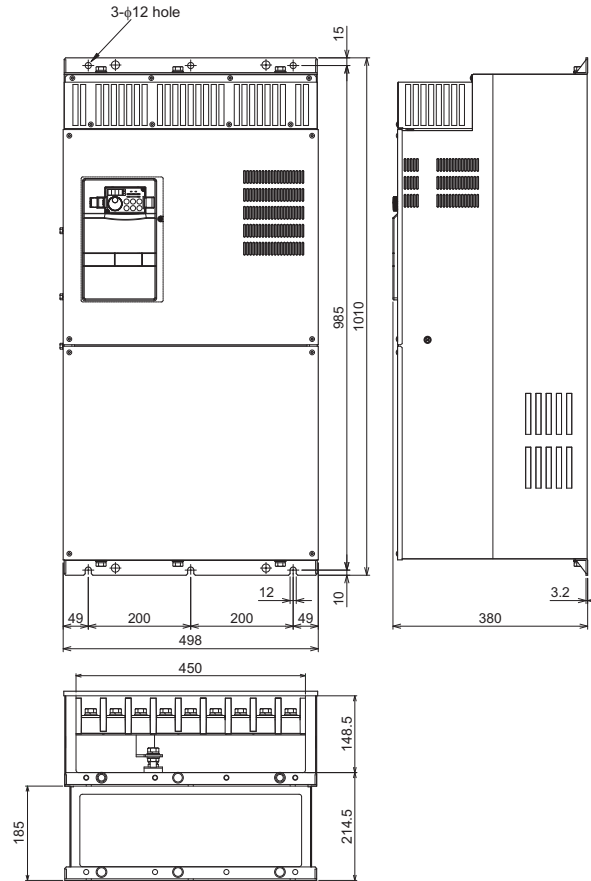

• DC reactor supplied

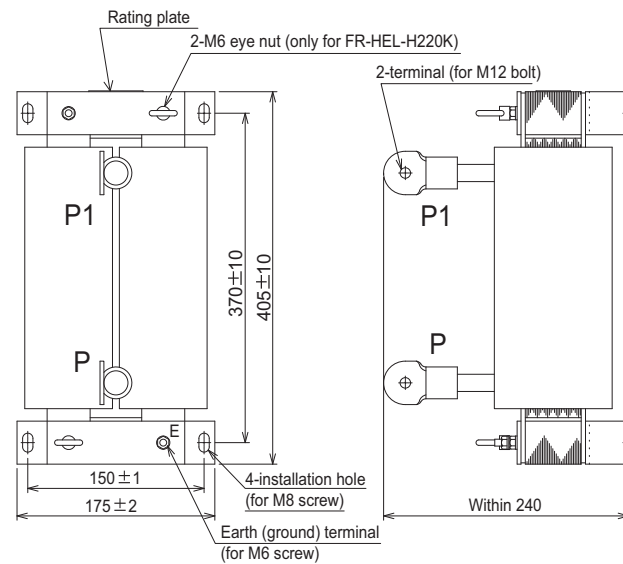

\* Remove the eye nut after installation of the product.

| DC reactor Model             | Mass (kg) |
|------------------------------|-----------|
| FR-HEL-H185K (FR-F740P-185K) | 29        |
| FR-HEL-H220K (FR-F740P-220K) | 30        |

(Unit: mm)



• FR-F740P-250K, 280K, 315K

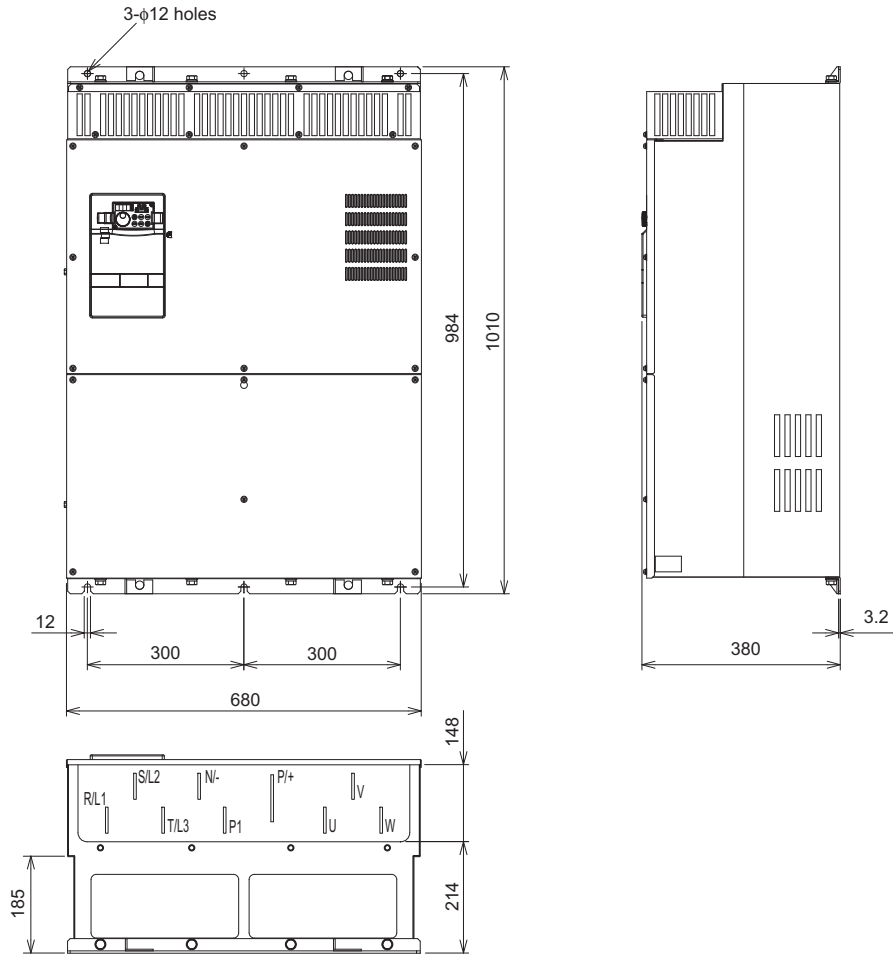

• DC reactor supplied

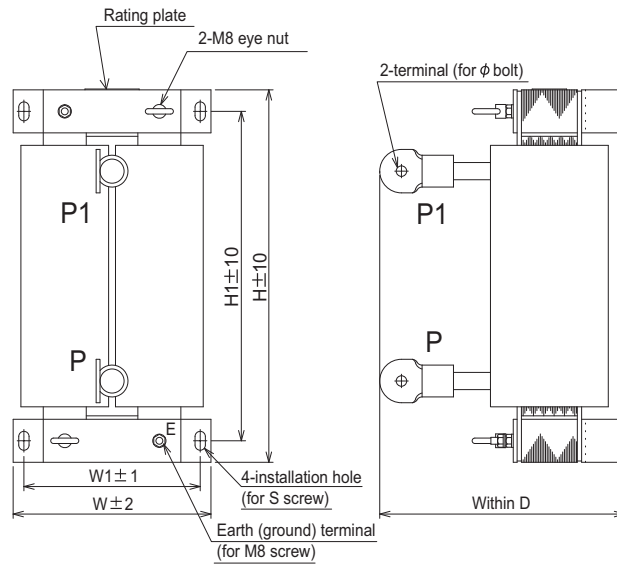

\* Remove the eye nut after installation of the product.

| DC reactor Model            | W   | W1  | H   | H1  | D   | S   | φ   | Mass (kg) |
|-----------------------------|-----|-----|-----|-----|-----|-----|-----|-----------|
| FR-HEL-H250K(FR-F740P-250K) | 190 | 165 | 440 | 400 | 250 | M8  | M12 | 35        |
| FR-HEL-H280K(FR-F740P-280K) | 190 | 165 | 440 | 400 | 255 | M8  | M16 | 38        |
| FR-HEL-H315K(FR-F740P-315K) | 210 | 185 | 495 | 450 | 250 | M10 | M16 | 42        |

(Unit: mm)

• FR-F740P-355K, 400K

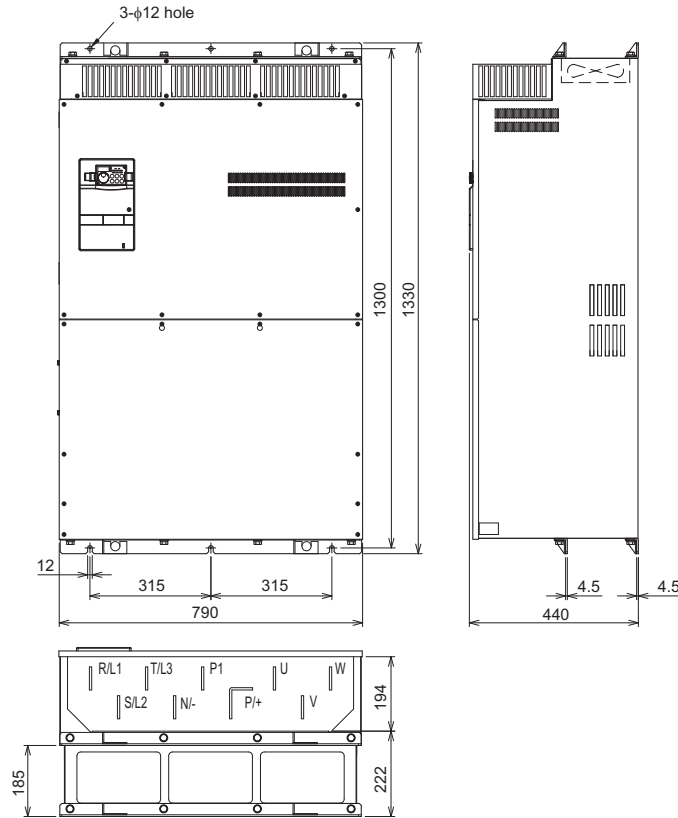

• DC reactor supplied

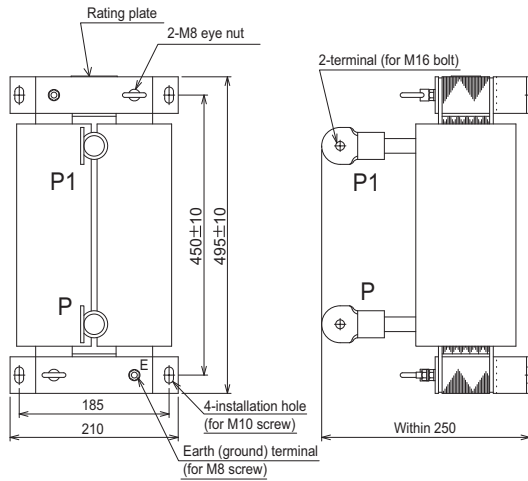

\* Remove the eye nut after installation of the product.

| DC reactor Model             | Mass (kg) |
|------------------------------|-----------|
| FR-HEL-H355K (FR-F740P-355K) | 46        |

• DC reactor supplied

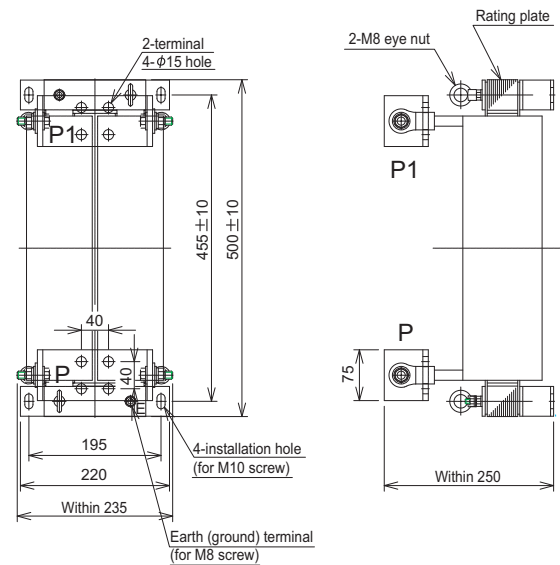

\* Remove the eye nut after installation of the product.

| DC reactor Model             | Mass (kg) |
|------------------------------|-----------|
| FR-HEL-H400K (FR-F740P-400K) | 50        |

(Unit: mm)



• FR-F740P-450K, 500K, 560K

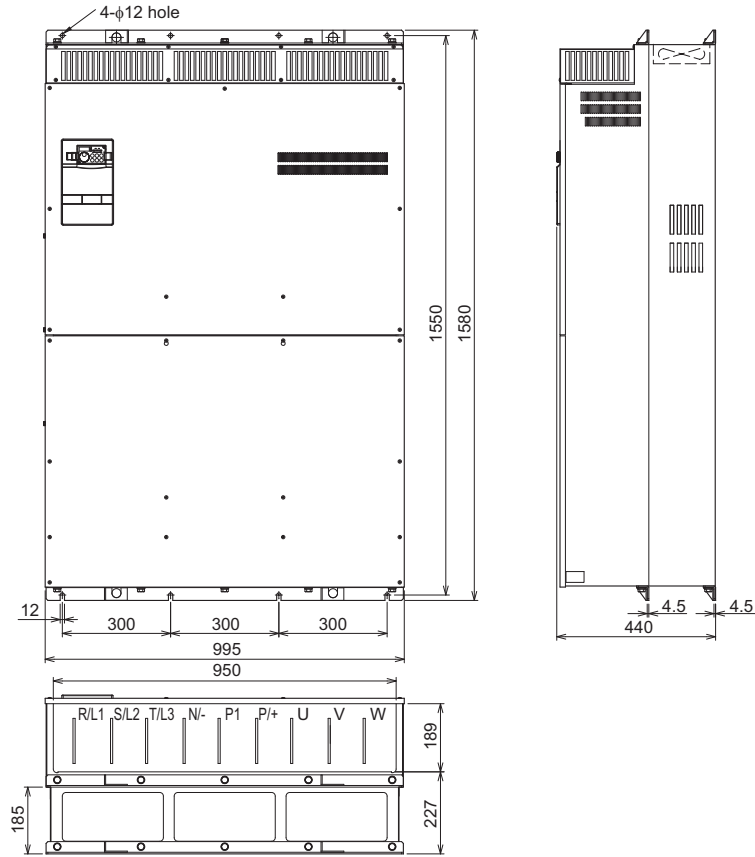

• DC reactor supplied

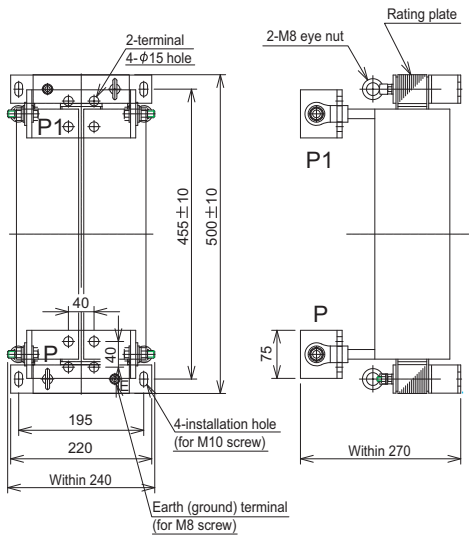

\* Remove the eye nut after installation of the product.

| DC reactor Model            | Mass (kg) |
|-----------------------------|-----------|
| FR-HEL-H450K(FR-F740P-450K) | 57        |

• DC reactor supplied

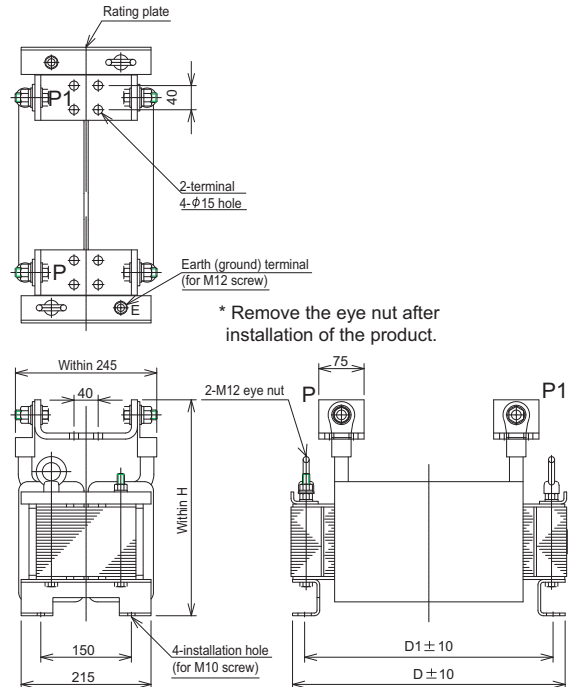

\* Remove the eye nut after installation of the product.

| DC reactor Model             | H   | D   | D1  | Mass (kg) |
|------------------------------|-----|-----|-----|-----------|
| FR-HEL-H500K (FR-F740P-500K) | 345 | 455 | 405 | 67        |
| FR-HEL-H560K (FR-F740P-560K) | 360 | 460 | 410 | 85        |

(Unit: mm)



• Operation panel (FR-DU07)

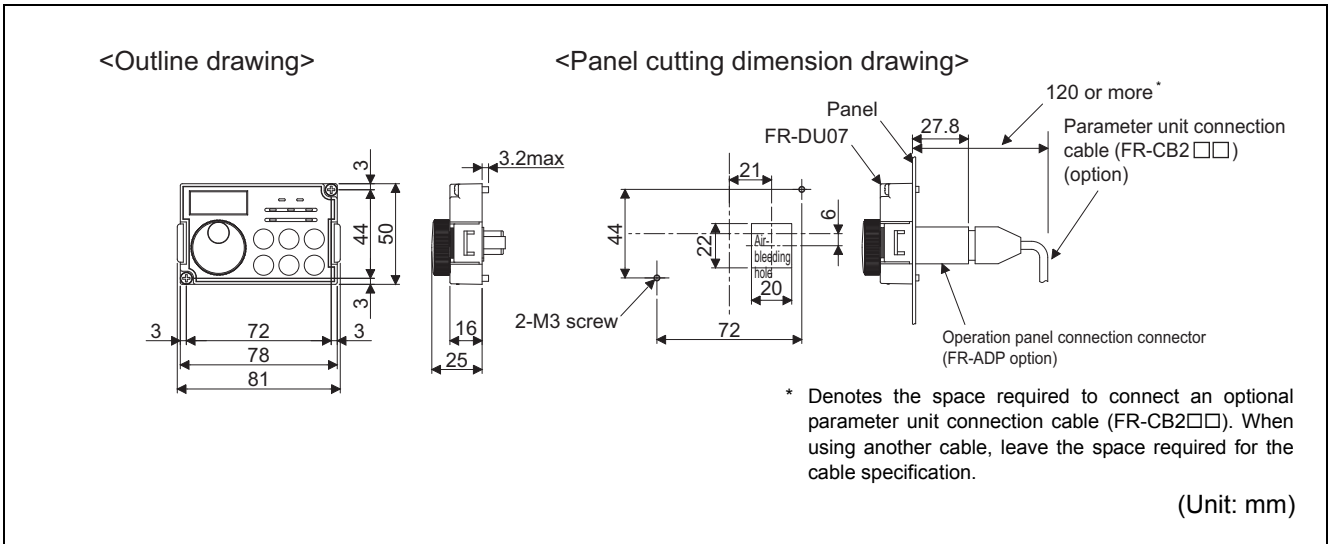

• Parameter unit (option) (FR-PU07)

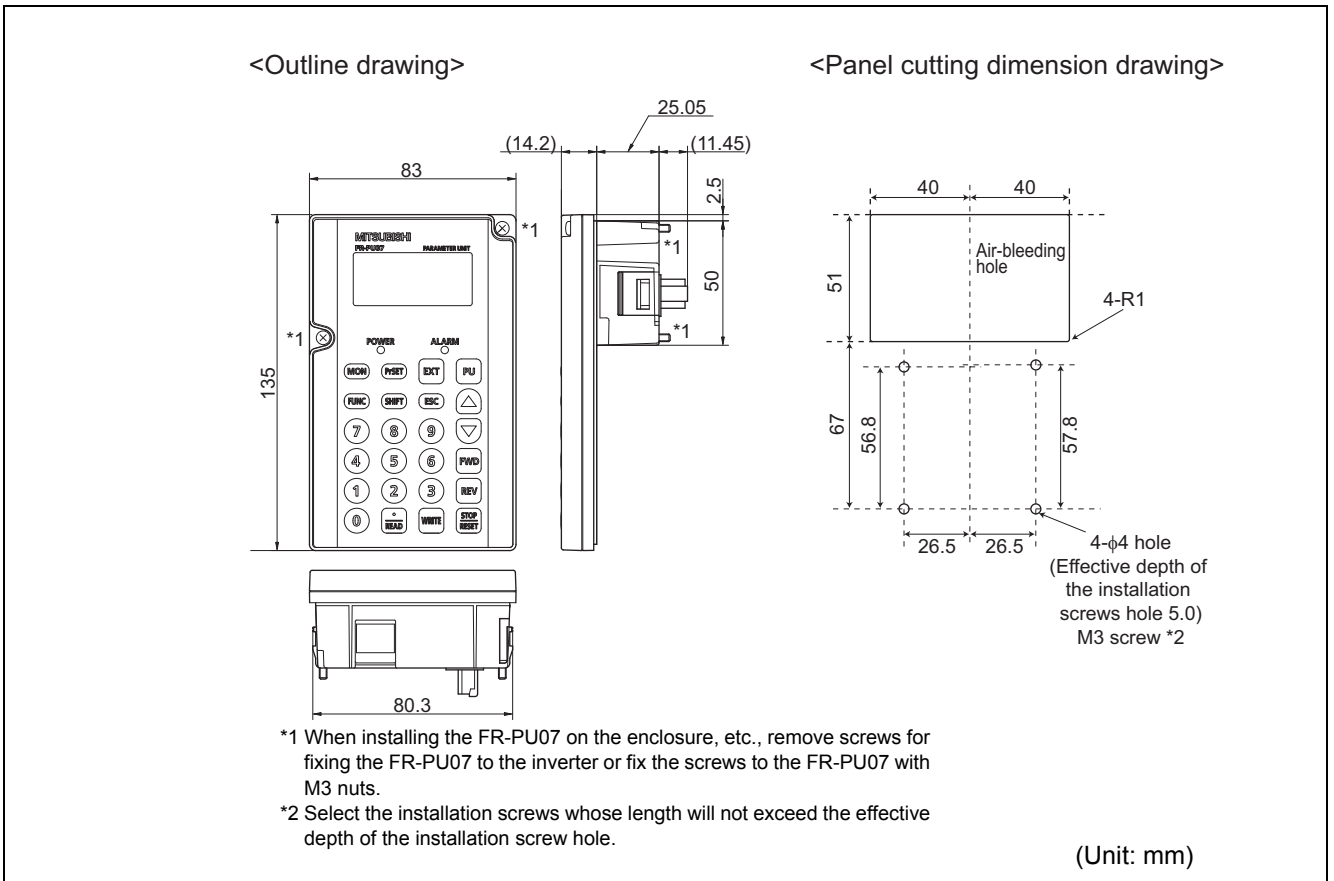





## 8.4 Specification of premium high-efficiency IPM motor [MM-EFS (1500r/min) series]

### ● Motor specification

| Motor model   | 200V class MM-EFS□1M                     | 7   | 15   | 22   | 37   | 55   | 75   | 11K  | 15K  | 18K  | 22K  | 30K  | 37K  | 45K  | 55K  |
|---|--|---|------|------|------|------|------|------|------|------|------|------|------|------|------|
|   | 400V class MM-EFS□1M4                    |   |      |      |      |      |      |      |      |      |      |      |      |      |      |
| Compatible inverter   | 200V class FR-F720P-□K                   | 0.75  | 1.5  | 2.2  | 3.7  | 5.5  | 7.5  | 11   | 15   | 18.5 | 22   | 30   | 37   | 45   | 55   |
|   | 400V class FR-F740P-□K                   |   |      |      |      |      |      |      |      |      |      |      |      |      |      |
| Continuous characteristic <sup>*1</sup>                         | Rated output (kW)                        | 0.75  | 1.5  | 2.2  | 3.7  | 5.5  | 7.5  | 11   | 15   | 18.5 | 22   | 30   | 37   | 45   | 55   |
|   | Rated torque (N·m)                       | 4.77  | 9.55 | 14   | 23.6 | 35   | 47.7 | 70   | 95.5 | 118  | 140  | 191  | 236  | 286  | 350  |
| Rated speed (r/min)   |  | 1500  |      |      |      |      |      |      |      |      |      |      |      |      |      |
| Maximum speed (r/min)   |  | 2250  |      |      |      |      |      |      |      |      |      |      |      |      |      |
| Number of poles   |  | 6   |      |      |      |      |      |      | 8    |      |      |      |      |      |      |
| Maximum torque  |  | 120% 60s  |      |      |      |      |      |      |      |      |      |      |      |      |      |
| Frame number  |  | 80M   | 90L  | 100L | 112M | 132S | 132M | 160M | 160L | 180M | 180L | 200L | 225S |      |      |
| Moment of inertia ( $\times 10^{-4} \text{kg}\cdot\text{m}^2$ ) |  | 20  | 40   | 55   | 110  | 275  | 280  | 760  | 770  | 1700 | 1700 | 1900 | 3400 | 3850 | 6500 |
| Rated current (A)   | 200V class                               | 3   | 6.0  | 8.2  | 13.4 | 20   | 27   | 40   | 54   | 66   | 79   | 110  | 128  | 157  | 194  |
|   | 400V class                               | 1.5   | 3.0  | 4.1  | 6.7  | 10   | 13.5 | 20   | 27   | 33   | 39.5 | 55   | 64   | 78.5 | 97   |
| Structure   |  | Totally-enclosed fan-cooled motor. With steel framed legs. (protective structure IP44 <sup>*2</sup> )     |      |      |      |      |      |      |      |      |      |      |      |      |      |
| Insulation class  |  | F class   |      |      |      |      |      |      |      |      |      |      |      |      |      |
| Vibration class   |  | V-15  |      |      |      |      |      |      |      |      |      |      |      |      |      |
| Environment   | Surrounding air temperature and humidity | -10°C to +40°C (non-freezing) · 90%RH or less (non-condensing)  |      |      |      |      |      |      |      |      |      |      |      |      |      |
|   | Storage temperature and humidity         | -20°C to +70°C (non-freezing) · 90%RH or less (non-condensing)  |      |      |      |      |      |      |      |      |      |      |      |      |      |
|   | Atmosphere                               | Indoors (not under direct sunlight), and free from corrosive gas, flammable gas, oil mist, dust and dirt. |      |      |      |      |      |      |      |      |      |      |      |      |      |
|   | Altitude                                 | Maximum 1,000m above sea level  |      |      |      |      |      |      |      |      |      |      |      |      |      |
|   | Vibration                                | 4.9m/s <sup>2</sup>   |      |      |      |      |      |      |      |      |      |      |      |      |      |
| Mass(kg)  |  | 11  | 15   | 22   | 31   | 50   | 53   | 95   | 100  | 135  | 155  | 215  | 230  | 285  |      |

\*1 The above characteristics apply when the rated AC voltage is input from the inverter. (Refer to page 149.)

Output and rated motor speed are not guaranteed when the power supply voltage drops.

\*2 This excludes the part where the axis passes through.

### ● Motor torque characteristic

The following figure shows the torque characteristic of the premium high-efficiency IPM motor [MM-EFS (1500r/min) series] when used with an inverter.

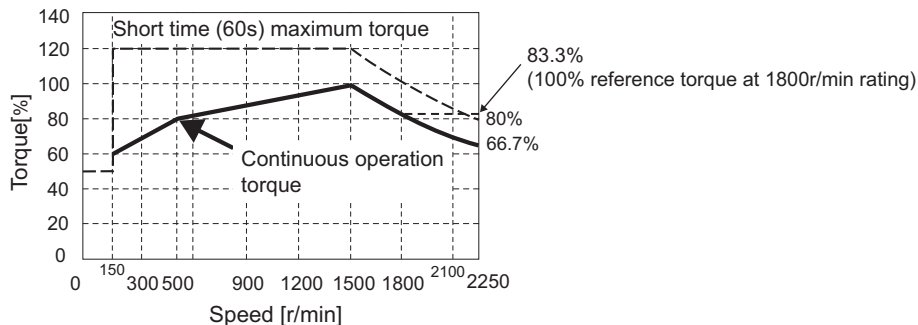

#### REMARKS

· The motor can also be used for applications which require the rated speed of 1800r/min.

#### CAUTION

- The torque characteristic is when the armature winding temperature is 20°C, and the input voltage to the inverter is 200VAC or 400VAC.
- Constant-speed operation cannot be performed for the speed of 150r/min or less.

## 8.5 Specification of premium high-efficiency IPM motor [MM-THE4 (1500r/min) series]

### ● Motor specification

| Motor type  |  | MM-THE4   |       |             |       |       |       |
|---|--|---|-------|-------------|-------|-------|-------|
| Voltage class   |  | 200V  |       | 400V        |       |       |       |
| Applicable inverter   |  | FR-F720P-□K   |       | FR-F740P-□K |       |       |       |
| Continuous characteristic *1                                    | Rated output (kW)                        | 75  | 75    | 90          | 110   | 132   | 160   |
|   | Rated torque (N·m)                       | 477   | 477   | 573         | 700   | 840   | 1018  |
| Rated speed (r/min)   |  | 1500  |       |             |       |       |       |
| Maximum speed (r/min)   |  | 1800  |       |             |       |       |       |
| Number of poles   |  | 6   |       |             |       |       |       |
| Maximum torque  |  | 120% 60s  |       |             |       |       |       |
| Frame number  |  | 250MA   | 250MA | 250MD       | 280MD |       |       |
| Moment of inertia ( $\times 10^{-4} \text{kg}\cdot\text{m}^2$ ) |  | 6000  | 6000  | 10000       | 17500 | 20500 | 23250 |
| Rated current (A)   |  | 270   | 135   | 170         | 195   | 230   | 280   |
| Structure   |  | Totally-enclosed fan-cooled motor. With molded frame legs. (protective structure IP44)                    |       |             |       |       |       |
| Insulation class  |  | F class   |       |             |       |       |       |
| Vibration class   |  | V-25  |       |             |       |       |       |
| Environment   | Surrounding air temperature and humidity | -10°C to +40°C (non-freezing) · 90%RH or less (non-condensing)  |       |             |       |       |       |
|   | Storage temperature and humidity         | -20°C to +70°C (non-freezing) · 90%RH or less (non-condensing)  |       |             |       |       |       |
|   | Atmosphere                               | Indoors (not under direct sunlight), and free from corrosive gas, flammable gas, oil mist, dust and dirt. |       |             |       |       |       |
|   | Altitude                                 | Maximum 1,000m above sea level  |       |             |       |       |       |
|   | Vibration                                | 4.9m/s <sup>2</sup>   |       |             |       |       |       |
| Mass (kg)   |  | 470   | 470   | 610         | 780   | 810   | 860   |

\*1 Output and rated motor speed are not guaranteed when the power supply voltage drops.

### ● Motor torque characteristic

The following figure shows the torque characteristic of a premium high-efficiency IPM motor [MM-THE4 (1500r/min) series] when used with an inverter.

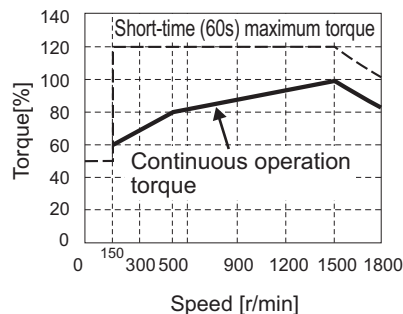

#### REMARKS

- The motor can also be used for applications where the rated speed is 1800r/min.

#### CAUTION

- The torque characteristic is when the armature winding temperature is 20°C, and the input voltage to the inverter is 200V AC or 400V AC.
- Constant-speed operation cannot be performed for the speed of 150r/min or less.

## 8.6 Specification of high-efficiency IPM motor [MM-EF (1800r/min) series]

### ● Motor specification

| Motor model  | 200V class MM-EF□2                       | 4   | 7    | 15   | 22   | 37   | 55   | 75   | 11K  | 15K  | 18K  | 22K     | 30K          | 37K  | 45K  | 55K  | 75K          | —    | —    |
|--|--|---|------|------|------|------|------|------|------|------|------|---------|--------------|------|------|------|--------------|------|------|
|  | 400V class MM-EF□24                      |   |      |      |      |      |      |      |      |      |      |         |              |      |      |      |              | 90K  | 110K |
| Compatible inverter                                      | 200V class FR-F720P-□K                   | 0.75  | 0.75 | 1.5  | 2.2  | 3.7  | 5.5  | 7.5  | 11   | 15   | 18.5 | 22      | 30           | 37   | 45   | 55   | 75           | —    | —    |
|  | 400V class FR-F740P-□K                   |   |      |      |      |      |      |      |      |      |      |         |              |      |      |      |              | 90   | 110  |
| Continuous characteristic <sup>*1</sup>                  | Rated output (kW)                        | 0.4   | 0.75 | 1.5  | 2.2  | 3.7  | 5.5  | 7.5  | 11   | 15   | 18.5 | 22      | 30           | 37   | 45   | 55   | 75           | 90   | 110  |
|  | Rated torque (N·m)                       | 2.12  | 3.98 | 7.96 | 11.7 | 19.6 | 29.2 | 39.8 | 58.4 | 79.6 | 98.1 | 117     | 159          | 196  | 239  | 292  | 398          | 477  | 584  |
| Rated speed (r/min)                                      |  | 1800 (90Hz)   |      |      |      |      |      |      |      |      |      |         | 1800 (120Hz) |      |      |      |              |      |      |
| Maximum speed (r/min)                                    |  | 2700 (135Hz)  |      |      |      |      |      |      |      |      |      |         | 2700 (180Hz) |      |      |      | 2400 (160Hz) |      |      |
| Number of poles  |  | 6   |      |      |      |      |      |      |      |      |      |         | 8            |      |      |      |              |      |      |
| Maximum torque   |  | 120% 60s  |      |      |      |      |      |      |      |      |      |         |              |      |      |      |              |      |      |
| Frame number   |  | 80M   |      |      | 90L  | 100L | 112M |      | 132S |      | 160M |         | 160L         | 180L |      | 200L |              | 225S |      |
| Moment of inertia (×10 <sup>-4</sup> kg·m <sup>2</sup> ) |  | 10.4  | 10.4 | 18.4 | 36.9 | 51.2 | 125  | 153  | 274  | 354  | 815  |         | 1050         | 2215 | 2400 | 4300 | 5200         | 8700 | 9500 |
| Rated current (A)  | 200V class                               | 1.6   | 3.0  | 5.9  | 8.7  | 14.4 | 22   | 29   | 43   | 55   | 70.5 | 83.5    | 109          | 136  | 162  | 195  | 272          | —    | —    |
|  | 400V class                               | 0.8   | 1.5  | 3.0  | 4.4  | 7.2  | 11   | 14.5 | 21.5 | 27.5 | 35   | 42      | 57           | 68   | 81   | 96.5 | 136          | 160  | 197  |
| Structure  |  | Totally-enclosed fan-cooled motor (protective structure IP44 <sup>-2</sup> )                              |      |      |      |      |      |      |      |      |      |         |              |      |      |      |              |      |      |
| Insulation class   |  | B class   |      |      |      |      |      |      |      |      |      | F class |              |      |      |      |              |      |      |
| Environment  | Surrounding air temperature and humidity | -10°C to +40°C (non-freezing) · 90%RH or less (non-condensing)  |      |      |      |      |      |      |      |      |      |         |              |      |      |      |              |      |      |
|  | Storage temperature and humidity         | -20°C to +70°C (non-freezing) · 90%RH or less (non-condensing)  |      |      |      |      |      |      |      |      |      |         |              |      |      |      |              |      |      |
|  | Atmosphere                               | Indoors (not under direct sunlight), and free from corrosive gas, flammable gas, oil mist, dust and dirt. |      |      |      |      |      |      |      |      |      |         |              |      |      |      |              |      |      |
|  | Altitude                                 | Maximum 1,000m above sea level  |      |      |      |      |      |      |      |      |      |         |              |      |      |      |              |      |      |
|  | Vibration                                | 4.9m/s <sup>2</sup> (0.5G)  |      |      |      |      |      |      |      |      |      |         |              |      |      |      |              |      |      |
| Mass(kg)   |  | 8.5   | 9.0  | 11   | 15   | 23   | 33   | 38   | 52   | 60   | 105  | 105     | 119          | 167  | 178  | 240  | 290          | 360  | 390  |

\*1 The above characteristics apply when the rated AC voltage is input from the inverter. (Refer to page 149.)

Output and rated motor speed are not guaranteed when the power supply voltage drops.

\*2 This excludes the part where the axis passes through.

### ● Motor torque characteristic

The following figures show the torque characteristics of high-efficiency IPM motors [MM-EF (1800r/min) series] when used with inverters.

• 75K or lower

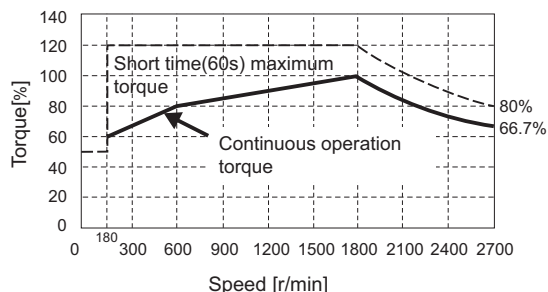

• 90K or higher

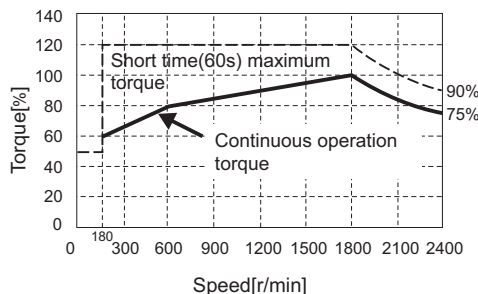

#### CAUTION

- The torque characteristic is when the armature winding temperature is 20°C, and the input voltage to the inverter is 200VAC or 400VAC.
- Constant-speed operation cannot be performed for the speed of 180r/min or less.

## 8.7 Heatsink protrusion attachment procedure

When encasing the inverter in an enclosure, the generated heat amount in an enclosure can be greatly reduced by installing the heatsink portion of the inverter outside the enclosure. When installing the inverter in a compact enclosure, etc., this installation method is recommended.

### 8.7.1 When using a heatsink protrusion attachment (FR-A7CN)

For the FR-F720P-2.2K to 110K, FR-F740P-0.75K to 160K, a heatsink can be protruded outside the enclosure using a heatsink protrusion attachment (FR-A7CN). (Attachment is not required when protruding the heatsink for 185K or higher.) For a panel cut dimension drawing and an installation procedure of the heatsink protrusion attachment (FR-A7CN) to the inverter, refer to a manual of "heatsink protrusion attachment (FR-A7CN)".

### 8.7.2 Protrusion of heatsink of the FR-F740P-185K or higher

(1) Panel cutting

Cut the panel of the enclosure according to the inverter capacity.

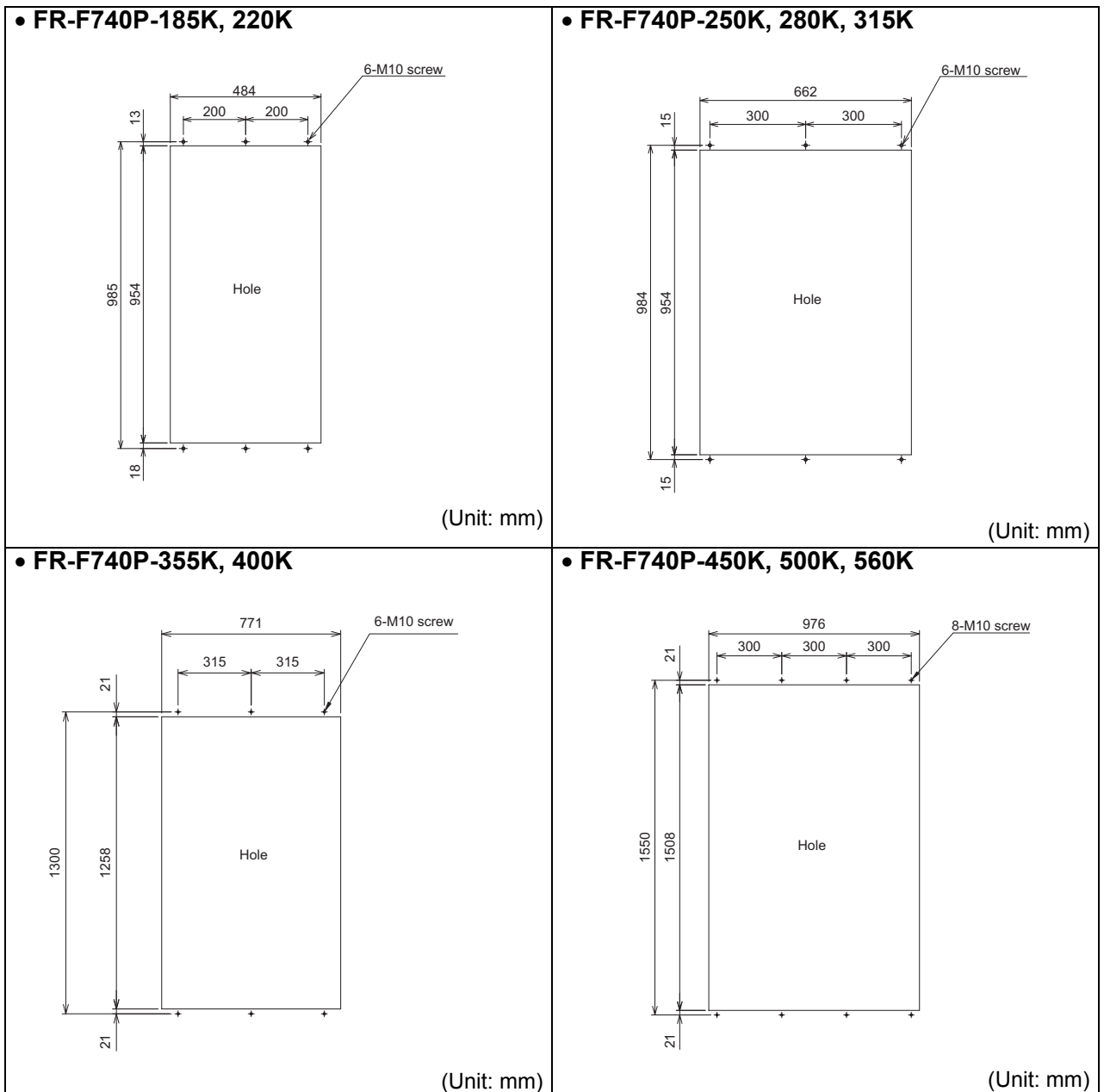

(2) Shift and removal of a rear side installation frame

• FR-F740P-185K to 315K

One installation frame is attached to each of the upper and lower part of the inverter. Change the position of the rear side installation frame on the upper and lower side of the inverter to the front side as shown on the right. When changing the installation frames, make sure that the installation orientation is correct.

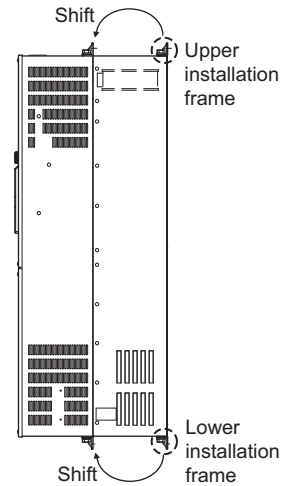

• FR-F740P-355K or higher

Two installation frames each are attached to the upper and lower parts of the inverter. Remove the rear side installation frame on the upper and lower side of the inverter as shown on the right.

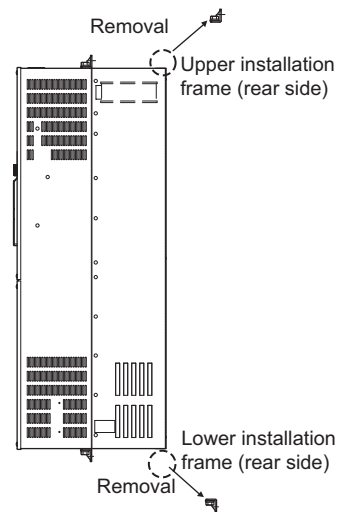

(3) Installation of the inverter

Push the inverter heatsink portion outside the enclosure and fix the enclosure and inverter with upper and lower installation frame.

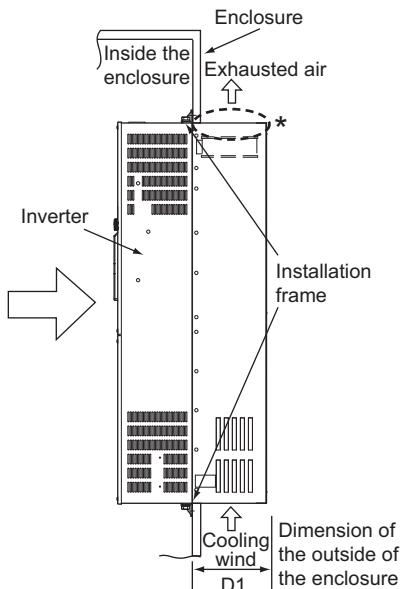

\* For the FR-F740P-185K or higher, there are finger guards behind the enclosure. Therefore, the thickness of the panel should be less than 10mm(\*1) and also do not place anything around finger guards to avoid contact with the finger guards.

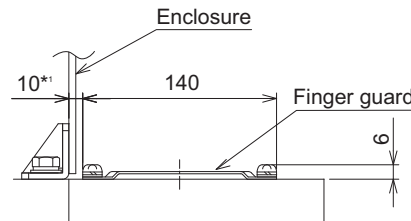

(Unit: mm)

| Inverter Model        | D1(mm) |
|-----------------------|--------|
| FR-F740P-185K, 220K   | 185    |
| FR-F740P-250K to 560K | 184    |

**CAUTION**

- Having a cooling fan, the cooling section which comes out of the enclosure cannot be used in the environment of water drops, oil, mist, dust, etc.
- Be careful not to drop screws, dust etc. into the inverter and cooling fan section.

# APPENDICES

## Appendix 1 For customers who are replacing the conventional model with this inverter

### Appendix 1-1 Replacement of the FR-F500 series

#### (1) Instructions for installation

- 1) Removal procedure of the front cover was changed. (with screws) Please note. (Refer to page 6.)
- 2) Removal procedure of the operation panel was changed. (with screws) Please note. (Refer to page 6.)
- 3) Plug-in options of the F500 series are not compatible
- 4) Operation panel (FR-DU04) cannot be used.
- 5) Setup software (FR-SW0-SETUP) cannot be used.

#### (2) Wiring instructions

- 1) The control circuit terminal block can be used for the FR-F700P series without removing wiring. Note that the wiring cover (0.75K to 22K) is not compatible.

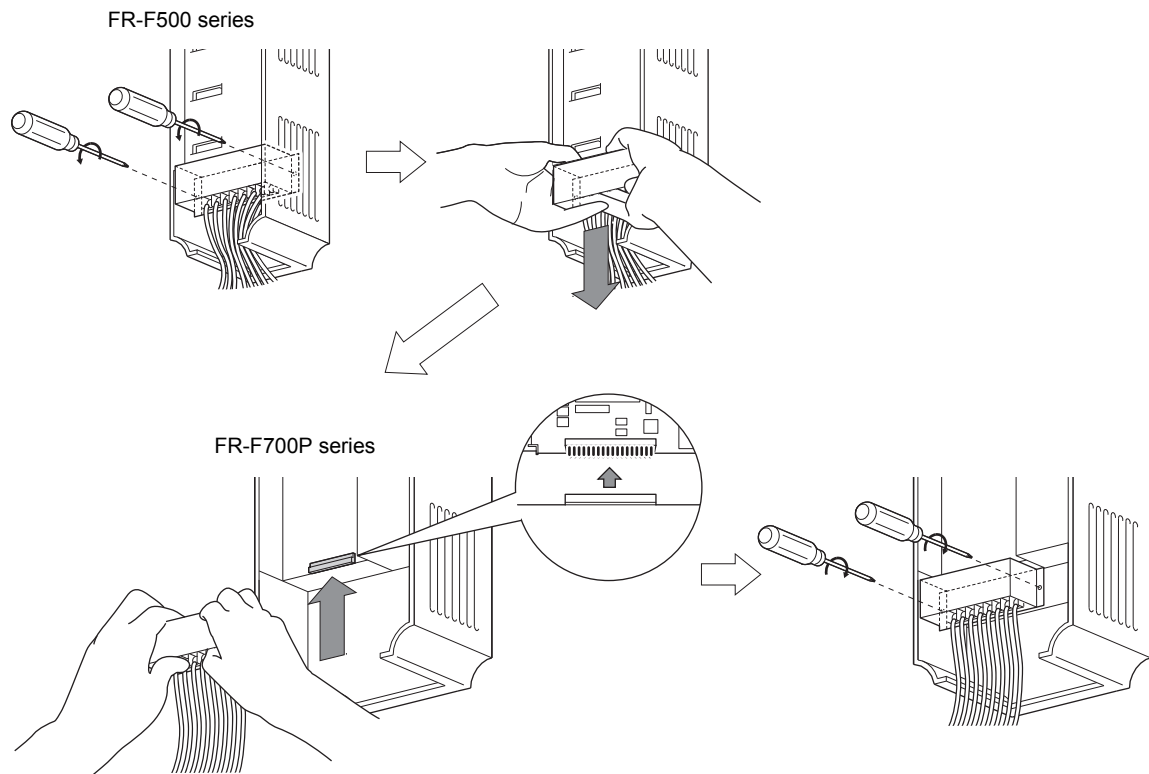

(Note that the relay output 2 (A2, B2, C2) specific for the FR-F700P series cannot be used with the FR-F500 series terminals.)

#### (3) Instructions for continuous use of the FR-PU04 (parameter unit)

- 1) For the FR-F700P series, many functions (parameters) have been added. When setting these parameters, the parameter name and setting range are not displayed. Parameter list, change list, initial value list, initial value list 2 and parameter clear of the HELP function cannot be used.
- 2) For the FR-F700P series, many protective functions have been added. These functions activate, but all faults are displayed as "Fault 14". When the faults history has been checked, "E.14" appears. Added faults display will not appear on the parameter unit.
- 3) User initial value setting cannot be used.
- 4) User registration/clear (user group 2) cannot be used.
- 5) Parameter copy/verification function cannot be used.

#### (4) Main differences and compatibilities with the FR-F500(L) series

| Item                  |   | FR-F500(L)  | FR-F700P   |
|-----------------------|---|---|--|
| Changed function      | Simple mode parameter   | 61 parameters   | 17 parameters  |
|                       | User group  | User group 1 (16 parameters), User group 2 (16 parameters) ( <i>Pr.160, Pr.173 to Pr.175</i> )  | User group (16 parameters) only<br>Setting methods were partially changed ( <i>Pr.160, Pr.172 to Pr.173</i> )  |
|                       | Communication option  | Performing the parameter clear or all parameter clear (H5A96 or HAA99) from the DeviceNet communication option (FR-A5ND) clears the <i>Pr. 345</i> and <i>Pr. 346</i> settings. | Performing the parameter clear or all parameter clear (H5A96 or HAA99) from the DeviceNet communication option (FR-A7ND) does not clear the <i>Pr. 345</i> and <i>Pr. 346</i> settings.  |
| Changed initial value | <i>Pr.0</i><br>Torque boost   | 2% for 11K to 55K   | 2% for 11K to 37K, 1.5% for 45K and 55K<br>(If the torque boost setting was being used in the initial setting in the FR-F500 series, the setting does not need to be changed from the initial setting after the inverter is replaced with the FR-F700P series. ) |
| Deleted function      | User initial value setting ( <i>Pr.199</i> )  | Available   | Not available<br>Substitutable with the copy function of the operation panel (FR-DU07)   |
|                       | DC injunction function with terminal  | With a terminal (X13 signal)<br>(Setting value "8888" for <i>Pr.11</i> , setting value "13" for <i>Pr.180 to Pr.186</i> )   | Not available<br>Start in the reverse rotation is possible with the flying start function (frequency search of the automatic restart after instantaneous power failure function)   |
|                       | Long wire mode  | Setting values "10 and 11" for <i>Pr.240</i>  | Setting is not necessary<br>(Setting values "10 and 11" for <i>Pr.240</i> are deleted.)  |
|                       | Intelligent optimum acceleration/ deceleration  | Available<br>( <i>Pr.60</i> setting "3" and <i>Pr.61 to Pr.63</i> )   | Not available<br>For deceleration time, overvoltage fault can be avoided with the regeneration avoidance function ( <i>Pr.882 to Pr.885</i> ).   |
|                       | Automatic torque boost  | <i>Pr.38, Pr.39</i>   | The automatic torque boost is deleted because the Simple magnetic flux vector ( <i>Pr.80</i> ) has been added.   |
| Terminal block        | Removable terminal block  | Removable terminal block<br>Upward compatibility (Terminal block of the F500 can be mounted)  |  |
| PU                    | FR-PU04, DU04   | FR-PU07<br>FR-DU07<br>FR-DU04 unavailable (Partly restricted when the FR-PU04 is used. <i>Refer to page 167.</i> )  |  |
| Plug-in option        | Dedicated plug-in option (not compatible)   |   |  |
|                       | Computer link, relay output option<br>FR-A5NR   | Built into the inverter<br>(RS-485 terminal, relay output 2 points)   |  |
|                       | Three boards can be mounted   | One board can be mounted  |  |
| Installation size     | FR-F720P-0.75K, 2.2K, 3.7K, 7.5K, 18.5K, 22K, 37K, 45K,<br>FR-F740P-0.75K to 3.7K, 7.5K, 11K, 22K, 37K to 55K are compatible in mounting dimensions<br>For other capacities, an optional intercompatibility attachment (FR-AAT) is necessary. |   |  |

#### Appendix 1-2 Replacement of the FR-A100 <EXCELENT> series

##### Instructions for installation

- When using the installation holes of the FR-A100(E) series, FR-A5AT (intercompatibility attachment) is necessary.

## Appendix 2 Instructions for compliance with the EU Directives

The EU Directives are issued to standardize different national regulations of the EU Member States and to facilitate free movement of the equipment, whose safety is ensured, in the EU territory.

Since 1996, compliance with the EMC Directive that is one of the EU Directives has been legally required. Since 1997, compliance with the Low Voltage Directive, another EU Directive, has been also legally required. When a manufacturer confirms its equipment to be compliant with the EMC Directive and the Low Voltage Directive, the manufacturer must declare the conformity and affix the CE marking.

### ● The authorized representative in the EU

The authorized representative in the EU is shown below.

Name: Mitsubishi Electric Europe B.V.

Address: Gothaer Strasse 8, 40880 Ratingen, Germany

### ● Note

We declare that this inverter conforms with the EMC Directive in industrial environments and affix the CE marking on the inverter. When using the inverter in a residential area, take appropriate measures and ensure the conformity of the inverter used in the residential area.

### (1) EMC Directive

We declare that this inverter conforms with the EMC Directive and affix the CE marking on the inverter.

- EMC Directive: 2004/108/EC
- Standard(s): EN61800-3:2004 (Second environment / PDS Category "C3")

Note: First environment

Environment including residential buildings. Includes buildings directly connected without a transformer to the low voltage power supply network which supplies power to residential buildings.

Second environment

Environment including all buildings except buildings directly connected without a transformer to the low voltage power supply network which supplies power to residential buildings.

### ● Note

Set the EMC filter valid and install the inverter and perform wiring according to the following instructions.

- \* The inverter is equipped with a built-in EMC filter. Set the EMC filter valid. (The EMC filter is invalid when shipped from the factory. (The FR-F720P-0.75K and 1.5K are always valid.) For details, refer to page 10.)
- \* Connect the inverter to an earthed power supply.
- \* Install a motor and a control cable according to the instructions written in the EMC Installation Guidelines (BCN-A21041-204 (For the manual, please contact your sales representative.) ).
- \* The cable length between the inverter and the motor is 5 m maximum.
- \* Confirm that the final integrated system with the inverter conforms with the EMC Directive.
- \* This inverter does not conform with the EU Directives when used with an IPM motor.



## (2) Low Voltage Directive

We have self-confirmed our inverters as products compliant to the Low Voltage Directive (Conforming standard EN 50178) and affix the CE mark on the inverters.

### Outline of instructions

- \* Do not use an earth leakage current breaker as an electric shock protector without connecting the equipment to the earth. Connect the equipment to the earth securely.
- \* Wire the earth terminal independently. (Do not connect two or more cables to one terminal.)
- \* Use the cable sizes on *page 14* under the following conditions.
  - Surrounding air temperature: 40°C maximum
 If conditions are different from above, select appropriate wire according to EN60204 Appendix C TABLE 5.
- \* Use a tinned (plating should not include zinc) crimping terminal to connect the earth (ground) cable. When tightening the screw, be careful not to damage the threads.
 

For use as a product compliant with the Low Voltage Directive, use PVC cable whose size is indicated on *page 14*.
- \* Use the moulded case circuit breaker and magnetic contactor which conform to the EN or IEC Standard.
- \* When using an earth leakage current breaker, use a residual current operated protective device (RCD) of type B (breaker which can detect both AC and DC). If not, provide double or reinforced insulation between the inverter and other equipment, or put a transformer between the main power supply and inverter.
- \* Use the inverter under the conditions of overvoltage category II (usable regardless of the earth (ground) condition of the power supply), overvoltage category III (usable with the earthed-neutral system power supply, 400V class only) and pollution degree 2 or lower specified in IEC60664.
  - To use the inverter of 37K or higher (IP00) under the conditions of pollution degree 2, install it in the enclosure of IP 2X or higher.
  - To use the inverter under the conditions of pollution degree 3, install it in the enclosure of IP54 or higher.
  - To use the inverter of 30K or lower (IP20) outside of an enclosure in the environment of pollution degree 2, fix a fan cover with fan cover fixing screws enclosed.

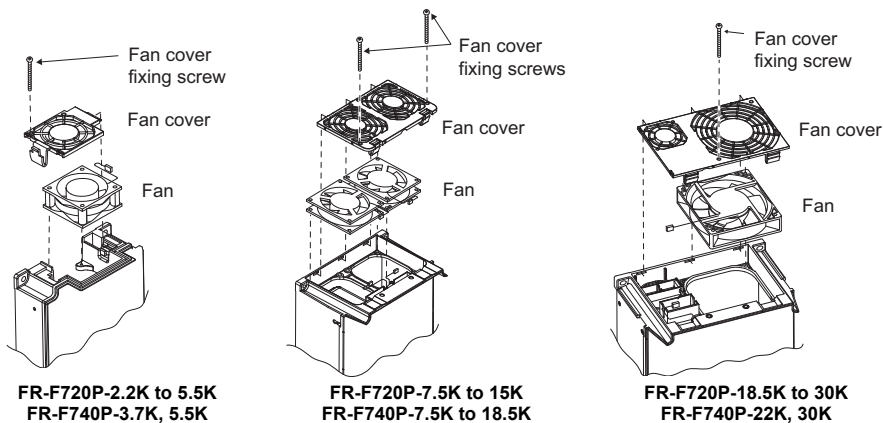

- \* On the input and output of the inverter, use cables of the type and size set forth in EN60204 Appendix C.
- \* The operating capacity of the relay outputs (terminal symbols A1, B1, C1, A2, B2, C2) should be 30VDC, 0.3A. (Relay output has basic isolation from the inverter internal circuit.)
- \* Control circuit terminals on *page 9* are safely isolated from the main circuit.
- \* Environment

|                             | During Operation | In Storage     | During Transportation |
|-----------------------------|------------------|----------------|-----------------------|
| Surrounding air temperature | -10°C to +50°C   | -20°C to +65°C | -20°C to +65°C        |
| Ambient humidity            | 90% RH or less   | 90% RH or less | 90% RH or less        |
| Maximum altitude            | 1000m            | 1000m          | 10000m                |

- \* This inverter does not conform with the EU Directives when used with an IPM motor.

## Appendix 3 Instructions for UL and cUL compliance

(Standard to comply with: UL 508C, CSA C22.2 No.14)

### (1) General Precaution

CAUTION - Risk of Electric Shock -

The bus capacitor discharge time is 10 minutes. Before starting wiring or inspection, switch power off, wait for more than 10 minutes, and check for residual voltage between terminal P/+ and N/- with a meter etc., to avoid a hazard of electrical shock.

ATTENTION - Risque de choc électrique -

La durée de décharge du condensateur de bus est de 10 minutes. Avant de commencer le câblage ou l'inspection, mettez l'appareil hors tension et attendez plus de 10 minutes.

### (2) Environment

Before installation, check that the environment meets following specifications.

|                                       |   |  |  |
|---------------------------------------|---|--|--|
| <b>Surrounding air temperature</b> *1 | Constant torque: -10°C to + 50°C Maximum (non-freezing) |  |  |
|                                       | <b>Ambient humidity</b>                                 |  | 90%RH or less (non-condensing)   |
|                                       | <b>Storage temperature</b>                              |  | -20°C to + 65°C  |
|                                       | <b>Ambience</b>   |  | Indoors (No corrosive and flammable gases, oil mist, dust and dirt.)                   |
|                                       | <b>Altitude, vibration</b>                              |  | Below 1000m, 5.9m/s <sup>2</sup> or less *2 at 10 to 55Hz (directions of X, Y, Z axes) |

\*1 Surrounding Air Temperature is a temperature measured at a measurement position in an enclosure.  
Ambient Temperature is a temperature outside an enclosure.

\*2 2.9m/s<sup>2</sup> or less for the 185K or more

### (3) Installation

The below types of inverter have been approved as products for use in enclosure and approval tests were conducted under the following conditions. Design the enclosure so that the surrounding air temperature, humidity and ambience of the inverter will satisfy the above specifications.

#### Branch Circuit Protection

For installation in the United States, Class RK5, Class J, Class CC, Class L, Class T or any faster acting fuses or UL 489 Molded Case Circuit Breaker (MCCB) must be provided, in accordance with the National Electrical Code and any applicable local codes.

For installation in Canada, Class RK5, Class J, Class CC, Class L, Class T or any faster acting fuses or UL 489 Molded Case Circuit Breaker (MCCB) must be provided, in accordance with the Canada Electrical Code and any applicable provincial codes.

For the FR-F740P-75K to 560K, Class RK5, Class J, Class CC, Class L or Class T fuses or UL 489 Molded Case Circuit Breaker (MCCB) must be provided.

| FR-F720P-□□K   | 0.75                                   | 1.5 | 2.2 | 3.7 | 5.5 | 7.5 | 11  | 15  | 18.5 | 22  | 30  | 37  | 45  | 55  |
|--|--|-----|-----|-----|-----|-----|-----|-----|------|-----|-----|-----|-----|-----|
| Rated fuse voltage(V)  | 240V or more                           |     |     |     |     |     |     |     |      |     |     |     |     |     |
| Fuse maximum allowable rating (A)*                               | Without power factor improving reactor |     |     |     |     |     |     |     |      |     |     |     |     |     |
|  | 15                                     | 20  | 30  | 40  | 60  | 80  | 150 | 175 | 200  | 225 | 300 | 350 | 400 | 500 |
|  | With power factor improving reactor    |     |     |     |     |     |     |     |      |     |     |     |     |     |
|  | 15                                     | 20  | 20  | 30  | 50  | 70  | 125 | 150 | 200  | 200 | 250 | 300 | 350 | 400 |
| Molded case circuit breaker (MCCB) Maximum allowable rating (A)* | 15                                     | 15  | 20  | 35  | 50  | 70  | 100 | 125 | 175  | 200 | 250 | 350 | 400 | 500 |

| FR-F720P-□□K   | 75                                     | 90  | 110  |
|--|--|-----|------|
| Rated fuse voltage(V)  | 240V or more                           |     |      |
| Fuse maximum allowable rating (A)*                               | Without power factor improving reactor |     |      |
|  | —                                      | —   | —    |
|  | With power factor improving reactor    |     |      |
|  | 500                                    | 600 | 700  |
| Molded case circuit breaker (MCCB) Maximum allowable rating (A)* | 700                                    | 800 | 1000 |

| FR-F740P-□□K   | 0.75                                   | 1.5 | 2.2 | 3.7 | 5.5 | 7.5 | 11 | 15 | 18.5 | 22  | 30  | 37  | 45  | 55  |
|--|--|-----|-----|-----|-----|-----|----|----|------|-----|-----|-----|-----|-----|
| Rated fuse voltage(V)  | 480V or more                           |     |     |     |     |     |    |    |      |     |     |     |     |     |
| Fuse maximum allowable rating (A)*                               | Without power factor improving reactor |     |     |     |     |     |    |    |      |     |     |     |     |     |
|  | 6                                      | 10  | 15  | 20  | 30  | 40  | 70 | 80 | 90   | 110 | 150 | 175 | 200 | 250 |
|  | With power factor improving reactor    |     |     |     |     |     |    |    |      |     |     |     |     |     |
|  | 6                                      | 10  | 10  | 15  | 25  | 35  | 60 | 70 | 90   | 100 | 125 | 150 | 175 | 200 |
| Molded case circuit breaker (MCCB) Maximum allowable rating (A)* | 15                                     | 15  | 15  | 15  | 25  | 40  | 50 | 70 | 80   | 100 | 125 | 175 | 200 | 250 |

| FR-F740P-□□K   |  | 75           | 90  | 110 | 132 | 160 | 185 | 220  | 250  | 280  | 315  | 355  | 400  | 450  | 500  | 560  |
|--|--|--------------|-----|-----|-----|-----|-----|------|------|------|------|------|------|------|------|------|
| Rated fuse voltage(V)  |  | 500V or more |     |     |     |     |     |      |      |      |      |      |      |      |      |      |
| Fuse maximum allowable rating (A)*                               | Without power factor improving reactor | —            | —   | —   | —   | —   | —   | —    | —    | —    | —    | —    | —    | —    | —    | —    |
|  | With power factor improving reactor    | 250          | 300 | 350 | 400 | 500 | 600 | 700  | 800  | 900  | 1000 | 1100 | 1200 | 1350 | 1500 | 1800 |
| Molded case circuit breaker (MCCB) Maximum allowable rating (A)* |  | 350          | 450 | 500 | 650 | 800 | 800 | 1000 | 1200 | 1200 | 1200 | 1600 | 1600 | 2000 | 2000 | 2500 |

\* Maximum allowable rating by US National Electrical Code.  
Exact size must be chosen for each installation.

#### (4) Wiring of the power supply and motor

For wiring the input (R/L1, S/L2, T/L3) and output (U, V, W) terminals of the inverter, use the UL Listed copper, stranded wires (rated at 75°C) and round crimping terminals. Crimp the crimping terminals with the crimping tool recommended by the terminal maker.

#### (5) Short circuit ratings

- 200V class  
Suitable For Use in A Circuit Capable Of Delivering Not More Than 100kA rms Symmetrical Amperes, 264V Maximum.
- 400V class  
55K or lower  
Suitable For Use in A Circuit Capable Of Delivering Not More Than 100kA rms Symmetrical Amperes, 528V Maximum.  
75K or higher  
Suitable For Use in A Circuit Capable Of Delivering Not More Than 100kA rms Symmetrical Amperes, 550V Maximum.

#### (6) Motor overload protection

When using the electronic thermal relay function as motor overload protection, set the rated motor current to *Pr. 9*  
*Electronic thermal O/L relay.*

Electronic thermal relay function operation characteristic

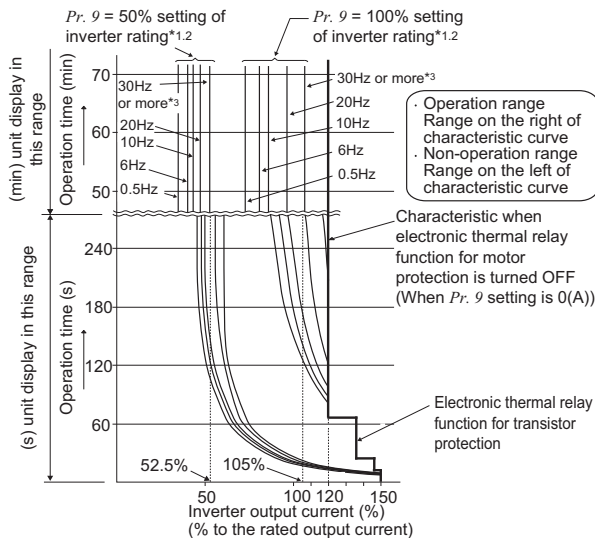

This function detects the overload (overheat) of the motor, stops the operation of the inverter's output transistor, and stops the output. (The operation characteristic is shown on the left)

- When using the Mitsubishi constant-torque motor
  - 1) Set "1" in *Pr. 71*. (This provides a 100% continuous torque characteristic in the low-speed range.)
  - 2) Set the rated current of the motor in *Pr. 9*.

- \*1 When 50% of the rated inverter output current (current value) is set in *Pr. 9*
- \*2 The % value denotes the percentage to the inverter rated output current. It is not the percentage to the rated motor current.
- \*3 When you set the electronic thermal relay function dedicated to the Mitsubishi constant-torque motor, this characteristic curve applies to operation at 6Hz or higher.

#### CAUTION

- The internal accumulated heat value of the electronic thermal relay function is reset by inverter power reset and reset signal input. Avoid unnecessary reset and power-OFF.
- When using multiple motors with one inverter, or using a multi-pole motor or a specialized motor, provide an external thermal relay (OCR) between the inverter and motor. And for the setting of the thermal relay, add the line-to-line leakage current to the current value on the motor rating plate. For low-speed operation where the cooling capability of the motor reduces, it is recommended to use a thermal protector or thermistor-incorporated motor.
- When the difference between the inverter and motor capacities is large and the setting is small, the protective characteristics of the electronic thermal relay function will be deteriorated. In this case, use an external thermal relay.
- Motor over temperature sensing is not provided by the drive.

•The use of FR-F700P with an IPM motor is not certified by the UL nor cUL.

# MEMO

REVISIONS

\*The manual number is given on the bottom left of the back cover.

| Print Date | *Manual Number      | Revision  |
|------------|---------------------|---|
| Sep. 2010  | IB(NA)-0600411ENG-A | First edition   |
| May 2011   | IB(NA)-0600411ENG-B | <p><b>Addition</b></p> <ul style="list-style-type: none"> <li>• MM-EFS71M4 to 55K1M4</li> <li>• Setting value "210" for <i>Pr. 71 Applied motor</i></li> <li>• Setting values "12 and 112" for <i>Pr. 998 IPM parameter initialization</i></li> <li>• Setting value "12" for <i>IPM IPM parameter initialization</i></li> <li>• Compliance with the Radio Waves Act (South Korea)</li> </ul>  |
| Feb. 2015  | IB(NA)-0600411ENG-C | <p><b>Addition</b></p> <ul style="list-style-type: none"> <li>• MM-EFS 200V class compatibility</li> <li>• Overspeed detection (E.OS) function</li> <li>• Setting values "10 and 11" for <i>Pr.154 Voltage reduction selection during stall prevention operation</i></li> <li>• MM-THE4 75kW to 160kW</li> <li>• <i>Pr.552 Frequency jump range</i></li> </ul> <p><b>Modification</b></p> <ul style="list-style-type: none"> <li>• Rated current of MM-EFS151M(4) to MM-EFS371M(4)</li> </ul> |
|            |                     |   |

 **For Maximum Safety**

- Mitsubishi inverters are not designed or manufactured to be used in equipment or systems in situations that can affect or endanger human life.
- When considering this product for operation in special applications such as machinery or systems used in passenger transportation, medical, aerospace, atomic power, electric power, or submarine repeating applications, please contact your nearest Mitsubishi sales representative.
- Although this product was manufactured under conditions of strict quality control, you are strongly advised to install safety devices to prevent serious accidents when it is used in facilities where breakdowns of the product are likely to cause a serious accident.
- Please do not use this product for loads other than three-phase induction motors.

**mitsubishi electric corporation**  
HEAD OFFICE: TOKYO BUILDING 2-7-3, MARUNOUCHI, CHIYODA-KU, TOKYO 100-8310, JAPAN

|               |  |
|---------------|--|
| MODEL         | FR-F700P<br>INSTRUCTION MANUAL (BASIC) |
| MODEL<br>CODE | 1A2-P39                                |