

## A800

# FR-A862 (SEPARATED CONVERTER TYPE) INSTRUCTION MANUAL (HARDWARE)

*High functionality and high performance*

**FR-A862-05450 to 08500**

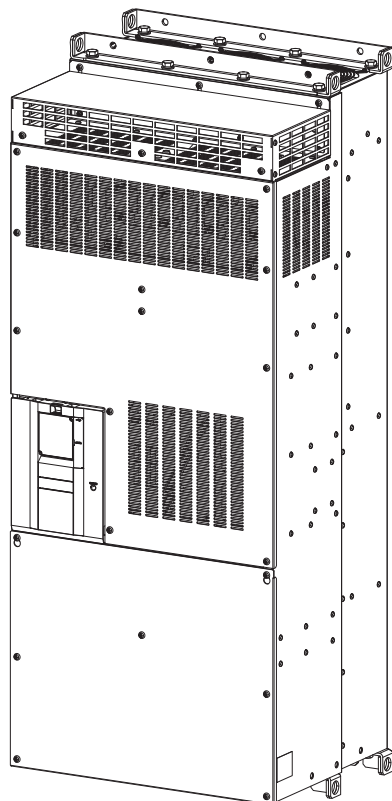

INTRODUCTION	1
INSTALLATION AND WIRING	2
PRECAUTIONS FOR USE OF THE INVERTER	3
PROTECTIVE FUNCTIONS	4
PRECAUTIONS FOR MAINTENANCE AND INSPECTION	5
SPECIFICATIONS	6

Thank you for choosing this Mitsubishi Electric inverter.

This Instruction Manual describes handling and cautions about the hardware, such as installation and wiring, for the FR-A862 (separated converter type) that are different from the FR-A860.

Information about the software, such as basic operations and parameters, is described in the FR-A860 Instruction Manual (Detailed) in the CD-ROM enclosed with the product.

In addition to this manual, please read the manuals in the enclosed CD-ROM carefully. Do not use this product until you have a full knowledge of the equipment, safety information and instructions.

Please forward this Instruction Manual to the end user.

### Safety Instructions

Do not attempt to install, operate, maintain or inspect the product until you have read through this Instruction Manual and appended documents carefully and can use the equipment correctly. Do not use this product until you have a full knowledge of the equipment, safety information and instructions.

Installation, operation, maintenance and inspection must be performed by qualified personnel. Here, an expert means a person who meets all the conditions below.

• A person who took a proper engineering training. Such training may be available at your local Mitsubishi Electric office. Contact your local sales office for schedules and locations.

• A person who can access operating manuals for the protective devices (e.g. light curtain) connected to the safety control system. A person who has read and familiarized himself/herself with the manuals.

In this Instruction Manual, the safety instruction levels are classified into "WARNING" and "CAUTION"



#### WARNING

Incorrect handling may cause hazardous conditions, resulting in death or severe injury.



#### CAUTION

Incorrect handling may cause hazardous conditions, resulting in medium or slight injury, or may cause only material damage.

Note that even the  level may even lead to a serious consequence according to conditions. Be sure to follow the instructions of both levels as they are critical to personal safety.

### ◆ Electric Shock Prevention



#### WARNING

- While the inverter power is ON, do not remove the front cover or the wiring cover. Do not run the inverter with the front cover or the wiring cover removed, as accidental contact with exposed high-voltage terminals and internal components may occur, resulting in an electrical shock.
- Even if power is OFF, do not remove the front cover except for wiring or periodic inspection. You may accidentally touch the charged inverter circuits and get an electric shock.
- Before wiring or inspection, power lamp must be switched OFF. Any person who is involved in wiring or inspection shall wait for at least 10 minutes after the power supply has been switched OFF and check that there are no residual voltage using a tester or the like. The capacitor is charged with high voltage for some time after power OFF, and it is dangerous.
- This inverter must be earthed (grounded). Earthing (grounding) must conform to the requirements of national and local safety regulations and electrical code (NEC section 250, IEC 61140 class 1 and other applicable standards).
- Any person who is involved in wiring or inspection of this equipment shall be fully competent to do the work.
- The inverter must be installed before wiring. Otherwise you may get an electric shock or be injured.
- Setting dial and key operations must be performed with dry hands to prevent an electric shock. Otherwise you may get an electric shock.
- Do not subject the cables to scratches, excessive stress, heavy loads or pinching. Doing so may cause an electric shock.
- Do not change the cooling fan while power is ON. It is dangerous to change the cooling fan while power is ON.
- Do not touch the printed circuit board or handle the cables with wet hands. Doing so may cause an electric shock.
- A PM motor is a synchronous motor with high-performance magnets embedded in the rotor. Motor terminals holds high-voltage while the motor is running even after the inverter power is turned OFF. Before wiring or inspection, the motor must be confirmed to be stopped. In an application, such as fan and blower, where the motor is driven by the load, a low-voltage manual motor starter must be connected at the inverter's output side, and wiring and inspection must be performed while the motor starter is open. Otherwise you may get an electric shock.

### ◆ Fire Prevention



#### CAUTION

- Inverter must be installed on a nonflammable wall without holes (so that nobody touches the inverter heat sink on the rear side, etc.). Mounting it to or near flammable material may cause a fire.
- If the inverter has become faulty, the inverter power must be switched OFF. A continuous flow of large current may cause a fire.
- Be sure to perform daily and periodic inspections as specified in the Instruction Manual. If a product is used without any inspection, a burst, breakage, or a fire may occur.

### ◆ Injury Prevention



#### CAUTION

- The voltage applied to each terminal must be the ones specified in the Instruction Manual. Otherwise an explosion or damage may occur.
- The cables must be connected to the correct terminals. Otherwise an explosion or damage may occur.
- The polarity (+ and -) must be correct. Otherwise burst, damage, etc. may occur.
- While power is ON or for some time after power-OFF, do not touch the inverter as it will be extremely hot. Touching these devices may cause a burn.

### ◆ Additional Instructions

The following instructions must be also followed. If the product is handled incorrectly, it may cause unexpected fault, an injury, or an electric shock.



#### CAUTION

##### Transportation and installation

- Any person who is opening a package using a sharp object, such as a knife and cutter, must wear gloves to prevent injuries caused by the edge of the sharp object.
- The product must be transported in correct method that corresponds to the weight. Failure to do so may lead to injuries.
- Do not stand or rest heavy objects on the product.
- Do not stack the boxes containing inverters higher than the number recommended.
- When carrying the inverter, do not hold it by the front cover; it may fall off or fail.
- During installation, caution must be taken not to drop the inverter as doing so may cause injuries.
- The product must be installed on the surface that withstands the weight of the inverter.
- Do not install the product on a hot surface.
- The mounting orientation of the inverter must be correct.
- The inverter must be installed on a strong surface securely with screws so that it will not drop.
- Do not install or operate the inverter if it is damaged or has parts missing.
- Foreign conductive objects must be prevented from entering the inverter. That includes screws and metal fragments or other flammable substance such as oil.
- As the inverter is a precision instrument, do not drop or subject it to impact.
- The surrounding air temperature for LD and ND (initial setting) models must be between -10 and +50°C (non-freezing). The surrounding air temperature for SLD and HD models must be between -10 and +40°C (non-freezing). Otherwise the inverter may be damaged.
- The ambient humidity must be 95%RH or less (non-condensing). Otherwise the inverter may be damaged. (Refer to [page 17](#) for details.)

## ⚠ CAUTION

### Transportation and installation

- The storage temperature (applicable for a short time, e.g. during transit) must be between -20 and +65°C. Otherwise the inverter may be damaged.
- The product must be used indoors (without corrosive gas, flammable gas, oil mist, dust and dirt etc.) Otherwise the inverter may be damaged.
- The inverter must be used at an altitude of 2500 m or less, with 2.9 m/s<sup>2</sup> or less vibration at 10 to 55 Hz (directions of X, Y, Z axes). Otherwise the inverter may be damaged. (For installation at an altitude above 1000 m, consider a 3% reduction in the rated current per 500 m increase in altitude.)
- If halogen-based materials (fluorine, chlorine, bromine, iodine, etc.) infiltrate into a Mitsubishi Electric product, the product will be damaged. Halogen-based materials are often included in fumigant, which is used to sterilize or disinfect wooden packages. When packaging, prevent residual fumigant components from being infiltrated into Mitsubishi Electric products, or use an alternative sterilization or disinfection method (heat disinfection, etc.) for packaging. Sterilization or disinfection of wooden package should also be performed before packaging the product.

### Wiring

- Do not install a power factor correction capacitor or surge suppressor/capacitor type filter on the inverter output side. These devices on the inverter output side may be overheated or burn out.
- The output side terminals (terminals U, V, and W) must be connected correctly. Otherwise the motor will rotate inversely.
- PM motor terminals (U, V, W) hold high-voltage while the PM motor is running even after the power is turned OFF. Before wiring, the PM motor must be confirmed to be stopped. Otherwise you may get an electric shock.
- Never connect a PM motor to the commercial power supply. Applying the commercial power supply to input terminals (U, V, W) of a PM motor will burn the PM motor. The PM motor must be connected with the output terminals (U, V, W) of the inverter.

### Trial run

- Before starting operation, each parameter must be confirmed and adjusted. A failure to do so may cause some machines to make unexpected motions.

## ⚠ WARNING

### Usage

- Everyone must stay away from the equipment when the retry function is set as it will restart suddenly after a trip.
- Since pressing the STOP/RESET key may not stop output depending on the function setting status, separate circuit and switch that make an emergency stop (power OFF, mechanical brake operation for emergency stop, etc.) must be provided.
- OFF status of the start signal must be confirmed before resetting the inverter fault. Resetting inverter fault with the start signal ON restarts the motor suddenly.
- Do not use a PM motor for an application where the PM motor is driven by its load and runs at a speed higher than the maximum motor speed.
- Use this inverter only with three-phase induction motors or with a PM motor. Connection of any other electrical equipment to the inverter output may damage the equipment.
- Performing pre-excitation (LX signal and X13 signal) under torque control (Real sensorless vector control) may start the motor running at a low speed even when the start command (STF or STR) is not input. The motor may run also at a low speed when the speed limit value = 0 with a start command input. It must be confirmed that the motor running will not cause any safety problem before performing pre-excitation.
- Do not modify the equipment.
- Do not perform parts removal which is not instructed in this manual. Doing so may lead to fault or damage of the product.

## ⚠ CAUTION

### Usage

- The electronic thermal relay function does not guarantee protection of the motor from overheating. It is recommended to install both an external thermal and PTC thermistor for overheat protection.
- Do not use a magnetic contactor on the inverter input for frequent starting/stopping of the inverter. Doing so may shorten the life of this product.
- The effect of electromagnetic interference must be reduced by using a noise filter or by other means. Otherwise nearby electronic equipment may be affected.
- Appropriate measures must be taken to suppress harmonics. Otherwise power supply harmonics from the inverter may heat/damage the power factor correction capacitor and generator.
- When driving a 600V class motor by the inverter, the motor must be an insulation-enhanced motor or measures must be taken to suppress surge voltage. Surge voltage attributable to the wiring constants may occur at the motor terminals, deteriorating the insulation of the motor.
- When parameter clear or all parameter clear is performed, the required parameters must be set again before starting operations because all parameters return to their initial values.
- The inverter can be easily set for high-speed operation. Before changing its setting, the performances of the motor and machine must be fully examined.
- Stop status cannot be hold by the inverter's brake function. In addition to the inverter's brake function, a holding device must be installed to ensure safety.
- Before running an inverter which had been stored for a long period, inspection and test operation must be performed.
- Static electricity in your body must be discharged before you touch the product.
- Only one PM motor can be connected to an inverter.
- A PM motor must be used under PM sensorless vector control. Do not use a synchronous motor, induction motor, or synchronous induction motor.
- Do not connect a PM motor in the induction motor control settings (initial settings). Do not use an induction motor in the PM sensorless vector control settings. It will cause a failure.
- In the system with a PM motor, the inverter power must be turned ON before closing the contacts of the contactor at the output side.

### Emergency stop

- A safety backup such as an emergency brake must be provided for devices or equipment in a system to prevent hazardous conditions in case of failure of this product or an external device controlling this product.
- When the breaker on the inverter input side trips, the wiring must be checked for fault (short circuit), and internal parts of the inverter for a damage, etc. The cause of the trip must be identified and removed before turning ON the power of the breaker.
- When a protective function is activated, take an appropriate corrective action, then reset the inverter, and resume the operation.

### Maintenance, inspection and parts replacement

- Do not carry out a megger (insulation resistance) test on the control circuit of the inverter. It will cause a failure.



### Disposal

- The inverter must be treated as industrial waste.

**Application of caution labels**

Caution labels are used to ensure safety during use of the Mitsubishi Electric inverters. Apply the following labels to the inverter if the "retry function" and/or "automatic restart after instantaneous power failure" have been enabled.

- For the retry function

	<b>CAUTION</b> (Retry Function Has Been Selected)
 Stay away from the motor and machine. They will start suddenly (after given time has elapsed) when alarm occurs.	

- For automatic restart after instantaneous power failure

	<b>CAUTION</b> (Automatic Restart after Instantaneous Power Failure Has Been Selected)
 Stay away from the motor and machine. They will start suddenly (after reset time has elapsed) when instantaneous power failure occurs.	

**Application of motor control labels**

Apply the following labels to the inverter to avoid connecting motors not intended for a particular motor control setting.

<b>Induction motor setting</b>	
 The inverter is set for the induction motor control. Do not connect a PM motor.	

<b>PM motor control setting</b>	
 The inverter is set for the PM motor control. Do not connect an induction motor.	

**General instruction**

- For clarity, illustrations in this Instruction Manual may be drawn with covers or safety guards removed. Ensure all covers and safety guards are properly installed prior to starting operation. For details on the PM motor, refer to the Instruction Manual of the PM motor.

# CONTENTS

<b>1</b>	<b>INTRODUCTION</b>	<b>7</b>
1.1	Product checking	8
1.2	Inverter component names	9
1.3	About the related manuals	10
<b>2</b>	<b>INSTALLATION AND WIRING</b>	<b>11</b>
2.1	Peripheral devices	12
2.1.1	Inverter and peripheral devices	12
2.1.2	Peripheral devices	14
2.2	Removal and reinstallation of the front covers	15
2.3	Installation of the inverter and enclosure design	17
2.3.1	Inverter installation environment	17
2.3.2	Amount of heat generated by the inverter	19
2.3.3	Cooling system types for inverter enclosure	20
2.3.4	Inverter installation	21
2.3.5	Protruding the heat sink through a panel	23
2.4	Terminal connection diagrams	25
2.5	Main circuit terminals	27
2.5.1	Details on the main circuit terminals of the inverter	27
2.5.2	Details on the main circuit terminals of the converter unit (FR-CC2)	27
2.5.3	Terminal layout of the main circuit terminals, wiring of power supply and the motor	28
2.5.4	Applicable cables and wiring length	29
2.5.5	Earthing (grounding) precautions	31
2.6	Control circuit	32
2.6.1	Details on the control circuit terminals of the inverter	32
2.6.2	Details on the control circuit terminals of the converter unit (FR-CC2)	35
2.6.3	Control logic (sink/source) change	36
2.6.4	Wiring of inverter control circuit	38
2.6.5	Wiring precautions	40
2.6.6	When using separate power supplies for the control circuit and the main circuit	41
2.6.7	When supplying 24 V external power to the control circuit	42
2.7	Communication connectors and terminals	44
2.7.1	PU connector	44
2.7.2	USB connector	45
2.7.3	RS-485 terminal block	46
2.8	Connection of motor with encoder (Vector control)	47
2.9	Parameter settings for a motor with encoder	51
<b>3</b>	<b>PRECAUTIONS FOR USE OF THE INVERTER</b>	<b>53</b>

<b>3.1</b>	<b>Electro-magnetic interference (EMI) and leakage currents</b>	<b>54</b>
3.1.1	Leakage currents and precautions .....	54
3.1.2	Precautions against inverter-generated EMI .....	55
<b>3.2</b>	<b>Power supply harmonics</b>	<b>57</b>
3.2.1	Power supply harmonics.....	57
<b>3.3</b>	<b>Installation of a reactor</b>	<b>57</b>
<b>3.4</b>	<b>Power-OFF and magnetic contactor (MC)</b>	<b>58</b>
<b>3.5</b>	<b>Precautions against deterioration of the 600 V class motor insulation</b>	<b>59</b>
<b>3.6</b>	<b>Checklist before starting operation</b>	<b>60</b>
<b>3.7</b>	<b>Failsafe system which uses the inverter</b>	<b>63</b>

---

## **4 PROTECTIVE FUNCTIONS 65**

<b>4.1</b>	<b>Inverter fault and indications</b>	<b>66</b>
<b>4.2</b>	<b>Reset method for the protective functions</b>	<b>66</b>
<b>4.3</b>	<b>List of fault displays</b>	<b>67</b>

---

## **5 PRECAUTIONS FOR MAINTENANCE AND INSPECTION 69**

<b>5.1</b>	<b>Inspection item</b>	<b>70</b>
5.1.1	Daily inspection.....	70
5.1.2	Periodic inspection.....	70
5.1.3	Daily and periodic inspection .....	71
5.1.4	Checking the inverter and converter modules .....	72
5.1.5	Cleaning.....	73
5.1.6	Replacement of parts.....	73
5.1.7	Removal and reinstallation of the control circuit terminal block.....	76
<b>5.2</b>	<b>Measurement of main circuit voltages, currents and powers</b>	<b>77</b>
5.2.1	Measurement of powers .....	79
5.2.2	Measurement of voltages .....	79
5.2.3	Measurement of currents.....	79
5.2.4	Example of measuring converter unit (FR-CC2) input power factor .....	79
5.2.5	Measurement of converter output voltage (across terminals P and N).....	79
5.2.6	Measurement of inverter output frequency .....	80
5.2.7	Insulation resistance test using megger .....	80
5.2.8	Withstand voltage test .....	80

---

## **6 SPECIFICATIONS 81**

<b>6.1</b>	<b>Inverter rating</b>	<b>82</b>
------------	------------------------	-----------

---

<b>6.2</b>	<b>Common specifications</b>	<b>83</b>
<b>6.3</b>	<b>Outline dimension drawings</b>	<b>85</b>
6.3.1	Inverter outline dimension drawings.....	85

---

## **APPENDIX 87**

Appendix 1	For customers replacing the conventional model with this inverter.....	88
Appendix 2	Comparison with FR-A860.....	90
Appendix 3	Instructions for UL and cUL.....	91
Appendix 4	Restricted Use of Hazardous Substances in Electronic and Electrical Products.....	93

# 1 INTRODUCTION

This chapter contains the descriptions that must be read before using this product.

Always read the instructions before using the equipment.

1.1	Product checking.....	8
1.2	Inverter component names .....	9
1.3	About the related manuals.....	10

#### <Abbreviations>

DU .....	Operation panel (FR-LU08) (option)
Operation panel .....	Operation panel (FR-LU08) (option)
Parameter unit .....	Parameter unit (FR-PU07)
PU .....	Operation panel and parameter unit
Inverter .....	Mitsubishi Electric inverter FR-A860 series
Vector control compatible option.....	FR-A8AP/FR-A8AL/FR-A8APA/FR-A8APR/FR-A8APS (plug-in option), FR-A8TP (control terminal option)
Pr. ....	Parameter number (Number assigned to function)
PU operation .....	Operation using the PU (operation panel/parameter unit)
External operation .....	Operation using the control circuit signals
Combined operation .....	Combined operation using the PU (operation panel/parameter unit) and External operation

#### <Notes on descriptions in this Instruction Manual>

- Connection diagrams in this Instruction Manual suppose that the control logic of the input terminal is the sink logic, unless otherwise specified. (For the control logic, refer to [page 36](#).)



# 1.1 Product checking

Unpack the product and check the rating plate and the capacity plate of the inverter to ensure that the model agrees with the order and the product is intact.

## ◆ Inverter model

Symbol	Voltage class	Symbol	Structure, functionality	Symbol	Description
6	600 V class	2	Separated converter type	05450 to 08500	SLD rated inverter current (A)

FR - A 8 **6** **2** - 05450 - 1 - **60**

Symbol	Circuit board coating (conforming to IEC 60721-3-3 3C2/3S2)	Plated conductor
60	With	Without
06	With	With

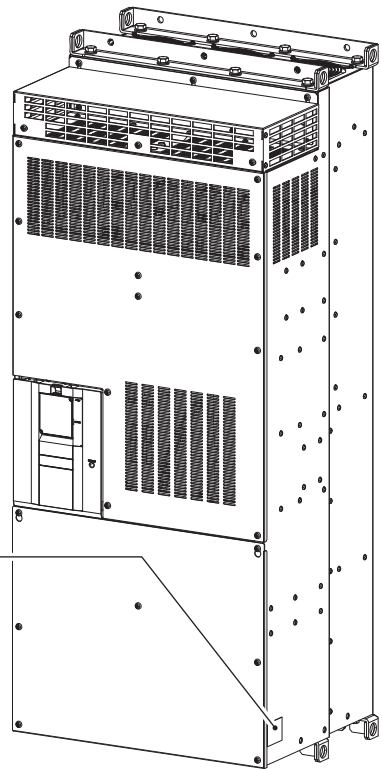
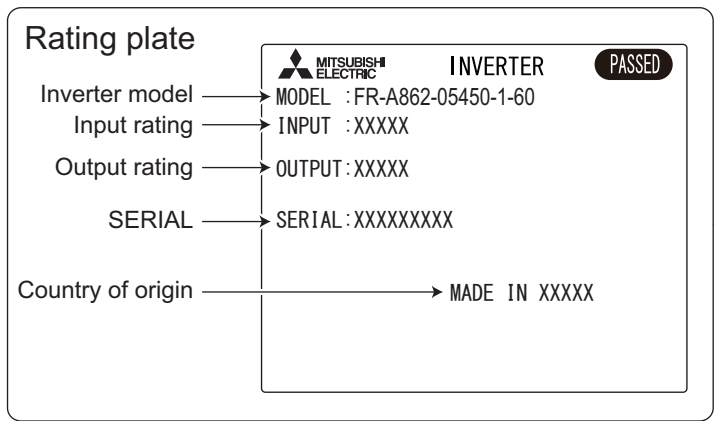

## ◆ How to read the SERIAL number

Rating plate example

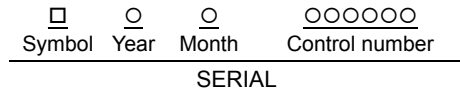

The SERIAL consists of one symbol, two characters indicating the production year and month, and six characters indicating the control number. The last digit of the production year is indicated as the Year, and the Month is indicated by 1 to 9, X (October), Y (November), or Z (December).

# 1.2 Inverter component names

Component names are shown below.

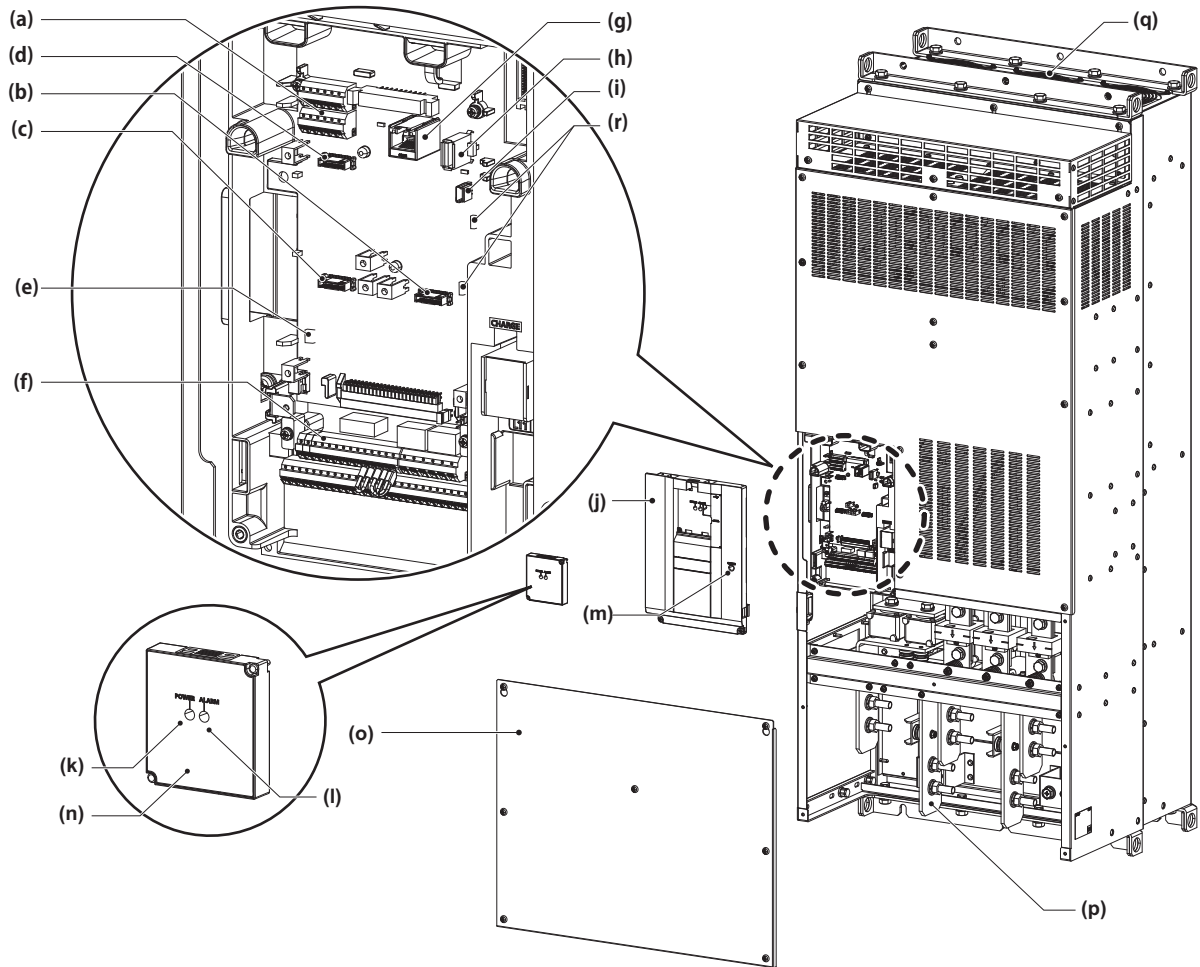

Symbol	Name	Description	Refer to page
(a)	RS-485 terminals	Enables RS-485 and MODBUS RTU communication.	46
(b)	Plug-in option connector 1	Connects a plug-in option or a communication option.	Instruction Manual of the option
(c)	Plug-in option connector 2		
(d)	Plug-in option connector 3		
(e)	Voltage/current input switch	Selects between voltage and current for terminal 2 and 4 inputs.	*1
(f)	Control circuit terminal block	Connects cables for the control circuit.	32
(g)	PU connector	Connects the operation panel or the parameter unit (FR-PU07). This connector also enables the RS-485 communication.	44
(h)	USB A connector	Connects a USB memory device.	45
(i)	USB mini B connector	Connects a personal computer and enables communication with FR Configurator2.	45
(j)	Front cover (upper side)	Remove this cover for the control circuit wiring, installation of a plug-in (communication) option, RS-485 terminal wiring, switching of the voltage/current input switch, etc.	15
(k)	Power lamp	Stays ON while the power is supplied to the control circuit (R1/L11, S1/L21).	28
(l)	Alarm lamp	Turns ON when the protective function of the inverter is activated.	65
(m)	Charge lamp	Stays ON while the power is supplied to the main circuit.	28
(n)	Accessory cover	Remove this cover for using the PU connector.	*1
(o)	Front cover (lower side)	Remove this cover for wiring.	15
(p)	Main circuit terminal block	Connects cables for the main circuit.	27
(q)	Cooling fan	Cools the inverter.	74
(r)	Switches for manufacturer setting (SW3 and SW4)	Do not change the initial setting (OFF  OFF/ON).	—

\*1 Refer to the FR-A860 Instruction Manual (Detailed).

## 1.3 About the related manuals

---

The manuals related to the FR-A862 are shown below.

Manual name	Manual number
FR-A860 Instruction Manual (Detailed)	IB-0600563ENG
FR-CC2 Instruction Manual	IB-0600572ENG
FR Configurator2 Instruction Manual	IB-0600516ENG
PLC Function Programming Manual	IB-0600492ENG

---

# **2** **INSTALLATION AND WIRING**

---

This chapter explains the "installation" and the "wiring" of this product.

Always read the instructions before use.

---

<b>2.1</b>	<b>Peripheral devices .....</b>	<b>12</b>
<b>2.2</b>	<b>Removal and reinstallation of the front covers.....</b>	<b>15</b>
<b>2.3</b>	<b>Installation of the inverter and enclosure design .....</b>	<b>17</b>
<b>2.4</b>	<b>Terminal connection diagrams .....</b>	<b>25</b>
<b>2.5</b>	<b>Main circuit terminals .....</b>	<b>27</b>
<b>2.6</b>	<b>Control circuit .....</b>	<b>32</b>
<b>2.7</b>	<b>Communication connectors and terminals .....</b>	<b>44</b>
<b>2.8</b>	<b>Connection of motor with encoder (Vector control).....</b>	<b>47</b>
<b>2.9</b>	<b>Parameter settings for a motor with encoder .....</b>	<b>51</b>

# 2.1 Peripheral devices

## 2.1.1 Inverter and peripheral devices

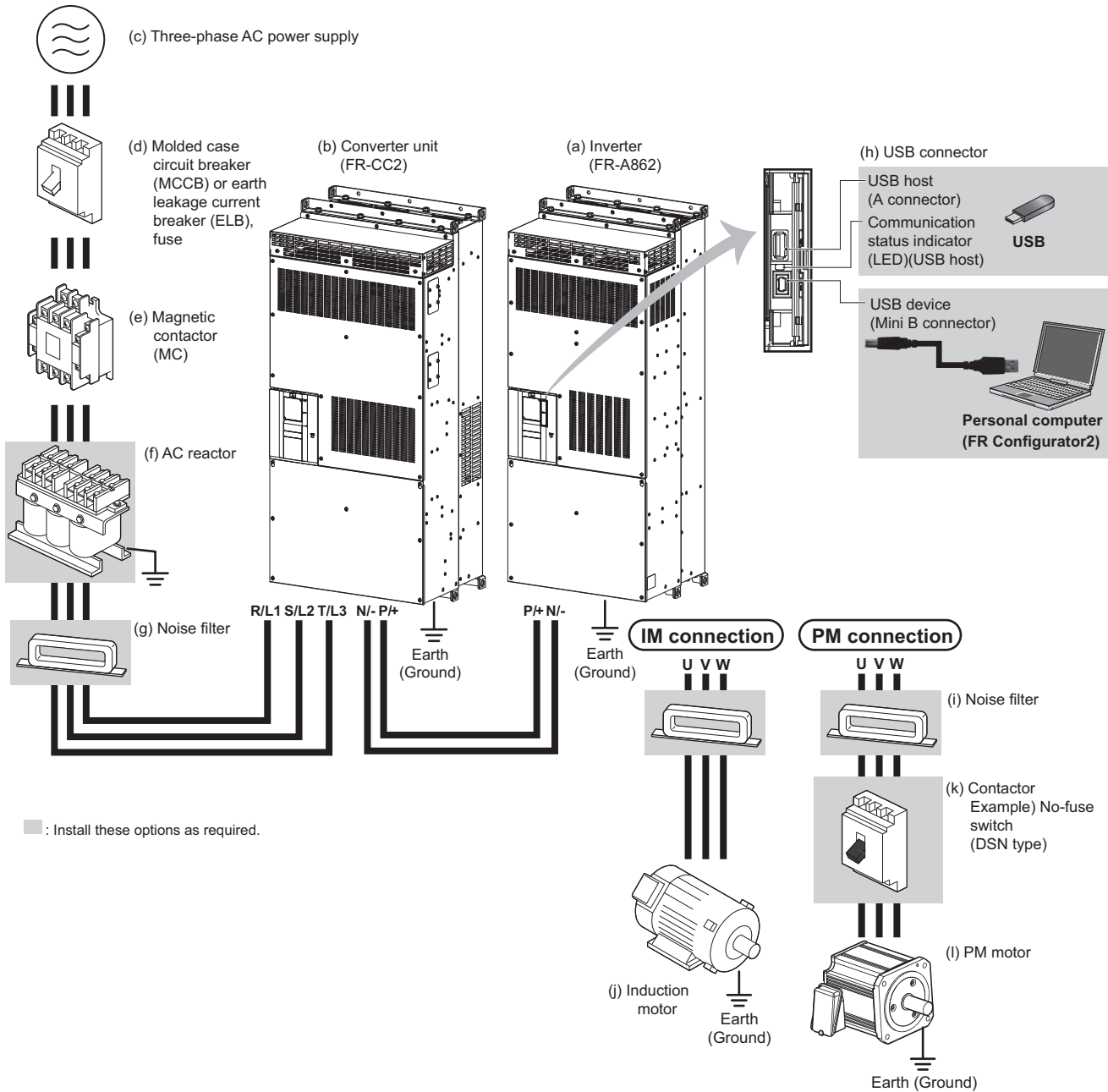

**NOTE**

- To prevent an electric shock, always earth (ground) the motor, the inverter, and the converter unit.
- Do not install a power factor correction capacitor, surge suppressor, or capacitor type filter on the inverter's output side. Doing so will cause the inverter shut off or damage the capacitor or surge suppressor. If any of the above devices is connected, immediately remove it. When installing a molded case circuit breaker on the output side of the inverter, contact the manufacturer of the molded case circuit breaker.
- Electromagnetic wave interference  
The input/output (main circuit) of the inverter or the converter unit includes high frequency components, which may interfere with the communication devices (such as AM radios) used near the inverter or the converter unit. Refer to [page 55](#) for countermeasures.
- For details of options and peripheral devices, refer to the respective Instruction Manual.
- A PM motor cannot be driven by the commercial power supply.
- A PM motor is a motor with permanent magnets embedded inside. High voltage is generated at the motor terminals while the motor is running. Before closing the contactor at the output side, make sure that the inverter power is ON and the motor is stopped.

Symbol	Name	Overview	Refer to page
(a)	Inverter (FR-A862)	The life of the inverter and the converter unit is influenced by the surrounding air temperature. The surrounding air temperature should be as low as possible within the permissible range. This must be noted especially when the inverter is installed in an enclosure.	17 25
(b)	Converter unit (FR-CC2)	Incorrect wiring may lead to damage of the inverter and the converter unit. The control signal lines must be kept fully away from the main circuit lines to protect them from noise.	
(c)	Three-phase AC power supply	Must be within the permissible power supply specifications of the converter unit.	82
(d)	Molded case circuit breaker (MCCB), earth leakage circuit breaker (ELB), or fuse	Must be selected carefully since an inrush current flows in the converter unit at power ON.	14
(e)	Magnetic contactor (MC)	Install this to ensure safety. Do not use this to start and stop the inverter. Doing so will shorten the life of the inverter and the converter unit.	58
(f)	AC reactor	Install this to suppress harmonics and to improve the power factor. An AC reactor is required when installing the inverter near a large power supply system (1000 kVA or more). Under such condition, the inverter and the converter unit may be damaged if you do not use a reactor. Select a reactor according to the applied motor capacity.	57
(g)	Noise filter	Suppresses the noise radiated from the power supply side of the converter unit.	55
(h)	USB connection	Connect between the inverter and a personal computer with a USB (ver. 1.1) cable. Use a USB memory device to copy parameter settings or use the trace function.	45
(i)	Noise filter	Install this to reduce the electromagnetic noise generated from the inverter and the converter unit. The noise filter is effective in the range from about 0.5 to 5 MHz.	55
(j)	Induction motor	Connect a squirrel-cage induction motor.	—
(k)	Contactors Example) No-fuse switch (DSN type)	Connect this for an application where a PM motor is driven by the load even while the inverter power is OFF. Do not open or close the contactor while the inverter is running (outputting).	—
(l)	PM motor	A PM motor can be used. A PM motor cannot be driven by the commercial power supply.	—

## 2.1.2 Peripheral devices

### ◆ Selecting the converter unit (FR-CC2)

Select the capacity of the FR-CC2 converter unit according to the connected motor capacity.

Converter unit FR-CC2-[ ]	Inverter			
	Model FR-A862-[ ]	Rated current (A)	Motor capacity (kW) *1	
C355K	05450	SLD	545	400
		LD	496	355
		ND	402	280
		HD	304	220
C400K	06470	SLD	647	450
		LD	589	400
		ND	496	355
		HD	402	280
C560K	08500	SLD	850	630
		LD	773	560
		ND	663	450
		HD	589	400

\*1 The motor capacity indicated is the maximum capacity applicable for use of the 4-pole standard motor.

### ◆ Selecting the breaker/magnetic contactor

Check the model of the inverter and the converter unit you purchased. Appropriate peripheral devices must be selected according to the capacity.

Refer to the following table to prepare appropriate peripheral devices.

Motor output (kW)*1	Applicable converter model	Applicable inverter model	Molded case circuit breaker (MCCB)*2 or earth leakage circuit breaker (ELB) (NF, NV type)	Input-side magnetic contactor*3
280	FR-CC2-C355K	FR-A862-05450	600 A	373 A
355	FR-CC2-C400K	FR-A862-06470	800 A	469 A
450	FR-CC2-C560K	FR-A862-08500	1000 A	617 A

\*1 Assumes the use of a Mitsubishi Electric 4-pole standard motor with the power supply voltage of 575 VAC 50 Hz.

\*2 Select an MCCB according to the power supply capacity.

Install one MCCB per converter.

(For the use in the United States or Canada, refer to [page 91](#) to select an appropriate fuse.)

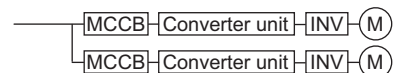

\*3 The magnetic contactor is selected based on the AC-1 class. The electrical durability of magnetic contactor is 500,000 times. When the magnetic contactor is used for emergency stops during motor driving, the electrical durability is 25 times.

If using an MC for emergency stop during driving the motor, select an MC regarding the converter unit input side current as JEM 1038-AC-3 class rated current. When using an MC on the inverter output side for commercial-power supply operation switching using a general-purpose motor, select an MC regarding the rated motor current as JEM 1038-AC-3 class rated current.

#### NOTE

- When the converter unit capacity is larger than the motor capacity, select an MCCB and a magnetic contactor according to the converter unit model, and select cables and reactors according to the motor output.
- When the breaker on the converter unit's input side trips, check for the wiring fault (short circuit), damage to internal parts of the inverter and the converter unit, etc. The cause of the trip must be identified and removed before turning ON the power of the breaker.

## 2.2 Removal and reinstallation of the front covers

### ◆ Removal of the front cover (lower side)

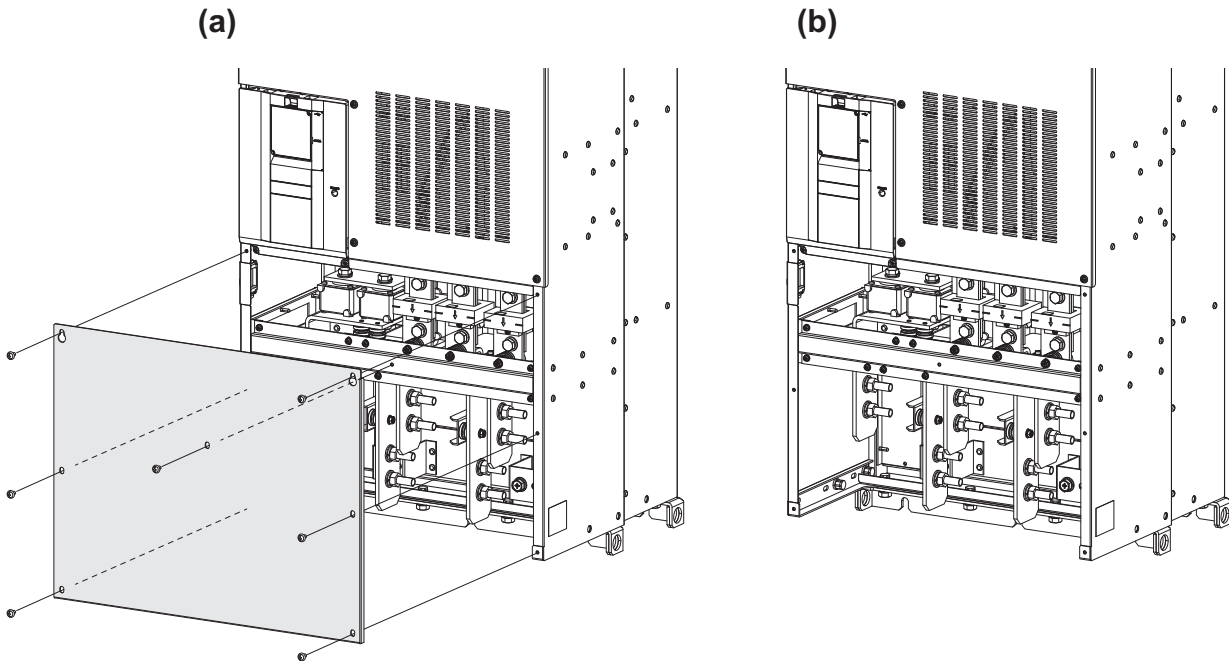

- (a) When the mounting screws are removed, the front cover (lower side) can be removed. (The number of the mounting screws differs by the capacity.)
- (b) With the front cover (lower side) removed, wiring of the main circuit terminals can be performed.

### ◆ Removal of the front cover (upper side)

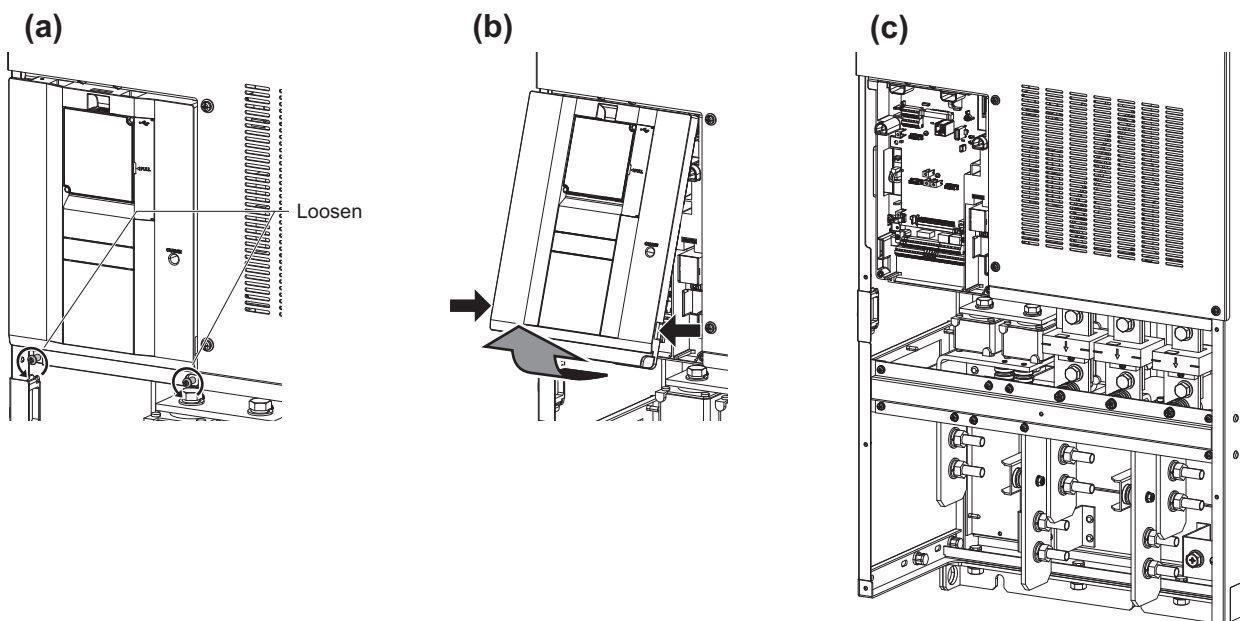

- (a) With the front cover (lower side) removed, loosen the mounting screws on the front cover (upper side). These screws cannot be removed.
- (b) While holding the areas around the installation hooks on the sides of the front cover (upper side), pull out the front cover (upper side) using its upper side as a support.
- (c) With the front cover (upper side) removed, wiring of the control circuit and the RS-485 terminals, and installation of the plug-in option can be performed.



### ◆ Reinstallation of the front covers

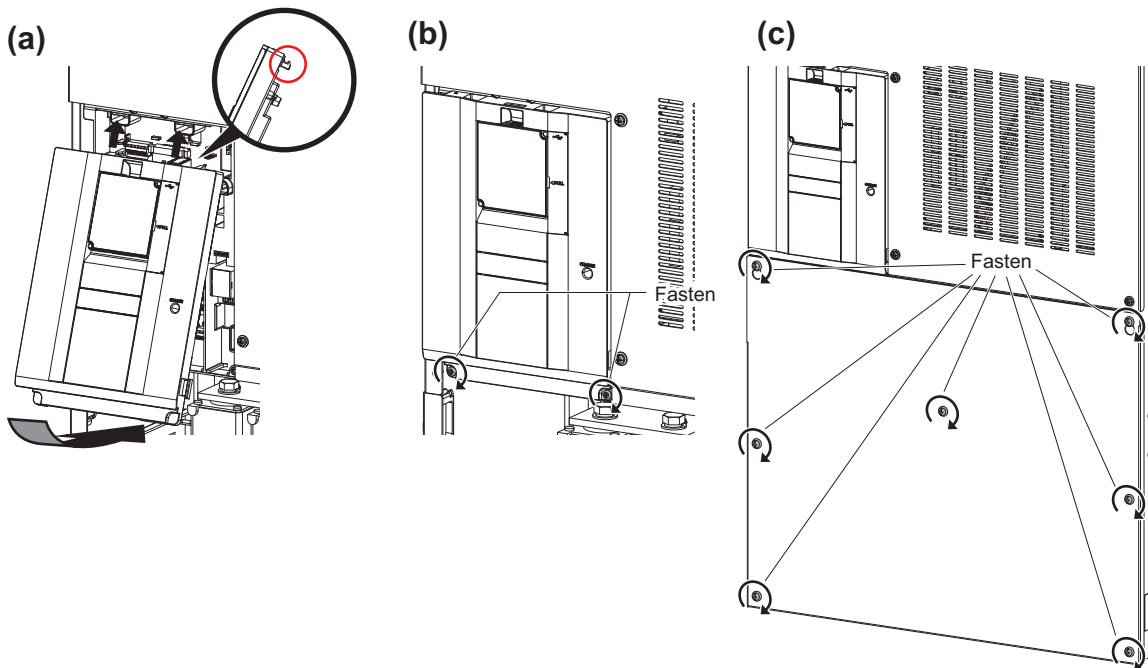

- (a) Insert the upper hooks of the front cover (upper side) into the sockets of the inverter.  
Securely install the front cover (upper side) to the inverter by fixing the hooks on the sides of the cover into place.
- (b) Tighten the mounting screws at the lower part of the front cover (upper side).
- (c) Fasten the front cover (lower side) with the mounting screws. (The number of the mounting screws differs by the capacity.)

#### **NOTE**

- When installing the front cover (upper side), fit the connector of the operation panel securely along the guides of the PU connector.
- Fully make sure that the front cover has been reinstalled securely. Always tighten the installation screws of the front covers.

## 2.3 Installation of the inverter and enclosure design

When designing or manufacturing an inverter enclosure, determine the structure, size, and device layout of the enclosure by fully considering the conditions such as heat generation of the contained devices and the operating environment. An inverter uses many semiconductor devices. To ensure higher reliability and long period of operation, operate the inverter in the ambient environment that completely satisfies the equipment specifications.

### 2.3.1 Inverter installation environment

The following table lists the standard specifications of the inverter installation environment. Using the inverter in an environment that does not satisfy the conditions deteriorates the performance, shortens the life, and causes a failure. Refer to the following points, and take adequate measures.

#### ◆ Standard environmental specifications of the inverter

Item		Description	
Surrounding air temperature *3	LD, ND (initial setting)	-10 to +50°C (non-freezing)	
	SLD, HD	-10 to +40°C (non-freezing)	
Surrounding air humidity		95% RH or less (non-condensing)	
Storage temperature		-20 to + 65°C*1	
Atmosphere		Indoors (free from corrosive gas, flammable gas, oil mist, dust and dirt)	
Altitude		Maximum 2500 m*2	
Vibration		2.9 m/s <sup>2</sup> or less at 10 to 55 Hz (directions of X, Y, Z axes)	

\*1 Temperature applicable for a short time, for example, in transit.

\*2 For the installation at an altitude above 1000 m, consider a 3% reduction in the rated current per 500 m increase in altitude.

\*3 Surrounding Air Temperature is a temperature measured at a measurement position in an enclosure.  
Ambient Temperature is a temperature outside an enclosure.

#### ◆ Temperature

The permissible surrounding air temperature of the inverter is between -10°C and +50°C (-10°C and +40°C at the SLD and HD ratings). Always operate the inverter within this temperature range. Operation outside this range will considerably shorten the service lives of the semiconductors, parts, capacitors and others. Take the following measures to keep the surrounding air temperature of the inverter within the specified range.

(a) Measures against high temperature

- Use a forced ventilation system or similar cooling system. (Refer to [page 20](#).)
- Install the enclosure in an air-conditioned electric chamber.
- Block direct sunlight.
- Provide a shield or similar plate to avoid direct exposure to the radiated heat and wind of a heat source.
- Ventilate the area around the enclosure well.

(b) Measures against low temperature

- Provide a space heater in the enclosure.
- Do not power OFF the inverter. (Keep the start signal of the inverter OFF.)

(c) Sudden temperature changes

- Select an installation place where temperature does not change suddenly.
- Avoid installing the inverter near the air outlet of an air conditioner.
- If temperature changes are caused by opening/closing of a door, install the inverter away from the door.



- For the amount of heat generated by the inverter unit, refer to [page 19](#).

### ◆ Humidity

Operate the inverter within the ambient air humidity of usually 45 to 95%. Too high humidity will pose problems of reduced insulation and metal corrosion. On the other hand, too low humidity may cause a spatial electrical breakdown. The humidity conditions for the insulation distance defined in JEM 1103 standard "Insulation Distance from Control Equipment" is 45 to 85%.

(a) Measures against high humidity

- Make the enclosure enclosed, and provide it with a hygroscopic agent.
- Provide dry air into the enclosure from outside.
- Provide a space heater in the enclosure.

(b) Measures against low humidity

Air with proper humidity can be blown into the enclosure from outside. Also when installing or inspecting the unit, discharge your body (static electricity) beforehand, and keep your body away from the parts and patterns.

(c) Measures against condensation

Condensation may occur if frequent operation stops change the in-enclosure temperature suddenly or if the outside air temperature changes suddenly.

Condensation causes such faults as reduced insulation and corrosion.

- Take the measures against high humidity in (a).
- Do not power OFF the inverter. (Keep the start signal of the inverter OFF.)

### ◆ Dust, dirt, oil mist

Dust and dirt will cause such faults as poor contacts, reduced insulation and cooling effect due to the moisture-absorbed accumulated dust and dirt, and in-enclosure temperature rise due to a clogged filter. In an atmosphere where conductive powder floats, dust and dirt will cause such faults as malfunction, deteriorated insulation and short circuit in a short time. Since oil mist will cause similar conditions, it is necessary to take adequate measures.

Precautions

- Place the inverter in a totally enclosed enclosure.  
Take measures if the in-enclosure temperature rises. (Refer to [page 20](#).)
- Purge air.  
Pump clean air from outside to make the in-enclosure air pressure higher than the outside air pressure.

### ◆ Corrosive gas, salt damage

If the inverter is exposed to corrosive gas or to salt near a beach, the printed board patterns and parts will corrode or the relays and switches will result in poor contact.

In such places, take the measures given above.

### ◆ Explosive, flammable gases

As the inverter is non-explosion proof, it must be contained in an explosion-proof enclosure. In places where explosion may be caused by explosive gas, dust or dirt, an enclosure cannot be used unless it structurally complies with the guidelines and has passed the specified tests. This makes the enclosure itself expensive (including the test charges). The best way is to avoid installation in such places and install the inverter in a non-hazardous place.

### ◆ High altitude

Use the inverter at an altitude of within 2500 m. For use at an altitude above 1000 m, consider a 3% reduction in the rated current per 500 m increase in altitude.

If it is used at a higher place, it is likely that thin air will reduce the cooling effect and low air pressure will deteriorate dielectric strength.

## ◆ Vibration, impact

The vibration resistance of the inverter is up to  $2.9 \text{ m/s}^2$  at 10 to 55 Hz frequency and 1 mm amplitude for the directions of X, Y, Z axes. Applying vibration and impacts for a long time may loosen the structures and cause poor contacts of connectors, even if those vibration and impacts are within the specified values.

Especially when impacts are applied repeatedly, caution must be taken because such impacts may break the installation feet.

Precautions

- Provide the enclosure with rubber vibration isolators.
- Strengthen the structure to prevent the enclosure from resonance.
- Install the enclosure away from the sources of the vibration.

## 2.3.2 Amount of heat generated by the inverter

### ◆ Regarding the amount of heat generated in the FR-A860 series inverter

The amount of heat generated by the inverter unit and converter unit is shown in the following tables.

Inverter model	Amount of heat generated (W)							
	SLD		LD		ND		HD	
FR-CC2-C355K	2500	7300	2300	6600	1750	5100	1300	3750
FR-A862-05450	4800		4300		3350		2450	
FR-CC2-C400K	3000	8600	2600	7700	2200	6500	1700	5000
FR-A862-06470	5600		5100		4300		3300	
FR-CC2-C560K	3700	11400	3200	10200	2700	8500	2300	7400
FR-A862-08500	7700		7000		5800		5100	

#### NOTE

- The amount of heat generated shown assumes that the output current is inverter rated current, and carrier frequency is 2 kHz.

## 2.3.3 Cooling system types for inverter enclosure

From the enclosure that contains the inverter, the heat of the inverter and other equipment (transformers, lamps, resistors, etc.) and the incoming heat such as direct sunlight must be dissipated to keep the in-enclosure temperature lower than the permissible temperatures of the in-enclosure equipment including the inverter.

The cooling systems are classified as follows in terms of the cooling calculation method.

- (a) Cooling by natural heat dissipation from the enclosure surface (totally enclosed type)
- (b) Cooling by heat sink (aluminum fin, etc.)
- (c) Cooling by ventilation (forced ventilation type, pipe ventilation type)
- (d) Cooling by heat exchanger or cooler (heat pipe, cooler, etc.)

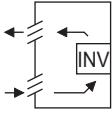
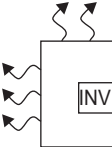
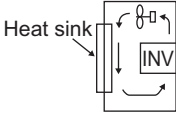
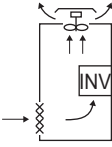
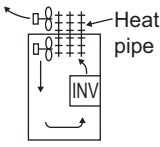
Cooling system		Enclosure structure	Comment
Natural	Natural ventilation (enclosed type / open type)		This system is low in cost and generally used, but the enclosure size increases as the inverter capacity increases. This system is for relatively small capacities.
	Natural ventilation (totally enclosed type)		Being a totally enclosed type, this system is the most appropriate for hostile environment having dust, dirt, oil mist, etc. The enclosure size increases depending on the inverter capacity.
Forced air	Heat sink cooling		This system has restrictions on the heat sink mounting position and area. This system is for relatively small capacities.
	Forced ventilation		This system is for general indoor installation. This is appropriate for enclosure downsizing and cost reduction, and often used.
	Heat pipe		This is a totally enclosed for enclosure downsizing.

## 2.3.4 Inverter installation

### ◆ Inverter placement

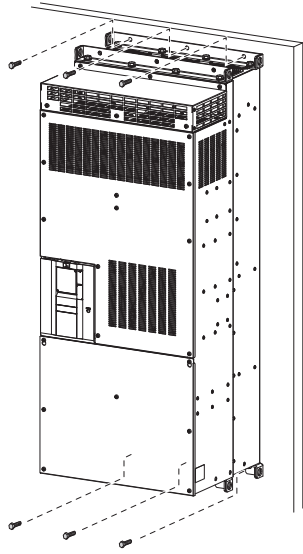

- Install the inverter on a strong surface securely with screws.
- Leave enough clearances and take cooling measures.
- Avoid places where the inverter is subjected to direct sunlight, high temperature and high humidity.
- Install the inverter on a nonflammable wall surface.
- When encasing multiple inverters in an enclosure, install them in parallel as a cooling measure.
- For heat dissipation and maintenance, keep clearance between the inverter and the other devices or enclosure surface. The clearance below the inverter is required as a wiring space, and the clearance above the inverter is required as a heat dissipation space.
- When designing or building an enclosure for the inverter, carefully consider influencing factors such as heat generation of the contained devices and the operating environment.

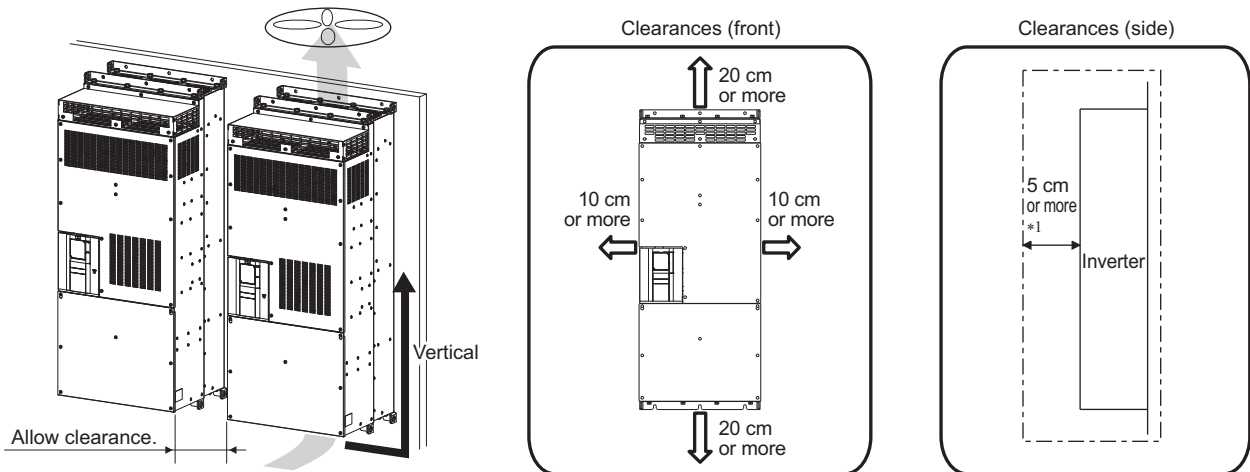

### ◆ Installation orientation of the inverter

Install the inverter on a wall as specified. Do not mount it horizontally or in any other way.

### ◆ Above the inverter

Heat is blown up from inside the inverter by the small fan built in the unit. Any equipment placed above the inverter should be heat resistant.

### ◆ Arrangement of multiple inverters and converter units

When multiple inverters and converter units are placed in the same enclosure, generally arrange them horizontally as shown in the figure on the right.

Do not place multiple products vertically. The exhaust air temperature of the inverter and the converter unit may be increased.

When mounting multiple inverters and converter units, fully take caution not to make the surrounding air temperature of the inverter and the converter unit higher than the permissible value by providing ventilation and increasing the enclosure size.

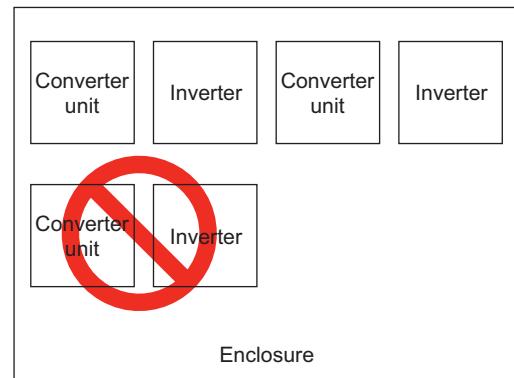

Arrangement of multiple inverters and converter units

### ◆ Arrangement of the ventilation fan and inverter

Heat generated in the inverter is blown up from the bottom of the unit as warm air by the cooling fan. When installing a ventilation fan for that heat, determine the place of ventilation fan installation after fully considering an air flow. (Air passes through areas of low resistance. Make an airway and airflow plates to expose the inverter to cool air.)

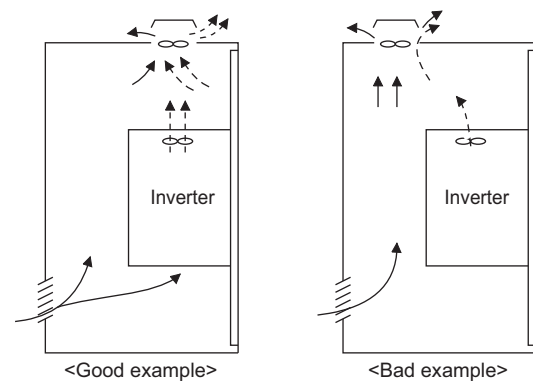

Arrangement of the ventilation fan and inverter

## 2.3.5 Protruding the heat sink through a panel

When encasing an inverter to an enclosure, the heat generated in the enclosure can be greatly reduced by protruding the heat sink of the inverter.

When installing the inverter in a compact enclosure, etc., this installation method is recommended.

### ◆ Panel cutting

Cut the panel of the enclosure according to the inverter capacity.

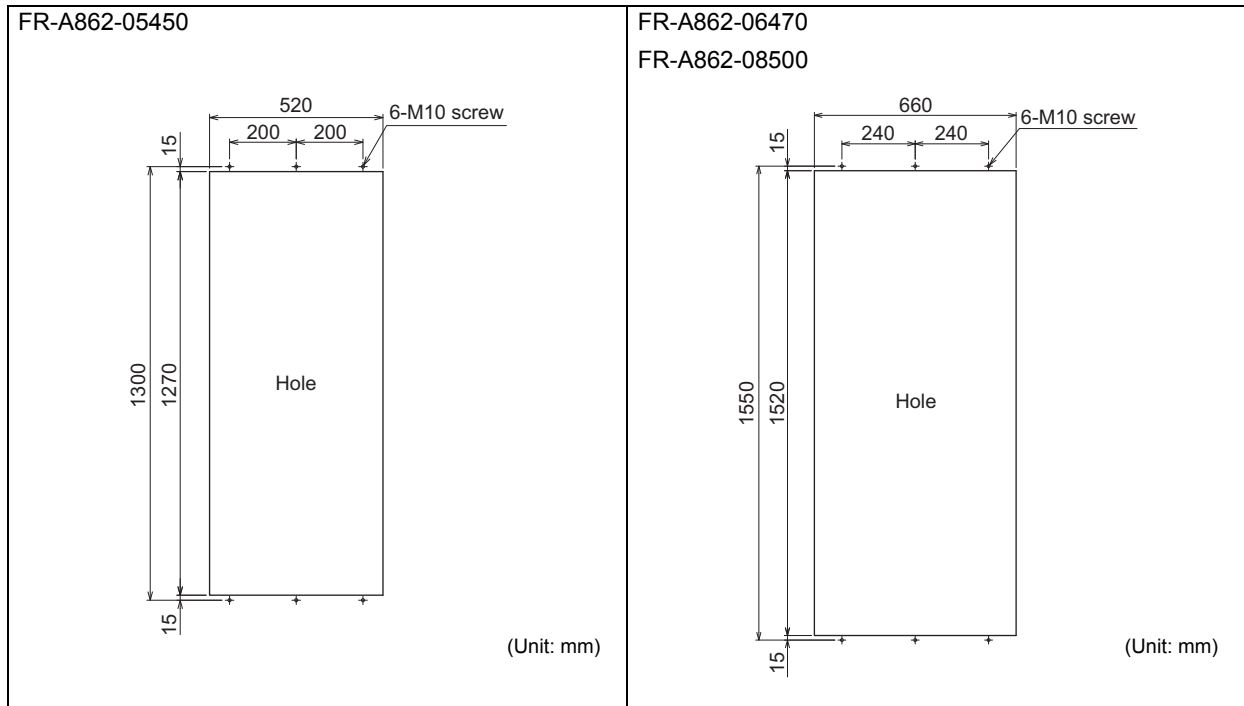



### ◆ Removal of the rear installation frame

Two installation frames are attached to each of the upper and lower parts of the inverter. Remove the rear side installation frame on the top and bottom of the inverter as shown on the right.

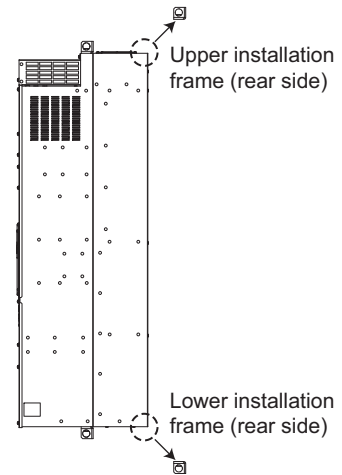

### ◆ Installation of the inverter

Push the inverter heat sink portion outside the enclosure and fix the enclosure and inverter with upper and lower installation frame.

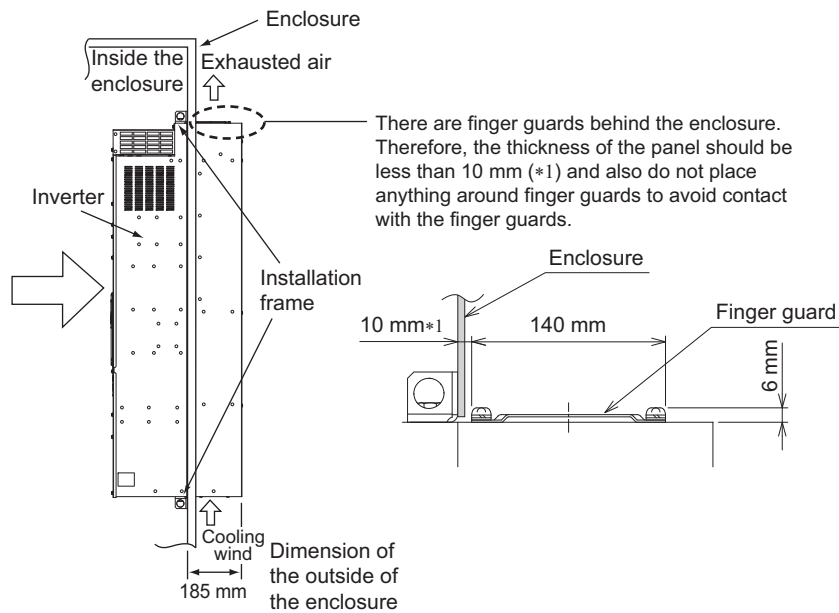

#### NOTE

- Having a cooling fan, the cooling section which comes out of the enclosure cannot be used in the environment of water drops, oil, mist, dust, etc.
- Be careful not to drop screws, dust etc. into the inverter and cooling fan section.

# 2.4 Terminal connection diagrams

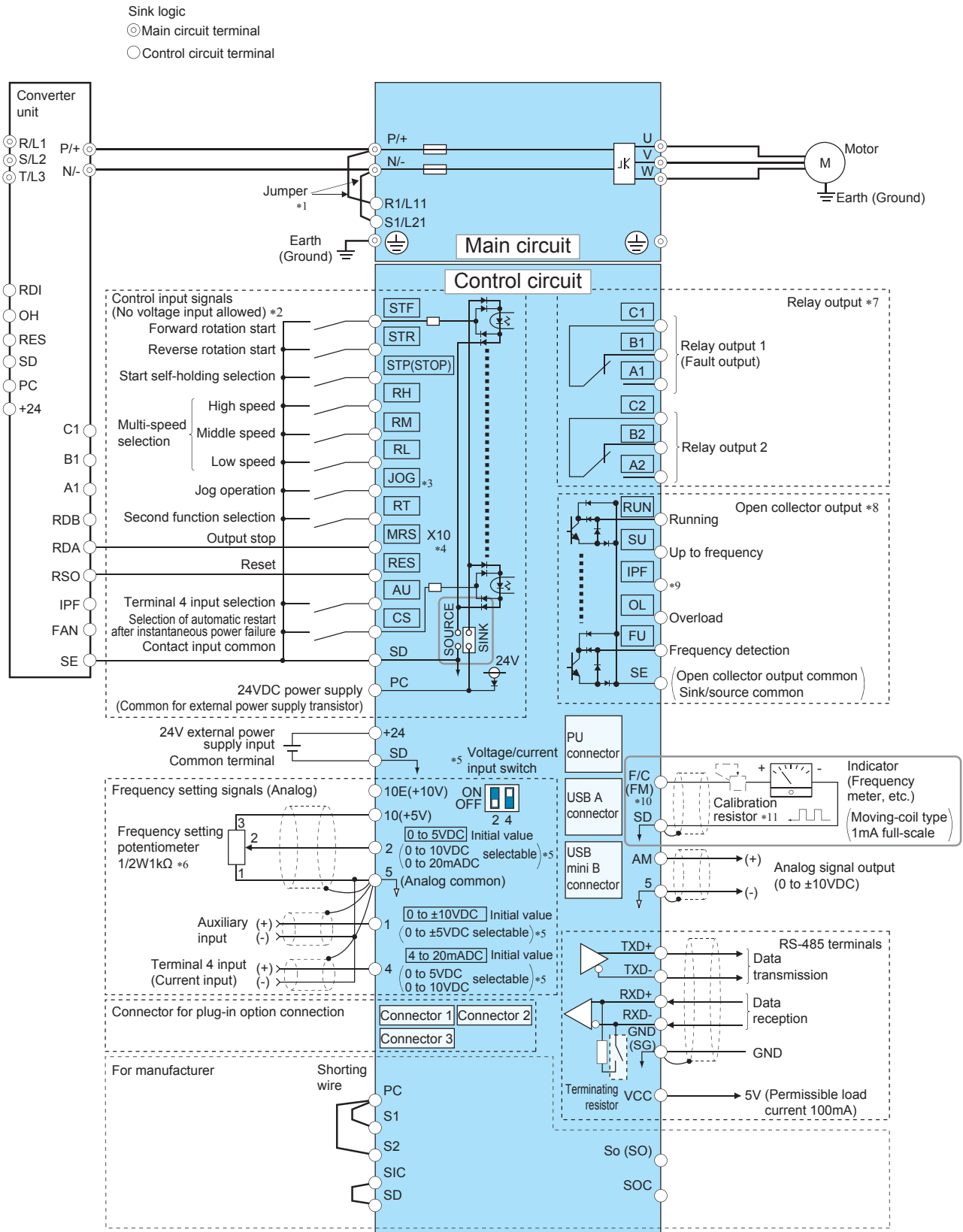

## Terminal connection diagrams

- \*1 A jumper is installed across terminal R1/L11 and terminal P/+, and across terminal S1/L21 and terminal N/-. When using a separate power supply for the control circuit, remove the jumpers from R1/L11 and S1/L21.
- \*2 The function of these terminals can be changed with the input terminal assignment (**Pr.178 to Pr.189**).
- \*3 Terminal JOG is also used as the pulse train input terminal. Use **Pr.291** to choose JOG or pulse.
- \*4 The X10 signal (NC contact input specification) is assigned to terminal MRS in the initial setting. Set **Pr.599** = "0" to change the input specification of the X10 signal to NO contact.
- \*5 Terminal input specifications can be changed by analog input specification switchover (**Pr.73, Pr.267**). To input a voltage (0 to 5 V/0 to 10 V), set the voltage/current input switch OFF. To input a current (4 to 20 mA), set the voltage/current input switch ON. Terminals 10 and 2 are also used as a PTC input terminal. (**Pr.561**)
- \*6 It is recommended to use 2 W 1 kΩ when the frequency setting signal is changed frequently.
- \*7 The function of these terminals can be changed with the output terminal assignment (**Pr.195, Pr.196**).
- \*8 The function of these terminals can be changed with the output terminal assignment (**Pr.190 to Pr.194**).
- \*9 No function is assigned in the initial setting. Use **Pr.192** for function assignment.
- \*10 Terminal FM can be used to output pulse trains as open collector output by setting **Pr.291**.
- \*11 Not required when calibrating the scale with the operation panel.

### NOTE

- To prevent a malfunction due to noise, keep the signal cables 10 cm or more away from the power cables. Also, keep the cables of the main circuit for input and output separated.
- After wiring, wire offcuts must not be left in the inverter.  
Wire offcuts can cause an alarm, failure or malfunction. Always keep the inverter clean.  
When drilling mounting holes in an enclosure etc., take caution not to allow chips and other foreign matter to enter the inverter.
- Set the voltage/current input switch correctly. Incorrect setting may cause a fault, failure or malfunction.
- Terminals S1, S2, SIC, So (SO), and SOC are for manufacturer setting. Do not remove the shorting wires across terminals S1 and PC, terminals S2 and PC, and terminals SIC and SD. When the shorting wires are removed, the inverter does not operate.

## ◆ Connection between the converter unit and the inverter

Perform wiring so that the commands sent from the converter unit are transmitted to the inverter without fail. Incorrect connection may damage the converter unit and the inverter.

For the wiring length, refer to the table below.

Total wiring length	Across terminals P and P and terminals N and N	50 m or lower
	Other control signal cables	30 m or lower

For the cable gauge of the cable across the main circuit terminals P/+ and N/- (P and P, N and N), refer to [page 29](#).

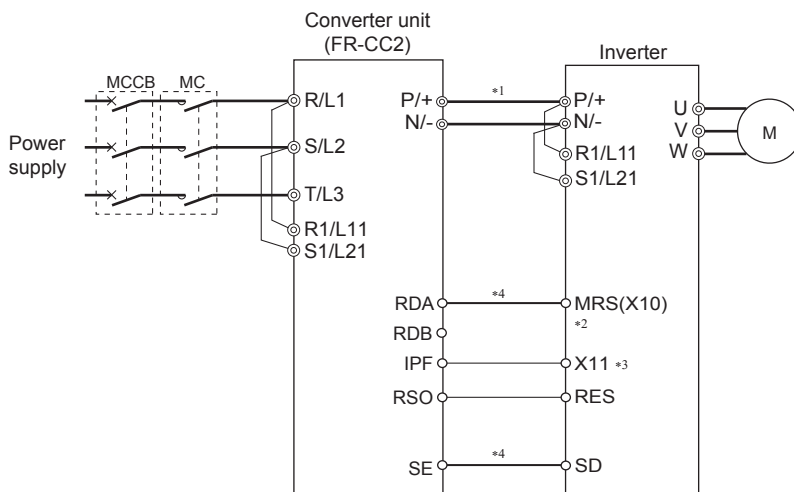

- \*1 Do not install an MCCB across terminals P/+ and N/- (across terminals P and P/+ or across N and N/-). Connecting the opposite polarity of terminals N/- and P/+ will damage the inverter.
- \*2 For the terminal used for the X10 signal input, set "10" in any of **Pr.178 to Pr.189 (input terminal function selection)** to assign the function. (The X10 signal is assigned to terminal MRS in the initial setting.)  
For the X10 signal, NC contact input specification is selected in the initial setting. Set **Pr.599** = "0" to change the input specification to NO contact.
- \*3 For the terminal used for the X11 signal input, set "11" in any of **Pr.178 to Pr.189 (input terminal function selection)** to assign the function. For RS-485 or any other communication where the start command is only transmitted once, use the X11 signal to save the operation mode at the time of an instantaneous power failure.
- \*4 Always connect terminal RDA of the converter unit and terminal MRS (X10) of the inverter, and terminal SE of the converter unit and terminal SD (sink logic) of the inverter. Not connecting these terminals may damage the converter unit.

## 2.5 Main circuit terminals

### 2.5.1 Details on the main circuit terminals of the inverter

Terminal symbol	Terminal name	Terminal function description	Refer to page
U, V, W	Inverter output	Connect these terminals to a three-phase squirrel cage motor or a PM motor.	-
R1/L11, S1/L21	Power supply for the control circuit	Connected to terminals P/+ and N/-. To retain the fault display and fault output, or to use the converter unit (FR-CC2), remove the jumpers installed across terminals R1/L11 and S1/L21, and supply external power to these terminals. The power capacity necessary when separate power is supplied from terminals R1/L11 and S1/L21 is 80 VA.	41
P/+, N/-	Converter unit connection	Connect the converter unit (FR-CC2).	25
	Earth (ground)	For earthing (grounding) the inverter chassis. This must be earthed (grounded).	31

### 2.5.2 Details on the main circuit terminals of the converter unit (FR-CC2)

Terminal symbol	Terminal name	Terminal function description	Refer to page
R/L1, S/L2, T/L3	AC power input	Connect these terminals to the commercial power supply.	-
R1/L11, S1/L21	Power supply for the control circuit	Connected to the AC power supply terminals R/L1 and S/L2. To retain the fault display and fault output, remove the jumpers across terminals R/L1 and R1/L11 and across S/L2 and S1/L21, and supply external power to these terminals. When using a separate power supply from R1/L11 and S1/L21, the necessary power capacity of the separate power supply is 80 VA.	41
P/+, N/-	Inverter connection	Connect to terminals P/+ and N/- of the inverter.	25
	Earth (ground)	For earthing (grounding) the converter unit chassis. Be sure to earth (ground) the converter.	31

## 2.5.3 Terminal layout of the main circuit terminals, wiring of power supply and the motor

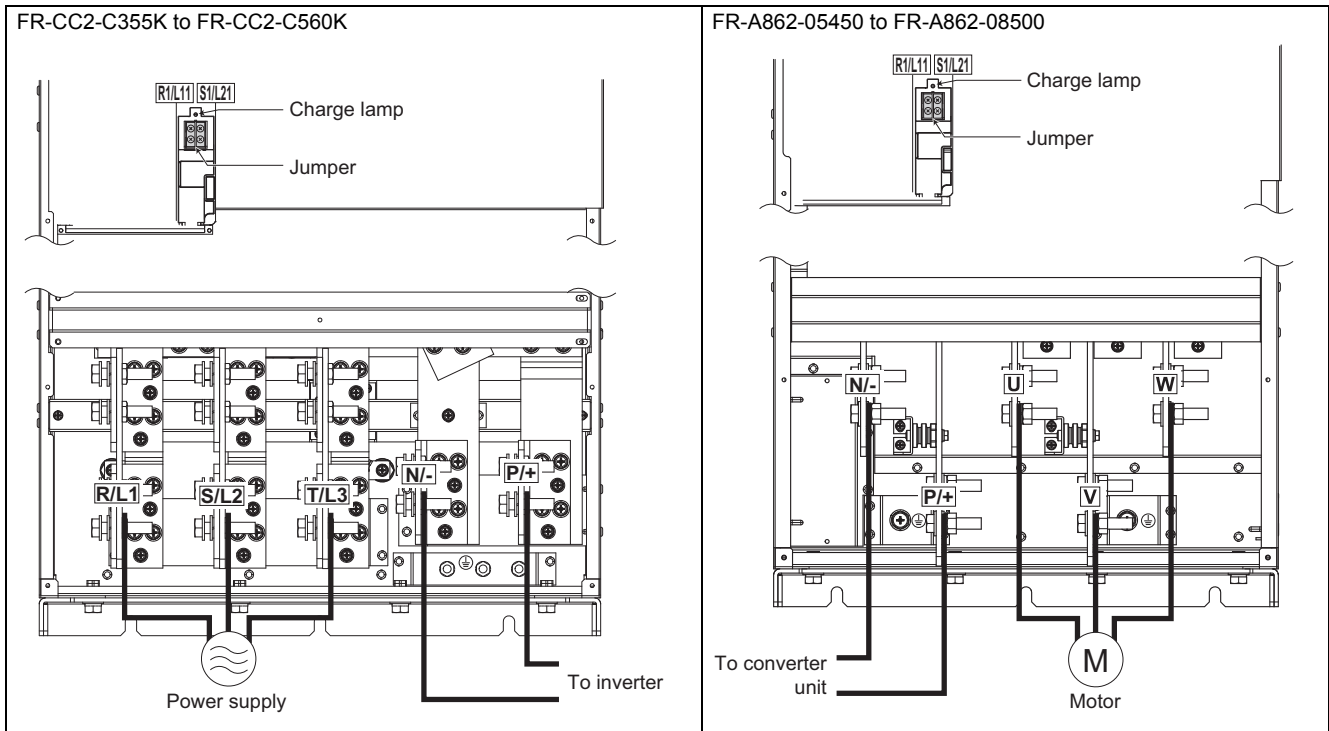

**NOTE**

- Make sure the power cables are connected to terminals R/L1, S/L2, and T/L3 of the converter unit. (Phase need not be matched.) Never connect the power cable to terminals U, V, and W of the inverter. Doing so will damage the inverter.
- Connect the motor to terminals U, V, and W of the inverter. (The phases must be matched.)
- When wiring the main circuit conductor, tighten a nut from the right side of the conductor. When wiring two wires, place wires on both sides of the conductor. (Refer to the diagram below.) For wiring, use bolts (nuts) provided with the inverter.

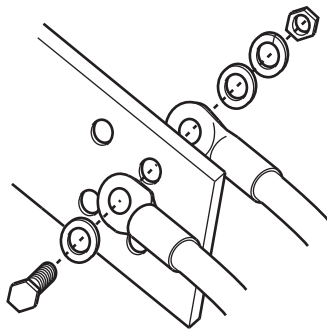

- When wiring the main circuit conductor (terminals R/L1, S/L2, T/L3) of the converter unit (FR-CC2), use the bolts (nuts) for main circuit wiring, which are provided on the front side of the conductor.

FR-CC2-C355K

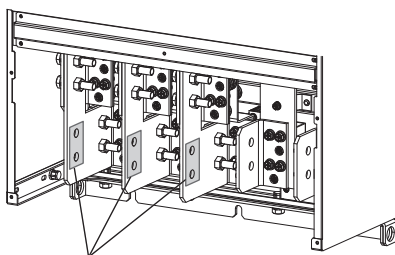

Connect the cables here.

FR-CC2-C400K, C560K

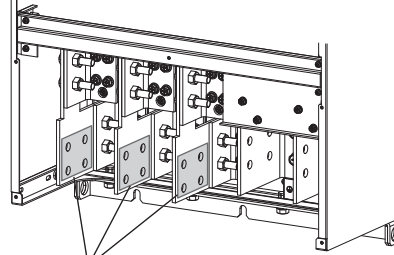

Connect the cables here.

## 2.5.4 Applicable cables and wiring length

Select a recommended cable size to ensure that the voltage drop ratio is within 2%.

If the wiring distance is long between the inverter and motor, the voltage drop in the main circuit will cause the motor torque to decrease especially at a low speed.

The following table shows a selection example for the wiring length of 20 m (575 V input power supply, 150% overload current rating for 1 minute).

- Converter unit (FR-CC2)

Converter model FR-CC2-[ ]	Terminal screw size*3	Tightening torque N·m	Crimp terminal			Cable gauge					
						HIV cables, etc. (mm <sup>2</sup> )*1			AWG/MCM *2		
			R/L1, S/L2, T/L3	P/+, N/-	Earthing (grounding) cable	R/L1, S/L2, T/L3	P/+, N/-	Earthing (grounding) cable	R/L1, S/L2, T/L3	P/+, N/-	Earthing (grounding) cable
C355K	M12 (M10)	46	2×80-12	2×100-12	100-10	2×80	2×100	100	2×4/0	2×300	4/0
C450K	M12 (M10)	46	2×125-12	2×150-12	100-10	2×125	2×150	100	2×300	2×350	300
C560K	M12 (M10)	46	2×200-12	2×250-12	100-10	2×200	2×250	100	2×400	2×500	300

- Inverter

Inverter model FR-A862-[ ]	Terminal screw size*3	Tightening torque N·m	Crimp terminal			Cable gauge					
						HIV cables, etc. (mm <sup>2</sup> )*1			AWG/MCM*2		
			U, V, W	P/+, N/-	Earthing (grounding) cable	U, V, W	P/+, N/-	Earthing (grounding) cable	U, V, W	P/+, N/-	Earthing (grounding) cable
05450	M12 (M10)	46	2×80-12	2×100-12	100-10	2×80	2×100	100	2×250	2×300	4/0
06470	M12 (M10)	46	2×125-12	2×150-12	100-10	2×125	2×150	100	2×300	2×350	300
08500	M12 (M10)	46	2×200-12	2×250-12	100-10	2×200	2×250	100	2×400	2×500	300

\*1 It is the gauge of the cable with the continuous maximum permissible temperature of 90°C or higher. (LMFC (heat resistant flexible cross-linked polyethylene insulated cable), etc.). It assumes a surrounding air temperature of 50°C or lower and in-enclosure wiring.

\*2 It is the gauge of the cable with continuous maximum permissible temperature of 90°C (THHN cable). It assumes a surrounding air temperature of 40°C or lower and in-enclosure wiring.  
(For the use in the United States or Canada, refer to [page 91](#).)

\*3 The terminal screw size indicates the size of a terminal screw for R/L1, S/L2, T/L3, U, V, W, P/+, N/-, and a screw for earthing (grounding).  
The screw size for earthing (grounding) terminal is indicated in parentheses.

The line voltage drop can be calculated by the following formula:

$$\text{Line voltage drop [V]} = \frac{\sqrt{3} \times \text{wire resistance [m}\Omega\text{/m]} \times \text{wiring distance [m]} \times \text{current [A]}}{1000}$$

Use a larger diameter cable when the wiring distance is long or when it is desired to decrease the voltage drop (torque reduction) in the low speed range.

### NOTE

- Tighten the terminal screw to the specified torque.  
A screw that has been tightened too loosely can cause a short circuit or malfunction.  
A screw that has been tightened too tightly can cause a short circuit or malfunction due to the unit breakage.
- Use crimp terminals with insulation sleeves to wire the power supply and motor.

### ◆ Total wiring length

#### ◆ With induction motor

Connect one or more general-purpose motors within the total wiring length 500 m. (The wiring length should be 100 m or less under vector control.)

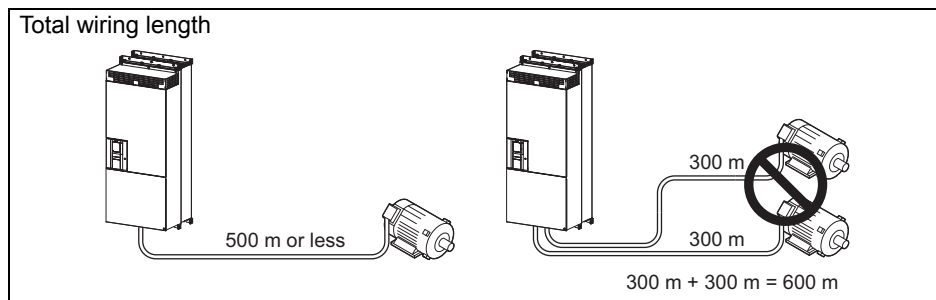

#### ◆ With PM motor

Use the wiring length of 100 m or shorter when connecting a PM motor.

Use one PM motor for one inverter. Multiple PM motors cannot be connected to an inverter.

When the wiring length exceeds 50 m for a 600 V class motor driven by an inverter under PM sensorless vector control, set "9" (6 kHz) or less in **Pr.72 PWM frequency selection**.

#### NOTE

- Especially for long-distance wiring, the inverter may be affected by a charging current caused by the stray capacitances of the wiring, leading to a malfunction of the overcurrent protective function or fast response current limit function or a malfunction or fault of the equipment connected on the inverter output side. If the fast-response current limit function malfunctions, disable this function. (For the details of **Pr.156 Stall prevention operation selection**, refer to the Instruction Manual (Detailed) of the FR-A860.)
- For the details of **Pr.72 PWM frequency selection**, refer to the Instruction Manual (Detailed) of the FR-A860.
- The carrier frequency is limited during PM sensorless vector control. Refer to the Instruction Manual (Detailed) of the FR-A860.

## 2.5.5 Earthing (grounding) precautions

- Always earth (ground) the motor, the inverter, and the converter unit.

### ◆ Purpose of earthing (grounding)

Generally, an electrical apparatus has an earth (ground) terminal, which must be connected to the ground before use. An electrical circuit is usually insulated by an insulating material and encased. However, it is impossible to manufacture an insulating material that can shut off a leakage current completely, and actually, a slight current flows into the case. The purpose of earthing (grounding) the case of an electrical apparatus is to prevent operators from getting an electric shock from this leakage current when touching it.

To avoid the influence of external noises, the earthing (grounding) is important to EMI-sensitive equipment that handle low level signals or operate very fast such as audio equipment, sensors, computers.

### ◆ Earthing (grounding) system to be established

As described previously, the purpose of earthing (grounding) is roughly classified into the electrical shock prevention and the prevention of malfunction due to the influence of electromagnetic noise. These two purposes should be clearly distinguished, and the appropriate earth (ground) system must be established to prevent the leakage current having the inverter's high frequency components from reversing through another earth (ground) point for malfunction prevention by following these instructions.

- Make the separate earth (ground) connection (I) for high frequency products such as the inverter from any other devices (EMI-sensitive devices described above) wherever possible.

Establishing adequate common (single-point) earth (ground) system (II) shown in the following figure is allowed only in cases where the separate earth (ground) system (I) is not feasible. Do not make inadequate common (single-point) earth (ground) connection (III).

As leakage currents containing many high frequency components flows into the earthing (grounding) cables of the inverter and peripheral devices the inverter must also be earthed (grounded) separately from the EMI-sensitive devices described above.

In a high building, it may be effective to use its iron structure frames as earthing (grounding) electrode for EMI prevention in order to separate from the earth (ground) system for electric shock prevention.

- Earthing (Grounding) must conform to the requirements of national and local safety regulations and electrical codes (NEC section 250, IEC 61140 class 1 and other applicable standards).

A neutral-point earthed (grounded) power supply in compliance with EN standard must be used.

- Use the thickest possible earthing (grounding) cable. The earthing (grounding) cable should be equal to the size indicated in the table on [page 29](#).
- The earthing (grounding) point should be as close as possible to the inverter, and the earth (ground) cable length should be as short as possible.
- Run the earthing (grounding) cable as far away as possible from the I/O wiring of the EMI-sensitive devices and run them in parallel in the minimum distance.

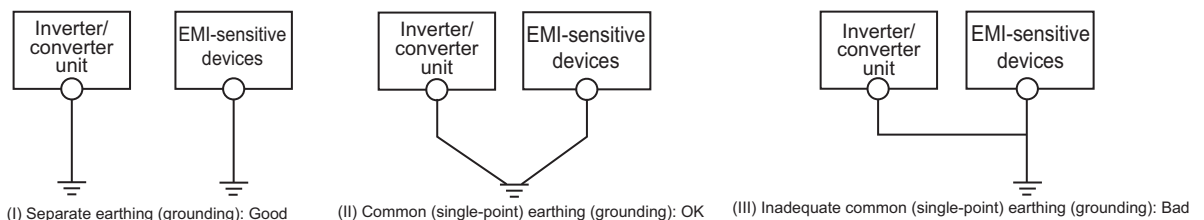



## 2.6 Control circuit

### 2.6.1 Details on the control circuit terminals of the inverter

The input signal function of the terminals in  can be selected by setting **Pr.178 to Pr.196 (I/O terminal function selection)**.

For the parameter details, refer to the FR-A860 Instruction Manual (Detailed).

#### ◆ Input signal

Type	Terminal symbol	Terminal name	Terminal function description		Rated specification
Contact input	STF	Forward rotation start	Turn ON the STF signal to start forward rotation and turn it OFF to stop.	When the STF and STR signals are turned ON simultaneously, the stop command is given.	Input resistance: 4.7 kΩ Voltage when contacts are open: 21 to 27 VDC Current when contacts are short-circuited: 4 to 6 mADC
	STR	Reverse rotation start	Turn ON the STR signal to start reverse rotation and turn it OFF to stop.		
	STOP	Start self-holding selection	Turn ON the STOP signal to self-hold the start signal.		
	RH RM RL	Multi-speed selection	Multi-speed can be selected according to the combination of the RH, RM and RL signals.		
	JOG	Jog mode selection	Turn ON the JOG signal to enable JOG operation (initial setting) and turn ON the start signal (STF or STR) to start JOG operation.		Input resistance: 2 kΩ Current when contacts are short-circuited: 8 to 13 mADC
		Pulse train input	Terminal JOG is also used as the pulse train input terminal. To use as a pulse train input terminal, change the <b>Pr.291</b> setting. (maximum input pulse: 100k pulses/s)		
	RT	Second function selection	Turn ON the RT signal to enable the second function. When the second function such as "second torque boost" and "second V/F (base frequency)" is set, turning ON the RT signal enables the selected function.		Input resistance: 4.7 kΩ Voltage when contacts are open: 21 to 27 VDC Current when contacts are short-circuited: 4 to 6 mADC
	MRS (X10)	Output stop (Inverter operation enable)	Connect to terminal RDA of the converter unit (FR-CC2). When the RDA signal is turned OFF, the inverter output is shut off. The X10 signal (NC contact) is assigned to terminal MRS in the initial setting. Use <b>Pr.599</b> to change the specification to NO contact.		
	RES	Reset	Use this signal to reset a fault output provided when a protective function is activated. Turn ON the RES signal for 0.1 second or longer, then turn it OFF. In the initial setting, reset is always enabled. By setting <b>Pr.75</b> , reset can be enabled only at an inverter fault occurrence. The inverter recovers about 1 second after the reset is released.		
	AU	Terminal 4 input selection	Terminal 4 function is available only when the AU signal is ON. Turning ON the AU signal disables terminal 2 function.		
	CS	Selection of automatic restart after instantaneous power failure	When the CS signal is left ON, the inverter restarts automatically at power restoration. Note that restart setting is necessary on both the inverter and the converter unit for this operation. In the initial setting, a restart is disabled.		
	SD	Contact input common (sink)*2	Common terminal for the contact input terminal (sink logic) and terminal FM		—
		External transistor common (source)	Connect this terminal to the power supply common terminal of a transistor output (open collector output) device, such as a programmable controller, in the source logic to avoid malfunction by undesirable current.		
		24 VDC power supply common	Common terminal for the 24 VDC power supply (terminal PC, terminal +24) Isolated from terminals 5 and SE.		
PC	External transistor common (sink)*2	Connect this terminal to the power supply common terminal of a transistor output (open collector output) device, such as a programmable controller, in the source logic to avoid malfunction by undesirable current.		Power supply voltage range: 19.2 to 28.8 VDC Permissible load current: 100 mA	
	Contact input common (source)	Common terminal for contact input terminal (source logic).			
	24 VDC power supply common	Can be used as a 24 VDC 0.1 A power supply.			

Type	Terminal symbol	Terminal name	Terminal function description	Rated specification
Frequency setting	10E	Frequency setting power supply	When connecting the frequency setting potentiometer at an initial status, connect it to terminal 10. Change the input specifications of terminal 2 using in <b>Pr.73</b> when connecting it to terminal 10E.	10 V $\pm$ 0.4 VDC Permissible load current: 10 mA
	10			5 V $\pm$ 0.5 VDC Permissible load current: 10 mA
	2	Frequency setting (voltage)	Inputting 0 to 5 VDC (or 0 to 10 V, 0 to 20 mA) provides the maximum output frequency at 5 V (10 V, 20 mA) and makes input and output proportional. Use <b>Pr.73</b> to switch among input 0 to 5 VDC (initial setting), 0 to 10 VDC, and 0 to 20 mA. Set the voltage/current input switch in the ON position to select current input (0 to 20 mA).*1	For voltage input, Input resistance: 10 $\pm$ 1 k $\Omega$ Maximum permissible voltage: 20 VDC
	4	Frequency setting (current)	Inputting 4 to 20 mADC (or 0 to 5 V, 0 to 10 V) provides the maximum output frequency at 20 mA and makes input and output proportional. This input signal is valid only when the AU signal is ON (terminal 2 input is invalid). Use <b>Pr.267</b> to switch among input 4 to 20 mA (initial setting), 0 to 5 VDC, and 0 to 10 VDC. Set the voltage/current input switch in the OFF position to select voltage input (0 to 5 V/0 to 10 V).*1 Use <b>Pr.858</b> to switch terminal functions.	For current input, Input resistance: 245 $\pm$ 5 $\Omega$ Permissible maximum current: 30 mA
	1	Frequency setting auxiliary	Input 0 to $\pm$ 5 VDC or 0 to $\pm$ 10 VDC to add this signal to the frequency setting signal input via terminal 2 or 4. Use <b>Pr.73</b> to switch between input 0 to $\pm$ 5 VDC and 0 to $\pm$ 10 VDC (initial setting). Use <b>Pr.868</b> to switch terminal functions.	Input resistance: 10 $\pm$ 1 k $\Omega$ Permissible maximum voltage: $\pm$ 20 VDC
	5	Frequency setting common	Common terminal for the frequency setting signal input via terminal 2 or 4 frequency setting signal (via terminal 2, 1 or 4) for the and analog output terminal AM. Do not earth (ground).	—
Thermistor	10 2	PTC thermistor input	For receiving PTC thermistor outputs. When PTC thermistor is valid ( <b>Pr.561</b> $\neq$ "9999"), terminal 2 is not available for frequency setting.	Applicable PTC thermistor specification Overheat detection resistance: 0.5 to 30 k $\Omega$ (Set by <b>Pr.561</b> )
External power supply input	+24	24 V external power supply input	For connecting a 24 V external power supply. If a 24 V external power supply is connected, power is supplied to the control circuit while the main power circuit is OFF.	Input voltage: 23 to 25.5 VDC Input current: 1.4 A or less

\*1 Set **Pr.73**, **Pr.267**, and the voltage/current input switch correctly, then input an analog signal in accordance with the setting. Applying a voltage with the voltage/current input switch ON (current input is selected) or a current with the switch OFF (voltage input is selected) could cause component damage of the inverter or analog circuits of output devices. (For the details, refer to the Instruction Manual (Detailed) of the FR-A860.)

\*2 Sink logic is initially set.

2

## ◆ Output signal

Type	Terminal symbol	Terminal name	Terminal function description	Rated specification
Relay	A1, B1, C1	Relay output 1 (fault output)	1 changeover contact output that indicates that an inverter's protective function has been activated and the outputs are stopped. Fault: discontinuity across B and C (continuity across A and C), Normal: continuity across B and C (discontinuity across A and C)	Contact capacity: 230 VAC 0.3 A (power factor = 0.4) 30 VDC 0.3 A
	A2, B2, C2	Relay output 2	1 changeover contact output	

## Control circuit

Type	Terminal symbol	Terminal name	Terminal function description	Rated specification
Open collector	RUN	Inverter running	The output is in LOW state when the inverter output frequency is equal to or higher than the starting frequency (initial value: 0.5 Hz). The output is in HIGH state during stop or DC injection brake operation.	Permissible load: 24 VDC (maximum 27 VDC) 0.1 A (The voltage drop is 2.8 V at maximum while the signal is ON.) The open collector transistor is ON (conductive) in LOW state. The transistor is OFF (not conductive) in HIGH state.
	SU	Up to frequency	The output is in LOW state when the output frequency is within the set frequency range $\pm 10\%$ (initial value). The output is in HIGH state during acceleration/deceleration and at a stop.	
	OL	Overload alarm	The output is in LOW state when stall prevention is activated by the stall prevention function. The output is in HIGH state when stall prevention is canceled.	
	IPF	Open collector output	No function is assigned in the initial setting. The function can be assigned by setting <b>Pr.192</b> .	
	FU	Frequency detection	The output is in LOW state when the inverter output frequency is equal to or higher than the preset detection frequency, and is in HIGH state when it is less than the preset detection frequency.	
	SE	Open collector output common	Common terminal for terminals RUN, SU, OL, IPF, FU	
Pulse	FM	For meter	Among several monitor items such as output frequency, select one to output it via these terminals. The signal is not output during an inverter reset. The size of output signal is proportional to the magnitude of the corresponding monitoring item. Use <b>Pr.55</b> , <b>Pr.56</b> , and <b>Pr.866</b> to set full scales for the monitored output frequency, output current, and torque.	Output item: Output frequency (initial setting) Permissible load current: 2 mA For full scale: 1440 pulses/s
		NPN open collector output		This terminal can be used for open collector outputs by setting <b>Pr.291</b> .
Analog	AM	Analog voltage output		Output item: Output frequency (initial setting) Output signal 0 to 10 VDC, Permissible load current: 1 mA (load impedance 10 k $\Omega$ or more) Resolution: 8 bits

## ◆ Communication

Type	Terminal symbol	Terminal name	Terminal function description
RS-485	—	PU connector	With the PU connector, communication can be made through RS-485. (For connection on a 1:1 basis only) Conforming standard: EIA-485 (RS-485) Transmission format: Multidrop link Communication speed: 4800 to 115200 bps Wiring length: 500 m
	RS-485 terminals	TXD+	The RS-485 terminals support the RS-485 communication. Conforming standard: EIA-485 (RS-485) Transmission format: Multidrop link Communication speed: 300 to 115200 bps Overall length: 500 m
		TXD-	
		RXD+	
		RXD-	
	GND (SG)	Earthing (grounding)	
USB	—	USB A connector	A connector (receptacle). Plug a USB memory device into this connector to copy parameter settings or use the trace function.
		USB B connector	Mini B connector (receptacle). By connecting an inverter to the personal computer through USB, FR Configurator2 can be used for setting the inverter, monitoring, and testing the operation.

## ◆ Terminals for manufacturer setting

Terminal symbol	Terminal function description
S1, S2, SIC, So (SO), SOC	Terminals S1, S2, SIC, So (SO), and SOC are for manufacturer setting. Do not connect anything to there. Doing so may cause an inverter failure. Do not remove the shorting wires across terminals S1 and PC, terminals S2 and PC, and terminals SIC and SD. Removing either shorting wire disables the inverter operation.

## 2.6.2 Details on the control circuit terminals of the converter unit (FR-CC2)

The input signal function of the terminals in  can be selected by setting **Pr.178**, **Pr.187**, **Pr.189** to **Pr.195** (I/O terminal function selection).

For the parameter details, refer to the Instruction Manual of the FR-CC2-C.

## ◆ Input signal

Type	Terminal symbol	Terminal name	Terminal function description	Rated specification
Contact input	RES	Reset	Use this signal to reset a fault output provided when a protective function is activated. Turn ON the RES signal for 0.1 second or longer, then turn it OFF. In the initial setting, reset is always enabled. By setting <b>Pr.75</b> , reset can be set enabled only at fault occurrence of the converter unit. The inverter recovers about 1 second after the reset is released.	Input resistance: 4.7 kΩ Voltage when contacts are open: 21 to 27 VDC Current when contacts are short-circuited: 4 to 6 mADC
	OH	External thermal relay input	The External thermal relay input (OH) signal is used when using an external thermal relay or a thermal protector built into the motor to protect the motor from overheating. When the thermal relay is activated, the inverter is shut off due to the fault occurrence of the external thermal relay operation (E.OHT).	
	RDI	Contact input	The function can be assigned by setting <b>Pr.178</b> .	
	SD	Contact input common (sink)	Common terminal for contact input terminal (sink logic) and terminal FM	—
		External transistor common (source)	Connect this terminal to the power supply common terminal of a transistor output (open collector output) device, such as a programmable controller, in the source logic to avoid malfunction by undesirable current.	
		24 VDC power supply common	Common terminal for the 24 VDC power supply (terminal PC, terminal +24) Isolated from terminals 5 and SE.	
	PC	External transistor common (sink)	Connect this terminal to the power supply common terminal of a transistor output (open collector output) device, such as a programmable controller, in the source logic to avoid malfunction by undesirable current.	Power supply voltage range: 19.2 to 28.8 VDC Permissible load current 100 mA
		Contact input common (source)	Common terminal for contact input terminal (source logic).	
		24 VDC power supply common	Can be used as a 24 VDC 0.1 A power supply.	
	Power supply input	+24	24 V external power supply input	For connecting a 24 V external power supply. If a 24 V external power supply is connected, power is supplied to the control circuit while the main power circuit is OFF.

### ◆ Output signal

Type	Terminal symbol	Terminal name	Terminal function description	Rated specification
Relay	A1, B1, C1	Relay output 1 (fault output)	1 changeover contact output that indicates that the protective function of the converter unit has been activated and the outputs are stopped. Fault: discontinuity across B and C (continuity across A and C), Normal: continuity across Band C (discontinuity across A and C)	Contact capacity: 230 VAC 0.3 A (power factor = 0.4) 30 VDC 0.3 A
	88R, 88S	For manufacturer setting. Do not use.		
Open collector	RDA	Inverter operation enable (NO contact)	The output is in LOW state when the converter unit operation is ready. Assign the signal to terminal MRS (X10) of the inverter. The inverter can be started when the RDA status is LOW.	Permissible load: 24 VDC (27 VDC at maximum) 0.1 A (The voltage drop is 2.8 V at maximum while the signal is ON.) The open collector transistor is ON (conductive) in LOW state. The transistor is OFF (not conductive) in HIGH state.
	RDB	Inverter operation enable (NC contact)	The output is in LOW state when a converter unit fault occurs or the converter is reset. The inverter can be started when the RDB status is HIGH.	
	RSO	Inverter reset	The output is in LOW state when the converter is reset (RES-ON). Assign the signal to terminal RES of the inverter. The inverter is reset when it is connected with the RSO status LOW.	
	IPF	Instantaneous power failure	The output is in LOW state when an instantaneous power failure is detected.	
	FAN	Cooling fan fault	The output is in LOW state when a cooling fan fault occurs.	
	SE	Open collector output common	Common terminal for terminals RDA, RDB, RSO, IPF, FAN Connect this terminal to terminal SD (sink logic) or PC (source logic) of the inverter.	

**⚠ CAUTION**

- Do not use the empty terminals (NCs) of the control circuit. Doing so may lead to damage of the converter unit and the inverter.
- Always connect between terminal RDA of the converter unit and terminal MRS (X10) of the inverter, and between terminal SE of the converter unit and terminal SD (terminal PC in the source logic) of the inverter. Failure to do so may lead to damage of the converter unit.

## 2.6.3 Control logic (sink/source) change

Switch the control logic of input signals as necessary.

To change the control logic, change the jumper connector position on the control circuit board.

Connect the jumper connector to the connector pin of the desired control logic.

The control logic of input signals is initially set to the sink logic (SINK).

(The output signals may be used in either the sink or source logic independently of the jumper connector position.)

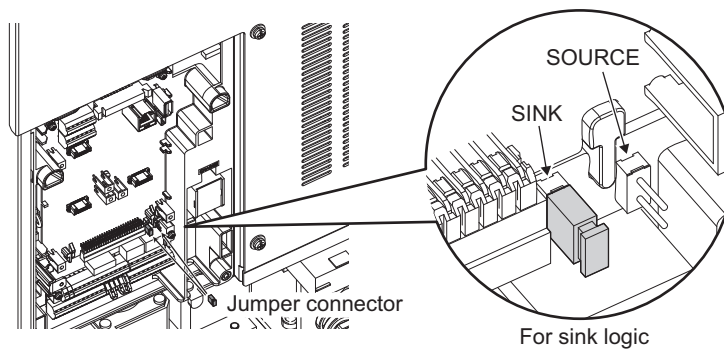

**NOTE**

- Make sure that the jumper connector is installed correctly.
- Never change the control logic while power is ON.

### ◆ Sink logic and source logic

- In the sink logic, a signal turns ON when a current exits from the corresponding signal input terminal. Terminal SD is common to the contact input signals. Terminal SE is common to the open collector output signals.
- In the source logic, a signal turns ON when a current enters into the corresponding signal input terminal. Terminal PC is common to the contact input signals. Terminal SE is common to the open collector output signals.

● Current flow concerning the input/output signal when sink logic is selected

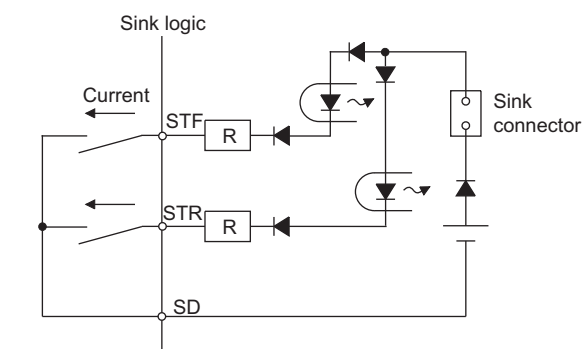

● Current flow concerning the input/output signal when source logic is selected

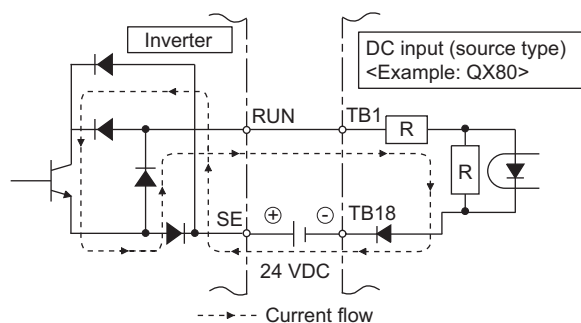
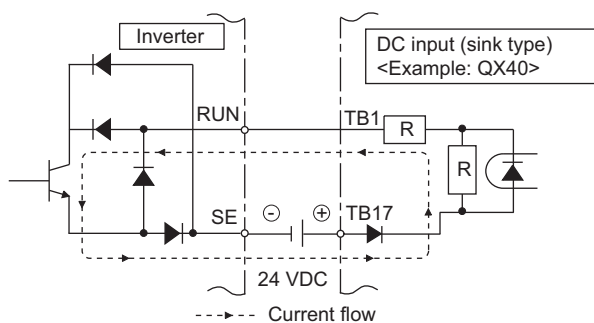
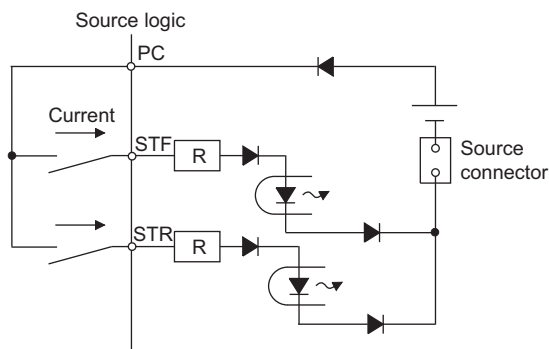

- When using an external power supply for transistor output

#### Sink logic

Use terminal PC as a common terminal, and perform wiring as follows. (Do not connect terminal SD on the inverter with terminal 0 V for the external power supply. When using terminals PC-SD as a 24 VDC power supply, do not install an external power supply in parallel with the inverter. Doing so may cause a malfunction in the inverter due to undesirable currents.)

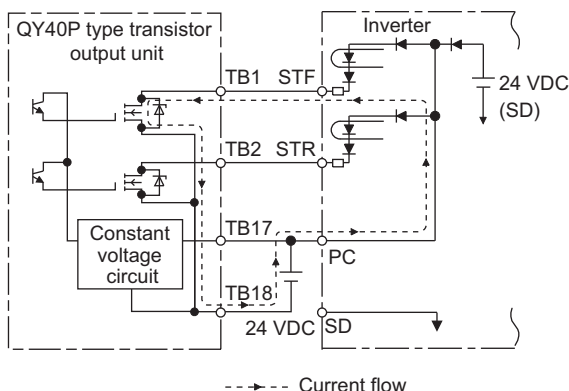

#### Source logic

Use terminal SD as a common terminal, and perform wiring as follows. (Do not connect terminal PC on the inverter with terminal +24 V for the external power supply. When using terminals PC-SD as a 24 VDC power supply, do not install an external power supply in parallel with the inverter. Doing so may cause a malfunction in the inverter due to undesirable currents.)

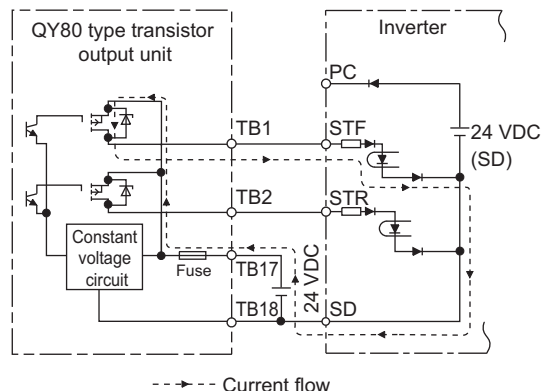

## 2.6.4 Wiring of inverter control circuit

### ◆Control circuit terminal layout

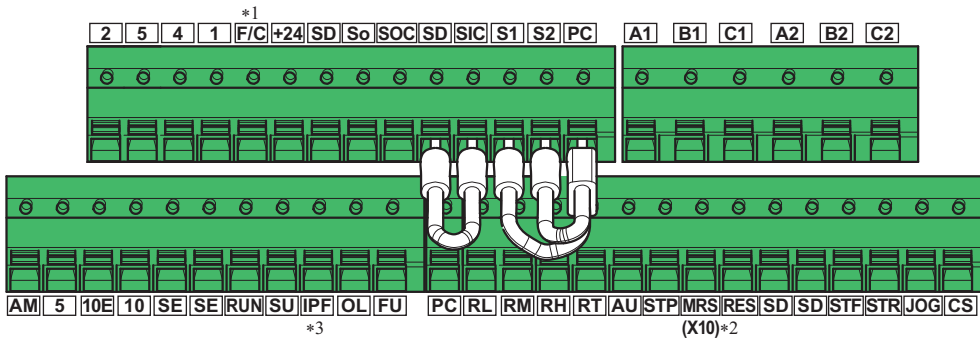

- \*1 This terminal functions as terminal FM.
- \*2 The X10 signal is assigned in the initial setting.
- \*3 No signal is assigned in the initial setting.

### ◆Wiring method

- Power supply connection

Use crimp terminals and stripped wire for the control circuit wiring. For single wire, the stripped wire can be used without crimp terminal.

Connect the end of wires (crimp terminal or stranded wire) to the terminal block.

- (1) Strip the signal wires as shown below. If too much of the wire is stripped, a short circuit may occur with neighboring wires. If not enough of the wire is stripped, wires may become loose and fall out. Twist the stripped end of wires to prevent them from fraying. Do not solder it.

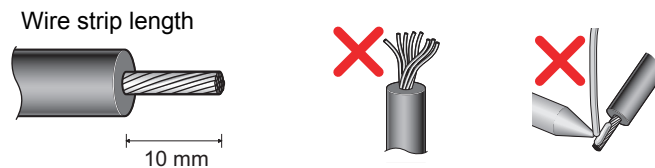

- (2) Use appropriate crimp terminals (ferrules, blade terminals, etc.).

Insert wires to the crimp terminal, and check that the wires come out for about 0 to 0.5 mm from a sleeve.

Check the condition of the crimp terminals after crimping. Do not use the crimp terminals of which the crimping is inappropriate, or the face is damaged.

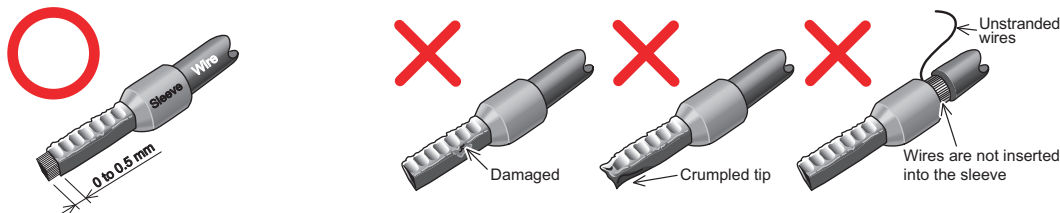

- Crimp terminals commercially available (as of January 2017)

Phoenix Contact Co., Ltd.

Wire gauge (mm <sup>2</sup> )	Ferrule part No.			Crimping tool model No.
	With insulation sleeve	Without insulation sleeve	For UL wire *1	
0.3	AI 0,34-10TQ	-	-	CRIMPFOX 6
0.5	AI 0,5-10WH	-	AI 0,5-10WH-GB	
0.75	AI 0,75-10GY	A 0,75-10	AI 0,75-10GY-GB	
1	AI 1-10RD	A 1-10	AI 1-10RD/1000GB	
1.25, 1.5	AI 1,5-10BK	A 1,5-10	AI 1,5-10BK/1000GB*2	
0.75 (for two wires)	AI-TWIN 2 × 0,75-10GY	-	-	

\*1 A ferrule terminal with an insulation sleeve compatible with the MTW wire which has a thick wire insulation.

\*2 Applicable for terminals A1, B1, C1, A2, B2, and C2 only.

NICHIFU Co., Ltd.

Wire gauge (mm <sup>2</sup> )	Blade terminal part No.	Insulation cap part No.	Crimping tool model No.
0.3 to 0.75	BT 0.75-11	VC 0.75	NH 69

(3) Insert the wires into a socket.

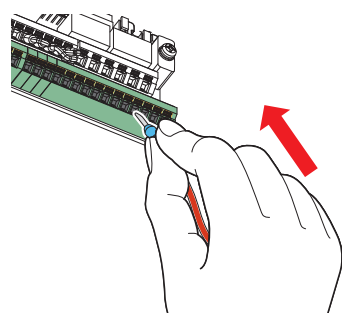

When using a single wire or stranded wires without a blade terminal, push the open/close button all the way down with a flathead screwdriver, and insert the wire.

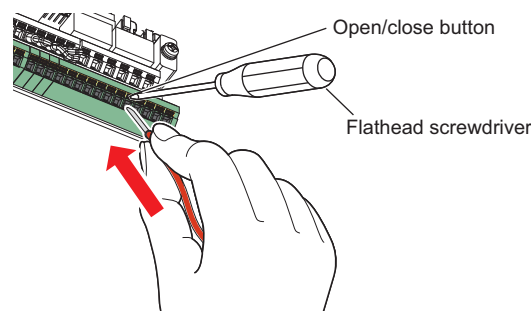

#### NOTE

- When using stranded wires without a blade terminal, twist enough to avoid short circuit with a nearby terminals or wires.
- Never change the control logic while power is ON.

#### • Wire removal

Pull the wire while pushing the open/close button all the way down firmly with a flathead screwdriver.

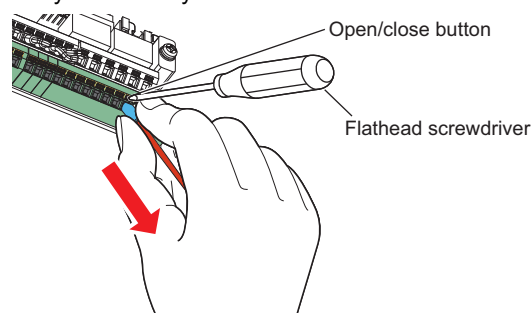

#### NOTE

- Pulling out the wire forcefully without pushing the open/close button all the way down may damage the terminal block.
- Use a small flathead screwdriver (tip thickness: 0.4 mm/tip width: 2.5 mm).

If a flathead screwdriver with a narrow tip is used, terminal block may be damaged.

Commercially available products (as of February 2016)

Name	Model	Manufacturer
Screwdriver	SZF 0- 0,4 × 2,5	Phoenix Contact Co., Ltd.

- Place the flathead screwdriver vertical to the open/close button. In case the blade tip slips, it may cause an inverter damage or injury.

## ◆ Common terminals of the control circuit (SD, PC, 5, SE)

- Terminals SD (sink logic), PC (source logic), 5, and SE are common terminals (0 V) for I/O signals. (All common terminals are isolated from each other.) Do not earth (ground) these terminals. Avoid connecting terminal SD (sink logic) with terminal 5, terminal PC (source logic) with terminal 5, and terminal SE with terminal 5.
- In the sink logic, terminal SD is a common terminal for the contact input terminals (STF, STR, STOP, RH, RM, RL, JOG, RT, MRS, RES, AU, and CS) and the pulse train output terminal (FM). The open collector circuit is isolated from the internal control circuit by photocoupler.
- In the source logic, terminal PC is a common terminal for the contact input terminals (STF, STR, STOP, RH, RM, RL, JOG, RT, MRS, RES, AU, and CS). The open collector circuit is isolated from the internal control circuit by photocoupler.
- Terminal 5 is a common terminal for the frequency setting terminals (2, 1, and 4) and the analog output terminals (AM). It should be protected from external noise using a shielded or twisted cable.
- Terminal SE is a common terminal for the open collector output terminals (RUN, SU, OL, IPF, and FU). The contact input circuit is isolated from the internal control circuit by photocoupler.



### ◆ Signal inputs by contactless switches

The contact input terminals of the inverter (STF, STR, STOP, RH, RM, RL, JOG, RT, MRS, RES, AU, CS) can be controlled using a transistor instead of a contact switch as shown below.

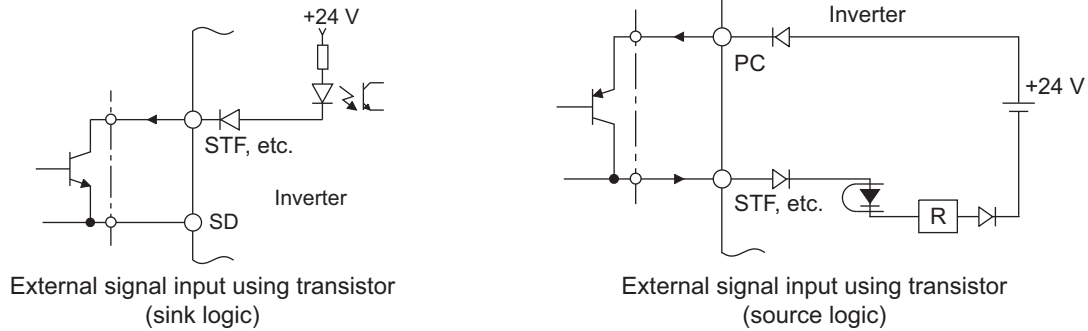

## 2.6.5 Wiring precautions

- It is recommended to use a cable of 0.75 mm<sup>2</sup> for the connection to the control circuit terminals.
  - The wiring length should be 30 m (200 m for terminal FM) at the maximum.
  - Use two or more parallel micro-signal contacts or twin contacts to prevent contact faults when using contact inputs since the control circuit input signals are micro-currents.
  - To suppress EMI, use shielded or twisted cables for the control circuit terminals and run them away from the main and power circuits (including the 200 V relay sequence circuit). For the cables connected to the control circuit terminals, connect their shields to the common terminal of the connected control circuit terminal. When connecting an external power supply to terminal PC, however, connect the shield of the power supply cable to the negative side of the external power supply. Do not directly earth (ground) the shield to the enclosure, etc.
  - Always apply a voltage to the fault output terminals (A1, B1, C1, A2, B2, C2) via a relay coil, lamp, etc.
  - Separate the wiring of the control circuit away from the wiring of the main circuit.
- Make cuts in rubber bush of the inverter side and lead the wires through.

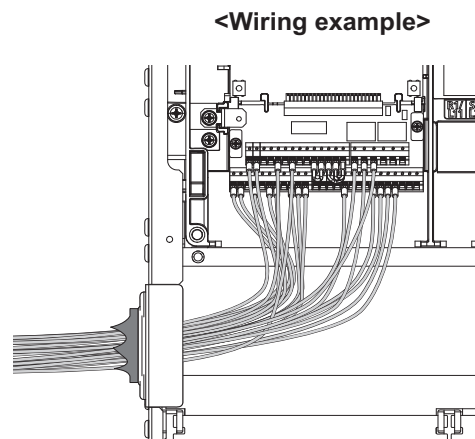
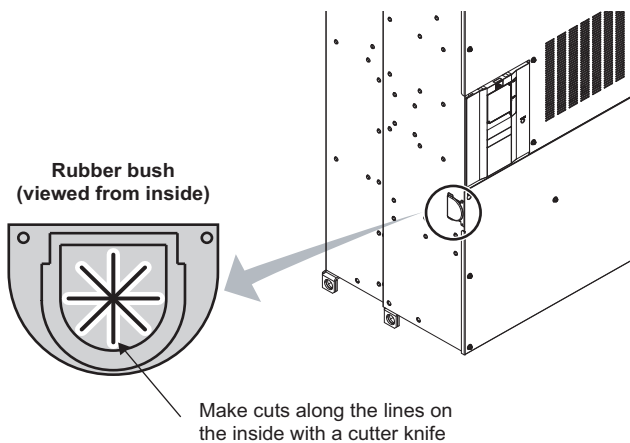
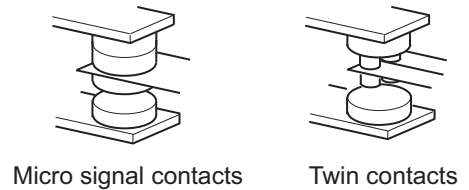

## 2.6.6 When using separate power supplies for the control circuit and the main circuit

### ◆ Cable size for the control circuit power supply (terminals R1/L11 and S1/L21)

- Terminal screw size: M4
- Cable gauge: 0.75 mm<sup>2</sup> to 2 mm<sup>2</sup>
- Tightening torque: 1.5 N·m

### ◆ Connection method

When a fault occurs, opening of the electromagnetic contactor (MC) on the inverter power supply side results in power loss in the control circuit, disabling the fault output signal retention. Terminals R1/L11 and S1/L21 are provided to hold a fault signal. In this case, connect the power supply terminals R1/L11 and S1/L21 of the control circuit to the input side of the MC.

Terminals R1/L11 and S1/L21 are connected to terminals P/+ and N/- with a jumper respectively. Do not connect the power cable to incorrect terminals. Doing so may damage the inverter.

<Connection diagram>

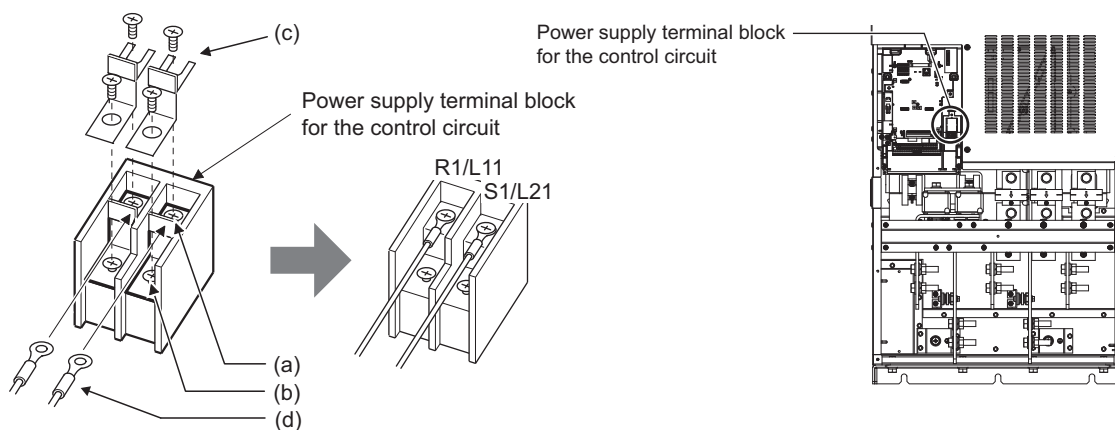
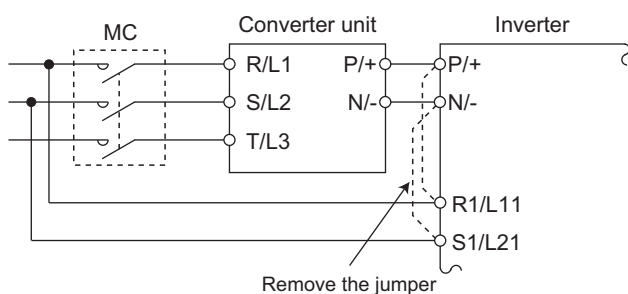

- Remove the upper screws.
- Remove the lower screws.
- Pull the jumper toward you to remove.
- Connect the separate power supply cable for the control circuit to the upper terminals (R1/L11, S1/L21).

### NOTE

- When using separate power supplies, always remove the jumpers from terminals R1/L11 and S1/L21. The inverter may be damaged if the jumpers are not removed.
- The voltage should be the same as that of the main control circuit when the control circuit power is supplied from other than the input side of the MC.
- When using a separate power supply from R1/L11 and S1/L21, the necessary power capacity of the separate power supply is 80 VA.
- If the main circuit power is switched OFF (for 0.1 s or more) then ON again, the inverter is reset and a fault output will not be held.

## 2.6.7 When supplying 24 V external power to the control circuit

Connect a 24 V external power supply across terminals +24 and SD. Connecting a 24 V external power supply enables I/O terminal ON/OFF operation, operation panel displays, control functions, and communication during communication operation even during power-OFF of inverter's main circuit power supply. When the main circuit power supply is turned ON, the power supply changes from the 24 V external power supply to the main circuit power supply.

### ◆ Specification of the applied 24 V external power supply

Item	Rated specification
Input voltage	23 to 25.5 VDC
Input current	1.4 A or lower

Commercially available products (as of February 2015)

Model	Manufacturer
S8JX-N05024C *1 Specifications: Capacity 50 W, output voltage 24 VDC, output current 2.1 A Installation method: Front installation with cover  or  S8VS-06024 *1 Specifications: Capacity 60 W, output voltage 24 VDC, output current 2.5 A Installation method: DIN rail installation	OMRON Corporation

\*1 For the latest information about OMRON power supply, contact OMRON corporation.

### ◆ Starting and stopping the 24 V external power supply operation

- Supplying 24 V external power while the main circuit power is OFF starts the 24 V external power supply operation. Likewise, turning OFF the main circuit power while supplying 24 V external power starts the 24 V external power supply operation.
- Turning ON the main circuit power stops the 24 V external power supply operation and enables the normal operation.

#### NOTE

- When the 24 V external power is supplied while the main circuit power supply is OFF, the inverter operation is disabled.
- In the initial setting, when the main power supply is turned ON during the 24 V external power supply operation, a reset is performed in the inverter, then the power supply changes to the main circuit power supply. (The reset can be disabled using Pr.30.)

### ◆ Confirming the 24 V external power supply input

- During the 24 V external power supply operation, the alarm lamp blinks.
- During the 24 V external power supply operation, the 24 V external power supply operation signal (EV) is output. To use the EV signal, set "68 (positive logic) or 168 (negative logic)" in one of Pr.190 to Pr.196 (output terminal function selection) to assign function to an output terminal.

## ◆ Operation while the 24 V external power is supplied

- Fault records and parameters can be read and parameters can be written (when the parameter write from the operation panel is enabled) using the operation panel keys.
- The safety stop function is disabled during the 24 V external power supply operation.
- During the 24 V external power supply operation, monitored items and signals related to inputs to main circuit power supply, such as output current and converter output voltage, are invalid.
- The alarms, which have occurred when the main circuit power supply is ON, continue to be output after the power supply is changed to the 24 V external power supply. Perform the inverter reset or turn OFF then ON the power to reset the faults.
- The output data is retained when "1 or 11" is set in **Pr.495 Remote output selection**.

### NOTE

- Inrush current equal to or higher than the 24 V external power supply specification may flow at power-ON. Confirm that the power supply and other devices are not affected by the inrush current and the voltage drop caused by it. Depending on the power supply, the inrush current protection may be activated to disable the power supply. Select the power supply and capacity carefully.
- When the wiring length between the external power supply and the inverter is long, the voltage often drops. Select the appropriate wiring size and length to keep the voltage in the rated input voltage range.
- In a serial connection of several inverters, the current increases when it flows through the inverter wiring near the power supply. The increase of the current causes voltage to drop further. Use the inverter after confirming that the input voltage of each converter unit is within the rated input voltage range. Depending on the power supply, the inrush current protection may be activated to disable the power supply. Select the power supply and capacity carefully.
- "E.SAF" or "E.P24" may appear when the start-up time of the 24 V power supply is too long (less than 1.5 V/s) in the 24 V external power supply operation.
- "E.P24" may appear when the 24 V external power supply input voltage is low. Check the external power supply input.
- Do not touch the control circuit terminal block (circuit board) during the 24 V power supply operation (when conducted). Otherwise you may get an electric shock or burn.

# 2.7 Communication connectors and terminals

## 2.7.1 PU connector

### ◆ Removal and reinstallation of the accessory cover

- Loosen the two screws on the accessory cover. (These screws cannot be removed.)
- Push the upper part of the accessory cover and pull the accessory cover to remove.

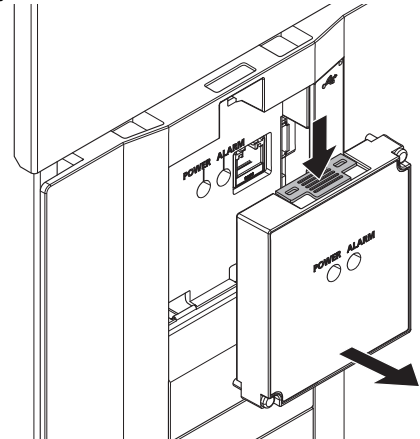
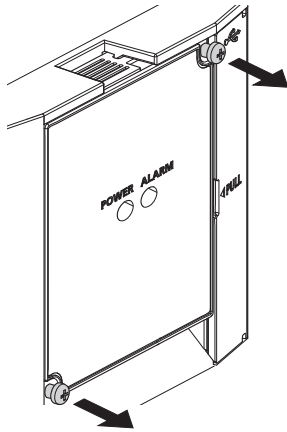

To install the accessory cover, fit it securely and tighten the screws. (Tightening torque: 0.40 to 0.45 N·m)

### ◆ Mounting the operation panel (FR-LU08) or parameter unit (FR-PU07) on the enclosure surface

- The operation panel can be used for setting the inverter parameters, monitoring various items, and checking fault indications.
- Having an operation panel (FR-LU08) or a parameter unit (FR-PU07) on the enclosure surface is convenient. With a connection cable, the operation panel (FR-LU08) or the parameter unit (FR-PU07) can be mounted to the enclosure surface and connected to the inverter.

Use the option FR-CB2[ ], or connectors and cables available on the market.  
 (To install the operation panel (FR-LU08), the optional connector (FR-ADP) is required.)  
 Securely insert one end of the connection cable until the stoppers are fixed.

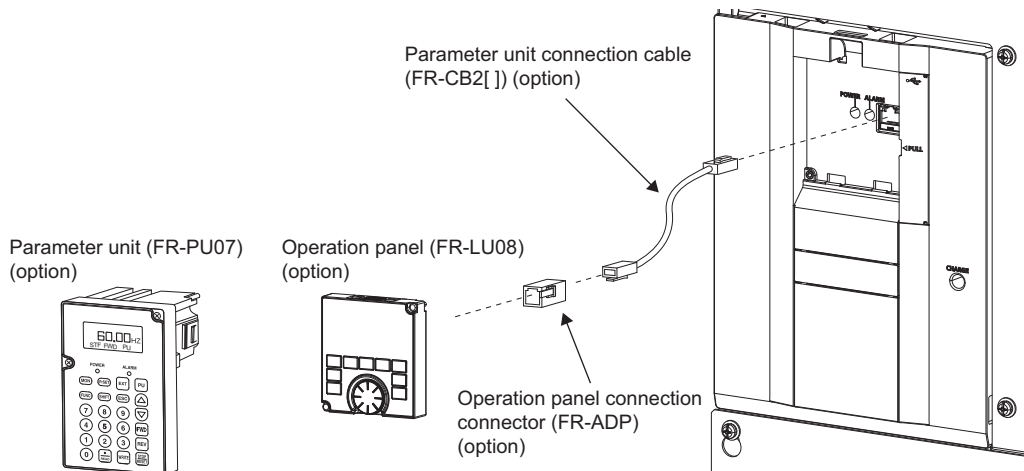

**NOTE**

- Refer to the following table when fabricating the cable on the user side. Keep the total cable length within 20 m.
- Commercially available products (as of February 2015)

Name	Model	Manufacturer
Communication cable	SGLPEV-T (Cat5e/300 m) 24AWG × 4P	Mitsubishi Cable Industries, Ltd.
RJ-45 connector	5-554720-3	Tyco Electronics

• For the details of the FR-LU08, refer to the FR-LU08 Instruction Manual.

### ◆ Communication operation

- Using the PU connector enables communication operation from a personal computer, etc. When the PU connector is connected with a personal, FA or other computer by a communication cable, a user program can run to monitor the inverter or read and write parameters.

Communication can be performed with the Mitsubishi inverter protocol (computer link operation).

(For details, refer to the Instruction Manual (Detailed) of the FR-A860.)

## 2.7.2 USB connector

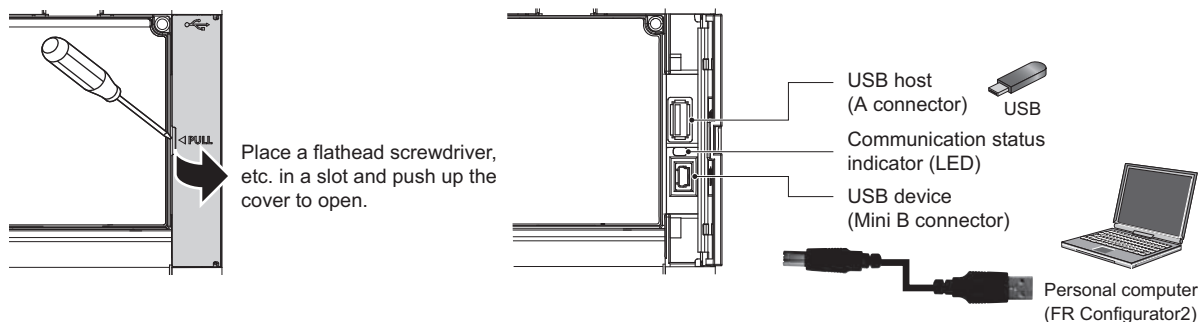

### ◆ USB host communication

<b>Interface</b>		Conforms to USB 1.1
<b>Transmission speed</b>		12 Mbps
<b>Wiring length</b>		Maximum 5 m
<b>Connector</b>		USB A connector (receptacle)
<b>Compatible USB memory</b>	<b>(Format)</b>	FAT32
	<b>Capacity</b>	1 GB or more (used in the recorder mode of the trace function)
	<b>Encryption function</b>	Not available

- Different inverter data can be saved in a USB memory device. The USB host communication enables the following functions.

Function	Description
Parameter copy	<ul style="list-style-type: none"> <li>Copies the parameter setting from the inverter to the USB memory device. A maximum of 99 parameter setting files can be saved in a USB memory device.</li> <li>The parameter setting data copied in the USB memory device can be copied to other inverters. This function is useful in backing up the parameter setting or for sharing the parameter setting among multiple inverters.</li> <li>The parameter setting data copied in the USB memory device can be saved in a personal computer and edited in FR Configurator2.</li> </ul>
Trace	<ul style="list-style-type: none"> <li>The monitored data and output status of the signals can be saved in a USB memory device.</li> <li>The saved data can be imported to FR Configurator2 to diagnose the operating status of the inverter.</li> </ul>
PLC function data copy	<ul style="list-style-type: none"> <li>This function copies the PLC function project data to a USB memory device when the PLC function is used.</li> <li>The PLC function project data copied in the USB memory device can be copied to other inverters.</li> <li>This function is useful in backing up the parameter setting and for allowing multiple inverters to operate by the same sequence programs.</li> </ul>

- The operating status of the USB host can be checked on the LED display of the inverter.

LED display status	Operating status
OFF	No USB connection.
ON	The communication is established between the inverter and the USB device.
Fast blinking	The USB memory device is being accessed. (Do not remove the USB memory device.)
Slow blinking	Error in the USB connection.

- When a device such as a USB battery charger is connected to the USB connector and an excessive current (500 mA or more) flows, USB host error (UF warning) is displayed on the operation panel.
- If a UF warning occurs, disconnect the USB device and set **Pr.1049** = "1" to cancel the USB error. (The UF warning can also be canceled by resetting the inverter power or resetting with the RES signal.)

**NOTE**

- Do not connect devices other than a USB memory device to the inverter.
- If a USB device is connected to the inverter via a USB hub, the inverter cannot recognize the USB memory device properly.
- For the details of usage, refer to the Instruction Manual (Detailed) of the FR-A860.

**◆ USB device communication**

A USB (Ver. 1.1) cable connects the inverter with a personal computer. Parameter setting and monitoring can be performed by FR Configurator2.

<b>Interface</b>	Conforms to USB 1.1
<b>Transmission speed</b>	12 Mbps
<b>Wiring length</b>	Maximum 5 m
<b>Connector</b>	USB mini B connector (receptacle)
<b>Power supply</b>	Self-powered

**NOTE**

- For the details of FR Configurator2, refer to the Instruction Manual of FR Configurator2.

### 2.7.3 RS-485 terminal block

**◆ Communication operation**

<b>Conforming standard</b>	EIA-485 (RS-485)
<b>Transmission format</b>	Multidrop link
<b>Communication speed</b>	115200 bps maximum
<b>Overall length</b>	500 m
<b>Connection cable</b>	Twisted pair cable (4 pairs)

The RS-485 terminals enables communication operation from a personal computer, etc. When the PU connector is connected with a personal, FA or other computer by a communication cable, a user program can run to monitor the inverter or read and write parameters.

Communication can be performed with the Mitsubishi inverter protocol (computer link operation) and MODBUS RTU protocol. (For details, refer to the FR-A860 Instruction Manual (Detailed).)

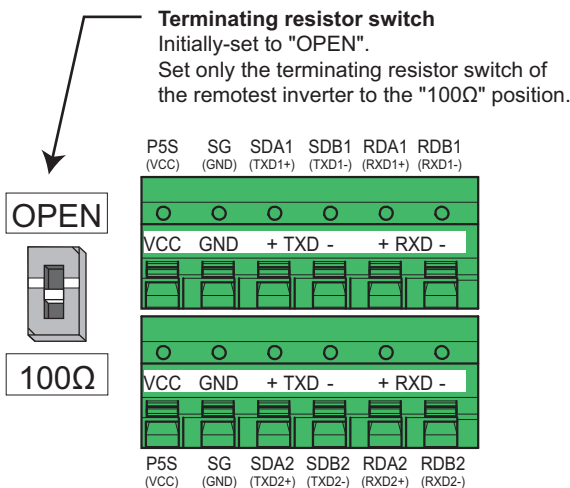

**NOTE**

- To avoid malfunction, keep the RS-485 terminal wires away from the control circuit board.
- For wiring of the RS-485 terminals used with a plug-in option, lead the wires on the left side of the plug-in option.

## 2.8 Connection of motor with encoder (Vector control)

Using encoder-equipped motors together with a vector control compatible option enables speed, torque, and positioning control operations under orientation control, encoder feedback control, and full-scale vector control.

This section explains wiring for use of the FR-A8AP.

### ◆ Appearance and parts name of the FR-A8AP

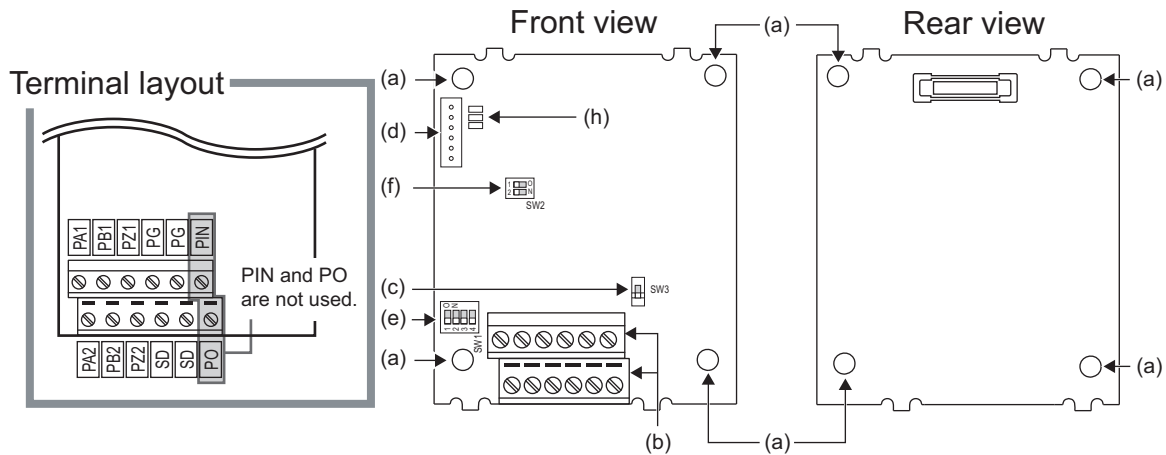

Symbol	Name	Description	Refer to page
a	Mounting hole	Used for installation to the inverter.	—
b	Terminal block	Connected with the encoder.	49
c	Encoder type selection switch (SW3)	Switches the encoder type (differential line driver/complementary).	48
d	CON2 connector	Used for extension.	—
e	Terminating resistor selection switch (SW1)	Switches ON or OFF the internal terminating resistor.	48
f	Switch for manufacturer setting (SW2)	Do not change from the initially-set status. (Switches 1 and 2 are OFF  .)	—
g	Connector	Connected to the option connector of the inverter.	9
h	LED for manufacturer check	Not used.	—

### ◆ Terminals of the FR-A8AP

Terminal symbol	Terminal name	Description
PA1	Encoder A-phase signal input terminal	A-, B- and Z-phase signals are input from the encoder.
PA2	Encoder A-phase inverse signal input terminal	
PB1	Encoder B-phase signal input terminal	
PB2	Encoder B-phase inverse signal input terminal	
PZ1	Encoder Z-phase signal input terminal	
PZ2	Encoder Z-phase inverse signal input terminal	
PG	Encoder power supply (positive side) input terminal	Input terminal for the encoder power supply. Connect the external power supply (5 V, 12 V, 15 V, 24 V) and the encoder power cable. When the encoder output is the differential line driver type, only 5 V can be input. Make the voltage of the external power supply same as the encoder output voltage. (Check the encoder specification.)
SD	Encoder power supply ground terminal	
PIN	Not used.	
PO		

#### NOTE

- When the encoder's output voltage differs from its input power supply voltage, the signal loss detection (E.ECT) may occur.
- Incorrect wiring or faulty setting to the encoder will cause a fault such as an overcurrent (E.OC[ ] ) and an inverter overload (E.THT).  
Correctly perform the encoder wiring and setting.



### ◆ Switches of the FR-A8AP

- Encoder type selection switch (SW3)
 

Selects either the differential line driver or complementary setting.  
It is initially set to the differential line driver. Switch its position according to the output circuit.

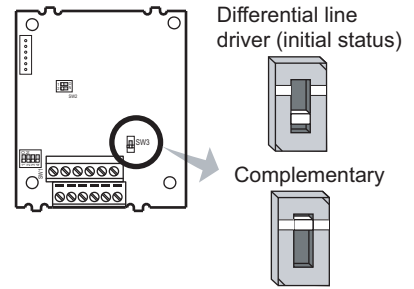

- Terminating resistor selection switch (SW1)
 

Selects ON/OFF of the internal terminating resistor.  
Set the switch to ON (initial status) when an encoder output type is differential line driver, and set to OFF when complementary.  
ON: with internal terminating resistor (initial status)  
OFF: without internal terminating resistor

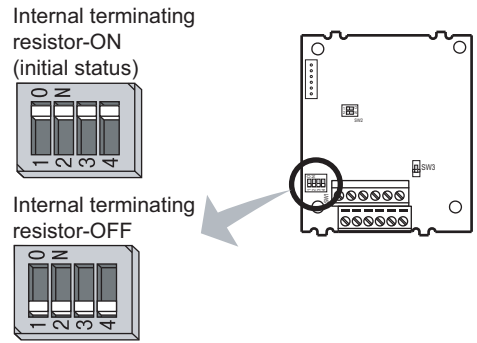

**NOTE**

- Set all switches to the same setting (ON/OFF).
- Set the switch "OFF" when sharing an encoder with another unit (NC (computerized numerical controller), etc.) having a terminating resistor under the differential line driver setting.
- Prepare an encoder's power supply (5 V/12 V/15 V/24 V) according to the encoder's output voltage. When the encoder output is the differential line driver type, only 5 V can be input.
- The SW2 switch is for manufacturer setting. Do not change the setting.

### ◆ Encoder specification

Item	Specification
Resolution	0 to 4096 pulses/rev (setting by Pr. 369)
Power supply voltage	5 V, 12 V, 15 V, 24 V
Output signal form	A, B phases (90° phase shift) Z phase: 1 pulse/rev
Output circuit	Differential line driver or complementary

### ◆Encoder cable

- As the terminal block of the FR-A8AP is an insertion type, cables need to be treated when the encoder cables of the inverter have crimp terminals. Cut the crimp terminal of the encoder cable and strip its sheath to make its cable wires loose. Also, treat the shielding wires of the shielded twisted pair cable to ensure that they will not contact conductive areas. Wire the stripped cable after twisting it to prevent it from becoming loose. In addition, do not solder it.

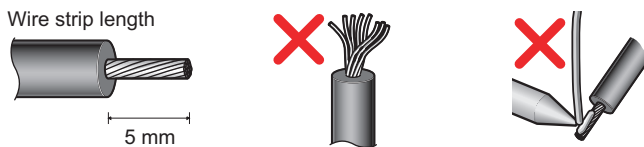

**NOTE**

- Crimp terminals  
Commercially available (as of January 2017)  
Phoenix Contact Co., Ltd.

Terminal screw size	Wire gauge (mm <sup>2</sup> )	Ferrule part No.		Crimping tool model
		(With insulation sleeve)	(Without insulation sleeve)	
M2	0.3	AI 0,34-6TQ	A 0,34-7	CRIMPFOX 6
	0.5	AI 0,5-6WH	A 0,5-6	

NICHIFU Co., Ltd.

Terminal screw size	Wire gauge (mm <sup>2</sup> )	Blade terminal part No.	Insulation cap part No.	Crimping tool model
M2	0.3 to 0.75	BT 0.75-7	VC 0.75	NH 69

- When using a blade terminal (without insulation sleeve), take caution that the twisted wires do not come out.

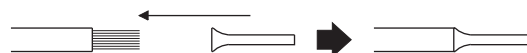

### ◆Wiring example

- Speed control

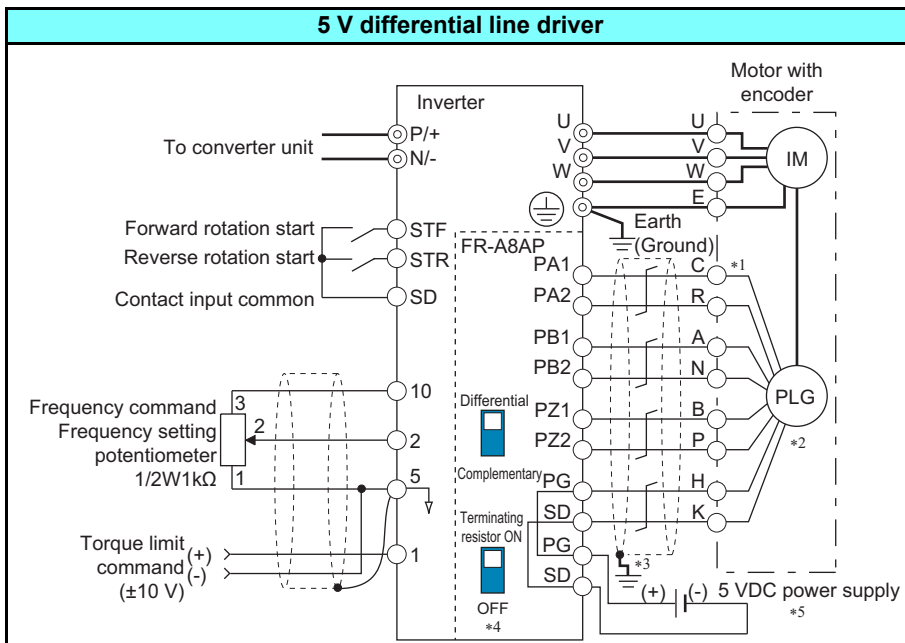

- \*1 The pin number differs according to the encoder used. Speed, control, torque control, and position control by pulse train input are available with or without the Z-phase being connected.
- \*2 Connect the encoder so that there is no looseness between the motor and motor shaft. Speed ratio must be 1:1.
- \*3 Earth (ground) the shield of the encoder cable to the enclosure using a tool such as a P-clip. (Refer to page 50.)
- \*4 For the complementary, set the terminating resistor selection switch to OFF position. (Refer to page 48.)
- \*5 A separate power supply of 5 V / 12 V / 15 V / 24 V is necessary according to the encoder power specification. When the encoder output is the differential line driver type, only 5 V can be input. Make the voltage of the external power supply the same as the encoder output voltage, and connect the external power supply between PG and SD.

### ◆ Instructions for encoder cable wiring

- Use shielded twisted pair cables (0.2 mm<sup>2</sup> or larger) to connect the FR-A8AP. For wiring to terminals PG and SD, use several cables in parallel or use a thick cable, according to the wiring length.  
To protect the cables from noise, run them away from any source of noise (such as the main circuit and power supply voltage).

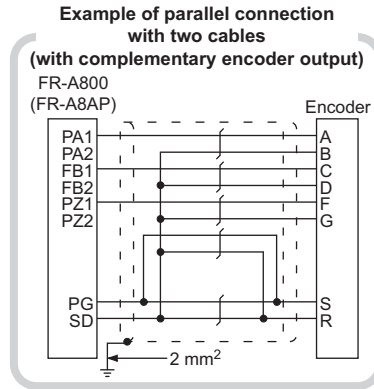

Wiring length	Parallel connection	Larger-size cable
Within 10 m	At least two cables in parallel	Cable gauge 0.2 mm <sup>2</sup>
Within 20 m	At least four cables in parallel	
Within 100 m*1	At least six cables in parallel	
		0.4 mm <sup>2</sup> or larger
		0.75 mm <sup>2</sup> or larger
		1.25 mm <sup>2</sup> or larger

\*1 When differential line driver is set and a wiring length is 30 m or more.

The wiring length can be extended to 100 m by increasing the 5 V power supply (approximately to 5.5 V) while using six or more 0.2 mm<sup>2</sup> gauge cables in parallel or a 1.25 mm<sup>2</sup> or larger gauge cable. The voltage applied must be within power supply specifications of encoder.

- To reduce noise of the encoder cable, earth (ground) the encoder's shielded cable to the enclosure (as close as possible to the inverter) with a P-clip or U-clip made of metal.

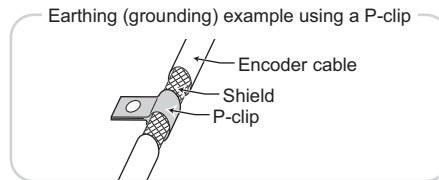

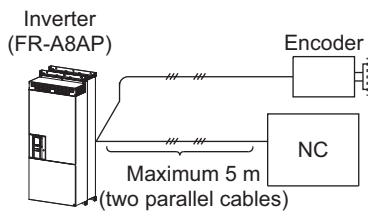

- When one encoder is shared between FR-A8AP and CNC (computerized numerical controller), its output signal should be connected as shown below. In this case, the wiring length between FR-A8AP and CNC should be as short as possible, within 5 m.



## 2.9 Parameter settings for a motor with encoder

### ◆ Parameter for the encoder (Pr.359, Pr.369, Pr.851, Pr.852)

- Set the encoder specifications.

Pr.	Name	Initial value	Setting range	Description		
359 C141	852 C241	Encoder rotation direction	1	0	Set when using a motor for which forward rotation (encoder) is clockwise (CW) viewed from the shaft. 	Set for the operation at 120 Hz or less.
				100	Set for the operation at a frequency higher than 120 Hz.	
				1	Set when using a motor for which forward rotation (encoder) is counterclockwise (CCW) viewed from the shaft. 	Set for the operation at 120 Hz or less.
				101	Set for the operation at a frequency higher than 120 Hz.	
369 C140	851 C240	Number of encoder pulses	1024	0 to 4096	Set the number of encoder pulses output. Set the number of pulses before it is multiplied by 4.	

The parameters above can be set when a vector control compatible option is installed.

- The following table shows parameters to be set according to a vector control compatible option to be used.

Item	FR-A8AP/FR-A8AL/ FR-A8APA parameter	FR-A8APR parameter	FR-A8APS parameter	FR-A8TP parameter
Encoder/Resolver rotation direction	Pr.359			Pr.852
Number of detector pulses	Pr.369	— (fixed 1024 pulses)	— (Obtained via communication from the encoder)	Pr.851

### ◆ Parameter settings for the motor under vector control

Motor name	Pr.9 Electronic thermal O/L relay	Pr.71 Applied motor	Pr.80 Motor capacity	Pr.81 Number of motor poles	Pr.359 Encoder rotation direction	Pr.369 Number of encoder pulses
Standard motor (thermal characteristic: standard)	Rated motor current	0	Motor capacity	Number of motor poles	1	1024
Constant-torque motor (thermal characteristic: constant torque)	Rated motor current	1	Motor capacity	4	1	1024
Vector control dedicated motor	0 *3	30	Motor capacity	4	1	2048
Other manufacturer's standard motor	Rated motor current	0 (3) *1	Motor capacity	Number of motor poles	*2	*2
Other manufacturer's constant-torque motor	Rated motor current	1 (13) *1	Motor capacity	Number of motor poles	*2	*2

\*1 Offline auto tuning is required (Refer to the FR-A860 Instruction Manual (Detailed))

\*2 Set this parameter according to the motor.

\*3 Use the thermal protector input provided with the motor.

# MEMO

---

# **3 PRECAUTIONS FOR USE OF THE INVERTER**

---

This chapter explains the precautions for use of this product.  
Always read the instructions before using the equipment.

---

<b>3.1</b>	<b>Electro-magnetic interference (EMI) and leakage currents ..</b>	<b>54</b>
<b>3.2</b>	<b>Power supply harmonics .....</b>	<b>57</b>
<b>3.3</b>	<b>Installation of a reactor .....</b>	<b>57</b>
<b>3.4</b>	<b>Power-OFF and magnetic contactor (MC) .....</b>	<b>58</b>
<b>3.5</b>	<b>Precautions against deterioration of the 600 V class motor insulation .....</b>	<b>59</b>
<b>3.6</b>	<b>Checklist before starting operation .....</b>	<b>60</b>
<b>3.7</b>	<b>Failsafe system which uses the inverter .....</b>	<b>63</b>

# 3.1 Electro-magnetic interference (EMI) and leakage currents

## 3.1.1 Leakage currents and precautions

Capacitances exist between the inverter I/O cables, other cables and earth and in the motor, through which a leakage current flows. Since its value depends on the static capacitances, carrier frequency, etc., low acoustic noise operation at the increased carrier frequency of the inverter will increase the leakage current. Therefore, take the following precautions. Select the earth leakage current breaker according to its rated sensitivity current, independently of the carrier frequency setting.

### ◆ To-earth (ground) leakage currents

Leakage currents may flow not only into the inverter's own line but also into the other lines through the earthing (grounding) cable, etc. These leakage currents may operate earth leakage circuit breakers and earth leakage relays unnecessarily.

● Precautions

- If the carrier frequency setting is high, decrease the **Pr.72 PWM frequency selection** setting.  
Note that motor noise increases. Selecting **Pr.240 Soft-PWM operation selection** makes the sound inoffensive.
  - By using earth leakage circuit breakers designed for harmonic and surge suppression in the inverter's own line and other line, operation can be performed with the carrier frequency kept high (with low noise).
- To-earth (ground) leakage currents
- Take caution as long wiring will increase the leakage current. Decreasing the carrier frequency of the inverter reduces the leakage current.
  - Increasing the motor capacity increases the leakage current.

### ◆ Line-to-line leakage currents

Harmonics of leakage currents flowing in static capacitances between the inverter output cables may operate the external thermal relay unnecessarily.

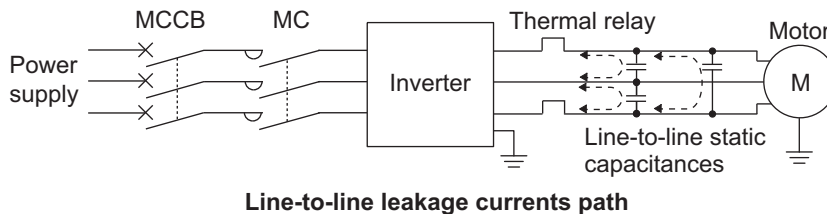

● Precautions

- Use **Pr.9 Electronic thermal O/L relay**.
  - If the carrier frequency setting is high, decrease the **Pr.72 PWM frequency selection** setting.  
Note that motor noise increases. Selecting **Pr.240 Soft-PWM operation selection** makes the sound inoffensive.  
To ensure that the motor is protected against line-to-line leakage currents, it is recommended to use a temperature sensor to directly detect motor temperature.
- Installation and selection of the molded case circuit breaker
- Install a molded case circuit breaker (MCCB) on the power receiving side to protect the wiring at the inverter input side. Select an MCCB according to the inverter input side power factor, which depends on the power supply voltage, output frequency and load. Especially for a completely electromagnetic MCCB, a slightly large capacity must be selected since its operation characteristic varies with harmonic currents. (Check it in the data of the corresponding breaker.)

### 3.1.2 Precautions against inverter-generated EMI

Some electromagnetic noises enter the inverter or the converter unit to cause its malfunction, and others are radiated by the inverter or the converter unit to cause the peripheral devices to malfunction. Though the inverter or the converter unit is designed to have high immunity performance, it handles low-level signals, so it requires the following basic techniques. Also, since the inverter chops outputs at high carrier frequency, that could generate electromagnetic noises. To prevent peripheral devices from malfunctioning due to electromagnetic noise, take precautions to suppress EMI. These techniques differ slightly depending on EMI paths.

- Basic techniques
  - Do not run the power cables (I/O cables) and signal cables of the inverter or the converter unit in parallel with each other and do not bundle them.
  - Use shielded twisted pair cables for the detector connecting and control signal cables and connect the sheathes of the shielded cables to terminal SD.
  - Ground (Earth) the inverter or the converter unit, motor, etc. at one point.

- Techniques to reduce electromagnetic noises that enter and cause a malfunction of the inverter or the converter unit (EMI precautions)

When devices that generate many electromagnetic noises (which use magnetic contactors, electromagnetic brakes, many relays, for example) are installed near the inverter or the converter unit and it may malfunction due to electromagnetic noises, the following precautions must be taken:

- Provide surge suppressors for devices that generate many electromagnetic noises to suppress electromagnetic noises.
- Install data line filters (page 56) to signal cables.
- Ground (Earth) the shields of the detector connection and control signal cables with cable clamp metal.

- Techniques to reduce electromagnetic noises that are radiated by the inverter or converter unit to cause the peripheral devices to malfunction (EMI precautions)

Noises generated from the inverter or the converter unit are largely classified into those radiated by the cables connected to the inverter or the converter unit and its main circuits (I/O), those electromagnetically and electrostatically induced to the signal cables of the peripheral devices close to the main circuit power supply, and those transmitted through the power supply cables.

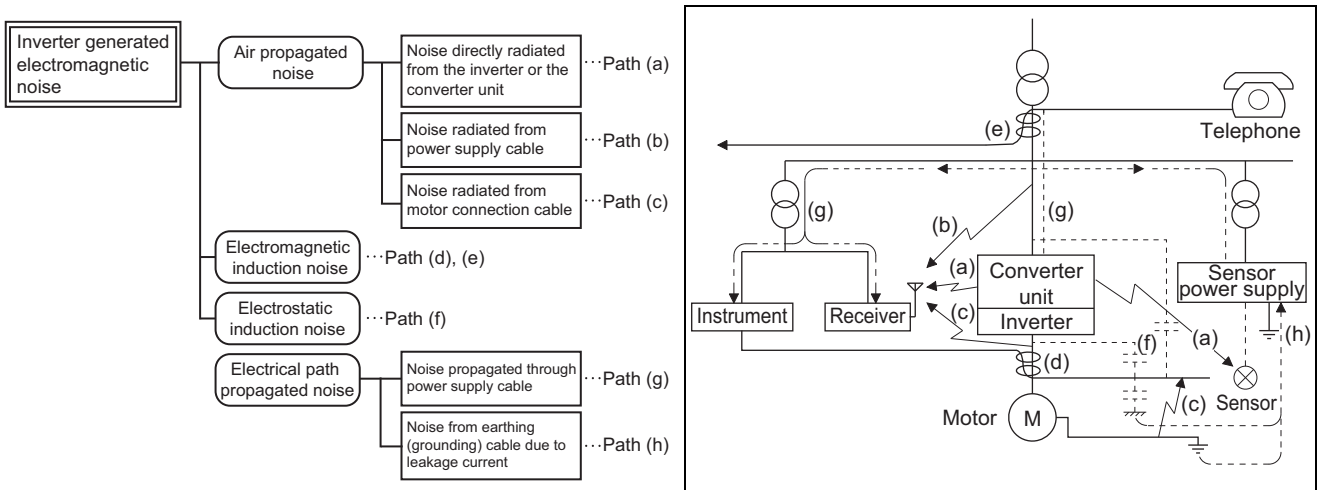



# Electro-magnetic interference (EMI) and leakage currents

Noise propagation path	Countermeasure
(a)(b)(c)	<p>When devices that handle low-level signals and are liable to malfunction due to electromagnetic noises, e.g. instruments, receivers and sensors, are contained in the enclosure that contains the inverter or the converter unit, or when their signal cables are run near the inverter, the devices may malfunction due to by air-propagated electromagnetic noises. The following precautions must be taken:</p> <ul style="list-style-type: none"> <li>• Install easily affected devices as far away as possible from the inverter or the converter unit.</li> <li>• Run easily affected signal cables as far away as possible from the inverter or the converter unit, and its I/O cables.</li> <li>• Do not run the signal cables and power cables (inverter or converter unit I/O cables) in parallel with each other and do not bundle them.</li> <li>• Inserting a line noise filter into the output suppresses the radiated noise from the cables.</li> <li>• Use shielded cables as signal cables and power cables and run them in individual metal conduits to produce further effects.</li> </ul>
(d)(e)(f)	<p>When the signal cables are run in parallel with or bundled with the power cables, magnetic and static induction noises may be propagated to the signal cables to cause malfunction of the devices and the following precautions must be taken:</p> <ul style="list-style-type: none"> <li>• Install easily affected devices as far away as possible from the inverter or the converter unit.</li> <li>• Run easily affected signal cables as far away as possible from the inverter or the converter unit, and its I/O cables.</li> <li>• Do not run the signal cables and power cables (inverter or converter unit I/O cables) in parallel with each other and do not bundle them.</li> <li>• Use shielded cables as signal cables and power cables and run them in individual metal conduits to produce further effects.</li> </ul>
(g)	<p>When the power supplies of the peripheral devices are connected to the power supply of the inverter or the converter unit in the same line, its generated noises may flow back through the power supply cables to cause malfunction of the devices and the following precautions must be taken:</p> <ul style="list-style-type: none"> <li>• Install the line noise filter to the power cables (output cables) of the inverter.</li> </ul>
(h)	<p>When a closed loop circuit is formed by connecting the peripheral device wiring to the inverter or the converter unit, leakage currents may flow through the earthing (grounding) cable of the inverter or the converter unit to cause the device to malfunction. In that case, disconnecting the earthing (grounding) cable from the device may stop the malfunction of the device.</p>

## ●Data line filter

Data line filter is effective as an EMI precautions. Provide a data line filter for the detector cable, etc.

## ●EMI precautions example

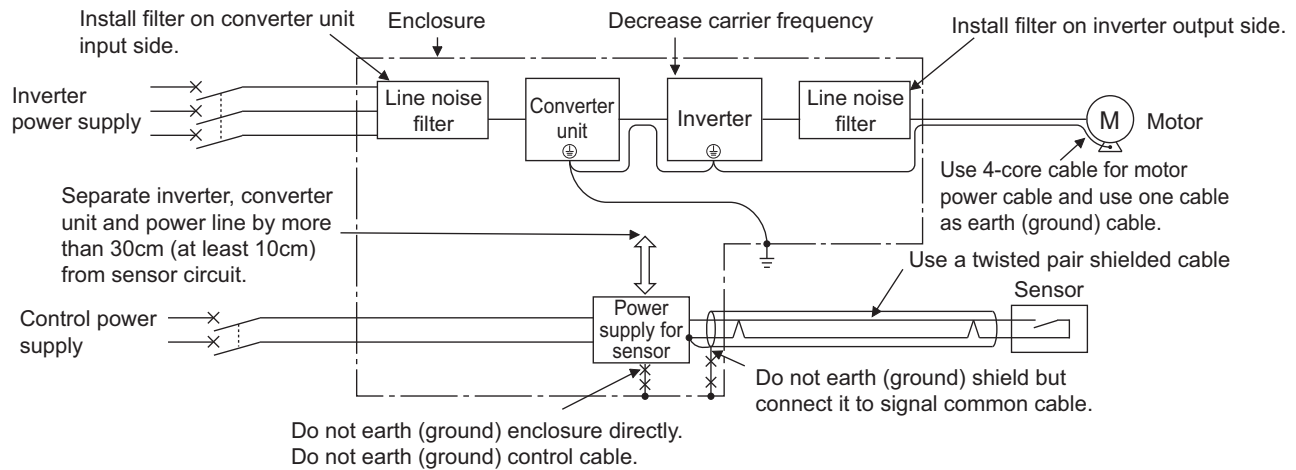

## 3.2 Power supply harmonics

### 3.2.1 Power supply harmonics

The inverter may generate power supply harmonics from its converter circuit to affect the power generator, power factor correction capacitor etc. Power supply harmonics are different from noise and leakage currents in source, frequency band and transmission path. Take the following precaution suppression techniques.

- The differences between harmonics and noises

Item	Harmonics	Noise
Frequency	Normally 40th to 50th degrees or less (3 kHz or less).	High frequency (several 10 kHz to 1 GHz order).
Environment	To-electric channel, power impedance.	To-space, distance, wiring path,
Quantitative understanding	Theoretical calculation possible.	Random occurrence, quantitative grasping difficult.
Generated amount	Nearly proportional to the load capacity.	Changes with the current variation ratio. (Gets larger as switching speed increases.)
Affected equipment immunity	Specified by standards per equipment.	Different depending on maker's equipment specifications.
Precaution	Provide a reactor.	Increase distance.

- Precautions

The harmonic current generated from the inverter to the input side differs according to various conditions such as the wiring impedance, whether a reactor is used or not, and output frequency and output current on the load side. For the output frequency and output current, we understand that this should be calculated in the conditions under the rated load at the maximum operating frequency.

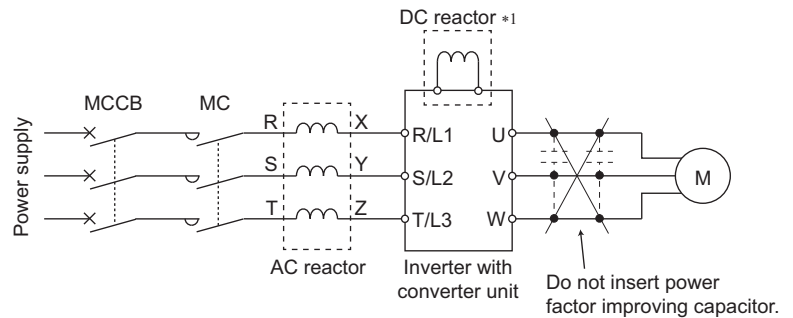

\*1 The converter unit (FR-CC2) is equipped with the DC reactor.

#### NOTE

- The power factor improving capacitor and surge suppressor on the inverter output side may be overheated or damaged by the harmonic components of the inverter output. Also, since an excessive current flows in the inverter to activate overcurrent protection, do not provide a capacitor and surge suppressor on the inverter output side when the motor is driven by the inverter. For power factor improvement, install a reactor on the inverter input side or in the DC circuit.

## 3.3 Installation of a reactor

When the inverter is connected near a large-capacity power transformer (1000 kVA or more) or when a power factor correction capacitor is to be switched over, an excessive peak current may flow in the power input circuit, damaging the converter circuit. To prevent this, always install an AC reactor.

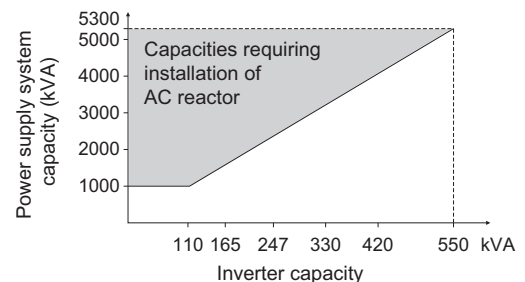
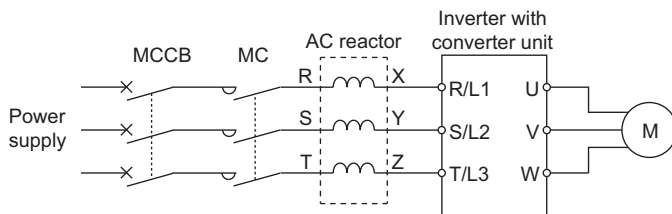

## 3.4 Power-OFF and magnetic contactor (MC)

### ◆ Converter unit input side magnetic contactor (MC)

On the converter unit input side, it is recommended to provide an MC for the following purposes:

(Refer to [page 14](#) for selection.)

- To disconnect the inverter from the power supply at activation of a protective function or at malfunctioning of the driving system (emergency stop, etc.).
- To prevent any accident due to an automatic restart at power restoration after an inverter stop made by a power failure.
- To separate the inverter from the power supply to ensure safe maintenance and inspection work.

If using an MC for emergency stop during operation, select an MC regarding the converter unit input side current as JEM 1038-AC-3 class rated current.

#### NOTE

- Since repeated inrush currents at power ON will shorten the life of the converter circuit (switching life is about 1,000,000 times), frequent starts and stops of the magnetic contactor must be avoided. Turn ON/OFF the inverter start controlling terminals (STF, STR) to run/stop the inverter.
- Inverter start/stop circuit example

As shown below, always use the start signal (ON or OFF of STF(STR) signal) to make a start or stop.

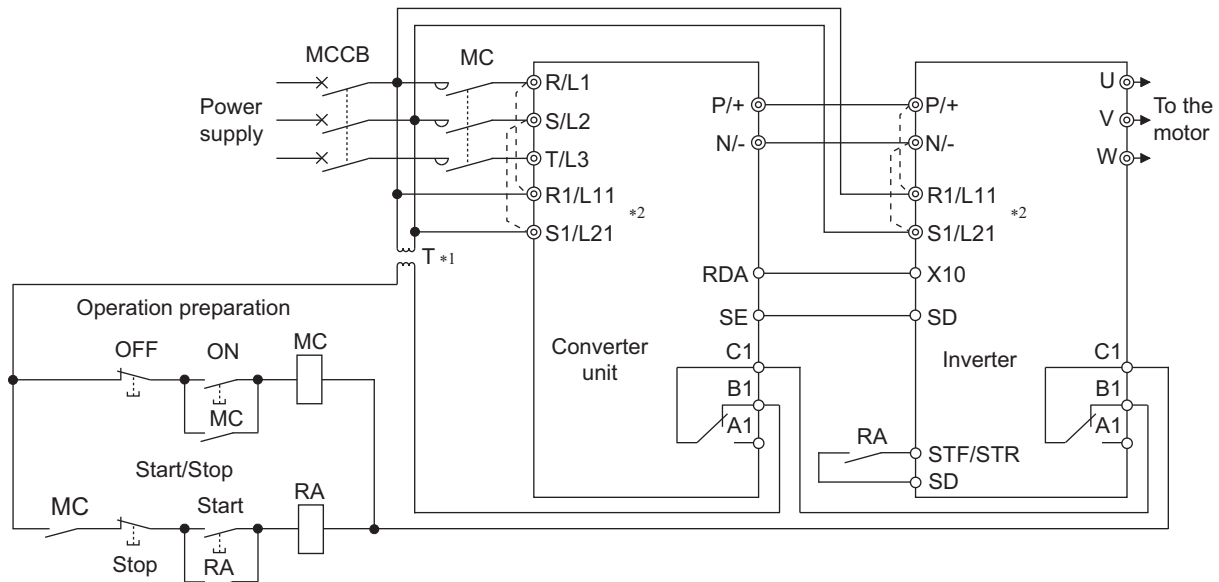

\*1 Install a stepdown transformer.

\*2 Connect the power supply terminals R1/L11, S1/L21 of the control circuit to the input side of the MC to hold an alarm signal when the inverter's protective circuit is activated. At this time, remove jumpers across terminals R1/L11 and S1/L21. (Refer to [page 41](#) for removal of the jumper.)

### ◆ Handling of the magnetic contactor on the inverter's output side

Switch the magnetic contactor between the inverter and motor only when both the inverter and motor are at a stop. When the magnetic contactor is turned ON while the inverter is operating, overcurrent protection of the inverter and such will activate. When an MC is provided to switch to a commercial power supply, for example, it is recommended to use the electronic bypass function [Pr.135 to Pr.139](#). (The commercial power supply operation is not available with vector control dedicated motors nor with PM motors.)

### ◆ Handling of the manual contactor on the inverter's output side

A PM motor is a synchronous motor with high-performance magnets embedded inside. High-voltage is generated at the motor terminals while the motor is running even after the inverter power is turned OFF. In an application where the PM motor is driven by the load even after the inverter is powered OFF, a low-voltage manual contactor must be connected at the inverter's output side.

**NOTE**

- Before wiring or inspection for a PM motor, confirm that the PM motor is stopped. In an application, such as fan and blower, where the motor is driven by the load, a low-voltage manual contactor must be connected at the inverter's output side, and wiring and inspection must be performed while the contactor is open. Otherwise you may get an electric shock.
- Do not open or close the contactor while the inverter is running (outputting).

## 3.5 Precautions against deterioration of the 600 V class motor insulation

In the PWM type inverter, a surge voltage attributable to wiring constants is generated at the motor terminals. Especially for a 600 V class motor, the surge voltage may deteriorate the insulation.

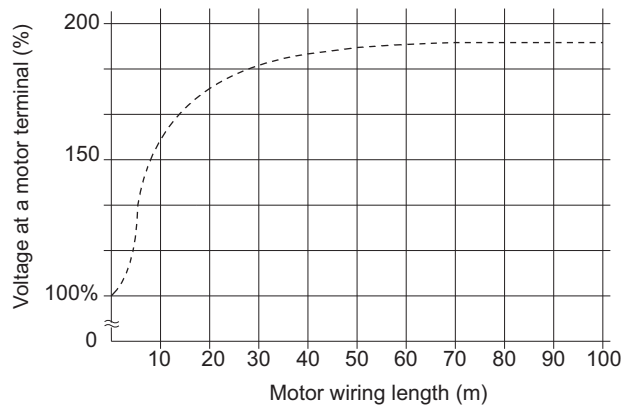

Surge voltage at a motor terminal by motor wiring length (reference)

When the 600 V class motor is driven by the inverter, consider the following measures:

### ◆ Measures

- Inverter duty motor  
Select an inverter duty motor. Many motor manufacturers sell motors with insulation systems designed to withstand the stress imposed by PWM inverters
- AC reactor  
For added protection, install an AC reactor on the inverter output

## 3.6 Checklist before starting operation

The FR-A860 series inverter and FR-CC2 converter unit are highly reliable products, but incorrect peripheral circuit making or operation/handling method may shorten the product life or damage the products.

Before starting operation, always recheck the following points.

Checkpoint	Countermeasure	Refer to page	Check by user
Crimp terminals are insulated.	Use crimp terminals with insulation sleeves to wire the power supply and the motor.	-	
The wiring between the power supply (R/L1, S/L2, T/L3) and the motor (U, V, W) is correct.	Application of power to the output terminals (U, V, W) of the inverter will damage the inverter. Never perform such wiring.	28	
No wire offcuts are left from the time of wiring.	Wire offcuts can cause an alarm, failure or malfunction. Always keep the inverter and the converter unit clean. When drilling mounting holes in an enclosure etc., take caution not to allow chips and other foreign matter to enter the inverter and the converter unit.	-	
The main circuit cable gauge is correctly selected.	Use an appropriate cable gauge to suppress the voltage drop to 2% or less. If the wiring distance is long between the inverter and motor, the voltage drop in the main circuit will cause the motor torque to decrease especially during the output of a low frequency.	29	
The total wiring length is within the specified length.	Keep the total wiring length is within the specified length. In long distance wiring, charging currents due to stray capacitance in the wiring may degrade the fast-response current limit operation or cause the equipment on the inverter's output side to malfunction. Pay attention to the total wiring length.	29	
Precautions are taken against EMI.	The input/output (main circuit) of the inverter and the converter unit includes high frequency components, which may interfere with the communication devices (such as AM radios) used near the inverter and the converter unit. In such case, install a noise filter to minimize interference.	55	
Countermeasures are taken against electrical corrosion on the motor bearing.	When a motor is driven by the inverter, axial voltage is generated on the motor shaft, which may cause electrical corrosion of the bearing in rare cases depending on the wiring, load, operating conditions of the motor or a specific inverter setting (high carrier frequency). Contact your sales representative to take appropriate countermeasures for the motor. The following shows examples of countermeasures for the inverter. • Decrease the carrier frequency. • Provide a common mode choke on the output side of the inverter. *1  *1 Recommended common mode choke: FT-3KM F series FINEMET® common mode choke cores manufactured by Hitachi Metals, Ltd. FINEMET is a registered trademark of Hitachi Metals, Ltd.	-	
On the inverter's output side, there is no power factor correction capacitor, surge suppressor, or radio noise filter installed.	Doing so will cause the inverter to trip or the capacitor and surge suppressor to be damaged. If any of the above devices is connected, immediately remove it.	-	
When performing an inspection or rewiring on the product that has been energized, the operator has waited long enough after shutting off the power supply.	For a short time after the power-OFF, a high voltage remains in the smoothing capacitor, and it is dangerous. Before performing an inspection or rewiring, wait 10 minutes or longer after the power supply turns OFF, then confirm that the voltage across the main circuit terminals P/+ and N/- of the inverter is low enough using a tester, etc.	-	
The inverter's output side has no short circuit or ground fault occurring.	• A short circuit or earth (ground) fault on the inverter's output side may damage the inverter module. • Fully check the insulation resistance of the circuit prior to inverter operation since repeated short circuits caused by peripheral circuit inadequacy or an earth (ground) fault caused by wiring inadequacy or reduced motor insulation resistance may damage the inverter module. • Fully check the to-earth (ground) insulation and phase-to-phase insulation of the inverter's output side before power-ON. Especially for an old motor or use in hostile atmosphere, securely check the motor insulation resistance, etc.	-	
The circuit is not configured to use the converter unit's input-side magnetic contactor to start/stop the inverter frequently.	Since repeated inrush currents at power ON will shorten the life of the inverter and the converter unit, frequent starts and stops of the magnetic contactor must be avoided. Turn ON/OFF the inverter's start signals (STF, STR) to run/ stop the inverter.	58	

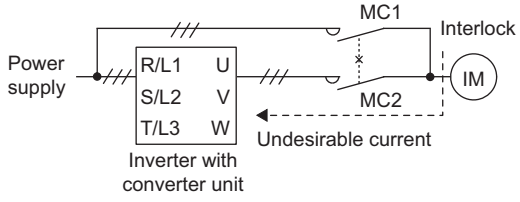
Checkpoint	Countermeasure	Refer to page	Check by user
The voltage applied to the I/O signal circuits of the inverter and the converter unit is within the specifications.	Application of a voltage higher than the permissible voltage to the I/O signal circuits of the inverter and the converter unit or opposite polarity may damage the I/O devices. Especially check the wiring to prevent the speed setting potentiometer from being connected incorrectly to short circuit terminals 10E and 5.	32	
The converter unit and the inverter are correctly connected.	<ul style="list-style-type: none"> <li>Make sure that terminal P/+ of the converter unit and terminal P/+ of the inverter, and terminal N/- of the converter unit and terminal N/- of the inverter are correctly connected. Connecting the opposite polarity of terminals N/- and P/+ will damage the inverter.</li> <li>Also, do not install an MCCB across terminals P/+ and N/- (across terminals P and P/+ or across N and N/-).</li> <li>Always connect terminal RDA of the converter unit and terminal MRS (X10) of the inverter, and terminal SE of the converter unit and terminal SD (terminal PC for source logic) of the inverter.</li> <li>Not connecting these terminals may damage the converter unit.</li> </ul>	26	
When using the electronic bypass operation, electrical and mechanical interlocks are provided between the electronic bypass contactors MC1 and MC2.	<p>When using a switching circuit as shown below, chattering due to mis-configured sequence or arc generated at switching may allow undesirable current to flow in and damage the inverter. Mis-wiring may also damage the inverter. (The commercial power supply operation is not available with vector control dedicated motors nor with PM motors.)</p>  <p>If switching to the commercial power supply operation while a failure such as an output short circuit has occurred between the magnetic contactor MC2 and the motor, the damage may further spread. If a failure has occurred between the MC2 and the motor, a protection circuit such as using the OH signal input must be provided.</p>	-	
Precautions are taken for power restoration after a power failure.	If the machine must not be restarted when power is restored after a power failure, provide an MC in the converter unit's input side and also make up a sequence which will not switch ON the start signal. If the start signal (start switch) remains ON after a power failure, the inverter will automatically restart as soon as the power is restored.	-	
When using the vector control, the encoder is properly installed.	The encoder must be directly connected to a motor shaft without any backlash. (Real sensorless vector control, PM sensorless vector control do not require an encoder.)	47	
A magnetic contactor (MC) is installed on the converter unit's input side.	<p>On the converter unit's input side, connect an MC for the following purposes:</p> <ul style="list-style-type: none"> <li>To disconnect the inverter and the converter unit from the power supply at activation of a protective function or at malfunctioning of the driving system (emergency stop, etc.).</li> <li>To prevent any accident due to an automatic restart at power restoration after an inverter stop made by a power failure.</li> <li>To separate the inverter and the converter unit from the power supply to ensure safe maintenance and inspection work.</li> </ul> <p>If using an MC for emergency stop during operation, select an MC regarding the converter unit input side current as JEM 1038-AC-3 class rated current.</p>	58	
The magnetic contactor on the inverter's output side is properly handled.	Switch the magnetic contactor between the inverter and motor only when both the inverter and motor are at a stop.	58	
When using a PM motor, a low-voltage manual contactor is installed on the inverter's output side.	A PM motor is a synchronous motor with high-performance magnets embedded inside. High-voltage is generated at the motor terminals while the motor is running even after the inverter power is turned OFF. In an application, such as fan and blower, where the motor is driven by the load, a low-voltage manual contactor must be connected at the inverter's output side, and wiring and inspection must be performed while the contactor is open. Otherwise you may get an electric shock.	58	

## Checklist before starting operation

Checkpoint	Countermeasure	Refer to page	Check by user
EMC precautions are taken for the frequency setting signals.	<p>If electromagnetic noise generated from the inverter and the converter unit causes frequency setting signal to fluctuate and the motor rotation speed to be unstable when changing the motor speed with analog signals, the following precautions are effective:</p> <ul style="list-style-type: none"> <li>• Do not run the signal cables and power cables (inverter and converter unit I/O cables) in parallel with each other and do not bundle them.</li> <li>• Run signal cables as far away as possible from power cables (inverter and converter I/O cables).</li> <li>• Use shielded cables.</li> <li>• Install a ferrite core on the signal cable.</li> </ul>	-	
A countermeasure is provided for an overload operation.	<p>When performing frequent starts/stops by the inverter, rise/fall in the temperature of the transistor element of the inverter will repeat due to a repeated flow of large current, shortening the life from thermal fatigue. Since thermal fatigue is related to the amount of current, the life can be increased by reducing current at locked condition, starting current, etc. Reducing current may extend the service life but may also cause torque shortage, which leads to a start failure. Adding a margin to the current can eliminate such a condition. For an induction motor, use the inverter and the converter unit of a higher capacity (up to two ranks). For a PM motor, use the inverter and the converter unit, and PM motor of higher capacities.</p>	-	
The specifications and rating match the system requirements.	Make sure that the specifications and rating match the system requirements.	-	

## 3.7 Failsafe system which uses the inverter

When a fault is detected by the protective function, the protective function is activated to output a fault signal. However, a fault signal may not be output at an inverter's fault occurrence when the detection circuit or output circuit fails, etc. Although Mitsubishi Electric assures the best quality products, provide an interlock which uses inverter status output signals to prevent accidents such as damage to the machine when the inverter fails for some reason. Also at the same time consider the system configuration where a failsafe from outside the inverter, without using the inverter, is enabled even if the inverter fails.

### ◆ Interlock method which uses the inverter status output signals

By combining the inverter output signals to provide an interlock as shown below, an inverter failure can be detected.

No.	Interlock method	Check method	Used signals
a	Inverter protective function operation	Operation check of an alarm contact. Circuit error detection by negative logic.	Fault (ALM) signal
b	Inverter operating status	Operation ready signal check.	Inverter operation ready (RY) signal
c	Inverter running status	Logic check of the start signal and running signal.	Start signal (STF signal, STR signal) Inverter running signal (RUN signal)
d	Inverter running status	Logic check of the start signal and output current.	Start signal (STF signal, STR signal) Output current detection (Y12) signal

(a) Checking by the output of the inverter fault signal

When the inverter's protective function is activated and the inverter trips, the Fault (ALM) signal is output. (The ALM signal is assigned to terminal A1B1C1 in the initial setting).

With this signal, check that the inverter operates properly.

In addition, negative logic can be set. (ON when the inverter is normal, OFF when the fault occurs.)

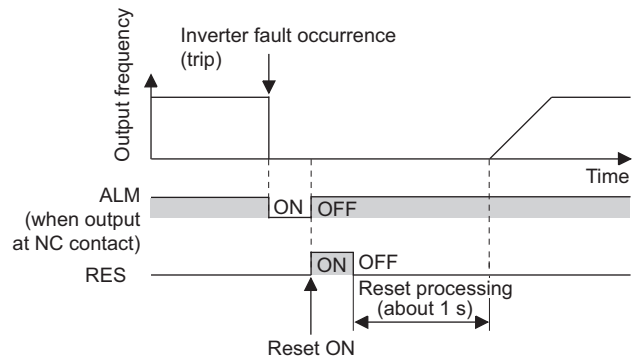

(b) Checking the inverter operating status by the inverter operation ready completion signal

The Inverter operation ready (RY) signal is output when the inverter power is ON and the inverter becomes operative.

Check if the RY signal is output after powering ON the inverter.

(c) Checking the inverter operating status by the start signal input to the inverter and inverter running signal

The Inverter running (RUN) signal is output when the inverter is running. (The RUN signal is assigned to terminal RUN in the initial setting.)

Check if the Y12 signal is being output while inputting a start signal to the inverter. (The STF signal is a forward rotation signal, and the STR signal is a reverse rotation signal.) Even after the start signal is turned OFF, the RUN signal is kept output until the inverter makes the motor to decelerate and to stop. For the logic check, configure a sequence considering the inverter's deceleration time.

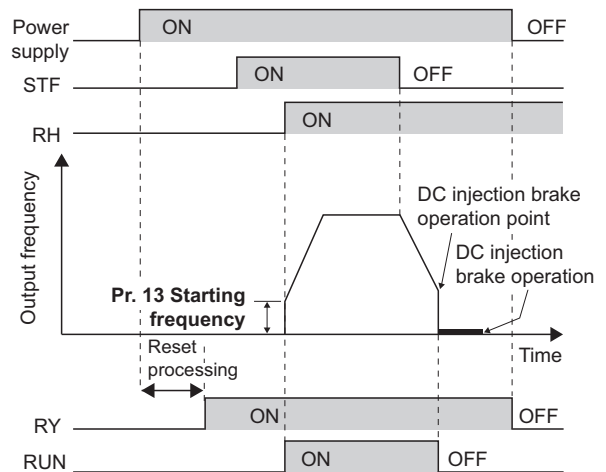



## Failsafe system which uses the inverter

- (d) Checking the motor operating status by the start signal input to the inverter and inverter output current detection signal  
 The Output current detection (Y12) signal is output when the inverter operates and current flows into the motor.  
 Check if the Y12 signal is being output while inputting a start signal to the inverter. (The STF signal is a forward rotation signal, and the STR signal is a reverse rotation signal.) The Y12 signal is initially set to be output at 150% rated inverter current. Adjust the level to around 20% using no load current of the motor as reference with **Pr.150 Output current detection level**.

Like the Inverter running (RUN) signal, even after the start signal is turned OFF, the Y12 signal is kept output until the inverter stops the output to a decelerating motor. For the logic check, configure a sequence considering the inverter's deceleration time.

Output signal	Pr.190 to Pr.196 setting	
	Positive logic	Negative logic
ALM	99	199
RY	11	111
RUN	0	100
Y12	12	112

- When using various signals, assign the functions to **Pr.190 and Pr.196 (Output terminal function selection)** referring to the table on the left.

### NOTE

- Changing the terminal assignment using **Pr.190 and Pr.196 (Output terminal function selection)** may affect the other functions. Set parameters after confirming the function of each terminal.
- For the details of the parameters and signals, refer to the Instruction Manual (Detailed) of the FR-A860.

## ◆ Backup method outside the inverter

Even if the interlock is provided by the inverter status signal, enough failsafe is not ensured depending on the failure status of the inverter itself. For example, if an inverter CPU fails in a system interlocked with the inverter's fault, start, and RUN signals, no fault signal will be output and the RUN signal will be kept ON because the inverter CPU is down.

Provide a speed detector to detect the motor speed and current detector to detect the motor current and consider the backup system such as performing a check as below according to the level of importance of the system.

- (a) Start signal and actual operation check

Check the motor running and motor current while the start signal is input to the inverter by comparing the start signal to the inverter and detected speed of the speed detector or detected current of the current detector. Note that the current is flowing through the motor while the motor coasts to stop, even after the inverter's start signal is turned OFF. For the logic check, configure a sequence considering the inverter's deceleration time. In addition, it is recommended to check the three-phase current when using the current detector.

- (b) Command speed and actual operation check

Check for a gap between the actual speed and commanded speed by comparing the inverter's speed command and the speed detected by the speed detector.

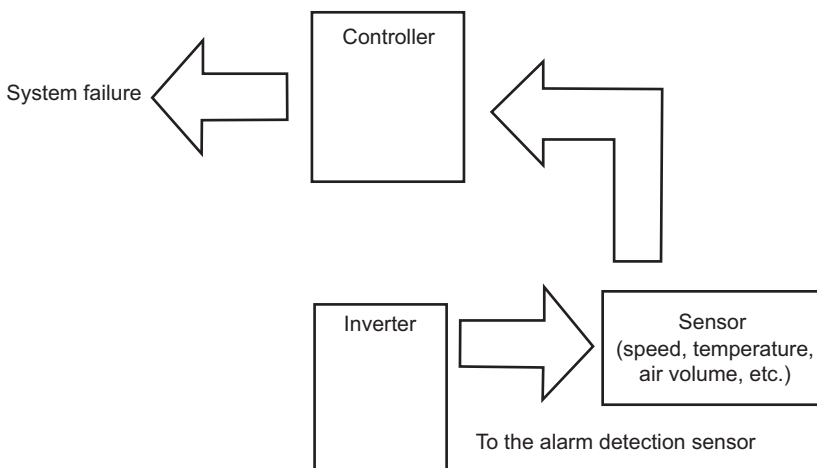

---

# **4** PROTECTIVE FUNCTIONS

---

This chapter explains the "PROTECTIVE FUNCTIONS" that operates in this product.

Always read the instructions before using the equipment.

---

<b>4.1</b>	<b>Inverter fault and indications.....</b>	<b>66</b>
<b>4.2</b>	<b>Reset method for the protective functions.....</b>	<b>66</b>
<b>4.3</b>	<b>List of fault displays .....</b>	<b>67</b>

# 4.1 Inverter fault and indications

- When a fault occurs in the inverter, a protective function is automatically activated to shut off the inverter output and show an indication on the operation panel of the inverter.
- When any fault occurs, take an appropriate corrective action, then reset the inverter, and resume the operation. Restarting the operation without a reset may break or damage the inverter.
- When a protective function is activated, note the following points.

Item	Description
Fault output signal	Opening the magnetic contactor (MC) provided on the input side of the inverter at a fault occurrence shuts off the control power to the inverter, therefore, the fault output will not be retained.
Fault or alarm indication	When a protective function is activated, the operation panel displays a fault indication.
Operation restart method	While a protective function is activated, the inverter output is kept shutoff. Reset the inverter to restart the operation.

- Inverter fault or alarm indications are categorized as below.

Displayed item	Description
Error message	A message regarding an operational fault and setting fault by the operation panel and parameter unit is displayed. The inverter output is not shut off.
Warning	The inverter output is not shut off even when a warning is displayed. However, failure to take appropriate measures will lead to a fault.
Alarm	The inverter output is not shut off. An Alarm (LF) signal can also be output with a parameter setting.
Fault	A protective function is activated to shut off the inverter output and output a Fault (ALM) signal.

**NOTE**

- For the details of fault displays and other malfunctions, refer to the Instruction Manual (Detailed) of the FR-A860.
- The past eight faults can be displayed on the operation panel. (Fault history) (For the operation, refer to the operation panel or the parameter unit Instruction Manual.)

# 4.2 Reset method for the protective functions

Reset the inverter by performing any of the following operations. Note that the accumulated heat value of the electronic thermal relay function and the number of retries are cleared (erased) by resetting the inverter.

The inverter recovers about 1 s after the reset is released.

- On the operation panel, press the STOP/RESET key to reset the inverter.  
(This may only be performed when a fault occurs.)
- Switch power OFF once, then switch it ON again.
- Turn ON the Inverter reset (RES) signal for 0.1 s or more. (If the RES signal is kept ON, "Err" appears (blinks) to indicate that the inverter is in a reset status.)

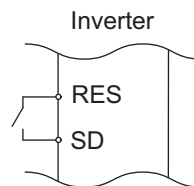
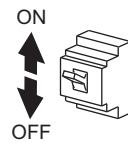
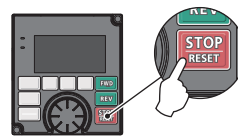

**NOTE**

- OFF status of the start signal must be confirmed before resetting the inverter fault. Resetting an inverter fault with the start signal ON restarts the motor suddenly.

## 4.3 List of fault displays

For details, refer to the Instruction Manual (Detailed) of the FR-A860.

Abbreviation		Name	Abbreviation		Name	
Error message	HOLD	Operation panel lock	Fault	E.GF	Output side earth (ground) fault overcurrent	
	LOCD	Password locked		E.LF	Output phase loss	
	Er1 to Er4 Er8	Parameter write error		E.OHT	External thermal relay operation	
	rE1 to rE8	Copy operation error		E.PTC	PTC thermistor operation	
	Err.	RES signal ON or communication circuit fault		E.OPT	Option fault	
Warning	OL	Stall prevention (overcurrent)		E.OP1 to E.OP3	Communication option fault	
	oL	Stall prevention (overvoltage)		E.16 to E.20	User definition error by the PLC function	
	TH	Electronic thermal relay function pre-alarm		E.PE	Parameter storage device fault	
	PS	PU stop		E.PUE	PU disconnection	
	SL	Speed limit indication (output during speed limit)		E.RET	Retry count excess	
	CF	Continuous operation during communication fault		E.PE2	Parameter storage device fault	
	CP	Parameter copy		E.CPU E. 5 to E. 7	CPU fault	
	SA	SA		E.CTE	Operation panel power supply short circuit RS-485 terminals power supply short circuit	
	MT1 to MT3	Maintenance timer 1 to 3		E.P24	24 VDC power fault	
	UF	USB host error		E.CDO	Abnormal output current detection	
	HP1	Home position return setting error		E.SER	Communication fault (inverter)	
	HP2	Home position return uncompleted		E.AIE	Analog input fault	
	HP3	Home position return parameter setting error		E.USB	USB communication fault	
	Alarm	FN		Fan alarm	E.SAF	Safety circuit fault
	Fault	E.OC1		Overcurrent trip during acceleration	E.PBT E.13	Internal circuit fault
E.OC2		Overcurrent trip during constant speed	E.OS	Overspeed occurrence		
E.OC3		Overcurrent trip during deceleration or stop	E.OSD	Speed deviation excess detection		
E.OV1		Regenerative overvoltage trip during acceleration	E.ECT	Signal loss detection		
E.OV2		Regenerative overvoltage trip during constant speed	E.OD	Excessive position fault		
E.OV3		Regenerative overvoltage trip during deceleration or stop	E.MB1 to E.MB7	Brake sequence fault		
E.THT		Inverter overload trip (electronic thermal relay function)	E.EP	Encoder phase fault		
E.THM		Motor overload trip (electronic thermal relay function)	E.MP	Magnetic pole position unknown		
E.FIN		Heat sink overheat	E.EF	External fault during output operation		
E.OLT		Stall prevention stop	E.LCI	4 mA input fault		
E.SOT		Loss of synchronism detection	E.PCH	Pre-charge fault		
			E.PID	PID signal fault		
		E. 1 to E. 3	Option fault			
		E.11	Opposite rotation deceleration fault			
		Others	E.0	No fault history		
			RD	Backup in progress		
			WR	Restoration in progress		

If faults other than the above appear, contact your sales representative.

# MEMO

---

# **5 PRECAUTIONS FOR MAINTENANCE AND INSPECTION**

---

This chapter explains the "PRECAUTIONS FOR MAINTENANCE AND INSPECTION" for this product.

Always read the instructions before using the equipment.

---

<b>5.1</b>	<b>Inspection item.....</b>	<b>70</b>
<b>5.2</b>	<b>Measurement of main circuit voltages, currents and powers .....</b>	<b>77</b>

## Inspection item

---

The inverter is a static unit mainly consisting of semiconductor devices. Daily inspection must be performed to prevent any fault from occurring due to the adverse effects of the operating environment, such as temperature, humidity, dust, dirt and vibration, changes in the parts with time, service life, and other factors.

### ●Precautions for maintenance and inspection

When accessing the inverter for inspection, wait for at least 10 minutes after the power supply has been switched OFF, and then make sure that the voltage across the main circuit terminals P/+ and N/- of the inverter is not more than 30 VDC using a tester, etc.

## 5.1 Inspection item

---

### 5.1.1 Daily inspection

Basically, check for the following faults during operation.

- Motor operation fault
- Improper installation environment
- Cooling system fault
- Abnormal vibration, abnormal noise
- Abnormal overheat, discoloration

### 5.1.2 Periodic inspection

Check the areas inaccessible during operation and requiring periodic inspection.

Consult us for periodic inspection.

- Check and clean the cooling system. .... Clean the air filter, etc.
- Check the tightening and retighten. .... The screws and bolts may become loose due to vibration, temperature changes, etc. Check and tighten them.  
Tighten them according to the specified tightening torque. (Refer to [page 29](#).)
- Check the conductors and insulating materials for corrosion and damage.
- Measure the insulation resistance.
- Check and change the cooling fan and relay.

### 5.1.3 Daily and periodic inspection

Area of inspection	Inspection item	Description	Inspection interval		Corrective action at fault occurrence	Check by the user	
			Daily	Periodic *3			
General	Surrounding environment	Check the surrounding air temperature, humidity, dirt, corrosive gas, oil mist, etc.	○		Improve the environment.		
	Overall unit	Check for unusual vibration and noise.	○		Check fault location and retighten.		
		Check for dirt, oil, and other foreign material.*1	○		Clean.		
	Power supply voltage	Check that the main circuit voltages and control voltages are normal.*2	○		Inspect the power supply.		
Main circuit	General	(1) Check with megger (across main circuit terminals and earth (ground) terminal).		○	Contact the manufacturer.		
		(2) Check for loose screws and bolts.		○	Retighten.		
		(3) Check for overheat traces on the parts.		○	Contact the manufacturer.		
		(4) Check for stain.		○	Clean.		
	Conductors, cables	(1) Check conductors for distortion.		○	Contact the manufacturer.		
		(2) Check cable sheaths for breakage and deterioration (crack, discoloration, etc.).		○	Contact the manufacturer.		
Transformer/reactor	Check for unusual odor and abnormal increase of whining sound.	○		Stop the equipment and contact the manufacturer.			
Terminal block	Check for a damage.		○	Stop the equipment and contact the manufacturer.			
Smoothing aluminum electrolytic capacitor	(1) Check for liquid leakage.		○	Contact the manufacturer.			
	(2) Check for safety valve projection and bulge.		○	Contact the manufacturer.			
Relay/contactors	(3) Judge by visual check		○				
	Check that the operation is normal and no chattering sound is heard.		○	Contact the manufacturer.			
Control circuit, protective circuit	Operation check	(1) Check that the output voltages across phases are balanced while operating the inverter alone.		○	Contact the manufacturer.		
		(2) Check that no fault is found in protective and display circuits in a sequence protective operation test.		○	Contact the manufacturer.		
	Components check	Overall	(1) Check for unusual odor and discoloration.		○	Stop the equipment and contact the manufacturer.	
		(2) Check for serious rust development.		○	Contact the manufacturer.		
Aluminum electrolytic capacitor	(1) Check for liquid leakage in a capacitor and deformation trace.		○	Contact the manufacturer.			
	(2) Visual check and judge by the life check of the control circuit capacitor. (Refer to the Instruction Manual (Detailed) of the FR-A860.)		○				
Cooling system	Cooling fan	(1) Check for unusual vibration and noise.	○		Replace the fan.		
		(2) Check for loose screws and bolts.		○	Fix with the fan cover fixing screws		
(3) Check for stain.			○	Clean.			
Heat sink	(1) Check for clogging.		○	Clean.			
	(2) Check for stain.		○	Clean.			
Display	Indication	(1) Check that indications are correct.	○		Contact the manufacturer.		
	(2) Check for stain.		○	Clean.			
Meter/counter	Check that readouts are correct.	○		Stop the equipment and contact the manufacturer.			
Load motor	Operation check	Check for vibration and abnormal increase in operation noise.	○		Stop the equipment and contact the manufacturer.		

\*1 Oil component of the heat dissipation grease used inside the inverter may leak out. The oil component, however, is not flammable, corrosive, nor conductive and is not harmful to humans. Wipe off such oil component.

\*2 It is recommended to install a voltage monitoring device for checking the voltage of the power supplied to the inverter.

\*3 One to two years of periodic inspection cycle is recommended. However, it differs according to the installation environment. Consult us for periodic inspection.



• Continuous use of a leaked, deformed, or degraded smoothing aluminum electrolytic capacitor (as shown in the table above) may lead to a burst, breakage or fire. Replace such capacitor without delay.



## 5.1.4 Checking the inverter and converter modules

### ◆Preparation

- Disconnect the external power supply cables (R/L1, S/L2, T/L3) and motor cables (U, V, W). (The inverter and the converter unit (FR-CC2) can be measured with those cables connected.)
- Prepare a continuity tester. (For the resistance measurement, use the 100 Ω range.)

### ◆Checking method

Change the polarity of the tester alternately at a semiconductor device (transistor) on an electrical path between two terminals among the inverter main circuit terminals R/L1, S/L2, T/L3, U, V, W, P/+, and N/- to check the electric continuity.

#### NOTE

- Before measurement, check that the smoothing capacitor is discharged.
- At the time of electric discontinuity, the measured value is almost ∞. When there is an instantaneous electric continuity, due to the smoothing capacitor, the tester may not indicate ∞. At the time of electric continuity, the measured value is several Ω to several tens of Ω. When all measured values are almost the same (although values may not be constant depending on the tester type), it shows that there are no electrical paths with problems.

### ◆Device number and target terminal

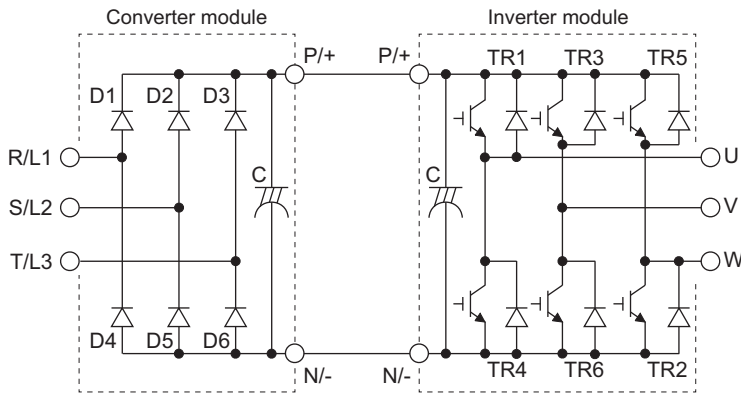

		Tester polarity		Continuity			Tester polarity		Continuity
		⊕	⊖				⊕	⊖	
Converter module	D1	R/L1, P/+		No	D4	R/L1, N/-		Yes	
		P/+ R/L1,		Yes		N/- R/L1,		No	
	D2	S/L2, P/+		No	D5	S/L2, N/-		Yes	
		P/+ S/L2,		Yes		N/- S/L2,		No	
	D3	T/L3 P/+		No	D6	T/L3 N/-		Yes	
		P/+ T/L3		Yes		N/- T/L3		No	
Inverter module	TR1	U P/+		No	TR4	U N/-		Yes	
		P/+ U		Yes		N/- U		No	
	TR3	V P/+		No	TR6	V N/-		Yes	
		P/+ V		Yes		N/- V		No	
	TR5	W P/+		No	TR2	W N/-		Yes	
		P/+ W		Yes		N/- W		No	

(Assuming that an analog meter is used.)

## 5.1.5 Cleaning

Always run the inverter in a clean status.

When cleaning the inverter, gently wipe dirty areas with a soft cloth immersed in neutral detergent or ethanol.

### NOTE

- Do not use solvent, such as acetone, benzene, toluene and alcohol, as these will cause the inverter surface paint to peel off.
- The display, etc. of the operation panel (FR-LU08) and parameter unit (FR-PU07) are vulnerable to detergent and alcohol. Therefore, avoid using them for cleaning.

## 5.1.6 Replacement of parts

The inverter consists of many electronic parts such as semiconductor devices.

The following parts may deteriorate with age because of their structures or physical characteristics, leading to reduced performance or fault of the inverter. For preventive maintenance, the parts must be replaced periodically.

Use the life check function as a guidance of parts replacement.

Part name	Estimated lifespan*1	Description
Cooling fan	10 years	Replace (as required)
Main circuit smoothing capacitor	10 years*2	Replace (as required)
On-board smoothing capacitor	10 years*2	Replace the board (as required)
Relays	—	As required
Main circuit fuse	10 years	Replace (as required)

\*1 Estimated lifespan for when the yearly average surrounding air temperature is 40°C.  
(without corrosive gas, flammable gas, oil mist, dust and dirt etc.)

\*2 Output current (80% of the inverter rating)

### NOTE

- For parts replacement, contact the nearest Mitsubishi Electric FA center.

### ◆ Inverter parts life display

The inverter diagnoses the control circuit capacitor and the cooling fan by itself, and estimates their lives.

The self-diagnostic warning is output when the life span of each part is near its end. It gives an indication of replacement time.

**The life warning output can be used as a guideline for life judgment.**

Parts	Judgment level
Control circuit capacitor	Estimated remaining life 10%
Cooling fan	Not more than the specified speed

### NOTE

- Refer to the Instruction Manual (Detailed) of the FR-A860 to perform the life check of the inverter parts.

### ◆ Replacement procedure of the cooling fan

The replacement interval of the cooling fan used for cooling the parts generating heat such as the main circuit semiconductor is greatly affected by the surrounding air temperature. When unusual noise and/or vibration are noticed during inspection, the cooling fan must be replaced immediately.

#### ◆ Removal

- 1) Remove the fan cover fixing screws, and remove the fan cover.
- 2) Disconnect the fan connector and remove the fan block.
- 3) Remove the fan fixing screws, and remove the fan.

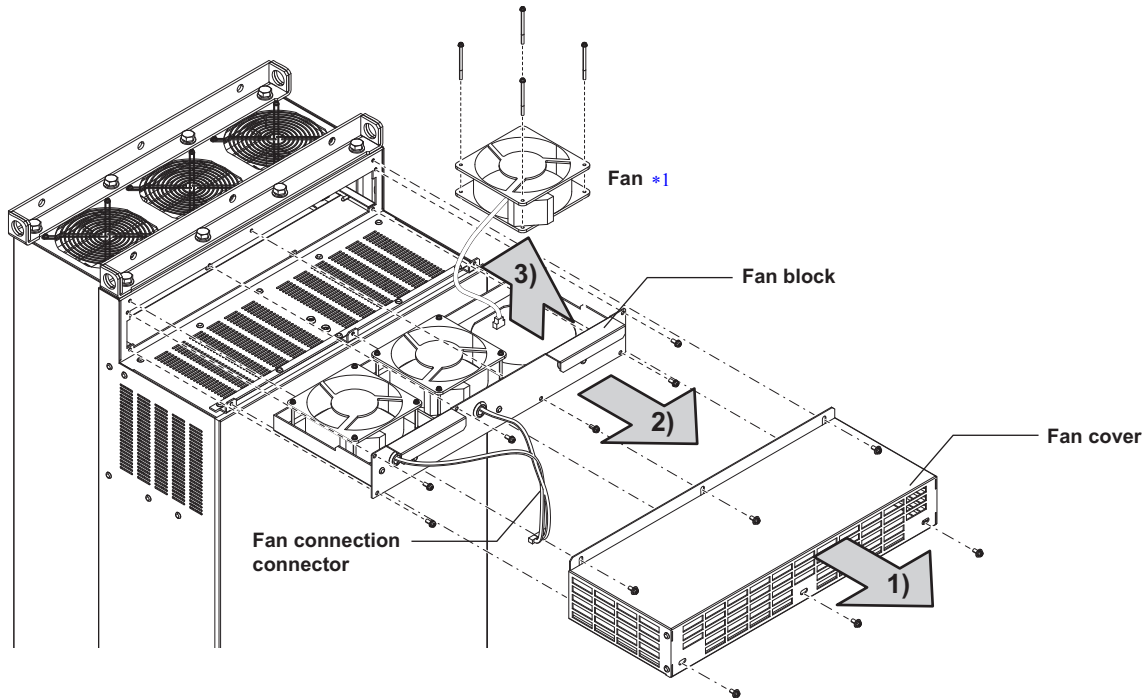

\*1 The number of cooling fans differs according to the inverter capacity.

#### ◆ Reinstallation

- 1) Before installing the new fan, check the orientation of the fan to be sure that the "AIR FLOW" arrow printed on the side of the fan points upward.

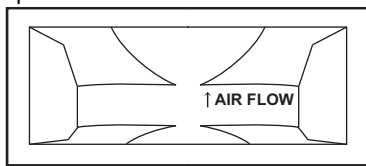

<Fan side face>

- 2) For reconnection of the fan, refer to the above figure.

#### NOTE

- Installing the fan in the opposite direction of air flow can cause the inverter life to be shorter.
- Prevent the cable from being caught when installing a fan.
- Switch the power OFF before replacing fans. Since the inverter circuits are charged with voltage even after power OFF, replace fans only when the inverter cover is on the inverter to prevent an electric shock accident.

## ◆Smoothing capacitors

A large-capacity aluminum electrolytic capacitor is used for smoothing in the DC section of the main circuit, and an aluminum electrolytic capacitor is used for stabilizing the control power in the control circuit. Adverse effects from ripple currents deteriorate capacitors. Replacement intervals of capacitors vary greatly with surrounding temperatures and operating conditions. Replace them roughly every 10 years when used in normal air-conditioned environments.

Inspecting the product visually:

- Case: Check that the sides and bottom of the capacitor have not ruptured.
- Rubber seal: Check for any noticeable bulging or severe cracks.
- Check for external cracks, discoloration, leakage, etc. It is assumed that the capacitor has reached the end of its life when its capacity has dropped below 80% of its rated capacity.

### NOTE

- The inverter diagnoses the control circuit capacitor by itself and can estimate its remaining life. (Refer to the FR-A860 Instruction Manual (Detailed).)

## ◆Relay output terminals

- The contacts of relays deteriorate over time. To prevent faults from occurring, relays must be replaced when they have reached the maximum of switching operations (switching life).
- The control terminal block must be replaced (refer to [page 76](#)) in case of failure of either relay connected to the relay output terminals A1, B1, and C1, or A2, B2, and C2. (After replacing the control terminal block, connect the jumper connector to the correct position in accordance with the control logic of input signals. (Refer to [page 36](#).)

## ◆Main circuit fuse

A fuse is used inside the inverter. Replacement intervals of fuses vary with surrounding temperatures and operating conditions. Replace them roughly every 10 years when used in normal air-conditioned environments.

## 5.1.7 Removal and reinstallation of the control circuit terminal block

The FR-A800 series inverter has a removable control circuit terminal block, which can be replaced with a new one or a control terminal option.

### ◆ Removal and reinstallation

- 1) Loosen the two mounting screws at the both side of the control circuit terminal block. (These screws cannot be removed.) Slide down the control circuit terminal block to remove it.

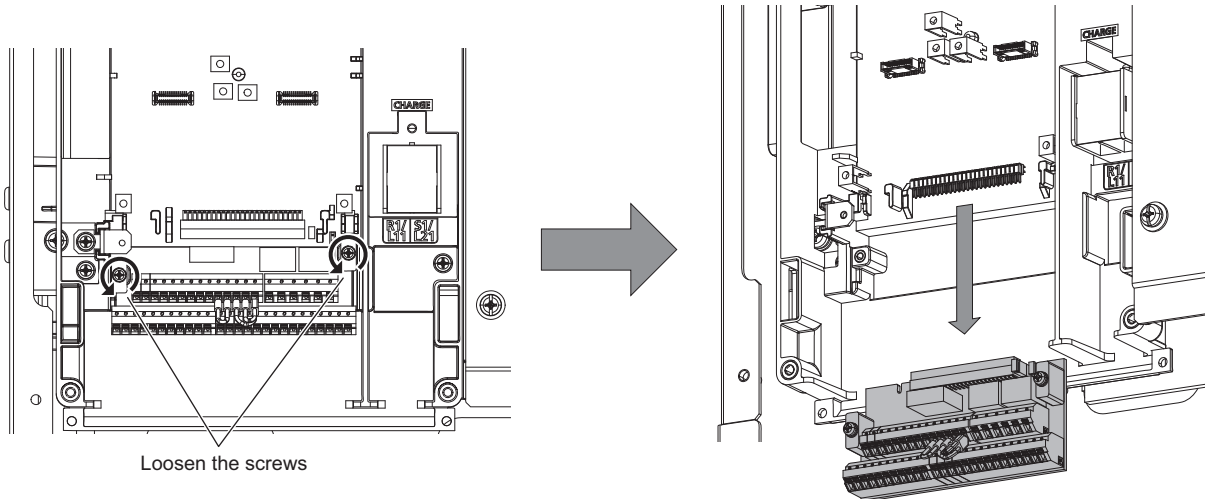

- 2) Be careful not to bend the pins of the inverter's control circuit connector, reinstall the control circuit terminal block and fix it with the mounting screws.

#### NOTE

- Before starting the replacement, power OFF the inverter, wait for at least 10 minutes, and then check that the charge lamp is OFF to ensure safety.

### ◆ Removal and reinstallation precautions

Precautions to be taken when removing or reinstalling the control circuit terminal block are shown below.

Observe the following precautions and handle the inverter properly to avoid malfunctions or failures.

- To remove or reinstall the control circuit terminal block, keep it upright so that it is parallel with the inverter.
- To install the control circuit terminal block, slide it upward so that the tongues on the inverter slot into the grooves on the terminal block.
- Check that the terminal block is parallel to the inverter and the pins on the inverter control circuit connector are not bent.

After checking proper connection, fix the terminal block in place with two screws.

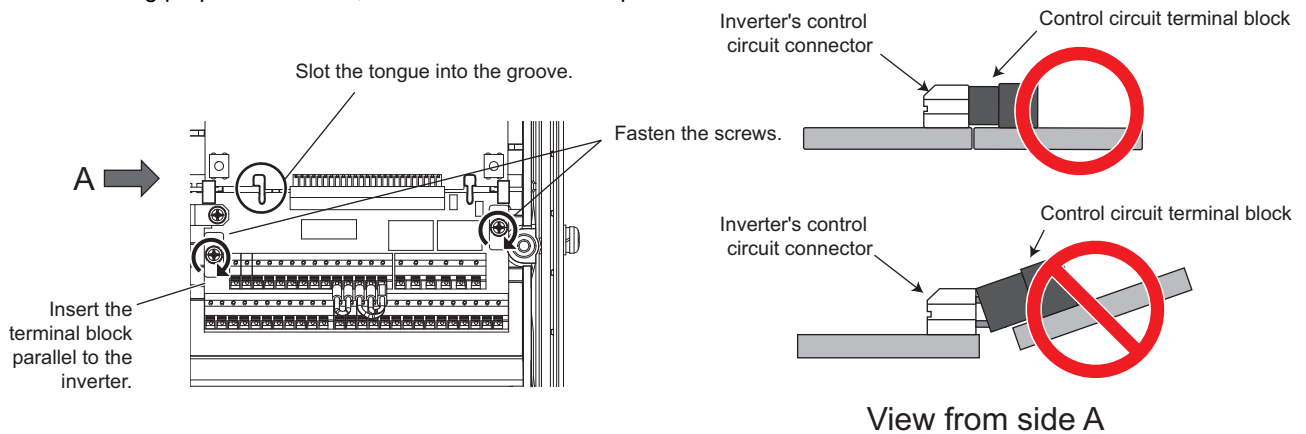

#### NOTE

- Do not tilt the terminal block while tightening the screws or removing it from the inverter. (Otherwise, stress applied to the control circuit terminal block or the control circuit connector may damage the pins.)
- After replacing the control terminal block, connect the jumper connector to the correct position in accordance with the control logic of input signals. (Refer to [page 36](#).)

## 5.2 Measurement of main circuit voltages, currents and powers

Since the voltages and currents on the inverter power supply and output sides include harmonics, measurement data depends on the instruments used and circuits measured.

When instruments for commercial frequency are used for measurement, measure the following circuits with the instruments given on the next page.

**NOTE**

- When installing meters etc. on the inverter output side  
When the wiring length between the inverter and the motor is large, the meters and CTs may generate heat due to line-to-line leakage current. Therefore, choose the equipment which has enough allowance for the current rating.  
To measure and display the output voltage and output current of the inverter, it is recommended to use terminal AM and FM output functions of the inverter.

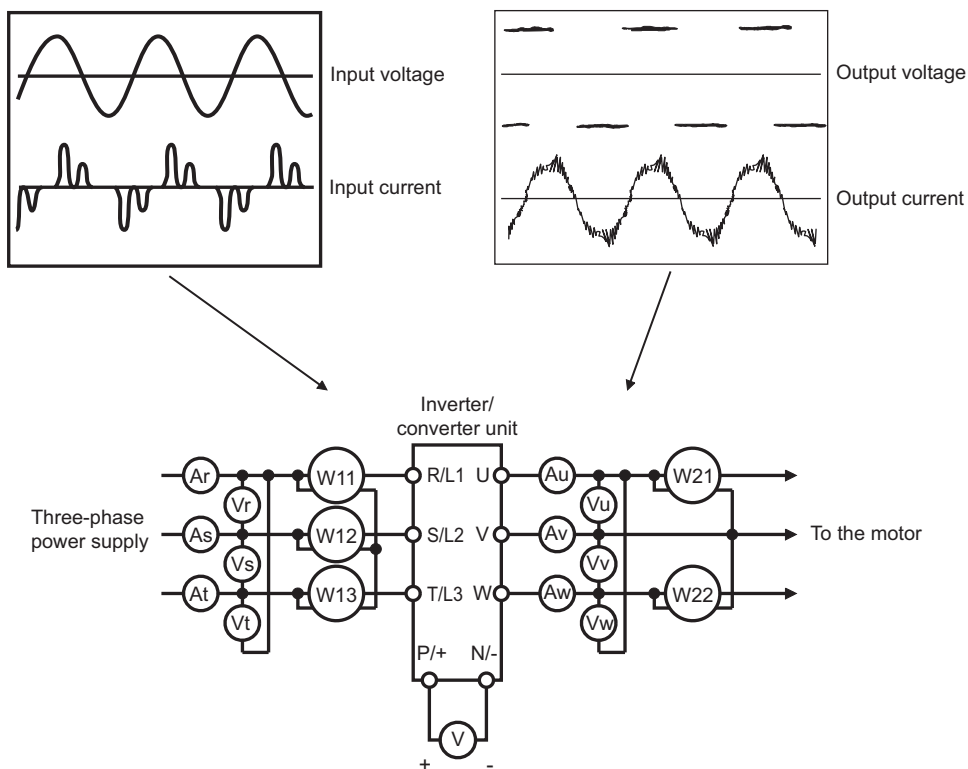

◆ Measuring points and instruments

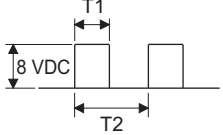
	Item	Measuring point	Measuring instrument	Remarks (reference measured value)	
Converter unit (FR-CC2)	Power supply voltage V1	Across R/L1 and S/L2, S/L2 and T/L3, T/L3 and R/L1	Digital power meter (for inverter)	Commercial power supply Within permissible AC voltage fluctuation (Refer to page 82.)	
	Power supply side current I1	R/L1, S/L2, T/L3 line current		P1 = W11 + W12 + W13 (3-wattmeter method)	
	Power supply side power P1	R/L1, S/L2, T/L3 and Across R/L1 and S/L2, S/L2 and T/L3, T/L3 and R/L1			
	Power supply side power factor Pf1	Calculate after measuring power supply voltage, power supply side current and power supply side power. $Pf_1 = \frac{P_1}{\sqrt{3}V_1 \times I_1} \times 100\%$			
	Converter output	Across P/+ and N/-	Such as tester	Inverter LED is lit. 1.35 × V1	
	Operation enable signal External thermal relay signal Reset signal	Across RDI, OH, RES(+) and SD (for sink logic)	Digital multimeter or other tester, or moving-coil type instrument (internal resistance 50 kΩ or more)	When open 20 to 30 VDC ON voltage: 1 V or less	"SD" is common.
	Alarm signal	Across A1 and C1 Across B1 and C1	Digital multimeter or other tester	Continuity check*3 Across A1 and C1 Across B1 and C1	[Normal] [Fault] Discontinuity Continuity Continuity Discontinuity
Inverter	Output side voltage V2	Across U and V, V and W, and W and U	Digital power meter (for inverter)*1	Difference between the phases is within 1% of the maximum output voltage.	
	Output side current I2	U, V and W line currents		Difference between the phases is 10% or lower of the rated inverter current.	
	Output side power P2	U, V, W and across U and V, V and W	Digital power meter (for inverter)	P2 = W21 + W22 2-wattmeter method (or 3-wattmeter method)	
	Output side power factor Pf2	Calculate in similar manner to power supply side power factor. $Pf_2 = \frac{P_2}{\sqrt{3}V_2 \times I_2} \times 100\%$			
	Frequency setting signal	Across 2, 4(+) and 5 Across 1(+) and 5	Digital multimeter or other tester, or moving-coil type instrument (internal resistance 50 kΩ or more)	0 to 10 VDC, 4 to 20 mA	"5" is common.
	Frequency setting power supply	Across 10(+) and 5 Across 10E(+) and 5		0 to ±5 VDC and 0 to ±10 VDC	
				5.2 VDC	
				10 VDC	
	Frequency meter signal Start signal Select signal Reset signal Output stop signal	Across AM(+) and 5		Approximately 10 VDC at maximum frequency (without frequency meter)	
		Across FM(+) and SD	Approximately 5 VDC at maximum frequency (without frequency meter)		
Fault signal	Across STF, STR, RH, RM, RL, JOG, RT, AU, STOP, CS, RES, MRS(+) and SD (for sink logic)	Digital multimeter or other tester	 <p>Pulse width T1: Adjust with Pr.900. Pulse cycle T2: Set with Pr.55. (frequency monitor only)</p>	"SD" is common.	
			When open 20 to 30 VDC ON voltage: 1 V or less		
	Across A1 and C1 Across B1 and C1	Digital multimeter or other tester	Continuity check*3 Across A1 and C1 Across B1 and C1	[Normal] [Fault] Discontinuity Continuity Continuity Discontinuity	

\*1 Use an FFT to measure the output voltage accurately. A tester or general measuring instrument cannot measure accurately.

\*2 When the carrier frequency exceeds 5 kHz, do not use this instrument since using it may increase eddy current losses produced in metal parts inside the instrument, leading to burnout. In this case, use an approximate-effective value type.

\*3 When the setting of Pr.195 ABC1 terminal function selection is the positive logic

## 5.2.1 Measurement of powers

Use a digital power meter (for inverter) for the input side of the converter unit (FR-CC2) and the output side of the inverter.

## 5.2.2 Measurement of voltages

### ◆ Converter unit (FR-CC2) input side

Use a digital power meter for inverters for the input side voltage.

### ◆ Inverter output side

Always use a digital power meter for inverter for measurement as the output side voltage has a PWM-controlled rectangular wave. The value monitored on the operation panel is the inverter-controlled voltage itself. Hence, that value is accurate and it is recommended to monitor values (analog output) using the operation panel.

## 5.2.3 Measurement of currents

Use digital power meters (for converter) for the both of inverter input and output side.

Since current on the converter unit input side tends to be unbalanced, measurement of three phases is recommended.

Correct value cannot be obtained by measuring only one or two phases. On the other hand, the unbalanced ratio of each phase of the output side current should be within 10%.

The inverter output current can be monitored on the operation panel. The value monitored on the operation panel is accurate if the output frequency varies, and it is recommended to monitor values (provide analog output) using the operation panel.

## 5.2.4 Example of measuring converter unit (FR-CC2) input power factor

Calculate using effective power and apparent power. A power-factor meter cannot indicate an exact value.

$$\begin{aligned} \text{Total power factor of the converter unit} &= \frac{\text{Effective power}}{\text{Apparent power}} \\ &= \frac{\text{Three-phase input power found by the 3-wattmeter method}}{\sqrt{3} \times V (\text{power supply voltage}) \times I (\text{input current effective value})} \end{aligned}$$

## 5.2.5 Measurement of converter output voltage (across terminals P and N)

The output voltage of the converter is output across terminals P and N, and can be measured with a voltmeter such as a digital multimeter. Although the voltage varies according to the power supply voltage, approximately 800 to 900 V is output when no load is connected and voltage decreases during driving load operation.

When energy is regenerated from the motor during deceleration, for example, the converter output voltage rises to nearly 1100 to 1300 V maximum.



## 5.2.6 Measurement of inverter output frequency

In the initial setting, a pulse train proportional to the output frequency is output across the pulse train output terminals FM and SD of the inverter. This pulse train output can be counted by a frequency counter, or a meter can be used to read the mean value of the pulse train output voltage. When a meter is used to measure the output frequency, approximately 5 VDC is indicated at the maximum frequency.

For detailed specifications of the pulse train output terminal FM, refer to the FR-A860 Instruction Manual (Detailed).

## 5.2.7 Insulation resistance test using megger

- For the inverter and the converter unit (FR-CC2), conduct the insulation resistance test on the main circuit only as shown below and do not perform the test on the control circuit. (Use a 500 VDC megger.)

### NOTE

- Before performing the insulation resistance test on the external circuit, disconnect the cables from all terminals of the inverter and the converter unit so that the test voltage is not applied to the inverter and the converter unit.
- For the continuity test of the control circuit, use a tester (high resistance range) and do not use the megger or buzzer.

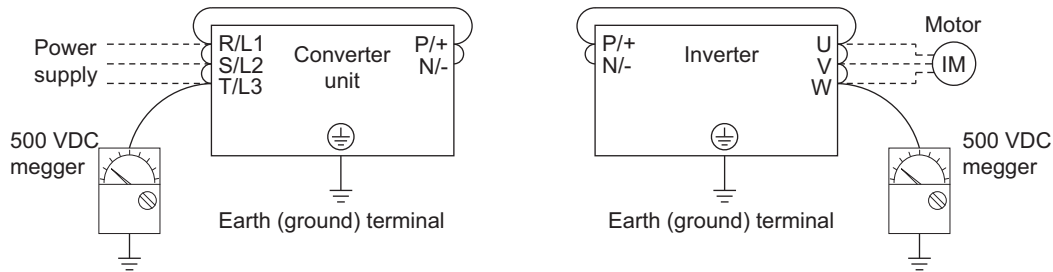

## 5.2.8 Withstand voltage test

Do not conduct a withstand voltage test. Deterioration may occur.

---

# **6** SPECIFICATIONS

---

This chapter explains the "SPECIFICATIONS" of this product.  
Always read the instructions before using the equipment.

---

<b>6.1</b>	<b>Inverter rating.....</b>	<b>82</b>
<b>6.2</b>	<b>Common specifications .....</b>	<b>83</b>
<b>6.3</b>	<b>Outline dimension drawings.....</b>	<b>85</b>

# 6.1 Inverter rating

• Inverter

Model FR-A862-[ ]		05450	06470	08500
Applicable motor capacity (kW) *1	SLD	400	450	630
	LD	355	400	560
	ND (initial setting)	280	355	450
	HD	220	280	400
Rated capacity (kVA) *2	SLD	543	645	847
	LD	494	587	770
	ND (initial setting)	401	494	661
	HD	303	401	578
Rated current (A) *3	SLD	545 (463)	647 (549)	850 (722)
	LD	496 (421)	589 (500)	773 (657)
	ND (initial setting)	402 (341)	496 (421)	663 (563)
	HD	304 (258)	402 (341)	589 (500)
Output Overload current rating *4	SLD	110% 60 s, 120% 3 s (inverse-time characteristics) at surrounding air temperature of 40°C		
	LD	120% 60 s, 150% 3 s (inverse-time characteristics) at surrounding air temperature of 50°C		
	ND (initial setting)	150% 60 s, 200% 3 s (inverse-time characteristics) at surrounding air temperature of 50°C		
	HD	200% 60 s, 250% 3 s, 280% 0.5 s (inverse-time characteristics) at surrounding air temperature of 40°C		
Rated voltage *5		Three-phase 525 to 600 V		
Regenerative braking torque*6 (When the converter unit (FR-CC2) is used)		Maximum brake torque	10% torque/continuous	
Input power	DC power supply voltage		618 to 933 VDC	
	Control power supply auxiliary input		Single phase 525 to 600 V 50 Hz/60 Hz	
	Permissible control power supply auxiliary input fluctuation		Frequency ±5%, voltage ±10%	
Protective structure (IEC 60529)		Open type (IP00)		
Cooling system		Forced air cooling		
Approx. mass (kg)		163	243	243

- \*1 The applicable motor capacity indicated is the maximum capacity applicable for use of the 4-pole standard motor.
- \*2 The rated output capacity indicated assumes that the output voltage is 575 V.
- \*3 When an operation is performed with the carrier frequency set to 3 kHz or more, and the inverter output current reaches the value indicated in the parenthesis, the carrier frequency is automatically lowered. The motor noise becomes louder accordingly.
- \*4 The % value of the overload current rating indicated is the ratio of the overload current to the inverter's rated output current. For repeated duty, allow time for the inverter and motor to return to or below the temperatures under 100% load.
- \*5 The maximum output voltage does not exceed the power supply voltage. The maximum output voltage can be changed within the setting range. However, the maximum point of the voltage waveform at the inverter output side is the power supply voltage multiplied by about  $\sqrt{2}$ .
- \*6 ND rating reference value

## 6.2 Common specifications

Control specifications	Control method		Soft-PWM control, high carrier frequency PWM control (selectable among V/F control, Advanced magnetic flux vector control, Real sensorless vector control), Optimum excitation control, Vector control*1, and PM sensorless vector control	
	Output frequency range		0.2 to 590 Hz (The upper-limit frequency is 400 Hz under Advanced magnetic flux vector control, Real sensorless vector control, Vector control*1, and PM sensorless vector control.)	
	Frequency setting resolution	Analog input	0.015 Hz/60 Hz (terminal 2, 4: 0 to 10 V/12 bits) 0.03 Hz/60 Hz (0 to 5 V/11 bits or 0 to 20 mA/approx. 11 bits for terminals 2 and 4, 0 to ±10 V/12 bits for terminal 1) 0.06 Hz/60 Hz (0 to ±5 V/11 bits for terminal 1)	
		Digital input	0.01 Hz	
	Frequency accuracy	Analog input	Within ±0.2% of the max. output frequency (25°C ±10°C)	
		Digital input	Within 0.01% of the set output frequency	
	Voltage/frequency characteristics		Base frequency can be set from 0 to 590 Hz. Constant-torque/variable-torque pattern or adjustable 5 points V/F can be selected.	
	Starting torque		SLD rating: 120% 0.3 Hz, LD rating: 150% 0.3 Hz, ND rating: 200%*2 0.3 Hz, HD rating: 250%*2 0.3 Hz (under Real sensorless vector control or vector control*1)	
	Torque boost		Manual torque boost	
	Acceleration/deceleration time setting		0 to 3600 s (acceleration and deceleration can be set individually), linear or S-pattern acceleration/ deceleration mode, backlash countermeasures acceleration/deceleration can be selected.	
	DC injection brake (induction motor)		Operation frequency (0 to 120 Hz), operation time (0 to 10 s), operation voltage (0 to 30%) variable	
	Stall prevention operation level		Activation range of stall prevention operation (SLD rating: 0 to 120%, LD rating: 0 to 150%, ND rating: 0 to 220%, HD rating: 0 to 280%). Whether to use the stall prevention or not can be selected. (V/F control, Advanced magnetic flux vector control)	
Torque limit level		Torque limit value can be set (0 to 400% variable). (Real sensorless vector control, Vector control*1, PM sensorless vector control)		
Operation specifications	Frequency setting signal	Analog input	Terminals 2 and 4: 0 to 10 V, 0 to 5 V, 4 to 20 mA (0 to 20 mA) are available. Terminal 1: -10 to +10 V, -5 to 5 V are available.	
		Digital input	Input using the setting dial of the operation panel or parameter unit Four-digit BCD or 16-bit binary (when used with option FR-A8AX)	
	Start signal		Forward and reverse rotation or start signal automatic self-holding input (3-wire input) can be selected.	
	Input signals (twelve terminals)		Low-speed operation command, Middle-speed operation command, High-speed operation command, Second function selection, Terminal 4 input selection, Jog operation selection, Selection of automatic restart after instantaneous power failure, flying start, Output stop, Start self-holding selection, Forward rotation command, Reverse rotation command, Inverter reset The input signal can be changed using <b>Pr.178 to Pr.189 (Input terminal function selection)</b> .	
	Pulse train input		100k pulses/s	
	Operational functions		Maximum and minimum frequency settings, multi-speed operation, acceleration/deceleration pattern, thermal protection, DC injection brake, starting frequency, JOG operation, output stop (MRS), stall prevention, regeneration avoidance, increased magnetic excitation deceleration, frequency jump, rotation display, automatic restart after instantaneous power failure, electronic bypass sequence, remote setting, automatic acceleration/deceleration, retry function, carrier frequency selection, fast-response current limit, forward/reverse rotation prevention, operation mode selection, slip compensation, droop control, load torque high-speed frequency control, speed smoothing control, traverse, auto tuning, applied motor selection, gain tuning, RS-485 communication, PID control, PID pre-charge function, easy dancer control, cooling fan operation selection, stop selection (deceleration stop/coasting), stop-on-contact control, PLC function, life diagnosis, maintenance timer, current average monitor, multiple rating, orientation control*1, speed control, torque control, position control, pre-excitation, torque limit, test run, 24 V power supply input for control circuit, safety stop function, anti-sway control	
	Output signal Open collector output (five terminals) Relay output (two terminals)		Inverter running, Up to frequency, Overload warning, Output frequency detection, Fault The output signal can be changed using <b>Pr.190 to Pr.196 (Output terminal function selection)</b> . Fault codes of the inverter can be output (4 bits) from the open collector.	
	Pulse train output		50k pulses/s	
	Indication	For meter	Pulse train output	Max. 2.4 kHz: one terminal (output frequency) The monitored item can be changed using <b>Pr.54 FM/CA terminal function selection</b> .
			Voltage output	Max. 10 VDC: one terminal (output voltage) The monitored item can be changed using <b>Pr.158 AM terminal function selection</b> .

## Common specifications

<b>Protective/warning function</b>	<b>Protective function</b>	Overcurrent trip during acceleration, Overcurrent trip during constant speed, Overcurrent trip during deceleration or stop, Regenerative overvoltage trip during acceleration, Regenerative overvoltage trip during constant speed, Regenerative overvoltage trip during deceleration or stop, Inverter overload trip (electronic thermal relay function), Motor overload trip (electronic thermal relay function), Heat sink overheat, Stall prevention stop, Loss of synchronism detection*4, Output side earth (ground) fault overcurrent, Output short circuit, Output phase loss, External thermal relay operation*4, PTC thermistor operation*4, Option fault, Communication option fault, Parameter storage device fault, PU disconnection, Retry count excess*4, Parameter storage device fault, CPU fault, Operation panel power supply short circuit/RS-485 terminals power supply short circuit, 24 VDC power fault, Abnormal output current detection*4, Communication fault (inverter), Analog input fault, USB communication fault, Overspeed occurrence*4, Speed deviation excess detection*1*4, Signal loss detection*1*4, Excessive position fault*1*4, Brake sequence fault*4, Encoder phase fault*1*4, 4 mA input fault*4, Pre-charge fault*4, PID signal fault*4, Option fault, Opposite rotation deceleration fault*4, Internal circuit fault, Magnetic pole position unknown*1, External fault during output operation*4
	<b>Warning function</b>	Fan alarm, Stall prevention (overcurrent), Stall prevention (overvoltage), Electronic thermal relay function pre-alarm, PU stop, Speed limit indication (output during speed limit)*4, Parameter copy, Maintenance timer 1 to 3*4, USB host error, Home position return setting error*4, Home position return uncompleted*4, Home position return parameter setting error*4, Operation panel lock*4, Password locked*4, Parameter write error, Copy operation error, 24 V external power supply operation, Continuous operation during communication fault
<b>Environment</b>	<b>Surrounding air temperature</b>	-10°C to +50°C (non-freezing) (LD, ND ratings) -10°C to +40°C (non-freezing) (SLD, HD ratings)
	<b>Surrounding air humidity</b>	With circuit board coating (conforming to IEC 60721-3-3 3C2/3S2): 95% RH or less (non-condensing)
	<b>Storage temperature*3</b>	-20°C to +65°C
	<b>Atmosphere</b>	Indoors (without corrosive gas, flammable gas, oil mist, dust and dirt, etc.)
	<b>Altitude/vibration</b>	Maximum 2500 m (For the installation at an altitude above 1000 m, consider a 3% reduction in the rated current per 500 m increase in altitude.), 2.9 m/s <sup>2</sup> or less at 10 to 55 Hz (directions of X, Y, Z axes)

\*1 Available only when a Vector control compatible option is mounted.

\*2 In the initial setting, it is limited to 150% by the torque limit level.

\*3 Temperature applicable for a short time, e.g. in transit.

\*4 This protective function is not available in the initial status.

## 6.3 Outline dimension drawings

### 6.3.1 Inverter outline dimension drawings

FR-A862-05450

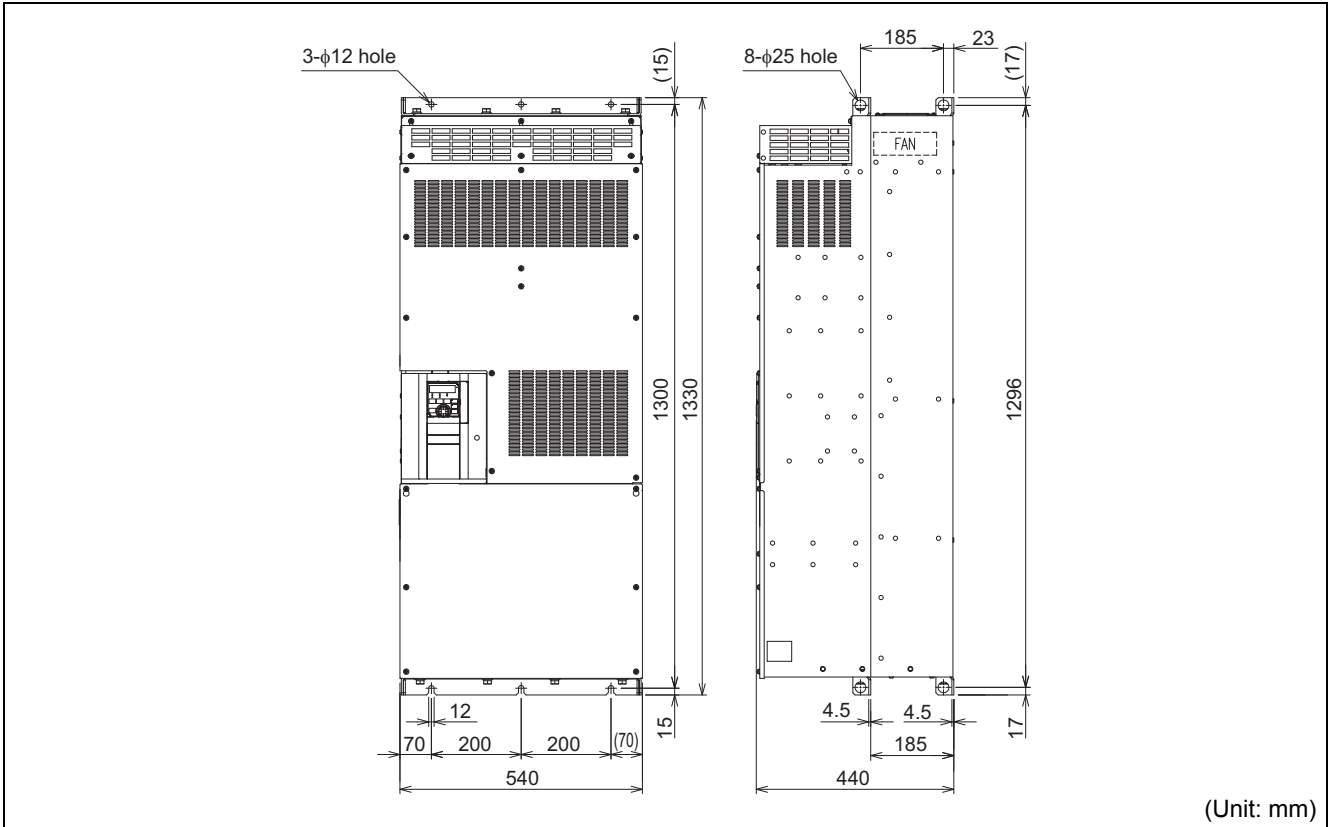

FR-A862-06470, FR-A862-08500

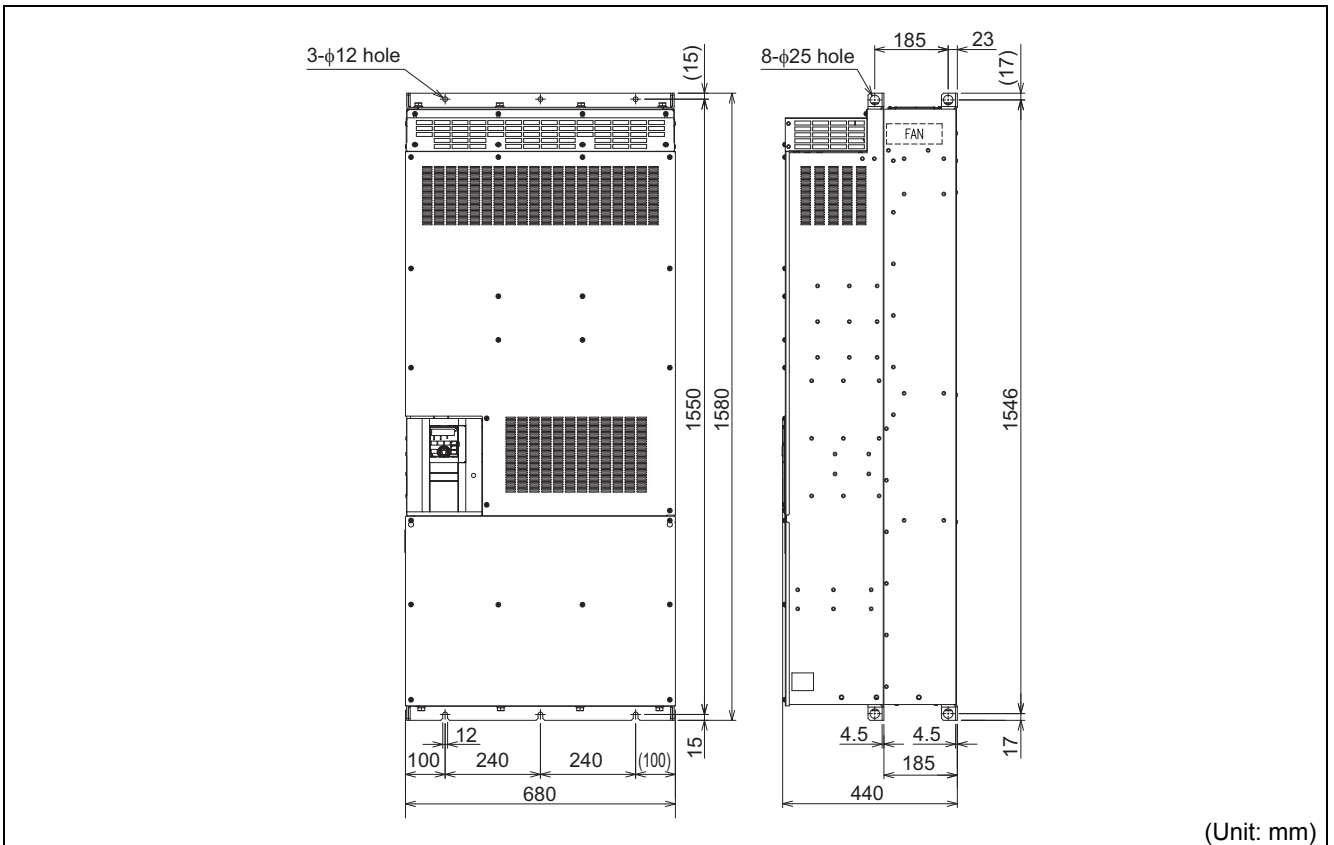

# MEMO



---

# APPENDIX

---

**APPENDIX provides the reference information for use of this product.  
Refer to APPENDIX as required.**

---

<b>Appendix 1 For customers replacing the conventional model with this inverter .....</b>	<b>88</b>
<b>Appendix 2 Comparison with FR-A860 .....</b>	<b>90</b>
<b>Appendix 3 Instructions for UL and cUL .....</b>	<b>91</b>
<b>Appendix 4 Restricted Use of Hazardous Substances in Electronic and Electrical Products .....</b>	<b>93</b>



# Appendix 1 For customers replacing the conventional model with this inverter

## Appendix 1.1 Replacement of the FR-A700 series

### ◆ Difference and compatibility with FR-A700 series

Item		FR-A760	FR-A862
<b>Control method</b>		V/F control Advanced magnetic flux vector control Real sensorless vector control Vector control (with plug-in option used)	V/F control Advanced magnetic flux vector control Real sensorless vector control Vector control (with plug-in option used) PM sensorless vector control (IPM motor/SPM motor)
<b>Maximum output frequency</b>	<b>V/F control</b>	400 Hz	590 Hz
	<b>Advanced magnetic flux vector control</b>	120 Hz	400 Hz
	<b>Real sensorless vector control</b>	120 Hz	400 Hz
	<b>Vector control</b>	120 Hz	400 Hz
	<b>PM sensorless vector control</b>	—	400 Hz
<b>PID control</b>		Turn the X14 signal ON to enable PID control.	When the X14 signal is not assigned, just set a value other than "0" in <b>Pr.128</b> to enable PID control. When the X14 signal is assigned, turn the X14 signal ON while <b>Pr.128</b> ≠ "0" to enable PID control. The PID pre-charge function and dancer control are added.
<b>Automatic restart after instantaneous power failure</b>		Turn the CS signal ON to enable restart.	CS signal assignment not required. (Restart is enabled with the <b>Pr.57</b> setting only.)
<b>Number of motor poles V/F control switching</b>		The V/F switchover (X18) signal is valid when <b>Pr.81</b> = "12 to 20 (2 to 10 poles)".	<b>Pr.81</b> = "12 (12 poles)" X18 is valid regardless of the <b>Pr.81</b> setting. (The <b>Pr.81</b> settings "14 to 20" are not available.)
<b>PTC thermistor input</b>		Input from terminal AU (The function of terminal AU is switched by a switch.)	Input from terminal 2. (The function of terminal 2 is switched by the <b>Pr.561</b> setting.)
<b>USB connector</b>		B connector	Mini B connector
<b>Control circuit terminal block</b>		Removable terminal block (screw type)	Removable terminal block (spring clamp type)
<b>Terminal response level</b>		The FR-A800's I/O terminals have better response level than the FR-A700's terminals. By setting <b>Pr.289 Inverter output terminal filter</b> and <b>Pr.699 Input terminal filter</b> , the terminal response level can be compatible with that of FR-A700. Set to approximately 5 to 8 ms and adjust the setting according to the system.	
<b>PU</b>	<b>Standard</b>	FR-DU07 (4-digit LED)	None (FR-DU07 is not supported.)
	<b>Optional</b>	FR-PU07	FR-LU08 (LCD) FR-PU07 (Some functions are unavailable.)
<b>Plug-in option</b>		Dedicated plug-in options (not interchangeable)	
<b>Communication option</b>		Connected to the connector 3.	Connected to the connector 1.
<b>Installation size</b>		Installation size is not compatible. (New mounting holes are required.)	
<b>Converter</b>		Built in for all capacities	The converter unit (FR-CC2) is required.
<b>DC reactor</b>		DC reactor is provided.	Built in the converter unit (FR-CC2)

### ◆ Installation precautions

- Removal procedure of the front cover is different. (Refer to [page 15](#).)
- Plug-in options of the FR-A700 series are not compatible.
- The operation panel (FR-DU07) cannot be used.

---

## ◆Wiring precautions

- The spring clamp type terminal block has changed to the screw type. Use of blade terminals is recommended.

## ◆Instructions for continuous use of the FR-PU07 (parameter unit) manufactured in September 2015 or earlier

- For the FR-A800 series, many functions (parameters) have been added. When setting these parameters, the parameter names and setting ranges are not displayed.
- Only the parameter with the numbers up to "999" can be read and set. The parameters with the numbers after "999" cannot be read or set.
- Many protective functions have been added for the FR-A800 series. These functions are available, but all faults are displayed as "Fault". When the fault history is checked, "ERR" appears. Added faults will not appear on the parameter unit. (However, MT1 to MT3 are displayed as MT.)
- Parameter copy/verification function are not available.

## ◆Copying parameter settings

- The FR-A700 series' parameter setting can be easily copied to the FR-A800 series by using the setup software (FR Configurator2). (Not supported by the setup software FR-SW3-SETUP or older.)

# Appendix 1.2 Replacement of the FR-A500(L) series

## ◆Installation precautions

- Installation size is not compatible. (New mounting holes are required.)
- The optional converter unit (FR-CC2) is required.

# Appendix 2 Comparison with FR-A860

Item	FR-A860	FR-A862
<b>Pr.30 Regenerative function selection</b>	Setting ranges "0 to 2, 10, 11, 20, 21, 100 to 102, 110, 111, 120, 121" Initial value "0"	Setting ranges "2, 10, 11, 102, 110, 111" Initial value "10"
<b>Pr.70 Special regenerative brake duty</b>	With the parameter	Without the parameter
<b>Monitor function (Pr.52, Pr.54, Pr.158, Pr.774 to Pr.776, Pr.992, Pr.1027 to Pr.1034)</b>	Regenerative brake duty With (Acceptable)	Regenerative brake duty Without (Unacceptable)
<b>Input terminal function selection (Pr.178 to Pr.189)</b>	DC feeding operation permission (X70), DC feeding cancel (X71) With (Acceptable)	DC feeding operation permission (X70), DC feeding cancel (X71) Without (Unacceptable)
<b>Pr.187 MRS terminal function selection</b>	Initial value "24" (MRS)	Initial value "10" (X10)
<b>Output terminal function assignment selection (Pr.190 to Pr.196, Pr.313 to Pr.322)</b>	Instantaneous power failure/undervoltage (IPF), Regenerative brake pre-alarm (RBP), DC current feeding (Y85), Main circuit capacitor life (Y87), Inrush current limit circuit life (Y89) With (Acceptable)	Instantaneous power failure/undervoltage (IPF), Regenerative brake pre-alarm (RBP), DC current feeding (Y85), Main circuit capacitor life (Y87), Inrush current limit circuit life (Y89) Without (Unacceptable)
<b>Pr.192 IPF terminal function selection</b>	Initial value "2" (IPF)	Initial value "9999" (No function)
<b>Inrush current limit circuit life display, Main circuit capacitor life display (Pr.256, Pr.258, Pr.259)</b>	With the parameter	Without the parameter
<b>Pr.599 X10 terminal input selection</b>	Initial value "0" (NO contact specification)	Initial value "1" (NC contact specification)
<b>Pr.872 Input phase loss protection selection</b>	With the parameter	Without the parameter
<b>Warning, protective functions</b>	Regenerative brake pre-alarm (RB), Instantaneous power failure (E.IPF), Undervoltage (E.UVT), Input phase loss (E.ILF), Brake transistor alarm detection (E.BE), Inrush current limit circuit fault (E.IOH) Available	Regenerative brake pre-alarm (RB), Instantaneous power failure (E.IPF), Undervoltage (E.UVT), Input phase loss (E.ILF), Brake transistor alarm detection (E.BE), Inrush current limit circuit fault (E.IOH) Not available

---

# Appendix 3 Instructions for UL and cUL

---

(Standard to comply with: UL 508C, CSA C22.2 No.274-13)

## ◆ General Precaution

CAUTION - Risk of Electric Shock -

The bus capacitor discharge time is 10 minutes. Before starting wiring or inspection, switch power off, wait for more than 10 minutes, and check for residual voltage between terminal P/+ and N/- with a meter etc., to avoid a hazard of electrical shock.

ATTENTION - Risque de choc électrique -

La durée de décharge du condensateur de bus est de 10 minutes. Avant de commencer le câblage ou l'inspection, mettez l'appareil hors tension et attendez plus de 10 minutes.

## ◆ Installation

The FR-A802 inverters with the below types of converter unit have been approved as products for use in enclosure. Design the enclosure so that the surrounding air temperature, humidity and ambience of the inverter will satisfy the specifications. (Refer to [page 17](#).)

### ◆ Wiring protection

For installation in the United States, Class T, Class J, Class CC, or Class L fuse must be provided, in accordance with the National Electrical Code and any applicable local codes.

For installation in Canada, Class T, Class J, Class CC, or Class L fuse must be provided, in accordance with the Canadian Electrical Code and any applicable local codes.

FR-CC2-[ ]	C355K	C400K	C560K
Rated fuse voltage (V)	575 V or more		
Fuse allowable rating (A)	700	800	1000

## ◆ Wiring to the power supply and the motor

Refer to the National Electrical Code (Article 310) regarding the allowable current of the cable. Select the cable size for 125% of the rated current according to the National Electrical Code (Article 430).

For wiring the input (R/L1, S/L2, T/L3) terminals of the converter unit and output (U, V, W) terminals of the inverter, use the UL listed copper, stranded wires (rated at 75°C) and round crimp terminals. Crimp the terminals with the crimping tool recommended by the terminal manufacturer.

## ◆ Short circuit ratings

Suitable for use in a circuit capable of delivering not more than 100 kA rms symmetrical amperes, 600 V maximum.

## ◆ Motor overload protection

When using the electronic thermal relay function as motor overload protection, set the rated motor current in **Pr.9 Electronic thermal O/L relay**.

Operation characteristics of electronic thermal relay function

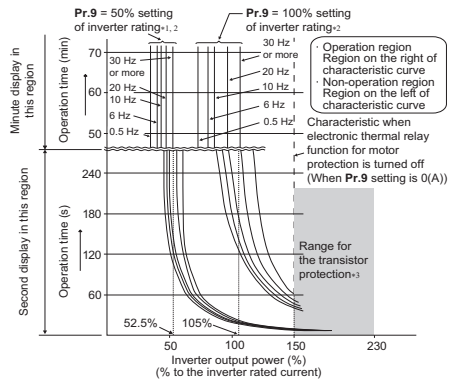

This function detects the overload (overheat) of the motor and trips the inverter by stopping the operation of the transistor at the inverter output side. (The operation characteristic is shown on the left.)

- \*1 When a value 50% of the inverter rated output current (current value) is set in **Pr.9**
- \*2 The % value denotes the percentage to the rated inverter current. It is not the percentage to the rated motor current.
- \*3 Transistor protection is activated depending on the temperature of the heat sink. The protection may be activated even with less than 150% depending on the operating conditions.

### NOTE

- The internal accumulated heat value of the electronic thermal relay function is reset by inverter power reset and reset signal input. Avoid unnecessary reset and power-OFF.
- Install an external thermal relay (OCR) between the inverter and motors to operate several motors, a multi-pole motor or a dedicated motor with one inverter. Note that the current indicated on the motor rating plate is affected by the line-to-line leakage current (refer to [page 54](#)) when selecting the setting for an external thermal relay.
- The cooling effect of the motor drops during low-speed operation. Use a thermal protector or a motor with built-in thermistor.
- When the difference between the inverter and motor capacities is large and the setting is small, the protective characteristics of the electronic thermal relay function will be deteriorated. In such case, use an external thermal relay.
- A dedicated motor cannot be protected by an electronic thermal O/L relay. Use an external thermal relay.
- Motor over temperature sensing is not provided by the drive.

# Appendix 4 Restricted Use of Hazardous Substances in Electronic and Electrical Products

The mark of restricted use of hazardous substances in electronic and electrical products is applied to the product as follows based on the "Management Methods for the Restriction of the Use of Hazardous Substances in Electrical and Electronic Products" of the People's Republic of China.

电器电子产品有害物质限制使用标识要求



本产品中所含有的有害物质的名称、含量、含有部件如下表所示。

- 产品中所含有害物质的名称及含量

部件名称 *2	有害物质 *1					
	铅 (Pb)	汞 (Hg)	镉 (Cd)	六价铬 (Cr (VI))	多溴联苯 (PBB)	多溴二苯醚 (PBDE)
电路板组件 (包括印刷电路板及其构成的零部件, 如电阻、电容、集成电路、连接器等)、电子部件	×	○	×	○	○	○
金属壳体、金属部件	×	○	○	○	○	○
树脂壳体、树脂部件	○	○	○	○	○	○
螺丝、电线	○	○	○	○	○	○

上表依据 SJ/T11364 的规定编制。

○: 表示该有害物质在该部件所有均质材料中的含量均在 GB/T26572 规定的限量要求以下。

×: 表示该有害物质在该部件的至少一种均质材料中的含量超出 GB/T26572 规定的限量要求。

\*1 即使表中记载为 ×, 根据产品型号, 也可能会有有害物质的含量为限制值以下的情况。

\*2 根据产品型号, 一部分部件可能不包含在产品中。

---

## WARRANTY

When using this product, make sure to understand the warranty described below.

### 1. Warranty period and coverage

We will repair any failure or defect (hereinafter referred to as "failure") in our FA equipment (hereinafter referred to as the "Product") arisen during warranty period at no charge due to causes for which we are responsible through the distributor from which you purchased the Product or our service provider. However, we will charge the actual cost of dispatching our engineer for an on-site repair work on request by customer in Japan or overseas countries. We are not responsible for any on-site readjustment and/or trial run that may be required after a defective unit are repaired or replaced.

#### [Term]

The term of warranty for Product is twelve months after your purchase or delivery of the Product to a place designated by you or eighteen months from the date of manufacture whichever comes first ("Warranty Period"). Warranty period for repaired Product cannot exceed beyond the original warranty period before any repair work.

#### [Limitations]

- (1) You are requested to conduct an initial failure diagnosis by yourself, as a general rule. It can also be carried out by us or our service company upon your request and the actual cost will be charged.  
However, it will not be charged if we are responsible for the cause of the failure.
- (2) This limited warranty applies only when the condition, method, environment, etc. of use are in compliance with the terms and conditions and instructions that are set forth in the instruction manual and user manual for the Product and the caution label affixed to the Product.
- (3) Even during the term of warranty, the repair cost will be charged on you in the following cases;
  - a failure caused by your improper storing or handling, carelessness or negligence, etc., and a failure caused by your hardware or software problem
  - a failure caused by any alteration, etc. to the Product made on your side without our approval
  - a failure which may be regarded as avoidable, if your equipment in which the Product is incorporated is equipped with a safety device required by applicable laws and has any function or structure considered to be indispensable according to a common sense in the industry
  - a failure which may be regarded as avoidable if consumable parts designated in the instruction manual, etc. are duly maintained and replaced
  - any replacement of consumable parts (condenser, cooling fan, etc.)
  - a failure caused by external factors such as inevitable accidents, including without limitation fire and abnormal fluctuation of voltage, and acts of God, including without limitation earthquake, lightning and natural disasters
  - a failure generated by an unforeseeable cause with a scientific technology that was not available at the time of the shipment of the Product from our company
  - any other failures which we are not responsible for or which you acknowledge we are not responsible for

### 2. Term of warranty after the stop of production

- (1) We may accept the repair at charge for another seven (7) years after the production of the product is discontinued. The announcement of the stop of production for each model can be seen in our Sales and Service, etc.
- (2) Please note that the Product (including its spare parts) cannot be ordered after its stop of production.

### 3. Service in overseas

Our regional FA Center in overseas countries will accept the repair work of the Product; however, the terms and conditions of the repair work may differ depending on each FA Center. Please ask your local FA center for details.

### 4. Exclusion of loss in opportunity and secondary loss from warranty liability

Regardless of the gratis warranty term, Mitsubishi Electric shall not be liable for compensation to:

- (1) Damages caused by any cause found not to be the responsibility of Mitsubishi Electric.
- (2) Loss in opportunity, lost profits incurred to the user by Failures of Mitsubishi Electric products.
- (3) Special damages and secondary damages whether foreseeable or not, compensation for accidents, and compensation for damages to products other than Mitsubishi Electric products.
- (4) Replacement by the user, maintenance of on-site equipment, start-up test run and other tasks.

### 5. Change of Product specifications

Specifications listed in our catalogs, manuals or technical documents may be changed without notice.

### 6. Application and use of the Product

- (1) For the use of our product, its applications should be those that may not result in a serious damage even if any failure or malfunction occurs in product, and a backup or fail-safe function should operate on an external system to product when any failure or malfunction occurs.
- (2) Our product is designed and manufactured as a general purpose product for use at general industries.  
Therefore, applications substantially influential on the public interest for such as atomic power plants and other power plants of electric power companies, and also which require a special quality assurance system, including applications for railway companies and government or public offices are not recommended, and we assume no responsibility for any failure caused by these applications when used.  
In addition, applications which may be substantially influential to human lives or properties for such as airlines, medical treatments, railway service, incineration and fuel systems, man-operated material handling equipment, entertainment machines, safety machines, etc. are not recommended, and we assume no responsibility for any failure caused by these applications when used.  
We will review the acceptability of the abovementioned applications, if you agree not to require a specific quality for a specific application. Please contact us for consultation.

## ◆ About the enclosed CD-ROM

- The enclosed CD-ROM contains PDF copies of the manuals related to this product.

## ◆ Before using the enclosed CD-ROM

- The copyright and other rights of the enclosed CD-ROM all belong to Mitsubishi Electric Corporation.
- No part of the enclosed CD-ROM may be copied or reproduced without the permission of Mitsubishi Electric Corporation.
- Specifications of the enclosed CD-ROM are subject to change for modification without notice.
- We are not responsible for any damages and lost earnings, etc. from use of the enclosed CD-ROM.

- Trademarks

Microsoft, Windows, Windows Vista, and Internet Explorer are either registered trademarks or trademarks of Microsoft Corporation in the United States and/or other countries.

Adobe and Adobe Reader are either registered trademarks or trademarks of Adobe Systems Incorporated in the United States and/or other countries.

Intel and Pentium are trademarks of Intel Corporation in the United States and/or other countries.

Any trade names and product names of companies herein are all trademarks or registered trademarks of those respective companies.

- Warranty

We do not provide a warranty against defects in the enclosed CD-ROM and related documents.



- This is a personal computer dedicated CD-ROM. Do not attempt to play it on ordinary audio devices. The loud volume may damage hearing and speakers.

## ◆ System requirements for the enclosed CD-ROM

- The following system is required to read instruction manuals contained in the enclosed CD-ROM.

Item	Specifications
OS	Microsoft® Windows® 10, Windows® 8.1, Windows® 8, Windows® 7, Windows Vista®
CPU	Intel® Pentium® or better processor
Memory	128 MB of RAM
Hard disk	90 MB of available hard-disk space
CD-ROM drive	Double speed or more (more than quadruple speed is recommended)
Monitor	800×600 dots or more
Application	Adobe® Reader® 7.0 or more Internet Explorer® 6.0 or more

## ◆ Operating method of the enclosed CD-ROM

- How to read instruction manuals

Step 1. Start a personal computer and place the enclosed CD-ROM in the CD-ROM drive.

Step 2. The main window automatically opens by the web browser.

Step 3. Click a manual you want to read in the "INSTRUCTION MANUAL" list.

Step 4. PDF manual you clicked opens.

- Manual opening of the enclosed CD-ROM

Step 1. Start a personal computer and place the enclosed CD-ROM in the CD-ROM drive.

Step 2. Open "index.html" file in the enclosed CD-ROM.

Step 3. The main window opens by the web browser. Follow the instructions from Step 3 of "How to read instruction manuals".

- PDF data of the instruction manual are stored in "MANUAL" folder on the enclosed CD-ROM.



REVISIONS

\*The manual number is given on the bottom left of the back cover.

Revision Date	*Manual Number	Revision
Nov. 2014	IB(NA)-0600571ENG-A	First edition
Oct. 2016	IB(NA)-0600571ENG-B	Addition <ul style="list-style-type: none"> <li>• Restricted Use of Hazardous Substances in Electronic and Electrical Products</li> </ul>
Mar. 2019	IB(NA)-0600571ENG-C	Addition <ul style="list-style-type: none"> <li>• Application of caution labels</li> </ul> Modification <ul style="list-style-type: none"> <li>• Removal and reinstallation of the control circuit terminal block</li> </ul>

# FR-A800/A800 Plus Series

## Instruction Manual Supplement

### 1 Internal storage device fault (E.PE6)

The operation of the storage device in the inverter can be checked.

If a data fault occurs in the storage device in the inverter, the protective function (E.PE6) is activated.

When the read value of **Pr.890** is "7" or smaller, an inverter reset after All parameter clear can return the operation to normal. (The parameters that had been changed before All parameter clear must be set again.)

Operation panel indication	E.PE6	E. PEE	FR-LU08 indication	Fault
<b>Name</b>	Internal storage device fault			
<b>Description</b>	This protective function is activated by an inverter reset if writing data fails due to power-OFF or a data fault occurs in the storage device during parameter operations <sup>*1</sup> .			
<b>Check point</b>	Check if the power was turned OFF during parameter operations.			
<b>Corrective action</b>	Check the power supply or the devices on the power system to check that the devices have no fault. <ul style="list-style-type: none"> <li>When E.PE6 occurs due to power-OFF during parameter operations: Check the read value of <b>Pr.890</b>. When the value is "7" or smaller, perform All parameter clear and then an inverter reset. The parameters that had been changed before All parameter clear must be set again.</li> <li>When E.PE6 occurs due to other reason (such as turning OFF/ON the power or an inverter reset): Contact your sales representative.</li> </ul>			

\*1 For example, when parameter clear, All parameter clear, Parameter copy, or offline auto tuning is performed in the inverter, or when parameter batch write is performed in FR Configurator2.

#### NOTE

- "E.PE6" does not activate the retry function.
- "E.PE6" outputs the Fault output 3 (Y91) signal.
- "E.PE6" turns OFF the Safety monitor output (SAFE) signal.
- "E.PE6" is not cleared by turning ON the Fault clear (X51) signal.
- "E.PE6" is not activated during emergency drive operation.
- The communication data code for "E.PE6" is 172 (HAC).

### ◆ Checking faulty area in the internal storage device

When E.PE6 occurs, faulty area in the internal storage device can be checked by reading **Pr.890**.

Pr.	Name	Initial value	Setting range	Description
<b>890</b> <b>H325</b>	<b>Internal storage device status indication</b>	0	(0 to 9999)	A faulty area detected by self-check function can be indicated in the internal storage device.



- Use the read value of **Pr.890** to check the faulty area.
- The following table shows faulty areas indicated by the read value of **Pr.890**. Some read values indicate that there are multiple faulty areas. (For example, the read value "7" indicates that all the areas described in No. 1 to No. 3 are faulty.)

No.	Read value	Description
1	1, 3, 5, 7	Storage area other than the area for parameter settings is faulty (such as area for the set frequency). (When All parameter clear is performed, the set frequency, remotely-set frequency, host name for Ethernet communication, position pulse, multi-revolution counter, and offline auto tuning data are cleared.)
2	2, 3, 6, 7	Storage area for standard parameter settings is faulty.
3	4, 5, 6, 7	Storage area for communication parameter settings is faulty.
4	8 to 9999	Area for manufacturer setting

# FR-A800/A800 Plus Series

## Instruction Manual Supplement

### 1 Earth (ground) fault detection at start / restricting reset method for an earth (ground) fault

The reset method for the output side earth (ground) fault overcurrent (E.GF) can be restricted.

- Select whether to enable or disable the earth (ground) fault detection at start. When enabled, the earth (ground) fault detection is performed immediately after a start signal input to the inverter.
- Select whether to restrict the reset method for an earth (ground) fault.

Pr.	Name	Initial value	Setting range	Description	
				Earth (ground) fault	Reset method
249 H101	Earth (ground) fault detection at start	0	0	Not detected at start	Not restricted
			1	Detected at start	
			2		Restricted

#### ◆ Selecting whether to perform the earth (ground) fault detection at start

- If an earth (ground) fault is detected at start while **Pr.249** = "1 or 2", the output side earth (ground) fault overcurrent (E.GF) is detected and output is shut off.
- Earth (ground) fault detection at start is enabled under V/F control and Advanced magnetic flux vector control.
- When the **Pr.72 PWM frequency selection** setting is high, enable the earth (ground) fault detection at start.

#### NOTE

- Because the detection is performed at start, output is delayed for approx. 20 ms every start.
- Use **Pr.249** to enable/disable the earth (ground) fault detection at start. During operation, earth (ground) faults are detected regardless of the **Pr.249** setting.

#### ◆ Restricting reset method for an earth (ground) fault

- The reset method when the output is shut off due to the output side earth (ground) fault overcurrent (E.GF) can be restricted. When E.GF occurs while **Pr.249** = "2", E.GF can be reset only by turning OFF the control circuit power.
- This restriction prevents the inverter from being damaged due to repeated reset operations by the other methods such as entering the RES signal.
- When E.GF occurs while **Pr.249** = "2", the output short-circuit detection (ALM4) signal can be output.
- For the terminal used to output the ALM4 signal, set "23" (positive logic) or "123" (negative logic) in any of **Pr.190 to Pr.196 (Output terminal function selection)**.
- If **Pr.249** is set to "2" while the retry function is enabled (**Pr.67** is not set to "0"), no retry is performed even when E.GF occurs.
- If **Pr.249** is set to "2" while the automatic bypass switching after inverter fault is enabled (**Pr.138** is not set to "1"), the operation is not switched to the commercial power supply operation even when E.GF occurs.

#### NOTE

- Changing the terminal assignment using **Pr.190 to Pr.196 (Output terminal function selection)** may affect the other functions. Set parameters after confirming the function of each terminal.
- E.GF is not cleared by turning ON the Fault clear (X51) signal when **Pr.249** = "2".
- If E.GF occurs during emergency drive operation when **Pr.249** = "2", the output is shut off.

## 2 Output short-circuit fault (E.SCF)

Select the reset operation and fault indication for an output short-circuit.

Pr.	Name	Initial value	Setting range	Description	
				Operation after detection	Reset method
521 H194	Output short-circuit detection	0	0	E.OC1 to E.OC3	Not restricted
			1	E.SCF	Restricted

- The fault indication for an output short-circuit (E.OC1 to E.OC3, and E.SCF) can be changed by the **Pr.521** setting.
- When an output short-circuit is detected while **Pr.521** = "1", E.SCF is displayed and the inverter output is shut off.
- When E.SCF occurs while **Pr.521** = "1", E.SCF can be reset only by turning OFF the control circuit power. (E.OC1 to E.OC3 can be reset by any reset method.)
- This restriction prevents the inverter from being damaged due to repeated reset operations by the other methods such as entering the RES signal.
- When E.SCF occurs, the output short-circuit detection (ALM4) signal can be output.
- For the terminal used to output the ALM4 signal, set "23" (positive logic) or "123" (negative logic) in any of **Pr.190 to Pr.196 (Output terminal function selection)**.
- If the automatic bypass switching after inverter fault is enabled (**Pr.138** is not set to "1"), the operation is not switched to the commercial power supply operation even when E.SCF occurs.

Operation panel indication	E.SCF	<i>E. SCF</i>	FR-LU08 indication	Fault
<b>Name</b>	Output short-circuit fault			
<b>Description</b>	The inverter output is shut off when an output short-circuit is detected while <b>Pr.521</b> = "1". When <b>Pr.521</b> = "0" (initial value), E.OC1, E.OC2, or E.OC3 appears when an output short-circuit is detected.			
<b>Check point</b>	Check for output short-circuit.			
<b>Corrective action</b>	Check the wiring to make sure that any output short circuit does not occur, then turn OFF the control circuit power to reset the inverter.			

### NOTE

- When short-circuit resistance is large, the current does not reach the short-circuit detection level. In such a case, an output short-circuit cannot be detected.
- Changing the terminal assignment using **Pr.190 to Pr.196 (Output terminal function selection)** may affect the other functions. Set parameters after confirming the function of each terminal.
- E.SCF does not activate the retry function.
- E.SCF is not cleared by turning ON the Fault clear (X51) signal.
- If E.SCF occurs during emergency drive operation, the output is shut off.
- The communication data code for E.SCF is 20 (H14).

### 3 Extended detection time of the output current and zero current

The setting range of the **Pr.151 Output current detection signal delay time** and **Pr.153 Zero current detection time** is extended.

Pr.	Name	Initial value	Setting range	Description
<b>151 M461</b>	<b>Output current detection signal delay time</b>	0 s	0 to 300 s	Set the output current detection time. Enter the time from when the output current reaches the set current or higher to when the Output current detection (Y12) signal is output.
<b>153 M463</b>	<b>Zero current detection time</b>	0.5 s	0 to 300 s	Set the time from when the output current drops to the <b>Pr.152</b> setting or lower to when the Zero current detection (Y13) signal is output.

### 4 Selecting the command interface in the Network operation mode (Pr.338, Pr.339)

- The proximity dog (X76) signal can be input via communication.
- The following table shows the command interface for the function in the Network operation mode, determined by the parameter settings: an external terminal or a communication interface (RS-485 terminals or communication option).

<b>Pr.338 Communication operation command source</b>		<b>0: NET</b>			<b>1: EXT</b>		
<b>Pr.339 Communication speed command source</b>		<b>0: NET</b>	<b>1: EXT</b>	<b>2: EXT</b>	<b>0: NET</b>	<b>1: EXT</b>	<b>2: EXT</b>
X76	Proximity dog	Combined			EXT		

[Explanation of Terms in Table]

EXT: External terminal only

Combined: Either external terminal or communication interface

# FR-A862

## Instruction Manual Supplement

---

### 1 Instructions for UL and cUL

---

---

(Standard to comply with: UL 61800-5-1, CSA C22.2 No. 274)

#### ◆ Applicable models

- FR-A862-05450 to 08500
- The above models are compliant with both UL 508C and UL 61800-5-1, CSA C22.2 No. 274.  
For the instructions for UL 61800-5-1, CSA C22.2 No. 274, refer to this Instruction Manual Supplement.  
For the instructions for UL 508C, refer to the FR-A862 (SEPARATED CONVERTER TYPE)  
INSTRUCTION MANUAL (HARDWARE).

#### ◆ Product handling information / Informations sur la manipulation du produit

-WARNING- Operation of this product requires detailed installation and operation instructions provided in the Instruction Manual (HARDWARE) and the Instruction Manual (Detailed) intended for use with this product. Please forward relevant manuals to the end user.

-AVERTISSEMENT-

L'utilisation de ce produit nécessite des instructions détaillées d'installation et d'utilisation fournies dans les manuels d'instructions en anglais (Instruction Manual (HARDWARE) et Instruction Manual (Detailed)) destinés à être utilisés avec ce produit. Veuillez transmettre les manuels correspondants à l'utilisateur final.

#### ◆ Precautions for compliance with CSA C22.2 No.274

Use the inverter under the conditions of overvoltage category III and pollution degree 2 or lower specified in IEC 60664.

#### ◆ Branch circuit protection

For installation in the United States, branch circuit protection must be provided in accordance with the National Electrical Code and any applicable provincial codes.

For installation in Canada, branch circuit protection must be provided in accordance with the Canadian Electrical Code and any applicable provincial codes. Short circuit protection of the inverter cannot be used as branch circuit protection. Integral solid state short circuit protection does not provide branch circuit protection. Branch circuit protection must be provided in accordance with the National Electrical Code and any additional local code.

#### ■ Precautions for opening the branch-circuit protective device / Précautions pour ouvrir le dispositif de protection du circuit de dérivation

-WARNING- If the fuse melts down or the breaker trips on the input side of this product, check for wiring faults (such as short circuits). Identify and remove the cause of melting down or the trip before replacing the fuse or resetting the tripped breaker (or before applying the power to the inverter again).

-AVERTISSEMENT-

Si le fusible fond ou si le disjoncteur se déclenche du côté entrée de ce produit, vérifier les défauts de câblage (tels que les courts-circuits). Identifier et éliminer la cause de la fonte ou du déclenchement avant de remplacer le fusible ou de réinitialiser le disjoncteur déclenché (ou avant de remettre sous tension l'onduleur).

## ■ Fuse selection

Fuses are selected based on IEC/EN/UL 61800-5-1 and CSA C22.2 No. 274.

For installation in the United States, the following semi-conductor fuses must be provided, in accordance with the National Electrical Code and any applicable local codes. For installation in Canada, the following semi-conductor fuses must be provided, in accordance with the Canada Electrical Code and any applicable provincial codes. Always install the following semiconductor fuses for branch circuit protection.

Converter model	Cat. No.	Manufacturer	Rating (A)
FR-CC2-C355K	PC33UD69V800TF	Mersen	800
FR-CC2-C400K	PC33UD69V1250TF	Mersen	1250
FR-CC2-C560K	PC33UD69V1250TF	Mersen	1250

## ◆ Capacitor discharge time / Temps de décharge du condensateur

CAUTION -Risk of Electric Shock-

Before wiring or inspection, check that the LED indicator turns OFF. Any person who is involved in wiring or inspection shall wait for 10 minutes or longer after power OFF and check that there are no residual voltage using a digital multimeter or the like. The capacitor is charged with high voltage for some time after power OFF, and it is dangerous.

ATTENTION -Risque de choc électrique-

Avant le câblage ou l'inspection, vérifier que le témoin LED s'éteint. Toute personne impliquée dans le câblage ou l'inspection doit attendre 10 minutes ou plus après la mise hors tension et vérifier l'absence de tension résiduelle à l'aide d'un multimètre numérique ou similaire. Le condensateur est chargé avec une haute tension pendant un certain temps après la mise hors tension, ce qui est dangereux. Précautions pour ouvrir le dispositif de protection du circuit de dérivation.

## ◆ Wiring to the power supply and the motor

- Refer to the National Electrical Code (Article 310) regarding the allowable current of the cable. Select the cable size for 125% of the rated current according to the National Electrical Code (Article 430). For wiring the input (R/ L1, S/L2, T/L3) and output (U, V, W) terminals of the inverter, use the UL listed copper, stranded wires (rated at 75°C) and round crimp terminals. Crimp the terminals with the crimping tool recommended by the terminal manufacturer.

## ◆ Short circuit ratings

- Suitable for use in a circuit capable of delivering not more than 100 kA rms symmetrical amperes, 600 V maximum.

## ◆ Motor overload protection

When using the electronic thermal relay function as motor overload protection, set the rated motor current in **Pr.9**

### Electronic thermal O/L relay.

Operation characteristics of electronic thermal relay function

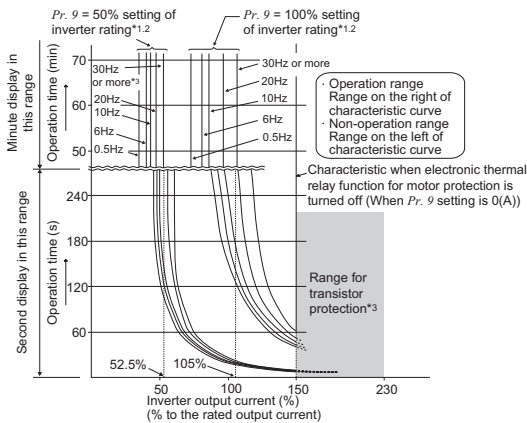

This function detects the overload (overheat) of the motor, stops the operation of the inverter's output transistor, and stops the output. (The operation characteristic is shown on the left.)

- \*1 When a value 50% of the inverter rated output current (current value) is set in **Pr.9**
- \*2 The % value denotes the percentage to the inverter rated current. It is not the percentage to the rated motor current.
- \*3 Transistor protection is activated depending on the temperature of the heat sink. The protection may be activated even with less than 150% depending on the operating conditions.

### NOTE

- The internal accumulated heat value of the electronic thermal relay function is reset by inverter power reset and reset signal input. Avoid unnecessary reset and power-OFF.
- When multiple motors are driven with a single inverter or when a multi-pole motor or a special motor is driven, install an external thermal relay (OCR) between the inverter and motors. Note that the current indicated on the motor rating plate is affected by the line-to-line leakage current (details in the Instruction Manual (HARDWARE)) when selecting the setting for an external thermal relay.
- The cooling effect of the motor drops during low-speed operation. Use a thermal protector or a motor with built-in thermistor.
- When the difference between the inverter and motor capacities is large and the setting is small, the protective characteristics of the electronic thermal relay function will be deteriorated. In this case, use an external thermal relay.
- A special motor cannot be protected by the electronic thermal relay function. Use an external thermal relay.
- Motor over temperature sensing is not provided by the drive.

## ◆ Applicable power supply

For use at an altitude above 2000 m (maximum 2500 m), only a neutral-point earthed (grounded) power supply can be used.



# MEMO

**mitsubishi electric corporation**  
HEAD OFFICE: TOKYO BUILDING 2-7-3, MARUNOUCHI, CHIYODA-KU, TOKYO 100-8310, JAPAN