



# INVERTER CC2

## FR-CC2-P (CONVERTER UNIT FOR PARALLEL OPERATION) INSTRUCTION MANUAL

### *Converter Unit*

### FR-CC2-H400K to H560K-P

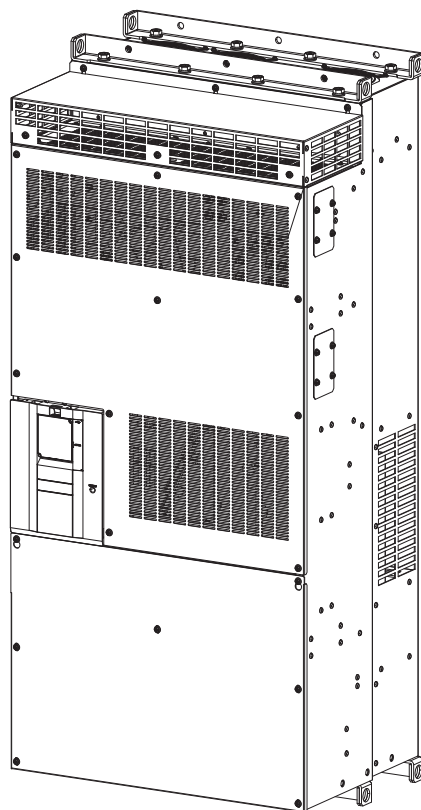

INTRODUCTION	1
INSTALLATION AND WIRING	2
PRECAUTIONS FOR USE OF THE CONVERTER UNIT	3
BASIC OPERATION	4
PARAMETER	5
PROTECTIVE FUNCTIONS	6
PRECAUTIONS FOR MAINTENANCE AND INSPECTION	7
SPECIFICATIONS	8

Thank you for choosing this Mitsubishi Electric converter unit.

This Instruction Manual provides handling information and precautions for use of the FR-CC2-P series.

Incorrect handling might cause an unexpected fault. Before using this converter unit, always read this Instruction Manual carefully to use this product correctly.

### Safety instructions

Do not attempt to install, operate, maintain or inspect the product until you have read through this Instruction Manual and appended documents carefully and can use the equipment correctly. Do not use this product until you have a full knowledge of the equipment, safety information and instructions.

Installation, operation, maintenance and inspection must be performed by qualified personnel. Here, qualified personnel means a person who meets all the conditions below.

- A person who possesses a certification in regard with electric appliance handling, or person took a proper engineering training.

Such training may be available at your local Mitsubishi office. Contact your local sales office for schedules and locations.

- A person who can access operating manuals for the protective devices (e.g. light curtain) connected to the safety control system. A person who has read and familiarized himself/herself with the manuals.

In this Instruction Manual, the safety instruction levels are classified into "WARNING" and "CAUTION".



**WARNING**

Incorrect handling may cause hazardous conditions, resulting in death or severe injury.



**CAUTION**

Incorrect handling may cause hazardous conditions, resulting in medium or slight injury, or may cause only material damage.

Even items that are marked with the  icon may lead to a potentially critical situation, depending on the circumstances. Both instruction levels must be followed because these are important to personal safety.

### ◆ Electric Shock Prevention



**WARNING**

- While the converter power is ON, do not remove the front cover or the wiring cover. Do not run the converter with the front cover or the wiring cover removed. Otherwise you may access the exposed high voltage terminals or the charging part of the circuitry and get an electric shock.
- Even if power is OFF, do not remove the front cover except for wiring or periodic inspection. Accidentally touching the charged converter circuits will result in electric shock.
- Before wiring or inspection, LED indication of the operation panel must be switched OFF. Any person who is involved in wiring or inspection shall wait for at least 10 minutes after the power supply has been switched OFF and check that there are no residual voltage using a tester or the like. The capacitor is charged with high voltage for some time after power OFF, and it is dangerous.
- A neutral-point earthed (grounded) power supply for converter unit in compliance with EN standard must be used.
- Any person who is involved in wiring or inspection of this equipment shall be fully competent to do the work.
- The converter unit must be installed before wiring. Otherwise you may get an electric shock or be injured.
- Do not touch the setting dial or keys with wet hands. Doing so may cause an electric shock.
- Do not subject the cables to scratches, excessive stress, heavy loads or pinching. Doing so may cause an electric shock.
- Do not change the cooling fan while power is ON as it is dangerous.
- Do not touch the printed circuit board or handle the cables with wet hands. Doing so may cause an electric shock.

### ◆ Fire Prevention



**CAUTION**

- The converter unit must be installed on a nonflammable wall without holes in it so that its components cannot be touched from behind. Installing it on or near flammable material may cause a fire.
- If the converter unit becomes faulty, the converter power must be switched OFF. A continuous flow of large current may cause a fire.
- Be sure to perform daily and periodic inspections as specified in the Instruction Manual. There is a possibility of explosion, damage, or fire if this product is used without inspection.

### ◆ Injury Prevention



**CAUTION**

- The voltage applied to each terminal must be the ones specified in the Instruction Manual. Otherwise an explosion or damage may occur.
- The cables must be connected to the correct terminals. Otherwise an explosion or damage may occur.
- The polarity (+ and -) must be correct. Otherwise a an explosion or damage may occur.
- While power is ON or for some time after power OFF, do not touch the converter unit as it will be extremely hot. Touching these devices may cause burns.

### ◆ Additional instructions

The following instructions must be also followed. If the product is handled incorrectly, it may cause unexpected fault, an injury, or an electric shock.



**CAUTION**

#### Transportation and installation

- To prevent injury, wear cut-resistant gloves when opening packaging with sharp tools.
- Use proper lifting techniques or a trolley when carrying products. Failure to do so may lead to injuries.
- Do not stand or rest heavy objects on the product.
- Do not stack the boxes containing converters higher than the number recommended.
- When carrying the converter, do not hold it by the front cover or setting dial; it may fall or break.
- During installation, caution must be taken not to drop the converter unit as doing so may cause injuries.
- The product must be installed on a surface that withstands the weight of the converter unit.
- Do not install the product on a hot surface.
- Ensure the mounting orientation of this product is correct.
- Ensure this product is mounted securely in its enclosure.
- Do not install or operate the converter unit if it is damaged or has parts missing.
- Foreign conductive objects must be prevented from entering the converter unit. That includes screws and metal fragments or other flammable substance such as oil.
- As the converter unit is a precision instrument, do not drop or subject it to impact.
- The surrounding air temperature must be between -10 and +50°C (non-freezing). Otherwise the converter unit may be damaged.
- The ambient humidity must be 95%RH or less (non-condensing). Otherwise the converter unit may be damaged. (For the details, refer to [page 20](#).)

## ⚠ CAUTION

### Transportation and installation

- The storage temperature (applicable for a short time, e.g. during transit) must be between -20 and +65°C. Otherwise the converter unit may be damaged.
- The converter unit must be used indoors (without corrosive gas, flammable gas, oil mist, dust and dirt etc.) Otherwise the converter unit may be damaged.
- Do not use this product at an altitude above 2500 m. Vibration should not exceed 2.9 m/s<sup>2</sup> at 10 to 55 Hz in X, Y, and Z directions. Otherwise the converter unit may be damaged. (For the details, refer to [page 20](#).)
- If halogens (including fluorine, chlorine, bromine, and iodine) contained in fumigants for wood packages enter this product, the product may be damaged. Prevent the entry of fumigant residuals or use an alternative method such as heat disinfection. Note that sterilization or disinfection of wood packages should be performed before packing the product.

### Test run

- Before starting operation, each parameter must be confirmed and adjusted. A failure to do so may cause some machines to make unexpected motions.

## ⚠ WARNING

### Usage

- Depending on the function settings of this product, the product does not stop its output even when the STOP/RESET key on the operation panel is pressed. To prepare for it, provide a separate circuit and switch (to turn OFF the power of this product, or apply a mechanical brake, etc.) for an emergency stop.
- Be sure to turn OFF the start (STF/STR) signal before clearing the fault as this product will restart the motor suddenly after a fault is cleared.
- Do not modify the equipment.
- Do not perform parts removal which is not instructed in this manual. Doing so may lead to fault or damage of the product.

## ⚠ CAUTION

### Usage

- Do not repeatedly start or stop the inverter with a magnetic contactor on its input side. Doing so may shorten the life of the inverter and the converter unit.
- Use a noise filter or other means to minimize electromagnetic interference with other electronic equipment used nearby this product.
- Appropriate precautions must be taken to suppress harmonics. Otherwise power supply harmonics from the inverter or the converter unit may heat/damage the power factor correction capacitor and generator.
- As all parameters return to their initial values after the Parameter clear or All parameter clear is performed, the parameters must be set again as required before the operation is started.
- Perform an inspection and test operation of this product if it has been stored for a long period of time.
- Static electricity in your body must be discharged before you touch the product.
- To maintain the security (confidentiality, integrity, and availability) of the Converter unit, drive unit and the system against unauthorized access, DoS \*1 attacks, computer viruses, and other cyberattacks from external devices via network, take appropriate measures such as firewalls, virtual private networks (VPNs), and antivirus solutions. We shall have no responsibility or liability for any problems involving Converter unit, drive unit trouble and system trouble by DoS attacks, unauthorized access, computer viruses, and other cyberattacks.
- When the emergency drive function is enabled, the operation is continued or the retry operation (automatic reset and restart) is repeated even if a fault occurs, which may damage or burn the inverter, the converter unit, or the motor. Before restarting the normal operation after the operation using the emergency drive function, make sure that the inverter, the converter unit, and the motor have no fault.

### Emergency stop

- A safety backup such as an emergency brake must be provided for devices or equipment in a system to prevent hazardous situations from occurring in case of failure of an external device controlling the converter unit or the inverter.
- A safety backup such as an emergency brake must be provided to prevent hazardous conditions to the machine and equipment in case of converter unit failure.
- If the breaker installed on the input side of this product trips, check for wiring faults (such as short circuits) and damage to internal parts of this product, etc. Identify and remove the cause of the trip before resetting the tripped breaker and applying the power to this product again.
- When a protective function is activated, take an appropriate corrective action, then reset the converter unit (inverter), and resume the operation.

### Maintenance, inspection and parts replacement

- Do not carry out a megger (insulation resistance) test on the control circuit of the inverter. It will cause a failure.

### Disposal

- The converter must be treated as industrial waste.

\*1 DoS: A denial-of-service (DoS) attack disrupts services by overloading systems or exploiting vulnerabilities, resulting in a denial-of-service (DoS) state.

## General instruction

- Many of the diagrams and drawings in the Instruction Manual show the product without a cover or partially open for explanation. Never operate the product in this manner. The cover must be always reinstalled and the instruction in the Instruction Manual must be followed when operating the product.

# CONTENTS

<b>1</b>	<b>INTRODUCTION</b>	<b>7</b>
1.1	Product checking	8
1.2	Component names	9
1.3	Related manuals	10
<b>2</b>	<b>INSTALLATION AND WIRING</b>	<b>11</b>
2.1	Peripheral devices	12
2.1.1	Converter unit and peripheral devices	12
2.1.2	Peripheral device	13
2.2	Removal and reinstallation of the front cover	18
2.3	Installation of the converter unit and enclosure design	20
2.3.1	Converter unit installation environment	20
2.3.2	Cooling system types for converter unit enclosure	22
2.3.3	Installation of the converter unit	23
2.3.4	Protruding the heat sink	25
2.4	Terminal connection diagrams	27
2.5	Main circuit terminals (6-phase rectification)	35
2.5.1	Details on the main circuit terminals	35
2.5.2	Terminal layout of the main circuit terminals, wiring of the power supply and the inverter	35
2.5.3	Applicable cables	37
2.5.4	Earthing (grounding) precautions	38
2.6	Main circuit terminals (for 12-phase rectification)	39
2.6.1	Details on the main circuit terminals	39
2.6.2	Connection diagram with 12-phase rectifier power transformer	39
2.6.3	12-phase rectifier power transformer	39
2.6.4	Wiring method	40
2.6.5	Recommended cables	41
2.6.6	Earthing (grounding) precautions	42
2.7	Control circuit	43
2.7.1	Details on the control circuit terminals	43
2.7.2	Control logic (sink/source) change	45
2.7.3	Wiring of control circuit	47
2.7.4	Wiring precautions	49
2.7.5	When using separate power supplies for the control circuit and the main circuit	50
2.7.6	When supplying 24 V external power to the control circuit	51
2.8	Communication connectors and terminals	53
2.8.1	RS-485 terminal block	53
2.8.2	PU connector	55
2.9	Setting parameters for parallel operation	56

---

## **3 PRECAUTIONS FOR USE OF THE CONVERTER UNIT** **59**

---

<b>3.1</b>	<b>Electro-magnetic interference (EMI) and leakage currents</b>	<b>60</b>
3.1.1	Leakage currents and countermeasures .....	60
3.1.2	Countermeasures against EMI generated by the inverter or the converter unit.....	62
3.1.3	Built-in EMC filter.....	65
<b>3.2</b>	<b>Power supply harmonics</b>	<b>66</b>
3.2.1	Power supply harmonics .....	66
3.2.2	Harmonic Suppression Guidelines .....	67
<b>3.3</b>	<b>Power-OFF and magnetic contactor (MC)</b>	<b>70</b>
<b>3.4</b>	<b>Checklist before starting operation</b>	<b>71</b>

---

## **4 BASIC OPERATION** **73**

---

<b>4.1</b>	<b>Operation panel</b>	<b>74</b>
4.1.1	Components of the operation panel .....	74
4.1.2	Basic operation of the operation panel.....	75
4.1.3	Correspondences between digital and actual characters.....	76
4.1.4	Changing the parameter setting value .....	77
<b>4.2</b>	<b>Monitoring the converter unit status</b>	<b>78</b>
4.2.1	Monitoring of converter output voltage and input current .....	78
4.2.2	First monitored item.....	78

---

## **5 PARAMETER** **79**

---

<b>5.1</b>	<b>Parameter list</b>	<b>80</b>
5.1.1	Parameter list (by parameter number) .....	80
5.1.2	Parameter display by function group.....	83
5.1.3	Parameter list (by function group) .....	84
<b>5.2</b>	<b>(E) Environment setting parameters</b>	<b>86</b>
5.2.1	Simple clock function.....	87
5.2.2	Reset selection / disconnected PU detection / reset limit.....	88
5.2.3	Buzzer control .....	89
5.2.4	Display-off mode .....	89
5.2.5	Setting dial key lock operation selection .....	90
5.2.6	Parameter write selection .....	90
5.2.7	Password function .....	91
5.2.8	Free parameter.....	93
5.2.9	Converter unit parts life display .....	93
5.2.10	Maintenance timer alarm .....	95
<b>5.3</b>	<b>(H) Protective function parameter</b>	<b>96</b>
5.3.1	Varying the activation level of the undervoltage protective function.....	96
5.3.2	Initiating a protective function.....	96
5.3.3	Input phase loss protection selection .....	97
5.3.4	Emergency drive .....	97

---

<b>5.4</b>	<b>(M) Monitor display and monitor output signal</b>	<b>101</b>
5.4.1	Monitor display selection using operation panel or via communication .....	101
5.4.2	Output terminal function selection .....	105
5.4.3	Detection of control circuit temperature .....	108
<b>5.5</b>	<b>(T) Multi-function input terminal parameters</b>	<b>109</b>
5.5.1	Input terminal function selection .....	109
5.5.2	Operation selection for the external thermal relay input (Pr.876) .....	110
<b>5.6</b>	<b>(A) Application parameters</b>	<b>111</b>
5.6.1	Self power management.....	111
5.6.2	Automatic restart after instantaneous power failure selection .....	113
5.6.3	Power failure time deceleration-to-stop function.....	114
<b>5.7</b>	<b>(N) Operation via communication and its settings</b>	<b>115</b>
5.7.1	Wiring and configuration of PU connector .....	115
5.7.2	EEPROM write selection during communication operation .....	117
5.7.3	Initial settings and specifications of RS-485 communication .....	118
5.7.4	Mitsubishi inverter protocol (computer link communication).....	119
<b>5.8</b>	<b>Parameter clear / all parameter clear</b>	<b>131</b>
<b>5.9</b>	<b>Copying and verifying parameters</b>	<b>132</b>
5.9.1	Parameter copy .....	132
5.9.2	Parameter verification.....	134
<b>5.10</b>	<b>Checking parameters changed from their initial values (Initial value change list)</b>	<b>135</b>

---

## **6 PROTECTIVE FUNCTIONS 137**

<b>6.1</b>	<b>Converter unit fault and alarm indications</b>	<b>138</b>
<b>6.2</b>	<b>Reset method for the protective functions</b>	<b>138</b>
<b>6.3</b>	<b>Check and clear of the fault history</b>	<b>139</b>
<b>6.4</b>	<b>Fault history and the list of fault displays</b>	<b>141</b>
<b>6.5</b>	<b>Causes and corrective actions</b>	<b>142</b>
<b>6.6</b>	<b>Check first when you have trouble</b>	<b>150</b>
6.6.1	Converter unit does not operate properly .....	150
6.6.2	The power lamp is OFF .....	150
6.6.3	The charge lamp is OFF .....	150
6.6.4	Operation panel display is not operating .....	150
6.6.5	Inverter cannot be operated.....	151
6.6.6	Unable to write parameter setting.....	151
6.6.7	Breaker trips .....	151
6.6.8	Converter unit generates abnormal noise.....	151

---

## **7 PRECAUTIONS FOR MAINTENANCE AND INSPECTION 153**

<b>7.1</b>	<b>Inspection item</b>	<b>154</b>
7.1.1	Daily inspection .....	154
7.1.2	Periodic inspection .....	154
7.1.3	Daily and periodic inspection.....	155
7.1.4	Checking the converter semiconductor devices.....	157
7.1.5	Cleaning .....	157
7.1.6	Replacement of parts .....	158
7.1.7	Converter unit replacement.....	160

<b>7.2</b>	<b>Measurement of main circuit voltages, currents and powers</b>	<b>161</b>
7.2.1	Measurement of powers.....	162
7.2.2	Measurement of voltages .....	162
7.2.3	Measurement of currents .....	162
7.2.4	Example of measuring converter unit input power factor .....	162
7.2.5	Measurement of converter output voltage (across terminals P and N) .....	162
7.2.6	Insulation resistance test using megger .....	163
7.2.7	Withstand voltage test.....	163

---

## **8 SPECIFICATIONS** **165**

<b>8.1</b>	<b>Converter unit rating</b>	<b>166</b>
<b>8.2</b>	<b>Common specifications</b>	<b>166</b>
<b>8.3</b>	<b>Outline dimension drawings</b>	<b>167</b>
8.3.1	Converter unit outline dimension drawings .....	167

---

## **APPENDIX** **169**

Appendix 1	Instruction code list.....	170
Appendix 2	Instructions for compliance with the EU Directives .....	172
Appendix 3	Instructions for UL and cUL .....	176
Appendix 4	Instructions for EAC.....	178
Appendix 5	Restricted Use of Hazardous Substances in Electronic and Electrical Products .....	179
Appendix 6	Referenced Standard (Requirement of Chinese standardized law).....	179
Appendix 7	Compliance with the UK certification scheme.....	180

# 1 INTRODUCTION

This chapter contains the descriptions that must be read before using this product.

Always read the instructions before using the equipment.

1.1	Product checking.....	8
1.2	Component names.....	9
1.3	Related manuals .....	10

#### <Abbreviations>

Operation panel ..... Operation panel of the inverter (FR-DU08)

Converter unit ..... Converter unit FR-CC2-P series (for parallel operation)

Inverter..... Mitsubishi Electric FR-A802-P series inverter (separated converter type for parallel operation)

Pr. .... Parameter number (Number assigned to function)

#### <Trademarks>

- Microsoft and Visual C++ are registered trademarks of Microsoft Corporation in the United States and other countries.
- Other company and product names herein are the trademarks and registered trademarks of their respective owners.

#### <Notes on descriptions in this Instruction Manual>

- Connection diagrams in this Instruction Manual suppose that the control logic of the input terminal is the sink logic, unless otherwise specified. (For the control logic, refer to [page 45](#).)

#### Harmonic Suppression Guidelines

All the models of the inverters used by specific consumers are covered by "the Harmonic Suppression Guidelines for Consumers Who Receive High Voltage or Special High Voltage". (For the details, refer to [page 67](#).)



# 1.1 Product checking

Unpack the product and check the rating plate and the capacity plate of the converter unit to ensure that the model agrees is as ordered and the product is intact.

## ◆ Converter unit model

Symbol	Voltage class	Symbol	Description	Symbol	Function
H	400V class	400K to 560K	Rated converter unit capacity (kW)	P	Parallel operation

F R - C C 2 - H 400K - 60 P

Symbol	Circuit board coating (conforming to IEC60721-3-3:1994 3C2/3S2)	Plated conductor
60	With	Without
06	With	With

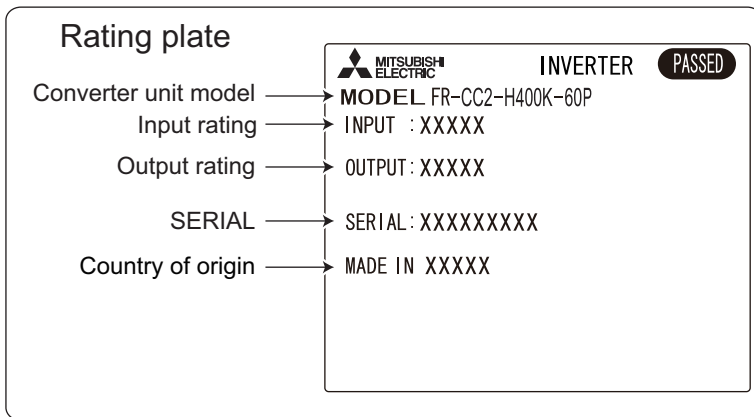
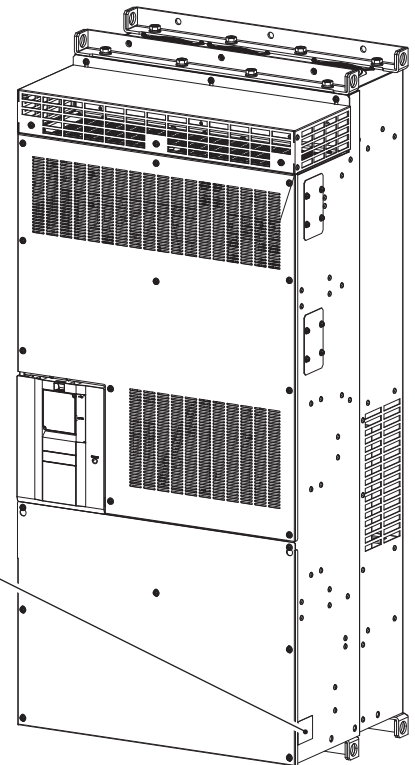

## ◆ How to read the SERIAL number

Rating plate example

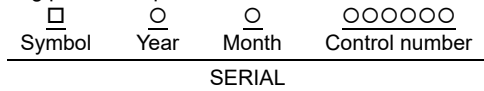

The SERIAL consists of one symbol, two characters indicating the production year and month, and six characters indicating the control number.

The last digit of the production year is indicated as the Year, and the Month is indicated by 1 to 9, X (October), Y (November), or Z (December).

## ◆ Accessory

- Ferrite core (ZCAT3035-1330) × 2: Use two cores on RS-485 cables for communication between two converter units to reduce noise. (Refer to [page 53](#).)



# 1.2 Component names

Component names are shown below.

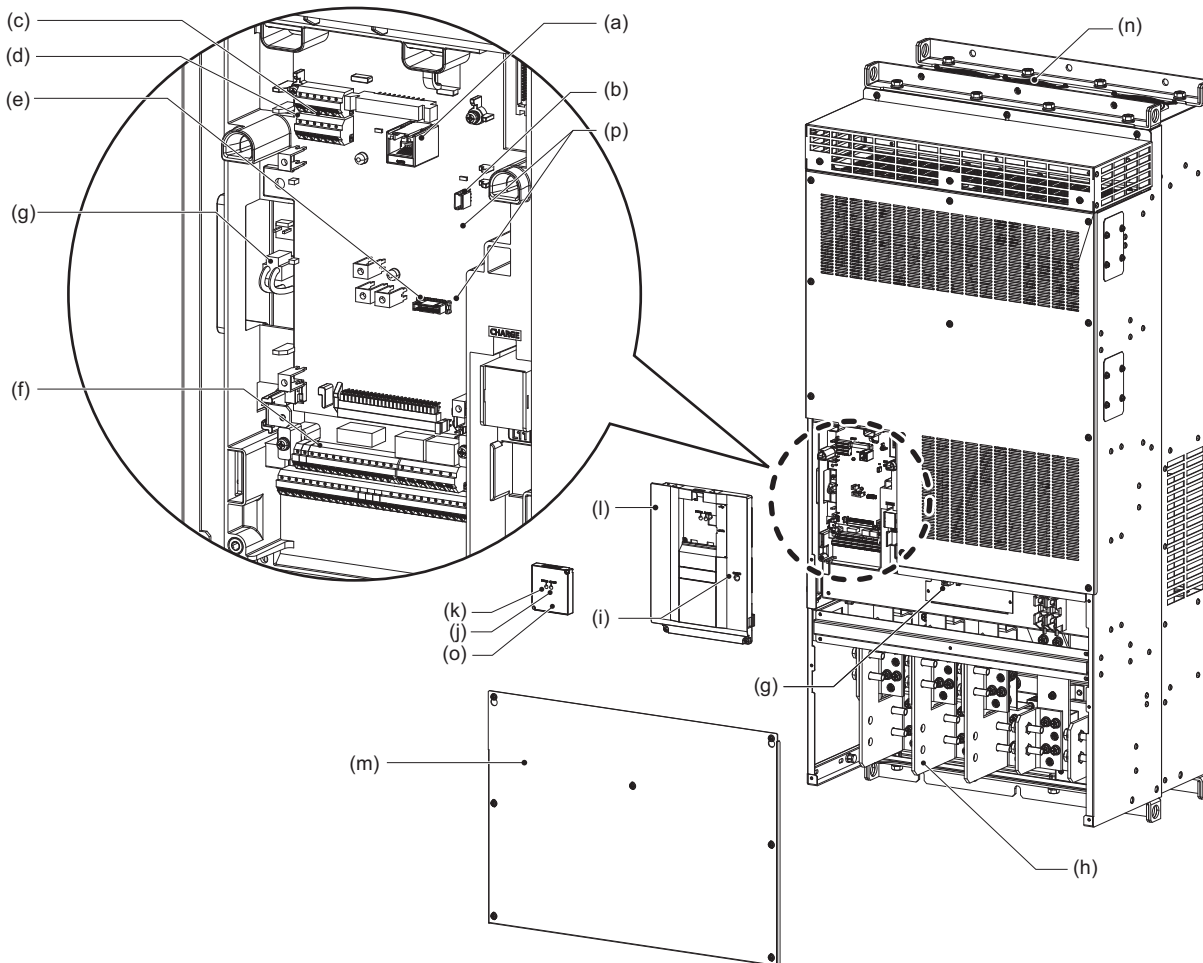

1

Symbol	Name	Description	Refer to page
(a)	PU connector	Connects the operation panel. This connector also enables the RS-485 communication.	55
(b)	For manufacturer setting. Do not use.		-
(c)	RS-485 terminals	Enable RS-485 communication between the master and the slave for the parallel operation.	50
(d)	Terminating resistor selection switch (SW1)	Select whether or not to use the terminating resistor for RS-485 communication.	53
(e)	For manufacturer setting. Do not use.		-
(f)	Control circuit terminal block	Connects cables for the control circuit.	43
(g)	EMC filter ON/OFF connector	Turns ON/OFF the EMC filter.	65
(h)	Main circuit conductor	Connects cables for the main circuit.	35
(i)	Charge lamp	Stays ON while the power is supplied to the main circuit.	35
(j)	Alarm lamp	Turns ON when the protective function of the converter is activated.	35
(k)	Power lamp	Stays ON while the power is supplied to the control circuit (R1/L11, S1/L21).	35
(l)	Front cover (upper side)	Remove this cover for wiring to the control circuit terminals, the RS-485 terminals, etc.	18
(m)	Front cover (lower side)	Remove this cover for wiring.	18
(n)	Cooling fan	Cools the converter.	159
(o)	Accessory cover	Covers the operation panel installation area	18
(p)	Switches for manufacturer setting (SW3 and SW4)	Do not change the initial setting (OFF  OFF ON).	-

# 1.3 Related manuals

---

Manuals related to the FR-CC2-P converter unit are shown in the following table.

Name	Manual number
FR-A802-P Instruction Manual (Hardware)	IB-0600651ENG
Parallel Operation Function Manual	IB-0600654ENG
FR-A800 Instruction Manual (Detailed)	IB-0600503ENG

---

# **2** **INSTALLATION AND WIRING**

---

This chapter explains the "installation" and the "wiring" of this product.

Always read the instructions before using the equipment.

---

<b>2.1</b>	<b>Peripheral devices .....</b>	<b>12</b>
<b>2.2</b>	<b>Removal and reinstallation of the front cover.....</b>	<b>18</b>
<b>2.3</b>	<b>Installation of the converter unit and enclosure design .....</b>	<b>20</b>
<b>2.4</b>	<b>Terminal connection diagrams .....</b>	<b>27</b>
<b>2.5</b>	<b>Main circuit terminals (6-phase rectification).....</b>	<b>35</b>
<b>2.7</b>	<b>Control circuit .....</b>	<b>43</b>
<b>2.8</b>	<b>Communication connectors and terminals .....</b>	<b>53</b>
<b>2.9</b>	<b>Setting parameters for parallel operation.....</b>	<b>56</b>

# 2.1 Peripheral devices

## 2.1.1 Converter unit and peripheral devices

- For operating two units in parallel

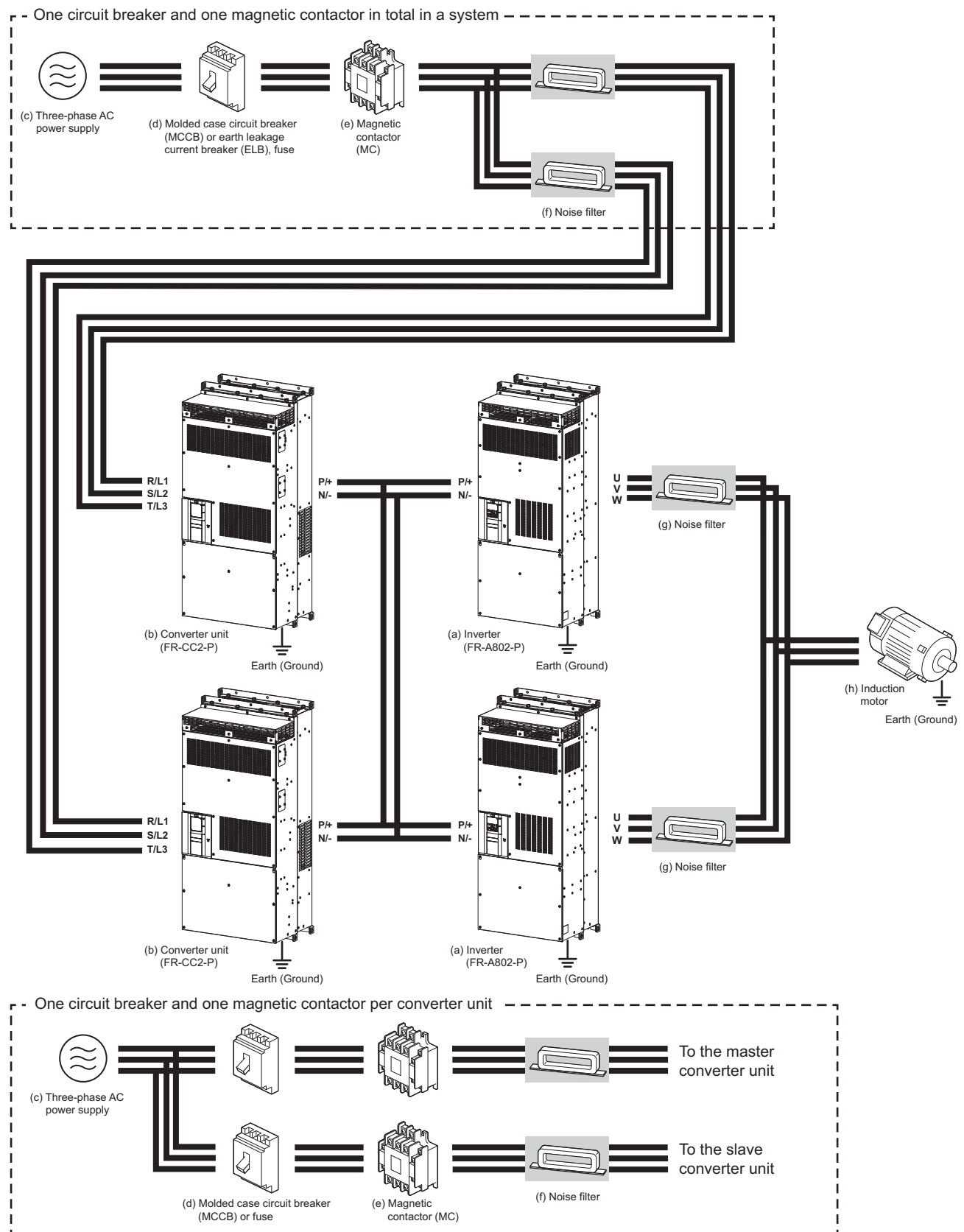

■ : Install these options as required.

Symbol	Name	Overview	Refer to page
(a)	Inverter (FR-A802-P)	The life of the inverter and the converter unit is influenced by the surrounding air temperature. The surrounding air temperature should be as low as possible within the permissible range. This must be noted especially when the inverter is installed in an enclosure.	20 27 65
(b)	Converter unit (FR-CC2-P)	Incorrect wiring may lead to damage of the inverter and the converter unit. The control signal lines must be kept fully away from the main circuit lines to protect them from noise. The built-in EMC filter of the converter unit can reduce the noise.	
(c)	Three-phase AC power supply	Must be within the permissible power supply specifications of the converter unit.	166
(d)	Molded case circuit breaker (MCCB), earth leakage circuit breaker (ELB), or fuse*1	Must be selected carefully since an inrush current flows in the converter unit at power ON.	13
(e)	Magnetic contactor (MC)*2	Install this to ensure safety. Do not use this to start and stop the inverter. Doing so will shorten the life of the inverter and the converter unit.	70
(f)	Noise filter	Suppresses the noise radiated from the power supply side of the converter unit.	62
(g)	Noise filter	Install this to reduce the electromagnetic noise generated from the inverter or the converter unit. The noise filter is effective in the range from about 0.5 MHz to 5 MHz.	62
(h)	Induction motor	Connect a squirrel-cage induction motor.	—

\*1 Do not use an earth leakage circuit breaker as a circuit breaker which is intended to be installed per converter unit. Doing so may cause unintended operation of the inverter.

\*2 For every magnetic contactor installed for a converter unit in parallel connection, the ON/OFF timing of the magnetic contactors is critical to supplying power to the converters simultaneously. Otherwise, the converter units may be damaged.

### NOTE

- To prevent an electric shock, always earth (ground) the converter unit, the inverter, and the motor.
- Do not install a power factor correction capacitor or surge suppressor or capacitor type filter on the inverter's output side. Doing so will cause the inverter output shutoff or the capacitor and surge suppressor to be damaged. If any of the above devices is connected, immediately remove it. When installing a molded case circuit breaker on the output side of the inverter, contact the manufacturer of the molded case circuit breaker.
- Electromagnetic wave interference  
The input/output (main circuit) of the inverter or the converter unit includes high frequency components, which may interfere with the communication devices (such as AM radios) used near the inverter or the converter unit. In this case, activating the EMC filter may minimize interference. (Refer to [page 65](#).)
- For details of options and peripheral devices, refer to the respective Instruction Manual.

## 2.1.2 Peripheral device

### ◆Compatible inverters

The table below shows the converter units compatible with the inverters according to the connected motor capacity. The capacity of all converter units must be the same in a system, and that of all inverters also must be the same.

Number of units in parallel	Converter unit FR-CC2-[ ]-P	Inverter					
		LD (light duty)			ND (normal duty, initial value)		
		Model FR-A842-[ ]-P	Rated current (A)		Model FR-A842-[ ]-P	Rated current (A)	
2	H400K	—	—	—	400K	09620	1232
	H450K	400K	09620	1386	450K	10940	1386
	H500K	450K	10940	1539	500K	12120	1539
	H560K	500K	12120	1750	—	—	—
3	H400K	—	—	—	400K	09620	1848
	H450K	400K	09620	2078	450K	10940	2078
	H500K	450K	10940	2309	500K	12120	2309
	H560K	500K	12120	2626	—	—	—

### ◆ Selecting the breaker/magnetic contactor 6-phase transformer

Check the model of the inverter and the converter unit you purchased. Appropriate peripheral devices must be selected according to the capacity.

Refer to the table below to prepare appropriate peripheral devices.

- One circuit breaker and one magnetic contactor in total in a system

When a single wound motor or a multi-wound motor is connected under V/F control or Advanced magnetic flux vector control

Number of units in parallel	Applicable converter unit FR-CC2-[ ]-P	Molded case circuit breaker (MCCB)*1 or earth leakage circuit breaker (ELB) (NF, NV type)	Input-side magnetic contactor*2
2	H400K	1500 A	1300 A rated product
	H450K	1600 A	1400 A rated product
	H500K	1800 A	1600 A rated product
	H560K	2100 A*3	1800 A rated product
3	H400K	2200 A*3	1900 A rated product
	H450K	2400 A*3	2100 A rated product
	H500K	2700 A*3	2400 A rated product
	H560K	3100 A*3	2700 A rated product

When a multi-wound motor is connected under Real sensorless vector control or Vector control

Number of units in parallel	Applicable converter unit FR-CC2-[ ]-P	Molded case circuit breaker (MCCB)*1 or earth leakage circuit breaker (ELB) (NF, NV type)	Input-side magnetic contactor*2
2	H400K	1800 A	1600 A rated product
	H450K	2100 A	1800 A rated product
	H500K	2200 A	1900 A rated product
	H560K	2400 A	2100 A rated product

\*1 Select an MCCB according to the power supply capacity.

Install one MCCB per converter unit. (For the use in the United States or Canada, refer to [page 176](#) to select an appropriate fuse or molded case circuit breaker (MCCB).)

\*2 The magnetic contactor is selected based on the AC-1 class. The electrical durability of magnetic contactor is 500,000 times. When the magnetic contactor is used for emergency stops during motor driving, the electrical durability is 25 times.

If using an MC for emergency stop during driving the motor, select an MC regarding the converter unit input side current as JEM1038-AC-3 class rated current. When providing an MC to use the commercial power supply during general-purpose motor operation, select an MC regarding the rated motor current as JEM1038-AC-3 class rated current.

\*3 An air circuit breaker (ACB) is also applicable in a system in which a 2000 A breaker or higher is applicable.

- One circuit breaker and one magnetic contactor per converter unit

When a single wound motor or a multi-wound motor is connected under V/F control or Advanced magnetic flux vector control

Number of units in parallel	Applicable converter unit FR-CC2-[ ]-P	Molded case circuit breaker (MCCB)*1 (NF type)	Input-side magnetic contactor*2
2	H400K	900 A	S-N800
	H450K	1000 A	1000 A rated product
	H500K	1200 A	1000 A rated product
	H560K	1500 A	1200 A rated product
3	H400K	900 A	S-N800
	H450K	1000 A	1000 A rated product
	H500K	1200 A	1000 A rated product
	H560K	1500 A	1200 A rated product

When a multi-wound motor is connected under Real sensorless vector control or Vector control

Number of units in parallel	Applicable converter unit FR-CC2-[ ]-P	Molded case circuit breaker (MCCB)*1 or earth leakage circuit breaker (ELB) (NF, NV type)	Input-side magnetic contactor*2
2	H400K	900 A	S-N800
	H450K	1000 A	1000 A rated product
	H500K	1200 A	1000 A rated product
	H560K	1500 A	1200 A rated product

- \*1 Select an MCCB according to the power supply capacity.  
Install one MCCB per converter unit. (For the use in the United States or Canada, refer to [page 176](#) to select an appropriate fuse or molded case circuit breaker (MCCB).)
- \*2 The magnetic contactor is selected based on the AC-1 class. The electrical durability of magnetic contactor is 500,000 times. When the magnetic contactor is used for emergency stops during motor driving, the electrical durability is 25 times.  
If using an MC for emergency stop during driving the motor, select an MC regarding the converter unit input side current as JEM1038-AC-3 class rated current. When providing an MC to use the commercial power supply during general-purpose motor operation, select an MC regarding the rated motor current as JEM1038-AC-3 class rated current.

### NOTE

- When the breaker on the converter unit's input side trips, check for the wiring fault (short circuit), damage to internal parts of the inverter or the converter unit, etc. The cause of the trip must be identified and removed before turning ON the power of the breaker.

## ◆ Selecting the breaker / magnetic contactor (for 12-phase rectification)

Check the model name of the inverter and the converter unit you purchased. Appropriate peripheral devices must be selected according to each capacity.

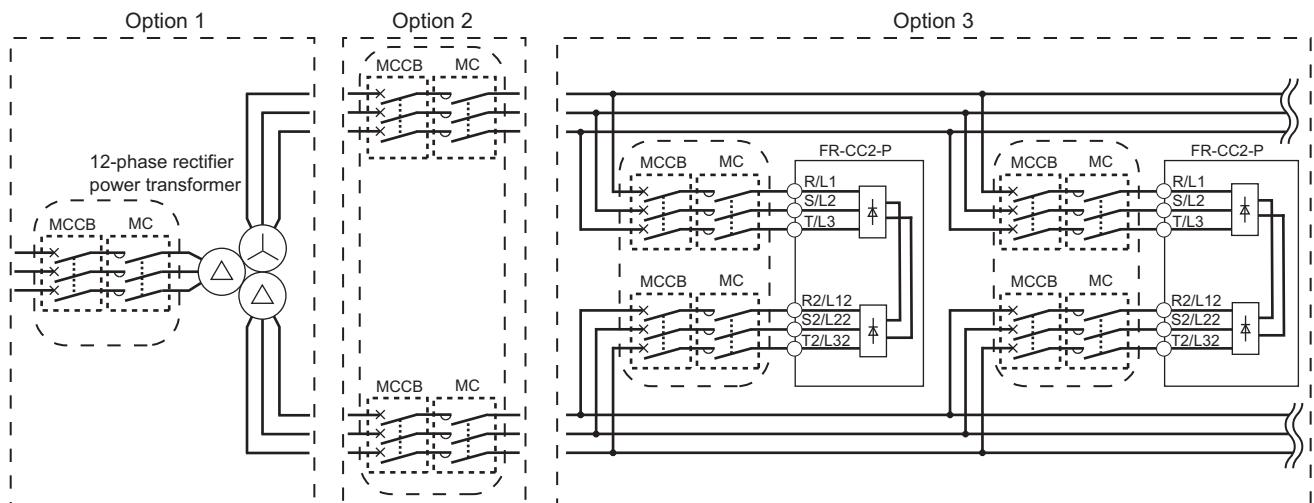

Choose one of the options shown above or combine them to connect the power distribution control equipment. To turn ON/OFF the power supply, option 1 is recommended.

### CAUTION

When the power supply capacity of 12-phase rectifier power transformer (3-winding transformer) exceeds 3000 kVA in total (1500 kVA for delta connection and 1500 kVA for wye connection), an excessive peak current may flow in the power input circuit, damaging the converter circuit. Observe the following precautions.

- Do not perform the power reset on the output side of the transformer.  
If it is inevitable to do so, turn ON the power again after 1 second when the power failure stop function is disabled (Pr.261 Power failure stop selection = "0"), or after 10 minutes when the power failure stop function is enabled (Pr.261 = "1, 2, 21, or 22").
- Avoid wiring that allows charging to the main circuit capacitor of only one converter unit when power is shut off or supplied at different timings to each converter unit at the time of instantaneous power failure, repowering, or other incident.

Refer to the following to prepare appropriate equipment.

- Option 1  
To connect the equipment to the input side of the 12-phase rectifier transformer before branching, prepare the same equipment as for the 6-phase rectifier transformer (refer to the FR-CC2-P Instruction Manual).
- Option 2  
To connect the equipment to the output side of the 12-phase rectifier transformer before branching, refer to the following table and prepare appropriate equipment.  
When a single wound motor or a multi-wound motor is connected under V/F control or Advanced magnetic flux vector



## Peripheral devices

control

Number of units in parallel	Applicable converter unit FR-CC2-[ ]-P	Rated input current for one circuit (A)	Molded case circuit breaker (MCCB)*1 (NF type) (A)	Magnetic contactor (MC)*2 on converter unit's input side
2	H400K	819	1000	900 A rated product
	H450K	922	1200	1000 A rated product
	H500K	1024	1300	1100 A rated product
	H560K	1165	1500	1300 A rated product
3	H400K	1229	1500	1400 A rated product
	H450K	1382	1700	1500A rated product
	H500K	1536	2000	1700A rated product
	H560K	1747	2200	1900A rated product

When a multi-wound motor is connected under Real sensorless vector control or Vector control

Number of units in parallel	Applicable converter unit FR-CC2-[ ]-P	Rated input current for one circuit (A)	Molded case circuit breaker (MCCB)*1 (NF type) (A)	Magnetic contactor (MC)*2 on converter unit's input side
2	H400K	1024	1300	1100 A rated product
	H450K	1152	1500	1300 A rated product
	H500K	1280	1600	1400 A rated product
	H560K	1456	1800	1600 A rated product

\*1 Select an MCCB according to the power supply capacity.

Install one MCCB per converter circuit in the converter unit.

For the use in the United States or Canada, provide appropriate fuses in accordance with any applicable local codes.

\*2 The magnetic contactor is selected based on the AC-1 class. The electrical durability of magnetic contactor is 500,000 times. When the magnetic contactor is used for emergency stops during motor driving, the electrical durability is 25 times.

When using an MC for emergency stop during driving the motor, select the MC with JEM 1038-AC-3 class rated current for the converter unit input current. When providing an MC on the inverter output side for switching to commercial power supply during general-purpose motor operation, select the MC with JEM 1038-AC-3 class rated current for the rated motor current.

### • Option 3

To connect the equipment to the output side of the 12-phase rectifier transformer after branching, refer to the following table and prepare appropriate equipment.

When a single wound motor or a multi-wound motor is connected under V/F control or Advanced magnetic flux vector control

Applicable converter unit FR-CC2-[ ]-P	Rated input current for one circuit (A)	Molded case circuit breaker (MCCB)*1 (NF type) (A)	Magnetic contactor (MC)*2 on converter unit's input side
H315K	406	500	S-N400
H355K	454	600	S-N400
H400K	512	600	S-N600
H450K	576	700	S-N600
H500K	640	800	S-N600
H560K	728	900	S-N800
H630K	806	1000	S-N800

When a multi-wound motor is connected under Real sensorless vector control or Vector control

Applicable converter unit FR-CC2-[ ]-P	Rated input current for one circuit (A)	Molded case circuit breaker (MCCB)*1 (NF type) (A)	Magnetic contactor (MC)*2 on converter unit's input side
H400K	512	600	S-N600
H450K	576	700	S-N600
H500K	640	800	S-N600
H560K	728	900	S-N800

\*1 Select an MCCB according to the power supply capacity.

Install one MCCB per converter circuit in the converter unit.

For the use in the United States or Canada, provide appropriate fuses in accordance with any applicable local codes.

\*2 The magnetic contactor is selected based on the AC-1 class. The electrical durability of magnetic contactor is 500,000 times. When the magnetic contactor is used for emergency stops during motor driving, the electrical durability is 25 times.

When using an MC for emergency stop during driving the motor, select the MC with JEM 1038-AC-3 class rated current for the converter unit input current. When providing an MC on the inverter output side for switching to commercial power supply during general-purpose motor operation, select the MC with JEM 1038-AC-3 class rated current for the rated motor current.

 **NOTE**

- When the converter unit capacity is larger than the motor capacity, select an MCCB and an MC (magnetic contactor) according to the converter unit model, and select cables and reactors according to the motor output.
- When the breaker on the converter unit's input side trips, check for the wiring fault (short circuit), damage to internal parts of the inverter or the converter unit, etc. The cause of the trip must be identified and removed before turning ON the power of the breaker.
- When the inverter is operated while the power distribution control equipment connected between the delta wiring of the transformer and terminals R2/L12, S2/L22, and T2/L32 is OFF, the converter unit may be damaged.

## 2.2 Removal and reinstallation of the front cover

### ◆ Removal of the accessory cover and installation of the operation panel

- Loosen the two fixing screws on the accessory cover. (These screws cannot be removed.)
- Push the upper edge of the accessory cover and pull the accessory cover to remove.

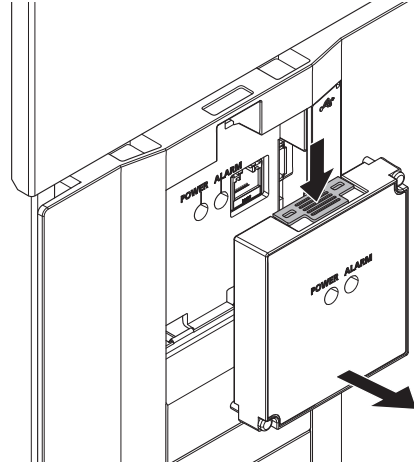
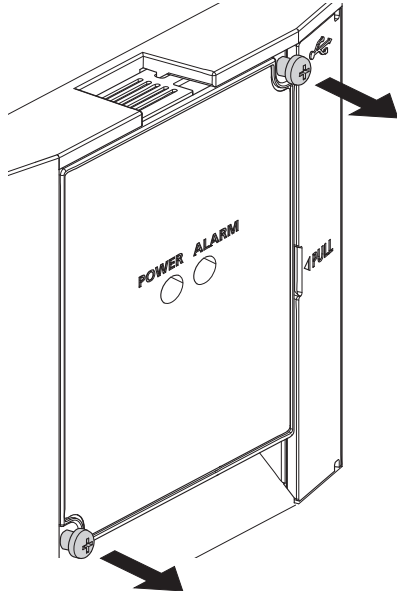

- To install the inverter operation panel, align its connector on the back with the PU connector of the inverter, and insert the operation panel. After confirming that the operation panel is fit securely, tighten the screws. (Tightening torque: 0.40 to 0.45 N•m)

### ◆ Removal of the front cover (lower side)

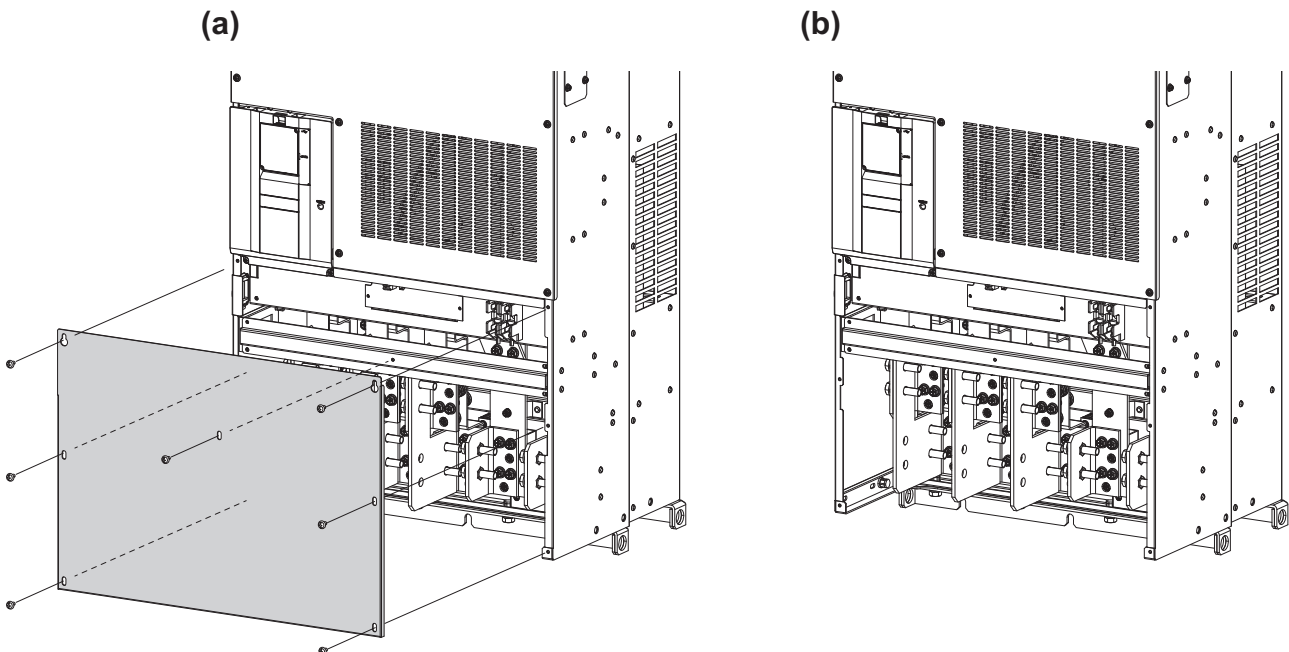

- (a) Remove the mounting screws to remove the front cover (lower side).
- (b) With the front cover (lower side) removed, wiring of the main circuit terminals can be performed.

◆ Removal of the front cover (upper side)

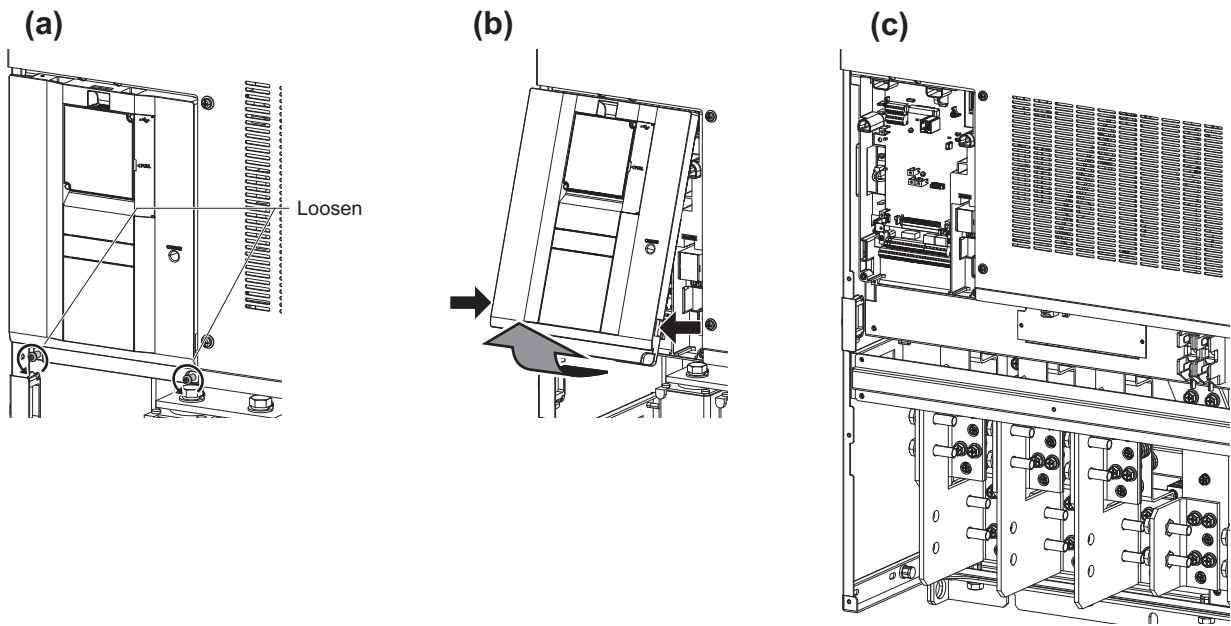

- (a) With the front cover (lower side) removed, loosen the mounting screws on the front cover (upper side). (These screws cannot be removed.)
- (b) While holding the areas around the installation hooks on the sides of the front cover (upper side), pull out the front cover (upper side) using its upper side as a support.
- (c) With the front cover (upper side) removed, wiring of the control circuit or the RS-485 terminals can be performed.

◆ Reinstallation of the front cover

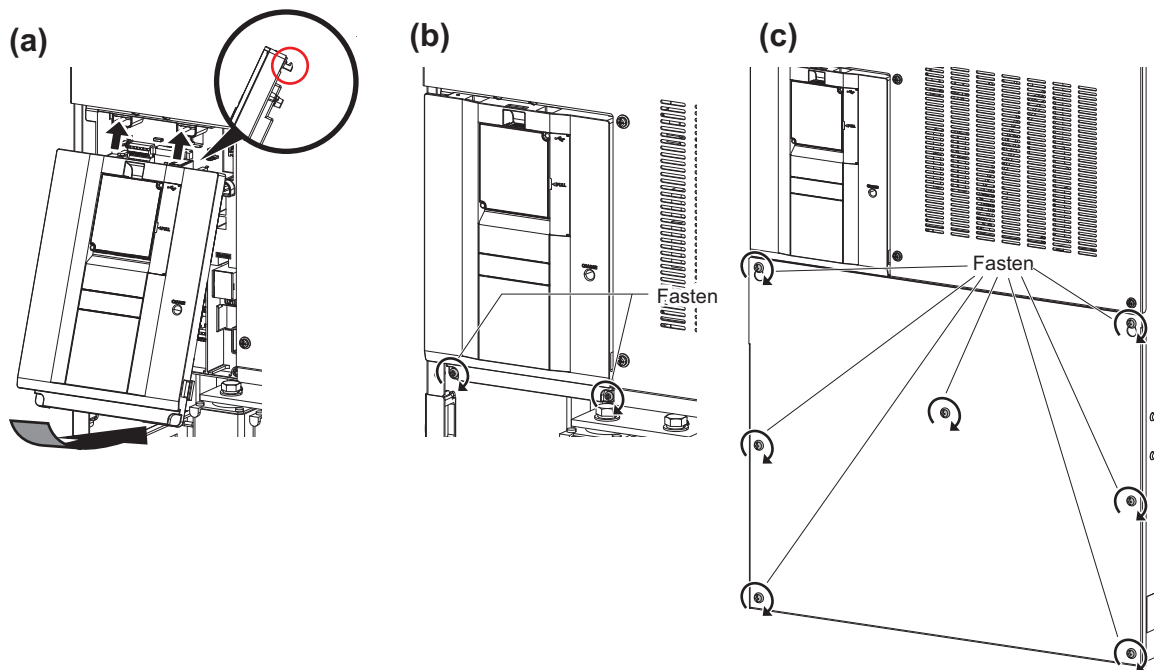

- (a) Insert the upper hooks of the front cover (upper side) into the sockets of the converter unit.
- (b) Tighten the mounting screw at the lower part of the front cover (upper side).
- (c) Fasten the front cover (lower side) with the mounting screws.

**NOTE**

- Fully make sure that the front cover is installed securely. Always tighten the mounting screws of the front cover.

## 2.3 Installation of the converter unit and enclosure design

When designing or manufacturing an enclosure to contain the converter unit, determine the structure, size, and device layout of the enclosure by fully considering the conditions such as heat generation of the contained devices and the operating environment. A converter unit uses many semiconductor devices. To ensure higher reliability and long period of operation, operate the converter unit in the ambient environment that completely satisfies the equipment specifications.

### 2.3.1 Converter unit installation environment

The following table lists the standard specifications of the converter unit installation environment. Using the converter unit in an environment that does not satisfy the conditions deteriorates the performance, shortens the life, and causes a failure. Refer to the following points, and take adequate measures.

#### ◆ Standard environmental specifications of the converter unit

Item	Description
Surrounding air temperature	-10 to +50°C (non-freezing) <div style="text-align: center;"> </div>
Surrounding air humidity	95% RH or less (non-condensing)
Storage temperature	-20 to +65°C*1
Atmosphere	Indoors (free from corrosive gas, flammable gas, oil mist, dust and dirt)
Altitude	1,000 m or lower*2
Vibration	2.9 m/s <sup>2</sup> or less at 10 to 55 Hz (directions of X, Y, Z axes)

\*1 Temperature applicable for a short time, e.g. in transit.

\*2 For the installation at an altitude above 1000 m (up to 2500 m), consider a 3% reduction in the rated current per altitude increase of 500 m.

#### ◆ Temperature

The permissible surrounding air temperature of the converter unit is between -10°C and +50°C. Always operate the converter unit within this temperature range. Operation outside this range will considerably shorten the service lives of the semiconductors, parts, capacitors and others. Take the following measures to keep the surrounding air temperature of the converter unit within the specified range.

##### (a) Measures against high temperature

- Use a forced ventilation system or similar cooling system. (Refer to [page 22.](#))
- Install the enclosure in an air-conditioned electric chamber.
- Block direct sunlight.
- Provide a shield or similar plate to avoid direct exposure to the radiated heat and wind of a heat source.
- Ventilate the area around the enclosure well.

##### (b) Measures against low temperature

- Provide a space heater in the enclosure.
- Do not power OFF the converter unit.

##### (c) Sudden temperature changes

- Select an installation place where temperature does not change suddenly.
- Avoid installing the inverter near the air outlet of an air conditioner.
- If temperature changes are caused by opening/closing of a door, install the inverter away from the door.

#### ◆ Humidity

Operate the converter unit within the ambient air humidity of usually 45 to 95%. Too high humidity will pose problems of reduced insulation and metal corrosion. On the other hand, too low humidity may cause a spatial electrical breakdown. The insulation distance defined in JEM1103 "Control Equipment Insulator" is humidity of 45 to 85%.

(a) Measures against high humidity

- Make the enclosure enclosed, and provide it with a hygroscopic agent.
- Provide dry air into the enclosure from outside.
- Provide a space heater in the enclosure.

(b) Measures against low humidity

Air with proper humidity can be blown into the enclosure from outside. Also when installing or inspecting the unit, discharge your body (static electricity) beforehand, and keep your body away from the parts and patterns.

(c) Measures against condensation

Condensation may occur if frequent operation stops change the in-enclosure temperature suddenly or if the outside air temperature changes suddenly.

Condensation causes such faults as reduced insulation and corrosion.

- Take the measures against high humidity in (a).
- Do not power OFF the converter unit.

### ◆Dust, dirt, oil mist

Dust and dirt will cause such faults as poor contacts, reduced insulation and cooling effect due to the moisture-absorbed accumulated dust and dirt, and in-enclosure temperature rise due to a clogged filter. In an atmosphere where conductive powder floats, dust and dirt will cause such faults as malfunction, deteriorated insulation and short circuit in a short time. Since oil mist will cause similar conditions, it is necessary to take adequate measures.

Countermeasure

- Place the inverter in a totally enclosed enclosure.  
Take measures if the in-enclosure temperature rises. (Refer to [page 22](#).)
- Purge air.  
Pump clean air from outside to make the in-enclosure air pressure higher than the outside air pressure.

### ◆Corrosive gas, salt damage

If the converter unit is exposed to corrosive gas or to salt near a beach, the printed board patterns and parts will corrode or the relays and switches will result in poor contact.

In such places, take the above-mentioned measures.

### ◆Explosive, flammable gases

As the converter unit is non-explosion proof, it must be contained in an explosion-proof enclosure. In places where explosion may be caused by explosive gas, dust or dirt, an enclosure cannot be used unless it structurally complies with the guidelines and has passed the specified tests. This makes the enclosure itself expensive (including the test charges). The best way is to avoid installation in such places and install the inverter in a non-hazardous place.

### ◆High altitude

Use the converter unit at an altitude of within 1000 m. For use at an altitude above 1000 m (up to 2500 m), derate the rated current 3% per 500 m.

If it is used at a higher place, it is likely that thin air will reduce the cooling effect and low air pressure will deteriorate dielectric strength.

### ◆Vibration, impact

The vibration resistance of the converter unit is up to 2.9 m/s<sup>2</sup> at 10 to 55 Hz frequency and 1 mm amplitude for the directions of X, Y, Z axes. Applying vibration and impacts for a long time may loosen the structures and cause poor contacts of connectors, even if those vibration and impacts are within the specified values.

Especially when impacts are applied repeatedly, caution must be taken because such impacts may break the installation feet.

Countermeasure

- Provide the enclosure with rubber vibration isolators.
- Strengthen the structure to prevent the enclosure from resonance.
- Install the enclosure away from the sources of the vibration.

## 2.3.2 Cooling system types for converter unit enclosure

From the enclosure that contains the converter unit, the heat of the converter unit and other equipment (transformers, lamps, resistors, etc.) and the incoming heat such as direct sunlight must be dissipated to keep the in-enclosure temperature lower than the permissible temperatures of the in-enclosure equipment including the converter unit.

The cooling systems are classified as follows in terms of the cooling calculation method.

- (a) Cooling by natural heat dissipation from the enclosure surface (totally enclosed type)
- (b) Cooling by heat sink (aluminum fin, etc.)
- (c) Cooling by ventilation (forced ventilation type, pipe ventilation type)
- (d) Cooling by heat exchanger or cooler (heat pipe, cooler, etc.)

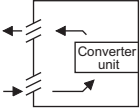
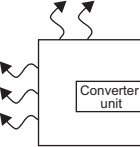
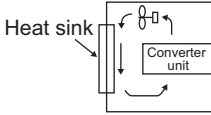
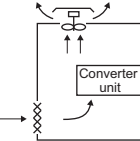
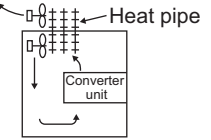
Cooling system		Enclosure structure	Comment
Natural cooling	Natural ventilation (enclosed ventilated type)		This system is low in cost and generally used, but the enclosure size increases as the converter unit capacity increases. This system is for relatively small capacities.
	Natural ventilation (totally enclosed type)		Being a totally enclosed type, this system is the most appropriate for hostile environment having dust, dirt, oil mist, etc. The enclosure size increases depending on the converter unit capacity.
Forced cooling	Heat sink cooling		This system has restrictions on the heat sink mounting position and area. This system is for relatively small capacities.
	Forced ventilation		This system is for general indoor installation. This is appropriate for enclosure downsizing and cost reduction, and often used.
	Heat pipe		This is a totally enclosed for enclosure downsizing.

## 2.3.3 Installation of the converter unit

### ◆ Installation of the converter unit

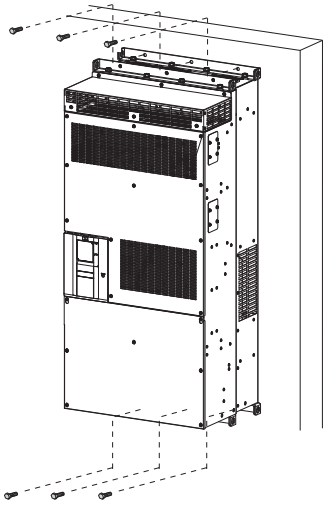

Fix six positions.

- Install the converter unit on a strong surface securely with screws.
- Leave enough clearances and take cooling measures.
- Avoid places where the converter unit is subjected to direct sunlight, high temperature and high humidity.
- Install the converter unit on a nonflammable wall surface.
- When encasing multiple converter units in an enclosure, install them in parallel as a cooling measure.
- For heat dissipation and maintenance, keep clearance between the converter unit and the other devices or enclosure surface. The clearance below the converter unit is required as a wiring space, and the clearance above the converter unit is required as a heat dissipation space.

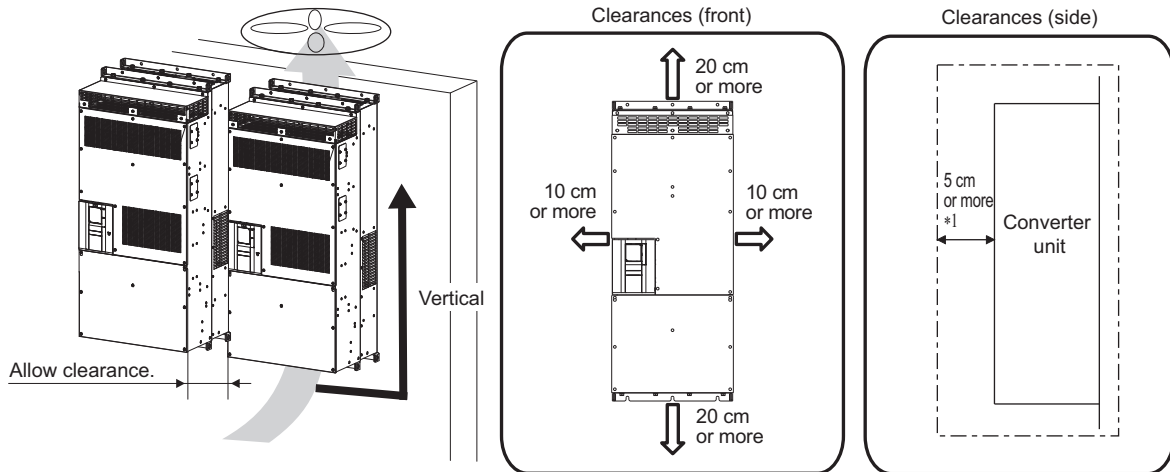

\*1 For replacing the cooling fan, 30 cm or more of space is necessary in front of the converter unit. Refer to [page 159](#) for fan replacement.

### ◆ Installation orientation of the converter unit

Install the converter unit on a wall as specified. Do not mount it horizontally or in any other way.

### ◆ Above the converter unit

Heat is blown up from inside the converter unit by the small fan built in the unit. Any equipment placed above the converter unit should be heat resistant.



### ◆ Encasing multiple inverters and converter units

When multiple inverters and converter units are placed in the same enclosure, generally arrange them horizontally as shown in the figure on the right. Do not place multiple converter units or the converter unit and the inverter vertically. The exhaust air temperature of the converter unit may be increased.

When mounting multiple inverters and converter units, fully take caution not to make the surrounding air temperature of the inverter and the converter unit higher than the permissible value by providing ventilation and increasing the enclosure size.

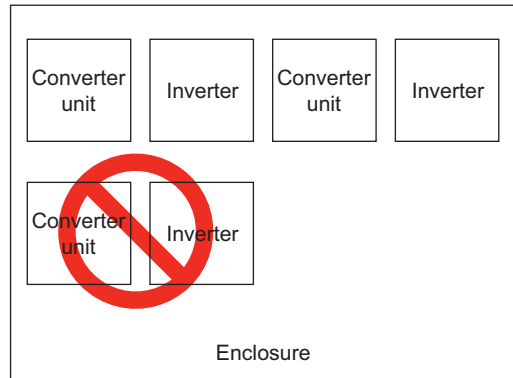

Arrangement of multiple inverters and converter units

### ◆ Arrangement of the ventilation fan and the converter unit

Heat generated in the converter unit is blown up from the bottom of the unit as warm air by the cooling fan. When installing a ventilation fan for that heat, determine the place of ventilation fan installation after fully considering an air flow. (Air passes through areas of low resistance. Make an airway and airflow plates to expose the converter unit to cool air.)

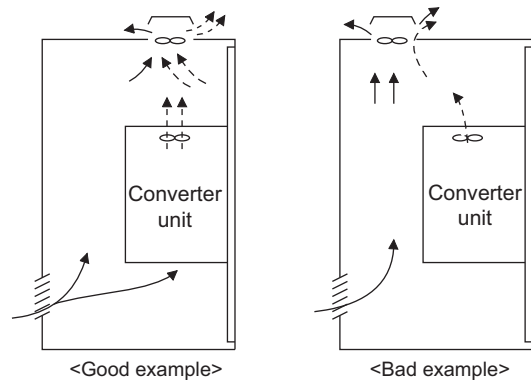

Arrangement of the ventilation fan and the converter unit

## 2.3.4 Protruding the heat sink

When encasing an converter unit to an enclosure, the heat generated in the enclosure can be greatly reduced by protruding the heat sink of the converter unit.

When installing the converter unit in a compact enclosure, etc., this installation method is recommended.

### ◆ Panel cutting

Cut the panel of the enclosure.

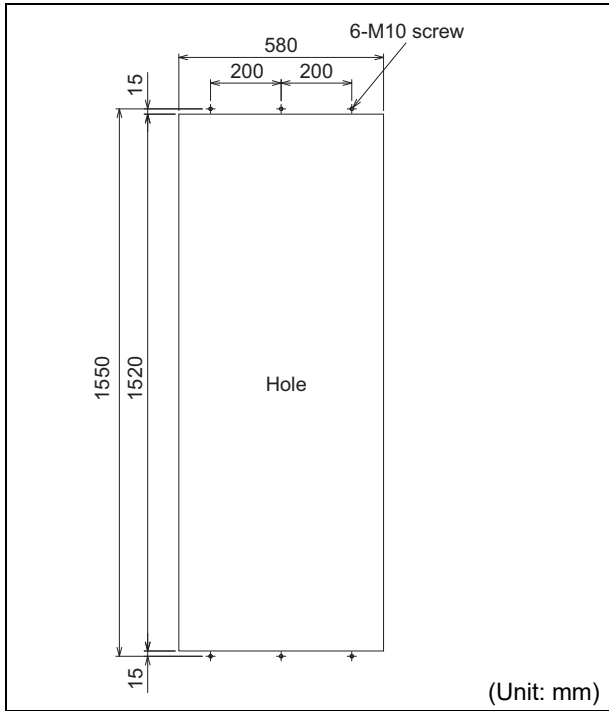

◆ Shift and removal of a rear side installation frame

One installation frame is attached to each of the upper and lower parts of the converter unit. Remove the rear side installation frame on the top and bottom sides of the converter unit as shown on the right.

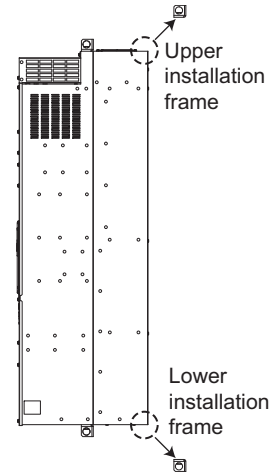

◆ Installation of the converter unit

Push the converter unit heat sink portion outside the enclosure and fix the enclosure and converter unit with upper and lower installation frame.

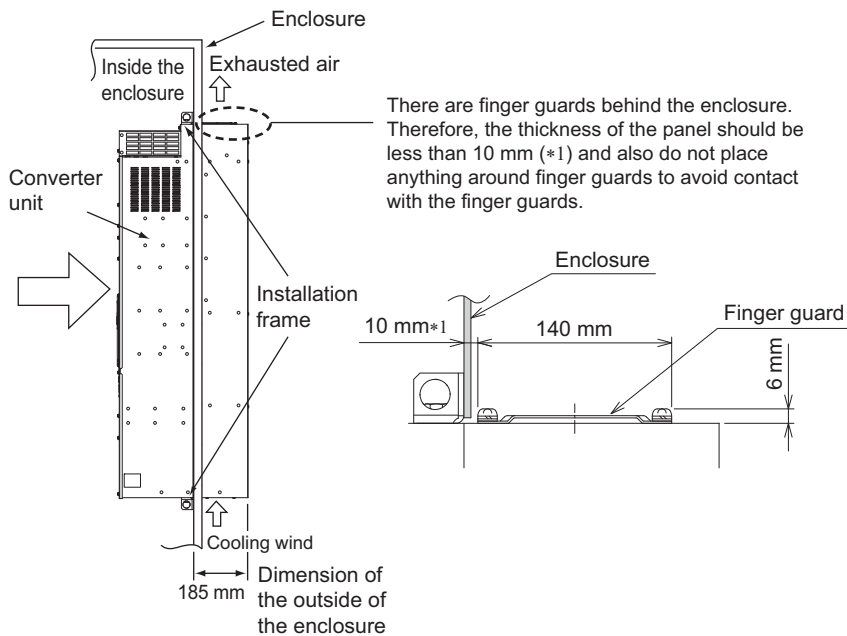

**NOTE**

- Having a cooling fan, the cooling section which comes out of the enclosure cannot be used in the environment of water drops, oil, mist, dust, etc.
- Be careful not to drop screws, dust etc. into the converter unit and cooling fan section.

## 2.4 Terminal connection diagrams

### ◆ When the sink logic is selected

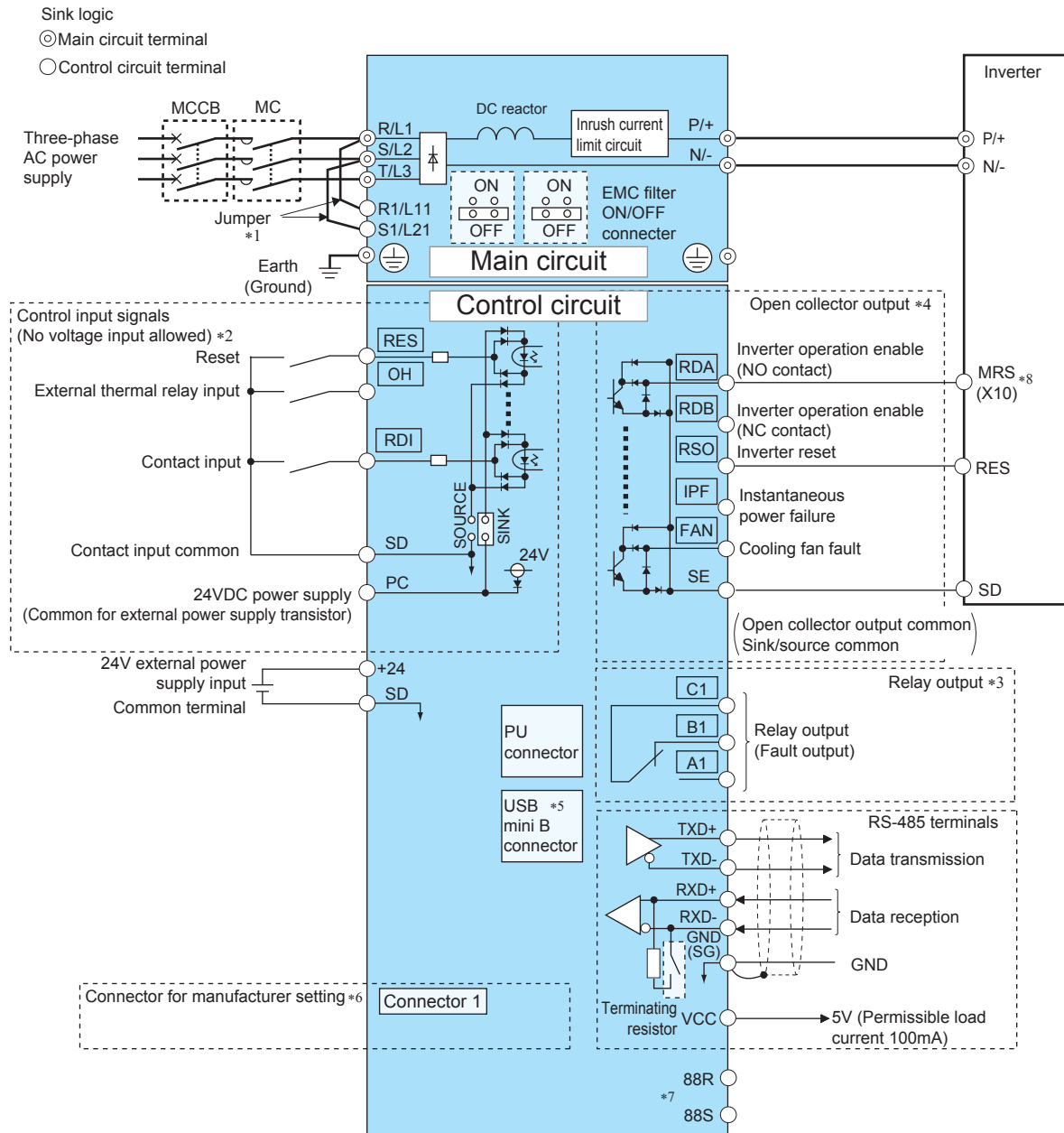

\*1 When using separate power supply for the control circuit, remove the jumpers from R1/L11 and S1/L21.

\*2 The function of these terminals can be changed with the input terminal assignment (Pr.178, Pr.187, Pr.189).

\*3 The function of these terminals can be changed with the output terminal assignment (Pr.195).

\*4 The function of these terminals can be changed with the output terminal assignment (Pr.190 to Pr.194).

\*5 The connector is for manufacturer setting. Do not use.

\*6 Plug-in options cannot be used.

\*7 For manufacturer setting. Do not use.

\*8 To use the RDA signal of the converter unit, select the NC contact input specification for the input logic of MRS signal or X10 signal of the inverter.

To use the RDB signal of the converter unit, select the NO contact input specification for the input logic of MRS signal or X10 signal of the inverter. (For changing the input logic, refer to the Instruction Manual of the inverter.)

#### NOTE

- To prevent a malfunction due to noise, keep the signal cables 10 cm or more away from the power cables. Also, separate the main circuit cables at the input side from the main circuit cables at the output side.
- After wiring, wire offcuts must not be left in the inverter or the converter unit.  
Wire offcuts can cause an alarm, failure or malfunction. Always keep the inverter and the converter unit clean.  
When drilling mounting holes in an enclosure etc., take caution not to allow chips and other foreign matter to enter the inverter or the converter unit.

◆ When the source logic is selected

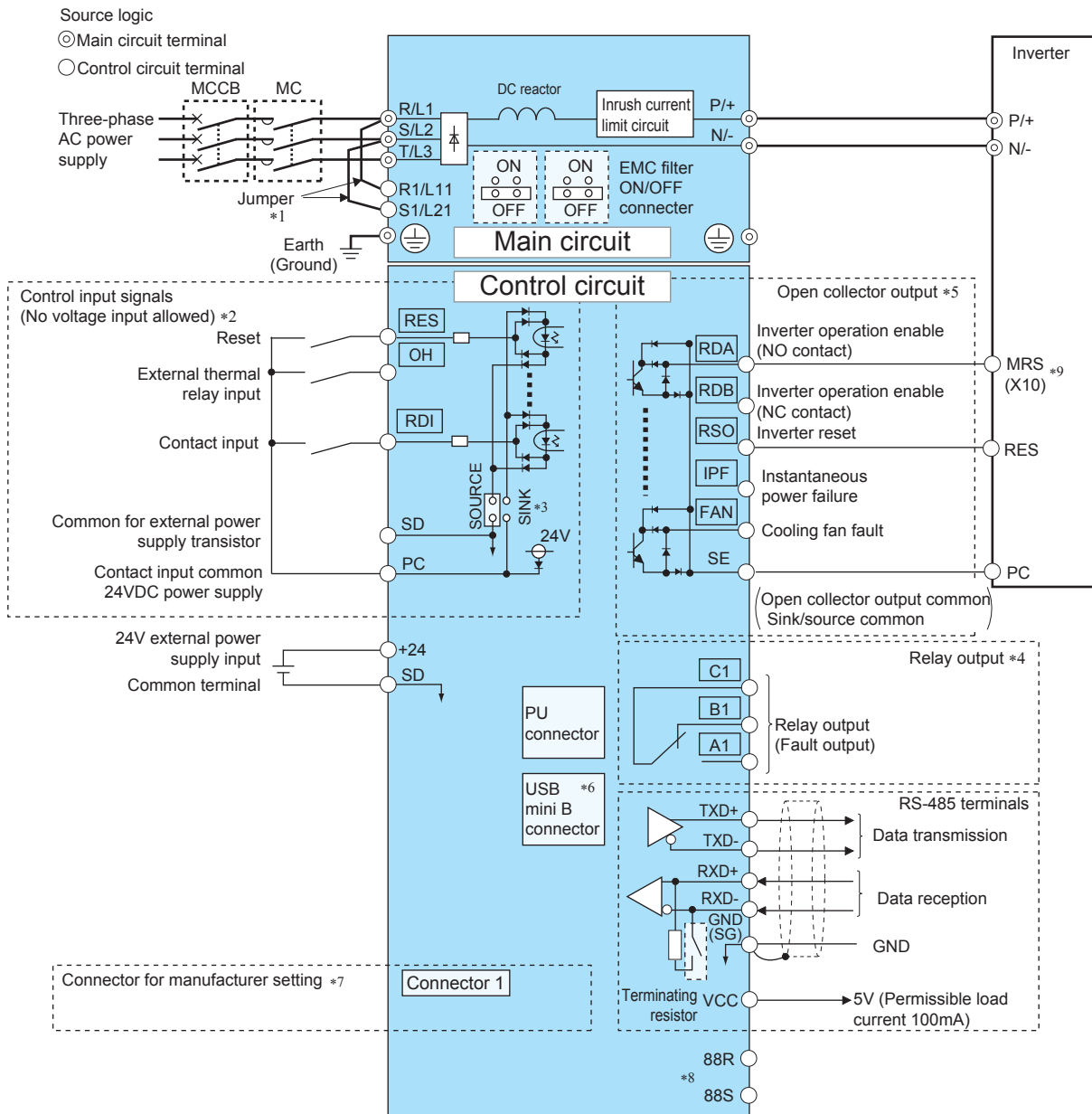

- \*1 When using separate power supply for the control circuit, remove the jumpers from R1/L11 and S1/L21.
- \*2 The function of these terminals can be changed with the input terminal assignment (Pr.178, Pr.187, Pr.189).
- \*3 The sink logic is initially set. The control logic can be changed with the jumper connector position.
- \*4 The function of these terminals can be changed with the output terminal assignment (Pr.195).
- \*5 The function of these terminals can be changed with the output terminal assignment (Pr.190 to Pr.194).
- \*6 The connector is for manufacturer setting. Do not use.
- \*7 Plug-in options cannot be used.
- \*8 For manufacturer setting. Do not use.
- \*9 To use the RDA signal of the converter unit, select the NC contact input specification for the input logic of MRS signal or X10 signal of the inverter.  
To use the RDB signal of the converter unit, select the NO contact input specification for the input logic of MRS signal or X10 signal of the inverter. (For changing the input logic, refer to the Instruction Manual of the inverter.)

**NOTE**

- To prevent a malfunction due to noise, keep the signal cables 10 cm or more away from the power cables. Also, separate the main circuit cables at the input side from the main circuit cables at the output side.
- After wiring, wire offcuts must not be left in the inverter or the converter unit.  
Wire offcuts can cause an alarm, failure or malfunction. Always keep the inverter and the converter unit clean.  
When drilling mounting holes in an enclosure etc., take caution not to allow chips and other foreign matter to enter the inverter or the converter unit.

## ◆ System configuration example (for operating two units in parallel)

- Wire the RS-485 terminals between the converter units as shown in the diagram in [page 30](#). (For the details on wiring the RS-485 terminals, refer to [page 53](#).)
- Wire the terminals of the converter units and the inverters as shown in [page 30](#). (For details on wiring converter units to inverters, refer to [page 34](#).)
- Set **Pr.1001 Parallel operation selection** of the converter unit as shown in the table below. (Refer to [page 56](#) for the details on **Pr.1001**.)

Converter unit	Pr.1001 setting
Master station	200
Slave station	1 or 2

Parameter setting procedure

- 1** Wire the RS-485 terminals of the converter units.
- 2** Set "1 or 2" in Pr.1001 of the slave converter unit, and then reset the converter unit.
- 3** Set "200" in Pr.1001 of the master converter unit, and then reset the converter unit.

- Communication between the converter units will start automatically once the RS-485 terminals have been wired and Pr.1001 has been set on all converters.

### NOTE

- Set up the slave converter unit first before the master converter unit by the **Pr.1001** setting and the converter unit reset. Otherwise, an error may occur in communication between the converter units.
- For inverters that are connected in parallel, ensure that the three-phase wiring between each motor and inverter is the same length. Otherwise, normal operation may not be possible.
- The Parallel operation ready (Y227) signal will turn ON once the parameters are set and the RS-485 terminals have been wired to the converter units correctly. (Refer to [page 56](#) for the details on the Y227 signal.)

### CAUTION

- Be sure to set Pr.1001 correctly. Operation with incorrect settings may damage the converter units.
- Ensure that the motor is wired to the inverter outputs (U, V, and W) in the correct phase sequence. Use the correct phase sequence when wiring the master and slave inverter outputs. Otherwise the inverters may be damaged.

## Terminal connection diagrams

- Terminal connection diagram for two units in parallel (for driving a single wound motor)

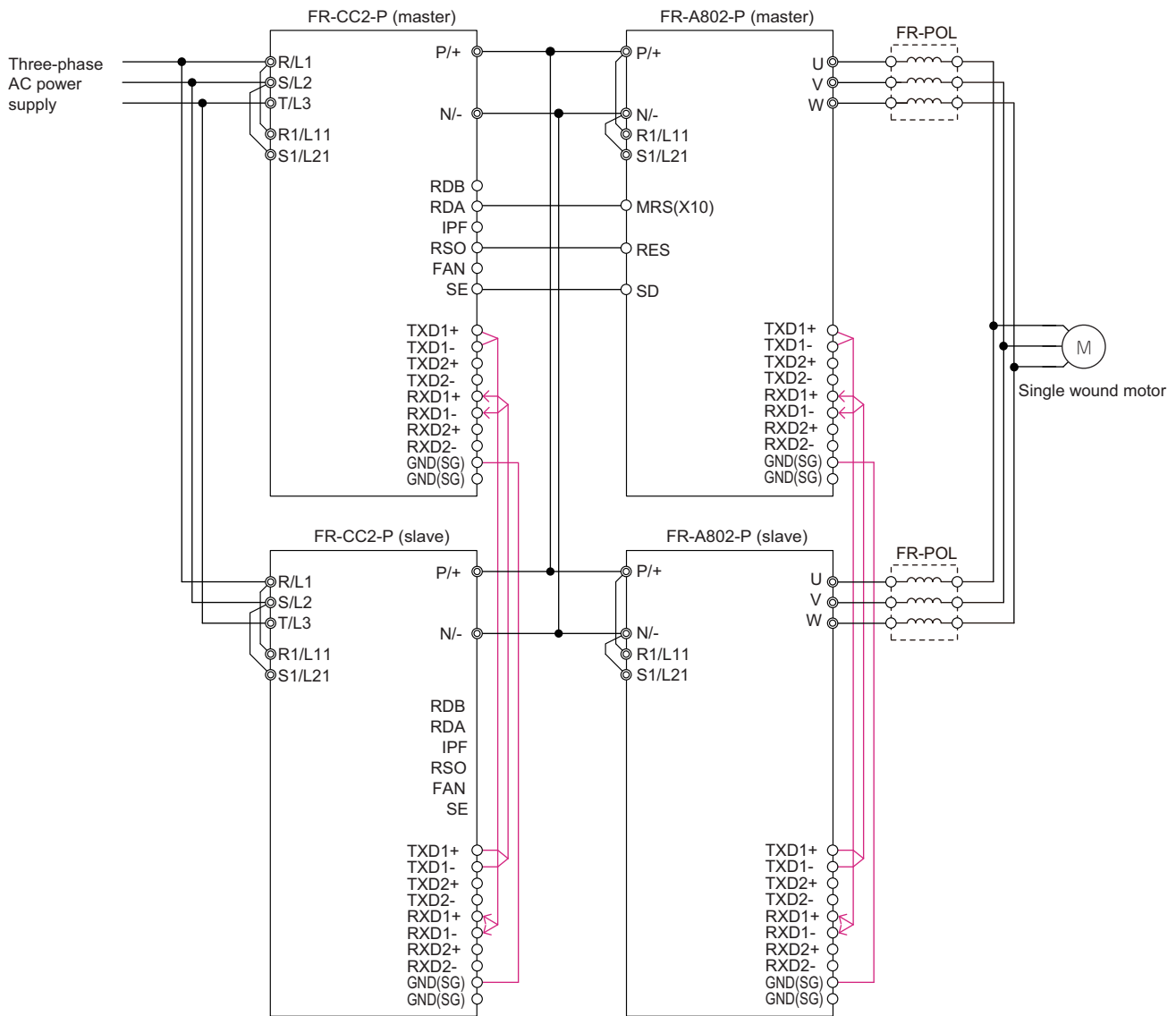

### NOTE

- When the wiring length from a unit to a node point is less than 10 m, a balance reactor (FR-POL) is required.

- Terminal connection diagram for two units in parallel (for driving a multi-wound motor)

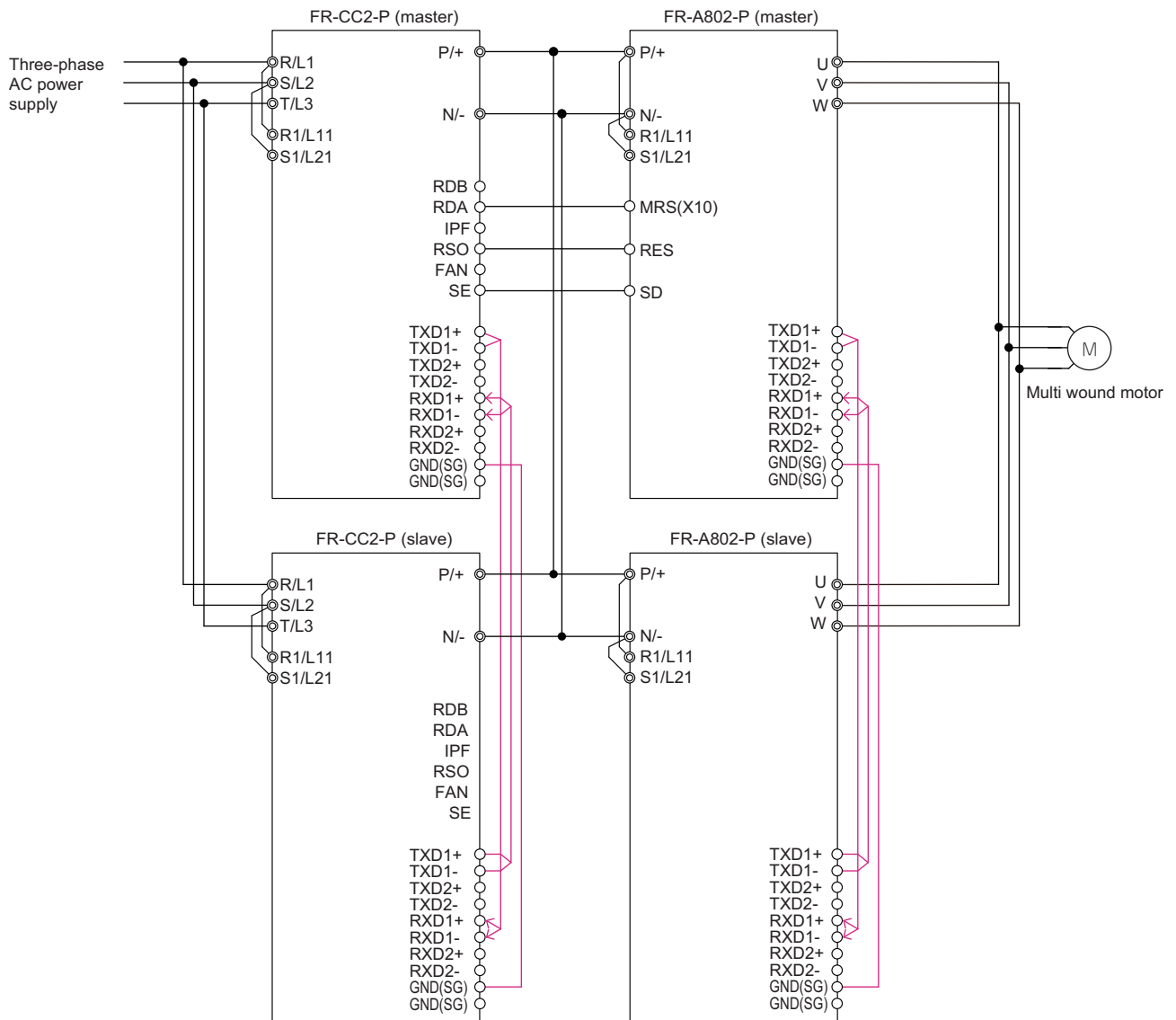

- When a multi-wound motor is driven, a balance reactor (FR-POL) is not required.
- To comply with the UL standard, do not connect terminals P/+ and terminals N/- between the master station and the slave station.
- Do not join the cables for terminals U, V, and W on the output sides of the master station and the slave station.



### ◆ System configuration example (for operating three units in parallel)

- Wire the RS-485 terminals between the converter units as shown in the diagram in [page 33](#). (For the details on wiring the RS-485 terminals, refer to [page 53](#).)
- Wire the terminals of the converter units and the inverters as shown in [page 33](#). (For details on wiring converter units to inverters, refer to [page 34](#).)
- Set **Pr.1001** of the converter unit as shown in the table below. (Refer to [page 56](#) for the details on **Pr.1001**.)

Converter unit	Pr.1001 setting
Master station	300
Slave station 1	1
Slave station 2	2

Parameter setting procedure

- 1** Wire the RS-485 terminals of the converter units.
  - 2** Set "1" in Pr.1001 of the slave converter unit 1, and then reset the converter unit.
  - 3** Set "2" in Pr.1001 of the slave converter unit 2, and then reset the converter unit.
  - 4** Set "300" in Pr.1001 of the master converter unit, and then reset the converter unit.
- Communication between the converter units will start automatically once the RS-485 terminals have been wired and Pr.1001 has been set on all converters.

#### NOTE

- It is not important which order steps 2 and 3 are performed in.
- Set up the slave converter unit first before the master converter unit by the **Pr.1001** setting and the converter unit reset. Otherwise, an error may occur in communication between the converter units.
- For inverters that are connected in parallel, ensure that the 3-phase wiring between each motor and inverter is the same length. Otherwise, normal operation may not be possible.
- The Parallel operation ready (Y227) signal will turn ON once the parameters are set and the RS-485 terminals have been wired to the converter units correctly. (Refer to [page 56](#) for the details on the Y227 signal.)

#### CAUTION

- Be sure to set **Pr.1001** correctly. Operation with incorrect settings may damage the converter units.
- Ensure that the motor is wired to the inverter outputs (U, V, and W) in the correct phase sequence. Use the correct phase sequence when wiring the master and slave inverter outputs. Otherwise the inverters may be damaged.

- Terminal connection diagram for three units in parallel

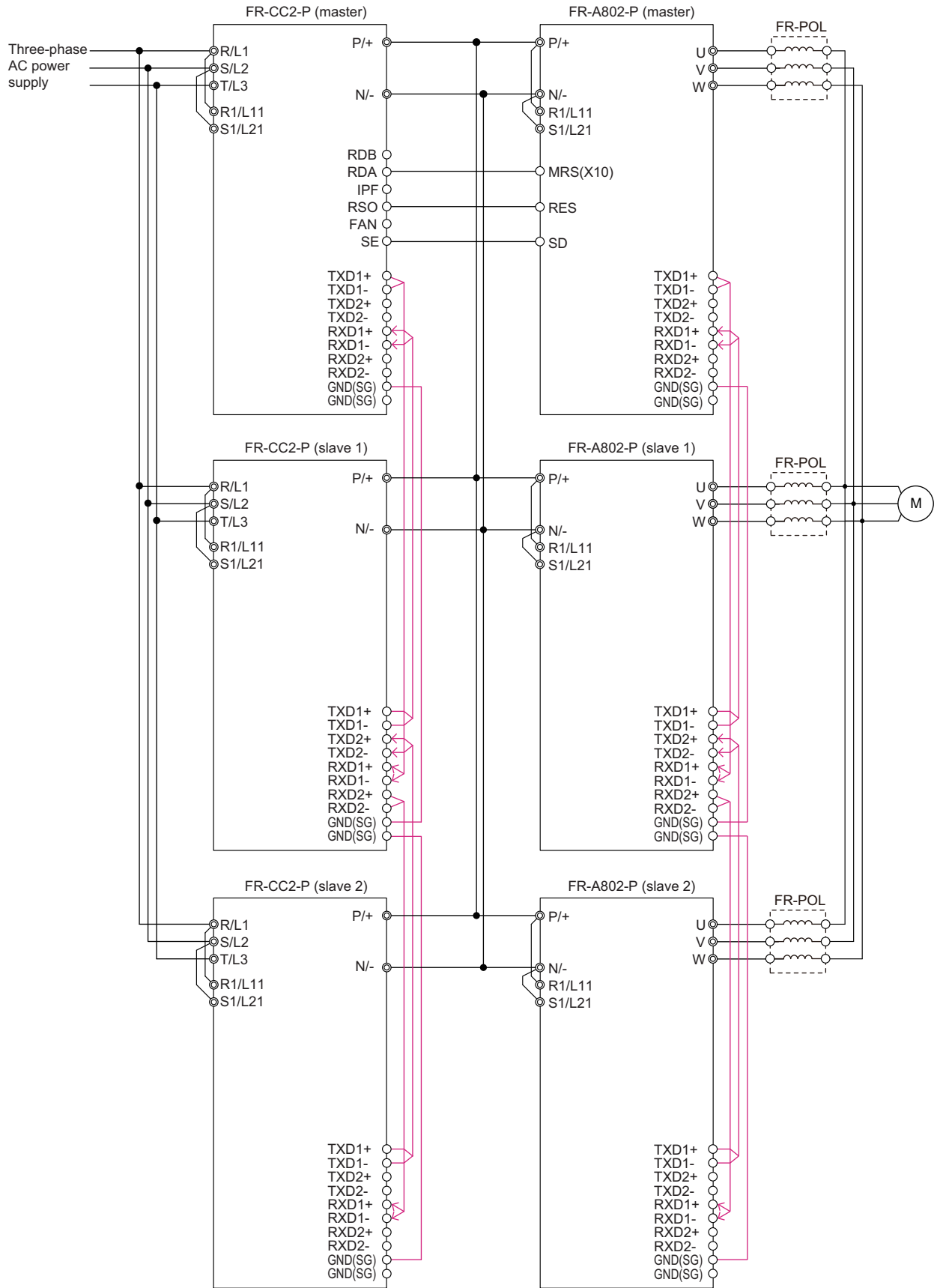

## ◆ Wiring converter units and inverters

### ◆ Main circuit terminals

- Wire the converter unit to the inverter at each terminal P and terminal N. Pair the masters or the slaves (1 with 1 or 2 with 2). Otherwise, incorrect connection may damage the converter unit and the inverter.
- Use cables of 50 m or shorter each to connect the converter unit and the inverter (for terminal P or N).
- For information about the gauge of cable for terminal P or N, refer to [page 37](#).

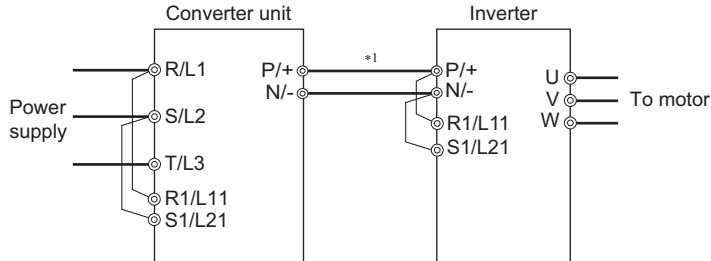

\*1 Do not install an MCCB for terminal P or N. Ensure correct connection in polarity of terminals P and N; which may damage the inverter.

### ◆ Control circuit terminals

- The control circuit terminals of the master inverter and master converter unit must be wired. Ensure that the terminals are wired correctly so that the commands output from the converter unit are properly transmitted to the inverter. Otherwise, the converter unit and the inverter may be damaged.
- Use cables of 30 m or shorter each to wire the control circuits.

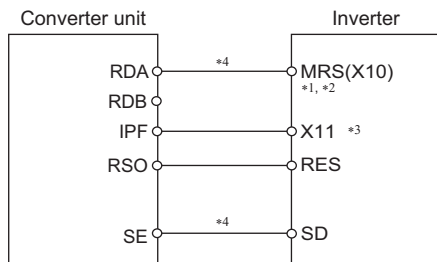

- \*1 For the terminal used for the X10 signal input, set "10" in any of **Pr.178 to Pr.189 (Input terminal function selection)** to assign the function.
- \*2 To use the RDA signal of the converter unit, select the NC contact input specification for the input logic of the MRS signal or X10 signal of the inverter.  
To use the RDB signal of the converter unit, select the NO contact input specification for the input logic of the MRS signal or X10 signal of the inverter.  
(For changing the input logic, refer to the Instruction Manual of the inverter.)
- \*3 For the terminal used for the X11 signal input, set "11" in any of **Pr.178 to Pr.189 (Input terminal function selection)** to assign the function.  
For RS-485 or other communication operation where the start command is only transmitted once, use the X11 signal to keep the operation mode before an instantaneous power failure.
- \*4 Always connect terminal RDA of the converter unit and terminal MRS (X10) of the inverter, and terminal SE of the converter unit and terminal SD (sink logic) of the inverter. Otherwise, the converter unit may be damaged.

## 2.5 Main circuit terminals (6-phase rectification)

### 2.5.1 Details on the main circuit terminals

Terminal symbol	Terminal name	Terminal function description	Refer to page
R/L1, S/L2, T/L3	AC power input	Connect these terminals to the commercial power supply.	—
R1/L11, S1/L21	Power supply for the control circuit	Connected to the AC power supply terminals R/L1 and S/L2. To retain the fault display and fault output, remove the jumpers across terminals R/L1 and R1/L11 and across S/L2 and S1/L21 and supply external power to these terminals. When using a separate power supply connected to terminals R1/L11 and S1/L21, the required power capacity is 80 VA.	50
P/+, N/-	Inverter connection	Wire the terminals as shown in the terminal connection diagram. (Wire one terminal P/+ to another terminal P/+, and do likewise for terminal N/-.)	30, 33
	Earth (ground)	For earthing (grounding) the converter unit chassis. Be sure to earth (ground) the converter unit.	38

### 2.5.2 Terminal layout of the main circuit terminals, wiring of the power supply and the inverter

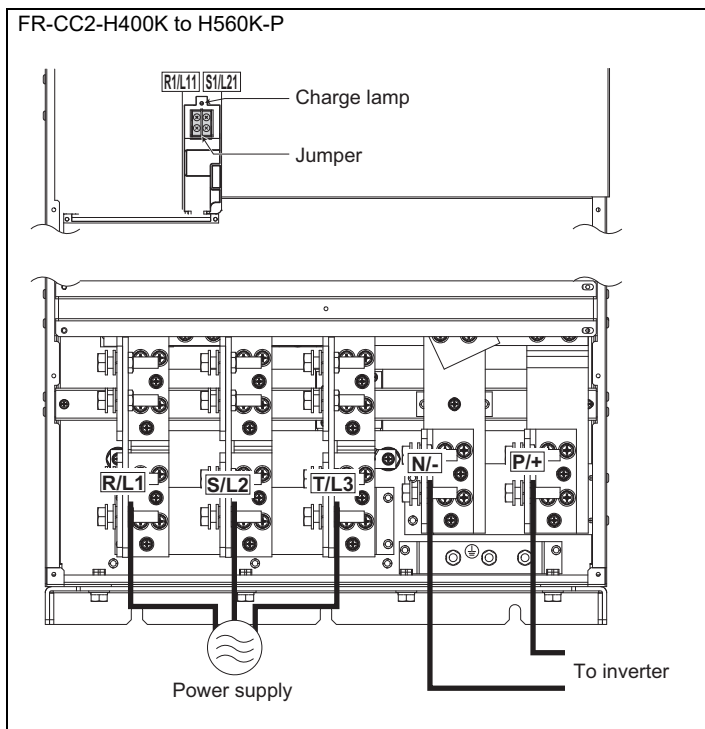

## Main circuit terminals (6-phase rectification)

---

### NOTE

- Make sure the power cables are connected to the R/L1, S/L2, and T/L3. (Phase need not be matched.)
- When wiring the main circuit conductor, tighten a nut from the right side of the conductor.  
When wiring two wires, place wires on both sides of the conductor. (Refer to the drawing below.)  
For wiring, use bolts (nuts) provided with the converter unit.

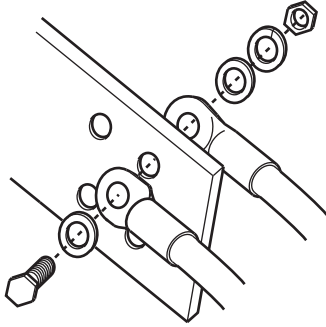

- When wiring cables to the main circuit conductor (R/L1, S/L2, T/L3) of the converter unit, use the bolts (nuts) for main circuit wiring, which are provided on the front side of the conductor.

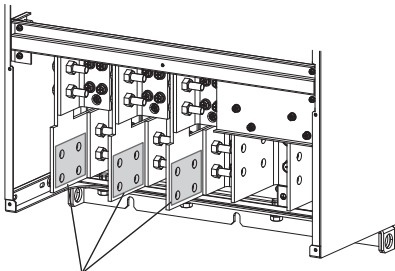

Connect the cables here.

## 2.5.3 Applicable cables

Select a recommended cable size to ensure that the voltage drop will be 2% or less.

The following table indicates a selection example for the wiring length of 20 m per converter unit. (440 V input power supply, 150% overload current rating for 1 minute).

Converter model FR-CC2-[]-P	Terminal screw Size*4	Tightening Torque N•m	Crimp terminal	Cable gauge					
				HIV cables, etc. (mm <sup>2</sup> )*1			AWG/MCM *2	PVC cables, etc. (mm <sup>2</sup> )*3	
				R/L1, S/L2, T/L3	R/L1, S/L2, T/L3	P/+, N/-	Earthing (grounding) cable	R/L1, S/L2, T/L3	R/L1, S/L2, T/L3
H400K	M12 (M10)	46	C2-200	2×200	2×200	100	2×400	2×185	2×95
H450K	M12 (M10)	46	C2-250	2×250	2×250	100	2×500	2×240	2×120
H500K	M12 (M10)	46	C2-200	3×200	3×200	2×100	2×500	2×240	2×120
H560K	M12 (M10)	46	C2-200	3×200	3×200	2×100	3×350	3×185	2×150

\*1 LMFC (heat resistant flexible cross-linked polyethylene insulated cable), etc. with a continuous maximum permissible temperature of 90°C or higher. It is assumed that the cables will be used in a surrounding air temperatures of 50° C or less and housed in an enclosure.

\*2 THHN cable with a continuous maximum permissible temperature of 90°C. It is assumed that the cables will be used in a surrounding air temperatures of 40° C or less and housed in an enclosure.

(For the use in the United States or Canada, refer to [page 176](#) to select an appropriate fuse or molded case circuit breaker (MCCB).)

\*3 XLPE cable with a continuous maximum permissible temperature of 90°C. It is assumed that the cables will be used in a surrounding air temperatures of 40° C or less and housed in an enclosure.

(Selection example for use mainly in Europe.)

\*4 Screws for terminals R/L1, S/L2, T/L3, P/+, N/-, and the screw for earthing (grounding).

The size of the earthing (grounding) screw is indicated in parentheses.

The line voltage drop can be calculated by the following formula:

$$\text{Line voltage drop [V]} = \frac{\sqrt{3} \times \text{wire resistance [m}\Omega\text{/m]} \times \text{wiring distance [m]} \times \text{current [A]}}{1000}$$

Use a larger diameter cable when the wiring distance is long or when it is desired to decrease the voltage drop (torque reduction) in the low speed range.

### NOTE

- Tighten the terminal screw to the specified torque.  
A screw that has been tightened too loosely can cause a short circuit or malfunction.  
A screw that has been tightened too tightly can cause a short circuit or malfunction due to the unit breakage.
- Use crimp terminals with insulation sleeves to wire the power supply and motor.

## 2.5.4 Earthing (grounding) precautions

- Always earth (ground) the converter unit.

### ◆ Purpose of earthing (grounding)

Generally, an electrical apparatus has an earth (ground) terminal, which must be connected to the ground before use. An electrical circuit is usually insulated by an insulating material and encased. However, it is impossible to manufacture an insulating material that can shut off a leakage current completely, and actually, a slight current flows into the case. The purpose of earthing (grounding) the case of an electrical apparatus is to prevent operators from getting an electric shock from this leakage current when touching it.

To avoid the influence of external noises, this earthing (grounding) is important to audio equipment, sensors, computers and other apparatuses that handle low-level signals or operate very fast.

### ◆ Earthing (grounding) methods and earthing (grounding) work

As described previously, earthing (grounding) is roughly classified into an electrical shock prevention type and a noise-influenced malfunction prevention type. Therefore, these two types should be clearly distinguished, and the following work must be done to prevent the leakage current having the converter unit's high frequency components from entering for malfunction prevention:

- Whenever possible, use the independent earthing (grounding) for the converter unit.  
Establishing adequate common (single-point) earth (ground) system (II) shown in the following figure is allowed only in cases where the separate earth (ground) system (I) is not feasible. Do not make inadequate common (single-point) earth (ground) connection (III).
- A leakage current containing many high frequency components flows into the earthing (grounding) cables of the converter unit. Because of this, the converter unit must be earthed (grounded) separately from EMI-sensitive devices.
- In a high building, it may be effective to use the EMI prevention type earthing (grounding) connecting to an iron structure frame, and electric shock prevention type earthing (grounding) with the independent earthing (grounding) together.
- Earthing (Grounding) must conform to the requirements of national and local safety regulations and electrical codes. (NEC section 250, IEC 61140 class 1 and other applicable standards).  
A neutral-point earthed (grounded) power supply in compliance with EN standard must be used.
- Use the thickest possible earthing (grounding) cable. The size of the earthing (grounding) cable should be the same or larger than the one indicated in the table on [page 37](#).
- The earthing (grounding) point should be as close as possible to the converter unit, and the earth (ground) wire length should be as short as possible.
- Run the earthing (grounding) cable as far away as possible from the I/O wiring of equipment sensitive to noises and run them in parallel in the minimum distance.

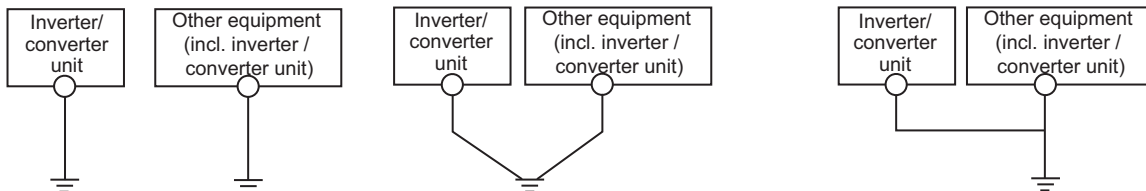

(I) Separate earthing (grounding).....Good (II) Common (single-point) earthing (grounding).....OK (III) Inadequate common (single-point) earthing(grounding).....Bad

### NOTE

- To be compliant with the EU Directive (Low Voltage Directive), refer to [page 172](#).

## 2.6 Main circuit terminals (for 12-phase rectification)

### 2.6.1 Details on the main circuit terminals

Terminal symbol	Terminal name	Terminal function description	Refer to page
R/L1, S/L2, T/L3	AC power input	Connect these terminals to the output terminals in the wye connection of a 12-phase transformer (3-winding transformer).	40
R2/L12, S2/L22, T2/L32	AC power input	Connect these terminals to the output terminals in the delta connection of a 12-phase transformer (3-winding transformer).	40
R1/L11, S1/L21	Power supply for the control circuit	Connected to the AC power supply terminals R/L1 and S/L2. To retain the fault display and fault output, remove the jumpers across terminals R/L1 and R1/L11 and across S/L2 and S1/L21, and apply external power to these terminals. When using a separate power supply connected to terminals R1/L11 and S1/L21, the required power capacity is 80 VA.	50
P/+, N/-	Inverter connection	Wire the terminals as shown in the terminal connection diagram. (Wire one terminal P/+ to another terminal P/+, and do likewise for terminal N/-.)	27
	Earth (ground)	For earthing (grounding) the converter unit chassis. Be sure to earth (ground) the converter unit.	42

### 2.6.2 Connection diagram with 12-phase rectifier power transformer

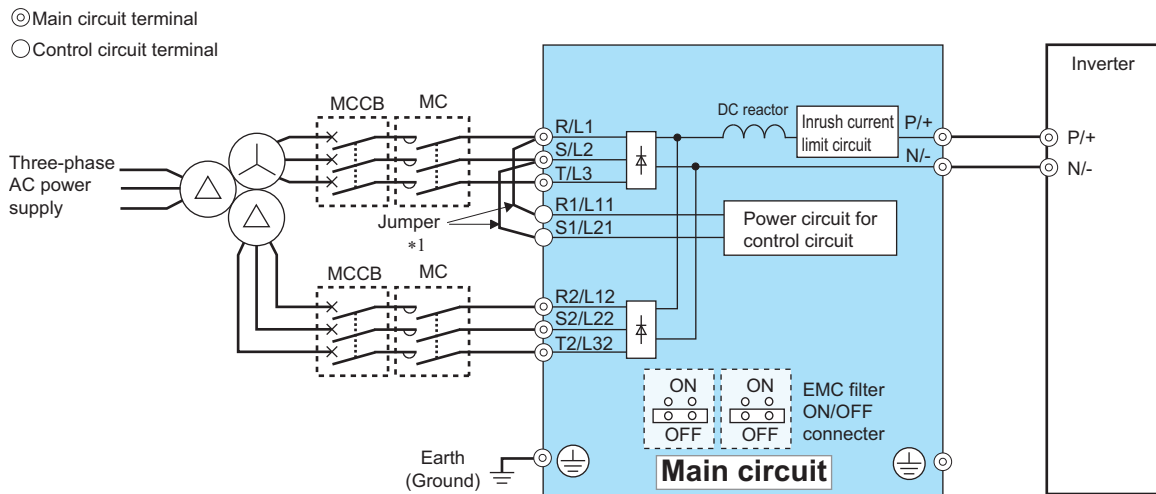

\*1 When using separate power supply for the control circuit, remove the jumpers from R1/L11 and S1/L21.

#### NOTE

- The 12-phase rectification specification is not certified as compliant with the Radio Waves Act (South Korea).
- For wiring to the control circuit terminals of the converter unit, refer to [page 27](#) (when the sink logic is selected) and [page 28](#) (when the source logic is selected).

### 2.6.3 12-phase rectifier power transformer

For 12-phase rectification, a 12-phase rectifier power transformer (3-winding transformer) is required (customer's purchase).

To prevent imbalances in output current from the power transformers, adjust the current as follows.

- Control imbalances in output voltage from the power transformers to within the range of  $\pm 0.5\%$ . Control an imbalance in power impedance ( $\%Z$ ) to within the range of  $\pm 10\%$ .



## 2.6.4 Wiring method

- In the initial status, terminals R/L1 and R2/L12, S/L2 and S2/L22, and T/L3 and T2/L32 of the converter unit are respectively shorted with shorting conductors. For 12-phase rectification, remove the bolts and nuts shown in the figure below to remove the shorting conductors.

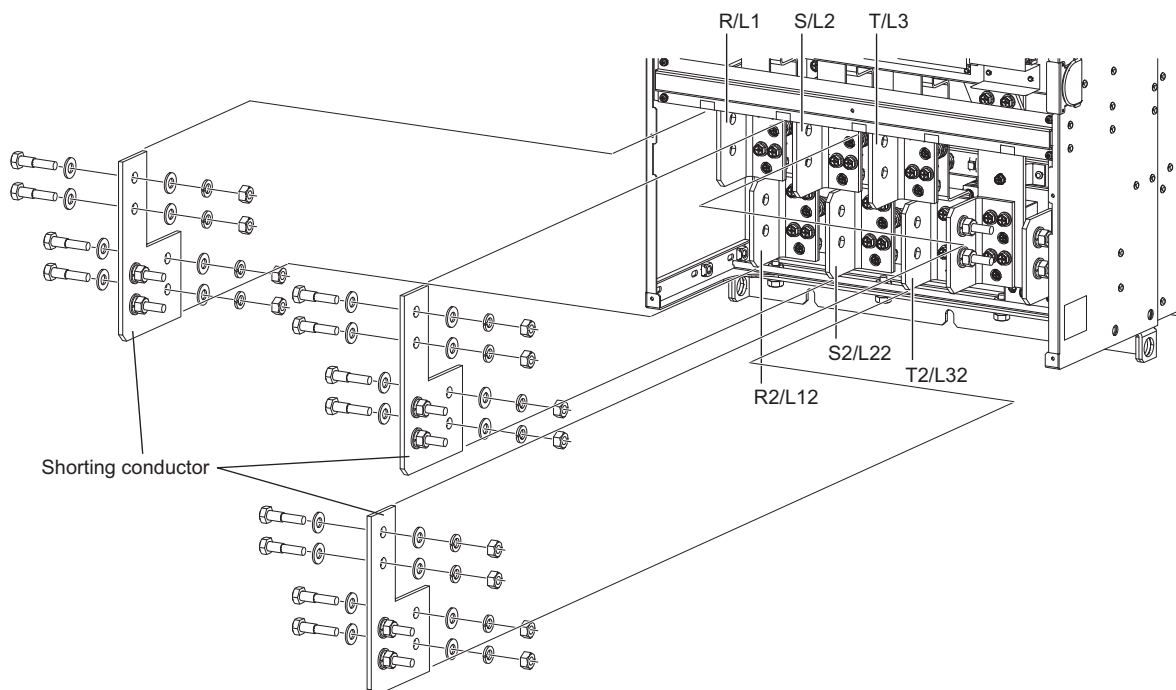

- As shown below, make sure to connect the output terminals in the star connection of the 12-phase rectifier power transformer (3-winding transformer) with terminals R/L1, S/L2, and T/L3 of the converter unit. Likewise, connect the output terminals in the delta connection of the transformer with terminals R2/L12, S2/L22, and T2/L32 of the converter unit. (Use the bolts and nuts removed earlier for these connections.)

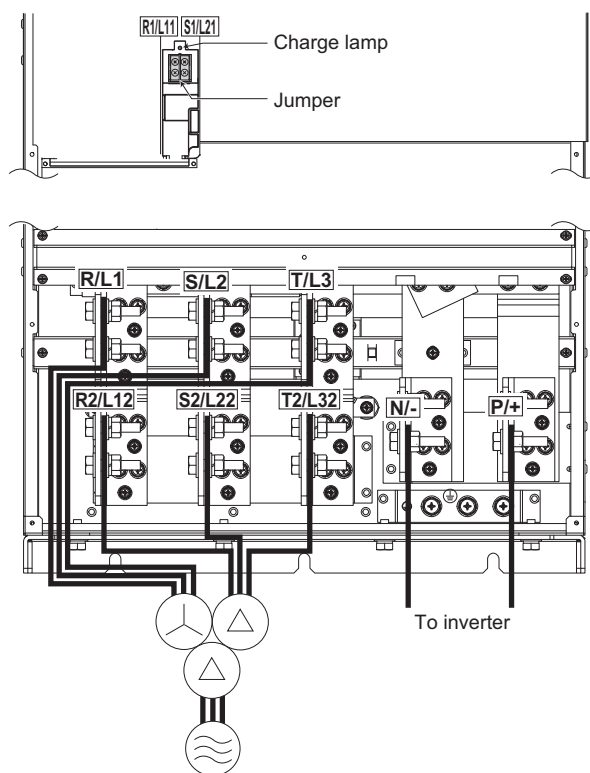
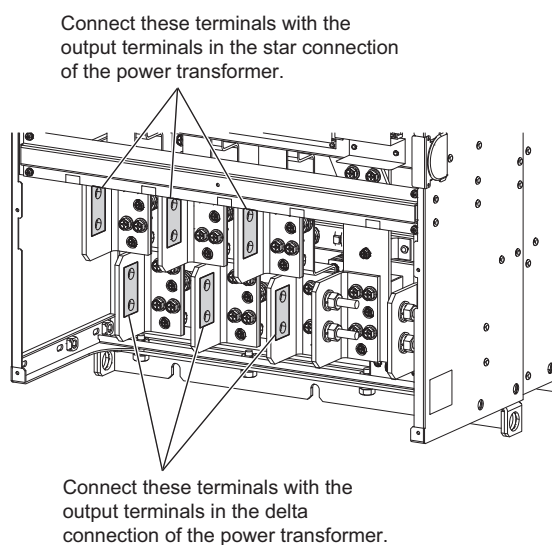

### NOTE

- Make sure to connect the power cables to the right terminals: one set to terminals R/L1, S/L2, and T/L3, and the other set to terminals R2/L12, S2/L22, and T2/L32.

- When wiring cables to the main circuit conductor, tighten each nut from the right of the conductor as seen from the front of the unit. When wiring two cables, place cables on both sides of the conductor. Use the bolts and nuts removed earlier for these connections. (Refer to the following figure.)

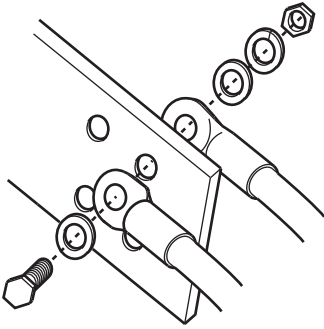

- For the installation of the noise filter on the power input line to the converter unit, install one common mode choke\*1 per line between the wye/delta connection and the converter unit.

\*1 Recommended common mode choke: FT-3KM F200160PB FINEMET® common mode choke cores manufactured by Hitachi Metals, Ltd. FINEMET is a registered trademark of Hitachi Metals, Ltd.

### CAUTION

- For 12-phase rectification, make sure to remove all of the shorting conductors between terminals R/L1 and R2/L12, between terminals S/L2 and S2/L22, and between terminals T/L3 and T2/L32 of the converter unit. If the power transformer is connected without removing these conductors, it may be burned.
- Check the correct connection between the output terminals in the star/delta connection of the power transformer and the terminals of the converter unit. Otherwise a burst, damage, etc. may occur in the converter unit or the power transformer.

## 2.6.5 Recommended cables

Select a recommended size cable to ensure that the voltage drop ratio is within 2%.

The following table shows the recommended cable size for cables that are 20 m in length (440 V input power supply, 150% overload current rating for 1 minute).

Converter model FR-CC2-□-P	Terminal screw size *4	Tightening torque N·m	Crimping terminal R/L1, S/L2, T/L3 (per circuit)*5	Cable gauge					
				HIV cables, etc. (mm <sup>2</sup> )*1			PVC cables, etc. (mm <sup>2</sup> )*3		
				R/L1, S/L2, T/L3 (per circuit)*5	P/+, N/-	Earthing (grounding) cable	R/L1, S/L2, T/L3 (per circuit)*5	R/L1, S/L2, T/L3 (per circuit)*5	Earthing (grounding) cable
H400K	M12 (M10)	46	150-12	2 × 150	2 × 200	100	2 × 4/0	2 × 95	2 × 95
H450K	M12 (M10)	46	150-12	2 × 150	2 × 250	100	2 × 250	2 × 120	2 × 120
H500K	M12 (M10)	46	150-12	2 × 150	3 × 200	2 × 100	2 × 300	2 × 150	2 × 120
H560K	M12 (M10)	46	C2-200	2 × 200	3 × 200	2 × 100	2 × 350	2 × 185	2 × 150

\*1 It is the gauge of the cable with the continuous maximum permissible temperature of 90°C or higher (LMFC (heat resistant flexible cross-linked polyethylene insulated cable), etc.). It assumes a surrounding air temperature of 50°C or lower and in-enclosure wiring.

\*2 It is the gauge of the cable with continuous maximum permissible temperature of 90°C (THHN cable). It assumes a surrounding air temperature of 40°C or lower and in-enclosure wiring. (Selection example mainly for use in the United States.)

\*3 It is the gauge of the cable with continuous maximum permissible temperature of 90°C (XLPE cable). It assumes a surrounding air temperature of 40°C or lower and in-enclosure wiring. (Selection example mainly for use in Europe.)

\*4 It is applied to the screws for terminals R/L1, S/L2, T/L3, P/+, and N/-, and a screw for earthing (grounding).  
Screw size for earthing (grounding) is indicated in parentheses.

\*5 The crimp terminals are the same for R2/L12, S2/L22, and T2/L32.

The line voltage drop can be calculated by the following formula:

$$\text{Line voltage drop [V]} = \sqrt{3} \times \text{wire resistance [m}\Omega\text{/m]} \times \text{wiring distance [m]} \times \text{current [A]} / 1000$$

Use a larger diameter cable when the wiring distance is long or when the voltage drop (torque reduction) in the low speed range needs to be reduced.

**NOTE**

- Tighten the terminal screw to the specified torque.  
A screw that has been tightened too loosely can cause a short circuit or malfunction.  
A screw that has been tightened too tightly can cause a short circuit or malfunction due to the unit breakage.
- Use crimping terminals with insulation sleeves to wire the power supply and motor.

## 2.6.6 Earthing (grounding) precautions

- Always earth (ground) the converter unit.

### ◆ Purpose of earthing (grounding)

Generally, an electrical apparatus has an earth (ground) terminal, which must be connected to the ground before use.

An electrical circuit is usually insulated by an insulating material and encased.

However, it is impossible to manufacture an insulating material that can shut off a leakage current completely, and actually, a slight current flows into the case. The purpose of earthing (grounding) the case of an electrical apparatus is to prevent operators from getting an electric shock from this leakage current when touching it.

To avoid the influence of external noises, this earthing (grounding) is important to audio equipment, sensors, computers and other apparatuses that handle low-level signals or operate very fast.

### ◆ Earthing (grounding) methods and earthing (grounding) work

As described previously, earthing (grounding) is roughly classified into an electrical shock prevention type and a noise-influenced malfunction prevention type. Therefore, these two types should be clearly distinguished, and the following work must be done to prevent the leakage current having the converter unit's high frequency components from entering for malfunction prevention:

- Whenever possible, use the independent earthing (grounding) for the converter unit.

Establishing adequate common (single-point) earth (ground) system (II) shown in the following figure is allowed only in cases where the separate earth (ground) system (I) is not feasible. Do not make inadequate common (single-point) earth (ground) connection (III).

A leakage current containing many high frequency components flows into the earthing (grounding) cables of the converter unit. Because of this, the converter unit must be earthed (grounded) separately from EMI-sensitive devices.

In a high building, it may be effective to use the EMI prevention type earthing (grounding) connecting to an iron structure frame, and electric shock prevention type earthing (grounding) with the independent earthing (grounding) together.

- Earthing (grounding) must conform to the requirements of national and local safety regulations and electrical codes. (NEC section 250, IEC 61140 class 1 and other applicable standards).

A neutral-point earthed (grounded) power supply in compliance with EN standard must be used.

- Use the thickest possible earthing (grounding) cable. The size of the earthing (grounding) cable should be the same or larger than the one indicated in the table on [page 41](#).
- The earthing (grounding) point should be as close as possible to the converter unit, and the earth (ground) wire length should be as short as possible.
- Run the earthing (grounding) cable as far away as possible from the I/O wiring of equipment sensitive to noises and run them in parallel in the minimum distance.

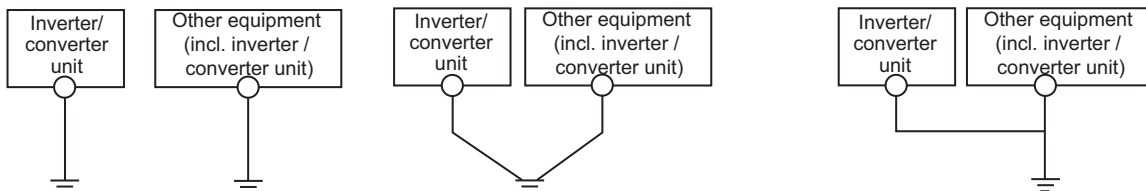

(I) Separate earthing (grounding).....Good (II) Common (single-point) earthing (grounding).....OK (III) Inadequate common (single-point) earthing(grounding).....Bad

**NOTE**

To be compliant with the EU Directive (Low Voltage Directive), refer to [page 172](#).

## 2.7 Control circuit

### 2.7.1 Details on the control circuit terminals

The input signal function of the terminals in  can be selected by setting **Pr.178, Pr.187, Pr.189 to Pr.195** (I/O terminal function selection). (Refer to [page 105, 109.](#))

#### ◆ Input signal

Type	Terminal Symbol	Terminal name	Terminal function description	Rate Specification
Contact input	RES	Reset	Use this signal to reset a fault output provided when a protective function is activated. Turn ON the RES signal for 0.1 s or longer, then turn it OFF. In the initial setting, reset is always enabled. Setting <b>Pr.75</b> makes reset possible only after the occurrence of a converter unit fault. The converter unit will restart about 1s after reset.	Input resistance 4.7 kΩ Voltage when contacts are open: 21 to 27 VDC When contacts are short-circuited: 4 to 6 mADC
	OH	External thermal relay input	The external thermal relay input (OH) signal is used when using an external thermal relay or a thermal protector built into the motor to protect the motor from overheating. When the thermal relay is activated, the inverter output is shut off by the external thermal relay operation (E.OHT).	
	RDI	Contact input	No function is assigned in the initial setting. The function can be assigned by setting <b>Pr.178</b> .	
	SD	Contact input common (sink)	Common terminal for contact input terminal (sink logic).	_____
		External transistor common (source)	Connect this terminal to the power supply common terminal of a transistor output (open collector output) device, such as a programmable controller, in the source logic to avoid malfunction by undesirable current.	
		24 VDC power supply common	Common terminal for the 24 VDC power supply (terminal PC, terminal +24) Isolated from terminals 5 and SE.	
	PC	External transistor common (sink)	Connect this terminal to the power supply common terminal of a transistor output (open collector output) device, such as a programmable controller, in the source logic to avoid malfunction by undesirable current.	Power supply voltage range 19.2 to 28.8 VDC Permissible load current 100 mA
		Contact input common (source)	Common terminal for contact input terminal (source logic).	
		24 VDC power supply common	Can be used as a 24 VDC 0.1 A power supply.	
	External power supply input	+24	24 V external power supply input	For connecting a 24 V external power supply. If a 24 V external power supply is connected, power is supplied to the control circuit while the main power circuit is OFF.

◆ Output signal

Type	Terminal Symbol	Terminal name	Terminal function description	Rate Specification
Relay	A1, B1, C1	Relay output 1 (fault output)	1 changeover contact output that indicates that the protective function of the converter unit has been activated and the outputs are stopped. Fault: discontinuity across B and C (continuity across A and C), Normal: continuity across Band C (discontinuity across A and C)	Contact capacity 230 VAC 0.3 A (power factor = 0.4) 30 VDC 0.3 A
	88R, 88S	For manufacturer setting. Do not use.		
Open collector	RDA	Inverter operation enable (NO contact)	Switched to LOW when the converter unit operation is ready. Assign the signal to terminal MRS (X10) of the inverter. The inverter can be started when the RDA status is LOW.	Permissible load 24 VDC (maximum 27 VDC) 0.1 A (The voltage drop is 2.8 V at maximum while the signal is ON.) LOW is when the open collector output transistor is ON (conducted). HIGH is when the transistor is OFF (not conducted).
	RDB	Inverter operation enable (NC contact)	Switched to LOW when a converter unit fault occurs or the converter is reset. The inverter can be started when the RDB status is HIGH.	
	RSO	Inverter reset	Switched to LOW when the converter is reset (RES-ON). Assign the signal to terminal RES of the inverter. The inverter is reset when it is connected with the RSO status LOW.	
	IPF	Instantaneous power failure	Switched to LOW when an instantaneous power failure is detected.	
	FAN	Cooling fan fault	Switched to LOW when a cooling fan fault occurs.	
	SE	Open collector output common	Common terminal for terminals RDA, RDB, RSO, IPF, FAN	

◆ Communication

Type	Terminal symbol	Terminal name	Terminal function description	
RS-485	—	PU connector	With the PU connector, communication can be made through RS-485. (For connection on a 1:1 basis only) Conforming standard: EIA-485 (RS-485) Transmission format: Multidrop link Communication speed: 4800 to 115200 bps Wiring length: 500 m	
	RS-485 terminals	TXD+	Converter unit transmission terminal	Two converter units in parallel connection have the RS-485 communication via the RS-485 terminals on each converter unit. Total wiring length: 5 m or less
		TXD-		
		RXD+	Converter unit reception terminal	
		RXD-		
GND (SG)	Earthing (grounding)			

 CAUTION

- Do not use the empty terminals (NC) of the control circuit. Doing so may lead to damage of the converter unit and the inverter.
- Always connect terminal RDA of the master converter unit and terminal MRS (X10) of the master inverter, and terminal SE of the master converter unit and terminal SD (PC for source logic) of the master inverter. Not doing so may lead to damage of the converter unit.

## 2.7.2 Control logic (sink/source) change

Change the control logic of input signals as necessary.

To change the control logic, change the jumper connector position on the control circuit board.

Connect the jumper connector to the connector pin of the desired control logic.

The jumper connector is in the sink logic (SINK) when shipped from the factory.

(The output signals may be used in either the sink or source logic independently of the jumper connector position.)

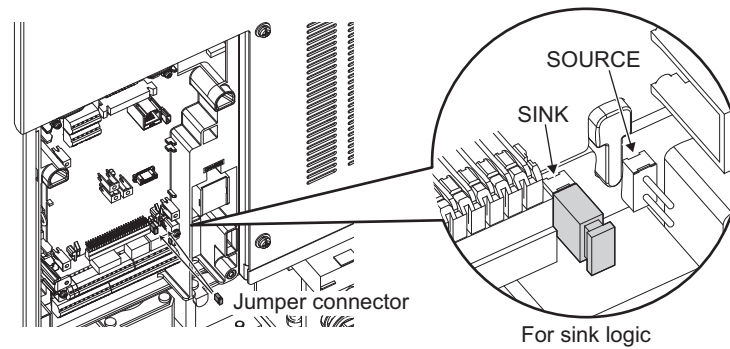

### NOTE

- Make sure that the jumper connector is installed correctly.
- Never change the control logic while power is ON.

### ◆ Sink logic and source logic

- In the sink logic, a signal switches ON when a current flows from the corresponding signal input terminal. Terminal SD is common to the contact input signals. Terminal SE is common to the open collector output signals.
- In the source logic, a signal switches ON when a current flows into the corresponding signal input terminal. Terminal PC is common to the contact input signals. Terminal SE is common to the open collector output signals.

● Current flow concerning the input/output signal when sink logic is selected

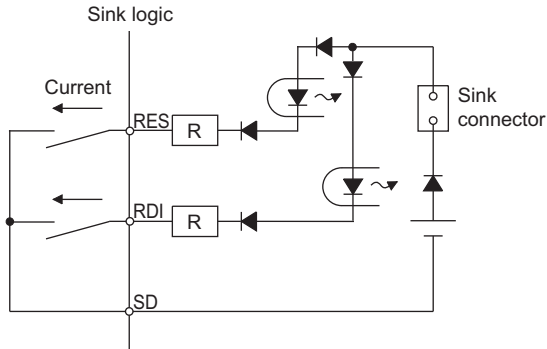

● Current flow concerning the input/output signal when source logic is selected

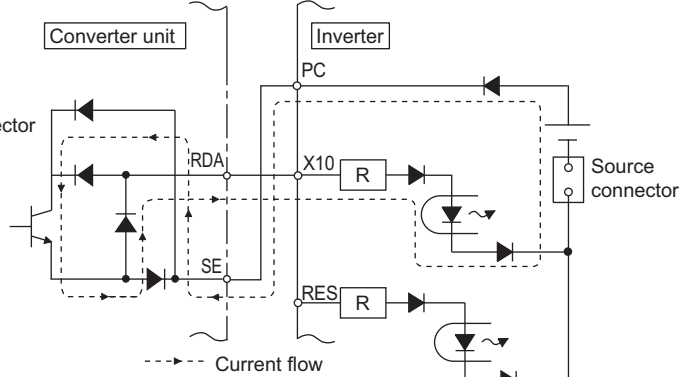
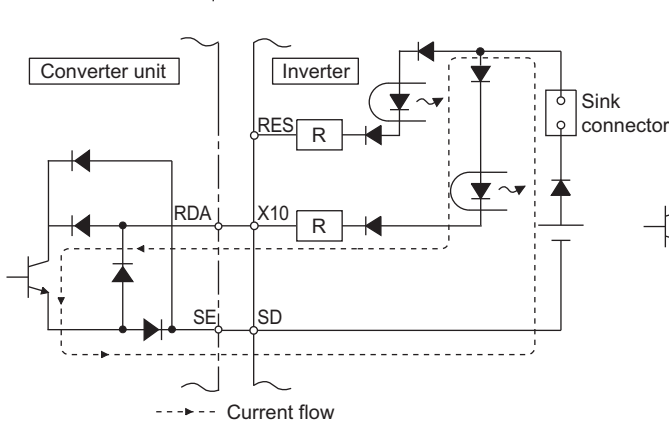
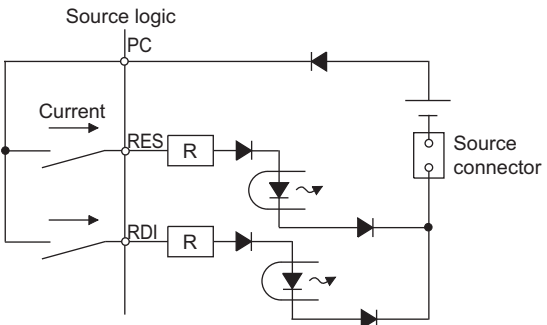

- When using an external power supply for transistor output

#### Sink logic

Use terminal PC as a common terminal, and perform wiring as shown below. (Do not connect terminal SD of the converter unit with terminal 0 V of the external power supply. When using terminals PC-SD as a 24 VDC power supply, do not install an external power supply in parallel with the converter unit. Doing so may cause a malfunction in the converter unit due to undesirable currents.)

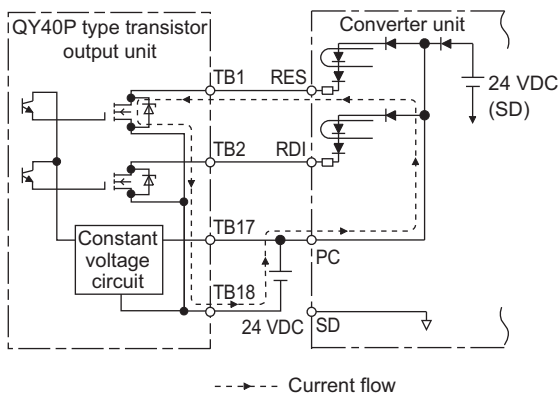

#### Source logic

Use terminal SD as a common terminal, and perform wiring as shown below. (Do not connect terminal PC of the converter unit with terminal +24V of the external power supply. When using terminals PC-SD as a 24 VDC power supply, do not install an external power supply in parallel with the converter unit. Doing so may cause a malfunction in the converter unit due to undesirable currents.)

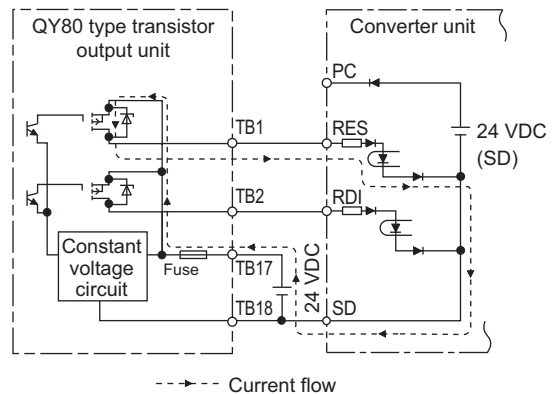

## 2.7.3 Wiring of control circuit

### ◆Control circuit terminal layout

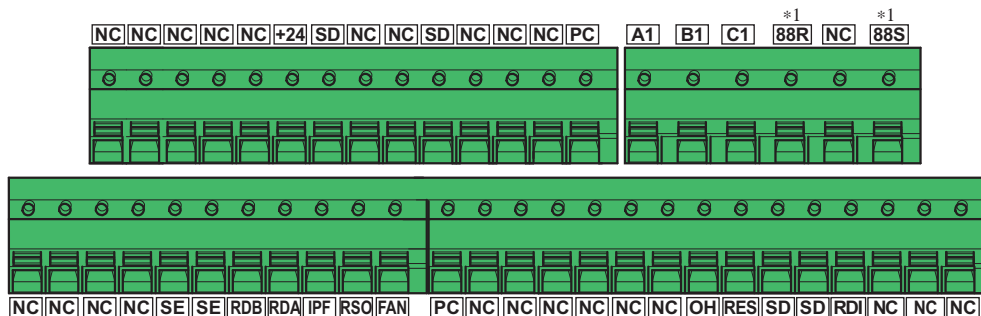

**! CAUTION**

- Do not use the empty terminals (NC) of the control circuit. Doing so may lead to damage of the converter unit and the inverter.

### ◆Wiring method

- Power supply connection

Use crimp terminals and stripped wire for the control circuit wiring. For single wire, the stripped wire can be used without crimp terminal.

Connect the end of wires (crimp terminal or stranded wire) to the terminal block.

(1) Strip the signal wires as shown below. If too much of the wire is stripped, a short circuit may occur with neighboring wires.

If not enough of the wire is stripped, wires may become loose and fall out.

Twist the stripped end of wires to prevent them from fraying. Do not solder them.

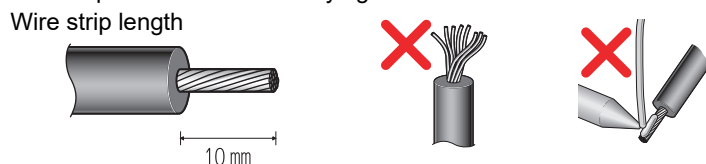

(2) Crimp the terminals on the wire.

Insert the wire into a crimp terminal, making sure that 0 to 0.5 mm of the wire protrudes from the end of the sleeve.

Check the condition of the crimp terminals after crimping. Do not use the crimp terminals of which the crimping is inappropriate, or the face is damaged.

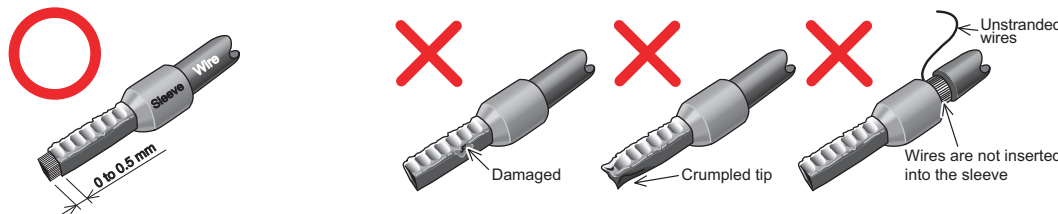

- Crimp terminals commercially available (as of October 2020)  
Phoenix Contact Co., Ltd.

Cable gauge (mm <sup>2</sup> )	Ferrule terminal model			Crimping tool name
	With insulation sleeve	Without insulation sleeve	For UL wire*1	
0.3	AI 0, 34-10TQ	-	-	CRIMPFOX 6
0.5	AI 0, 5-10WH	-	AI 0, 5-10WH-GB	
0.75	AI 0, 75-10GY	A 0, 75-10	AI 0, 75-10GY-GB	
1	AI 1-10RD	A 1-10	AI 1-10RD/1000GB	
1.25, 1.5	AI 1, 5-10BK	A 1, 5-10	AI 1, 5-10BK/1000GB*2	
0.75 (for two wires)	AI-TWIN 2 × 0, 75-10GY	-	-	



## Control circuit

Cable gauge (mm <sup>2</sup> )	Ferrule terminal model			Crimping tool name
	With insulation sleeve	Without insulation sleeve	For UL wire*1	

\*1 A ferrule terminal with an insulation sleeve compatible with the MTW wire which has a thick wire insulation.

\*2 Applicable for terminals A1, B1, C1, A2, B2, and C2 only.

NICHIFU Co., Ltd.

Cable gauge (mm <sup>2</sup> )	Blade terminal product number	Insulation cap product number	Crimping tool product number
0.3 to 0.75	BT 0.75-11	VC 0.75	NH 69

(3) Insert the wires into a socket.

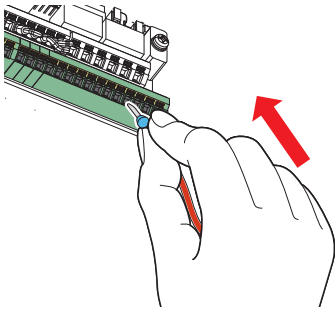

When using a single wire or stranded wires without a blade terminal, push the open/close button all the way down with a flathead screwdriver, and insert the wire.

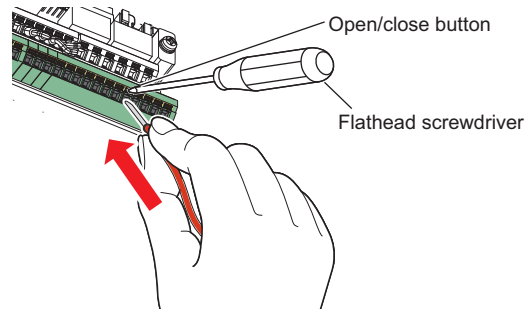

### NOTE

- When using stranded wires without a blade terminal, twist enough to avoid short circuit with a nearby terminals or wires.
- Place the flathead screwdriver vertical to the open/close button. In case the blade tip slips, it may cause a converter unit damage or injury.

• Wire removal  
Pull the wire while pushing the open/close button all the way down firmly with a flathead screwdriver.

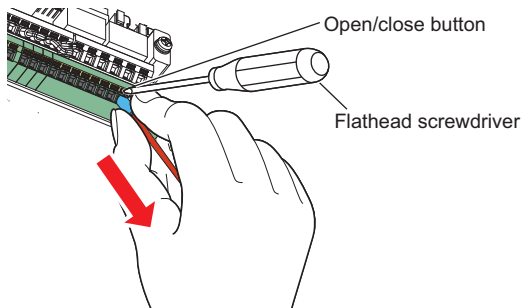

### NOTE

- Pulling out the wire forcefully without pushing the open/close button all the way down may damage the terminal block.
- Use a small flathead screwdriver (tip thickness: 0.4 mm/tip width: 2.5 mm).

If a flathead screwdriver with a narrow tip is used, terminal block may be damaged.

Commercially available products (as of October 2020)

Name	Model	Manufacturer
Driver	SZF 0- 0,4 × 2,5	Phoenix Contact Co., Ltd.

- Place the flathead screwdriver vertical to the open/close button. In case the blade tip slips, it may cause a converter unit damage or injury.

## ◆ Common terminals of the control circuit (SD, PC, SE)

- Terminals SD (sink logic), PC (source logic), and SE are common terminals (0 V) for I/O signals. (All common terminals are isolated from each other.) Do not earth (ground) these terminals.
- In the sink logic, terminal SD is a common terminal for the contact input terminals (RES, OH, RDI). The open collector circuit is isolated from the internal control circuit by photocoupler.
- In the source logic, terminal PC is a common terminal for the contact input terminals (RES, OH, RDI). The open collector circuit is isolated from the internal control circuit by photocoupler.
- Terminal SE is a common terminal for the open collector output terminals (RDA, RDB, RSO, IPF, FAN). The contact input circuit is isolated from the internal control circuit by photocoupler.

## ◆ Signal inputs by contactless switches

The contact input terminals of the converter unit (RES, OH, RDI) can be controlled using a transistor instead of a contact switch as shown below.

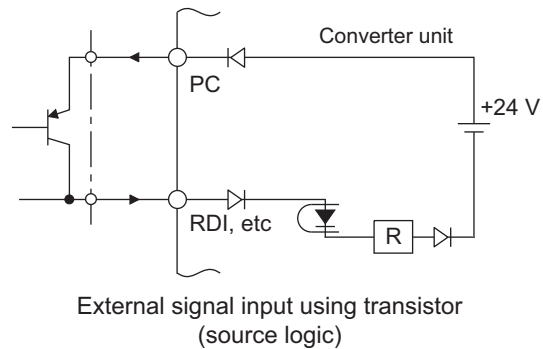
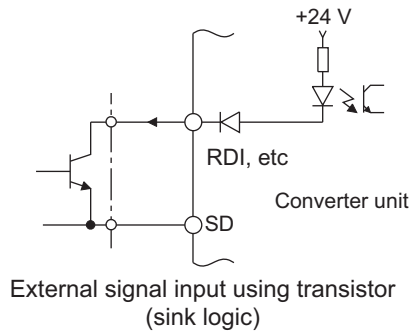

## 2.7.4 Wiring precautions

- It is recommended to use a cable of 0.75 mm<sup>2</sup> for connection to the control circuit terminals.
- The wiring length should be 30 m at the maximum.
- Use two or more parallel micro-signal contacts or twin contacts to prevent contact faults when using contact inputs since the control circuit input signals are micro-currents.
- To suppress EMI, use shielded or twisted cables for the control circuit terminals and run them away from the main and power circuits (including the 200 V relay sequence circuit). For the cables connected to the control circuit terminals, connect their shields to the common terminal of the connected control circuit terminal. When connecting an external power supply to terminal PC, however, connect the shield of the power supply cable to the negative side of the external power supply. Do not directly earth (ground) the shield to the enclosure, etc.
- Separate the wiring of the control circuit away from the wiring of the main circuit. Make cuts in rubber bush of the converter unit side and lead the wires through.

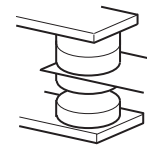

Micro signal contacts

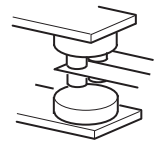

Twin contacts

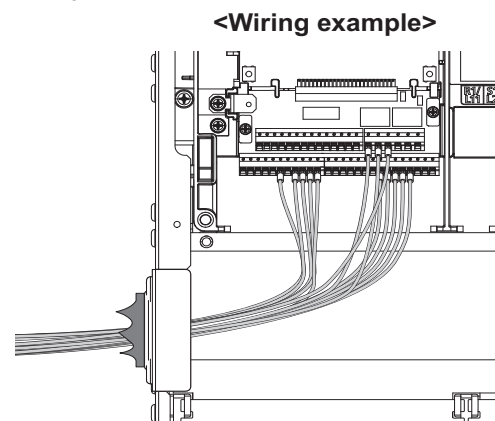
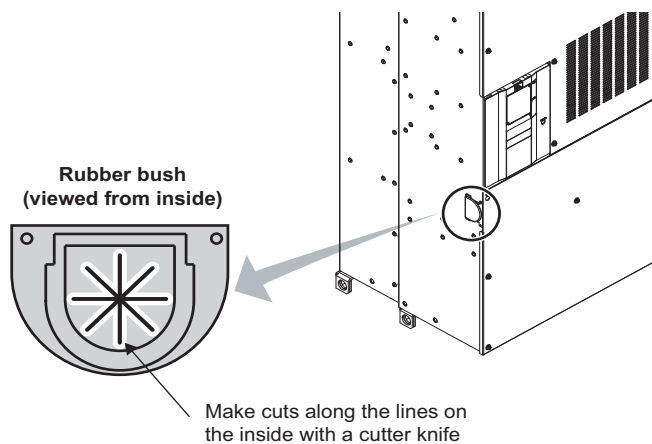

## 2.7.5 When using separate power supplies for the control circuit and the main circuit

### ◆ Cable size for the control circuit power supply (terminals R1/L11 and S1/L21)

- Terminal screw size: M4
- Cable gauge: 0.75 mm<sup>2</sup> to 2 mm<sup>2</sup>
- Tightening torque: 1.5 N•m

### ◆ Connected to

When a fault occurs, opening of the electromagnetic contactor (MC) on the converter unit power supply side results in power loss in the control circuit, disabling the fault output signal retention. Terminals R1/L11 and S1/L21 are provided to hold a fault signal. In this case, connect the power supply terminals R1/L11 and S1/L21 of the control circuit to the input side of the MC. Do not connect the power cable to incorrect terminals. Doing so may damage the converter unit.

<Connection diagram>

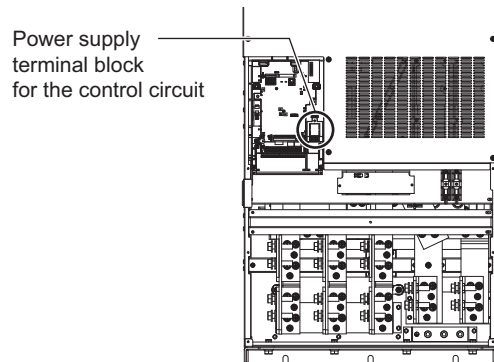
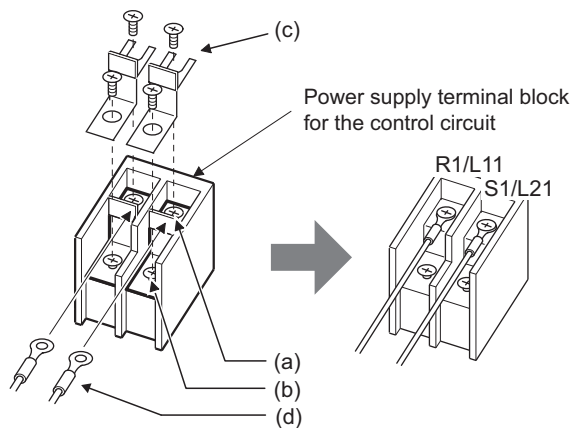
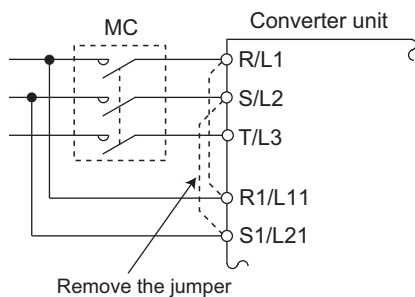

- Remove the upper screws.
- Remove the lower screws.
- Pull the jumper toward you to remove.
- Connect the separate power supply cable for the control circuit to the upper terminals (R1/L11, S1/L21).

### NOTE

- When using separate power supplies, always remove the jumpers from terminals R1/L11 and S1/L21. The converter unit may be damaged if the jumpers are not removed.
- The voltage should be the same as that of the main control circuit when the control circuit power is supplied from other than the input side of the MC.
- The power capacity necessary when separate power is supplied from R1/L11 and S1/L21 is 80 VA.
- If the main circuit power is switched OFF (for 0.1 s or more) then ON again, the converter unit is reset and a fault output will not be held.
- When a power supply is provided for the control circuit separately from the main circuit and a capacitive device (such as an EMC filter or a radio noise filter) is connected, connect a noise filter (example: RTMN5006 manufactured by TDK-Lambda Corporation) to the control circuit power supply.

## 2.7.6 When supplying 24 V external power to the control circuit

Connect a 24 V external power supply across terminals +24 and SD. Connecting a 24 V external power supply enables I/O terminal ON/OFF operation, operation panel displays, control functions, and communication during communication operation even during power-OFF of converter unit's main circuit power supply. When the main circuit power supply is turned ON, the power supply changes from the 24 V external power supply to the main circuit power supply.

### ◆ Specification of the applied 24 V external power supply

Item	Rate Specification
Input voltage	23 to 25.5 VDC
Input current	1.4 A or lower

Commercially available products (as of October 2020)

Model	Product overview	Manufacturer
S8FSG05024C*1	Specifications: Capacity 50 W, output voltage 24 VDC, output current 2.2 A Installation method: Direct installation, screw type terminal block with cover Input: Single-phase 100 to 240 VAC	OMRON Corporation
S8VK-S06024*1	Specifications: Capacity 60 W, output voltage 24 VDC, output current 2.5 A Installation method: DIN rail, push-in (spring) type terminal block Input: Single-phase 100 to 240 VAC	
S8VKWA24024*1	Specifications: Capacity 240 W, output voltage 24 VDC, output current 10 A Installation method: DIN rail, push-in (spring) type terminal block Input: Three-phase 200 to 240 VAC	

\*1 For the latest information about OMRON power supply, contact OMRON corporation.

### ◆ Starting and stopping the 24 V external power supply operation

- Supplying 24 V external power while the main circuit power is OFF starts the 24 V external power supply operation. Likewise, turning OFF the main circuit power while supplying 24 V external power starts the 24 V external power supply operation.
- Turning ON the main circuit power stops the 24 V external power supply operation and enables the normal operation.

#### NOTE

- When the 24 V external power is supplied while the main circuit power supply is OFF, the converter unit operation is disabled.
- In the initial setting, when the main power supply is turned ON during the 24 V external power supply operation, a reset is performed in the converter unit, then the power supply changes to the main circuit power supply.

2

### ◆ Confirming the 24 V external power supply input

- During the 24 V external power supply operation, the ALARM lamp of the accessory cover blinks. When the operation panel is installed, "EV" blinks.

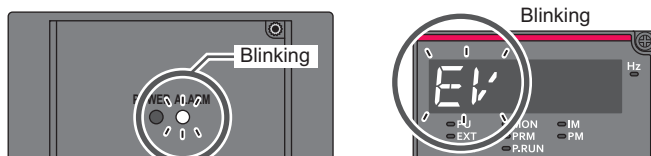

- During the 24 V external power supply operation, the 24 V external power supply operation signal (EV) is output. To use the EV signal, set "68 (positive logic) or 168 (negative logic)" in one of **Pr.190 to Pr.195 (Output terminal function selection)** to assign function to an output terminal.

### ◆ Operation while the 24 V external power is supplied

- Fault history and parameters can be read and parameters can be written using the operation panel keys.
- During the 24 V external power supply operation, monitored items and signals related to inputs to main circuit power supply, such as input current and converter output voltage are invalid.
- The alarms, which have occurred when the main circuit power supply is ON, continue to be output after the power supply is changed to the 24 V external power supply. Perform the converter reset or turn OFF then ON the power to reset the faults.

#### NOTE

- Inrush current equal to or higher than the 24 V external power supply specification may flow at power-ON. Confirm that the power supply and other devices are not affected by the inrush current and the voltage drop caused by it. Depending on the power supply, the inrush current protection may be activated to disable the power supply. Select the power supply and capacity carefully.
- When the wiring length between the external power supply and the converter unit is long, the voltage often drops. Select the appropriate wiring size and length to keep the voltage in the rated input voltage range.
- In a serial connection of several converter units, the current increases when it flows through the converter unit wiring near the power supply. The increase of the current causes voltage to drop further. Use the converter units after confirming that the input voltage of each converter unit is within the rated input voltage range. Depending on the power supply, the inrush current protection may be activated to disable the power supply. Select the power supply and capacity carefully.
- When an external 24 V power supply is used, "E.P24" may appear if the power supply start-up time is too long (less than 1.5 V/s).
- "E.P24" may appear when the 24 V external power supply input voltage is low. Check the external power supply input.
- Do not touch the control circuit terminal block (circuit board) during the 24 V power supply operation (when conducted). Otherwise you may get an electric shock or burn.

## 2.8 Communication connectors and terminals

### 2.8.1 RS-485 terminal block

Connecting the RS-485 terminals of the master/slave converter units enables communication for parallel operation.

#### ◆RS-485 terminal layout

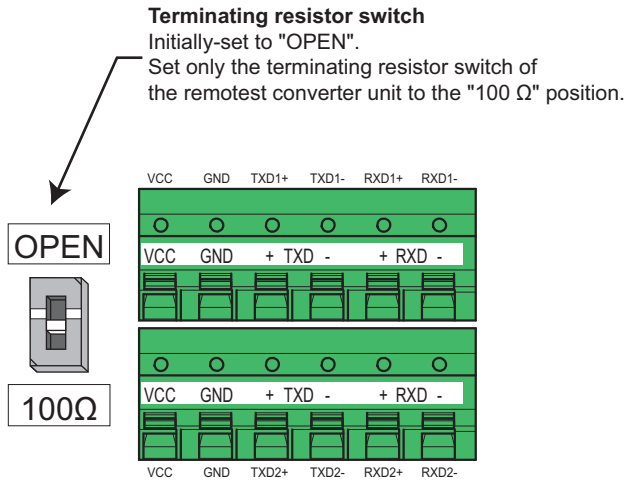

Name	Description
RXD1+	Converter unit receive+
RXD1-	Converter unit receive-
RXD2+	Converter unit receive+ (for branch)
RXD2-	Converter unit receive- (for branch)
TXD1+	Converter unit send+
TXD1-	Converter unit send-
TXD2+	Converter unit send+ (for branch)
TXD2-	Converter unit send- (for branch)
VCC	5 V Permissible load current 100 mA
GND	Earth (ground) (connected to terminal SD)

#### ◆Wiring the RS-485 terminals

- Use a four, twisted-pair wires for connection.
- The size of RS-485 terminal block is the same as that of the control circuit terminal block. Refer to [page 47](#) for the wiring method.

#### NOTE

- The total length of the wires between the RS-485 terminals must be within 5 m.
- To avoid malfunction, keep the RS-485 terminal wires away from the control circuit board.

### ◆ RS-485 terminal wiring method

- Operating two converter units in parallel

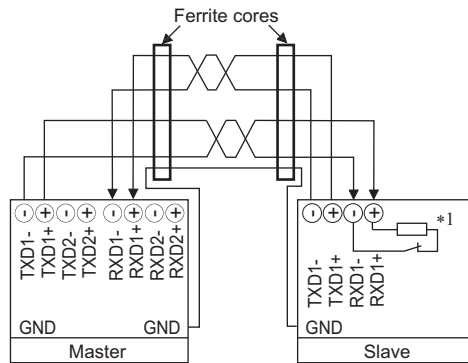

- Operating three converter units in parallel

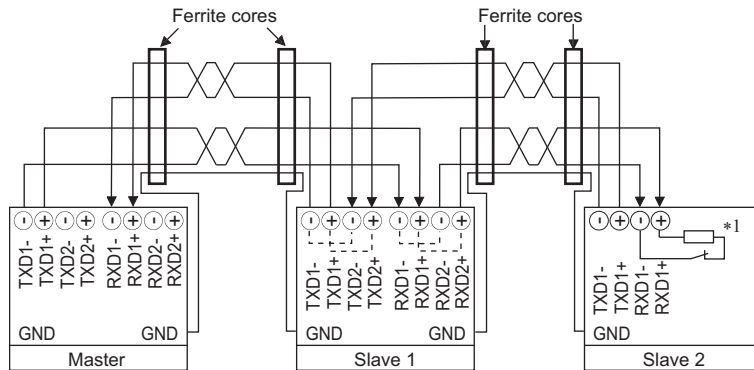

\*1 Set the terminating resistor switch to 100 Ω.

**NOTE**

- Refer to the diagrams above to connect the converter units with RS-485 cables. Wind the wires together around each ferrite core (accessory of the inverter) once (two turns). Install each ferrite core on within 10 cm of the converter unit.
- For branching, connect the wires as shown below.

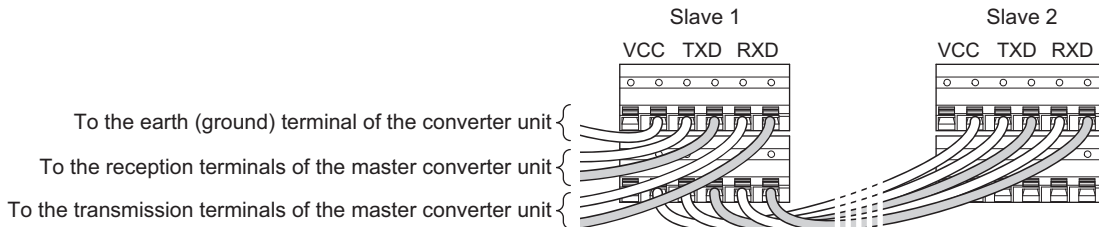

## 2.8.2 PU connector

### ◆ Installing the operation panel on the enclosure surface

- Having an operation panel on the enclosure surface is convenient. With a connection cable, you can install the operation panel on the enclosure surface, and connect it to the converter unit.

Use the option FR-CB2[ ], or connectors and cables available on the market.

(To install the operation panel, the optional connector (FR-ADP) is required. )

Securely insert one end of the connection cable until the stoppers are fixed.

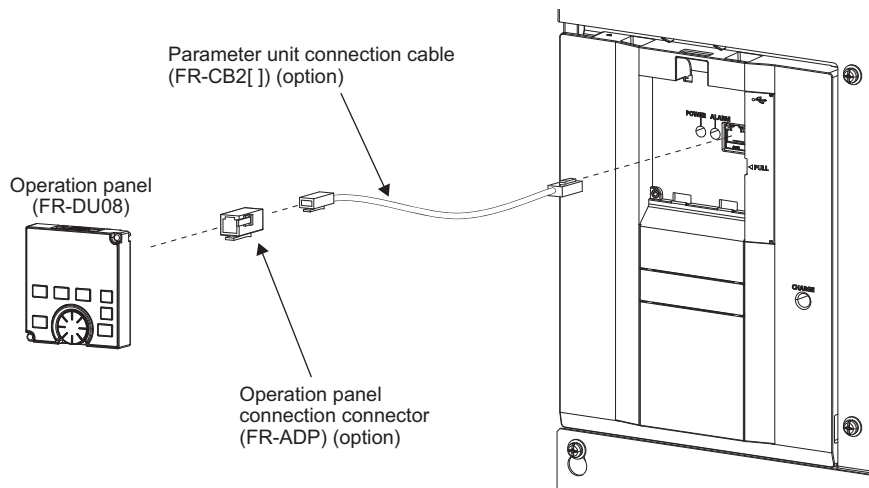

#### NOTE

- Refer to the following table when fabricating the cable on the user side. Keep the total cable length within 20 m.
- Commercially available products (as of February 2015)

Name	Remarks
Communication cable	Cable compliant with EIA-568 (such as 10BASE-T cable)

### ◆ Communication operation

- Using the PU connector enables communication operation from a personal computer, etc. When the PU connector is connected with a personal, FA or other computer by a communication cable, a user program can run to monitor the converter unit or read and write parameters.

Communication can be performed with the Mitsubishi inverter protocol (computer link operation).

For the details, refer to [page 115](#).



## 2.9 Setting parameters for parallel operation

### ◆ Parallel operation selection (Pr.1001)

Pr.	Name	Initial value	Setting range	Description	
				Master/slave station	Number of slave station
1001 E390	Parallel operation selection	100	1	Slave station 1	—
			2	Slave station 2	—
			100 (initial value)	Master station	0
			200		1
			300		2

- To operate two converter units in parallel, set "200", and "1" or "2" in **Pr.1001 Parallel operation selection** of the master and slave converter units respectively. (Setting either slave 1 or 2 will perform the operation.)
- To operate three converter units in parallel, set "300", "1", and "2" in **Pr.1001** of the master, slave 1, and slave 2 converter units respectively.
- Set "100 (initial value)" in **Pr.1001** to enable operation using just one converter unit in the event of an emergency.

#### NOTE

- The setting of **Pr.1001** will be applied after next power ON or converter unit reset.
- When the operation panel is installed to the converter units, the first monitor screen shows SLV.1 (parallel operation slave 1) on the slave 1 converter unit (**Pr.1001** = "1") and SLV.2 (parallel operation slave 2) on the slave 2 converter unit (**Pr.1001** = "2").

### CAUTION

- **Be sure to set Pr.1001 correctly. Operation with incorrect settings may damage the converter units.**

### ◆ Precautions when setting parameters for parallel operation

- Always set **Pr.1001** of the master and reset the converter unit after setting **Pr.1001** of the slave and resetting the converter unit. If the parameter is set in the reverse order, the communication between the master and the slave may not be performed correctly.
- Before the parallel operation, set the same values between the master and the slave in **Pr.30**, **Pr.57**, **Pr.261**, and **Pr.598**. If the settings are not correct, parallel operation will not work correctly.

### ◆ Resetting the converter during the parallel operation

- When the RES signal of the master remains ON, the master keeps attempting to perform the converter reset. However, the slave performs the converter reset only once and does not keep attempting to perform the reset.
- For the converter reset, reset the master converter unit. The slave converter unit will be reset simultaneously.

## ◆ Parallel operation communication check time (Pr.652)

Pr.	Name	Initial value	Setting range	Description
652 N092	Parallel operation communication check time	1 s	0	Parallel operation communication disabled
			0.1 to 120 s	Set the interval of the communication check (signal loss detection) time. If a no-communication state persists for the permissible time or longer, the inverter will trip.
			9999	No communication check (signal loss detection)

- If the communication between the master and the slave is lost for a certain period, the converter unit assumes it is in disconnection state and activates the protective function (E.SER) to shut off the output.
- If communication is lost for the time set in **Pr.652** while the converter unit is stopped, the signal loss detection is assumed and the protective function (E.SER) is activated.
- When the **Pr.652** setting is 0.1 to 120 seconds, the signal loss detection is made.
- When the **Pr.652** setting is "9999", the signal loss detection is not made.
- When the **Pr.652** setting is "0", the parallel operation communication is not possible.

## ◆ Parallel operation ready (Y227) signal

- When wiring to the RS-485 terminals and setting **Pr.1001** are completed, communication between the master/slave converter units are started automatically and prepared for the parallel operation. When the converter units are ready, the Parallel operation ready (Y227) signal turns ON.
- For the Y277 signal, set "227 (positive logic) or 327 (negative logic)" in any parameter from **Pr.190 to Pr.195 (Output terminal function selection)** to assign the function to the output terminal.

### NOTE

- Changing the terminal assignment using **Pr.190 to Pr.195 (output terminal function selection)** may affect the other functions. Set parameters after confirming the function of each terminal.

# MEMO

---

# **3 PRECAUTIONS FOR USE OF THE CONVERTER UNIT**

---

This chapter explains the precautions for use of this product.  
Always read the instructions before using the equipment.

---

<b>3.1</b>	<b>Electro-magnetic interference (EMI) and leakage currents ..</b>	<b>60</b>
<b>3.2</b>	<b>Power supply harmonics .....</b>	<b>66</b>
<b>3.3</b>	<b>Power-OFF and magnetic contactor (MC) .....</b>	<b>70</b>
<b>3.4</b>	<b>Checklist before starting operation .....</b>	<b>71</b>

# 3.1 Electro-magnetic interference (EMI) and leakage currents

## 3.1.1 Leakage currents and countermeasures

Capacitances exist between the I/O cables or other cables of the inverter or the converter unit and earth, and in the motor, through which a leakage current flows. The amount of current leakage depends on the size of the capacitance. Take the following precautions to prevent current leakage. Earth leakage circuit breakers should be selected based on their rated current sensitivity.

### ◆ To-earth (ground) leakage currents

Leakage currents may flow not only into the power system of the inverter and converter unit but also into the other power systems through the earthing (grounding) cable, etc. These leakage currents may operate earth leakage circuit breakers and earth leakage relays unnecessarily.

#### ● Precautions

- Use an earth leakage circuit breaker with a weak sensitivity in a high frequency range.

The output current of the inverter or the converter unit contains a high-frequency leakage current component, which gives relatively low impacts to human bodies. The detention level for this high-frequency leakage current component can be set weaker to prevent unnecessary operations.

- Minimize the stray capacitance to the earth.

Use the cables insulated with low dielectric constant material, and perform wiring to make the wiring length between the inverter and the motor to be as short as possible.

#### ● To-earth (ground) leakage currents

- Take caution as long wiring will increase the leakage current.
- Increasing the motor capacity increases the leakage current.

### ◆ Line-to-line leakage currents

Harmonics of leakage currents flowing in static capacitances between the output cables of the inverter or the converter unit may operate the external thermal relay unnecessarily.

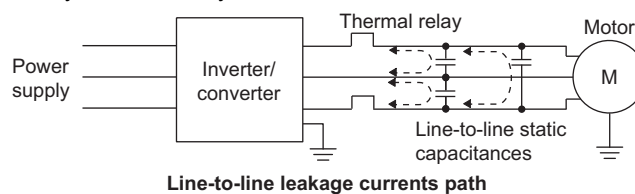

#### ● Precautions

- Use **Pr.9 Electronic thermal O/L relay**.

- To ensure that the motor is protected against line-to-line leakage currents, it is recommended to use a temperature sensor to directly detect motor temperature.

- Increase the external thermal overload relay setting by the amount of the leakage current.

- Minimize the stray capacitance between the lines.

Use the cables insulated with low dielectric constant material, and perform wiring to make the wiring length between the inverter and the motor to be as short as possible.

#### ● Installation and selection of the molded case circuit breaker

Install a molded case circuit breaker (MCCB) on the power receiving side to protect the wiring at the input side of the inverter or the converter unit. Select an MCCB according to the inverter input side power factor, which depends on the power supply voltage, output frequency and load. Especially for a completely electromagnetic MCCB, a slightly large capacity must be selected since its operation characteristic varies with harmonic currents. (Check it in the data of the corresponding breaker.)

As an earth leakage current breaker, use the Mitsubishi earth leakage current breaker designed for harmonics and surge suppression.

### ◆ Selecting the rated sensitivity current for the earth leakage circuit breaker

When using the earth leakage circuit breaker with the inverter or the converter unit circuit, select its rated sensitivity current as follows.

- Breaker designed for harmonic and surge suppression  
 Rated sensitivity current  
 $I \Delta n \geq 10 \times (I_{g1} + I_{gn} + I_{gi} + I_{g2} + I_{gm})$
  - Standard breaker  
 Rated sensitivity current  
 $I \Delta n \geq 10 \times \{I_{g1} + I_{gn} + I_{gi} + 3 \times (I_{g2} + I_{gm})\}$
- $I_{g1}$ ,  $I_{g2}$ : Leakage currents in wire path during commercial power supply operation  
 $I_{gn}$ : Leakage current of inverter input side noise filter  
 $I_{gm}$ : Leakage current of motor during commercial power supply operation  
 $I_{gi}$ : Leakage current of inverter unit  
 (When the converter unit is connected, add the leakage current of converter unit.)

Example of leakage current per 1 km during the commercial power supply operation when the CV cable is routed in metal conduit

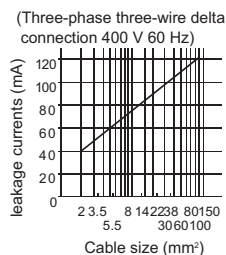

Leakage current example of three-phase induction motor during the commercial power supply operation

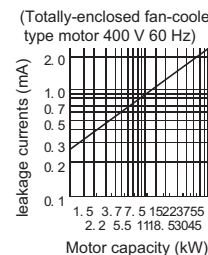

For "Δ" connection, the amount of leakage current is approx. 1/3 of the above value.

<Example>

- Selection example for the Δ connection of the 400 V class

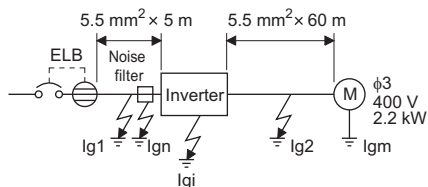

Item	Breaker designed for harmonic and surge suppression	Standard breaker
Leakage current $I_{g1}$ (mA)	$\frac{1}{3} \times 66 \times \frac{5 \text{ m}}{1000 \text{ m}} = 0.11$	
Leakage current $I_{gn}$ (mA)	0 (without noise filter)	
Leakage current $I_{gi}$ (mA)	1 (without EMC filter) For the leakage current of the inverter, refer to the following table.	
Leakage current $I_{g2}$ (mA)	$\frac{1}{3} \times 66 \times \frac{60 \text{ m}}{1000 \text{ m}} = 1.32$	
Motor leakage current $I_{gm}$ (mA)	0.36	
Total leakage current (mA)	2.79	6.15
Rated sensitivity current (mA) ( $\geq I_g \times 10$ )	30	100

3

- Leakage currents of the inverter and the converter unit with a 6-phase transformer 400 V class (input power condition: 440 V/60 Hz, power supply unbalance within 3%)

Inverter/ converter unit	FR-A802-P (Separated converter type)	Converter unit FR-CC2-P	
		ON	OFF
EMC filter	-		
Phase earthing (grounding)	2	70	2
Earthed-neutral system	1	2	1

(mA)

- Leakage currents of the converter unit with a 12-phase transformer

## Electro-magnetic interference (EMI) and leakage currents

400 V class (input power condition: 440 V/60 Hz, power supply unbalance within 3%)

EMC filter	ON	OFF
Wye connection / Delta connection	37	3

(mA)

### NOTE

- Install the earth leakage circuit breaker (ELB) on the input side of the converter unit.
- In the  $\Delta$  connection earthed-neutral system, the sensitivity current is blunt against a ground fault at the output side of the inverter. Earthing (Grounding) must conform to the requirements of national and local safety regulations and electrical codes. (NEC section 250, IEC 536 class 1 and other applicable standards)
- When the breaker is installed on the output side of the inverter, it may be unnecessarily operated by harmonics even if the effective value is within the rating.  
In this case, do not install the breaker since the eddy current and hysteresis loss will increase, leading to temperature rise.
- The following models are standard breakers..... BV-C1, BC-V, NVB, NV-L, NV-G2N, NV-G3NA, NV-2F earth leakage relay (except NV-ZHA), and NV with AA neutral wire open-phase protection.  
The other models are designed for harmonic and surge suppression..... NV-C/NV-S/MN series, NV30-FA, NV50-FA, BV-C2, earth leakage alarm breaker (NF-Z), NV-ZHA, and NV-H.
- For the motor leakage current, contact the motor manufacturer.

## 3.1.2 Countermeasures against EMI generated by the inverter or the converter unit

Some electromagnetic noises enter the inverter or the converter unit to cause the inverter or the converter unit malfunction, and others are radiated by the inverter or the converter unit to cause the peripheral devices to malfunction. Though the inverter or the converter unit is designed to have high immunity performance, it handles low-level signals, so it requires the following basic techniques. Also, since the inverter chops outputs at high carrier frequency, that could generate electromagnetic noises. If these electromagnetic noises cause peripheral devices to malfunction, EMI countermeasures should be taken to suppress noises. These techniques differ slightly depending on EMI paths.

- Basic techniques
  - Do not run the power cables (I/O cables) and signal cables of the inverter or the converter unit in parallel with each other and do not bundle them.
  - Use shielded twisted pair cables for the detector connecting and control signal cables and connect the sheathes of the shielded cables to terminal SD.
  - Ground (Earth) the inverter, converter unit, motor, etc. at one point.
- Techniques to reduce electromagnetic noises that enter and cause a malfunction of the inverter or the converter unit (EMI countermeasures)  
When devices that generate many electromagnetic noises (which use magnetic contactors, electromagnetic brakes, many relays, for example) are installed near the inverter or the converter unit, and the inverter or the converter unit may malfunction due to electromagnetic noises, the following countermeasures must be taken:
  - Provide surge suppressors for devices that generate many electromagnetic noises to suppress electromagnetic noises.
  - Install data line filters (page 64) to signal cables.
  - Ground (Earth) the shields of the detector connection and control signal cables with cable clamp metal.

- Techniques to reduce electromagnetic noises that are radiated by the inverter or the converter unit to cause the peripheral devices to malfunction (EMI countermeasures)

Noises generated from the inverter or the converter unit are largely classified into those radiated by the cables connected to the inverter or the converter unit and their main circuits (I/O), those electromagnetically and electrostatically induced to the signal cables of the peripheral devices close to the main circuit cables, and those transmitted through the power supply cables.

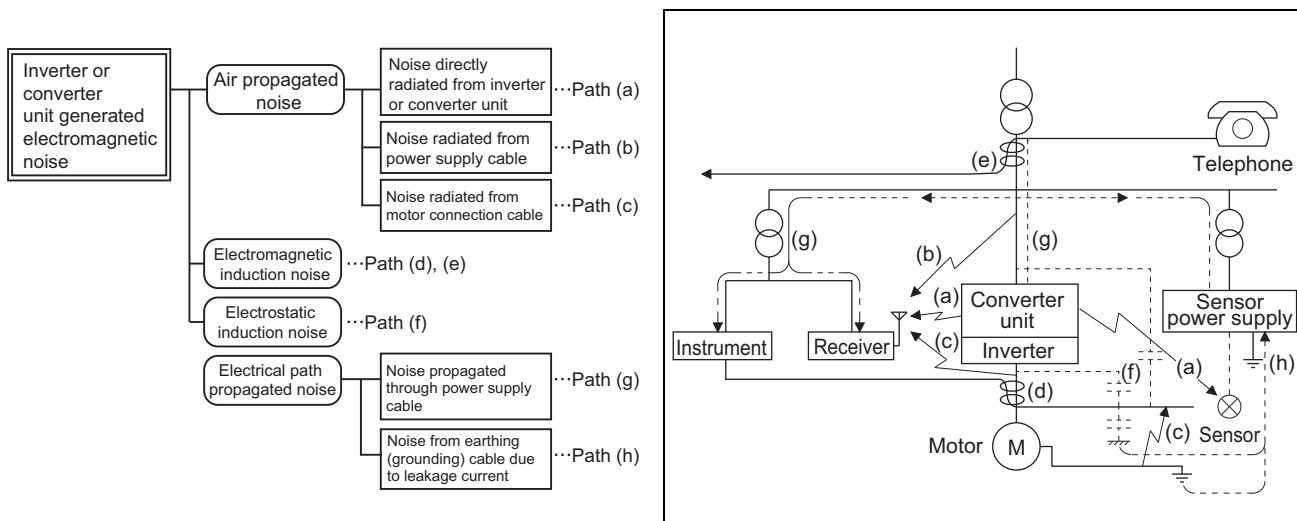

Noise propagation path	Countermeasure
(a) (b) (c)	<p>When devices that handle low-level signals and are liable to malfunction due to electromagnetic noises, e.g. instruments, receivers and sensors, are contained in the enclosure that contains the inverter or the converter unit, or when their signal cables are run near the inverter or the converter unit, the devices may malfunction due to by air-propagated electromagnetic noises. The following countermeasures must be taken:</p> <ul style="list-style-type: none"> <li>Install easily affected devices as far away as possible from the inverter or the converter unit.</li> <li>Run easily affected signal cables as far away as possible from the inverter or the converter unit, and their I/O cables.</li> <li>Do not run the signal cables and power cables (I/O cables of the inverter or the converter unit) in parallel with each other and do not bundle them.</li> <li>Set the EMC filter ON/OFF connector of the converter unit to the ON position. (Refer to <a href="#">page 65</a>.)</li> <li>Inserting a line noise filter into the output suppresses the radiated noise from the cables.</li> <li>Use shielded cables as signal cables and power cables and run them in individual metal conduits to produce further effects.</li> </ul>
(d) (e) (f)	<p>When the signal cables are run in parallel with or bundled with the power cables, magnetic and static induction noises may be propagated to the signal cables to cause malfunction of the devices and the following countermeasures must be taken:</p> <ul style="list-style-type: none"> <li>Install easily affected devices as far away as possible from the inverter or the converter unit.</li> <li>Run easily affected signal cables as far away as possible from the I/O cables of the inverter or the converter unit.</li> <li>Do not run the signal cables and power cables (I/O cables of the inverter or the converter unit) in parallel with each other and do not bundle them.</li> <li>Use shielded cables as signal cables and power cables and run them in individual metal conduits to produce further effects.</li> </ul>
(g)	<p>When the peripheral devices use the power system of the inverter or the converter unit, noises generated from the inverter or the converter unit may flow back through the power supply cables to cause malfunction of the devices and the following countermeasures must be taken:</p> <ul style="list-style-type: none"> <li>Set the EMC filter ON/OFF connector of the converter unit to the ON position. (Refer to <a href="#">page 65</a>.)</li> <li>Install the line noise filter to the power cables (output cables) of the inverter.</li> </ul>
(h)	<p>When a closed loop circuit is formed by connecting the peripheral device wiring to the inverter or the converter unit, leakage currents may flow through the earthing (grounding) cable of the inverter or the converter unit to cause the device to malfunction. In that case, disconnecting the earthing (grounding) cable from the device may stop the malfunction of the device.</p>



# Electro-magnetic interference (EMI) and leakage currents

## ●Data line filter

Data line filter is effective as an EMI countermeasure. Provide a data line filter for the detector cable, etc.

<Example> Data line filter : ZCAT3035-1330 (by TDK)  
 : ESD-SR-250 (by NEC TOKIN)  
 Impedance (ZCAT3035-1330)

Impedance (Ω)	
10 to 100 MHz	100 to 500 MHz
80	150

The impedance values above are reference values, and not guaranteed values.

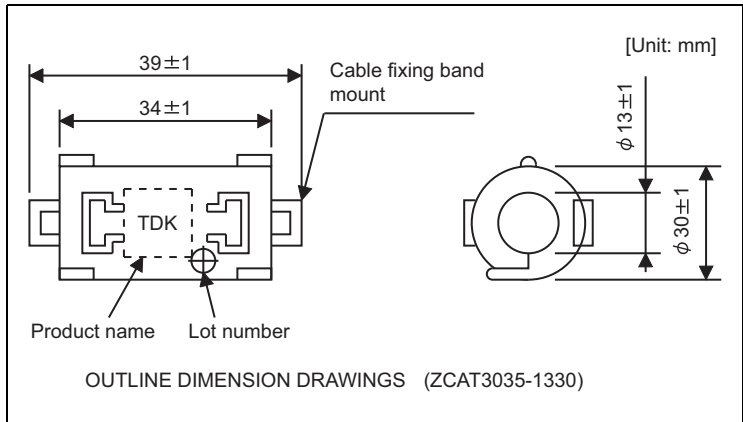

## ●EMI countermeasure example

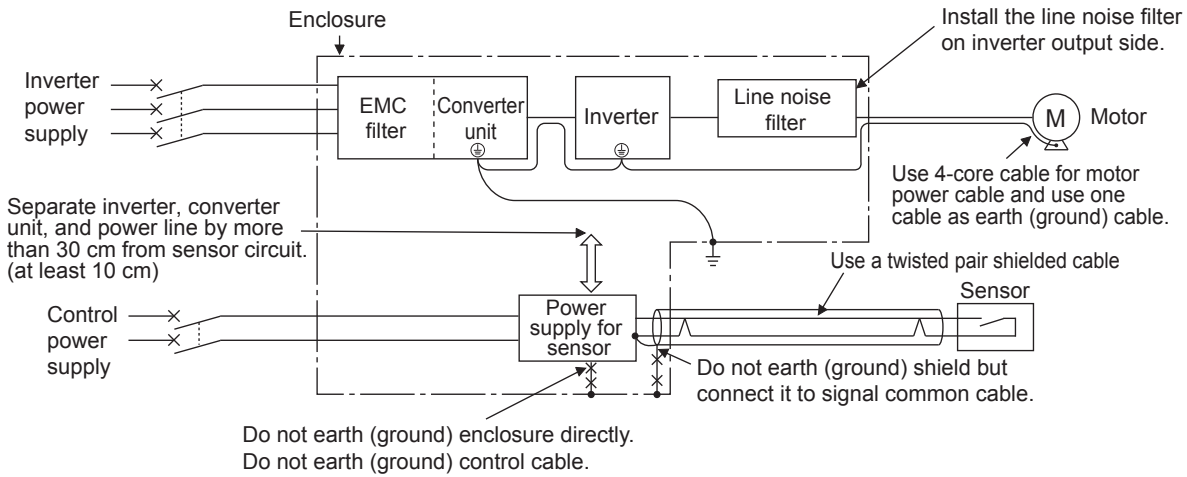

### NOTE

• For compliance with the EU EMC Directive, refer to [page 172](#).

### 3.1.3 Built-in EMC filter

The converter unit is equipped with a built-in EMC filter (capacitive filter).

The filter is effective in reducing air-propagated noise on the input side of the converter unit.

Two EMC filter ON/OFF connectors are provided. Both connectors are initially set to the "disabled" (OFF) position.

To enable the EMC filters, fit both of the EMC filter ON/OFF connectors to the "enabled" (ON) position.

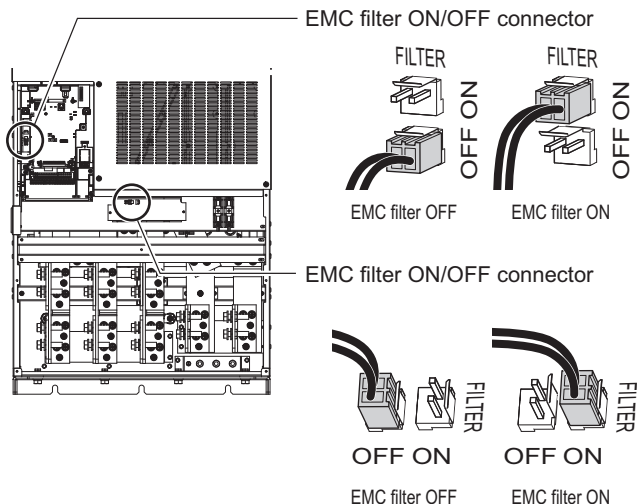

<Switching ON/OFF the filter>

- Before removing a front cover, check to make sure that the indication of the inverter operation panel is OFF, wait for at least 10 minutes after the power supply has been switched OFF, and check that there is no residual voltage using a tester or the like.
- When disconnecting the connector, push the fixing tab and pull the connector straight without pulling the cable or forcibly pulling the connector with the tab fixed.

When installing the connector, also engage the fixing tab securely.

(If it is difficult to disconnect the connector, use a pair of needle-nose pliers, etc.)

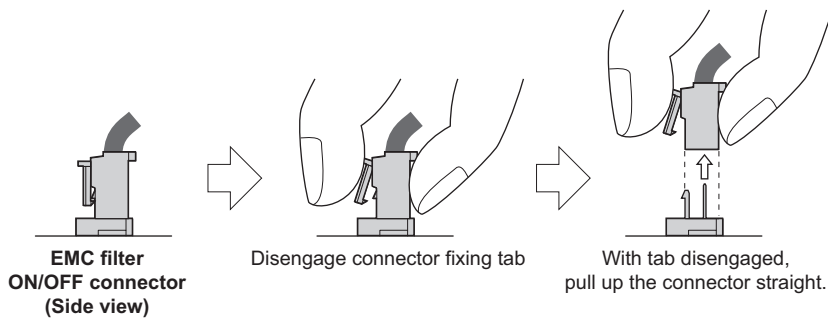

**NOTE**

- Fit the connector to either ON or OFF position.
- Enabling (turning ON) the EMC filter increases leakage current. (Refer to [page 61](#).)

**⚠ WARNING**

● While power is ON, do not open the front cover. Otherwise you may get an electric shock.

## 3.2 Power supply harmonics

### 3.2.1 Power supply harmonics

The inverter or the converter unit may generate power supply harmonics from its converter circuit to affect the power generator, power factor correction capacitor etc. Power supply harmonics are different from noise and leakage currents in source, frequency band and transmission path. Take the following countermeasure suppression techniques.

- The differences between harmonics and noises

Item	Harmonics	Noise
Frequency	Normally 40th to 50th degrees or less (3 kHz or less).	High frequency (several 10 kHz to 1 GHz order).
Environment	To-electric channel, power impedance.	To-space, distance, wiring path,
Quantitative understanding	Theoretical calculation possible.	Random occurrence, quantitative grasping difficult.
Generated amount	Nearly proportional to the load capacity.	Changes with the current variation ratio. (Gets larger as switching speed increases.)
Affected equipment immunity	Specified by standards per equipment.	Different depending on maker's equipment specifications.
Countermeasure	Provide a reactor.	Increase distance.

- Countermeasures

The harmonic current generated from the inverter or the converter unit to the input side differs according to various conditions such as the wiring impedance, whether a reactor is used or not, and output frequency and output current on the load side.

For the output frequency and output current, we understand that this should be calculated in the conditions under the rated load at the maximum operating frequency.

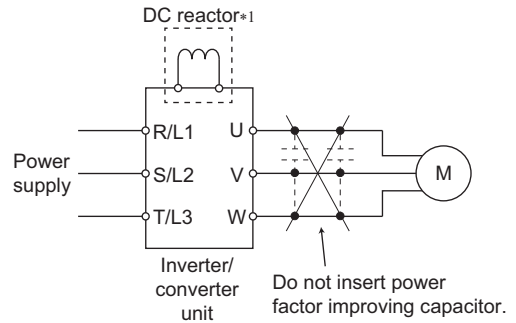

\*1 The converter unit is equipped with the DC reactor.

#### NOTE

- The power factor improving capacitor and surge suppressor on the inverter output side may be overheated or damaged by the harmonic components of the inverter output. Also, since an excessive current flows in the inverter to activate overcurrent protection, do not provide a capacitor and surge suppressor on the inverter output side when the motor is driven by the inverter.

### 3.2.2 Harmonic Suppression Guidelines

Harmonic currents flow from the inverter or the converter unit to a power receiving point via a power transformer. The Harmonic Suppression Guidelines was established to protect other consumers from these outgoing harmonic currents. The three-phase 200 V input specifications 3.7 kW or lower were previously covered by "the Harmonic Suppression Guidelines for Household Appliances and General-purpose Products" and other models were covered by "the Harmonic Suppression Guidelines for Consumers Who Receive High Voltage or Special High Voltage". However, the transistorized inverter has been excluded from the target products covered by "the Harmonic Suppression Guidelines for Household Appliances and General-purpose Products" in January 2004 and "the Harmonic Suppression Guideline for Household Appliances and General-purpose Products" was repealed on September 6, 2004.

All capacity and all models of general-purpose inverter used by specific consumers are now covered by "the Harmonic Suppression Guidelines for Consumers Who Receive High Voltage or Special High Voltage" (hereinafter referred to as "the Specific Consumer Guidelines").

- "Specific Consumer Guidelines"

This guideline sets forth the maximum harmonic currents outgoing from a high-voltage or especially high-voltage receiving consumer who will install, add or renew harmonic generating equipment. If any of the maximum values is exceeded, this guideline requires that consumer to take certain suppression measures.

- Maximum values of outgoing harmonic currents per 1 kW contract power

Received power voltage	5th	7th	11th	13th	17th	19th	23rd	Over 23rd
6.6 kV	3.5	2.5	1.6	1.3	1.0	0.9	0.76	0.70
22 kV	1.8	1.3	0.82	0.69	0.53	0.47	0.39	0.36
33 kV	1.2	0.86	0.55	0.46	0.35	0.32	0.26	0.24

#### ◆ Application of the specific consumer guidelines

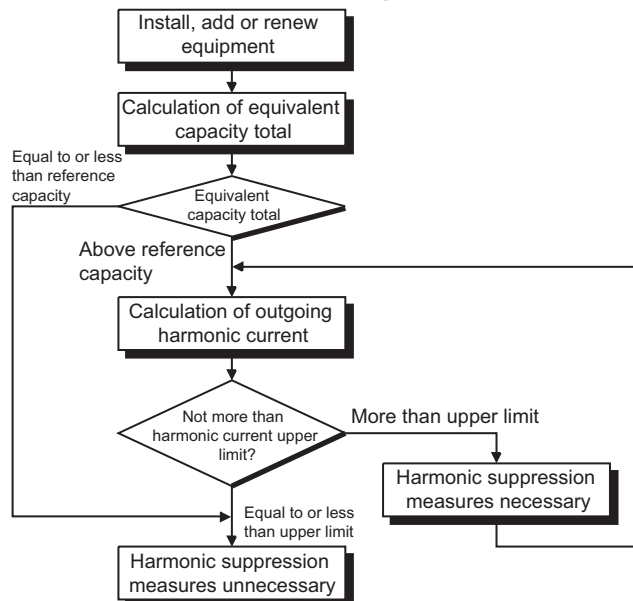

- Conversion factor for 6-phase rectification

Classification	Circuit type		Conversion coefficient Ki
3	Three-phase bridge (Capacitor smoothing)	With reactor (DC side)	K33 = 1.8

- Conversion factor for 12-phase rectification

Classification	Circuit type		Conversion coefficient Ki
3	Three-phase bridge (Capacitor smoothing)	12 Pulse converter With reactor (DC side)	K37 = 0.8



## Power supply harmonics

- Equivalent capacity limits

Received power voltage	Reference capacity
6.6 kV	50 kVA
22/33 kV	300 kVA
66 kV or more	2000 kVA

- Harmonic contents for 6-phase rectification (values of the fundamental current are 100%)

Reactor	5th	7th	11th	13th	17th	19th	23rd	25th
Used (DC side)	30	13	8.4	5.0	4.7	3.2	3.0	2.2

- Harmonic contents for 12-phase rectification (values of the fundamental current are 100%)

Reactor	5th	7th	11th	13th	17th	19th	23rd	25th
Used (DC side)	1.4	1.5	7.2	4.1	0.8	0.7	1.6	1.4

- Calculation of equivalent capacity P0 of harmonic generating equipment

"Equivalent capacity" is the capacity of a 6-pulse converter converted from the capacity of consumer's harmonic generating equipment and is calculated by the following equation: If the sum of equivalent capacities is higher than the limit (refer to [page 68](#)), harmonics must be calculated with the following procedure:

$$P0 = \sum (Ki \times Pi) \text{ [kVA]}$$

Ki: Conversion coefficient (Refer to [page 61](#).)

Pi: Rated capacity of harmonic generating equipment\*1 [kVA]

i: Number indicating the conversion circuit type

\*1 Rated capacity: Determined by the capacity of the applied motor and found in the table below. The rated capacity used here is used to calculate the generated harmonic amount and is different from the power supply capacity required for actual inverter drive.

- Calculation of outgoing harmonic current

Outgoing harmonic current = fundamental wave current (value converted from received power voltage) × operation ratio × harmonic content

- Operation ratio: Operation ratio = actual load factor × operation time ratio during 30 minutes
- Harmonic content: Found in [page 68](#)

- Rated capacities and outgoing harmonic currents for inverter drive

Applicable motor (kW)	Fundamental wave current (A)	Fundamental wave current converted from 6.6 kV (mA)	Rated capacity (kVA)	Outgoing harmonic current converted from 6.6 kV (mA) (With a DC reactor, 100% operation ratio)							
	400 V			5th	7th	11th	13th	17th	19th	23rd	25th
75	123	7455	87.2	2237	969	626	373	350	239	224	164
90	147	8909	104	2673	1158	748	445	419	285	267	196
110	179	10848	127	3254	1410	911	542	510	347	325	239
132	216	13091	153	3927	1702	1100	655	615	419	393	288
160	258	15636	183	4691	2033	1313	782	735	500	469	344
220	355	21515	252	6455	2797	1807	1076	1011	688	645	473
250	403	24424	286	7327	3175	2052	1221	1148	782	733	537
280	450	27273	319	8182	3545	2291	1364	1282	873	818	600
315	506	30667	359	9200	3987	2576	1533	1441	981	920	675
355	571	34606	405	10382	4499	2907	1730	1627	1107	1038	761
400	643	38970	456	11691	5066	3274	1949	1832	1247	1169	857
450	723	43818	512	13146	5696	3681	2191	2060	1402	1315	964
500	804	48727	570	14618	6335	4093	2436	2290	1559	1462	1072
560	900	54545	638	16364	7091	4582	2727	2564	1746	1636	1200
630	1013	61394	718	18418	7981	5157	3070	2886	1965	1842	1351

- Determining if a countermeasure is required

A countermeasure for harmonics is required if the following condition is satisfied: outgoing harmonic current > maximum value per 1 kW contract power × contract power.

- Harmonic suppression techniques

Item	Description
Reactor installation	With the DC reactor equipped on its DC side, the converter unit can suppress the outgoing harmonic current.

Item	Description
Installation of power factor improving capacitor	When used with a reactor connected in series, the power factor improving correction capacitor can absorb harmonic currents.
Transformer multi-phase operation	Use two transformers with a phase angle difference of 30° as in $\lambda$ - $\Delta$ and $\Delta$ - $\Delta$ combinations to provide an effect corresponding to 12 pulses, reducing low-degree harmonic currents.
Passive filter (AC filter)	A capacitor and a reactor are used together to reduce impedances at specific frequencies. Harmonic currents are expected to be absorbed greatly by using this technique.
Active filter (Active filter)	This filter detects the current in a circuit generating a harmonic current and generates a harmonic current equivalent to a difference between that current and a fundamental wave current to suppress the harmonic current at the detection point. Harmonic currents are expected to be absorbed greatly by using this technique.

### 3.3 Power-OFF and magnetic contactor (MC)

#### ◆ Converter unit input side magnetic contactor (MC)

On the converter unit input side, it is recommended to provide an MC for the following purposes:

(Refer to [page 13](#) for selection.)

- To disconnect the inverter from the power supply at activation of a protective function or at malfunctioning of the driving system (emergency stop, etc.).
- To prevent any accident due to an automatic restart at power restoration after an inverter stop made by a power failure.
- To separate the inverter from the power supply to ensure safe maintenance and inspection work.

If using an MC for emergency stop during operation, select an MC regarding the converter unit input side current as JEM1038-AC-3 class rated current.

#### NOTE

- Since repeated inrush currents at power ON will shorten the life of the converter circuit (switching life is about 1,000,000 times), frequent starts and stops of the magnetic contactor must be avoided. Turn ON/OFF the inverter start controlling terminals (STF, STR) to run/stop the inverter.
- Inverter start/stop circuit example

As shown below, always use the start signal (ON or OFF of the STF or STR signal) to make a start or stop.

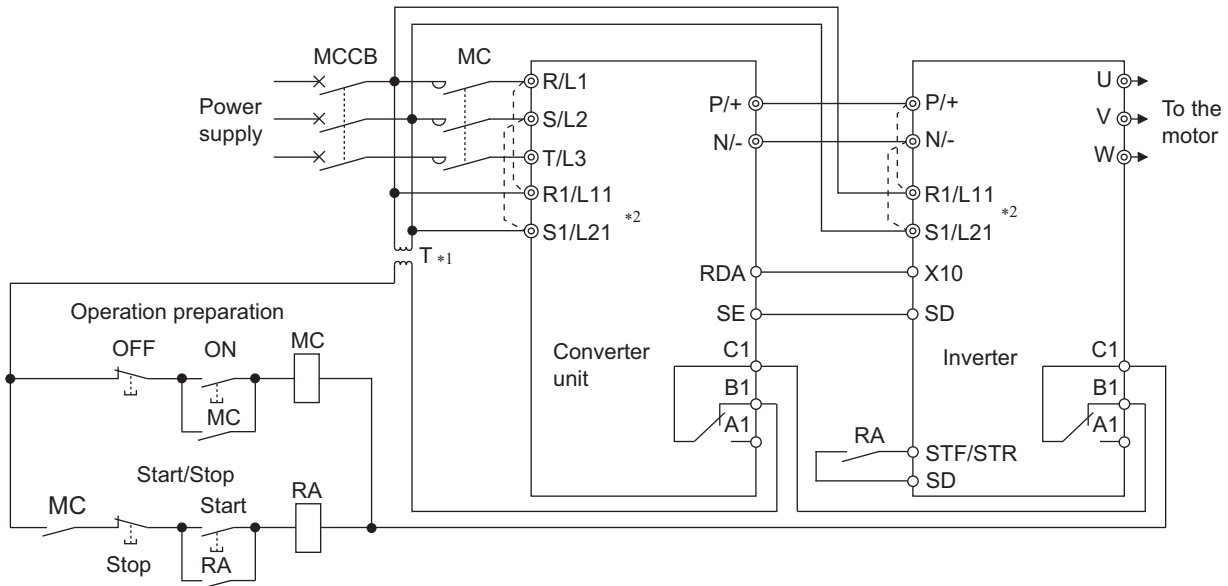

\*1 When the power supply is 400 V class, install a stepdown transformer.

\*2 Connect the power supply terminals R1/L11, S1/L21 of the control circuit to the input side of the MC to hold an alarm signal when the inverter's protective circuit is activated. At this time, remove jumpers across terminals R1/L11 and S1/L21. (Refer to [page 50](#) for removal of the jumper.)

#### ◆ Handling of the magnetic contactor on the inverter's output side

Switch the magnetic contactor between the inverter and motor only when both the inverter and motor are at a stop. When the magnetic contactor is turned ON while the inverter is operating, overcurrent protection of the inverter and such will activate.

When an MC is provided to switch to a commercial power supply, for example, it is recommended to use the commercial power supply-inverter switchover function **Pr.135 to Pr.139**. (The commercial power supply operation is not available with vector control dedicated motors.)

#### NOTE

- Do not open or close the contactor while the inverter is running (outputting).

## 3.4 Checklist before starting operation

The converter unit is a highly reliable product, but incorrect peripheral circuit making or operation/handling method may shorten the product life or damage the product.

Before starting operation, always recheck the following points.

Checkpoint	Countermeasure	Refer to page	Check by user
Crimp terminals are insulated.	Use crimp terminals with insulation sleeves to wire the power supply and the inverter.	—	
No wire offcuts are left from the time of wiring.	Wire offcuts can cause an alarm, failure or malfunction. Always keep the converter unit clean. When drilling mounting holes in an enclosure etc., take caution not to allow chips and other foreign matter to enter the converter unit.	—	
The main circuit cable gauge is correctly selected.	Use an appropriate cable gauge to suppress the voltage drop to 2% or less.	37	
The total wiring length is within the specified length.	Keep the total wiring length within the specified length. In long distance wiring, charging currents due to stray capacitance in the wiring may cause the equipment on the converter unit's output side to malfunction. Pay attention to the total wiring length.	37	
Countermeasures are taken against EMI.	The input/output (main circuit) of the converter unit includes high frequency components, which may interfere with the communication devices (such as AM radios) used near the converter unit. In such case, activate the EMC filter (turn ON the EMC filter ON/OFF connector) to minimize interference.	65	
When performing an inspection or rewiring on the product that has been energized, the operator has waited long enough after shutting off the power supply.	For a short time after the power-OFF, a high voltage remains in the smoothing capacitor, and it is dangerous. Before performing an inspection or rewiring, wait 10 minutes or longer after the power supply turns OFF, then confirm that the voltage across the main circuit terminals P/+ and N/- of the converter unit is low enough using a tester, etc.	—	
The voltage applied to the converter unit I/O signal circuits is within the specifications.	Application of a voltage higher than the permissible voltage to the converter unit I/O signal circuits or opposite polarity may damage the I/O devices. Check the wiring beforehand.	43	
A magnetic contactor (MC) is installed on the converter unit's input side.	On the converter unit's input side, connect an MC for the following purposes: • To disconnect the converter unit from the power supply at activation of a protective function or at malfunctioning of the driving system (emergency stop, etc.). • To prevent any accident due to an automatic restart at power restoration after an inverter stop made by a power failure. • To separate the converter unit from the power supply to ensure safe maintenance and inspection work. If using an MC for emergency stop during operation, select an MC regarding the converter unit input side current as JEM1038-AC-3 class rated current.	70	
The specifications and rating match the system requirements.	Make sure that the specifications and rating match the system requirements.	—	
The converter unit and the inverter are correctly connected.	• Make sure that terminal P/+ of the converter unit and terminal P/+ of the inverter, and terminal N/- of the converter unit and terminal N- of the inverter are correctly connected. Connecting the opposite polarity of terminals N/- and P/+ will damage the inverter. Also, do not install an MCCB across terminals P/+ and N/- (across terminals P and P/+ or across N and N/-). • Always connect terminal RDA of the master converter unit and terminal MRS (X10) of the master inverter, and terminal SE of the master converter unit and terminal SD (PC for source logic) of the master inverter. Not connecting these terminals may damage the converter unit.	34	
The RS-485 terminals are correctly connected.	Always connect wiring between the RS-485 terminals of the master/slave converter units. If the RS-485 communication is not performed correctly, the parallel operation cannot be made.	53	



# MEMO

---

# **4** **BASIC OPERATION**

---

This chapter explains the "BASIC OPERATION" of this product.  
Always read the instructions before using the equipment.

---

4.1	Operation panel.....	74
4.2	Monitoring the converter unit status .....	78

# 4.1 Operation panel

## 4.1.1 Components of the operation panel

Install the operation panel of the inverter on the converter unit.

To mount the operation panel on the enclosure surface, refer to [page 55](#).

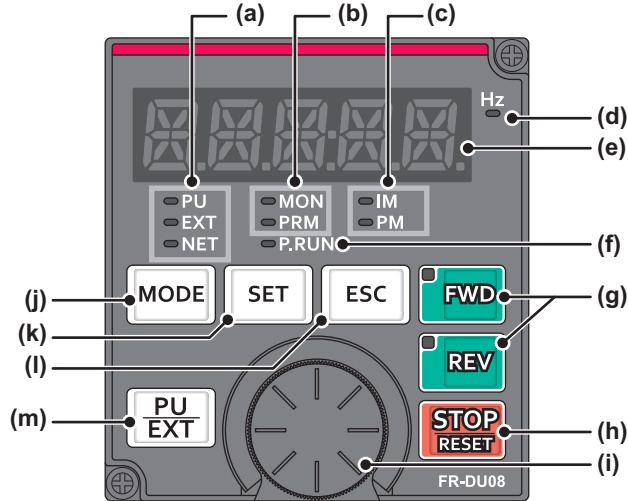

No.	Component	Name	Description
(a)		—	Not used.
(b)		Operation panel status indicator	MON: ON to indicate the monitor mode. Quickly blinks twice intermittently while the protective function is activated. Slowly blinks in the display-off mode. PRM: ON to indicate the parameter setting mode.
(c)		—	Not used.
(d)		—	Not used.
(e)		Monitor (5-digit LED)	Shows the monitored status, parameter number, etc. (Using <b>Pr.774</b> to <b>Pr.776</b> , the monitored item can be changed.)
(f)		—	Not used.
(g)		—	Not used.
(h)		STOP/RESET key	Resets the converter unit when the protective function is activated.
(i)		Setting dial	Changes the parameter settings. Press the setting dial to perform the following operations: · To display a monitored item set in <b>Pr.992</b> · To display a fault history number in the fault history mode
(j)		MODE key	Switches to different modes. Holding this key for 2 seconds locks the operation. The key lock is invalid when <b>Pr.161</b> = "0" (initial setting). (Refer to <a href="#">page 90</a> .)
(k)		SET key	Enters each setting. If pressed during the operation, monitored item changes as the following: (Using <b>Pr.774</b> to <b>Pr.776</b> , the monitored item can be changed.) When the initial setting is set <div style="display: flex; align-items: center; justify-content: center; gap: 10px;"> <div style="border: 1px solid black; padding: 2px;">Converter output voltage</div> <div style="font-size: 10px;">→</div> <div style="border: 1px solid black; padding: 2px;">Input current</div> <div style="font-size: 10px;">→</div> <div style="border: 1px solid black; padding: 2px;">Electric thermal relay function load factor</div> </div>
(l)		ESC key	Goes back to the previous display. Holding this key for a long time changes the mode back to the monitor mode.
(m)		—	Not used.

## 4.1.2 Basic operation of the operation panel

### ◆ Basic operation

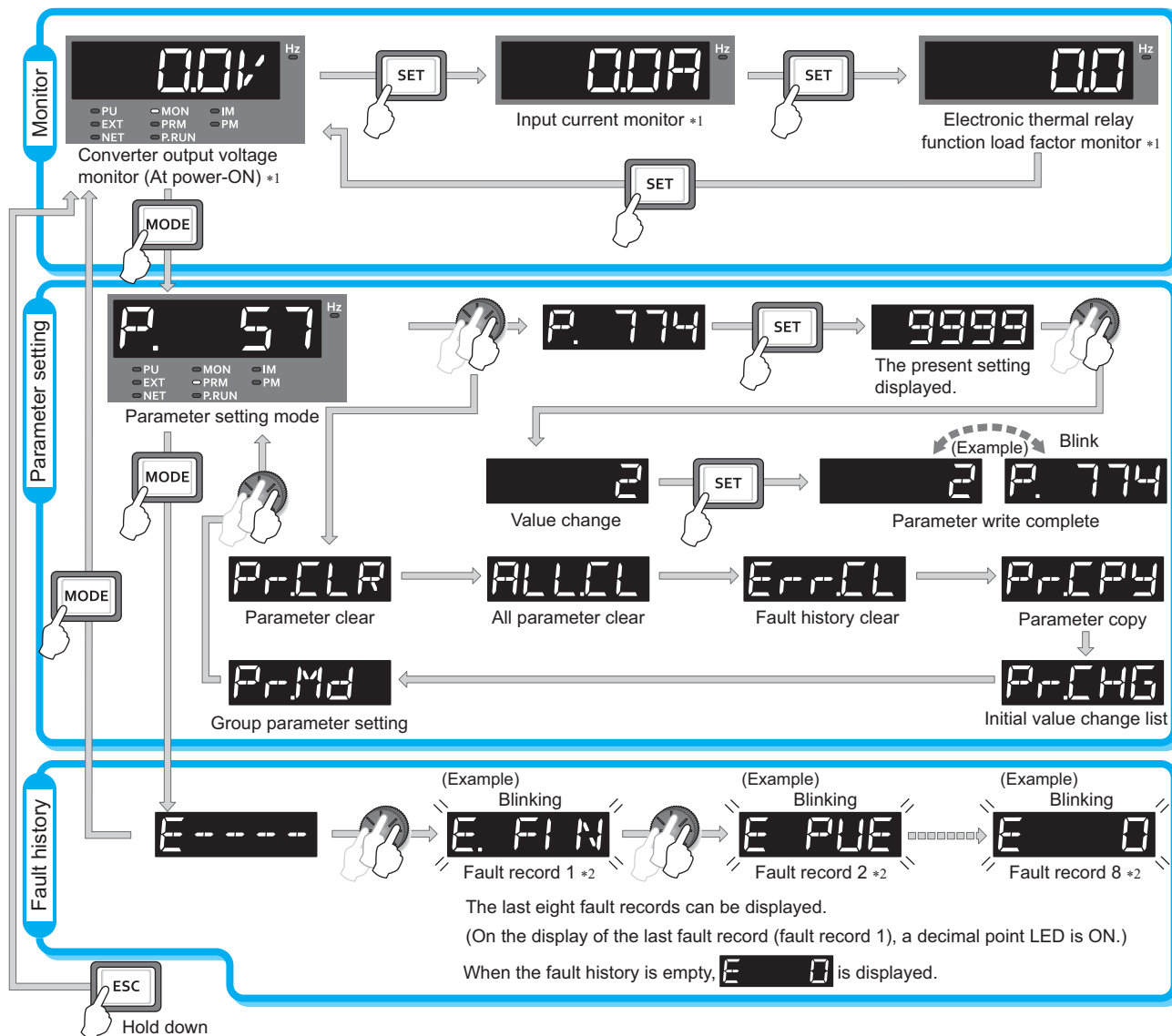

\*1 Monitored items can be changed. (Refer to page 101.)

\*2 For the details of fault history, refer to page 142.

### ◆Parameter setting mode

In the parameter setting mode, converter unit functions (parameters) are set. The following table explains the indications in the parameter setting mode.

Operation panel indication	Function name	Description	Refer to page
P.	Parameter setting mode	Under this mode, the set value of the displayed parameter number is read or changed.	77
PrCLR	Parameter clear	Clears and resets parameter settings to the initial values. However, parameters such as terminal function selection parameters are not cleared. For the details of the uncleared parameters, refer to <a href="#">page 170</a> .	131
ALLCL	All parameter clear	Clears and resets parameter settings to the initial values. Terminal function selection parameters are also cleared. For the details of the uncleared parameters, refer to <a href="#">page 170</a> .	131
ErrCL	Fault history clear	Deletes the fault history.	139
PrCPY	Parameter copy	Copies the parameter settings saved in the converter unit to the operation panel. The parameters copied to the operation panel can be also copied to other converter units.	132
PrCHG	Initial value change list	Identifies the parameters that have been changed from their initial settings.	135
PrMd	Group parameter setting	Displays parameter numbers by function groups.	83









## 4.1.3 Correspondences between digital and actual characters

There are the following correspondences between the actual alphanumeric characters and the digital characters displayed on the operation panel:

0	1	2	3	4	5	6	7	8	9	A	B(b)	C	c	D(d)
0	1	2	3	4	5	6	7	8	9	A	b	C	c	d
E(e)	F(f)	G(g)	H	h	I(i)	J(j)	K(k)	L(l)	M(m)	N	n	O	o	P(p)
E	F	G	H	h	I	J	K	L	M	N	n	O	o	P
Q(q)	R	r	S(s)	T(t)	U	u	V	v	W	w	X(x)	Y(y)	Z(z)	
Q	R	r	S	T	U	u	V	v	W	w	X	Y	Z	

## 4.1.4 Changing the parameter setting value

Changing example Change Pr.774 Operation panel monitor selection 1.

Operation	
1.	Screen at power-ON The monitor display appears.
2.	Parameter setting mode Press  to choose the parameter setting mode. (The parameter number read previously appears.)
3.	Selecting the parameter number Turn  until <b>P. 774 (Pr.774)</b> appears. Press  to read the present set value. "9999" (initial value) appears.
4.	Changing the setting value Turn  to change the set value to "2". Press  to enter the setting. "2" and "P. 774" blink alternately.  <ul style="list-style-type: none"> <li>·Turn  to read another parameter.</li> <li>·Press  to show the setting again.</li> <li>·Press  twice to show the next parameter.</li> <li>·Press  twice to return to the monitor display of the converter output voltage.</li> </ul>

### NOTE

- **Er 1** is displayed... Why?
  - **Er 1** appears... Write disable error
- For the details, refer to [page 142](#).

## 4.2 Monitoring the converter unit status

### 4.2.1 Monitoring of converter output voltage and input current

#### POINT

- Pressing  in the monitor mode switches the monitored item to converter output voltage, input current, and then to electronic thermal relay function load factor.

Operation	
1.	Press <input type="button" value="MODE"/> to monitor the converter output voltage. [V] appears.
2.	Press <input type="button" value="SET"/> to monitor the input current. [A] appears.
3.	Press <input type="button" value="SET"/> to monitor the electronic thermal relay function load factor.

#### NOTE

- Use Pr.774 to Pr.776 Operation panel monitor selection 1 to 3 to change the monitored items. (Refer to [page 101](#).)

### 4.2.2 First monitored item

The first monitored item to be displayed in the monitor mode is selectable.

To set a monitored item as the first monitored item, display a monitored item, and press  for a while.

Set the input current as the first monitored item.

Operation	
1.	Select the monitor mode, and select the input current.
2.	Press <input type="button" value="SET"/> for a while (1 s). The input current is set as the first monitored item.
3.	When the monitor mode is selected next time, the input current is monitored first.

#### NOTE

- Use Pr.774 Operation panel monitor selection 1 to change the monitored item. (Refer to [page 101](#).)

---

# **5** **PARAMETER**

---

**This chapter explains the function setting for use of this product.  
Always read the instructions before using the equipment.**

---



# 5.1 Parameter list

## 5.1.1 Parameter list (by parameter number)

- Set the necessary parameters to meet the load and operational specifications. Parameter setting, change and check can be performed from the operation panel. Install the operation panel of the inverter on the FR-CC2-P.
- The list of FR-CC2-P parameters (including the availability for the master and the slave) is as follows.
  - indicates the parameter in which all the settings are valid. △ indicates the parameter in which some settings are invalid. × indicates the parameter in which all the settings are invalid.

### NOTE

- Refer to Appendix 1 (page 170) for instruction codes for communication and availability of parameter clear, all clear, and parameter copy of each parameter.

Pr.	Pr. group	Name	Setting range	Minimum setting increments	Initial value	Master station	Slave station	Refer to page	Customer setting
30	E300	Reset selection during power supply to main circuit	0, 100	1	0	○	○	111	
57	A702	Restart selection	0, 9999	1	9999	○	○	113	
65	H300	Parameter for manufacturer setting. Do not set.							
67	H301	Number of retries at fault occurrence	0 to 10, 101 to 110	1	0	○	×	97	
68	H302	Parameter for manufacturer setting. Do not set.							
69	H303	Retry count display erase	0	1	0	○	×	97	
75	-	Reset selection/disconnected PU detection/reset limit	14 to 17, 114 to 117	1	14	○	○	88	
	E100	Reset selection	0, 1		0				
	E101	Disconnected PU detection							
	E107	Reset limit							
77	E400	Parameter write selection	1, 2	1	2			90	
117	N020	PU communication station number	0 to 31	1	0	○	○	118	
118	N021	PU communication speed	48, 96, 192, 384, 576, 768, 1152	1	192	○	○	118	
119	-	PU communication stop bit length / data length	0, 10	1	1	○	○	118	
	N022	PU communication data length	0, 1		0	○	○		
	N023	PU communication stop bit length	0, 1		1	○	○		
120	N024	PU communication parity check	0 to 2	1	2	○	○	118	
121	N025	Number of PU communication retries	0 to 10, 9999	1	1	○	○	118	
122	N026	PU communication check time interval	0, 0.1 to 999.8 s, 9999	0.1 s	9999	○	○	118	
123	N027	PU communication waiting time setting	0 to 150 ms, 9999	1 ms	9999	○	○	118	
124	N028	PU communication CR/LF selection	0 to 2	1	1	○	○	118	
161	E200	Key lock operation selection	0, 10	1	0	○	○	90	
168	E000	Parameter for manufacturer setting. Do not set.							
	E080								
169	E001								
	E081								
170	M020	Watt-hour meter clear	0, 10, 9999	1	9999	○	×	101	

Pr.	Pr. group	Name	Setting range	Minimum setting increments	Initial value	Master station	Slave station	Refer to page	Customer setting
178	T700	RDI terminal function selection	7, 62, 84, 9999	1	9999	○	○	109	
187	T709	OH terminal function selection		1	7	○	○	109	
189	T711	RES terminal function selection		1	62	○	○	109	
190	M400	RDB terminal function selection	2, 8, 11, 17, 25, 26, 64 to 66, 68, 90, 94, 95, 98, 99, 102, 108, 111, 125, 126, 164 to 166, 168, 190, 194, 195, 198, 199, 206, 207, 209, 210, 214, 227, 306, 307, 309, 310, 327, 9999	1	111	○	△	105	
191	M401	RDA terminal function selection		1	11	○	△	105	
192	M402	IPF terminal function selection		1	2	○	△	105	
193	M403	RSO terminal function selection		1	209	○	△	105	
194	M404	FAN terminal function selection		1	25	○	△	105	
195	M405	ABC1 terminal function selection		1	99	○	△	105	
248	A006	Self power management selection	0, 1, 2	1	0	○	×	111	
255	E700	Life alarm status display	(0 to 15)	1	0	○	○	93	
256	E701	Inrush current limit circuit life display	(0 to 100%)	1%	100%	○	○	93	
257	E702	Control circuit capacitor life display	(0 to 100%)	1%	100%	○	○	93	
261	A730	Power failure stop selection	0, 1, 2, 21, 22	1	0	○	○	114	
268	M022	Monitor decimal digits selection	0, 1, 9999	1	9999	○	○	101	
269	E023	Parameter for manufacturer setting. Do not set.							
290	M044	Monitor negative output selection	0, 2, 4, 6	1	0	○	○	101	
296	E410	Password lock level	0 to 3, 5, 6, 100 to 103, 105, 106, 9999	1	9999	○	○	91	
297	E411	Password lock/unlock	(0 to 5), 1000 to 9998, 9999	1	9999	○	○	91	
331	N030	Parameter for manufacturer setting. Do not set.							
332	N031								
333	N032								
	N033								
334	N034								
335	N035								
336	N036								
337	N037								
341	N038								
342	N001								
343	N080	Parameter for manufacturer setting. Do not set.							
503	E710	Maintenance timer 1	0 (1 to 9998)	1	0	○	○	95	
504	E711	Maintenance timer 1 warning output set time	0 to 9998, 9999	1	9999	○	○	95	
514	H324	Emergency drive dedicated retry waiting time	0.1 to 600, 9999	0.1s	9999	○	×	97	
515	H322	Emergency drive dedicated retry count	1 to 200, 9999	1	1	○	×	97	
523	H320	Emergency drive selection	100, 200, 9999	1	9999	○	×	97	
539	N002	Parameter for manufacturer setting. Do not set.							
549	N000								
563	M021	Energization time carrying-over times	(0 to 65535)	1	0	○	○	101	
598	H102	Undervoltage level	350 to 430 V, 9999	0.1 V	9999	○	○	96	
652	N092	Parallel operation communication check time	0, 0.1 to 120 s, 9999	0.1 s	1 s	○	○	56	

## Parameter list

### Parameter list (by parameter number)

Pr.	Pr. group	Name	Setting range	Minimum setting increments	Initial value	Master station	Slave station	Refer to page	Customer setting
663	M060	Control circuit temperature signal output level	0 to 100°C	1°C	0°C	○	○	108	
686	E712	Maintenance timer 2	0 (1 to 9998)	1	0	○	○	95	
687	E713	Maintenance timer 2 warning output set time	0 to 9998, 9999	1	9999	○	○	95	
688	E714	Maintenance timer 3	0 (1 to 9998)	1	0	○	○	95	
689	E715	Maintenance timer 3 warning output set time	0 to 9998, 9999	1	9999	○	○	95	
774	M101	Operation panel monitor selection 1	2, 8, 13, 20, 25, 43, 44, 55, 62, 68, 98, 9999	1	9999	○	×	101	
775	M102	Operation panel monitor selection 2		1	9999	○	△	101	
776	M103	Operation panel monitor selection 3		1	9999	○	△	101	
872	H201	Input phase loss protection selection	0, 1	1	1	○	○	97	
876	T723	OH input selection	0 to 2	1	0	○	○	110	
888	E420	Free parameter 1	0 to 9999	1	9999	○	○	93	
889	E421	Free parameter 2	0 to 9999	1	9999	○	○	93	
891	M023	Cumulative power monitor digit shifted times	0, 4, 9999	1	9999	○	○	101	
990	E104	PU buzzer control	0, 1	1	1	○	○	89	
992	M104	Operation panel setting dial push monitor selection	2, 8, 13, 20, 25, 43, 44, 55, 62, 98	1	8	○	△	101	
997	H103	Fault initiation	0 to 255, 9999	1	9999	○	○	96	
1001	E390	Parallel operation selection	1, 2, 100, 200, 300	1	100	○	○	56	
1006	E020	Clock (year)	2000 to 2099	1	2000	○	○	87	
1007	E021	Clock (month, day)	1/1 to 12/31	1	101	○	○	87	
1008	E022	Clock (hour, minute)	0:00 to 23:59	1	0	○	○	87	
1048	E106	Display-off waiting time	0 to 60 minutes	1 minutes	0	○	○	89	
	Pr.CLR	Parameter clear	(0), 1	1	0	○	○	131	
	ALL.CL	All parameter clear	(0), 1	1	0	○	○	131	
	Err.CL	Fault history clear	(0), 1	1	0	○	○	131	
	Pr.CPY	Parameter copy	(0), 1 to 3	1	0	○	○	132	
	Pr.CHG	Initial value change list	-	1	0	○	○	135	
	Pr.MD	Group parameter setting	(0), 1, 2	1	0	○	○	83	

## 5.1.2 Parameter display by function group

The monitor display can be changed to the parameter display by function group.

Parameter numbers are displayed by function group. The related parameters can be set easily.

### ◆ Changing to the grouped parameter numbers

Pr.MD setting value	Description
0	Default parameter display method
1	Parameter display by parameter number
2	Parameter display by function group

Operation	
1.	Screen at power-ON The monitor display appears.
2.	Parameter setting mode Press <b>MODE</b> to choose the parameter setting mode. (The parameter number read previously appears.)
3.	Selecting the parameter number Turn until <b>Pr.Md</b> (parameter display method) appears. Press <b>SET</b> . "0" (initial value) will appear.
4.	Changing to the group parameter display Turn to change the set value to "2" (Parameter display by function group). Press <b>SET</b> to select the parameter setting by function group "2" and "Pr.Md" blink alternately after the setting is completed.

### ◆ Changing parameter settings in the group parameter display

Changing example Change the **P.M101 (Pr.774) Operation panel monitor selection 1**.

Operation	
1.	Screen at power-ON The monitor display appears.
2.	Parameter setting mode Press <b>MODE</b> to choose the parameter setting mode. (The parameter number read previously appears.)
3.	Parameter group selection Press <b>PRD</b> several times until <b>ESC</b> appears. Parameter groups can now be selected.
4.	Parameter group selection Turn until <b>PM 1</b> (monitor parameter 1) appears. Press <b>SET</b> to display "PM 1--" and make the group parameters of the monitor parameter 1 selectable.
5.	Parameter selection Turn until <b>PM 10 1</b> ( <b>P.M101 Operation panel monitor selection 1</b> ) appears. Press <b>SET</b> to read the present set value. "9999" (initial value) appears.
6.	Changing the setting value Turn to change the set value to "2". Press <b>SET</b> to enter the setting. "2" and "PM 10 1" blink alternately after the setting is completed.

## 5.1.3 Parameter list (by function group)

### ◆(E) Environment setting parameters

Parameters that set the converter unit operation characteristics.

Pr. group	Pr.	Name	Refer to page
E000	168	Parameter for manufacturer setting. Do not set.	
E001	169		
E020	1006	Clock (year)	87
E021	1007	Clock (month, day)	87
E022	1008	Clock (hour, minute)	87
E023	269	Parameter for manufacturer setting. Do not set.	
E080	168		
E081	169		
E100	75	Reset selection	88
E101	75	Disconnected PU detection	88
E104	990	PU buzzer control	89
E106	1048	Display-off waiting time	89
E107	75	Reset limit	88
E200	161	Key lock operation selection	90
E300	30	Reset selection during power supply to main circuit	111
E390	1001	Parallel operation selection	56
E400	77	Parameter write selection	90
E410	296	Password lock level	91
E411	297	Password lock/unlock	91
E420	888	Free parameter 1	93
E421	889	Free parameter 2	93
E700	255	Life alarm status display	93
E701	256	Inrush current limit circuit life display	93
E702	257	Control circuit capacitor life display	93
E710	503	Maintenance timer 1	95
E711	504	Maintenance timer 1 warning output set time	95
E712	686	Maintenance timer 2	95
E713	687	Maintenance timer 2 warning output set time	95
E714	688	Maintenance timer 3	95
E715	689	Maintenance timer 3 warning output set time	95

### ◆(H) Protective function parameters

Parameters to protect the converter unit.

Pr. group	Pr.	Name	Refer to page
H102	598	Undervoltage level	96
H103	997	Fault initiation	96
H201	872	Input phase loss protection selection	97
H300	65	Parameter for manufacturer setting. Do not set.	
H301	67	Number of retries at fault occurrence	97
H302	68	Parameter for manufacturer setting. Do not set.	
H303	69	Retry count display erase	97
H320	523	Emergency drive selection	97
H322	515	Emergency drive dedicated retry waiting time	97
H324	514	Emergency drive dedicated retry waiting time	97

### ◆(M) Monitor display and monitor output signal

Parameters regarding the converter unit's operating status. These parameters are used to set the monitors and output signals.

Pr. group	Pr.	Name	Refer to page
M020	170	Watt-hour meter clear	101
M021	563	Energization time carrying-over times	101
M022	268	Monitor decimal digits selection	101
M023	891	Cumulative power monitor digit shifted times	101
M044	290	Monitor negative output selection	101
M060	663	Control circuit temperature signal output level	108
M101	774	Operation panel monitor selection 1	101
M102	775	Operation panel monitor selection 2	101
M103	776	Operation panel monitor selection 3	101
M104	992	Operation panel setting dial push monitor selection	101
M400	190	RDB terminal function selection	105
M401	191	RDA terminal function selection	105
M402	192	IPF terminal function selection	105
M403	193	RSO terminal function selection	105
M404	194	FAN terminal function selection	105
M405	195	ABC1 terminal function selection	105

### ◆(T) Multi-function input terminal parameters

Parameters for the input terminals where converter unit commands are received through.

Pr. group	Pr.	Name	Refer to page
T700	178	RDI terminal function selection	109
T709	187	OH terminal function selection	109
T711	189	RES terminal function selection	109
T723	876	OH input selection	109

### ◆(A) Application parameters

Parameters to set a specific application.

Pr. group	Pr.	Name	Refer to page
A006	248	Self power management selection	111
A702	57	Restart selection	113
A730	261	Power failure stop selection	114

### ◆(N) Operation via communication and its settings

Parameters for communication operation. These parameters set the communication specifications and operation.

Pr. group	Pr.	Name	Refer to page
N000	549	Parameter for manufacturer setting. Do not set.	
N001	342	Communication EEPROM write selection	117
N002	539	Parameter for manufacturer setting. Do not set.	
N020	117	PU communication station number	118
N021	118	PU communication speed	118
N022	119	PU communication data length	118
N023	119	PU communication stop bit length	118
N024	120	PU communication parity check	118
N025	121	Number of PU communication retries	118
N026	122	PU communication check time interval	118
N027	123	PU communication waiting time setting	118
N028	124	PU communication CR/LF selection	118
N030	331	Parameter for manufacturer setting. Do not set.	
N031	332		
N032	333		
N033	333		
N034	334		
N035	335		
N036	336		
N037	337		
N038	341		
N080	343		
N092	652	Parallel operation communication check time	56

## 5.2 (E) Environment setting parameters

Purpose	Parameter to set			Refer to page
To set the time	Simple clock function	P.E020 to P.E022	Pr.1006 to Pr.1008	87
To set a limit for the reset function. To shut off output if the operation panel disconnects.	Reset selection / disconnected PU detection / reset limit	P.E100, P.E101, P.E107	Pr.75	88
To control the buzzer of the operation panel	PU buzzer control	P.E104	Pr.990	89
To turn OFF the operation panel when not using it for a certain period of time	Display-off mode	P.E106	Pr.1048	89
To disable the operation panel.	Operation panel operation selection	P.E200	Pr.161	90
To set the master/slave for the parallel operation.	Parallel operation selection	P.E390	Pr.1001	56
To prevent parameter rewriting	Parameter write disable selection	P.E400	Pr.77	90
To restrict parameters with a password	Password function	P.E410, P.E411	Pr.296, Pr.297	91
To use parameters freely	Free parameter	P.E420, P.E421	Pr.888, Pr.889	93
To understand the maintenance time of converter unit parts and peripheral devices	Converter unit parts life display	P.E700 to P.E702	Pr.255 to Pr.257	93
	Maintenance output function	P.E710 to P.E715	Pr.503, Pr.504, Pr.686 to Pr.689	95

## 5.2.1 Simple clock function

The time can be set. The time can only be updated while the converter unit power is ON.

The real time clock function is enabled using an optional LCD operation panel (FR-LU08).

Pr.	Name	Initial value	Setting range	Description
<b>1006</b> <b>E020</b>	<b>Clock (year)</b>	2000	2000 to 2099	Set the year.
<b>1007</b> <b>E021</b>	<b>Clock (month, day)</b>	101 (January 1)	101 to 131, 201 to 228, (229), 301 to 331, 401 to 430, 501 to 531, 601 to 630, 701 to 731, 801 to 831, 901 to 930, 1001 to 1031, 1101 to 1130, 1201 to 1231	Set the month and day. 1000 and 100 digits: January to December 10 and 1 digits: 1 to the end of month (28, 29, 30 or 31) For December 31, set "1231".
<b>1008</b> <b>E022</b>	<b>Clock (hour, minute)</b>	0 (00:00)	0 to 59, 100 to 159, 200 to 259, 300 to 359, 400 to 459, 500 to 559, 600 to 659, 700 to 759, 800 to 859, 900 to 959, 1000 to 1059, 1100 to 1159, 1200 to 1259, 1300 to 1359, 1400 to 1459, 1500 to 1559, 1600 to 1659, 1700 to 1759, 1800 to 1859, 1900 to 1959, 2000 to 2059, 2100 to 2159, 2200 to 2259, 2300 to 2359	Set the hour and minute using the 24-hour clock. 1000 and 100 digits: 0 to 23 hours 10 and 1 digits: 0 to 59 minutes For 23:59, set "2359".

- When the year, month, day, time and minute are set in **Pr.1006 to Pr.1008**, the converter unit counts the date and time. The date and time can be checked by reading **Pr.1006 to Pr.1008**.

### NOTE

- The clock's count-up data is saved in the converter unit's EEPROM every 10 minutes.
- The clock does not count up while the control circuit power supply is OFF. The clock function must be reset after turning ON the power supply. Use a separate power supply, such as an external 24 V power supply, for the control circuit of the simple clock function, and supply power continuously to this control circuit.
- Converter reset is performed if supplying power to the main circuit power supply is started with power supplied only to the control circuit power supply. Thus, the clock information stored in the EEPROM is restored. Reset at the start of supplying power to the main circuit can be disabled by setting **Pr.30 Reset selection during power supply to main circuit**. (Refer to [page 111](#))
- The date set in **Pr.1006 to Pr.1008** is also used for the function in the fault history (refer to [page 139](#)), etc.



## 5.2.2 Reset selection / disconnected PU detection / reset limit

The reset input acceptance, the disconnected operation panel connector detection function, and the reset limit function can be selected.

Pr.	Name	Initial value	Setting range	Description
75	Reset selection/disconnected PU detection/reset limit	14	14 to 17, 114 to 117	For the initial setting, reset is always enabled, PU disconnection is not detected, and the reset limit function is disabled.
E100	Reset selection	0	0	Reset input is always enabled.
			1	Reset input is enabled only when the protective function is activated.
E101	Disconnected PU detection	0	0	Operation continues even when the operation panel is disconnected.
			1	The inverter output is shut off when the operation panel is disconnected.
E107	Reset limit	0	0	Reset limit is disabled.
			1	Reset limit is enabled.

The parameters above will not return to their initial values even if parameter (all) clear is executed.

Pr.75 Setting value	Reset selection	Disconnected PU detection	Reset limit function
14 (initial value)	Reset input always enabled	Operation continues even when the operation panel is disconnected.	Invalid
15	Reset input enabled only when the protective function activated.		
16	Reset input always enabled		
17	Reset input enabled only when the protective function activated.	The inverter output is shut off when the operation panel is disconnected.	Enabled
114	Reset input always enabled	Operation continues even when the operation panel is disconnected.	
115	Reset input enabled only when the protective function activated.		
116	Reset input always enabled	The inverter output is shut off when the operation panel is disconnected.	
117	Reset input enabled only when the protective function activated.		

### ◆ Reset selection (P.E100)

- When P.E100 = "1" or Pr.75 = "15, 17, 115, or 117", reset (reset command via RES signal or communication) input is enabled only when the protective function is activated.

#### NOTE

- When the reset signal (RES) is input during operation, the inverter is also reset. The motor coasts since the inverter being reset shuts off the output. Also, the cumulative value of electronic thermal O/L relay is cleared.
- The input of the operation panel reset key is only enabled when the protective function is activated, regardless of the P.E100 and Pr.75 settings.

### ◆ Disconnected PU detection (P.E101)

- If the converter unit detects that the operation panel has been disconnected for 1 s or longer while P.E101 = "1" or Pr.75 = "16, 17, 116 or 117", the protective function (E.PUE) is activated and the inverter output is shut off.

#### NOTE

- If the operation panel is disconnected before power-ON, the output is not shut off.
- To restart, confirm that the operation panel is connected and then reset the converter unit.
- When RS-485 communication operation is performed through the PU connector, the reset selection is valid but the disconnected PU detection function is invalid. (The communication is checked according to Pr.122 PU communication check time interval.)

### ◆ Reset limit function (P.E107)

- Setting **P.E107="1"** or **Pr.75 = any of "114 to 117"** will make the inverter to refuse any reset operation (RES signal, etc.) for 3 minutes after the first activation of an electronic thermal function (E.THC).

#### NOTE

- Resetting the converter unit power (turning OFF the control power) will clear the accumulated thermal value.

### ⚠ CAUTION

- Do not perform a reset while an inverter start signal is being input. Doing so will cause a sudden start of the motor, which is dangerous.

## 5.2.3 Buzzer control

The buzzer can be set to "beep" when the keys of the operation panel are operated.

Pr.	Name	Initial value	Setting range	Description
990 E104	PU buzzer control	1	0	Without buzzer
			1	With buzzer

#### NOTE

- When with buzzer is set, the buzzer sounds if a converter unit fault occurs.

## 5.2.4 Display-off mode

The LED of the operation panel can be turned OFF when it has not been used for a certain period of time.



Pr.	Name	Initial value	Setting range	Description
1048 E106	Display-off waiting time	0	0	Display-off mode is disabled.
			1 to 60 minutes	Set time until the LED of the operation panel is turned OFF.

- If the operation panel has not been operated for the time set in **Pr.1048**, the display-off mode is enabled and its LED is turned OFF.
- In the display-off mode, the "MON" LED blinks slowly.
- The count to display off is reset to "0" to restart at installation/removal of the operation panel, power-ON/OFF of the converter unit, or converter reset.
- Display-off mode end condition
  - Operation of the operation panel
  - Occurrence of a warning, alarm, or fault
  - Installation/removal of the operation panel, power-ON/OFF of the converter unit, or converter reset

## 5.2.5 Setting dial key lock operation selection

The key operation of the operation panel can be disabled.

Pr.	Name	Initial value	Setting range	Description
161 E200	Key lock operation selection	0	0	Key lock mode disabled
			10	Key lock mode enabled

- Operation using the setting dial and keys of the operation panel can be disabled to prevent unexpected parameter changes.
- Set **Pr.161** to "10" and then press  for 2 s to disable setting dial or key operations.
- When setting dial and key operations are disabled, *HOLD* appears on the operation panel. If setting dial or key operation is attempted while dial and key operations are disabled, *HOLD* appears. (When a setting dial or key operation is not performed for 2 s, the monitor display appears.)
- To enable the setting dial and key operation again, press  for 2 s.

### NOTE

- Even if setting dial and key operations are disabled, the monitor indicator and  are enabled.

## 5.2.6 Parameter write selection

Whether to enable the writing to various parameters or not can be selected. Use this function to prevent parameter values from being rewritten by misoperation.

Pr.	Name	Initial value	Setting range	Description
77 E400	Parameter write selection	2	1	Parameter writing is disabled.
			2	Parameter writing is enabled.

- **Pr.77** can be set at any time. (Setting through communication is unavailable.)

### ◆ Disabling parameter write (Pr.77 = "1")

- Parameter write, parameter clear and all parameter clear are disabled. (Parameter read is enabled.)
- The following parameters can be written even if **Pr.77** = "1".

Pr.	Name
75	Reset selection/disconnected PU detection/ reset limit
77	Parameter write selection
296	Password lock level
297	Password lock/unlock
997	Fault initiation

### ◆ Writing parameters (Pr.77 = "2")

- These parameters can always be written.

## 5.2.7 Password function

Registering a 4-digit password can restrict parameter reading/writing.

Pr.	Name	Initial value	Setting range	Description
296 E410	Password lock level	9999	0 to 3, 5, 6, 100 to 103, 105, 106	Select restriction level of parameter reading/writing when a password is registered.
			9999	No password lock
297 E411	Password lock/unlock	9999	1000 to 9998	Register a 4-digit password.
			(0 to 5) *1	Displays password unlock error count. (Reading only) (Valid when Pr.296 = "100 to 103, 105 or 106")
			9999 *1	No password lock

\*1 When Pr.297 = "0, 9999", writing is always enabled, but setting is disabled. (The display cannot be changed.)

### ◆Parameter reading/writing restriction level (Pr.296)

- The level of the reading/writing restriction using the operation panel or via RS-485 communication can be selected with Pr.296.

Pr.296 setting	Operation panel		RS-485 communication	
	Read	Write*1	Read	Write*1
9999	○	○	○	○
0, 100	×	×	×	×
1, 101	○	×	○	×
2, 102	○	×	○	○
3, 103	○	○	○	×
5, 105	×	×	○	○
6, 106	○	○	×	×

○: Enabled, ×: Disabled

\*1 If the parameter writing is restricted by the Pr.77 Parameter write selection setting, those parameters are unavailable for writing even when "○" is indicated.

### ◆Registering a password (Pr.296, Pr.297)

- The following section describes how to register a password.
  - Set the parameter reading/writing restriction level. (Pr.296 ≠ "9999")

Pr.296 setting	Password unlock error restriction	Pr.297 display
0 to 3, 5, 6	No restriction	Always displays 0
100 to 103, 105, 106*1	Restricted at fifth error	Displays the error count (0 to 5)

\*1 During Pr.296 = any of "100 to 103, 105 or 106", if password unlock error has occurred five times, correct password will not unlock the restriction. All parameter clear can unlock the restriction. (In this case, the parameters are returned to their initial values.)

- Write a four-digit number (1000 to 9998) to Pr.297 as a password. Writing is disabled when Pr.296 = "9999".) When a password is registered, parameter reading/writing is restricted with the restriction level set in Pr.296 until unlocking.

#### NOTE

- After registering a password, the read value of Pr.297 is always one of "0" to "5".
- LOCd appears when a password restricted parameter is read/written.
- Even if a password is registered, the parameters, which the converter unit itself writes, such as converter unit parts life are overwritten as needed.

## (E) Environment setting parameters

### ◆ Unlocking a password (Pr.296, Pr.297)

- There are two ways of unlocking the password.
- Enter the password in **Pr.297**. If the password matches, it unlocks. If the password does not match, an error occurs and the password does not unlock. During **Pr.296** = any of "100 to 103, 105 or 106", if password unlock error has occurred five times, correct password will not unlock the restriction. (Password lock in operation.)
- Perform all parameter clear.

#### NOTE

- If the password is forgotten, it can be unlocked with all parameter clear, but doing so will also clear the other parameters.
- All parameter clear cannot be performed during the operation.
- For the all parameter clear method, refer to the following.  
(For the operation panel, refer to [page 131](#) for the Mitsubishi inverter protocol of RS-485 communication, refer to [page 119](#).)

### ◆ Parameter operations during password locking/unlocking

Operation		Password unlocked		Password locked	Password lock in operation
		Pr.296 = 9999 Pr.297 = 9999	Pr.296 ≠ 9999 Pr.297 = 9999	Pr.296 ≠ 9999 Pr.297 = 0 to 4 (read value)	Pr.296 = 100 to 103, 105, 106 Pr.297 = 5 (read value)
Pr.296	Read	○	○	○	○
	Write	○	○	×	×
Pr.297	Read	○	○	○	○
	Write	×	○	○	○*1
Parameter clear execution		○	○	×	×
All parameter clear execution		○	○	○	○
Parameter copy execution		○	○	×	×

○: Enabled, ×: Disabled

\*1 Correct password will not unlock the restriction.

#### NOTE

- When the password is being locked, parameter copy using the operation panel is not enabled.

#### ◀ Parameters referred to ▶

Pr.77 Parameter write selection  [page 90](#)

## 5.2.8 Free parameter

Any number within the setting range of 0 to 9999 can be input.

For example, these numbers can be used:

- As a unit number when multiple units are used.
- As a pattern number for each operation application when multiple units are used.
- As the year and month of introduction or inspection.

Pr.	Name	Initial value	Setting range	Description
888 E420	Free parameter 1	9999	0 to 9999	Any value can be input. The settings are retained even if the converter unit power is turned OFF.
889 E421	Free parameter 2	9999	0 to 9999	

### NOTE

- Pr.888 and Pr.889 do not influence the operation of the converter unit.

## 5.2.9 Converter unit parts life display

The degree of deterioration of the control circuit capacitor, cooling fan, and inrush current limit circuit can be diagnosed on the monitor.

When a part approaches the end of its life, an alarm can be output by self diagnosis to prevent a fault.

(Note that the life diagnosis of this function should be used as a guideline only, because the life values are theoretical calculations.)

Pr.	Name	Initial value	Setting range	Description
255 E700	Life alarm status display	0	(0 to 15)	Displays whether or not the parts of the control circuit capacitor, cooling fan, and inrush current limit circuit have reached the life alarm output level. Read-only.
256 E701	Inrush current limit circuit life display	100%	(0 to 100%)	Displays the deterioration degree of the inrush current limit circuit. Read-only.
257 E702	Control circuit capacitor life display	100%	(0 to 100%)	Displays the deterioration degree of the control circuit capacitor. Read-only.

## (E) Environment setting parameters

### ◆ Life alarm display and signal output (Y90 signal, Pr.255)

- Whether or not the parts of the control circuit capacitor, cooling fan, or inrush current limit circuit have reached the life alarm output level can be checked with **Pr.255 Life alarm status display** and the life alarm signal (Y90).

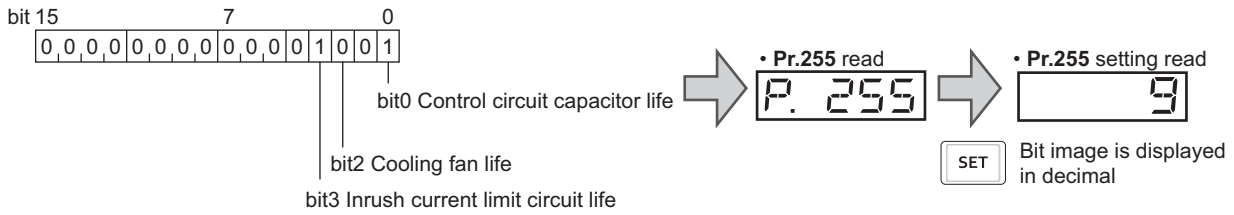

Pr.255		bit 3	bit 2	bit 0
Decimal	Binary			
13	1101	○	○	○
12	1100	○	○	×
9	1001	○	×	○
8	1000	○	×	×
5	0101	×	○	○
4	0100	×	○	×
1	0001	×	×	○
0	0000	×	×	×

○: With warnings, ×: Without warnings

- The life alarm signal (Y90) turns ON when any of the control circuit capacitor, cooling fan, or inrush current limit circuit reaches the life alarm output level.
- For the terminal used for the Y90 signal, set "90" (positive logic) or "190" (negative logic) in any of **Pr.190 to Pr.195 (Output terminal function selection)**.

#### NOTE

- Changing the terminal assignment using **Pr.190 and Pr.195 (Output terminal function selection)** may affect the other functions. Set parameters after confirming the function of each terminal.

### ◆ Life display of the inrush current limit circuit (Pr.256)

- The life of the inrush current limit circuit (relay, contactor and inrush resistor) is displayed in **Pr.256**.
- The number of contact (relay, contactor, thyristor) ON times is counted, and it is counted down from 100% (0 time) every 1%/10,000 times. As soon as 10% (900,000 times) is reached, **Pr.255** bit 3 is turned ON and also a warning is output to the Y90 signal.

### ◆ Life display of the control circuit capacitor (Pr.257)

- The deterioration degree of the control circuit capacitor is displayed in **Pr.257**.
- In the operating status, the control circuit capacitor life is calculated from the energization time and temperature, and is counted down from 100%. As soon as the control circuit capacitor life falls below 10%, **Pr.255** bit 0 is turned ON and also a warning is output to the Y90 signal

### ◆ Life display of the cooling fan

- If a cooling fan speed of less than about 1700 r/min is detected, Fan alarm  $FN$  (FN) is displayed on the operation panel. As an alarm display, **Pr.255** bit 2 is turned ON and also a warning is output to the Y90 signal and Alarm (LF) signal.
- For the terminal used for the LF signal, set "98" (positive logic) or "198" (negative logic) in any of **Pr.190 to Pr.195 (Output terminal function selection)**.

#### NOTE

- When the converter unit is mounted with two or more cooling fans, "FN" is displayed with one or more fans with the speed below the warning level.
- Changing the terminal assignment using **Pr.190 to Pr.195 (Output terminal function selection)** may affect the other functions. Set parameters after confirming the function of each terminal.
- For replacement of each part, contact the nearest Mitsubishi FA center.

## 5.2.10 Maintenance timer alarm

The maintenance timer output signal (Y95) is output when the converter unit's cumulative energization time reaches the time period set with the parameter. MT1, MT2 or MT3 is displayed on the operation panel.

This can be used as a guideline for the maintenance time of peripheral devices.

Pr.	Name	Initial value	Setting range	Description
503 E710	Maintenance timer 1	0	0 (1 to 9998)	Displays the converter unit's cumulative energization time in increments of 100 h (read-only). Writing the setting of "0" clears the cumulative energization time while <b>Pr.503</b> = "1 to 9998". (Writing is disabled when <b>Pr.503</b> = "0".)
504 E711	Maintenance timer 1 warning output set time	9999	0 to 9998	Set the time until the maintenance timer signal (Y95) is output. MT1 is displayed on the operation panel.
			9999	No function
686 E712	Maintenance timer 2	0	0 (1 to 9998)	The same function as <b>Pr.503</b> .
687 E713	Maintenance timer 2 warning output set time	9999	0 to 9998	The same function as <b>Pr.504</b> . MT2 is displayed on the operation panel.
			9999	
688 E714	Maintenance timer 3	0	0 (1 to 9998)	The same function as <b>Pr.503</b> .
689 E715	Maintenance timer 3 warning output set time	9999	0 to 9998	The same function as <b>Pr.504</b> . MT3 is displayed on the operation panel.
			9999	

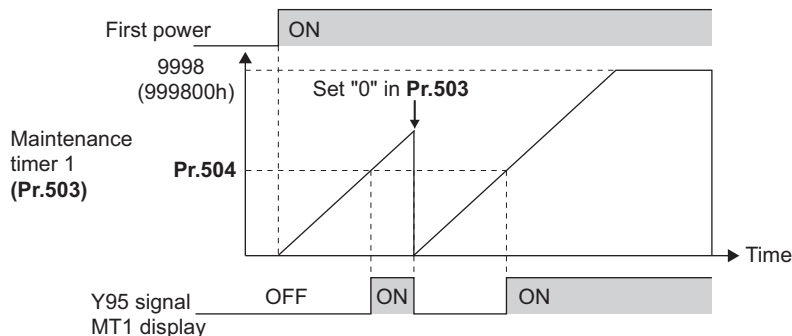

Operation example of the maintenance timer 1 (**Pr.503**, **Pr.504**) (with both MT2 and MT3 OFF)

- The cumulative energization time of the converter unit is stored in the EEPROM every hour and displayed in **Pr.503** (**Pr.686**, **Pr.688**) in 100 h increments. **Pr.503** (**Pr.686**, **Pr.688**) is clamped at 9998 (999800 h).
- When the value in **Pr.503** (**Pr.686**, **Pr.688**) reaches the time (100 h increments) set in **Pr.504** (**Pr.687**, **Pr.689**), Maintenance timer signal (Y95) is output, and also  $M1$  (MT1),  $M2$  (MT2), or  $M3$  (MT3) is displayed on the operation panel.
- For the terminal used for Y95 signal output, assign the function by setting "95 (positive logic)" or "195 (negative logic)" in any of **Pr.190 to Pr.195** (**Output terminal function selection**).

### NOTE

- The Y95 signal turns ON when any of MT1, MT2 or MT3 is activated. It does not turn OFF unless all of MT1, MT2 and MT3 are cleared.
- If all of MT1, MT2 and MT3 are activated, they are displayed in the priority of "MT1 > MT2 > MT3".
- The cumulative energization time is counted every hour. Energization time of less than 1 h is not counted.
- Changing the terminal assignment using **Pr.190 to Pr.195** (**Output terminal function selection**) may affect the other functions. Set parameters after confirming the function of each terminal.

### Parameters referred to

**Pr.190 to Pr.195** (**Output terminal function selection**) [page 105](#)



## 5.3 (H) Protective function parameter

Purpose	Parameter to set			Refer to page
To vary the operating level of the undervoltage protective function	Undervoltage level	P.H102	Pr.598	96
To initiate an inverter protective function	Fault initiation	P.H103	Pr.997	96
To disable the I/O phase loss protective function	Input phase loss protection selection	P.H201	Pr.872	97
To operate without activating protective functions in case of emergency	Emergency drive	P.H301, P.H320, P.H322, P.H324	Pr.67, Pr.514 Pr.515, Pr.523	97

### 5.3.1 Varying the activation level of the undervoltage protective function

If the undervoltage protection (E.UVT) is activated due to unstable voltage in the power supply, the undervoltage level (DC bus voltage value) can be changed.

Pr.	Name	Initial value	Setting range	Description
598 H102	Undervoltage level	9999	350 to 430 VDC	Set the DC voltage value at which E.UVT occurs.
			9999	E.UVT occurs at 430 VDC.

### 5.3.2 Initiating a protective function

A fault (protective function) is initiated by setting the parameter.

This function is useful to check how the system operates at activation of a protective function.

Pr.	Name	Initial value	Setting range	Description
997 H103	Fault initiation	9999	16 to 253	The setting range is same with the one for fault data codes of the converter unit (which can be read through communication). Written data is not stored in EEPROM.
			9999	The read value is always "9999". With this setting, the protective function is not activated.

- To initiate a fault (protective function), set the assigned number of the protective function you want to initiate in **Pr.997**.
- The value set in **Pr.997** is not stored in EEPROM.
- When the protective function is activated, the inverter output is shut off and the converter unit displays a fault to output a Fault (ALM, ALM2) signal.
- The latest fault in the fault history is displayed while the fault initiation function is in operation. After a reset, the fault history goes back to the previous status. (The protective function generated by the fault is not saved in the fault history.)
- Perform converter reset to cancel the protective function.
- For the selectable parameter by **Pr.997** and the corresponding protective functions, refer to [page 141](#).

#### NOTE

- If a protective function is already operating, no protective function cannot be initiated by **Pr.997**.
- If a fault occurs after a protective function has been activated, the protective function indication does not change. The fault is not saved in the fault history either.

### 5.3.3 Input phase loss protection selection

The input phase loss protective function on the converter unit input side (R/L1, S/L2, T/L3) can be enabled or disabled.

Pr.	Name	Initial value	Setting range	Description
872 H201	Input phase loss protection selection	1	0	Without input phase loss protection
			1	With input phase loss protection

- When Pr.872 = "1 (initial value)", the Input phase loss (E.ILF) protection will be activated if one of three phases is detected continuously lost for 1 second.

#### NOTE

- In the case of R/L1, S/L2 phase loss, the input phase loss protection will not operate, and the inverter will trip.
- If an input phase loss continues for a long time, the converter unit capacitor life will be shorter.

### 5.3.4 Emergency drive

This function is used in case of emergency such as a fire to forcibly continue inverter operation to drive a motor without activating protective functions even if the inverter detects a fault. Using this function may cause damage of the motor or the inverter because driving the motor is given the highest priority. Use this function for emergency operation only. When the inverter is damaged by a fault, the motor operation can be continued by switching to the commercial power supply operation. The emergency drive function is available only when the function is set in the master inverter. To enable the emergency drive function, the function must be set in both the master inverter (FR-802-P) and the master converter unit.

By setting the emergency drive function in the inverter, the operation can be switched to the commercial power supply operation at the occurrence of a fault which may cause damage of the converter unit or the inverter. The inverter does not detect faults in the converter unit. When faults occur frequently in the converter unit, modify the wiring to enable switchover to the commercial power supply operation using a programmable controller.

Pr.	Name	Initial value	Setting range	Description
67 H301*1	Input phase loss protection selection	0	0 to 10, 101 to 110	Select whether to output the Fault (ALM) signal during the retry operation while the emergency drive operation is performed. 0 to 10: The ALM signal is not output during retry. 101 to 110: The ALM signal is output during retry.
69 H303*1	Retry count display erase	0	0	Setting "0" clears the retry success counter ("retry success" means that the inverter successfully restarts).
523 H320*1	Emergency drive mode selection	9999	100, 200	Select the operation mode of the emergency drive.
			9999	Emergency drive disabled.
515 H322*1	Emergency drive dedicated retry count	1	1 to 200	Set the retry count during emergency drive operation.
			9999	Without retry count excess (no restriction on the number of retries)
514 H324*1	Emergency drive dedicated retry waiting time	9999	0.1 to 600 s	Set the retry waiting time during emergency drive operation.
			9999	Waiting time: 1 s
57 A702*2	Restart selection	9999	0	Selected
			9999	Not selected

\*1 The function is available only when the parameter is set in the master converter unit. Settings in the slave does not enable the function.

\*2 When setting Pr.57, set the same setting value in the master and the slave.

## (H) Protective function parameter

### ◆ Connection diagram

A connection diagram of the emergency drive is shown below.

- Two units connected in parallel (for driving a single wound motor)

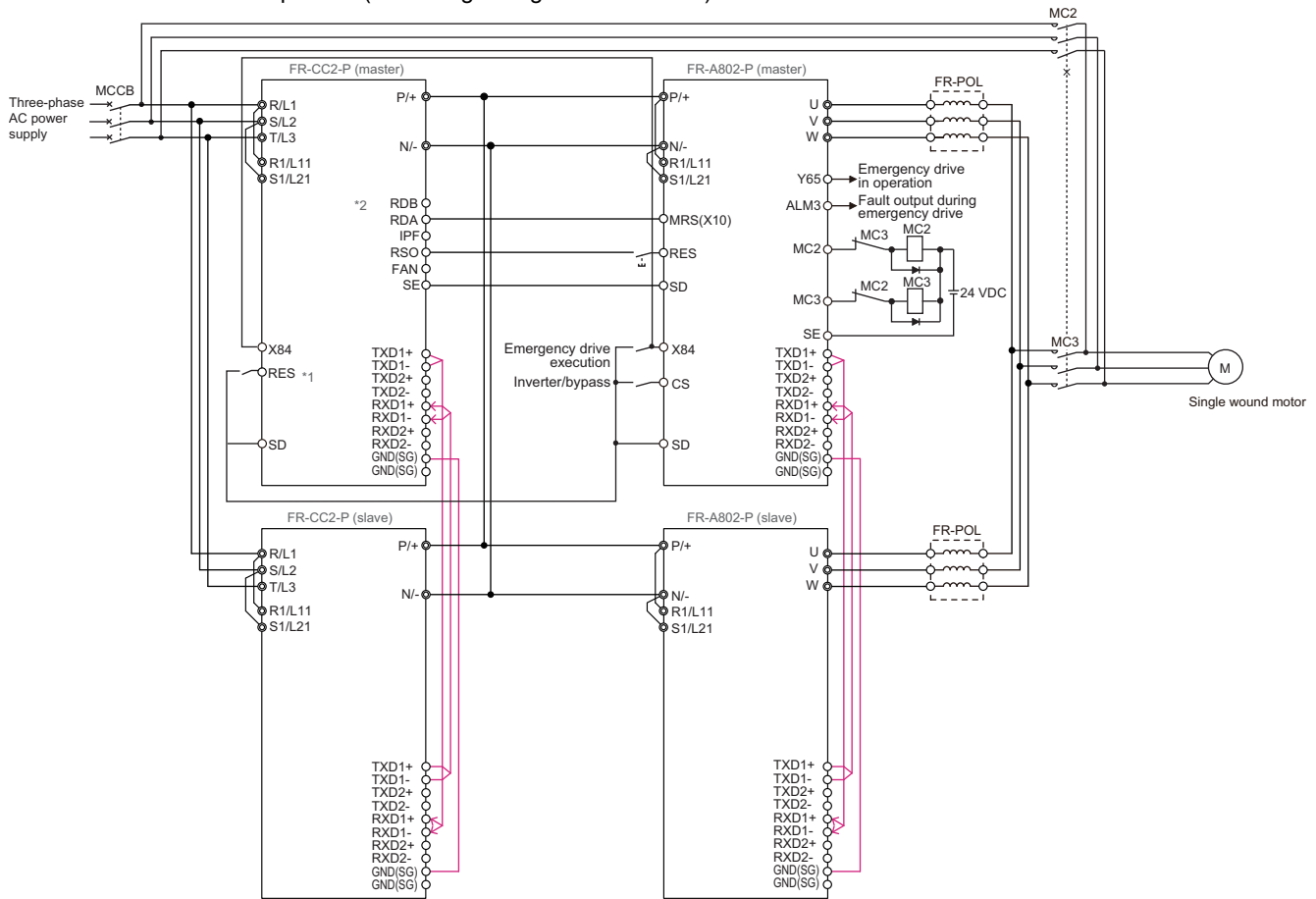

\*1 The applied terminals differ by the settings of **Pr.178**, **Pr.187**, and **Pr.189** (Input terminal function selection).

\*2 The applied terminals differ by the settings of **Pr.190** to **Pr.195** (Output terminal function selection).

#### NOTE

- Parameter settings for the emergency drive function are enabled in the master converter unit only. Settings in the slave does not enable the function.
- Settings in the master inverter (FR-A802-P) is also required to enable the emergency drive function.

### ◆ Emergency drive execution sequence

- When the X84 signal is ON for 3 seconds, the emergency drive is activated.
- The Y65 signal turns ON during emergency drive operation.
- "ED" appears on the operation panel during emergency drive operation.
- The ALM3 signal turns ON when a fault occurs during emergency drive operation.
- Operation of the emergency drive function (when the retry in case of critical faults is selected)

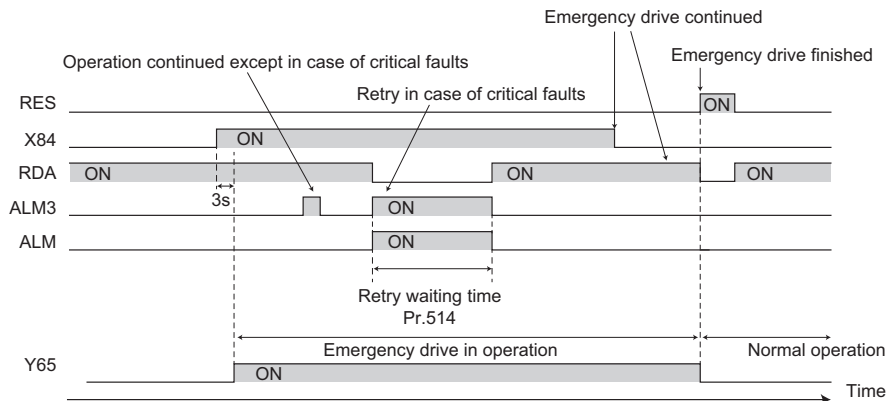

## ◆ Emergency drive operation selection (Pr.523)

Use **Pr.523** Emergency drive mode selection to select the emergency drive operation.

Pr.523 setting	Description
100	When a critical fault occurs, the RDA signal is turned OFF and the RDB signal is turned ON to disable inverter operation.
200	Retry operation when a critical fault occurs. (When a critical fault for which retry is not permitted occurs, the RDA signal is turned OFF and the RDB signal is turned ON to disable inverter operation.) When a critical fault for which retry is not permitted occurs or when the retry count is exceeded, the RDA signal is turned OFF and the RDB signal is turned ON to disable inverter operation.
9999	Emergency drive disabled.

## ◆ Retry operation during emergency drive (Pr.515, Pr.514)

- Set the retry operation during emergency drive operation. Use **Pr.515** Emergency drive dedicated retry count to set the retry count, and use **Pr.514** Emergency drive dedicated retry waiting time to set the retry waiting time.
- The ALM signal output conditions depend on the **Pr.67** Number of retries at fault occurrence setting.
- For the protective functions (critical faults) for which a retry is performed during emergency drive operation, refer to [page 99](#).

## ◆ Retry count check (Pr.69)

- Reading the **Pr.69** value provides the cumulative number of successful restart times made by retries. The cumulative count in **Pr.69** increases by 1 when a retry is successful. Retry is regarded as successful when normal operation continues without a fault for the **Pr.514** setting multiplied by four or longer (3.1 seconds at the shortest). (When retry is successful, the cumulative number of retry failures is cleared.)
- Writing "0" in **Pr.69** clears the cumulative count.

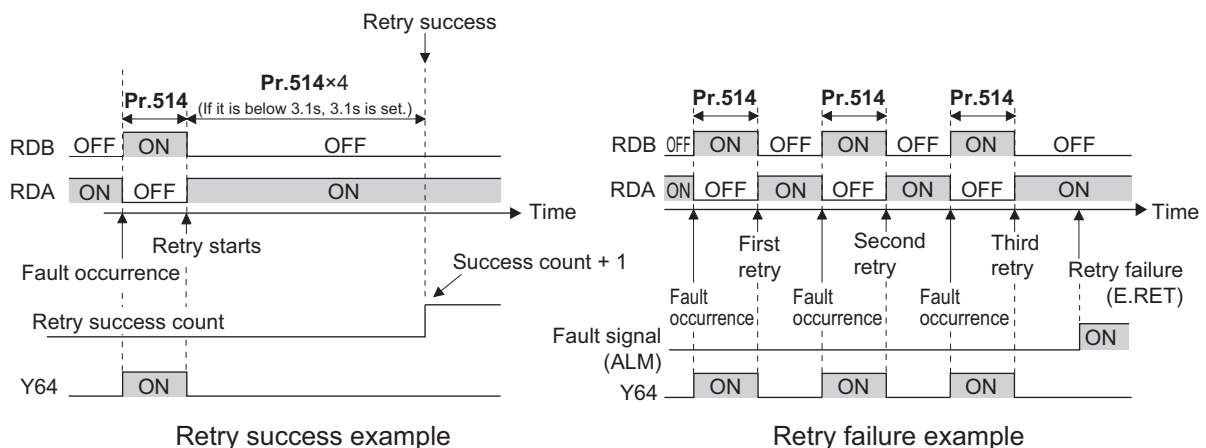

## ◆ Operation of protective functions during emergency drive

- Operation of protective functions during emergency drive is as follows.

Protective function	Operation during emergency drive	Protective function	Operation during emergency drive	Protective function	Operation during emergency drive
E.OVT	Retry	E.OP1	The function is disabled.	E.CTE	The function is disabled.
E.THC	Retry	E.PA1	Retry or Output shutoff*1	E.P24	The function is disabled.
E.FIN	Retry	E.PA2	Retry or Output shutoff*1	E.IOH	Output shutoff
E.IPF	The function is disabled.	E.PE	Output shutoff	E.SER	Retry*2
E.UVT	The function is disabled.	E.PUE	The function is disabled.	E.PBT	Retry
E.ILF	The function is disabled.	E.RET	Output shutoff	E.5	Retry
E.OHT	Retry	E.PE2	Output shutoff	E.6	Retry
E.OPT	The function is disabled.	E.CPU	Retry	E.7	Retry
				E.13	Output shutoff

\*1 The output is shut off when one of the faults to shut off the output shown in the table occurs in a slave.

\*2 The output is shut off when the protection function is activated in the slave converter unit.

## (H) Protective function parameter

- The fault output during emergency drive operation is as follows.

Signal	Pr.190 to Pr.196 setting		Description
	Positive logic	Negative logic	
Y65	65	165	Turns ON during emergency drive operation.
ALM	99	199	Turns ON at the occurrence of a fault that causes the above-mentioned "retry" or "output shutoff" during emergency drive operation. Use <b>Pr.67 Number of retries at fault occurrence</b> to select whether to output the Fault (ALM) signal during the retry operation. In the initial setting, "0" is set (the ALM signal is not output during retry).
ALM3	66	166	Output when a fault occurs during emergency drive operation. During emergency drive operation, if a fault that does not activate any protective function occurs, the signal turns ON for 3 seconds and then turns OFF.

### ◆ Input signal operation

- The following table shows status of input signals during emergency drive operation..

Input signal status	Description
Valid	OH, RES
Held	X84

### ◆ Emergency drive status monitor

- Set "68" in Pr.774 to Pr.776, Pr.992 to monitor the status of the emergency drive on the operation panel.
- Description of the status monitor

Operation panel indication	Description	
	Emergency drive setting	Emergency drive operating status
0	Emergency drive function setting is not available.	-
1	Emergency drive	During normal operation
2		Operating properly
3		A certain alarm is occurring.
4		Emergency drive in operation A critical fault is occurring. The operation is being continued by the retry.
5		A critical fault is occurring. The continuous operation is not allowed due to output shutoff.

#### NOTE

- When the "retry" (Pr.523 = "200") is selected, it is recommended to use the automatic restart after instantaneous power failure function at the same time.
- Parameter setting is not available during emergency drive operation.
- To return to the normal operation during emergency drive operation, reset the converter unit or the inverter, or turn OFF the power supply. (The operation will not be returned to normal only by turning OFF the X84 signal.)

#### CAUTION

- When the emergency drive operation is performed, the operation is continued or the retry is repeated even when a fault occurs, which may damage or burn the inverter, converter unit and motor. Before restarting the normal operation after using this function, make sure that the inverter, converter unit and motor have no fault. Any damage of the inverter, converter unit or the motor caused by using the emergency drive function is not covered by the warranty even within the guarantee period.

## 5.4 (M) Monitor display and monitor output signal

Purpose	Parameter to set			Refer to page
To change the monitored item on the operation panel	Operation panel monitor selection Cumulative monitor clear	P.M020 to P.M023, P.M044, P.M100 to P.M104	Pr.170, Pr.268, Pr.290, Pr.563, Pr.774 to Pr.776, Pr.891, Pr.992	101
To assign functions to output terminals	Output terminal function assignment	P.M400 to P.M405	Pr.190 to Pr.195	105
To detect the control circuit temperature	Control circuit temperature monitor	P.M060	Pr.663	108

### 5.4.1 Monitor display selection using operation panel or via communication

The monitored item to be displayed on the operation panel can be selected. Install the operation panel of the inverter on the converter unit.

Pr.	Name	Initial value	Setting range	Description
774 M101	Operation panel monitor selection 1	9999 (Converter output voltage)	2, 8, 13, 20, 25, 43, 44, 55, 62, 68, 98, 9999	The converter output voltage, input current and electronic thermal relay function load factor monitor that are displayed in monitor mode on the operation panel can be switched to a specified monitor.
775 M102	Operation panel monitor selection 2	9999 (Input current)		
776 M103	Operation panel monitor selection 3	9999 (Electric thermal relay function load factor)		
992 M104	Operation panel setting dial push monitor selection	8 (Converter output voltage)	2, 8, 13, 20, 25, 43, 44, 55, 62, 68, 98	Select the monitor to be displayed when the setting dial on the operation panel is pushed.
170 M020	Watt-hour meter clear	9999	0	Set "0" to clear the watt-hour monitor.
			10	Sets the maximum value for the monitoring from 0 to 9999 kWh.
			9999	Sets the maximum value for the monitoring from 0 to 65535 kWh.
563 M021	Energization time carrying-over times	0	(0 to 65535) (Read-only.)	Displays the numbers of times that the cumulative energization time monitor exceeded 65535 h. Read-only.
268 M022	Monitor decimal digits selection	9999	0	Displays as integral value.
			1	Displays in 0.1 increments.
			9999	No function
891 M023	Cumulative power monitor digit shifted times	9999	0 to 4	Set the number of times to shift the cumulative power monitor digit. The monitored value is clamped at the maximum value.
			9999	No shift. The monitored value is cleared when it exceeds the maximum value.
290 M044	Monitor negative output selection	0	0, 2, 4, 6	Set the availability of output with a minus sign for the operation panel display or monitoring via communication.

## (M) Monitor display and monitor output signal

### ◆ Monitor item list (Pr.774 to Pr.776, Pr.992)

- The monitor items of the FR-CC2-P (including the availability for the master and the slave during the parallel operation) is as follows. ○ indicates that the monitor is valid. × indicates that the monitor is invalid ("0" is displayed). Use **Pr.774 to Pr.776 and Pr.992** to select a monitored item to be displayed on the operation panel.
- Refer to the following table and set the monitor to be displayed. (The items with — are not available for monitoring.) The circle in the minus (—) display column denotes availability of the minus sign display.

Pr.774 to Pr.776, Pr.992	RS-485 communication dedicated monitor (hexadecimal)	Types of monitor	Unit	Minus (-) display	Description	Master station	Slave station	
2	H02	Input current*2*3*6	0.1 A		Displays the converter unit input current effective value.	○*7*10	○	
8	H08	Converter output voltage*2	0.1 V		Displays the DC bus voltage value.	○	○	
13	H0D	Input power	0.1 kW		Displays the power at the converter unit input side.	○*8	×	
20	H14	Cumulative energization time*1	1 h		Displays the cumulative energization time since the converter unit shipment. Check how many times the monitor value exceeded 65535 h with <b>Pr.563</b> .	○	○	
25	H19	Cumulative power*2	0.1 kWh		Displays the cumulative energy based on the input power monitor. This can be cleared by <b>Pr.170</b> . (Refer to <a href="#">page 103</a> )	○*9	×	
43	H2B	Parameter for manufacturer check. Do not set.						
44	H2C	Station number (PU)	1		Displays which station number (0 to 31) can currently be used for communication from the PU connector.	○	○	
55	H0F*4	Input terminal status	—		Displays input terminal ON/OFF state of the converter unit. (For operation panel indication, refer to <a href="#">page 103</a> .)	○	○	
	H10*5	Output terminal status	—		Displays output terminal ON/OFF state of the converter unit. (For operation panel indication, refer to <a href="#">page 103</a> .)			
62	H3E	Electric thermal relay function load factor	0.1%		Displays the accumulated heat value of the converter thermal O/L relay. The converter overload trip (electronic thermal relay function) (E.THC) occurs at 100%.	○	○	
68	H44	Emergency drive status	1		Displays the emergency drive status	○	×	
—	H4D	32-bit cumulative power (lower 16 bits)	1 kWh		Displays the 32-bit cumulative power value in multiples of 16 bits. Monitoring can be performed via RS-485 communication.	○*9	×	
—	H4E	32-bit cumulative power (upper 16 bits)	1 kWh			○*9	×	
—	H4F	32-bit cumulative power (lower 16 bits)	0.1 kWh			○*9	×	
—	H50	32-bit cumulative power (upper 16 bits)	0.1 kWh			○*9	×	
98	H62	Control circuit temperature	1°C	○	Displays the temperature of the control circuit board. Without minus sign: 0 to 100°C With minus sign: -20 to 100°C	○	○	

\*1 The cumulative energization time is accumulated from 0 to 65535 hours, then cleared, and accumulated again from 0.

\*2 Since the voltage and current display on the operation panel is shown in four digits, a monitor value of more than "9999" is displayed as "----".

\*3 0 A appears during regenerative driving.

\*4 Input terminal monitor details ("1" denotes terminal ON, "0" denotes terminal OFF, and "—" denotes undetermined value.)

b15

b0

—	—	—	—	—	RES	—	OH	—	—	—	—	—	—	—	—	RDI
---	---	---	---	---	-----	---	----	---	---	---	---	---	---	---	---	-----

\*5 Output terminal monitor details ("1" denotes terminal ON, "0" denotes terminal OFF, and "—" denotes undetermined value.)

b15

b0

—	—	—	—	—	—	—	—	—	—	—	ABC1	FAN	RSO	IPF	RDA	RDB
---	---	---	---	---	---	---	---	---	---	---	------	-----	-----	-----	-----	-----

\*6 The monitored values are retained even if a converter unit fault occurs. Resetting will clear the retained values.

\*7 The total input current of the master and slave converter units is displayed. If the current is 5% or less of the rated input current of the converter unit multiplied by the number of units operated in parallel, "0" is displayed.

- \*8 The total input power value of the master and slave converter units is displayed.
- \*9 The total cumulative power value of the master and slave converter units is displayed.
- \*10 While the input current of the converter unit for 12-phase rectification is monitored, a total amount of input current in the star-delta connections is shown as an effective value of input current. (It is not an effective value of input current in each star/delta connection.)

### ◆ Monitor display for operation panel (Pr.774 to Pr.776)

- The monitor displayed at power ON is the first monitor (the converter output voltage monitor in the initial setting). Display the monitor that will be the first monitor, and continue pressing **SET** for 1 s. (To return to the converter output voltage monitor, display the converter output voltage monitor and press **SET** for 1 s.)

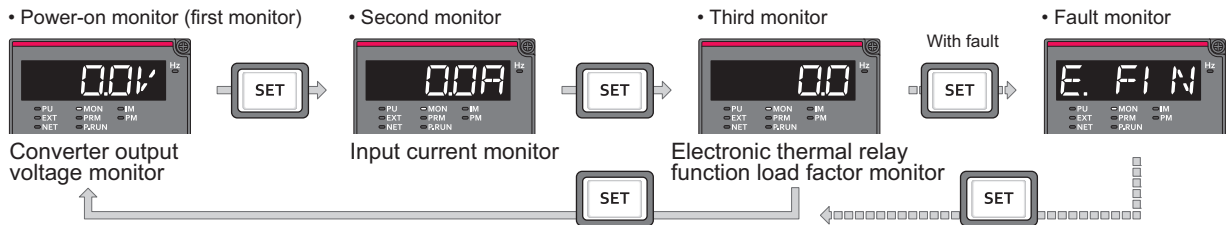

- **Pr.774** sets the first monitor, **Pr.775** sets the second monitor, and **Pr.776** sets the third monitor to be displayed.

#### NOTE

- The converter unit set in slave 1 (**Pr.1001 Parallel operation selection = "1"**) / slave 2 (**Pr.1001 = "2"**) displays SLV.1 (parallel operation slave 1) / SLV.2 (parallel operation slave 2) on the first monitor screen regardless of the **Pr.774** setting. (Refer to page 149.)

### ◆ Operation panel setting dial push monitor selection (Pr.992)

- The monitored item to be displayed at the operation panel's setting dial push can be selected with **Pr.992**. In the initial setting (**Pr.992 = "8"**), the converter output voltage monitor is displayed.

### ◆ Operation panel I/O terminal monitor (Pr.774 to Pr.776)

- When **Pr.774 to Pr.776 = "55"**, the I/O terminal status can be monitored on the operation panel.
- The LED is ON when the terminal is ON, and the LED is OFF when the terminal is OFF. The center line of LED is always ON.

Pr.774 to Pr.776 setting	Monitor description
55	Displays the I/O terminal ON/OFF state of the converter unit.

- On the I/O terminal monitor (**Pr.774 to Pr.776 = "55"**), the upper LEDs denote the input terminal state, and the lower LEDs denote the output terminal state.

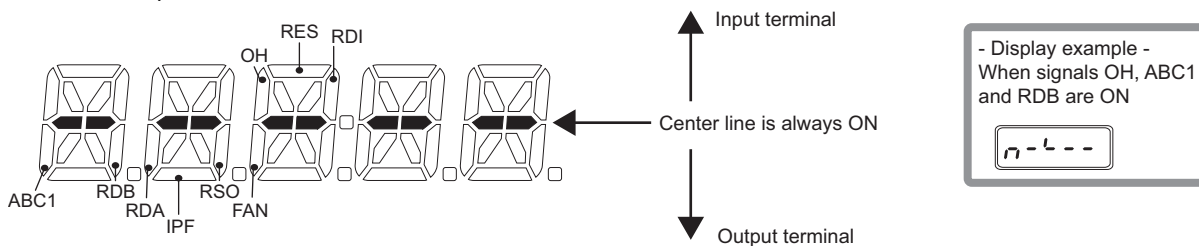

### ◆ Cumulative power monitor and clear (Pr.170, Pr.891)

- On the cumulative power monitor (**Pr.774 to Pr.776 = "25"**), the input power monitor value is added up and updated in 100 ms increments. (The values are saved in EEPROM every hour.)
- Display increments and display ranges of the operation panel and communication (RS-485 communication) are as indicated below.

Operation panel *1		Communication		
Range	Unit	Range		Unit
		Pr.170 = 10	Pr.170 = 9999	
0 to 999.99 kWh	0.01 kWh	0 to 9999 kWh	0 to 65535 kWh (initial value)	1 kWh
1000.0 to 9999.9 kWh	0.1 kWh			
10000 to 99999 kWh	1 kWh			



## (M) Monitor display and monitor output signal

\*1 Power is measured in the range of 0 to 99999.99 kWh, and displayed in five digits. When the monitor value exceeds "999.99", a carry occurs, for example "1000.0", so the value is displayed in 0.1 kWh increments.

- Digits in the cumulative power monitor can be shifted to the right for the numerical set in **Pr.891 Cumulative power monitor digit shifted times**.

For example, if the cumulative power value is 1278.56 kWh when **Pr.891** = "2", the operation panel display is 12.78 (display in 100 kWh increments) and the communication data is 12.

- If the maximum value is exceeded at **Pr.891** = "0 to 4", the monitor value is clamped at the maximum value, indicating that a digit shift is necessary. If the maximum value is exceeded at **Pr.891** = "9999", the monitor value returns to 0, and the counting starts again.
- Writing "0" in **Pr.170** clears the cumulative power monitor.

### NOTE

- If "0" is written to **Pr.170**, and **Pr.170** is read again, "9999" or "10" is displayed.

## ◆ Cumulative energization time monitor (Pr.563)

- Cumulative energization time monitor (**Pr.774 to Pr.776** = "20") accumulates energization time from shipment of the converter unit every one hour.
- If the number of monitor value exceeds 65535, it is added up from 0. Use **Pr.563** to check the numbers of times that the cumulative energization time monitor exceeded 65535 h.
- Writing "0" in **Pr.171** clears the actual operation time monitor. (The energization time monitor cannot be cleared.)

### NOTE

- The cumulative energization time does not increase if the power is ON for less than an hour.

## ◆ Hiding the decimal places for the monitors (Pr.268)

- The numerical figures after a decimal point displayed on the operation panel may fluctuate during analog input, etc. The decimal places can be hidden by selecting the decimal digits with **Pr.268**.

Pr.268 setting	Description
9999 (initial value)	No function
0	For the first or second decimal places (0.1 increments or 0.01 increments) of the monitor, numbers in the first decimal place and smaller are rounded to display an integral value (1 increments). The monitor value equal to or smaller than 0.99 is displayed as 0.
1	When monitoring with the second decimal place (0.01 increments), the 0.01 decimal place is dropped and the monitor displays the first decimal place (0.1 increments). When the monitor display is incremented by one, the display will not change.

### NOTE

- The number of display digits on the cumulative energization time (**Pr.774 to Pr.776** = "20") and the cumulative power (**Pr.774 to Pr.776** = "25") does not change.

## ◆ Minus sign display for the monitors (Pr.290)

- Values with minus signs can be displayed on the monitor indicator of the operation panel. For a list of monitored items that can be displayed with minus signs, refer to the monitor description list (on [page 102](#)).

Pr.290 setting	Minus-sign display on operation panel	Monitoring via communication
0 (initial value)	-	-
2	Displayed with minus sign.	-
4	-	Displayed with minus sign.
6	Displayed with minus sign.	Displayed with minus sign.

-: Output without minus sign (positive only)

## 5.4.2 Output terminal function selection

Use the following parameters to change the functions of the open collector output terminals and relay output terminals.

Pr.	Name		Initial value	Initial signal	Setting range
190 M400	RDB terminal function selection	Open collector output terminal	111	RDB (Inverter operation enable (NC contact))	2, 8, 11, 17, 25, 26, 64 to 66, 68, 90, 94, 95, 98, 99, 102, 108, 111, 125, 126, 164 to 166, 168, 190, 194, 195, 198, 199, 206, 207, 209, 210, 214, 227, 306, 307, 309, 310, 327, 9999
191 M401	RDA terminal function selection		11	RDA (Inverter operation enable (NO contact))	
192 M402	IPF terminal function selection		2	IPF (Instantaneous power failure/undervoltage)	
193 M403	RSO terminal function selection		209	RSO (Inverter reset)	
194 M404	FAN terminal function selection		25	FAN (Fan fault output)	
195 M405	ABC1 terminal function selection	Relay output terminal	99	ALM (Fault)	

### ◆ Output signal list

- The functions of the output terminals can be set.
- Refer to the following table and set the parameters. (0 to 99: Positive logic, 100 to 199: Negative logic)

Setting		Signal name	Function	Operation	Related parameter	Refer to page
Positive logic	Negative logic					
2	102	IPF	Instantaneous power failure/undervoltage	Output when an instantaneous power failure or undervoltage protection operation occurs.	Pr.57	113
8	108	THP	Electronic thermal O/L relay pre-alarm	Output when the cumulative electronic thermal O/L relay value reaches 85% of the trip level. (Electronic thermal O/L relay protection (E.THC) is activated when the value reaches 100%.)	—	106
11	—	RDA	Inverter operation enable (NO contact)	Output when the converter unit operation is ready.	—	107
—	111	RDB	Inverter operation enable (NC contact)	Output when a converter unit fault occurs or the converter is reset. (inverse to the logic of RDA)	—	107
17	—	Y17 *2	Control signal for main circuit power supply MC	Output while the self power management function is enabled. Turns OFF when a fault activating the self power management operation occurs.	Pr.248, Pr.30	111
25	125	FAN	Fan fault output	Output when a fan fault occurs.	—	107
26	126	FIN	Heat sink overheat pre-alarm	Output when the heat sink temperature reaches about 85% of the heat sink overheat protection operation temperature.	—	145
64	164	Y64	During retry	Output during retry operation.	Pr.67, Pr.514, Pr.515, Pr.523	97
65	165	Y65	Emergency drive in operation	Output during emergency drive operation.		
66	166	ALM3	Fault output during emergency drive	Output when a fault occurs during emergency drive operation.		
68	168	EV	24 V external power supply operation	Output while operating with a 24 V power supply input from an external source.	—	51
90	190	Y90	Life alarm	Output when any of the control circuit capacitor, the inrush current limit circuit, or the cooling fan approaches the end of its life.	Pr.255 to Pr.257	93
94	194	ALM2	Fault output 2	Output when the converter unit's protective function is activated to stop the output (at fault occurrence). The signal output continues even during a converter reset, and the signal output stops after the reset release. *1	—	108
95	195	Y95	Maintenance timer signal	Output when Pr.503 reaches the Pr.504 setting or higher.	Pr.503, Pr.504	95

## (M) Monitor display and monitor output signal

Setting		Signal name	Function	Operation	Related parameter	Refer to page
Positive logic	Negative logic					
98	198	LF	Alarm	Output when an alarm (fan fault or communication error warning) occurs.	Pr.121	107, 125
99	199	ALM	Fault	Output when the converter unit's protective function is activated to stop the output (at fault occurrence). The signal output is stopped after a reset.	—	108
206	306	Y206	Cooling fan operation command signal	Output when the cooling fan operation is commanded.	—	107
207	307	Y207	Control circuit temperature signal	Output when the temperature of the control circuit board reaches the detection level or higher.	Pr.663	108
209	309	RSO	Inverter reset	Output at the converter reset.	—	107
210	310	PWF	Power failure stop signal	Output during instantaneous power failure, undervoltage, or input phase loss.	Pr.261	114
214	—	Y214	Converter unit fault (E.OHT, E.CPU)	The signal turns ON when the converter unit is in the normal state. The signal turns OFF when the converter unit's protective function (E.OHT, E.CPU) is activated (at fault occurrence).	—	—
227	327	Y227	Parallel operation ready	Output when the converter unit is set ready for the parallel operation.	—	56
9999	—	—	No function	—	—	—

\*1 When the power is reset, the fault output 2 signal (ALM2) turns OFF at the same time as the power turns OFF.

\*2 For the slave, the setting is invalid.

### NOTE

- The same function may be set to more than one terminal
- The terminal conducts during function operation when the setting is "0 to 99, 200 to 299", and does not conduct when the setting is "100 to 199, 300 to 399".
- Changing the terminal assignment using **Pr.190 to Pr.195 (Output terminal function selection)** may affect the other functions. Set parameters after confirming the function of each terminal.
- Do not assign signals which frequently repeat switching between ON and OFF to terminals A1B1C1. Otherwise the life of the relay contacts decreases.

## ◆ Electronic thermal O/L relay pre-alarm (TH) and warning signal (THP)

- If the accumulated electronic thermal value reaches 85%, Electronic thermal relay function pre-alarm (TH) is displayed and the Electronic thermal O/L relay pre-alarm (THP) signal is output. If the value reaches 100% of the setting, the electronic thermal O/L relay protection (E.THCH) is activated to shut off the inverter output. The inverter output is not shut off with the TH display.
- For the terminal used for THP signal output, set "8 (positive logic)" or "108 (negative logic)" in any of **Pr.190 to Pr.195 (Output terminal function selection)** to assign the function.

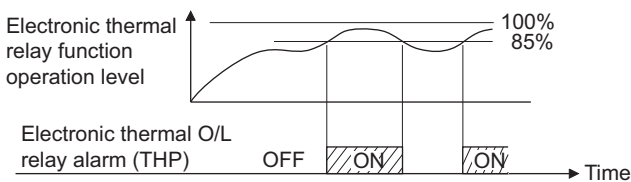

- 100%: Electronic thermal O/L relay activation value

### NOTE

- Changing the terminal assignment using **Pr.190 to Pr.195 (Output terminal function selection)** may affect the other functions. Set parameters after confirming the function of each terminal.

## ◆ Fan fault output signal (FAN)

- A cooling fan operates at power ON of the converter unit. If the fan stops at this time, fan operation is regarded as faulty, Fan alarm  $\overline{FN}$  (FN) is displayed on the operation panel, and the Fan fault output (FAN) and Alarm (LF) signals are output.
- To assign the FAN signal to the terminal, set "25 (positive logic) or 125 (negative logic)" in one of **Pr.190 to Pr.195 (Output terminal function selection)**. To assign the LF signal, set "98 (positive logic) or 198 (negative logic)".

## ◆ Cooling fan operation command signal (Y206)

- The Cooling fan operation command (Y206) signal can be output when the converter unit cooling fan meets the conditions for running. The function can be used when the fan installed on the enclosure is synchronized with the converter unit cooling fan.
- Y206 signal indicates the operating command condition of the converter unit cooling fan depending on the power supply ON/OFF. The signal does not indicate the actual operation of the cooling fan. (The signal is output even if the cooling fan is stopped due to a fault.)
- To use the Y206 signal, set "206 (positive logic) or 306 (negative logic)" in any of **Pr.190 to Pr.195 (Output terminal function selection)** to assign the function to the output terminal.

### NOTE

- Changing the terminal assignment using **Pr.190 to Pr.195 (Output terminal function selection)** may affect the other functions. Set parameters after confirming the function of each terminal.

## ◆ Inverter operation enable signals (RDA and RDB) and Inverter reset signal (RSO)

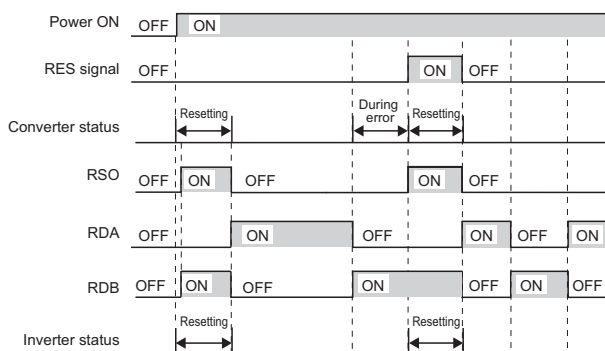

- The Inverter operation enable (RDA) signal (NO contact) turns ON when the converter unit operation is ready, and turns OFF when a converter unit fault occurs, the Y227 signal is turned OFF (refer to [page 56](#)) or the converter is reset.
- A logic inverse to that of RDA is applied to the Inverter operation enable (RDB) signal (NC contact). (However, the RDB signal is in the OFF status while the converter unit power supply is turned OFF.)
- When the RDA and RDB signals of the slave are turned OFF, the RDA and RDB signals of the master are also turned OFF.
- The RDA and RDB signals are initially assigned to terminals RDA and RDB respectively. By setting "11" for the RDA signal or "111" for the RDB signal in either **Pr.190 to Pr.195 (Output terminal function selection)**, the signals can be assigned to other terminals.
- When the Converter reset (RES) signal is input to the converter unit, the Inverter reset (RSO) signal is output to the inverter.
- The RSO signal is assigned to terminal RSO in the initial status. The RSO signal can also be assigned to other terminals by setting "209 (positive logic) or 309 (negative logic)" in any of **Pr.190 to Pr.195 (Output terminal function selection)**.

**(M) Monitor display and monitor output signal**

**◆ Fault output signals (ALM, ALM2)**

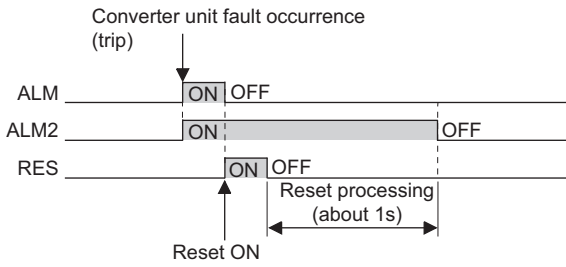

- The Fault (ALM, ALM2) signals are output when the converter unit protective function is activated.
- The ALM2 signal stays ON during the reset period after the fault occurs.
- To use the ALM2 signal, set "94 (positive logic) or 194 (negative logic)" in any of **Pr.190 to Pr.195 (Output terminal function selection)** to assign the function to the output terminal.
- The ALM signal is assigned to the A1B1C1 contacts in the initial status.

**NOTE**

• For the details of converter unit faults, refer to [page 142](#).

**5.4.3 Detection of control circuit temperature**

The temperature of the control circuit board of the converter unit can be monitored, and a signal can be output according to the predetermined temperature setting.

Pr.	Name	Initial value	Setting range	Description
<b>663</b> <b>M060</b>	<b>Control circuit temperature signal output level</b>	0°C	0 to 100°C	Set the temperature where the Y207 signal turns ON.

**◆ Control circuit temperature monitor**

- The operation panel can be used to monitor the temperature of the control circuit board within the range of 0 to 100°C.
- The range becomes -20 to 100°C by setting the display with a minus sign in **Pr.290 Monitor negative output selection**.

**◆ Control circuit temperature detection (Pr.663, Y207 signal)**

- The Y207 signal can be output when the control circuit temperature reaches the **Pr.663** setting or higher.
- For the Y207 signal, set "207 (positive logic) or 307 (negative logic)" in one of **Pr.190 to Pr.195 (Output terminal function selection)** to assign the function to the output terminal.

**NOTE**

- The Y207 signal is turned OFF when the control circuit temperature becomes 5°C or more lower than the **Pr.663** setting.
- Changing the terminal assignment using **Pr.190 to Pr.195 (Output terminal function selection)** may affect the other functions. Set parameters after confirming the function of each terminal.

**Parameters referred to**

Pr.190 to Pr.195 (Output terminal function selection) [page 105](#)

Pr.290 Monitor negative output selection [page 101](#)

## 5.5 (T) Multi-function input terminal parameters

Purpose	Parameter to set			Refer to page
To assign functions to input terminals	Input terminal function selection	P.T700, P.T709, P.T711	Pr.178, Pr.187, Pr.189	109
To change operation when the OH signal is input	OH input selection	P.T723	Pr.876	110

### 5.5.1 Input terminal function selection

Use the following parameters to select or change the input terminal functions.

Pr.	Name	Initial value	Initial signal	Setting range
178 T700	RDI terminal function selection	9999	No function	7, 62, 84, 9999
187 T709	OH terminal function selection	7	OH (External thermal relay input)	
189 T711	RES terminal function selection	62	RES (Converter reset)	

#### ◆ Input terminal function assignment

- Using **Pr.178**, **Pr.187**, and **Pr.189**, set the functions of the input terminals. Refer to the following table and set the parameters.
- The input signals below are available for both the master and slave converter units.

Setting value	Signal name	Function	Related parameter	Refer to page
7	OH	External thermal relay input	<b>Pr.876</b>	110
62	RES	Converter reset Operation status reset*1	—	88
84	X84	Emergency drive execution command	—	97
9999	—	No function	—	—

\*1 For description on the status of input terminals during emergency drive operation, refer to [page 99](#).

#### NOTE

- Same function can be assigned to two or more terminals. In this case, the logic of terminal input is OR.
- When the terminal assignment is changed using **Pr.178**, **Pr.187**, and **Pr.189** (**Input terminal function selection**), the terminal name will be different, which may result in an error of wiring, or affect other functions. Set parameters after confirming the function of each terminal.

## 5.5.2 Operation selection for the external thermal relay input (Pr.876)

The operation when the external thermal relay input (OH) signal is input can be changed by the Pr.876 setting.

Pr.	Name	Initial value	Setting range	Description
876 T723	OH input selection	0	0	No function
			1	The converter unit output is shut off by turning OFF the OH signal. (NC contact)
			2	The converter unit output is shut off by turning ON the OH signal. (NO contact)

### ◆ External thermal relay (OH signal, E.OHT)

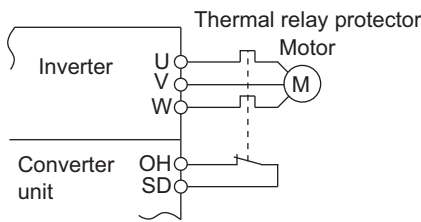

External thermal relay input connection diagram

- The External thermal relay input (OH) signal is used when using the external thermal relay or the thermal protector built into the motor to protect the motor from overheating.
- When the thermal relay is activated, the inverter output is shut off by the External thermal relay operation (E.OHT).
- The OH signal is assigned to terminal OH in the initial status. Set "7" in any of Pr.178, Pr.187, or Pr.189 (Input terminal function selection) to assign the OH signal to another terminal.

#### NOTE

- Changing the terminal assignment using Pr.178, Pr.187, or Pr.189 (Input terminal function selection) may affect the other functions. Set parameters after confirming the function of each terminal.

### ◆ Operation selection for the OH signal (Pr.876)

- The OH signal input status and the Pr.876 setting for the converter operation are as shown below.

OH signal input status (external terminal)	Converter unit operation		
	Pr.876 = "0"	Pr.876 = "1" (NC contact)	Pr.876 = "2" (NO contact)
ON	No function	Continuous operation	Inverter trip (E.OHT)
OFF	No function	Inverter trip (E.OHT)	Continuous operation

## 5.6 (A) Application parameters

Purpose	Parameter to set			Refer to page
To reduce the standby power	Self power management	P.A006, P.E300	Pr.30, Pr.248	111
To restart after instantaneous power failure	Automatic restart operation after instantaneous power failure	P.A702	Pr.57	113
To decelerate the motor to a stop at instantaneous power failure	Power failure time deceleration-to-stop function	P.A730	Pr.261	114

### 5.6.1 Self power management

By turning ON the magnetic contactor (MC) on the input side before the motor is started and turning OFF the MC after the motor is stopped, power is not supplied to the main circuit, reducing the standby power.

Pr.	Name	Initial value	Setting range	Description
248 A006	Self power management selection	0	0	Self power management function disabled
			1	Self power management function enabled (main circuit OFF at protective function activation)
			2	Self power management function enabled (main circuit OFF at protective function activation due to a circuit failure or at protective function activation of the slave)
30 E300	Reset selection during power supply to main circuit	0	0	When power is supplied only to the control circuit, and then switched to be supplied to both the control and main circuits, converter reset is performed.
			100	When power is supplied only to the control circuit, and then switched to be supplied to both the control and main circuits, converter reset is not performed.

#### ◆ Connection diagram

- For sink logic and Pr.192 = "17" (terminal R1, S1 inputs)

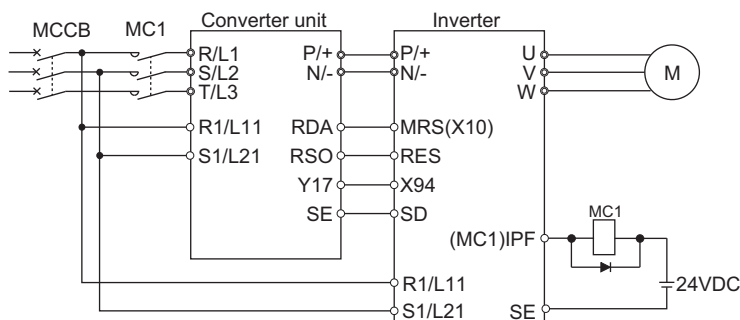

- For sink logic and Pr.192 = "17" (24 V external power supply input)

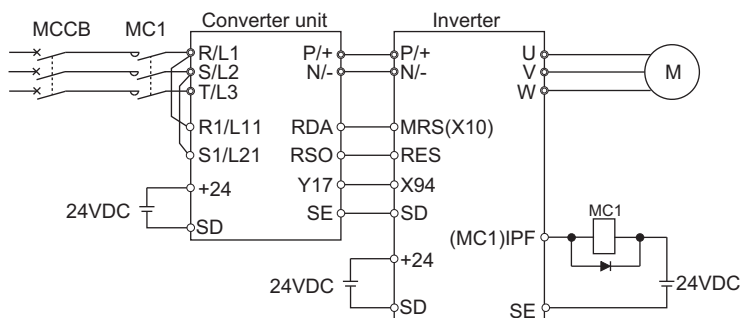



### ◆ Operation of the self power management function

- This is a function to control the input side magnetic contactor (MC) with an output relay to reduce standby power. Use separate power supplies for the main circuit and the control circuit by using terminals R1/L11 or S1/L21 (refer to [page 50](#)) and 24 V external power supply input (refer to [page 51](#)). Control the main circuit power supply MC by the electronic bypass MC1 signal of the inverter.
- Set **Pr.248 Self power management selection** = "1 or 2", and **Pr.190 to Pr.195 (Output terminal function selection)** = "17 (positive logic)" to assign the control signal for main circuit power supply MC (Y17 signal) to an output terminal. (Set **Pr.248** in accordance with the **Pr.248** setting of the inverter.)
- The Y17 signal turns ON while the self power management function is enabled.
- When the protective function of the converter unit is activated, the Y17 signal immediately turns OFF according to the **Pr.248** setting.

When **Pr.248** = "1", the Y17 signal turns OFF whenever a protective function is activated.

When **Pr.248** = "2", the Y17 signal turns OFF only when a protective function is activated by a fault originating in the converter unit circuit or a connection fault (refer to the table below). (For the fault details, refer to [page 142](#).)

If the protective function of the slave is activated, the Y17 signal turns OFF regardless of the fault contents.

Fault record
Inrush current limit circuit fault (E.IOH)
CPU fault (E.CPU)
CPU fault (E.6)
CPU fault (E.7)
Parameter storage device fault (E.PE)
Parameter storage device fault (E.PE2)
24 VDC power fault (E.P24)
Operation panel power supply short circuit / RS-485 terminals power supply short circuit (E.CTE)
Internal circuit fault (E.13/E.PBT)

#### NOTE

- Repeated operation of the magnetic contactor due to frequent start and stop or activation of the protective function may shorten the inverter and the converter unit life.
- Changing the terminal assignment using **Pr.190 to Pr.195 (Output terminal function selection)** may affect the other functions. Set parameters after confirming the function of each terminal.

### ◆ Selection between resetting or not resetting during power supply to main circuit (Pr.30 = "100")

- Converter reset is not performed if **Pr.30 Reset selection during power supply to main circuit** = "100", and supplying power to the main circuit (R/L1, S/L2, T/L3 input) is started when power is supplied only to the control circuit (R1/L11, S1/L12 input, or 24 V external power supply input).

#### NOTE

- When supplying power to the main circuit is started when power is supplied only to the control circuit, there is a slight waiting time before starting.
- When supplying power to the main circuit is started while the protective function of the converter unit is activated, converter reset is performed even when "not resetting after power-ON" is selected.

#### Parameters referred to

Pr.190 to Pr.195 (Output terminal function selection)  [page 105](#)

## 5.6.2 Automatic restart after instantaneous power failure selection

The converter unit can be restarted after power restoration from instantaneous power failure.

Pr.	Name	Initial value	Setting range	Description
57 A702	Restart selection	9999	0	Restarts the motor after power restoration from instantaneous power failure
			9999	Does not restart the motor.

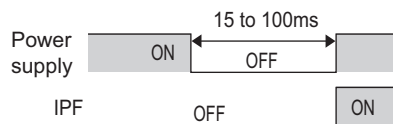

- When the automatic restart after instantaneous power failure is selected on the inverter side, set **Pr.57 Restart selection** = "0" on the converter unit side.
- When the automatic restart after instantaneous power failure function is set, the motor is restarted after power restoration from instantaneous power failure or undervoltage condition. (E.IPF and E.UVT are not activated.)
- When **Pr.57** = "9999" (initial value), the inverter output is shut off at the activation of the instantaneous power failure protection (E.IPF or E.UVT) of the converter unit, even when the automatic restart after instantaneous power failure is selected on the inverter side. (Refer to [page 142](#) for E.IPF or E.UVT.)
- When E.IPF or E.UVT is activated, the Instantaneous power failure/undervoltage (IPF) signal is output.
- The IPF signal is assigned to terminal IPF in the initial status. The IPF signal can also be assigned to other terminals by setting "2 (positive logic) or 102 (negative logic)" in any of **Pr.190 to Pr.195 (Output terminal function selection)**.

### CAUTION

- If the automatic restart after instantaneous power failure function has been selected, motor suddenly restarts at the power restoration after an instantaneous power failure (after the reset time has elapsed).  
Stay away from the motor and machine.  
If the automatic restart after instantaneous power failure function has been selected, apply the CAUTION stickers, which are supplied with the Inverter Manual, to easily visible places.

## 5.6.3 Power failure time deceleration-to-stop function

This is a function to decelerate the motor to a stop when an instantaneous power failure or undervoltage occurs.

Pr.	Name	Initial value	Setting range	Description
261	Power failure stop selection	0	0	Power failure time deceleration-to-stop function disabled
A730			1, 2, 21, 22	Power failure time deceleration-to-stop function enabled

### ◆ Connection and parameter setting

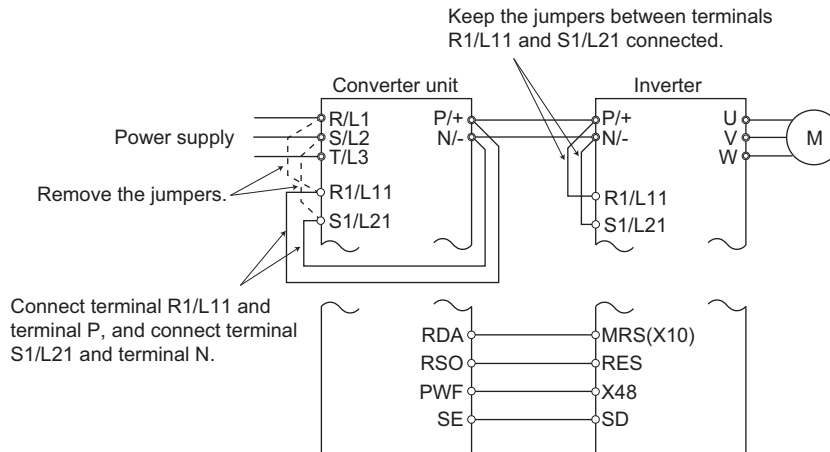

- Remove the jumpers between terminals R/L1 and R1/L11 and terminals S/L2 and S1/L21 of the converter unit, and connect terminals R1/L11 and P and terminals S1/L21 and N. Do not remove the jumpers of terminal R1/L11 and terminal S1/L21 of the inverter. (In the initial status of the inverter, terminals P and R1/L11 and terminals N and S1/L21 are connected.)
- Connect the terminal to which PWF signal of the converter unit is assigned and the terminal to which X48 signal of the inverter is assigned. Also, set **Pr.261** of the converter unit in accordance with the inverter setting.

Pr.261 setting		Description	Power failure time deceleration-to-stop function when the automatic restart after instantaneous power failure is enabled (Pr.57 ≠ "9999")
Inverter	Converter unit		
0	0	Power failure time deceleration-to-stop function disabled	—
1, 11	1	Power failure time deceleration-to-stop function enabled	Disabled
2, 12	2		Enabled
21	21		Disabled
22	22		Enabled

### ◆ Power failure stop (PWF) signal

- Power failure stop (PWF) signal turns ON during instantaneous power failure, undervoltage, or input phase loss.
- For the PWF signal, assign the function by setting "210 (positive logic)" or "310 (negative logic)" in any of **Pr.190 to Pr.195 (Output terminal function selection)**.

When the input specification of the Power failure stop external (X48) signal is the NC contact, set the negative logic for the PWF signal of the converter unit. When the input specification of the X48 signal is the NO contact, set the positive logic for the PWF signal of the converter unit. (For the X48 signal, the initial setting is the NC contact input specification. For changing the input logic, refer to the Instruction Manual of the inverter.)

#### NOTE

- When the power failure time deceleration-to-stop function is selected, undervoltage protection (E.UVT), instantaneous power failure protection (E.IPF) and input phase loss protection (E.ILF) are not invalid.
- Changing the terminal assignment using **Pr.190 to Pr.195 (Output terminal function selection)** may affect the other functions. Set parameters after confirming the function of each terminal.

#### Parameters referred to

Pr.190 to Pr.195 (Output terminal function selection) page 105

Pr.872 Input phase loss protection selection page 97

## 5.7 (N) Operation via communication and its settings

Purpose	Parameter to set			Refer to page
To start operation via communication	Initial setting of operation via communication	P.N001	Pr.342	117
To operate via communication from PU connector	Initial setting of computer link communication (PU connector)	P.N020 to P.N028	Pr.117 to Pr.124	118
To set the signal loss detection time for parallel operation communication.	Parallel operation communication check time	P.N092	Pr.652	56

### 5.7.1 Wiring and configuration of PU connector

Using the PU connector enables communication operation from a personal computer, etc.

When the PU connector is connected with a personal, FA or other computer by a communication cable, a user program can run to monitor the converter unit or read and write parameters.

#### ◆ PU connector pin-outs

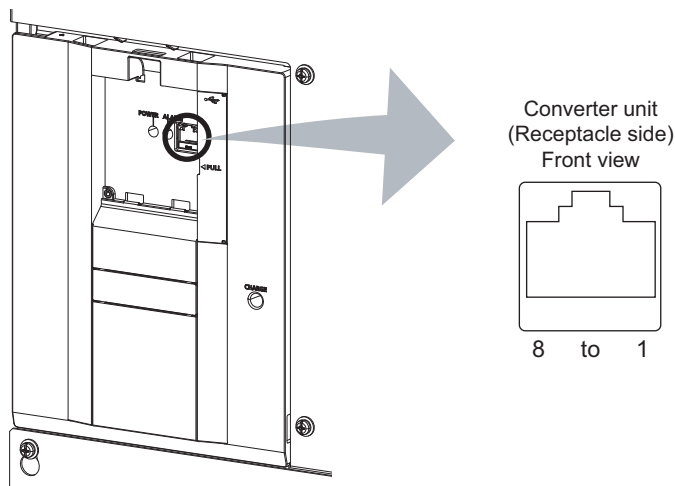

Pin number	Name	Description
1	SG	Earthing (grounding)
2	-	Operation panel power supply
3	RDA	Converter unit receive+
4	SDB	Converter unit send-
5	SDA	Converter unit send+
6	RDB	Converter unit receive-
7	SG	Earthing (grounding)
8	-	Operation panel power supply

#### NOTE

- Pins No. 2 and 8 provide power to the operation panel. Do not use these pins during RS-485 communication.
- Do not connect the cable to a computer's LAN board, to a fax modem socket, or to a telephone connector. Doing so may damage the product due to the differences in the electric specifications.

## ◆ Configuration and wiring of PU connector communication system

- System configuration

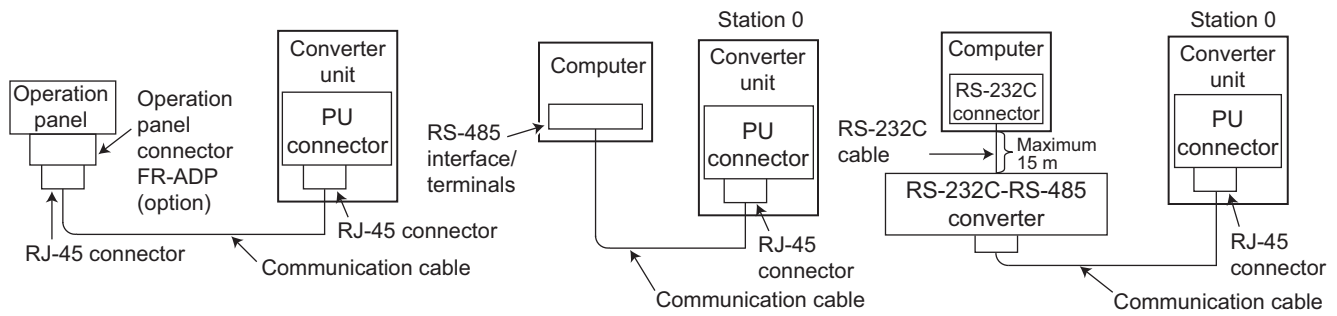

- Wiring of computer by RS-485

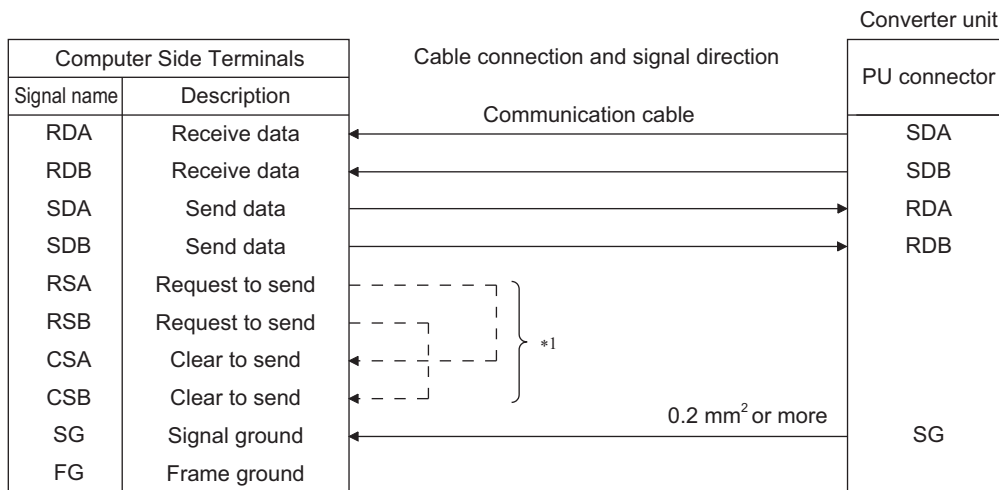

### NOTE

- Computer-converter unit connection cable  
Refer to the following for the connection cable (RS-232C ⇔ RS-485 converter) between the computer with an RS-232C interface and a converter unit. Commercially available products (as of October 2020)

Model	Manufacturer
Interface embedded cable DAFXIH-CAB (D-SUB25P for personal computer side) DAFXIH-CABV (D-SUB9P for personal computer side) +	Diatrend Corp.
Connector conversion cable DINV-485CAB (for converter unit side) *2	
Interface embedded cable dedicated for converter unit DINV-CABV *2	

- \*2 The conversion cable cannot connect multiple converter units. (The computer and the converter unit are connected in a 1:1 pair.) This product is a RS-232C ⇔ RS-485 conversion cable that has a built-in converter. No additional cable or connector is required. For the product details, contact the cable manufacturer.

- Use Ethernet cables compliant with the following standards when fabricating the cable.

Ethernet cable	Model	Type
Category 5e or higher straight cable (double shielded / STP)*3	RJ-45 connector	The cables compliant with the following standards: • IEEE802.3 (1000BASE-T) • ANSI/TIA/EIA-568-B (Category 5e)

- \*3 Do not use pins No. 2 and 8 of the communication cable.

## 5.7.2 EEPROM write selection during communication operation

Set the action when the converter unit is performing operation via communication.

Pr.	Name	Initial value	Setting range	Description
342 N001	Communication EEPROM write selection	0	0	Parameter values written by communication are written to the EEPROM and RAM.
			1	Parameter values written by communication are written to the RAM.

### ◆ Communication EEPROM write selection (Pr.342)

- When parameter write is performed from RS-485 communication with the converter unit PU connector, the parameter storage device can be changed from EEPROM and RAM to RAM only. Use this function if parameter settings are changed frequently.
- When changing the parameter values frequently, set "1" in **Pr.342 Communication EEPROM write selection** to write them to the RAM only. The life of the EEPROM will be shorter if parameter write is performed frequently with the setting unchanged from "0 (initial value)" (EEPROM write).

#### NOTE

- Turning OFF the converter unit's power supply clears the modified parameter settings when **Pr.342** = "1 (write only to RAM)". Therefore, parameter settings at next power-ON will be the ones that are last stored to EEPROM.
- The parameter setting written in RAM cannot be checked on the operation panel. (The values displayed on the operation panel are the ones stored in EEPROM.)

### 5.7.3 Initial settings and specifications of RS-485 communication

Use the following parameters to perform required settings for the RS-485 communication between the converter unit and a personal computer.

- Use the PU connector of the converter unit.
- Parameter setting, monitoring, etc. can be performed using the Mitsubishi inverter protocol.
- To make communication between the personal computer and the converter unit, initial setting of the communication specifications must be made to the converter unit in advance.

Data communication cannot be made if the initial settings are not made or if there is any setting error.

Pr.	Name	Initial value	Setting range	Description
117 N020	PU communication station number	0	0 to 31	Specify the converter unit station number. Set the converter unit station numbers when two or more converter units are connected to one personal computer.
118 N021	PU communication speed	192	48, 96, 192, 384, 576, 768, 1152	Set the communication speed. The setting value × 100 equals the communication speed. For example, if 192 is set, the communication speed is 19200 bps.
N022	PU communication data length	0	0 1	Data length 8 bits Data length 7 bits
N023	PU communication stop bit length	1	0 1	Stop bit length 1 bit Stop bit length 2 bits
119	PU communication stop bit length / data length	1	0 1 10 11	Stop bit length 1 bit Stop bit length 2 bits Data length 8 bits Stop bit length 1 bit Stop bit length 2 bits Data length 7 bits
120 N024	PU communication parity check	2	0 1 2	Without parity check With odd parity With even parity
121 N025	Number of PU communication retries	1	0 to 10 9999	Set the permissible number of retries for unsuccessful data reception. If it is still unsuccessful after the permissible number of retries, the inverter will trip. The inverter will not trip even when the communication is unsuccessful.
122 N026	PU communication check time interval	9999	0 0.1 to 999.8 s 9999	PU connector communication is disabled. Set the interval of the communication check (signal loss detection) time. If a no-communication state persists for longer than the permissible time, the inverter will trip. No communication check (signal loss detection)
123 N027	PU communication waiting time setting	9999	0 to 150 ms 9999	Set the waiting time between data transmission to the converter unit and the response. Set with communication data.
124 N028	PU communication CR/LF selection	1	0 1 2	Without CR/LF With CR With CR/LF

**NOTE**

- Always reset the converter after making the initial settings of the parameters. After changing the communication-related parameters, communication cannot be made until the converter is reset.

## 5.7.4 Mitsubishi inverter protocol (computer link communication)

Parameter settings and monitoring are possible by using the Mitsubishi inverter protocol (computer link communication) via inverter PU connector.

### ◆ Communication specifications

- The communication specifications are given below.

Item	Description	Related parameter	
Communication protocol	Mitsubishi protocol (computer link)	—	
Conforming standard	EIA-485 (RS-485)	—	
Connectable units	1:N (maximum 32 units), setting is 0 to 31 stations	Pr.117	
Communication speed	Selected among 4800/9600/19200/38400 bps	Pr.118	
Control procedure	Start-stop synchronization method	—	
Communication method	Half-duplex system	—	
Communication specifications	Character system	ASCII (7 bits or 8 bits can be selected.)	Pr.119
	Start bit	1 bit	—
	Stop bit length	1 bit or 2 bits can be selected.	Pr.119
	Parity check	Check (even or odd) or no check can be selected.	Pr.120
	Error check	Sum code check	—
Terminator	CR/LF (presence/absence selectable)	Pr.124	
Waiting time setting	Selectable between presence and absence	Pr.123	

### ◆ Communication procedure

- Data communication between the computer and the converter unit is made in the following procedure.
  - Request data is sent from the computer to the converter unit. (The converter unit will not send data unless requested.)
  - After waiting for the waiting time,
  - The converter unit sends reply data to the computer in response to the computer request.
  - After waiting for the converter unit data processing time,
  - An answer from the computer in response to reply data (c) of the converter unit is transmitted. (Even if (e) is not sent, subsequent communication is made properly.)

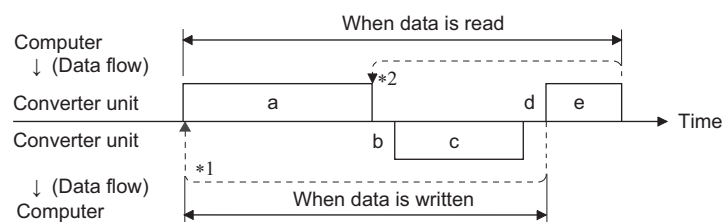

\*1 If a data error is detected and a retry must be made, perform retry operation with the user program. The converter unit output is shut off when the number of consecutive retries exceeds the parameter setting.

\*2 On receipt of a data error occurrence, the converter unit returns reply data (c) to the computer again. The converter unit output is shut off when the number of consecutive data errors exceeds the parameter setting.



## (N) Operation via communication and its settings

### ◆ Communication operation presence/absence and data format types

- Data communication between the computer and the converter unit is made in ASCII code (hexadecimal code).
- Communication operation presence/absence and data format types are as follows.

Symbol	Operation	Special monitor write	Pr. write	Converter reset	Monitor	Pr. read	
a	Communication request is sent to the converter unit in accordance with the user program in the computer.	A1	A	A	B	B	
b	Converter unit data processing time	With	With	Without	With	With	
c	Reply data from the computer unit (Data <b>a</b> ) is checked for an error)	No error *1 (Request accepted)	C	C	C*2	E, E1, E2, E3	E
		With error (Request rejected)	D	D	D*2	D	D
d	Computer processing delay time	10 ms or more					
e	Answer from computer in response to reply data <b>c</b> (Data <b>c</b> is checked for error)	No error *1 (No converter unit processing)	Without	Without	Without	Without (C)	Without (C)
		With error (Converter unit outputs <b>c</b> again.)	Without	Without	Without	F	F

\*1 In the communication request data from the computer to the converter unit, 10 ms or more is also required after "no data error (ACK)". (Refer [page 123](#).)

\*2 Reply from the converter unit to the converter reset request can be selected. (Refer to [page 128](#).)

- Data writing format

#### a. Communication request data from the computer to the converter unit

Format	Number of characters												
	1	2	3	4	5	6	7	8	9	10	11	12	13
A	ENQ *1	Converter unit station No.*2	Instruction code			*3	Data				Sum check		*4
A1	ENQ *1	Converter unit station No.*2	Instruction code			*3	Data	Sum check			*4		

#### c. Reply data from the converter unit to the computer (No data error detected)

Format	Number of characters			
	1	2	3	4
C	ACK *1	Converter unit station No.*2		*4

#### c. Reply data from the converter unit to the computer (Data error detected)

Format	Number of characters				
	1	2	3	4	5
D	NAK *1	Converter unit station No.*2	Error code		*4

\*1 Indicates a control code.

\*2 Specifies the converter unit station numbers in the range of H00 to H1F (stations 0 to 31) in hexadecimal.

\*3 Set the delay time. When a value other than "9999" is set in **Pr.123 PU communication waiting time setting**, create the communication request data without "delay time" in the data format. (The number of characters decreases by 1.)

\*4 CR, LF code: When data is transmitted from the computer to the converter unit, codes CR (carriage return) and LF (line feed) are automatically set at the end of a data group on some computers. In this case, setting must be also made on the converter unit according to the computer. Whether the CR and LF codes will be present or absent can be selected using **Pr.124 (CR/LF selection)**.

## (N) Operation via communication and its settings

- Data reading format

a. Communication request data from the computer to the converter unit

Format	Number of characters								
	1	2	3	4	5	6	7	8	9
B	ENQ *1	Converter unit station No. *2		Instruction code		*3	Sum check		*4

c. Reply data from the converter unit to the computer (No data error detected)

Format	Number of characters												
	1	2	3	4	5	6	7	8	9	10	11	12	13
E	STX *1	Converter unit station No. *2		Read data				ETX *1	Sum check		*4		
E1	STX *1	Converter unit station No. *2		Read data		ETX *1	Sum check		*4				
E2	STX *1	Converter unit station No. *2		Read data (model information, capacity)					ETX *1	Sum check		*4	

Format	Number of characters											
	1	2	3	4 to 23				24	25	26	27	
E3	STX *1	Converter unit station No. *2		Read data (model information, model name)				ETX *1	Sum check		*4	

c. Reply data from the converter unit to the computer (Data error detected)

Format	Number of characters				
	1	2	3	4	5
D	NAK *1	Converter unit station No. *2		Error code	*4

e. Transmission data from the computer to the converter unit

Format	Number of characters			
	1	2	3	4
C (No data error detected)	ACK *1	Converter unit station No. *2		*4
F (Data error detected)	NAK *1	Converter unit station No. *2		*4

\*1 Indicates a control code.

\*2 Specifies the converter unit station numbers in the range of H00 to H1F (stations 0 to 31) in hexadecimal.

\*3 When **Pr.123 (Waiting time setting)** ≠ 9999, create a communication request data without "waiting time" in the data format. (The number of characters decreases by 1.)

\*4 CR, LF code: When data is transmitted from the computer to the converter unit, codes CR (carriage return) and LF (line feed) are automatically set at the end of a data group on some computers. In this case, setting must be also made on the converter unit according to the computer. Whether the CR and LF codes will be present or absent can be selected using **Pr.124 (CR/LF selection)**.

## (N) Operation via communication and its settings

### ◆ Data definitions

- Control code

Signal name	ASCII code	Description
STX	H02	Start Of Text (Start of data)
ETX	H03	End Of Text (End of data)
ENQ	H05	Enquiry (Communication request)
ACK	H06	Acknowledge (No data error detected)
LF	H0A	Line Feed
CR	H0D	Carriage Return
NAK	H15	Negative Acknowledge (Data error detected)

- Converter unit station No.  
Specify the station number of the converter unit which communicates with the computer.
- Instruction code  
Specify the processing request, for example, monitoring, given by the computer to the converter unit. Therefore, the converter unit can be run and monitored in various ways by specifying the instruction code appropriately. (Refer [page 128.](#))
- Data  
Indicates the data such as frequency and parameters transferred to and from the converter unit. The definitions and ranges of set data are determined in accordance with the instruction codes. (Refer [page 128.](#))
- Waiting time  
Specify the waiting time between the receipt of data at the converter unit from the computer and the transmission of reply data. Set the waiting time in accordance with the response time of the computer in the range of 0 to 150 ms in 10 ms increments. (Example; 1: 10 ms, 2: 20 ms)  
When a value other than "9999" is set in **Pr.123 PU communication waiting time setting**, the **Pr.123** setting is effective as the delay time.  
Create the communication request data without "delay time" in the data format. (The number of characters decreases by 1.)

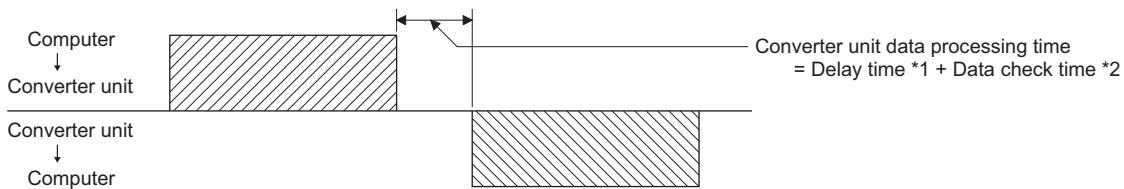

- \*1 Number set in data × 10 (ms) when **Pr.123** = "9999". **Pr.123** setting (ms) when **Pr.123** ≠ "9999".
- \*2 About 10 to 30 ms. It varies depending on the instruction code.

#### NOTE

- The data check time varies depending on the instruction code. (Refer [page 123.](#))
- Sum check code  
The sum check code is a 2-digit ASCII (hexadecimal) representing the lower 1 byte (8 bits) of the sum derived from the checked ASCII data.

## (N) Operation via communication and its settings

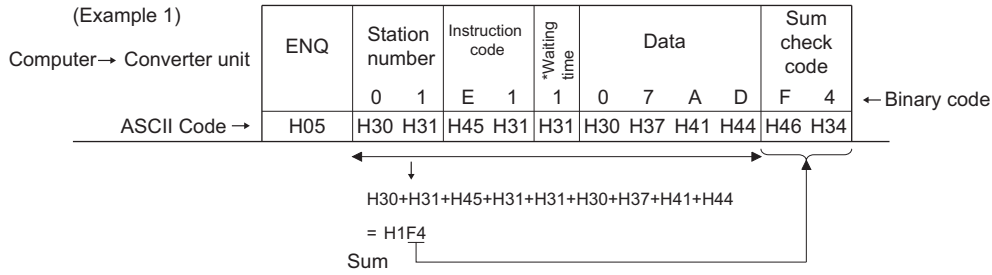

\* When the **Pr. 123 Waiting time setting** ≠ "9999", create the communication request data without "waiting time" in the data format. (The number of characters decreases by 1.)

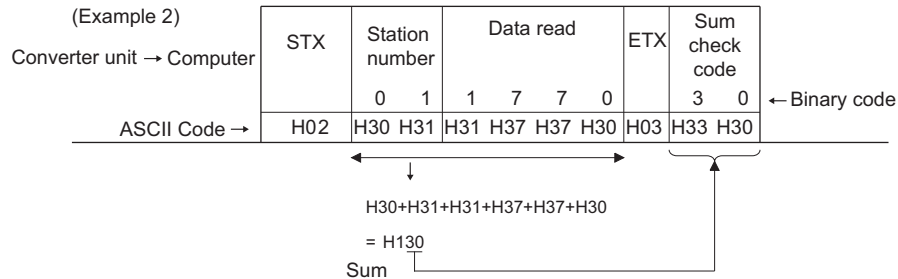

### • Error code

If any error is found in the data received by the converter unit, its error definition is sent back to the computer together with the NAK code.

Error code	Error item	Fault definition	Converter unit operation
H0	Computer NAK error	The transmission request data from the computer was containing errors for the permissible number of retries or more.	Output is shut off (E.PUE/ E.SER) if error occurs continuously more than the permissible number of retries.
H1	Parity error	The parity check result does not match the specified parity.	
H2	Sum check error	The sum check code in the computer does not match that of the data received by the converter unit.	
H3	Protocol error	The data received by the converter unit has a grammatical mistake. Or, data receive is not completed within the predetermined time. CR or LF is not as set in the parameter.	
H4	Framing error	The stop bit length differs from the initial value.	
H5	Overrun	New data has been sent by the computer before the converter unit completes receiving the preceding data.	
H6	—	—	—
H7	Character error	The character received is invalid (other than 0 to 9, A to F, control code).	Does not accept the received data. The converter unit output is not stopped by the fault.
H8	—	—	—
H9	—	—	—
HA	Mode error	Parameter write was attempted in other than the computer link operation mode, when operation command source is not selected or during converter unit operation.	Does not accept the received data. The fault does not occur.
HB	Instruction code error	The specified instruction code does not exist.	
HC	Data range error	Invalid data has been specified for parameter writing, etc.	
HD	—	—	
HE	—	—	
HF	Normal (no error)	—	

### ◆ Response time

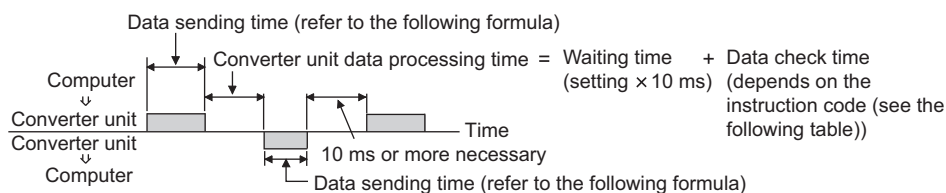

## (N) Operation via communication and its settings

[Formula for data transmission time]

$$\frac{1}{\text{Communication speed (bps)}} \times \text{Number of data characters} \times \text{Communication specifications (Total number of bits)} = \text{data transmission time (s)}$$

(Refer to [page 120.](#)) **Refer to the following section.**

● Communication specifications

Name		Number of bits
Stop bit length		1 bit 2 bits
Data length		7 bits 8 bits
Parity check	With	1 bit
	Without	0

In addition to the above, 1 start bit is necessary.  
 Minimum number of total bits ..... 9 bits  
 Maximum number of total bits ..... 12 bits

● Data check time

Item	Check time
Various monitored values	<12 ms
Parameter read/write	<30 ms
Parameter clear / all clear	<5 s
Reset command	No answer

### ◆ Retry count setting (Pr.121)

- Set the permissible number of retries for data receive error occurrence. (Refer to [page 123](#) for data receive error for retry.)
- When the data receive errors occur consecutively and the number of retries exceeds the permissible number setting, a communication fault (E.PUE) occurs and the inverter output is shut off.
- When a data transmission error occurs while "9999" is set, the inverter output is not shut off but outputs the Alarm (LF) signal. To use the LF signal, set "98 (positive logic) or 198 (negative logic)" in any of **Pr.190 to Pr.195 (Output terminal function selection)** to assign the function to an output terminal.

Example: Pr.121 = "1" (initial value)

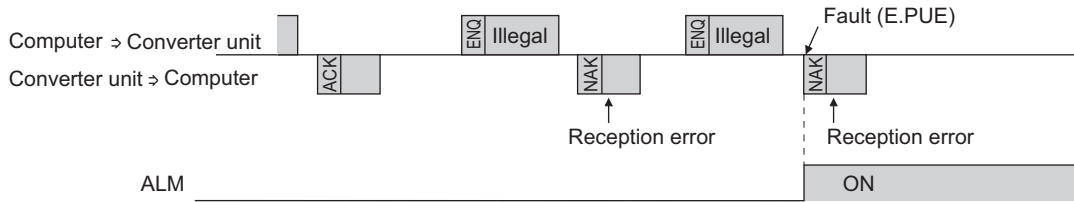

Example: Pr.121 = "9999"

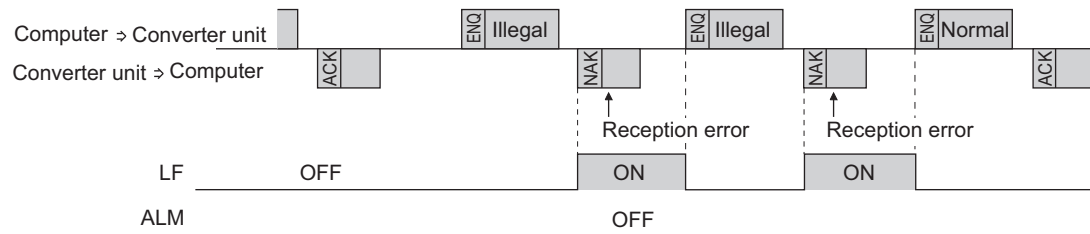

### ◆ Signal loss detection (Pr.122)

- If signal loss is detected between the converter unit and the computer, the communication fault (E.PUE) will occur and the inverter output is shut off.
- When the setting is "9999", communication check (signal loss detection) is not made.
- When the setting is "0", communication is not possible.
- Setting any value from 0.1 s to 999.8 s will enable signal loss detection. To detect signal loss, data must be sent from the computer within the communication check time interval (for further information on control codes, refer to [page 122](#)). (The converter unit makes a communication check (clearing of communication check counter) regardless of the station number setting of the data sent from the master.)

Example: PU connector communication, Pr.122 = 0.1 to 999.8 s

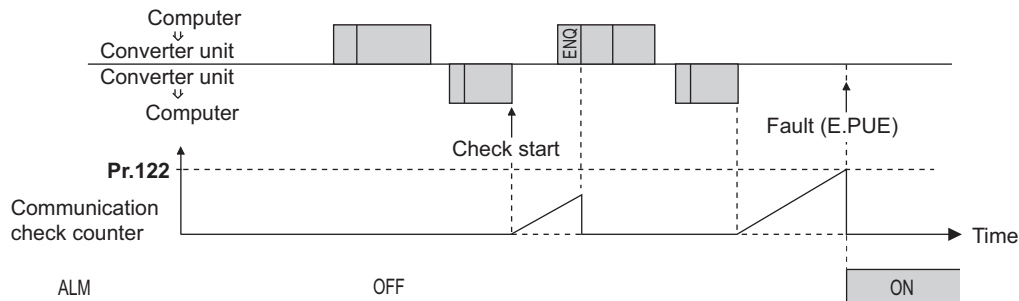

### ◆ Instructions for the program

- When data from the computer has any error, the converter unit does not accept that data. Hence, in the user program, always insert a retry program for data error.
- All data communication, for example, monitoring, are started when the computer gives a communication request. The converter unit does not return any data without the computer's request. Hence, design the program so that the computer gives a data read request for monitoring, etc. as required.
- Program example) Writing "0" in **Pr.57**

### Microsoft® Visual C++® (Ver. 6.0) programming example

```
#include <stdio.h>
#include <windows.h>

void main(void){
    HANDLE          hCom;          // Communication handle
    DCB              hDcb;         // Structure for setting communication settings
    COMMTIMEOUTS    hTim;         // Structure for setting timeouts

    char            szTx[0x10];    // Send buffer
    char            szRx[0x10];    // Receive buffer
    char            szCommand[0x10]; // Command
    int              nTx,nRx;       // For storing buffer size
    int              nSum;          // For calculating sum code
    BOOL            bRet;
    int              nRet;
    int              i;

    //**** Open COM1 port ****
    hCom = CreateFile("COM1", (GENERIC_READ | GENERIC_WRITE), 0, NULL, OPEN_EXISTING, FILE_ATTRIBUTE_NORMAL, NULL);
    if(hCom != NULL) {
        //**** Set COM1 port communication ****
        GetCommState(hCom,&hDcb); // Get current communication information
        hDcb.DCBLength = sizeof(DCB); // Structure size setting
        hDcb.BaudRate = 19200; // Communication speed = 19200 bps
        hDcb.ByteSize = 8; // Data length = 8 bits
        hDcb.Parity = 2; // Even parity
        hDcb.StopBits = 2; // Stop bit = 2 bits
        bRet = SetCommState(hCom,&hDcb); // Setting of changed communication information
        if(bRet == TRUE) {
            //**** Set COM1 port timeout ****
            GetCommTimeouts(hCom,&hTim); // Get current timeout values
            hTim.WriteTotalTimeoutConstant = 1000; // Write timeout 1 second
            hTim.ReadTotalTimeoutConstant = 1000; // Read timeout 1 second
            SetCommTimeouts(hCom,&hTim); // Setting of changed timeout values
            //**** Setting a command to write "0" in Pr.57 of the station number 1 converter unit ****
            sprintf(szCommand,"01B910000"); // Send data (Parameter write)
            nTx = strlen(szCommand); // Send data size
            //**** Generate sum code ****
            nSum = 0; // Initialize sum data
            for(i = 0;i < nTx;i++) {
                nSum += szCommand[i]; // Calculate sum code
                nSum &= (0xff); // Mask data
            }

            //**** Generate send data ****
            memset(szTx,0,sizeof(szTx)); // Initialize send buffer
            memset(szRx,0,sizeof(szRx)); // Initialize receive buffer
            sprintf(szTx,"%5s%02X",szCommand,nSum); // ENQ code + send data + sum code
            nTx = 1 + nTx + 2; // Number of ENQ codes + number of send data + number of sum codes

            nRet = WriteFile(hCom,szTx,nTx,&nTx,NULL);
            //**** Send ****
            if(nRet != 0) {
                nRet = ReadFile(hCom,szRx,sizeof(szRx),&nRx,NULL);
                //**** Receive ****
                if(nRet != 0) {
                    //**** Display receive data ****
                    for(i = 0;i < nRx;i++) {
                        printf("%02X ",(BYTE)szRx[i]); // Output received data to console
                        // Display ASCII code in Hexadecimal' In case of 0, "30" is displayed.
                    }
                    printf("\n\r");
                }
            }
            CloseHandle(hCom); // Close communication port
        }
    }
}
```

General flowchart

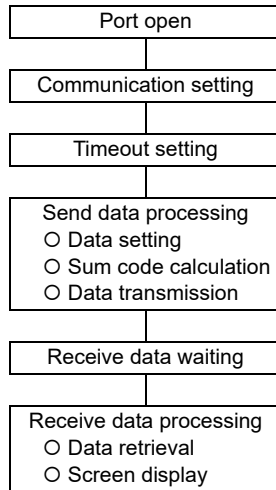

### CAUTION

- Always set the communication check time interval before starting operation to prevent hazardous conditions.
- Data communication is not started automatically but is made only once when the computer provides a communication request. If communication is disabled during operation due to signal cable breakage etc., the inverter cannot be stopped. When the communication check time interval has elapsed, the inverter output will be shut off (E.PUE).  
The inverter can be coasted to a stop by switching ON the RES signals or by switching the power OFF.
- If communication is broken due to signal cable breakage, computer fault etc., the converter unit does not detect such a fault. This should be fully noted.



## (N) Operation via communication and its settings

### ◆ Setting items and set data

- After completion of parameter settings, set the instruction codes and data, then start communication from the computer to allow reading/writing of parameters and monitoring.

Item	Read/write	Instruction code	Data description	Number of data digits (Format)*1																																																			
Monitor	Converter output voltage	Read	H6F	H0000 to HFFFF: Converter output voltage (hexadecimal) in 0.1 V increments	4 digits (B.E/D)																																																		
	Input current	Read	H70	H0000 to HFFFF: Input current (hexadecimal) in 0.1 A increments	4 digits (B.E/D)																																																		
	Electric thermal relay function load factor	Read	H71	H0000 to HFFFF: Electronic thermal relay function load factor (hexadecimal) in 0.1% increments	4 digits (B.E/D)																																																		
	Special monitor	Read	H72	H0000 to HFFFF: Monitor data selected in the instruction code HF3	4 digits (B.E/D)																																																		
	Special monitor selection No.	Read	H73	Monitor selection data (Refer to <a href="#">page 101</a> on selection No.)	2 digits (B.E1/D)																																																		
		Write	HF3		2 digits (A1, C/D)																																																		
	Fault record	Read	H74 to H77	<p>H0000 to HFFFF: Two latest fault records</p> <table style="margin-left: 40px;"> <tr> <td style="text-align: center;">b15</td> <td style="text-align: center;">b8 b7</td> <td style="text-align: center;">b0</td> </tr> <tr> <td>H74</td> <td>Second fault in past</td> <td>Latest fault</td> </tr> <tr> <td>H75</td> <td>Fourth fault in past</td> <td>Third fault in past</td> </tr> <tr> <td>H76</td> <td>Sixth fault in past</td> <td>Fifth fault in past</td> </tr> <tr> <td>H77</td> <td>Eighth fault in past</td> <td>Seventh fault in past</td> </tr> </table> <p>Fault record display example (instruction code H74)</p> <p>With the read data H3040                      (Last fault : E.THC)                      (Present fault : E.FIN)</p> <table style="margin-left: 40px;"> <tr> <td style="text-align: center;">b15</td> <td style="text-align: center;">b8 b7</td> <td style="text-align: center;">b0</td> </tr> <tr> <td>0</td><td>0</td><td>1</td><td>1</td><td>0</td><td>0</td><td>0</td><td>0</td><td>0</td><td>1</td><td>0</td><td>0</td><td>0</td><td>0</td><td>0</td><td>0</td> </tr> <tr> <td colspan="8" style="text-align: center;">Last fault (H30)</td> <td colspan="8" style="text-align: center;">Present fault (H40)</td> </tr> </table> <p>(Refer to <a href="#">page 141</a> for details on fault record read data.)</p>	b15	b8 b7	b0	H74	Second fault in past	Latest fault	H75	Fourth fault in past	Third fault in past	H76	Sixth fault in past	Fifth fault in past	H77	Eighth fault in past	Seventh fault in past	b15	b8 b7	b0	0	0	1	1	0	0	0	0	0	1	0	0	0	0	0	0	Last fault (H30)								Present fault (H40)								4 digits (B.E/D)
	b15	b8 b7	b0																																																				
	H74	Second fault in past	Latest fault																																																				
	H75	Fourth fault in past	Third fault in past																																																				
H76	Sixth fault in past	Fifth fault in past																																																					
H77	Eighth fault in past	Seventh fault in past																																																					
b15	b8 b7	b0																																																					
0	0	1	1	0	0	0	0	0	1	0	0	0	0	0	0																																								
Last fault (H30)								Present fault (H40)																																															
Converter status monitor (extended)	Read	H79	Status of the output signals can be monitored. (For the details, refer to <a href="#">page 130</a> .)	4 digits (B.E/D)																																																			
Converter status monitor	Read	H7A		2 digits (B.E1/D)																																																			
Converter reset	Write	HFD	H9696: Converter unit reset • As the converter unit is reset at the start of communication by the computer, the converter unit cannot send reply data back to the computer.	4 digits (A, C/D)																																																			
			H9966: Converter unit reset • When data is sent normally, ACK is returned to the computer, and then the converter is reset.	4 digits (A, D)																																																			
Fault history batch clear	Write	HF4	H9696: Fault history batch clear	4 digits (A, C/D)																																																			

## (N) Operation via communication and its settings

Item	Read/write	Instruction code	Data description	Number of data digits (Format)*1
Parameter clear All clear	Write	HFC	<p>All parameters return to initial values. Whether to clear communication parameters or not can be selected according to the data.</p> <ul style="list-style-type: none"> <li>Parameter clear H9696: Communication parameters are cleared. H5A5A: Communication parameters are not cleared.*2</li> <li>All parameter clear H9966: Communication parameters are cleared. H55AA: Communication parameters are not cleared.*2</li> </ul> <p>For the details of whether or not to clear parameters, refer to <a href="#">page 170</a>. When a clear is performed with H9696 or H9966, communication related parameter settings also return to the initial values. When resuming the operation, set the parameters again. Performing a clear will clear the instruction code HEC, HF3, and HFF settings. Only H9966 and H55AA (all parameter clear) are valid during the password lock (refer to <a href="#">page 91</a>).</p>	4 digits (A, C/D)
Parameter	Read	H00 to H63	Refer to the instruction code ( <a href="#">page 170</a> ) and write and/or read parameter values as required.	4 digits (B,E/D)
	Write	H80 to HE3	When setting <b>Pr.100</b> and later, the link parameter extended setting must be set.	4 digits (A, C/D)
Link parameter extended setting	Read	H7F	Parameter settings are switched according to the H00 to H0D settings.	2 digits (B,E1/D)
	Write	HFF	For details of the settings, refer to the <b>instruction code</b> ( <a href="#">page 170</a> ).	2 digits (A1, C/D)
Model information monitor	Model	Read H7C	<p>Reading the model name in ASCII code. "H20" (blank code) is set for blank area. For "FR-CC2-H-P" H46, H52, H2D, H43, H43, H32, H2D, H48, H2D, H50, H20, H20 .... H20</p>	20 digits (B, E3/D)
	Capacity	Read H7D	<p>Reading the converter capacity in ASCII code. Data is read in increments of 0.1 kW. "H20" (blank code) is set for blank area. Example) 400K....." 4000" (H20, H20, H34, H30, H30, H30)</p>	6 digits (B, E2/D)

\*1 Refer to [page 120](#) for data formats (A, A1, B, C, C1, D, E, E1, E2, E3, F).

\*2 Turning OFF the power supply while clearing parameters with H5A5A or H55AA sets back the communication parameter settings to the initial settings.

### NOTE

- Set 65520 (HFFF0) as a parameter value "8888" and 65535 (HFFFF) as "9999".
- For the instruction codes HFF, HEC and HF3, their values are held once written but cleared to zero when a converter reset or all clear is performed.
- When a 32-bit parameter setting or monitored value is read and the read value exceeds HFFFF, the reply data will be HFFFF.

◆ Converter status monitor









Item	Instruction code	Bit length	Description*1	Example
Converter status monitor	H7A	8 bits	b0: RDB (inverter operation enable signal (NC contact)) b1: Fixed to 0 b2: Fixed to 0 b3: RDA (inverter operation enable signal (NO contact)) b4: RSO (inverter reset signal) b5: IPF (instantaneous power failure/undervoltage) b6: FAN (fan fault signal) b7: ABC1 (Fault)	[Example 1] H01...Inverter operation enable signal (NC contact) ON b7 b0 0 0 0 0 0 0 0 1 [Example 2] H80...Fault occurrence b7 b0 1 0 0 0 0 0 0 0
Converter status monitor (extended)	H79	16 bits	b0: RDB (inverter operation enable signal (NC contact)) b1: Fixed to 0 b2: Fixed to 0 b3: RDA (inverter operation enable signal (NO contact)) b4: RSO (inverter reset signal) b5: IPF (instantaneous power failure/undervoltage) b6: FAN (fan fault signal) b7: ABC1 (Fault) b8 to b14: — b15: Fault occurrence	[Example 1] H0001...Inverter operation enable signal (NC contact) ON b15 b0 0 0 0 0 0 0 0 0 0 0 0 0 0 0 0 1 [Example 2] H8080...Fault occurrence b15 b0 1 0 0 0 0 0 0 0 0 1 0 0 0 0 0 0

\*1 The signal within parentheses ( ) is the initial status. The description changes depending on the setting of Pr.190 to Pr.195 (Output terminal function selection).

## 5.8 Parameter clear / all parameter clear

### POINT

- Set "1" to **Pr.CLR Parameter clear, ALL.CL All parameter clear** to initialize all parameters. (Parameters cannot be cleared when **Pr.77 Parameter write selection** = "1".)
- Terminal function selection parameters are not cleared with Pr.CL.
- Refer to the parameter list on [page 170](#) for availability of parameter clear and all parameter clear for each parameter.

Operation	
1.	Screen at power-ON The monitor display appears.
2.	Parameter setting mode Press  to choose the parameter setting mode. (The parameter number read previously appears.)
3.	Selecting the parameter number To perform a parameter clear, turn  to <i>Pr.CLR</i> , and to perform all parameter clear, turn it to <i>ALL.CL</i> and press  . "0" (initial value) appears.
4.	Parameter clear Turn  to change the set value to "1". Press  to enter the setting. "1" and "Pr.CLR" ( <i>ALL.CL</i> ) blink alternately after parameters are cleared. <ul style="list-style-type: none"> <li>• Turn  to read another parameter.</li> <li>• Press  to show the setting again.</li> <li>• Press  twice to show the next parameter.</li> </ul>

Setting value	Description	
	Pr.CLR Parameter clear	ALL.CL All parameter clear
0	Initial display (Parameters are not cleared.)	
1	Returns parameters excluding <b>terminal function selection parameters</b> , etc. to their initial values.	Returns all parameters which can be cleared including <b>terminal function selection parameters</b> to their initial values.

# 5.9 Copying and verifying parameters

Pr.CPY setting value	Description
0.---	Initial display
1.RD	Copy the source parameters to the operation panel.
2.WR	The parameters copied to the operation panel can be also copied to the destination converter units.
3.VFY	Verify parameters in the converter unit and the operation panel. (Refer to <a href="#">page 134</a> .)



**NOTE**

- When the destination is other than the FR-CC2-P series or when parameter copy is attempted after the parameter copy reading was stopped, "model error (r-E4)" appears.
- Refer to the parameter list on [page 170](#) for availability of parameter copy.
- When the power is turned OFF or an operation panel is disconnected, etc. during parameter copy writing, write again or check the setting values by parameter verification.
- If parameters are copied from an older converter unit to a newer converter unit that has additional parameters, out-of-range setting values may be written in some parameters. In this case, those parameters operate as if they were set to their initial values.

## 5.9.1 Parameter copy

- The converter unit parameter settings can be copied to other converter units.







### ◆ Reading the parameter settings of the converter unit to the operation panel

Operation	
1.	Connects the operation panel to the source converter unit.
Parameter setting mode	
2.	Press <b>MODE</b> to choose the parameter setting mode. (The parameter number read previously appears.)
Selecting the parameter number	
3.	Turn  to <b>Pr.CPY</b> (parameter copy), and press <b>SET</b> . "0.---" appears.
Reading to the operation panel	
4.	Turn  to change the set value to "RD". Press <b>SET</b> to start reading of the converter unit parameter settings by the operation panel. (It takes about 30 seconds to read all the settings. During reading, "RD" blinks.)
End reading	
5.	"RD" and "Pr.CPY" blink alternately after settings are read.

**NOTE**

- r-E 1 appears... Why?  
-Parameter read error. Perform the operation from step 3 again.

## ◆ Copying parameter settings read to the operation panel to the converter unit



Operation	
1.	Connects the operation panel to the destination converter unit.
Parameter setting mode	
2.	Press  to choose the parameter setting mode. (The parameter number read previously appears.)
Selecting the parameter number	
3.	Turn  to <i>P-R-C-P-Y</i> (parameter copy), and press  . "0. - - -" appears.
Selecting parameter copy	
4.	Turn  to change the set value to "2WR", then press  . 2. ALL appears.
Copying to the converter unit	
5.	Press  to start copying to the converter unit. (It takes about 60 seconds to copy all the settings. During copying, "2. ALL" blinks.)
Ending copying	
6.	"2WR" and "P-R-C-P-Y" blink alternately after copying ends.
7.	When parameters are written to the destination converter unit, reset the converter unit before operation by, for example, turning the power supply OFF.

### NOTE

- *r-E2* appears... Why?  
-Parameter write error. Perform the operation from step 3 again.

## 5.9.2 Parameter verification

- Whether the parameter settings of converter units are the same or not can be checked.



Operation	
1.	Copy the parameter settings of the verification source converter unit to the operation panel according to the procedure on <a href="#">page 132</a> .
2.	Move the operation panel to the converter unit to be verified.
Screen at power-ON	
3.	The monitor display appears.
Parameter setting mode	
4.	Press <b>MODE</b> to choose the parameter setting mode. (The parameter number read previously appears.)
Selecting the parameter number	
5.	Turn  to <b>PRCPY</b> (parameter copy), and press <b>SET</b> . "0- - - -" appears.
Parameter verification	
6.	Turn  to change to the setting value " <b>3VF4</b> " (parameter copy verification mode). Press <b>SET</b> . Verification of the parameter settings copied to the operation panel and the parameter settings of the verification destination converter unit is started. (It takes about 60 seconds to verify all the settings. During verification, " <b>3VF4</b> " blinks.) <ul style="list-style-type: none"><li>• If there are different parameters, the different parameter number and "<b>rE3</b>" blink.</li><li>• To continue verification, press <b>SET</b>.</li></ul>
7.	" <b>PRCPY</b> " and " <b>3VF4</b> " blink alternately after verification ends.

 **NOTE**

- **rE3** blinks... Why?
  - The parameter settings may be different between the verification source converter unit and the verification destination converter unit. To continue verification, press **SET**.

## 5.10 Checking parameters changed from their initial values (Initial value change list)

Parameters changed from their initial values can be displayed.

	Operation
1.	Screen at power-ON The monitor display appears.
2.	Parameter setting mode Press <b>MODE</b> to choose the parameter setting mode. (The parameter number read previously appears.)
3.	Selecting the parameter number Turn  to <b>Pr-CHG</b> (initial value change list), and press <b>SET</b> . "P.-- -- --" appears.
4.	Checking the initial value change list Turn  . The parameter numbers that have been changed from their initial value appear in order. • If <b>SET</b> is pressed with parameters that have been changed, the parameter settings can be changed as they are. (Parameter numbers are no longer displayed in the list when they are returned to their initial values.) Other changed parameters appear by turning  . • "P.-- -- --" appears again when the last changed parameter is displayed.

### NOTE

- The initial value change list can be used also for parameter setting.



# MEMO

---

# **6** PROTECTIVE FUNCTIONS

---

This chapter explains the "PROTECTIVE FUNCTION" that operates in this product.

Always read the instructions before using the equipment.

---

<b>6.1</b>	<b>Converter unit fault and alarm indications .....</b>	<b>138</b>
<b>6.2</b>	<b>Reset method for the protective functions.....</b>	<b>138</b>
<b>6.3</b>	<b>Check and clear of the fault history .....</b>	<b>139</b>
<b>6.4</b>	<b>Fault history and the list of fault displays .....</b>	<b>141</b>
<b>6.5</b>	<b>Causes and corrective actions .....</b>	<b>142</b>
<b>6.6</b>	<b>Check first when you have trouble .....</b>	<b>150</b>

# 6.1 Converter unit fault and alarm indications

- When the converter unit detects a fault, depending on the nature of the fault, the operation panel displays an error message or warning, or a protective function is activated to shut off the inverter output.
- When a protective function is activated, take an appropriate corrective action, then reset the converter unit (inverter), and resume the operation. Restarting the operation without a reset may break or damage the converter unit (inverter).
- When a protective function is activated, note the following points.

Item	Description
Fault output signal	Opening the magnetic contactor (MC) provided on the input side of the converter unit at a fault occurrence shuts off the control power to the converter unit, therefore, the fault output will not be retained.
Fault or alarm indication	When a protective function is activated, the operation panel displays a fault indication.
Operation restart method	While a protective function is activated, the inverter output is kept shutdown. Reset the converter unit (inverter) to restart the operation.

- Converter unit fault or alarm indications are categorized as below.

Displayed item	Description
Error message	A message regarding an operational fault and setting fault by the operation panel is displayed. The inverter output is not shut off.
Warning	The inverter output is not shut off even when a warning is displayed. However, failure to take appropriate measures will lead to a fault.
Alarm	The inverter output is not shut off. An Alarm (LF) signal can also be output with a parameter setting.
Fault	A protective function is activated to shut off the inverter output and output a Fault (ALM) signal.

**NOTE**

- The past eight faults can be displayed on the operation panel. (Fault history) (For the operation, refer to [page 139](#).)

# 6.2 Reset method for the protective functions

Reset the converter unit by performing any of the following operations. Note that the accumulated heat value of the electronic thermal relay function is cleared (erased) by resetting the inverter.

The converter unit recovers about 1 s after the reset is released.

- On the operation panel, press  to reset the converter unit. (This may only be performed when a fault occurs. (Refer to [page 145](#) of the Instruction Manual for faults.))
- Switch power OFF once, then switch it ON again.
- Turn ON the reset signal (RES) for 0.1 s or more. (If the RES signal is kept ON, "Err" appears (blinks) to indicate that the converter unit is in a reset status.)

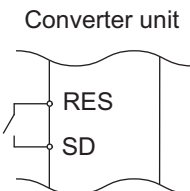
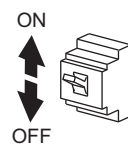
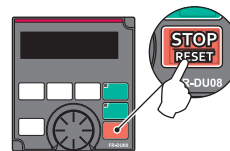

**NOTE**

- Resetting a converter unit fault with the inverter start signal ON restarts the inverter suddenly. OFF status of the inverter start signal must be confirmed before resetting.

# 6.3 Check and clear of the fault history

The operation panel stores the fault indications which appears when a protective function is activated to display the fault record for the past eight faults. (Fault history)

## ◆ Check for the fault history

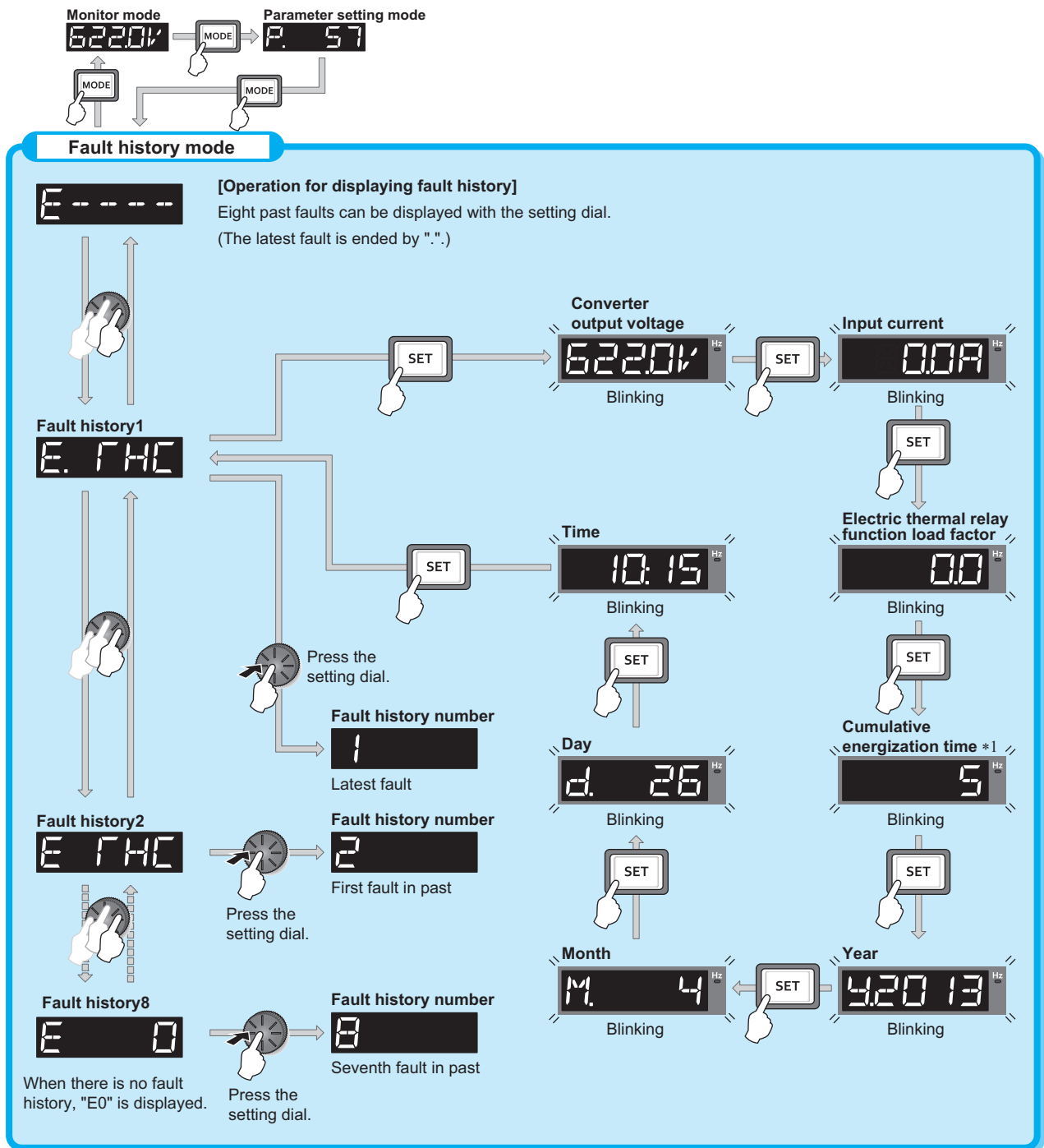

\*1 The cumulative energization time is accumulated from 0 to 65535 hours, then cleared, and accumulated again from 0.

**NOTE**

- The fault history can be checked when the operation panel of the inverter is installed on the converter unit.









### ◆ Fault history clearing procedure



#### POINT

- Set Err.CL Fault history clear = "1" to clear the fault history.

#### Operation

1. Screen at power-ON  
The monitor display appears.
2. Parameter setting mode  
Press  to choose the parameter setting mode. (The parameter number read previously appears.)
3. Selecting the parameter number  
Turn  until "Err.CL" (fault history clear) appears. Press  to read the present set value. "0" (initial value) appears.
4. Fault history clear  
Turn  to change the set value to "1". Press  to start clear.  
"1" and "Err.CL" blink alternately after parameters are cleared.
  - Turn  to read another parameter.
  - Press  to show the setting again.
  - Press  twice to show the next parameter.

## 6.4 Fault history and the list of fault displays

If the displayed message does not correspond to any of the following or if you have any other problem, contact your sales representative.

### ◆ Error message

- A message regarding an operational fault and setting fault by the operation panel is displayed. The inverter output is not shut off.

Operation panel indication	Name	Refer to page
HOLD	Operation panel lock	142
LOCd	Password locked	142
Er1	Parameter write error	142
Er2	Parameter write error	142
rE1 to rE4	Copy operation error	142 143
Err.	Error	143

### ◆ Warning

- The inverter output is not shut off even when a warning is displayed. However, failure to take appropriate measures will lead to a fault.

Operation panel indication	Name	Refer to page
TH	Electronic thermal relay function pre-alarm	143
MF1 to MF3	Maintenance timer 1 to 3	143
Ed	Emergency drive in operation	144

### ◆ Alarm

- The inverter output is not shut off. An Alarm (LF) signal can be output with a parameter setting.

Operation panel indication	Name	Refer to page
FN	Fan alarm	145

### ◆ Fault

- A protective function is activated to trip the inverter and output a Fault (ALM) signal.
- The data code is used for checking the fault via communication or for setting **Pr.997 Fault initiation**.

Operation panel indication	Name	Data code	Refer to page
E. OVF	Overvoltage trip	32 (H20)	145
E. FHC	Converter overload trip (electronic thermal relay function)	48 (H30)	145
E. FIN	Heat sink overheat	64 (H40)	145
E. IPF	Instantaneous power failure	80 (H50)	146
E. UVF	Undervoltage	81 (H51)	146

Operation panel indication	Name	Data code	Refer to page
E. ILF	Input phase loss	82 (H52)	146
E. OHT	External thermal relay operation	144 (H90)	146
E. PA1	Parallel operation slave 1 fault *1	169 (HA9)	146
E. PA2	Parallel operation slave 2 fault *1	170 (HAA)	147
E. PE	Parameter storage device fault	176 (HB0)	147
E. PUE	PU disconnection	177 (HB1)	147
E. REF	Retry count excess	178 (HB2)	147
E. PE2	Parameter storage device fault	179 (HB3)	147
E. CPU	CPU fault	192 (HC0)	147
E. 5		245 (HF5)	
E. 6		246 (HF6)	
E. 7		247 (HF7)	
E. CFE	Operation panel power supply short circuit / RS-485 terminals power supply short circuit	193 (HC1)	148
E. P24	24 VDC power fault	194 (HC2)	148
E. IOH	Inrush current limit circuit fault	197 (HC5)	148
E. SER	Communication fault (inverter)	198 (HC6)	148
E. P6F	Internal circuit fault	202 (HCA)	148
E. 13		253 (HFD)	
E. 1	Option fault	241 (HF1)	149

### ◆ Others

- The fault history and the operation status of the converter unit are displayed. It is not a fault.

Operation panel indication	Name	Refer to page
E. ---	Fault history	139
EV	24 V external power supply operation	149
SLV.1	Parallel operation slave 1 *2	149
SLV.2	Parallel operation slave 2 *2	149



\*1 For the slave, the protective function is not activated.

\*2 For the master, the function is not activated.

## 6.5 Causes and corrective actions

### ◆ Error message

A message regarding operational troubles is displayed. The inverter output is not shut off.

Operation panel indication	HOLD	HOLD
Name	Operation panel lock	
Description	Operation lock is set. Operation other than  is invalid. (Refer to <a href="#">page 90</a> .)	
Check point	_____	
Corrective action	Press  for 2 s to release the lock.	

Operation panel indication	LOCD	LOCD
Name	Password locked	
Description	Password function is active. Display and setting of parameters are restricted.	
Check point	_____	
Corrective action	Enter the password in <b>Pr.297 Password lock/unlock</b> to unlock the password function before operating. (Refer to <a href="#">page 91</a> .)	

Operation panel indication	Er1	Er 1
Name	Parameter write error	
Description	<ul style="list-style-type: none"> <li>Parameter setting was attempted while <b>Pr.77 Parameter write selection</b> is set to disable parameter write.</li> <li>The operation panel and converter unit cannot make normal communication.</li> </ul>	
Check point	<ul style="list-style-type: none"> <li>Check the <b>Pr.77</b> setting. (Refer to <a href="#">page 90</a>.)</li> <li>Check the connection between the operation panel and the converter unit.</li> </ul>	

Operation panel indication	Er2	Er 2
Name	Parameter write error	
Description	<ul style="list-style-type: none"> <li>Parameter write was attempted during emergency drive operation.</li> </ul>	
Check point	<ul style="list-style-type: none"> <li>Check for any attempt of parameter write during emergency drive operation.</li> </ul>	

Operation panel indication	rE1	rE 1
Name	Parameter read error	
Description	A failure has occurred at the operation panel side EEPROM while reading the copied parameters.	
Check point	_____	
Corrective action	<ul style="list-style-type: none"> <li>Perform parameter copy again. (Refer to <a href="#">page 132</a>.)</li> <li>The operation panel may be faulty. Contact your sales representative.</li> </ul>	

Operation panel indication	rE2	rE 2
Name	Parameter write error	
Description	A failure has occurred at the operation panel side EEPROM while writing the copied parameters.	
Check point	_____	
Corrective action	<ul style="list-style-type: none"> <li>The operation panel may be faulty. Contact your sales representative.</li> <li>Perform parameter copy again. (Refer to <a href="#">page 132</a>.)</li> </ul>	

Operation panel indication	rE3	rE3
Name	Parameter verification error	
Description	<ul style="list-style-type: none"> <li>The data in the converter unit are different from the data in the operation panel.</li> <li>A failure has occurred at the operation panel side EEPROM during parameter verification.</li> </ul>	
Check point	Check the parameter setting of the source converter unit against the setting of the destination converter unit.	
Corrective action	<ul style="list-style-type: none"> <li>Continue the verification by pressing .</li> <li>Perform parameter verification again. (Refer to <a href="#">page 134</a>.)</li> <li>The operation panel may be faulty. Contact your sales representative.</li> </ul>	

Operation panel indication	rE4	rE4
Name	Model error	
Description	<ul style="list-style-type: none"> <li>A different model was used when parameter copy from the operation panel or parameter verification was performed.</li> <li>The data in the operation panel were not correct when parameter copy from the operation panel or parameter verification was performed.</li> </ul>	
Check point	<ul style="list-style-type: none"> <li>Check that the parameter copy or verification source converter unit is of the same model.</li> <li>Check that parameter copy to the operation panel was not interrupted by switching OFF the power or by disconnecting the operation panel.</li> </ul>	
Corrective action	<ul style="list-style-type: none"> <li>Perform parameter copy and parameter verification between converter units of the same model (FR-CC2-P series).</li> <li>Perform parameter copy to the operation panel from the converter unit again.</li> </ul>	

Operation panel indication	Err.	Err.
Description	<ul style="list-style-type: none"> <li>The RES signal is turned ON.</li> <li>The operation panel and converter unit cannot make normal communication. (contact faults of the connector).</li> <li>This error may occur when the voltage at the input side of the converter unit drops.</li> <li>When using a separate power source for the control circuit power (R1/L11, S1/L21) from the main circuit power (R/L1, S/L2, T/L3), this error may appear at turning ON of the main circuit. It is not a fault.</li> </ul>	
Corrective action	<ul style="list-style-type: none"> <li>Turn OFF the RES signal.</li> <li>Check the connection between the operation panel and the converter unit.</li> <li>Check the voltage on the input side of the converter unit.</li> </ul>	

◆Warning

The inverter output is not shut off when a protective function is activated.

Operation panel indication	TH	TH
Name	Electronic thermal relay function pre-alarm	
Description	<p>If the accumulated electronic thermal value reaches 85%, TH is displayed and the THP signal is output. If the cumulative value reaches or exceeds the specified value, the protection circuit is activated to stop the outputs of the converter unit.</p> <p>For the terminal used for the THP signal output, set "8 (positive logic)" or "108 (negative logic)" in any of <b>Pr.190 to Pr.195 (Output terminal function selection)</b> to assign the function.</p>	
Check point	Check for large load or sudden acceleration.	
Corrective action	Reduce the load and frequency of operation.	

Operation panel indication	MT1 to MT3	MT 1 to MT 3
Name	Maintenance timer 1 to 3	
Description	<p>Appears when the converter unit's cumulative energization time reaches or exceeds the parameter set value. Set the time until the MT is displayed by setting <b>Pr.504 Maintenance timer 1 warning output set time (MT1)</b>, <b>Pr.687 Maintenance timer 2 warning output set time (MT2)</b>, and <b>Pr.689 Maintenance timer 3 warning output set time (MT3)</b>.</p> <p>MT does not appear when the settings of <b>Pr.504</b>, <b>Pr.687</b>, and <b>Pr.689</b> are initial values (9999).</p>	
Check point	The set time of maintenance timer has been exceeded. (Refer to <a href="#">page 95</a> .)	
Corrective action	<p>Take appropriate countermeasures according to the purpose of the maintenance timer setting.</p> <p>Setting "0" in <b>Pr.503 Maintenance timer 1</b>, <b>Pr.686 Maintenance timer 2</b>, and <b>Pr.688 Maintenance timer 3</b> erases the indication.</p>	



## Causes and corrective actions

---

<b>Operation panel indication</b>	<b>ED</b>	<b>Ed</b>
<b>Name</b>	Emergency drive in operation	
<b>Description</b>	Appears during emergency drive operation.	
<b>Check point</b>	Emergency drive operation is performed by turning ON the X84 signal.	
<b>Corrective action</b>	The display is cleared when the emergency drive operation ends.	

### ◆Alarm

The inverter output is not shut off when a protective function is activated. An alarm can also be output with a parameter setting.

(Set "98" in Pr.190 to Pr.195 (Output terminal function selection). (Refer to page 105.)

Operation panel indication	FN	FN
Name	Fan alarm	
Description	FN appears on the operation panel when the cooling fan of the converter unit stops due to a fault or when the speed decreases.	
Check point	Check the cooling fan for a failure.	
Corrective action	Check for fan failure. Contact your sales representative.	

### ◆Fault

When a protective function activates, the inverter output is not shut off and a fault signal is output.

Operation panel indication	E.OVT	E. OVT
Name	Overvoltage trip	
Description	If the converter unit's internal main circuit DC voltage reaches or exceeds the specified value, the protective circuit is activated to stop the inverter output. The circuit may also be activated by a surge voltage produced in the power supply system.	
Check point	<ul style="list-style-type: none"> <li>• Check for sudden load change or excessive regeneration.</li> <li>• Check for power fault.</li> </ul>	
Corrective action	<ul style="list-style-type: none"> <li>• Keep the load stable.</li> <li>• Check the power supply.</li> </ul>	

Operation panel indication	E.THC	E. THC
Name	Converter overload trip (electronic thermal relay function)*1	
Description	For the protection of converter unit diode, the electronic thermal O/L relay is activated in inverse-time characteristics against the converter unit input current to shut off the inverter output.	
Check point	<ul style="list-style-type: none"> <li>• Check the motor for the use under overload.</li> <li>• Check that the capacity of the inverter used is not larger than that of the converter unit.</li> </ul>	
Corrective action	<ul style="list-style-type: none"> <li>• Reduce the load.</li> <li>• Check the configuration of the inverter and the converter unit again.</li> </ul>	

\*1 Resetting the converter unit initializes the internal cumulative heat value of the electronic thermal O/L relay function.

Operation panel indication	E.FIN	E. FIN
Name	Heat sink overheating	
Description	When the heat sink overheats, the temperature sensor activates, and the inverter output is stopped. The FIN signal can be output when the temperature reaches approximately 85% of the heat sink overheating protection operation temperature. For the terminal used for the FIN signal output, assign the function by setting "26 (positive logic) or 126 (negative logic)" in any of Pr.190 to Pr.195 (Output terminal function selection). (Refer to page 105.)	
Check point	<ul style="list-style-type: none"> <li>• Check for too high surrounding air temperature.</li> <li>• Check for heat sink clogging.</li> <li>• Check that the cooling fan is not stopped. (Check that FN is not displayed on the operation panel.)</li> </ul>	
Corrective action	<ul style="list-style-type: none"> <li>• Set the surrounding air temperature to within the specifications.</li> <li>• Clean the heat sink.</li> <li>• Replace the cooling fan.</li> </ul>	

## Causes and corrective actions

<b>Operation panel indication</b>	<b>E.IPF</b>	<b>E. I PF</b>
<b>Name</b>	Instantaneous power failure*1	
<b>Description</b>	If a power failure occurs for longer than 15 ms (this also applies to converter unit input shut-off), the instantaneous power failure protective function is activated to trip the inverter in order to prevent the control circuit from malfunctioning. If a power failure persists for 100 ms or longer, the fault output is not provided, and the inverter restarts if the inverter start signal is ON upon power restoration. (The inverter continues operating if an instantaneous power failure is within 15 ms.) In some operating status (load magnitude, acceleration/deceleration time setting, etc.), overcurrent or other protection may be activated by the inverter upon power restoration. When instantaneous power failure protection is activated, the IPF signal is output. (Refer to <a href="#">page 113</a> .)	
<b>Check point</b>	Find the cause of the instantaneous power failure occurrence.	
<b>Corrective action</b>	<ul style="list-style-type: none"> <li>• Recover from the instantaneous power failure condition.</li> <li>• Prepare a backup power supply in case of an instantaneous power failure.</li> <li>• Set the function of automatic restart after instantaneous power failure (<b>Pr.57</b>). (Refer to <a href="#">page 113</a>.)</li> </ul>	

\*1 E.IPF is not activated in the delta connection (for terminals R2/L12, S2/L22, and T2/L32) even if the power fails for longer than 15 ms while the converter unit is used with a 12-phase transformer.

<b>Operation panel indication</b>	<b>E.UVT</b>	<b>E. UVT</b>
<b>Name</b>	Undervoltage	
<b>Description</b>	If the power supply voltage of the converter unit decreases, the control circuit will not perform normal functions. In addition, the motor torque will be insufficient and/or heat generation will increase. To prevent this, if the power supply voltage decreases to about 300 VAC or below, this function shuts off the inverter output. When undervoltage protection is activated, the IPF signal is output. (Refer to <a href="#">page 113</a> .)	
<b>Check point</b>	Check if a high-capacity motor is driven.	
<b>Corrective action</b>	<ul style="list-style-type: none"> <li>• Check the power supply system equipment such as the power supply.</li> <li>• If the problem still persists after taking the above measure, contact your sales representative.</li> </ul>	

<b>Operation panel indication</b>	<b>E.ILF*2</b>	<b>E. I L F</b>
<b>Name</b>	Input phase loss	
<b>Description</b>	The inverter output is shut off if one of the three power input phases is lost when <b>Pr.872 Input phase loss protection selection</b> = "1 (initial value)". (Refer to <a href="#">page 97</a> .)	
<b>Check point</b>	Check for a break in the cable for the three-phase power supply input.	
<b>Corrective action</b>	<ul style="list-style-type: none"> <li>• Wire the cables properly.</li> <li>• Repair a break portion in the cable.</li> </ul>	

\*2 E.ILF is not activated when input is lost for one of the three phases (terminals R2/L12, S2/L22, and T2/L32) while the converter unit is used with a 12-phase transformer.

<b>Operation panel indication</b>	<b>E.OHT</b>	<b>E. OHT</b>
<b>Name</b>	External thermal relay operation	
<b>Description</b>	While "1" (NC contact) or "2" (NO contact) is set in <b>Pr.876 OH input selection</b> to enable the function, the inverter output is shut off if output of the device such as a thermostat is input as the OH signal, and the OH signal turns ON (NO contact input) or turns OFF (NC contact input). The OH signal function is assigned to terminal OH in the initial status. This protective function is not available in the initial setting of <b>Pr.876</b> ( <b>Pr.876</b> = "0"). (Refer to <a href="#">page 110</a> .)	
<b>Check point</b>	<ul style="list-style-type: none"> <li>• Check for overheating of the thermostat for overheat protection of peripheral devices.</li> <li>• Check that the value "7" (OH signal) is set correctly to any of <b>Pr.178</b>, <b>Pr.187</b> or <b>Pr.189</b> (<b>Input terminal function selection</b>).</li> </ul>	
<b>Corrective action</b>	<ul style="list-style-type: none"> <li>• Reduce the load and operation duty.</li> <li>• Even if the thermostat automatically returns to normal, the converter unit (inverter) will not restart unless it is reset.</li> </ul>	

<b>Operation panel indication</b>	<b>E.PA1</b>	<b>E. PA 1</b>
<b>Name</b>	Parallel operation slave 1 fault	
<b>Description</b>	Appears on the operation panel of the master at an occurrence of a slave 1 converter fault during the parallel operation. Appears on the master converter unit even when the RS-485 terminals are incorrectly connected.	
<b>Check point</b>	<ul style="list-style-type: none"> <li>• Check that the protective function of the slave 1 is activated.</li> <li>• Check the RS-485 terminal wiring.</li> </ul>	
<b>Corrective action</b>	<ul style="list-style-type: none"> <li>• Remove the fault of the slave 1.</li> <li>• Perform correct wiring of the RS-485 terminals.</li> </ul>	

Operation panel indication	E.PA2	E. PA2
Name	Parallel operation slave 2 fault	
Description	Appears on the operation panel of the master at an occurrence of a slave 2 converter fault during the parallel operation. Appears on the master converter unit even when the RS-485 terminals are incorrectly connected.	
Check point	<ul style="list-style-type: none"> <li>• Check that the protective function of the slave 2 is activated.</li> <li>• Check the RS-485 terminal wiring.</li> </ul>	
Corrective action	<ul style="list-style-type: none"> <li>• Remove the fault of the slave 2.</li> <li>• Perform correct wiring of the RS-485 terminals.</li> </ul>	

Operation panel indication	E.PE	E. PE
Name	Parameter storage device fault (control circuit board)	
Description	The inverter output is shut off if a fault occurs in the parameter stored. (EEPROM failure)	
Check point	Check for too many number of parameter write times.	
Corrective action	Contact your sales representative. When performing parameter writing frequently for communication purposes, set "1" in <b>Pr.342 Communication EEPROM write selection</b> to enable RAM write. Note that writing to RAM goes back to the initial status at power OFF.	

Operation panel indication	E.PUE	E. PUE
Name	PU disconnection	
Description	<ul style="list-style-type: none"> <li>• The inverter output is shut off if the communication between the operation panel and the inverter is canceled by removing the operation panel while the disconnected PU detection function is enabled by <b>Pr.75 Reset selection/disconnected PU detection/reset limit</b>.</li> <li>• The inverter output is shut off if communication errors occur consecutively for the permissible number of retries or more during the RS-485 communication from the PU connector with <b>Pr.121 Number of PU communication retries</b> ≠ "9999."</li> <li>• The inverter output is shut off if communication is broken for the period of time set in <b>Pr.122 PU communication check time interval</b> during the RS-485 communication from the PU connector.</li> </ul>	
Check point	<ul style="list-style-type: none"> <li>• Check that the operation panel is connected properly.</li> <li>• Check the <b>Pr.75</b> setting.</li> </ul>	
Corrective action	Connect the operation panel securely.	

Operation panel indication	E.RET	E. RET
Name	Retry count excess	
Description	Set the retry count during emergency drive operation( <b>Pr.515 Emergency drive dedicated retry count</b> ). If operation cannot be resumed properly within the number of retries, this function stops the outputs of the inverter.	
Check point	Find the cause of the fault occurrence.	
Corrective action	Eliminate the cause of the fault preceding this fault indication.	

Operation panel indication	E.PE2	E. PE2
Name	Parameter storage device fault (main circuit board)	
Description	The inverter output is shut off if a fault occurs in the parameter stored. (EEPROM failure)	
Check point	—	
Corrective action	Contact your sales representative.	

Operation panel indication	E.CPU	E. CPU
	E.5	E. 5
	E.6	E. 6
	E.7	E. 7
Name	CPU fault	
Description	The inverter output is shut off if the communication fault of the built-in CPU occurs.	
Check point	Check for devices producing excess electrical noises around the converter unit.	
Corrective action	<ul style="list-style-type: none"> <li>• Take measures against noise if there are devices producing excess electrical noises around the converter unit.</li> <li>• Contact your sales representative.</li> </ul>	

## Causes and corrective actions

Operation panel indication	E.CTE	E. CTE
Name	Operation panel power supply short circuit / RS-485 terminals power supply short circuit	
Description	<ul style="list-style-type: none"> <li>When the power supply for the operation panel (PU connector) is shorted, the power output is shutoff and the inverter output is shut off. At this time, the use of the operation panel and the RS-485 communication via the PU connector are disabled. To reset, enter the RES signal, reset via communication through the RS-485 terminals, or switch power OFF then ON again.</li> <li>When the power supply for the RS-485 terminals are short circuited, this function shuts off the power output.  At this time, communication from the RS-485 terminals cannot be made. To reset, use  of the operation panel, enter the RES signal, or switch power OFF then ON again.</li> </ul>	
Check point	<ul style="list-style-type: none"> <li>Check that the PU connector cable is not shorted.</li> <li>Check that the RS-485 terminals are connected correctly.</li> </ul>	
Corrective action	<ul style="list-style-type: none"> <li>Check the operation panel and the cable.</li> <li>Check the connection of the RS-485 terminals.</li> </ul>	

Operation panel indication	E.P24	E. P24
Name	24 VDC power fault	
Description	<ul style="list-style-type: none"> <li>If the 24 VDC power supply output from terminal PC is shorted, or the voltage of the external 24 VDC power supply is low, the power output is shutoff. At this time, all external contact inputs turn OFF. The inverter cannot be reset by inputting the RES signal. To reset it, use the operation panel, or switch power OFF, then ON again.</li> </ul>	
Check point	<ul style="list-style-type: none"> <li>Check for a short circuit in the PC terminal output.</li> <li>Check if the voltage supplied from the 24 V external power supply is correct.</li> </ul>	
Corrective action	<ul style="list-style-type: none"> <li>Repair the short-circuited portion.</li> <li>Supply the power at 24 V. (If the power with insufficient voltage is supplied to the 24 V input circuit for a long time, the internal circuit may heats up. Input power at correct voltage although it will not damage the converter unit.)</li> </ul>	

Operation panel indication	E.IOH	E. IOH
Name	Inrush current limit circuit fault	
Description	The inverter output is shut off when the resistor of the inrush current limit circuit is overheated. The inrush current limit circuit failure	
Check point	<ul style="list-style-type: none"> <li>Check that frequent power ON/OFF is not repeated.</li> <li>Check if the input side fuse (5A) in the power supply circuit of the inrush current limit circuit contactor is blown.</li> <li>Check that the power supply circuit of inrush current limit circuit contactor is not damaged.</li> </ul>	
Corrective action	<ul style="list-style-type: none"> <li>Configure a circuit where power ON/OFF is not repeated.</li> <li>If the situation does not improve after taking the above measure, contact your sales representative.</li> </ul>	

Operation panel indication	E.SER	E. SER
Name	Communication fault (inverter)	
Description	The inverter output is shut off when the RS-485 terminals are incorrectly connected. The inverter output is shut off if communication has been cut off for the time set in <b>Pr.652 Parallel operation communication check time</b> while the converter unit is stopped.	
Check point	<ul style="list-style-type: none"> <li>Check the RS-485 terminal wiring.</li> <li>Check that the time set in <b>Pr.652</b> is appropriate.</li> <li>Check for excessive noise around the converter unit.</li> </ul>	
Corrective action	<ul style="list-style-type: none"> <li>Perform wiring of the RS-485 terminals properly.</li> <li>Set the time set in <b>Pr.652</b> longer.</li> <li>Take measures against noise if there are devices producing excess electrical noises around the converter unit. If the situation does not improve after taking the above measure, contact your sales representative.</li> </ul>	

Operation panel indication	E.PBT	E. PBT
	E.13	E. 13
Name	Internal circuit fault	
Description	The inverter output is shut off when an internal circuit fault occurs in the converter unit.	
Corrective action	Contact your sales representative.	

<b>Operation panel indication</b>	<b>E. 1</b>	<b>E. 1</b>
<b>Name</b>	Option fault	
<b>Description</b>	The inverter output is shut off if a plug-in option is disconnected while the converter unit power is ON.	
<b>Check point</b>	<ul style="list-style-type: none"> <li>• Check if a plug-in option is connected.</li> <li>• Check for excessive noise around the converter unit.</li> </ul>	
<b>Corrective action</b>	<ul style="list-style-type: none"> <li>• Disconnect the plug-in option. (Plug-in options cannot be used.)</li> <li>• Take measures against noise if there are devices producing excess electrical noises around the converter unit.</li> </ul> If the situation does not improve after taking the above measure, contact your sales representative.	

### ◆Others

The fault history and the operation status of the inverter are displayed. It is not a fault.

<b>Operation panel indication</b>	<b>EV</b>	<b>EV</b>
<b>Name</b>	24 V external power supply operation	
<b>Description</b>	Blinks when the main circuit power supply is off and the 24 V external power supply is being input.	
<b>Check point</b>	Power is supplied from a 24 V external power supply.	
<b>Corrective action</b>	<ul style="list-style-type: none"> <li>• Turning ON the power supply (main circuit) of the converter unit clears the indication.</li> <li>• If the indication is still displayed after turning ON of the power supply (main circuit) of the converter unit, the power supply voltage may be low.</li> </ul>	

<b>Operation panel indication</b>	<b>SLV.1</b>	<b>SLV.1</b>
<b>Name</b>	Parallel operation slave 1	
<b>Description</b>	Appears on the first monitor screen of the slave 1 inverter ( <b>Pr.1001 Parallel operation selection = "1"</b> ).	

<b>Operation panel indication</b>	<b>SLV.2</b>	<b>SLV.2</b>
<b>Name</b>	Parallel operation slave 2	
<b>Description</b>	Appears on the first monitor screen of the slave 2 inverter ( <b>Pr.1001 Parallel operation selection = "2"</b> ).	

### NOTE

- If faults other than the above appear, contact your sales representative.

## 6.6 Check first when you have trouble

### POINT

- If the cause is still unknown after every check, it is recommended to initialize the parameters (initial value) then set the required parameter values and check again.

### 6.6.1 Converter unit does not operate properly

Checkpoints	Cause	Countermeasure	Refer to page
Main circuit Control Circuit	Wiring or installation is improper.	Check for the wiring and the installation.	27
Main circuit	Appropriate power supply voltage is not applied. (Operation panel display is not provided.)	Power on a molded case circuit breaker (MCCB) or a magnetic contactor (MC).	—
		Check for the decreased input voltage, input phase loss, and wiring.	—
		If only the control power is ON when using a separate power source for the control circuit, turn ON the main circuit power.	50

### 6.6.2 The power lamp is OFF

Checkpoints	Cause	Countermeasure	Refer to page
Main circuit Control Circuit	Wiring or installation is improper.	Check for the wiring and the installation. Power lamp is lit when power is supplied to the control circuit (R1/L11, S1/L21).	35

### 6.6.3 The charge lamp is OFF

Checkpoints	Cause	Countermeasure	Refer to page
Main circuit Control Circuit	Wiring or installation is improper.	Check for the wiring and the installation. Charge lamp is lit when power is supplied to the control circuit (R1/L1, S/L2, T/L3).	35

### 6.6.4 Operation panel display is not operating

Checkpoints	Cause	Countermeasure	Refer to page
Main circuit Control Circuit	Power is not input.	Input the power.	27
Front cover	Operation panel is not properly connected to the converter unit.	Check that the front cover is installed securely.	18

## 6.6.5 Inverter cannot be operated

Checkpoints	Cause	Countermeasure	Refer to page
<b>Control Circuit</b>	Terminals RDA and SE of the converter unit are not connected to terminals MRS (X10 signal) and SD of the inverter respectively.	Check for the wiring.	27
<b>PARAMETER</b>	Inverter parameter settings are incorrect.	Check for the inverter parameter settings.	Refer to the Instruction Manual (Detailed) of the inverter.

## 6.6.6 Unable to write parameter setting

Checkpoints	Cause	Countermeasure	Refer to page
<b>Parameter setting</b>	Parameter is disabled by the <b>Pr.77 Parameter write selection</b> setting.	Check the <b>Pr.77</b> setting.	90
	Key lock mode is enabled by the <b>Pr.161 Key lock operation selection</b> setting.	Check the <b>Pr.161</b> setting.	90

## 6.6.7 Breaker trips

Checkpoints	Cause	Countermeasure	Refer to page
<b>Main circuit</b>	Wiring or installation is improper.	Check for the wiring and the installation.	27
	Appropriate power supply voltage is not applied.	Check that the power supply voltage is applied.	—

## 6.6.8 Converter unit generates abnormal noise

Checkpoints	Cause	Countermeasure	Refer to page
<b>fan</b>	Fan cover was not correctly installed when a cooling fan was replaced.	Install a fan cover correctly.	159



# MEMO

---

# **7** PRECAUTIONS FOR MAINTENANCE AND INSPECTION

---

This chapter explains the "PRECAUTIONS FOR MAINTENANCE AND INSPECTION" for this product.

Always read the instructions before using the equipment.

---

7.1	Inspection item.....	154
7.2	Measurement of main circuit voltages, currents and powers .....	161

## Inspection item

---

The converter unit is a static unit mainly consisting of semiconductor devices. Daily inspection must be performed to prevent any fault from occurring due to the adverse effects of the operating environment, such as temperature, humidity, dust, dirt and vibration, changes in the parts with time, service life, and other factors.

### ● Precautions for maintenance and inspection

When accessing the converter unit for inspection, wait for at least 10 minutes after the power supply has been switched OFF because the smoothing capacitor voltage remains high for a while, and then make sure that the voltage across the main circuit terminals P/+ and N/- of the converter unit is not more than 30 VDC using a tester, etc.

## 7.1 Inspection item

---

### 7.1.1 Daily inspection

Basically, check for the following faults during operation.

- Motor operation fault
- Improper installation environment
- Cooling system fault
- Abnormal vibration, abnormal noise
- Abnormal overheat, discoloration

### 7.1.2 Periodic inspection

Check the areas inaccessible during operation and requiring periodic inspection.

Consult us for periodic inspection.

- Check and clean the cooling system. .... Clean the air filter, etc.
- Check the tightening and retighten. .... The screws and bolts may become loose due to vibration, temperature changes, etc. Check and tighten them.  
Tighten them according to the specified tightening torque. (Refer to [page 37.](#))
- Check the conductors and insulating materials for corrosion and damage.
- Measure the insulation resistance.
- Check and change the cooling fan and relay.

## 7.1.3 Daily and periodic inspection

Area of inspection	Inspection item	Description	Inspection interval		Corrective action at fault occurrence	Check by the user		
			Daily	Periodic *3				
General	Surrounding environment	Check the surrounding air temperature, humidity, dirt, corrosive gas, oil mist, etc.	○		Improve the environment.			
	Overall unit	Check for unusual vibration and noise.	○		Check fault location and retighten.			
		Check for dirt, oil, and other foreign material.*1	○		Clean.			
	Power supply voltage	Check that the main circuit voltages and control voltages are normal.*2	○		Inspect the power supply.			
Main circuit	General	(1) Check with megger (across main circuit terminals and earth (ground) terminal).		○	Contact the manufacturer.			
		(2) Check for loose screws and bolts.		○	Retighten.			
		(3) Check for overheat traces on the parts.		○	Contact the manufacturer.			
		(4) Check for stain.		○	Clean.			
	Conductors, cables	(1) Check conductors for distortion. (2) Check cable sheaths for breakage and deterioration (crack, discoloration, etc.).			○	Contact the manufacturer.		
					○	Contact the manufacturer.		
	Transformer/reactor	Check for unusual odor and abnormal increase of whining sound.	○		Stop the equipment and contact the manufacturer.			
Terminal block	Check for a damage.			○	Stop the equipment and contact the manufacturer.			
Smoothing aluminum electrolytic capacitor	(1) Check for liquid leakage. (2) Check for safety valve projection and bulge. (3) Visual check and judge by the life check of the main circuit capacitor. (Refer to <a href="#">page 158.</a> )			○	Contact the manufacturer.			
				○	Contact the manufacturer.			
Relay/contactors	Check that the operation is normal and no chattering sound is heard.			○	Contact the manufacturer.			
Control circuit protection circuit	Operation check	(1) Check that the output voltages across phases are balanced while operating the inverter alone.			○	Contact the manufacturer.		
		(2) Check that no fault is found in protective and display circuits in a sequence protective operation test.			○	Contact the manufacturer.		
	Components check	Overall	(1) Check for unusual odor and discoloration.			○	Stop the equipment and contact the manufacturer.	
			(2) Check for serious rust development.			○	Contact the manufacturer.	
	Aluminum electrolytic capacitor	(1) Check for liquid leakage in a capacitor and deformation trace. (2) Visual check and judge by the life check of the control circuit capacitor. (Refer to <a href="#">page 158.</a> )			○	Contact the manufacturer.		
					○	Contact the manufacturer.		
Cooling system	Cooling fan	(1) Check for unusual vibration and noise.	○		Replace the fan.			
		(2) Check for loose screws and bolts.			○	Fix with the fan cover fixing screws		
(3) Check for stain.				○	Clean.			
	Heat sink	(1) Check for clogging.			○	Clean.		
		(2) Check for stain.			○	Clean.		

## Inspection item

Area of inspection	Inspection item	Description	Inspection interval		Corrective action at fault occurrence	Check by the user
			Daily	Periodic *3		
Display	Indication	(1) Check that display is normal. (2) Check for stain.	○	○	Contact the manufacturer. Clean.	
	Meter	Check that reading is normal.	○		Stop the equipment and contact the manufacturer.	
Load motor	Operation check	Check for vibration and abnormal increase in operation noise.	○		Stop the equipment and contact the manufacturer.	

\*1 Oil component of the heat dissipation grease used inside the converter unit may leak out. The oil component, however, is not flammable, corrosive, nor conductive and is not harmful to humans. Wipe off such oil component.

\*2 It is recommended to install a voltage monitoring device for checking the voltage of the power supplied to the converter unit.

\*3 One to two years of periodic inspection cycle is recommended. However, it differs according to the installation environment. Consult us for periodic inspection.

### NOTE

- Continuous use of a leaked, deformed, or degraded smoothing aluminum electrolytic capacitor (as shown in the table above) may lead to a burst, breakage or fire. Replace such capacitor without delay.

## 7.1.4 Checking the converter semiconductor devices

### ◆Preparation

- Disconnect the external power supply cables (R/L1, S/L2, T/L3, P/+, and N/-).
- Prepare a tester. (For the resistance measurement, use the 100 Ω range.)

### ◆Checking method

Change the polarity of the tester alternately at the converter unit terminals R/L1, S/L2, T/L3, P/+, and N/- and check the electric continuity.

#### NOTE

- Before measurement, check that the smoothing capacitor is discharged.
- At the time of electric discontinuity, the measured value is almost ∞. When there is an instantaneous electric continuity, due to the smoothing capacitor, the tester may not indicate ∞. At the time of electric continuity, the measured value is several Ω to several tens of Ω. If all measured values are almost the same, although these values are not constant depending on the module type and tester type, the modules are without fault.

### ◆Semiconductor device numbers and terminals to be checked

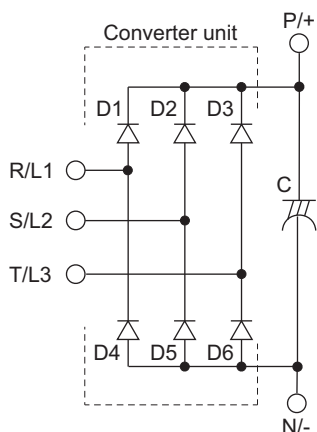

Converter unit	Tester polarity		Result
	⊕	⊖	
D1	R/L1	P/+	Discontinuity
	P/+	R/L1	Continuity
D2	S/L2	P/+	Discontinuity
	P/+	S/L2	Continuity
D3	T/L3	P/+	Discontinuity
	P/+	T/L3	Continuity
D4	R/L1	N/-	Continuity
	N/-	R/L1	Discontinuity
D5	S/L2	N/-	Continuity
	N/-	S/L2	Discontinuity
D6	T/L3	N/-	Continuity
	N/-	T/L3	Discontinuity

(Assumes the use of an analog meter.)

## 7.1.5 Cleaning

Always run the converter unit in a clean status.

When cleaning the converter unit, gently wipe dirty areas with a soft cloth immersed in neutral detergent or ethanol.

#### NOTE

- Do not use solvent, such as acetone, benzene, toluene and alcohol, as these will cause the converter unit surface paint to peel off.
- The display, etc. of the operation panel are vulnerable to detergent and alcohol. Therefore, avoid using them for cleaning.

## 7.1.6 Replacement of parts

The converter unit consists of many electronic parts such as semiconductor devices.

The following parts may deteriorate with age because of their structures or physical characteristics, leading to reduced performance or fault of the converter unit. For preventive maintenance, the parts must be replaced periodically.

Use the life check function as a guidance of parts replacement.

Part name	Estimated lifespan*1	Description
Cooling fan	10 years	Replace (as required)
Main circuit smoothing capacitor	10 years*2	Replace (as required)
On-board smoothing capacitor	10 years*2	Replace the board (as required)
Relays	—	As required
Main circuit fuse	10 years	Replace (as required)

\*1 Estimated lifespan for when the yearly average surrounding air temperature is 40°C.  
(without corrosive gas, flammable gas, oil mist, dust and dirt etc.)

\*2 Input current: 80% of the converter unit rating



- For parts replacement, contact the nearest Mitsubishi FA center.

### ◆ Converter unit parts life display

The converter unit diagnoses the control circuit capacitor, cooling fan, and inrush current limit circuit by itself and estimates their lives.

The self-diagnostic warning is output when the life span of each part is near its end. It gives an indication of replacement time.

**The life warning output can be used as a guideline for life judgment.**

Parts	Judgment level
Control circuit capacitor	Estimated remaining life 10%
Inrush current limit circuit	Estimated remaining life 10% (Power ON: 100,000 times left)
Cooling fan	Less than 50% of the specified speed.



- Refer to [page 93](#) to perform the life check of the converter unit parts.

## ◆ Replacement procedure of the cooling fan

The replacement interval of the cooling fan used for cooling the parts generating heat such as the main circuit semiconductor is greatly affected by the surrounding air temperature. When unusual noise and/or vibration are noticed during inspection, the cooling fan must be replaced immediately.

### ◆ Removal

- 1) Remove the fan cover fixing screws, and remove the fan cover.
- 2) Disconnect the fan connector and remove the fan block.
- 3) Remove the fan fixing screws, and remove the fan.

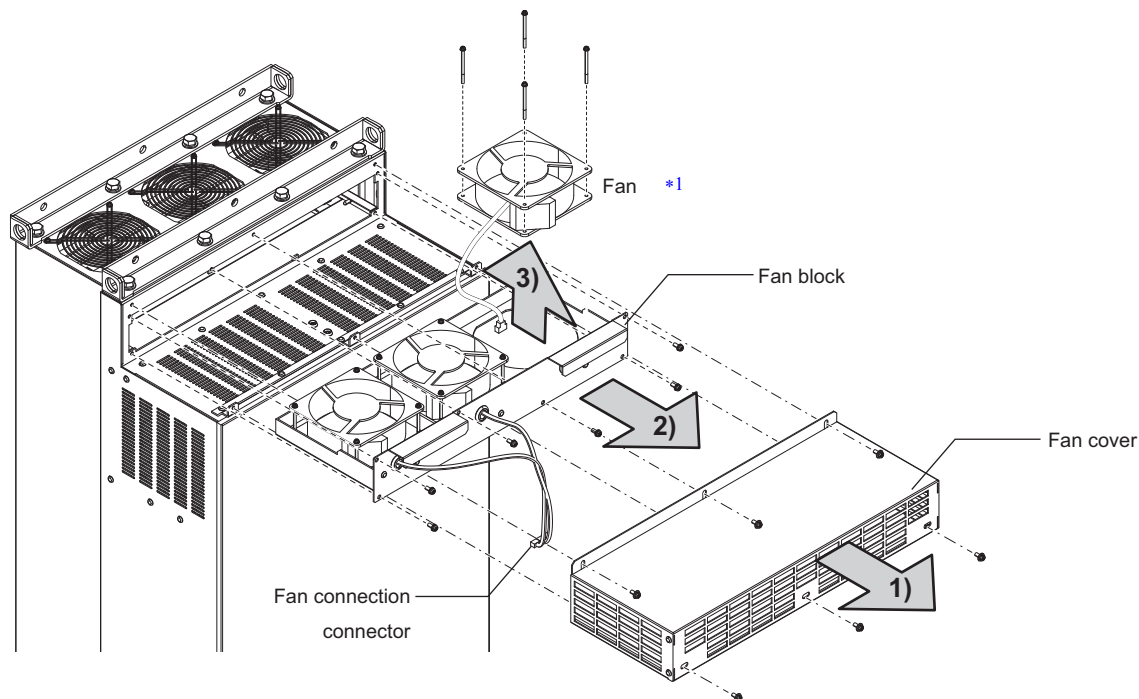

\*1 The number of cooling fans differs according to the converter unit capacity.

### ◆ Reinstallation

- 1) After confirming the orientation of the fan, reinstall the fan so that the "AIR FLOW" faces up.

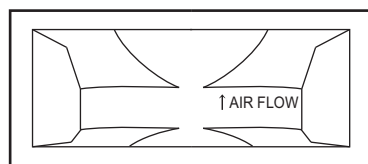

<Fan side face>

- 2) For reconnection of the fan, refer to the above figure. The tightening torque of the fan fixing screws is 0.73 N•m.

### NOTE

- Installing the fan in the opposite direction of air flow can cause the converter unit life to be shorter.
- Prevent the cable from being caught when installing a fan.
- Switch the power OFF before replacing fans. Since the converter unit circuits are charged with voltage even after power OFF, replace fans only when the converter unit cover is on the converter unit to prevent an electric shock accident.



### ◆Smoothing capacitors

A large-capacity aluminum electrolytic capacitor is used for smoothing in the DC section of the main circuit, and an aluminum electrolytic capacitor is used for stabilizing the control power in the control circuit. Adverse effects from ripple currents deteriorate capacitors. Replacement intervals of capacitors vary greatly with surrounding temperatures and operating conditions. Replace them roughly every 10 years when used in normal air-conditioned environments.

Inspecting the product visually:

- Case: Check that the sides and bottom of the capacitor have not ruptured.
- Rubber seal: Check for any noticeable bulging or severe cracks.
- Check for external cracks, discoloration, leakage, etc. It is assumed that the capacitor has reached the end of its remaining life when its capacity has dropped below 80% of its rated capacity.

**NOTE**

- The converter unit diagnoses the control circuit capacitor by itself and can estimate its remaining life. (Refer to [page 93](#).)

### ◆Relay output terminals

- The contacts of relays deteriorate over time. To prevent faults from occurring, relays must be replaced when they have reached the maximum number of switching operations (switching life).
- The control terminal block must be replaced in case of failure of the relay connected to the relay output terminals A1, B1, and C1. (After installing a new control terminal block, set up the control logic for input signals with the jumper connector (control logic selector). (Refer to [page 45](#).)

### ◆Main circuit fuse

A fuse is used inside the converter unit. Replacement intervals of fuses vary with surrounding temperatures and operating conditions. Replace them roughly every 10 years when used in normal air-conditioned environments.

## 7.1.7 Converter unit replacement

The converter unit can be replaced with the control circuit wiring kept connected.

- 1) Loosen the two mounting screws at the both side of the control circuit terminal block. (These screws cannot be removed.) Slide down the control circuit terminal block to remove it.

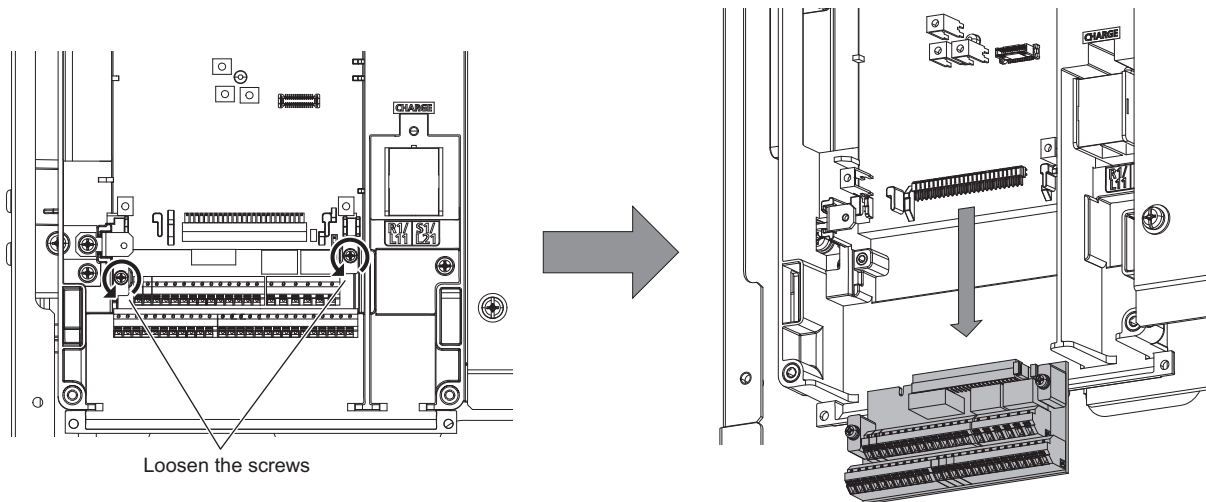

- 2) Be careful not to bend the pins of the converter unit's control circuit connector, reinstall the control circuit terminal block, and fix it with the mounting screws.

**NOTE**

- Before starting converter unit replacement, switch power OFF, wait for at least 10 minutes, and then check the voltage with a tester and such to ensure safety.

# 7.2 Measurement of main circuit voltages, currents and powers

Since the voltages and currents on the converter unit power supply and output sides include harmonics, measurement data depends on the instruments used and circuits measured. When instruments for commercial frequency are used for measurement, measure the following circuits with the instruments given on the next page.

**NOTE**

- When installing meters etc. on the converter unit output side  
When the wiring length between the converter unit and the inverter is large, the meters and CTs may generate heat due to line-to-line leakage current. Therefore, choose the equipment which has enough allowance for the current rating.

### ◆ Examples of measuring points and instruments

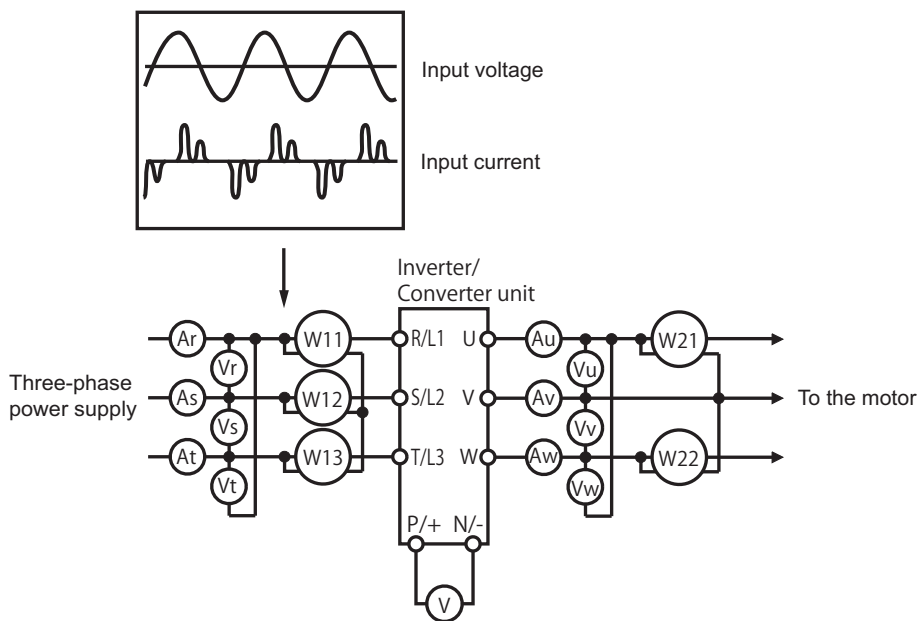

### ◆ Measuring points and instruments

Item	Measuring point	Measuring instrument	Remarks (reference measured value)
Power supply voltage V1	Across R/L1 and S/L2, S/L2 and T/L3, T/L3 and R/L1	Digital power meter (designed for inverter)	Commercial power supply Within permissible AC voltage fluctuation (Refer to page 166.)
Power supply side current I1	R/L1, S/L2, T/L3 line current		
Power supply side power P1	R/L1, S/L2, T/L3 and Across R/L1 and S/L2, S/L2 and T/L3, T/L3 and R/L1		P1=W11 + W12 + W13 (3-wattmeter method)
Power supply side power factor Pf1	Calculate after measuring power supply voltage, power supply side current and power supply side power. $Pf_1 = \frac{P_1}{\sqrt{3}V_1 \times I_1} \times 100\%$		
Converter output	Across P/+ and N/-	Digital multimeter or other tester	Converter unit LED is ON. 1.35 × V1
Input signal	Across RDI, OH, RES(+) and SD (for sink logic)	Digital multimeter or other tester or moving-coil type instrument (internal resistance 50 kΩ or more)	When open 20 to 30 VDC ON voltage: 1 V or less
Fault signal	Across A1 and C1 Across B1 and C1	Digital multimeter or other tester	Continuity check*1 [Normal] [Fault] Across A1 and C1 Discontinuity Continuity Across B1 and C1 Continuity Discontinuity

\*1 When the setting of Pr.195 ABC1 terminal function selection is the positive logic

### 7.2.1 Measurement of powers

Use a digital power meter (for inverter) for the input side of converter unit.

### 7.2.2 Measurement of voltages

#### ◆ Converter unit input side

Use a digital power meter (for inverter) for the input side voltage.

### 7.2.3 Measurement of currents

Use a digital power meter (for inverter) for the input side of the converter unit.

Since the converter unit input current tends to be unbalanced, measurement of three phases is recommended. The correct value cannot be obtained by measuring only one or two phases.

The converter unit input current can be monitored on the operation panel. The value displayed on the operation panel is accurate even if the output frequency varies. Hence, it is recommended to monitor values on the operation panel.

### 7.2.4 Example of measuring converter unit input power factor

Calculate using effective power and apparent power. A power-factor meter cannot indicate an exact value.

$$\begin{aligned} \text{Total power factor of the converter unit} &= \frac{\text{Effective power}}{\text{Apparent power}} \\ &= \frac{\text{Three-phase input power found by the 3-wattmeter method}}{\sqrt{3} \times V \text{ (power supply voltage)} \times I \text{ (input current effective value)}} \end{aligned}$$

### 7.2.5 Measurement of converter output voltage (across terminals P and N)

The output voltage of the converter is output across terminals P and N, and can be measured with a voltmeter such as a digital multimeter. Although the voltage varies according to the power supply voltage, approximately 540 to 600 V is output when no load is applied. The voltage decreases when a load is applied.

When energy is regenerated from the motor during deceleration, for example, the converter output voltage rises to nearly 800 to 900 V maximum.

## 7.2.6 Insulation resistance test using megger

- For the converter unit, conduct the insulation resistance test on the main circuit only as shown below and do not perform the test on the control circuit. (Use a 500 VDC megger.)

### NOTE

- Before performing the insulation resistance test on the external circuit, disconnect the cables from all terminals of the converter unit so that the test voltage is not applied to the converter unit.
- For the continuity test of the control circuit, use a tester (high resistance range) and do not use the megger or buzzer.

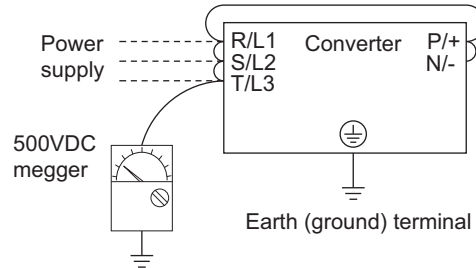

## 7.2.7 Withstand voltage test

Do not conduct a withstand voltage test.

# MEMO

---

# **8** SPECIFICATIONS

---

This chapter explains the "SPECIFICATIONS" of this product.  
Always read the instructions before using the equipment.

---

8.1 Converter unit rating .....	166
8.2 Common specifications .....	166
8.3 Outline dimension drawings.....	167

# 8.1 Converter unit rating

Model FR-CC2-H[]-P	Two in parallel				Three in parallel			
	400K	450K	500K	560K	400K	450K	500K	560K
Applicable motor capacity (kW)	630	710	800	900	945	1065	1200	1350
Output	Overload current rating *1							
	150% 60 s, 200% 3 s							
Power supply	Rated voltage *2							
	430 to 780 VDC *3							
Power supply	Rated input AC voltage/frequency							
	Three-phase 380 to 500 V 50/60 Hz							
Power supply	Permissible AC voltage fluctuation							
	Three-phase 323 to 550 V 50/60 Hz							
Power supply	Permissible frequency fluctuation							
	±5%							
Power supply	Rated input current (A) *4							
	1232	1386	1539	1750	1848	2078	2309	2626
Power supply	Power supply capacity (kVA) *5							
	939	1056	1173	1334	1409	1584	1759	2002
Protective structure (IEC 60529)								
Open type (IP00)								
Cooling system								
Forced air cooling								
DC reactor								
Built-in								
Approx. mass (kg)*6								
564	570	576	586	846	855	864	879	

- \*1 The % value of the overload current rating indicated is the ratio of the overload current to the inverter's rated output current. For repeated duty, allow time for the converter unit and the inverter to return to or below the temperatures under 100% load.
- \*2 The converter unit output voltage varies according to the input power supply voltage and the load. The maximum point of the voltage waveform at the converter unit output side is approximately the power supply voltage multiplied by  $\sqrt{2}$ .
- \*3 The permissible voltage imbalance ratio is 3% or less. (Imbalance ratio = (highest voltage between lines - average voltage between three lines) / average voltage between three lines × 100)
- \*4 The input current is the total current of the master and slave converter units during the parallel operation.
- \*5 The power supply capacity is the value when at the rated output current. It varies by the impedance at the power supply side (including those of the input reactor and cables).
- \*6 The mass is the total mass of the master and slave converter units during the parallel operation.

# 8.2 Common specifications

Input signals (three terminals)		External thermal relay input, Converter reset The input signal can be changed using <b>Pr.178, Pr.187, and Pr.189 (Input terminal function selection)</b> .
Operational functions		Thermal protection, DC injection brake, automatic restart after instantaneous power failure, RS-485 communication, life diagnosis, maintenance timer, 24 V power supply input for control circuit
Output signal Open collector output (five terminals) Relay output (one terminal)		Inverter operation enable (positive logic, negative logic), Instantaneous power failure/undervoltage, Inverter reset, Fan fault output, Fault The output signal can be changed using <b>Pr.190 to Pr.195 (Output terminal function selection)</b> .
Operation panel*4	Operating status	Converter output voltage, Input current, Electric thermal relay function load factor The monitored item can be changed using <b>Pr.774 to Pr.776 Operation panel monitor selection 1 to 3</b> .
	Fault record	Fault record is displayed when a fault occurs. Past 8 fault records and the conditions immediately before the fault (converter output voltage/input current/electronic thermal relay function load factor/cumulative energization time/year/month/date/time) are saved.
Protective/warning function	Protective function	Overvoltage trip, Converter overload trip (electronic thermal relay function), Heat sink overheat, Instantaneous power failure, Undervoltage, Input phase loss, External thermal relay operation, PU disconnection*3, Parameter storage device fault, CPU fault, 24 VDC power fault, Inrush current limit circuit fault, Communication fault (inverter), Option fault, Operation panel power supply short circuit / RS-485 terminals power supply short circuit, Internal circuit fault, Retry count excess, Parallel operation slave 1 fault, Parallel operation slave 2 fault
	Warning function	Fan alarm, Electronic thermal relay function pre-alarm, Maintenance timer 1 to 3*3, Operation panel lock*3, Password locked*3, Parameter write error, Copy operation error, 24 V external power supply operation, Emergency drive in operation*3
Environment	Surrounding air temperature	-10°C to +50°C (non-freezing)
	Surrounding air humidity	95% RH or less (non-condensing)
	Storage temperature*1	-20°C to +65°C
	Atmosphere	Indoors (without corrosive gas, flammable gas, oil mist, dust and dirt, etc.)
	Altitude/vibration	1000 m or lower*2, 2.9 m/s <sup>2</sup> or less at 10 to 55 Hz (directions of X, Y, Z axes)

- \*1 Temperature applicable for a short time, e.g. in transit.
- \*2 For the installation at an altitude above 1000 m (up to 2500 m), consider a 3% reduction in the rated current per altitude increase of 500 m.
- \*3 This protective function is not available in the initial status.
- \*4 In the initial status, monitoring using the operation panel is not available. Remove the accessory cover and install the inverter operation panel (Refer to [page 18](#))

## 8.3 Outline dimension drawings

### 8.3.1 Converter unit outline dimension drawings

FR-CC2-H400K, H450K, H500K, H560K-P

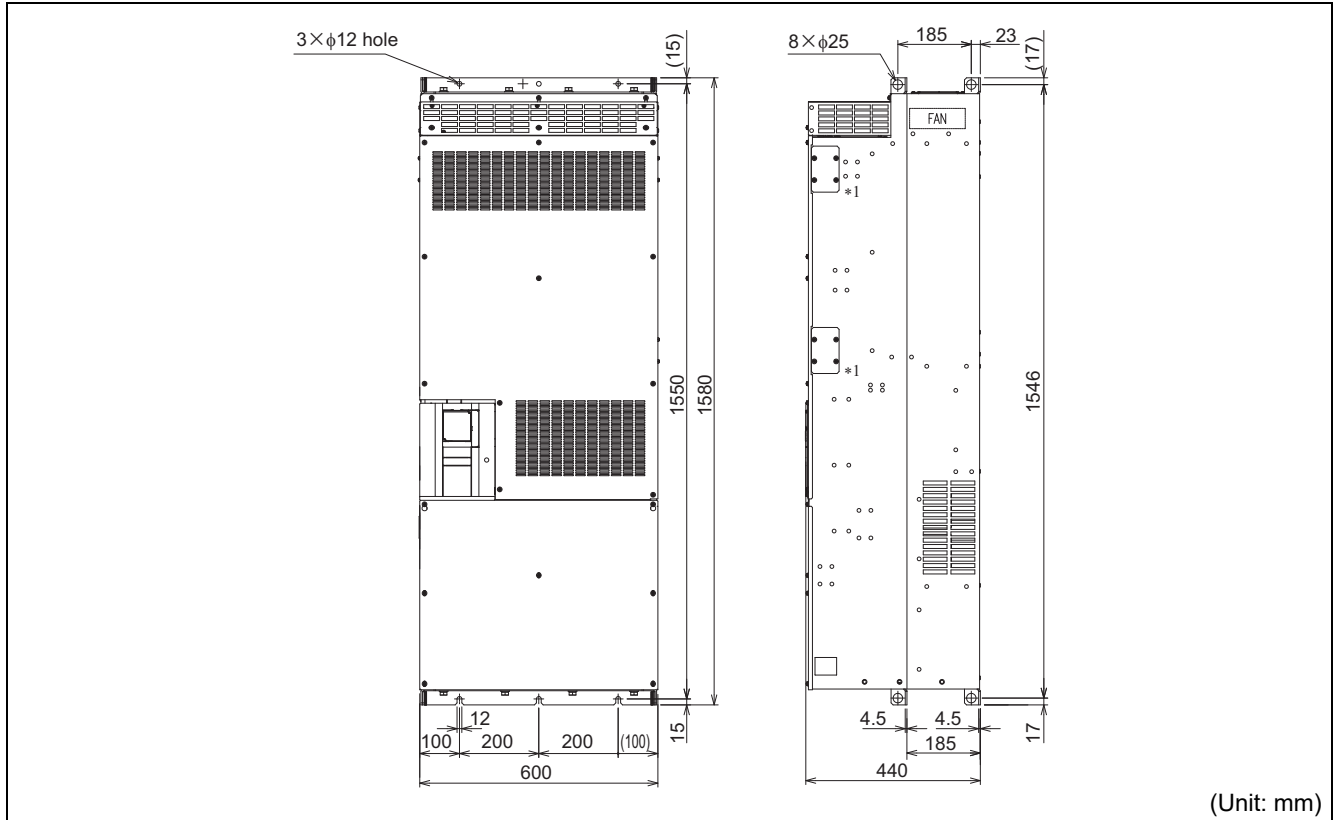

\*1 Do not remove the cover on the side of the converter unit.



# MEMO



# APPENDIX

---

---

**APPENDIX** provides the reference information for use of this product.

Refer to **APPENDIX** as required.

---

<b>Appendix 1</b>	<b>Instruction code list.....</b>	<b>170</b>
<b>Appendix 2</b>	<b>Instructions for compliance with the EU Directives.....</b>	<b>172</b>
<b>Appendix 3</b>	<b>Instructions for UL and cUL.....</b>	<b>176</b>
<b>Appendix 4</b>	<b>Instructions for EAC.....</b>	<b>178</b>
<b>Appendix 5</b>	<b>Restricted Use of Hazardous Substances in Electronic and Electrical Products .....</b>	<b>179</b>
<b>Appendix 6</b>	<b>Referenced Standard (Requirement of Chinese standardized law).....</b>	<b>179</b>
<b>Appendix 7</b>	<b>Compliance with the UK certification scheme.....</b>	<b>180</b>

# Appendix 1 Instruction code list

- \*1 Instruction codes are used to read and write parameters by using the Mitsubishi inverter protocol via RS-485 communication. (For the RS-485 communication, refer to [page 118](#).)
- \*2 For "parameter copy", "parameter clear", and "all parameter clear", "O" indicates the function is available, and × indicates the function is not available.
- \*3 Communication parameters that are not cleared by parameter clear (all clear) via the RS-485 communication. (For the RS-485 communication, refer to [page 118](#).)

Pr.	Name	Instruction code*1			PARAMETER		
		Read	Write	Extended	Copy *2	Clear *2	All clear *2
30	Reset selection during power supply to main circuit	1E	9E	0	○	○	○
57	Restart selection	39	B9	0	○	○	○
65	Parameter for manufacturer setting. Do not set.						
67	Number of retries at fault occurrence	43	C3	0	○	○	○
68	Parameter for manufacturer setting. Do not set.						
69	Retry count display erase	45	C5	0	○	○	○
75	Reset selection/disconnected PU detection/reset limit	4B	CB	0	○	×	×
77	Parameter write selection	4D	CD	0	○	○	○
117	PU communication station number	11	91	1	○	○*3	○*3
118	PU communication speed	12	92	1	○	○*3	○*3
119	PU communication stop bit length / data length	13	93	1	○	○*3	○*3
120	PU communication parity check	14	94	1	○	○*3	○*3
121	Number of PU communication retries	15	95	1	○	○*3	○*3
122	PU communication check time interval	16	96	1	○	○*3	○*3
123	PU communication waiting time setting	17	97	1	○	○*3	○*3
124	PU communication CR/LF selection	18	98	1	○	○*3	○*3
161	Key lock operation selection	01	81	2	○	×	○
168	Parameter for manufacturer setting. Do not set.						
169	Parameter for manufacturer setting. Do not set.						
170	Watt-hour meter clear	0A	8A	2	○	×	○
178	RDI terminal function selection	12	92	2	○	×	○
187	OH terminal function selection	1B	9B	2	○	×	○
189	RES terminal function selection	1D	9D	2	○	×	○
190	RDB terminal function selection	1E	9E	2	○	×	○
191	RDA terminal function selection	1F	9F	2	○	×	○
192	IPF terminal function selection	20	A0	2	○	×	○
193	RSO terminal function selection	21	A1	2	○	×	○
194	FAN terminal function selection	22	A2	2	○	×	○
195	ABC1 terminal function selection	23	A3	2	○	×	○

Pr.	Name	Instruction code*1			PARAMETER									
		Read	Write	Extended	Copy *2	Clear *2	All clear *2							
248	Self power management selection	38	B8	2	○	○	○							
255	Life alarm status display	3F	BF	2	×	×	×							
256	Inrush current limit circuit life display	40	C0	2	×	×	×							
257	Control circuit capacitor life display	41	C1	2	×	×	×							
261	Power failure stop selection	45	C5	2	○	○	○							
268	Monitor decimal digits selection	4C	CC	2	○	○	○							
269	Parameter for manufacturer setting. Do not set.													
290	Monitor negative output selection	62	E2	2	○	○	○							
296	Password lock level	68	E8	2	○	×	○							
297	Password lock/unlock	69	E9	2	○	○	○							
331	Parameter for manufacturer setting. Do not set.													
332														
333														
334														
335														
336														
337														
341														
342								Communication EEPROM write selection	2A	AA	3	○	○	○
343								Parameter for manufacturer setting. Do not set.						
503	Maintenance timer 1	03	83	5	×	×	×							
504	Maintenance timer 1 warning output set time	04	84	5	○	×	○							
514	Emergency drive dedicated retry waiting time	0E	8E	5	○	×	○							
515	Emergency drive dedicated retry count	0F	8F	5	○	×	○							
523	Emergency drive mode selection	17	97	5	○	×	○							
539	Parameter for manufacturer setting. Do not set.													
549	Parameter for manufacturer setting. Do not set.													
563	Energization time carrying-over times	3F	BF	5	×	×	×							
598	Undervoltage level	62	E2	5	○	○	○							
652	Parallel operation communication check time	34	B4	6	○	○	○							
663	Control circuit temperature signal output level	3F	BF	6	○	○	○							
686	Maintenance timer 2	56	D6	6	×	×	×							
687	Maintenance timer 2 warning output set time	57	D7	6	○	×	○							
688	Maintenance timer 3	58	D8	6	×	×	×							
689	Maintenance timer 3 warning output set time	59	D9	6	○	×	○							

Pr.	Name	Instruction code*1			PARAMETER		
		Read	Write	Extended	Copy *2	Clear *2	All clear *2
774	Operation panel monitor selection 1	4A	CA	7	○	○	○
775	Operation panel monitor selection 2	4B	CB	7	○	○	○
776	Operation panel monitor selection 3	4C	CC	7	○	○	○
872	Input phase loss protection selection	48	C8	8	○	○	○
876	OH input selection	4C	CC	8	○	○	○
888	Free parameter 1	58	D8	8	○	×	×
889	Free parameter 2	59	D9	8	○	×	×
891	Cumulative power monitor digit shifted times	5B	DB	8	○	○	○
990	PU buzzer control	5A	DA	9	○	○	○
992	Operation panel setting dial push monitor selection	5C	DC	9	○	○	○
997	Fault initiation	61	E1	9	×	×	×
1001	Parallel operation selection	01	81	A	○	×	×
1006	Clock (year)	06	86	A	×	×	×
1007	Clock (month, day)	07	87	A	×	×	×
1008	Clock (hour, minute)	08	88	A	×	×	×
1048	Display-off waiting time	30	B0	A	○	○	○

---

# Appendix 2 Instructions for compliance with the EU Directives

---

The EU Directives are issued to standardize different national regulations of the EU Member States and to facilitate free movement of the equipment, whose safety is ensured, in the EU territory.

Since 1996, compliance with the EMC Directive that is one of the EU Directives has been legally required. Since 1997, compliance with the Low Voltage Directive, another EU Directive, has been also legally required. When a manufacturer confirms its equipment to be compliant with the EMC Directive and the Low Voltage Directive, the manufacturer must declare the conformity and affix the CE marking.

- The authorized representative in the EU

The authorized representative in the EU is shown below.

Company name: Mitsubishi Electric Europe B.V.

Address: Mitsubishi-Electric-Platz 1, 40882 Ratingen, Germany

- Note

We declare that this converter unit conforms with the EMC Directive in industrial environments and affix the CE marking on the converter unit. When using the converter unit in a residential area, take appropriate measures and ensure the conformity of the converter unit used in the residential area.

## ◆ EMC Directive

We declare that this converter unit conforms with the EMC Directive and affix the CE marking on the converter unit.

- EMC Directive: 2014/30/EU
- Standard(s): EN61800-3:2004+A1:2012 (Second environment / PDS Category "C3")
- Please ensure you chose the right converter unit for the intended environment. Ensure the converter unit is suitable for the environment in which it is to be used when using it in residential areas.
- The installer shall provide a guide for installation and use, including recommended mitigation devices.

Note:

First environment

Environment including buildings/facilities which are directly connected to a low voltage main supply which also supplies residential buildings. Directly connected means that there is no intermediate transformer between these buildings.

Second environment

Environment including all buildings/facilities which are not directly connected to a low voltage main supply which also supplies residential buildings.

### ◆ Note

Ensure the EMC filter is enabled, install the product as stated below, and then carry out any wiring.

- The converter unit has a built-in EMC filter (Class C3). Enable the EMC filter. (For details, refer to [page 65](#).)
- Connect the inverter and the converter unit to an earthed (grounded) power supply.
- Install the motor and controller cable found in the EMC Installation Manual (BCN-A21041-204) and Technical News (MFS-113, 115) according to the instructions.
- Ensure that the finalized system which includes an inverter and converter unit complies with the EMC Directive.

## ◆ Low Voltage Directive

We have self-confirmed our converter units as products compliant to the Low Voltage Directive and affix the CE marking on the converter units.

- Low Voltage Directive: 2014/35/EU
- Standard(s): EN 61800-5-1:2007

### ◆ Outline of instructions

- Do not use an earth leakage current breaker as an electric shock protector without connecting the equipment to the earth. Connect the equipment to the earth (ground) securely.
- Wire the earth (ground) terminal independently. (Do not connect two or more cables to one terminal.)
- Use the earth (ground) cable and the cable sizes on [page 37](#) under the following conditions.
  - Surrounding air temperature: 40°C maximumIf conditions are different from above, select appropriate wire according to EN 60204-1 or IEC 60364-5-52.
- Use a tinned (plating should not include zinc) crimping terminal to connect the earth (ground) cable. When tightening the screw, be careful not to damage the threads.

For use as a product compliant with the Low Voltage Directive, use a PVC cable whose size is indicated on [page 37](#).
- Use the molded case circuit breaker and magnetic contactor which conform to the EN or IEC Standard.
- DC current may flow from the converter unit to a protective earth (ground) conductor. When using a residual current device (RDC) or residual current monitor (RDM), connect a type B RCD or RCM to the power supply side.
- Use the converter unit under the conditions of overvoltage category II (usable regardless of the earth (ground) condition of the power supply), overvoltage category III (usable with the earth-neutral system power supply, 400 V class only) and pollution degree 2 or lower specified in IEC60664.
  - To use the converter unit under the conditions of pollution degree 2, install it in the enclosure of IP2X or higher.
  - To use the converter unit under the conditions of pollution degree 3, install it in the enclosure of IP54 or higher.
- On the input and output of the inverter and the converter unit, use cables of the size and type set forth in EN 60204-1 or IEC 60364-5-52.
- The operating capacity of the relay outputs (terminal symbols A1, B1, C1, A2, B2, C2) should be 30 VDC, 0.3 A. (Relay output has basic isolation from the internal circuit of the inverter and the converter unit.)
- Control circuit terminals on [page 27](#) are safely isolated from the main circuit.
- Environment (For the detail, refer to [page 20](#).)

	During operation	In storage	During transportation
Surrounding air temperature	-10 to +40°C	-20 to +65°C	-20 to +65°C
Ambient humidity	95% RH or less	95% RH or less	95% RH or less
Maximum altitude	2500 m*1	2500 m	10000 m

\*1 For installation at an altitude above 1000 m, consider a 3% reduction in the rated current per 500 m increase in altitude.

- When the output side of the 12-phase transformer is not earthed (grounded), the power supply system of the converter unit is used as an isolated-neutral (IT) system. Install an insulation monitoring device (IMD) for protection against insulation failure.
- To use the system as a TN-C system, earth a neutral point on the output side of the transformer (wye connection) and connect all devices to the protective conductor (PEN).

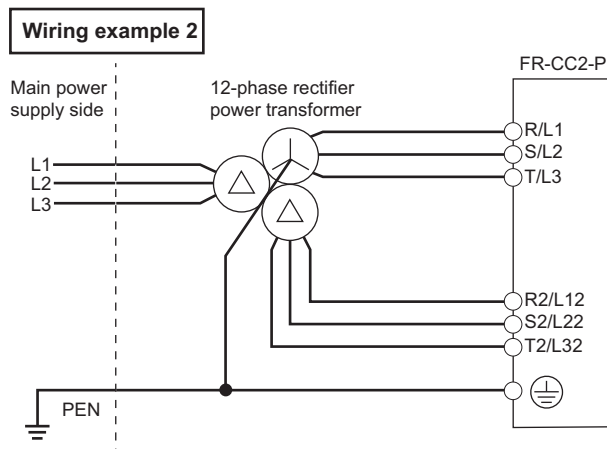
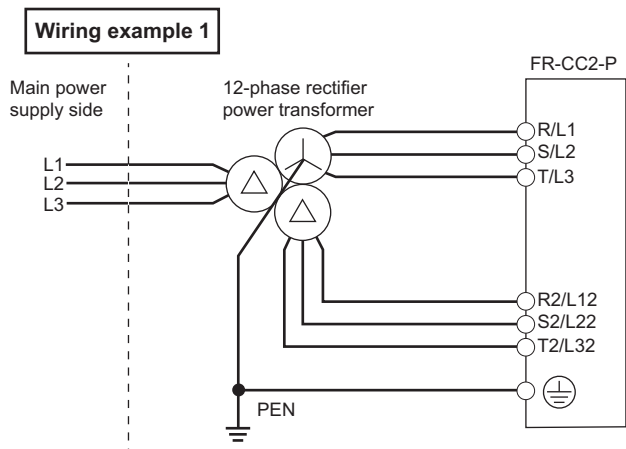

### ◆ Wiring protection

- 6-phase rectification

Provide a Class T, Class J, Class CC, or Class L fuse.

FR-CC2-□-P	H400K	H450K	H500K	H560K
Rated fuse voltage (V)	500 V or more			
Fuse maximum allowable rating (A) *1	1350	1500	1800	1800

\*1 Maximum allowable rating by US National Electrical Code. Exact size must be chosen for each installation.

- 12-phase rectification

Connection diagram

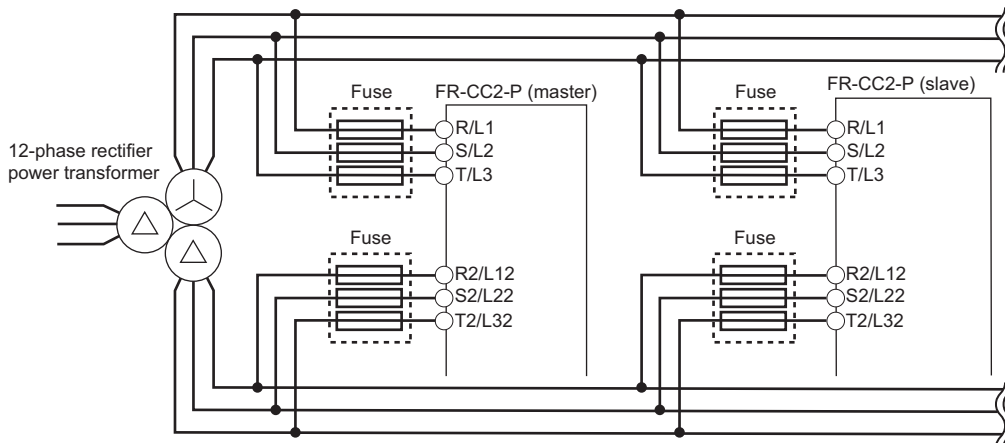

Provide the appropriate fuse in accordance with the table below

Converter model	Fuse type	Model	Manufacturer	Rating
FR-CC2-H400K-P	UL Recognized High Speed	170M6013, 170M6113	Bussmann	900 A, 700 VAC
FR-CC2-H450K-P		170M6014, 170M6114		1000 A, 700 VAC
FR-CC2-H500K-P		170M6015, 170M6115		1100 A, 700 VAC
FR-CC2-H560K-P		170M6016, 170M6116		1250 A, 700 VAC

### ◆ Short circuit ratings

Suitable For Use in A Circuit Capable of Delivering Not More Than 100 kA rms Symmetrical Amperes, 500 V Maximum.

### ◆ EU RoHS Directive

We have declared that our converter units are compliant to the EU RoHS Directive (2011/65/EU) and affix the CE marking on the converter units.

## ◆ Rated specifications per converter unit

The following table shows the rated specifications per converter unit. (For the rated specifications for operating two or three units in parallel, refer to [page 166](#).)

Model FR-CC2-H□-P		400K	450K	500K	560K
Applicable motor capacity (kW)		320	360	400	450
Output	Overload current rating*1	150% 60 s, 200% 3 s			
	Rated voltage*2	430 to 780 VDC*4			
Power supply	Rated input current (A)	616	692.8	769.6	875.2
	Rated input AC voltage/frequency	Three-phase 380 to 500 V 50/60 Hz			
	Permissible AC voltage fluctuation	Three-phase 323 to 550 V 50/60 Hz			
	Permissible frequency fluctuation	±5%			
	Power supply capacity (kVA)*3	470	528	586	667
Protective structure (IEC 60529)		Open type (IP00)			
Approx. mass (kg)		282	285	288	293

\*1 The % value of the overload current rating indicated is the ratio of the overload current to the inverter's rated output current. For repeated duty, allow time for the converter unit and the inverter to return to or below the temperatures under 100% load.

\*2 The converter unit output voltage varies according to the input power supply voltage and the load. The maximum point of the voltage waveform at the converter unit output side is approximately the power supply voltage multiplied by  $\sqrt{2}$ .

\*3 The power supply capacity is the value when at the rated output current. It varies by the impedance at the power supply side (including those of the input reactor and cables).

\*4 The permissible voltage imbalance ratio is 3% or less. (Imbalance ratio = (highest voltage between lines - average voltage between three lines) / average voltage between three lines × 100)



# Appendix 3 Instructions for UL and cUL

(Standard to comply with: UL 508C, CSA C22.2 No.274-13)

## ◆ General Precaution

CAUTION - Risk of Electric Shock -

The bus capacitor discharge time is 10 minutes. Before starting wiring or inspection, switch power off, wait for more than 10 minutes, and check for residual voltage between terminal P/+ and N/- with a meter etc., to avoid a hazard of electrical shock.

ATTENTION - Risque de choc électrique -

La durée de décharge du condensateur de bus est de 10 minutes. Avant de commencer le câblage ou l'inspection, mettez l'appareil hors tension et attendez plus de 10 minutes.

## ◆ Installation

The below types of converter unit have been approved as products for use in enclosure.

Design the enclosure so that the surrounding air temperature, humidity and ambience of the converter unit will satisfy the specifications. (Refer to [page 20](#).)

### ◆ Wiring protection

For installation in the United States, Class T, Class J, Class CC, or Class L fuse must be provided, in accordance with the National Electrical Code and any applicable local codes.

For installation in Canada, Class T, Class J, Class CC, or Class L fuse must be provided, in accordance with the Canadian Electrical Code and any applicable local codes.

FR-CC2-□-P	H400K	H450K	H500K	H560K
Rated fuse voltage (V)	500 V or more			
Fuse maximum allowable rating (A)	1350	1500	1800	1800

## ◆ Wiring to the power supply and the motor

Refer to the National Electrical Code (Article 310) regarding the allowable current of the cable. Select the cable size for 125% of the rated current according to the National Electrical Code (Article 430).

For wiring the input (R/L1, S/L2, T/L3) terminals of the converter unit and output (U, V, W) terminals of the inverter, use the UL listed copper, stranded wires (rated at 75°C) and round crimping terminals. Crimp the crimping terminals with the crimping tool recommended by the terminal manufacturer.

## ◆ Short circuit ratings

Suitable For Use in A Circuit Capable of Delivering Not More Than 100 kA rms Symmetrical Amperes, 500 V Maximum.

## ◆ Rated specifications per converter unit

The following table shows the rated specifications per converter unit. (For the rated specifications for operating two or three units in parallel, refer to [page 166](#).)

Model FR-CC2-H□-P		400K	450K	500K	560K
Applicable motor capacity (kW)		320	360	400	450
Output	Overload current rating*1	150% 60 s, 200% 3 s			
	Rated voltage*2	430 to 780 VDC*4			
Power supply	Rated input current (A)	616	692.8	769.6	875.2
	Rated input AC voltage/frequency	Three-phase 380 to 500 V 50/60 Hz			
	Permissible AC voltage fluctuation	Three-phase 323 to 550 V 50/60 Hz			
	Permissible frequency fluctuation	±5%			
	Power supply capacity (kVA)*3	470	528	586	667
Protective structure (IEC 60529)		Open type (IP00)			
Approx. mass (kg)		282	285	288	293

\*1 The % value of the overload current rating indicated is the ratio of the overload current to the inverter's rated output current. For repeated duty, allow time for the converter unit and the inverter to return to or below the temperatures under 100% load.

\*2 The converter unit output voltage varies according to the input power supply voltage and the load. The maximum point of the voltage waveform at the converter unit output side is approximately the power supply voltage multiplied by  $\sqrt{2}$ .

\*3 The power supply capacity is the value when at the rated output current. It varies by the impedance at the power supply side (including those of the input reactor and cables).

\*4 The permissible voltage imbalance ratio is 3% or less. (Imbalance ratio = (highest voltage between lines - average voltage between three lines) / average voltage between three lines × 100)

---

# Appendix 4 Instructions for EAC

---

## EAC

The product certified in compliance with the Eurasian Conformity has the EAC marking.

Note: EAC marking

In 2010, three countries (Russia, Belarus, and Kazakhstan) established a Customs Union for the purposes of revitalizing the economy by forming a large economic bloc by abolishing or reducing tariffs and unifying regulatory procedures for the handling of articles.

Products to be distributed over these three countries of the Customs Union must comply with the Customs Union Technical Regulations (CU-TR), and the EAC marking must be affixed to the products.

For information on the country of origin, manufacture year and month, and authorized sales representative (importer) in the CU area of this product, refer to the following:

- Country of origin indication  
Check the rating plate of the product. (Refer to [page 8](#).)  
Example: MADE IN JAPAN
- Manufactured year and month  
Check the SERIAL number indicated on the rating plate of the product. (Refer to [page 8](#).)
- Authorized sales representative (importer) in the CU area  
The authorized sales representative (importer) in the CU area is shown below.  
Name: Mitsubishi Electric (Russia) LLC  
Address: 52, bld 1 Kosmodamianskaya Nab 115054, Moscow, Russia  
Phone: +7 (495) 721-2070  
Fax: +7 (495) 721-2071

# Appendix 5 Restricted Use of Hazardous Substances in Electronic and Electrical Products

The mark of restricted use of hazardous substances in electronic and electrical products is applied to the product as follows based on the "Management Methods for the Restriction of the Use of Hazardous Substances in Electrical and Electronic Products" of the People's Republic of China.

电器电子产品有害物质限制使用标识要求



本产品中所含有的有害物质的名称、含量、含有部件如下表所示。

- 产品中所含有害物质的名称及含量

部件名称 *2	有害物质 *1					
	铅 (Pb)	汞 (Hg)	镉 (Cd)	六价铬 (Cr (VI))	多溴联苯 (PBB)	多溴二苯醚 (PBDE)
电路板组件 (包括印刷电路板及其构成的零部件, 如电阻、电容、集成电路、连接器等)、电子部件	×	○	×	○	○	○
金属壳体、金属部件	×	○	○	○	○	○
树脂壳体、树脂部件	○	○	○	○	○	○
螺丝、电线	○	○	○	○	○	○

上表依据 SJ/T11364 的规定编制。

○: 表示该有害物质在该部件所有均质材料中的含量均在 GB/T26572 规定的限量要求以下。

×: 表示该有害物质在该部件的至少一种均质材料中的含量超出 GB/T26572 规定的限量要求。

\*1 即使表中记载为 ×, 根据产品型号, 也可能会有有害物质的含量为限制值以下的情况。

\*2 根据产品型号, 一部分部件可能不包含在产品中。

# Appendix 6 Referenced Standard (Requirement of Chinese standardized law)

This Product is designed and manufactured accordance with following Chinese standards.

Electrical safety	GB 12668.501
EMC	GB/T 12668.3

---

# Appendix 7 Compliance with the UK certification scheme

---

We declare that this product conforms with the related technical requirements under UK legislation, and affix the UKCA (UK Conformity Assessed) marking on the product.

Approval conditions are the same as those for the EU Directives.

(Refer to [page 172](#).)



UKCA marking:

The UKCA marking is used for products sold in the markets of Great Britain (England, Wales, and Scotland) from January 1, 2021 after the departure of the UK from the EU on January 31, 2020.

---

## WARRANTY

When using this product, make sure to understand the warranty described below.

### 1. Warranty period and coverage

We will repair any failure or defect (hereinafter referred to as "failure") in our FA equipment (hereinafter referred to as the "Product") arisen during warranty period at no charge due to causes for which we are responsible through the distributor from which you purchased the Product or our service provider. However, we will charge the actual cost of dispatching our engineer for an on-site repair work on request by customer in Japan or overseas countries. We are not responsible for any on-site readjustment and/or trial run that may be required after a defective unit are repaired or replaced.

#### [Term]

The term of warranty for Product is twelve months after your purchase or delivery of the Product to a place designated by you or eighteen months from the date of manufacture whichever comes first ("Warranty Period"). Warranty period for repaired Product cannot exceed beyond the original warranty period before any repair work.

#### [Limitations]

- (1) You are requested to conduct an initial failure diagnosis by yourself, as a general rule. It can also be carried out by us or our service company upon your request and the actual cost will be charged.  
However, it will not be charged if we are responsible for the cause of the failure.
- (2) This limited warranty applies only when the condition, method, environment, etc. of use are in compliance with the terms and conditions and instructions that are set forth in the instruction manual and user manual for the Product and the caution label affixed to the Product.
- (3) Even during the term of warranty, the repair cost will be charged on you in the following cases;
  - a failure caused by your improper storing or handling, carelessness or negligence, etc., and a failure caused by your hardware or software problem
  - a failure caused by any alteration, etc. to the Product made on your side without our approval
  - a failure which may be regarded as avoidable, if your equipment in which the Product is incorporated is equipped with a safety device required by applicable laws and has any function or structure considered to be indispensable according to a common sense in the industry
  - a failure which may be regarded as avoidable if consumable parts designated in the instruction manual, etc. are duly maintained and replaced
  - any replacement of consumable parts (condenser, cooling fan, etc.)
  - a failure caused by external factors such as inevitable accidents, including without limitation fire and abnormal fluctuation of voltage, and acts of God, including without limitation earthquake, lightning and natural disasters
  - a failure caused by using the emergency drive function
  - a failure generated by an unforeseeable cause with a scientific technology that was not available at the time of the shipment of the Product from our company
  - any other failures which we are not responsible for or which you acknowledge we are not responsible for

### 2. Term of warranty after the stop of production

- (1) We may accept the repair at charge for another seven (7) years after the production of the product is discontinued. The announcement of the stop of production for each model can be seen in our Sales and Service, etc.
- (2) Please note that the Product (including its spare parts) cannot be ordered after its stop of production.

### 3. Service in overseas

Our regional FA Center in overseas countries will accept the repair work of the Product; however, the terms and conditions of the repair work may differ depending on each FA Center. Please ask your local FA center for details.

### 4. Exclusion of loss in opportunity and secondary loss from warranty liability

Regardless of the gratis warranty term, Mitsubishi shall not be liable for compensation to:

- (1) Damages caused by any cause found not to be the responsibility of Mitsubishi.
- (2) Loss in opportunity, lost profits incurred to the user by Failures of Mitsubishi products.
- (3) Special damages and secondary damages whether foreseeable or not, compensation for accidents, and compensation for damages to products other than Mitsubishi products.
- (4) Replacement by the user, maintenance of on-site equipment, start-up test run and other tasks.

### 5. Change of Product specifications

Specifications listed in our catalogs, manuals or technical documents may be changed without notice.

### 6. Application and use of the Product

- (1) For the use of our product, its applications should be those that may not result in a serious damage even if any failure or malfunction occurs in product, and a backup or fail-safe function should operate on an external system to product when any failure or malfunction occurs.
- (2) Our product is designed and manufactured as a general purpose product for use at general industries.  
Therefore, applications substantially influential on the public interest for such as atomic power plants and other power plants of electric power companies, and also which require a special quality assurance system, including applications for railway companies and government or public offices are not recommended, and we assume no responsibility for any failure caused by these applications when used.  
In addition, applications which may be substantially influential to human lives or properties for such as airlines, medical treatments, railway service, incineration and fuel systems, man-operated material handling equipment, entertainment machines, safety machines, etc. are not recommended, and we assume no responsibility for any failure caused by these applications when used.  
We will review the acceptability of the abovementioned applications, if you agree not to require a specific quality for a specific application. Please contact us for consultation.

REVISIONS

\*The manual number is given on the bottom left of the back cover.

Revision Date	*Manual number	Revision
Nov. 2016	IB(NA)-0600657ENG-A	First edition
Jan. 2022	IB(NA)-0600657ENG-B	Added Emergency drive <ul style="list-style-type: none"> <li>• Pr.67 Number of retries at fault occurrence</li> <li>• Pr.514 Emergency drive dedicated retry waiting time</li> <li>• Pr.515 Emergency drive dedicated retry count</li> <li>• Pr.523 Emergency drive selection</li> </ul>

**mitsubishi electric corporation**  
HEAD OFFICE: TOKYO BUILDING 2-7-3, MARUNOUCHI, CHIYODA-KU, TOKYO 100-8310, JAPAN