

Plug-in option

FR-A8AVP

INSTRUCTION MANUAL (FOR INVERTER/CONVERTER SWITCHING)

Changeover between inverter and high power factor converter

Compatible inverters: FR-A842-07700(315K) to 12120(500K)

OUTLINE	1
INVERTER-TO- CONVERTER CONVERSION	2
INSTALLATION AND WIRING	3
PRECAUTIONS FOR USE OF THE CONVERTER	4
PARAMETERS	5
PROTECTIVE FUNCTIONS	6
PRECAUTIONS FOR MAINTENANCE AND INSPECTION	7
SPECIFICATIONS	8
CONVERTER-TO- INVERTER CONVERSION	9

Thank you for choosing this Mitsubishi Electric inverter plug-in option.

This Instruction Manual provides handling information and precautions for use of the this product. Incorrect handling might cause an unexpected fault. Before using this product, always read this Instruction Manual carefully to ensure proper use. Please forward this Instruction Manual to the end user.

Safety instructions

Do not attempt to install, operate, maintain or inspect this product until you have read through this Instruction Manual and appended documents carefully and can use the equipment correctly. Do not use this product until you have a full knowledge of the equipment, safety information and instructions.

In this Instruction Manual, the safety instruction levels are classified into "WARNING" and "CAUTION"



WARNING

Incorrect handling may cause hazardous conditions, resulting in death or severe injury.



CAUTION

Incorrect handling may cause hazardous conditions, resulting in medium or slight injury, or may cause only material damage.

Note that even the  level may lead to a serious consequence depending on conditions. Be sure to follow the instructions of both levels as they are critical to personnel safety.

◆ Electric shock prevention



WARNING

- Do not remove the front cover or the wiring cover while the inverter or the high power factor converter (converted from the inverter, hereafter called "converter") is powered ON. Do not operate the inverter/converter with any cover or wiring cover removed, as accidental contact with exposed high-voltage terminals and internal components may occur, resulting in an electrical shock.
- Even if power is OFF, do not remove the front cover except for wiring or periodic inspection as the inside of the inverter/converter is charged. Doing so may cause an electric shock.
- Before wiring or inspection, check that the LED display of the operation panel is OFF. Any person who is involved in wiring or inspection shall wait for 10 minutes or longer after the power supply has been cut off, and check that there are no residual voltage using a tester or the like. The capacitor is charged with high voltage for some time after power OFF, and it is dangerous.
- The inverter/converter must be earthed (grounded). Earthing (grounding) must conform to the requirements of national and local safety regulations and electrical code (NEC section 250, IEC 61140 class 1 and other applicable standards).
- Any person who is involved in wiring or inspection of this product shall be fully competent to do the work.
- The inverter/converter must be installed before wiring. Otherwise, electric shock or injury may result.
- Do not touch the setting dial or keys with wet hands. Doing so may cause an electric shock.
- Do not subject the cables to scratches, excessive stress, heavy loads or pinching. Doing so may cause an electric shock.
- Do not change the cooling fan while the inverter/converter is powered ON as it is dangerous.
- Do not touch the printed circuit board or handle the cables with wet hands. Doing so may cause an electric shock.

◆ Fire prevention



CAUTION

- The inverter/converter must be installed on a nonflammable wall without holes. Installing it to or near flammable material can cause a fire.
- If the inverter/converter has become faulty, its power must be switched OFF. A continuous flow of large current may cause a fire.
- Be sure to perform daily and periodic inspections as specified in the Instruction Manual. If the inverter/converter is used without any inspection, a burst, breakage, or a fire may occur.

◆ Injury prevention



CAUTION

- The voltage applied to each terminal must be as specified in the Instruction Manual. Otherwise a burst, damage, etc. may occur.
- The cables must be connected to the correct terminals. Otherwise a burst, damage, etc. may occur.
- The polarity (+ and -) must be correct. Otherwise a burst, damage, etc. may occur.
- While power is ON or for some time after power-OFF, do not touch the inverter/converter, reactor 1, reactor 2, phase detection transformer box, filter capacitor, and inrush current limit resistor as they will be extremely hot. Doing so may cause a burn.

◆ Additional instructions

The following instructions must be also followed. If the inverter/converter is handled incorrectly, it may cause an unexpected fault, injury, or electric shock.



CAUTION

Transportation and installation

- The inverter/converter must be transported in correct method that corresponds to the weight. Failure to do so may lead to injuries.
- Do not stack the boxes containing products higher than the number recommended.
- The inverter/converter must be installed in a position where it withstands the weight of the product according to the information in the Instruction Manual.
- Do not install or operate the inverter/converter if it is damaged or has parts missing.
- When carrying the inverter/converter, do not hold it by the front cover. Doing so may cause a fall or failure.
- Do not stand or rest heavy objects on the inverter/converter.
- The installing orientation of the inverter/converter must be correct.
- Foreign conductive objects must be prevented from entering the inverter/converter. That includes screws and metal fragments or other flammable substance such as oil.
- As the inverter/converter is a precision instrument, do not drop or subject it to impact.
- The surrounding air temperature must be between 10 and +50°C (non-freezing). Otherwise, the inverter/converter may be damaged.
- The ambient humidity must be 95% RH or less (non-condensing). Otherwise, the inverter/converter may be damaged. (For the details, refer to [page 24](#).)
- The temporary storage temperature (applicable to a short limited time such as a transportation time) must be between -20 and +65°C. Otherwise, the inverter/converter may be damaged.
- The inverter/converter must be used indoors (without corrosive gas, flammable gas, oil mist, dust and dirt etc.) Otherwise, the inverter/converter may be damaged.
- The inverter/converter must be used at an altitude of 2500 m or less. Vibration should not exceed 2.9 m/s² at 10 to 55 Hz in X, Y, and Z directions. Otherwise, the inverter/converter may be damaged. (For the details, refer to [page 24](#).)
- If halogens (including fluorine, chlorine, bromine, and iodine) contained in fumigants for wood packages enter this product, the product may be damaged. Prevent the entry of fumigant residuals or use an alternative method such as heat disinfection. Note that sterilization or disinfection of wood packages should be performed before packing the product.

Test operation

- Before starting the test operation, confirm or adjust the parameter settings. Failure to do so may cause some machines to make unexpected motions.
- Before starting the operation, check the wiring of each peripheral device. Faulty wiring may cause some machines to make expected motions.

WARNING

Usage

- Stay away from the equipment when the retry function is set as the inverter/converter will restart suddenly after its output shutoff.
- Depending on the function settings, the inverter/converter does not stop its output even when the STOP/RESET key on the operation panel is pressed. To prepare for it, provide a separate circuit and switch (to turn OFF the power or to take other actions) for an emergency stop.
- Be sure to turn OFF the start (STF/STR) signal before clearing the fault as the inverter/converter will restart the motor suddenly after a fault is cleared.
- Use only the specified inverters for the connection with the converter. Connection of any other electrical equipment to the output of the converter may damage the equipment.
- Do not modify the inverter/converter.
- Do not remove any part which is not instructed to be removed in the Instruction Manual. Doing so may lead to a failure or damage.

CAUTION

Usage

- Do not repeatedly start or stop the inverter/converter with a magnetic contactor on its input side. Doing so may shorten the life of the inverter/converter.
- Use a noise filter or other means to minimize the electromagnetic interference with other electronic equipment used nearby the inverter/converter.
- As all parameters return to their initial values after the Parameter clear or All parameter clear is performed, the parameters must be set again as required before the operation is started.
- Before running an inverter/converter which have been stored and not been operated for a long period, perform an inspection and a test operation.
- To avoid damage due to static electricity, static electricity in your body must be discharged before you touch the inverter/converter.

Emergency stop

- A safety backup such as an emergency brake must be provided for devices or equipment in a system to prevent hazardous conditions in case of failure of the inverter/converter or its external controller.
- If the breaker installed on the input side of the inverter/converter trips, check for wiring faults (short circuits etc.) and damage to internal parts of this product.
- When any fault occurs, take an appropriate corrective action, then reset the inverter/converter, and resume the operation.

Maintenance, inspection and parts replacement

- Do not carry out a megger (insulation resistance) test on the control circuit of the inverter/converter.

Disposal

- This product must be treated as industrial waste.

General instruction

- For clarity, illustrations in this Instruction Manual may be drawn with covers or safety guards removed. Ensure all covers and safety guards are properly installed prior to starting operation.

CONTENTS

1	OUTLINE	7
1.1	Pre-operation instructions	8
1.1.1	Unpacking and checking the product.....	9
1.1.2	Component names	10
1.2	Pre-installation instructions for the FR-A8AVP	11
1.3	Installing the FR-A8AVP	11
2	INVERTER-TO-CONVERTER CONVERSION	13
2.1	Conversion flowchart	14
2.2	Conversion procedure	15
2.2.1	Preparation for the conversion.....	15
2.2.2	Inverter-to-converter conversion (Pr.328).....	16
2.2.3	Application of stickers supplied with the product	17
2.3	Troubleshooting	18
3	INSTALLATION AND WIRING	19
3.1	Peripheral devices	20
3.1.1	Converter and peripheral devices.....	20
3.2	Selection of breaker, magnetic contactor, and fuse	21
3.3	Compatible inverter for the high power factor converter	22
3.3.1	Applicable inverter capacity	22
3.3.2	Inverter parameter settings.....	23
3.4	Installation of the converter and enclosure design	24
3.4.1	Converter installation environment	24
3.4.2	Cooling system types for converter enclosure.....	26
3.4.3	Installation of the converter.....	27
3.4.4	Protruding the heat sink through a panel.....	28
3.5	Installation of stand-alone options for converter	29
3.5.1	Installation of the reactor 1 (FR-A8BL1) and reactor 2 (FR-A8BL2).....	29
3.5.2	Installation of the phase detection transformer box (FR-A8VPB).....	30
3.5.3	Installation of the filter capacitor (FR-A8BC)	33
3.5.4	Installation of the dedicated circuit parts for inrush current protection (FR-A8MC)	34
3.5.5	Terminals of stand-alone options for the converter	36
3.6	Main circuit terminal specification	37
3.6.1	Details on the main circuit terminals	37
3.6.2	Main circuit terminal block layout.....	37
3.6.3	Cable size of the main circuit terminals and the earth (ground) terminal.....	38
3.7	Wiring of main circuit	40
3.7.1	Connection diagram (when using with the FR-A800 series).....	40
3.7.2	Wiring of main circuit	42

3.8	Earthing (Grounding) precautions	47
3.9	Wiring of control circuit	49
3.9.1	Details on the control circuit terminals.....	49
3.9.2	Control logic (sink/source) change	53
3.9.3	Wiring of control circuit.....	55
3.9.4	Wiring precautions.....	57
3.9.5	When using separate power supplies for the control circuit and the main circuit.....	58
3.9.6	When supplying 24 V external power to the control circuit.....	59
3.10	Communication connectors and terminals	61
3.10.1	PU connector.....	61
3.10.2	USB connector	62
3.10.3	RS-485 terminal block	63
3.11	Connection of the converter and multiple inverters	64

4 PRECAUTIONS FOR USE OF THE CONVERTER 67

4.1	Features of the converter	68
4.2	Harmonic suppression guidelines in Japan	69
4.3	Techniques and measures for electromagnetic compatibility (EMC)	72
4.3.1	Countermeasures against inverter-generated EMI	72
4.3.2	Selecting the rated sensitivity current for the earth leakage circuit breaker	78

5 PARAMETERS 79

5.1	Operation panel (FR-DU08)	80
5.1.1	Components of the operation panel	80
5.1.2	Basic Operation of the Operation Panel.....	81
5.1.3	Digital characters and their corresponding printed equivalents.....	82
5.1.4	Changing the parameter setting value	82
5.2	Parameter unit (FR-PU07)	83
5.2.1	Components of the parameter unit.....	83
5.2.2	Description of keys	83
5.2.3	Monitoring function.....	84
5.2.4	Function menu.....	85
5.3	Parameter List	87
5.4	Parameter details	90
5.4.1	Setting the phase detection transformer box (FR-A8VPB) input voltage	90
5.4.2	Power frequency input to the converter (Pr.1 and Pr.2)	91
5.4.3	Operation selection for the SOF signal and the OH signal (Pr.8 and Pr.9)	91
5.4.4	DC voltage control (Pr.22, Pr.23, Pr.80, Pr.81, and Pr.157)	92
5.4.5	Instantaneous power failure detection hold signal (Pr.44)	93
5.4.6	Terminal FM (pulse train output) and terminal AM/CA (analog output) reference (Pr.49, Pr.51, Pr.53, Pr.55, Pr.56).....	94
5.4.7	Monitor item selection on operation panel or via communication.....	96
5.4.8	Monitor display selection for terminals FM/CA and AM.....	100
5.4.9	Operation selection at instantaneous power failure (Pr.57)	101

5.4.10	Retry function (Pr.65, Pr.67 to Pr.69)	102
5.4.11	Reset selection / disconnected PU detection / PU stop selection (Pr.75)	104
5.4.12	Parameter write disable selection (Pr.77)	106
5.4.13	Current control (Pr.82 and Pr.83)	107
5.4.14	Power factor adjustment function (Pr.84 and Pr.85)	107
5.4.15	Wiring and configuration of PU connector	108
5.4.16	Wiring and configuration of RS-485 terminals	110
5.4.17	Initial setting of operation via communication	113
5.4.18	Initial settings and specifications of RS-485 communication	113
5.4.19	Mitsubishi inverter protocol (computer link communication)	115
5.4.20	PU display language selection	126
5.4.21	Disabling the setting dial and keys on the operation panel	126
5.4.22	Input terminal function selection (Pr.178 to Pr.189)	127
5.4.23	Operation selection for the RDY signal and the RSO signal (Pr.190 and Pr.191)	128
5.4.24	Output terminal function selection (Pr.192 to Pr.194, Pr.196)	129
5.4.25	Cooling fan operation selection	131
5.4.26	Converter parts life display (Pr.255 to Pr.257)	132
5.4.27	Maintenance timer alarm	134
5.4.28	Detection of control circuit temperature	135
5.4.29	Adjustment of terminal FM/CA and terminal AM	136
5.4.30	Free parameter	139
5.4.31	Beep control	140
5.4.32	PU contrast adjustment	140
5.4.33	Initiating a protective function	140
5.4.34	Simple clock function	141
<hr/>		
5.5	Parameter clear / All parameter clear on the operation panel	142
<hr/>		
5.6	Copying and verifying parameters on the operation panel	143
5.6.1	Parameter copy	143
5.6.2	Parameter verification	145
<hr/>		
5.7	Checking parameters changed from their initial values (initial value change list)	146

6 PROTECTIVE FUNCTIONS 147

6.1	Converter fault and indication	148
<hr/>		
6.2	Reset method for the protective functions	148
<hr/>		
6.3	Check and clear of the fault history	149
<hr/>		
6.4	List of indications	151
<hr/>		
6.5	Causes and corrective actions	153
<hr/>		
6.6	Check first when you have a trouble	162

7 PRECAUTIONS FOR MAINTENANCE AND INSPECTION 163

7.1	Inspection item	164
7.1.1	Daily inspection	164
7.1.2	Periodic inspection	164
7.1.3	Daily and periodic inspection list	165

7.1.4	Continuity test.....	166
7.1.5	Cleaning	166
7.1.6	Replacement of parts	167
7.1.7	Removal and reinstallation of the control circuit terminal block	170
7.2	Measurement of main circuit voltages, currents, and powers	172
7.2.1	Insulation resistance test using megger	173
7.2.2	Withstand voltage test	173

8 SPECIFICATIONS 175

8.1	Converter rated specifications	176
8.2	Common specifications	177
8.3	Outline dimension drawings	178
8.3.1	Reactor 1 (FR-A8BL1).....	178
8.3.2	Reactor 2 (FR-A8BL2).....	178
8.3.3	Phase detection transformer box (FR-A8VPB-H).....	179
8.3.4	Filter capacitor (FR-A8BC)	180
8.3.5	Dedicated circuit parts for inrush current protection (FR-A8MC)	181
8.3.6	Parameter unit.....	184
8.4	Compatible options	184

9 CONVERTER-TO-INVERTER CONVERSION 185

9.1	Converter-to-inverter conversion	186
9.1.1	Preparation for the conversion	186
9.1.2	Converter-to-inverter conversion (Pr.328).....	187
9.1.3	Removal of the stickers	187

APPENDIX 189

Appendix 1	Instruction code list.....	190
Appendix 2	Instructions for compliance with the EU Directives	192
Appendix 3	Instructions for UL and cUL	194
Appendix 4	Instructions for EAC.....	195
Appendix 5	Restricted Use of Hazardous Substances in Electronic and Electrical Products	196
Appendix 6	Referenced Standard (Requirement of Chinese standardized law).....	196

1 OUTLINE

This chapter explains the outline of this product.
Always read the instructions before use.

1.1	Pre-operation instructions	8
1.2	Pre-installation instructions for the FR-A8AVP	11
1.3	Installing the FR-A8AVP	11

<Abbreviations>

DU	Operation panel (FR-DU08)
PU	Operation panel (FR-DU08) or parameter unit (FR-PU07)
Inverter	Mitsubishi Electric inverter
Converter	High power factor converter converted from the inverter by using the FR-A8AVP
Pr.	Parameter number (Number assigned to function of the inverter or the converter)

<Trademarks>

- Ethernet is a registered trademark of Fuji Xerox Corporation in Japan.
- Microsoft and Visual C++ are registered trademarks of Microsoft Corporation in the United States and other countries.
- Other company and product names herein are the trademarks and registered trademarks of their respective owners.

<Notes on descriptions in this Instruction Manual>

Connection diagrams in this Instruction Manual appear with the control logic of the input terminals as sink logic, unless otherwise specified. (For the control logic, refer to [page 53](#).)

1.1 Pre-operation instructions

Incorrect handling may cause the equipment to operate improperly or reduce its life considerably, and in the worst case, the converter and the connected inverter to be damaged. Please handle the converter properly in accordance with the information on each section as well as the precautions and instructions of this manual.

◆ Features of the product

Install the plug-in option FR-A8AVP on a separated converter type inverter and set parameters. The inverter will be converted into a high power factor converter. To use the converter, use the options specifically made for the converter: the phase detection transformer box, filter reactor, reactor for PWM control, filter capacitor, and inrush current limit resistor. The converter can be changed back to the inverter.



- To use the phase-synchronized bypass switching function, refer to the other instruction manual which is included with the FR-A8AVP which is dedicated to the function (manual number: IB-0600809ENG).

◆ Option lineup for the converter

To use the converter, be sure to use the following options according to the capacity of the converter. Check the model and quantity of each option. (The abbreviated names are used in this document to facilitate descriptions.)



Option model	Component model	Name	Abbreviation	Quantity				
				Converter capacity (FR-A842-□)				
				07700 (15K)	08660 (355K)	09620 (400K)	10940 (450K)	12120 (500K)
FR-A8VPB-H	FR-A8VPB-H	Phase detection transformer box		1	1	1	1	1
FR-A8BL1-H315K	FR-A8BL1-H315K	Dedicated filter reactor	Reactor 1	1	—	—	—	—
FR-A8BL1-H355K	FR-A8BL1-H355K			—	1	—	—	—
FR-A8BL1-H400K	FR-A8BL1-H400K			—	—	1	—	—
FR-A8BL1-H450K	FR-A8BL1-H450K			—	—	—	1	—
FR-A8BL1-H500K	FR-A8BL1-H500K			—	—	—	—	1
FR-A8BL2-H315K	FR-A8BL2-H315K	Dedicated reactor for PWM control	Reactor 2	1	—	—	—	—
FR-A8BL2-H355K	FR-A8BL2-H355K			—	1	—	—	—
FR-A8BL2-H400K	FR-A8BL2-H400K			—	—	1	—	—
FR-A8BL2-H450K	FR-A8BL2-H450K			—	—	—	1	—
FR-A8BL2-H500K	FR-A8BL2-H500K			—	—	—	—	1
FR-A8BC-H400K	FR-A8BC-H400K	Dedicated filter capacitor	Filter capacitor	1	1	1	—	—
FR-A8BC-H500K	FR-A8BC-H500K			—	—	—	1	1
FR-A8MC-H355K		Dedicated circuit parts for inrush current protection		—	—	—	—	—
	BKO-CA2573H01	Inrush current limit resistor (without thermostat)		3	3	—	—	—
	BKO-CA2573H11	Inrush current limit resistor (with thermostat)		3	3	—	—	—
	BKO-CA2571H01	Stepdown transformer for power source of magnetic contactor (400 to 220 V)		1	1	—	—	—
	S-N400 AC200V 2A2B	Inrush current limit magnetic contactor		3	3	—	—	—
	SR-T5 AC200V 5A	Buffer relay		1	1	—	—	—
	MYQ4Z AC200/220	Mini relay		1	1	—	—	—
	PYF14T	Mini relay terminal block		1	1	—	—	—
PYC-A1	Mini relay clip		2	2	—	—	—	
FR-A8MC-H500K		Dedicated circuit parts for inrush current protection		—	—	—	—	—
	BKO-CA2573H01	Inrush current limit resistor (without thermostat)		—	—	6	6	6
	BKO-CA2573H11	Inrush current limit resistor (with thermostat)		—	—	3	3	3
	BKO-CA2571H01	Stepdown transformer for power source of magnetic contactor (400 to 220 V)		—	—	1	1	1
	S-N400 AC200V 2A2B	Inrush current limit magnetic contactor		—	—	3	3	3
	SR-T5 AC200V 5A	Buffer relay		—	—	1	1	1
	MYQ4Z AC200/220	Mini relay		—	—	1	1	1
	PYF14T	Mini relay terminal block		—	—	1	1	1
PYC-A1	Mini relay clip		—	—	2	2	2	

1.1.1 Unpacking and checking the product

Take the product out of the package, check the product name, and confirm that the product is as you ordered and intact. The FR-A8AVP is a plug-in option for the FR-A802 inverters (separated converter type).

◆Product confirmation

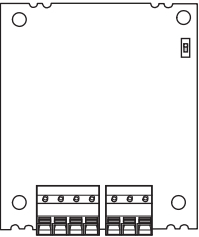
Check the enclosed items.

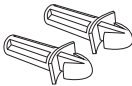
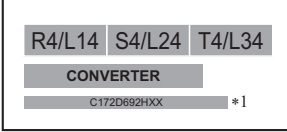
Plug-in option: 1 	Mounting screw (M3 × 8 mm): 2 (Refer to page 11.) 	Spacer: 2 (Refer to page 11.) 	• Converter sticker sheet: 1 (Refer to page 16 and page 187.) 
--	--	---	--

*1 Not used.

◆SERIAL (serial number) check

The inverter/converter switching function is available for the inverter/converter which satisfies both of the following conditions.

- The inverter has two rating plates: one for the inverter, and the other for the high power factor converter.
- The inverter/converter has the following SERIAL (printed on the rating plate and the package).

Applicable model	Country of origin indication	SERIAL
FR-A842-12120(500K)	MADE in Japan	□7Z○○○○○○ or later
FR-A842-07700(315K) to 10940(450K)		□86○○○○○○ or later
FR-A842-07700(315K) to 12120(500K)	MADE in China	□87○○○○○○ or later

□ 7 Z ○○○○○○ *1
 Symbol Year Month Control number

*1 The SERIAL consists of one symbol, two characters indicating the production year and month, and six characters indicating the control number. The last digit of the production year is indicated as the Year, and the Month is indicated by 1 to 9, X (October), Y (November), or Z (December).



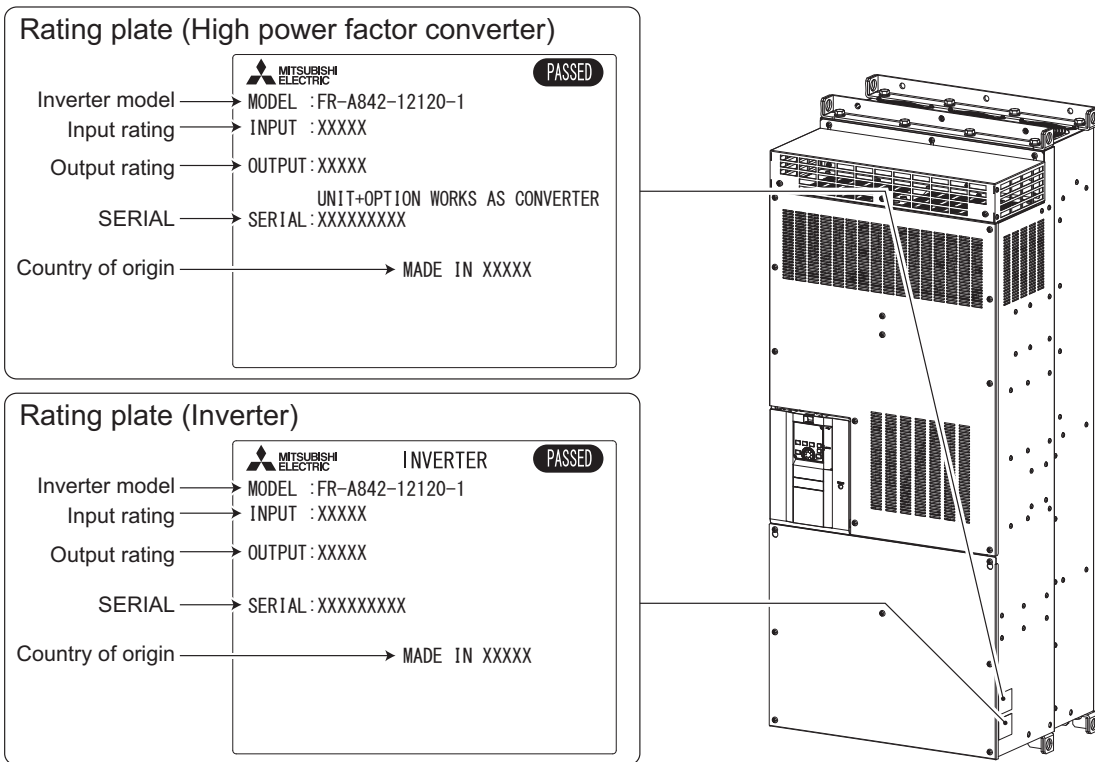



NOTE

• Ethernet communication is not available when the FR-A802-E inverter has been converted to the high power factor converter.

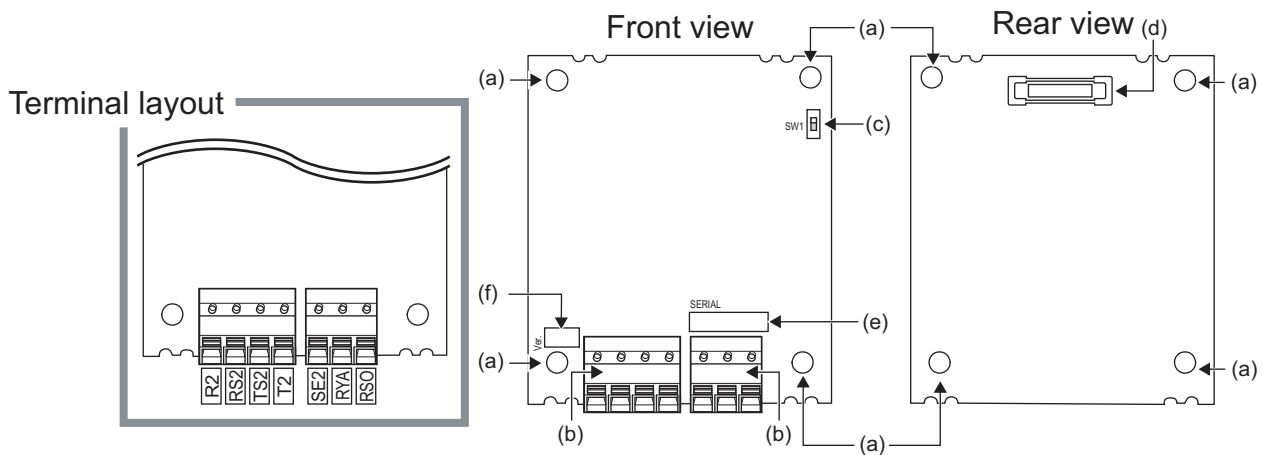
1.1.2 Component names



Symbol	Name	Description	Refer to page
a	Mounting hole	Fix the option to the inverter (converter) with the screws, or insert spacers.	11
b	Terminal block	Used to connect the converter (converted from the inverter) to the phase detection transformer box and to an inverter.	49
c	Switch (SW1) for manufacturer setting	Do not change from the initially-set status (OFF: )	—
d	Connector	Connected to the option connector of the inverter (converter).	11
e	SERIAL (serial number)	The SERIAL of the FR-A8AVP is printed.	—
f	Version information	The product version of the FR-A8AVP is printed.	—

1.2 Pre-installation instructions for the FR-A8AVP

Check that the inverter's input power and the control circuit power are both OFF.

! CAUTION

- Do not install or remove the FR-A8AVP while the inverter power is ON. Doing so may damage the inverter or plug-in option.
- To avoid damage due to static electricity, static electricity in your body must be discharged before you touch the product.

1.3 Installing the FR-A8AVP

- (1) Remove the inverter front cover.
- (2) Insert spacers into the two mounting holes that will not be tightened with the option mounting screws (see the following figure).
- (3) Fit the connector of the FR-A8AVP to the guide of the connector of the inverter, and insert the option as far as it goes.
- (4) Fasten the FR-A8AVP onto the inverter by fastening the mounting screws into the holes on the both sides (tightening torque: 0.33 to 0.40 N·m). If the connector is not inserted deep enough, the screws cannot be tightened properly. Check the connector.

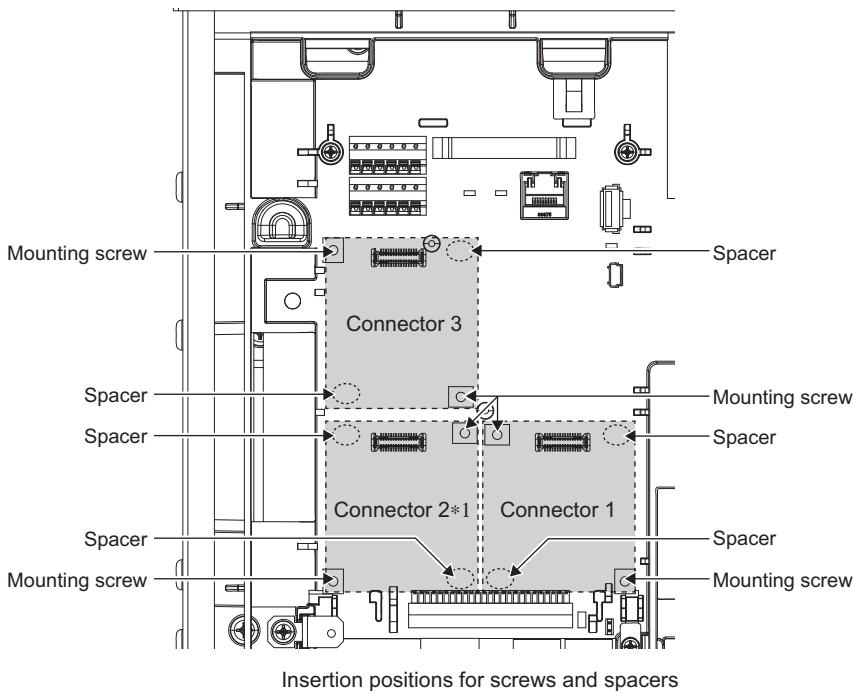
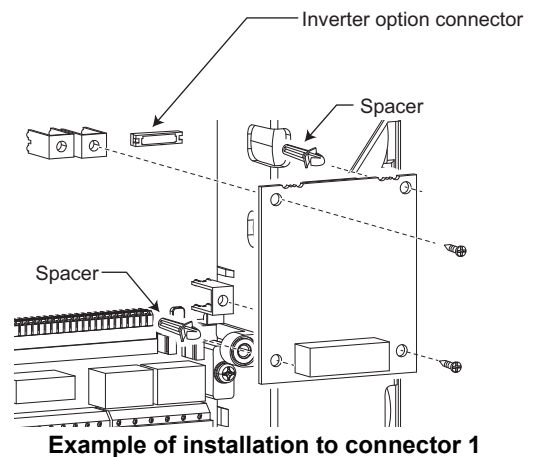

*1 The option connector 2 on the FR-A800-E inverters (separated converter type) is not available for use because it is occupied by the Ethernet board which is pre-installed in the initial status. To install the FR-A8AVP to the option connector 2, remove the Ethernet board.

Installing the FR-A8AVP

NOTE

- When installing/removing an option, hold the sides of the circuit board. Do not press on the parts on the circuit board. Stress applied to the parts by pressing, etc. may cause a failure.
- Take caution not to drop screws during installation and removal of the option.
- Two or more of the same plug-in options cannot be connected. When multiple options are installed, priority is given to option connectors 1, 2 and 3 on the inverter in this order, and options having a lower priority do not function.
- When the inverter cannot recognize the FR-A8AVP due to improper installation or any other reason, the protective function (E.1 to E.3) is activated and the inverter cannot be operated. The indication to be shown depends on the position (option connector 1 to 3) used.

Mounted position	Fault indication
Option connector 1	E. 1
Option connector 2	E. 2
Option connector 3	E. 3

- When removing the plug-in option, remove the two screws on the left and right, then pull it straight out. Pressure applied to the connector and to the option board may break the option.

2 INVERTER-TO- CONVERTER CONVERSION

This chapter explains how to convert the inverter into a high power factor converter.

Always read the instructions before use.

2.1	Conversion flowchart	14
2.2	Conversion procedure.....	15
2.3	Troubleshooting.....	18

2.1 Conversion flowchart

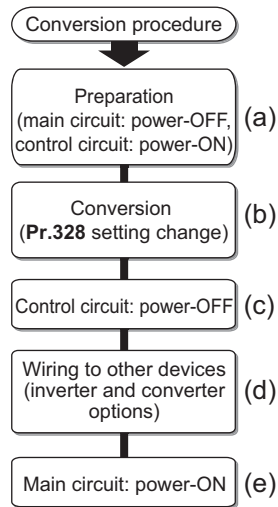

Symbol	Description	Refer to page
(a)	Preparation for the inverter-to-converter conversion. Be sure to turn OFF the main circuit power of the inverter, and turn ON the control circuit power of the inverter (supplied via terminals R1/L11 and S1/L21 from a separate power source).	15
(b)	Change the setting of Pr.328 in the inverter to convert the inverter into a high power factor converter.	16
(c)	Turn OFF the control circuit power.	16
(d)	Connect an inverter and the converter options to the converter.	40
(e)	After the wiring is completed, turn ON the main circuit power of the converter.	—

2.2 Conversion procedure

This section explains the procedure to convert the inverter to the high factor converter.

2.2.1 Preparation for the conversion

Before starting the conversion, check the following conditions of the inverter (all the conditions must be satisfied).

Check the following while the control circuit power of the inverter is OFF.

- The FR-A8AVP is installed in one of the option connectors (1 to 3). (Refer to [page 11](#).)
- All of the main circuit terminals are left open.
- Terminals R1/L11 and S1/L21 are used to supply power to the control circuit of the inverter.
- No USB memory device is connected.

Check the following while the control circuit power of the inverter is ON.

- The inverter is in the PU operation mode (not in the External/PU combined operation mode 1 or 2).
- The PLC function is disabled (**Pr.414** = "0").
- The inverter is in normal state and its operation is stopped (its output is shut off). (No protective function is activated.)

NOTE

- When terminal +24 is used to supply power to the control circuit of the inverter, the conversion to the converter is disabled.
- Sequence programs stored in the inverter for the PLC function will be cleared after the conversion. Be sure to back up the programs before conversion.

2.2.2 Inverter-to-converter conversion (Pr.328)

Pr.	Name	Initial value	Setting range	Description
328 E310	Inverter/converter switching	—	0 to 9999	Change the setting of this parameter according to the predetermined inverter-to-converter conversion procedure.

◆ Inverter-to-converter conversion procedure

The following shows the setting procedure for the inverter-to-converter conversion.

Enter the following values in **Pr.328** in the following order. If the procedure from step 1 to step 3 is not followed, the parameter setting will be cleared (the **Pr.328** setting returns to its initial value "0"). In that case, restart the procedure from step 1.

1 Enter "3100".

Check that "3100" is displayed for **Pr.328**.

2 Enter "5010".

Check that "5010" is displayed for **Pr.328**.

3 Enter "1000".

The inverter-to-converter conversion starts when "1000" is entered. The communication status LED indicator starts blinking. (The following figure shows the location of the LED indicator.)

The LED indicator stays ON after the conversion is completed.

(It takes about 300 seconds to complete the conversion.)

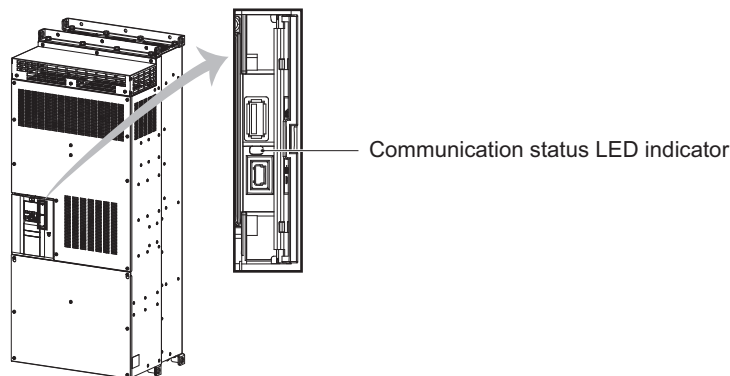

NOTE

- After entering "1000", do not operate the PU until the LED indicator stays ON.

4 Reset the control circuit power.

After the reset, "9999" will be displayed for **Pr.328**.

Functions as an inverter will not be available after this point.

5 After checking that "9999" is displayed for **Pr.328**, enter "1".

Inverter reset and All parameter clear will start automatically. After the reset, converter functions are available.

6 Press the setting dial on the operation panel (FR-DU08) and check that "CNV" (converter) is displayed.

NOTE

- If the control circuit power is turned OFF once and then turned ON again, conversion may restart depending on the timing of power OFF.

2.2.3 Application of stickers supplied with the product

Attach the "CONVERTER" sticker and the main circuit terminal stickers ("R4/L14", "S4/L24", and "T4/L34" stickers) supplied with the FR-A8AVP for indication of the converter.

- Attach the "CONVERTER" sticker to the front cover of the converter as shown in the following figure.

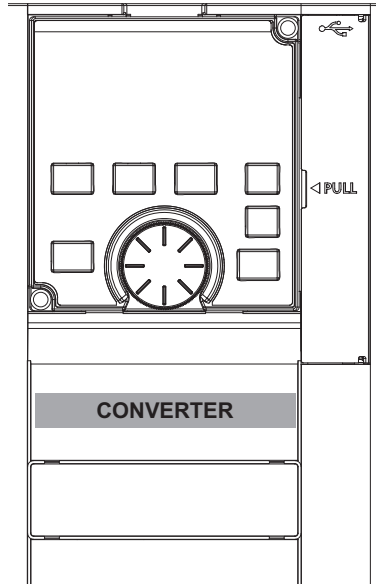

- Check that the power of the converter is OFF and open the terminal block cover. Attach the main circuit terminal stickers over the existing "U", "V", and "W" stickers as shown in the following figure.

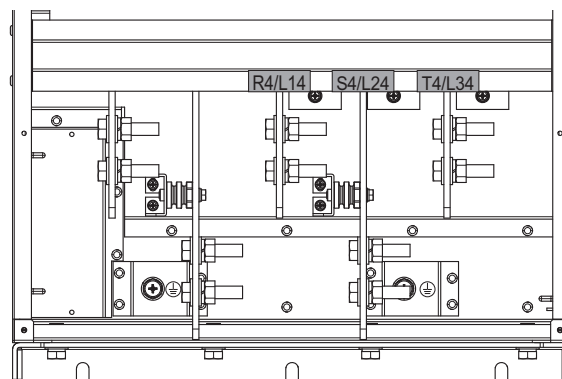

2.3 Troubleshooting

Condition	Possible cause	Countermeasure
Pr.328 cannot be overwritten.	Preparation for the conversion has not been completed.	Complete the preparation. (Refer to page 15 .)
The Pr.328 setting returns to "0 (initial value)".	The procedure from step 1 to step 3 was not followed properly.	Follow the procedure from step 1 to step 3 properly. (Refer to page 16 .)
The communication status LED will not change from blinking to constantly lit.	The inverter is in the process of the conversion (the conversion takes 300 seconds after Pr.328 has been set to "1000").	Contact your sales representative if the communication status LED indicator remains blinking (does not become solid) even after a lapse of 300 seconds.
Checking of the current state (inverter or converter) is required.	—	<ul style="list-style-type: none"> • Press the setting dial on the operation panel (FR-DU08) and check the indication. (Refer to page 16.) • Check the Pr.328 setting. (Refer to page 16.)
"11" is displayed for Pr.328 after the conversion.	—	Please contact your sales representative.

3 **INSTALLATION AND WIRING**

This chapter explains the installation and the wiring of the converter. Always read the instructions before use.

3.1	Peripheral devices	20
3.2	Selection of breaker, magnetic contactor, and fuse	21
3.3	Compatible inverter for the high power factor converter	22
3.4	Installation of the converter and enclosure design.....	24
3.5	Installation of stand-alone options for converter	29
3.6	Main circuit terminal specification	37
3.7	Wiring of main circuit	40
3.8	Earthing (Grounding) precautions	47
3.9	Wiring of control circuit	49
3.10	Communication connectors and terminals	61
3.11	Connection of the converter and multiple inverters.....	64

3.1 Peripheral devices

3.1.1 Converter and peripheral devices

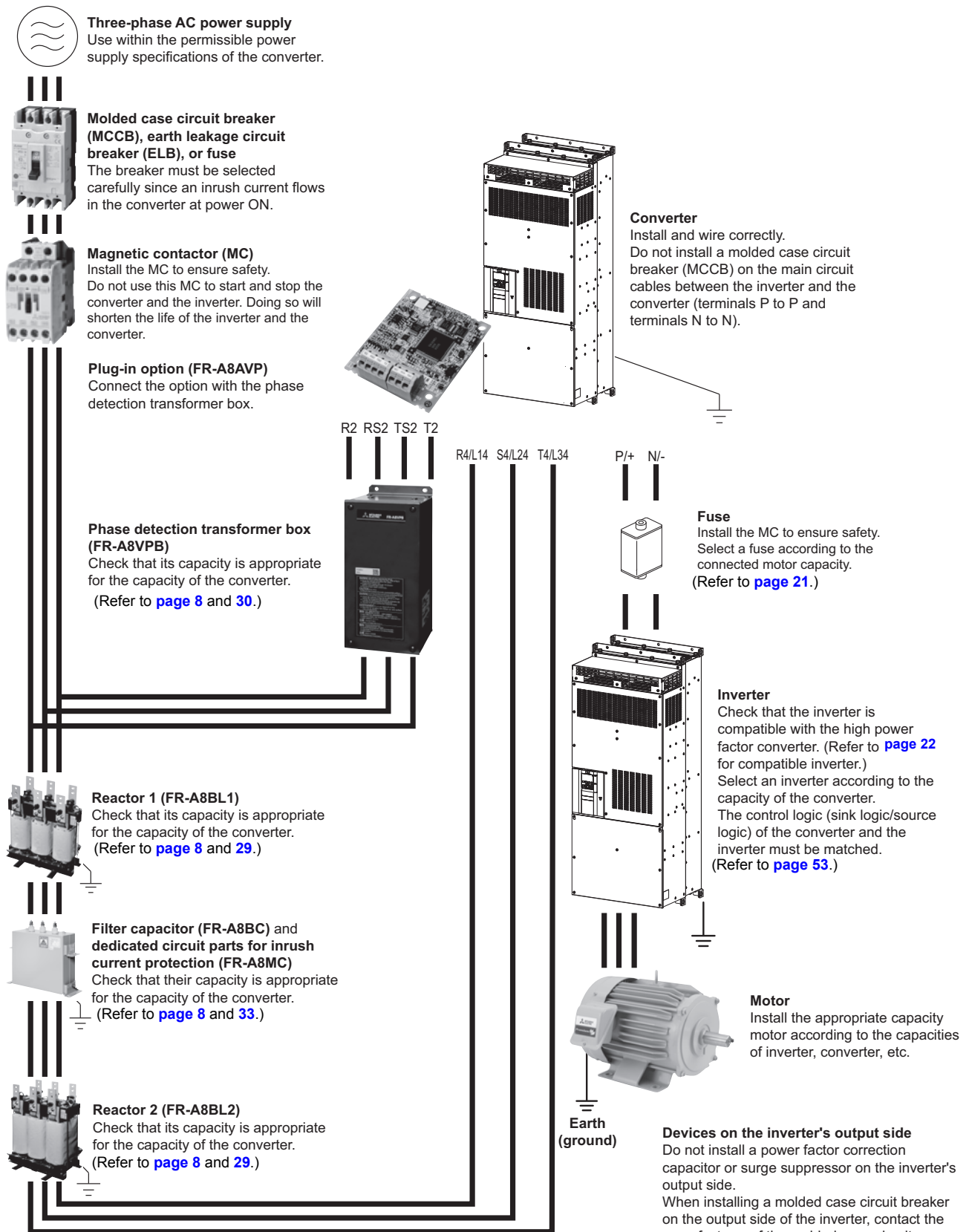

Three-phase AC power supply
Use within the permissible power supply specifications of the converter.

Molded case circuit breaker (MCCB), earth leakage circuit breaker (ELB), or fuse
The breaker must be selected carefully since an inrush current flows in the converter at power ON.

Magnetic contactor (MC)
Install the MC to ensure safety. Do not use this MC to start and stop the converter and the inverter. Doing so will shorten the life of the inverter and the converter.

Plug-in option (FR-A8AVP)
Connect the option with the phase detection transformer box.

Phase detection transformer box (FR-A8VPB)
Check that its capacity is appropriate for the capacity of the converter. (Refer to [page 8](#) and [30](#).)

Reactor 1 (FR-A8BL1)
Check that its capacity is appropriate for the capacity of the converter. (Refer to [page 8](#) and [29](#).)

Filter capacitor (FR-A8BC) and dedicated circuit parts for inrush current protection (FR-A8MC)
Check that their capacity is appropriate for the capacity of the converter. (Refer to [page 8](#) and [33](#).)

Reactor 2 (FR-A8BL2)
Check that its capacity is appropriate for the capacity of the converter. (Refer to [page 8](#) and [29](#).)

Converter
Install and wire correctly. Do not install a molded case circuit breaker (MCCB) on the main circuit cables between the inverter and the converter (terminals P to P and terminals N to N).

Fuse
Install the MC to ensure safety. Select a fuse according to the connected motor capacity. (Refer to [page 21](#).)

Inverter
Check that the inverter is compatible with the high power factor converter. (Refer to [page 22](#) for compatible inverter.) Select an inverter according to the capacity of the converter. The control logic (sink logic/source logic) of the converter and the inverter must be matched. (Refer to [page 53](#).)

Motor
Install the appropriate capacity motor according to the capacities of inverter, converter, etc.

Devices on the inverter's output side
Do not install a power factor correction capacitor or surge suppressor on the inverter's output side. When installing a molded case circuit breaker on the output side of the inverter, contact the manufacturer of the molded case circuit breaker.

Earth (ground)
Always earth (ground) the converter, converter options, inverter, and motor.

3.2 Selection of breaker, magnetic contactor, and fuse

◆Circuit breakers and magnetic contactors

Check the model of the converter. The correct breaker and magnetic contactor must be installed with the appropriate converter capacity.

Refer to the following table to select the appropriate breaker and magnetic contactor.

High power factor converter model	Molded case circuit breaker (MCCB)*1 or earth leakage circuit breaker (NF, NV type)	Magnetic contactor (MC)*2
FR-A842-07700(315K)	700 A	S-N600
FR-A842-08660(355K)	800 A	S-N600
FR-A842-09620(400K)	900 A	S-N800
FR-A842-10940(450K)	1000 A	S-N400 (3 in parallel)
FR-A842-12120(500K)	1200 A	S-N400 (3 in parallel)

- *1 Select an MCCB according to the power supply capacity. Install one MCCB per converter. (For the use in the United States or Canada, refer to [page 194](#), and select the appropriate fuse.)

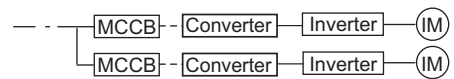

- *2 The magnetic contactor is selected based on the AC-1 class. The electrical durability of magnetic contactor is 500,000 times. When the magnetic contactor is used for emergency stops during motor driving, the electrical durability is 25 times. If using an MC for emergency stop during motor driving or using it on the motor side during commercial power supply operation, select an MC with the class AC-3 rated current for the rated motor current.

NOTE

- When the breaker installed at the converter's input line is shut off, check for the wiring fault (short circuit), damage to internal parts of the converter, etc. The cause of the trip must be identified and removed before turning ON the power of the breaker.

◆Fuse

Installation of a fuse is recommended between the converter and an inverter. Select a fuse according to the capacity of the connected motor. When using a motor, of which the capacity is smaller than the inverter capacity by two ranks or more, select the fuse with the capacity that is one rank lower than the inverter capacity. (For the details, refer to [page 45](#).)

- Fuse selection table

Motor capacity (kW)	Fuse rating (A)	Model*1
315	1600	6.9 URD 232 TDF 1600 or 6.9 URD 31 TTF 0800 × 2 (parallel connection)*2
355	1800	6.9 URD 232 TDF 1800 or 6.9 URD 32 TTF 0900 × 2 (parallel connection)*2
400	1800	6.9 URD 232 TDF 1800 or 6.9 URD 32 TTF 0900 × 2 (parallel connection)*2
450	2500	6.9 URD 33 TTF 1250 × 2 (parallel connection)*2
500	2700	6.9 URD 32 TTF 0900 × 3 (parallel connection)*2

- *1 Manufacturer: Mersen Japan KK
Contact: Sun-Wa Technos Corporation
- *2 When installing several fuses in parallel, leave a space of 12 mm or more between the fuses.

NOTE

- Install fuses across terminals P/+ and P/+, and across terminals N/- and N/- of the converter and an inverter.
- Fuses are not required when the converter is used in combination with a FR-A842-07700(315K) to 12120(500K) inverter, which has internal fuses.

- Estimated lifespan of fuses

Components	Estimated lifespan*1	Replacement method
Fuse	10 years	Replace by new one

- *1 Estimated lifespan for when the yearly average surrounding air temperature is 50°C (without corrosive gas, flammable gas, oil mist, dust and dirt etc.).

NOTE

- If the fuse melts down, wiring failure such as a short circuit may be the cause. Find out the cause and remove it before replacing the fuse.

3.3 Compatible inverter for the high power factor converter

3.3.1 Applicable inverter capacity

The required converter capacity differs by the multiple rating selection setting of the inverter.

Refer to the following table for the connectable inverter capacities when connecting one inverter to a high power factor converter. (The combination with the inverter not specified in the table is not applicable.)

○: Applicable.

-: Usable as a common converter or regenerative converter, but the harmonic suppression effect decreases.

x: Not applicable.



• For details of the inverter capacity, refer to the rating specifications in the Instruction Manual of the inverter.

Example: FR-A820

Model FR-A820-[]	00046	00077	00105
	0.4K	0.75K	1.5K
SLD	0.75	1.5	2.2

◆ When the inverter capacity and the applicable motor capacity are equal (FR-A800 (ND rating), FR-F800 (LD rating), and 700 series inverters)

Converter capacity	Inverter capacity													
	132K or lower	160K	185K	220K	250K	280K	315K	355K	375K	400K	450K	500K	530K	560K
FR-A842-07700(315K)	-	-	○	○	○	○	○	x	x	x	x	x	x	x
FR-A842-08660(355K)	-	-	○	○	○	○	○	○	x	x	x	x	x	x
FR-A842-09620(400K)	-	-	-	○	○	○	○	○	○	○	x	x	x	x
FR-A842-10940(450K)	-	-	-	-	○	○	○	○	○	○	○	x	x	x
FR-A842-12120(500K)	-	-	-	-	○	○	○	○	○	○	○	○	x	x

◆ When the applicable motor capacity is higher than the inverter capacity (FR-A800 (LD rating), FR-A800 (SLD rating), and FR-F800 (SLD rating))

Refer to the table above to check the applicability of the converter. When the capacity of a motor to be installed is larger than the converter capacity, read the "inverter capacity" in the table above as the applicable "motor capacity".

◆ When the applicable motor capacity is lower than the inverter capacity (FR-A800 (HD rating))

Converter capacity	Inverter capacity												
	132K or lower	160K	185K	220K	250K	280K	315K	355K	400K	450K	500K	560K	
FR-A842-07700(315K)	-	-	○	○	x	x	x	x	x	x	x	x	
FR-A842-08660(355K)	-	-	○	○	○	x	x	x	x	x	x	x	
FR-A842-09620(400K)	-	-	-	○	○	○	x	x	x	x	x	x	
FR-A842-10940(450K)	-	-	-	-	○	○	○	x	x	x	x	x	
FR-A842-12120(500K)	-	-	-	-	○	○	○	○	x	x	x	x	

3.3.2 Inverter parameter settings

When using the converter with the inverter, some inverter parameters must be set. The parameter settings differ by the inverter series. The parameter settings differ by the inverter series.

For the parameters and inverters not listed below, refer to the Instruction Manual of the inverter.

Inverter series	Pr.30 Regenerative function selection	V/F control	Other than V/F control
		Pr.19 Base frequency voltage	Pr.83 Rated motor voltage
FR-A800, FR-F800	2, 102	Rated motor voltage	
FR-E700, FR-F700PJ, FR-D700	0 (initial value), 2 (when the automatic restart after instantaneous power failure function is enabled)		

3.4 Installation of the converter and enclosure design

When designing or manufacturing an enclosure, determine the structure, size, and device layout by fully considering the conditions such as heat generation of the contained devices and the operating environment. The converter uses many semiconductor devices. To increase reliability and prolong the life of the product, operate the converter in an environment that sufficiently satisfies the standard environmental specifications.

3.4.1 Converter installation environment

The following table lists the standard specifications of the converter installation environment. Using the converter in an environment that does not satisfy the conditions deteriorates the performance, shortens the life, and causes a failure. Refer to the following points, and take adequate measures.

◆ Standard environmental specifications of the converter

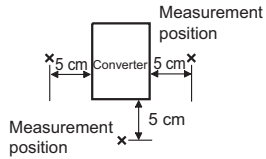
Item	Description
Surrounding air temperature	-10 to +50°C (non-freezing) 
Surrounding air humidity	With circuit board coating: 95% RH or less (non-condensing) Without circuit board coating: 90% RH or less (non-condensing)
Storage temperature	-20 to +65°C*1
Atmosphere	Indoors (free from corrosive gas, flammable gas, oil mist, dust and dirt)
Altitude	2500 m or lower*2
Vibration	2.9 m/s ² or less at 10 to 55 Hz (directions of X, Y, Z axes)

*1 Temperature applicable for a short time, for example, in transit.

*2 For the installation at an altitude above 1000 m, consider a 3% reduction in the rated current per 500 m increase in altitude.

◆ Temperature

The permissible surrounding air temperature of the converter is between -10 and +50°C. Always operate the converter within this temperature range. Operation outside this range will considerably shorten the service lives of the semiconductors, parts, capacitors and others. Take the following measures to keep the surrounding air temperature of the converter within the specified range.

(a) Measures against high temperature

- Use a forced ventilation system or similar cooling system. (Refer to [page 26](#).)
- Install the enclosure in an air-conditioned electric chamber.
- Block direct sunlight.
- Provide a shield or similar plate to avoid direct exposure to the radiated heat and wind of a heat source.
- Ventilate the area around the enclosure well.

(b) Measures against low temperature

- Provide a space heater in the enclosure.
- Do not power OFF the converter. (Keep the start signal of the inverter OFF.)

(c) Sudden temperature changes

- Select an installation place where temperature does not change suddenly.
- Avoid installing the converter near the air outlet of an air conditioner.
- If temperature changes are caused by opening/closing of a door, install the converter away from the door.

◆ Humidity

Operate the converter within the ambient air humidity range of 45 to 90% (up to 95% with circuit board coating). Too high humidity will pose problems of reduced insulation and metal corrosion. On the other hand, too low humidity may cause a spatial electrical breakdown. The humidity conditions for the insulation distance defined in JEM 1103 standard "Insulation Distance from Control Equipment" is 45 to 85%.

(a) Measures against high humidity

- Make the enclosure enclosed, and provide it with a hygroscopic agent.
- Provide dry air into the enclosure from outside.
- Provide a space heater in the enclosure.

(b) Measures against low humidity

Air with proper humidity can be blown into the enclosure from outside. Also when installing or inspecting the unit, discharge your body (static electricity) beforehand, and keep your body away from the parts and patterns.

(c) Measures against condensation

Condensation may occur if frequent operation stops change the in-enclosure temperature suddenly or if the outside air temperature changes suddenly.

Condensation causes such faults as reduced insulation and corrosion.

- Take the measures against high humidity in (a).
- Do not power OFF the converter. (Keep the start signal of the inverter OFF.)

◆Dust, dirt, oil mist

Dust and dirt will cause such faults as poor contacts, reduced insulation and cooling effect due to the moisture-absorbed accumulated dust and dirt, and in-enclosure temperature rise due to a clogged filter. In an atmosphere where conductive powder floats, dust and dirt will cause such faults as malfunction, deteriorated insulation and short circuit in a short time. Since oil mist will cause similar conditions, it is necessary to take adequate measures.

Countermeasure

- Place the converter in a totally enclosed enclosure.
Take measures if the in-enclosure temperature rises. (Refer to [page 26](#).)
- Purge air.
Pump clean air from outside to make the in-enclosure air pressure higher than the outside air pressure.

◆Corrosive gas, salt damage

If the converter is exposed to corrosive gas or to salt near a beach, the printed board patterns and parts will corrode or the relays and switches will result in poor contact.

In such places, take the measures given in the previous paragraph.

◆Explosive, flammable gases

As the converter is non-explosion proof, it must be contained in an explosion-proof enclosure. In places where explosion may be caused by explosive gas, dust or dirt, an enclosure cannot be used unless it structurally complies with the guidelines and has passed the specified tests. This makes the enclosure itself expensive (including the test charges). The best way is to avoid installation in such places and install the converter in a non-hazardous place.

◆High altitude

Use the converter at an altitude of within 2500 m. For use at an altitude above 1000 m, consider a 3% reduction in the rated current per 500 m increase in altitude.

If it is used at a higher place, it is likely that thin air will reduce the cooling effect and low air pressure will deteriorate dielectric strength.

◆Vibration, impact

The vibration resistance of the converter is up to 2.9 m/s² at 10 to 55 Hz frequency and 1 mm amplitude for the directions of X, Y, Z axes. Applying vibration and impacts for a long time may loosen the structures and cause poor contacts of connectors, even if those vibration and impacts are within the specified values.

Especially when impacts are applied repeatedly, caution must be taken because such impacts may break the installation feet.

Countermeasure

- Provide the enclosure with rubber vibration isolators.
- Strengthen the structure to prevent the enclosure from resonance.
- Install the enclosure away from the sources of the vibration.

3.4.2 Cooling system types for converter enclosure

From the enclosure that contains the converter, the heat of the converter and other equipment (inverter, transformers, reactors, lamps, resistors, etc.) and the incoming heat such as direct sunlight must be dissipated to keep the in-enclosure temperature lower than the permissible temperatures of the in-enclosure equipment including the converter.

The cooling systems are classified as follows in terms of the cooling calculation method.

- (a) Cooling by natural heat dissipation from the enclosure surface (totally enclosed type)
- (b) Cooling by heat sink (aluminum fin, etc.)
- (c) Cooling by ventilation (forced ventilation type, pipe ventilation type)
- (d) Cooling by heat exchanger or cooler (heat pipe, cooler, etc.)

Cooling system		Enclosure structure	Comment
Natural	Natural ventilation (enclosed type / open type)		This system is low in cost and generally used, but the enclosure size increases as the converter capacity increases. This system is for relatively small capacities.
	Natural ventilation (totally enclosed type)		Being a totally enclosed type, this system is the most appropriate for hostile environment having dust, dirt, oil mist, etc. The enclosure size increases depending on the converter capacity.
Forced air	Heat sink cooling		This system has restrictions on the heat sink mounting position and area. This system is for relatively small capacities.
	Forced ventilation		This system is for general indoor installation. This is appropriate for enclosure downsizing and cost reduction, and often used.
	Heat pipe		This system is a totally enclosed type, and is appropriate for enclosure downsizing.

3.4.3 Installation of the converter

◆ Placement of the converter

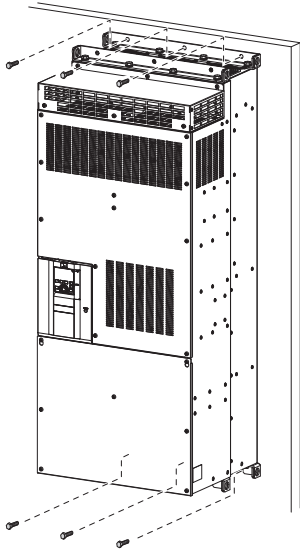

- Install the converter on a strong surface securely with screws.
- Leave enough clearances and take cooling measures.
- Avoid places where the converter is subjected to direct sunlight, high temperature and high humidity.
- Install the converter on a nonflammable wall surface.
- When encasing multiple converters in an enclosure, install them in parallel as a cooling measure.
- For heat dissipation and maintenance, keep clearance between the converter and the other devices or enclosure surface. The clearance below the converter is required as a wiring space, and the clearance above the converter is required as a heat dissipation space.
- When designing or building an enclosure for the converter, carefully consider influencing factors such as heat generation of the contained devices and the operating environment.

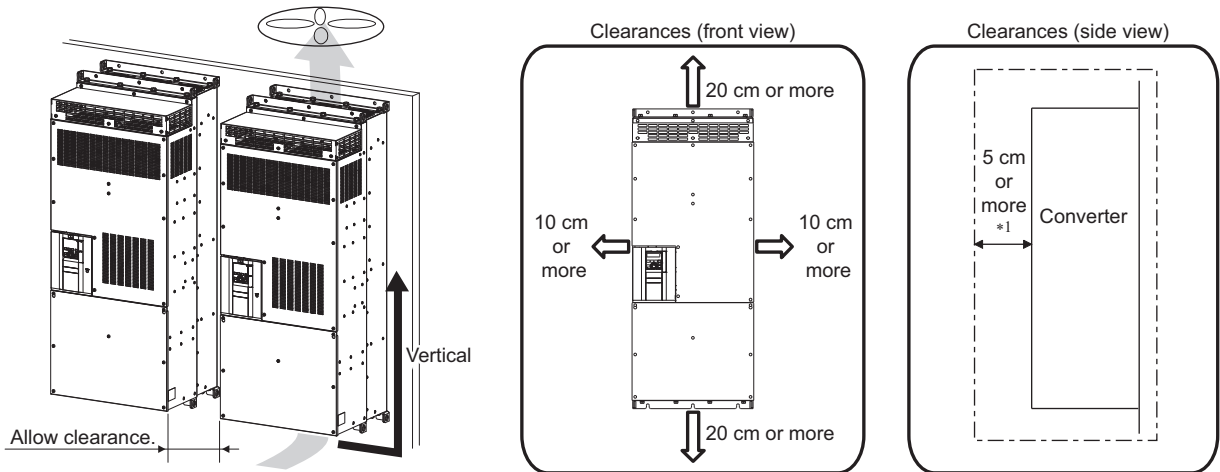

*1 For replacing the cooling fan, 30 cm of space is necessary in front of the converter. Refer to [page 167](#) for fan replacement.

◆ Installation orientation of the converter

Install the converter on a wall as specified. Do not mount it horizontally or in any other way.

◆ Above the converter

Heat is blown up from inside the converter by the small fan built in the unit. Any equipment placed above the converter should be heat resistant.

◆Arrangement of multiple inverters and converters

When multiple inverters and converters are placed in the same enclosure, generally arrange them horizontally as shown in the figure (a). When it is inevitable to arrange them vertically to minimize space as shown in the figure (b), take such measures as to provide guides since heat generated in the units in bottom row can increase the temperatures in the units in top row, causing the failure of the units in top row.

When mounting multiple inverters and converters, fully take caution not to make the surrounding air temperature of the inverter and the converter higher than the permissible value by providing ventilation and increasing the enclosure size.

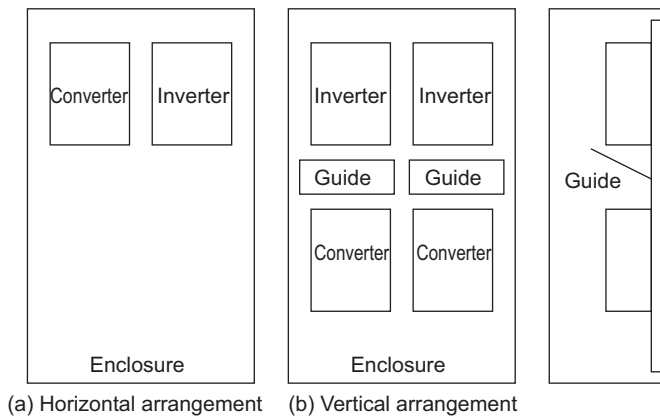

Arrangement of multiple inverters and converters

◆Placement of the ventilation fan and converter

Heat generated in the converter is blown up from the bottom of the unit as warm air by the cooling fan. When installing a ventilation fan for that heat, determine the place of ventilation fan installation after fully considering an air flow. (Air passes through areas of low resistance. Make an airway and airflow plates to expose the converter to cool air.)

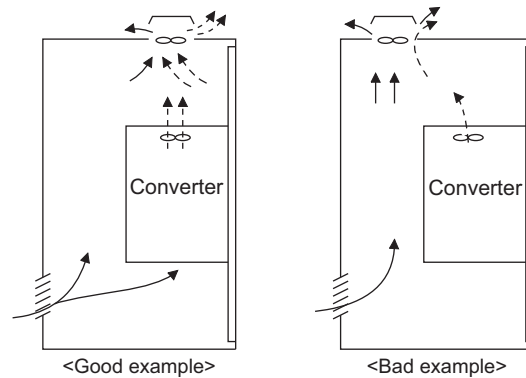

Arrangement of the ventilation fan and converter

NOTE

- To remove or reinstall the front cover or the operation panel (FR-DU08) of the converter, refer to the FR-A802 Instruction Manual (Hardware) as the procedure is the same as that for the inverter.

3.4.4 Protruding the heat sink through a panel

When encasing the converter to an enclosure, the heat generated in the enclosure can be greatly reduced by protruding its heat sink through the rear panel of the enclosure. To protrude the heat sink, refer to the FR-A802 Instruction Manual (Hardware) as the procedure is the same as that for the inverter.

3.5 Installation of stand-alone options for converter

3.5.1 Installation of the reactor 1 (FR-A8BL1) and reactor 2 (FR-A8BL2)

◆ Model confirmation

Before installing the reactor 1 and reactor 2, check the model on their rating plate (see the following figure) to avoid confusing them with each other as they look very similar. Refer to [page 178](#) to check the rating plate position.

Rating plate example: Reactor 1 (FR-A8BL1)

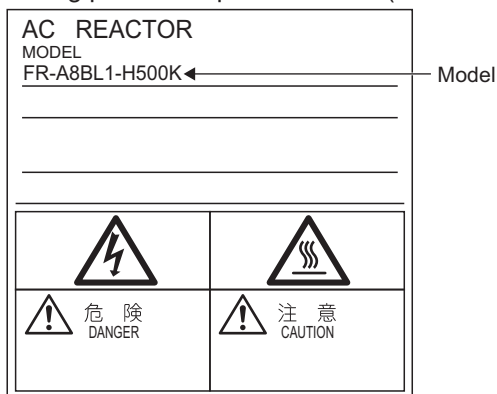

◆ Clearances

As the reactors generate heat, leave sufficient space around them.

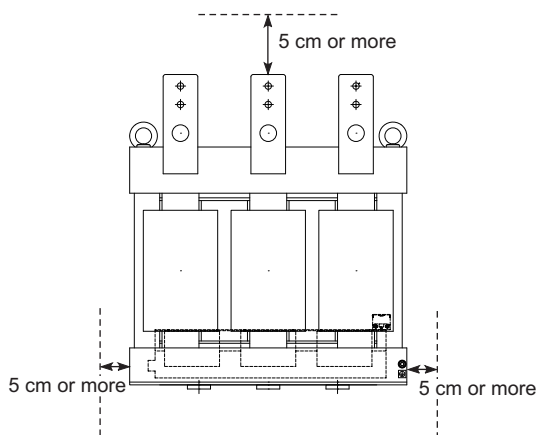

◆ Installation place

Install the reactors on nonflammable material. Installing them directly on flammable material will cause a fire.

◆ Surrounding environment

Avoid places where the reactors are subjected to oil mist, flammable gases, fluff, dust, dirt, etc.

Choose a clean place for installation, or protect it from suspended substances using a dust filter or the like.

◆ Installation orientation

To prevent looseness, install the reactors on a horizontal surface securely with screws or bolts.
Do not install them on a vertical surface. Install them on a mounting stand which can withstand its weight.

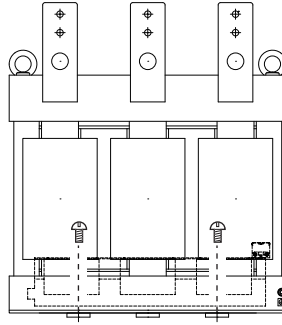

NOTE

- As the charged sections of the reactors are uncovered, fully protect them to prevent ground fault and electric shock.
- Intrusion of wire offcuts or dust into the cooling fan of the reactors can cause a failure or malfunction.
Keep clean environment for the reactors.

3.5.2 Installation of the phase detection transformer box (FR-A8VPB)

◆ Checking the Phase detection transformer box rating plate

Before installing the transformer box, check the values to be set in **Pr.1344** and **Pr.1345** described on its rating plate, and take a note of them. The same values must be set in **Pr.1344** and **Pr.1345** of the converter. (Refer to [page 90](#).)

◆ Clearances

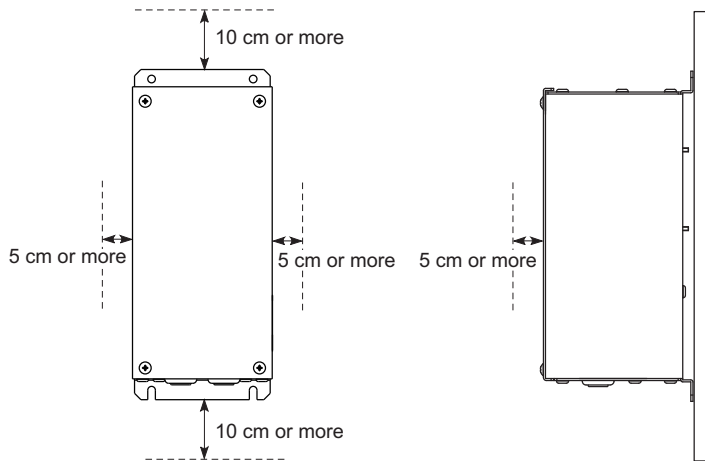

◆ Installation place

Install the transformer box on nonflammable material. Installing it directly on flammable material will cause a fire.

◆ Surrounding environment

Avoid places where the transformer box is subjected to oil mist, flammable gases, fluff, dust, dirt, etc.
Install the transformer box in a clean place or protect it from suspended substances.

◆ Installation orientation

Install the transformer box in a vertical position.

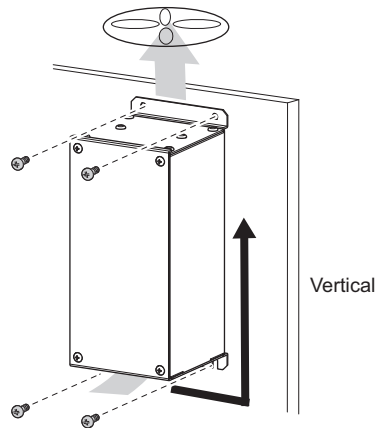

◆ Removal and reinstallation of the cover

◆ Removal

- Loosen the mounting screws of the cover.
- Pull out the cover to remove it.

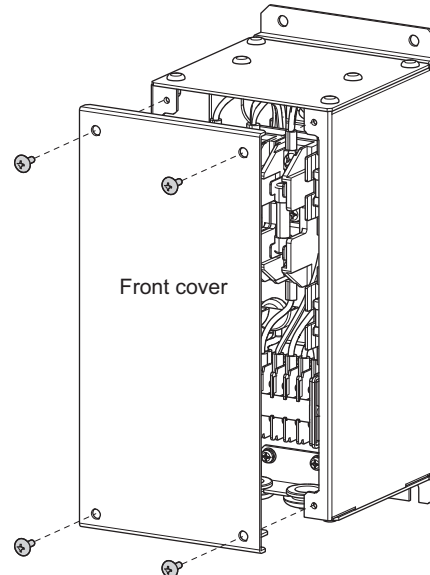
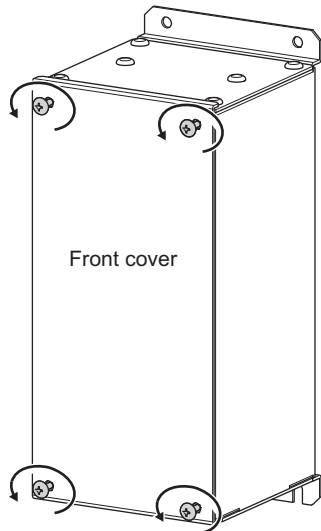

◆ Reinstallation

- Align the screw holes on the cover with the holes on the transformer box, and place the cover back into position.
- Fix the cover with the mounting screw (tightening torque: 1.7 N·m).

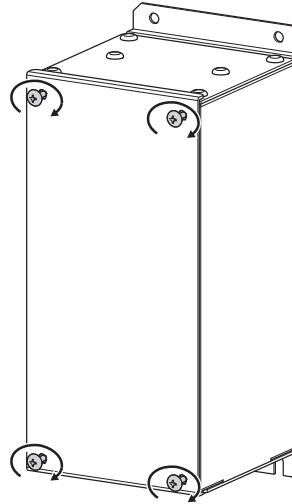
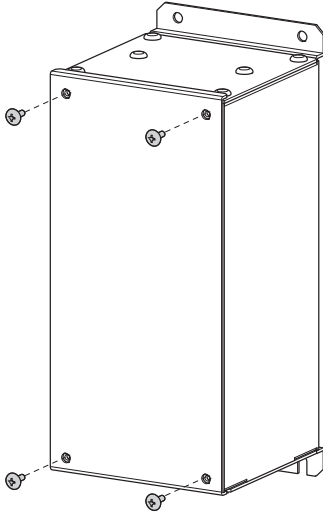

NOTE

- Fully make sure that the front cover has been reinstalled securely. Always tighten the mounting screws of the cover.
- The capacity plate is placed on the cover, and the rating plate is on the remainder of the transformer box. For reinstallation, check the serial number on the capacity plate against the one on the rating plate to make sure they are identical with each other.

◆ Wiring method

Cut small slits in the rubber grommets mounted on the underside of the transformer box, and pass the cables through the slits.

NOTE

- To satisfy IP20 protection requirements, note the following points for wiring of the transformer box.
 - Do not cut slits in the rubber grommets which are not used for wiring.
 - Do not use the transformer box with the rubber grommets removed.

3.5.3 Installation of the filter capacitor (FR-A8BC)

◆Clearances

As the filter capacitor generates heat, leave sufficient space around them.

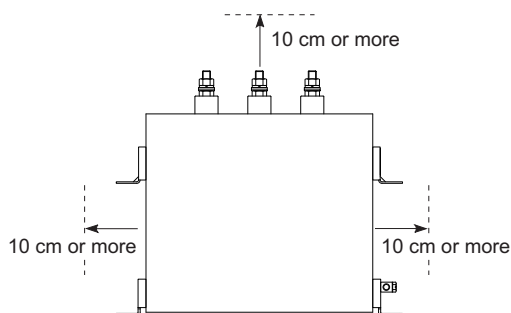

◆Installation place

Install the filter capacitor on nonflammable material. Installing it directly on flammable material will cause a fire.

◆Surrounding environment

Avoid places where the filter capacitor is subjected to oil mist, flammable gases, fluff, dust, dirt, etc.

Install the filter capacitor in a clean place or protect it from suspended substances.

◆Installation of fixing brackets (FR-A8BC-H400K)

Two fixing brackets come with the FR-A8BC-H400K filter capacitor. Hang the hook of fixing brackets on top of both sides of the capacitor as shown in the following figure. Fasten the capacitor with screws to a stand through the mounting holes on the brackets.

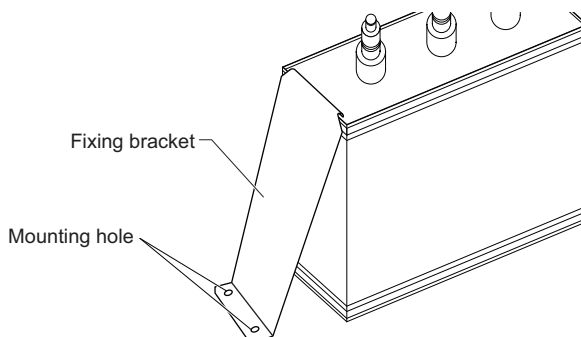

◆Installation orientation

To prevent looseness, install the filter capacitor on a horizontal surface securely with screws or bolts.

Do not install it on a vertical surface. Install it on a mounting stand which can withstand its weight.

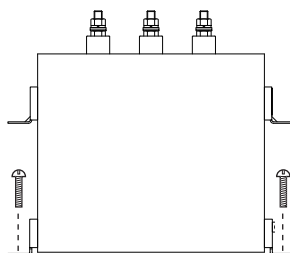

NOTE

- As the charged sections of the filter capacitor is uncovered, fully protect it to prevent ground fault and electric shock.

3.5.4 Installation of the dedicated circuit parts for inrush current protection (FR-A8MC)

◆ Inrush current limit resistor

◆ Clearances

As the inrush current limit resistor generates heat, leave sufficient space around them.

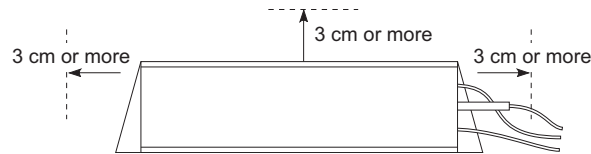

◆ Installation place

Install the resistor on nonflammable material. Installing directly on or near a flammable material will cause a fire.

◆ Surrounding environment

Avoid places where the resistor is subjected to oil mist, flammable gases, fluff, dust, dirt, etc.

Install the resistor in a clean place or protect it from suspended substances.

Do not place a flammable material near the resistor.

◆ Installation orientation

To prevent looseness, install the resistor on a horizontal or vertical surface securely with screws or bolts.

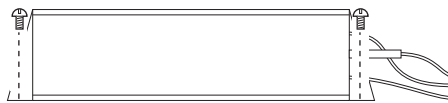

◆ MC power supply stepdown transformer

◆ Clearances

As the stepdown transformer generates heat, leave sufficient space around them.

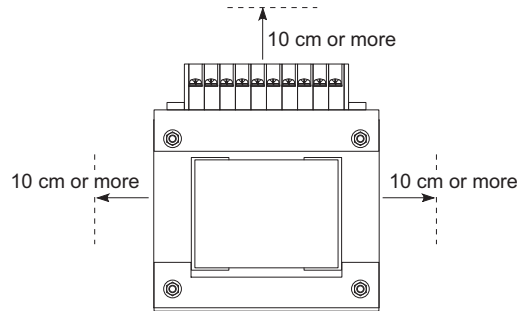

◆ Installation place

Install the stepdown transformer on nonflammable material. Installing it directly on flammable material will cause a fire.

◆ Surrounding environment

Avoid places where the stepdown transformer is subjected to oil mist, flammable gases, fluff, dust, dirt, etc. Install the stepdown transformer in a clean place or protect it from suspended substances.

◆ Installation orientation

To prevent looseness, install the stepdown transformer on a horizontal or vertical surface securely with screws or bolts.

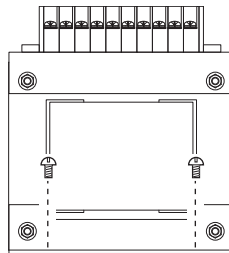

NOTE

- As the charged sections of the stepdown transformer is uncovered, fully protect it to prevent ground fault and electric shock.

3.5.5 Terminals of stand-alone options for the converter

◆ Reactor 1

Terminal symbol	Description
R/L1, S/L2, T/L3	Connected to the commercial power supply.
R2/L12, S2/L22, T2/L32	Connected to the reactor 2. Between two reactors, the filter capacitor and the dedicated circuit parts for inrush current protection must be installed.
R5, S5	Connected to the cooling fan power output terminals on the stepdown transformer for power source of MC.
TP1, TP2	If reactor 1 overheats, the circuit will open (thermostat output) between TP1 and TP2. • TP1: Connected to the converter terminal to which the LOH signal is assigned. • TP2: Connected to terminal TP3 of the reactor 2.
	Earthing (grounding) of the reactor 1. This must be earthed (grounded).

◆ Reactor 2

Terminal symbol	Description
R3/L13, S3/L23, T3/L33	Connected to the reactor 1. Between two reactors, the filter capacitor and the dedicated circuit parts for inrush current protection must be installed.
R4/L14, S4/L24, T4/L34	Connected to the converter.
R5, S5	Connected to the cooling fan power output terminals on the stepdown transformer for power source of MC.
TP3, TP4	If reactor 2 overheats, the circuit will open (thermostat output) between TP3 and TP4. • TP3: Connected to terminal TP2 of the reactor 1. • TP4: Connected to terminal SD of the converter.
	Earthing (grounding) of the reactor 2. This must be earthed (grounded).

◆ Filter capacitor

Terminal symbol	Description
R2/L12, S2/L22, T2/L32	Connected to the output terminals of the reactor 1 and the input terminals of the inrush current limit resistor.
	Earthing (grounding) of the filter capacitor. This must be earthed (grounded).

◆ Phase detection transformer box

Terminal symbol	Description	Rated specification
R	Input terminal for detection of the R-phase voltage of the system power supply.	Maximum permissible input voltage: 506 VAC
S	Input terminal for detection of the S-phase voltage of the system power supply.	
T	Input terminal for detection of the T-phase voltage of the system power supply.	
R2	Output terminal for the analog signal used for the R-S detection. Isolated from the main circuit.	Maximum output voltage: 26 VAC
RS2	Common terminal for terminal R2.	—
T2	Output terminal for the analog signal used for the T-S detection. Isolated from the main circuit.	Maximum output voltage: 26 VAC
TS2	Common terminal for terminal T2.	—
	Earthing (grounding) of the phase detection transformer box. This must be earthed (grounded).	—

3.6 Main circuit terminal specification

3.6.1 Details on the main circuit terminals

Terminal symbol	Description	Refer to page
R4/L14, S4/L24, T4/L34	Connected to the reactor 2.	—
R1/L11, S1/L21	Connected to terminals P/+ and N/- in the initial status. To retain the fault display and fault output, remove the jumpers and apply external power through these terminals.	58
P/+, N/-	Connected to the inverter terminals P/+ and N/-.	40
	For earthing (grounding) of the converter chassis. This must be earthed (grounded).	47

3.6.2 Main circuit terminal block layout

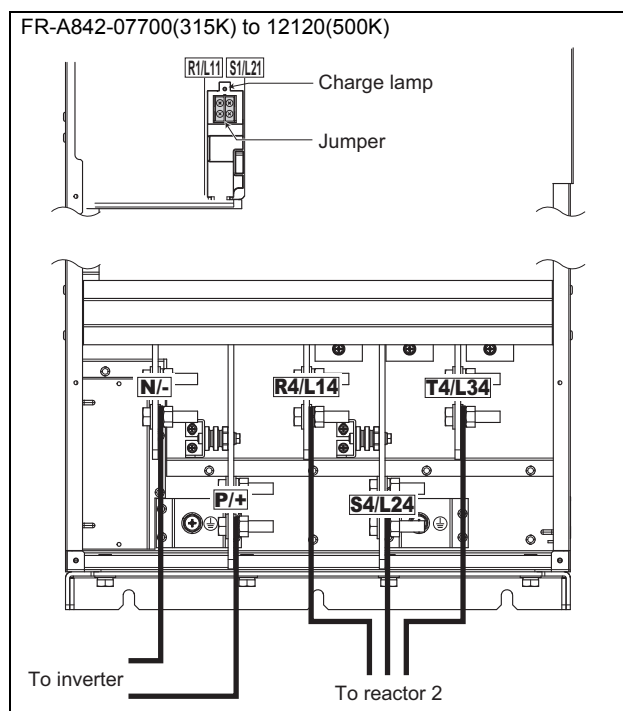

3.6.3 Cable size of the main circuit terminals and the earth (ground) terminal

Select cables of recommended gauge size to ensure that the voltage drop will be 2% or less.

The following table shows a selection example for the wiring length of 20 m.

- Converter

Model FR-A842-□	Terminal screw size*4	Tightening torque N·m *4	Crimp terminal	Cable gauge					
				HIV cables, etc. (mm ²)*1			AWG/ MCM*2	PVC cables, etc. (mm ²)*3	
				R4/L14, S4/L24, T4/L34	P/+, N/- *5	Earthing (grounding) cable	R4/L14, S4/L24, T4/L34	R4/L14, S4/L24, T4/L34	Earthing (grounding) cable
07700(315K)	M12 (M10)	46 (24)	150-12	2 × 150	2 × 150	100	2 × 300	2 × 150	150
08660(355K)	M12 (M10)	46 (24)	C2-200	2 × 200	2 × 200	100	2 × 350	2 × 185	2 × 95
09620(400K)	M12 (M10)	46 (24)	C2-200	2 × 200	2 × 200	100	2 × 400	2 × 185	2 × 95
10940(450K)	M12 (M10)	46 (24)	C2-250	2 × 250	2 × 250	100	2 × 500	2 × 240	2 × 120
12120(500K)	M12 (M10)	46 (24)	C2-250	2 × 250	3 × 200	2 × 100	2 × 500	2 × 240	2 × 120

- Reactor 1 (FR-A8BL1)

Model FR-A8BL1-□	Terminal screw size*4	Tightening torque N·m *4	Crimp terminal	Cable gauge		
				HIV cables, etc. (mm ²)*1	AWG/MCM*2	PVC cables, etc. (mm ²)*3
				R/L11, S/L21, T/L31, R2/L12, S2/L22, T2/L32	R/L11, S/L21, T/L31, R2/L12, S2/L22, T2/L32	R/L11, S/L21, T/L31, R2/L12, S2/L22, T2/L32
H315K	M12 (M8)	46 (24)	150-12	2 × 150	2 × 300	2 × 150
H355K	M12 (M8)	46 (24)	C2-200	2 × 200	2 × 350	2 × 185
H400K	M12 (M8)	46 (24)	C2-200	2 × 200	2 × 400	2 × 185
H450K	M12 (M8)	46 (24)	C2-250	2 × 250	2 × 500	2 × 240
H500K	M12 (M8)	46 (24)	C2-250	2 × 250	2 × 500	2 × 240

- Reactor 2 (FR-A8BL2)

Model FR-A8BL2-□	Terminal screw size*4	Tightening torque N·m *4	Crimp terminal	Cable gauge		
				HIV cables, etc. (mm ²)*1	AWG/MCM*2	PVC cables, etc. (mm ²)*3
				R3/L13, S3/L23, T3/L33, R4/L14, S4/L24, T4/L34	R3/L13, S3/L23, T3/L33, R4/L14, S4/L24, T4/L34	R3/L13, S3/L23, T3/L33, R4/L14, S4/L24, T4/L34
H315K	M12 (M8)	46 (24)	150-12	2 × 150	2 × 300	2 × 150
H355K	M12 (M8)	46 (24)	C2-200	2 × 200	2 × 350	2 × 185
H400K	M12 (M8)	46 (24)	C2-200	2 × 200	2 × 400	2 × 185
H450K	M12 (M8)	46 (24)	C2-250	2 × 250	2 × 500	2 × 240
H500K	M12 (M8)	46 (24)	C2-250	2 × 250	2 × 500	2 × 240

- Filter capacitor (FR-A8BC)

Model FR-A8BC-□	Terminal screw size*4	Tightening torque N·m *4	Crimp terminal	Cable gauge		
				HIV cables, etc. (mm ²)*1	AWG/MCM*2	PVC cables, etc. (mm ²)*3
				R2/L12, S2/L22, T2/L32, R3/L13, S3/L23, T3/L33	R2/L12, S2/L22, T2/L32, R3/L13, S3/L23, T3/L33	R2/L12, S2/L22, T2/L32, R3/L13, S3/L23, T3/L33
H400K	M12 (M5)	20 (3)	60-12	60	1/0	50
H500K	M12 (M8)	20 (12)	80-12	80	1/0	70

*1 It is the gauge of the cable with the continuous maximum permissible temperature of 90°C or higher (LMFC (heat resistant flexible cross-linked polyethylene insulated cable), etc.). It assumes a surrounding air temperature of 50°C or lower and in-enclosure wiring.

*2 It is the gauge of the cable with continuous maximum permissible temperature of 90°C (THHN cable). It assumes a surrounding air temperature of 40°C or lower and in-enclosure wiring.
(For the use in the United States or Canada, refer to [page 194](#).)

*3 It is the gauge of the cable with continuous maximum permissible temperature of 90°C (XLPE cable). It assumes a surrounding air temperature of 40°C or lower and in-enclosure wiring.
(Selection example mainly for use in Europe.)

*4 Screw size for earthing (grounding) is indicated in parenthesis. (Refer to [page 47](#) for earthing (grounding).)

*5 If a cable thinner than the recommended cable size is used, it may not be protected by the DC fuse. (Refer to [page 21](#) for the fuse selection.)

3.7 Wiring of main circuit

- Perform wiring securely to allow compliance with the harmonic suppression guidelines issued by the former Ministry of International Trade and Industry (currently the Ministry of Economy, Trade and Industry). Incorrect wiring will cause a fault indication, failure, or damage.
- Refer to the Instruction Manual of each inverter for the wiring of the inverter. Special attention must be paid to the wiring length and cable size.

3.7.1 Connection diagram (when using with the FR-A800 series)

Connection method differs by the inverter series. Perform connection by referring to the Instruction Manual of the inverter.

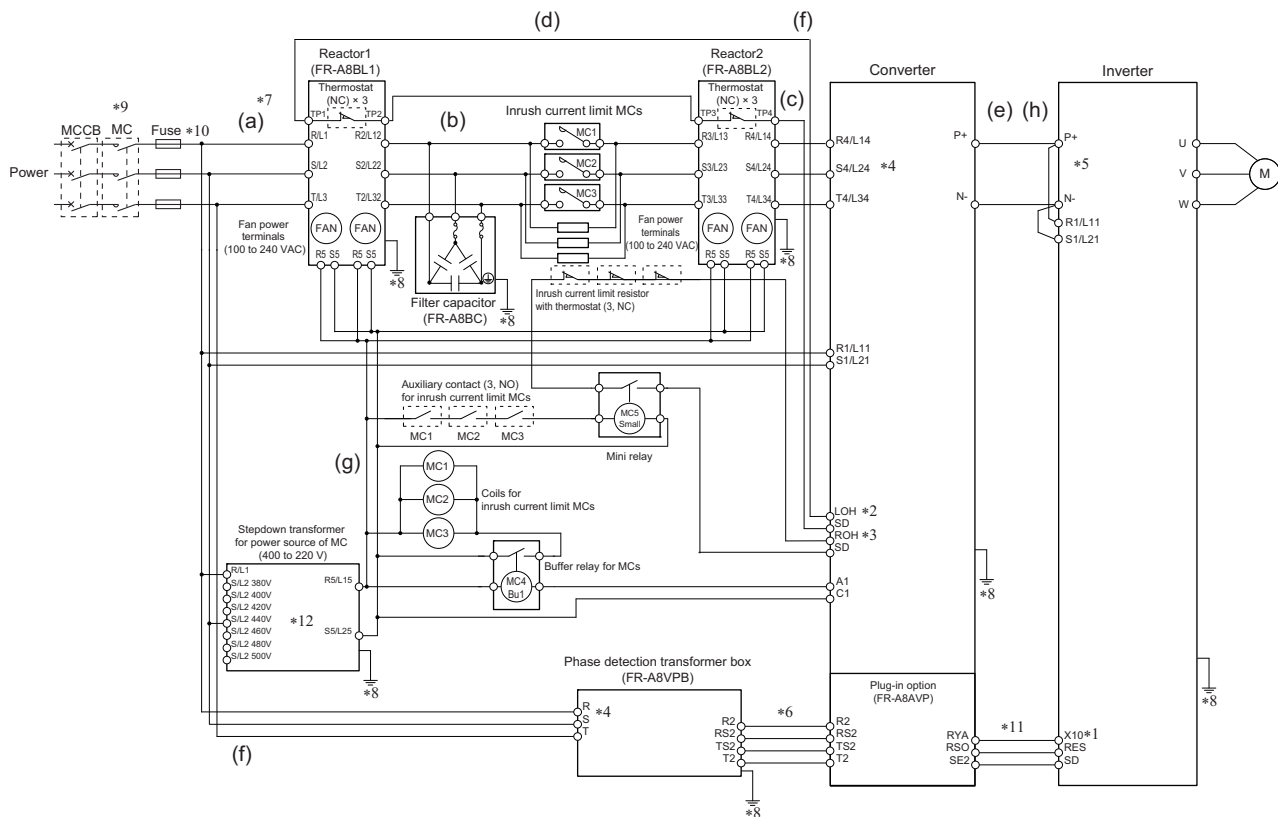

- *1 Use the Input terminal function selection to assign the X10 signal to a terminal. The signal is assigned to terminal MRS in the initial status. (Refer to the Instruction Manual of the inverter.)
- *2 The LOH signal function is assigned to terminal RT in the initial status. Set "33" in any of **Pr.178 to Pr.189 (Input terminal function selection)** to assign the LOH signal to another terminal.
- *3 The ROH signal function is assigned to terminal AU in the initial status. Set "34" in any of **Pr.178 to Pr.189 (input terminal function selection)** to assign the ROH signal to another terminal.
- *4 Confirm the correct voltage phase sequence between the converter (terminals R4/L14, S4/L24, and T4/L34) and the phase detection transformer box (terminals R, S, and T).
- *5 Do not install any MCCB between the inverter and the converter (P to P and N to N). Connecting opposite polarity of terminals P and N will damage the converter and the inverter.
- *6 Always connect terminals R2, RS2, TS2, and T2 of the FR-A8AVP installed on the converter and the identically-named terminals of the phase detection transformer box. If the inverter is operated without connecting between the terminals, the converter will be damaged.
- *7 Do not install an MCCB or MC between the reactor 1 input terminals (R/L1, S/L2, and T/L3) (a) and the converter input terminals (R4/L14, S4/L24, and T4/L34) (c) except for those specified in the connection diagram. Doing so disrupts proper operation.
- *8 Securely perform grounding (earthing) by using the grounding (earthing) terminal.
- *9 Install an MC for each phase.
- *10 Install the UL listed fuse (refer to [page 194](#)) on the input side of the converter to meet the UL/cUL standards.
- *11 Always connect terminal RYA on the FR-A8AVP (installed on the converter) and the inverter terminal to which the X10 signal is assigned, and connect terminal SE2 on the FR-A8AVP and the inverter terminal SD (terminal PC in the source logic). Failure to do so may lead to damage of the converter.
- *12 Select a terminal S/L2 according to the input voltage.

- Symbols shown in the connection diagram on [page 40](#) correspond to the symbols shown in the following table. For the details of wiring of each section, refer to the page shown in the following table.)

Symbol	Wiring	Refer to page
(a)	Wiring between the power supply and reactor 1	42
(b)	Wiring between the reactor 1, filter capacitor, inrush current limit resistor, inrush current limit MC, and reactor 2	43
(c)	Wiring between the reactor 2 and converter	44
(d)	Wiring between the thermostats of the reactors 1 and 2 and the converter	44
(e)	Wiring between the converter and inverter	45
(f)	Wiring between the reactor 1, stepdown transformer for power source of MC, phase detection transformer box, and converter	45
(g)	Wiring between the fans of the reactors 1 and 2 and the stepdown transformer for power source of MC	46
(h)	Wiring between the converter and the control circuit power terminal on the inverter	46

NOTE

- The control logic (sink logic (initial setting) /source logic) of the converter and the inverter must be matched. The converter does not operate properly if the control logic is not consistent with each other.
(Refer to [page 53](#) for the switching of the control logic of the converter. Refer to the Instruction Manual of the inverter for the switching of the control logic of the inverter.)
- Keep the wiring length between terminals as short as possible.
- When the power is distorted or falls off sharply, the reactors may generate abnormal acoustic noise. This acoustic noise is caused by the power supply fault and not by the damage of the converter.
- Do not connect the DC reactor to the inverter when using a high power factor converter.
- When using a sine wave filter for the converter, use the MT-BSL-HC reactor.

CAUTION

- Refer to the connection diagram on [page 40](#) to check that the reactor 1 and reactor 2 are connected in the right places. Incorrect connection may damage the converter and reactors.
- Always connect terminal RYA of the FR-A8AVP installed on the converter and the inverter terminal to which the X10 signal is assigned, and connect terminal SE2 of the FR-A8AVP and inverter terminal SD (terminal PC in the source logic). Failure to do so may lead to damage of the converter.

3.7.2 Wiring of main circuit

◆(a) Wiring between the power supply and reactor 1

The following table shows the recommended cable specifications.

Model	Cable gauge (mm ²)
FR-A8BL1-H315K	2 × 150
FR-A8BL1-H355K	2 × 200
FR-A8BL1-H400K	2 × 200
FR-A8BL1-H450K	2 × 250
FR-A8BL1-H500K	2 × 250

The following table shows the recommended specifications for the molded case circuit breaker (MCCB), earth leakage circuit breaker (ELB), and magnetic contactor (MC).

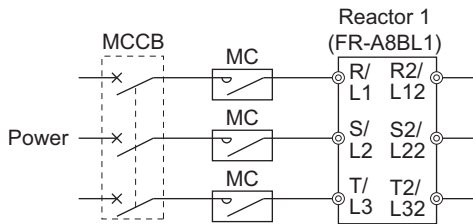

Model	Molded case circuit breaker (MCCB) or earth leakage circuit breaker (ELB) (type NF or NV)	Magnetic contactor (MC)
FR-A8BL1-H315K	700 A	S-N600
FR-A8BL1-H355K	800 A	S-N600
FR-A8BL1-H400K	900 A	S-N800
FR-A8BL1-H450K	1000 A	S-N400 (3 in parallel)
FR-A8BL1-H500K	1200 A	S-N400 (3 in parallel)

◆(b) Wiring between the reactor 1, filter capacitor, inrush current limit resistor, inrush current limit MC, and reactor 2

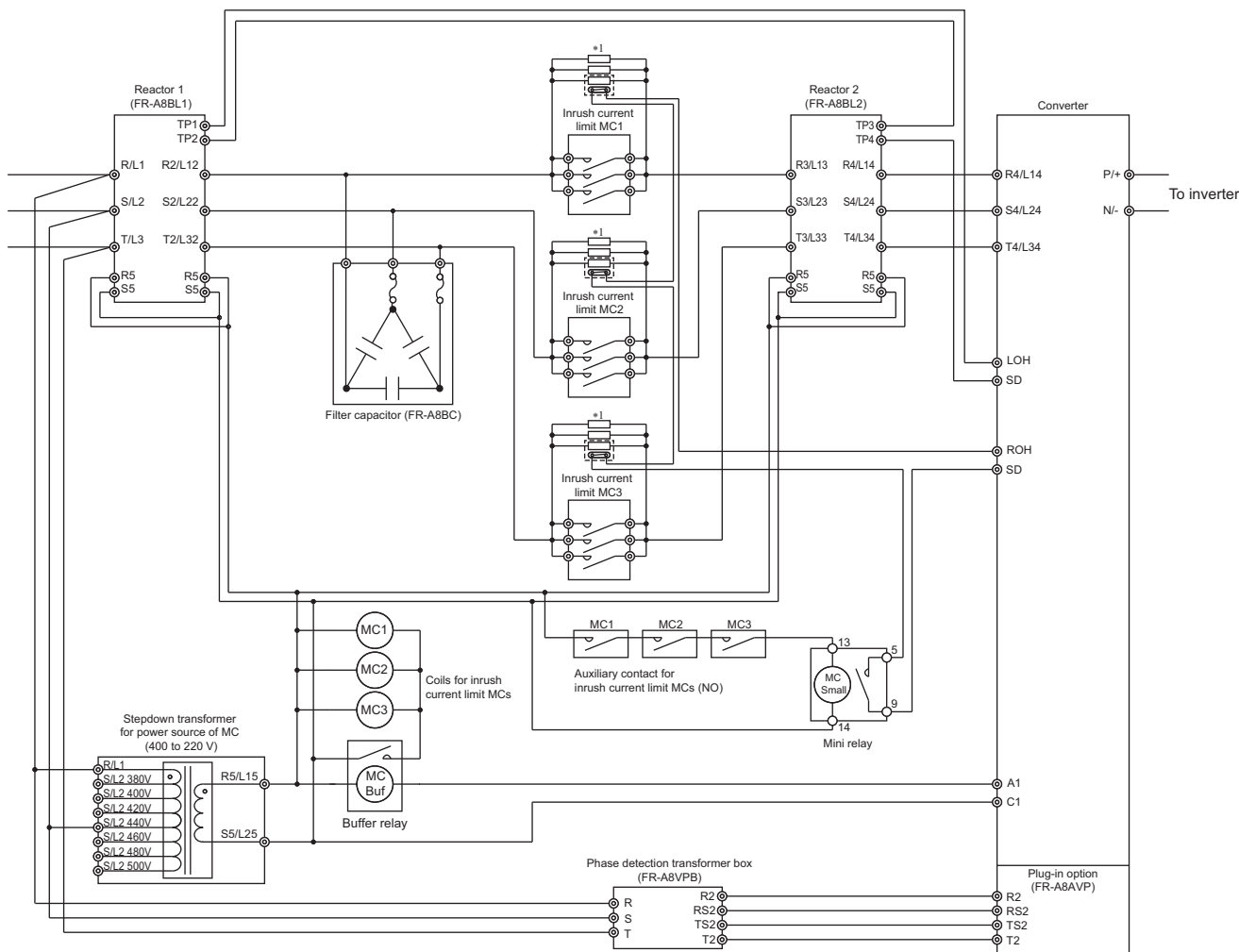

*1 Inrush current limit resistor

Connect the following devices to the inrush current limit MC used for each phase of the converter: one BKO-CA2573H01 (resistor without thermostat) and one BKO-CA2573H11 (resistor with thermostat) for FR-A842-08660(355K) converters or lower, and two BKO-CA2573H01 (resistor without thermostat) and one BKO-CA2573H11 (resistor with thermostat) for FR-A842-09620(400K) converters or higher.

Resistor (with thermostat)
BKO-CA2573H11

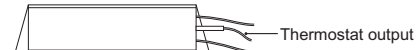

◆ Filter capacitor

Connect the filter capacitor to the output terminals of the reactor 1 and to the input terminals of the inrush current limit MCs.

The following table shows the recommended specifications of the cables used for connection of the filter capacitor.

Model	Cable gauge (mm ²)	Wiring length
FR-A8BC-H400K	60	Within 2 m
FR-A8BC-H500K	80	Within 2 m

Wiring of main circuit

◆ Inrush current limit resistor and inrush current limit MC

Short three poles of the inrush current limit MC, and use one MC for one phase of the converter.

For FR-A842-08660(355K) converters or lower, connect two inrush current limit resistors (connected in parallel) for each MC (either resistor must have a thermostat).

For FR-A842-09620(400K) converters or higher, connect three inrush current limit resistors (connected in parallel) for each MC (either resistor must have a thermostat) as shown in the following figure.

Connect the three MCs (with the inrush current limit resistors connected) between the output terminals of the reactor 1 and the input terminals of the reactor 2.

MC (Example for one phase)

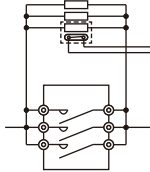

The following table shows the recommended specifications of the cables used for connection of each phase between the reactors 1 and 2.

Model	Cable gauge (mm ²)	Total wiring length
FR-A8BL1-H315K FR-A8BL2-H315K	2 × 150	10 m or less
FR-A8BL1-H355K FR-A8BL2-H355K	2 × 200	10 m or less
FR-A8BL1-H400K FR-A8BL2-H400K	2 × 200	10 m or less
FR-A8BL1-H450K FR-A8BL2-H450K	2 × 250	10 m or less
FR-A8BL1-H500K FR-A8BL2-H500K	2 × 250	10 m or less

◆ Connecting resistor thermostats to the converter

Connect the thermostats of the R-phase, S-phase, and T-phase resistors in series, and connect the thermostats to the converter terminal to which the ROH signal is assigned and to converter terminal SD, as shown in the connection diagram on [page 43](#).

The following table shows the conditions of the cables (control signal cables).

Cable gauge (mm ²)	Total wiring length
0.75 to 1.25	10 m or less

◆(c) Wiring between the reactor 2 and converter

The following table shows the recommended cable specifications.

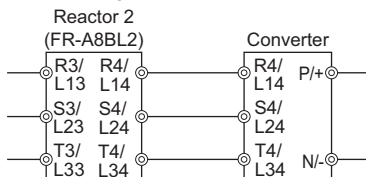

Model	Cable gauge (mm ²)	Total wiring length
FR-A8BL2-H315K	2 × 150	10 m or less
FR-A8BL2-H355K	2 × 200	10 m or less
FR-A8BL2-H400K	2 × 200	10 m or less
FR-A8BL2-H450K	2 × 250	10 m or less
FR-A8BL2-H500K	2 × 250	10 m or less

◆(d) Wiring between the thermostats of the reactors 1 and 2 and the converter

Connect the thermostat output terminals on the reactor 1 (terminals TP1 and TP2) and reactor 2 (terminals TP3 and TP4) and the converter terminals (terminal to which the LOH signal is assigned and terminal SD) in series, as shown in the connection diagram on [page 43](#).

The following table shows the recommended cable specifications.

Cable gauge (mm ²)	Total wiring length
0.75 to 1.25	10 m or less

◆(e) Wiring between the converter and inverter

Wire correctly to ensure the command transmission from the converter to the inverter.

Connection method differs by the inverter series. Perform connection by referring to the Instruction Manual of the inverter.

The following table shows the recommended wiring length.

Between terminals P and P and terminals N and N	50 m or less
Other control signal cables	30 m or less

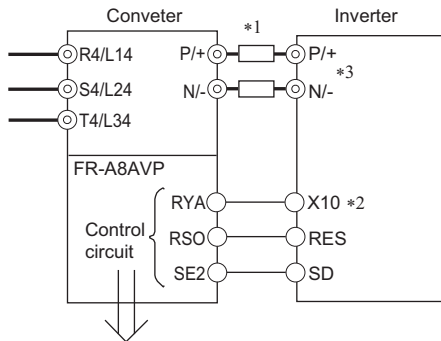

Control circuit cable gauge	0.75 to 1.25 mm ²
-----------------------------	------------------------------

*1 For inverters other than the separated converter type of the FR-A802/F802 inverters, installation of a fuse on each cable is recommended to prevent the spread of damage caused by an inverter failure. Select a fuse according to the motor capacity. When using a motor, of which the capacity is smaller than the inverter capacity by two ranks or more, select the fuse with the capacity that is one rank lower than the inverter capacity. Refer to the fuse selection tables on [page 21](#).

For connection of multiple inverters, use the same gauge cable as the inverter's power cable for wiring between the inverter main circuit terminal (P/+ or N/-) and a junction terminal. (Refer to the Instruction Manual of the inverter.)

*2 The function needs to be assigned to an inverter terminal to be connected to terminal RYA of the FR-A8AVP.

*3 Refer to the Instruction Manual of the Inverter. Do not install any MCCB between the inverter and the converter (P to P and N to N).

NOTE

- Do not connect anything to power input terminals (R/L1, S/L2, and T/L3) of the inverter. Incorrect power input connection will damage the inverter. Connecting opposite polarity of terminals P/+ and N/- will damage the inverter and the converter.
- Do not connect a DC reactor to the inverter when using the converter.

◆(f) Wiring between the reactor 1, stepdown transformer for power source of MC, phase detection transformer box, and converter

As shown in the connection diagram on [page 43](#), connect the output cables of the phase detection transformer box to the FR-A8AVP's terminals R2, RS2, TS2, and T2 for power detection.

Select a terminal S/L2 on the stepdown transformer according to the input voltage.

Connect the output cables from the MC start command terminals (A1, C1) on the converter to the inrush current limit MCs (for three phases) through the buffer relay for driving MCs.

The following table shows the recommended cable specifications.

Item	Cable gauge (mm ²)	Total wiring length
Input cable for the stepdown transformer	2	10 m or less
Output cable for the stepdown transformer	2	10 m or less
Cable between the phase detection transformer box and converter	0.75 to 1.25	5 m or less

NOTE

- The terminals R2, RS2, TS2, and T2 on the FR-A8AVP are control terminals used to detect power phases of the power supply. Confirm the correct voltage phase sequence between the reactor 1 (terminals R/L1, S/L2, and T/L3) and the phase detection transformer box (terminals R, S, and T). If these terminals are not connected correctly, the converter does not operate properly.
- If the inverter is operated while the converter terminals R2, RS2, TS2, and T2 are not connected to the power supply, the converter will be damaged.

◆(g) Wiring between the fans of the reactors 1 and 2 and the stepdown transformer for power source of MC

The reactors 1 and 2 have an AC cooling fan. As shown in the connection diagram on [page 43](#), connect the output cables from the stepdown transformer terminals (R5/L15, S5/L25) in parallel to the fan power terminals (R5, S5) of the reactors 1 and 2.

The following table shows the recommended cable specifications.

Cable gauge (mm ²)	Total wiring length
2	10 m or less

NOTE

- Be sure to connect cables to the reactor cooling fans. Otherwise, the reactors may be overheated, resulting in output shutoff or malfunction of the converter.

◆(h) Wiring between the converter and the control circuit power terminal on the inverter

Connect the control power supply to the inverter terminals P/+ and N/-. The terminals R1/L11 and S1/L21 are initially connected to the terminals P/+ and N/- with a jumper respectively.

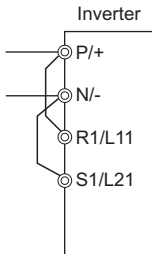

Cable gauge	0.75 to 2 mm ²
-------------	---------------------------

NOTE

- To use inverters equipped with terminals R1/L11 and S1/L21 other than the separated converter type of the FR-A802 or FR-F802 inverters, remove jumpers across main circuit terminals R/L1 and R1/L11 and across S/L2 and S1/L21 on the inverter (refer to the Instruction Manual of the inverter).
- Terminals R1/L11 and S1/L21 on the inverter are control power input terminals. If the terminals are left open, the inverter output may be shut off by an activation of a protective function, or the inverter may be damaged.
- If the FR-A842/F842 inverters are connected to the converter, and the inverter control power is supplied via terminals P/+ and N/- (initial setting), a protective function (E.P24) may be activated in the inverter at the occurrence of a power shutoff.

3.8 Earthing (Grounding) precautions

Always earth (ground) the converter and the converter options.

◆ Purpose of earthing (grounding)

Generally, an electrical apparatus has an earth (ground) terminal, which must be connected to the ground before use. An electrical circuit is usually insulated by an insulating material and encased. However, it is impossible to manufacture an insulating material that can shut off a leakage current completely, and actually, a slight current flows into the case. The purpose of earthing (grounding) the case of an electrical apparatus is to prevent operators from getting an electric shock from this leakage current when touching it.

To avoid the influence of external noises, the earthing (grounding) is important to EMI-sensitive equipment that handle low-level signals or operate very fast such as audio equipment, sensors, computers.

◆ Earthing (grounding) system to be established

As described previously, the purpose of earthing (grounding) is roughly classified into the electrical shock prevention and the prevention of malfunction due to the influence of electromagnetic noise. These two purposes should be clearly distinguished, and the appropriate earth (ground) system must be established to prevent the leakage current having the converter's high frequency components from reversing through another earth (ground) point for malfunction prevention by following these instructions:

- Make the separate earth (ground) connection for the converter and the converter options from any other devices and equipment wherever possible.

Establishing adequate common (single-point) earth (ground) system (II) shown in the following figure is allowed only in cases where the separate earth (ground) system (I) is not feasible. Do not make inadequate common (single-point) earth (ground) connection (III).

As leakage currents containing many high frequency components flows into the earthing (grounding) cables of the converter and the converter options, they must also be earthed (grounded) separately from the EMI-sensitive devices described above.

In a high building, it may be effective to use its iron structure frames as earthing (grounding) electrode for EMI prevention in order to separate from the earth (ground) system for electric shock prevention.

- Earthing (grounding) must conform to the requirements of national and local safety regulations and electrical codes (NEC section 250, IEC 61140 class 1 and other applicable standards). A neutral-point earthed (grounded) power supply must be used to be compliant with EN standard.
- Use the thickest possible earthing (grounding) cable. The earthing (grounding) cable should have the same or larger gauge than the one indicated in the table on [page 38](#).
- The earthing (grounding) point should be as close to the converter and the converter options as possible, and the earth (ground) cable length should be as short as possible.
- Run the earthing (grounding) cable as far away as possible from the I/O wiring of the EMI-sensitive devices, and run them in parallel in the minimum distance.

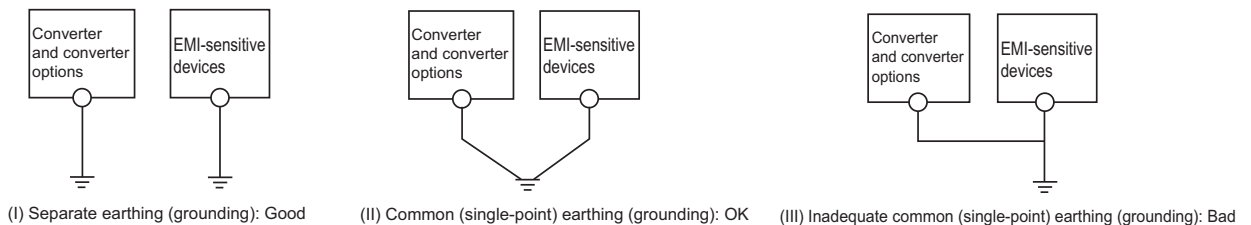

◆ Earthing (grounding) of the reactors

- Use the earth (ground) terminal for earthing (grounding) of the reactor 1 and reactor 2. (Refer to [page 178](#) to check the earth (ground) terminal position.)
- The earthing (grounding) cable of the reactors should have the same gauge as the one for the earthing (grounding) cable of the converter (refer to [page 38](#)).

◆ Example of earthing (grounding)

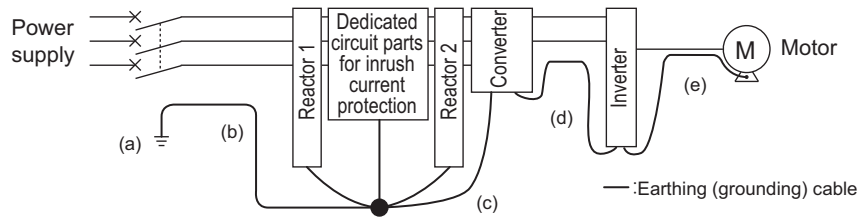

Symbol	Description
a	Make the separate earth (ground) connection for the converter and the converter options from any other devices and equipment wherever possible.
b	The earthing (grounding) cable should be as close as possible to the power cables, and all these cables should be wired in parallel.
c	The converter and the converter options are allowed to have the common (single-point) earth (ground) system (unless the reactors 1 and 2 are earthed (grounded) by being mounted on a panel of the enclosure).
d	If the inverter and the converter are installed far apart and the main circuit cables between them (P to P and N to N) are too long to store in an enclosure, the inverter earthing (grounding) cable is allowed to be connected to the converter and run as close as possible to the main circuit cables in parallel. When the cables are short enough to store in an enclosure, the inverter is allowed to join in the common (single-point) earth (ground) connection (c).
e	The motor earthing (grounding) cable is allowed be connected to the inverter earth (ground) terminal.

3.9 Wiring of control circuit

3.9.1 Details on the control circuit terminals

■ indicates that terminal functions can be selected using Pr.178 to Pr.189 (Input terminal function selection) or Pr.192 to Pr.194, or Pr.196 (Output terminal function selection). (Refer to page 127 and 129.)

◆ Input signal

Type	Terminal symbol	Converter terminal function (initial status)	Signal name	Terminal function description	Rated specification
Contact input	STF	— (No function)	—	No function is assigned in the initial setting. Use Pr.178 to assign a function to the terminal.	Input resistance: 4.7 kΩ, voltage when contacts are open: 21 to 27 VDC, current when contacts are short-circuited: 4 to 6 mADC
	STR	— (No function)	—	No function is assigned in the initial setting. Use Pr.179 to assign a function to the terminal.	
	STP	SOF	Converter stop	When the SOF signal is turned ON, the converter stops. The RDY signal turns OFF, and the inrush current limit resistor MC turns ON.	
	RH	— (No function)	—	No function is assigned in the initial setting. Use Pr.182 to assign a function to the terminal.	
	RM	— (No function)	—	No function is assigned in the initial setting. Use Pr.181 to assign a function to the terminal.	
	RL	— (No function)	—	No function is assigned in the initial setting. Use Pr.180 to assign a function to the terminal.	
	JOG	— (No function)	—	No function is assigned in the initial setting. Use Pr.185 to assign a function to the terminal.	
	RT	LOH	Reactor overheat protection	Connected in series with all the thermostat output terminals on the reactors 1 and 2.	
	MRS	OH	External thermal relay input	The External thermal relay input (OH) signal is used when using the external thermal relay or the thermal protector built into the motor to protect the motor from overheating. When the thermal relay is activated, the inverter output is shut off by the external thermal relay operation (E.OHT) of the converter.	
	RES	RES	Reset	Use this signal to reset a fault output provided when a protective function is activated. Turn ON the RES signal for 0.1 second or longer, then turn it OFF. In the initial setting, reset is always enabled. By changing the Pr.75 setting, reset input is enabled only when a protective function of the converter is activated. The converter recovers about 1 second after the reset is released.	
	AU	ROH	Inrush current limit resistor overheat protection	Connect auxiliary contacts of an inrush current limit resistor's MC (normally-open) and inrush current limit resistors (with thermostat) (normally-closed) to stop the converter operation when overheating of the resistor becomes a concern or when a filter capacitor is faulty.	
	CS	— (No function)	—	No function is assigned in the initial setting. Use Pr.186 to assign a function to the terminal.	
SD	SD	Contact input common (sink)*1	Common terminal for the contact input terminal (sink logic) and terminal FM.	—	
		External transistor common (source)*2	Connect this terminal to the power supply common terminal of a transistor output (open collector output) device, such as a programmable controller, in the source logic to avoid malfunction by undesirable current.		
		24 VDC power supply common	Common terminal for the 24 VDC power supply (terminal PC, terminal +24) Isolated from terminals 5 and SE.		

Wiring of control circuit

Type	Terminal symbol	Converter terminal function (initial status)	Signal name	Terminal function description	Rated specification
Contact input	PC	PC	External transistor common (sink)*1	Connect this terminal to the power supply common terminal of a transistor output (open collector output) device, such as a programmable controller, in the sink logic to avoid malfunction by undesirable current.	Power supply voltage range: 19.2 to 28.8 VDC, permissible load current: 100 mA
			Contact input common (source)*2	Common terminal for contact input terminal (source logic).	
			24 VDC power supply common	Can be used as a 24 VDC 0.1 A power supply.	
Frequency setting	5	5	Analog output terminal common	Common terminal for the analog output terminals AM and CA. Do not earth (ground).	—
Power supply input	+24	+24	24 V external power supply input	Connected to a 24 V external power supply. If a 24 V external power supply is connected, power is supplied to the control circuit while the main power circuit is OFF.	Input voltage: 23 to 25.5 VDC, input current: 1.4 A or less
—	10E, 10, 2, 4, 1	Not used.			

*1 Sink logic is initially set for the FM-type converter.

*2 Source logic is initially set for the CA-type converter.

◆ Output signal

Type	Terminal symbol	Converter terminal function (initial status)	Terminal name	Terminal function description	Rated specification
Relay	A1	A1	MC connection terminal	Used for the control of the inrush current limit MC.	—
	C1	C1			
Open collector	A2, B2, C2	ALM	Relay output (fault output)	1 changeover contact output that indicates that an inverter's protective function has been activated and the outputs are stopped. Fault: discontinuity across B and C (continuity across A and C), Normal: continuity across B and C (discontinuity across A and C)	Contact capacity: 230 VAC 0.3 A (power factor = 0.4), 30 VDC 0.3 A
	OL	OL	Overload alarm	The output is in LOW state when stall prevention is activated by the stall prevention function. The output is in HIGH state when stall prevention is canceled.	Permissible load: 24 VDC (27 VDC at maximum) 0.1 A (The voltage drop is 2.8 V at maximum while the signal is ON.) The open collector transistor is ON (conductive) in LOW state. The transistor is OFF (not conductive) in HIGH state.
	IPF	IPF	Instantaneous power failure	The output is in LOW state when an instantaneous power failure occurs or when the undervoltage protection is activated.	
	FU	CVO	Converter running	This signal is output during the converter operation.	
	SE	SE	Open collector output common	Common terminal for terminals OL, IPF, and FU.	—

Type	Terminal symbol	Converter terminal function (initial status)	Terminal name	Terminal function description		Rated specification
Pulse	FM *1	FM	For indication on external meters	A signal is output for a selected monitor item such as power supply frequency. The signal is not output during a converter reset. The output signal is proportional to the magnitude of the corresponding monitor item.	Monitor item: Power supply frequency (initial setting)	Permissible load current: 2 mA. For full scale 1440 pulses/s
Analog	AM	AM	Analog voltage output			Output signal: 0 ±10 VDC, permissible load current: 1 mA (load impedance: 10 kΩ or more), resolution: 8 bits
	CA *2	CA	Analog current output			Load impedance: 200 Ω to 450 Ω, output signal: 0 to 20 mADC
—	RUN, SU, B1, S1*3, S2*3, SIC*3, So, SOC	Not used.				

*1 Terminal FM is provided in the FM-type converter.

*2 Terminal CA is provided in the CA-type converter.

*3 Do not remove the shorting wires across terminals S1 and PC, across terminals S2 and PC, and across terminals SIC and SD. Doing so disables the converter operation.

◆Communication

Type	Terminal symbol	Terminal name	Terminal function description	
RS-485	—	PU connector	RS-485 communication can be made through the PU connector (for connection on a 1:1 basis only). Conforming standard: EIA-485 (RS-485) Transmission format: Multidrop link Communication speed: 4800 to 115200 bps Wiring length: 500 m	
	RS-485 terminals	TXD+	Converter send	The RS-485 terminals enable the communication by RS-485. Conforming standard: EIA-485 (RS-485) Transmission format: Multidrop link Communication speed: 300 to 115200 bps Overall length: 500 m
		TXD-		
		RXD+	Converter receive	
		RXD-		
	GND (SG)	Earthing (grounding)		
USB	—	USB B connector	Mini B connector (receptacle) The USB connection with a personal computer can be established.	Interface: conforms to USB1.1 (USB2.0 full-speed compatible) Transmission speed: 12 Mbps
	—	USB A connector	Not used.	

◆ Plug-in option FR-A8AVP

Type	Terminal symbol	Terminal name	Terminal function description	Rated specification
Input terminal	R2	R-S detection analog signal input	Input terminal for the analog signal used for the R-S detection. Connected to the same-name terminal on the phase detection transformer box.	Maximum permissible input voltage: 28 VAC
	RS2	R2 common		
	T2	T-S detection analog signal input	Input terminal for the analog signal used for the T-S detection. Connected to the same-name terminal on the phase detection transformer box.	Maximum permissible input voltage: 28 VAC
	TS2	T2 common		
Output terminal	RYA	Inverter run enable	Output when the inverter is ready.	Permissible load: 24 VDC (27 VDC at maximum) 0.1 A (The voltage drop is 2.8 V at maximum while the signal is ON.) The open collector transistor is ON (conductive) in LOW state. The transistor is OFF (not conductive) in HIGH state.
	RSO	Converter reset	Output during a converter reset.	
	SE2	Open collector output common	Common terminal for terminals RYA and RSO.	

 **CAUTION**

- Always connect terminal RYA on the FR-A8AVP (installed on the converter) and the inverter terminal to which the X10 signal is assigned, and connect terminal SE2 on the FR-A8AVP and the inverter terminal SD (terminal PC in the source logic). Failure to do so may lead to damage of the converter.

3.9.2 Control logic (sink/source) change

Change the control logic of input signals as necessary.

To change the control logic, change the jumper connector position on the control circuit board.

Connect the jumper connector to the connector pin of the desired control logic.

The control logic of input signals is initially set to the sink logic (SINK) for the FM type.

The control logic of input signals is initially set to the source logic (SOURCE) for the CA type.

(The output signals may be used in either the sink or source logic independently of the jumper connector position.)

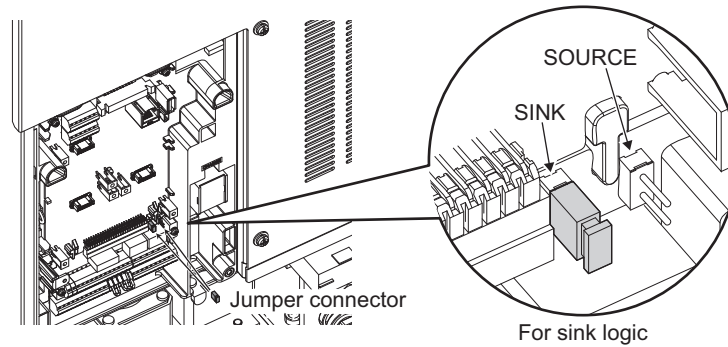

NOTE

- Make sure that the jumper connector is installed correctly.
- Never change the control logic while power is ON.

◆ Sink logic and source logic

- In the sink logic, a signal turns ON when a current exits from the corresponding signal input terminal. Terminal SD is common to the contact input signals. Terminal SE is common to the open collector output signals.
- In the source logic, a signal turns ON when a current enters into the corresponding signal input terminal. Terminal PC is common to the contact input signals. Terminal SE is common to the open collector output signals.

• Current flow for the I/O signal in the sink logic

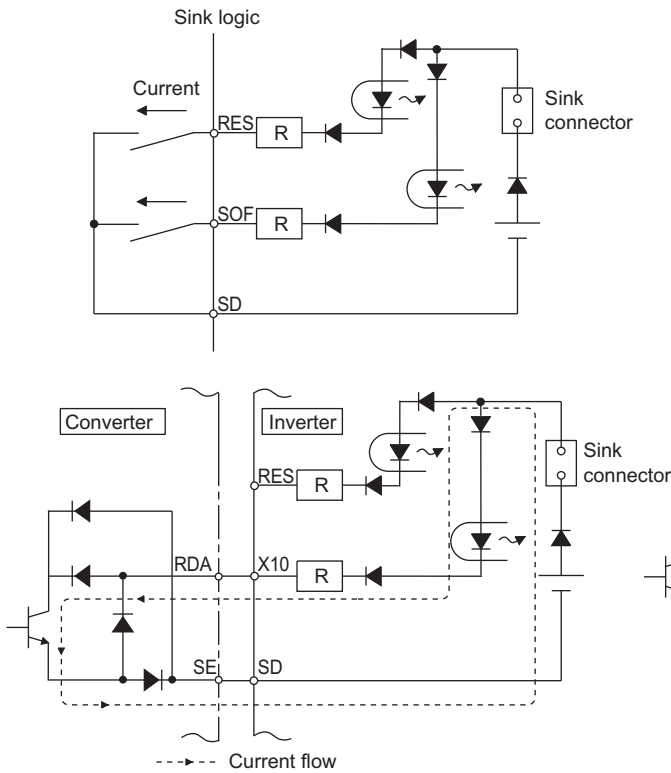

• Current flow for the I/O signal in the source logic

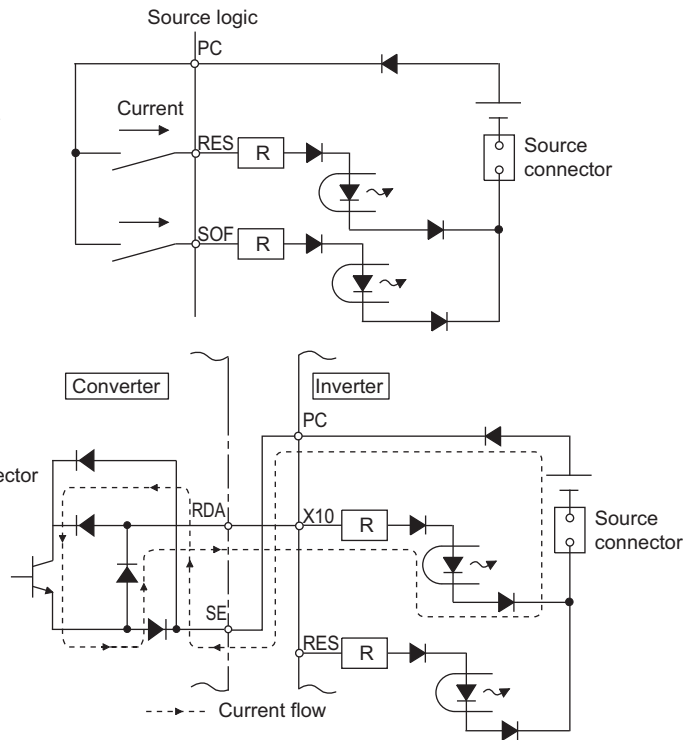

- When using an external power supply for transistor output

Sink logic

Use terminal PC as a common terminal, and perform wiring as follows. (Do not connect terminal SD of the converter with the terminal 0 V of the external power supply. Do not install an external power source in parallel with the internal 24 VDC power source (connected to terminals PC and SD) to use them together. Doing so may cause a malfunction in the converter due to undesirable currents.)

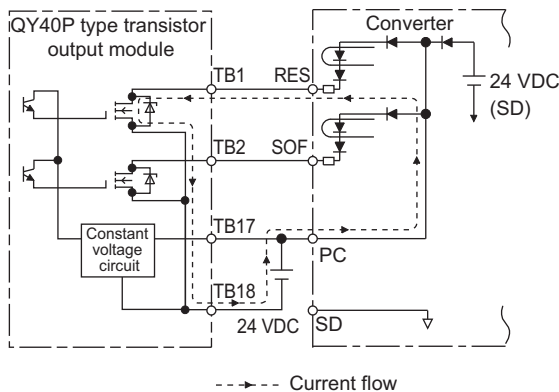

Source logic

Use terminal SD as a common terminal, and perform wiring as follows. (Do not connect terminal PC on the converter with the terminal of +24 V for the external power supply. Do not install an external power source in parallel with the internal 24 VDC power source (connected to terminals PC and SD) to use them together. Doing so may cause a malfunction in the inverter due to undesirable currents.)

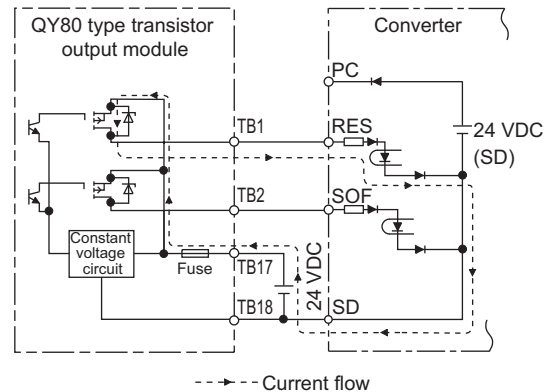

3.9.3 Wiring of control circuit

◆ Control circuit terminal layout

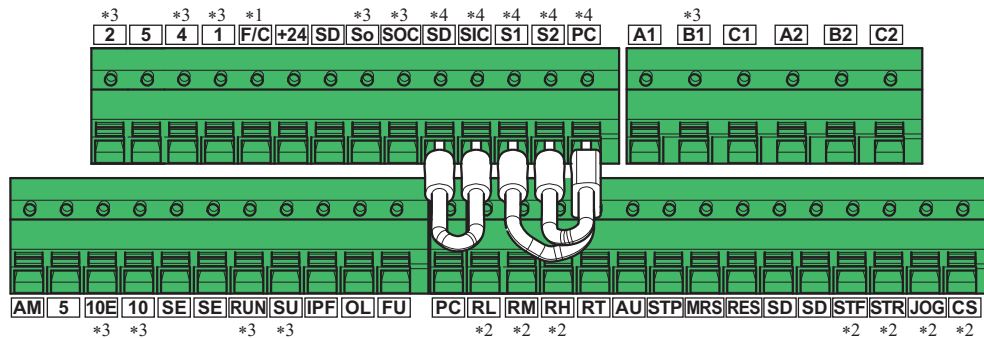

- *1 This terminal operates as terminal FM for the type FM. This terminal operates as terminal CA for the type CA.
- *2 No function is assigned in the initial setting.
- *3 Not used.
- *4 Not used. Do not remove the shorting wires.

◆ Wiring method

- Power supply connection

For the control circuit wiring, strip off the sheath of a cable, and use it with a blade terminal. For a single wire, strip off the sheath of the wire and apply directly.

Insert the blade terminal or the single wire into a socket of the terminal.

- (1) Strip off the sheath for the below length. If the length of the sheath peeled is too long, a short circuit may occur with neighboring wires. If the length is too short, wires might come off.

Wire the stripped cable after twisting it to prevent it from becoming loose. In addition, do not solder it.

Cable sheath stripping length



- (2) Crimp the blade terminal.

Insert wires to a blade terminal, and check that the wires come out for about 0 to 0.5 mm from a sleeve.

Check the condition of the blade terminal after crimping. Do not use a blade terminal of which the crimping is inappropriate, or the face is damaged.

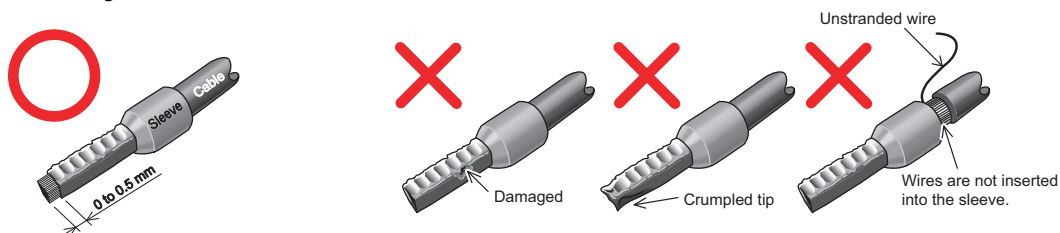

- Blade terminals commercially available (as of January 2017.)

Phoenix Contact Co., Ltd.

Cable gauge (mm ²)	Ferrule terminal model			Crimping tool product number
	With insulation sleeve	Without insulation sleeve	For UL wire*1	
0.3	AI 0, 34-10TQ	—	—	CRIMPFOX 6
0.5	AI 0,5-10WH	—	AI 0,5-10WH-GB	
0.75	AI 0,75-10GY	A 0,75-10	AI 0,75-10GY-GB	
1	AI 1-10RD	A 1-10	AI 1-10RD/1000GB	
1.25,1.5	AI 1,5-10BK	A 1,5-10	AI 1,5-10BK/1000GB*2	
0.75 (for 2 wires)	AI-TWIN 2×0,75-10GY	—	—	

*1 A ferrule terminal with an insulation sleeve compatible with the MTW wire which has a thick wire insulation.

*2 Applicable for terminals A1, B1, C1, A2, B2, and C2.

Wiring of control circuit

NICHIFU Co., Ltd.

Cable gauge (mm ²)	Blade terminal product number	Insulation cap product number	Crimping tool product number
0.3 to 0.75	BT 0.75-11	VC 0.75	NH 69

(3) Insert the wires into a socket.

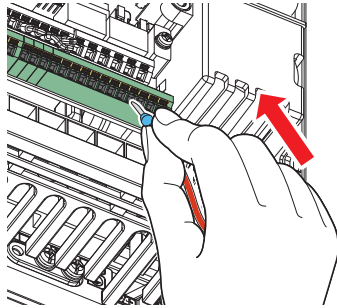

When using a single wire or stranded wires without a blade terminal, push the open/close button all the way down with a flathead screwdriver, and insert the wire.

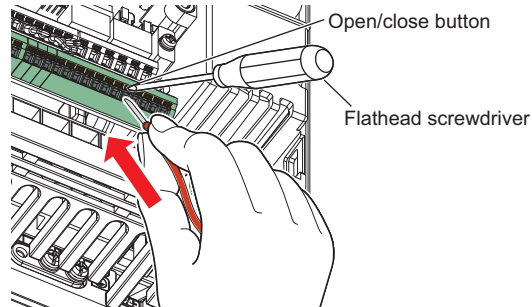

NOTE

- When using stranded wires without a blade terminal, twist enough to avoid short circuit with a nearby terminals or wires.
- Never change the control logic while power is ON.

• Wire removal

Pull the wire while pushing the open/close button all the way down firmly with a flathead screwdriver.

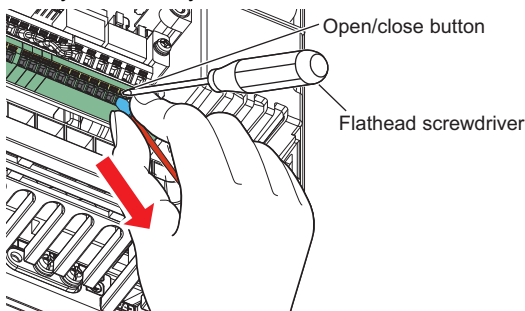

NOTE

- Pulling out the wire forcefully without pushing the open/close button all the way down may damage the terminal block.
- Use a small flathead screwdriver (tip thickness: 0.4 mm / tip width: 2.5 mm).
If a flathead screwdriver with a narrow tip is used, terminal block may be damaged.

Commercially available product (as of February 2016.)

Name	Model	Manufacturer
Driver	SZF 0- 0,4 × 2,5	Phoenix Contact Co., Ltd.

- Place the flathead screwdriver vertical to the open/close button. In case the blade tip slips, it may cause an inverter damage or injury.

◆ Common terminals of the control circuit (SD, PC, 5, SE)

- Terminals SD (sink logic), PC (source logic), 5, and SE are common terminals (0 V) for I/O signals. (All common terminals are isolated from each other.) Do not earth (ground) these terminals. Avoid connecting terminal SD (sink logic) with terminal 5, terminal PC (source logic) with terminal 5, and terminal SE with terminal 5.
- In the sink logic, terminal SD is a common terminal for the contact input terminals (STF, STR, STP, RH, RM, RL, JOG, RT, MRS, RES, AU, and CS) and the pulse train output terminal (FM*1). The open collector circuit is isolated from the internal control circuit by photocoupler.
- In the source logic, terminal PC is a common terminal for the contact input terminals (STF, STR, STP, RH, RM, RL, JOG, RT, MRS, RES, AU, CS). The open collector circuit is isolated from the internal control circuit by photocoupler.
- Terminal 5 is a common terminal for the analog output terminals AM and CA*2. It should be protected from external noise using a shielded or twisted cable.
- Terminal SE is a common terminal for the open collector output terminals (OL, IPF, and FU). The contact input circuit is isolated from the internal control circuit by photocoupler.

*1 Terminal FM is provided in the FM-type converter.

*2 Terminal CA is provided in the CA-type converter.

◆Signal inputs by contactless switches

The contact input terminals of the converter (terminals STF, STR, STP, RH, RM, RL, JOG, RT, MRS, RES, AU, and CS) can be controlled using a transistor instead of a contact switch as shown in the following figure.

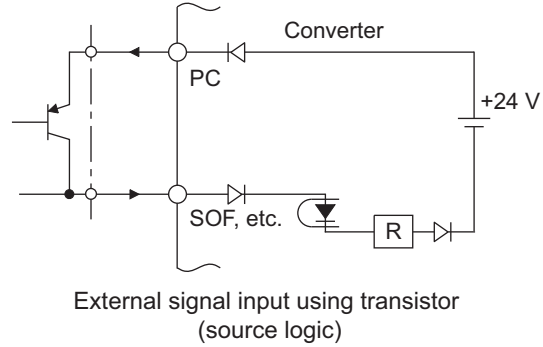
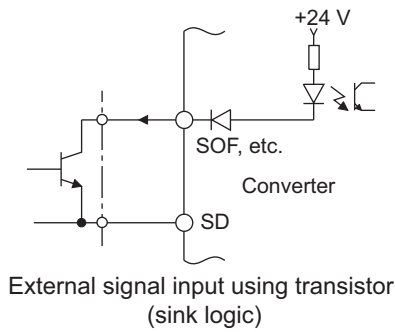

3.9.4 Wiring precautions

- It is recommended to use a cable of 0.75 mm² for connection to the control circuit terminals.
- The wiring length should be 30 m (200 m for terminal FM) at the maximum.
- Use two or more parallel micro-signal contacts or twin contacts to prevent contact faults when using contact inputs since the control circuit input signals are micro-currents.
- To suppress EMI, use shielded or twisted control cables, or install ferrite cores to control cables, and run them away from the main and power circuits (including the 200 V relay sequence circuit). For the cables connected to the control circuit terminals, connect their shields to the common terminal of the connected control circuit terminal. When connecting an external power supply to terminal PC, however, connect the shield of the power supply cable to the negative side of the external power supply. Do not directly earth (ground) the shield to the enclosure, etc.
- Always apply a voltage to the fault output terminals (A2, B2, and C2) via a relay coil, lamp, etc.
- Separate the wiring of the control circuit away from the wiring of the main circuit.

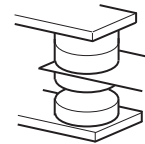

Micro signal contacts

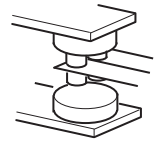

Twin contacts

Make cuts in rubber bush of the converter side and lead wires.

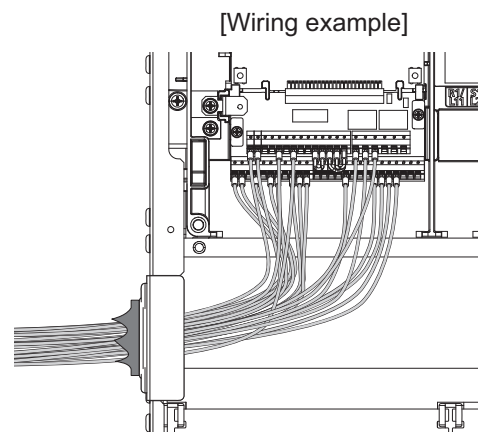
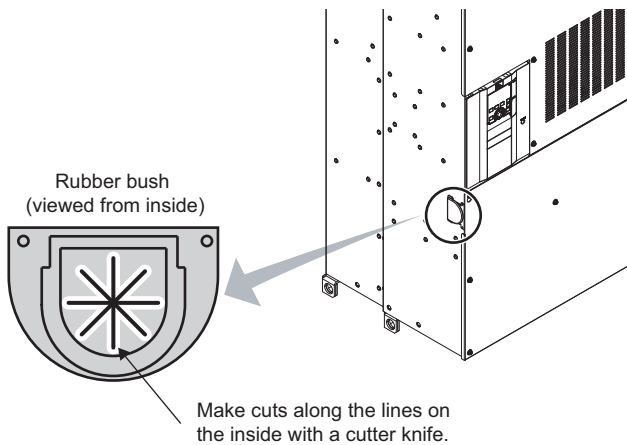

3.9.5 When using separate power supplies for the control circuit and the main circuit

◆ Cable size for the control circuit power supply (terminals R1/L11 and S1/L21)

- Terminal screw size: M4
- Cable gauge: 0.75 mm² to 2 mm²
- Tightening torque: 1.5 N·m

◆ Connection method

When the protection circuit is activated, opening of the electromagnetic contactor (MC) on the input side of the converter results in power loss in the control circuit of the converter, disabling the fault output signal retention. Terminals R1/L11 and S1/L21 of the control circuit are provided to hold a fault signal. To use these terminals, add the node points joined to the control circuit power supply terminals R1/L11 and S1/L21 on the MC power cable.

Terminals R1/L11 and S1/L21 are connected to terminals P/+ and N/- with a jumper respectively. Do not connect the power cable to incorrect terminals. Doing so may damage the converter.

[Connection diagram]

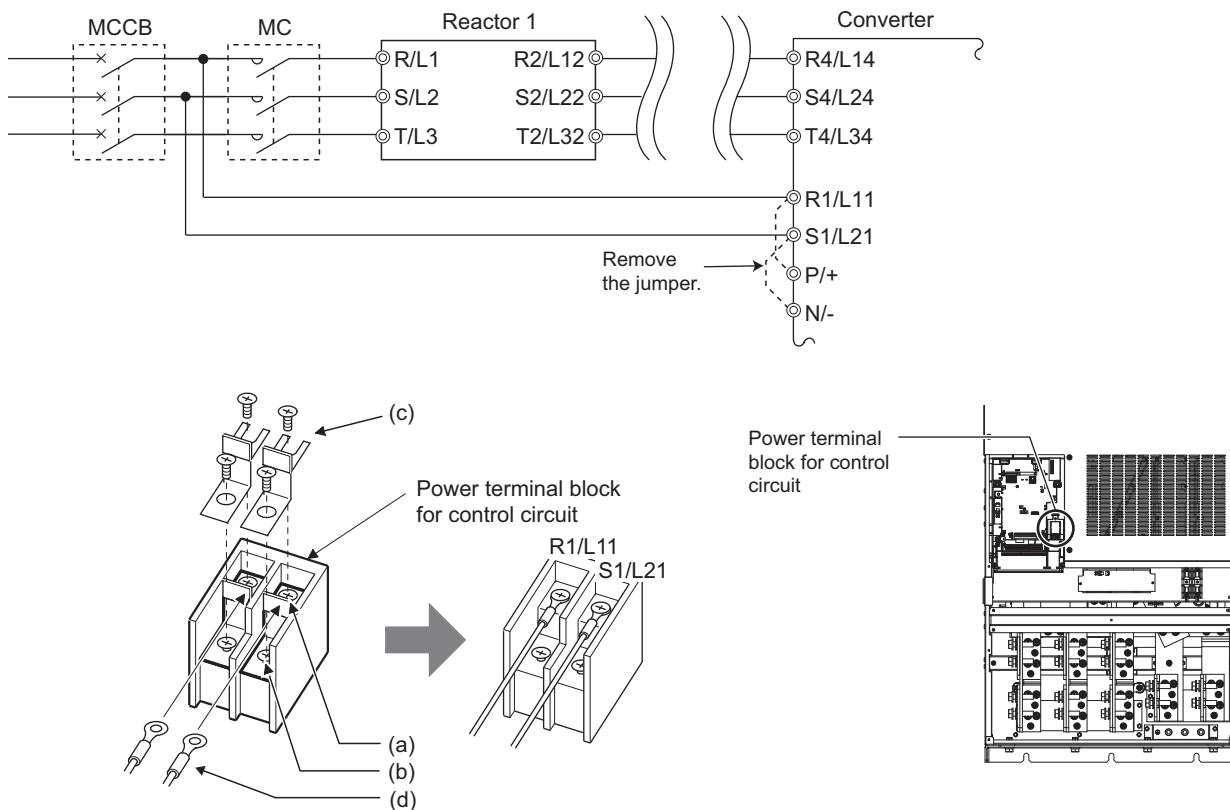

- (a) Remove the upper screws.
- (b) Remove the lower screws.
- (c) Pull the jumper toward you to remove.
- (d) Connect the separate power supply cable for the control circuit to the upper terminals (R1/L11, S1/L21).

NOTE

- When using separate power supplies, always remove the jumpers connected to terminals R1/L11 and S1/L21. Failure to do so may lead to damage of the converter.
- The voltage should be the same as that of the main control circuit when the control circuit power is supplied from other than the input side of the MC.
- When using a separate power supply connected to terminals R1/L11 and S1/L21, the necessary power capacity is 80 VA.
- If the main circuit power is switched OFF (for 0.1 seconds or more) then ON again, the converter is reset and a fault output will not be held.

3.9.6 When supplying 24 V external power to the control circuit

Connect the 24 V external power supply across terminals +24 and SD to turn the I/O terminal ON/OFF operation, keep the operation panel ON, and carry out communication during communication operation even at power-OFF state of converter's main circuit power supply. When the main circuit power supply is turned ON, the power supply changes from the 24 V external power supply to the main circuit power supply.

◆ Specification of the applied 24 V external power supply

Item	Rated specification
Input voltage	23 to 25.5 VDC
Input current	1.4 A or less

Commercially available product (as of February 2015).

Model	Manufacturer
S8JX-N05024C*1 Specifications: Capacity 50 W, output voltage (DC) 24 V, output current 2.1 A Installation method: Front installation with cover or S8VS-06024*1 Specifications: Capacity 60 W, output voltage 24 VDC, output current 2.5 A Installation method: DIN rail installation	OMRON Corporation
*1 For the latest information about OMRON power supply, contact OMRON corporation.	

◆ Starting and stopping the 24 V external power supply operation

- Supplying 24 V external power while the main circuit power is OFF starts the 24 V external power supply operation. Likewise, turning OFF the main circuit power while supplying 24 V external power starts the 24 V external power supply operation.
- Turning ON the main circuit power stops the 24 V external power supply operation and enables the normal operation.

NOTE

- When the 24 V external power is supplied while the main circuit power supply is OFF, the converter operation is disabled.
- In the initial setting, when the main power supply is turned ON during the 24 V external power supply operation, a reset is performed in the converter, then the power supply changes to the main circuit power supply.

◆ Confirming the 24 V external power supply input

- During the 24 V external power supply operation, "EV" blinks on the operation panel. The alarm lamp also blinks. Thus, the 24 V external power supply operation can be confirmed even when the operation panel is removed.

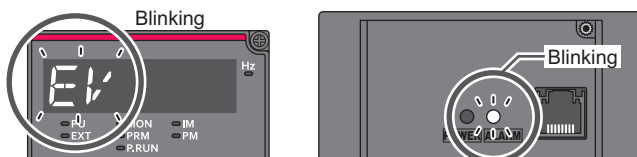

- During the 24 V external power supply operation, the 24 V external power supply operation (EV) signal is output. To use the EV signal, set "68 (positive logic) or 168 (negative logic)" in any of **Pr.192 to Pr.194** or **Pr.196 (Output terminal function selection)** to assign the function to the output terminal.

◆ Operation while the 24 V external power is supplied

- Fault history and parameters can be read and parameters can be written (when the parameter write from the operation panel is enabled) using the operation panel keys.
- During the 24 V external power supply operation, monitoring function and signals related to the main circuit power supply are not available (for example, monitoring the bus voltage or outputting the IPF signal is disabled).
- The alarms, which have occurred when the main circuit power supply is ON, continue to be output after the power supply is changed to the 24 V external power supply. Perform the converter reset or turn OFF then ON the power to reset the faults.

NOTE

- Inrush current equal to or higher than the 24 V external power supply specification may flow at power-ON. Confirm that the power supply and other devices are not affected by the inrush current and the voltage drop caused by it. Depending on the power supply, the inrush current protection may be activated to disable the power supply. Select the power supply and capacity carefully.
- When the wiring length between the external power supply and the converter is long, the voltage often drops. Select the appropriate wiring size and length to keep the voltage in the rated input voltage range.
- In a serial connection of several inverters, the current increases when it flows through the inverter wiring near the power supply. The increase of the current causes voltage to drop further. Use the converter and inverters after confirming that the input voltage of each inverter is within the rated input voltage range. Depending on the power supply, the inrush current protection may be activated to disable the power supply. Select the power supply and capacity carefully.
- "E.P24" may appear when the power supply start-up time is too long for the 24 V external power supply operation.
- "E.P24" may appear when the 24 V external power supply input voltage is low. Check the external power supply input.
- Do not touch the control circuit terminal block (circuit board) during the 24 V power supply operation (when conducted). Doing so may cause an electric shock or burn.

3.10 Communication connectors and terminals

3.10.1 PU connector

◆ Mounting the operation panel (FR-DU08) or parameter unit (FR-PU07) on the enclosure surface

- Having an operation panel (FR-DU08) or a parameter unit (FR-PU07) on the enclosure surface is convenient. With a connection cable, the operation panel (FR-DU08) or the parameter unit (FR-PU07) can be mounted to the enclosure surface and connected to the converter.

Use the option FR-CB2[], or connectors and cables available on the market.

(To mount the operation panel (FR-DU08), the optional connector (FR-ADP) is required.)

Securely insert one end of the connection cable until the stoppers are fixed.

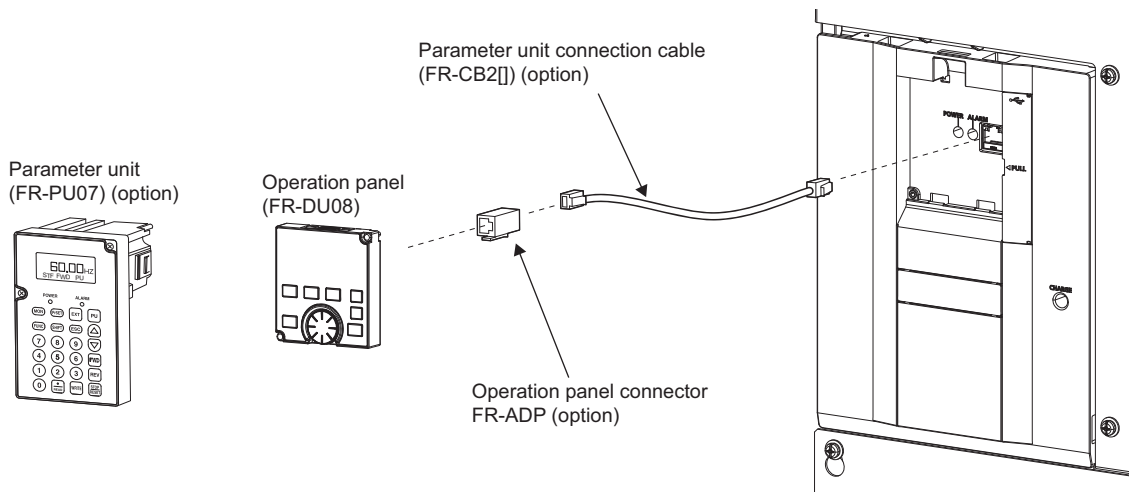

NOTE

- Refer to the following table when fabricating the cable on the user side. Keep the total cable length within 20 m.
- Commercially available products (as of February 2015)

Name	Model	Manufacturer
Communication cable	SGLPEV-T (Cat5e/300 m) 24AWG × 4P	Mitsubishi Cable Industries, Ltd.
RJ-45 connector	5-554720-3	Tyco Electronics

◆ Communication operation

- Using the PU connector as a computer network port enables communication operation from a personal computer, etc. When the PU connector is used for connection between the converter and a personal, FA, or other computer with a communication cable, a user program can run to monitor the inverter or read and write parameters. Communication can be performed with the Mitsubishi inverter protocol (computer link operation). (For the details, refer to [page 108](#).)

3.10.2 USB connector

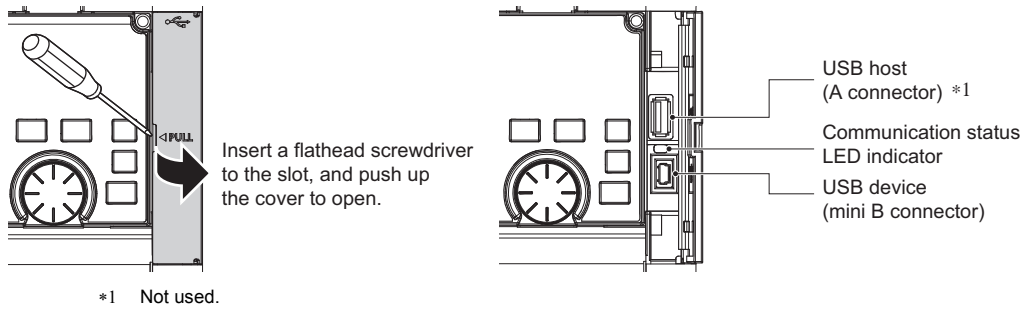

◆USB device communication

The converter can be connected to a personal computer with a USB (ver. 1.1) cable.

Interface	Conforms to USB1.1
Transmission speed	12 Mbps
Wiring length	Maximum 5 m
Connector	USB mini B connector (receptacle)
Power source	Self-powered

3.10.3 RS-485 terminal block

◆ Communication operation

Conforming standard	EIA-485 (RS-485)
Transmission format	Multidrop link
Communication speed	Maximum 115200 bps
Overall length	500 m
Connection cable	Twisted pair cable (4 pairs)

The RS-485 terminals enable communication operation from a personal computer, etc. When the PU connector is connected with a personal, FA or other computer by a communication cable, a user program can run to monitor the converter or read and write parameters.

Communication can be performed with the Mitsubishi inverter protocol (computer link operation).

For details, refer to the Instruction Manual (Detailed) of the FR-A800 inverter.

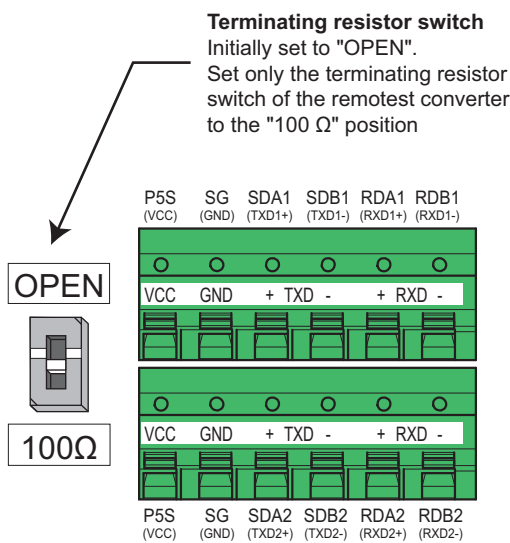

NOTE

- To avoid malfunction, keep the RS-485 terminal wires away from the control circuit board.
- Lead the wires on the left side of the plug-in option for wiring of the RS-485 terminals.
- The FR-A802-E converters do not have the RS-485 terminal block.

3.11 Connection of the converter and multiple inverters

Up to 10 inverters are connectable to a single converter. Be sure to use the converter with the capacity equal to or higher than the total capacity of inverters/motors. Additionally, the total capacity of the inverters or motors needs to be equal to or higher than half the capacity of the converter. (Converter capacity $\times 1/2 \leq$ total capacity of connected inverters or motors \leq converter capacity)

If the total inverter capacity or the total motor capacity is less than half the capacity of the converter, the converter can be used as a common converter or a regenerative converter. However, its harmonic suppression effect reduces.

- Junction terminals and cross wiring may be required for the wiring of the multiple inverters. For the gauge of cable used between the two junction terminals, refer to the descriptions in the following figure. Total capacity of higher-number axis inverters must be considered for the cable selection.
- For the multiple inverter connection, place the higher capacity inverter in the lower number axis.
- It is recommended to install a fuse for each inverter according to the capacity of motor connected to the inverter as shown in the following figure. Select a fuse according to the motor capacity.

When using a motor, of which the capacity is smaller than the inverter capacity by two ranks or more, select the fuse with the capacity that is one rank lower than the inverter capacity. (Refer to [page 21](#).)

- Keep the length of cables between the converter and the final axis inverter on each terminal within 50 m.

◆ Main circuit wiring example

The following diagram shows a connection example of the FR-A842-12120(500K) converter and three inverters: the FR-A842-07700(315K), FR-A840-04320(160K), and FR-A840-00620(22K) (497 kW capacity in total).

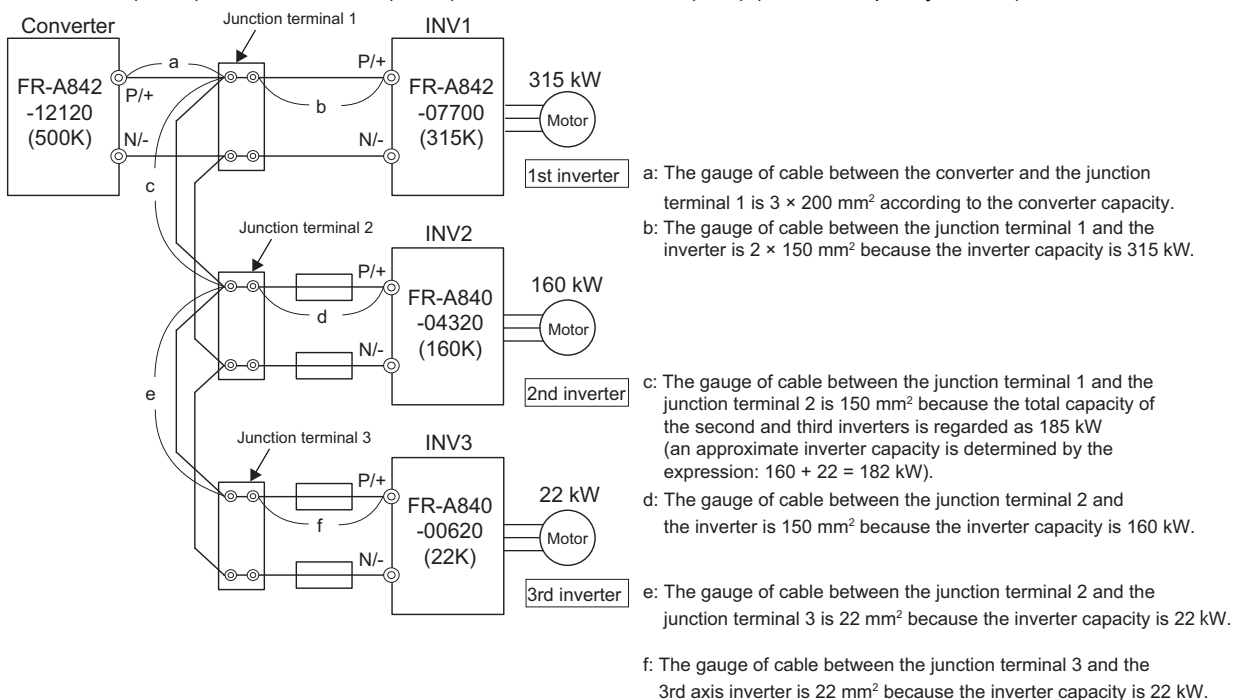

◆ Control circuit wiring example

- For the control circuit wiring, use shielded or twisted wires, and separate the wire from the main circuit and high-voltage circuits.
- Keep the length of cables between the converter and the final axis inverter on each terminal within 30 m.

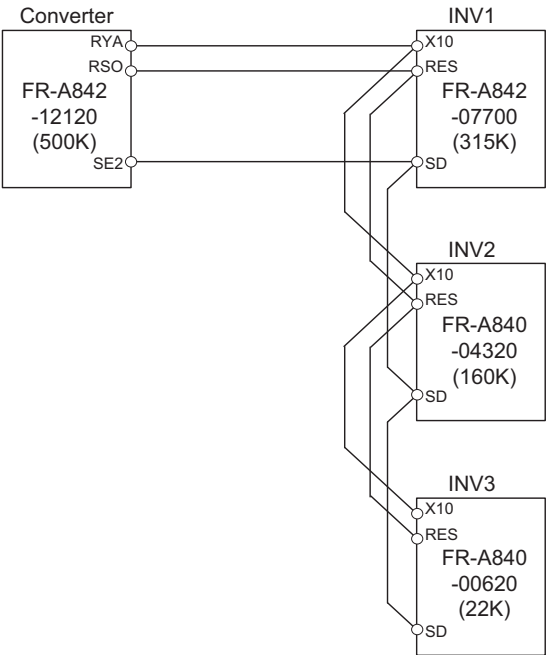

MEMO

4 PRECAUTIONS FOR USE OF THE CONVERTER

This chapter explains the precautions for use of the converter.
Always read the instructions before use.

4.1	Features of the converter.....	68
4.2	Harmonic suppression guidelines in Japan.....	69
4.3	Techniques and measures for electromagnetic compatibility (EMC)	72

4.1 Features of the converter

Power supply harmonics generated from the converter part of an inverter may affect devices including a dynamo and a static capacitor. Power supply harmonics are different from noise and leakage currents in source, frequency band and transmission path. By using a high power factor converter, power supply harmonics may be suppressed, allowing the compliance with the harmonic suppression guideline issued by the former Japanese Ministry of International Trade and Industry (currently the Ministry of Economy, Trade and Industry). The converter is classified as the self-excitation three-phase bridge circuit, and achieves K5 (the conversion factor) = 0. (It is assumed that the converter generates no harmonics.)

NOTE

- Inverter parameters must be set. The parameter settings differ by the inverter series. Refer to [page 23](#).

• Power supply harmonic suppression effect

(Condition) Load: 100%

Power factor: 1

[When high power factor converter is not connected]

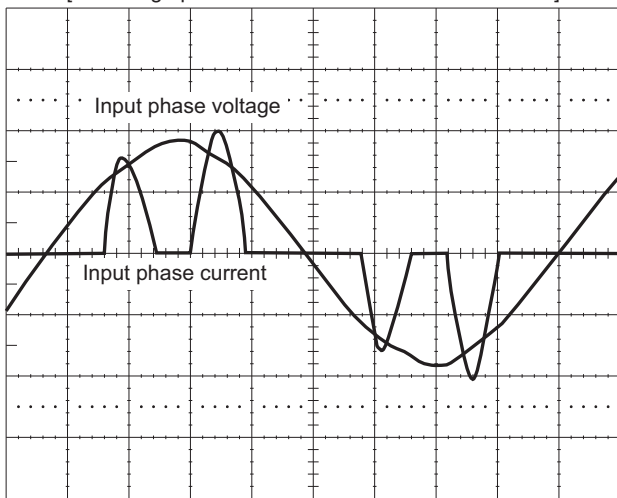

[When high power factor converter is connected]

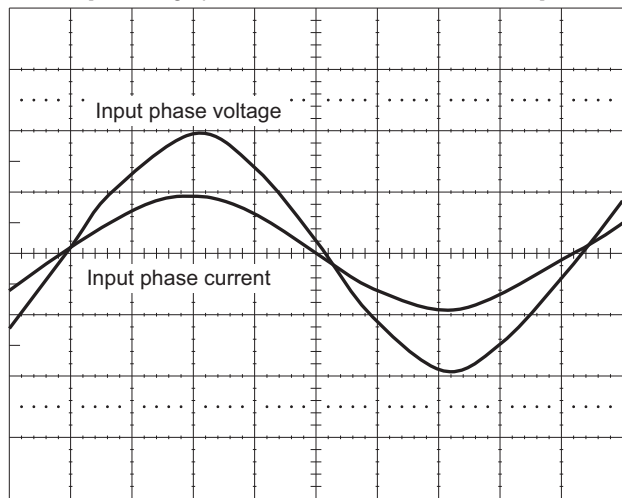

NOTE

- It does not mean that any harmonic components completely disappear.
- When the load is light, harmonic suppression effect declines.
- When the power supply voltage is unstable, power harmonics flow in, making the harmonic current increase.
- The power factor decreases when the setting of **Pr.84** or **Pr.85** is changed from the initial setting. (Refer to [page 107](#).)

4.2 Harmonic suppression guidelines in Japan

Harmonic currents flow from the inverter to a power receiving point via a power transformer. The Harmonic Suppression Guidelines was established to protect other consumers from these outgoing harmonic currents.

All capacity and all models of general-purpose inverter used by specific consumers are now covered by "the Harmonic Suppression Guidelines for Consumers Who Receive High Voltage or Special High Voltage" (hereinafter referred to as "the Specific Consumer Guidelines").

- "Specific Consumer Guidelines"

This guideline sets forth the maximum harmonic currents outgoing from a high-voltage or especially high-voltage receiving consumer who will install, add or renew harmonic generating equipment. If any of the maximum values is exceeded, this guideline requires that consumer to take certain suppression measures.

- Maximum values of outgoing harmonic currents per 1 kW contract power

Received power voltage	5th	7th	11th	13th	17th	19th	23rd	Over 23rd
6.6 kV	3.5	2.5	1.6	1.3	1.0	0.9	0.76	0.70
22 kV	1.8	1.3	0.82	0.69	0.53	0.47	0.39	0.36
33 kV	1.2	0.86	0.55	0.46	0.35	0.32	0.26	0.24

◆ Application of the specific consumer guidelines

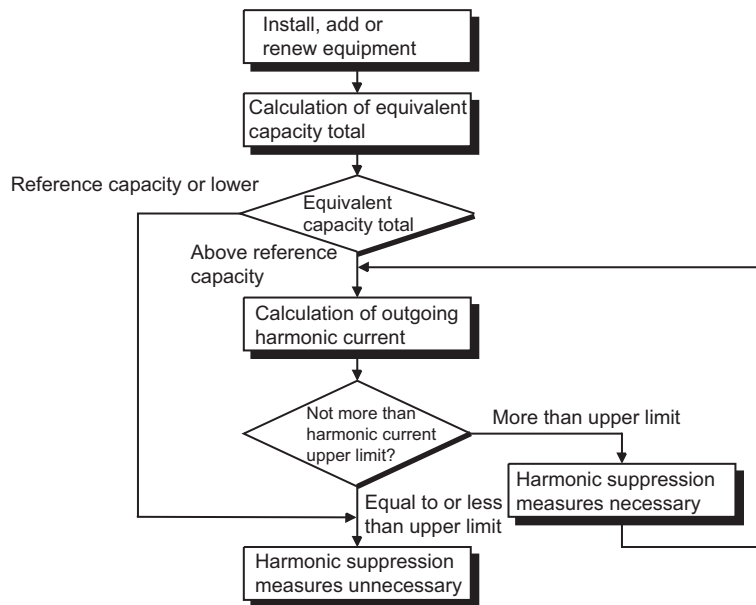

- Conversion coefficient

Classification	Circuit type	Conversion coefficient Ki	
1	Three-phase bridge	6-pulse converter	K11 = 1
		12-pulse converter	K12 = 0.5
		24-pulse converter	K13 = 0.25
3	Three-phase bridge (Capacitor smoothing)	Without reactor	K31 = 3.4
		With reactor (AC side)	K32 = 1.8
		With reactor (on DC side)	K33 = 1.8
		With reactors (AC, DC sides)	K34 = 1.4
4	Single-phase bridge (capacitor smoothing, double voltage rectification)	Without reactor	K41 = 2.3
		With reactor (AC side)	K42 = 0.35
	Single-phase bridge (capacitor smoothing, full-wave rectification)	Without reactor	K43 = 2.9
		With reactor (AC side)	K44 = 1.3
5	Self-excitation three-phase bridge	When a high power factor converter is used	K5 = 0

Harmonic suppression guidelines in Japan

- Equivalent capacity limit

Received power voltage	Reference capacity
6.6 kV	50 kVA
22/33 kV	300 kVA
66 kV or more	2000 kVA

- Harmonic contents (values of the fundamental current is 100%)

Reactor	5th	7th	11th	13th	17th	19th	23rd	25th
Not used	65	41	8.5	7.7	4.3	3.1	2.6	1.8
Used (AC side)	38	14.5	7.4	3.4	3.2	1.9	1.7	1.3
Used (DC side)	30	13	8.4	5.0	4.7	3.2	3.0	2.2
Used (AC, DC sides)	28	9.1	7.2	4.1	3.2	2.4	1.6	1.4

- Calculation of equivalent capacity P0 of harmonic generating equipment

"Equivalent capacity" is the capacity of a 6-pulse converter converted from the capacity of consumer's harmonic generating equipment and is calculated by the following equation: If the sum of equivalent capacities is higher than the limit (refer to [page 70](#)), harmonics must be calculated by the equation in next subheading.

$$P0 = \sum (Ki \times Pi) \text{ [kVA]}$$

Ki: Conversion factor (Refer to [page 69](#).)

Pi: Rated capacity of harmonic generating equipment*1 [kVA]

i: Number indicating the conversion circuit type

*1 Rated capacity: Determined by the capacity of the applied motor and found in Table 5. The rated capacity used here is used to calculate the generated harmonic amount and is different from the power supply capacity required for actual inverter drive.

- Calculation of outgoing harmonic current

Outgoing harmonic currents = fundamental wave current (value converted from received power voltage) × operation ratio × harmonic contents

- Operation ratio: actual load factor × operation time ratio during 30 minutes
- Harmonic content: Refer to [page 70](#).

- Rated capacities and outgoing harmonic currents of inverter-driven motors

Applicable motor (kW)	Rated current (A)	Fundamental wave current converted from 6.6 kV (mA)	Rated capacity (kVA)	Outgoing harmonic current converted from 6.6 kV (mA) (No reactor, 100% operation ratio)							
				5th	7th	11th	13th	17th	19th	23rd	25th
0.4	0.81	49	0.57	31.85	20.09	4.165	3.773	2.107	1.519	1.274	0.882
0.75	1.37	83	0.97	53.95	34.03	7.055	6.391	3.569	2.573	2.158	1.494
1.5	2.75	167	1.95	108.6	68.47	14.20	12.86	7.181	5.177	4.342	3.006
2.2	3.96	240	2.81	156.0	98.40	20.40	18.48	10.32	7.440	6.240	4.320
3.7	6.50	394	4.61	257.1	161.5	33.49	30.34	16.94	12.21	10.24	7.092
5.5	9.55	579	6.77	376.1	237.4	49.22	44.58	24.90	17.95	15.05	10.42
7.5	12.8	776	9.07	504.4	318.2	65.96	59.75	33.37	24.06	20.18	13.97
11	18.5	1121	13.1	728.7	459.6	95.29	86.32	48.20	34.75	29.15	20.18
15	24.9	1509	17.6	980.9	618.7	128.3	116.2	64.89	46.78	39.24	27.16
18.5	30.7	1860	21.8	1209	762.6	158.1	143.2	79.98	57.66	48.36	33.48
22	36.6	2220	25.9	1443	910.2	188.7	170.9	95.46	68.82	57.72	39.96
30	49.0	2970	34.7	1931	1218	252.5	228.7	127.7	92.07	77.22	53.46
37	60.4	3660	42.8	2379	1501	311.1	281.8	157.4	113.5	95.16	65.88
45	73.5	4450	52.1	2893	1825	378.3	342.7	191.4	138.0	115.7	80.10
55	89.9	5450	63.7	3543	2235	463.3	419.7	234.4	169.0	141.7	98.10

Applicable motor (kW)	Rated current (A)	Fundamental wave current converted from 6.6 kV (mA)	Rated capacity (kVA)	Outgoing harmonic current converted from 6.6 kV (mA) (With a DC reactor, 100% operation ratio)							
	400 V			5th	7th	11th	13th	17th	19th	23rd	25th
75	123	7455	87.2	2237	969	626	373	350	239	224	164
90	147	8909	104	2673	1158	748	445	419	285	267	196
110	179	10848	127	3254	1410	911	542	510	347	325	239
132	216	13091	153	3927	1702	1100	655	615	419	393	288
160	258	15636	183	4691	2033	1313	782	735	500	469	344
220	355	21515	252	6455	2797	1807	1076	1011	688	645	473
250	403	24424	286	7327	3175	2052	1221	1148	782	733	537
280	450	27273	319	8182	3545	2291	1364	1282	873	818	600
315	506	30667	359	9200	3987	2576	1533	1441	981	920	675
355	571	34606	405	10382	4499	2907	1730	1627	1107	1038	761
400	643	38970	456	11691	5066	3274	1949	1832	1247	1169	857
450	723	43818	512	13146	5696	3681	2191	2060	1402	1315	964
500	804	48727	570	14618	6335	4093	2436	2290	1559	1462	1072
560	900	54545	638	16364	7091	4582	2727	2564	1746	1636	1200

- Determining if a countermeasure is required

A countermeasure for harmonics is required if the following condition is satisfied: outgoing harmonic current > maximum value per 1 kW contract power × contract power.

- Harmonic suppression techniques

No.	Item	Description
1	Reactor (FR-HAL, FR-HEL)	Install an AC reactor (FR-HAL) on the AC side of the inverter or a DC reactor (FR-HEL) on its DC side, or install both to suppress outgoing harmonic currents.
2	High power factor converter	The converter switches the converter section ON/OFF to reshape an input current waveform into a sine wave, greatly suppressing harmonics. Use the converter with the dedicated options such as the phase detection transformer box, AC reactor, and filter capacitor.
3	Power factor improving static capacitor	When used with a reactor connected in series, the power factor improving correction capacitor can absorb harmonic currents.
4	Transformer multi-phase operation	Use two transformers with a phase angle difference of 30° in combinations of λ to Δ and Δ to Δ , to provide an effect corresponding to 12 pulses, reducing low-degree harmonic currents.
5	Passive filter (AC filter)	A capacitor and a reactor are used together to reduce impedances at specific frequencies. Harmonic currents are expected to be absorbed greatly by using this technique.
6	Active filter	This filter detects the current in a circuit generating a harmonic current and generates a harmonic current equivalent to a difference between that current and a fundamental wave current to suppress the harmonic current at the detection point. Harmonic currents are expected to be absorbed greatly by using this technique.

4.3 Techniques and measures for electromagnetic compatibility (EMC)

4.3.1 Countermeasures against inverter-generated EMI

In this section, electromagnetic noises refer to the high frequency (the 40th to 50th order harmonics) of irregular waveform in a power distribution system.

Some electromagnetic noises enter the converter to cause the converter malfunction, and others are radiated by the converter to cause the peripheral devices to malfunction. (The former is called EMS problem, the latter is called EMI problem, and both is called EMC problem.) Though the high power factor converter is designed to be immune to noises, it requires the following basic measures and EMS measures as it handles low-level signals. The high power factor converter chops output voltage at high carrier frequency, it could generate noises. In a system including the converter, the noise created by the system increases when both the converter and an inverter are operated. If these noises cause peripheral devices to malfunction, EMI measures should be taken to suppress noises. Techniques differ slightly depending on EMI paths.

◆Basic techniques

- Do not run the power cables (I/O cables) and signal cables of the converter in parallel with each other and do not bundle them.
- Use shielded twisted pair cables for the detector connecting and control signal cables and connect the sheathes of the shielded cables to terminal SD.
- Ground (earth) devices such as the reactor 1, reactor 2, phase detection transformer box, and converter at one point. (Refer to [page 47](#).)
- Install the recommended noise filter on the converter (refer to [page 76](#)). The noise filter is effective against the noises that enter the converter and the noises that are radiated from the converter.
- Do not earth (ground) the shields of the communication or control cables of the converter or inverter.

◆EMS measures to reduce electromagnetic noises that enter the converter and cause it to malfunction

When devices that generate many electromagnetic noises (which use magnetic contactors, electromagnetic brakes, many relays, for example) are installed near the converter and the converter may malfunction due to electromagnetic noises, the following countermeasures must be taken.

- Provide surge suppressors for devices that generate many electromagnetic noises to suppress electromagnetic noises.
- Install data line filters to signal cables.
- Ground (Earth) the shields of the detector connection and control signal cables with cable clamp metal.

◆ EMI measures to reduce electromagnetic noises that are radiated by the converter to cause the peripheral devices to malfunction

Converter-generated noises are largely classified into those radiated by the converter itself and by the cables (I/O) connected to its main circuit, those electromagnetically and electrostatically induced to the signal cables of the peripheral devices close to the power cable connected to the converter main circuit, and those transmitted through the power cables.

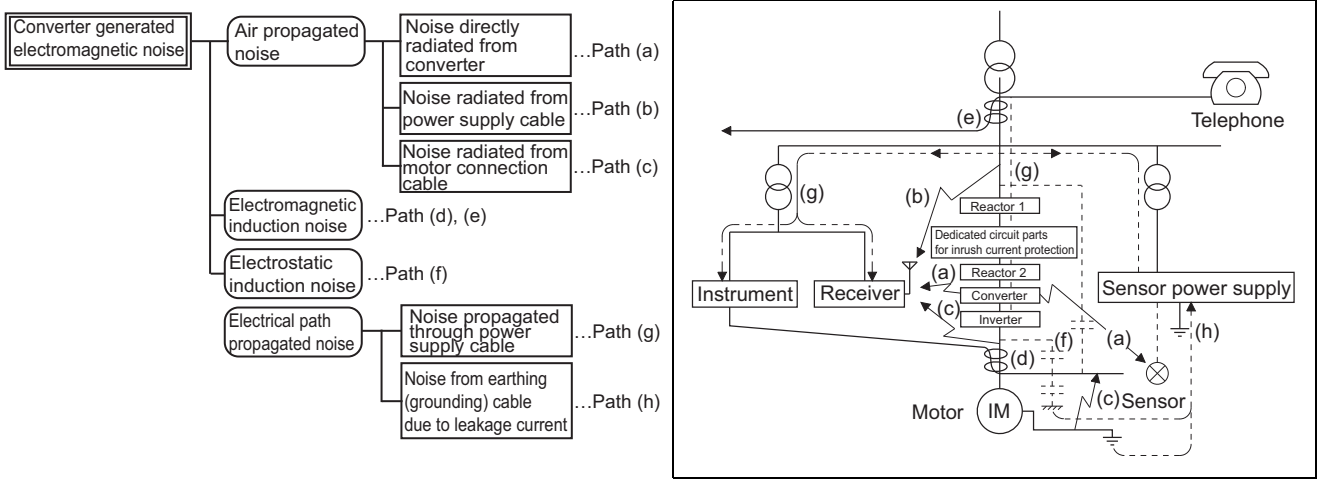

Noise propagation path	Measure
(a), (b), (c)	<p>When devices that handle low-level signals and are liable to malfunction due to electromagnetic noises, e.g. instruments, receivers and sensors, are contained in the enclosure that contains the converter or when their signal cables are run near the converter, the devices may malfunction due to by air-propagated electromagnetic noises. The following measures must be taken:</p> <ul style="list-style-type: none"> • Install the easily affected devices as far away from the converter and the inverter as possible. • Place the easily affected signal cables as far away from the converter and the inverter as possible. • Do not run the signal cables and power cables (converter I/O cables) in parallel with each other and do not bundle them. • Install the recommended noise filters (refer to page 76) or the radio noise filters (FR-BIF) on the input side of the converter, and install the line noise filters (FR-BLF, or non-Mitsubishi product RC5128 *1 or FINEMET® FT-3KM F / FT-3KL F *2) on the output side of the inverter to suppress radiated noises from the cables. • Use shielded cables as signal cables and power cables and run them in individual metal conduits to produce further effects.
(d), (e), (f)	<p>When the signal cables are run in parallel with or bundled with the power cables, magnetic and static induction noises may be propagated to the signal cables to cause malfunction of the devices. The following measures must be taken:</p> <ul style="list-style-type: none"> • Install the easily affected devices as far away from the converter and the inverter as possible. • Place the easily affected signal cables as far away from the converter and the inverter as possible. • Do not run the signal cables and power cables (I/O cables of the converter and inverter) in parallel with each other and do not bundle them. • Use shielded cables as signal cables and power cables and run them in individual metal conduits to produce further effects.
(g)	<p>When the power supplies of the peripheral devices are connected to the power supply of the converter in the same line, converter-generated noises may flow back through the power supply cables to cause malfunction of the devices. The following measures must be taken:</p> <ul style="list-style-type: none"> • Install the recommended noise filter on the power input cables of the converter. • Install a line noise filter (FR-BLF, RC5128*1, FINEMET® FT-3KM F / FT-3KL F series*2) to the power output cables of the inverter.
(h)	<p>When a closed loop circuit is formed by connecting the peripheral devices wiring to the converter, leakage currents may flow through the earthing (grounding) cable of the converter to cause the devices to malfunction. In that case, disconnecting the earthing (grounding) cables from the devices may stop the malfunction of the devices.</p>

*1 RC5128 is available on the market, manufactured by Soshin Electric Co., Ltd.

*2 The FINEMET® FT-3KM F / FT-3KL F is available on the market, manufactured by Hitachi Metals, Ltd. FINEMET is a registered trademark of Hitachi Metals, Ltd.

• EMI measure example

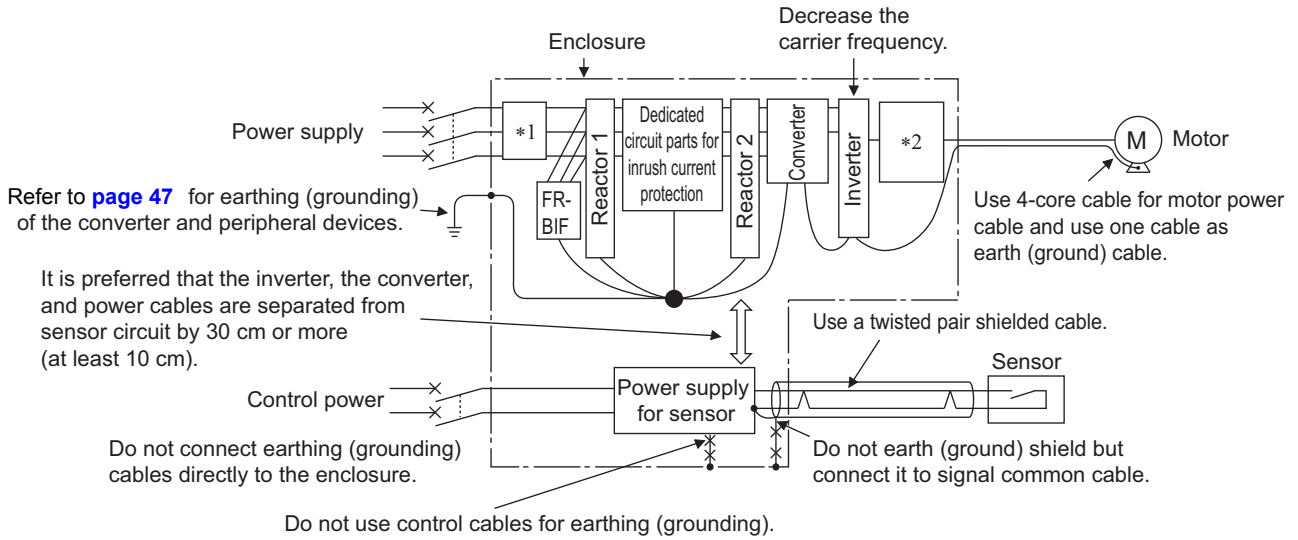

*1 Recommended noise filter (Refer to page 76.)

*2 Line noise filters (FR-BLF, RC5128, or non-Mitsubishi product FINEMET® FT-3KM F / FT-3KL F) (Refer to page 76.)

◆ EMI measures to reduce electromagnetic noises using stand-alone options

By using the radio noise filter (FR-BIF), line noise filter, and the recommended noise filter, the noise radiated from the connection cable can be suppressed. Refer to the Instruction Manual of each option for the details of the radio noise filter (FR-BIF) and line noise filter. Refer to [page 76](#) for the details of the recommended noise filter.

- Connection diagram example (for a FR-A800 series inverter)

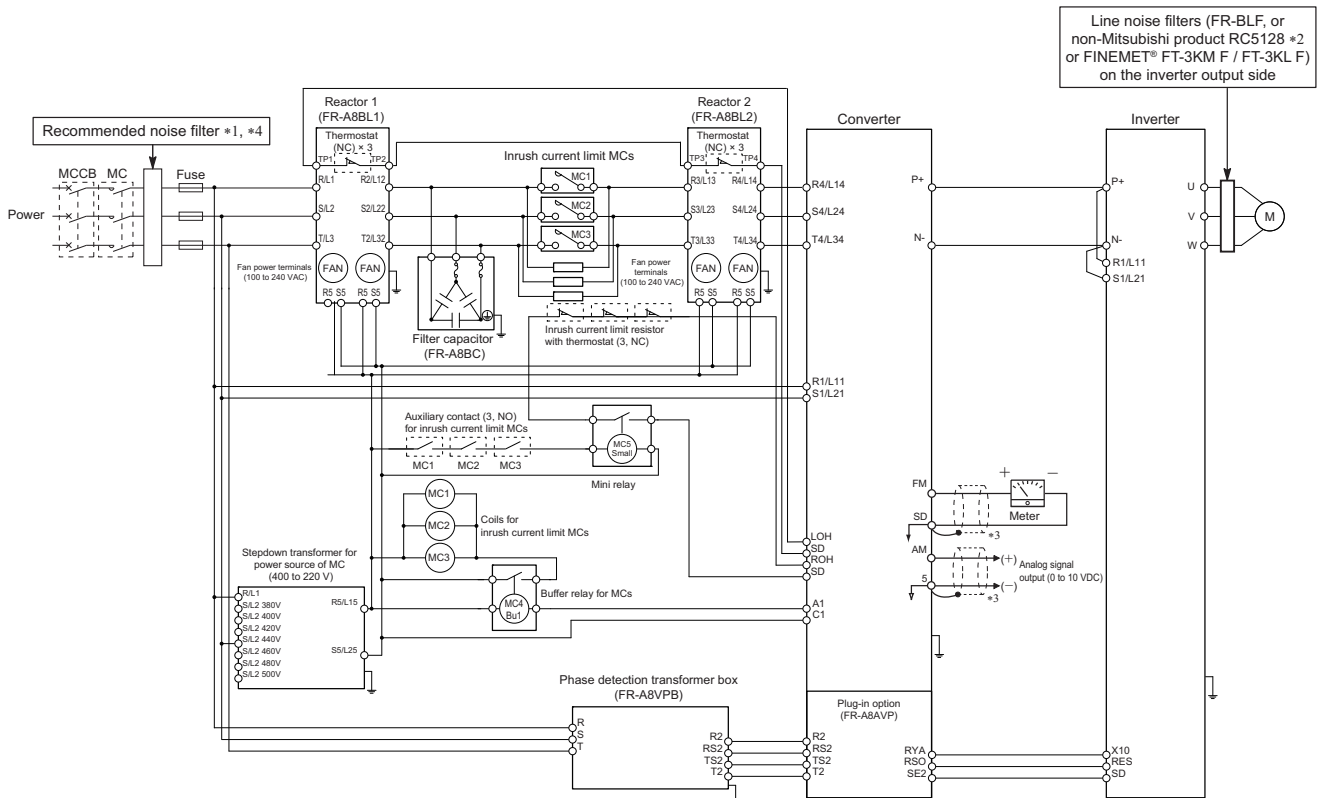

- *1 Install the filter on the input side of Terminals R, S, and T of the converter.
- *2 RC5128: manufactured by Soshin Electric Co., Ltd.
- *3 Do not earth (ground) the shield but connect it to the signal common.
- *4 Refer to [page 76](#) for the installation method of the recommended noise filter.
- *5 The FINEMET® FT-3KM F / FT-3KL F is available on the market, manufactured by Hitachi Metals, Ltd. FINEMET is a registered trademark of Hitachi Metals, Ltd.

NOTE

- Configure a system where the magnetic contactor at the converter input side shuts off the power supply at a failure of the converter or the connected inverter. (The converter does not shut off the power supply by itself.) Failure to do so may overheat and burn the resistors in the converter and the connected inverter.

◆ Recommended noise filter

Install this to reduce the electromagnetic noise.

- Connection diagram

Install a noise filter composed of common mode chokes (ring cores) and damping resistors on the input side of the high power factor converter.

Use the FINEMET® common mode chokes (manufactured by Hitachi Metals, Ltd.) for the zero-phase reactors and the inverter option brake resistor FR-ABR for the damping resistors.

FINEMET is a registered trademark of Hitachi Metals, Ltd.

The noise filter installed on the input side of the converter is effective in suppressing noises arising from a leakage current flowing along the path shown in the following figure.

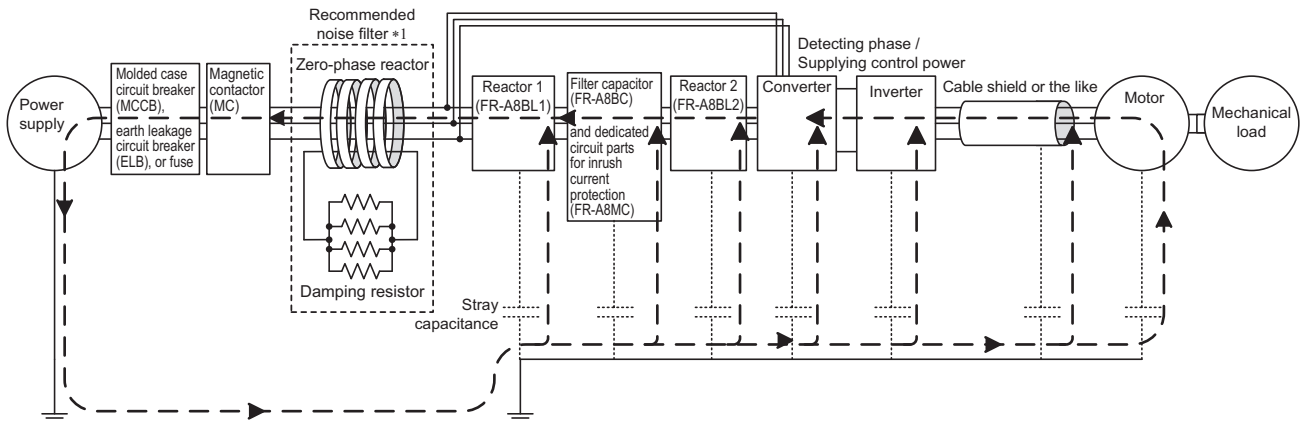

*1 Suppression effectiveness of the recommended noise filter remains the same wherever it is installed between the power supply and the reactor 1 (FR-A8BL1).

Observe the following precautions for installation of the recommended noise filter.

- As a guide, the total length of cable between the noise filter and the converter should be short enough to fit into an enclosure (about 4 m or shorter).
- Do not divert some of the current from bus cables between the noise filter and the reactor 1.

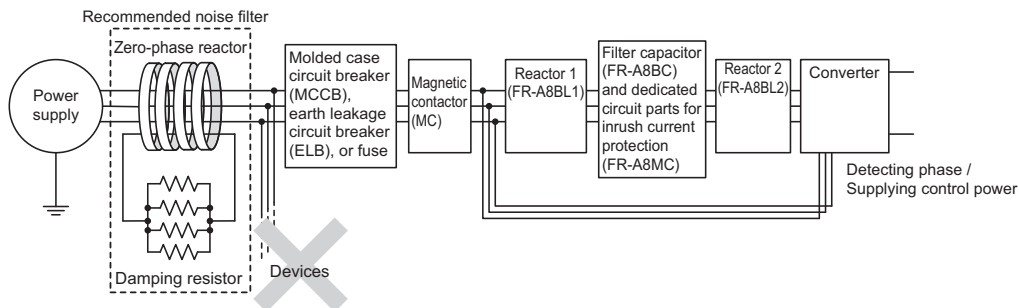

- Components

Item	FR-A842-[]					
	07700(315K)	08660(355K)	09620(400K)	10940(450K)	12120(500K)	
Zero-phase reactor	Model	FT-3KM F200160PB*1		FT-3KM F200160PB*1		
	Quantity	4 pcs (penetrated)				
Damping resistor	Model	FR-ABR-H22K*2				
	Quantity	4 pcs in parallel (combined resistance: 13 Ω)				
Damping resistor cable	Wire diameter	5.5 mm ² or more (when using HIV cable, etc.) AWG 10 or less (when using THHW cable, etc.) 6 mm ² or more (when using PVC cable, etc.)				
	Cable length	As short as possible within 10 m.				
	Voltage specifications	Equal voltage resistance to the main circuit cables.				

*1 Manufactured by Hitachi Metals, Ltd.

*2 The FR-ABR-H22K consists of two damping resistors. Order two FR-ABR-H22K to have a total of 4 damping resistors.

NOTE

- Observe the instructions given in the Instruction Manual of each component.
- The damping resistor (FR-ABR) requires 5 cm clearance or more around it for directions. Besides, the distance between the damping resistors should be 1 cm or more.
- As a reference, the surface temperature increase of the damping resistor (FR-ABR) is about 30°C and the total resistance loss is about 300 W (dependent on the environment).
- For the converters not shown in the table above, installing the recommended noise filter is not required.

If leakage current from the inverter and/or the converter flows along the path shown in the following figure, installing a line noise filter between the inverter and the motor is effective in suppressing noises arising from the leakage current.

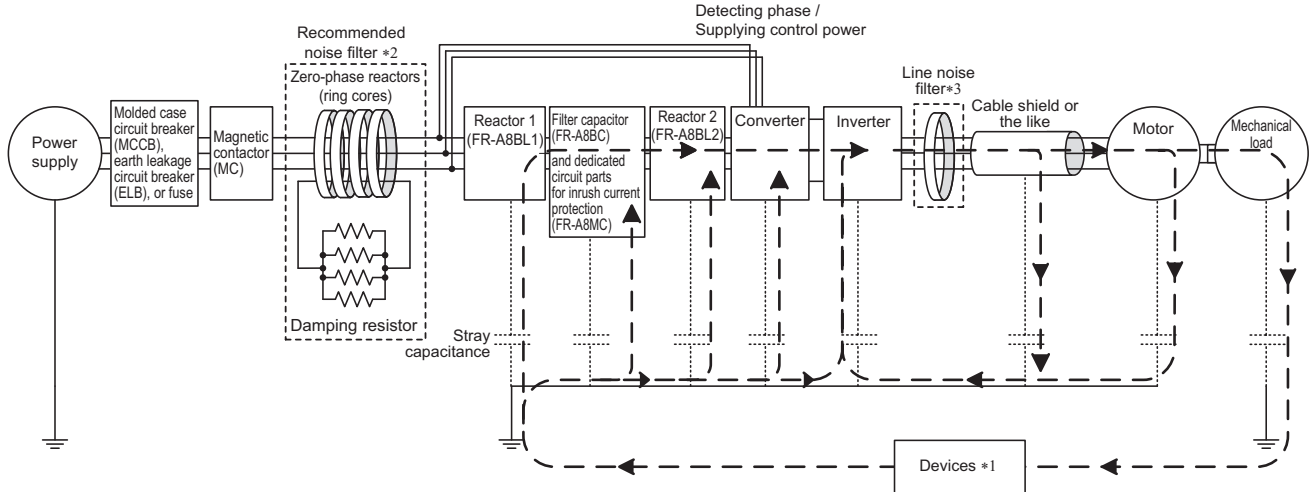

*1 The leakage current can cause a malfunction of devices placed over the leakage current path.

*2 Suppression effectiveness of the recommended noise filter remains the same wherever it is installed between the power supply and the reactor 1 (FR-A8BL1).

Observe the following precautions for installation of the recommended noise filter.

- As a guide, the total length of cable between the noise filter and the converter should be short enough to fit into an enclosure (about 4 m or shorter).
- Do not divert some of the current from bus cables between the noise filter and the reactor 1.

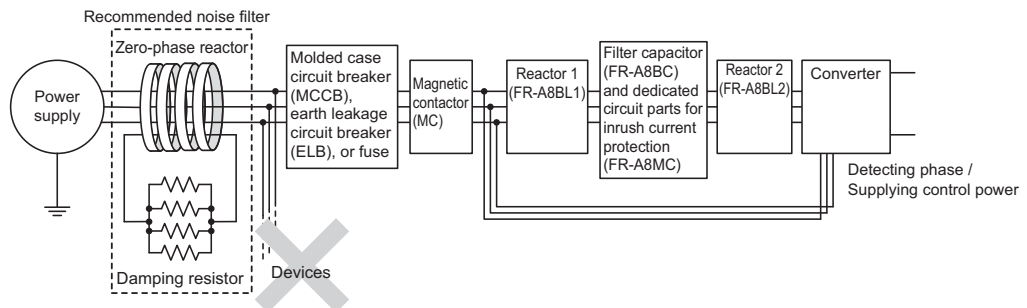

*3 Recommended line noise filters include the FR-BLF, RC5128, FINEMET® FT-3KM F or FT-3KL F series.
 RC5128: manufactured by Soshin Electric Co., Ltd.
 FINEMET® FT-3KM F / FT-3KL F series: manufactured by Hitachi Metals, Ltd.

4.3.2 Selecting the rated sensitivity current for the earth leakage circuit breaker

To install the earth leakage circuit breaker on the inverter circuit, select its rated sensitivity current as follows.

- Breaker designed for harmonic and surge suppression
Rated sensitivity current $I\Delta n \geq 10 \times (I_{g1} + I_{gn} + I_{g2} + I_{g3} + I_{gm})$
- Standard breaker
Rated sensitivity current $I\Delta n \geq 10 \times \{I_{g1} + I_{gn} + I_{g2} + 3 \times (I_{g3} + I_{gm})\}$

- I_{g1}, I_{g2}, I_{g3} : Leakage currents in wire path during commercial power supply operation
- I_{gn} : Leakage current from noise filters on the input side of the converter
- I_{gm} : Leakage current from the motor during commercial power supply operation

Example of leakage current per 1km during the commercial power supply operation when the CV cable is routed in metal conduit (200 V 60 Hz)

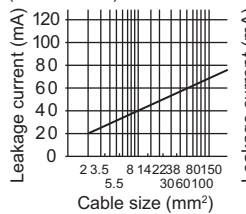

Leakage current example of three phase induction motor during the commercial power supply operation (200 V 60 Hz)

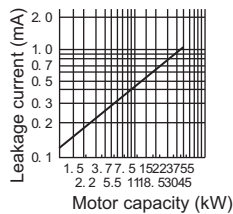

Example of leakage current per 1km during the commercial power supply operation when the CV cable is routed in metal conduit (Three-phase three-wire delta connection 400 V 60 Hz)

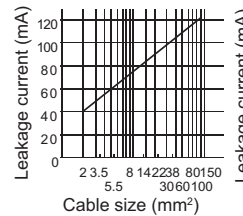

Leakage current example of three phase induction motor during the commercial power supply operation (Totally-enclosed fan-cooled type motor 400 V 60 Hz)

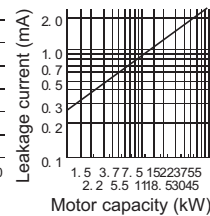

For wye connection, the amount of leakage current is approx. 1/3 or the above value.

Selection example (diagram shown on the left) (mA)

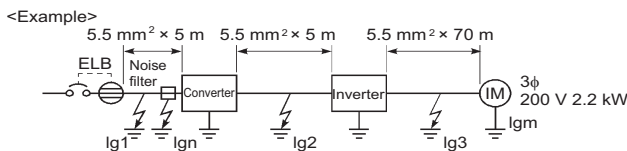

	Breaker designed for harmonic and surge suppression	Standard breaker
Leakage current I_{g1} (mA)	$33 \times \frac{5 \text{ m}}{1000 \text{ m}} = 0.17$	
Leakage current I_{gn} (mA)	0 (without noise filter)	
Leakage current I_{g2} (mA)	$33 \times \frac{5 \text{ m}}{1000 \text{ m}} = 0.17$	
Leakage current I_{g3} (mA)	$33 \times \frac{70 \text{ m}}{1000 \text{ m}} = 2.31$	
Motor leakage current I_{gm} (mA)	0.18	
Total leakage current (mA)	2.83	7.81
Rated sensitivity current ($\geq I_g \times 10$) (mA)	30	100

NOTE

- Install the earth leakage circuit breaker (ELB) on the input side of the converter.
- In the Δ connection earthed-neutral system, the sensitivity current is blunt against a ground fault in the inverter output side. Earthing (Grounding) must conform to the requirements of national and local safety regulations and electrical codes. (NEC section 250, IEC 61140 class 1 and other applicable standards)
- Do not install the breaker on the output side of the inverter. Doing so may cause unnecessarily operations by harmonics even if the effective value is within the rating, since the eddy current and hysteresis loss will increase, leading to temperature rise.
- The following models are standard breakers: BV-C1, BC-V, NVB, NV-L, NV-G2N, NV-G3NA, and NV-2F earth leakage relay (except NV-ZHA) and the NV class earth leakage circuit breaker with AA neutral wire open-phase protection. The other models are designed for harmonic and surge suppression: NV-C/NV-S/MN series, NV30-FA, NV50-FA, BV-C2, earth leakage alarm breaker (NF-Z), NV-ZHA, and NV-H.

5 PARAMETERS

This chapter explains the parameters in the converter.
Always read the instructions before use.

5.1	Operation panel (FR-DU08)	80
5.2	Parameter unit (FR-PU07)	83
5.3	Parameter List	87
5.4	Parameter details	90
5.5	Parameter clear / All parameter clear on the operation panel.....	142
5.6	Copying and verifying parameters on the operation panel ..	143
5.7	Checking parameters changed from their initial values (initial value change list).....	146

5.1 Operation panel (FR-DU08)

5.1.1 Components of the operation panel

To mount the operation panel (FR-DU08) on the enclosure surface, refer to [page 61](#).

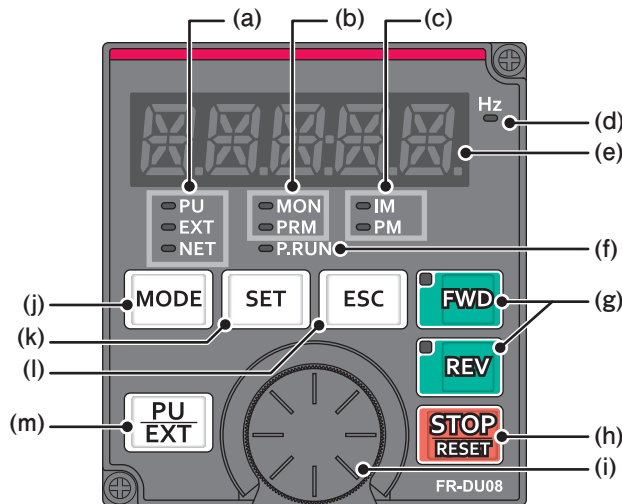

No.	Component	Name	Description
(a)		—	Not available for the converter.
(b)		Operation panel mode LED indicator	MON: ON when the operation panel is in the monitor mode. Quickly blinks twice intermittently while the converter protective function is activated. PRM: ON when the operation panel is in the parameter setting mode.
(c)		—	Not available for the converter.
(d)		Frequency unit indicator	ON to indicate frequency.
(e)		Monitor (5-digit LED)	Shows a numeric value, a parameter number, etc. (The monitor item can be changed according to the Pr.52 setting.)
(f)		—	Not available for the converter.
(g)		FWD key, REV key	FWD key: Its LED is ON during power driving. REV key: Its LED is ON during regenerative driving. The LEDs are OFF when the converter stops its operation due to power supply failure or when a fault occurs. The LEDs blink when the converter stops its operation due to a cause except the above-mentioned cause.
(h)		STOP/RESET key	Used to reset the converter when the protective function is activated.
(i)		Setting dial	Turn the setting dial to select a parameter or change the parameter setting. Press the setting dial to perform the following operations: • To display the "CNV" (converter) indication. • To display a fault history number in the fault history mode.
(j)		MODE key	Switches the operation panel to a different mode. Holding this key for 2 seconds locks the operation of the operation panel. The key inoperable function is invalid when Pr.161 = "0 (initial setting)". (Refer to page 126 .)
(k)		SET key	Used to confirm each selection. Switches the monitor screen in the monitor mode. (The monitor item can be changed according to the Pr.52 setting.) When the initial setting is set Power supply frequency → Input current → Input voltage
(l)		ESC key	Goes back to the previous display. Holding this key for a longer time changes the display back to the monitor mode.
(m)		PU/EXT key	Cancels the PU stop warning.

5.1.2 Basic Operation of the Operation Panel

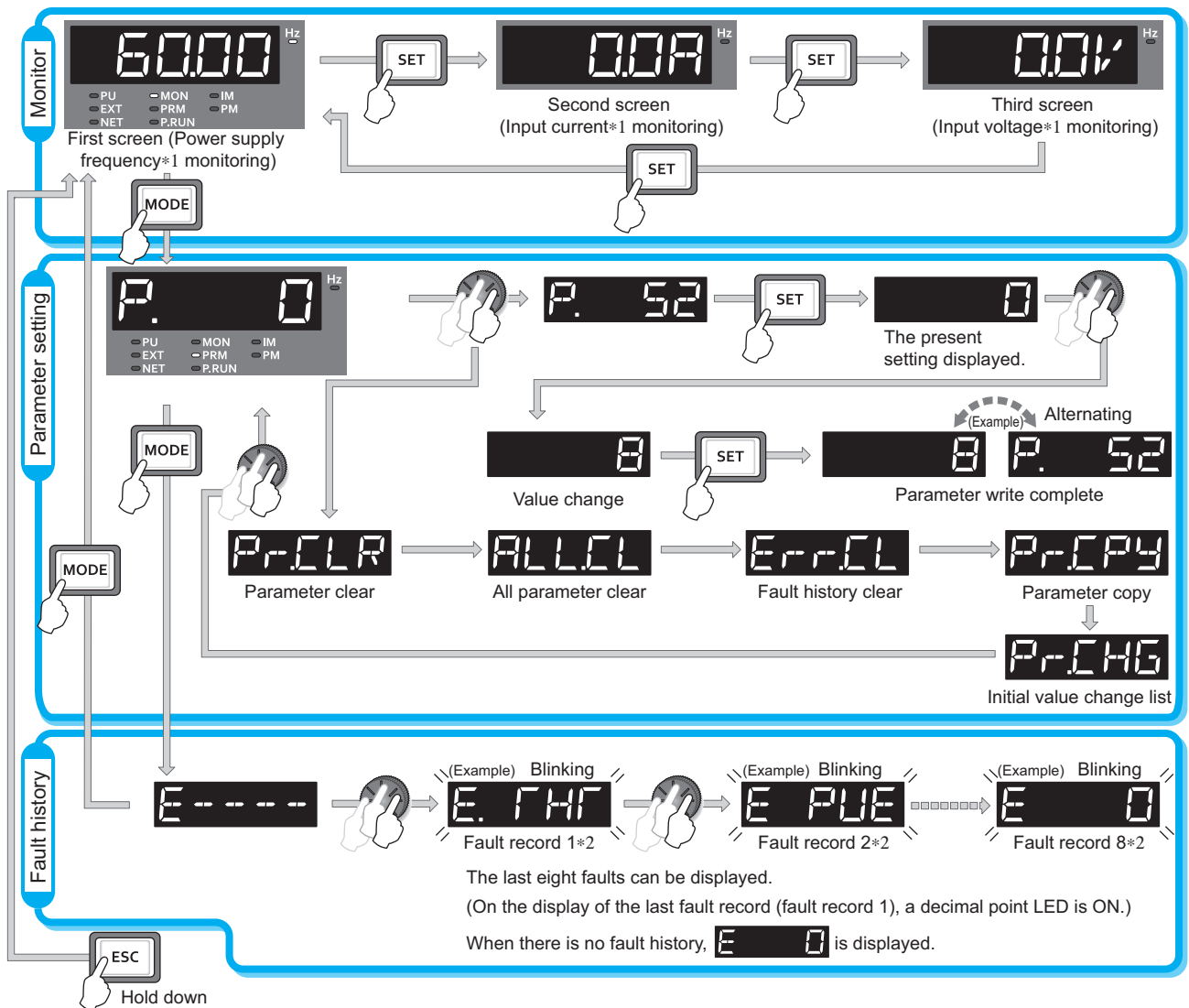

*1 The monitor item can be changed. (Refer to page 123.)
 *2 For the details of fault history, refer to page 149.

◆Parameter setting mode

In the parameter setting mode, converter functions (parameters) can be set. The following table explains the indications in the parameter setting mode.

Operation panel indication	Function name	Definition	Refer to page
P.	Parameter setting mode	The set value of the displayed parameter number is read or changed.	82
Pr-CLR	Parameter clear	Clears and resets parameter settings to the initial values. However, terminal function selection parameters are not cleared. For the details of the uncleared parameters, refer to page 190.	142
ALLCL	All parameter clear	Clears and resets parameter settings to the initial values. Terminal function selection parameters are also cleared. For the details of the uncleared parameters, refer to page 190.	142
Err-CL	Fault history clear	Deletes the fault history.	149
Pr-CPY	Parameter copy	Copies the parameter settings saved in the converter to the operation panel. The parameters copied to the operation panel can be also copied to other converter.	143
Pr-CHG	Initial value change list	Identifies the parameters that have been changed from their initial settings.	146

5.1.3 Digital characters and their corresponding printed equivalents

Digital characters displayed on the operation panel display are as follows.

0	1	2	3	4	5	6	7	8	9	A	B(b)	C	c	D(d)
0	1	2	3	4	5	6	7	8	9	A	b	C	c	d
E(e)	F(f)	G(g)	H	h	I(i)	J(j)	K(k)	L(l)	M(m)	N	n	O	o	P(p)
E	F	G	H	h	I	J	K	L	M	N	n	O	o	P
Q(q)	R	r	S(s)	T(t)	U	u	V	v	W	w	X(x)	Y(y)	Z(z)	
Q	R	r	S	T	U	u	V	v	W	w	X	Y	Z	

5.1.4 Changing the parameter setting value



Changing example Change the setting of Pr.52 DU/PU main display data selection.

Operating procedure

1. Turning ON the power of the converter
The operation panel is in the monitor mode.

2. Selecting the parameter setting mode
Press **MODE** to choose the parameter setting mode. (The parameter number read previously appears.)

3. Selecting the parameter number
Turn  until "Pr. 52" (Pr.52) appears. Press **SET** to read the present set value. "0" (initial value) appears.

4. Changing the setting value
Turn  to change the set value to "8". Press **SET** to enter the setting. "8" and "Pr. 52" are displayed alternately.
 - Turn  to read another parameter.
 - Press **SET** to show the setting again.
 - Press **SET** twice to show the next parameter.
 - Press **MODE** three times to return the monitor display to the indication of the power supply frequency.

NOTE

• If a parameter write condition is not satisfied, a parameter write error appears. (Refer to [page 153](#).)

Error code	Error description
Er 1	Parameter write error

5.2 Parameter unit (FR-PU07)

Installing the optional parameter unit (FR-PU07) on the converter allows to set the converter parameters and monitor the converter status. However, the available functions in the parameter unit installed on the converter are limited compared to those in the parameter unit installed on the inverter.

5.2.1 Components of the parameter unit

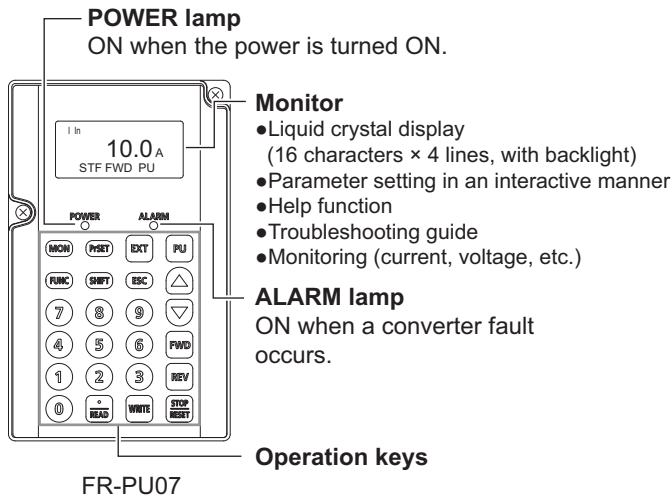

5.2.2 Description of keys

Key	Description
	Used for parameter setting. Press this key to select the parameter setting mode.
	Used to display the first priority monitoring screen. In the initial setting, the power supply frequency is displayed.
	Used to cancel the operation.
	Used to display the function menu. A variety of functions can be used from the function menu.
	Used to shift to the next item in the setting or monitoring mode.
	Used to enter a parameter number or set value.
	Used to clear the "PS" indication which appears when the converter is stopped by pressing (by the PU stop function).
	Not available for the converter.
	<ul style="list-style-type: none"> • Press either of these keys on the parameter setting mode screen to change the parameter setting value sequentially. • On the selecting screen, these keys are used to move the cursor. • Hold down and press either of these keys to advance or return the display screen one page.
	Not available for the converter.
	Not available for the converter.
	<ul style="list-style-type: none"> • Stop command key. • Used to reset the converter when a fault occurs.
	<ul style="list-style-type: none"> • Used to write a set value in the setting mode. • Used as a clear command key for All parameter clear or the alarm clear (resetting the fault history).
	<ul style="list-style-type: none"> • Used to enter a decimal point when entering numerical value. • Used as a parameter number read key in the parameter setting mode. • Used as an item select key on the menu screen such as parameter list or monitoring list. • Used to show the details of each fault in the alarm (fault) history mode. • Used as a command voltage read key in the calibration mode.

NOTE

- Do not operate the keys with sharp tools.
- Do not press the LCD part.

5.2.3 Monitoring function

◆ Indications displayed on the monitoring screen

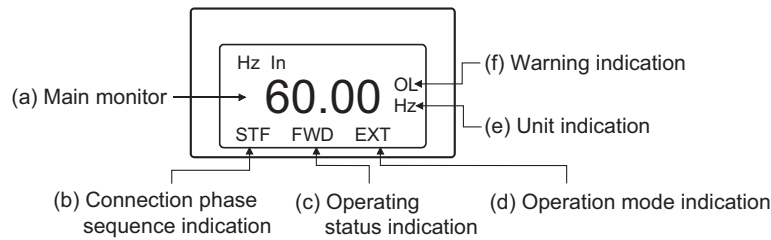

(a) Main monitor

The power supply frequency, input current, input voltage, alarm (fault) history or other monitor data is displayed.

Press to display the monitoring list.

Select an item from the monitoring list and press to monitor the selected item.

The following items can be monitored.

- Hz In : Power supply frequency (Hz)
- I In : Input current (A)
- V In : Input voltage (V)
- Alarm His : Fault history (the last 8 faults)*1
- Dc Bus : Bus voltage (V)
- THT % : Electronic thermal O/L relay load factor (%)
- Cum Pwr : Cumulative power (kW)
- Cum Opr : Cumulative energization time (h)
- Pwr In : Input power (kW)
- I/P Signal : Input signal
- O/P Signal : Output signal

*1 When the converter is used as an inverter before conversion, fault records are displayed for both before and after the conversion (the indication can be switched for up to eight records).

(After the eighth fault occurs in the converted converter, only the converter's fault records will be displayed.)

NOTE

- If setting **Pr.52** has changed the monitor item for the first or the second monitor screen, the monitoring list does not recognize that the monitor item for the first or the second monitor screen has been changed until the monitoring list is read (displayed). If a monitor item change has been performed while the monitoring list is displayed, the monitoring list does not recognize the change and the target item displayed does not turn to the new item.

(b) Connection phase sequence indication

The following phase sequence is displayed.

- STF : Positive
- STR : Negative
- : Power supply not detected

(c) Operating status indication

The operating status of the converter is displayed.

- STOP : Stop state
- FWD : Power driving
- REV : Regenerative driving
- ALAR : Fault state

(d) Operation mode indication

"EXT" (External operation mode) is always indicated.

(e) Unit indication

The unit of the main monitor item is indicated.

(f) Warning indication

The following is indicated when the converter outputs a warning.

Nothing is indicated when there is no warning output.

For the details, refer to [page 153](#).

- OL : Overload signal detection
- TH : Electronic thermal relay function pre-alarm
- PS : PU stop
- MT1 to MT3 : Maintenance signal output
- SL : Power supply not detected
- CP : Parameter copy

5.2.4 Function menu

Press **FUNC** in any operation mode to call the function menu, on which you can perform various functions.



- There are menus in which some functions are not available.

◆ Function menu list

Function menu	Description
1. MONITOR	The monitoring list appears, and the functions on monitoring such as the monitor item selection to be displayed, the first priority monitoring screen selection.
2. PU Oper	The menu appears, but every function in the menu is disabled.
3. Pr.List	The parameter menu appears, and the parameter setting and the displaying of the initial value change list are available.
4. Pr.Clear	The menu to clear parameters appears. Parameter clear and All parameter clear can be executed.
5. Alarm His	The last 8 faults are displayed.
6. AlarmClear	The fault history (all fault records) can be cleared.
7. Inv.Reset	The converter can be reset. (The inverter can also be reset simultaneously.)
8. T/Shooting	The menu appears, but every function in the menu is disabled.
9. S/W	This function displays the software control number of the converter.
10. Selectop	The menu appears, but every function in the menu is disabled.
11. Option	The option connector (1 to 3) occupancy condition is displayed.
12. FRCpy set	Parameter copy (reading, writing, and verifying of parameters) can be performed.

◆ Function menu transition

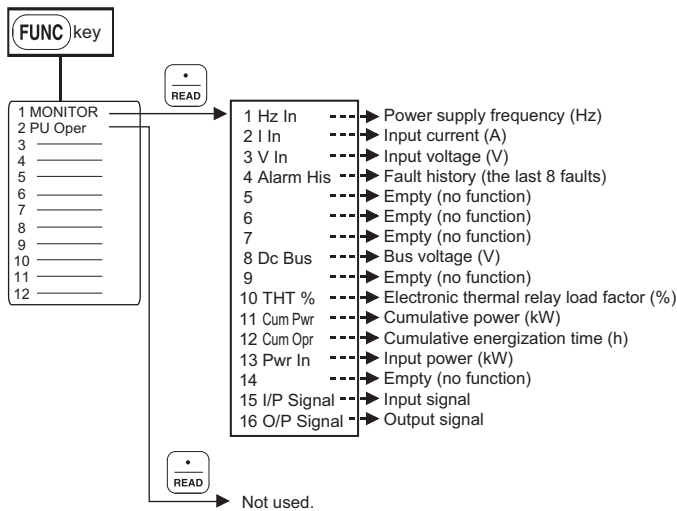

Parameter unit (FR-PU07)

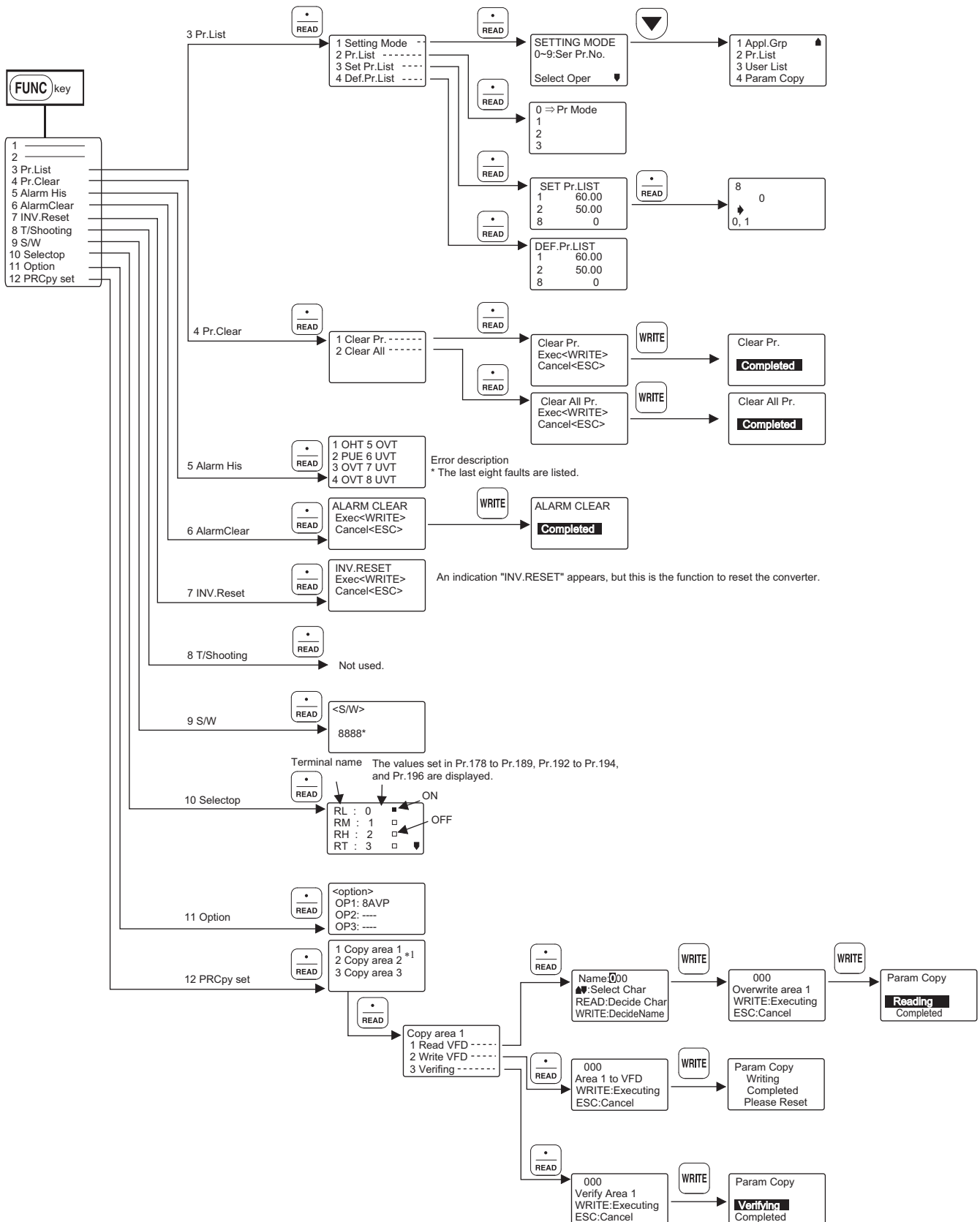

*1 Only the copy area 1 is available to store a parameter setting of the converter. Do not use the copy area 2 for any other product to preserve the converter parameter setting stored in the copy area 1. Doing so will delete the converter parameter setting stored in the copy area 1.

5.3 Parameter List

The following table shows the parameters that can be read after the inverter-to-converter switching.



- The setting of parameters in highlighted cells is changeable during operation even if "1" (write disabled) is set in Pr.77 Parameter write selection.

Pr.	Name	Setting range	Minimum setting increments	Initial value		Refer to page	Customer setting
				FM	CA		
1	Maximum frequency	60 Hz	0.01 Hz	60 Hz		91	
2	Minimum frequency	50 Hz	0.01 Hz	50 Hz		91	
8	SOF input selection	0, 2	1	0		91	
9	OH input selection	0, 1	1	0		91	
22	Current limit level	0 to 220%	0.1%	150%		92	
23	Current limit level (regenerative)	0 to 220%, 9999	0.1%	9999		92	
44	Instantaneous power failure detection signal clear	0, 9999	1	9999		93	
49	Power supply frequency monitoring reference	45 to 65 Hz	0.01 Hz	60 Hz		94	
51	Input power monitoring reference	0 to 3600 kW	0.1 kW	Rated capacity		94	
52	DU/PU main display data selection	0, 8, 10, 13, 14, 20, 25, 55, 98	1	0		96	
53	Input voltage monitoring reference	0 to 500 V	0.1 V	440 V		94	
54	FM/CA terminal function selection	1 to 3, 8, 10, 13, 14, 21, 98	1	1		100	
55	Bus voltage monitoring reference	0 to 1000 V	0.1 V	680 V		94	
56	Current monitoring reference	0 to 500 A	0.01 A	Rated converter current		94	
57	Restart selection	0, 9999	1	9999		101	
65	Retry selection	0 to 5	1	0		102	
67	Number of retries at fault occurrence	0 to 10, 101 to 110, 1001 to 1010, 1101 to 1110	1	0		102	
68	Retry waiting time	0.1 to 600 s	0.1 s	1 s		102	
69	Retry count display erase	0	1	0		102	
75	Reset selection/disconnected PU detection/PU stop selection	0 to 3, 14 to 17 100 to 103, 114 to 117	1	14		104	
77	Parameter write selection	1, 2	1	2		106	
80	Voltage control proportional gain	0 to 1000%	1%	100%		92	
81	Voltage control integral gain	0 to 1000%	1%	100%		92	
82	Current control proportional gain	0 to 200%	1%	100%		107	
83	Current control integral gain	0 to 200%	1%	100%		107	
84	Power factor command value	0.8 to 1	0.001	1		107	
85	Power factor lead/lag setting	0, 1	1	0		107	
117	PU communication station number	0 to 31	1	0		113	
118	PU communication speed	48, 96, 192, 384, 576, 768, 1152	1	192		113	
119	PU communication stop bit length	0, 1, 10, 11	1	1		113	
120	PU communication parity check	0, 1, 2	1	2		113	
121	PU communication retry count	0 to 10, 9999	1	1		113	
123	PU communication waiting time setting	0 to 150 ms, 9999	1 ms	9999		113	
124	PU communication CR/LF selection	0, 1, 2	1	1		113	
145	PU display language selection	0 to 7	1	0		126	
157	OL signal output timer	0 to 25 s, 9999	0.1 s	0 s		92	
158	AM terminal function selection	1 to 3, 8, 10, 13, 14, 21, 98	1	1		100	
161	Key lock operation selection	0, 10	1	0		126	
168	Parameter for manufacturer setting. Do not set.						
169							
170	Watt-hour meter clear	0, 10, 9999	1	9999		96	

Parameter List

Pr.	Name	Setting range	Minimum setting increments	Initial value		Refer to page	Customer setting
				FM	CA		
178	STF terminal function selection	0, 7, 33, 34, 62, 9999	1	9999		127	
179	STR terminal function selection		1	9999		127	
180	RL terminal function selection		1	9999		127	
181	RM terminal function selection		1	9999		127	
182	RH terminal function selection		1	9999		127	
183	RT terminal function selection		1	33		127	
184	AU terminal function selection		1	34		127	
185	JOG terminal function selection		1	9999		127	
186	CS terminal function selection		1	9999		127	
187	MRS terminal function selection		1	7		127	
188	STOP terminal function selection		1	0		127	
189	RES terminal function selection		1	62		127	
190	RDY signal logic selection	0, 100	1	0		128	
191	RSO signal logic selection	1, 101	1	1		128	
192	IPF terminal function selection	0 to 5, 7, 8, 16, 25, 26, 32,	1	2		129	
193	OL terminal function selection	64, 68, 90, 95, 98 to 105,	1	3		129	
194	FU terminal function selection	107, 108, 116, 125, 126,	1	4		129	
196	ABC2 terminal function selection	132, 164, 168, 190, 195, 198, 199, 206 to 208, 306 to 308, 9999	1	99		129	
244	Cooling fan operation selection	0, 1	1	1		131	
255	Life alarm status display	(0, 1, 4, 5, 8, 9, 12, 13)	1	0		132	
256	Inrush current limit circuit life display	(0 to 100%)	1%	100%		132	
257	Control circuit capacitor life display	(0 to 100%)	1%	100%		132	
269	Parameter for manufacturer setting. Do not set.						
290	Monitor negative output selection	0 to 7	1	0		96	
328	Inverter/converter switching	0 to 9999	1	—		16, 187	
331	RS-485 communication station number	0 to 31	1	0		113	
332	RS-485 communication speed	3, 6, 12, 24, 48, 96, 192, 384, 576, 768, 1152	1	96		113	
333	RS-485 communication stop bit length / data length	0, 1, 10, 11	1	1		113	
334	RS-485 communication parity check selection	0, 1, 2	1	2		113	
335	RS-485 communication retry count	0 to 10, 9999	1	1		113	
337	RS-485 communication waiting time setting	0 to 150, 9999	1	9999		113	
341	RS-485 communication CR/LF selection	0, 1, 2	1	1		113	
342	Communication EEPROM write selection	0, 1	1	0		113	
503	Maintenance timer	0 (1 to 9998)	1	0		134	
504	Maintenance timer warning output set time	0 to 9999	1	9999		134	
547	Parameter for manufacturer setting. Do not set.						
548	Parameter for manufacturer setting. Do not set.						
563	Energization time carrying-over times	(0 to 65535)	1	0		96	
663	Control circuit temperature signal output level	0 to 100°C	1°C	0°C		135	
686	Maintenance timer 2	0 (1 to 9998)	1	0		134	
687	Maintenance timer 2 warning output set time	0 to 9998, to 9999	1	9999		134	
688	Maintenance timer 3	0 (1 to 9998)	1	0		134	
689	Maintenance timer 3 warning output set time	0 to 9998, to 9999	1	9999		134	
867	AM output filter	0 to 5 s	0.01 s	0.01 s		136	
869	Current output filter	0 to 5 s	0.01 s	—	0.02 s	136	
888	Free parameter 1	0 to 9999	1	9999		139	
889	Free parameter 2	0 to 9999	1	9999		139	

Pr.	Name	Setting range	Minimum setting increments	Initial value		Refer to page	Customer setting
				FM	CA		
891	Cumulative power monitor digit shifted times	0 to 4, 9999	1	9999		96	
C0 (900)*1	FM/CA terminal calibration	—	—	—		136	
C1 (901)*1	AM terminal calibration	—	—	—		136	
C8 (930)*1	Current output bias signal	0 to 100%	0.1%	0%		136	
C9 (930)*1	Current output bias current	0 to 100%	0.1%	0%		136	
C10 (931)*1	Current output gain signal	0 to 100%	0.1%	100%		136	
C11 (931)*1	Current output gain current	0 to 100%	0.1%	100%		136	
989	Parameter for manufacturer setting. Do not set.						
990	PU buzzer control	0, 1	1	1		140	
991	PU contrast adjustment	0 to 63	1	58		140	
997	Fault initiation	0 to 255, 9999	1	9999		140	
1006	Clock (year)	2000 to 2099	1	2000		141	
1007	Clock (month, day)	Jan. 1 to Dec. 31	1	101		141	
1008	Clock (hour, minute)	0:00 to 23:59	1	0		141	
1202	Inrush current limit circuit life setting	0 to 100%, 9999	1%	9999		132	
1344	R-S turns ratio compensation	95.0 to 105.0%, 9999	0.1%	9999		90	
1345	T-S turns ratio compensation	95.0 to 105.0%, 9999	0.1%	9999		90	
1499	Parameter for manufacturer setting. Do not set.						
Pr.CLR	Pr.Clear	0, 1	1	0		142	
ALL.CL	All parameter clear	0, 1	1	0		142	
Err.CL	Fault history clear	0, 1	1	0		149	
Pr.CPY	PRCpy set	0, 1, 2, 3	1	0		143	
Pr.CHG	Initial value change list	—	1	0		146	

*1 The parameter number in parentheses is the one for use with the parameter unit (FR-PU07).

5.4 Parameter details

5.4.1 Setting the phase detection transformer box (FR-A8VPB) input voltage

Adjust the phase detection transformer box (FR-A8VPB) input voltage as follows.

Pr.	Name	Initial value	Setting range	Description
1344*1	R-S turns ratio compensation	9999	95.0 to 105.0%	Compensates for fluctuations in the input voltage.
			9999	Compensation disabled.
1345*1	T-S turns ratio compensation	9999	95.0 to 105.0%	Compensates for fluctuations in the input voltage.
			9999	Compensation disabled.

*1 The setting is applied after converter reset.

- Set the values specified on the rating plate of the FR-A8VPB in **Pr.1344** and **Pr.1345**. (If the **Pr.1344** and **Pr.1345** settings are not consistent with the values specified on the rating plate of the FR-A8VPB, protective functions for overcurrent or overvoltage may not be activated when the input voltage suddenly changes according to the load, or the converter's performance specifications such as the power factor or harmonic suppression characteristics may not be satisfied.)

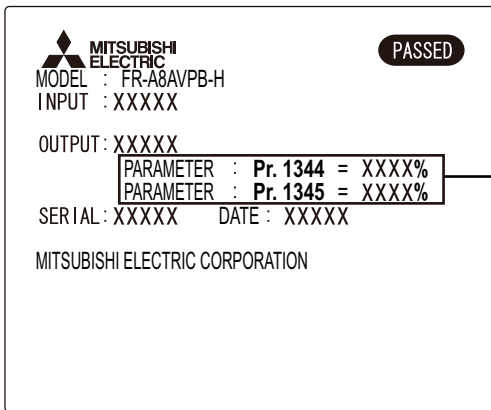

Set **Pr.1344** and **Pr.1345** as specified.

NOTE

- Stop the converter operation before setting **Pr.1344** and **Pr.1345**. When inverters or other peripheral devices are connected to the converter, be sure to stop their operation.

5.4.2 Power frequency input to the converter (Pr.1 and Pr.2)

The following parameters show that the allowable power frequency for the converter is between 50 and 60 Hz.

Pr.	Name	Initial value	Setting range	Description
1	Maximum frequency	60 Hz	60 Hz	The parameter shows that the upper limit of allowable range of the power frequency is 60 Hz. (Read only)
2	Minimum frequency	50 Hz	50 Hz	The parameter shows that the lower limit of allowable range of the power frequency is 50 Hz. (Read only)

5.4.3 Operation selection for the SOF signal and the OH signal (Pr.8 and Pr.9)

The converter operations can be changed by using Pr.8 for the SOF signal and Pr.9 for the OH signal.

Pr.	Name	Initial value	Setting range	Description
8	SOF input selection	0	0	NO contact: Turning ON of the SOF signal stops the converter operation.
			2	NC contact: Turning OFF of the SOF signal stops the converter operation.
9	OH input selection	0	0	NO contact: Turning ON of the OH signal activates a protective function of the converter to shut off its output.
			1	NC contact: Turning OFF of the OH signal activates a protective function of the converter to shut off its output.

- Converter operation determined by the SOF signal input status and the Pr.8 setting

SOF signal input status	Converter operation	
	Pr.8 = "0" (NO contact)	Pr.8 = "2" (NC contact)
OFF	Operation continues.	Operation stops.
ON	Operation stops.	Operation continues.

- Converter operation determined by the OH signal input status and the Pr.9 setting

OH signal input status	Converter operation	
	Pr.9 = "0" (NO contact)	Pr.9 = "1" (NC contact)
OFF	Operation continues.	Operation stops due to the fault.
ON	Operation stops due to the fault.	Operation continues.

5.4.4 DC voltage control (Pr.22, Pr.23, Pr.80, Pr.81, and Pr.157)

Use the following parameters to control DC voltage output from the converter as commanded. Operation can be stable enough with these parameters in the initial setting, however, some adjustments may be required if voltage vibration occurs depending on the conditions of the power supply or connected inverters.

Pr.	Name	Initial value	Setting range	Description
22	Current limit level	150%	0 to 220%	Set the current limit where the current limit operation starts.
23	Current limit level (regenerative)	9999	0 to 220%	Set the current limit where the current limit operation starts (during regenerative driving).
			9999	The same setting in Pr.22 is applied.
157	OL signal output timer	0 s	0 to 25 s, 9999	Set the OL signal output start time at the activation of torque limit operation.
80	Voltage control proportional gain	100%	0 to 1000%	Set the proportional gain for the voltage control. Increasing the setting value reduces the DC voltage fluctuation caused by external disturbance.
81	Voltage control integral gain	100%	0 to 1000%	Set the integral gain for the voltage control. Increasing the setting value shortens the recovery time from the DC voltage fluctuation caused by external disturbance.

◆ Adjusting DC voltage fluctuation (Pr.80 and Pr.81)

- Adjust the fluctuation range of the DC voltage by setting **Pr.80**.
Increasing the setting value reduces the DC voltage fluctuation caused by external disturbance.
- Adjust the recovery time to the commanded value at a fluctuation of DC voltage by setting **Pr.81**.
Increasing the setting value shortens the recovery time from the DC voltage fluctuation caused by external disturbance.

NOTE

- Setting **Pr.80** too large makes the operation unstable.
- Setting only **Pr.81** makes the operation unstable.

◆ Setting the current limit level (Pr.22, Pr.23, Pr.157)

- Limit the output current not to exceed the specified value.
Set the current limit level by using **Pr.22**.
Current limit level at the regenerative operation can be individually set by setting a value other than "9999" to **Pr.23**.
Set the current limits as a percentage (set current limit ratios) with 100 being equal to the converter rated current in **Pr.22** and **Pr.23**.
- The OL signal is output when output currents are limited by the current limit level (when the current limit function is active).
Use **Pr.157** to set a delay time between the time when the current reaches the limit level and the time when the OL signal is output.

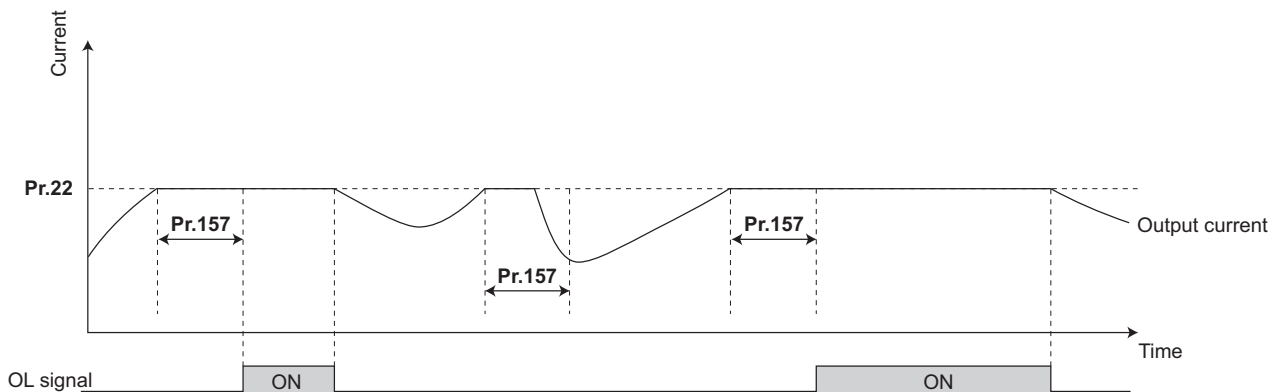

NOTE

- When the output current reaches the current limit level, DC voltage decreases during power driving, and DC voltage increases during regeneration.

5.4.5 Instantaneous power failure detection hold signal (Pr.44)

Use this parameter to set the state of the Y16 signal to check the history of instantaneous power failures.

Pr.	Name	Initial value	Setting range	Description
44	Instantaneous power failure detection signal clear	9999	0	Turns OFF the Instantaneous power failure detection hold (Y16) signal.
			9999	Function disabled.

- The Instantaneous power failure detection hold (Y16) signal turns ON when the Instantaneous power failure (IPF) signal turns ON during the converter operation. The Y16 signal turns OFF when a converter reset is performed or **Pr.44** is set to "0".
- For the terminal used for the Y16 signal, set "16 (positive logic)" or "116 (negative logic)" to any of **Pr.192 to Pr.194**, and **Pr.196 (Output terminal function selection)**.

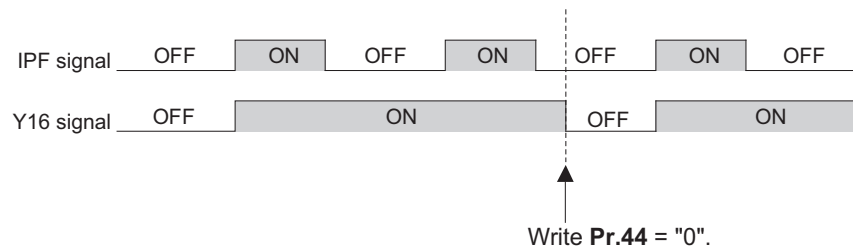

NOTE

- Pr.44** always reads "9999".
- Changing the terminal assignment using **Pr.192 to Pr.194**, and **Pr.196 (Output terminal function selection)** may affect the other functions. Set parameters after confirming the function of each terminal.

5.4.6 Terminal FM (pulse train output) and terminal AM/CA (analog output) reference (Pr.49, Pr.51, Pr.53, Pr.55, Pr.56)

Two types of monitor output, pulse train output from the terminal FM and analog output from the terminal AM/CA, are available. Set the reference of the signal output from terminals FM and AM/CA.

Pr.	Name	Initial value	Setting range	Description
49	Power supply frequency monitoring reference	60 Hz	45 to 65 Hz	Set the full-scale value when the output frequency monitor value is output through terminal FM, CA, or AM.
51	Input power monitoring reference	Converter rated power	0 to 3600 kW	Set the full-scale value when the input power monitor value is output through terminal FM, CA, or AM.
53	Input voltage monitoring reference	440 V	0 to 500 V	Set the full-scale value when the input voltage monitor value is output through terminal FM, CA, or AM.
55	Bus voltage monitoring reference	680 V	0 to 1000 V	Set the full-scale value when the bus voltage monitor value is output through terminal FM, CA, or AM.
56	Current monitoring reference	Converter rated current	0 to 3600 A	Set the full-scale value when the input current monitor value is output through terminal FM, CA, or AM.

◆ Reference for power supply frequency monitor (Pr.49)

- For the FM type converter, enter the full-scale value of the meter corresponding to a pulse train of 1440 pulses/s output via terminal FM.

Enter the frequency value at full scale of the meter (1 mA analog meter) installed between terminal FM and terminal SD. The pulse speed is proportional to the power supply frequency. (The maximum pulse train output is 2400 pulses/s.)

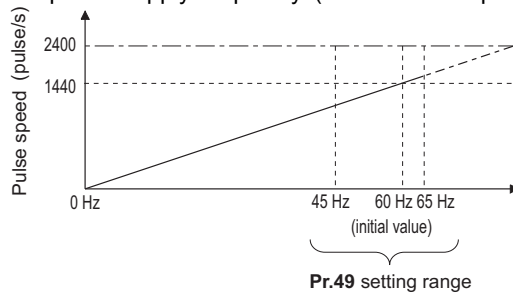

- For the CA type converter, enter the full-scale value of the meter corresponding to a current of 20 mA output via terminal CA. Enter the current value at full scale of the meter (20 mA ammeter) installed between terminal CA and terminal 5. The output current is proportional to the frequency. (The maximum output current is 20 mADC.)

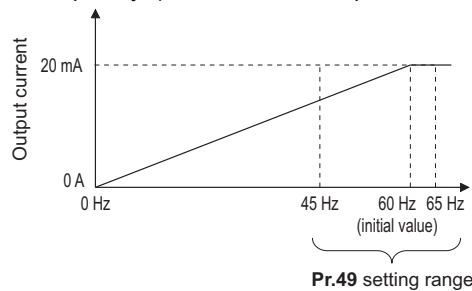

- Enter the full-scale value of the meter corresponding to a voltage of 10 VDC output via terminal AM. Enter the frequency value at full scale of the meter (10 VDC voltmeter) installed between terminal AM and terminal 5. The output voltage is proportional to the frequency. (The maximum output voltage is 10 VDC.)

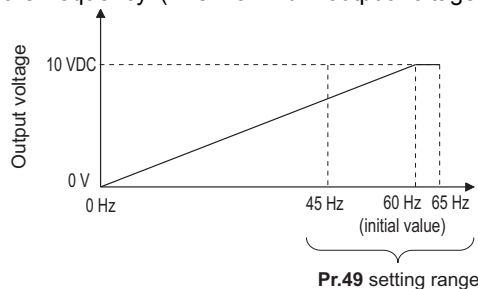

◆ Reference for input power monitor (Pr.51), input voltage monitor (Pr.53), bus voltage monitor (Pr.55), and current monitor (Pr.56)

- For the FM type converter, enter the full-scale value of the meter corresponding to a pulse train of 1440 pulses/s output via terminal FM.

Enter the power (kW), voltage (V), or current (A) value at full scale of the meter (1 mA analog meter) installed between terminal FM and terminal SD.

The pulse speed is proportional to the monitored value. (The maximum pulse train output is 2400 pulses/s.)

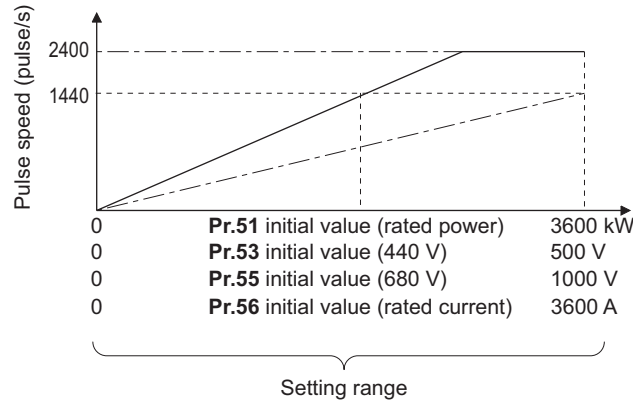

- For the CA type converter, enter the full-scale value of the meter corresponding to a current of 20 mA output via terminal CA. Enter the current value at full scale of the meter (20 mA ammeter) installed between terminal CA and terminal 5.

The output current is proportional to the power (kW), voltage (V), or current (A). (The maximum output current is 20 mADC.)

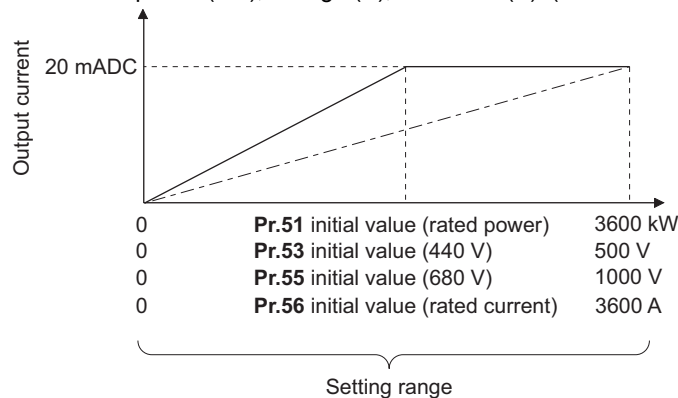

- Enter the full-scale value of the meter corresponding to a voltage of 10 VDC output via terminal AM. Enter the power (kW), voltage (V), or current (A) value at full scale of the meter (10 VDC voltmeter) installed between terminal AM and terminal 5.

The output voltage is proportional to the monitored value. (The maximum output voltage is 10 VDC.)

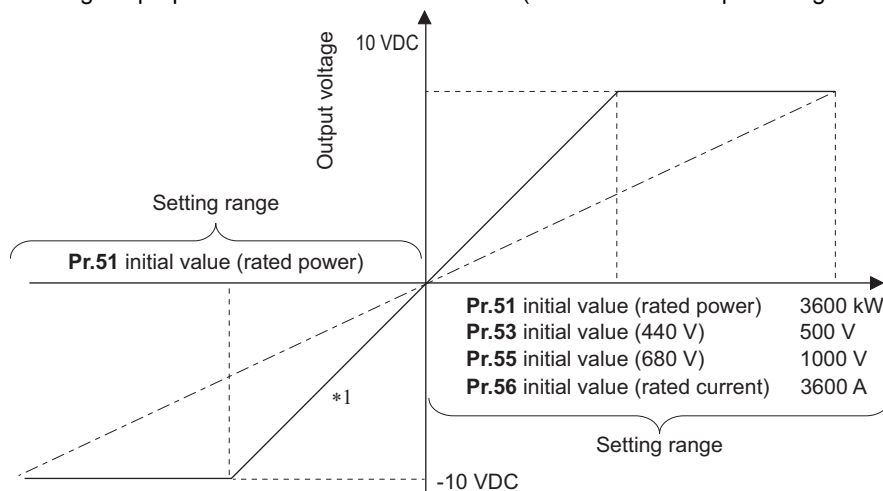

*1 When the input power monitor (with regenerative driving indication) is selected as the monitor item, monitor values during regenerative driving are displayed with a minus sign.

5.4.7 Monitor item selection on operation panel or via communication

The monitor item to be displayed on the operation panel or the main monitor of the parameter unit can be selected.

Pr.	Name	Initial value	Setting range	Description
52	DU/PU main display data selection	0	0, 8, 10, 13, 14, 20, 25, 55, 98	Select the item monitored on the operation panel or parameter unit. Refer to the following table for the monitor item selection.
170	Watt-hour meter clear	9999	0	Set "0" to clear the watt-hour monitor.
			10	Set "10" to monitor the cumulative power in the range of 0 to 9999 kWh via communication.
			9999	Set "9999" to monitor the cumulative power in the range of 0 to 65535 kWh via communication.
290	Monitor negative output selection	0	0 to 7	Set the availability of negative signals output via terminal AM and to the operation panel.
563	Energization time carrying-over times	0	(0 to 65535) (Read-only)	The number of times that the cumulative energization time reaches 65535 hours is displayed. Read-only.
891	Cumulative power monitor digit shifted times	9999	0 to 4	Set the number of places the decimal point on the watt-hour meter is shifted to left. The meter stops at the maximum number.
			9999	Shifting disabled. The meter is reset to 0 when it reaches the maximum number.

◆ Monitor description list (Pr.52)

- Use Pr.52 DU/PU main display data selection to select the item to monitor on the operation panel or the parameter unit.
- Refer to the following table and select the item to be monitored. (The items marked with "—" cannot be selected.)

Monitor item	Increment and unit	Pr.52 setting	RS-485 dedicated monitor (hexadecimal)	Minus (-) display *7	Description
Power supply frequency	0.01 Hz	0	H01		The power supply frequency is monitored.
Input current	0.1 A	0	H02		The input current to the converter is monitored.
Input voltage	0.1 V	0	H03		The effective value of input voltage to the converter is monitored.
Bus voltage	0.1 V	8	H08		The converter output voltage is monitored.
Fault indication	—	0	—		Each of the last 8 faults is displayed individually.
Electronic thermal O/L relay load factor	0.1%	10	H0A		The cumulative value of the electronic thermal O/L relay is displayed as a percentage of the thermal O/L relay trip level.
Input power	0.1 kW	13	H0D		The input power to the converter is monitored.
Input power (with regenerative driving indication)	1 kW	14	H0E	○	The input power to the converter is monitored. Negative values with a minus sign (-) are displayed during regenerative driving. *4*5
Cumulative energization time*1	1 h	20	H14		The counter of cumulative energization time since the converter shipment is displayed. The number of times an integrated value has reached the maximum value of 65535 hours can be checked in Pr.563.
Cumulative power	0.1 kWh*2*3	25	H19		The counter of cumulative power calculated from the input power monitor value is displayed. Use Pr.170 to clear the counter. (Refer to page 98.)

Monitor item	Increment and unit	Pr.52 setting	RS-485 dedicated monitor (hexadecimal)	Minus (-) display *7	Description
Input terminal status	—	55*6	H0F		ON/OFF status of the I/O signals is displayed on the operation panel. (Refer to page 98 .)
Output terminal status	—		H10		
Control circuit temperature	°C	98	H62	○	The temperature of the control circuit board is monitored. (Refer to page 135) Terminal FM/CA: 0 to 100°C Terminal AM: -20 to 100°C

- *1 The cumulative energization time is accumulated from 0 to 65535 hours, then cleared, and accumulated again from 0.
- *2 On the parameter unit (FR-PU07), "kW" is displayed.
- *3 When the value is monitored via communication, the value is displayed in 1-kWh increments.
- *4 Only the FR-DU08 supports a signed number indication and a negative value is displayed during regenerative driving. The minus-sign indication is available only on the FR-DU08. Negative values are displayed during regenerative driving regardless of the setting in **Pr.290 Monitor negative output selection**.
- *5 Unsigned values are displayed on the FR-PU07 even during regenerative driving.
- *6 Parameter setting is not valid to set the item as the main monitor item on the parameter unit (FR-PU07). Use the monitor function of the FR-PU07 for the setting.
- *7 The circle in this column indicates that the indication of negative signed numbers is available.

◆ Monitor display for operation panel (Pr.52)

- When **Pr.52** = "0" (initial value), the monitoring of power supply frequency, input current, input voltage and fault display can be selected in sequence by pressing **SET**.
- The monitor set in **Pr.52** is displayed in the third screen (initially set to monitor the input voltage).
- The first screen (initially set to monitor the power supply frequency) is displayed at power-ON in the initial setting. To change the screen displayed at power-ON, display the screen you want to display at power-ON, and hold down **SET** for 1 second. (To monitor the power supply frequency at power-ON again, display the screen of power supply frequency, and hold down **SET** for 1 second.)

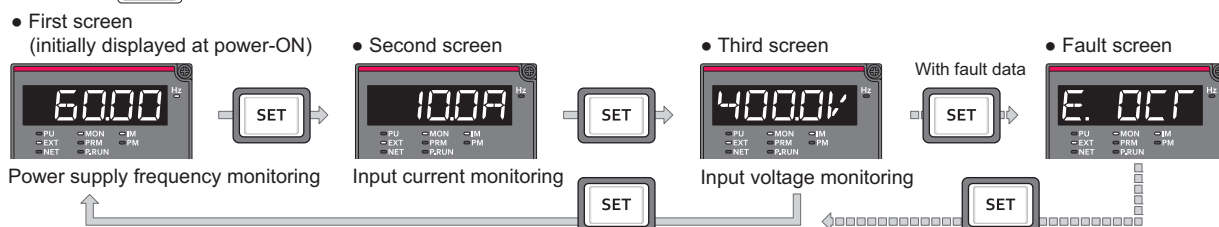

The following is the screen flow diagram when **Pr.52** = "20" (cumulative energization time).

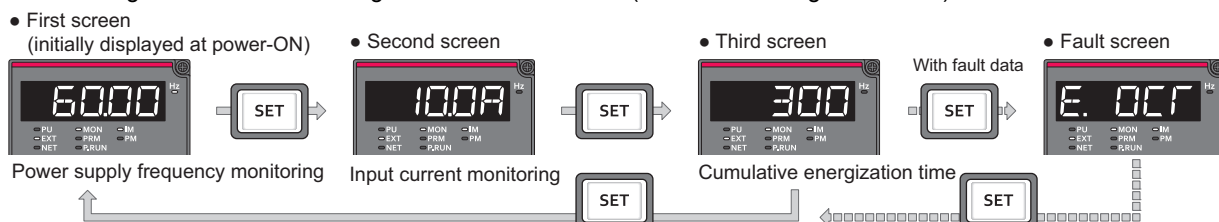

◆ Monitoring I/O terminals on the operation panel (FR-DU08) (Pr.52)

- When Pr.52 = "55", the I/O terminal states can be monitored on the operation panel (FR-DU08).
- The I/O terminal monitor is displayed on the third screen.
- When a terminal is ON, the corresponding LED segment is ON. The center LED segments are always ON.
- On the I/O terminal monitoring screen (Pr.52 = "55"), the upper LEDs indicate the input terminal status, and the lower LEDs indicate the output terminal status.

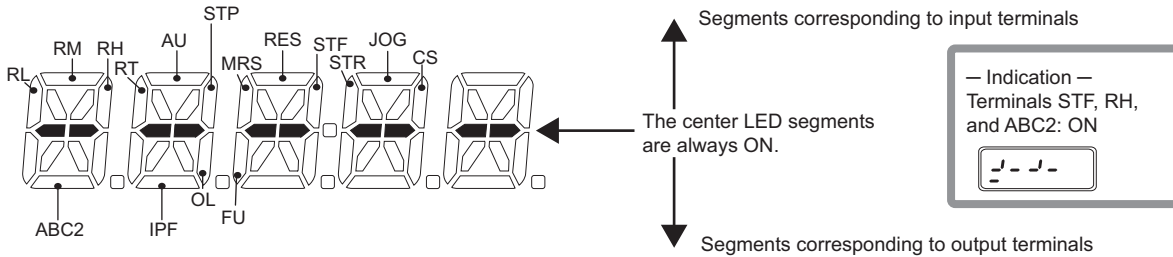

◆ Cumulative energy monitoring and resetting (Pr.170, Pr.891)

- When the cumulative power is monitored (Pr.52 = "25"), the output power monitor value is added up and is updated in 100 ms increments. (The values are saved in EEPROM every hour.)
- The output power monitor value is added to the cumulative power monitor value during power driving, and is subtracted from the cumulative power monitor value during regenerative driving.
- Increments and ranges of monitoring on the operation panel or parameter unit or via communication (RS-485 communication) are as follows.

On operation panel / parameter unit*1		Communication		
Range	Increment	Range		Increment
		Pr.170 = 10	Pr.170 = 9999	
0 to 999.99 kWh	0.01 kWh	0 to 9999 kWh	0 to 65535 kWh (initial value)	1 kWh
1000.0 to 9999.9 kWh	0.1 kWh			
10000 to 99999 kWh	1 kWh			

*1 Power is measured in the range of 0 to 99999.99 kWh, and the values are displayed in five digits. After the watt-hour meter (cumulative power counter) reaches "999.99" (999.99 kWh), the meter displays values in 0.1 increments such as "1000.0" (1000.0 kWh).

- The decimal point position on the watt-hour meter can be shifted to left. The number of digits to be shifted is equal to the setting of Pr.891 Cumulative power monitor digit shifted times. For example, when the cumulative power is 1278.56 kWh and Pr.891 is set to "2", "12.78" is displayed (in 100's of units) on the operation panel and the communication data is converted into "12".
- When Pr.891 = "0 to 4" and the cumulative value exceeds the upper limit, the decimal point position must be shifted. When Pr.891 = "9999" and the cumulative value exceeds the upper limit, the meter returns to 0 and the counting starts again.
- Writing "0" in Pr.170 clears the cumulative power monitor.

NOTE

- When Pr.170 is read just after "0" has been written in Pr.170, the setting "9999" or "10" is displayed.

◆ Monitoring cumulative energization time (Pr.563)

- Cumulative energization time monitoring (Pr.52 = "20") accumulates energization time of the converter every hour.
- When the cumulative energization time counter reaches 65535, it starts from 0 again. The number of times the cumulative energization time counter reaches 65535 can be checked with Pr.563.

NOTE

- The cumulative energization time does not increase if the power is turned OFF after less than an hour.
- When the converter is used as an inverter before conversion, the total energization time for both before and after the conversion is displayed.

◆ Input power (with regenerative driving indication) (Pr.52 = "14")

- When input power is monitored and the regenerative driving indication is enabled (Pr.52 = "14"), values with a minus sign are available for indication of the input power to the converter.
- The values of input power are displayed with unsigned numbers during power driving, and with signed numbers during regenerative driving on the operation panel (FR-DU08).

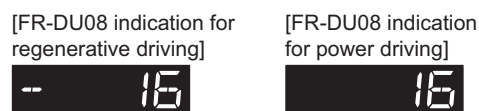

The leftmost digit is used to indicate a minus sign.

- 999 kW is indicated when the input power value reaches 10000 kW for power driving, and -999 kW is indicated when the value reaches -1000 kW for regenerative driving.
- Unsigned values are displayed on the FR-PU07 for both power driving and regenerative driving.

◆ Negative output selection for monitoring (Pr.290)

- Negative values can be used for indication via terminal AM (analog voltage output) and on the operation panel. To check which items can be indicated with negative numbers, refer to the monitor description list (on [page 96](#)).

Pr.290 setting	Negative output through terminal AM	Negative indication on operation panel
0 (initial value), 4	—	—
1, 5	Enabled	—
2, 6	—	Enabled
3, 7	Enabled	Enabled

—: Disabled (unsigned numbers only)

NOTE

- When indication with negative numbers is enabled for the output via terminal AM (analog voltage output), the output is within the range of -10 to +10 VDC. Connect the meter with which output level is matched.
- Parameter unit (FR-PU07) displays only unsigned numbers.

5.4.8 Monitor display selection for terminals FM/CA and AM

Monitored values are output in either of the following: analog voltage (terminal AM), pulse train (terminal FM) for the FM type inverter, or analog current (terminal CA) for the CA type inverter.

The signal (monitor item) to be output via terminal FM/CA and terminal AM can be selected.

Pr.	Name	Initial value	Setting range	Description
54	FM/CA terminal function selection	1 (output frequency)	1 to 3, 8, 10, 13, 14, 21, 98	Select the item monitored via terminal FM or CA.
158	AM terminal function selection		1 to 3, 8, 10, 13, 14, 21, 98	Select the item monitored via terminal AM.
290	Monitor negative output selection	0	0 to 7	Set the availability of negative values for indication via terminal AM and on the operation panel. (Refer to page 99.)

◆ Monitor description list (Pr.54, Pr.158)

- Set **Pr.54 FM/CA terminal function selection** for monitoring via terminal FM (pulse train output) or terminal CA (analog current output).
- Set **Pr.158 AM terminal function selection** for monitoring via terminal AM (analog voltage output). Negative values can be used for indication via terminal AM (output range: -10 to +10 VDC). The circle in the [Negative output (-)] column indicates that the output of negative signals is available via terminal AM. (To enable or disable the output of negative signals, refer to [page 99.](#))
- Refer to the following table and select the item to be monitored. (Refer to [page 123](#) for the list of monitor items.)

Monitor item	Increment and unit	Pr.54 (FM/CA) / Pr.158 (AM) setting	Terminal FM/CA/AM full-scale value	—*3	Description
Power supply frequency	0.01 Hz	1	Pr.49		The power supply frequency is monitored.
Input current	0.1 A	2	Pr.56		The input current to the converter is monitored.
Input voltage	0.1 V	3	Pr.53		The effective value of input voltage to the converter is monitored.
Bus voltage	0.1 V	8	Pr.55		The converter output voltage is monitored.
Electronic thermal O/L relay load factor	0.1%	10	Thermal O/L relay trip level (100%)		The cumulative value of the electronic thermal O/L relay is displayed as a percentage of the thermal O/L relay trip level.
Input power	0.1 kW	13	Pr.51		The input power to the converter is monitored.
Input power (with regenerative driving indication)	1 kW	14	Pr.51 (rounded down to integer value)	○	The input power to the converter is monitored. Output to indicate negative values with a minus sign (-) during regenerative driving. *1*2
Reference voltage output	—	21	—		Terminal FM: 1440 pulse/s is output. Terminal CA: Output is 20 mA. Terminal AM: 10 V is output.
Control circuit temperature	°C	98	100°C	○	The temperature of the control circuit board is displayed. (Refer to page 135.) Without minus sign: 0 to 100°C With minus sign: -20 to 100°C

*1 Output to indicate negative values during regenerative driving regardless of the setting in **Pr.290 Monitor negative output selection**.

*2 Absolute values are used for indication for terminal FM. (Signed numbers are not available.)

*3 The circle in this column indicates that the output of negative signals is available.

5.4.9 Operation selection at instantaneous power failure (Pr.57)

When an instantaneous power failure occurs, the converter can restart at the power restoration.

Pr.	Name	Initial value	Setting range	Description
57	Restart selection	9999	0	The converter restarts operation at the power restoration from instantaneous power failure.
			9999	The converter does not restart operation automatically at the power restoration from instantaneous power failure.

- When the automatic restart after instantaneous power failure is selected on the inverter, set "0" in **Pr.57 Restart selection** of the converter.

When **Pr.57** = "9999", the converter output is shut off at the activation of the protective function (E.IPF), even when the automatic restart after instantaneous power failure is selected on the inverter side.

CAUTION

- The motor and machine will start suddenly after occurrence of an instantaneous power failure (after the reset time has elapsed).
Stay away from the motor and machine when automatic restart after instantaneous power failure has been selected.

5.4.10 Retry function (Pr.65, Pr.67 to Pr.69)

If a fault occurs, the converter resets itself automatically to restart. Faults which trigger the retry operation can be selected.

Pr.	Name	Initial value	Setting range	Description
65	Retry selection	0	0 to 5	Faults which trigger the retry operation can be selected. (Refer to the table in the next page.)
67	Number of retries at fault occurrence	0	0	The retry function disabled.
			1 to 10	Set the number of retries at a fault occurrence. A fault output is not provided during the retry operation.
			101 to 110	Set the number of retries at a fault occurrence. (The setting value minus 100 is the number of retries.) A fault output is provided during the retry operation.
			1001 to 1010	Set the number of retries at a fault occurrence. (The setting value minus 1000 is the number of retries.) A fault output is not provided during the retry operation. The RDY signal ON state is retained during retry.
			1101 to 1110	Set the number of retries at a fault occurrence. (The setting value minus 1100 is the number of retries.) A fault output is provided during the retry operation. The RDY signal ON state is retained during retry.
68	Retry waiting time	1 s	0.1 to 600 s	Set the time delay from when a converter fault occurs until the retry operation starts.
69	Retry count display erase	0	0	Setting "0" clears the retry success counter ("retry success" means that the converter successfully restarts).

Retry success example

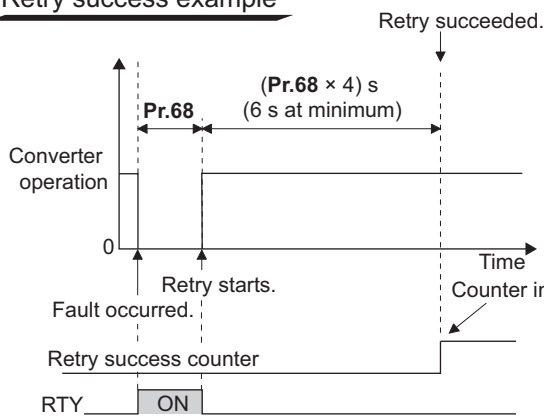

Retry failure example (when Pr.67 = "3")

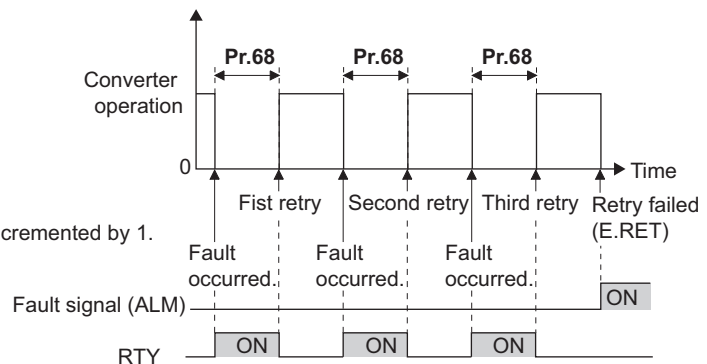

- When the converter protective function is activated (fault indication is displayed) while the retry function is enabled, the retry function automatically deactivates (resets) the protective function and restarts the operation after a lapse of the time set in **Pr.68**.
- The retry function is enabled when the **Pr.67** setting is other than "0". Set the number of retries at activation of the protective function in **Pr.67**.

Pr.67 setting	Retry times	Fault output	RDY signal ON state during retry
0	The retry function disabled.	—	—
1 to 10	Number of times equal to Pr.67 setting.	No.	Not held.
101 to 110	Number of times calculated by subtracting 100 from Pr.67 setting.	Yes.	Not held.
1001 to 1010	Number of times calculated by subtracting 1000 from Pr.67 setting.	No.	Held.*1
1101 to 1110	Number of times calculated by subtracting 1100 from Pr.67 setting.	Yes.	Held.*1

*1 The signal will be held when a protective function with fault indication of E.OCT, E.OVT, or E.CDO occurs.

- When retries fail consecutively more than the number of times set in **Pr.67**, the protective function (E.RET) is activated to shut off the converter output. (Refer to the figure of retry failure example.)
- Use **Pr.68** to set the delay from a protective function activation to a retry in the range of 0 to 600 seconds.
- The cumulative number of successful restart times made by retries (retry success counter) can be checked by reading the **Pr.69** value.

The retry counter (**Pr.69** value) is incremented by 1 every time a retry succeeds. Retry is regarded as successful when normal operation restarts and continues with no other faults for the time set in **Pr.68** multiplied by four (6 seconds at least.) (When retry is successful, the cumulative number of retry failures is cleared.)

- Writing "0" in **Pr.69** clears the cumulative count.
- During a retry, the RTY signal is ON. For the RTY signal, assign the function by setting "64 (forward action)" or "164 (reverse action)" in any of **Pr.192 to Pr.194**, or **Pr.196 (Output terminal function selection)**.
- Faults which trigger the retry operation can be selected with **Pr.65**. The faults not described in the following table do not enable the retry function. (For the fault details, refer to [page 153](#).)

"•" indicates the fault selected.

Retry-triggering fault	Pr.65 setting					
	0	1	2	3	4	5
E.OCT	•	•		•	•	•
E.OVT	•		•	•	•	
E.THT	•					
E.IPF	•				•	
E.UVT	•				•	
E.ILF	•				•	
E.BE	•				•	
E.OHT	•					
E.OPT	•				•	
E.PE	•				•	
E.CDO	•				•	
E.8	•				•	

NOTE

- Changing the terminal assignment using **Pr.192 to Pr.194**, or **Pr.196** may affect the other functions. Set parameters after confirming the function of each terminal.
- Only the first fault is recorded in the fault history during retries.
- If a fault that does not trigger a retry occurs during retry operation, the converter output is shut off after the retry operation is finished.
- The fault reset by the retry function does not reset the accumulated data such as the electronic thermal relay function data. (The reset result is different from the power-ON reset.)

CAUTION





- Stay away from the motor and machine when the converter shuts off its output while the retry function is enabled. Motor and machine will start suddenly (after the reset time has elapsed) after the shutoff.

5.4.11 Reset selection / disconnected PU detection / PU stop selection (Pr.75)

The reset input acceptance, disconnected PU (FR-DU08/FR-PU07) connector detection function, and PU stop function can be selected.

Pr.	Name	Initial value	Setting range	Description
75	Reset selection/disconnected PU detection/PU stop selection	14	0 to 3, 14 to 17, 100 to 103, 114 to 117	For the initial setting, reset is always enabled, without disconnected PU detection, and with the PU stop function.

- **Pr.75** can be set any time. The setting does not return to its initial values even if Parameter clear / All parameter clear is executed.

Pr.75 setting*1	Reset selection	Disconnected PU detection	PU stop selection
0, 100	Reset input is always enabled.	Operation continues even when PU is disconnected.	Operation cannot be stopped by using  .
1, 101	Reset input is enabled only when the protective function is activated.		
2, 102	Reset input is always enabled.	Converter output is shut off when PU is disconnected.	Operation can be stopped by using  .
3, 103	Reset input is enabled only when the protective function is activated.		
14 (initial value), 114	Reset input is always enabled.	Operation continues even when PU is disconnected.	Operation can be stopped by using  .
15, 115	Reset input is enabled only when the protective function is activated.		
16, 116	Reset input is always enabled.	Converter output is shut off when PU is disconnected.	Operation can be stopped by using  .
17, 117	Reset input is enabled only when the protective function is activated.		

*1 Setting **Pr.75** = any of "100 to 103 and 114 to 117" enables the reset limit function.

◆ Reset selection

- The conditions where the reset command can input (using the RES signal or through communication) can be selected.
- When **Pr.75** is set to any of "1, 3, 15, 17, 101, 103, 115, and 117", the reset input is enabled only when the protective function is activated.

NOTE

- When the RES signal is input during operation, the inverter is also reset. The motor coasts since the inverter being reset shuts off the output. Also, the cumulative value of the electronic thermal O/L relay is cleared.
- The reset input by using the reset key on the parameter unit is enabled only when the protective function is activated, regardless of the **Pr.75** setting.

◆ Disconnected PU detection

- If the PU (FR-DU08/FR-PU07) is detected to be disconnected from the converter for 1 second or longer while **Pr.75** = "2, 3, 16, 17, 102, 103, 116, or 117", PU disconnection (E.PUE) is displayed and the converter output is shut off.



NOTE

- When the PU has been disconnected since before power-ON, the output is not shut off.
- To restart operation, make sure that the PU is connected and then reset the converter.
- When RS-485 communication operation is performed through the PU connector, the reset selection / PU stop selection function is enabled but the disconnected PU detection function is disabled.

◆ PU stop selection

- The converter operation can be stopped by pressing  on the PU when **Pr.75** = "14 to 17 or 114 to 117".
- When the operation is stopped by the PU stop, the warning indication "PS" is displayed on the PU. A fault output is not provided.

◆ How to restart operation stopped by using on the PU ("PS" (PU stop) warning reset method)

- For the operation panel (FR-DU08)
 - (a) Turn ON the SOF signal to stop the converter operation.
 - (b) Press . (The PS warning is reset.)
 - (c) Turn OFF the SOF signal to restart the converter operation.
- For the parameter unit (FR-PU07)
 - (a) Turn ON the SOF signal to stop the converter operation.
 - (b) Press . (The PS warning is reset.)
 - (c) Turn OFF the SOF signal to restart the converter operation.

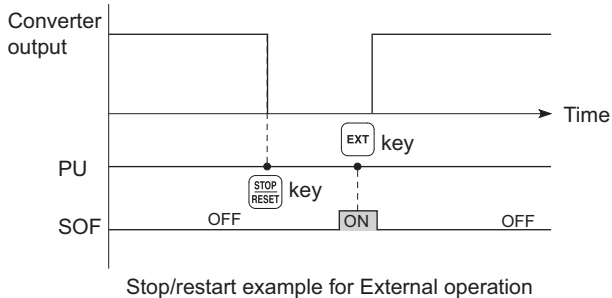

Stop/restart example for External operation

- The converter is also restarted after performing the reset by turning OFF and ON the power or inputting the RES signal.

◆ Reset limit function

- When **Pr.75** = any of "100 to 103 and 114 to 117", if an electronic thermal O/L relay or an overcurrent protective function (E.THM or E.OCT) is activated while either of them has been already activated within 3 minutes, the converter does not accept any reset command (RES signal, etc.) for about 3 minutes from the second activation.

NOTE

- Resetting the converter power (turning OFF the control power) clears the accumulated thermal value.
- When the retry function is set enabled (**Pr.67 Number of retries at fault occurrence** ≠ "0"), the reset limit function is disabled.

CAUTION

- Do not reset the converter while the inverter start signal is being input. Doing so will cause a sudden start of the motor, which is dangerous.

5.4.12 Parameter write disable selection (Pr.77)

Whether to enable the parameter write or not can be selected. Use this function to prevent parameter values from being rewritten by misoperation.

Pr.	Name	Initial value	Setting range	Description
77	Parameter write selection	2	1	Parameter write is disabled.
			2	Parameter write is enabled regardless of operation status.

Pr.77 can be set at any time regardless of the operation status.

◆Parameter write disabled (Pr.77 = "1")

- Parameter write is disabled.
(Parameter read is enabled.)
- Parameter clear and All parameter clear are also disabled.
- The parameters listed in the table at right can be written even if Pr.77 = "1".

Pr.	Name
75	Reset selection/disconnected PU detection/PU stop selection
77	Parameter write selection

◆Parameter write enabled during operation (Pr.77 = "2")

- Parameters can always be written.
- The following parameters cannot be written during operation even if Pr.77 = "2". To change the parameter setting value, stop the operation.

Pr.	Name
170	Watt-hour meter clear
178	STF terminal function selection
179	STR terminal function selection
180	RL terminal function selection
181	RM terminal function selection
182	RH terminal function selection
183	RT terminal function selection
184	AU terminal function selection
185	JOG terminal function selection
186	CS terminal function selection
187	MRS terminal function selection
188	STOP terminal function selection
189	RES terminal function selection
190	RDY signal logic selection
191	RSO signal logic selection
192	IPF terminal function selection
193	OL terminal function selection
194	FU terminal function selection
196	ABC2 terminal function selection
328	Inverter/converter switching

5.4.13 Current control (Pr.82 and Pr.83)

Use this function to control current output from the converter as commanded.

Operation can be stable enough with these parameters in the initial setting, however, some adjustments may be required if current vibration occurs depending on the conditions of the power supply or connected inverters.

Pr.	Name	Initial value	Setting range	Description
82	Current control proportional gain	100%	0 to 200%	Set the proportional gain for the current control. Increasing the setting value reduces the current fluctuation caused by external disturbance.
83	Current control integral gain	100%	0 to 200%	Set the integral gain for the current control. Increasing the setting value shortens the recovery time from the current fluctuation caused by external disturbance.

- Adjust the fluctuation range of current by setting **Pr.82**.
Increasing the setting value reduces the current fluctuation caused by external disturbance.
- Adjust the recovery time to the commanded current after a current fluctuation by setting **Pr.83**.
Increasing the setting value shortens the recovery time from the current fluctuation caused by external disturbance.

NOTE

- Setting **Pr.82** too large makes the operation unstable.
- Setting only **Pr.83** makes the operation unstable.

5.4.14 Power factor adjustment function (Pr.84 and Pr.85)

The power factor can be adjusted.

Pr.	Name	Initial value	Setting range	Description
84	Power factor command value	1	0.8 to 1	Set the power factor command value.
85	Power factor lead/lag setting	0	0	Leading power factor (The phase current leads the phase voltage.)
			1	Lagging power factor (The phase current lags the phase voltage.)

- To adjust the power factor, set a desired power factor command value in **Pr.84**.
For example, when "0.8" is set in **Pr.84**, the applicable inverter capacity of 500 kW will be reduced to 400 kW according to the following formula.
 $500 \text{ kW (inverter rated capacity)} \times 0.8 \text{ (Pr.84 setting)} = 400 \text{ kW}$
- Set **Pr.85** = "0 (initial value)" for the leading power factor, and set **Pr.85** = "1" for the lagging power factor.

NOTE

- Decreasing **Pr.84** setting increases the input current, which makes the electronic thermal O/L relay more likely to operate.

5.4.15 Wiring and configuration of PU connector

Using the PU connector as a computer network port enables communication operation from a personal computer, etc. When the PU connector is connected with a personal, FA, or other computer by a communication cable, a user program can run and monitor the converter or read and write to parameters.

◆PU connector pin-outs

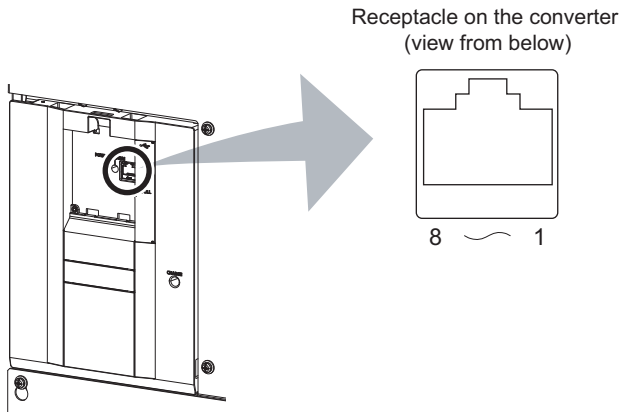

Pin number	Name	Description
1	SG	Earthing (grounding) (connected to terminal 5)
2	—	Operation panel power supply
3	RDA	Converter receive +
4	SDB	Converter send -
5	SDA	Converter send +
6	RDB	Converter receive -
7	SG	Earthing (grounding) (connected to terminal 5)
8	—	Operation panel power supply

NOTE

- Pins No. 2 and 8 provide power to the operation panel or parameter unit. Do not use these pins for RS-485 communication.
- Do not connect the PU connector to the computer's LAN board, FAX modem socket or telephone modular connector. The product could be damaged due to differences in electrical specifications.

◆ Wiring and configuration of PU connector communication system

◆ System configuration

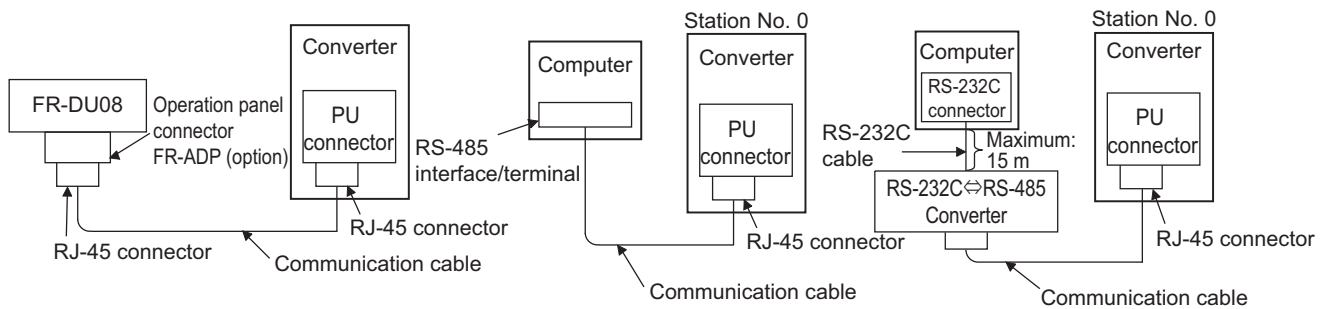

◆ Wiring between a computer and a converter for RS-485 communication

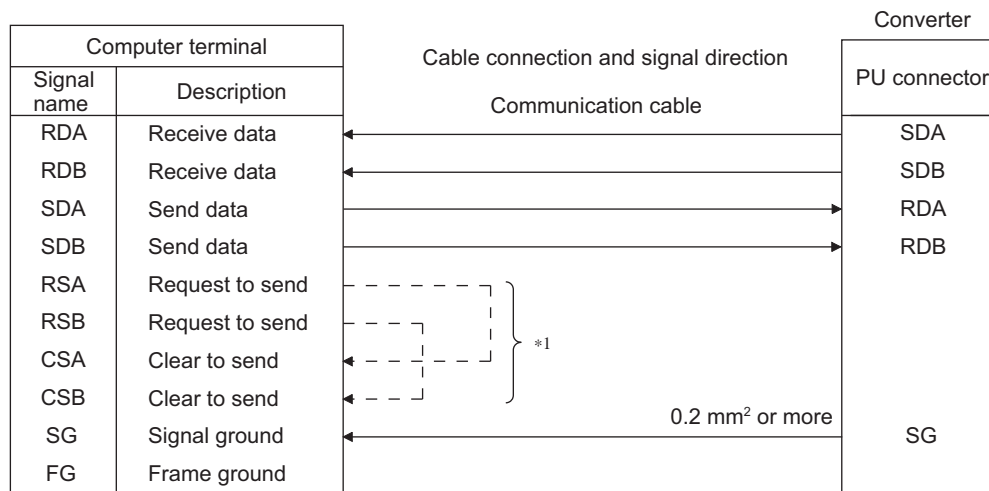

*1 Make connection in accordance with the Instruction Manual of the computer to be used with. Fully check the terminal numbers of the computer since they vary with the model.

NOTE

- Computer-converter connection cable

Refer to the following for the connection cable (RS-232C to RS-485 converter) between the computer with an RS-232C interface and a converter. Commercially available products (as of February 2015)

Model	Manufacturer
Interface embedded cable (for personal computer) DAFXIH-CAB (D-SUB25P for personal computer) / DAFXIH-CABV (D-SUB9P for personal computer) and Connector conversion cable DINV-485CAB (for converter)*1	Diatrend Corp.
Interface embedded cable dedicated for inverter DINV-CABV*1	

*1 The conversion cable cannot connect multiple inverters. (The computer and inverter are connected in a 1:1 pair.) This is an RS232C-to-RS485 converter-embedded conversion cable. No additional cable or connector is required. For the product details, contact the manufacturer.

- Refer to the following table when fabricating the cable on the user side.
Commercially available products (as of February 2015).

Product name	Model	Manufacturer
Communication cable	SGLPEV-T (Cat5e/300m) 24AWG × 4P*2	Mitsubishi Cable Industries, Ltd.
RJ-45 connector	5-554720-3	Tyco Electronics

*2 Do not use pins No. 2 and 8 of the communication cable.

5.4.16 Wiring and configuration of RS-485 terminals

◆RS-485 terminal layout

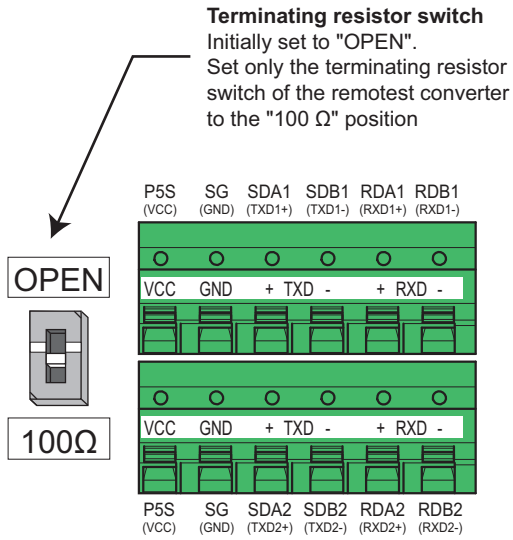

Name	Description
RDA1 (RXD1+)	Converter receive +
RDB1 (RXD1-)	Converter receive -
RDA2 (RXD2+)	Converter receive + (for branch)
RDB2 (RXD2-)	Converter receive - (for branch)
SDA1 (TXD1+)	Converter send +
SDB1 (TXD1-)	Converter send -
SDA2 (TXD2+)	Converter send + (for branch)
SDB2 (TXD2-)	Converter send - (for branch)
P5S (VCC)	5 V permissible load current: 100 mA
SG (GND)	Earthing (grounding) (connected to terminal SD)

◆Connection of RS-485 terminals and wires

- The size of RS-485 terminal block is the same as that of the control circuit terminal block. Refer to [page 55](#) for the wiring method.

NOTE

- To avoid malfunction, keep the RS-485 terminal wires away from the control circuit board.

◆ System configuration of RS-485 terminals

- Computer and converter connection (1:1)

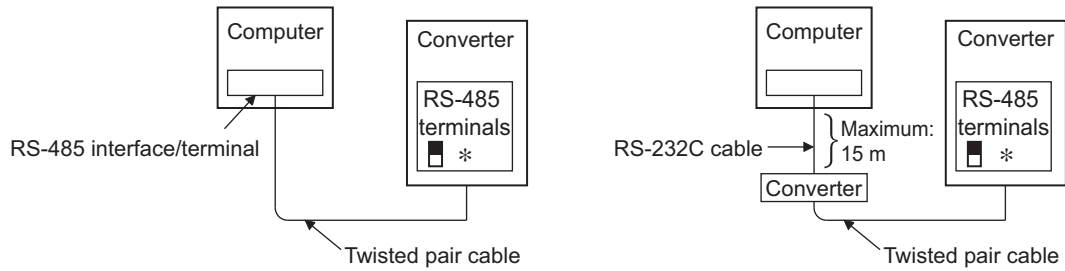

*Set the terminating resistor switch to the 100 Ω side.

- Combination of a computer and multiple converters (1:n)

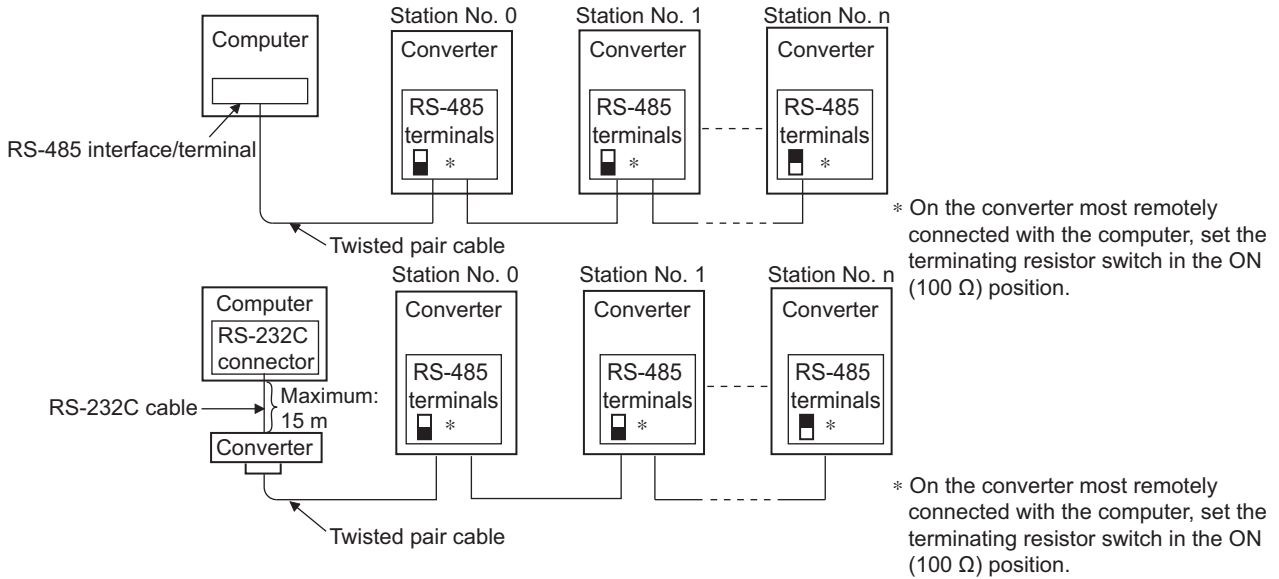

* On the converter most remotely connected with the computer, set the terminating resistor switch in the ON (100 Ω) position.

* On the converter most remotely connected with the computer, set the terminating resistor switch in the ON (100 Ω) position.

◆RS-485 terminal wiring method

- Wiring between a computer and a converter for RS-485 communication

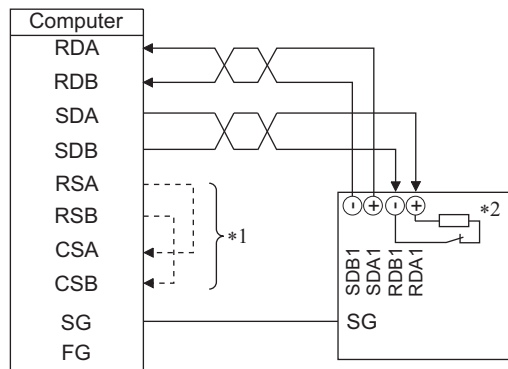

- Wiring between a computer and multiple converters for RS-485 communication

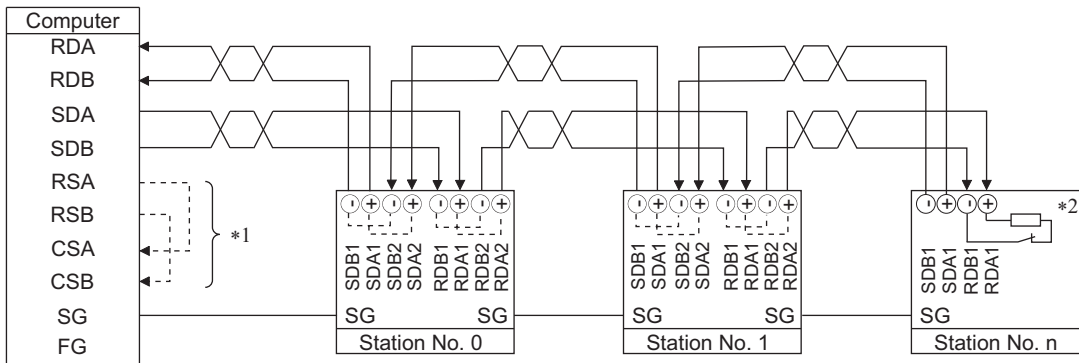

- *1 Make connection in accordance with the Instruction Manual of the computer to be used with. Fully check the terminal numbers of the computer since they vary with the model.
- *2 On the converter most remotely connected with the computer, set the terminating resistor switch in the ON (100 Ω) position.

NOTE

- For branching, connect the wires as follows.

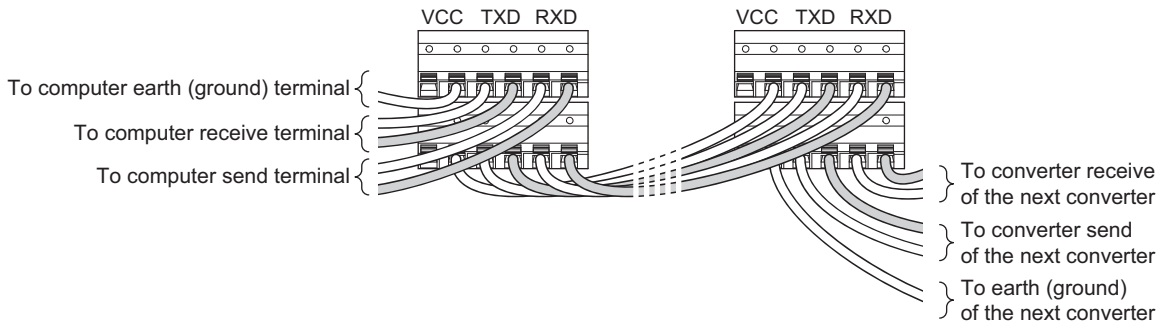

◆Two-wire type connection

- If the computer is 2-wire type, a connection from the inverter can be changed to 2-wire type by passing wires across reception terminals and transmission terminals of the RS-485 terminals.

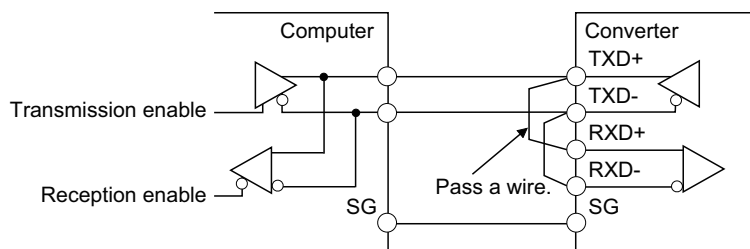

NOTE

- A program should be created so that transmission is disabled (receiving state) when the computer is not sending and reception is disabled (sending state) during sending to prevent the computer from receiving its own data.

5.4.17 Initial setting of operation via communication

When parameter write is performed via RS-485 communication, the parameters storage device can be changed from EEPROM + RAM to RAM only. Use this function if parameter settings are changed frequently.

Pr.	Name	Initial value	Setting range	Description
342	Communication EEPROM write selection	0	0	Parameter values written by communication are written to the EEPROM and RAM.
			1	Parameter values written by communication are written to the RAM.

- When changing the parameter values frequently, set "1" in **Pr.342** to write them to the RAM only. The life of the EEPROM will be shorter if parameter write is performed frequently with the setting unchanged from "0 (initial value)" (EEPROM write).

NOTE

- Turning OFF the converter's power supply clears the modified parameter settings when **Pr.342** = "1 (write only to RAM)". Therefore, parameter settings at next power-ON will be the ones that are last stored to EEPROM.
- The parameter setting written in RAM cannot be checked on the operation panel. (The values displayed on the operation panel are the ones stored in EEPROM.)

5.4.18 Initial settings and specifications of RS-485 communication

Use the following parameters to perform required settings for RS-485 communication between the converter and a personal computer.

- There are two types of communication, communication using the converter's PU connector and communication using the RS-485 terminals.
- The Mitsubishi inverter protocol is used. Parameter setting, monitoring, etc. can be performed through communication.
- To make communication between the personal computer and the converter, setting of the communication specifications must be made to the converter in advance.

Data communication cannot be made if the initial settings are not made or if there is any setting error.

◆Parameters related to PU connector communication

Pr.	Name	Initial value	Setting range	Description	
117	PU communication station number	0	0 to 31	Use this parameter to specify the converter station number. Set the station number for each converter when two or more converters are connected to one personal computer.	
118	PU communication speed	192	48, 96, 192, 384, 576, 768, 1152	Set the communication speed. The setting value × 100 equals the communication speed. For example, if 192 is set, the communication speed is 19200 bps.	
119	PU communication stop bit length	1	0	Stop bit length 1 bit	Data length 8 bits
			1	Stop bit length 2 bits	
			10	Stop bit length 1 bit	Data length 7 bits
			11	Stop bit length 2 bits	
120	PU communication parity check	2	0	Parity check disabled.	
			1	Parity check (odd parity) enabled.	
			2	Parity check (even parity) enabled.	

Parameter details

Pr.	Name	Initial value	Setting range	Description
121	PU communication retry count	1	0 to 10	Set the permissible number of retries for unsuccessful data reception. If it is still unsuccessful after the permissible number of retries, the converter stops retrying communication.
			9999	The converter does not retry communication even when the communication is unsuccessful.
123	PU communication waiting time setting	9999	0 to 150 ms	Set the time delay between data transmission to the converter and the response.
			9999	The time delay is not set in this parameter but in communication data.
124	PU communication CR/LF selection	1	0	Without CR/LF
			1	With CR
			2	With CR/LF

NOTE

- Always reset the converter after making the initial settings of the parameters. After changing the communication-related parameters, communication cannot be made until the converter is reset.

◆Parameters related to RS-485 terminal communication

Pr.	Name	Initial value	Setting range	Description
331	RS-485 communication station number	0	0 to 31	Specify the station number of the converter. (Same specifications as Pr.117)
332	RS-485 communication speed	96	3, 6, 12, 24, 48, 96, 192, 384, 576, 768, 1152	Select the communication speed. (Same specifications as Pr.118)
333	RS-485 communication stop bit length / data length	1	0, 1, 10, 11	Select the stop bit length and data bit length. (Same specifications as Pr.119)
334	RS-485 communication parity check selection	2	0, 1, 2	Select the parity check specifications. (Same specifications as Pr.120)
335	RS-485 communication retry count	1	0 to 10, 9999	Set the permissible number of retries for unsuccessful data reception. (Same specifications as Pr.121)
337	RS-485 communication waiting time setting	9999	0 to 150 ms, 9999	Set the time delay between data transmission to the converter and the response. (Same specifications as Pr.123)
341	RS-485 communication CR/LF selection	1	0, 1, 2	Select the presence/absence of CR/LF. (Same specifications as Pr.124)

NOTE

- Always reset the inverter after making the initial settings of the parameters. After changing the communication-related parameters, communication cannot be made until the converter is reset.

5.4.19 Mitsubishi inverter protocol (computer link communication)

- Parameter setting and monitoring, etc. are possible through communication using the Mitsubishi inverter protocol (computer link communication) via the PU connector or RS-485 terminals on the converter.

◆ Communication specifications

- The communication specifications are shown in the following table.

Item	Description	Related parameter
Communication protocol	Mitsubishi inverter protocol (computer link communication)	—
Conforming standard	EIA-485 (RS-485)	—
Number of connectable units	1: N (maximum 32 units), the setting range of station number is 0 to 31.	Pr.117 Pr.331
Communication speed	PU connector	Selected among 4800/9600/19200/38400/57600/76800/115200 bps.
	RS-485 terminals	Selected among 300/600/1200/2400/4800/9600/19200/38400/57600/76800/115200 bps.
Control procedure	Asynchronous method	—
Communication method	Half-duplex system	—
Communication specifications	Character system	ASCII (7 bits or 8 bits can be selected.)
	Start bit	1 bit
	Stop bit length	1 bit or 2 bits can be selected.
	Parity check	Check (at even or odd numbers) or no check can be selected.
	Error check	Sum code check
	Terminator	CR/LF (whether or not to use it can be selected)
Time delay setting	Availability of the setting is selectable.	Pr.123 Pr.337

◆ Communication procedure

- In communication between the computer and the converter, the following data is exchanged in the order from a to e.
 - Request data: sent from the computer to the converter. (The converter will not send data unless requested.)
 - Communication delay time
 - Reply data: sent from the converter to the computer in response to the computer request (data a)
 - Converter data processing time
 - Answer data: sent from the computer in response to the reply data sent from the converter (data c) (Even if (e) is not sent, subsequent communication is made properly.)

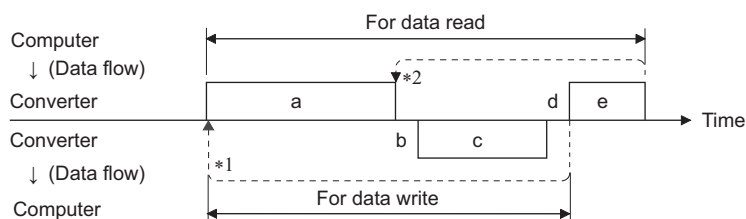

*1 If a data error is detected and a retry must be made, perform retry operation with the user program. The converter stops retrying and outputs the LF signal when the number of consecutive retries exceeds the parameter setting.

*2 On receipt of a data error occurrence, the converter returns reply data (c) to the computer again. The converter stops retrying and outputs the LF signal when the number of consecutive data errors exceeds the parameter setting.

◆ Communication operation presence/absence and data format types

- Data communication between the computer and converter uses ASCII codes (hexadecimal codes).
- Communication operation presence/absence (with/without) and data format type (A to F) are as follows.

Data	Operation	Parameter/monitor write	Converter reset	Monitoring	Parameter read	
a	Communication request: sent to the converter from the computer in accordance with the user program	A, A1	A	B	B	
b	Converter data processing time	With	Without	With	With	
c	Reply data from the converter (Data a is checked for an error.)	No data error detected. *1 (Request accepted)	C	C*2	E, E1	E
		Data error detected. (Request rejected)	D	D*2	D	D
d	Computer processing delay time	10 ms or more				
e	Answer from computer in response to reply data (data c) (Data c is checked for an error.)	No data error detected.*1 (No converter processing)	Without	Without	Without (C)	Without (C)
		Data error detected. (Converter outputs data c again.)	Without	Without	F	F

- *1 In the communication request data from the computer to the converter, the time of 10 ms or more is also required after an acknowledgement (ACK) signal showing "No data error detected" is sent. (Refer to [page 118.](#))
- *2 Reply from the converter to the converter reset request can be selected. (Refer to [page 123.](#))

- Data writing format

Data a: Communication request data from the computer to the converter

Format	Number of Characters												
	1	2	3	4	5	6	7	8	9	10	11	12	13
A	ENQ *1	Station No. *2		Instruction code		*3	Data				Sum check		*4
A1	ENQ *1	Station No. *2		Instruction code		*3	Data		Sum check		*4		

Data c: Reply data from the converter to the computer (No data error detected)

Format	Number of characters			
	1	2	3	4
C	ACK *1	Station No. *2		*4

Data c: Reply data from the converter to the computer (Data error detected)

Format	Number of Characters				
	1	2	3	4	5
D	NAK *1	Station No. *2		Error code	*4

- *1 A control code.
- *2 The converter station number is specified in hexadecimal in the range of H00 to H1F (stations No. 0 to 31).
- *3 Set the delay time.
When **Pr.123 (time delay setting)** ≠ 9999, create a communication request data without "waiting time" in the data format. (The number of characters decreases by 1.)
- *4 CR+LF code
When a computer transmits data to the converter, some computers automatically provide either one or both of the codes CR (carriage return) and LF (line feed) at the end of a data group. In this case, the same setting is required for data sent from the converter to the computer. Use **Pr.124 (CR/LF selection)** for the CR+LF code setting.

• Data reading format

Data a: Communication request data from the computer to the converter

Format	Number of Characters								
	1	2	3	4	5	6	7	8	9
B	ENQ *1	Station No. *2		Instruction code		*3	Sum check		*4

Data c: Reply data from the converter to the computer (No data error detected)

Format	Number of Characters										
	1	2	3	4	5	6	7	8	9	10	11
E	STX *1	Station No. *2		Read data				ETX *1	Sum check		*4
E1	STX *1	Station No. *2		Read data		ETX *1	Sum check		*4		

Data c: Reply data from the converter to the computer (Data error detected)

Format	Number of Characters				
	1	2	3	4	5
D	NAK *1	Station No. *2		Error code	*4

Data e: Transmission data from the computer to the converter

Format	Number of Characters			
	1	2	3	4
C (No data error detected)	ACK *1	Station No. *2		*4
F (Data error detected)	NAK *1	Station No. *2		*4

*1 A control code.

*2 The converter station number is specified in hexadecimal in the range of H00 to H1F (stations No. 0 to 31).

*3 Set the delay time.

When **Pr.123 (time delay setting)** ≠ 9999, create a communication request data without time delay in the data format. (The number of characters decreases by 1.)

*4 CR+LF code

When a computer transmits data to the converter, some computers automatically provide either one or both of the codes CR (carriage return) and LF (line feed) at the end of a data group. In this case, the same setting is required for data sent from the converter to the computer. Use **Pr.124 (CR/LF selection)** for the CR+LF code setting.

◆ Data definitions

- Control code

Signal name	ASCII code	Description
STX	H02	Start Of Text (Start of data)
ETX	H03	End Of Text (End of data)
ENQ	H05	Enquiry (Communication request)
ACK	H06	Acknowledge (No data error detected)
LF	H0A	Line feed
CR	H0D	Carriage return
NAK	H15	Negative acknowledge (Data error detected)

- Station No.

Specify the station number of the converter which communicates with the computer.

- Instruction code

Specify the processing request, for example, operation or monitoring, given by the computer to the converter. Therefore, the operation or monitoring an item is enabled by specifying the corresponding instruction code. (Refer to [page 123](#).)

- Data

Read/write data such as parameters transmitted from/to the converter. The definition and range of set data are determined in accordance with the instruction code. (Refer to [page 123](#).)

- Time delay

Specify the delay time (time period between the time when the converter receives data from the computer and the time when the converter starts transmission of reply data). Set the delay time in accordance with the response time of the computer in the range of 0 to 150 ms in 10 ms increments. (For example: 1=10 ms, 2=20 ms)

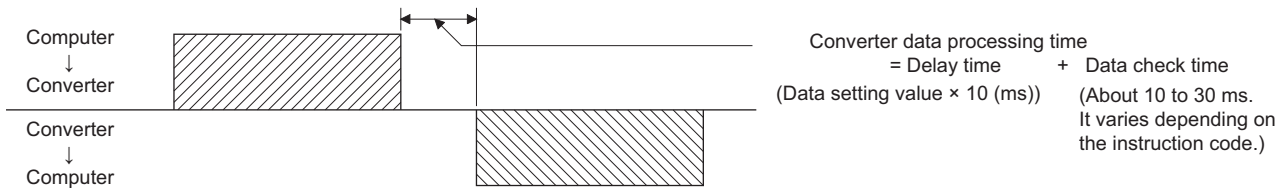

NOTE

- When **Pr.123 (time delay setting) ≠ 9999**, create a communication request data without "waiting time" in the data format. (The number of characters decreases by 1.)
- The data check time varies depending on the instruction code. (Refer to [page 119](#).)

- Sum check code

The sum check code is a 2-digit ASCII (hexadecimal) representing the lower 1 byte (8 bits) of the sum (binary) derived from the checked ASCII data.

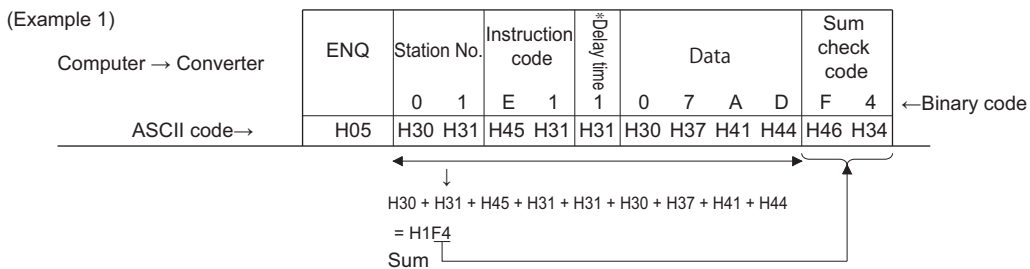

- * When the **Pr.123 PU communication waiting time setting** is other than "9999", create the communication request data without delay time in the data format. (The number of characters decreases by 1.)

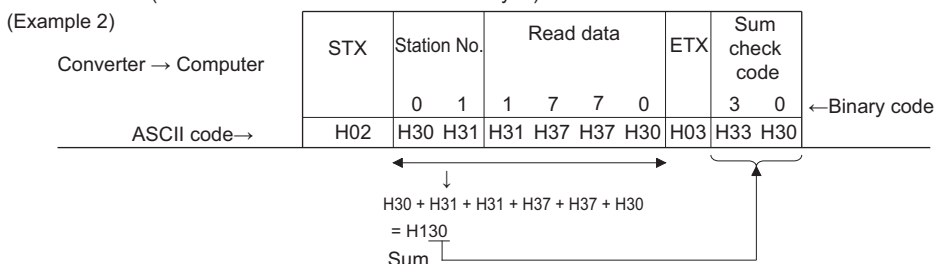

• Error code

If any error is found in the data received by the converter, its error definition is sent back to the computer together with the NAK code.

Error code	Error item	Error Description	Converter operation
H0	Computer NAK error	The number of errors consecutively detected in communication request data from the computer is greater than the permissible number of retries.	The LF signal is output.
H1	Parity error	The parity check result does not match the specified parity.	
H2	Sum check error	The sum check code in the computer does not match that of the data received by the converter.	
H3	Protocol error	The data the converter received has a grammatical mistake. Or, data receive is not completed within the predetermined time. CR or LF code specification is not the same as the setting of the parameter.	
H4	Framing error	The stop bit length differs from the parameter setting.	
H5	Overrun	New data has been sent by the computer before the converter completes receiving the preceding data.	
H6	—	—	—
H7	Character error	The converter received an unusable character (other than 0 to 9, A to F, and control codes).	The converter does not accept the data sent to the converter.
H8	—	—	—
H9	—	—	—
HA	Mode error	Parameter write was attempted when the converter does not perform computer link communication, when the operation commands are not given through communication, or when parameter write is set to be disabled.	The converter does not accept the data sent to the converter.
HB	Instruction code error	The specified instruction code does not exist.	
HC	Data range error	Invalid data has been specified for parameter write, etc.	
HD	—	—	
HE	—	—	—
HF	—	—	—

◆ Response time

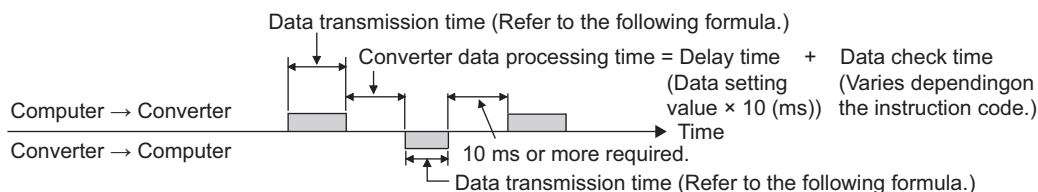

[Formula for data transmission time]

$$\frac{1}{\text{Communication speed (bps)}} \times \text{Number of data characters}^*1 \times \text{Communication specifications (Total number of bits)}^*2+3 = \text{Data transmission time (s)}$$

*1 Refer to "page 116"

*2 Communication specifications

Name		Number of bits
Stop bit length		1 bit/ 2 bits
Data length		7 bits/ 8 bits
Parity check	Enabled	1 bit
	Disabled	0

In addition to the above, 1 start bit is necessary.

Minimum number of total bits: 9 bits

Maximum number of total bits: 12 bits

*3 Data check time

Item	Check time
Monitoring	Less than 12 ms
Parameter read/write	Less than 30 ms
Parameter clear / All parameter clear	Less than 5 s
Reset command	No reply

◆ Retry count setting (Pr.121, Pr.335)

- Set the permissible number of retries at data receive error occurrence. (Refer to [page 119](#) for data receive error for retry.)
- While any of "0 to 10" is set in the parameter, the converter outputs the Alarm (LF) signal if the number of data receive errors that occur consecutively exceeds the preset number. (The converter does not stop.)
- While "9999" is set in the parameter, the converter outputs the LF signal if a data transmission error occurs. (The converter does not stop.)
- To use the LF signal, set "98 (positive logic) or 198 (negative logic)" in any of **Pr.192 to Pr.194, Pr.196 (Output terminal function selection)** to assign the function to an output terminal.

Example: PU connector communication when Pr.121 = "1 (initial value)"

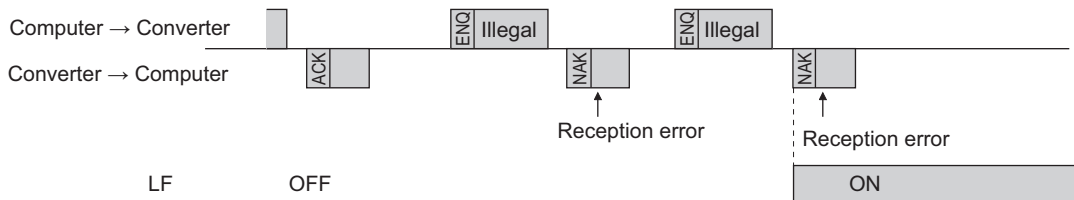

Example: PU connector communication when Pr.121 = "9999"

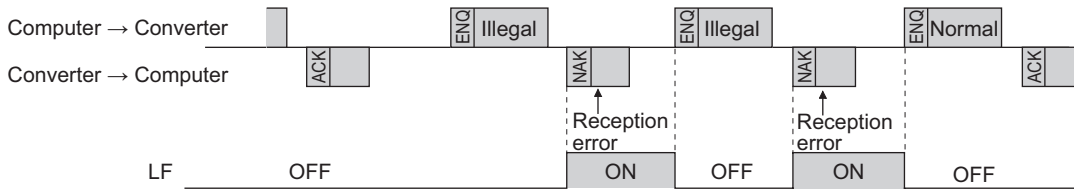

◆ Programming instructions

- When data from the computer has any error, the converter does not accept that data. Hence, in the user program, always insert a retry program for data error.
- Data communication starts when the computer gives a communication request to the converter. The converter does not send any data without the computer's request. Hence, design the program so that the computer gives a data read request for monitoring, etc. as required.
- Program example

Performing Parameter clear of the converter

Microsoft® Visual C++® (Ver.6.0) programming example

```
#include <stdio.h>
#include <windows.h>

void main(void){
    HANDLE      hCom;          // Communication handle
    DCB          hDcb;         // Structure for setting communication
    COMMTIMEOUTS hTim;        // Structure for setting timeouts

    char        szTx[0x10];    // Send buffer
    char        szRx[0x10];    // Receive buffer
    char        szCommand[0x10]; // Command
    int         nTx,nRx;       // For storing buffer size
    int         nSum;          // For calculating sum code
    BOOL        bRet;
    int         nRet;
    int         i;

    /***** Open COM1 port *****/
    hCom = CreateFile("COM1", (GENERIC_READ | GENERIC_WRITE), 0, NULL, OPEN_EXISTING, FILE_ATTRIBUTE_NORMAL, NULL);
    if(hCom != NULL) {
        /*****Set COM1 port communication *****/
        GetCommState(hCom,&hDcb); // Get current communication information
        hDcb.DCBlength = sizeof(DCB); // Set structure size
        hDcb.BaudRate = 19200; // Communication speed = 19200 bps
        hDcb.ByteSize = 8; // Data length = 8 bits
        hDcb.Parity = 2; // Even parity
        hDcb.StopBits = 2; // Stop bit = 2 bits
        bRet = SetCommState(hCom,&hDcb); // Set the changed communication information
        if(bRet == TRUE) {
            /***** Set COM1 port timeout *****/
            GetCommTimeouts(hCom,&hTim); // Get current timeout values
            hTim.WriteTotalTimeoutConstant = 1000; // Writing timeout = 1 second
            hTim.ReadTotalTimeoutConstant = 1000; // Reading timeout = 1 second
            SetCommTimeouts(hCom,&hTim); // Set the changed timeout values
            /***** Set command to perform Parameter clear of the station 1 converter *****/
            sprintf(szCommand,"01FC15A5A"); // Transmission data (Parameter clear)
            nTx = strlen(szCommand); // Transmission data size
            /***** Generate sum code *****/
            nSum = 0; // Initialize sum data
            for(i = 0;i < nTx;i++) {
                nSum += szCommand[i]; // Calculate sum code
                nSum &= (0xff); // Mask data
            }

            /***** Generate transmission data *****/
            memset(szTx,0,sizeof(szTx)); // Initialize send buffer
            memset(szRx,0,sizeof(szRx)); // Initialize receive buffer
            sprintf(szTx,"%5s%02X",szCommand,nSum); // ENQ code, transmission data, sum code
            nTx = 1 + nTx + 2; // Number of ENQ code, send data, sum code

            nRet = WriteFile(hCom,szTx,nTx,&nTx,NULL);
            /***** Send *****/
            if(nRet != 0) {
                nRet = ReadFile(hCom,szRx,sizeof(szRx),&nRx,NULL);
                /***** Receive *****/
                if(nRet != 0) {
                    /***** Display received data *****/
                    for(i = 0;i < nRx;i++) {
                        printf("%02X ",(BYTE)szRx[i]); // Output received data to console
                        // ASCII character code is displayed in hexadecimal. Character "0" is represented as hexadecimal "30".
                    }
                    printf("\n\r");
                }
            }
        }
        CloseHandle(hCom); // Close communication port
    }
}
```

Parameter details

General flowchart

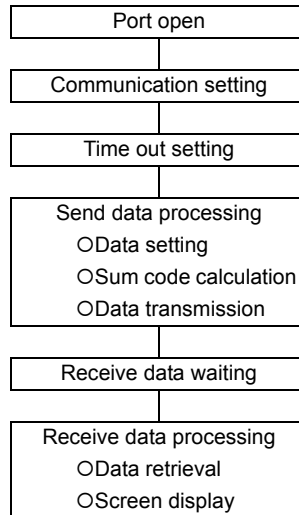

CAUTION

- Data communication is not started automatically but is made only once when the computer provides a communication request. If communication is disabled during operation due to signal cable breakage etc., the converter/inverter cannot be controlled.
- Note that the converter does not detect a fault if communication is broken due to signal cable breakage, computer fault etc.

◆ Setting items and set data

- After completion of parameter settings, set the instruction codes and data, then start communication from the computer to allow various types of operation control and monitoring.

Item		Read/Write	Instruction code	Data description	Number of data digits (format)																																																			
Monitoring	Power supply frequency	Read	H6F	H0000 to HFFFF: Power supply frequency (hexadecimal) in 0.01 Hz increments.	4 digits (B and E/D)																																																			
	Input current	Read	H70	H0000 to HFFFF: Input current (hexadecimal) in 0.1 A increments.	4 digits (B and E/D)																																																			
	Input voltage	Read	H71	H0000 to HFFFF: Input voltage (hexadecimal) in 0.1 V increments.	4 digits (B and E/D)																																																			
	Special monitor	Read	H72	H0000 to HFFFF: Data of the monitor item selected with the instruction code HF3.	4 digits (B and E/D)																																																			
	Special monitor selection No.	Read	H73	Monitor selection data (Refer to page 96 for details on selection No.)	2 digits (B and E1/D)																																																			
		Write	HF3		2 digits (A1 and C/D)																																																			
	Fault record	Read	H74 to H77	<p>H0000 to HFFFF: Two fault records per code.</p> <div style="text-align: center;"> <table border="1" style="margin: auto;"> <tr> <td style="text-align: center;">b15</td> <td style="text-align: center;">b8b7</td> <td style="text-align: center;">b0</td> </tr> <tr> <td style="text-align: center;">H74</td> <td style="text-align: center;">Second latest fault</td> <td style="text-align: center;">Latest fault</td> </tr> <tr> <td style="text-align: center;">H75</td> <td style="text-align: center;">Fourth latest fault</td> <td style="text-align: center;">Third latest fault</td> </tr> <tr> <td style="text-align: center;">H76</td> <td style="text-align: center;">Sixth latest fault</td> <td style="text-align: center;">Fifth latest fault</td> </tr> <tr> <td style="text-align: center;">H77</td> <td style="text-align: center;">Eighth latest fault</td> <td style="text-align: center;">Seventh latest fault</td> </tr> </table> </div> <p>Fault monitor details (example of the instruction code H74)</p> <p>When data read is H3040 (Second latest fault: E.THT) (Latest fault: E.FIN)</p> <div style="text-align: center;"> <table border="1" style="margin: auto;"> <tr> <td style="text-align: center;">b15</td> <td style="text-align: center;">b8 b7</td> <td style="text-align: center;">b0</td> </tr> <tr> <td style="text-align: center;">0</td><td style="text-align: center;">0</td><td style="text-align: center;">1</td><td style="text-align: center;">1</td><td style="text-align: center;">0</td><td style="text-align: center;">0</td><td style="text-align: center;">0</td><td style="text-align: center;">0</td><td style="text-align: center;">0</td><td style="text-align: center;">1</td><td style="text-align: center;">0</td><td style="text-align: center;">0</td><td style="text-align: center;">0</td><td style="text-align: center;">0</td><td style="text-align: center;">0</td><td style="text-align: center;">0</td><td style="text-align: center;">0</td> </tr> <tr> <td colspan="8" style="text-align: center;">Second latest fault (H30)</td> <td colspan="8" style="text-align: center;">Latest fault (H40)</td> </tr> </table> </div> <p>(Refer to page 151 for details on fault record read data.)</p>	b15	b8b7	b0	H74	Second latest fault	Latest fault	H75	Fourth latest fault	Third latest fault	H76	Sixth latest fault	Fifth latest fault	H77	Eighth latest fault	Seventh latest fault	b15	b8 b7	b0	0	0	1	1	0	0	0	0	0	1	0	0	0	0	0	0	0	Second latest fault (H30)								Latest fault (H40)								4 digits (B and E/D)
	b15	b8b7	b0																																																					
	H74	Second latest fault	Latest fault																																																					
	H75	Fourth latest fault	Third latest fault																																																					
H76	Sixth latest fault	Fifth latest fault																																																						
H77	Eighth latest fault	Seventh latest fault																																																						
b15	b8 b7	b0																																																						
0	0	1	1	0	0	0	0	0	1	0	0	0	0	0	0	0																																								
Second latest fault (H30)								Latest fault (H40)																																																
Monitoring of converter status (extended)	Read	H79	The status of output signals during power/regenerative driving can be monitored. (For the details, refer to page 125 .)	4 digits (B and E/D)																																																				
Monitoring of converter status	Read	H7A		2 digits (B and E1/D)																																																				
Converter reset	Write	HFD	H9696: Resets the converter. <ul style="list-style-type: none"> As the converter is reset after the computer starts communication, the converter cannot send reply data back to the computer. 	4 digits (A and C/D)																																																				
			H9966: Resets the converter. <ul style="list-style-type: none"> After the computer correctly starts communication and send data to the converter, the converter returns the ACK signal to the computer before being reset. 	4 digits (A and D)																																																				
Fault history clear	Write	HF4	H9696: Fault history is cleared.	4 digits (A and C/D)																																																				

Parameter details

Item		Read/Write	Instruction code	Data description	Number of data digits (format)													
Parameter clear All parameter clear		Write	HFC	<p>Parameters return to initial values. Whether to clear communication parameters or not can be selected according to the data. (○: Cleared, ×: Not cleared) Refer to page 190 for Parameter clear, All parameter clear, and communication parameters.</p> <table border="1"> <thead> <tr> <th>Clear type</th> <th>Data</th> <th>Communication parameters</th> </tr> </thead> <tbody> <tr> <td rowspan="2">Parameter clear</td> <td>H9696</td> <td>○</td> </tr> <tr> <td>H5A5A</td> <td>×*1</td> </tr> <tr> <td rowspan="2">All parameter clear</td> <td>H9966</td> <td>○</td> </tr> <tr> <td>H55AA</td> <td>×*1</td> </tr> </tbody> </table> <p>When a clear is performed with H9696 or H9966, the setting of communication parameters also returns to the initial setting. So, set the parameters again when resuming the operation. Performing clear will clear the setting of the instruction codes HF3 and HFF.</p>	Clear type	Data	Communication parameters	Parameter clear	H9696	○	H5A5A	×*1	All parameter clear	H9966	○	H55AA	×*1	4 digits (A and C/D)
Clear type	Data	Communication parameters																
Parameter clear	H9696	○																
	H5A5A	×*1																
All parameter clear	H9966	○																
	H55AA	×*1																
Parameter setting		Read	H00 to H63	Refer to the instruction code list (on page 190) to read/write parameter settings as required.	4 digits (B and E/D)													
		Write	H80 to HE3	For the setting of Pr.100 or later, the link parameter extended setting is required.	4 digits (A and C/D)													
Link parameter extended setting		Read	H7F	Parameter settings are switched (extended) according to a setting from H00 to H0D.	2 digits (B and E1/D)													
		Write	HFF	For details of the settings, refer to the extended code in the instruction code list (on page 190).	2 digits (A1 and C/D)													
Second parameter changing (instruction code HFF = 1, 9)		Read	H6C	When setting the calibration parameters*2 H00: Frequency	2 digits (B and E1/D)													
		Write	HEC	H01: Parameter-set analog value H02: Analog value input from terminal	2 digits (A1 and C/D)													
Product profile	Model	Read	H7C	The model name can be read in ASCII code. "H20" (blank code) is set for blank area. Example) FR-A840-1 (FM type): H46, H52, H2D, H41, H38, H34, H30, H2D, H31, H20, H20...H20	20 digits (B and E3/D)													
	Capacity	Read	H7D	The converter capacity can be read in ASCII code. Data read is displayed in increments of 0.1 kW (rounded down to one decimal place). "H20" (blank code) is set for blank area. Example) 0.75K: "7" (H20, H20, H20, H20, H20, H37)	6 digits (B and E2/D)													

*1 Turning OFF the converter power during clearing parameters with H5A5A or H55AA returns the setting of communication parameters to the initial setting.

*2 Refer to the calibration parameter list below for details on calibration parameters.

NOTE

- Set 65520 (HFFF0) as a parameter value "8888" and 65535 (HFFFF) as "9999".
- For the instruction codes HFF and HF3, their values are held once they are written but cleared to zero when a converter reset or all clear is performed.

◆ List of calibration parameters

Pr.	Name	Instruction code		
		Read	Write	Extended
C8 (930)	Current output bias signal	1E	9E	9
C9 (930)	Current output bias current	1E	9E	9
C10 (931)	Current output gain signal	1F	9F	9
C11 (931)	Current output gain current	1F	9F	9

◆ Monitoring of converter status

Item	Instruction code	Bit length	Description	Example
Monitoring of converter status	H7A	8 bits	b0: RDY (Inverter run enable) b1: Power driving b2: Regenerative driving b3: RSO (Converter reset) b4: OL (overload)*1 b5: IPF (Instantaneous power failure)*1 b6: CVO (converter running)*1 b7: –	[Example] H43: Power driving. b7 b0 0 1 0 0 0 0 1 1
Monitoring of converter status (extended)	H79	16 bits	b0: RDY (Inverter run enable) b1: Power driving b2: Regenerative driving b3: RSO (Converter reset) b4: OL (overload)*1 b5: IPF (Instantaneous power failure)*1 b6: CVO (converter running)*1 b7: – b8: ALM (Fault)*1 b9: – b10: – b11: – b12: – b13: – b14: – b15: Fault occurrence	[Example 1] H0043: Power driving. b15 b0 0 0 0 0 0 0 0 0 0 0 1 0 0 0 0 1 1 [Example 2] H8100: Stopped due to a fault. b15 b0 1 0 0 0 0 0 0 1 0 0 0 0 0 0 0 0

*1 The signals indicated in parentheses are assigned in the initial setting. The function changes depending on the setting of Pr.192 to Pr.194, and Pr.196 (Output terminal function selection).

5.4.20 PU display language selection



You can switch the display language of the parameter unit (FR-PU07) to another.

Pr.	Name	Initial value	Setting range	Description
145	PU display language selection	—	0	Japanese
			1	English
			2	German
			3	French
			4	Spanish
			5	Italian
			6	Swedish
			7	Finnish

5.4.21 Disabling the setting dial and keys on the operation panel

The keys on the operation panel can be disabled.

Pr.	Name	Initial value	Setting range	Description
161	Key lock operation selection	0	0	The keys are operable.
			10	The keys are inoperable.

- The setting dial and keys on the operation panel can be disabled to prevent unexpected parameter changes.
- Set **Pr.161** to "10" and then press  for 2 seconds to disable setting dial or key operations.
- When setting dial and key operations are disabled, "HOLD" appears on the operation panel. If the setting dial or any key is used while keys are inoperable, "HOLD" appears on the operation panel. (When the setting dial or any key is not used for 2 seconds, the operation panel switches to the monitor mode.)
- To enable the setting dial and keys again, press  for 2 seconds.

NOTE

- Even if setting dial and key operations are disabled, the monitor indication and  are enabled.

5.4.22 Input terminal function selection (Pr.178 to Pr.189)

Use the following parameters to select or change the input terminal functions.

Pr.	Name	Initial value (signal name)		Setting range
178	STF terminal function selection	9999	— (No function)	0, 7, 33, 34, 62, 9999
179	STR terminal function selection	9999	— (No function)	
180	RL terminal function selection	9999	— (No function)	
181	RM terminal function selection	9999	— (No function)	
182	RH terminal function selection	9999	— (No function)	
183	RT terminal function selection	33	LOH (Reactor overheat protection)	
184	AU terminal function selection	34	ROH (Inrush current limit resistor overheat detection)	
185	JOG terminal function selection	9999	— (No function)	
186	CS terminal function selection	9999	— (No function)	
187	MRS terminal function selection	7	OH (External thermal relay input)	
188	STOP terminal function selection	0	SOF (Converter stop)	
189	RES terminal function selection	62	RES (Converter reset)	

◆ Input terminal function assignment

• Use Pr.178 to Pr.189 to set the functions of the input terminals. Refer to the following table and set the parameters.

Setting	Signal name	Function		Related parameter	Refer to page
0	SOF	Converter stop	When this signal turns ON, the converter operation stops. The converter operation for this signal can be changed by using Pr.8.	Pr.8	91
7	OH	External thermal relay input	The signal is input from the external thermal relay. When this signal turns ON, the protective function (E.OHT) is activated to stop the converter operation. The converter operation for this signal can be changed by using Pr.9.	Pr.9	91
33	LOH	Reactor overheat protection	This signal is input from the thermostat of reactors 1 and 2. When reactors are overheated and the signal from the thermostat turns OFF, the protective function (E.LOH) is activated to stop the converter operation.	—	—
34	ROH	Inrush current limit resistor overheat detection	When this signal turns OFF due to possibility of overheating of the inrush current limit resistor, the protective function (E.IOH) is activated to stop the converter operation.	—	—
62	RES	Converter reset	When the RES signal turns ON, the converter reset is performed.	—	—
9999	—	No function.		—	—

NOTE

- When a signal (other than the ROH signal or the LOH signal) is assigned to more than one terminals, the function of the signal will be enabled while any one of the terminals is ON.
- When the ROH signal or the LOH signal is assigned to more than one terminals and any one of the terminals turns OFF, the protective function E.IOH or E.LOH) remains active to stop the converter operation until all of the signal assigned terminals turn ON.
- Changing the terminal assignment using Pr.178 to Pr.189 (Input terminal function selection) may affect the other functions. Set parameters after confirming the function of each terminal.

5.4.23 Operation selection for the RDY signal and the RSO signal (Pr.190 and Pr.191)

Use **Pr.190** to determine the operation when the signal assigned to terminal RYA on the FR-A8AVP (RDY signal) or the RDY signal of the converter is output. Use **Pr.191** to determine the operation when the signal assigned to terminal RSO on the FR-A8AVP (RSO signal) or the RSO signal of the converter is output.

Pr.	Name	Initial value	Setting range	Description
190	RDY signal logic selection	0	0	ON: Inverter run enable (NO contact)
			100	OFF: Inverter run enable (NC contact)
191	RSO signal logic selection	1	1	ON: Converter reset (NO contact)
			101	OFF: Converter reset (NC contact)

- Converter operation determined by the RDY signal status and the **Pr.190** setting

RDY signal output	Converter operation	
	Pr.190 = "0" (NO contact)	Pr.190 = "100" (NC contact)
OFF	The converter is faulty or the reset signal is input.	Inverter operation is enabled.
ON	Inverter operation is enabled.	The converter is faulty or the reset signal is input.

- Converter operation determined by the RSO signal status and the **Pr.191** setting

RSO signal output	Converter operation	
	Pr.191 = "1" (NO contact)	Pr.191 = "101" (NC contact)
OFF	Operation continues.	Converter reset.
ON	Converter reset.	Operation continues.

NOTE

- For the RDY signal, the initial setting is normally-open contact input specification. To change the RDY signal input specification to normally-closed, select the normally-open contact input specification for the input logic of the X10 signal of the inverter.

5.4.24 Output terminal function selection (Pr.192 to Pr.194, Pr.196)

Use the following parameters to change the functions of the open collector output terminals and relay output terminals.

Pr.	Name	Initial value	Signal name	Setting range
192	IPF terminal function selection	2	IPF (Instantaneous power failure)	0 to 5, 7, 8, 16, 25, 26, 32, 64, 68, 90, 95, 98 to 105, 107, 108, 116, 125, 126, 132, 164, 168, 190, 195, 198, 199, 206 to 208, 306 to 308, 9999
193	OL terminal function selection	3	OL (Overload warning)	
194	FU terminal function selection	4	CVO (Converter running)	
196	ABC2 terminal function selection	99	ALM (Fault output)	

◆ Output signal list

- Functions listed below can be assigned to any of the output terminal.
- Refer to the following table and set the parameters. (0 to 99: Positive logic, 100 to 199: Negative logic)

Setting		Signal name	Function	Operation	Related parameter	Refer to page
Positive logic	Negative logic					
0	100	RDY	Inverter run enable	Output when the inverter is ready.	Pr.190	128
1	101	RSO	Converter reset	Output during a converter reset.	Pr.191	128
2	102	IPF	Instantaneous power failure	Output when the protective function for instantaneous power failure is activated.	Pr.57	101
3	103	OL	Overload alarm	Output when the current limit function is active.	Pr.22, Pr.23	92
4	104	CVO	Converter running	Output when the converter is running.	—	—
5	105	Y5	Output voltage match	Output when the detected bus voltage equals to the commanded bus voltage.	—	—
7	107	PHS	Power supply phase detection	Output when a phase is confirmed after a completion of the power supply phase detection.	—	—
8	108	THP	Electronic thermal O/L relay pre-alarm	Output when the cumulative electronic thermal O/L relay value reaches 85% of the trip level. (Electronic thermal relay protection (E.THT) is activated when the value reaches 100%.	—	—
16	116	Y16	Instantaneous power failure detection hold	Output when the IPF signal turns ON. This signal is held until a converter reset is performed or Pr.44 is set to "0". Output when the converter is running.	Pr.44	93
25	125	Fan	Fan fault output	Output when a fan fault occurs.	Pr.244	131
26	126	FIN	Heat sink overheat pre-alarm	Output when the heat sink temperature reaches about 85% of the heat sink overheat protection operation temperature.	—	—
32	132	Y32	Regenerative drive recognition	Output during regenerative driving.	—	—
64	164	RTY	During retry	Output during retry processing.	Pr.65, Pr.67 to Pr.69	102
68	168	EV	24 V external power supply operation	Output while the converter operated with a 24 V power supplied from an external source.	—	59
90	190	Y90	Life alarm	Output when any of the control circuit capacitor, main circuit capacitor, inrush current limit circuit, or the cooling fan approaches the end of its life.	Pr.255 to Pr.257	132
95	195	Y95	Maintenance timer	Output when Pr.503 reaches the Pr.504 setting or higher.	Pr.503, Pr.504	134
98	198	LF	Alarm output	Output when an alarm (fan fault or communication error warning) occurs.	Pr.121, Pr.244	108, 131
99	199	ALM	Fault	Output when the converter's protective function is activated to stop the power output (when the Fault occurs).	—	—

Parameter details

Setting		Signal name	Function	Operation	Related parameter	Refer to page
Positive logic	Negative logic					
206	306	Y206	Cooling fan operation command signal	Output when the cooling fan operation is commanded.	Pr.244	131
207	307	Y207	Control circuit temperature	Output when the temperature of the control circuit board reaches the detection level or higher.	Pr.663	135
208	308	PS	PU stopped	Output while the PU is stopped.	Pr.75	104
9999		—	No function.	—	—	—

5.4.25 Cooling fan operation selection

A cooling fan built into the converter can be controlled.

Pr.	Name	Initial value	Setting range	Description
244	Cooling fan operation selection	1	0	A cooling fan operates at power ON. Cooling fan ON/OFF control is disabled. (The cooling fan is always ON at power ON.)
			1	Cooling fan ON/OFF control is enabled. The fan is always ON while the converter is running. During a stop, the converter status is monitored and the fan switches ON/OFF according to the temperature.

◆ Cooling fan always ON (Pr.244 = "0")

- When **Pr.244** = "0", the cooling fan operates at power ON. If the fan stops at this time, fan operation is regarded as faulty, Fan alarm "F_N" (FN) is displayed on the operation panel, and the Fan fault output (FAN) and Alarm (LF) signals are output.
- For the terminal used for the FAN signal output, set "25 (positive logic)" or "125 (negative logic)" in any of **Pr.192 to Pr.194** and **Pr.196 (Output terminal function selection)**, and for the LF signal, set "98 (positive logic)" or "198 (negative logic)".

◆ Cooling fan operation control (Pr.244 = "1 (initial value)")

- The cooling fan operation is controlled when **Pr.244** = "1". When the converter is running, the cooling fan operates constantly. When the converter is stopped, the cooling fan operates depending on the temperature of the converter heat sink. If the fan stops although it meets the conditions for running, fan operation is regarded as faulty, "F_N" (FN) is displayed on the operation panel, and the FAN signal and LF signal are output.

◆ Cooling fan operation command (Y206) signal

- The Cooling fan operation command (Y206) signal can be output when the converter cooling fan meets the conditions for running. The function can be used when the fan installed on the enclosure is synchronized with the converter cooling fan.
- The Y206 signal indicates the operating command condition of the converter cooling fan depending on the power supply ON/OFF or the **Pr.244** settings. The signal does not indicate the actual operation of the cooling fan. (The signal is output even if the cooling fan is stopped due to a fault.)
- To use the Y206 signal, set "206 (positive logic) or 306 (negative logic)" in any of **Pr.192 to Pr.194** and **Pr.196 (Output terminal function selection)** to assign the function to the output terminal.

NOTE

- Changing the terminal assignment using **Pr.192 to Pr.194** or **Pr.196 (Output terminal function selection)** may affect the other functions. Set parameters after confirming the function of each terminal.

Parameters referred to

Pr.192 to Pr.194, Pr.196 (Output terminal function selection)  page 129

5.4.26 Converter parts life display (Pr.255 to Pr.257)

The degrees of deterioration of main circuit capacitor, cooling fan, and inrush current limit circuit can be diagnosed on the monitor.

When a part approaches the end of its life, an alarm can be output by self diagnosis to prevent a fault.

(Note that the life diagnosis of this function should be used as a guideline only, the life values are theoretical calculations.)

Pr.	Name	Initial value	Setting range	Description
255	Life alarm status display	0	(0, 1, 4, 5, 8, 9, 12, 13)	Displays whether or not the parts of the control circuit capacitor, cooling fan, and inrush current limit circuit have reached the life alarm output level. Read-only.
256	Inrush current limit circuit life display	100%	(0 to 100%)	Displays the deterioration degree of the inrush current limit circuit. Read-only.
257	Control circuit capacitor life display	100%	(0 to 100%)	Displays the deterioration degree of the control circuit capacitor. Read-only.
1202	Inrush current limit circuit life setting	9999	0 to 100%	Displays the deterioration degree of the inrush current limit circuit. Set "100" after replacing the old FR-A8MC (dedicated circuit parts for inrush current protection) with new one.
			9999	No function. The read value is always "9999".

◆ Life alarm display and signal output (Y90 signal, Pr.255)

- Whether or not the parts of the control circuit capacitor, cooling fan, or inrush current limit circuit have reached the life alarm output level can be checked with **Pr.255 Life alarm status display** and the Life alarm (Y90) signal.

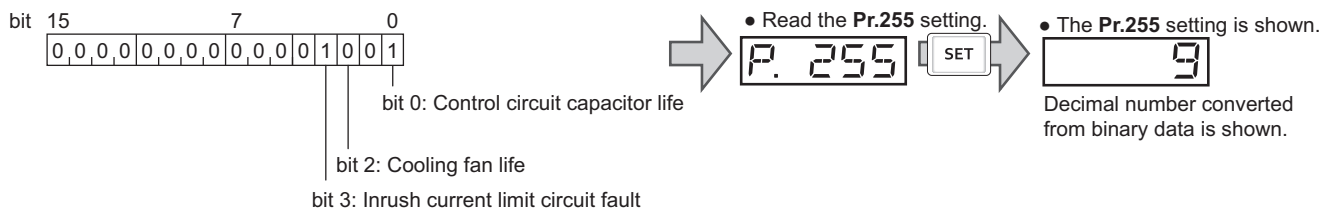

Pr.255		bit3	bit2	bit0
Decimal	Binary			
13	1101	○	○	○
12	1100	○	○	×
9	1001	○	×	○
8	1000	○	×	×
5	0101	×	○	○
4	0100	×	○	×
1	0001	×	×	○
0	0000	×	×	×

○: Alarm output, ×: Alarm not output

- The Life alarm (Y90) signal turns ON when any of the control circuit capacitor, cooling fan, and inrush current limit circuit reaches the life alarm output level.
- For the terminal used for the Y90 signal, set "90" (positive logic) or "190" (negative logic) in any of **Pr.192 to Pr.194 and Pr.196 (Output terminal function selection)**.

NOTE

- Changing the terminal assignment using **Pr.192 to Pr.194 or Pr.196 (Output terminal function selection)** may affect the other functions. Set parameters after confirming the function of each terminal.

◆ Life display and setting of the inrush current limit circuit (Pr.256, Pr.1202)

- The life of the inrush current limit circuit (relay, contactor, and inrush resistor) is displayed in **Pr.256**.
- The number of times the contacts of relay, contactor, and thyristor turn ON is counted down from 100% (0 times) by 1% every 1000 times. When the counter reaches 10% (90000 times), bit 3 of **Pr.255** turns ON and the life alarm is output by the Y90 signal turned ON.
- Use **Pr.1202** to set the life of the inrush current limit circuit. Set **Pr.1202** = "100" after replacing the old FR-A8MC (dedicated circuit parts for inrush current protection) with new one.

◆ Life display of the control circuit capacitor (Pr.257)

- The deterioration degree of the control circuit capacitor is displayed in **Pr.257**.
- In the operating status, the control circuit capacitor life is calculated from the energization time and temperature, and is counted down from 100%.
When the counter reaches 10%, bit 0 of **Pr.255** turns ON and the life alarm is output by the Y90 signal turned ON.

◆ Life display of the cooling fan

- When a cooling fan speed less than approximately 1700 r/min is detected, the fan alarm indication "FAN" (FN) appears on the operation panel or the parameter unit. When the alarm indication is displayed, bit 2 of **Pr.255** turns ON and the life alarm is output by the Y90 signal turned ON.

NOTE

- The life alarm and the signal are output when the fan speed of any of the cooling fans reaches the detection level.
- For parts replacement, consult the nearest Mitsubishi Electric FA Center.

5.4.27 Maintenance timer alarm

The Maintenance timer (Y95) signal is output when the converter's cumulative energization time reaches the time period set with the parameter. MT1, MT2 or MT3 is displayed on the operation panel.

This can be used as a guideline for the maintenance time of peripheral devices (such as the cooling fan of the reactor 1 or reactor 2).

Pr.	Name	Initial value	Setting range	Description
503	Maintenance timer	0	0 (1 to 9998)	Displays the converter's cumulative energization time in increments of 100 hours (read-only). Writing the setting of "0" clears the cumulative energization time while Pr.503 = "1 to 9998". (Writing is disabled when Pr.503 = "0".)
504	Maintenance timer warning output set time	9999	0 to 9998	Set the time until the Maintenance timer (Y95) signal is output. MT1 is displayed on the operation panel.
			9999	No function.
686	Maintenance timer 2	0	0 (1 to 9998)	The same function as Pr.503 .
687	Maintenance timer 2 warning output set time	9999	0 to 9998	The same function as Pr.504 .
			9999	MT2 is displayed on the operation panel.
688	Maintenance timer 3	0	0 (1 to 9998)	The same function as Pr.503 .
689	Maintenance timer 3 warning output set time	9999	0 to 9998	The same function as Pr.504 .
			9999	MT3 is displayed on the operation panel.

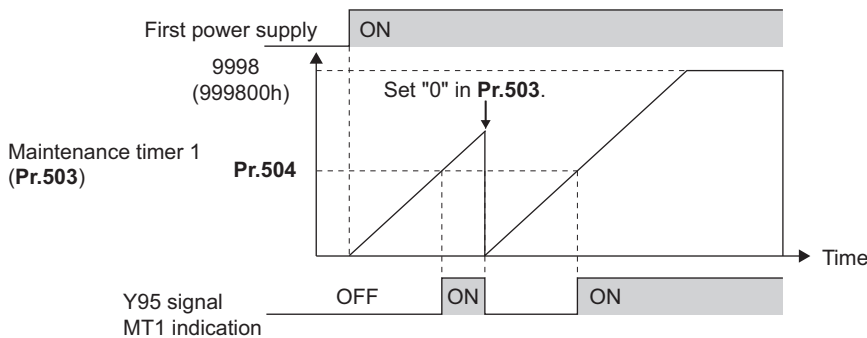

Operation example of the maintenance timer 1 (**Pr.503** and **Pr.504**) (with both MT2 and MT3 OFF)

- The cumulative energization time of the converter is stored in the EEPROM every hour and displayed in **Pr.503 (Pr.686, Pr.688)** in 100 hours increments. The number indication on **Pr.503 (Pr.686, Pr.688)** stops at 9998 (999800 hours).
- When the value in **Pr.503 (Pr.686, Pr.688)** reaches the time (100 hour increments) set in **Pr.504 (Pr.687, Pr.689)**, the Maintenance timer (Y95) signal is output and the warning indication "MT1" (MT1), "MT2" (MT2), or "MT3" (MT3) is displayed on the operation panel.
- For the terminal used for the Y95 signal, set "95 (positive logic)" or "195 (negative logic)" to any of **Pr.192 to Pr.194 and Pr.196 (Output terminal function selection)**.

NOTE

- The Y95 signal turns ON when any of MT1, MT2 or MT3 is activated. It does not turn OFF unless all of MT1, MT2 and MT3 are cleared.
- If all of MT1, MT2 and MT3 are activated, they are displayed in the priority of "MT1 > MT2 > MT3".
- The cumulative energization time is counted every hour. The energization time of less than 1 hour is not counted.
- Changing the terminal assignment using **Pr.192 to Pr.194** or **Pr.196 (Output terminal function selection)** may affect the other functions. Set parameters after confirming the function of each terminal.

Parameters referred to

Pr.192 to Pr.194, Pr.196 (Output terminal function selection) page 129

5.4.28 Detection of control circuit temperature

The temperature of the control circuit board can be monitored, and a signal can be output according to a predetermined temperature setting.

Pr.	Name	Initial value	Setting range	Description
663	Control circuit temperature signal output level	0°C	0 to 100°C	Set the temperature where the Y207 signal turns ON.

◆ Control circuit temperature monitoring

- The temperature of the control circuit board can be monitored within the range of 0 to 100°C on the operation panel, or via terminal FM/CA, or terminal AM. (Refer to [page 96](#) and [100](#) for information on how to select the monitor item.)
- When **Pr.290 Monitor negative output selection** is set to enable display of the negative numbers for monitoring on the operation panel or via terminal AM, the range of monitoring is -20 to 100°C.
- The monitor value is a rough approximation of the change in the surrounding air temperature of the converter. Use this parameter to grasp the operating environment of the converter.

◆ Control circuit temperature detection (Pr.663, Y207 signal)

- The Y207 signal can be output when the control circuit temperature reaches the **Pr.663** setting or higher.
- For the Y207 signal, set "207 (positive logic) or 307 (negative logic)" in one of **Pr.192 to Pr.194 and Pr.196 (Output terminal function selection)** to assign the function to the output terminal.

NOTE

- The Y207 signal is turned OFF when the control circuit temperature becomes 5°C or more lower than the **Pr.663** setting.
- Changing the terminal assignment using **Pr.192 to Pr.194 or Pr.196 (Output terminal function selection)** may affect the other functions. Set parameters after confirming the function of each terminal.

Parameters referred to

Pr.54 FM/CA terminal function selection  [page 100](#)

Pr.158 AM terminal function selection  [page 100](#)

Pr.192 to Pr.194, Pr.196 (Output terminal function selection)  [page 129](#)

Pr.290 Monitor negative output selection  [page 96](#)

5.4.29 Adjustment of terminal FM/CA and terminal AM

The output via terminal FM, CA, or AM corresponding to the full-scale value of a meter can be adjusted (calibrated) on the operation panel or the parameter unit.

Pr.	Name	Initial value		Setting range	Description
		FM	CA		
867	AM output filter	0.01 s		0 to 5 s	Set a filter for output via terminal AM.
869	Current output filter	—	0.02 s	0 to 5 s	Set a filter for output via terminal CA.
C0 (900)*1	FM/CA terminal calibration	—		—	Calibrates the scale of the meter connected to terminals FM/CA.
C1 (901)*1	AM terminal calibration	—		—	Calibrates the scale of the analog meter connected to terminal AM.
C8 (930)*1	Current output bias signal	0%		0 to 100%	Set the signal value at the minimum analog current output.
C9 (930)*1	Current output bias current	0%		0 to 100%	Set the current value at the minimum analog current output.
C10 (931)*1	Current output gain signal	100%		0 to 100%	Set the signal value at the maximum analog current output.
C11 (931)*1	Current output gain current	100%		0 to 100%	Set the current value at the maximum analog current output.

*1 The parameter number in parentheses is the one for use with the parameter unit.

◆ Terminal FM calibration (C0 (Pr.900))

- The terminal FM is preset to output pulses. By setting **C0 (Pr.900)**, the meter connected to the converter can be calibrated by parameter setting without use of a calibration resistor.
- The pulse train output via terminal FM can be used for digital display on a digital counter. The monitor value is 1440 pulses/s output at the full-scale value of monitor description list ([page 96](#)) (**Pr.54 FM/CA terminal function selection**).

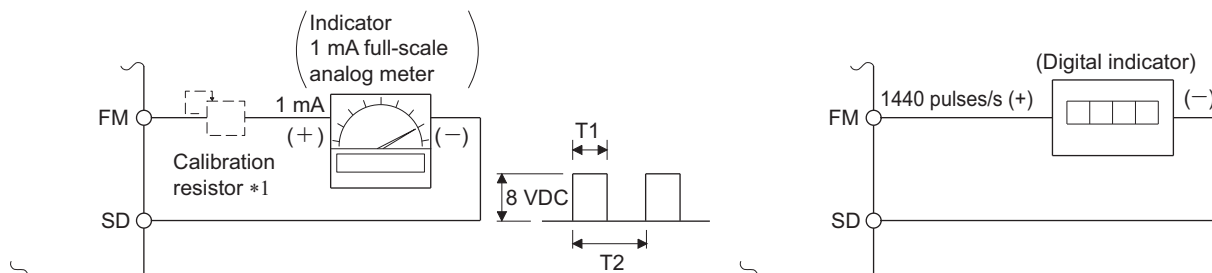

Pulse width T1: Adjust with **C0 (Pr.900)**.
 Pulse cycle T2: Set with **Pr.49, Pr.51, Pr.53, Pr.55, or Pr.56**

- *1 Not needed when the operation panel or the parameter unit is used for calibration.
 Use a calibration resistor when the indicator (frequency meter) needs to be calibrated by a neighboring device because the indicator is located far from the converter.
 However, the frequency meter needle may not deflect to full-scale if the calibration resistor is connected. In this case, perform calibration using the operation panel or parameter unit.

















- Calibrate the output via terminal FM in the following procedure.
 - 1) Connect an indicator (frequency meter) across terminals FM and SD on the converter. (Note the polarity. The terminal FM is positive.)
 - 2) When a calibration resistor has already been connected, adjust the resistance to "0" or remove the resistor.
 - 3) Set a monitor item in **Pr.54 FM/CA terminal function selection**. (Refer to [page 100](#).)
 When you selected an item that needs full-scale setting, set a voltage or current value at which the output signal will be 1440 pulses/s, using **Pr.49, Pr.51, Pr.53, Pr.55, and Pr.56**. Normally, at 1440 pulses/s the meter deflects to full-scale.
 - 4) If the meter needle does not point to maximum even at maximum output, calibrate it with **C0 (Pr.900)**.

 **NOTE**

- When outputting an item such as the input current, which cannot reach a 100% value easily by operation, set **Pr.54** to "21" (reference voltage output) and calibrate. A pulse train of 1440 pulses/s are output via terminal FM.
- The wiring length to terminal FM should be 200 m at maximum.
- The initial value of the calibration parameter **C0 (Pr.900)** is set to 1 mA full-scale and 1440 pulses/s terminal FM pulse train output at 60 Hz. The maximum pulse train output of terminal FM is 2400 pulses/s.
- When connecting a frequency meter between terminals FM-SD and monitoring the running frequency, it is necessary to change **Pr.55** to the maximum frequency, since the FM terminal output will be saturated at the initial value when the maximum frequency reaches 100 Hz or greater.

◆ Calibration procedure for terminal FM when using the operation panel (FR-DU08)

Operating procedure

1.	Turning ON the power of the converter The operation panel is in the monitor mode.
2.	Parameter setting mode Press  to choose the parameter setting mode. (The parameter number read previously appears.)
3.	Calibration parameter selection Turn  until "  " appears. Press  to display "  -- -- -- -- ".
4.	Selecting a parameter Turn  until "   " (C0 (Pr.900) FM/CA terminal calibration) appears. Press  to enable the parameter setting. The monitored value of the item (initially the power supply frequency) selected by Pr.54 FM/CA terminal function selection will appear.
5.	Scale adjustment Turn  to move the meter needle to a desired position.
6.	Setting completed Press  to enter the setting. The monitored value and "   " are displayed alternately. <ul style="list-style-type: none"> • Turn  to read another parameter. • Press  to return to the "  -- -- -- -- " display. • Press  twice to show the next parameter.

 **NOTE**

- Calibration can be performed during operation.
- For the operation from the parameter unit, refer to the Instruction Manual of the parameter unit.

◆ Terminal CA calibration (C0 (Pr.900), C8 (Pr.930) to C11 (Pr.931))

- Terminal CA is initially set to provide a 20 mADC output in the full-scale state of the corresponding monitor item. The calibration parameter **C0 (Pr.900)** allows the output current ratio (gains) to be adjusted according to the meter scale. Note that the maximum output current is 20 mADC.
- Set a value at the minimum current output in the calibration parameters **C8 (Pr.930)** and **C9 (Pr.930)**. The calibration parameters **C10 (Pr.931)** and **C11 (Pr.931)** are used to set a value at the maximum current output.
- Set the output signal values (output monitor set with **Pr.54**) at zero or at the maximum current output via terminal CA using the calibration parameters **C8 (Pr.930)** and **C10 (Pr.931)**. The full scale for each monitor is 100% at this time.
- Set the output current values (output monitor set with **Pr.54**) at zero and at the maximum current output via terminal CA (using the calibration parameters **C9 (Pr.930)** and **C11 (Pr.931)**). The output current calibrated by the calibration parameter **C0 (Pr.900)** is 100% at this time.

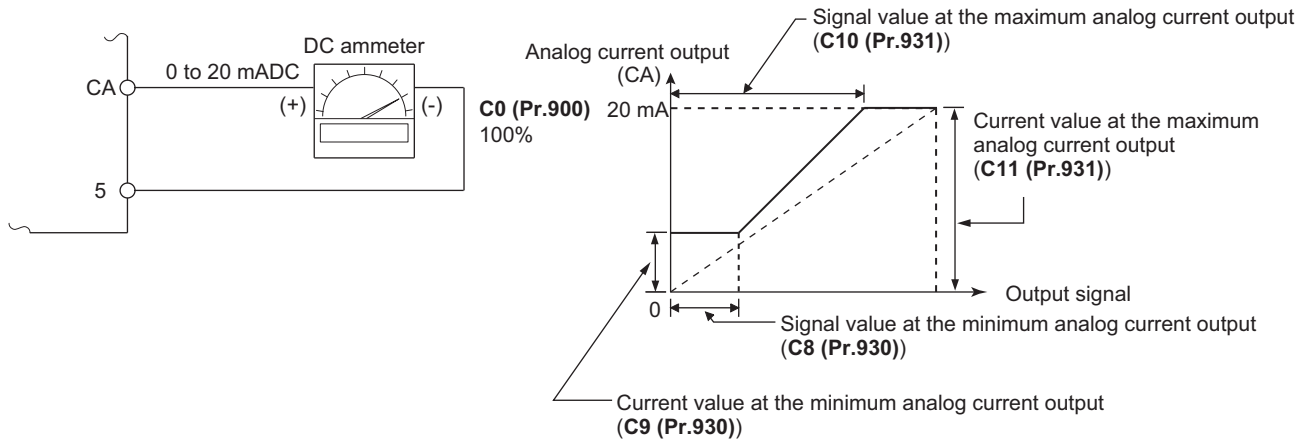

- Calibrate the output via terminal CA in the following procedure.
 - 1) Connect a 0-20 mADC indicator (frequency meter) across terminals CA and 5 on the converter. (Note the polarity. The terminal CA is positive.)
 - 2) Set the initial value of the calibration parameter **C8 (Pr.930)** to **C11 (Pr.931)**. If the meter needle does not indicate zero when the current input is at zero, calibrate the meter using **C8 (Pr.930)** and **C9 (Pr.930)**.
 - 3) Refer to the monitor description list ([page 96](#)) and set **Pr.54**.
When you selected an item that needs full-scale setting, set a power supply frequency or current value at which the output signal will be 20 mA, using **Pr.49, Pr.51, Pr.53, Pr.55, and Pr.56**.
 - 4) If the meter needle does not point to maximum even at maximum output, calibrate it with **C0 (Pr.900)**.

NOTE

- When outputting an item such as output current, which cannot reach a 100% value easily by operation, set **Pr.54** to "21" (Reference voltage output) and calibrate. A current of 20 mADC is output via terminal CA.
- The output via terminal CA is enabled even if **C8 (Pr.930) ≥ C10 (Pr.931)**, **C9 (Pr.930) ≥ C11 (Pr.931)**.

◆ Adjusting the response of terminal CA (Pr.869)

- Using **Pr.869**, the output voltage response of terminal CA can be adjusted in the range of 0 to 5 seconds. Increasing the setting stabilizes the output via terminal CA more but reduces the response level. (Setting "0" sets the response level to 7 ms.)

◆ Calibration of terminal AM (C1 (Pr.901))

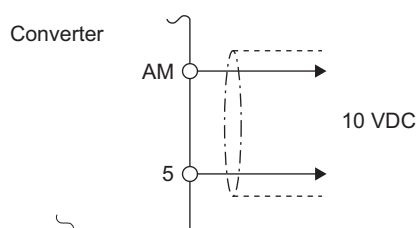

- Terminal CA is initially set to provide a 10 VDC output in the full-scale state of the corresponding monitor item. The calibration parameter **C1 (Pr.901) AM terminal calibration** allows the output voltage ratio (gains) to be adjusted according to the meter scale. Note that the maximum output voltage is 10 VDC.

- Calibrate the terminal FM in the following procedure.
 - 1) Connect a 0-10 VDC indicator (frequency meter) across terminals AM and 5 of the converter. (Note the polarity. The terminal AM is positive.)
 - 2) Refer to the monitor description list ([page 96](#)) and set **Pr.158 AM terminal function selection**.
When you selected an item that needs full-scale setting, set a power supply frequency or current value at which the output signal will be 10 V, using **Pr.49, Pr.51, Pr.53, Pr.55, and Pr.56**.
 - 3) If the meter needle does not point to maximum even at maximum output, calibrate it with **C1 (Pr.901)**.

NOTE

- When outputting an item such as input current, which cannot reach a 100% value easily by operation, set **Pr.158** to "21" (reference voltage output) and calibrate. A voltage of 10 VDC is output via terminal AM.
- Use **Pr.290 Monitor negative output selection** to enable negative signals output via terminal AM. The output voltage range is -10 to +10 VDC. Calibrate the maximum positive value output via terminal AM.

◆ Adjusting the response of terminal AM (Pr.867)

- Use **Pr.867** to adjust the output voltage response of the terminal AM in the range of 0 to 5 seconds.
- Increasing the setting stabilizes the output via terminal AM more but reduces the response level. (Setting "0" means the setting of the response level to 7 ms.)

Parameters referred to

Pr.54 FM/CA terminal function selection [page 100](#)

Pr.55 Bus voltage monitoring reference [page 94](#)

Pr.56 Current monitoring reference [page 94](#)

Pr.158 AM terminal function selection [page 100](#)

Pr.290 Monitor negative output selection [page 96](#)

5.4.30 Free parameter

Any number within the setting range of 0 to 9999 can be input.

For example, these numbers can be used:

- As a unit number when multiple units are used.
- As a pattern number for each operation application when multiple units are used.
- As the year and month of introduction or inspection.

5

Pr.	Name	Initial value	Setting range	Description
888	Free parameter 1	9999	0 to 9999	Any value can be input. Data is held even if the converter power is turned OFF.
889	Free parameter 2	9999	0 to 9999	

NOTE

- Pr.888 and Pr.889** do not influence the operation of the converter.

5.4.31 Beep control

The PU (operation panel or parameter unit) key sound and buzzer can be turned ON/OFF.

Pr.	Name	Initial value	Setting range	Description
990	PU buzzer control	1	0	Turns the key sound and buzzer OFF.
			1	Turns the key sound and buzzer ON.

NOTE

- When the buzzer is set to ON, a warning sound will be audible when a fault occurs.

5.4.32 PU contrast adjustment

Contrast of the LCD on the parameter unit (FR-PU07) can be adjusted.

Decreasing the setting value lowers the contrast.

Pr.	Name	Initial value	Setting range	Description
991	PU contrast adjustment	58	0 to 63	0: Lowest → 63: Highest

The above parameter is displayed as a simple mode parameter only when the parameter unit (FR-PU07) is connected.

5.4.33 Initiating a protective function

A fault (protective function) is initiated by setting the parameter.

This function can be used to check how the system operates at activation of a protective function.

Pr.	Name	Initial value	Setting range	Description
997	Fault initiation	9999	16 to 253	The setting range is same with the one for fault data codes of the converter (which can be read through communication). Written data is not stored in EEPROM.
			9999	The read value is always "9999". The protective function is not activated with this setting.

- To initiate a fault (protective function), set the assigned number of the protective function you want to initiate in **Pr.997**.
- The value set in **Pr.997** is not stored in EEPROM.
- When the protective function is activated, the inverter output is shut off, and the converter displays a fault and outputs the Fault (ALM) signal.
- While the initiated fault is occurring, the fault is displayed as the latest fault in the fault history. After a reset, the fault history goes back to the previous status. (The protective function generated by the fault is not saved in the fault history.)
- Perform converter reset to cancel the protective function.
- For the selectable parameter by **Pr.997** and the corresponding protective functions, refer to [page 151](#).

NOTE

- If a protective function is already operating, no fault can be activated by **Pr.997**.
- The retry function is disabled when a protective function has been initiated by the fault initiation function.
- If a fault occurs after a protective function has been activated, the protective function indication does not change. The fault is not saved in the fault history either.

5.4.34 Simple clock function

The time can be set. The time can only be updated while the converter power is ON.

Pr.	Name	Initial value	Setting range	Description
1006	Clock (year)	2000	2000 to 2099	Set the year.
1007	Clock (month, day)	101 (January 1)	101 to 131, 201 to 228, (229), 301 to 331, 401 to 430, 501 to 531, 601 to 630, 701 to 731, 801 to 831, 901 to 930, 1001 to 1031, 1101 to 1130, 1201 to 1231	Set the month and day. 1000 and 100 digits: January to December 10 and 1 digits: 1 to the end of month (28, 29, 30 or 31) For December 31, set "1231".
1008	Clock (hour, minute)	0 (00:00)	0 to 59, 100 to 159, 200 to 259, 300 to 359, 400 to 459, 500 to 559, 600 to 659, 700 to 759, 800 to 859, 900 to 959, 1000 to 1059, 1100 to 1159, 1200 to 1259, 1300 to 1359, 1400 to 1459, 1500 to 1559, 1600 to 1659, 1700 to 1759, 1800 to 1859, 1900 to 1959, 2000 to 2059, 2100 to 2159, 2200 to 2259, 2300 to 2359	Set the hour and minute using the 24-hour clock. 1000 and 100 digits: 0 to 23 hours 10 and 1 digits: 0 to 59 minutes For 23:59, set "2359".

- When the year, month, day, time and minute are set in **Pr.1006 to Pr.1008**, the converter unit counts the date and time. The date and time can be checked by reading **Pr.1006 to Pr.1008**.

NOTE









- The clock's count-up data is saved in the converter's EEPROM every 10 minutes.
- The clock does not count up while the control circuit power supply is OFF. The clock function must be reset after turning ON the power supply. Use a separate power supply, such as an external 24 V power supply, for the control circuit of the simple clock function, and supply power continuously to this control circuit.
- In the initial setting, converter reset is performed if supplying power to the main circuit is started when power is supplied only to the control circuit. Then, the clock information stored in EEPROM is restored.
- The set clock is also used for functions such as fault history.

5.5 Parameter clear / All parameter clear on the operation panel

 **POINT**

- Set "1" to **Pr.CLR Parameter clear** or **ALL.CL All parameter clear** to initialize all parameters. (Parameters cannot be cleared when **Pr.77 Parameter write selection** = "1".)
- **Pr.CLR** does not clear calibration parameters or the terminal function selection parameters.
- For availability of the Parameter clear or All parameter clear operation for each parameter, refer to the parameter list on [page 190](#).

Operating procedure

- Turning ON the power of the converter
The operation panel is in the monitor mode.
- Selecting the parameter setting mode
Press  to choose the parameter setting mode. (The parameter number read previously appears.)
- Selecting a parameter
Turn  to "Pr.CLR" for Parameter clear or turn it to "ALLCL" for All parameter clear, and press . "0" (initial value) appears.
- Parameter clear
Turn  to change the set value to "1". Press  to enter the setting. "1" and "Pr.CLR" or "ALLCL" are displayed alternately after parameters are cleared.
 - Turn  to read another parameter.
 - Press  to show the setting again.
 - Press  twice to show the next parameter.

Setting	Description	
	Pr.CLR Parameter clear	ALL.CL All parameter clear
0	Initial display (Parameters are not cleared.)	
1	The settings of parameters except for calibration parameters and terminal function selection parameters are initialized.	The settings of all the parameters, including calibration parameters and terminal function selection parameters , are initialized.

5.6 Copying and verifying parameters on the operation panel

Pr.CPY setting	Description
0.---	Initial display
1.RD	Read the parameters from the source converter and store them to the operation panel.
2.WR	Write the parameters copied to the operation panel into the destination high power factor converter.
3.VFY	Verify parameters in the converter and those in the operation panel. (Refer to page 145.)

NOTE



- When the copy destination is other than the FR-A842 converter or when Parameter copy is attempted after the parameter copy reading was stopped, the product series error indication "r-E4" appears.
- Refer to the parameter list on [page 190](#) for the availability of parameter copy.
- When the power is turned OFF or an operation panel is disconnected, etc. during parameter copy writing, perform parameter copy writing again or check the setting values by using parameter verification.
- If parameters are copied from a not-upgraded converter to an upgraded converter that has additional parameters due to upgrade, out-of-range setting values may be written in some parameters. In that case, those parameters operate as if they were set to initial values.

5.6.1 Parameter copy

- Parameter settings in a converter can be copied to another converter.

◆ Reading the parameter settings in the converter and storing them in the operation panel

Operating procedure



1. Connect the operation panel to the source converter.
2. Selecting the parameter setting mode
Press **MODE** to choose the parameter setting mode. (The parameter number read previously appears.)
3. Selecting a parameter
Turn  to "Pr.CPY" (Parameter copy), and press **SET**.
"0.---" appears.
4. Reading to the operation panel
Turn  to change the set value to "1.RD". Press **SET** to start reading the parameter settings from the converter and storing them in the operation panel. (It takes about 30 seconds to read and store all the settings. During reading, "1.RD" blinks.)
5. End of reading
"1.RD" and "Pr.CPY" are displayed alternately after the reading is completed.

NOTE

- "r-E1" appears... Why?
- Parameter read error. Perform operation from Step 3 again.

◆ Writing parameter settings stored in the operation panel to the converter

Operating procedure

1. Connect the operation panel to the target converter.
2. **Selecting the parameter setting mode**
Press **MODE** to choose the parameter setting mode. (The parameter number read previously appears.)
3. **Selecting a parameter**
Turn  to "Pr-COPY" (parameter copy), and press **SET**.
"0. ---" appears.
4. **Selecting parameter write**
Turn  to change the set value to "2WR", then press **SET**.
"2. ALL" appears.
5. **Writing to the converter**
Press **SET** to start writing the parameter settings stored in the operation panel to the converter. (It takes about 60 seconds to write all the settings. During writing, "2. ALL" blinks.)
 - Perform this step while the converter is stopped. (Parameter settings cannot be copied during operation.)
6. **End of copying**
"2WR" and "Pr-COPY" are displayed alternately after copying ends.
7. When parameters are written to the target converter, reset the converter before operation by, for example, turning the power OFF.







NOTE

- "r-E2" appears... Why?
 - Parameter write error. Perform operation from Step 3 again.

5.6.2 Parameter verification

- Whether the parameter settings of converters are the same or not can be checked.

Operating procedure

1.	Copy the parameter settings in the verification source converter to the operation panel according to the procedure on page 143 .
2.	Detach the operation panel from the source converter and attach it to the verification target converter.
3.	Turning ON the power of the converter The operation panel is in the monitor mode.
4.	Selecting the parameter setting mode Press  to choose the parameter setting mode. (The parameter number read previously appears.)
5.	Selecting a parameter Turn  to "P-R-C-P-Y" (Parameter copy), and press  . "0. -- --" appears.
6.	Parameter verification Turn  to change the setting value to "3/F4" (Parameter copy verification). Press  . Verification of the parameter settings copied to the operation panel and the parameter settings in the verification target converter is started. (It takes about 60 seconds to verify all the settings. During verification, "3/F4" blinks.) • If there are different parameters, the different parameter number and "r-E3" are displayed alternately. • To continue verification, press  .
7.	"P-R-C-P-Y" and "3/F4" are displayed alternately after verification ends.

NOTE







- "r-E3" blinks... Why?

- The set frequency may be incorrect. To continue verification, press .

5.7 Checking parameters changed from their initial values (initial value change list)

Parameters changed from their initial values can be displayed.

Operating procedure

1. Turning ON the power of the converter
The operation panel is in the monitor mode.
2. Selecting the parameter setting mode
Press  to choose the parameter setting mode. (The parameter number read previously appears.)
3. Selecting a parameter
Turn  to "Pr. CHG" (Initial value change list), and press .
"Pr. ---" appears.
4. Checking the Initial value change list
Turn . The parameter numbers that have been changed from their initial value appear in order.
 - When  is pressed with a changed parameter displayed, the setting change process of the parameter starts. (Parameter numbers are no longer displayed in the list when they are returned to their initial values.)Other changed parameters appear by turning .
 - The indication returns to "Pr. ---" when the last changed parameter is displayed.

NOTE

- The calibration parameters (C0 (Pr.900), C1 (Pr.900), C8 (Pr.930) to C11 (Pr.931)) are not displayed even when these are changed from the initial settings.
- Parameter setting using the initial value change list is also possible.

6 PROTECTIVE FUNCTIONS

This chapter explains the protective functions in the converter.
Always read the instructions before use.

6.1	Converter fault and indication	148
6.2	Reset method for the protective functions.....	148
6.3	Check and clear of the fault history	149
6.4	List of indications	151
6.5	Causes and corrective actions	153
6.6	Check first when you have a trouble	162

6.1 Converter fault and indication

When a fault occurs in the converter, a protective function is automatically activated to shut off the converter output and show an indication on the PU.

If the fault does not correspond to any of the following faults or if you have any other problem, please contact your sales representative.

- Indication: When a protective function is activated, the display on the operation panel automatically shows an indication.
- Resetting: While a protective function is activated, the converter output is kept shutdown. Reset the converter to restart the operation. (Refer to [page 148](#).)
- When any protective function is activated, take an appropriate corrective action before resetting the converter to resume the operation.
Failure to do so may break or damage the converter.

The converter indications are roughly categorized as follows.

- Error message
A message regarding operational fault or setting fault on the operation panel is displayed. The converter output is not shut off.
- Warning
The converter output is not shut off even when a warning is displayed on the operation panel. However, failure to take appropriate measures will lead to a fault.
- Alarm
The converter output is not shut off. The Alarm (LF) signal can be output depending on the parameter setting.
- Fault
When a protective function is activated, the converter output is shut off and the Fault (ALM) signal is output.

6.2 Reset method for the protective functions

◆ How to reset the converter

Reset the converter by performing any of the following operations. Note that the internal accumulated heat value of the electronic thermal relay function and the number of retries are cleared (erased) by resetting the converter.

The converter recovers about 1 second after the reset is released.

- On the operation panel, press  to reset the converter.
(This method is available only when a fault occurs. Refer to [page 156](#) for details of faults.)
- Switch OFF the converter power once, then switch it ON again.
- Turn ON the Reset (RES) signal and keep it ON for more than 0.1 seconds. (If the RES signal is kept ON, "Err" appears (blinks) to indicate that the converter is in a reset status.)

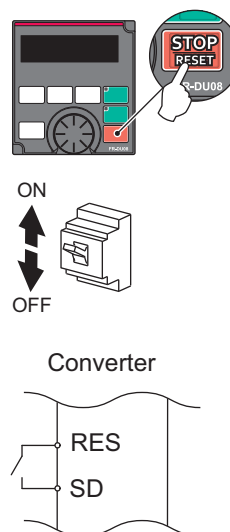

6.3 Check and clear of the fault history

◆ Check and clear of the fault history

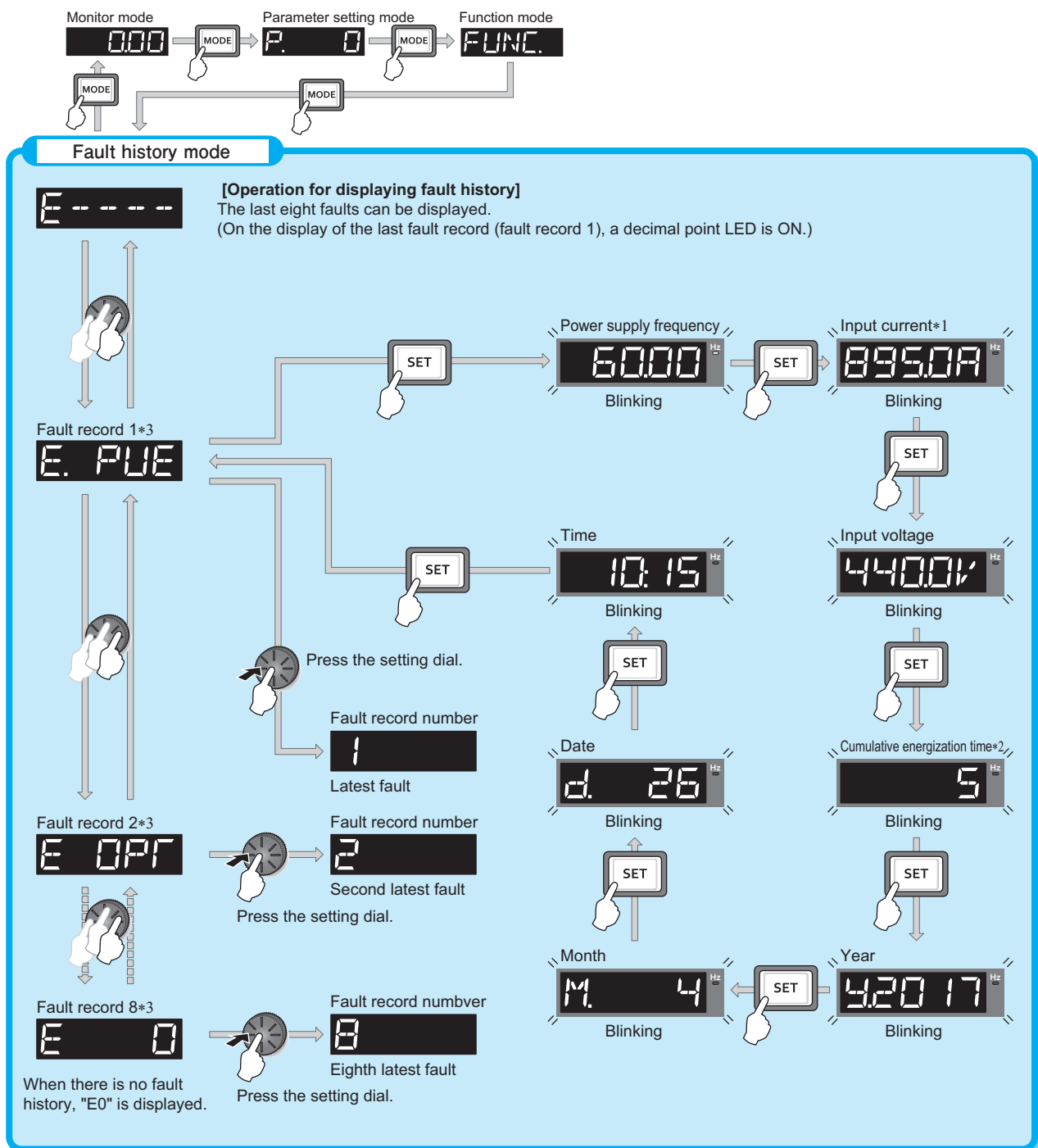



- *1 When an overcurrent trip occurs by an instantaneous overcurrent, the monitored current value saved in the fault history may be lower than the actual current that has flowed.
- *2 The cumulative energization time and actual operation time are accumulated from 0 to 65535 hours, then cleared, and accumulated again from 0.
- *3 When the converter is used as an inverter before conversion, fault records are displayed for both before and after the conversion (the indication can be switched for up to eight records).
(After the eighth fault occurs in the converted converter, only the converter's fault records will be displayed.)

◆ Clearing procedure



- Set "1" in **Err.CL Fault history clear** to clear the fault history.

Operating procedure

1. Turning ON the power of the converter
The operation panel is in the monitor mode.
2. Parameter setting mode
Press **MODE** to choose the parameter setting mode. (The parameter number read previously appears.)
3. Selecting the parameter number
Turn  until "Err.CL" (Fault history clear) appears. Press **SET** to read the present set value. "0" (initial value) appears.
4. Fault history clear
Turn  to change the set value to "1". Press **SET** to start clear.
"1" and "Err.CL" are displayed alternately after the fault history is cleared.
 - Turn  to read another parameter.
 - Press **SET** to show the setting again.
 - Press **SET** twice to show the next parameter.

6.4 List of indications

If any indication which is not shown in the following list of indications appears or if you have any other problem, please contact your sales representative.

◆ Error message

A message regarding operational troubles is displayed. The converter output is not shut off.

Operation panel indication	Name	Refer to page
HOLD	Operation panel lock	153
Er 1	Parameter write error	153
rE1 to rE4	Copy operation fault	153
Err.	Error	154

◆ Warning

- Output is not shut off when a protective function is activated.

Operation panel indication	Name	Refer to page
OL	Overload signal detection	154
TH	Electronic thermal O/L relay pre-alarm	154
SL	Power supply not detected	155
PS	PU stop	155
SA	SA	155
MF 1 to MF 3	Maintenance timer 1 to 3	155

◆ Alarm

- Output is not shut off when a protective function is activated. An alarm can also be output with a parameter setting.

Operation panel indication	Name	Refer to page
FN	Fan alarm	155

◆ Fault

- When a protective function is activated, the converter output is shut off and the Fault (ALM) signal is output. Output of the connected inverters are also shut off.
- The data code is used for checking the fault via communication or for setting **Pr.997 Fault initiation**.

Operation panel indication	Name	Data code	Refer to page
E. OCF	Overcurrent trip	19 (H13)	156
E. OVF	Overvoltage trip	35 (H23)	156
E. THF	Overload trip (electronic thermal relay function)	48 (H30)	156
E. FIN	Heat sink overheat	64 (H40)	156
E. IPF	Instantaneous power failure	80 (H50)	157
E. UVF	Undervoltage	81 (H51)	157
E. ILF	Input phase loss	82 (H52)	157
E. OMF	External thermal relay operation	144 (H90)	157
E. OPF	Option fault	160 (HA0)	157
E. VER	Invalid version	171 (HAB)	158
E. PE	Parameter storage device fault	176 (HB0)	158
E. PUE	PU disconnection	177 (HB1)	158
E. REF	Retry count excess	178 (HB2)	158
E. PE2	Parameter storage device fault	179 (HB3)	158
E. LOH	Reactor overheat	183 (HB7)	158
E. CPU	CPU fault	192 (HC0)	159
E. 5		245 (HF5)	
E. 6		246 (HF6)	
E. 7		247 (HF7)	
E. CFE	Operation panel power supply short circuit / RS-485 terminals power supply short circuit	193 (HC1)	159
E. P24	24 VDC power fault	194 (HC2)	159
E. IOH	Inrush current limit circuit fault	197 (HC5)	159
E. SAF	Safety circuit fault	201 (HC9)	160

List of indications

Operation panel indication	Name	Data code	Refer to page
E. P6F	Internal circuit fault	202 (HCA)	160
E. 13		253 (HFD)	
E. 1	Option fault	241 (HF1)	160
E. 2		242 (HF2)	
E. 3		243 (HF3)	
E. 8	Input power supply fault	248 (HF8)	160

◆Others

The fault history or the operation status of the converter is notified. It is not a fault indication.



Operation panel indication	Name	Refer to page
E - - - -	Fault history	148
E. 0	No fault history	161
E V	24 V external power supply operation	161

If any indications other than the above appear, contact your sales representative.

6.5 Causes and corrective actions

◆ Error message

A message regarding operational troubles is displayed. The converter output is not shut off.

Operation panel indication	HOLD	HOLD
Name	Operation panel lock	
Description	Operation lock is set. Operation other than  is invalid. (Refer to page 126 .)	
Check point	—	
Corrective action	Press  for 2 seconds to release the lock.	

Operation panel indication	Er1	Er 1
Name	Parameter write error	
Description	<ul style="list-style-type: none"> Parameter setting was attempted while Pr.77 Parameter write selection is set to disable parameter write. The PU and the converter cannot make normal communication. An attempt is made to change the setting of a parameter that cannot be changed during converter operation. 	
Check point	<ul style="list-style-type: none"> Parameter write was attempted while Pr.77 Parameter write selection = "1". (Refer to page 106.) Check for a connection failure between the PU and the converter. Check that the converter is stopped. 	
Corrective action	<ul style="list-style-type: none"> Set Pr.77 Parameter write selection = "2" and retry. Check the connection of the PU and the converter. After stopping the operation, make parameter setting. 	

Operation panel indication	rE1	rE 1
Name	Parameter read error	
Description	A failure has occurred at EEPROM in the operation panel during reading of the parameter settings for Parameter copy.	
Check point	—	
Corrective action	<ul style="list-style-type: none"> Perform Parameter copy again. (Refer to page 143.) The operation panel (FR-DU08) may be faulty. Contact your sales representative. 	

Operation panel indication	rE2	rE 2
Name	Parameter write error	
Description	A failure has occurred at EEPROM in the operation panel during writing of the parameter settings for Parameter copy.	
Check point	The [FWD] or [REV] LED indicator on the operation panel (FR-DU08) is blinking.	
Corrective action	The operation panel (FR-DU08) may be faulty. Contact your sales representative.	

Operation panel indication	rE3	rE 3
Name	Parameter verification error	
Description	<ul style="list-style-type: none"> The data in the converter are different from the data in the operation panel. A failure has occurred at EEPROM in the operation panel during parameter verification. 	
Check point	Check the parameter setting of the source converter against the setting of the target converter.	
Corrective action	<ul style="list-style-type: none"> Continue the verification by pressing . Perform the parameter verification again. (Refer to page 145.) The operation panel (FR-DU08) may be faulty. Contact your sales representative. 	

Causes and corrective actions

Operation panel indication	rE4	rE4
Name	Product series error	
Description	<ul style="list-style-type: none"> The series of source converter for Parameter copy or the parameter writing/verification is different from that of target converter. Parameter copy is attempted after the parameter copy reading was stopped. 	
Check point	<ul style="list-style-type: none"> Check that the verifying converter is the same model. Check that reading was not interrupted during Parameter copy by switching OFF the power or by disconnecting the operation panel. Parameter copy was attempted while Pr.77 Parameter write selection = "1". 	
Corrective action	<ul style="list-style-type: none"> Perform Parameter copy or the parameter verification between converters of the same series. Perform Parameter copy again. Set Pr.77 Parameter write selection = "2" and retry. 	

Operation panel indication	Err.	Err.
Description	<ul style="list-style-type: none"> When RES signal is ON. When the PU and the high power factor converter cannot make normal communication. (Contact faults of the connector) This error may occur when the voltage at the input side of the converter drops. When using a separate power source for the control circuit power (R1/L11, S1/L21) from the main circuit power (R4/L14, S4/L24, T4/L34), this error may appear at turning ON of the main circuit. It is not a fault indication. 	
Corrective action	<ul style="list-style-type: none"> Turn OFF the RES signal. Check the connection between the PU and the converter. Check the voltage on the input side of the converter. 	



◆ Warning

Output is not shut off when a protective function is activated.

Operation panel indication	OL	OL	FR-PU07	OL
Name	Overload signal detection			
Description	Appears when the current limit function of the converter activates.			
Check point	<ul style="list-style-type: none"> Check that the acceleration/deceleration time of the inverter is not too short. Check that the load is not too heavy. Check for any failures in peripheral devices. Check that Pr.22 Current limit level is appropriate. (Refer to page 92.) 			
Corrective action	<ul style="list-style-type: none"> Set the acceleration/deceleration time of the inverter longer. Reduce the load. Check that the peripheral devices are operating properly. The limit level of the output current can be set with Pr.22 Current limit level. (Initial value is 150%.) Set the current limit level higher with Pr.22 Current limit level. 			

Operation panel indication	TH	TH	FR-PU07	TH
Name	Electronic thermal O/L relay pre-alarm			
Description	<p>Appears if the cumulative value of the electronic thermal relay reaches or exceeds 85% of the preset level. If the specified value is reached, the protection circuit is activated to stop the converter control.</p> <p>THP signal can be simultaneously output with the [TH] display. For the terminal used for the THP signal output, set "8 (positive logic)" or "108 (negative logic)" in any of Pr.192 to Pr.194 or Pr.196 (Output terminal function selection) to assign the function. (Refer to page 129.)</p>			
Check point	Check for large load or sudden acceleration.			
Corrective action	Reduce the load and frequency of operation.			

Operation panel indication	SL	SL	FR-PU07	SL
Name	Power supply not detected			
Description	<ul style="list-style-type: none"> • Appears when the power supply detection ends incompletely at a power failure. • Appears when power is supplied only to the control circuit through terminals R1/L11 and S1/L12. • Appears when a fuse is blown in the phase detection transformer box. 			
Check point	<ul style="list-style-type: none"> • Check the power supply and the wiring. • Check the wiring for power supply detection. • Check if the fuse is blown in the phase detection transformer box. 			
Corrective action	<ul style="list-style-type: none"> • Perform wiring correctly. • Contact your sales representative. 			

Operation panel indication	PS	PS	FR-PU07	PS
Name	PU stop			
Description	The PU stop (stop of the converter operation by pressing  on the PU) is enabled by the setting of Pr.75 Reset selection/disconnected PU detection/PU stop selection . (For the details of Pr.75 , refer to page 104 .)			
Check point	Check for a stop made by pressing  of the operation panel.			
Corrective action	To reset the indication, turn ON the Converter stop (SOF) signal to stop the converter output, and press  .			

Operation panel indication	MT1 to MT3	MT 1 to MT 3	FR-PU07	MT1 to MT3
Name	Maintenance timer 1 to 3			
Description	Appears when the converter's cumulative energization time reaches or exceeds the parameter set value. Set the time until the MT is displayed using Pr.504 Maintenance timer warning output set time (MT1) , Pr.687 Maintenance timer 2 warning output set time (MT2) , and Pr.689 Maintenance timer 3 warning output set time (MT3) . MT does not appear when the settings of Pr.504 , Pr.687 , and Pr.689 are initial values (9999).			
Check point	The set time of maintenance timer has been exceeded.			
Corrective action	Take appropriate countermeasures according to the purpose of the maintenance timer setting. Setting "0" in Pr.503 Maintenance timer , Pr.686 Maintenance timer 2 , or Pr.688 Maintenance timer 3 clears the indication.			

Operation panel indication	SA	SA	FR-PU07	SA
Name	SA			
Description	Appears when the shorting wire across terminals S1 and PC or terminals S2 and PC is disconnected. (Refer to page 49 .)			
Check point	Check if the shorting wire across terminals S1 and PC or terminals S2 and PC is disconnected.			
Corrective action	<ul style="list-style-type: none"> • Short across terminals S1 and PC and across S2 and PC with shorting wire to operate the converter. • If "SA" is indicated when wires across S1 and SIC and across S2 and SIC are both conducted, internal failure might be the cause. Check the wiring of terminals S1, S2 and SIC and contact your sales representative if the wiring has no fault. 			

◆ Alarm

Output is not shut off when a protective function is activated. An alarm can also be output with a parameter setting. (Set "98" in any of **Pr.192 to Pr.194** and **Pr.196** (Output terminal function selection) (refer to [page 129](#)).

Operation panel indication	FN	FN	FR-PU07	FN
Name	Fan alarm			
Description	"FN" appears on the operation panel when the cooling fan in the converter stops due to a fault, slows down, or moves differently from the Pr.244 Cooling fan operation selection setting.			
Check point	Check the cooling fan for a failure.			
Corrective action	Check for fan failure. Please contact your sales representative.			

◆ Fault

When a protective function is activated, the converter output is shut off and the Fault (ALM) signal is output. Output of the connected inverters are also shut off.

Operation panel indication	E.OCT	E. OCT	FR-PU07	E.OCT
Name	Overcurrent trip			
Description	The converter output is shut off if the input current exceeds the specified level during operation.			
Check point	<ul style="list-style-type: none"> • Check for sudden load change. • Check for a short-circuit in the output circuit. • Check that the wiring is performed correctly. • Check that any power supply failure did not occur. 			
Corrective action	<ul style="list-style-type: none"> • Keep the load stable. • Check the wiring to make sure that output short circuit does not occur. • Check the wiring. • Check the power supply. 			

Operation panel indication	E.OVT	E. OVT	FR-PU07	E.OVT
Name	Overvoltage trip			
Description	If the converter's internal main circuit DC voltage reaches or exceeds the specified value, the protective circuit is activated to shut off the output of the converter. The circuit may also be activated by a surge voltage produced in the power supply system.			
Check point	<ul style="list-style-type: none"> • Check for sudden load change and excessive regeneration. • Check that any power supply failure did not occur. 			
Corrective action	<ul style="list-style-type: none"> • Keep the load stable. • Check the power supply. 			

Operation panel indication	E.THT	E. THT	FR-PU07	Inv. Overload
Name	Overload trip (electronic thermal relay function)*1			
Description	For the protection of transistor, electronic thermal relay is activated in inverse-time characteristics against the converter input to shut off the output of the converter.			
Check point	<ul style="list-style-type: none"> • Check the motor for the use under overload. • Check that the total capacity of the inverters used is not larger than the capacity of the converter. 			
Corrective action	<ul style="list-style-type: none"> • Reduce the load. • Reconsider the configuration of the inverters for the converter. 			

*1 Resetting the converter initializes the internal cumulative heat value of the electronic thermal O/L relay function.

Operation panel indication	E.FIN	E. FIN	FR-PU07	H/Sink O/Temp
Name	Heat sink overheat			
Description	<p>When the heat sink overheats, the temperature sensor is activated, and the converter output is shut off. The FIN signal can be output when the temperature becomes approximately 85% of the heat sink overheat protection operation temperature.</p> <p>For the terminal used for the FIN signal output, set "26 (positive logic)" or "126 (negative logic)" in any of Pr.192 to Pr.194 or Pr.196 (Output terminal function selection) to assign the function. (Refer to page 129.)</p>			
Check point	<ul style="list-style-type: none"> • Check for too high surrounding air temperature. • Check for heat sink clogging. • Check that the cooling fan is not stopped. (Check that FN is not displayed on the operation panel.) 			
Corrective action	<ul style="list-style-type: none"> • Set the surrounding air temperature to within the specifications. • Clean the heat sink. • Replace the cooling fan. 			

Operation panel indication	E.IPF	E. 1PF	FR-PU07	Inst. Pwr. Loss
Name	Instantaneous power failure			
Description	<ul style="list-style-type: none"> When a power failure occurs (or when power input to the converter is shut off), the instantaneous power failure protection function is activated to shut off the output of the converter and prevent the control circuit from malfunctioning. If a power failure persists for 100 ms or longer, the fault output is not provided, and the converter and the inverter restart if the start signal is ON upon power restoration. In some operating status (load magnitude, acceleration/deceleration time setting of the inverter, etc.), overcurrent or other protection may be activated upon power restoration. The IPF signal is output when a power failure is detected. (Refer to page 129.) When a fuse is blown in the phase detection transformer box, the converter output is shut off. 			
Check point	<ul style="list-style-type: none"> Find the cause of instantaneous power failure occurrence. Check if the fuse is blown in the phase detection transformer box. 			
Corrective action	<ul style="list-style-type: none"> Remedy the instantaneous power failure. Prepare a backup power supply for instantaneous power failure. Set the function of automatic restart after instantaneous power failure (Pr.57). (Refer to page 101.) If a fuse is blow in the transformer box, contact your sales representative. 			

Operation panel indication	E.UVT	E. UVF	FR-PU07	Under Voltage
Name	Undervoltage			
Description	If the power supply voltage of the converter decreases, the control circuit will not perform normal functions. To prevent this, the converter output is shut off when the power supply voltage drops to about 300 VAC or lower.			
Check point	Check if a high-capacity motor is driven.			
Corrective action	Check the power supply system equipment such as the power supply. If the problem still persists after taking the above measure, contact your sales representative.			

Operation panel indication	E.ILF	E. 1LF	FR-PU07	Input phase loss
Name	Input phase loss			
Description	<ul style="list-style-type: none"> This protective function is activated when any of the three phases of power input is lost. When a fuse is blown in the phase detection transformer box, the converter output is shut off. 			
Check point	<ul style="list-style-type: none"> Check for a break in the cable for the three-phase power supply input. Check if the fuse is blown in the phase detection transformer box. 			
Corrective action	<ul style="list-style-type: none"> Wire the cables properly. Repair a break portion in the cable. If a fuse is blow in the transformer box, contact your sales representative. 			

Operation panel indication	E.OHT	E. OHF	FR-PU07	OH Fault
Name	External thermal relay operation			
Description	If an overheat protection device such as a thermostat is activated, the converter output is shut off. This function is available when "7" (OH signal) is set in any of Pr.178 to Pr.189 (input terminal function selection) . This protective function is not available in the initial status. (OH signal is not assigned.)			
Check point	<ul style="list-style-type: none"> Check for the overheat of a thermostat or other similar peripheral devices. Check if the input specification (NO/NC contact) of the OH signal is incorrect. 			
Corrective action	<ul style="list-style-type: none"> Check the wiring. Use Pr.9 OH input selection to change the input specification. (Refer to page 91.) Even if the thermostat restarts automatically, the converter does not restart unless it is reset. 			

Operation panel indication	E.OPT	E. OPF	FR-PU07	Option Fault
Name	Option fault			
Description	When the FR-A8AVP is not installed in the converter, the converter output is shut off.			
Check point	<ul style="list-style-type: none"> Check that the FR-A8AVP is not removed from the converter. Check for a contact fault between the FR-A8AVP and the converter. 			
Corrective action	Install the FR-A8AVP to the converter correctly.			

Causes and corrective actions

Operation panel indication	E.VER	E. VER	FR-PU07	Fault
Name	Invalid version			
Description	Appears when an incompatible FR-A8AVP is used for the converter.			
Check point	Check if the FR-A8AVP installed at the time of conversion to the converter was removed, and another FR-A8AVP with a different firmware version has been installed.			
Corrective action	Install the correct FR-A8AVP which was used for conversion to the converter. First, convert the converter back into the inverter, and then convert the inverter into the converter again.			

Operation panel indication	E.PE	E. PE	FR-PU07	Corrupt Memry
Name	Parameter storage device fault (control circuit board)			
Description	The converter output is shut off if a fault occurs in the parameters stored. (EEPROM failure)			
Check point	Check for too many number of parameter write times.			
Corrective action	Contact your sales representative. Set "1" in Pr.342 (write to RAM) for the operation which requires frequent parameter writing via communication, etc. Note that writing to RAM goes back to the initial status at power OFF.			

Operation panel indication	E.PUE	E. PUE	FR-PU07	PU Leave Out
Name	PU disconnection			
Description	The converter output is shut off if communication between the converter and PU is suspended, e.g. the operation panel or parameter unit is disconnected, when the disconnected PU detection function is enabled by Pr.75 Reset selection/disconnected PU detection/PU stop selection. This protective function is not enabled in the initial setting (Pr.75 = "14").			
Check point	<ul style="list-style-type: none"> • Check that the FR-DU08 or the parameter unit (FR-PU07) is connected properly. • Check the Pr.75 setting. 			
Corrective action	Install FR-DU08 or the parameter unit (FR-PU07) securely.			

Operation panel indication	E.RET	E. RET	FR-PU07	Retry No Over
Name	Retry count excess			
Description	If operation cannot be resumed properly within the number of retries set, this function shut off the output of the converter. This function is enabled when Pr.67 Number of retries at fault occurrence is set. This protective function is disabled in the initial setting (Pr.67 = "0").			
Check point	Find the cause of the fault occurrence.			
Corrective action	Eliminate the cause of the error preceding this error indication.			

Operation panel indication	E.PE2	E. PE2	FR-PU07	PR storage alarm
Name	Parameter storage device fault (main circuit board)			
Description	The converter output is shut off if a fault occurs in the parameters stored. (EEPROM failure)			
Check point				
Corrective action	Contact your sales representative.			

Operation panel indication	E.LOH	E. LOH	FR-PU07	Fault
Name	Reactor overheat			
Description	When the reactor is overheated, the converter output is shut off. (This function is not available when power is supplied only to the control circuit.)			
Check point	<ul style="list-style-type: none"> • The reactor 1 or 2 is not connected. • Check the wiring between the overheat detection thermostat of reactor and the terminal to which the LOH signal is assigned. • The fan power terminals for the reactors 1 and 2 are not connected to the MC power supply stepdown transformer. 			
Corrective action	<ul style="list-style-type: none"> • Connect the reactors 1 and 2. • Correct the wiring between the overheat detection thermostat of reactor and the terminal to which the LOH signal is assigned. • Correct the wiring between the MC power supply stepdown transformer and the fan power terminals for the reactors 1 and 2. 			

Operation panel indication	E. 5	E. 5	FR-PU07	Fault 5
	E. 6	E. 6		Fault 6
	E. 7	E. 7		Fault 7
	CPU	E. CPU		CPU Fault
Name	CPU fault			
Description	The converter output is shut off if the communication fault in the built-in CPU occurs.			
Check point	Check for devices producing excess electrical noises around the converter.			
Corrective action	<ul style="list-style-type: none"> Take measures against noises if there are devices producing excess electrical noises around the high power factor converter. Contact your sales representative. 			

Operation panel indication	E.CTE	E. CTE	FR-PU07	E.CTE
Name	Operation panel power supply short circuit, RS-485 terminal power supply short circuit			
Description	<p>When the operation panel power supply (PU connector) is short circuited, this function shuts off the power output and stops the converter. The use of the operation panel (parameter unit) and the RS-485 communication via the PU connector are disabled. To reset, enter RES signal, or switch power OFF then ON again.</p> <p>When the power supply for the RS-485 terminals are short circuited, this function shuts off the power output. At this time, the use of the RS-485 communication via the RS-485 terminals are disabled.</p> <p>To reset, use  of the operation panel, enter the RES signal, or switch power OFF then ON again.</p>			
Check point	<ul style="list-style-type: none"> Check that the PU connector cable is not shorted. Check that the RS-485 terminals are connected correctly. 			
Corrective action	<ul style="list-style-type: none"> Check PU and the cable. Check the connection of the RS-485 terminals. 			

Operation panel indication	E.P24	E. P24	FR-PU07	E.P24
Name	24 VDC power output short circuit			
Description	When the 24 VDC power output from the PC terminal is shorted, this function shuts off the power output. At this time, all external contact inputs switch OFF. The inverter cannot be reset by inputting the RES signal. To reset it, use the operation panel, or switch power OFF, then ON again.			
Check point	<ul style="list-style-type: none"> Check for a short circuit in the PC terminal output. Check that the 24 V external power supply voltage is correct. 			
Corrective action	<ul style="list-style-type: none"> Repair the short-circuited portion. Supply the power at 24 V. (If the power with insufficient voltage is supplied to the 24 V input circuit for a long time, the inverter internal circuit may heats up. Although it will not damage the inverter, supply power at the correct voltage .) 			

Operation panel indication	E.IOH	E. IOH	FR-PU07	Inrush overheat
Name	Inrush current limit circuit fault			
Description	<p>Stops the converter operation when the inrush current limit contactor does not turn ON or a thermostat of the inrush current limit resistor is activated.</p> <p>The inrush current limit circuit is faulty.</p> <p>When the terminal PC and SD are shorted, the ROH signal turns OFF and the converter output is shut off.</p>			
Check point	<ul style="list-style-type: none"> Check the wiring between the resistor thermostat and the terminal to which the ROH signal is assigned. Check that the inrush current limit circuit contactor and buffer circuit are not damaged. Check that frequent power ON/OFF is not repeated. Check that the resistor thermostat is connected with the terminal to which the ROH signal is assigned. Check for a short circuit between terminals PC and SD. 			
Corrective action	<ul style="list-style-type: none"> Connect the resistor thermostat with the terminal to which the ROH signal is assigned. Configure a circuit where frequent power ON/OFF is not repeated. Check the wiring between the resistor thermostat and the terminal to which the ROH signal is assigned. Check the wiring between terminals PC and SD. <p>If the problem still persists after taking the above measure, contact your sales representative.</p>			

Causes and corrective actions

Operation panel indication	E.SAF	E. SAF	FR-PU07	Safety circuit fault
Name	Safety circuit fault			
Description	<ul style="list-style-type: none"> The converter output is shut off when a safety circuit fault occurs. The converter output is shut off when the shorting wire across terminals S1 and PC or terminals S2 and PC is disconnected. 			
Check point	Check if the shorting wire across terminals S1 and PC or terminals S2 and PC is disconnected.			
Corrective action	<ul style="list-style-type: none"> Short across terminals S1 and PC and terminals S2 and PC with shortening wires. (Refer to page 55.) If this fault occurs even though the shorting wire across the terminals S1 and PC or the terminals S2 and PC is connected, contact your sales representative. 			

Operation panel indication	E.PBT	E. PBT	FR-PU07	E.PBT
	E.13	E. 13		Fault 13
Name	Internal circuit fault			
Description	The converter output is shut off when an internal circuit fault occurs.			
Corrective action	Contact your sales representative.			

Operation panel indication	E. 1 to E. 3	E. 1 to E. 3	FR-PU07	Fault 1 to Fault 3
Name	Option fault			
Description	<ul style="list-style-type: none"> The converter output is shut off when a plug-in option other than the FR-A8AVP is installed in the converter, or the FR-A8AVP is not recognized by the converter due to a contact fault or other reason. Appears if the switch for manufacturer setting of the FR-A8AVP has been changed. 			
Check point	<ul style="list-style-type: none"> Check that a plug-in option other than the FR-A8AVP is installed in the converter. Check that FR-A8AVP is connected to the connector securely. (1 to 3 indicate connector numbers for connection of the option.) Check for excess electrical noises around the high power factor converter. 			
Corrective action	<ul style="list-style-type: none"> Connect the FR-A8AVP securely. Take measures against noises if there are devices producing excessive electrical noises around the converter. If the situation does not improve after taking the above measure, please contact your sales representative. Set the manufacturer setting switch on the FR-A8AVP back to the initial setting. (Refer to page 9.) 			

Operation panel indication	E.8	E. 8	FR-PU07	Fault 8
Name	Input power supply fault			
Description	<ul style="list-style-type: none"> When a fault is detected in the power supply frequency, When the phase detection cannot be performed for the normal power supply, When an overvoltage occurs during power failure or at an input phase loss. When the power supply amplitude changes suddenly, When a fuse is blown in the phase detection transformer box, it is regarded as a power supply fault, and the outputs of the converter and the inverter are stopped. 			
Check point	<ul style="list-style-type: none"> Check the power supply and the wiring. Check if the fuse is blown in the phase detection transformer box. 			
Corrective action	<ul style="list-style-type: none"> Perform wiring correctly. If a fuse is blow in the transformer box, contact your sales representative. 			

◆Others

Indicates the status of the converter. It is not a fault indication.

Operation panel indication	E.0	<i>E. 0</i>	FR-PU07	No Alarm
Name	No fault history			
Description	Appears when no fault records are stored. (Appears when the fault history is cleared after the protective function has been activated.)			

Operation panel indication	EV	<i>EV</i>	FR-PU07	EV
Name	24 V external power supply in operation			
Description	Blinks when the main circuit power supply is off and the 24 V external power supply is being input.			
Check point	Power is supplied from a 24 V external power supply.			
Corrective action	<ul style="list-style-type: none"> • Turning ON the power supply (main circuit) of the converter clears the indication. • If the indication is still displayed after turning ON of the power supply (main circuit) of the converter, the power supply voltage may be low. 			

 **NOTE**

- If faults other than the above appear, contact your sales representative.

6.6 Check first when you have a trouble

Condition	Check point
The converter does not operate properly.	Check the following about connection: <ul style="list-style-type: none"> ● Wiring is performed correctly. ● Appropriate power supply voltage is applied. ● The phase sequence is correct. ↳ When the phase sequence is correct, check for the short circuit across terminals SOF and SD and across terminals RES and SD.
The power lamp is OFF.	Check the following about connection: <ul style="list-style-type: none"> ● Connection is performed correctly. ● Wiring for the main circuit terminals R4/L14, S4/L24, and T4/L34 is performed correctly. ● The inrush current limit resistor is not damaged.
The charge lamp on the converter does not come on.	Check the following about connection: <ul style="list-style-type: none"> ● Connection is performed correctly. ● Wiring for the main circuit terminals R4/L14, S4/L24, and T4/L34 is performed correctly.
Reactor heats up abnormally.	Check the following about connection: <ul style="list-style-type: none"> ● Check if the sequence of the reactors 1 and 2 is correct.
The inverter does not run.	Check the following about the setting: The parameter settings in the inverter are appropriate. (Parameter setting method differs by the inverter series. For the parameter setting method, refer to page 23)
Unusual noises are generated from the reactor.	The phase sequence is correct.
A breaker trips.	Check the following about connection: <ul style="list-style-type: none"> ● Wiring is performed correctly. ● Appropriate power supply voltage is applied. ● The phase sequence is correct. Identify the cause of the trip and remove it before turning ON the power of the breaker.

7 PRECAUTIONS FOR MAINTENANCE AND INSPECTION

This chapter explains the precautions for maintenance and inspection of the converter.

Always read the instructions before use.

7.1	Inspection item.....	164
7.2	Measurement of main circuit voltages, currents, and powers.....	172

Inspection item

The converter is a static unit mainly consisting of semiconductor devices. Daily inspection must be performed to prevent any fault from occurring due to the adverse effects of the operating environment, such as temperature, humidity, dust, dirt and vibration, changes in the parts with time, service life, and other factors.

- Precautions for maintenance and inspection

When accessing the converter for inspection, wait for at least 10 minutes after the power supply has been switched OFF. Then, make sure that the voltage across the main circuit terminals P/+ and N/- on the converter is not more than 30 VDC using a tester, etc.



CAUTION

- **Reactor 1 and reactor 2 are extremely hot. Take caution not to get burned.**

7.1 Inspection item

7.1.1 Daily inspection

Basically, check for the following faults during operation.

- Improper installation environment
- Cooling system fault
- Abnormal vibration, abnormal noise
- Abnormal overheat, discoloration

7.1.2 Periodic inspection

Check the areas inaccessible during operation and requiring periodic inspection.

Consult us for periodic inspection.

- Check for cooling system fault.Clean the air filter, etc.
- Check the tightening and retighten.The screws and bolts may become loose due to vibration, temperature changes, etc. Check and tighten them.
Tighten them according to the specified tightening torque. (Refer to [page 38](#).)
- Check the conductors and insulating materials for corrosion and damage.
- Measure the insulation resistance.
- Check and change the cooling fan and relay.

7.1.3 Daily and periodic inspection list

Area of inspection	Inspection Item	Description	Inspection interval		Corrective action at fault occurrence	Check by the user	
			Daily	Periodic *3			
General	Surrounding environment	Check the surrounding air temperature, humidity, dirt, corrosive gas, oil mist, etc.	○		Improve the environment.		
	Overall unit	Check for unusual vibration and noise.	○		Check fault location and retighten.		
		Check for dirt, oil, and other foreign material.*1	○		Clean.		
	Power supply voltage	Check that the main circuit voltage and control circuit voltage are normal.*2	○		Inspect the power supply.		
Main circuit	General	(1) Check with megger (between main circuit terminals and earth (ground) terminal).		○	Contact the manufacturer.		
		(2) Check for loose screws and bolts.		○	Retighten.		
		(3) Check for overheat traces on the parts.		○	Contact the manufacturer.		
		(4) Check for stains.		○	Clean.		
	Conductors and cables	(1) Check conductors for distortion.		○	Contact the manufacturer.		
		(2) Check cable sheaths for breakage and deterioration (crack, discoloration, etc.).		○	Contact the manufacturer.		
	Transformer/reactor	Check for unusual odor and abnormal increase of whining sound.	○		Stop the equipment and contact the manufacturer.		
	Terminal block	Check for a damage.		○	Stop the equipment and contact the manufacturer.		
	Smoothing aluminum electrolytic capacitor	(1) Check for liquid leakage.		○	Contact the manufacturer.		
		(2) Check for safety valve projection and bulge.		○	Contact the manufacturer.		
(3) Visual check			○				
Relay/contactor	Check that the operation is normal and no chattering sound is heard.		○	Contact the manufacturer.			
Control circuit Protective circuit	Operation check	Check that no fault is found in protective and display circuits in a sequence protective operation test.		○	Contact the manufacturer.		
	Components check	Overall	(1) Check for unusual odor and discoloration.		○	Stop the equipment and contact the manufacturer.	
			(2) Check for serious rust development.		○	Contact the manufacturer.	
		Aluminum electrolytic capacitor	(1) Check for liquid leakage in a capacitor and deformation trace.		○	Contact the manufacturer.	
			(2) Visual check		○		
Cooling system	Cooling fan	(1) Check for unusual vibration and noise.	○		Replace the fan.		
		(2) Check for loose screws and bolts.		○	Retighten.		
		(3) Check for stains.		○	Clean.		
	Heat sink	(1) Check for clogging.		○	Clean.		
		(2) Check for stains.		○	Clean.		
	Air filter, etc.	(1) Check for clogging.		○	Clean or replace.		
(2) Check for stains.			○	Clean or replace.			
Display	Indication	(1) Check that indications are correct.	○		Contact the manufacturer.		
		(2) Check for stains.		○	Clean.		
	Meter/counter	Check that readouts are correct.	○		Stop the equipment and contact the manufacturer.		

*1 Oil component of the heat dissipation grease used inside the converter may leak out. The oil component, however, is not flammable, corrosive, nor conductive and is not harmful to humans. Wipe off such oil component.

*2 It is recommended to install a device to monitor voltage for checking the power supply voltage to the converter.

*3 One to two years of periodic inspection cycle is recommended. However, it differs according to the installation environment. Consult us for periodic inspection.

NOTE

- Continuous use of a leaked, deformed, or degraded smoothing aluminum electrolytic capacitor (as shown in the table above) may lead to a burst, breakage, or fire. Replace such capacitor without delay.

7.1.4 Continuity test

◆Preparation

- Disconnect the external power cables from terminals R4/L14, S4/L24, T4/L34, P/+, and N/-.
- Prepare a continuity tester. (For the resistance measurement, use the 100 Ω range.)

◆Checking method

Change the polarity of the tester alternately at a semiconductor device (transistor) on an electrical path between two terminals among the converter main circuit terminals R4/L14, S4/L24, T4/L34, P/+, and N/- to check the electric continuity.

NOTE

- Before measurement, check that the smoothing capacitor is discharged.
- At the time of electric discontinuity, the measured value is almost ∞. When there is an instantaneous electric continuity, due to the smoothing capacitor, the tester may not indicate ∞. At the time of electric continuity, the measured value is several Ω to several tens of Ω. If all measured values are almost the same, although these values are not constant depending on the module type and tester type, the modules are without fault.

◆Device number and target terminal

Device No.	Tester polarity		Continuity
	⊕	⊖	
TR1	R4/L14	P/+	No
	P/+	R4/L14	Yes
TR2	T4/L34	N/-	Yes
	N/-	T4/L34	No
TR3	S4/L24	P/+	No
	P/+	S4/L24	Yes
TR4	R4/L14	N/-	Yes
	N/-	R4/L14	No
TR5	T4/L34	P/+	No
	P/+	T4/L34	Yes
TR6	S4/L24	N/-	Yes
	N/-	S4/L24	No

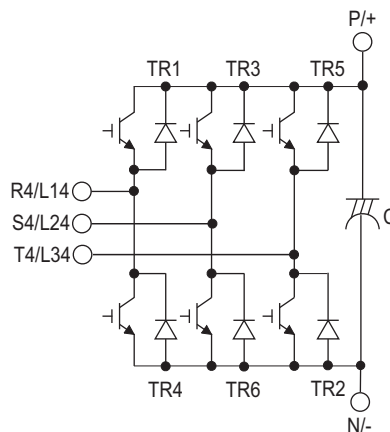

(Assuming that an analog meter is used.)

7.1.5 Cleaning

Always run the converter in a clean status.

When cleaning the converter, gently wipe dirty areas with a soft cloth immersed in neutral detergent.

NOTE

- Do not use solvent, such as acetone, benzene, toluene and alcohol, as these will cause the converter surface paint to peel off.
- The display, etc. of the operation panel (FR-DU08) and parameter unit (FR-PU07) are vulnerable to detergent and alcohol. Therefore, avoid using them for cleaning.

7.1.6 Replacement of parts

Each of the converter, reactor 1, and reactor 2 consists of many electronic parts such as semiconductor devices. The following parts may deteriorate with age because of their structures or physical characteristics, leading to reduced performance or fault of the converter, reactor 1, or reactor 2. For preventive maintenance, the parts must be replaced periodically.

- The standard replacement interval of the converter parts is as follows.

Part name	Estimated lifespan* ₁	Description
Cooling fan	10 years	Replace (as required).
Main circuit smoothing capacitor	10 years* ₂	Replace (as required).
On-board smoothing capacitor	10 years* ₂	Replace the board (as required).
Relays	—	As required.
Main circuit fuse	10 years	Replace (as required).

- The standard replacement interval of the reactor parts is as follows.

Part name	Estimated lifespan* ₁	Description
Cooling fan	10 years	Replace (as required).

*1 Estimated lifespan for when the yearly average surrounding air temperature is 40°C (without corrosive gas, flammable gas, oil mist, dust and dirt etc.)

*2 Input current: 80% of the converter rating



- For replacement of each part, contact the nearest Mitsubishi Electric FA center.

◆ Replacement procedure of the cooling fan

The replacement interval of the cooling fan used for cooling the parts generating heat such as the main circuit semiconductor is greatly affected by the surrounding air temperature. When unusual noise and/or vibration are noticed during inspection, the cooling fan must be replaced immediately.

◆ Removal of the cooling fan of the converter

- 1) Remove the fan cover fixing screws, and remove the fan cover.
- 2) Disconnect the fan connector and remove the fan block.
- 3) Remove the fan fixing screws, and remove the fan.

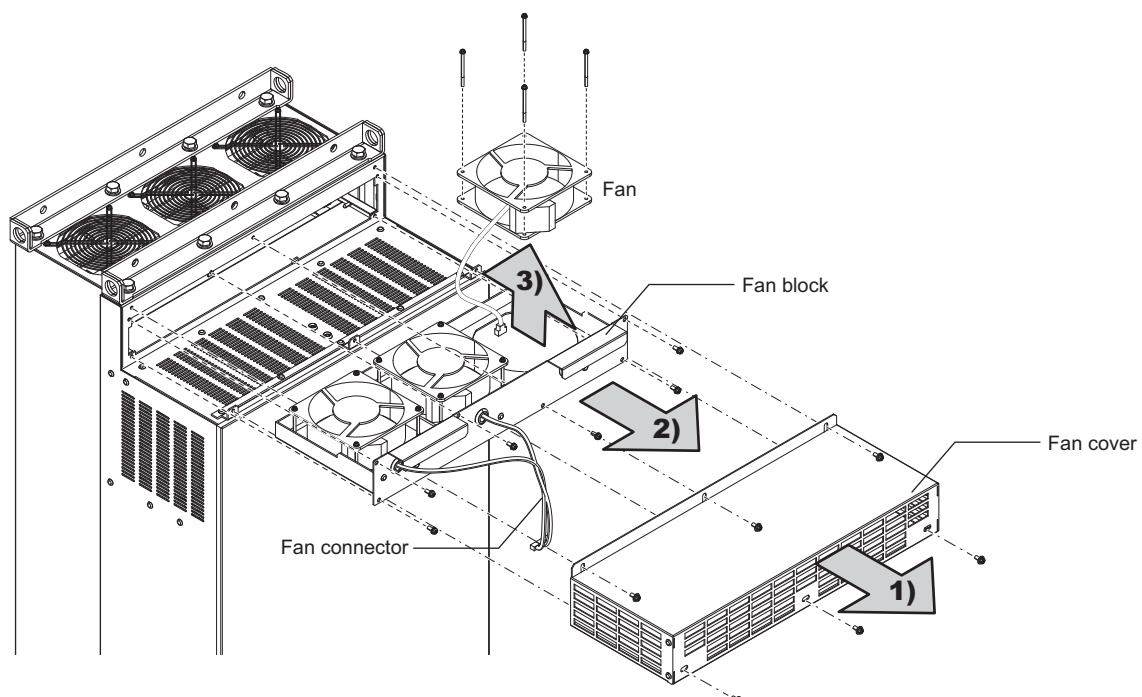

◆ Replacement of the cooling fan of the reactors

- Remove/connect the fan block from/to the reactor as follows.

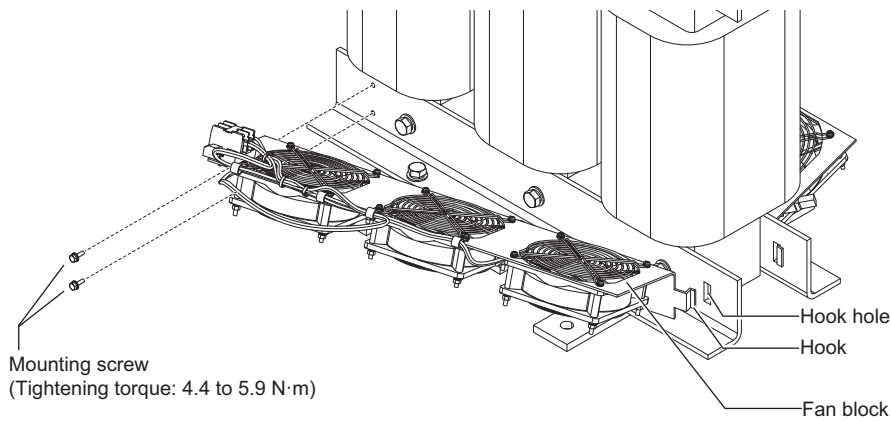

- Remove/connect the fan from/to the fan block as follows.

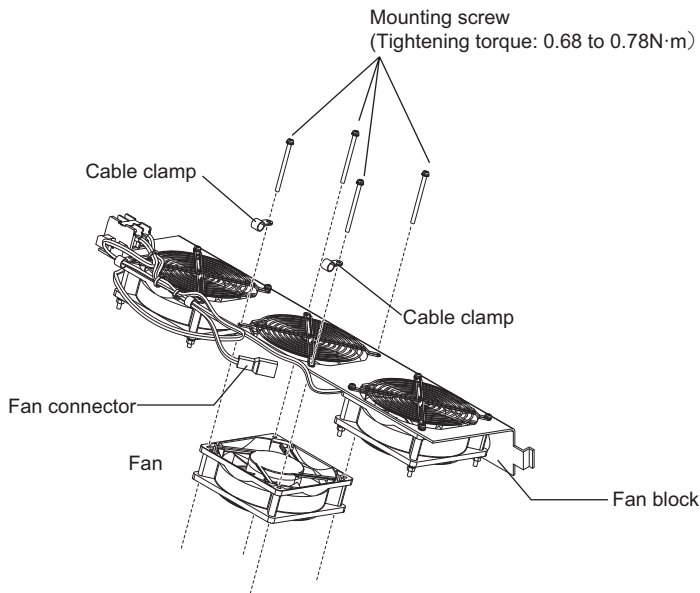

NOTE

- The fan block has a hook. To remove the fan block from the reactor, first pull the hook-less side of the fan block away from the reactor, and then disengage the hook from the hole, as shown in the first figure above.
- When fitting the cooling fan into the fan block, first pass the fan cable through the cable clamps if the clamps have been removed for removal of the fan. Next, fasten the fan to the fan block using the mounting screws (some of them passing through holes in the clamps). Improper installation may damage the fan. For example, loose fan wires may get caught in the fan.

◆ Installation orientation of the cooling fan of the converter and reactors

After confirming the orientation of the fan, reinstall the fan so that the "AIR FLOW" faces up.

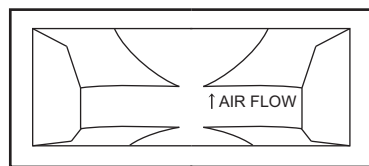

<Fan side view>

NOTE

- Installing the cooling fan in the opposite direction may shorten the product life.
- Installing the reactor cooling fan in the opposite direction may cause overheating of the reactor, which results in activation of the converter protective function (E.LOH).
- Prevent the cable from being caught when installing a fan.
- Switch the power OFF before replacing fans. Since the converter circuits are charged with voltage even after power OFF, replace fans only when the converter cover is on the converter to prevent an electric shock accident.

◆ Smoothing capacitors

A large-capacity aluminum electrolytic capacitor is used for smoothing in the DC section of the main circuit, and an aluminum electrolytic capacitor is used for stabilizing the control power in the control circuit. Adverse effects from ripple currents deteriorate capacitors. Replacement intervals of capacitors vary greatly with surrounding temperatures and operating conditions. Replace them roughly every 10 years when used in normal air-conditioned environments.

When a certain period of time has elapsed, capacitors will deteriorate more rapidly. Check capacitors at least every year (less than six months if the life will be expired soon).

Check the following during inspection to determine the end of product life.

- Case: Check that the sides and bottom of the capacitor have not ruptured.
- Rubber seal: Check for any noticeable bulging or severe cracks.
- Top (vent): Check for swollen, open, or exploded vent.
- Others: Check for external cracks, discoloration, and leakage.

◆ Relay output terminals

The contacts of relays deteriorate over time. To prevent faults from occurring, relays must be replaced when they have reached the maximum number of switching operations (switching life).

The control circuit terminal block on the converter must be replaced in case of failure of either relay connected to the relay output terminals A1, B1, and C1, or terminals A2, B2, and C2. (Refer to [page 171](#).)

◆ Main circuit fuse

Fuses are used in some converters. The surrounding air temperature and operating condition affect the life of fuses. When the inverter is used in a normal air-conditioned environment, replace its fuse after about 10 years.

7.1.7 Removal and reinstallation of the control circuit terminal block

The FR-A800 series inverter has a removable control circuit terminal block, which can be replaced with a new one or a control terminal option.

◆ Removal and reinstallation

- 1) Loosen the two mounting screws at the both side of the control circuit terminal block. (These screws cannot be removed.) Slide down the control circuit terminal block to remove it.

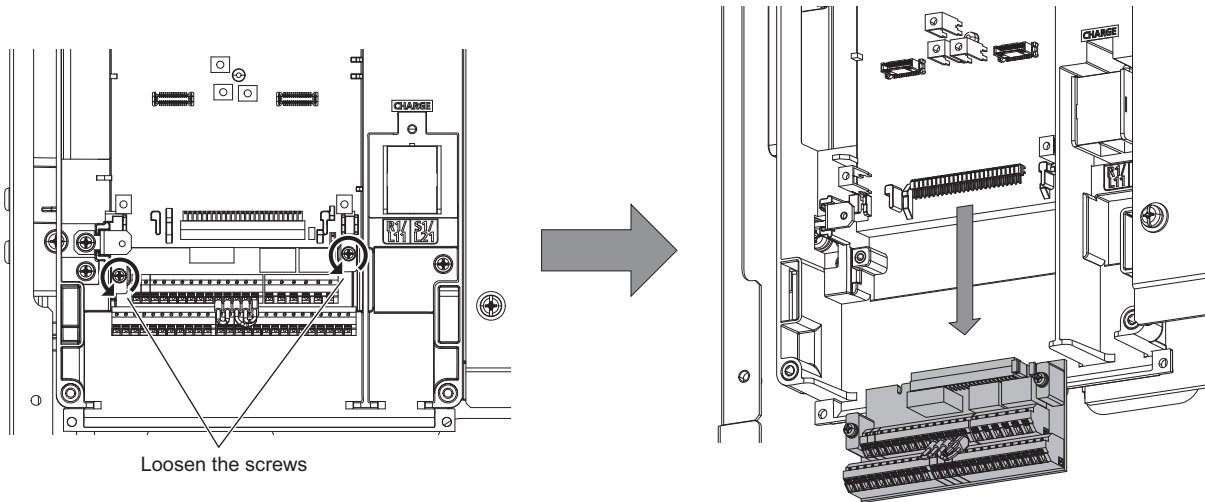

- 2) Be careful not to bend the pins of the converter's control circuit connector, reinstall the control circuit terminal block and fix it with the mounting screws.

NOTE

- Before starting converter replacement, switch power OFF, wait for at least 10 minutes, and then check the voltage with a tester and such to ensure safety.

◆ Removal and reinstallation precautions

Precautions to be taken when removing or reinstalling the control circuit terminal block are shown below.

Observe the following precautions and handle the converter properly to avoid malfunctions or failures.

- To remove or reinstall the control circuit terminal block, keep it upright so that it is parallel with the converter.
- To install the control circuit terminal block, slide it upward so that the tongues on the converter slot into the grooves on the terminal block.
- Check that the terminal block is parallel to the converter and the pins on the inverter control circuit connector are not bent.

After checking proper connection, fix the terminal block in place with two screws.

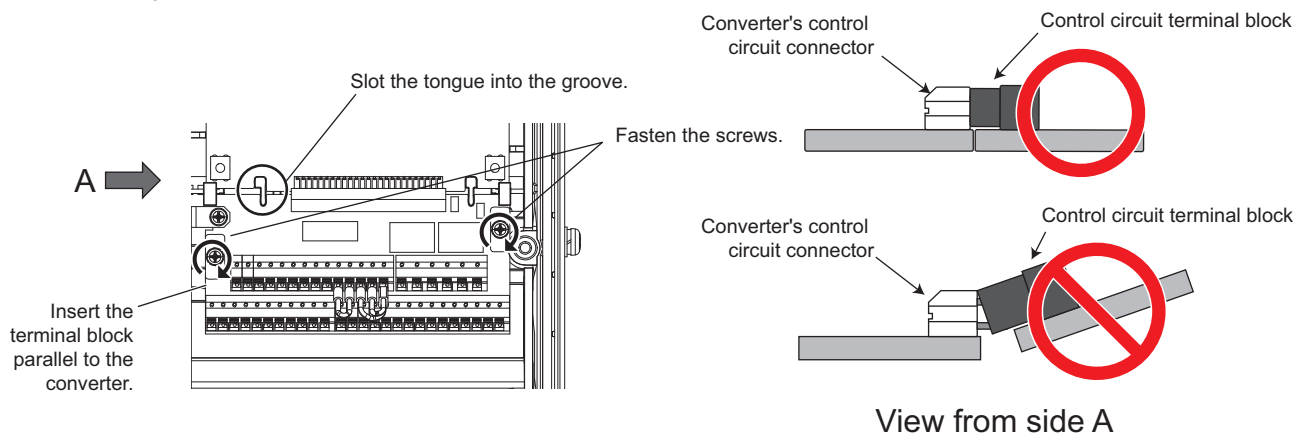

NOTE

- Do not tilt the terminal block while tightening the screws or removing it from the converter. (Otherwise, stress applied to the control circuit terminal block or the control circuit connector may damage the pins.)
- After replacing the control terminal block, connect the jumper connector to the correct position in accordance with the control logic of input signals. (Refer to [page 53](#).)

7.2 Measurement of main circuit voltages, currents, and powers

- Measurement method of voltage and current at each section:
When instruments for commercial frequency are used for measurement, measure the following circuits with the instruments given below.
- When installing meters etc. on the output side of the high power factor converter:
When the converter-to-inverter wiring length is long, the meters may generate heat due to line-to-line leakage current. Therefore, choose the equipment which has enough allowance for the current rating.
- The output voltage across terminals P/+ and N/- on the converter can be measured with a moving-coil type meter (tester).
The voltage varies according to the power supply voltage. The voltage decreases when a load is applied.

◆ Examples of measuring points and instruments

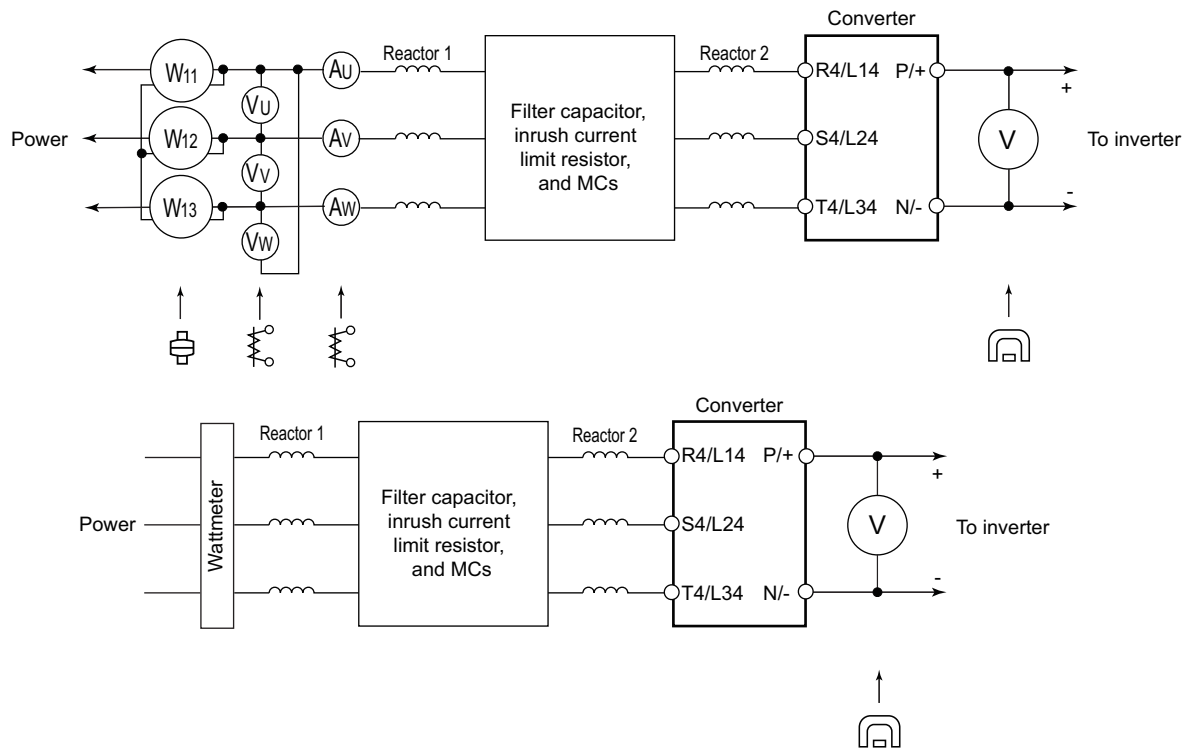

◆ Operation principle and application to electric meters

Type	Symbol	Operation principle	Measurement	Applicable meter	Characteristics
Moving-coil type		Uses kinetic energy generated between the magnetic field of a permanent magnet and the current that flows through the moving-coil.	DC (Average)	Voltmeter/ ammeter/ resistance meter/ thermometer/ flux meter/ speed meter	Highly sensitive and commonly used. Low energy consumption, small influence of external magnetic field.
Moving-iron		Uses kinetic energy generated between the moving-iron and the magnetic field of the current that flows through the fixed coil.	AC (RMS)	Voltmeter/ ammeter	Strongly build and inexpensive. Large influence of external magnetic field, frequency, and waveform.
Electrodynamic	Air-core coil 	Uses kinetic energy generated between the currents that flow through two different coils.	AC/DC (RMS)	Wattmeter/ voltmeter/ ammeter	Scale is divided equally when using a wattmeter. Large influence of external magnetic field, high energy consumption. This can be used as a standard meter for AC and DC.

◆ Measuring points and instruments

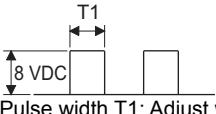
Item	Measuring point	Measuring instrument	Remarks (reference measured value)
Input voltage V ₁	Across terminals R4/L14 and S4/L24, S4/L24 and T4/L34, and T4/L34 and R4/L14.	Moving-iron type AC voltmeter* ₁	Commercial power, within permissible AC voltage fluctuation. (Refer to page 176.)
Input current I ₁	Line current at terminal R4/L14, S4/L24, and T4/L34	Moving-iron type AC ammeter* ₁	
Input power P ₁	At terminals R4/L14, S4/L24, T4/L34 and across terminals R4/L14 and S4/L24, S4/L24 and T4/L34, and T4/L34 and R4/L14.	Electrodynamic single-phase wattmeter	P ₁ = W ₁₁ + W ₁₂ + W ₁₃ (3-wattmeter method)
Input power factor Pf ₁	Calculate after measuring power supply voltage, power supply side current and power supply side power. $Pf_1 = \frac{P_1}{\sqrt{3}V_1 \times I_1} \times 100\%$		
Converter output	Across P/+ and N/-	Moving-coil type instrument (such as tester)	A measured value can be monitored on the PU. Reference value: 1.35 × V ₁ Maximum value: 760 V (during regenerative driving)
Signal for indication on external meters	Across terminals AM and 5	Moving-coil type (Tester and such may be used, with internal resistance 50 kΩ or more.)	Approximately 10 VDC at maximum frequency (without frequency meter)
	Across terminals CA and 5		Approximately 20 mADC at maximum frequency
	Across FM(+) and SD		Approximately 5 VDC at maximum frequency (without meter)  Pulse width T1: Adjust with C0 (Pr.900).
Input signal	At terminals RES and SOF and across terminals ROH(+) and SD		Voltage when terminal is open: 20 to 30 VDC Voltage when signal is ON: 1 V or less
Fault signal	Across terminals A and C Across terminals B and C	Moving-coil type (such as tester)	Continuity check* ₂ [Normal] [Fault] Across A and C Discontinuity Continuity Across B and C Continuity Discontinuity

*1 A digital power meter (designed for inverter) can also be used to measure.

*2 When the setting of Pr.196 ABC2 terminal function selection is the positive logic

7.2.1 Insulation resistance test using megger

- For the converter, conduct the insulation resistance test on the main circuit only as shown below and do not perform the test on the control circuit. (Use a 500 VDC megger.)

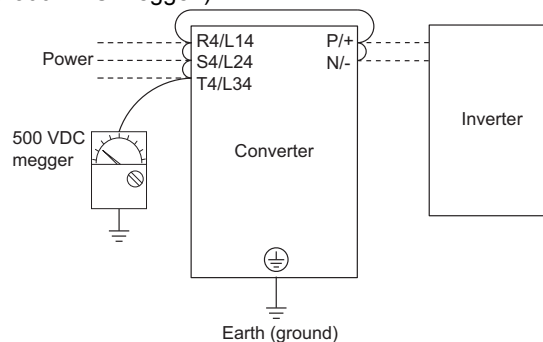

⚠ CAUTION

- Before performing the insulation resistance test on the external circuit, disconnect the cables from all terminals of the converter so that the test voltage is not applied to the converter.
- For the continuity test of the control circuit, use a tester (high resistance range), and do not use the megger or buzzer.

7.2.2 Withstand voltage test

Do not conduct a Withstand voltage test. Deterioration may occur.

MEMO

8 SPECIFICATIONS

This chapter explains the specifications of the converter.
Always read the instructions before use.

8.1	Converter rated specifications	176
8.2	Common specifications	177
8.3	Outline dimension drawings.....	178
8.4	Compatible options	184

8.1 Converter rated specifications

Model FR-A842-[]	07700	08660	09620	10940	12120
	315K	355K	400K	450K	500K
Applicable inverter capacity (kW)	315	355	400	450	500
Rated output capacity (kW)*1	375	423	476	536	595
Rated voltage (V) *2*3	Three-phase 380 to 500 V, 50/60 Hz*6*7				
Rated current (A)	564	636	716	806	895
Overload current rating*4	150% 60 s				
Permissible power supply voltage fluctuation	323 to 506 V, 50/60 Hz				
Permissible power supply frequency fluctuation	±5%				
Input power factor	0.99 or more (when load ratio is 100%)				
Power supply capacity (kVA)	456	515	580	652	724
Protective structure of the converter*5	Open type (IP00)				
Cooling system	Forced air				
Approx. mass (kg)	163	163	243	243	243

- *1 DC output capacity when the input voltage is 400 VAC.
- *2 Change the stepdown transformer tap according to the input voltage. (Refer to [page 45](#).)
- *3 The output voltage is approx. 594 VDC at an input voltage of 400 VAC, approx. 653 VDC at 440 VAC, and approx. 742 VDC at 500 VAC.
- *4 The percentage of the overload current rating is the ratio of the overload current to the converter's rated input current. For repeated duty, allow time for the temperatures of the converter and the inverter to return to or below the temperatures under 100% load.
- *5 FR-DU08: IP40 (except for the PU connector)
- *6 The permissible voltage imbalance ratio is 3% or less. (Imbalance ratio = (highest voltage between lines - average voltage between three lines) / average voltage between three lines × 100)
- *7 Voltage rating is between 380 and 480 V for inverters with a current rating of 110 A or less for the FR-F840-01800(75K) inverter.

8.2 Common specifications

Control specifications	Control method		PWM control
	Power supply frequency range		50 to 60 Hz
	Current limit level		Current limit value selectable (0 to 220% variable)
Operation specifications	Input signal (twelve terminals)		The following signals can be assigned to Pr.178 to Pr.189 (Input terminal function selection) : Converter stop, External thermal relay input, Reactor overheat protection, Inrush current limit resistor overheat detection, and Reset.
	Output signal Open collector output (4) Relay output (1)		The following signals can be assigned to Pr.192 to Pr.194 or Pr.196 (Output terminal function selection) : Inverter run enable, Converter reset, Instantaneous power failure, Overload warning, Converter running, Output voltage match, Power supply phase detection, Electronic thermal O/L relay pre-alarm, Instantaneous power failure detection hold, Fan fault output, Heat sink overheat pre-alarm, Regenerative drive recognition, During retry, 24 V external power supply operation, Life alarm, Maintenance timer, Alarm output, Fault, Cooling fan operation command, Control circuit temperature, and PU stop.
	Operating status		
	For indication on external meters Pulse train output (Max. 2.4 kHz: one terminal) Analog output (Max. 10 VDC: one terminal)		The monitor item can be changed using Pr.54 FM/CA terminal function selection (pulse train output) or Pr.158 AM terminal function selection (analog output) : power supply frequency, input current, input voltage, bus voltage, electronic thermal relay function load factor, input power, input power (with regenerative display), reference voltage output, and control circuit temperature.
Indication	Operation panel (FR-D08)	Operating status	Power supply frequency, input current, input voltage, bus voltage, fault display, electronic thermal relay function load factor, input power, input power (with regenerative display), cumulative energization time, cumulative energy, input terminal status*1, output terminal status*1, and control circuit temperature.
		Fault record	When a protective function is activated, a fault indication is displayed, and the latest monitored value of input voltage, input current, bus voltage, cumulative energization time are recorded. The last eight fault records are stored.
	Parameter unit (FR-PU07)	Interactive guidance	Help function for operation guide*2.
Protective/warning function	Protective function		Overcurrent trip, Overvoltage trip, Overload trip (electronic thermal relay function), Heat sink overheat, Instantaneous power failure, Undervoltage, Input phase loss, Input power supply fault, External thermal relay operation*4, Parameter storage device fault, PU disconnection*4, Retry count excess*4, Inverter/converter switching fault, CPU fault, Operation panel power supply short circuit / RS-485 terminals power supply short circuit, 24 VDC power fault, Inrush current limit circuit fault, communication fault (converter), Safety circuit fault, Internal circuit fault, Option fault, Input power supply fault, Reactor overheat
	Warning function		Fan alarm, Overload signal detection, Electronic thermal O/L relay pre-alarm, PU stop, Maintenance timer 1 to 3*4, Parameter write error, Copy operation fault, Operation panel lock, Power supply not detected, 24 V external power supply operation
Environment	Surrounding air temperature		-20 to +50°C (non-condensing)
	Surrounding air humidity		With circuit board coating: 95% RH or less (non-condensing) Without circuit board coating: 90% RH or less (non-condensing)
	Storage temperature*3		-20 to +65°C
	Atmosphere		Indoors (without corrosive gas, flammable gas, oil mist, dust and dirt, etc.)
	Altitude/vibration		Maximum 2500 m*5, 2.9 m/s ² or less at 10 to 55 Hz (directions of X, Y, Z axes)

*1 Can be displayed only on the operation panel (FR-DU08).

*2 Can be displayed only on the option parameter unit (FR-PU07).

*3 Applicable to conditions for a short time, for example, in transit.

*4 This protective function is not available in the initial status.

*5 For the installation at an altitude above 1000 m, consider a 3% reduction in the rated current per 500 m increase in altitude.

8.3 Outline dimension drawings

8.3.1 Reactor 1 (FR-A8BL1)

◆FR-A8BL1-H315K to H500K

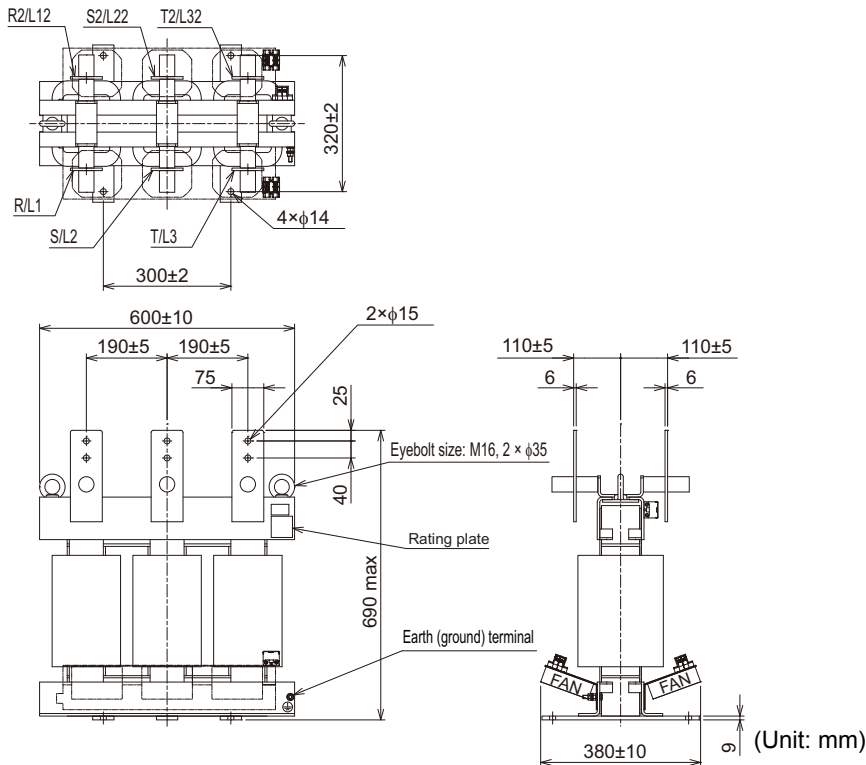

Model name	Mass
FR-A8BL1-H315K	198 kg
FR-A8BL1-H355K	209 kg
FR-A8BL1-H400K	209 kg
FR-A8BL1-H450K	209 kg
FR-A8BL1-H500K	215 kg

8.3.2 Reactor 2 (FR-A8BL2)

◆FR-A8BL2-H315K to H500K

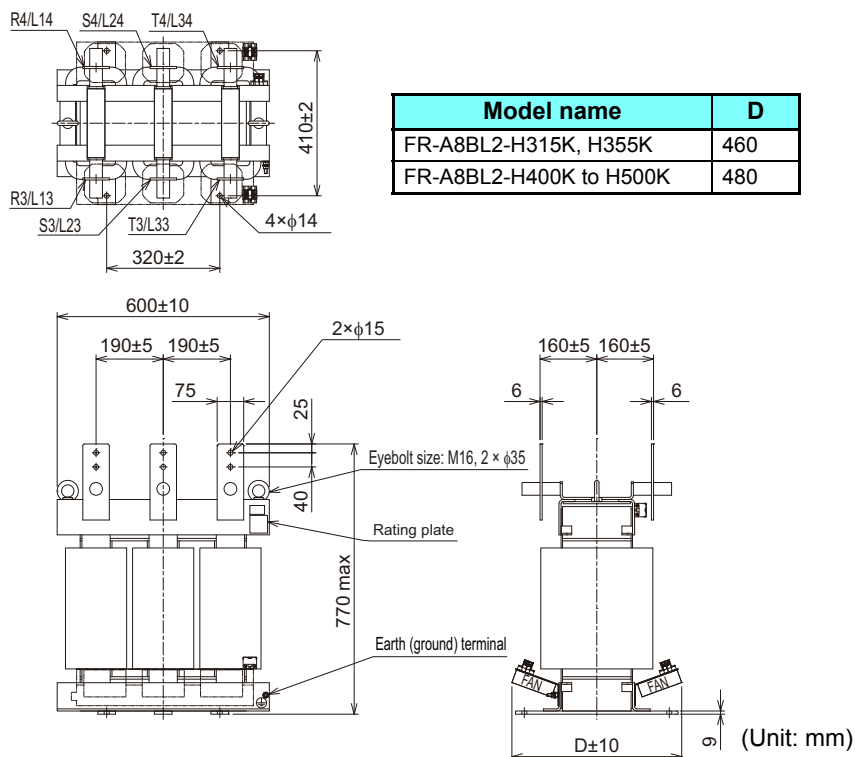

Model name	D
FR-A8BL2-H315K, H355K	460
FR-A8BL2-H400K to H500K	480

Model name	Mass
FR-A8BL2-H315K	380 kg
FR-A8BL2-H355K	385 kg
FR-A8BL2-H400K	429 kg
FR-A8BL2-H450K	457 kg
FR-A8BL2-H500K	457 kg

8.3.3 Phase detection transformer box (FR-A8VPB-H)

◆ Outline dimension drawings

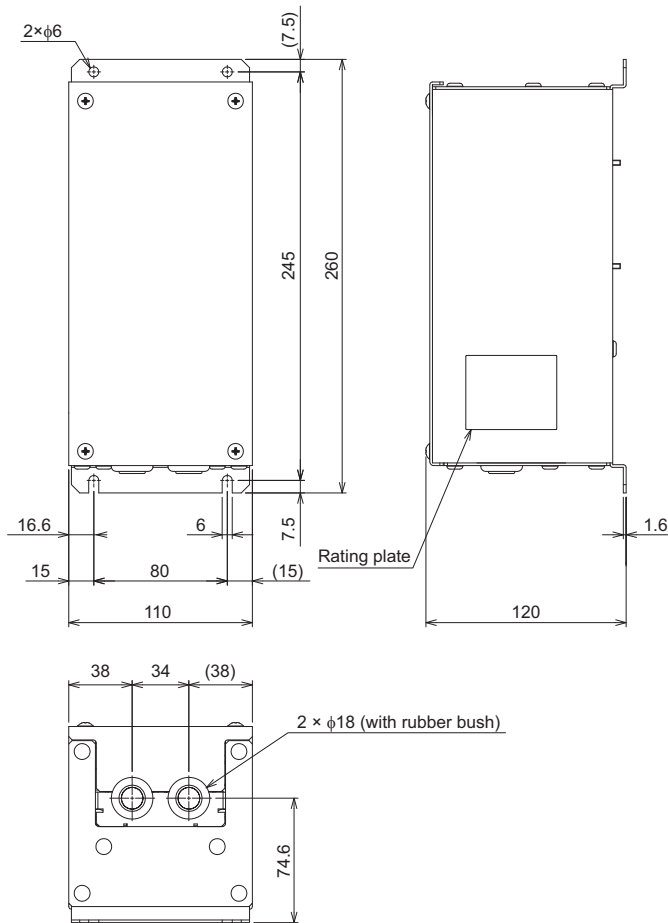

(Unit: mm)
Mass: 3.2 kg

◆ Terminal block

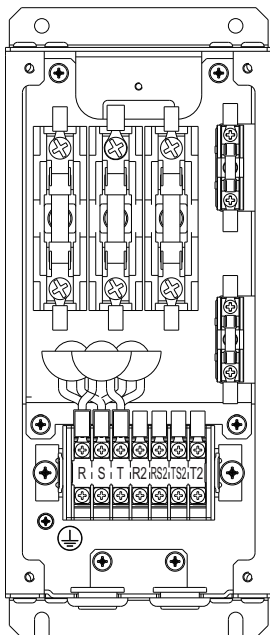

Terminal screw size

Model	Terminals R, S, T, R2, RS2, TS2, and T2	Earth (ground) terminal
FR-A8VPB-H	M3.5	M3.5

8.3.4 Filter capacitor (FR-A8BC)

◆FR-A8BC-H400K

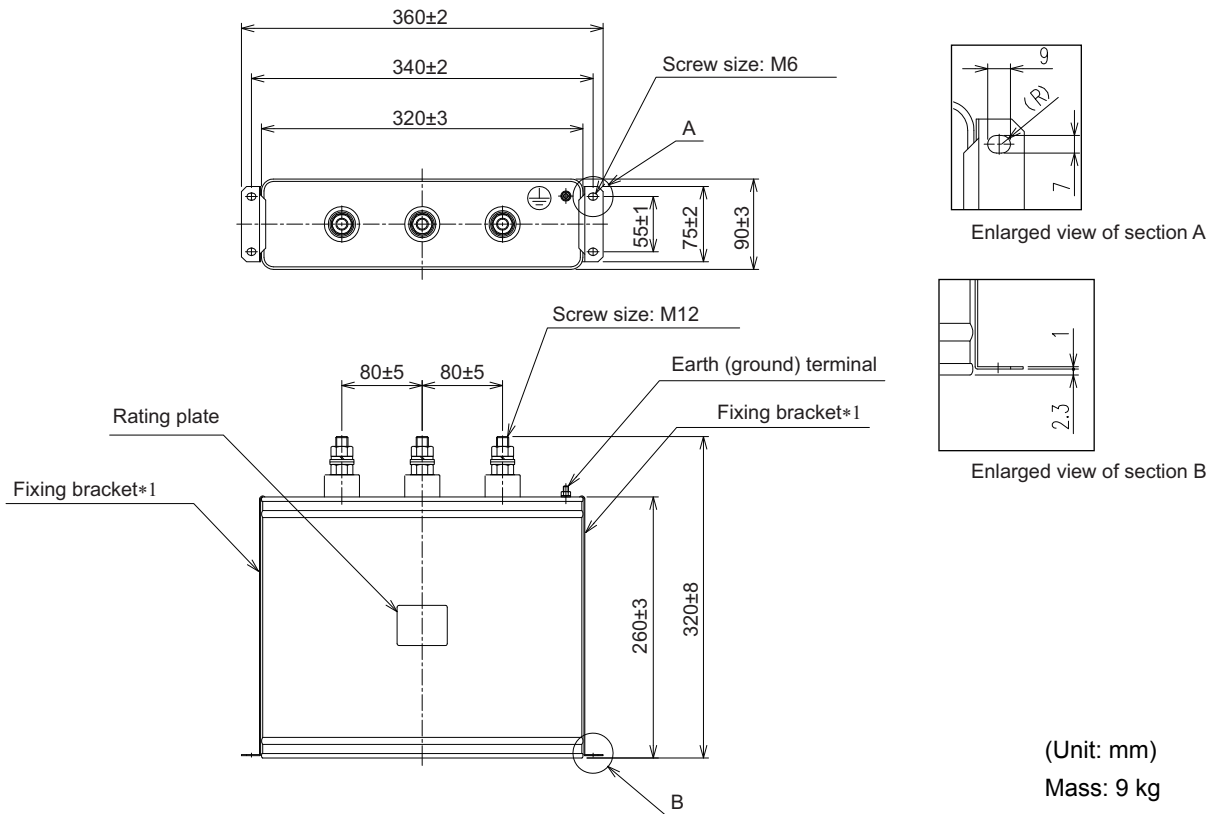

(Unit: mm)
Mass: 9 kg

*1 Attach the fixing brackets to the capacitor (refer to [page 33](#)).

◆FR-A8BC-H500K

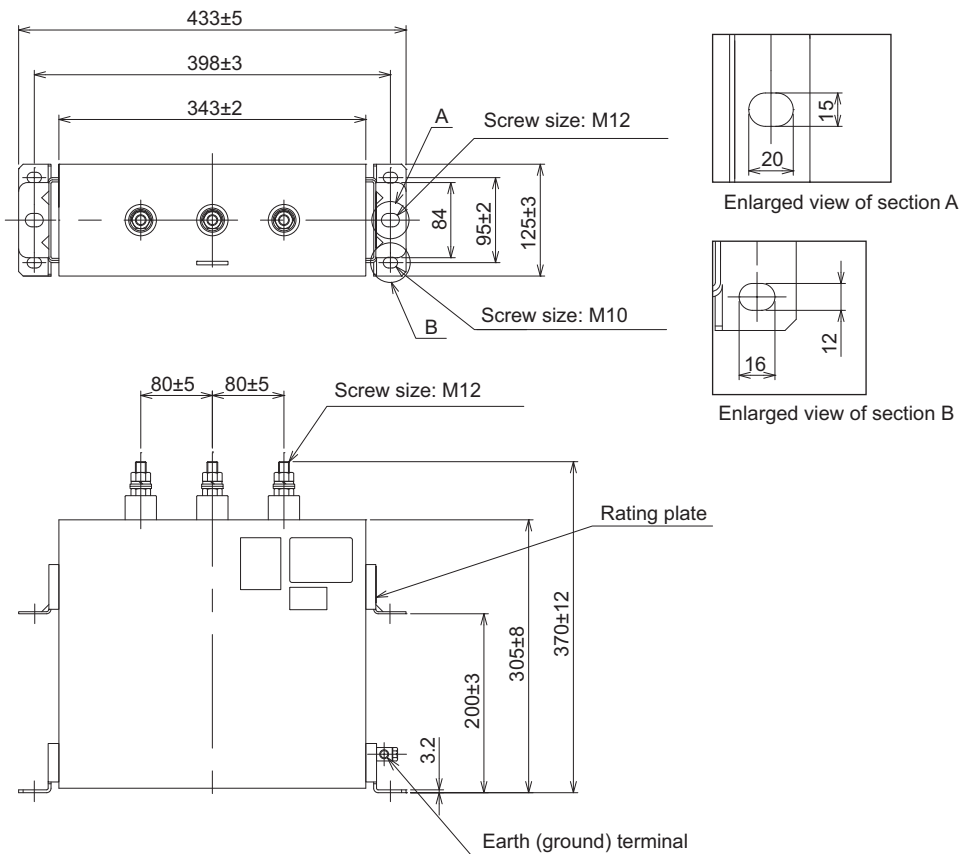

(Unit: mm)
Mass: 20 kg

8.3.5 Dedicated circuit parts for inrush current protection (FR-A8MC)

◆FR-A8MC-H315K, H500K

- Inrush current limit MC (S-N400 AC200V 2A2B)

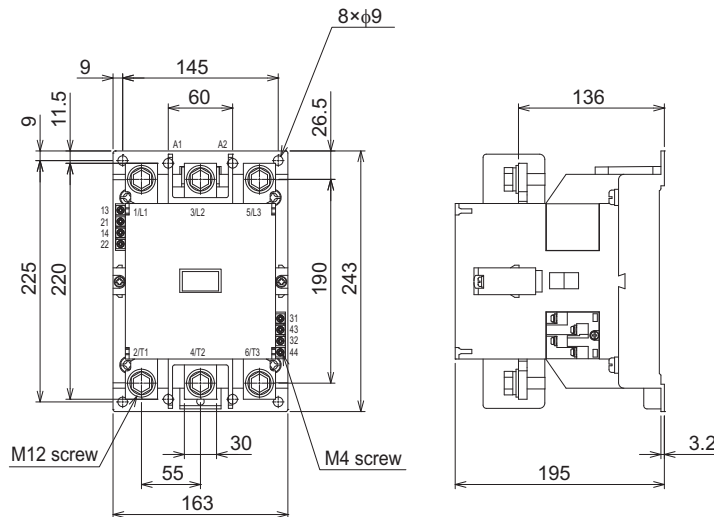

(Unit: mm)
Mass: 9.5 kg

Outline dimension drawings

- MC power supply stepdown transformer (BKO-CA2571H01)

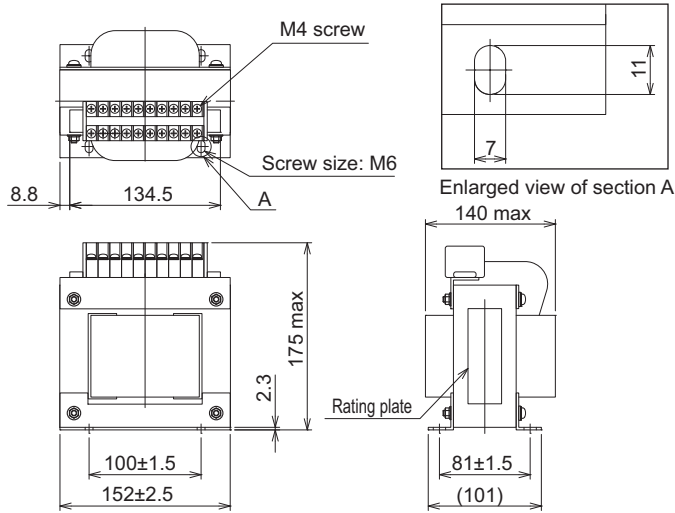

(Unit: mm)
Mass: 9 kg

- Buffer relay (SR-T5 AC200V 5A)

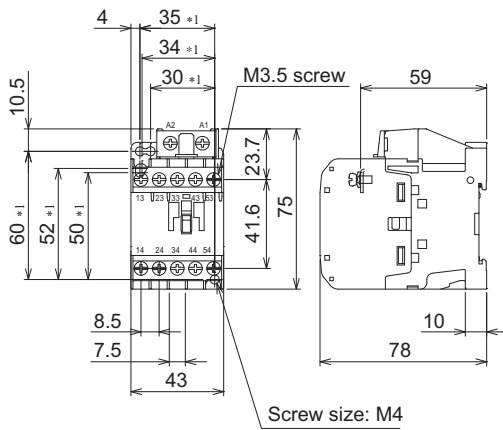

(Unit: mm)
Mass: 0.27 kg

*1 The position of the upper-left mounting hole is selectable. Combinations of the horizontal and vertical dimensions are as follows: 35 and 60, 30 and 60, 34 and 52, 35 and 50-52.

- Mini relay (MYQ4Z AC200/220)

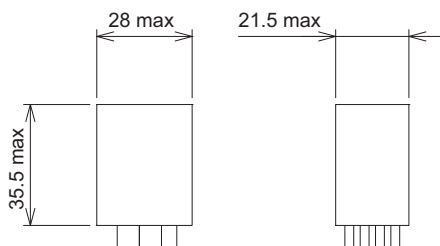

(Unit: mm)
Mass: 35 g

- Mini relay terminal block (PYF14T)

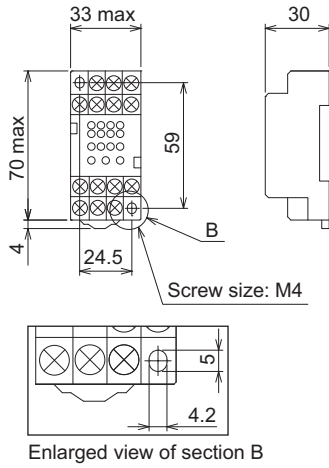

(Unit: mm)

Mass: 53 g

- Inrush current limit resistor with thermostat (BKO-CA2573H11)
- Inrush current limit resistor without thermostat (BKO-CA2573H01)

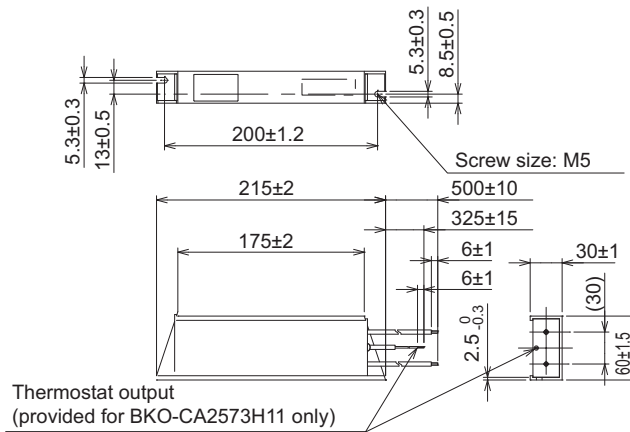

(Unit: mm)

Mass: 0.8 kg

8.3.6 Parameter unit

- Operation panel (FR-DU08)

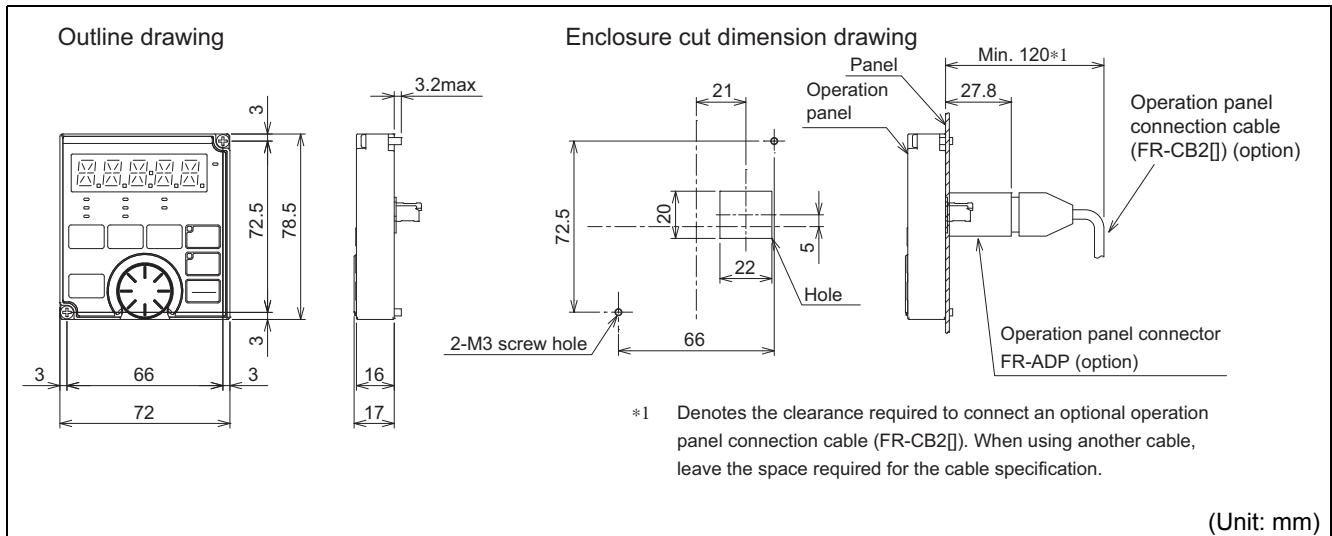

- Parameter unit (option) (FR-PU07)

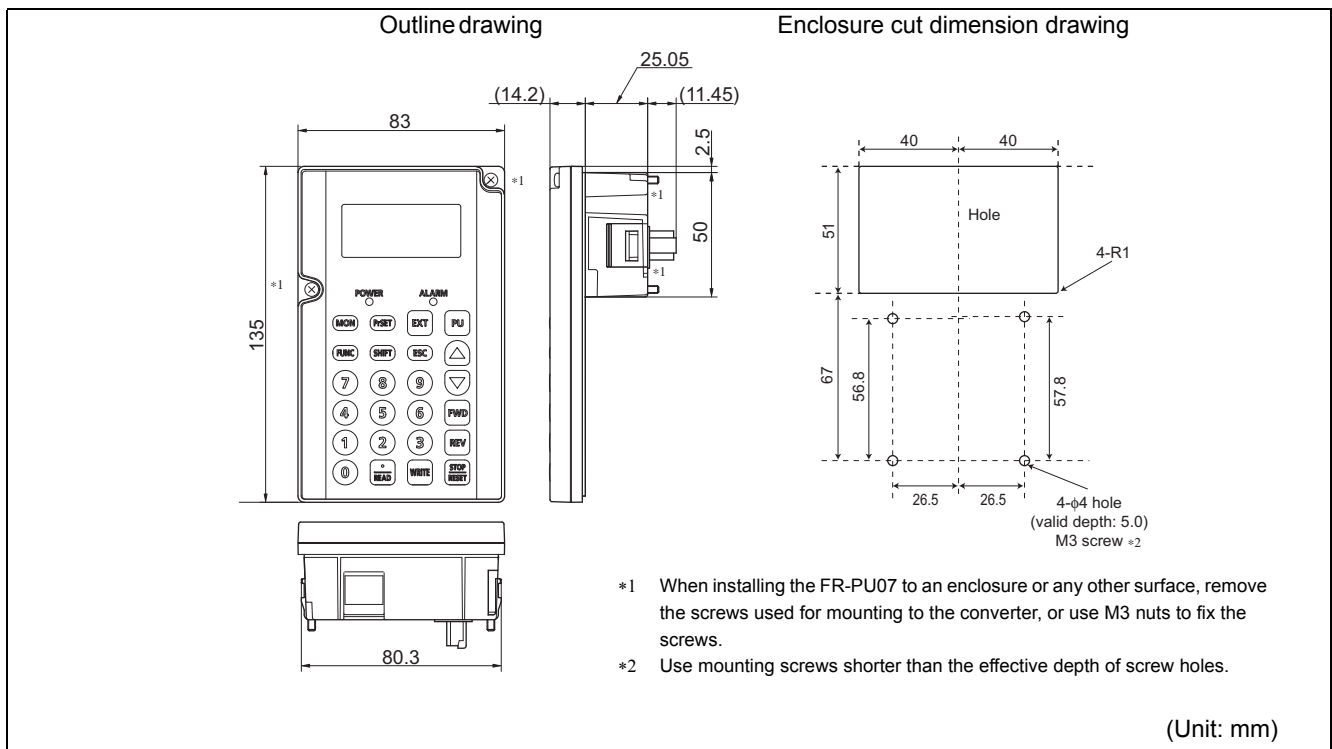

8.4 Compatible options

It is not possible to use any other plug-in option when the FR-A8AVP is installed on the converter.
All terminal options become unusable too.

9 **CONVERTER-TO- INVERTER CONVERSION**

This chapter explains how to convert the converter back into the original inverter.
Always read the instructions before use.

9.1	Converter-to-inverter conversion.....	186
------------	--	------------

9.1 Converter-to-inverter conversion

This section explains the procedure to convert the high factor converter back into the inverter.

9.1.1 Preparation for the conversion

Before starting the conversion, check the following conditions of the converter (all the conditions must be satisfied).

Check the following while the control circuit power of the converter is OFF.

- The FR-A8AVP is installed in one of the option connectors (1 to 3). (Refer to [page 11](#).)
- All of the main circuit terminals are open without wires connecting to them.
- Terminals R1/L11 and S1/L21 are used to supply power to the control circuit of the converter.
- No USB memory device is connected.

Check the following while the control circuit power of the converter is ON.

- The converter is in normal state and its operation is stopping. (Other than E.VER, no protective function is activated.)



- When terminal +24 is used to supply power to the control circuit of the converter, the conversion to the inverter is disabled.

9.1.2 Converter-to-inverter conversion (Pr.328)

Pr.	Name	Initial value	Setting range	Description
328	Inverter/converter switching	—	0 to 9999	Change the setting of this parameter according to the predetermined converter-to-inverter conversion procedure.

◆ Converter-to-inverter conversion procedure

The following shows the setting procedure on the PU for the converter-to-inverter conversion.

Enter the following values in **Pr.328** in the following order. If the procedure from step 1 to step 3 is not followed, the parameter setting will be cleared (the **Pr.328** setting returns to its initial value "1"). In that case, restart the procedure from step 1.

1 Enter "3100".

Check that "3100" is displayed for **Pr.328**.

2 Enter "1080".

Check that "1080" is displayed for **Pr.328**.

3 Enter "2000".

The converter-to-inverter conversion starts when "2000" is entered. The communication status LED indicator starts blinking. (The following figure shows the location of the LED indicator.)

The LED indicator stays ON after the conversion is completed.

(It takes about 300 seconds to complete the conversion.)

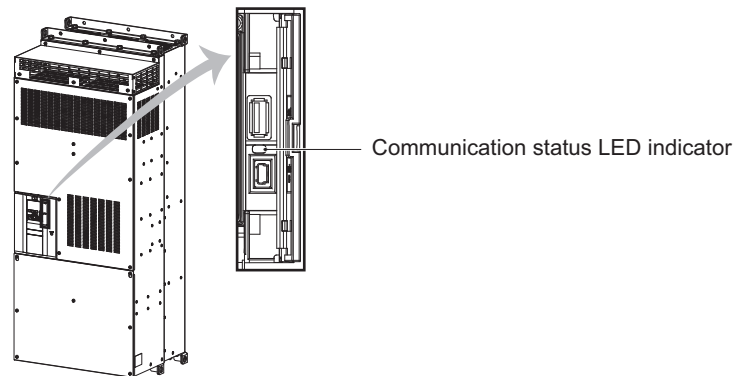

NOTE

- After entering "2000", do not operate the PU until the LED indicator stays ON.

4 Reset the control circuit power.

After the reset, "9999" will be displayed for **Pr.328**. Functions as a converter will not be available after this point.

5 After checking that "9999" is displayed for **Pr.328**, enter "0".

Converter reset will start automatically. After the reset, inverter functions are available.

6 Press the setting dial on the operation panel (FR-DU08) and check that "CNV" (converter) is not displayed.

NOTE

- If the control circuit power is turned OFF once and then turned ON again, conversion may restart depending on the timing of power OFF.

9.1.3 Removal of the stickers

Remove the "CONVERTER" sticker and the main circuit terminal stickers attached for use as the converter.

Check that the power of the inverter is OFF and open the terminal block cover to remove the main circuit terminal stickers. (Refer to [page 16](#).)

MEMO



APPENDIX

APPENDIX provides the reference information for use of the converter. Refer to APPENDIX as required.

Appendix 1	Instruction code list.....	190
Appendix 2	Instructions for compliance with the EU Directives.....	192
Appendix 3	Instructions for UL and cUL.....	194
Appendix 4	Instructions for EAC.....	195
Appendix 5	Restricted Use of Hazardous Substances in Electronic and Electrical Products.....	196
Appendix 6	Referenced Standard (Requirement of Chinese standardized law).....	196

Appendix 1 Instruction code list

- *1 These instruction codes are used to write or read parameters through RS-485 communication. (Refer to [page 113](#).)
 *2 For Parameter copy, Parameter clear, and All parameter clear, ○ indicates the function is available, and × indicates the function is not available.
 *3 These parameters are communication parameters that are not cleared when Parameter clear (All parameter clear) is executed from RS-485 communication. (Refer to [page 113](#).)
 *4 Reading and writing is enabled when commands are sent through communication via the PU connector.

Pr.	Name	Instruction code ^{*1}			Parameter ^{*2}		
		Read	Write	Extended	Copy	Clear	All clear
1	Maximum frequency	01	81	0	○	×	×
2	Minimum frequency	02	82	0	○	×	×
8	SOF input selection	08	88	0	○	×	○
9	OH input selection	09	89	0	○	×	○
22	Current limit level	16	96	0	○	○	○
23	Current limit level (regenerative)	17	97	0	○	○	○
44	Instantaneous power failure detection signal clear	2C	AC	0	×	×	×
49	Power supply frequency monitoring reference	31	B1	0	○	○	○
51	Input power monitoring reference	33	B3	0	○	○	○
52	DU/PU main display data selection	34	B4	0	○	○	○
53	Input voltage monitoring reference	35	B5	0	○	○	○
54	FM/CA terminal function selection	36	B6	0	○	○	○
55	Bus voltage monitoring reference	37	B7	0	○	○	○
56	Current monitoring reference	38	B8	0	○	○	○
57	Restart selection	39	B9	0	○	○	○
65	Retry selection	41	C1	0	○	○	○
67	Number of retries at fault occurrence	43	C3	0	○	○	○
68	Retry waiting time	44	C4	0	○	○	○
69	Retry count display erase	45	C5	0	○	○	○
75	Reset selection/disconnected PU detection/PU stop selection	4B	CB	0	○	×	×
77 ^{*4}	Parameter write selection	4D	CD	0	○	○	○
80	Voltage control proportional gain	50	D0	0	○	○	○
81	Voltage control integral gain	51	D1	0	○	○	○
82	Current control proportional gain	52	D2	0	○	○	○
83	Current control integral gain	53	D3	0	○	○	○
84	Power factor command value	54	D4	0	○	○	○
85	Power factor lead/lag setting	55	D5	0	○	○	○
117	PU communication station number	11	91	1	○ ^{*3}	○ ^{*3}	○
118	PU communication speed	12	92	1	○ ^{*3}	○ ^{*3}	○
119	PU communication stop bit length	13	93	1	○ ^{*3}	○ ^{*3}	○

Pr.	Name	Instruction code ^{*1}			Parameter ^{*2}		
		Read	Write	Extended	Copy	Clear	All clear
120	PU communication parity check	14	94	1	○ ^{*3}	○ ^{*3}	○
121	PU communication retry count	15	95	1	○ ^{*3}	○ ^{*3}	○
123	PU communication waiting time setting	17	97	1	○ ^{*3}	○ ^{*3}	○
124	PU communication CR/LF selection	18	98	1	○ ^{*3}	○ ^{*3}	○
145	PU display language selection	2D	AD	1	○	×	×
157	OL signal output timer	39	B9	1	○	○	○
158	AM terminal function selection	3A	BA	1	○	○	○
161	Key lock operation selection	3D	BD	1	○	×	○
168	Parameter for manufacturer setting. Do not set.						
169							
170	Watt-hour meter clear	46	C6	1	○	×	○
178	STF terminal function selection	4E	CE	1	○	×	○
179	STR terminal function selection	4F	CF	1	○	×	○
180	RL terminal function selection	50	D0	1	○	×	○
181	RM terminal function selection	51	D1	1	○	×	○
182	RH terminal function selection	52	D2	1	○	×	○
183	RT terminal function selection	53	D3	1	○	×	○
184	AU terminal function selection	54	D4	1	○	×	○
185	JOG terminal function selection	55	D5	1	○	×	○
186	CS terminal function selection	56	D6	1	○	×	○
187	MRS terminal function selection	57	D7	1	○	×	○
188	STOP terminal function selection	58	D8	1	○	×	○
189	RES terminal function selection	59	D9	1	○	×	○
190	RDY signal logic selection	5A	DA	1	○	×	○
191	RSO signal logic selection	5B	DB	1	○	×	○
192	IPF terminal function selection	5C	DC	1	○	×	○
193	OL terminal function selection	5D	DD	1	○	×	○
194	FU terminal function selection	5E	DE	1	○	×	○
196	ABC2 terminal function selection	60	E0	1	○	×	○
244	Cooling fan operation selection	2C	AC	2	○	○	○

Pr.	Name	Instruction code ⁻¹			Parameter ⁻²		
		Read	Write	Extended	Copy	Clear	All clear
255	Life alarm status display	37	B7	2	○	×	×
256	Inrush current limit circuit life display	38	B8	2	○	×	×
257	Control circuit capacitor life display	39	B9	2	○	×	×
269	Parameter for manufacturer setting. Do not set.						
290	Monitor negative output selection	5A	DA	2	○	×	○
328	Inverter/converter switching	1C	9C	3	×	×	×
331	RS-485 communication station number	1F	9F	3	○*3	○*3	○
332	RS-485 communication speed	20	A0	3	○*3	○	○
333	RS-485 communication stop bit length / data length	21	A1	3	○*3	○*3	○
334	RS-485 communication parity check selection	22	A2	3	○*3	○*3	○
335	RS-485 communication retry count	23	A3	3	○*3	○*3	○
337	RS-485 communication waiting time setting	25	A5	3	○*3	○*3	○
341	RS-485 communication CR/LF selection	29	A9	3	○*3	○*3	○
342	Communication EEPROM write selection	2A	AA	3	○	○	○
503	Maintenance timer	03	83	5	×	×	×
504	Maintenance timer warning output set time	04	84	5	○	×	○
547	Parameter for manufacturer setting. Do not set.						
548	Parameter for manufacturer setting. Do not set.						
563	Energization time carrying-over times	3F	BF	5	×	×	×
663	Control circuit temperature signal output level	3F	BF	6	○	○	○
686	Maintenance timer 2	56	D6	6	○	×	×
687	Maintenance timer 2 warning output set time	57	D7	6	○	×	○
688	Maintenance timer 3	58	D8	6	○	○	○
689	Maintenance timer 3 warning output set time	59	D9	6	○	×	○
867	AM output filter	43	C3	8	○	○	○
869	Current output filter	45	C5	8	○	○	○
888	Free parameter 1	58	D8	8	○	×	×
889	Free parameter 2	59	D9	8	○	×	×
891	Cumulative power monitor digit shifted times	5B	DB	8	○	○	○
C0 (900)	FM/CA terminal calibration	00	80	9	○	×	○
C1 (901)	AM terminal calibration	01	81	9	○	×	○

Pr.	Name	Instruction code ⁻¹			Parameter ⁻²		
		Read	Write	Extended	Copy	Clear	All clear
C8 (930)	Current output bias signal	1E	9E	9	○	○	○
C9 (930)	Current output bias current	1E	9E	9	○	○	○
C10 (931)	Current output gain signal	1F	9F	9	○	○	○
C11 (931)	Current output gain current	1F	9F	9	○	○	○
989	Parameter for manufacturer setting. Do not set.						
990	PU buzzer control	5A	DA	9	○	○	○
991	PU contrast adjustment	5B	DB	9	○	×	○
997	Fault initiation	61	E1	9	×	○	○
1006	Clock (year)	06	86	A	×	×	×
1007	Clock (month, day)	07	87	A	×	×	×
1008	Clock (hour, minute)	08	88	A	×	×	×
1202	Inrush current limit circuit life setting	02	82	C	×	×	×
1344	R-S turns ratio compensation	2C	AC	D	×	×	×
1345	T-S turns ratio compensation	2D	AD	D	×	×	×
1499	Parameter for manufacturer setting. Do not set.						

Appendix 2 Instructions for compliance with the EU Directives

The EU Directives are issued to standardize different national regulations of the EU Member States and to facilitate free movement of the equipment, whose safety is ensured, in the EU territory.

Since 1996, compliance with the EMC Directive that is one of the EU Directives has been legally required. Since 1997, compliance with the Low Voltage Directive, another EU Directive, has been also legally required. When a manufacturer confirms its equipment to be compliant with the EMC Directive and the Low Voltage Directive, the manufacturer must declare the conformity and affix the CE marking.

- The authorized representative in the EU

The authorized representative in the EU is shown below.

Company name: Mitsubishi Electric Europe B.V.

Address: Mitsubishi-Electric-Platz 1, 40882 Ratingen, Germany

◆ EMC Directive

We declare that this high power factor converter conforms with the EMC Directive and affix the CE marking on the converter.

- EMC Directive: 2014/30/EU
- Standard(s): EN61800-3:2004+A1:2012 (Second environment / PDS Category "C3")
- This converter is not intended to be used on a low-voltage public network which supplies domestic premises. Ensure the converter is suitable for the environment in which it is to be used when using it in residential areas.
- Radio frequency interference is expected if used on such a network.
- The installer shall provide a guide for installation and use, including recommended mitigation devices.

Note:

First environment

Environment including buildings/facilities which are directly connected to a low voltage main supply which also supplies residential buildings. Directly connected means that there is no intermediate transformer between these buildings.

Second environment

Environment including all buildings/facilities which are not directly connected to a low voltage main supply which also supplies residential buildings.

◆ Note

Install the converter with the EMC filter, and perform wiring according to the following instructions.

- Set the EMC Directive compliant EMC filter to the converter. Use a recommended EMC compliant EMC filter shown in the table below. Insert line noise filters and ferrite cores to the power and control cables as required.
- Recommended EMC compliant EMC filter (Manufactured by: SOSHIN ELECTRIC CO., LTD.)

Converter model	FR-A842-07700(315K)	FR-A842-08660(355K)	FR-A842-09620(400K)	FR-A842-10940(450K)	FR-A842-12120(500K)
EMC compliant EMC filter	NF31000C-SDK	NF31000C-SDK	NF31000C-SDK	NF31000C-SDK	NF31000C-SDK
Rated filter current	1000A	1000A	1000A	1000A	1000A

- EMC Directive compliant EMC filter connection diagram

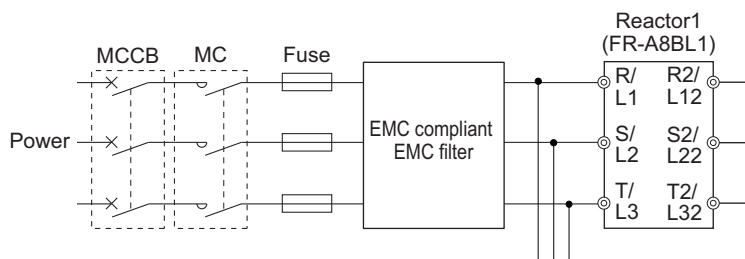

- Connect the inverter and the converter to an earthed (grounded) power supply.
- Install the motor and controller cable found in the EMC Installation Manual (BCN-A21041-204) and Technical News (MF-S-113, 115) according to the instructions.
- Ensure that the finalized system which includes an inverter and converter unit complies with the EMC Directive.

◆ Low Voltage Directive

We have self-confirmed our converters as products compliant to the Low Voltage Directive (Conforming standard EN 61800-5-1) and affix the CE marking on the converters.

◆ Outline of instructions

- Do not use an earth leakage current breaker as an electric shock protector without connecting the equipment to the earth. Connect the equipment to the earth (ground) securely.
- Wire the earth (ground) terminal independently. (Do not connect two or more cables to one terminal.)
- Use the earth (ground) cable and the cable sizes on [page 38](#) under the following conditions.
 - Surrounding air temperature: 40°C maximum
 If conditions are different from above, select appropriate wire according to EN60204.
- Use a tinned (plating should not include zinc) crimping terminal to connect the earth (ground) cable. When tightening the screw, be careful not to damage the threads.

For use as a product compliant with the Low Voltage Directive, use a PVC cable whose size is indicated on [page 38](#).
- Use the molded case circuit breaker and magnetic contactor which conform to the EN or IEC Standard.
- DC current may flow from the converter to a protective earth (ground) conductor. When using a residual current device (RDC) or residual current monitor (RDM), connect a type B RCD or RCM to the power supply side.
- Use the converter under the conditions of overvoltage category II (usable regardless of the earth (ground) condition of the power supply), overvoltage category III (usable with the earth-neutral system power supply, 400 V class only) and pollution degree 2 or lower specified in IEC60664.
 - To use the converter under the conditions of pollution degree 2, install it in the enclosure of IP2X or higher.
 - To use the converter under the conditions of pollution degree 3, install it in the enclosure of IP54 or higher.
- On the input and output of the inverter and the converter, use cables of the type and size set forth in EN60204.
- The operating capacity of the relay outputs (terminal symbols A1, B1, C1, A2, B2, C2) should be 30 VDC, 0.3 A. (Relay output has basic isolation from the internal circuit of the inverter and the converter.)
- Control circuit terminals on [page 40](#) are safely isolated from the main circuit.
- The amount of current leakage from the converter measures 20 mA at maximum (in AC/DC current measuring range specified in IEC 60990).
- Environment (For the detail, refer to [page 24](#).)

	During Operation	In Storage	During Transportation
Surrounding air temperature	-10 to +50°C	-20 to +65°C	-20 to +65°C
Ambient humidity	95% RH or less	95% RH or less	95% RH or less
Maximum altitude	2500 m*1	2500 m	10000 m

*1 For the installation at an altitude above 1000 m, consider a 3% reduction in the rated current per 500 m increase in altitude.

◆ Wiring protection

Provide the UL and cUL listed fuse in accordance with the table below.

Converter model	Fuse type	Manufacturer	Rating
FR-A842-07700(315K)	170M6111	Bussmann	700 V, 700 A
FR-A842-08660(355K)	170M6112	Bussmann	700 V, 800 A
FR-A842-09620(400K)	170M6113	Bussmann	700 V, 900 A
FR-A842-10940(450K)	170M6114	Bussmann	700 V, 1000 A
FR-A842-12120(500K)	170M6115	Bussmann	700 V, 1100 A

Fuse connection diagram

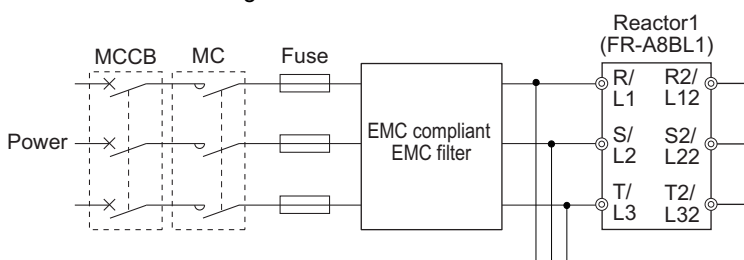

◆ Short circuit ratings

Suitable for use in a circuit capable of delivering not more than 100 kA rms symmetrical amperes, 500 V maximum.

Appendix 3 Instructions for UL and cUL

(Standard to comply with: UL 508C, CSA C22.2 No.274-13)

◆ General precaution

CAUTION - Risk of Electric Shock -

The bus capacitor discharge time is 10 minutes. Before starting wiring or inspection, switch power off, wait for more than 10 minutes, and check for residual voltage between terminal P/+ and N/- with a meter etc., to avoid a hazard of electrical shock.

ATTENTION - Risque de choc électrique -

La durée de décharge du condensateur de bus est de 10 minutes. Avant de commencer le câblage ou l'inspection, mettez l'appareil hors tension et attendez plus de 10 minutes.

◆ Installation

The below types of high power factor converter have been approved as products for use in enclosure.

Design the enclosure so that the surrounding air temperature, humidity and ambience of the converter will satisfy the above specifications. (Refer to [page 24.](#))

◆ Branch circuit protection

For installation in the United States, branch circuit protection must be provided in accordance with the National Electrical Code and any applicable provincial codes.

For installation in Canada, branch circuit protection must be provided in accordance with the Canadian Electrical Code and any applicable provincial codes.

Provide the appropriate fuse in accordance with the table below.

Converter model	Fuse type	Manufacturer	Rating
FR-A842-07700(315K)	170M6111	Bussmann	700 V, 700 A
FR-A842-08660(355K)	170M6112	Bussmann	700 V, 800 A
FR-A842-09620(400K)	170M6113	Bussmann	700 V, 900 A
FR-A842-10940(450K)	170M6114	Bussmann	700 V, 1000 A
FR-A842-12120(500K)	170M6115	Bussmann	700 V, 1100 A

Fuse connection diagram

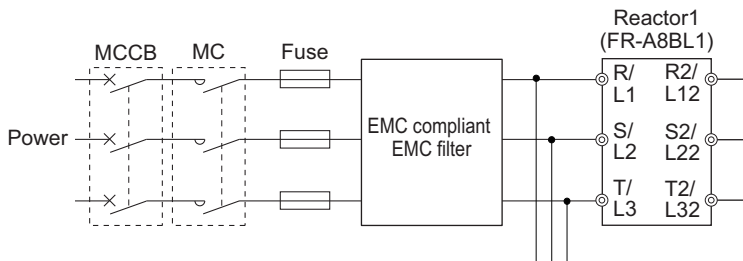

◆ Wiring to the power supply and the motor

Refer to the National Electrical Code (Article 310) regarding the allowable current of the cable. Select the cable size for 125% of the rated current according to the National Electrical Code (Article 430).

For wiring the input (R/L1, S/L2, T/L3) terminals of the converter and output (U, V, W) terminals of the inverter, use the UL listed copper, stranded wires (rated at 75°C) and round crimping terminals. Crimp the crimping terminals with the crimping tool recommended by the terminal maker.

◆ Short circuit ratings

Suitable for use in a circuit capable of delivering not more than 100 kA rms symmetrical amperes, 500 V maximum.

◆ Combination of the converter and the inverter (Back-to-back connection)

Use the converter in combination with the inverter specified in the following table. In addition, it is necessary to use the peripheral devices specified in the following table for the use of the converter (the peripheral devices are only UL-approved when used with the converter).

Applicable motor capacity	Converter	Plug-in option	Phase detection transformer box	Dedicated circuit parts for inrush current protection	Reactor 1	Reactor 2	Filter capacitor	Inverter	Applicable rating
315kW	FR-A842-07700(315K)	FR-A8AVP	FR-A8VPB-H	FR-A8MC-H355K	FR-A8BL1-H315K	FR-A8BL2-H315K	FR-A8BC-H400K	FR-A842-07700(315K)	ND
355kW	FR-A842-08660(355K)	FR-A8AVP	FR-A8VPB-H	FR-A8MC-H355K	FR-A8BL1-H355K	FR-A8BL2-H355K	FR-A8BC-H400K	FR-A842-08660(355K)	ND
400kW	FR-A842-09620(400K)	FR-A8AVP	FR-A8VPB-H	FR-A8MC-H500K	FR-A8BL1-H400K	FR-A8BL2-H400K	FR-A8BC-H400K	FR-A842-09620(400K)	ND
450kW	FR-A842-10940(450K)	FR-A8AVP	FR-A8VPB-H	FR-A8MC-H500K	FR-A8BL1-H450K	FR-A8BL2-H450K	FR-A8BC-H500K	FR-A842-10940(450K)	ND
500kW	FR-A842-12120(500K)	FR-A8AVP	FR-A8VPB-H	FR-A8MC-H500K	FR-A8BL1-H500K	FR-A8BL2-H500K	FR-A8BC-H500K	FR-A842-12120(500K)	ND

Appendix 4 Instructions for EAC



The product certified in compliance with the Eurasian Conformity has the EAC marking.

Note: EAC marking

In 2010, three countries (Russia, Belarus, and Kazakhstan) established a Customs Union for the purposes of revitalizing the economy by forming a large economic bloc by abolishing or reducing tariffs and unifying regulatory procedures for the handling of articles.

Products to be distributed over these three countries of the Customs Union must comply with the Customs Union Technical Regulations (CU-TR), and the EAC marking must be affixed to the products.

For information on the country of origin, manufacture year and month, and authorized sales representative (importer) in the CU area of this product, refer to the following:

- Country of origin indication

Check the rating plate of the product. (Refer to [page 9](#).)

Example: MADE IN JAPAN

- Year and month of manufacture

Check the SERIAL number indicated on the rating plate of the product. (Refer to [page 9](#).)

Rating plate example

□ ○ ○ ○ ○ ○ ○ ○

Symbol Year Month Control number

SERIAL

The SERIAL consists of one symbol, two characters indicating the production year and month, and six characters indicating the control number.

The last digit of the production year is indicated as the Year, and the Month is indicated by 1 to 9, X (October), Y (November), or Z (December).

- Authorized sales representative (importer) in the CU area

The authorized sales representative (importer) in the CU area is shown below.

Name: Mitsubishi Electric (Russia) LLC

Address: 52, bld 1 Kosmodamianskaya Nab 115054, Moscow, Russia

Phone: +7 (495) 721-2070

FAX: +7 (495) 721-2071

Appendix 5 Restricted Use of Hazardous Substances in Electronic and Electrical Products

The mark of restricted use of hazardous substances in electronic and electrical products is applied to the product as follows based on the "Management Methods for the Restriction of the Use of Hazardous Substances in Electrical and Electronic Products" of the People's Republic of China.

电器电子产品有害物质限制使用标识要求

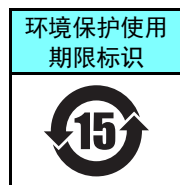

本产品中所含有的有害物质的名称、含量、含有部件如下表所示。

• 产品中所含有害物质的名称及含量

部件名称*2	有害物质*1					
	铅 (Pb)	汞 (Hg)	镉 (Cd)	六价铬 (Cr (VI))	多溴联苯 (PBB)	多溴二苯醚 (PBDE)
电路板组件 (包括印刷电路板及其构成的零部件, 如电阻、电容、集成电路、连接器等)、电子部件	×	○	×	○	○	○
金属壳体、金属部件	×	○	○	○	○	○
树脂壳体、树脂部件	○	○	○	○	○	○
螺丝、电线	○	○	○	○	○	○

上表依据SJ/T11364的规定编制。

○：表示该有害物质在该部件所有均质材料中的含量均在GB/T26572规定的限量要求以下。

×：表示该有害物质在该部件的至少一种均质材料中的含量超出GB/T26572规定的限量要求。

*1 即使表中记载为×，根据产品型号，也可能会有有害物质的含量为限制值以下的情况。

*2 根据产品型号，一部分部件可能不包含在产品中。

Appendix 6 Referenced Standard (Requirement of Chinese standardized law)

This Product is designed and manufactured accordance with following Chinese standards.

EMC : GB/T 12668.3

WARRANTY

When using this product, make sure to understand the warranty described below.

1. Warranty period and coverage

We will repair any failure or defect (hereinafter referred to as "failure") in our FA equipment (hereinafter referred to as the "Product") arisen during warranty period at no charge due to causes for which we are responsible through the distributor from which you purchased the Product or our service provider. However, we will charge the actual cost of dispatching our engineer for an on-site repair work on request by customer in Japan or overseas countries. We are not responsible for any on-site readjustment and/or trial run that may be required after a defective unit are repaired or replaced.

[Term]

The term of warranty for Product is twelve months after your purchase or delivery of the Product to a place designated by you or eighteen months from the date of manufacture whichever comes first ("Warranty Period"). Warranty period for repaired Product cannot exceed beyond the original warranty period before any repair work.

[Limitations]

- (1) You are requested to conduct an initial failure diagnosis by yourself, as a general rule. It can also be carried out by us or our service company upon your request and the actual cost will be charged.
However, it will not be charged if we are responsible for the cause of the failure.
- (2) This limited warranty applies only when the condition, method, environment, etc. of use are in compliance with the terms and conditions and instructions that are set forth in the instruction manual and user manual for the Product and the caution label affixed to the Product.
- (3) Even during the term of warranty, the repair cost will be charged on you in the following cases;
 - a failure caused by your improper storing or handling, carelessness or negligence, etc., and a failure caused by your hardware or software problem
 - a failure caused by any alteration, etc. to the Product made on your side without our approval
 - a failure which may be regarded as avoidable, if your equipment in which the Product is incorporated is equipped with a safety device required by applicable laws and has any function or structure considered to be indispensable according to a common sense in the industry
 - a failure which may be regarded as avoidable if consumable parts designated in the instruction manual, etc. are duly maintained and replaced
 - any replacement of consumable parts (condenser, cooling fan, etc.)
 - a failure caused by external factors such as inevitable accidents, including without limitation fire and abnormal fluctuation of voltage, and acts of God, including without limitation earthquake, lightning and natural disasters
 - a failure generated by an unforeseeable cause with a scientific technology that was not available at the time of the shipment of the Product from our company
 - any other failures which we are not responsible for or which you acknowledge we are not responsible for

2. Term of warranty after the stop of production

- (1) We may accept the repair at charge for another seven (7) years after the production of the product is discontinued. The announcement of the stop of production for each model can be seen in our Sales and Service, etc.
- (2) Please note that the Product (including its spare parts) cannot be ordered after its stop of production.

3. Service in overseas

Our regional FA Center in overseas countries will accept the repair work of the Product; however, the terms and conditions of the repair work may differ depending on each FA Center. Please ask your local FA center for details.

4. Exclusion of loss in opportunity and secondary loss from warranty liability

Regardless of the gratis warranty term, Mitsubishi Electric shall not be liable for compensation to:

- (1) Damages caused by any cause found not to be the responsibility of Mitsubishi Electric.
- (2) Loss in opportunity, lost profits incurred to the user by Failures of Mitsubishi Electric products.
- (3) Special damages and secondary damages whether foreseeable or not, compensation for accidents, and compensation for damages to products other than Mitsubishi Electric products.
- (4) Replacement by the user, maintenance of on-site equipment, start-up test run and other tasks.

5. Change of Product specifications

Specifications listed in our catalogs, manuals or technical documents may be changed without notice.

6. Application and use of the Product

- (1) For the use of our product, its applications should be those that may not result in a serious damage even if any failure or malfunction occurs in product, and a backup or fail-safe function should operate on an external system to product when any failure or malfunction occurs.
- (2) Our product is designed and manufactured as a general purpose product for use at general industries.
Therefore, applications substantially influential on the public interest for such as atomic power plants and other power plants of electric power companies, and also which require a special quality assurance system, including applications for railway companies and government or public offices are not recommended, and we assume no responsibility for any failure caused by these applications when used.
In addition, applications which may be substantially influential to human lives or properties for such as airlines, medical treatments, railway service, incineration and fuel systems, man-operated material handling equipment, entertainment machines, safety machines, etc. are not recommended, and we assume no responsibility for any failure caused by these applications when used.
We will review the acceptability of the abovementioned applications, if you agree not to require a specific quality for a specific application. Please contact us for consultation.

REVISIONS

*The manual number is given on the bottom left of the back cover.

Revision Date	*Manual Number	Revision
Jan. 2018	IB(NA)-0600777ENG-A	First edition
May 2018	IB(NA)-0600777ENG-B	Addition <ul style="list-style-type: none"> FR-A842-07700(315K) to 10940(450K)
Feb. 2019	IB(NA)-0600777ENG-C	Modification <ul style="list-style-type: none"> Instructions for compliance with the EU Directives Instructions for UL and cUL Referenced Standard (Requirement of Chinese standardized law)

mitsubishi **MITSUBISHI ELECTRIC CORPORATION**
HEAD OFFICE: TOKYO BUILDING 2-7-3, MARUNOUCHI, CHIYODA-KU, TOKYO 100-8310, JAPAN