

INTRODUCTION

Thank you for choosing the Mitsubishi MELSOFT series Integrated FA software.

Read this manual and make sure you understand the functions and performance of MELSEC series sequencer thoroughly in advance to ensure correct use.

Please make this manual available to the end user.

SAFETY PRECAUTIONS.....	A - 1
REVISIONS.....	A - 2
CONTENTS.....	A - 3
About Manuals	A - 13
How the manual describes the explanation is shown below	A - 14
Abbreviations and Terms in This Manual.....	A - 16

CONTENTS

Chapter 1 GENERAL DESCRIPTION	1- 1 to 1- 13
1.1 Functions Lists	1- 3
1.2 FX Series Programming	1- 11
1.3 Basic Key Specifications.....	1- 13
Chapter 2 SYSTEM CONFIGURATION	2- 1 to 2- 10
2.1 Connection from the Serial Port	2- 1
2.2 Connection from the Interface Boards.....	2- 4
2.3 System Equipment Lists	2- 5
2.4 Precautions for Handling Project on the Earier Versions	2- 8
2.4.1 When handling a project on GX Developer (SW4D5-GPPW-E) or earlier.....	2- 8
2.4.2 When handling a project on GX Developer (SW5D5-GPPW-E) or earlier.....	2- 9
2.4.3 Handling a Project in GX Developer (SW6D5-GPPW-E 6.04E or Older)	2- 10
Chapter 3 COMMON OPERATIONS	3- 1 to 3- 23
3.1 List of Shortcut Keys and Access Keys.....	3- 1
3.2 Project Designation.....	3- 5
3.2.1 Saving a project.....	3- 6
3.2.2 Opening a project.....	3- 9
3.3 Cut, Copy, and Paste.....	3- 10
3.3.1 Cut and paste	3- 10
3.3.2 Copy and paste	3- 12
3.3.3 Notes on cutting, copying and pasting network parameters.....	3- 14
3.4 Toolbar	3- 16
3.5 Status Bar.....	3- 17
3.6 Zooming in on or out of the Edit Screen.....	3- 18
3.7 Project Data List.....	3- 19
3.8 Comment Display.....	3- 21
3.9 Statement Display.....	3- 21
3.10 Note Display	3- 21
3.11 Alias Display.....	3- 22
A - 3	A - 3

3.12 Comment Format	3- 22
3.13 Alias format display	3- 23
3.13.1 Replace device name and display	3- 23
3.13.2 Arrange with device and display	3- 23

Chapter 4 INITIALIZATION	4- 1 to 4- 29
---------------------------------	----------------------

4.1 Creating a Project	4- 1
4.2 Opening the Existing Project File	4- 3
4.3 Closing a Project File	4- 5
4.4 Saving a Project	4- 5
4.5 Saving a Project with a New Name	4- 6
4.6 Deleting a Project	4- 6
4.7 Verifying Data in Projects	4- 7
4.8 Copying a Project	4- 9
4.9 Adding Data to a Project	4- 11
4.10 Copying Data within a Project	4- 12
4.11 Deleting Data in a Project	4- 14
4.12 Renaming Data in a Project	4- 15
4.13 Changing the Ladder and SFC with each other	4- 16
4.14 Changing the PLC Type of a Project	4- 17
4.15 Reading Other Format Files	4- 18
4.15.1 Reading GPPQ, GPPA, FXGP(DOS) or FXGP(WIN) files	4- 18
4.15.2 Reading a MELSEC MEDOC format file (Printout)	4- 22
4.15.3 Reading a MELSEC MEDOC format file	4- 23
4.16 Exporting GPPQ, GPPA, FXGP(DOS) or FXGP(WIN) Files	4- 25
4.17 Starting Multiple Projects	4- 29
4.18 Existing GX Developer	4- 29

Chapter 5 STANDARDIZING THE PROGRAMS	5- 1 to 5- 30
---	----------------------

5.1 Label programming	5- 1
5.1.1 Label programming sequence	5- 6
5.1.2 Label programming input method	5- 7
5.1.3 Making global variable/local variable setting	5- 9
5.1.4 Making automatic device setting	5- 13
5.1.5 Deleting External	5- 14
5.1.6 All deletion	5- 14
5.1.7 Importing device comments	5- 15
5.1.8 Exporting to device comments	5- 16
5.1.9 Converting label programs into actual programming (Compile)	5- 18
5.1.10 Displaying the Device Program	5- 20
5.2 About Macros	5- 21
5.2.1 Registering a macro	5- 23
5.2.2 Utilizing a macro	5- 25
5.2.3 Deleting a macro	5- 27
5.2.4 Displaying macro	5- 28

6.1 Restrictions on Circuit Creation	6- 7
6.1.1 Restrictions in circuit display window	6- 7
6.1.2 Restrictions in circuit edit window	6- 8
6.2 Creating and Editing Circuits	6- 12
6.2.1 Inputting contacts and application instructions.....	6- 12
6.2.2 Inputting lines (vertical and horizontal)	6- 14
6.2.3 Deleting contacts and application instructions	6- 16
6.2.4 Deleting connecting lines	6- 17
6.2.5 Inserting and deleting in circuit blocks.....	6- 18
6.2.6 Inserting NOPs	6- 20
6.2.7 Deleting NOPs.....	6- 20
6.2.8 Cutting, copying and pasting circuits	6- 21
6.2.9 Undo the last operation.....	6- 23
6.2.10 Returning to the status after ladder conversion	6- 24
6.3 Changing T/C Setting Values	6- 25
6.4 Find and Replace	6- 27
6.4.1 Finding a device	6- 29
6.4.2 Finding an instruction	6- 31
6.4.3 Finding a step No.	6- 32
6.4.4 Finding a character string.....	6- 33
6.4.5 Finding a contact/coil.....	6- 35
6.4.6 Finding data.....	6- 36
6.4.7 Replacing a device	6- 37
6.4.8 Replacing an instruction.....	6- 39
6.4.9 Changing A and B contacts	6- 41
6.4.10 Replacing a character string	6- 42
6.4.11 Replacing the module's first I/O number	6- 44
6.4.12 Changing the statement or note type	6- 45
6.4.13 Replacing data	6- 46
6.4.14 Searching for a contact coil.....	6- 47
6.4.15 Searching for a device-use instruction	6- 49

7.1 Common Notes on Instruction List Creation	7- 1
7.2 Creating a Program Instruction list	7- 3
7.2.1 Inputting a contact or application instruction	7- 3
7.2.2 Changing the existing program in overwrite mode	7- 4
7.2.3 Inserting or adding the existing program	7- 5
7.2.4 Deleting the existing program list.....	7- 6
7.2.5 Inserting NOPs	7- 7
7.2.6 Deleting NOPs	7- 7
7.3 Find and Replace	7- 8
7.3.1 Finding a device	7- 8
7.3.2 Finding an instruction	7- 8
7.3.3 Finding a step No.	7- 8

7.3.4 Finding a character string.....	7- 8
7.3.5 Finding a contact/coil.....	7- 8
7.3.6 Replacing a device.....	7- 8
7.3.7 Replacing an instruction.....	7- 8
7.3.8 Changing an A or B contact.....	7- 9
7.3.9 Replacing a character string.....	7- 9
7.3.10 Change module start address.....	7- 9
7.3.11 Changing the statement or note type.....	7- 9
7.3.12 Searching for a contact coil.....	7- 9
7.3.13 Searching for an instruction using a device.....	7- 9
7.4 Display.....	7- 10
7.4.1 Displaying a Alias.....	7- 10
7.5 Switching Read and Write Modes.....	7- 11
7.5.1 Switching to read mode.....	7- 11
7.5.2 Switching to write mode.....	7- 11
7.5.3 Switching to circuit mode.....	7- 11
7.6 Changing T/C Setting Values.....	7- 11

Chapter 8 CONVERSION	8- 1 to 8- 2
-----------------------------	---------------------

8.1 Converting an Edit Program.....	8- 1
8.2 Converting Multiple Edit Programs.....	8- 1

Chapter 9 SETTING DEVICE COMMENTS	9- 1 to 9- 28
--	----------------------

9.1 Points to be Noted before Comment Creation with GX Developer.....	9- 1
9.1.1 Editing comments only on peripheral devices.....	9- 4
9.1.2 Writing to ACPU/GPPA file.....	9- 6
9.1.3 Reading from ACPU/GPPA file.....	9- 7
9.1.4 Writing to QCPU(Q mode) QnACPU/GPPQ file.....	9- 9
9.1.5 Reading from QCPU(Q mode) QnACPU.....	9- 9
9.1.6 Writing to FXCPU/FXGP(DOS), FXGP(WIN) file.....	9- 10
9.1.7 Reading from FXCPU/FXGP(DOS), FXGP(WIN) file.....	9- 11
9.2 List of Device Comments.....	9- 12
9.3 Common Comments and Comments by Program.....	9- 13
9.4 Creating Device Comments.....	9- 16
9.4.1 Creating device comments on the device comment edit window.....	9- 16
9.4.2 Creating device comments for the created circuit.....	9- 18
9.4.3 Creating device comments after creating a circuit.....	9- 19
9.4.4 Editing comments on the ladder editing screen.....	9- 20
9.5 Deleting Device Comments.....	9- 21
9.5.1 Deleting all device comments and Alias.....	9- 21
9.5.2 Deleting display device comments and Alias.....	9- 21
9.6 Setting Comment Types.....	9- 22
9.7 Setting Comment Ranges.....	9- 24

Chapter 10 SETTING STATEMENTS AND NOTES	10- 1 to 10- 20
--	------------------------

10.1 About the Statements/Notes.....	10- 1
10.2 About Merging Operation Procedure.....	10- 6

10.3	Creating and Deleting Statements	10- 7
10.3.1	When editing the circuit window	10- 7
10.3.1(1)	Creating statements in the circuit edit window	10- 7
10.3.1(2)	Deleting statements in the circuit edit window	10- 8
10.3.2	When editing the list window	10- 9
10.3.2(1)	Editing statements on the list edit window	10- 9
10.3.2(2)	Deleting statements on the list edit window.....	10- 10
10.3.3	Creating statements in the statement edit mode	10- 11
10.4	Creating and Deleting Notes	10- 12
10.4.1	Creating notes on the circuit edit window.....	10- 12
10.4.1 (1)	Creating notes on the circuit edit window	10- 12
10.4.1 (2)	Deleting notes in the circuit edit window.....	10- 13
10.4.2	Creating notes in the list edit window	10- 14
10.4.2 (1)	Creating notes in the list edit window.....	10- 14
10.4.2 (2)	Deleting notes in the list edit window	10- 15
10.4.3	Creating notes in the note edit mode	10- 16
10.5	Botch-Editing the Statements/Notes	10- 17

Chapter 11 SETTING DEVICE MEMORY (DWR SETTING)	11- 1 to 11- 6
---	-----------------------

11.1	Device Memory	11- 1
11.2	Device Value Input.....	11- 2
11.3	All Clear	11- 5
11.3.1	Clearing all devices	11- 5
11.3.2	Clearing all display devices.....	11- 5
11.4	Making Fill Settings.....	11- 6

Chapter 12 SETTING DEVICE INITIALIZATION VALUES	12- 1 to 12- 2
--	-----------------------

Chapter 13 SETTING THE PARAMETERS	13- 1 to 13- 24
--	------------------------

13.1	Setting the PLC Parameters.....	13- 3
13.1.1	Common Notes on Parameters	13- 4
13.1.2	PLC Parameter Item Lists.....	13- 7
13.1.3	Explanations for PLC Parameter Setting Screen.....	13- 14
13.2	Setting the Network Parameters	13- 15
13.2.1	About items common to the Network parameters.....	13- 16
13.2.2	Network parameter item lists	13- 18
13.2.3	Explanation for network parameter setting screen	13- 23
13.3	Setting the Remote Password	13- 24

Chapter 14 PRINT	14- 1 to 14- 37
-------------------------	------------------------

14.1	Setting Up a Printer.....	14- 2
14.2	Setting a Page Layout.....	14- 4
14.3	Previewing a Print Image.....	14- 7
14.4	Printing	14- 9
14.5	Setting the Details for Printing	14- 12
14.5.1	Creating a title	14- 12

14.5.2	Setting a ladder print range.....	14- 13
14.5.3	Setting a Instruction list print range	14- 16
14.5.4	Setting a TC setting value print range.....	14- 18
14.5.5	Setting a device comment print range.....	14- 19
14.5.6	Setting a device use list print range.....	14- 21
14.5.7	Setting a device memory print range.....	14- 23
14.5.8	Setting a device initial value print range.....	14- 24
14.5.9	Setting a PLC parameter print item	14- 26
14.5.10	Setting a network parameter print item	14- 27
14.5.11	Setting a list of contact coil used	14- 28
14.5.12	Displaying a project contents list	14- 29
14.5.13	Setting the TEL data print area.....	14- 30
14.5.14	Product information list.....	14- 31
14.5.15	Printing labels.....	14- 32
14.6	Print Examples	14- 33

Chapter 15 OTHER FUNCTIONS	15- 1 to 15- 37
----------------------------	-----------------

15.1	Checking Programs	15- 1
15.2	Merging Programs	15- 3
15.3	Checking Parameters	15- 6
15.4	All-clearing the Parameters	15- 7
15.5	IC Memory Card (GX Developer ↔ IC Memory Card)	15- 8
15.5.1	Reading the data of the IC memory card	15- 10
15.5.2	Writing data to the IC memory card.....	15- 11
15.6	Intelligent Function Utility.....	15- 12
15.7	Transferring ROM Data	15- 14
15.7.1	ROM reading, writing, and verification	15- 20
15.7.2	Writing to files in ROM format.....	15- 22
15.8	Batch-Deleting the Unused Device Comments	15- 24
15.9	Customizing Keys	15- 25
15.10	Changing the Display Color.....	15- 26
15.11	Setting Options.....	15- 27
15.12	Displaying Multiple Windows	15- 35
15.13	Opening a Specific Project Using a Shortcut.....	15- 36
15.14	Starting the Ladder Logic Test Tool.....	15- 37
15.15	Outline of Help Function	15- 37

Chapter 16 CONNECTING A PLC	16- 1 to 16- 83
-----------------------------	-----------------

16.1	Specifying the Connection Target	16- 1
16.1.1	When accessing the own station	16- 1
16.1.2	When accessing the other station	16- 4
16.1.3	Accessing multiple CPUs.....	16- 10
16.1.3 (1)	About access to other multiple CPU modules	16- 10
16.1.3 (2)	About network access via multiple CPUs	16- 12
16.2	Making access via Ethernet, CC-Link, G4 module, C24 or telephone line.....	16- 15
16.2.1	Setting method for communication via the ethernet board.....	16- 15
16.2.1 (1)	For A series.....	16- 15

16.2.1 (2) For QnA series.....	16- 20
16.2.1 (3) For Q series	16- 23
16.2.2 Setting Method for Communication Via CC-Link (AJ65BT-G4)	16- 26
16.2.2 (1) For A series.....	16- 26
16.2.2 (2) For QnA series.....	16- 29
16.2.2 (3) For Q series	16- 33
16.2.3 Setting Method for Communication Via C24.....	16- 37
16.2.3 (1) Connection in the form of one-for-one	16- 37
16.2.3 (2) Connection in the form of multidrop.....	16- 39
16.2.4 Setting method for communication via a modem interface module	16- 44
16.3 Using PLC Read/Write.....	16- 52
16.3.1 Executing PLC read/PLC write	16- 52
16.3.2 Setting the read/write range for device data	16- 58
16.3.3 Setting the program reading/writing range.....	16- 60
16.3.4 Setting the comment read/write range	16- 61
16.4 Verifying the Peripheral Side and PLC Side Data	16- 64
16.5 Write to PLC (Flash ROM).....	16- 67
16.5.1 Write the program memory to ROM	16- 67
16.5.2 Write to PLC (Flash ROM).....	16- 68
16.6 Deleting Data in the PLC	16- 69
16.7 Changing PLC Data Attributes	16- 71
16.8 Reading/Writing PLC User Data.....	16- 74
16.8.1 Reading	16- 74
16.8.2 Writing PLC user data.....	16- 75
16.9 Executing Online Change.....	16- 76
16.10 Concept of the Routing Parameters.....	16- 82

Chapter 17 MONITORING	17- 1 to 17- 34
------------------------------	------------------------

17.1 Monitoring, and Stopping/Resuming Monitoring.....	17- 3
17.2 Monitoring/Stopping Monitoring in All Windows.....	17- 6
17.3 Editing Programs During Ladder Monitoring.....	17- 7
17.4 Switching Present Values Between Decimal and Hexadecimal	17- 9
17.5 Batch Monitoring Devices/Buffer Memories.....	17- 10
17.5.1 Batch monitoring devices/buffer memories	17- 10
17.5.2 Batch-monitoring the multi-CPU buffer memory	17- 14
17.6 Monitoring after Registering Devices	17- 15
17.7 Setting Monitor Conditions/Stop Conditions	17- 18
17.8 Program List Monitor.....	17- 20
17.9 Monitoring the Interrupt Program List.....	17- 23
17.10 Measuring Scan Time.....	17- 24
17.11 Executing Sampling Trace.....	17- 25
17.11.1 Setting execution & status display.....	17- 26
17.11.2 Setting trace data	17- 29
17.11.3 Setting trace conditions.....	17- 31
17.12 Monitoring the Ladders Registered	17- 33
17.13 Deleting All Ladders Registered.....	17- 34

Chapter 18 DEBUGGING PROGRAMS

18- 1 to 18- 18

18.1 Carrying Out a Device Test	18- 2
18.2 Registering/Canceling the Forced I/O	18- 5
18.2.1 Registration to PLC CPU	18- 5
18.2.2 Registration/cancellation to remote I/O station	18- 6
18.3 Carrying Out Partial Operation	18- 7
18.4 Executing Step Run	18- 11
18.5 Setting the Scan Range.....	18- 14
18.6 Operating the PLC Remotely.....	18- 16

Chapter 19 REGISTERING KEYWORD/PASSWORDS

19- 1 to 19- 10

19.1 Registering Keyword	19- 1
19.1.1 Registering new keyword/changing keyword	19- 1
19.1.2 Canceling a keyword	19- 4
19.1.3 Releasing a keyword	19- 5
19.2 Registering Passwords	19- 6
19.2.1 Register new passwords/changing passwords.....	19- 7
19.2.2 Delete the passwords.....	19- 9
19.2.3 Disable the passwords.....	19- 10

Chapter 20 PLC MEMORY

20- 1 to 20- 10

20.1 Clearing the PLC Memory	20- 1
20.1.1 All-clearing on ACPU memory.....	20- 1
20.1.2 All-clearing the QCPU, QnACPU device memory	20- 3
20.1.3 All-clearing an FXCPU memory.....	20- 4
20.2 Formatting a QCPU (Q mode), QnACPU Memory.....	20- 6
20.3 Sorting the QCPU (Q mode), QnACPU Memory.....	20- 8
20.4 Setting for the PLC's Clock.....	20- 9

Chapter 21 DIAGNOSIS

21- 1 to 21- 48

21.1 Diagnosing the PLC	21- 1
21.1.1 Diagnosing an ACPU	21- 1
21.1.2 Diagnosing a QCPU (Q mode), QnACPU.....	21- 3
21.1.3 Diagnosing the QCPU (Q Mode).....	21- 5
21.1.4 Diagnosing an FXCPU.....	21- 7
21.2 Diagnosing a Network.....	21- 8
21.2.1 Testing a network.....	21- 10
21.2.2 Performing a loop test	21- 11
21.2.3 Performing a setting confirmation test	21- 12
21.2.4 Performing a station order confirmation test	21- 14
21.2.5 Performing a transmission test	21- 16
21.2.6 Monitoring the error history	21- 17
21.2.7 Network monitor details	21- 19
21.2.8 Monitoring other station information	21- 20
21.3 Running CC-Link Diagnostics.....	21- 23

21.3.1	Monitoring the line (own station).....	21- 23
21.3.2	Conducting a line test.....	21- 25
21.3.3	Monitoring the lines (other stations)	21- 26
21.4	Making Ethernet Diagnostics.....	21- 27
21.4.1	Ethernet diagnostics.....	21- 27
21.4.2	Parameter status.....	21- 29
21.4.3	Error history.....	21- 31
21.4.4	Status of each connection.....	21- 33
21.4.5	Status of each protocol	21- 34
21.4.6	LED status.....	21- 36
21.4.7	Received e-mail information	21- 37
21.4.8	Send e-mail information	21- 39
21.4.9	PING test.....	21- 41
21.4.10	Loopback test.....	21- 43
21.5	System Monitor	21- 45

Chapter 22	SETTING A6TEL/Q6TEL/FX _{2N} DATA	22- 1 to 22- 38
------------	---	-----------------

22.1	Function Setting Item List.....	22- 2
22.2	Preparations for Connecting the Telephone Line	22- 3
22.2.1	Making remote access/pager notice (for ACPU)	22- 3
22.2.2	Making remote access/pager notice (for QnACPU).....	22- 5
22.2.3	Making remote access to FXCPU	22- 7
22.2.4	Making Q6TEL-Q6TEL communication	22- 9
22.3	Making Initial Setting of Data.....	22- 12
22.3.1	Creating a phone number book.....	22- 12
22.3.2	Registering the AT command	22- 16
22.3.3	Registering A6TEL data.....	22- 19
22.3.4	Registering Q6TEL data	22- 23
22.3.5	Setting the FX PLC	22- 28
22.4	Connecting/Disconnecting the Line.....	22- 32
22.4.1	Connecting the line automatically.....	22- 32
22.4.2	Connecting the line via a switchboard (manual connection)	22- 36
22.4.3	Disconnecting the line.....	22- 38

Chapter 23	MXCHANGE CONVERSION FUNCTIONS	23- 1 to 23- 14
------------	-------------------------------	-----------------

23.1	Function List.....	23- 1
23.2	General Procedure for Using the MXChange Conversion Functions	23- 2
23.3	Logging in to the Server.....	23- 3
23.4	Logging off the Server.....	23- 5
23.5	MXChange Data Base Conversion	23- 6
23.6	Import from MXChange Tags	23- 8
23.7	Export to MXChange Tags	23- 10
23.8	MXChange Troubleshooting.....	23- 14

16. CONNECTING A PLC

16.1 Specifying the Connection Target

16.1.1 When accessing the own station

A	Q/QnA	FX
<input type="radio"/>	<input type="radio"/>	<input type="radio"/>

[Purpose]
Specify when making access to the own station.

[Operating Procedure]
Select [Online] → [Transfer setup].

[Dialog Box]

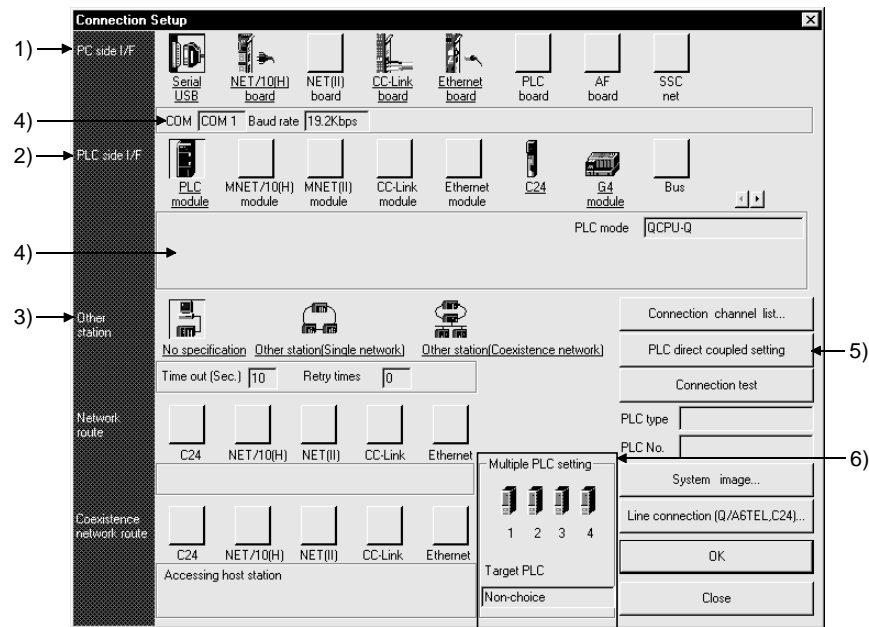

POINT

An underline on the setting screen indicates that detailed setting can be made by double-clicking it.
 The icons displayed can be selected.
 The icon shown yellow means that it has already been selected.

[Description]

- 1) PC side I/F
For Q series

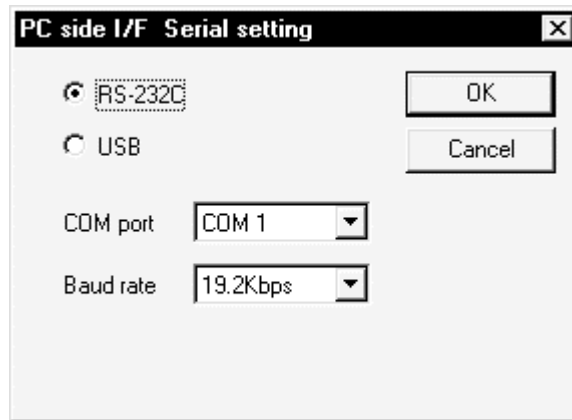

- USB may be set only when the QCPU (Q mode) has been selected.
- Precautions for communication at 115.2/57.6kbps
Fast communication cannot be made if the personal computer used is not compatible with the communication speed of 115.2/57.6kbps.
If communications delay due to communications tries or a communication error occurs, reduce the baud rate setting and restart communication.
- Refer to (4), (5), (6) in POINT of Section 16.1 for precautions for making USB communication.

QnA/A/FX series

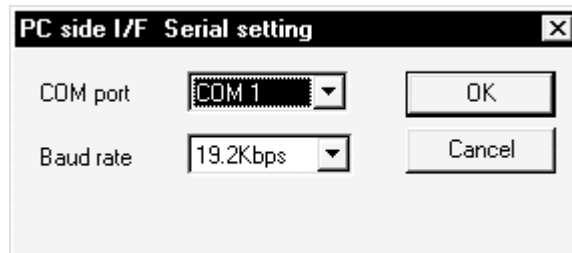

- The baud rate value that may be chosen differs between the PLC series and PLC types.
- For the QnA series, the CPU that can communicate at the communication speed of 38.4kbps is the QnACPU whose function version is B or later. Refer to Appendix 7 for the way to identify the unit version.
Refer to Section 22.3.3 when using the A6TEL as a converter.

- 2) PLC side I/F
Choose the PLC series of the PLC to be connected with GX Developer.
For A series

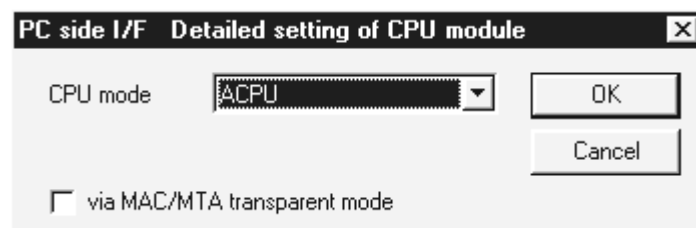

- Via MAC/MTA transparent mode (QnA/A/FX only)
Please make settings only when using MAC/MTA.

- 3) Other station
Choose No specification when specifying the own station.
When power-off, hardware reset or the like of the PLC CPU is performed during ladder monitor, it will take time until a communications error appears.
Until the error appears, during execution is displayed in Monitor status.
The longest time until the error appears can be found by the following expression.
(Time specified for communications time check) × 3 × (Count specified for the number of retries + 1)
For example, when the communications time check is specified as 30 seconds and the number of retries as 0 times, the resultant time is (30 seconds) × 3 × (0 + 1) = 90 seconds, and the error appears after a maximum of 90 seconds have elapsed.
- 4) Detailed settings display column
Shows the setting status.
- 5) PLC direct coupled setting button
This button is useful to change from Other station to the own station.
- 6) Multiple PLC Setting (setting may be made for only the function version B or later of the QCPU (Q mode))
Refer to Section 16.1.3 (1).

16.1.2 When accessing the other station

A	Q/QnA	FX
○	○	×

[Purpose]

Specify when making access to the other station.

[Operating Procedure]

Select [Online] → [Transfer Setup].

[Dialog Box]

When specifying the other station, it will be convenient to specify the connection target while looking at the connection channel diagram from Connection channel list.

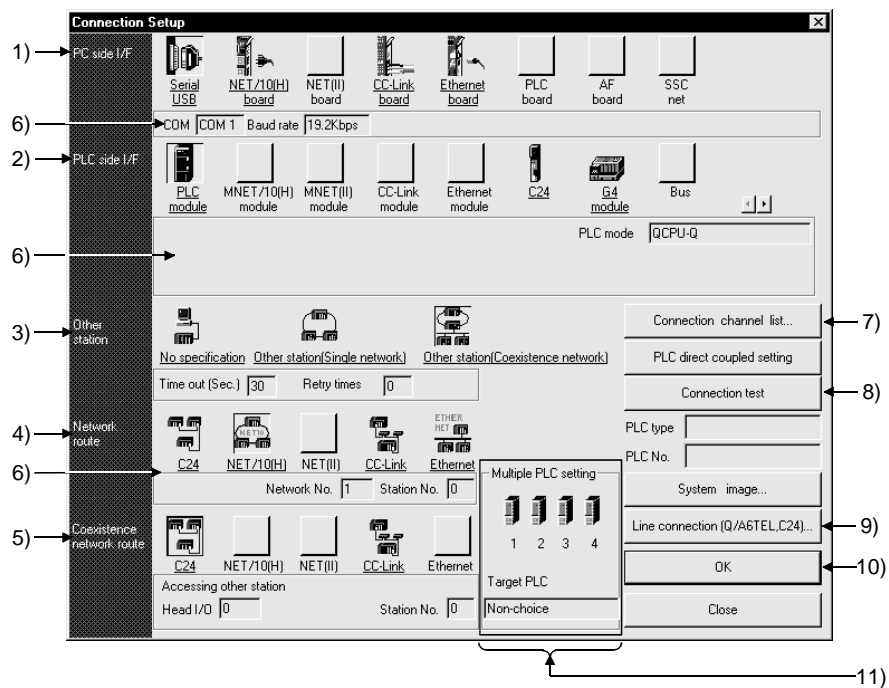

POINT

An underline on the setting screen indicates that detailed setting can be made by double-clicking it.
 The icons displayed can be selected.
 The icon shown yellow means that it has already been selected.

[Description]

- 1) PC side I/F
Refer to Section 16.1.1
- 2) PLC side I/F
Choose the unit to be connected with the personal computer.

3) Other station

What is Single network?

It indicates a system which is configured by a single network and a multilevel system, e.g., only MELSECNET/10 or only Ethernet. (Since Ethernet is regarded as the MELSECNET/10, specify Single network for an MELSECNET/10 and Ethernet mixed system.)

What is Coexistence network?

Set this network when making access to the other station PLC via two different networks.

This network indicates a system which is made up of different networks, e.g. from MELSECNET/10 to CC-Link unit or from Q-compatible C24/QC24 to MELSECNET/10.

This network cannot be chosen for the A series.

4) Network route

When Single network is selected

Choose the network type, network No., station number and first I/O No. to be accessed.

The setting items depend on the network type that has been set.

When Coexistence network is selected

Choose this when making access to the network different from the one where the personal computer is connected.

5) Coexistence network route

Choose the network type, network No., station number and first I/O No. to be accessed.

The setting items depend on the network type that has been set.

6) Detailed settings display column

Shows the setting status.

7) Connection channel list

You can set the connection target while looking at the Connection channel list. As clicking **OK** automatically sets the connection channel on the Connection Setup screen, settings can be made easily if a complicated system is configured. Set the network number, station number and others as desired according to the access target.

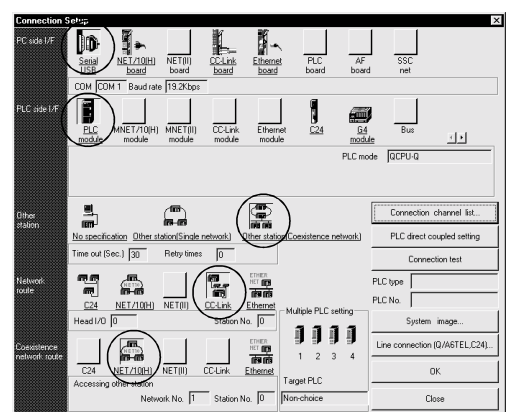
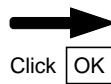
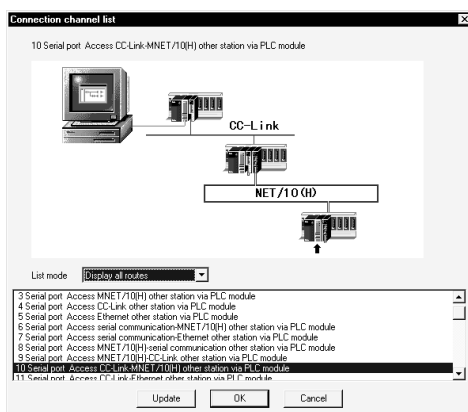

Clicking the **OK** button automatically sets the connection channel (areas enclosed by circles) on the Connection Setup screen.

Changing from one display to another

Convenient usage of Display selected routes

When Display selected routes are selected by specifying the PC side I/F and PLC side I/F on the Connection Setup screen, only the routes in the accessible range are displayed from among the other station, network route and coexistence network route.

A list of system configurations different in series can also be displayed.

Request Source	PC-Connected PLC	Relay Station	Access Target
Personal computer	QCPU (Q mode)	QCPU (Q mode)	Q series
			QnA series
			A series

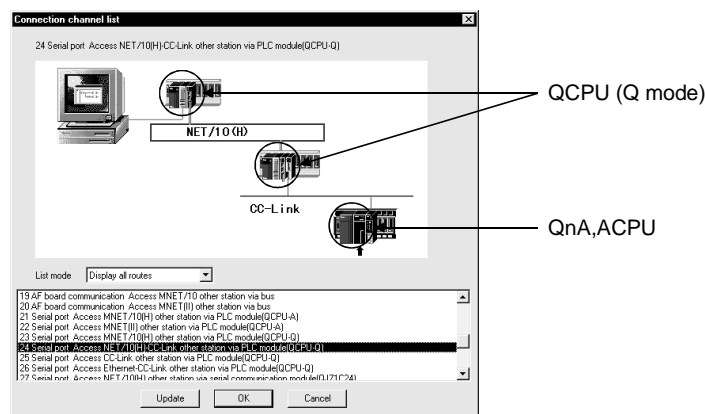

8) Connection test

Tests whether proper access can be made to the PLC set as the access target on the Connection Setup screen.

If proper access can be made, the model name of the PLC as the access target appears in the CPU type field.

9) System image

Illustrates the preset connection channel.

10) Line connection (Q/A6TEL, C24) button

Set when using a telephone line to make communication.

Refer to Section 23.4 for the way to set the Line connection setting screen.

11) Multiple PLC setting

Specify when the access target is multiple CPUs.

For details, refer to Section 16.1.3 (2).

Screen setting for MELSECNET/10 and Ethernet combined system (Single network)
In an MELSECNET/10 and Ethernet mixed system configuration, specify Single network to access the other station. (Since Ethernet is equivalent to the MELSECNET/10)

An example of the Connection Setup setting screen is provided for the following system configuration (Q/QnA only).

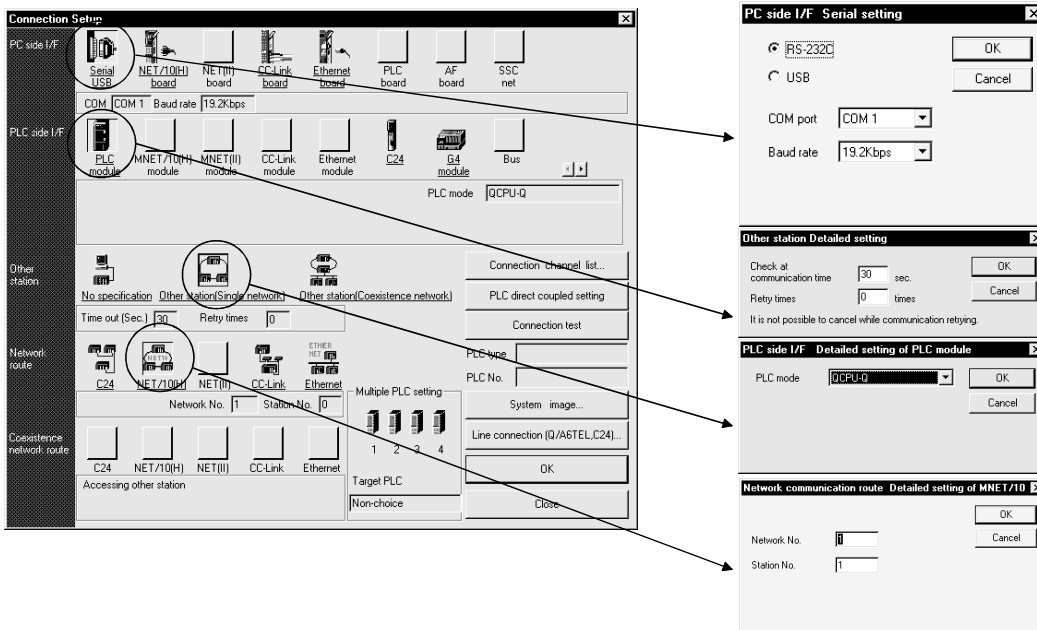
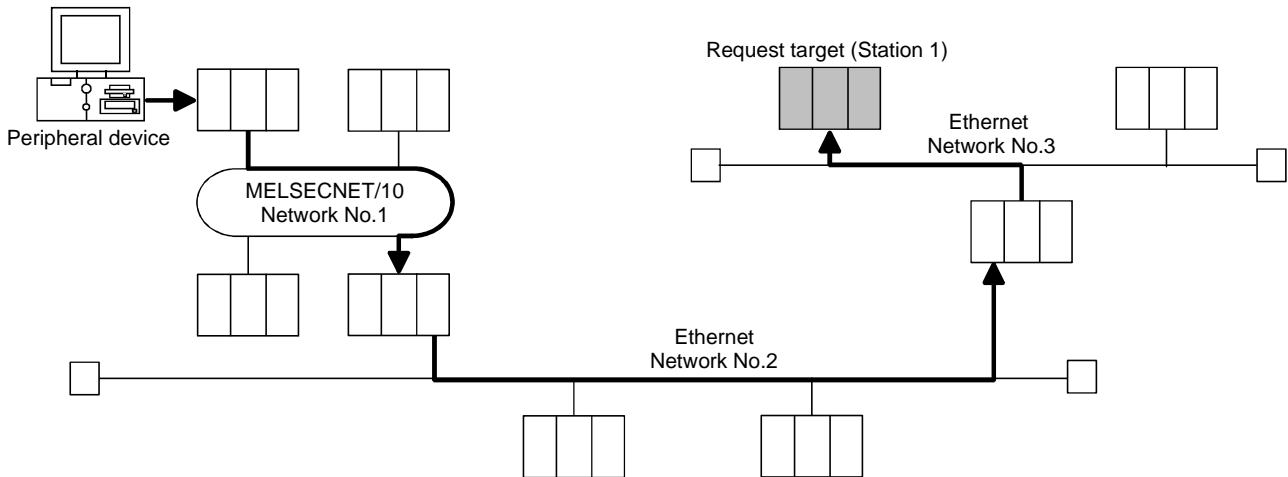

For access to the other station or multilevel system, not only the Connection Setup but also the routing parameters should be set to enable communications.

Screen setting for MELSECNET/H, MELSECNET/10 and C24 mixed system (Coexistence network)

Specify Coexistence network when accessing the other station via different networks, e.g. from MELSECNET/H, MELSECNET/10 to Q-compatible C24/QC24. An example of the Connection Setup setting screen is provided for the following system configuration (Q/QnA only).

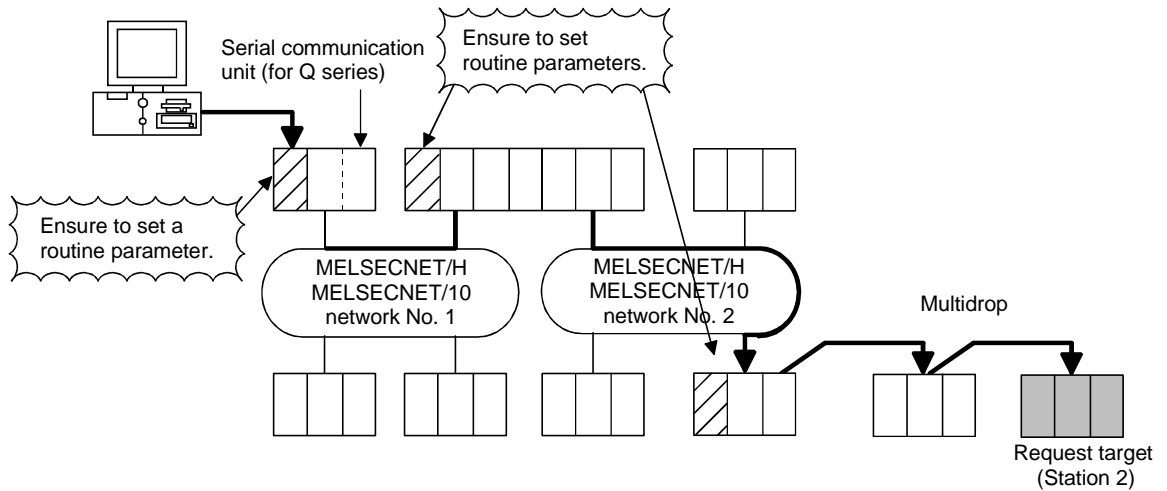

The screenshot shows the 'Connection Setup' dialog box. Callouts from the diagram above point to the following settings:

- PC side I/F:** The 'Serial setting' dialog is open, showing 'RS-232C' selected, 'COM 1' as the port, and '19.2Kbps' as the baud rate.
- Other station:** The 'Detailed setting of C24' dialog is open, showing 'QJ71C24' as the CPU type, '0' as the station number, 'Odd' parity, and 'Existence' sum check.
- Coexistence network route:** The 'Detailed setting of Computer I/F' dialog is open, showing '3' as the head I/O and '0' as the station number.
- Network route:** The 'Detailed setting of MNET/10' dialog is open, showing '0' as the network number and '1' as the station number.

REMARKS

Precautions are indicated for when accessing to other station like the following system example.

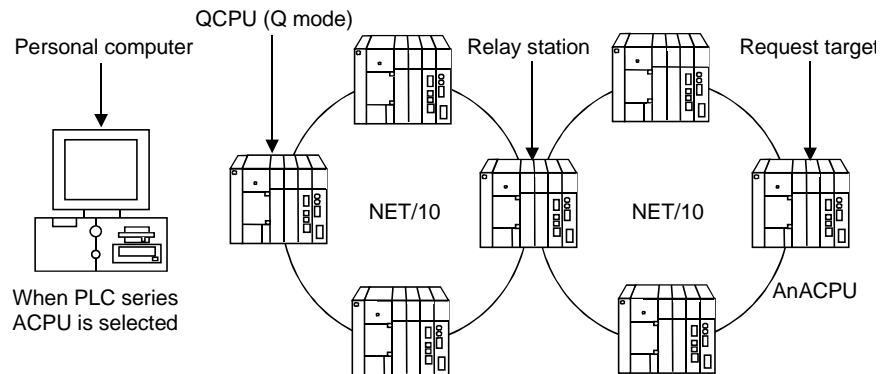

1. Change the personal computer to the PLC type of the request target. Communication cannot be made if the PLC type differs.
2. The relay station used should be the QCPU (Q mode), AnUCPU.

16.1.3 Accessing multiple CPUs

16.1.3 (1) About access to other multiple CPU modules

A	Q/QnA	FX
×	○*	×

*: This function is compatible with the QCPU (Q mode) function version B.

[Purpose]

Specify when accessing multiple CPUs.

[Operating Procedure]

Select [Online] → [Connection setup].

[Dialog Box]

The following setting example assumes that the personal computer is connected to the No. 1 module by a cable to access the No. 4 module.

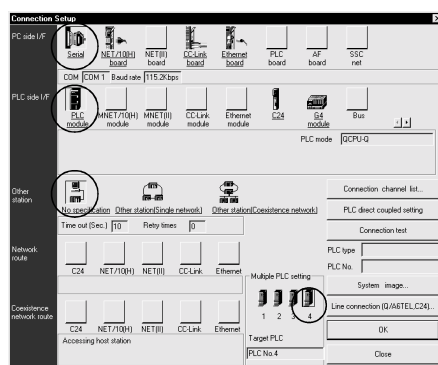

[Description]

When accessing other than the connected PLC CPU, always specify the module No. to be accessed in Multiple PLC setting.

Note that if it is not specified in Multiple PLC setting, access will be made to the PLC CPU with which the cable is connected.

How to set "No module No. specified" in Multiple PLC setting

No module No. specified is indicated by the icons of the PLC No. 1 to PLC No. 4 modules in Multiple PLC setting which are not selected (when selected, the icons are shown yellow).

When the icons of the PLC No. 1 to PLC No. 4 modules have been selected, clicking the selected icon sets it to "No module No. specified".

An example on the above setting screen is shown by the following image sketch.

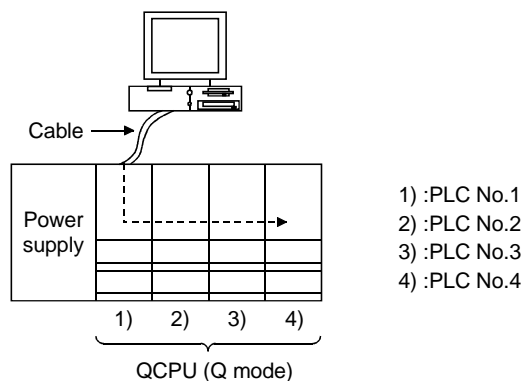

Restrictions on access to Q motion CPU

Access to the Q motion CPU cannot be made using the personal computer where GX Developer and GSV are installed.

Prepare personal computers for GX Developer and GSV, respectively.

<Connection example>

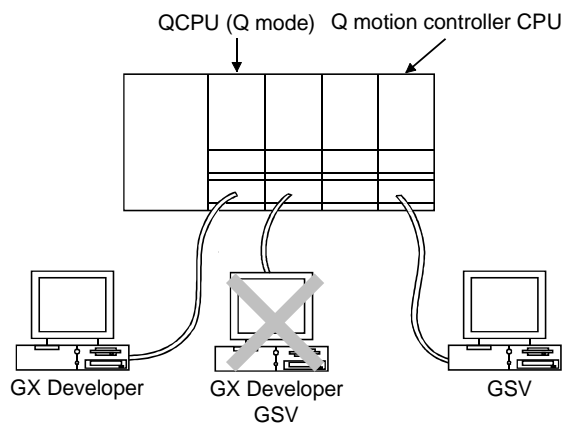

POINT

The Q motion CPU is incompatible with GX Developer.
 Accordingly, do not connect GX Developer to the Q motion CPU.
 Accidental connection will cause a communication error. In that case, reconnect it to the PLC CPU.

16.1.3 (2) About network access via multiple CPUs

A	Q/QnA	FX
○	○*	○

*: This function is compatible with the QCPU (Q mode) function version B.

[Purpose]

Access is made to any network station under control of the own module.

[Operating Procedure]

Select [Online] → [Connection setup].

[Dialog Box]

The following setting assumes that access will be made to the accessed station (PLC No. 1 to PLC No. 4 modules) in [Description].

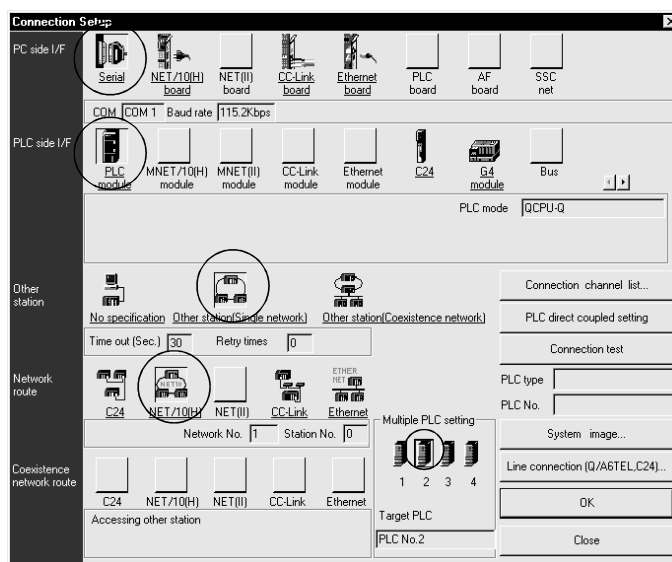

[Description]

The concept of an access path in the following system configuration will be described.

When access is made to non-control PLC as module used for routing of the accessed other station in a Multiple CPU system, the relay modules and QCPUs of the own station, all relay stations and accessed station should be the modules of function version B.

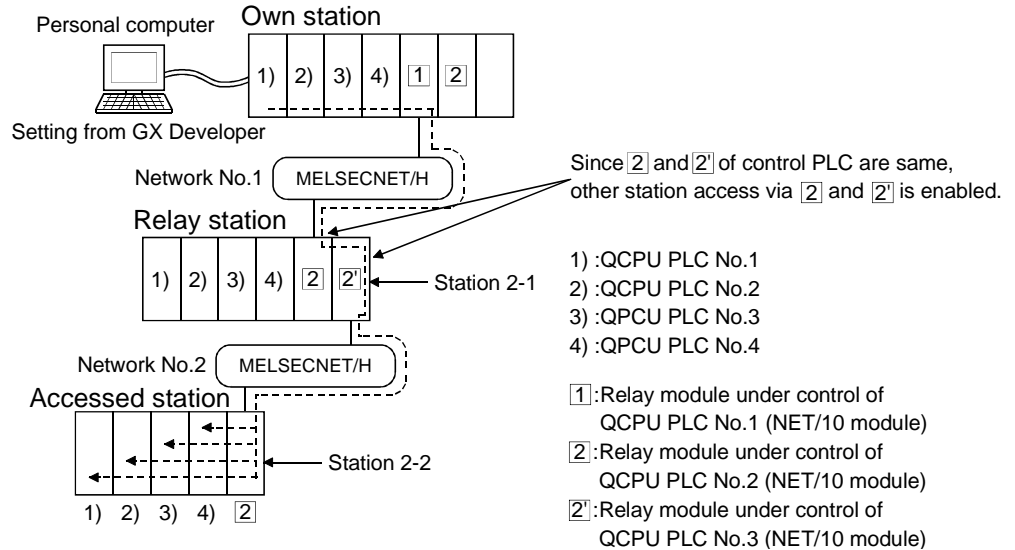

Precautions for and restrictions on access to other station

- (1) When accessing the CPU controlled or not controlled by the accessed station, change the accessed module in "Multiple PLC setting" on the Connection setup screen.
- (2) Assign the two network modules on the relay station to the same control CPU.
- (3) When the network module of the accessed station is that of function version B, access can be made to PLC No. 1 to PLC No. 4 modules.
When the the network module of the accessed station is that of function version A, access may be made to only the control PLC by the network module (PLC No. 1).

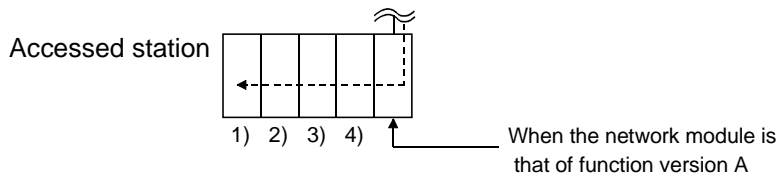

POINT

Setting the routing parameters of the MELSECNET/H, MELSECNET/10 (including Ethernet) allows access to the other station PLC within the range of the network system specifications.

POINTS

- (1) Precautions for access to the other stations of the MELSECNET (II, /10) via the computer link unit (for A series) or E71
GX Developer recognizes the MELSECNET/10 as the MELSECNET (II) when the other stations are to be accessed via the computer link unit (for A series) or E71. When the same station exists on the MELSECNET (II) and MELSECNET/10, the other stations beyond the MELSECNET/10 may not be accessed if Via MELSECNET/10 has been selected in Connection Setup. (Because communications from the station of the unit set in the "Unit valid for other station access" network parameter are executed.)
When you want to access all other stations via the computer link unit (for A series) or E71, do not set the same station number on the networks.
- (2) When the MELSECNET/10 /CC-Link card is used, the time check is fixed to 30 seconds.
- (3) Precautions for access to the motion controller (SCPU) via the MELSECNET (II, /10)
 - Set the A171SH/A172SH as the A2SH.
 - Set the A273UH(S3) as the A3U.In this case, the instructions dedicated to the motion controller (SCPU) cannot be used.
- (4) A communications error may occur if communications are made with the PLC after setting the resume function, suspend setting, power-saving function or standby mode of the personal computer.
Hence, any of the above functions should not be set for making communications with the PLC.
- (5) Connecting/disconnecting the USB cable, resetting the PLC, or switching power OFF/ON frequently during communications with the PLC can cause a communications error, from which recovery may not be made. Hence, place GX Developer in an offline status* where possible before connecting/disconnecting the USB cable, resetting the PLC, or switching power OFF/ON.
If recovery cannot be made from the communications error, completely disconnect the USB cable once and reconnect it in more than five seconds. (Even after this operation, an error may occur at the initial communication, but communications will be made properly at the second time and later.)
*Offline status: Indicates the status other than PLC write/read, monitor, test and PLC diagnostic
- (6) Communication errors may occur depending on the type of personal computer used or USB cable assembly In this case.
Please execute communication again according to the error message contents.
- (7) When fast communication is made after the baud rate has been changed on the personal computer's serial port (personal computer side interface), communications may not be made or communications retries may take place to delay communications, depending on the performance of the personal computer.
If communications cannot be made in fast communication, reduce the baud rate and make communication.
- (8) Other station access cannot be made for the 171SHCPU and A172SHCPU of the motion controller (SCPU).
Access may be made to only the own station.

16.2 Making access via Ethernet, CC-Link, G4 module, C24 or telephone line

16.2.1 Setting method for communication via the ethernet board

16.2.1 (1) For A series

A	Q/QnA	FX
○	×	×

For communication from GX Developer via the E71, there are the following setting items and precautions. The explanations in this section will be made for the following system configuration.

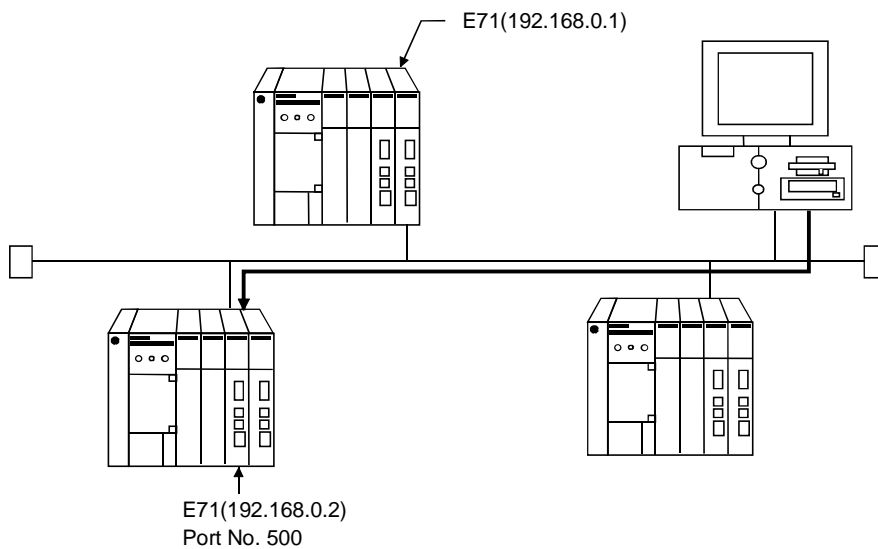

Procedure for communications via E71

Restrictions

- (a) When the AnUCPU type has been started on the personal computer, change the PLC type to the AnACPU.
- (b) Communications can be made only within the same segment. Communication cannot be made via the router or gateway.

(1) Compatible models

AJ71E71-S3, A1SJ71E71-B2-S3, A1SJ71E71-B5-S3

(2) E71 switch settings

	AJ71E71-S3	A1SJ71E71-B2-S3, A1SJ71E71-B5-S3
Operation mode setting switch	0 (online mode)	0 (online mode)
Communications condition setting switch	SW2 OFF (BIN code)	SW2 OFF (BIN code)
CPU communications timing setting switch	SW7 ON (online program correction enabled)	SW3 ON (online program correction enabled)

- (3) Sequence program
 An initial processing and communication line open processing sequence program is required.
 Required communications parameters and a sequence program example are given below.

(Communications parameters)
 The value marked (*1) is fixed.
 Any settings may be made for other than the value marked (*1).

Item	Setting
Application settings *2	100H
E71's IP address	192.168.0.2
E71 port number	500H
Other node IP address	FFFFFFFF
Other node port number	FFFF(*1)

*2: Values specified for application settings
 Settings of 4), 5) and 6) are fixed.

b15	b14	b13	b12	b11	b10	b9	b8	b7	b6	b5	b4	b3	b2	b1	b0
6)	0	0	0	0	5)	4)	3)	0	0	0	0	0	0	2)	1)

- 1) Fixed buffer application
 0: For send/no communications
 1: For receive
- 2) Existence check
 0: No
 1: Yes
- 3) Pairing open
 0: No
 1: Yes
- 4) Communication system (*1)
 0: TCP/IP
 1: UDP/IP
- 5) Fixed buffer communications (*1)
 0: With protocol
 1: Without protocol
- 6) Open system (*1)
 00: Active, UDP/IP
 10: Unpassive
 11: Fullpassive

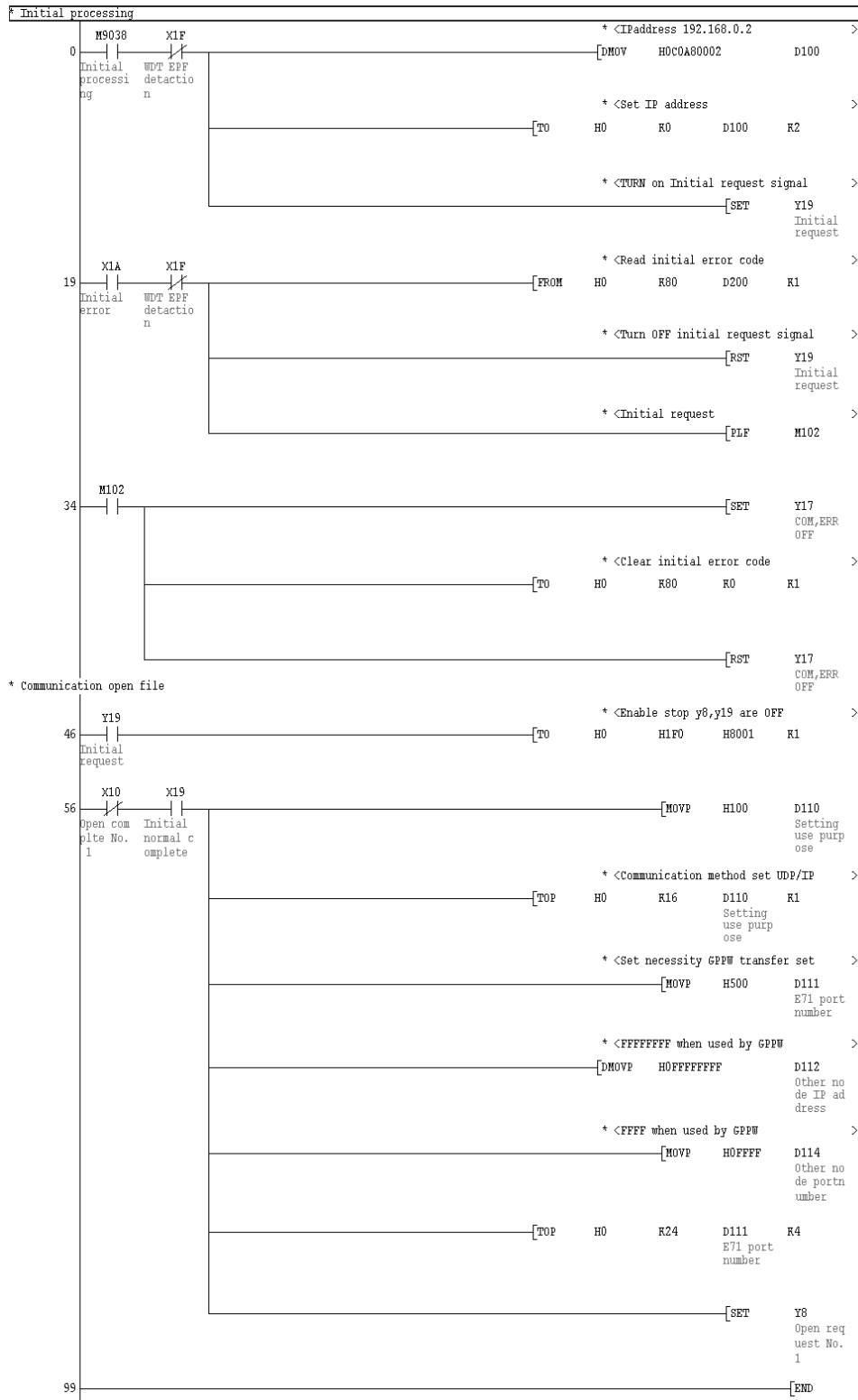

In a communications-ready status, the E71's RUN LED comes on and RDY LED flickers.

- (4) Setting on the personal computer
Set the IP address.
- (5) Communications check
When the preparations for communications via the E71 are complete, execute a Ping test. Refer to Section 21.4.9 for the operation method.

When connections are OK

C:\>ping 192. 168. 0. 2

Reply from 192. 168. 0. 2:bytes=32 time<10ms TTL=32

When connections are not good

C:\>ping 192. 168. 0. 2

Request timed out.

If ping does not pass through, check the cable and unit connections and Windows® side IP address and other settings.

- (6) Connection Setup screen
Setting screen for communication via Ethernet unit

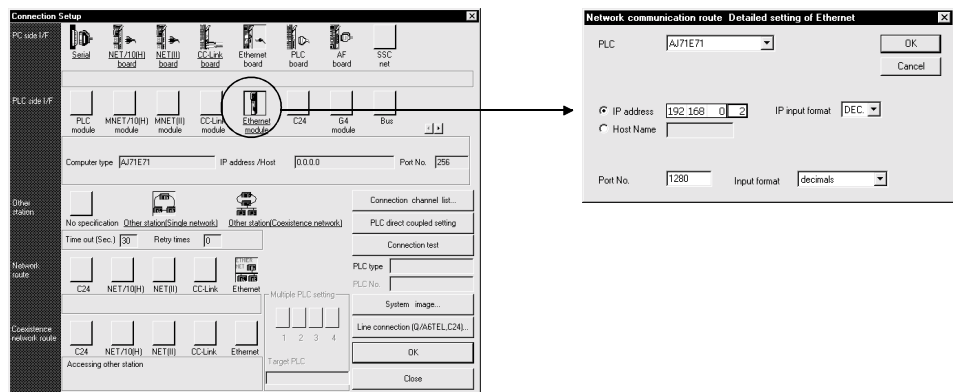

- (a) Double-click the Ethernet icon on PLC side I/F to choose the unit model to be connected.
- (b) The detail setting screen for the Ethernet unit to be connected opens.
 - 1) Set the IP address assigned to the E71 to be connected.
(When the host name has been selected, specify the name preset in the hosts file within 64 characters.)
 - 2) As the port No., set the port No. of the connected E71 set in the sequence program.

POINT

When connecting to the QCPU (A mode) or AnUCPU via Ethernet, set the PLC model name to the AnACPU using New project

When accessing the A173UHCPU/A273UHCPU of the motion controller (SCPU), specify A3A to start the project. When accessing the A171SHCPU/A172SHCPU, specify the PLC name of the access target to start the project.

Access can be made within the range that can be handled by the AnACPU, e.g. sequence program, device memory. Therefore, access cannot be made to the devices and network parameters which have been extended by subprogram 2/3, QCPU (A mode) or AnUCPU.

However, access to the AnUCPU via the QJ71E71 can be made within the range that can be handled by the AnUCPU.

16.2.1 (2) For QnA series

A	Q/QnA	FX
×	○*	×

*: This function is excluded from the Q series.

For communication from GX Developer via the QE71, there are the following setting items and precautions. The explanations in this section will be made for the following system configuration.

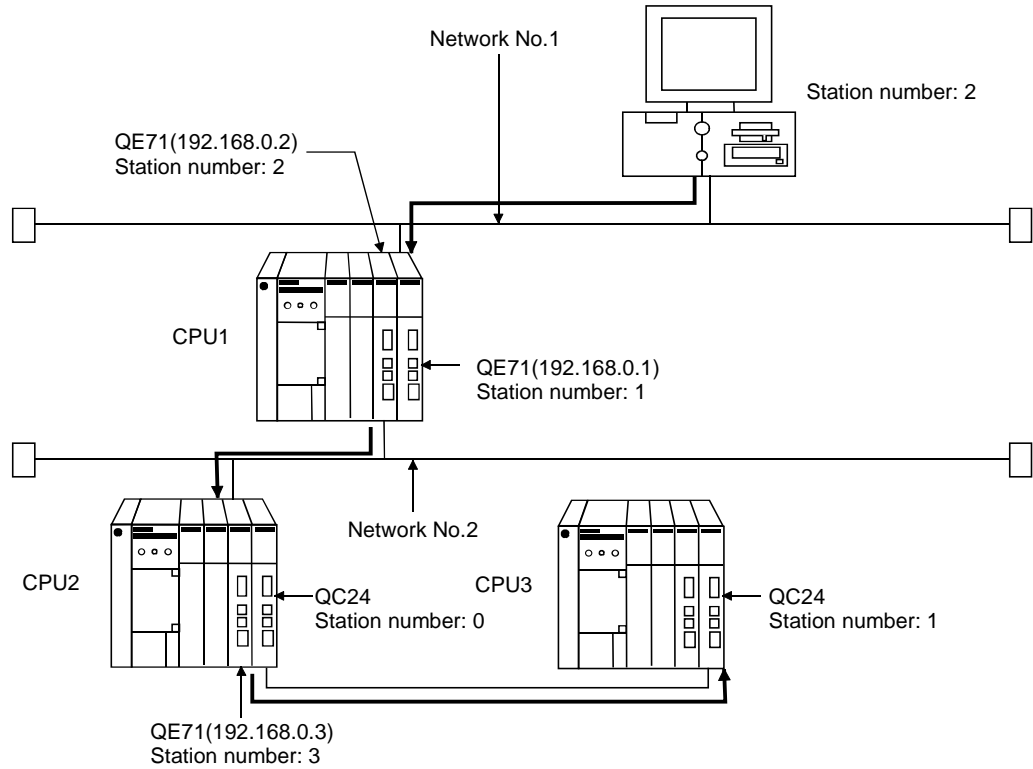

Procedure for communications via QE71

Restrictions

- (a) Communications cannot be made via the MELSECNET(II).
 - (b) Communications can be made only within the same segment. Communication cannot be made via the router or gateway.
- (1) Compatible models
Use the QE71 and PLC whose function version is B or later.

- (2) QE71 switch settings
 Operation mode setting switch..... 0 (online)
 Automatic start mode..... SW3 ON
 When SW3 is ON, initial processing is performed independently of Y19 (initial processing request). Communications are also enabled if the CPU module is STOPped.
 For the way to perform initial processing using Y19 (initial processing request), refer to the AJ71QE71 User's Manual and create an initial processing program.
- (3) Parameter setting
 On the MELSECNET/Ethernet network parameter setting screen, set the network type, starting I/O No., network No., group No., station number and IP address.

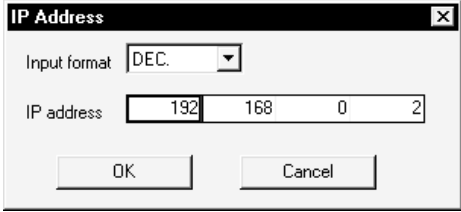
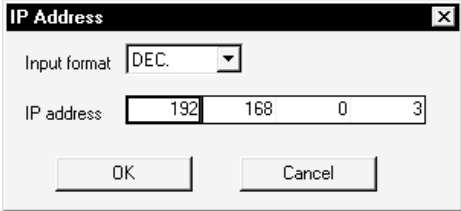
Setting Screen Examples																																	
CPU1	Ethernet parameters																																
	<table border="1" style="width: 100%; border-collapse: collapse;"> <thead> <tr> <th></th> <th style="text-align: center;">Unit No.1</th> <th style="text-align: center;">Unit No.2</th> </tr> </thead> <tbody> <tr> <td>Network type</td> <td style="text-align: center;">Ethernet</td> <td style="text-align: center;">Ethernet</td> </tr> <tr> <td>Start I/O No.</td> <td style="text-align: center;">0040</td> <td style="text-align: center;">0060</td> </tr> <tr> <td>Network No.</td> <td style="text-align: center;">2</td> <td style="text-align: center;">1</td> </tr> <tr> <td>Total number of stations</td> <td></td> <td></td> </tr> <tr> <td>Group No.</td> <td style="text-align: center;">0</td> <td style="text-align: center;">0</td> </tr> <tr> <td>Station No.</td> <td style="text-align: center;">2</td> <td style="text-align: center;">1</td> </tr> <tr> <td>IP addressDEC</td> <td style="text-align: center;">192.168. 0. 2</td> <td style="text-align: center;">192.168. 0. 1</td> </tr> <tr> <td></td> <td style="text-align: center;">MNET/I/O routing information</td> <td style="text-align: center;">MNET/I/O routing information</td> </tr> <tr> <td></td> <td style="text-align: center;">FTP Parameters</td> <td style="text-align: center;">FTP Parameters</td> </tr> <tr> <td></td> <td style="text-align: center;">Routing information</td> <td style="text-align: center;">Routing information</td> </tr> </tbody> </table>		Unit No.1	Unit No.2	Network type	Ethernet	Ethernet	Start I/O No.	0040	0060	Network No.	2	1	Total number of stations			Group No.	0	0	Station No.	2	1	IP addressDEC	192.168. 0. 2	192.168. 0. 1		MNET/I/O routing information	MNET/I/O routing information		FTP Parameters	FTP Parameters		Routing information
	Unit No.1	Unit No.2																															
Network type	Ethernet	Ethernet																															
Start I/O No.	0040	0060																															
Network No.	2	1																															
Total number of stations																																	
Group No.	0	0																															
Station No.	2	1																															
IP addressDEC	192.168. 0. 2	192.168. 0. 1																															
	MNET/I/O routing information	MNET/I/O routing information																															
	FTP Parameters	FTP Parameters																															
	Routing information	Routing information																															
	IP address setting																																
																																	
CPU2	Ethernet parameters																																
	<table border="1" style="width: 100%; border-collapse: collapse;"> <thead> <tr> <th></th> <th style="text-align: center;">Unit No.1</th> <th style="text-align: center;">Unit No.2</th> </tr> </thead> <tbody> <tr> <td>Network type</td> <td style="text-align: center;">Ethernet</td> <td style="text-align: center;">None</td> </tr> <tr> <td>Start I/O No.</td> <td style="text-align: center;">0040</td> <td></td> </tr> <tr> <td>Network No.</td> <td style="text-align: center;">2</td> <td></td> </tr> <tr> <td>Total number of stations</td> <td></td> <td></td> </tr> <tr> <td>Group No.</td> <td style="text-align: center;">0</td> <td></td> </tr> <tr> <td>Station No.</td> <td style="text-align: center;">3</td> <td></td> </tr> <tr> <td>IP addressDEC</td> <td style="text-align: center;">192.168. 0. 3</td> <td></td> </tr> <tr> <td></td> <td style="text-align: center;">MNET/I/O routing information</td> <td></td> </tr> <tr> <td></td> <td style="text-align: center;">FTP Parameters</td> <td></td> </tr> <tr> <td></td> <td style="text-align: center;">Routing information</td> <td></td> </tr> </tbody> </table>		Unit No.1	Unit No.2	Network type	Ethernet	None	Start I/O No.	0040		Network No.	2		Total number of stations			Group No.	0		Station No.	3		IP addressDEC	192.168. 0. 3			MNET/I/O routing information			FTP Parameters			Routing information
	Unit No.1	Unit No.2																															
Network type	Ethernet	None																															
Start I/O No.	0040																																
Network No.	2																																
Total number of stations																																	
Group No.	0																																
Station No.	3																																
IP addressDEC	192.168. 0. 3																																
	MNET/I/O routing information																																
	FTP Parameters																																
	Routing information																																
	IP address setting																																
																																	
CPU3	Set the station number with the rotary switches of the module.																																

- (4) Routing parameter setting
Set the routing parameters on the Ethernet parameter setting screen. Refer to Section 16.10 for the concept of the routing parameters.

		Setting Screen Examples			
CPU1		Target networkNo.	Relay networkNo.	Relay StationNo.	Via StationNo.
	1	1	2	2	
	2	2	1	1	
	3				
CPU2		Target networkNo.	Relay networkNo.	Relay StationNo.	Via StationNo.
	1	1	2	2	
	2				
	3				

After parameter setting is over, write the parameters to the PLC using Write to PLC. In a communications-ready status, the QE71's RUN LED comes on and RDY LED flickers.

- (5) Communications check
Refer to Section 16.2.1 (1) for communications check.
- (6) Connection Setup screen

Item	Description
PC side I/F	Set the network No. and station number.
PLC side I/F	Set the model name, station number, IP address, etc. of the unit connected to the personal computer.
Network route	As access is made to the other station via the Ethernet unit, choose "Other station in the same loop or access to multilevel system".
Coexistence network route	Set the first I/O address and station number of the station to be accessed.

16.2.1 (3) For Q series

A	Q/QnA	FX
×	○*	×

*: Except the QnA series.

For communication from GX Developer via the Q-compatible E71, there are the following setting items and precautions. The explanations in this section will be made for the following system configuration.

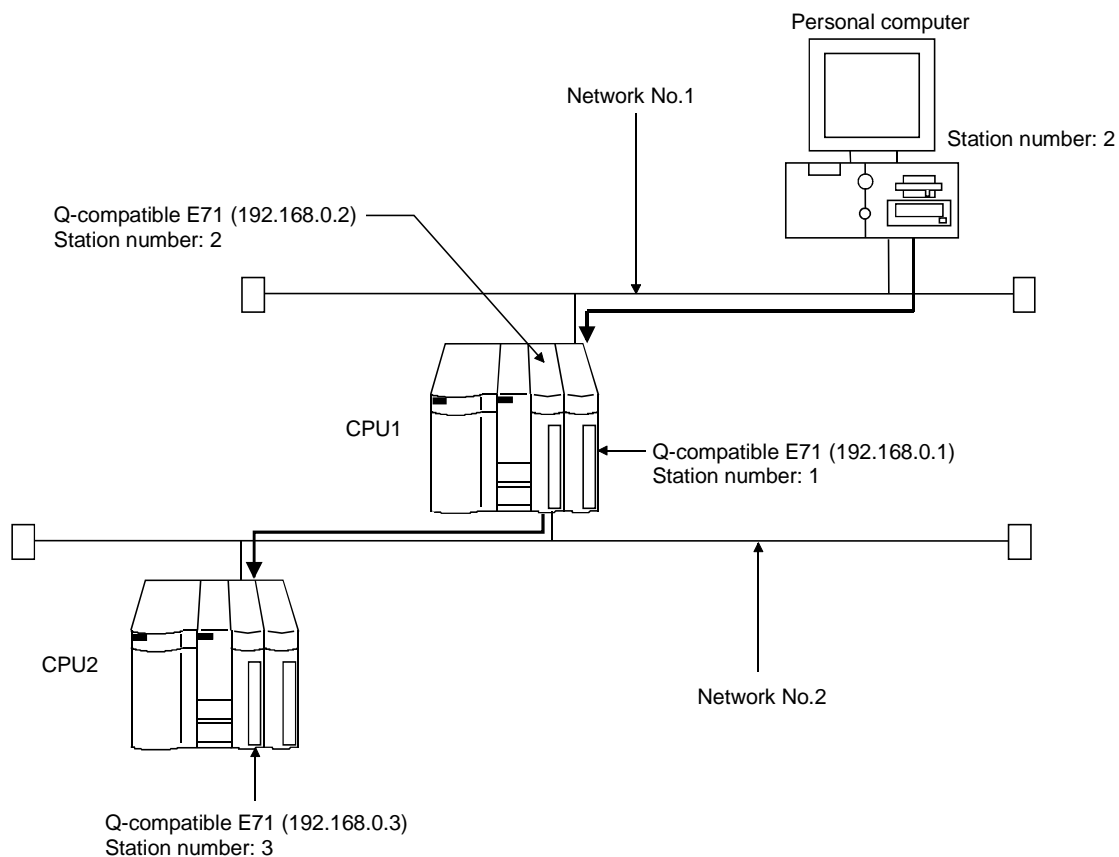

Procedure for and restrictions on communications via Q-compatible E71

- (1) Compatible models
QJ71E71, QJ71E71-B2

- (2) Network parameter setting
 Parameter setting can be made from the MELSECNET/ETHERNET network parameter setting screen.
 Set the network type, first I/O No., network No., group No., station number, mode and operation setting.

Setting Screen Examples																																																					
CPU1	<table border="1" style="width: 100%; border-collapse: collapse;"> <thead> <tr> <th colspan="3" style="text-align: center;">Ethernet parameters</th> </tr> <tr> <th></th> <th style="text-align: center;">Unit 1</th> <th style="text-align: center;">Unit 2</th> </tr> </thead> <tbody> <tr> <td>Network type</td> <td style="text-align: center;">Ethernet</td> <td style="text-align: center;">Ethernet</td> </tr> <tr> <td>Starting I/O No.</td> <td style="text-align: center;">0000</td> <td style="text-align: center;">0020</td> </tr> <tr> <td>Network No.</td> <td style="text-align: center;">2</td> <td style="text-align: center;">1</td> </tr> <tr> <td>Total stations</td> <td></td> <td></td> </tr> <tr> <td>Group No.</td> <td style="text-align: center;">0</td> <td style="text-align: center;">0</td> </tr> <tr> <td>Station No.</td> <td style="text-align: center;">2</td> <td style="text-align: center;">1</td> </tr> <tr> <td>Mode</td> <td style="text-align: center;">On line</td> <td style="text-align: center;">On line</td> </tr> <tr> <td></td> <td style="text-align: center;">Operational settings</td> <td style="text-align: center;">Operational settings</td> </tr> <tr> <td></td> <td style="text-align: center;">Initial settings</td> <td style="text-align: center;">Initial settings</td> </tr> <tr> <td></td> <td style="text-align: center;">Open settings</td> <td style="text-align: center;">Open settings</td> </tr> <tr> <td></td> <td style="text-align: center;">Routing information</td> <td style="text-align: center;">Routing information</td> </tr> <tr> <td></td> <td style="text-align: center;">MNET/10 routing information</td> <td style="text-align: center;">MNET/10 routing information</td> </tr> <tr> <td></td> <td style="text-align: center;">FTP Parameters</td> <td style="text-align: center;">FTP Parameters</td> </tr> <tr> <td></td> <td style="text-align: center;">E-mail settings</td> <td style="text-align: center;">E-mail settings</td> </tr> <tr> <td></td> <td style="text-align: center;">Interrupt settings</td> <td style="text-align: center;">Interrupt settings</td> </tr> </tbody> </table>	Ethernet parameters				Unit 1	Unit 2	Network type	Ethernet	Ethernet	Starting I/O No.	0000	0020	Network No.	2	1	Total stations			Group No.	0	0	Station No.	2	1	Mode	On line	On line		Operational settings	Operational settings		Initial settings	Initial settings		Open settings	Open settings		Routing information	Routing information		MNET/10 routing information	MNET/10 routing information		FTP Parameters	FTP Parameters		E-mail settings	E-mail settings		Interrupt settings	Interrupt settings	
Ethernet parameters																																																					
	Unit 1	Unit 2																																																			
Network type	Ethernet	Ethernet																																																			
Starting I/O No.	0000	0020																																																			
Network No.	2	1																																																			
Total stations																																																					
Group No.	0	0																																																			
Station No.	2	1																																																			
Mode	On line	On line																																																			
	Operational settings	Operational settings																																																			
	Initial settings	Initial settings																																																			
	Open settings	Open settings																																																			
	Routing information	Routing information																																																			
	MNET/10 routing information	MNET/10 routing information																																																			
	FTP Parameters	FTP Parameters																																																			
	E-mail settings	E-mail settings																																																			
	Interrupt settings	Interrupt settings																																																			
CPU2	<table border="1" style="width: 100%; border-collapse: collapse;"> <thead> <tr> <th colspan="3" style="text-align: center;">Ethernet parameters</th> </tr> <tr> <th></th> <th style="text-align: center;">Unit 1</th> <th style="text-align: center;">Unit 2</th> </tr> </thead> <tbody> <tr> <td>Network type</td> <td style="text-align: center;">Ethernet</td> <td style="text-align: center;">None</td> </tr> <tr> <td>Starting I/O No.</td> <td style="text-align: center;">0000</td> <td></td> </tr> <tr> <td>Network No.</td> <td style="text-align: center;">2</td> <td></td> </tr> <tr> <td>Total stations</td> <td></td> <td></td> </tr> <tr> <td>Group No.</td> <td style="text-align: center;">0</td> <td></td> </tr> <tr> <td>Station No.</td> <td style="text-align: center;">3</td> <td></td> </tr> <tr> <td>Mode</td> <td style="text-align: center;">On line</td> <td></td> </tr> <tr> <td></td> <td style="text-align: center;">Operational settings</td> <td></td> </tr> <tr> <td></td> <td style="text-align: center;">Initial settings</td> <td></td> </tr> <tr> <td></td> <td style="text-align: center;">Open settings</td> <td></td> </tr> <tr> <td></td> <td style="text-align: center;">Routing information</td> <td></td> </tr> <tr> <td></td> <td style="text-align: center;">MNET/10 routing information</td> <td></td> </tr> <tr> <td></td> <td style="text-align: center;">FTP Parameters</td> <td></td> </tr> <tr> <td></td> <td style="text-align: center;">E-mail settings</td> <td></td> </tr> <tr> <td></td> <td style="text-align: center;">Interrupt settings</td> <td></td> </tr> </tbody> </table>	Ethernet parameters				Unit 1	Unit 2	Network type	Ethernet	None	Starting I/O No.	0000		Network No.	2		Total stations			Group No.	0		Station No.	3		Mode	On line			Operational settings			Initial settings			Open settings			Routing information			MNET/10 routing information			FTP Parameters			E-mail settings			Interrupt settings		
Ethernet parameters																																																					
	Unit 1	Unit 2																																																			
Network type	Ethernet	None																																																			
Starting I/O No.	0000																																																				
Network No.	2																																																				
Total stations																																																					
Group No.	0																																																				
Station No.	3																																																				
Mode	On line																																																				
	Operational settings																																																				
	Initial settings																																																				
	Open settings																																																				
	Routing information																																																				
	MNET/10 routing information																																																				
	FTP Parameters																																																				
	E-mail settings																																																				
	Interrupt settings																																																				

***: Operation settings**

To make communications with GX Developer, ask the person in charge of the network about the IP address setting to confirm, and set the IP address. Since "any" values may be set to the other items, set them according to the specifications of the other node and application connected to the Q series-compatible E71.

The following are the operation setting items that may be set to "any" values on GX Developer.

- (1) Communication data code
 Either "Binary code" or "ASCII code" may be specified.
- (2) Initial Timing
 Independently of this setting, communications can be made from GX Developer if the PLC CPU is at a STOP.
- (3) Enable Write at RUN time
 Independently of this setting, online program correction or device test can be performed from GX Developer.

- (3) Routing parameter setting
Set the routing parameters on the Ethernet parameter setting screen. Refer to Section 16.10 for the concept of the routing parameters.

		Setting Screen Examples			
CPU1			Transfer to network No.	Intermediate network No.	Intermediate station No.
	1		1	2	2
	2		2	1	1
	3				
CPU2			Transfer to network No.	Intermediate network No.	Intermediate station No.
	1		1	2	2
	2				
	3				

After parameter setting is over, write the parameters to the PLC using Write to PLC. In a communications-ready status, the RUN LED and INIT. LED of the Q-compatible E71 are lit.

- (4) Communications check
Refer to Section 16.2.1 (1) for communications check.
- (5) Connection Setup screen

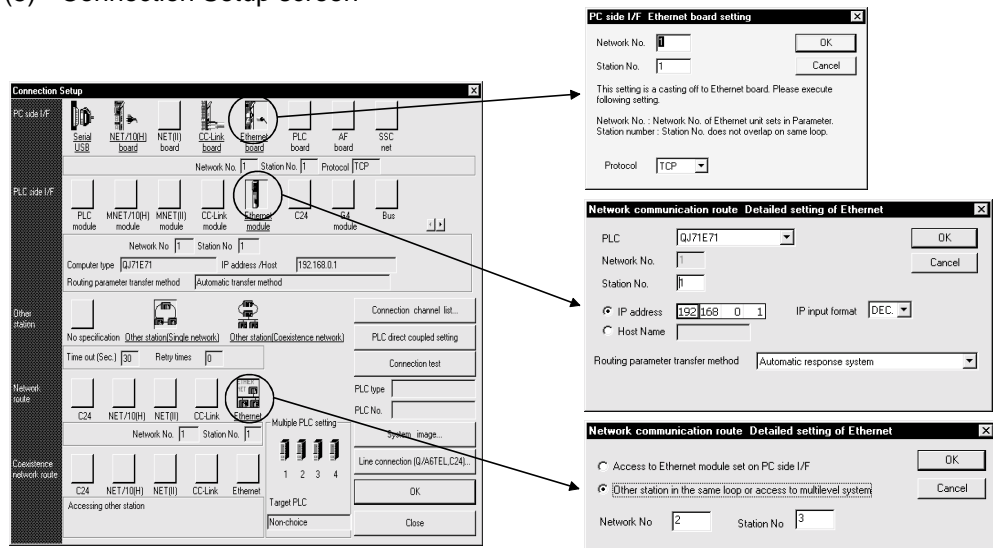

Item	Description
PC side I/F	Set the network No. and station number.
PLC side I/F	Set the model name, station number, IP address, etc. of the unit connected to the personal computer.
Network route	Set the network number and station number of the station to be accessed.

16.2.2 Setting Method for Communication Via CC-Link (AJ65BT-G4)

16.2.2 (1) For A series

A	Q/QnA	FX
○	×	×

This section indicates the setting examples of the switches, parameters, program and others of the unit based on the following system configuration.

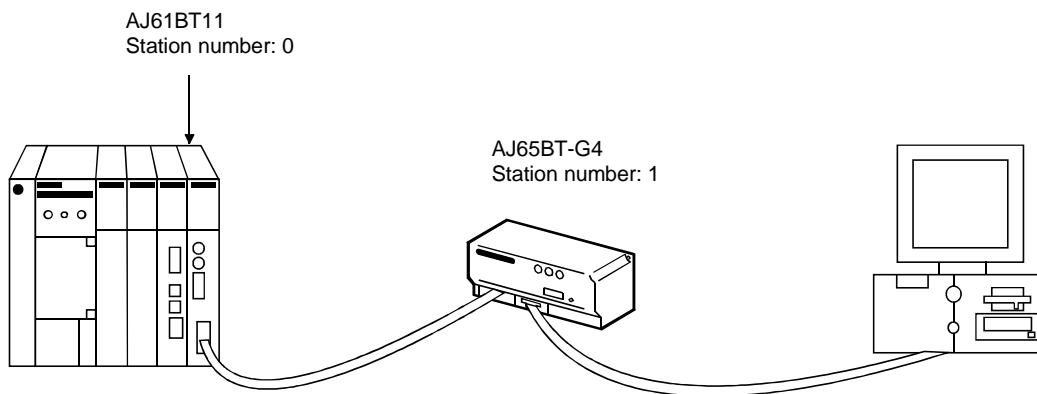

(1) Module switch settings

For G4 Module

Unit Name	Name		Setting	Description	
AJ61BT11	STATION No. (station number setting switches)		0	Station 0 (master station)	
	MODE (mode setting switch)		0	Online	
	B RATE (transmission speed setting switch)		4	10Mbps	
	Condition setting switches		All OFF	All OFF	
AJ65BT-G4	STATION No. (station number setting switches)		1	Station 1 (local station)	
	B RATE (data link transmission speed setting switch)		4	10Mbps	
	Operation setting DIP switches	Operation mode setting	SW1	OFF	A mode
		To-personal computer transmission speed setting	SW2	OFF	Fixed to 9600bps
			SW3	OFF	
		Parity bit yes/no setting	SW4	OFF	Fixed
			SW5	OFF	
		Not used	SW6	OFF	--
Not used	SW7	OFF	--		
Test mode setting	SW8	OFF	Online mode		

G4 unit or G4-S3 unit

Unit Name	Switch Name		Setting	Description	
AJ61BT11	STATION No. (station number setting switches)		0	Station 0 (master station)	
	MODE (mode setting switch)		0	Online	
	B RATE (transmission speed setting switch)		4	10Mbps	
	Condition setting switches		All OFF	All OFF	
AJ65BT-G4-S3	STATION No. (station number setting switches)		1	Station 1 (local station)	
	B RATE (data link transmission speed setting switch)		4	10Mbps	
	Operation setting DIP switches	Operation mode setting	SW1	OFF	A mode set by combination of SW1 and SW6
		To-personal computer transmission speed setting	SW2	No need to set	Invalid in A mode (Automatic setting)
			SW3		
		Parity bit yes/no setting	SW4	OFF	Fixed
			SW5	OFF	
		Operation mode	SW6	OFF	A mode set by combination of SW1 and SW6
Not used		SW7	OFF	—	
Test mode setting	SW8	OFF	Online mode		

(2) Cable connection

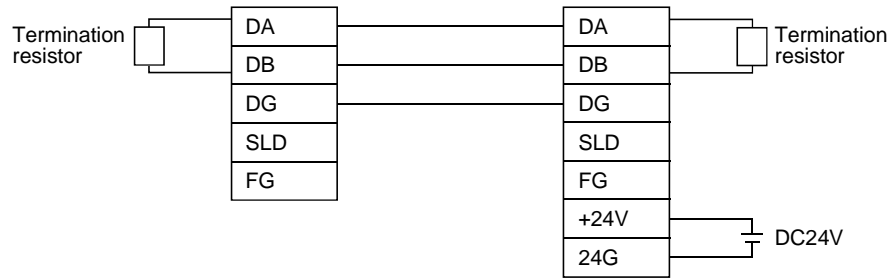

(3) Parameter setting

The parameter setting items and sequence program example for data link are given below.

Parameter setting items

Address	Item	Description	Setting
1H	Number of connected modules	Set the number of remote station/local station modules connected.	1H
20H	Station information	G4 module or G4-S3 module	2101H

Sequence program

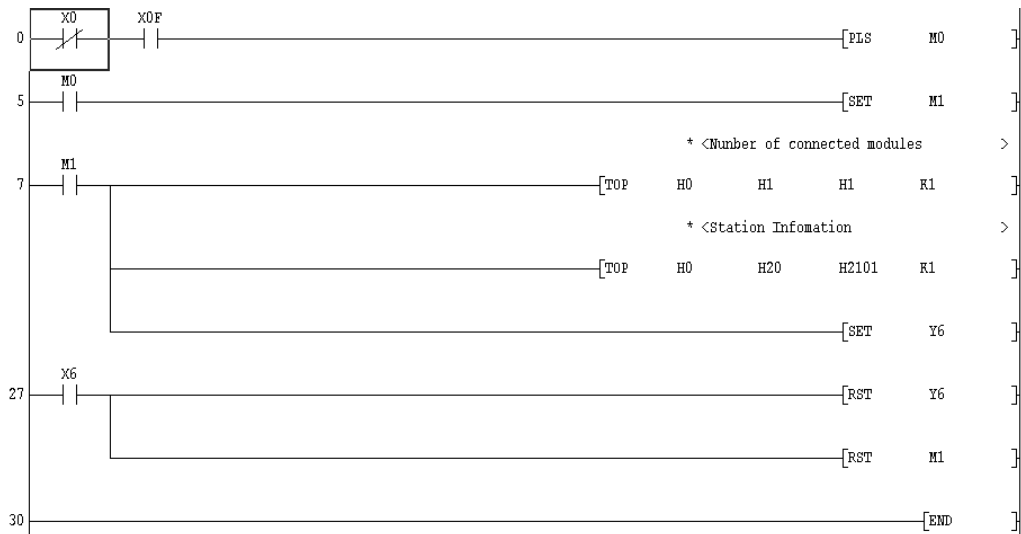

POINT

When the G4 module or G4-S3 module is connected, accessible stations are stations 0 to 64 in other station access via CC-Link.

16.2.2 (2) For QnA series

A	Q/QnA	FX
×	○*	×

*: This function is compatible with the QnACPU.

For the Q series, omit this section.

This section indicates the setting examples of the switches, parameters, program and others of the unit based on the following system configuration.

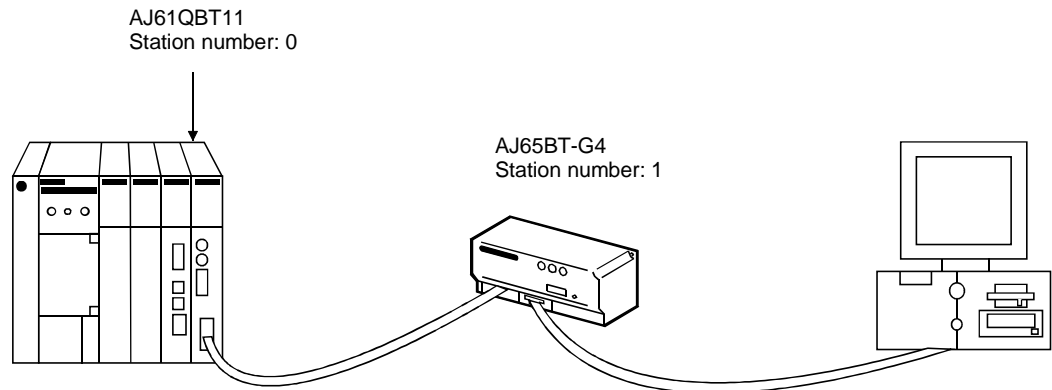

(1) Module switch settings

G4 module

Unit Name	Name		Setting			Description	
AJ61QBT11	STATION No. (station number setting switches)		0			Station 0 (master station)	
	MODE (mode setting switch)		0			Online	
	B RATE (transmission speed setting switch)		4			10Mbps	
	Condition setting switches		All OFF			All OFF	
AJ65BT-G4	STATION No. (station number setting switches)		1			Station 1 (local station)	
	B RATE (data link transmission speed setting switch)		4			10Mbps	
	Operation setting DIP switches	Operation mode setting	SW1	OFF			QnA mode
		To-personal computer transmission speed setting (Kbps)	SW2	9.6	19.2	38.4	Set to the same transmission speed as that of GX Developer.
				OFF	ON	OFF	
				OFF	OFF	ON	
		Parity bit yes/no setting	SW4	OFF			Fixed
			SW5	OFF			
Not used		SW6	OFF			—	
Not used		SW7	OFF			—	
Test mode setting		SW8	OFF			Online mode	

For G4-S3 module

Unit Name	Switch Name		Setting			Description	
AJ61QBT11	STATION No. (station number setting switches)		0			Station 0 (master station)	
	MODE (mode setting switch)		0			Online	
	B RATE (transmission speed setting switch)		4			10Mbps	
	Condition setting switches		All OFF			All OFF	
AJ65BT-G4-S3	STATION No. (station number setting switches)		1			Station 1 (local station)	
	B RATE (data link transmission speed setting switch)		4			10Mbps	
	Operation setting DIP switches	Operation mode setting	SW1	ON			QnA mode set by combination of SW1 and SW6
		To-personal computer transmission speed setting (Kbps)	SW2	9.6	19.2	38.4	Matched to transmission of GX Developer
				OFF	ON	OFF	
				OFF	OFF	ON	
		Parity bit yes/no setting	SW4	OFF			Fixed
			SW5	OFF			
Operation mode setting		SW6	OFF			QnA mode set by combination of SW1 and SW6	
Not used	SW7	OFF			—		
Test mode setting	SW8	OFF			Online mode		

(2) Cable connection

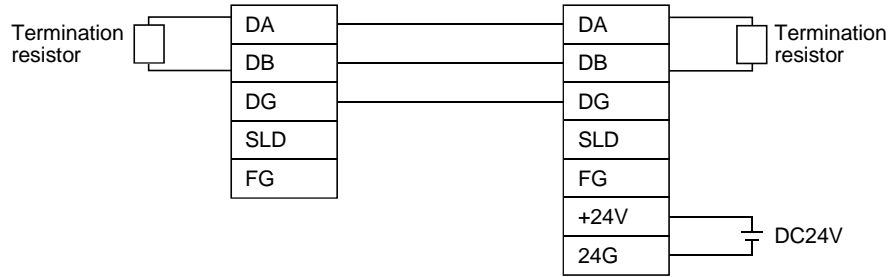

(3) Parameter setting

Parameter setting can be made from either the CC-Link network parameter setting screen or the sequence program.

(a) Setting the parameters on the CC-Link setting screen

Set the first I/O No., type, total number of connected units, and station information.

Set the other items as required.

CC-Link parameter setting screen

No. of boards in Boards Blank: no setting 0 boards: Set by the sequence program.

	1	2	3	4
Start I/O No.	0000			
Type	Master station			
All connect count	1			
Remote input(RX)				
Remote output(RY)				
Remote register(RW/r)				
Remote register(RW/w)				
Special relay(SB)				
Special register(SW)				
Retry count	3			
Automatic reconnection station count	1			
Wait master station No.	0			
PLC down select	Stop			
Scan mode setting	Asynchronously			
Delay information setting	0			
Station information setting	Station information			

Station information setting screen

CC-Link station information unit 1 [X]

StationNo.	Station type	Exclusive station count	Reserve/invalid station select	Intelligent buffer select(word)		
				Send	Receive	Automatic ic
1/1	Remote/I/O station	Exclusive station 1	No setting			

Default Check End setup Cancel

After setting the CC-Link parameters, write them to the PLC.

- (b) Setting the parameters in the sequence program
 The parameter setting items and sequence program example for parameter setting in the sequence program are given below.

Parameter setting items

Address	Item	Description	Setting
1H	Number of connected modules	Set the number of remote station/local station modules connected.	1H
20H	Station information	G4 module or G4-S3 module	2101H

When creating the network parameters in the sequence program, set the number of units to 0 on the CC-Link setting screen.

Sequence program

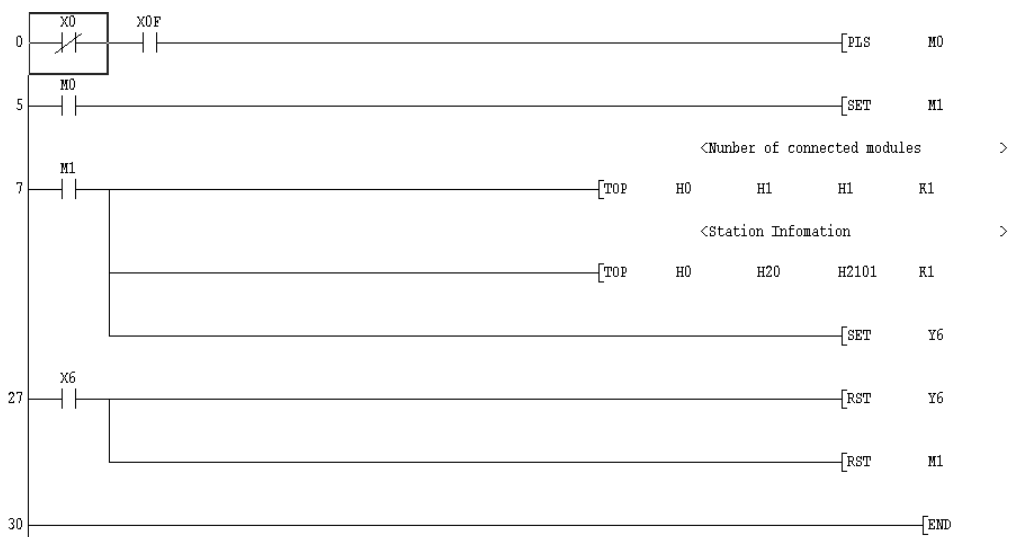

POINTS
<ul style="list-style-type: none"> • When connection is made to the CPU directly or via computer link, accessible stations are stations 0 (master) to 63 in other station access via CC-Link. • When the G4 module or G4-S3 module is connected, accessible stations are stations 0 to 64 in other station access via CC-Link.

16.2.2 (3) For Q series

A	Q/QnA	FX
×	○*	×

*: This function is compatible with the QCPU (Q mode).

This section gives a setting example of the switches, parameters, program and others of the units based on the following system configuration.

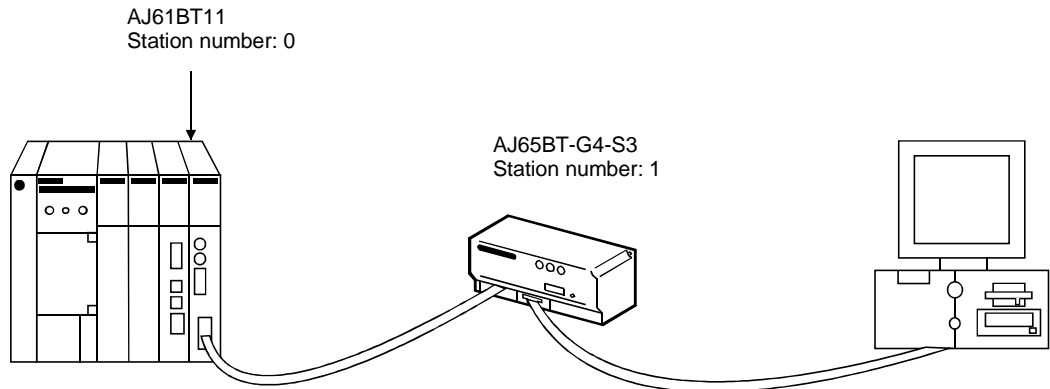

(1) Module switch settings

For G4-S3 module

Unit Name	Switch Name		Setting	Description	
AJ61QBT11	STATION No. (station number setting switches)		0	Station 0 (master station)	
	MODE (mode setting switch)		0	Online	
	B RATE (transmission speed setting switch)		4	10Mbps	
	Condition setting switches		All OFF	All OFF	
AJ65BT-G4-S3	STATION No. (station number setting switches)		1	Station 1 (local station)	
	B RATE (data link transmission speed setting switch)		4	10Mbps	
	Operation setting DIP switches	Operation mode setting	SW1	OFF	Q mode set by combination of SW1 and SW6
		To-personal computer transmission speed setting (Kbps)	SW2	No need to set	Invalid in Q mode (Automatic setting)
			SW3		
		Parity bit yes/no setting	SW4	OFF	Fixed
			SW5	OFF	
		Operation mode setting	SW6	ON	Q mode set by combination of SW1 and SW6
Not used	SW7	OFF	—		
Test mode setting	SW8	OFF	Online mode		

(2) Cable connection

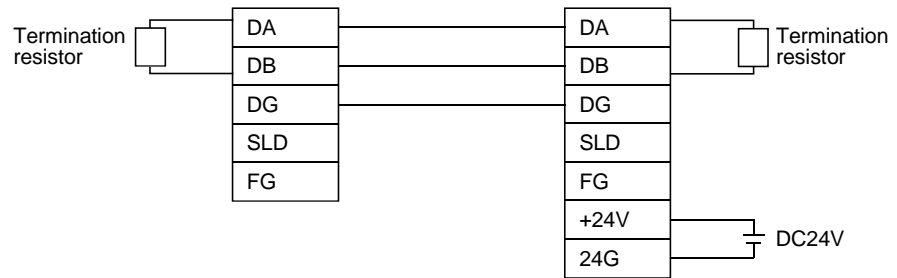

(3) Parameter setting

Parameter setting may either be made from the CC-Link network parameter setting screen or the sequence program.

(a) Setting the parameters on the CC-Link setting screen

Set the starting I/O No., type, total number of connected units, and station information.

Set the other items as required.

CC-Link parameter setting screen

No. of boards in Boards Blank: no setting 0 boards: Set by the sequence program.

	1	2	3	4
Start I/O No.	0000			
Type	Master station			
All connect count	1			
Remote input(RX)				
Remote output(RY)				
Remote register(RW/r)				
Remote register(RW/w)				
Special relay(SB)				
Special register(SW)				
Retry count	3			
Automatic reconnection station count	1			
Wait master station No.	0			
PLC down select	Stop			
Scan mode setting	Asynchronously			
Delay information setting	0			
Station information setting	Station information			

Station information setting screen

CC-Link station information unit 1

StationNo.	Station type	Exclusive station count	Reserve/invalid station select	Intelligent buffer select(word)		
				Send	Receive	Automatic
1/1	Remote/I/O station	Exclusive station 1	No setting			

Default Check End setup Cancel

After setting the CC-Link parameters, write them to the PLC CPU.

(b) Setting the parameters with the sequence program

The following parameter setting items and sequence program example are used when the parameter values are set with the sequence program.

Parameter setting items

Address	Item	Description	Setting
1H	Number of units connected	Set the number of remote/local station units connected.	1H
20H	Station information	G4-S3 module	2101H

When creating network parameters using the sequence program, set the number of units to 0 on the CC-Link setting screen.

Sequence program

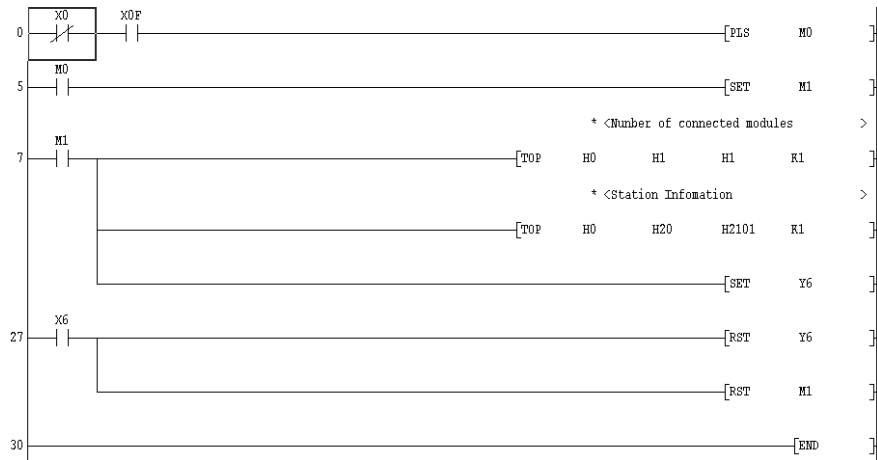

- | POINTS |
|--|
| <ul style="list-style-type: none"> • When connection is made to the CPU directly or via computer link, accessible station numbers are stations 0 (master) to 63 in other station access via CC-Link. • When the G4-S3 module is connected, accessible stations are stations 0 to 64 in other station access via CC-Link. |

16.2.3 Setting Method for Communication Via C24

16.2.3 (1) Connection in the form of one-for-one

A	Q/QnA	FX
○	○	×

This section indicates the setting examples of the switches and others of the unit based on the following system configuration.



(1) UC24 switch settings

The A1SJ71UC24-R24 or A1SJ71C24-R4 cannot be connected.

Item	Setting
Mode setting switch	1
STATION No.	0
Main channel setting	RS-232C
Data bit setting	8
Transmission speed setting	9600bps/19200bps
Parity bit yes/no setting	Odd
Stop bit setting	1
Sum check yes/no setting	Yes
Online change enable/disable setting	Enable
Computer link/multidrop link setting	Computer link (set computer link also for multidrop)

A cable of AC30N2A can be diverted for this connection.
 Refer to Appendix 5.1 for the pin assignment of the cable.
 When GX Developer is connected to the 2) loaded UC24 and the 9-25 pin conversion connector + AC30N2A equivalent are used, write 1 (CD terminal not checked) to 10B of the buffer memory.

(2) Serial communication unit (QnA series) switch settings

Item	Setting	Item	Setting
Mode setting switch	5	Sum check yes/no setting	Yes
STATION No.	0	Online change enable/disable setting	Enable
Operation setting	Independent setting	Setting change enable/disable setting	Enable
Data bit setting	8	Transmission speed setting	9600bps/19200bps
Parity bit yes/no setting	Odd	—	SW13 to SW15 are all OFF.
Stop bit setting	1	—	—

A cable of AC30N2A can be diverted for this connection.
 Refer to Appendix 5.2 for the pin assignment of the cable.
 When an AC30N2A cable is connected, use the 9-25 pin conversion connector.

(3) Serial communication unit (for Q series) switch settings

Make switch settings of the units on the GX Developer I/O assignment setting screen.

For details of switch settings, refer to the Q-compatible C24 serial communication unit user's manual (basic manual).

Item	Description		Setting
Switch 1	CH1 communication speed	CH1 transmission setting	0000H
Switch 2	—	CH1 communications protocol	0000H
Switch 3	CH2 communication speed	CH2 transmission setting	Set according to the application on CH2 side.
Switch 4	—	CH2 communications protocol	Set according to the application on CH2 side.
Switch 5	Module station number		0000H

For the connection cable, refer to Appendix 5.3.

As switch 5 is used to set the station number, set the value (0 to 31 (decimal)) as required. (Note that if the value is other than 0, match it with the value which was set by choosing Connection Setup → PC side I/F → Station number.)

Detailed description of settings

Item	Setting
Operation setting	Independent setting
Data bit setting	8
Parity bit yes/no setting	Yes
Odd/even parity bit	Odd
Stop bit setting	1
Sum check yes/no setting	Yes
Online change enable/disable setting	Enable
Setting change enable/disable setting	Disable
Transmission speed setting	19200bps
Communications protocol	GX Developer link

- (4) Connection target setting
 The screen setting example for access from GX Developer to C24 is given below.

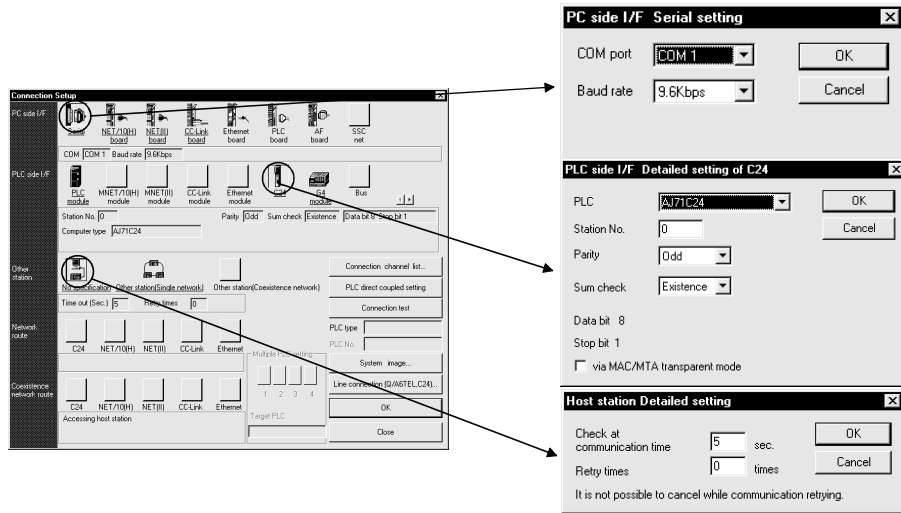

Item	Description
PC side I/F	Set the COM port and baud rate.
PLC side I/F	Set the model name, station number, etc. of the C24 connected.
Network route	Set the station number of the connection target C24.

16.2.3 (2) Connection in the form of multidrop

A	Q/QnA	FX
○	○	×

This section indicates the setting examples of the switches and others of the unit based on the following system configuration.

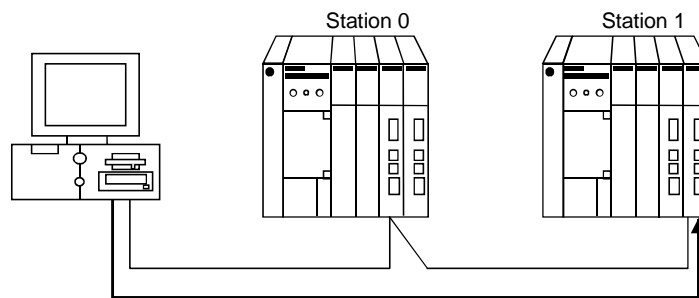

- (1) Computer link module switch settings
 Station 0 (Connect GX Developer to the RS-232C connector of the computer link module.)

Item	Setting
Mode setting switch	A
STATION No.	0
Main channel setting	RS-232C
Data bit setting	8
Transmission speed setting	9600bps
Parity bit yes/no setting	Odd
Stop bit setting	1
Sum check yes/no setting	Yes
Online change enable/disable setting	Enable
Computer link/multidrop link setting	Computer link (set computer link also for multidrop)

A cable of AC30N2A can be diverted for this connection.
 Refer to Appendix 5.1 for the pin assignment of the cable.
 When GX Developer is connected to the UC24 and the 9-25 pin conversion connector + AC30N2A are used, write 1 (CD terminal not checked) to 10B of the buffer memory.

Station 1

Item	Setting
Mode setting switch	5
STATION No.	1
Main channel setting	RS-422
Data bit setting	8
Transmission speed setting	9600bps
Parity bit yes/no setting	Odd
Stop bit setting	1
Sum check yes/no setting	Yes
Online change enable/disable setting	Enable
Computer link/multidrop link setting	Computer link (set computer link also for multidrop)

- (2) Serial communication module (for QnA series) switch settings
 The AJ71QC24-R4 or A1SJ71QC24-R4 cannot be connected.
 Station 0 (Connect GX Developer to the RS-232C connector of the serial communication module.)

Item		Setting
Mode setting switch	CH 1	0
	CH 2	5
STATION No.		0
Operation setting		Interlock setting
Data bit setting		8
Parity bit yes/no setting		Odd
Stop bit setting		1
Sum check yes/no setting		Yes
Online change enable/disable setting		Enable
Setting change enable/disable setting		Enable
Transmission speed setting		9600bps

A cable of AC30N2A can be diverted for this connection.
 Refer to Appendix 5.2 for the pin assignment of the cable.
 When an AC30N2A cable is used, use a 9-25 pin conversion connector.

Station 1

Item		Setting
Mode setting switch	CH 1	Set to meet the application of CH1.
	CH 2	5
STATION No.		1
Operation setting		Independent setting
Data bit setting		8
Parity bit yes/no setting		Odd
Stop bit setting		1
Sum check yes/no setting		Yes
Online change enable/disable setting		Enable
Setting change enable/disable setting		Enable
Transmission speed setting		9600bps

- (3) Serial communication module (for Q series) switch settings
 Make switch settings of the units on the GX Developer I/O assignment setting window.
 For details of the switch settings, refer to the Q-compatible C24 serial communication unit user's manual (basic manual).

Station 0

Item	Description		Setting
Switch 1	CH1 communication speed	CH1 transmission setting	0726H
Switch 2	—	CH1 communications protocol	0008H
Switch 3	CH2 communication speed	CH2 transmission setting	0727H
Switch 4	—	CH2 communications protocol	0000H
Switch 5	Module station number		0000H

For the connection cable, refer to Appendix 5.3.

Station 1

Item	Description		Setting
Switch 1	CH1 communication speed	CH1 transmission setting	0726H
Switch 2	—	CH1 communications protocol	0000H
Switch 3	CH2 communication speed	CH2 transmission setting	0727H
Switch 4	—	CH2 communications protocol	0000H
Switch 5	Module station number		0001H

Detailed description of settings

Item	Setting
Operation setting	Independent setting
Data bit setting	8
Parity bit yes/no setting	Yes
Odd/even parity bit	Odd
Stop bit setting	1
Sum check yes/no setting	Yes
Online change enable/disable setting	Enable
Setting change enable/disable setting	Disable
Transmission speed setting	19200bps
Communications protocol	GX Developer link

- (4) Connection target setting
 The screen setting example for access from GX Developer to C24 is given below.

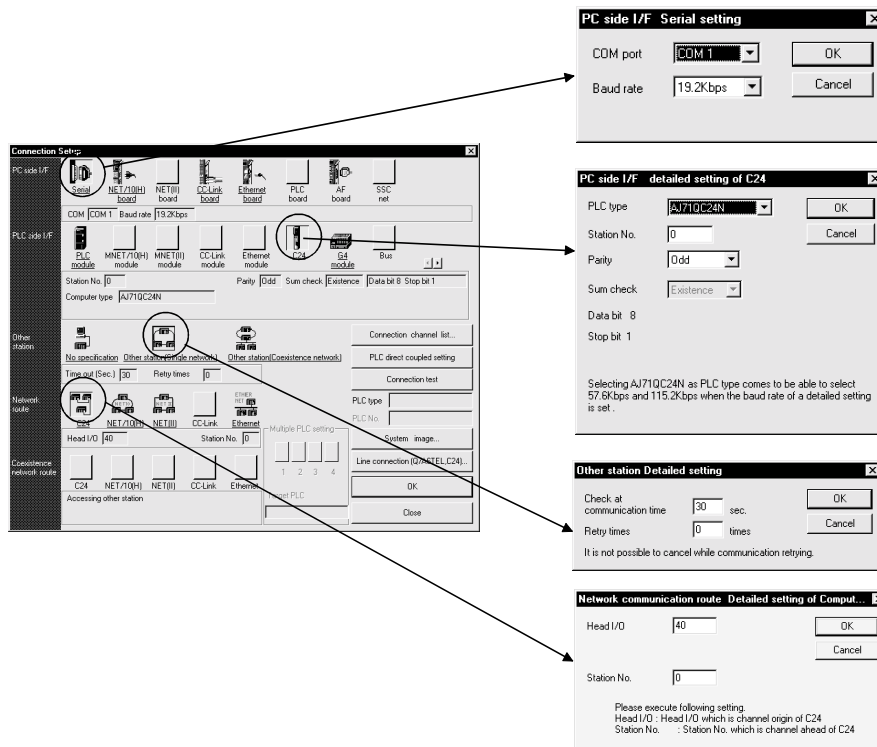

Item	Description
PC side I/F	Set the COM port and baud rate.
PLC side I/F*1	Set the model name, station number, etc. of the C24 connected.
Other station designation	Set the no specification of other station when not making access to the other station.
Network route	Set the top I/O number of a station connected to GX Developer and a station number of the station to be accessed.

*1: When making access to the other station with the computer link module, designate a station number setting item of the PLC side I/F. The icons of the Network route cannot be selected.

16.2.4 Setting method for communication via a modem interface module

A	Q/QnA	FX
○	○	○

This section provides how to set the functions and information on line connection to line disconnection for use of the A6TEL modem interface module (hereafter called the A6TEL) and the Q6TEL modem interface module (hereafter called the Q6TEL). The A6TEL is a modem interface module designed to connect the A series PLC CPU and modem.

The Q6TEL is a modem interface module designed to connect the A/QnA series PLC CPU and modem. (The Q6TEL can connect to either the A CPU or QnACPU using the A mode/QnA mode select switch.)

The modems shown in the following system configuration include the external type, modem built in personal computer, PC card modem (PIMCIA) and TA (terminal adapter).

(1) Between PLC and A6TEL/Q6TEL (A/QnA series only)

Functions such as monitoring, test and program write/read can be performed via remote access over the telephone line.

For the operation procedures, see Sections 22.2.1 and 22.2.2.

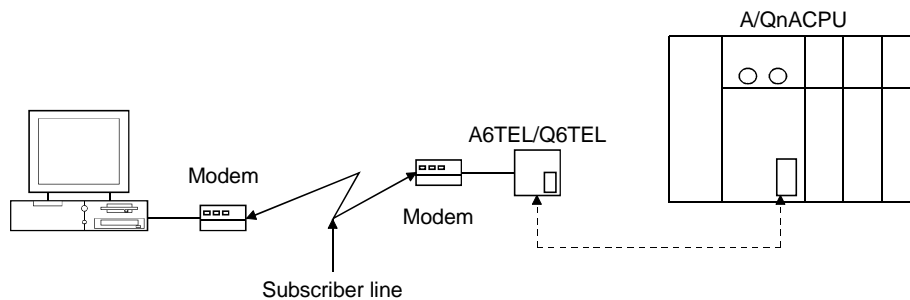

(2) For access to FXCPU (FX series only)

Functions such as monitoring, test and program write/read can be performed via remote access over the telephone line by connecting the FX_{2N}/FX_{2NC} PLC using a modem.

For the operation procedures, see Section 22.2.3.

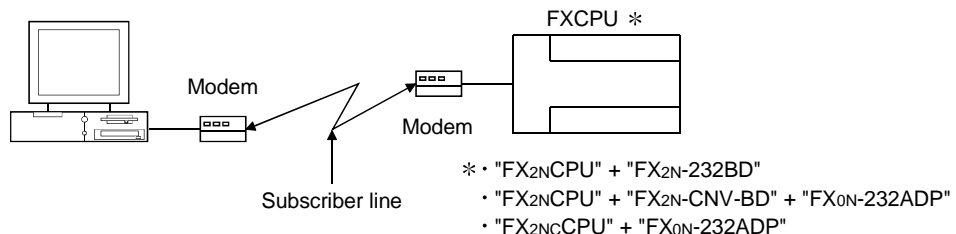

(3) When making access from personal computer to serial communication module Q/QnA series only)

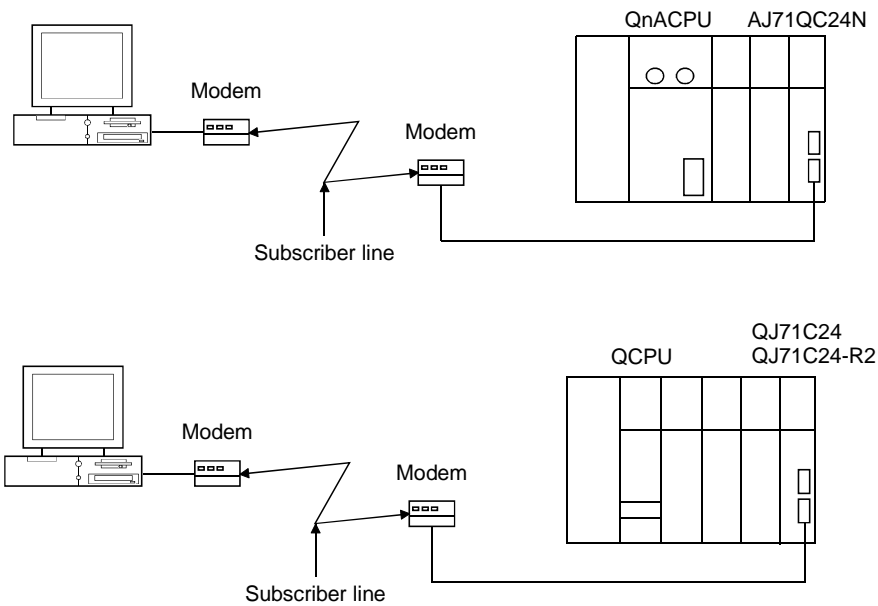

For access from the personal computer to the serial communication module, choose [Tools] → [Set TEL data/Connect via modem] → [Connect]. Refer to Section 22.4 for the setting of items on the line connection screen. For the switch settings of the corresponding modules, refer to the following manuals.

- QnA series : Serial Communication Module User's Manual (Details Manual) (Additional modem function version)
- Q series : Q-compatible Serial Communication Module User's Manual (Application)

(a) Switch settings of serial communication module (Q series)

Item		Setting	
Switch 1	Transmission setting	Operation setting	Independent
		Data length	8
		Parity bit	No
		Even/odd parity	Match to modem specifications
		Stop bit	1
		Sum check	Yes
		Online change	Enable
		Setting change	Disable
	Communication speed	Match to modem specifications	
Switch 2	Communications protocol	5	

When using the QC24N, use the above settings as reference.

(b) Connection of QJ71C24 and modem

A program is needed to make the following buffer memory settings.

Buffer Memory Address	Name and Setting
2EH	Modem connection CH designation 0: None 1: CH1 2: CH2
34H *1	Initialization data No. designation 0H: Sending of initialization data specified in sending user registration frame designation area 7D0H to 7D4H: Initialization data No.
36H	GX Developer link designation 0: No 1: Yes

*1: The following initialization data have been registered to the QJ71C24.
If the modem used is included in any of 7D0(2000) to 7DA(2010) of the
initialization data, specify that registration No.
If the modem used is other than the registered, you can use it after
registering the AT command to the buffer memory address 1B00 of the
serial communication module.

Registration No.		Initialization Command
Hexadecimal	Decimal	
7D0H	2000	ATQ0V1E1X1¥J0¥Q2¥V2¥N3S0=1
7D1H	2001	ATQ0V1E1X1¥Q2¥V2¥N3S0=1
7D2H	2002	ATQ0V1E1X1&K3¥N3S0=1
7D3H	2003	ATQ0V1E1X1&H1&R2&A3&D2S0=1
7D4H	2004	ATQ0V1E1X1¥J0¥Q2¥N3S0=1
7D5H	2005	ATE1Q0V1&C1&D2&H1&I0&R2&S0S0=1
7D6H	2006	ATE1Q0V1&C1&D2&K3&S0S0=1
7D7H	2007	ATE1Q0V1&C1&D2&K3&S1S0=1
7D8H	2008	ATE1Q0V1&C1&D2&K3&S0S0=1
7D9H	2009	ATE1Q0V1&C1&D1¥Q2&S0S0=1
7DAH	2010	ATE1Q0V1&C1&D2¥Q3&S0S0=1

Sample program

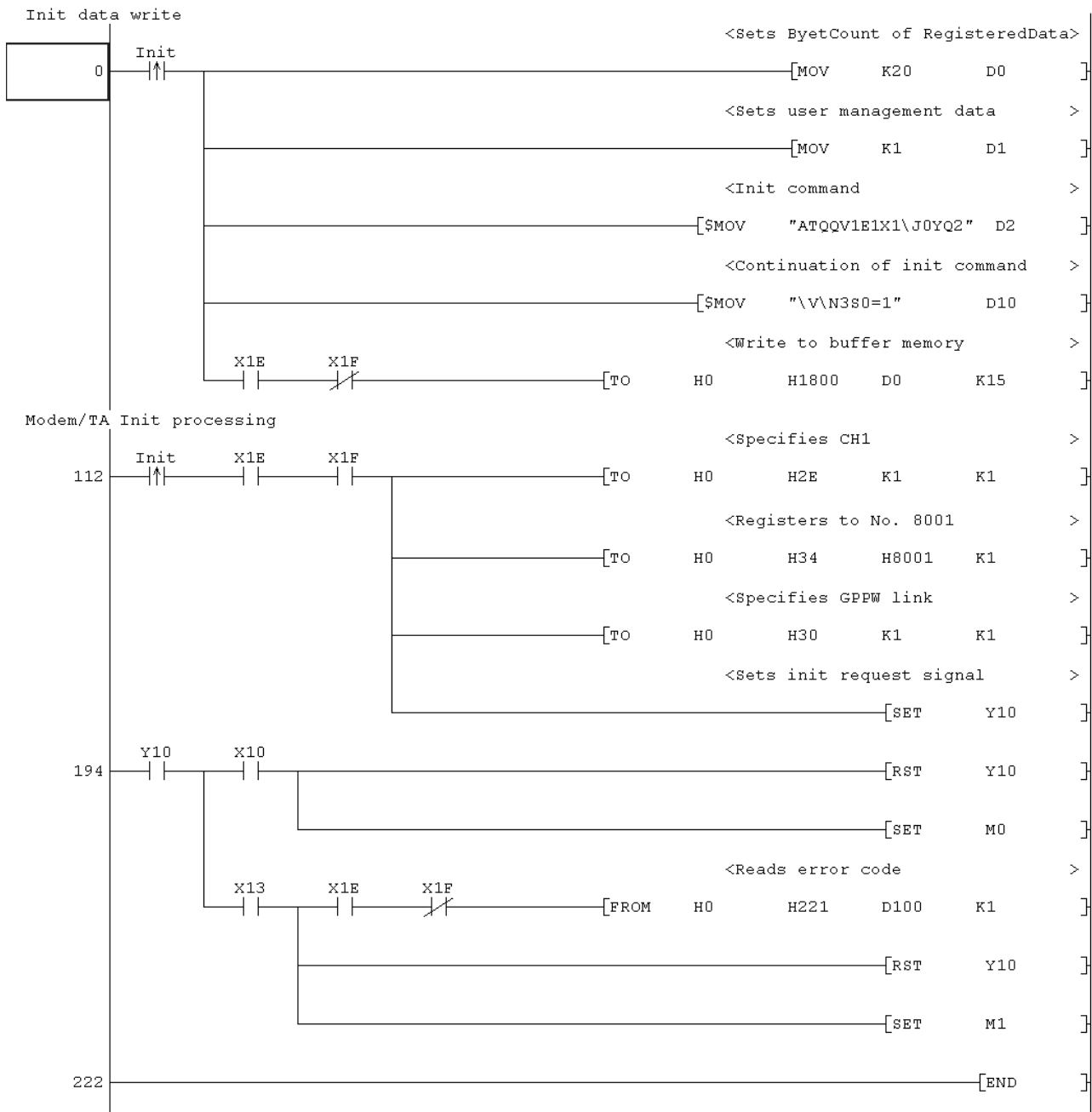

(4) Pager notice (A/QnA series only)

An on-the-spot trouble occurrence can be notified with a message.
 For the A6TEL or the A mode of the Q6TEL, you can set up to 10 characters.
 For the QnA mode of the Q6TEL, you can set up to 10 characters or notice data of up to 480 points of a word device. (Note that the number of characters displayed on the pager depends on the pager used.)
 For the operating procedure, refer to Sections 22.2.1 and 22.2.2.)

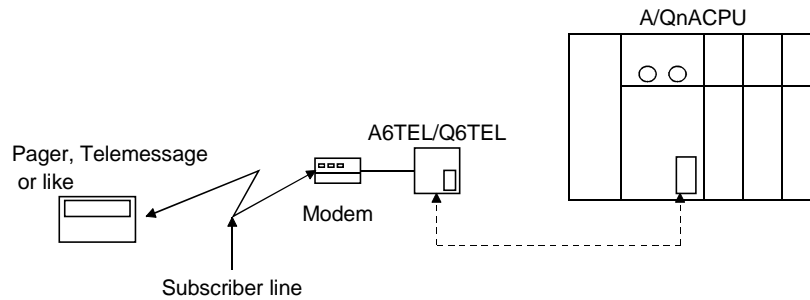

(5) Q6TEL-Q6TEL communication (only QnA mode of Q6TEL)

When the device condition set to the send side Q6TEL holds, the word device data of up to 480 words can be transferred to the device specified in the receive side PLC.
 Local devices cannot be used as a transfer or trigger condition.
 For the operating procedure, refer to Section 22.2.4.

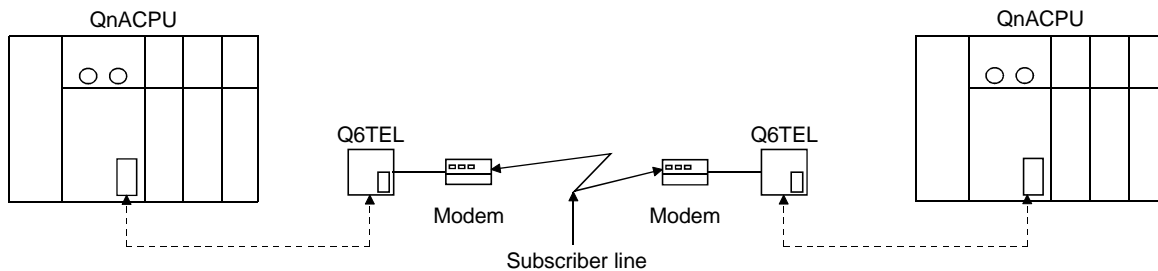

(6) Modem specifications

When using modems, choose the ones which satisfy the following specifications.
 In addition, you can make communication from a personal computer with a built-in modem or a PC card modem (PCMCIA) for use in connection with a notebook personal computer.

(a) When using subscriber telephone line/private branch telephone

- AT command compatible (initialization command)
- Only the DR terminal can be turned ON (High) independently
- (Example: You cannot use the modem whose CD terminal turns on at the same time when only the DR terminal is turned on.)
- Communication standards: ITU-T V.90/V.34/V.32bis/V.32/V.22bis/V.22/V.21/V.FC
 Bell 212A/103

(b) Manual line connection (for connection via an operator)

- Specifications as in above (a)
- Switching can be made between the "ANS mode" and "ORG mode". (AIWA's some modems have the above mode switch.)

Communication may not be made depending on the line status.

POINT	<ul style="list-style-type: none"> When a modem built in personal computer or the PC card (PCMCIA) is used to make communication, COM port setting is required on the connection destination specifying screen. Also, the COM port of the modem built in personal computer or the PC card (PCMCIA) is determined internally. For the setting method, refer to the personal computer manual. The standard AT command cannot be used in some modems. If the standard command is selected but the modem cannot connect with the line, the user should designate the AT command. For the standard and AT command designation setting, refer to Section 22.4.1.
--------------	--

- (7) Connection cable
For connection of the personal computer and modem, use the RS-232C cable supplied with the modem or the specified cable.
Since the personal computer may have a different connector, check the specifications of the connector when purchasing the modem.
- (8) Modem setting
Make modem setting.
The following screen can be browsed using Line connection or AT command help for AT command registration.

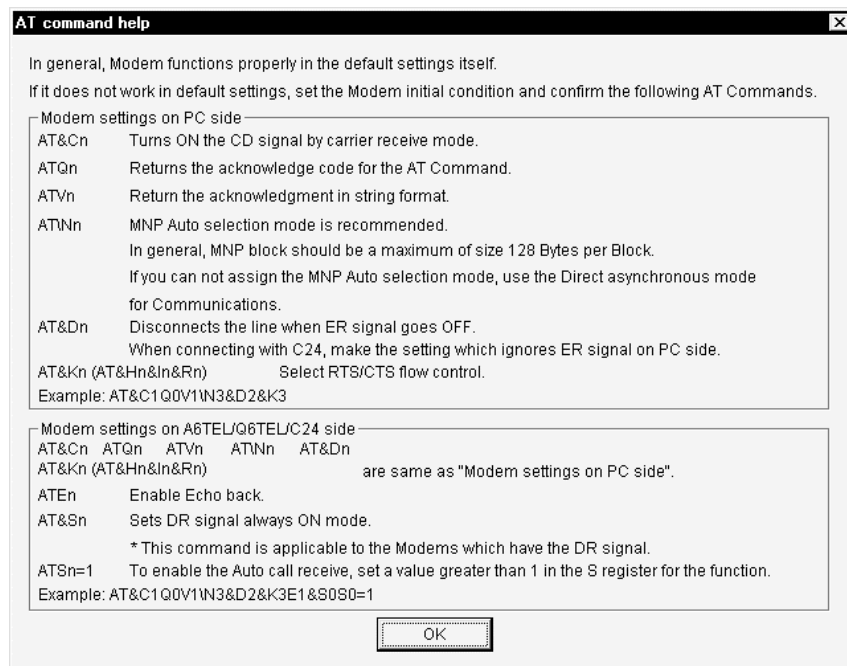

POINT	<ul style="list-style-type: none"> When you used the modem for the other purpose previously, return the modem to the factory-set status using the following command. AT&F&W
--------------	---

(9) About RS-232C interface
 When the TEL data set on GX Developer is transferred from the personal computer to the A6TEL/Q6TEL, the RS-232C interface specifications on the A6TEL/Q6TEL side are as follows.

Pin Number	Signal Abbreviation	Signal Name	Signal Direction	Modem Side
2	SD(TXD)	Send data	————→	Equivalent to RD
3	RD(RXD)	Receive data	←————	Equivalent to SD
4	ER(DTR)	Terminal ready notification	————→	Equivalent to ER
5	SG	Signal ground	————	SG
6	DR(DSR)	Data equipment ready	←————	Equivalent to DR
7	RS(RTS)	Request to send	————→	Equivalent to RS
8	CS(CTS)	Clear to send	←————	Equivalent to CS
9	RI(CI)	Receive indication (Call detection)	←————	Equivalent to RI(CI)

The following wiring example is for proximate connection.

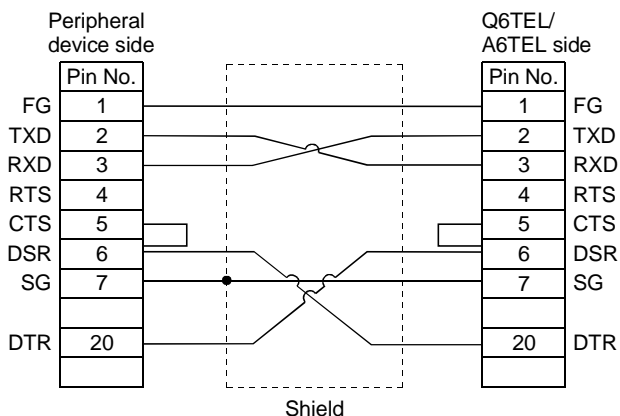

- (10) Restrictions on telephone line
- (a) Do not use the call-waiting phone line.
On the call-waiting phone line, interruption ringers may corrupt the data or disconnect the telephone line.
 - (b) Avoid using a party line.
If you pick up the receiver during telephone line connection, the telephone line may be disconnected.
 - (c) An analog two-wire type telephone line can be used.
Note that a digital line can be connected by using a terminal adopter.

POINT

<p>The telephone line of four wire type may not be connected depending on the modular jack wiring type.</p>

<p>For the four wire type, conduct a connection test in advance to check whether connection can be made or not.</p>

- (d) Instructions for cellular phones
 - 1) About the modem for radio communication using a cellular phone
Though different makers call modems differently, this manual call them a cellular phone communication unit as a generic name.
Choose the model according to the cellular phone used.
For details, contact the company of the cellular phone you use.
 - 2) Although the cellular phone model which can automatically get an incoming call has no problems when it connects to the line, the model which cannot automatically get an incoming call cannot connect to the line if the modem is not provided with the ANS/ORG/TEL select switch.
As the line connection procedure depends on the phone company or model, consult the maker of the phone you use.

16.3 Using PLC Read/Write

PLC read and PLC write access the PLC and read/write data.

Since the same kind of dialog box is used for PLC read and PLC write operations, a common explanation is given for both here.

Refer to Section 19.2 for the PLC read/write password for the Q series.

About the remote password

When the remote password has been set to the serial communication module (for Q series) or Q series-compatible E71, making access to the PLC shows the remote password clearing dialog box. Access to the PLC CPU cannot be made unless the remote password is cleared.

Refer to Section 13.3 for the setting of the remote password.

When the permissible number of remote password mismatches or permissible cumulative number of remote password mismatches has been set on SW0D5C-QSCU, the following status will occur if password mismatch operation is performed more than the preset number of times. In that case, refer to the Q-compatible serial communication module user's manual (applications).

Permissible number of remote password mismatches..... Line is cut off automatically.
 Permissible cumulative number of remote password mismatches Module's error LED is lit.

16.3.1 Executing PLC read/PLC write

A	Q/QnA	FX
○	○	○

[Purpose]

Selects data and subjects it to a PLC read or PLC write operation.

[Operating Procedure]

Select [Online] → [Read from PLC] ([Write to PLC]), or click ().

[Dialog Box]

The Write from PLC screen is shown below. The **Password** button does not appear on the Read from PLC screen.

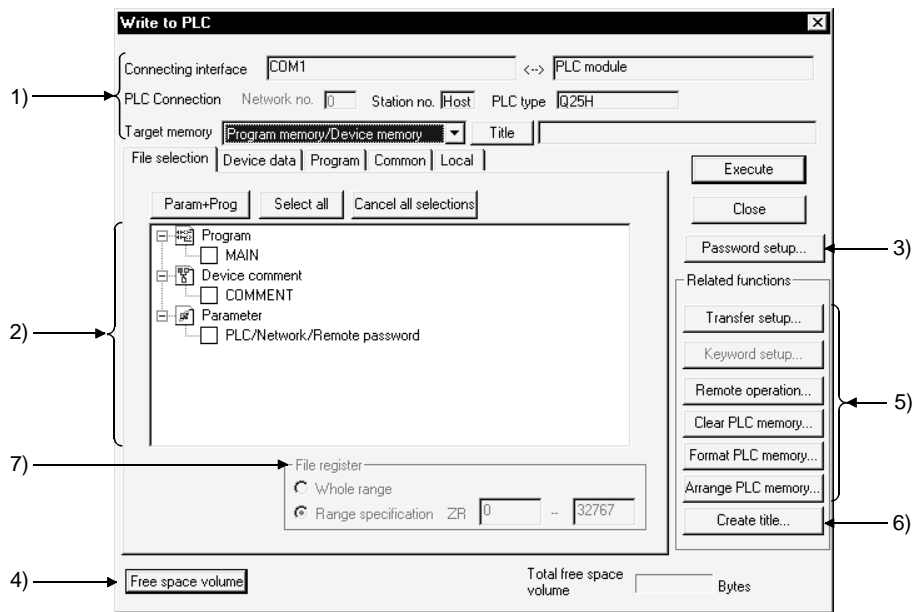

[Description]

Items in parentheses relate to "PLC write."

- 1) Connecting interface
Shows the connected interface and access target station.
For the Q/QnA series, set the target memory.

Series		Selectable Memory
QnA series		Built-in RAM, memory card (RAM), memory card (ROM)
Q series	CPU	Program memory, standard RAM, standard ROM, memory card (RAM), memory card (ROM)
	Remote I/O	Standard ROM

When performing write to the remote I/O station, the write destination is fixed to the standard ROM. For the applications of the memory cards, refer to the following manuals.

QnA series

QnACPU Programming Manual (Fundamentals)

Q series

QCPU (Q Mode) User's Manual (Function Explanation/Program Fundamentals)

Clicking the button displays the title attached to the Q/QnA series memory.

- 2) PLC data (active data)
- For "PLC read", the list of data in the applicable memory is displayed.
For "PLC read", if there is no data for either comment 1/comment 2 or extension comment, nothing is displayed. Note that is not possible to select more than one data item each for file register and device initial value (when using Q/QnA series).
 - For label programming, you cannot perform [PLC read].
[PLC read] is enabled for only compiled programs.
 - For "PLC write", a data list of the opened project is displayed.
 - Select the parameters and all programs of the project with the buttons.
 - Clear all data with the button.
For the Q series, the intelligent function module parameters are displayed on the screen if their values have been written or set.
 - Device data name (read only)
Clicking this button sets a data name to be read when multiple device memories are present.
 - button (read only)
Clicking this button updates the PLC data in the PLC read window.
This button is not featured with "PLC write."
When several personal computers are connected to the PLC, click the button to check the latest PLC data before reading the PLC file.
- 3) Password
Refer to Section 19.2.
- 4) button (Q/QnA series only)
Clicking this button shows the maximum contiguous area (QnA series only) and total free area of the applicable memory.
This button is not effective for the A series.

5) Related function

Clicking the buttons displays functions related to PLC read/PLC write.

See Section 16.1 Specifying the Connection Target

See Section 18.6 Operating the PLC Remotely

See Section 19.1.1 Registering New Entry Codes/Changing Entry Codes

See Section 20.1 Clearing the PLC Memory

See Section 20.2 Formatting a QCPU (Q mode), QnACPU

See Section 20.3 Sorting the QCPU (Q mode), QnACPU Memory

6) Create title

Creates a label for the applicable memory when using Q/QnA series.

Clicking this button displays the dialog box shown below.



Set a label of up to 32 characters, then click the **OK** button.

7) Extension file register

For A series:

A block No. can be designated only if extension file register was selected at 2).



For Q/QnA series:

- You cannot choose Whole range.
- When there are multiple file registers, the value of each file register is read (written) according to the range specified.

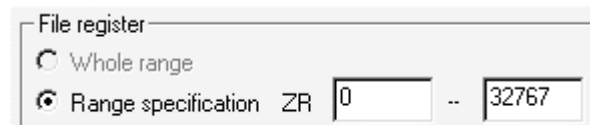

For FX series:
This setting is not possible with the FX series.

File register registration procedure

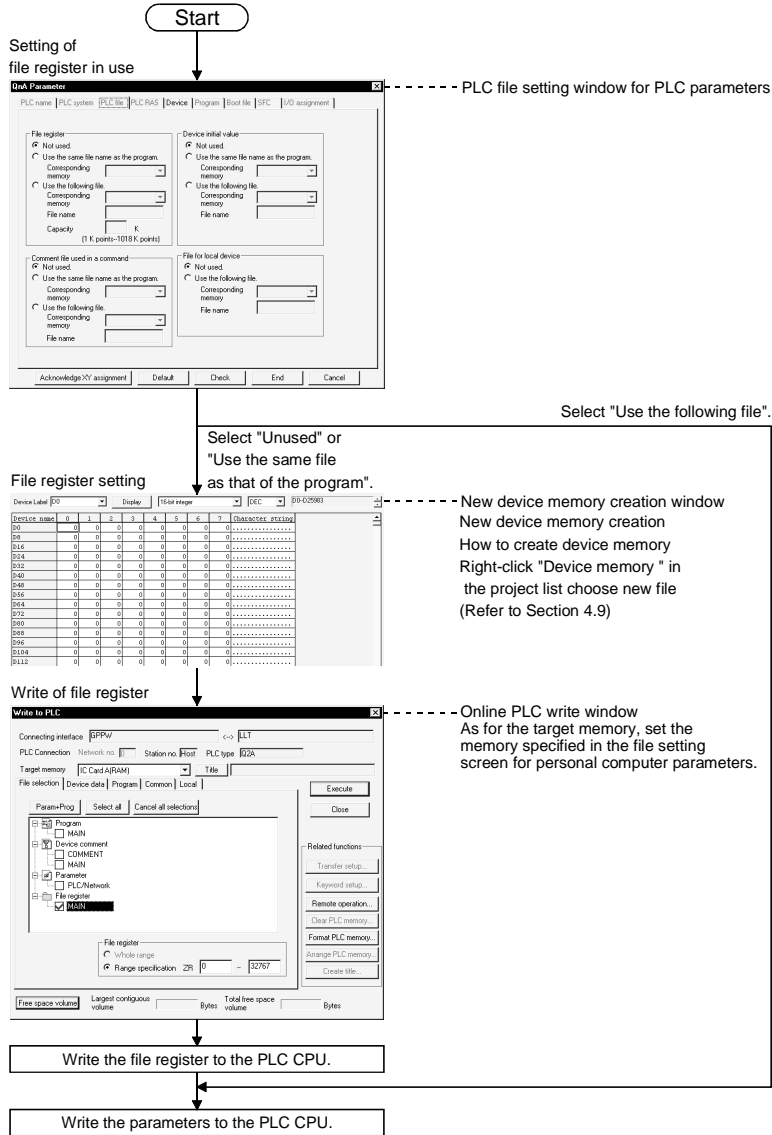

[Operating Procedure]

1. Set the access destination as described in "Specifying the Connection Destination."
2. Display the PLC read (write) dialog box.
3. At 2), check the checkbox of the data name for which PLC read (write) is to be carried out.
4. When the file selection is a program, device comment, or device memory, set the range setting and other settings on the relevant tabbed sheet.
5. Click the **Execute** button.
 When the PLC is in the RUN mode, the After STOP remotely is the PLC writing executed? dialog box appears. Choose **Yes**.
 At this time, check the peripheral and PLC side parameters.
 If the parameter check results in mismatch, read (write) is suspended.
 Also, if data of the same name exists at the read destination (write destination) on the Q/QnA series, the overwrite confirmation dialog box appears.
 When you click **Yes all**, the confirmation dialog box does not appear and you can perform batch read from (write to) PLC.
 When write to PLC is finished, the PLC state is STOP. Is remote-RUN executed? dialog box appears. Choose **Yes**.

Precautions for PLC write

- (1) When PLC write is performed from multiple personal computers
 Do not perform write from multiple personal computers to one PLC CPU simultaneously.
 1. When connected to the network
 2. When multiple projects were started on one personal computer
- (2) When the free space of the PLC CPU drive is insufficient (Q/QnA series only)
 Performing PLC write displays the following dialog box to delete all files being written.
 For example, if the free file space is insufficient for parameter write, the parameters in the PLC CPU are deleted.



If the above dialog box has appeared, delete unnecessary data and re-execute [Write to PLC].

POINTS						
<ul style="list-style-type: none"> • If online change is necessary, set this function by selecting [Tools] → [Options], and setting to the online change mode from the write mode or monitor mode. Alternatively, select [Convert] → [Convert (Online change)]. For details on online change, see Section 16.9. For details on online change settings, see Section 15.11. • With the A series, as long as the program capacity settings match, program reading (writing) is possible, even if there is a mismatch with, for example, the device comment capacity. However, if parameter reading (writing) is executed at the same time, no capacity mismatch will occur. • When writing to the E²PROM of a memory cassette with built-in RAM/E²PROM for AnUCPU (A4UMCA-8E, 32E, 128E), set the memory switch to "ROM." • The number of subprograms that can be written with an A4UCPU differs according to the installed memory cassette. The subprograms that can be written are indicated below. 						
	Memory Cassette	A3NMCA-0 to 56	A3AMCA-96	A4UMCA-128	A4UMCA-8E,32E	A4UMCA-128E
<ul style="list-style-type: none"> • With the Q/QnA series, if a program with peripheral statements/notes appended is written, the statements/notes are not written to the PLC. Therefore, when reading out a program from the PLC, be careful not to save (by overwriting) the program with no statements or notes. Since the CPU/GPP setting is made when the statements/notes are created, see Section 10.1. • When using the Q/QnA series, it is not possible to write a device memory to an IC memory card. Similarly, it is not possible to write file registers to the built-in RAM. • When using the Q/QnA series, when multiple sequence programs are written to the memory using "PLC write", carry out program setting in the PLC parameters. • When batch writing data to an FX series model, set the PLC to the STOP status. If the PLC is in the RUN status, batch writing is not possible; in this case use the online change function described above. • If the program memory of an FX series model is an EPROM cassette, write programs with a ROM writer. If it is an EEPROM cassette, set the protect switch OFF before writing. • When the A171SH project of MOTION (SCPU) is open, performing PLC read/write to A172SH executes it as A171SH. When the A172SH project of MOTION (SCPU) is open, performing PLC read/write to A171SH executes it as A171SH. • PLC write cannot be performed if an instruction code error program exists after the END instruction. Delete it in the list mode. 	Writing possible Subprograms	Sub 1 only	Sub 1,2,3	Sub 1,2,3	Sub 1 only	Sub 1,2,3

16.3.2 Setting the read/write range for device data

A	Q/QnA	FX
○	○	○

[Purpose]

Sets the type, range, etc., of the devices to be read (written) when device memory has been selected on the <<File selection>> sheet. The device memory contents are not written to the program memory of the PLC. They are written to the device memory area.

[Operating Procedure]

Select [Online] → [Read from PLC] ([write to PLC]) → <<Device data>> tab, or click () → then click the <<Device data>> tab

[Dialog Box]

The screen for "PLC read" is shown here; the screen for "PLC write" is of the same type.

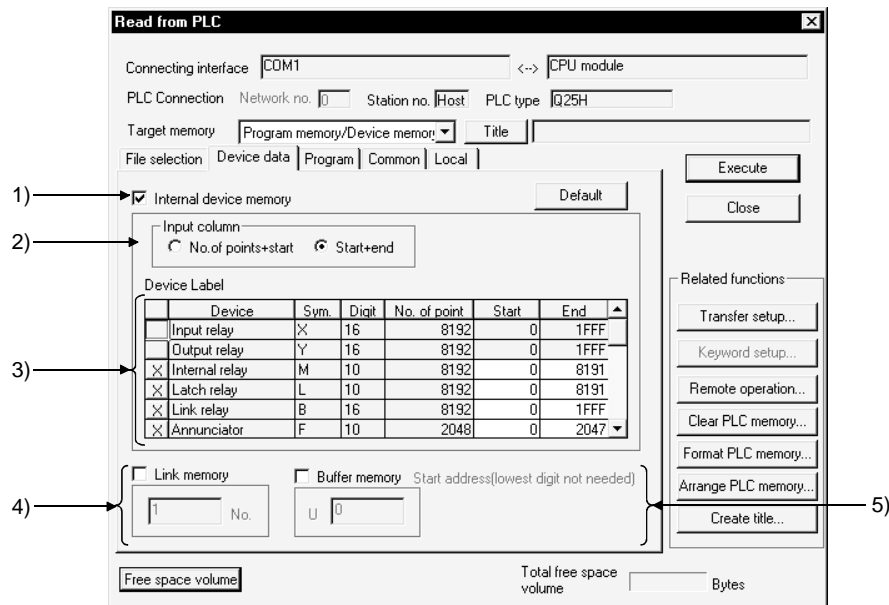

[Description]

- 1) Internal device memory
 Reads (writes) the designated built-in device data.
 Check the checkbox to select it.
 If device memory has been selected in the <<File selection>> sheet, an error will be displayed if the Internal device data checkbox is cleared.
- 2) Input column (Q/QnA/A series only)
 Sets the range designation method for the devices to be read (written).
 - No. of points + start
 Set the number of device points and the first device number.
 - Start + end
 Set the first device number and the final device number.

3) Device Laval

The default settings are for all device types, and the entire range of each. The devices that can be read (written) with the A series and Q/QnA series are indicated below.

A series

Readable/writ able devices	M/L/S *1, B, F, T *2, C *2, D, W, A, Z, V
Readable devices	X, Y, special D, special M

Q/QnA series

Readable/writ able devices	M, L, B, F, SB, V, S, T *2, ST *2, C *2, D, W, SW, FX, FY, FD, Z
Readable devices	X, Y, SM, SD

*1 : With the A series, a single range setting is made for the three device types M, L, and S.

*2 : Three types - contact, coil, and present value - are read (written).

FX series

With the FX series, all the readable/writ able devices are designated.

4) Link memory Start address (Q/QnA series only)

Checking this checkbox with the Q/QnA series causes batch reading of the link memory of the designated data link module or network module.

The range of modules that can be designated is 1 to 4.

Since "PLC write" is not possible with a link memory, only reading can be designated.

The data can be read to J*\W** of the device memory.

For details on the device designation method, see the Q/QnACPU Programming Manual (Common Instructions).

This setting is not possible with the A series.

5) Buffer memory start address (Q/QnA series only)

Checking this checkbox with the Q/QnA series causes batch reading of the buffer memory of the designated special function module.

To designate the special function module, set the first output number (however, the lowest digit is unnecessary).

The setting range is 0 to 1FF.

Since "PLC write" is not possible with respect to a buffer memory, only reading can be set.

The data can be read to U*\G** of the device memory.

For details on the device designation method, see the Q/QnACPU Programming Manual (Common Instructions).

This setting is not possible with the A series.

<Setting Example>

Case where the first I/O number is 40

U	4
---	---



16.3.3 Setting the program reading/writing range

A	Q/QnA	FX
○	○	○

[Purpose]

Sets the program range for reading/writing.

[Operating Procedure]

Select [Online] → [Read from PLC] ([Write to PLC]) → <<Program>> tab, or click ( ) → then click the <<Program>> tab.

[Dialog Box]

The dialog box for "PLC read" is shown here; the dialog box for "PLC write" is of the same type.

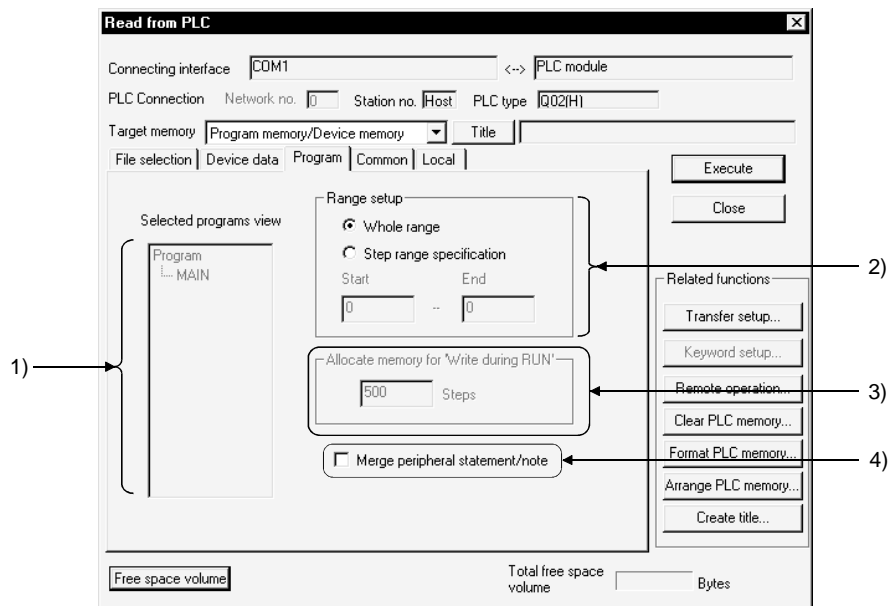

[Description]

- 1) Selected programs view
Displays a list of programs selected for read (write) data using file selection.
- 2) Range setup
Sets the range for programs selected for read (write) data.
When multiple programs have been selected, the All range setting is automatically made.
 - Ⓐ Whole range
The whole range is read (written).
 - Ⓑ Step range specification
The range designated by first and final step numbers is read (written).
- 3) Allocate memory for "Write during RUN" (Q/QnA series only)
With the Q/QnA series, to accommodate the increase in steps during online change, an area equivalent to the number of steps secured for online change is secured when a program is written to the PLC.
For details on online change, see Section 16.9.
This setting is not possible with the A series and FX series.
- 4) Merge peripheral statement/note
Refer to Section 10.2.

16.3.4 Setting the comment read/write range

A	Q/QnA	FX
<input type="radio"/>	<input type="radio"/>	<input type="radio"/>

[Operating Procedure]

- Reading (writing) comments common to all programs
 Select [Online] → [Read from PLC] ([Write to PLC]) → <<Common>> tab, or click (), then click the <<Common>> tab.
- Reading (writing) program-specific comments
 Select [Online] → [Read from PLC] ([Write to PLC]) → <<Local>> tab, or click , then click the <<Local>> tab.

[Dialog Box]

A series PLC read the <<Common>> sheet and Q/QnA series PLC write. The <<Common>> sheet is shown here; the <<Local>> sheet is of the same type. (However, the A series <<Local>> sheet has no range setting for extension comments.)

- A series PLC read <<Common>> sheet:

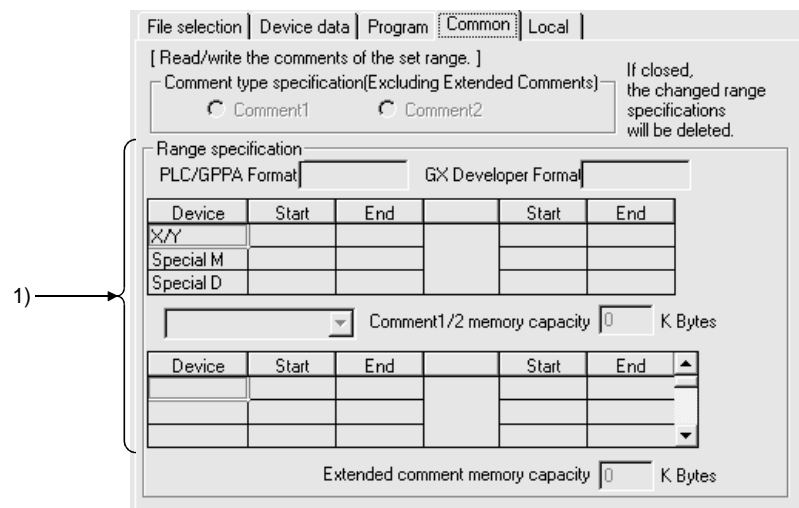

- Q/QnA series PLC write <<Common>> sheet:

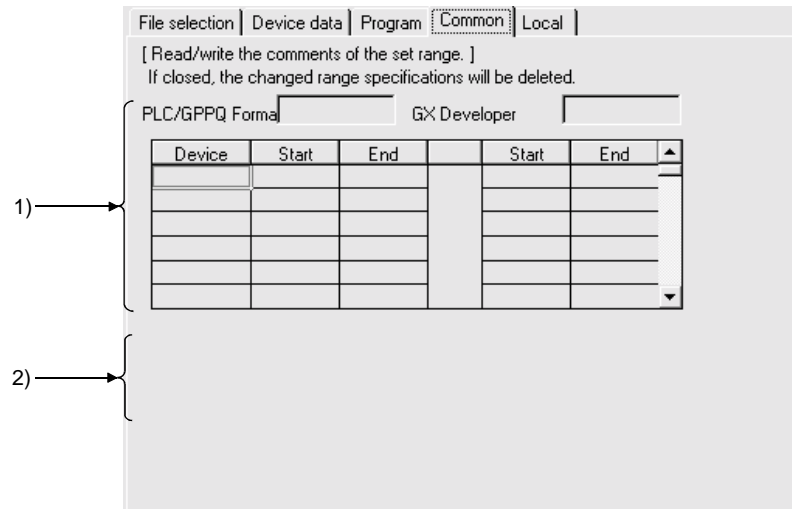

[Dialog Box]

The FX series PLC read <<Common>> sheet and PLC write <<Common>> sheet are shown here. With the FX series, there is no <<Local>> tab.

- FX series PLC read <<Common>> sheet:

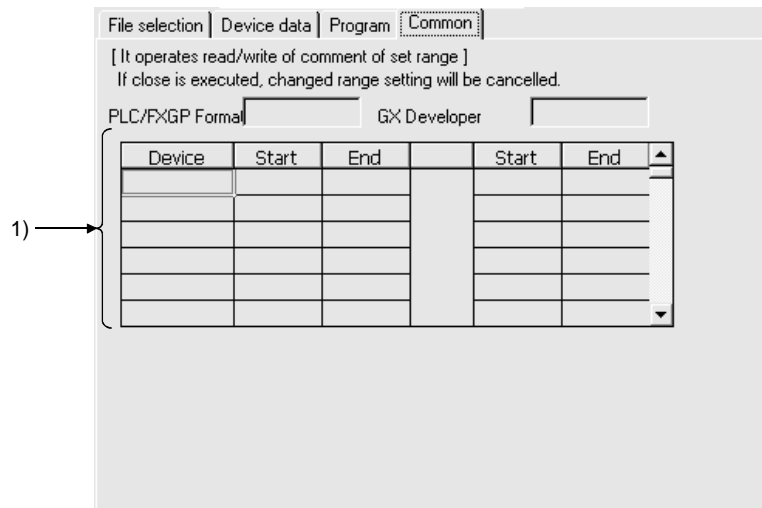

- FX series PLC write <<Common>> sheet:

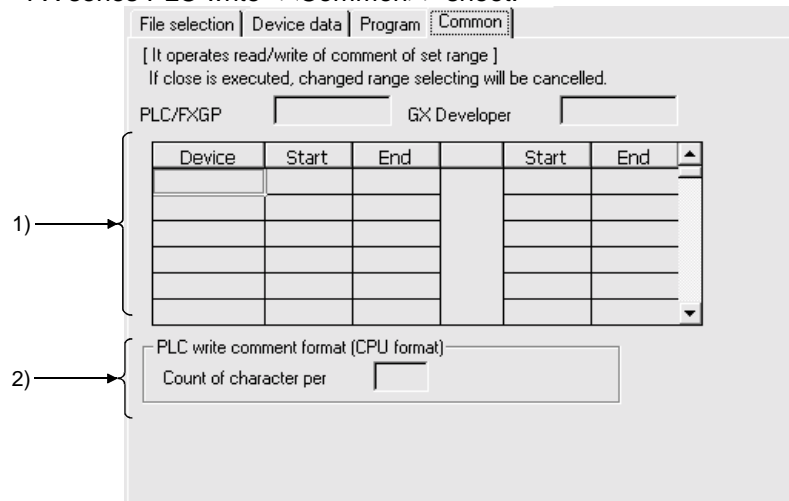

[Description]

1) Device range setting

Sets the range of device comments to be read (written) when device comment data has been selected by file selection.

The details of comment range setting when editing device comments are set. If the read (write) range is incorrect, it is changed.

However, when the range is changed, the comment range setting for device comment editing is also automatically changed.

For details on comment range setting, see Section 9.7.

When writing with the A series, always carry out range setting. Note, however, that no range designation is required when the entire range is to be read.

When reading (writing) the entire range with the QnA series, no range designation is required.

For the Q series, up to 64k points can be written to the PLC. There are no restrictions on saving onto the HD/FD of the personal computer.

When reading with the FX series, all that is required is to select the comment data file: range setting is not necessary.

2) PLC write comment form (Q/QnA series only)

Sets the number of characters of comments written to a Q/QnA series PLC.

In device comment editing, comments of up to 32 characters can be created, but memory capacity can be saved by reducing the number of characters written to the PLC.

The setting range is 2 to 32 characters.

There is no setting for reading.

This setting is not possible with the A series.

POINTS

- There are two types of device comment: comments common to all programs and program-specific comments. This is not the case with previous packages (GPPA, GPPQ, FXGP(DOS), FXGP(WIN)). Therefore, first read Section 9 "SETTING DEVICE COMMENTS" before reading (writing) device comments.
- With the A series, it is not possible to read (write) device comments unless a comment memory capacity setting has been made. Make the PLC parameter memory capacity setting by referring to the comment capacity displayed under the range designation.
- With the Q/QnA series, device comment reading is CPU format.

16.4 Verifying the Peripheral Side and PLC Side Data

A	Q/QnA	FX
<input type="radio"/>	<input type="radio"/>	<input type="radio"/>

[Purpose]

Compares and verifies the program, parameters and device comments in the PLC CPU and the data on the personal computer side.

[Operating Procedure]

[Online] → [Verify with PLC]

[Dialog Box]

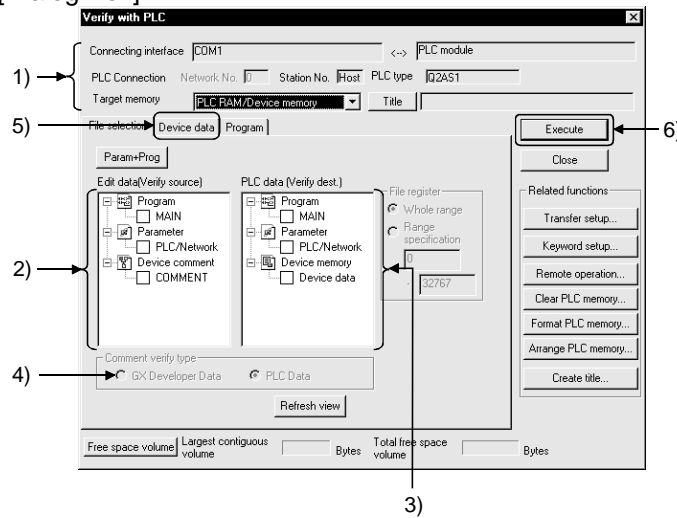

[Description]

- 1) Connection destination information
Shows the connected interface and accessed station.
For the QnA series, set the corresponding memory.
- 2) Edited data (verify source)
Lists the programs and parameter data of the project.
Check the data name check box to make selection.
- 3) PLC data (verify destination)
Lists the programs and parameter data in the PLC CPU.
Check the data name check box to make selection.
If extended comments have not been written to the PLC CPU, the extended comment item does not appear.

- 4) Comment verify type
 Select whether the device comments of the edited data (verify source) comments or those of the PLC data (verify destination) are used as the basis of verify.

The verify basis is indicted below.

PLC Data	
ACPU QCPU (A mode), Motion Controller	QCPU (Q mode), QnA
Edited data area=PLC data area Comments outside the PLC data area are not verified.	
Edited data area=PLC data area All devices will be the target of verify.	
Edited data area=PLC data area Comment sections not existing in the edited data are handled as "no comment".	
Verify is executed in the device area set to the comments of the comment type (kana/kanji, extended) selected in the PLC data and written to the PLC CPU.	Verify is executed in the device area set to the comment file selected in the PLC data.

Gppw Data	
ACPU QCPU (A mode), Motion Controller	QCPU (Q mode), QnA
Edited data area=PLC data area Comments outside the PLC data area are not verified.	
Edited data area=PLC data area All devices will be the target of verify.	
Edited data area=PLC data area Comment sections not existing in the edited data are handled as "no comment".	
Verify is executed in the device area set in the PLC write range setting of the comments of the comment type (kana/kanji, extended) selected in the PLC data. If PLC write range setting has not been made, verify is executed in the whole edit device area in GX Developer.	Verify is executed in the device area set in the PLC write range setting of the comments selected in the edit data. If PLC write range setting has not been made, verify is executed in the whole edit device area in GX Developer.

POINTS
<ul style="list-style-type: none"> • The following instruction applies to the verify of comments on the QnA series. When selecting multiple comment files, verify the identical file names. • The M, L and S of the ACPU or QCPU (A mode) must be verified when the device range setting has been made with reference to the editing data range. Otherwise, the verify results of the M, L and S will be illegal.

- 5) Program tab
Click this tab to show the following screen.

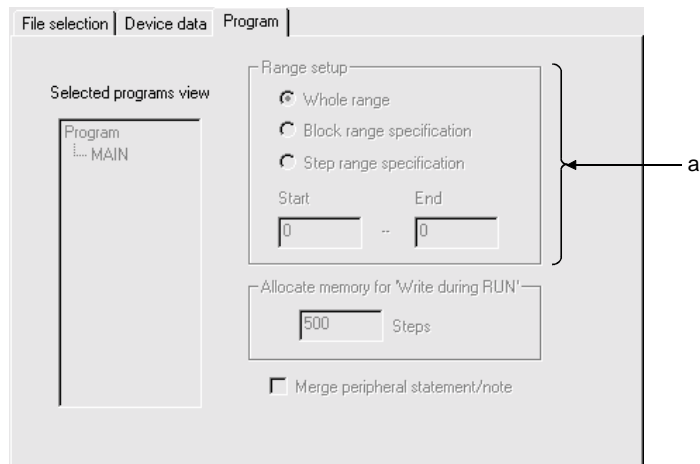

- a) Range setup
Set the verify area of the program.
- Whole range
All area of the selected programs is verified.
 - Step range specification
Only the specified area of the selected programs is verified.
Set the area with the first and last step numbers.

- 6) **Execute** button
Click this button when the setting is finished.

[Setting Procedure]

1. Set the access destination in Transfer setup.
2. Show the PLC verify screen.
3. Check the desired data check boxes at 2) and 3) to make selection.
4. When verifying programs, set the area at 5).
5. After the setting is over, click 6).
After completion, the verify result dialog box appears.

POINTS
<ul style="list-style-type: none"> • When multiple pieces of data have been chosen in file selection, verify is performed between identical data names. Also, if the data names selected do not correspond between the verify source and destination, an error message appears. When sequence programs are to be verified one by one between the verify source and destination, you can specify different data names. • If more than 100 discrepancies are found in the verify results, the results of up to 100 discrepancies are displayed and verify is suspended at that point. Before restarting verify of the area at and after the point of verify suspension, specify the range or correct the verify data.

16.5 Write to PLC (Flash ROM)

16.5.1 Write the program memory to ROM

A	Q/QnA	FX
○*	○*	×

*: This function is compatible with the QCPU (Q mode).

*: This function is compatible with the QCPU (A mode).

[Purpose]

Batch-writes the data of the program memory to the standard ROM or linear flash ROM. (Q series only)

To write to the ATA, choose [Online] → [Write to PLC].

[Operating Procedure]

Select [Online] → [Write to PLC (Flash ROM)] → [Write the program memory to ROM].

[Dialog Box]

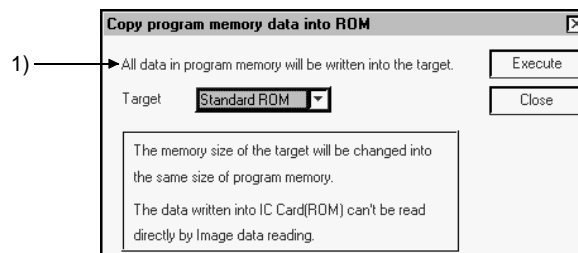

[Description]

1) Target

Choose Standard ROM or IC Card (ROM) (for linear flash ROM).

POINTS
<ul style="list-style-type: none"> • Data of the program memory written to the ROM cannot be read in image data reading. Read it directly from the PLC. • If program memory data is written to the ROM, device memory data cannot be written to the ROM.

16.5.2 Write to PLC (Flash ROM)

A	Q/QnA	FX
×	○*	×

*: This function is compatible with the QCPU (Q mode).

[Purpose]

Writes data to the standard ROM or flash ROM. (Q series only)

Since transfer/write may take time depending on the performance of the personal computer, use the following menu to write a program to the ROM.

When writing the program memory data of the PLC to ROM

Select [Online] → [Write to PLC (Flash ROM)] → [Write the program memory to ROM].

When writing the project data to ROM (PLC card slot required)

Select [Tools] → [IC memory card] → [Write IC memory card].

To write to the ATA, choose [Online] → [Write to PLC].

As the corresponding memory, choose Memory card (ROM).

[Operating Procedure]

Select [Online] → [Write to PLC (Flash ROM)] → [Write to PLC (Flash ROM)].

[Dialog Box]

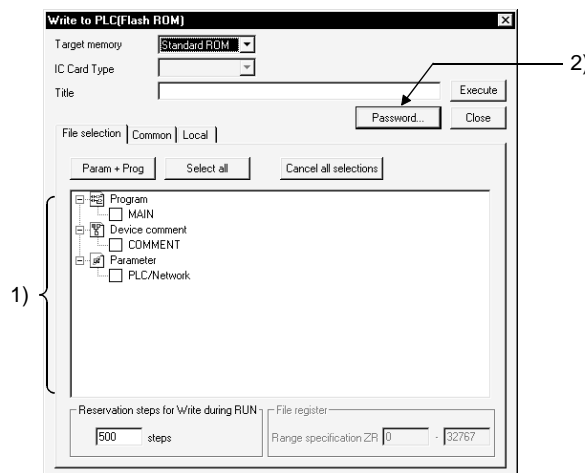

[Description]

- 1) PLC write setting
Refer to Section 16.5.
- 2) **Password** button
Refer to Section 19.2.

POINT

For Write to PLC (Flash ROM) with the other station specified, set the time check (seconds) to 45 seconds on the Transfer setup screen.

16.6 Deleting Data in the PLC

A	Q/QnA	FX
×	○	×

[Purpose]

Deletes data such as programs and parameters in the PLC when using the QnA series.

[Operating Procedure]

Select [Online] → [Delete PLC data].

[Dialog Box]

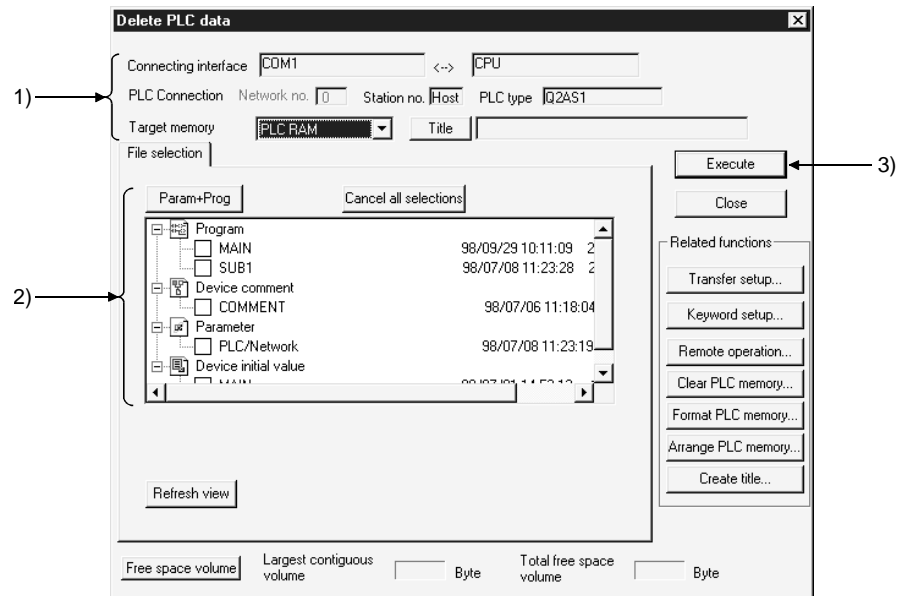

[Description]

- 1) Connection destination information
Displays the connected interface/applicable station for access.
Set the applicable memory.
- 2) PLC data
Displays the list of data in the applicable memory.
Check the checkbox for the data name to be deleted to select it.
Select the project parameters and all programs by clicking the **Param + Prog** buttons.
Cancel all data by clicking the **Cancel all selections** button.
- 3) **Execute** button
Click this button after setting the necessary settings.

[Operating Procedure]

1. Set the access destination as described in "Specifying the Connection Destination."
2. Display the PLC file delete dialog box.
3. Check the checkbox for the data name to be deleted in 2) to select it.
4. After making the necessary settings, click 3).

POINT

- PLC file deletion is possible for the Q/QnA series only.
When using the A series, select [Online] → [clear PLC memory] to all-clear the data in the memory cassette, then write only the necessary data again.
For details on PLC memory clear, see Section 20.1.1.

16.7 Changing PLC Data Attributes

A	Q/QnA	FX
×	○*	×

*: This function is compatible with the QnACPU.

[Purpose]

Changes the attributes to "writing disabled" and "display disabled" in order to protect programs, parameter data and other data in QnA series PLC from unwanted access. (QnA series only)

[Operating Procedure]

Select [Online] → [Change PLC data attributes].

[Dialog Box]

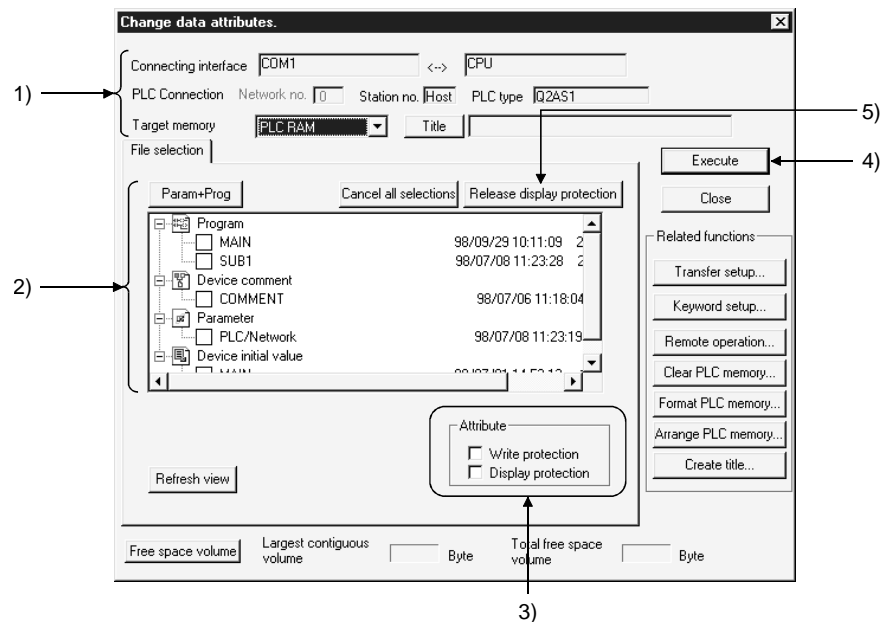

[Description]

- 1) Connection destination information
Displays the connected interface/applicable station for access.
Set the applicable memory.
- 2) PLC data
Displays the list of data in the applicable memory.
Check the checkbox for the data name whose attributes are to be changed to select it.
Select the project parameters and all programs by clicking the **Param + Prog** buttons.
Cancel all data by clicking the **Cancel all selections** button.

- 3) **Attribute**
Sets the data attributes.
If both the Display prohibited and Write prohibited checkboxes are selected by checking them, data is neither written nor displayed.
- When write disable is selected:
Data cannot be written or deleted by access from a personal computer.
 - When display disable is selected:
The existence of the data is not indicated in the display on accessing from a personal computer.
- 4) **Execute** button
Click this button after setting the necessary settings.
- 5) **Release display prohibition** button
Releases data for which the display disable or write disable status is set from the disabled status.
On clicking the **Release display prohibition** button, the dialog box shown below is displayed.

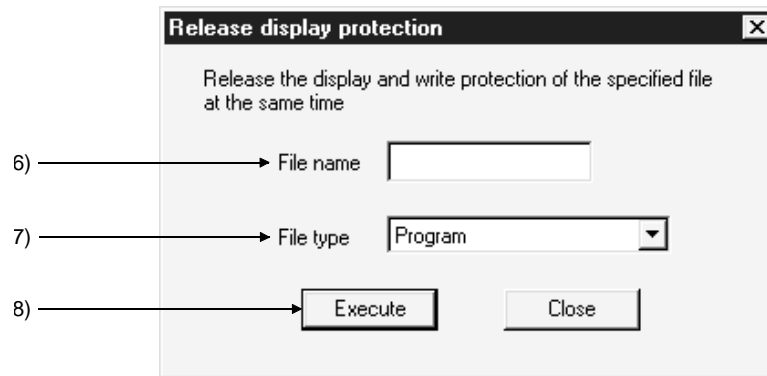

- 6) **File name**
Set the file name for which the display disable or write disable status is to be canceled.
If the file name for which the parameter has been changed and the set file name do not match, the "disabled" status cannot be released.
- 7) **File type**
Set the file type for which the disabled status is to be cancelled.
- 8) **Execute** button
After setting the file name and file type, click the **Execute** button.
If the set file name or file type does not agree with that at the PLC side, the disabled status cannot be canceled.

[Operating Procedure]

- Changing to the "write disabled"/"display disabled" status
 1. Set the access destination by as described in "Specifying the Connection Destination."
 2. Display the PLC data attribute change dialog box.
 3. Check the checkbox for the data name to be deleted at 2) to select it.
 4. Set the type of attribute at 3).
 5. Click 4).
- Canceling the write disabled or display disabled status
 1. Set the access destination as described in "Specifying the Connection Destination."
 2. Display the PLC data attribute change dialog box.
 3. Click 5) to display the display disabled cancellation dialog box.
 4. Set 6) and 7).
 5. After setting the necessary settings, click 8).

POINTS

- | |
|---|
| <ul style="list-style-type: none">• Be sure not to forget a data name whose display has been disabled.
If the correct data name cannot be set, it will not be possible to designate the data for access, making reading and writing impossible.
To delete or change display disabled data when you have forgotten the name, initialize the memory by selecting [Online] → [format PLC memory], then write the necessary data again.
See Section 20.2 for details on PLC memory formatting.• It is possible to change the same attribute of several data at the same time, but disabled statuses have to be canceled one by one.• If neither selection has been made in attribute designation, the write disabled status of the selected data is canceled. |
|---|

16.8 Reading/Writing PLC User Data

16.8.1 Reading

A	Q/QnA	FX
×	○*	×

*: This function is compatible with the QCPU (Q mode).

[Purpose]

Reads CSV format and other files written on the IC memory card to the personal computer.

Refer to the following manual for the way to use the user data with the sequence program.

QCPU (Q mode)/QnA programming manual (common instructions manual)

[Operating Procedure]

Select [Online] → [PLC user data] → [Read PLC user data].

[Dialog Box]

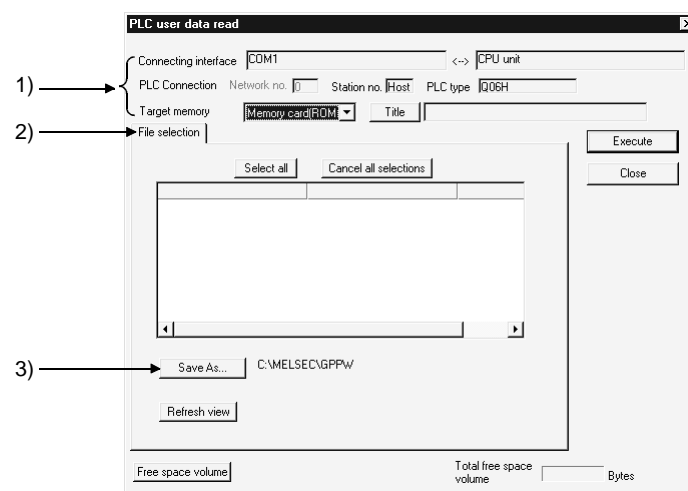

[Description]

- 1) Memory card read target setting
Set the read destination of data.
- 2) Read data setting
Refer to Section 16.3.
- 3) **Save As** button
Set the save target of the read data.

REMARKS

Use Delete PLC user data to delete data.

16.8.2 Writing PLC user data

A	Q/QnA	FX
×	○*	×

*: This function is compatible with the QCPU (Q mode).

[Purpose]

Writes data created in the CSV format and others to the ATA.
(Q series only)

[Operating Procedure]

Select [Online] → [PLC user data] → [Write PLC user data].

[Dialog Box]

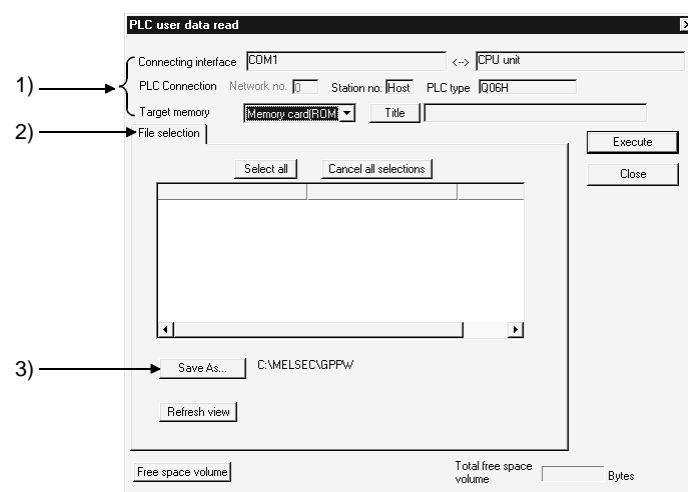

[Description]

- 1) Memory card write target setting
Set the write destination of data.
- 2) Written data setting
Refer to Section 16.3.
- 3) **Save As** button
Set the save target of the written data.

POINTS

- Use Format PLC memory to format the IC memory card.
- The attributes (read only, hidden file) of a project file are invalid if they are set on Windows[®] Explorer or the like.

16.9 Executing Online Change

A	Q/QnA	FX
○	○	○

[Purpose]

In the ladder editing window, changes a part of a sequence program and then writes it to the PLC while it is in the RUN status.

Online change is possible in the write mode and in the monitor write mode.

Online change cannot be made when the PLC is in the STEP-RUN mode.

The Caution points for executing Write during RUN are listed on the next page.

Read these points before executing a Write during RUN.

There are the following two types of online change.

- When making online change frequently
Online change is executed by simply selecting [Tools] → [Options] to preset online change and then making conversion.
- When not making online change frequently
Choose the [Convert (Online change)] menu at the time of program conversion to execute online change.

[Operating Procedure]

- Setting online change by menu operation before conversion.
 1. Change and correct the program.
 2. Convert the program by selecting [Convert] → [Convert (Online change)] (**Shift** + **F4**).

Confirm online change in the dialog box shown below.
- Executing online change at program conversion by options setting
 1. Select [Tools] → [Options] → <<Common>> and then set the online change setting to "Write during RUN (while PLC is running)." See Section 15.11 for details on the online change setting.
 2. Change and correct the program.
 3. Convert the program by selecting [Convert] (**F4**).

Execute online change in the dialog box shown below.

Online change confirmation dialog box

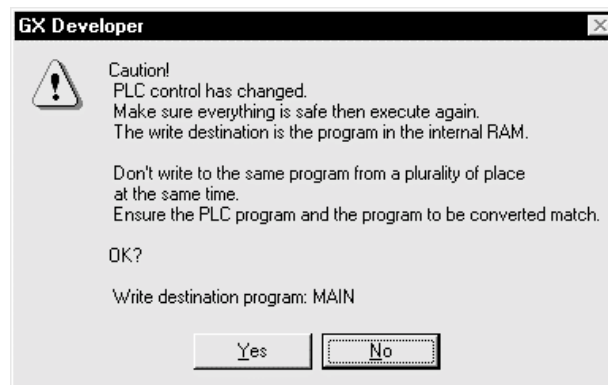

The following tables list precautions for making online change.
 (1) For A series

Item	Description
EEP-ROM of other than AnUCPU	<ul style="list-style-type: none"> Online change cannot be made to EEPROM of other than AnUCPU.
Online change to other stations	<ul style="list-style-type: none"> Online change can be made to other stations via the MELSECNET (II, /10). However, note that the sequence program will be corrupted if online change is made from multiple personal computers to a single PLC.
A2CCPU, A2CJCPU	<ul style="list-style-type: none"> To make online change, select [Tools] → [Options] → (Common) sheet and set the edit object (shift forward setting) to "1 ladder block (Don't shift the program forward)" on the (Common) sheet. Otherwise, an error will occur, bringing the PLC down. For shift forward setting, refer to Section 15.11.
Deletion of corresponding device from program	<ul style="list-style-type: none"> If a deletion during execution of the OUT instruction or changing a device No. has removed the corresponding device from the program, the output status is held. Force the unnecessary coil outputs for control to be switched off by selecting [Online] → [Debug] → [Device test]. For the device test, refer to Section 18.1 "Carrying Out a Device Test".

(2) For Q/QnA series

Item	Description
Online change to other stations	<ul style="list-style-type: none"> Online change can be made to other stations via the MELSECNET II (QnA series only), MELSECNET/10, MELSECNET/H.
Online change to built-in RAM during boot operation	<ul style="list-style-type: none"> If online change has been made to the built-in RAM during boot operation, write the converted program to the IC memory card after STOP using Write to PLC.
Deletion of corresponding device from program	<ul style="list-style-type: none"> If a deletion during execution of the OUT instruction or changing a device No. has removed the corresponding device from the program, the output status is held. Force the unnecessary coil outputs for control to be switched off by selecting [Online] → [Debug] → [Device test]. For the device test, refer to Section 18.1 "Carrying Out a Device Test".

Steps secured for online change

QnA series	<ul style="list-style-type: none"> Online change cannot be made beyond the number of steps set as those secured for online change on the (Program/SFC program) sheet after selecting [Online] → [Write to PLC] → (Sequence/SFC program) sheet. The number of secured steps for online change is reduced for each online change. If the currently set number of secured steps is exceeded by online change, convert the program offline and select [Online] → [Write to PLC]. If the number of steps is greatly increased by online change, preset a large number of steps secured for online change during program write.
Q series	<ul style="list-style-type: none"> If the currently set number of secured steps is exceeded by online change, the following dialog box appears. Set new secured steps. If the number of secured steps is set to 0 in the following dialog box, only the sequence program which has exceeded the secured step range is written. If online change is made to the sequence program whose password has been set, the password deletion dialog box appears. Start online change after deleting the password. If the password cannot be deleted, online change cannot be made. The secured steps newly set in the following dialog box do not appear on the (program) sheet of Write to PLC.

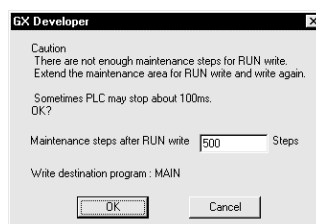

Q/QnA Series Table Continued

Item	Description
Online change during slow execution type program run	<p>While the slow execution type program is run, online change is started on all completion of the slow execution type program. During online change, the slow execution type program run is suspended.</p> <p>However, online change cannot be made if "PRG TIME OVER(5010)" keeps occurring during slow execution type program run.</p> <p>In this case, after setting the PLC CPU to STOP, increase the settings of the constant scan and slow execution type program run time in the PLC parameters, and perform write to PLC again.</p>

(3) For FX series

Item	Description	
CPU which can make online change		
Model name	FX2C series/FX2 series (version No. V2.1 or later), FX0N series (version No. V1.10 or later), FX2N/FX2NC series	
Memory type	FX2N series	Built-in RAM, optional RAM cassette or optional EEPROM cassette (protect switch OFF)
	FX2NC series	Built-in RAM or optional memory card (protect switch OFF)
	FX2/FX2C series	Built-in RAM or optional RAM cassette
	FX0N series	Built-in EEPROM
Use of FX0N, FX2, FX2C, FX2N, FX2NC	<ul style="list-style-type: none"> Corrected ladders do not have additions, deletions and changes to labels P, I. 	
	<ul style="list-style-type: none"> Change cannot be made if any ladder before or after corrections includes the output (OUT) instruction of high-speed counter C235 to 255 or the application instruction FNC90 to 98. 	
	<ul style="list-style-type: none"> There should be no new 1ms retentive timers inserted. 	
Use of FX2 (V3.07 or later), FX2c	<ul style="list-style-type: none"> A substitute instruction for a new instruction cannot be inserted into a program or rewritten. 	
	<ul style="list-style-type: none"> If a substitute instruction has already been programmed, the function of this substitute instruction is lost by executing online change at that part. FNC10 to 12 (CMP, ZCP, MOV) and FNC20 to 25 (ADD, SUB, MUL, DIV, INC, DEC) instructions are increased in operation speed when neither a word device with digit designation nor index qualification is used. However, when online change or insertion is made, the high-speed processing function of this part is lost. 	
	<ul style="list-style-type: none"> The OFF execution time of the application instructions of the FX2 (V3.07 or later) and FX2C is shortened. However, when online change or insertion is executed, the shortening function of this part is lost, and the value becomes approximately 60% of that of the FX2 (V2.30 or earlier) series. 	
Use of FX2 (V2.1 to V2.30)	<ul style="list-style-type: none"> When additional application instructions and device numbers are written with the FX2 (V3.07 or later) PLC, these instructions are written directly to the program memory of the PLC. At this time, the PLC continues running, handling them as no operations. However, as soon as the operation mode of the PLC is switched from STOP to RUN, a program check is performed and the "PROG-E LED" flickers. In this case, change the incompatible application instructions and device numbers, then batch-transfer a correct program. 	
	<ul style="list-style-type: none"> If a device number not supported by the FX2 (V2.1 to V2.30) is specified as the operand of an application instruction, this instruction is written directly to the program memory of the PLC. At this time, an operation error occurs because the device number for this instruction is outside the range, but the PLC continues running, handling it as a no operation. However, as soon as the operation mode of the PLC is switched from STOP to RUN, a program check is performed and the "PROG-E LED" flickers. In this case, batch-transfer a program with a correct operand set for the application instruction. 	
Use of FX0N (V1.10 or later)	<ul style="list-style-type: none"> When a device number that is not compatible with the FX0N is written, the "It cannot write during RUN because order or device that cannot write in changed program during RUN is included" message appears and changes to the program are suspended. 	
	<ul style="list-style-type: none"> Since the FX0N has no pulse execution type application instructions, writing this type of instruction displays the "Write bad" message and suspends changes to the program. 	

*1: Each function is restored by switching the PLC from STOP to RUN after online change has been made.

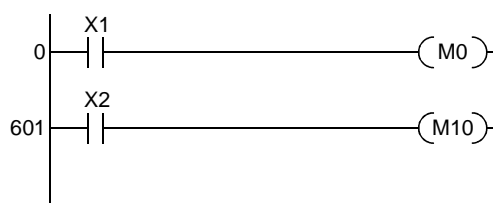
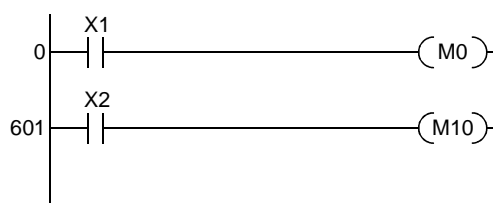
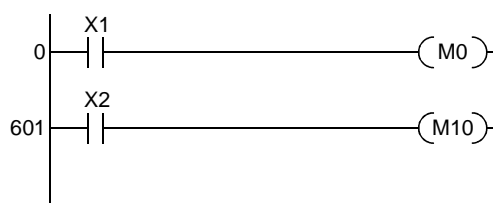
POINTS			
	<p>The following numbers of steps can be written by a single online change.</p> <p>(1) Q/QnA/A series A series Number of program steps after editing (addition/deletion): Within 250 steps Q/QnA series Number of program steps after editing (addition/deletion): Within 512 steps However, if the existing program is not modified but a program is added to it by pasting and line insertion, the maximum number of steps cannot be written by a single online change. In this case, reduce the number of steps written at one time and make online change several times. Also be careful when the following corrections have been made. If a correction is made to step 2 in a program and an addition made to step 540, online change cannot be made since steps 2 to 540 will be the object of a single online change. In this case, perform online change every time a correction is made.</p> <p>(2) FX series (FX0N/FX2/FX2C/FX2N/FX2NC only) Ladder modification is made within a single ladder block once and the number of program steps after editing (addition/deletion) is within 127 steps. (Including the NOP immediately after the ladder block, but with the exception of the last ladder) Program modifications exceeding the above should be batch-transferred.</p> <p>Precautions for online change The case where online change cannot be made and its correction method are described below.</p> <ul style="list-style-type: none"> • If the ladder block has no NOP instructions and the number of steps is greater than 250 (ACPU)/512 (Q/QnACPU)/127 (FXCPU), delete unnecessary instructions before starting online change. • If NOP instructions exist after the ladder block and the online change range is exceeded, choose "Don't shift the program forward" and start online change. <p>Refer to Section 15.11 for shift forward setting. Note that when step 0 (LD X1) of the following program is to be changed to LD X3, online change cannot be made if "Shift the program forward" has been selected.</p> <table style="width: 100%; border: none;"> <tr> <td style="width: 50%; vertical-align: top; padding: 5px;"> <p>Ladder mode</p>  </td> <td style="width: 50%; vertical-align: top; padding: 5px;"> <p>List mode</p> <pre> 0 LD X1 1 OUT MO 2 NOP 3 NOP to 600 NOP 601 LD X2 602 OUT M10 </pre> </td> </tr> </table> <p>Shift the program forward Online change cannot be made as steps 0 to 600 will be the target of online change. Don't shift the program forward Online change can be made as steps 0 to 1 will be the target of online change.</p> <p>(3) When multiple sequence programs are specified for file write If there is an online change-disabled file, set the PLC to a remote stop and write to that file. For the Q series, online change can be made to the PLC program-by-program. This is useful when there are many corrections and additions in a program being debugged. However, if online change has made the memory area of the PLC short, STOP the PLC, then delete the program in the PLC, and perform write to PLC.</p>	<p>Ladder mode</p> 	<p>List mode</p> <pre> 0 LD X1 1 OUT MO 2 NOP 3 NOP to 600 NOP 601 LD X2 602 OUT M10 </pre>
<p>Ladder mode</p> 	<p>List mode</p> <pre> 0 LD X1 1 OUT MO 2 NOP 3 NOP to 600 NOP 601 LD X2 602 OUT M10 </pre>		

POINTS				
<p>(4) If there is a pulse instruction in the ladder block to be converted, that instruction is executed when the pulse execution condition turns from OFF to ON after online change. For Rise/Fall commands, refer to the programming manual for each series. The commands below are given as examples. Rise instructions PLS, MOV, LDP, MEP, FROMP, TOP, etc. Fall instructions..... PLF, LDF, ANDF, ORF, MEF, EGF, FCALLP</p>				
Continuity at Online Change	Rise Instruction		Fall Instruction	
	RAM	EEPROM	RAM	EEPROM
OFF	Not executed		Only the pulse instruction to be edited is executed.	Pulse instructions having the numbers of the one to be edited and later are executed.
ON	Not executed		Not executed	

16.10 Concept of the Routing Parameters

A	Q/QnA	FX
○	○	○

The routing function is used by the station of the PLC in a multi-level system to make transient transmission to the station of another network No.
 To perform the routing function, the "Routing parameters" must be set to associate the network No.s and stations acting as bridges.
 For communication via the MELSECNET II, the routing function cannot be used.

- (1) The routing parameters must be set to the request source and relay station of the PLC.
 - (a) The request source must be set to make access to the request target.
 - (b) The relay station must be set to make access from the request source to the request target and to make access from the request target to the request source.
 - (c) The request target needs no setting.

For example, to make transient transmission from 1Ns3 to 3Ns4 in the following diagram, the routing parameters must be set to the PLC 1Ns3 which makes transient transmission, to the PLCs 1Ns4 and 2Mp1 which serve as bridges, and to the PLCs 2Ns4 and 3Ns5.

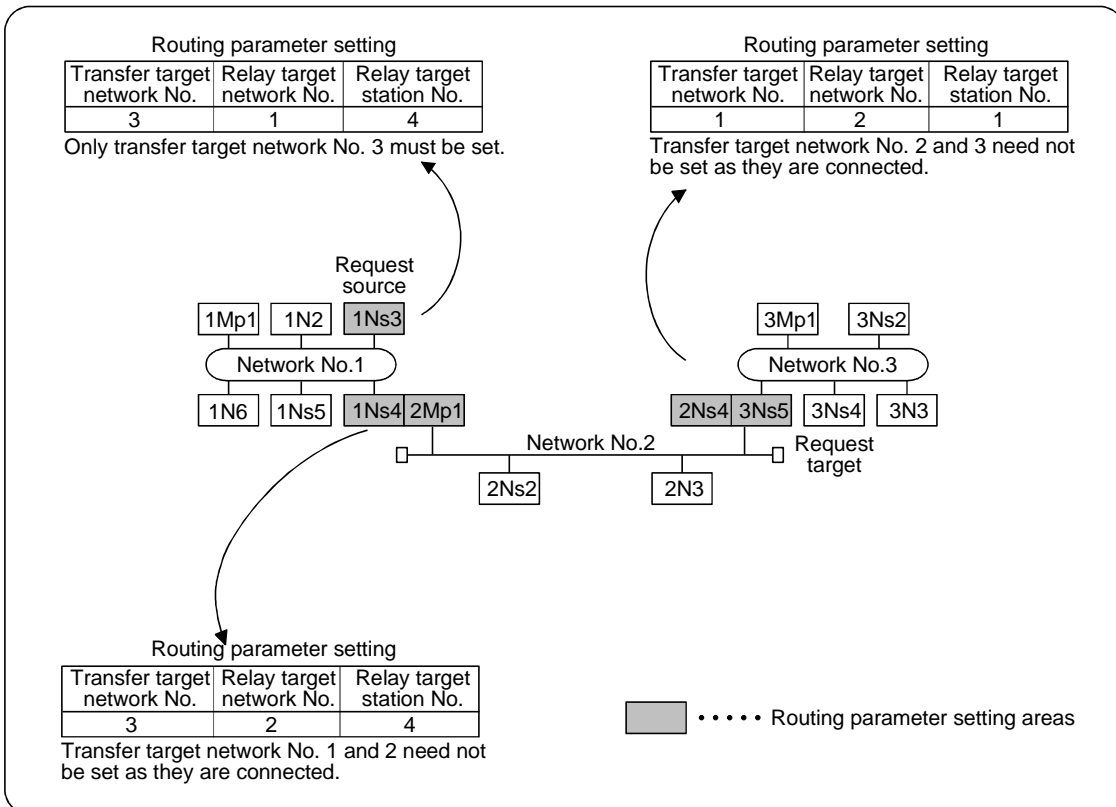

- (2) Up to 16 "transfer target network No.s" can be set to the PLC. 16 different network No.s allow the own station to be a request source or other stations to be accessed via the own station.

- (3) Routing parameter setting areas and data
For transient transmission, the routing parameter setting areas depend on the system.

- (a) Two-level system

The routing parameters need not be set because transient transmission is made to within the same network.

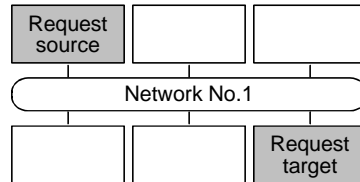

- (b) Multi-level 1 (two networks)

Set the routing parameters only to the station of the request source. To the request source, set the data to access the request target (network No. 2).

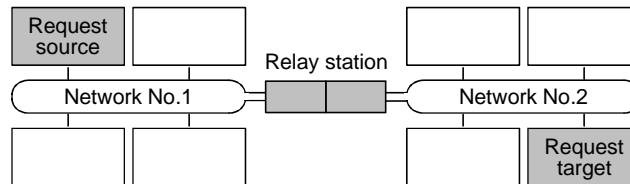

- (c) Multi-level 2 (three networks)

Set the routing parameters to the request source and relay stations. To the request source, set the data to access the request target (network No. 3). To the relay station 1), set the data to access the request target (network No. 3). To the relay station 2), set the data to access the request source (network No. 1).

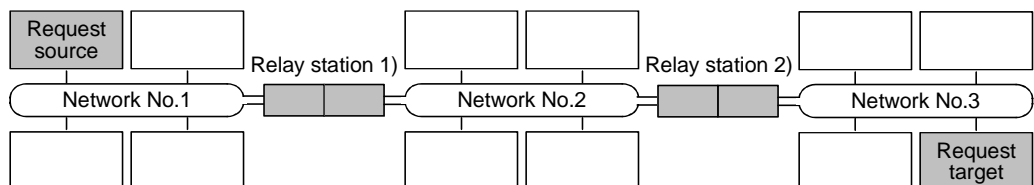

- (d) Multi-level 3 (four or more networks)

Set the routing parameters to the request source and relay stations. To the request source, set the data to access the request target (network No. 4). To the relay station 1) (the nearest relay station to the request source), set the data to access the request target (network No. 4). To the relay station 2) (the nearest relay station to the request target), set the data to access the request source (network No. 1). To the relay station 3) (relay station other than 1) and 2)), set the data to access the request target (network No. 4) and request source (network No. 1).

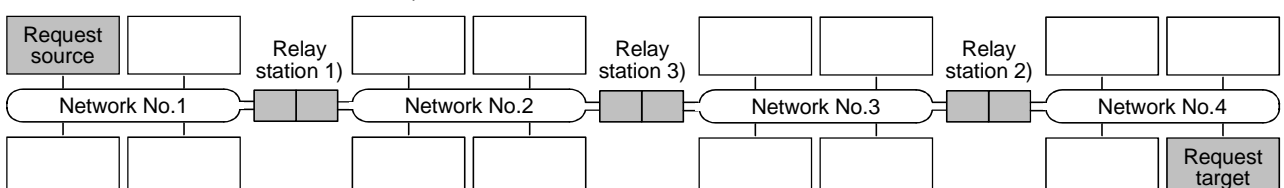

17. MONITORING

This section describes the monitoring of the operation processing of the PLC through an online connection between the personal computer and PLC.

(1) Monitor mode

In the monitor mode, the monitor status dialog box shown below is displayed whether during monitoring or when monitoring it is stopped.

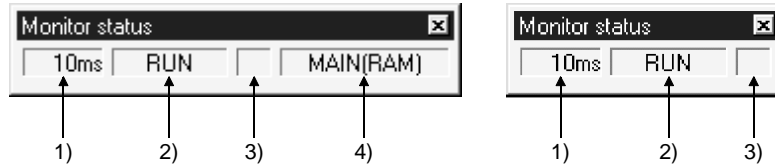

1) Scan time

Indicates the maximum scan time of the monitored PLC.
 For the A series, it is in 10 ms units.
 For the QnA series, it is in 1ms units.
 For the Q series, it is in 0.1ms units.

2) PLC status

Indicates the operating state of the PLC, as determined by the PLC key switch or by remote operation from a personal computer.

3) Monitor execution status

Flashes while monitoring is in progress.

4) Active program

With the A series and FX series, the name of the program currently being executed at the PLC is displayed.
 With QCPU (Q mode)/QnA, nothing is displayed.

(2) ON/OFF status

The ladder ON/OFF status is determined as follows.

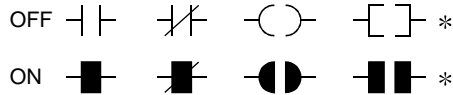

* : Only comparison instructions which are equivalent to contacts, and SET, RST, PLS, PLF, SFT, SFTP, MC, FF, DELTA, DELTAP instructions, which are equivalent to coils, are supported.
 (FF, DELTA, and DELTAP are QnA series instructions.)



In list mode

In the list mode, the ON and OFF states are displayed as follows.

- For bit device
 The device name and monitor status are displayed under the row where the list instruction is displayed.
 OFF: [X0=OFF], ON: [X0=ON]
- For word device
 The present value is displayed.

Refer to Section 17.1 for the list monitor screen.

POINTS

- The display of ON/OFF statuses and present values is maintained while monitoring is stopped.
- The indication for the monitoring of RST instructions is the ON/OFF status of the device being reset.
When the device to be reset is OFF 
When the device to be reset is ON 
- Note that the following functions will not be monitored properly if they are monitored from two or more personal computers simultaneously.
Program monitor list, Interrupt program monitor list, Monitor condition setup, Monitor stop condition setup, Scan time measurement
- For points to note about monitoring display when the FX series is selected see Appendix 11.
- For the AnACPU or AnUCPU, the status at execution of the END instruction is monitored. For the AnACPU or AnUCPU, however, note that the status at any point during scan execution may be monitored.
Though the monitor result may differ, the program run is not different.

17.1 Monitoring, and Stopping/Resuming Monitoring



A	Q/QnA	FX
○	○	○

[Purpose]

Monitors the continuity, energized state, and ON/OFF states of contacts and coils while displaying the ladder.

Also stops monitoring and resumes monitoring after it has been stopped.

[Operating Procedure]

- For monitoring
 Select [Online] → [Monitor] → [Monitor mode], or click  ([F3]).
- To stop monitoring
 Select [Online] → [Monitor] → [Stop Monitor], or click  ([Alt] + [F3]).
- To resume monitoring
 Select [Online] → [Monitor] → [Start Monitor], or click  ([F3]).

[Window]

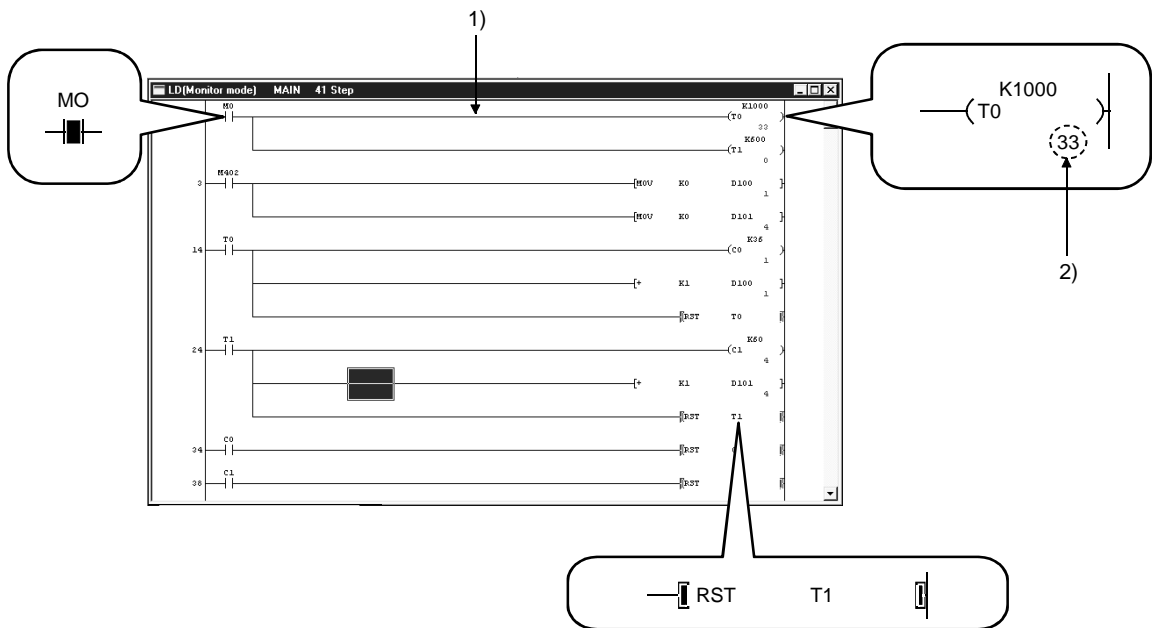

List monitor screen example

```

List(Monitor mode Monitoring)  MAIN  615 Step
80  OUT      YOBB
    <YOBB    =  ON    >
81  LD       X2
    <X2      =  ON    >
82  AND      YOBB
    <YOBB    =  ON    >
83  MOV      K1000  D12287
    <D12287  = 1000   >
85  AND      X0A1
    <X0A1    =  OFF   >
86  TO       D12286  K0      D12287  K1
    <D12286  =    0    >
    <D12287  = 1000   >
91  BCD      D12287  D12285
    <D12287  = 1000   >

```

[Description]

1) Ladder monitoring

During monitoring, the ON/OFF states of contacts and coils and the present values of devices are displayed, and they change in accordance with the operating state of the PLC.

When monitoring is stopped the display is maintained, and is updated when monitoring is resumed.

2) Present value

Displays the present values of word devices.

The present values can be switched between decimal and hexadecimal.

For details on this switching of present values, see Section 17.4.

When monitoring a double word containing ten or more characters, it is displayed by making the characters smaller.

Present values can be displayed in double words or as real numbers in accordance with the data type used with an instruction.

POINTS

- In the monitor mode, check whether the status is "monitoring in progress" or "monitoring stopped" either in the monitor status dialog box display or from the Tool button display shown below.

Monitoring in progress   Monitoring stopped  

- Contacts in the ladder monitor window can be forcibly switched ON/OFF by using **[Shift]** key + double click (**[Enter]**).
- When a word device being monitored is **[Shift]** key + double-clicked (**[Enter]**), the present value change dialog box shown below is displayed.

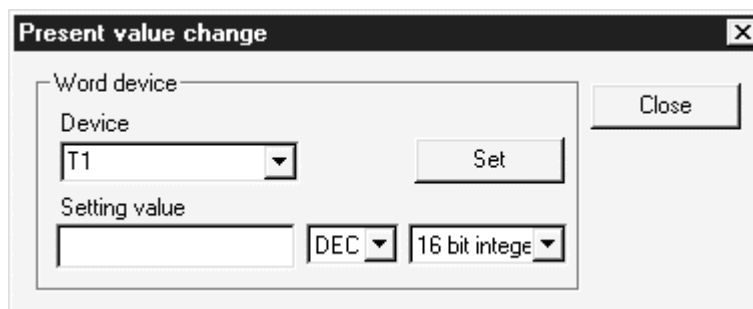

Enter the value to be changed, then click the **[Set]** button.

- The present values of double word instructions (DMOV, DFRO, etc.) are displayed as double words.
Check the values of double words in device batch monitoring or registered device monitoring.
For details on device batch monitoring, see Section 17.5.
For details on registered device monitoring, see Section 17.6.
- Ladder monitoring, device entry monitoring and ladder entry monitoring allow devices with digits, e.g. MOV D0 K4Y20, to be monitored.
- The FD device is monitored as a word value.
- During the ladder monitoring or device batch-monitoring, connection setup and change of PLC type cannot be performed.

17.2 Monitoring/Stopping Monitoring in All Windows

A	Q/QnA	FX
○	○	○

[Purpose]

Starts monitoring in all open windows: ladder monitor, device batch monitor, registered device monitor, and buffer memory batch monitor.
Also stops monitoring in all the windows where monitoring is in progress.

[Operating Procedure]

- To monitor in all windows:
Select [Online] → [Monitor] → [Start monitor (All windows)].
- To stop monitoring in all windows:
Select [Online] → [Monitor] → [Stop Monitor (All windows)].

[Window]

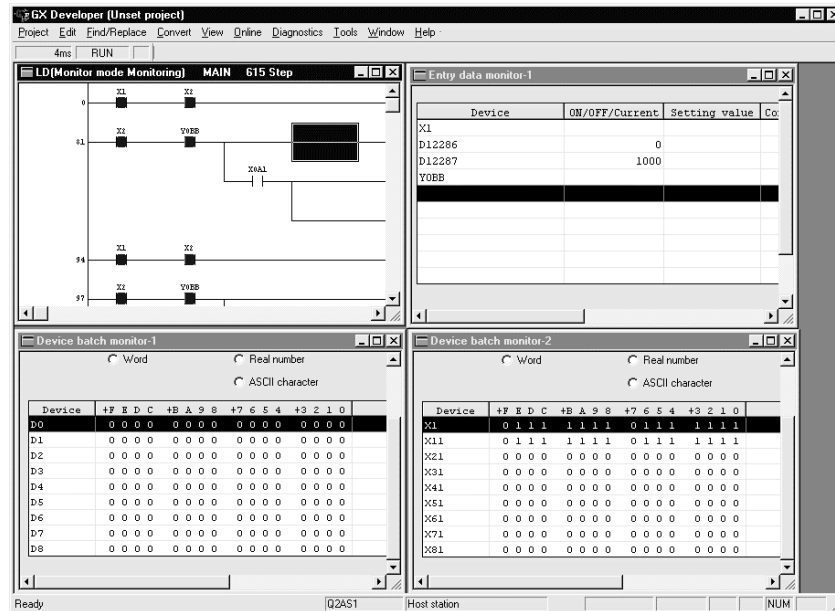

POINT
<ul style="list-style-type: none"> • When monitoring multiple windows, if the windows are overlapped they are difficult to view. By selecting [Window] → [Tile horizontally] ([Tile vertically]), the windows are not overlapped and are easier to view.

17.3 Editing Programs During Ladder Monitoring

A	Q/QnA	FX
○	○	○

[Purpose]

Allows programs to be edited while ladder monitoring is in progress by setting the ladder window to the monitor writing mode.

[Operating Procedure]

Select [Online] → [Monitor] → [Monitor (Write mode)], or click  ([Shift] + [F3]).

[Dialog Box]

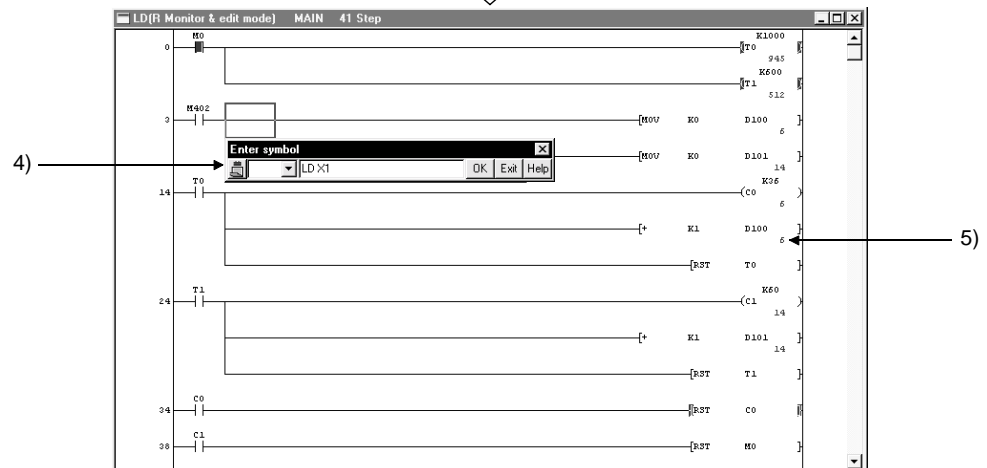
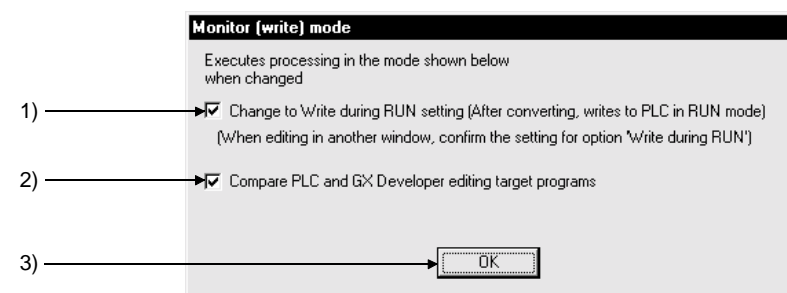

[Description]

- 1) Change to Write during RUN setting (while PLC is running)".
When the checkbox is checked, on changing to the monitor write mode the online change setting is also changed simultaneously.
See Section 15.11 for details on online change setting.
- 2) Compare PLC and GX Developer editing target programs
When the checkbox is checked, on changing to the monitor write mode the program in the connected PLC is verified against that at GX Developer.
By verifying the program in advance, it is possible to avoid program mismatches during online change.

- 3) **[OK]** button
Clicking this button sets the ladder window in the monitor write mode.
- 4) Ladder input window
Opened to create, and change, ladder programs.
See Section 6 "CREATING CIRCUITS"
- 5) Ladder (monitor write) window
Allows ladder monitoring while displaying ON/OFF statuses and present values.

[Operating Procedure]

1. Use the "operating procedure" above while the ladder window is displayed to display the dialog box.
2. Click (1)/(2) as required.
3. Click (3).
4. The ladder window enters the monitor write mode.
5. Create/change the ladder program.
6. Convert the ladder.
If the online change setting is "Write during RUN (while PLC is running)" at this time, online change is executed on pressing "convert" (**[F4]**).
Online change can also be executed by pressing [Convert (Online change (**[Shift]** + **[F4]**)).
See Section 16.9 "Executing Online Program Change (Write During RUN)"

POINTS
<ul style="list-style-type: none">• If, simultaneously with switching to the monitor write mode, the online change setting is made "Write during RUN (while PLC is running)", the online change (write during RUN) setting will remain in effect thereafter, even if the write mode is changed.• When using the FX series, program editing during ladder monitoring is only possible when a PLC that supports online change is in the online change enabled status (see Section 16.9.).

17.4 Switching Present Values Between Decimal and Hexadecimal

A	Q/QnA	FX
○	○	○

[Purpose]

Displays the device present values in the ladder monitor window in decimal or in hexadecimal format.

[Operating Procedure]

- For display in decimal:
Select [Online] → [Monitor] → [Change current value monitor (Decimal)].
- For display in hexadecimal:
Select [Online] → [Monitor] → [Change current value monitor (Hexadecimal)].

[Window]

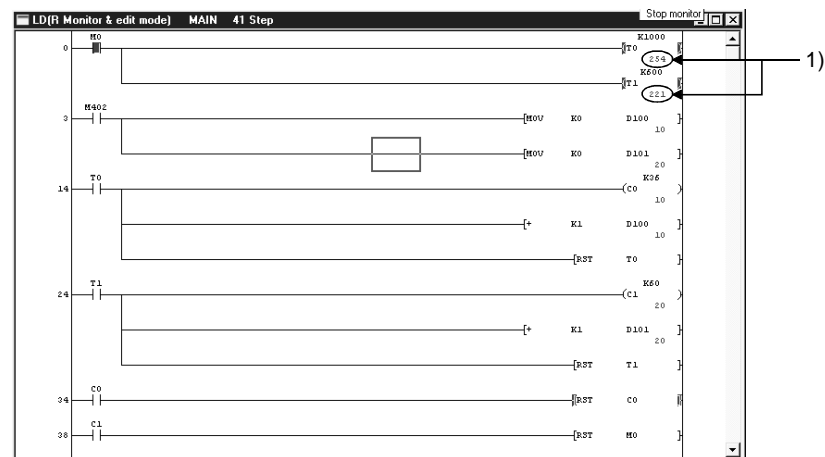

[Description]

- 1) Device present value
Sets display in decimal or hexadecimal notation.

POINT
<ul style="list-style-type: none"> • Convert numbers stored in binary coded decimal (BCD) to hexadecimal.

17.5 Batch Monitoring Devices/Buffer Memories

17.5.1 Batch monitoring devices/buffer memories

A	Q/QnA	FX
○	○*	○

*: This function is also compatible with the remote I/O of the QCPU (Q mode).

[Purpose]

In device batch monitoring, one designated type of device is monitored.
 In buffer memory batch monitoring, a special function module is designated and its buffer memory is monitored.
 When using FXCPU, note that the only PLCs that support buffer memory monitoring are the FX2N series and the FX2NC series.
 However, when the GX Simulator is connected, buffer memory monitoring can also be done on FX2, FX2C and FX0N series.
 To monitor the buffer memory or link memory, select [Tool] → [Options], and select "Monitor buffer memory/link memory" in the <<Program common>> tab sheet.

[Operating Procedure]

- For device batch monitoring:
 Select [Online] → [Monitor] → [Device batch], or click .
- For buffer memory batch monitoring:
 Select [Online] → [Monitor] → [Buffer memory batch].

[Dialog Box]

The dialog box for device batch monitoring is shown here; the dialog box for buffer memory batch monitoring is of the same type.

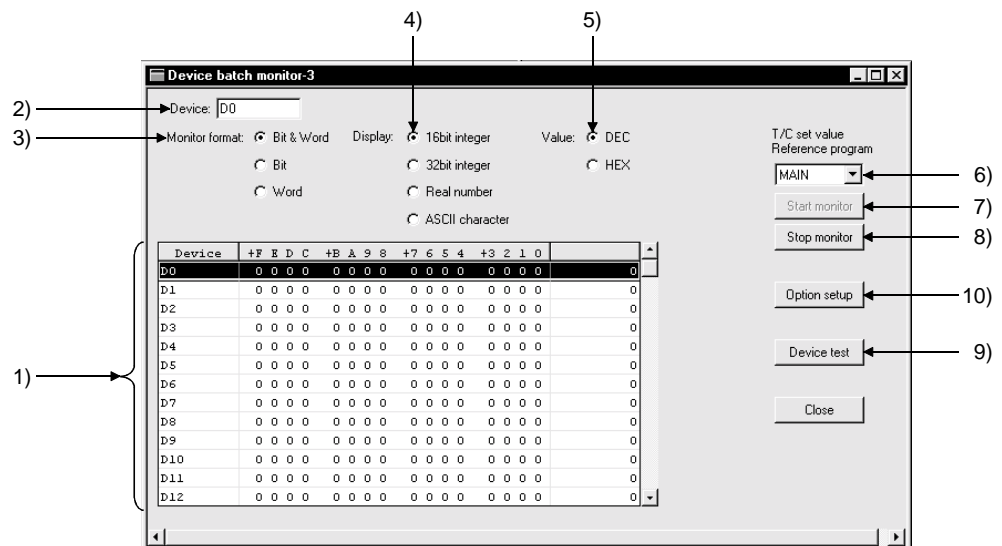

[Description]

Items in parentheses relate to buffer memory batch monitoring.

- 1) Device batch monitor (buffer memory batch monitor)
 The designated device (buffer memory) is displayed in accordance with the monitor format, display, value, and option settings.
 The range not currently displayed can also be monitored by using the scroll bar.
 However, when T or C devices are designated for device batch monitoring, the timer/counter multi-point format is used.

2) Device (buffer memory) designation

- For device batch monitoring:
Designate the device type and actual device number.
Device designation by qualification (index, digit designation, and word device bit designation) is not possible.
- For buffer memory batch monitoring:
The following is displayed for buffer memory batch monitoring.

Unit start address:

Buffer memory address: HEX ▾

Designate the first I/O number (lowest digit not required) of the special function module used for monitoring, and the buffer memory address (decimal/hexadecimal).

If using the FX series, enter the block number (0 to 7) of the special expansion device for the module's first address.

However, FX_{0N}-3A, FX_{2N}-2AD, and FX_{2N}-2DA do not come into the scope of monitoring of the buffer memory.

For the buffer memory address, enter the BFM No. (0 to 32766).

3) Monitor format

Sets the monitoring format.

When T or C is designated for device batch monitoring, the format is automatically set as timer/counter multi-point format.

Bit & WordDevices (buffer memories) are monitored as both bits and words.

Bit multi-pointDevices (buffer memories) are monitored as bits.

Word multi-point Devices (buffer memories) are monitored as words.

4) Display

Sets the word device (buffer memory) display when monitoring in the Bit & Word or Word multi-point format.

16bit integerDisplayed as 16-bit integers.

32bit integerDisplayed as 32-bit integers.

Real numberDisplayed as real numbers.

ASCIIDisplayed as ASCII characters

5) Value

Sets the format of numbers to be displayed when monitoring in the 16bit integer or 32bit integer format.

DecimalDisplayed in decimal notation.

HexadecimalDisplayed in hexadecimal notation.

6) T/C set value Reference

Designates the program whose set values are to be displayed when batch monitoring T or C devices.

- 7) **Start monitor** button
Clicking this button after setting the device (buffer memory address) starts monitoring.
- 8) **Stop monitor** button
Stops device (buffer memory) batch monitoring.
- 9) **Device test** button
Clicking this button displays the device test dialog box.
See Section 18.1 "Carrying Out a Device Test"

- 10) **Option setup** button
Clicking this button displays the option setting dialog box shown below.

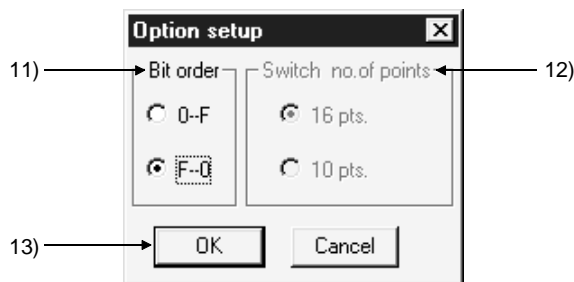

- 11) **Bit order**
Sets the order in which the bit devices are arranged when "Bit & Word" is selected as the monitoring format.
 - 0-F
Display in ascending order from the right
Suited to the monitoring of bit devices.
 - F-0
Display in ascending order from the left
Suited to the monitoring of the bits of word devices (buffer memories).
- 12) **Switch no. of point**
Set the number of bit device points displayed in the Bit & Word format for device/word batch monitoring.
 - In Bit & Word/Bit multi-point/Word multi-point format
 - 16 pts.
Set when monitoring hexadecimal devices such as X and Y.
 - 10 pts.
Set when monitoring decimal devices such as M and L.
 - In Word multi-point format
 - 8 pts.
Set when monitoring hexadecimal devices such as B and W.
 - 10 pts.
Set when monitoring decimal devices such as M and D.
- 13) **OK** button
Click this button after setting the option settings.

17.5.2 Batch-monitoring the multi-CPU buffer memory

A	Q/QnA	FX
×	○*	×

※: This function is compatible with the QCPU (Q mode).

[Purpose]

Monitors the buffer memory of the own or other PLC CPU module.

[Operating Procedure]

Select [Online] → [Monitor] → [Device batch].

[Dialog Box]

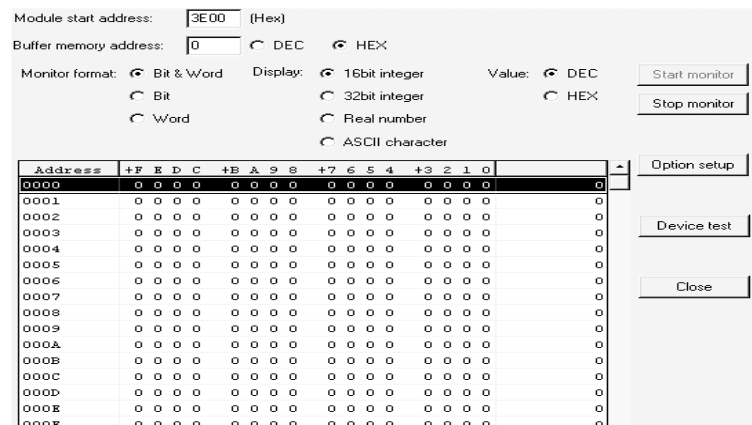

[Description]

- 1) Module start address
Specify the buffer memory of the PLC CPU to be monitored.
Specifying method: No. 1 module ... 3E00, No. 2 module ... 3E10,
No. 3 module ... 3E20, No. 4 module ... 3E30
- 2) Buffer memory address
Set the buffer memory address.

The following table indicates accessibility to the multi-CPU shared memory (buffer memory) of the multiple CPUs.

Item	Accessibility
Monitor mode	×
Device batch	×
Entry data monitor	×
Buffer memory monitor	○
Monitor condition setup	×
Monitor stop condition setup	×
Partial execution	×
Device test	×

Devices (e.g. U3E0Z0¥G0) indexing the multi-CPU shared memory cannot be monitored.

17.6 Monitoring after Registering Devices

A	Q/QnA	FX
○	○*	○

*: This function is compatible with the remote I/O of the QCPU (Q mode).

[Purpose]

Simultaneously monitors devices at some distance from each other within the ladder, or multiple types of device, in the same display.

[Operating Procedure]

Select [Online] → [Monitor] → [Device registration], or click .

[Dialog Box]

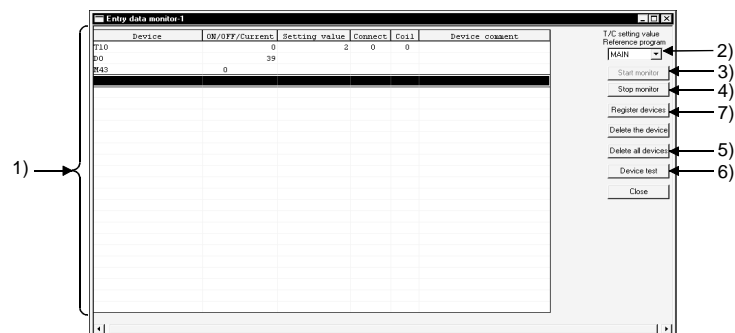

[Description]

- 1) Registered device monitor
 - Displays up to 64 registered device points in accordance with the device type. Doubling clicking (Enter) on a vacant field opens the device registration dialog box.
 - T and C devices are displayed in the counter/timer format.
 - 32-bit integral values are displayed with "D" appended after the device as follows: D100 (D).
For real values, (E) is appended and for ASCII characters, (S) is appended.
For the QCPU/QnA, FD devices to be registered cannot be specified in the real number format.
 - For a remote I/O project, the comment field is displayed blank.
 - For label programming, device entry monitoring-enabled conditions are indicated:
 - (a) Set global or local variables.
 - (b) Compile the label program.
- 2) T/C setting value Reference program
Sets the program whose set values are to be displayed when T or C values are registered and monitored.
- 3) **Start monitor** button
Click this button after completing device registration to start monitoring.
- 4) **Stop monitor** button
Click this button to stop monitoring.
- 5) **Delete all device** button
Clicking this button cancels the registration of a device.

- 6) **Device test** button

Clicking this button displays the device test dialog box.

See Section 18.1 "Carrying Out a Device Test"

- 7) **Register devices** button

Clicking this button displays the device registration dialog box.

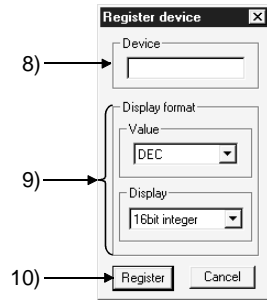

- 8) **Device**
Sets the device to be registered.

- 9) **Display format**
Set when word devices are monitored.
Numeric values can be set in decimal or hexadecimal format.
The available display settings are: 16-bit integral value, 32-bit integral value, real number, ASCII characters.

- 10) **Register** button
Click this button after setting the necessary settings.

[Monitor format]

	Device	ON/OFF/Current	Setting value	Connect	Coil
Counter/timer format →	T0		25	1	1
	C0		24	111	1
Bit format →	X0	0			
Word format →	D100		0		
	A	B	C	D	

A Indicates the registered device.

B Indicates the ON/OFF status or present value of the registered device.
(1 : ON 0 : OFF).

C When T or C devices are registered, the set value is indicated.

D When T or C devices are registered, the ON/OFF statuses of contacts and coils are indicated (1 : ON 0 : OFF)

[Operating Procedure]

1. Click 7) to display the device registration dialog box.
2. Set 8) and 9) in the device registration dialog box.
3. Click 10): the devices are displayed at 1).
4. By following steps 2 and 3, register all the devices to be monitored.
5. On completion of device registration, close the device registration dialog box.
6. Click 3).

POINTS

- When the ladder window is set to the read or monitor mode, devices can be registered by dropping and dragging with the **[Ctrl]** key pressed after the area to be registered has been selected. It is also possible to batch drag and drop a range selected by **[Shift]** key + clicking from the ladder cursor position.

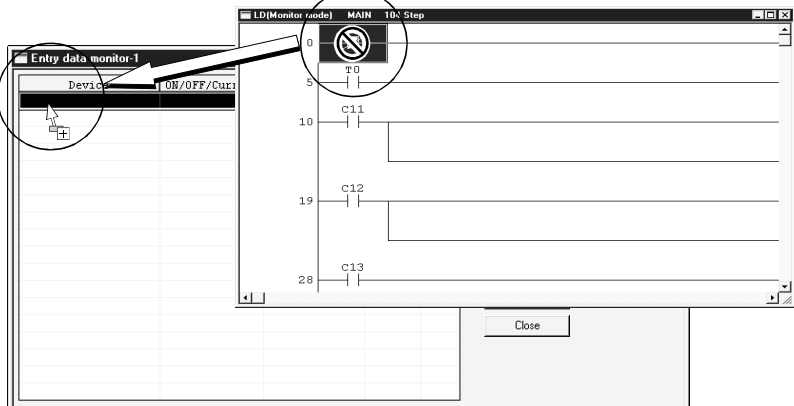

- When registered device monitoring, device batch monitoring, or buffer memory batch monitoring is started up several times, the time lapse until monitoring starts, and the monitoring interval, may become longer.
- **[Shift]** key + double clicking (**[Enter]** key) on a device name in the registration monitoring area displays the device test dialog box.
See Section 18.1 "Carrying Out a Device Test"
- With the QnA series, apart from actual device numbers, it is also possible to register words with bit designations, bit designated within a word, index qualifications, and buffer memories. An example of device registration is given below.

Device to be Registered	Example
Monitoring M0 to M15 by digit designation	K4M0
D100F that monitors b15 of D100 using bit designation	D100.F
Monitoring Xn by index qualification with Z1	X0Z1
Monitoring a special function module buffer memory with first I/O number 40 and address K30(H2E)	U4\G30

See the QnACPU Programming Manual (Common Instructions).

- Setting a 32-bit integer/real number to the FD device will result in an error.

17.7 Setting Monitor Conditions/Stop Conditions

A	Q/QnA	FX
×	○	×

[Purpose]

Sets the conditions under which monitoring is started and stopped on the ladder monitor window.

This setting is not possible with the A series.

[Operating Procedure]

- For setting monitor conditions:
Select [Online] → [Monitor] → [Monitor condition setup].
- For setting monitor stop conditions:
Select [Online] → [Monitor] → [Monitor stop condition setup].

[Dialog Box]

Monitor condition dialog box

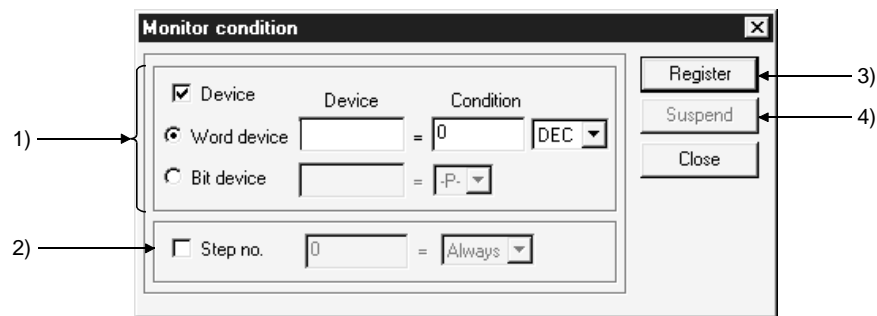

Monitor stop condition dialog box

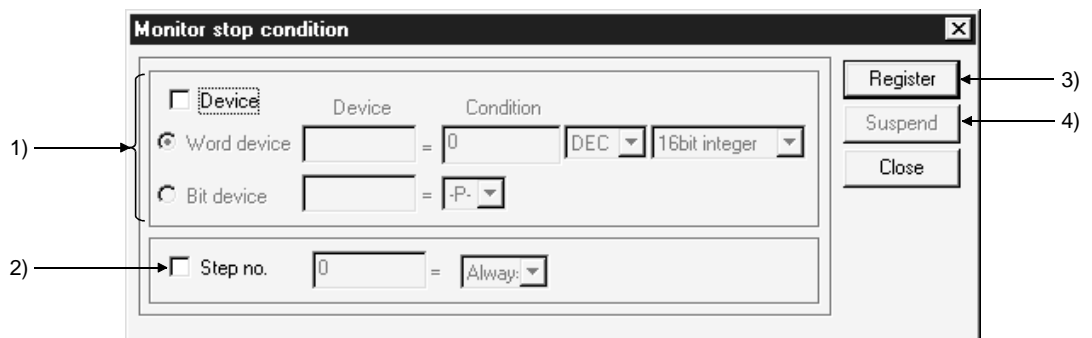

[Description]

1) Device

Sets a device condition as the monitor condition (monitor stop condition). The device that is to act as the condition can be a word device or bit device.

○ Word device

Set the word device and numeric value (decimal or hexadecimal integral value) that is to be the condition.

For a stop condition, set a 16-bit integral value, 32-bit integral value, or real number.

○ Bit device

Set a bit device and condition (-P- : at leading edge -F- : at trailing edge)

- 2) Step no.
Sets, as the condition, the execution status of a designated step number in the program.
Select the execution status from among the following:
-P-..... Transition from OFF to ON
-F-..... Transition from ON to OFF
ON.....During ON status
OFF.....During OFF status
Always..... At all times during execution (if the relevant step is jumped the condition is not satisfied)
- 3) button
Clicking this button registers the set condition.
- 4) button
Clicking this button cancels the registered condition.

POINTS
<ul style="list-style-type: none">• If both device and step No. conditions are set at the same time, the monitor condition (monitor stop condition) is met when both are satisfied.• If the device condition has been designated (including when both device and step No. conditions are set at the same time), monitoring may not stop at the point when the condition is met first after condition designation.• Monitor condition/monitor stop condition setting is enabled only under the following conditions:<ol style="list-style-type: none">1. Own station connection2. MELSECNET/10 or MELSECNET/H other station accessThis function cannot be set when the other station is specified via Ethernet, CC-Link or the like.

17.8 Program List Monitor

A	Q/QnA	FX
×	○	×

[Purpose]

Displays the processing time of the program currently being executed.

[Operating Procedure]

Select [Online] → [Monitor] → [Program monitor list].

[Dialog Box]

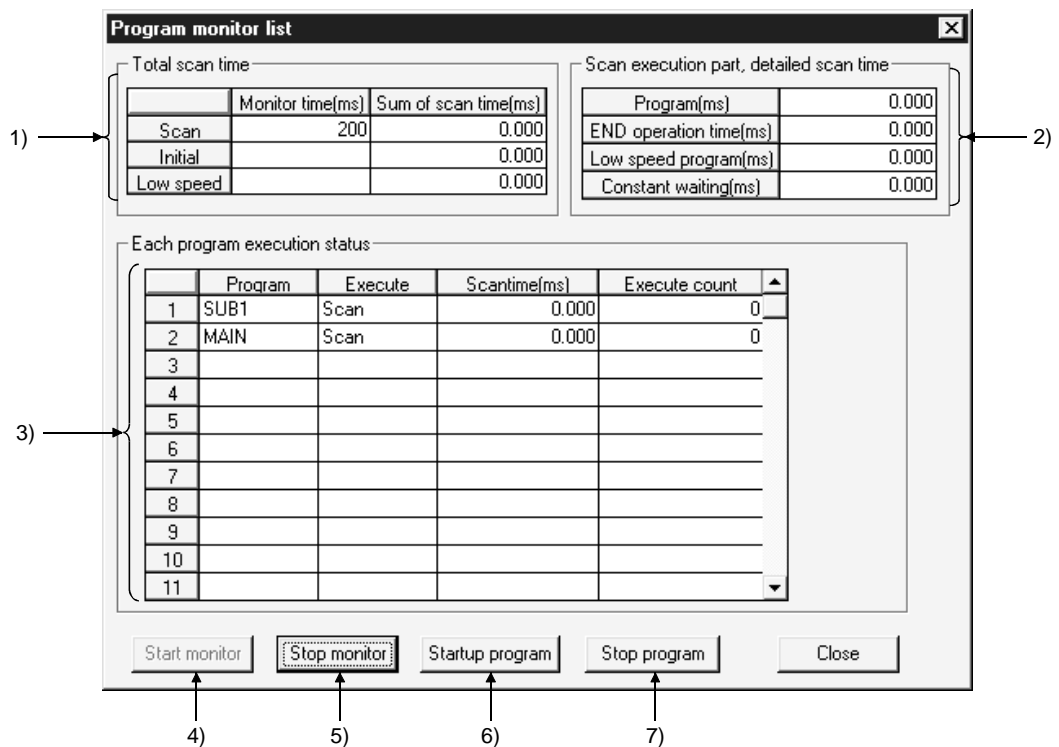

[Description]

1) Total scan time

Indicates the time set for the WDT setting in the PLC RAS settings of the PLC parameters.

• Monitor time

Indicates the WDT times for scan programs, initial programs, and low-speed programs.

If the scan time exceeds the indicated value, a WDT error is indicated at the CPU.

However, the constant scan execution program is not displayed.

To display the scan time, use scan time measurement.

• Sum of scan time

Indicates the total time for each item in "Scan execution part detailed scan time."

2) Scan execution part, detailed scan time

Indicates the processing execution time for each item.

"Constant" indicates the constant scan waiting time when the setting is for constant scan.

However, if a low-speed program execution time is also set, this becomes 0.000 ms.

- 3) Each program execution status
Indicates the execution status of the program set in program setting in the PLC parameters.
- Program
Indicates program names in the order set in the parameters.
 - Execute
Indicates the program type set in the parameters.
 - Scan time
Indicates the actual scan time (present value). In the program stop (standby) status, the scan time is indicated as 0.000 ms.
 - Execute count
Indicates the number of times a program has been executed, taking the count when counting starts to be "0."
(When the maximum count of 65536 is reached, the count returns to 0.) The count is retained during the program stop status.
- 4) **Start Monitor** button
Clicking this button starts a stopped program.
- 5) **Stop Monitor** button
Stops monitoring.
- 6) **Startup program** button
Clicking this button displays the dialog box shown below.

[Dialog Box]

Program startup dialog box

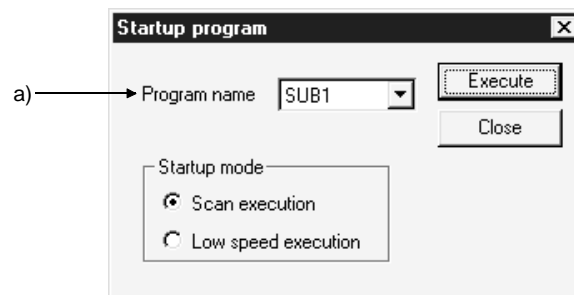

- a) Program name
Only programs that have been set in PLC parameter program selection can be selected.
It is not possible to type any required program name.

Program stop dialog box

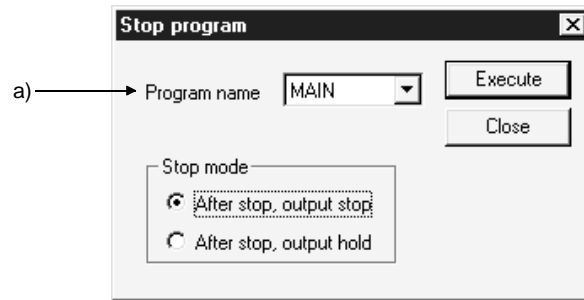

- a) Program name
Only programs that have been set in PLC parameter program selection can be selected.
It is not possible to type any required program name.

17.9 Monitoring the Interrupt Program List

A	Q/QnA	FX
×	○	×

[Purpose]

Indicates the number of times interrupt programs have been executed.

[Operating Procedure]

Select [Online] → [Monitor] → [Interrupt program monitor list].

[Dialog Box]

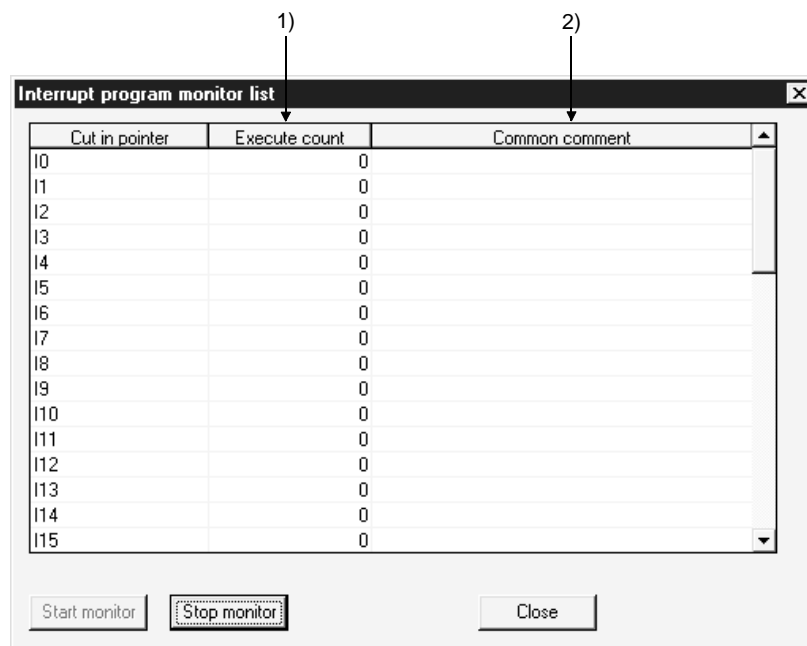

[Description]

1) Execute count

Indicates the number of times a program has been executed, taking the count when counting starts to be "0."

(When the maximum count of 65536 is reached, the count returns to 0.)

The count is cleared to zero when the operating state of the PLC is set to RUN.

2) Common comment

Indicates comments created as device comments.

Only common comments can be indicated.

17.10 Measuring Scan Time

A	Q/QnA	FX
×	○	×

[Purpose]

Indicates the processing time for any required section of program.

[Operating Procedure]

Select [Online] → [Monitor] → [Scan time measurement].

[Dialog Box]

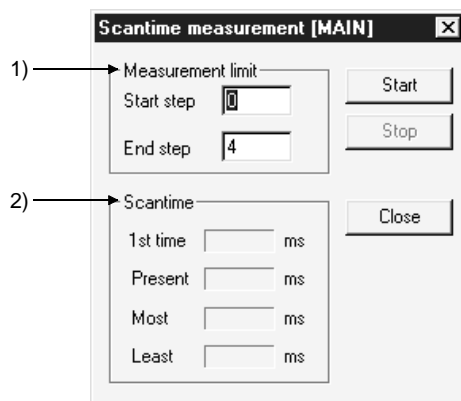

[Description]

- 1) Measurement limit
Set so that the start step is smaller than the end step.
- 2) Scantime
It is not possible to measure times that straddle different program files.
If the measured time is within 0.100 ms, it is indicated as 0.000 ms.

POINT
<p>Selection range</p> <ol style="list-style-type: none"> 1 Move the cursor to a position outside the left bus line and [Shift] key+ click to set the range. During dragging the selected range turns blue. (END instructions cannot be selected.) 2 On selecting [Online] → [Monitor] → [Scan time measurement], the start step and end step are set in the part of the program defined by the selected range.

17.11 Executing Sampling Trace

A	Q/QnA	FX
○	○	○

[Purpose]

Samples the contents of the designated device (ON/OFF status and present value) at constant intervals, and stores the result in the sampling trace area of the memory.

Reads and displays this stored data.

By using this function, it is possible to follow changes in the data contents of the designated device, and to monitor the ON/OFF timing of contacts and coils.

[Operating Procedure]

- 1 Set the trace count on the <<Conditions>> sheet.
- 2 Set the trace point on the <<Conditions>> sheet.
- 3 Set the trigger point on the <<Conditions>> sheet.
(When executing an STRA instruction (A/QnA series) or when performing trigger operation at a personal computer (Q/QnA series), set the TRACE instruction (Q series) or make detailed settings (Q/QnA series).)
- 4 Set the device setting on the <<Trace data>> sheet.
- 5 Write the set data to the PLC.
- 6 Select Start trace on the <<Execute and status>> sheet.
- 7 Write the execution result after tracing to the PLC.
- 8 Read the result with the Trace result button.

POINTS

- When using AnNCPUs, set the memory capacity in the PLC parameters.
- The setting data and trace result data is in GX Developer format and there is therefore no compatibility with GPPA or GPPQ data.
- When using the A series, it is not possible to set Execute trigger on the <<Execute and status>> sheet, or the Trace data (Conditions + Results) storing data.
- When using the A series, it is not possible to set the Information with trace or trigger point setting on the <<Conditions>> sheet.
- When using extension file registers with AnACPU or AnUCPU, there may be blocks that cannot be used, depending on the memory cassette.
Block numbers other than No. 0 to 24, 29 to 40, and 45 to 48 of A3AMCA-96, A4AMCA-128, and A4AMCA-128E cannot be used.

17.11.1 Setting execution & status display

A	Q/QnA	FX
○	○	○

[Purpose]

Facilitates operations such as those for trace start and trigger execution when "When a peripheral trigger operations" is set for the trigger point setting in the trace condition settings.

Sets the storage destination for trace data (condition + result).

[Operating Procedure]

Select [Online] → [Trace] → [Sampling trace].

[Dialog Box]

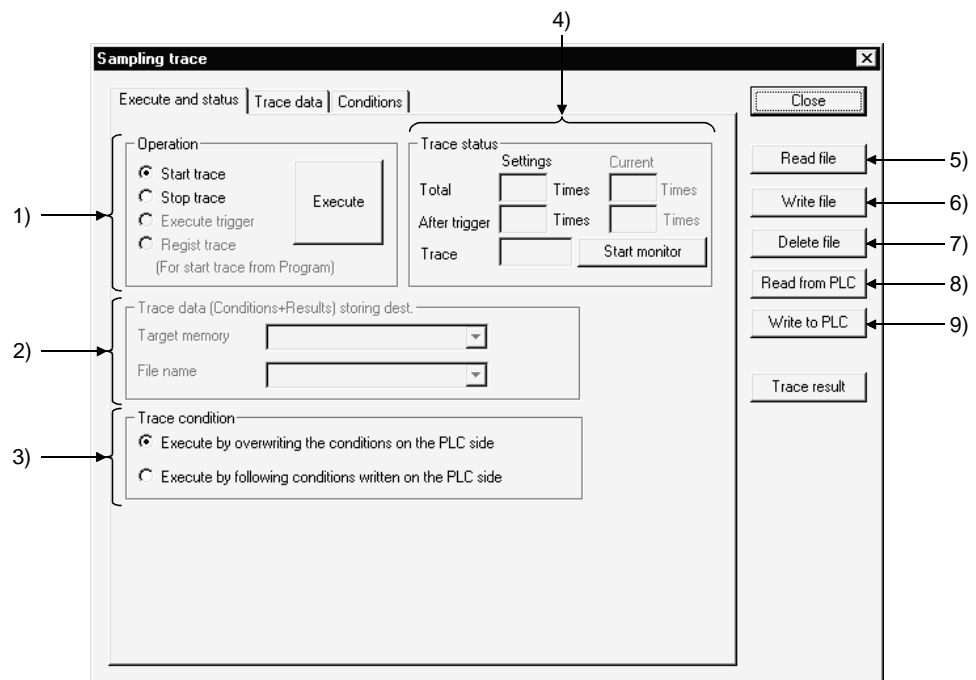

[Description]

1) Operation

When using the A series, trigger execution cannot be set.

The Q/QnA series allows a trace to be triggered from the sequence program.

(Regist trace)

Clicking the Execute button, starts trace status monitoring.

2) Trace data (Conditions + Results) storing data (QnA series only)

Select the ROM, RAM of the IC memory card.

Designate an arbitrary name for the file name for storage.

The currently active sequence program name is displayed as the default.

This setting is not possible with the FX series.

3) Trace condition

Sets whether the trace is to be executed using the conditions set at the personal computer or the settings at the PLC side.

- 4) Trace status
 - Indicates the current trace status.
 - <Total count>
Indicates the setting count after the trigger presently being executed, and the present trace count.
The count set at the GX Developer side is displayed.
In cases where, for example, "Execute by following conditions written on the PLC side" is selected, the field is blank.
(For example when the count is undefined.)
 - <Count after trigger>
Indicates the setting count after the trigger currently being executed and the execution count after the present trigger.
 - <Trace status>
Indicates the execution status of the present trace.
- 5) Read file
 - Reads the sampling trace condition + trace result.
- 6) Write file
 - Writes the sampling trace condition + trace result.
- 7) Delete file
 - Deletes the sampling trace condition + trace result.
- 8) Read from PLC
 - Reads the sampling trace condition + trace result to the PLC.
- 9) Write to PLC
 - Writes the sampling trace condition + trace result to the PLC.

POINTS

- Points to check at trace execution
If sampling trace cannot be executed check the following points.

<Common points>
If the communicating PLC is of a different type, the trace cannot be executed.
Trace execution status check (trace execution command cannot be given during trace)

<Check when conditions are overwritten at the PLC side>
Device check (checks for consistency with the parameter settings)
Trace condition setting check (checks for omissions in trace condition setting, and inconsistency)
Capacity check (checks if the trace result can be accommodated in the setting capacity)
The PLC parameter and personal computer parameter settings are checked.
If there is a mismatch the trace cannot be executed.
Applicable memory check (checks whether the selected applicable memory can be used or not)
File name check (checks if a file name is set)
Extension file register block use possibility check (checked for AnACPU and AnUCPU, QCPU(Amode)).
- When the PLC type is changed, the sampling trace data written to file (settings + results) are deleted. (Even if the project is not saved, they are deleted and cannot be recovered.)

Example: A2N → A3A Deleted
 A2A → A3A Not deleted

17.11.2 Setting trace data

A	Q/QnA	FX
<input type="radio"/>	<input type="radio"/>	<input type="radio"/>

[Purpose]

Sets devices for sampling trace (bit devices, word devices).

[Operating Procedure]

Select [Online] → [Trace] → [Sampling trace] → <<Trace data>> sheet.

[Dialog Box]

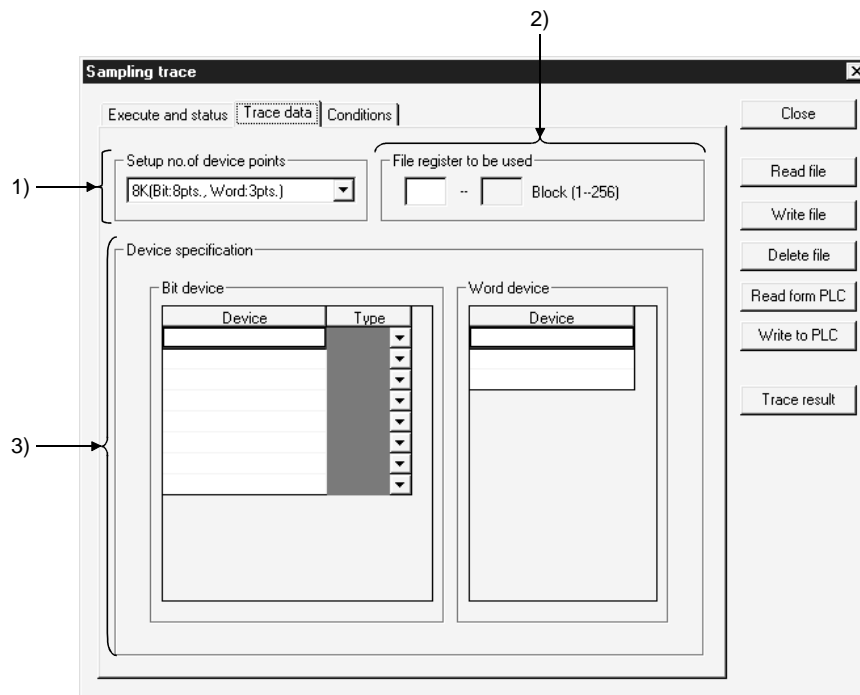

[Description]

1) Setup no. of device points

Set for AnACPU and AnUCPU, QCPU(Amode) only.

The relationship between the number of points and capacity in the settings is as follows.

8 K (8 bit points, 3 word points 1 block)

15 K (16 bit points, 6 word points 1 block)

23 K (16 bit points, 10 word points 2 blocks)

2) File register to be used

Designates the number of the extension file register used to store result data when executing an online sampling trace with AnACPU or AnUCPU, QCPU(Amode).

For the setting, designate the first number of the extension file register.

- 3) Device specification
 Sets the devices (bit devices, word devices) for executing a trace.
 The devices, and number of points, that can be set differ for each PLC.

	Bit Devices That can be Set	Word Devices That can be Set	Devices That can be Registered
AnNCPU	8 points	3 points	X,Y,M,L,S,B,F,T,C T,C,D,W,R,A,Z,V
AnACPU AnUCPU QCPU-A	Depends on the number of device points setting		
QnACPU Required memory capacity: up to 60K	50 points The maximum number of input characters is 16 characters (bit device)	50 points The maximum number of input characters is 17 characters (bit device)	
QCPU (Qmode)	50 points The maximum number of input characters is 16 characters (bit device)	50 points The maximum number of input characters is 17 characters (bit device)	X,Y, M, L, F, SM, FX, FY, V, DX, DY, T, C, ST, D, SD, FD, B, SB, W, SW, R, Z, RZ, constant, U□G, J□X, J□Y, J□B, J□SB, J□W, J□SW, BL□S, BL□TR Extension designation, bit designation for word devices with index qualification Digit designation for bit devices Indirect designation is not possible.
FXCPU *1	10 points	3 points	Contacts : X,Y,M,S,T,C Coils : T,C(Y,M *2) Present values : T,C,D,V,Z

*1 : The PLCs that support sampling trace are the FX₂, FX_{2C}, FX_{2N}, and FX_{2NC} series.
 *2 : It is also possible to register Y and M as coils, but - depending on the details of operation of the PLC the ON/OFF operation of the coil may not be reflected in the sampling results.)
 Therefore, Y and M are usually registered as contacts.

POINTS
<ul style="list-style-type: none"> • About M, L, S of A series CPUs: When using an A/QCPU(Amode), M, L, and S devices are automatically corrected in accordance with the parameters when they are input and displayed in the device setting field. After registration, even if, for example, there are changes in the parameter settings, on redisplay the display is automatically corrected in accordance with the parameters. • About the type setting field: Setting is not possible if there has been no device input, or if devices other than T, C have been input.

17.11.3 Setting trace conditions

A	Q/QnA	FX
○	○	○

[Purpose]

Sets trace counts, trace points, and trigger points.

[Operating Procedure]

Select [Online] → [Trace] → [Sampling trace] → <<Conditions>> sheet.

[Dialog Box]

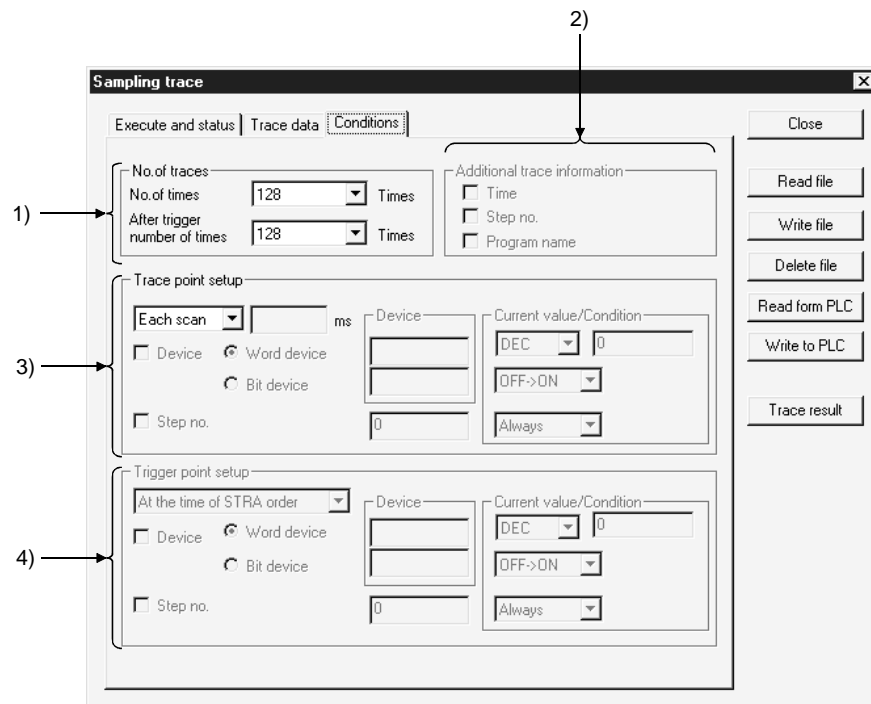

[Description]

1) No. of traces

Set so that the total count is larger than the count after the trigger.
 When using the A series, the count can only be selected from the menu.
 With the Q/QnA series, any required count up to 8192 can be set.
 With the FX series, it is not possible to set a total count. The count after the trigger can be set in the range of 1 to 512 from the menu, or alternatively any required count can be set.

2) Additional trace Information (QnA series only)

As information when the trace is executed, the time, step, and program name can displayed with the results.

3) Trace point setup

With A series
 The per time setting range is 10 to 2000 ms.
 Settings can be made in 10 ms units.

With QnA series

The per time setting range is 5 to 10000 ms.

Settings can be made in 5 ms units.

With FX series

When a per scan setting is made, it is not possible to make settings in the detailed setting field.

When per scan is designated, the execution of the END instruction by the PLC becomes the trace point.

The per time setting range is 10 to 2000 ms.

Settings can be made in 10 ms units.

Detailed setting

It is possible to set both a device and step number as the trace point at the same time.

In this case, sampling trace is executed with an AND condition.

4) Trigger point setup (QnA series, FX series only)

Sets the trigger (condition) that is the origin (0 point) for trace execution.

In the input area, only those input areas that are required for the selected trigger condition are valid.

With FX series

Read the expressions associated with the sampling trace function of FXGP (DOS) or FXGP (WIN) and the expressions associated with GX Developer in the following way.

FXGP (DOS), FXGP (WIN)	GX Developer
Without trigger	→ Wentrigger actuated
Win trigger	→ Detailed settings

For details on the detailed settings, see the trace point settings.

POINT

- **Note on repeated execution of a sampling trace:**
If a trace count of 2000 is set and the trace is actually completed at a count of 1000, note that the results of 1000 traces from the previous execution will remain.

17.12 Monitoring the Ladders Registered

A	Q/QnA	FX
○	○	○

[Purpose]

You can batch-monitor related multiple ladder blocks.

[Operating Procedure]

[Online] → [Monitor] → [Entry ladder monitor]

[Dialog Box]

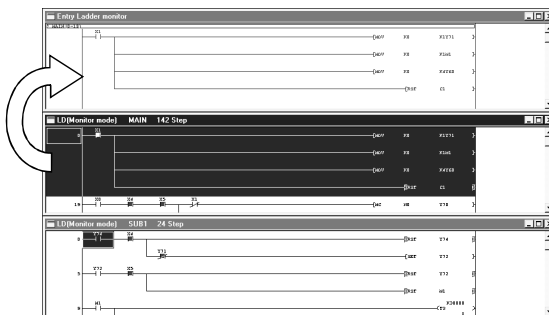

Ladder registration monitor screen

*The ladder block registered to the ladder registration screen is shown in blue.

[Description]

- You can register ladders by copy and paste or drag and drop.
- Registration may be made only from the ladder screen.
(Registration from the list screen or listing of the registered ladders cannot be made.)
- The registerable ladder size is up to 6K steps for any series.
- Functions that can be performed on the ladder registration screen
 1. Ladder deletion on ladder block basis
 2. Device search, instruction search, character string search
 3. Comment/statement/note display
 4. Device test
 5. Screen magnification/reduction
 6. Drag and drop to device registration monitor

17.13 Deleting All Ladders Registered

A	Q/QnA	FX
<input type="radio"/>	<input type="radio"/>	<input type="radio"/>

[Purpose]

You can batch-delete the ladder blocks registered.

[Operating Procedure]

[Online] → [Monitor] → [Delete all entry ladder]

18. DEBUGGING PROGRAMS

After a program has been written to the PLC, you can check it by carrying out a device test, partial operation, and step run. However, note that when using the FX series, the partial operation, step run and skip run functions are only valid when the GX Simulator is connected.

Also note that if skip run is set before partial operation and step run, the program range designated for skip run will not be processed.

The following shows the operation status during partial operation and step run operation, and an example of the execution range when skip run is set.

For the Q series, you can use the GX Simulator to perform partial execution, step execution or skip execution. (When it is connected to the PLC, partial execution, step execution and skip execution cannot be performed.)

<Partial operation>

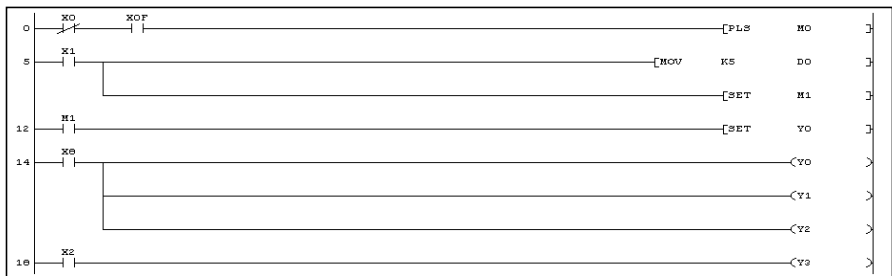

Runs the program from the designated step or pointer to the set stop condition.

See Section 18.3 "Carrying Out Partial Operation."

<Step run>



Executes the designated program range one instruction at a time.

See Section 18.4 "Executing Step Run."

When skip run is set with the Q/QnA series or FX series, partial operation or step run is executed without processing the program range designated for this function.

<Skip run>



Executes partial operation or step run while skipping (not processing) the part of the program between the designated steps.

See Section 18.5 "Setting the Scan Range."

18.1 Carrying Out a Device Test

A	Q/QnA	FX
○	○	○

[Purpose]

Forcibly turns ON/OFF the bit devices of the PLC, and changes the present values of word devices.

[Operating Procedure]

Select [Online] → [Debug] → [Device test], or click  ([Alt] + [1]).

[Dialog Box]

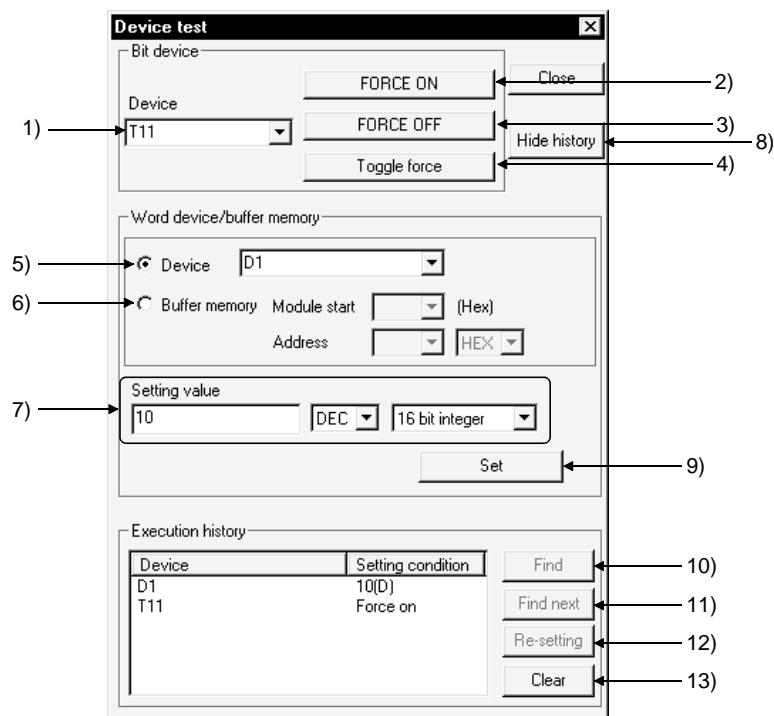

[Description]

- 1) Bit device
Designates the bit device to be forcibly turned ON or OFF.
- 2) **FORCE ON** button
Forcibly turns the designated bit device ON.
- 3) **FORCE OFF** button
Forcibly turns the designated bit device OFF.
- 4) **FORCE ON/OFF inversion** button
Forcibly inverts the ON/OFF statuses of designated bit devices.
- 5) Device
Designates the word device whose present value is to be changed.
- 6) Buffer memory
Designates the first I/O number (lowest digit unnecessary) and buffer memory address (decimal/hexadecimal) of the monitoring special function module.

- 7) **Setting value**
Sets the value to be changed.
Before setting the value, designate decimal or hexadecimal, and 16-bit integral value, 32-bit integral value, or real number.
- 8) **Hide history (Display history)**
Select whether the execution result of device test is to be displayed or hidden.
When the screen display area of the personal computer is 800×600 pixels, it is recommended to choose Hide since a large dialog box appears if the execution result is displayed.
- 9) **Set** button
Click this button after making the necessary settings.
The word device present value change operation is executed.
- 10) **Find** button
When the device is specified in the history field, the corresponding ladder program appears.
- 11) **Find next** button
Continuously searches for the device found by clicking the **Find** button.
When there are two or more sequence programs, these programs are searched for the device.
- 12) **Re-setting**
Clicking the Re-setting button after specifying the device in the history field sets data in the Bit device setting field for the bit device, or in the Word device setting field for the word device/buffer memory.
The device can be re-set by double-clicking after specifying the device in the history field.
- 13) **Clear** button
Deletes all devices displayed in the history field.





POINTS

- Executing a device may change the control of the PLC. Check safety carefully before executing the test.
- When a coil whose output condition input signal is OFF is forcibly turned ON while the PLC is in the RUN state, the execution of the program is given priority and the coil output comes ON only momentarily.
- Since the device designated for a device test is temporarily stored in memory, it can be selected the second and subsequent times with  button while the project continues.

Device

D101 

C1



- With the Q/QnA series, a device test can be carried out by bit designation of word devices, or by digit designation of bit devices.
In addition, a link module memory can be designated as follows "J*\B**" "J*\W**", and the buffer memory of a special function module can be designated as follows: "U*\G**."
See the QnACPU Programming Manual (Common Instructions)
-  key + doubling-clicking () a contact in the ladder monitor window forcibly switches it between ON and OFF.
-  key + double-clicking () a word device that is being monitored displays the present value change dialog box shown below.

Word device

Device

T1 

Setting value

After entering the value to be changed, click the  button.

- When making a device test during label programming, compile the label program.

18.2 Registering/Canceling the Forced I/O

18.2.1 Registration to PLC CPU

A	Q/QnA	FX
×	○*	×

*: This function is compatible with the QCPU (Q mode).

[Purpose]

If the program is running, a device X/Y can be forced to turn ON/OFF without influence of the input (X) from the external device and the output (Y) from the program.

For the PLC CPU version which can perform this function, check Appendix 7.

[Operating Procedure]

Select [Online] → [Debug] → [Forced input output registration/cancellation]

[Dialog Box]

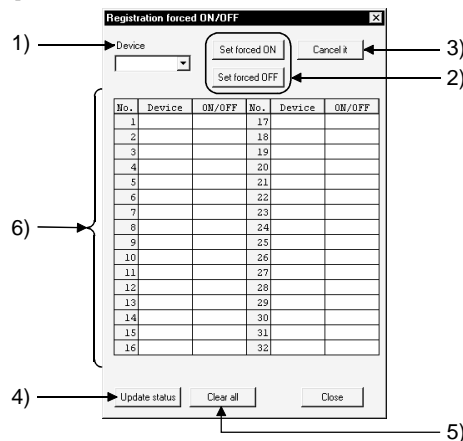

[Description]

- 1) Device
Enter the device to be forced to turn ON/OFF or to be canceled.
- 2) **Set forced ON**, **Set forced OFF** button
Register the set device to turn ON/OFF.
- 3) **Cancel it** button
Cancels the device X/Y registered to the PLC CPU.
- 4) **Update status** button
Reads the updated registration status.
- 5) **Clear all** button
Cancels all forced I/Os registered to the PLC CPU.
- 6) Registration status display area
Shows the forced I/O registration status registered to the PLC CPU.
When this function is performed for one PLC CPU by two or more persons via the other station, the forced I/O registration status is read from the accessed PLC CPU to confirm it.

POINT

Note that since exclusive control is not exercised on the PLC CPU side, forced device I/O registration may cause the registration to be changed from multiple GX Developer programs or from the equipment which can register/cancel forced I/O.

18.2.2 Registration/cancellation to remote I/O station

A	Q/QnA	FX
×	○*	×

※: This function is compatible with the Q series remote I/O.

[Purpose]

Disables the refresh of the device Y between the MELSECNET/H remote master and remote I/O stations or the device X in the input module on the remote station to enable a device test.

[Operating Procedure]

Select [Online] → [Debug] → [Forced input output registration/cancellation]

[Dialog Box]

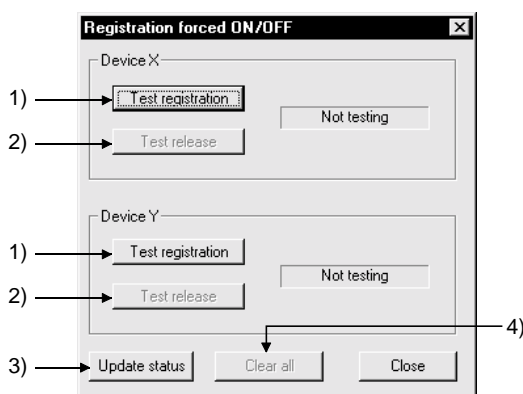

[Description]

- 1) Test registration
Disables the refresh of X/Y for the remote I/O station.
- 2) Test release
Cancels refresh disable.
- 3) Update status
Reads the latest registration status.
- 4) Clear all
Cancels all forced I/Os registered to the PLC CPU.

18.3 Carrying Out Partial Operation

A	Q/QnA	FX
<input type="radio"/>	<input type="radio"/>	<input type="radio"/>

[Purpose]

Executes a program from the designated step or pointer to the point where the set condition is established.

When Q/FX series is selected, only GX Simulator is applicable.

[Operating Procedure]

1. Select [Online] → [Debug] → [Debug] (Choose the STEP-RUN mode).
2. Select [Online] → [Debug] → [Partial operation], or click  ([Alt] + [3]).

[Dialog Box]

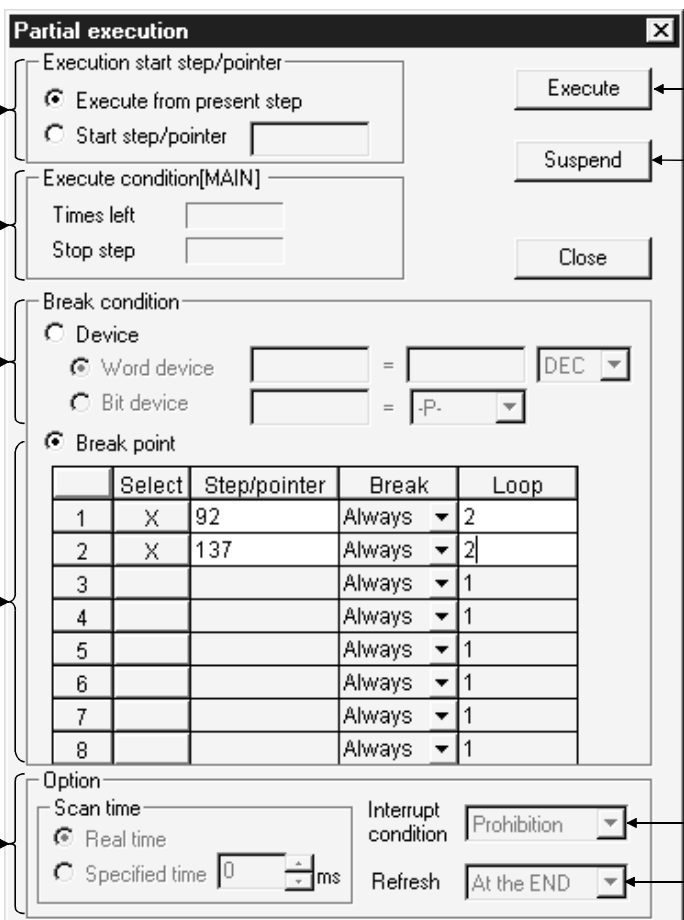

The dialog box is titled "Partial execution" and contains the following sections:

- 1) Execution start step/pointer:** Includes radio buttons for "Execute from present step" (selected) and "Start step/pointer" with an adjacent text input field.
- 2) Execute condition[MAIN]:** Includes "Times left" and "Stop step" text input fields.
- 3) Break condition:** Includes radio buttons for "Device", "Word device" (selected), and "Bit device". The "Word device" section has two input fields and a "DEC" dropdown. The "Bit device" section has an input field and a "-P-" dropdown.
- 4) Break point:** A table with columns: Select, Step/pointer, Break, and Loop.

	Select	Step/pointer	Break	Loop
1	X	92	Always	2
2	X	137	Always	2
3			Always	1
4			Always	1
5			Always	1
6			Always	1
7			Always	1
8			Always	1
- 5) Option:** Includes "Scan time" with radio buttons for "Real time" (selected) and "Specified time" with a numeric input field and "ms" unit. It also includes "Interrupt condition" (dropdown set to "Prohibition") and "Refresh" (dropdown set to "At the END").

Buttons on the right side include "Execute" (8), "Suspend" (9), and "Close".

[Description]

- 1) Execution start step/pointer
 - Execution from present step
The program is executed from the step at which execution is presently stopped.
 - Start step/pointer
The program is executed from the designated step or pointer.
For step designation : **
For pointer designation : P**
I**
** = Number of designated step or pointer

- 2) Execution condition
Indicates the execution status of the program.
- 3) Break condition
Sets the device condition that stops partial operation.
 - ⊙ Word device
The condition is satisfied when the set device has the same value as the set value.
Set the device and numeric value (decimal or hexadecimal).
 - ⊙ Bit device
The condition is satisfied when the set device is in the set condition.
Set the device status (-P-: leading edge, -F-: trailing edge).
- 4) Break point
Sets the break condition and loop count for a partial operation range.
With the A series and FX series, the condition can only be "Always."

	Select	Step/pointer	Break	Loop
1	X	92	-P- ▼	2
2	X	137	ON ▼	2
3			Always ▼	1
4			Always ▼	1
5			Always ▼	1
6			Always ▼	1
7			Always ▼	1
8			Always ▼	1

A
B
C
D

- A: Selection
Setting causes it to be executed as the break point.
- B: Step/pointer
Set the step/pointer number that defines the range for partial operation.
- C: Break
Set a status of the designated step/pointer as the break condition after the number of scans set by the loop count.
 - Always : On reaching the number of loops indicated by the designated count, execution stops.
 - ON : Execution stops when the designated step/pointer is ON.
 - OFF : Execution stops when the designated step/pointer is OFF.
 - ↑ : Execution stops when the status of the designated step/pointer changes from OFF to ON.
 - ↓ : Execution stops when the status of the designated step/pointer changes from ON to OFF.
- D: Loop
Sets the number of scans until the break.
The setting range is 1 to 32767.

- 5) Scan time (Q/QnA series only)
Sets the processing time for a program that is executing partial operation.
This setting is not possible with the A series and FX series.
- Ⓒ Real time
The program is executed at intervals corresponding to normal RUN operation.
 - Ⓒ Specified time
The program is executed at the designated interval.
The setting range is 10 ms to 2000 ms in 10 ms units.
- 6) Interrupt condition (Q/QnA series only)
Sets whether or not the interrupt program is executed when an interrupt cause occurs during partial operation.
This setting is not possible with the A series and FX series.
By programming..... Depends on the execution results of EI and DI instructions.
Prohibition..... The execution of the interrupt program is disabled.
- 7) Refresh (Q/QnA series only)
Sets the refresh timing for I/O devices (X/Y).
This setting is not possible for the A series and FX series.
One by one..... Direct I/O refresh
At the END..... Batch refresh at END processing
- 8) button
Click this button after setting the necessary settings.
Partial operation is executed.
- 9) button
Aborts partial operation.

[Operating Procedure]

1. Display the ladder monitor window.
2. Set the PLC to the STEP-RUN operating state by remote operation or with the key switch.
3. Set 1) through 7).
4. Click 8) to execute.
5. Operation stops when the break condition is established.
6. To quit, click the button.
A dialog box is displayed and the PLC returns to the RUN state.

POINTS

- When executing partial operation with a range encompassing several programs, if there is a break in a program that is not displayed, execution stops at the position of the same step number in the program that is displayed.
- When the PLC is switched from RUN to STEP-RUN, the final output status under RUN is held.
- When a break point is designated as a step, if the designated step is part way through an instruction, execution stops at the first step of the instruction.
- If a step designated as a stopped step is passed without execution in a conditional jump or interrupt program, the scan count cannot be counted as "1."
For example, if the break point is set at step 1000, the scan count is set as 1, and there is an instruction for a conditional jump to step 1200 at step 800, execution cannot stop at step 1000.
- With the A series and FX series, it is not possible to set a device break condition and a step/pointer break point at the same time.
- With the Q/QnA series, it is possible to set a device break condition and a step/pointer break point at the same time.
If they are set at the same time, partial operation stops when both conditions are satisfied.
- When more than one program is being executed with the Q/QnA series, partial operation starts from the program being monitored and is executed in the order in which programs are set in the PLC parameters.
- With the Q/QnA series the following types of setting are possible for a break condition: bit device digit designation, word device bit designation, index qualification.

18.4 Executing Step Run

A	Q/QnA	FX
○	○	○

[Purpose]

Executes the designated range of the PLC program one instruction at a time. When using the Q/FX series, step run is valid only when the GX Simulator is connected.



[Operating Procedure]

1. Select [Online] → [Debug] → [Debug] (Choose the STEP-RUN mode).
2. Select [Online] → [Debug] → [Step execution], or click  ([Alt] + [4]).

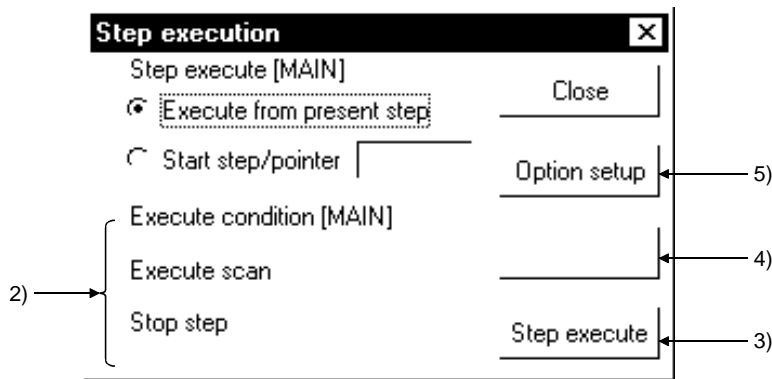
[Dialog Box]



[Description]

- 1) Step execute
 - Execute from present step
Execute the program from the step where it is currently stopped.
 - Start step/pointer
Execute the program from the designated step or pointer.
For step designation : **
For pointer designation : P**
 I**
 ** = Number of designated step or pointer
- 2) Execute condition
Indicates the execution status of the program.
- 3)  button
Clicking this button starts execution of a number of steps corresponding to the repetition count set in the option dialog box. On completion of repetition count execution, clicking this button once causes execution of one instruction.
- 4)  button
Aborts execution of step run.

- 5) **Option setup** button
 Displays the step run option setting dialog box shown below.
 Set the repetition count, repetition interval, and break point.

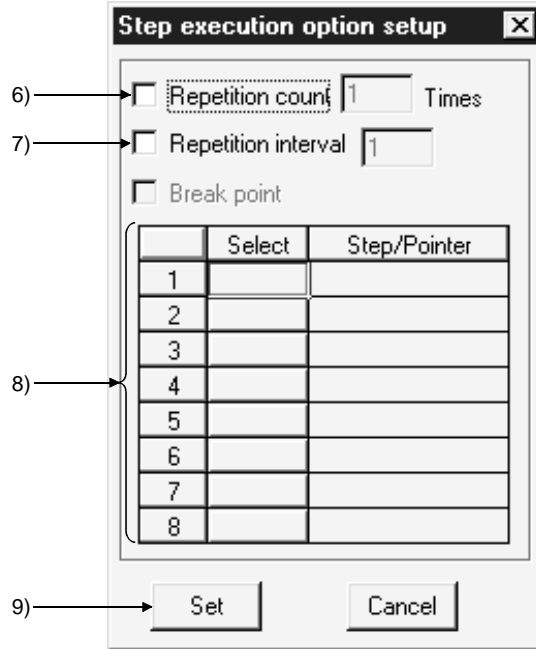

- 6) **Repetition count**
 On checking the check box to select it, step run is executed for the number of instructions corresponding to the set count only.
 After execution of this number of steps, each time the **Step execute** button is clicked program execution proceeds by one instruction.
 The setting range is 1 to 32767.
- 7) **Repetition interval**
 On checking the check box to select it, step run is executed at intervals of the set value. The unit for the interval is equivalent to the interval in which one interruption is issued from the personal computer to the PLC. If step run is executed with only the repetition interval set in the option settings, execution proceeds with no limit on the repetition count.
 The setting range is 1 to 32767.
- 8) **Break point**
 Sets the step or pointer at which step run operation stops.
 This setting is not possible for the A series or FX series.
 Note also that if step run is executed with only the break point set and no repetition count setting, it will be executed from the start step to the break point.
 After the break, program execution will proceed by one instruction each time the **Step execute** button is clicked.
 For step designation : **
 For pointer designation : P**
 I**
 ** = Number of designated step or pointer
- 9) **Set** button
 Click this button after making the necessary settings; the display returns to the step run dialog box.

[Operating Procedure]

1. Display the ladder monitor window.
2. Set the PLC to the STEP-RUN operating state by remote operation or with the key switch.
3. In the step run dialog box, set 1), and - as necessary - 6) to 8).
4. Click 3) to execute.
5. To quit, click the **Close** button.
A dialog box is displayed and the operating state of the PLC can be set to RUN in remote operation.

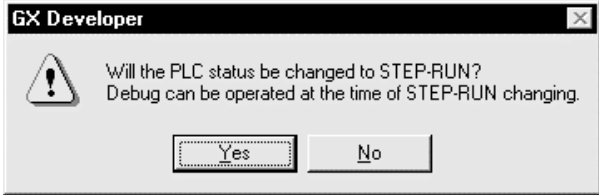
POINTS																									
	<ul style="list-style-type: none"> • When executing step run with a range encompassing several programs, if there is a break in a program that is not displayed, execution stops at the position of the same step number in the program that is displayed. • The following dialog box will appear if step run is performed when the PLC CPU is in other than the STEP-RUN mode. 																								
																									
	<p>When the PLC CPU is in the RUN mode, it cannot be switched to STEP-RUN.</p> <ul style="list-style-type: none"> • The timer present values during step run are as follows. <table border="1" style="width: 100%; border-collapse: collapse;"> <tbody> <tr> <td style="width: 50%;">10 ms timer</td> <td>Incremented by one each scan</td> </tr> <tr> <td>100 ms timer, 100 ms retentive timer</td> <td>Incremented by one every ten scans</td> </tr> </tbody> </table> <ul style="list-style-type: none"> • The special relay timing clocks during step run are as follows. <p>A series</p> <table border="1" style="width: 100%; border-collapse: collapse;"> <tbody> <tr> <td style="width: 50%;">M9030 (0.1 second clock)</td> <td>Goes ON/OFF every 5 scans</td> </tr> <tr> <td>M9031 (0.2 second clock)</td> <td>Goes ON/OFF every 10 scans</td> </tr> <tr> <td>M9032 (1 second clock)</td> <td>Goes ON/OFF every 50 scans</td> </tr> <tr> <td>M9033 (2 second clock)</td> <td>Goes ON/OFF every 100 scans</td> </tr> <tr> <td>M9034 (1 minute clock)</td> <td>Goes ON/OFF every 3000 scans</td> </tr> </tbody> </table> <p>Q/QnA series</p> <table border="1" style="width: 100%; border-collapse: collapse;"> <tbody> <tr> <td style="width: 50%;">SM410 (0.1 second clock)</td> <td>Goes ON/OFF every 5 scans</td> </tr> <tr> <td>SM411 (0.2 second clock)</td> <td>Goes ON/OFF every 10 scans</td> </tr> <tr> <td>SM412 (1 second clock)</td> <td>Goes ON/OFF every 50 scans</td> </tr> <tr> <td>SM413 (2 second clock)</td> <td>Goes ON/OFF every 100 scans</td> </tr> <tr> <td>SM414 (n second clock)</td> <td>Goes ON/OFF every n x 50 scans</td> </tr> </tbody> </table>	10 ms timer	Incremented by one each scan	100 ms timer, 100 ms retentive timer	Incremented by one every ten scans	M9030 (0.1 second clock)	Goes ON/OFF every 5 scans	M9031 (0.2 second clock)	Goes ON/OFF every 10 scans	M9032 (1 second clock)	Goes ON/OFF every 50 scans	M9033 (2 second clock)	Goes ON/OFF every 100 scans	M9034 (1 minute clock)	Goes ON/OFF every 3000 scans	SM410 (0.1 second clock)	Goes ON/OFF every 5 scans	SM411 (0.2 second clock)	Goes ON/OFF every 10 scans	SM412 (1 second clock)	Goes ON/OFF every 50 scans	SM413 (2 second clock)	Goes ON/OFF every 100 scans	SM414 (n second clock)	Goes ON/OFF every n x 50 scans
10 ms timer	Incremented by one each scan																								
100 ms timer, 100 ms retentive timer	Incremented by one every ten scans																								
M9030 (0.1 second clock)	Goes ON/OFF every 5 scans																								
M9031 (0.2 second clock)	Goes ON/OFF every 10 scans																								
M9032 (1 second clock)	Goes ON/OFF every 50 scans																								
M9033 (2 second clock)	Goes ON/OFF every 100 scans																								
M9034 (1 minute clock)	Goes ON/OFF every 3000 scans																								
SM410 (0.1 second clock)	Goes ON/OFF every 5 scans																								
SM411 (0.2 second clock)	Goes ON/OFF every 10 scans																								
SM412 (1 second clock)	Goes ON/OFF every 50 scans																								
SM413 (2 second clock)	Goes ON/OFF every 100 scans																								
SM414 (n second clock)	Goes ON/OFF every n x 50 scans																								

18.5 Setting the Scan Range

A	Q/QnA	FX
×	○	○

[Purpose]

Sets the range to be skipped (not processed) when executing partial operation or step run.

When using the Q/FX series, this setting is only effective when the GX Simulator is connected.

[Operating Procedure]

1. Select [Online] → [Debug] → [Debug] (Choose the STEP-RUN mode).
2. Select [Online] → [Debug] → [Skip execution], or click  (Alt + 2).

[Dialog Box]

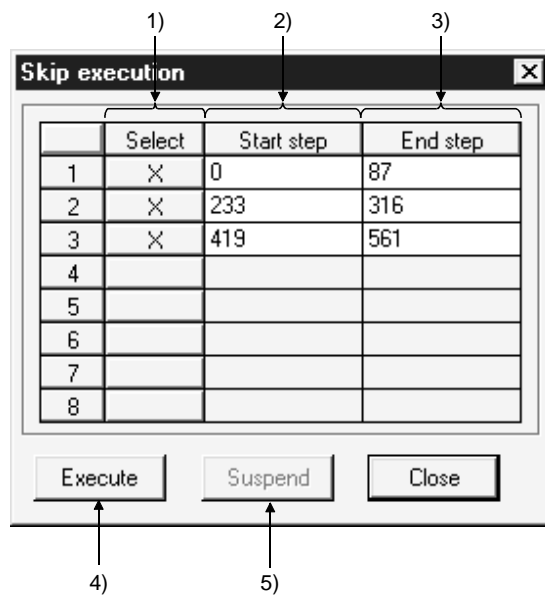

[Description]

- 1) Select
On setting, the designated range is skipped.
The skip range is in instruction units.
- 2) Start step
Designates the beginning of the skip range.
Set the first step number of the first instruction.
Pre-selecting the area in the ladder and choosing the step execution menu sets the step number at the first step.



- 3) End step
Designates the end of the skip range.
Set the first step number of the final instruction.
Pre-selecting the area in the ladder and choosing the step execution menu sets the step number at the last step.

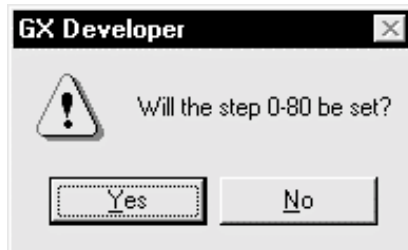

- 4) **Execute** button
Registers the skip range.
If the PLC is in an operating state other than STEP-RUN at this time, a dialog box allowing the state to be changed to STEP-RUN is displayed.
To continue with partial operation or step run, set the state to STEP-RUN.
However, if the PLC is in a state other than RUN it is not possible to change to STEP-RUN.
- 5) **Suspend** button
Cancels registration of the skip range.

[Operating Procedure]

1. Display the ladder monitor window.
2. Set 1), 2), and 3) in the skip execution dialog box.
3. Click 4).
A dialog box is displayed: to continue with partial operation or step run, set to STEP-RUN.
4. Close the skip execution window.
5. Execute partial operation or step run.

POINT

- To cancel the STEP-RUN state, either turn the key switch momentarily to RESET, or change the state by remote operation.

See Section 18.6 "Operating the PLC Remotely."

18.6 Operating the PLC Remotely

A	Q/QnA	FX
○	○	○

[Purpose]

Switches the execution status of the PLC from the personal computer. However, with the A series and the Q/QnA series, remote operation is possible only when the PLC is in the RUN state. When using the FX series, remember that only the FX1N FX2N and FX2NC support remote operation. Remote operation is possible when the CPU is in either the RUN or STOP state.

[Operating Procedure]

Select [Online] → [Remote operation] (**[Alt] + [6]**).

[Dialog Box]

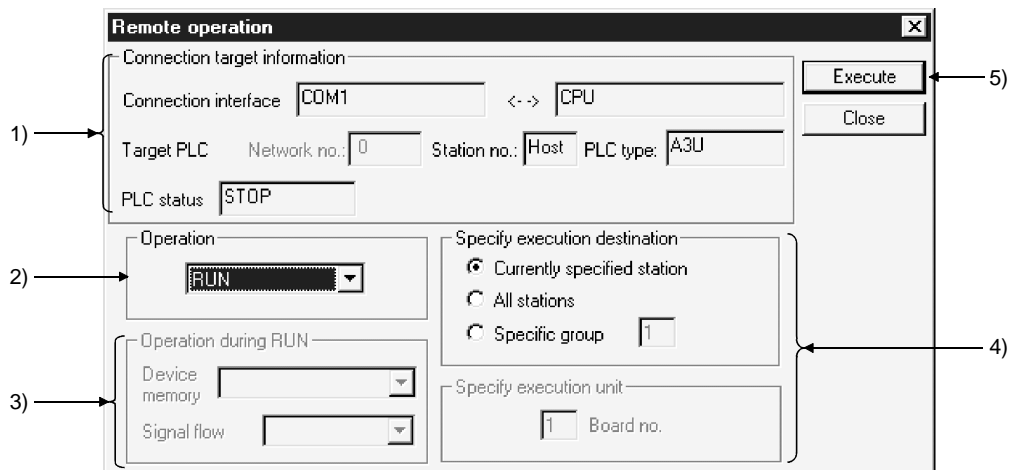

[Description]

- 1) Connection target information
Indicates information on the connection destination designation. For details on the connection destination designation, see Section 16.1.
- 2) Operation
Designates the operating state of the PLC. For the A series and Q/QnA series, the following designations are possible: STOP, PAUSE, STEP-RUN, RUN. With the Q/QnA series, RESET and latch clear can also be designated. With the FX series, STOP and RUN can be designated.
- 3) Operation during RUN,STEP-RUN
Sets the operation with respect to the device memory and signal flow in the RUN and STEP-RUN states. This setting is not possible with the FX series.

- 4) Specify execution destination
Sets the applicable station for remote operation.
Currently specified station..... Executed only at the station with the connection destination designation.
- All stations..... Executed at all stations of the network designated as the presently designated station. 1 to 4 modules can be set for execution module designation.
- Specific group..... Executed in a specific group of the network designated as the presently designated station. Set 1 to 4 modules for execution module designation and set the group number.
This setting is not possible with the FX series.
- 5) button
Click this button after setting the necessary settings.

POINTS																																																				
	<ul style="list-style-type: none"> Remote operation is valid when the PLC is in the RUN state. However, since the remote operation setting is memorized when the key switch is set to STOP, on setting the key switch to RUN, the state set in remote operation applies. For example, if remote operation is set to STOP while the key switch is at STOP, the PLC will remain in the STOP state even if the key switch is set to RUN. Similarly, if STEP-RUN is set in remote operation while the key switch is set to STOP, when the key switch is set to RUN the PLC enters the STEP-RUN state. In this kind of case, the RUN state has to be established by remote operation. If there is any disagreement in the key switch, remote operation, and remote RUN/PAUSE contact operations at the PLC, the following order of priority applies. <table border="1" style="margin: 10px auto; border-collapse: collapse; text-align: center;"> <thead> <tr> <th>Operations to the PLC</th> <th>Order of Priority</th> </tr> </thead> <tbody> <tr> <td>STOP</td> <td>1</td> </tr> <tr> <td>PAUSE</td> <td>2</td> </tr> <tr> <td>STEP-RUN</td> <td>3</td> </tr> <tr> <td>RUN</td> <td>4</td> </tr> </tbody> </table> <ul style="list-style-type: none"> The PLC operation is determined by the combination of the key switch position and remote operation as follows. <p style="margin-left: 20px;">A series</p> <table border="1" style="margin: 10px auto; border-collapse: collapse; text-align: center;"> <thead> <tr> <th style="border-bottom: none;">Remote operation \ Key switch</th> <th>RUN</th> <th>PAUSE</th> <th>STOP</th> </tr> </thead> <tbody> <tr> <th style="border-right: none;">RUN</th> <td>RUN</td> <td>PAUSE</td> <td>STOP</td> </tr> <tr> <th style="border-right: none;">STEP-RUN</th> <td>STEP-RUN</td> <td>PAUSE</td> <td>STOP</td> </tr> <tr> <th style="border-right: none;">PAUSE</th> <td>PAUSE</td> <td>PAUSE</td> <td>STOP</td> </tr> <tr> <th style="border-right: none;">STOP</th> <td>STOP</td> <td>STOP</td> <td>STOP</td> </tr> </tbody> </table> <p style="margin-left: 20px;">QnA series</p> <table border="1" style="margin: 10px auto; border-collapse: collapse; text-align: center;"> <thead> <tr> <th style="border-bottom: none;">Remote operation \ Key switch</th> <th>RUN</th> <th>STEP-RUN</th> <th>PAUSE</th> <th>STOP</th> <th>RESET *1</th> <th>Latch clear</th> </tr> </thead> <tbody> <tr> <th style="border-right: none;">RUN</th> <td>RUN</td> <td>STEP-RUN</td> <td>PAUSE</td> <td>STOP</td> <td>Operation not possible *2</td> <td>Operation not possible *2</td> </tr> <tr> <th style="border-right: none;">STOP</th> <td>STOP</td> <td>STOP</td> <td>STOP</td> <td>STOP</td> <td>RESET</td> <td>Latch clear</td> </tr> </tbody> </table> <ul style="list-style-type: none"> *1 : Remote reset must be enabled by PLC system setting in the PLC parameters. *2 : Operation possible when set to STOP by remote operation. <ul style="list-style-type: none"> In remote operation of the FX2N and FX2NC CPU, M8035 (forced RUN mode), M8036 (forced RUN) and M8037 (forced STOP) are controlled. Note that remote operation is possible regardless of the status of the RUN, STOP switches at the PLC side. When removing the memory card, switch on SM605. If you remove the memory card with removal not yet authorized, the PLC will result in an error. 	Operations to the PLC	Order of Priority	STOP	1	PAUSE	2	STEP-RUN	3	RUN	4	Remote operation \ Key switch	RUN	PAUSE	STOP	RUN	RUN	PAUSE	STOP	STEP-RUN	STEP-RUN	PAUSE	STOP	PAUSE	PAUSE	PAUSE	STOP	STOP	STOP	STOP	STOP	Remote operation \ Key switch	RUN	STEP-RUN	PAUSE	STOP	RESET *1	Latch clear	RUN	RUN	STEP-RUN	PAUSE	STOP	Operation not possible *2	Operation not possible *2	STOP	STOP	STOP	STOP	STOP	RESET	Latch clear
Operations to the PLC	Order of Priority																																																			
STOP	1																																																			
PAUSE	2																																																			
STEP-RUN	3																																																			
RUN	4																																																			
Remote operation \ Key switch	RUN	PAUSE	STOP																																																	
RUN	RUN	PAUSE	STOP																																																	
STEP-RUN	STEP-RUN	PAUSE	STOP																																																	
PAUSE	PAUSE	PAUSE	STOP																																																	
STOP	STOP	STOP	STOP																																																	
Remote operation \ Key switch	RUN	STEP-RUN	PAUSE	STOP	RESET *1	Latch clear																																														
RUN	RUN	STEP-RUN	PAUSE	STOP	Operation not possible *2	Operation not possible *2																																														
STOP	STOP	STOP	STOP	STOP	RESET	Latch clear																																														

19. REGISTERING KEYWORD/PASSWORDS

Entry code registration (for A/QnA/FX series) or password registration (for Q series) protects data in the PLC.

19.1 Registering Keyword

19.1.1 Registering new keyword/changing keyword

A	Q/QnA	FX
<input type="radio"/>	<input type="radio"/> *	<input type="radio"/>

*: This function is compatible with the QnACPU.

[Purpose]

For the A/QnA/FX series, registers a new keyword to the PLC or changes the entry code.

[Operating Procedure]

Select [Online] → [Keyword setup] → [Register keyword].

[Dialog Box]

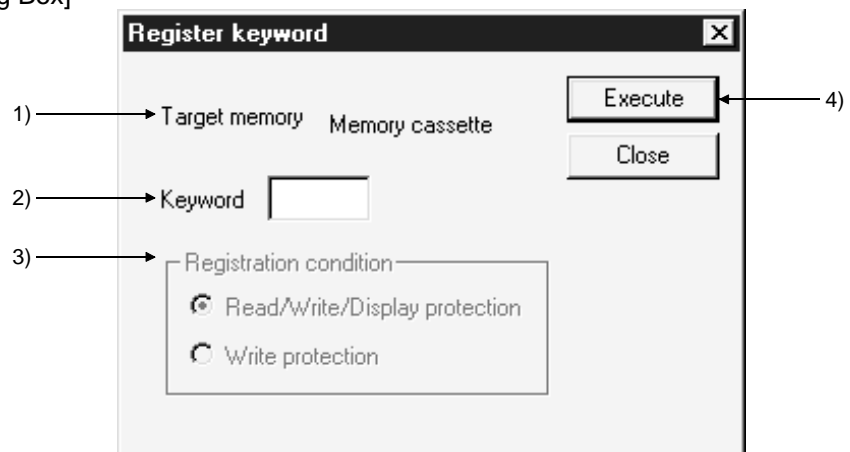

[Description]

- 1) Target memory (Except FX series)
Sets the memory whose keyword is to be registered or changed.
For the A series, this is a memory cassette.
- 2) Keyword
A series : Set the keyword (6 numeric characters and A through F).
QnA series : Set the keyword (6 numeric characters).
FX series : Set the keyword (8 numeric characters and A through F).
- 3) Registration condition (Except FX series)
Select the functions restricted by the keyword.
For the A series this is reading/writing and disabling of the display only.
 - Read/Write/Display protection
Writing, reading, verification, deletion, and list display are restricted by the keyword.
 - Write protection
Writing is restricted by the keyword.

- 4) **Execute** button

Click this button after setting the necessary settings.

However, in the case of an keyword change or condition change, the dialog box shown below is displayed.

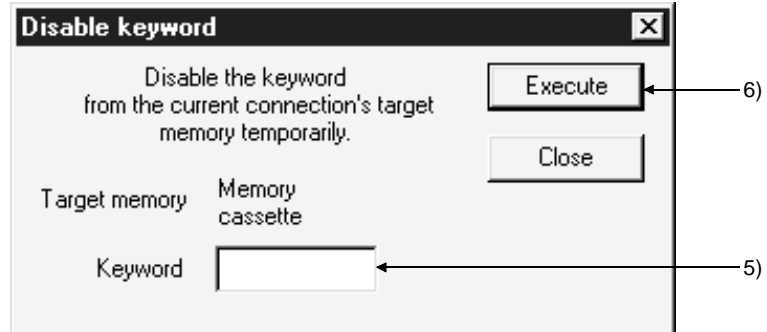

- 5) Keyword

Sets the keyword that has been registered for the PLC.

- 6) **Execute** button

Click this button after setting the necessary settings.

[Operating Procedure]

1. Set 2) in the Register new keyword dialog box.
With the QnA series, set 1) and 3) also.
2. Click 4).
For an keyword change, the present keyword is now displayed in the dialog box.
3. Set 5) and click 6).

POINTS
<ul style="list-style-type: none"> • If you forget the entry code when using the A series or FX series, all-clear the data in the memory cassette with "PLC all clear." With the QnA series, format the PLC memory. However, note that regardless of whether you are using the A series, QnA series or the FX series, all the data apart from the keyword is also deleted, and therefore all the data must be rewritten. • On executing the registration condition function before releasing an keyword, the current entry code dialog box is automatically displayed. Enter the keyword and release it. • Since the keyword is written directly into the PLC on registration, there is no need to write parameters or other data to the PLC. Note that the keyword becomes functional immediately after registration. • With the A series and FX series, parameters for which an keyword is registered can be written to the ROM.

19.1.2 Canceling a keyword

A	Q/QnA	FX
○	○*	○

*: This function is compatible with the QnACPU.

[Purpose]

For the A/QnA/FX series, cancels (deletes) the keyword registered to the PLC.

[Operating Procedure]

Select [Online] → [Keyword setup] → [Delete keyword].

[Dialog Box]

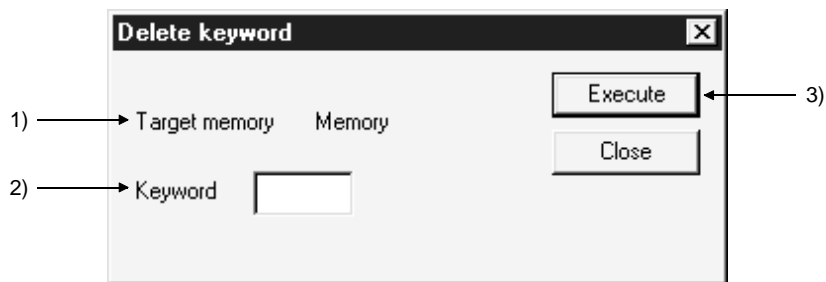

[Description]

- 1) Target memory (Except FX series)
Sets the applicable memory for the keyword cancellation.
For the A series, this is a memory cassette.
- 2) Keyword
Sets the currently registered keyword.
- 3) **Execute** button
Click this button after setting the necessary settings.

19.1.3 Releasing a keyword

A	Q/QnA	FX
<input type="radio"/>	<input type="radio"/> *	<input type="radio"/>

*: This function is compatible with the QnACPU.

[Purpose]

For the A/QnA/FX series, releases the lock imposed by a keyword in order to allow access to the PLC for which the keyword is registered.

After a keyword has been released, there is free access to the PLC until the project is quit.

[Operating Procedure]

Select [Online] → [Keyword setup] → [Disable keyword].

[Dialog Box]

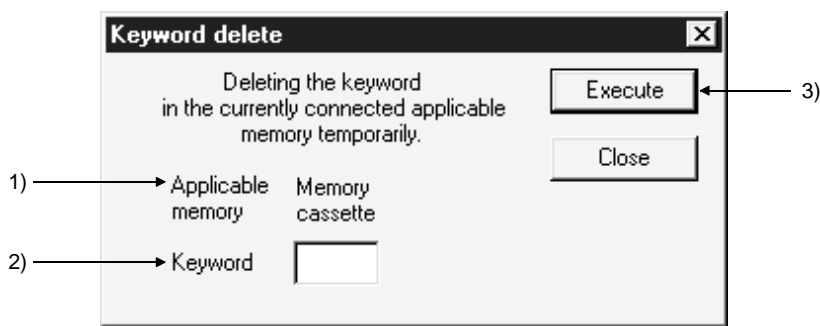

[Description]

- 1) Target memory (Except FX series)
Indicates the currently connected memory.
For the A series this is a memory cassette.
- 2) Keyword
Sets the keyword registered for the PLC.
- 3) **Execute** button
Click this button after setting the necessary settings.

19.2 Registering Passwords

A	Q/QnA	FX
×	○*	×

*: This function is compatible with the QCPU (Q mode).

For the Q series, you can set a password to each of the programs, comments and device inits in a project.

The passwords are set to the PLC and the project currently open on GX Developer.

States of Passwords and Registration Conditions for Operations Performed

Operation	States of Password and Registration Condition
Read from/Write to PLC	
Read from PLC	If passwords exist in the read source PLC, the password settings are also read.
Write to PLC (to read source PLC)	Password settings are written to the write destination PLC.
Write to PLC (to other than read source PLC)	Password settings are written to the write destination PLC.
Write to PLC (read from IC card and write to PLC)	Password settings are written to the write destination PLC.
Edit project	
Open project	If passwords exist in the read source, the password settings are also read.
Save	If passwords exist in the save source, the password settings are also saved.
Save as	If passwords exist in the save source, the password settings are also saved.
Delete project	Passwords are deleted together with the project.
Copy project	If passwords exist in the copy source, the password settings are also copied.
Copy data	If passwords exist in the copy source, the password settings are also copied.
Save and write after data name change	If passwords exist in the old data name, the password settings are also saved.
Edit ladder (paste ladder to other GX Developer)	Password settings are not added.
Merge data	Password settings are not added.
Automatic save	If passwords exist in the save source, the password settings are also saved.
Change PLC type	
Save and write after PLC type change QCPU → QCPU	If passwords exist in the old PLC type, the password settings are also saved.
Save and write after PLC type change QCPU → other than QCPU	Password settings are not added.
Read/write IC card	
Read IC card	If passwords exist in the read source IC card, the password settings are also read.
Write IC card (to read source IC card)	Password settings are written to the write destination IC card.
Write IC card (to other than read source IC card)	Password settings are written to the write destination IC card.
Write IC card (read from PLC and write to IC card)	Password settings are written to the write destination IC card.

19.2.1 Register new passwords/changing passwords

A	Q/QnA	FX
×	○	×

*: This function is compatible with the QCPU (Q mode).

[Purpose]

Registering passwords protects the data in the PLC (corresponding memory). (Q series only)

[Operating Procedure]

Select [Online] → [Password setup] → [Register password].

[Dialog Box]

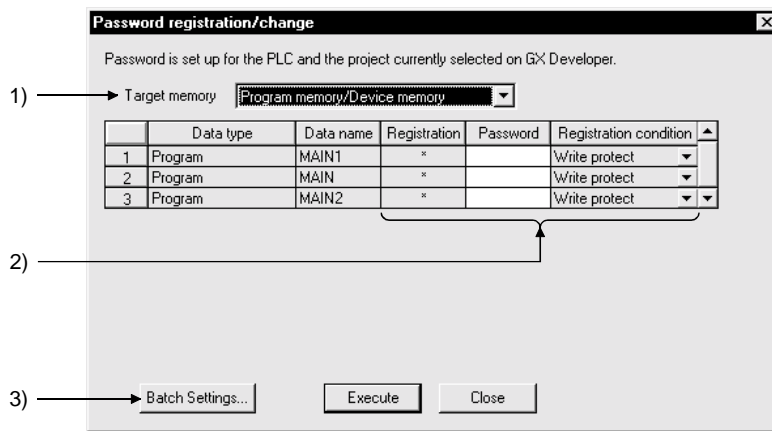

[Description]

1) Target memory

Set the memory whose password is to be registered or changed.

2) Registration, Password, Registration condition

○ Registration condition

× appears if a password has already been registered.

If you have selected [Register password] in Password setup, the data written to the PLC appears.

If you have chosen [Write to PLC], [Write IC memory card] or [Write image data], the data opening on the personal computer appears.

○ Password

Register four ASCII alphanumeric characters.

(Upper- and lower-case characters are differentiated.)

○ Registration condition

• Write protect

Write operation is restricted by the password.

• Read/Write protect

Write/read operation is restricted by the password.

• Clear

Password is cleared.

3) Batch settings

Batch-sets the same password and registration condition to each data.

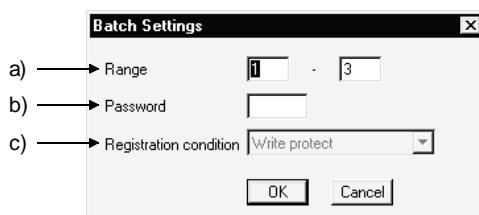

- a) Range
Set the range where the same password will be batch-set.
- b) Password
Register four alphanumeric characters in ASCII code.
(Upper- and lower-case characters are differentiated.)
- c) Registration condition
 - Write protect
Write operation is restricted by the password.
 - Read/Write protect
Write/read operation is restricted by the password.
 - Clear
Password is cleared.

POINTS

- When changing the password
After setting a new password in the Register/Change password dialog box, set the old password in the Check password dialog box.
- If you forgot the password
Format the PLC memory.
However, this also clears all data including the passwords, all data should be written once more.
- When erasing the passwords in the project data
Choose "Clear" as the registration condition in the password setting for Write IC memory card or Write to PLC, and save the project.
- "Checking password" appears during communications with the PLC, but it is also displayed when no password has been set.
Checking password : Passwords and setting conditions of all files are checked.

19.2.2 Delete the passwords

A	Q/QnA	FX
×	○*	×

*: This function is compatible with the QCPU (Q mode).

[Purpose]

Deletes the passwords which have been set in the files within the PLC. (Q series only)

[Operating Procedure]

Select [Online] → [Password setup] → [Delete password].

[Dialog Box]

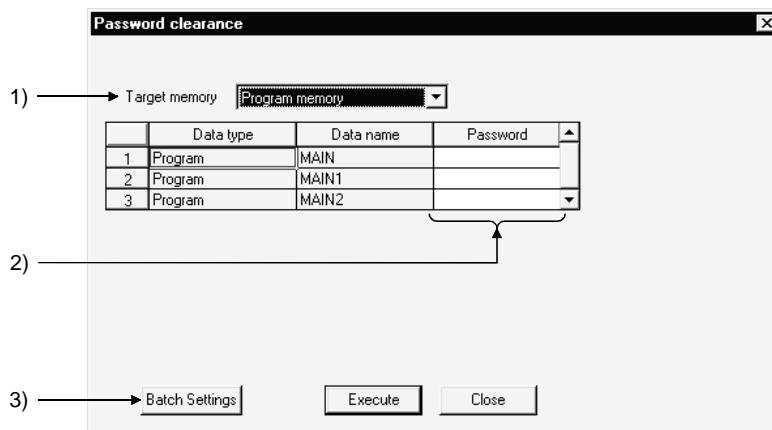

[Description]

- 1) Target memory
Set the memory whose passwords will be deleted.
- 2) Password
Set the passwords currently registered.
- 3) Batch settings
Batch-deletes the passwords and registration conditions.

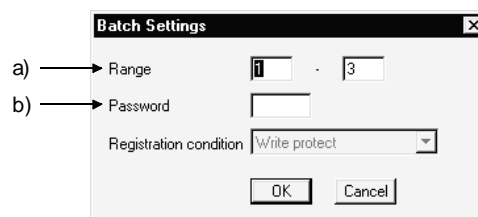

- a) Range
Set the range where the passwords and registration conditions will be batch-deleted.
- b) Password
Set the password currently registered.
Take care to differentiate between the upper- and lower-case characters.

POINT

- If the same data name exists in the project, the password of the project data will also be deleted.

19.2.3 Disable the passwords

A	Q/QnA	FX
×	○*	×

*: This function is compatible with the QCPU (Q mode).

[Purpose]

Disables the passwords which have been set in the files within the PLC. Disabling does not delete the passwords which have been set to the data in the PLC. It enables access to the PLC. (Q series only)

[Operating Procedure]

Select [Online] → [Password setup] → [Disable password].

[Dialog Box]

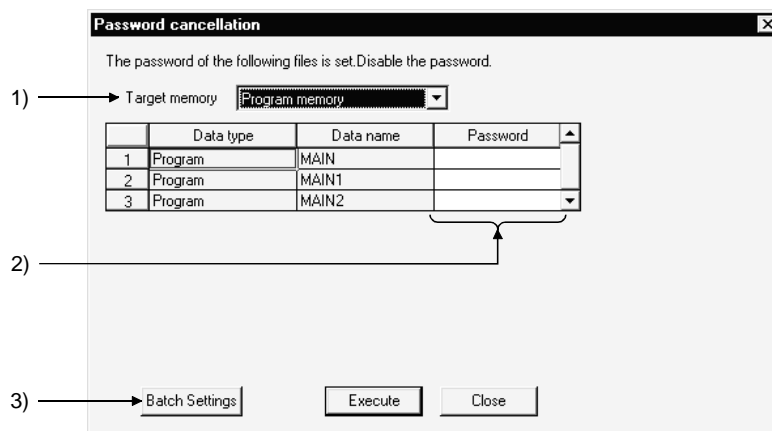

[Description]

- 1) Target memory
Set the memory whose passwords will be disabled.
- 2) Password
Set the passwords currently registered.
- 3) Batch settings
Batch-disables the passwords and registration conditions.

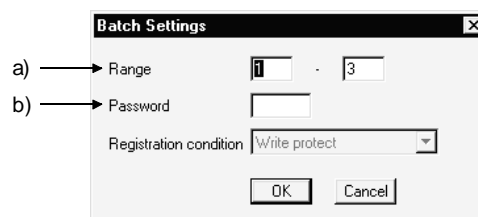

- a) Range
Set the range where the passwords and registration conditions will be batch-disabled.
- b) Password
Set the password currently registered.
Take care to differentiate between the upper- and lower-case characters.

POINT

Note that the password disable setting is not made valid unless the project where the passwords have been set is closed.

20. PLC MEMORY

This chapter describes PLC memory all-clear, formatting, memory area sorting, and time setting for the internal clock of the PLC.

20.1 Clearing the PLC Memory

20.1.1 All-clearing on ACPU memory

A	Q/QnA	FX
○	×	×

[Purpose]

All-clears the device memory and memory cassette of A series PLCs.

[Operating Procedure]

Select [Online] → [Memory Clear PLC memory]

[Dialog Box]

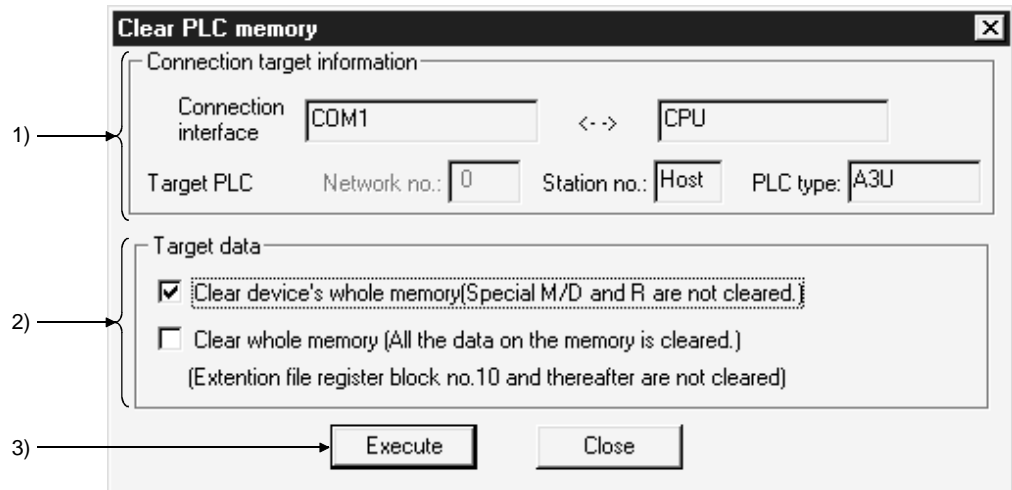

[Description]

1) Connection target information

Indicates information on the connection destination designation.

2) Target data

Clear device's whole memory (Social M/D and R are not cleared.)

Checking this check box to select it clears all the data in the device memory in the PLC.

However, special relays, special registers, and file registers are excepted.

Clear whole memory (All the data on the memory is cleared.)

Checking this check box to select it clears all the data in the memory cassette of the PLC with the exception of block No. 10 onward of the extension file registers.

- 3) **Execute** button
Click this button after setting the necessary settings.

POINTS
<ul style="list-style-type: none">• Device memory all clear can only be executed when the PLC is in the STOP state• When the data in a memory cassette is all-cleared, the range cleared is 144K bytes. Data beyond the 144K byte range (from extension file register block 10 onward) is not cleared.• After all-clearing the data in a memory cassette, all of the data values in the memory cassette are "1." When file registers (R) are set and read after all clear, the result is HFFF (K-1).

20.1.2 All-clearing the QCPU, QnACPU device memory

A	Q/QnA	FX
×	○	×

[Purpose]

All-clears the device memory of a Q/QnA series PLC.
The flash ROM cannot be all-cleared.

[Operating Procedure]

Select [Online] → [Clear PLC memory].

[Dialog Box]

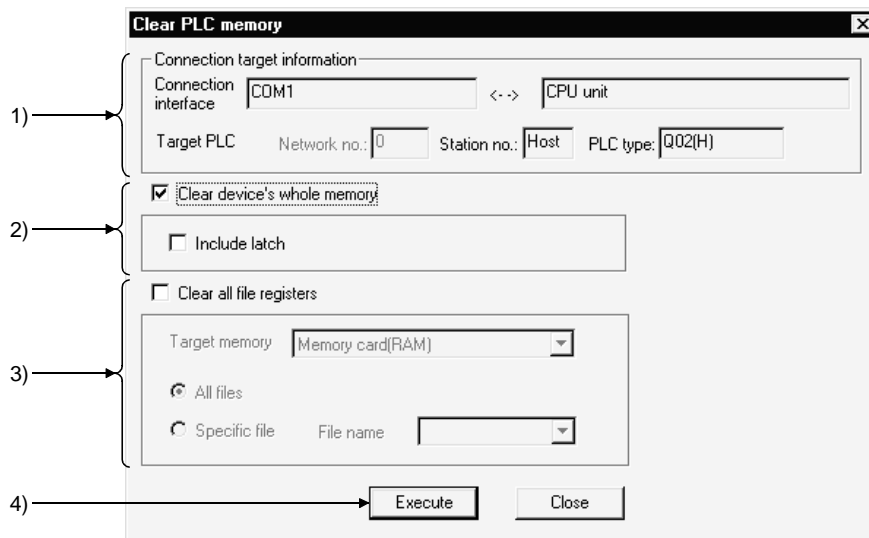

[Description]

- 1) **Connection target information**
Indicates information on the connection destination designation.
- 2) **Clear device's whole memory**
When this check box is checked to select it, the device memory is all-cleared.
You can set whether or not the devices designated in latch range designation are cleared.
- 3) **Clear all file registers**
Sets all file register data to "0."
The area and file names are not cleared.
To designate a file, designate the applicable memory and the file name.
- 4) **Execute button**
Click this button after setting the necessary settings.

POINTS
<ul style="list-style-type: none"> • If the latched range is included in the device memory all clear operation, the latch clear key invalid area is also cleared. • All clear is not possible when the PLC is in the RUN state.

20.1.3 All-clearing an FXCPU memory

A	Q/QnA	FX
×	×	○

[Purpose]

All-clears the memory in an FX series PLC.

[Operating Procedure]

Select [Online] → [Clear PLC memory].

[Dialog Box]

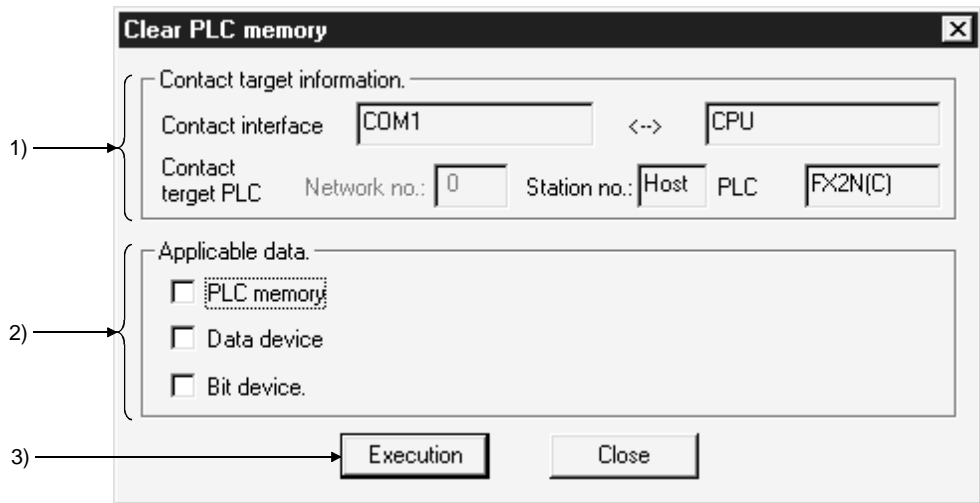

[Description]

- 1) **Connect target information**
Indicates information about the connection destination designation.

- 2) **Applicable data**
 - PLC memory**
When this check box is checked to select it, all of the data in the PLC is cleared. (Programs, comments, parameters, file registers, device memory)

 - Data device**
When this check box is checked to select it, the registers in the PLC are cleared to "0."
(Data registers, file registers, RAM file registers, special registers)

 - Bit device**
When this check box is checked to select it, all of the bit devices in the PLC are turned OFF.
(X, Y, M, S, T, C)
The present values of T and C devices are also set to 0.

- 3) **Execution** button
Click this button after setting the necessary settings.

POINTS

Execution conditions

• PLC memory

Memory : Internal memory, RAM/EEPROM (protect switch: OFF) cassette.
All clear cannot be executed with an EEPROM (protect switch ON)
or EPROM cassette.

• Data device

Memory : Same as the execution conditions for "PLC memory."

• Bit device

Memory : Can be executed with all memories

Operate the PLC in the STOP state. The memory cannot be cleared in the RUN state.

20.2 Formatting a QCPU(Qmode), QnACPU Memory

A	Q/QnA	FX
×	○	×

[Purpose]

Formats the PLC internal RAM or IC memory card of Q/QnA series models.
SRAM and ATA can be formatted.
The flash ROM cannot be formatted.

[Operating Procedure]

Select [Online] → [Format PLC Memory].

[Dialog Box]

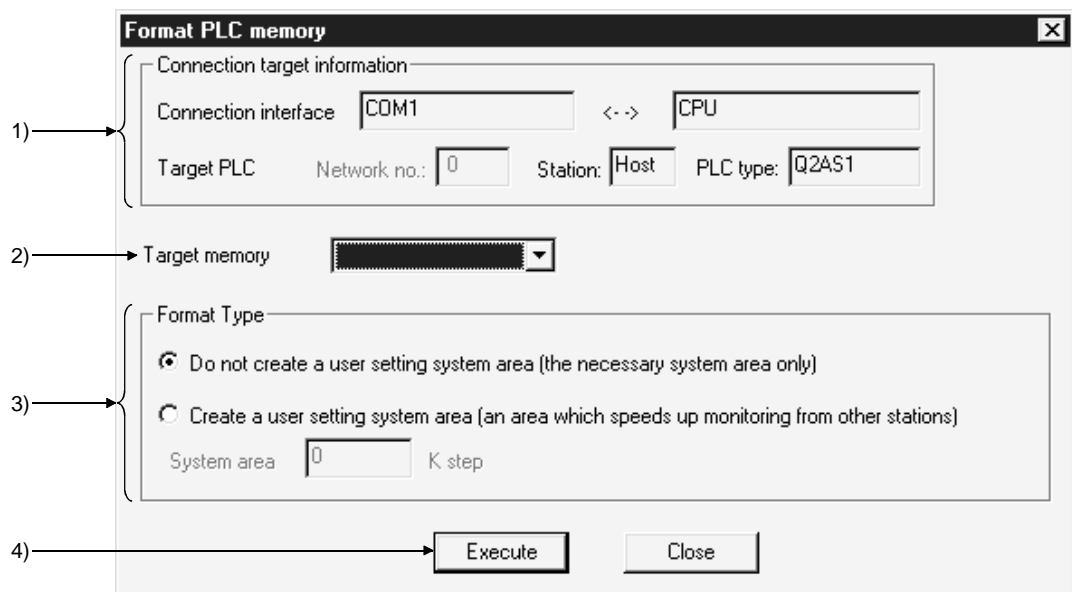

[Description]

- 1) **Connection target information**
Indicates information on the connection destination designation.
- 2) **Target memory**
Sets the object of PLC memory formatting.
- 3) **Format Type**
 - Ⓐ Do not create a user setting system area (the necessary system area only)
Only the system area that is essential for the applicable memory is created.
 - Ⓑ Create a user setting system area (an area which speeds up monitoring from other stations)
A mandatory system area and a system area for high-speed monitoring from other stations (user-set) are created.
The setting range is 0 to 15K steps.
- 4) **Execute** button
Click this button after setting the necessary settings.

POINTS	
<ul style="list-style-type: none"> • There are two types of system area: "mandatory" and "user-set." The mandatory system area is automatically created during formatting, but the user-set system area is created according to the user's required settings. • When the user-set system area is created, the data storage area for sequence programs and other data is reduced. Check the data capacity before setting the range for the user-set system area. 	<p style="text-align: center;">QnACPU internal RAM</p>
<ul style="list-style-type: none"> • Files in the system area cannot be displayed as a data list. • Create the user-set system area in the internal RAM. If it is set in an IC memory card, the speed of other station monitoring will not change. 	

20.3 Sorting the QCPU(Qmode), QnACPU Memory

A	Q/QnA	FX
×	○	×

[Purpose]

Sorts the data in the internal RAM or IC memory card of a Q/QnA series PLC to secure contiguous free memory.
The flash ROM cannot be sorted.

[Operating Procedure]

Select [Online] → [Arrange PLC memory].

[Dialog Box]

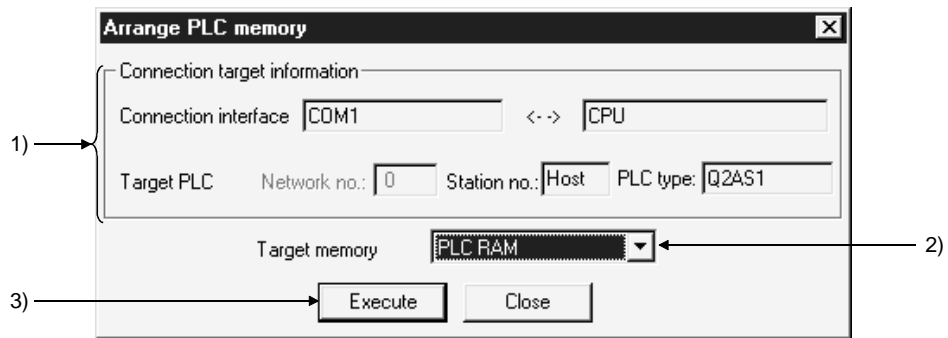

[Description]

- 1) Connection target information
Indicates information on the connection destination designation.
- 2) Target memory
Sets the PLC memory that is to be sorted.
- 3) **Execute** button
Click this button after setting the necessary settings.

POINT			
<ul style="list-style-type: none"> An example of the execution of PLC memory sorting is given below. <div style="text-align: center; margin: 10px 0;"> </div> <table style="width: 100%; border: none;"> <tr> <td style="width: 33%; border: none;"> <ul style="list-style-type: none"> • Total free capacity 8K • Max. contiguous free area 8K </td> <td style="width: 33%; border: none;"> <ul style="list-style-type: none"> • Total free capacity 14K • Max. contiguous free area 8K </td> <td style="width: 33%; border: none;"> <ul style="list-style-type: none"> • Total free capacity 14K • Max. contiguous free capacity 14K </td> </tr> </table> <p style="margin-top: 10px;">Note that PLC memory sorting is not possible in the following cases.</p> <ol style="list-style-type: none"> 1. When the drive memory is faulty. 2. When one file is not stored in a single contiguous area. 	<ul style="list-style-type: none"> • Total free capacity 8K • Max. contiguous free area 8K 	<ul style="list-style-type: none"> • Total free capacity 14K • Max. contiguous free area 8K 	<ul style="list-style-type: none"> • Total free capacity 14K • Max. contiguous free capacity 14K
<ul style="list-style-type: none"> • Total free capacity 8K • Max. contiguous free area 8K 	<ul style="list-style-type: none"> • Total free capacity 14K • Max. contiguous free area 8K 	<ul style="list-style-type: none"> • Total free capacity 14K • Max. contiguous free capacity 14K 	

20.4 Setting for the PLC's Clock

A	Q/QnA	FX
○	○	○

[Purpose]

Sets the time for the internal clock of the PLC.

[Operating Procedure]

Select [Online] → [Set time]

[Dialog Box]

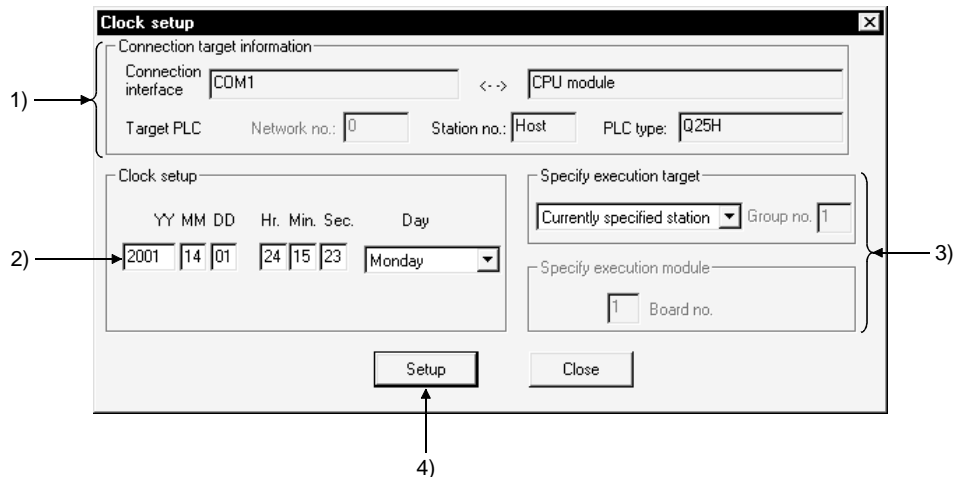

[Description]

- 1) Connection target information
Indicates information on the connection destination designation.

- 2) Clock setup
Sets the date, time, and day of the week.
For the Q series, enter the year in four digits. (Example: 2000)
You cannot set the year 2038 or later.

- 3) Specify execution target
Sets the location where the clock setting is to be made.

Currently specified station	Executed only at the station with the connection destination designation.
Specify all station	Executed at all stations of the network designated as the presently designated station. 1 to 4 modules can be set for execution module designation.
Specify group	Executed in a specific group of the network designated as the presently designated station. Set 1 to 4 modules for execution module designation and set the group number.

This setting is not possible with the FX series.

4) **Setup** button

Click this button after setting the necessary settings.

With the A series, clock setting can only be executed when the PLC is in the STOP state.

With the Q/QnA series and FX series, it can be executed even when the PLC is in the RUN state.

POINTS

- Clock setting is not possible for A0J2HCPU, A2CCPU and A2CJCPU since they do not have a clock function.
- With the A series, when the applicable station is in the RUN state, first set it to the STOP state using remote operation or other means, then carry out clock setting.
- With the A series, clock setting is possible regardless of the ON/OFF setting of the special relay for clock setting "M9028."
However, after execution, "M9208" goes OFF.
- With the Q/QnA series, clock setting is possible regardless of the ON/OFF status of the device for clock setting "SM1028."
Note that the ON/OFF status of "SM1028" does not change after execution.
- The applicable PLCs in the FX series are as follows.
FX_{2N} series (internal clock)
FX, FX₂, FX_{2C} (only when RTC cassette is mounted)
- With the FX series, clock setting is possible regardless of the ON/OFF status of the special relay for clock setting.
- Note that in clock setting, an error equivalent to the transmission time is generated.

21. DIAGNOSIS

21

Diagnosis displays the error statuses, fault history, etc. of the programmable controller, and carries out checks which depend on the network, including system status checks.

21.1 Diagnosing the PLC

21.1.1 Diagnosing an ACPU

A	Q/QnA	FX
○	×	×

[Purpose]

Displays the status and error codes of an A series CPU.
 Present ERROR indicates the error normally monitored, and Error log indicates the history status when the PLC Diagnostics window has opened.

[Operating Procedure]

Select [Diagnostics] → [Diagnostics PLC].

[Dialog Box]

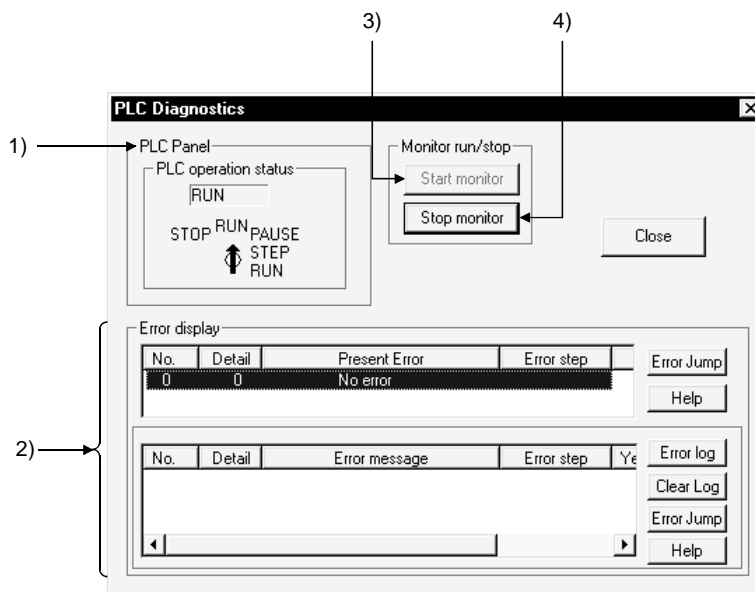

[Description]

- 1) CPU Panel
 Indicates the status of the PLC designated as the connection destination.

- 2) Error display explanation
 The upper error display field shows the current error.
 The lower error display field shows the error history.
 No. indicates the error code and Detail indicates the detailed error code.
 With the **PLC error** button, you can confirm the error detail.

For the QCPU-A, AnUCPU and AnACPU, clicking the **Error log** button displays up to 16 latest errors.

For the QCPU-A, AnUCPU and AnACPU, clicking the **Clear log** button clears the error history.

Choosing the error item and clicking the **Error Jump** button causes a jump to the corresponding sequence program. A jump takes place for any of the following errors that occurred from the ACPU.

10 INSTRUCT CODE ERR

13 CAN'T EXECUTE(P)

15 CAN'T EXECUTE(I)

46 SP. UNIT ERROR

50 OPERATION ERROR

A jump does not occur for SFC and SUB program errors.

The occurrence of a sequence program error causes a jump to MAIN.

- 3) **Start monitor** button
 Clicking this button initiates communication with the PLC and updates the display.
 On clicking the **Current error** button or the **Error log** button, monitoring is automatically stopped.
- 4) **Stop monitor** button
 Clicking this button stops communication with the PLC and holds the display.

POINT

- | |
|---|
| <ul style="list-style-type: none"> • Display and clearance of the error history is possible only with QCPU-A, AnACPU and AnUCPU. |
|---|

21.1.2 Diagnosing a QCPU(Qmode), QnACPU

A	Q/QnA	FX
×	○*	×

*: This function is compatible with the QnACPU.

[Purpose]

Checks the status and errors of a Q/QnA PLC.

[Operating Procedure]

Select [Diagnosis] → [Diagnostics PLC]

[Diagnosis]

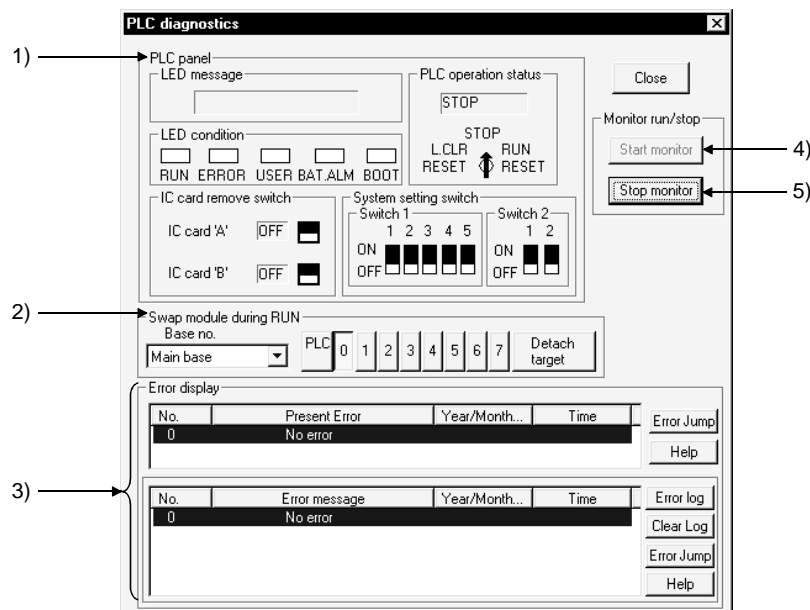

[Description]

- 1) CPU panel
Indicates the status of the PLC designated as the connection destination. For the QCPU(Qmode), any status other than the PLC operation status is masked.
- 2) Swap module during RUN
Set the base and slot number for the module to be mounted or removed in the RUN status, then click the **Detach target** button. Masked for the QCPU(Qmode).
- 3) Error display
Clicking the **Error log** button displays up to 16 of the most recent errors. Clicking the **Clear log** button clears the error history in the PLC. Clicking the **Error jump** button causes a jump to the sequence program step number at which the currently selected error occurred.
- 4) **Start monitor** button
Clicking this button initiates communication with the PLC and updates the panel display.

5) **Stop monitor** button

Clicking this button initiates communication with the PLC and updates the display.

On clicking the **Current error** button or the **Error log** button, monitoring stops automatically.

[Operating Procedure]

The procedure for mounting/removing a module in the RUN status is as follows.

1. Set the applicable base and slot at 2) and click the **Detach target** button: the RUN module mount/remove dialog box is displayed.
2. Mount or remove the module at the designated slot of the designated base.
3. After completing mounting/removal of the module, click the **End substitution** button in the RUN module mount/remove dialog box.

POINT

By double-clicking the current error in the error display list box, the Common error information dialog box opens and displays the contents of SD5 to 15 (common information for errors), and SD16 to 26 (information on an individual error) of the PLC.

No.	Error message	Year/Month...	Time
2110	SP.UNIT ERROR	98-9-28	18:13:27

Double-click the list item

Error details X

Common error information		Individual error information	
Unit no.	0	File name	MAIN .QPG
I/O No	0	SFC block	Nothing
		SFC step	Nothing
		SFC switching	Nothing
		Block no.	0
		Step	0
		Sequence step	30

Close

21.1.3 Diagnosing the QCPU (Q Mode)

A	Q/QnA	FX
×	○*	×

*: This function is compatible with the QCPU (Q mode).

[Purpose]

Checks the PLC CPU for abnormal conditions and errors.
 When the function version B of the PLC CPU is used, No. 1 to No. 4 modules can be diagnosed.

[Operating Procedure]

Select [Diagnostics] → [PLC diagnostics]

[Diagnosis]

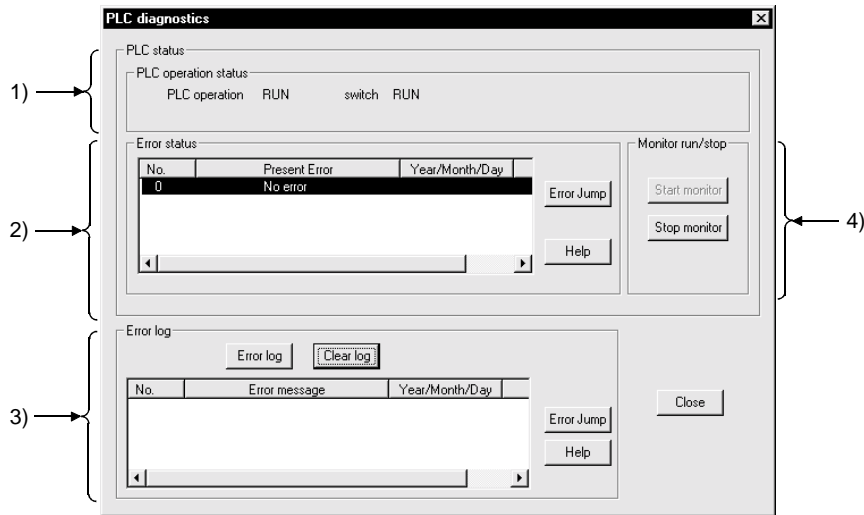

[Description]

- 1) PLC operation status
 None appears when a slot is empty in a multi-CPU system configuration.
- 2) Present Error
 Clicking the **Error Jump** button jumps to the sequence program step number in the currently selected error.
 Clicking the **Help** button shows the explanation screen corresponding to the error number selected in the Present Error display field.
 If two or more HELPs of the same error number exist, the search result screen starts.
 Choose the topic you want to display, and double-click (the **View** button).

3) Error log

Clicking the **Error log** button shows the latest error history.

Clicking the **Clear log** button clears the currently displayed error list.

Clicking the **Error Jump** button jumps to the sequence program step number in the currently selected error.

Clicking the **Help** button shows the explanation screen corresponding to the error number selected in the Present Error display field.

If two or more HELPs of the same error number exist, the search result screen starts.

Choose the topic you want to display, and double-click (the **View** button).

4) Monitor run/stop

Clicking the **Start monitor** button starts communications with the PLC CPU and updates the panel indication.

Clicking the **Stop monitor** button starts communications with the PLC CPU and stops the indication.

Clicking the current error button or **Error log** button automatically stops monitoring.

POINT

- Double-clicking the current error in the error display area shows the definitions of SD5 to 15 (error common information) and SD16 to 26 (error individual information) of the PLC CPU in the error detail dialog box.

No.	Error message	Year/Month...	Time
2110	SP.UNIT ERROR	98-9-28	18:13:27

Double-click the list item

↓

Error details [X]

Common error information		Individual error information	
Unit no.	0	File name	MAIN .QPG
I/O No	0	SFC block	Nothing
		SFC step	Nothing
		SFC switching	Nothing
		Block no.	0
		Step	0
		Sequence step	30

Close

21.1.4 Diagnosing an FXCPU

A	Q/QnA	FX
×	×	○

[Purpose]

Displays the status and error codes of an FX series PLC.

[Operating Procedure]

Select [Diagnostics] → [Diagnostics PLC].

[Dialog Box]

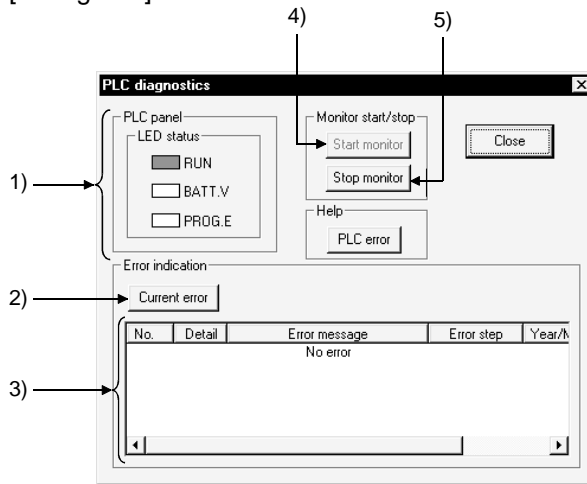

[Description]

1) **PLC Panel**

Indicates the status of the connected PLC.

RUN : Lit in green when the PLC is in the RUN status.

BATT.V : Lit in red when the voltage of the battery for memory back up has dropped.

PROG.E : Lit in red when an error has occurred (when one of the following is ON: M8061, M8064, M8065, M8066).

2) **Current error** button

Clicking this button displays errors that have occurred at the PLC.

The date and time values are not those when the error occurred but when the **Current error** button was clicked.

3) **Error indication**

Displays current errors at the PLC.

The error details are displayed as the error code and error message.

4) **Start monitor** button

Clicking this button initiates communication with the PLC and updates the display.

5) **Stop monitor** button

Clicking this button initiates communication with the PLC and holds the display.

21.2 Diagnosing a Network

A	Q/QnA	FX
○	○	×

[Purpose]

Checks the status of MELSECNET (II) or MELSECNET/10, MELSECNET/H from the host station, which is designated the connection destination.

[Operating Procedure]

Select [Diagnostics] → [Diagnostics network].

[Dialog Box]

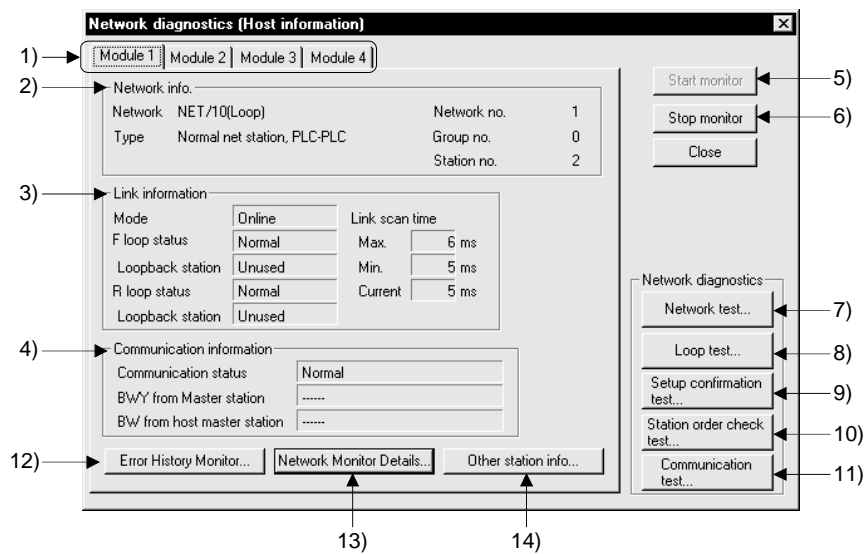

[Description]

- 1) Link module selection tabs
Switch among network diagnosis result displays for the first to fourth link modules.
With AnNCPU and AnACPU, there are only module 1 and module 2.
- 2) Network info.
Indicates the network information of the host station set in connection destination designation.
With MELSECNET (II), the network No. and group No. are not displayed.
- 3) Link information
Indicates the network status.
- 4) Communication information
Indicates the communication status of the applicable network.
For MELSECNET/10, MELSECNET/H only the communication status is indicated.

- 5) **Start monitor** button
Clicking this button starts network diagnostics.
During monitoring, the indication is updated.
- 6) **Stop monitor** button
Clicking this button stops network diagnostics.
During a monitoring stop, the indication is held.
- 7) **Network test** button
Refer to Section 21.2.1.
- 8) **Loop test** button
Refer to Section 21.2.2.
- 9) **Setup confirmation test** button
Refer to Section 21.2.3
- 10) **Station order check test** button
Refer to Section 21.2.4
- 11) **Transmission Test** button
Refer to Section 21.2.5
- 12) **Error History Monitor** button
Refer to Section 21.2.6.
- 13) **Network Monitor Details** button
Refer to Section 21.2.7.
- 14) **Other station info** button
Refer to Section 21.2.8.

POINTS

- Indicates the number of link modules that can be mounted for each network type.
MELSECNET (II) 2
MELSECNET/10, MELSECNET/H 4
- The object of network diagnosis is the network of the connected host station.
To change the network that is the object of diagnosis, change the applicable station in the connection destination designation.
- Network diagnosis is not possible if remote I/O stations are connected.
- About host station information and other station information:
When the routing is through E71, an AnUCPU executes monitoring equivalent to that of an AnACPU, which means that MELSECNET (II) information can be monitored but MELSECNET/10, MELSECNET/H modules cannot be monitored.

21.2.1 Testing a network

A	Q/QnA	FX
○	○	×

[Purpose]

Starts/stops link operation for the MELSECNET/10, MELSECNET/H host station/designated station/ all stations.

[Operating Procedure]

Select [Diagnostics] → [Diagnostics network] → then click the **Network test** button.

[Dialog Box]

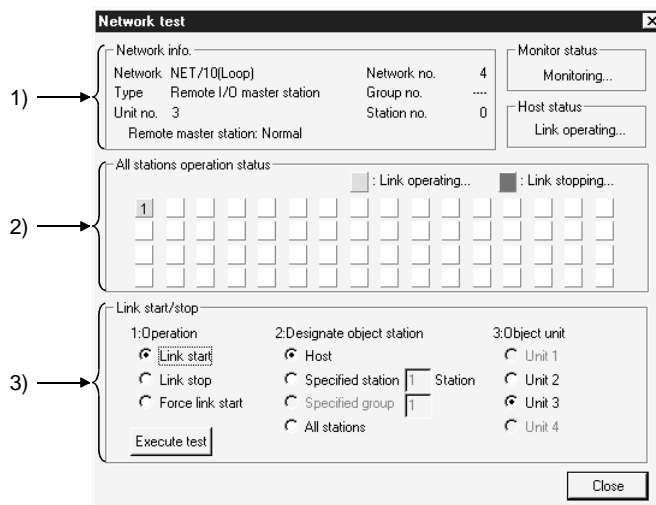

[Description]

1) Network info.

Indicates the network information of the host station designated in the connection destination designation.

2) All stations operation status

Indicates the link status of the modules for which the test is executed.

3) Link start/stop

The order of priority for link start/stop is as follows:
Link start < Link stop < Forced link start

<Start>

- Stations that have been stopped from the host station can be started.
- Stations that have been stopped from an other station cannot be started.

<Stop>

- Stations can be stopped from the host station or other stations.

<Forced start>

- Stations can be started regardless of whether they were stopped from the host station or an other station.
However, forced starting in station units is not possible when all stations are stopped.
- Forced start is not possible when there is an other station designation for the connection destination.
- Whether or not execution is possible at a personal computer can be checked by monitoring SB and SW; whether execution has been started/stopped at the host station can be checked by monitoring SW0000 to SW0004 and SB0000 to SB0003.
- When the connection destination is routed through C24, UC24, or QC24, execution is possible.
- Execution is not possible when using a MELSECNET (II)/MELSECNET/10 board.
- Execution is not possible with routing through E71/QE71.

21.2.2 Performing a loop test

A	Q/QnA	FX
○	○*	×

*: This function is also compatible with the Q series remote I/O.

[Purpose]

Checks the status of the MELSECNET/10, MELSECNET/H loop.

[Operating Procedure]

Select [Diagnostics] → [Diagnostics network] → **Loop test** button.

[Dialog Box]

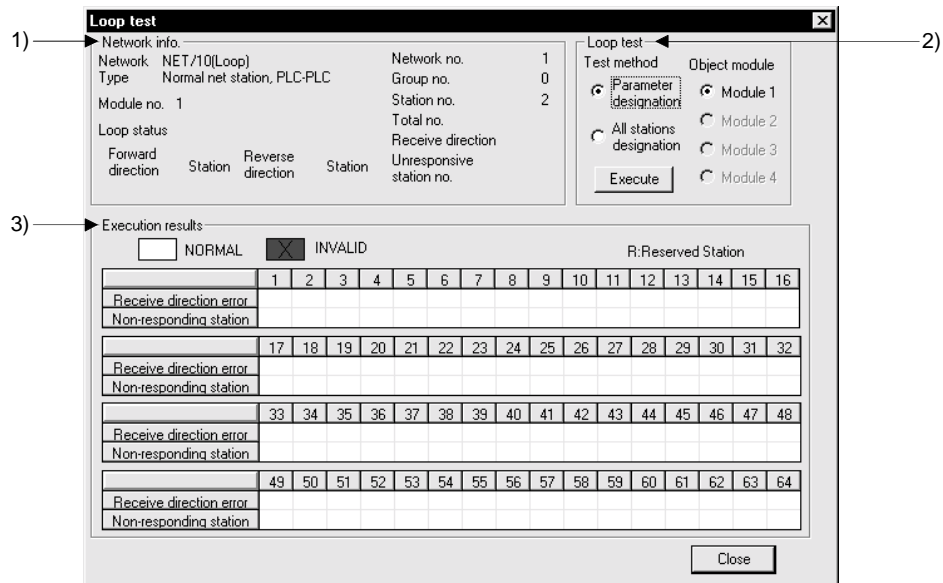

[Description]

1) Network Information

Shows own station's network information set in Connection destination specification.

2) Loop Test

Set the test enact method and target module, and click the **Execute** button to start a loop test.

A loop test made with connection of remote stations may be conducted only on the connected remote I/O network.

A change in target module will result in an error.

- Test enact method

- Parameter settings

Tests the parameter-set stations (except the reserved stations).

When there are no parameter settings, all stations will be tested.

- Set all nodes

Tests all stations.

- Object unit

Choose the module on which a loop test will be conducted.

The default is the module selected in line monitor (own station).

3) Execution Result

Shows the number of stations and results (normal/abnormal, reserved stations: R).

21.2.3 Performing a setting confirmation test

A	Q/QnA	FX
○	○*	×

*: This function is also compatible with the Q series remote I/O.

[Purpose]

Checks the status of the following settings made for each station: station number, network number, group number.

[Operating Procedure]

Select [Diagnostics] → [Diagnostics network] → then click the **Setup confirmation test** button.

[Dialog Box]

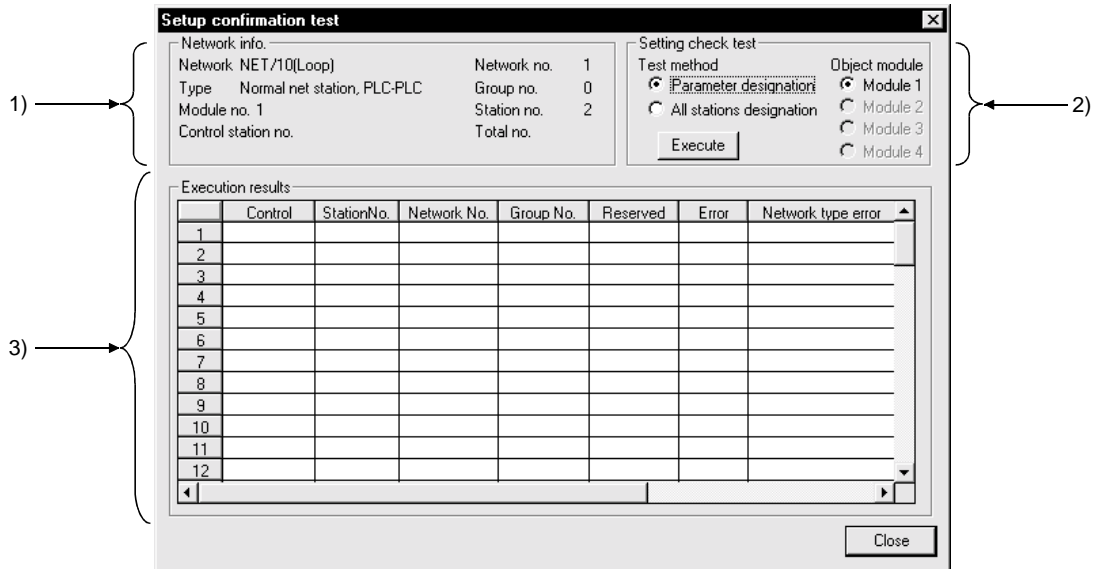

[Description]

- 1) Network info.
Indicates the network information of an other station designated at the connection destination.
- 2) Setting check test
 - Test method
 - ⊙ Parameter designation
All the stations set in the parameters, with the exception of reserve stations, are subject to the setting confirmation test.
If no network settings have been set (default), all stations are subject to the test.
 - ⊙ All stations designation
All stations are subject to the setting confirmation test.
There is no number of stations designation.
 - Object unit
The module selected for the line monitor (own station) is set as the default.
If there is no MELSECNET/10, MELSECNET/H module, an error occurs.

3) Execution results

<Station No.>

Indicates station numbers up to that subject to the setting confirmation test.
Up to 64 stations are indicated.

<Control>

If control stations have been set at two or more locations, " * " is displayed.

<Station No.>

If stations have been set at two or more locations, " * " is displayed.

<Network No. >

If the same station number has been set at two or more locations, " * " is displayed.

Stations whose network number differs from the network number of the host station are indicated in red.

<Group No.>

Indicates the group number of the station where the setting confirmation test is carried out.

In the case of a remote I/O net, the indication for stations with errors is blank.

<Reserve stations>

" * " is displayed for stations set as reserve stations in the parameters.

(Where "Parameter designation" has been set as the test execution designation.)

<Error>

If a station is reserved in the parameter settings, or a module in all station designation is faulty, " * " is displayed.

<Network type error> QnA series only

" * " is displayed for stations whose parameter setting and actual connection type do not agree.

<Multiplex remote master station duplication> QnA series only

" * " is displayed for stations where there is more than one submaster station of the same network.

<Parallel remote submaster station duplication> QnA series only

" * " is displayed for stations where there is more than one submaster station of the same network.

POINTS

- The test cannot be executed at more than one station at the same time.
- Note that cyclic transmission is stopped while the test is being executed.

21.2.4 Performing a station order confirmation test

A	Q/QnA	FX
○	○*	×

*: This function is also compatible with the Q series remote I/O.

[Purpose]

Confirms the station order in the forward/reverse loops of a MELSECNET/10, MELSECNET/H system.

[Operating Procedure]

Select [Diagnostics] → [Diagnostics network] → click the **Station order check test** button.

[Dialog Box]

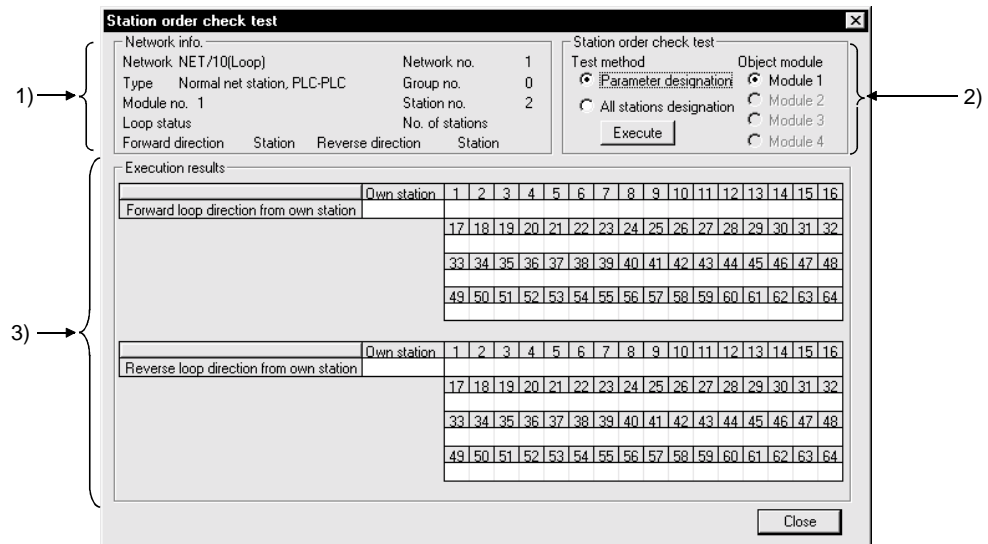

[Description]

- 1) Network info.
 - Indicates the network information of an other station designated at the connection destination.
 - For the loop status, the forward/reverse loop / forward loop / reverse loop / loopback status is indicated.
 - The total number of stations indicated is that determined by including the reserve stations in the test.
- 2) Loop test
 - Test method
 - Parameter designation
 - Stations set in the parameters, with the exception of reserve stations, are subject to the test.
 - If the network parameters have not been set (default), all stations are subject to the test.
 - All stations designation
 - All stations are subject to the station order confirmation test.
 - There is no number of stations designation.
 - Object unit
 - The module selected for the line monitor (own station) is set as the default.
 - If there is no MELSECNET/10, MELSECNET/H module, an error occurs.

3) Execution results

The order of stations in the forward loop direction and reverse loop direction, starting from the host station, is indicated.

For loopback, only the order in the forward loop direction from the host station is indicated.

The station numbers of reserve stations are not indicated.

POINTS

- | |
|---|
| <ul style="list-style-type: none">• The test cannot be executed at more than one station at the same time.• Note that cyclic transmission is stopped while the test is being executed. |
|---|

21.2.5 Performing a transmission test

A	Q/QnA	FX
○	○*	×

*: This function is also compatible with the Q series remote I/O.

[Purpose]

Conducts a transmission test between networks on the MELSECNET/10(H).

[Operating Procedure]

Select [Diagnostics] → [Diagnostics network] → **Transmission test** button.

[Dialog Box]

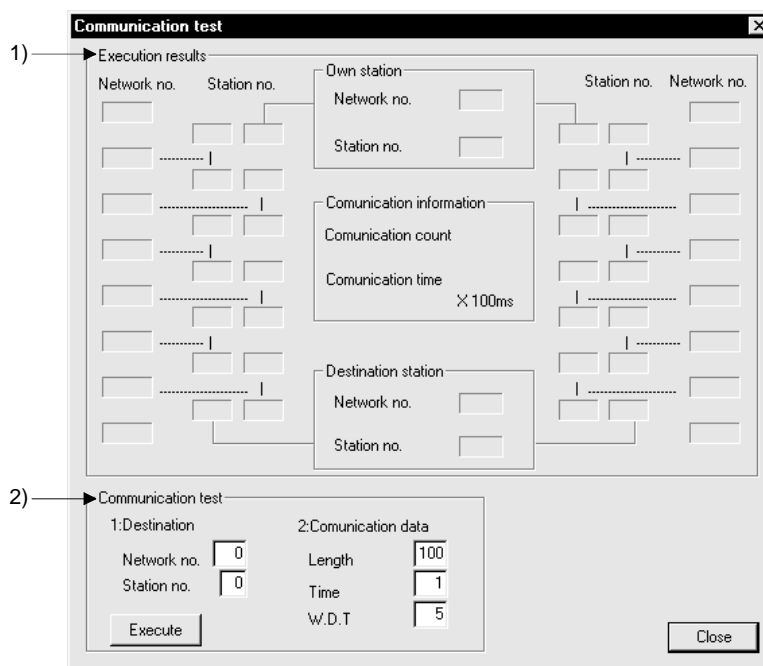

[Description]

- 1) Execution Result
Shows the transmission test results between the networks.
- 2) Communication Test
Set Destination Setting, Transmission Data Setting and Target Module, and click the **Execute** button to start a transmission test.
A change in target module will result in an error.
 - Destination Setting
Set the network No. (1 to 255 for A series, 1 to 239 for Q/QnA series) and station number (1 to 64).
 - Transmission Data Setting
Set Data length (1 to 900 bytes), Number of Transmission (1 to 100 times) and Transmission Inspection Time (1 to 100 seconds).

21.2.6 Monitoring the error history

A	Q/QnA	FX
○	○*	×

*: This function is also compatible with the Q series remote I/O.

[Purpose]

Shows the error history of the MELSECNET/10(H).

[Operating Procedure]

Select [Diagnostics] → [Diagnostics network] → **Error History Monitor** button.

[Dialog Box]

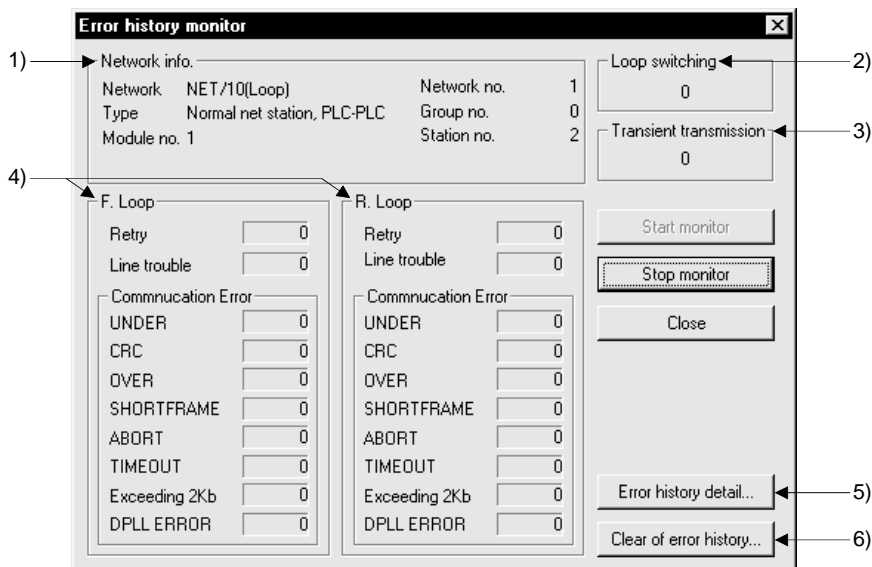

[Description]

- 1) Network Information
Shows each information of the network.
- 2) Loop switching
Shows the number of loop conversions.
- 3) Transient transmission
Shows the number of transient transmission errors.
- 4) F Loop/R Loop
Shows each item for monitoring execution.

- 5) **Error History Details** button
Shows the details of Number of Loop Conversions and Peer to Peer Transmission Error.

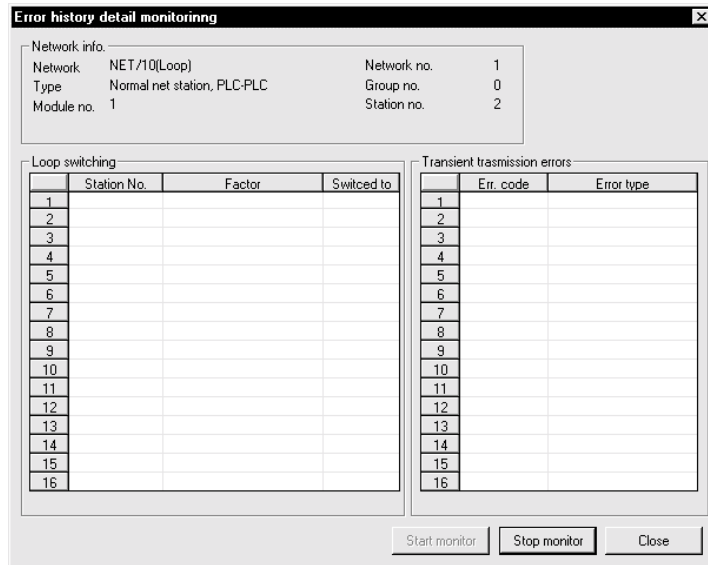

- 6) **Clear of Error History** button

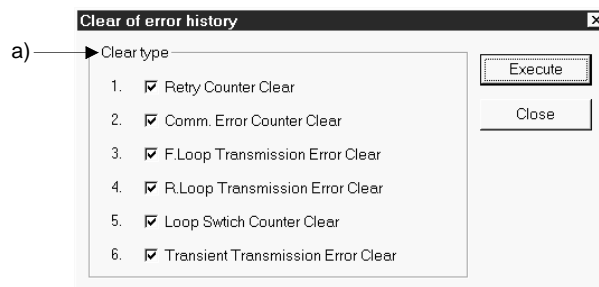

- a) Clear type
Choose any item to be cleared.

21.2.7 Network monitor details

A	Q/QnA	FX
○	○*	×

*: This function is also compatible with the Q series remote I/O.

[Purpose]

Shows the network line status of the MELSECNET/10(H).

[Operating Procedure]

Select [Diagnostics] → [Diagnostics network] → **Network Monitor Details** button.

[Dialog Box]

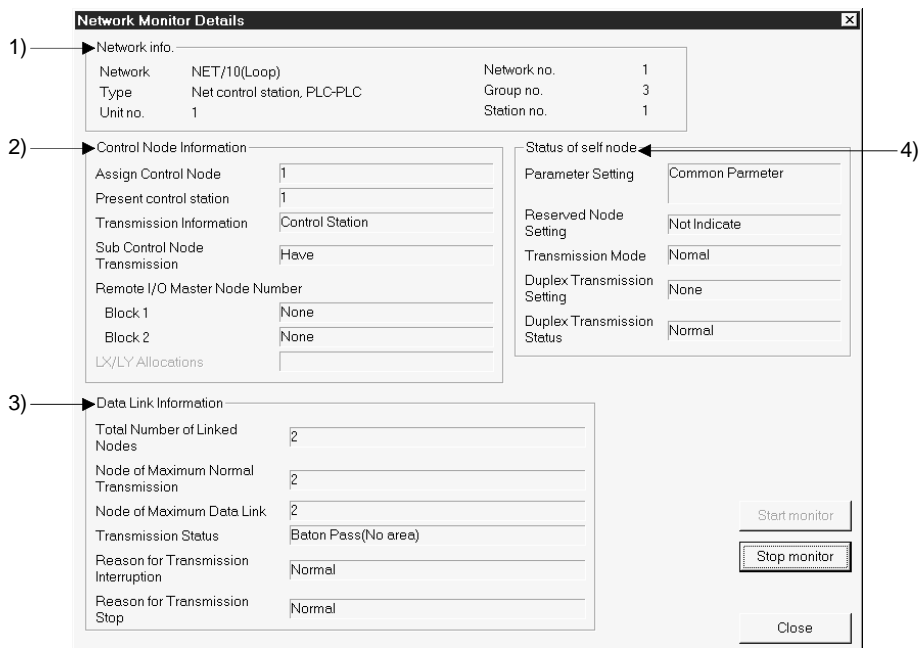

[Description]

- 1) **Network Information**
Shows each information of the network.
- 2) **Control Node Information**
Shows each information of the control station.
Remote I/O master station appears only for the inter-PLC network.
LX/LY assignment appears only for the remote I/O network.
- 3) **Data Link Information**
Shows each information of data link.
- 4) **Status of self node**
Shows each status of the own station.
Parameter setting appears only for the inter-PLC network.

21.2.8 Monitoring other station information

A	Q/QnA	FX
○	○*	×

*: This function is also compatible with the Q series remote I/O.

[Purpose]

Monitors other stations connected to MELSECNET(II), MELSECNET/10, MELSECNET/H.

[Operating Procedure]

Select **[Diagnostics]** → **[Diagnostics network]** → then click the **[Other station information]** button.

[Dialog Box]

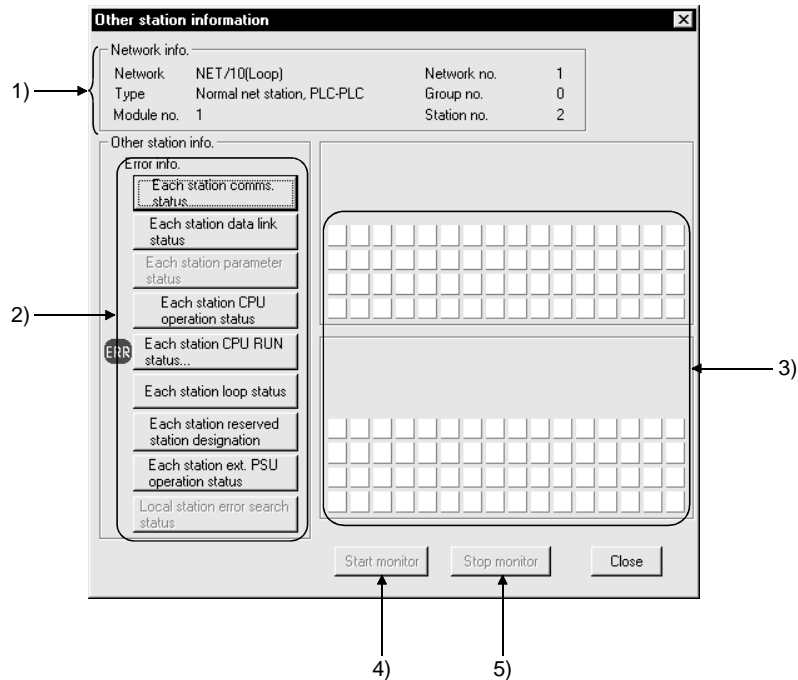

[Description]

- 1) Network info.
Indicates the network information of the other station designated at the connection destination.
- 2) Error info.
"ERR" will appear in the error information display field when the faulty station, STOP station, reserved station and station supplied with external power are detected for the corresponding items.
"RSV" will appear in the error information display field when the reserved station is specified.
Choose the corresponding item buttons to display their details in 3).
- 3) Detailed error information display field
When a station information item is selected, indicates the station status relevant to that item.
- 4) **[Start monitor]** button
Starts monitoring if it is stopped.
Not effective if monitoring is in progress.

- 5) Stop monitor button
 Stops monitoring when it is in progress.
 Not effective if monitoring is already stopped.

- The following other station information items cannot be selected with the A series.

		MELSECNET/10						MELSECNET(II)	
		MELSECNET/10				MELSECNET(II)		—	
		Control Station		Normal Station		Master Station		Master	Local
		Loop	Path	Loop	Path	Loop	Path	—	—
1	Communication status for each station	○	○	○	○	○	○	○	×
2	Data link status for each station	○	○	○	○	○	○	×	×
3	Parameter status for each station	○	○	×	×	○	○	○	×
4	CPU operating state for each station	○	○	○	○	×	×	×	×
5	CPU RUN state for each station	○	○	○	○	×	×	○	○
6	Loop status for each station	○	×	○	×	○	×	○	×
7	Reserve station designation for each station	○	○	○	○	○	○	×	×
8	External power supply operation status for each station	×	×	×	×	×	×	×	×
9	Local station error detection status	×	×	×	×	×	×	○	×

○: Can be selected ×: Cannot be selected (mask display)
: Different selection to GPPA, GPPQ possible/not possible

- The following other station information items cannot be selected with the Q/QnA series.

		MELSECNET/10, MELSECNET/H						MELSECNET(II)	
		MELSECNET/10, MELSECNET/H				MELSECNET(II)		—	
		Control Station		Normal Station		Master Station		Master	Local
		Loop	Path	Loop	Path	Loop	Path	—	—
1	Communication status for each station	○	○	○	○	○	○	○	×
2	Data link status for each station	○	○	○	○	○	○	×	×
3	Parameter status for each station	○	○	×	×	○	○	○	×
4	CPU operating state for each station	○	○	○	○	×	×	×	×
5	CPU RUN state for each station	○	○	○	○	×	×	○	○
6	Loop status for each station	○	×	○	×	○	×	○	×
7	Reserve station designation for each station	○	○	○	○	○	○	×	×
8	External power supply operation status for each station	○	×	○	×	○	×	×	×
9	Local station error detection status	×	×	×	×	×	×	○	×

○: Can be selected ×: Cannot be selected (mask display)

■: Different selection from GPPA, GPPQ possible/not possible

21.3 Running CC-Link Diagnostics

CC-Link diagnostics monitor the network information of each station and diagnose and test the network status.

CC-Link diagnostics can be run via the PLC CPU when the CC-Link module is the master station/standby master station/local station.

POINTS
<ul style="list-style-type: none"> • The QCPU diagnoses the QJ61BT11 only. • Use the AJ61BT11/A1SJ61BT11 module with the QCPU-A. • When refresh parameters have been created in a sequence program for the A series, Data link start and Monitoring Other station, Network test are disabled.

21.3.1 Monitoring the line (own station)

A	Q/QnA	FX
○	○*	×

*: This function is also compatible with the QCPU (Q mode) remote I/O.

[Purpose]

Monitors the own station line of CC-Link connected to the PLC CPU.

[Operating Procedure]

Select [Diagnostics] → [CC-Link diagnostics].

[Dialog Box]

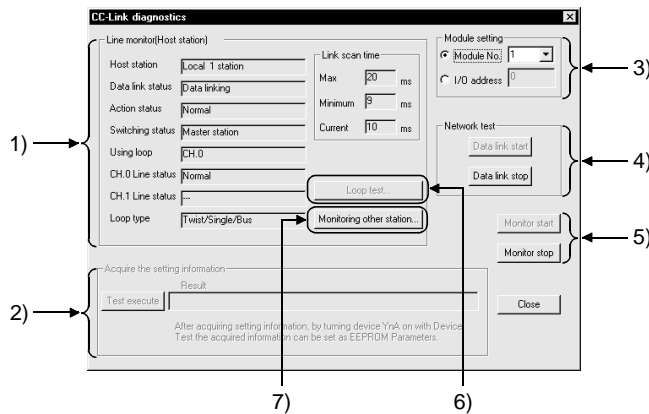

[Description]

- 1) Own station information
The special M (SB) and special D (SW) assigned to the display items will be described below.
- 2) Acquire the setting information (A/QnA series only)
Executing this item sets the CC-Link system status set to the work area of the CC-Link module.

- 3) Module setting
Specify the CC-Link module to be monitored.
The setting range is 1 to 4 modules.
When the A/QnA series module of function version A is used, the number of modules cannot be set. Set the I/O address.
- 4) Network test
A data link start/stop is made for the CC-Link modules (all stations specified) set in Unit setting.

IMPORTANT

In the following system configuration, making a "data link stop" for the master station disables communications from GX Developer.
To make a data link start or resume communications from GX Developer, the PLC CPU of the station whose data link was stopped must be reset.

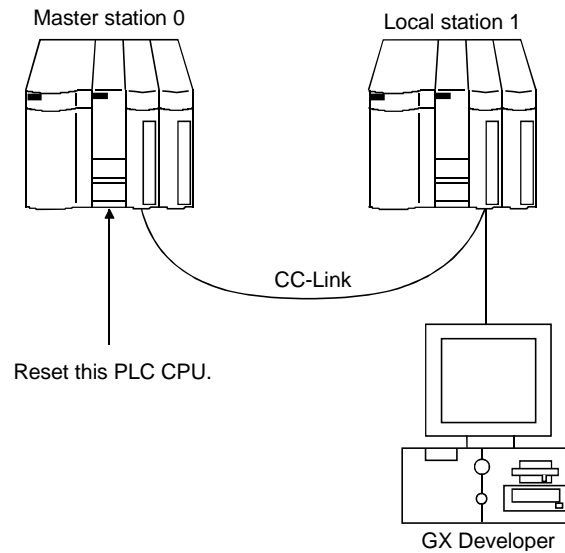

- 5) Monitor start / stop button
Used to start/stop the own station monitoring.
- 6) Loop test button
Refer to Section 21.3.2.
- 7) Monitoring other station button
Refer to Section 21.3.3.

21.3.2 Conducting a line test

A	Q/QnA	FX
○	○*	×

*: This function is also compatible with the QCPU (Q mode) remote I/O.

[Purpose]

Tests all stations or the specified station.
Valid only when the master station has been specified in Transfer setup.

[Operating Procedure]

Select [Diagnostics] → [CC-Link diagnostics]. → **Loop test** button.

[Dialog Box]

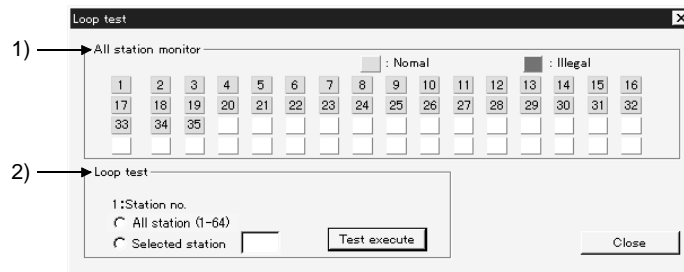

[Description]

- 1) All station monitor
Monitors the operating states of all CC-Link stations.
Faulty stations are shown in red.
- 2) Loop test
A line test is made by specifying the own station or another station (station number).
All station: Test will be run on all 64 stations.
Selected station: Test will be conducted on the specified stations.
Specify the first one of the occupied stations.

<Example>

- When there are 4 and 2 occupied stations connected



Specify 1 Specify 5
Specifying 2,3,4 or 6 will result in a faulty station.

21.3.3 Monitoring the lines (other stations)

A	Q/QnA	FX
○	○*	×

*: This function is also compatible with the QCPU (Q mode) remote I/O.

[Purpose]

Monitors the other station lines of CC-Link connected to the PLC CPU.
Can be executed only during Linking Data.

[Operating Procedure]

Select [Diagnostics] → [CC-Link diagnostics] → Monitoring other station button.

[Dialog Box]

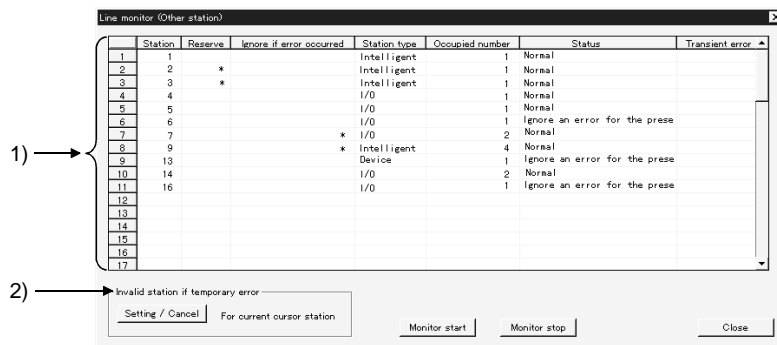

[Description]

- 1) Other station information
Shows the information on the other stations.
When the own station is a local station, the status of the CC-Link system is monitored in other station monitoring, and therefore no reserved stations are displayed.
- 2) Invalid station if temporary error
A module is changed without the corresponding remote station being error-detected while it is online.

The temporary error invalidation setting must be made by specifying the first station number.
Therefore, when there is no parameter setting, the status and transient error information is shown on the assumption that one station occupies 32 points, and you must make this setting by specifying the station number for which you want to make the invalidation setting.
(The invalidation setting is ignored if it is made for the station which is not in the first position of actual assignment.)

21.4 Making Ethernet Diagnostics

You can check various settings of the Ethernet module.

For details, refer to the sections which explain the error codes and buffer memory in the corresponding items of the following manuals.

- Q-Compatible Ethernet Interface Module User's Manual (Fundamentals)
- QnA-Compatible Ethernet Interface Module User's Manual (Details)
- AJ71E71-S3, A1SJ71E71-B2-S3, A1SJ71E71-B5-S3 Ethernet Interface Module User's Manual (Details)

21.4.1 Ethernet diagnostics

A	Q/QnA	FX
○	○	×

[Purpose]

You can check the parameter status, error log, status of each connection, status of each protocol, LED status, received e-mail information and send e-mail information.

[Operating Procedure]

Select [Diagnostics] → [Ethernet diagnostics]

[Dialog Box]

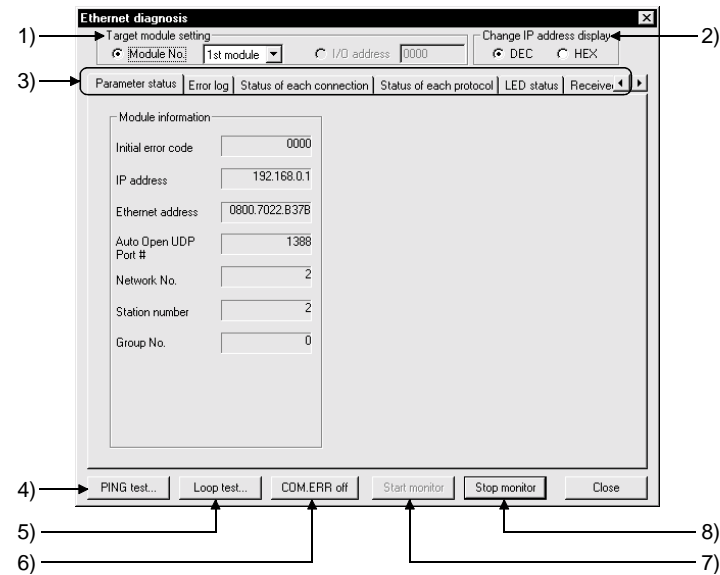

[Description]

- 1) Target module setting
Specify the Ethernet module to be monitored.
The setting range is 1 to 4 modules.
When the A/QnA series module of function version A is used, the number of modules cannot be set. Set the I/O address.
- 2) Change IP address display
Change the IP address indication between decimal and hexadecimal.
- 3) Selection of information monitor
Various information on the Ethernet module can be monitored.
- 4) **PING test**
Used to perform a PING test on the equipment on other end.
Refer to Section 2.4.9.
- 5) **Loop test**
Used to perform a loopback test on the network.
Refer to Section 2.4.10.
- 6) **COM. ERR off**
Click this button to extinguish the [COM ERR] LED.
- 7) **Start monitor**
Click this button to start Ethernet diagnostics.
The display is updated during monitoring.
- 8) **Stop monitor**
Click this button to stop Ethernet diagnostics.
The display is held during monitoring stop.

21.4.2 Parameter status

A	Q/QnA	FX
○	○	×

[Purpose]

Monitors the parameter status of the Ethernet module.

[Operating Procedure]

Select [Diagnostics] → [Ethernet diagnostics] → <<Parameter status>> tab.

[Dialog Box]

For Q series

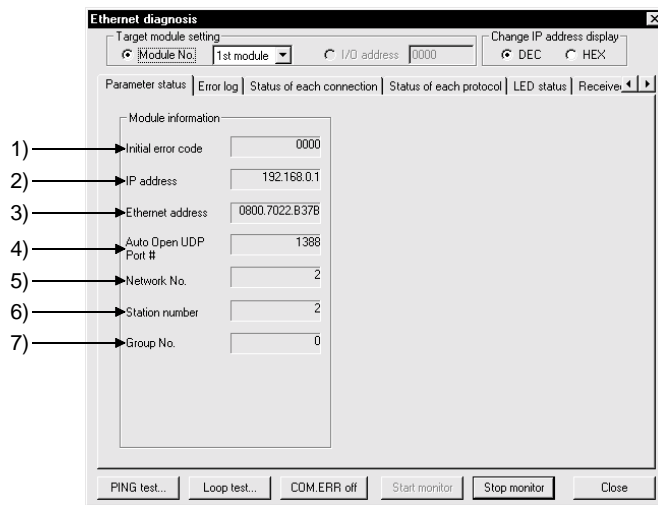

For QnA series

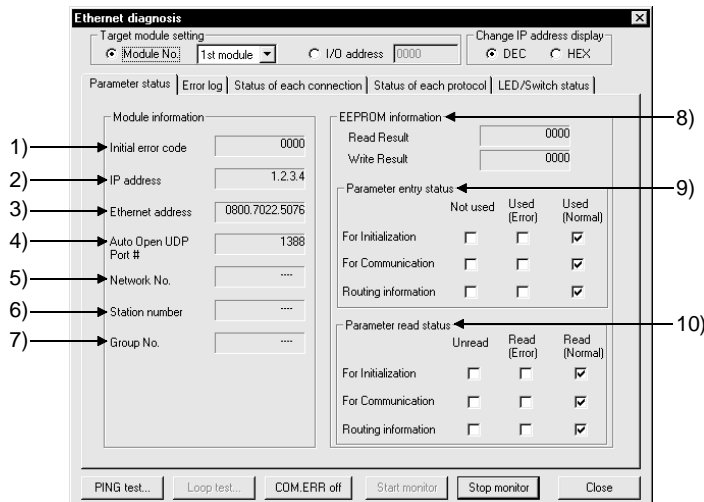

For A series

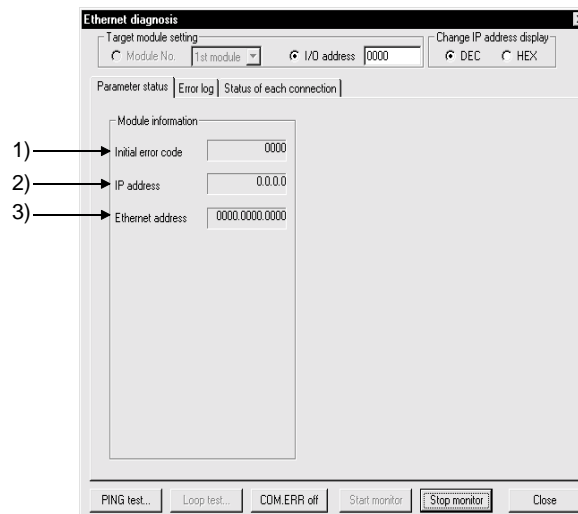

[Description]

- 1) Initial error code
Displays the initial error code.
- 2) IP address
Displays the own station IP address.
- 3) Ethernet address
Displays the own station Ethernet address.
- 4) Auto Open UDP Port #
Displays the automatic OPEN UDP port number.
- 5) Network No.
Displays the target module-specified network number.
- 6) Station number
Displays the target module-specified station number.
- 7) Group No.
Displays the target module-specified group number.
- 8) EEPROM information
0000 appears when normal.
The error code appears when abnormal.
Refer to the manual of the corresponding model and take corrective action.
- 9) Parameter entry status
Displays the preset parameter status.
- 10) Parameter read status
Displays the preset parameter status.

21.4.3 Error history

A	Q/QnA	FX
○	○	×

[Purpose]
Monitors the error log area.

[Operating Procedure]
Select [Diagnostics] → [Ethernet diagnostics] → <<Error log>> tab.

[Dialog Box]
For Q/QnA series

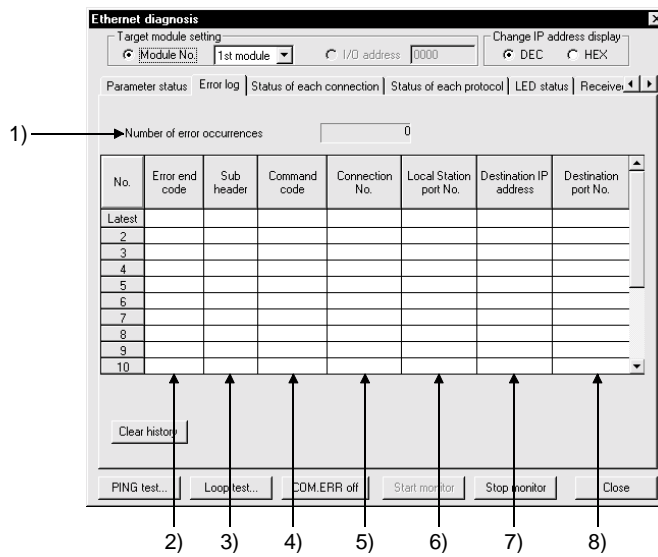

For A series

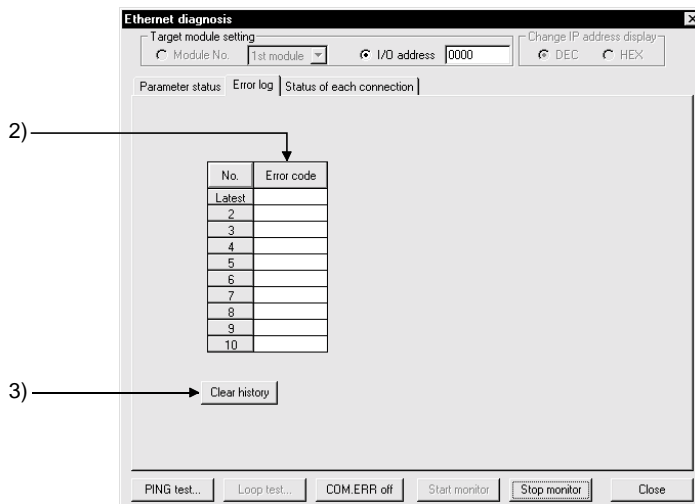

[Description]

- 1) Number of error occurrences
Displays the number of error occurrences.
- 2) Error end code
Displays the error/termination code.
Displays only the error code for the A series.
- 3) Sub header
Displays the sub header.
- 4) Command Code
Displays the command code.
- 5) Connection No.
Displays the connection number.
- 6) Local Station port No.
Displays the own station port number.
- 7) Destination IP address
Displays the IP address on the other end of communication.
- 8) Destination Port No.
Displays the port number on the other end of communication.
- 9) Clear history button
Clears the error history.

21.4.4 Status of each connection

A	Q/QnA	FX
○	○	×

[Purpose]

Monitors the status of each connection.
 Up to numbers 16 are displayed for the Q series.
 Up to numbers 8 are displayed for the QnA/A series.

[Operating Procedure]

Select [Diagnostics] → [Ethernet diagnostics] → <<Status of each connection>> tab.

[Dialog Box]

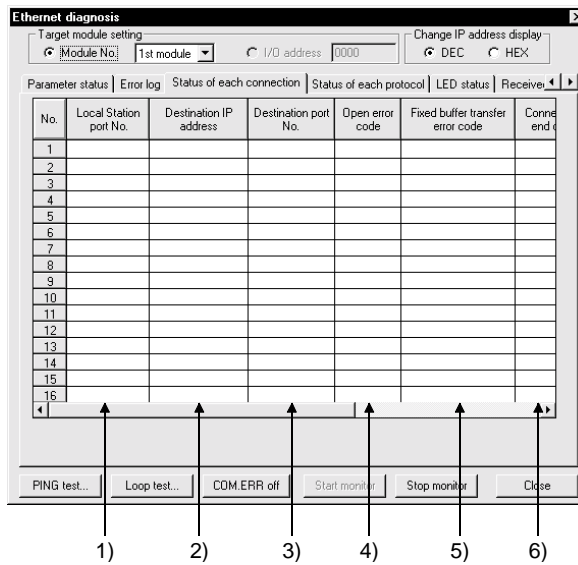

[Description]

- 1) Local Station port No.
Displays the own station port number.
- 2) Destination IP address
Displays the IP address on the other end of communication.
- 3) Destination port No.
Displays the port number on the other end of communication.
- 4) Open error code
Displays the open error code.
- 5) Fixed buffer transfer error code
Displays the fixed buffer send error code.
- 6) Connection end code
Displays the connection termination code.
- 7) Protocol
Displays the UDP or TCP.
- 8) Open system
Displays Active, Unpassive or Full passive.
- 9) Pairing open
Displays whether pairing is made or not.
- 10) Existence confirmation
Displays whether check is made or not.

21.4.5 Status of each protocol

A	Q/QnA	FX
×	○	×

[Purpose]
Monitors the status of each protocol.

[Operating Procedure]
Select [Diagnostics] → [Ethernet diagnostics] → <<Status of each protocol>> tab.

[Dialog Box]

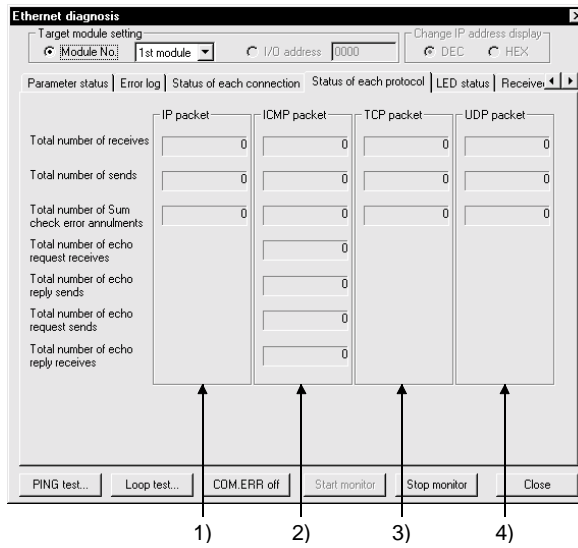

[Description]

1) IP Packet

Total number of receivesDisplays the total number of receive IP packets.

Total number of sends.....Displays the total number of send IP packets.

Total number of Sum

check error annulments.....Displays the number of times when the receive IP packets were discarded due to sumcheck error.

- 2) ICMP Packet
- Total number of receivesDisplays the total number of receive ICMP packets.
 - Total number of sendsDisplays the total number of send ICMP packets.
 - Total number of Sum check error annulmentsDisplays the number of times when the receive ICMP packets were discarded due to sumcheck error.
 - Total number of echo request receivesDisplays the total number of receive ICMP's echo requests.
 - Total number of echo reply sendsDisplays the total number of send ICMP's echo replies.
 - Total number of echo request sendsDisplays the total number of send ICMP's echo requests.
 - Total number of echo reply receivesDisplays the total number of receive ICMP's echo replies.
- 3) TCP Packet
- Total number of receivesDisplays the total number of receive TCP packets.
 - Total number of sendsDisplays the total number of send TCP packets.
 - Total number of Sum check error annulmentsDisplays the number of times when the receive TCP packets were discarded due to sumcheck error.
- 4) UDP Packet
- Total number of receivesDisplays the total number of receive UDP packets.
 - Total number of sendsDisplays the total number of send UDP packets.
 - Total number of Sum check error annulmentsDisplays the number of times when the receive UDP packets were discarded due to sumcheck error.

21.4.6 LED status

A	Q/QnA	FX
×	○	×

[Purpose]

Monitors the LED light-up status on the Ethernet module front.

[Operating Procedure]

Select [Diagnostics] → [Ethernet diagnostics] → <<LED status>> tab.

[Dialog Box]

Q series

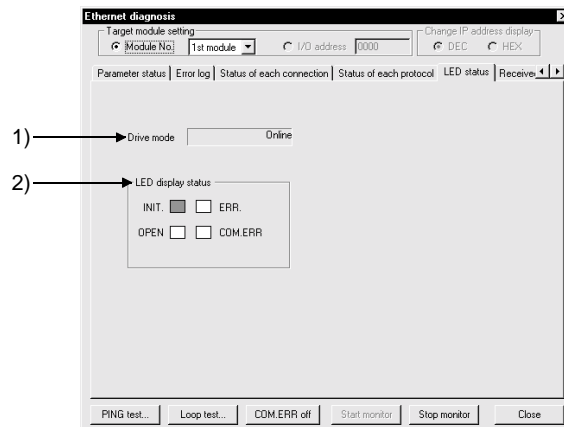

QnA series

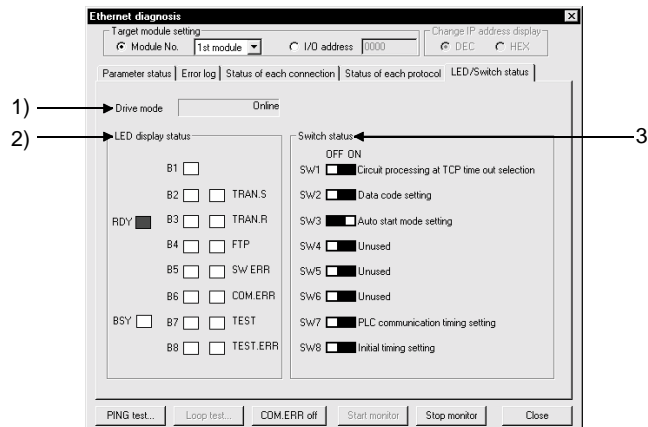

[Description]

- 1) Drive mode
Displays the switch status (operation mode setting).
A PLC communication error will occur if a RAM or ROM test is preset by the switch setting of the Ethernet module.
- 2) LED display status
Displays the statuses of the INIT, OPEN, ERR. and COM.ERR LEDs.
- 3) Switch status (QnA series only)
Displays the DIP switch statuses of the QE71.

21.4.7 Received e-mail information

A	Q/QnA	FX
×	○*	×

*: This function is compatible with the QCPU (Q mode).

[Purpose]

Monitors the received e-mail information.

[Operating Procedure]

Select [Diagnostics] → [Ethernet diagnostics] → <<Received e-mail information>> tab.

[Dialog Box]

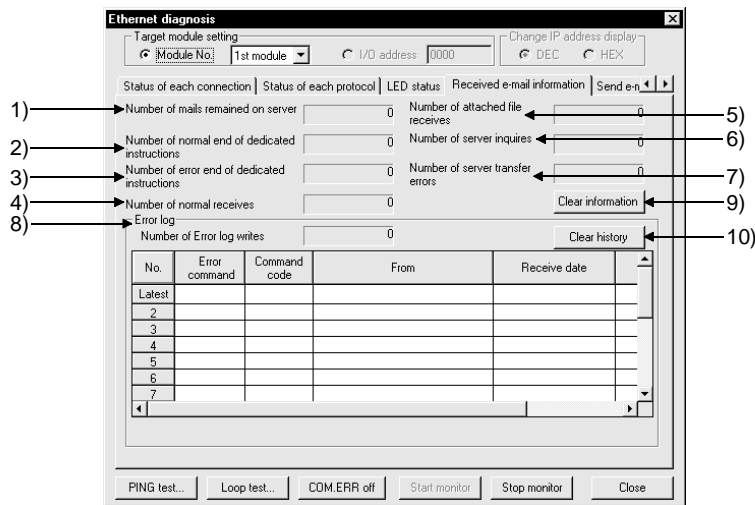

[Description]

- 1) Number of mails remained on server
Displays the number of mails remaining in the server.
- 2) Number of normal end of dedicated instructions
Displays the number of times when dedicated instructions were completed normally.
- 3) Number of error end of dedicated instructions
Displays the number of times when dedicated instructions were completed abnormally.
- 4) Number of normal receives
Displays the number of times when mails were received normally.
- 5) Number of attached file receives
Displays the number of times when attached files were received.
- 6) Number of server inquiries
Displays the number of server inquiries.
- 7) Number of server transfer errors
Displays the number of server communication errors.

- 8) Error log
Displays the number of error log write times.
The error log items are indicated below.
 - Error command
 - Command code
 - Sender
 - Receiving date/hour
 - Subject
- 9) button
Clears the count to zero.
- 10) button
Clears the error log write count to zero and clears all error history.

21.4.8 Send e-mail information

A	Q/QnA	FX
×	○*	×

*: This function is compatible with the QCPU (Q mode).

[Purpose]

Monitors the send e-mail information.

[Operating Procedure]

Select [Diagnostics] → [Ethernet diagnostics] → <<Send e-mail information>> tab.

[Dialog Box]

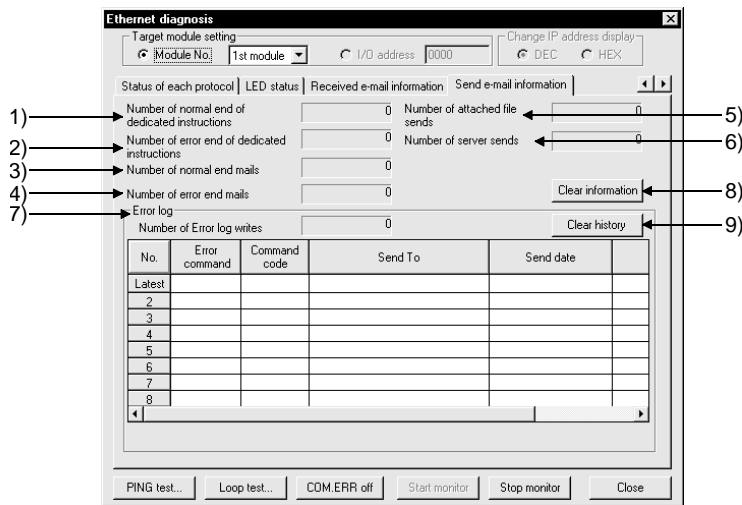

[Description]

- 1) Number of normal end of dedicated instructions
Displays the number of times when dedicated instructions were completed normally.
- 2) Number of error end of dedicated instructions
Displays the number of times when dedicated instructions were completed abnormally.
- 3) Number of normal end mails
Displays the number of mails which were completed normally.
- 4) Number of error end mails
Displays the number of mails which were completed abnormally.
- 5) Number of attached file sends
Displays the number of times when attached files were sent.
- 6) Number of server sends
Displays the number of server send times.

- 7) Error log
Displays the number of error log write times.
The error log items are indicated below.
 - Error command
 - Command code
 - Send destination
 - Sending date/hour
 - Subject
- 8) button
Clears the count to zero.
- 9) button
Clears the error log write count to zero and clears all error history.

21.4.9 PING test

A	Q/QnA	FX
○	○	×

[Purpose]

This test checks the Ethernet module which has completed initial processing on the Ethernet line or the existence of the specified IP address.

[Operating Procedure]

Select [Diagnostics] → [Ethernet diagnostics] → **PING** button.

Select [Diagnostics] → [Ethernet diagnostics] → **Loop** button → **PING** button.

[Required Setting Items]

- Before starting a PING test, always set the Ethernet parameters and MNET/10 routing information. Refer to Section 16.2.1 for the setting example.
- Make sure that the RUN and INIT LEDs of the Ethernet module are lit.

[PING Test Image Diagram]

Via Ethernet board

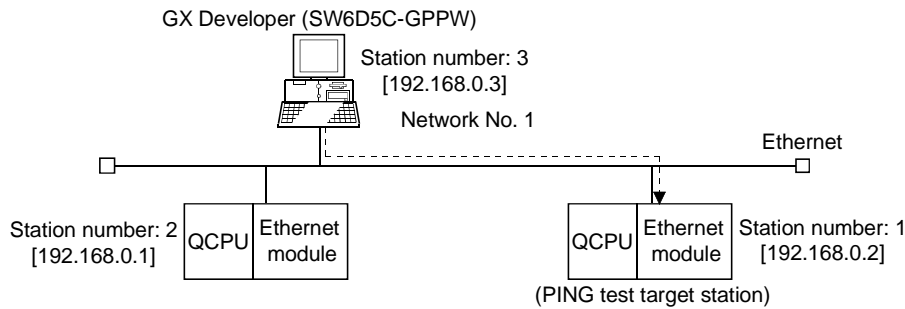

A PING test from GX Developer is also valid for the Q, QnA and A series Ethernet modules.

Performing a PING test on the system consisting of the Q series allows you to check:

- Whether the line between the own station and the equipment on other end are connected properly.
- Whether parameter setting for the own station Ethernet modules was made properly.
- Whether initial processing for the own station Ethernet module was completed normally.

POINTS
<ul style="list-style-type: none"> • A PING test is valid for only the system consisting of Ethernet only. • A PING test cannot be made via the MELSECNET/10, MELSECNET/H, CC-Link, computer link or the like. • A PING test cannot be conducted when GX Developer is directly connected to the PLC CPU. It can be made only via the Ethernet board.

[Dialog Box]

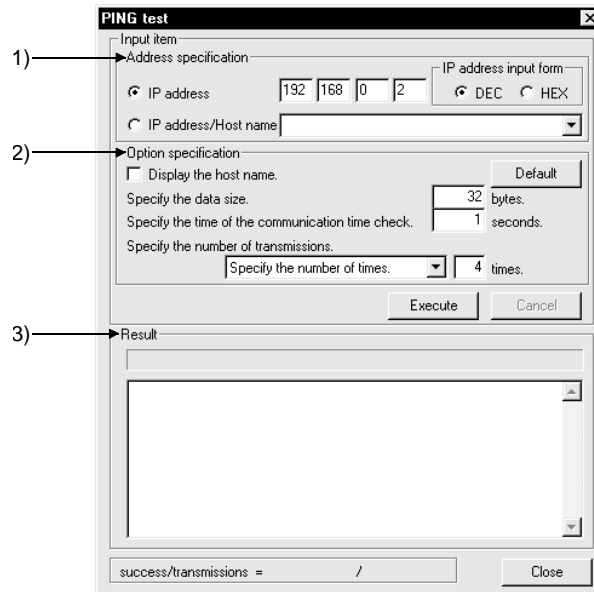

[Description]

- 1) Address specification
Set the IP address of the module to be PING tested.
- 2) Option specification
Turning on Display the host name displays the host name in Result.
The range setting for specifying the data size is 1 to 8192 bytes.
Communication time check period: 1 to 30 seconds
Send count: 1 to 50 times or executed until a stop.
- 3) Result
When OK
Pinging Host name [192.168.0.2] with 32 bytes of data:
Reply from 192.168.0.2: bytes = 32 time < 10ms TTL = 32
When NG
Request timed out.

21.4.10 Loopback test

A	Q/QnA	FX
×	○*	×

*: This function is compatible with the QCPU (Q mode).

[Purpose]

This test sends a loopback test message to the Q-compatible E71s (function version B) of the specified network number and station number in order to check whether the initial processing of each module has been completed. A loopback test is compatible with only the function version B of the QJ71E71. The responses of the Q-compatible E71s of function version A and the QnA/A series Ethernet modules are handled as no response if they are connected actually.

[Operating Procedure]

Select [Diagnostics] → [Ethernet diagnostics] → **Loopback test** button.

[Required Setting Items]

- Before starting a loopback test, always set the Ethernet parameters and MNET/10 routing information. Refer to Section 16.2.1 for the setting example.
- Make sure that the RUN and INIT LEDs of the Ethernet modules are lit.

[Loopback Test Image Diagram]

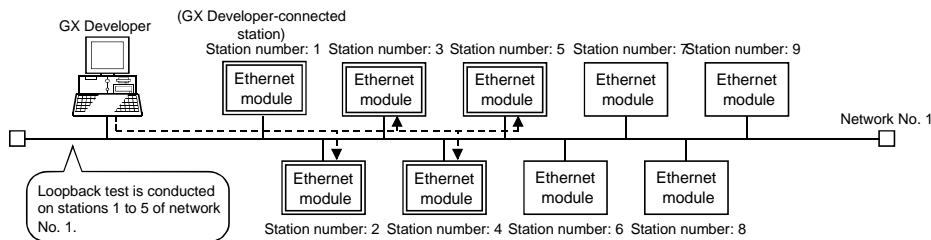

If a loopback test is performed on network No. 2 in the following system configuration, the response of station 2 acting as a relay station is handled as "no response".

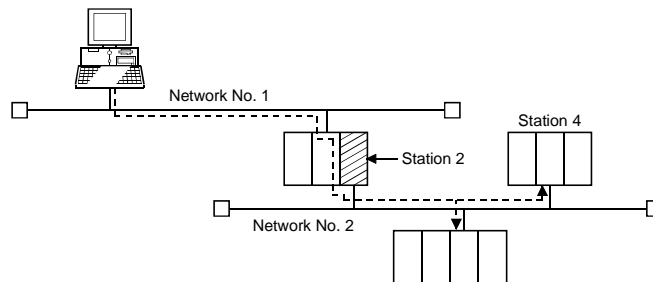

POINTS
<ul style="list-style-type: none"> • A loopback test is valid for only the system consisting of Ethernet only. A loopback test cannot be made via the MELSECNET/10, MELSECNET/H, CC-Link, computer link or the like. • A loopback test cannot be conducted when GX Developer is directly connected to the PLC CPU. It can be made only via the Ethernet board.

[Dialog Box]

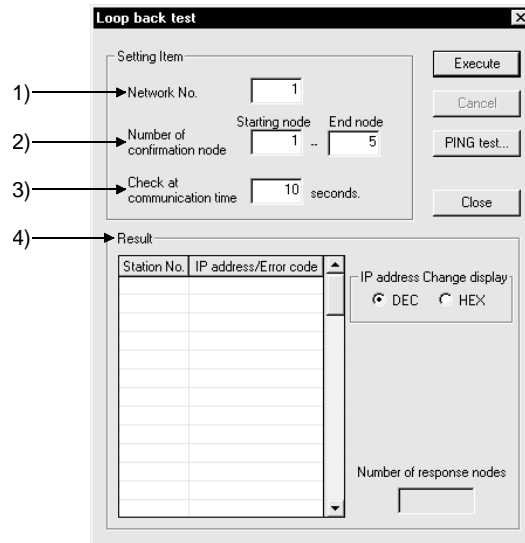

[Description]

- 1) Network No.
Set the network number to be loopback tested.
The setting range is 1 to 239.
- 2) Number of confirmation node
Specify the station numbers you want to check.
The setting range is 1 to 64.
- 3) Check at communication time
The setting range is 1 to 99 seconds.
The Ethernet parameters have TCP re-send timer in Initial settings Unless the communication time check period setting of a loopback test is longer than the TCP re-send timer setting, the Ethernet module may be regarded as non-existing if its connection is proper.
- 4) Result
A loopback test is made in order, starting from station 1, and whether a response is given or not within the communication time check period is displayed in order of station numbers.
Overlapping IP addresses, if any, are displayed red.

21.5 System Monitor

A	Q/QnA	FX
×	○*	×

*: This function is compatible with the QCPU (Q mode).

*: This function is compatible with the Q series remote I/O.

[Purpose]

Monitors the system status of the PLC.

This function may be selected for the Q series only.

[Operating Procedure]

[Diagnostics] → [System monitor].

[Dialog Box]

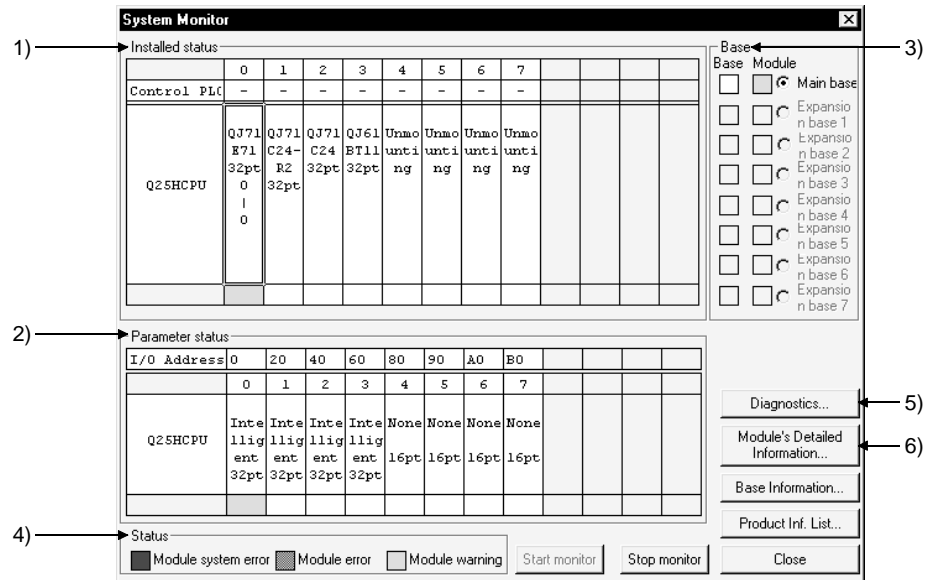

[Description]

1) Installed status

Shows the special and similar modules loaded to the base selected among the main base and extension bases 1 to 7. (Double-clicking the model name indication shows the module detail information dialog box.)

When the A series is added to connect the special function modules of the A, "A intelli" appears on the screen.

The following table indicates the error status display categories for the PLC CPUs in a multi-CPU configuration.

Display Color	Category	Error Definition	PLC CPU Status
Red	Major error	MAIN CPU down	CPU reset, etc.
Orange	Middle error	Stop error	Parameter error Instruction code error CPU STOP, etc.
Yellow	Minor error	Continuation error	Battery error Annunciator error ON CPU RUN enable error, etc.

- 2) Parameter status
Shows the parameter settings written to the PLC. The parameters not set do not appear.
- 3) Base
Normal bases are shown white and abnormal bases red.
For the modules, refer to 4) Status.
- 4) Status
 - Unit system error
Indicates that a module hardware fault (error equivalent to WDT error) has occurred or a module inoperative condition is detected.
 - Unit error
Indicates that the environment required for the module to function is not completed. (Error equivalent to parameter error has occurred)
 - Unit warning
Indicates inadequacy in user operation or sequence program (e.g. FROM, TO).

	Display Color	PLC Status
Unit normal	White	RUN
Unit system error	Red	STOP
Unit error	Yellow	RUN
Unit warning	Orange	RUN

- 5) **PLC diagnostics** button
Move the cursor to the special module displayed in Installed status and click the **PLC diagnostics** button to show the following screen.
The following screen does not appear if the utility package has not been installed.
For details, refer to the corresponding utility manual.

<Example> Serial communication module monitoring

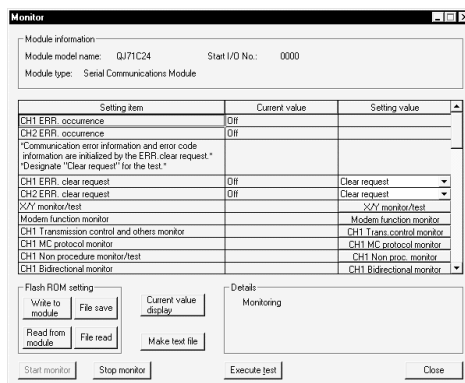

6) **Module Detail Information** button

When you choose the module model name displayed in Installed status, the following dialog box appears.

"-B" in Product information indicates the function version of the module.

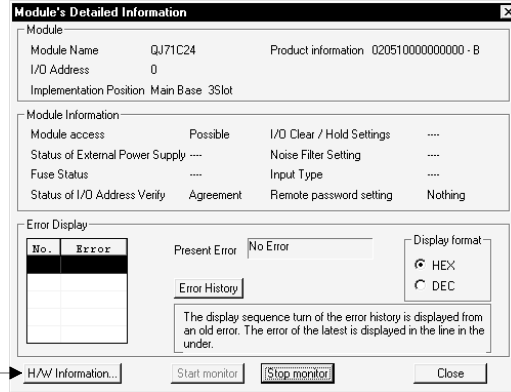

a) **H/W Information** button

H/W LED: As the module status is displayed, refer to the corresponding module manual for details.

H/W SW Information: Shows the hardware switch states.

Data changes with the combination of GX Developer SW4D5-GPPW-E, GX Developer SW5D5-GPPW-E, GX Developer SW6D5-GPPW-E and module version.

For details, refer to the corresponding module user's manual.

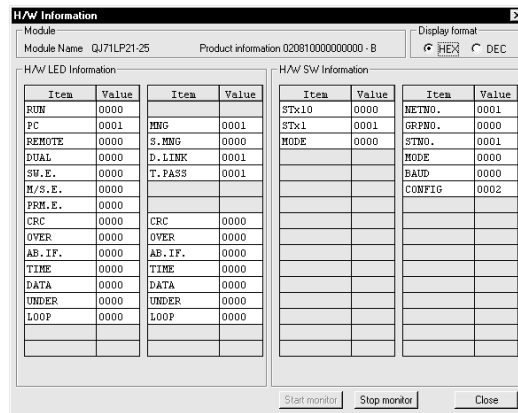

7) **Base Information**

Shows the following information on the base.

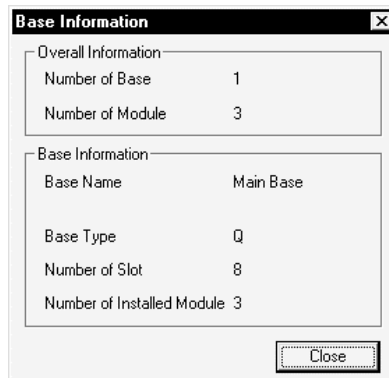

8) Product Information List

Shows the product information list of the modules mounted on the base.

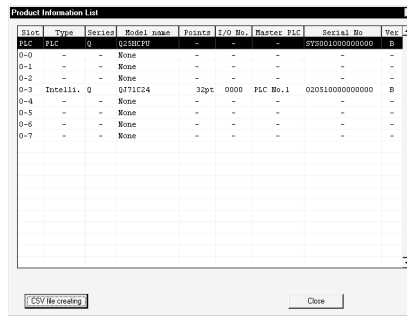

As clicking the **CSV file creating** button shows the [Save as] screen, set the file name.

The file can be opened using Excel or the like.

POINTS					
<ul style="list-style-type: none"> The following table appears if there are differences between PLC parameter I/O assignment and actual Installed status. Therefore, set the PLC parameter I/O assignment to meet the actual Installed status. 					
System monitor display status					
Assignment	Actual Loading	Empty	Input	Output	Intelli
0 empty points	Installed status	Unmounting	m input points	m output points	m intelli points
	Parameter status	0 empty points	0 empty points	0 empty points	0 empty points
n empty points	Installed status	Unmounting	m input points	m output points	m intelli points
	Parameter status	n empty points	n empty points	n empty points	n empty points
0 input points	Installed status	Unmounting	m input points	m output points	m intelli points
	Parameter status	0 empty points	0 empty points	0 empty points	Assignment error
n input points	Installed status	Unmounting	m input points	m output points	m intelli points
	Parameter status	n empty points	n input points	n input points	Assignment error
0 output points	Installed status	Unmounting	m input points	m output points	m intelli points
	Parameter status	0 empty points	0 empty points	0 empty points	Assignment error
n output points	Installed status	Unmounting	m input points	m output points	m intelli points
	Parameter status	n empty points	n output points	n output points	Assignment error
0 intelli points	Installed status	Unmounting	m input points	m output points	m intelli points
	Parameter status	0 empty points	Assignment error	Assignment error	Assignment error
n intelli points	Installed status	Unmounting	m input points	m output points	m intelli points
	Parameter status	n empty points	Assignment error	Assignment error	n intelli points
No assignment	Installed status	Unmounting	m input points	m output points	m intelli points
	Parameter status	p empty points	m input points	m output points	m intelli points

n points : Number of assignment points
 m points : Number of actual loading points
 p points : Number of empty slot points

22 SETTING A6TEL/Q6TEL/FX_{2N} DATA

The telephone line can be used for connection with the PLC. When the telephone line is used to make communication, it is made via the modem interface module (A6TEL/Q6TEL modem interface module), serial communication.

The following table lists the modules usable with each series. Modem Interface.

	interface module		Serial Communication	
	A6TEL	Q6TEL	QnA Series	Q Series
Qseries	—	—	○	—
QnAseries	—	○	—	○
Aseries	○	○	—	—
FXseries	—	—	—	—

*1: Since the QCPU (A mode) cannot use the A6TEL/Q6TEL, make communication via the serial communication module (Q series).

*2: Communication can be made by connecting a modem to the RS-232C connector of the FX_{2N}.

REMARK

For connection of telephone lines through QC24N and QJ71C24, refer to Section 16.2.4.

22.1 Function Setting Item List

A	Q/QnA	FX
○	○*	○

*:This function is compatible with the QnACPU

(1) Q6TEL/A6TEL

The following setting item list indicates what data may be created and written to the personal computer and A6TEL/Q6TEL when performing any function.
(A/QnA series)

Setting		A6TEL/Q6TEL Connection Method	Proximate Connection	Remote Access	Pager Notice	Q6TEL-Q6TEL Communication
PLC side	A6TEL		1) Cable connection 2) Switch setting	1) AT command registration 2) Switch setting 3) Cable connection 4) TEL data registration (a) AT command (b) Phone number	1) AT command registration 2) Phone number book creation 3) Switch setting 4) Cable connection 5) TEL data registration (a) AT command (b) Phone number (c) Notice data	No setting
	Q6TEL		1) Cable connection 2) Switch setting	1) AT command registration 2) Switch setting 3) Cable connection 4) TEL data registration (a) AT command (b) Phone number	1) AT command registration 2) Phone number book creation 3) Switch setting 4) Cable connection 5) TEL data registration (a) AT command (b) Phone number (c) Notice data	1) AT command registration 2) Phone number book creation 3) Switch setting 4) Cable connection 5) TEL data registration (a) AT command (b) Phone number (c) Q6TEL-Q6TEL communication data registration
Personal computer side (GX Developer)			No setting	1) AT command registration 2) Phone number book creation	No setting	No setting

Switch setting: For the A6TEL/Q6TEL DIP switch setting, refer to Appendix 13. For connection cable details, refer to Section 2.1, 16.2.4.

(2) FXCPU series

Only remote access may be made. (Pager notices and Q6TEL-Q6TEL communication cannot be made.)

Setting	Remote Access
PLC side	1) PC system setting (1) 2) PC system setting (2) 3) If you set modem initialization to the user registration mode in PC system setting (1), you must set the AT command in the sequence program.
Personal computer side	1) AT command registration 2) Phone number registration

22.2 Preparations for Connecting the Telephone Line

This section provides the procedures to start the remote access function, notice function and Q6TEL-Q6TEL communication function (QnA mode only) in a system using the A6TEL/Q6TEL.

22.2.1 Making remote access/pager notice (for ACPU)

A	Q/QnA	FX
○	×	×

Since the A modes of the A6TEL and Q6TEL are the same, read "Q6TEL" as "A6TEL" when using the A6TEL.

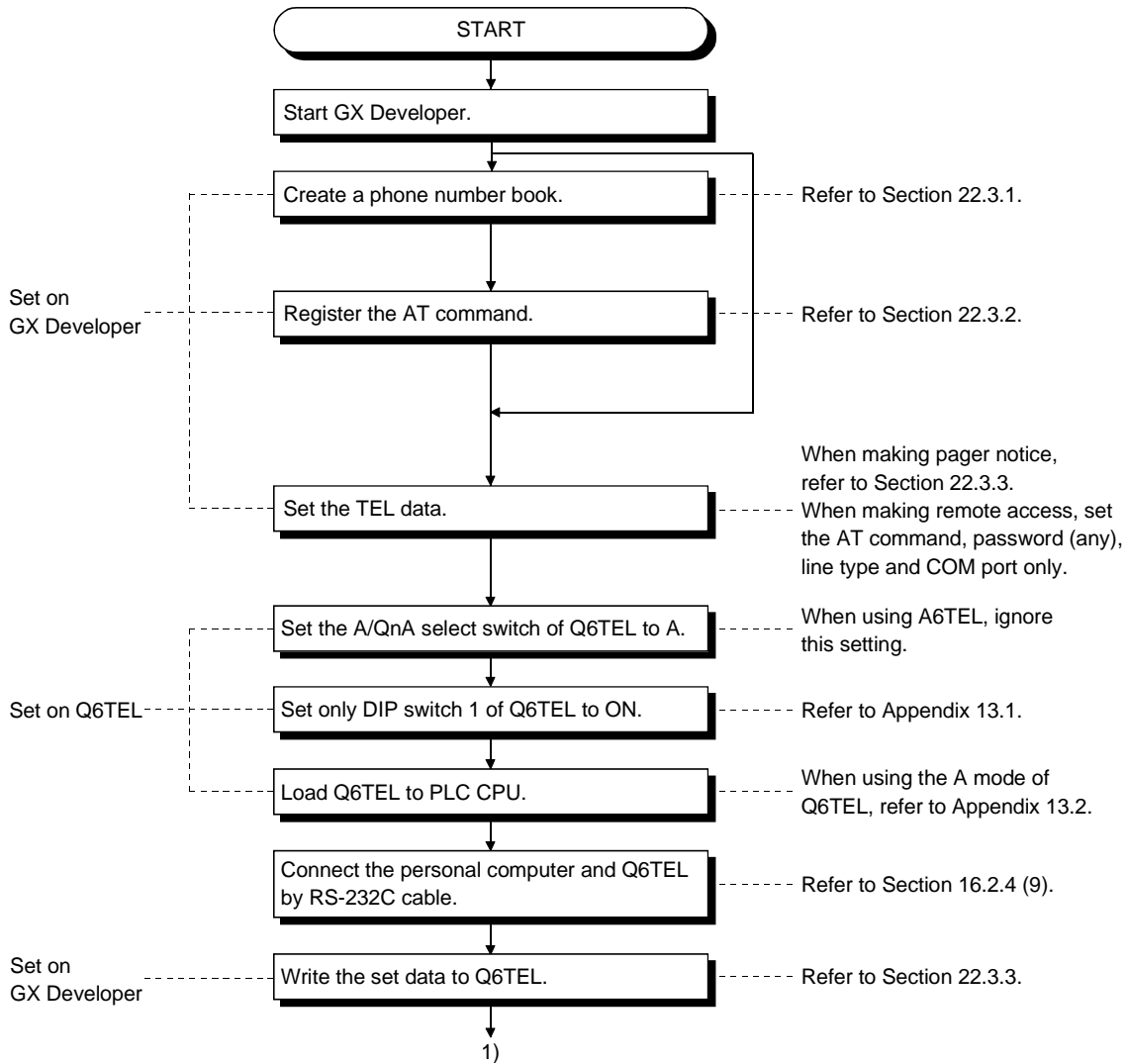

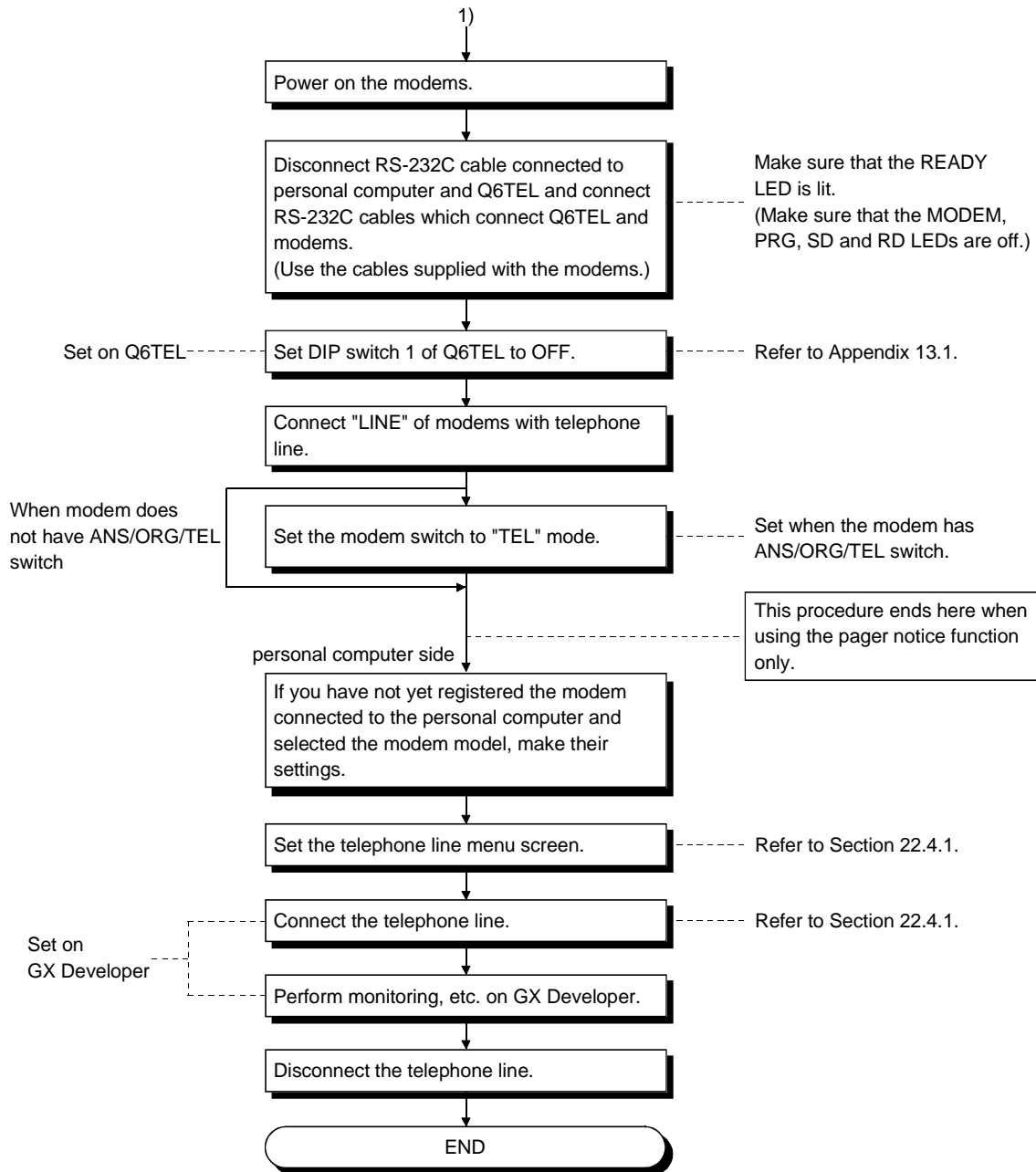

POINT

- Set the connection destination before connecting the telephone line.

22.2.2 Making remote access/pager notice (for QnACPU)

A	Q/QnA	FX
×	○*	×

*:This function is compatible with the QnACPU

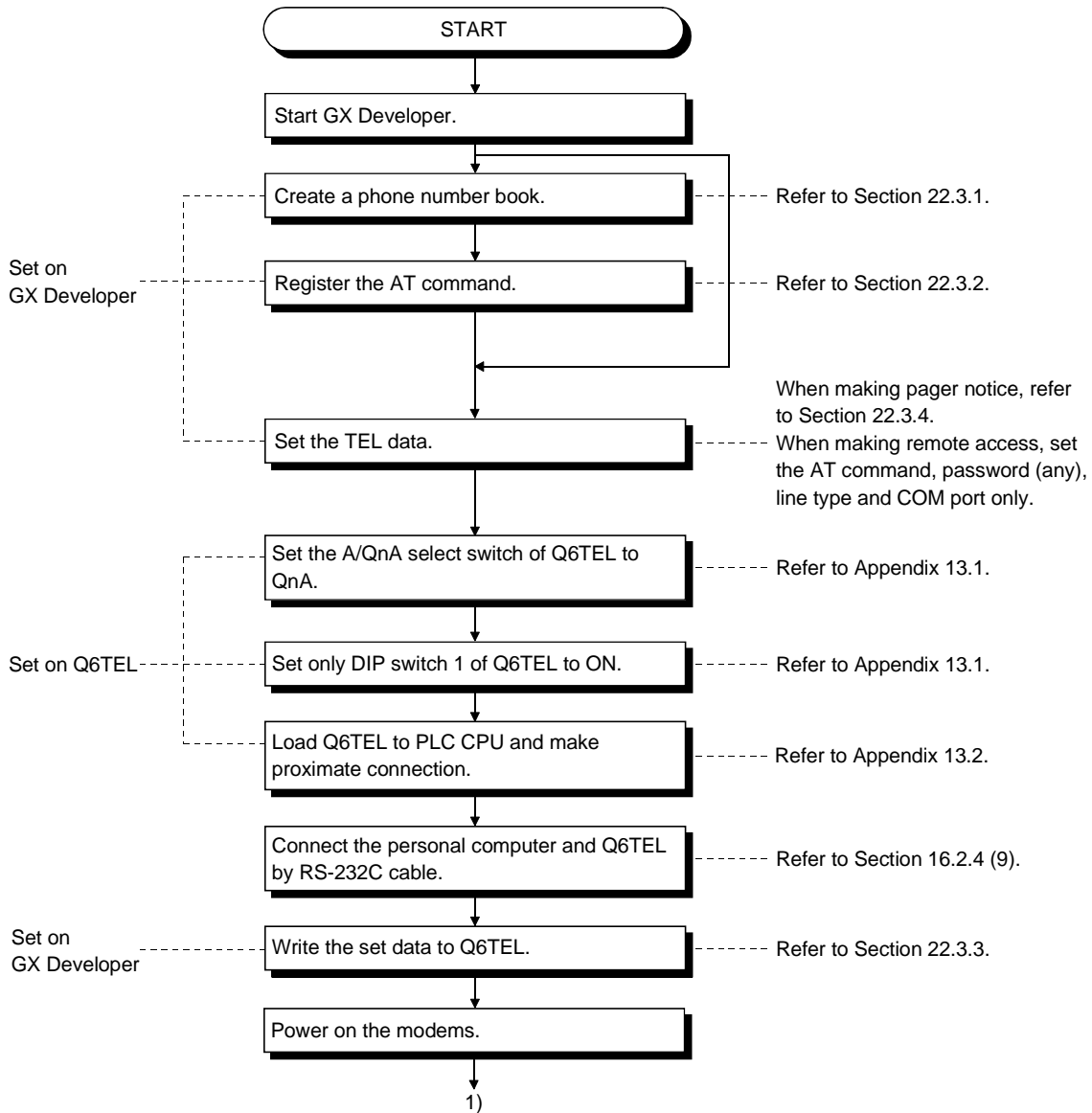

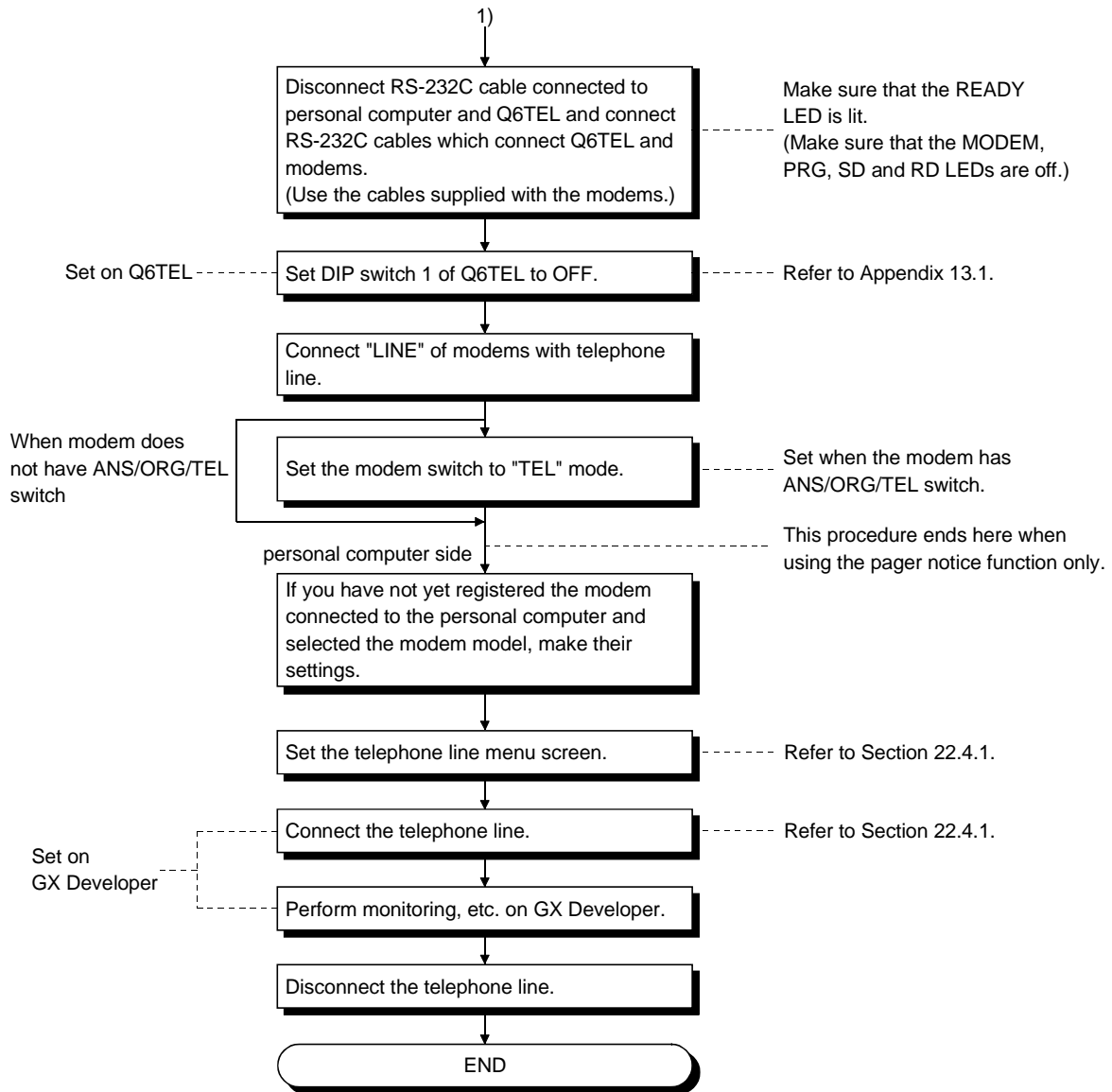

POINT
<ul style="list-style-type: none"> • Set the connection destination before connecting the telephone line.

22.2.3 Making remote access to FXCPU

A	Q/QnA	FX
×	×	○

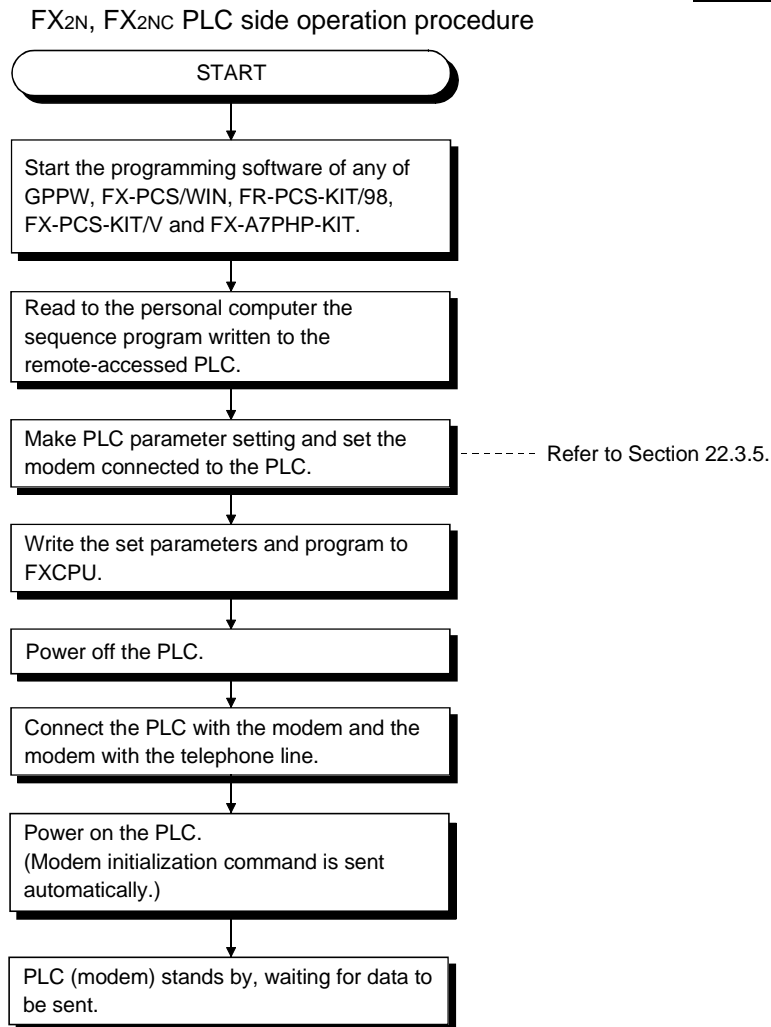

- Always power on in the modems and PLC in this order.
 If the PLC is powered on earlier than the modems, the initialization command sent to the modems at power-on of the PLC is made invalid, and a communication error will occur at the time of remote access. Also, if only the modems are powered on after power-on, the initialization command is cleared, resulting in a communication error similarly. In this case, switch power on again in the order of modems and PLC.
- The PLC which was placed in the standby status in this procedure can be remote-controlled by FX-PCS/WIN programming software.

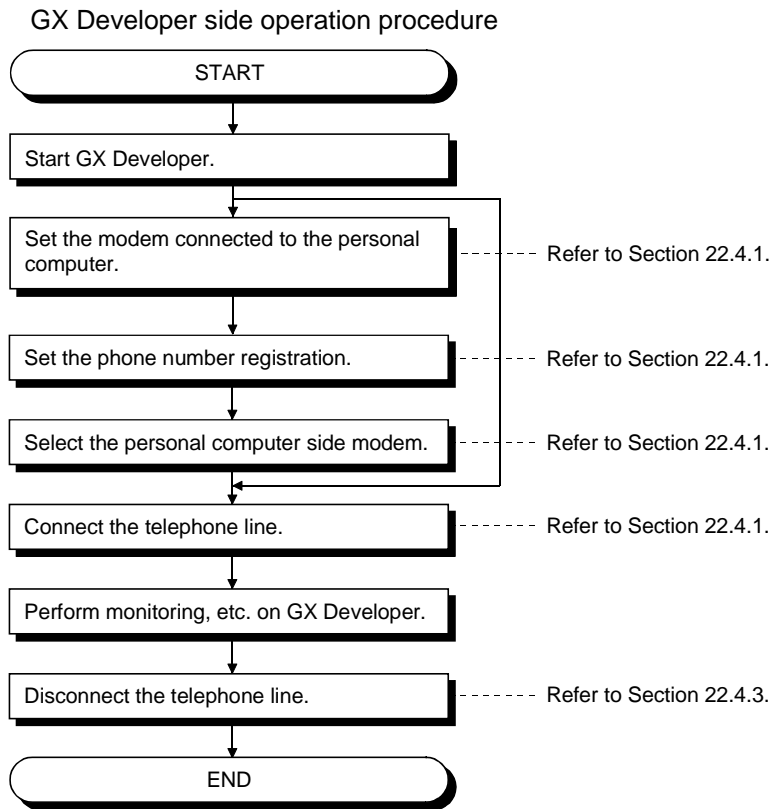

22.2.4 Making Q6TEL-Q6TEL communication

A	Q/QnA	FX
×	○*	×

*:This function is compatible with the QnACPU

(1) Send side

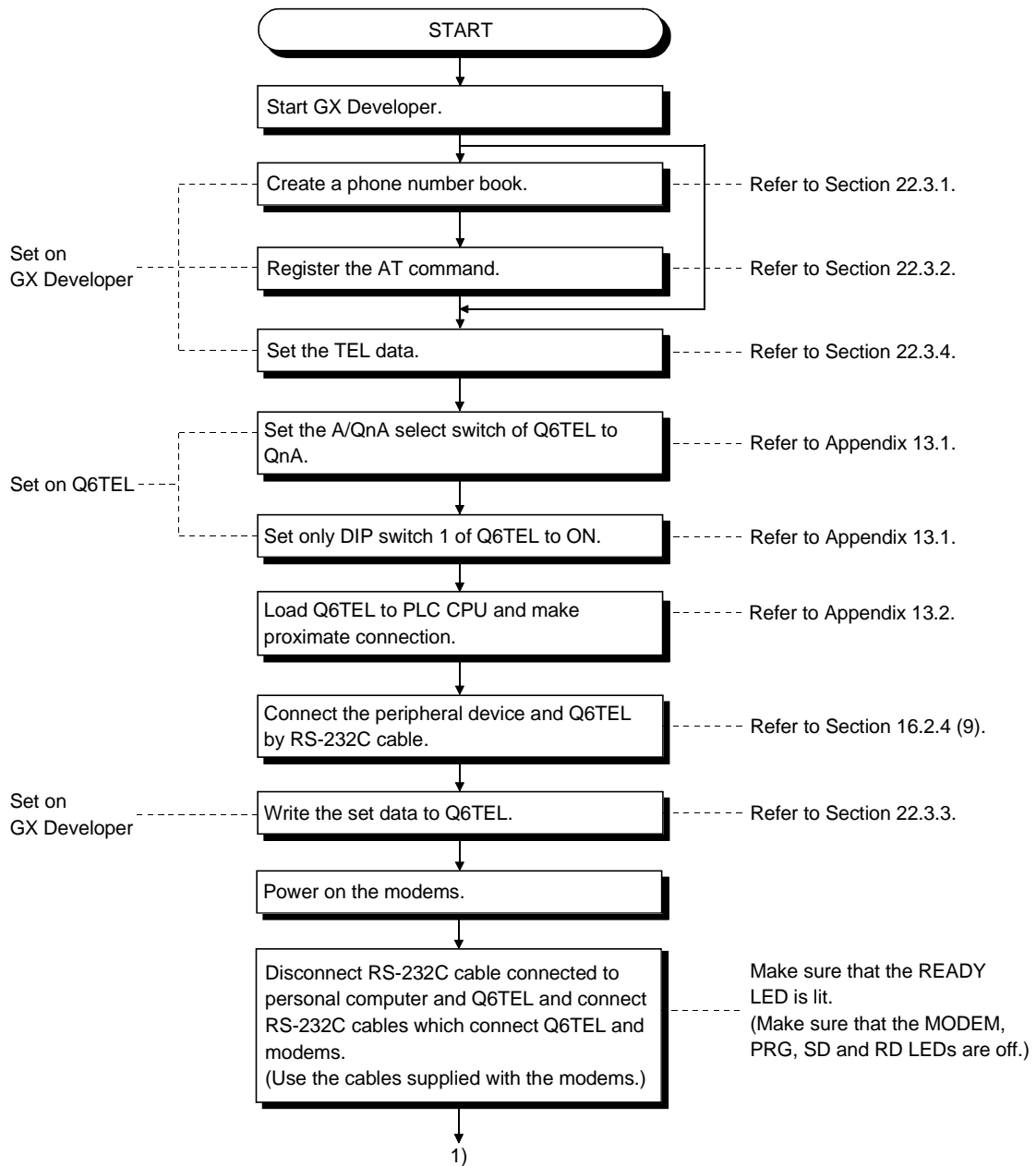

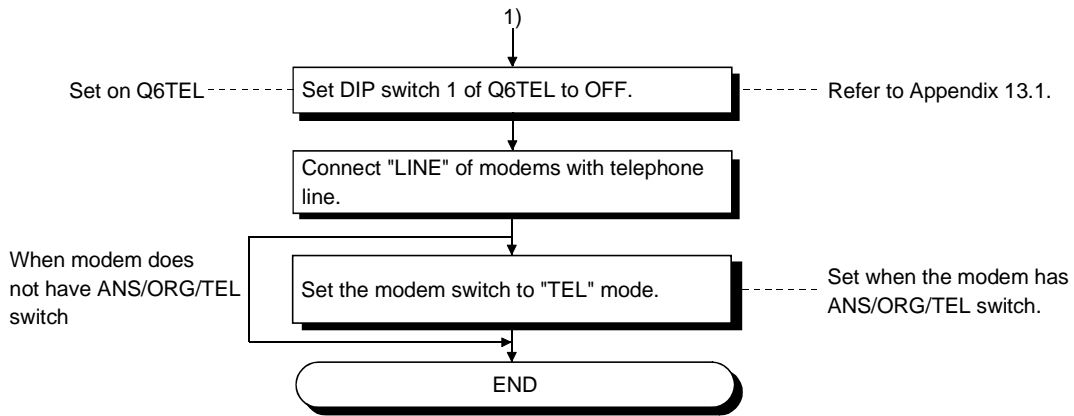

(2) Receive side

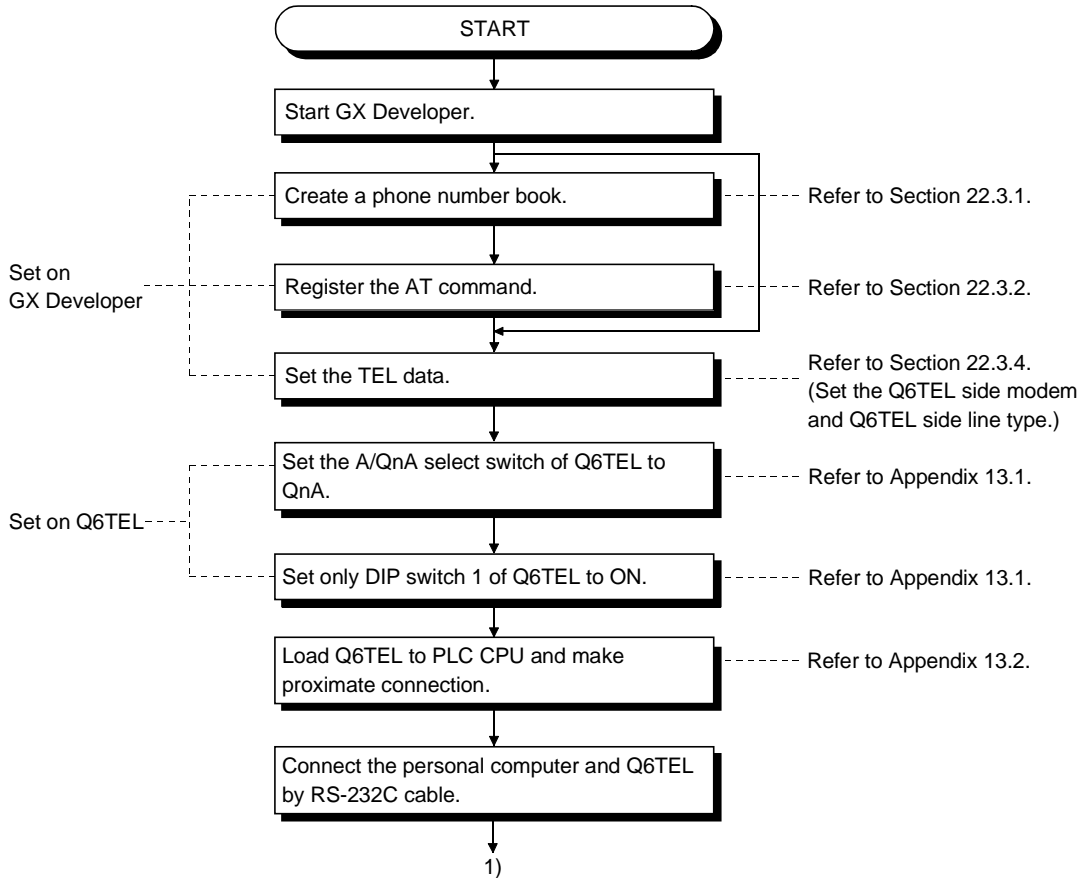

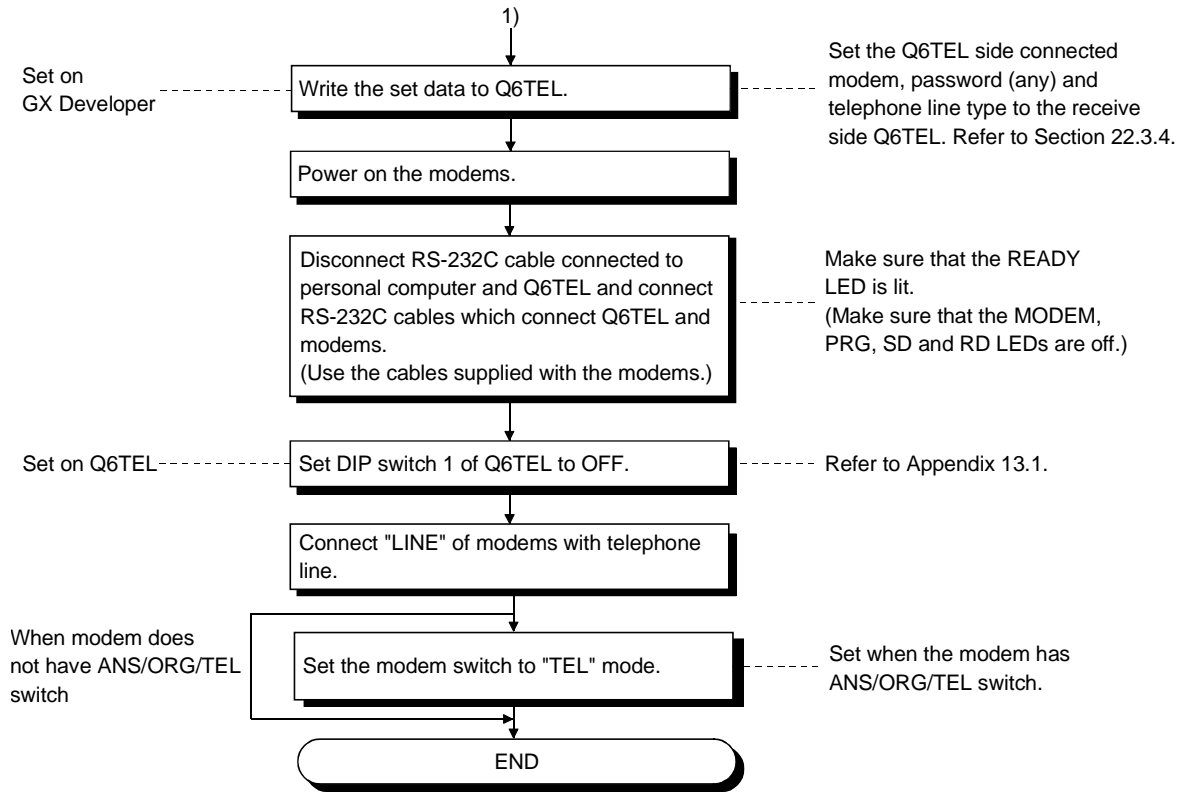

22.3 Making Initial Setting of Data

22.3.1 Creating a phone number book

A	Q/QnA	FX
○	○	○

[Purpose]
Registers phone numbers.

[Operating Procedure]
[Tools] → [Set TEL data] → [Call book]

[Window]

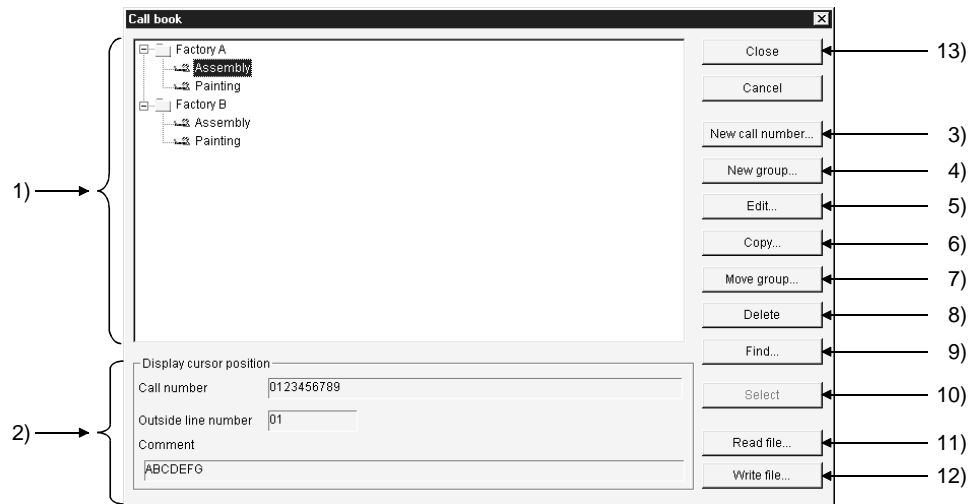

[Description]

- 1) Registered phone number display list
Shows the group names and the other end names of the phone numbers.
Registered phone number 18 or more characters
Outside line access number2 or more characters
- 2) Display cursor position field
Shows the registered data selected in the registered phone number display list.

- 3) **New call number** button
Register a new phone number.

The screenshot shows a 'Call number setting' dialog box with the following fields and labels:

- a) Group name: Factory A
- b) Destination name: Assembly
- c) Call number: 0123456789
- d) Outside line number: 01
- e) For only line connection: Password: ****
- f) Comment: ABCDEFGG
- g) OK button

- a) **Group name**
Shows the group name of the registered number.
- b) **Destination name**
Enter the other end name of the phone number to be set.
The number of set characters is within 50.
- c) **Call number**
Enter the phone number.
The number of set characters is within 50.
- d) **Outside line number**
Set the outside line access number.
The number of set characters is within 10.
- e) **For only connection**
When a password has been set to the A6TEL/Q6TEL, making this setting automatically starts password processing and connects the line.
When a password has not been set to the A6TEL/Q6TEL, making this setting connects the line.
- f) **Comment**
Enter the memo to the registered data.
The number of set characters is within 60.
- g) **OK** button
Click this button when the setting is finished.
- 4) **New group** button
Create a new group.
Clicking the New group button shows the group setting dialog box.
Enter and set the group name.
The number of set characters is within 50.

- 5) **Edit** button
Edits the registered data.
Choose the registered data you want to edit in the registered phone number display list.
Clicking the Edit button shows the phone number setting dialog box.
Edit each data.
- 6) **Copy** button
Copies the registered phone numbers to another group.
Choose the registered data you want to copy in the registered phone number display list.
Clicking the Copy button shows the group setting dialog box.
Choose the copy destination group and click the **OK** button.
- 7) **Move** group button
Moves the registered phone numbers to another group.
Choose the registered data you want to copy in the registered phone number display list.
Clicking the Move group button shows the group setting dialog box.
Choose the move destination group and click the **OK** button.
- 8) **Delete** button
Deletes the registered group and phone numbers.
(You cannot batch-delete on a group basis.)
- 9) **Find** button
Searches for the registered phone number. (Search match condition is partial match.)
All registered data are searched.
 - Searching advance
When search conditions are entered into both the other end and phone number, data which satisfies both search conditions is searched for.
- 10) **Select** button
Performs the phone number setting selection processing when the line connection dialog box is browsed.
- 11) **Read** file button
Reads to GX Developer the phone number data registered to GPPA or GPPQ.
The operation method is the same as the TEL data creation file reading operation.
- 12) **Write** file button
Writes the created phone number book to any folder specified.
- 13) **Close** button
Saves the edited data and terminates the phone number book function.

[Setting Procedure]

1. Click the New group button. (When newly creating data)
Enter the group name and create the group.
2. Choose the group where you want to register the phone number from the registered phone number display list.
3. Click the new phone number button.
Enter and set each data (other end name, phone number, outside line access number, memo).

22.3.2 Registering the AT command

A	Q/QnA	FX
○	○	○

[Purpose]
Register the AT command.

[Operating Procedure]
[Tools] → [Set TEL data] → [AT command]

[Dialog Box]

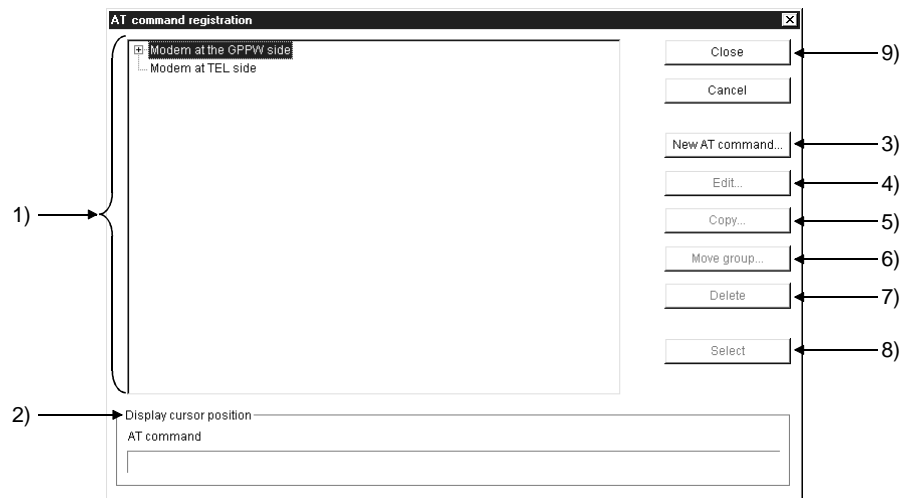

[Description]

- 1) Registered AT command display list
Shows the headings of the AT commands.
- 2) Display cursor position field
Shows the registered data selected in the registered AT command display list.

- 3) **New AT** command button
Registers a new AT command.

The screenshot shows a dialog box titled "AT command registration". It contains three text input fields. The first field, labeled "Group name", contains the text "Modem at the GPPW side". The second field, labeled "Title", contains "ABCD Modem". The third field, labeled "AT command", contains "ATQ0E1VX1S0=1". At the bottom of the dialog are three buttons: "OK", "Cancel", and "Help of AT command...". Arrows labeled "a)", "b)", and "c)" point to the "Group name", "Title", and "AT command" fields respectively.

- a) **Group name**
Shows the group name of the new command.
- b) **Heading**
Enter the heading for the AT command to be registered.
- c) **AT command**
Enter the AT command for modem initialization.
The number of entered characters is up to 70 (70 for A6TEL/40 for Q6TEL).
- 4) **Edit** button
Edits the registered data.
Choose the registered data you want to edit in the registered AT command display list.
Clicking the Edit button shows the AT command registration dialog box.
Edit each data.
- 5) **Copy** button
Copies the registered AT command to any other end.
Choose the registered data you want to copy in the registered AT command display list.
Clicking the Copy button shows the group specifying dialog box.
Choose the copy destination (any other end) and click the **OK** button.
- 6) **Move group** button
Moves the registered AT command to any other end.
Choose the registered data you want to move in the registered AT command display list.
Clicking the Move group button shows the group specifying dialog box.
Choose the move destination (any other end) and click the **OK** button.

- 7) button
Deletes the registered AT commands.
(You cannot batch-delete on a group basis.)
- 8) button
Performs the AT command selection processing when the line connection dialog box or TEL data creation dialog box is browsed.
- 9) button
Saves the edited data and terminates the AT command registration function.

[Setting Procedure]

1. Choose the side where you want to register the AT command from the registered AT command display list.
2. Click the New AT command button.
Enter the heading and AT command to create the AT command.

22.3.3 Registering A6TEL data

A	Q/QnA	FX
○	×	×

[Purpose]
Register the A6TEL data.

[Operating Procedure]
[Tools] → [Set TEL data] → [TEL data]

[Dialog Box] (For use of A series)

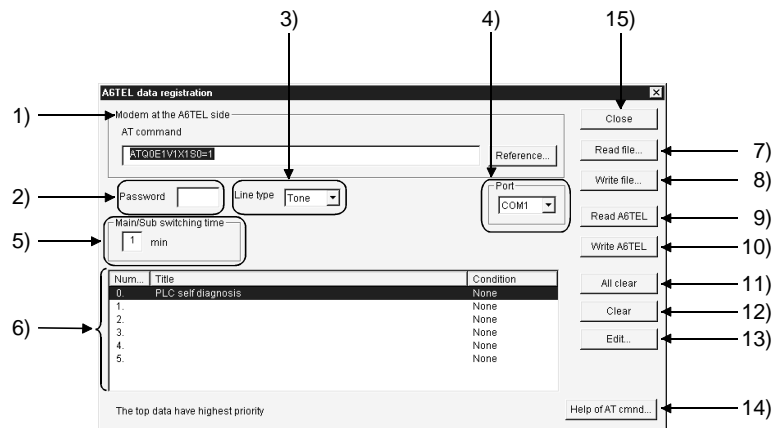

[Description] (For use of A series)

- 1) Modem at the A6TEL side
Set the AT command of the A6TEL side modem.
Direct input
Enter directly. The number of set characters is 70.
Browse (Only the AT command of the TEL side connection modem may be browsed)
Clicking the Browse button shows the AT command dialog box.
Choose the AT command you want to set, and click the Select button.
- 2) Password (Set any password)
Set the password for access to the A6TEL.
Set in four characters.
- 3) Line type
Choose the tone or pulse.

- 4) Port
Set the communication port number used to read/write the A6TEL data.

- 5) Main/Sub switching time
Regular and sub phone numbers can be set.
 - Notice destination when the regular and sub phone numbers have been registered

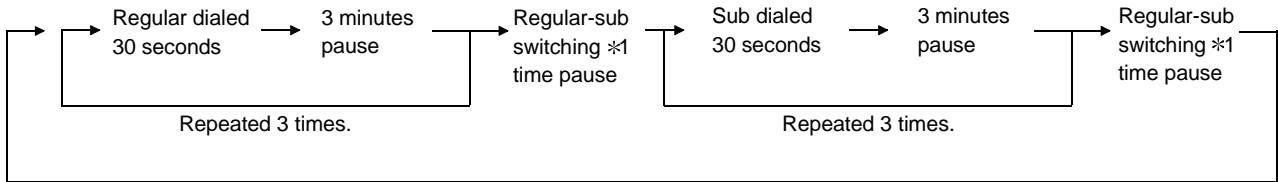

Repeated until the handset is made on-hook at notice destination.

- Notice destination when only the regular phone number has been registered

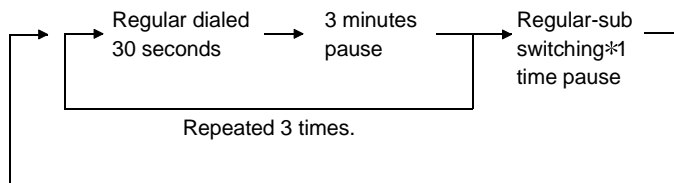

Permanent notice *2

- *1: Time can be set within the range 0 to 99 in increments of 1 minute.
- *2: Notice continues if the handset is made off-hook at notice destination.
Clear the permanent notice by
 - Placing the personal computer and A6TEL online (telephone line connected), or
 - Moving the DIP switch 1 or 2 of the A6TEL from ON to OFF.

- 6) Notice data list
Shows the titles and set conditions of the notice data.
- 7) **Read file** button
Reads the A6TEL data file or GPPA format A6TEL data file.
- 8) **Write file** button
Saves the TEL data created with GX Developer onto HD, FD or the like.
- 9) **Read A6TEL** button
Reads the TEL data set to the A6TEL.
The read data appears on the screen.
- 10) **Write A6TEL** button
Writes the TEL data created with GX Developer to the A6TEL.

- 11) **Clear all** button
Deletes all notice data registered.
- 12) **Clear** button
Deletes only the notice data selected in the notice data list.
- 13) **Edit** button

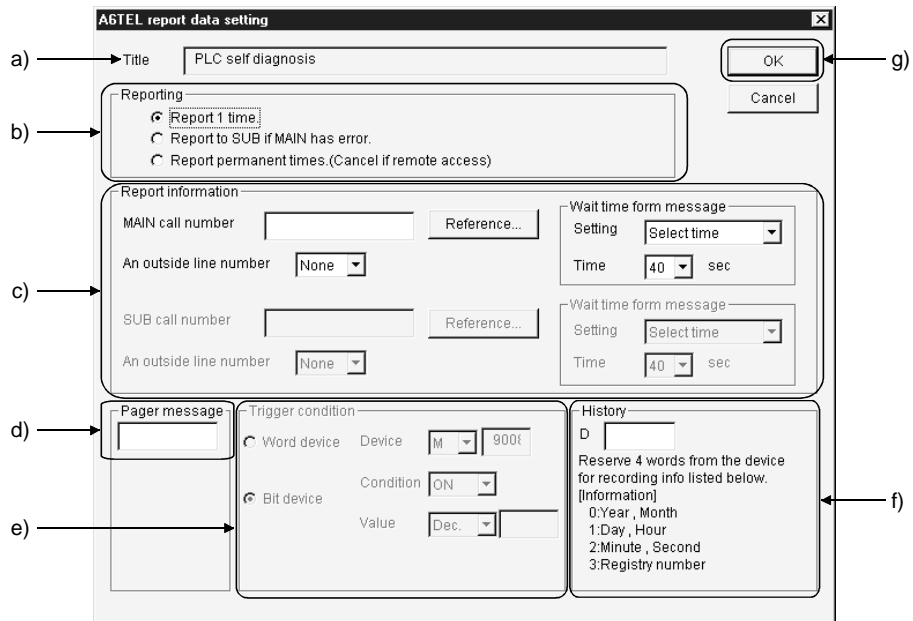

- a) **Heading**
Sets the heading to the data to be set as the notice destination of the A6TEL.
When the data written to the A6TEL once is reread, the heading is not displayed. (Since it is written to the personal computer only.)
The number of set characters is 60.
- b) **Reporting**
Choose the processing performed after the trigger conditions hold.
- c) **Notice destination information**
Set the notice destination information.
Phone number
Set the phone number of the notice destination.
 - Only 0 to 9, *, # and - may be used.
 - The number of set characters is 17.**Outside line access number**
 - Set the outside line access number of the notice destination.
 - 0 to 9, # and * may be selected.**Pager announcement time**
 - **Setting**
Choose the time setting.
 - **Set time (dial message pause time)**
Set pause time when it is needed from when the A6TEL make a phone call until it sends a message.
The time that may be set is 0 to 99 seconds.

- d) Pager message
Set the message to be sent to the pager.
Message
 - Up to 10 characters may be set using 0 to 9, # and *.
- e) Trigger condition
Set the trigger device, the device number, and the status (ON/OFF) for a bit device, or the device value for a word device, which are used when the A6TEL performs notice processing.
- f) History
Set the data registers which store the other end, date and time when the A6TEL notified the pager. The setting range is D0 to 25980.

	b15	to	b8	b7	to	b0
Dn	Year			Month		
Dn+1	Day			Hour		
Dn+2	Minute			Second		
Dn+3	Notice destination					

- g) **OK** button
Click this button when the setting is over.

- 14) **Help of AT command** button
Gives instructions for AT command setting.

- 15) **Close** button
Saves the edited data and terminates the TEL data registration function.

POINT

- When using the A6TEL as a converter, double-click the PC side I/F icon on the Connection Setup screen and set the items of the following screen.

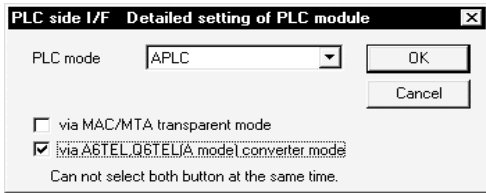

Also, the setting status appears on the Connection Setup screen.

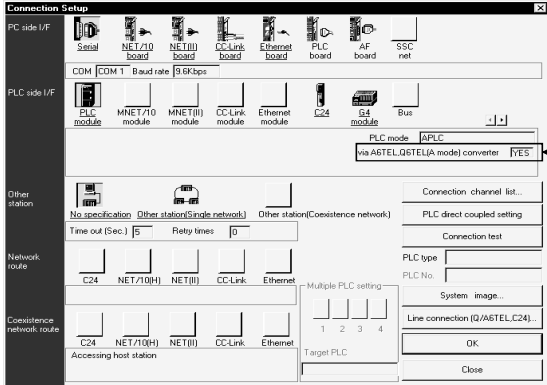

22.3.4 Registering Q6TEL data

A	Q/QnA	FX
×	○*	×

*:Setting may be made for the QnACPU only.

[Purpose]
Register the TEL data.

[Operating Procedure]
[Tools] → [Set TEL data] → [TEL data]

[Dialog Box] (For use of QnA series)

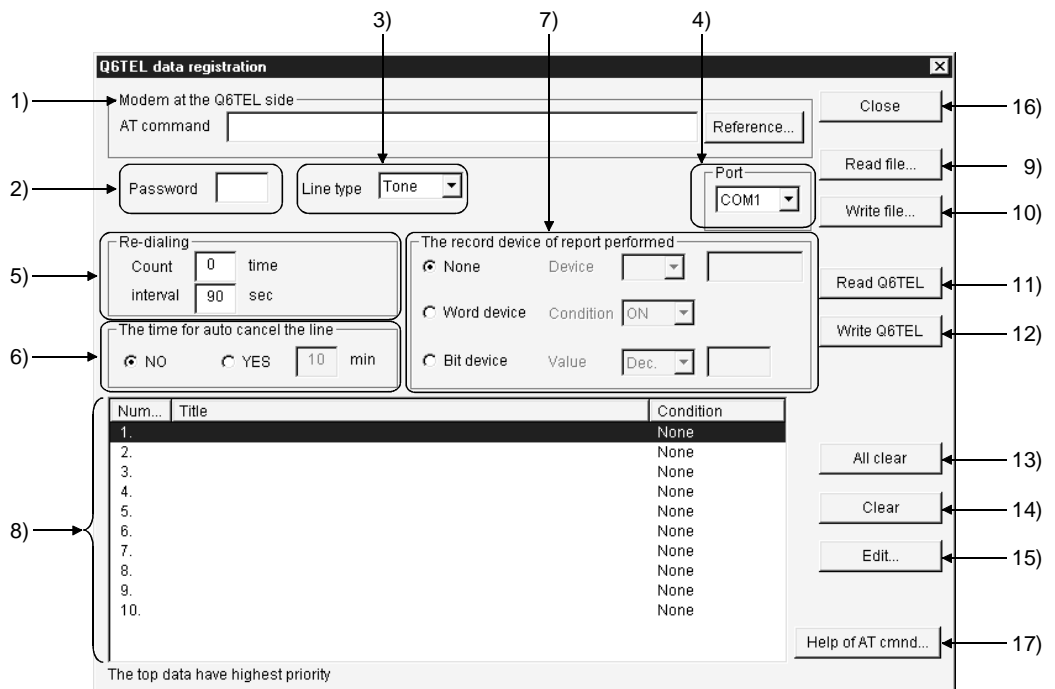

[Description] (For use of QnA series)

- 1) Modem at the Q6TEL side
Set the AT command of the Q6TEL side modem.
Direct input
Enter directly.
The number of set characters is 40.
Browse (Only the AT command of the TEL side connection modem may be browsed)
Clicking the Browse button shows the AT command dialog box.
Choose the AT command you want to set, and click the Select button.
- 2) Password (may be omitted)
Set the password for access to the Q6TEL.
Set in four characters.
- 3) Line type
Choose the tone, pulse or ISDN.

- 4) Port
Set the communication port number used to read/write the Q6TEL data.
- 5) Redial
Set the redialing function.
Number of times that may be set
Any number of times can be set between 1 and 99.
Interval that may be set
Any seconds can be set between 90 and 255 seconds.
- 6) The time for auto cancel the line
Set the line disconnection time at no response.
Time that may be set (The line is disconnected if there is no response after the set time has elapsed.)
Any minutes can be set between 1 and 120 minutes.
- 7) The record device of report performed
Set the device records of whether the Q6TEL has notified or not.
 No
Device record is not made.
 Word device
The set value of the word device is used for recording.
Set the device/device number and device value.
Usable device/device number
 - D0 to D25983
 - R0 to 32767
 - W0 to 657F
 - ZR0 to 65535
Usable device value
 - Decimal -32768 to 32767
 - Hexadecimal 0 to FFFF (K0 to K32767 for T/C) Bit device
The set value of the bit device is used for recording.
Set the device/device number and device status (ON, OFF).
Usable device/device number
 - X0 to 1FFF
 - Y0 to 1FFF
 - M0 to 32767
 - L0 to 32767
 - B0 to B7FFF
 - F0 to 32767
 - D0.0 to 25983.F
 - W0.0 to 657F.F
 - R0.0 to 32767.F
 - ZR0.0 to 1042431.F
 - SM0 to 2047
 - SB0 to 7FF
 - SD0.0 to SD2047.F
 - SW0.0 to 7FF.F
- 8) Notice data list
Shows the titles and set conditions of the notice data.
- 9) Read file button
Reads the Q6TEL data file or GPPQ format Q6TEL data file.

- 10) **Write file** button
Writes the Q6TEL data to a file as GX Developer format Q6TEL data.
- 11) **Read Q6TEL** button
Reads the TEL data set to the Q6TEL.
The read data appears on the screen.
- 12) **Write Q6TEL** button
Writes the TEL data created with GX Developer to the Q6TEL.
- 13) **Clear all** button
Deletes all notice data registered.
- 14) **Clear** button
Deletes only the notice data selected in the notice data list.
- 15) **Edit** button

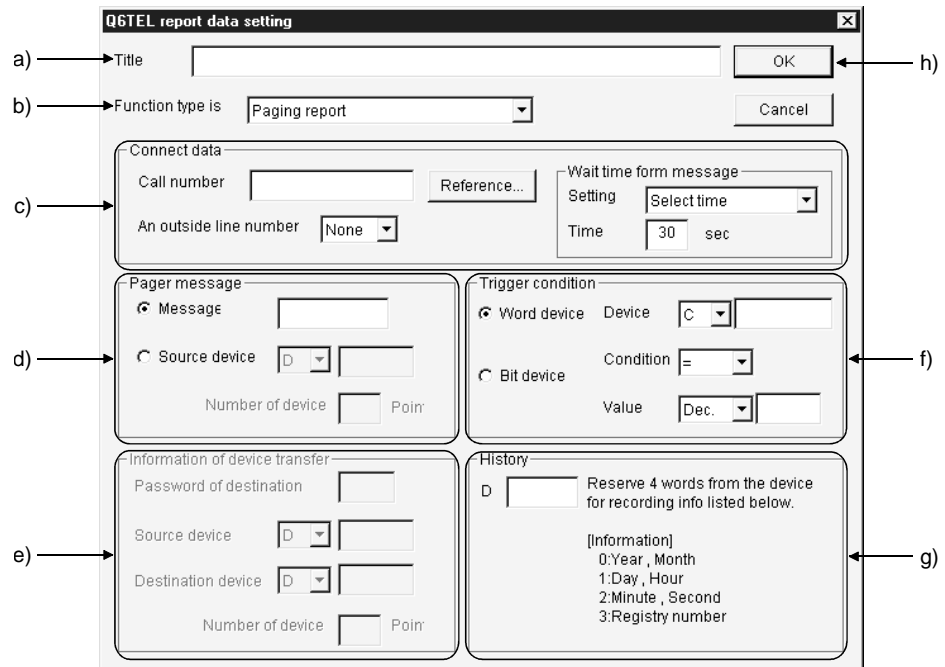

- a) **Heading**
Sets the heading to the data to be set as the notice destination of the Q6TEL.
When the data written to the Q6TEL once is reread, the heading is not displayed. (Since it is written to the personal computer only.)
The number of set characters is 60.
- b) **Function type is**
Set the notice destination.

- c) Notice destination information
Set the notice destination information.
- Phone number
- Set the phone number of the notice destination.
 - Only 0 to 9, *, # and - may be used.
(* and # are used for ISDN sub-address)
 - The number of set characters is 17.
- Outside line access number
- Set the outside line access number of the notice destination.
- Pager announcement time
- Setting
Choose the time setting.
 - Set time (dial message pause time)
Set pause time when it is needed from when the Q6TEL make a phone call until it sends a message.
The time that may be set is 0 to 99 seconds.
- d) Pager message
Set the message to be sent to the pager.
- Message
- 0 to 9, # and * may be selected.
 - Set within 10 characters.
- Transfer device
- When specifying the device, specify the first device of the transfer source and set how many points will be transferred.
- Transferable device
- D0 to D25983 • ZR0 to ZR65535
 - W0 to 657F • R0 to R32767
- The number of device points set is between 1 to 480.
Note that the number of characters displayed on the pager depends on the pager used.
- e) Device transfer information (may be set only when Q6TEL-Q6TEL communication is set)
Set the device whose data will be transferred between the Q6TELS.
- D0 to D25983 • R0 to R32767
 - ZR0 to ZR65535 • W0 to 657F
- f) Trigger condition
Set the trigger device, the device number, and the status (ON/OFF) for a bit device, or the device value for a word device, which are used when the Q6TEL performs notice processing.

- g) History
Set the data registers which store the other end, date and time when the Q6TEL notified the pager. The setting range is D0 to 25980.

	b15	to	b8	b7	to	b0
Dn	Year			Month		
Dn+1	Day			Hour		
Dn+2	Minute			Second		
Dn+3	Notice destination					

- h) button
Click this button when the setting is over.
- 16) command button
Gives instructions for AT command setting.
- 17) button
Saves the edited data and terminates the TEL data registration function.

POINT
<ul style="list-style-type: none"> Note that the device settings in the notice completion record device setting, transfer devices, device transfer information and history depend on the PLC parameter device setting.

22.3.5 Setting the FX PLC

A	Q/QnA	FX
×	×	○

[Purpose]

Set the modem function of the FX_{1S}, FX_{1N}, FX_{2N} or FX_{2NC} PLC.

[Operating Procedure]

[PLC parameter] → <<PLC system (1)>>, <<PLC system (2)>> tab

[Dialog Box]

<<PLC system (1)>>

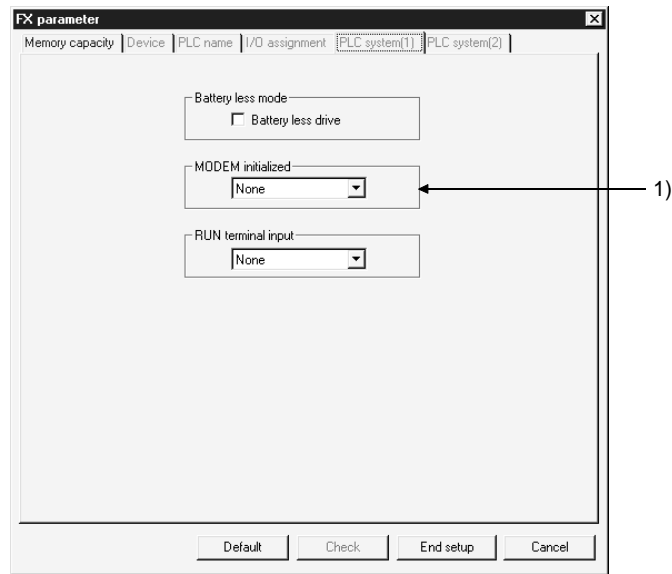

<<PLC system (2)>>

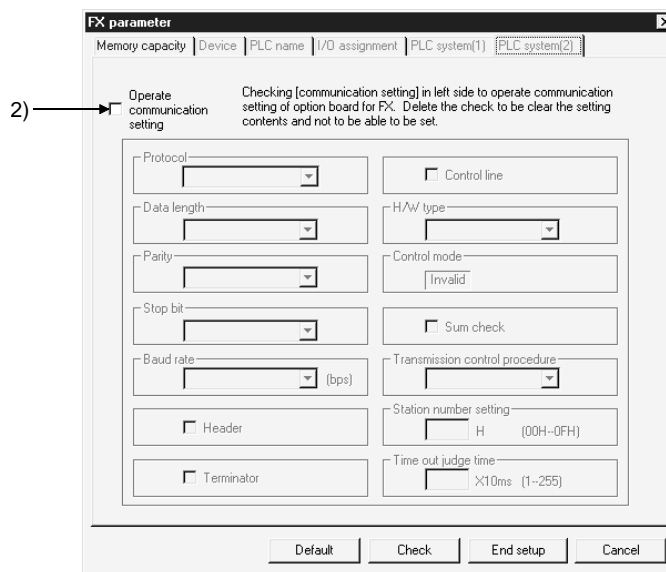

[Description]

1) MODEM initialized

Set the command to initialize the PLC side modem used for remote access to the PLC.

2) Operate communication setting

Uncheck the check box to set the PLC to be remote-accessed.

[Instructions for sequence program]

To make remote access, the special data register D8120 (communication format) value of the PLC must be set to "0".

This setting can be cleared to "0" by unchecking the "Operate communication setting" check box in PLC system. However, remote access cannot be made if any value other than "0" is written in D8120 in the sequence program. In this case, correct the sequence program so that a specific value is not written to D8120.

[User setting of the modem]

If you set the modem initialization to the "user setting mode" in PLC system, set the AT command of the modem in the following procedure.

- Initialization command system
To initialize the modem, use the AT command developed by Hayes, U.S.A. This command is generally represented in the following format.

A	T	Command+parameter	Command+parameter	Command+parameter	-----	CR	LF
---	---	-------------------	-------------------	-------------------	-------	----	----

Confirm the details of the AT command in the manual of the modem used.

- If you choose the "user registration mode" in the aforementioned "PLC mode setting", FX_{1N}, FX_{2N}, or FX_{2NC} PLC transmits the contents of data registers D1000 to D1059 and FX_{1S} transmits the contents of data registers D200 to D255 as the modem initialization command to the modem via the RS-232C communication device after it has sent the AT&F (initialization to factory setting) command at power-on of the PLC.

Write the user-specified modem initialization command in advance to data registers D1000 to D1059 (FX_{1N}, FX_{2N}, FX_{2NC}) and D200 to D255 (FX_{1S}) using the personal computer current value changing function or sequence program.

Initialization command entry example: ATE0S0=2Q1&D0&M4Q0JO&W

Register No.	ASCII	Hexadecimal	Register No.	ASCII	Hexadecimal
D1000	A	41	D1013	&	26
D1001	T	54	D1014	M	4D
D1002	E	45	D1015	4	34
D1003	0	30	D1016	\	5C
D1004	S	53	D1017	Q	51
D1005	0	30	D1018	0	30
D1006	=	3D	D1019	\	5C
D1007	2	32	D1020	J	4A
D1008	Q	51	D1021	0	30
D1009	1	31	D1022	&	26
D1010	&	26	D1023	W	57
D1011	D	44	D1024	CR	0D
D1012	0	30	D1025	LF	0A

The initialization command registered by the user may be specified in D1000 and subsequent (FX_{1N}, FX_{2N}, FX_{NC}) and in D200 and subsequent (FX_{1S}), but its transmission is ended as soon as "0" is read at any point during transmission.

In creating a sequence program, note that the input area of this initialization command for the modem should not overlap the area of the data registers used in a general sequence program.

- Settings of registered modem
The following table lists the setting items and their data of the AT command of the modem pre-registered to the PLC.
The setting items and their data may change with the modem. Confirm the actual settings in the manual of the modem used.

Setting Item	PV-AF288 (AIWA) ATE0S0=2Q1&D0&M5\Q0\JO&W	ME3314 (OMRON) * ATE0S0=2Q1&D0&H0&R1S15=8&W
Command echo setting	E0 (no)	E0 (no)
Number of automatic incoming call ringers	S0=2 (twice)	S0=2 (twice)
Result code indication	Q1 (no)	Q1 (no)
DTR control	&D0 (normally ON)	&D0 (normally ON)
Communication mode	&M5 (V.42bis)	S15=8 (V.42bis)
Terminal flow control system	\Q0 (no)	&R1 (no)
Send data flow control	—	&H0 (no)
Terminal speed fixed mode	\J0 (fixed)	—
Write to nonvolatile memory	&W	&W

*: The setting of the AT command compatible with the ME3314 (OMRON) has been added to version V2.01 or later (serial No. 78 or later) of the FX_{2N} PLC.
The FX_{1S}, FX_{1N}, FX_{2NC} PLC is compatible from its first products.

[Setting by programming software other than GX Developer]

- The FX_{2N} or FX_{2NC} PLC side setting may also be made using any of the following programming software.
FX-PCS/WIN Version V2.10 or later (for Windows[®])
FX-PCS-KIT/98 Version V4.00 or later (for PC-9800)
FX-PCS-KIT/V Version V2.00 or later (for PC/AT)
FX-A7PHP-KIT Version V3.00 or later (for A7PHP)
- Set the modem to be used in the "PLC mode setting" of any software.
- If D8120 (communication format) must be cleared to zero in the software other than FX-PCS/WIN, clear all PLC parameters and then re-set the parameters other than [], the keywords, etc.
- Use the user setting method, etc. for the modem as described in this manual.

22.4 Connecting/Disconnecting the Line

22.4.1 Connecting the line automatically

A	Q/QnA	FX
○	○	○

[Purpose]

The connection method for remote access is described.

[Operating Procedure]

[Tools] → [Set TEL data] → [Connection]

[Dialog Box]

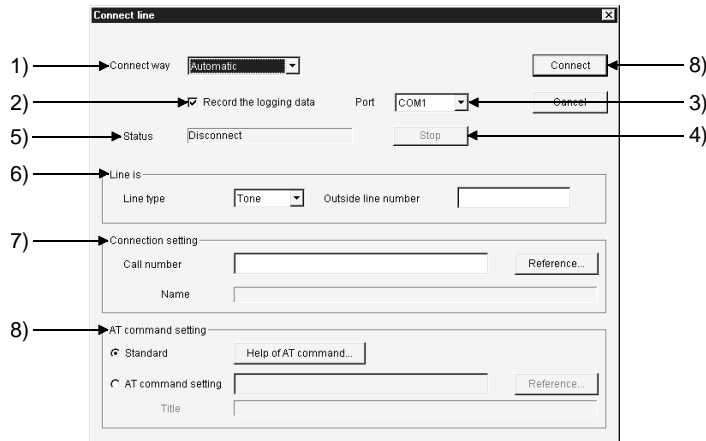

[Description]

1) Connect way

Choose the automatic or manual (line connection via switchboard) system. For manual connection, refer to Section 22.4.2.

2) Record the logging data

In the log file, you can check the line connection time, line disconnection time, line usage time, line connection destination name, other end phone number, and call back or normal connection.

The storage place and file name of the log file are as follows.

Storage place: GX Developer installation destination\log (Default:

Melsec\Gppw\log)

Log file name : Year/Month/Day.data (e.g. 980929.log)

- 3) Port
Choose the COM port No. connected with the modem.
- 4) button
Suspends line connection during line connection.
- 5) Status
Shows the connection status of the line.
- 6) Line designation
Line type
Choose the tone, pulse or ISDN.
Outside line access number
- 7) Connection destination designation
Set the phone number of the other end.
Also, presetting the phone number in the phone number book allows the phone number of the other end to be set from the button.
- 8) AT command designation
 - Standard
Specify the standard command of the modem.
 - AT command designation
If the line does not connect properly using the standard AT command, refer to the data displayed by pressing the button and the manual of the modem, and create the AT command.
When the FX PLC is connected, create the AT command in accordance with the information of Help.

[Setting Procedure]

1. Set the line connection system.
2. Set the port.
3. Set the line type.
4. Set the phone number of the other end.
5. Specify the AT command. (Normally set the standard command.)
6. Click the button.

POINTS	<ul style="list-style-type: none"> • Telephone line connection may also be made from "Online" → "Transfer setup". • If a password has been set to the A6TEL/Q6TEL, the following dialog box appears to clear the password. If the password is wrong, the line is not connected.
--------	---



- If the line being connected is disconnected due to disturbance, the following dialog box appears to select whether the line is to be connected or disconnected.



- When the line is connected, the line usage time dialog box appears. The connection time is shown in increments of 5 seconds, and the dialog box closes after the line is disconnected. To select whether the dialog box is shown or hidden, use "View" → "Elapsed time".
- If the connection destination is changed to another COM port or communication board (e.g. MELSECNET/10) by the connection destination designation during telephone line connection, the telephone line is kept connected and communication can be made in any communication path.

REMARKS

The following items are to be set on the PLC and personal computer sides when a telephone line is used for serial communication (for the Q/QnA series).

Serial communication (Q series)

	Remote Access
PLC	1) I/O assignment setting Set the following items by software switching setting. <ul style="list-style-type: none"> • Baudrate, transmission specifications, transmission speed, mode, station number. 2) Set the following items in a sequence program. <ul style="list-style-type: none"> • Write the initialization command (ATS0=1). • Set the initialization request. Write the initialization command (ATS0=1) in a sequence program.
Personal computer	1) AT command registration 2) Telephone number registration

Serial communication (QnA series)

	Remote Access
PLC	1) Set the DIP switches of the module. 2) Set the following items in a sequence program. <ul style="list-style-type: none"> • Write the initialization command (ATS0=1). • Set the initialization request.
Personal computer	1) AT command registration 2) Telephone number registration

22.4.2 Connecting the line via a switchboard (manual connection)

A	Q/QnA	FX
○	○*	○

*: Compatible with only the QnACPU.

This section explains the way to connect to a private branch line via a switchboard. Manual line connection cannot be made if the modem does not have the ANS/ORG/TEL select switch.

(1) System configuration

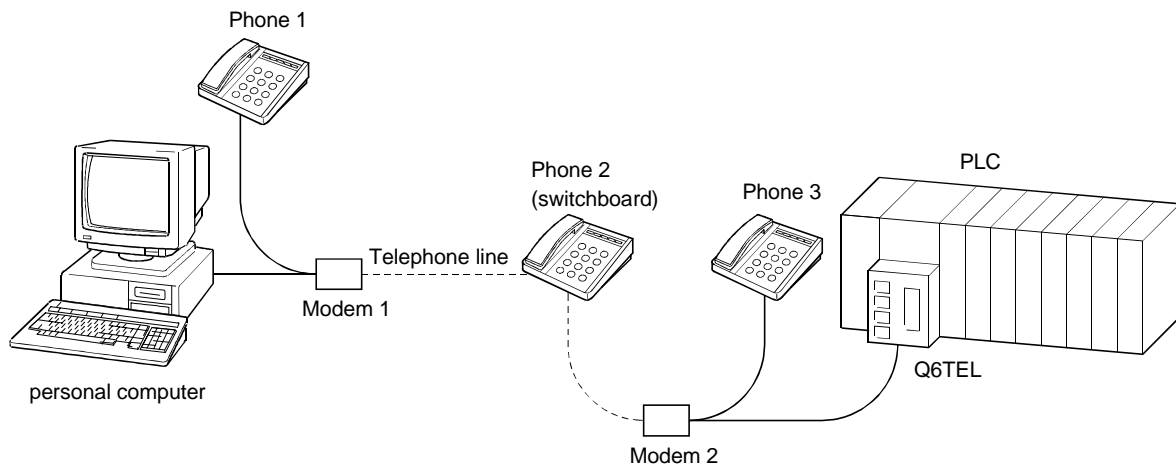

(2) Operation procedure

- [Tools] → [Set TEL data] → [Connection]
(Choose "Manual" as the line connection system in the line connection dialog box. For the operation procedure, refer to Section 23.4.1.)
- Set modem 1 on the phone 1 side to the ORG mode and place modem 2 on the phone 3 side to the ANS mode.
- Make a call from phone 1 to phone 2 (switchboard).
- Connect phone 1 and phone 3 to the line at phone 2 (switchboard).
- In conversation between phone 1 and phone 3, determine that the A6TEL/Q6TEL will be connected to the line.
- Turn on the DATA switch of modem 2 on the phone 3 side.
- After confirming the "beep" of modem 1 on the phone 1 side, turn on the DATA switch.
- As soon as the "beep" of modem 1 on the phone 1 side has gone, press the **Connection** button of the personal computer.

When the line is connected properly, the "Line connected" dialog box appears.

(3) Instructions

- 1) The operation timings in steps 6 and 7 are delicate.
If connection is not made well, repeat the operation several times to adjust the timings.
- 2) The modems for manual line connection must have the "ANS ↔ ORG" select switch.
AIWA PV-AF3361WW
- 3) For manual line connection, the automatic incoming call mode must have been cleared in the A6TEL/Q6TEL/FX_{2N} side modem.
 - For the modem which uses a switch to set to the automatic incoming call mode
Set the automatic incoming call mode switch to the clear position.
 - Change "S0" to "S0=0" in the initialization command.
When "S0" has already been set to other than 0, change it to "S0=0".
 - If the modem has been set to other than the user registration mode in the PC system setting (1) of the FX_{2N} or FX_{2CN} PLC, "S0=2" is set in the initialization command.
When making manual line connection, place the modem in the user registration mode and program the initialization command including "S0=0" for D1000 to D1059.
Refer to Section 22.3.5.

22.4.3 Disconnecting the line

A	Q/QnA	FX
○	○	○

[Purpose]

The disconnection of the telephone line being connected is described.

[Operating Procedure]

[Tools] → [Set TEL data] → [Disconnection]

[Dialog Box]



23. MXCHANGE CONVERSION FUNCTIONS

The MXChange conversion functions are designed to share the device comment data of a GX Developer project among applications. Programs, device memory and others cannot be converted.

23.1 Function List

A	Q/QnA	FX
○	○	○

The following functions can be performed from GX Developer.

Function	Description
MXChange data base →GX Developer device comment read	The tag information of the MXChange data base is read onto GX Developer and converted into GX Developer device comments. (Refer to Section 23.6)
MXChange data base ← GX Developer device comment write	GX Developer device comments are converted into the tag information of the MXChange data base and the results are written to the MXChange data base. (Refer to Section 23.7)
MXChange server designation	Among multiple MXChange data bases, specify the data base server which reads/writes the device comment data of GX Developer. (Refer to Section 23.3)
Tag change notice	When the MXChange data base is updated from another application, it can be confirmed that the tag information has been changed. (Refer to Section 23.3)
Password setting	Set the password used when you log in to the MXChange server. (Refer to Section 23.3)

The following table lists the devices supported.

Bit devices

	M	SM	Special M	S	L	F	V	X	Y	B	SB	DX	DY	BL
QCPU (Q mode)	○	○	—	×	○	○	○	○	○	○	○	○	○	○
QnACPU	○	○	—	×	○	○	○	○	○	○	○	○	○	○
ACPU	○	—	○	○	○	×	×	○	○	○	—	—	—	—
FXCPU	○	—	○	○	×	×	×	○	○	×	—	—	—	—

Word devices

	D	SD	Special D	R	ZR	W	SW	T	C	ST	P	I	U	J
QCPU (Q mode)	○	○	—	○	○	○	○	○	○	○	○	○	○	○
QnACPU	○	○	—	○	○	○	○	○	○	○	○	○	○	○
ACPU	○	—	○	○	×	○	—	○	○	×	○	○	—	—
FXCPU	○	—	○	×	×	×	—	○	○	×	○	○	—	—

23.2 General Procedure for Using the MXChange Conversion Functions

A	Q/QnA	FX
○	○	○

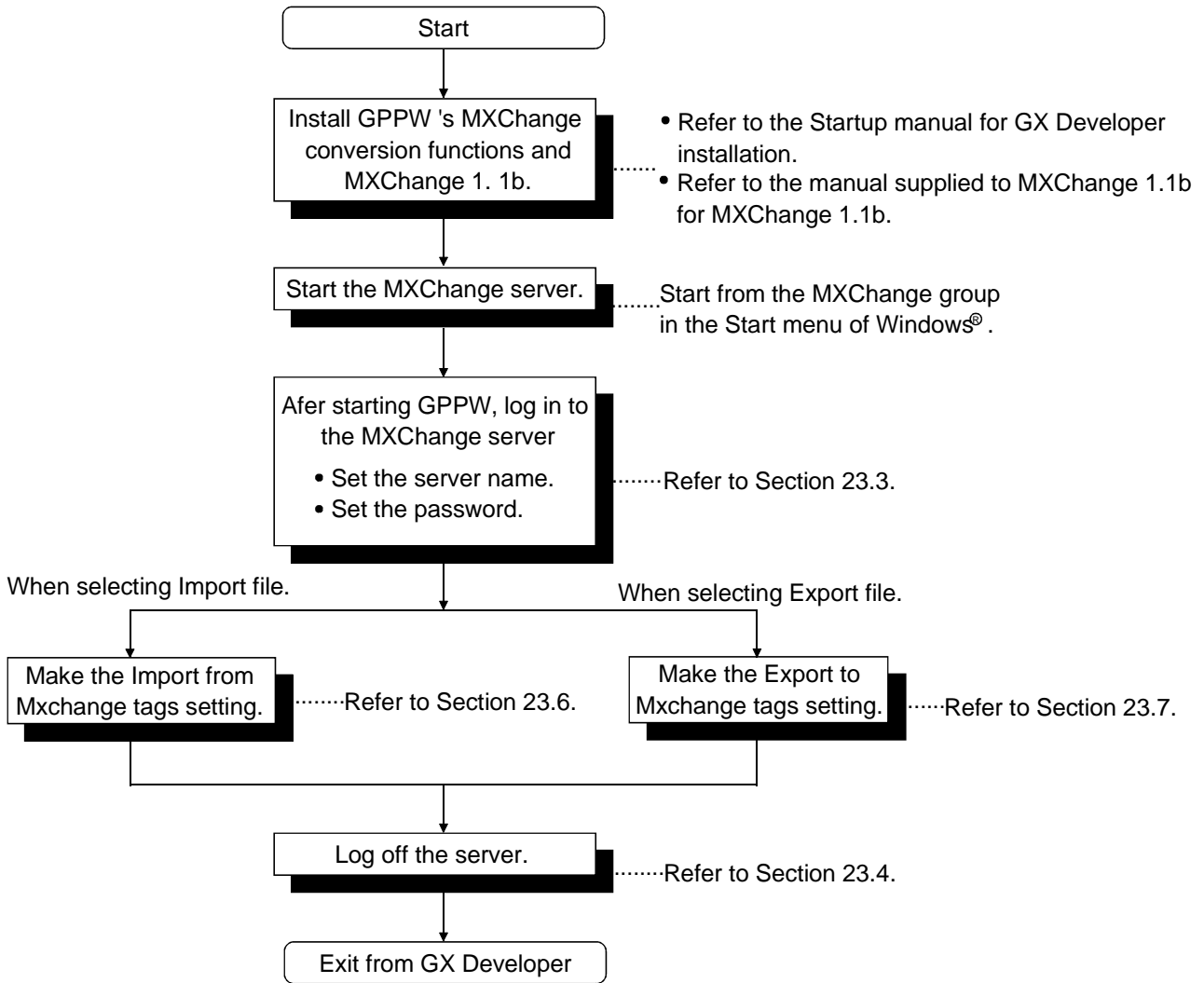

23.3 Logging in to the Server

A	Q/QnA	FX
○	○	○

[Purpose]

Makes the MXChange data base conversion functions available.
Menu selection cannot be made unless the project is open on GX Developer.

[Operating Procedure]

Select [Tool] → [MXChange actions] → [Login].

[Dialog Box]

[Description]

- 1) Server Name
Type the MXChange server name (or IP address) to which GX Developer is connected.
- 2) **Use Local Address** button
The computer name in current use is set as the Server Name.
- 3) **Browse** button
A connectable server list is displayed.
Choose the Server Name and click the **Select** button.
- 4) Time Out
Set the time-out value when making connection to the server.
The range setting is 0 to 200000ms.
- 5) User Name
Defaults to Admin.
The User Name cannot be changed.

6) Password

Set the password (max. 1024 characters) used when making connection to the server with the specified login name.

How to set the password change

1. Choose [Tool] → [MXChange actions] → [Password].
2. In "Old Password", set the password currently used.
In "New Password" or "Retype", set a new password.
3. Click the **OK** button.

7) Option

When any change has been made to the data of the MXChange data base, GX Developer receives that change and you can confirm it in the following dialog box.



Clicking the **Show Changes** button displays the following screen.

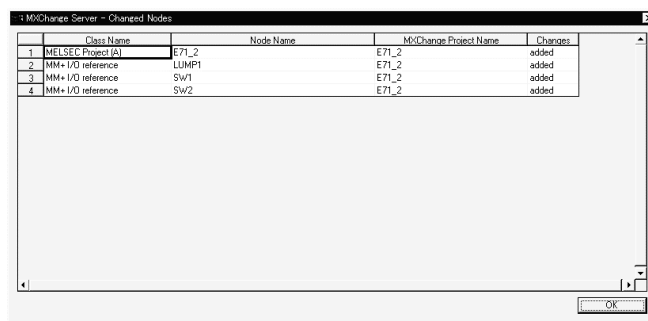

Item	Description
Class Name	Any of the following is displayed. When changes were made to the project node <ul style="list-style-type: none"> • MELSEC project (A) • MELSEC project (Q) • MELSEC project (FX) • MELSEC project (QnA) • MELSEC project (Motion) When changes were made to the tag <ul style="list-style-type: none"> • MM+ I/O Reference
Node Name	The name of the GX Developer node to which changes were made is displayed.
MXChange Project Name	The name of the project to which changes were made is displayed.
Changes	Any of the following is displayed. <ul style="list-style-type: none"> • deleted : The displayed node or tag was erased from another application. • modified : Comment data changes were made to the displayed node or tag was erased from another application. • added : Additions were made to the displayed node or tag from another application.

23.4 Logging off the Server

A	Q/QnA	FX
○	○	○

[Purpose]

Stops connection to the MXChange server.

[Operating Procedure]

Select [Tool] → [MXChange actions] → [Logoff].

23.5 MXChange Data Base Conversion

A	Q/QnA	FX
○	○	○

This section indicates correspondences between the GX Developer project data and MXChange data base data for execution of MXChange data base conversion.

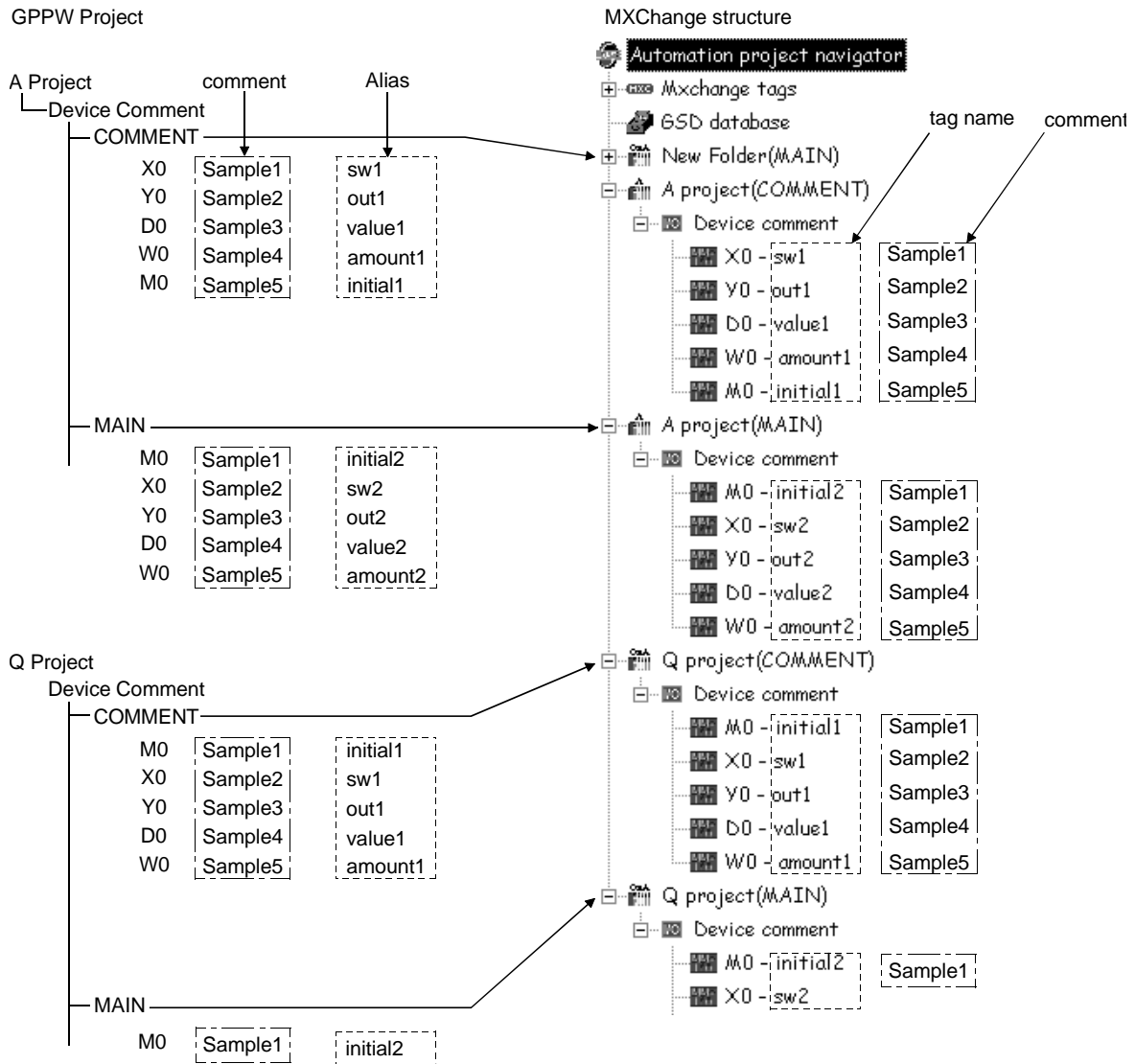

In the MXChange data base, the comment types of the GX Developer device comments correspond to the respective project nodes (FX Project (COMMENT), Q Project (MAIN), etc.).

For Import from MXChange server to GX Developer, the data names correspond as indicated below.

MXChange tag		GX Developer Project
Tag Name	→	Alias
Device	→	Device
Comment	→	Comment

For Export from GX Developer to MXChange server, the data names correspond as indicated below.

GX Developer Project		MXChange tag
Device	→	Device
Comment	→	Comment
Label	→	Tag Name

POINT
<ul style="list-style-type: none"> • When the Alias created on GX Developer is exported to the MXChange data base, do not use any characters other than the alphabets, numerals and "_". In addition, do not enter a space or numeral at the beginning of the Label. • If nothing has been set to the Alias of GX Developer at the time of Export, Device changes to Tag name.

23.6 Import from MXChange Tags

A	Q/QnA	FX
○	○	○

[Purpose]

Reads comment data in the MXChange server.

[Operating Procedure]

Select [Project] → [Import file] → [Import from MXChange tags].

[Dialog Box]

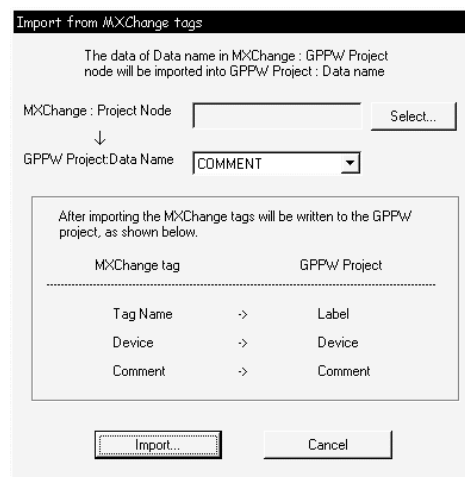

[Description]

- 1) MXChange : Project Node
Set the MELSEC Project node.
Make setting from the **Select** button.
- 2) GX Developer Project : Data name
Make selection as the data names existing in the currently open GX Developer project appear.

3) **Import** button

Deletes all comment data existing on GX Developer and reads comment data from the MXChange server to GX Developer.

The following dialog box appears if the same data (device number) exists in the device within the imported tag.

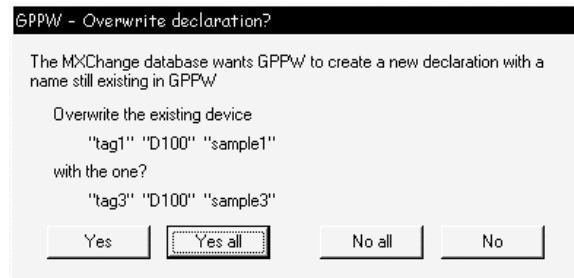

Yes :Replaces the device comment displayed in "Overwrite the existing declaration" with the data displayed in "with the new one".

Yes all :Replaces all with the newly read data.

No all :Does not make replacement if the tag name read from MXChange exists in the Alias of the GX Developer comment data.

No :Does not replace the device comment displayed in "Overwrite the existing declaration" with the data displayed in "with the new one".

Selecting **Yes** or **Yes all** performs the following processing.

MXChange Data			GX Developer Data		
Tag	Device	COMMENT	Device	COMMENT	Alias
TAG1	D100	Sample1	D100	Sample3	TAG3
TAG2	M0	Sample2	M0	Sample2	TAG2
TAG3	D100	Sample3			

TAG1 D100 Sample1 is overwritten by TAG3 D100 Sample3.

When importing the MXChange data different in PLC type on GX Developer
The data within the PLC type range of the GX Developer project is imported.

POINT	<ul style="list-style-type: none"> • When importing the MXChange tag (64 characters) to GX Developer, the first 8 characters of the MXChange data are read to the GX Developer Alias. • When importing the comment (64 characters) of the MXChange tag to GX Developer, the first 32 characters of the MXChange data are read to the GX Developer comment.
--------------	--

23.7 Export to MXChange Tags

A	Q/QnA	FX
<input type="radio"/>	<input type="radio"/>	<input type="radio"/>

[Purpose]

Writes the device comments and Alias created on GX Developer to the MXChange data base server.

[Operating Procedure]

Select [Project] → [Export file] → [Export to MXChange tags].

[Dialog Box]

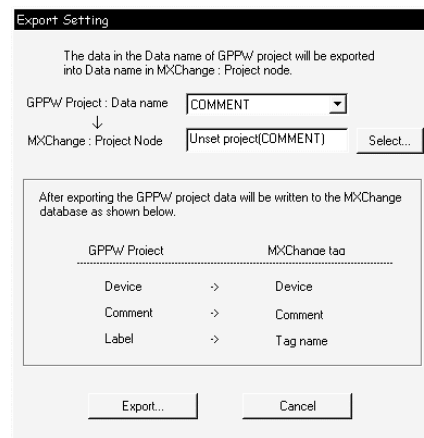

[Description]

- 1) GX Developer Project : Data name
The data name of the project name currently edited appears.
Set the data name to be written to the MELSEC data base.
- 2) MXChange : Project Node
Set the MELSEC Project Node at the export destination of MXChange.
When selecting the existing Project Node, setting can be made from the **Select** button.

3) **Export** button

Makes conversion to the comment data of the MXChange data base.

The following dialog box appears if the MELSEC Project Node set on the Export Settings screen does not exist.

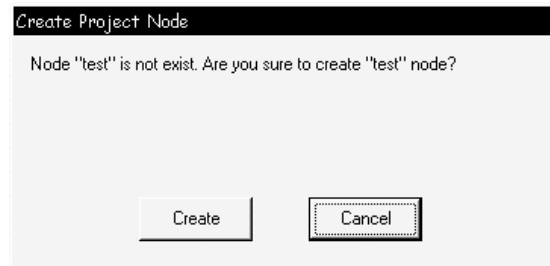

Clicking the **Create** button creates a new MXChange node (MELSEC Project node, comment node) with the input node name.

The following dialog box appears if the PLC type set for the selected project node differs from the PLC type of the GX Developer project to be exported. Perform operation in accordance with the message of the following dialog box.

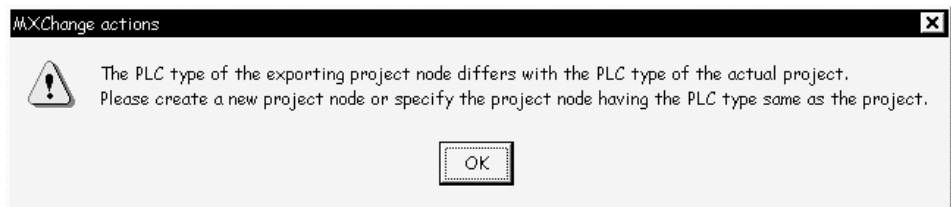

The following dialog box appears if the Alias of the GX Developer project includes any character other than the alphabets, numerals and "_" or if the first character is a space or numeral.

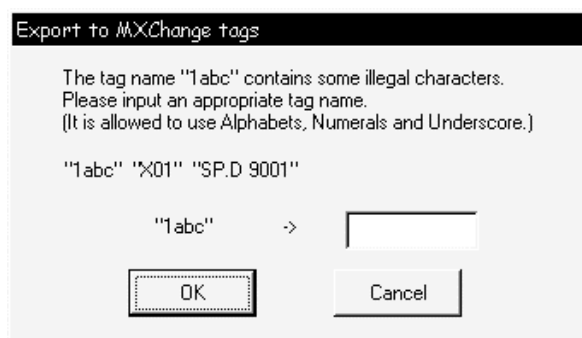

The following dialog box appears if the same tag name already exists in the MXChange database or if overlapping data exist in the device comments or aliases of GX Developer.



- Yes** :Replaces the tag displayed in "Overwrite the existing declaration" with the tag displayed in "with the new one".
- Yes all** :Replaces all data with new data.
- No all** :Does not replace if the same tag name exists at the write destination.
- No** :Does not replace the tag displayed in "Overwrite the existing declaration" with the tag displayed in "with the new one".

Choosing **Yes** or **Yes all** performs the following process.

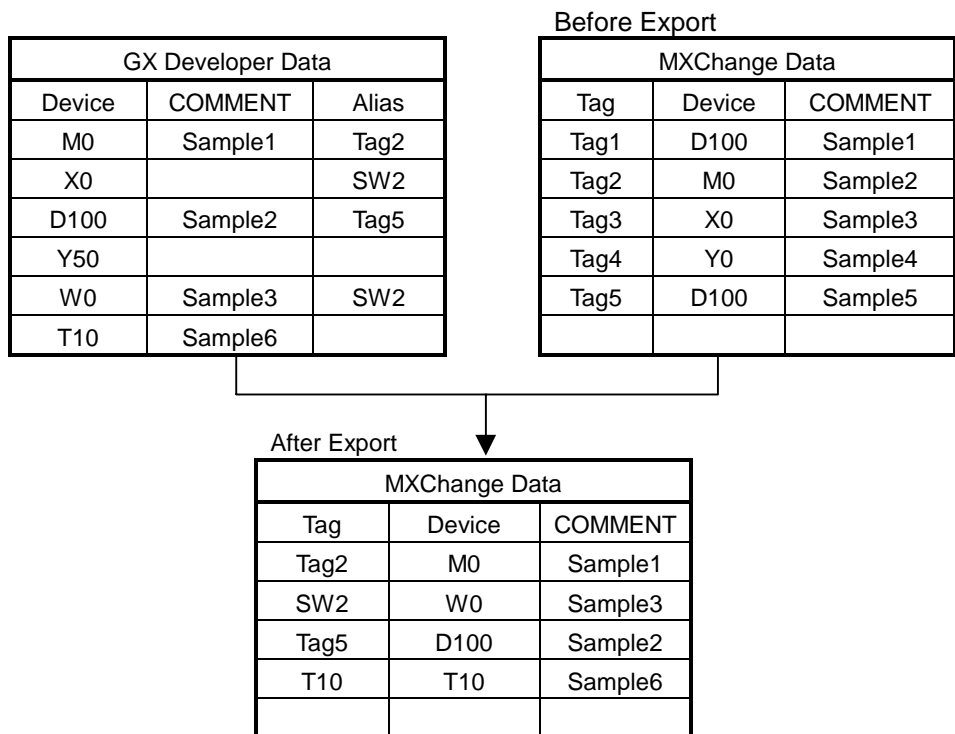

- Y50 of GX Developer is not exported since it has no COMMENT and Alias.
- If there is no data set in Alias of GX Developer at the time of Export, the device changes to the tag name.

Exporting the data in the preceding table shows the following dialog box. The following dialog box appears since Tag5 D100 Sample2 exists in the GX Developer data and Tag5 D100 Sample5 exists in the MXChange data.

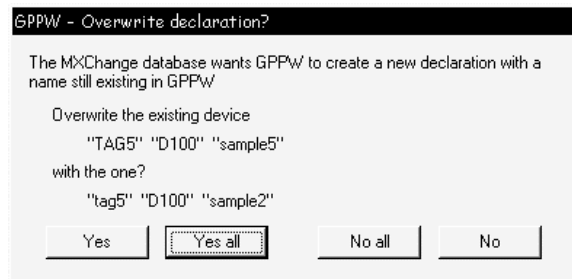

Since multiple sw2's exist as the Alias of the GX Developer data, the following dialog box appears.



23.8 MXChange Troubleshooting

The following table indicates error messages and their corrective actions.

Error Message	Corrective Action
"The connection to the MXChange server timed out!"	Increase the time-out value in the Login dialog box.
"The MXChange server has been disconnected!"	Start the MXChange server or log in again.
"Not logged in, or insufficient right to perform the action!"	Type the password correctly.
"Logoff incorrect! ¥n¥n confirmed %d"	Make sure that the server has been started. Inform the developer of the error code.
"Close Connection unsuccessful! ¥n¥n confirmed %d"	Make sure that the server has been started. Inform the developer of the error code.
"The server has no current database!"	Create a new data base in the MXChange server.
"The request object dose not exist!"	Start the MXChange server.
"Please input the Project node."	Set the project of the export destination.
"Comment data was not found."	Create a new comment data name on GX Developer.
"The old password was incorrect."	Set a correct password.
"Licencing limits exceeded."	Export within the permitted number of tags.
"The PLC type of the exporting project node differs with the PLC type of the actual project. Please create a new Project node or specify the project node having the PLC type same as the project."	Create a new project of the export destination separately, or choose the project of the same PLC type as that of GX Developer for the export destination.
"MXChange server Disconnect!"	Start the MXChange server or log in again.
"Bad 1st character of MXChange tag name."	Using correct characters, re-set the tag name.
"The connection is broken. Processing is canceled. A partial data was Exported. ¥n"	Log in to the server again.
"Project is already used by used!"	Execute after logging off MXChange in the corresponding application.
"Project node is not exist in MXChange server!"	Perform operation after create the MELSEC Project node.
"This PLC type is not available in MXChange."	An attempt was made to export the comment data of the PLC type of the GX Developer project not supported by MXChange.

APPENDICES

Appendix 1 GPP Function Access Ranges in MELSECNET(II/10) Systems

1.1 Access Range with MELSECNET (II)

APP

A	Q/QnA	FX
○	○	×

[PLC No. Designation Example]
For MELSECNET (II), MELSECNET/B:

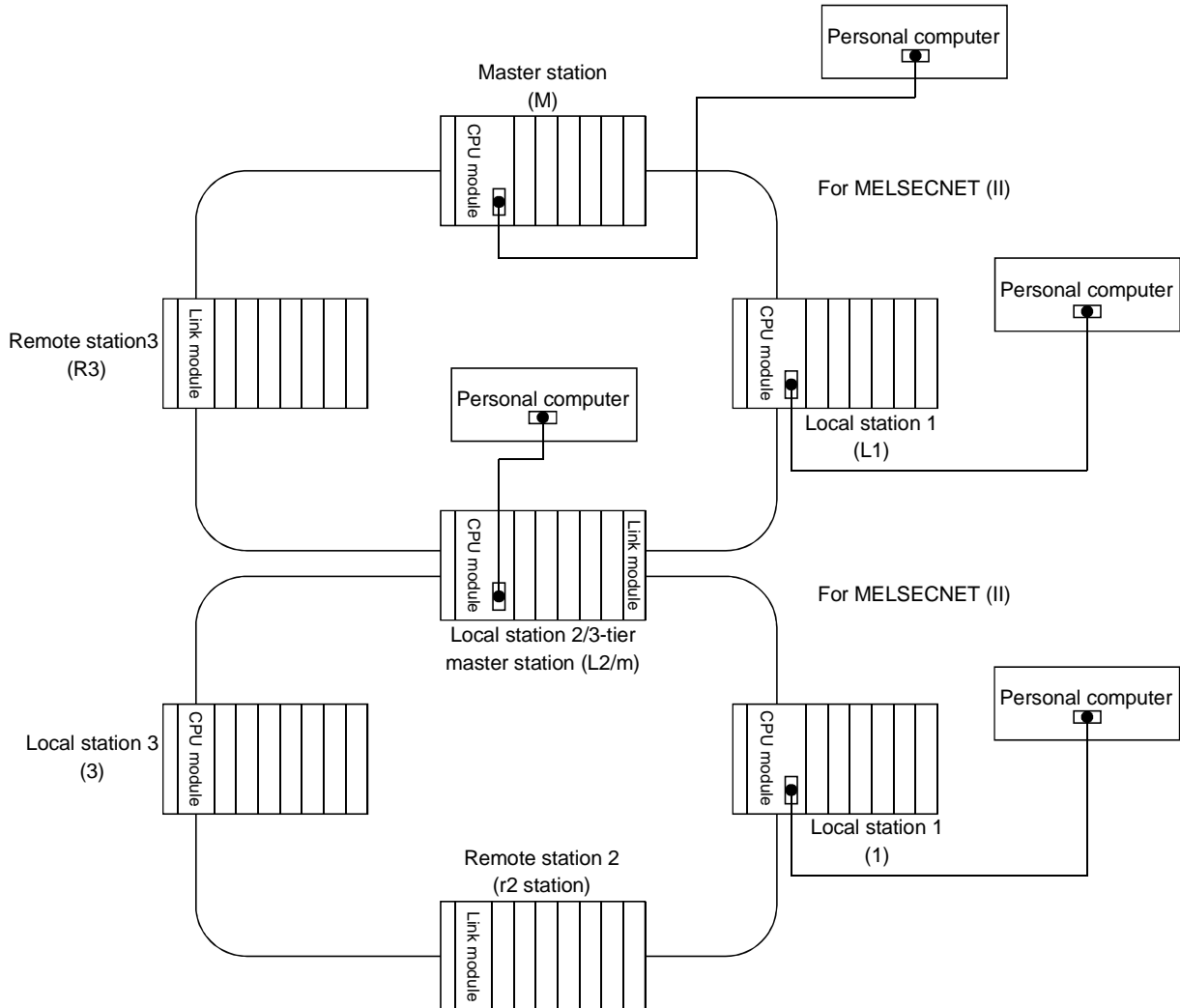

Designated PLC number

Personal computer-connected Station	PLC Accessed by Personal computer						
	M	L1	L2/m	R3	I1	r2	I3
M	○	○	○	×	×	×	×
L1	○	○	×	×	×	×	×
L2/m	○	×	○	×	○	×	○
R3	○	×	×	×	×	×	×
I1	×	×	○	×	○	×	×
r2	×	×	○	×	×	×	×
I3	×	×	○	×	×	×	○

○ ... Designating the PLC number (station number) of the relevant programmable controller allows access to all devices.

APP

POINT
<ol style="list-style-type: none"> 1. Even if any tier in the figure above is MELSECNET/B, the designated numbers are the same.

1.2 Access Range for an A Series Start

A	Q/QnA	FX
○	○	×

For PLC to PLC network
When using a MELSECNET/10 2-tier system:

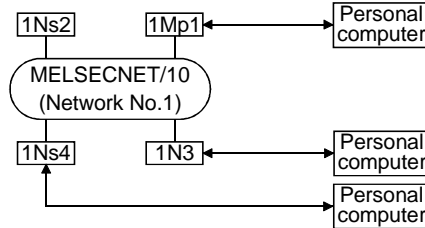

Personal computer-connected station	Station Accessible from Personal computer			
	1Mp1	1Ns2	1N3	1Ns4
1Mp1	FF	1-2	1-3	1-4
1N3	1-1	×	FF	×
1Ns4	1-1	1-2	1-3	FF

- [MELSECNET/10]
- [PLC to PLC network]
- Mp station...Control station
- Ns station...Normal station (AnUCPU)
- N station...Normal station (CPUs excluding AnU (AnA/AnNCPU))
- [MELSECNET (II)]
- M station...Master station
- L station...Local station
- R station...Remote station
- FF: Host station

• When using a MELSECNET/10 multi-tier system:

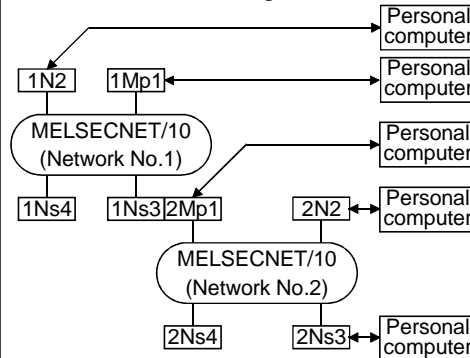

Personal computer-connected Station	Station Accessible from Personal computer						
	1Mp1	1N2	1Ns3/2Mp1	1Ns4	2N2	2Ns3	2Ns4
1Mp1	FF	1-2	1-3	1-4	2-2	2-3	2-4
1N2	1-2	FF	×	×	×	×	×
1Ns3/2Mp1	1-1	1-2	FF	1-4	2-2	2-3	2-4
2N2	×	×	2-1	×	FF	×	×
2Ns3	1-1	1-2	2-1	1-4	2-2	2-3	FF

• When using a MELSECNET/10 / MELSECNET(II) composite system:

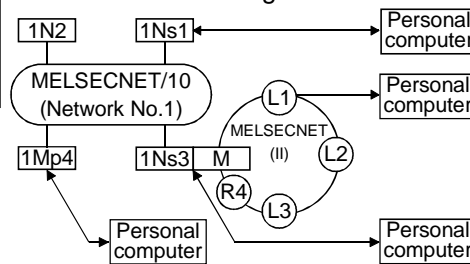

Personal computer-connected Station	Station Accessible from Personal computer							
	1Ns1	1N2	1Ns3/M	1Mp4	L1	L2	L3	R4
1Ns1	FF	1-2	1-3	1-4	×	×	×	×
1Ns3/M	1-1	1-2	FF	1-4	1	2	3	×
1Mp4	1-1	1-2	1-3	FF	×	×	×	×
L1	×	×	0	×	FF	×	×	×

"Station accessible from Personal computer" in the tables:
<Example>

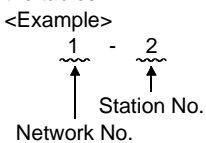

• When using an AnA/AnNCPU as an intermediate station:

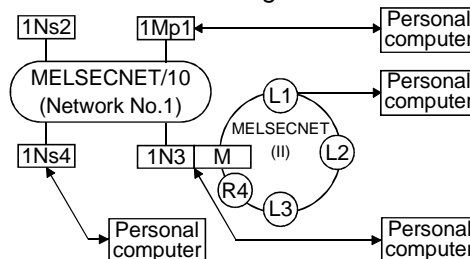

Personal computer-connected station	Station Accessible from Personal computer							
	1Mp1	1Ns2	1N3/M	1Ns4	L1	L2	L3	R4
1Mp1	FF	1-2	1-3	1-4	×	×	×	×
1N3/M	1-1	×	1-3	×	1	2	3	×
1Ns4	1-1	1-2	1-3	FF	×	×	×	×
L1	×	×	0	×	FF	×	×	×

For remote I/O network

- When using a MELSECNET/10 2-tier system:

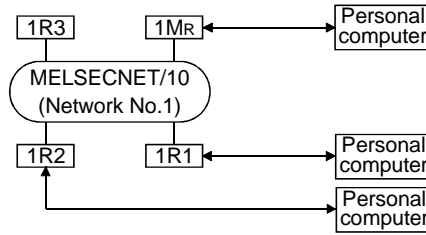

Personal computer-connected Station	Station Accessible from Personal computer			
	1MR	1R1	1R2	1R3
1MR	FF	×	×	×
1R1	0	×	×	×
1R2	0	×	×	×

- When using a MELSECNET/10 multi-tier system:

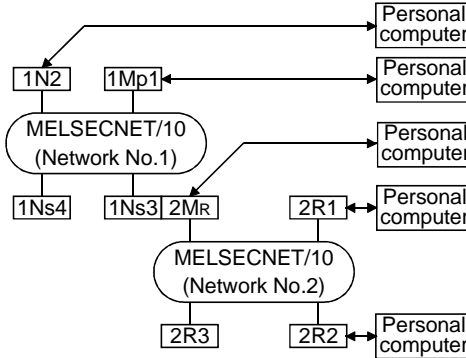

Personal computer-connected Station	Station Accessible from Personal computer						
	1Mp1	1N2	1Ns3/2MR	1Ns4	2R1	2R2	2R3
1Mp1	FF	1-2	1-3	1-4	×	×	×
1N2	×	FF	×	×	×	×	×
1Ns3/2MR	1-1	1-2	FF	1-4	×	×	×
2R1	1-1	1-2	0	1-4	×	×	×
2R2	1-1	1-2	0	1-4	×	×	×

- When using a MELSECNET/10, MELSECNET (II) composite system:

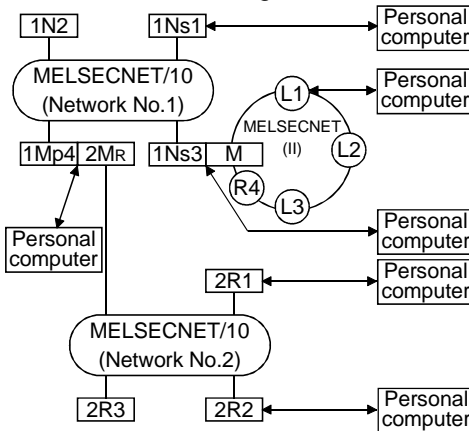

Personal computer-connected Station	Station Accessible from Personal computer										
	1Ns1	1N2	1Ns3/M	1Mp4/2MR	2R1	2R2	2R3	L1	L2	L3	R4
1Ns1	FF	1-2	1-3	1-4	×	×	×	×	×	×	×
1Ns3/M	1-1	1-2	FF	1-4	×	×	×	1	2	3	×
1Mp4/2MR	1-1	1-2	1-3	FF	×	×	×	×	×	×	×
2R1	1-1	1-2	1-3	0	×	×	×	×	×	×	×
2R2	1-1	1-2	1-3	0	×	×	×	×	×	×	×
L1	×	×	0	×	×	×	×	FF	×	×	×

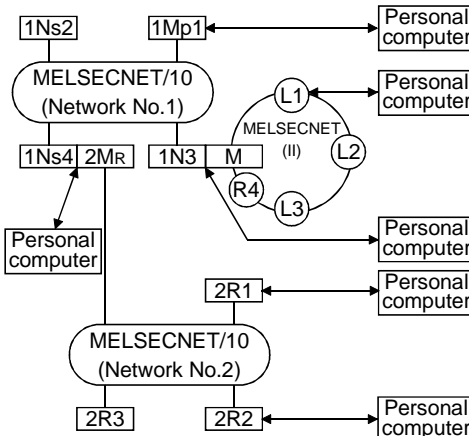

Personal computer-connected Station	Station Accessible from Personal computer										
	1Mp1	1Ns2	1N3/M	1Ns4/2MR	2R1	2R2	2R3	L1	L2	L3	R4
1Mp1	FF	1-2	1-3	1-4	×	×	×	×	×	×	×
1N3/M	×	×	FF	×	×	×	×	1	2	3	×
1Ns4/2MR	1-1	1-2	1-3	FF	×	×	×	×	×	×	×
2R1	1-1	1-2	1-3	0	×	×	×	×	×	×	×
2R2	1-1	1-2	1-3	0	×	×	×	×	×	×	×
L1	×	×	0	×	×	×	×	FF	×	×	×

1.3 Access Range for a QnA Series Start

A	Q/QnA	FX
×	○*	×

*: This function is compatible with the QnACPU

For MELSECNET/10 PLC to PLC network

- When using a MELSECNET/10 2-tier system:

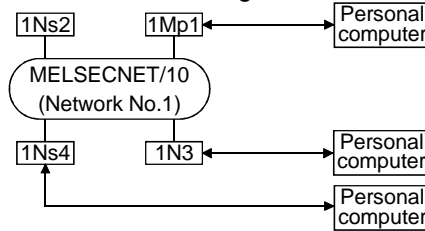

Designated PLC number

Personal computer-connected Station	Station Accessible from Personal computer			
	1Mp1	1Ns2	1N3	1Ns4
1Mp1	FF	1-2	×	1-4
1N3	×	×	×	×
1Ns4	1-1	1-2	×	FF

× : Access not possible

- When using a MELSECNET/10 multi-tier system:

Mp station...Control station
Ns station...Normal station (QnACPU)
N station...Normal station (CPUs excluding QnA (AnU/AnA/AnNCPU))

In the figure to the right, the first digit for each station indicates the network number and the final line indicates the station number.
FF: Host station

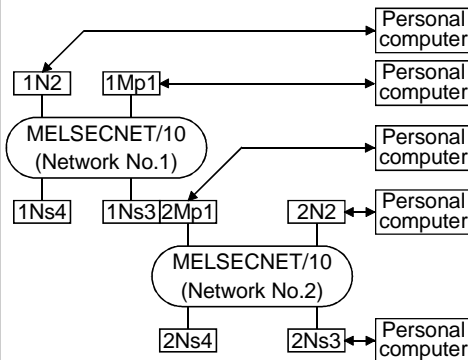

Designated PLC number

Personal computer-connected Station	Station Accessible from Personal computer						
	1Mp1	1N2	1Ns3/2Mp1	1Ns4	2N2	2Ns3	2Ns4
1Mp1	FF	×	1-3	1-4	×	2-3	2-4
1N2	×	×	×	×	×	×	×
1Ns3/2Mp1	1-1	×	FF	1-4	×	2-3	2-4
2N2	×	×	×	×	×	×	×
2Ns3	1-1	×	2-1	1-4	×	FF	2-4

× : Access not possible

- When using a MELSECNET/10, MELSECNET (II) composite system: (Intermediate station: QnACPU)

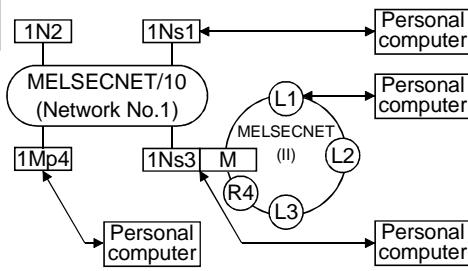

Designated PLC number

Personal computer-connected Station	Station Accessible from Personal computer							
	1Ns1	1N2	1Ns3/M	1Mp4	L1	L2	L3	R4
1Ns1	FF	×	1-3	1-4	×	×	×	×
1Ns3/M	1-1	×	FF	1-4	1	2	3	×
1Mp4	1-1	×	1-3	FF	×	×	×	×
L1	×	×	0	×	FF	×	×	×

× : Access not possible

- (Intermediate station: AnU/AnA/AnNCPU)

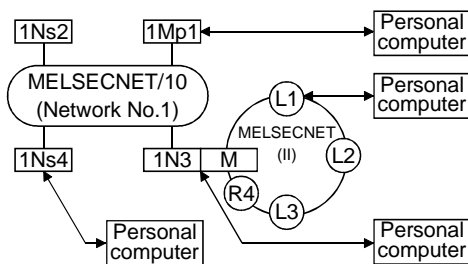

Designated PLC number

Personal computer-connected Station	Station Accessible from Personal computer							
	1Mp1	1Ns2	1N3/M	1Ns4	L1	L2	L3	R4
1Mp1	FF	1-2	×	1-4	×	×	×	×
1N3/M	×	×	×	×	×	×	×	×
1Ns4	1-1	1-2	×	FF	×	×	×	×
L1	×	×	×	×	FF	×	×	×

× : Access not possible

"Station accessible from Personal computer" in the tables:
<Example>

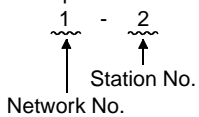

POINT

- To access a PLC in another station, routing parameters must be set by using the Personal computer function.
For details on setting network parameters, refer to the "online" manual.
For details of the network parameters themselves, refer to the MELSECNET/10 Network System Reference Manual.

For MELSECNET/10 remote I/O network

- When using a MELSECNET/10 2-tier system

[MELSECNET/10 PLC to PLC network]
 Mp station....Control station
 Ns station....Normal station (QnACPU)
 N station.....Normal station (CPUs excluding QnA) (AnU/AnA/AnNCPU)

[MELSECNET/10 Remote I/O network]
 MR station...Master station (QnACPU)
 R station.....Remote station

[MELSECNET (II)]
 M station.....Master station
 L station.....Local station
 R station.....Remote station

In the figure to the right, the first digit for each station indicates the network number and the final line indicates the station number. However, the station number of MR (master station) is not shown because it is "0."

FF: Host station

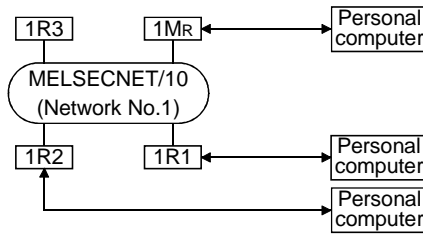

Designated PLC number

Personal computer-connected Station	Station Accessible from Personal computer			
	1MR	1R1	1R2	1R3
1MR	FF	×	×	×
1R1	0	×	×	×
1R2	0	×	×	×

× : Access not possible

1. The following devices of a remote I/O station connected to GX Developer can be monitored : X, Y, B, W.
2. Ladder monitoring, status monitoring (in remote I/O stations connected to GX Developer, the CPU connected to the master station can be monitored).
3. Loop test, setting confirmation test, station order confirmation test, communication test (testing with a remote station treated as the host station is possible).

- When using a MELSECNET/10 multi-tier system:

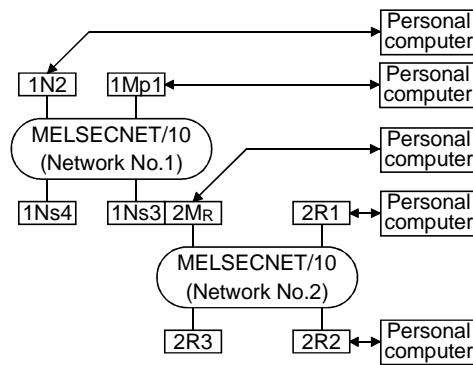

Designated PLC number

Personal computer-connected Station	Station Accessible from Personal computer						
	1Mp1	1N2	1Ns3/2MR	1Ns4	2R1	2R2	2R3
1Mp1	FF	×	1-3	1-4	×	×	×
1N2	×	×	×	×	×	×	×
1Ns3/2MR	1-1	×	FF	1-4	×	×	×
2R1	1-1	×	1-3	1-4	×	×	×
2R2	1-1	×	0	1-4	×	×	×

× : Access not possible

- When using a MELSECNET/10, MELSECNET (II) composite system:

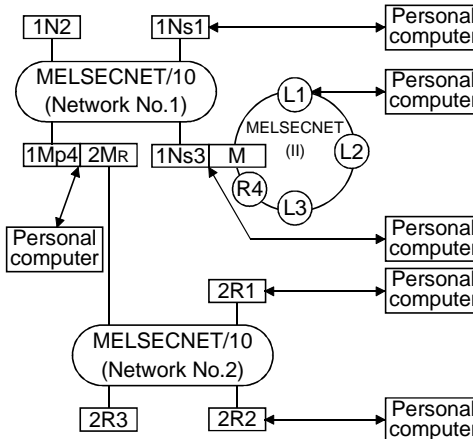

Designated PLC number

Personal computer-connected Station	Station Accessible from Personal computer										
	1Ns1	1N2	1Ns3/M	1Mp4/2MR	2R1	2R2	2R3	L1	L2	L3	R4
1Ns1	FF	×	1-3	1-4	×	×	×	×	×	×	×
1Ns3/M	1-1	×	FF	1-4	×	×	×	1	2	3	×
1Mp4/2MR	1-1	×	1-3	FF	×	×	×	×	×	×	×
2R1	1-1	×	1-3	0	×	×	×	×	×	×	×
2R2	1-1	×	1-3	0	×	×	×	×	×	×	×
L1	×	×	0	×	×	×	×	FF	×	×	×

× : Access not possible

"Station accessible from Personal computer" in the tables:
 <Example>

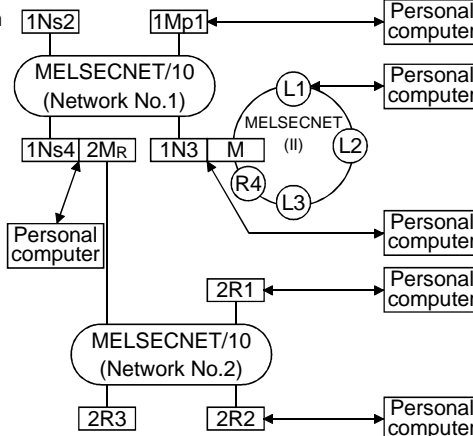
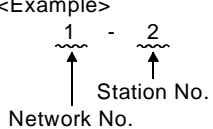

Designated PLC number

Personal computer-connected Station	Station Accessible from Personal computer										
	1Mp1	1Ns2	1N3/M	1Ns4/2MR	2R1	2R2	2R3	L1	L2	L3	R4
1Mp1	FF	1-2	×	1-4	×	×	×	×	×	×	×
1N3/M	×	×	×	×	×	×	×	×	×	×	×
1Ns4/2MR	1-1	1-2	×	FF	×	×	×	×	×	×	×
2R1	1-1	1-2	×	0	×	×	×	×	×	×	×
2R2	1-1	1-2	×	0	×	×	×	×	×	×	×
L1	×	×	0	×	×	×	×	FF	×	×	×

× : Access not possible

1.4 Access Range at Q Series Start

A	Q/QnA	FX
×	○	×

For inter-PLC network of MELSECNET/10
 • MELSECNET/10 two-tier system:

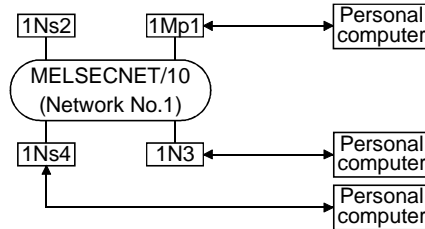

PLC numbers to be specified

Personal computer Connection Station	Station Accessible from Personal computer			
	1Mp1	1Ns2	1N3	1Ns4
1Mp1	FF	1-2	×	1-4
1N3	×	×	×	×
1Ns4	1-1	1-2	×	FF

× : Access not possible

Mp station...Control station
 Ns station...Normal station (QCPU)
 N station....Ordinary station (CPU except Q/QnA (QCPU-A, AnU, AnA, AnNCPU))
 The first digit of each station shown on the right indicates the network number, and the last digit the station number.

• MELSECNET/10 multi-tier system:

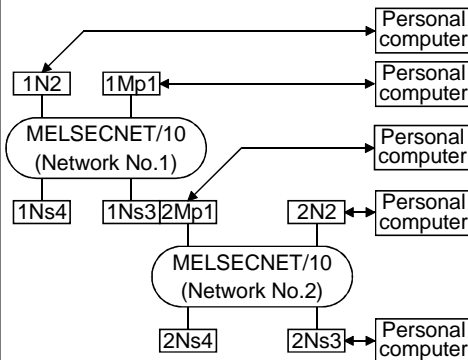

PLC numbers to be specified

Personal computer-connected Station	Station Accessible from Personal computer						
	1Mp1	1N2	1Ns3/2Mp1	1Ns4	2N2	2Ns3	2Ns4
1Mp1	FF	×	1-3	1-4	×	2-3	2-4
1N2	×	×	×	×	×	×	×
1Ns3/2Mp1	1-1	×	FF	1-4	×	2-3	2-4
2N2	×	×	×	×	×	×	×
2Ns3	1-1	×	2-1	1-4	×	FF	2-4

× : Access not possible

"Station accessible from Personal computer" in the tables:

<Example>

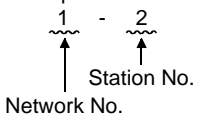

For remote I/O network of MELSECNET/H

• MELSECNET/H two-tier system

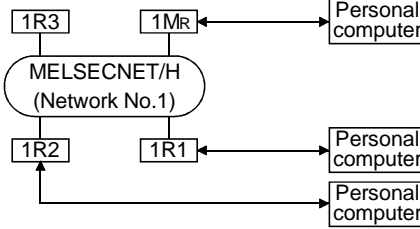

PLC numbers to be specified

Personal computer-connected Station	Station Accessible from Personal computer			
	1Mr	1R1	1R2	1R3
1Mr	FF	1-1	1-2	1-3
1R1	0	FF	1-2	1-3
1R2	0	1-1	FF	1-3

- *1: 1. The devices X, Y, B and W of the remote I/O station connected with GX Developer can be monitored.
- 2. Line monitoring
- 3. Loop test, setting check test, station order check test, communication test (test can be made when remote station is connected to own station)

× : Access not possible

[MELSECNET/10 inter-PLC network]
 Mp station....Control station
 Ns station.... Ordinary station (QCPU (Q mode))
 N station..... Ordinary station (CPU except Q/QnA (AnU/AnA/AnNCPU))
 [MELSECNET/10 remote I/O network]
 Mr station...Master station (QCPU (Q mode))
 R station.....Remote station

The first digit of each station in the network area indicated on the right denotes the network number, and the last digit the station number.
 However, the station number of Mr (master station) is not given since it is 0.

• MELSECNET/H multi-tier system

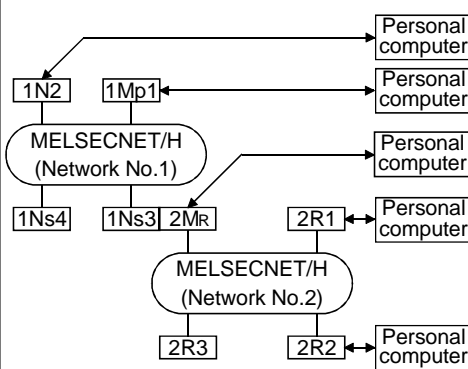

PLC numbers to be specified

Personal computer-connected Station	Station Accessible from Personal computer						
	1Mp1	1N2	1Ns3/2Mr	1Ns4	2R1	2R2	2R3
1Mp1	FF	×	1-3	1-4	2-1	2-2	2-3
1N2	×	×	×	×	×	×	×
1Ns3/2Mr	1-1	×	FF	1-4	2-1	2-2	2-3
2R1	1-1	×	0	1-4	FF	2-2	2-3
2R2	1-1	×	0	1-4	2-1	FF	2-3

× : Access not possible

"Station accessible from Personal computer" in the tables:

<Example>

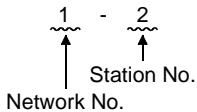

Appendix 2 MELSECNET/10 Board Access Range

2.1 MELSECNET/10 Board

A	Q/QnA	FX
○	○	×

When using a MELSECNET/10 board, confirm the MELSECNET board model names and driver versions indicated below.

	Board	Driver
MELSECNET board for PC/AT	A70BDE-J71LP23GE(fiber optic cable)	SW11VDWT-10P

2.1.1 "A" series start

A	Q/QnA	FX
○	×	×

For MELSECNET/10 PLC-to-PLC network

- When using a MELSECNET/10 2-tier system:

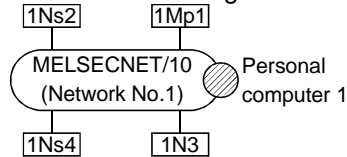

Designated PLC number

	Station Accessible from Personal computer			
	1Mp1	1Ns2	1N3	1Ns4
Personal computer 1	1-1	1-2	1-3	1-4

× : Access not possible

- When using a MELSECNET/10 multi-tier system:

Mp station...Control station
Ns station...Normal station (AnUCPU)
N station....Normal station
(CPUs excluding AnU) (AnA/AnNCPU)
Peripheral devices 1 and 2 are peripheral devices that incorporate a MELSECNET/10 board.
In the figure to the right, the first digit for each station indicates the network number and the final line indicates the station number.

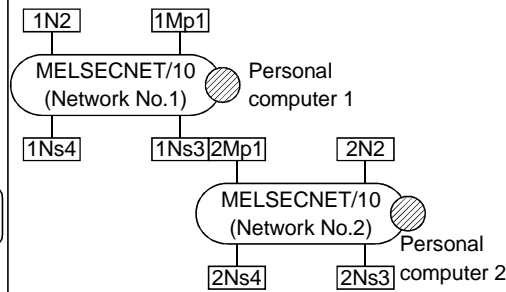

Designated PLC number

	Station Accessible from Personal computer								
	1Mp1	1N2	1Ns3/2Mp1	Personal computer 1	1Ns4	2N2	2Ns3	2Ns4	Personal computer 2
Personal computer 1	1-1	1-2	1-3	×	1-4	2-2	2-3	2-4	×
Personal computer 2	1-1	1-2	1-3	×	1-4	2-2	2-3	2-4	×

× : Access not possible

- When using a MELSECNET/10 / MELSECNET (II) composite system:

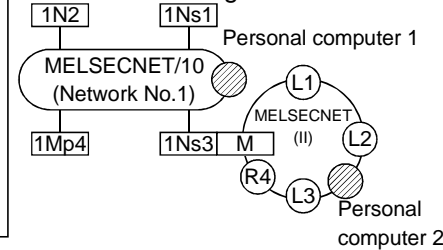

Designated PLC number

	Station Accessible from Personal computer								
	1Mp1	1N2	1Ns3/2Mp1	1Ns4	Personal computer 1	L1	L2	R4	Personal computer 2
Personal computer 1	1-1	1-2	1-3	1-4	×	×	×	×	×
Personal computer 2	×	×	×	×	×	×	×	×	×

× : Access not possible

"Station accessible from Personal computer" in the tables:
<Example>

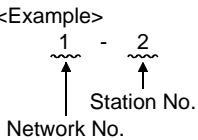

(Intermediate station: AnA/AnNCPU)

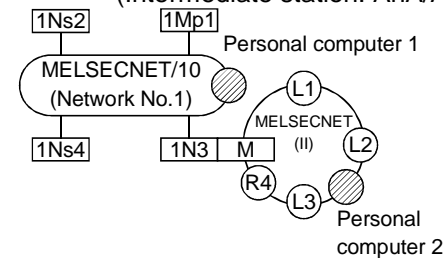

Designated PLC number

	Station Accessible from Personal computer								
	1Mp1	1N2	1Ns3/2Mp1	1Ns4	Personal computer 1	L1	L2	R4	Personal computer 2
Personal computer 1	1-1	1-2	1-3	1-4	×	×	×	×	×
Personal computer 2	×	×	×	×	×	×	×	×	×

× : Access not possible

POINT

- To access a PLC in another station, routing parameters must be set by using the GX Developer.
For details of the network parameters themselves, refer to the MELSECNET/10 Network System Reference Manual.

For MELSECNET/10 remote I/O network

- When using a MELSECNET/10 multi-tier system:

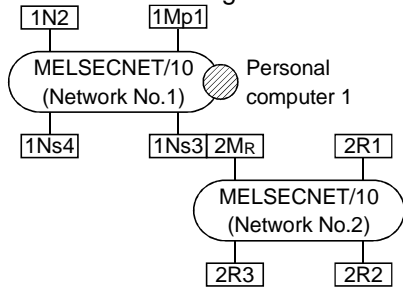

Designated PLC number

	Station Accessible from Personal computer						
	1Mp1	1N2	1Ns3/ 2M _R	1Ns4	2R1	2R2	2R3
Personal computer 1	1-1	1-2	1-3	1-4	×	×	×

× : Access not possible

- MELSECNET/10 /MELSECNET (II) composite system

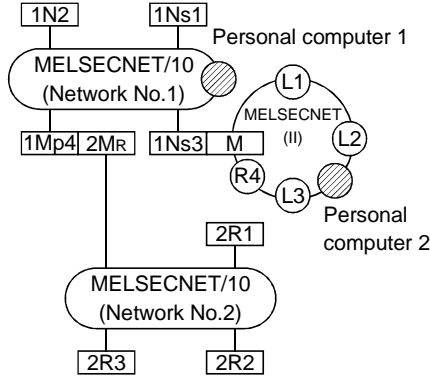

Designated PLC number

	Station Accessible from Personal computer										
	1Ns1	1N2	1Ns3/ M	1Mp4/ 2M _R	2R1	2R2	2R3	L1	L2	L3	R4
Personal computer 1	1-1	1-2	1-3	1-4	×	×	×	×	×	×	×
Personal computer 2	×	×	×	×	×	×	×	×	×	×	×

× : Access not possible

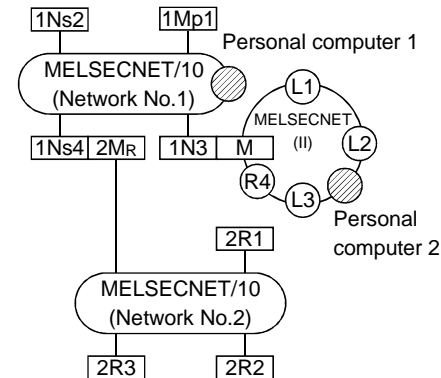

Designated PLC number

	Station Accessible from Personal computer										
	1Mp1	1Ns2	1N3/M	1Ns4/ 2M _R	2R1	2R2	2R3	L1	L2	L3	R4
Personal computer 1	1-1	1-2	1-3	1-4	×	×	×	×	×	×	×
Personal computer 2	×	×	×	×	×	×	×	×	×	×	×

× : Access not possible

**[MELSECNET/10
PLC to PLC network]**
 Mp station....Control station
 Ns station....Normal station (AnUCPU)
 N station.....Normal station
 (CPUs excluding AnU (AnA/AnNCPU))
**[MELSECNET/10
Remote I/O network]**
 M_R station...Master station (AnUCPU)
 R station.....Remote station

[MELSECNET (II)]
 M station.....Master station
 L station.....Local station
 R station.....Remote station

Peripheral devices 1 and 2 are peripheral devices that incorporate a MELSECNET/10 board.
 In the figure to the right, the first digit for each station indicates the network number and the final line indicates the station number.
 However, the station number of M_R (master station) is not shown because it is "0."

"Station accessible from Personal computer" in the tables:

<Example>

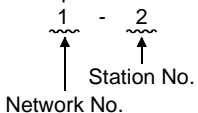

2.1.2 QnA series start

A	Q/QnA	FX
×	○	×

For MELSECNET/10 PLC-to-PLC network

- When using a MELSECNET/10 2-tier system:

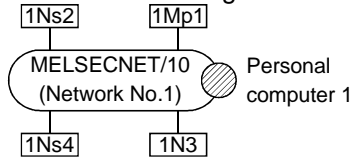

Designated PLC number

	Station Accessible from Personal computer			
	1Mp1	1Ns2	1N3	1Ns4
Personal computer 1	1-1	1-2	×	1-4

× : Access not possible

- When using a MELSECNET/10 multi-tier system:

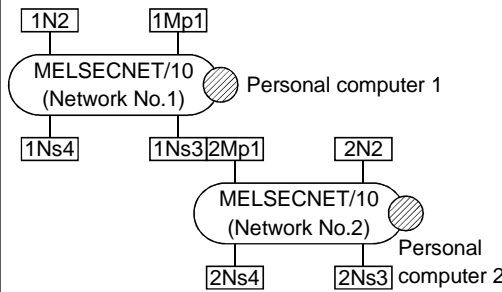

Designated PLC number

	Station Accessible from Personal computer								
	1Mp1	1N2	1Ns3/ 2Mp1	Personal computer 1	1Ns4	2N2	2Ns3	2Ns4	Personal computer 2
Personal computer 1	1-1	×	1-3	×	1-4	×	2-3	2-4	×
Personal computer 2	1-1	×	1-3	×	1-4	×	2-3	2-4	×

× : Access not possible

- When using a MELSECNET/10 / MELSECNET (II) composite system:

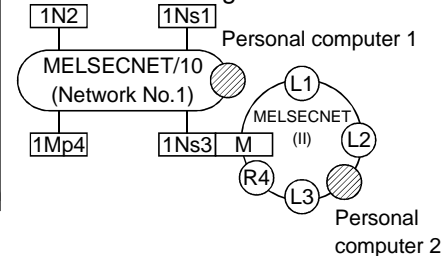

Designated PLC number

	Station Accessible from Personal computer								
	1Mp1	1N2	1Ns3/ 2Mp1	1Ns4	Personal computer 1	L1	L2	R4	Personal computer 2
Personal computer 1	1-1	×	1-3	1-4	×	×	×	×	×
Personal computer 2	×	×	×	×	×	×	×	×	×

× : Access not possible

(Intermediate station: AnU/AnA/AnNCPU)

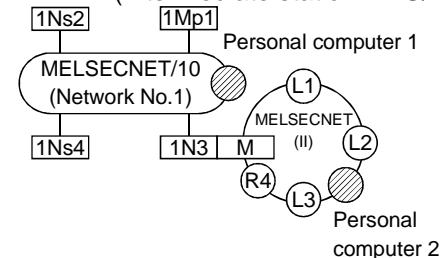

Designated PLC number

	Station Accessible from Personal computer								
	1Mp1	1Ns2	1Ns3/ 2Mp1	1Ns4	Personal computer 1	L1	L2	R4	Personal computer 2
Personal computer 1	1-1	1-2	×	1-4	×	×	×	×	×
Personal computer 2	×	×	×	×	×	×	×	×	×

× : Access not possible

Mp station...Control station
Ns station...Normal station (QnACPU)
N station...Normal station (CPUs excluding AnU (AnU/AnA/AnNCPU))
Peripheral devices 1 and 2 are peripheral devices that incorporate a MELSECNET/10 board.
In the figure to the right, the first digit for each station indicates the network number and the final line indicates the station number accessible from "Station accessible from Personal computer" in the tables:

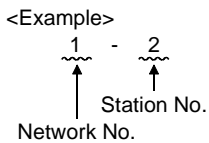

POINT

- To access a PLC in another station, routing parameters must be set by using the GX Developer.
For details of the network parameters themselves, refer to the MELSECNET/10 Network System Reference Manual.

For MELSECNET/10 remote I/O network

- When using a MELSECNET/10 multi-tier system:

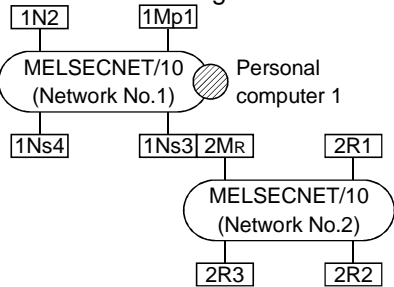

Designated PLC number

	Station Accessible from Personal computer						
	1Mp1	1N2	1Ns3/ 2MR	1Ns4	2R1	2R2	2R3
Personal computer 1	1-1	×	1-3	1-4	×	×	×

× : Access not possible

- MELSECNET/10 /MELSECNET (II) composite system

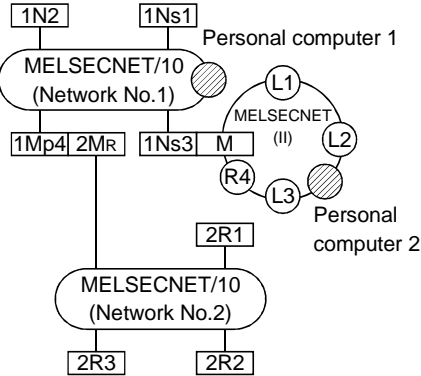

Designated PLC number

	Station Accessible from Personal computer										
	1Ns1	1N2	1Ns3/ M	1Mp4/ 2MR	2R1	2R2	2R3	L1	L2	L3	R4
Personal computer 1	1-1	×	1-3	1-4	×	×	×	×	×	×	×
Personal computer 2	×	×	×	×	×	×	×	×	×	×	×

× : Access not possible

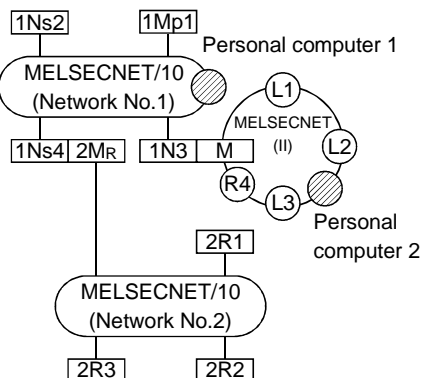

Designated PLC number

	Station Accessible from Personal computer										
	1Mp1	1Ns2	1N3/M	1Ns4/ 2MR	2R1	2R2	2R3	L1	L2	L3	R4
Personal computer 1	1-1	1-2	×	1-4	×	×	×	×	×	×	×
Personal computer 2	×	×	×	×	×	×	×	×	×	×	×

× : Access not possible

**[MELSECNET/10
PLC to PLC network]**
 Mp station....Control station
 Ns station....Normal station (QnACPU)
 N station.....Normal station
 (CPUs excluding QnA) (AnU/AnA/AnNCPU)
**[MELSECNET/10
Remote I/O network]**
 Mr station...Master station (QnACPU)
 R station.....Remote station
[MELSECNET (II)]
 M station.....Master station
 L station.....Local station
 R station.....Remote station
 Peripheral devices 1 and 2 are peripheral devices that incorporate a MELSECNET/10 board.
 In the figure to the right, the first digit for each station indicates the network number and the final line indicates the station number.
 However, the station number of Mr (master station) is not shown because it is "0."

"Station accessible from Personal computer" in the tables:

<Example>

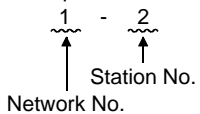

2.1.3 At Q series start

A	Q/QnA	FX
×	○	×

For inter-PLC network of MELSECNET/10

- MELSECNET/10 two-tier system:

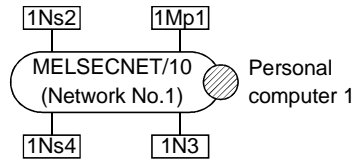

PLC numbers to be specified

	Station Accessible from Personal computer			
	1Mp1	1Ns2	1N3	1Ns4
Personal computer 1	1-1	1-2	×	1-4

× : Access not possible

- MELSECNET/10 multi-tier system:

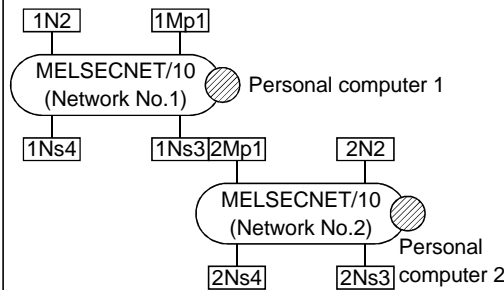

PLC numbers to be specified

	Station Accessible from Personal computer								
	1Mp1	1N2	1Ns3/ 2Mp1	Periph- -eral Device 1	1Ns4	2N2	2Ns3	2Ns4	Periph- -eral Device 2
Personal computer 1	1-1	×	1-3	×	1-4	×	2-3	2-4	×
Personal computer 2	1-1	×	1-3	×	1-4	×	2-3	2-4	×

× : Access not possible

For MELSECNET/10 remote I/O network

- MELSECNET/H multi-tier system

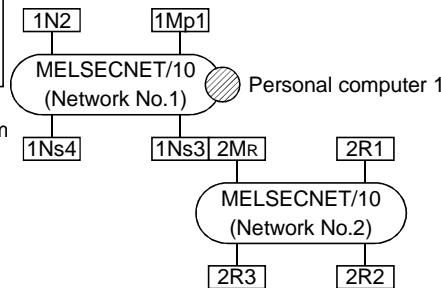

PLC numbers to be specified

	Station Accessible from Personal computer						
	1Mp1	1N2	1Ns3/ 2Mr	1Ns4	2R1	2R2	2R3
Personal computer 1	1-1	×	1-3	1-4	×	×	×

× : Access not possible

Mp station...Control station
Ns station...Ordinary station
QCPU
N station....Ordinary station
CPU except Q/QnA (QCPU-A, AnU, AnA, AnNCPU)
Peripheral devices 1, 2 are those which have built-in MELSECNET/10 boards.
The first digit of each station shown on the right indicates the network number, and the last digit the station number.

"Station accessible from Personal computer" in the tables:

<Example>

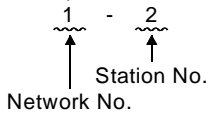

POINT
<ul style="list-style-type: none"> • To access the other station PLC, routing parameter setting must be made using the GX Developer. For network parameter setting, refer to the Offline Manual. For details of the network parameters, refer to the MELSECNET/10 Network System Reference Manual.

2.2 Access Range via an Ethernet Board

A	Q/QnA	FX
○	○	×

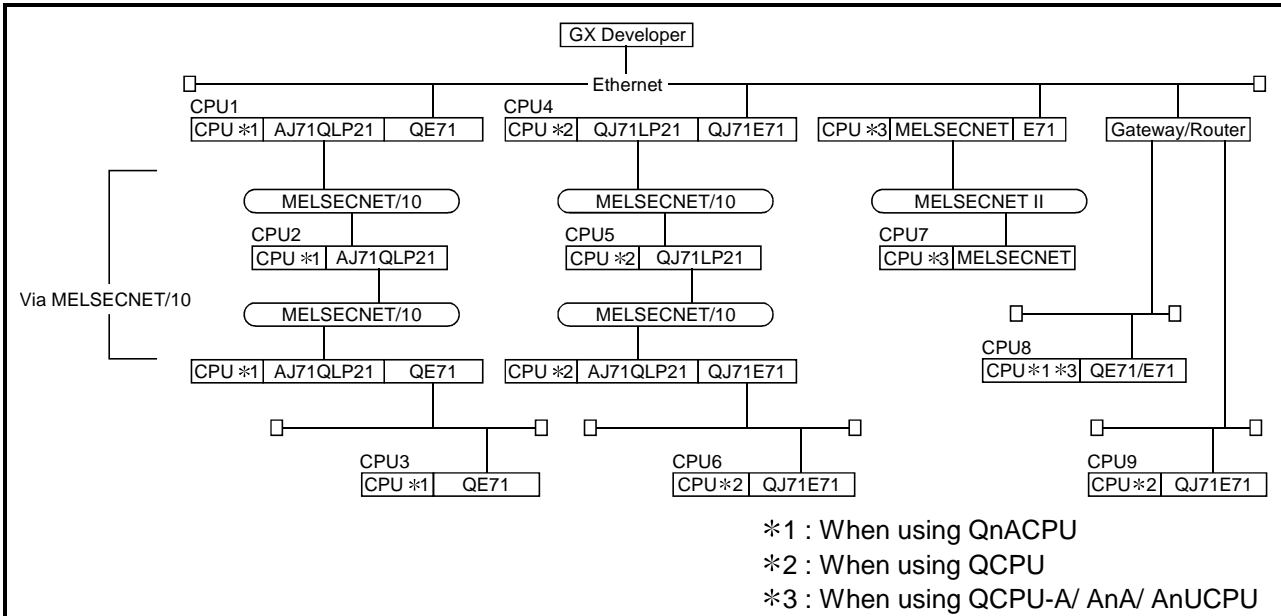

- The access range to master stations/local stations/remote stations/control stations/normal stations via MELSECNET (II)/MELSECNET/10 is the same as via a PLC direct link (via MELSECNET).

Function \ Applicable PLC	CPU1	CPU2	CPU3	CPU4	CPU5	CPU6	CPU7	CPU8	CPU9
PLC read/write	○	○	○	○	○	○	○	×	○
Compare with PLC	○	○	○	○	○	○	○	×	○
Delete PLC *1	○	○	○	○	○	○	○	×	○
Change PLC data attributes *1	○	○	○	○	○	○	○	×	○
Keyword setup	○	○	○	○	○	○	○	×	○
Clear PLC memory	○	○	○	○	○	○	○	×	○
Format PLC memory *1	○	○	○	○	○	○	○	×	○
Arrange PLC memory *1	○	○	○	○	○	○	○	×	○
Set time	○	○	○	○	○	○	○	×	○
Remote operation	○	○	○	○	○	○	○	×	○
Ladder monitor	○	○	○	○	○	○	○	×	○
Batch monitor	○	○	○	○	○	○	○	×	○
Registration monitor	○	○	○	○	○	○	○	×	○
Buffer memory	○	○	○	○	○	○	○	×	○
Monitor condition/stop condition	×	×	×	×	×	×	×	×	×
Device test	○	○	○	○	○	○	○	×	○
Step execution	○	○	○	○	○	○	○	×	○
Partial execution	○	○	○	○	○	○	○	×	○
Skip execution *1	○	○	○	○	○	○	○	×	○
Sampling trace	○	○	○	○	○	○	○	×	○
Diagnostics PLC	○	○	○	○	○	○	○	×	○
Diagnostics network *2	○	○	○	○	○	○	○	×	○
Online change*1	○	○	○	○	○	○	○	×	○
Change TC setting	○	○	○	○	○	○	○	×	○

○: Access possible ×: Access not possible

*1: Accessible only to Q/QnACPU.

*2 Accessible only to network monitoring own and other stations.
(AnUCPU is handled as equivalent to AnACPU.)

A series

Corresponding Models	Corresponding Versions	Remarks
AJ71E71,AJ71E71-B5	Initially shipped version and later versions	If a remote I/O is installed, or during communication, the error LED lights.
A1SJ71QE71-B2,A1SJ71QE71-B5	Initially shipped version and later versions	

- The following restrictions apply for access to AnUCPU via Ethernet.
 - The PLC type must be set as "AnACPU."
 - Sequence programs, device memories, etc. can be used with the AnACPU specification range.
This means that subprogram 2, subprogram 3, devices extended with AnUCPU, and network parameters, cannot be accessed.

QnA series

Corresponding Models	Corresponding Versions	Remarks
AJ71QE71,AJ71QE71-B5	E and later	—
A1SJ71QE71-B2,A1SJ71QE71-B5	E and later	—

Q series

Corresponding Models	Corresponding Versions	Remarks
QJ71E71, QJ71E71-B2	Initially shipped version and later versions	—

2.3 Access Range via CC-Link (AJ65BT-G4)

A	Q/QnA	FX
○	○	×

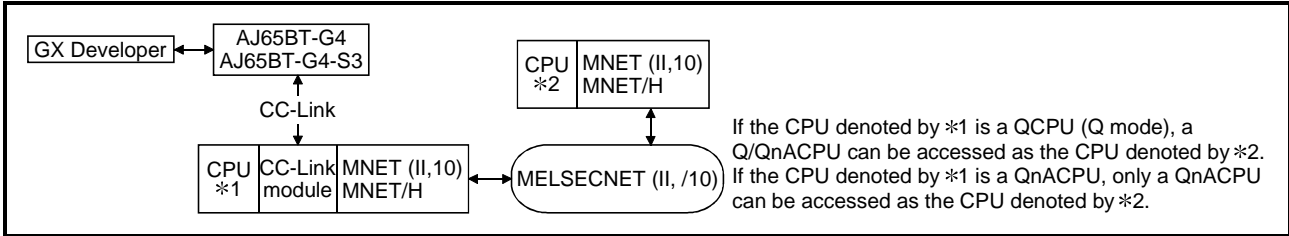

- The access range to master stations/local stations/remote stations/control stations/normal stations via MELSECNET (II)/MELSECNET/10 is the same as via a PLC direct link (via MELSECNET).
- When connecting to ACPUs, routing through MELSECNET (II) or MELSECNET/10 is not possible.

○ : Access possible × : Access not possible – : Function not supported by ACPUs

Applicable PLC / Function	ACPU	QnACPU	QCPU(Q mode)
PLC read/write	○	○	○
Compare with PLC	○	○	○
Delete PLC	—	○	○
Change PLC data attributes	—	○	○
Keyword setup	○	○	○
Clear PLC memory	○	○	○
Format PLC memory	—	○	○
Arrange PLC memory	—	○	○
Set time	○	○	○
Remote operation	○	○	○
Ladder monitor	○	○	○
Batch monitor	○	○	○
Registration monitor	○	○	○
Buffer memory	○	○	○
Monitor condition/stop condition	—	×	×
Device test	○	○	○
Step execution	○	○	○
Partial execution	○	○	○
Skip execution	—	○	○
Sampling trace	○	○	○
Diagnostics PLC	○	○	○
Diagnostics network	×	○ *1	○ *1
Online change	○	○	○
Change TC setting	○	○	○

*1: Only the network monitor host station and other stations can be accessed. (AnUCPU is treated as equivalent to AnACPU.)

Confirm that the AJ65BT-G4 is running one of the following software versions.

CPU	Module Name	AJ65BT-G4 Software Version
ACPU	AJ65BT-G4	A and later
QnACPU		B and later

2.4 Access Range via Computer Link

A	Q/QnA	FX
○	×	×

The table below shows whether or not each function can be performed via the computer link module.

When accessing the master station, local station, remote station, control station or normal station via MELSECNET II or MELSECNET/10, the access range will be the same as when it is directly connected to the PLC CPU (via MELSECNET).

Some functions cannot be used depending on the type of the PLC CPU. For details on the availability of each function, see the user's manual of each PLC CPU.

Function	Applicable PLC	ACPU
PLC read/write		○
Compare with PLC		○
Delete PLC		—
Change PLC data attributes		—
Keyword setup		○
Clear PLC memory		×
Format PLC memory		—
Arrange PLC memory		—
Set time		○
Remote operation		○
Ladder monitor		○
Batch monitor		○
Registration monitor		○
Buffer memory		×
Monitor condition/stop condition		—
Device test		○
Step execution		×
Partial execution		×
Skip execution		—
Sampling trace		×
Diagnostics PLC		○
Diagnostics network		×
Online change		×
Change TC setting		○
Clear Log		×
Log		×

○: Access possible ×, —: Access not possible

The restrictions when executing ladder monitoring, batch monitoring, registration monitoring, device tests, or TC set value changes from a PLC via a computer link module are indicated below.

Connected PLC \ Computer Link	For AnACPU *2	For AnUCPU
AnACPU	○	○
AnUCPU	Possible within AnACPU range *1	○
Other than AnACPU, AnUCPU	○	○

*1 : Network parameters cannot be read.

*2 : When for AnA (C24) has been designated in connection destination designation when using a computer link module for AnUCPU.

- Setting of transmission specification setting switch

The setting switches at the C24 side are shown below.

Setting Item	Setting Made	Remarks
Main channel setting	RS-232C	—
Data bit setting	8 bits	—
Transmission speed	Match with setting at GX Developer	—
Parity yes/no setting	Match with setting at GX Developer	—
Even/odd parity	Match with setting at GX Developer	—
Stop bits	1 bit	—
Sum check yes/no	Match with setting at GX Developer	—
Online program change (write during RUN) yes/no	Match with setting at GX Developer	—
Send side terminal resistor yes/no	Depends on system configuration *1	—
Receive side terminal resistor yes/no	Depends on system configuration *1	—
Computer link/multidrop setting	Computer link	AJ71UC24 A1SJ71UC24-R4 A1SJ71C24-R4

*1: Refer to the Computer Link/Multidrop Link Module User's Manual (Computer Link/Function, Printer Function).

2.5 Access Range via Serial Communication

A	Q/QnA	FX
×	○	×

The following table indicates whether each function that can be performed via serial communication is possible or not.

Function	Applicable PLC	QCPU	QnACPU
PLC read/write		○	○
Compare with PLC		○	○
Delete PLC		○	○
Change PLC data attributes		○	○
Keyword setup		—	○
Password setup		○	—
Clear PLC memory		○	○
Format PLC memory		○	○
Arrange PLC memory		○	○
Set time		○	○
Remote operation		○	○
Ladder monitor		○	○
Batch monitor		○	○
Registration monitor		○	○
Buffer memory		○	○
Monitor condition/stop condition		×	×
Device test		○	○
Step execution		○	○
Partial execution		○	○
Skip execution		○	○
Sampling trace		○	○
Diagnostics PLC		○	○
Diagnostics network		○	○
Online change		○	○
Change TC setting		○	○

○: Access possible

2.6 Access Range for Mixed System

A	Q/QnA	FX
×	○	×

A combination example of Ethernet, MELSECNET/10 and CC-Link will be described. Set the network parameters (network numbers, station numbers, etc.) to CPU1 - CPU4, and write them to the PLC. (For parameter details, refer to Chapter 14.)

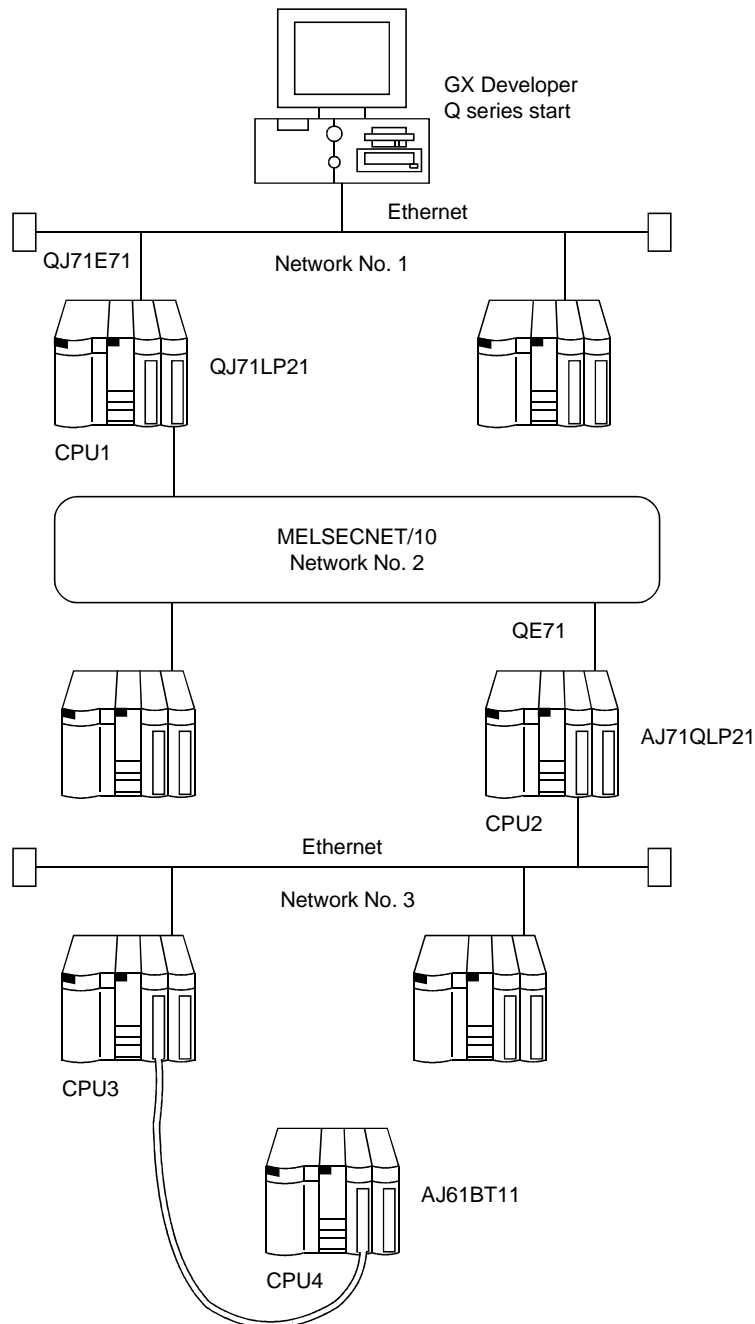

POINT
<ul style="list-style-type: none"> • Ethernet is equivalent to MELSECNET/10. Set the network numbers and station numbers with the network parameters.

Function \ Applicable PLC	CPU1	CPU2	CPU3	CPU4
PLC read/write	○	○	○	○
Compare with PLC	○	○	○	○
Delete PLC	○	○	○	○
Change PLC data attributes	○	○	○	○
Keyword setup	○	○	○	○
Clear PLC memory	○	○	○	○
Format PLC memory	○	○	○	○
Arrange PLC memory	○	○	○	○
Set time	○	○	○	○
Remote operation	○	○	○	○
Ladder monitor	○	○	○	○
Batch monitor	○	○	○	○
Registration monitor	○	○	○	○
Buffer memory	○	○	○	○
Monitor condition/stop condition	×	×	×	×
Device test	○	○	○	○
Step execution	○	○	○	○
Partial execution	○	○	○	○
Skip execution	○	○	○	○
Sampling trace	○	○	○	○
Diagnostics PLC	○	○	○	○
Diagnostics network	○	○	○	○
Online change	○	○	○	○
Change TC setting	○	○	○	○

○: Access possible
 ×: Access not possible

POINT

- If the E71 module is connected to network No. 2 or No. 3, it cannot be accessed from GX Developer.

Appendix 3 Using Data of Other Applications

3.1 Using Excel Files as Device Comments

A	Q/QnA	FX
○	○	○

[Purpose]

Uses data created with Excel as device comments.

[Operating Procedure]

This explanation assumes that you have already started up Excel and GX Developer.

- (1) Drag the Excel cell and designate the range that will enable it to be used as a comment in GX Developer.

(Operation in Excel)

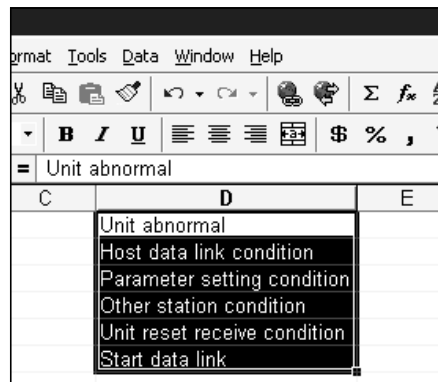

- (2) In Excel, select [Edit] → [Copy], or click  ([Ctrl] + [C]).

- (3) Click the position where the comment is to be pasted and move the cursor.

(Operation at GX Developer)

Device	Comment	Label
X0		
X1		
X2		
X3		
X4		
X5		
X6		
X7		
X8		

(4) In GX Developer, select [Edit] → [Paste], or click  ([Ctrl] + [V]) to paste the Excel comment to GX Developer.

Device X0 <input type="button" value="Display"/>			
Device	Comment	Label	
X0	Unit abnormal		
X1	Host data link condition		
X2	Parameter setting condition		
X3	Other station condition		
X4	Unit reset receive condition		
X5	Start data link		
X6			
X7			
X8			

3.2 Using a Word File as a Device Comment

A	Q/QnA	FX
○	○	○

[Purpose]

Uses data created in Word as device comments.

[Operating Procedure]

This explanation assumes that you have already started up Word and GX Developer.

- (1) Enter the comments in Word.
After each device comment, press the **Enter** key to insert a carriage return.
- (2) Drag the created comments and designate the range for their use as GX Developer comments.

(Operation in Word)

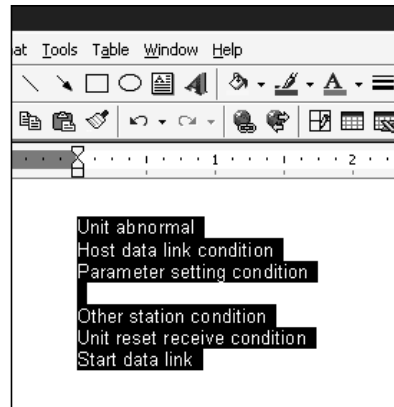

(2) In Word, select [Edit] → [Copy], or click (**Ctrl** + **C**).

(3) Click the location where the comment is to be pasted and move the cursor.

(Operation at GX Developer)

Device	X0	Display
Device	Comment	Label
X0		
X1		
X2		
X3		
X4		
X5		
X6		
X7		
X8		

- (4) In GX Developer, select [Edit] → [Paste], or click  ([Ctrl] + [V]) to paste the Word comment in GX Developer.

Device	Comment	Label
X0	Unit abnormal	
X1	Host data link condition	
X2	Parameter setting condition	
X3		
X4	Other station condition	
X5	Unit reset receive condition	
X6	Start data link	
X7		
X8		

POINTS

- When entering device comments, inserting a carriage return between two comments makes one line of the comment table blank.
- When creating comments in Word, if they are entered continuously without carriage returns they are handled as a single comment: always insert carriage returns between individual comments.

Appendix 4 Restrictions on PLC Type Change

A	Q/QnA	FX
○	○	○

When the PLC series/type is changed, there are the following restrictions.

(1) Restrictions on PLC series/type change

Refer to the following table for the restrictions on PLC series/type change.

After Change / Before Change	A	QnA	Q (A mode) *1	Q (Q mode) *2	Motion controller (SCPU) *3	FX
A	Table 1/Table 1.1	Table 2	Table 1 (A→A4U equivalent)	Table 2/ Table 3 *4 (A→QnA equivalent)	Table 1 (A→A equivalent)	Table 6
QnA	Table 2	No restrictions	Table 2 (QnA→A4U equivalent)	Table 4	Table 2 (QnA→A equivalent)	Change not possible
Q (A mode) *1	Table 1 (A4U→A equivalent)	Table 2 (A4U→QnA equivalent)	No restrictions	Table 2/ Table 3 *4 (A4U→QnA equivalent)	Table 1 (A4U→A equivalent)	Table 4 (A4U→FX equivalent)
Q (Q mode) *2	Table 2/ Table 3 *4 (QnA→A equivalent)	Table 4	Table 2/ Table 3 *4 (QnA→A4U equivalent)	No restrictions	Table 2/ Table 3 *4 (QnA→A4U equivalent)	Change not possible
Motion controller (SCPU) *3	Table 5 (A→A equivalent)	Table 5 (A→QnA equivalent)	Table 5 (A→A4U equivalent)	Table 5 (A→QnA equivalent)	Table 1 (A→A equivalent)	Table 5 (A→FX equivalent)
FX	Table 6	Change not possible	Table 4 (FX→A4U equivalent)	Change not possible	Table 4 (FX→A equivalent)	Table 7/Table 7.1

*1: The QCPU-A has the specifications equivalent to those of the A4U.

For the restrictions on any change from/to the QCPU-A, regard it as the A4U and refer to the table.

*2: The QCPU has the specifications equivalent to those of the QnA series.

For the restrictions on any change from/to the QCPU, regard it as the QnA series and refer to the table.

*3: The motion controller (SCPU) has the specifications equivalent to those of the A series.

For the restrictions on any change from/to the motion controller (SCPU), regard it as the A series and refer to the table.

*4: Refer to Table 2 (A↔QnA) and Table 3 (A↔QCPU) from the specifications as listed above (*1, *2, *3).

*5: When multi-CPU related setting has been made, the programs, parameters and device comments are handled as follows.

Parameters

(1) The multi CPU setting is deleted.

(2) When the multiple CPUs have been I/O assigned, the multi CPU setting is deleted and the special and I/O module assignment is shifted forward.

(3) When the PLC type is changed to the A series, the type data is deleted if characters other than alphanumeric characters are set in the type setting field of I/O assignment.

Device comments

(1) The device ranges (U200 to U3FF, U3E0#G** to U3FF#G**) increased for multiple CPUs are deleted.

(2) Unchangeable instructions/devices

Unchangeable instructions/devices are changed into M1255/D1255, etc.

In this case, refer to search/replacement or Appendix 12 and correct them to instructions/devices usable with the PLC series/type after change.

(3) PLC type change in label program

During label programming, the PLC type change may be converted only between the same series CPUs, i.e. between QCPU (Q mode) and QCPU (Q mode) or between QnACPU and QnACPU.

POINT
• For CPU details, refer to the corresponding User's Manual.

Table 1 Restrictions on PLC Type Change between ACPU and ACPU

Item	Restrictions																		
Programs	<ul style="list-style-type: none"> If there are devices that are outside the PLC handling range, write a program to the PLC after making corrections. Devices outside the range may be displayed on the ladder display screen but an error will occur at the time of PLC RUN. When the PLC type after change is the one which cannot create subprograms, subprograms are deleted. 																		
PLC parameters																			
Memory capacity	<ul style="list-style-type: none"> If the PLC type capacity before change is smaller than the PLC type capacity after change, the capacity of the PLC type before change is used. If the PLC type capacity before change is larger than the PLC type capacity after change, the capacity of the PLC type after change is used. In this case, part of the program before change may sometimes be deleted. When the PLC type after change is the one which cannot create subprograms, sub sequence programs are deleted. If the sequence + microcomputer program capacity exceeds the capacity of the PLC type after change, the microcomputer capacity is zeroed. Also, part of the program before change may sometimes be deleted. 																		
PLC RAS, PLC system, devices	<ul style="list-style-type: none"> If the PLC type after change has the same item or range, the data of the PLC type before change is retained. However, if there are devices that cannot be used at the PLC type after change, the default is set. 																		
I/O allocation	<ul style="list-style-type: none"> All cleared. 																		
Network parameters																			
MELSECNET, MELSECNET(II), MELSECNET(II) combination, MELSECNET/10, MELSECNET/MINI	<table border="1"> <thead> <tr> <th colspan="2" data-bbox="448 1133 751 1169">PLC Type</th> <th data-bbox="751 1133 1398 1169">Description</th> </tr> </thead> <tbody> <tr> <td data-bbox="448 1169 563 1330" rowspan="3">AnN</td> <td data-bbox="563 1169 638 1330" rowspan="3">→</td> <td data-bbox="638 1169 1398 1218">AnN • Settings are retained.</td> </tr> <tr> <td data-bbox="638 1218 1398 1256">AnA • Settings are retained.</td> </tr> <tr> <td data-bbox="638 1256 1398 1330">AnU • Settings are retained. However, the module's first I/O No. is set to 00H.</td> </tr> <tr> <td data-bbox="448 1330 563 1525" rowspan="3">AnA</td> <td data-bbox="563 1330 638 1525" rowspan="3">→</td> <td data-bbox="638 1330 1398 1411">AnN • MELSECNET master station settings are retained. Other station settings but the above are deleted.</td> </tr> <tr> <td data-bbox="638 1411 1398 1449">AnA • Settings are retained.</td> </tr> <tr> <td data-bbox="638 1449 1398 1525">AnU • Settings are retained. However, the module's first I/O No. is set to 00H.</td> </tr> <tr> <td data-bbox="448 1525 563 1906" rowspan="3">AnU</td> <td data-bbox="563 1525 638 1906" rowspan="3">→</td> <td data-bbox="638 1525 1398 1606">AnN • MELSECNET master station settings are retained. Other station settings but the above are deleted.</td> </tr> <tr> <td data-bbox="638 1606 1398 1715">AnA • MELSECNET master station, MELSECNET(II) combination master station and MELSECNET(II) settings are retained. Other station settings but the above are deleted.</td> </tr> <tr> <td data-bbox="638 1715 1398 1906">AnU • Settings are retained. However, if there is any one module whose setting of the network's first I/O No exceeds that of the actual I/O of the PLC after change, 0H, 20H, 40H or 60H is automatically assigned to the first I/O No.</td> </tr> </tbody> </table>	PLC Type		Description	AnN	→	AnN • Settings are retained.	AnA • Settings are retained.	AnU • Settings are retained. However, the module's first I/O No. is set to 00H.	AnA	→	AnN • MELSECNET master station settings are retained. Other station settings but the above are deleted.	AnA • Settings are retained.	AnU • Settings are retained. However, the module's first I/O No. is set to 00H.	AnU	→	AnN • MELSECNET master station settings are retained. Other station settings but the above are deleted.	AnA • MELSECNET master station, MELSECNET(II) combination master station and MELSECNET(II) settings are retained. Other station settings but the above are deleted.	AnU • Settings are retained. However, if there is any one module whose setting of the network's first I/O No exceeds that of the actual I/O of the PLC after change, 0H, 20H, 40H or 60H is automatically assigned to the first I/O No.
	PLC Type		Description																
	AnN	→	AnN • Settings are retained.																
			AnA • Settings are retained.																
			AnU • Settings are retained. However, the module's first I/O No. is set to 00H.																
	AnA	→	AnN • MELSECNET master station settings are retained. Other station settings but the above are deleted.																
			AnA • Settings are retained.																
			AnU • Settings are retained. However, the module's first I/O No. is set to 00H.																
	AnU	→	AnN • MELSECNET master station settings are retained. Other station settings but the above are deleted.																
			AnA • MELSECNET master station, MELSECNET(II) combination master station and MELSECNET(II) settings are retained. Other station settings but the above are deleted.																
			AnU • Settings are retained. However, if there is any one module whose setting of the network's first I/O No exceeds that of the actual I/O of the PLC after change, 0H, 20H, 40H or 60H is automatically assigned to the first I/O No.																

Table 1.1 PLC Parameter Settings for PLC Type Change between ACPU and ACPU

After Change Before Change	A0J2H	A1FX	A1N	A2N A2N-S1	A3N	A1S A1SJ	A1SH A1SJH	A2S (S1)	A2SH	A2C A2CJ	A2A-S1	A2A	A3A	A2USH-S1	A2U A2U-S1 A2US A2US-S1 A2AS-S30 A2AS-S60	A3U	A4U
A0J2H	○	-	○	○	○	-	○	○	○	-	-	-	-	-	-	-	-
A1FX	-	○	-	○	○	-	○	○	○	-	-	-	-	-	-	-	-
A1N	○	-	○	○	○	○	○	○	○	-	-	-	-	-	-	-	-
A2N A2N-S1	-	-	-	○	○	-	○	○	○	-	-	-	-	-	-	-	-
A3N	-	-	-	-	○	-	-	-	-	-	-	-	-	-	-	-	-
A1S A1SJ	-	-	-	○	○	○	○	○	○	-	-	-	-	-	-	-	-
A1SH A1SJH	-	-	-	-	○	-	○	-	○	-	-	-	-	-	-	-	-
A2S	-	-	-	○	○	-	○	○	○	-	-	-	-	-	-	-	-
A2SH	-	-	-	-	○	-	○	○	○	-	-	-	-	-	-	-	-
A2C A2CJ	-	-	-	-	-	-	-	-	-	○	-	-	-	-	-	-	-
A2A A2A-S1	-	-	-	-	-	-	-	-	-	-	○	○	○	○	○	○	○
A3A	-	-	-	-	-	-	-	-	-	-	-	○	○	○	○	○	○
A2U A2U-S1 A2US A2US-S1	-	-	-	-	-	-	-	-	-	-	-	-	-	○	○	○	○
A2USH-S1	-	-	-	-	-	-	-	-	-	-	-	-	-	○	○	○	○
A3U	-	-	-	-	-	-	-	-	-	-	-	-	-	-	-	○	○
A4U	-	-	-	-	-	-	-	-	-	-	-	-	-	-	-	○	○

○: Settings of PLC type before change are retained

-: Default to settings of PLC type after change, or partial deletion

Table 2 Restrictions on PLC Type Change between ACPU and QnACPU

Item	Restrictions																																														
	A → QnA	QnA → A																																													
Programs	All programs are changed.	<ul style="list-style-type: none"> • Unchangeable data names (other than MAIN, SUB1, etc.) are deleted. • If the maximum number of steps is exceeded, part of the program is deleted. Note that if the same instruction is used, the number of steps of the A series may become greater. 																																													
Instructions, devices	<ul style="list-style-type: none"> • Unchangeable instructions and devices are changed into M1255/D1255. 	<ul style="list-style-type: none"> • Unchangeable instructions and devices are changed into M9255/D9255. 																																													
	<ul style="list-style-type: none"> • Changeable only when "special module's first I/O number designation" or "network's other station number designation" has been constant specified using changeable dedicated instructions (e.g. ZCOM). <Example> <table border="1" style="width: 100%; border-collapse: collapse;"> <thead> <tr> <th style="width: 50%;">Changeable</th> <th style="width: 50%;">Unchangeable</th> </tr> </thead> <tbody> <tr> <td>LEDA ZCOM</td> <td>LEDA ZCOM</td> </tr> <tr> <td>SUB H0</td> <td>LEDC D0 Unchangeable since the network module's first</td> </tr> <tr> <td>LEDR</td> <td>LEDR I/O No. is device specified.</td> </tr> </tbody> </table>	Changeable	Unchangeable	LEDA ZCOM	LEDA ZCOM	SUB H0	LEDC D0 Unchangeable since the network module's first	LEDR	LEDR I/O No. is device specified.																																						
Changeable	Unchangeable																																														
LEDA ZCOM	LEDA ZCOM																																														
SUB H0	LEDC D0 Unchangeable since the network module's first																																														
LEDR	LEDR I/O No. is device specified.																																														
Comments, device memories	<ul style="list-style-type: none"> • All of them are changed. 	<ul style="list-style-type: none"> • Device comments which exceed the device range of the PLC type after change and non-existing device comments are deleted. Comments other than the above are retained intact. 																																													
Device initial values	<ul style="list-style-type: none"> • Ignored as the ACPU has none. 	<ul style="list-style-type: none"> • Deleted as the ACPU has none. 																																													
Parameters																																															
Memory capacity	<ul style="list-style-type: none"> • No change 	<ul style="list-style-type: none"> • For any of MAIN, SUB1, SUB2 and SUB3, set the maximum capacity of the PLC after change. • For comments, extension comments, etc., set them to the default. 																																													
Latch range	<table border="1" style="width: 100%; border-collapse: collapse;"> <thead> <tr> <th style="width: 30%;">A</th> <th style="width: 10%;"></th> <th style="width: 30%;">QnA</th> <th style="width: 10%;"></th> <th style="width: 30%;">QnA</th> <th style="width: 10%;"></th> <th style="width: 30%;">A</th> </tr> </thead> <tbody> <tr> <td>L</td> <td rowspan="10" style="text-align: center; vertical-align: middle;">→</td> <td>No change</td> <td rowspan="10" style="text-align: center; vertical-align: middle;">→</td> <td>B</td> <td rowspan="10" style="text-align: center; vertical-align: middle;">→</td> <td>B</td> </tr> <tr> <td>Extension counters</td> <td>No change</td> <td>F</td> <td>Not subject to change</td> </tr> <tr> <td>Retentive timers</td> <td>No change</td> <td>V</td> <td>Not subject to change</td> </tr> <tr> <td>C latch range</td> <td>C latch range</td> <td>T</td> <td>Low-speed timers</td> </tr> <tr> <td>D latch range</td> <td>D latch range</td> <td>ST</td> <td>Not subject to change</td> </tr> <tr> <td>B latch range</td> <td>B latch range</td> <td>C</td> <td>C</td> </tr> <tr> <td>W latch range</td> <td>W latch range</td> <td>D</td> <td>D</td> </tr> <tr> <td>Lowest device number of: Low-speed timers High-speed timers Extension low-speed timers Extension high-speed timers</td> <td rowspan="2" style="text-align: center; vertical-align: middle;">→</td> <td rowspan="2">Head of T latch range</td> <td rowspan="2">W</td> <td rowspan="2">W</td> </tr> <tr> <td>Highest device number of: Low-speed timers High-speed timers Extension low-speed timers Extension high-speed timers</td> <td rowspan="2">End of T latch range</td> </tr> </tbody> </table>	A		QnA		QnA		A	L	→	No change	→	B	→	B	Extension counters	No change	F	Not subject to change	Retentive timers	No change	V	Not subject to change	C latch range	C latch range	T	Low-speed timers	D latch range	D latch range	ST	Not subject to change	B latch range	B latch range	C	C	W latch range	W latch range	D	D	Lowest device number of: Low-speed timers High-speed timers Extension low-speed timers Extension high-speed timers	→	Head of T latch range	W	W	Highest device number of: Low-speed timers High-speed timers Extension low-speed timers Extension high-speed timers	End of T latch range	<ul style="list-style-type: none"> • Set the device numbers exceeding the ACPU's device ranges to the maximum values of the corresponding devices.
	A		QnA		QnA		A																																								
L	→	No change	→	B	→	B																																									
Extension counters		No change		F		Not subject to change																																									
Retentive timers		No change		V		Not subject to change																																									
C latch range		C latch range		T		Low-speed timers																																									
D latch range		D latch range		ST		Not subject to change																																									
B latch range		B latch range		C		C																																									
W latch range		W latch range		D		D																																									
Lowest device number of: Low-speed timers High-speed timers Extension low-speed timers Extension high-speed timers		→		Head of T latch range		W	W																																								
Highest device number of: Low-speed timers High-speed timers Extension low-speed timers Extension high-speed timers								End of T latch range																																							
I/O allocation		Settings are retained intact.																																													

(To the next page)

Table 2 Restrictions on PLC Type Change between ACPU and QnACPU (Continue)

Item	Restrictions	
	A → QnA	QnA → A
Network parameters		
MELSECNET(II, 10)	<p>AnA/AnN → QnA</p> <ul style="list-style-type: none"> Settings are retained. Module's first I/O No. is set to 00H because there is no module's first I/O No. in the network parameters of the AnN/AnA. <p>AnU → QnA</p> <ul style="list-style-type: none"> Settings are retained. 	<p>QnA → AnN</p> <ul style="list-style-type: none"> MELSECNET master station settings are retained. <p>QnA → AnA</p> <ul style="list-style-type: none"> MELSECNET master station, MELSECNET(II) combination master station and MELSECNET(II) settings are retained. <p>QnA → AnU</p> <ul style="list-style-type: none"> Any of the following items set is deleted. <ul style="list-style-type: none"> MELSECNET/10 (standby station) MELSECNET/10 (multiple remote master station) MELSECNET (parallel remote master station) MELSECNET/10 (multiple remote sub station) MELSECNET/10 (parallel remote sub station) Ethernet, CC-Link Settings but the above are deleted.
MELSECNET/MINI	<ul style="list-style-type: none"> Settings are retained. 	<ul style="list-style-type: none"> Settings are retained. However, the transmission status at line error is deleted.

Table 3 Restrictions on PLC Type Change between ACPU and QCPU

Item	Restrictions	
	A → Q (Q mode)	Q (Q mode) → A
Programs	<ul style="list-style-type: none"> All programs are changed. 	<ul style="list-style-type: none"> Unchangeable data names (other than MAIN, SUB1, etc.) are deleted. If the maximum number of steps is exceeded, part of the program is deleted. Note that if the same instruction is used, the number of steps of the A series may become greater.
Instructions, devices	<ul style="list-style-type: none"> Unchangeable instructions and devices are changed into M1255/D1255. 	<ul style="list-style-type: none"> Unchangeable instructions and devices are changed into M9255/D9255.
Comments, device memories	<ul style="list-style-type: none"> All are changed. 	<ul style="list-style-type: none"> Unchangeable SD/SM are deleted.
Parameters	<ul style="list-style-type: none"> All are changed. 	<ul style="list-style-type: none"> Unchangeable parameters are deleted. However, the type, points, model name, first I/O of I/O allocation are changed. Also, when the base mode setting for the QCPU is 8 or more modules, the on-base positions and first I/O number may differ from the actual ones.
Network parameters		
MELSECNET(II)	<ul style="list-style-type: none"> MELSECNET(II) parameters are deleted. 	—————
MELSECNET/10(H)	<ul style="list-style-type: none"> MELSECNET/10 parameters are changed into those in MELSECNET/10 mode. 	<ul style="list-style-type: none"> Setting of relay station number in MELSECNET/10(H) routing parameters is discarded.
MELSECNET/MINI	<ul style="list-style-type: none"> MELSECNET/MINI parameters are deleted. 	—————
CC-Link	—————	<ul style="list-style-type: none"> CC-Link parameters are deleted.
Ethernet	—————	<ul style="list-style-type: none"> Ethernet parameters are deleted.

Table 4 Restrictions on PLC Type Change between QnACPU and QCPU

Item	Restrictions	
	QnA → Q (Q mode)	Q (Q mode) → QnA
Instructions	<ul style="list-style-type: none"> Unchangeable instructions are changed into SM1255. 	
Devices, device comments	<ul style="list-style-type: none"> All are changed. 	
Parameters	<ul style="list-style-type: none"> All are changed. 	<ul style="list-style-type: none"> Unchangeable parameters are deleted. However, only the type, points, model name, first I/O of I/O allocation are changed. Also, when the base mode setting for the QCPU is 8 or more modules, the on-base positions and first I/O number may differ from the actual ones.
Network parameters		
MELSECNET(II)	<ul style="list-style-type: none"> MELSECNET(II) parameters are deleted. 	—————
MELSECNET/10(H)	<ul style="list-style-type: none"> MELSECNET/10 parameters are changed into those in MELSECNET/10 mode. 	<ul style="list-style-type: none"> Setting of the relay station number in MELSECNET/10(H) routing parameters is discarded. Only 0 to 1FFF(H) of the MELSECNET/10(H) common parameters are changed. Station settings of 2000(H) and later are deleted.
MELSECNET/MINI	<ul style="list-style-type: none"> MELSECNET/MINI parameters are deleted. 	—————
CC-Link	<ul style="list-style-type: none"> When the CC-Link parameters of 5 or more modules have been set, those of the fifth module and later are deleted. 	<ul style="list-style-type: none"> Unchangeable CC-Link parameters are deleted.
Ethernet	—————	<ul style="list-style-type: none"> Ethernet parameters are deleted.

Table 5 Restrictions on PLC Type Change between Motion Controller (SCPU) and Other CPU

The A171SHCPU has specifications equivalent to those of the A2HCPU, the A172SHCPU has specifications equivalent to those of the A2SHCPU memory or I/O enhancement, and the A273UHCPU(S3) has specifications equivalent to those of the A3UCPU.

Other CPU	Restrictions	
	Motion controller (SCPU) → Other PLC series	Other PLC series → Motion controller (SCPU)
A series	<ul style="list-style-type: none"> Motion controller-dedicated instructions are changed as they are. However, making a program check results in instruction code error. 	Equivalent to A series → A series. Refer to Table 1.
QnA series/Q series	<ul style="list-style-type: none"> Motion controller-dedicated instructions are changed into M1255. 	Equivalent to QnA series → A series. Refer to Table 2. Equivalent to Q series → A series. Refer to Tables 2 and 3.
FX series	<ul style="list-style-type: none"> Motion controller-dedicated instructions are changed into M8255. 	Equivalent to FX series → A series. Refer to Table 6.

Table 6 Restrictions on PLC Type Change between ACPU and FXCPU

Item	Restrictions	
	A → FX	FX → A
Programs	<ul style="list-style-type: none"> AnA and AnU dedicated instructions are deleted. Subprograms are deleted. Excess program part after change is deleted. 	
	<ul style="list-style-type: none"> Unchangeable devices are changed into M8255/D8255. Unchangeable instructions are changed into OUT M8255. 	<ul style="list-style-type: none"> Unchangeable devices are changed into M9255/D9255. Unchangeable instructions are changed into OUT M9255. However, LDP, LDF, ORP, ORF, ANDP and ANDF instructions become contact instructions without P and F, and devices are changed into M9255. Also, INV is changed into AND M9255, and STL into OUT M9255.
	<ul style="list-style-type: none"> The instructions and devices which have been changed into M9255/D9255 and M8255/D8255 should be corrected by the device check of the program check function. However, when the FX0(S), FX0N or FX1 PLC CPU has been selected, replacement for these device numbers cannot be made. In this case, execute the device check of the program check function. 	
Memory capacity	<ul style="list-style-type: none"> Changed into the maximum capacity of the PLC type after change. 	
File register capacity, comment capacity	<ul style="list-style-type: none"> Set to 0 blocks if the PLC type after change is not compatible with this function. 	<ul style="list-style-type: none"> Set to the defaults of the PLC type after change.
Network parameters	<ul style="list-style-type: none"> Not changed because of absence in the FX. 	<ul style="list-style-type: none"> Set to the defaults of the PLC type after change.
Statements, notes	Settings are retained intact. However, the range in excess of the setting capacity is deleted.	
Device comments, device memories	Settings are retained intact. However, devices not existing in the PLC after change or the data in excess of the range are deleted.	

Table 7 Restrictions on PLC Type Change between FXCPU and FXCPU

Item	Restrictions
Programs	<ul style="list-style-type: none"> Unchangeable element numbers and application instructions are not changed. Therefore, correct programs properly before or after change and make a program check. (If programs before corrections are transferred to the PLC, a program error will occur.) Excess program part is deleted. If the PLC type after change is the FX0/FX0sCPU, the memory capacity is set to 2000. The part exceeding this CPU's actual step count of 800 is deleted. For the file registers and RAM file registers, their settings are retained intact. After change, therefore, correct them by search/replacement to have proper device numbers.
Memory capacity	<ul style="list-style-type: none"> If the maximum capacity of the PLC type before change is larger than that of the PLC type after change, the maximum capacity of the PLC type after change is used.
File register capacity, comment capacity	<ul style="list-style-type: none"> Set to 0 blocks if the PLC type after change is not compatible with this function.

Table 7.1 Changes Made between PLC Types (FXCPU ↔ FXCPU)

Change Type	Memory Capacity	Comment Capacity	File Register Capacity	Latch Range	Entry Code	Title	PLC mode: Serial Setting	I/O Allocations
FX _{1N} → FX ₀	● (2000)	● (Block 0)	● (Block 0)	●	⊙	●	●	●
FX _{1N} → FX _{0N}	● (2000)	★ (Block 0 to 3)	★ (Block 0 to 3)	●	⊙	⊙	●	●
FX _{1N} → FX ₁	★ (2000 to 4000)	★	● (Block 0)	●	⊙	⊙	●	●
FX _{1N} → FX _{1S}	● (2000)	★ (Block 0 to 3)	★ (Block 0 to 3)	●	⊙	⊙	⊙	●
FX _{1N} → FX ₂	★ (2000 to 8000)	★	★	●	⊙	⊙	●	●
FX _{1N} → FX _{2N}	★ (2000 to 16000)	★	★	●	⊙	⊙	⊙	●
FX _{1S} → FX ₀	● (2000)	● (Block 0)	● (Block 0)	●	⊙	●	●	●
FX _{1S} → FX _{0N}	● (2000)	★ (Block 0 to 3)	★ (Block 0 to 3)	●	⊙	⊙	●	●
FX _{1S} → FX ₁	★ (2000 to 4000)	★	● (Block 0)	●	⊙	⊙	●	●
FX _{1S} → FX _{1N}	★ (2000 to 8000)	★	★	●	⊙	⊙	⊙	●
FX _{1S} → FX ₂	★ (2000 to 8000)	★	★	●	⊙	⊙	●	●
FX _{1S} → FX _{2N}	★ (2000 to 16000)	★	★	●	⊙	⊙	⊙	●
FX ₀ → FX _{0N}	● (2000)	★ (Block 0 to 3)	★ (Block 0 to 3)	●	⊙	⊙	●	●
FX ₀ → FX ₁	★ (2000 to 4000)	★	● (Block 0)	●	⊙	⊙	●	●
FX ₀ → FX _{1N}	★ (2000 to 8000)	★	★	●	⊙	⊙	●	●
FX ₀ → FX _{1S}	● (2000)	★ (Block 0 to 3)	★ (Block 0 to 3)	●	⊙	⊙	●	●
FX ₀ → FX ₂	★ (2000 to 8000)	★	★	●	⊙	⊙	●	●
FX ₀ → FX _{2N}	★ (2000 to 16000)	★	★	●	⊙	⊙	●	●
FX _{0N} → FX ₀	● (2000)	● (Block 0)	● (Block 0)	●	⊙	●	●	●
FX _{0N} → FX ₁	★ (2000 to 4000)	★	● (Block 0)	●	⊙	⊙	●	●
FX _{0N} → FX _{1S}	● (2000)	★ (Block 0 to 3)	★ (Block 0 to 3)	●	⊙	⊙	●	●
FX _{0N} → FX _{1N}	★ (2000 to 8000)	★	★	●	⊙	⊙	●	●
FX _{0N} → FX ₂	★ (2000 to 8000)	★	★	●	⊙	⊙	●	●
FX _{0N} → FX _{2N}	★ (2000 to 16000)	★	★	●	⊙	⊙	●	●
FX ₁ → FX ₀	● (2000)	● (Block 0)	● (Block 0)	●	⊙	●	●	●
FX ₁ → FX _{0N}	● (2000)	★ (Block 0 to 3)	★ (Block 0 to 3)	●	⊙	⊙	●	●
FX ₁ → FX _{1S}	● (2000)	★ (Block 0 to 3)	★ (Block 0 to 3)	●	⊙	⊙	●	●
FX ₁ → FX _{1N}	★ (2000 to 8000)	★	★	●	⊙	⊙	●	●
FX ₁ → FX ₂	★ (2000 to 8000)	★	★	●	⊙	⊙	●	●
FX ₁ → FX _{2N}	★ (2000 to 16000)	★	★	●	⊙	⊙	●	●
FX ₂ → FX ₀	● (2000)	● (Block 0)	● (Block 0)	●	⊙	●	●	●
FX ₂ → FX _{0N}	● (2000)	★ (Block 0 to 3)	★ (Block 0 to 3)	●	⊙	⊙	●	●
FX ₂ → FX _{1S}	● (2000)	★ (Block 0 to 3)	★ (Block 0 to 3)	●	⊙	⊙	●	●
FX ₂ → FX _{1N}	★ (2000 to 8000)	★	★	●	⊙	⊙	●	●
FX ₂ → FX _{2N}	★ (2000 to 16000)	★	★	●	⊙	⊙	●	●

Change Type	Memory Capacity	Comment Capacity	File Register Capacity	Latch Range	Entry Code	Title	PLC mode: Serial Setting	I/O Allocations
FX _{2N} → FX ₀	● (2000)	● (Block 0)	● (Block 0)	●	⊙	●	●	●
FX _{2N} → FX _{0N}	● (2000)	★ (Block 0 to 3)	★ (Block 0 to 3)	●	⊙	⊙	●	●
FX _{2N} → FX _{1S}	● (2000)	★ (Block 0 to 3)	★ (Block 0 to 3)	●	⊙	⊙	●	●
FX _{2N} → FX _{1S}	● (2000)	★ (Block 0 to 3)	★ (Block 0 to 3)	●	⊙	⊙	⊙	●
FX _{2N} → FX _{1N}	★ (2000 to 8000)	★	★	●	⊙	⊙	⊙	●
FX _{2N} → FX ₂	★ (2000 to 8000)	★	★	●	⊙	⊙	●	●

⊙: Settings before change are retained.

●: Defaults of the CPU type after change are set.

★: Change can be designated in a dialog box.

When the comment or file register capacities can be changed in a dialog box, the range of setting may vary according to the memory capacity setting.

Appendix 5 Examples of Wiring RS-232C Cable for Connection of C24 and Personal computer

5.1 A Series

A	Q/QnA	FX
○	×	×

- Connection of RS-232C interface

(1) When a 25-pin connector is used in a computer link module

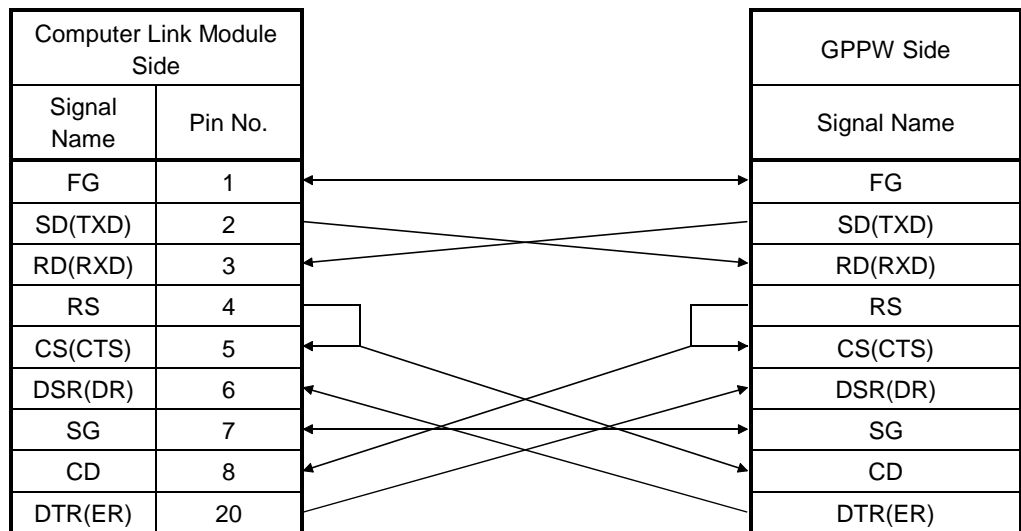

(2) When a 25-pin connector is used in a computer link module

If the connection between the computer link module and the GPPW is made in the manner shown below, designate "without CD terminal check".

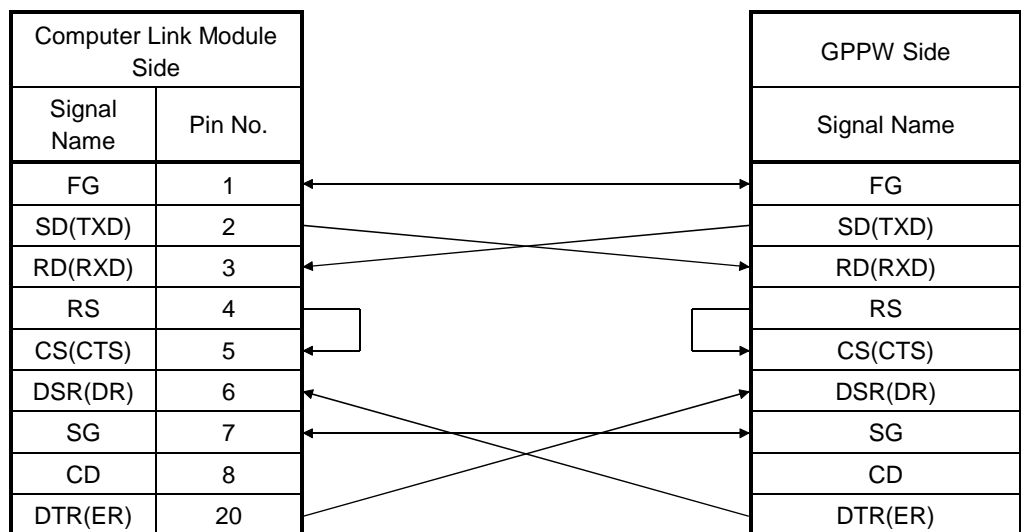

Buffer memory setting

CD terminal check (address 10Bh): Without check

DTR control (address 11Ah): Yes (C24-S8, UC24)

(3) When an 9-pin connector is used in a computer link module
 (Example of connection)

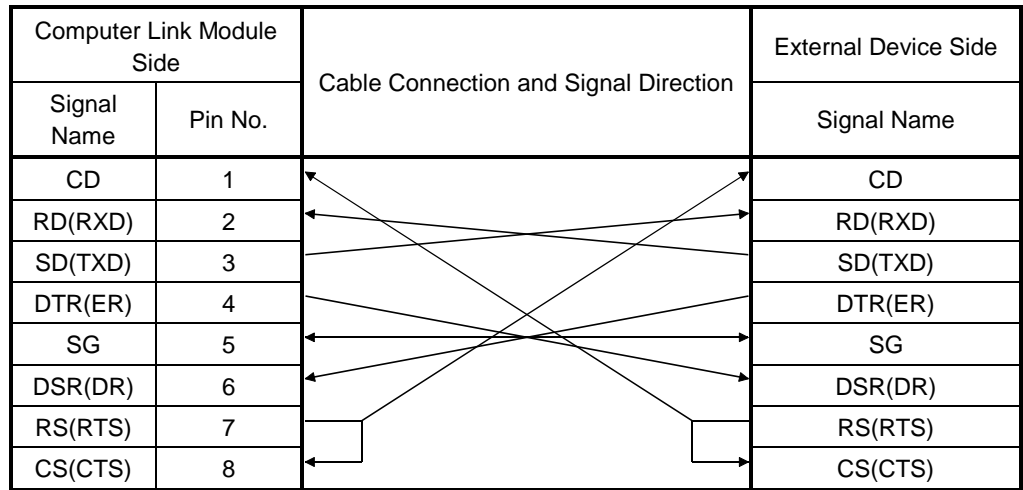

Set "without CD terminal check".

(4) When an 9-pin connector is used in a computer link module
 (Example of connection)

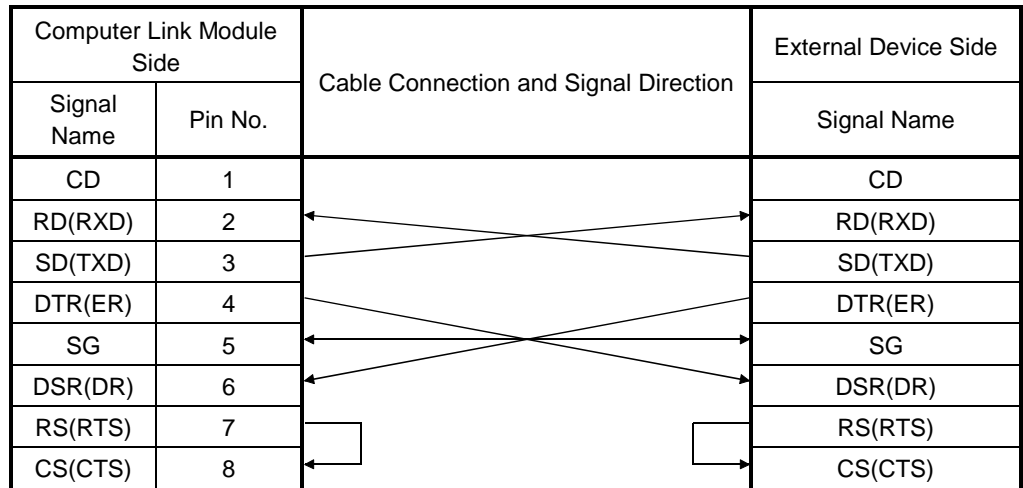

*: DC code control or DTR/DSR control is enabled by connecting the DTR and DSR signals of the computer link module to an external device as shown above.

5.2 QnA Series

A	Q/QnA	FX
×	○*	×

*:Compatible with the QnACPU only.

- (1) For large-scale QC24 (N)
 - (a) Example of connection to an external device that allows the CD signal (No. 8 pin) to be turned ON/OFF

Large-scale QC24 (N) Side		Cable Connection and Signal Direction (Full-/Half-Duplex Communication)	External Device Side
Signal Name	Pin No.		Signal Name
FG	1	↔	FG
SD(TXD)	2	↔	SD(TXD)
RD(RXD)	3	↔	RD(RXD)
RS	4	↔	RS
CS(CTS)	5	↔	CS(CTS)
DSR(DR)	6	↔	DSR(DR)
SG	7	↔	SG
CD	8	↔	CD
DTR(ER)	20	↔	DTR(ER)

DC code control or DTR/DSR control is enabled by connecting the QC24 (N) to an external device as shown above.

- (b) Example of connection to an external device that does not allow the CD signal (No. 8 pin) to be turned ON/OFF

Large-scale QC24 (N) Side		Cable Connection and Signal Direction (Full-Duplex Communication)	External Device Side
Signal Name	Pin No.		Signal Name
FG	1	↔	FG
SD(TXD)	2	↔	SD(TXD)
RD(RXD)	3	↔	RD(RXD)
RS	4	↔	RS
CS(CTS)	5	↔	CS(CTS)
DSR(DR)	6	↔	DSR(DR)
SG	7	↔	SG
CD	8	↔	CD
DTR(ER)	20	↔	DTR(ER)

DC code control or DTR/DSR control is enabled by connecting the QC24 (N) to an external device as shown above.

(2) For compact QC24 (N)

(a) Example of connection to an external device that allows the CD signal (No. 1 pin) to be turned ON/OFF

Compact QC24 (N) Side		Cable Connection and Signal Direction (Full- / Half-Duplex Communication)	External Device Side
Signal Name	Pin No.		Signal Name
CD	1		CD
RD(RXD)	2		RD(RXD)
SD(TXD)	3		SD(TXD)
DTR(ER)	4		DTR(ER)
SG	5		SG
DSR(DR)	6		DSR(DR)
RS(RTS)	7		RS(RTS)
CS(CTS)	8		CS(CTS)

DC code control or DTR/DSR control is enabled by connecting the QC24 (N) to an external device as shown above.

(b) Example of connection to an external device that does not allow the CD signal (No. 1 pin) to be turned ON/OFF

Large-scale QC24 (N) Side		Cable Connection and Signal Direction (Full-Duplex Communication)	External Device Side
Signal Name	Pin No.		Signal Name
CD	1		CD
RD(RXD)	2		RD(RXD)
SD(TXD)	3		SD(TXD)
DTR(ER)	4		DTR(ER)
SG	5		SG
DSR(DR)	6		DSR(DR)
RS(RTS)	7		RS(RTS)
CS(CTS)	8		CS(CTS)

DC code control or DTR/DSR control is enabled by connecting the QC24 (N) to an external device as shown above.

5.3 Q Series

A	Q/QnA	FX
×	○*	×

*: Compatible with the QCPU (Q mode) only.

The connector specifications are indicated below.

Pin Number	Signal Code	Signal Name	Signal Direction Q-compatible C24 ↔ external device
1	CD	Receive carrier detection	←
2	RD (RXD)	Receive data	←
3	SD (TXD)	Send data	→
4	DTR (ER)	Data terminal ready	→
5	SG	Send ground	↔
6	DSR (DR)	Data set ready	←
7	RS (RTS)	Request to send	→
8	CS (CTS)	Clear to send	←
9	RI (CI)	Call indication	←

(1) Connection example which can turn ON/OFF CD signal (No. 1 pin)

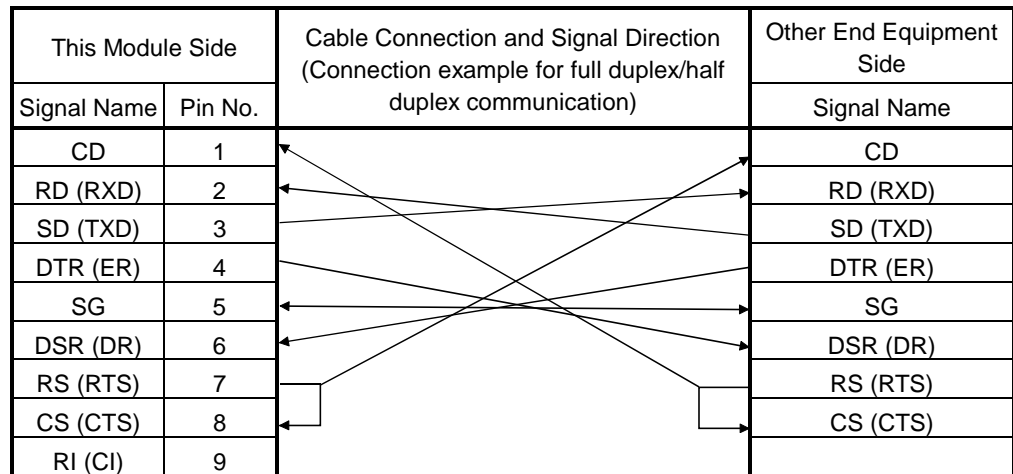

(2) Connection example which cannot turn ON/OFF CD signal (No. 1 pin)
 Connection example for exercising DC code control or DTR/DSR control

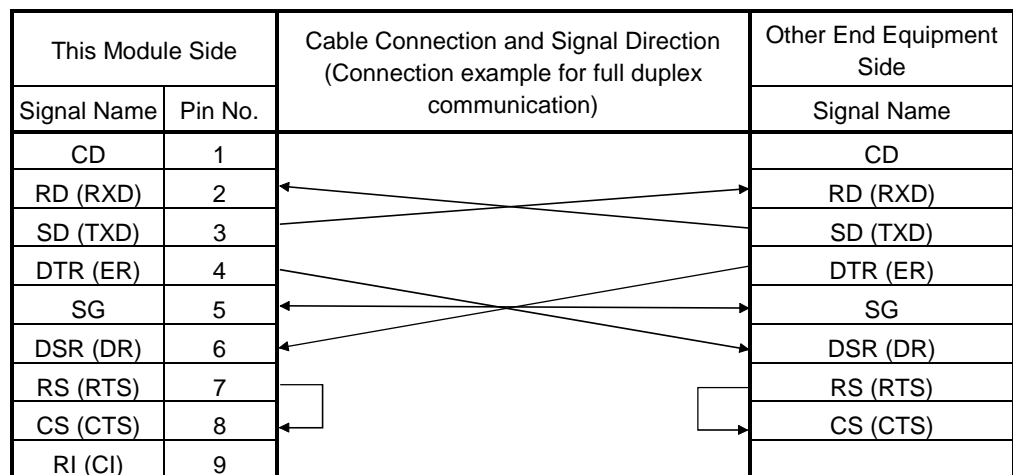

Appendix 6 ROM Writer Wiring Examples

A	Q/QnA	FX
○	×	○

The wiring of the RS-232C cable that connects a personal computer and ROM writer is shown here.

Make the cable used for the wiring shown below yourself in accordance with the specifications of the ROM writer to be used.

Personal computer		Cable Connection and Signal Direction	ROM WRITER	
Signal Name	Pin No.		Pin No.	Signal Name
FG	-		1	FG
SD	3		2	SD
RD	2		3	RD
RST	7		4	RTS
CTS	8		5	CTS
DSR	6		6	DSR
SG	5		7	SG
DTR	4		20	DTR

An example of wiring of the RS-232C cable that connects a personal computer and ROM writer is shown here.

If RTS and CTS are not used at the ROM writer side, short RTS and CTS at the personal computer side.

Appendix 7 PLC CPU Version Correspondence Chart

7.1 About QnA series function versions

A	QnA	FX
×	○	×

When using the functions shown in the table, use the module for function version B. To use the functions in this manual listed following, each version of QnACPU (except Q4ARCPU), Ethernet interface module, and CC-Link system master/local modules have restrictions. (See Appendix 7.1.2 for more information about Q4ARCPU.) If there is a version higher than those listed in the table, the corresponding functions can be used.

Module \ Function	PLC Q2ACPU, Q2AS1CPU, Q3ACPU, Q4A CPU, Q2AS(H)CPU, Q2AS(H)S1	Ethernet AJ71QE71(B5), A1SJ71QE71-B2, A1SJ71QE71-B5	CC-Link AJ61QBT11, A1SJ61QBT11
Local device Monitoring/testing	9707B or later	—	—
High-speed communication	9707B or later	—	—
Ethernet parameters	9707B or later	9707B or later	—
CC-Link parameters	9707B or later	—	9707B or later

—: Irrelevant function

POINT

- When using the functions above, use a module that has the following code (9707B or later) inscribed in the DATE entry on the ratings nameplate.



Year/month of manufacture: 9707
Function version: B

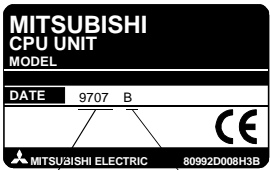

Year/month of manufacture: 9707
Function version: B

7.2 About Q4ARCPU function version

A	QnA	FX
×	○	×

The table below explains the items listed following.

1. Comparisons between QnACPU functions of other than Q4ARCPU and Q4ARCPU.
2. Comparisons of the differences between versions of Q4ARCPU.

When connecting to the Ethernet, use the improved version of the Q4ARCPU (production date (last two numbers of the Western calendar year and the two numbers for the month) is "0012" or later, that software product is version B or higher) and QE71 function version B.

Because the Q4ARCPU does not support the settings, do not make settings for the Ethernet parameters FTP parameters/routing information.

	PLC CPU Version	Ethernet Connection		CC-Link Parameters	High Speed Communication	Local Device Monitor/Test
		Local Station	Other Station			
Q2ACPU, Q2AS1CPU, Q3ACPU, Q4ACPU, Q2AS(H)CPU, Q2AS(H)S1	Function Version A	×*1	×*1	×*1	×	×
	Function Version B	○	○	○	○	○
Q4ARCPU	Production date is "0012", software product is version A or earlier	×*1	×*1	×*1	×	×
	Production date is "0012", software product is version B or later	○	○	×*1	×	×

*1: Parameters can be set by the GX Developer

Even if you write parameters set with GX Developer (SW6D5C-GPPW-E 6.04E or earlier product) to the Q4ARCPU, the Q4ARCPU will ignore the set parameters.

7.3 About the Q series function version

A	Q	FX
×	○	×

The following is how to confirm the function version of the module.
 If the version of your module is as indicated in the table or later, the corresponding functions are available.

Function	Module	PLC CPU	Q-Compatible E71	Serial Communication Module (Q Series)
			Q02(H), Q06H Q12H, Q25H	QJ71E71 QJ71E71-B2
Multi CPU setting		Function version B	—	—
Remote password		Function version A Product whose upper 5 digits of serial No. 02092***** is 02092 or later	Function version B	Function version B
Forced I/O registration/cancel		Function version A Product whose upper 5 digits of serial No. 02092***** is 02092 or later	—	—

The function version of the module can be checked by confirming the rating plate on the right hand side of the module and GX Developer.

- (1) To make check in the "SERIAL field of the rating plate" on the right hand side of the module

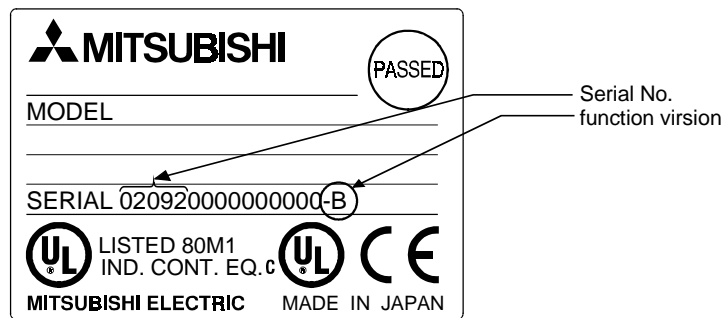

- (2) To make check on GX Developer
 [Operating Procedure]

Choose [Diagnostics] → [System monitor] → Module's Detailed Information button → "Product information".
 For details, refer to Section 21.4 "System Monitor".

Appendix 8 Restrictions and Cautions

A	Q/QnA	FX
○	○	×

The following is a list of restrictions and cautions to be observed when operating GX Developer.

Read these restrictions before attempting GX Developer operations.

The symbol "^" is appended to those restrictions in the list that also apply to GPPA/GPPQ.

Items in the list that are marked "<Caution>" are cautions relating to GX Developer only.

[Interpreting the Lists]

Example:

GPPA	GPPQ
○	—

..... Indicates that the restriction when using ACPU with GX Developer is the same as that which applies when using GPPA.

GPPA	GPPQ
○ <Caution>	—

..... Indicates that the caution when using ACPU with GX Developer is the same as that which applies when using GPPA.

GPPA	GPPQ
— <Caution>	—

..... Indicates that the caution when using ACPU with GX Developer is exclusive to GX Developer.

Item	Restrictions/Cautions	GPPA	GPPQ
Comment reading/writing	When editing comments there is no particular need to set a comment capacity. However, an error is displayed on writing to the CPU if no capacity is found to be set on checking the parameters of the personal computer.	— <Caution>	—
	When extension comments have been designated for a program created with GPPA (valid program setting), when these extension comments are read by GX Developer, they are assigned to common comments regardless of the GPPA designation.	— <Caution>	—
	When a file created with ACPU or GPPA is written to GX Developer, if there is any duplication between the comments for common devices and extension comments, the extension comments take priority and therefore the common device comments cannot be read.	—	—
	When comments created with GX Developer are written in GPPA format to the FD or HD of a personal computer, the comments can be written regardless of the comment capacity in the parameters. The comments can be used when GPPA is started up by carrying out comment memory capacity setting, then reading the comments in the file maintenance mode.	○	—
	With GX Developer, device comments and device memories can be created within the ranges designated in the parameters, but even after completing writing to the GPPQ format, it may not be possible to write to GPPQ. In this case the size of the data to be written must be reduced.	—	—
	When second half M comments for main and sub use are read to GX Developer, since the range setting is included in S, they are allocated to S.	—	—

Item	Restrictions/Cautions	GPPA	GPPQ
Comment reading/writing	If X/Y comments 2 are written without range setting at GX Developer, reading is carried out in accordance with the X and Y attributes respectively.	—	—
	The restriction on sub-system names is up to 10 characters for GPPQ and up to 8 characters for GX Developer. On reading subsystem names from GPPQ format, they are shortened to 8 characters. If these subsystem names are written back to GPPQ, they are written as 8 characters.	—	○
	When peripheral statements/notes created with GPPQ are written to a PLC, they cannot be read out with GX Developer; they must be read with GPPQ.	—	— <Caution>
	When comments are written in GPPA format, one of the original files at the GPPA side is deleted. When writing comments 2, comments 1 are deleted; when writing comments 1, comments 2 are deleted.	— <Caution>	—
	When comments are written to an A1NCPU, if MAIN (program-classified comment) is selected when writing to the PLC, comments F0 to F127 are written unconditionally to the PLC, regardless of range selection. Reading is carried out in the same way.	— <Caution>	—
	When comments edited as comments 2 at GX Developer are written to an ACPU/GPPA format file as comments 1, they are displayed as incorrect characters by GPPA.	— <Caution>	—
	When comments are written to an ACPU/GPPA format file, if a two-byte character starts at the 16th character (for comments 2)/15th character (for comments 1), writing is carried out with the 16th/15th character left blank.	—	—
Parameter setting	When using a memory cassette larger than A3MCA-18, if the total capacity - excluding extension comments - set in capacity setting in the parameters exceeds 144 K bytes, when the extension comments are written it may not be possible to write the second half. In this case the first half 1024 points must be divided into 64-point units.	○	—
	When local device or latch clear key valid/invalid designations are made in the parameters, set a range in device setting.	—	○
	When file registers are set, a file register capacity must be set in the parameters.	○	—
	When parameters for which no settings have been made with GPPA, or whose parameter screens have been opened in GPPA but then closed with "END" without making any settings, are verified - in GPPA - against GX Developer parameters set in the same way, a verification mismatch may occur. The mismatch occurs due errors, for example, in the initial value data of blank items, but there is no difference in operation when the parameter data is written to a PLC and executed, so there is no problem in actual use.	—	—
	When file registers are designated in the MELSECNET/10 refresh parameter settings, a capacity setting must be made for file registers in the memory capacity settings.	○	—
	Since MELSECNET/10 network parameters store the time at which the parameter settings were made with GX Developer, when network parameters are verified between GPPA/GPPQ and GX Developer, the result may be a setting time mismatch even if the set data matches.	— <Caution>	○
	If MELSECNET/10 (multiplex remote master) or MNET/10 (parallel remote master) is set for four modules in the network parameters and these settings are written in GPPQ format and verified against the same parameter settings in GPPQ, a verification error will occur. Since the parameters themselves are correct, there is no problem in actual use.	—	—

Item	Restrictions/Cautions	GPPA	GPPQ								
Parameter settings	If a blanks are set for "refresh parameters" and "link parameter constant scan (GPPA only)" in the GPPA/GPPQ and GX Developer parameters, this is the same as settings of "0 points" and "0 ms." respectively at GPPA.	—	—								
	When the device settings are changed, the following files that have already been written to the PLC must be written again: Sequence programs, SFC programs, monitor registration, sampling trace data, device initial values.	—	○								
	With regard to PLC data reading of the network parameters: 1. When parameters are set (written) in the PLC, the written parameters are read. 2. When parameters have not been set in the PLC, the actual link module mounting status detected by the PLC is read.	—	○								
	When verification against parameters created with SW0IVD-GPPQ or SW1IVD-GPPQ is executed, a "parameter mismatch" may occur even if the settings match. If this happens, first read the parameters with SW2IVD-GPPQ, then write the parameters again.	—	○								
	To create a subsequence, a capacity of 2K or more must be set in the parameter mode.	○	—								
Change PLC type	If a PLC type change is made to a PLC type that does not allow the creation of subprograms, subprograms are deleted.	— <Caution>	—								
	When a program is written to the PLC after changing the PLC type, out-of-range devices/instructions cause an error and cannot be written. When data is written to a GPPA format file and read with GPPA, instruction code abnormalities are displayed. The same applies when data is written to a GPPQ format file and read with GPPQ.	—	—								
	If the PLC type is changed in the network system shown below, all the network parameters before the change are retained. However, in the case of AnUCPU, if there is even one module for which the first network I/O number exceeds the actual I/O range of the PLC type changed to, the first I/O numbers are automatically allocated to 0H, 20H, 40H, 60H (assuming there are four modules). (Where A4U changes to A3U, A4U changes to A2U, A3U changes to A2U) For changes between network systems, the changes are to the defaults.	—	—								
	<table border="1" style="margin-left: auto; margin-right: auto;"> <thead> <tr> <th>Network system</th> <th>PLC system</th> </tr> </thead> <tbody> <tr> <td>AnN systems</td> <td>A0J2H, A1N, A2N, A3N, A1S, A1SH, A2S (S1), A2SH, A2C</td> </tr> <tr> <td>AnA systems</td> <td>A2A (S1), A3A</td> </tr> <tr> <td>AnU systems</td> <td>A2U, A2USH-S1, A3U, A4U, A2AS (S1), A2AS-S30, A2AS-S60</td> </tr> </tbody> </table>	Network system	PLC system	AnN systems	A0J2H, A1N, A2N, A3N, A1S, A1SH, A2S (S1), A2SH, A2C	AnA systems	A2A (S1), A3A	AnU systems	A2U, A2USH-S1, A3U, A4U, A2AS (S1), A2AS-S30, A2AS-S60	—	—
	Network system	PLC system									
AnN systems	A0J2H, A1N, A2N, A3N, A1S, A1SH, A2S (S1), A2SH, A2C										
AnA systems	A2A (S1), A3A										
AnU systems	A2U, A2USH-S1, A3U, A4U, A2AS (S1), A2AS-S30, A2AS-S60										
If microcomputer programs cannot be accommodated when a PLC type change is made, all microcomputer programs are deleted.	—	—									
If the capacity before the change is smaller than the maximum capacity of the PLC type changed to, the memory capacity is set as that before the change. If it is larger than the maximum memory capacity of the PLC type to be changed to, the memory capacity is set as the maximum memory capacity of the PLC type changed to.	○	—									

Item	Restrictions/Cautions	GPPA	GPPQ
Change PLC type	If the program capacity decreases, the programs are curtailed at the number of steps equivalent to the reduced capacity. (If this curtailment occurs part way through a ladder program, the entire block is eliminated.)	—	—
	If the sequence programs + microcomputer programs exceed the capacity of the PLC type changed to, the microcomputer program capacity is set to 0.	—	—
	To execute "PLC read" when connected to a CPU that is not in the PLC type list, carry out a PLC type change as follows. <ul style="list-style-type: none"> When connecting to A1SCPU with a PLC type other than A1S at the GX Developer side, read by changing the PLC type to A2N. 	—	—
	When a PLC type change is executed, if there are devices that cannot be used at the PLC after the change, that range of devices is automatically deleted. (For the "A" series, this includes device comments.)	○	—
	When a PLC type change is executed, if a setting that exceeds the maximum device range for the PLC after the change is made, the setting is automatically changed to the maximum possible. (For the "A" series, this includes device comments.)	○	—
PLC type	A connected CPU that does not support A1, A2, or A3 is recognized as AnN but cannot be used.	—	—
Ladder input	The ladder block has 24 lines of parallel contacts and line insertion is not possible.	—	○
	The line return destination and source must have the same number. The same number cannot be used more than once.	○	○
	The line return numbers must be serial numbers. It is not possible to insert a ladder between the line return source and destination.	○	○
	If the contacts/coils to be overwritten straddle multiple contacts, ladder input is not possible.	—	○
	Inserting a contact in the first row does not make it possible to make an insertion at a line return.	—	○
	If a vertical line that crosses an instruction is drawn, conversion will not be possible.	—	○
	In a ladder block with two or more lines where an instruction cannot be accommodated on one line, you must create a line return and input the instruction on the next line.	—	—
	<input type="text" value="Enter"/> When ladder information has been read into the key-in data field by pressing the [Enter] key, the cursor cannot be moved.	—	—
	The maximum number of instruction and device characters that can be written at one contact is eight. If the total number of characters is more than this, multiple rows must be used.	—	—
	If a vertical line that crosses a statement is drawn, a conversion error occurs on attempting conversion.	—	○
A CHG instruction input check is not performed on programs of PLCs that do not allow the creation of subprograms, such as A2ACPU and A2UCPU. When the PLC is set to RUN an error occurs.	—	—	
Online change	When online change is executed with respect to an A4UMCA-128E memory cassette, the transmission may take several minutes. During the transmission, operation continues in accordance with the program before the change. After the transmission, sequence processing stops for a maximum of 2 seconds.	○	—
	When online change is executed with respect to an A3NCP, the CHG instruction is automatically disabled. On completion of conversion, the CHG instruction is executed.	○	—
	During online change, RUN/STOP/PAUSE/STEP RUN key switch operations are prohibited.	○	○
	If there is a pulse instruction in the program to be written, the PLC does not execute this instruction after the PLC write operation. It is executed after its execution condition changes from OFF to ON.	○	○

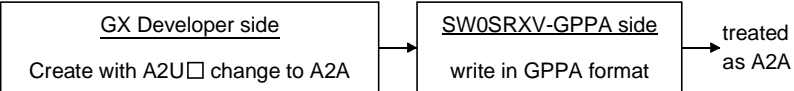
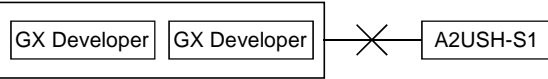
Item	Restriction/Note	GPPA	GPPQ
Import file /Export file	<p>Depending on the GPPA, there are versions that cannot be selected although the same model name exists in the PLC type list.</p> <p>If the PLC type is not represented with GPPA, change to a PLC type that is represented with GPPA (at GX Developer) and then write the data.</p> <p>Example:</p> 	—	—
	<p>Since they are not represented in the PLC type list at the GPPA side, files created with models such as A3HCPU cannot be read with GX Developer. (It is not possible to read or write files of incompatible PLCs.)</p>	—	—
	<p>When a GPPA/GPPQ format program that contains an END instruction part way through is read to GX Developer, the part of the program up to the END instruction is read. The part after the END instruction is not read.</p>	—	—
	<p>On reading a device memory from ACPU/GPPA format with GX Developer, the information of the preceding coils of T/C devices is not read out, and consequently when the data is written again to ACPU/GPPA format and verified at GPPA, a preceding coil mismatch occurs.</p>	—	—
Device test	<p>When a forced set/reset operation is executed while the PLC is in the RUN state, program execution at the PLC is given priority.</p>	○	○
	<p>When an input (X) is forcibly reset, the PLC operates as though it were ON even if program input is OFF. If a process input is ON the PLC will process it as ON even if a forced reset is executed.</p>	○	○
	<p>The local device test requires a range to be set in the parameters in advance.</p>	—	○
	<p>Even if the present value is set to a smaller value than the set value after time up of a timer or counter, the time up status is retained.</p>	○	○
PLC write/read	<p>When a ladder with peripheral statements is written to a PLC, the statements are not written to the PLC, and the ladder must therefore be stored in the HD.</p>	○ <Caution>	○ <Caution>
	<p>When the PLC read dialog box is opened again after writing a ladder to the PLC and displaying the list, and then using another programming tool (GX Developer/GPPA/GPPQ, etc.) to, for example, delete PLC data, the contents of the data list may differ from the current status of the PLC data.</p> <p>In this case the list must be updated.</p>	—	—
PLC communication	<p>When communicating with a PLC, no distinction is made between A2US(S1)CPU and A2U(S1)CPU, and therefore access to a CPU when using an A2US(S1)/A2U(S1) is dealt with as access to A2U(S1)CPU.</p>	—	—
	<p>PLC communication is not possible with a GX Developer started up.</p> <p>PLC communication is possible with one of these only, under the conditions indicated below.</p> <ul style="list-style-type: none"> When GX Developer is used, check if there is a system (control panel) COM port. If there is not, one must be registered. In this state, PLC communication using GPPA/GPPQ is not possible. When using GPPA/GPPQ, eliminate the system (control panel) COM port. In this state, PLC communication using GX Developer is not possible. PLC communication with respect to A2USH-S1 with two GX Developers started up is not possible. 	—	—
	<p>During communication, e.g. PLC read/PLC write, do not disconnect the cable for connection of the personal computer and PLC CPU and connect it to another PLC.</p>	—	—

Item	Restriction/Note	GPPA	GPPQ
TC set value	When a TC set value change is applied twice, the change is made to the first set value. If there is a duplicated set value change, the program contents must be checked in a program data check.	—	—
	Since GPPA allows reading/writing of T/C set values alone, there are T/C set values that are not used in the program. Since GX Developer only reads and writes set values for T/C values that exist in the program, set values that do not exist in the program cannot be handled. (When T/C set values are read and written, unused T/C set values at an ACPU are deleted.)	—	—
	T/C set values used in SAP2 are not handled by GX Developer and they are therefore cleared to 0 when written to an APC/GPPA format file.	—	—
Printing	Data is not printed and displayed in accordance with PAGE# (the designated No. becomes the printed page number).	—	—
	GPPA/ACPU print titles are not read/written.	—	—
	Since #CPU# prints the data for the CPU type from the designated position, if the CPU type exceeds 5 characters, blanks must be created at the rear.	—	—
File reading/writing	For file reading/writing with respect to a GPPA that does not allow selection of the same PLC model name, the PLC is treated as a PLC type within the range supported by the GPPA.	—	—
	Reading/writing to files created with SW0S is not possible.	—	—
Note creation	Notes cannot be created for instructions that straddle multiple lines.	—	—
	Notes cannot be created for dedicated instructions.	—	—
	If the coil associated with a note is deleted, the note is also deleted.	—	○ <Caution>
	The note of the first coil in a ladder block is made to correspond to the first step of the ladder block. Other notes are written to the steps of individual coils.	—	—
Find/Replace	It is not possible to search for character strings in comments and device names in the ladder display window. (This is possible for notes and statements only.)	—	○
	When the device with the searched device name has both common and program-specific device name settings, the comment reflection destination/reference destination in the options is not followed.	—	—
	When an online change setting is made for a write conversion setting, the find/Replace menu cannot be selected.	—	○
Statements/notes	P/I statements that are not used in a program with GPPA are not written to GX Developer.	—	—
	When multiple P,I statements have been created for the same P,I with GX Developer, the first P,I statement encountered is written in GPPA format. The other, redundant, P,I statements are not written.	—	—
	When line statements/notes are created other than at the head of a ladder block with GPPA, statements at steps part way through a block are not written to GX Developer.	—	—
	If a note is allocated to the first step of a ladder block, it is read in association with the first coil of the ladder block. For other notes, if the step they are assigned to is a coil, they are read in association with that coil.	—	—

Item	Restriction/Note	GPPA	GPPQ
Use of other packages at the same port	It is not possible to communicate with a PLC while using GPPA/GPPQ at the same port. Either use a different port or quit GPPA/GPPQ (close the DOS prompt too), before using the port.	—	—
	When using the Windows version of, for example, SW[]NIW-GOT800P, simultaneous access to the same port is not possible. Communication with one of the packages only is possible.	—	—
Step execution/ Partial execution	After the set break condition has been satisfied, the PLC breaks operation after running for several steps.	—	○
	Step run via A7BD-J71AP21/AR21 is only possible with A2ACPU and A3ACPU.	○	—
Fault history	If storing the fault history file at a location other than the internal RAM, use the drive name and file name.	—	○
Video card	When using an S3 TRIO64V+ video card, the display may not be normal; in this case "none" must be set for "hardware accelerator" in the graphics detailed setting dialog box.	—	—
Ladder display	Out-of-range devices can be displayed in the ladder display. However, an error occurs if an out-of-range designation is made in ladder editing. Out-of-range devices can be checked in the program check.	—	○ <Caution>
	For an illegal ladder that has no MPP corresponding to MPS, a ladder error is displayed by GPPA, but GX Developer displays the ladder, treating this as a ladder creation fault.	—	—
Processing at GX Developer	When operations that take some time, such as PLC memory clear, are executed, it may not be possible to redisplay the GX Developer display, or the operation of another application may be held up.	—	—
Device memory clear	Since latch clear/non-clearance follows the latch range of the PLC parameters of the project that is currently opened at the personal computer, if there is a discrepancy between the parameters stored in the CPU and the latch range, the latch range may be cleared even if latched devices are designated as not included in the range for clearance.	—	—
Writing to a memory cassette	When using an A4UMCA-*E EEPROM, the memory setting switch must be set to the ROM side.	○	—
Device name registration	With GPPA, the first 8 characters of a comment are input as the device name, but with GX Developer the device name must be registered. Similarly, when printing with device names, the device names must be registered.	—	—
Starting the initialization file	The maximum number of windows that can be automatically opened by starting program restart or initialization files is 20.	—	—
Instruction input by device name	When instructions are input in a ladder by using device names (LD, 'LS11), they are input by searching for the device that corresponds to the device name from the comment data, but when the same device name is set more than once, the device found first in the search is used.	—	—
Short cut keys	Numeric keys cannot be used as shortcut keys.	—	—
Windows	Up to ten monitor windows (ladder monitor, registration monitor, etc.) can be displayed. When more than one GX Developer is started up, up to ten windows can be used with each GX Developer.	—	—

Item	Restriction/Note	GPPA	GPPQ
Windows task bar	When GX Developer is started up while "Always on Top" or "Auto hide" is not specified in the property settings of the Windows task bar, nothing can be displayed in front of the task bar. To display in front of the task bar, set " Always on Top " or " Auto hide " for the task bar.	—	—
Parameter mismatch	When the same data as parameter data written in GPPA format is created with GPPA, there may be a mismatch in the data contents. However, both are correct as parameters and can be used without problems.	—	—
Memory capacity setting	When A1NCPU is selected with GPPA, the default for the comment capacity in memory capacity setting is 64K bytes, but the GX Developer default for comment capacity is 0K bytes.	—	—
Window No.	When the device batch monitor, registration monitor, or buffer memory batch monitor window is opened, the window whose number is one higher than the window last opened is displayed. Even if you close the open window and open another one, the number of the window opened last is counted up.	—	—
Compare	If verification is executed when there is an END instruction part way through the program in the PLC, the part of the program up to the END instruction is verified.	—	—
Duplicate coil result display	The duplicate coil check result display displays details of the step positions where duplicate coils were found in a search from the head of the program.	—	—
About access to remote I/O	When a cable is connected to a master station/control station/remote I/O and remote I/O is designated, communication is not possible. A master station/other station that is not remote I/O must be designated.	—	—
Printing	When printing with device names, device comments and contact use destinations appended on the right, characters in the final line of device comments may be missing, depending on the printer. This problem can be avoided by making the left and right margins smaller in page setting.	—	—
	When printing a large quantity of data, set the printer spool setting to "send printing data directly to the printer."	—	—
Monitoring	When ladder monitoring is executed after setting a monitor condition and monitor stop condition, it is not possible to carry out device test/batch/registration monitoring, or PLC diagnosis. When multiple GX Developers are started on the same personal computer and access to the same PLC is made from the same port, the following functions are not executed concurrently. Monitor values may become abnormal. <ul style="list-style-type: none"> • Program list monitor, monitoring the interrupt program list, setting monitor conditions, setting monitor stop conditions, measuring scan time. 	—	—
Personal computer	Depending on the personal computer, the GX Developer may be sent incorrect information on the remaining capacity of the main memory, leading to problems with starting and operation. In this case, you must close other applications and increase the free memory area.	—	—
Import file (reading immediately after starting GX Developer)	This applies to A series. When a project has been created at the reading destination PLC type and the data is read (the status is "project name not set"), comments are read in accordance with the comment range at the GPPA side.	—	—
Monitoring with Ethernet	It is not possible to simultaneously monitor with another GPP via an Ethernet connection.	—	—

Item	Restriction/Note	GPPA	GPPQ
Open project	Read-only and write-protected (e.g. FD) projects cannot be opened. When a project which was saved when displayed in a large GX Developer window on a personal computer with high resolution is opened on a low-resolution personal computer, it may be displayed at the original large window size and project off the screen. Projects that are saved in their maximized state present no problem.	—	—
Connection destination designation	QCPU-A is inaccessible in the following case. GX Developer ↔ AF board or CPU board ↔ MELSECNET/10 other station QCPU-A	—	—

Appendix 9 About SW D5-GPPW Compatibility

- (1) When opening the GX Developer (SW6D5-GPPW-E) created data in the package of GX Developer (SW2D5-GPPW-E) or earlier

Function, Data	Restrictions
SFC program	SFC data cannot be read.
Macro	Macro-registered (with device comments) device comments are developed as line-to-line comments.
Project name	If the project name of 9 or more characters has been set on GX Developer (SW4D5-GPPW-E), 8 and latter characters are not displayed when the project name is read on the version of GX Developer (SW2D5-GPPW-E) or earlier.

- (2) When opening the GX Developer (SW6D5-GPPW-E) created data in the package of GX Developer (SW3D5-GPPW-E) or earlier

Function, Data	Restrictions
Comment display	Comment display format is fixed to 3×5. (Cannot be changed to 2×8 or 4×8)

- (3) When using the package of GX Developer (SW3D5-GPPW-E) or earlier to open the data created on GX Developer (SW6D5-GPPW-E)

Function, Data	Restrictions
Project	When the Q series project was created on GX Developer (SW6D5C-GPPW-E), it cannot be handled on the version of GX Developer (SW3D5-GPPW-E) or earlier.

- (4) When opening the GX Developer (SW6D5-GPPW-E) created data in the package of GX Developer (SW4D5-GPPW-E) or earlier

Function, Data	Restrictions
Device memory	If multiple device memories have been created with GX Developer (SW5D5C-GPPW-E), they cannot be handled on the version of GX Developer (SW4D5C-GPPW-E) or earlier. (For details, refer to Section 2.4.)

- (5) When using the package of GX Developer (SW5D5-GPPW-E) or earlier to open the data created on GX Developer (SW6D5-GPPW-E)

Function, Data	Restrictions
Parameters	When multi-CPU parameter setting was made on GX Developer (SW6D5C-GPPW-E), parameters cannot be handled on the version of GX Developer (SW5D5C-GPPW-E) or earlier. (Refer to Section 2.5.2 for details.)

- (6) When opening the GX Developer (SW6D5C-GPPW-E) created data in the package of GX Developer (SW5D5C-GPPW-E or earlier)

Function, Data	Restrictions
Parameters	When multi-CPU parameters were set, for example, they cannot be handled on the GX Developer (SW5D5C-GPPW-E or earlier) version. (Refer to Section 2.5.2 for details.)
Label program	On GX Developer (SW5D5C-GPPW-E or earlier), only actual programs converted from label programs may be read.
Remote I/O project	Remote I/O projects cannot be handled on the GX Developer (SW5D5C-GPPW-E or earlier) version.

- (7) When opening data created in GX Developer SW6D5-GPPW-E 6.05F in an older version of GX Developer package (SW6D5-GPPW 6.04E-E or older)

Function, Data	Restrictions
Parameter	When the Ethernet parameter "MELSOFT connection" is enabled, the data cannot be handled in certain versions of GX Developer (SW6D5C-GPPW-E 6.04E or older). (See 2.4.3 for details.)

Appendix 10 GX Developer and LLT Operations

The version combinations when the logic test function (LLT) is used with GX Developer are indicated below.

		SW6D5C-GPPW-E
		SW6D5C-GPPW-EA SW6D5C-GPPW-VA
Logic test function (LLT)	SW2D5-LLT-E	△ (*1 *2 *3 *4)
	SW3D5-LLT-E	△ (*2 *3 *4)
	SW4D5-LLT-E	△ (*3 *4)
	SW5D5-LLT-E	○ *4

Note 1: When the A series is selected, buffer memory monitoring by LLT cannot be executed from GX Developer.

Note 2: The Q series (Q mode, A mode) logic test function (LLT) cannot be started from GX Developer.

Note 3: The LLT for FX_{1S} and FX_{1N} cannot be started from GX Developer.

Note 4: Multi-CPU operations and label programs cannot be executed.

Appendix 11 Notes on FX Series Programming

The points to note when programming with the FX series are given here. For general points of difference and notes, see Section 1.3.

11.1 Ladder Monitor Display

A	Q/QnA	FX
×	×	○

The differences between the FXGP(DOS)/FXGP(WIN) monitor display and GX Developer monitor display are indicated here.

- Differences in monitor display of PLS and PLF instructions**
 In GX Developer, the GX Developer format display method is set as the default, but if the "PLSPLF instruction ladder monitor" check box in the [Tools] → [Options] <<program common>> sheet is checked, display is in the FXGP(DOS) or FXGP(WIN) format. Whichever display is selected, there is no effect on the actual operation of FXCPU.

Example: Comparison of monitor displays according to setting contents

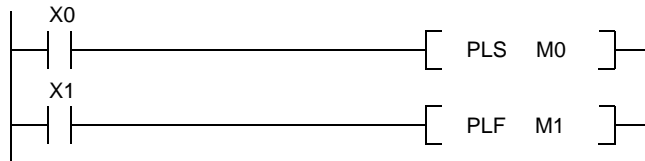

(1) Monitoring PLS instructions

- GX Developer format display

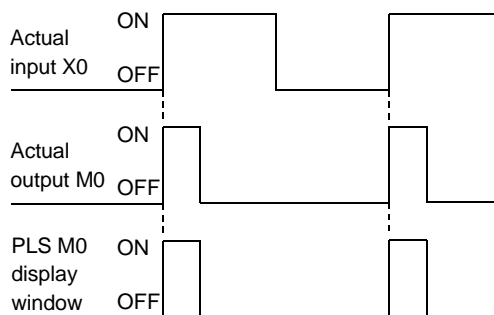

- FXGP(DOS), FXGP(WIN) format display

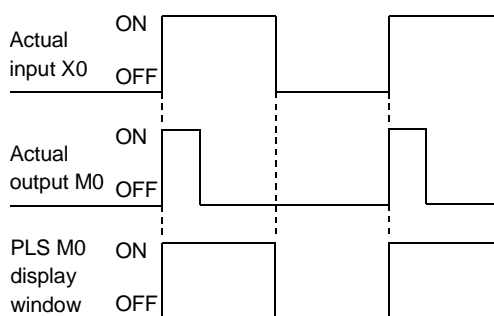

Monitoring PLF instructions

- GX Developer format display

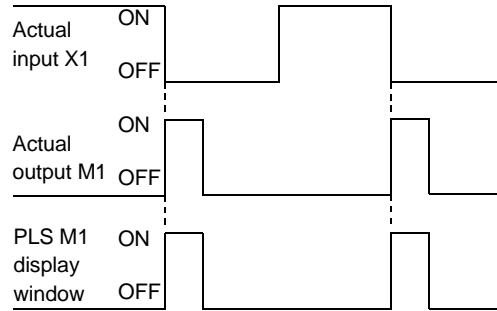

- FXGP(DOS), FXGP(WIN) format display

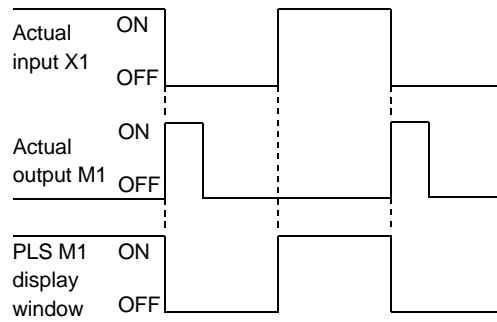

- Differences in monitoring OUT T and OUT C instructions
The OUT coil monitor display on resetting timer and counter present values is different when using the "A" series or QnA series than it is when using the FX series.

- Display when using the "A" series or QnA series

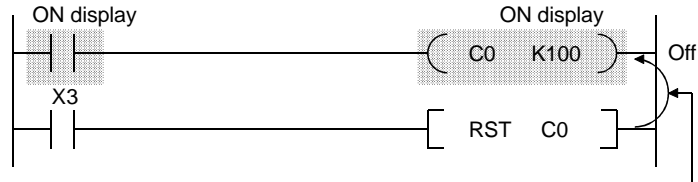

When RST C0 is driven with X3 ON, the present value of C0 is reset and the display of OUT C0 is also turned off.

- Display when using the FX series



When RST C0 is driven with X3 ON, the present value of C0 is reset but the display of OUT C0 remains unchanged. (ON display continues until the drive contact of OUT C0 goes OFF.)

11.2 Handling of Comments

A	Q/QnA	FX
×	×	○

- With FXGP(DOS), a distinction is made when entering comments: comments written in the PLC are called "comments 1", and comments held only at the Personal computer side are called "comments 2."
With GX Developer, all comments are managed as device comments, and the distinction between comments 1 and comments 2 does not exist.
When device comments are written to a PLC, a comment capacity must be secured in "PLC parameter setting" (see Section 13.1), and the comment range among the device comments to be written to the PLC must be set in "comment range setting" (see Section 9.7.)
- Comments of up to 16 characters can be written to a PLC, but some models, such as FXGP(DOS) and A6GPP, can only handle up to 15 characters, which means that the 16th character cannot be displayed. When comments are used in common, enter device comments of up to 15 characters (see Section 9.1.6).
- Comparison of comment configuration

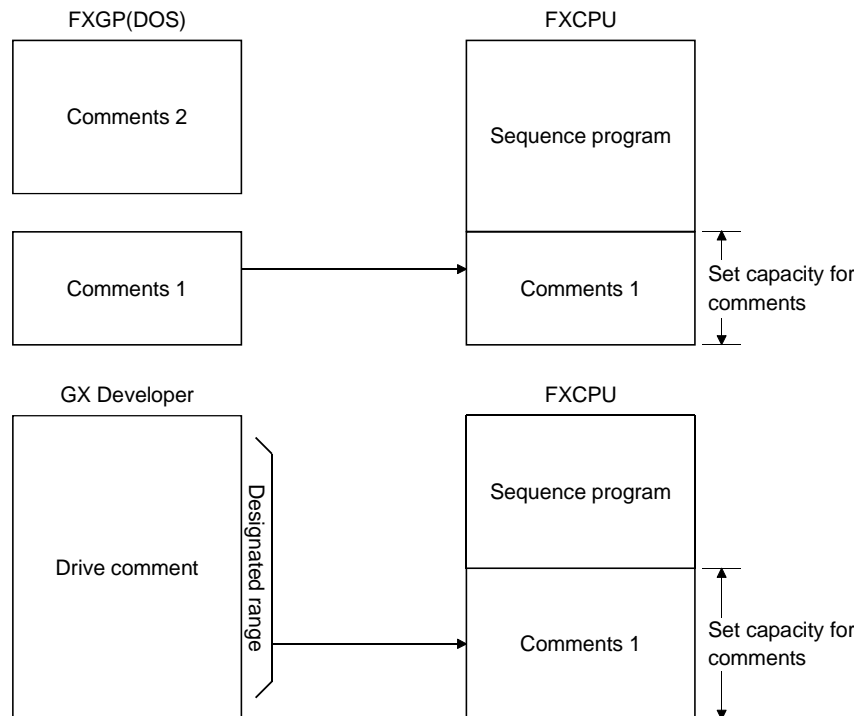

Appendix 12 Instruction Conversion Lists

12.1 Instruction Conversion List for A ↔ Q/QnA Conversions

A	Q/QnA	FX
○	○	×

A ↔ Q/QnA conversions will not be successful under the following conditions: in these cases make the necessary correction after executing the conversion instruction by referring to the following lists.

The instruction conversion list for conversions from A to Q/QnA is given in pages 51 to 66. The instruction conversion list for conversions from Q/QnA to A is given in pages 67 to 79. The indications *, *1, *2, *3, *4, *5, *6, and *7 in the lists refer to sources and destinations.

Device correspondence table for A → QnA conversions

A Series	Q/QnA Series	Remarks
M	M	
M9000 to	SM1000 to	
L	L	
F	F	
S	M	
X	X	
Y	Y	
B	B	
D	D	
D9000 to	SD1000 to	
A0, 1	SD718, 719	
R	R	
W	W	
T	T, ST	ST is governed by the parameter settings
C	C	

Device correspondence table for A → Q/QnA conversions (continued)

A Series	QnA Series	Remarks
P	P	If out-of-range, the instruction becomes OUT SM1255
I	I	If out-of-range, the instruction becomes OUT SM1255
N	N	If out-of-range, the instruction becomes OUT SM1255
K	K	
H	H	
“ “	“ “	Character strings are handled
Z, Z1~Z6	Z0~Z6	
K	K	
V, V1 to V6	Z7 to Z13	

Devices that contain out-of-range device parts or extension parts are changed to SM1255 if bits and SD1255 if words.

Converting "A" standard instructions to Q/QnA series:

A Series	Q/QnA Series	Remarks
OUT T* *2	OUT T* *2	H(OUTH) and ST are governed by the parameter settings
	OUT ST* *2	
	OUT C* *2	
OUT C* *2	OUTH T* *2	
	OUTH ST* *2	
	OUTH C* *2	
SUB *1	OUT SM1255	A dedicated instructions are excepted.
CHG	OUT SM1255	
SUM *1	SUM *1 SD718	
DSUM *1	DSUM *1 SD718	
ASC *1 *2	OUT SM1255	
LRDP *1 *2 *3 *4	OUT SM1255	
LWTP *1 *2 *3 *4	OUT SM1255	
RFRP *1 *2 *3 *4	OUT SM1255	
RTOP *1 *2 *3 *4	OUT SM1255	

Converting "A" standard instructions to QnA series:

A Series	QnA Series	Remarks
LEDA *1	OUT SM1255	"A" dedicated instructions are excepted.
LEDB *2	OUT SM1255	"A" dedicated instructions are excepted.
CHK *1 *2	OUT SM1255	
STC	OUT SM1255	
CLC	OUT SM1255	

Converting structured program dedicated instructions to QnA series:

Refer to the QCPU (Q mode)/QnACPU Programming Manual (Common Instructions) (for AnACPU/AnUCPU)

A Series	Q/QnA Series	Remarks
LEDA(LEDB) IX LEDC *1 LEDR	OUT SM1255 LEDC *1 LEDR	Section 7.6.9 Index qualification of entire ladder
LEDA IXEND	OUT SM1255	
LEDA CHK	OUT SM1255	Section 7.10.1 Special format failure checks
LEDA CHKEND	OUT SM1255	Section 7.10.2 Changing check format of CHK instruction

Converting character string processing instructions to QnA series (for AnACPU/AnUCPU)

A Series	Q/QnA Series	Remarks
LEDA/LEDB SCMP LEDC *1 LEDC *2 LEDC *3 LEDR	OUT SM1255 LEDC *1 LEDC *2 LEDC *3 LEDR	Section 6.1.4 Character string data comparisons

Converting instructions for file registers to QnA series (for AnACPU/AnUCPU)

A Series	Q/QnA Series	Remarks
LEDA/LEDB RSET LEDC/SUB *1 LEDR	OUT SM1255 LEDC *1/OUT SM1255 LEDR	Section 7.14.1 Switching file register numbers
LEDA/LEDB BMOVR LEDC *1 LEDC *2 LEDC/SUB *3 LEDR	OUT SM1255 LEDC *1 LEDC *2 LEDC *3/OUT SM1255 LEDR	Section 6.4.5 Block 16-bit data transfers
LEDA/LEDB BXCHR LEDC *1 LEDC *2 LEDC/SUB *3 LEDR	OUT SM1255 LEDC *1 LEDC *2 LEDC *3/OUT SM1255 LEDR	Section 6.4.8 Block 16-bit data exchanges
LEDA/LEDB ZRRD	OUT SM1255	Section 7.18.3 Direct 1-byte read from file register
LEDA/LEDB ZRWR	OUT SM1255	Section 7.18.4 File register direct 1-byte write
LEDA/LEDB ZRRDB	OUT SM1255	Section 7.18.3 Direct 1-byte read from file register
LEDA/LEDB ZRWRB	OUT SM1255	Section 7.18.4 File register direct 1-byte write

Converting instructions for data link to Q/QnA series (for AnACPU/AnUCPU)

A Series	Q/QnA Series	Remarks
LEDA/LEDB LRDP SUB *1 LEDC *2 LEDC *3 SUB *4 LEDC *5 LEDR	OUT SM1255 OUT SM1255 LEDC *2 LEDC *3 OUT SM1255 LEDC *5 LEDR	Section 8.3.2 Reading device data from local stations (MELSECNET)
LEDA/LEDB LWTP SUB *1 LEDC *2 LEDC *3 SUB *4 LEDC *5 LEDR	OUT SM1255 OUT SM1255 LEDC *2 LEDC *3 OUT SM1255 LEDC *5 LEDR	Section 8.3.4 Writing data to devices at local stations (MELSECNET)
LEDA/LEDB ZNFR SUB K/H* SUB *1 LEDC *2 SUB *3 SUB *4 LEDC *5 LEDR	OUT SM1255 OUT SM1255 OUT SM1255 LEDC *2 OUT SM1255 OUT SM1255 LEDC *5 LEDR	Section 8.2.8 Reading data from special function modules at remote I/O stations
LEDA/LEDB ZNTO SUB K/H* SUB *1 LEDC *2 SUB *3 SUB *4 LEDC *5 LEDR	OUT SM1255 OUT SM1255 OUT SM1255 LEDC *2 OUT SM1255 OUT SM1255 LEDC *5 LEDR	Section 8.2.9 Writing data to special function module of remote I/O station

Converting program switching instructions to Q/QnA series (for AnACPU/AnUCPU)

A Series	QnA Series	Remarks
LEDA ZCHG0	OUT SM1255	Model Q2AS(H) CPU(S1) User's Manual Appendix 4.5
LEDA ZCHG1	OUT SM1255	
LEDA ZCHG2	OUT SM1255	
LEDA ZCHG3	OUT SM1255	Q2A(S1)/Q3A/Q4ACPU User's Manual Appendix 4.5

Converting instructions for CC-Link to Q/QnA series

Refer to the CC-Link System Master Local Module type AJ61QBT11 /A1SJQBT11 User's Manual (for AnSHCPU)

A Series	Q/QnA Series	Remarks
LEDA/LEDB RLPA SUB K/H* LEDC *1 LEDC *2 LEDR	OUT SM1255 OUT SM1255 LEDC *1 LEDC *2 LEDR	Q/QnACPU PROGRAMING MANUAL (Common Instructions) Section 7.8.1 Special function modules 1-and 2- word data read operations Section 7.8.2 Special function modules 1-and 2- word data write operations.
LEDA/LEDB RRPA SUB K/H* LEDC *1 LEDR	OUT SM1255 OUT SM1255 LEDC *1 LEDR	
LEDA/LEDB RITO SUB K/H* SUB *1 LEDC *2 LEDC *3 LEDR	OUT SM1255 OUT SM1255 OUT SM1255 LEDC *2 LEDC *3 LEDR	Section 15.6.9 RITO instruction
LEDA/LEDB RIWT SUB K/H* SUB *1 LEDC *2 LEDC *3 LEDR	OUT SM1255 OUT SM1255 OUT SM1255 LEDC *2 LEDC *3 LEDR	Section 15.6.5 RIWT instruction
LEDA/LEDB RIRCV SUB K/H* SUB *1 LEDC *2 LEDC *3 LEDC *4 LEDR	OUT SM1255 OUT SM1255 OUT SM1255 LEDC *2 LEDC *3 LEDC *4 LEDR	Section 15.6.7 RIRCV instruction

Converting instructions for CC-Link to Q/QnA series (for AnSHCPU) (Continued)

A Series	Q/QnA Series	Remarks
LEDA/LEDB RISEND SUB K/H* SUB *1 LEDC *2 LEDC *3 LEDC *4 LEDR	OUT SM1255 OUT SM1255 OUT SM1255 LEDC *2 LEDC *3 LEDC *4 LEDR	Section 15.6.6 RISEND instruction
LEDA/LEDB RDGET SUB K/H* SUB *1 LEDC *2 LEDC *3 LEDR	OUT SM1255 OUT SM1255 OUT SM1255 LEDC *2 LEDC *3 LEDR	Section 15.6.10 RDGET instruction
LEDA/LEDB RDPUT SUB K/H* SUB *1 LEDC *2 LEDC *3 LEDR	OUT SM1255 OUT SM1255 OUT SM1255 LEDC *2 LEDC *3 LEDR	Section 15.6.11 RDPUT instruction
LEDA/LEDB RDMON SUB K/H* SUB *1 LEDC *2 LEDC *3 LEDR	OUT SM1255 OUT SM1255 OUT SM1255 LEDC *2 LEDC *3 LEDR	Section 15.6.12 RDMON instruction

Device correspondence table for Q/QnA → A conversions

Q/QnA Series	A Series	Remarks
M	M	
SM	M9255	
SM1000 to	M9000 to	
L	L	
F	F	
V	M9255	
S	M9255	
TR	M9255	
X	X	
Y	Y	
FX	M9255	
FY	M9255	
B	B	
SB	M9255	
DX	X	
DY	Y	
D	D	
SD	D9255	
SD718, 719	A0, 1	
SD1000 to	D9000 to	
FD	D9255	
G	D9255	
SG	D9255	
VD	D9255	
A	D9255	
R	R	
ZR0 to 8191	R0 to 8191	
ZR8192 to	D9255	
W	W	
SW	D9255	
T	T	
C	C	
ST	T	
Z0 to Z6	Z, Z1 to Z6	
Z7 to Z13	V, V1 to V6	
Z14 to	D9255	
P	P	If out-of-range, the instruction becomes OUT M9255
I	I	If out-of-range, the instruction becomes OUT M9255
N	N	If out-of-range, the instruction becomes OUT M9255
U	M9255	All instructions become OUT M9255
J	M9255	All instructions become OUT M9255
BL	M9255	All instructions become OUT M9255
K	K	
H	H	

Device correspondence table for Q/QnA → A conversions (Continued)

Q/QnA Series	A Series	Remarks
E	D9255	
“ “	“ “	
Z0 to Z6	Z, Z1 to Z6	If the device part is a device that cannot be converted, all devices containing this code become M9255 or D9255.
Z7 to Z13	V, V1 to V6	If the device part is a device that cannot be converted, all devices containing this code become M9255 or D255.
Z14 to	M9255, D9255	All devices containing this code become M9255 or D9255.
K	K	If the device part is a device that cannot be converted, all devices containing this code become M9255 or D255.
.	M9255, D9255	All devices containing this code become M9255 or D9255.
@	M9255, D9255	All devices containing this code become M9255 or D9255.
U	M9255, D9255	All devices containing this code become M9255 or D9255.
J	M9255, D9255	All devices containing this code become M9255 or D9255.
BL	M9255, D9255	All devices containing this code become M9255 or D9255.

Devices that contain out-of-range device parts or extension parts are changed to M9255 if bits and D9255 if words.

Converting Q/QnA series instructions to A series instructions

Q/QnA Series	A Series	
	Common Instructions	Dedicated Instructions (for AnA, AnUCPU)
LDP *1	LD M9255	
LDF *1	LD M9255	
ORP *1	OR M9255	
ORF *1	OR M9255	
ANDP *1	AND M9255	
ANDF *1	AND M9255	
EGP *1	AND M9255	
EGF *1	AND M9255	
MEP	AND M9255	
MEF	AND M9255	
INV	AND M9255	
OUT DY *	OUT M9255	LEDA DOUT LEDC Y* LEDR
OUT T/ST/C256 *2	OUT M9255	
OUTH T/ST/C256 *2	OUT M9255	
SET DY*	OUT M9255	LEDA/LEDB DSET LEDC Y* LEDR

Converting Q/QnA series instructions to A series instructions (continued)

Q/QnA Series	A Series	
	Common Instructions	Dedicated Instructions (for AnA, AnUCPU)
RST DY*	OUT M9255	LEDA/LEDB DRST LEDC Y* LEDR
FF *1	OUT M9255	LEDB FF LEDC *1 LEDR
DELTA *1	OUT M9255	
PAGE *1	OUT M9255	
LDE= *1 *2 ORE= *1 *2 ANDE= *1 *2	LD= D9255 D9255 OR= D9255 D9255 AND= D9255 D9255	
LDE<> *1 *2 ORE<> *1 *2 ANDE<> *1 *2	LD<> D9255 D9255 OR<> D9255 D9255 AND<> D9255 D9255	
LDE> *1 *2 ORE> *1 *2 ANDE> *1 *2	LD> D9255 D9255 OR> D9255 D9255 AND> D9255 D9255	
LDE>= *1 *2 ORE>= *1 *2 ANDE>= *1 *2	LD>= D9255 D9255 OR>= D9255 D9255 AND>= D9255 D9255	
LDE< *1 *2 ORE< *1 *2 ANDE< *1 *2	LD< D9255 D9255 OR< D9255 D9255 AND< D9255 D9255	
LDE<= *1 *2 ORE<= *1 *2 ANDE<= *1 *2	LD<= D9255 D9255 OR<= D9255 D9255 AND<= D9255 D9255	
LD\$= *1 *2 OR\$= *1 *2 AND\$= *1 *2	LD= D9255 D9255 OR= D9255 D9255 AND= D9255 D9255	
LD\$<> *1 *2 OR\$<> *1 *2 AND\$<> *1 *2	LD<> D9255 D9255 OR<> D9255 D9255 AND<> D9255 D9255	
LD\$> *1 *2 OR\$> *1 *2 AND\$> *1 *2	LD> D9255 D9255 OR> D9255 D9255 AND> D9255 D9255	
LD\$>= *1 *2 OR\$>= *1 *2 AND\$>= *1 *2	LD>= D9255 D9255 OR>= D9255 D9255 AND>= D9255 D9255	
LD\$< *1 *2 OR\$< *1 *2 AND\$< *1 *2	LD< D9255 D9255 OR< D9255 D9255 AND< D9255 D9255	
LD\$<= *1 *2 OR\$<= *1 *2 AND\$<= *1 *2	LD<= D9255 D9255 OR<= D9255 D9255 AND<= D9255 D9255	

Converting Q/QnA series instructions to A series instructions (continued)

Q/QnA Series	A Series	
	Common Instructions	Dedicated Instructions (for AnA, AnUCPU)
BKCMPE *1 *2 *3 *4	OUT M9255	
BKCMPE<> *1 *2 *3 *4	OUT M9255	
BKCMPE> *1 *2 *3 *4	OUT M9255	
BKCMPE>= *1 *2 *3 *4	OUT M9255	
BKCMPE< *1 *2 *3 *4	OUT M9255	
BKCMPE<= *1 *2 *3 *4	OUT M9255	
E+ *1 *2	OUT M9255	
E+ *1 *2 *3	OUT M9255	LEDA/LEDB ADD LEDC *1 LEDC *2 LEDC *3 LEDR
E- *1 *2	OUT M9255	
E- *1 *2 *3	OUT M9255	LEDA/LEDB SUB LEDC *1 LEDC *2 LEDC *3 LEDR
E* *1 *2 *3	OUT M9255	LEDA/LEDB MUL LEDC *1 LEDC *2 LEDC *3 LEDR
E/ *1 *2 *3	OUT M9255	LEDA/LEDB DIV LEDC *1 LEDC *2 LEDC *3 LEDR
\$+ *1 *2	OUT M9255	
\$+ *1 *2 *3	OUT M9255	LEDA/LEDB SADD LEDC *1 LEDC *2 LEDC *3 LEDR
BK+ *1 *2 *3 *4	OUT M9255	
BK- *1 *2 *3 *4	OUT M9255	
INT *1 *2	OUT M9255	LEDA/LEDB INT LEDC *1 LEDC *2 LEDR
DINT *1 *2	OUT M9255	LEDA/LEDB DINT LEDC *1 LEDC *2 LEDR

Converting Q/QnA series instructions to A series instructions (continued)

Q/QnA Series	A Series	
	Common Instructions	Dedicated Instructions (for AnA, AnUCPU)
FLT *1 *2	OUT M9255	LEDA/LEDB FLOAT LEDC/SUB *1 LEDC *2 LEDR
DFLT *1 *2	OUT M9255	LEDA/LEDB DFLOAT LEDC/DXNR *1 LEDC *2 LEDR
DBL *1 *2	OUT M9255	
WORD *1 *2	OUT M9255	
GRY *1 *2	OUT M9255	
DGRY *1 *2	OUT M9255	
GBIN *1 *2	OUT M9255	
DGBIN *1 *2	OUT M9255	
DNEG *1	OUT M9255	
ENEG *1	OUT M9255	
BKBCD *1 *2 *3	OUT M9255	
BKBIN *1 *2 *3	OUT M9255	
EMOV *1 *2	OUT M9255	
\$MOV *1 *2	OUT M9255	LEDA/LEDB SMOV LEDC *1 LEDC *2 LEDR
BXCH *1 *2	OUT M9255	
SWAP *1	OUT M9255	LEDA/LEDB SWAP LEDC *1 LEDR
GOEND	OUT M9255	
RFS *1 *2	OUT M9255	
DAND *1 *2 *3	OUT M9255	
DOR *1 *2 *3	OUT M9255	
DXOR *1 *2 *3	OUT M9255	
DXNR *1 *2 *3	OUT M9255	
BKAND *1 *2 *3 *4	OUT M9255	
BKOR *1 *2 *3 *4	OUT M9255	
BKXOR *1 *2 *3 *4	OUT M9255	
BKXNR *1 *2 *3 *4	OUT M9255	
TEST *1 *2 *3	OUT M9255	LEDA/LEDB TEST LEDC *1 LEDC/SUB *2 LEDC *3 LEDR

Converting Q/QnA series instructions to A series instructions (continued)

Q/QnA Series	A Series	
	Common Instructions	Dedicated Instructions (for AnA, AnUCPU)
DTEST *1 *2 *3	OUT M9255	LEDA/LEDB DTEST LEDC *1 LEDC/SUB *2 LEDC *3 LEDR
BKRST *1 *2	OUT M9255	
DSER *1 *2 *3 *4	OUT M9255	LEDA/LEDB DSER LEDC *1 LEDC *2 LEDC/SUB *4 LEDR
NDIS *1 *2 *3	OUT M9255	LEDA/LEDB DIS LEDC *1 LEDC *2 LEDC *3 LEDR
NUNI *1 *2 *3	OUT M9255	LEDA/LEDB UNI LEDC *1 LEDC *2 LEDC *3 LEDR
WTOB *1 *2 *3	OUT M9255	LEDA/LEDB WTOB LEDC *1 LEDC *2 LEDC/SUB *3 LEDR
BTOW *1 *2 *3	OUT M9255	LEDA/LEDB BTOW LEDC *1 LEDC *2 LEDC/SUB *3 LEDR
MAX *1 *2 *3	OUT M9255	
DMAX *1 *2 *3	OUT M9255	
MIN *1 *2 *3	OUT M9255	
DMIN *1 *2 *3	OUT M9255	
SORT *1 *2 *3 *4 *5	OUT M9255	
DSORT *1 *2 *3 *4 *5	OUT M9255	
WSUM *1 *2 *3	OUT M9255	
DWSUM *1 *2 *3	OUT M9255	
BREAK *1 *2	OUT M9255	
CALL *1 *2	OUT M9255	
CALL *1 *2 *3	OUT M9255	
CALL *1 *2 *3 *4	OUT M9255	
CALL *1 *2 *3 *4 *5	OUT M9255	

Converting Q/QnA series instructions to A series instructions (continued)

Q/QnA Series	A Series	
	Common Instructions	Dedicated Instructions (for AnA, AnUCPU)
CALL *1 *2 *3 *4 *5 *6	OUT M9255	
FCALL *1	OUT M9255	
FCALL *1 *2	OUT M9255	
FCALL *1 *2 *3	OUT M9255	
FCALL *1 *2 *3 *4	OUT M9255	
FCALL *1 *2 *3 *4 *5	OUT M9255	
FCALL *1 *2 *3 *4 *5 *6	OUT M9255	
ECALL *1 *2	OUT M9255	
ECALL *1 *2 *3	OUT M9255	
ECALL *1 *2 *3 *4	OUT M9255	
ECALL *1 *2 *3 *4 *5	OUT M9255	
ECALL *1 *2 *3 *4 *5 *6	OUT M9255	
ECALL *1 *2 *3 *4 *5 *6 *7	OUT M9255	
EFCALL *1 *2	OUT M9255	
EFCALL *1 *2 *3	OUT M9255	
EFCALL *1 *2 *3 *4	OUT M9255	
EFCALL *1 *2 *3 *4 *5	OUT M9255	
EFCALL *1 *2 *3 *4 *5 *6	OUT M9255	
EFCALL *1 *2 *3 *4 *5 *6 *7	OUT M9255	
IXSET *1 *2	OUT M9255	
FPOP *1 *2	OUT M9255	
FINS *1 *2 *3	OUT M9255	
FDEL *1 *2 *3	OUT M9255	
CHKST	OUT M9255	
CHK	OUT M9255	
CHKCIR	OUT M9255	
CHKEND	OUT M9255	
PTRA	OUT M9255	
PTRAR	OUT M9255	
PTRAEXE	OUT M9255	
BINDA *1 *2	OUT M9255	LEDA/LEDB BINDA LEDC/SUB *1 LEDC *2 LEDR
DBINDA *1 *2	OUT M9255	LEDA/LEDB DBINDA LEDC/DXNR *1 LEDC *2 LEDR
BINHA *1 *2	OUT M9255	LEDA/LEDB BINHA LEDC/SUB *1 LEDC *2 LEDR

Converting Q/QnA series instructions to A series instructions (continued)

Q/QnA Series	A Series	
	Common Instructions	Dedicated Instructions (for AnA, AnUCPU)
DBINHA *1 *2	OUT M9255	LEDA/LEDB DBINHA LEDC/DXNR *1 LEDC *2 LEDR
BCDDA *1 *2	OUT M9255	LEDA/LEDB BCDDA LEDC/SUB *1 LEDC *2 LEDR
DBCDDA *1 *2	OUT M9255	LEDA/LEDB DBCDDA LEDC/DXNR *1 LEDC *2 LEDR
DABIN *1 *2	OUT M9255	LEDA/LEDB DABIN LEDC *1 LEDC *2 LEDR
DDABIN *1 *2	OUT M9255	LEDA/LEDB DDABIN LEDC *1 LEDC *2 LEDR
HABIN *1 *2	OUT M9255	LEDA/LEDB HABIN LEDC *1 LEDC *2 LEDR
DHABIN *1 *2	OUT M9255	LEDA/LEDB DHABIN LEDC *1 LEDC *2 LEDR
DABCD *1 *2	OUT M9255	LEDA/LEDB DABCD LEDC *1 LEDC *2 LEDR
DDABCD *1 *2	OUT M9255	LEDA/LEDB DDABCD LEDC *1 LEDC *2 LEDR
COMRD *1 *2	OUT M9255	LEDA/LEDB COMRD LEDC *1 LEDC *2 LEDR

Converting Q/QnA series instructions to A series instructions (continued)

Q/QnA Series	A Series	
	Common Instructions	Dedicated Instructions (for AnA, AnUCPU)
LEN *1 *2	OUT M9255	LEDA/LEDB LEN LEDC *1 LEDC *2 LEDR
STR *1 *2 *3	OUT M9255	LEDA/LEDB STR LEDC *1 LEDC/SUB *2 LEDC *3 LEDR
DSTR *1 *2 *3	OUT M9255	LEDA/LEDB DSTR LEDC *1 LEDC/DXNR *2 LEDC *3 LEDR
VAL *1 *2 *3	OUT M9255	LEDA/LEDB VAL LEDC *1 LEDC *2 LEDC *3 LEDR
DVAL *1 *2 *3	OUT M9255	LEDA/LEDB DVAL LEDC *1 LEDC *2 LEDC *3 LEDR
ESTR *1 *2 *3	OUT M9255	
EVAL *1 *2	OUT M9255	
ASC *1 *2 *3	OUT M9255	LEDA/LEDB ASC LEDC *1 LEDC *2 LEDC/SUB *3 LEDR
HEX *1 *2 *3	OUT M9255	LEDA/LEDB HEX LEDC *1 LEDC *2 LEDC/SUB *3 LEDR
RIGHT *1 *2 *3	OUT M9255	
LEFT *1 *2 *3	OUT M9255	
MIDR *1 *2 *3	OUT M9255	
MIDW *1 *2 *3	OUT M9255	
INSTR *1 *2 *3 *4	OUT M9255	
EMOD *1 *2 *3	OUT M9255	
EREXP *1 *2 *3	OUT M9255	

Converting Q/QnA series instructions to A series instructions (continued)

Q/QnA Series	A Series	
	Common Instructions	Dedicated Instructions (for AnA, AnUCPU)
SIN *1 *2	OUT M9255	LEDA/LEDB SIN LEDC *1 LEDC *2 LEDR
COS *1 *2	OUT M9255	LEDA/LEDB COS LEDC *1 LEDC *2 LEDR
TAN *1 *2	OUT M9255	LEDA/LEDB TAN LEDC *1 LEDC *2 LEDR
ASIN *1 *2	OUT M9255	LEDA/LEDB ASIN LEDC *1 LEDC *2 LEDR
ACOS *1 *2	OUT M9255	LEDA/LEDB ACOS LEDC *1 LEDC *2 LEDR
ATAN *1 *2	OUT M9255	LEDA/LEDB ATAN LEDC *1 LEDC *2 LEDR
RAD *1 *2	OUT M9255	LEDA/LEDB RAD LEDC *1 LEDC *2 LEDR
DEG *1 *2	OUT M9255	LEDA/LEDB DEG LEDC *1 LEDC *2 LEDR
SQR *1 *2	OUT M9255	LEDA/LEDB SQR LEDC *1 LEDC *2 LEDR
EXP *1 *2	OUT M9255	LEDA/LEDB EXP LEDC *1 LEDC *2 LEDR

Converting Q/QnA series instructions to A series instructions (continued)

Q/QnA Series	A Series	
	Common Instructions	Dedicated Instructions (for AnA, AnUCPU)
LOG *1 *2	OUT M9255	LEDA/LEDB LOG LEDC *1 LEDC *2 LEDR
BSQR *1 *2	OUT M9255	LEDA/LEDB BSQR LEDC/SUB *1 LEDC *2 LEDR
BDSQR *1 *2	OUT M9255	LEDA/LEDB BDSQR LEDC/DXNR *1 LEDC *2 LEDR
BSIN *1 *2	OUT M9255	LEDA/LEDB BSIN LEDC/SUB *1 LEDC *2 LEDR
BCOS *1 *2	OUT M9255	LEDA/LEDB BCOS LEDC/SUB *1 LEDC *2 LEDR
BTAN *1 *2	OUT M9255	LEDA/LEDB BTAN LEDC/SUB *1 LEDC *2 LEDR
BASIN *1 *2	OUT M9255	LEDA/LEDB BASIN LEDC *1 LEDC *2 LEDR
BACOS *1 *2	OUT M9255	LEDA/LEDB BACOS LEDC *1 LEDC *2 LEDR
BATAN *1 *2	OUT M9255	LEDA/LEDB BATAN LEDC *1 LEDC *2 LEDR
LIMIT *1 *2 *3 *4	OUT M9255	LEDA/LEDB LIMIT LEDC/SUB *1 LEDC/SUB *2 LEDC/SUB *3 LEDC *4 LEDR

Converting Q/QnA series instructions to A series instructions (continued)

Q/QnA Series	A Series	
	Common Instructions	Dedicated Instructions (for AnA, AnUCPU)
DLIMIT *1 *2 *3 *4	OUT M9255	LEDA/LEDB DLIMIT LEDC/DXNR *1 LEDC/DXNR *2 LEDC/DXNR *3 LEDC *4 LEDR
BAND *1 *2 *3 *4	OUT M9255	LEDA/LEDB BAND LEDC/SUB *1 LEDC/SUB *2 LEDC/SUB *3 LEDC *4 LEDR
DBAND *1 *2 *3 *4	OUT M9255	LEDA/LEDB DBAND LEDC/DXNR *1 LEDC/DXNR *2 LEDC/DXNR *3 LEDC *4 LEDR
ZONE *1 *2 *3 *4	OUT M9255	LEDA/LEDB ZONE LEDC/SUB *1 LEDC/SUB *2 LEDC/SUB *3 LEDC *4 LEDR
DZONE *1 *2 *3 *4	OUT M9255	LEDA/LEDB DZONE LEDC/DXNR *1 LEDC/DXNR *2 LEDC/DXNR *3 LEDC *4 LEDR
RSET *1	OUT M9255	
QDRSET *1	OUT M9255	
QCDSET *1	OUT M9255	
DATERD *1	OUT M9255	LEDA/LEDB DATERD LEDC *1 LEDR
DATEWR *1	OUT M9255	LEDA/LEDB DATEWR LEDC *1 LEDR
DATE+ *1 *2 *3	OUT M9255	
DATE- *1 *2 *3	OUT M9255	
SECOND *1 *2	OUT M9255	
HOUR *1 *2	OUT M9255	

Converting Q/QnA series instructions to A series instructions (continued)

Q/QnA Series	A Series	
	Common Instructions	Dedicated Instructions (for AnA, AnUCPU)
PIDINIT *1	OUT M9255	LEDA/LEDB PIDINIT LEDC *1 LEDR
PIDCONT *1	OUT M9255	LEDA PIDCONT LEDC *1 LEDR
PID57 *1 *2 *3	OUT M9255	LEDA PID57 SUB *1 LEDC/SUB *2 LEDC *3 LEDR
PIDSTOP *1	OUT M9255	
PIDRUN *1	OUT M9255	
PIDPRMW *1 *2	OUT M9255	
MSG *1	OUT M9255	
PKEY *1	OUT M9255	
PSTOP *1	OUT M9255	
POFF *1	OUT M9255	
PSCAN *1	OUT M9255	
PLOW *1	OUT M9255	
ZRRDB *1 *2	OUT M9255	
ZRWRB *1 *2	OUT M9255	
ADRSET *1 *2	OUT M9255	
KEY *1 *2 *3 *4	OUT M9255	LEDA KEY LEDC *1 LEDC *2 LEDC *3 LEDC *4 LEDR
UDCNT1 *1 *2 *3	OUT M9255	
UDCNT2 *1 *2 *3	OUT M9255	
TTMR *1 *2	OUT M9255	
STMR *1 *2 *3	OUT M9255	
ROTC *1 *2 *3 *4	OUT M9255	
RAMP *1 *2 *3 *4 *5	OUT M9255	
SPD *1 *2 *3	OUT M9255	
PLSY *1 *2 *3	OUT M9255	
PWM *1 *2 *3	OUT M9255	
MTR *1 *2 *3 *4	OUT M9255	
IMASK *1	OUT M9255	
IX *1	OUT M9255	
IXEND	OUT M9255	

Converting Q/QnA series instructions to A series instructions (continued)

Q/QnA Series	A Series	
	Common Instructions	Dedicated Instructions (for AnA, AnUCPU)
IXDEV	OUT M9255	
S. ****	OUT M9255	
Z. ****	OUT M9255	
G. ****	OUT M9255	
J. ****	OUT M9255	

12.2 A Instruction Conversion List for FX Series Conversions

A	Q/QnA	FX
○	×	○

The rules for device and instruction conversions when performing A ↔ FX conversions are given here.

For instructions that cannot be converted, make a correction after instruction conversion by referring to the lists.

The instruction conversion list for conversions from A to FX is given in pages 72 to 77.

The instruction conversion list for conversions from FX to A is given in pages 78 to 84.

The indications *1, *2, *3, *4, *5, *6, and *7 in the lists refer to sources and destinations.

Device correspondence table for A → FX conversions

A Series	FX Series	Remarks
M	M	
M9000 to	M8255	
L	M8255	
F	M8255	
S	S	
X	X	The hexadecimal input numbers of the "A" series are condensed as octal numbers headed by X0 for the FX series
Y	Y	The hexadecimal input numbers of the "A" series are condensed as octal numbers headed by X0 for the FX series
B	M8255	
D	D	
D9000 to	D8255	
A0□1	D8255	
R	D1000 to	
W	D8000 to	
T	T	
C	C	
Z, Z1 to Z6	Z, Z1 to Z6	
172.16.	V, V1 to V6	
P	P	If out-of-range, the instruction becomes OUT M8255
I	I	If out-of-range, the instruction becomes OUT M8255
N	N	If out-of-range, the instruction becomes OUT M8255
K	K	
H	H	
" "	" "	
Z, Z1 to Z6	Z, Z1 to Z6	
K	K	
V, V1 to V6	V, V1 to V6	

Devices that contain out-of-range device parts or extension parts are changed to M8255 if bits and D8255 if words.

Converting A series to FX series

A Series	FX Series	Remarks
NOP	NOP	
LD *1	LD *1	
LDI *1	LDI *1	
OR *1	OR *1	
ORI *1	ORI *1	
AND *1	AND *1	
ANI *1	ANI *1	
ORB	ORB	
ANB	ANB	
MPS	MPS	
MRD	MRD	
MPP	MPP	
OUT *1	OUT *1	
OUT T/C* *2	OUT T/C* *2	
SET *1	SET *1	
RST *1	RST *1	
PLS *1	PLS *1	
PLF *1	PLF *1	
SFT *1	OUT M8255	
SFTP *1	OUT M8255	
MC *1 *2	MC *1 *2	
STOP	OUT M8255	
MCR *1	MCR *1	
FEND	FEND	
END	END	
NOPLF	OUT M8255	
P*,I*	P*,I*	
LD= *1 *2	LD= *1 *2	For models other than FX1S, FX1N, FX2N(C): LD/OR/AND M8255
OR= *1 *2	OR= *1 *2	
AND= *1 *2	AND= *1 *2	
LD<> *1 *2	LD<> *1 *2	For models other than FX1S, FX1N, FX2N(C): LD/OR/AND M8255
OR<> *1 *2	OR<> *1 *2	
AND<> *1 *2	AND<> *1 *2	
LD> *1 *2	LD> *1 *2	For models other than FX1S, FX1N, FX2N(C): LD/OR/AND M8255
OR> *1 *2	OR> *1 *2	
AND> *1 *2	AND> *1 *2	
LD>= *1 *2	LD>= *1 *2	For models other than FX1S, FX1N, FX2N(C): LD/OR/AND M8255
OR>= *1 *2	OR>= *1 *2	
AND>= *1 *2	AND>= *1 *2	
LD< *1 *2	LD< *1 *2	For models other than FX1S, FX1N, FX2N(C): LD/OR/AND M8255
OR< *1 *2	OR< *1 *2	
AND< *1 *2	AND< *1 *2	

(continued on next page)

A Series	FX Series	Remarks
LD<= *1 *2	LD<= *1 *2	
OR<= *1 *2	OR<= *1 *2	For models other than FX1S, FX1N, FX2N(C):
AND<= *1 *2	AND<= *1 *2	LD/OR/AND M8255
LDD= *1 *2	LDD= *1 *2	
ORD= *1 *2	ORD= *1 *2	For models other than FX1S, FX1N, FX2N(C):
ANDD= *1 *2	ANDD= *1 *2	LD/OR/AND M8255
LDD<> *1 *2	LDD<> *1 *2	
ORD<> *1 *2	ORD<> *1 *2	For models other than FX1S, FX1N, FX2N(C):
ANDD<> *1 *2	ANDD<> *1 *2	LD/OR/AND M8255
LDD> *1 *2	LDD> *1 *2	
ORD> *1 *2	ORD> *1 *2	For models other than FX1S, FX1N, FX2N(C):
ANDD> *1 *2	ANDD> *1 *2	LD/OR/AND M8255
LDD>= *1 *2	LDD>= *1 *2	
ORD>= *1 *2	ORD>= *1 *2	For models other than FX1S, FX1N, FX2N(C):
ANDD>= *1 *2	ANDD>= *1 *2	LD/OR/AND M8255
LDD< *1 *2	LDD< *1 *2	
ORD< *1 *2	ORD< *1 *2	For models other than FX1S, FX1N, FX2N(C):
ANDD< *1 *2	ANDD< *1 *2	LD/OR/AND M8255
LDD<= *1 *2	LDD<= *1 *2	
ORD<= *1 *2	ORD<= *1 *2	For models other than FX1S, FX1N, FX2N(C):
ANDD<= *1 *2	ANDD<= *1 *2	LD/OR/AND M8255
+ *1 *2	ADD *1 *2 D8255	
+ *1 *2 *3	ADD *1 *2 *3	
- *1 *2	SUB *1 *2 D8255	
- *1 *2 *3	SUB *1 *2 *3	
D+ *1 *2	DADD *1 *2 D8255	
D+ *1 *2 *3	DADD *1 *2 *3	
D- *1 *2	DSUB *1 *2 D8255	
D- *1 *2 *3	DSUB *1 *2 *3	
* *1 *2 *3	MUL *1 *2 *3	
/ *1 *2 *3	DIV *1 *2 *3	
D* *1 *2 *3	DMUL *1 *2 *3	
D/ *1 *2 *3	DDIV *1 *2 *3	
B+ *1 *2	OUT M8255	
B+ *1 *2 *3	OUT M8255	
B- *1 *2	OUT M8255	
B- *1 *2 *3	OUT M8255	
DB+ *1 *2	OUT M8255	
DB+ *1 *2 *3	OUT M8255	
DB- *1 *2	OUT M8255	
DB- *1 *2 *3	OUT M8255	
B* *1 *2 *3	OUT M8255	
B/ *1 *2 *3	OUT M8255	

(continued on next page)

A Series	FX Series	Remarks
DB* *1 *2 *3	OUT M8255	
DB/ *1 *2 *3	OUT M8255	
INC *1	INC *1	
DINC *1	DINC *1	
DEC *1	DEC *1	
DDEC *1	DDEC *1	
BCD *1 *2	BCD *1 *2	
DBCD *1 *2	DBCD *1 *2	
BIN *1 *2	BIN *1 *2	
DBIN *1 *2	DBIN *1 *2	
NEG *1	NEG *1	FX _{1N} , FX _{1S} , FX ₁ , FX _{0N} , FX ₀ : OUT M8255
MOV *1 *2	MOV *1 *2	
DMOV *1 *2	DMOV *1 *2	
CML *1 *2	CML *1 *2	For FX _{1N} , FX _{1S} , FX ₁ , FX _{0N} , FX ₀ : OUT M8255
DCML *1 *2	DCML *1 *2	For FX _{1N} , FX _{1S} , FX ₁ , FX _{0N} , FX ₀ : OUT M8255
BMOV *1 *2 *3	BMOV *1 *2 *3	For FX _{1N} , FX _{1S} , FX ₁ , FX ₀ : M8255
FMOV *1 *2 *3	FMOV *1 *2 *3	For FX _{1N} , FX _{1S} , FX ₁ , FX _{0N} , FX ₀ : OUT M8255
XCH *1 *2	XCH *1 *2	For FX _{1N} , FX _{1S} , FX ₁ , FX _{0N} , FX ₀ : OUT M8255
DXCH *1 *2	DXCH *1 *2	For FX _{1N} , FX _{1S} , FX ₁ , FX _{0N} , FX ₀ : OUT M8255
CJ *1	CJ *1	
SCJ *1	CJ *1	
SUB *1	OUT M8255	
CHG	OUT M8255	
WAND *1 *2	WAND *1 *2 D8255	
WAND *1 *2 *3	WAND *1 *2 *3	
WOR *1 *2	WOR *1 *2 D8255	
WOR *1 *2 *3	WOR *1 *2 *3	
WXOR *1 *2	WXOR *1 *2 D8255	
WXOR *1 *2 *3	WXOR *1 *2 *3	
WXNR *1 *2	OUT M8255	
WXNR *1 *2 *3	OUT M8255	
DAND *1 *2	DAND *1 *2 D8255	
DOR *1 *2	DOR *1 *2 D8255	
DXOR *1 *2	DXOR *1 *2 D8255	
DXNR *1 *2	OUT M8255	
ROR *1	ROR D8255 *1	For FX _{1N} , FX _{1S} , FX ₁ , FX _{0N} , FX ₀ : OUT M8255
RCR *1	ROR D8255 *1	For FX _{1N} , FX _{1S} , FX ₁ , FX _{0N} , FX ₀ : OUT M8255
ROL *1	ROL D8255 *1	For FX _{1N} , FX _{1S} , FX ₁ , FX _{0N} , FX ₀ : OUT M8255
RCL *1	RCL D8255 *1	For FX _{1N} , FX _{1S} , FX ₁ , FX _{0N} , FX ₀ : OUT M8255
DROR *1	OUT M8255	
DRCR *1	OUT M8255	
DROL *1	OUT M8255	
DRCL *1	OUT M8255	

(continued on next page)

A Series	FX Series	Remarks
SFR *1 *2	OUT M8255	
SFL *1 *2	OUT M8255	
BSFR *1 *2	OUT M8255	
BSFL *1 *2	OUT M8255	
DSFR *1 *2	OUT M8255	
DSFL *1 *2	OUT M8255	
BSET *1 *2	OUT M8255	
BRST *1 *2	OUT M8255	
DECO *1 *2 *3	DECO *1 *2 *3	
ENCO *1 *2 *3	ENCO *1 *2 *3	
SEG *1 *2	SEGD *1 *2	For FX _{1N} , FX _{1S} , FX ₁ , FX _{0N} , FX ₀ : OUT M8255
DIS *1 *2 *3	OUT M8255	
UNI *1 *2 *3	OUT M8255	
SER *1 *2 *3	SER *1 *2 D8255 *3	For FX _{1N} , FX _{1S} , FX ₁ , FX _{0N} , FX ₀ : OUT M8255
SUM *1	SUM *1 D8255	For FX _{1N} , FX _{1S} , FX ₁ , FX _{0N} , FX ₀ : OUT M8255
DSUM *1	DSUM *1 D8255	For FX _{1N} , FX _{1S} , FX ₁ , FX _{0N} , FX ₀ : OUT M8255
ASC *1 *2	ASC *1 *2	For FX _{1N} , FX _{1S} , FX ₁ , FX _{0N} , FX ₀ : OUT M8255
CALL *1	CALL *1	For FX _{1N} , FX _{1S} , FX _{0N} , FX ₀ : M8255
FIFW *1 *2	OUT M8255	
FIFR *1 *2	OUT M8255	
FROM *1 *2 *3 *4	FROM *1 *2 *3 *4	For FX _{1S} , FX ₁ , FX ₀ : M8255
DFRO *1 *2 *3 *4	DFROM *1 *2 *3 *4	For FX _{1S} , FX ₁ , FX ₀ : M8255
TO *1 *2 *3 *4	TO *1 *2 *3 *4	For FX _{1S} , FX ₁ , FX ₀ : M8255
DTO *1 *2 *3 *4	DTO *1 *2 *3 *4	For FX _{1S} , FX ₁ , FX ₀ : M8255
LRDP *1 *2 *3 *4	OUT M8255	
LWTP *1 *2 *3 *4	OUT M8255	
RFRP *1 *2 *3 *4	OUT M8255	
RTOP *1 *2 *3 *4	OUT M8255	
PR *1 *2	PR *1 *2	For FX _{1N} , FX _{1S} , FX _{0N} , FX ₀ : M8255
PRC *1 *2	OUT M8255	
LED *1	OUT M8255	
LEDC *1	OUT M8255	
LEDR	OUT M8255	
LEDA *1	OUT M8255	
LEDB *1	OUT M8255	
SLT	OUT M8255	
SLTR	OUT M8255	
STRA	OUT M8255	
STRAR	OUT M8255	
WDT	WDT	
DUTY *1 *2 *3	OUT M8255	
CHK *1 *2	OUT M8255	
STC	SET M8022	

(continued on next page)

A Series	FX Series	Remarks
CLC	RST M8022	
JMP *1	CJ *1	
DI	DI	
EI	EI	
IRET	IRET	
FOR *1	FOR *1	
NEXT	NEXT	
RET	SRET	For FX ₁ , FX ₀ : M8255
COM	OUT M8255	

Device correspondence table for FX → A conversions

FX Series	A Series	Remarks
M	M	
M8000 to	M9255	
S	M9255	The octal input numbers of the FX series are condensed as hexadecimal numbers headed by X0 for the "A" series
X	X	The octal input numbers of the FX series are condensed as hexadecimal numbers headed by X0 for the "A" series
Y	Y	
D	D	
D8000 to	D9255	
T	T	
C	C	
Z, Z1 to Z6	Z, Z1 to Z6	
V, V1 to V6	V, V1 to V6	
V7, Z7	D9255	
P	P	If out-of-range, the instruction becomes OUT M9255
I	I	If out-of-range, the instruction becomes OUT M9255
N	N	If out-of-range, the instruction becomes OUT M9255
K	K	
H	H	
""	""	
Z, Z1 to Z6	Z, Z1 to Z6	If the device part is a device that cannot be converted, all devices containing this code become M9255 or D255.
V, V1 to V6	V, V1 to V6	If the device part is a device that cannot be converted, all devices containing this code become M9255 or D255.
V7, Z7	M9255, D9255	All devices containing this code become M9255 or D9255.
K	K	If the device part is a device that cannot be converted, all devices containing this code become M9255 or D255.

Devices that contain out-of-range device parts or extension parts are changed to M9255 if bits and D9255 if words.

Converting FX series to A series

FX Series	A Series	Remarks
NOP	NOP	
LD *1	LD *1	
LDI *1	LDI *1	
LDP *1	LD M9255	
LDF *1	LD M9255	
OR *1	OR *	
ORI *1	ORI *1	
ORP *1	OR M9255	
ORF *1	OR M9255	
AND *1	AND *1	
ANI *1	ANI *1	
ANDP *1	AND M9255	
ANDF *1	AND M9255	
INV	AND M9255	
ORB	ORB	
ANB	ANB	
MPS	MPS	
MRD	MRD	
MPP	MPP	
OUT *1	OUT *1	
OUT T/C0 to 199 *2	OUT T/C *2	
OUT C200 to *2	OUT M9255	32-bit counters are not changed.
SET *1	SET *1	
RST *1	RST *1	
PLS *1	PLS *	
PLF *1	PLF *	
MC *1 *2	MC *1 *2	
MCR *1	MCR *1	
FEND	FEND	
END	END	
P*,I*	P*,I*	
LD= *1 *2	LD= *1 *2	
OR= *1 *2	OR= *1 *2	
AND= *1 *2	AND= *1 *2	
LD<> *1 *2	LD<> *1 *2	
OR<> *1 *2	OR<> *1 *2	
AND<> *1 *2	AND<> *1 *2	
LD> *1 *2	LD> *1 *22	
OR> *1 *2	OR> *1 *2	
AND> *1 *2	AND> *1 *2	
LD>= *1 *2	LD>= *1 *2	
OR>= *1 *2	OR>= *1 *2	
AND>= *1 *2	AND>= *1 *2	

(continued on next page)

FX Series	A Series	Remarks
LD< *1 *2	LD< *1 *2	
OR< *1 *2	OR< *1 *2	
AND< *1 *2	AND< *1 *2	
LD<= *1 *2	LD<= *1 *2	
OR<= *1 *2	OR<= *1 *2	
AND<= *1 *2	AND<= *1 *2	
LDD= *1 *2	LDD= *1 *2	
ORD= *1 *2	ORD= *1 *2	
ANDD= *1 *2	ANDD= *1 *2	
LDD<> *1 *2	LDD<> *1 *2	
ORD<> *1 *2	ORD<> *1 *2	
ANDD<> *1 *2	ANDD<> *1 *2	
LDD> *1 *2	LDD> *1 *2	
ORD> *1 *2	ORD> *1 *2	
ANDD> *1 *2	ANDD> *1 *2	
LDD>= *1 *2	LDD>= *1 *2	
ORD>= *1 *2	ORD>= *1 *2	
ANDD>= *1 *2	ANDD>= *1 *2	
LDD< *1 *2	LDD< *1 *2	
ORD< *1 *2	ORD< *1 *2	
ANDD< *1 *2	ANDD< *1 *2	
LDD<= *1 *2	LDD<= *1 *2	
ORD<= *1 *2	ORD<= *1 *2	
ANDD<= *1 *2	ANDD<= *1 *2	
CMP	OUT M9255	
DCMP	OUT M9255	
ZCP	OUT M9255	
DZCP	OUT M9255	
DECMP	OUT M9255	
DEZCP	OUT M9255	
ADD *1 *2 *2	+ *1 *2 *3	
SUB *1 *2 *2	- *1 *2 *3	
DADD *1 *2 *2	D+ *1 *2 *3	
DSUB *1 *2 *2	D- *1 *2 *3	
MUL *1 *2 *3	* *1 *2 *3	
DIV *1 *2 *3	/ *1 *2 *3	
DMUL *1 *2 *3	D* *1 *2 *3	
DDIV *1 *2 *3	D/ *1 *2 *3	
DEADD *1 *2 *3	OUT M9255	
DESUB *1 *2 *3	OUT M9255	
DEMUL *1 *2 *3	OUT M9255	
DEDIV *1 *2 *3	OUT M9255	
INC *1	INC *1	
DINC *1	DINC *1	

(continued on next page)

FX Series	A Series	Remarks
DEC *1	DEC *1	
DDEC *1	DDEC *1	
BCD *1 *2	BCD *1 *2	
DBCD *1 *2	DBCD *1 *2	
BIN *1 *2	BIN *1 *2	
DBIN *1 *2	DBIN *1 *2	
INT *1 *2	OUT M9255	
DINT *1 *2	OUT M9255	
GRY *1 *2	OUT M9255	
DGRY *1 *2	OUT M9255	
GBIN *1 *2	OUT M9255	
DGBIN *1 *2	OUT M9255	
NEG *1	NEG *1	
DNEG *1	OUT M9255	
DEBCD	OUT M9255	
DEBIN	OUT M9255	
MOV *1 *2	MOV *1 *2	
DMOV *1 *2	DMOV *1 *2	
CML *1 *2	CML *1 *2	
DCML *1 *2	DCML *1 *2	
BMOV *1 *2 *3	BMOV *1 *2 *3	
FMOV *1 *2 *3	FMOV *1 *2 *3	
XCH *1 *2	XCH *1 *2	
DXCH *1 *2	DXCH *1 *2	
SWAP *1	OUT M9255	
SMOV	OUT M9255	
DSWAP *1	OUT M9255	
DFMOV *1 *2 *3	OUT M9255	
CJ *1	CJ *1	
REF	OUT M9255	
REFF	OUT M9255	
HSCS	OUT M9255	
DHSCS	OUT M9255	
HSCR	OUT M9255	
DHSCR	OUT M9255	
HSZ	OUT M9255	
DHSZ	OUT M9255	
WAND *1 *2 *3	WAND *1 *2 *3	
WOR *1 *2 *3	WOR *1 *2 *3	
WXOR *1 *2 *3	WXOR *1 *2 *3	
DAND *1 *2 *3	DAND *1 *2	
DOR *1 *2 *3	DOR *1 *2	
DXOR *1 *2 *3	DXOR *1 *2	

(continued on next page)

FX Series	A Series	Remarks
ROR *1 *2	ROR *2	
RCR *1 *2	RCR *2	
ROL *1 *2	ROL *2	
RCL *1 *2	RCL *2	
DROR *1 *2	DROR *2	
DRCR *1 *2	DRCR *2	
DROL *1 *2	DROL *2	
DRCL *1 *2	DRCL *2	
SFTR *1 *2 *3 *4	OUT M9255	
SFTL *1 *2 *3 *4	OUT M9255	
WSFR *1 *2 *3 *4	OUT M9255	
WSFL *1 *2 *3 *4	OUT M9255	
SFWR *1 *2 *3	OUT M9255	
SFRD *1 *2 *3	OUT M9255	
SER *1 *2 *3 *4	SER *1 *2 *4	
DSER *1 *2 *3 *4	OUT M9255	
DECO *1 *2 *3	DECO *1 *2 *3	
ENCO *1 *2 *3	ENCO *1 *2 *3	
SORT *1 *2 *3 *4 *5	OUT M9255	
ASC *1 *2	ASC *1 *2	
ZRST *1 *2	OUT M9255	
SUM *1 *2	SUM *1	
DSUM *1 *2	DSUM *1	
BON *1 *2 *3	OUT M9255	
DBON *1 *2 *3	OUT M9255	
MEAN *1 *2 *3	OUT M9255	
DMEAN *1 *2 *3	OUT M9255	
ANS *1 *2 *3	OUT M9255	
ANR	OUT M9255	
FLT *1 *2	OUT M9255	
DFLT *1 *2	OUT M9255	
CALL *1	CALL *1	
FROM *1 *2 *3 *4	FROM *1 *2 *3 *4	
DFROM *1 *2 *3 *4	DFRO *1 *2 *3 *4	
TO *1 *2 *3 *4	TO *1 *2 *3 *4	
DTO *1 *2 *3 *4	DTO *1 *2 *3 *4	
PR *1 *2	PR *1 *2	
HEX *1 *2 *3	OUT M9255	
ASCI *1 *2 *3	OUT M9255	
SQR *1 *2	OUT M9255	
DSQR	OUT M9255	
DESQR *1 *2	OUT M9255	

(continued on next page)

FX Series	A Series	Remarks
DSIN *1 *2	OUT M9255	
DCOS *1 *2	OUT M9255	
DTAN *1 *2	OUT M9255	
TCMP	OUT M9255	
TZCP	OUT M9255	
TADD	OUT M9255	
TSUB	OUT M9255	
TRD	OUT M9255	
TWR	OUT M9255	
PID	OUT M9255	
TKY	OUT M9255	
DTKY	OUT M9255	
HKY	OUT M9255	
DHKY	OUT M9255	
DSW	OUT M9255	
SEGD	OUT M9255	
SEGL	OUT M9255	
ARWS	OUT M9255	
RS	OUT M9255	
PRUN	OUT M9255	
DPRUN	OUT M9255	
CCD	OUT M9255	
VRRD	OUT M9255	
VRSC	OUT M9255	
MNET	OUT M9255	
ANRD	OUT M9255	
ANWR	OUT M9255	
RMST	OUT M9255	
RMWR	OUT M9255	
DRMWR	OUT M9255	
RMRD	OUT M9255	
DRMRD	OUT M9255	
RMMN	OUT M9255	
BLK	OUT M9255	
MCDE	OUT M9255	
WDT	WDT	
TTMR	OUT M9255	
STMR	OUT M9255	
ROTC	OUT M9255	
SPD	OUT M9255	
PLSY	OUT M9255	
PWM	OUT M9255	

(continued on next page)

FX Series	A Series	Remarks
MTR	OUT M9255	
DPLSY	OUT M9255	
IST	OUT M9255	
ABSD	OUT M9255	
DABSD	OUT M9255	
INCD	OUT M9255	
ALT	OUT M9255	
RAMP	OUT M9255	
PLSR	OUT M9255	
DPLSR	OUT M9255	
DI	DI	
EI	EI	
IRET	IRET	
SRET	RET	
FOR *1	FOR *1	
NEXT	NEXT	
STL *1	OUT M9255	
RET	OUT M9255	
DABS	OUT M9255	
ZRN	OUT M9255	
DZRN	OUT M9255	
PLSV	OUT M9255	
DPLSV	OUT M9255	
DRVI	OUT M9255	
DDRVI	OUT M9255	
DRVA	OUT M9255	
DDRVA	OUT M9255	
HOUR	OUT M9255	
DHOUR	OUT M9255	
RD3A	OUT M9255	
WR3A	OUT M9255	

12.3 List of Instruction Conversions for Change between Q Series and A/QnA Series

A	Q/QnA	FX
○	○	×

When the PC type is changed from QCPU to ACPU or from QCPU to QnACPU, the instructions added newly to the Q series are all changed into M9255 (A series) or SM1255 (QnA series).

The following instructions have become compatible with the Q series.

Instruction	Description
UNIRD	Reads module information
TRACE	Sets trace
TRACER	Resets trace
S.FWRITE	Writes binary data
S.FREAD	Reads binary data
S.FORMAT	Reads word devices from other PLC
G.READ	
G.SREAD	Writes word devices from other PLC
G.SWRITE	
S.REQ	Transient request from other PLC
GINT	Interrupt instruction from other PLC
PLOAD	Program load from memory card
PUNLOAD	Program unload from SPM
PSWAP	Load + unload
RBMMOV	High-speed file register block transfer

POINT

When the A series is changed to the Q series, any instruction existing in the QnA series but not existing in the Q series is changed as a single line (SM1255). Also, any instruction existing in the A series but not existing in the Q/QnA series is changed as more than one line.

Because of incompatibility with the Q series, the following instructions are changed into SM1255 when the QnA series is changed to the Q series.

	Description	Instruction Name
AD57/A58 control instructions	Display mode setting	G.MCODE
	Canvas screen display	G.CPS
	VRAM display address change	G.CPS1
	Canvas transfer	G.CPS2
	Screen clear	G.CMOV
	VRAM clear	G.CLS
	Scroll up/down	G.CLV
	Cursor display	G.CSCRU, G.CSCRD
	Cursor erasure	G.COFF
	Cursor locating	G.LOCATE
	Normal/reverse display of displayed characters	G.CNOR, G.CREV
	Character color designation	G.COLOR, G.CCDSP, G.CCDSPV
	ASCII character display	G.PRN, G.PR
	ASCII character write	G.PRNV, G.PRV
	Character display	G.EPRN, G.EPRV
	Character write	G.EPRNV, G.EPRV
	Continuous display of the same character	G.CR1, G.CR2, G.CC1, G.CC2
	Minus display	G.CINMP
	Hyphen display	G.CINHP
	Period display	G.CINTP
	Numeric character display	G.CIN0 to G.CIN9
	Alphabetic character display	G.CINA to G.CINZ
	Space display	G.CINP
	Designated field clear	G.CINCLR
	ASCII code conversion	G.INPUT
	VRAM data read	G.GET
	VRAM data write	G.PUT
Display status read	G.STAT	
PID monitor	G.PID57	
AJ71PT32-S3 control instructions	Key input from operation box	G.INPUT
	Data transmission of the specified number of bytes in no-protocol mode	G.PRN
	Data transmission up to 00H code in no-protocol mode	G.PR
	Data receive in no-protocol mode	G.INPUT
	Communication to/from remote terminal module	G.MINI
	Error reset to remote terminal module	G.MINIERR
	Communication status read	G.SPBUSY
	Forced suspension of communication processing	G.SPCLR

	Description	Instruction Name
AJ71C21(S1) control instructions	Data transmission of the specified number of bytes	G.PRN2, G.PRN4
	Data transmission up to 00H	G.PR2, G.PR4
	Data receive	G.INPUT2, G.INPUT4
	Access to RAM memory	G.GET, G.PUT
	Communication status read	G.SPBUSY
	Forced suspension of communication processing	G.SPCLR
AD59(S1) control instructions	Printer output	G.PRN, G.PR
	Data read/write from/to memory card	G.GET, G.PUT
Write to EEPROM	Write to EEPROM	EROMWR
Sampling trace, status latch related instructions	Sampling trace	STRA
	Sampling trace reset	STRAR
	Status latch set	SLT
	Status latch reset	SLTR
Program trace related instructions	Program trace trigger	PTRA
	Program trace reset	PTRAR
	Program trace execution	PTRAEXE
LED indication related instructions	LED indication of ASCII code	LED
	LED indication instruction for comment	LEDC
	LED indication of comment	LEDC

Appendix 13 About the A6TEL/Q6TEL

13.1 A6TEL/Q6TEL Switch Settings

(1) A6TEL

A6TEL right side face

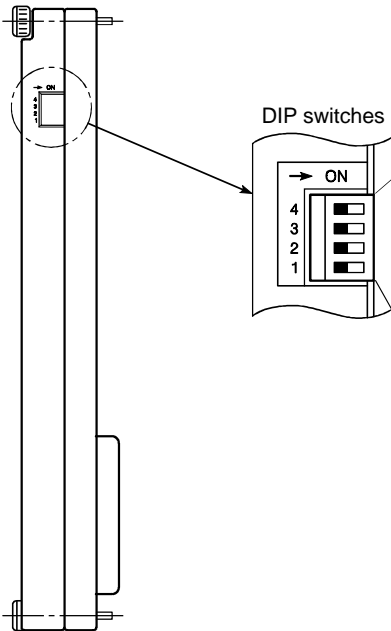

Switch No.	Setting	Description
4	—	Unused (kept in OFF)
3	OFF	Remote access enable mode (when telephone line connection is enabled from peripheral device)
	ON	Remote access disable mode (notice processing may be executed)
2	OFF	Notice processing execution mode
	ON	Proximate connection enable mode
1	OFF	Telephone line connection mode/proximate connection mode
	ON	EEPROM write mode (for initial setting, password, notice data write)

(2) Q6TEL

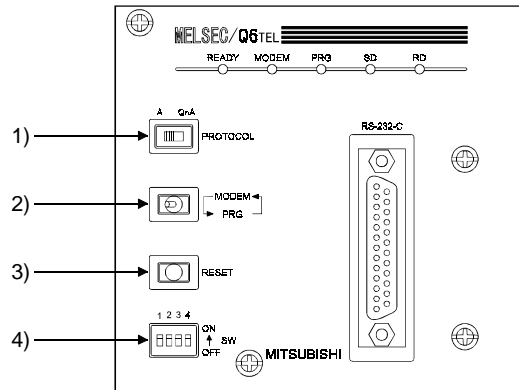

1) A/QnA select switch

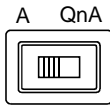

Setting	Description
QnA	When the connected CPU is QnACPU
A	When the connected CPU is ACPU

2) MODEM/PRG select switch

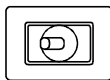

Setting	Description
MODEM/PRG (remote/proximate)	The switch is an alternate switch. The "MODEM" LED is lit to indicate remote access. The "PRG" LED is lit to indicate the proximate connection mode.

3) RESET switch

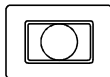

Resets the Q6TEL.

4) DIP switches

The following table explains the DIP switches for QnACPU access.

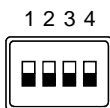

Switch No.	Setting	Description
1	OFF	Telephone line connection mode/GPP function (proximate connection mode)
	ON	Q6TEL data (E2PROM write) setting mode (for initial setting, password, notice data write)
2	—	—
3	—	—
4	—	—

Note: When "A" is selected with the A/QnA select switch, the description is the same as that of the DIP switches of the A6TEL.

The following table explains the DIP switch for ACPU access.

Switch No.	Setting	Description
1	OFF	Telephone line connection mode/proximate connection mode
	ON	A6TEL data (E ² PROM write) setting mode (for initial setting, password, notice data write)
2	OFF	Notice processing execution mode (also set DIP switch 1 to OFF)
	ON	Proximate connection mode
3	OFF	Remote access enable mode (when telephone line connection from A7PHP/LM series is enabled)
	ON	Remote access disable mode (notice processing may be executed)
4	—	Unused (keep in OFF)

[Q6TL's DIP switch settings] (for ACPU access)

Switch No.	Remote Access	Notice Processing	E ² PROM Mode	Proximate Connection
1	OFF	OFF	ON	OFF
2	OFF	OFF	ON/OFF	ON
3	OFF	ON/OFF	ON/OFF	ON/OFF
4	OFF			

ON/OFF indicates that the corresponding switch may either be ON or OFF.

13.2 How to Change the Proximate Mode of the Q6TEL

This section gives the way to choose the proximate connection mode with the Q6TEL fitted to the PLC CPU.

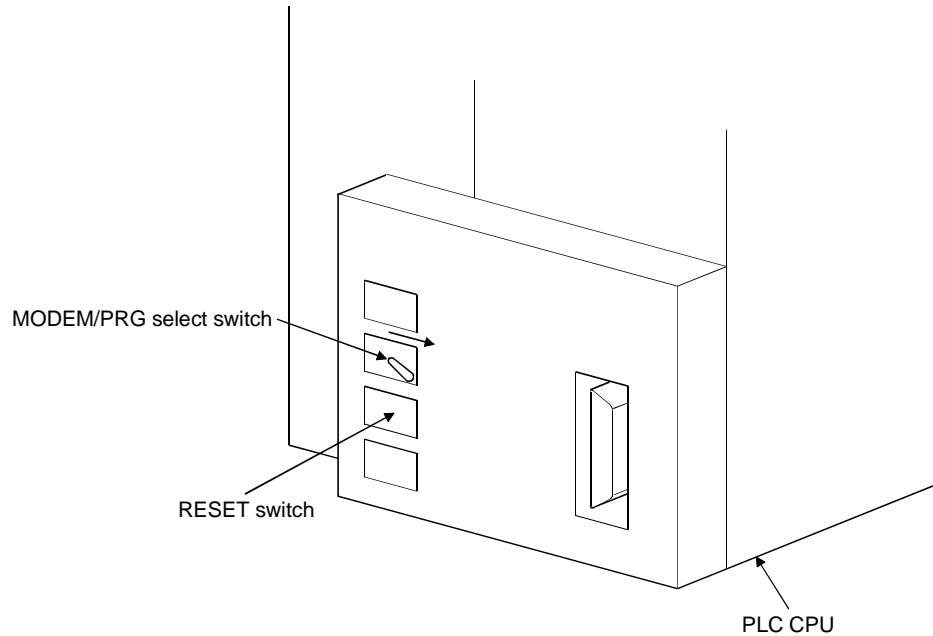

Operation procedure

- 1) Hold the MODEM/PRG select switch in the right position and press the RESET switch.
- 2) Release only the RESET switch.
- 3) After making sure that the "READY" LED and "PRG" LED are lit (about 3 seconds until they turn on), release the MODEM/PRG select switch.
This operation selects the proximate connection mode.

Appendix 14 Functions Added to Update from Previous Version

The following functions which were not available for SW5D5-GPPW were added to SW6D5C-GPPW.

Item	Description
Read from PLC	Merge processing of statements/notes can be performed.
Import file	
Read IC memory card	
Read image data	
Parameters	Remote password can be set.
Print	Product information list can be printed.
Find/replace	Module's first I/O No. can be replaced.
Edit	Statement/note block editing can be performed.
Debug	Forced I/O registration/cancel can be made.
Display color change	Colors of the ladder mode and other screens can be changed.
Connection setup	Access to multiple CPUs can be made. Narrowed-down display can be provided in the connection setup channel list.
Diagnostics	Multi-CPU system monitoring can be performed. Ethernet diagnostics can be made.
Ladder creation	Label programming can be performed. Instruction help can be browsed.
Project	Project can be created for the Q series remote station. (Parameter setting of remote I/O station can be made)
List monitoring	Ladder, SFC (Zoom) and list monitoring can be performed.
Label programming	Program can be created with label names.

Functions added to SW6D5-GPPW-E 6.05F, which were not available in SW6D5-GPPW-E 6.04E, are shown below.

Item	Description	Reference
Label programming	Label programming and actual device information can be displayed simultaneously.	5.1.10
	The program display screen can be split horizontally or vertically (into the label program side and the actual program side).	5.1.10
	The display of label programming and that of actual device program can be synchronized.	5.1.10
	The number of steps in the label program can be differentiated in parentheses from the number of steps in the actual program.	5.1.2
	When converting a program, compiling can be performed at the same time.	5.1.9
Search/replacement	The search target (label program, actual device) can be selected using the Cross reference list.	6.4.14
	The search target (label program, actual device) can be selected using the List of used device.	6.4.16
Parameter	"MELSOFT connection" can be set as an Ethernet parameter.	13.2.3
Online	The Q4ARCPU can be accessed via the Ethernet board.	16.2.2 (2)
Print	Label program or actual device print option can be selected in the circuit/list printing of label programming.	14.5.2 14.5.3
Save project	When specifying the drive/path, space entered at the end of the folder name is deleted.	3.2.1
Display the reference window	The Zoom panel of other transition condition/operating output can be opened without closing the Zoom panel of the currently displayed transition condition/operating output.	SFC 3.13.8

The strings which can not be used in label programming	
W	W,WORD,WORD(P),WORD_TO_BOOL(BYTE,DINT,DWORD,INT,REAL,SINT,UDINT,UINT,USINT),WRITE,WSTRING,X,XCH(P),W_BCD_TO_DINT(INT,SINT)
X	XOR,XORN
Y	Y
Z	Z,ZCOM,ZNRD,ZNRF,ZNTO,ZNWR,ZR

The error may occurred when a string which perfectly matches with the above strings.
But, the error may occurred when of device name contains the hexadecimal characters from 0 to F is after it.

Ex. XFFF, M100

Other points to note regarding the label definition

1. Can not use the space character.
2. Can not use the numerals as the starting character.
3. Can not use the following:

(,)*,/,+,-,<,>,&!,",#,\$,%,'^,|,@,[,],{,},;,:,;,.,,?,\,_

But, in case of underscore character, an error may occurred when it is present at the end or two or more underscore characters are used consecutively

GX Developer Version 6

Operating Manual

MODEL	SW6D5-GPPW-EL-OPE
MODEL CODE	—
IB(NA)-0800134-C(0012)MEE	



HEAD OFFICE : MITSUBISHI DENKI BLDG MARUNOUCHI TOKYO 100-8310 TELEX : J24532 CABLE MELCO TOKYO
NAGOYA WORKS : 1-14 , YADA-MINAMI 5 , HIGASHI-KU, NAGOYA , JAPAN

When exported from Japan, this manual does not require application to the Ministry of International Trade and Industry for service transaction permission.

Specifications subject to change without notice.