

MITSUBISHI

Peripheral Connection Module

User's Manual (Hardware)

AJ65BT-G4-S3

Thank you for buying the Mitsubishi general-purpose programmable controller MELSEC-A Series

Prior to use, please read both this manual and detailed manual thoroughly and familiarize yourself with the product.



MODEL	AJ65BTG4S3-U-HW
MODEL CODE	13JT07
IB(NA)-0800137-C(0901)MEE	

● SAFETY PRECAUTIONS ●

(Always read these instructions before using this equipment.)

Before using this product, please read this manual and the relevant manuals introduced in this manual carefully and pay full attention to safety to handle the product correctly. The instructions given in this manual are concerned with this product. For the safety instructions of the programmable controller system, please read the CPU module user's manual. In this manual, the safety instructions are ranked as "DANGER" and "CAUTION".



DANGER

Indicates that incorrect handling may cause hazardous conditions, resulting in death or severe injury.



CAUTION

Indicates that incorrect handling may cause hazardous conditions, resulting in medium or slight personal injury or physical damage.

Note that the  CAUTION level may lead to a serious consequence according to the circumstances.

Always follow the instructions of both levels because they are important to personal safety.

Please save this manual to make it accessible when required and always forward it to the end user.

[Design Precautions]

DANGER

- When using the peripheral device for the online operation of the running programmable controller (e.g. data change, forced output, program change or operating status change (remote RUN/STOP etc.)), establish an interlock circuit outside the programmable controller system so that the whole system always operates on the safe side. Also, the user should determine corrective and other actions to be taken when a data communication error occurs between the peripheral device and programmable controller.

CAUTION

- Do not bunch the control wires or communication cables with the main circuit or power wires, or install them close to each other. They should be installed 100 mm (3.94 inch) or more from each other. Not doing so could result in noise that would cause erroneous operation.

[Installation Precautions]

CAUTION

- Use the programmable controller in an environment that meets the general specifications contained in the CPU user's manual to use. Using this module in an environment outside the range of the general specifications could result in fire, malfunction, and damage to or deterioration of the product.
- Securely fix the module using the DIN rail or mounting screws and fully tighten the mounting screws within the specified torque range. If the screws are loose, it may result in fallout, short circuits, or malfunctions. Tightening the screw too far may cause damages to the screws and/or the module, resulting in a fallout, short circuits, or malfunctions.
- Do not directly touch the module's conductive parts or electronic components. Touching the conductive parts could cause an operation failure or give damage to the module.

[Wiring Precautions]

DANGER

- Before starting installation or wiring work, be sure to shut off all phases of external power supply used by the system. Not doing so could result in electric shock or damage to the product.
- When switching power on or starting operation after mounting, wiring, operation check or other work, always close the terminal cover. Not doing so can cause a short circuit or misoperation due to module damage or cable connection fault.

CAUTION

- When wiring in the programmable controller, be sure that it is done correctly by checking the product's rated voltage and the terminal layout. Connecting a power supply that is different from the rating or incorrectly wiring the product could result in fire or damage.
- Tighten the terminal screws with the specified torque. If the terminal screws are loose, it could result in short circuits, fire, or erroneous operation. Tightening the terminal screws too far may cause damages to the terminal screws and/or the module, resulting in short circuits, or malfunctions.
- Be sure there are no foreign substances such as sawdust or wiring debris inside the module. Such debris could cause fires, damage, or erroneous operation.

[Wiring Precautions]

CAUTION

- Be sure to ground the FG terminals to the protective ground conductor. Not doing so may cause misoperation.
- Do not install the control lines together with the communication cables, or bring them close to each other. Failure to do so may cause malfunctions due to noise.
- The communication cables and power supply cable connected to the module must be placed in a conduit or fixed with a clamp. Not doing so can damage the module or cables due to dangling, moved or accidentally pulled cables or can cause misoperation due to cable contact failure.
- Do not grab on the cable when removing the communication or power cable connected to the module. When removing the cable with a connector, hold the connector on the side that is connected to the module. When disconnecting a cable without a connector, first loosen the screws on the part that is connected to the module. Pulling the cable when it is still connected to the module may cause damage to the module or cable, or misoperation due to cable contact failure.
- Before connecting the cables, check the type of interface to be connected. Do not connect the cables to the equipment of different interface specifications. It can cause the module to fail.
- Perform correct pressure-displacement, crimp-contact or soldering for wire connections using the tools specified by the manufactures. Attach connectors to the module securely. Doing so could cause malfunction or failure in the module.

REVISIONS

* The manual number is given on the bottom right of the front cover.

Print Date	* Manual Number	Revision
Sep., 2000	IB (NA)-0800137-A	First edition
Jul., 2006	IB (NA)-0800137-B	Partial Correction SAFETY PRECAUTIONS, Conformation to the EMC Directive and Low Voltage Instruction, Chapter 1, Section 2.1, 2.2, 3.1, Chapter 4, 5
Jan., 2009	IB (NA)-0800137-C	Partial Correction SAFETY PRECAUTIONS, Compliance with the EMC and Low Voltage Directives, Section 2.1

This manual confers no industrial property rights or any rights of any other kind, nor does it confer any patent licenses. Mitsubishi Electric Corporation cannot be held responsible for any problems involving industrial property rights which may occur as a result of using the contents noted in this manual.

CONTENTS

1. OVERVIEW	1
2. SPECIFICATIONS	1
2.1 General Specifications	1
2.2 Performance Specifications	2
3. LOADING AND INSTALLATION	3
3.1 Handling Instructions.....	3
3.2 Installation Environment.....	3
4. NAMES OF THE PARTS AND THEIR SETTINGS	3
5. EXTERNAL WIRING.....	6
6. EXTERNAL DIMENSIONS	6

ABOUT MANUAL

The following manual is also related to this product.
In necessary, order it by quoting the details in the table below.

Detailed manual

Manual name	Manual number (Model code)
AJ65BT-G4-S3 Peripheral Connection Module User's Manual	SH-080105 (13JR17)

Compliance with the EMC and Low Voltage Directives

(1) For programmable controller system

To configure a system meeting the requirements of the EMC and Low Voltage Directives when incorporating the Mitsubishi programmable controller (EMC and Low Voltage Directives compliant) into other machinery or equipment, refer to the "EMC AND LOW VOLTAGE DIRECTIVES" chapter of the User's Manual for the CPU module used. The CE mark, indicating compliance with the EMC and Low Voltage Directives, is printed on the rating plate of the programmable controller.

(2) For the product

For the compliance of this product with the EMC and Low Voltage Directives, refer to the "CC-Link module" section in the "EMC AND LOW VOLTAGE DIRECTIVES" chapter of the User's Manual for the CPU module used.

1. OVERVIEW

This manual provides the specifications, handling instructions and other information of the AJ65BT-G4-S3 peripheral connection module (hereafter abbreviated to the G4-S3) used in a CC-Link system.

After unpacking the module, confirm that any of the following products is enclosed.

Model name	Product name	Quantity
AJ65BT-G4-S3	AJ65BT-G4-S3 peripheral connection module	1

2. SPECIFICATIONS

The following table shows the specifications of the G4-S3.

2.1 General Specifications

Item	Specifications					
Operating ambient temperature	0 to 50 °C					
Storage ambient temperature	-20 to 75 °C					
Operating ambient humidity	10 to 90 % RH, non-condensation					
Storage ambient humidity	10 to 90 % RH, non-condensation					
Vibration resistance	Conforming to JIS B 3502, IEC 61131-2	—	Frequency	Acceleration	Amplitude	Sweep count
		Under intermittent vibration	10 to 57Hz	—	0.075mm	10 times each in X, Y and Z directions
			57 to 150Hz	9.8m/s ²	—	
		Under continuous vibration	10 to 57Hz	—	0.035mm	—
57 to 150Hz	4.9m/s ²		—			
Shock resistance	Conforming to JIS B 3502, IEC 61131-2 (147 m/s ² , 3 times in each of 3 directions X, Y, Z)					
Operating ambience *3	No corrosive gases					
Operating altitude	2000m (6562ft.) max.					
Installation location	Inside control panel					
Overvoltage category *1	II max.					
Pollution level *2	2 max.					

*1: This indicates the section of the power supply to which the equipment is assumed to be connected between the public electrical power distribution network and the machinery within premises. Category II applies to equipment for which electrical power is supplied from fixed facilities. The surge voltage withstand level for up to the rated voltage of 300 V is 2500 V.

- *2: This index indicates the degree to which conductive material is generated in terms of the environment in which the equipment is used.
Pollution level 2 is when only non-conductive pollution occurs. A temporary conductivity caused by condensing must be expected occasionally.
- *3: Do not use or store the programmable controller in the environment where the pressure is higher than the atmospheric pressure at sea level.
Otherwise, malfunction may result. To use the programmable controller in high-pressure environment, contact your nearest Mitsubishi representative.

2.2 Performance Specifications

Item	Specifications
RS-422 interface	For connection of peripheral device, 1 channel
CC-Link station type	Intelligent device station
Number of stations occupied	1 station: RX/RY 32 points each RWr/RWw 4 points each
Permissible instantaneous power failure time	1ms
Transmission speed/max. transmission distance	(Refer to Control & Communication Link System Master/Local Module User's Manual.)
Connection cable (for CC-Link)	
Max. number of modules connected	Up to 26
Terminal block	7-pin terminal block (M3.5 × 7screws)
Applicable cable size	0.75 to 2.00mm ²
Applicable crimping terminal	RAV1.25-3, RAV2-3.5 (conforming to JIS C 2805)
Module mounting screws	Screws of M4 × 0.7mm × 16mm or larger DIN rail may also be used for mounting.
Applicable DIN rails	TH35-7.5Fe, TH35-7.5Al, TH35-15Fe (conforming to JIS C 2812)
24VDC internal current consumption	0.19A
Power supply (for module drive)	24VDC (15.6 to 28.8V)
Noise immunity	Measure using a noise simulator of noise voltage 500Vp-p, noise width 1μs and noise frequency 25 to 60Hz.
Insulation resistance	10MΩ or more across all DC external terminals and grounding terminal using a 500VDC insulation resistance tester.
Withstanding voltage	500VAC for 1 minute across all DC external terminals and grounding terminal
Weight	0.36kg
External dimensions	80mm (3.15inch) × 170mm (6.70inch) × 63.5mm (2.50inch)

3. LOADING AND INSTALLATION

3.1 Handling Instructions

This section gives the handling instructions of the G4-S3.

POINT

For handling instructions such as module installation/removal, read ●SAFETY PRECAUTIONS● given at the beginning of this manual.

(1) Tighten the mounting screws of the module within the following ranges.

Screw location	Tightening torque range
Module mounting screw (M4 screw)	0.78 to 1.18N•m
Terminal block terminal screw (M3.5 screw)	0.59 to 0.88N•m
Terminal block mounting screw (M4 screw)	0.78 to 1.18N•m
RS-422 connector mounting screw (M2.6 screw)	0.19 to 0.24N•m

(2) When using the DIN rail adapter, note the following in mounting the DIN rail.

(a) Applicable DIN rail type (conforming to JIS C 2812)

TH35-7.5Fe, TH35-7.5Al, TH35-15Fe

(b) DIN rail mounting screw pitch

When mounting the DIN rail, tighten screws in 200mm(7.88inch) or less pitch.

3.2 Installation Environment

Refer to the user's manual of the CPU module used.

4. NAMES OF THE PARTS AND THEIR SETTINGS

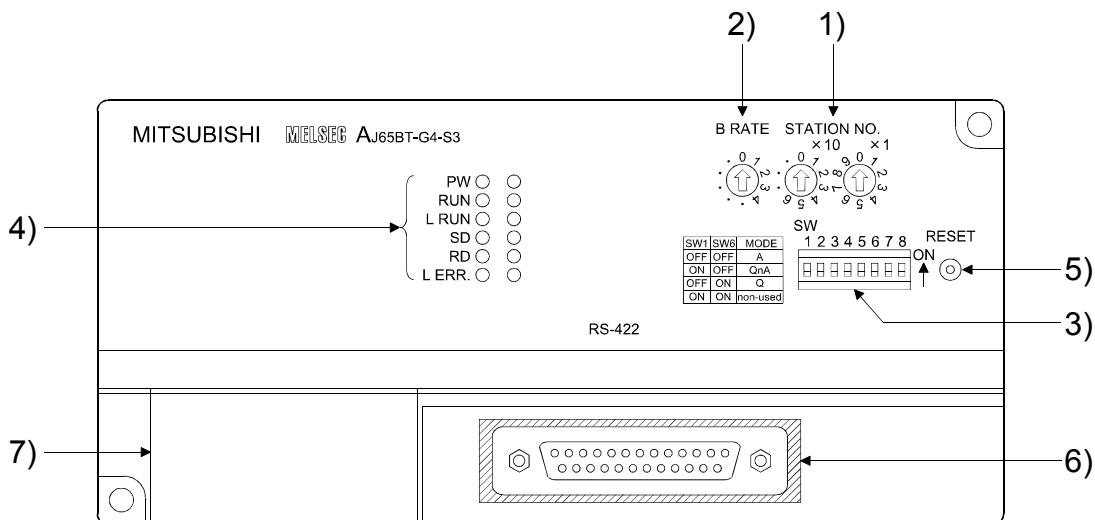

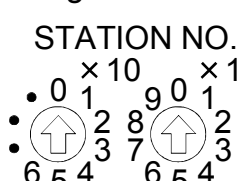
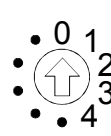
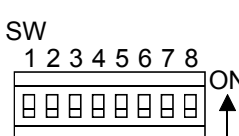
No.	Name	Description																																																																
1)	Station number setting switches STATION NO. 	Set the station number of the G4-S3 within the range 1 to 63 or 1 to 64. (If the station number you set is other than 1 to 64, the L ERR. LED is ON.) Use "x10" to set the station number tens place. Use "x1" to set the station number unit's place. (Factory setting: 00) *1																																																																
2)	Data link transmission speed setting switch B RATE 	Used to set the transmission speed of the G4-S3. (For data link) <table border="1" data-bbox="582 492 1492 840"> <thead> <tr> <th>No. to be set</th> <th>Transmission speed</th> </tr> </thead> <tbody> <tr> <td>0</td> <td>156kbps</td> </tr> <tr> <td>1</td> <td>625kbps</td> </tr> <tr> <td>2</td> <td>2.5Mbps</td> </tr> <tr> <td>3</td> <td>5Mbps</td> </tr> <tr> <td>4</td> <td>10Mbps</td> </tr> <tr> <td>Other than 0 to 4</td> <td>Unused (If the value you set is other than 0 to 4, the L ERR. LED is ON to indicate a communication error.)</td> </tr> </tbody> </table> (Factory setting: 0 (156kbps))	No. to be set	Transmission speed	0	156kbps	1	625kbps	2	2.5Mbps	3	5Mbps	4	10Mbps	Other than 0 to 4	Unused (If the value you set is other than 0 to 4, the L ERR. LED is ON to indicate a communication error.)																																																		
No. to be set	Transmission speed																																																																	
0	156kbps																																																																	
1	625kbps																																																																	
2	2.5Mbps																																																																	
3	5Mbps																																																																	
4	10Mbps																																																																	
Other than 0 to 4	Unused (If the value you set is other than 0 to 4, the L ERR. LED is ON to indicate a communication error.)																																																																	
3)	Operation setting DIP switches 	Used to set the operational specifications of the G4-S3. <table border="1" data-bbox="582 929 1492 2049"> <thead> <tr> <th rowspan="2">SW No.</th> <th rowspan="2">Setting item</th> <th colspan="2">Setting switch position</th> <th rowspan="2">Description</th> </tr> <tr> <th>ON</th> <th>OFF</th> </tr> </thead> <tbody> <tr> <td rowspan="5">1,6</td> <td rowspan="5">Operation mode</td> <td colspan="2"> <table border="1" data-bbox="837 1064 1149 1321"> <thead> <tr> <th>SW1</th> <th>SW6</th> <th>Operation mode</th> </tr> </thead> <tbody> <tr> <td>OFF</td> <td>OFF</td> <td>A mode</td> </tr> <tr> <td>ON</td> <td>OFF</td> <td>QnA mode</td> </tr> <tr> <td>OFF</td> <td>ON</td> <td>Q mode</td> </tr> <tr> <td>ON</td> <td>ON</td> <td>Must not be set.</td> </tr> </tbody> </table> </td> <td colspan="2"> When using GX Developer Version 6 or later, set to the Q mode. When using any other software, make setting according to the accessed programmable controller CPU. Can be changed during operation. </td> </tr> <tr> <td rowspan="4">2,3</td> <td rowspan="4">Peripheral device transmission speed (bps)</td> <td colspan="2"> <table border="1" data-bbox="837 1467 1149 1780"> <thead> <tr> <th>SW2</th> <th>SW3</th> <th>Transmission speed</th> </tr> </thead> <tbody> <tr> <td>OFF</td> <td>OFF</td> <td>9600bps</td> </tr> <tr> <td>ON</td> <td>OFF</td> <td>19200bps</td> </tr> <tr> <td>OFF</td> <td>ON</td> <td>38400bps</td> </tr> <tr> <td>ON</td> <td>ON</td> <td>Must not be set.</td> </tr> </tbody> </table> </td> <td colspan="2"> When setting the operation mode of the G4-S3 to the QnA mode, make setting according to the peripheral device. (Valid for only the QnA mode.) Invalid for the A and Q modes. Must not be changed during operation. </td> </tr> <tr> <td>4,5</td> <td>Parity bit yes/no</td> <td colspan="2">Fixed to OFF</td> <td>_____</td> </tr> <tr> <td>7</td> <td>Not used</td> <td colspan="2">Fixed to OFF</td> <td>_____</td> </tr> <tr> <td>8</td> <td>Test mode</td> <td>Test mode</td> <td>Online mode</td> <td>Set this switch to ON when making hardware test.</td> </tr> </tbody> </table> (Factory setting: All switches in OFF position)	SW No.	Setting item	Setting switch position		Description	ON	OFF	1,6	Operation mode	<table border="1" data-bbox="837 1064 1149 1321"> <thead> <tr> <th>SW1</th> <th>SW6</th> <th>Operation mode</th> </tr> </thead> <tbody> <tr> <td>OFF</td> <td>OFF</td> <td>A mode</td> </tr> <tr> <td>ON</td> <td>OFF</td> <td>QnA mode</td> </tr> <tr> <td>OFF</td> <td>ON</td> <td>Q mode</td> </tr> <tr> <td>ON</td> <td>ON</td> <td>Must not be set.</td> </tr> </tbody> </table>		SW1	SW6	Operation mode	OFF	OFF	A mode	ON	OFF	QnA mode	OFF	ON	Q mode	ON	ON	Must not be set.	When using GX Developer Version 6 or later, set to the Q mode. When using any other software, make setting according to the accessed programmable controller CPU. Can be changed during operation.		2,3	Peripheral device transmission speed (bps)	<table border="1" data-bbox="837 1467 1149 1780"> <thead> <tr> <th>SW2</th> <th>SW3</th> <th>Transmission speed</th> </tr> </thead> <tbody> <tr> <td>OFF</td> <td>OFF</td> <td>9600bps</td> </tr> <tr> <td>ON</td> <td>OFF</td> <td>19200bps</td> </tr> <tr> <td>OFF</td> <td>ON</td> <td>38400bps</td> </tr> <tr> <td>ON</td> <td>ON</td> <td>Must not be set.</td> </tr> </tbody> </table>		SW2	SW3	Transmission speed	OFF	OFF	9600bps	ON	OFF	19200bps	OFF	ON	38400bps	ON	ON	Must not be set.	When setting the operation mode of the G4-S3 to the QnA mode, make setting according to the peripheral device. (Valid for only the QnA mode.) Invalid for the A and Q modes. Must not be changed during operation.		4,5	Parity bit yes/no	Fixed to OFF		_____	7	Not used	Fixed to OFF		_____	8	Test mode	Test mode	Online mode	Set this switch to ON when making hardware test.
SW No.	Setting item	Setting switch position			Description																																																													
		ON	OFF																																																															
1,6	Operation mode	<table border="1" data-bbox="837 1064 1149 1321"> <thead> <tr> <th>SW1</th> <th>SW6</th> <th>Operation mode</th> </tr> </thead> <tbody> <tr> <td>OFF</td> <td>OFF</td> <td>A mode</td> </tr> <tr> <td>ON</td> <td>OFF</td> <td>QnA mode</td> </tr> <tr> <td>OFF</td> <td>ON</td> <td>Q mode</td> </tr> <tr> <td>ON</td> <td>ON</td> <td>Must not be set.</td> </tr> </tbody> </table>		SW1	SW6	Operation mode	OFF	OFF	A mode			ON	OFF	QnA mode	OFF	ON	Q mode	ON	ON	Must not be set.	When using GX Developer Version 6 or later, set to the Q mode. When using any other software, make setting according to the accessed programmable controller CPU. Can be changed during operation.																																													
		SW1	SW6	Operation mode																																																														
		OFF	OFF	A mode																																																														
		ON	OFF	QnA mode																																																														
		OFF	ON	Q mode																																																														
ON	ON	Must not be set.																																																																
2,3	Peripheral device transmission speed (bps)	<table border="1" data-bbox="837 1467 1149 1780"> <thead> <tr> <th>SW2</th> <th>SW3</th> <th>Transmission speed</th> </tr> </thead> <tbody> <tr> <td>OFF</td> <td>OFF</td> <td>9600bps</td> </tr> <tr> <td>ON</td> <td>OFF</td> <td>19200bps</td> </tr> <tr> <td>OFF</td> <td>ON</td> <td>38400bps</td> </tr> <tr> <td>ON</td> <td>ON</td> <td>Must not be set.</td> </tr> </tbody> </table>		SW2	SW3	Transmission speed	OFF	OFF	9600bps	ON	OFF	19200bps	OFF	ON	38400bps	ON	ON	Must not be set.	When setting the operation mode of the G4-S3 to the QnA mode, make setting according to the peripheral device. (Valid for only the QnA mode.) Invalid for the A and Q modes. Must not be changed during operation.																																															
		SW2	SW3	Transmission speed																																																														
		OFF	OFF	9600bps																																																														
		ON	OFF	19200bps																																																														
OFF	ON	38400bps																																																																
ON	ON	Must not be set.																																																																
4,5	Parity bit yes/no	Fixed to OFF		_____																																																														
7	Not used	Fixed to OFF		_____																																																														
8	Test mode	Test mode	Online mode	Set this switch to ON when making hardware test.																																																														

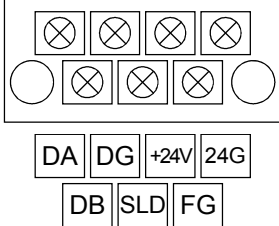
No.	Name	Description	
4)	Indicator LEDs PW ○ RUN ○ L RUN ○ SD ○ RD ○ L ERR.○	PW	ON : Power on. OFF : Power off.
		RUN	ON : Normal operation. OFF : 24VDC power OFF or Watchdog timer error.
		L RUN	ON : Normal communication. OFF : Communication fault. (time excess error.)
		SD	ON to indicate data transmission.
		RD	ON to indicate data receive.
		L ERR.	ON : Indicates a communication data error (CRC error) or station number setting/data link transmission speed setting error. Flicker at regular intervals: Indicates that the station number setting or data link transmission speed setting switch position was changed while power is on. Flicker at irregular intervals: Indicates that the terminating resistor is left unconnected or that the module or CC-Link dedicated cable is affected by noise. OFF : Normal communication
5)	Reset switch RESET 	Hardware reset. Used to reset to the power-on status.	
6)	RS-422 interface *2	Interface for connecting the peripheral device. The cable as used to connect the peripheral device and QnACPU/ACPU may be used as the connection cable. Refer to the operating manual of the MELSEC programmable controller programming software used.	
7)	Power supply and data link terminal block	Terminal block for power supply and data link. For the wiring method, refer to Chapter 5. 	

*1: Refer to the user's manual for the setting of the G4-S3's station number.

*2: Do not connect the RS-232 equipment to the RS-422 interface.

Doing so will damage the RS-422 interface hardware of the G4-S3, disabling communication.

5. EXTERNAL WIRING

This chapter shows how to wire the CC-Link dedicated cables between the master and remote modules and how to wire the power supplies.

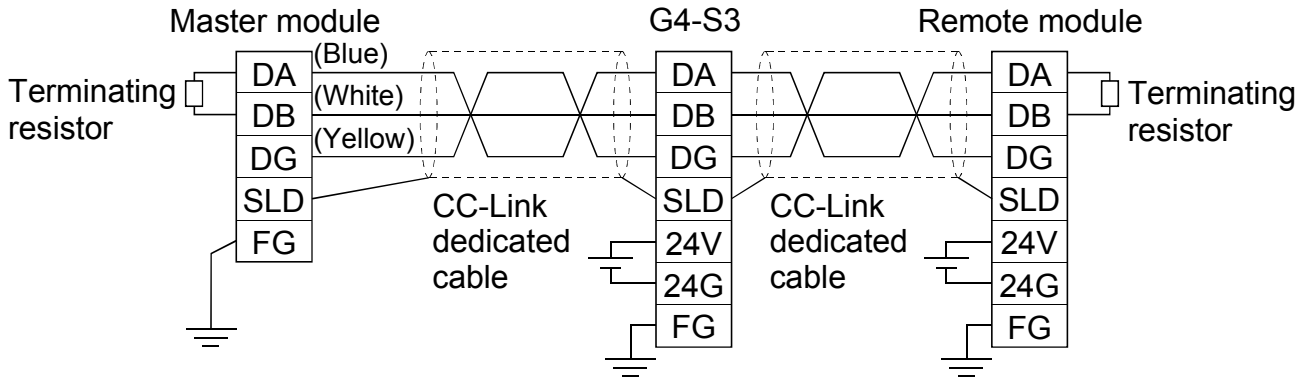

POINT

"Terminating resistors" must be connected to the sections between DA and DB of the modules at the both ends of the CC-Link.
 When connecting the terminating resistor to the G4-S3, use the terminating resistor supplied with the master module.
 (Refer to the Control & Communication Link System Master/Local Module User's Manual.)

6. EXTERNAL DIMENSIONS

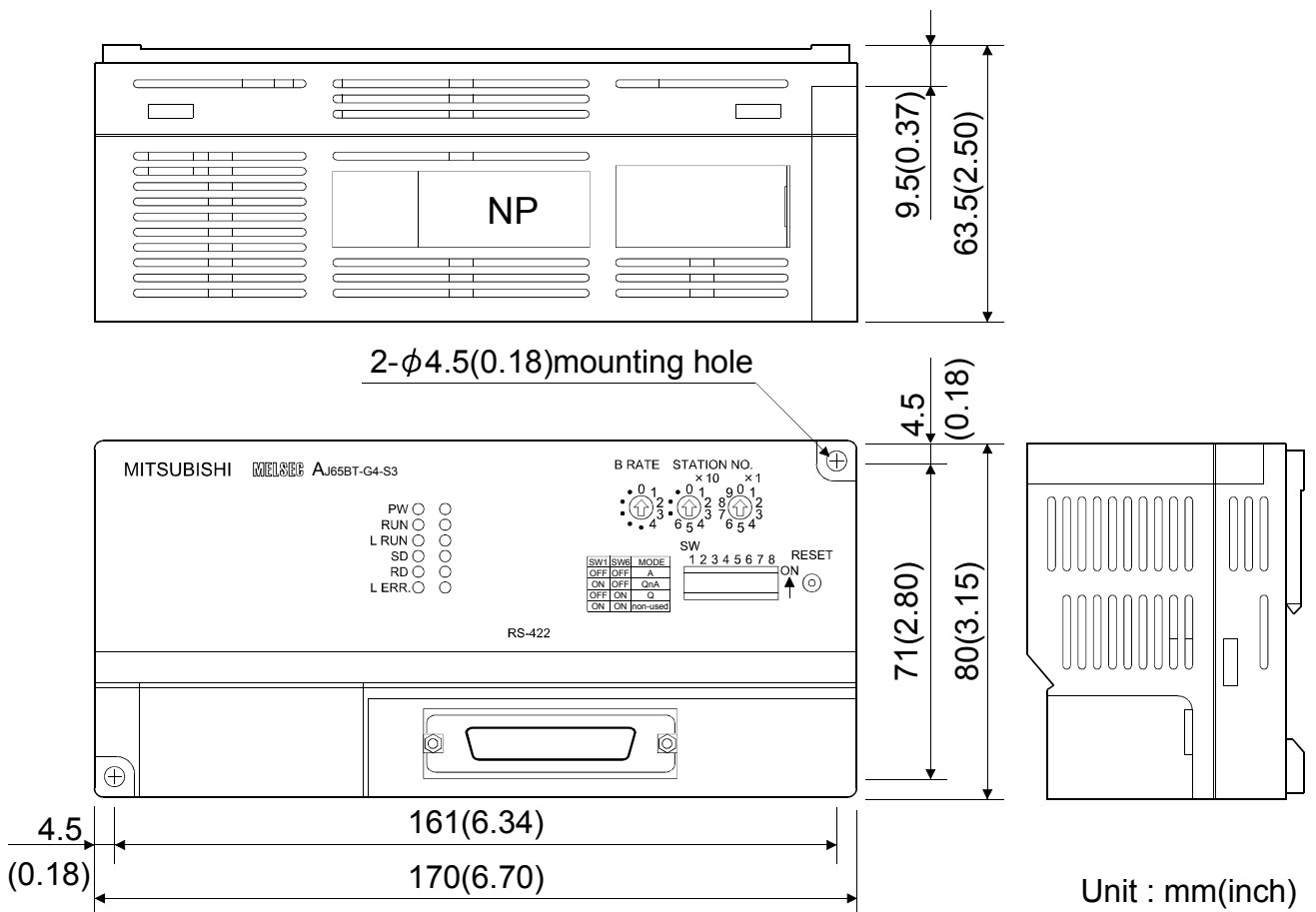

Warranty

Mitsubishi will not be held liable for damage caused by factors found not to be the cause of Mitsubishi; machine damage or lost profits caused by faults in the Mitsubishi products; damage, secondary damage, accident compensation caused by special factors unpredictable by Mitsubishi; damages to products other than Mitsubishi products; and to other duties.

⚠ For safe use

- This product has been manufactured as a general-purpose part for general industries, and has not been designed or manufactured to be incorporated in a device or system used in purposes related to human life.
- Before using the product for special purposes such as nuclear power, electric power, aerospace, medicine or passenger movement vehicles, consult with Mitsubishi.
- This product has been manufactured under strict quality control. However, when installing the product where major accidents or losses could occur if the product fails, install appropriate backup or failsafe functions in the system.

Country/Region	Sales office/Tel	Country/Region	Sales office/Tel
U.S.A	Mitsubishi Electric Automation Inc. 500 Corporate Woods Parkway Vernon Hills, IL 60061, U.S.A. Tel : +1-847-478-2100	Hong Kong	Mitsubishi Electric Automation (Hong Kong) Ltd. 10th Floor, Manulife Tower, 169 Electric Road, North Point, Hong Kong Tel : +852-2887-8870
Brazil	MELCO-TEC Rep. Com.e Assessoria Tecnica Ltda. Rua Correia Dias, 184, Edificio Paraiso Trade Center-8 andar Paraiso, Sao Paulo, SP Brazil Tel : +55-11-5908-8331	China	Mitsubishi Electric Automation (Shanghai) Ltd. 4/F Zhi Fu Plazz, No.80 Xin Chang Road, Shanghai 200003, China Tel : +86-21-6120-0808
Germany	Mitsubishi Electric Europe B.V. German Branch Gothaer Strasse 8 D-40880 Ratingen, GERMANY Tel : +49-2102-486-0	Taiwan	Setsuyo Enterprise Co., Ltd. 6F No.105 Wu-Kung 3rd.Rd, Wu-Ku Hsiang, Taipei Hsine, Taiwan Tel : +886-2-2299-2499
U.K	Mitsubishi Electric Europe B.V. UK Branch Travellers Lane, Hatfield, Hertfordshire., AL10 8XB, U.K. Tel : +44-1707-276100	Korea	Mitsubishi Electric Automation Korea Co., Ltd. 1480-6, Gayang-dong, Gangseo-ku Seoul 157-200, Korea Tel : +82-2-3660-9552
Italy	Mitsubishi Electric Europe B.V. Italian Branch Centro Dir. Colleoni, Pal. Perseo-Ingr.2 Via Paracelso 12, I-20041 Agrate Brianza., Milano, Italy Tel : +39-039-60531	Singapore	Mitsubishi Electric Asia Pte, Ltd. 307 Alexandra Road #05-01/02, Mitsubishi Electric Building, Singapore 159943 Tel : +65-6470-2460
Spain	Mitsubishi Electric Europe B.V. Spanish Branch Carretera de Rubi 76-80, E-08190 Sant Cugat del Valles, Barcelona, Spain Tel : +34-93-565-3131	Thailand	Mitsubishi Electric Automation (Thailand) Co., Ltd. Bang-Chan Industrial Estate No.111 Moo 4, Serithai Rd, T.Kannayao, A.Kannayao, Bangkok 10230 Thailand Tel : +66-2-517-1326
France	Mitsubishi Electric Europe B.V. French Branch 25, Boulevard des Bouvets, F-92741 Nanterre Cedex, France TEL: +33-1-5568-5568	Indonesia	P.T. Autoteknindo Sumber Makmur Muara Karang Selatan, Block A/Utara No.1 Kav. No.11 Kawasan Industri Pergudangan Jakarta - Utara 14440, P.O.Box 5045 Jakarta, 11050 Indonesia Tel : +62-21-6630833
South Africa	Circuit Breaker Industries Ltd. Private Bag 2016, ZA-1600 Isando, South Africa Tel : +27-11-928-2000	India	Messung Systems Pvt, Ltd. Electronic Sadan NO:III Unit No15, M.I.D.C Bhosari, Pune-411026, India Tel : +91-20-2712-3130
		Australia	Mitsubishi Electric Australia Pty. Ltd. 348 Victoria Road, Rydalmere, N.S.W 2116, Australia Tel : +61-2-9684-7777

MITSUBISHI ELECTRIC CORPORATION

HEAD OFFICE : TOKYO BUILDING, 2-7-3 MARUNOUCHI, CHIYODA-KU, TOKYO 100-8310, JAPAN
NAGOYA WORKS : 1-14, YADA-MINAMI 5-CHOME, HIGASHI-KU, NAGOYA, JAPAN

When exported from Japan, this manual does not require application to the Ministry of Economy, Trade and Industry for service transaction permission.

Specifications subject to change without notice.

Printed in Japan on recycled paper.