

Safety Programmable Controller

MELSEC **QS** series

Safety Guidelines

Thank you for purchasing the Mitsubishi Electric safety programmable controller MELSEC-QS series.

The MELSEC-QS series programmable controller is suitable for establishing safety functions for general industrial machinery.

Prior to use, please read both this manual and detailed manual thoroughly and familiarize yourself with the product.

MODEL	QS-SR-U-HW
MODEL CODE	13JZ09
IB(NA)-0800411-L(2204)MEE	

● SAFETY PRECAUTIONS ●

(Read these precautions before using this product.)

Before using this product, please read this manual and the relevant manuals carefully and pay full attention to safety to handle the product correctly.

In this manual, the safety precautions are classified into two levels:

"⚠ WARNING" and "⚠ CAUTION".



Indicates that incorrect handling may cause hazardous conditions, resulting in death or severe injury.



Indicates that incorrect handling may cause hazardous conditions, resulting in minor or moderate injury or property damage.

Under some circumstances, failure to observe the precautions given under "⚠ CAUTION" may lead to serious consequences.

Observe the precautions of both levels because they are important for personal and system safety.

Make sure that the end users read this manual and then keep the manual in a safe place for future reference.

This instruction is the original version.

[Design Precautions]

WARNING

- A safety relay module turns OFF all outputs by safety input or a failure of external power supply. Create an external circuit to securely stop the power of hazard by turning OFF the outputs.
Incorrect configuration may result in an accident.
- When a load current exceeding the rated current or an overcurrent caused by a load short-circuit flows for a long time, it may cause smoke and fire. To prevent this, configure an external safety circuit, such as a fuse.
- Create short-circuit current protection for a safety relay and a protection circuit such as a fuse and breaker, outside a safety relay module.

[Design Precautions]

WARNING

- To inhibit a restart without manual operation after safety function of the safety relay module was performed and outputs were turned OFF, create reset start-up circuit using such as a reset switch outside the safety relay module.
- The safety relay module may consume excessive current due to a failure. If this occurs, the DC power supply connected to the safety power supply part (+24V (SAFETY) and 24G (SAFETY) terminals) of the module detects an overcurrent and may shut off the output.
To the DC power supply connected to the safety relay module, connect only the equipment and the devices that will not affect the system even if they are simultaneously stopped due to power-off.
- Use an extension module whose input type is the same as that of the main module.
The modules of different input types (input P and N types) cannot be connected.

[Design Precautions]

CAUTION

- The safety category is evaluated by the whole equipment. Make sure that the whole equipment meets the requirements before use.
- Use the module in an environment that meets the general specifications in this manual.
Failure to do so may result in electric shock, fire, malfunction, or damage to or deterioration of the product.
- The life of safety relay used for the safety relay module depends on the open-close condition and load. Be sure to operate the equipment by use conditions to make sure that the number of allowable times that the relay opens/closes.
- Do not install the cables of external devices or communication cables together with the main circuit lines or power cables. Keep a distance of 100mm or more between them. Failure to do so may result in malfunction due to noise.

[Installation Precautions]

WARNING

- Do not use the product in flammable gas atmosphere or explosive gas atmosphere. Doing so may result in fire or explosion due to such as an arc caused by opening/closing the relays.

[Installation Precautions]

CAUTION

- To mount the Q series safety relay module, while pressing the module mounting lever located in the lower part of the module, fully insert the module fixing projection(s) into the hole(s) in the base unit and press the module until it snaps into place.
Incorrect mounting may cause malfunction, failure, or drop of the module.
When using the programmable controller in an environment of frequent vibrations, fix the module with a screw.
Tighten the screw within the specified torque range.
Undertightening can cause drop of the screw, short circuit or malfunction.
Overtightening can damage the screw and/or module, resulting in drop, short circuit, or malfunction.
- Make sure to fix CC-Link safety relay module and extension safety relay module with a DIN rail fixing bracket.
- Shut off the external power supply for the system in all phases before mounting or removing the module.
Failure to do so may result in damage to the product.
- When mounting a module, make room for 5cm or more at above and below of the module for ventilation.
When powering ON a contact at 3A or more consecutively, make room for 5mm or more at the sides of the contact for ventilation.
- Do not directly touch any conductive part of the module. Doing so can cause malfunction or failure of the module.
- Securely connect connectors for each cable to the applied parts.
Poor contact may cause malfunction.

[Wiring Precautions]

WARNING

- Shut off the external power supply for the system in all phases before wiring. Failure to do so may result in electric shock or damage to the product.
- After installation and wiring, close the included terminal block cover to the module before turning it on for operation. Failure to do so may result in electric shock.

[Wiring Precautions]

CAUTION

- Ground the FG and LG terminals to the protective ground conductor dedicated to the programmable controller. Failure to do so may result in electric shock or malfunction.
- Check the rated voltage and terminal layout before wiring to the module, and connect the cables correctly. Connecting a power supply with a different voltage rating or incorrect wiring may cause a fire or failure.
- Prevent foreign matter such as dust or wire chips from entering the module. Such foreign matter can cause a fire, failure, or malfunction.
- Tighten a terminal block mounting screw, terminal screw, and module mounting screw within the specified torque range.
If the terminal block mounting screw or terminal screw is too loose, it may cause a short circuit, fire, or malfunctions. If too tight, it may damage the screw and/or the module, resulting in a drop of the screw or module, a short circuit or malfunctions. If the module mounting screw is too loose, it may cause a drop of the screw or module.
Over tightening the screw may cause a drop due to the damage of the screw or module.
- Place the communication cables or power cables in a duct or clamp them. If not, dangling cable may swing or inadvertently be pulled, resulting in damage to the module or cables or malfunction due to poor contact.
- When disconnecting the communication cable or power cable from the module, do not pull the cable by the cable part.
For the cable connected to the terminal block, loosen the terminal screw. Pulling the cable connected to the module may result in malfunction or damage to the module or cable.
- Use applicable solderless terminals and crimp them with a tool specified by maker. Incomplete connections may cause short circuit, fire, or malfunction.

[Wiring Precautions]

CAUTION

- A protective film is attached to the top of the Q series safety relay module to prevent foreign matter such as wire chips from entering the module during wiring. Do not remove the film during wiring. Remove it for heat dissipation before system operation.
- Install our programmable controller in a control panel complying with the IP standard of 54 or more.
Connect the main power supply to the power supply module in the control panel through a relay terminal block.
Wiring and replacement of a power supply module must be performed by qualified maintenance personnel with knowledge of protection against electric shock.
For wiring methods, refer to the QCPU User's Manual (Hardware Design, Maintenance and Inspection).
- Do not install the control lines together with the communication cables or bring them close to each other.
Doing so may cause a malfunction due to noise.
- Pay attention when using a flathead screwdriver to push the open/close button of the spring clamp terminal block. Failure to do so can result in an injury.

[Startup and Maintenance precautions]

WARNING

- Do not touch any terminal while power is on.
Doing so will cause electric shock.
- Turn off all phases of the external supply power used in the system when cleaning the module or retightening the terminal block mounting screws, terminal screws, or module mounting screws. Not doing so could result in electric shock.
Tighten a terminal block mounting screw and module mounting screw within the specified torque range. If the terminal block mounting screw is too loose, it may cause a short-circuit, fire or malfunctions.
If too tight, it may damage the screw and/or the module, resulting in a drop of the screw or module, a short circuit or malfunctions.
If the module mounting screw is too loose, it may cause a drop of the screw or module. Over tightening the screw may cause a drop due to the damage of the screw or module.

[Startup and Maintenance precautions]

CAUTION

- Do not disassemble or modify the module. Doing so may cause failure, malfunction, injury, or a fire.
If the product is repaired or remodeled by other than the specified FA centers or us, the warranty is not covered.
- A electric fuse for overcurrent prevention is incorporated in the control circuit part of the safety relay module.
If the electric fuse operates, power OFF the module once, and power it ON again after resolving the failure.
- After the first use of the product, do not mount/remove the module to/from the base unit, and the terminal block to/from the module more than 50 times (IEC 61131-2 compliant) respectively. Exceeding the limit may cause malfunction.
- Do not drop or apply strong shock to the module case since it is made from resin. Doing so may damage the module.
- Completely turn off the externally supplied power used in the system before mounting or removing the module to/from the panel.
Not doing so may result in a failure or malfunctions of the module.
- Use any radio communication device such as a cellular phone or PHS (Personal Handy-phone System) more than 25cm away in all directions from the programmable controller.
- Before handling the module, touch a conducting object such as a grounded metal to discharge the static electricity from the human body.
Failure to do so may cause the module to fail or malfunction.

[Disposal Precautions]

CAUTION

- When disposing of this product, treat it as industrial waste.

● PRÉCAUTIONS DE SÉCURITÉ ●

(Lire ces précautions avant toute utilisation du produit.)

Avant d'utiliser ce produit, lire attentivement ce manuel ainsi que les manuels auxquels il renvoie, et toujours considérer la sécurité comme de la plus haute importance en manipulant le produit correctement.

Dans ce manuel, les précautions de sécurité sont classées en deux niveaux, à savoir : "⚠️ AVERTISSEMENT" et "⚠️ ATTENTION"

⚠️ AVERTISSEMENT

Attire l'attention sur le fait qu'une négligence peut créer une situation de danger avec risque de mort ou de blessures graves.

⚠️ ATTENTION

Attire l'attention sur le fait qu'une négligence peut créer une situation de danger avec risque de blessures légères ou de gravité moyennes ou risque de dégâts matériels.

Dans certaines circonstances, le non-respect d'une précaution de sécurité introduite sous le titre "⚠️ ATTENTION" peut avoir des conséquences graves. Les précautions de ces deux niveaux doivent être observées dans leur intégralité car elles ont trait à la sécurité des personnes et aussi du système. Veiller à ce que les utilisateurs finaux lisent ce manuel qui doit être conservé soigneusement à portée de main pour s'y référer autant que de besoin. Ces instructions sont en version originale.

[Précautions lors de la conception]

⚠️ AVERTISSEMENT

- Un module relais de sécurité désactive toutes les sorties suite à une entrée de sécurité ou en cas de défaillance de l'alimentation externe. Constituer un circuit externe coupant infailliblement l'alimentation en cas de danger pour désactiver les sorties.
Une configuration incorrecte peut être à l'origine d'un accident.
- Un courant de charge plus fort que le courant nominal ou une surtension due à un court-circuit à la charge, peuvent dans la durée être à l'origine d'un dégagement de fumée ou d'un départ de feu. Pour éviter cela, il faut configurer un circuit de sécurité, avec un fusible par exemple.
- Prévoir, à l'extérieur du module des relais de sécurité, une protection contre les courants de court-circuit pour les relais de sécurité et un circuit de protection avec disjoncteur.

[Précautions lors de la conception]

AVERTISSEMENT

- *Pour interdire tout redémarrage sans intervention manuelle après déclenchement de la fonction de sécurité du module de relais de sécurité et mise hors tension des sorties, prévoir un circuit de réarmement, comme par exemple un poussoir de réarmement à l'extérieur du module de relais de sécurité.*
- *La consommation de courant du module de relais de sécurité peut être excessive en raison d'une défaillance.
Le cas échéant, une surtension sera détectée à l'alimentation c.c. (bornes +24V (SAFETY) et 24G (SAFETY)) du module, ce qui couperait la sortie.
À l'alimentation cc utilisée par le module de relais de sécurité, ne raccorder que des équipements ou dispositifs qui peuvent être arrêtés sans inconvénient pour le système en cas de coupure d'alimentation.*
- *Utiliser un module d'extension dont le type d'entrée est le même que celui du module principal.
Il n'est pas possible de raccorder des modules de type d'entrée différent (types d'entrée P et N).*

[Précautions lors de la conception]

ATTENTION

- *L'évaluation de classe de sécurité est faite pour l'ensemble de l'équipement.
Avant usage, s'assurer que l'ensemble de l'équipement est conformes aux exigences..*
- *Utiliser le module dans un environnement conforme aux spécifications générales du présent manuel.
Faute de quoi, il a risque d'électrocution, de départ de feu, de dysfonctionnement, d'endommagement ou de détérioration du produit.*
- *La longévité des relais utilisés dans le module relais de sécurité dépend des conditions d'ouverture-fermeture et de la charge. Vérifier que les conditions d'utilisation de l'équipement sont compatibles avec la fréquence admissible des ouvertures/fermetures des relais.*
- *Ne pas installer les câbles de dispositifs externes ou les câbles de communication avec les lignes des circuits principaux ou les câbles d'alimentation. Les installer en maintenant entre eux une distance minimum de 100 mm. Faute de quoi, il y a risque de dysfonctionnement par un bruit.*

[Précautions d'installation]

AVERTISSEMENT

- *Ne pas utiliser ce produit en atmosphère gazeuse inflammable ou explosive. Cela pourrait être à l'origine d'un départ de feu ou d'une explosion produite par l'arc d'ouverture/fermeture des relais.*

[Précautions d'installation]

ATTENTION

- *Pour mettre le module de relais de sécurité en place, en tenant le loquet de blocage du module pressé, introduire le ou les ergot(s) de fixation du module à fond dans le(s) trou(s) de l'unité de base et appuyer sur le module jusqu'à encliquètement.
Mal fixé en place, le module risque de se détacher, de ne pas fonctionner ou de présenter des dysfonctionnements. Si l'automate programmable est installé dans un environnement exposé aux vibrations, le module doit être immobilisé par une vis de blocage.
Serrer la vis dans les limites du couple de serrage prescrit.
Si les vis sont insuffisamment serrées, le module risque de tomber et il peut y avoir des court-circuits ou des dysfonctionnements.
Un serrage excessif peut endommager les vis et/ou le module, avec aussi un risque de chute, de court-circuits et de dysfonctionnements.*
- *Il est indispensable de fixer le module de relais de sécurité CC-Link et le module de relais de sécurité d'extension avec une ferrure de fixation sur rail DIN.*
- *Couper l'alimentation externe du système sur toutes les phases avant la mise en place ou le retrait du module.
Faute quoi, le produit risquerait d'être endommagé.*
- *À l'installation d'un module, prévoir un espacement de 5cm ou plus en dessus et en dessous du module pour la ventilation.
Pour les contacts adjacents d'un ampérage de 3A et plus, prévoir entre eux un espacement de 5mm ou plus pour la ventilation.*
- *Éviter tout contact direct avec les parties conductrices du module. Une manipulation incorrecte peut être à l'origine de dysfonctionnements ou de pannes du module.*
- *Raccorder fermement les connecteurs de chacun des câbles sur leurs contreparties.
Tout mauvais contact peut être source de dysfonctionnements.*

[Précautions de câblage]

AVERTISSEMENT

- *Couper l'alimentation externe du système sur toutes les phases avant de commencer à câbler. Faute de quoi, il y a risque d'électrocution et d'endommagement du produit.*
- *En fin d'installation et de câblage, mettre le couvre-bornes fourni en place sur le module avant de mettre sous tension et de mettre en marche. Faute de quoi, il y a risque d'électrocution.*

[Précautions de câblage]

ATTENTION

- *Mettre à la masse les bornes FG et LG sur le conducteur réservé à la protection à la terre de l'automate programmable. Faute de quoi, il y a risque d'électrocution et de dysfonctionnement.*
- *Vérifier la tension nominale et l'affectation des bornes avant le câblage du module et raccorder les câbles correctement. Le raccordement d'une alimentation d'une tension autre que la tension nominale ou une erreur de câblage peut être à l'origine d'un départ de feu ou d'une panne.*
- *Veiller à ne pas laisser la poussière, les copeaux métalliques ou d'autres corps étrangers pénétrer dans le module. De telles corps étrangers peuvent être à l'origine d'un départ de feu, d'une panne ou d'un dysfonctionnement.*
- *Serrer les vis de fixation du bornier, les vis de borne et les vis de fixation du module dans les limites du couple de serrage prescrit. Une vis de fixation de bornier ou un vis de borne mal serrée peut être à l'origine d'un court-circuit, d'un départ de feu ou de dysfonctionnements. Un serrage excessif peut endommager la vis et/ou le module, et une chute de vis ou de module risque d'entraîner un court-circuit ou des dysfonctionnements. Un serrage insuffisant des vis de fixation de module peut être à l'origine d'une chute des vis ou du module. Un serrage excessif peut endommager la vis et entraîner la chute de la vis ou du module.*
- *Les câbles de communication ou câbles d'alimentation doivent être placés dans un conduit ou doivent être attachés. Faute de quoi, le ballonnement ou le déplacement des câbles pourrait endommager le module ou les câbles et être à l'origine de dysfonctionnements par mauvais contact.*

[Précautions de câblage]

ATTENTION

- *Pour débrancher le câble de communication ou le câble d'alimentation du module, ne jamais tirer sur le câble proprement dit.
Pour un câble raccordé sur une plaque à bornes, desserrer la vis de la borne. Tirer sur un câble raccordé au module peut endommager le câble ou le module et être à l'origine de dysfonctionnements.*
- *Utiliser les bornes sans soudure préconisées en les sertissant avec l'outil prescrit par le fabricant. Des connexions imparfaites peuvent être à l'origine de court-circuits, départs de feu ou dysfonctionnements.*
- *Le haut du module relais de sécurité de série Q est recouvert d'un film protecteur pour éviter toute pénétration de corps étrangers comme des copeaux métalliques pendant le câblage. Ne pas retirer le film protecteur avant de terminer le câblage. Il doit cependant être retiré avant la mise en service du système pour une meilleure dispersion de la chaleur.*
- *Installer notre automate programmable dans un tableau de commande conforme à la norme IP 54 ou mieux.
Raccorder l'alimentation principale au module d'alimentation dans le tableau de commande sur une plaque à bornes avec relais.
Le câblage et le remplacement d'un module d'alimentation doivent être effectués par un personnel de maintenance qualifié et formé à la protection contre les risques d'électrocution.
Pour les méthodes de câblage, se reporter au QCPU User's Manual (Hardware Design, Maintenance and Inspection) (Manuel de l'utilisateur QCPU (conception du matériel, maintenance et inspection)).*
- *Ne pas installer les lignes de commande avec les câbles de communication et ne pas les placer à proximité.
Il pourrait en résulter des dysfonctionnements par suite d'interférences.*
- *Attention à ne rien endommager en appuyant avec un tournevis plat sur le bouton d'ouverture/fermeture de l'étrier de la plaque à bornes. Faute de quoi, il y aurait risque de blessure.*

 **AVERTISSEMENT**

- *Ne toucher à aucun des bornes quand le système est sous tension. Il y aurait risque d'électrocution.*
- *Couper l'alimentation externe utilisée par le système sur toutes phases avant de nettoyer le module ou de resserrer les vis de fixation du bornier, les vis de bornes ou les vis de fixation du module. Faute de quoi, il y a risque de choc électrique.*

Serrer les vis de fixation du bornier et les vis de fixation du module dans les limites du couple de serrage prescrit. Une vis de fixation de bornier mal serrée peut être à l'origine d'un court-circuit, d'un départ de feu ou de dysfonctionnements.

Un serrage excessif peut endommager la vis et/ou le module, et une chute de vis ou de module risque d'entraîner un court-circuit ou des dysfonctionnements.

Un serrage insuffisant des vis de fixation de module peut être à l'origine d'une chute des vis ou du module. Un serrage excessif peut endommager la vis et entraîner la chute de la vis ou du module.

[Précautions de démarrage et de maintenance]

ATTENTION

- *Ne pas démonter ni modifier le module. Cela pourrait entraîner des pannes ou dysfonctionnements et être à l'origine de blessures ou de départs de feu. Si le produit est réparé ou modifié par quiconque autre que nous-mêmes ou un de nos centre d'automatisation industrielles agréés, il n'est plus couvert par la garantie.*
- *Un fusible électrique ou une protection contre les surtensions est incorporé à la section circuit de commande du module relais de sécurité. Si le fusible a sauté, mettre le module hors tension et le remettre sous tension après suppression de la cause du problème.*
- *Après la mise en service du produit, le nombre maximum admissible d'opérations d'insertion/retrait du module sur le socle ou de la plaque à bornes sur le module est de 50 (matériel selon norme IEC 61131-2). Le dépassement de cette limite peut être à l'origine de dysfonctionnements.*
- *Le boîtier étant en plastique, ne pas faire tomber le module et le pas le soumettre à des chocs. Cela risquerait d'endommager le module.*
- *Couper complètement toute alimentation externe utilisée par le système avant de mettre en place ou de retirer le module du tableau. Faute de quoi, il y a risque de panne ou de dysfonctionnement du module.*
- *Tout type d'appareil de communication radio, comme un téléphone portable ou PHS (Personal handy-phone system), doit être tenu éloigné de plus de 25 cm de l'automate programmable, dans tous les sens. Le non-respect de cette précaution expose à des dysfonctionnements.*
- *Avant de manipuler un module, se débarrasser de la charge électrostatique qu'accumule le corps humain en touchant un objet conducteur approprié. Le non-respect de cette précaution peut être à l'origine de pannes ou de dysfonctionnements du module.*

[Précautions de mise au rebut]

ATTENTION

- *Lors de sa mise au rebut, ce produit doit être traité comme un déchet industriel.*

● CONDITIONS OF USE FOR THE PRODUCT ●

- (1) Although MELCO has obtained the certification for Product's compliance to the international safety standard ISO13849-1 from TUV SUD, this fact does not guarantee that Product will be free from any malfunction or failure. The user of this Product shall comply with any and all applicable safety standard, regulation or law and take appropriate safety measures for the system in which the Product is installed or used and shall take the second or third safety measures other than the Product. MELCO is not liable for damages that could have been prevented by compliance with any applicable safety standard, regulation or law.

- (2) MELCO prohibits the use of Products with or in any application involving, and MELCO shall not be liable for a default, a liability for defect warranty, a quality assurance, negligence or other tort and a product liability in these applications.
 - (a) power plants,
 - (b) trains, railway systems, airplanes, airline operations, other transportation systems,
 - (c) hospitals, medical care, dialysis and life support facilities or equipment,
 - (d) amusement equipments,
 - (e) incineration and fuel devices,
 - (f) handling of nuclear or hazardous materials or chemicals,
 - (g) mining and drilling,
 - (h) and other applications where the level of risk to human life, health or property are elevated.

REVISIONS

*The manual number is given on the bottom right of the cover.

Print date	*Manual number	Revision
April 2008	IB(NA)-0800411-A	First edition
September 2008	IB(NA)-0800411-B	Correction of errors in writing
May 2010	IB(NA)-0800411-C	Addition of descriptions (Machinery Directive compliant)
May 2011	IB(NA)-0800411-D	Correction of errors in writing
October 2011	IB(NA)-0800411-E	Addition of descriptions of SAFETY PRECAUTIONS(Chinese)
November 2013	IB(NA)-0800411-F	Addition of descriptions (UL508 compliant)
June 2014	IB(NA)-0800411-G	Addition of descriptions (cUL)
April 2015	IB(NA)-0800411-H	Correction in accordance with the amendments of safety standards
December 2016	IB(NA)-0800411-I	Correction in accordance with the amendments of safety standards
June 2018	IB(NA)-0800411-J	Descriptions are revised due to compliance with the Chinese standardized law.
October 2021	IB(NA)-0800411-K	Correction in accordance with the amendments of safety standards
April 2022	IB(NA)-0800411-L	Correction in accordance with the amendments of safety standards

This manual confers no industrial property rights or any rights of any other kind, nor does it confer any patent licenses. Mitsubishi Electric Corporation cannot be held responsible for any problems involving industrial property rights which may occur as a result of using the contents noted in this manual.

© 2008 MITSUBISHI ELECTRIC CORPORATION

CONTENTS

1. OVERVIEW.....	1
1.1 Included Parts.....	1
1.2 Product List.....	1
2. GENERAL SPECIFICATIONS.....	2
2.1 Safety Standards.....	3
2.2 Module Replacement.....	3
2.3 Safety Category and Performance level.....	3
2.4 Response time.....	3
2.5 Wiring Diagrams.....	4
3. MODULE STATUS AFTER POWER-ON AND LED INDICATION.....	16
4. INSTALLATION.....	18
4.1 Q Series Safety Relay Module.....	18
4.2 CC-Link Safety Relay Module, Extension Safety Relay Module.....	20
5. SAFETY CIRCUIT PART EXTENSION CABLES.....	20
6. SPRING CLAMP TERMINAL BLOCK.....	21
7. PRECAUTIONS FOR USE.....	22
8. EU DECLARATION OF CONFORMITY FOR MACHINERY DIRECTIVE.....	23

ABOUT MANUALS

Before constructing or designing the safety-related system, be sure to read the following manual.

Introduction Manual	
Manual name	Manual number (Model code)
Safety Relay Module User's Manual Explains the specifications, procedures and settings before system operation, parameter setting, and troubleshooting of the Safety relay module. (Sold separately)	SH-080746ENG (13JY62)

COMPLIANCE WITH THE EMC, LOW VOLTAGE, AND MACHINERY DIRECTIVES

- (1) Method of ensuring compliance
To ensure that Mitsubishi programmable controllers maintain EMC, Low Voltage, and Machinery Directives when incorporated into other machinery or equipment, certain measures may be necessary. Please refer to the manual included with the base unit. The CE mark on the side of the programmable controller indicates compliance with EMC, Low Voltage, and Machinery Directives.
 - (a) Sales representative in EU member states
The sales representative in EU member states is:
Company: MITSUBISHI ELECTRIC EUROPE B.V.
Address: Mitsubishi-Electric-Platz 1, 40882 Ratingen, Germany
- (2) Additional measures
This product complies with the EMC, Low Voltage, and Machinery Directives. Before using this product, please read this manual, the relevant manuals, the manuals for standard programmable controllers, and the safety standards carefully and pay full attention to safety to handle the product correctly.
The descriptions are based on the requirements of the Directives and the harmonized standards. However, they do not guarantee that the entire machinery constructed according to the descriptions complies with the EMC, Low Voltage, and Machinery Directives. The manufacture of the machinery must determine the testing method for compliance and declare conformity to the EMC, Low Voltage, and Machinery Directives.

1. OVERVIEW

This manual explains precautions for using the safety relay module in safety.

1.1 Included Parts

The following tables list the parts included with the corresponding modules.

(1) Q series safety relay module

Product Name	Quantity
Module	1
This manual	1

(2) CC-Link safety relay module

Product Name	Quantity
Module	1
This manual	1

(3) Extension safety relay module

Product Name	Quantity
Module	1
This manual	1

1.2 Product List

Product Name	Model	Description
Q series safety relay module	QS90SR2SP-Q	Safety relay module for MELSEC-Q series. Dual input with positive commons.
	QS90SR2SN-Q	Safety relay module for MELSEC-Q series. Dual input with positive common and negative common.
CC-Link safety relay module	QS90SR2SP-CC	Safety relay module for CC-Link field network. Dual input with positive commons.
	QS90SR2SN-CC	Safety relay module for CC-Link field network. Dual input with positive common and negative common.
Extension safety relay module	QS90SR2SP-EX	Safety relay module for extension. Dual input with positive commons.
	QS90SR2SN-EX	Safety relay module for extension. Dual input with positive common and negative common.

2. GENERAL SPECIFICATIONS

This section explains specifications common to various modules.

Item	Specification					
Operating ambient temperature <i>Température ambiante de fonctionnement</i>	0 to 55°C 0 à 55 °C					
Storage ambient temperature	-25 to 75°C *3					
Operating ambient humidity	30 to 85%RH, non-condensing					
Storage ambient humidity						
Vibration resistance	Compliant with JIS B 3502 and IEC 61131-2		Frequency	Constant Acceleration	Half amplitude	Sweep count
		Under intermittent vibration	5 to 8.4Hz	----	3.5mm	
			8.4 to 150Hz	9.8m/s ²	----	
		Under continuous vibration	5 to 8.4Hz	----	1.75mm	----
8.4 to 150Hz	4.9m/s ²		----			
Shock resistance	Compliant with JIS B 3502 and IEC 61131-2 (147 m/s ² , duration of action 11ms, 3 times each in 3 directions X, Y, Z by sine half-wave pulse)					
Operating atmosphere	No corrosive gases					
Operating altitude *4	0 to 2000m					
Installation location	Inside a control panel (IP54 or higher)					
Overvoltage category *1	III or less					
Pollution degree *2	2 or less					
Equipment class	Class I					

*1 This indicates the section of the power supply to which the equipment is assumed to be connected between the public electrical power distribution network and the machinery within premises.

Category III applies to devices in fixed equipment such as switching device and industrial machine. The surge voltage withstand level for up to the rated voltage of 300V is 4000V.

*2 This index indicates the degree to which conductive material is generated in terms of the environment in which the equipment is used.

Pollution level 2 is when only non-conductive pollution occurs. A temporary conductivity caused by condensing must be expected occasionally.

*3 The storage ambient temperature is -20 to 75 if the system includes any CC-Link safety relay modules or extension safety relay modules.

*4 Do not use or store the programmable controller under pressure higher than the atmospheric pressure of altitude 0m. Doing so may cause malfunction. When using the programmable controller under pressure, please consult your local Mitsubishi Electric representative.

2.1 Safety Standards

Normes de sécurité

Use the product according to the following safety standards.

Region	Safety Standards
International	ISO13849-1: 2015, IEC60204-1(ed6)
Europe	EN ISO13849-1: 2015, EN60204-1:2018, EN61496-1: 2013, EN50178: 1997, EN55011:2016+A1:2017+A11:2020 ^{*1} , EN IEC61000-6-2:2019
North America	UL508

*1 The standard was not part of the TÜV SÜD certification.

Utiliser le produit dans le respect des normes de sécurité suivantes.

Région	Normes de sécurité
International	ISO13849-1: 2015, IEC60204-1(ed6)
Europe	EN ISO13849-1:2015, EN60204-1:2018, EN61496-1:2013, EN50178:1997, EN55011:2016+A1:2017+A11:2020 ^{*1} , EN IEC61000-6-2:2019
Amérique du Nord	UL508

*1 La norme ne faisait pas partie de la certification TÜV SÜD.

2.2 Module Replacement

Replace the module according to the following replacement cycle.

Module	Replacement Cycle
Safety relay module	10 years

2.3 Safety Category and Performance level

As the following table, a system complying with Category and Performance level of EN ISO13849-1 can be configured depending on the safety input device to be connected and rated load current.

Condition	Safety input device to be connected		Rated load current		EN ISO13849-1	
	Contact-type input device	Type 4 light curtain	5.0A max.	3.6A max.	Category	Performance level (PL)
Dual input with positive commons (Input P type)	Yes	—	Yes	—	3	d
	Yes	—	—	Yes	3	d
	—	Yes	Yes	—	3	d
	—	Yes	—	Yes	4	e
Dual input with positive common and negative common (Input N type)	Yes	—	Yes	—	3	d
	Yes	—	—	Yes	4	e
	—	Not connectable	—	—	—	—

2.4 Response time

The following table shows the response time of the safety output.

- Time unit output ON (safety input ON → safety output ON): 50ms or less^{*1}
- Time unit output OFF (safety input OFF → safety output OFF): 20ms or less

*1 Manual operation such as start-up switch operation is excluded.

2.5 Wiring Diagrams

(1) QS90SR2SP-Q

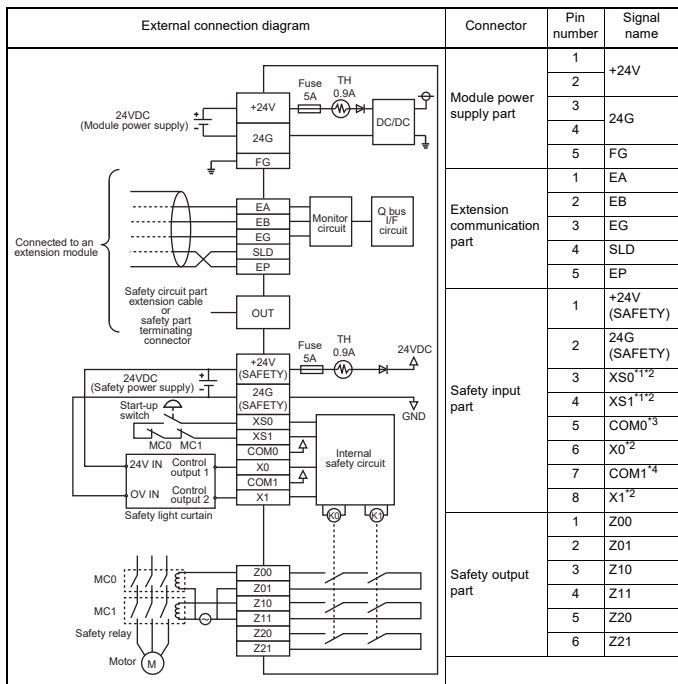

English	French	English	French
External connection diagram	<i>Schéma des connexions externes</i>	Safety output part	<i>Partie sortie de sécurité</i>
Connector	<i>Connecteur</i>	Connected to an extension module	<i>Raccordé à un module d'extension</i>
Pin number	<i>Broche N°</i>	Safety circuit part extension cable or safety part terminating connector	<i>Câble d'extension partie circuit de sécurité ou connecteur d'extrémité partie sécurité</i>
Signal name	<i>Nom de signal</i>	Fuse	<i>Fusible</i>
Module power supply part	<i>Partie alimentation du module</i>	Monitor circuit	<i>Circuit de contrôle</i>
Extension communication part	<i>Partie communication d'extension</i>	Q bus I/F circuit	<i>Circuit I/F de bus Q</i>
Safety input part	<i>Partie entrée de sécurité</i>	Start-up switch	<i>Commutateur de démarrage</i>
Control output 1	<i>Sortie de commande 1</i>	Control output 2	<i>Sortie de commande 2</i>
Safety light curtain	<i>Rideau lumineux de sécurité</i>	Internal safety circuit	<i>Circuit de sécurité interne</i>
Safety relay	<i>Relais de sécurité</i>	Motor	<i>Moteur</i>

- *1 When connecting an electromagnetic switch and such for output, connect its normally closed contacts in series between XS0 and XS1.
- *2 Do not connect equipment other than a switch or sensor to each terminal of X0, X1, XS0, and XS1.
- *3 X0 and X1 must be connected to different common terminals. Connect X0 to COM0.
- *4 X0 and X1 must be connected to different common terminals. Connect X1 to COM1.
- *1 *Pour raccorder en sortie une organe de coupure comme un commutateur électromagnétique, en raccorder les contacts normalement fermés en série entre XS0 et XS1.*
- *2 *Ne pas raccorder d'équipement autre qu'un commutateur ou un capteur à chacune des bornes de X0, X1, XS0 et XS1.*
- *3 *X0 et X1 se raccordent à des bornes communes différentes. Destination de connexion commun de X0 est COM0.*
- *4 *X0 et X1 se raccordent à des bornes communes différentes. Destination de connexion commun de X1 est COM1.*

(2) QS90SR2SN-Q

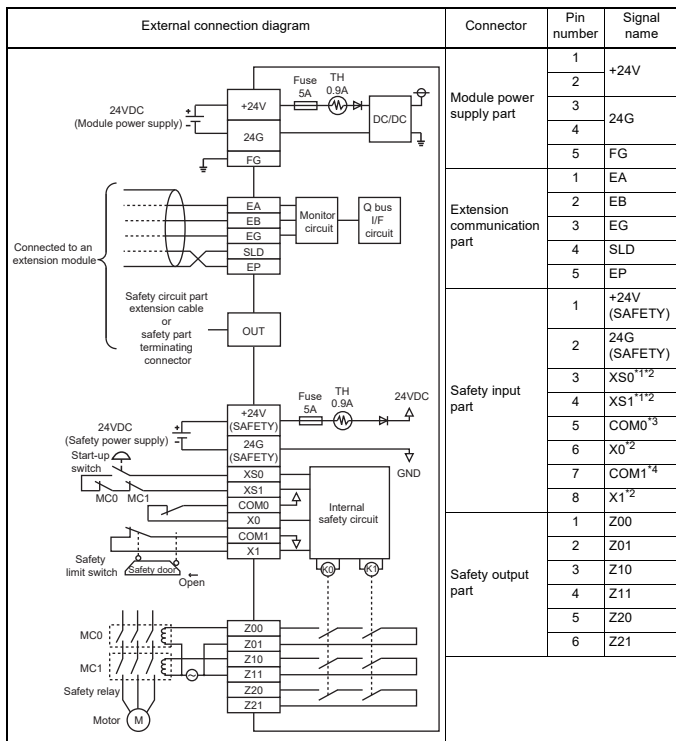

English	French	English	French
External connection diagram	<i>Schéma des connexions externes</i>	Safety circuit part extension cable or safety part terminating connector	<i>Câble d'extension partie circuit de sécurité ou connecteur d'extrémité partie sécurité</i>
Connector	<i>Connecteur</i>	Fuse	<i>Fusible</i>
Pin number	<i>Broche N°</i>	Monitor circuit	<i>Circuit de contrôle</i>
Signal name	<i>Nom de signal</i>	Q bus I/F circuit	<i>Circuit I/F de bus Q</i>
Module power supply part	<i>Partie alimentation du module</i>	Start-up switch	<i>Commutateur de démarrage</i>
Extension communication part	<i>Partie communication d'extension</i>	Safety limit switch	<i>Interrupteur de fin de course de sécurité</i>
Safety input part	<i>Partie entrée de sécurité</i>	Safety door	<i>Porte de sécurité</i>
Safety output part	<i>Partie sortie de sécurité</i>	Internal safety circuit	<i>Circuit de sécurité interne</i>
Connected to an extension module	<i>Raccordé à un module d'extension</i>	Safety relay	<i>Relais de sécurité</i>
Motor	<i>Moteur</i>		

- *1 When connecting an electromagnetic switch and such for output, connect its normally closed contacts in series between XS0 and XS1.
- *2 Do not connect equipment other than a switch or sensor to each terminal of X0, X1, XS0, and XS1.
- *3 X0 and X1 must be connected to different common terminals. Connect X0 to COM0.
- *4 X0 and X1 must be connected to different common terminals. Connect X1 to COM1.
- *1 *Pour raccorder en sortie une organe de coupure comme un commutateur électromagnétique, en raccorder les contacts normalement fermés en série entre XS0 et XS1.*
- *2 *Ne pas raccorder d'équipement autre qu'un commutateur ou un capteur à chacune des bornes de X0, X1, XS0 et XS1.*
- *3 *X0 et X1 se raccordent à des bornes communes différentes. Destination de connexion commun de X0 est COM0.*
- *4 *X0 et X1 se raccordent à des bornes communes différentes. Destination de connexion commun de X1 est COM1.*

(3) QS90SR2SP-CC

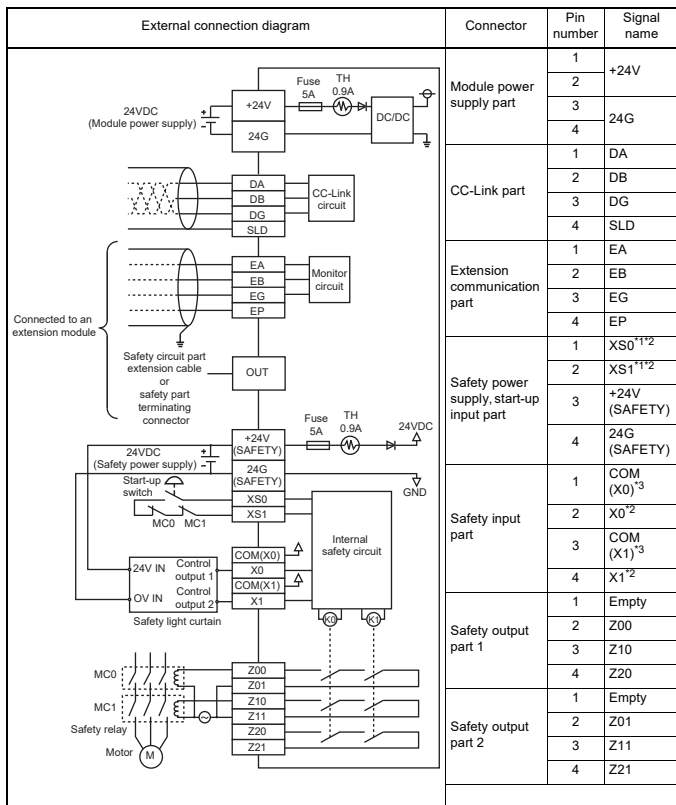

English	French	English	French
External connection diagram	<i>Schéma des connexions externes</i>	Safety circuit part extension cable or safety part terminating connector	<i>Câble d'extension partie circuit de sécurité ou connecteur d'extrémité partie sécurité</i>
Connector	<i>Connecteur</i>	Fuse	<i>Fusible</i>
Pin number	<i>Broche N°</i>	Monitor circuit	<i>Circuit de contrôle</i>
Signal name	<i>Nom de signal</i>	CC-Link circuit	<i>Circuit CC-Link</i>
Module power supply part	<i>Partie alimentation du module</i>	Start-up switch	<i>Commutateur de démarrage</i>
CC-Link part	<i>Partie CC-Link</i>	Control output 1	<i>Sortie de commande 1</i>
Extension communication part	<i>Partie communication d'extension</i>	Control output 2	<i>Sortie de commande 2</i>
Safety power supply, start-up input part	<i>Alimentation de sécurité, partie entrée de démarrage</i>	Safety light curtain	<i>Rideau lumineux de sécurité</i>
Safety input part	<i>Partie entrée de sécurité</i>	Internal safety circuit	<i>Circuit de sécurité interne</i>
Safety output part 1	<i>Partie sortie de sécurité 1</i>	Safety relay	<i>Relais de sécurité</i>
Safety output part 2	<i>Partie sortie de sécurité 2</i>	Motor	<i>Moteur</i>
Connected to an extension module	<i>Raccordé à un module d'extension</i>		

- *1 When connecting an electromagnetic switch and such for output, connect its normally closed contacts in series between XS0 and XS1.
- *2 Do not connect equipment other than a switch or sensor to each terminal of X0, X1, XS0, and XS1.
- *3 X0 and X1 must be connected to different common terminals. Pay attention to the printing on the module at the time of wiring.
In the external connection diagram, they are represented as COM (X0) and COM (X1).
- *1 *Pour raccorder en sortie une organe de coupure comme un commutateur électromagnétique, en raccorder les contacts normalement fermés en série entre XS0 et XS1.*
- *2 *Ne pas raccorder d'équipement autre qu'un commutateur ou un capteur à chacune des bornes de X0, X1, XS0 et XS1.*
- *3 *Les bornes communes ne sont pas les mêmes pour X0 et X1. Lors du câblage, prêter attention aux inscriptions sur le module.
Sur le schéma des connexions externes, les indications correspondantes sont COM (X0) et COM (X1).*

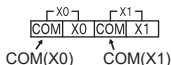

(4) QS90SR2SN-CC

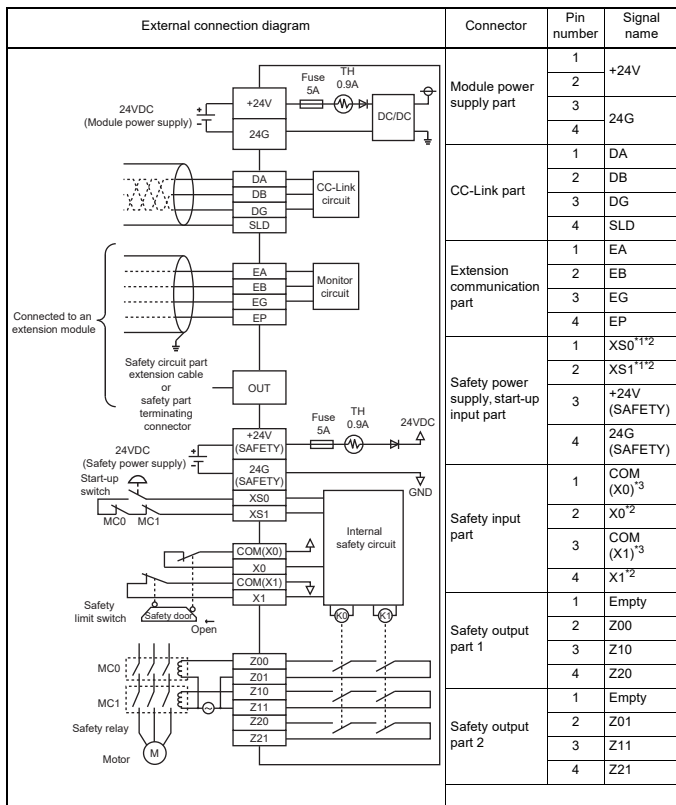

English	French	English	French
External connection diagram	<i>Schéma des connexions externes</i>	Safety circuit part extension cable or safety part terminating connector	<i>Câble d'extension partie circuit de sécurité ou connecteur d'extrémité partie sécurité</i>
Connector	<i>Connecteur</i>	Fuse	<i>Fusible</i>
Pin number	<i>Broche N°</i>	Monitor circuit	<i>Circuit de contrôle</i>
Signal name	<i>Nom de signal</i>	CC-Link circuit	<i>Circuit CC-Link</i>
Module power supply part	<i>Partie alimentation du module</i>	Start-up switch	<i>Commutateur de démarrage</i>
CC-Link part	<i>Partie CC-Link</i>	Safety limit switch	<i>Interrupteur de fin de course de sécurité</i>
Extension communication part	<i>Partie communication d'extension</i>	Safety door	<i>Porte de sécurité</i>
Safety power supply, start-up input part	<i>Alimentation de sécurité, partie entrée de démarrage</i>	Internal safety circuit	<i>Circuit de sécurité interne</i>
Safety input part	<i>Partie entrée de sécurité</i>	Safety relay	<i>Relais de sécurité</i>
Safety output part 1	<i>Partie sortie de sécurité 1</i>	Motor	<i>Moteur</i>
Safety output part 2	<i>Partie sortie de sécurité 2</i>	Connected to an extension module	<i>Raccordé à un module d'extension</i>

- *1 When connecting an electromagnetic switch and such for output, connect its normally closed contacts in series between XS0 and XS1.
- *2 Do not connect equipment other than a switch or sensor to each terminal of X0, X1, XS0, and XS1.
- *3 X0 and X1 must be connected to different common terminals. Pay attention to the printing on the module at the time of wiring.
In the external connection diagram, they are represented as COM (X0) and COM (X1).
- *1 *Pour raccorder en sortie une organe de coupure comme un commutateur électromagnétique, en raccorder les contacts normalement fermés en série entre XS0 et XS1.*
- *2 *Ne pas raccorder d'équipement autre qu'un commutateur ou un capteur à chacune des bornes de X0, X1, XS0 et XS1.*
- *3 *Les bornes communes ne sont pas les mêmes pour X0 et X1. Lors du câblage, prêter attention aux inscriptions sur le module.
Sur le schéma des connexions externes, les indications correspondantes sont COM (X0) et COM (X1).*

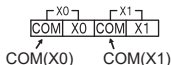

(5) QS90SR2SP-EX

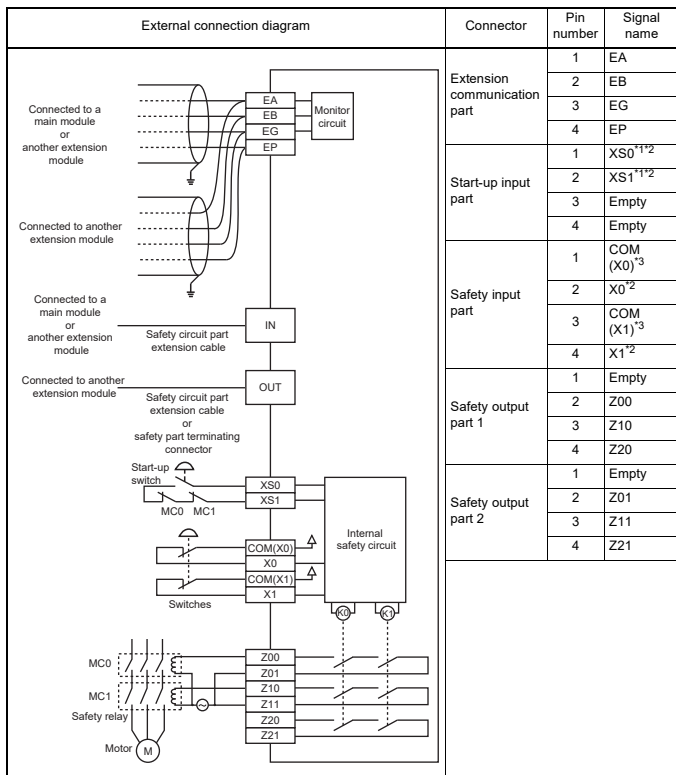

English	French	English	French
External connection diagram	<i>Schéma des connexions extermes</i>	Connected to another extension module	<i>Raccordé à un autre module d'extension</i>
Connector	<i>Connecteur</i>	Monitor circuit	<i>Circuit de contrôle</i>
Pin number	<i>Broche N°</i>	Safety circuit part extension cable	<i>Câble d'extension partie circuit de sécurité</i>
Signal name	<i>Nom de signal</i>	Safety circuit part extension cable or safety part terminating connector	<i>Câble d'extension partie circuit de sécurité ou connecteur d'extrémité partie sécurité</i>
Extension communication part	<i>Partie communication d'extension</i>	Start-up switch	<i>Commutateur de démarrage</i>
Start-up input part	<i>Partie entrée de démarrage</i>	Switches	<i>Commutateurs</i>
Safety input part	<i>Partie entrée de sécurité</i>	Internal safety circuit	<i>Circuit de sécurité interne</i>
Safety output part 1	<i>Partie sortie de sécurité 1</i>	Safety relay	<i>Relais de sécurité</i>
Safety output part 2	<i>Partie sortie de sécurité 2</i>	Motor	<i>Moteur</i>
Connected to a main module or another extension module	<i>Raccordé à un module principal ou à un autre module d'extension.</i>		

- *1 When connecting an electromagnetic switch and such for output, connect its normally closed contacts in series between XS0 and XS1.
- *2 Do not connect equipment other than a switch or sensor to each terminal of X0, X1, XS0, and XS1.
- *3 X0 and X1 must be connected to different common terminals. Pay attention to the printing on the module at the time of wiring.
In the external connection diagram, they are represented as COM (X0) and COM (X1).
- *1 *Pour raccorder en sortie une organe de coupure comme un commutateur électromagnétique, en raccorder les contacts normalement fermés en série entre XS0 et XS1.*
- *2 *Ne pas raccorder d'équipement autre qu'un commutateur ou un capteur à chacune des bornes de X0, X1, XS0 et XS1.*
- *3 *Les bornes communes ne sont pas les mêmes pour X0 et X1. Lors du câblage, prêter attention aux inscriptions sur le module.
Sur le schéma des connexions externes, les indications correspondantes sont COM (X0) et COM (X1).*

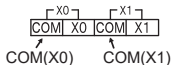

(6) QS90SR2SN-EX

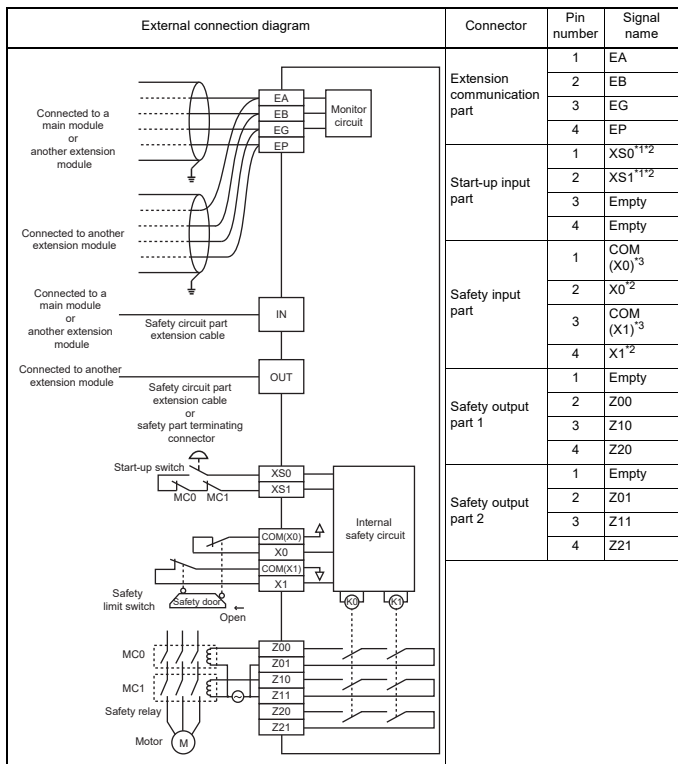

English	French	English	French
External connection diagram	<i>Schéma des connexions externes</i>	Connected to another extension module	<i>Raccordé à un autre module d'extension</i>
Connector	<i>Connecteur</i>	Monitor circuit	<i>Circuit de contrôle</i>
Pin number	<i>Broche N°</i>	Safety circuit part extension cable	<i>Câble d'extension partie circuit de sécurité</i>
Signal name	<i>Nom de signal</i>	Safety circuit part extension cable or safety part terminating connector	<i>Câble d'extension partie circuit de sécurité ou connecteur d'extrémité partie sécurité</i>
Extension communication part	<i>Partie communication d'extension</i>	Start-up switch	<i>Commutateur de démarrage</i>
Start-up input part	<i>Partie entrée de démarrage</i>	Safety limit switch	<i>Interrupteur de fin de course de sécurité</i>
Safety input part	<i>Partie entrée de sécurité</i>	Safety door	<i>Porte de sécurité</i>
Safety output part 1	<i>Partie sortie de sécurité 1</i>	Internal safety circuit	<i>Circuit de sécurité interne</i>
Safety output part 2	<i>Partie sortie de sécurité 2</i>	Safety relay	<i>Relais de sécurité</i>
Connected to a main module or another extension module	<i>Raccordé à un module principal ou à un autre module d'extension.</i>	Motor	<i>Moteur</i>

- *1 When connecting an electromagnetic switch and such for output, connect its normally closed contacts in series between XS0 and XS1.
- *2 Do not connect equipment other than a switch or sensor to each terminal of X0, X1, XS0, and XS1.
- *3 X0 and X1 must be connected to different common terminals. Pay attention to the printing on the module at the time of wiring.
In the external connection diagram, they are represented as COM (X0) and COM (X1).
- *1 *Pour raccorder en sortie un organe de coupure comme un commutateur électromagnétique, en raccorder les contacts normalement fermés en série entre XS0 et XS1.*
- *2 *Ne pas raccorder d'équipement autre qu'un commutateur ou un capteur à chacune des bornes de X0, X1, XS0 et XS1.*
- *3 *Les bornes communes ne sont pas les mêmes pour X0 et X1. Lors du câblage, prêter attention aux inscriptions sur le module.
Sur le schéma des connexions externes, les indications correspondantes sont COM (X0) et COM (X1).*

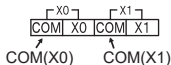

3. MODULE STATUS AFTER POWER-ON AND LED INDICATION

A safety programmable controller performs initial processing (such as self-diagnostics) after power-on or reset. The LEDs of each module indicate the module operating status after initial processing.

(1) Q Series safety relay module

No.	Name	Application
1)	PW LED	Indicates the status of module power supply. On: Power is being supplied. Off: Power is not supplied or an electric fuse has blown.
2)	ERR. LED	Indicates the host station error status. Flashing: A self-diagnostics error has occurred or power is not supplied. Off: The module is operating normally.
3)	Z LED	Indicates the status of the safety output. On: The module is outputting a safety signal. Off: The module is not outputting a safety signal.
4)	X0, X1 LED	Indicates the status of safety power supply. On: Power is being supplied. Off: Power is not supplied or an electric fuse has blown.
5)	S PW LED	Indicates the status of safety power supply. On: Power is being supplied. Off: Power is not supplied or an electric fuse has blown.
6)	K0, K1 LED	Indicates the operating status (coil status) of the internal safety relay (K0, K1). On: The operating status of the internal safety relay is on. Off: The operating status of the internal safety relay is off.

(2) CC-Link safety relay module

No.	Name	Application
1)	PW LED	Refer to Q series safety relay module.
2)	ERR. LED	Refer to Q series safety relay module.
3)	L RUN LED	Indicates the communication status in the CC-Link system. On: The module is communicating normally. Off: The module is not communicating. (A timeout error has occurred.)
4)	SD LED	On: The module is sending data.
5)	RD LED	On: The module is receiving data.
6)	L ERR. LED	Indicates a communication error in the CC-Link system. On: A setting value of the station number setting switch or the transmission speed setting switch is out of range. Flashing regularly: A setting value of the station number setting switch or the transmission speed setting switch has been changed during operation. Flashing irregularly: A terminating resistor is not attached or is wrongly attached. Or, the module is affected by noise. Off: The module is communicating normally.
7)	S PW LED	Refer to Q series safety relay module.
8)	Z LED	Refer to Q series safety relay module.
9)	X0, X1 LED	Refer to Q series safety relay module.
10)	K0, K1 LED	Refer to Q series safety relay module.

(3) Extension safety relay module

No.	Name	Application
1)	PW LED	Refer to Q series safety relay module.
2)	ERR. LED	Indicates the host station error status. Flashing: A self-diagnostics error has occurred, power is not supplied, or communication with upper module(s) is disabled. Off: The module is operating normally.
3)	Z LED	Refer to Q series safety relay module.
4)	X0, X1 LED	Refer to Q series safety relay module.
5)	K0, K1 LED	Refer to Q series safety relay module.

4. INSTALLATION

When installing a programmable controller to a control panel or similar, fully consider its operability, maintainability, and environmental resistance. For details, refer to the Safety Relay Module User's Manual.

4.1 Q Series Safety Relay Module

(1) Installation position

Keep the clearances shown below between the top/ bottom faces of the modules and the control panel or other parts so that good ventilation is ensured and the modules can be easily replaced.

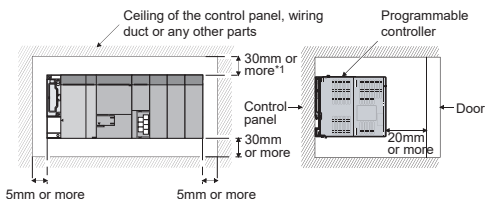

*1: A clearance required when the wiring duct is 50mm or less in height.
A 40mm or more clearance is required when the wiring duct is longer.

(2) Module mounting orientation

(a) Mount modules in the following orientation to ensure good ventilation for heat release.

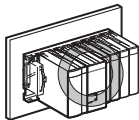

(b) Do not mount modules in the following orientations.

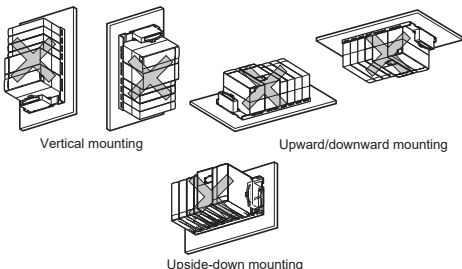

(3) Installation precautions

(a) Install a base unit on a flat surface.

If the surface is not flat, the printed circuit board is distorted, resulting in malfunction of the modules mounted.

(b) If there is a vibration source, such as an electromagnetic contactor or no fuse breaker, separate the control panel or keep enough clearance from the vibration source to install the programmable controller.

In addition, keep the clearances shown below between the programmable controller and devices (such as contactors and relays) to avoid being affected by radiated noise or heat.

- In front of the programmable controller: 100mm or more
- On the right or left of the programmable controller: 50mm or more

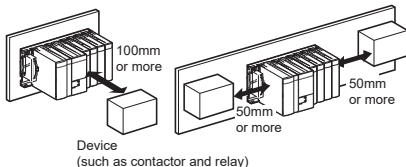

(c) When installing a programmable controller to a control panel, do not mount any module in the rightmost slot of the base unit. Before uninstalling, remove the module mounted in the rightmost slot of the base unit.

4.2 CC-Link Safety Relay Module, Extension Safety Relay Module

(1) Installation orientations

The CC-Link safety relay module and extension safety relay module can be installed in five orientations as shown below.

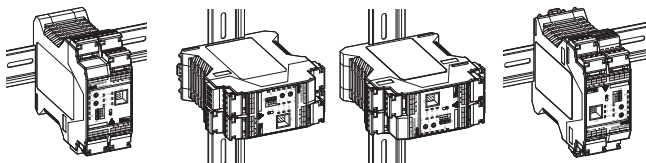

Vertical or horizontal installation

Upward installation

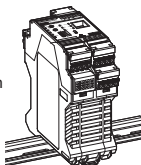

When mounting a module, make room for 5cm or more at above and below of the module for ventilation.

When powering ON a contact at 3A or more consecutively, make room for 5mm or more at the sides of the contact for ventilation.

5. SAFETY CIRCUIT PART EXTENSION CABLES

The following table shows the specifications of cables used for adding a safety relay module. Use the following cable for adding the safety part. If using a cable other than the following, the operation is not guaranteed.

Name	Model	Cable length
Safety circuit part extension cable	QS90CBL-SE01	10cm
	QS90CBL-SE15	1.5m

6. SPRING CLAMP TERMINAL BLOCK

(1) Method for connecting a cable to the spring clamp terminal block

(a) Connecting a cable

1) For module power supply part/safety power supply part/safety input part/safety output part terminal block

While pressing the open/close button with a flathead screwdriver, insert a cable into the insertion hole.

For use of bar terminals, the cable can be inserted without pressing the open/close button.

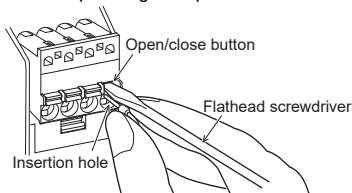

2) For extension communication part terminal block

Insert a flathead screwdriver into the open/close button, and insert a cable into the hole while pressing the driver.

For use of bar terminals, the cable can be inserted without pressing the open/close button.

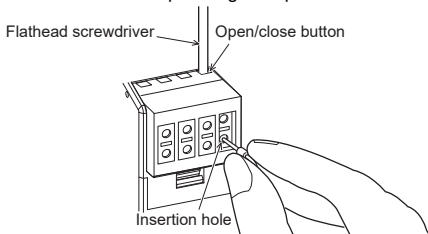

Pay attention when using a flathead screwdriver to push the open/close button of the spring clamp terminal block. Failure to do so can result in an injury.

- (b) Disconnecting a cable
- 1) For module power supply part/safety power supply part/safety input part/safety output part terminal block
While fully pressing the open/close button with a flathead screwdriver, pull out the cable.
 - 2) For extension communication part terminal block
While fully inserting a flathead screwdriver into the open/close button, pull out the cable from the insertion hole.

7. PRECAUTIONS FOR USE

Users must prove that their entire safety system complies with the safety standards and the Machinery Directive. The third-party certification organization will validate the safety of product for the entire safety system, including a safety relay module and safety components. To establish a safety system, calculate the target performance level (PL) for each safety application (safety function) based on the MTTFd and DCavg values of the safety relay module and connected safety components. The calculation equation is shown in ISO13849-1: 2015.

MTTFd and DCavg of the safety relay module are shown in following.

Module	MTTFd	DCavg
Safety relay module	>100 years	99%

8. EU DECLARATION OF CONFORMITY FOR MACHINERY DIRECTIVE



EU DECLARATION OF CONFORMITY

We,

Manufacturer : MITSUBISHI ELECTRIC CORPORATION
Address : TOKYO 100-8310, JAPAN
(Place of Declare)
Brand Name :  MITSUBISHI

declare under our sole responsibility that the product

Description : Safety Relay Module
Type of Model : MELSEC-QS series
Notice : Refer to next page about each type name

to which this declaration relates is in conformity with the following standard and directive.

Directive		Harmonized Standard	Notified Body
EMC Directive	2014/30/EU	EN IEC 61000-6-2:2019 EN55011:2016+A1:2017+A11:2020	—
Machinery Directive	2006/42/EC	EN ISO 13849-1:2015	1
RoHS Directive	2011/65/EU,(EU)2015/863*1	EN IEC 63000:2018	—

*1: Category 9 "Industrial monitoring and control instruments" is applicable.

This declaration is based on the conformity assessment of following Notified Body			
No.	Name and Address	Identification Number	Issued certificate No.
1	TUV SUD PRODUCT SERVICE GMBH, Ridlerstraße 65 80339 München Germany	0123	M6A 066509 0057

Authorized representative in Europe
(The person authorized to compile the Technical file or relevant Technical documentation)
Hartmut Pütz
FA Product Marketing, Director, MITSUBISHI ELECTRIC EUROPE B.V., German Branch
Mitsubishi-Electric-Platz 1, 40882 Ratingen, Germany
Issue Date (Date of Declaration): 8 Mar. 2022

Signed for and on behalf of

(Signature) 

[Takahiko Yamanaka]
Senior Manager, FA Standard Module Development Section
FA Systems Dept.2
MITSUBISHI ELECTRIC CORPORATION NAGOYA WORKS

BCN-P9999-0621-K

Appendix List of type name to declare

QS90SR2SN-CC
QS90SR2SN-EX
QS90SR2SN-Q
QS90SR2SP-CC
QS90SR2SP-EX
QS90SR2SP-Q

WARRANTY

Please confirm the following product warranty details before using this product.

1. Limited Warranty and Product Support.

- a. Mitsubishi Electric Company ("MELCO") warrants that for a period of eighteen (18) months after date of delivery from the point of manufacture or one year from date of Customer's purchase, whichever is less, Mitsubishi MELSEC Safety programmable logic controllers (the "Products") will be free from defects in material and workmanship.
- b. At MELCO's option, for those Products MELCO determines are not as warranted, MELCO shall either repair or replace them or issue a credit or return the purchase price paid for them.
- c. For this warranty to apply:
 - (1) Customer shall give MELCO (i) notice of a warranty claim to MELCO and the authorized dealer or distributor from whom the Products were purchased, (ii) the notice shall describe in reasonable details the warranty problem, (iii) the notice shall be provided promptly and in no event later than thirty (30) days after the Customer knows or has reason to believe that Products are not as warranted, and (iv) in any event, the notice must be given within the warranty period;
 - (2) Customer shall cooperate with MELCO and MELCO's representatives in MELCO's investigation of the warranty claim, including preserving evidence of the claim and its causes, meaningfully responding to MELCO's questions and investigation of the problem, grant MELCO access to witnesses, personnel, documents, physical evidence and records concerning the warranty problem, and allow MELCO to examine and test the Products in question onsite or at the premises where they are installed or used; and
 - (3) If MELCO requests, Customer shall remove Products it claims are defective and ship them to MELCO or MELCO's authorized representative for examination and, if found defective, for repair or replacement. The costs of removal, shipment to and from MELCO's designated examination point, and reinstallation of repaired or replaced Products shall be at Customer's expense.
 - (4) If Customer requests and MELCO agrees to effect repairs onsite at any domestic or overseas location, the Customer will pay for the costs of sending repair personnel and shipping parts. MELCO is not responsible for any re-commissioning, maintenance, or testing on-site that involves repairs or replacing of the Products.
- d. Repairs of Products located outside of Japan are accepted by MELCO's local authorized service facility centers ("FA Centers"). Terms and conditions on which each FA Center offers repair services for Products that are out of warranty or not covered by MELCO's limited warranty may vary.
- e. Subject to availability of spare parts, MELCO will offer Product repair services for (7) years after each Product model or line is discontinued, at MELCO's or its FA Centers' rates and charges and standard terms in effect at the time of repair. MELCO usually produces and retains sufficient spare parts for repairs of its Products for a period of seven (7) years after production is discontinued.
- f. MELCO generally announces discontinuation of Products through MELCO's Technical Bulletins. Products discontinued and repair parts for them may not be available after their production is discontinued.

2. Limits of Warranties.

- a. MELCO does not warrant or guarantee the design, specify, manufacture, construction or installation of the materials, construction criteria, functionality, use, properties or other characteristics of the equipment, systems, or production lines into which the Products may be incorporated, including any safety, fail-safe and shut down systems using the Products.
- b. MELCO is not responsible for determining the suitability of the Products for their intended purpose and use, including determining if the Products provide appropriate safety margins and redundancies for the applications, equipment or systems into which they are incorporated.
- c. Customer acknowledges that qualified and experienced personnel are required to determine the suitability, application, design, construction and proper installation and integration of the Products. MELCO does not supply such personnel.
- d. MELCO is not responsible for designing and conducting tests to determine that the Product functions appropriately and meets application standards and requirements as installed or incorporated into the end-user's equipment, production lines or systems.
- e. MELCO does not warrant any Product:
- (1) repaired or altered by persons other than MELCO or its authorized engineers or FA Centers;
 - (2) subjected to negligence, carelessness, accident, misuse, or damage;
 - (3) improperly stored, handled, installed or maintained;
 - (4) integrated or used in connection with improperly designed, incompatible or defective hardware or software;
 - (5) that fails because consumable parts such as batteries, backlights, or fuses were not tested, serviced or replaced;
 - (6) operated or used with equipment, production lines or systems that do not meet applicable and commensurate legal, safety and industry-accepted standards;
 - (7) operated or used in abnormal applications;
 - (8) installed, operated or used in contravention of instructions, precautions or warnings contained in MELCO's user, instruction and/or safety manuals, technical bulletins and guidelines for the Products;
 - (9) used with obsolete technologies or technologies not fully tested and widely accepted and in use at the time of the Product's manufacture;
 - (10) subjected to excessive heat or moisture, abnormal voltages, shock, excessive vibration, physical damage or other improper environment; or
 - (11) damaged or malfunctioning due to Acts of God, fires, acts of vandals, criminals or terrorists, communication or power failures, or any other cause or failure that results from circumstances beyond MELCO's control.
- f. All Product information and specifications contained on MELCO's website and in catalogs, manuals, or technical information materials provided by MELCO are subject to change without prior notice.
- g. The Product information and statements contained on MELCO's website and in catalogs, manuals, technical bulletins or other materials provided by MELCO are provided as a guide for Customer's use. They do not constitute warranties and are not incorporated in the contract of sale for the Products.
- h. These terms and conditions constitute the entire agreement between Customer and MELCO with respect to warranties, remedies and damages and supersede any other understandings, whether written or oral, between the parties. Customer expressly acknowledges that any representations or statements made by MELCO or others concerning the Products outside these terms are not part of the basis of the bargain between the parties and are not factored into the pricing of the Products.
- i. THE WARRANTIES AND REMEDIES SET FORTH IN THESE TERMS ARE THE EXCLUSIVE AND ONLY WARRANTIES AND REMEDIES THAT APPLY TO THE PRODUCTS.
- j. MELCO DISCLAIMS THE IMPLIED WARRANTIES OF MERCHANTABILITY AND FITNESS FOR A PARTICULAR PURPOSE.

3. Limits on Damages.

- a. MELCO'S MAXIMUM CUMULATIVE LIABILITY BASED ON ANY CLAIMS FOR BREACH OF WARRANTY OR CONTRACT, NEGLIGENCE, STRICT TORT LIABILITY OR OTHER THEORIES OF RECOVERY REGARDING THE SALE, REPAIR, REPLACEMENT, DELIVERY, PERFORMANCE, CONDITION, SUITABILITY, COMPLIANCE, OR OTHER ASPECTS OF THE PRODUCTS OR THEIR SALE, INSTALLATION OR USE SHALL BE LIMITED TO THE PRICE PAID FOR PRODUCTS NOT AS WARRANTED.
- b. Although MELCO has obtained the certification for Product's compliance to the international safety standard ISO13849-1 from TUV SUD, this fact does not guarantee that Product will be free from any malfunction or failure. The user of this Product shall comply with any and all applicable safety standard, regulation or law and take appropriate safety measures for the system in which the Product is installed or used and shall take the second or third safety measures other than the Product. MELCO is not liable for damages that could have been prevented by compliance with any applicable safety standard, regulation or law.
- c. MELCO prohibits the use of Products with or in any application involving power plants, trains, railway systems, airplanes, airline operations, other transportation systems, amusement equipments, hospitals, medical care, dialysis and life support facilities or equipment, incineration and fuel devices, handling of nuclear or hazardous materials or chemicals, mining and drilling, and other applications where the level of risk to human life, health or property are elevated.
- d. MELCO SHALL NOT BE LIABLE FOR SPECIAL, INCIDENTAL, CONSEQUENTIAL, INDIRECT OR PUNITIVE DAMAGES, FOR LOSS OF PROFITS, SALES, OR REVENUE, FOR INCREASED LABOR OR OVERHEAD COSTS, FOR DOWNTIME OR LOSS OF PRODUCTION, FOR COST OVERRUNS, OR FOR ENVIRONMENTAL OR POLLUTION DAMAGES OR CLEAN-UP COSTS, WHETHER THE LOSS IS BASED ON CLAIMS FOR BREACH OF CONTRACT OR WARRANTY, VIOLATION OF STATUTE, NEGLIGENCE OR OTHER TORT, STRICT LIABILITY OR OTHERWISE.
- e. In the event that any damages which are asserted against MELCO arising out of or relating to the Products or defects in them, consist of personal injury, wrongful death and/or physical property damages as well as damages of a pecuniary nature, the disclaimers and limitations contained in these terms shall apply to all three types of damages to the fullest extent permitted by law. If, however, the personal injury, wrongful death and/or physical property damages cannot be disclaimed or limited by law or public policy to the extent provided by these terms, then in any such event the disclaimer of and limitations on pecuniary or economic consequential and incidental damages shall nevertheless be enforceable to the fullest extent allowed by law.
- f. In no event shall any cause of action arising out of breach of warranty or otherwise concerning the Products be brought by Customer more than one year after the cause of action accrues.
- g. Each of the limitations on remedies and damages set forth in these terms is separate and independently enforceable, notwithstanding the unenforceability or failure of essential purpose of any warranty, undertaking, damage limitation, other provision of these terms or other terms comprising the contract of sale between Customer and MELCO.

4. Delivery/Force Majeure.

- a. Any delivery date for the Products acknowledged by MELCO is an estimated and not a promised date. MELCO will make all reasonable efforts to meet the delivery schedule set forth in Customer's order or the purchase contract but shall not be liable for failure to do so.
- b. Products stored at the request of Customer or because Customer refuses or delays shipment shall be at the risk and expense of Customer.
- c. MELCO shall not be liable for any damage to or loss of the Products or any delay in or failure to deliver, service, repair or replace the Products arising from shortage of raw materials, failure of suppliers to make timely delivery, labor difficulties of any kind, earthquake, fire, windstorm, flood, theft, criminal or terrorist acts, war, embargoes, governmental acts or rulings, loss or damage or delays in carriage, acts of God, vandals or any other circumstances reasonably beyond MELCO's control.

5. Choice of Law/Jurisdiction.

These terms and any agreement or contract between Customer and MELCO shall be governed by the laws of the State of New York without regard to conflicts of laws. To the extent any action or dispute is not arbitrated, the parties consent to the exclusive jurisdiction and venue of the federal and state courts located in the Southern District of the State of New York. Any judgment there obtained may be enforced in any court of competent jurisdiction.

6. Arbitration.

Any controversy or claim arising out of, or relating to or in connection with the Products, their sale or use or these terms, shall be settled by arbitration conducted in accordance with the Center for Public Resources (CPR) Rules for Non-Administered Arbitration of International Disputes, by a sole arbitrator chosen from the CPR's panels of distinguished neutrals. Judgment upon the award rendered by the Arbitrator shall be final and binding and may be entered by any court having jurisdiction thereof. The place of the arbitration shall be New York City, New York. The language of the arbitration shall be English. The neutral organization designated to perform the functions specified in Rule 6 and Rules 7.7(b), 7.8 and 7.9 shall be the CPR.

Country/ Region	Sales office/ Tel	Country/ Region	Sales office/ Tel
USA	MITSUBISHI ELECTRIC AUTOMATION, INC. 500 Corporate Woods Parkway, Vernon Hills, IL 60061, U.S.A. Tel : +1-847-478-2100	Turkey	MITSUBISHI ELECTRIC TURKEY A.Ş. Umraniye Branch Serifali Mah. Kale Sok. No:41 34775 Umraniye - Istanbul, Turkey Tel : +90-216-969-2500
Mexico	MITSUBISHI ELECTRIC AUTOMATION, INC. Mexico Branch Mariano Escobedo #69, Col. Zona Industrial, Tlalnepanitla Edo. Mexico, C.P.54030 Tel : +52-55-3067-7500	UAE	MITSUBISHI ELECTRIC EUROPE B.V. Dubai Branch Dubai Silicon Oasis, P.O.BOX 341241, Dubai, U.A.E. Tel : +971-4-3724716
Brazil	MITSUBISHI ELECTRIC DO BRASIL COMÉRCIO E SERVIÇOS LTDA. Avenida Adelino Cardana, 293, 21 andar, Bethaville, Barueri SP, Brazil Tel : +55-11-4689-3000	South Africa	ADROIT TECHNOLOGIES 20 Waterford Office Park, 189 Witkoppen Road, Fourways, South Africa Tel : +27-11-658-8100
Germany	MITSUBISHI ELECTRIC EUROPE B.V. German Branch Mitsubishi-Electric-Platz 1, 40882 Ratingen, Germany Tel : +49-2102-486-0	China	MITSUBISHI ELECTRIC AUTOMATION (CHINA) LTD. No.1386 Hongqiao Road, Mitsubishi Electric Automation Center, Shanghai, China Tel : +86-21-2322-3030
UK	MITSUBISHI ELECTRIC EUROPE B.V. UK Branch Travellers Lane, Hatfield, Hertfordshire, AL10 8XB, U.K. Tel : +44-1707-28-8780	Taiwan	SETSUYO ENTERPRISE CO., LTD. 6F, No.105, Wugong 3rd Road, Wugu District, New Taipei City 24889, Taiwan Tel : +886-2-2299-2499
Ireland	MITSUBISHI ELECTRIC EUROPE B.V. Irish Branch Westgate Business Park, Ballymount, Dublin 24, Ireland Tel : +353-1-4198800	Korea	MITSUBISHI ELECTRIC AUTOMATION KOREA CO., LTD. 7F-9F, Gangseo Hangang Xi-tower A, 401, Yangcheon-ro, Gangseo-Gu, Seoul 07528, Korea Tel : +82-2-3660-9530
Italy	MITSUBISHI ELECTRIC EUROPE B.V. Italian Branch Centro Direzionale Colleoni-Palazzo Sirio Viale Colleoni 7, 20864 Agrate Brianza(Milano) Italy Tel : +39-039-60531	Singapore	MITSUBISHI ELECTRIC ASIA PTE. LTD. 307, Alexandra Road, Mitsubishi Electric Building, Singapore 159943 Tel : +65-6473-2308
Spain	MITSUBISHI ELECTRIC EUROPE, B.V. Spanish Branch Carretera de Rubí, 76-80-Apdo. 420, 08190 Sant Cugat del Vallés (Barcelona), Spain Tel : +34-935-65-3131	Thailand	MITSUBISHI ELECTRIC FACTORY AUTOMATION (THAILAND) CO., LTD. 12th Floor, SV City Building, Office Tower 1, No. 896/19 and 20 Rama 3 Road, Kwaeng Bangpangpang, Khet Yannawa, Bangkok 10120, Thailand Tel : +66-2682-6522
France	MITSUBISHI ELECTRIC EUROPE B.V. French Branch 25, Boulevard des Bouvets, 92741 Nanterre Cedex, France Tel : +33-1-55-68-55-68	Vietnam	MITSUBISHI ELECTRIC VIETNAM COMPANY LIMITED Hanoi Branch 6th Floor, Detech Tower, 8 Ton That Thuyet Street, My Dinh 2 Ward, Nam Tu Liem District, Hanoi, Vietnam Tel : +84-4-3937-8075
Czech Republic	MITSUBISHI ELECTRIC EUROPE B.V. Czech Branch Avenir Business Park, Radlicka 751/113e, 158 00 Prahá5, Czech Republic Tel : +420-251-551-470	Malaysia	MITSUBISHI ELECTRIC SALES MALAYSIA SDN. BHD. Lot 11, Jalan 219, 46100 Petaling Jaya, Selangor Darul Ehsan, Malaysia Tel : +60-3-7626-5000
Poland	MITSUBISHI ELECTRIC EUROPE B.V. Polish Branch ul. Krakowska 50, 32-083 Balice, Poland Tel : +48-12-347-65-00	Indonesia	PT. MITSUBISHI ELECTRIC INDONESIA Gedung Jaya 11th Floor, JL. MH. Thamrin No.12, Jakarta Pusat 10340, Indonesia Tel : +62-21-3192-6461
Sweden	MITSUBISHI ELECTRIC EUROPE B.V. (Scandinavia) Fjellievägen 8, SE-22736 Lund, Sweden Tel : +46-8-625-10-00	India	MITSUBISHI ELECTRIC INDIA PVT. LTD. Pune Branch Emerald House, EL-3, J Block, M.I.D.C., Bhosari, Pune-411026, Maharashtra, India Tel : +91-20-2710-2000
Russia	MITSUBISHI ELECTRIC (RUSSIA) LLC St. Petersburg Branch Piskarevsky pr. 2, bld 2, lit "Sch", BC "Benua", office 720; 195027 St. Petersburg, Russia Tel : +7-812-633-3497	Australia	MITSUBISHI ELECTRIC AUSTRALIA PTY. LTD. 348 Victoria Road, P.O. Box 11, Rydalmere, N.S.W 2116, Australia Tel : +61-2-9684-7777

MITSUBISHI ELECTRIC CORPORATION

HEAD OFFICE : TOKYO BUILDING, 2-7-3 MARUNOUCHI, CHIYODA-KU, TOKYO 100-8310, JAPAN
NAGOYA WORKS : 1-14, YADA-MINAMI 5-CHOME, HIGASHI-KU, NAGOYA, JAPAN

When exported from Japan, this manual does not require application to the Ministry of Economy,
Trade and Industry for service transaction permission.

Specifications subject to change without notice.