



Programmable Controller

MELSEC **Q**series MELSEC *L*series

MELSEC-Q/L Ethernet Interface Module User's Manual (Application)

-QJ71E71-100
-QJ71E71-B5
-QJ71E71-B2
-LJ71E71-100

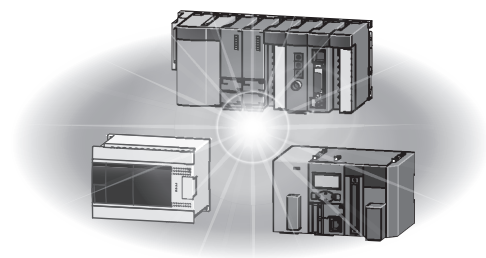

● SAFETY PRECAUTIONS ●

(Read these precautions before using this product.)

Before using this product, please read this manual and the relevant manuals carefully and pay full attention to safety to handle the product correctly.

The precautions given in this manual are concerned with this product only. For the safety precautions of the programmable controller system, refer to the user's manual for the CPU module used.

In this manual, the safety precautions are classified into two levels: "⚠ WARNING" and "⚠ CAUTION".



Indicates that incorrect handling may cause hazardous conditions, resulting in death or severe injury.



Indicates that incorrect handling may cause hazardous conditions, resulting in minor or moderate injury or property damage.

Under some circumstances, failure to observe the precautions given under "⚠ CAUTION" may lead to serious consequences.

Observe the precautions of both levels because they are important for personal and system safety.

Make sure that the end users read this manual and then keep the manual in a safe place for future reference.

Precautions for using the MELSEC-Q series Ethernet interface module

[Design Precautions]

WARNING

- For the operating status of each station after a communication failure, refer to relevant manuals for the network.
Failure to do so may result in an accident due to an incorrect output or malfunction.
- To prevent the malfunction of the programmable controller system due to harmful e-mails, take preventive measures (such as antivirus measures) so that the mail server for this module does not receive harmful e-mails.
- When connecting a peripheral with the CPU module or connecting a personal computer with an intelligent function module to modify data of a running programmable controller, configure an interlock circuit in the sequence program to ensure that the entire system will always operate safely.
For other forms of control (such as program modification or operating status change) of a running programmable controller, read the relevant manuals carefully and ensure that the operation is safe before proceeding.
Especially, when a remote programmable controller is controlled by an external device, immediate action cannot be taken if a problem occurs in the programmable controller due to a communication failure.
To prevent this, configure an interlock circuit in the sequence program, and determine corrective actions to be taken between the external device and CPU module in case of a communication failure.
- Do not write any data to the "system area" of the buffer memory in the intelligent function module.
Also, do not use any "use prohibited" signals as an output signal from the programmable controller CPU to the intelligent function module.
Doing so may cause malfunction of the programmable controller system.

[Design Precautions]

CAUTION

- Do not install the control lines or communication cables together with the main circuit lines or power cables.
Keep a distance of 100mm or more between them.
Failure to do so may result in malfunction due to noise.
- When changing the operating status of the programmable controller CPU (such as remote RUN/STOP) from the external device, select "Always wait for OPEN (Communication possible at STOP time)" for the "Initial timing" setting in the network parameter.
The communication line will be closed when "Do not wait for OPEN (Communications impossible at STOP time)" is selected and the remote STOP is executed from the external device.
Consequently, the programmable controller CPU cannot reopen the communication line, and the external device cannot execute the remote RUN.

[Security Precautions]

WARNING

- To maintain the security (confidentiality, integrity, and availability) of the programmable controller and the system against unauthorized access, denial-of-service (DoS) attacks, computer viruses, and other cyberattacks from external devices via the network, take appropriate measures such as firewalls, virtual private networks (VPNs), and antivirus solutions.

[Installation Precautions]

CAUTION

- Use the programmable controller in an environment that meets the general specifications in the user's manual for the CPU module used.
Failure to do so may result in electric shock, fire, malfunction, or damage to or deterioration of the product.
- To mount the module, while pressing the module mounting lever located in the lower part of the module, fully insert the module fixing projection(s) into the hole(s) in the base unit and press the module until it snaps into place.
Incorrect interconnection may cause malfunction, failure, or drop of the module.
When using the programmable controller in an environment of frequent vibrations, fix the module with a screw.
- Tighten the screws within the specified torque range.
Undertightening can cause drop of the screw, short circuit, or malfunction.
Overtightening can damage the screw and/or module, resulting in drop, short circuit, or malfunction.
- Shut off the external power supply (all phases) used in the system before mounting or removing a module.
Failure to do so may result in damage to the product.
- Do not directly touch any conductive parts and electronic components of the module.
Doing so can cause malfunction or failure of the module.

[Wiring Precautions]

CAUTION

- Connectors for external connection must be crimped or pressed with the tool specified by the manufacturer, or must be correctly soldered.
Incomplete connections may cause short circuit, fire, or malfunction.
- Shut off the external power supply for the system in all phases before connecting the AUI cable.
- When connecting a cable with connector to the module, connect the connector part to the module securely.
- Make sure to place the communication and power cables to be connected to the module in a duct or fasten them using a clamp.
If not, dangling cable may swing or inadvertently be pulled, resulting in damage to the module or cables or malfunction due to poor contact.
- Tighten the terminal screws using the specified torque.
Undertightening can cause short circuit or malfunction.
Overtightening can damage the screw and/or module, resulting in drop, short circuit, or malfunction.
- When disconnecting the cable from the module, do not pull the cable by the cable part.
For the cable with connector, hold the connector part of the cable.
For the cable connected to the terminal block, loosen the terminal screw.
Pulling the cable connected to the module may result in malfunction or damage to the module or cable.
- Prevent foreign matter such as dust or wire chips from entering the module.
Such foreign matter can cause a fire, failure, or malfunction.
- When a protective film is attached to the top of the module, remove it before system operation. If not, inadequate heat dissipation of the module may cause a fire, failure, or malfunction.
- Correctly solder coaxial cable connectors. Incomplete soldering may result in malfunction.

[Startup and Maintenance Precautions]

CAUTION

- Do not disassemble or modify the module. Doing so may cause failure, malfunction, injury, or a fire.
- Shut off the external power supply (all phases) used in the system before mounting or removing a module.
Failure to do so may cause the module to fail or malfunction.
- After the first use of the product, do not mount/remove the module to/from the base unit more than 50 times (in accordance with IEC 61131-2).
Exceeding the limit may cause malfunction.
- Do not touch any terminal while power is on.
Failure to do so may cause malfunction.
- Shut off the external power supply (all phases) used in the system before cleaning the module or retightening the terminal screws or module fixing screws.
Failure to do so may cause the module to fail or malfunction.
Undertightening can cause drop of the screw, short circuit, or malfunction.
Overtightening can damage the screw and/or module, resulting in drop, short circuit, or malfunction.
- Before handling the module, touch a conducting object such as a grounded metal to discharge the static electricity from the human body.
Failure to do so may cause the module to fail or malfunction.

[Operating Precautions]

CAUTION

- When changing data and operating status, and modifying program of the running programmable controller from a personal computer connected to an intelligent function module, read relevant manuals carefully and ensure the safety before operation.
Incorrect change or modification may cause system malfunction, damage to the machines, or accidents.

[Disposal Precautions]

CAUTION

- When disposing of this product, treat it as industrial waste.

Precautions for using the MELSEC-L series Ethernet interface module

[Design Precautions]

WARNING

- For the operating status of each station after a communication failure, refer to relevant manuals for the network. Failure to do so may result in an accident due to an incorrect output or malfunction.
- To prevent the malfunction of the programmable controller system due to harmful e-mails, take preventive measures (such as antivirus measures) so that the mail server for this module does not receive harmful e-mails.
- When connecting a peripheral with the CPU module or connecting an external device, such as a personal computer, with an intelligent function module to modify data of a running programmable controller, configure an interlock circuit in the program to ensure that the entire system will always operate safely. For other forms of control (such as program modification or operating status change) of a running programmable controller, read the relevant manuals carefully and ensure that the operation is safe before proceeding. Especially, when a remote programmable controller is controlled by an external device, immediate action cannot be taken if a problem occurs in the programmable controller due to a communication failure. To prevent this, configure an interlock circuit in the program, and determine corrective actions to be taken between the external device and CPU module in case of a communication failure.
- Do not write any data to the "system area" of the buffer memory in the intelligent function module. Also, do not use any "use prohibited" signals as an output signal from the CPU module to the intelligent function module. Doing so may cause malfunction of the programmable controller system.

[Design Precautions]

CAUTION

- Do not install the control lines or communication cables together with the main circuit lines or power cables. Keep a distance of 100mm or more between them. Failure to do so may result in malfunction due to noise.
- When changing the operating status of the CPU module (such as remote RUN/STOP) from the external device, select "Always wait for OPEN (Communication possible at STOP time)" for the "Initial timing" setting in the network parameter. The communication line will be closed when "Do not wait for OPEN (Communications impossible at STOP time)" is selected and the remote STOP is executed from the external device. Consequently, the CPU module cannot reopen the communication line, and the external device cannot execute the remote RUN.

[Security Precautions]

WARNING

- To maintain the security (confidentiality, integrity, and availability) of the programmable controller and the system against unauthorized access, denial-of-service (DoS) attacks, computer viruses, and other cyberattacks from external devices via the network, take appropriate measures such as firewalls, virtual private networks (VPNs), and antivirus solutions.

[Installation Precautions]

CAUTION

- Use the programmable controller in an environment that meets the general specifications in the Safety Guidelines included with the MELSEC-L series CPU module.
Failure to do so may result in electric shock, fire, malfunction, or damage to or deterioration of the product.
- To interconnect modules, engage the respective connectors and securely lock the module joint levers until they click. Incorrect interconnection may cause malfunction, failure, or drop of the module.
- Shut off the external power supply (all phases) used in the system before mounting or removing a module. Failure to do so may result in damage to the product.
- Do not directly touch any conductive parts and electronic components of the module. Doing so can cause malfunction or failure of the module.

[Wiring Precautions]

CAUTION

- When connecting a cable with connector to the module, connect the connector part to the module securely.
- Make sure to place the communication and power cables to be connected to the module in a duct or fasten them using a clamp. If not, dangling cable may swing or inadvertently be pulled, resulting in damage to the module or cables or malfunction due to poor contact.
- Prevent foreign matter such as dust or wire chips from entering the module. Such foreign matter can cause a fire, failure, or malfunction.
- When a protective film is attached to the top of the module, remove it before system operation. If not, inadequate heat dissipation of the module may cause a fire, failure, or malfunction.

[Startup and Maintenance Precautions]

WARNING

- Shut off the external power supply (all phases) used in the system before cleaning the module. Failure to do so may result in electric shock.

[Startup and Maintenance Precautions]

CAUTION

- Do not disassemble or modify the module. Doing so may cause failure, malfunction, injury, or a fire.
- Shut off the external power supply (all phases) used in the system before mounting or removing a module. Failure to do so may cause the module to fail or malfunction.
- After the first use of the product (module and display unit), the number of connections/disconnections is limited to 50 times (in accordance with IEC 61131-2). Exceeding the limit may cause malfunction.
- Before handling the module, touch a conducting object such as a grounded metal to discharge the static electricity from the human body. Failure to do so may cause the module to fail or malfunction.

[Operating Precautions]

CAUTION

- When changing data and operating status, and modifying program of the running programmable controller from a personal computer connected to an intelligent function module, read relevant manuals carefully and ensure the safety before operation. Incorrect change or modification may cause system malfunction, damage to the machines, or accidents.

[Disposal Precautions]

CAUTION

- When disposing of this product, treat it as industrial waste.

● CONDITIONS OF USE FOR THE PRODUCT ●

- (1) Mitsubishi programmable controller ("the PRODUCT") shall be used in conditions;
- i) where any problem, fault or failure occurring in the PRODUCT, if any, shall not lead to any major or serious accident; and
 - ii) where the backup and fail-safe function are systematically or automatically provided outside of the PRODUCT for the case of any problem, fault or failure occurring in the PRODUCT.
- (2) The PRODUCT has been designed and manufactured for the purpose of being used in general industries. MITSUBISHI SHALL HAVE NO RESPONSIBILITY OR LIABILITY (INCLUDING, BUT NOT LIMITED TO ANY AND ALL RESPONSIBILITY OR LIABILITY BASED ON CONTRACT, WARRANTY, TORT, PRODUCT LIABILITY) FOR ANY INJURY OR DEATH TO PERSONS OR LOSS OR DAMAGE TO PROPERTY CAUSED BY the PRODUCT THAT ARE OPERATED OR USED IN APPLICATION NOT INTENDED OR EXCLUDED BY INSTRUCTIONS, PRECAUTIONS, OR WARNING CONTAINED IN MITSUBISHI'S USER, INSTRUCTION AND/OR SAFETY MANUALS, TECHNICAL BULLETINS AND GUIDELINES FOR the PRODUCT.
- ("Prohibited Application")
- Prohibited Applications include, but not limited to, the use of the PRODUCT in;
- Nuclear Power Plants and any other power plants operated by Power companies, and/or any other cases in which the public could be affected if any problem or fault occurs in the PRODUCT.
 - Railway companies or Public service purposes, and/or any other cases in which establishment of a special quality assurance system is required by the Purchaser or End User.
 - Aircraft or Aerospace, Medical applications, Train equipment, transport equipment such as Elevator and Escalator, Incineration and Fuel devices, Vehicles, Manned transportation, Equipment for Recreation and Amusement, and Safety devices, handling of Nuclear or Hazardous Materials or Chemicals, Mining and Drilling, and/or other applications where there is a significant risk of injury to the public or property.
- Notwithstanding the above restrictions, Mitsubishi may in its sole discretion, authorize use of the PRODUCT in one or more of the Prohibited Applications, provided that the usage of the PRODUCT is limited only for the specific applications agreed to by Mitsubishi and provided further that no special quality assurance or fail-safe, redundant or other safety features which exceed the general specifications of the PRODUCTS are required. For details, please contact the Mitsubishi representative in your region.
- (3) Mitsubishi shall have no responsibility or liability for any problems involving programmable controller trouble and system trouble caused by DoS attacks, unauthorized access, computer viruses, and other cyberattacks.

INTRODUCTION

Thank you for purchasing the Mitsubishi Electric MELSEC-Q or -L series programmable controllers. This manual describes the functions and programming of the Ethernet interface module for Ethernet communications. Before using this product, please read this manual and the relevant manuals carefully and develop familiarity with the functions and performance of the MELSEC-Q or -L series programmable controller to handle the product correctly. When applying the program examples introduced in this manual to an actual system, ensure the applicability and confirm that it will not cause system control problems. Note that the menu names and operating procedures may differ depending on an operating system in use and its version. When reading this manual, replace the names and procedures with the applicable ones as necessary.

Please make sure that the end users read this manual.

Remark

Unless otherwise specified, this manual describes the program examples in which the I/O numbers of X/Y00 to X/Y1F are assigned for an Ethernet interface module. For I/O number assignment, refer to the User's Manual (Function Explanation, Program Fundamentals) for the CPU module used.

RELEVANT MANUALS

The manuals related to this product are listed below.

Please place an order as needed.

Manual name	Manual number (Model code)
Q Corresponding Ethernet Interface Module User's Manual (Basic) Specifications, procedures for data communication with external devices, line connection (open/close), fixed buffer communication, random access buffer communication, and troubleshooting of the Ethernet interface module (Sold separately)	SH-080009 (13JL88)
MELSEC-L Ethernet Interface Module User's Manual (Basic) Specifications, procedures for data communication with external devices, line connection (open/close), fixed buffer communication, random access buffer communication, and troubleshooting of the Ethernet interface module (Sold separately)	SH081105ENG (13JZ73)
MELSEC-Q/L Ethernet Interface Module Use's Manual (Web function) How to use the Web function of the Ethernet interface module (Sold separately)	SH-080180 (13JR40)
MELSEC Communication Protocol Reference Manual Communication methods and control procedures through the MC protocol for the external devices to read and write data from/to the programmable controller CPU using the serial communication module/Ethernet interface module (Sold separately)	SH-080008 (13JF89)

Memo

CONTENTS

SAFETY PRECAUTIONS	1
CONDITIONS OF USE FOR THE PRODUCT	9
INTRODUCTION	10
RELEVANT MANUALS	10
MANUAL'S USE AND STRUCTURE	16
TERMS	19
LIST OF DISCONTINUED MODELS	21
<hr/>	
CHAPTER 1 OVERVIEW	22
<hr/>	
1.1 Overview	22
1.2 Additional Functions in Function Version B or Later	25
<hr/>	
CHAPTER 2 USING THE E-MAIL FUNCTION	26
<hr/>	
2.1 E-mail Function	26
2.1.1 Sending/receiving e-mail by the programmable controller CPU	26
2.1.2 Sending e-mail using the programmable controller CPU monitor function	28
2.2 Configuration and Environment of the Applicable System	30
2.3 Precautions for Using the E-mail Function	31
2.4 E-mail Specifications	33
2.5 Processing Procedure of the E-mail Function	34
2.6 E-mail Setting Using a Programming Tool	35
2.7 Sending/Receiving E-mail (Attached Files) by the Programmable Controller CPU	39
2.7.1 When sending data as an attached file	39
2.7.2 When receiving data in the attached file	44
2.7.3 Contents of the attached files	49
2.8 Sending E-mail (Main Text) by the Programmable Controller CPU	51
2.8.1 When sending data as main text of e-mail	51
2.9 Sending E-mails Using the Programmable Controller CPU Monitoring Function	55
2.9.1 News setting	55
2.9.2 Receiving a news e-mail	59
<hr/>	
CHAPTER 3 COMMUNICATIONS VIA OTHER NETWORKS	63
<hr/>	
3.1 CC-Link IE Controller Network, CC-Link IE Field Network, MELSECNET/H, MELSECNET/10 Relay Communication Function	63
3.2 Range of Accessible Other Station's Programmable Controllers and Accessible Stations	64
3.2.1 Accessible range and stations	64
3.3 Settings for Accessing Other Stations	67
3.3.1 Setting the Station No. <-> IP information	68
3.3.2 Convert format between the Network No./station number and IP address/port number	71
3.3.3 Routing parameter settings	77
3.4 Procedure for Accessing Other Stations	83
3.5 Precautions for Accessing Other Stations	84

CHAPTER 4 WHEN THE Q/LCPU ACCESSES THE PROGRAMMABLE CONTROLLER OF ANOTHER STATION USING THE DATA LINK INSTRUCTION	85
--	-----------

4.1	Access to Other Stations with the Data Link Instruction	85
4.2	Precautions for Accessing Other Stations	86
4.3	Using the Data Link Instructions	89
4.4	Data Link Instructions	92
4.5	Data Sending/Receiving	96
4.5.1	Data sending/receiving for receive with the main program (SEND/RECV)	97
4.5.2	Data sending/receiving for receive with an interrupt program (SEND/RECVS)	103
4.6	Reading/Writing Word Devices of Other Stations (READ/WRITE)	107
4.7	Reading/Writing Word Devices of Other Stations (ZNRD/ZNWR)	114
4.8	Reading/Writing Clock Data, Remote RUN/Remote STOP (REQ)	120
4.9	Error Codes for Data Link Instructions	126

CHAPTER 5 WHEN USING FILE TRANSFER FUNCTIONS (FTP SERVER)	127
--	------------

5.1	File Transfer Functions	127
5.1.1	FTP server support functions of the Ethernet module	128
5.2	File Transferable Range	130
5.3	FTP Parameter Settings for File Transfer from a Programming Tool	131
5.4	Procedure and Required Processing on the External Device Side (FTP Client)	133
5.5	Precautions when Using the File Transfer Functions	138
5.6	FTP Commands	142
5.6.1	File designation method	142
5.6.2	Q/LCPU user file list	144
5.6.3	Response code	145
5.6.4	FTP operation command	146

CHAPTER 6 DEDICATED INSTRUCTIONS	156
---	------------

6.1	Dedicated Instruction List and Available Devices	156
6.2	ZPMRECV	158
6.2.1	Setting data	158
6.2.2	Control data	159
6.2.3	Receive data	161
6.2.4	Functions	161
6.2.5	Errors	162
6.2.6	Caution	163
6.2.7	Program example	163
6.3	ZPMSEND	164
6.3.1	Setting data	164
6.3.2	Control data	165
6.3.3	Send data	166
6.3.4	Functions	166
6.3.5	Errors	168
6.3.6	Caution	168

6.3.7	Program example.....	168
6.4	JP/GP.READ.....	170
6.4.1	Setting data.....	171
6.4.2	Control data.....	172
6.4.3	Functions.....	174
6.4.4	Errors.....	175
6.4.5	Program example.....	176
6.5	JP/GP.RECV (for the Main Program).....	177
6.5.1	Setting data.....	177
6.5.2	Control data.....	178
6.5.3	Functions.....	180
6.5.4	Errors.....	181
6.5.5	Program example.....	182
6.6	Z.RECVS (for Interrupt Programs).....	183
6.6.1	Setting data.....	183
6.6.2	Control data.....	184
6.6.3	Receive data.....	184
6.6.4	Functions.....	185
6.6.5	Errors.....	186
6.6.6	Program example.....	186
6.7	J(P)/G(P).REQ (Remote RUN/STOP).....	187
6.7.1	Setting data.....	188
6.7.2	Control data.....	188
6.7.3	Request data (All values are set by the user).....	191
6.7.4	Response data (All values are set by the system).....	191
6.7.5	Functions.....	192
6.7.6	Errors.....	193
6.7.7	Program example.....	194
6.8	J(P)/G(P).REQ (Clock Data Read/Write).....	195
6.8.1	Request data (All values are set by the user).....	195
6.8.2	Response data (All values are set by the system).....	196
6.8.3	Program example.....	197
6.9	JP/GP.SEND.....	198
6.9.1	Setting data.....	198
6.9.2	Control data.....	199
6.9.3	Functions.....	203
6.9.4	Errors.....	204
6.9.5	Program example.....	205
6.10	JP/GP.SREAD.....	206
6.10.1	Setting data.....	207
6.10.2	Control data.....	208
6.10.3	Functions.....	208
6.10.4	Errors.....	210
6.10.5	Program example.....	210
6.11	JP/GP.SWRITE.....	211
6.11.1	Setting data.....	212
6.11.2	Control data.....	213

6.11.3	Functions	213
6.11.4	Errors	215
6.11.5	Program example	215
6.12	JP/GP.WRITE	216
6.12.1	Setting data	217
6.12.2	Control data	218
6.12.3	Functions	221
6.12.4	Errors	223
6.12.5	Program example	223
6.13	J(P).ZNRD	224
6.13.1	Setting data	224
6.13.2	Functions	225
6.13.3	Errors	226
6.13.4	Program example	227
6.14	J(P).ZNWR	227
6.14.1	Setting data	228
6.14.2	Functions	229
6.14.3	Errors	230
6.14.4	Program example	231

APPENDIX	232
-----------------	------------

Appendix 1	Calculating the Setting Values of the Data Link Instructions (Control Data)	232
Appendix 1.1	Calculation formulas	232
Appendix 1.2	Setting examples	235

INDEX	239
--------------	------------

REVISIONS	241
WARRANTY	243
TRADEMARKS	244
COPYRIGHTS	244

MANUAL'S USE AND STRUCTURE

(1) How to use this manual

In this manual, explanations are given for each special function of the Ethernet modules (QJ71E71-100, QJ71E71-B5, QJ71E71-B2, and LJ71E71-100).

Please use this manual using the following key items below as a reference.

(a) To learn about an overview of the special functions

- Page 22, CHAPTER 1 provides an overview of each of the special functions available for the Ethernet modules.

(b) To use the e-mail transmission/reception function and the programmable controller CPU monitoring function

- Page 30, Section 2.2 describes the environment in which e-mails can be used.
- Page 35, Section 2.6 illustrates the screens for parameter settings with a programming tool to use the e-mail function.
- Page 55, Section 2.9 describes the parameter settings to monitor the status of the programmable controller CPU.

(c) To communicate with programmable controller CPUs of other stations via a network module or an Ethernet module

- Page 64, Section 3.2 describes the accessible range and accessible stations when accessing other stations via the Ethernet modules.
- Page 67, Section 3.3 describes the parameter settings using a programming tool to communicate data with the programmable controller CPUs of other stations.
- Page 71, Section 3.3.2 provides an overview of the processing for Station No. <-> IP information conversion.

(d) To use the file transfer (FTP) function

- Page 131, Section 5.3 describes the parameter settings using a programming tool to transfer a file.
- Page 142, Section 5.6 describes the FTP operation command on the FTP client (external device) side that is supported by the Ethernet module.

Point

To know about the following items, see the User's Manual (Basic).

- Detailed descriptions of the error codes
Troubleshooting, error check methods, descriptions and reference manuals of error codes
 - Storage locations of the error codes for the Ethernet module
Storage locations (buffer memories) of error codes
-

(2) Structure of this manual

(a) Setting Parameters with a programming tool

- By setting parameters with a programming tool, the sequence programs for communicating with external devices can be simplified in the Ethernet module.
- In this manual, parameter settings using a programming tool are explained in detail for each item displayed on the setting screens.^{*1}
- For details on the types of the setting screens, objectives of the settings, the setting items and an outline of the setting operation using a programming tool, see the User's Manual (Basic).

^{*1} Refer to the chapters related to the functions to be used and set the required parameters. Then load the set parameters to the programmable controller CPU of a station where an Ethernet module is connected.

(3) Setting screen of a programming tool

This manual explains the parameter settings with a programming tool in the following format.
The following illustration is for explanation purpose only, and should not be referred to as an actual documentation.

2.6 E-mail Setting Using a Programming Tool

This section describes the settings required to send and receive e-mails using a programming tool.

(1) DNS setting
 [Purpose of setting]
 Specify the IP address of the DNS server when setting the mail server name using the domain name by the e-mail setting (☞ Page 36, Section 2.6 (2)).
 [Start procedure]
 Network parameter setting screen → "Initial Setting"
 [Setting screen]

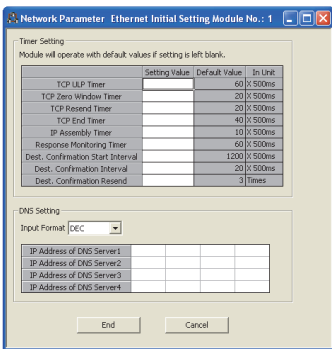

(a) DNS setting
 Designate the Internet service provider used by the local station's Ethernet module and the IP addresses of the domain name servers (DNS) designated by a system administrator.

- Select the input format (decimal/hexadecimal) of the IP addresses.
- Designate the IP addresses of the DNS servers to DNS servers 1 to 4.

1) Shows how to start the setting screen.

2) Shows the setting screen of GX Developer.

3) Shows a description of the setting.

Depending on the function used, "(Address: □□□□H)" may be indicated after some function names.
This address indicates the buffer memory address of the Ethernet module in which the setting values from a programming tool are stored.

For more details on the buffer memory, see the User's Manual (Basic).

- Open the network parameter screens as follows.
 - QCPU: Project window ⇒ [Parameter] ⇒ [Network Parameter] ⇒ [Ethernet/CC IE/MELSECNET]
 - LCPU: Project window ⇒ [Parameter] ⇒ [Network Parameter] ⇒ [Ethernet/CC IE Field]

TERMS

This manual uses the following generic terms and abbreviations to describe the QJ71E71-100, QJ71E71-B5, QJ71E71-B2, and LJ71E71-100 Ethernet interface modules, unless otherwise specified.

Term	Description
ACPU	A generic term for the AnNCPU, AnACPU, and AnUCPU
AnACPU	A generic term for the A2ACPU, A2ACPU-S1, A2ACPUP21/R21, A2ACPUP21/R21-S1, A3ACPU, and A3ACPUP21/R21
AnNCPU	A generic term for the A1NCPU, A1NCPUP21/R21, A2NCPU, A2NCPU-S1, A2NCPUP21/R21, A2NCPUP21/R21-S1, A3NCPU, and A3NCPUP21/R21
AnUCPU	A generic term for the A2UCPU, A2UCPU-S1, A2ASCPU, A2ASCPU-S1, A3UCPU, and A4UCPU
Basic model QCPU	A generic term for the Q00JCPU, Q00CPU, and Q01CPU
BUFRCV	The abbreviation for ZP.BUFRCV
BUFRCVS	The abbreviation for Z.BUFRCVS
BUFSND	The abbreviation for ZP.BUFSND
Built-in Ethernet port QCPU	A generic term for the Q03UDVCP, Q03UDECP, Q04UDVCP, Q04UDEHCP, Q06UDVCP, Q06UDEHCP, Q10UDEHCP, Q13UDVCP, Q13UDEHCP, Q20UDEHCP, Q26UDVCP, Q26UDEHCP, Q50UDEHCP, and Q100UDEHCP
CLOSE	The abbreviation for ZP.CLOSE
Control CPU	A programmable controller CPU that controls connected I/O modules and intelligent function modules. In a multiple CPU system, there are multiple CPU modules and each connected module can be controlled by a different CPU module.
Control system CPU	A programmable controller CPU that controls operations in a redundant system
CPU module	A generic term for the QCPU and LCPU
ERRCLR	The abbreviation for ZP.ERRCLR
ERRRD	The abbreviation for ZP.ERRRD
Ethernet Address	A machine-specific address that is also referred to as the MAC (Media Access Control) address. This is used to identify the addresses of external devices over a network. The Ethernet address of the Ethernet module can be verified on the MAC ADD column of the rating plate.
Ethernet module	The abbreviation for the QJ71E71-100, QJ71E71-B5, QJ71E71-B2, and LJ71E71-100 Ethernet interface modules. (Indicated as the Ethernet module or E71 in the figures)
Ethernet network system	The abbreviation for 10BASE2, 10BASE5, 10BASE-T, and 100BASE-TX network systems
External device	A generic term for personal computers, computers, work station (WS) and Ethernet module etc. that are connected by the Ethernet for data communication
GX Developer	The product name of the software package for the MELSEC programmable controllers
GX Works2	
High Performance model QCPU	A generic term for the Q02CPU, Q02HCP, Q06HCP, Q12HCP, and Q25HCP
L series Ethernet module	The abbreviation for the LJ71E71-100 Ethernet interface module
LCPU	Another term for the MELSEC-L series CPU module
LCPU station	Another term for the MELSEC-L series CPU module
MELSECNET/10	The abbreviation for the MELSECNET/10 network system
MELSECNET/H	The abbreviation for the MELSECNET/H network system
MRECV	The abbreviation for ZP.MRECV
MSEND	The abbreviation for ZP.MSEND
Network module (N/W module)	The abbreviation for interface modules compatible with the CC-Link IE Controller Network, CC-Link IE Field Network, MELSECNET/H, MELSECNET/10 network system
OPEN	The abbreviation for ZP.OPEN
Process CPU	A generic term for the Q02PHCP, Q06PHCP, Q12PHCP, and Q25PHCP
Programming tool	A generic term for GX Developer and GX Works2
Q series Ethernet module	The abbreviation for the QJ71E71-100, QJ71E71-B5, and QJ71E71-B2 Ethernet interface modules
QCPU	A generic term for a Basic model QCPU, High Performance model QCPU, Process CPU, Redundant CPU, and Universal model QCPU
QCPU station	The abbreviation for the programmable controller where the QCPU is connected

Term	Description
QnACPU	A generic term for the Q2ACPU, Q2ACPU-S1, Q2ASCPU, Q2ASCPU-S1, Q2ASHCPU, Q2ASHCPU-S1, QA3ACPU, Q4ACPU, and Q4ARCPU
QnUDVCPUCPU	A generic term for the Q03UDVCPUCPU, Q04UDVCPUCPU, Q06UDVCPUCPU, Q13UDVCPUCPU, and Q26UDVCPUCPU
READ	The abbreviation for JP.READ and GP.READ
RECV	The abbreviation for JP.RECV and GP.RECV
RECVS	The abbreviation for Z.RECVS
Redundant CPU	A generic term for the Q12PRHCPU and Q25PRHCPU
Reference Manual	The abbreviation for the MELSEC Communication Protocol Reference Manual
REQ	The abbreviation for J.REQ, JP.REQ, G.REQ and GP.REQ
Safety CPU	A generic term for the QS001CPU
SEND	The abbreviation for JP.SEND and GP.SEND
SREAD	The abbreviation for JP.SREAD and GP.SREAD
Standby system CPU	A programmable controller CPU where the system B connector of a tracking cable is connected in a redundant system
SWRITE	The abbreviation for JP.SWRITE and GP.SWRITE
System A CPU	A programmable controller CPU where the system A connector of a tracking cable is connected in a redundant system
System B CPU	A programmable controller CPU where the system B connector of a tracking cable is connected in a redundant system
UINI	The abbreviation for ZP.UINI
Universal model QCPU	A generic term for the Q00UJCPU, Q00UCPU, Q01UCPU, Q02UCPU, Q03UDCPU, Q03UDVCPUCPU, Q03UDECPUCPU, Q04UDHCPU, Q04UDVCPUCPU, Q04UDEHCPU, Q06UDHCPU, Q06UDVCPUCPU, Q06UDEHCPU, Q10UDHCPU, Q10UDEHCPU, Q13UDHCPU, Q13UDVCPUCPU, Q13UDEHCPU, Q20UDHCPU, Q20UDEHCPU, Q26UDHCPU, Q26UDVCPUCPU, Q26UDEHCPU, Q50UDEHCPU, and Q100UDEHCPU
User's Manual (Application)	The abbreviation for the MELSEC-Q/L Ethernet Interface Module User's Manual (Application)
User's Manual (Basic)	The abbreviation for the Q Corresponding Ethernet Interface Module User's Manual (Basic) and MELSEC-L Ethernet Interface Module User's Manual (Basic)
User's Manual (Web function)	The abbreviation for the MELSEC-Q/L Ethernet Interface Module User's Manual (Web function)
WRITE	The abbreviation for JP.WRITE and GP.WRITE
ZNRD	The abbreviation for J.ZNRD and JP.ZNRD
ZNWR	The abbreviation for J.ZNWR and JP.ZNWR

LIST OF DISCONTINUED MODELS

The following table lists discontinued models described in this manual.

For onerous repair term after discontinuation of production, refer to WARRANTY in this manual.

Model	Production discontinuation
QJ71E71-B5	February 2017
QJ71E71-B2	February 2017

CHAPTER 1 OVERVIEW

This manual describes the special functions of an Ethernet interface module (hereinafter, abbreviated as Ethernet module). When applying the following program examples to the actual system, make sure to examine the applicability and confirm that it will not cause system control problems.

This chapter describes an overview of the special functions that are available for the Ethernet module.

1.1 Overview

(1) Send/receive e-mails (☞ Details are explained in Page 26, CHAPTER 2)

This function allows the transmission and reception of a maximum of 6K words of CPU information as the main text or attached file of e-mail to/from computers and programmable controller CPUs via the Internet.

Furthermore, by setting the automatic notification, the Ethernet module sends e-mail when the notification conditions set by the user match for the transmission from programmable controllers.

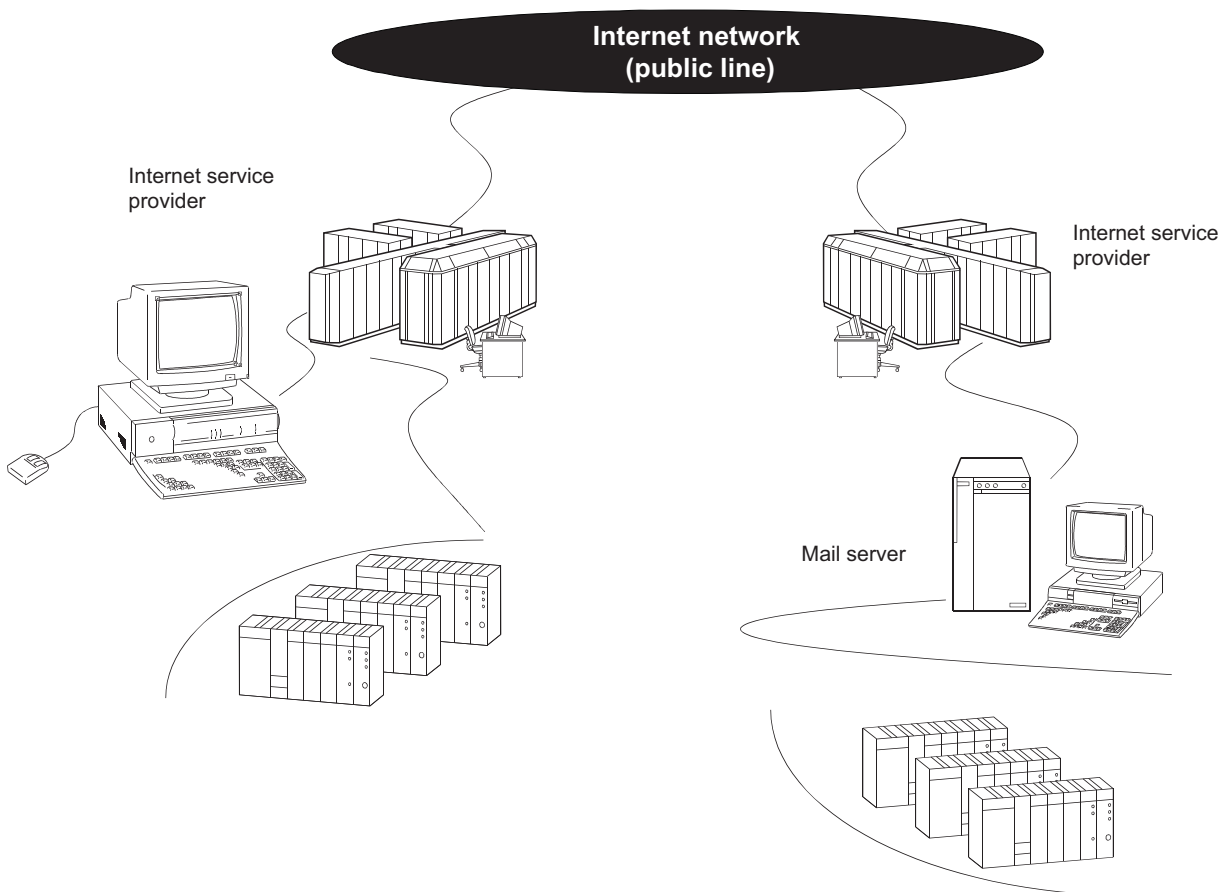

(2) Communicate with a programmable controller in another station via other networks (Details are explained in Page 63, CHAPTER 3)

This function enables accessing other stations via multiple networks in the network system shown below. This function is used for multiple relays through a network in which the Ethernet and CC-Link IE Controller Network, CC-Link IE Field Network, MELSECNET/H, MELSECNET/10 network systems coexist as well as through a network in which multiple Ethernet network systems are connected.

Using this function, a programmable controller in another station is accessible via other networks and Ethernet.

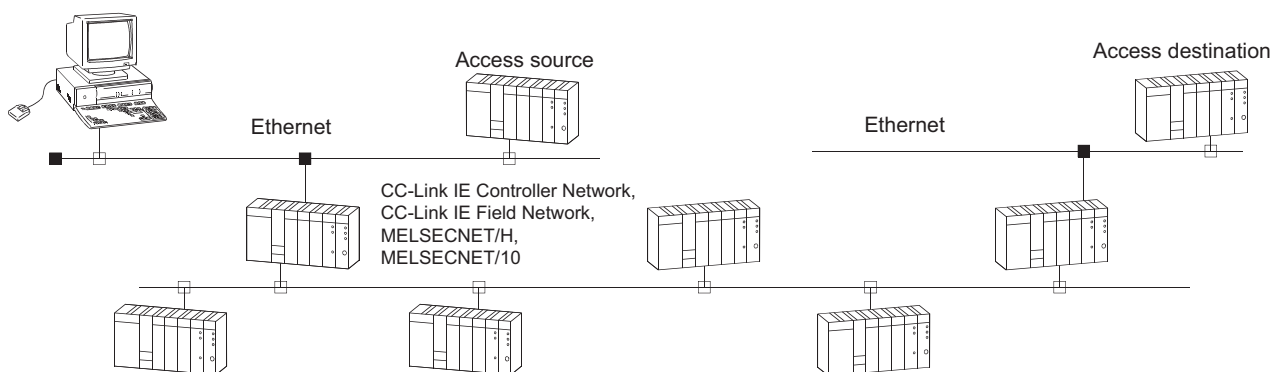

(3) Perform data communication between programmable controller CPUs (Details are explained in Page 85, CHAPTER 4)

This function sends and receives data to/from another station's programmable controller CPU via the Ethernet using the data link instructions (SEND/RECV/READ/WRITE/REQ/ZNRD/ZNWR).*1

It also sends and receives data to/from a programmable controller CPU in another station via Ethernet and other networks.

*1 The ZNRD and ZNWR instructions are not available for the CC-Link IE Field Network.

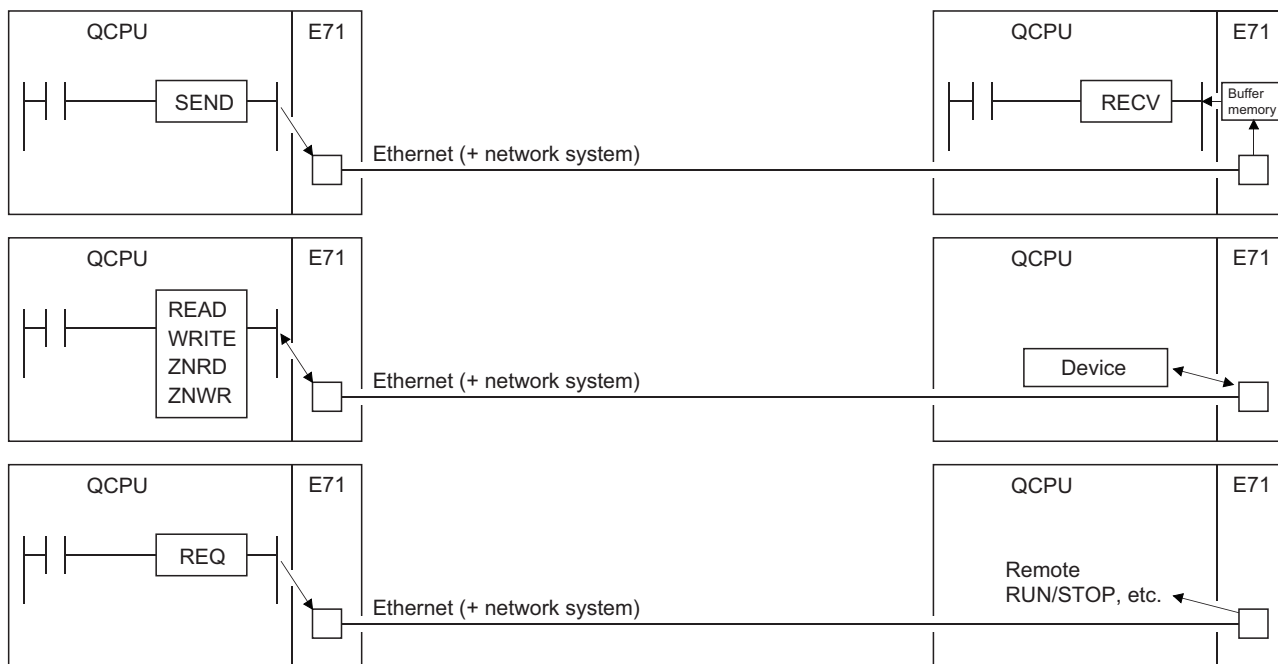

(4) Perform file transfer (FTP) ( **Details are explained in Page 127, CHAPTER 5**)

The Ethernet module supports the server function of the TCP/IP standard protocol, FTP (File Transfer Protocol). By using the FTP commands, files in a CPU module can be read or written in file units. This allows files in a CPU module to be managed with devices such as computers. This also allows files to be transferred or a file list to be browsed as needed.

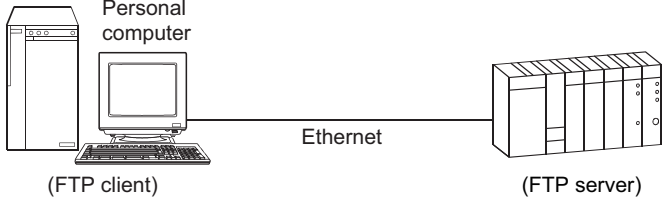

1.2 Additional Functions in Function Version B or Later

The following table lists the functions added to Q series Ethernet modules of function version B or later.

Point

- The added/changed functions shown in this section includes the functions added in the first products or later of function version B and function version D.
For the function version, serial No., and software version of the Ethernet module and related products (CPU module and programming tool) with the added/changed functions, refer to the User's Manual (Basic).
- For functional comparisons depending on the Ethernet module function version, refer to the User's Manual (Basic).

(1) Functions added for function version B

Function		Overview	Reference section
When using the e-mail function	Sending files in CSV format as attachment	Sends a file in CSV format as attachment to e-mail from the Ethernet module.	Page 26, CHAPTER 2
	Sending main text	Sends main text of up to 960 words from the Ethernet module.	
	Support for encoding/decoding	The following encoding/decoding is supported. <ul style="list-style-type: none"> • Encode the Subject using 7 bits encoding and send it from the Ethernet module. • Decode and receive an e-mail encoded with Quoted Printable by the Ethernet module. 	
When using the file transfer (FTP server) function	Remote password check	Unlocks/locks the remote password of the QCPU. The unlock processing enables access to the QCPU using FTP commands.	Page 127, CHAPTER 5
	Support for multiple CPU systems	The QCPU transfers files to the control CPU/non-control CPU of the Ethernet module when a multiple CPU system configuration is used.	

(2) Function added for function version D

Function		Overview	Reference section
When using the e-mail function	Sending character strings in the e-mail's main text by the programmable controller CPU monitoring function	The programmable controller CPU monitoring function allows transmission of character string information stored in word devices by the e-mail's main text.	Page 26, CHAPTER 2
Specifying target station number in data link instructions		In the following data link instructions, the target station number 65 to 120 can be specified. (Specification of the station number 65 to 120 in the CC-Link IE Controller Network and CC-Link IE Field Network is available.) <ul style="list-style-type: none"> • SEND • READ/SREAD • WRITE/SWRITE • REQ 	Page 85, CHAPTER 4 Page 156, CHAPTER 6
Specifying target station's CPU type in data link instructions		In the following data link instructions, the target station's CPU type can be specified ((S1)+3). (Specification of control/standby system or system A/B in the redundant system is available.) <ul style="list-style-type: none"> • READ/SREAD • WRITE/SWRITE • REQ 	
Increased data length of data link instructions (480 → 960 words)		The data length can be specified up to 960 words in the following data link instructions: ^{*1} <ul style="list-style-type: none"> • SEND • RECV/RECVS • READ/SREAD • WRITE/SWRITE 	
Setting the arrival monitoring time of the data link instruction in 100ms increments		Using the following data link instructions, arrival monitoring time can be set in 100ms increments. <ul style="list-style-type: none"> • READ/SREAD instructions • WRITE/SWRITE instructions 	Page 156, CHAPTER 6

*1 In a multiple network system, when transferring data exceeding 480 words to a station of another network No., specify the Q or L series models to all of the request source, relay station and request target.

CHAPTER 2 USING THE E-MAIL FUNCTION

2.1 E-mail Function

The e-mail function sends and receives CPU information (programmable controller CPU status and device values) to/from PCs or programmable controller CPUs in remote locations via the Internet.

The following two methods are available to send/receive e-mail using this function.

(1) Sending/receiving e-mail by the programmable controller CPU

Executed by a sequence program using dedicated instructions.

(2) Sending e-mail using the Ethernet module's programmable controller CPU monitor function

Executed by the Ethernet module according to the Ethernet module parameter setting (news setting) of a programming tool.

2.1.1 Sending/receiving e-mail by the programmable controller CPU

(1) Sending/receiving e-mail by the programmable controller CPU

In sending/receiving e-mail by the programmable controller CPU, the CPU information of a station in which an Ethernet module is installed is sent to another Ethernet modules or an external device such as a PC as the main text or attached file of e-mail. E-mail sent from other Ethernet modules and PCs can also be received.

Sending e-mail by the programmable controller CPU (MSEND instruction)		External device			Remarks
		Ethernet module (MRECV instruction)	PC	Portable terminal (device that cannot handle attached files)	
Subject		○*1	○	○	—
Attached file	Binary format	○	○	×	Maximum 6K words
	Binary → ASCII conversion	△*2			
	Binary → CSV conversion	×			
Main text	Designating using ASCII data	×	○	○	Maximum 960 words

○: Can receive data, △: Some restrictions apply, ×: Cannot receive data

*1 The Ethernet module receives the Subject without decoding.

*2 The MRECV instruction is normally completed when a data size (the size the MRECV instruction receives) after conversion is within 6144 words.

(a) Sending e-mail by the programmable controller CPU (MSEND instruction)

Data transmission is performed via the main text or attached file of e-mail using the MSEND instruction.

- For an attached file, device data and other information is sent by converting into binary/ASCII/CSV data format.
- For the main text, ASCII code data (character string data) created by a sequence program is sent.

(b) Receiving e-mail by the programmable controller CPU (MRECV instruction)

Receives attached file data of e-mail using the MRECV instruction. The main text data of e-mail cannot be received.

(2) Data conversion method used by the Ethernet module

The following shows the data conversion method used by the Ethernet module.

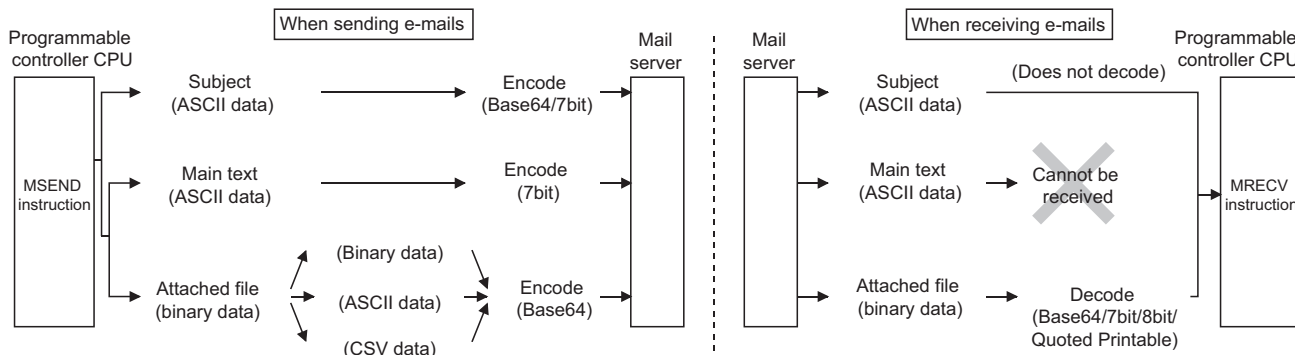

(3) Flow of the e-mail

The following diagram illustrates the flow of e-mail sent by the programmable controller CPU to its reception by the external device:

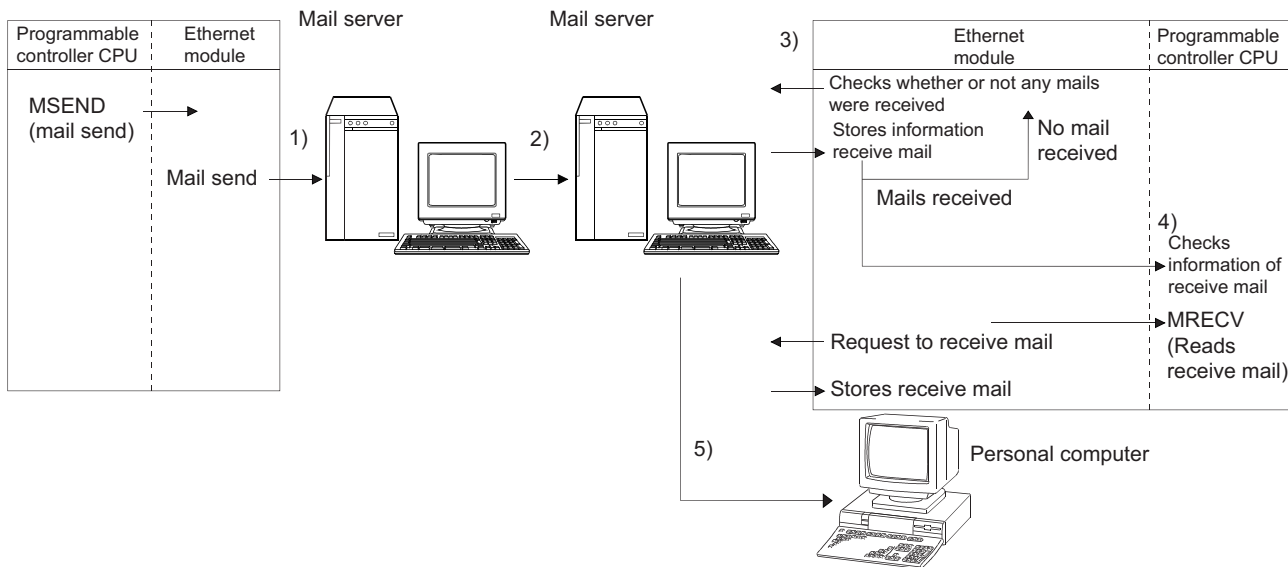

- 1) Send an e-mail to the send mail server of the own station's Ethernet module.
 - 2) The send mail server of the own station's Ethernet module sends the e-mail to the receive mail server of the send destination device.
- [When receiving by the Ethernet module]
- 3) The Ethernet module checks whether any mail has arrived at the inquiry interval set with a programming tool and stores the results to the buffer memory.
 - 4) By executing the MRECV instruction, the Ethernet module reads e-mails from the e-mail server to the mail buffer.*1
- The programmable controller CPU reads one e-mail and stores it in the mail buffer of the programmable controller CPU's device.
- [When receiving by a PC]
- 5) Mails are received using a mail user agent.

*1 By user designation with the MRECV instruction, the Ethernet module reads the number of remaining receive mails on the mail server and stores this number in the buffer memory.

Point

The e-mail send/reception function using the programmable controller CPU and the communication function using the random access buffer cannot be used together. Only one of them can be used at a time.

2.1.2 Sending e-mail using the programmable controller CPU monitor function

(1) Monitor function of the programmable controller CPU

The monitor function of the programmable controller CPU is used to regularly monitor the status of the programmable controller CPU and device values, and send e-mail to the designated external device when they match with the notification conditions (programmable controller CPU status and device values) set by the user.

Sending e-mail using the programmable controller CPU monitor function (news setting)*1		External device			Remarks
		Ethernet module (MRECV instruction)	PC	Portable terminal (device that cannot handle attached files)	
Subject		○*2	○	○	—
Attached file	Binary format	○	○	×	Maximum 960 words
	Binary → ASCII conversion	○			
	Binary → CSV conversion	×			
Main text	Binary format	×	○	○	Maximum 960 words
	Binary → ASCII conversion				

*1 For the notification of CPU status monitoring, only the Subject (that stores the programmable controller CPU status) will be sent.

*2 The Ethernet module receives the Subject without decoding.

(a) The programmable controller CPU in the Ethernet module loaded station is monitored for every CPU inquiry time interval set by the user. The following information can be registered as the notification conditions.

- Device monitoring of the programmable controller CPU
 - Monitoring the numeric values stored in the word device
 - Monitoring the bit device ON/OFF status
- Monitoring of the programmable controller CPU status
 - Monitoring the CPU module status (RUN/STOP/PAUSE)

(b) The device monitoring result of the programmable controller CPU is sent by either the main text or attached file of e-mail.

- The attached file is sent by converting the device monitoring data into binary/ASCII/CSV data format.
- The main text is sent by converting the device monitoring data into Binary or ASCII format data.

(c) As for the status monitoring result of the programmable controller CPU, only the Subject (that stores the programmable controller CPU status) is sent.

(d) When more than one send mail address are specified in the new specification setting, the smallest numbered address is set in the "To" field of the mail header.

The other addresses are set into the "Cc" field for transmission.

(2) Data conversion method used by the Ethernet module

The following shows the data conversion method used by the Ethernet module.

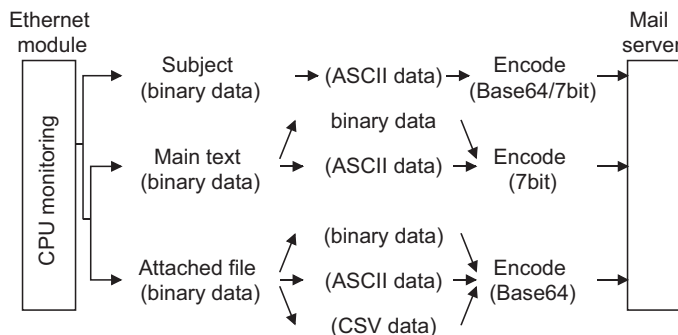

(3) Flow of the e-mail

The diagram shown below illustrates the flow of e-mails from the own station's Ethernet module to the external device after the monitor values match with the news conditions.

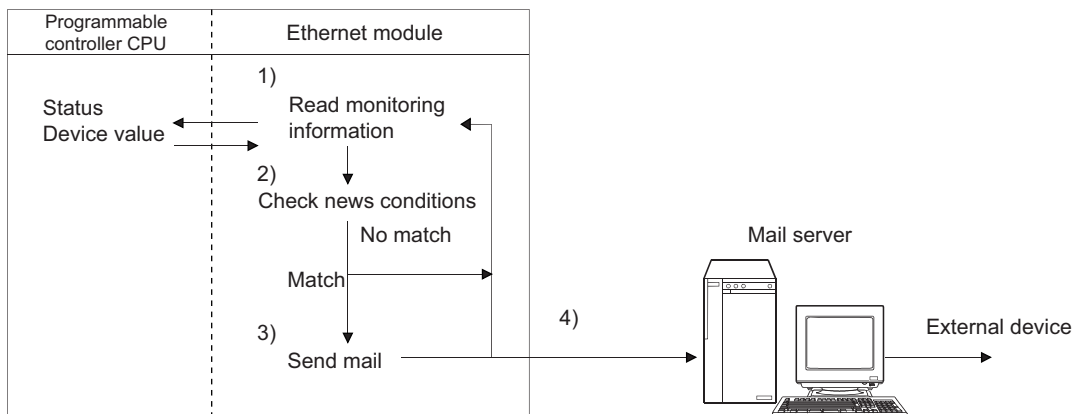

- 1) Reads the monitoring information (such as status and device values) of the programmable controller CPU.
- 2) Checks whether the monitoring information read and the news conditions set by the user match. (Checks match/mismatch of the news conditions.)^{*1}
- 3) Sends an e-mail when the monitored values match with the news conditions.
- 4) The Subject of e-mail, which is sent when the notification conditions match, is fixed data. The format of the Subject is as follows. (☞ Page 59, Section 2.9.2)

• When monitoring the CPU status

Subject = "No. of transmissions (^{*2}), CPU model name, Status, Detection time"

• When monitoring the CPU device

Subject = "No. of transmissions (^{*2}), Matched condition device, Monitoring value ..."

^{*1} Multiple news conditions may be set so that an e-mail can be sent (notified) when any of the conditions matches. (☞ Page 55, Section 2.9.1)

Set the CPU inquiry time interval used by the Ethernet module to monitor the programmable controller CPU, considering the interval of change time in the monitoring target.

After a news condition match occurs, the Ethernet module must confirm the mismatches of other news conditions for the same monitoring target.

The next e-mail can be sent only after the Ethernet module confirms the mismatches of these news conditions.

^{*2} This is the number automatically added each time an Ethernet module sends an e-mail. The numbers are counted up from 1. When the number reaches 4294967296, the number is cleared to 0. Then the numbers are counted up from 0 again to 4294967296.

Point

The e-mail send function using programmable controller CPU monitoring function and the communication function using the random access buffer can be used together.

2.2 Configuration and Environment of the Applicable System

This section explains the environment and system configuration for using the e-mail function from the Ethernet module.

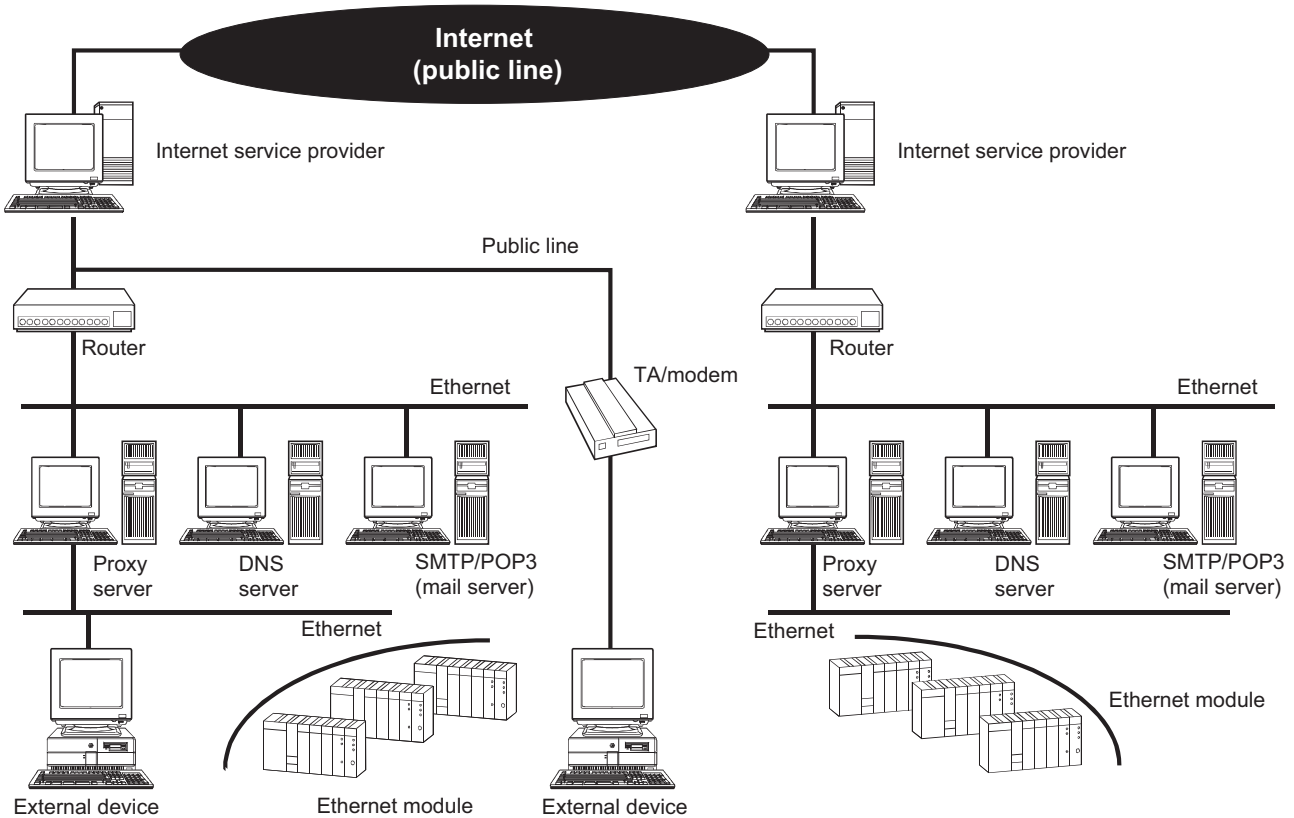

- E-mails can be sent and received in an environment where the Internet service is available as shown above.
- Set each Internet mail setting value for the Ethernet module and PC following the directions from the Internet service provider or system administrator.
- Use a programming tool to set each parameter for use of the e-mail function in an Ethernet module.

2.3 Precautions for Using the E-mail Function

The following explains precautions when using the e-mail function of the Ethernet module.

(1) Precautions regarding the system

- (a) Design the system so that the entire system operates normally at all times when sending/receiving e-mails to/from a running system and controlling the programmable controller.
- (b) In order to avoid programmable controller system malfunctions caused by receptions of illegal e-mails from the outside sources, take precautions in preventing illegal e-mails from being received on the mail served on the Ethernet module side (using an anti-virus program, etc).

(2) Precautions regarding the external device

- (a) E-mails can be sent to programmable controller CPU stations with Q series Ethernet modules connected.

Note that A/QnA series Ethernet modules do not have the e-mail function; therefore, e-mails cannot be sent to programmable controller CPU stations.

- (b) To send files to the Ethernet module as attachments to e-mail, specify the encoding method (Base 64/7 bits/8 bits/Quoted Printable) of the attached files.

(3) Common precautions

- (a) The Ethernet module stores the data of attached files received from the external device in the device specified by the MRECV instruction without converting it from ASCII to binary.
- (b) The maximum sizes of data that can be sent/received by the Ethernet module are as follows:
 - Data size of attached files: Up to 6K words
 - Data size of main text: Up to 960 words
- (c) Mails that are sent and received do not support encrypted data, compressed data, and data conversion.
- (d) When the external device could not be found in an e-mail sending from the Ethernet module, the error code can be checked through the reception processing with the MRECV instruction.
 - If an external device cannot be found when sending e-mail using the MSEND instruction, failure of e-mail transmission may not be recognized, depending on the operation of the mail server. Be sure to verify the receiver's e-mail address in advance.
 - Error codes are stored within the control data of the MRECV instruction. (For details on error codes, refer to the User's Manual (Basic).)

- (e) The e-mail function is supported for the SMTP and POP3 servers.
- (f) When communication errors of e-mails cannot be checked by a dedicated instruction, check the error codes stored in the mail send/reception error log area of the buffer memory.
- (g) If e-mails cannot be received, try one of the following.
- Execute the MRECV instruction once.
 - Shorten the "Enquiry Interval" time in the e-mail settings of a programming tool.
 - Check the number of incoming mails remaining on the mail server. (Can be checked with the buffer memory address 5870H area.)
- (h) When the receive data of an e-mail sent using the MSEND instruction is abnormal (garbled characters, etc.), review the transmission data format (binary/ASCII/CSV) designated with the MSEND instruction.
- The Subject should be designated in ASCII code data. (It is not converted to ASCII format.)
- (i) Confirm with a system administrator regarding the minimum time intervals for accessing the mail server when sending mails, reading receive mails, and inquiring whether or not there are receive mails.
- Depending on the mail server's security setting, frequent access may be prohibited.
- (j) The e-mail send/reception function using the programmable controller CPU and the communication function using the random access buffer cannot be used together. Only one of them can be used at a time.
- The e-mail send function using programmable controller CPU monitoring function and the communication function using the random access buffer can be used together.
- (k) A Subject that has been sent by the MSEND instruction from an Ethernet module of the following versions, cannot be received normally by the MRECV instruction.
- Ethernet modules with serial numbers where the first 5 digits are 03101 or less
- Different methods are used for converting Subject data at send and reception. (☞ Page 27, Section 2.1.1 (3))
- When sending: Encodes the Subject and then send it.
 - When receiving: Receives the Subject without decoding it.

2.4 E-mail Specifications

The following table lists the specifications of the e-mail function.

Item		Specification	
Transmission specifications Transmission and reception data	Data size	Attached file	6K words × 1
		Main text	960 words × 1
	Data transfer method		When sending: Sends either a file as attachment or main text (select one). When receiving: Received a file as attachment.
	Subject		Us-ASCII format or ISO-2022-JP (Base 64)
	Attached file format		MIME format
	MIME		Version 1.0
	Data of attached file format		Binary/ASCII/CSV can be selected. File name: XXXX.bin (binary), XXXX.asc (ASCII), XXXX.csv (CSV) (CSV: Comma Separated Value)
	Division of attached file		Cannot be divided (only one file can be sent/received) ^{*1}
	When sending (encode)		Subject: Base 64/7 bits Main text: 7 bits Attached file: Base 64
	When receiving (decode)		Subject: (Does not decode) Main text: (Cannot be received) Attached file: Base 64/7 bits/8 bits/Quoted Printable ^{*2}
	Encryption		No
	Compression		No
	Communication with mail server		SMTP (sending server) Port number = 25 POP3 (receiving server) Port number = 110
	Operation check mailer		Microsoft® Corporation Microsoft Office Outlook 2003

*1 If any divided files are received, only the first file will be received and the remaining files will be discarded.

*2 If e-mail is sent from the external device to the programmable controller side, specify the encoding method (Base 64/7 bits/8 bits/Quoted Printable) of the attached file.

Remark

Internet mail terminology list:

- DNS server: Server that manages networks
- SMTP server: Server that delivers (transfers) e-mail between mail servers
- POP3 server: Server that transfers received e-mail addressed to subscribers to the corresponding subscribers

2.5 Processing Procedure of the E-mail Function

The following flowchart illustrates the procedure that is required before sending and receiving e-mails:

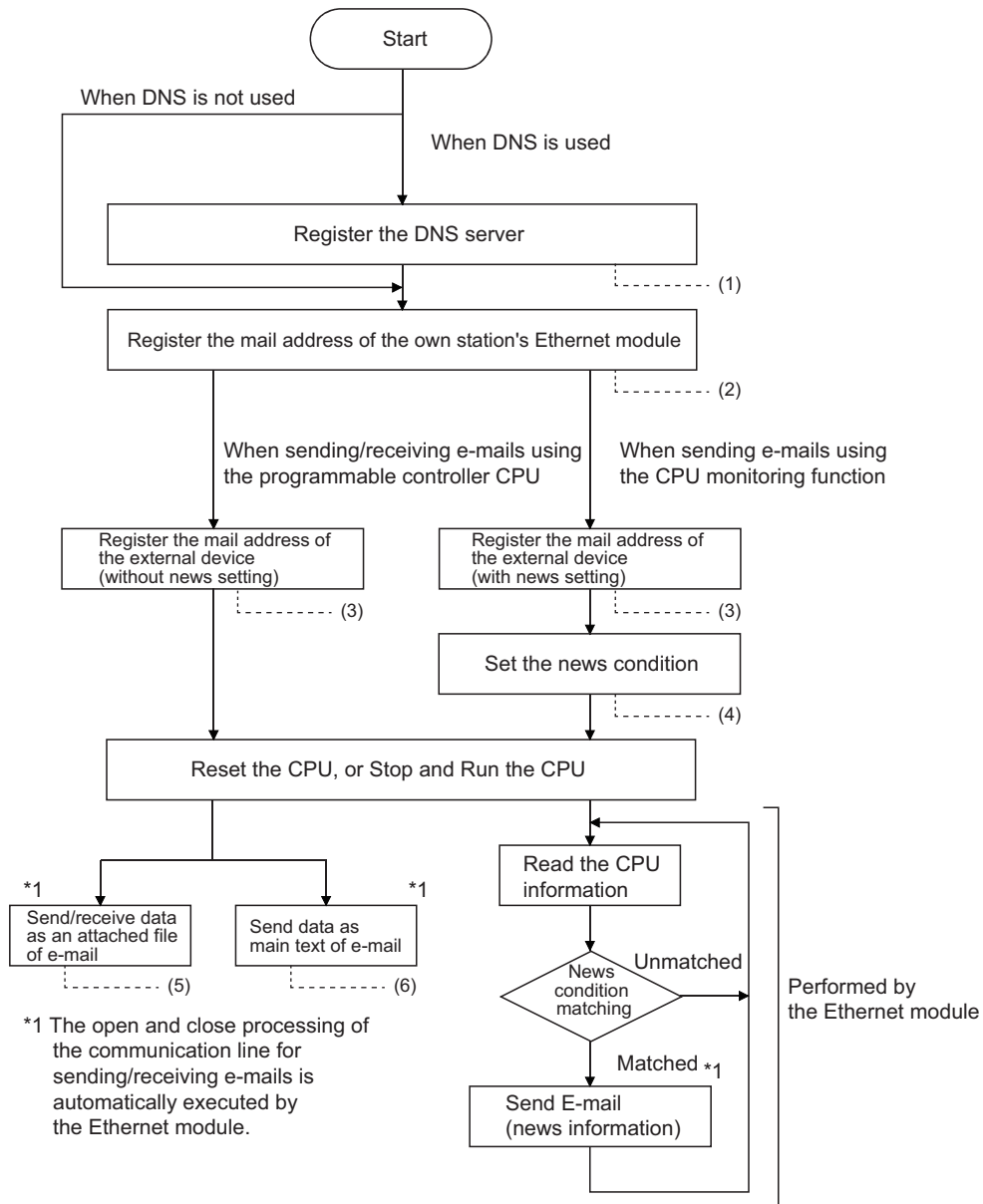

- (1) Page 35, Section 2.6 (1)
- (2) Page 36, Section 2.6 (2)
- (3) Page 38, Section 2.6 (3)
- (4) Page 55, Section 2.9.1
- (5) Page 39, Section 2.7
- (6) Page 51, Section 2.8

2.6 E-mail Setting Using a Programming Tool

This section describes the settings required to send and receive e-mails using a programming tool.

(1) DNS setting

[Purpose of setting]

Specify the IP address of the DNS server when setting the mail server name using the domain name by the e-mail setting (☞ Page 36, Section 2.6 (2)).

[Start procedure]

Network parameter setting screen ⇨ "Initial Setting"

[Setting screen]

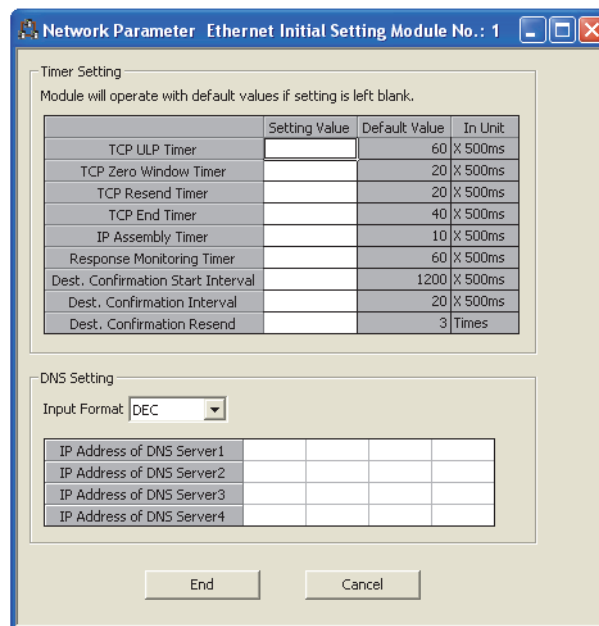

[Setting item]

	Item name	Description of setting	Setting range/option
Timer Setting ^{*1}	TCP ULP Timer	Set the time of packet existence at TCP data send.	2 to 32767
	TCP Zero Window Timer	Set the interval for checking the receive enabled status.	2 to 32767
	TCP Resend Timer	Set the time to resend at TCP data send.	2 to 32767
	TCP End Timer	Set the confirmation wait time at TCP close processing.	2 to 32767
	IP Assembly Timer	Set the wait time for division data packets.	1 to 32766
	Response Monitoring Timer	Set the response wait time.	2 to 32767
	Dest. Confirmation Start Interval	Set the time to start confirming existence of an external device after communication with it has terminated.	1 to 32767
	Dest. Confirmation Interval	Set the time interval between reconfirming existence.	1 to 32767
	Dest. Confirmation Resend	Set the number of times to reconfirm existence when a response to the existence confirmation is not received.	1 to 32767
DNS Setting	Input Format	Select the input format of the IP addresses of the DNS servers.	DEC/HEX
	IP Address of DNS Server 1	Set the IP address of DNS server 1.	—
	IP Address of DNS Server 2	Set the IP address of DNS server 2.	—
	IP Address of DNS Server 3	Set the IP address of DNS server 3.	—
	IP Address of DNS Server 4	Set the IP address of DNS server 4.	—

*1 For details, refer to the User's Manual (Basic).

(a) DNS setting

Designate the Internet service provider used by the own station's Ethernet module and the IP addresses of the domain name servers (DNS) designated by a system administrator.

- Select the input format (decimal/hexadecimal) of the IP addresses.
- Designate the IP addresses of the DNS servers to DNS servers 1 to 4.

Point

- The DNS servers manage networks.
DNS settings are required to search for the SMTP server and POP3 server from a domain name.
- Make the DNS setting when the mail server name shown in Page 36, Section 2.6 (2) is specified with a domain name.
No setting is required when it is specified with an IP address.
- When obtaining the IP addresses from a domain name, the DNS servers are searched sequentially starting from the first DNS server.

(2) E-mail setting

[Purpose of setting]

Perform the setting to use the e-mail function.

[Start procedure]

Network parameter setting screen ⇒ "E-mail Setting"

[Setting screen]

[Setting item]

	Item name	Description of setting	Setting range/option
General Setting	Password	Set the password to the mail server.	Up to 63 characters
	Mail Address	Set the mail address for the Ethernet module.	Up to 256 characters
	Check Received Mail	Select whether or not to make inquiries to the incoming mail server regarding the receiving status.	<ul style="list-style-type: none"> • Check mark (Inquire) • No check mark (Do not inquire)
	Enquiry Interval	Set the time interval and unit for making inquiries to the incoming mail server.	<ul style="list-style-type: none"> • 30s to 24h • h/min/s

Item name		Description of setting	Setting range/option
Mail server name	Send Mail Setting	SMTP Server Name	Set the send mail server name. Up to 256 characters
		Input Format	Select the input format of the send mail server's IP address. • DEC • HEX
		IP Address	Set the IP address of send mail server. 00000001H to FFFFFFFEH
	Receive Mail Setting	POP Server Name	Set the receive mail server name. Up to 256 characters
		Input Format	Select the input format of the receive mail server's IP address. • DEC • HEX
		IP Address	Set the IP address of the receive mail server. 00000001H to FFFFFFFEH

(a) General settings

Designate the mail setting values that have been registered with the Internet service provider of the own station's Ethernet module or the mail registration information designated by the system administrator.

- Password:

Designate the mail password of the own station's Ethernet module.

- Mail address:

Designate the mail address of the own station's Ethernet module.

- Check receive mails:

Select whether or not to check if receive mails have arrived and set the checking time interval when incoming mails are checked.

When receive mail check is designated, set the time interval for inquiring the mail server whether or not there are mails addressed to the user.

The following table shows each setting range of the inquiry time intervals for checking receive mails. (30s to 24h)

Time unit	Setting range (default: 5 min)
Hour	1 to 24
Minute	1 to 1440
Second	30 to 3600

Point

If the inquiry time interval from the programmable controller CPU or other module to the server is short because of the POP3 server specifications, access may be restricted (lock status) on the server side. Check the POP3 server specifications, and set the inquiry time interval accordingly. (It is recommended to set the setting value of the inquiry time interval to the default (5 minutes) or more.)

(b) Mail server name

Set the Internet service provider and the domain name or IP addresses of the mail servers designated by the system administrator, used by the own station's Ethernet module.

- Designate the domain name of the mail server.
- Select the input format (decimal/hexadecimal) of the IP addresses.
- Set the IP address of the outgoing mail server (SMTP).
- Set the IP address of the incoming mail server (POP3).

Point

- The SMTP server delivers (transfers) e-mails between mail servers.
- The POP3 server transfers received e-mails addressed to users to the corresponding users.
- The mail server names must be designated to use the e-mail function. (Page 35, Section 2.6 (1))

(3) Send mail address setting

[Purpose of setting]

Register the e-mail address of the external devices where e-mail is to be sent.

[Start procedure]

E-mail setting screen ⇒ "Send Mail Address Setting"

[Setting screen]

No.	Send Mail Address	News Specification
1		
2		
3		
4		
5		
6		
7		
8		
9		
10		
11		
12		
13		
14		
15		
16		

[Setting item]

Item name	Description of setting	Setting range/option
Send Mail Address	Set the mail address of the transmission destination	Up to 256 characters
News Specification	Select whether or not to set news	<ul style="list-style-type: none"> • No Execute • Execute News

(a) Send mail address

- Designate the mail addresses of a maximum of 16 external devices to which mails are sent from the own station's Ethernet module. (Only one e-mail address can be specified for each area.)
- In the send e-mail address setting, sequentially set up e-mail addresses starting from No.1. To delete an e-mail address with a mid-setting number, specify dummy e-mail addresses before that address. (If it is preceded by any empty e-mail address areas, subsequent setting numbers and areas will move forward to fill in any empty numbers and areas after each setting, so the setting numbers will change.)
- When sending (MSEND instruction) e-mail by the programmable controller CPU, specify these setting numbers (1 through 16) in the control data.

(b) News specification

Designate whether or not to send the news information set with the CPU monitoring function.

Item	Explanation
News Specification*1	Execute News
	No Execute

*1 For more details on the news settings, refer to Page 55, Section 2.9.

2.7 Sending/Receiving E-mail (Attached Files) by the Programmable Controller CPU

This section explains how to send and receive attached files of e-mail using the dedicated instructions (MSEND/MRECV) available for the Ethernet module.

2.7.1 When sending data as an attached file

The following explains the MSEND instruction and program for sending e-mail.

The following illustration shows how the MSEND instruction is used to store data in an attached file and send it to an external device.

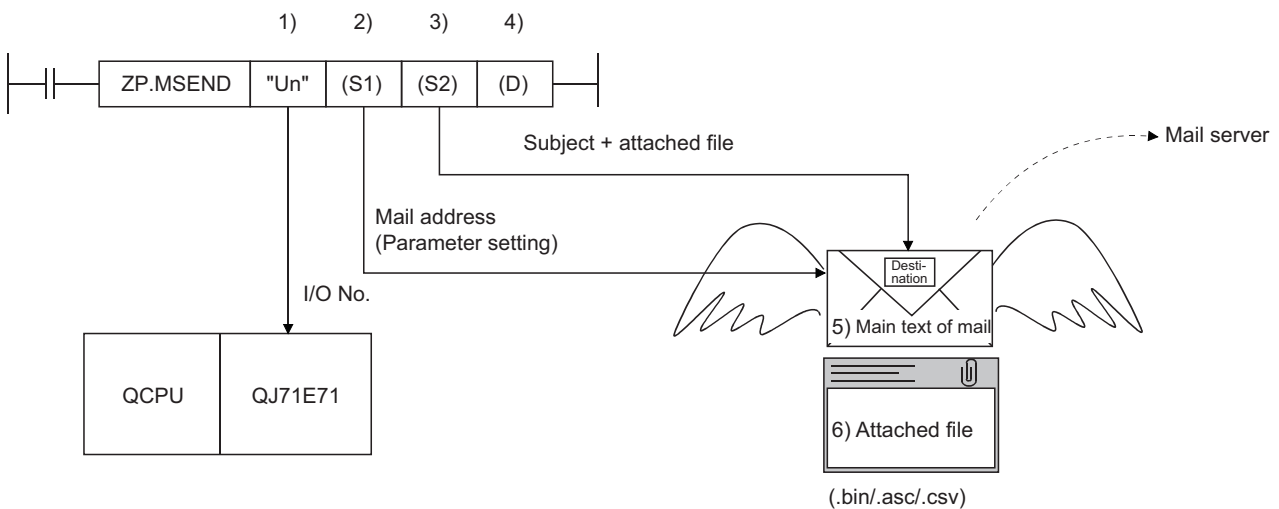

- 1) I/O number of the Ethernet module
- 2) Control data (such as send mail address)

This indicates the mail address of the send destination device set on the send mail address settings screen.

- 3) Send mail (subject + attached file)

Subject consists of No. of transmissions and the character data designated by the sequence program. (It is not converted to ASCII format.)^{*1}

- 4) Complete bit
- 5) Main text of e-mail

There is no data for the main text of e-mail.^{*2}

- 6) Attached file

This indicates the device data designated by the MSEND instruction.

The attached file is sent in either one of binary format, ASCII format or CSV format. The transmission format for attached file is designated in the control data of the MSEND instruction. (☞ Page 41, Section 2.7 (3))

*1 The Subject should be designated in the sequence program in ASCII characters.

*2 The send data is included in the attached file.

(1) Send using the sequence program

The following explains how an e-mail is sent using a sequence program.

For details, refer to Page 164, Section 6.3.

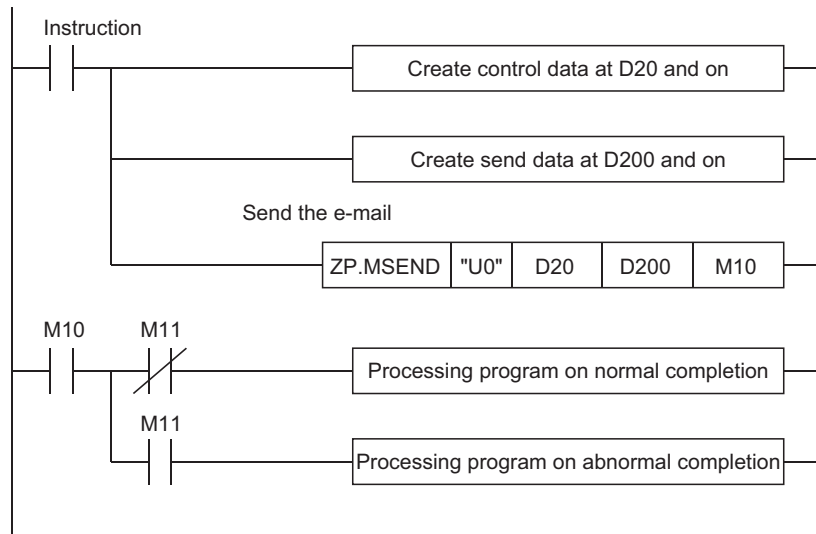

(2) Execution timing of the instruction

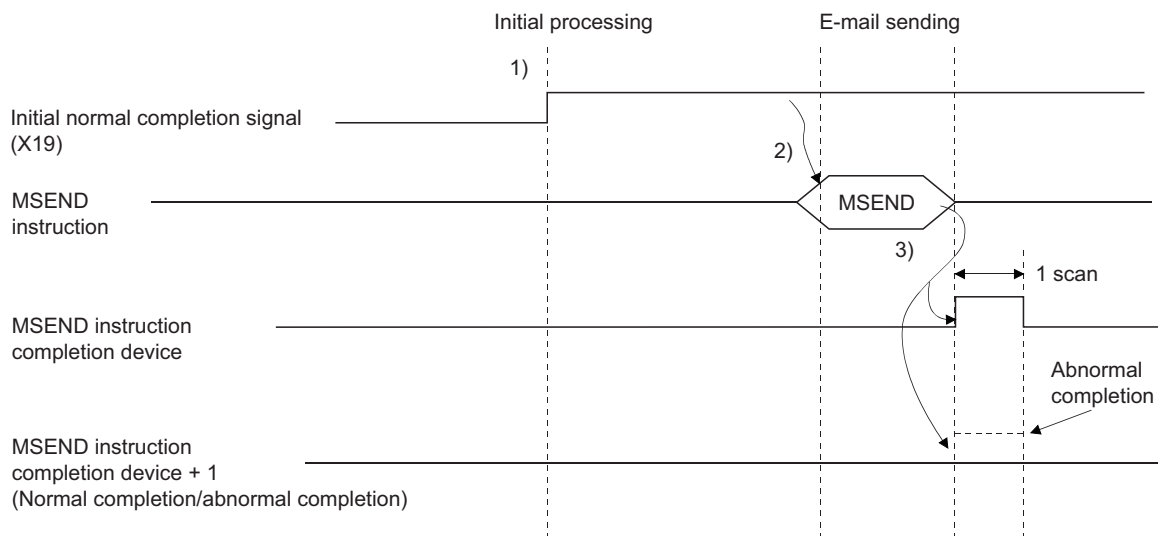

1) Start the own station programmable controller.

The parameters for the e-mail function are stored in the Ethernet module.

2) Execute the MSEND instruction.

The e-mail designated with the MSEND instruction is sent to the mail server.

3) When the e-mail sending to the send mail server is completed, the MSEND instruction completion device turns on.

When the completion device +1 (abnormal completion signal) turns on, the error code is stored in the control data completion status ((S1) + 1).^{*1}

^{*1} For details on the causes of errors, refer to the User's Manual (Basic).

(3) Sample program

The following shows a sample program for sending e-mails by the programmable controller CPU. Perform e-mail send processing using the send command (X20). The contents of the send data are shown in Page 43, Section 2.7.1 (4). When I/O signals of the Ethernet module are X/Y00 to X/Y1F

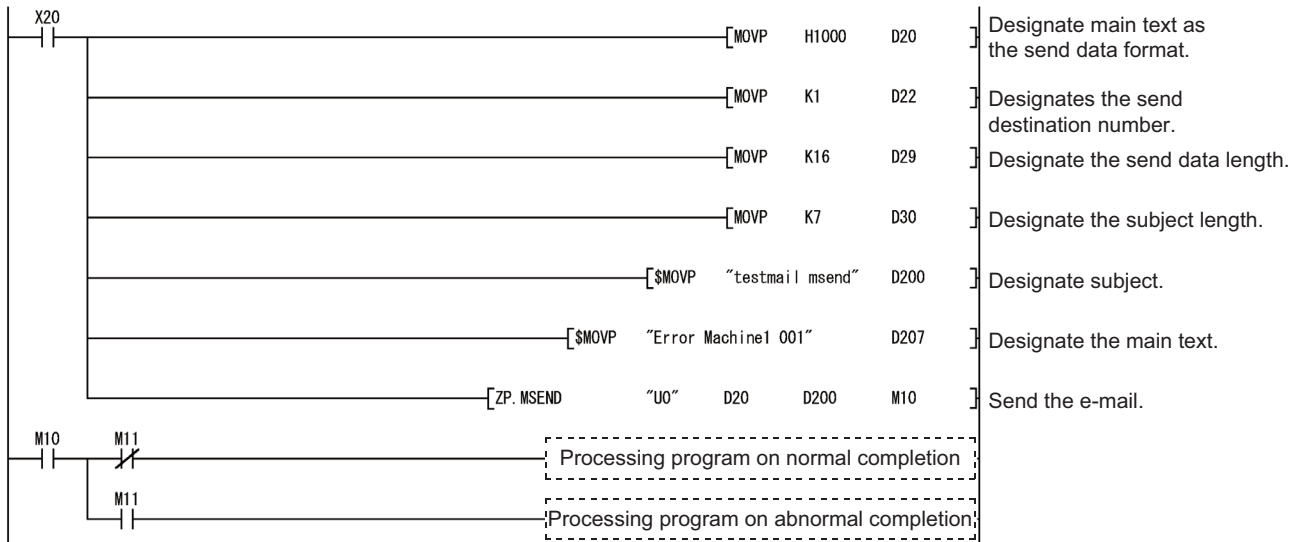

Remark When an error occurs while sending e-mail from the sending mail server to an external device, an error code is stored in the receiving error log area.

The following shows the transmission format of the attached file designated in the control data of the MSEND instruction. For details on how to select the binary format, ASCII format, and CSV format, refer to Page 164, Section 6.3.

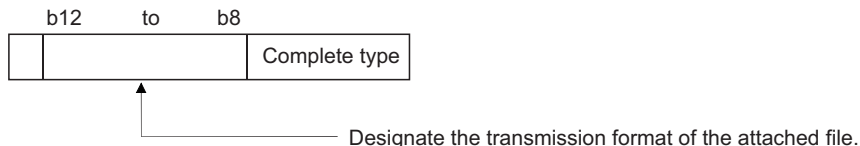

Setting values for designating the attached file transmission format					Format set	Applicable station	Description of processing
b12	b11	b10	b9	b8			
0	0	0	0	0	Binary	Ethernet module Personal computer/UNIX	Sends the attached file in binary format. (***.bin)
0	1	0	0	0	ASCII	Ethernet module Personal computer/UNIX	Sends the attached file in ASCII format. The Ethernet module converts the attached file from binary to ASCII. (***.asc) Note that some restrictions apply to receive an attached file in ASCII format sent with the MSEND instruction by an Ethernet module. (Page 42, Section 2.7 (3) (a))
0	1	0	0	1	CSV	Personal computer/UNIX	Sends the attached file in CSV format. The Ethernet module converts the attached file from binary to CSV. (***.csv)

- (a) Select binary format or ASCII format for communications between Ethernet modules. To use ASCII format, set a data size (the size the MRECV instruction receives) after conversion into ASCII within 6144 words. The attached file of the MSEND instruction will be sent as is.**

The name of the attached file is mmddhhss.bin (system date.bin).

mm: Month

dd: Date

hh: Hour

ss: minute

- (b) Designate either binary format, ASCII format or CSV format when a PC/UNIX receives e-mail sent from an Ethernet module. The attached file of the MSEND instruction will be sent in the designated format. *1*2**

- When binary format is designated

The name of the attached file is mmddhhss.bin (system date.bin).

mm: Month

dd: Date

hh: Hour

ss: minute

- When ASCII format is designated

The name of the attached file is mmddhhss.asc (system date.asc).

mm: Month

dd: Date

hh: Hour

ss: minute

- When CSV format is designated

The name of the attached file is mmddhhss.csv (system date.csv).

mm: Month

dd: Date

hh: Hour

ss: minute

*1 For details on how to receive e-mails, refer to Page 43, Section 2.7 (4).

*2 The system date for the file name is the data managed by the programmable controller of the station in which the Ethernet module is installed.

(4) Receiving by a personal computer

The following explains how a PC/UNIX receives e-mails sent from the Ethernet module.

After setting the environment where the Internet is accessible with a mail user agent, receive an e-mail on the receiving message screen as follows.

Ex. The following shows an example of the reception of e-mail sent using the MSEND instruction (Page 41, Section 2.7 (3)).

(The following is a screen of Microsoft® Corporation's Microsoft Office Outlook 2003.)

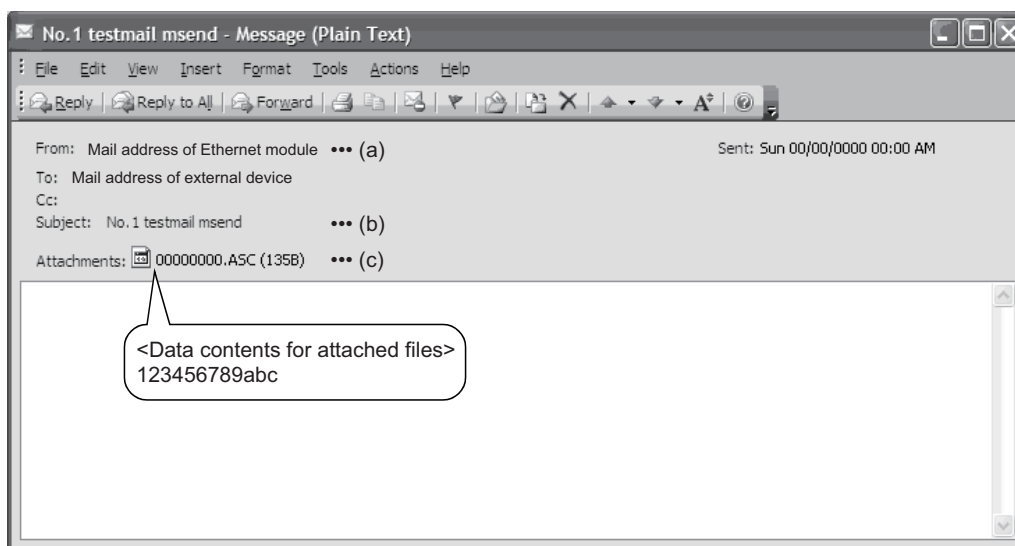

(a) From

Displays the e-mail address of the Ethernet module.

Remark

By entering the mail addresses of the send destination devices in the address book, the registered names (display names) can be displayed and it makes the management easier.

(b) Subject

This indicates the No. of transmissions*¹ and the Subject written by a sequence program.

*¹ This is the number automatically added each time an Ethernet module sends an e-mail. The numbers are counted up from 1. When the number reaches 4294967296, the number is cleared to 0. Then the numbers are counted up from 0 again to 4294967296.

(c) Attached file

This indicates the name of the attached file sent by the Ethernet module.

Point

Data in the attached file in CSV format can be read in cell units in Excel, etc., for each 1 word of data.

2.7.2 When receiving data in the attached file

This section explains the MRECV instruction and a program to receive e-mails sent from external devices. The MRECV instruction reads the attached file received.

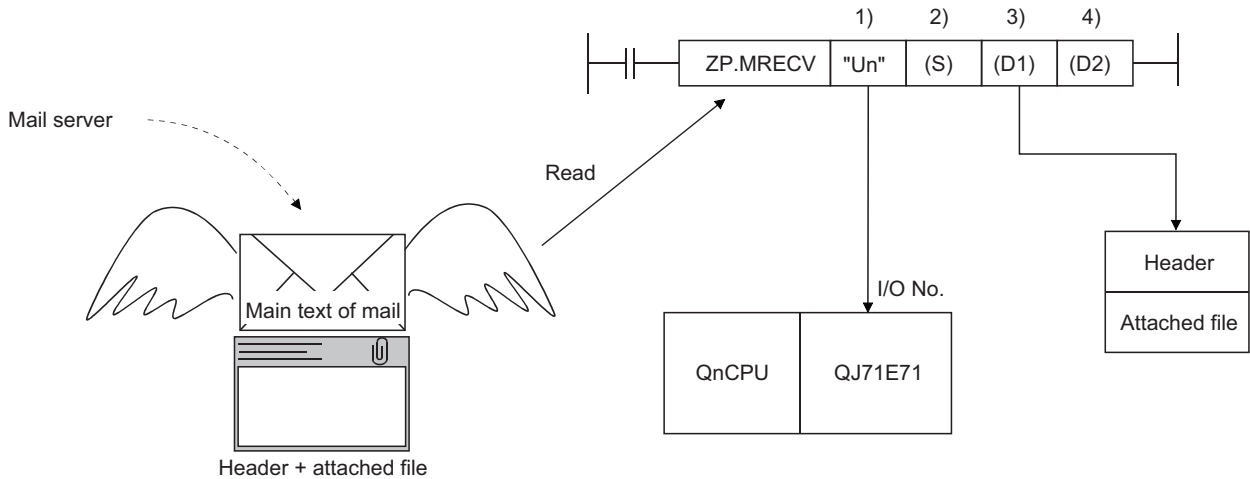

- 1) I/O number of the Ethernet module
- 2) Control data (such as mail No. to be read)
- 3) Storage device of header + attached file
- 4) Complete bit

Receive mail is temporarily stored in the buffer memory shown below.

Address (hexadecimal)	Item	Description	Remarks
2680H	Received e-mail size	Indicates the size of received e-mail (header + attached file) data.	
2681H	Header size	Indicates the size of the header data.	—
2682H	Mail information	*1	
2683H	Head address of attached file	Indicates the head address where the attached file data information is stored.	
2684H	Head address of header	Indicates the head address where the header information is stored.	
2685H	From head address	Indicates the head address of this data stored in the header information.	
2686H	Date head address	Indicates the head address of this data stored in the header information.	*2
2687H	Subject head address	Indicates the head address of this data stored in the header information.	
2688H	Attached file name head address	Indicates the head address of this data stored in the header information.	
2689H	Message ID head address	Indicates the head address of this data stored in the header information.	
268AH	System area	—	
268BH to 3FFFH	Header information (maximum of 373 words)	Indicates the content of the header designation items above.	
	Attached file (maximum of 6144 words)	Indicates the contents of the attached file data.	—
4000H	System area	—	

*1 In the mail information storage area, the following information related to the receive mail is stored in the corresponding bits.

Mail information storage area address 2682H(9858)	b15	b14	to	b5	b4	b3	b2	b1	b0
	7)		6)	5)	4)	3)	2)	1)	

- 1) Indicates whether the information (maximum of 128 words) in the From head address storage area is valid (1) or invalid (0).
 - 2) Indicates whether the information (maximum of 4 words) in the Date head address storage area is valid (1) or invalid (0).
 - 3) Indicates whether the information (maximum of 64 words) in the Subject head address storage area is valid (1) or invalid (0).
 - 4) Indicates whether or not there is an attached file Yes (1) or No (0).
- For "Yes", it indicates that the information (maximum of 12 words) stored at addresses starting from the Attached file name head address is valid.
- 5) Indicates whether or not there is information in the Message ID head address storage area Yes (1) or No (0).
 - 6) Indicates the system information.
 - 7) Indicates whether the receive mail that has not been read to the programmable controller CPU is stored in the Ethernet module. (Yes (1) or No (0))

*2 The value stored in each head address shown in the table indicates the offset address (0H to nH) from the head address of the buffer memory in which the applicable address is stored (address: 268BH to 3FFFH).

Point

- The Ethernet module checks whether there is any incoming mail addressed to the own station in the mail server at the time interval set in "Enquiry Interval" under the e-mail setting screen of a programming tool.
If there are incoming mails addressed to the own station, the reception information is stored in the following areas of the buffer memory.
 - Bit 15 is turned on in the mail information storage area*1.
 - The number of receive mails on the mail server is stored in the receive mail count storage area (address 5870H).
When more than one receive mails are stored on the mail server, the receive mail information can be stored in the buffer memory in the same way as described above by designating "Inquire" in the MRECV instruction's control data item.
Receive mails can successively be read based on this stored information.
- Read receive mails stored on the mail server using the MRECV instruction. Receive mails will accumulate on the mail server if the MRECV instruction is not executed.
- After executing the MRECV instruction, e-mails that have been read are deleted from the mail server. (Receive mails read will not remain on the mail server.)
- If the Ethernet module has received e-mail longer than the reception data length specified with the MRECV instruction, it stores the data equivalent to the reception data length and ignores the remaining data.

(1) Reception using the sequence program

The following explains the designation method in a sequence program.
For details, refer to Page 158, Section 6.2.

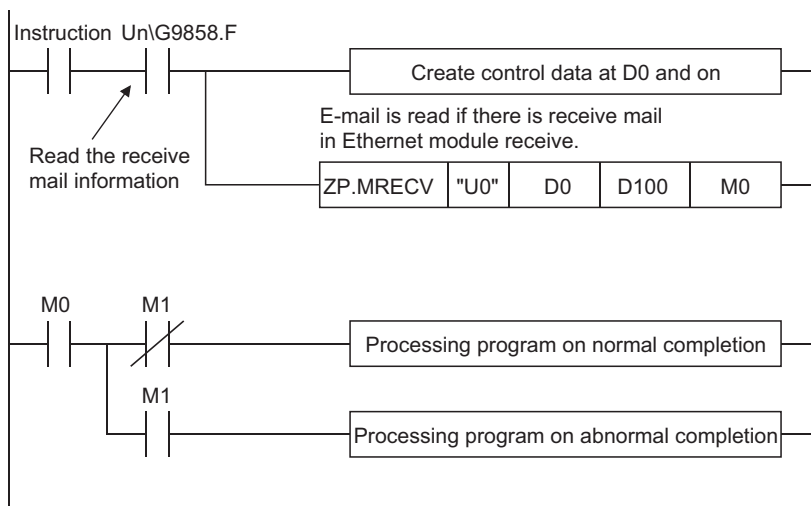

(2) Execution timing of the instruction

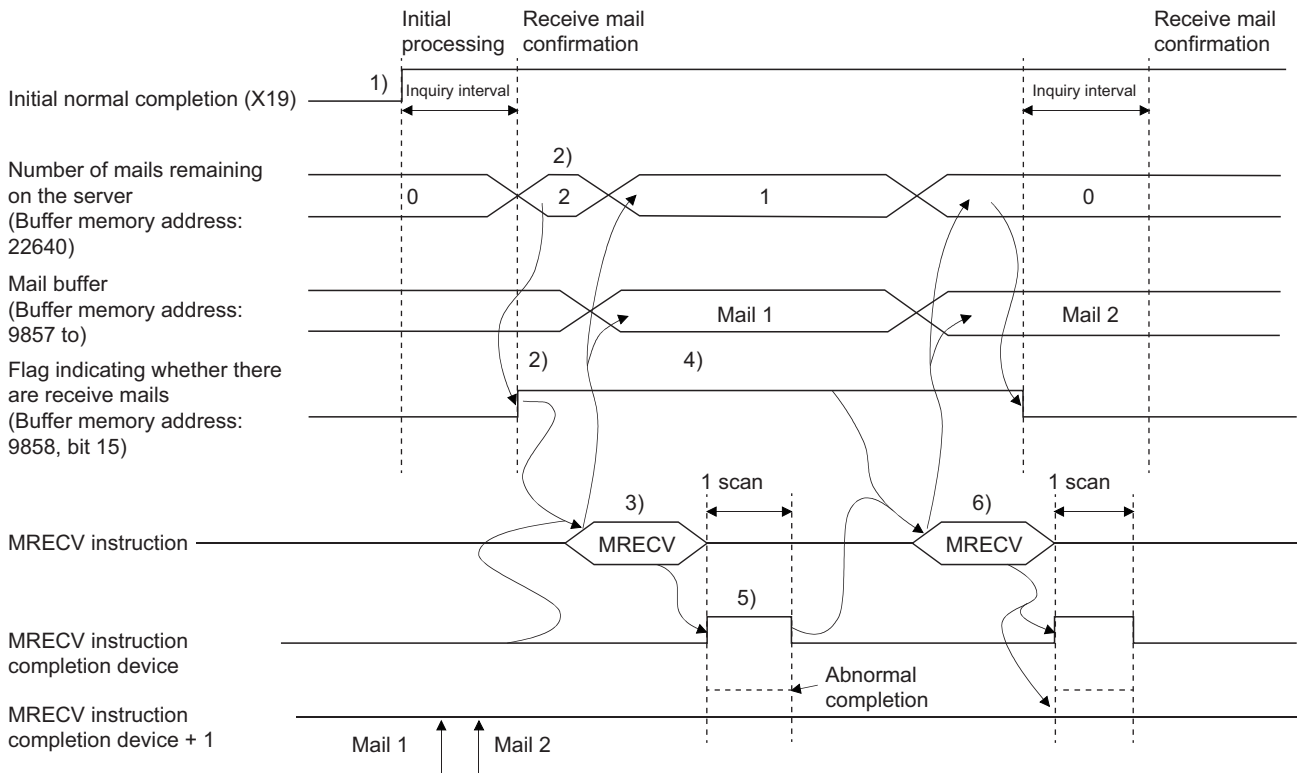

1) Start the own station programmable controller.

The parameters for the e-mail function are stored in the Ethernet module.

2) Check whether or not any received e-mails are stored on the mail server.

If any receive mail has been stored, the receive mail information is stored in the buffer memory.

3) Execute the MRECV instruction.

Read e-mails from the server.*1

4) The flag indicating whether or not there is a receive mail stays on by designating "Inquire" with MRECV instruction's control data item.

5) When reading e-mails is completed, the MRECV instruction completion device turns on.

When the completion device + 1 (abnormal completion signal) turns on, the error code is stored in the control data completion status ((S) + 1).*2

6) Execute the MRECV instruction.

Continue to read e-mails remaining on the mail server.

*1 E-mails that have been read will not remain on the mail server.

*2 For details on the causes of errors, refer to the User's Manual (Basic).

Point

- Reading receive mails to the Ethernet module

The Ethernet module automatically checks the mail server to see whether there is any incoming mail at the inquiry interval set with a programming tool.

If there are any receive mails addressed to the own station, the reception information is stored in the buffer memory; the MRECV instruction should be executed based on this information.

- When there are two or more receive mails on the mail server

By designating "Inquire" in the MRECV instruction's control data, the Ethernet module also reads the information of the remaining receive mails on the mail server and stores it in the buffer memory when the MRECV instruction is executed. Continue to execute the MRECV instruction based on this information.

(3) Sample program

The following is a sample program for receiving e-mail by a programmable controller CPU. This program performs e-mail receive processing using the receive command (X21). When I/O signals of the Ethernet module are X/Y00 to X/Y1F

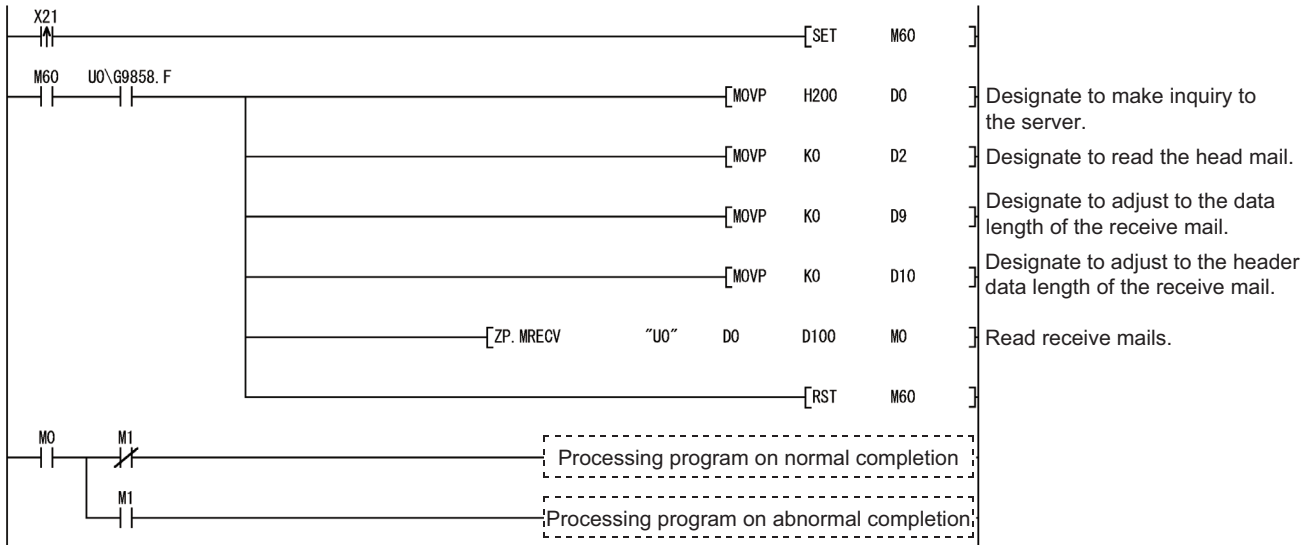

The following explains the types of execution that can be designated in the MRECV instruction's control data. For more details on how to designate the execution types, refer to Page 158, Section 6.2.

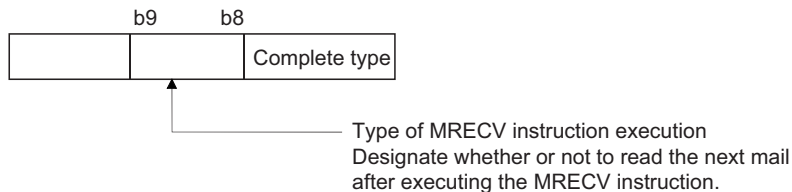

Setting value for designating the type of execution		Setting type	Description of processing	Merit	Demerit
b9	b8				
0	0	Do not inquire ^{*1}	Execute only e-mail read processing. The inquiry (read) processing of the remaining receive mail information is executed after the time set with a parameter of a programming tool.	Inquiries to the mail server can be less frequent.	The next receive mail cannot be read immediately. Mails tend to accumulate on the mail server.
1	0	Inquire ^{*2}	Execute read processing of e-mails. After executing the MRECV instruction, the inquiry (read) processing of the remaining receive mail information is also executed.	Mails received by the mail server can be read in succession.	Inquiries to the mail server are more frequent. More processing in the module affects other internal processing.

*1 Do not read
*2 Read

(4) Sending an e-mail from a personal computer

This section explains how to send e-mails from a PC/UNIX to the Ethernet module.

After setting the environment where the Internet is accessible with a mail user agent, create and send an e-mail on the sending message creation screen as follows.

Point

To send an e-mail to an Ethernet module, use a mail user agent where the encoding method (Base 64/7 bits/8 bits/Quoted Printable) of attached files can be specified.

The screenshot shows a 'New Message' window with the following fields:

- To:** Mail address of Ethernet module ... (a)
- Subject:** TESTMAIL ... (b)
- Attach:** 01234567.bin (12 bytes) ... (d)(e)
- Main text area:** (c)

(a) To

Designate the mail address of the Ethernet module.

(b) Subject

Designate the subject of the e-mail to be sent to the Ethernet module in ASCII format.

(c) Main text

Do not designate data (the Ethernet module ignores it.)

(d) Attached file

Data can be sent as an attached file.*¹

Send the attached file data as binary data.

*¹ The Ethernet module does not convert the received attached file data from ASCII to binary.

(e) Attached file name

Designate the name of the attached file using alphanumeric characters. (It is recommended to use the name within eight characters.)

Designate either ".bin" or ".asc" for the attached file extension.

The stored data will be received as binary data.

Remark

Designate a single attached file when sending e-mail to the Ethernet module.

If two or more files are attached, the destination Ethernet module will store only the first file and ignore the rest of the attached files.

2.7.3 Contents of the attached files

The following explains the contents of the attached file data.

The data format of the attached file is ASCII code (ASCII format, CSV format) or binary code (binary format).

The following example shows the transmission contents for each data format (binary/ASCII/CSV) when the Ethernet module sends the data register value as an attached file.

(1) When sending from the Ethernet module

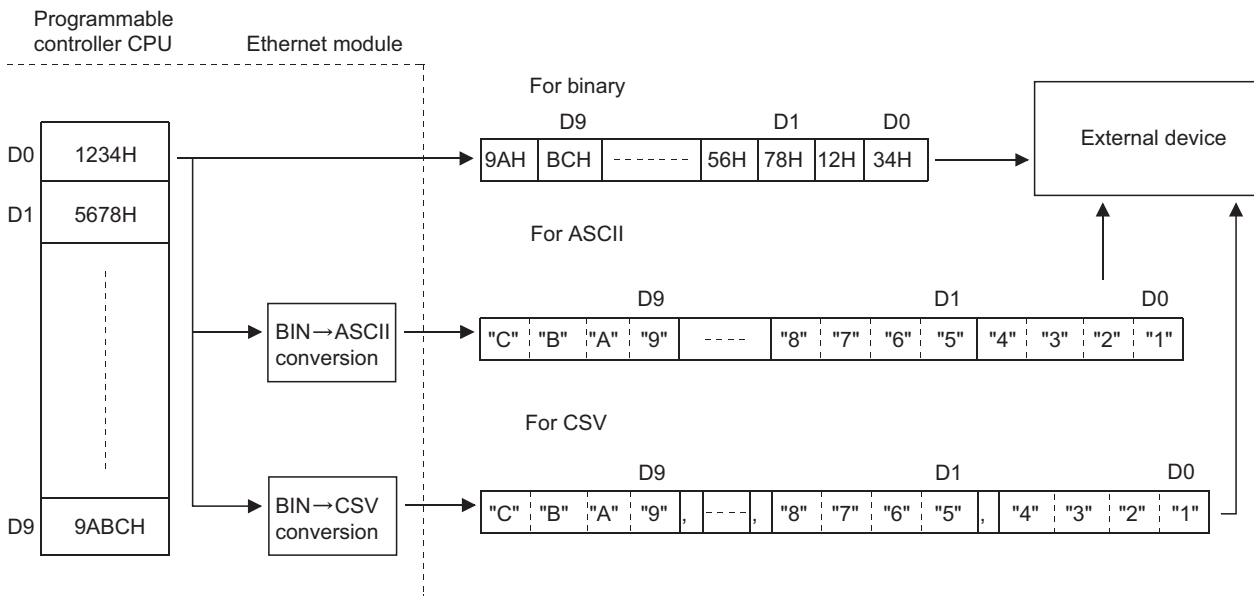

(2) When receiving by the Ethernet module

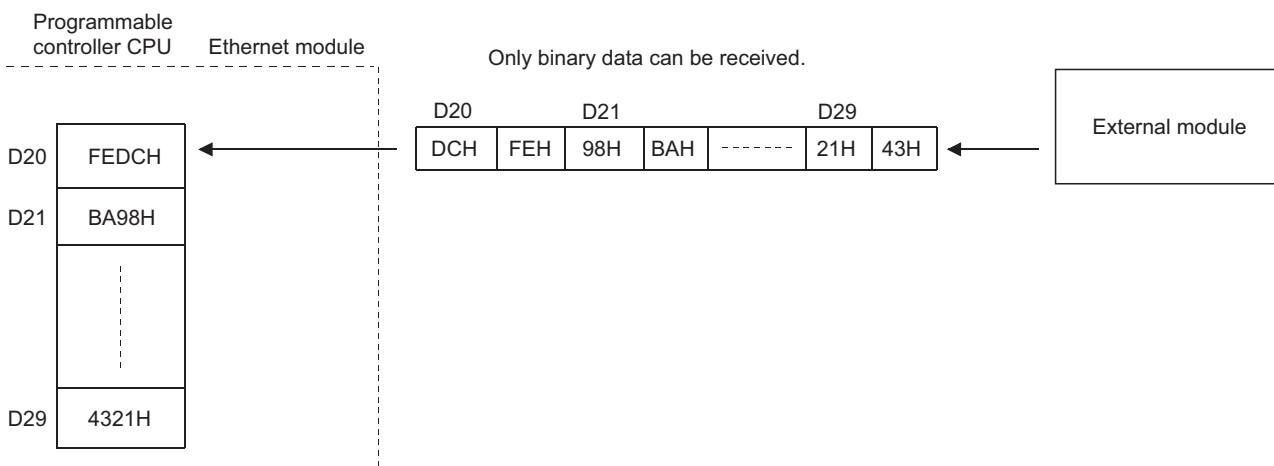

Remark

For details on the order of data items when sending/receiving bit device data, see the figure shown in Page 59, Section 2.9.2.

(3) Data configuration in CSV format

Data in CSV format can be used as control data for the cell units in Excel, etc.

Data in CSV format handled by the Ethernet module is the data expressed as follows.

- 1 word (16 bits) binary data is converted to four digit ASCII code when expressed as a hexadecimal. (4 bytes of ASCII code)
- When handling multiple word data, insert comma data between each word (4 bytes of ASCII code).

Data designated by the MSEND instruction or data subject to the news function is sent in the following arrangement.

(a) Arrangement of data sent by the MSEND instruction

- In addition to the data conversion and insertion described above, CR (code: 0DH) and LF (code: 0AH) are inserted for each 8 words of data.
- The arrangement of data sent in CSV format is shown below.

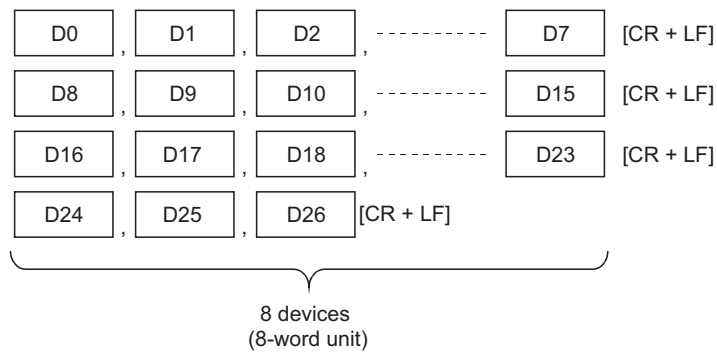

(b) Arrangement of data sent using the news function

- In addition to the data conversion and insertion of comma data described above, CR (code: 0DH) and LF (code: 0AH) are inserted for each setting device range.
- A maximum of 16 types of device ranges can be set for news data.*1
- The arrangement of data sent in CSV format is shown below.

*1 For details, refer to Page 55, Section 2.9.

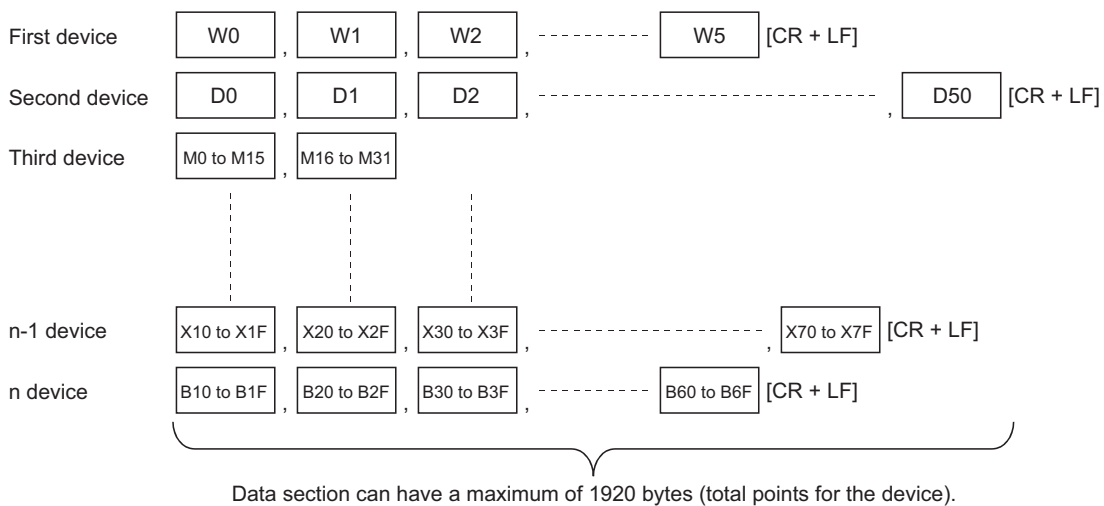

2.8 Sending E-mail (Main Text) by the Programmable Controller CPU

This section explains how to send the main text of e-mail using the dedicated MSEND instruction available for the Ethernet module.

2.8.1 When sending data as main text of e-mail

The following explains the MSEND instruction and program for sending e-mail.

The following illustration shows how the MSEND instruction is used to store data in the main text of e-mail and send it to an external device.

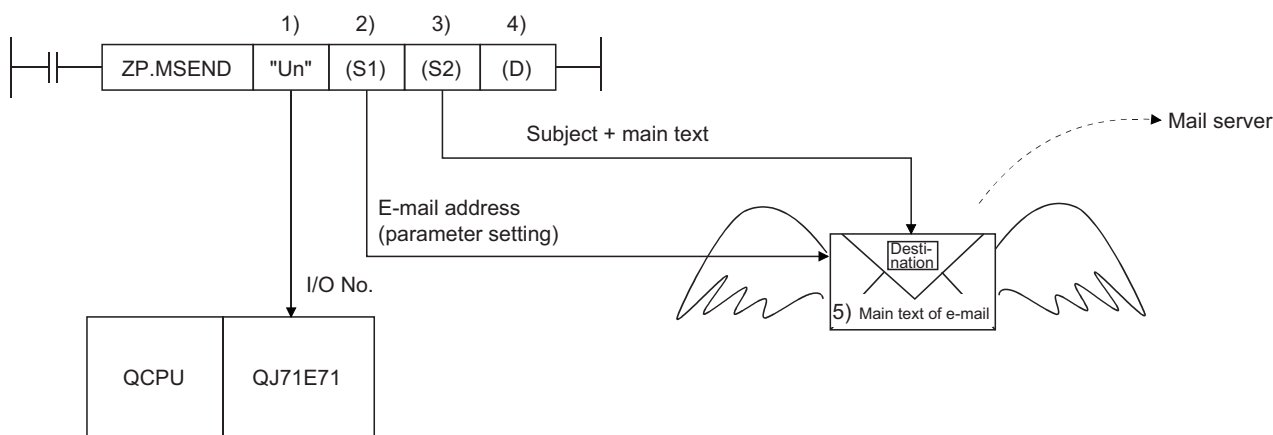

- 1) I/O number of the Ethernet module
- 2) Control data (such as send mail address)

This indicates the mail address of the send destination device set on the send mail address settings screen.

- 3) Sending e-mail (Subject + main text)

Subject consists of No. of transmissions and the character data designated by the sequence program. (It is not converted to ASCII format.)*1

- 4) Complete bit
- 5) Main text of e-mail

This indicates the character string designated by the MSEND instruction.

It is not converted to ASCII format by the Ethernet module.*1*2*3

- 6) Attached file

No attached file can be sent when sending data as the main text of e-mail.

- *1 Designate the main text data in ASCII characters in sequence programs.
- *2 The following binary code data is processed as control codes:
0D0AH: Line feed code CR+LF
00H: End of main text
- *3 It is recommended to use 78 characters or less data when writing each line of the main text (sending data).
(Be sure to add a line feed code CR+LF (0D0AH) at the end of the main text lines.)

(1) Send using the sequence program

The following explains how an e-mail is sent using a sequence program.

For details, refer to Page 164, Section 6.3.

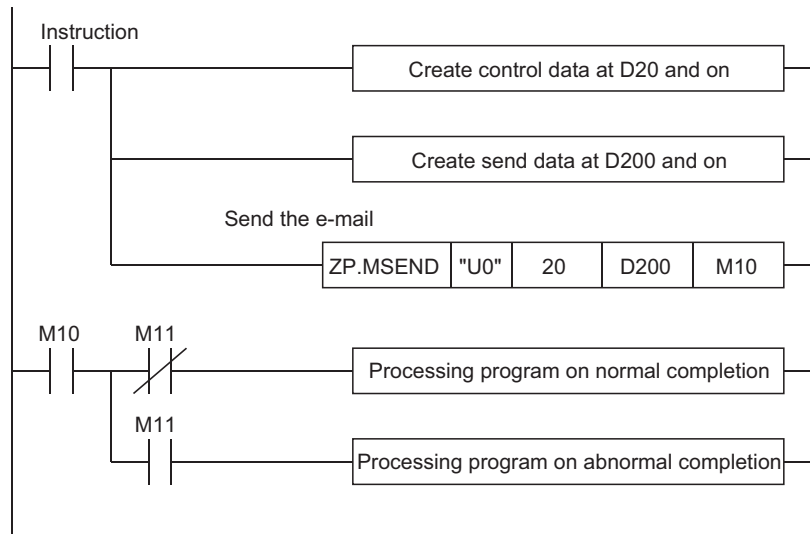

(2) Execution timing of the instruction

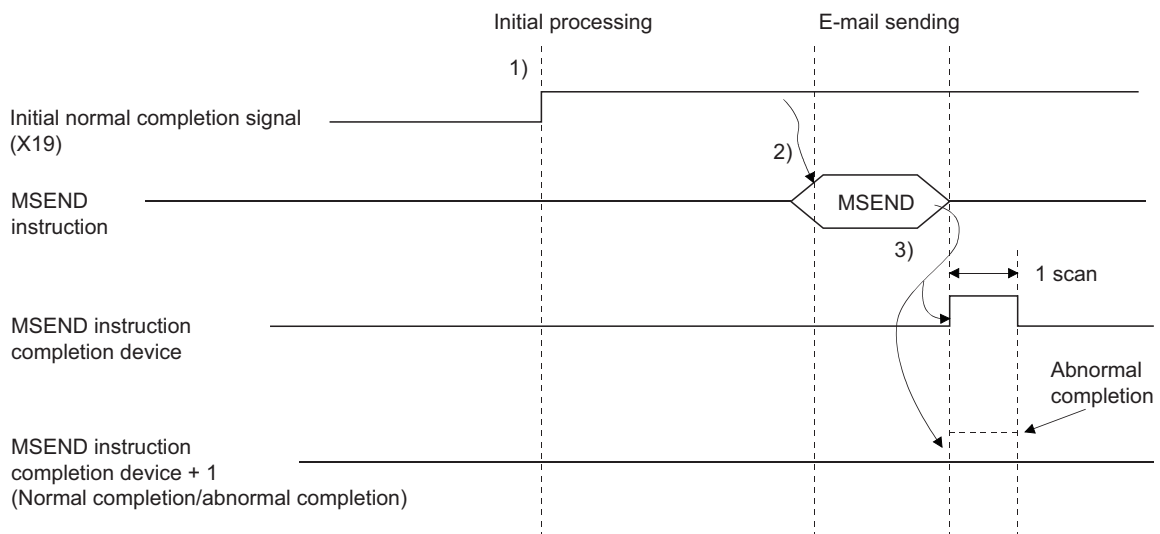

1) Start the own station programmable controller.

The parameters for the e-mail function are stored in the Ethernet module.

2) Execute the MSEND instruction.

The e-mail designated with the MSEND instruction is sent to the mail server.

3) When the e-mail sending to the send mail server is completed, the MSEND instruction completion device turns on.

When the completion device +1 (abnormal completion signal) turns on, the error code is stored in the control data completion status ((S1) + 1).^{*1}

^{*1} For details on the causes of errors, refer to the User's Manual (Basic).

(3) Sample program

The following shows a sample program for sending e-mails by the programmable controller CPU. Perform e-mail send processing using the send command (X20). The contents of the send data are shown in Page 54, Section 2.8.1 (4). When I/O signals of the Ethernet module are X/Y00 to X/Y1F

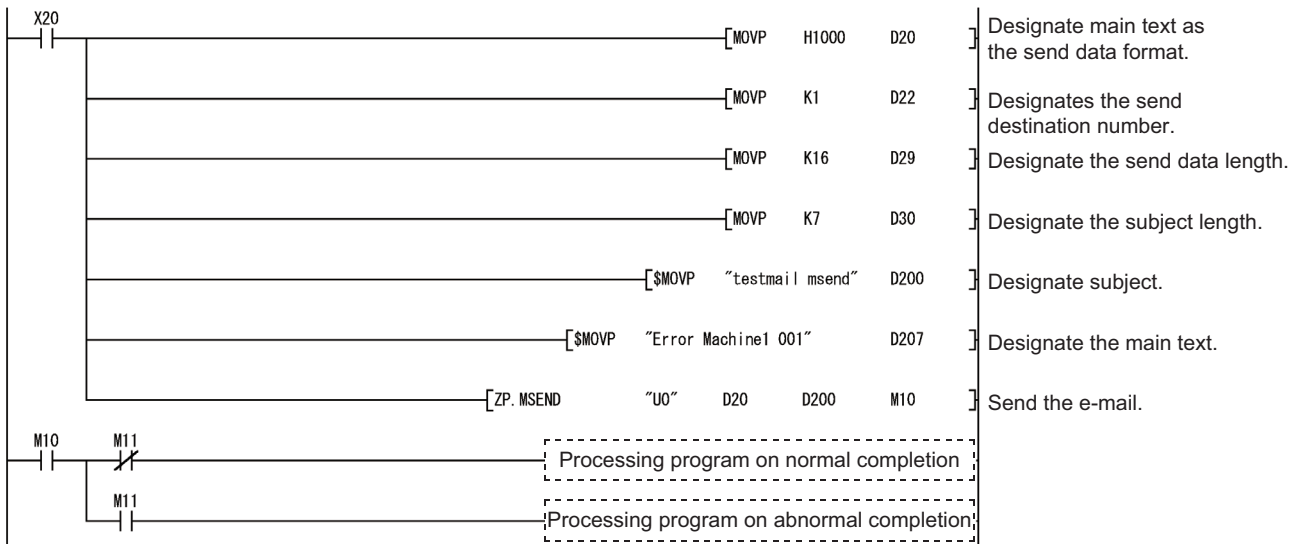

Remark When an error occurs while sending e-mail from the sending mail server to an external device, an error code is stored in the receiving error log area.

The following shows the transmission format of the main text designated in the control data of the MSEND instruction. If data is sent as the main text of e-mail, the Ethernet module does not convert the transmission format. Designate the main text data in ASCII characters in sequence programs.

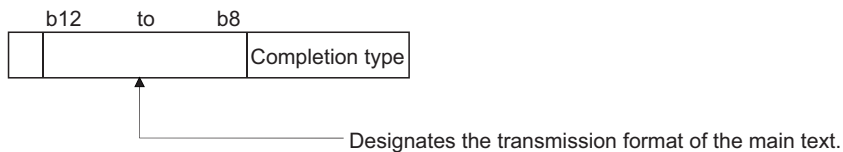

Setting values for designating the main text data transmission format					Format set	Applicable station	Description of processing
b12	b11	b10	b9	b8			
1	0	0	0	0	No conversion	Personal computer/UNIX/portable terminal	Send the main text data. The Ethernet module does not convert the transmission format.*1

*1 Designate the main text data in ASCII characters in sequence programs.

(4) Receiving by a personal computer

The following explains how a PC/UNIX/portable terminal receives e-mail sent from the Ethernet module. After setting the environment where the Internet is accessible with a mail user agent, receive an e-mail on the receiving message screen as follows.

Ex. The following shows an example of the reception of e-mail sent using the MSEND instruction (Page 53, Section 2.8.1 (3)).

(The following is a screen of Microsoft® Corporation's Microsoft Office Outlook 2003.)

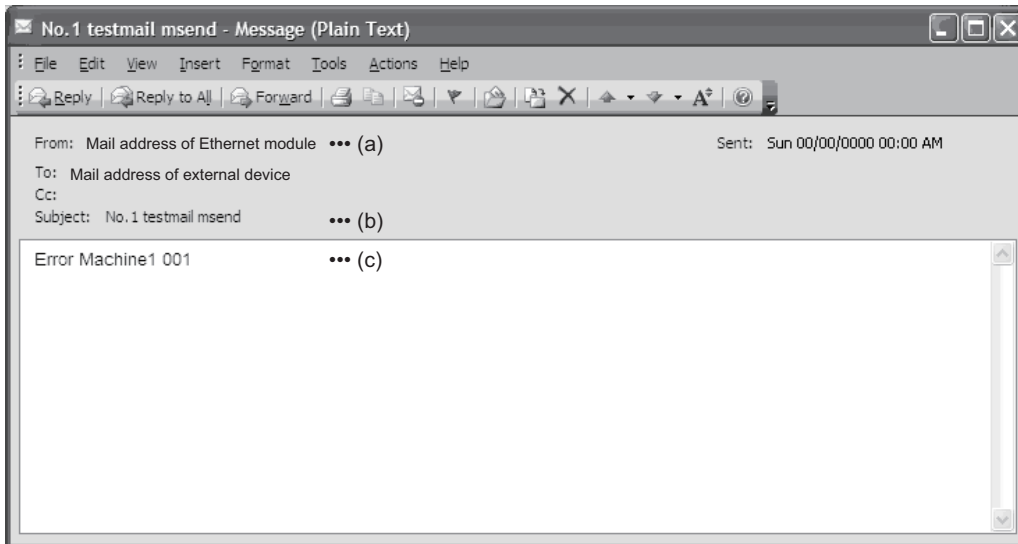

(a) From

Displays the e-mail address of the Ethernet module.

Remark

By entering the mail addresses of the send destination devices in the address book, the registered names (display names) can be displayed and it makes the management easier.

(b) Subject

This indicates the No. of transmissions^{*1} and the Subject written by a sequence program.

^{*1} This is the number automatically added each time an Ethernet module sends an e-mail. The numbers are counted up from 1. When the number reaches 4294967296, the number is cleared to 0. Then the numbers are counted up from 0 again to 4294967296.

(c) Main text of e-mail

This indicates the main text of e-mail sent by the Ethernet module.

2.9 Sending E-mails Using the Programmable Controller CPU Monitoring Function

When the monitoring information read from the Q/LCPU matches with the news conditions set by the user, the Ethernet module sends an e-mail to the external device.

2.9.1 News setting

[Purpose of setting]

The monitoring conditions (notification conditions) of the programmable controller CPU can be set on the news setting screen of a programming tool.

The monitoring function of the programmable controller CPU can be used according to this setting.

Both CPU status monitoring and device monitoring can be designated as notification conditions.

[Start procedure]

E-mail setting screen ⇒ "News Setting"

[Setting screen]

No	Condition Device	Condition for Inspection	Monitoring Value	News Data Storage Device	News Data Points
1	W0	Device Value Match	100	W0	2
2	D0	Device Value <= Monitoring Value(Unsigned)	50	D0	10
3	M0	Pulse Up		M0	80
4	X10	Pulse Up		X10	48
5	B10	Pulse Up		B10	64
6					
7					
8					

[Setting item]

Item name	Description of setting	Notification condition		Setting range/option
		CPU status monitoring *1	Device monitoring	
Condition for PLC Inspection	Select the monitoring condition for the CPU	○	×	<ul style="list-style-type: none"> • No Setting • Normal STOP • Serious/Fatal Error (moderate/major error) • Warning STOP (minor error STOP) • Normal RUN • Warning RUN (minor error RUN) • PAUSE
Send Method	Select the data send method.	×	○	<ul style="list-style-type: none"> • Send Attached File • Send Text Mail
Attached File Form	Set the data format for the attached file	×	○	<ul style="list-style-type: none"> • Binary • ASCII • CSV
Attached File Name	Set the attached file name	×	○	<ul style="list-style-type: none"> • Up to 8 characters
PLC Inquiry Interval	Set time interval between reading the CPU status and device values and the units (h/min/s)	○	○	<ul style="list-style-type: none"> • 30 s to 24 h
Input Format of Inspection Value	Select the input format of the monitoring data	×	○	<ul style="list-style-type: none"> • DEC/HEX
Condition Device	Set the condition device	×	○	<ul style="list-style-type: none"> • A device in the CPU module
Condition for Inspection	Set the monitoring condition	×	○	—
Monitoring Value	Set the monitoring value	×	○	<ul style="list-style-type: none"> • -32768 to 32767
News Data Storage Device	News data storage device value	×	○	—
News Data Points	Set the news data points	×	○	[Maximum points for a device] <ul style="list-style-type: none"> • Word device: 960 points • Bit device: 8192 points [Total number of points] <ul style="list-style-type: none"> • Total number of news data points: 1920 bytes (One bit point is rounded up to one word point.)

○: Setting item, ×: Setting not required

*1 When an e-mail is sent with the programmable controller status inspection, only subject (programmable controller CPU status is stored) is sent.

(1) Condition for PLC inspection

Condition for PLC inspection	Description
Normal STOP	Sends an e-mail when the programmable controller CPU is placed in the STOP status normally.
Serious/Fatal Error	Sends an e-mail when an error that stops the CPU execution has occurred.
Warning STOP	Sends an e-mail when the programmable controller CPU is stopped by an external operation, etc. while an error that allows to continue the CPU execution has occurred.
Normal RUN	Sends an e-mail when the programmable controller CPU is placed in the RUN status normally.
Warning RUN	Sends an e-mail when an error that does not allow to continue the CPU execution has occurred while the programmable controller CPU is in the RUN status. (The programmable controller CPU is in operation.)
PAUSE	Sends an e-mail when the programmable controller CPU is placed in the PAUSE status.

(2) Send method

Select the send method of the device monitoring results.

Item	Explanation
Send Attached File	Sends data as an attached file in the file format designated in Page 57, Section 2.9.1 (3).
Send Text Mail	Sends data as the main text of e-mail in ASCII code format. It is not necessary to designate items Page 57, Section 2.9.1 (3) and Page 57, Section 2.9.1 (4) when this setting is used.

(3) Attached file format

Item	Explanation
Binary	Sends the attached file in binary format. The Ethernet module sends the attached file as they are with the code currently in use. (Binary to ASCII conversion is not performed.)
ASCII	Sends the attached file in ASCII format. The Ethernet module converts the attached file from binary to ASCII.
CSV	Sends the attached file in CSV format. The Ethernet module converts the attached file from binary to CSV.

(4) Attached file name

Designate the name of an attached file. If a file name is not designated, the Ethernet module automatically names it and sends the file named mmddhhss (month, date, hour, minute) (same as for e-mail sending).

(5) PLC inquiry interval

Designate the interval for the Ethernet module to read the CPU status and device values from the programmable controller CPU.

The user can designate any inquiry time interval (time) within the ranges listed below.

Time unit	Setting range (default: 5 min)
Hour	1 to 24
Minute	1 to 1440
Second	30 to 3600

(6) Input format of inspection value

Select the input format (decimal/hexadecimal) of the monitoring value.

(7) Condition device

Designate the device to be monitored.

Point

- A maximum of 16 devices can be monitored.
- It is possible to designate devices that can be accessed for communication using the MC protocol directly as condition devices (see the Reference Manual). (📖 Reference Manual)
In this case, Timer, Retentive timer and Counter should be designated by T, ST, or C.
The following devices cannot be designated:
 - Step relay (S)
 - Direct input (DX)
 - Direct output (DY)
 - Index qualification
 - Indirect designation
- After completion of the news setting, the system will rearrange the condition devices in the order; word devices first and then bit devices.
Display the news setting screen again to confirm the condition device settings.

(8) Condition for inspection

Designate the news conditions to monitor the devices of the programmable controller CPU.

The following table lists the comparison conditions for the designated device.

	Condition of comparison	Notification condition
Bit device	No conditional settings	For each monitoring.
	Rise	When switching from off to on is detected.
	Drop	When switching from on to off is detected.
Word device	No conditional settings	For each monitoring.
	No conditional settings (Character String send)	For each monitoring. (Selectable when "Send text mail" and "Word device" are set for "Send method" and "Condition device" respectively.)
	Device value = monitoring value	When the monitoring device value and the value set by the user are the same.
	Device value ≠ monitoring value	When the monitoring device value and the value set by the user are different.
	Device value ≤ monitoring value (unsigned)	When the monitoring device value is equal to or less than the value set by the user.
	Device value < monitoring value (unsigned)	When the monitoring device value is less than the value set by the user.
	Device value ≥ monitoring value (unsigned)	When the monitoring device value is equal to or greater than the value set by the user.
	Device value > monitoring value (unsigned)	When the monitoring device value is greater than the value set by the user.
	Device value ≤ monitoring value (signed)	When the monitoring device value is equal to or less than the value set by the user.
	Device value < monitoring value (signed)	When the monitoring device value is less than the value set by the user.
	Device value ≥ monitoring value (signed)	When the monitoring device value is equal to or greater than the value set by the user.
	Device value > monitoring value (signed)	When the monitoring device value is greater than the value set by the user.

(9) Monitoring value

Designate the comparison value of the condition of comparison given in Page 58, Section 2.9.1 (8) above.

(10) News data storage device

The condition device that stores the news data is set when the news condition is satisfied.

When the CPU monitoring condition listed in Page 56, Section 2.9.1 (1) is "No Setting", a programming tool automatically sets the condition device; therefore, the user does not need to set it.

(11) News data points

Designate how many devices should be read (number of points read) from the devices designated in Page 58, Section 2.9.1 (10) above.

(a) The number of device points that can be sent at a time is calculated as follows.

Word device points × 2 + bit device points ÷ 8 (round up) ≤ 1920

- Designate the settings so that the total number of points satisfies the equation above when multiple news conditions are satisfied when monitoring multiple condition devices.
- When multiple bit devices are to be designated, be aware of following:
 - One device occupies 16 device points.

2.9.2 Receiving a news e-mail

The designated external device side can open the news e-mail from the Ethernet module in the same way as opening a mail received from the programmable controller CPU.

(1) When monitoring the CPU status

(a) When the result of the CPU status monitoring matches the monitoring condition, the Subject will be sent.

The attached file or main text will not be sent.

(b) The following shows the contents for the Subject sent.

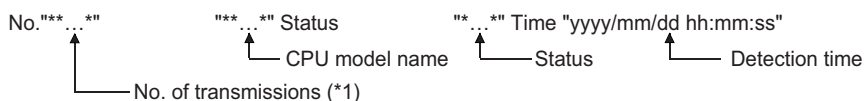

*1 This is the number automatically added each time an Ethernet module sends an e-mail. The numbers are counted up from 1. When the number reaches 4294967296, the number is cleared to 0. Then the numbers are counted up from 0 again to 4294967296.

(Send contents of the parts for the status)

CPU module status		Send contents
During RUN	At normal	"Status: RUN"
	At module warning occurrence	"Status: RUN (Warning)" or "Status: RUN (Slight Abnormal)"
During STOP	At normal	"Status: STOP"
	At module warning occurrence	"Status: STOP (Warning)" or "Status: STOP (Slight Abnormal)"
	During the module error or module system error	"Status: STOP (Serious/Fatal Error)" or "Status: STOP (Abnormal)"
During PAUSE	—	"Status: PAUSE"

(2) When monitoring a device

(a) When any of the results of the device monitoring matches the monitoring condition among the devices having the conditions designated on the news setting screen, the Subject and attached file, or the Subject and main text will be sent.

(b) The following shows the contents for the Subject sent.

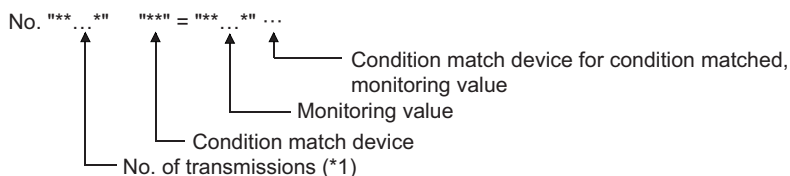

*1 This is the number automatically added each time an Ethernet module sends an e-mail. The numbers are counted up from 1. When the number reaches 4294967296, the number is cleared to 0. Then the numbers are counted up from 0 again to 4294967296.

(c) All device values for the number of registered points designated on the news setting screen are recorded in the attached file or main text.

The size of the data recorded in the attached file or main text is calculated as follows:

$$\text{Information of bit devices: } \frac{\text{Registered points (number of bits)} + 16}{(\text{Round up to a whole number})} \times 2 \text{ bytes}$$

$$\text{Information of word devices: Registered points (number of devices)} \times 2 \text{ bytes}$$

(d) The contents of the data recorded are as follows.

<When sending data as an attached file*1>

- If the data format is binary, values are recorded from the lower byte (L) side.
- If the data format is ASCII, target values are converted to 4-digit hexadecimal ASCII codes and recorded from the higher byte (H) side of the values.
- If the data format is CSV, target values are converted to 4-digit hexadecimal ASCII codes and recorded from the higher byte (H) side of the values. When handling multiple word data, insert comma data between each word (4 bytes of ASCII code). Insert CR (Code: 0DH) and LF (Code: 0AH) for each setting device range.

Ex. In case of M15 to M0 = 0001H, M31 to M16 = 0002H, ..., W0 = 001AH, W1 = 002BH, ...

(For M15 to M0)

M15	to	M12	to	M8	to	M4	to	M0
0	0	0	0	0	0	0	0	1

For binary

W0(L)	W0(H)	W1(L)	W1(H)	D0(L)	D0(H)	D1(L)	D1(H)	-----	D8(L)	D8(H)	D9(L)	D9(H)								
1A	00	2B	00	11	00	12	00	-----	19	00	1A	00								
M0	M8	M16	M24	-----	M72	X10	X18	X20	-----	X38	B10	B18	-----	B40	B48					
01	00	02	00	03	00	04	00	05	00	60	00	61	00	62	00	30	00	-----	33	00

For ASCII

W0	W1	D0	D1	D2	D3	D4	D5	D6	D7	D8	D9
001A	002B	0011	0012	0013	0014	0015	0016	0017	0018	0019	001A
M0	M16	M32	M48	M64	X10	X20	X30	B10	B20	B30	B40
0001	0002	0003	0004	0005	0060	0061	0062	0030	0031	0032	0033

For CSV

W0	W1	[CR+LF]								
001A,	002B									
D0	D1	D2	D3	D4	D5	D6	D7	D8	D9	[CR+LF]
0011,	0012,	0013,	0014,	0015,	0016,	0017,	0018,	0019,	001A	
M0	M16	M32	M48	M64	[CR+LF]					
0001,	0002,	0003,	0004,	0005						
X10	X20	X30	[CR+LF]							
0060,	0061,	0062								
B10	B20	B30	B40	[CR+LF]						
0030,	0031,	0032,	0033							

*1 The spaces and lines between device numbers and device values are inserted for the purpose of explanation. They are not recorded in the attached file.

<When sending data as main text>

- When data format is CSV^{*2}
 - Target data values are converted to 4-digit hexadecimal ASCII codes and recorded from the higher byte (H) side of the values.
 - The device name and display device No. are recorded for each setting device.
 - When handling multiple word data, insert comma data between each word (4 bytes of ASCII code). Insert a CR (code: 0DH) and a LF (code: 0AH) for each setting device range or 8-word data.

Ex. In case of M15 to M0 = 0001H, M31 to M16 = 0002H, ..., W0 = 001AH, W1 = 002BH, ...

(For M15 to M0)

M15	to	M12	to	M8	to	M4	to	M0
0	0	0	0	0	0	0	0	1

For the main text of e-mail

```

W0-W1 [CR+LF]
001A, 002B [CR+LF]
-----
D0-D9 [CR+LF]
0011, 0012, 0013, 0014, 0015, 0016, 0017, 0018 [CR+LF]
0019, 001A [CR+LF]
-----
M0-M79 [CR+LF]
0001, 0002, 0003, 0004, 0005 [CR+LF]
-----
X10-X3F [CR+LF]
0060, 0061, 0062 [CR+LF]
-----
B10-B4F [CR+LF]
0030, 0031, 0032, 0033 [CR+LF]

```

*2 The dotted boarder lines between the device values in the above figure are for explanation purpose only. They are not actually recorded in the main text.

- When data format is character strings (binary)^{*3}
 - The device name and display device No. are recorded for each setting device.
 - When "Condition for inspection" is set to "No conditional settings (character string send)", "Notification data storage device" records the data of specified notification points starting from the low byte (L) of the specified value. (If NULL (00H) exists in the range, contiguous data immediately before it are recorded.)
 - Insert CR (Code: 0DH) and LF (Code: 0AH) for each setting device range.

Ex. Setting "No conditional settings (character strings send)" to "Condition for inspection", "D0" to "Notification data storage device", and "20 points" to "Notif. data points":
This means that "Normal system start completion" is stored in D0 to D19 by the \$MOV instruction.

For the main text of e-mail (character string (binary) format)

```

D0-D19 [CR+LF]
Normal system start completion [CR+LF]

```

*3 ASCII or SHIFT-JIS format values must be set in the Notification data storage device.

- When e-mail is sent after the result of the device monitoring and the monitoring condition match, the Subject and attached file, or the Subject and main text will be sent.
As a device monitoring result, the data that was read from the programmable controller CPU by the Ethernet module in order to determine whether or not the conditions match will be sent.
For details on the correspondence between the word device values and the data format of the attached file, see the figure in Page 49, Section 2.7.3.
The main text will be sent after converting the data read into ASCII code data.
If the condition for inspection is set to "No conditional settings (character strings send)" for e-mail text transmission, however, binary code data are sent without being converted.
 - When e-mail is sent after the result of the CPU status monitoring and the monitoring condition match, only the Subject will be sent. The attached file and main text will not be sent.
 - Mail contents are not properly displayed on the receiving side when both of the following conditions are met:
 - the format of data notified in the main text is in binary (character string)
 - the value set in the news data storage device is in a format other than ASCII format or SHIFT-JIS format
-

CHAPTER 3 COMMUNICATIONS VIA OTHER NETWORKS

An Ethernet module can access other stations from an external device or a Q/LCPU in a station where an Ethernet module is connected via Ethernet and the following networks:

- CC-Link IE Controller Network
- CC-Link IE Field Network
- MELSECNET/H
- MELSECNET/10

This chapter describes the CC-Link IE Controller Network, CC-Link IE Field Network, MELSECNET/H, MELSECNET/10 relay communication function to communicate data with other stations via an Ethernet module and network modules.

3.1 CC-Link IE Controller Network, CC-Link IE Field Network, MELSECNET/H, MELSECNET/10 Relay Communication Function

By setting the parameter described in Page 67, Section 3.3, the other station access becomes possible with the CC-Link IE Controller Network, CC-Link IE Field Network, MELSECNET/H, MELSECNET/10 relay communication function.

Function that can be used for communication	Communication range		Communication request source	Reference
	When using this function	When not using this function		
Communication using the MC protocol	Possible to read/write data from/to another station's programmable controller, which is the access request destination, from an access source device via multiple networks and Ethernet	Only possible to read/write data from/to the programmable controllers of other stations in Ethernet where a station with an Ethernet module is connected (Example) Only the access 1) shown in the figure in Page 64, Section 3.2.1 is accessible.	External device	Reference manual
Communication using the data link instructions			CPU in a station where a network module is connected	Page 85, CHAPTER 4
Communication with other stations using a programming tool			Programming tool	Operating manual for the programming tool used

3.2 Range of Accessible Other Station's Programmable Controllers and Accessible Stations

The accessible range and the stations when performing the other station access via Ethernet module using the CC-Link IE Controller Network, CC-Link IE Field Network, MELSECNET/H, MELSECNET/10 relay communication function is described.

3.2.1 Accessible range and stations

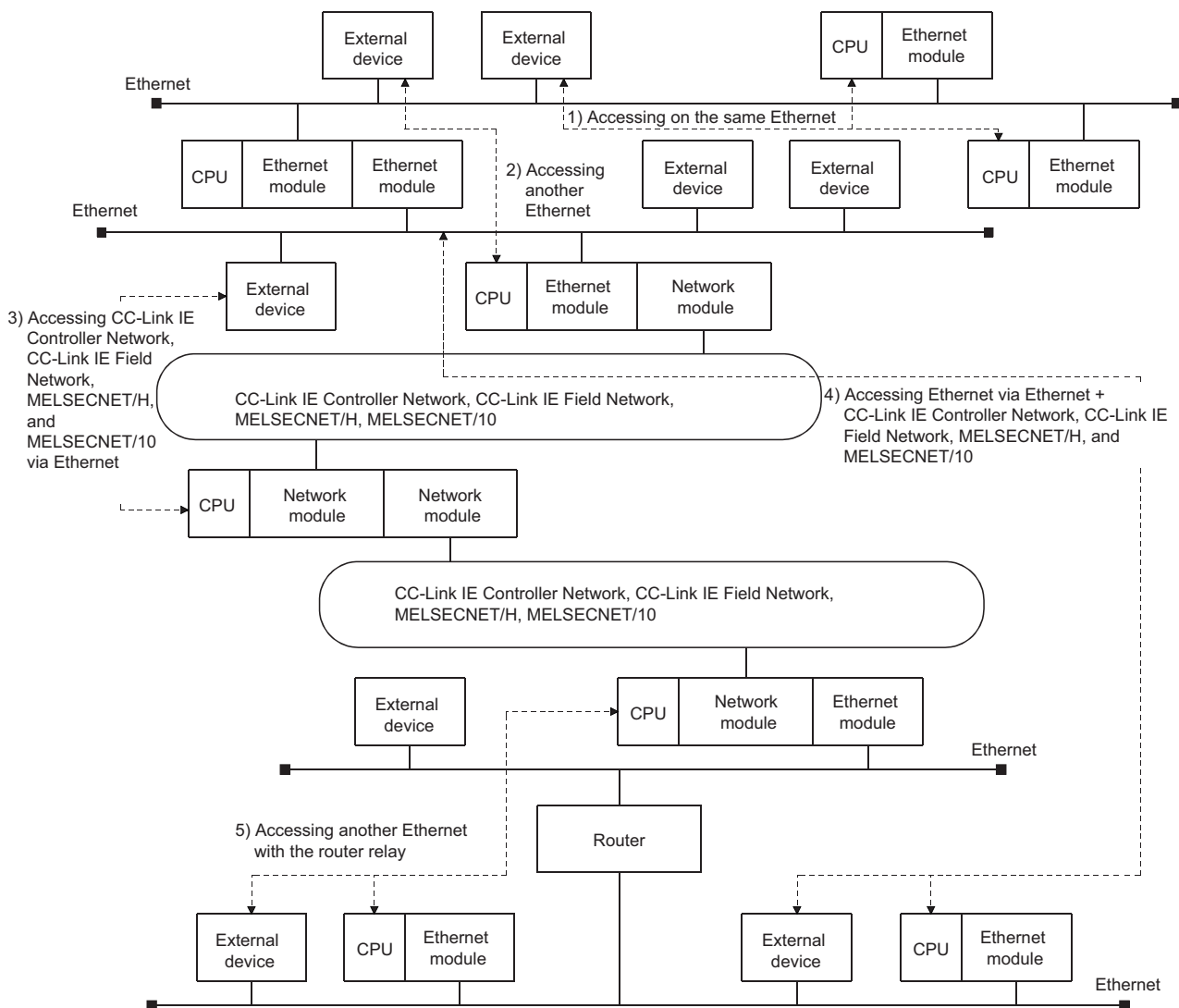

(1) Accessible range

- (a) Routing via the Ethernet and CC-Link IE Controller Network, CC-Link IE Field Network, MELSECNET/H, MELSECNET/10 network systems is allowed within the range of the CC-Link IE Controller Network, CC-Link IE Field Network, MELSECNET/H, and MELSECNET/10 specifications.

Another station is accessible between devices indicated in 1) to 5) of the figure above.

(b) The only networks that can be routed are the CC-Link IE Controller Network, CC-Link IE Field Network, MELSECNET/H, MELSECNET/10 and Ethernet.

(2) Accessible stations (communication request destination stations) and relay stations (communication relay stations)

This relay communication function allows communication with programmable controllers of other stations if the communication destination programmable controllers (communication request destination stations) and all the relay stations to the communication destination stations (communication relay stations) are configured with the modules listed below.

(a) Accessible modules (communication request destination stations: other stations)

- Programmable controller CPU

Classification	Model name	
QCPU (Q mode)	Basic model QCPU	Q00JCPU, Q00CPU, Q01CPU
	High performance model QCPU	Q02CPU, Q02HCPU, Q06HCPU, Q12HCPU, Q25HCPU
	Process CPU	Q02PHCPU, Q06PHCPU, Q12PHCPU, Q25PHCPU
	Redundant CPU	Q12PRHCPU, Q25PRHCPU
	Universal model QCPU	Q00UJCPU, Q00UCPU, Q01UCPU, Q02UCPU, Q03UDCPU, Q03UDVCPU, Q03UDECPU, Q04UDHCPU, Q04UDVCPU, Q04UDEHCPU, Q06UDHCPU, Q06UDVCPU, Q06UDEHCPU, Q10UDHCPU, Q10UDEHCPU, Q13UDHCPU, Q13UDVCPU, Q13UDEHCPU, Q20UDHCPU, Q20UDEHCPU, Q26UDHCPU, Q26UDVCPU, Q26UDEHCPU, Q50UDEHCPU, Q100UDEHCPU
LCPU	L02CPU, L02CPU-P, L02SCPU, L26CPU, L26CPU-BT, L26CPU-PBT	
Safety CPU*1	QS001CPU	
QnACPU	Q2ACPU, Q2ACPU-S1, Q2ASCPU, Q2ASCPU-S1, Q2ASHCPU, Q2ASHCPU-S1, Q3ACPU, Q4ACPU	
QnACPU (Redundant CPU)	Q4ARCPU	
ACPU QCPU (A mode)	A1NCP, A2NCP, A2NCP-S1, A3NCP, A2ACPU, A2ACPU-S1, A3ACPU, A2UCPU, A2UCPU-S1, A3UCPU, A4UCPU, A1SCPU, A1SJCPU(-S3), A1SHCPU, A1SJHCPU, A2SCPU, A2SHCPU, A2USCPU, A2USCPU-S1, A2USHCPU-S1, A0J2HCPU, Q02CPU-A, Q02HCPU-A, Q06HCPU-A	

*1 The safety CPU can be used only as a request target station, and cannot be used as a relay station.

- CC-Link IE Field Network

Classification	Model name
Head module	LJ72GF15-T2

- MELSECNET/H, MELSECNET/10

Classification	Model name
MELSECNET/H Remote I/O station	QJ72LP25-25, QJ72LP25G, QJ72BR15
MELSECNET/10 Remote I/O station*2	AJ72QLP25, AJ72QBR15, A1SJ72QLP25, A1SJ72QBR15, AJ72LP25(G), AJ72BR15

*2 Data can be read/written from/to the buffer memory of an intelligent function module in a MELSECNET/10 remote I/O station.

(b) Modules that can act as relays between networks (communication relay stations)

Classification	Model name
CPU module* ²	Q03UDVCP, Q04UDVCP, Q06UDVCP, Q13UDVCP, Q26UDVCP
CC-Link IE Controller Network	QJ71GP21-SX, QJ71GP21S-SX
CC-Link IE Field Network	QJ71GF11-T2, LJ71GF11-T2
MELSECNET/H	QJ71LP21, QJ71LP21-25, QJ71LP21S-25, QJ71LP21GE, QJ71BR11, QJ71NT11B (MELSECNET/H mode)
MELSECNET/10	QJ71LP21, QJ71LP21-25, QJ71LP21S-25, QJ71LP21GE, QJ71BR11 (MELSECNET/10 mode)
	AJ71QLP21(S/G), AJ71QBR11, A1SJ71QLP21, A1SJ71QBR11
	AJ71LP21(G), AJ71LR21, AJ71BR11, A1SJ71LP21, A1SJ71BR11
Ethernet* ¹	QJ71E71-100, QJ71E71-B5, QJ71E71-B2, QJ71E71, LJ71E71-100
	AJ71QE71N3-T, AJ71QE71N-B5, AJ71QE71N-B2, AJ71QE71N-T, AJ71QE71N-B5T, A1SJ71QE71N3-T, A1SJ71QE71N-B5, A1SJ71QE71N-B2, A1SJ71QE71N-T, A1SJ71QE71N-B5T, AJ71QE71, AJ71QE71-B5, A1SJ71QE71-B2, A1SJ71QE71-B5

- *1 QnA series Ethernet interface modules can act as relays between networks if the function version is B or later. Verify the function version with the production date shown in the "Date column of the rated plate", which is attached to the side of the module.
(Manufactured date: Year (last two digits), Month (two digits), function version (one digit))
- *2 Only the QnUDVCP with a serial number (first five digits) of "17052" or later can act as relays when the MELSOFT connection extended setting is configured. (📖 QnUCPU User's Manual (Communication via Built-in Ethernet Port))

3.3 Settings for Accessing Other Stations

This section explains the parameters and setting items that need to be set with a programming tool to access other stations via the Ethernet using the CC-Link IE Controller Network, CC-Link IE Field Network, MELSECNET/H, MELSECNET/10 relay communication function.

(1) Network parameter

- Network No., group number, station number (station No.), etc. for using the Ethernet module are set on this screen.
- Make sure to set the values by seeing the User's Manual (Basic).

(2) Setting the Station No. <-> IP information

- The Ethernet's routing method, correspondences of the Ethernet module's IP address and Network No./station number, etc. for using the CC-Link IE Controller Network, CC-Link IE Field Network, MELSECNET/H, MELSECNET/10 relay communication function are set on this screen.
- Set these values by seeing Page 68, Section 3.3.1.

(3) Routing information setting

- On this screen, the routing parameters between Ethernet modules for accessing other stations on other networks are set, in the same way as for the routing parameter settings of other networks.^{*1}
- These settings are required for a station where two or more Ethernet modules or network modules are connected.
- Set these values by seeing Page 77, Section 3.3.3.

*1 The Network No. and station number of the first communication relay station as seen from the own station are set.

3.3.1 Setting the Station No. <-> IP information

This section explains the Station No. <-> IP information settings that are required to access other stations via the Ethernet module using the CC-Link IE Controller Network, CC-Link IE Field Network, MELSECNET/H, MELSECNET/10 relay communication function.

In the network parameter screen of a programming tool, start the "Station No. <-> IP Information" screen.

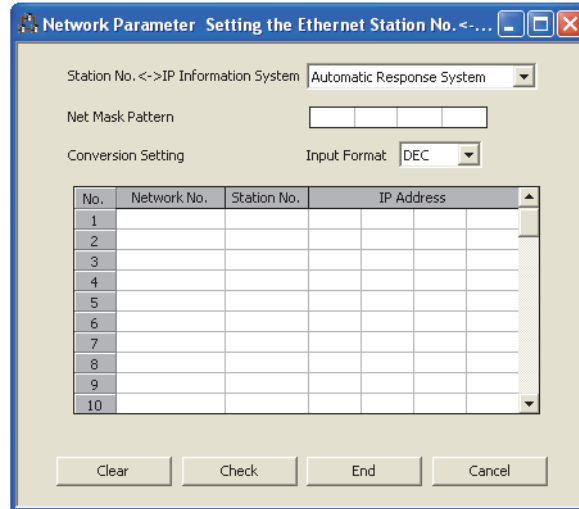

Setting the Station No. <-> IP information

Item name	Description of setting	Setting range/option
Station No. <-> IP Information System	Select the Station No. <-> IP information system (conversion method).	<ul style="list-style-type: none"> • Automatic Response System • IP Address Computation System • Table Exchange System • Use-Together System
Net Mask Pattern	<ul style="list-style-type: none"> • This setting is required when "IP Address Computation System" or "Use-Together System" is selected as the conversion method. • Set the mask value used in the logical product with the own station's IP address. 	C0000000H to FFFFFFFFH
Input Format	Select the input format of "Net Mask Pattern" and "IP Address".	<ul style="list-style-type: none"> • DEC • HEX
Network No.	<ul style="list-style-type: none"> • This setting is required when "Table Computation System" or "Use-Together System" is selected as the conversion method. • Set the Network Nos. of the communication request destination/source stations. 	1 to 239 (set in decimal)
Station No.	<ul style="list-style-type: none"> • This setting is required when "Table Computation System" or "Use-Together System" is selected as the conversion method. • Set the station number of the communication request destination/source stations. 	1 to 64 (set in decimal)
IP Address	<ul style="list-style-type: none"> • This setting is required when "Table Computation System" or "Use-Together System" is selected as the conversion method. • Set the IP address of the communication request destination/source stations. 	A value other than 00000000H and FFFFFFFFH

(1) Station No. <-> IP information system (conversion method) (address: 4H ... b7, b6)

- (a) There are four kinds of Station No. <-> IP information methods as shown below.
- (b) Select one of them according to Page 71, Section 3.3.2 and make sure to set the values on this screen using the method selected. (The default conversion method is the Automatic response method.)

Parameter settings requirement

Conversion method	Net mask pattern	Conversion setting
Automatic response system	×	×
IP address computation system	○	×
Table exchange system	×	○
Use-together system	○	○

○: Setting required, ×: Setting not required

(2) Net mask pattern (address: 3A9H)

Designate the mask value based on the guidelines given below. This pattern is used in a logical sum with the own station's IP address when calculating the IP address of the external device using the IP address computation system.

- (a) When setting the sub-net mask, designate the target settings of the IP address class, network address, and sub-net address so that all bits are "1" in the mask pattern.

The mask pattern is designated with a decimal/hexadecimal value obtained by dividing the 32-bit mask value into 8-bit segments.

- (b) When the sub-net mask is not designated, the mask pattern designation is not necessary.

When the mask pattern is not designated, the following mask value is used as the mask pattern according to the own station IP Address class.

Class	Mask value used
Class A	FF.00.00.00H
Class B	FF.FF.00.00H
Class C	FF.FF.FF.00H

(3) Conversion setup (conversion information) (address: 229H to 3A8H)

- (a) The conversion setting is required to obtain the IP address from the Network No. and station number using the table exchange system.**
- (b) If the own station is an Ethernet module and the next station to which the communication request /response message is passed to access other station is also an Ethernet module, designate the Network No., station number, and IP address of the next station's Ethernet module.**

Specify the values set on the network parameter setting screen.

- (c) Designate the Network No. in the range of 1 to 239 (1H to EFH) and the station number in the range of 1 to 64 (1H to 40H).**

Point

- Communication between the Ethernet module and Q/LCPU is performed according to the network No. and station No., and communication between two Ethernet modules are performed according to the IP address and UDP port number. Thus, the Ethernet module must convert the data below:
The network No. and station No. of other networks ↔ IP address and UDP port number of Ethernet
 - The Station No. <-> IP information are required when other stations are accessed via other Ethernet network systems and must be registered in all the Q/LCPU stations in which the Ethernet modules are connected.
 - The Station No. <-> IP information should be set on the "Station No. <-> IP Information" screen and written in the programmable controller CPUs of the applicable stations where Ethernet modules are installed.
-

3.3.2 Convert format between the Network No./station number and IP address/port number

The process overview of the conversion method set by the Station No. <-> IP information screen for performing the other station access via Ethernet module using the CC-Link IE Controller Network, CC-Link IE Field Network, MELSECNET/H, MELSECNET/10 relay communication function is explained.

Select one of the conversion methods to set.

(1) Automatic response system (Convert format of Ethernet module default value)

(a) Overview of automatic response system

- The automatic response system differs from the other convert format in that designations can only be made when the Ethernet module installed station is the communication request destination station or communication relay receiving station.
- The partner station IP Address or port number setting are not necessary with this conversion method; therefore, relay communications via other networks can be performed easily.

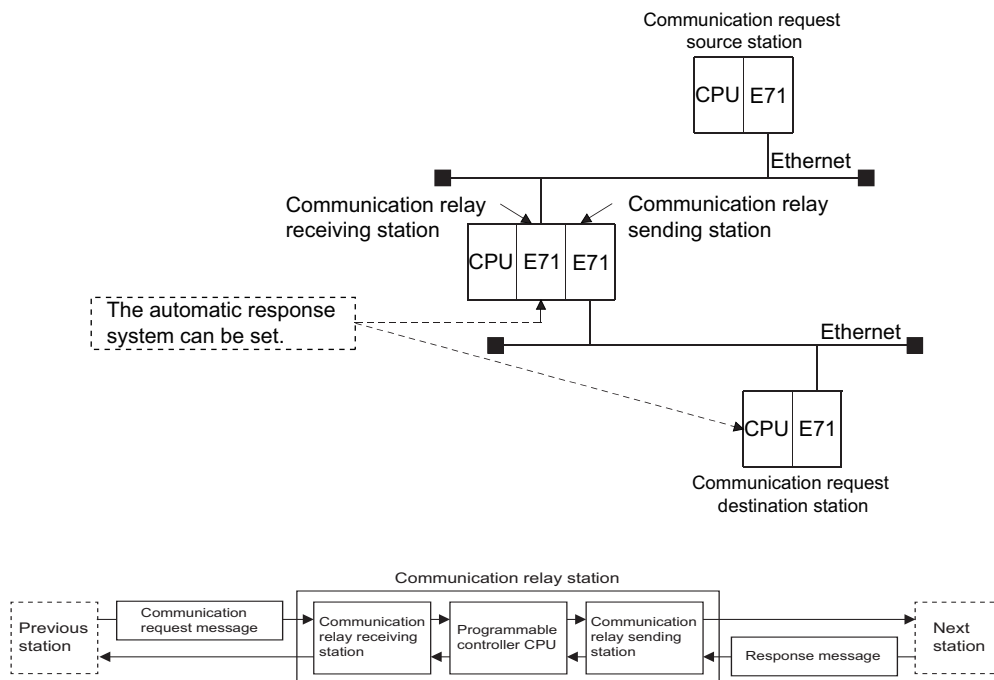

(b) Convert format of Automatic response system

- When the Ethernet module receives other station access communication request message (command frame) from the CC-Link IE Controller Network, CC-Link IE Field Network, MELSECNET/H, MELSECNET/10 relay communication function, the send source Network No., IP address, and UDP port number in the request message, are stored internally. The response message (response) for the communication request message is returned to the destination IP address and UDP port number calculated from the stored Network No. and station number. Therefore, by receiving the other station access communication request message first, the communication partner stations can be maintained.
- The maximum number of station information that can be set is 64. When more than 64 other station access communication request message is received, the Ethernet module starts deleting from the oldest data to store the station information in the newly received message communication request message. However, it is ignored if the station information is the same as the station information already stored.*1

*1 Information from the same station is not stored twice.

(2) IP address computation system

(a) Overview of the IP address computation system

During calculation, the IP address of the partner station is obtained from the calculation equation below according to the Network No. and station number, and the UDP port number predefined for the Ethernet module system is used as the UDP port number of the destination.

For more information about the net mask pattern for routing other networks, refer to Page 68, Section 3.3.1.

$$\text{IP address of the partner station} = \left(\begin{array}{c} \text{IP address of} \\ \text{the own station} \end{array} \right) \text{ Logical product } \left(\begin{array}{c} \text{Net mask pattern for} \\ \text{CC-Link IE Controller Network,} \\ \text{CC-Link IE Field Network,} \\ \text{MELSECNET/H,} \\ \text{MELSECNET/10 routing} \end{array} \right) \text{ Logical sum } \left(\begin{array}{c} \text{Network number} \\ \text{and station number} \\ \text{of the destination} \end{array} \right)$$

(b) Conversion processing of the IP address computation system

- When a communication request message (command frame) to access other station is received, the IP address is calculated from the Network No. and station number of the destination in the communication request message, and the communication request message is sent to the next station. ^{*1}
- The response message (response) for the communication request message is returned based on the return IP address and the stored data above.

*1 The Network No. and station number of the destination in the communication request message are stored in the Ethernet module.

(c) IP address computation example

The logical sum is calculated differently depending on the class of the own station IP address. An IP address is calculated as follows.

(For class A)

- When the own station IP Address is 79238102H
- When the Net Mask Pattern for routing other networks is FF00000H
- When the destination Network No. is 03H, and the station number is 05H

Own station IP Address		7	9	.	2	3	.	8	1	.	0	2
Net Mask Pattern	Logical product	F	F	.	0	0	.	0	0	.	0	0
Logical product value		7	9	.	0	0	.	0	0	.	0	0
Network No. and station No.	Logical sum							0	3	.	0	5
Partner station IP Address		7	9	.	0	0	.	0	3	.	0	5

(For class B)

- When the own station IP Address is 8438FA0AH
- When the Net Mask Pattern for routing other networks is FFFF0000H
- When the destination Network No. is 03H, and the station number is 05H

Own station IP Address		8	4	.	3	8	.	F	A	.	0	A
Net Mask Pattern	Logical product	F	F	.	F	F	.	0	0	.	0	0
Logical product value		8	4	.	3	8	.	0	0	.	0	0
Network No. and station No.	Logical sum	0 3 . 0 5										
Partner station IP Address		8	4	.	3	8	.	0	3	.	0	5

(For class C)

- When the own station IP Address is CA65300AH
- When the Net Mask Pattern for routing other networks is FFFFFFF00H
- When the destination station number is 02H (The Network number is not used.)

Own station IP Address		C	A	.	6	5	.	3	0	.	0	A
Net Mask Pattern	Logical product	F	F	.	F	F	.	F	F	.	0	0
Logical product value		C	A	.	6	5	.	3	0	.	0	0
Network No. and station No.	Logical sum	0 2										
Partner station IP Address		C	A	.	6	5	.	3	0	.	0	2

Remark

- IP address configuration of class A

	31	30 to 24	23	to	16	15	to	0			
Class	Network address		Host address								

- IP address configuration of class B

	31	30	29	to	16	15	to	0	
Class	Network address			Host address					

- IP address configuration of class C

	31 to 29	28	to	8	7	to	0
Class	Network address				Host address		

.....

(3) Table exchange system

(a) Overview of the table exchange system

- This method uses the Network No., station number, and IP address set in the conversion table of the Station No. <-> IP information, and uses the UDP port number predefined for the Ethernet module system as the UDP port number of the destination.
- If duplicate network and station numbers are set in the conversion table, the data set with the younger registration number is used. If all the required values are not set, communication may not be performed successfully.

(b) Conversion processing of the table exchange system

- When a communication request message (command frame) to access other station is received, the same Network No. and station number are searched in the conversion table of the Station No. <-> IP information, and the communication request message is sent to the partner station with the corresponding IP address.
- The response message (response) for the communication request message is returned based on the return IP address and the data in the conversion table above.

(c) Designation example

(Setting example)

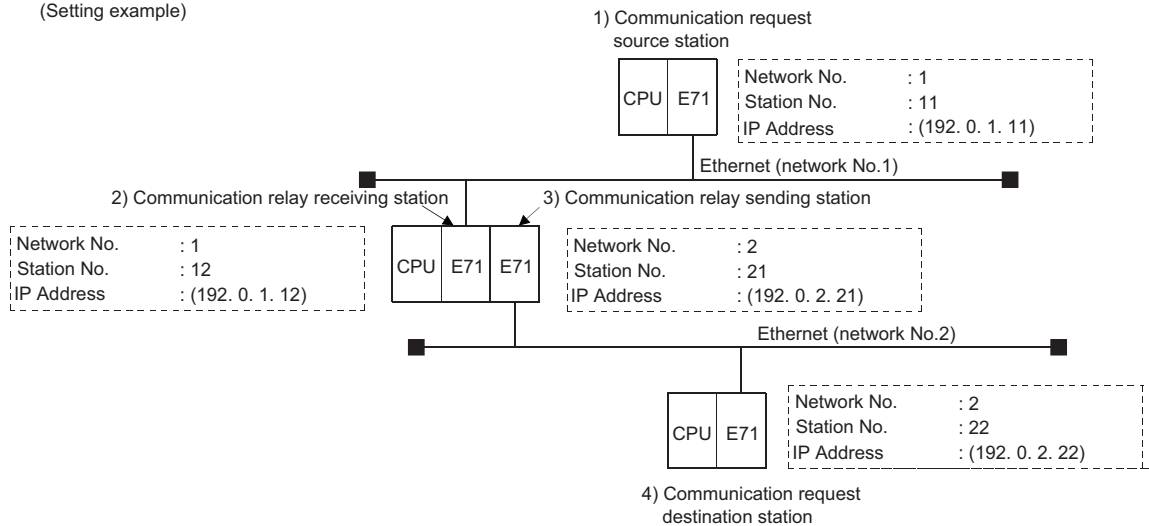

Item		E71 module setting details when accessing from CPU 1) to CPU 2)**1			
		1) Communication request source station ①	2)	3)	4)
Setting value (Decimal)	Network No. Station No.	1, 12	Setting not necessary	Setting not necessary	Setting not necessary
	IP Address	192.0.1.12			

Item		E71 module setting details when accessing from CPU 1) to CPU 4)**1			
		1) Communication request source station ①	2) Communication relay receiving station ②	3) Communication relay sending station ①	4) Communication request destination station ②
Setting value (Decimal)	Network No. Station No.	1, 12	1, 11	2, 22	2, 21
	IP Address	192.0.1.12	192.0.1.11	192.0.2.22	192.0.2.21

Item		E71 module setting details when accessing from CPU 2) to CPU 1)* ¹			
		1)	2) Communication request destination station ①	3)	4)
Setting value (Decimal)	Network No. Station No.	Setting not necessary	1, 11	Setting not necessary	Setting not necessary
	IP Address		192.0.1.11		

Item		E71 module setting details when accessing from CPU 3) to CPU 4)* ¹			
		1)	2)	3) Communication relay sending station ①	4)
Setting value (Decimal)	Network No. Station No.	Setting not necessary	Setting not necessary	2, 22	Setting not necessary
	IP Address			192.0.2.22	

Item		E71 module setting details when accessing from CPU 4) to CPU 1)* ¹			
		1) Communication request source station ②	2) Communication relay sending station ①	3) Communication relay receiving station ②	4) Communication request destination station ①
Setting value (Decimal)	Network No. Station No.	1, 12	1, 11	2, 22	2, 21
	IP Address	192.0.1.12	192.0.1.11	192.0.2.22	192.0.2.21

Item		E71 module setting details when accessing from CPU 4) to CPU 3)* ¹			
		1)	2)	3)	4) Communication request destination station ①
Setting value (Decimal)	Network No. Station No.	Setting not necessary	Setting not necessary	Setting not necessary	2, 21
	IP Address				192.0.2.21

*1 The ① and ② in the E71 station setting details column indicate whether the value is for the communication request message transmission or response message transmission.

①: For communication request message transmission

②: For response message transmission

(4) Use-together system

(a) Overview of the Use-together system

- This method uses both the IP address computation system and the table exchange system.
- Select this method to access other stations with the same Network No., accessing other stations in other networks or accessing Ethernet with different Network No., and relaying from other networks to the Ethernet network system.
- The set target Ethernet module can be installed either at a communication request source station, communication relay station, or communication request destination station.

(b) Conversion processing of the Use-together system

- When a communication request message (command frame) to access other station is received, the communication request message is sent to the next station obtained by the table exchange system at first.
- If the IP address of the Ethernet module cannot be obtained by the table exchange system, the IP address is obtained by the IP address computation system in order to send the communication request message.
- The response message (response) to the communication request message is returned based on the return IP address and the data in the conversion table or the stored data.

Remark

The relationship between the Convert Format and definition of the Ethernet module installed station is as follows.

Conversion method	Ethernet module installed station definition			
	Communication request source station	Communication relay station		Communication request destination station
		Relay receiving station	Relay sending station	
Automatic response system	× ^{*1}	○	× ^{*1}	○
IP address computation system	○	○	○	○
Table exchange system	○	○	○	○
Use-together system	○	○	○	○

○: Can be designation, ×: Cannot be designated

- *1 For the external device that completed the communication, the station can be a communication request source station or a relay sending station.

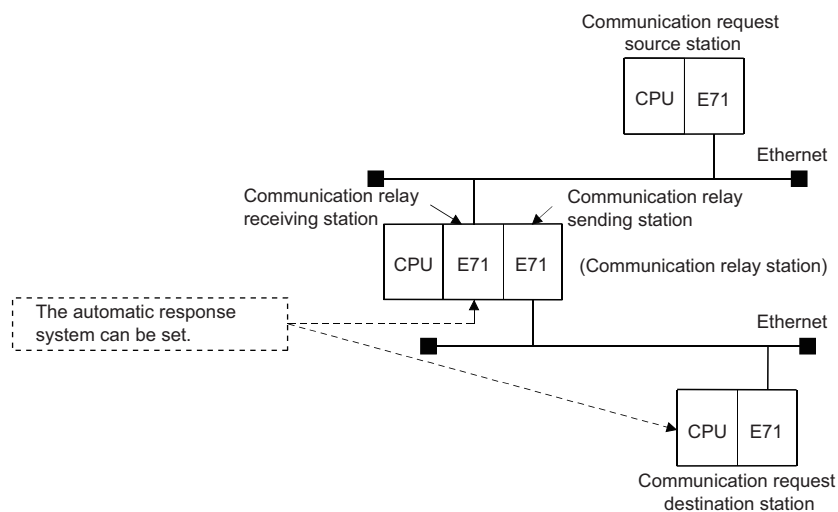

3.3.3 Routing parameter settings

The routing parameters contain information of the Ethernet modules passed through when accessing other stations. This section explains the routing parameters that must be set in order to access other stations via the Ethernet module using the CC-Link IE Controller Network, CC-Link IE Field Network, MELSECNET/H, MELSECNET/10 relay communication function.

Open the "Routing Information" screen under the network parameter screen of a programming tool.

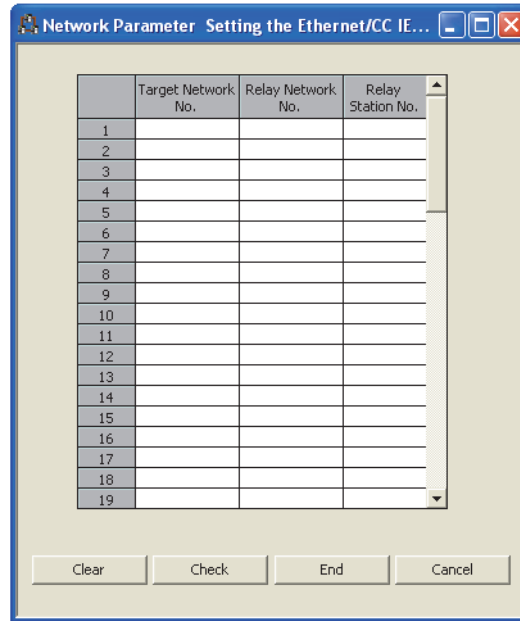

Routing information setting

Item name	Description of setting	Setting range/option
Target Network No.	Set the Network No. of the Ethernet or CC-Link IE Controller Network, CC-Link IE Field Network, MELSECNET/H, MELSECNET/10 to which the communication request destination station or the communication request source station is connected when sending a communication request message or a response message, respectively.	1 to 239
Relay Network No.	Set the Network No. of the Ethernet or other networks to which the next communication relay receive station or the next communication relay send station is connected when sending a communication request message or a response message, respectively.	1 to 239
Relay Station No.	Set the station number of the target Ethernet module/network module that is used as relay to the network set by the Relay station No.	Universal model QCPU, LCPU: 0 to 120 A module other than a Universal model QCPU and an LCPU: 0 to 64

(1) Target Network No.

Designate the Network No. of Ethernet or other networks to which the communication request destination station or the communication request source station is connected when sending a communication request message or a response message, respectively.

(2) Relay Network No.

Designate the Network No. of Ethernet or other networks to which the next communication relay reception station or the next communication relay transmission station is connected when sending a communication request message or a response message, respectively.

(3) Relay Station No.

Designate the station number of the target Ethernet module/network module that is used as a relay to the network set by the Relay station No.

Point

The following stations require the routing parameters to be set and registered:

- The programmable controller CPU of the communication request source station
- The programmable controller CPU of the stations (relay reception station and relay transmission station) that relay communication request messages.
- The programmable controller CPU of the stations (relay reception station and relay transmission station) that relay response messages.

Remark

- The routing parameters setting is not necessary for the other station access on the same Ethernet network as the external device/own station Q/LCPU.
- The routing parameters are designated in the following manner:

To go to a station on the network No.○, relay through the station No.□, on the network No.△, which is the first communication relay from the own station.

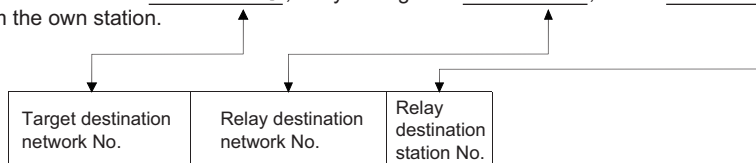

- As an example, to perform other station access from station 1Ns3 to 3Ns4 in the diagram in the next page, the following values are set to the stations which require the routing parameter setting.^{*1*2}
 - Communication request source station: Station 1Ns3
 - Communication relay station: Station 1Ns4/2Mp1, and Station 2Ns4/3Ns5
- *1 The code used for each station in the diagram indicates the Network No. of other networks or Ethernet, station type, and station number.
- *2 A maximum of 64 "Target Network No." can be set in the Q/LCPU. 64 types of Network No. can be accessed to other station via own station or can be the request source. However, the same transfer destination Network No. cannot be set two or more times (multiple times).

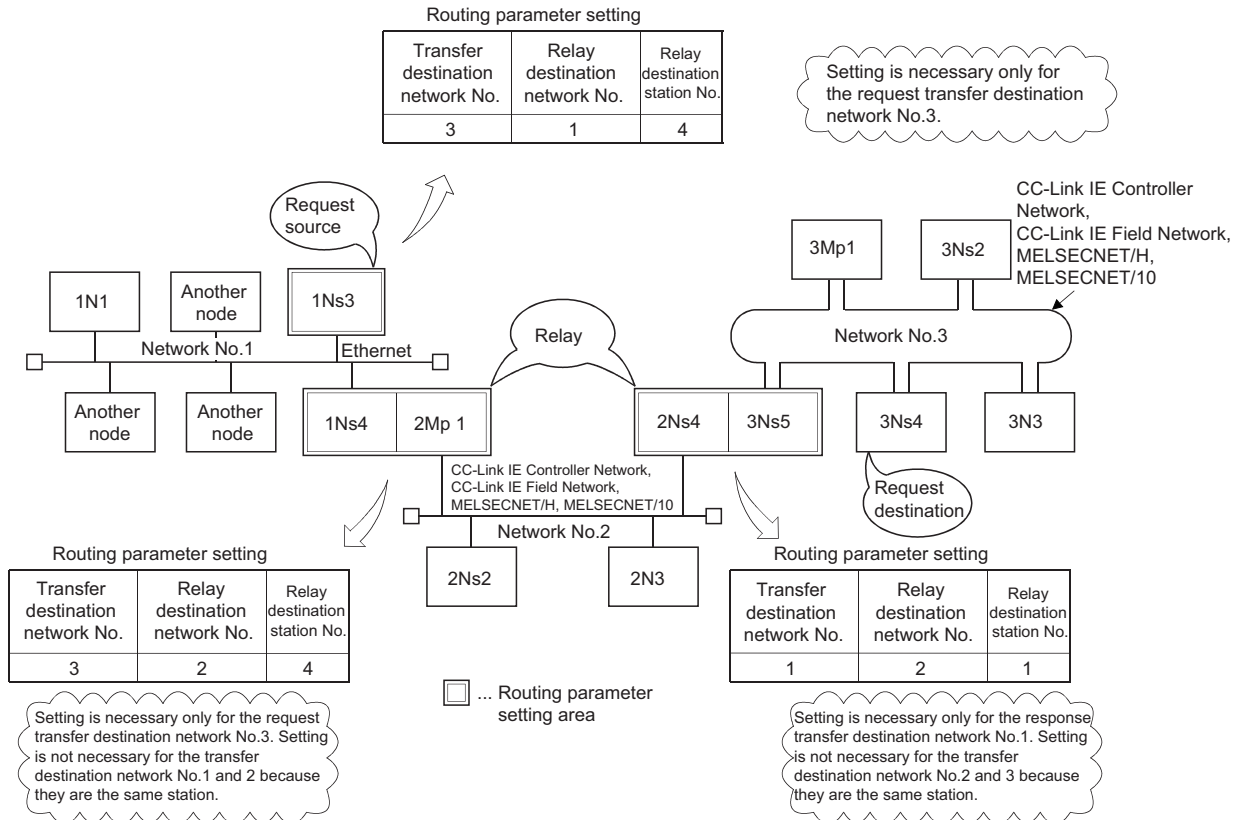

(The meanings of the symbols used for the stations shown in the diagram)

- Network system (CC-Link IE Controller Network, CC-Link IE Field Network, MELSECNET/H, MELSECNET/10)

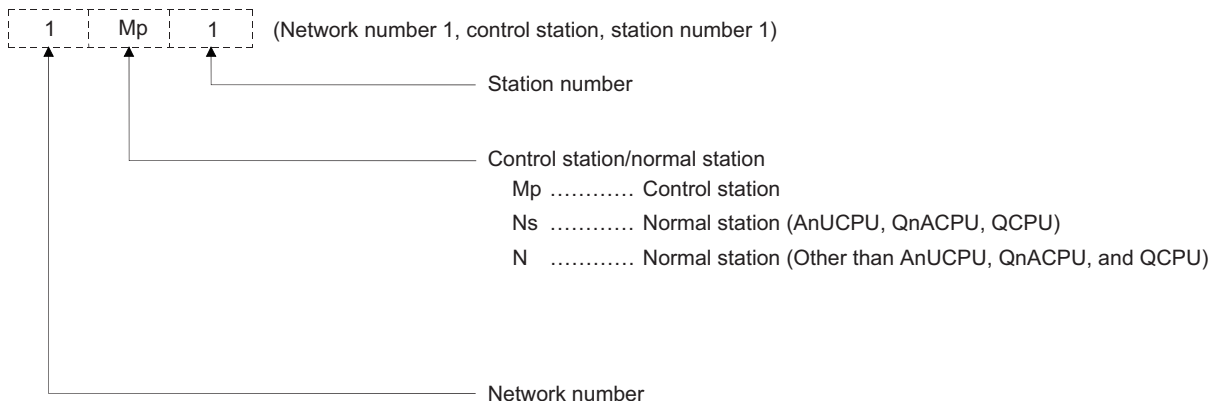

(4) Using the example of a system shown below, the accessible stations and the stations that require parameter settings when an external device or Q/LCPU access other stations are explained.*1

*1 Stations that require the setting of the "setting the Ethernet router relay parameter" as mentioned in the User's Manual (Basic) are also shown.

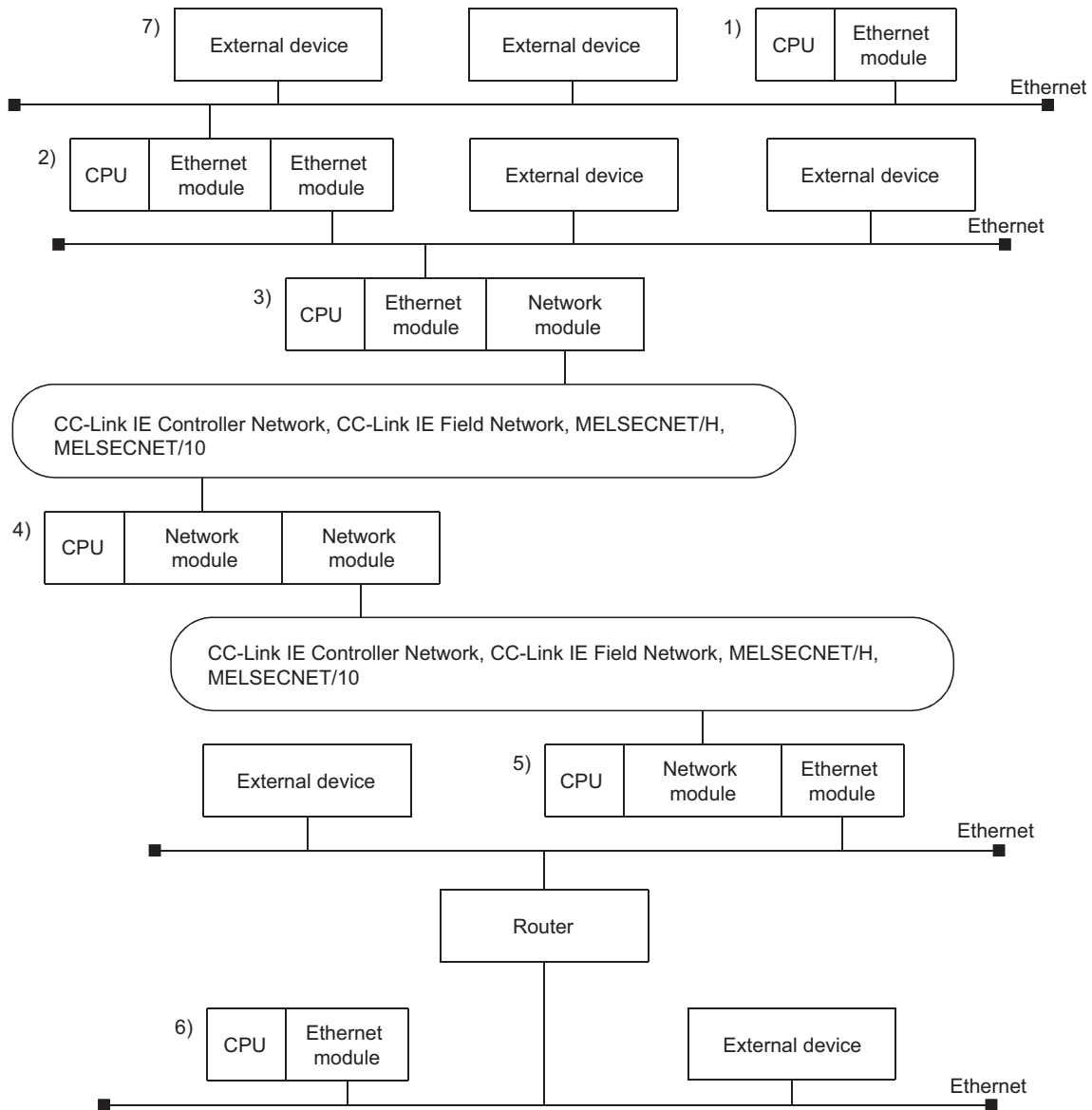

Accessible/not accessible combination	Access destination					
	1)	2)	3)	4)	5)	6)
1)	—	○	○	○	○	○
2)	○	—	○	○	○	○
3)	○	○	—	○	○	○
4)	○	○	○	—	○	○
5)	○	○	○	○	—	○
6)	○	○	○	○	○	—
7)	○	○	○	○	○	○

○: Accessible, ×: Not accessible, △: Accessible (The number of access points, etc., is restricted.)

(a) When performing a remote access from 1) to 2)

Setting item	Station that does (●)/does not (×) require setting						
	1)	2)	3)	4)	5)	6)	7)
Network parameter	●	●	×	×	×	×	×
Routing information setting	×	×	×	×	×	×	×
Setting the Ethernet Station No. <-> IP information	●	●	×	×	×	×	×
Setting the Ethernet router relay parameter	×	×	×	×	×	×	×

(b) When performing a remote access from 1) to 3)

Setting item	Station that does (●)/does not (×) require setting						
	1)	2)	3)	4)	5)	6)	7)
Network parameter	●	●	●	×	×	×	×
Routing information setting	●	●	×	×	×	×	×
Setting the Ethernet Station No. <-> IP information	●	●	●	×	×	×	×
Setting the Ethernet router relay parameter	×	×	×	×	×	×	×

(c) When performing a remote access from 1) to 5)

Setting item	Station that does (●)/does not (×) require setting						
	1)	2)	3)	4)	5)	6)	7)
Network parameter	●	●	●	●	●	×	×
Routing information setting	●	●	●	●	×	×	×
Setting the Ethernet Station No. <-> IP information	●	●	●	×	×	×	×
Setting the Ethernet router relay parameter	×	×	×	×	×	×	×

(d) When performing a remote access from 1) to 6)

Setting item	Station that does (●)/does not (×) require setting						
	1)	2)	3)	4)	5)	6)	7)
Network parameter	●	●	●	●	●	●	×
Routing information setting	●	●	●	●	●	×	×
Setting the Ethernet Station No. <-> IP information	●	●	●	×	●	●	×
Setting the Ethernet router relay parameter	×	×	×	×	●	× ^{*1}	×

*1 This setting is required to access the programmable controllers 1) to 5) from the device 6).

(e) When performing a remote access from 7) to 1)

Setting item	Station that does (●)/does not (×) require setting						
	1)	2)	3)	4)	5)	6)	7)
Network parameter	●	×	×	×	×	×	×
Routing information setting	×	×	×	×	×	×	×
Setting the Ethernet Station No. <-> IP information	●	×	×	×	×	×	×
Setting the Ethernet router relay parameter	×	×	×	×	×	×	×

(f) When performing a remote access from 7) to 3)

Setting item	Station that does (●)/does not (×) require setting						
	1)	2)	3)	4)	5)	6)	7)
Network parameter	×	●	●	×	×	×	×
Routing information setting	×	●	×	×	×	×	×
Setting the Ethernet Station No. <-> IP information	×	●	●	×	×	×	×
Setting the Ethernet router relay parameter	×	×	×	×	×	×	×

(g) When performing a remote access from 7) to 4)

Setting item	Station that does (●)/does not (×) require setting						
	1)	2)	3)	4)	5)	6)	7)
Network parameter	×	●	●	●	●	×	×
Routing information setting	×	●	●	×	×	×	×
Setting the Ethernet Station No. <-> IP information	×	●	●	×	×	×	×
Setting the Ethernet router relay parameter	×	×	×	×	×	×	×

(h) When performing a remote access from 7) to 6)

Setting item	Station that does (●)/does not (×) require setting						
	1)	2)	3)	4)	5)	6)	7)
Network parameter	×	●	●	●	●	●	×
Routing information setting	×	●	●	●	●	×	×
Setting the Ethernet Station No. <-> IP information	×	●	●	×	●	●	×
Setting the Ethernet router relay parameter	×	×	×	×	●	×	×

3.4 Procedure for Accessing Other Stations

This section explains the procedure for accessing other stations via the Ethernet using the CC-Link IE Controller Network, CC-Link IE Field Network, MELSECNET/H, MELSECNET/10 relay communication function as well as the required processing.

(1) Setting the parameters

The parameters shown in Page 67, Section 3.3 must be set using a programming tool.

(2) Accessing other stations

Access to other stations is performed from an external device/own station Q/LCPU using the CC-Link IE Controller Network, CC-Link IE Field Network, MELSECNET/H, MELSECNET/10 relay communication function.

Remark

- Access to other stations with the CC-Link IE Controller Network, CC-Link IE Field Network, MELSECNET/H, MELSECNET/10 relay communication function is performed using the UDP/IP protocol and data is always communicated in binary code.
- In the data communication, the port number (for the UDP/IP port) for the Ethernet module system is used.
- It is possible to continue accessing other stations while the initial normal completion signal (X19) is on. When the initial normal completion signal (X19) is turned off, the Ethernet module forcefully closes the connection although other station is being accessed.

(3) End processing of the Ethernet module

When ending access to other station with the CC-Link IE Controller Network, CC-Link IE Field Network, MELSECNET/H, MELSECNET/10 relay communication function that has been made using a connection opened by user, execute the close processing of the connection by seeing the User's Manual (Basic).

When the following two functions are used to access other station, the close processing is not required.

- Communication using the data link instructions
- Communication with other stations using a programming tool

3.5 Precautions for Accessing Other Stations

The following describes precautions when accessing other stations via the Ethernet module using the CC-Link IE Controller Network, CC-Link IE Field Network, MELSECNET/H, MELSECNET/10 relay communication function.

- Set a network number different from that of another network. In addition, set a station number different from that of a station in the same network.
- Access to other stations with the CC-Link IE Controller Network, CC-Link IE Field Network, MELSECNET/H, MELSECNET/10 relay communication function is performed using the UDP/IP protocol and data is always communicated in binary code.

Point

Refer to the manual for each network module for the interlock signals and the send/receive processing and processing time of the link data when performing data communication with Q/LCPUs of other stations via other networks.

CHAPTER 4 WHEN THE Q/LCPU ACCESSES THE PROGRAMMABLE CONTROLLER OF ANOTHER STATION USING THE DATA LINK INSTRUCTION

With the CC-Link IE Controller Network, CC-Link IE Field Network, MELSECNET/H, MELSECNET/10 relay communication function, the Q/LCPU can perform data communication with the programmable controller CPUs of other stations as follows using the data link instructions.

- Programmable controller CPUs of other stations on the same Ethernet network system
- Programmable controller CPUs on other Ethernet networks accessed via routers (using the router relay function)
- Programmable controller CPUs on other Ethernet networks or other networks accessed via a network module (using the CC-Link IE Controller Network, CC-Link IE Field Network, MELSECNET/H, MELSECNET/10 relay communication function)

This chapter describes how to use data link instructions for data communications between a Q/LCPU in the own station and a programmable controller CPU in another station using an Ethernet module via Ethernet or a network module.

Point

When accessing other stations using data link instructions via Ethernet module, set the parameters shown in Page 63, CHAPTER 3.

4.1 Access to Other Stations with the Data Link Instruction

The data link instruction is an instruction for a Q/LCPU to send/receive data, read/write data from/to the word device memory, and access other stations (such as remote RUN/STOP) with a Q/LCPU in other stations connected to other networks or Ethernet.

If the initial processing of the own station, relay station, and access station's Ethernet module is finished correctly, it will be possible to access other stations by the data link instruction.

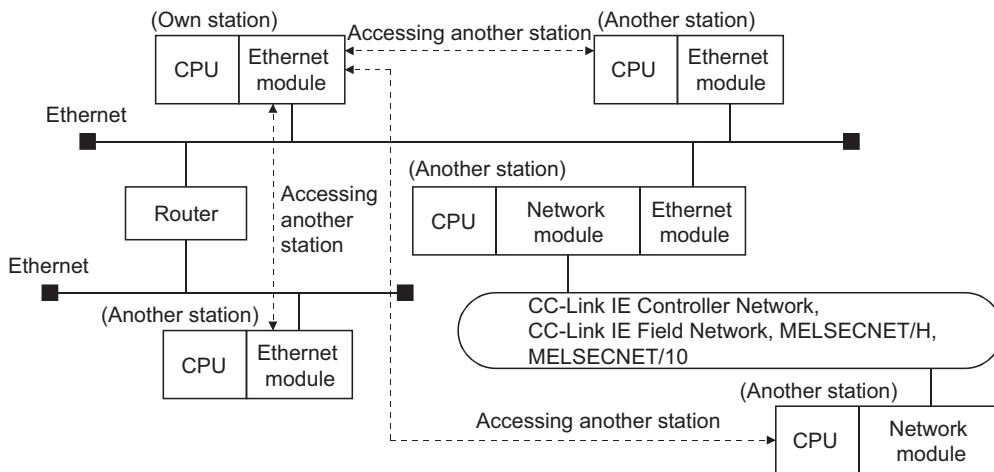

4.2 Precautions for Accessing Other Stations

The following describes precautions when accessing other stations via the Ethernet module using the data link instructions.

(1) Executing multiple instructions at one time (common to the data link instructions)

- (a) When simultaneously accessing multiple other stations from the own station, change the channel setting of the own station for each request target.

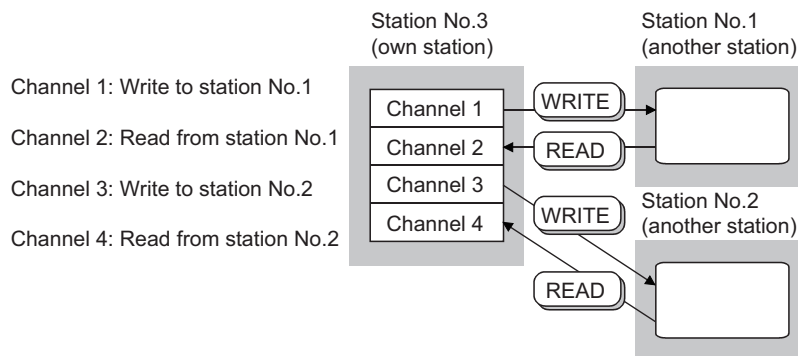

- (b) When accessing other stations using the same channel number, access the next station after the last access to other station is completed.

The completion status can be checked by the completion device of the data link instruction.

- (c) When making access mutually between the own station and another station, change the channel of the own station for each dedicated link instruction.

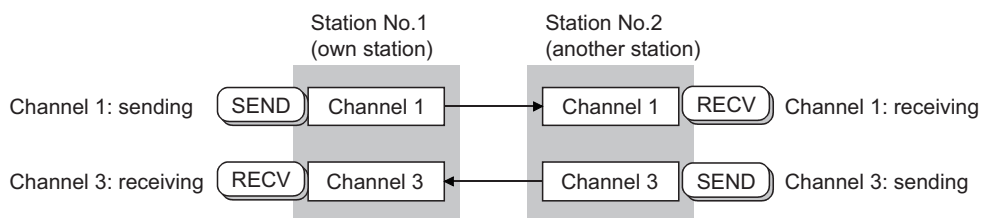

A maximum of eight instructions can be executed at one time as long as the channel numbers (1 to 8) designated in the control data of each instruction do not overlap.

- (d) Channels used for RECV instructions cannot be used for any other instructions. Channels used for other instructions must be changed.

(2) Setting the arrival monitoring time of the control data storage device

When the setting unit of arrival monitoring time is "1s", set a value greater than or equal to the TCP resend timer value set in the initial processing parameter for the arrival monitoring time designation area of the control data storage device.

When the monitoring time is equal to or less than the TCP resend timer value, the TCP resend timer value is set as the arrival monitoring time.*1

(When the setting value is less than or equal to the TCP resend timer value, the arrival monitoring timer equals the TCP resend timer value.)

*1 Although the units of setting values for the TCP resend timer (setting value units: 0.5 s) and the arrival monitoring timer (setting value units: s) are different, the TCP resend timer value is used as is.

(3) Checking the execution result of each data link instruction

The execution result (completion status) of each data link instruction is stored in the areas shown as binary values.

After the execution of an instruction is completed, read the execution result from the storage area and verify either normal or abnormal completion.

- Stored value at normal completion: 0
- Stored value at abnormal completion: A value other than 0 (error code)

When an error code that indicates abnormal completion is stored, take an action by seeing the User's Manual (Basic).

Instruction	Storage area of execution result	
SEND	The completion status storage device of the control data storage device of the instruction used.	
RECV, RECVS		
READ, SREAD		
WRITE, SWRITE		
REQ		
ZNRD	Data link instruction execution result storage area in buffer	Address CFH (207)
ZNWR	memory	Address D1H (209)

(4) Clock data when each of the data link instructions ends abnormally

In the clock data stored as control data when each of the data link instructions ends abnormally (set only upon an error), the year data (upper 2 digits) is stored only when the Q/LCPU is the error detection station. If the error detection station is not a Q/LCPU, 00H is stored.

(5) Channels used by the ZNRD and ZNWR instructions

The ZNRD and ZNWR instructions for Ethernet modules are executed using the following channels of the target Ethernet module.

- ZNRD: Channel 1
- ZNWR: Channel 2

Do not use the channels used by the ZNRD and ZNWR instructions listed above for other data link instructions in an Ethernet module mounted station that executes the ZNRD and ZNWR instructions.

Also, do not execute data link instructions from other stations on the channels listed above in an Ethernet module mounted station that executes the ZNRD and ZNWR instructions.

Point

- See Page 63, CHAPTER 3 for details of the following when performing other station access using the data link instructions.
 - The accessible range and accessible stations of the other stations
 - Setting to perform other station access
 - Other station access procedure
 - The communication using the data link instructions on the Ethernet is performed with UDP/IP. When executing each data link instruction except for ZNRD and ZNWR, it is recommended to designate a value greater than "1" to the number of retries setting area of the control data storage device.
 - See the reference manual for each network regarding the link data send/receive processing and processing time in data communication with the programmable controller CPU of another station via other networks.
 - For details of the data designation method for the data link instruction, refer to Page 156, CHAPTER 6.
-

4.3 Using the Data Link Instructions

This section explains how to use the data link instructions when accessing other stations via the Ethernet module.

(1) SEND instruction

- When performing simultaneous other station accesses from multiple communication request source stations to the same communication request destination station, change the channel number of the communication request destination station for each communication request source station. If the channel number is being used at the communication request source station (being accessed from other station using the same channel number) when other station is accessed, the data link instruction ends in error. So, re-execute the instruction.*1
- When performing other station access from the same communication request source station to the same communication request destination station, change the channel number at the communication request destination station side. When designating the same channel number on the communication request destination station side, perform the second other station access after the first other station access is complete. If the second SEND instruction is executed before the first SEND instruction is completed, the SEND instruction ends in error.

*1 If the channel number used is different at the communication request destination station side, simultaneous other station access can be performed from a maximum of eight communication request source stations to the same station.

(2) Instruction other than the SEND instruction

- When simultaneous other station access is performed to the same communication request destination station from multiple communication request source station, and a busy error (being accessed from other station) occurs, re-execute the instruction.
- When accessing other station from the same communication request source station to the same communication request destination station, execute the second data link command after other station access by the first data link instruction is complete.

(3) Broadcast (Simultaneous broadcast)

When FFH is designated as the target station number in the control data when executing SEND/WRITE (SWRITE)/REQ on the Ethernet, the command is sent to all external devices on the network.

Ex. IP address when the command is sent (for class B)

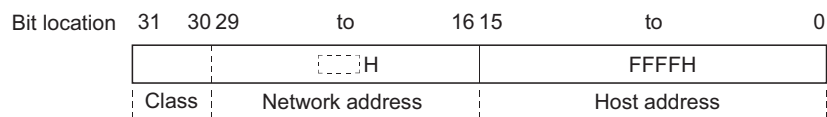

Read-dump the received commands not related to the own station on the external device.

- The COM.ERR.LED indicator of an Ethernet module may turn on and an error code may be stored in the following buffer memory area when a response to a simultaneous broadcast from the Ethernet module is returned from an external device: Error code/end code area (address: from E5H (229))
- These processing are performed automatically with the Ethernet module.

(4) Interlock when executing the data link instruction

(a) Via Ethernet

Execute the data link command when the own station (communication request source station) Ethernet module is at the following I/O signal state.

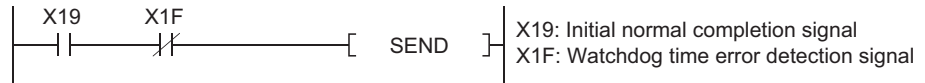

(b) Via other networks

Check the status of the own station (communication request source station), communication relay station, and access destination (communication request destination station) using the following devices. Execute the data link instruction if the status is normal.

- Link special relay: SB20, SB47, SB70, etc.
- Link special register: SW70 to 73, SW74 to 77, etc.

See the reference manual for each network for the interlock signals, link data send/receive processing, and processing time when performing data communication with the programmable controller CPU of another station via other networks.

(5) Specifying the number of times to resend the data link instructions

When executing each data link instruction except for ZNRD and ZNWR, it is recommended to designate a value greater than "1" for the number of resend designation area of the control data storage device.

The resend timing when the READ command is executed after designating the number of resend is described below.

Ex. READ instruction execution timing

- Communication timing when the READ instruction completed successfully (when resend is not performed)

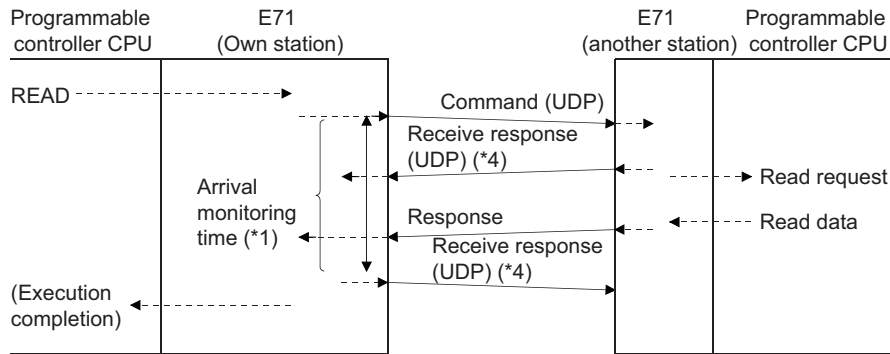

- Communication timing when the READ instruction completed successfully (when resend is performed)

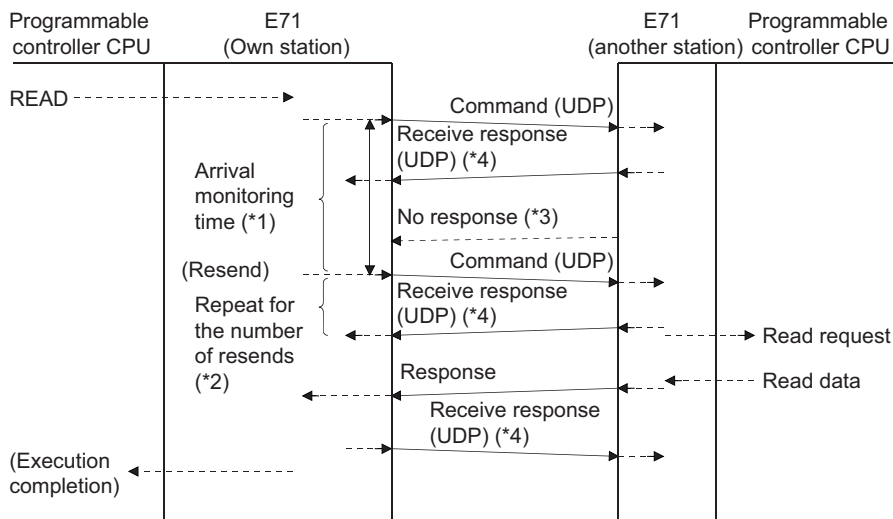

- *1 The user designates the arrival monitoring time with the READ instruction control data ((S1)+8).
- *2 The user designates the number of resend with the READ instruction control data ((S1)+7). This item must be set at every instruction execution.
- *3 The Ethernet module performs a resend of the command for the number of resend when this response is not received.
- *4 The receiving side Ethernet module notifies the sending side Ethernet module of successful data reception.

4.4 Data Link Instructions

This section explains the overview of the data send/receive in each data link instruction when accessing via Ethernet Module.

Channels 1 to 8 of the Ethernet module and network module in the figure of the following table are the OS areas that store send/receive data with each data link instruction.

Instruction	Description	Instruction execution station (own station)	Applicable station	
		Station type	Station type	Target station type
SEND	<p>Data is sent (SEND) and received (RECV) between the Q/L/QnACPU stations.^{12**2}</p> <p>Page 97, Section 4.5.1, Page 103, Section 4.5.2</p>	<ul style="list-style-type: none"> ■Ethernet Ethernet module ■MELSECNET/H, MELSECNET/10 Control station Normal station Remote master station Multiple remote master station Parallel remote master station Multiple remote submaster station Parallel remote submaster station ■CC-Link IE Controller Network Control station Normal station Control station (extended mode) Normal station (extended mode) ■CC-Link IE Field Network Master station Local station Submaster station 	<ul style="list-style-type: none"> ■Ethernet Ethernet module ■MELSECNET/H, MELSECNET/10 Control station Normal station Remote master station Multiple remote master station Parallel remote master station Multiple remote submaster station Parallel remote submaster station ■CC-Link IE Controller Network Control station Normal station Control station (extended mode) Normal station (extended mode) ■CC-Link IE Field Network Master station Local station Submaster station 	<ul style="list-style-type: none"> • QCPU • QnACPU • LCPU • Interface board for a personal computer³
RECV RECVS		<ul style="list-style-type: none"> ■Ethernet Ethernet module 	<ul style="list-style-type: none"> ■Ethernet Ethernet module 	<ul style="list-style-type: none"> • QCPU • LCPU

Instruction	Description	Instruction execution station (own station)	Applicable station	
		Station type	Station type	Target station type
<p>READ SREAD</p>	<p>Reads data from another station's word device.*² (With SREAD, the completion device on the target station can be turned on.)</p> <p>Page 107, Section 4.6</p>	<p>■Ethernet Ethernet module ■MELSECNET/H, MELSECNET/10 Control station Normal station Remote master station Multiple remote master station Parallel remote master station Multiple remote submaster station Parallel remote submaster station ■CC-Link IE Field Network Control station Normal station Control station (extended mode) Normal station (extended mode) ■CC-Link IE Field Network Master station Local station Submaster station</p>	<p>■Ethernet Ethernet module ■MELSECNET/H, MELSECNET/10 Control station Normal station Remote master station Multiple remote master station Parallel remote master station Multiple remote submaster station Parallel remote submaster station ■CC-Link IE Field Network Control station Normal station Control station (extended mode) Normal station (extended mode) ■CC-Link IE Field Network Master station Local station Intelligent device station Submaster station</p>	<ul style="list-style-type: none"> • QCPU • QnACPU • LCPU
<p>WRITE SWRITE</p>	<p>Writes data to another station's word device.*² (With SWRITE, the completion device on the target station can be turned on.)*⁴</p> <p>Page 107, Section 4.6</p>	<p>■Ethernet Ethernet module ■MELSECNET/H, MELSECNET/10 Control station Normal station Remote master station Multiple remote master station Parallel remote master station Multiple remote submaster station Parallel remote submaster station ■CC-Link IE Controller Network Control station Normal station Control station (extended mode) Normal station (extended mode) ■CC-Link IE Field Network Master station Local station Submaster station</p>	<p>■Ethernet Ethernet module ■MELSECNET/H, MELSECNET/10 Control station Normal station Remote master station Multiple remote master station Parallel remote master station Multiple remote submaster station Parallel remote submaster station ■CC-Link IE Controller Network Control station Normal station Control station (extended mode) Normal station (extended mode) ■CC-Link IE Field Network Master station Local station Intelligent device station Submaster station</p>	<ul style="list-style-type: none"> • QCPU • QnACPU • LCPU

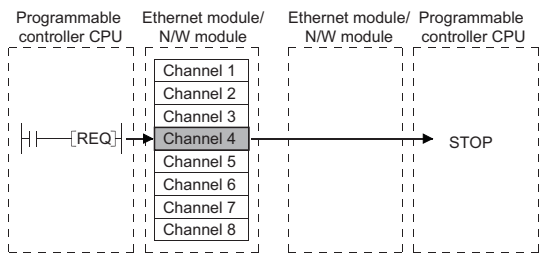
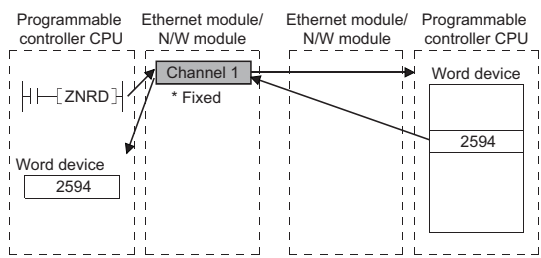
Instruction	Description	Instruction execution station (own station)	Applicable station	
		Station type	Station type	Target station type
REQ	<p>Performs remote RUN/STOP to other station.*¹ Performs "clock data read and write" for other stations.*⁴</p>  <p>Page 120, Section 4.8</p>	<p>■Ethernet Ethernet module ■MELSECNET/H, MELSECNET/10 Control station Normal station Remote master station Multiple remote master station Parallel remote master station Multiple remote submaster station Parallel remote submaster station</p> <p>■CC-Link IE Controller Network Control station Normal station Control station (extended mode) Normal station (extended mode)</p> <p>■CC-Link IE Field Network Master station Local station Submaster station</p>	<p>■Ethernet Ethernet module ■MELSECNET/H, MELSECNET/10 Control station Normal station Remote master station Multiple remote master station Parallel remote master station Multiple remote submaster station Parallel remote submaster station</p> <p>■CC-Link IE Controller Network Control station Normal station Control station (extended mode) Normal station (extended mode)</p> <p>■CC-Link IE Field Network Master station Local station Submaster station</p>	<ul style="list-style-type: none"> • QCPU • QnACPU • LCPU
ZNRD	<p>Reads data from another station's word device.*¹</p>  <p>Page 114, Section 4.7</p>	<p>■Ethernet Ethernet module ■MELSECNET/H, MELSECNET/10 Control station Normal station Remote master station Multiple remote master station Parallel remote master station Multiple remote submaster station Parallel remote submaster station</p> <p>■CC-Link IE Controller Network Control station Normal station Control station (extended mode) Normal station (extended mode)</p> <p>■CC-Link IE Field Network Master station Local station Submaster station</p>	<p>■Ethernet Ethernet module ■MELSECNET/H, MELSECNET/10 Control station Normal station Remote master station Multiple remote master station Parallel remote master station Multiple remote submaster station Parallel remote submaster station</p> <p>■CC-Link IE Controller Network Control station Normal station Control station (extended mode) Normal station (extended mode)</p> <p>■CC-Link IE Field Network Master station Local station Submaster station</p>	<ul style="list-style-type: none"> • QCPU • QnACPU • LCPU • A CPU other than those listed above⁵

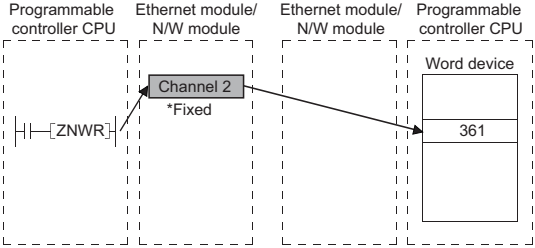
Instruction	Description	Instruction execution station (own station)		
		Station type	Station type	Target station type
ZNWR	<p>Writes data to another station's word device.*1</p>  <p>Page 114, Section 4.7</p>	<ul style="list-style-type: none"> ■Ethernet Ethernet module ■MELSECNET/H, MELSECNET/10 Control station Normal station Remote master station Multiple remote master station Parallel remote master station Multiple remote submaster station Parallel remote submaster station ■CC-Link IE Controller Network Control station Normal station 	<ul style="list-style-type: none"> ■Ethernet Ethernet module ■MELSECNET/H, MELSECNET/10 Control station Normal station Remote master station Multiple remote master station Parallel remote master station Multiple remote submaster station Parallel remote submaster station ■CC-Link IE Controller Network Control station Normal station ■CC-Link IE Field Network Master station Local station Submaster station 	<ul style="list-style-type: none"> • QCPU • QnACPU • LCPU • A CPU other than those listed above*5

- *1 The instruction cannot be used when the source or target station is a safety CPU.
- *2 Up to the channel 2 can be used in the CC-Link IE Field Network.
- *3 The following interface boards for a personal computer with the SEND/RCV function are accessible:
 - CC-Link IE Controller Network interface board
 - CC-Link IE Field Network interface board
 - MELSECNET/H board
 - MELSECNET/10 board
- *4 Data cannot be written from other stations to a safety CPU.
- *5 To access a programmable controller CPU other than a Q/L/QnACPU, use the one in a station connected to MELSECNET/10.

Point

- The CC-Link IE Controller Network, CC-Link IE Field Network, MELSECNET/H, MELSECNET/10 network No., group No., and station No., for the Ethernet module in the data link instruction setting data, designate the network No., group No., and station No., assigned to the Ethernet module by the "Setting the number of Ethernet/CC IE/MELSECNET cards" indicated in the User's Manual (Basic).*6
- For details of the data designation method for the data link instruction, refer to Page 156, CHAPTER 6.
- A maximum of eight instructions can be performed simultaneously, as long as the channel number (1 to 8) designated in each instruction control data do not overlap with each other.
- *6 This operation is required for a Q/LCPU to access other stations with the Ethernet network system identified equivalent as other network systems.
There is no difference in operation between the instruction format [JP.] and [GP.] and [J.] and [G.]

[Precautions for data link instruction]



WARNING

- In a system where AnUCPU coexist, never execute the following instruction from the Q/L/QnACPU to other station's AnUCPU.
The AnUCPU that has been executed such instruction results in "MAIN CPU DOWN" or "WDT ERROR," and may stop the operation.
1) SEND, 2) READ, 3) SREAD, 4) WRITE, 5) SWRITE, 6) REQ
- When accessing for all Q/L/QnACPU stations on the MELSECNET/10 including programmable controller CPU other than Q/L/QnACPU, perform the access using the group No. designation.

4.5 Data Sending/Receiving

This section explains the arbitrary data sending/receiving function, instruction format and programs using the data send/receive instructions (SEND, RECV and RECVS instructions).

(1) The SEND, RECV, and RECVS instructions are used for sending and receiving arbitrary data to/from the programmable controller CPU with which communicate is being performed.

(2) Data sending is performed using the SEND instruction and data receiving is performed using the RECV or RECVS instruction.

The RECV instruction and the RECVS instruction are used differently as follows.

(a) The RECV instruction is used in the receiving processing in the main program.

The main program reads from the RECV instruction executing request area in the buffer memory and executes the RECV instruction using a switch from off to on of a bit corresponding to the data receiving channel number as a trigger.

(b) The RECVS instruction is used in the receiving processing in an interrupt program.

An interrupt program is started when data is received from the programmable controller CPU with which communication is being performed to enable receive data reading to the programmable controller CPU.

To start the interrupt program, set the parameters on the following screens of a programming tool.

- "Network Parameter Ethernet Interrupt Settings" screen

Set the control number (SI) on the Ethernet module side when an interrupt request is made to the programmable controller CPU from the Ethernet module.

- "Intelligent Function Module Interrupt Pointer Setting" screen

Associate the control number (SI) set in the "Ethernet Interrupt Settings" above with the interrupt pointer (Ixx) used in the sequence program.

The settings on the two screens above are the same as when received data is read by an interrupt program in the fixed buffer communication.

For details on the settings and setting method on these screens, see the User's Manual (Basic).

Point

- To start an interrupt program, the following settings with a programming tool and interrupt permission in a sequence program are required.
 - Interrupt settings in the network parameter screen and intelligent function module interrupt pointer setting
 - Create interrupt enable/disable programs in the main program in order to start the interrupt program. Use the EI, DI and IMASK instructions for this.
 - In cases where receive data is read on the same channel, the main program for reading receive data and the interrupt program for reading receive data can not be used together.
Please use one of the programs to read receive data.
Received data cannot be read with the main program when the settings to read receive data with an interrupt program are being configured using a programming tool.
-

4.5.1 Data sending/receiving for receive with the main program (SEND/RECV)

This section explains the format and program examples of the SEND and RECV instructions that are used to send/receive data between the programmable controller CPUs.

For details, refer to Page 177, Section 6.5 and Page 198, Section 6.9.

(1) Instruction format

(a) SEND instruction

[Network number designation]

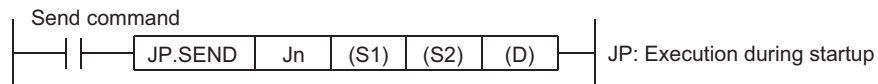

[Network module/Ethernet module start I/O signal designation]

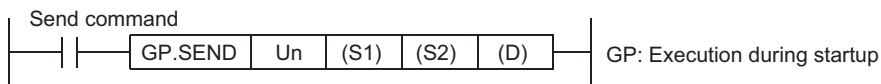

Type	Setting details	Setting range
Jn	Own station network number	1 to 239: Network number 254: Network designated in a valid module for other station access
Un	Start I/O signal of the own station network module/ Ethernet module Designate by higher two digits when the I/O signal is expressed by three digits.	0 to FEH
(S1)	Control data storage head device Designate the head device of the own station that stores the control data.	Word device ^{*2}
(S2)	Send data storage head device Designate the head device of the own station that stores the send data.	Word device ^{*2}
(D)	Send completion device Designate the device to turn on one scan when the send is complete. (D) ... OFF: Incomplete, ON: Complete (D) + 1 ... OFF: Normal, ON: Error	Bit device ^{*1} Word device bit designation ^{*3}

*1 Bit device ... X, Y, M, L, F, V, B

*2 Word device ... T, C, D, W, ST, R, ZR

*3 Word device bit designation ... [Word device.Bit number]

(b) RECV instruction (for receive by the main program)

[Network number designation]

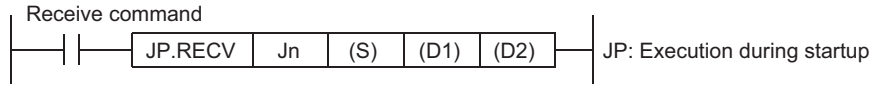

[Network module/Ethernet module start I/O signal designation]

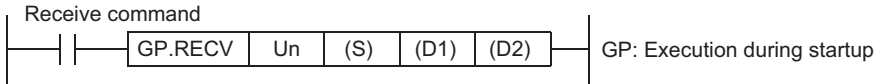

Type	Setting details	Setting range
Jn	Own station network number	1 to 239: Network number 254: Network designated in a valid module for other station access
Un	Start I/O signal of the own station network module/ Ethernet module Designate by higher two digits when the I/O signal is expressed by three digits.	0 to FEH
(S)	Control data storage head device Designate the head device of the own station that stores the control data.	Word device ^{*2}
(D1)	Receive data storage head device Designate the head device of the own station that stores the receive data.	Word device ^{*2}
(D2)	Receive completion device Designate the device to turn on one scan when the receive is complete. (D2) ... OFF: Incomplete, ON: Complete (D2) + 1 ... OFF: Normal, ON: Error	Bit device ^{*1} Word device bit designation ^{*3}

*1 Bit device ... X, Y, M, L, F, V, B

*2 Word device ... T, C, D, W, ST, R, ZR

*3 Word device bit designation ... [Word device.Bit number]

(2) Instruction execution timing (for receive processing by the main program)

(a) When normal completion

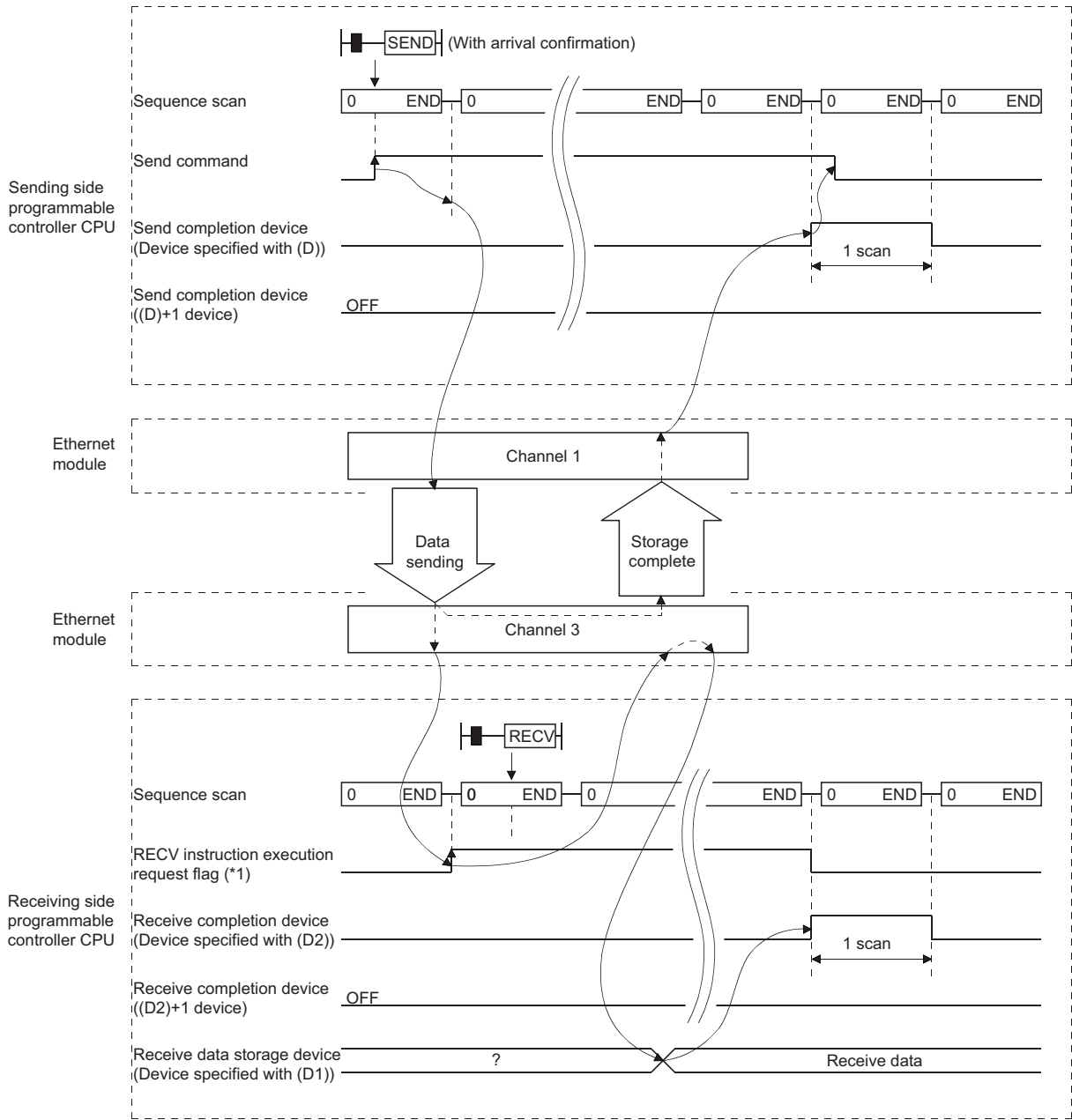

*1 The RECV instruction execution request flag for Channel 3 used at the receiving side programmable controller CPU is as listed below.

- For an Ethernet module: Bit 2 of the RECV instruction execution request area (address: 205) in the buffer memory
- For an N/W module: SBA2 of the link special relay

(b) When abnormal completion

- SEND instruction

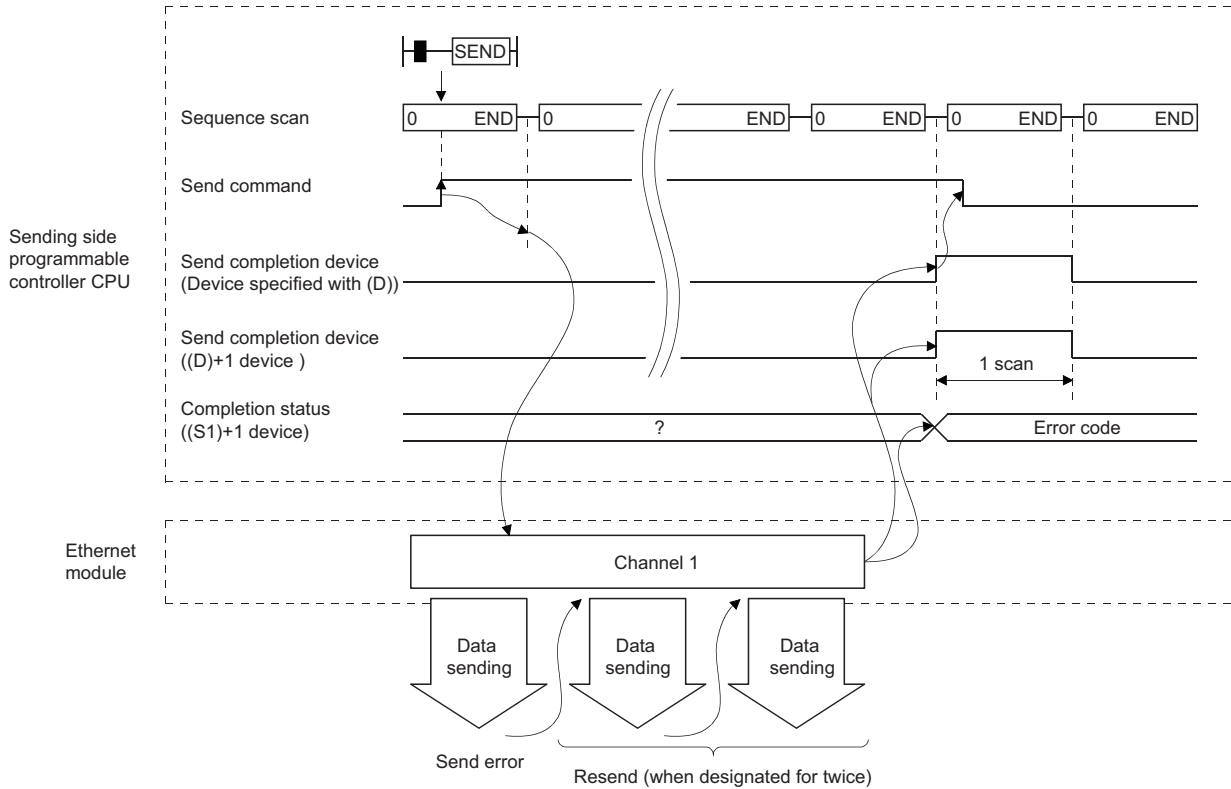

- RECV instruction

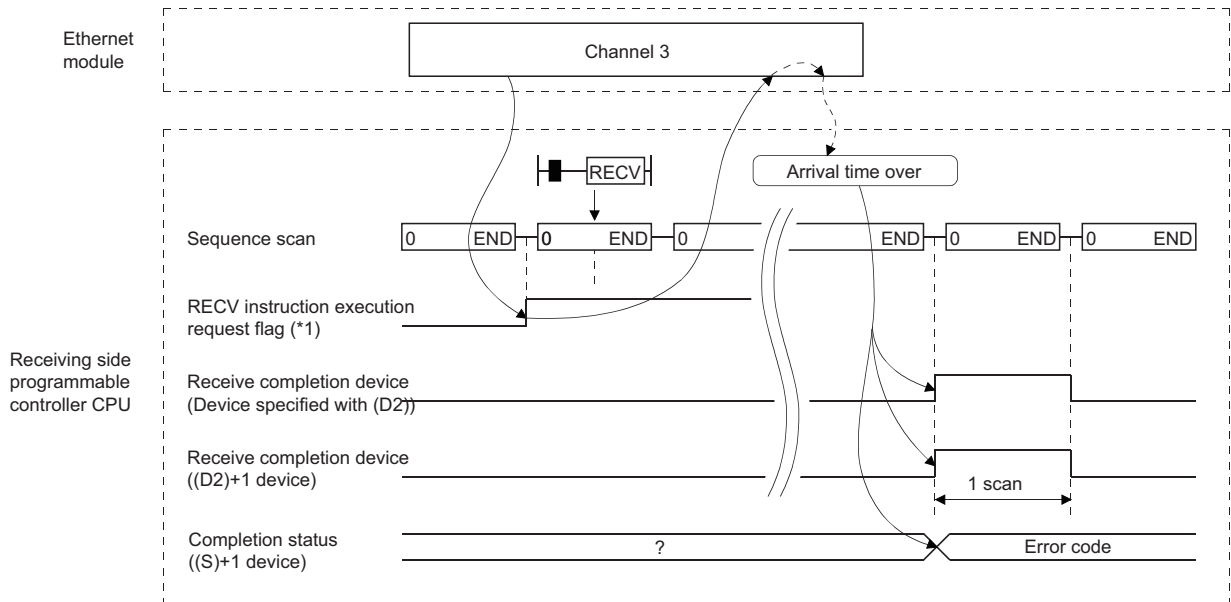

*1 The RECV instruction execution request flag for Channel 3 used at the receiving side programmable controller CPU is as listed below.

- For an Ethernet module: Bit 2 of the RECV instruction execution request area (address: 205) in the buffer memory
- For an N/W module: SBA2 of the link special relay

(3) Program examples

Station 3 uses channel 3 with a SEND instruction and sends data to station 15 using channel 5. When data is received at station 15, data is read from channel 5.

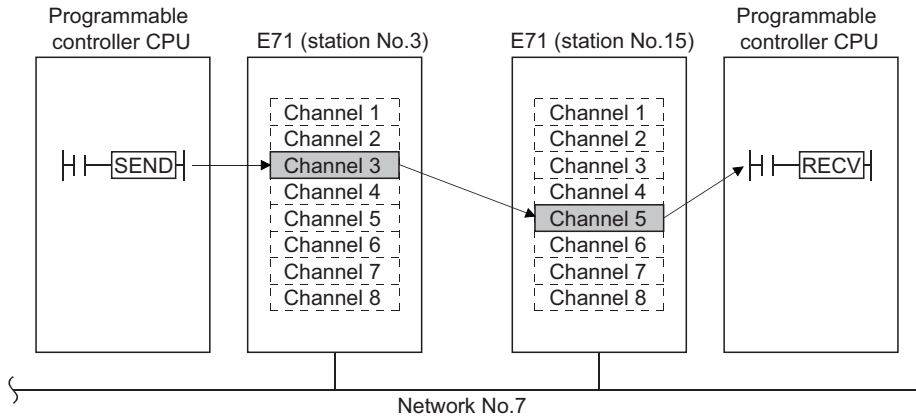

(a) Station 3 program (SEND instruction)

When I/O signals of the Ethernet module are X/Y00 to X/Y1F

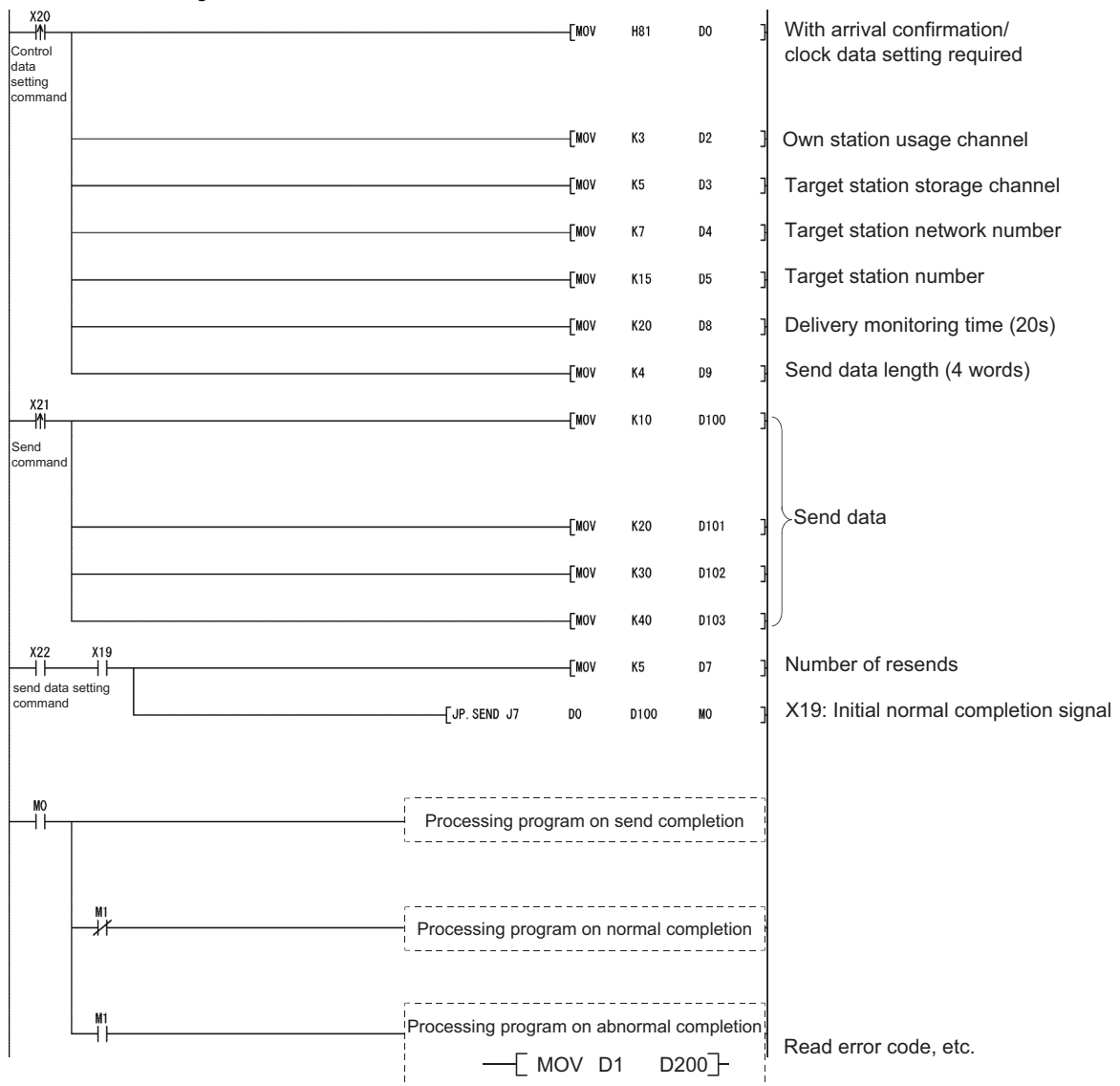

(b) Station 15 program (RECV instruction)

When I/O signals of the Ethernet module are X/Y00 to X/Y1F

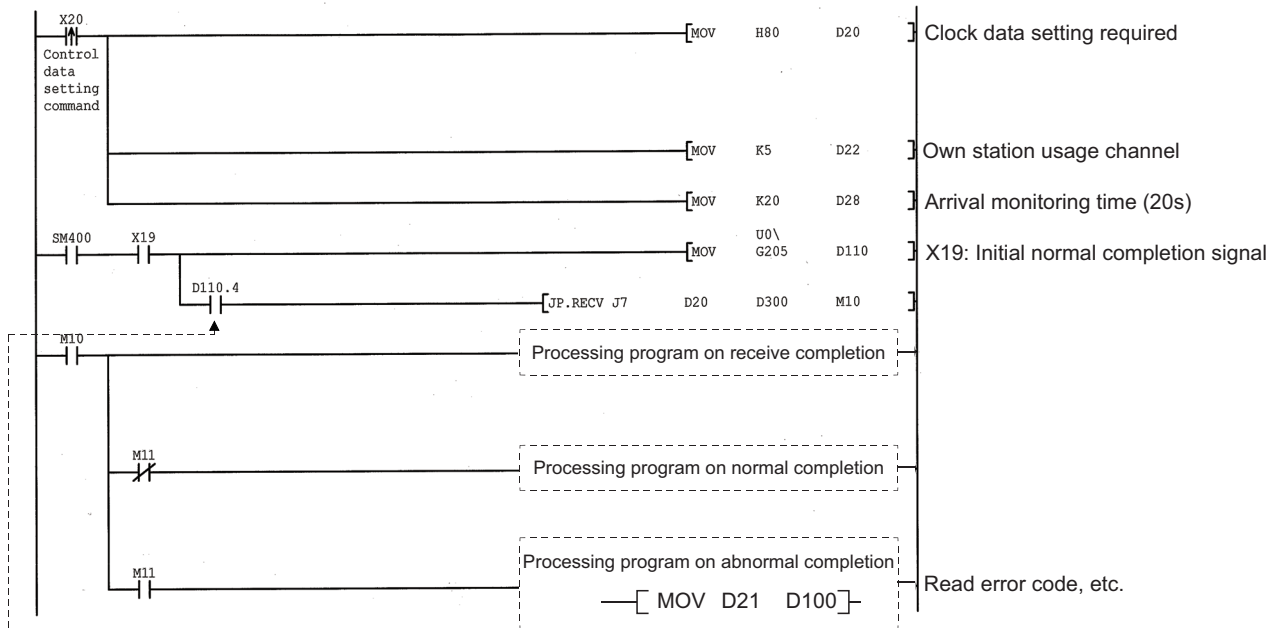

When the data is stored in the receiving station channel, the bit corresponding to each channel of buffer memory RECV instruction execution request area turns on. Data can be read automatically by using this signal for the receive command. The signal turns off when the RECV instruction is completed.

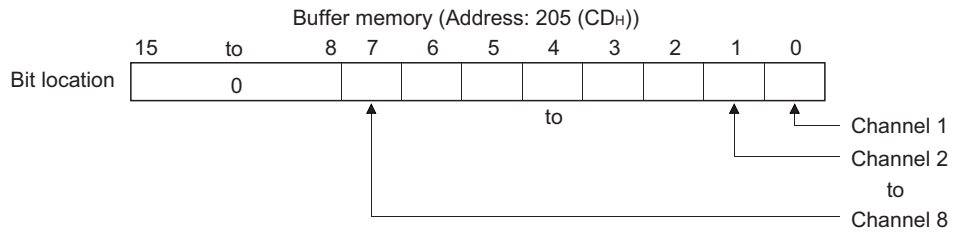

4.5.2 Data sending/receiving for receive with an interrupt program (SEND/RCVS)

This section explains the format and program examples of the RCVS instruction for receive when sending/receiving data between the programmable controller CPUs.

For details on the instruction format and program examples of the SEND instruction, refer to Page 97, Section 4.5.1.

For details, refer to Page 183, Section 6.6 and Page 198, Section 6.9.

(1) Instruction format

(a) SEND instruction

Same as the instruction format described in Page 97, Section 4.5.1.

(b) RCVS instruction

[Ethernet module start I/O signal designation]

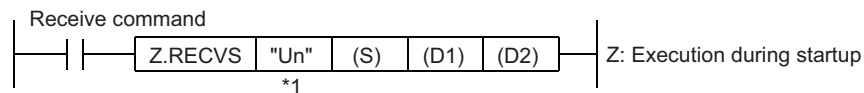

*1 If the originating station is a Basic model QCPU (function version B or later), a Universal model QCPU, or an LCPU, " " (double quotation) of the first argument can be omitted.

Type	Setting details	Setting range
Un	Start I/O signal of the own station's Ethernet module Designate by higher two digits when the I/O signal is expressed by three digits.	0 to FEH
(S)	Control data storage head device Designate the head device of the own station that stores the control data.	Word device ^{*3}
(D1)	Receive data storage head device Designate the head device of the own station that stores the receive data.	Word device ^{*3}
(D2)	Designate dummy data	Bit device ^{*2} Word device bit designation ^{*4}

*2 Bit device ... X, Y, M, L, F, V, B

*3 Word device ... T, C, D, W, ST, R, ZR

*4 Word device bit designation ... [Word device.Bit number]

(2) Execution timing of the instruction (When executing reception processing by an interrupt program)

(a) When normal completion

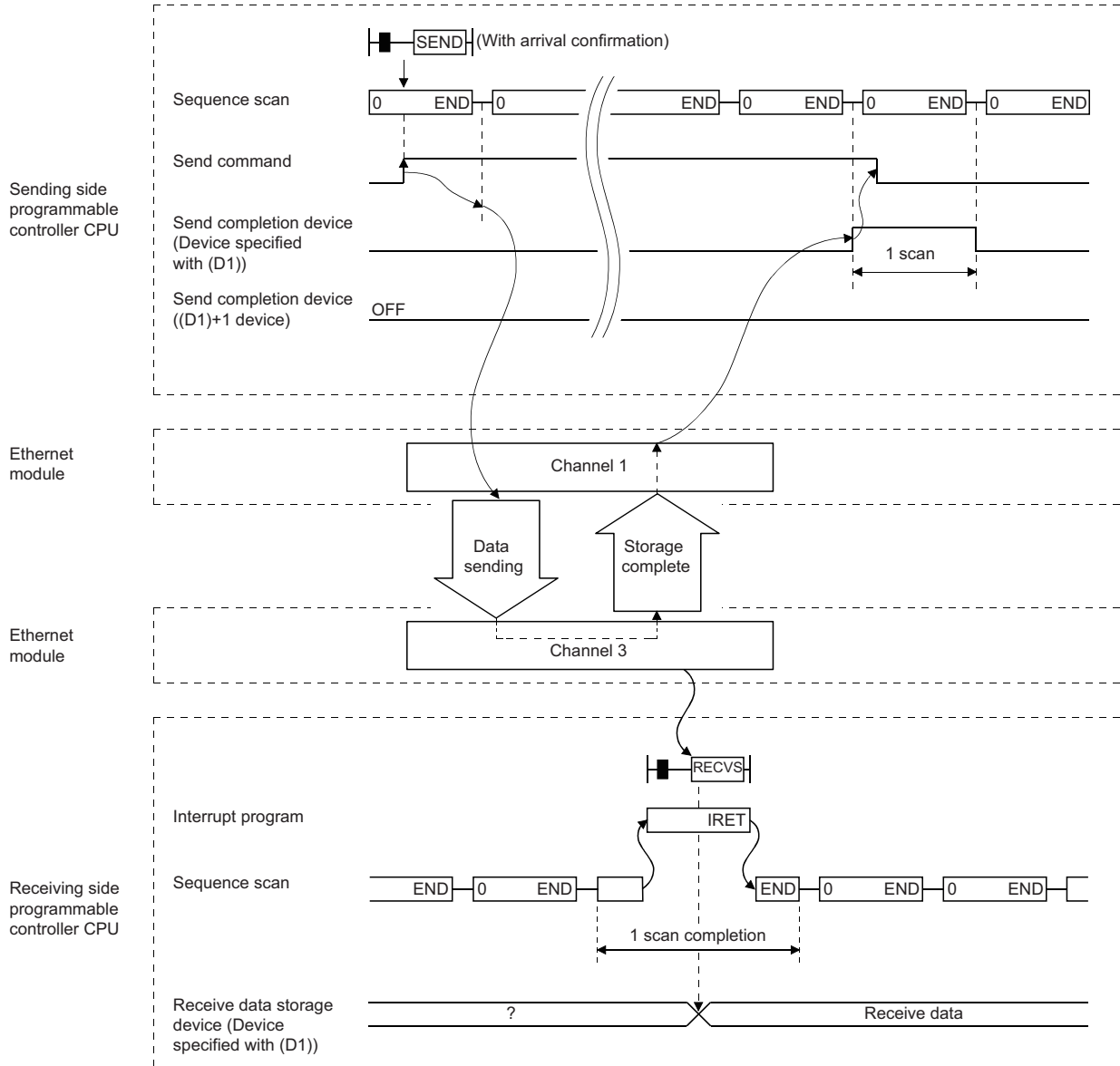

(b) When abnormal completion

- SEND instruction

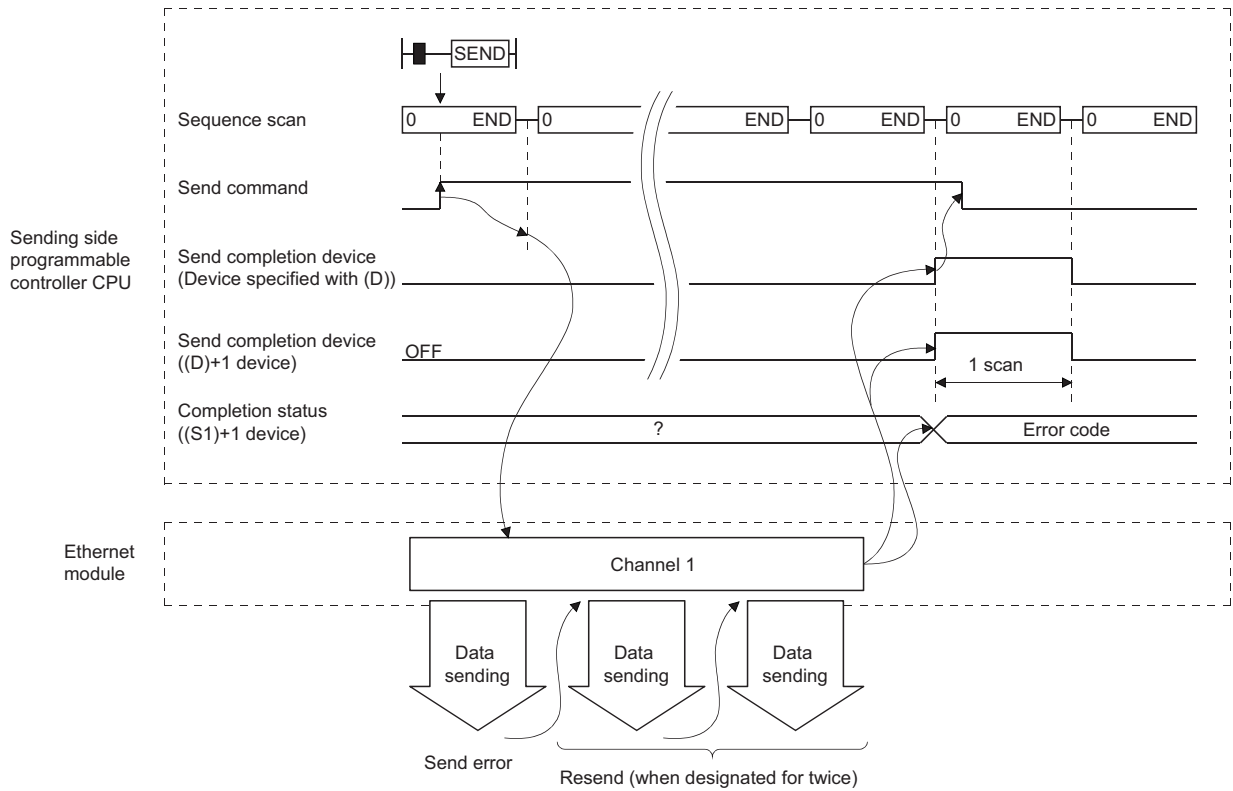

- RECVS instruction

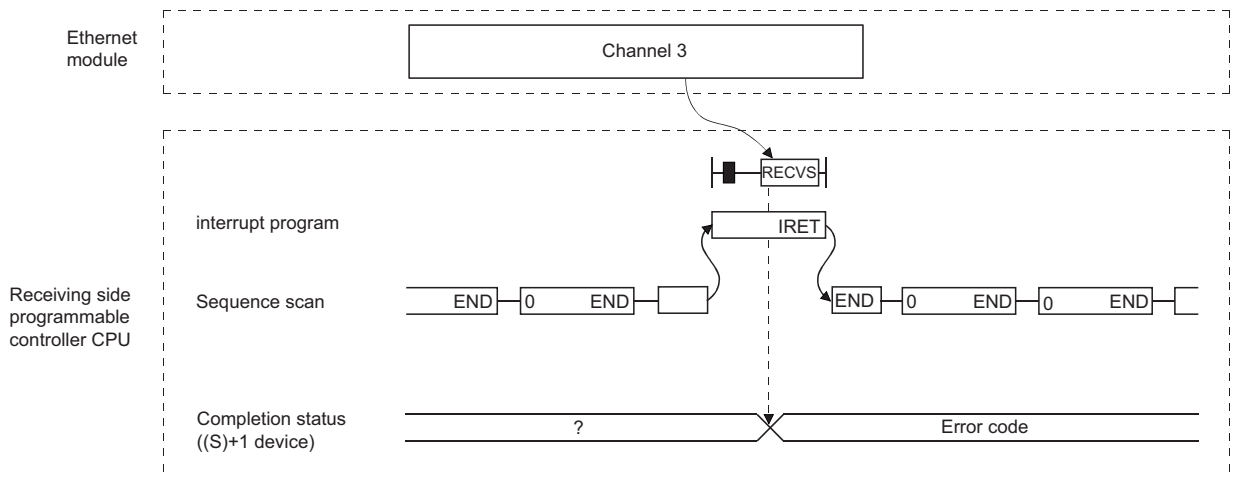

(3) Program examples

Station 3 uses channel 3 with an SEND instruction and sends data to station 15 using channel 5.
 When data is received at station 15, data is read from channel 5.

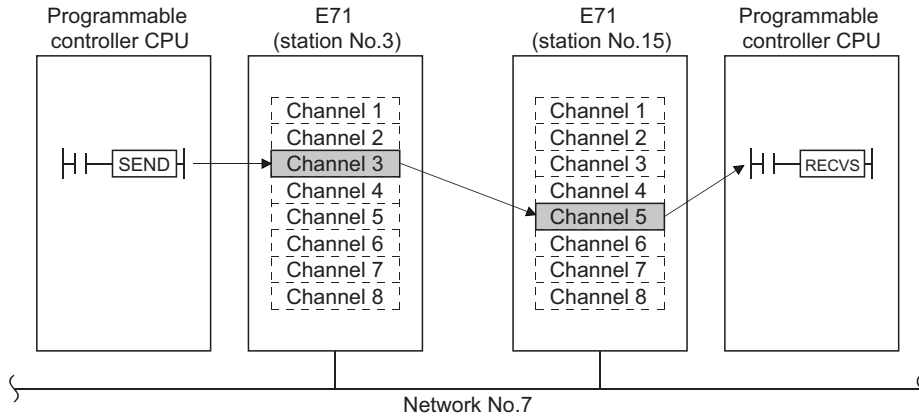

(a) Station 3 program (SEND instruction)

Same as the program shown in Page 97, Section 4.5.1.

(b) Program for station number 15 (RECVS instruction)

When I/O signals of the Ethernet module are X/Y00 to X/Y1F

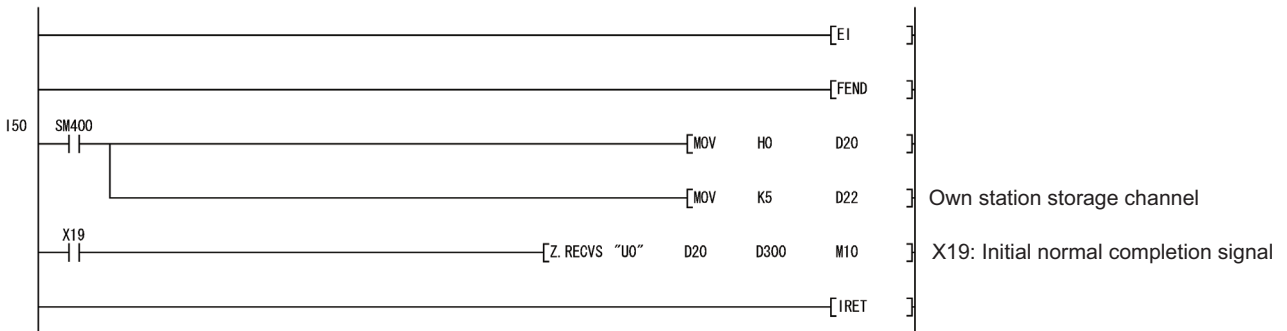

Remark

Create interrupt enable/disable programs in the main program in order to start the interrupt program.
 Use the EI, DI and IMASK instructions for this.
 To check the descriptions of errors, see the completion status (S1)+ 1 indicated in the control data.

4.6 Reading/Writing Word Devices of Other Stations (READ/WRITE)

This section explains the format and program examples of the READ/WRITE instructions that are used to read and write data of word devices of other stations.

For details, refer to Page 170, Section 6.4, and Page 206, Section 6.10 to Page 216, Section 6.12.

(1) Instruction format

(a) READ/SREAD instructions

[Network number designation]

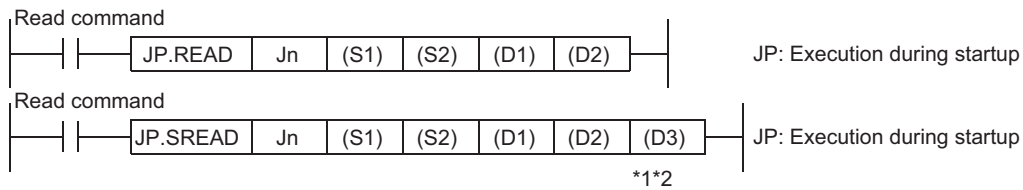

[Network module/Ethernet module start I/O signal designation]

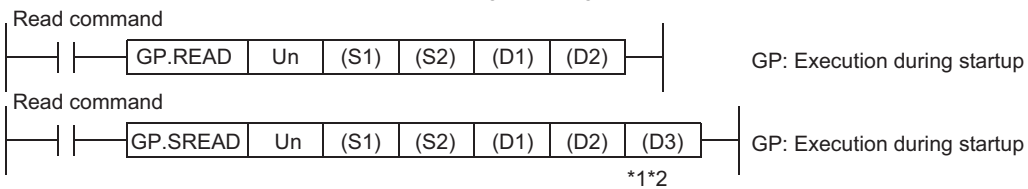

- *1 The SREAD instruction can be programmed without argument (D3). However, in such a case, the operation is identical to the READ instruction. With the SREAD instruction, different operations are available depending on whether (D3) is omitted or not.
- *2 When the target station is a Basic model QCPU or safety CPU, the read notification device set as argument (D3) for the target station is ignored. (Same operation as with the READ instruction)

Type	Setting details	Setting range
Jn	Own station network number	1 to 239: Network number 254: Network designated in a valid module for other station access
Un	Start I/O signal of the own station network module/ Ethernet module Designate by higher two digits when the I/O signal is expressed by three digits.	0 to FEH
(S1)	Control data storage head device Designate the head device of the own station that stores the control data.	Word device*4
(S2)	Read data storage head device (target station) Designate the head device of the target station that stores the data to read.	Word device*5
(D1)	Read data storage head device (own station) Designate the head device of the own station that stores the data to read.	Word device*4
(D2)	Read completion device (own station) Designate device that is turned on for one scan by the read completion (D2) ... OFF: Incomplete, ON: Complete (D2) + 1 ... OFF: Normal, ON: Error	Bit device*3 Word device bit designation*6
(D3)	Read notify device (target station) Designate the device of the target station to turn on one scan when the read is complete. (Can recognize data of target station has been read from other station.) (D3) ... OFF: Incomplete, ON: Complete	Bit device*3 Word device bit designation*6

- *3 Bit device ... X, Y, M, L, F, V, B
- *4 Word device ... T, C, D, W, ST, R, ZR
- *5 Word device ... T, C, D, W, ST, SD, SW, R, ZR
- *6 Word device bit designation ... [Word device.Bit number]

(b) WRITE/SWRITE instructions

[Network number designation]

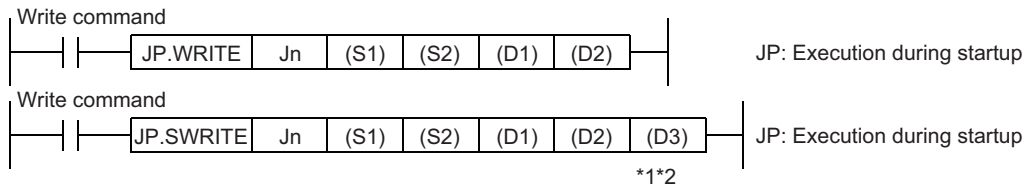

[Network module/Ethernet module start I/O signal designation]

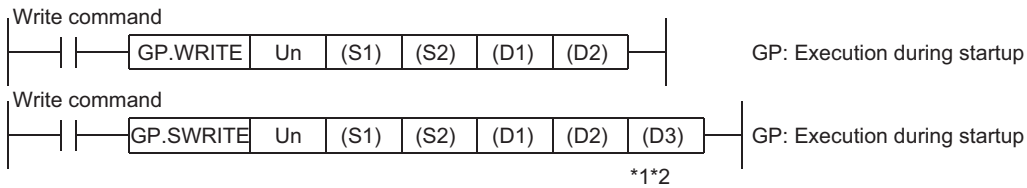

- *1 The SWRITE instruction can be programmed without argument (D3). However, in such a case, the operation is identical to the WRITE instruction. With the SWRITE instruction, different operations are available depending on whether (D3) is omitted or not.
- *2 When the target station is a Basic model QCPU or safety CPU, the write notification device set as argument (D3) for the target station is ignored. (Same operation as with the WRITE instruction)

Type	Setting details	Setting range
Jn	Own station network number	1 to 239: Network number 254: Network designated in a valid module for other station access
Un	Start I/O signal of the own station network module/ Ethernet module Designate by higher two digits when the I/O signal is expressed by three digits.	0 to FEH
(S1)	Control data storage head device Designate the head device of the own station that stores the control data.	Word device ^{*4}
(S2)	Write data storage head device (own station) Designate the head device of the own station that stores the data to be written.	Word device ^{*4}
(D1)	Write data storage head device (target station) Designate the head device of the target station to which data is written.	Word device ^{*5}
(D2)	Write completion device (own station) Designate device that is turned on for one scan by the write completion. (D2) ... OFF: Incomplete, ON: Complete (D2) + 1 ... OFF: Normal, ON: Error	Bit device ^{*3} Word device bit designation ^{*6}
(D3)	Write notify device (target station) Designate the device of the target station to turn on one scan when the write is complete. (Can recognize data of target station has been write from other station.) (D3) ... OFF: Incomplete, ON: Complete	Bit device ^{*3} Word device bit designation ^{*6}

*3 Bit device ... X, Y, M, L, F, V, B

*4 Word device ... T, C, D, W, ST, R, ZR

*5 Word device ... T, C, D, W, ST, SD, SW, R, ZR

For SD/SW, data can be written within the setting range allowed for the user. For details on SD/SW, refer to the manual for the programmable controller CPU or N/W module of the target station.

*6 Word device bit designation ... [Word device.Bit number]

(2) Execution timing of the instruction

(a) When normal completion

- READ instruction, SREAD instruction

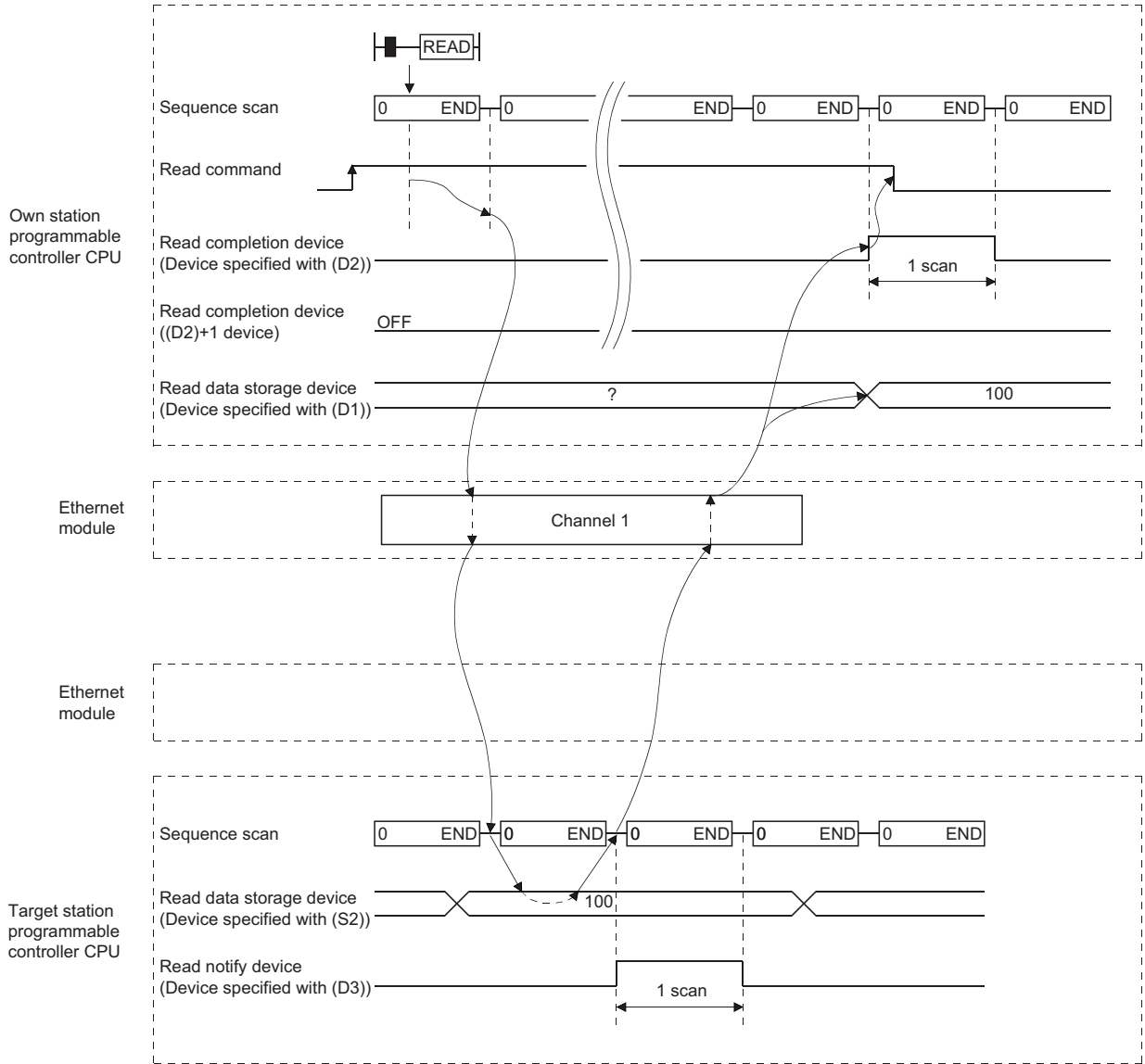

- WRITE instruction, SWRITE instruction

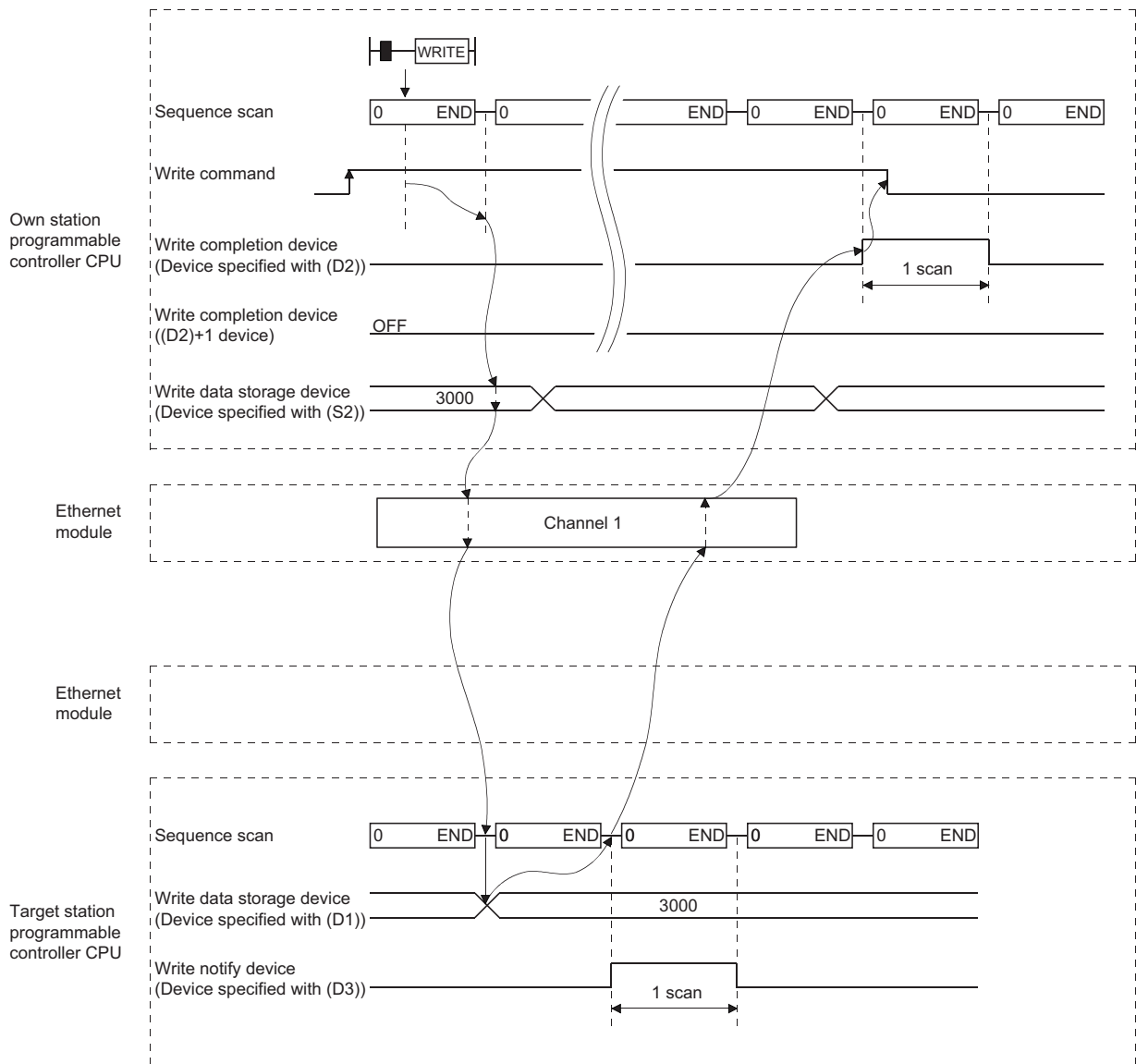

(b) When abnormal completion

- READ instruction, SREAD instruction

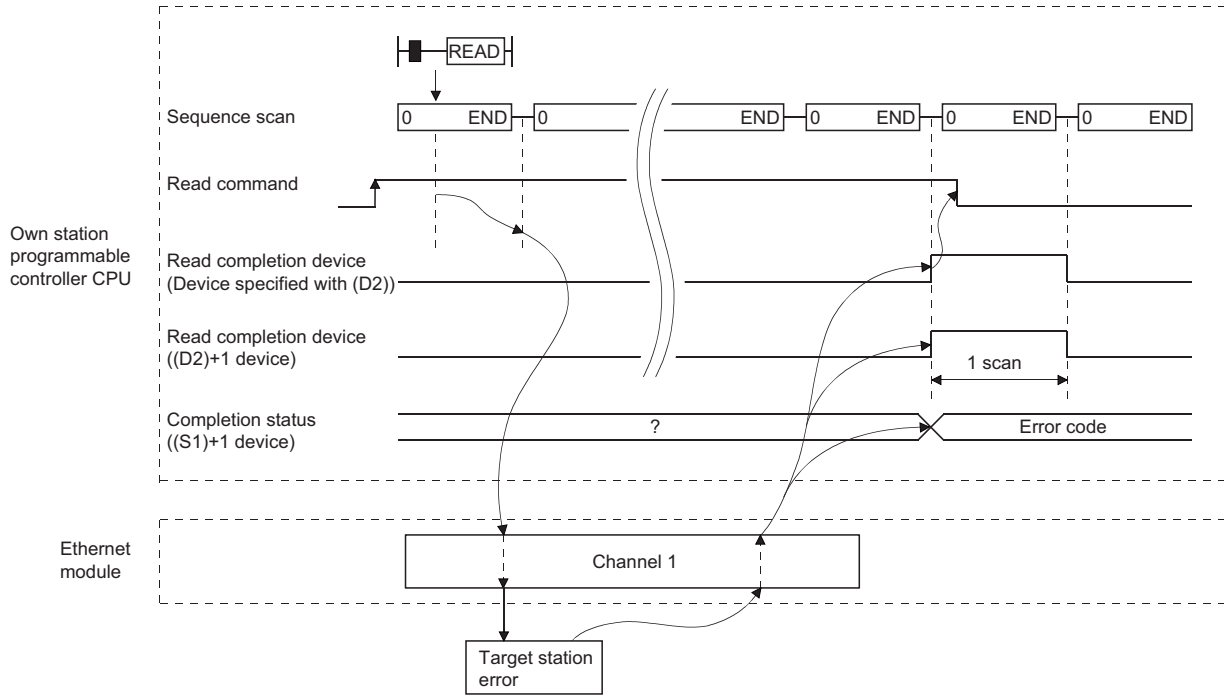

- WRITE instruction, SWRITE instruction

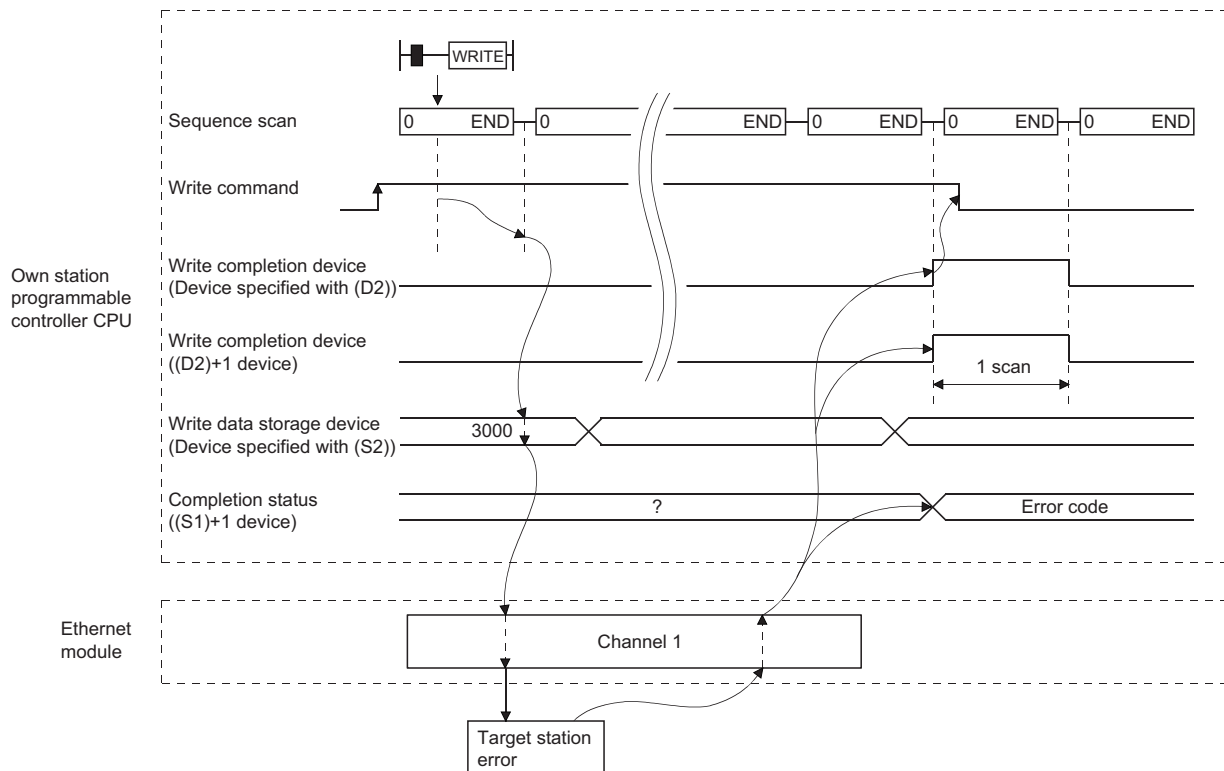

(3) Program examples

Read data from D10 to 14 of station 4 to D200 to 204 of station 1.

Write the data stored in D300 to 303 of station 2 to D50 to 53 of station 3.

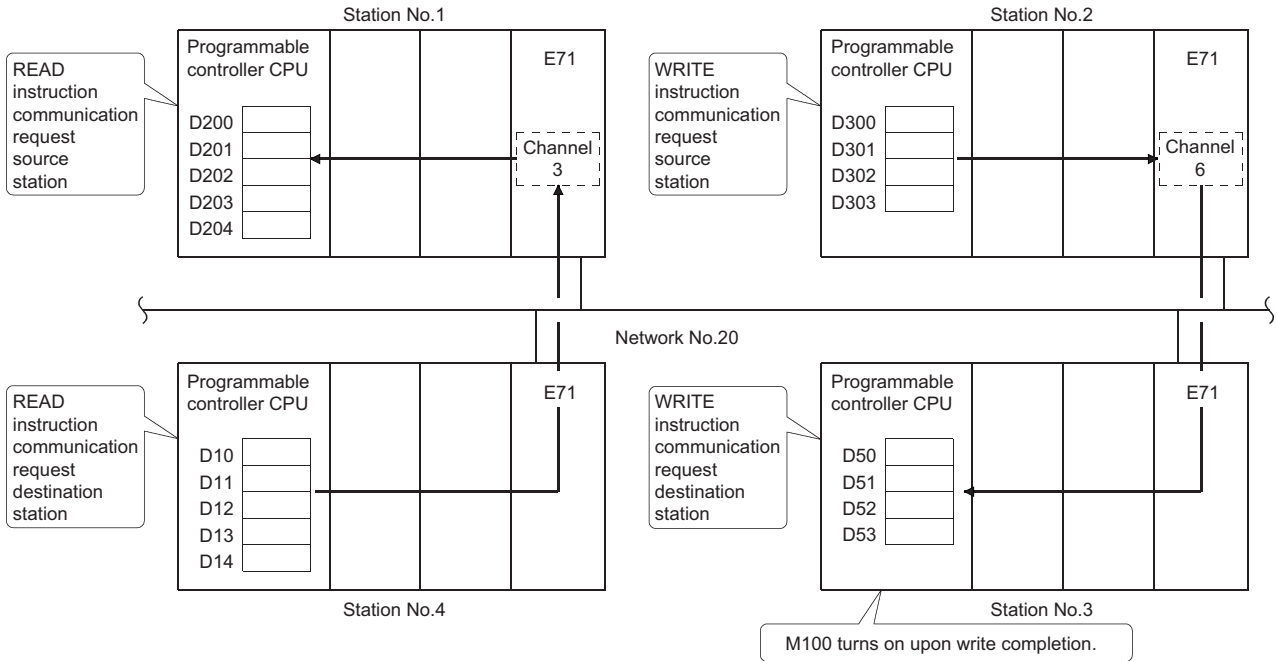

(a) Station 1 program (READ instruction)

When I/O signals of the Ethernet module are X/Y40 to X/Y5F

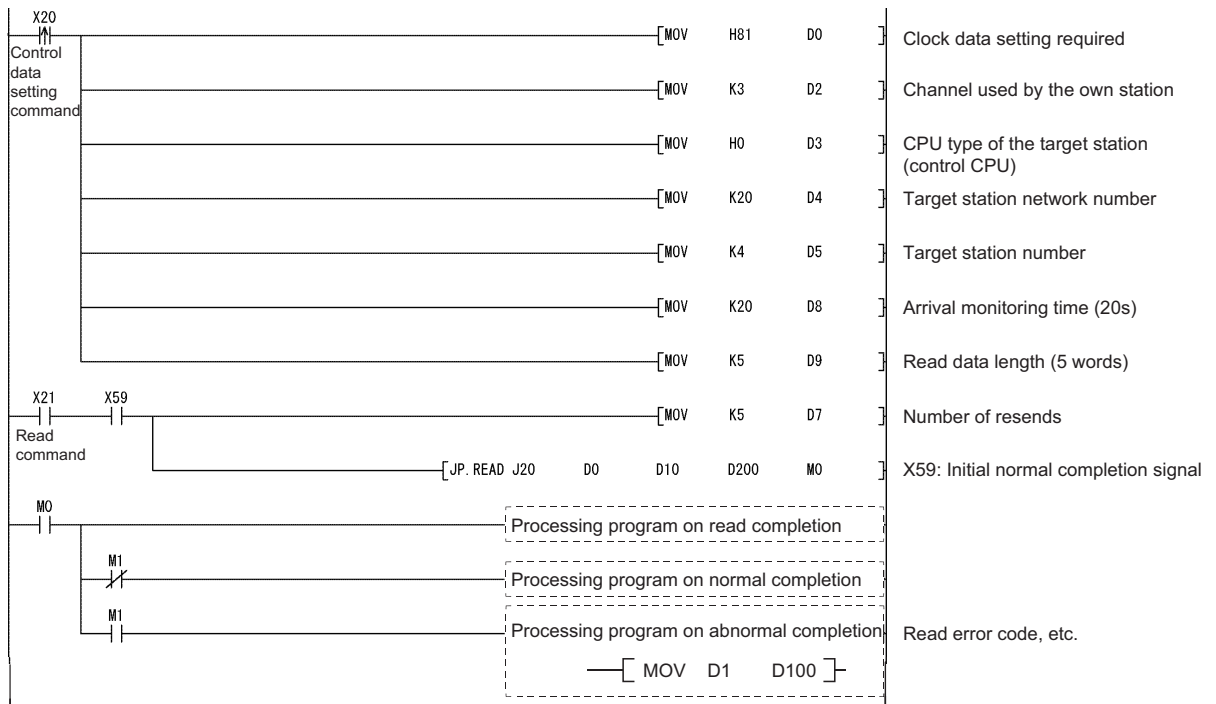

(b) Station 2 programs (SWRITE instruction)

When I/O signals of the Ethernet module are X/Y40 to X/Y5F

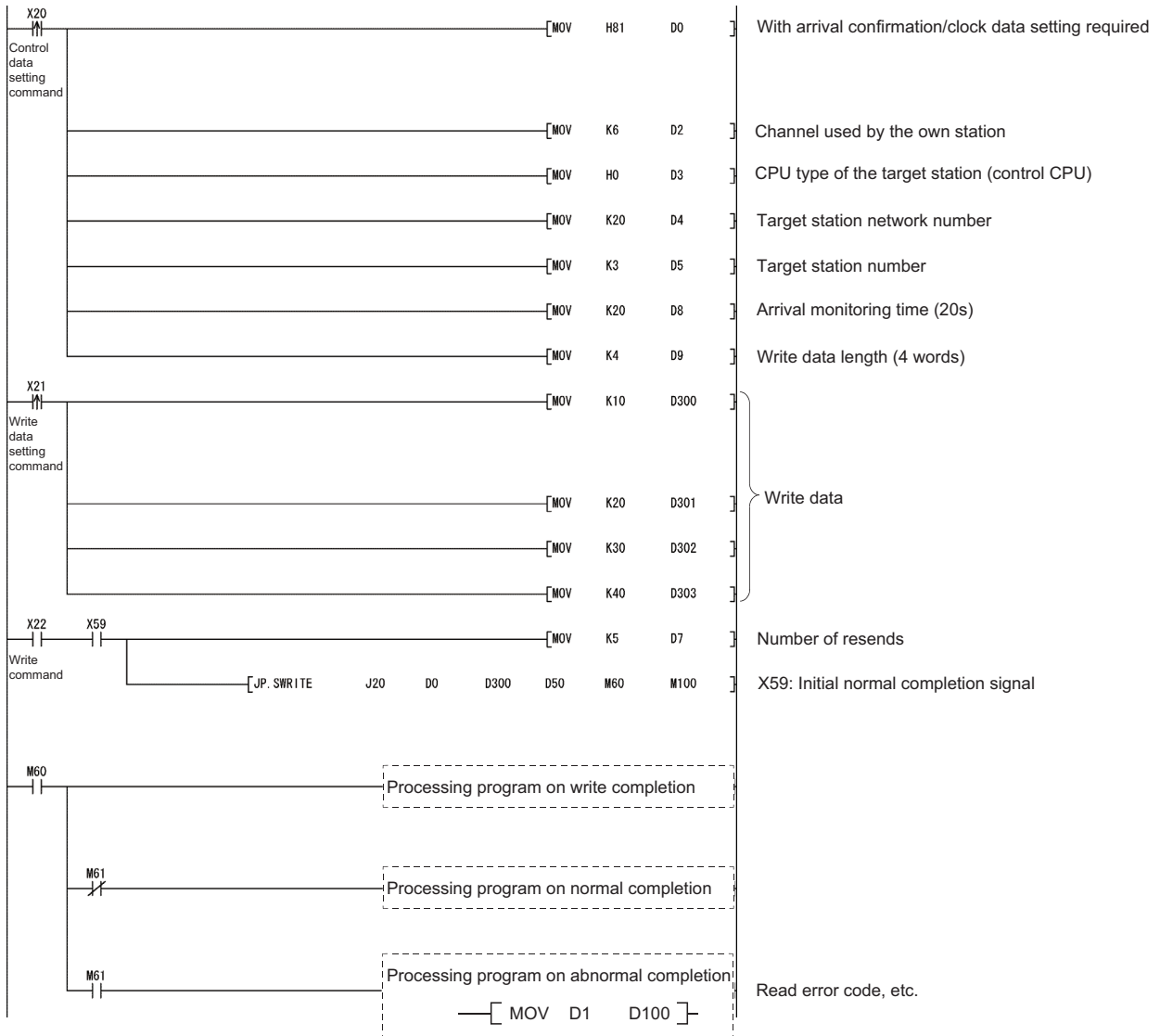

4.7 Reading/Writing Word Devices of Other Stations (ZNRD/ZNWR)

This section explains the format and program examples of the ZNRD/ZNWR instructions that are used to read and write data of word devices of other station.

For details, refer to Page 224, Section 6.13 and Page 227, Section 6.14.

(1) Instruction format

(a) ZNRD

[Network number designation]

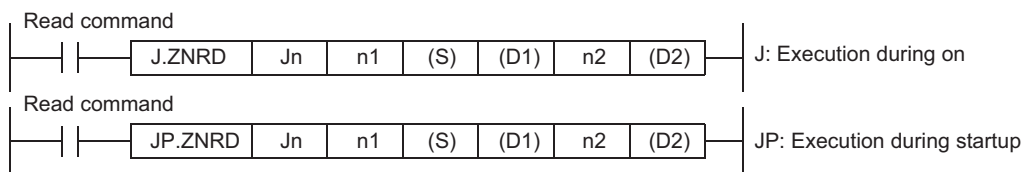

Type	Setting details	Setting range
Jn	Target station network number Designate the network number of the target station.	1 to 239
n1	Target station number Designates the station number of the target station.	1 to 64 (constant) Bit device digit designation ^{*2} Word device ^{*3}
(S)	Read data storage head device (target station) Designate the head device of the target station that stores the data to read.	T, C, D, W
(D1)	Read data storage head device (own station) Designate the head device of the own station that stores the data to read.	Word device ^{*3}
n2	Read data length Designates the number of data (word count) to be read.	When reading from Q/L/QnACPU 1 to 230 (constant) When reading from a programmable controller CPU other than Q/L/QnACPU 1 to 32 (constant) Bit device digit designation ^{*2} Word device ^{*3}
(D2)	Read completion device (own station) Designate device that is turned on for one scan by the read completion (D2) ... OFF: Incomplete, ON: Complete (D2) + 1 ... OFF: Normal, ON: Error	Bit device ^{*1} Word device bit designation ^{*4}

*1 Bit device ... X, Y, M, L, F, V, B

*2 Bit device digit designation ... [K Digit number Bit device head number]

*3 Word device ... T, C, D, W, ST, R, ZR

*4 Word device bit designation ... [Word device.Bit number]

Point

The normal or abnormal read completion status is stored in the data link instruction execution result (ZNRD instruction) storage area (address: 207).

If the read completion device ((D2)+ 1) is on due to abnormal end, read the error code stored in the area mentioned above and correct the error accordingly.

(User's Manual (Basic))

(b) ZNWR instruction

[Network number designation]

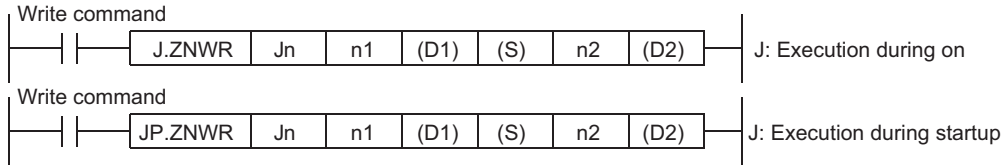

Type	Setting details	Setting range
Jn	Target station network number Designate the network number of the target station.	1 to 239
n1	Target station number Designates the station number of the target station.	1 to 64 (constant): Stations of station number 81H to 89H: All stations of group number FFH: All stations on the target network number Bit device digit designation* ² Word device* ³
(D1)	Write data storage head device (target station) Designate the head device of the target station to which data is written.	T, C, D, W
(S)	Write data storage head device (own station) Designate the head device of the own station that stores the data to be written.	Word device* ³
n2	Write data length Designate the number of data (words) to write.	When writing from Q/L/QnACPU 1 to 230 (constant) When writing from a programmable controller CPU other than Q/L/QnACPU 1 to 32 (constant) Bit device digit designation* ² Word device* ³
(D2)	Write completion device (own station) Designate device that is turned on for one scan by the write completion. (D2) ... OFF: Incomplete, ON: Complete (D2) + 1 ... OFF: Normal, ON: Abnormal	Bit device* ¹ Word device bit designation* ⁴

*1 Bit device ... X, Y, M, L, F, V, B
 *2 Bit device digit designation ... [K Digit number Bit device head number]
 *3 Word device ... T, C, D, W, ST, R, ZR
 *4 Word device bit designation ... [Word device.Bit number]

Point

The normal or abnormal write completion status is stored in the data link instruction execution result (ZNWR instruction) storage area (address: 209).
 If the write completion device ((D2)+ 1) is on due to abnormal end, read the error code stored in the area mentioned above and correct the error accordingly.
 (📖 User's Manual (Basic))

(2) Execution timing of the instruction

(a) When normal completion

- ZNRD instruction

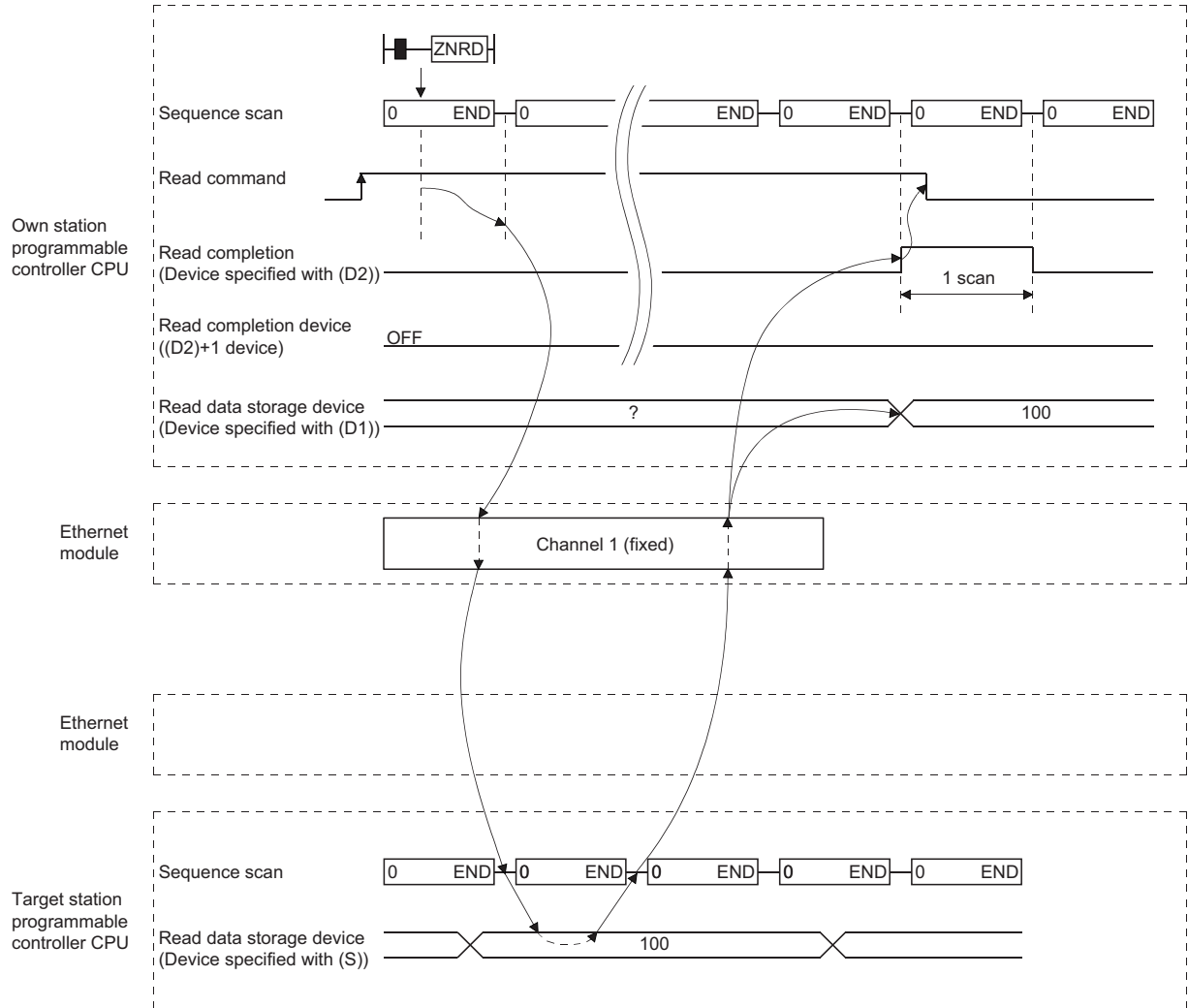

• ZNWR instruction

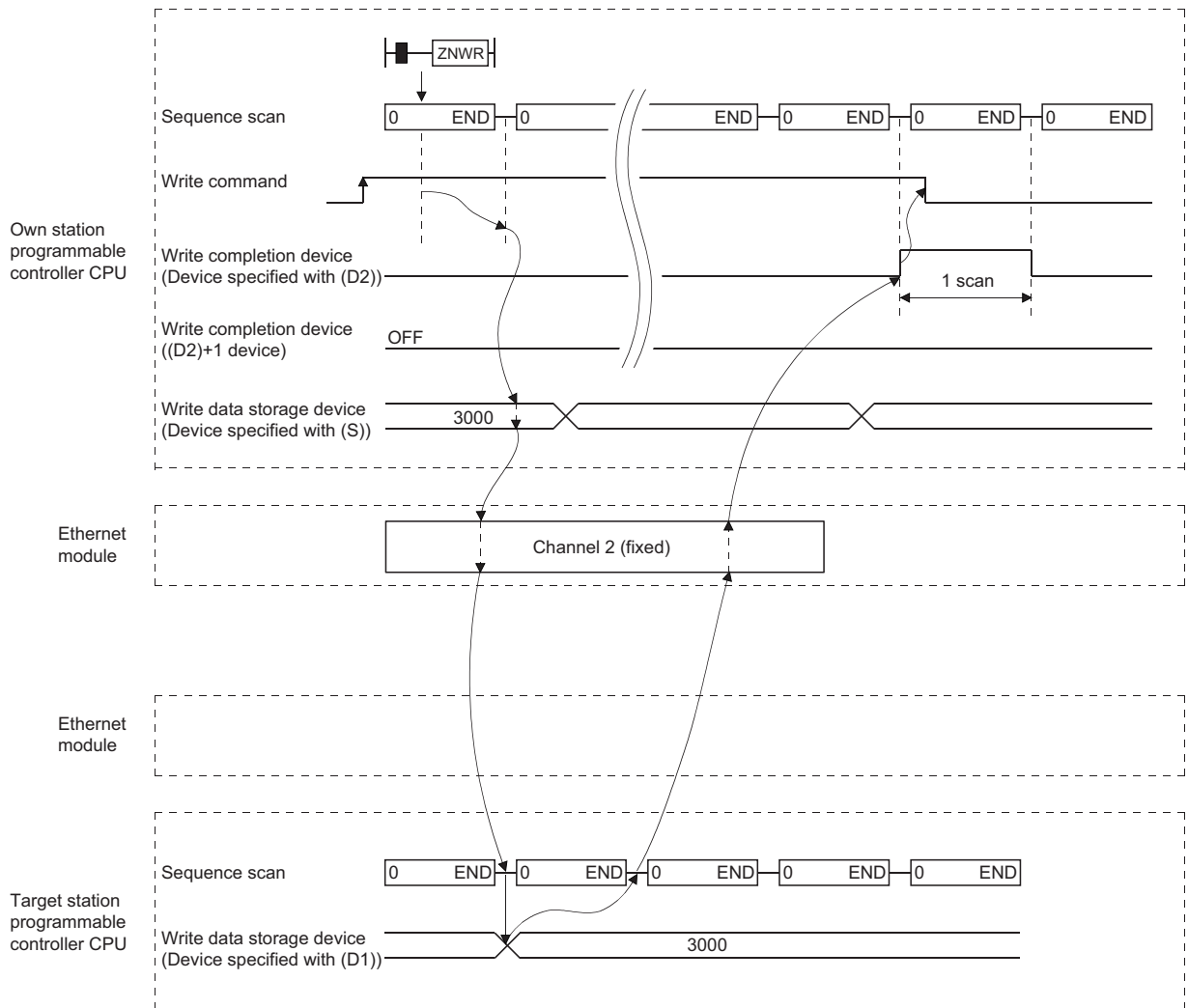

(b) When abnormal completion

- ZNRD instruction

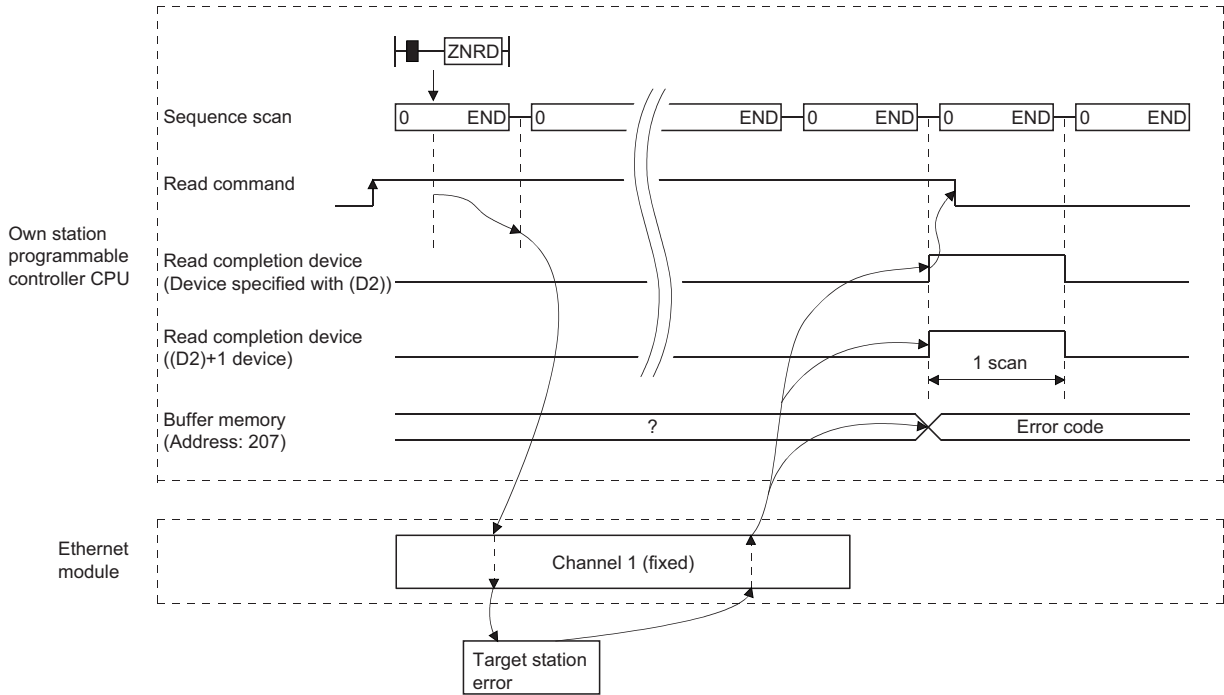

- ZNWR instruction

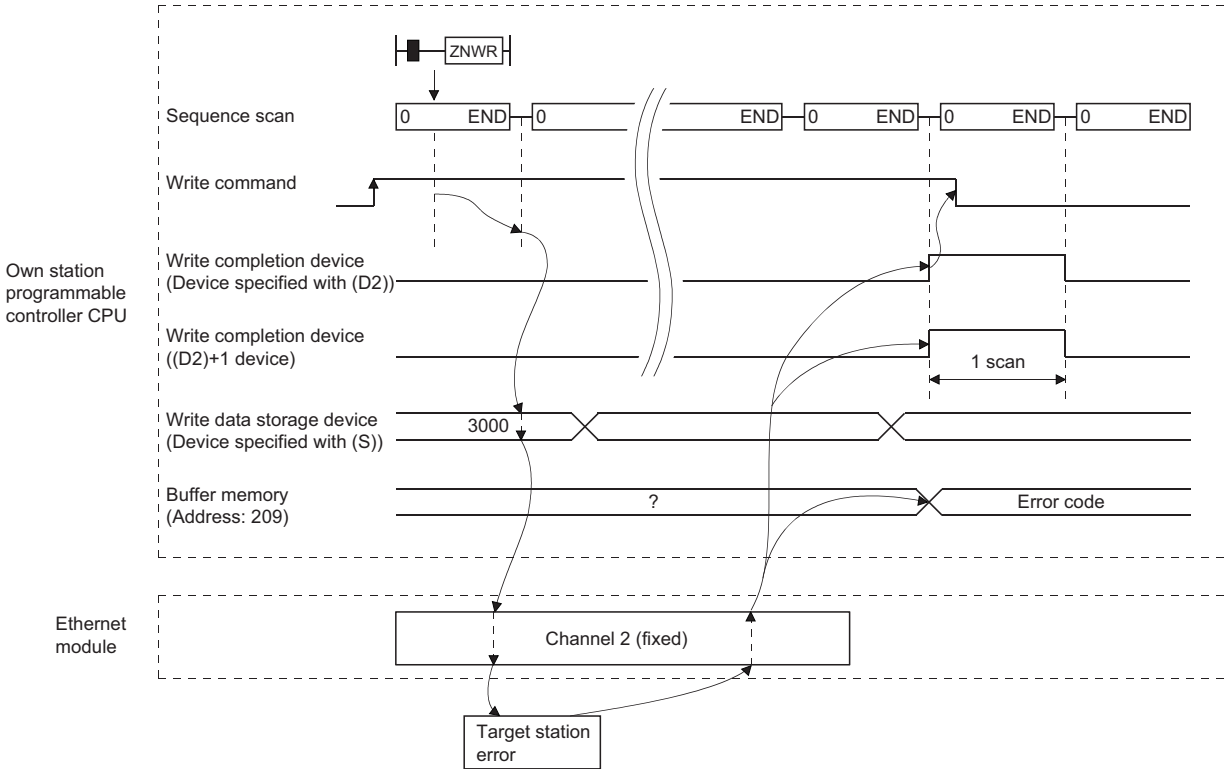

(3) Program examples

Read data from D10 to 14 of station 4 to D200 to 204 of station 1.

Write the data stored in D300 to 303 of station 2 to D50 to 53 of station 3.

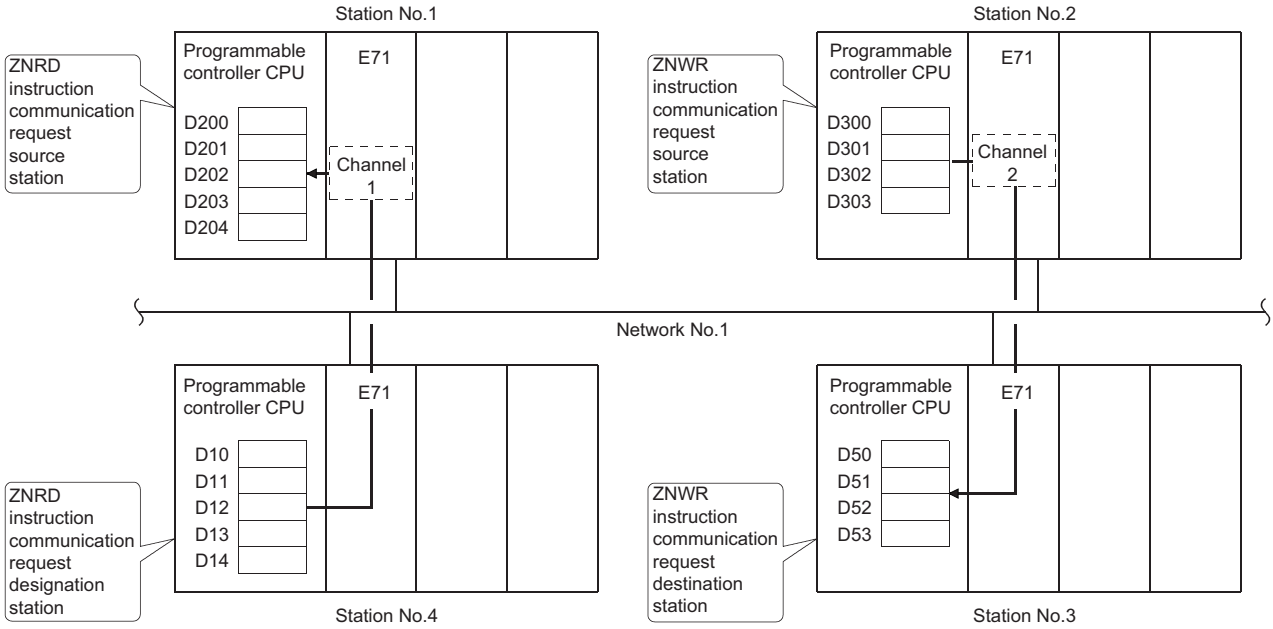

(a) Program of station 1 (ZNRD instruction)

When I/O signals of the Ethernet module are X/Y00 to X/Y1F

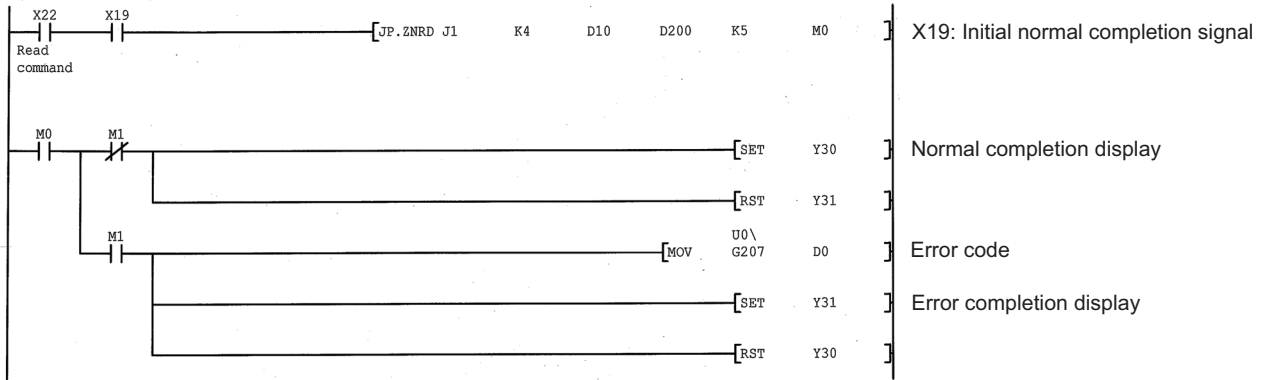

(b) Program of station 2 (ZNWR instruction)

When I/O signals of the Ethernet module are X/Y00 to X/Y1F

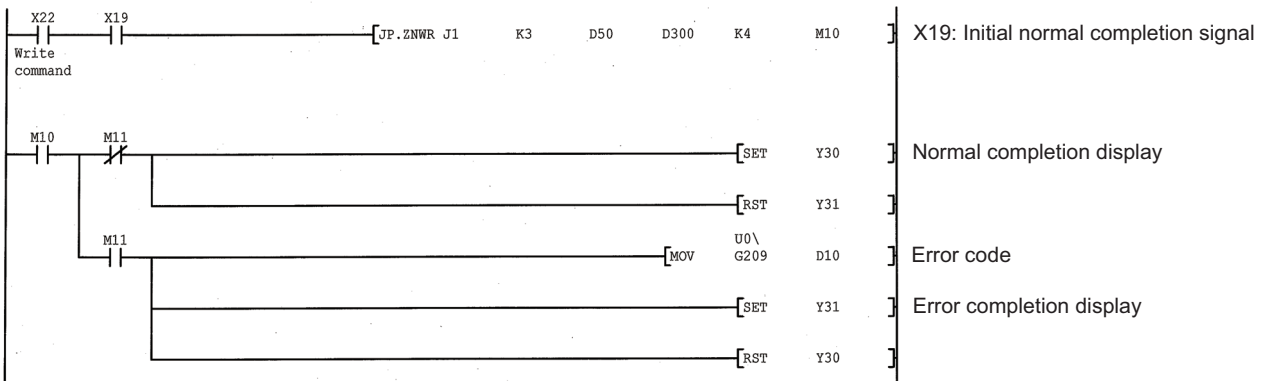

4.8 Reading/Writing Clock Data, Remote RUN/Remote STOP (REQ)

This section explains the format and program examples of the REQ instruction that is used to read/write clock data and remote RUN/remote STOP of the Q/L/QnACPU of other stations.

For details, refer to Page 187, Section 6.7 and Page 195, Section 6.8.

(1) Instruction format

[Network number designation]

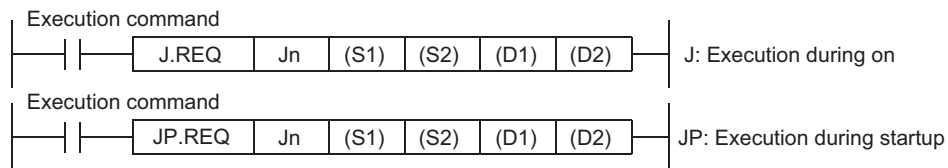

[Network module/Ethernet module start I/O signal designation]

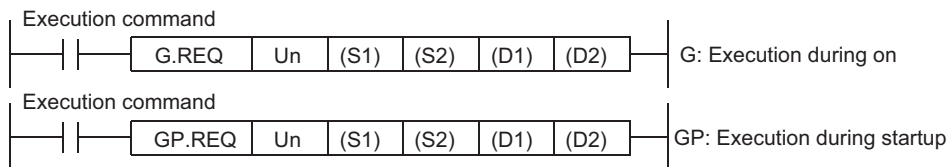

Type	Setting details	Setting range
Jn	Own station network number	1 to 239: Network number 254: Network designated in a valid module for other station access
Un	Start I/O signal of the own station network module/ Ethernet module Designate by higher two digits when the I/O signal is expressed by three digits.	0 to FEH
(S1)	Control data storage head device Designate the head device of the own station that stores the control data.	Word device*2
(S2)	Request data storage head device (own station) Designate the head device of the own station that stores the request data.	Word device*2
(D1)	Response data storage head device (own station) Designate the head device of the own station that stores the response data.	Word device*2
(D2)	Execution completion device (own station) Designate the device of the own station to turn on one scan when the execution is complete. (D2) ... OFF: Incomplete, ON: Complete (D2) + 1 ... OFF: Normal, ON: Error	Bit device*1 Word device bit designation*3

*1 Bit device ... X, Y, M, L, F, V, B

*2 Word device ... T, C, D, W, ST, R, ZR

*3 Word device bit designation ... [Word device.Bit number]

(2) Execution timing of the instruction

(a) When normal completion

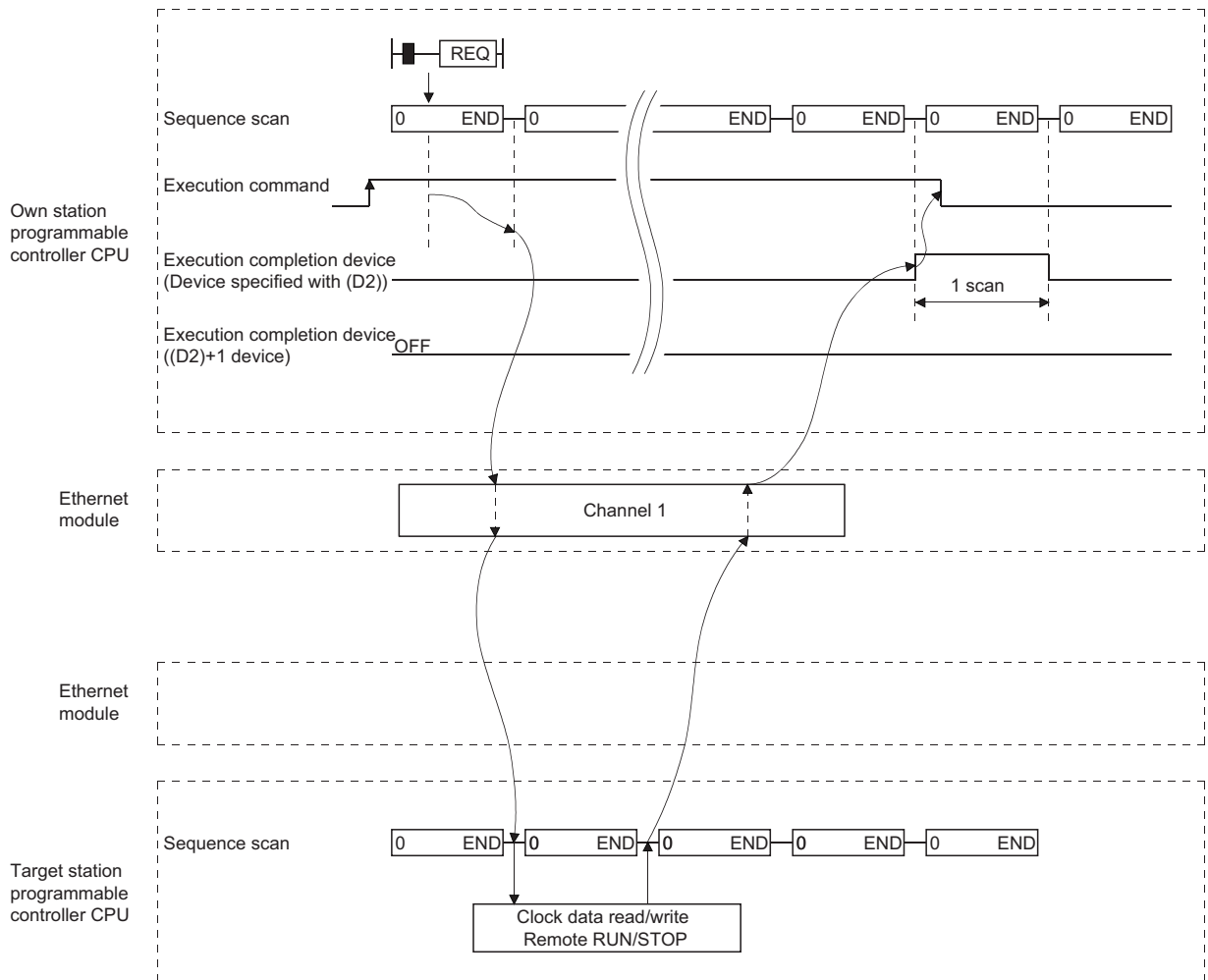

(3) Program examples

(a) A program that writes the clock data (8:30:00) to the Q/L/QnACPU of station number 13 using network number 7.

When I/O signals of the Ethernet module are X/Y00 to X/Y1F

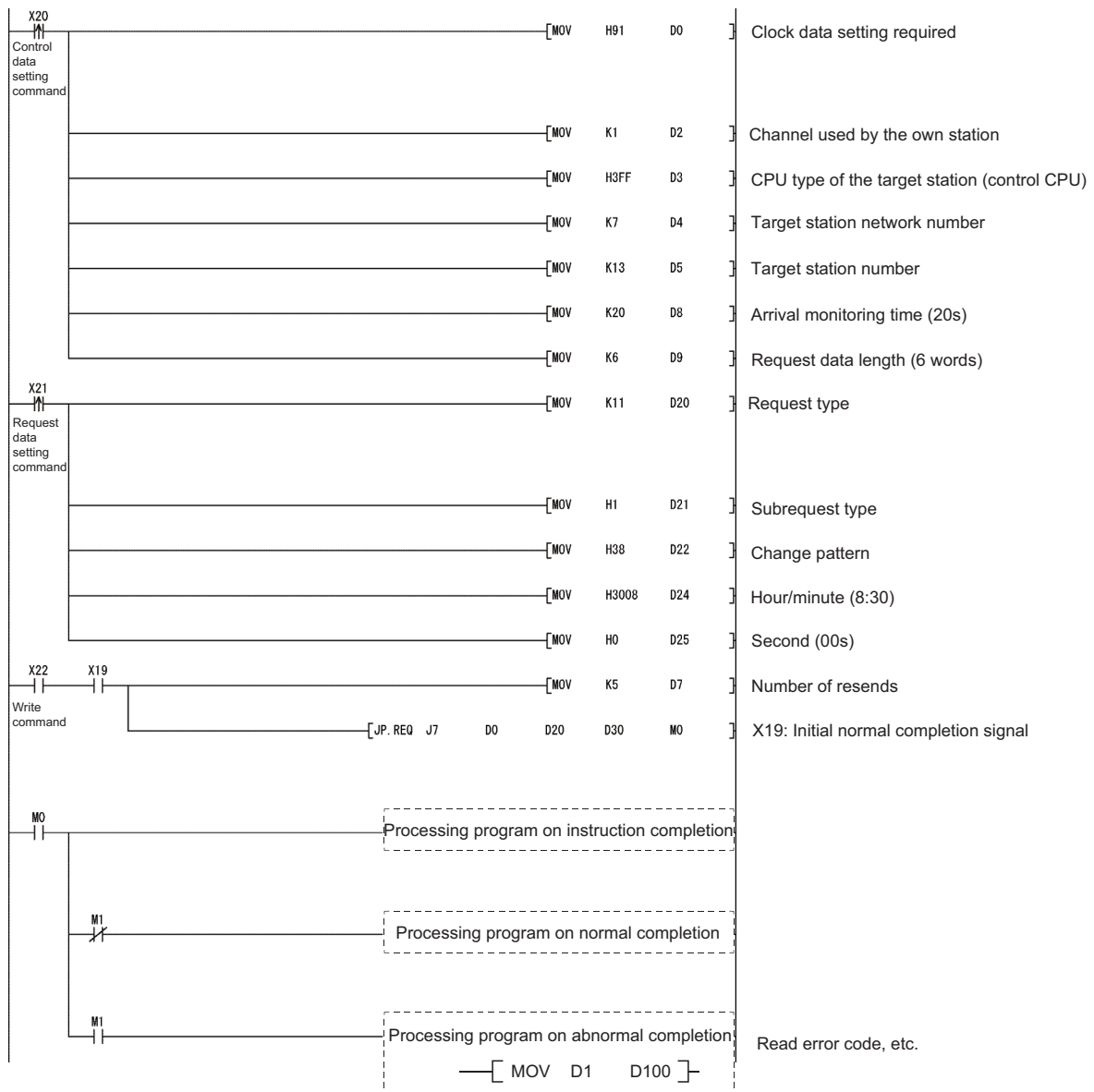
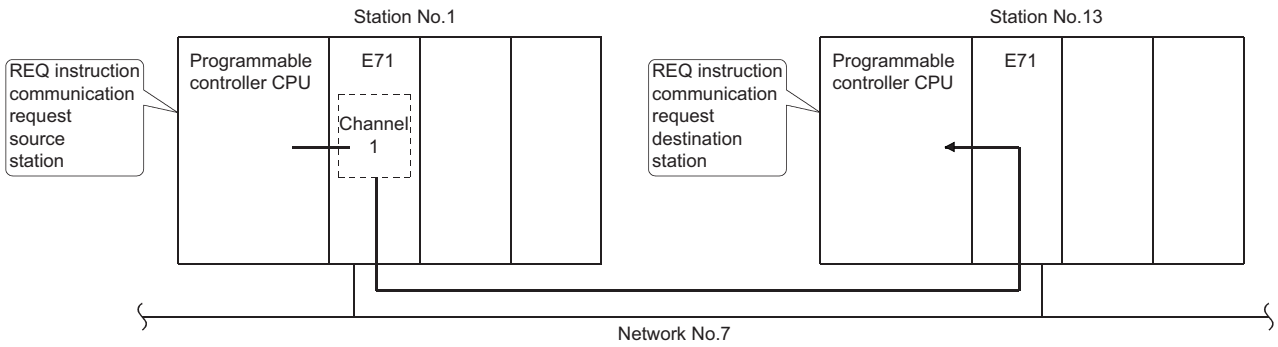

(b) A program to perform remote STOP to the Q/L/QnACPU with the station number 13 in the network number 7.

When I/O signals of the Ethernet module are X/Y00 to X/Y1F

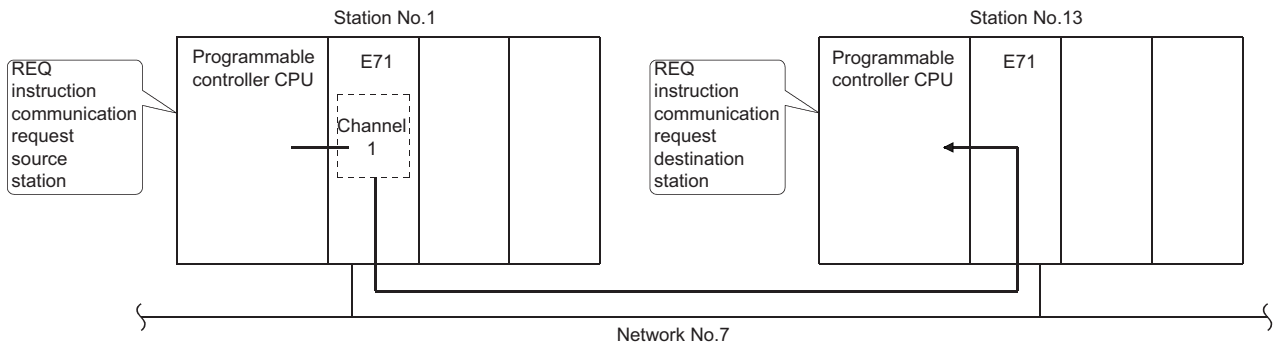

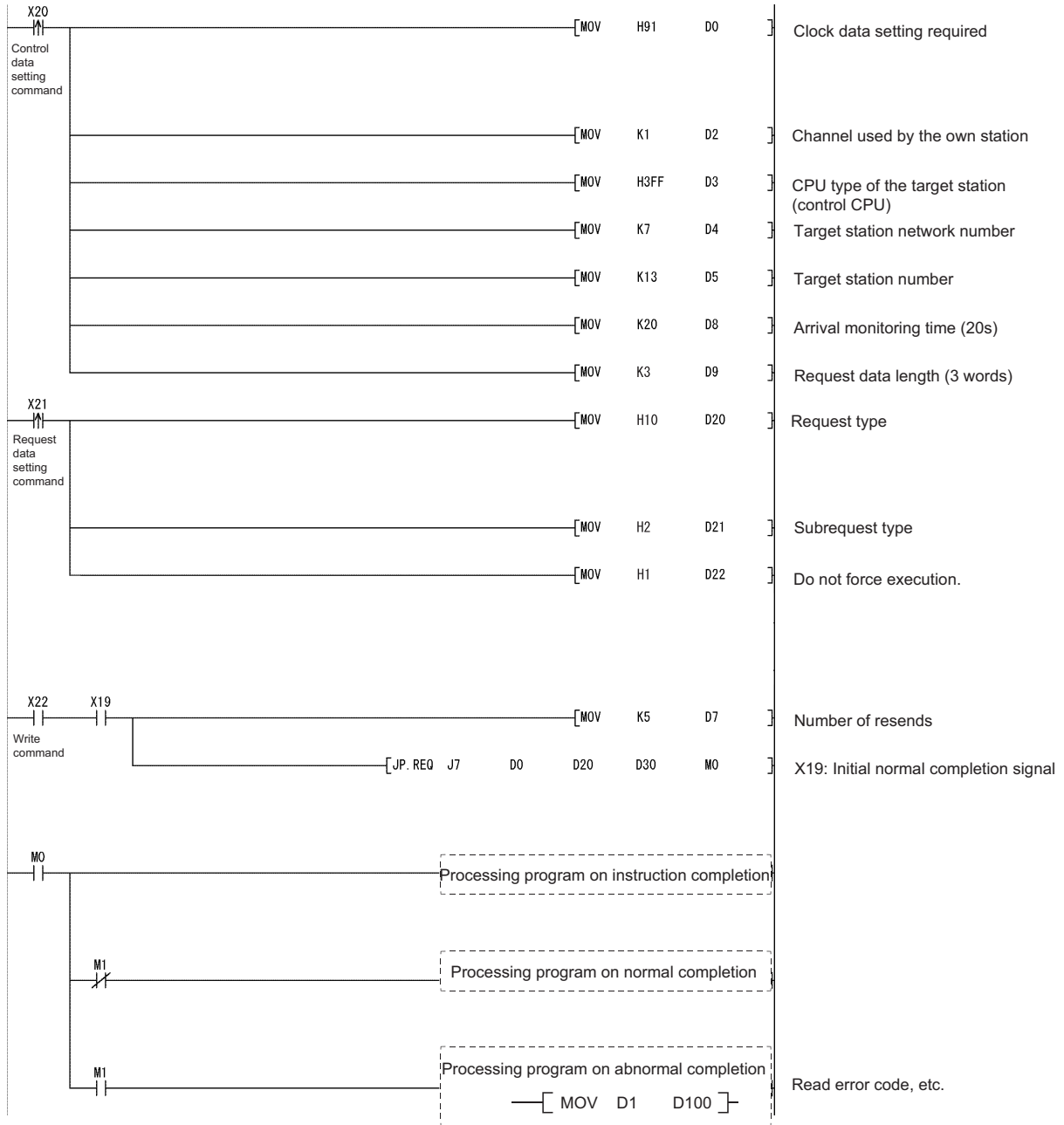

4.9 Error Codes for Data Link Instructions

For the error codes that are returned when the execution results of data link instructions in this chapter end abnormally, refer to the User's Manual (Basic).

The error code for data link instruction is stored in the Ethernet module error log area and the following area:

- SEND, RECV (RECVS), READ (SREAD), WRITE (SWRITE), REQ: Control data completion status ((S1) + 1)
- ZNRD: Buffer memory (Address 207)
- ZNWR: Buffer memory (Address 209)

CHAPTER 5 WHEN USING FILE TRANSFER FUNCTIONS (FTP SERVER)

Files in the own station Q/LCPU to which the Ethernet module is installed can be read and written from external device using the Ethernet module file transfer function.

In this chapter, how to use (command) the Ethernet module FTP function from an external device (personal computer, workstations, etc.) is explained.

Point

The access destination of files handled using the file transfer function is the own station Q/LCPU in the station to which the Ethernet module is connected.
Designate an access target CPU if the own station's QCPU is configured in a multiple CPU system.

5

5.1 File Transfer Functions

The file transfer functions (hereinafter called FTP server) of the Ethernet module to read/write the files in the Q/LCPU on the external device side are explained.

The Ethernet module supports the FTP (File Transfer Protocol) server function, which uses the protocol to transfer files between external devices. It functions as the file server for the files in the Q/LCPU.

The FTP commands are used to direct data transfers in file units.

The external device with the FTP client functions, can easily access (read/write) the user-created files in the Q/LCPU directly using the Ethernet module FTP server functions.

(1) Reading a file from the Q/LCPU (download)

Reading function for storing the Q/LCPU files in the external device.

(2) Writing a file to the Q/LCPU (upload)

Writing function for registering the file in the external device to the Q/LCPU.

(3) Scanning Q/LCPU files

Scanning function for checking the files registered in the Q/LCPU, from the external device.*1

*1 With these Ethernet module FTP server functions, all user files in the Q/LCPU (such as parameters, sequence programs, and data files) can be accessed using the FTP commands from the external device.

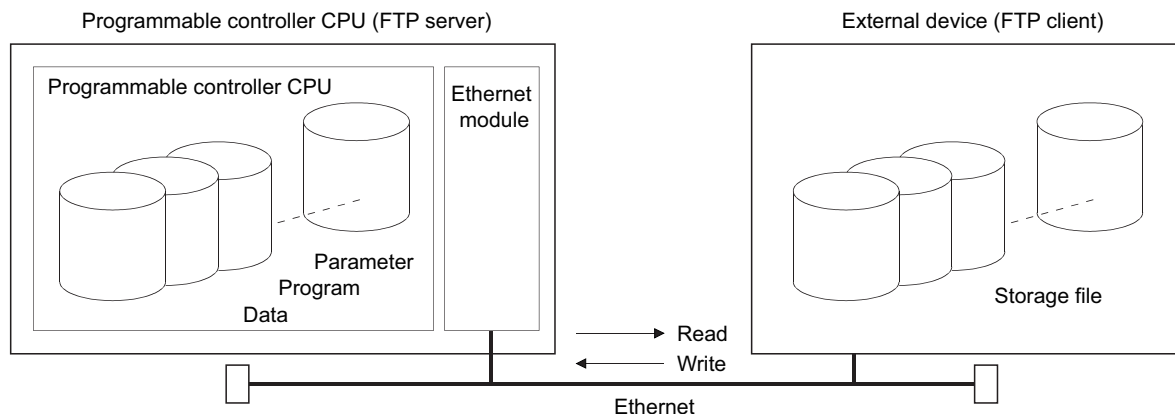

5.1.1 FTP server support functions of the Ethernet module

The FTP commands supported by Ethernet module when it serves as the FTP server are indicated below:

The "Write enable setting" and "Write disable setting" columns in the table indicate the settings in the "Ethernet Operation Setting" screen of a programming tool (checking the checkbox next to "Enable Online Change"). ("Write enable setting": check the checkbox, "Write disable setting": do not check the checkbox.)

The "Remote password" indicates whether the instruction can be executed when the FTP communication port is designated as a port subject to the remote password check in the remote password setting (parameter) for the Q/LCPU of the station where the Ethernet module is connected.

See the User's Manual (Basic) for the remote password.

(1) Client-side user interface command list (supported by Ethernet module)

Command	Function	Programmable controller CPU status			Remote password		Remarks
		During STOP	During RUN		While unlocked	While locked	
			Write enable setting	Write disable setting			
binary ^{*3}	Notify to transfer without converting file	<input type="radio"/>	<input type="radio"/>	<input type="radio"/>	<input type="radio"/>	<input checked="" type="checkbox"/>	
bye	Disconnect and end the connection with FTP server	<input type="radio"/>	<input type="radio"/>	<input type="radio"/>	<input type="radio"/>	<input type="radio"/>	
close	Disconnect the line with FTP server	<input type="radio"/>	<input type="radio"/>	<input type="radio"/>	<input type="radio"/>	<input type="radio"/>	
delete	Delete the file of a CPU module	<input type="radio"/>	<input type="radio"/> ^{*1}	<input checked="" type="checkbox"/>	<input type="radio"/>	<input checked="" type="checkbox"/>	
dir	Display the file information of a CPU module	<input type="radio"/>	<input type="radio"/>	<input type="radio"/>	<input type="radio"/>	<input checked="" type="checkbox"/>	
get	Read a file from a CPU module	<input type="radio"/>	<input type="radio"/>	<input type="radio"/>	<input type="radio"/>	<input checked="" type="checkbox"/>	
ls	Display the file name of a CPU module	<input type="radio"/>	<input type="radio"/>	<input type="radio"/>	<input type="radio"/>	<input checked="" type="checkbox"/>	
mdelete	Delete the file of a CPU module	<input type="radio"/>	<input type="radio"/> ^{*1}	<input checked="" type="checkbox"/>	<input type="radio"/>	<input checked="" type="checkbox"/>	
mdir	Store the file information of a CPU module into the displayed file	<input type="radio"/>	<input type="radio"/>	<input type="radio"/>	<input type="radio"/>	<input checked="" type="checkbox"/>	—
mget	Read a file from a CPU module	<input type="radio"/>	<input type="radio"/>	<input type="radio"/>	<input type="radio"/>	<input checked="" type="checkbox"/>	
mlls	Store the file name of a CPU module into a file	<input type="radio"/>	<input type="radio"/>	<input type="radio"/>	<input type="radio"/>	<input checked="" type="checkbox"/>	
mput	Write a file to a CPU module	<input type="radio"/>	<input type="radio"/>	<input checked="" type="checkbox"/>	<input type="radio"/>	<input checked="" type="checkbox"/>	
open	Connect with FTP server	<input type="radio"/>	<input type="radio"/>	<input type="radio"/>	<input type="radio"/>	<input type="radio"/>	
put	Write a file to a CPU module	<input type="radio"/>	<input type="radio"/>	<input checked="" type="checkbox"/>	<input type="radio"/>	<input checked="" type="checkbox"/>	
pwd	Display the current directory of a CPU module	<input type="radio"/>	<input type="radio"/>	<input type="radio"/>	<input type="radio"/>	<input checked="" type="checkbox"/>	
quit	Disconnect and end the connection with FTP server	<input type="radio"/>	<input type="radio"/>	<input type="radio"/>	<input type="radio"/>	<input type="radio"/>	
quote	Send FTP server sub-command	<input type="radio"/>	<input type="radio"/>	<input type="radio"/>	<input type="radio"/>	<input type="radio"/>	Can only use Ethernet module dedicated commands ^{*2}
rename	Change the file name of a CPU module	<input type="radio"/>	<input type="radio"/>	<input checked="" type="checkbox"/>	<input type="radio"/>	<input checked="" type="checkbox"/>	
user	Enter user name and password for Ethernet module	<input type="radio"/>	<input type="radio"/>	<input type="radio"/>	<input type="radio"/>	<input type="radio"/>	—

Command	Function	Programmable controller CPU status			Remote password		Remarks
		During STOP	During RUN		While unlocked	While locked	
			Write enable setting	Write disable setting			
status	Display the operating information of a CPU module	○	○	○	○	×	Ethernet module-FTP server dedicated commands
stop	Set a CPU module to STOP status	○	○	○	○	×	
run	Set a CPU module to RUN status	○ ^{*4}	○	○	○	×	
change	Display/change the file attribute of a CPU module	○	○	×	○	×	
cpuchg ^{*5}	Designate an access target CPU when configuring the multiple CPU system or display the present access target CPU	○	○	○	○	×	
password-lock	Change status of remote password from unlock to lock	○	○	○	○	×	
password-unlock	Change status of remote password from lock to unlock	○	○	○	○	○	
keyword-set ^{*5}	Set a file access password to an Ethernet module or display/clear the file access password set in an Ethernet module	○	○	○	○	×	
passwd-rd ^{*6}	Set a file access password (for read password) to an Ethernet module or display/clear the file access password (for read password) set in an Ethernet module	○	○	○	○	×	
passwd-wr ^{*6}	Set a file access password (for write password) to an Ethernet module or display/clear the file access password (for write password) set in an Ethernet module	○	○	○	○	×	

- *1 The parameter file and the sequence program file cannot be deleted when a CPU module is in RUN.
- *2 The list of Ethernet module dedicated commands used along with the quote command is described. When executing the commands from the FTP client, attach the command after the "quote" command. (Example) When executing the stop command Enter the following in the command prompt.
quote stop <ret>
- *3 This setting is automatically set to an Ethernet module. Files are transferred in binary regardless of the setting in the "Communication Data Code" field on the "Ethernet Operation Setting" screen of a programming tool.
- *4 This command becomes disabled with the switch of a programmable controller CPU set to STOP.
- *5 This command can be used only in a Q series Ethernet module.
- *6 This command can be used only in an L series Ethernet module.

Point 

Some of the commands in the table may not operate as described in this manual depending on the client-side FTP application. See the manual for the FTP client side (external device), and confirm the functions and operation methods as well.

5.2 File Transferable Range

The file transferable range from the external device (Q/LCPU in a station where an Ethernet module is connected) is explained.

The file transfer operation from the external device using the Ethernet module FTP server function can be performed from any external device with Ethernet module on the Ethernet.

When the router relay function is used, the external device on the Ethernet connected via the designated router can perform FTP functions.*1

File transfers can be performed from the following external device with ☉.

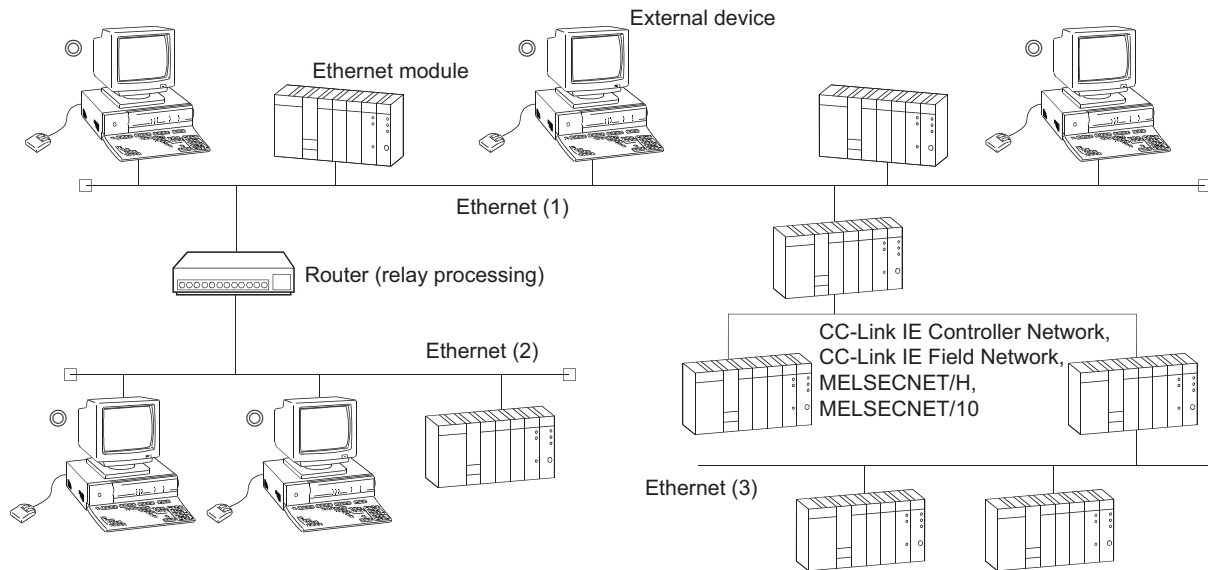

*1 File transfers cannot be performed from the external device on the Ethernet (3) which is connected via CC-Link IE Controller Network, CC-Link IE Field Network, MELSECNET/H, MELSECNET/10.

5.3 FTP Parameter Settings for File Transfer from a Programming Tool

This section explains how to set the Ethernet FTP parameters for the file transfer (FTP).

Open the "Setting the Ethernet FTP Parameter" screen in the network parameter screen of a programming tool. For how to open the screen, refer to the operating manual for the programming tool used.

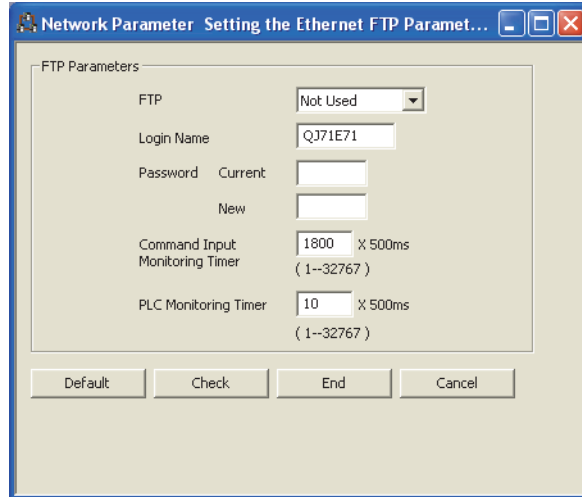

FTP parameter settings

Item name	Description of setting	Setting range/option
FTP	Select whether or not to use the FTP function.	<ul style="list-style-type: none"> • Not Used • Use
Login Name	Set the login name when a communication destination requests (login) file transfer to the Ethernet module by external device.	Up to 12 characters Initial login name: QJ71E71 or LJ71E71
Password	Current	Up to 8 characters Initial password: QJ71E71 or LJ71E71
	New	Up to 8 characters
Command Input Monitoring Timer	Set the monitoring time for the Ethernet module to monitor the command input time from the FTP client.	1 to 32767
PLC Monitoring Timer	Set the monitoring time for the Ethernet module to monitor the operation of the own station's CPU.	1 to 32767

(1) FTP (Address: 4H ... b8, b9) ... Default value: Do not use the FTP function

Set whether or not to use the FTP function of the Ethernet module.

Item	Explanation
FTP	Use the FTP function.
	Do not use the FTP function.

(2) Log-in name and password (Address: 3B0H), (3B6H) ... Default value: QJ71E71 (QCPU) and LJ71E71 (LCPU)

- (a) Set the login name and password for the external device to request (login) file transfer to the Ethernet module in order to use the FTP server function of the Ethernet module.**
- (b) If the FTP login name is changed and invalid characters are entered, QJ71E71 or LJ71E71 is set as the login name.**
- (c) If the password is changed and invalid characters are entered, QJ71E71 or LJ71E71 is set as the password.**

(3) Command input monitoring timer (address: 3BAH) ... Default value: 1800 (0708H) (15min)

- (a) Set the monitoring time for the Ethernet module to monitor the command input time from the FTP client when it operates as the FTP server.**
- (b) It is recommended to use the default value for this timer value as much as possible.**
When changing the setting value, determine the command input monitoring timer value upon consulting the administrator of the external device or system.
- (c) Designate the setting value in the range of <1H to 7FFFH/1 to 32767>.**
(15 min at the default value of 1800)
The FTP connection is disconnected if there is no command input from the FTP client side within the time designated by the command input monitoring timer value after the FTP client login.
When restarting the file transfer, start over from the login operation again.

(4) PLC monitoring timer (address: 3BBH); Default value: 10 (000AH) (5s)

- (a) Set the monitoring time for the Ethernet module to monitor the operation of the own station's Q/LCPU when the Ethernet module is operating as the FTP server.**
- (b) A timeout may occur due to long internal processing time when file operation is performed in a CPU module with a large program capacity. If a timeout occurs, extend the CPU monitoring timer value.**
- (c) Designate the setting value in the range of <1H to 7FFFH/1 to 32767>.**
The FTP connection is disconnected if a Q/LCPU monitoring error is detected after the FTP client login.
When restarting the file transfer, make sure that the own station's Q/LCPU is operating normally and start over from the login operation again.

5.4 Procedure and Required Processing on the External Device Side (FTP Client)

This section explains the procedure and required processing on the external device side for using the FTP server function of the Ethernet module.

In the explanation, the FTP operation commands and input formats used for the applicable operations are shown. (<ret> indicates input using the CR, Enter, or Return key.)

[FTP transfer operation procedure]

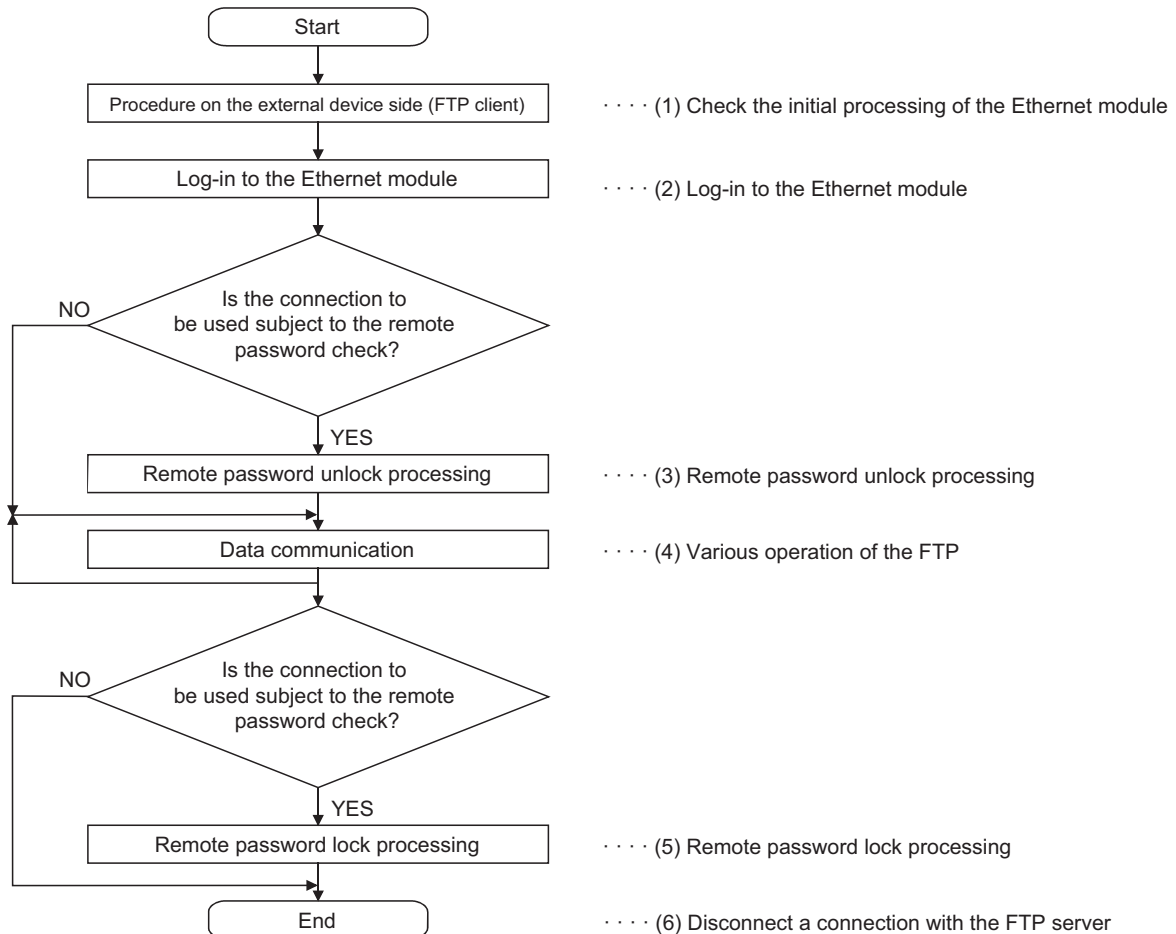

(1) Checking the initial processing of the Ethernet module

Make sure that the Ethernet module's initial processing has normally completed by checking the LED display/input signal of the Ethernet module.

- LED display: The [INIT.]LED on the front of the Ethernet module flashes.
- I/O signal: The initial normal completion signal (X19) turns on.

(2) Login to the Ethernet module

Once the Ethernet module's initial processing has completed normally, log in to the Ethernet module.

Ex. Start FTP from MS-DOS prompt of Microsoft® Windows®

```
Microsoft Windows XP [Version 5.1.2600]
(C) Copyright 1985-2001 Microsoft Corp.

G:\WINDOWS>cd\

1) → C:\>ftp
2) → ftp> open 10.97.79.14
   Connected to 10.97.79.14.
   220 QJ71E71 FTP server ready.
3) → User (10.97.79.14:(none)): QJ71E71
   331 Password required.
3) → Password:
   230 User logged in.
   ftp>
```

- 1) Start FTP (ftp<ret>).
 - 2) Connect with the FTP server (open IP address of the FTP server <ret>).
 - 3) Designate the login name (login name (default value: QJ71E71 or LJ71E71) <ret>).
- Designate the password (password (default value: QJ71E71 or LJ71E71) <ret>).

When logging in, use the FTP login name and password set on the "Ethernet FTP parameter settings" screen for setting the login name and password.

Upon reception of the login name and password from the external device (FTP client), the Ethernet module (FTP server) checks whether they match with the FTP login name and password set in the FTP parameter setting area of the buffer memory.

File transfer to the Ethernet module is allowed when the login name and password match, and not allowed if they do not match.

(3) Remote password unlock

Changes the status of the remote password from lock to unlock if the FTP communication port has been designated as a port subject to the password check using the remote password setting. (quote password-unlock remote password <ret>)

Point

If the FTP communication port has been designated as a port subject to the password check, other commands cannot be used until the remote password status is unlocked.

(4) Various operation of the FTP

- 1. Designate an access target CPU if the QCPU is configured as a multiple CPU system.**
The control CPU of the Ethernet module will be the access target CPU after login.
(quote cpuchg access target CPU <ret>)
- 2. Notifies file transfer to a target file without converting the file.**
(binary <ret>)
- 3. If a password is registered in the Q/LCPU file for file transfer, set the password in the Ethernet module.**
QCPU: (quote keyword-set password <ret>)
LCPU: (quote passwd-rd password <ret>) or (quote passwd-wr password <ret>)
- 4. Performs the file transfer operation using the FTP commands described in Page 142, Section 5.6.**

Point

Writing to a parameter file used in the current operation of the Q/LCPU and to a file of the running sequence program that is stored in the Q/LCPU program memory is performed after placing the Q/LCPU in the STOP status.

(5) Remote password lock

Changes the status of the remote password from unlock to lock if the FTP communication port has been designated as a port subject to the remote password check using the remote password setting. (quote password-lock <ret>)

(6) Disconnecting a connection with the FTP server

The connection with the FTP server is disconnected and various FTP operations ends. (bye <ret>)

Ex. File transfer operation procedure

The following two procedures performed between log in and log out are explained as FTP operation examples:

- Read the sequence program file from the Q/LCPU
- Write the sequence program file to the Q/LCPU

If the FTP communication port has been designated as a port subject to the remote password check, perform the remote password unlock processing/lock processing, in compliance with the FTP transfer operation procedure described in Page 133, Section 5.4.

(a) How to read the sequence program file from Q/LCPU (FTP client ← FTP server)

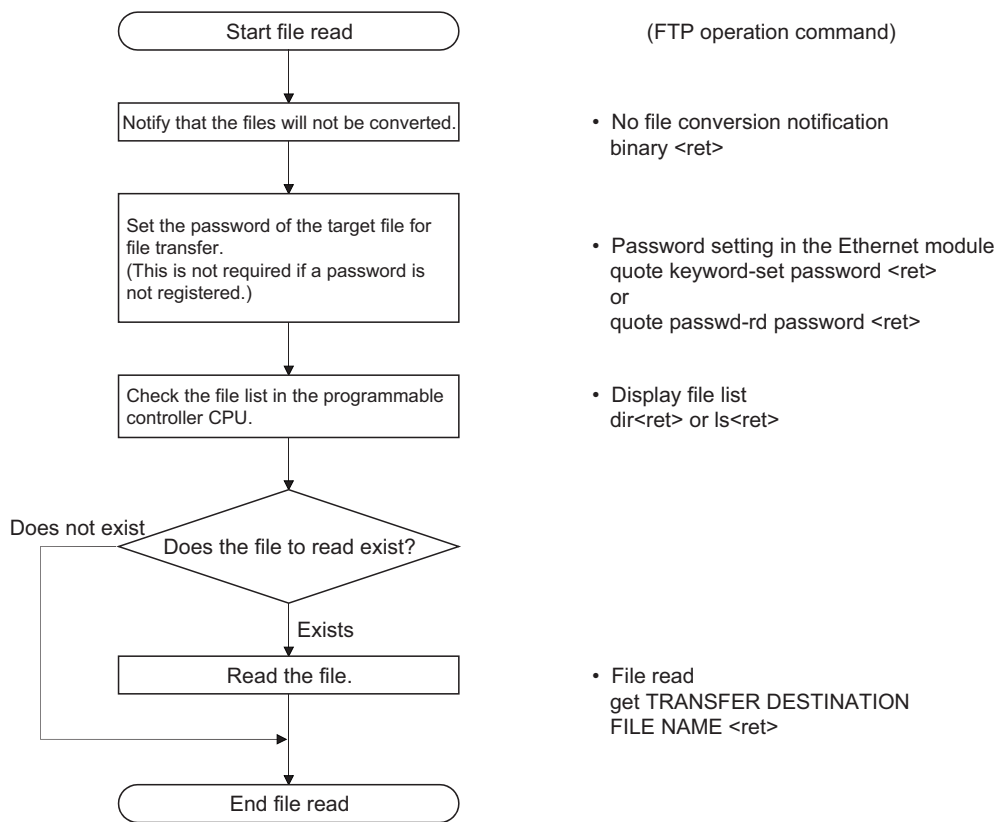

(b) How to write the sequence program file to Q/LCPU (FTP client → FTP server)

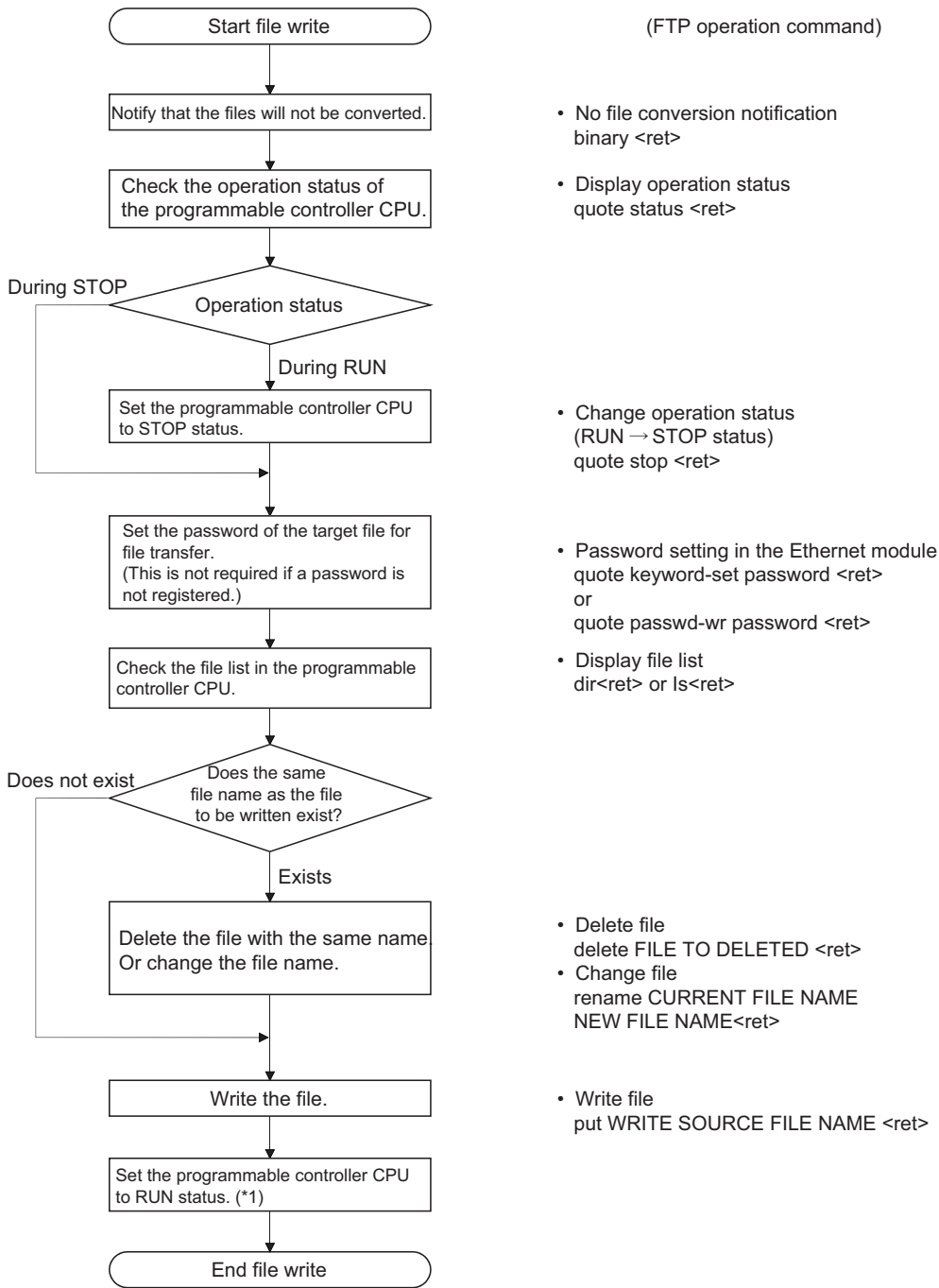

*1 The Q/LCPU must be set to STOP → RUN → STOP → RUN.
To restart the operation of the Q/LCPU after writing a file, it is recommended to set the switch of the Q/LCPU to RUN. The status of the Q/LCPU can be changed from STOP to RUN with the FTP command, however, pay full attention to the operation of the programmable controller system.

5.5 Precautions when Using the File Transfer Functions

The precautions when using the Ethernet module FTP server functions are explained.

(1) Precautions when designing a system which uses file transfer functions

(a) For the system

When performing file transfers with the system in operation or controlling the status of the programmable controller, design the system (such as configuring an interlocking circuit in the sequence program) so that the safety of the overall system is always maintained.

(b) For external devices

Some of the FTP operation commands on the FTP client (external devices) supported by the Ethernet module as a FTP server may not operate as described in this manual, depending on the client side FTP application. See the manual on the FTP client (external devices), and confirm the functions and operation methods.

(c) For the Q/LCPU

- Only files that can be created/generated by the user with a programming tool can be transferred. ( Page 144, Section 5.6.2)
- Files can be transferred only to the own station Q/LCPU with the Ethernet module connected. Designate an access target CPU if the own station's QCPU is configured in a multiple CPU system.
- When file read/write is performed by the file transfer functions while Q/LCPU is running, the Q/LCPU's sequence scan time may take longer than when using Ethernet module's other functions, and the file read/write take a few minutes or longer depending on the file size or sequence scan. The file read/write processing time may take even longer depending on various conditions such as the Ethernet line load (line traffic), number of connections used at the same time (exchange processing which uses another connection), and the system configuration.

(2) Precautions when starting up the Ethernet module

When the QCPU is write-protected (DIP switch 1 is on), file transfers which perform write (attribute change, file write, etc.) cannot be performed. (Excluding the Universal model QCPU.)

(3) Precautions common to any usage of the file transfer functions

(a) For an external device

When a timeout error occurs during file transfer using the FTP function, the FTP function line is closed (disconnection) regardless of the settings of the programming tool.

When restarting the file transfer, login to the Ethernet module from the FTP client again.

(b) For the Q/LCPU

- If a password is registered in the target file for file transfer, transfer that password (set in the Ethernet module) using the FTP operation command after login. If a password is registered, that file cannot be accessed unless a password of the same character string is designated. The password is a character string for file access that the user registers in the Q/LCPU and it allows/prohibits access to the target file.
- The Q/LCPU files of target file transfer must be only the files in the root directory for each memory.
- When the Q/LCPU file being accessed, do not perform any Q/LCPU key switch operations, change operation status with the programming tool (such as RUN → STOP and STOP → RUN), turn off power, reset power, or install/remove the memory card or SD memory card. If any of these operations are performed, the Q/LCPU files will corrupt and the Q/LCPU may not be able to start again.
- Do not perform any file operations (read/write/change file information) from the programming tool when the FTP function is in operation. When file operations are performed from a peripheral device, etc. while the FTP function is in operation, the FTP function may abnormally end.
- If the FTP communication port is designated as a port subject to the remote password check, perform the file transfer operation after changing the remote password status from lock to unlock. Perform the lock processing for the remote password when the file transfer processing is completed. If the FTP communication port is not designated as a port subject to the remote password check, the operation is completed normally when the remote password unlock processing is performed. The remote password is a character string registered in the Q/LCPU with a programming tool by a user and data to allow/prohibit access to the Q/LCPU of another station via the Q/LCPU in the station with the Ethernet module connected or via the station with the Ethernet module connected.

(4) Precaution when logging in to the Ethernet module (FTP server)

Only one external device (FTP client) can log in to the Ethernet module at a time.

(5) Precautions when writing a file

(a) Operation to overwrite an existing file cannot be performed.

Either delete corresponding file using the file delete command (delete, mdelete), or change the file name using rename command before the file is written.

(b) The program file set in the parameter file currently used for the Q/LCPU operation cannot be written.

Set the Q/LCPU to the STOP status, then write the file.

(c) File transmission (attributes change, file write, etc.) for file write can only be conducted for the Q/LCPU program memory or the RAM area of the memory card or SD memory card.

(d) Check the number of files that can be registered to the drive for the files to be stored.

File write cannot be performed to a drive where the number of files has already reached the allowed number of registered files.

The files are stored in the designated drive's cluster size units.

(e) Any drives which fit in the size of the continuous unused clusters in the designated drive memory can be written.

(f) To restart the Q/LCPU operation after writing a file, it is recommended to set the switch of the Q/LCPU to RUN.

The status of the Q/LCPU can be changed from STOP to RUN with the FTP command, however, pay full attention to the operation of the programmable controller system.

(g) When writing files, the Ethernet module creates temporary work files (FTP_lxxx.TMP) in the Q/LCPU.

The temporary files are automatically created in the designated drive during the file write (put or mput), and the file name is changed to the designated file name after the operation is completed.

The "xxx" in the temporary file name "FTP_lxxx.TMP" is the upper three digits of the four digits representing the Ethernet module's I/O signals from the Q/LCPU.

The temporary file is automatically deleted when the file write is successfully completed, line is shut down during transfer, or a file capacity error occurs with the Q/LCPU.

(h) The temporary work file may remain in the designated drive when the Q/LCPU power is disconnected or reset during the file write.

When the temporary file remains in the drive, delete the file using the FTP command.

(i) When file deletion and file writing are repeated while the Q/LCPU is in RUN status, the file size must be fixed in advance.

If a file is deleted and writing of another file larger than the deleted one is attempted, a 402B error will occur disabling the file writing.

(6) Precautions when deleting files

(a) When determining the timing to delete files, consider the system operation as a whole including the functions of Q/LCPU and a programming tool.

(b) The parameter file and program file cannot be deleted during the Q/LCPU is performing "RUN".

Delete these files after setting the Q/LCPU to the STOP status.

(c) Files with read-only attribute and files that are locked from another device or function cannot be deleted.

The file attributes can be changed using the FTP operation command, "quote change".

(d) Files can be deleted only from the Q/LCPU program memory or the RAM area of the memory card or SD memory card.

(e) After deleting a file with the Q/LCPU in RUN status, do not read or write the data of the deleted file by the sequence program.

Doing so may result in an operation error detected in the Q/LCPU.

(7) Precautions for FTP password

When forgetting the FTP password, reset FTP parameters in the following procedure.

1. Read the parameters from Q/LCPU to the programming tool.
2. Click the "Default" button in the "Setting the Ethernet FTP parameters." screen and then return all the parameters to the default values.
3. Set the FTP parameters again.
4. Write the set parameters to the Q/LCPU in the "Write to PLC" screen.
To open the "Write to PLC" screen, select [Online] ⇒ [Write to PLC].
5. Enable the parameters by powering off and on or resetting the CPU module.

5.6 FTP Commands

The FTP operation commands on the FTP client side (external devices) supported by the Ethernet module FTP server are described.

5.6.1 File designation method

The file designation method in the FTP operation command from the FTP client side is explained.

Designation descriptions
'': The part with the single quotation mark '' indicates one argument.
[]: The part with the brackets [] indicates that it is optional.

(1) Password

If a password is registered in the target file for file transfer, the password must be set in the Ethernet module prior to file transfer.

For how to set a password, see Page 146, Section 5.6.4.

- QCPU: keyword-set
- LCPU: passwd-rd or passwd-wr

(2) File path

(a) Select the file by differentiating the drive name and file name in the Q/LCPU.

(b) When designating a file in the Q/LCPU using the FTP functions, designate the file in the following manner:

[Designation format] [drive name': \] 'file name' .extension'

[Designation example]



[Designation details]

Drive name (drive No.)

- Designates the drive name for the memory used for file transfer.
- The relationships between the Q/LCPU memory used and drive name are as follows.

Drive name	Memory used	
	QCPU (QnUDVCPU excluded)	QnUDVCPU, LCPU
No designation	<ul style="list-style-type: none"> • High Performance model QCPU, Process CPU, Redundant CPU: Parameter valid drive designated with the DIP switches • A CPU other than those listed above: 	Program memory
0	Program memory	
1	SRAM card	Not used
2	Flash card, ATA card	SD memory card
3	Standard RAM	
4	Standard RAM	

- File name, extension
 - The corresponding file for the file transfer is designated.
 - The file name must be designated according to the file name rules of the programming tool. Alphabets (uppercase), numbers, and symbols can be used. Alphabets (lowercase) cannot be used.
File name: Max. 8 characters
Extension: Max. 3 characters
 - For the extension (identifier), the name fixed by the Q/LCPU must be used. The corresponding file extension is designated as seen in Page 142, Section 5.6.1.
 - For details on the file names and extensions, see the operating manual for the programming tool used.
 - When using a FTP operation command which can designate multiple files, the files (file names and extensions) are designated using wild card symbols, * / ?."
 - *: Files containing the characters before "*" and any set of characters (including none) replacing the "*" are designated.

Example 1 When designating all files with the "QPG" extension
 *.QPG

Example 2 When designating file names which start with "MAIN" and the extension is "QPG"
 MAIN*.QPG

?: The files containing the text string designated (including none), replacing ? with any character including none. ("?" can be used multiple times.)

Example 1 The letter after "MAIN" is any character and the extension is "QPG"
 MAIN?SEQ.QPG

Example 2 To designate all files whose extension start with "QP"
 *.QP?

Example 3 To designate all files whose extension start with "Q"
 *.Q??

Point

- In the description of the FTP operation commands, the file name indicates both the file name and extension.
- It is recommended to use the following method to treat the file name from the external device.
 - Use the ASCII code characters (upper case for the alphabet letters) for the file to be written to the FTP server.
 - Do not change the file name for the file read from the Q/LCPU.
- Each memory for Q/LCPU does not have any sub-directories.
Each file is stored in the root directory.

(3) Attributes

Specify the following when changing the attributes of the file stored in the Q/LCPU drive to be transferred:

"r" (Read Only) ↔ "w" (read/write enabled)

See the "quote change" command in Page 146, Section 5.6.4.

5.6.2 Q/LCPU user file list

The user-created files (files that are/can be created by the user with a programming tool) that can be designated for file transfer are described below:

Type	File type	File identifier	Drive that can store the file (☞ Page 142, Section 5.6.1)					Remarks
			0	1 ^{*1}	2 ^{*2}	3	4 ^{*2}	
For programs	Parameters	QPA	○	○	○	○	○	1 file/1 drive
	Sequence program ^{*1}	QPG	○	○	○	○	○	—
	SFC program							
For device	Device comments ^{*1}	QCD	○	○	○	○	○	The number of storable files varies depending on the CPU module used.
	Device initial values ^{*1}	QDI	○	○	○	○	○	
	File registers	QDR	×	○	○	○	○	
	Simulation data	QDS	×	○	×	○	×	—
	Local device	QDL	×	○	×	○	×	1 file/CPU
For debugging	Sampling trace data	QTD	×	○	×	○	×	—
	Status latch data	QTL						
	Program trace data	QTP						
	SFC trace data	QTR						
For diagnosis	Error history data	QFD	×	○	×	○	×	—

○: Can be stored, ×: Cannot be stored

*1 A password can be registered in program files, device comment files and device initial value files of the designated memory (program memory/standard ROM/memory card/SD memory card).
For passwords, see the User's Manual (Function Explanation, Program Fundamentals) for the CPU module used.

*2 The number of files that can be written with FTP is calculated with the following formula: (The maximum number of files that can be stored in the related drive) - 1

Point

- Each memory for Q/LCPU does not have any sub-directories. Each file is stored in the root directory.
- For the restrictions and details of the Q/LCPU user files, see the User's Manual (Function Explanation, Program Fundamentals) for the CPU module used.

5.6.3 Response code

For information regarding the response codes that are returned to the external device (FTP client) by the Ethernet module (FTP server), see the manual for the FTP client for the codes except the following 4000H.

Response code	Reference
Other than the following	See the manual for the FTP client.
4000H to 4FFFH	See the User's Manual (Hardware Design, Maintenance and Inspection) for the CPU module used to take corrective action.
C000H to CFFFH	See the User's Manual (Basic) to take corrective action.

Remark

The first two digits of the response code is described below:

1 2 3



- 1 : Response regarding the start of the request processing
- 2 : Response regarding the successful end of the request processing
- 3 : Response indicating the necessity for additional information pertaining to the request processing
- 4 : Response regarding abnormal end of the request processing
- 5 : Response regarding abnormal end of the request processing

0 : Response regarding a syntax error

- 1 : Response regarding information request, such as status
- 2 : Response regarding control or data connection
- 3 : Response regarding log-in processing or account processing
- 4 : (Unused)
- 5 : Response regarding the FTP server status

5.6.4 FTP operation command

The FTP operation command functions and usage on the FTP client (external device) side supported by the Ethernet module FTP server are explained.

CAUTION

- Some of the FTP operation commands on the FTP client (external device) side supported by the Ethernet module may not perform as explained in this manual, depending on the FTP application used on the client side.
See the manual on the FTP client (external devices), and confirm the functions and operation methods.

(1) FTP server support commands

(a) binary

Item	Description
Function	Notifies to the FTP server that the file transfer is performed without converting the file. The carriage return code and kanji code are not converted, either. This setting is automatically set to an Ethernet module.
Designation format	binary (Abbreviated as bin)

(b) bye

Item	Description
Function	Disconnects the FTP server connection, and ends FTP.
Designation format	bye
Same function	quit

(c) close

Item	Description
Function	Disconnects the FTP server connection.
Designation format	close

(d) delete

Item	Description
Function	Deletes the file stored in a CPU module.
Designation format	delete FILE PATH
Designation example	To delete a file stored in the RAM of memory card delete 1:\MAINSEQ1.QPG.
Caution	See section Page 138, Section 5.5 and Page 142, Section 5.6.1.
Similar function	mdelete

(e) dir

Item	Description
Function	Displays the file names, creation dates, and sizes of the files stored in a CPU module.
Designation format	dir [drive name:\]
Designation example	To display detailed information of files stored in the RAM of memory card: dir 1: \
Similar function	ls

(f) get

Item	Description
Function	Reads a file from a CPU module.
Designation format	get TRANSFER SOURCE FILE PATH [transfer destination file path]
Designation example 1	Reads the file stored in the RAM area of memory card, and stores using the same file name. get 1: \MAINSEQ1.QPG
Designation example 2	To read the file stored in the RAM area of memory card, and store using a different file name get 1: \SEQ1BAK.QPG\SEQ\SEQ1OLD.QPG
Caution	<ul style="list-style-type: none"> When the transfer destination file path (FTP client side) is not designated, the file is stored in the FTP client side with the same name as the transfer source file name (CPU module side). The transfer destination is the connected current directory of the FTP startup connection. See section Page 138, Section 5.5 and Page 142, Section 5.6.1.

(g) ls

Item	Description
Function	Displays the file names of the files stored in a CPU module.
Designation format	ls [drive name:]
Designation example	To display the file names of the files stored in the RAM area of memory card ls 1:\
Similar function	dir

(h) mdelete

Item	Description
Function	Deletes the file stored in a CPU module. When deleting the multiple files, the file name and extension are designated using wild cards (* or ?).
Designation format	mdelete FILE PATH (abbreviated as mdel)
Designation example	To delete all files with the extension "QPG" in the files stored in the RAM area of memory card mdelete 1:*.QPG
Caution	See section Page 138, Section 5.5 and Page 142, Section 5.6.1.
Similar function	delete

(i) mdir

Item	Description
Function	Stores the detailed information (file name, creation date, and size) of the files stored in a CPU module to the FTP client-side file as log data.
Designation format	mdir transfer source drive:\ transfer destination file path
Designation example	To store the detailed information of the files stored in the RAM area of memory card to S990901.LOG file mdir 1:\ S990901.LOG
Caution	<ul style="list-style-type: none"> Always designate "\" directly after the drive name of the transfer source. When designating the transfer destination file path (FTP client side), always designate the transfer source drive name. When the transfer destination file path is not designated, the file name set by the FTP application on the FTP client side is used to save the file. The transfer destination is the connected current directory of the FTP startup connection.
Similar function	mls

(j) mget

Item	Description
Function	Reads a file from a CPU module. When reading multiple files, the file name and extension for the file path is designated using wild cards (* or ?). Receive confirmation is performed for each file transfer.
Designation format	mget FILE PATH
Designation example	To read all files with extension "QPG" from the files stored in the RAM area of memory card mget 1:*.QPG
Caution	<ul style="list-style-type: none"> • The files read are stored on the FTP client side with the same file name. The destination is the connected current directory of the FTP startup connection. • See section Page 138, Section 5.5 and Page 142, Section 5.6.1.

(k) mls

Item	Description
Function	Stores the file names of the files stored in a CPU module into a FTP client-side file as log data.
Designation format	mls transfer source drive name:\ transfer destination file path name
Designation example 1	To store the file names of the files stored in the RAM area of memory card to the file S990901F.LOG mls 1:\S990901F.LOG
Designation example 2	To store the file names of the files in the memory where the parameter file used for the current operation of QCPU is stored to the file S990901F.LOG: mls \S990901F.LOG
Caution	<ul style="list-style-type: none"> • Always designate "\" directly after the drive name of the transfer source. • When designating the transfer destination file path (FTP client side), always designate the transfer source drive name. • When the transfer destination file path is not designated, the file name set by the FTP application on the FTP client side is used to save the file. • The transfer destination is the connected current directory of the FTP startup connection.
Similar function	mdir

(l) mput

Item	Description
Function	Writes a file to a CPU module. When writing multiple files, the file name and extension are designated using wild cards (* or ?). When writing multiple files, the send confirmation is performed for each file transfer.
Designation format	mput TRANSFER source file path
Designation example	When writing all files with extension "QPG" mput.QPG
Caution	<ul style="list-style-type: none"> • The transfer destination is the memory where the parameter file used for the current operation of a CPU module is stored. The destination file name is the same as the file name on the FTP client side. • See section Page 138, Section 5.5 and Page 142, Section 5.6.1.

(m) open

Item	Description
Function	Connects to the FTP server by designating the host name or IP address for the FTP server, along with the FTP login name and password. FTP server host name is displayed while connected to the server.
Designation format	open HOST NAME [user name [password]] open IP ADDRESS [user name [password]] Host name: Host name, domain name or synonym of the host name IP address: IP address of the Ethernet module User name: FTP login name set during Ethernet module initial processing Password: Password set during Ethernet module initial processing (See  Page 131, Section 5.3 for the FTP login name and password.)
Designation example 1	To connect to the FTP server by designating the host name open HOST
Designation example 2	To connect to the FTP server by designating the IP address open 192.0.1.254
Designation example 3	To connect to the FTP server by designating the host name and user name open HOST QJ71E71
Designation example 4	To connect to the FTP server by designating the host name, user name, and password open HOST QJ71E71 QJ71E71
Caution	<ul style="list-style-type: none"> • Normally, the connection can be established by designating the FTP server IP address during FTP startup. • When designating the domain name, the DNS environment must be set using the network parameters on the FTP client side. • The password entry from the keyboard is not displayed.

(n) put

Item	Description
Function	Writes a file to a CPU module.
Designation format	put TRANSFER SOURCE FILE PATH [transfer destination file path name]
Designation example 1	To write the file MAINSEQ1.QPG to the RAM area of memory card with same file name put MAINSEQ1.QPG 1:MAINSEQ1.QPG
Designation example 2	To write the file MAINSEQ.QPG file to the RAM area of memory card with different file name put MAINSEQ.QPG 1:MAINSEQ1.QPG
Caution	<ul style="list-style-type: none"> • When the directory is not designated for the transfer source file path (FTP client), the file is written to the connected current directory at FTP server startup connection. • When the transfer destination file path (FTP server side) is not designated, the file is stored to the memory where the parameter file used for the current operation of a CPU module is stored. • See section Page 138, Section 5.5 and Page 142, Section 5.6.1.

(o) pwd

Item	Description
Function	Displays the current directory name of a CPU module.
Designation format	pwd
Caution	Each memory of a CPU module do not have any sub-directories, and the files are stored in the root directory. Therefore, "/" is displayed as the execution result of the pwd command.

(p) quit

Item	Description
Function	Disconnects the FTP server connection, and ends FTP.
Designation format	quit
Same function	bye

(q) quote

Item	Description
Function	Sends the FTP server subcommand (Ethernet module dedicated command).
Designation format	quote Ethernet module DEDICATED COMMAND Ethernet module dedicated commands:  Page 151, Section 5.6.4 (2)
Designation example	quote status
Caution	Only the Ethernet module dedicated command shown in Page 151, Section 5.6.4 (2) can be designated directly after the quote command.

(r) rename

Item	Description
Function	Changes the file name of a CPU module.
Designation format	rename FILE PATH BEFORE CHANGE FILE PATH AFTER CHANGE (abbreviated as ren)
Designation example	To change the file name of the file stored in the RAM of memory card rename 1:\MAINSEQ1.QPG 1:\SEQ1OLD.QPG
Caution	<ul style="list-style-type: none">• Upon normal completion, either of the following response codes is shown. 350 Need more info. 250 Rename successful• See section Page 138, Section 5.5 and Page 142, Section 5.6.1.

(s) user

Item	Description
Function	Enter the user name and password for the connected FTP server.
Designation format	User: User name [Password] User name: FTP login name set during Ethernet module "FTP parameter setting" Password: Password set during Ethernet module "FTP parameter setting" (See  Page 131, Section 5.3 for the FTP login name and password.)
Designation example 1	To designate the user name user QJ71E71
Designation example 2	To designate both user name and password user QJ71E71 QJ71E71
Caution	The password entry from the keyboard is not displayed.

(2) Ethernet module dedicated commands

The Ethernet module dedicated commands to be attached to the FTP operation command "quote" are explained.

(a) status (Ethernet module dedicated command)

Item	Description
Function	Displays the operating information of a CPU module. This command is to check the operating information of a CPU module when a file is transferred to the CPU module.
Designation format	quote status One of the following is displayed as the execution result for a successful completion. <ul style="list-style-type: none"> • When the CPU module is in RUN status: "RUN" • When the CPU module is in STOP status: "STOP" • When the CPU module is in PAUSE status: "PAUSE"

(b) stop (Ethernet module dedicated command)

Item	Description
Function	Sets a CPU module to STOP status (remote STOP).
Designation format	quote stop The following message is displayed as the execution result when completed successfully. Displayed message: 200 Command successful
Caution	Before writing a program file of a CPU module, set the CPU module to STOP status with this command.

(c) run (Ethernet module dedicated command)

Item	Description
Function	Sets the CPU module to the RUN status (remote RUN). Device memory clear can be designated when setting to the RUN status.
Designation format	quote run [mode [clear mode]] Mode: Designate whether to force a remote RUN. 0: Normal RUN (default value) 1: Forced RUN Clear mode: Designate whether to clear (initialize) the CPU module device memory when starting the remote RUN operation. 0: Do not clear the device (default value) 1: Clear everything except for the latch range 2: Clear everything including the latch range The following message is displayed as the execution result when completed successfully. Displayed message: 200 Command successful
Designation example 1	To perform a normal remote RUN with "Do not clear the device memory" selected. quote run
Designation example 2	To perform a forced remote RUN with "Do not clear device memory" selected. quote run 1
Designation example 3	To perform a forced remote RUN with "Clear all device memory except for the latch range" selected. quote run 1 1
Caution	<ul style="list-style-type: none"> • The forced execution mode is only used to allow the forced remote RUN from another device when the CPU module cannot perform the remote RUN due to problems in the device which issued the remote STOP for the CPU module. When a normal RUN is designated and the system is already set to the STOP or PAUSE status by another device, the system is not set to the RUN status. • Select the clear mode of the device memory upon operation startup depending on the system configuration. After the CPU module performs the clear operation, the system runs according to the PLC parameter settings (PLC File ⇔ Initial Device Value).

(d) change (Ethernet module dedicated command)

Item	Description
Function	Displays/changes the file attribute of the file stored in the CPU module.
Designation format	<p>■When displaying the file attribute quote change FILE PATH One of the following is displayed as the execution result for a successful completion.</p> <ul style="list-style-type: none"> When the designated file is a read-only file: "----R" When the designated file is a file with read/write enabled: "----W" <p>■When changing the file attribute quote change FILE PATH ATTRIBUTE Designate either of the following for the attribute:</p> <ul style="list-style-type: none"> To change to read-only file: r To change to read/write enabled: w
Designation example 1	To display the file attribute for the file stored in the RAM area of memory card quote change 1:\MAINSEQ1.QPG
Designation example 2	To change the file attribute of the file stored in the RAM area of memory card quote change 1:\MAINSEQ1.QPG r
Caution	<ul style="list-style-type: none"> When the programmable controller CPU is set to RUN, an error occurs when the following files are designated: Parameter file File currently being executed by the program memory (drive name:0) The attribute changing is possible between read-only file and read/write enabled file. See section Page 138, Section 5.5 and Page 142, Section 5.6.1.

Point

The file attributes designated using the quote change command are explained.

- When changing the attribute of the file for file transfer, designate the attribute after the change.
- The attributes are for changing the file to read-only or read/write enabled file.
- The attribute can be changed to the following for the files stored in the CPU module memory using this command:
"r" (Read Only) ↔ "w" (read/write enabled)
- An user-created file has the read/write attribute, if it has not been changed.

(e) cpuchg (Q series Ethernet module's dedicated command)

Item	Description
Function	This command designates an access target CPU with a multiple CPU system configuration. Alternatively, it displays the current access target CPU.
Designation format	<p>quote cpuchg [access target CPU] Access target CPU: Designate the CPU to which file access is to be performed.</p> <ul style="list-style-type: none"> quote cpuchg: Checks the current access target CPU. quote cpuchg controlPLC: Designates the control CPU as the access target CPU. quote cpuchg no1: Designates the CPU No. 1 as the access target CPU. quote cpuchg no2: Designates the CPU No. 2 as the access target CPU. quote cpuchg no3: Designates the CPU No. 3 as the access target CPU. quote cpuchg no4: Designates the CPU No. 4 as the access target CPU. <p>When the command is successfully completed, the execution result is displayed as follows:</p> <ul style="list-style-type: none"> When setting the access target CPU: 200 Command Okey When displaying the access target CPU: 200 Target cpu is "access target CPU" <p>If the designated access target CPU does not exist, the following message is displayed. 557 Cpu not found</p>
Designation example 1	When designating the access target CPU as the control CPU quote cpuchg controlPLC
Designation example 2	When displaying the currently selected access target CPU quote cpuchg
Caution	The control CPU of the Ethernet module will be the access target CPU after logging in when the OPEN/USER command is executed to the Ethernet module.

(f) password-lock (Ethernet module dedicated commands)

Item	Description
Function	Designates the remote password set in the CPU module as unlocked and performs the lock processing. This command is executed if the FTP communication port is designated as a port subject to the remote password check.
Designation format	quote password-lock The following is displayed as the execution result for a successful completion. 200 Command Okey
Designation example 1	To designate the remote password (1234) quote password-lock

(g) password-unlock (Ethernet module dedicated commands)

Item	Description
Function	Designate the remote password set in a CPU module and perform the unlock processing. This command is used when the FTP communication port is designated as a port subject to the remote password check.
Designation format	quote password-unlock [remote password] Remote password: Designate the remote password set in the parameter of a CPU module. <ul style="list-style-type: none"> The following is displayed as the execution result for a successful completion. 200 Command Okey The following is displayed if the remote password does not match. 556 Password Error The following is displayed if another command is requested before the remote password unlock processing is performed. 555 Password Locked
Designation example 1	To designate the remote password (1234) quote password-lock
Caution	<ul style="list-style-type: none"> If the FTP communication port is designated as a port subject to the remote password check, the status will be "locked" when the user logs into the Ethernet module from an external device. Executing this command and performing the unlock processing prior to various operation of the FTP enables file operation in a CPU module. If the FTP communication port is not designated as a port subject to the remote password check, the operation is completed normally when the remote password unlock processing is performed.

(h) keyword-set (Q series Ethernet module dedicated command)

Item	Description
Function	Sets the registered password of the target file for file transfer in the Ethernet module. Or, display/clear the current password set in the Ethernet module. Use this command only if a password is registered in the target file of file transfer. The Ethernet module performs a password check when the designated file is accessed.
Designation format	quote keyword-set [password] Password: To set a password, designate the password registered in the file of the target memory of a CPU module. Designate "*****" to clear a password set in the Ethernet module. One of the following is displayed as the execution result for a successful completion. <ul style="list-style-type: none">• When setting a password: 200 Command successful• When displaying a password: 200 keyword is "password"• When clearing a password: 200 Command successful
Designation example 1	To set the password (1234) to the Ethernet module quote keyword-set 1234
Designation example 2	To display the password currently set in the Ethernet module quote keyword-set
Designation example 3	To clear the password currently set in the Ethernet module quote keyword-set ****
Caution	<ul style="list-style-type: none">• If a password is registered in the target file for file transfer, set the password in the Ethernet module prior to file transfer. Designating the password registered in the target file of a CPU module enables file operation in the CPU module.• One password can be set in the Ethernet module. If the target file for file transfer changes and a password is registered in the file which is at the changed destination, reset the password for the new target file in the Ethernet module.• When logging into the Ethernet module from the external device, the password set in the Ethernet module changes to "*****". (clear).• Set the password in the QnUDVCPU file with four characters. If a password with 5 or more characters is set, the file operation with FTP cannot be performed.

Point

The password designated using the quote keyword-set command is explained.

- If a password is registered in the target file for file transfer, use this command to set the password in the Ethernet module after logging into the Ethernet module prior to file transfer.
- The password is used so that the CPU module can allow/prohibit access to the target file from outside.
- The password for file access to the CPU module is registered with a programming tool.
The password designated with this command is for operations with the Ethernet module.
The user designates the same character string as that registered with a programming tool to the designated file of the CPU module.

(i) passwd-rd (L series Ethernet module dedicated command)

Item	Description
Function	Sets the registered read password of the target file for file transfer in the Ethernet module. Or, display/clear the current read password set in the Ethernet module. Use this command only if a read password is registered in the target file of file transfer. The Ethernet module performs a password check when the designated file is accessed.
Designation format	quote passwd-rd [read password] One of the following is displayed as the execution result for a successful completion. <ul style="list-style-type: none"> • When setting a read password: 200 Command successful • When displaying a read password: 200 Read-password is "read password" • When clearing a read password: 200 Command successful • When displaying a read password with the read password not set: 200 Read-password is not set.
Designation example 1	To set the read password (ABCD1234@efgh) to the Ethernet module quote passwd-rd ABCD1234@efgh
Designation example 2	To display the read password currently set in the Ethernet module quote passwd-rd
Designation example 3	To clear the read password currently set in the Ethernet module quote passwd-rd c or quote passwd-rd C
Caution	<ul style="list-style-type: none"> • One read password can be set in the Ethernet module. If the target file for file transfer changes and a password is registered in the file which is at the changed destination, set the read password for the new target file in the Ethernet module again. • Upon login to the Ethernet module, the read password set is initialized or cleared.

(j) passwd-wr (L series Ethernet module dedicated command)

Item	Description
Function	Sets the registered write password of the target file for file transfer in the Ethernet module. Or, display/clear the current write password set in the Ethernet module. Use this command only if a write password is registered in the target file of file transfer. The Ethernet module performs a password check when the designated file is accessed.
Designation format	quote passwd-wr [write password] One of the following is displayed as the execution result for a successful completion. <ul style="list-style-type: none"> • When setting a write password: 200 Command successful • When displaying a write password: 200 Write-password is "write password" • When clearing a write password: 200 Command successful • When displaying a write password with the write password not set: 200 Write-password is not set.
Designation example 1	To set the write password (ABCD1234@efgh) to the Ethernet module quote passwd-wr 1234@ABCDefgh
Designation example 2	To display the write password currently set in the Ethernet module quote passwd-wr
Designation example 3	To clear the write password currently set in the Ethernet module quote passwd-wr c or quote passwd-wr C
Caution	<ul style="list-style-type: none"> • One write password can be set in the Ethernet module. If the target file for file transfer changes and a password is registered in the file which is at the changed destination, set the write password for the new target file in the Ethernet module again. • Upon login to the Ethernet module, the write password set is initialized or cleared.

CHAPTER 6 DEDICATED INSTRUCTIONS

The dedicated instructions are used to simplify programming for using the functions available for the intelligent function module.

This chapter explains the dedicated instructions for the functions that are explained in this manual, among those dedicated commands available for the Ethernet module that can be used in Q/LCPU.

6.1 Dedicated Instruction List and Available Devices

(1) Dedicated Instruction List

The following table lists the dedicated instructions explained in this chapter.

Application	Dedicated instruction	Functional description	Reference	
For E-mail sending/receiving	MRECV	Reads received e-mails.*1	Page 158, Section 6.2	
	MSEND	Sends e-mails.*1	Page 164, Section 6.3	
For communication with the programmable controller CPU of other station*4	For reading/writing device data (For Q/L/QnACPU)	READ	Reads data from word devices of other station.	Page 170, Section 6.4
		SREAD	Reads from other station's device (with completion device).	Page 206, Section 6.10
		WRITE	Writes to other station's device.*2	Page 216, Section 6.12
		SWRITE	Writes to other station's device (with completion device).*2	Page 211, Section 6.11
	For reading/ writing device data (For ACPU)	ZNRD	Reads from other station's device.*1*3	Page 224, Section 6.13
		ZNWR	Writes to other station's device.*1*3	Page 227, Section 6.14
	For message (any data) sending/receiving	SEND	Sends data to other station.*1	Page 198, Section 6.9
		RECV	Reads receive data from other station. (For the main program)*1	Page 177, Section 6.5
		RECVS	Reads receive data from other station. (For interrupt programs)*1	Page 183, Section 6.6
	For reading/writing clock data Remote RUN/STOP	REQ	Performs remote RUN/STOP to other station.*1	Page 187, Section 6.7
			Reads/writes clock data of other station.*2	Page 195, Section 6.8

*1 The instruction cannot be used when the source or target station is a safety CPU.

*2 Data cannot be written from other stations to a safety CPU.

*3 When the target station is an A2UCPU(S1), A3UCPU, A4UCPU, or A2USCPU(S1), use a CPU module with the following version or later.

- A2UCPU(S1), A3UCPU, A4UCPU: Version AY (manufactured in July, 1995) or later
- A2ASCPU(S1), A2USCPU(S1): Version CP (manufactured in July, 1995) or later

*4 Data Link Instructions

Point

- The user should not change data (control data, request data, etc.) designated with any of the dedicated instructions until the execution of that instruction is completed.
- Only programmable controller CPUs of Q/LCPU modules can handle the higher two digits of the year (Gregorian calendar) in the clock data that are processed with dedicated instructions.
Thus, when executing dedicated instructions on programmable controller CPUs other than Q/LCPUs, the data portion of the higher two digits of the year is treated as "00H".
- All dedicated instructions must be executed online.
If any of the dedicated instructions is executed offline, no error will occur, but the execution of the dedicated instruction will not be completed.
- When accessing another station via an Ethernet module using a data link instruction, set the following parameters. (Page 67, Section 3.3)
 - Setting the Station No. <-> IP information
 - Routing parameter settings

(2) Applicable device

The following devices are available for the dedicated instructions:

Internal device		File register	Constant*2
Bit*1	Word		
X, Y, M, L, F, V, B	T, ST, C, D, W	R, ZR	K, H

- *1 Word device bit designation can be used as bit data.
Word device bit designation is done by designating [Word device, Bit No.]
(Designation of bit numbers is done in hexadecimal.)
For example, bit 10 of D0 is designated as [D0.A].
However, there can be no bit designation for timers (T), retentive timers (ST) and counters (C).
- *2 Available devices are given in each of the Constant field.

6.2 ZP.MRECV

This instruction reads received e-mails.

Setting data	Applicable device								
	Internal device		File register R, ZR	Link direct device J□□		Intelligent function module device U□\G□	Index register Zn	Constant K, H, \$	Others
	Bit	Word		Bit	Word				
(S)	—	○		—			—	—	
(D1)	—	○		—			—	—	
(D2)	○	○		—			—	—	



*1 If the originating station is a Basic model QCPU (function version B or later), a Universal model QCPU, or an LCPU, " " (double quotation) of the first argument can be omitted.

6.2.1 Setting data

Setting data	Description	Set by*1	Data type
"Un"/Un	Start I/O signal of the own station's Ethernet module (00 to FEH: Higher 2 digits of the 3-digit I/O signal)	User	String/Binary 16 bits
(S)	Head device of the own station that stores the control data.	User, system	Device name
(D1)	Head device of the own station that stores the contents of the received e-mail (header + attached file).	System	
(D2)	Own station device that is turned on for one scan by completion of the instruction. (D2) + 1 turns on if the instruction execution completes abnormally.		

*1 The "Set by" column indicates the following:

- User: Data is set by the user before executing a dedicated instruction.
- System: The programmable controller CPU stores the execution result of a dedicated instruction.

The local devices and the file register for each program cannot be used as the device used for the setting data.

Point

The MRECV instruction can be executed only when the own station is a Q/LCPU.

Remark

The number of steps for the MRECV instruction is 10.

6.2.2 Control data

Device	Item	Setting data	Setting range	Set by*1																
(S) + 0	Execution type/complete type	<table border="1" style="margin-left: auto; margin-right: auto;"> <tr> <td>b15</td><td>to</td><td>b10</td><td>b9</td><td>b8</td><td>b7</td><td>to</td><td>b0</td> </tr> <tr> <td>0</td><td></td><td>2)</td><td>0</td><td>1)</td><td></td><td>0</td><td></td> </tr> </table> <p>1) Complete type (bit 7) Set whether or not the clock data setting is required at abnormal completion. 0: Clock data setting not required Clock data is not stored in (S) + 11 to (S) + 15 when errors occur. 1: Clock data setting required Clock data is stored in (S) + 11 to (S) + 15 when errors occur.</p> <p>2) Execution type (bit 9)*2 Designate whether or not to inquire if there are more mails on the server after reading receive mails. 0: Do not inquire. (Do not read the receive mail information.) 1: Inquire (Read the receive mail information)</p>	b15	to	b10	b9	b8	b7	to	b0	0		2)	0	1)		0		0000H 0080H 0200H 0280H	User
b15	to	b10	b9	b8	b7	to	b0													
0		2)	0	1)		0														
(S) + 1	Completion status	Store the status at the completion of the instruction. 0: Normal Other than 0: Abnormal (error code)*3	—	System																
(S) + 2	Mail number to be read	Designate the mail number to be read when multiple mails are received. 0: Head mail 1 or higher: Designated mail	0 or higher	User																
(S) + 3 ⋮ (S) + 8	System area	—	—	—																
(S) + 9	Receive data length	At instruction execution	Designate the data length (header + attached file) of the e-mail that can be stored in (D1) + 0 to (D1) + n. + n (header: 1 to 373, attached file: 1 to 6144). 0: Adjust to the data length of the received e-mail. 1 to 6517: The number of data that will be stored in (D1 to D1 + n)	0 to 6517 (Words) Including the header length described below	User															
		At the instruction completion	This stores the data length (header + attached file) of the e-mail stored in (D1) + 0 to (D1) + n. 1 to 6517: The number of received data stored in (D1) + 0 to (D1) + n		System															
(S) + 10	Header length	At instruction execution	Designate the data length of the mail's header that can be stored in (D1) + 0 to (D1) + n. 0: Adjust to the header data length of the received mail. 1 to 373: The number of data that will be stored in (D1 to D1 + n)	0 to 373 (Words)	User															
		At the instruction completion	Store the data length of the mail's header that was stored in (D1) + 0 to (D1) + n. 1 to 373: The number of receive data that was stored in (D1 to D1 + n).	—	System															
(S) + 11	Clock set flag	Store the valid/invalid status of the clock data in ((S) + 12 to (S) + 15). 0: Invalid 1: Valid	—	System																
(S) + 12	Clock data (set only if an error occurs)	Higher 8 bits: month (01H to 12H), lower 8 bits: last 2 digits of year (00H to 99H)	—	System																
(S) + 13		Higher 8 bits: hour (00H to 23H), lower 8 bits: date (01H to 31H)																		
(S) + 14		Higher 8 bits: second (00H to 59H), lower 8 bits: minute (00H to 59H)																		
(S) + 15		Higher 8 bits: first 2 digits of year (00H to 99H), lower 8 bits: day of the week (00H (Sunday) to 06H (Saturday))																		

- *1 The "Set by" column indicates the following:
- User: Data is set by the user before executing a dedicated instruction.
 - System: The programmable controller CPU stores the execution result of a dedicated instruction.
- *2 The following shows a description of the processing after the MRECV instruction is executed by selecting the execution type.

Setting option	Description of processing	Merit	Demerit
Do not inquire (Do not read)	<ul style="list-style-type: none"> • Execute only the read processing of e-mails from the mail server. • Inquire (read) about information on receive mails remaining on the mail server after the time set in a programming tool parameter. 	No extra read processing is executed when there are no mails on the mail server.	Even if mails remain on the mail server, they cannot be read immediately. Mails tend to accumulate on the mail server.
Inquire (Read)	<ul style="list-style-type: none"> • Execute the read processing of e-mails from the mail server. • After executing the MRECV instruction, the inquiry (read) processing of information on receive mails remaining on the mail server is also executed. (Inquire whether or not mails are received immediately.) 	Receive mails stored on the mail server can be read in succession.	Inquiries to the mail server are more frequent. More processing in the module affects other internal processing.

- *3 For a list of error codes, see the User's Manual (Basic).

6.2.3 Receive data

Device	Item	Setting data	Setting range	Set by*1
(D1) + 0 ⋮ (D1) + n	Receive data	This stores the contents (header + attached file) of the received e-mail.	—	System

*1 The "Set by" column indicates the following:

- User: Data is set by the user before executing a dedicated instruction.
- System: The programmable controller CPU stores the execution result of a dedicated instruction.

Point

The receive data storage device (D1) requires a contiguous free area equal to or greater than the receive data length ((S) + 9) (maximum of 6517 words).

6.2.4 Functions

6

(1) This instruction reads receive mails from the mail server.

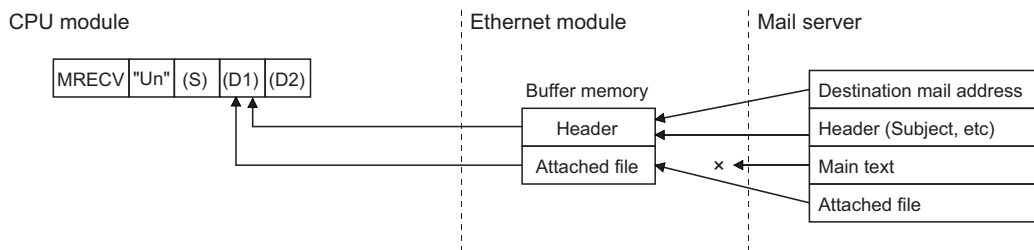

(2) If a received e-mail contains data exceeding the reception data length ((S) + 9) designated in the control data of the MRECV instruction, only the data equivalent to the designated reception data length will be stored and the remaining data will be ignored.

(3) Whether or not there are mails on the mail server can be determined by the on (receive mail)/off (no receive mail) of bit 15 of the mail information area (address: 2682H (9858)) in the buffer memory.

The information in the mail information area is updated when the MRECV instruction execution completes.

6.2.ZP.MRECV

(4) Whether the MRECV instruction is being executed or has been completed normally or abnormally can be checked with the completion device (D2) or completion status display flag ((D2) + 1) designated in the set data.

(a) Completion device (D2)

Turns on at the END processing of the scan where the MRECV instruction is completed, and turns off at the next END processing.

(b) Status display device at completion ((D2) + 1)

Turns on and off depending on the completion status of the MRECV instruction.

Normal completion: Stays off and does not change.

Abnormal completion: Turns on at the END processing of the scan where the MRECV instruction is completed, and turns off at the next END processing.

[Operation when the MRECV instruction is being executed]

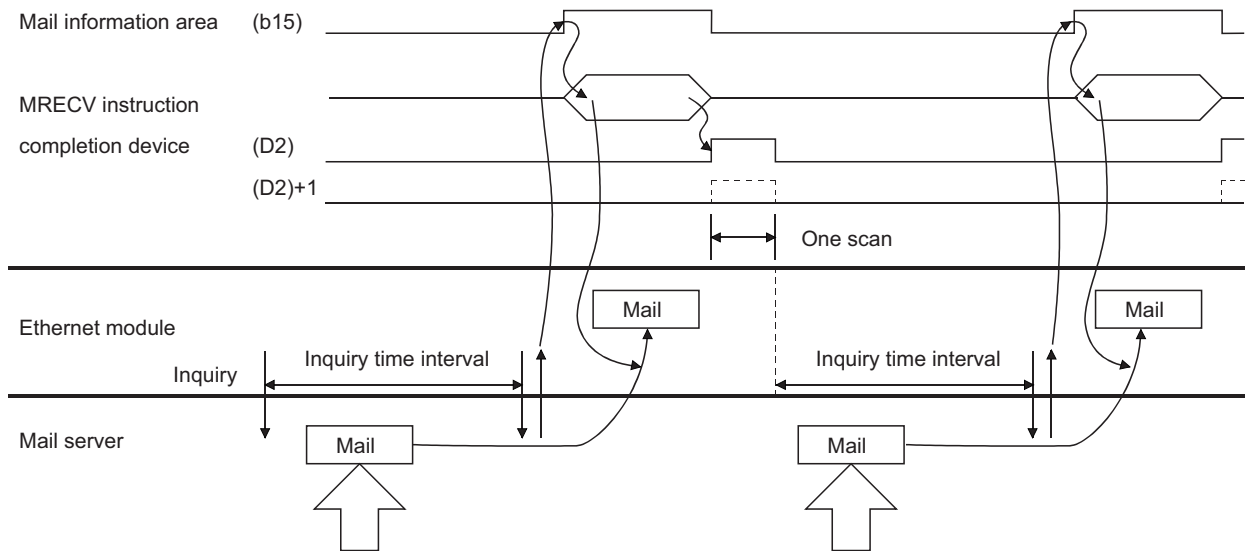

6.2.5 Errors

(1) When a dedicated instruction completes abnormally, the abnormal completion signal (D2) + 1 turns on and the error code is stored in the completion status (S) + 1.

See the following manuals regarding the error code, check the errors and take corrective actions.

<Error codes>

4FFFH or less: User's Manual (Hardware Design, Maintenance and Inspection) for the CPU module used

C000H or higher: User's Manual (Basic)

6.2.6 Caution

- (1) **Construct an interlock circuit to prevent the MSEND instruction from being executed while the MRECV instruction is being executed.**

(This is because the MRECV and MSEND instructions use the random access buffer memory area as a work area.)

6.2.7 Program example

The following example shows a program that receives e-mails.

This program performs e-mail processing using the receive command (X21).

When I/O signals of the Ethernet module are X/Y00 to X/Y1F

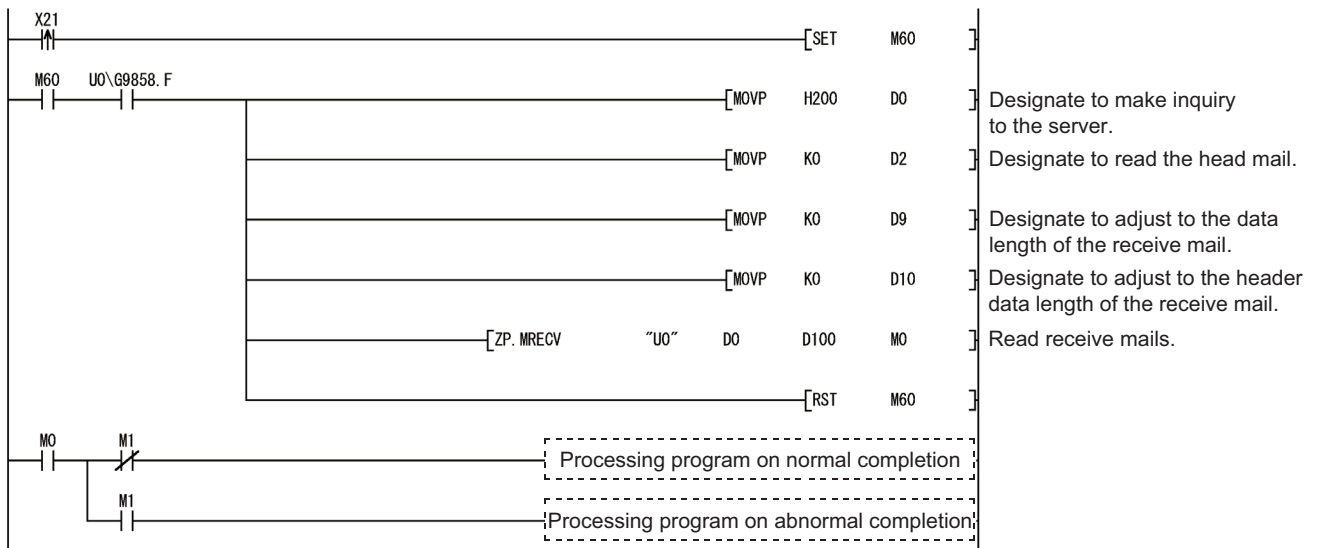

6.3 ZP.MSEND

This instruction sends e-mails.

Setting data	Applicable device								
	Internal device		File register R, ZR	Link direct device J□□		Intelligent function module device U□IG□	Index register Zn	Constant K, H, \$	Others
	Bit	Word		Bit	Word				
(S1)	—	○		—			—	—	
(S2)	—	○		—			—	—	
(D)	○	○		—			—	—	



*1 If the originating station is a Basic model QCPU (function version B or later), a Universal model QCPU, or an LCPU, " " (double quotation) of the first argument can be omitted.

6.3.1 Setting data

Setting data	Description	Set by*1	Data type
"Un"/Un	Start I/O signal of the own station's Ethernet module (00 to FEH: Higher 2 digits of the 3-digit I/O signal)	User	String/Binary 16 bits
(S1)	Head device of the own station that stores the control data.	User, system	Device name
(S2)	Head device of the own station that stores the contents of the e-mail to be sent ((Subject + attached file) or (Subject + main text)).	User	
(D)	Own station device that is turned on for one scan by completion of the instruction. (D) + 1 turns on if the instruction execution completes abnormally.	System	Bit

*1 The "Set by" column indicates the following:

- User: Data is set by the user before executing a dedicated instruction.
- System: The programmable controller CPU stores the execution result of a dedicated instruction.

The local devices and the file register for each program cannot be used as the device used for the setting data.

Point

The MSEND instruction can be executed only when the own station is a Q/LCPU.

Remark

The number of steps for the MSEND instruction is 10.

6.3.2 Control data

Device	Item	Setting data	Setting range	Set by*1																
(S1) + 0	Execution/complete type Send data format	<table border="1" style="margin-left: auto; margin-right: auto;"> <tr> <td>b15</td> <td>to</td> <td>b12</td> <td>to</td> <td>b8</td> <td>b7</td> <td>to</td> <td>b0</td> </tr> <tr> <td>0</td> <td></td> <td>2)</td> <td></td> <td>1)</td> <td></td> <td></td> <td>0</td> </tr> </table> <p>1) Complete type (bit 7) Set whether or not the clock data setting is required at abnormal completion. 0: Clock data setting is not required ... Clock data is not stored in (S1) + 11 to (S1) + 15 when errors occur. 1: Clock data setting required ... Clock data is stored in (S) + 11 to (S) + 15 when errors occur. 2) Send data format (bit 12 to bit 8) Designate the format of data to be sent. (When sending data as an attached file) • 00000: Binary data • 01000: ASCII data (converted from binary to ASCII) • 01001: CSV data (converted from binary to CSV) (When sending data as the main text) • 10000: Binary data [Precautions when designating the main text of e-mail] • The setting of (bit 11 to bit 8) is invalid when the main text is designated. • Designate the main text using ASCII characters in a sequence program (the Ethernet module does not convert it to ASCII). • The following binary code data is treated as control codes. 0D0AH: Line feed code CR + LF 00H: End of main text • It is recommended to limit the data written in one line of the main text to 78 characters or less. (Be sure to add a line feed code CR + LF (0D0AH) at the end of the main text lines.)</p>	b15	to	b12	to	b8	b7	to	b0	0		2)		1)			0	(As described in the left)	User
b15	to	b12	to	b8	b7	to	b0													
0		2)		1)			0													
(S1) + 1	Completion status	Store the status at the completion of the instruction. 0: Normal Other than 0: Abnormal (error code)*2	—	System																
(S1) + 2	Send destination number	Designate the external device to which the e-mail is sent by the setting number of the "Ethernet send mail address setting" with a programming tool. 1 to 16: The setting number of the destination external device	1 to 16	User																
(S1) + 3 ⋮ (S1) + 8	System area	—	—	—																
(S1) + 9	Send data length	Designate the data length ((Subject + attached file) or (Subject + main text)) of the e-mail stored in (S2) + 0 to (S2) + n. 1) When sending data as an attached file (Subject: 0 to 373, attached file: 1 to 6144) 1 to 6517: The data length of e-mail (words) 2) When sending data as the main text (Subject: 0 to 373, Main text: 1 to 960) 1 to 1333: The data length of e-mail (words)	1 to 6517 or 1 to 1333	User																
(S1) + 10	Subject length	Designate the data length of the Subject of the e-mail stored in (S2) + 0 to (S2) + n. 0 to 373: The data length of the Subject (words)	0 to 373	User																
(S1) + 11	Clock set flag	This stores the valid/invalid status of the clock data in ((S1) + 12 to (S1) + 15). 0: Invalid 1: Valid	—	System																
(S1) + 12	Clock data (set only if an error occurs)	Higher 8 bits: month (01H to 12H), lower 8 bits: last 2 digits of year (00H to 99H)	—	System																
(S1) + 13		Higher 8 bits: hour (00H to 23H), lower 8 bits: date (01H to 31H)																		
(S1) + 14		Higher 8 bits: second (00H to 59H), lower 8 bits: minute (00H to 59H)																		
(S1) + 15		Higher 8 bits: first 2 digits of year (00H to 99H), lower 8 bits: day of the week (00H (Sunday) to 06H (Saturday))																		

*1 The "Set by" column indicates the following:

- User: Data is set by the user before executing a dedicated instruction.
- System: The programmable controller CPU stores the execution result of a dedicated instruction.

*2 For a list of error codes, see the User's Manual (Basic).

6.3.3 Send data

Device	Item	Setting data	Setting range	Set by ^{*1}
(S2) + 0 ⋮ (S2) + n	Send data	Designate the contents of e-mail ((Subject + attached file) or (Subject + main text)) to be sent.	—	User

- *1 The "Set by" column indicates the following:
- User: Data is set by the user before executing a dedicated instruction.
 - System: The programmable controller CPU stores the execution result of a dedicated instruction.

6.3.4 Functions

(1) This instruction sends mails to the designated external device.

(a) When sending data as an attached file

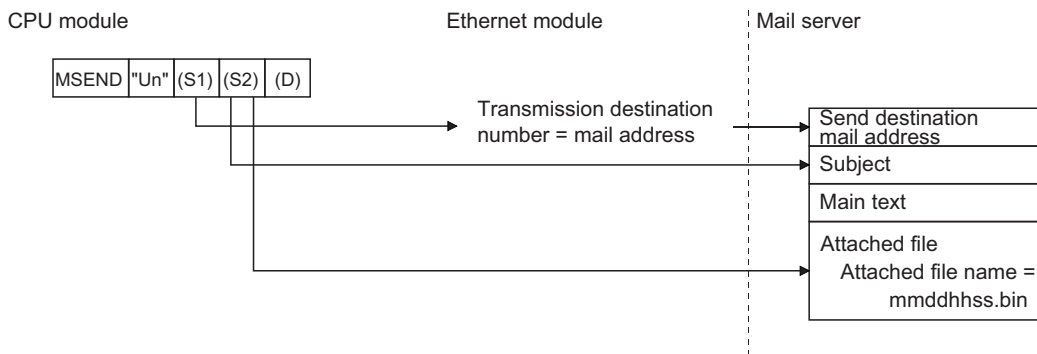

(b) When sending data as main text

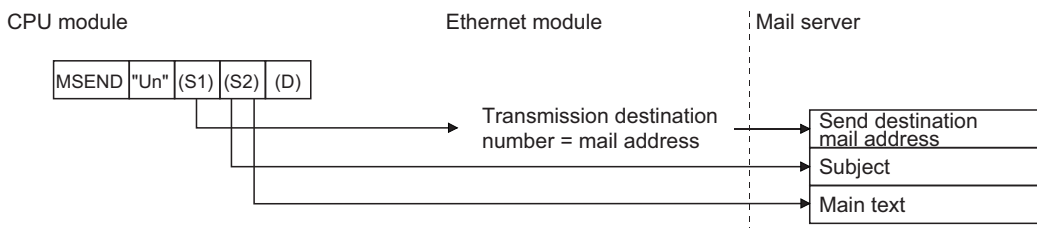

(2) Whether the MSEND instruction is being executed or has been completed normally or abnormally can be checked with the completion device (D) or completion status display flag ((D) + 1) designated in the set data.

(a) Completion device (D)

Turns on at the END processing of the scan where the MSEND instruction is completed, and turns off at the next END processing.

(b) Status display device at completion ((D) + 1)

Turns on and off depending on the completion status of the MSEND instruction.

Normal completion: Stays off and does not change.

Abnormal completion: Turns on at the END processing of the scan where the MSEND instruction is completed, and turns off at the next END processing.

[Operation when the MSEND instruction is being executed]

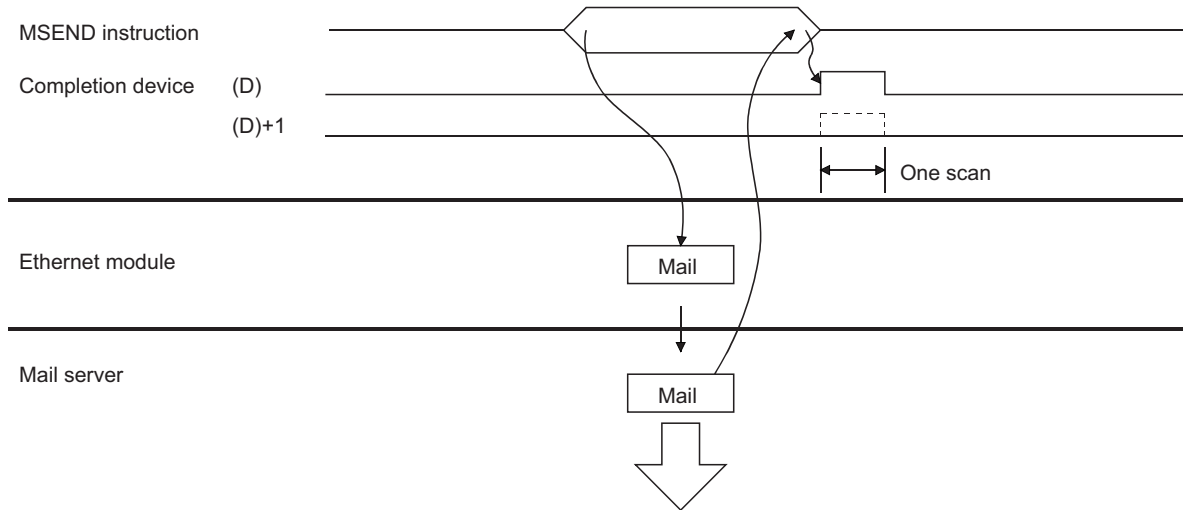

6.3.5 Errors

- (1) When a dedicated instruction completes abnormally, the abnormal completion signal (D) + 1 turns on and the error code is stored in the completion status (S1) + 1.

See the following manuals regarding the error code, check the errors and take corrective actions.

<Error codes>

4FFFH or less: User's Manual (Hardware Design, Maintenance and Inspection) for the CPU module used

C000H or higher: User's Manual (Basic)

6.3.6 Caution

- (1) Construct an interlock circuit to prevent the MSEND instruction from being executed while the MRECV instruction is being executed.

(This is because the MRECV and MSEND instructions use the random access buffer memory area as a work area.)

6.3.7 Program example

The following example shows a program that sends e-mails.

- (1) When sending data as an attached file

This program performs e-mail transmission processing using the send command (X20).

When I/O signals of the Ethernet module are X/Y00 to X/Y1F

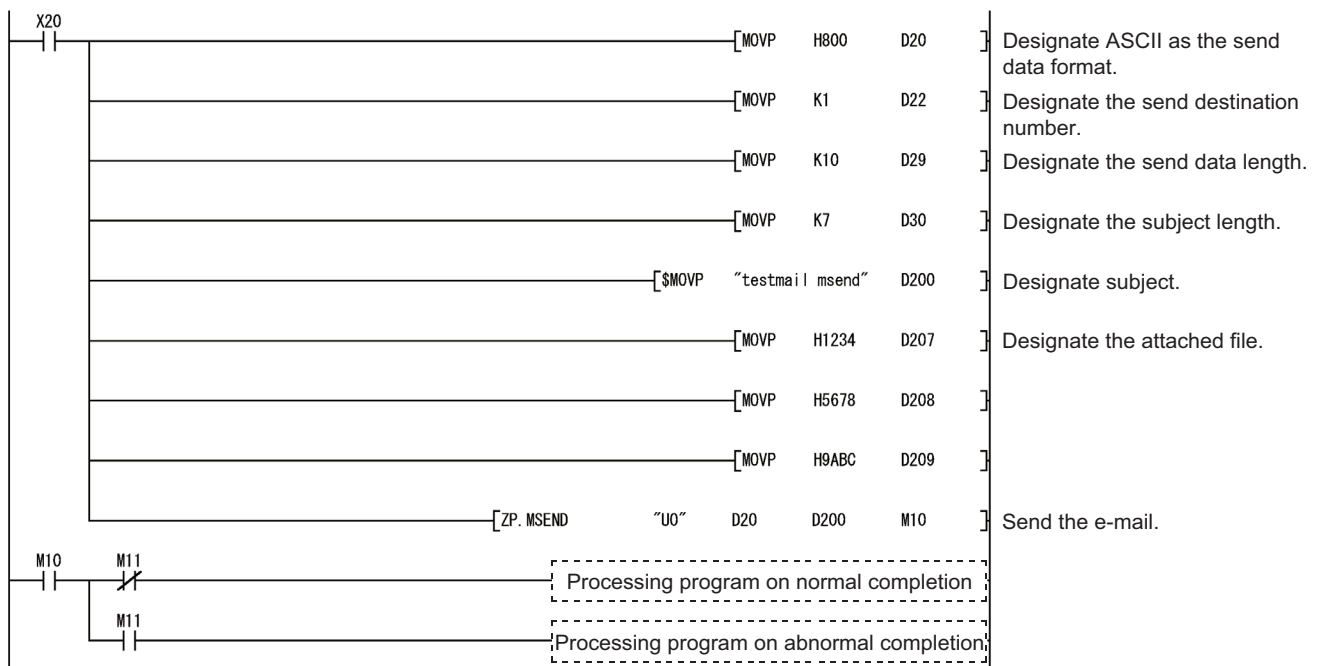

(2) When sending data as main text

This program performs e-mail transmission processing using the send command (X20).
When I/O signals of the Ethernet module are X/Y00 to X/Y1F

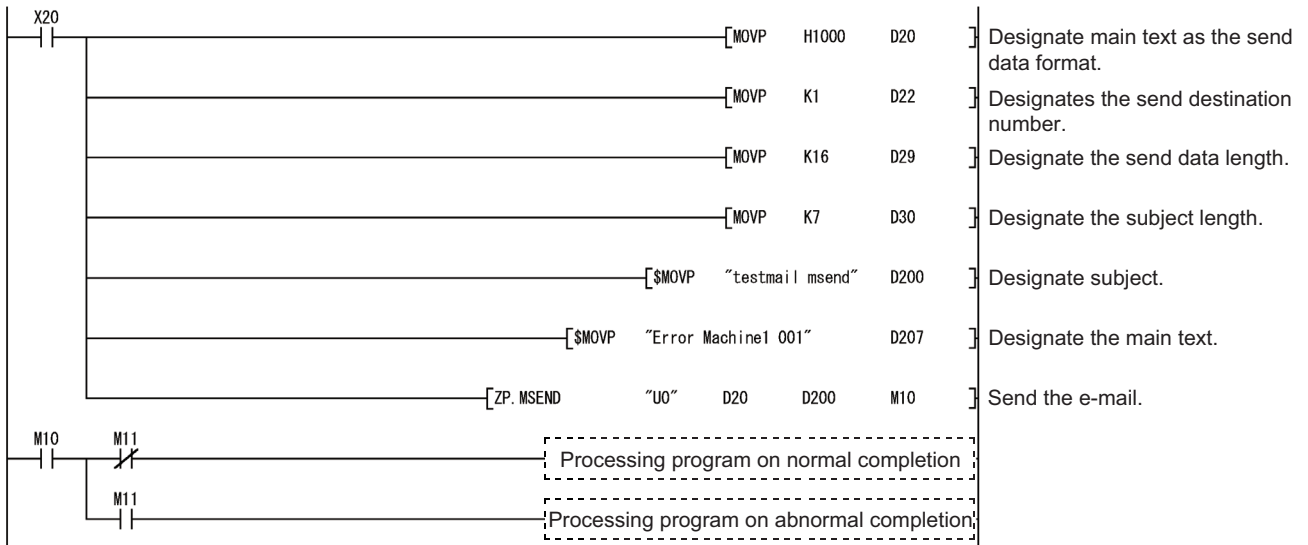

6.4 JP/GP.READ

This instruction reads data from word devices of other stations.

Setting data	Applicable device								
	Internal device		File register R, ZR	Link direct device J□□		Intelligent function module device U□\G□	Index register Zn	Constant K, H	Others
	Bit	Word		Bit	Word				
(S1)	—	○		—					
(S2)	—	○*1	○	—					
(D1)	—	○		—					
(D2)	○			—					

*1 T, C, D, W, ST, SD, or SW can be used.

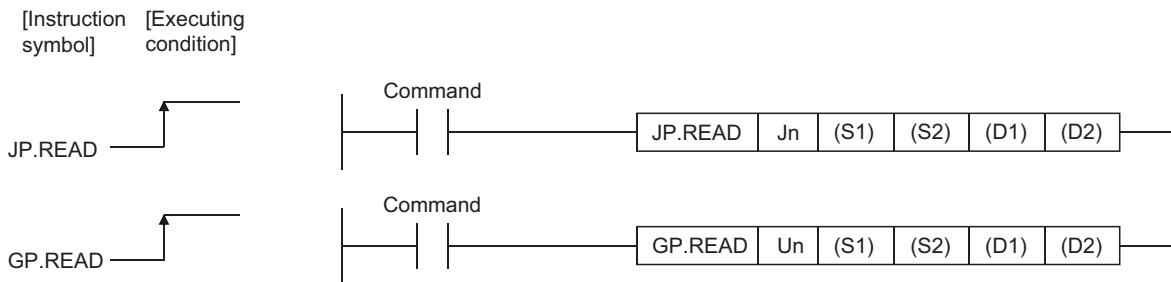

The following format can be used only when the own station is a Universal model QCPU or an LCPU.

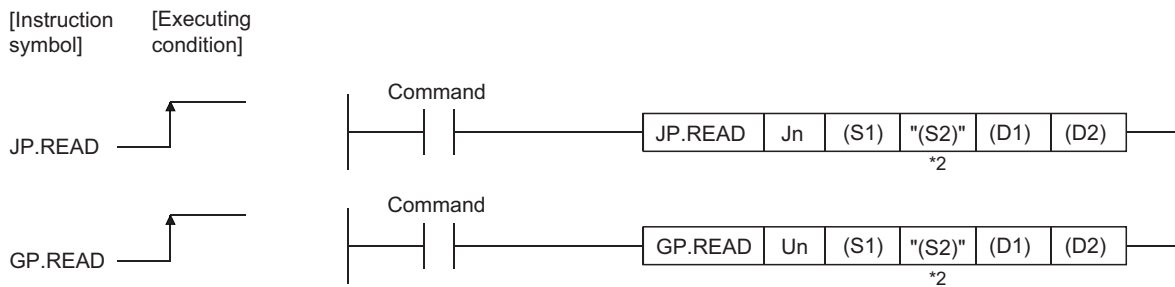

*2 If the device setting in PLC Parameter is different between the own and target stations, use "(S2)" (with doublequotation marks).

6.4.1 Setting data

Setting data	Description	Set by*1	Data type
Jn	Network number of the own station (1 to 239, 254) 254: Network designated in a valid module for other station access	User	Binary 16 bits
Un	Start I/O signal of the own station's Ethernet module (00 to FEH: The higher 2 digits of the 3-digit I/O signal)		Character string
(S1)	Head device of the own station that stores the control data.	User, system	Device name
(S2)	Head device of the target station from which data is read.	User	
(D1)	Head device of the own station that stores data read.	System	
(D2)	Own station device that is turned on for one scan by completion of the instruction. (D2) + 1 turns on if the instruction execution completes abnormally.		Bit

*1 The "Set by" column indicates the following:

- User: Data is set by the user before executing a dedicated instruction.
- System: The programmable controller CPU stores the execution result of a dedicated instruction.

The local devices and the file register for each program cannot be used as the device used for the setting data.

Point

- The READ instruction can be executed only when the target station is the Q/L/QnACPU.
(The READ instruction cannot be executed for an ACPU connected to the MELSECNET/10 or Ethernet network systems.)
Therefore, the target station numbers should be the station numbers of Q/L/QnACPU.
- When reading data from the other station CPU module device with the READ instruction, specify the device within the range applicable to the host station CPU module.
(Head device number to be read in other station CPU module (S2)) + (number of read points - 1) ≤ (last device number of host station CPU module)
Last device number in host station CPU module having the same device name as (S2).
- Use the file register (ZR) when specifying the expansion data register (D) or the expansion link register (W) that are out of area of the data register (D) or the link register (W) on the host CPU module respectively (excluding the Universal model QCPU and the LCPU).
For how to calculate areas for the file register (ZR), refer to the User's Manual (Function Explanation, Program Fundamentals) for the CPU module used.
(Example)
When not assigning the data register (D) of the other station CPU module, or assigning all of the 32K points of the file register (ZR) to the expansion data register (D).

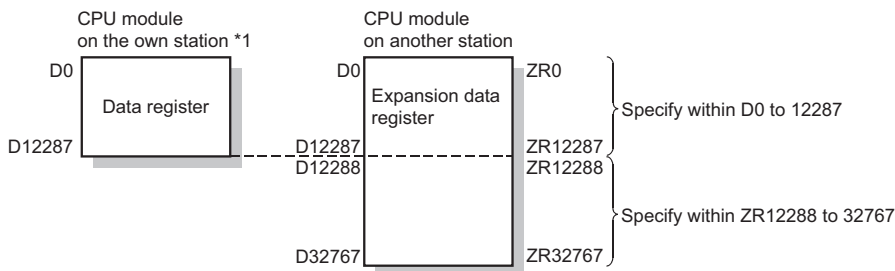

*1 File register with 32K points or more is required for the CPU module on the own station.

Remark

The number of steps for the READ instruction is 9.

6.4.2 Control data

Device	Item	Setting data	Setting range	Set by ^{*1}																		
(S1) + 0	Abnormal complete type	<div style="text-align: center;"> <table border="1" style="margin: auto;"> <tr> <td style="padding: 2px;">b15</td> <td style="padding: 2px;">to</td> <td style="padding: 2px;">b8</td> <td style="padding: 2px;">b7</td> <td style="padding: 2px;">to</td> <td style="padding: 2px;">b0</td> </tr> <tr> <td style="padding: 2px;">0</td> <td></td> <td style="padding: 2px;">2)</td> <td style="padding: 2px;">1)</td> <td></td> <td style="padding: 2px;">0</td> </tr> <tr> <td></td> <td></td> <td></td> <td></td> <td></td> <td style="padding: 2px;">1</td> </tr> </table> </div> <p>1) Abnormal complete type (bit 7) Set whether or not the clock data setting is required at abnormal completion. 0: Clock data setting is not required ... Clock data is not stored in (S1) + 11 to (S1) + 17 when errors occur. 1: Clock data setting required ... Clock data is stored in (S) + 11 to (S) + 17 when errors occur.</p> <p>2) Arrival monitoring time unit (bit 8) Set a unit for arrival monitoring time. Set the arrival monitoring time to (S1) + 8. 0: Increments of 1s 1: Increments of 100ms</p>	b15	to	b8	b7	to	b0	0		2)	1)		0						1	0001H 0081H 0101H 0181H	User
b15	to	b8	b7	to	b0																	
0		2)	1)		0																	
					1																	
(S1) + 1	Completion status	Store the status at the completion of the instruction. 0: Normal Other than 0: Abnormal (error code) ^{*2}	—	System																		
(S1) + 2	Channel used by the own station	Designate the channel used by the own station. 1 to 8 (channel)	1 to 8	User																		
(S1) + 3	Target station's CPU type ^{*3}	Specify the programmable controller CPU of the access destination in the target station. • 0000H: Control CPU (The access destination is the same as that with 03FFH selected.) • 03D0H: Control system CPU ^{*5} • 03D1H: Standby system CPU ^{*5} • 03D2H: System A CPU • 03D3H: System B CPU • 03FFH: Control CPU	0000H 03D0H to 03D3H 03FFH	User																		
(S1) + 4	Target station network number	Designate the network number of the target station. 1 to 239: Network number 254: When 254 is designated in Jn (The network designated by the valid module during other station access)	1 to 239, 254	User																		
(S1) + 5	Target station number	Specify the station number of the target station. When the own station is a Universal model QCPU or an LCPU: 1 to 120 When the own station is a Universal model QCPU or an LCPU: 1 to 120	1 to 120	User																		
(S1) + 6	—	—	0	User																		
(S1) + 7	Number of resends	1) At the instruction execution Set the number of resends when the instruction is not completed within the monitoring time designated by (S1) + 8. 0 to 15 (times) ^{*7} 2) At the instruction completion Store the number of resends executed (result). 0 to 15 (times)	0 to 15	User System																		
(S1) + 8	Arrival monitoring time	When the instruction fails to complete within the monitoring time, it is resent for the number of resends designated in (S1) + 7. ^{*7}	<p>When setting "1s" to (S1) + 0 (arrival monitoring time unit) Set a value greater than or equal to the TCP resend timer value for the monitoring time up to instruction processing termination. 0 to TCP resend timer value: Monitoring is performed by the time set to the TCP resend timer. (TCP resend timer value + 1) to 16383: Monitoring time (unit: Second)</p> <p>When setting "100ms" to (S1) + 0 (arrival monitoring time unit) 1 to 65535: Monitoring time (unit: 0.1 seconds)</p>	User																		
(S1) + 9	Read data length	Designate the number of data to be read. When reading from Q/LCPU: 1 to 960 (Word) When reading from QnACPU: 1 to 480 (Word) ^{*6}	1 to 960	User																		
(S1) + 10	(Not used)	—	—	—																		

Device	Item	Setting data	Setting range	Set by ^{*1}																																			
(S1) + 11	Clock set flag	Store the valid/invalid status of the data in ((S1) + 12 to (S1) + 17). This data is stored only when the bit 7 of Abnormal complete type ((S1) + 0) is 1. The stored value is not cleared even when the dedicated instruction is normally completed. 0: Invalid 1: Valid	—	System																																			
(S1) + 12 : (S1) + 15	Clock data (set only if an error occurs)	The clock data upon abnormal end is stored in BCD. This data is stored only when the bit 7 of Abnormal complete type ((S1) + 0) is 1. The stored value is not cleared even when the dedicated instruction is normally completed. <table border="1" style="margin-left: 40px;"> <thead> <tr> <th></th> <th>b15</th> <th>to</th> <th>b8</th> <th>b7</th> <th>to</th> <th>b0</th> </tr> </thead> <tbody> <tr> <td>(S1)+12</td> <td colspan="2">Month (01H to 12H)</td> <td colspan="4">Year (00H to 99H), Last 2 digits</td> </tr> <tr> <td>(S1)+13</td> <td colspan="2">Hour (00H to 23H)</td> <td colspan="4">Date (01H to 31H)</td> </tr> <tr> <td>(S1)+14</td> <td colspan="2">Second (00H to 59H)</td> <td colspan="4">Minute (00H to 59H)</td> </tr> <tr> <td>(S1)+15</td> <td colspan="2">Year (00H to 99H), First 2 digits</td> <td colspan="4">Day of the week (00H to 06H)</td> </tr> </tbody> </table> <p style="text-align: center;">00H (Sun.) to 06H (Sat.)</p>		b15	to	b8	b7	to	b0	(S1)+12	Month (01H to 12H)		Year (00H to 99H), Last 2 digits				(S1)+13	Hour (00H to 23H)		Date (01H to 31H)				(S1)+14	Second (00H to 59H)		Minute (00H to 59H)				(S1)+15	Year (00H to 99H), First 2 digits		Day of the week (00H to 06H)				—	System
	b15	to	b8	b7	to	b0																																	
(S1)+12	Month (01H to 12H)		Year (00H to 99H), Last 2 digits																																				
(S1)+13	Hour (00H to 23H)		Date (01H to 31H)																																				
(S1)+14	Second (00H to 59H)		Minute (00H to 59H)																																				
(S1)+15	Year (00H to 99H), First 2 digits		Day of the week (00H to 06H)																																				
(S1) + 16	Abnormal detection network number ^{*4}	Stores the network number of the station that detected an abnormality. This data is stored only when the bit 7 of Abnormal complete type ((S1) + 0) is 1. The stored value is not cleared even when the dedicated instruction is normally completed. 1 to 239 (Network number)	—	System																																			
(S1) + 17	Abnormal detection station number ^{*4}	Stores the station number of the station that detected an abnormality. This data is stored only when the bit 7 of Abnormal complete type ((S1) + 0) is 1. The stored value is not cleared even when the dedicated instruction is normally completed. 1 to 120 (Station number)	—																																				

Point

- The data read storage device (D1) requires a contiguous free area equal to or greater than the length of the data read ((S) + 9) (maximum of 960 words).
- The number of resends ((S1) + 7) must be set at every instruction execution.

*1 The "Set by" column indicates the following:

- User: Data is set by the user before executing a dedicated instruction.
- System: The programmable controller CPU stores the execution result of a dedicated instruction.

*2 For a list of error codes, see the User's Manual (Basic).

*3 It can be specified when the own station has an Ethernet module of function version D or later.
(Not available for any other case. Access to the control CPU is required.)

*4 Nothing is stored if the execution source detects an error when receiving an instruction.

*5 When the READ instruction is executed to the redundant system with a control system or standby system CPU specified, the instruction may be unsuccessfully completed due to system switching occurred on the target station (error code: 4244H, 4248H).
If this has occurred, execute the READ instruction again.

*6 When data of more than 480 words is specified, a C084H error occurs on the own station. Check the read data length (1 to 480 words) and execute the READ instruction.

*7 For how to determine the setting values of the number of resends and arrival monitoring time and their setting examples, refer to Page 232, Appendix 1.

Remark

The allowable read data length ((S1) + 9) of the READ instruction varies depending on the version. (User's Manual (Basic))
Specifying a length value outside the setting range will cause a 4101 error (OPERATION ERROR) on the own station.

6.4.3 Functions

- (1) This instruction designates the target network number and target station number of a station connected to other networks or Ethernet in the control data and reads the data of designated word devices of that station.

When reading the device data is completed, the completion device designated by (D2) turns on.

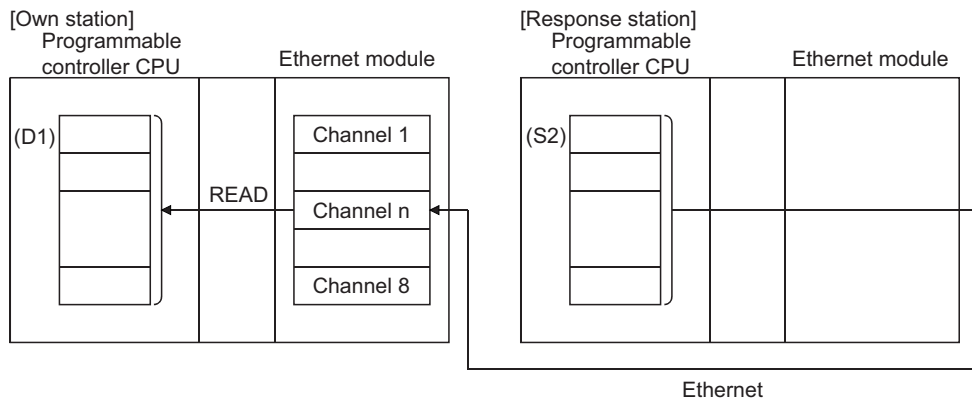

- (2) Device data can be read from stations connected to other networks or Ethernet having the specified network number, in addition to stations connected to the own station's network.
- (3) The data link instructions and the Ethernet instructions cannot be executed from two or more stations at the same time on the same channel.

If the execution conditions are met at two or more locations at the same time, instructions to be executed later have to wait until the channel becomes available because handshaking is automatically performed at the execution of the first instruction.

- (4) Whether the READ instruction is being executed or has been completed normally or abnormally can be checked with the completion device (D2) or completion status display flag ((D2) + 1) designated in the set data.**

(a) Completion device (D2)

Turns on at the END processing of the scan where the READ instruction is completed, and turns off at the next END processing.

(b) Status display device at completion ((D2) + 1)

Turns on and off depending on the completion status of the READ instruction.

Normal completion: Stays off and does not change.

Abnormal completion: Turns on at the END processing of the scan where the READ instruction is completed, and turns off at the next END processing.

[Operation of the own station when the READ instruction is being executed]

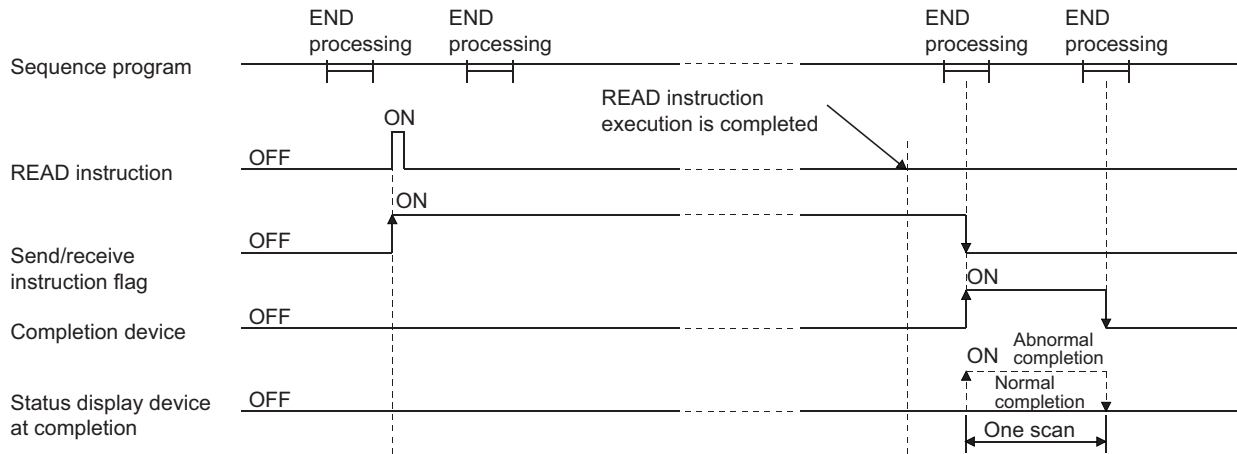

- (5) When executing the instruction using JP.READ/GP.READ, the read processing is executed only once when the read instruction flag switches from off to on (at rise).**

6.4.4 Errors

- (1) When a dedicated instruction completes abnormally, the abnormal completion signal (D2) + 1 turns on and the error code is stored in the completion status (S1) + 1.**

See the following manuals regarding the error code, check the errors and take corrective actions.

<Error codes>

4FFFH or less: User's Manual (Hardware Design, Maintenance and Inspection) for the CPU module used

C000H or higher: User's Manual (Basic)

6.4.5 Program example

The following example shows a program that reads data from D10 to 14 of station number 4 to D200 to 204 of station number 1.

When I/O signals of the Ethernet module are X/Y40 to X/Y5F

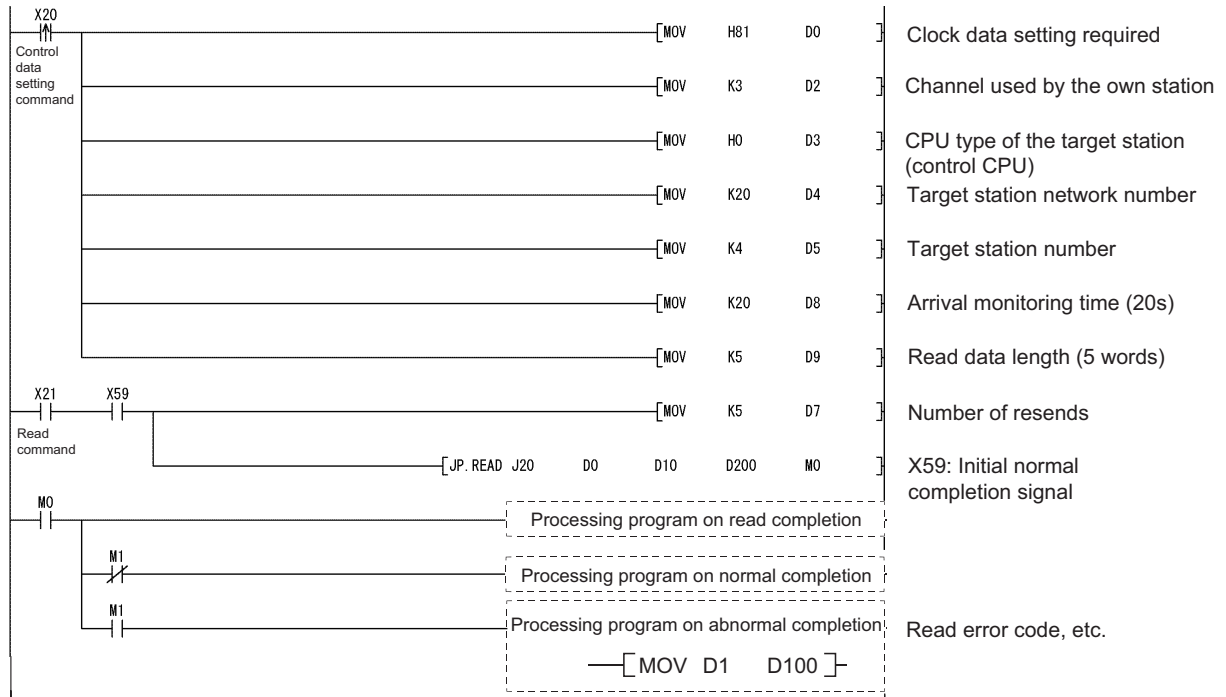

6.5 JP/GP.RECV (for the Main Program)

This instruction reads received data.

Setting data	Applicable device								
	Internal device		File register R, ZR	Link direct device J□□		Intelligent function module device U□G□	Index register Zn	Constant K, H	Others
	Bit	Word		Bit	Word				
(S)	—	○							
(D1)	—	○							
(D2)	○								

[Instruction symbol] [Executing condition]

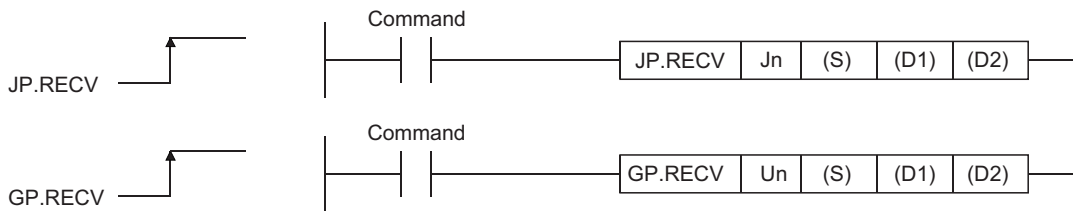

6.5.1 Setting data

Setting data	Description	Set by ^{*1}	Data type
Jn	Network number of the own station (1 to 239, 254) 254: Network designated in a valid module for other station access	User	Binary 16 bits
Un	Start I/O signal of the own station's Ethernet module (00 to FEH: The higher 2 digits of the 3-digit I/O signal)		Character string
(S)	Head device of the own station that stores the control data.	User, system	Device name
(D1)	Head device of the own station that stores the receive data.	System	
(D2)	Own station device that is turned on for one scan by completion of the instruction. (D2) + 1 turns on if the instruction execution completes abnormally.		

*1 The "Set by" column indicates the following:

- User: Data is set by the user before executing a dedicated instruction.
- System: The programmable controller CPU stores the execution result of a dedicated instruction.

The local devices and the file register for each program cannot be used as the device used for the setting data.

Point

The RECV instruction can be executed only when the own station is a Q/L/QnACPU.

Remark

The number of steps for the RECV instruction is 8.

6.5.2 Control data

Device	Item	Setting data	Setting range	Set by ^{*1}																														
(S) + 0	Abnormal complete type	<table border="1" style="margin-left: auto; margin-right: auto;"> <tr> <td style="text-align: center;">b15</td> <td style="text-align: center;">to</td> <td style="text-align: center;">b8</td> <td style="text-align: center;">b7</td> <td style="text-align: center;">b6</td> <td style="text-align: center;">to</td> <td style="text-align: center;">b0</td> </tr> <tr> <td style="text-align: center;">0</td> <td style="text-align: center;">to</td> <td style="text-align: center;">0</td> <td style="text-align: center;">1</td> <td style="text-align: center;">0</td> <td style="text-align: center;">to</td> <td style="text-align: center;">0</td> </tr> </table> <p>1) Abnormal complete type (bit 7) Set whether or not the clock data setting is required at abnormal completion. 0: Clock data setting is not required ... Clock data is not stored in (S1) + 11 to (S1) + 17 when errors occur. 1: Clock data setting required ... Clock data is stored in (S) + 11 to (S) + 17 when errors occur.</p>	b15	to	b8	b7	b6	to	b0	0	to	0	1	0	to	0	0000H 0080H	User																
b15	to	b8	b7	b6	to	b0																												
0	to	0	1	0	to	0																												
(S) + 1	Completion status	Store the status at the completion of the instruction. 0: Normal Other than 0: Abnormal (error code) ^{*2}	—	System																														
(S) + 2	Own station storage channel	Designate the channel of the own station, where receive data are stored. 1 to 8 (channel)	1 to 8	User																														
(S) + 3	Channel used by the sending station	Store the channel number used by the sending station. 1 to 8 (channel)	—	System																														
(S) + 4	Sending station network number	Store the network number of the sending station. 1 to 239: Network number	—	System																														
(S) + 5	Sending station number	Stores the station number of the sending station. 1 to 120: Station number (receive from the station with the indicated station number)	—	System																														
(S) + 6	(Not used)	—	—	—																														
(S) + 7	(Not used)	—	—	—																														
(S) + 8	Arrival monitoring time	Set a value greater than or equal to the TCP resend timer value for the monitoring time up to instruction processing termination. When the instruction fails to complete within the monitoring time, abnormal completion occurs. 0 to TCP resend timer value: Monitoring is performed by the time set to the TCP resend timer. (TCP resend timer value + 1) to 16383: Monitoring time (unit: s)	0 to 16383	User																														
(S) + 9	Receive data length	Stores the word count of the receive data stored in (D1) to (D1) + n. 0: No receive data 1 to 960: Word count of receive data	—	System																														
(S) + 10	(Not used)	—	—	—																														
(S) + 11	Clock set flag	Store the valid/invalid status of the data in ((S) + 12 to (S) + 17). This data is stored only when the bit 7 of Abnormal complete type ((S) + 0) is 1. The stored value is not cleared even when the dedicated instruction is normally completed. 0: Invalid 1: Valid	—	System																														
(S) + 12 : (S) + 15	Clock data (set only if an error occurs)	<p>The clock data upon abnormal end is stored in BCD. This data is stored only when the bit 7 of Abnormal complete type ((S) + 0) is 1. The stored value is not cleared even when the dedicated instruction is normally completed.</p> <table border="1" style="margin-left: auto; margin-right: auto;"> <tr> <td style="text-align: center;">b15</td> <td style="text-align: center;">to</td> <td style="text-align: center;">b8</td> <td style="text-align: center;">b7</td> <td style="text-align: center;">to</td> <td style="text-align: center;">b0</td> </tr> <tr> <td style="text-align: center;">(S1)+12</td> <td style="text-align: center;">Month (01H to 12H)</td> <td style="text-align: center;">Year (00H to 99H), Last 2 digits</td> <td colspan="3"></td> </tr> <tr> <td style="text-align: center;">(S1)+13</td> <td style="text-align: center;">Hour (00H to 23H)</td> <td style="text-align: center;">Date (01H to 31H)</td> <td colspan="3"></td> </tr> <tr> <td style="text-align: center;">(S1)+14</td> <td style="text-align: center;">Second (00H to 59H)</td> <td style="text-align: center;">Minute (00H to 59H)</td> <td colspan="3"></td> </tr> <tr> <td style="text-align: center;">(S1)+15</td> <td style="text-align: center;">Year (00H to 99H), First 2 digits</td> <td style="text-align: center;">Day of the week (00H to 06H)</td> <td colspan="3"></td> </tr> </table> <p style="text-align: center;">00H (Sun.) to 06H (Sat.)</p>	b15	to	b8	b7	to	b0	(S1)+12	Month (01H to 12H)	Year (00H to 99H), Last 2 digits				(S1)+13	Hour (00H to 23H)	Date (01H to 31H)				(S1)+14	Second (00H to 59H)	Minute (00H to 59H)				(S1)+15	Year (00H to 99H), First 2 digits	Day of the week (00H to 06H)				—	System
b15	to	b8	b7	to	b0																													
(S1)+12	Month (01H to 12H)	Year (00H to 99H), Last 2 digits																																
(S1)+13	Hour (00H to 23H)	Date (01H to 31H)																																
(S1)+14	Second (00H to 59H)	Minute (00H to 59H)																																
(S1)+15	Year (00H to 99H), First 2 digits	Day of the week (00H to 06H)																																
(S) + 16	Abnormal detection network number ^{*3}	Stores the network number of the station that detected an abnormality. This data is stored only when the bit 7 of Abnormal complete type ((S) + 0) is 1. The stored value is not cleared even when the dedicated instruction is normally completed. 1 to 239 (Network number)	—	System																														
(S) + 17	Abnormal detection station number ^{*3}	Stores the station number of the station that detected an abnormality. This data is stored only when the bit 7 of Abnormal complete type ((S) + 0) is 1. The stored value is not cleared even when the dedicated instruction is normally completed. 1 to 120 (Station number)	—																															

- *1 The "Set by" column indicates the following:
 - User: Data is set by the user before executing a dedicated instruction.
 - System: The programmable controller CPU stores the execution result of a dedicated instruction.
- *2 For a list of error codes, see the User's Manual (Basic).
- *3 Nothing is stored if the execution source detects an error when receiving an instruction.

Point

- The receive data storage device (D1) requires a contiguous free area equal to or greater than the receive data length ((S) + 9) (maximum of 960 words).
- Execute the RECV instruction every time the corresponding channel's bit in the RECV instruction execution request area (address: 205) of the buffer memory turns on (there is receive data).

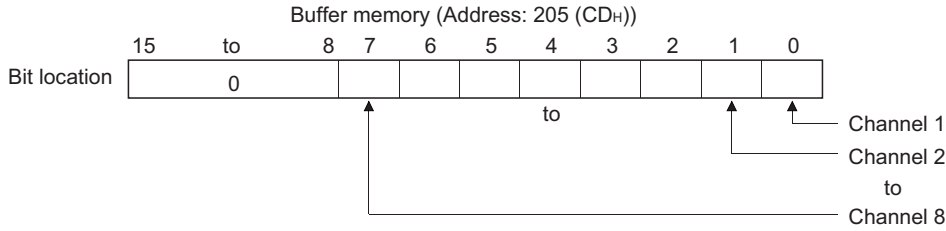

- When the Ethernet modules on the same network are installed at the receive station, execute RECV instruction by specifying Un of the Ethernet module which stores the data sent by SEND instruction. When the RECV instruction is executed with Jn specified, a programmable controller CPU executes the RECV instruction to a module having the smallest start I/O No. (Example) Specify "U2" when executing the RECV instruction at station No.3 in response to the SEND instruction from station No.1.

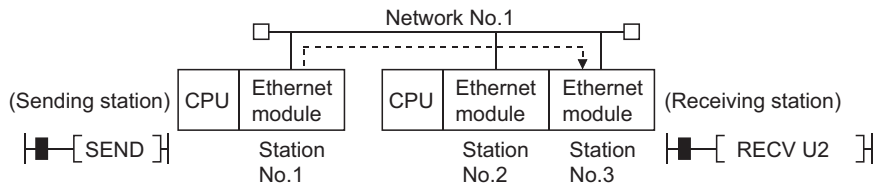

Remark

The allowable receive data length ((S) + 9) of the RECV instruction varies depending on the version. (User's Manual (Basic))
 Specifying a length value outside the setting range will cause a 4101 error (OPERATION ERROR) on the own station.

6.5.3 Functions

- (1) This instruction reads the data sent by a station connected to other networks or Ethernet that were specified with the network number and station number of the control data from the own station's Ethernet module.

Data is sent using the SEND instruction.

When data is received from the sending station, the receive data is stored in the channel of the own station designated with the sending station, and the corresponding bit in the RECV instruction execution request area (address: 205) of the Ethernet module buffer memory turns on. The received data is read from the receive data storage channel using the ON status of the corresponding bit of the RECV instruction execution request area to time the reading operations.

When reading the receive data from the Ethernet module is completed, the completion device designated by (D2) turns on.

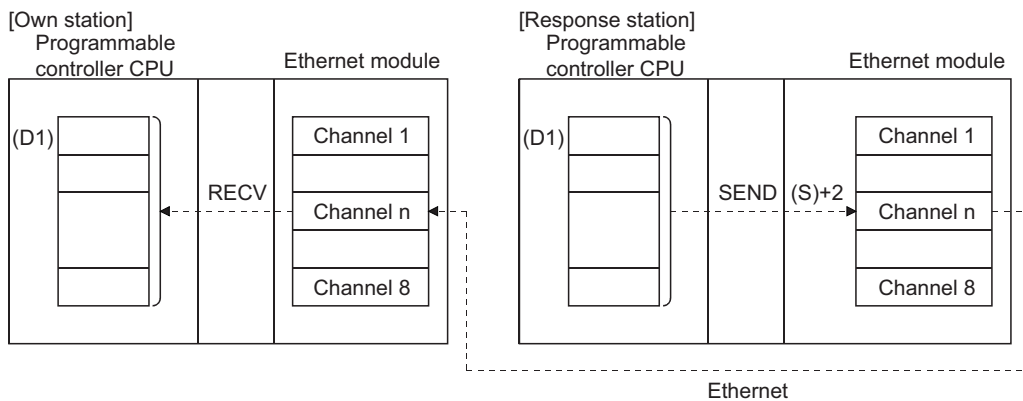

- (2) The instructions for Ethernet module cannot be executed to two or more locations for the same channel.

If the execution conditions are met at two or more locations at the same time, instructions to be executed later have to wait until the channel becomes available because handshaking is automatically performed at the execution of the first instruction.

- (3) RECVS instruction (for interrupt program) cannot be used with the instruction for data link in cases where the same channel is used to read receive data using the instruction for data link.

- (4) Whether the RECV instruction is being executed or has been completed normally or abnormally can be checked with the completion device (D2) or completion status display flag ((D2) + 1) designated in the set data.**

(a) Completion device (D2)

Turns on at the END processing of the scan where the RECV instruction is completed, and turns off at the next END processing.

(b) Status display device at completion ((D2) + 1)

Turns on and off depending on the completion status of the RECV instruction.

Normal completion: Stays off and does not change.

Abnormal completion: Turns on at the END processing of the scan where the RECV instruction is completed, and turns off at the next END processing.

[Operation of the own station when the RECV instruction is being executed]

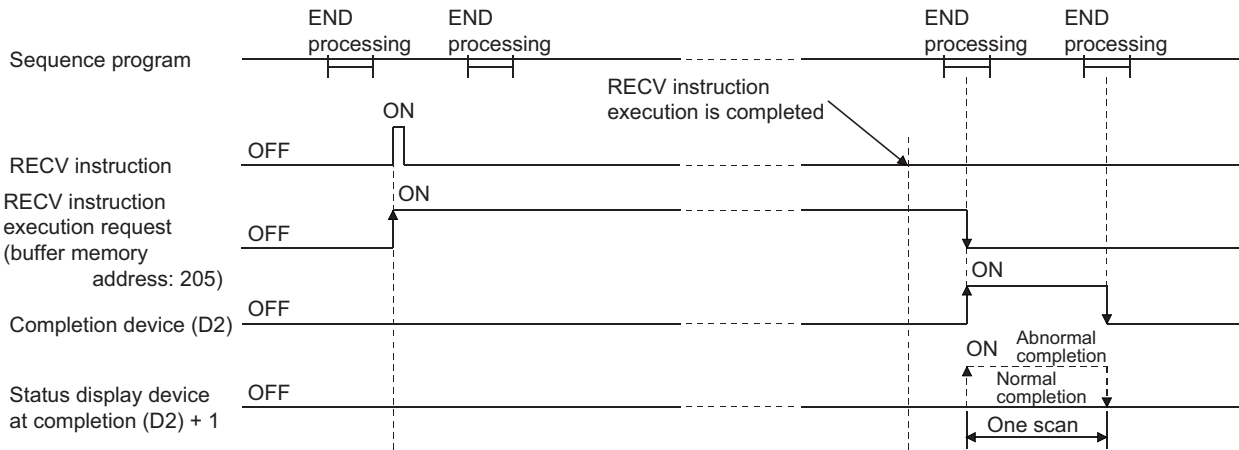

- (5) When executing the instruction using JP.RECV/GP.RECV, the read processing is executed only once when the read instruction flag goes from off to on (at rise).**

6.5.4 Errors

- (1) When a dedicated instruction completes abnormally, the abnormal completion signal (D2) + 1 turns on and the error code is stored in the completion status (S) + 1.**

See the following manuals regarding the error code, check the errors and take corrective actions.

<Error codes>

4FFFH or less: User's Manual (Hardware Design, Maintenance and Inspection) for the CPU module used

C000H or higher: User's Manual (Basic)

6.5.5 Program example

The following example shows a program that reads receive data from channel 5.
When I/O signals of the Ethernet module are X/Y00 to X/Y1F

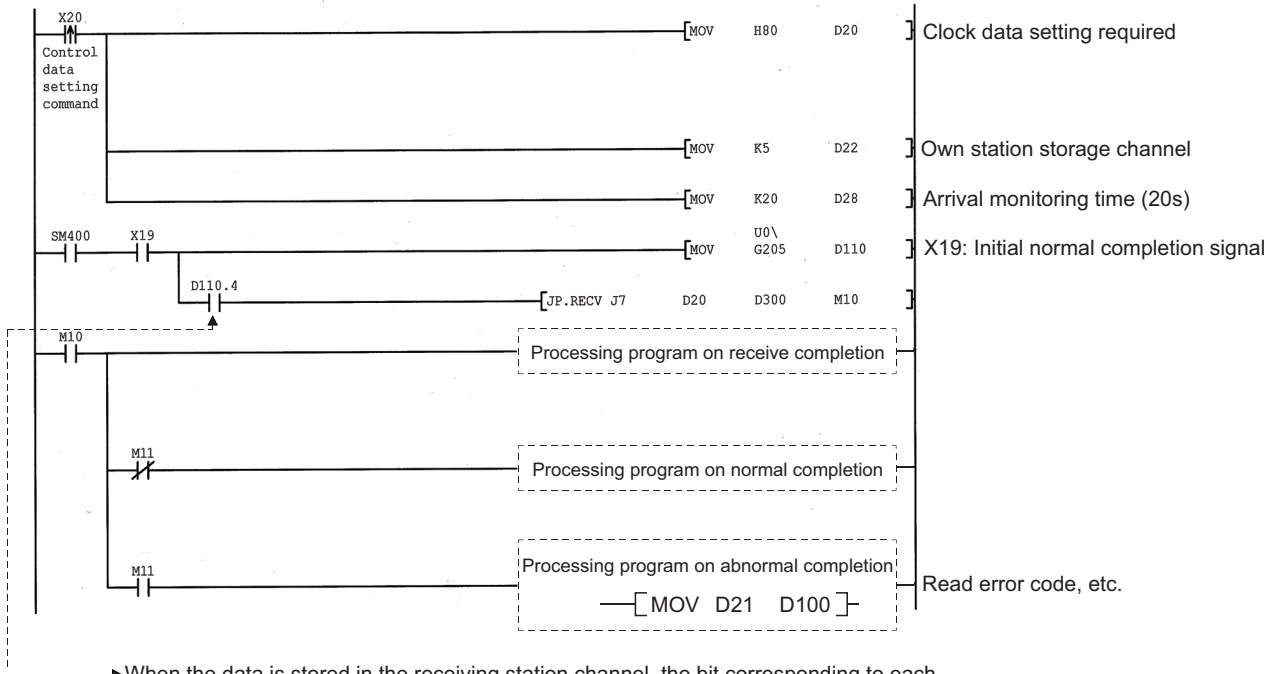

→ When the data is stored in the receiving station channel, the bit corresponding to each channel of buffer memory RECV instruction execution request area turns on. Data can be read automatically by using this signal for the receive command. The signal turns off when the RECV instruction is completed.

6.6 Z.RECVS (for Interrupt Programs)

This instruction reads received data.

Setting data	Applicable device								
	Internal device		File register R, ZR	Link direct device J□□		Intelligent function module device U□G□	Index register Zn	Constant K, H	Others
	Bit	Word		Bit	Word				
(S)	—	○	—		—				
(D1)	—	○	—		—				
(D2)	○	—		—					



*1 If the originating station is a Basic model QCPU (function version B or later), a Universal model QCPU, or an LCPU, " " (double quotation) of the first argument can be omitted.

6.6.1 Setting data

Setting data	Description	Set by ^{*1}	Data type
"Un"/Un	Start I/O signal of the own station's Ethernet module (00 to FEH: The higher 2 digits of the 3-digit I/O signal)	User	String/Binary 16 bits
(S)	Head device of the own station that stores the control data.	User, system	Device name
(D1)	Head device of the own station that stores the receive data.	System	
(D2)	(Designate as dummy.)		

*1 The "Set by" column indicates the following:

- User: Data is set by the user before executing a dedicated instruction.
- System: The programmable controller CPU stores the execution result of a dedicated instruction.

The local devices and the file register for each program cannot be used as the device used for the setting data.

Point

The RECVS instruction can be executed only when the own station is a Q/LCPU.

Remark

The number of steps for the RECV instruction is 10.

6.6.2 Control data

Device	Item	Setting data	Setting range	Set by ^{*1}
(S) + 0	Complete type	Designate 0.	0	User
(S) + 1	Completion status	Store the status at the completion of the instruction. 0: Normal Other than 0: Abnormal (error code) ^{*2}	—	System
(S) + 2	Own station storage channel	Designate the channel number that stores data to be read. 1 to 8: Channel number	1 to 8	User
(S) + 3	Channel used by the sending station	Store the channel number used by the sending station. 1 to 8: Channel number	—	System
(S) + 4	Sending station network number	Store the network number of the sending station. 1 to 239: Network number	—	System
(S) + 5	Sending station number	Stores the station number of the sending station. 1 to 120: Station number (receive from the station with the indicated station number)	—	System
(S) + 6 ⋮ (S) + 8	System area	—	—	—
(S) + 9	Receive data length	Stores the word count of the receive data stored in (D1) + 0 to (D1) + n. 0: No receive data 1 to 960: Word count of receive data	—	System
(S) + 10	System area	—	—	—

*1 The "Set by" column indicates the following:

- User: Data is set by the user before executing a dedicated instruction.
- System: The programmable controller CPU stores the execution result of a dedicated instruction.

*2 For a list of error codes, see the User's Manual (Basic).

6.6.3 Receive data

Device	Item	Setting data	Setting range	Set by ^{*1}
(D1) + 0 ⋮ (D1) + n	Receive data	Store the receive data.	—	System

Point

The receive data storage device (D1) requires a contiguous free area equal to or greater than the receive data length ((S) + 9) (maximum of 960 words).

*1 The "Set by" column indicates the following:

- User: Data is set by the user before executing a dedicated instruction.
- System: The programmable controller CPU stores the execution result of a dedicated instruction.

Remark

The allowable receive data length ((S) + 9) of the RECVS instruction varies depending on the version. ( User's Manual (Basic))

Specifying a length value outside the setting range will cause a 4101 error (OPERATION ERROR) on the own station.

6.6.4 Functions

- (1) This instruction reads the data received from other stations (a station connected to other networks or Ethernet) at the own station storage channel ((S) + 2) designated in the control data.

Data is sent using the SEND instruction.

When data is received from the transmission station, the receive data is stored in the channel of the own station designated with the transmission station, and the interrupt program with the interrupt number (Ixx) set with a programming tool is started.

The receive data is read using the RECVS instruction in this interrupt program.

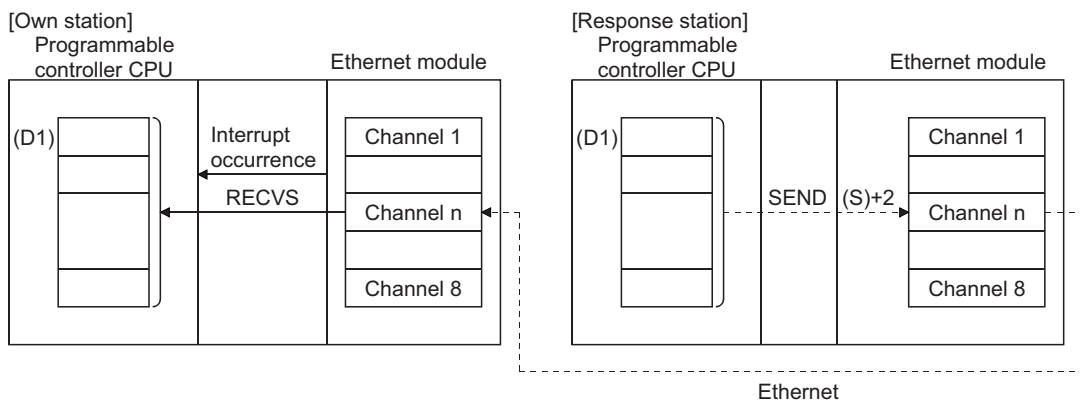

[Operation when the RECVS instruction is being executed]

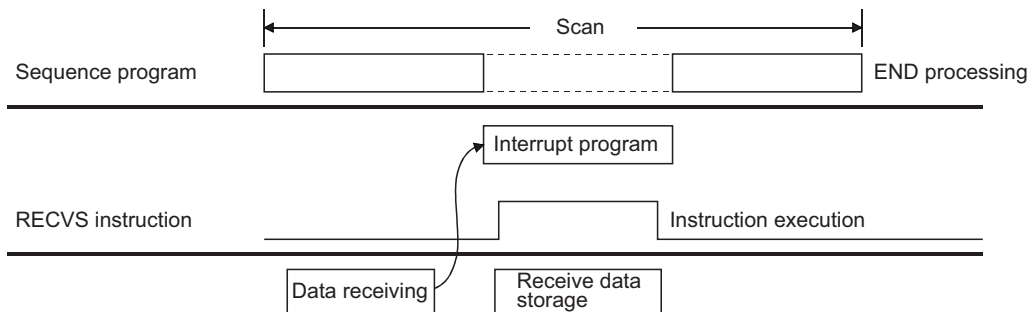

- (2) The Z.RECVS instruction is used in the interrupt program and its processing is completed within one scan.
- (3) RECVS instruction (interrupt program-use) cannot be used with the instruction for data link in cases where the same channel is used to read received data using the instruction for data link.

6.6.5 Errors

- (1) When a dedicated instruction completes abnormally, the abnormal completion signal (D2) + 1 turns on and the error code is stored in the completion status (S) + 1.

See the following manuals regarding the error code, check the errors and take corrective actions.

<Error codes>

4FFFH or less:  User's Manual (Hardware Design, Maintenance and Inspection) for the CPU module used

C000H or higher:  User's Manual (Basic)

6.6.6 Program example

The following example shows an interrupt program that reads the receive data from channel 5.

When I/O signals of the Ethernet module are X/Y00 to X/Y1F

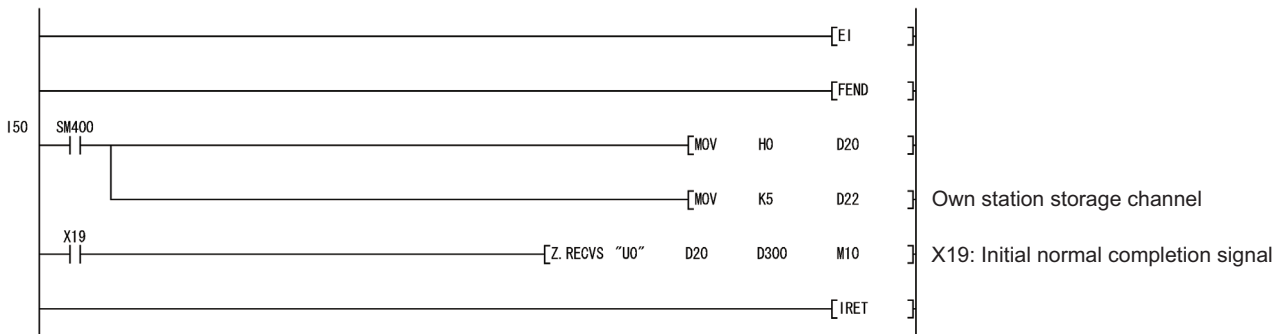

6.7 J(P)/G(P).REQ (Remote RUN/STOP)

This instruction issues remote RUN/STOP requests to programmable controller CPUs of other stations.

Setting data	Applicable device								
	Internal device		File register R, ZR	Link direct device J□□		Intelligent function module device U□G□	Index register Zn	Constant K, H	Others
	Bit	Word		Bit	Word				
(S1)	—	○		—					
(S2)	—	○		—					
(D1)	—	○		—					
(D2)	○			—					

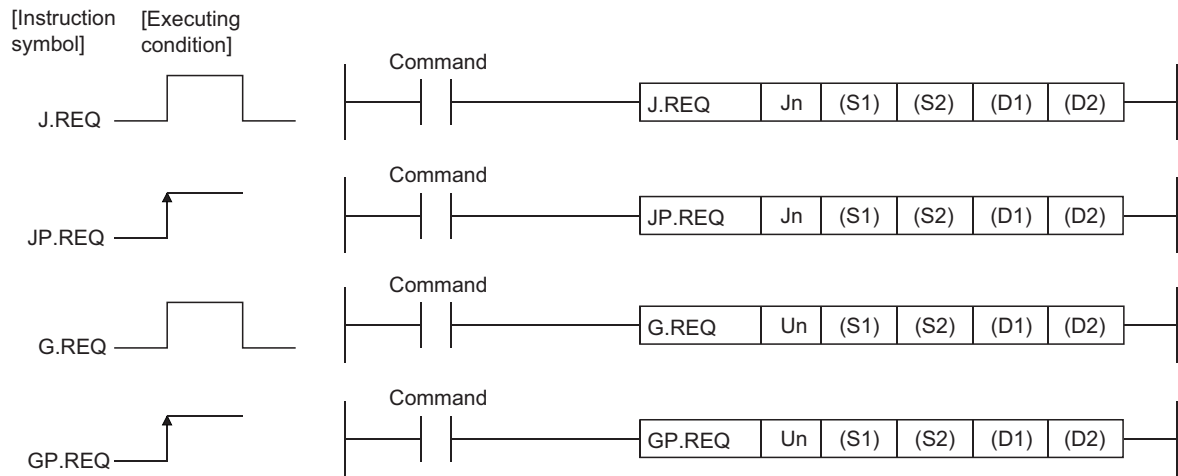

6

6.7 J(P)/G(P).REQ (Remote RUN/STOP)

6.7.1 Setting data

Setting data	Description	Set by ^{*1}	Data type
Jn	Network number of the own station (1 to 239, 254) 254: Network designated in a valid module for other station access	User	Binary 16 bits
Un	Start I/O signal of the own station's Ethernet module (00 to FEH: The higher 2 digits of the 3-digit I/O signal)		Character string
(S1)	Head device of the own station that stores the control data.	User, system	Device name
(S2)	Head device of the own station that stores the request data.	User	
(D1)	Head device of the own station that stores the response data.	System	
(D2)	Own station device that is turned on for one scan by completion of the instruction. (D2) + 1 turns on if the instruction execution completes abnormally.		Bit

*1 The "Set by" column indicates the following:

- User: Data is set by the user before executing a dedicated instruction.
- System: The programmable controller CPU stores the execution result of a dedicated instruction.

The local devices and the file register for each program cannot be used as the device used for the setting data.

Point

The REQ instruction can be executed only when the target station is a Q/L/QnACPU.
(The REQ instruction cannot be executed to an ACPU connected to a MELSECNET/10 or Ethernet network system.)

Remark

The number of basic steps for the REQ instruction is 9.

6.7.2 Control data

Device	Item	Setting data	Setting range	Set by ^{*1}														
(S1) + 0	Abnormal complete type	<table style="margin-left: auto; margin-right: auto; border-collapse: collapse;"> <tr> <td style="padding: 0 10px;">b15</td> <td style="padding: 0 10px;">to</td> <td style="padding: 0 10px;">b7</td> <td style="padding: 0 10px;">to</td> <td style="padding: 0 10px;">b4</td> <td style="padding: 0 10px;">to</td> <td style="padding: 0 10px;">b0</td> </tr> <tr> <td style="border: 1px solid black; text-align: center;">0</td> <td></td> <td style="border: 1px solid black; text-align: center;">1</td> <td></td> <td style="border: 1px solid black; text-align: center;">0</td> <td></td> <td style="border: 1px solid black; text-align: center;">1</td> </tr> </table> <p>1) Abnormal complete type (bit 7) Set whether or not the clock data setting is required at abnormal completion. 0: Clock data setting is not required ... Clock data is not stored in (S1) + 11 to (S1) + 17 when errors occur. 1: Clock data setting required ... Clock data is stored in (S1) + 11 to (S1) + 17 when errors occur.</p>	b15	to	b7	to	b4	to	b0	0		1		0		1	0011H 0091H	User
b15	to	b7	to	b4	to	b0												
0		1		0		1												
(S1) + 1	Completion status	Store the status at the completion of the instruction. 0: Normal Other than 0: Abnormal (error code) ^{*2}	—	System														
(S1) + 2	Channel used by the own station	Designate the channel used by the own station. 1 to 8 (channel)	1 to 8	User														
(S1) + 3	Target station's CPU type ^{*3}	Specify the programmable controller CPU of the access destination in the target station. • 0000H: Control CPU (The access destination is the same as that with 03FFH selected.) • 03D0H: Control system CPU ^{*5} • 03D1H: Standby system CPU ^{*5} • 03D2H: System A CPU • 03D3H: System B CPU • 03FFH: Control CPU	0000H 03D0H to 03D3H 03FFH	User														

Device	Item	Setting data	Setting range	Set by*1															
(S1) + 4	Target station network number	Designate the network number of the target station. 1 to 239: Network number 254: When 254 is designated in Jn (The network designated by the valid module during other station access)	1 to 239, 254	User															
(S1) + 5	Target station number	Designate the target station. 1) Station number specification When the own station is a Universal model QCPU or an LCPU: 1 to 120 When the own station is not a Universal model QCPU or an LCPU: 1 to 64 2) Specific group 81H to A0H: All stations with the indicated group number (only clock data write and remote RUN/STOP are allowed) 3) All stations FFH: All stations of the target network number (simultaneous broadcast) excluding the own station (only clock data write and remote RUN/STOP are allowed)	1 to 120 81H to A0H FFH	User															
(S1) + 6	—	(Fixed value)	0	User															
(S1) + 7	Number of resends	1) At the instruction execution Set the number of resends when the instruction is not completed within the monitoring time designated by (S1) + 8. 0 to 15 (times) 2) At the instruction completion Store the number of resends executed (result). 0 to 15 (times)	0 to 15	User System															
(S1) + 8	Arrival monitoring time	Set a value greater than or equal to the TCP resend timer value for the monitoring time up to instruction processing termination. When the instruction fails to complete within the monitoring time, it is resent for the number of resends designated in (S1) + 7. 0 to TCP resend timer value: Monitoring is performed by the time set to the TCP resend timer. (TCP resend timer value + 1) to 16383: Monitoring time (unit: s)	0 to 16383	User															
(S1) + 9	Request data length	Designate the number of request data (word). (Word count of data stored in the request data storage device (S2)) Remote RUN: 4 Remote STOP: 3 Clock data read: 2 Clock data write: 6	2 to 4, 6	User															
(S1) + 10	Response data length	Store the number of response data (word) (Word count of data stored in the response data storage device (D1)). Remote RUN/STOP: 2 Clock data read: 6 Clock data write: 2	—	System															
(S1) + 11	Clock set flag	Store the valid/invalid status of the clock data in (S1) + 12 to (S1) + 17. This data is stored only when the bit 7 of Abnormal complete type ((S1) + 0) is 1. The stored value is not cleared even when the dedicated instruction is normally completed. 0: Invalid 1: Valid	—	System															
(S1) + 12 ⋮ (S1) + 15	Clock data (set only if an error occurs)*2	The clock data upon abnormal end is stored in BCD. This data is stored only when the bit 7 of Abnormal complete type ((S1) + 0) is 1. The stored value is not cleared even when the dedicated instruction is normally completed. <table border="1" style="margin-left: auto; margin-right: auto;"> <thead> <tr> <th></th> <th>b15 to b8</th> <th>b7 to b0</th> </tr> </thead> <tbody> <tr> <td>(S1)+12</td> <td>Month (01H to 12H)</td> <td>Year (00H to 99H), Last 2 digits</td> </tr> <tr> <td>(S1)+13</td> <td>Hour (00H to 23H)</td> <td>Date (01H to 31H)</td> </tr> <tr> <td>(S1)+14</td> <td>Second (00H to 59H)</td> <td>Minute (00H to 59H)</td> </tr> <tr> <td>(S1)+15</td> <td>Year (00H to 99H), First 2 digits</td> <td>Day of the week (00H to 06H)</td> </tr> </tbody> </table> <p style="text-align: center;">00H (Sun.) to 06H (Sat.)</p>		b15 to b8	b7 to b0	(S1)+12	Month (01H to 12H)	Year (00H to 99H), Last 2 digits	(S1)+13	Hour (00H to 23H)	Date (01H to 31H)	(S1)+14	Second (00H to 59H)	Minute (00H to 59H)	(S1)+15	Year (00H to 99H), First 2 digits	Day of the week (00H to 06H)	—	System
	b15 to b8	b7 to b0																	
(S1)+12	Month (01H to 12H)	Year (00H to 99H), Last 2 digits																	
(S1)+13	Hour (00H to 23H)	Date (01H to 31H)																	
(S1)+14	Second (00H to 59H)	Minute (00H to 59H)																	
(S1)+15	Year (00H to 99H), First 2 digits	Day of the week (00H to 06H)																	

6

6.7 J(P)/G(P).REQ (Remote RUN/STOP)

Device	Item	Setting data	Setting range	Set by ^{*1}
(S1) + 16	Abnormal detection network number ^{*4}	Stores the network number of the station that detected an abnormality. This data is stored only when the bit 7 of Abnormal complete type ((S1) + 0) is 1. The stored value is not cleared even when the dedicated instruction is normally completed. 1 to 239 (Network number)	—	System
(S1) + 17	Abnormal detection station number ^{*4}	Stores the station number of the station that detected an abnormality. This data is stored only when the bit 7 of Abnormal complete type ((S1) + 0) is 1. The stored value is not cleared even when the dedicated instruction is normally completed. 1 to 120 (Station number)	—	

*1 The "Set by" column indicates the following:

- User: Data is set by the user before executing a dedicated instruction.
- System: The programmable controller CPU stores the execution result of a dedicated instruction.

*2 For a list of error codes, see the User's Manual (Basic).

*3 It can be specified when the own station has an Ethernet module of function version D or later.
(The setting value is fixed to "03FFH" for a module other than the above. Access to the control CPU is required.)

*4 Nothing is stored if the execution source detects an error when receiving an instruction.

*5 When the REQ instruction is executed to the redundant system with a control system or standby system CPU specified, the instruction may be unsuccessfully completed due to system switching occurred on the target station.
(Error code: 4244H, 4248H)
If this has occurred, execute the REQ instruction again.

6.7.3 Request data (All values are set by the user)

Device	Item	Description	Remote RUN	Remote STOP
(S2) + 0	Request type	0010H: When station No. is specified in (S1)+5 0030H: When all stations or a group is specified in (S1)+5	<input type="radio"/>	<input type="radio"/>
(S2) + 1	Sub-request type	0001H: Remote RUN 0002H: Remote STOP	<input type="radio"/>	<input type="radio"/>
(S2) + 2	Mode	Designate whether or not to forcefully execute remote RUN/STOP operations. 0001H: Do not force execution 0003H: Force execution (setting at remote STOP) (The forced execution is a function for forcefully executing remote RUN from other station when the station that executed the remote STOP is no longer able to execute remote RUN.)	<input type="radio"/>	<input type="radio"/>
(S2) + 3	Clear mode	Designate the status of the CPU's device memory only when executing remote RUN. 0000H: Do not clear (however, the local device will be cleared) 0001H: Clear (excluding setting and latch range at remote RUN) 0002H: Clear (including setting and latch range at remote RUN)Response data (All values are set by the system)	<input type="radio"/>	—

6.7.4 Response data (All values are set by the system)

When "all stations or a group (FFH or 81H to A0H)" is specified in Target station No. ((S1) + 5), no response data will be stored.

Device	Item	Description	Remote RUN	Remote STOP
(D1)	Request type	0090H: When station No. is specified in (S1) + 5	<input type="radio"/>	<input type="radio"/>
(D1) + 1	Sub-request type	0001H: Remote RUN 0002H: Remote STOP	<input type="radio"/>	<input type="radio"/>

Point

- Remote RUN/STOP becomes valid when the RUN/STOP key switch of the target station's Q/L/QnACPU is "RUN".
- Remote RUN/STOP cannot be executed when the system protection is activated on the target station's Q/L/QnACPU.
- When other station has executed a remote STOP/PAUSE operation on the target station, the RUN request cannot be executed if the mode of (S2) + 2 is "Do not force execution (0001H)."
- Resetting the Q/L/QnACPU of the target station where a remote STOP operation has been executed erases the information of the remote STOP.
- The clear mode ((S2) + 3) designates how the clear (initialization) processing of the Q/L/QnACPU device memory should be performed when the Q/L/QnACPU starts performing calculations after a remote RUN request has been issued to it.
- The number of resends ((S1) + 7) must be set at every instruction execution.

6.7.5 Functions

- (1) This instruction sends the request data designated in (S2) of the own station to the station connected to other networks or Ethernet that has been specified with the network number and station number in the control data to make a service request.

When the request to the target station is completed, the completion device designated with (D2) turns on.

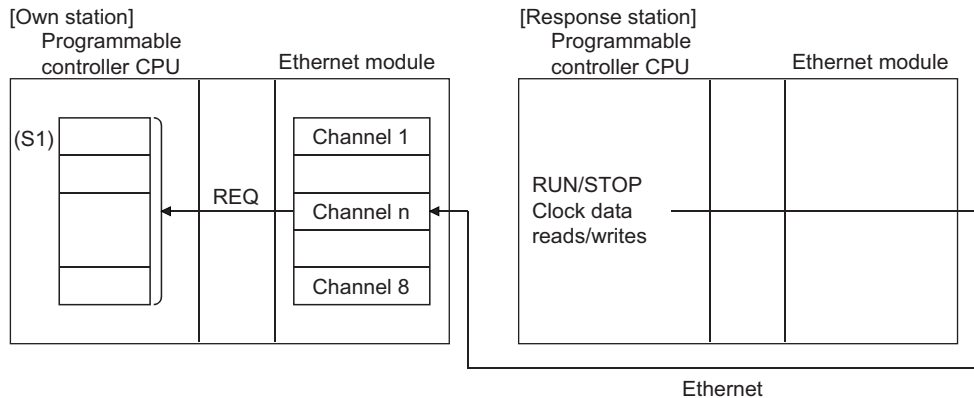

- (2) Device data can be sent from stations connected to other networks or Ethernet having the specified numbers, in addition to stations connected to the own station's network.
- (3) The data link instructions and the Ethernet instructions cannot be executed from two or more stations at the same time on the same channel.

If the execution conditions are met at two or more locations at the same time, instructions to be executed later have to wait until the channel becomes available because handshaking is automatically performed at the execution of the first instruction.

(4) Whether the REQ instruction is being executed or has been completed normally or abnormally can be checked with the complete device (D2) or completion status display flag ((D2) + 1) designated in the set data.

(a) Completion device (D2)

Turns on at the END processing of the scan where the REQ instruction is completed, and turns off at the next END processing.

(b) Status display device at completion ((D2) + 1)

Turns on and off depending on the completion status of the REQ instruction.

Normal completion: Stays off and does not change.

Abnormal completion: Turns on at the END processing of the scan where the REQ instruction is completed, and turns off at the next END processing.

[Operation of the own station when the REQ instruction is being executed]

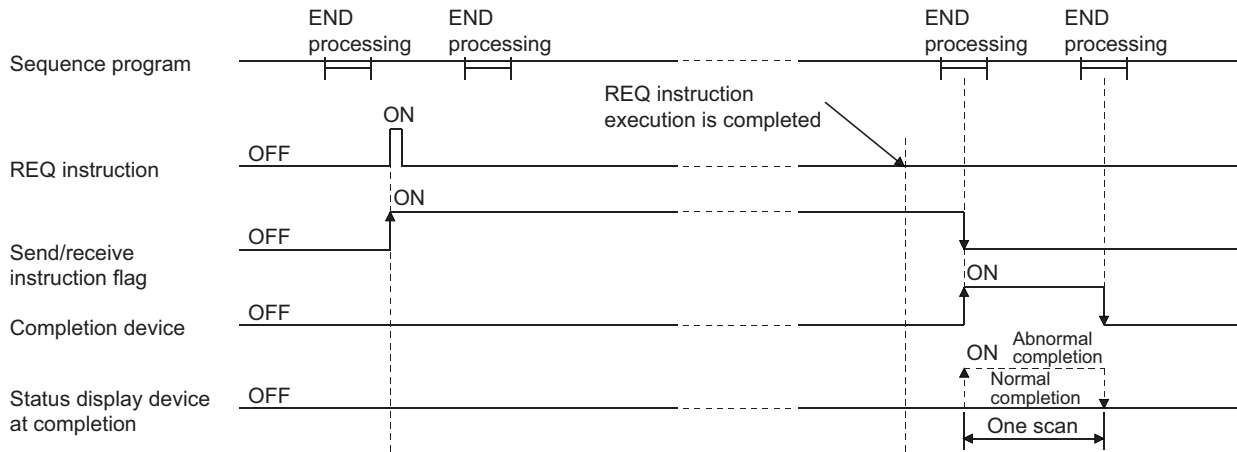

(5) When the instruction is executed using J.REQ/G.REQ, the next write processing is executed in succession after one processing is completed while the send/receive instruction flag is on.

When the instruction is executed using JP.REQ/GP.REQ, the processing is executed only once when the send/receive instruction flag switches from off to on (at rise).

6.7.6 Errors

(1) When a dedicated instruction completes abnormally, the abnormal completion signal (D2) + 1 turns on and the error code is stored in the completion status (S1) + 1.

See the following manuals regarding the error code, check the errors and take corrective actions.

<Error codes>

4FFFH or less: User's Manual (Hardware Design, Maintenance and Inspection) for the CPU module used

C000H or higher: User's Manual (Basic)

6.7.7 Program example

The following example shows a program that executes remote STOP on the Q/L/QnACPU of station number 13 in network number 7.

When I/O signals of the Ethernet module are X/Y00 to X/Y1F

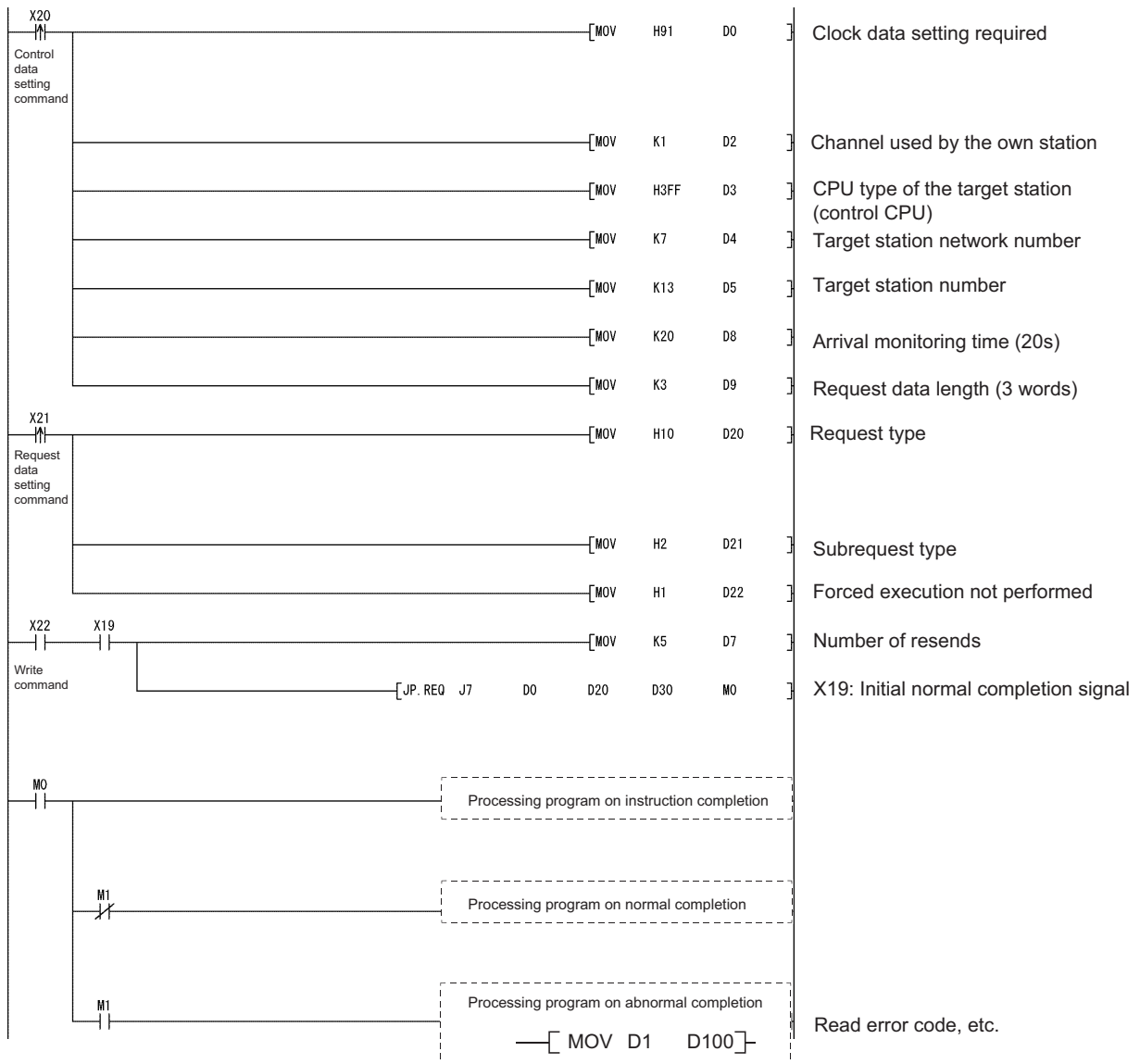

6.8 J(P)/G(P).REQ (Clock Data Read/Write)

This instruction reads/writes clock data from/to other stations.

Point

See Page 187, Section 6.7 for the following information on the REQ instruction for reading/writing clock data from/to other stations.

Since the same explanation as when executing remote RUN/STOP operations using the REQ instruction applies in this case, the explanation of these items is omitted in this section.

- Instruction format
- Devices that can be used with the instruction
- Control data in the setting data
- Functions
- Errors

6.8.1 Request data (All values are set by the user)

Device	Item	Setting data	Clock data read	Clock data write
(S2)	Request type	0001H: Clock data read 0011H: Clock data write (When station No. is specified in (S1) + 5) 0031H: Clock data write (When all stations or a group is specified in (S1) + 5)	○	○
(S2) + 1	Sub-request type	0002H: Clock data read 0001H: Clock data write	○	○
(S2) + 2	Change pattern Year to be changed	<p>1) Change pattern (bits 0 to 7) Specify which items are to be written to the fields of (high byte of (S2) + 2) to ((S2) + 5). 0: Do not change 1: Change</p> <p>2) Year to be changed (bits 8 to 15) Store year (last two digits of the year in the Gregorian calendar) as BCD code.</p> <p>b15 to b8 b7 b6 b5 b4 b3 b2 b1 b0 Year (00H to 99H) 0 [] [] [] [] [] [] [] [] → Year → Month → Date → Hour → Minute → Second → Day of the week</p>	—	○
(S2) + 3	Clock data to be changed (continued)	Higher 8 bits: date (01H to 31H), lower 8 bits: month (01H to 12H)	—	○
(S2) + 4		Higher 8 bits: minute (00H to 59H), lower 8 bits: hour (00H to 23H)	—	○
(S2) + 5		Higher 8 bits: day of the week (00H (Sunday) to 06H (Saturday)), lower 8 bits: second (00H to 59H)	—	○

In this function, the higher two digits of the year data cannot be changed.

When it is necessary to change the higher two digits of the year data, use other functions (such as a programming tool) to set the clock data.

6.8.2 Response data (All values are set by the system)

When "all stations or a group (FFH or 81H to A0H)" is specified in Target station No. ((S1) + 5), no response data will be stored.

Device	Item	Setting data	Clock data read	Clock data write
(D1) + 0	Request type	0081H: Clock data read 0091H: Clock data write (When station No. is specified in (S1) + 5)	○	○
(D1) + 1	Sub-request type	0002H: Clock data read 0001H: Clock data write	○	○
(D1) + 2	Clock data read	Higher 8 bits: month (01H to 12H), lower 8 bits: year ^{*1} (00H to 99H)	○	—
(D1) + 3		Higher 8 bits: hour (00H to 23H), lower 8 bits: date (01H to 31H)	○	—
(D1) + 4		Higher 8 bits: second (00H to 59H), lower 8 bits: minute (00H to 59H)	○	—
(D1) + 5		Higher 8 bits: (00H), lower 8 bits: day of the week (00H (Sunday) to 06H (Saturday)).	○	—

*1 Year: Lower two digits

Point

- The clock data cannot be written when the system protection is activated on the target station's Q/L/QnACPU.
- When the clock data is read, the response data storage device (D1) requires a contiguous free area of six words.

6.8.3 Program example

The following example shows a program to write the clock data (8:30:00) to the Q/L/QnACPU with the station number 13 in the network number 7.

When I/O signals of the Ethernet module are X/Y00 to X/Y1F

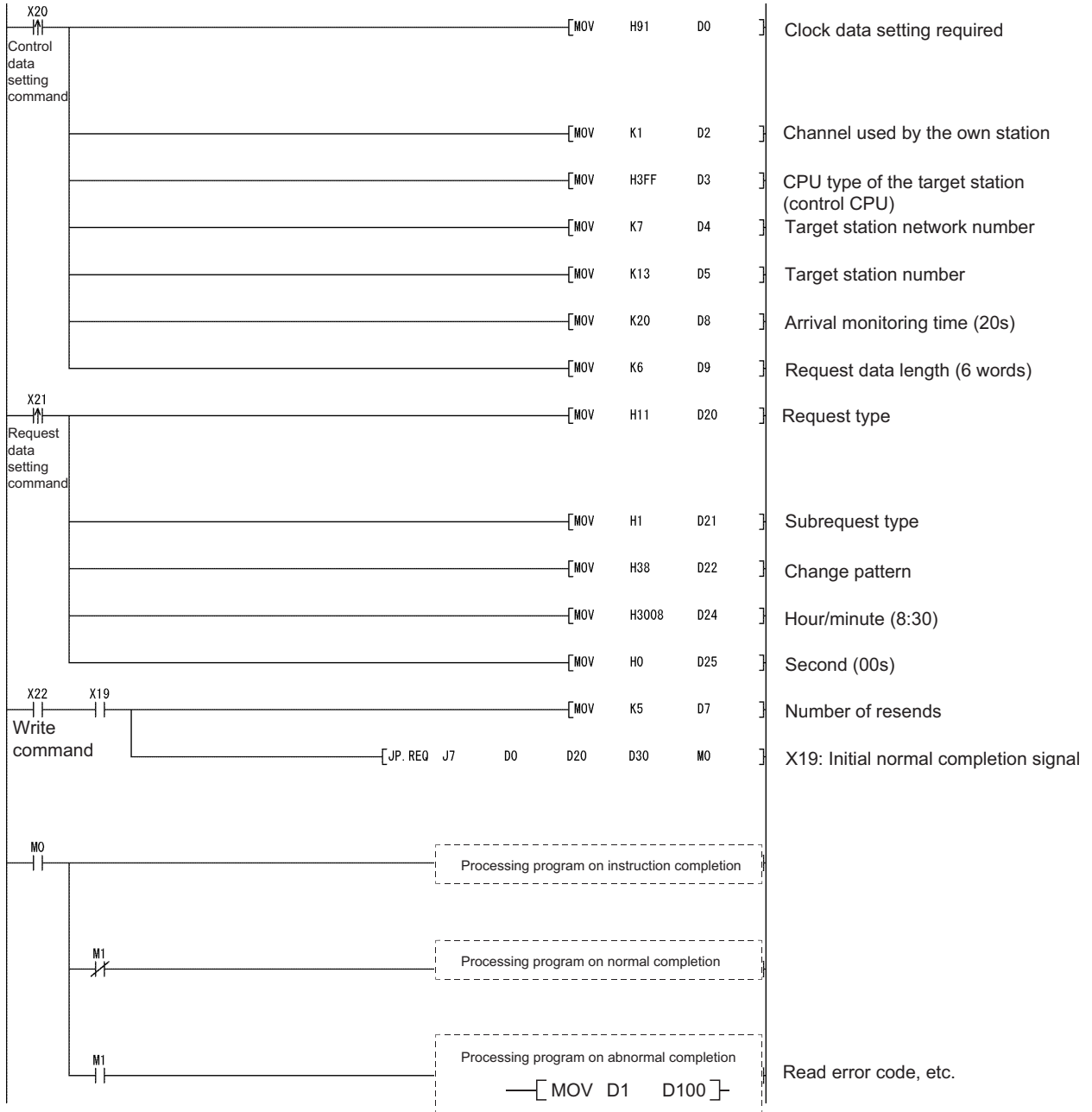

6

6.8 J(P)/G(P).REQ (Clock Data Read/Write)

6.9 JP/GP.SEND

This instruction sends data to another station's Q/L/QnACPU.

Setting data	Applicable device								
	Internal device		File register R, ZR	Link direct device J□□		Intelligent function module device U□\G□	Index register Zn	Constant K, H	Others
	Bit	Word		Bit	Word				
(S1)	—	○		—					
(S2)	—	○		—					
(D)	○			—					

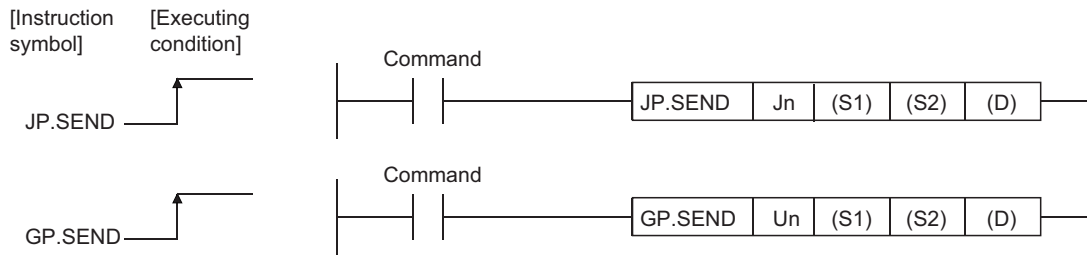

6.9.1 Setting data

Setting data	Description	Set by*1	Data type
Jn	Network number of the own station (1 to 239, 254) 254: Network designated in a valid module for other station access	User	Binary 16 bits
Un	Start I/O signal of the own station's Ethernet module (00 to FEH: The higher 2 digits of the 3-digit I/O signal)		Character string
(S1)	Head device of the own station that stores the control data.	User, system	Device name
(S2)	Head device of the own station that stores the send data.	User	
(D)	Own station device that is turned on for one scan by completion of the instruction. (D) + 1 turns on if the instruction execution completes abnormally.	System	Bit

*1 The "Set by" column indicates the following:

- User: Data is set by the user before executing a dedicated instruction.
- System: The programmable controller CPU stores the execution result of a dedicated instruction.

The local devices and the file register for each program cannot be used as the device used for the setting data.

Point

- The SEND instruction can be executed only when the target station is a Q/L/QnACPU.
(The SEND instruction cannot be executed for an ACPU connected to an MELSECNET/10 or Ethernet network system.)

Remark

- Setting values stored in Completion status ((S1) + 1) and Clock data ((S1) + 10 to (S1) + 14) are stored into control data upon completion of the instruction.
- The number of steps for the SEND instruction is 8.

6.9.2 Control data

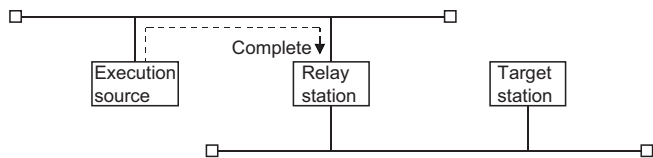
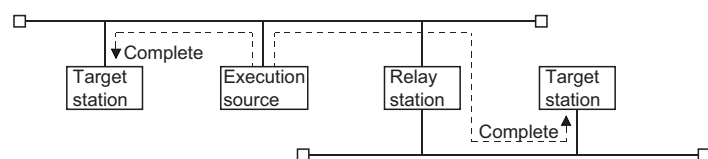
Device	Item	Setting data	Setting range	Set by ^{*1}															
(S1) + 0	Execution/abnormal complete type	<div style="text-align: center;"> <table border="1" style="margin: auto;"> <tr> <td style="width: 20px;">b15</td> <td style="width: 20px;">to</td> <td style="width: 20px;">b7</td> <td style="width: 20px;">to</td> <td style="width: 20px;">b0</td> </tr> <tr> <td style="text-align: center;">0</td> <td></td> <td style="text-align: center;">2)</td> <td></td> <td style="text-align: center;">0</td> </tr> <tr> <td></td> <td></td> <td></td> <td></td> <td style="text-align: center;">1)</td> </tr> </table> </div> <p>1) Execution type (bit 0) 0: No arrival confirmation When the target station is on the same network ... Completed when the data is sent from the own station.</p>  <p>When the target station is on other network ... Completed when the data arrives at the relay station on the network of the local station.</p>  <p>1: With arrival confirmation Completed when the data is stored in the target station's designated channel.</p>  <p>2) Abnormal complete type (bit 7) Set whether or not the clock data setting is required at abnormal completion. 0: Clock data setting is not required ... Clock data is not stored in (S1) + 11 to (S1) + 17 when errors occur. 1: Clock data setting required ... Clock data is stored in (S1) + 11 to (S1) + 17 when errors occur.</p>	b15	to	b7	to	b0	0		2)		0					1)	0000H 0001H 0080H 0081H	User
b15	to	b7	to	b0															
0		2)		0															
				1)															
(S1) + 1	Completion status	Store the status at the completion of the instruction. 0: Normal Other than 0: Abnormal (error code) ^{*2}	—	System															
(S1) + 2	Channel used by the own station	Set the channel used by the own station. 1 to 8 (channel)	1 to 8	User															
(S1) + 3	Target station storage channel	Designate the target station's channel that stores data. 1 to 8 (channel)	1 to 8	User															
(S1) + 4	Target station network number	Designate the network number of the target station. 1 to 239: Network number 254: When 254 is designated in Jn (The network designated by the valid module during other station access) ¹ 1 to 239, 254	1 to 239, 254	User															
(S1) + 5	Target station number	Designate the target station. 1) Station number specification When the own station is a Universal model QCPU or an LCPU: 1 to 120 When the own station is not a Universal model QCPU or an LCPU: 1 to 64 2) Specific group 81H to A0H: All stations of group number (Can be set when the execution type designated in (S1) is "0: No arrival confirmation.") 3) All stations FFH: All stations of the target network number (simultaneous broadcast) ... excluding the own station (Can be set when the execution type designated in (S1) is "0: No arrival confirmation.")	1 to 120 81H to A0H FFH	User															
(S1) + 6	—	(Fixed value)	0	User															

6

6.9 JP/GP.SEND

Device	Item	Setting data	Setting range	Set by*1															
(S1) + 7	Number of resends	Valid when the execution type designated in (S1) is "1: With arrival confirmation." 1) At the instruction execution Set the number of resends when the instruction is not completed within the monitoring time designated by (S1) + 8. 0 to 15 (times) 2) At the instruction completion Store the number of resends executed (result). 0 to 15 (times)	0 to 15	User, system															
(S1) + 8	Arrival monitoring time	Valid when the execution type designated in (S1) is "1: With arrival confirmation." "Set the monitoring time until the instruction completion equals to or becomes greater than the TCP resend timer value. When the instruction fails to complete within the monitoring time, it is resent for the number of resends designated in (S1) + 7. 0 to TCP resend timer value: Monitoring is performed by the time set to the TCP resend timer. (TCP resend timer value + 1) to 16383: Monitoring time (unit: s)	0 to 16383	User															
(S1) + 9	Send data length	Designate the number of send data in (S2) to (S2) + n. When sending to Q/LCPU: 1 to 960 (word) When sending to QnACPU: 1 to 480 (word)	1 to 960	User															
(S1) + 10	(Not used)	—	—	—															
(S1) + 11	Clock set flag	Store the valid/invalid status of the clock data in (S1) + 12 to (S1) + 17. This data is stored only when the bit 7 of Abnormal complete type ((S1) + 0) is 1. The stored value is not cleared even when the dedicated instruction is normally completed. 0: Invalid 1: Valid	—	System															
(S1) + 12 : (S1) + 15	Clock data (set only when abnormal)	The clock data upon abnormal end is stored in BCD. This data is stored only when the bit 7 of Abnormal complete type ((S1) + 0) is 1. The stored value is not cleared even when the dedicated instruction is normally completed. <table border="1" style="margin-left: auto; margin-right: auto;"> <thead> <tr> <th></th> <th>b15 to b8</th> <th>b7 to b0</th> </tr> </thead> <tbody> <tr> <td>(S1)+12</td> <td>Month (01H to 12H)</td> <td>Year (00H to 99H), Last 2 digits</td> </tr> <tr> <td>(S1)+13</td> <td>Hour (00H to 23H)</td> <td>Date (01H to 31H)</td> </tr> <tr> <td>(S1)+14</td> <td>Second (00H to 59H)</td> <td>Minute (00H to 59H)</td> </tr> <tr> <td>(S1)+15</td> <td>Year (00H to 99H), First 2 digits</td> <td>Day of the week (00H to 06H)</td> </tr> </tbody> </table> 00H (Sun.) to 06H (Sat.)		b15 to b8	b7 to b0	(S1)+12	Month (01H to 12H)	Year (00H to 99H), Last 2 digits	(S1)+13	Hour (00H to 23H)	Date (01H to 31H)	(S1)+14	Second (00H to 59H)	Minute (00H to 59H)	(S1)+15	Year (00H to 99H), First 2 digits	Day of the week (00H to 06H)	—	System
	b15 to b8	b7 to b0																	
(S1)+12	Month (01H to 12H)	Year (00H to 99H), Last 2 digits																	
(S1)+13	Hour (00H to 23H)	Date (01H to 31H)																	
(S1)+14	Second (00H to 59H)	Minute (00H to 59H)																	
(S1)+15	Year (00H to 99H), First 2 digits	Day of the week (00H to 06H)																	
(S1) + 16	Abnormal detection network number*3	Stores the network number of the station that detected an abnormality. This data is stored only when the bit 7 of Abnormal complete type ((S1) + 0) is 1. The stored value is not cleared even when the dedicated instruction is normally completed. 1 to 239 (Network number)	—	System															
(S1) + 17	Abnormal detection station number*3	Stores the station number of the station that detected an abnormality. This data is stored only when the bit 7 of Abnormal complete type ((S1) + 0) is 1. The stored value is not cleared even when the dedicated instruction is normally completed. 1 to 120 (Station number)	—																

*1 The "Set by" column indicates the following:

- User: Data is set by the user before executing a dedicated instruction.
- System: The programmable controller CPU stores the execution result of a dedicated instruction.

*2 For a list of error codes, see the User's Manual (Basic).

*3 Nothing is stored if the execution source detects an error when receiving an instruction.

Remark

The following explains the reception processing on the target station by the send data length of the SEND instruction. The allowable send data length ((S1) + 9) of the SEND instruction varies depending on the version. (User's Manual (Basic))

Specifying a length value outside the setting range will cause a 4101 error (OPERATION ERROR) on the own station.
 <When the target station is an Ethernet module>

Own station (SEND)	Target station (RECV/RECVS)				Target station (RECV)		
	L series Ethernet module	Q series Ethernet module		QnA series Ethernet module			
		Supporting receive data length of 960 words	Not supporting receive data length of 960 words (480 words)		QE71N (480 words)	QE71 (480 words)	
			Function version B, D	Function version A		9707B or later	9706 or earlier
1 to 480 words	○	○	○	○	○	○	—
481 to 960 words	○	○	× ^{*4}	× ^{*5}	× ^{*4}	× ^{*6}	—

○: Performs the processing normally.

×: Terminates abnormally and returns an error code to the request source.

*4 A C086H error occurs on the own station.

On the target station, the corresponding bit in the RECV instruction execution request area (address: 205) of the buffer memory remains OFF, and no error occurs.

*5 On the own station, although the initial transmission is completed normally, a C085H error will occur for the second one or later.

The target station behaves as follows:

- Upon the initial reception of the SEND instruction message, the corresponding bit in the RECV instruction execution request area (address: 205) of the buffer memory turns ON.
- Executing the RECV instruction generates a C1A6H error, by which the corresponding bit in the RECV instruction execution request area (address: 205) cannot be turned OFF.
- The RECV instruction generates an interrupt, however, the instruction is not be executed.

*6 On the own station, the SEND instruction is completed normally.

On the target station, execution of the RECV instruction generates a 4001H error and turns OFF the corresponding bit in the RECV instruction execution request area (address: 205).

Check the send data length (1 to 480 words) and execute the SEND instruction.

<When the target station is a network module>

Own station (SEND)	Target station (RECV/RECVS)				Target station (RECV)
	L series CC-Link IE Field Network module	Q series CC-Link IE Controller Network module, CC-Link IE Field Network module	Q series MELSECNET/H network module		QnA series MELSECNET/10 network module (489 words)
			Function version B, D (960 words)	Function version A (489 words)	
1 to 480 words	○	○	○	○	○
481 to 960 words	○	○	○	×	×

○: Performs the processing normally.

×: Terminates abnormally and returns an error code to the request source.

- The send data storage device (S2) requires a continuous free area equal to or greater than the send data length ((S1) + 9) (maximum of 960 words).
- In order to increase the reliability of the data, it is recommended to execute the instruction by setting the execution type to "With arrival confirmation" when a number from one to 120 is designated for the target station number. When 81H to A0H or FFH is designated for the target station number, the instruction should be executed by setting the execution type to "No arrival confirmation."
- When sending data to the same channel of the receive station, do so after the receive station reads data using the RECV instruction.
If the communication itself is normally completed when the execution type is set to "No arrival confirmation," the send is considered normally completed on the sending station even if the contents of the send data are abnormal.
In addition, even if the contents of the send data are normal, when the instruction is executed to the same station from multiple stations, a timeout error (C083H) will occur on the sending station side.
- When the execution type is set to "With arrival confirmation," if the sending station sends data to the same channel of the receive station before the receive station reads data using the RECV instruction, a buffer full-error will occur on the sending station side.

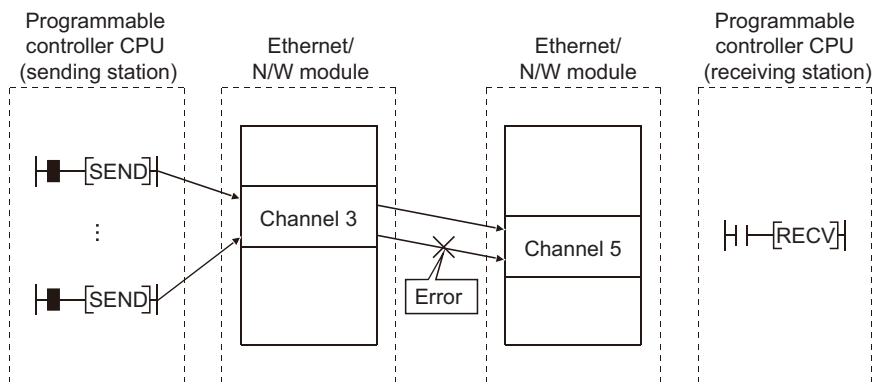

- Designate the target station sending data with the network No. and station No. of the network module or Ethernet module receiving the request from the sending station.
In the diagram below, designate the network No. and station No. of the first Ethernet module. The SEND instruction cannot be executed if a network module or Ethernet module other than the one receiving the request from the sending station is designated.
The SEND instruction cannot be executed if the network No. and station No. of the second Ethernet module is designated.

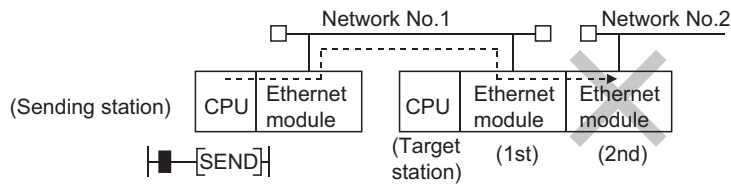

- The number of resends ((S1) + 7) must be set at every instruction execution.

6.9.3 Functions

- (1) This instruction sends data stored in the devices designated with the own station's (S2) to the station designated with the target station network number and target station number in the control data. The target station must be connected to other networks or Ethernet.

The sent data is stored in the channel set with the target station's (S2).

Use the RECV/RECVS instruction when reading the data sent on the target station.

When data sending to the target station number is completed, the completion device designated in (D) turns on.

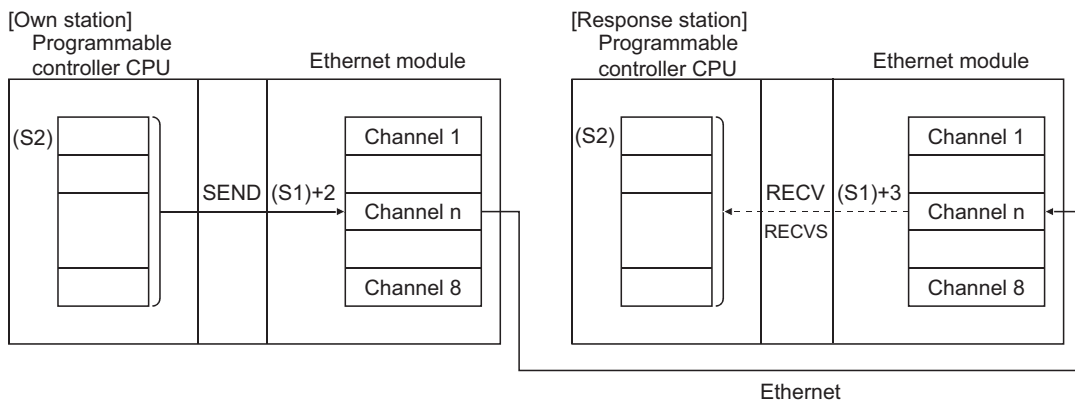

- (2) Data can be sent to stations connected to other networks or Ethernet having the specified numbers, in addition to stations connected to the own station's network.
- (3) The data link instructions and the Ethernet instructions cannot be executed from two or more stations at the same time on the same channel.

If the execution conditions are met at two or more locations at the same time, instructions to be executed later have to wait until the channel becomes available because handshaking is automatically performed at the execution of the first instruction.

(4) Whether the SEND instruction is being executed or has been completed normally or abnormally can be checked with the completion device (D2) or completion status display flag ((D2) + 1) designated in the set data.

(a) Completion device (D2)

Turns on at the END processing of the scan where the SEND instruction is completed, and turns off at the next END processing.

(b) Status display device at completion ((D2) + 1)

Turns on and off depending on the completion status of the SEND instruction.

Normal completion: Stays off and does not change.

Abnormal completion: Turns on at the END processing of the scan where the SEND instruction is completed, and turns off at the next END processing.

[Operation of the own station when the SEND instruction is being executed]

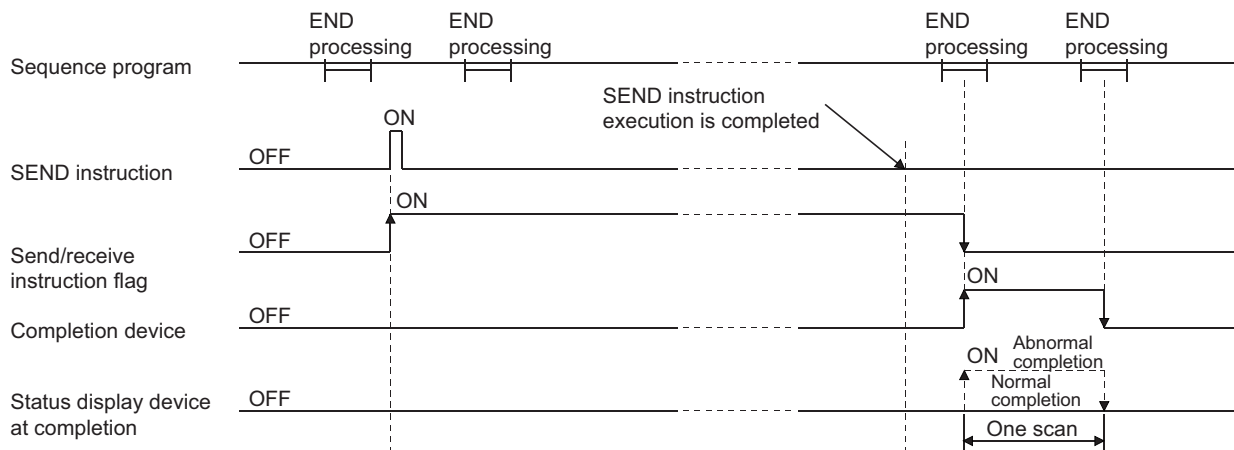

(5) When the instruction is executed using JP.SEND/GP.SEND, the send processing is executed only once when the send instruction flag switches from off to on (at rise).

6.9.4 Errors

(1) When a dedicated instruction completes abnormally, the abnormal completion signal (D) + 1 turns on and the error code is stored in the completion status (S1) + 1.

See the following manuals regarding the error code, check the errors and take corrective actions.

<Error codes>

4FFFH or less: User's Manual (Hardware Design, Maintenance and Inspection) for the CPU module used

C000H or higher: User's Manual (Basic)

6.9.5 Program example

The following example shows a program that sends data to channel 5 of station number 15.
When I/O signals of the Ethernet module are X/Y00 to X/Y1F

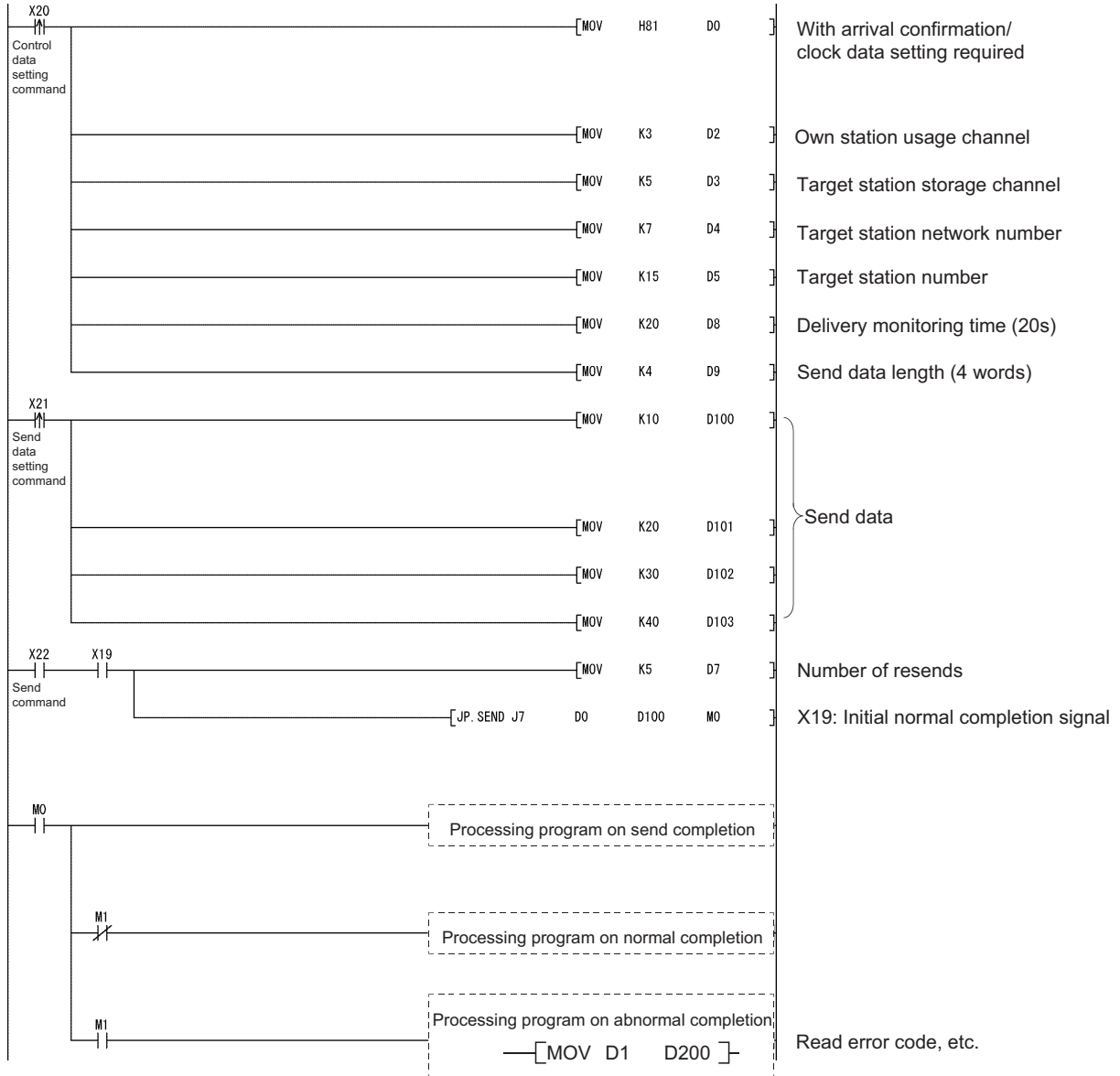

6

6.9 JP/GP.SEND

6.10 JP/GP.SREAD

This instruction reads data from word devices of other stations.

Setting data	Applicable device								
	Internal device		File register R, ZR	Link direct device J□□		Intelligent function module device U□V□	Index register Zn	Constant K, H	Others
	Bit	Word		Bit	Word				
(S1)	—	○							
(S2)	—	○*1	○						
(D1)	—	○							
(D2)	○								
(D3)	○								

*1 T, C, D, W, ST, SD, or SW can be used.

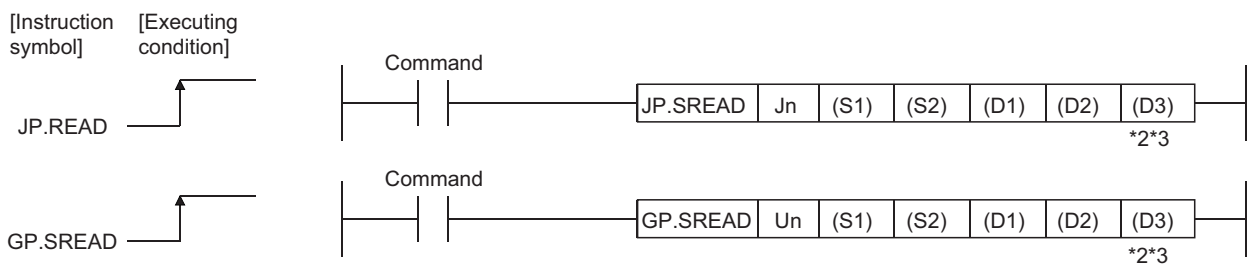

The following format can be used only when the own station is a Universal model QCPU or an LCPU.

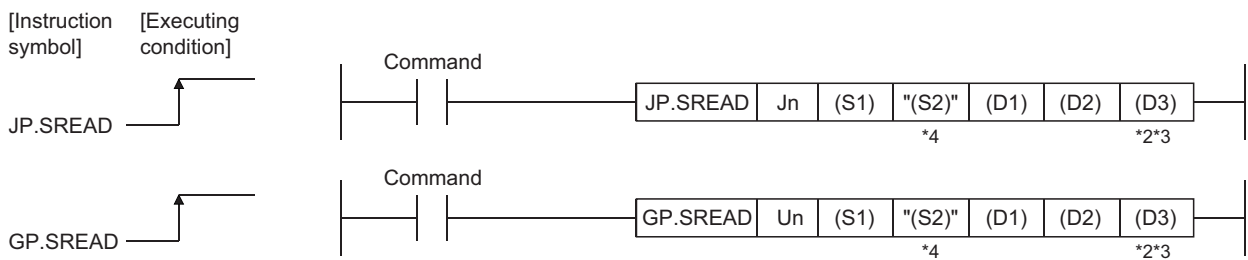

- *2 The SREAD instruction can be programmed without argument (D3). However, in such a case, the operation is identical to the READ instruction.
With the SREAD instruction, different operations are available depending on whether (D3) is omitted or not.
- *3 When the target station is a Basic model QCPU or safety CPU, the read notification device set as argument (D3) for the target station is ignored. (Same operation as with the READ instruction)
- *4 If the device setting in PLC Parameter is different between the own and target stations, use \"S2\" (with doublequotation marks).

6.10.1 Setting data

Setting data	Description	Set by ^{*1}	Data type
Jn	Network number of the own station (1 to 239, 254) 254: Network designated in a valid module for other station access	User	Binary 16 bits
Un	Start I/O signal of the own station's Ethernet module (00 to FEH: The higher 2 digits of the 3-digit I/O signal)		Character string
(S1)	Head device of the own station that stores the control data.	User, system	Device name
(S2)	Head device of the target station from which data is read.	User	
(D1)	Head device of the own station that stores data read.	System	
(D2)	Own station device that is turned on for one scan by completion of the instruction. (D2) + 1 turns on if the instruction execution completes abnormally.		
(D3)	Device of the target station that is turned on for one scan by completion of the instruction. (Read notification device)	System	Bit

*1 The "Set by" column indicates the following:

- User: Data is set by the user before executing a dedicated instruction.
- System: The programmable controller CPU stores the execution result of a dedicated instruction.

The local devices and the file register for each program cannot be used as the device used for the setting data.

Point

- The SREAD instruction can be executed only when the target station is Q/L/QnACPU.
(The SREAD instruction cannot be executed for an ACPU connected to the MELSECNET/10 or Ethernet network systems.)
Therefore, the target station numbers should be the station numbers of Q/L/QnACPU.
- When reading data from the other station CPU module device with the SREAD instruction, specify the device within the range applicable to the host station CPU module.
(Head device number to be read in other station CPU module (S2)) + (number of read points - 1) ≤ (last device number of host station CPU module)
Last device number in host station CPU module having the same device name as (S2).
- Use the file register (ZR) when specifying the expansion data register (D) or the expansion link register (W) that are out of area of the data register (D) or the link register (W) on the host CPU module respectively (excluding the Universal model QCPU and the LCPU).
For how to calculate areas for the file register (ZR), refer to the User's Manual (Function Explanation, Program Fundamentals) for the CPU module used.
(Example)
When not assigning the data register (D) of the other station CPU module, or assigning all of the 32K points of the file register (ZR) to the expansion data register (D).

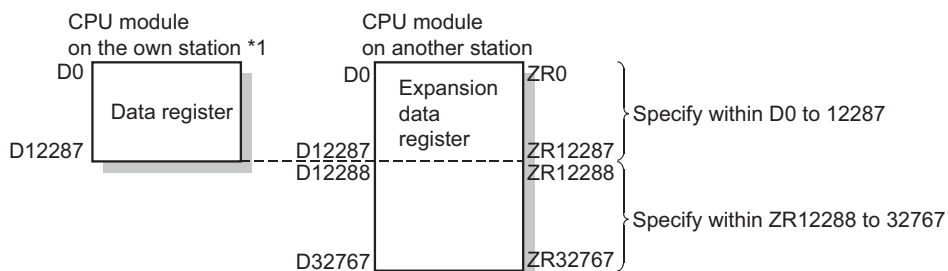

*1 File register with 32K points or more is required for the CPU module on the own station.

Remark

The number of steps for the SREAD instruction is 10.

6.10.2 Control data

See Page 170, Section 6.4 for how to handle the control data of the SREAD instruction when reading from the word device memory of other stations.

The control data should be handled in the same way as when reading the word device memory using the READ instruction.

Thus, this section omits its explanation.

6.10.3 Functions

- (1) This instruction reads the designated word device data of the station designated with the target station network number and target station number in the control data. The station must be connected to other networks or Ethernet.**

When reading the device data from other stations is completed, the completion device designated in (D2) turns on.

Also, when sending the device data designated in (S2) is completed, the device on other stations designated in (D3) turns on.

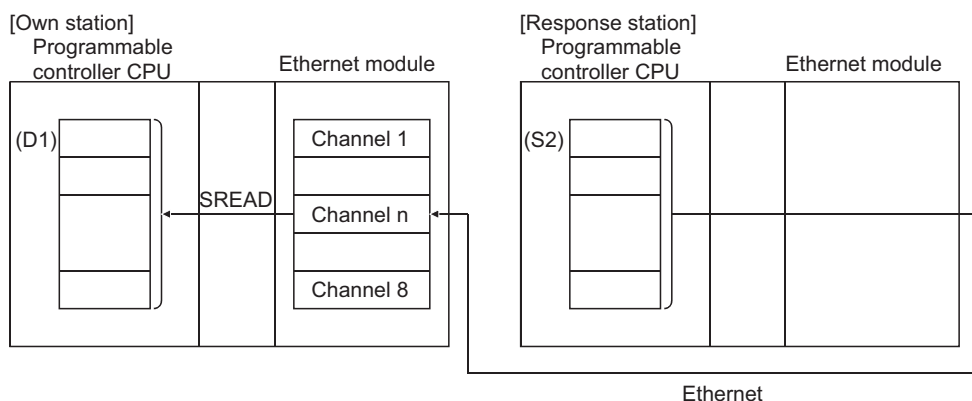

- (2) Device data can be read from stations connected to other networks or Ethernet having the specified numbers, in addition to stations connected to the own station's network.**

- (3) The data link instructions and the Ethernet instructions cannot be executed from two or more stations at the same time on the same channel.**

If the execution conditions are met at two or more locations at the same time, instructions to be executed later have to wait until the channel becomes available because handshaking is automatically performed at the execution of the first instruction.

(4) Whether the SREAD instruction is being executed or has been completed normally or abnormally can be checked with the send/receive instruction flag corresponding to the channel used, completion device (D2), or completion status display flag ((D2) + 1) designated in the set data.

(a) Completion device (D2)

Turns on at the END processing of the scan where the SREAD instruction is completed, and turns off at the next END processing.

(b) Status display device at completion ((D2) + 1)

Turns on and off depending on the completion status of the SREAD instruction.

Normal completion: Stays off and does not change.

Abnormal completion: Turns on at the END processing of the scan where the SREAD instruction is completed, and turns off at the next END processing.

[Operation of the own station when the SREAD instruction is being executed]

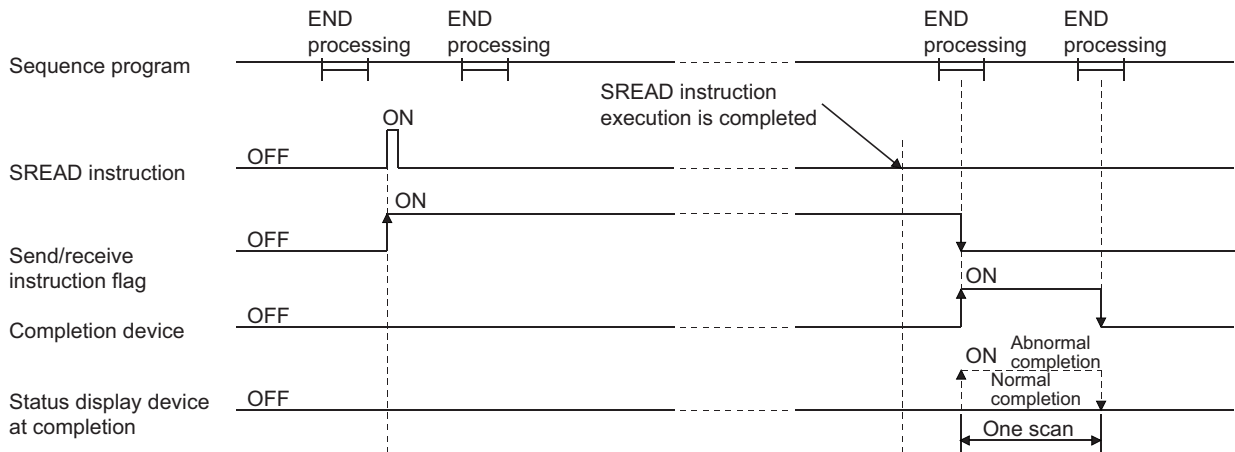

[Operation of the other station when the SREAD instruction is being executed]

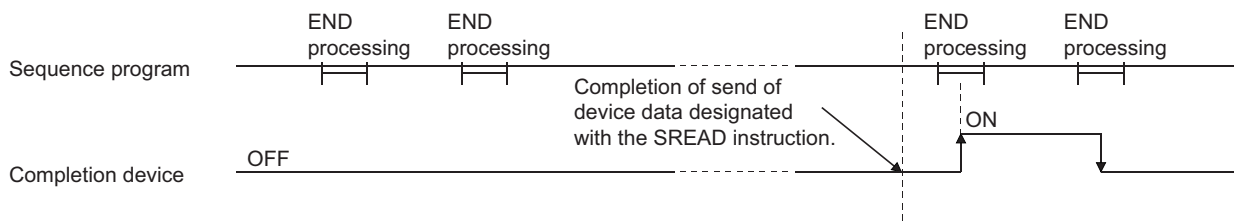

(5) When the instruction is executed using J.SREAD/G.SREAD, the next read processing is executed in succession after one read processing is completed while the read command is on.

When the instruction is executed using JP.SREAD/GP.SREAD, the read processing is executed only once when the read command switches from off to on (at rise).

6.10.4 Errors

- (1) **When a dedicated instruction completes abnormally, the abnormal completion signal (D2) + 1 turns on and the error code is stored in the completion status (S1) + 1.**

See the following manuals regarding the error code, check the errors and take corrective actions.

<Error codes>

4FFFH or less:  User's Manual (Hardware Design, Maintenance and Inspection) for the CPU module used

C000H or higher:  User's Manual (Basic)

6.10.5 Program example

See the program example of the READ instruction described in Page 170, Section 6.4.

The SREAD instruction only differs from the READ instruction on one point, namely that the read notification device (D3) is designated at the end of arguments.

6.11 JP/GP.SWRITE

This instruction writes data to word devices of other stations.

Setting data	Applicable device								
	Internal device		File register R, ZR	Link direct device J□\□		Intelligent function module device U□\G□	Index register Zn	Constant K, H	Others
	Bit	Word		Bit	Word				
(S1)	—	○		—					
(S2)	—	○		—					
(D1)	—	○*1	○	—					
(D2)	○			—					
(D3)	○			—					

- *1 T, C, D, W, ST, SD or SW can be used.
For SD/SW, data can be written within the setting range allowed for the user.
For details on SD/SW, refer to the manual for the programmable controller CPU or network module of the target station.

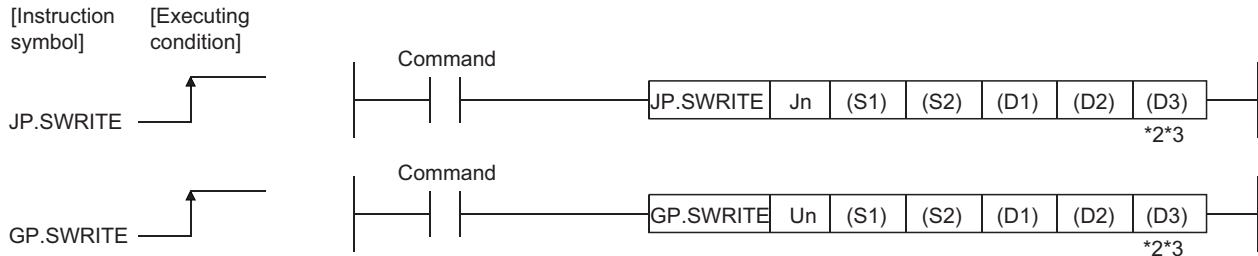

The following format can be used only when the own station is a Universal model QCPU or an LCPU.

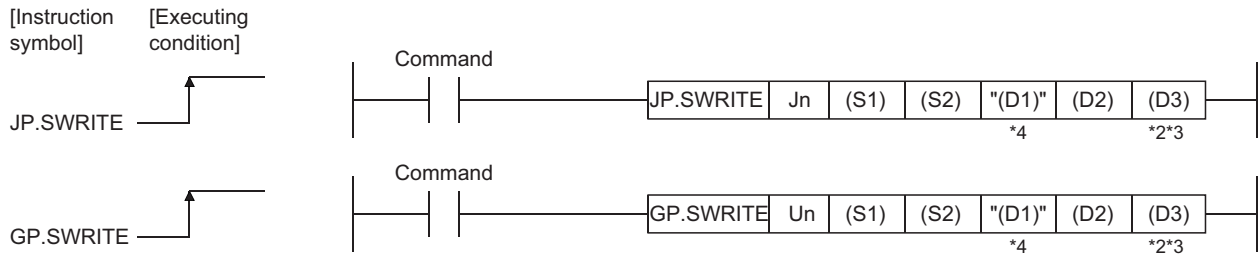

- *2 The SWRITE instruction can be programmed without argument (D3). However, in such a case, the operation is identical to the WRITE instruction.
With the SWRITE instruction, different operations are available depending on whether (D3) is omitted or not.
- *3 When the target station is a Basic model QCPU or safety CPU, the write notification device set as argument (D3) for the target station is ignored. (Same operation as with the WRITE instruction)
- *4 If the device setting in PLC Parameter is different between the own and target stations, use \"(D1)\" (with doublequotation marks).

6.11.1 Setting data

Setting data	Description	Set by*1	Data type
Jn	Network number of the own station (1 to 239, 254) 254: Network designated in a valid module for other station access	User	Binary 16 bits
Un	Start I/O signal of the own station's Ethernet module (00 to FEH: The higher 2 digits of the 3-digit I/O signal)		Character string
(S1)	Head device of the own station that stores the control data.	User, system	Device name
(S2)	Head device of the own station that stores data to be written.	User	
(D1)	Head device of the target station to which data is written.		
(D2)	Own station device that is turned on for one scan by completion of the instruction. (D2) + 1 turns on if the instruction execution completes abnormally.	System	Bit
(D3)	Device of the target station that is turned on for one scan by completion of the instruction. (Write notification device)		

*1 The "Set by" column indicates the following:

- User: Data is set by the user before executing a dedicated instruction.
- System: The programmable controller CPU stores the execution result of a dedicated instruction.

The local devices and the file register for each program cannot be used as the device used for the setting data.

Point

- The SWRITE instruction can be executed only when the target station is a Q/L/QnACPU.
(The SWRITE instruction cannot be executed for an ACPU connected to the MELSECNET/10 or Ethernet network system.)
Therefore, the target station numbers should be the station numbers of Q/L/QnACPU.
- When writing data from the other station CPU module device with the SWRITE instruction, specify the device within the range applicable to the host station CPU module.
(Head device number to be write in other station CPU module (D1)) + (number of write points - 1) ≤ (last device number of host station CPU module)
Last device number in host station CPU module having the same device name as (D1).
- Use the file register (ZR) when specifying the expansion data register (D) or the expansion link register (W) that are out of area of the data register (D) or the link register (W) on the host CPU module respectively (excluding the Universal model QCPU and the LCPU).
For how to calculate areas for the file register (ZR), refer to the User's Manual (Function Explanation, Program Fundamentals) for the CPU module used.
(Example)
When not assigning the data register (D) of the other station CPU module, or assigning all of the 32K points of the file register (ZR) to the expansion data register (D).

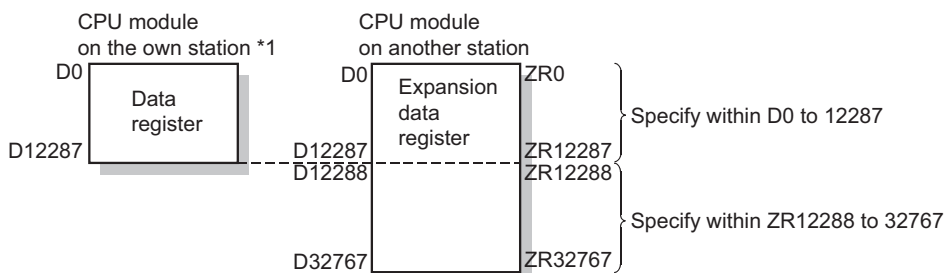

*1 File register with 32K points or more is required for the CPU module on the own station.

Remark

The number of steps for the SWRITE instruction is 11.

6.11.2 Control data

See Page 216, Section 6.12 for information about how to handle the control data of the SWRITE instruction when writing to the word device memory of other station.

The control data should be handled is the same as when writing to the word device memory using the WRITE instruction.

Thus, this section omits its explanation.

6.11.3 Functions

- (1) This instruction writes data in the device designated in (S2) and succeeding devices of the own station to the word devices of the station, which is connected to other networks or Ethernet that has been specified with the target station network number and target station number in the control data.**

When writing device data from other stations' number is completed, the completion device designated in (D2) turns on.

Also, when writing the device data designated in (S2) is completed, the device on other stations designated in (D3) turns on.

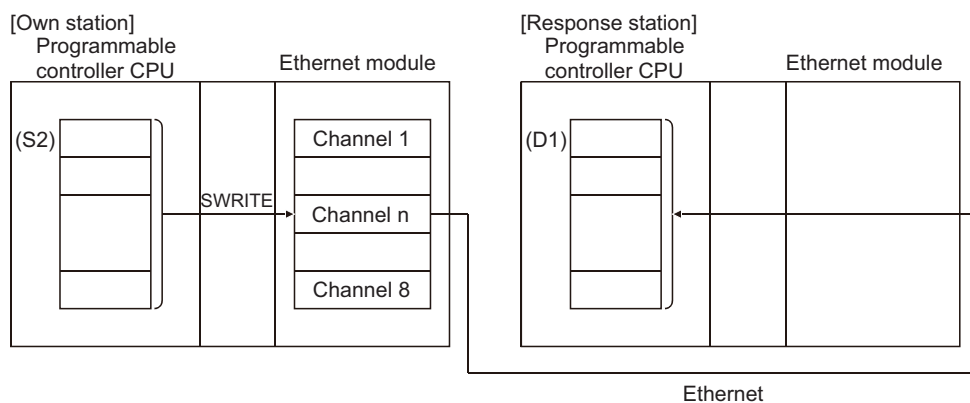

- (2) Device data can be written to stations connected to other networks or Ethernet having the specified numbers, in addition to stations connected to the own station's network.**
- (3) The data link instructions and the Ethernet instructions cannot be executed from two or more stations at the same time on the same channel.**

If the execution conditions are met at two or more locations at the same time, instructions to be executed later have to wait until the channel becomes available because handshaking is automatically performed at the execution of the first instruction.

(4) Whether the SWRITE instruction is being executed or has been completed normally or abnormally can be checked with the send/receive instruction flag corresponds to the channel used, completion device (D2), or completion status display flag ((D2) + 1) designated in the set data.

(a) Completion device (D2)

Turns on at the END processing of the scan where the SWRITE instruction is completed, and turns off at the next END processing.

(b) Status display device at completion ((D2) + 1)

Turns on and off depending on the completion status of the SWRITE instruction.

Normal completion: Stays off and does not change.

Abnormal completion: Turns on at the END processing of the scan where the SWRITE instruction is completed, and turns off at the next END processing.

[Operation of the own station when the SWRITE instruction is being executed]

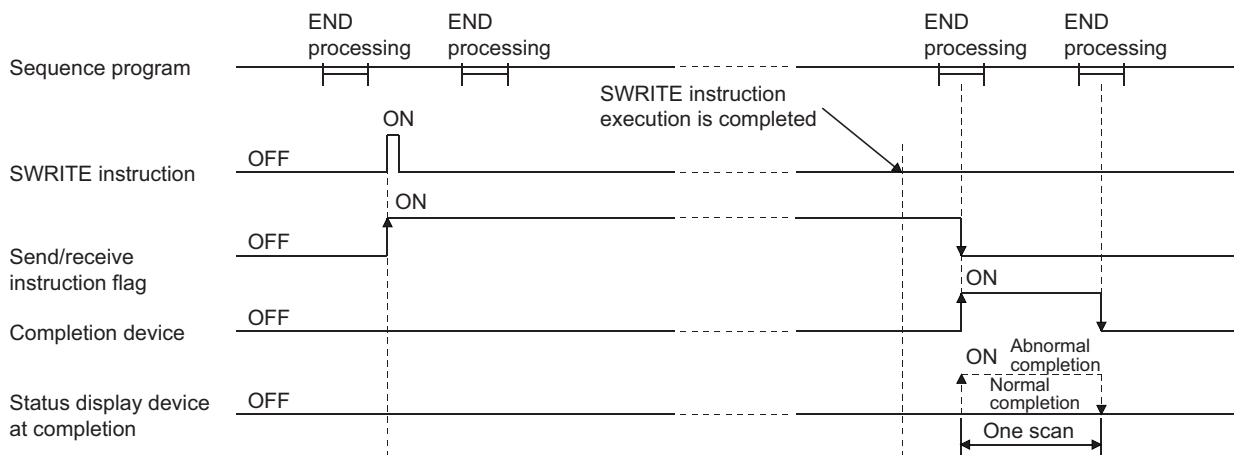

[Operation of the other station when the SWRITE instruction is being executed]

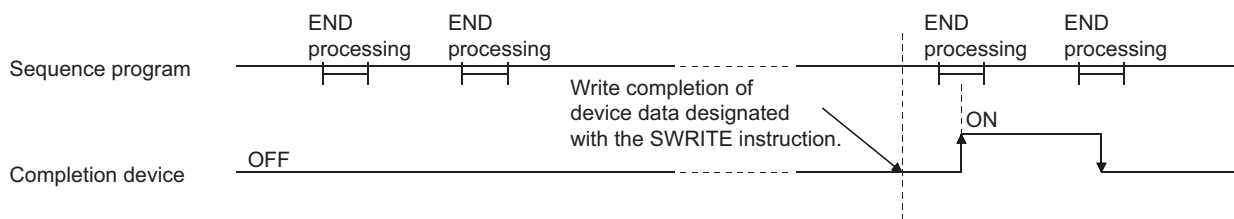

(5) When the instruction is executed using J.SWRITE/G.SWRITE, the next read processing is executed in succession after one read processing is completed while the read command is on.

When the instruction is executed using JP.SWRITE /GP.SWRITE, the read processing is executed only once when the read command switches from off to on (at rise).

6.11.4 Errors

- (1) When a dedicated instruction completes abnormally, the abnormal completion signal (D2) + 1 turns on and the error code is stored in the completion status (S1) + 1.

See the following manuals regarding the error code, check the errors and take corrective actions.

<Error codes>

4FFFH or less: User's Manual (Hardware Design, Maintenance and Inspection) for the CPU module used

C000H or higher: User's Manual (Basic)

6.11.5 Program example

The following example shows a program that writes the data stored in D300 to 303 of station number 3. When I/O signals of the Ethernet module are X/Y40 to X/Y5F

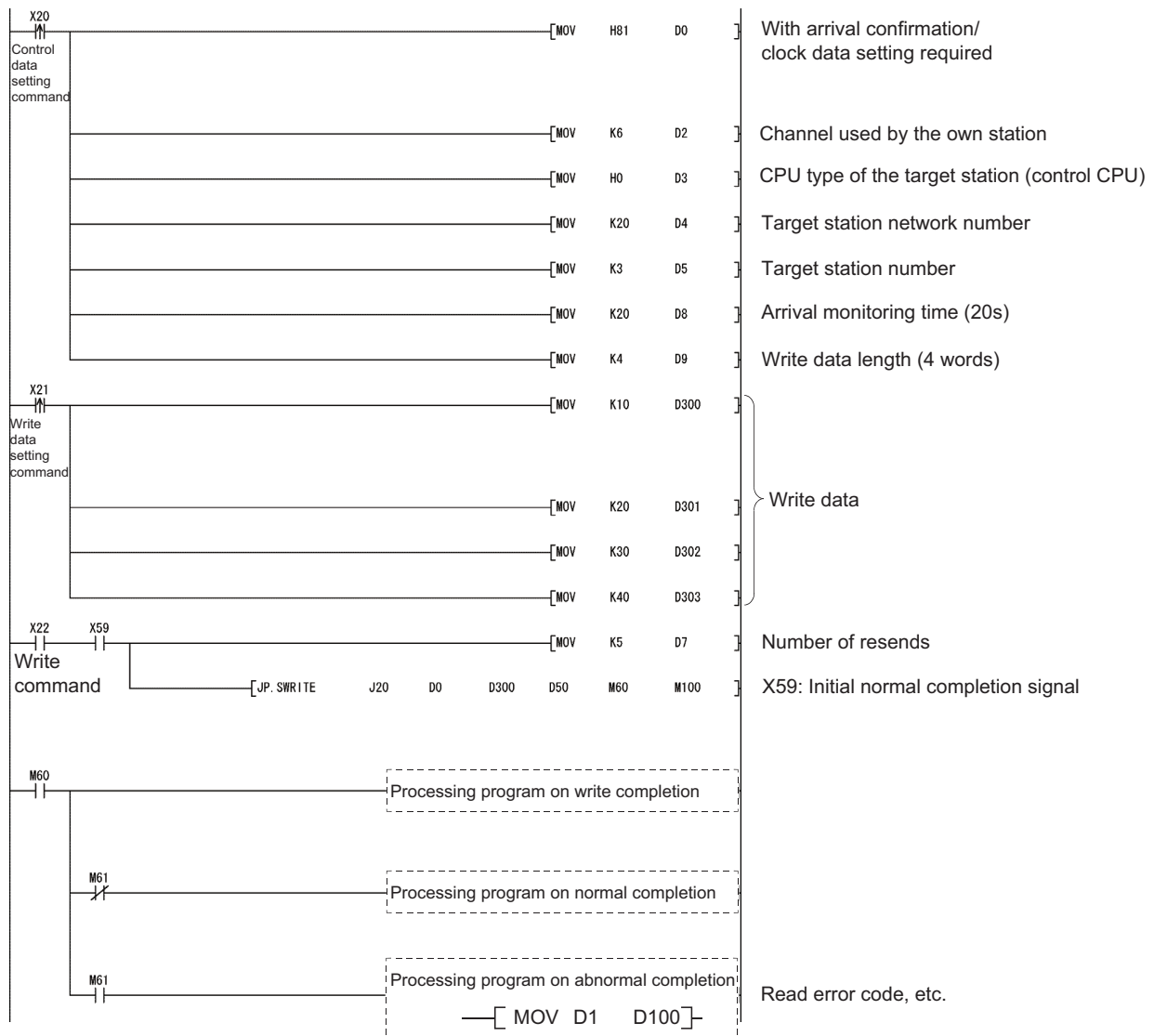

6.12 JP/GP.WRITE

This instruction writes data to word devices of other stations.

Setting data	Applicable device								
	Internal device		File register R, ZR	Link direct device J□\□		Intelligent function module device U□\G□	Index register Zn	Constant K, H	Others
	Bit	Word		Bit	Word				
(S1)	—	○		—					
(S2)	—	○		—					
(D1)	—	○*1	○	—					
(D2)	○			—					

*1 T, C, D, W, ST, SD or SW can be used.
 For SD/SW, data can be written within the setting range allowed for the user.
 For details on SD/SW, refer to the manual for the programmable controller CPU or network module of the target station.

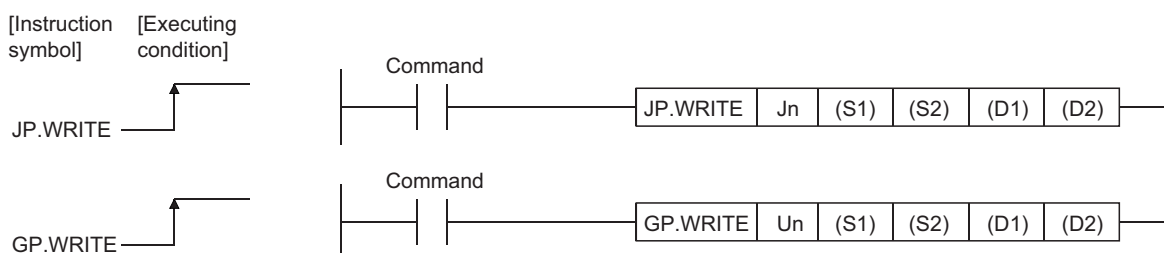

The following format can be used only when the own station is a Universal model QCPU or an LCPU.

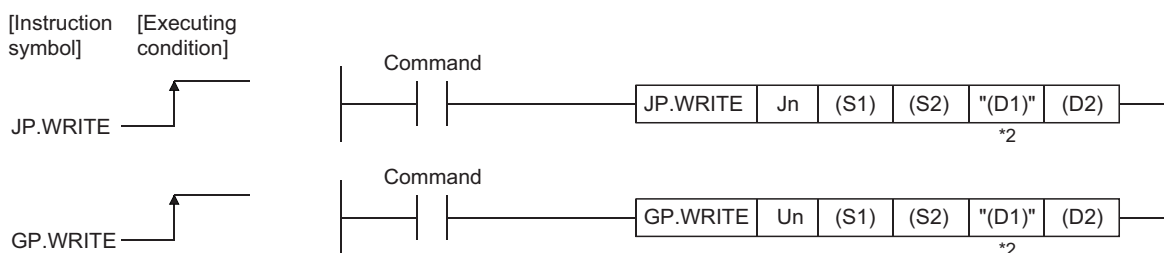

*2 If the device setting in PLC Parameter is different between the own and target stations, use \"(D1)\" (with doublequotation marks).

6.12.1 Setting data

Setting data	Description	Set by ^{*1}	Data type
Jn	Network number of the own station (1 to 239, 254) 254: Network designated in a valid module for other station access	User	Binary 16 bits
Un	Start I/O signal of the own station's Ethernet module (00 to FEH: The higher 2 digits of the 3-digit I/O signal)		Character string
(S1)	Head device of the own station that stores the control data.	User, system	Device name
(S2)	Head device of the own station that stores data to be written.	User	
(D1)	Head device of the target station to which data is written.		
(D2)	Own station device that is turned on for one scan by completion of the instruction. (D2) + 1 turns on if the instruction execution completes abnormally.	System	Bit

*1 The "Set by" column indicates the following:

- User: Data is set by the user before executing a dedicated instruction.
- System: The programmable controller CPU stores the execution result of a dedicated instruction.

The local devices and the file register for each program cannot be used as the device used for the setting data.

Point

- The WRITE instruction can be executed only when the target station is the Q/L/QnACPU.
(The WRITE instruction cannot be executed for an ACPU connected to the MELSECNET/10 or Ethernet network systems.)
Therefore, the target station numbers should be the station numbers of Q/L/QnACPU.
- When writing data from the other station CPU module device with the WRITE instruction, specify the device within the range applicable to the host station CPU module.
(Head device number to be write in other station CPU module (D1)) + (number of write points -1) ≤ (last device number of host station CPU module)
Last device number in host station CPU module having the same device name as (D1).
- Use the file register (ZR) when specifying the expansion data register (D) or the expansion link register (W) that are out of area of the data register (D) or the link register (W) on the host CPU module respectively (excluding the Universal model QCPU and the LCPU).
For how to calculate areas for the file register (ZR), refer to the User's Manual (Function Explanation, Program Fundamentals) for the CPU module used.
(Example)
When not assigning the data register (D) of the other station CPU module, or assigning all of the 32K points of the file register (ZR) to the expansion data register (D).

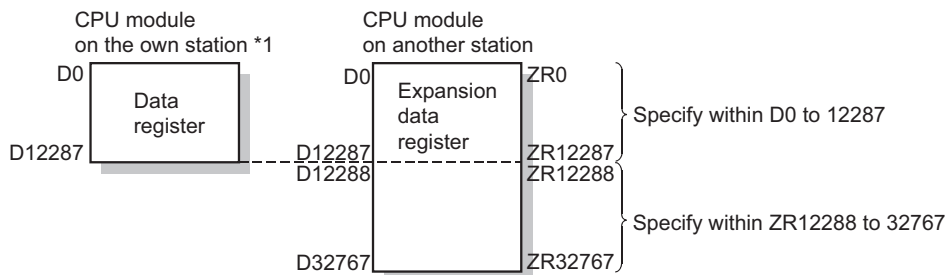

*1 File register with 32K points or more is required for the CPU module on the own station.

Remark

- Setting values stored in Completion status ((S1) + 1) and Clock data ((S1) + 10 to (S1) + 14) are stored into control data upon completion of the instruction.
- The number of steps for the WRITE instruction is 10.

6.12.2 Control data

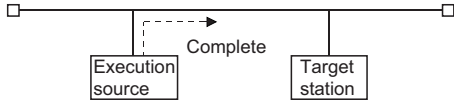
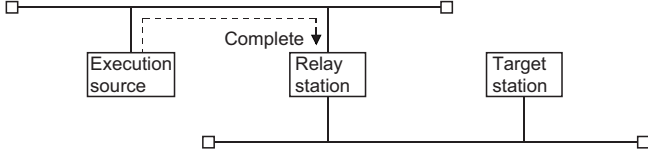
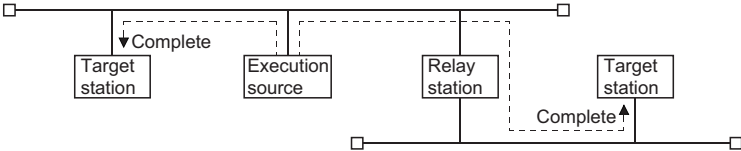
Device	Item	Setting data	Setting range	Set by ^{*1}
(S1) + 0	Execution/ab normal complete type	<p style="text-align: center;"> b15 to b8 b7 to b0 ┌───────────┬───────────┬──┬──┬───────────┬───────────┐ │ 0 │3)│2)│ 0 │ 1)│ └───────────┴───────────┴──┴──┴───────────┴───────────┘ </p> <p>1) Execution type (bit 0) 0: No arrival confirmation When the target station is on the same network ... Completed when the data is sent from the own station.</p>  <p>When the target station is on other network ... Completed when the data arrives at the relay station on the network of the local station.</p>  <p>1: With arrival confirmation Completed when data is written to the target station.</p>  <p>2) Abnormal complete type (bit 7) Set whether or not the clock data setting is required at abnormal completion. 0: Clock data setting is not required ... Clock data is not stored in (S1) + 11 to (S1) + 17 when errors occur. 1: Clock data setting required ... Clock data is stored in (S) + 11 to (S) + 17 when errors occur. 3) Arrival monitoring time unit (bit 8) Set a unit for arrival monitoring time. Set the arrival monitoring time to (S1) + 8. 0: Increments of 1s 1: Increments of 100ms</p>	0000H 0001H 0080H 0081H 0100H 0101H 0180H 0181H	User
(S1) + 1	Completion status	Store the status at the completion of the instruction. 0: Normal Other than 0: Abnormal (error code) ^{*2}	—	System
(S1) + 2	Channel used by the own station	Designate the channel used by the own station. 1 to 8 (channel)	1 to 8	User
(S1) + 3	Target station's CPU type ^{*3}	Specify the programmable controller CPU of the access destination in the target station. • 0000H: Control CPU (The access destination is the same as that with 03FFH selected.) • 03D0H: Control system CPU ^{*5} • 03D1H: Standby system CPU ^{*5} • 03D2H: System A CPU • 03D3H: System B CPU • 03FFH: Control CPU	0000H 03D0H to 03D3H 03FFH	User
(S1) + 4	Target station network number	Designate the network number of the target station. 1 to 239: Network number 254: When 254 is designated in Jn (The network designated by the valid module during other station access) ¹ 1 to 239, 254	1 to 239, 254	User

Device	Item	Setting data	Setting range	Set by ^{*1}															
(S1) + 5	Target station number	Designate the target station. 1) Station number specification When the own station is a Universal model QCPU or an LCPU: 1 to 120 When the own station is not a Universal model QCPU or an LCPU: 1 to 64 2) Specific group 81H to A0H: All stations of group number (Can be set when the execution type designated in (S1) is "0: No arrival confirmation.") 3) All stations FFH: All stations of the target network number (simultaneous broadcast) ... excluding the own station (Can be set when the execution type designated in (S1) is "0: No arrival confirmation.")	1 to 120 81H to A0H FFH	User															
(S1) + 6	—	(Fixed value)	0	User															
(S1) + 7	Number of resends	Valid when the execution type designated in (S1) is "1: With arrival confirmation." 1) At the instruction execution Set the number of resends when the instruction is not completed within the monitoring time designated by (S1) + 8. 0 to 15 (times) ^{*7} 2) At the instruction completion Store the number of resends executed (result). 0 to 15 (times)	0 to 15	User System															
(S1) + 8	Arrival monitoring time	When the instruction fails to complete within the monitoring time, it is resent for the number of resends designated in (S1) + 7. ^{*7}	When setting "1s" to (S1) + 0 (arrival monitoring time unit), set a value greater than or equal to the TCP resend timer value for the monitoring time up to instruction processing termination. 0 to TCP resend timer value: Monitoring is performed by the time set to the TCP resend timer. (TCP resend timer value + 1) to 16383: Monitoring time (unit: Second)	0 to 16383	User														
			When setting "100ms" to (S1) + 0 (arrival monitoring time unit) 1 to 65535: Monitoring time (unit: 0.1 seconds)	1 to 65535															
(S1) + 9	Write data length	Designate the number of write data in (S2) to (S2) + n. When writing to Q/LCPU: 1 to 960 (Word) When writing to QnACPU: 1 to 480 (Word) ^{*6}	1 to 960	User															
(S1) + 10	(Not used)	—	—	—															
(S1) + 11	Clock set flag	Store the valid/invalid status of the clock data in (S1) + 12 to (S1) + 17. This data is stored only when the bit 7 of Abnormal complete type ((S1) + 0) is 1. The stored value is not cleared even when the dedicated instruction is normally completed. 0: Invalid 1: Valid	—	System															
(S1) + 12 ⋮ (S1) + 15	Clock data (set only if an error occurs)	The clock data upon abnormal end is stored in BCD. This data is stored only when the bit 7 of Abnormal complete type ((S1) + 0) is 1. The stored value is not cleared even when the dedicated instruction is normally completed.	—	System															
		<table border="1" style="margin-left: auto; margin-right: auto;"> <thead> <tr> <th></th> <th>b15 to b8</th> <th>b7 to b0</th> </tr> </thead> <tbody> <tr> <td>(S1)+12</td> <td>Month (01H to 12H)</td> <td>Year (00H to 99H), Last 2 digits</td> </tr> <tr> <td>(S1)+13</td> <td>Hour (00H to 23H)</td> <td>Date (01H to 31H)</td> </tr> <tr> <td>(S1)+14</td> <td>Second (00H to 59H)</td> <td>Minute (00H to 59H)</td> </tr> <tr> <td>(S1)+15</td> <td>Year (00H to 99H), First 2 digits</td> <td>Day of the week (00H to 06H)</td> </tr> </tbody> </table> <p style="text-align: center;">00H (Sun.) to 06H (Sat.)</p>		b15 to b8	b7 to b0	(S1)+12	Month (01H to 12H)	Year (00H to 99H), Last 2 digits	(S1)+13	Hour (00H to 23H)	Date (01H to 31H)	(S1)+14	Second (00H to 59H)	Minute (00H to 59H)	(S1)+15	Year (00H to 99H), First 2 digits	Day of the week (00H to 06H)		
	b15 to b8	b7 to b0																	
(S1)+12	Month (01H to 12H)	Year (00H to 99H), Last 2 digits																	
(S1)+13	Hour (00H to 23H)	Date (01H to 31H)																	
(S1)+14	Second (00H to 59H)	Minute (00H to 59H)																	
(S1)+15	Year (00H to 99H), First 2 digits	Day of the week (00H to 06H)																	
(S1) + 16	Abnormal detection network number ^{*4}	Stores the network number of the station that detected an abnormality. This data is stored only when the bit 7 of Abnormal complete type ((S1) + 0) is 1. The stored value is not cleared even when the dedicated instruction is normally completed. 1 to 239 (Network number)	—	System															
(S1) + 17	Abnormal detection station number ^{*4}	Stores the station number of the station that detected an abnormality. This data is stored only when the bit 7 of Abnormal complete type ((S1) + 0) is 1. The stored value is not cleared even when the dedicated instruction is normally completed. 1 to 120 (Station number)	—																

6

6.12 JPI/GP.WRITE

- *1 The "Set by" column indicates the following:
 - User: Data is set by the user before executing a dedicated instruction.
 - System: The programmable controller CPU stores the execution result of a dedicated instruction.
- *2 For a list of error codes, see the User's Manual (Basic).
- *3 It can be specified when the own station has an Ethernet module of function version D or later.
(Not available for any other case. Access to the control CPU is required.)
- *4 Nothing is stored if the execution source detects an error when receiving an instruction.
- *5 When the WRITE instruction is executed to the redundant system with a control system or standby system CPU specified, the instruction may be unsuccessfully completed due to system switching occurred on the target station.
(Error code: 4244H, 4248H)
If this has occurred, execute the WRITE instruction again.
- *6 When data of more than 480 words is specified, a C084H error occurs on the own station.
Check the write data length (1 to 480 words) and execute the WRITE instruction.
- *7 For how to determine the setting values of the number of resends and arrival monitoring time and their setting examples, refer to Page 232, Appendix 1.

Point

- The data written storage device (D1) requires a contiguous free area equal to or greater than the write data length ((S1) + 9) (maximum of 960 words).
 - In order to increase the reliability of the data, it is recommended to execute the instruction by setting the execution type to "With arrival confirmation" when a number from one to 120 is designated for the target station number.
When 81H to A0H or FFH is designated for the target station number, the instruction should be executed by setting the execution type to "No arrival confirmation."
 - When writing to a device of the same station from multiple stations, make sure that the timings of the write operations do not coincide.
If the communication itself is normally completed when the execution type is set to "No arrival confirmation," the send is considered normally completed on the write source station even if the contents of the send data are abnormal.
In addition, even if the contents of the send data are normal, when the instruction is executed to the same station from multiple stations, a timeout error (C083H) will occur on the write source station.
 - The number of resends ((S1) + 7) must be set at every instruction execution.
-

Remark

The allowable write data length ((S1) + 9) of the WRITE instruction varies depending on the version. ( User's Manual (Basic))
Specifying a length value outside the setting range will cause a 4101 error (OPERATION ERROR) on the own station.

6.12.3 Functions

- (1) This instruction writes data for the device designated in (S2) of the own station and succeeding devices to the word devices of the station designated with the target station network number and target station number in the control data. The station must be connected to a network other than those designated or Ethernet.

When writing device data to other station number is completed, the completion device designated in (D2) turns on.

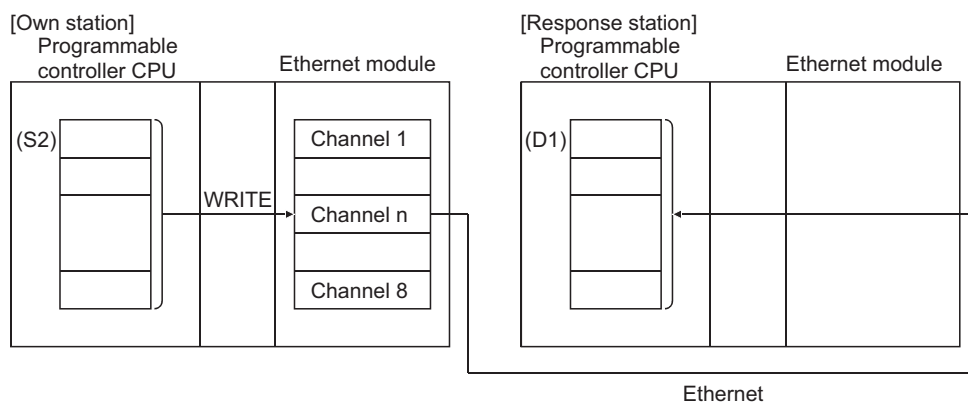

- (2) Device data can be written to stations connected to other networks or Ethernet having the specified numbers, in addition to stations connected to the own station's network.
- (3) The data link instructions and the Ethernet instructions cannot be executed from two or more stations at the same time on the same channel.

If the execution conditions are met at two or more locations at the same time, instructions to be executed later have to wait until the channel becomes available because handshaking is automatically performed at the execution of the first instruction.

(4) Whether the WRITE instruction is being executed or has been completed normally or abnormally can be checked with the completion device (D2) or completion status display flag ((D2) + 1) designated in the set data.

(a) Completion device (D2)

Turns on at the END processing of the scan where the WRITE instruction is completed, and turns off at the next END processing.

(b) Status display device at completion ((D2) + 1)

Turns on and off depending on the completion status of the WRITE instruction.

Normal completion: Stays off and does not change.

Abnormal completion: Turns on at the END processing of the scan where the WRITE instruction is completed, and turns off at the next END processing.

[Operation of the own station when the WRITE instruction is being executed]

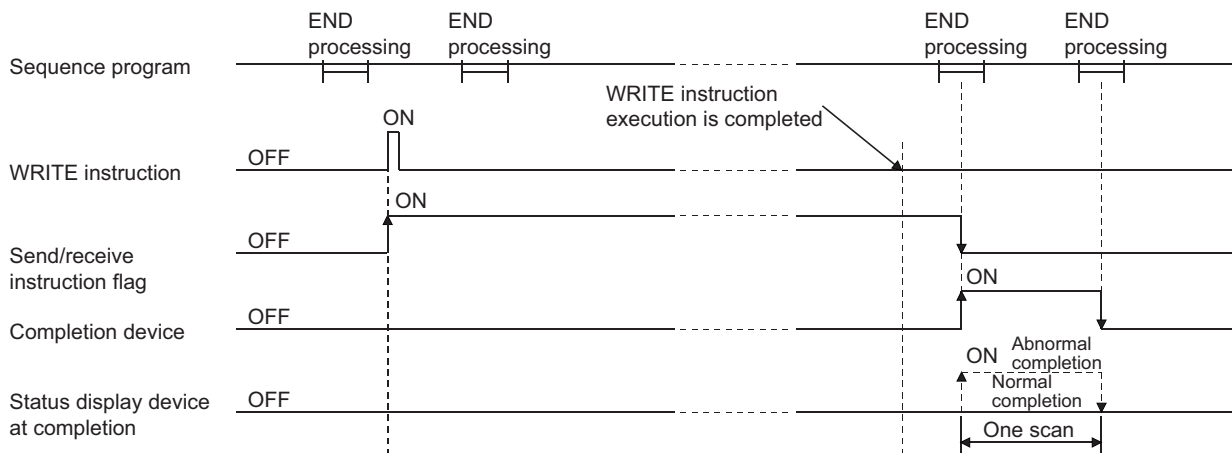

(5) When the instruction is executed using J.WRITE/G.WRITE, the next write processing is executed in succession after one write processing is completed while the write command is on.

When the instruction is executed using JP.WRITE/GP.WRITE, the write processing is executed only once when the write command switches from off to on (at rise).

6.12.4 Errors

- (1) When a dedicated instruction completes abnormally, the abnormal completion signal (D2) + 1 turns on and the error code is stored in the completion status (S1) + 1.

See the following manuals regarding the error code, check the errors and take corrective actions.

<Error codes>

4FFFH or less:  User's Manual (Hardware Design, Maintenance and Inspection) for the CPU module used

C000H or higher:  User's Manual (Basic)

6.12.5 Program example

See the program example of the SWRITE instruction described in Page 211, Section 6.11.

The SWRITE instruction only differs from the WRITE instruction on one point, namely that the write notification device (D3) is not designated at the end of arguments.

6.13 J(P).ZNRD

This instruction reads data from word devices of other stations (ACPU).

Setting data	Applicable device								
	Internal device		File register R, ZR	Link direct device J□□		Intelligent function module device U□\G□	Index register Zn	Constant K, H	Others
	Bit	Word		Bit	Word				
n1	—	○					○	—	
(S)	—	○*1	—				—	—	
(D1)	—	○					—	—	
n2	○						○	—	
(D2)	○						—	—	

*1 Can only use T, C, D, W

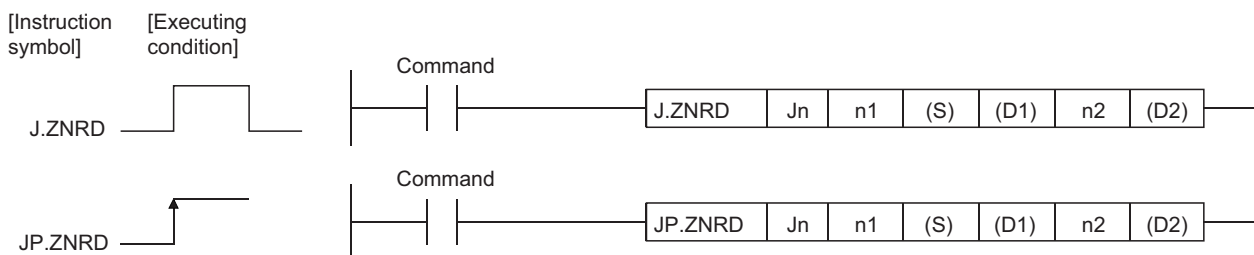

6.13.1 Setting data

Setting data ^{*1*2}	Description	Setting range	Set by ^{*3}	Data type
Jn	Target station network number Designate the network number of the target station.	1 to 239	User	Binary 16 bits
n1	Target station number Designates the station number of the target station.	1 to 64 (constant)		Character string
(S)	Read data storage head device (target station) Designate the head device of the target station that stores the data to read.	—	—	Device name
(D1)	Read data storage head device (own station) Designate the head device of the own station that stores the data to read.	—		
n2	Read data length Designates the number of data (word count) to be read.	When reading from Q/L/QnA/AnUCPU 1 to 230 (constant) When reading from programmable controller CPUs other than Q/L/QnA/AnUCPU 1 to 32 (constant)	User	BIN 16 bits
(D2)	Read completion device (own station) Designate device that is turned on for one scan by the read completion (D2) ... OFF: Incomplete, ON: Complete (D2) + 1 ... OFF: Normal, ON: Error	—	System	Bit

- *1 The local devices and the file register for each program cannot be used as the device used for the setting data.
- *2 In addition to the setting data, the ZNRD instruction is executed using the following fixed values.
 Channel used by own station: Channel 1
 Arrival monitoring time (monitoring time until instruction completion): 10 seconds
 Number of resends for arrival monitoring timeout: 5 times
- *3 The "Set by" column indicates the following:
- User: Data is set by the user before executing a dedicated instruction.
 - System: The programmable controller CPU stores the execution result of a dedicated instruction.

Point

- The ZNRD instruction can be executed when the target station is a Q/L/QnA/AnUCPU. Access to an AnUCPU is available via MELSECNET/10.
- When reading data from the other station CPU module device with the ZNRD instruction, specify the device within the range applicable to the host station CPU module.
 (Head device number to be read in other station CPU module (S)) + (number of read points -1) ≤ (last device number of host station CPU module)
 Last device number in host station CPU module having the same device name as (S).
- The normal or abnormal read completion status is stored in the data link instruction execution result (ZNRD instruction) storage area (address: 207).
 If the read completion device ((D2) + 1) is on due to abnormal end, read the error code stored in the area mentioned above and correct the error accordingly.

6.13.2 Functions

- (1) This instruction reads n2 points of data from the word device of the connected station having the network number designated by Jn/n1 in the Ethernet network system.

When reading the device data is completed, the completion device designated in (D2) turns on.

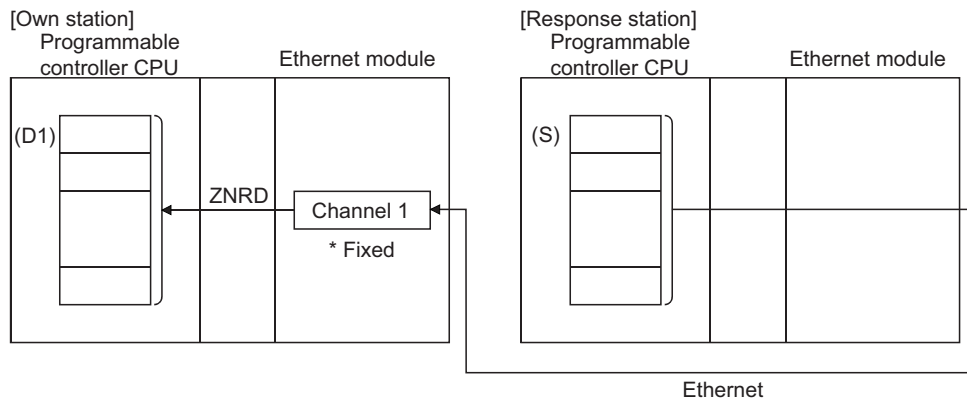

- (2) The ZNRD instruction is executed using channel 1 (fixed).

The data link instructions and the Ethernet instructions cannot be executed from two or more stations at the same time on the same channel.

If the execution conditions are met at two or more locations at the same time, instructions to be executed later have to wait until the channel becomes available because handshaking is automatically performed at the execution of the first instruction.

(3) Whether the ZNRD instruction is currently being executed or has been completed normally or abnormally can be checked with the completion device (D2) designated in the set data.

(a) Completion device (D2)

Turns on at the END processing of the scan where the ZNRD instruction is completed, and turns off at the next END processing.

(b) Status display device at completion ((D2) + 1)

Turns on and off depending on the completion status of the ZNRD instruction.

Normal completion: Stays off and does not change.

Abnormal completion: Turns on at the END processing of the scan where the ZNRD instruction is completed, and turns off at the next END processing.

[Operation of the own station when the ZNRD instruction is being executed]

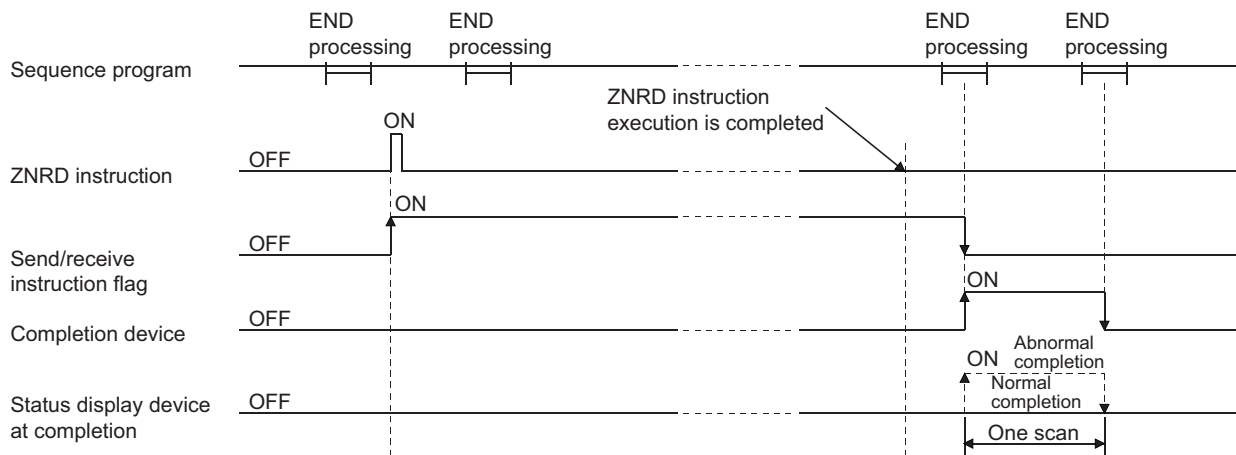

6.13.3 Errors

(1) When execution of a dedicated instruction ends with an error, the abnormal completion signal (D2)+1 turns ON and the result is stored in the data link instruction execution result (ZNRD instruction) storage area (address: 207) of the buffer memory.

See the following manuals regarding the error code, check the errors and take corrective actions.

<Error codes>

4FFFH or less: User's Manual (Hardware Design, Maintenance and Inspection) for the CPU module used

C000H or higher: User's Manual (Basic)

6.13.4 Program example

A program that reads the contents of D10 to 14 of station number 4 from D200 to 204 of station number 1.
When I/O signals of the Ethernet module are X/Y00 to X/Y1F

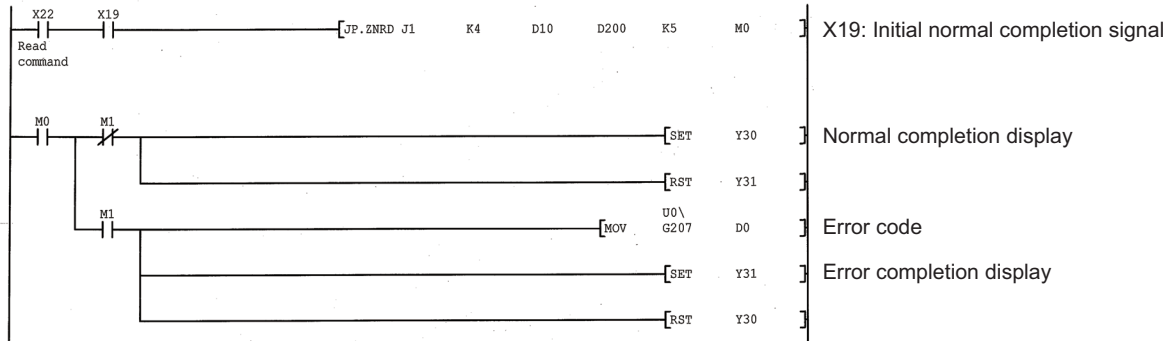

6.14 J(P).ZNWR

This instruction writes data to word devices of other stations (ACPU).

Setting data	Applicable device								
	Internal device		File register R, ZR	Link direct device J□□		Intelligent function module device U□\G□	Index register Zn	Constant K, H	Others
	Bit	Word		Bit	Word				
n1	—	○	—	—	—	—	○	—	
(D1)	—	○*1	—	—	—	—	—	—	
(S)	—	○	—	—	—	—	—	—	
n2	○	—	—	—	—	—	○	—	
(D2)	○	—	—	—	—	—	—	—	

*1 Can only use T, C, D, W

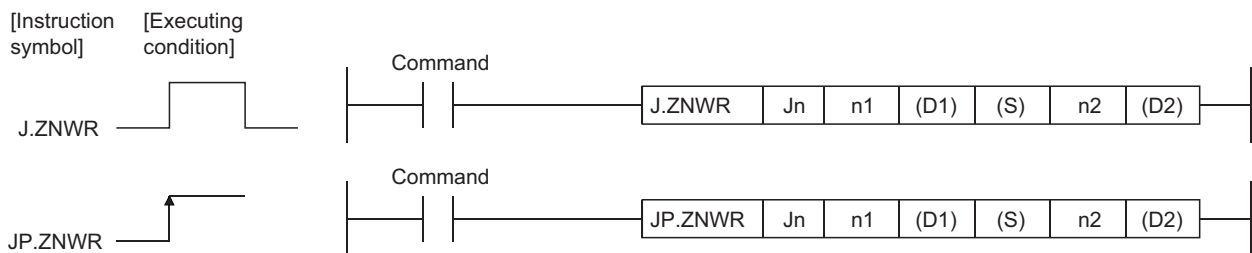

6.14 J(P).ZNWR

6.14.1 Setting data

Setting data ^{*1,2}	Description	Setting range	Set by ^{*3}	Data type
Jn	Target station network number Designate the network number of the target station.	1 to 239	User	BIN 16 bits
n1	Target station number Designates the station number of the target station.	1 to 64 (constant): Stations of station number 81H to 89H: All stations of group number FFH: All stations on the target network number		Character string
(D1)	Write data storage head device (target station) Designate the head device of the target station to which data is written.	—	—	Device name
(S)	Write data storage head device (own station) Designate the head device of the own station that stores the data to be written.	—		
n2	Write data length Designate the number of data (words) to write.	When writing to Q/L/QnA/AnUCPU 1 to 230 (constant) When writing to programmable controller CPUs other than Q/L/QnA/AnUCPU 1 to 32 (constant)	User	BIN 16 bits
(D2)	Write completion device (own station) Designate device that is turned on for one scan by the write completion. (D2) ... OFF: Incomplete, ON: Complete (D2) + 1 ... OFF: Normal, ON: Error	—	System	Bit

*1 The local devices and the file register for each program cannot be used as the device used for the setting data.

*2 In addition to the setting data, the ZNWR instruction is executed using the following fixed values.

Channel used by own station: Channel 2

Arrival monitoring time (monitoring time until instruction completion): 10 seconds

Number of resends for arrival monitoring timeout: 5 times

*3 The "Set by" column indicates the following:

- User: Data is set by the user before executing a dedicated instruction.
- System: The programmable controller CPU stores the execution result of a dedicated instruction.

Point

- The ZNWR instruction can be executed when the target station is a Q/L/QnA/AnUCPU. Access to an AnUCPU is available via MELSECNET/10.
- When writing data from the other station CPU module device with the ZNWR instruction, specify the device within the range applicable to the host station CPU module.
(Head device number to be write in other station CPU module (D1)) + (number of write points -1) ≤ (last device number of host station CPU module)
Last device number in host station CPU module having the same device name as (D1).
- The normal or abnormal write completion status is stored in the data link instruction execution result (ZNWR instruction) storage area (address: 209).
If the write completion device ((D2) + 1) is on due to abnormal end, read the error code stored in the area mentioned above and correct the error accordingly.

6.14.2 Functions

- (1) This instruction write n2 points of data from the word device designated by (S) of the own station to the word device of the connected station having the network number designated by Jn/n1 in the Ethernet network system.

When writing the device data to the target station is completed, the completion device designated in (D2) turns on.

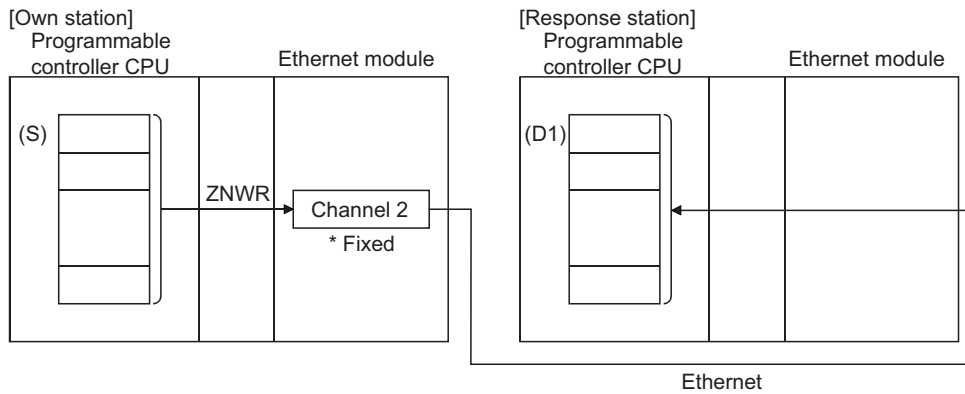

- (2) The ZNWR instruction is executed using channel 2 (fixed).

The data link instructions and the Ethernet instructions cannot be executed from two or more stations at the same time on the same channel.

If the execution conditions are met at two or more locations at the same time, instructions to be executed later have to wait until the channel becomes available because handshaking is automatically performed at the execution of the first instruction.

(3) Whether the ZNWR instruction is currently being executed or has been completed normally or abnormally can be checked with the completion device (D2) designated in the set data.

(a) Completion device (D2)

Turns on at the END processing of the scan where the ZNWR instruction is completed, and turns off at the next END processing.

(b) Status display device at completion ((D2) + 1)

Turns on and off depending on the completion status of the ZNWR instruction.

Normal completion: Stays off and does not change.

Abnormal completion: Turns on at the END processing of the scan where the ZNWR instruction is completed, and turns off at the next END processing.

[Operation of the own station when the ZNWR instruction is being executed]

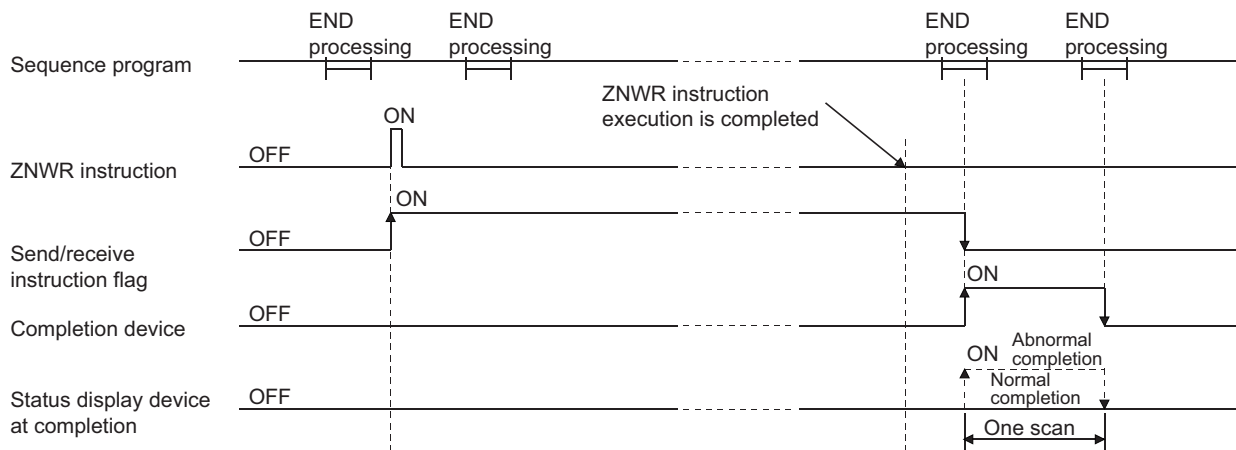

6.14.3 Errors

(1) When execution of a dedicated instruction ends with an error, the abnormal completion signal (D2)+1 turns ON and the result is stored in the data link instruction execution result (ZNWR instruction) storage area (address: 209) of the buffer memory.

See the following manuals regarding the error code, check the errors and take corrective actions.

<Error codes>

4FFFH or less: User's Manual (Hardware Design, Maintenance and Inspection) for the CPU module used

C000H or higher: User's Manual (Basic)

6.14.4 Program example

A program that writes the contents of D300 to 303 of station number 2 to D50 to 53 of station number 3.
 When I/O signals of the Ethernet module are X/Y00 to X/Y1F

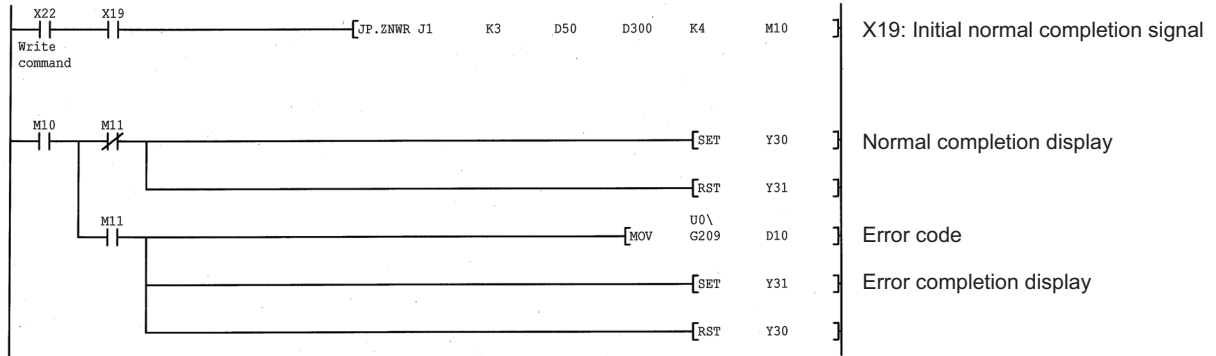

APPENDIX

Appendix 1 Calculating the Setting Values of the Data Link Instructions (Control Data)

This section explains how to determine values set to control data for the data link instructions (arrival monitoring time and the number of resends) and the processing time of the instructions.

The arrival monitoring time refers to monitoring time after the Ethernet module sends a request by the data link instruction until the instruction processing is ended.

When the processing is not ended, the instruction is resent by the number of resends.

The processing time described in this section depends on the network load ratio (line congestion) and system configuration. When applying the value to the system, make sure that it will not cause a problem in control.

Appendix 1.1 Calculation formulas

(1) Arrival monitoring time

The formula is shown using the following system configuration example.

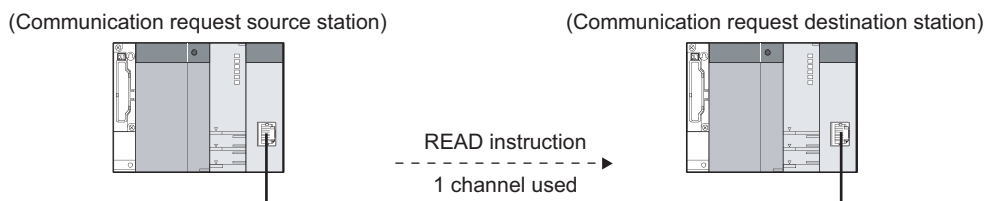

[Arrival monitoring time > $St \times 2 + Dt + Rt$]

- St: Sequence scan time of the CPU module on the communication request source station
- Dt: Communication processing time between the Ethernet modules on the communication request source station and on the communication request destination station
- Rt: Response time of the CPU module on the communication request destination station

(a) Sequence scan time of the CPU module on the communication request source station (St)

The sequence scan time can be checked by Current scan time (SD520, SD521).

(b) Communication processing time between the Ethernet modules on the communication request source station and on the communication request destination station (Dt)

Use the processing time of the dedicated instructions described in the User's Manual (Basic).

(c) Response time of the CPU module on the communication request destination station (Rt)

AFind the value by the following formula.

[Sequence scan time × Number of scans before executing service processing]

The sequence scan time can be checked by Current scan time (SD520, SD521).

For service processing, refer to the User's Manual (Function Explanation, Program Fundamentals) for the CPU module used.

Remark

The following shows the processing flow of the items shown in the formula.

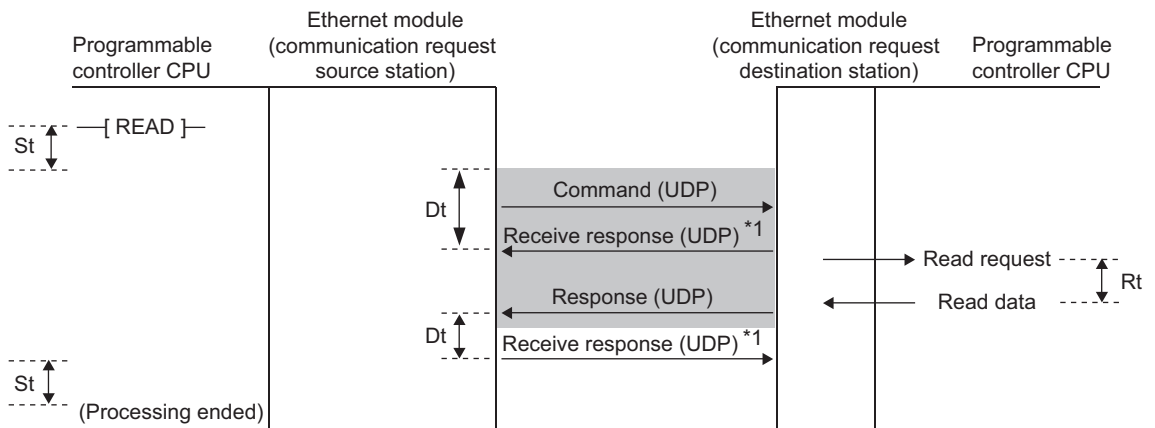

*1 The receiving side Ethernet module notifies the sending side Ethernet module of successful data reception.

(2) Setting arrival monitoring time

Set arrival monitoring time to the control data for the data link instruction.

Although the setting unit can be selected from 1s and 100ms, setting "100ms" is recommended.*1

When "1s" is selected, the arrival monitoring time cannot be set shorter than the TCP resend timer. To shorten arrival monitoring time, the TCP resend timer value must be reset.

When "100ms" is selected, arrival monitoring time can be set without considering the TCP resend timer value.

*1 The "100ms" option is available for the QJ71E71-100 and LJ71E71-100 with a serial number (first five digits) of "12062" or later.

(3) Number of resends

Set the number of resends in case that timeout occurs due to packet loss caused by poor line condition.

Remark

The following shows the resend processing flow of the Ethernet modules.

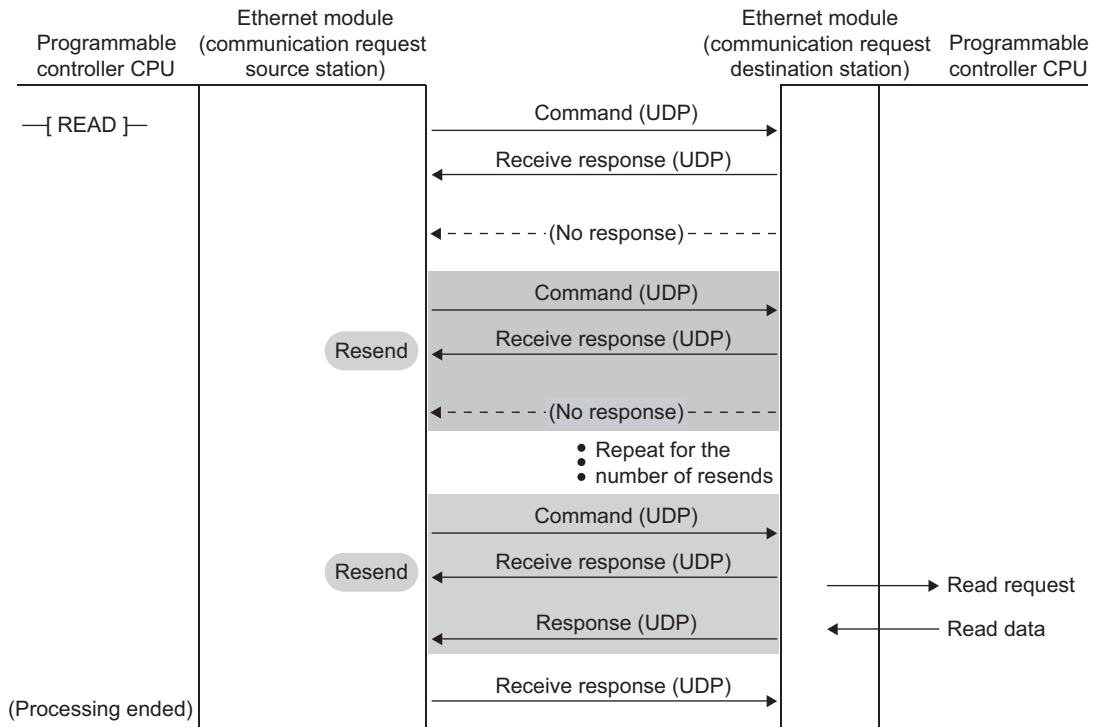

.....

(4) Total processing time of the data link instruction (when the instruction is resent)

The following shows the formula.

[Total processing time of the data link instruction (when the instruction is resent by the number of resends)= $St \times 2 + \text{Arrival monitoring time} \times \text{Number of resends} + Rt$]

- St: Sequence scan time of the CPU module on the communication request source station
- Rt: Response time of the CPU module on the communication request destination station

Appendix 1.2 Setting examples

This section explains the calculation example of arrival monitoring time setting value and the processing time of the data link instruction when the calculated value is set to the control data.

(1) Executing the READ instruction for one channel

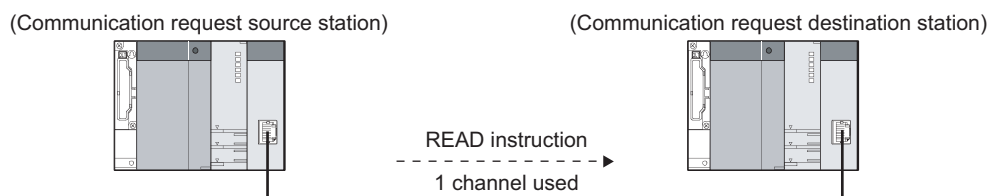

(a) Calculating arrival monitoring time

Apply the following values for sequence scan time of the CPU module on the communication request source station (St) and response time of the CPU module on the communication request destination station (Rt).

$$St = 20\text{ms}$$

$$Rt = 30\text{ms} \times 1 \text{ scan} = 30\text{ms}$$

Since the READ instruction is used, communication processing time between the Ethernet modules on the communication request source station and on the communication request destination station (Dt) will be the following value.

$$Dt = 9.9\text{ms}$$

Set a value larger than the following to the arrival monitoring time.

$$St \times 2 + Dt + Rt = 20 \times 2 + 9.9 + 30 = 79.9\text{ms}$$

(b) Number of resends

Set 3 times.

(c) Total processing time of the data link instruction (when the instruction is resent)

The processing time can be shortened by setting the arrival monitoring time shorter.

- Setting "100ms" for the setting unit of arrival monitoring time

Setting target	Item	Setting value	Processing time	
Communication request source station	Sequence scan time of the CPU module (St)	—	20ms	
	Control data for the data link instruction	Setting unit of arrival monitoring time (bit 8 of (S1) + 0)	Increments of 100ms (1)	—
		Arrival monitoring time	2 ^{*1}	200ms
		Number of resends	3	—
Communication request destination station	Response time of the CPU module (Rt)	—	30ms	
Total processing time of the data link instruction (when the instruction is resent by the number of resends) 20ms × 2 + 200ms × 3 + 30ms = 670ms			670ms	

*1 Since the arrival monitoring time value may be rounded off, add "100ms".

- Using the default for Ethernet module parameter (setting "1s" for arrival monitoring time unit)

Setting target	Item	Setting value	Processing time	
Communication request source station	Sequence scan time of the CPU module (St)	—	20ms	
	Control data for the data link instruction	Setting unit of arrival monitoring time (bit 8 of (S1) + 0)	In increments of 1s (0)	—
		Arrival monitoring time	0	10s ^{*2}
		Number of resends	3	—
Communication request destination station	Response time of the CPU module (Rt)	—	30ms	
Total processing time of the data link instruction (when the instruction is resent by the number of resends) 20ms × 2 + 10s × 3 + 30ms = 30.07s			30.07s	

*2 Since the arrival monitoring time value (default: 0) is smaller than the TCP resend timer value (default: 10s), the processing time will be the same as the TCP resend timer.

(2) Executing the READ instruction using 3 channels and monitoring devices with a programming tool

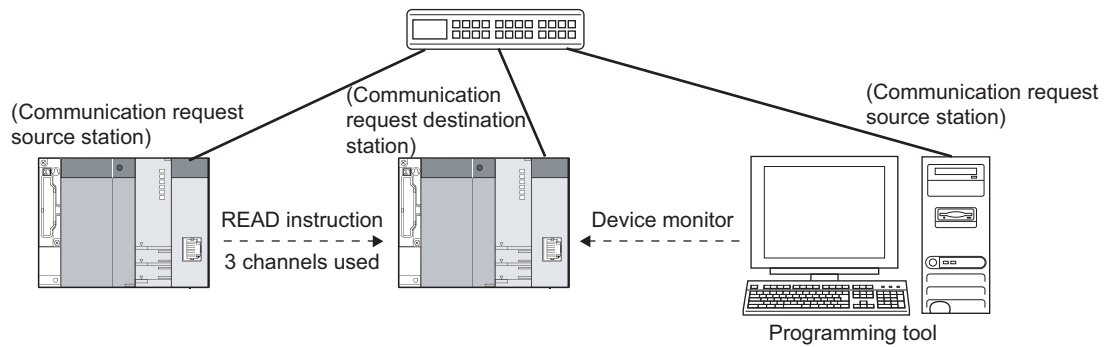

(a) Calculating arrival monitoring time

Apply the following values for sequence scan time of the CPU module on the communication request source station (St) and response time of the CPU module on the communication request destination station (Rt).

$$St = 20ms$$

$$Rt = 30ms \times 4 \text{ scans} = 120ms$$

Since the READ instruction is used, communication processing time between the Ethernet modules on the communication request source station and on the communication request destination station (Dt) will be the following value.

$$Dt = 9.9ms$$

Set a value larger than the following to the arrival monitoring time.

$$St \times 2 + Dt + Rt = 20 \times 2 + 9.9 + 120 = 169.9ms$$

Point

In this processing, the READ instruction is executed using 3 channels and device monitor is performed. Therefore, the maximum 4 scans may be required. ($30\text{ms} \times 4 \text{ scans} = 120\text{ms}$)

However, the processing can be performed in one scan by the following setting. ($30\text{ms} \times 1 \text{ scan} = 30\text{ms}$)

- Time reserved for communication processing (SD315)
- (other than the Universal model QCPU, LCPU)

(Example)

Arrival monitoring time when service processing is set to 4 times:

$$St \times 2 + Dt + Rt = 20 \times 2 + 9.9 + 30 = 79.9\text{ms}$$

For details on the setting, refer to the User's Manual (Function Explanation, Program Fundamentals) for the CPU module used.

(b) Number of resends

Set 3 times.

(c) Total processing time of the data link instruction (when the instruction is resent)

The processing time can be shortened by setting the arrival monitoring time shorter.

- Setting "100ms" for the setting unit of arrival monitoring time

Setting target	Item	Setting value	Processing time ^{*1}	
Communication request source station	Sequence scan time of the CPU module (St)	—	20ms	
	Control data for the data link instruction	Setting unit of arrival monitoring time (bit 8 of (S1) + 0)	Increments of 100ms (1)	
		Arrival monitoring time	3 ^{*2}	300ms (200ms)
		Number of resends	3	—
Communication request destination station	Response time of the CPU module (Rt)	—	120ms (30ms)	
Total processing time of the data link instruction (when the instruction is resent by the number of resends)				
20ms × 2 + 300ms × 3 + 120ms = 1060ms			1060ms	
(20ms × 2 + 200ms × 3 + 30ms = 670ms)			(670ms)	

*1 Values in parentheses are assumed that service processing is set to 4 times. (☞ Page 236, Appendix 1.2 (2) (a))

*2 Since the arrival monitoring time value may be rounded off, add "100ms".

- Using the default for Ethernet module parameter (setting "1s" for arrival monitoring time unit)

Setting target	Item	Setting value	Processing time ^{*3}	
Communication request source station	Sequence scan time of the CPU module (St)	—	20ms	
	Control data for the data link instruction	Setting unit of arrival monitoring time (bit 8 of (S1) + 0)	In increments of 1s (0)	
		Arrival monitoring time	0	10s ^{*4}
		Number of resends	3	—
Communication request destination station	Response time of the CPU module (Rt)	—	120ms (30ms)	
Total processing time of the data link instruction (when the instruction is resent by the number of resends)				
20ms × 2 + 10s × 3 + 120ms = 30.16s			30.16s	
(20ms × 2 + 10s × 3 + 30ms = 30.07s)			(30.07s)	

*3 Values in parentheses are assumed that service processing is set to 4 times. (☞ Page 236, Appendix 1.2 (2) (a))

*4 Since the arrival monitoring time value (default: 0) is smaller than the TCP resend timer value (default: 10s), the processing time will be the same as the TCP resend timer.

Memo

INDEX

A

Accessible range (CC-Link IE Controller Network, CC-Link IE Field Network, MELSECNET/H, MELSECNET/10)	64
Accessible range (FTP)	130
Arrival monitoring time	232
Attributes of file	143
Automatic response system	71

B

Broadcast (simultaneous broadcast)	89
--	----

C

CC-Link IE Controller Network, CC-Link IE Field Network, MELSECNET/H, MELSECNET/10 relay communication	83
CC-Link IE Controller Network, CC-Link IE Field Network, MELSECNET/H, MELSECNET/10 relay communication function	63
Channel	92
Check receive mail	37
Command input monitoring timer	132
Command list (Ethernet module dedicated commands)	129
Command list (FTP server support commands)	128
Condition device	57
Condition for inspection	58
Condition for PLC inspection	56
Controlling the status (remote RUN/STOP)	120
Conversion method	71

D

Data link instructions	92
DNS	36
Drive name	142

E

E-mail sending (attached file)	39
E-mail sending (main text)	51
E-mail sending and receiving	26
E-mail setting	36
Error code (data link instruction)	126
Error code (FTP response code)	145
Ethernet module dedicated commands (FTP)	128,151
Ethernet module support commands	128,146

F

File path	142
File transferable range	130
FTP	131,133
FTP (client)	127
FTP command	128,146

FTP log-in name	132
FTP parameter	131
FTP server response code	145

I

Inquiry time intervals for checking receive mail	37
IP address computation system	72

K

Keyword (FTP, password)	142
-----------------------------------	-----

L

Lock (FTP)	153
----------------------	-----

M

Mail address setting of the own station	37
Monitor function of the programmable controller CPU	28
Monitoring value	58
MRECV (instruction for e-mail)	44,158
MSEND (instruction for attached file, e-mail)	39,164
MSEND (instruction for main text, e-mail)	51,164

N

Name of attached file	42
Net mask pattern	68
News data points	58
News data storage device	58
News setting	55
News specification	38

P

Password (e-mail)	36
Password (FTP)	131,142
PLC inquiry interval	57
PLC monitoring timer	132
POP3 server	33,37
Processing procedure of the e-mail function	34

R

READ (data link instruction)	107,170
Receive e-mail	44
Receive mail setting	37
Receiving a news e-mail	59
RECV (data link instruction)	98,177
RECVS (data link instruction)	103,183
Relay network No.	77
Relay station No.	78
Remote RUN/Remote STOP (programmable controller CPU)	120
REQ (data link instruction)	120,187,195

Routing parameter settings 77

S

SEND (data link instruction) 97,198
Send mail address setting 38
Send mail setting 37
Simultaneous broadcast (UDP/IP) 89
SMTP server 33,37
SREAD (data link instruction) 107,206
Station No. <-> IP information 67
Station No. <-> IP information system (conversion
method) 68
SWRITE (data link instruction). 108,211

T

Table exchange system 74
Target network No. 77

U

Unlock (FTP) 134,153
Use-together system 76

W

WRITE (data link instruction). 108,216

Z

ZNRD (data link instruction) 114,224
ZNWR (data link instruction) 115,227

REVISIONS

*The manual number is given on the bottom left of the back cover.

Print date	*Manual number	Revision
Dec., 1999	SH(NA)-080010-A	First edition
Oct., 2000	SH(NA)-080010-B	<p>Reflect the contents of the function version B.</p> <p>Put Windows® base software products together from Mitsubishi Electric Programmable Controller MELSEC series to Mitsubishi Electric integrated FA software MELSOFT series. Standardize the name from software package (GPP function) to product name (GX Developer).</p> <p>[Correction] Entire manual (change MELSECNET/10H to MELSECNET/H), Contents, About Manuals, About the Generic Terms and Abbreviations, Chapter 1 (entire), Section 1.2 (POINT), Section 2.1, 2.5 (2), 2.6.1, 2.6.2, 2.7.1, 2.7.2, Section 3.2.1 (2). 3.3.3 (4), Section 4.1, 4.3, 4.5.2, Section 5.1.1, 5.2, 5.3, 5.4, 5.5, 5.6.1, 5.6.1 (2) 2), 5.6.2, 5.6.4, Section 6.2 to 6.8, 6.9 (POINT before the function), 6.10 to 6.14</p> <p>[Addition] Entire manual (add the explanation on MELSECNET/H remote I/O station), Section 4.3 (4), Chapter 5 POINT</p>
Jun., 2001	SH(NA)-080010-C	<p>Added the description of the model QJ71E71-100 Ethernet interface module.</p> <p>[Additional model] QJ71E71-100</p> <p>[Correction] About Manuals, The Manual's Usage and Structure, About the Generic Terms and Abbreviations, Section 1.1 (1), 1.2, Section 3.3.2 (3) (c), Section 4.2 (5), 4.3 (3), 4.4 (Table), 4.7, Section 5.4, 5.5 (c), Section 6.2, 6.3, 6.9 (POINT), 6.13 (Function), 6.14 (Function)</p> <p>[Addition] Chapter 2 (entire), Section 5.1, 5.6.4</p>
Oct., 2001	SH(NA)-080010-D	<p>[Correction] Section 1.2, Section 2.1, 2.3, 2.4, 2.7.2 (4) (POINT), 2.8, Section 4.5.1 (3) (b), Chapter 5 POINT, Section 5.1.1, 5.4 (4), 5.5 (c) 2), 5.6.4 (2) (cpuchg), Section 6.5</p>
Apr., 2003	SH(NA)-080010-E	<p>[Additional model] QJ71E71-B5</p> <p>[Deleted model] QJ71E71</p> <p>[Correction] SAFETY PRECAUTIONS, Section 1.2, Section 2.6 (POINT), 2.7, 2.8, 2.9, Section 3.2.1 (2), 3.3, , Section 4.2 (1), 4.6 (1), Section 5.6.4, Section 6.2, 6.3, 6.5, 6.6, 6.7, 6.10 (POINT), 6.11 (POINT), 6.12, 6.13, 6.14</p>
Dec., 2003	SH(NA)-080010-F	<p>[Correction] Section 6.13 (POINT), 6.14 (POINT)</p>
Jun., 2004	SH(NA)-080010-G	<p>[Correction] About the Generic Terms and Abbreviations, Section 1.2, Section 2.1.2 (1), Section 3.2.1 (2), Section 4.6, 4.8, Section 5.5 (5)(6), Section 6.4, 6.5, 6.6, 6.7, 6.8, 6.9, 6.11, 6.12</p>
Aug., 2005	SH(NA)-080010-H	<p>[Correction] SAFETY PRECAUTIONS, Section 1.2, Section 2.1.2, 2.7, 2.8, 2.9, Section 6.4, 6.5, 6.6, 6.9, 6.12</p>
Jun., 2006	SH(NA)-080010-I	<p>[Correction] Section 4.2, 4.7, Section 6.4, 6.7, 6.10, 6.11, 6.12, 6.13, 6.14</p> <p>[Addition] Section 6.1</p>
Jun., 2007	SH(NA)-080010-J	<p>[Change of a term] "PLC" was changed to "programmable controller".</p> <p>[Correction] About the Generic Terms and Abbreviations, Section 1.2, Section 3.2.1, 3.3.3, Section 4.2, 4.4, 4.5.2, Section 6.2 to 6.14</p>
Nov., 2007	SH(NA)-080010-K	<p>[Correction] Section 6.1</p>
Oct., 2008	SH(NA)-080010-L	<p>[Correction] SAFETY PRECAUTIONS, The Manual's Use and Structure, About the Generic Terms and Abbreviations, Section 1.1, 1.2, 2.6, Chapter 3, Section 4.1 to 4.4, 4.5.2, 4.6, Section 5.5.1, 5.2, 5.5, 5.6.2, 5.6.4, Section 6.1 to 6.7, 6.9 to 6.14</p>

Print date	*Manual number	Revision
Aug., 2010	SH(NA)-080010-M	[Correction] Addition of "CC-Link IE Field Network" to the whole manual SAFETY PRECAUTIONS, About the Generic Terms and Abbreviations, Section 3.2.1, Section 4.4, Section 5.5, Chapter 6 [Addition] CONDITIONS OF USE FOR THE PRODUCT
Feb., 2013	SH(NA)-080010-N	Overall revision with the addition of the LJ71E71-100 [Additional model] LJ71E71-100
Dec., 2014	SH(NA)-080010-O	[Correction] RELEVANT MANUALS, MANUAL'S USE AND STRUCTURE, TERMS, Section 1.1, 1.2, 2.3, 2.4, 2.5, 2.7.2, 3.2.1, 4.2, 4.8, 5.2, 5.6.2, 6.5.2, 6.8 [Change of manual structure] Subsections are added to Section 6.2 to 6.14.
Jun., 2015	SH(NA)-080010-P	[Correction] Section 3.2.1
Jul., 2020	SH(NA)-080010-Q	[Correction] SAFETY PRECAUTIONS, CONDITIONS OF USE FOR THE PRODUCT
Sep., 2022	SH(NA)-080010-R	[Correction] SAFETY PRECAUTIONS, INTRODUCTION, LIST OF DISCONTINUED MODELS, Section 2.5, 2.8.1, 3.3.3, 6.4.2, WARRANTY, TRADEMARK, COPYRIGHTS

Japanese manual version SH-080005-W

This manual confers no industrial property rights or any rights of any other kind, nor does it confer any patent licenses. Mitsubishi Electric Corporation cannot be held responsible for any problems involving industrial property rights which may occur as a result of using the contents noted in this manual.

© 1999 MITSUBISHI ELECTRIC CORPORATION

WARRANTY

Please confirm the following product warranty details before using this product.

1. Gratis Warranty Term and Gratis Warranty Range

If any faults or defects (hereinafter "Failure") found to be the responsibility of Mitsubishi occurs during use of the product within the gratis warranty term, the product shall be repaired at no cost via the sales representative or Mitsubishi Service Company.

However, if repairs are required onsite at domestic or overseas location, expenses to send an engineer will be solely at the customer's discretion. Mitsubishi shall not be held responsible for any re-commissioning, maintenance, or testing on-site that involves replacement of the failed module.

[Gratis Warranty Term]

The gratis warranty term of the product shall be for one year after the date of purchase or delivery to a designated place. Note that after manufacture and shipment from Mitsubishi, the maximum distribution period shall be six (6) months, and the longest gratis warranty term after manufacturing shall be eighteen (18) months. The gratis warranty term of repair parts shall not exceed the gratis warranty term before repairs.

[Gratis Warranty Range]

- (1) The range shall be limited to normal use within the usage state, usage methods and usage environment, etc., which follow the conditions and precautions, etc., given in the instruction manual, user's manual and caution labels on the product.
- (2) Even within the gratis warranty term, repairs shall be charged for in the following cases.
 1. Failure occurring from inappropriate storage or handling, carelessness or negligence by the user. Failure caused by the user's hardware or software design.
 2. Failure caused by unapproved modifications, etc., to the product by the user.
 3. When the Mitsubishi product is assembled into a user's device, Failure that could have been avoided if functions or structures, judged as necessary in the legal safety measures the user's device is subject to or as necessary by industry standards, had been provided.
 4. Failure that could have been avoided if consumable parts (battery, backlight, fuse, etc.) designated in the instruction manual had been correctly serviced or replaced.
 5. Failure caused by external irresistible forces such as fires or abnormal voltages, and Failure caused by force majeure such as earthquakes, lightning, wind and water damage.
 6. Failure caused by reasons unpredictable by scientific technology standards at time of shipment from Mitsubishi.
 7. Any other failure found not to be the responsibility of Mitsubishi or that admitted not to be so by the user.

2. Onerous repair term after discontinuation of production

- (1) Mitsubishi shall accept onerous product repairs for seven (7) years after production of the product is discontinued. Discontinuation of production shall be notified with Mitsubishi Technical Bulletins, etc.
- (2) Product supply (including repair parts) is not available after production is discontinued.

3. Overseas service

Overseas, repairs shall be accepted by Mitsubishi's local overseas FA Center. Note that the repair conditions at each FA Center may differ.

4. Exclusion of loss in opportunity and secondary loss from warranty liability

Regardless of the gratis warranty term, Mitsubishi shall not be liable for compensation to:

- (1) Damages caused by any cause found not to be the responsibility of Mitsubishi.
- (2) Loss in opportunity, lost profits incurred to the user by Failures of Mitsubishi products.
- (3) Special damages and secondary damages whether foreseeable or not, compensation for accidents, and compensation for damages to products other than Mitsubishi products.
- (4) Replacement by the user, maintenance of on-site equipment, start-up test run and other tasks.

5. Changes in product specifications

The specifications given in the catalogs, manuals or technical documents are subject to change without prior notice.

TRADEMARKS

Microsoft and Windows are trademarks of the Microsoft group of companies.

The company names, system names and product names mentioned in this manual are either registered trademarks or trademarks of their respective companies.

In some cases, trademark symbols such as [™] or [®] are not specified in this manual.

COPYRIGHTS

The screens (screenshots) are used in accordance with the Microsoft Corporation guideline.

SH(NA)-080010-R(2209)MEE

MODEL: QJ71E71-U-OU-E

MODEL CODE: 13JL89

MITSUBISHI ELECTRIC CORPORATION

HEAD OFFICE : TOKYO BUILDING, 2-7-3 MARUNOUCHI, CHIYODA-KU, TOKYO 100-8310, JAPAN
NAGOYA WORKS : 1-14 , YADA-MINAMI 5-CHOME , HIGASHI-KU, NAGOYA , JAPAN

When exported from Japan, this manual does not require application to the
Ministry of Economy, Trade and Industry for service transaction permission.

Specifications subject to change without notice.