



Programmable Controller

MELSEC *L*<sub>series</sub>

# MELSEC-L Serial Communication Module User's Manual (Basic)

---

-LJ71C24  
-LJ71C24-R2

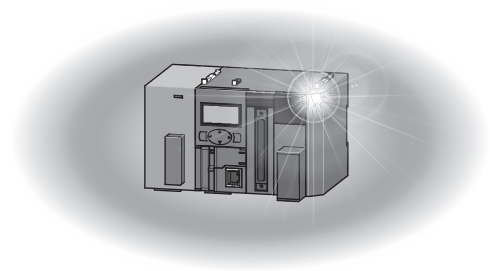



# ● SAFETY PRECAUTIONS ●

(Read these precautions before using this product.)

Before using this product, please read this manual and the relevant manuals carefully and pay full attention to safety to handle the product correctly.

The precautions given in this manual are concerned with this product only. For the safety precautions of the programmable controller system, refer to the user's manual for the CPU module used.

In this manual, the safety precautions are classified into two levels: "⚠ WARNING" and "⚠ CAUTION".



Indicates that incorrect handling may cause hazardous conditions, resulting in death or severe injury.



Indicates that incorrect handling may cause hazardous conditions, resulting in minor or moderate injury or property damage.

Under some circumstances, failure to observe the precautions given under "⚠ CAUTION" may lead to serious consequences.

Observe the precautions of both levels because they are important for personal and system safety.

Make sure that the end users read this manual and then keep the manual in a safe place for future reference.

## [Design Precautions]

### ⚠ WARNING

- For the operation status of each station at communication error in each station, refer to the respective manual for each station.  
Failure to do so may result in an accident due to an incorrect output or malfunction.
- When connecting a peripheral with the CPU module or connecting an external device, such as a personal computer, with an intelligent function module to modify data of a running programmable controller, configure an interlock circuit in the program to ensure that the entire system will always operate safely.  
For other forms of control (such as program modification or operating status change) of a running programmable controller, read the relevant manuals carefully and ensure that the operation is safe before proceeding.  
Especially, when a remote programmable controller is controlled by an external device, immediate action cannot be taken if a problem occurs in the programmable controller due to a communication failure.  
To prevent this, configure an interlock circuit in the program, and determine corrective actions to be taken between the external device and CPU module in case of a communication failure.
- Do not write any data to the "system area" of the buffer memory in the intelligent function module.  
Also, do not use any "use prohibited" signals as an output signal from the CPU module to the intelligent function module.  
Doing so may cause malfunction of the programmable controller system.

## [Design Precautions]

### CAUTION

- Do not install the control lines or communication cables together with the main circuit lines or power cables.  
Keep a distance of 100mm or more between them.  
Failure to do so may result in malfunction due to noise.

## [Installation Precautions]

### WARNING

- Shut off the external power supply (all phases) used in the system before mounting or removing a module.  
Failure to do so may result in electric shock or cause the module to fail or malfunction.

## [Installation Precautions]

### CAUTION

- Use the programmable controller in an environment that meets the general specifications in the Safety Guidelines provided with the CPU module or head module.  
Failure to do so may result in electric shock, fire, malfunction, or damage to or deterioration of the product.
- To interconnect modules, engage the respective connectors and securely lock the module joint levers until they click. Incorrect interconnection may cause malfunction, failure, or drop of the module.
- Do not directly touch any conductive parts and electronic components of the module.  
Doing so can cause malfunction or failure of the module.

## [Wiring Precautions]

### **WARNING**

- Shut off the external power supply (all phases) used in the system before wiring.  
Failure to do so may result in electric shock or cause the module to fail or malfunction.
- After installation and wiring, attach the included terminal cover to the module before turning it on for operation.  
Failure to do so may result in electric shock.

## [Wiring Precautions]

### **CAUTION**

- Use applicable solderless terminals and tighten them within the specified torque range.  
If any spade solderless terminal is used, it may be disconnected when a terminal block screw comes loose, resulting in failure.
- Connectors for external devices must be crimped or pressed with the tool specified by the manufacturer, or must be correctly soldered.  
Incomplete connections may cause short circuit, fire, or malfunction.
- Securely connect the connector to the module.
- Place the cables in a duct or clamp them.  
If not, dangling cable may swing or inadvertently be pulled, resulting in damage to the module or cables or malfunction due to poor contact.
- Check the interface type and correctly connect the cable. Incorrect wiring (connecting the cable to an incorrect interface) may cause failure of the module and external device.
- Tighten the terminal block screws within the specified torque range.  
Undertightening can cause short circuit, fire, or malfunction.  
Overtightening can damage the screw and/or module, resulting in drop, short circuit, fire, or malfunction.
- When disconnecting the cable from the module, do not pull the cable by the cable part.  
For the cable with connector, hold the connector part of the cable.  
For the cable connected to the terminal block, loosen the terminal screw.  
Pulling the cable connected to the module may result in malfunction or damage to the module or cable.
- Prevent foreign matter such as dust or wire chips from entering the module.  
Such foreign matter can cause a fire, failure, or malfunction.
- A protective film is attached to the top of the module to prevent foreign matter, such as wire chips, from entering the module during wiring.  
Do not remove the film during wiring.  
Remove it for heat dissipation before system operation.

## [Startup and Maintenance Precautions]

### **WARNING**

- Do not touch any terminal while power is on. Doing so will cause electric shock or malfunction.
- Shut off the external power supply (all phases) used in the system before cleaning the module or retightening the terminal block screws.  
Failure to do so may result in electric shock.

## [Startup and Maintenance Precautions]

### **CAUTION**

- Do not disassemble or modify the module. Doing so may cause failure, malfunction, injury, or a fire.
- Shut off the external power supply (all phases) used in the system before mounting or removing a module.  
Failure to do so may cause the module to fail or malfunction.
- Tighten the terminal block screws within the specified torque range.  
Undertightening can cause drop of the component or wire, short circuit, or malfunction.  
Overtightening can damage the screw and/or module, resulting in drop, short circuit, or malfunction.
- After the first use of the product (module and terminal block), do not connect/disconnect the product more than 50 times (in accordance with IEC 61131-2).  
Exceeding the limit may cause malfunction.
- Before handling the module, touch a conducting object such as a grounded metal to discharge the static electricity from the human body.  
Failure to do so may cause the module to fail or malfunction.

## [Operation Precautions]

### CAUTION

- When changing data and operating status, and modifying program of the running programmable controller from an external device such as a personal computer connected to an intelligent function module, read relevant manuals carefully and ensure the safety before operation.  
Incorrect data change, program modification, and status control may cause malfunction of the system, mechanical damage, or accidents.
- While set values in the buffer memory are being registered to the flash ROM in the module, do not turn off the power to the module and do not reset the CPU module.  
Doing so will affect the flash ROM data, and setting to the buffer memory and registration to the flash ROM need to be performed again. Also, it may cause failure or malfunction of the module.

## [Disposal Precautions]

### CAUTION

- When disposing of this product, treat it as industrial waste.

# ● CONDITIONS OF USE FOR THE PRODUCT ●

- (1) MELSEC programmable controller ("the PRODUCT") shall be used in conditions;
- i) where any problem, fault or failure occurring in the PRODUCT, if any, shall not lead to any major or serious accident; and
  - ii) where the backup and fail-safe function are systematically or automatically provided outside of the PRODUCT for the case of any problem, fault or failure occurring in the PRODUCT.
- (2) The PRODUCT has been designed and manufactured for the purpose of being used in general industries. MITSUBISHI ELECTRIC SHALL HAVE NO RESPONSIBILITY OR LIABILITY (INCLUDING, BUT NOT LIMITED TO ANY AND ALL RESPONSIBILITY OR LIABILITY BASED ON CONTRACT, WARRANTY, TORT, PRODUCT LIABILITY) FOR ANY INJURY OR DEATH TO PERSONS OR LOSS OR DAMAGE TO PROPERTY CAUSED BY the PRODUCT THAT ARE OPERATED OR USED IN APPLICATION NOT INTENDED OR EXCLUDED BY INSTRUCTIONS, PRECAUTIONS, OR WARNING CONTAINED IN MITSUBISHI ELECTRIC USER'S, INSTRUCTION AND/OR SAFETY MANUALS, TECHNICAL BULLETINS AND GUIDELINES FOR the PRODUCT.
- ("Prohibited Application")
- Prohibited Applications include, but not limited to, the use of the PRODUCT in;
- Nuclear Power Plants and any other power plants operated by Power companies, and/or any other cases in which the public could be affected if any problem or fault occurs in the PRODUCT.
  - Railway companies or Public service purposes, and/or any other cases in which establishment of a special quality assurance system is required by the Purchaser or End User.
  - Aircraft or Aerospace, Medical applications, Train equipment, transport equipment such as Elevator and Escalator, Incineration and Fuel devices, Vehicles, Manned transportation, Equipment for Recreation and Amusement, and Safety devices, handling of Nuclear or Hazardous Materials or Chemicals, Mining and Drilling, and/or other applications where there is a significant risk of injury to the public or property.
- Notwithstanding the above restrictions, Mitsubishi Electric may in its sole discretion, authorize use of the PRODUCT in one or more of the Prohibited Applications, provided that the usage of the PRODUCT is limited only for the specific applications agreed to by Mitsubishi Electric and provided further that no special quality assurance or fail-safe, redundant or other safety features which exceed the general specifications of the PRODUCTS are required. For details, please contact the Mitsubishi Electric representative in your region.
- (3) Mitsubishi Electric shall have no responsibility or liability for any problems involving programmable controller trouble and system trouble caused by DoS attacks, unauthorized access, computer viruses, and other cyberattacks.



# INTRODUCTION

---



Thank you for purchasing the Mitsubishi Electric MELSEC-L series programmable controllers. This manual describes the functions of the LJ71C24 and LJ71C24-R2 serial communication modules and programming.

Before using the equipment, please read this manual and the related manuals carefully to develop full familiarity with the functions and performance of the MELSEC-L series programmable controller you have purchased, so as to ensure correct use.

When applying the program examples introduced in this manual to an actual system, ensure the applicability and confirm that it will not cause system control problems.

Please make sure that the end users read this manual.

## Remark

- Unless otherwise specified, in the program examples introduced in this manual, I/O numbers X/Y00 to X/Y1F are assigned to the C24. I/O numbers must be assigned to apply the program examples introduced in this manual to an actual system.  
For I/O number assignment, refer to the following.  
 MELSEC-L CPU Module User's Manual (Function Explanation, Program Fundamentals)
- Operating procedures are explained using GX Works2.  
When using GX Developer or GX Configurator-SC, refer to  Page 364, Appendix 4.

# COMPLIANCE WITH EMC AND LOW VOLTAGE DIRECTIVES

---

## **(1) Method of ensuring compliance**

To ensure that Mitsubishi Electric programmable controllers maintain the EMC and Low Voltage Directives or other regulations when incorporated into other machinery or equipment, certain measures may be necessary. Please refer to one of the following manuals.

- MELSEC-L CPU Module User's Manual (Hardware Design, Maintenance and Inspection)
- MELSEC-L CC-Link IE Field Network Head Module User's Manual
- Safety Guidelines (This manual is included with the CPU module or head module.)

Certification marks on the side of the programmable controller indicate compliance with the relevant regulations.

## **(2) Additional measures**

No additional measures are necessary for the compliance of this product with the EMC and Low Voltage Directives.

# RELEVANT MANUALS

Basic specifications, functions, and usage of special functions can be confirmed in this manual.  
In addition, use the following manuals according to the intended use.

## (1) Relevant manuals for the C24

Manual name	Manual number (model code)
MELSEC-Q/L Serial Communication Module User's Manual (Application) Special functions (specifications, usage, and settings) and data communication methods (application) of the serial communication module  (Sold separately)	SH-080007 (13JL87)
MELSEC Communication Protocol Reference Manual Details of MELSEC communication protocol (MC protocol) that is used for data communication between a target device and a CPU module  (Sold separately)	SH-080008 (13JF89)

## (2) CPU module user's manual

Manual name	Manual number (model code)
MELSEC-L CPU Module User's Manual (Hardware Design, Maintenance and Inspection) Specifications of the CPU modules, power supply modules, display unit, branch module, extension module, SD memory cards, and batteries, information on how to establish a system, maintenance and inspection, and troubleshooting  (Sold separately)	SH-080890ENG (13JW10)
MELSEC-L CPU Module User's Manual (Function Explanation, Program Fundamentals) Functions and devices of the CPU module, and programming  (Sold separately)	SH-080889ENG (13JZ35)

## (3) Head module user's manual

Manual name	Manual number (model code)
MELSEC-L CC-Link IE Field Network Head Module User's Manual Specifications, procedures before operation, system configuration, installation, wiring, settings, and troubleshooting of the head module  (Sold separately)	SH-080919ENG (13JZ48)

#### (4) Operating manual

Manual name	Manual number (model code)
GX Works2 Version 1 Operating Manual (Common) System configuration, parameter settings, and online operations of GX Works2, which are common to Simple projects and Structured projects (Sold separately)	SH-080779ENG (13JU63)
GX Works2 Version1 Operating Manual (Intelligent Function Module) System configuration, parameter settings, and online operations (common to Simple project and Structured project) of GX Works2 (Sold separately)	SH-080921ENG (13JU69)
GX Developer Version 8 Operating Manual Operating methods of GX Developer, such as programming, printing, monitoring, and debugging (Sold separately)	SH-080373E (13JU41)

# Memo

---

# CONTENTS

SAFETY PRECAUTIONS .....	1
CONDITIONS OF USE FOR THE PRODUCT .....	6
INTRODUCTION .....	7
COMPLIANCE WITH EMC AND LOW VOLTAGE DIRECTIVES .....	8
RELEVANT MANUALS .....	9
TERMS .....	18
PACKING LIST .....	20
<hr/>	
<b>CHAPTER 1 SERIAL COMMUNICATION MODULE FUNCTIONALITY</b>	<b>22</b>
<hr/>	
<b>CHAPTER 2 PART NAMES</b>	<b>25</b>
<hr/>	
<b>CHAPTER 3 SPECIFICATIONS</b>	<b>27</b>
<hr/>	
3.1 General Specifications .....	27
3.2 Performance Specifications .....	27
3.2.1 Number of parameter settings .....	30
3.3 Function List .....	31
3.3.1 Basic functions .....	31
3.3.2 Additional functions .....	32
3.4 List of Input/Output Signals .....	34
<hr/>	
<b>CHAPTER 4 PROCEDURES PRIOR TO OPERATION</b>	<b>36</b>
<hr/>	
<b>CHAPTER 5 SYSTEM CONFIGURATION</b>	<b>38</b>
<hr/>	
5.1 Overall Configuration .....	38
5.2 Applicable Systems .....	40
5.2.1 Restrictions when the C24 is installed to the head module .....	40
5.3 Systems that can be Configured and Functions .....	41
5.4 Considerations for System Configurations .....	44
<hr/>	
<b>CHAPTER 6 SETTING AND WIRING</b>	<b>45</b>
<hr/>	
6.1 Installation Environment and Position of the Module .....	45
6.1.1 Handling precautions .....	45
6.2 External Wiring with RS-232 Interface .....	46
6.2.1 RS-232 connector specifications .....	46
6.2.2 RS-232 cable specification .....	50
6.2.3 Connecting the RS-232 interface (full-duplex communication) .....	51
6.3 External Wiring with RS-422/485 Interface .....	54
6.3.1 RS-422/485 terminal block specifications .....	54
6.3.2 RS-422/485 cable specifications .....	55
6.3.3 Connection method for the RS-422/485 interface .....	56
6.3.4 Precautions when transferring data using RS-422/485 circuit .....	61
6.3.5 Enabling or disabling echo back of the RS-422/485 interface .....	64
6.4 Individual Station Test .....	66
6.4.1 ROM/RAM/switch test .....	67

6.4.2	Self-loopback test . . . . .	69
6.5	Loopback Test . . . . .	71

---

<b>CHAPTER 7 SETTINGS FOR THE C24</b>	<b>73</b>
---------------------------------------	-----------

---

7.1	Adding the C24 to Projects . . . . .	74
7.2	List of Setting Items for C24 . . . . .	75
7.3	Switch Setting . . . . .	85
7.3.1	Transmission Setting . . . . .	86
7.3.2	Communication rate setting . . . . .	88
7.3.3	Communication protocol setting . . . . .	89
7.3.4	Station number setting . . . . .	90
7.3.5	Setting and data flow in linked operation . . . . .	91
7.3.6	Precautions . . . . .	93
7.4	Various Parameter Settings and Writing to the Flash ROM . . . . .	94
7.4.1	Parameter setting . . . . .	95
7.4.2	Writing to the flash ROM . . . . .	97
7.5	Auto Refresh . . . . .	99
7.5.1	Setting method for auto refresh . . . . .	99
7.6	Intelligent Function Module Interrupt Pointer Setting . . . . .	100
7.7	Monitor/Test . . . . .	102

---

<b>CHAPTER 8 DATA COMMUNICATION USING THE MC PROTOCOL</b>	<b>103</b>
---	------------

---

8.1	Data Communication . . . . .	104
8.1.1	Formats and applications of the data communication frames . . . . .	104
8.1.2	MC protocol system setting . . . . .	105
8.1.3	Support for the LCPU remote password function . . . . .	106
8.2	Utilizing the MX Component . . . . .	107

---

<b>CHAPTER 9 DATA COMMUNICATION USING THE PREDEFINED PROTOCOL</b>	<b>108</b>
---	------------

---

9.1	Data Communication Procedure . . . . .	110
9.2	Communication Type of Protocols . . . . .	113
9.3	Packet Elements . . . . .	114
9.4	Executing Condition of Predefined Protocol Communication . . . . .	132
9.5	Programming Example . . . . .	136
9.5.1	System configuration/wiring example . . . . .	136
9.5.2	Communication data . . . . .	137
9.5.3	Communication settings . . . . .	138

---

<b>CHAPTER 10 DATA COMMUNICATION USING THE NONPROCEDURAL PROTOCOL</b>	<b>146</b>
---	------------

---

10.1	Data Reception from the External Device . . . . .	147
10.1.1	Receiving methods . . . . .	147
10.1.2	The receive area and the received data list . . . . .	150
10.1.3	Sequence program for data reception . . . . .	154

10.1.4	How to detect and check the reception errors	157
10.1.5	Receive data clear	160
10.1.6	Received data count and receive complete code settings	166
10.2	Sending Data to the External Device	169
10.2.1	Transmission methods	169
10.2.2	Arrangement and contents of the transmission area and the transmission data	170
10.2.3	Sequence program for transmission data	171
10.2.4	How to detect and confirm transmission errors	175
10.2.5	Data Communications Precautions	177

---

<b>CHAPTER 11 DATA COMMUNICATION USING THE BIDIRECTIONAL PROTOCOL</b>	<b>178</b>
---	------------

---

11.1	Data Reception from the External Device	179
11.1.1	Receiving methods	179
11.1.2	Arrangement and contents of the receive area and the receive data	181
11.1.3	Sequence program for data reception	187
11.1.4	How to detect and check the reception errors	190
11.1.5	Receive data clear	192
11.2	Sending Data to the External Device	193
11.2.1	Transmission methods	193
11.2.2	Arrangement and contents of the transmission area and the transmission data	194
11.2.3	Sequence program for data transmission	196
11.2.4	How to detect and confirm transmission errors	199
11.3	Processing when Simultaneous Transmission Performed During Full-Duplex Communication	201
11.3.1	Processing when simultaneous transmissions occur	201
11.3.2	Communication data processing when simultaneous transmissions occur	202
11.4	Data Communications Precautions	204

---

<b>CHAPTER 12 DEDICATED INSTRUCTIONS</b>	<b>206</b>
--	------------

---

12.1	Dedicated Instruction List and Available Devices	206
12.2	G(P).ONDEMAND	208
12.3	G(P).CPRTCL	212
12.3.1	Functional protocol	218
12.4	G(P).OUTPUT	219
12.5	G.INPUT	223
12.6	G(P).BIDOUT	228
12.7	G(P).BIDIN	233
12.8	G(P).SPBUSY	237
12.9	ZP.CSET (Receive data clear)	239

---

<b>CHAPTER 13 DEBUG SUPPORT FUNCTION</b>	<b>243</b>
--	------------

---

13.1	Circuit Trace	243
13.1.1	Procedure for the circuit trace	244
13.1.2	Execution of the circuit trace	245



13.1.3	Circuit trace option setting	247
13.2	State Monitor	249
13.3	Protocol Execution Log Display Storage Function (for Predefined Protocol only)	254
13.3.1	Checking with GX Works2	255
13.3.2	Checking with the buffer memory	257

---

<b>CHAPTER 14</b>	<b>MAINTENANCE AND INSPECTION</b>	<b>258</b>
-------------------	-----------------------------------	------------

---

14.1	Inspection Items	258
14.2	When Replacing Modules	259
14.2.1	Procedure of C24 replacement and re-registration of data	260

---

<b>CHAPTER 15</b>	<b>TROUBLESHOOTING</b>	<b>262</b>
-------------------	------------------------	------------

---

15.1	Checking the Status of the C24	262
15.1.1	Checking the H/W LED information	263
15.1.2	Checking the H/W switch information	267
15.1.3	Reading the RS-232 control signal status	270
15.1.4	Reading the data communication status (Transmission sequence status)	271
15.1.5	Reading the switch setting status	273
15.1.6	How to read the current operation status	275
15.2	Error Code	277
15.2.1	How to check the error codes	277
15.2.2	Error code list	281
15.2.3	A compatible 1C frame communications error code list	297
15.2.4	Error code list while modem function is used	299
15.3	Troubleshooting by Symptom	301
15.3.1	The "RUN" LED is turned OFF	303
15.3.2	The "RD" LED does not blink even after message transmission from the external device	303
15.3.3	No response message is returned even though the external device transmitted a message and the "RD" LED blinked	304
15.3.4	Transmission request does not make the "SD" LED blink	305
15.3.5	Read request signal does not turn ON even though the external device transmitted a message and the "RD" LED was blinking	306
15.3.6	The CPRTCL instruction execution is not completed although the "RD" LED blinked	307
15.3.7	Communication error "NAK"	308
15.3.8	Communication error "C/N"	309
15.3.9	Communication error "P/S"	310
15.3.10	Communication error "PRO."	311
15.3.11	Communication error "SIO"	312
15.3.12	Communication error "CH1 ERR." or "CH2 ERR."	313
15.3.13	Communication is intermittent	316
15.3.14	Undecodable data are transmitted or received	318
15.3.15	Whether the communication error is caused on the C24 or external device is unclear	319
15.3.16	Communication is not available via the modem	320
15.3.17	Communication is not available with the ISDN sub-address	321
15.3.18	Constant cycle transmission is not performed normally	321
15.3.19	Condition agreement transmission is not performed normally	321

15.3.20	Data cannot be received due to by an interrupt program . . . . .	321
15.3.21	Data cannot be written to the flash ROM . . . . .	322
15.3.22	Troubleshooting on the protocol setting data reading/writing . . . . .	323
15.3.23	The "ERR." LED is lit . . . . .	324
15.4	Initializing Error Information of the Serial Communication Module . . . . .	325
15.5	Clearing the Programmable Controller CPU Information . . . . .	329

---

<b>APPENDICES</b>	<b>331</b>
-------------------	------------

---

Appendix 1	Buffer Memory . . . . .	331
Appendix 2	How to Confirm the Serial No. and Function Version . . . . .	362
Appendix 3	Differences between L Series C24 and Q Series C24 . . . . .	363
Appendix 3.1	Specification comparisons . . . . .	363
Appendix 3.2	Precautions for utilizing programs . . . . .	363
Appendix 4	When Using GX Developer or GX Configurator-SC . . . . .	364
Appendix 4.1	Compatible software packages . . . . .	364
Appendix 4.2	Specification comparisons . . . . .	364
Appendix 4.3	Operation comparison . . . . .	365
Appendix 4.3.1	Operation of GX Developer . . . . .	365
Appendix 4.3.2	Operation of GX Configurator-SC . . . . .	369
Appendix 5	Operation Image and Data Structure of Predefined Protocol . . . . .	372
Appendix 5.1	Operation image of each communication type of protocol . . . . .	372
Appendix 5.1.1	When communication type is "Send only" . . . . .	372
Appendix 5.1.2	When communication type is "Receive only" . . . . .	374
Appendix 5.1.3	When communication type is "Send & receive" . . . . .	376
Appendix 5.2	Verification operation of receive packet . . . . .	378
Appendix 5.3	Data examples of packet elements . . . . .	379
Appendix 5.3.1	Length . . . . .	379
Appendix 5.3.2	Non-conversion variable . . . . .	381
Appendix 5.3.3	Conversion variable . . . . .	383
Appendix 5.3.4	Check code . . . . .	386
Appendix 5.3.5	Non-verified reception . . . . .	395
Appendix 6	Communication Example when the C24 Is Used Installed to the Head Module . . . . .	396
Appendix 6.1	Restrictions on programming . . . . .	396
Appendix 6.2	System configuration example . . . . .	397
Appendix 6.3	Parameter setting . . . . .	402
Appendix 6.4	Execution program example of the predefined protocol . . . . .	405
Appendix 6.5	Sending/receiving data using the nonprocedural or bidirectional protocol . . . . .	410
Appendix 6.5.1	Receiving data using the nonprocedural or bidirectional protocol . . . . .	410
Appendix 6.5.2	Sending data using the nonprocedural or bidirectional protocol . . . . .	413
Appendix 7	Processing Time . . . . .	417
Appendix 8	ASCII-Code List . . . . .	420
Appendix 9	Usage Example of MX Component . . . . .	421
Appendix 10	Setting Value Recording Sheet . . . . .	429
Appendix 11	External Dimensions . . . . .	431

---

INDEX 432

---

REVISIONS ..... 434  
WARRANTY ..... 435  
TRADEMARKS ..... 436

# TERMS

Unless otherwise specified, this manual uses the following terms.

Term	Description
A compatible 1C frame (Formats 1 to 4)	One of the message formats for the C24 for performing communication using the MC protocol and ASCII data. This is the same message format as when communicating using the dedicated protocol for the A series computer link modules. Device memory read/write operations for the QCPU and LCPU are allowed within the device range of the AnACPU.
A series computer link module	Another term for the MELSEC-A series serial communication module
ACPU	Another term for the MELSEC-A series CPU module
Bidirectional protocol	A communication procedure for the C24 and one of the data communication functions for communicating any data between the CPU module and a target device
Buffer memory	The memory of an intelligent function module and special function module used to store data (such as setting values and monitored values) for communication with a CPU module.
BUFRCVS	Abbreviation for Z.BUFRCVS
C24	Another term for the MELSEC-L series serial communication module
L series C24	
CPRTCL	Abbreviation for G.CPRTCL or GP.CPRTCL
CPU module	The abbreviation for the MELSEC-L series CPU module
CSET	Abbreviation for ZP.CSET
Data communication function	Generic term for the MC protocol, predefined protocol, nonprocedural protocol, and bidirectional protocol
Display unit	A liquid crystal display to be attached to the CPU module
GETE	Abbreviation for G.GETE or GP.GETE
GX Configurator-SC	A setting and monitoring tool added in GX Developer (for serial communication modules)
GX Works2	The product name of the software package for the MELSEC programmable controllers
GX Developer	
Head module	Abbreviation for the LJ72GF15-T2 CC-Link IE Field Network head module
Independent operation	A mode of interface operation to communicate data with target devices using a function specified in each communication protocol setting. The interfaces of two C24s do not interact.
INPUT	Abbreviation for G.INPUT
Intelligent function module	A MELSEC-L series module that has functions other than input or output, such as A/D converter module and D/A converter module
LCPU	Another term for the MELSEC-L series CPU module
Linked operation	The operation mode of each of the two interfaces of C24s that are connected to target devices and linked to one another in order to send/receive data to/from the target devices. The two interfaces communicate data using the same data-communication function (MC protocol (identical type) or nonprocedural protocol) and the same transmission specifications. (Linked operation using the predefined protocol or bidirectional protocol is not allowed.)
MC protocol	Abbreviation for the MELSEC communication protocol, a protocol to access a CPU module from a target device in the Ethernet or serial communication
Message send function (Printer function)	This function registers character data (messages) to be sent to target devices (mainly printers) in the C24 as a user frame in advance, and sends the registered data for multiple user frames using the nonprocedural protocol.
Multidrop connection	A name of the connection when multiple target devices or other C24 are connected in a 1:n or m:n mode using the RS-422/485 interface of the C24.
MX Component	An active X <sup>®</sup> control library for serial communication
Nonprocedural protocol	A user's communication procedure and one of the data communication functions for communicating any data between the CPU module and a target device.

Term	Description
ONDEMAND	Abbreviation for G.ONDEMAND or GP.ONDEMAND
OUTPUT	Abbreviation for G.OUTPUT or GP.OUTPUT
Packet	A data string used for communication with target devices by the predefined protocol.
Predefined Protocol	One of the data communication functions available for the C24. In data communication between the C24 and a target device, data can be sent and received by using a protocol of the target device. This must be set in GX Works2 or GX Configurator-SC (Predefined protocol support function).
Predefined protocol support function	A function available in GX Works2 and GX Configurator-SC (Predefined protocol support function), which includes: <ul style="list-style-type: none"> <li>• Registration of the protocol appropriate to each target device</li> <li>• Writing protocol setting data to or reading them from the flash ROM of the C24</li> <li>• Debug support function</li> </ul>
PRR	Abbreviation for G.PRR or GP.PRR
PUTE	Abbreviation for G.PUTE or GP.PUTE
Q series C24	Another term for the MELSEC-Q series serial communication module
QCPU	Another term for the MELSEC-Q series CPU module
QnA compatible 2C frame (Formats 1 to 4)	One of the message formats for the C24 for performing communication using the MC protocol and ASCII data. This is the same message format as the communication frame using the dedicated protocol for the QnA series serial communication modules. <ul style="list-style-type: none"> <li>• QnA compatible 2C frame (Formats 1 to 4): QnA simplified frame (Formats 1 to 4)</li> </ul>
QnA compatible 3C frame (Formats 1 to 4)	One of the message formats for the C24 for performing communication using the MC protocol and ASCII data.
QnA compatible 4C frame (Formats 1 to 4)	This is the same message format as the communication frame using the dedicated protocol for the QnA series serial communication modules. <ul style="list-style-type: none"> <li>• QnA compatible 3C frame (Formats 1 to 4): QnA frame (Formats 1 to 4)</li> <li>• QnA compatible 4C frame (Formats 1 to 4): QnA extension frame (Formats 1 to 4)</li> </ul>
QnA compatible 4C frame (Format 5)	One of the message formats for the C24 for performing communication using the MC protocol and binary code data. This is the same message format as the communication frame using the dedicated protocol for the QnA series serial communication modules. <ul style="list-style-type: none"> <li>• QnA compatible 4C frame (Format 5): QnA extension frame (Format 5)</li> </ul>
QnA series serial communication module	Another term for the MELSEC-QnA series serial communication module
QnACPU	Another term for the MELSEC-QnA series CPU module
SPBUSY	Abbreviation for G.SPBUSY or GP.SPBUSY
Special function module	A MELSEC-QnA/A series modules that has functions other than input or output, such as A/D converter module and D/A converter module
UINI	Abbreviation for ZP.UINI
User frame	Data name when the fixed format portion of messages to be sent or received between the C24 and a target device is registered in the module and used for sending and receiving data. (The contents of a user frame data should conform to the specifications of the target device). The data array of the head and tail sections of a message (transmission control code, C24 station number, sum check, fixed data, etc.) to be sent and received is registered in the C24 before use. This type of data is used in the on-demand function of the MC protocol and the data communication function with the nonprocedural protocol.
User's Manual (Application)	Abbreviation for the Serial Communication Module User's Manual (Application)

# PACKING LIST

The following items are included in the package of the C24. Before use, check that all the items are included.

## (1) LJ71C24

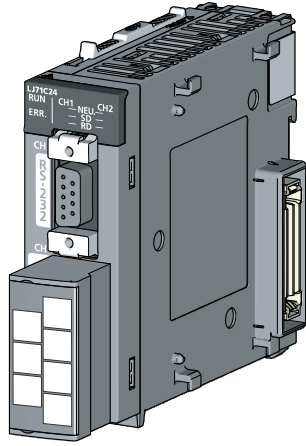

LJ71C24

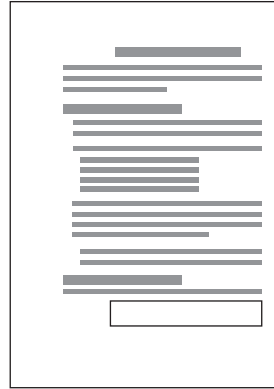

Before Using the Product

A set of terminating resistors

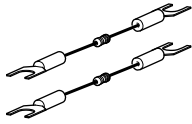

- Terminating resistor for RS-422 communication, 330  $\Omega$  1/4W  $\times$  2 (Orange-Orange-Brown, Gold)

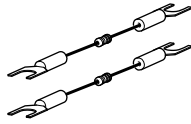

- Terminating resistor for RS-485 communication, 110  $\Omega$  1/2W  $\times$  2 (Brown-Brown-Brown, Gold)



- "CAUTION" note

**(2) LJ71C24-R2**

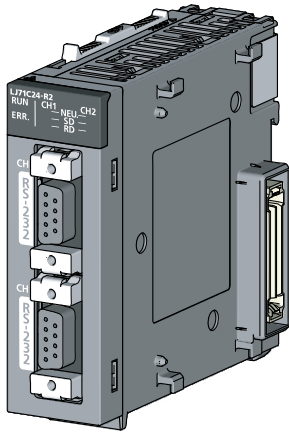

LJ71C24-R2

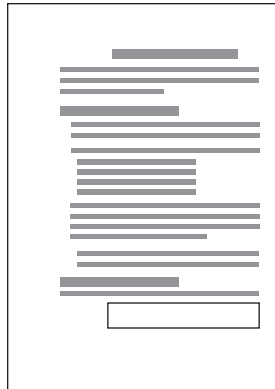

Before Using the Product

# CHAPTER 1 SERIAL COMMUNICATION MODULE FUNCTIONALITY

---

The C24 performs data communication with another device connected by an RS-232 or RS-422/485 line, using any of the following four protocols.

Through a modem or terminal adapter, a public line (analog/digital) can be used for data communication with a remotely located device.

## (1) MELSEC Communication protocol (hereinafter referred to as MC protocol)

Data can be read from or written into the CPU module device memory from the other external device.

Use this protocol when controlling the operation of CPU modules from the external device side.

Refer to  MELSEC Communication Protocol Reference Manual for the details.

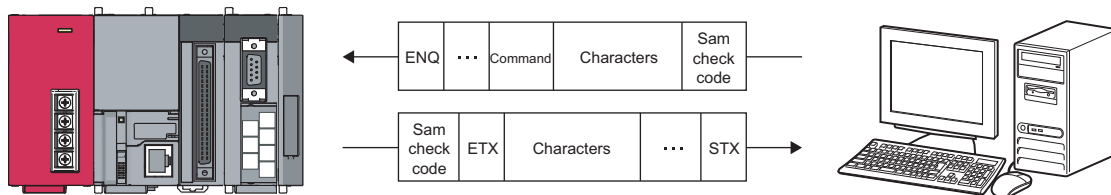



## (2) Predefined protocol

Data can be transferred in accordance with a protocol for the external device.

The same data communication can be performed in the nonprocedural protocol explained in (3). However, the following shows the convenient functions when comparing this protocol and the nonprocedural protocol.

- Sequence programs can be reduced since the GX Works2 predefined protocol support function allows simple protocol setting.
- Writing registered protocol setting data to the flash ROM reduces the volume of the program to be written to the CPU module.

### 1) Setting protocols

The setting can be performed simply, by GX Works2 predefined protocol support functions.

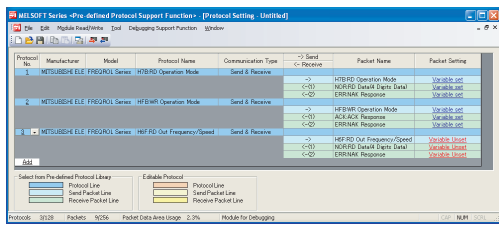

### 2) Writing protocols

The set protocols are written to the flash ROM of the C24.

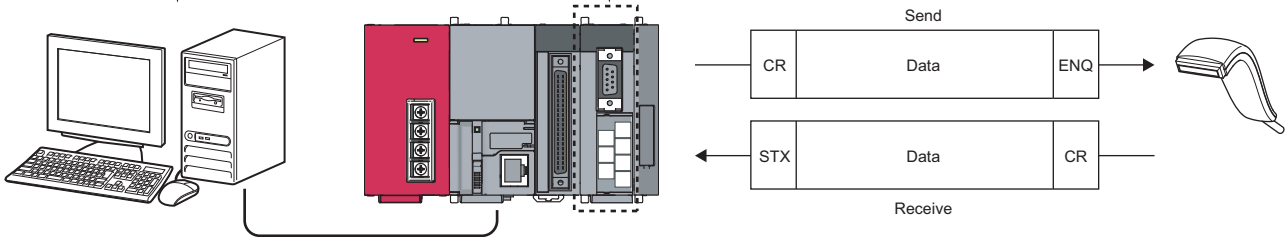
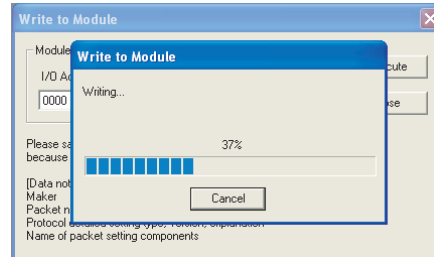

### 3) Executing protocols

Protocols can be executed with a dedicated instruction. One dedicated instruction can execute multiple protocols.

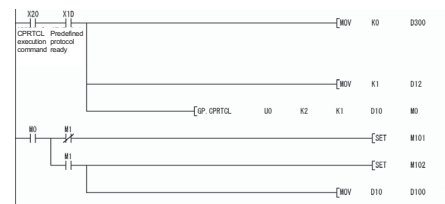

Data communications using protocols corresponding to the external device are available.

### (3) Nonprocedural protocol

Fixed or variable length messages can be received in accordance with the external device specifications. Nonprocedural protocol enables communication between an external device and the CPU module by freely setting the data format and transmission control procedures.

It is used for the data communication using the protocols of external devices, such as measuring instruments, barcode readers, etc.

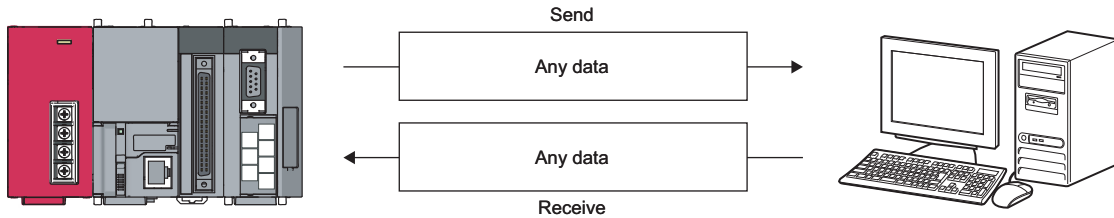

### (4) Bidirectional protocol

The bidirectional protocol enables communication between an external device and the CPU module using the data format and communication control procedures for the bidirectional protocol.

Use this protocol to check if the communication is successfully completed.

The data communication is performed as follows.

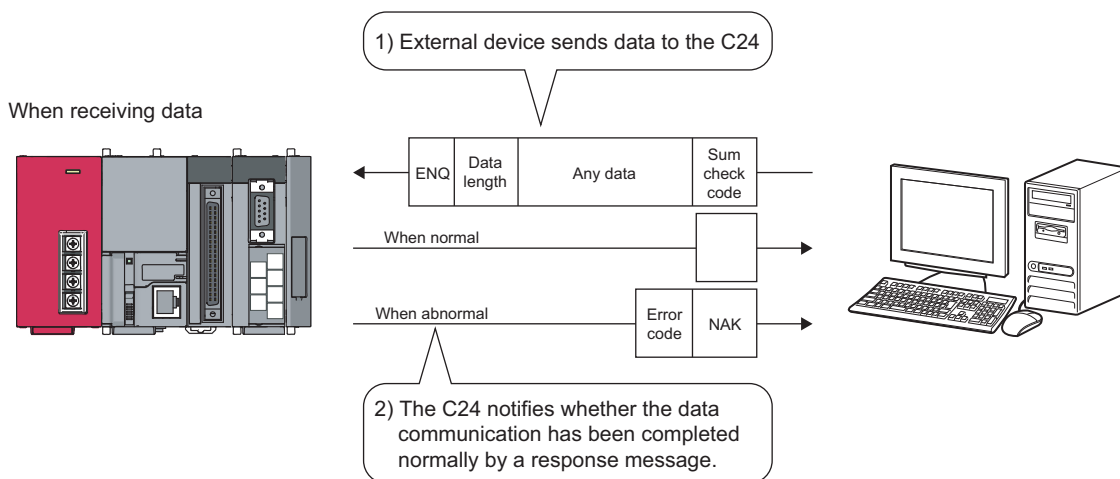

# CHAPTER 2 PART NAMES

This chapter shows part names of the C24.  
LJ71C24

2

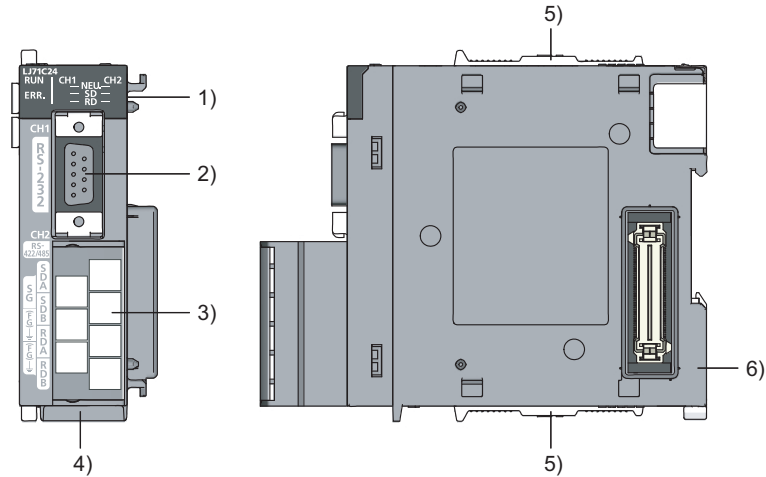

LJ71C24-R2

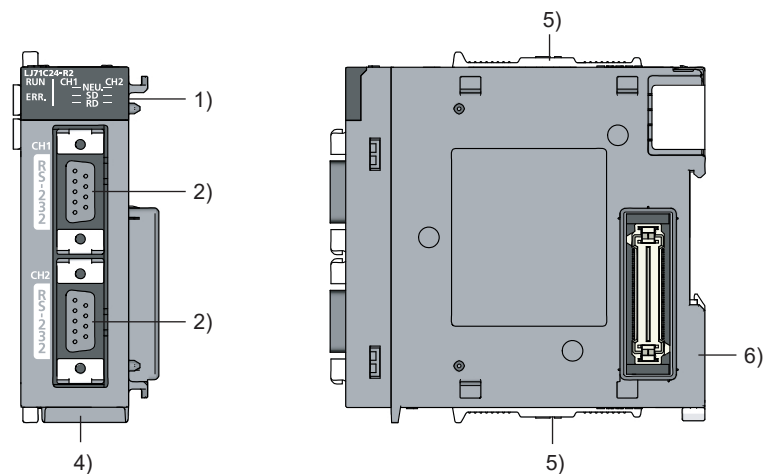

No.	Name	Description
1)	Indicator LED	Indicator LED (For details, refer to (1).)
2)	RS-232 interface	RS232 interface for serial communication with external devices (D-Sub 9 pin female)
3)	RS-422/485 interface	RS422/485 interface for serial communication with external devices (2-piece terminal block)
4)	Serial number display	Displays the serial number of the rating plate.
5)	Module joint lever	Hooks to fix the module connection.
6)	DIN rail hook	Hooks to install to DIN rails.

## (1) Indicator LED

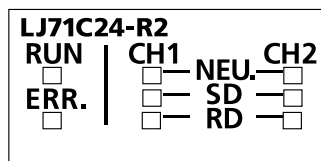
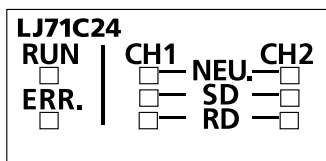

CH	LED	Description	On	Flashing	Off	Applicable protocol			
						MC	Nonprocedural	Bidirectional	Predefined
—	RUN	Normal operation	Normal	—	Faulty or reset	Valid			
	ERR.	Error (*1)	Error has occurred	—	Normal				
CH1	NEU. (*3)	Neutral status on the CH1 side (*2)	Waiting for MC protocol command message to be received	—	MC protocol command message being processed	Valid	Invalid (Off)		
	SD	Transmission status	Data being transmitted		Data not transmitted	Valid			
	RD	Reception status	Data being received		Data not received				
CH2	NEU. (*3)	Neutral status on the CH2 side (*2)	Waiting for MC protocol command message to be received	—	MC protocol command message being processed	Valid	Invalid (Off)		
	SD	Transmission status	Data being transmitted		Data not transmitted	Valid			
	RD	Reception status	Data being received		Data not received				

\*1 This LED turns on when an error occurs at C24 hardware or during data communication.  
(Refer to  Page 178, CHAPTER 11)

\*2 This LED displays the data communication status via the MC protocol.  
On: Waiting for the command message to be received from the external device.  
Off: Processing the command message received from the external device.

\*3 This LED is also valid when "MELSOFT Connection" is specified in communication protocol setting.

# CHAPTER 3 SPECIFICATIONS



This chapter explains the general specifications, performance specifications, function list, and I/O signals.

## 3.1 General Specifications

For the general specifications of C24, refer to "Safety Guidelines", the manual supplied with the CPU module or head module.

## 3.2 Performance Specifications

The following shows the C24 performance specifications.

For the transmission specifications when communicating via the modem function, refer to both  Page 27, Section 3.2 and  User's Manual (Application).

### (1) Transmission specification

Item		Model name	
		LJ71C24	LJ71C24-R2
Interface	CH1	RS-232-compliance (D-sub 9 pin female)	RS-232-compliance (D-sub 9 pin female)
	CH2	RS-422/485-compliance (2-piece terminal block)	RS-232-compliance (D-sub 9 pin female)
Communication system	Line (*1)	Full-duplex/half-duplex communications	
	MC protocol communication	Half-duplex communications	
	Predefined protocol communication	Full-duplex/half-duplex communications	
	Nonprocedural protocol communication	Full-duplex/half-duplex communications	
	Bidirectional protocol communication	Full-duplex/half-duplex communications	
Synchronization method		Start-stop synchronization method	
Transmission speed		50/300/600/1200/2400/4800/9600/14400/19200/28800/38400/57600/115200/230400 (bps) Transmission speed 230400 bps is available for only CH1. (Not available for CH2) Total transmission speed of two interfaces is available up to 230400 bps. Total transmission speed of two interfaces is available up to 115200 bps when the communication data monitoring function is used.	
Data format	Start bits	1	
	Data bits	7/8	
	Parity bits	1 (vertical parity) or none	
	Stop bits	1/2	

Item		Model name			
		LJ71C24		LJ71C24-R2	
Access cycle	MC protocol communication	Processes one request during the END processing of the CPU module of the station with the C24. * Number of scans that must be processed/number of link scans depends on the contents of the request. (Refer to the MELSEC Communication Protocol Reference Manual)			
	Predefined protocol communication	Sends or receives data when requested with the dedicated instruction (CPRTCL).			
	Nonprocedural protocol communication, Bidirectional protocol communication	Sends each time a send request is issued. Can receive at any time.			
Error detection	Parity check	Selected for all protocols and when this check is enabled, ODD or EVEN is selected by a parameter.			
	Sum check code	For the MC or bidirectional protocol, selected by a parameter. For the predefined protocol, whether or not a sum check code is needed depends on the selected protocol. For the nonprocedural protocol, selected in the user frame.			
Transmission control			RS-232	RS-422/485	
	DTR/DSR control		Enabled	Disabled	
	RS/CS control		Enabled	Disabled	
	CD(DCD) signal control		Enabled	Disabled	
	DC1/DC3 (Xon/Xoff) control DC2/DC4 control		Enabled	Enabled	
• DTR/DSR signal control and DC code control are selected by the user.					
Line configuration of connection (External device side: CPU module side) <sup>*2</sup>	RS-232	1:1		1:1	
	RS-422/485	1:1, 1:n, n:1, m:n		—	
Line configuration of data communication (External device side: CPU module side) <sup>*2</sup>	RS-232	MC protocol communication	1:1		1:1
		Predefined protocol communication	1:1		1:1
		Nonprocedural protocol communication	1:1		1:1
		Bidirectional protocols communication	1:1		1:1
	RS-422/485	MC protocol communication	1:1, 1:n, m:n		—
		Predefined protocol communication	1:1, n:1		
		Nonprocedural protocol communication	1:1, 1:n, n:1		
		Bidirectional protocols communication	1:1		

Item		Model name	
		LJ71C24	LJ71C24-R2
Transmission distance (Overall distance)	RS-232	Maximum 15m	Maximum 15m
	RS-422/485	Maximum 1200m (overall distance)	—
Flash ROM write count		Maximum 100,000 times to the same area	
Number of occupied I/O points		32 points (I/O assignment: Intelli: 32 points)	
5V DC internal current consumption		0.39A	0.26A
External dimensions		90 (H) × 28.5 (W) × 95 (D)[mm]	
Weight		0.17kg	0.14kg

\*1 Set to transfer data with external devices using a full-duplex communication system when the C24 is started.  
For switching to a half-duplex communication system, refer to  User's Manual (Application).

\*2 The total number of n and m+n is up to 32 stations.

## 3.2.1 Number of parameter settings

For the parameter settings of the initial setting and auto refresh setting of the C24, set parameters (including the parameters for other intelligent function modules) not to exceed the maximum number of parameters that can be set for a CPU module or the head module.

For the maximum number of parameters that can be set for a CPU module or the head module (maximum number of parameter settings), refer to the following manual.

 MELSEC-L CPU Module User's Manual (Hardware Design, Maintenance and Inspection)

 MELSEC-L CC-Link IE Field Network Head Module User's Manual

### (1) Number of parameters for the C24

The following number of parameters can be set for one C24.

Target module	Initial setting	Auto refresh setting
LJ71C24	0 (Not used)	50 (Maximum number of settings)
LJ71C24-R2	0 (Not used)	51 (Maximum number of settings)

### (2) Checking method

The number of parameters set for the intelligent function module and the maximum number of parameter settings can be confirmed by the following operation.

 Project window ⇒ [Intelligent Function Module] ⇒ Right click ⇒ [Intelligent Function Module Parameter List].

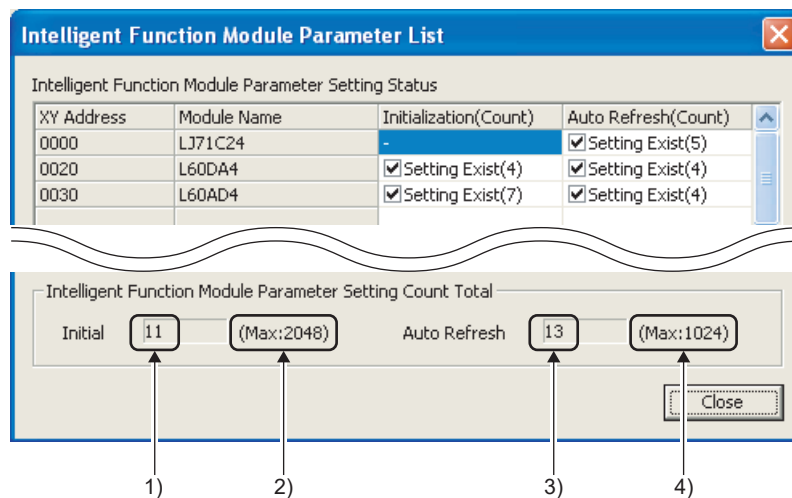

The screenshot shows the 'Intelligent Function Module Parameter List' dialog box. It contains a table titled 'Intelligent Function Module Parameter Setting Status' with the following data:

XY Address	Module Name	Initialization(Count)	Auto Refresh(Count)
0000	LJ71C24	-	✓ Setting Exist(5)
0020	L60DA4	✓ Setting Exist(4)	✓ Setting Exist(4)
0030	L60AD4	✓ Setting Exist(7)	✓ Setting Exist(4)

Below the table, there are two sections for parameter counts:

- Intelligent Function Module Parameter Setting Count Total:** Initial: 11 (Max:2048), Auto Refresh: 13 (Max:1024)
- Intelligent Function Module Parameter Setting Count Total:** Initial: 11 (Max:2048), Auto Refresh: 13 (Max:1024)

Arrows point from the numbers 1) through 4) to the corresponding values in the dialog box.

- 1) Total number of initial setting parameters marked with a check on the screen
- 2) Maximum number of parameter settings of initial settings
- 3) Total number of auto refresh setting parameters marked with a check on the screen
- 4) Maximum number of parameter settings of auto refresh settings



## 3.3 Function List

### 3.3.1 Basic functions

The following shows the basic functions of the C24.

Function	Description	Reference	
Communication with MC protocol	Reading/writing from/to the device memory of the CPU module	Executes batch read/write in bit/word units. Executes monitoring of device memory. Executes batch read/write of multiple blocks. Executes read/write by extension designation. Accesses other stations via network system.	Page 103, CHAPTER 8, MELSEC Communication Protocol Reference Manual
	Reading/writing from/to the buffer memory of the C24	Executes reading/writing from/to the buffer memory of the C24.	
	Reading/writing from/to the buffer memory of intelligent function modules	Executes reading/writing from/to the buffer memory of intelligent function modules.	
	Reading/writing from/to sequence program files and parameter files	Executes reading/writing from/to program files and parameter files stored in the CPU module.	
	Controlling the status of the CPU module (such as remote RUN/STOP)	Executes status control of the CPU module. Executes remote RUN/STOP/PAUSE/latch clear/reset operations from external devices.	
Communication with predefined protocol	Data transmission/reception	Executes data transmission/reception with the appropriate protocol for each external device. The external device side protocol can be easily selected, or created/edited from the predefined protocol library of GX Works2.	Page 108, CHAPTER 9 Page 372, Appendix 5 GX Works2 Version1 Operating Manual (Intelligent Function Module)
Communication with nonprocedural protocol	Data transmission/reception in any format	Data communication can be made in any format appropriate to specifications of external devices (measuring devices, personal computers etc.).	Page 146, CHAPTER 10
Communication with bidirectional protocol	Data transmission/reception in any format	Any data transmission/reception can be made with message formats and transmission control procedures for the bidirectional protocol.	Page 178, CHAPTER 11
Debug support function	Circuit trace	This function traces communication data and control signal between the C24 and device controller.	Page 243, Section 13.1
	State monitor	This function monitors the signal, communication error information, and operation setting switch of the C24. The protocol execution status is also monitored during the predefined protocol communication.	Page 249, Section 13.2
	Protocol execution log storage function	This function checks the detailed predefined protocol execution status and results for each channel.	Page 254, Section 13.3

## 3.3.2 Additional functions

The following shows the additional functions of the C24.

The following abbreviations appear in the protocol column of the function list.

MC	MC protocol
Pd	Predefined protocol
Non	Nonprocedural protocol
Bi	Bidirectional protocol

(○: Applicable protocol)

Function	Description	Protocol				Reference
		MC	Non	Bi	Pd	
Communication with ASCII code	Executes the communication with QnA compatible 2C/3C/4C frames.	○				Page 103, CHAPTER 8, MELSEC Communication Protocol Reference Manual
	Executes the communication with an A compatible 1C frame.	○				
Communication with binary code	Executes the communication with a QnA compatible 4C frame.	○				
Monitoring CPU modules (Programmable controller CPU monitoring function)	Monitors the operating status of CPU modules and the data in the device memory. The CPU module status and the device memory data can be sent to the external device at fixed intervals, when an error occurs in the machine equipment, or when certain conditions are satisfied.	○	○			
Turning on/off input signals of the C24 from an external device (global function)	Turns on/off input signals of the C24 from an external device.	○				
Data transmission from a CPU module to an external device (on-demand function)	Data can be sent from the programmable controller CPU to the external devices in each frame format of the MC protocol.	○				
Data transmission/reception by the user frame	Registers the fixed format portion of messages sent and received between C24 and an external device in the module. That portion can be used when sending and receiving data.	○	○			
Data reception by interrupt programs	To make the data reception faster, reads the reception data by interrupt programs.		○	○		User's Manual (Application)
ASCII data transmission/reception by ASCII-BIN conversion	Communication can be made with ASCII code data since the C24 executes ASCII-BIN conversion.		○	○		
Data transmission/reception by specifying transparent code	In data communication with external devices, one-byte data for transmission control of the external device side can be sent/received as an user data.		○	○		
Communication via public network, etc. (Modem function)	Data communication is performed via public line with a remotely located external device. Data communication with MC protocol, nonprocedural protocol, and bidirectional protocol are available.	○	○	○		User's Manual (Application)

Function		Description	Protocol				Reference
			MC	Non	Bi	Pd	
Transmission control	DC code control (including Xon/Xoff control)	This control notifies the availability of data reception in the host station and the effective range of sent/received data to external devices, using the data for transmission control in the C24.	○	○	○	○	User's Manual (Application)
	DTR/DSR control	This control notifies the availability of data reception in the host station to external devices, using the ER(DTR)/DR(DSR) signal of the RS-232 interface.					
Independent operation of each interface		Two interfaces of the C24 perform data communication with external devices without connecting each other.	○	○	○	○	Page 85, Section 7.3
Linked operation of each interface		All data received from one of the two interfaces is transmitted from the other interface.	○	○			Page 91, Section 7.3.5
Parameter registrations to the flash ROM		Initial values of the buffer memory can be changed by setting each parameter and writing to the flash ROM.	○	○	○	○	Page 94, Section 7.4
Remote password check function		Checks the password in the C24 when a remote user accesses to the LCPU with the modem function. This function prevents unauthorized accesses to the LCPU.	○				User's Manual (Application)
Enabling or disabling echo back of the RS-422/485 interface		When data are sent through RS-485 (2-wire type) from the RS-422/485 interface, the same data are also sent to RDA or RDB in the host station. Whether to receive the returned data or not (discard) can be specified.	○	○	○	○	Page 64, Section 6.3.5

## 3.4 List of Input/Output Signals

This section describes the input/output signals of the C24.

The following I/O signal assignment is based on the case where the start I/O No. of the C24 is "0000".

Device numbers starting with X indicate input signals from the C24 to the CPU module.

Device numbers starting with Y indicate output signals from the CPU module to the C24.

The following table lists the input/output signals for the CPU module.

Device number	Signal description		Reference	Device number	Signal description		Reference
X0 *1	CH1 Transmission normal completion	ON: Normal completion	—	Y0	CH1 Transmission request	ON: Requesting transmission	—
X1 *1	CH1 Transmission abnormal completion	ON: Abnormal completion		Y1	CH1 Reception data read completion	ON: Data read completed	
X2 *1	CH1 Transmission processing	ON: Transmission in progress		Y2	CH1 Mode switching request	ON: Requesting switch	
X3 *2	CH1 Reception data read request	ON: Requesting read	Page 147, Section 10.1 Page 179, Section 11.1	Y3	CH1 Protocol execution request	ON: Requesting execution	—
X4 *2	CH1 Reception abnormal detection	ON: Abnormal detection		Y4	Use prohibited		—
X5 *1	CH1 Protocol execution completion	ON: Execution completed	Y5				
X6 *3	CH1 Mode switching	ON: Switching	User's Manual (Application)	Y6			
X7 *1	CH2 Transmission normal completion	ON: Normal Completion	—	Y7	CH2 Transmission request	ON: Requesting transmission	—
X8 *1	CH2 Transmission abnormal completion	ON: Abnormal completion		Y8	CH2 Reception data read completion	ON: Data read completed	
X9 *1	CH2 Transmission processing	ON: Transmission in progress		Y9	CH2 Mode switching request	ON: Requesting switch	
XA *2	CH2 Reception data read request	ON: Requesting read	Page 147, Section 10.1 Page 179, Section 11.1	YA	CH2 Protocol execution request	ON: Requesting execution	—
XB *2	CH2 Reception abnormal detection	ON: Abnormal detection		YB	Use prohibited		—
XC *1	CH2 Protocol execution completion	ON: Execution completed	YC				
XD *3	CH2 Mode switching	ON: Switching	User's Manual (Application)	YD			
XE	CH1 ERR. occurrence	ON: Error occurring	Page 325, Section 15.4	YE	CH1 ERR. clear request	ON: Requesting error clear	Page 277, Section 15.2
XF	CH2 ERR. occurrence	ON: Error occurring		YF	CH2 ERR. clear request	ON: Requesting error clear	

Device number	Signal description		Reference	Device number	Signal description		Reference	
X10	Modem initialization completion	ON: Initialization completed	User's Manual (Application)	Y10	Modem initialization request (standby request)	ON: Requesting initialization	User's Manual (Application)	
X11	Dialing	ON: Dial in progress		Y11	Connection request	ON: Requesting connection		
X12	Connection	ON: Connection in progress		Y12	Modem disconnection request	ON: Requesting disconnection		
X13	Initialization/connection abnormal completion	ON: Initialization/connection abnormally completed		Y13	Use prohibited			—
X14	Modem disconnection complete	ON: Disconnection completed		Y14				
X15	Use prohibited			Y15				
X16			Y16					
X17 *1	Flash ROM read completion	ON: Completed	—	Y17	Flash ROM read request	ON: Requesting	—	
X18 *1	Flash ROM write completion	ON: Completed		Y18	Flash ROM write request	ON: Requesting		
X19	Flash ROM system setting write completion	ON: Completed		Y19	Flash ROM system setting write request	ON: Requesting		
X1A	CH1 Global signal	ON: Output instructed	MELSEC Communication Protocol Reference Manual	Y1A	Use prohibited		—	
X1B	CH2 Global signal	ON: Output instructed		Y1B				
X1C	System setting default completion	ON: Completed	—	Y1C	System setting default request	ON: Requesting	—	
X1D *6	Predefined protocol ready	ON: Ready	Page 132, Section 9.4	Y1D	Use prohibited		—	
X1E *4	C24 ready	ON: Accessible	—	Y1E				
X1F *5	Watchdog timer error (WDT error)	ON : Module error occurred ON : Module error occurred	—	Y1F				

- \*1 The device does not turn on/off by execution of a dedicated instruction when a function that corresponds to the input signal is used.
- \*2 The device does turn on/off by execution of a dedicated instruction when a function that corresponds to the input signal is used (from ON to OFF: Data read completed).
- \*3 The mode switching (X6/XD) turns ON when the following function is executed.  
Mode switching, transmission sequence initialization, reception data clear (by buffer memory), user frame use enable/disable designation, UINI instruction, programmable controller CPU information clear  
While the mode switching (X6/XD) is ON, do not issue a communication request to the target interface.  
(The communication processing of the C24 is stopped while the mode switching (X6/XD) is ON.)
- \*4 The C24 ready indicates whether or not it is possible to access the C24 from the CPU module.  
Use it as an interlock signal for a sequence program.
- \*5 Restart the CPU module when the watchdog timer error is turned on.  
If the error still occurs after restarting, refer to  Page 303, Section 15.3.1 to take corrective actions.
- \*6 Predefined protocol ready (X1D) is a signal that turns on when predefined protocol communication becomes ready.

### Point







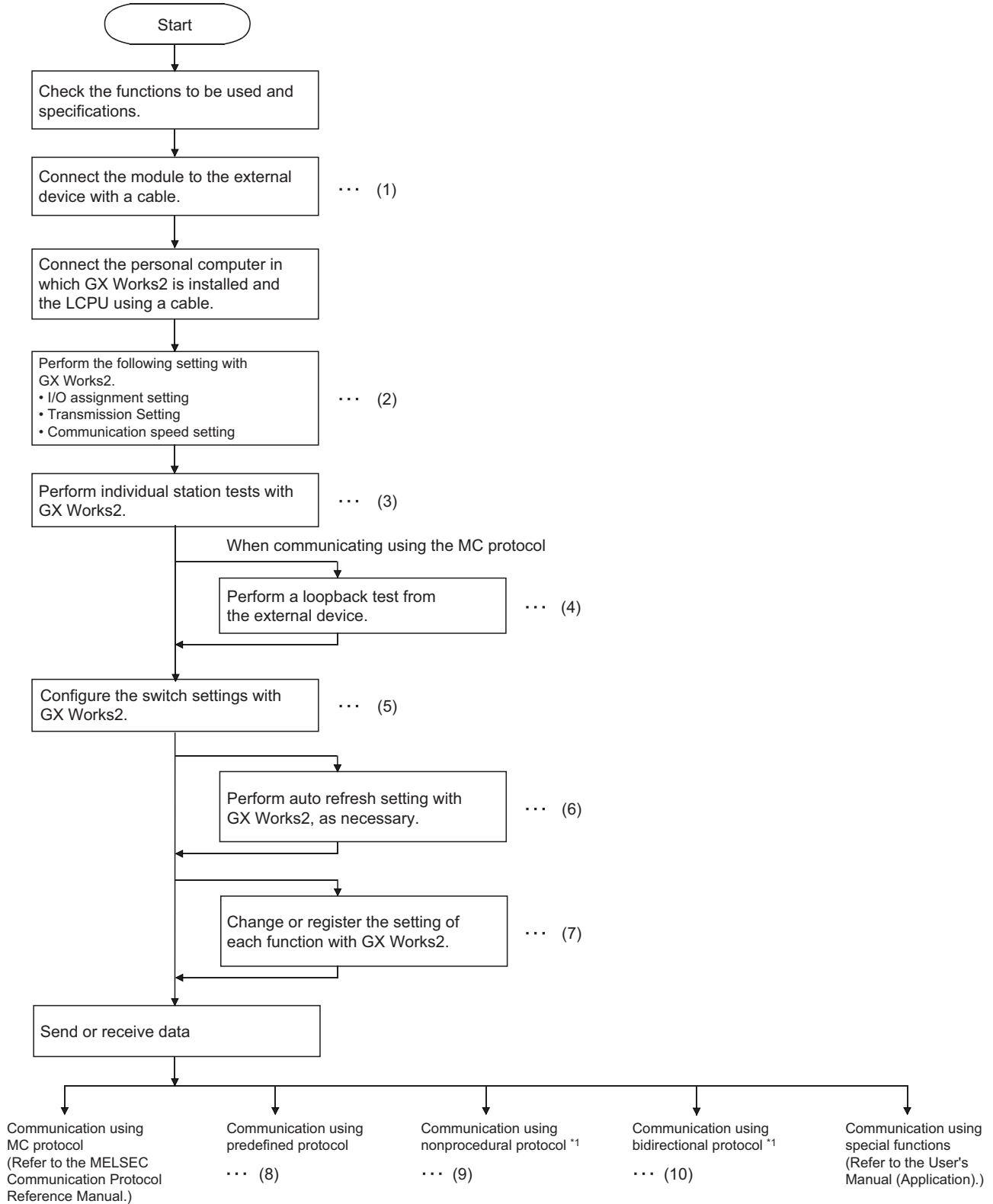



- Do not use any "use prohibited" signals as an output signal to the CPU module.  
Doing so may cause malfunction of the programmable controller system.
- If the modem function is not used, X10 to X16 and Y10 to Y16 cannot be used.

# CHAPTER 4 PROCEDURES PRIOR TO OPERATION

This chapter explains the procedures required before starting the operation.



\*1 The same communication is available using the predefined protocol. By the Predefined protocol, programs can be created easily, and the number of steps can be drastically reduced.

- (1)  Page 46, Section 6.2, Page 54, Section 6.3
- (2)  Page 74, Section 7.1, Page 86, Section 7.3.1, Page 88, Section 7.3.2
- (3)  Page 66, Section 6.4
- (4)  Page 71, Section 6.5
- (5)  Page 85, Section 7.3
- (6)  Page 99, Section 7.5
- (7)  Page 75, Section 7.2, Page 94, Section 7.4
- (8)  Page 108, CHAPTER 9
- (9)  Page 146, CHAPTER 10
- (10)  Page 178, CHAPTER 11

# CHAPTER 5 SYSTEM CONFIGURATION

This chapter explains the system configuration and the number of applicable modules of the C24.

## 5.1 Overall Configuration

### (1) When installing the C24 to the CPU module

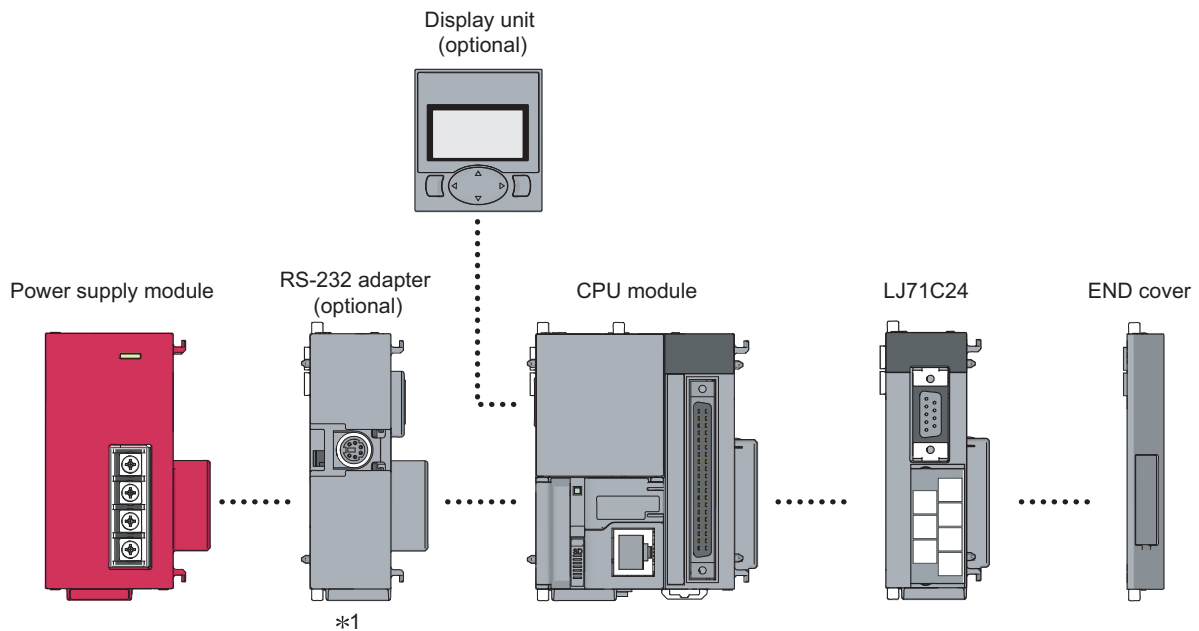

\*1 For the RS-232 adapter, refer to the following.  
📖 MELSEC-L CPU Module User's Manual (Hardware Design, Maintenance and Inspection)

### (2) When installing the C24 to the head module

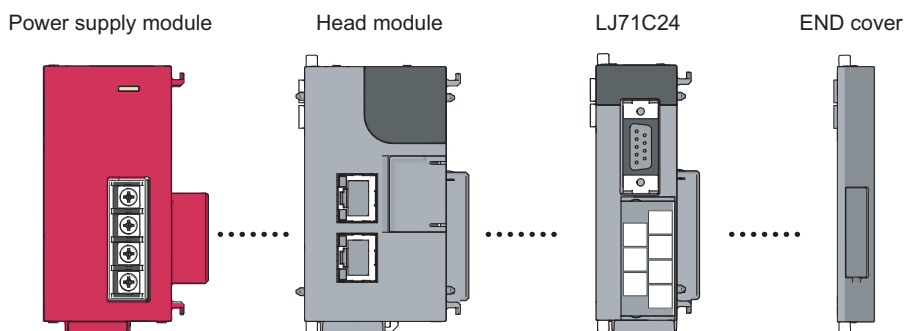



### (3) System examples

#### (a) Connecting two external devices to the C24

Connect external devices such as a GOT and a barcode reader to one C24.

Data can be exchanged between a GOT and a device such as a barcode reader via the C24.

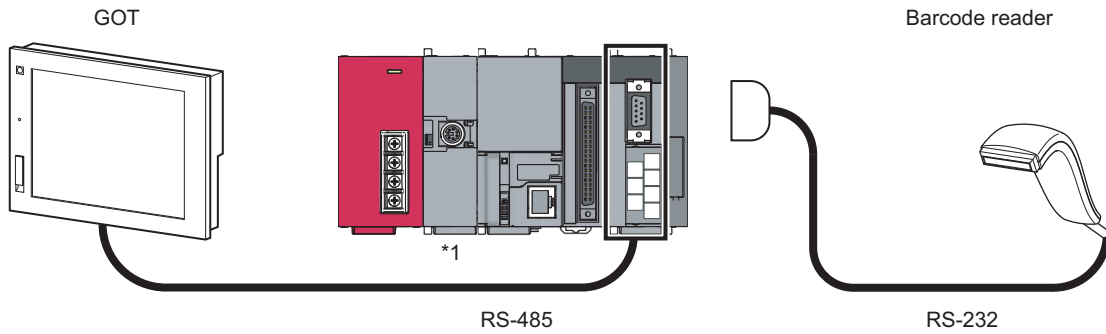

\*1 For the RS-232 adapter, refer to the following manual.  
 MELSEC-L CPU Module User's Manual (Hardware Design, Maintenance and Inspection)

#### (b) Connecting an external device and multiple C24s

Connect multiple C24s to a personal computer in a multidrop network.

From the personal computer, data in each CPU module can be written or read via each C24.

For the combinations of external devices and the C24, refer to Page 41, Section 5.3.

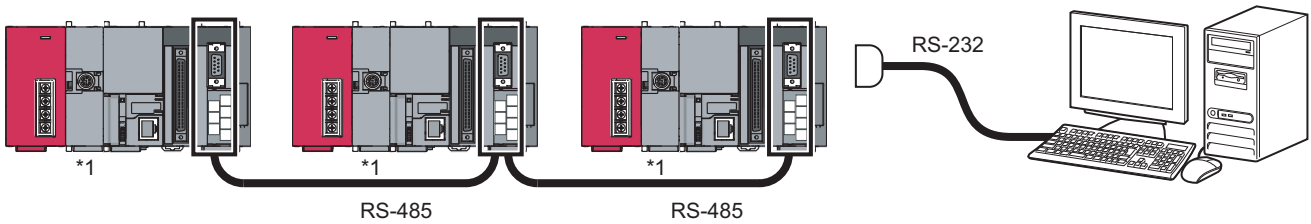

\*1 For the RS-232 adapter, refer to the following manual.  
 MELSEC-L CPU Module User's Manual (Hardware Design, Maintenance and Inspection)

## 5.2 Applicable Systems

---

### (1) Applicable CPU modules and No. of modules

Refer to the following.

 MELSEC-L CPU Module User's Manual (Hardware Design, Maintenance and Inspection)

 MELSEC-L CC-Link IE Field Network Head Module User's Manual

### (2) Supported software packages

#### (a) Setting and monitoring tools

Refer to the following.

 MELSEC-L CPU Module User's Manual (Hardware Design, Maintenance and Inspection)

 MELSEC-L CC-Link IE Field Network Head Module User's Manual

#### (b) Communication support tools for external devices

Item Name	Model	Remarks
MX Component	SWnD5C-ACT(-E)	ActiveX control library. The "n" in the model name is 0 or greater. (*1)

\*1 Depending on the version of MX Component used, different versions of the C24 are supported.  
For details, refer to  manual of MX Component.

## 5.2.1 Restrictions when the C24 is installed to the head module

---

For restrictions when the C24 is installed to the head module, refer to  Page 396, Appendix 6.1.

## 5.3 Systems that can be Configured and Functions

The following describes the system configurations and available functions when using the C24.

### (1) System configurations

System configurations (combinations of the C24 and external device) for data communication are shown below.

#### (a) External device and C24 with 1:1 system configuration

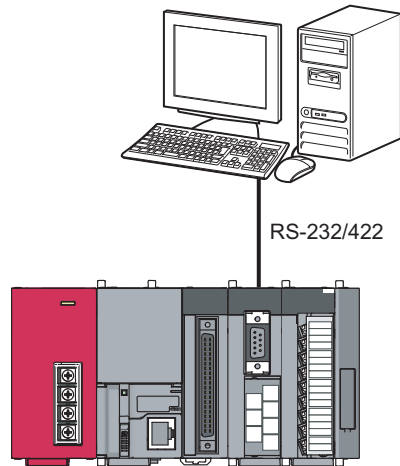

#### (b) External device and C24 with n:1 system configuration

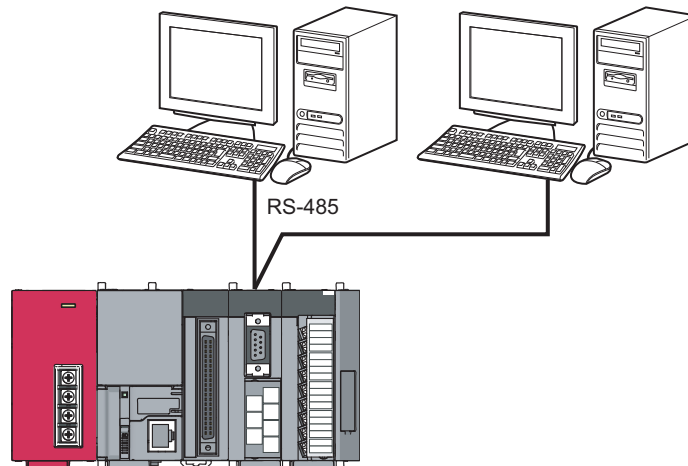

**(c) External device and C24 with 1:n system configuration**

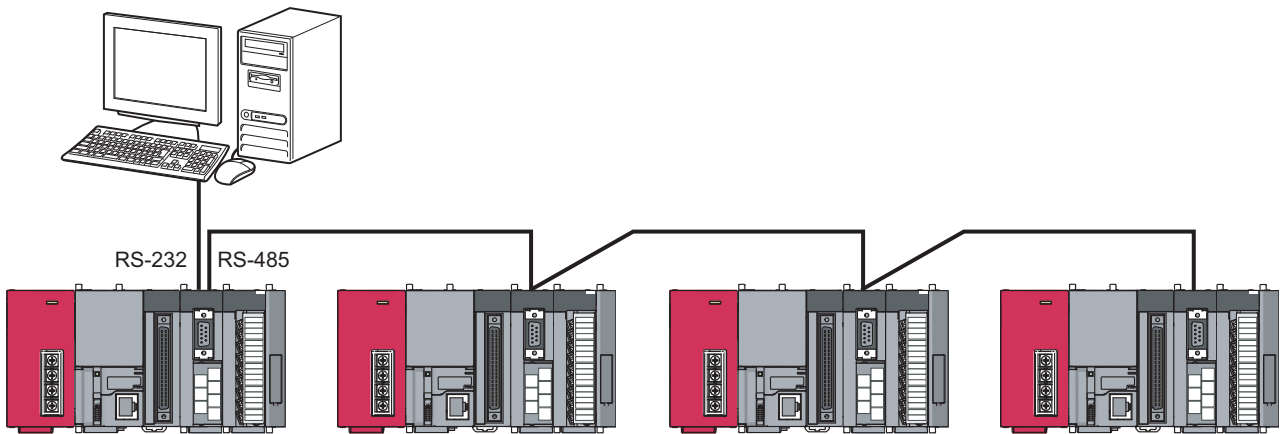
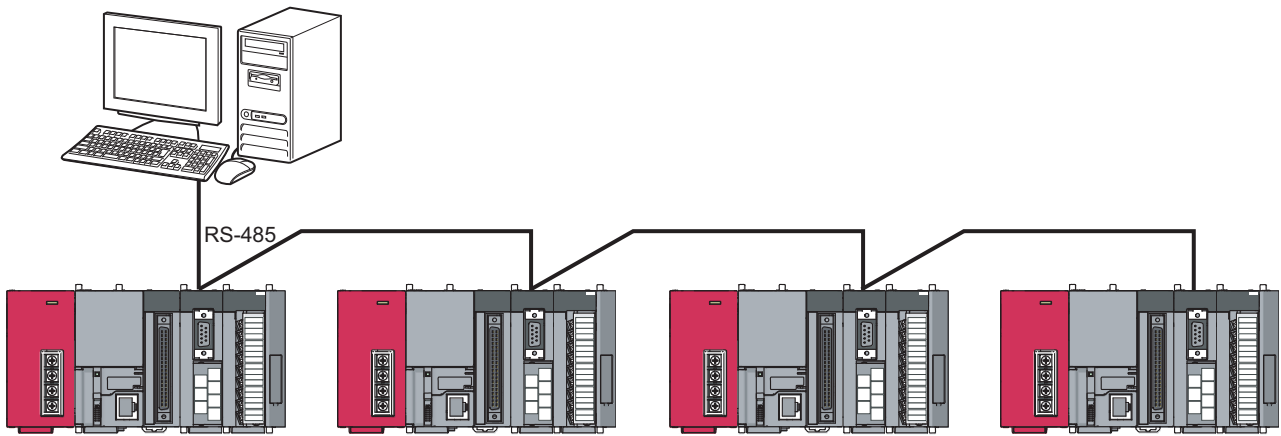

**(d) External device and C24 with m:n system configuration**

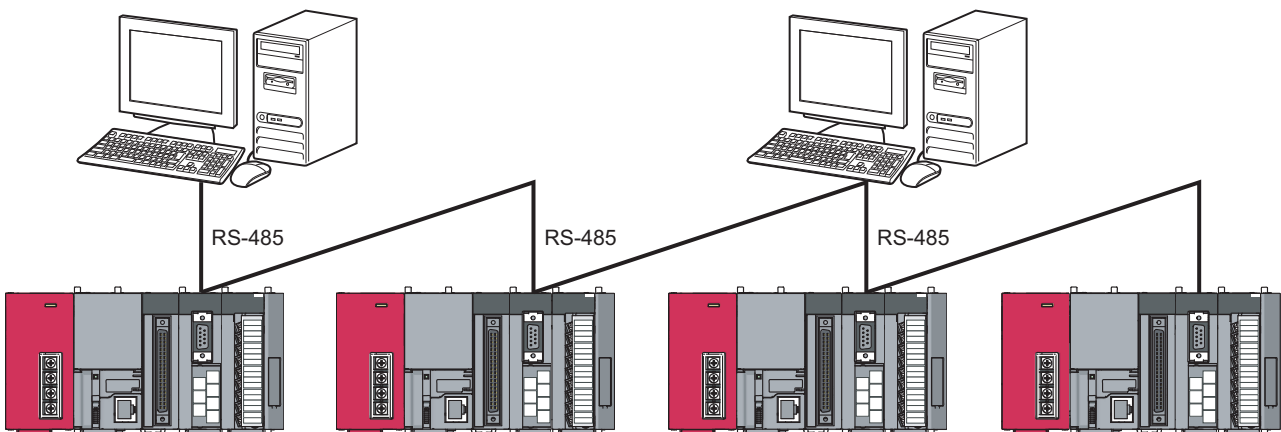

## (2) Correspondence between the data communication functions and system configurations

The following shows system configurations that can use the data communication functions of the C24.

### (a) Communication using the MC protocol

(○: Available, ×: Not available)

Function	System configuration (External device: C24)				Reference
	1:1	n:1	1:n	m:n	
CPU module device memory read/write	○	○	○	○	Page 103, CHAPTER 8, MELSEC Communication Protocol Reference Manual
Intelligent function module buffer memory read/write	○	○	○	○	
Sequence program read/write	○	○	○	○	
CPU module status control (remote RUN, STOP, etc.)	○	○	○	○	
On-demand function	○	×	×	×	User's Manual (Application)
Global function	○	○	○	○	MELSEC Communication Protocol Reference Manual
Programmable controller CPU monitoring function	○	×	×	×	User's Manual (Application)

### (b) Communication using the predefined protocol

(○: Available, ×: Not available)

Function	System configuration (External device: C24)				Reference
	1:1	n:1	1:n	m:n	
Data transmission/reception	○	○	×	×	Page 108, CHAPTER 9 GX Works2 Version1 Operating Manual (Intelligent Function Module)

### (c) Communication using the nonprocedural protocol

(○: Available, ×: Not available)

Function	System configuration (External device: C24)				Reference
	1:1	n:1	1:n	m:n	
Data transmission/receiving in arbitrary format	○	○	○	○	Page 146, CHAPTER 10
Data transmission/receiving with user frames	○	○	○	○	User's Manual (Application)
Programmable controller CPU monitoring function	○	×	×	×	
Reading received data using interrupt programs	○	○	○	○	
Sending/receiving ASCII data using ASCII-BIN conversion	○	○	○	○	

### (d) Communication using the bidirectional protocol

(○: Available, ×: Not available)

Function	System configuration (External device: C24)				Reference
	1:1	n:1	1:n	m:n	
Data transmission/receiving	○	×	×	×	Page 178, CHAPTER 11
Reading received data using interrupt programs	○	×	×	×	User's Manual (Application)
Sending/receiving ASCII data using ASCII-BIN conversion	○	×	×	×	

## 5.4 Considerations for System Configurations

This section explains considerations for the system configurations.

### (1) Considerations for system configurations of other than 1:1 basis between target device and C24

In general, when data is communicated in the system configuration of other than 1:1 basis, pay attention to the following.

- Avoid simultaneous transmission.
- Discard the received data other than that addressed to the local station.

### (2) Considerations for network communication route

When accessing a CPU module on another station from GX Developer, GX Works2, GOT, or target devices that communicate using MC protocol, use CH2 for RS-485 multidrop connection between C24s.

# CHAPTER 6 SETTING AND WIRING

This chapter explains the setting and wiring methods in the system for using the C24.

## 6.1 Installation Environment and Position of the Module

For the installation environment and position of the module, refer to the following manual.

 MELSEC-L CPU Module User's Manual (Hardware Design, Maintenance and Inspection)

 MELSEC-L CC-Link IE Field Network Head Module User's Manual

### 6.1.1 Handling precautions

When using the C24, note the following points.

- (1) Do not drop the C24 or subject it to heavy impact since its case is made of resin.
- (2) Tighten the screws such as terminal screws within the following torque ranges.

Screw	Tightening torque range	Remarks
RS-422/485 terminal block screw (M3 screw)	0.42 to 0.58 N·m	—
RS-422/485 terminal block mounting screws (M3.5 screw)	0.66 to 0.89N·m	—
RS-232 cable connector screw (M2.6 screw)	0.20 to 0.39N·m	Screw hole depth: L=3.2mm or less (Internal length from the surface)

## 6.2 External Wiring with RS-232 Interface

This section explains the specifications of RS-232 interface and how to connect with external devices.

### 6.2.1 RS-232 connector specifications

The following shows the specifications of the RS-232 connector that connects the C24 to an external device.

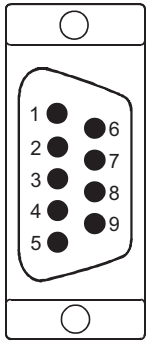

Pin No.	Abbreviation	Signal name	Direction	
			C24	External device
1	CD(DCD)	Data carrier detect	←	—
2	RD(RXD)	Received data	←	—
3	SD(TXD)	Transmitted data	—	→
4	ER(DTR)	Data terminal ready	—	→
5	SG	Signal ground	←	→
6	DR(DSR)	Data set ready	←	—
7	RS(RTS)	Request to send	—	→
8	CS(CTS)	Clear to send	←	—
9	CI(RI)	Ring indicator	←	—

**(1) The control signals are described below. (The pin numbers of the connector are enclosed in parentheses.)**

**(a) CD(DCD) signal (1)**

- The C24 operates according to the setting of the CD terminal check.

	CD terminal check enabled	CD terminal check disabled
Full-duplex communication	<ul style="list-style-type: none"> <li>The C24 performs send and receive processing when the CD(DCD) signal (receive carrier detection) is ON.</li> </ul>	<ul style="list-style-type: none"> <li>The C24 performs send and receive processing regardless of the ON/OFF status of the CD(DCD) signal.</li> <li>Data communications is possible with an external device that cannot turn the CD(DCD) signal ON/OFF.</li> </ul>
Half-duplex communication	 User's Manual (Application)	Setting impossible.

The CD terminal check can be set in GX Works2 as follows.

"Various\_Control\_Specification" screen ⇒ "For designation of communication control" ⇒ "CD terminal check designation (for RS-232)"

**(b) RD(RXD) signal (2)**

This is a signal to receive data.

**(c) SD(TXD) signal (3)**

This is a signal to send data.



**(d) ER(DTR) signal (4)**

- When communicating data using the nonprocedural protocol, the C24 turns this signal on or off (on when data is receivable) depending on the amount of unused memory in the OS area allocated for receive data storage, if DTR/DSR control is being performed.

Read the receive data from the sequence program, as the receive data is stored in the OS area when the ER(DTR) signal is OFF. If DTR/DSR control is not performed, the ER(DTR) signal is always ON.

- If an MC protocol or bidirectional protocol is performing data communication, this signal turns ON when communications is enabled.

**(e) DR(DSR) signal (6)**

- During DTR/DSR control, if this signal is OFF, the C24 does not send data to the external device. Be sure that this signal is always ON when the external device is ready to receive.
- If DTR/DSR control is not performed, the DR(DSR) signal status is ignored.

**(f) RS(RTS) signal (7)**

- The C24 turns ON/OFF this signal as shown below.
- While the communication system is full-duplex communication, the C24 turns ON the RS(RTS) signal when the C24 ready (X1E) is ON.
- When the communication system is half-duplex communication, the C24 turns on the RS(RTS) signal when it sends the data to an external device.
- The RS(RTS) signal does not turn OFF even when the receive data cannot be stored in the C24.

**(g) CS(CTS) signal (8)**

- The C24 does not send data to an external device when this signal is OFF.
- Be sure that this signal is always ON when the external device is ready to receive.

**(h) CI(RI) signal (9)**

- The CI(RI) signal is used when the modem status is monitored on the C24 side. Connect the modem as necessary.

The CI(RI) signal is not necessary when the modem is not connected.

**(2) The ON and OFF states of each signal indicate the following conditions:**

	(Output side)	(Input side)
ON	5V to 15VDC	3V to 15VDC
OFF	-15V to -5VDC	-15V to -3VDC

**(3) Interface connector**

The following RS-232 interface connector is used for the C24.

- DDK Ltd.  
9-pin D-sub (female) screw type (Mating screw M2.6)  
17L-10090-27 (D9AC) (-FA)

The following table shows the suitable connector shell for the RS-232 connector.

Type	Model
Connector shell	17JE-23090-02(D8A)(-CG)*1

\*1 Manufactured by DDK Ltd.

**(4) Tightening torque**

For details on the tightening torque for the RS-232 interface connector, refer to  Page 45, Section 6.1.1.

**Remark**

- Confirmation of RS-232 control signal status  
Each status of the control signals, ER(DTR), DR(DSR), RS(RTS) and CD(DCD) can be confirmed in RS-232 control signal status (address: 254<sub>H</sub>/264<sub>H</sub>).

Bit position	Buffer memory address	
	CH1 side	CH2 side
	254 <sub>H</sub>	264 <sub>H</sub>
b0	RS(RTS)	
b1	DR(DSR)	
b2	ER(DTR)	
b3	CD(DCD)	
b4	CS(CTS)	
b5	CI(RI)	
b6 to b15	—	

- Designation of RS and DTR signal status  
Normally, the ON/OFF status of the RS(RTS) or ER(DTR) signal is set by the C24.  
To specify the ON/OFF status of the RS(RTS) or ER(DTR) signal, turn ON/OFF the corresponding bit of the RS or DTR signal status designation (address: 92<sub>H</sub> /132<sub>H</sub>). \*1\*2\*3\*4

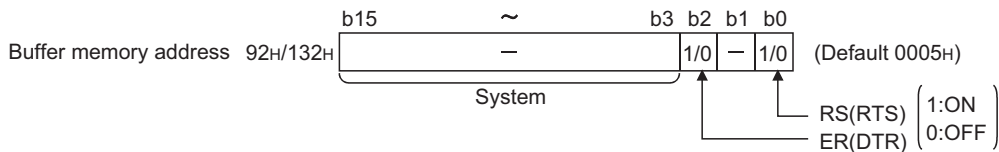

- \*1 The RS(RTS) signal is controlled by the C24 in the following cases. (Ignore setting contents.)
  - When data are communicated with half-duplex communication
  - When communication time and the RS and CS signals are controlled by the modem function
- \*2 The ER(DTR) signal is controlled by the C24 in the following cases. (Ignore setting contents.)
  - When the DTR and DSR signals are controlled
  - When data are communicated by the modem function
- \*3 After writing data to the buffer memory, a lag of 0 to 20ms occurs until they are reflected in the signal.
- \*4 When a functional protocol, RS/DTR signal status specification (protocol No. 204 to 207), is executed with the CPRTCL instruction, the corresponding bit of the RS/DTR signal status specification (address: 92<sub>H</sub>/132<sub>H</sub>) turns on or off.  
For details of the functional protocol, refer to Page 218, Section 12.3.1.

**Point**

Control the RS(RTS) and ER(DTR) signals with the system that includes the C24.  
Controlling the RS(RTS) and ER(DTR) signals by the user may cause data communication errors.

## 6.2.2 RS-232 cable specification

---

Use a cable conforming to the RS-232 standard with 15m or shorter in length.

Diameter	Type	Material	Temperature rating
28 to 24AWG	Stranded	Copper	60°C or more

[Recommended cable]

Oki Electric Cable Co., Ltd.

7/0.127 □P HRV-SV (□: Specify the number of pairs. For 13 pairs 7/0.127 13P HRV-SV)

## 6.2.3 Connecting the RS-232 interface (full-duplex communication)

The following shows the connection precautions and connection examples when using the C24 RS-232 interface for full-duplex communication.

### (1) Connection precautions

- Refer to  Page 431, Appendix 11 for the bend radius of the connection cable.
- Do not install the control lines or communication cables together with the main circuit lines or power cables. Keep a distance of 100mm or more between them. Failure to do so may result in malfunction due to noise.
- Connect the external device according to its specifications.
- Ground the shield at only one point.
- Connect the FG signal wire and shield as follows.

	Connection on the C24 side	Remarks
FG signal	Connect to the C24 connector housing	Do not short the FG and SG signal wires of the cable. When the FG and SG signal wires are connected inside the external device, do not connect the FG signal to the C24.
Shield	Connect to the FG terminal of the external device or the C24 connector housing	

- When normal data communication is not obtained due to external noise, perform the wiring as follows:
  - 1) Connect the FG terminals on the external device and the C24 using the shield of the connection cable.
  - 2) Signals other than SG must be connected to the SG signals with the twisted pair cables.

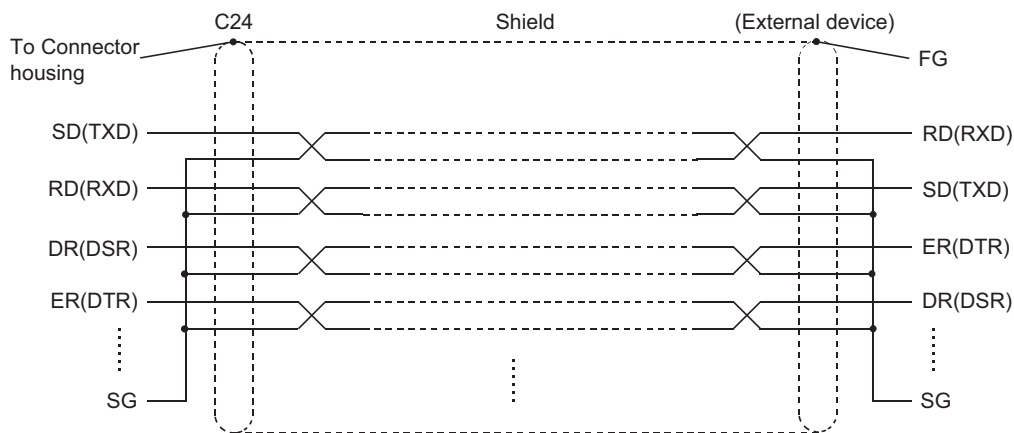

## (2) Connection examples

### (a) Connection example with an external device capable of turning on and off the CD(DCD) signal (Pin No.1)

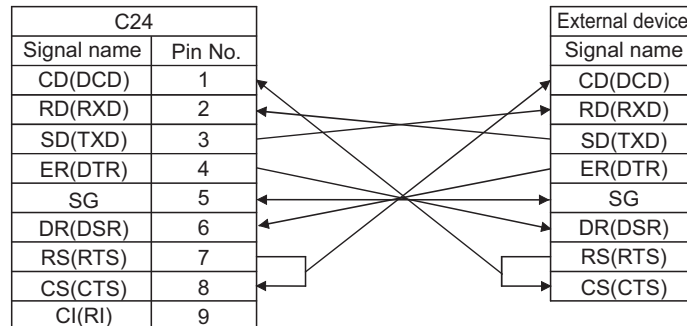

- The CD terminal check setting is set according to the specification of the external device.  
When wiring shown above, DTR/DSR control or DC code control are available.

### (b) Connection example with an external device not capable of turning on and off the CD(DCD) signal (Pin No.1)

[Connection example 1]

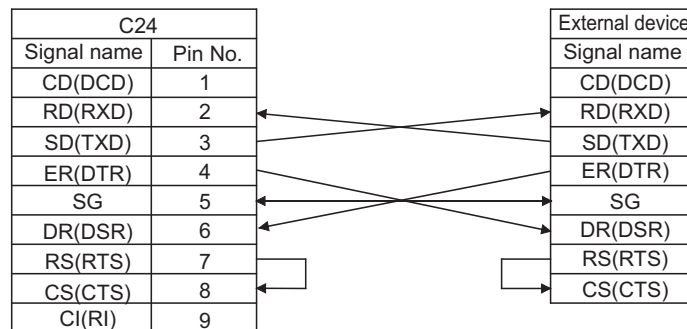

- When wiring shown above, DTR/DSR control or DC code control are available.

[Connection example 2]

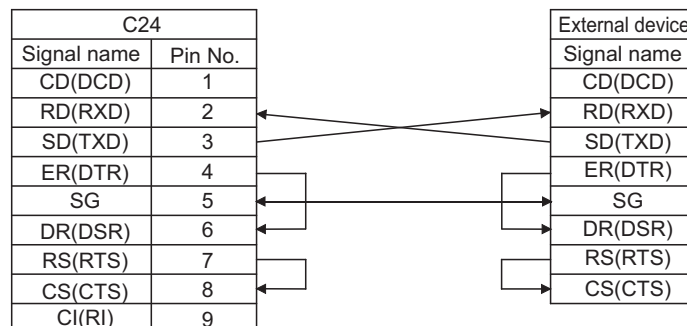

- When wiring shown above, DC code control are available.

**Point** 

---

If the CPU module and an external device cannot be communicated, try to perform data communication as a connection test, using the wiring connection in Connection example 2.

If data can be communicated using the wiring connection shown in Connection example 2, rewire after checking the interface specifications on the external device side.

---

## 6.3 External Wiring with RS-422/485 Interface

This section explains the specifications of RS-422/485 and how to connect them with external devices.

### 6.3.1 RS-422/485 terminal block specifications

The following shows the specifications of the RS-422 connector and RS-422/485 terminal block that connect to an external device.

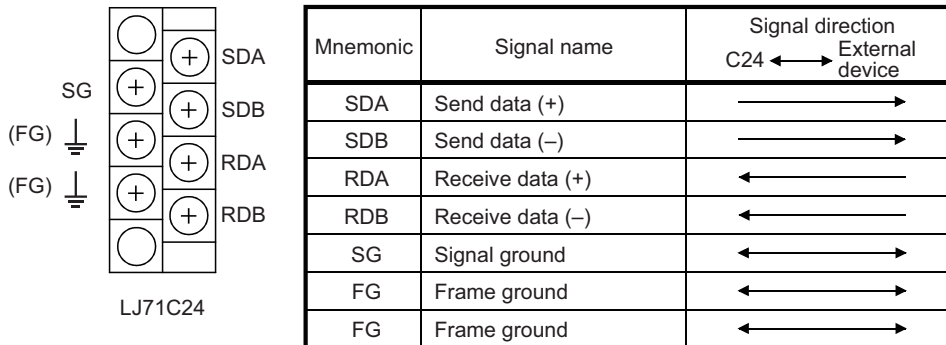

#### (1) The following describes the control signals.

- SDA, SDB signals  
These are signals to send data from the C24 to the external device.
- RDA, RDB signals  
These are signals for the C24 to receive data from the external device.

#### (2) Terminating resistor

Connect the termination resistor referring  Page 56, Section 6.3.3.

#### (3) Suitable crimp-on terminals

Use 1.25-3 for the solderless terminal to be attached on the terminal block.

Use the UL certified crimp-on terminal. For crimping the terminal, use the tools recommended by the crimp-on terminal manufactures. Crimp-on terminals with insulation sleeves cannot be used.

#### (4) Tightening torque

For details on the tightening torque for the RS-422/485 terminal block, refer to  Page 45, Section 6.1.1.



## 6.3.2 RS-422/485 cable specifications

The following shows the RS-422/485 cable specification.

- (1) Use a cable that satisfies the following specification for the RS-422/485 cable (cable to connect the C24 terminal block) within 1200m in length.

Item	Description
Cable type	Shielded cable
Number of pairs	3
Conductor resistance (20°C)	88.0Ω/km or less
Insulation resistance	10000MΩ·km or more
Dielectric strength	500VDC, 1 minute
Electrostatic capacitance (1 kHz)	60nF/km or less on average
Characteristic impedance (100 kHz)	110 ± 10Ω
Recommended conductor size	0.2 mm <sup>2</sup> to 0.75 mm <sup>2</sup>
Diameter	AWG22 to AWG16
Type	Stranded
Material	Copper
Temperature rating	60°C or more

[Recommended cable]

SPEV (SB)-MPC-0.2 × 3P (MITSUBISHI CABLE INDUSTRIES, Ltd.)

SPEV (SB)-0.2 × 3P (MITSUBISHI CABLE INDUSTRIES, Ltd.)

SPEV (SB)-0.3 × 3P (MITSUBISHI CABLE INDUSTRIES, Ltd.)

The recommended cables above have the same electrical characteristics, but different external diameter and internal wire colors.

- (2) The total distance must be within 1200m when two or more device are connected in a 1:n or m:n configuration.

## 6.3.3 Connection method for the RS-422/485 interface

The following explains the connection precautions and examples when using the C24 RS-422/485 interface.

### (1) Connection precautions

(a) Refer to  Page 431, Appendix 11 for the bend radius of the connection cable.

(b) Do not install the control lines or communication cables together with the main circuit lines or power cables.

Keep a distance of 100mm or more between them. Failure to do so may result in malfunction due to noise.

(c) The RS-422/485 interface terminal block uses M3 terminal screws.

Use the 1.25-3 solderless terminal. Solderless terminal with insulation sleeve cannot be used for terminal blocks.

It is recommended to cover the wire connection part of the solderless terminal with a mark tube or insulation tube.

(d) When connecting the C24 SG and FG signals to the external device, connect them according to the specifications of the external device.

(e) Ground the shield at only one point.

(f) Connect the shield of the connection cable to the FG terminal on either of the connected devices.

If normal data communication is not obtained due to external noise even if wiring is made as explained above, perform wiring as follows:

- Connect between the FG of both stations with the shield of the connection cable.  
On the external device side, however, follow the instruction manual of the external device.
- Connect the (FG) of the C24 side to the FG terminal at the power supply module of the station which has the C24 installed, or to the FG terminal of the control panel on which the C24 programmable controller installed.
- Connect nnA and nnB of each signal in the connection cable as a pair.

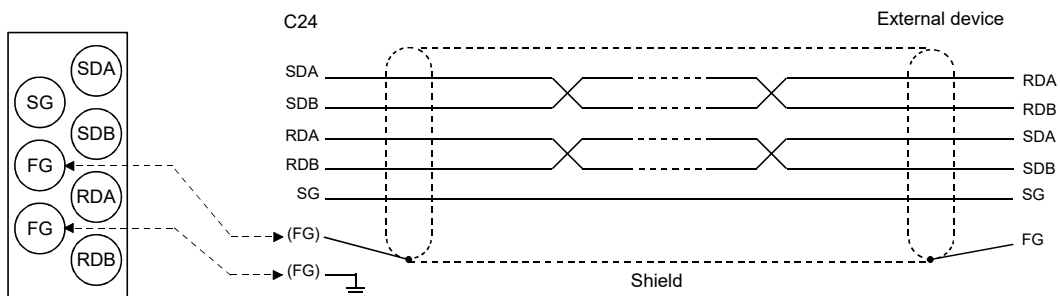

Correspondence of the RS-422/485 terminal block and signal position.

**(g) Terminating resistors must be set (or connected) for both terminal stations on the line.**

On the C24 side, match the specifications of the external device and connect the terminating resistor (included with the C24) according to  Page 56, Section 6.3.3.

On the external device side, connect, or set a terminating resistor according to the instruction manual of the external device.

(C24-side terminal resistor)

- For RS-422 communications, connect the terminating resistor of "330  $\Omega$  1/4 W".
- For RS-485 communications, connect the terminating resistor of "110  $\Omega$  1/2 W".

\* Differences between these terminating resistors

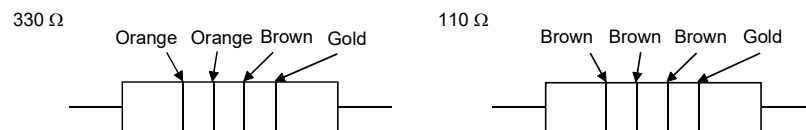

**(h) If data cannot be communicated with the external device at all, check the polarity of the external device. If the polarities of the C24 and the external device do not match, reverse the polarity of each signal on either device side and connect the devices with the cable so that the data may be communicated.**

**(i) Unify the connection of devices to the RS-422/485 interface of C24 (including the 1:n, n:1 and m:n connections ) to either RS-422 or RS-485.**

## (2) Connection examples

### (a) External device and C24 with 1:1 system configuration

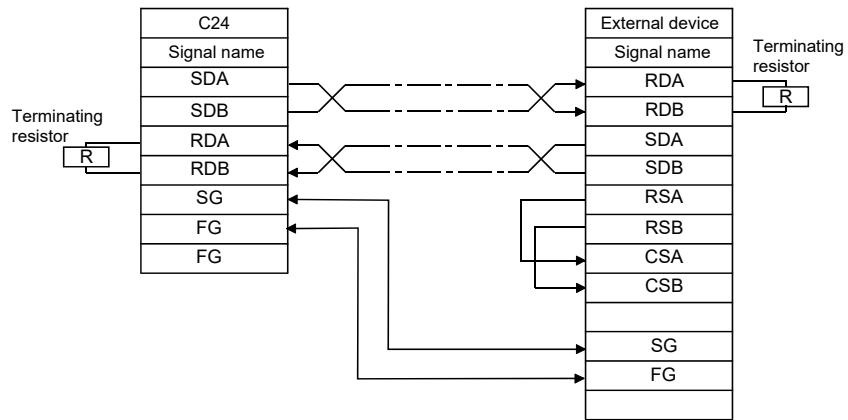

### (b) External device and C24 with 1:n (multidrop) system configuration

[Connection example 1]

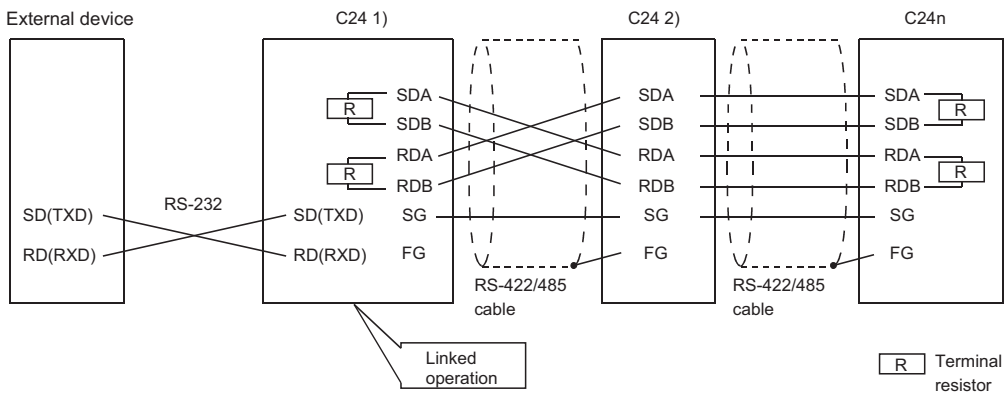

[Connection example 2]

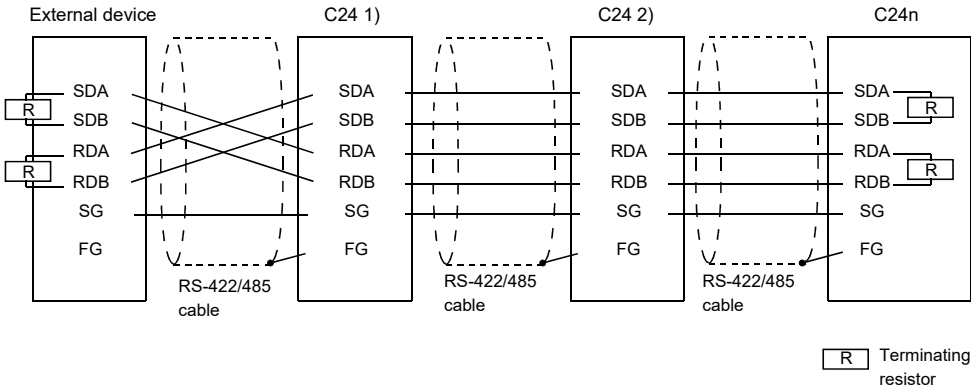

(c) External device and C24 with n:1 (multidrop) system configuration

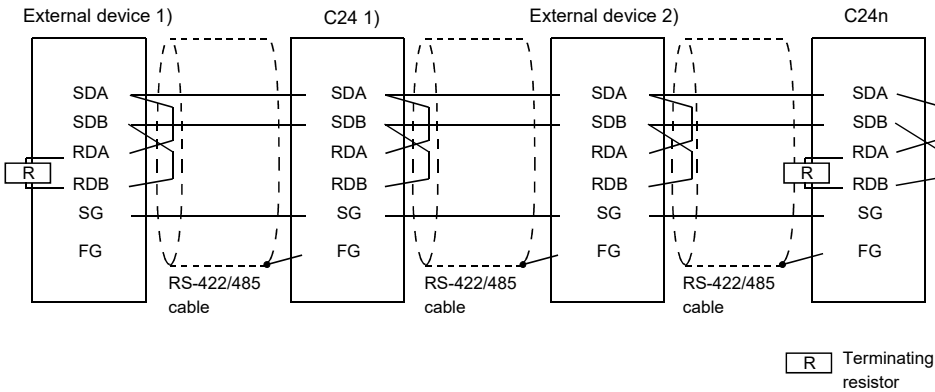

6

6.3 External Wiring with RS-422/485 Interface  
6.3.3 Connection method for the RS-422/485 Interface

**(d) External device and C24 with m:n (multidrop) system configuration**

[Connection example 1]

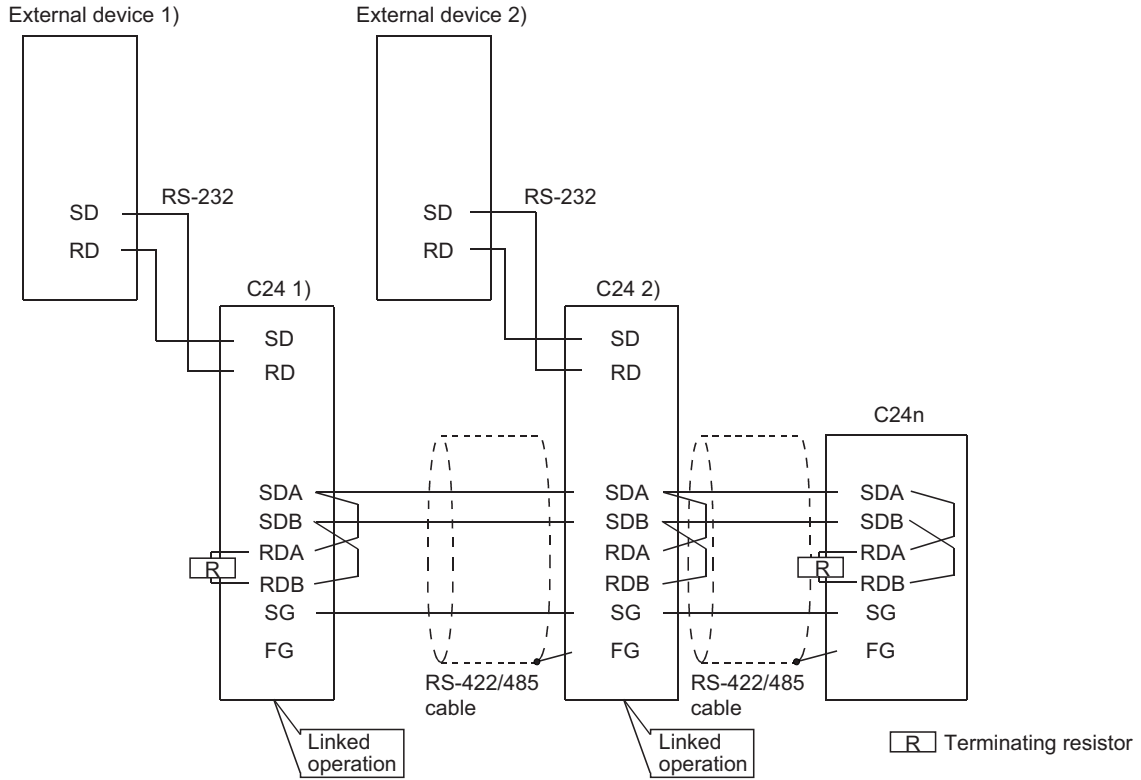

[Connection example 2]

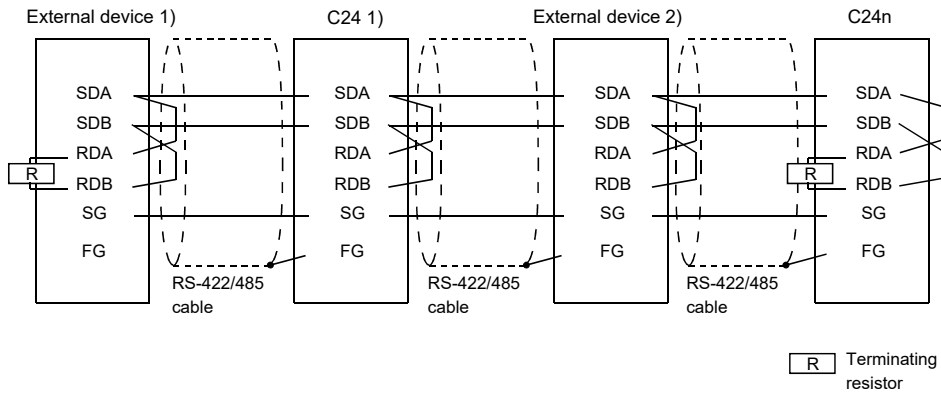

## 6.3.4 Precautions when transferring data using RS-422/485 circuit

The following precautions must be observed when transferring data with an external device through the C24 RS-422/485 interface.

Take the following into account when the transferring data with the external device.

### (1) Error receive data countermeasures at external device during RS-422/485 connection

If the external device may receive erroneous data, install a pull-up or pull-down resistor to the external device as follows.

Installing a pull-up or pull-down resistor (resistance value criteria: approx.  $4.7\text{k}\Omega/1/4\text{W}$ ) can prevent the reception of erroneous data.

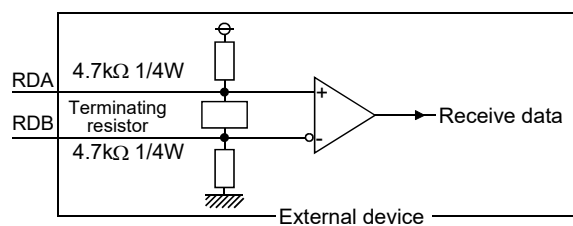

#### Point

When there is a pull-up or pull-down resistor on the external device, erroneous data is not received.

#### Remark

The following describes the case when a pull-up or pull-down resistor is not installed to the external device.

When no station is sending, the send line becomes high impedance and noise, etc. may cause the send line to change and the external device to receive erroneous data.

In this case, there is probably a parity error or framing error. Therefore, skip the erroneous data.

Since the first data during data reception is fixed in the following cases, also skip the receive data until the fixed head data is received.

- When using the MC protocol to send data, the first data is fixed according to the frame and format the user uses.
- When transferring data using user frames with nonprocedural protocol or bidirectional protocol, the first data is determined according to the user frame that the user registers to the C24.

## (2) RS-422/485 interface operation

### (a) RS-422-485 interface structure

The following illustration shows the structure of the C24 RS-422/485 interface driver (send)/receiver (receive).

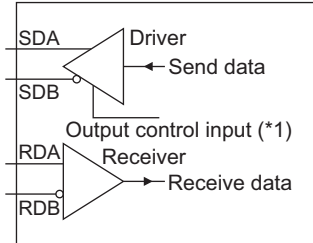

\*1 "Output control input" (also called send gate) of the driver (send) section of the illustration at the left determines whether or not data from SDA/SDB is output to the outside.

### (b) RS-422/485 interface operation

When the "Output control input" in the illustration above is ON, the interface enters the low impedance state (state in which data can be sent).

When the "Output control input" is OFF, the interface enters the high impedance state (state in which data cannot be sent).

### (c) Timing to start sending and to complete the transmission processing of the C24

- Timing to start sending

During data transmission, the C24 outputs the actual data after sending a mark of 2 characters or longer, after the high impedance set by the operations described in Page 62, Section 6.3.4 (2) (a) and Page 62, Section 6.3.4 (2) (b) is reset.

- Transmission processing completion timing

The following times are necessary as H/W gate OFF time from the time that data transmission is completed until transmission processing is completed (the state changes to the high impedance state). (The transmission rate set in the C24 is the object.)

When the transmission rate is 600bps or higher: Data transfer time of less than 1 bit.

When the transmission rate is 50bps, 300bps: several ms

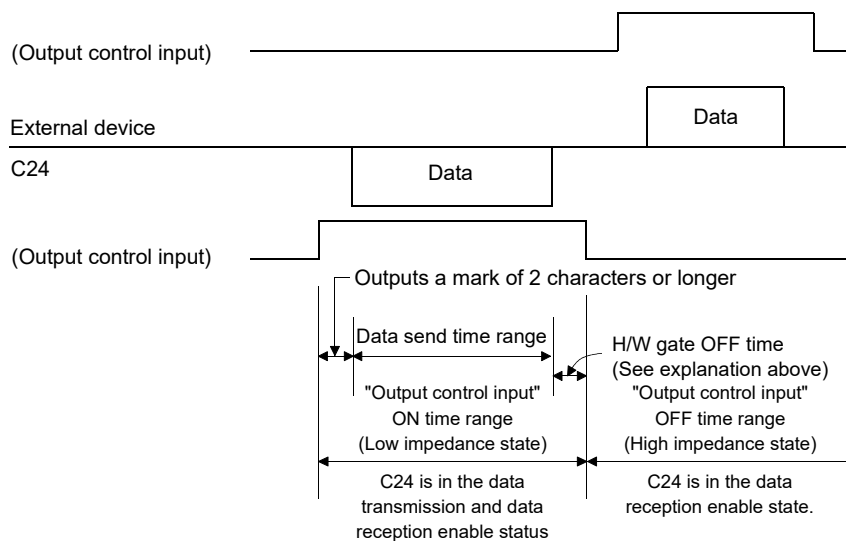



**Point**

- When the external device and the C24 connected in n:1 and m:n configurations  
 When the send signal of each device is connected as shown below, if the "Output control input" is turned ON at two or more devices, the relevant devices output (send) data at the same time.  
 For the external device to transfer data normally:
  - "Output control input" must be turned ON only when sending data.
  - "Output control input" must be turned OFF when not sending data.
 The C24 side automatically controls the output control input.

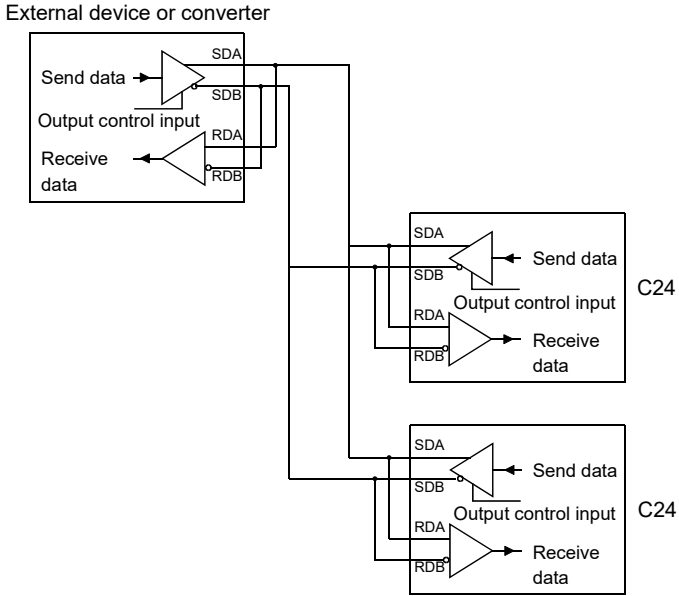

- When two interfaces are in linked operation (refer to Page 91, Section 7.3.5) in the C24, the transmission time for one character becomes equal to the hardware gate off time of the C24. (The C24 turns OFF the gate after the one-character send time.)

## 6.3.5 Enabling or disabling echo back of the RS-422/485 interface

The following describes the enabling and disabling of the echo back.

This function can be used for CH2 of the LJ71C24.

The echo back of the LJ71C24 is defined as the function that, when data are sent through RS-485 (2-wire type) from the RS-422/485 interface, the same data are also sent to RDA or RDB of the LJ71C24.

Whether to receive the returned data or not (discard) can be specified.

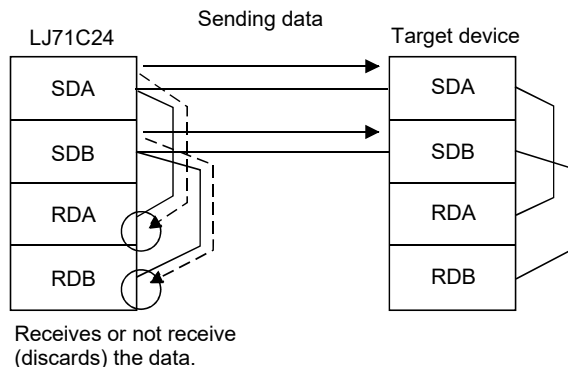

### (1) Application

- Disabling the echo back will eliminate the processing for ignoring unnecessary data, which has been programmed for nonprocedural protocol communication.
- When the same message format is used for request (command) and response in the predefined protocol communication, proper communication with the other device can be performed by disabling the echo back.

### (2) Setting method

- Setting by GX Works2

Configure the setting in the following item.

"Various\_Control\_Specification" screen ⇒ "For designation of communication control" ⇒ "Echo back allow/prohibit designation (for RS-422/485 I/F)"

For details, refer to Page 75, Section 7.2.

- Setting by the sequence program

Store either of the following values in the echo back enable/disable setting area (address: 450(1C2H)).

(Default: 0)

Setting value	Description
0: Enable echo back	When the LJ71C24 sends data, it also receives the sent data in its own RDA or RDB.
1: Disable echo back	When the LJ71C24 sends data, it does not receive the sent data in its own RDA or RDB. (The data are discarded.)

[Example of a setting in sequence program]

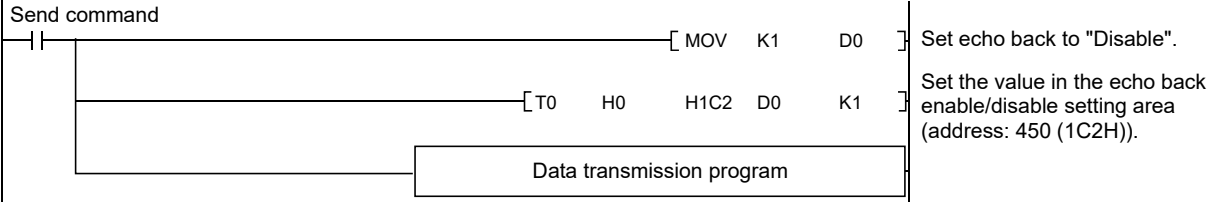

**Point**

The echo back enable/disable setting must be done before sending data. Any setting changed during transmission does not take effect.

## 6.4 Individual Station Test

---

After installing the C24 to a system, check the switch setting and operation of the C24 at first.  
The individual station test consists of the following two tests.

### (1) ROM/RAM/switch test

Checks the contents of the memory of the C24 and the switch settings set with GX Works2.

### (2) Self-loopback test

Checks the communication between the C24 and CPU modules and the operation of the communication function of the C24.

#### *Point*

---

- When a problem occurs during data communication with an external device, perform an individual station test to check whether or not there is any problem in the operation of the C24.
  - In order to avoid problems, set the CPU module to STOP status during the individual station test.
  - Cable removal and reconnection before and after the Self-loopback test should be performed with the power to the C24-connected station turned off.
  - To restart data communication with an external device after an individual station test, check the specifications of the devices used before defining various settings and reconnecting cables.
  - If an error occurs even though the correct settings have been made for the C24 through an individual station test, please consult your local Mitsubishi representative, explaining a detailed description of the problem.
-

## 6.4.1 ROM/RAM/switch test

A ROM/RAM/switch test checks the contents of the memory of the C24 and the switch settings set with GX Works2. Perform a ROM/RAM/switch test with the procedure described below.

### 1. Communication protocol setting and transmission setting (refer to Page 85, Section 7.3)

- (1) In the switch setting, set the communication protocol setting on the CH2 side to "ROM/RAM/Switch test".
- (2) Set the communication protocol setting on the CH1 side to the number used for data communication with an external device following the test.
- (3) Set the transmission settings and communication rate settings for the two interfaces to match the specifications used when communicating data with an external device.
- (4) Set the CPU module to STOP status and write the parameters to the CPU module.

### 2. Performing ROM/RAM/switch test

Restart or reset the CPU module. The test starts automatically in about one second. (Set the CPU module to the STOP status.)

### 3. Checking results of ROM/RAM/switch test

When the result of the test is normal



The CH1 NEU LED turns on and the ERR LED turns off.

When the result of the test is abnormal

The CH1 NEU LED turns on and the ERR LED turns on.

### 4. Ending a ROM/RAM/switch test

When the result of the test is normal



- (a) Perform an Self-loopback test.
  - Perform the test operation according to  Page 69, Section 6.4.2.
- (b) Start the data communication with external devices.
  - 1) Set the switch settings on GX Works2 according to in  Page 85, Section 7.3.
  - 2) Turn off the power to the station on which the C24 is installed and connect the communication cable with an external device.
  - 3) Turn on the power to the station on which the C24 is installed.

When the result of the test was abnormal

Check the contents of the error in the following items in the "Intelligent Function Module Monitor" screen of GX Works2.

Item	Current Value	Device	Data Type
<input type="checkbox"/> For LED Status, Communication Error Status Confirmation			
<input type="checkbox"/> CH1 Side LED Status, Communication Error Status			
CH1 SD.WAIT	OFF	U1\G513.0	Bit
CH1 SIO	OFF	U1\G513.1	Bit
CH1 PRO.	OFF	U1\G513.2	Bit
CH1 P/S	OFF	U1\G513.3	Bit
CH1 C/N	OFF	U1\G513.4	Bit
CH1 NAK	OFF	U1\G513.5	Bit
CH1 ACK.	OFF	U1\G513.6	Bit
CH1 NEU.	OFF	U1\G513.7	Bit
CH1 ERR.	ON	U1\G514.F	Bit
<input type="checkbox"/> CH2 Side LED Status, Communication Error Status			
CH2 SD.WAIT	OFF	U1\G514.0	Bit
CH2 SIO	OFF	U1\G514.1	Bit
CH2 PRO.	OFF	U1\G514.2	Bit
CH2 P/S	OFF	U1\G514.3	Bit
CH2 C/N	OFF	U1\G514.4	Bit
CH2 NAK	OFF	U1\G514.5	Bit
CH2 ACK.	OFF	U1\G514.6	Bit
CH2 NEU.	OFF	U1\G514.7	Bit
CH2 ERR.	ON	U1\G514.E	Bit

Setting station No.	Error	U1\G515.E	Bit
---------------------	-------	-----------	-----

Item	Current value	Status		Corrective action
CH□ SIO	1 (ON)	When linked operation setting	Transmission setting error	Check the set values (refer to  Page 85, Section 7.3) and perform the test again. (*1)
CH□ PRO.	1 (ON)		Protocol setting error	
CH□ P/S	1 (ON)	When independent operation setting	Transmission setting error	
CH□ C/N	1 (ON)		Protocol setting error	
CH□ NEU.	1 (ON)	Test completed		—
CH□ ERR.	1 (ON)	CH1: RAM error CH2: ROM error		Check the module installation status and perform the test again. (*1)
Setting station number	Error	Out of the setting station number range		Check the set values (refer to  Page 90, Section 7.3.4) and perform the test again. (*1)

\*1 When an error occurs even after performing the test again, please consult your local Mitsubishi representative.

## 6.4.2 Self-loopback test

The Self-loopback test checks the communication between the C24 and CPU modules and the operation of the communication function of the C24.

Also, tests two interfaces of the C24 at once.

Follow the procedure below to perform an Self-loopback test.

### 1. Connecting cable

Connect cables to two interfaces as follows.

- Connect cables to the RS-232 interface within the connector and install it to the interface.
- Connect cables to the RS-422/485 interface on a terminal block.

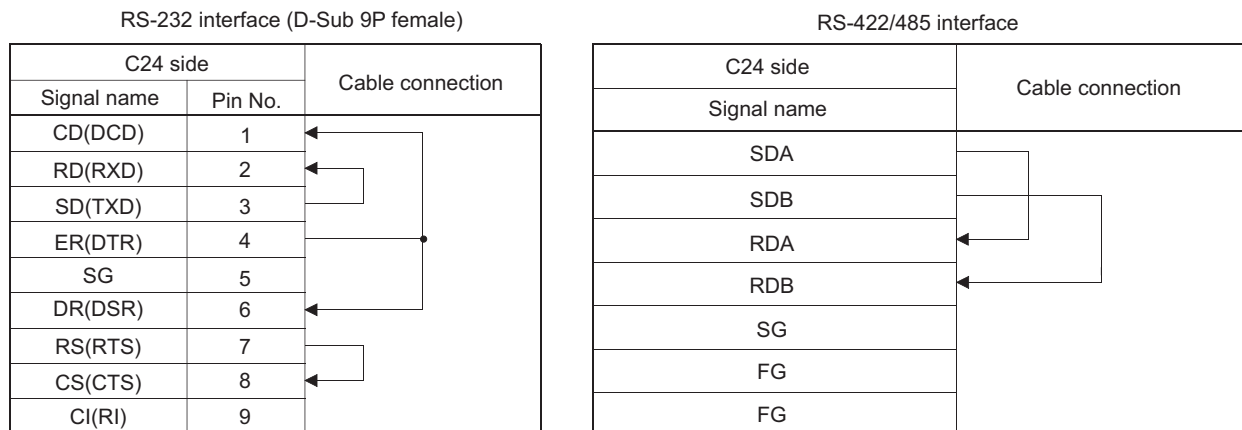

### 2. Communication protocol setting and transmission setting (refer to Page 85, Section 7.3)

- (1) In the switch setting, set the communication protocol setting of both interfaces to "Self-loopback test".
- (2) Set the transmission settings and communication rate settings for the two interfaces to match the specifications used when communicating data with an external device.
- (3) Set the CPU module to STOP status and write the parameters to the CPU module.

### 3. Performing the Self-loopback test

Restart or reset the CPU module. The test starts automatically in about one second.

(Set the CPU module to the STOP status.)

### 4. Checking the results of an Self-loopback test

When the result of the test is normal

If the ERR. LED turns off and the LED status of the CH1 and CH2 are as follows for over 5 seconds, the result is normal.

	CH1	CH2
NEU. LED	Flashing	Off
SD LED	Flashing	Flashing
RD LED	Flashing	Flashing

When the result of the test is abnormal

The ERR. LED turns on.

## 5. Ending the Self-loopback test

When the result of the test is normal

Start the data communication with external devices by the following procedure.

- 1) Set the switch settings on GX Works2 according to the procedure specified in  Page 85, Section 7.3.
- 2) Turn off the power to the station on which the C24 is installed and connect the communication cable with an external device.
- 3) Turn on the power to the station on which the C24 is installed.

When the result of the test is abnormal

Check the contents of the error in the following items in the "Intelligent Function Module Monitor" screen of GX Works2.

Item	Current Value	Device	Data Type
<input type="checkbox"/> For LED Status, Communication Error Status Confirm...			
<input type="checkbox"/> CH1 Side LED Status, Communication Error Status			
CH1 SD.WAIT	--	U1\G513.0	Bit
CH1 SID	--	U1\G513.1	Bit
CH1 PRO.	--	U1\G513.2	Bit
CH1 P/S	--	U1\G513.3	Bit
CH1 C/N	--	U1\G513.4	Bit
CH1 NAK	--	U1\G513.5	Bit
CH1 ACK.	--	U1\G513.6	Bit
CH1 NEU.	--	U1\G513.7	Bit
CH1 ERR.	--	U1\G514.F	Bit
<input type="checkbox"/> CH2 Side LED Status, Communication Error Status			
CH2 SD.WAIT	--	U1\G514.0	Bit
CH2 SID	--	U1\G514.1	Bit
CH2 PRO.	--	U1\G514.2	Bit
CH2 P/S	--	U1\G514.3	Bit
CH2 C/N	--	U1\G514.4	Bit
CH2 NAK	--	U1\G514.5	Bit
CH2 ACK.	--	U1\G514.6	Bit
CH2 NEU.	--	U1\G514.7	Bit
CH2 ERR.	--	U1\G514.E	Bit

Item	When the "Current Value" is 1 (ON)	Corrective action
CH <input type="checkbox"/> C/N	Error in the CPU module.	Remove errors in the CPU module.
	Insufficient power supply capacity.	Examine the power supply capacity.
	Module is not connected correctly.	Reinstall the module properly.
	Error in the cable, CPU module, or the C24.	Check each module and remove the cause of the error. Reconnect the cable correctly. Reinstall the module properly.
CH <input type="checkbox"/> ERR.	CH1: CH1 side communication error CH2: CH2 side communication error	Reconnect the cable correctly. Examine the test wiring connection.



## 6.5 Loopback Test

A loopback test performs a communication test using the loopback test function of the MC protocol, in order to check the connection between the C24 and an external device, the communication function of each device, and the operation of the communication program of the external device.

### 1. Connecting the C24 to an external device

Turn off the power to the station on which the C24 is installed and connect a communication cable to an external device to perform data communication using the MC protocol (Refer to  Page 46, Section 6.2).

### 2. Switch setting with GX Works2

- (1) Set the switch settings with GX Works2 as shown in  Page 85, Section 7.3 and write the parameters to the CPU module in order to perform data communication using the MC protocol.
- (2) The following shows an example of the settings when performing a loopback test on the interface on the CH1 side.

	Item	Setting value
Transmission Setting	Operation setting	Independent
	Data Bit	7
	Parity Bit	Exist
	Odd/even parity	Odd
	Stop bit	1
	Sum check code	None
	Online Change	Enable
	Setting modifications	Disable
	Communication rate setting	9600bps
	Communication protocol setting	MC protocol (Format 1)
	Station number setting	0

### 3. Performing a loopback test

- (1) Set the CPU module to the STOP status, and turn on or reset the CPU module (communication is enabled for approx. one second).
- (2) Create a program for a loopback test on the external device side and send a command message such as the following to the C24.

The commands used are as follows:

- When performing communication test in an A compatible 1C frame: TT command (For an example, refer to Page 72, Section 6.5 (1))
- When performing communication test in a QnA compatible frame: 0619 command
- \* When performing communication tests in a QnA compatible frame, refer to the following.

 MELSEC Communication Protocol Reference Manual

#### 4. Checking loopback test result

Check on the external device whether the data received from the C24 in response to the data received from the external device matches the data sent from the external device.

(The C24 sends back to the external device the received data, as is.)

When the result of the test is normal

The data received from the C24 in response to the data received from the external device matches the data sent from the external device.

When the result of the test is abnormal

The data received from the C24 in response to the data received from the external device does not match the data sent from the external device.

#### 5. Ending the loopback test



When the result of the test is normal

Perform the following procedure according to the function used, and start data communication.

- Set the switch settings with GX Works2. (Refer to  Page 85, Section 7.3)
- Turn on the station on which the C24 is installed.

When the result of the test is abnormal

Confirm the following items, and take the corrective actions.

Item	Corrective action
Examine the wiring connection of the connection cable.	Check if the wiring connection of the connection cable is correct. (Refer to  Page 46, Section 6.2)
Examine the C24 switch settings.	Check if the C24 switch settings (such as Transmission Setting and Communication rate setting) match the settings on the external device. (Refer to  Page 85, Section 7.3)
Check the error detection of the C24.	Check the error and take the corrective actions. (Refer to  Page 262, CHAPTER 15)

### (1) An example of control procedure when the TT command is used in the loopback test mentioned in Procedure 3. (Station number: 00, sum check code: Exist)

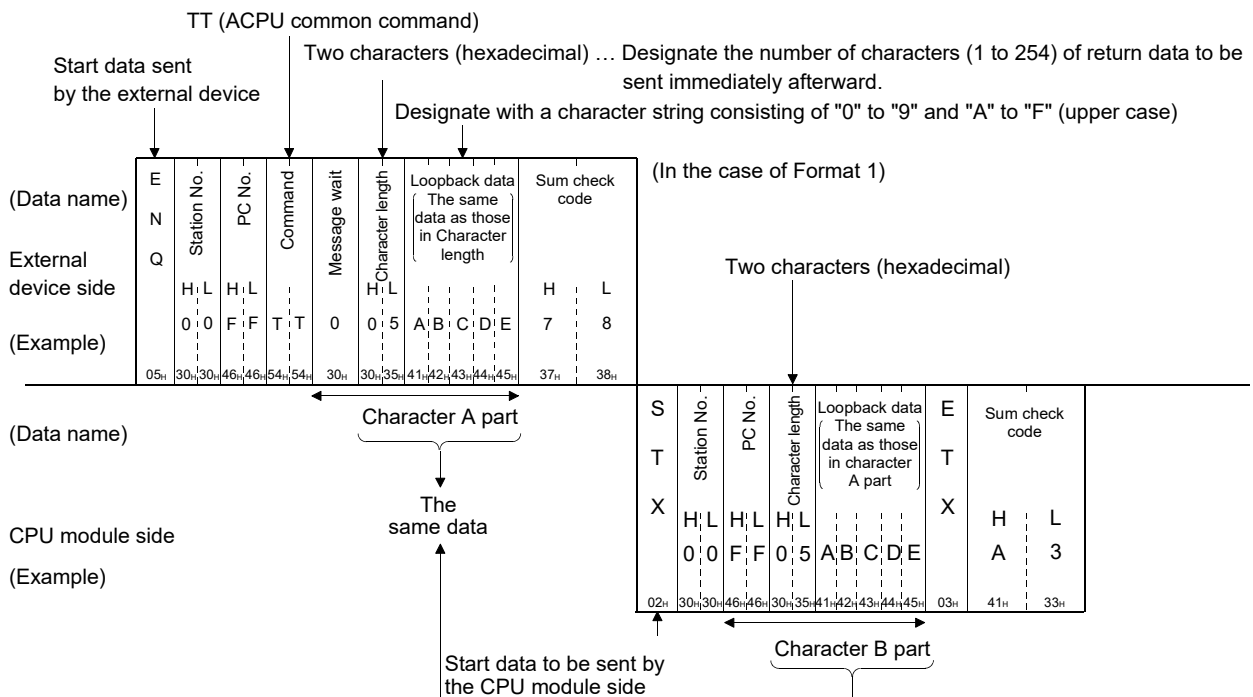

# CHAPTER 7 SETTINGS FOR THE C24

---

The switch settings, parameter settings, monitor/test and others for the C24 are performed by GX Works2.

The same settings can be configured in GX Developer and GX Configurator-SC.

For details, refer to  Page 364, Appendix 4.

Refer to  User's Manual (Application) when performing the remote password settings.

# 7.1 Adding the C24 to Projects

## (1) Setting purpose

Add the C24 to projects with GX Works2 to perform various settings.

## (2) Startup procedure

Display the "New Module" screen.

 Project window ⇒ [Intelligent Function Module] ⇒ Right click ⇒ [New Module]

## (3) Setting screen

## (4) Setting description

Item name		Settings
Module Selection	Module Type	Set "Serial Communication".
	Module Name	Select the module model name to connect. (Example: LJ71C24)
Mount Position	Mounted Slot No.	Set the slot No. where the module is connected.
	Specify start XY address	The start I/O signal (hexadecimal) of the target module corresponding to the mounted slot No. is set. It can be set arbitrarily.
Title Setting	Title	Enter any title.

## 7.2 List of Setting Items for C24

This section explains the items to be set in GX Works2 to perform the data communication with external devices. Before performing the following settings, add the C24 to the GX Works2 project and set the I/O range. For details, refer to  Page 74, Section 7.1.

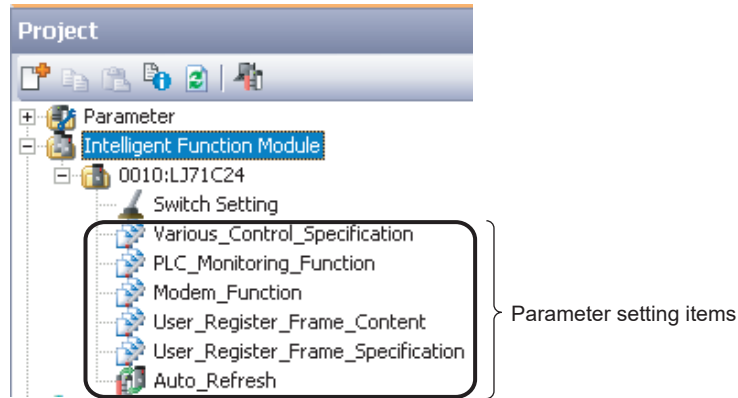

The following abbreviations appear in the protocol column of the function list.

MC	MC protocol
Pd	Predefined protocol
Non	Nonprocedural protocol
Bi	Bidirectional protocol

### (1) Switch Setting

Set the transmission specifications and communication protocols with external devices. Always perform this setting. For details, refer to  Page 85, Section 7.3.

### (2) Various\_Control\_Specification

Set the transmission specification with external devices.

(○: Applicable protocol)

Setting items		Protocol				Reference
		MC	Non	Bi	Pd	
Signal setting	RTS (RS) signal status designation	○	○	○	○	Page 46, Section 6.2.1
	DTR (ER) signal status designation					
For designation of transmission control	Transmission control					User's Manual (Application)
	DC1/DC3 control					
	DC2/DC4 control					
	DC1 code	○	○	○	○	
	DC3 code					
	DC2 code					
For designation of communication control	DC4 code					
	Word/byte units designation					Page 146, CHAPTER 10 Page 178, CHAPTER 11
	CD terminal check designation (for RS-232)	○	○	○	○	Page 46, Section 6.2.1
Communication system designation (for RS-232)						

Setting items		Protocol				Reference
		MC	Non	Bi	Pd	
For half-duplex communications control designation	Simultaneous transmission priority/non-priority designation	○	○	○	○	User's Manual (Application)
	Retransmission time transmission method designation					
For designation of transmission control	Receive data	—	—	○	—	Page 201, Section 11.3.1
	Transmission data	—	—	○	—	
For designation of data communication time monitoring	No-reception monitoring time (timer 0) designation	○	○	○	—	User's Manual (Application)
	Response monitoring time (timer 1) designation	○	—	○	○	
	Transmission monitoring time (timer 2) designation	○	○	○	—	
For designation of on-demand function	Buffer memory head address designation	○	—	—	—	User's Manual (Application)
	Data length designation	○	—	—	—	
For designation of transmission area	Transmission buffer memory head address designation	—	○	○	—	Page 146, CHAPTER 10 Page 178, CHAPTER 11
	Transmission buffer memory length designation	—	○	○	—	
For data reception	Received data count designation	—	○	—	—	Page 146, CHAPTER 10 Page 178, CHAPTER 11
	Receive complete code designation	—	○	—	—	
For designation of reception area	Receive buffer memory head address designation	—	○	○	—	User's Manual (Application)
	Receive buffer memory length designation	—	○	○	—	
For designation of transmission wait time	Message wait time designation	○	—	—	—	User's Manual (Application)
For conversion designation	ASCII-BIN conversion designation (for Nonprocedural, Bidirection)	—	○	○	—	
For designation of communication control	Echo back allow/prohibit designation (for RS-422/485 I/F)	○	○	○	○	Page 64, Section 6.3.5
Interrupt designation	Receive interrupt-issued designation	—	○	○	—	
For transmission control designation	Transmission control start free area designation	○	○	○	○	User's Manual (Application)
	Transmission control end free area designation	○	○	○	○	
	Nonprocedural and non reception monitoring time format designation	—	○	—	—	

Setting items		Protocol				Reference
		MC	Non	Bi	Pd	
Communication data monitoring function	Communication data monitoring designation	<input type="radio"/>	<input type="radio"/>	<input type="radio"/>	<input type="radio"/>	User's Manual (Application)
	Full stop designation	<input type="radio"/>	<input type="radio"/>	<input type="radio"/>	<input type="radio"/>	
	Timer 0 errors at occurrence stop designation	<input type="radio"/>	<input type="radio"/>	<input type="radio"/>	<input type="radio"/>	
	Monitor buffer head address designation	<input type="radio"/>	<input type="radio"/>	<input type="radio"/>	<input type="radio"/>	
	Monitor buffer size designation	<input type="radio"/>	<input type="radio"/>	<input type="radio"/>	<input type="radio"/>	
For designation of transparent code	Transmission transparent code designation (1st)	Transparent code	—	<input type="radio"/>	<input type="radio"/>	User's Manual (Application)
		Additional code	—	<input type="radio"/>	<input type="radio"/>	
	Receive transparent code designation	Transparent code	—	<input type="radio"/>	<input type="radio"/>	
		Additional code	—	<input type="radio"/>	<input type="radio"/>	
For designation of transparent code	Transmission transparent code designation (No.2 to No.10)	Transparent code	—	<input type="radio"/>	<input type="radio"/>	User's Manual (Application)
		Additional code	—	<input type="radio"/>	<input type="radio"/>	
For designation of protocol execution log	Execution log options designation	—	—	—	<input type="radio"/>	Page 254, Section 13.3

### (3) PLC\_Monitoring\_Function

Set the programmable controller CPU monitoring function.

(○: Applicable protocol)

Setting items		Protocol				Reference		
		MC	Non	Bi	Pd			
Cycle time units designation		○	○	—	—	User's Manual (Application)		
Cycle time designation (programmable controller CPU monitoring cycle time)		○	○	—	—			
Programmable controller CPU monitoring function designation		○	○	—	—			
Transmission pointer designation (for fixed cycle transmission and nonprocedural data transmission)		—	○	—	—			
Output count designation (for fixed cycle transmission and nonprocedural data transmission)		—	○	—	—			
Data No. for connection designation (for fixed cycle transmission)		○	○	—	—			
For designation of programmable controller CPU monitoring function	Block monitoring devices	Number of registered word blocks designation		○	○		—	—
		Number of registered bit blocks designation		○	○		—	—
		Programmable controller CPU abnormal monitoring designation		○	○		—	—
		No. 1 block monitoring device	Monitoring device designation	○	○		—	—
			Head device No. designation	○	○		—	—
			Read point designation	○	○		—	—
			Monitoring condition designation (judgment condition designation)	○	○		—	—
			Monitoring condition value designation	○	○	—	—	
		Transmission pointer designation (for condition agreement transmission and nonprocedural data transmission)	○	○	—	—		
		Output count designation (for condition agreement transmission and nonprocedural data transmission)	○	○	—	—		



Setting items				Protocol				Reference
				MC	Non	Bi	Pd	
For designation of programmable controller CPU monitoring function	Block monitoring devices	No. 1 block monitoring device	Data No. for connection designation (for condition agreement transmission)	○	○	—	—	User's Manual (Application)
		Block monitoring devices No.2 to 10	Same as the No.1 block monitoring device	○	○	—	—	
	Programmable controller CPU abnormal monitoring designation	Transmission pointer designation (for condition agreement transmission and nonprocedural data transmission)		○	○	—	—	
		Output count designation (for condition agreement transmission and nonprocedural data transmission)		○	○	—	—	
		Data No. for connection designation (for condition agreement transmission)		○	○	—	—	

## (4) Modem\_Function

Set for the data communication with the modem functions.

(○: Applicable protocol)

Setting items		Protocol				Reference	
		MC	Non	Bi	Pd		
For designation of modem function-1	Modem connection channel designation	○	○	○	—		
	Number of connection retries designation	○	○	○	—		
	Connection retry interval designation	○	○	○	—		
	Initialization/connection timeout designation	○	○	○	—		
	Number of initialization retries designation	○	○	○	—		
	Data No. for initialization designation	○	○	○	—		
	Data No. for connection designation	○	○	○	—		
	MELSOFT connection designation	○	○	○	—		
	No - communication interval time designation	○	○	○	—		
	RS/CS control yes/no designation	○	○	○	—		
For designation of modem function -2	Auto modem initialization designation	○	○	○	—		
	Modem initialization time DR (DSR) signal valid/invalid designation	○	○	○	—		
For designation of modem function -3	Circuit disconnect wait time (programmable controller CPU watch use)	○	○	—	—		
For remote password function	Remote password mismatch notification count designation	○	—	—	—	User's Manual (Application)	
	Remote password mismatch notification accumulated count designation	○	—	—	—		
For callback function	Callback function designation	○	—	—	—		
	Callback denial notification accumulated count designation	○	—	—	—		
	Data No. for callback designation 1 to 10	○	—	—	—		
Data for modem initialization	Modem initialization data No.2500	Initialization command	○	○	○	—	
		User control command	○	○	○	—	
	Modem initialization data No.2501 to 2529	Same as Modem initialization data No.2500	○	○	○	—	
Data for modem connection	Data for modem connection No.3000	External line dialing number	○	○	○	—	
		Line types	○	○	○	—	
		Telephone number	○	○	○	—	
		Comment	○	○	○	—	
	Data for modem connection No. 3001 to 3029	Same as Modem connection data No.3000	○	○	○	—	

**(5) User\_Register\_Frame\_Content**

Register user frames.

(○: Applicable protocol)

Setting items		Protocol				Reference
		MC	Non	Bi	Pd	
User frame	Registration frame No.1000 to No.1199	○	○	—	—	User's Manual (Application)

**(6) User\_Register\_Frame\_Specification**

Specify user frames.

(○: Applicable protocol)

Setting items		Protocol				Reference
		MC	Non	Bi	Pd	
For designation of on-demand user frame	First frame No. designation 1	○	—	—	—	User's Manual (Application)
	First frame No. designation 2	○	—	—	—	
	Last frame No. designation 1	○	—	—	—	
	Last frame No. designation 2	○	—	—	—	
For designation of receive user frame	User frame use enable/disable designation	—	○	—	—	
	First frame No. designation 1 to 4	—	○	—	—	
	Last frame No. designation 1 to 4	—	○	—	—	
For user frame being transmitted designation	CR/LF output designation	—	○	—	—	
	Output head pointer designation	—	○	—	—	
	Output count designation	—	○	—	—	
	Output frame No. designation 1 to 100	—	○	—	—	
For designation of user frame receiving method	User frame receive format designation 1 to 4	—	○	—	—	
	Exclusive format-1 received data count designation 1 to 4	—	○	—	—	

## (7) Auto\_Refresh

Set the device on the CPU module side to refresh the data of the buffer memory. For details, refer to  Page 99, Section 7.5.

### (a) Transfer to CPU

Setting items		Reference
User frame being transmitted	User frame being transmitted	User's Manual (Application)
For confirmation of LED ON status and communication error status	LED ON status and communication error status on CH1 side	SD.WAIT
		SIO
		PRO.
		P/S
		C/N
		NAK
		ACK.
		NEU.
		LED ON status and communication error status on CH2 side
	SIO	
	PRO.	
	P/S	
	C/N	
	NAK	
	ACK.	
	NEU.	
	CH2 ERR.	
	CH1 ERR.	
For confirmation of transmission control status	Communication protocol status (current)	
	Transmission status (current)	Operation setting
		Data Bit
		Parity Bit
		Odd/even parity
		Stop bit
		Sum check code
		Online Change
		Setting modifications
		Communication rate
Control signal status	RS-232 control signal status	RTS (RS)
		DSR (DR)
		DTR (ER)
		CD
		CS (CTS)
		RI (CI)

Setting items		Reference	
For confirmation of communication result	Transmission sequence status (For confirmation of MC protocol communication status)	Page 271, Section 15.1.4	
	On-demand execution result	MELSEC Communication Protocol Reference Manual	
	Data transmission result	Page 146, CHAPTER 10	
	Data reception result	Page 178, CHAPTER 11	
	MC protocol transmission error code	MELSEC Communication Protocol Reference Manual	
	Receive user frame (nth)	User's Manual (Application)	
Programmable controller CPU monitoring function	Programmable controller CPU monitoring function operation status	User's Manual (Application)	
	Programmable controller CPU monitoring function execution result (current)		
	Programmable controller CPU monitoring function number of transmission		
	Monitoring condition arrival block No.		
For Flash ROM access	Registration/read/delete result storage	Page 97, Section 7.4.2 Page 260, Section 14.2.1	
For confirmation of switch setting and mode switching	Switch setting error and mode switching error status	CH1 Communication protocol setting No.	Page 275, Section 15.1.6
		CH1 Communication rate setting	
		CH1 Setting change prohibit time mode switching	
		CH2 Communication protocol setting No.	
		CH2 Communication rate setting	
		CH2 Setting change prohibit time mode switching	
		Setting station No.	
		Linked operation setting	
For confirmation of user frame	Number of registered user frames	Page 331, Appendix 1	
For confirmation of flash ROM write result	Flash ROM system parameters write result	Page 331, Appendix 1	
For confirmation of modem function	Modem function error code	User's Manual (Application)	
	Modem function sequence status		
	Number of data registration for connection		
	Number of data registration for initialization		
For remote password function	Accumulated count of unlock process normal completion	User's Manual (Application)	
	Accumulated count of unlock process abnormal completion processing		
	Accumulated count of lock process based on circuit disconnection		
For receive data	Reception area	Page 146, CHAPTER 10 Page 178, CHAPTER 11	
	Reception area (User free area)	Page 331, Appendix 1	
	Reception area (User free area 2)	Page 331, Appendix 1	

Setting items		Reference
Predefined protocol function control data specification	Execution result	Page 331, Appendix 1
	Result of the executions	
	Matched receive packet No.1 to 8	
Checking predefined protocol function execution status	Execution status	Page 331, Appendix 1
	Predefined protocol function error code	
	Number of protocol executions	

**(b) Transfer to the Intelligent Function Module**

Setting items		Reference
For transmission data	Transmission area	Page 146, CHAPTER 10 Page 178, CHAPTER 11
	Transmission area (User free area)	Page 331, Appendix 1
	Transmission area (User free area 2)	Page 331, Appendix 1
Predefined protocol function control data specification	Number of continuous executions	Page 331, Appendix 1
	Execution protocol No. designation 1 to 8	

## 7.3 Switch Setting

### (1) Setting purpose

Set the transmission specifications and communication protocols for communication with external devices.

### (2) Startup procedure

Display the "Switch Setting" screen.

 Project window ⇒ [Intelligent Function Module] ⇒ Module model name ⇒ [Switch Setting]

### (3) Setting screen

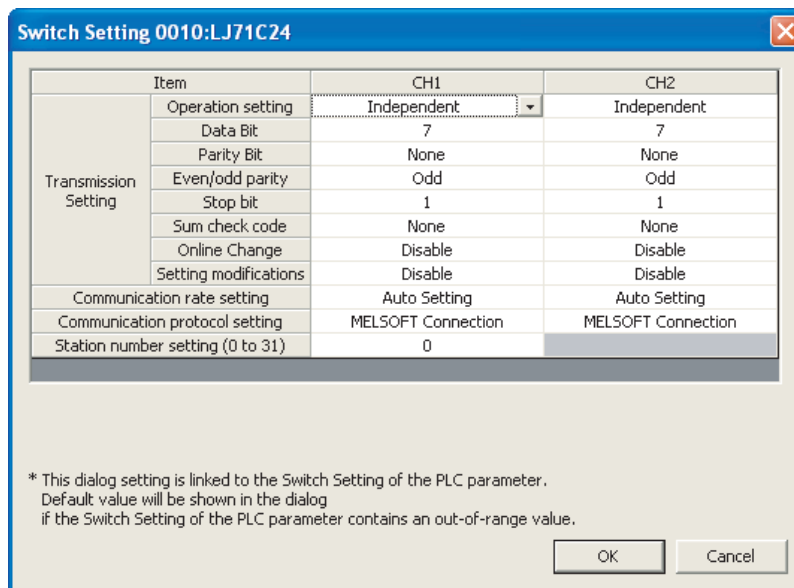

Item	CH1	CH2
Operation setting	Independent	Independent
Data Bit	7	7
Parity Bit	None	None
Even/odd parity	Odd	Odd
Stop bit	1	1
Sum check code	None	None
Online Change	Disable	Disable
Setting modifications	Disable	Disable
Communication rate setting	Auto Setting	Auto Setting
Communication protocol setting	MELSOFT Connection	MELSOFT Connection
Station number setting (0 to 31)	0	

\* This dialog setting is linked to the Switch Setting of the PLC parameter.  
Default value will be shown in the dialog  
if the Switch Setting of the PLC parameter contains an out-of-range value.

### Point

- When GX Works2 or a GOT is connected to the C24 on a 1:1 (one-to-one) basis:  
The switch setting of the interface connecting GX Works2 or a GOT is not required for accessing or monitoring an LCPU.  
(If the switches are not set, MELSOFT Connection mode will be active.)
- When GX Works2 or a GOT is connected to the C24 on a 1:n (multidrop) basis:  
Refer to  GX Works2 Version1 Operating Manual (Common).

## 7.3.1 Transmission Setting

---

Set the transmission specification with external devices.

### (1) Operation setting

The following two types of operations can be set.

#### (a) Independent operation

Two interfaces of the C24 perform data communication with external devices independently.

#### (b) Linked operation

All data received from one of the two interfaces are transmitted from the other interface.

For the settings of linked operation and data flow, refer to  Page 91, Section 7.3.5.

### (2) Data bit

This sets the bit length for one character in data communicated with an external device according to the specifications of the external device.

If "7" is set, the data are communicated by ignoring the most significant bit (8th bit).

Set to 8-bit for data communication using Format 5 of the MC protocol (for binary code communication), or bidirectional protocol.

### (3) Parity bit

This sets whether the parity bit (vertical parity) should be odd parity or even parity when adding the parity bit (vertical parity), according to the specifications of the external device.

The addition of the parity bit to the transmission data and the checking of the parity bit of receive data are performed by the C24.

### (4) Even/odd parity

This sets whether the parity bit (vertical parity) should be odd parity or even parity when adding the parity bit (vertical parity), according to the specifications of the external device.

### (5) Stop bit

This sets the stop bit length for one character in data communicated with an external device, according to the specifications of the external device.

### (6) Sum check code

This sets whether or not a sum check code is added to transmission and reception messages of each frame and format during data communication using the MC or bidirectional protocol, according to the specifications of the external device.

For an explanation of the message configuration and sum check code when a sum check code is added, refer to the applicable explanation of each protocol.



## (7) Online change

This sets whether or not data transmitted using the MC protocol is written to the CPU module from an external device while the CPU module is running, according to the system specifications.

When online change is prohibited (disabled), the data is not written and a NAK message is returned if the external device requests the CPU module to write data while it is running.

The available functions differ depending on the setting values when the online change is enabled.

Check in the "write allow setting" and "write prohibit" columns in the command list of  MELSEC Communication Protocol Reference Manual.

## (8) Setting modifications

This sets whether or not the following actions are enabled after starting up the C24.

- Specifications, and the switching mode of each interface
- Writing data to the flash ROM (writing the system setting values and user frame)

## 7.3.2 Communication rate setting

---

Set the communication rate for the data communication with external devices.

The following is the setting value list.

Communication rate (unit: bps)	
50	14400
300	19200
600	28800
1200	38400
2400	57600
4800	115200
9600	230400 <sup>*1</sup>

\*1 Communication rate of 230,400 bps is available for only CH1.

### (1) Precautions

- The transmission speed of the interface, whose communication protocol setting is set to "MELSOFT Connection", is automatically set to "Auto Setting". In this case, the data is transmitted at the speed set on GX Works2.  
Set "Auto Setting" for the other interface to which no external device is connected.
- When connecting external devices to both of two interfaces  
Perform the setting so that the total of the communication speed of two interfaces do not exceed 230,400 bps.
- When connecting an external device to either of two interfaces  
The maximum of 230,400 bps is available when the external device is connected to CH1.  
The maximum of 115,200 bps is available when the external device is connected to CH2.

## 7.3.3 Communication protocol setting

Set the communication protocol for the data communication with external devices.

The following shows the setting value list.

Setting items		Setting contents
MELSOFT Connection		For connection to MELSOFT products MELSOFT communication rate and transmission specifications are automatically set.
MC protocol	Format 1	Set for communication with ASCII code in the specified format of an A compatible 1C frame or QnA compatible 2C/3C/4C frames
	Format 2	
	Format 3	
	Format 4	
	Format 5	Set for communication with binary code in a QnA compatible 4C frame
Nonprocedural protocol		Set for communication using nonprocedural protocol
Bidirectional protocol		Set for communication using bidirectional protocol
For linked operation setting		Set to CH1 side when CH1 and CH2 interfaces are used in linked operation (operated with the communication protocol of the CH2 side). For details, refer to  Page 91, Section 7.3.5.
Predefined Protocol		Set for communication using predefined protocol
ROM/RAM/Switch test		Set for self-diagnosis of the modules
Self-loopback test		Set for checking operation of each interface of the modules

## 7.3.4 Station number setting

---

This setting is for communication using the MC protocol.

When several serial communication modules are connected on the same line with multidrop connection, specify the serial communication module to communicate with external devices by the station number.

Set the station numbers from 0 to 31.

Set the station number to 0 when the system configuration of the external device and the CPU module is 1:1.

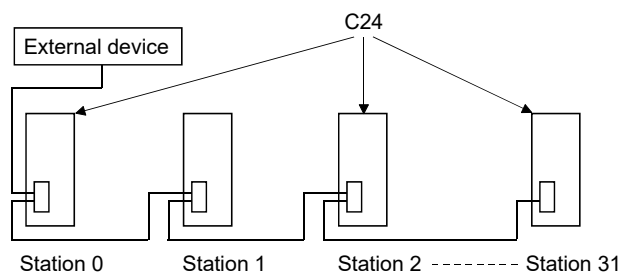

## 7.3.5 Setting and data flow in linked operation

In linked operation, all data received from one of the two interfaces are transmitted from the other interface. The linked operation is available only for the LJ71C24. It is not available for the LJ71C24-R2.

### Point

When two interfaces are in linked operation, the transmission time for one character becomes equal to the hardware gate off time of the L series.

### (1) Setting

For the linked operation, set the related switches as follows.

For details of the switch setting, refer to Page 86, Section 7.3.1 to Page 90, Section 7.3.4.

—	Settings	CH1 side	CH2 side
Settings	Transmission Setting	Operation setting	Linked
		Data Bit	Set each switch on both CH1 and CH2 sides to the same specification.
		to	
	Setting modifications	Set each switch on both CH1 and CH2 sides to the same specification.	
	Communication rate setting	Match the external device.	Match the external device.
Communication protocol setting	For linked operation setting	Set to any of the followings	
Station number setting (Common to CH1 and 2: 0 to 31)		Set according to  Page 90, Section 7.3.4.	<ul style="list-style-type: none"> <li>• MELSOFT Connection</li> <li>• MC protocol</li> <li>• Nonprocedural protocol</li> </ul>

### (2) The data flow in linked operation

Two interfaces operate linked together using functions defined with the communication protocol setting on the CH2 side (MC protocol in the same format or a nonprocedural protocol) within the transmission specifications set in the respective transmission settings.

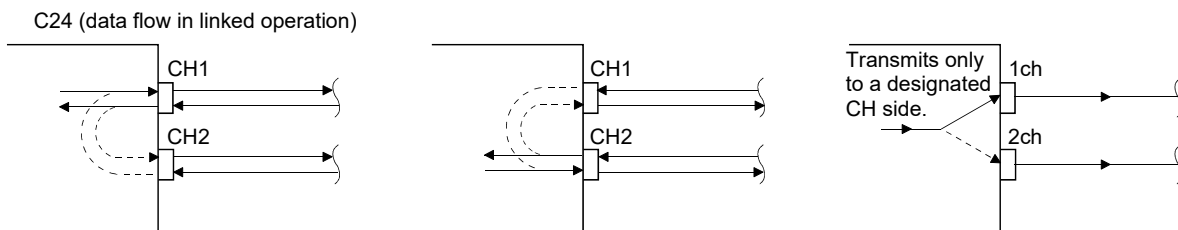

#### (a) When setting the CH2 side to Nonprocedural protocol

Exclusive control of the received data is necessary when data is communicated using the nonprocedural protocol since all the connected stations receive the data.

7

7.3 Switch Setting  
7.3.5 Setting and data flow in linked operation

## (b) When setting the CH2 side to MC protocol

When data communication is performed using the MC protocol, only the C24 having the station number designated in the message performs the process designated by the command.

Furthermore, when data communication is performed using QnA compatible 2C/3C/4C frames of the MC protocol, the header information for linked operation is added to messages directed to other stations linked by multidrop connection.

- Processing performed by the C24 connected to an external device
  - The header information is added to the command messages received from the external device that are directed to other stations and sends them to the stations through the other interface.
  - The header information is deleted from the response messages received from other stations and sends them to the external device using the other interface.  
(The header information is also sent during m:n connection.)
- Operation of the accessed station  
The accessed station processes the request contained in the command message, adds the header information to a response message, and sends it using the interface that received the command message.

### Remark

The following describes the header information that is added by the C24 to a message in linked operation.

- When communicating with ASCII code (Formats 1 to 4)  
The following 13- or 15-character header information is added immediately before the control code (ENQ/STX/ACK/NAK) at the start of each message (13 characters for Formats 1, 3 and 4; 15 characters for Format 2).
- When communicating in binary mode (Format 5)  
The following 10-byte header information is added immediately before the control code (DLE + STX) at the start of each message.

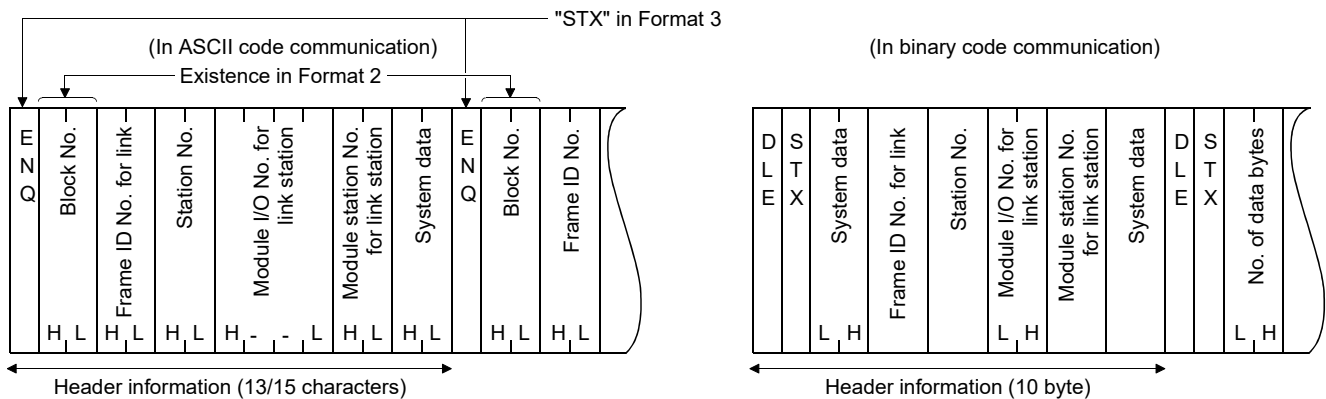

## (3) Restrictions

Do not use the above settings for the following cases, because linked operation cannot be performed.

- When using the LJ71C24-R2.
- When an external device is not connected to either of the interfaces.
- When using the predefined or bidirectional protocol.
- When communicating data using the modem function.

## 7.3.6 Precautions

For the interface that is not used for communication (no cable connection), define the switch settings as follows.

### (1) When not using the CH1

Set as follows.

Item		CH1	CH2
Transmission Setting	Operation setting	Independent	Independent
	Data Bit	7	7
	Parity Bit	None	None
	Even/odd parity	Odd	Odd
	Stop bit	1	1
	Sum check code	None	None
	Online Change	Disable	Disable
Setting modifications	Disable	Disable	
Communication rate setting		Auto Setting	300bps
Communication protocol setting		MELSOFT Connection	Nonprocedural protocol
Station number setting (0 to 31)		0	

### (2) When not using the CH2

Set as follows.

Item		CH1	CH2
Transmission Setting	Operation setting	Independent	Independent
	Data Bit	7	7
	Parity Bit	None	None
	Even/odd parity	Odd	Odd
	Stop bit	1	1
	Sum check code	None	None
	Online Change	Disable	Disable
Setting modifications	Disable	Disable	
Communication rate setting		300bps	Auto Setting
Communication protocol setting		MC protocol(Format 2)	MELSOFT Connection
Station number setting (0 to 31)		0	

## **7.4 Various Parameter Settings and Writing to the Flash ROM**

---

Initial values of the buffer memory can be changed by setting and writing various parameters to the flash ROM. Set various parameters according to the system in use.



# 7.4.1 Parameter setting

This section explains the procedures to set each parameter.

## (1) Displaying each parameter setting screen

- Select [Intelligent Function Module] ⇒ Module model name from the Project window, and select either of the parameter setting items.

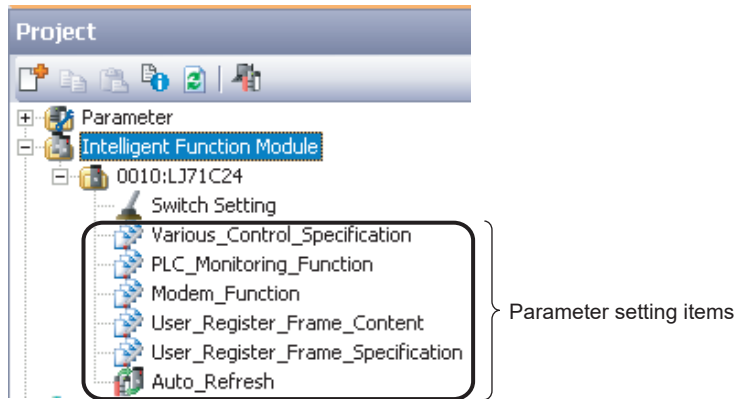

## (2) Setting

Set the parameters from each parameter setting screen.

For setting details of each item, refer to the function list in [Page 75, Section 7.2.](#)

Display Filter:

Item	CH1	CH2
Monitoring condition value designation	0 (0h)	0 (0h)
<b>Transmission pointer designation (for condition agreement transmission and</b>	0	0
Output count designation (for condition agreement transmission and non procedure data transmission)	0	0
Data No. for connection designation (for condition agreement transmission and non procedure data transmission)	0 (0h)	0 (0h)
<b>No.10 block monitoring device</b>	<b>Specifies device range for each block.</b>	
Monitoring device designation	0h:Not Specified	0h:Not Specified
Head device No. designation	0 (0h)	0 (0h)
Read point designation	0 (0h)	0 (0h)
Monitoring condition designation (judgment condition designation)	0000h:No designation	0000h:No designation
Monitoring condition value designation	0 (0h)	0 (0h)
Transmission pointer designation (for		

1) Select this item

2) An explanation of the selected item is displayed.

Transmits the selected user frame to the transmission frame No. specified area from the specified pointer position. 0 to 100

**Remark**

Display only the applicable parameters in the setting screen of each parameter for each protocol.  
The following shows the procedure.

- Display the setting screen of each parameter.
- Select a protocol from "Display Filter".

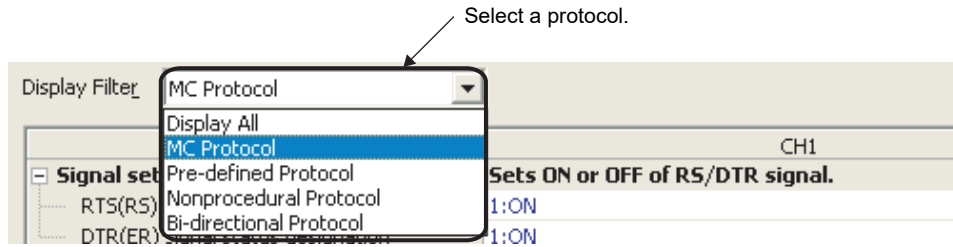

- The parameters, which can be set in the selected protocol, is displayed.

## 7.4.2 Writing to the flash ROM

This section explains the procedure to write the contents set in  Page 95, Section 7.4.1 to a flash ROM.

### (1) Displaying the screen for writing to the flash ROM

Display the "Flash ROM Operation" screen by the following procedure.

 [Online] ⇒ [Write to PLC...]

### (2) Selecting a module and the parameters to be written

(a) In the "PLC Module" tab, select the "Target" check box of "Intelligent Function Module (Initial Setting/Auto Refresh)".

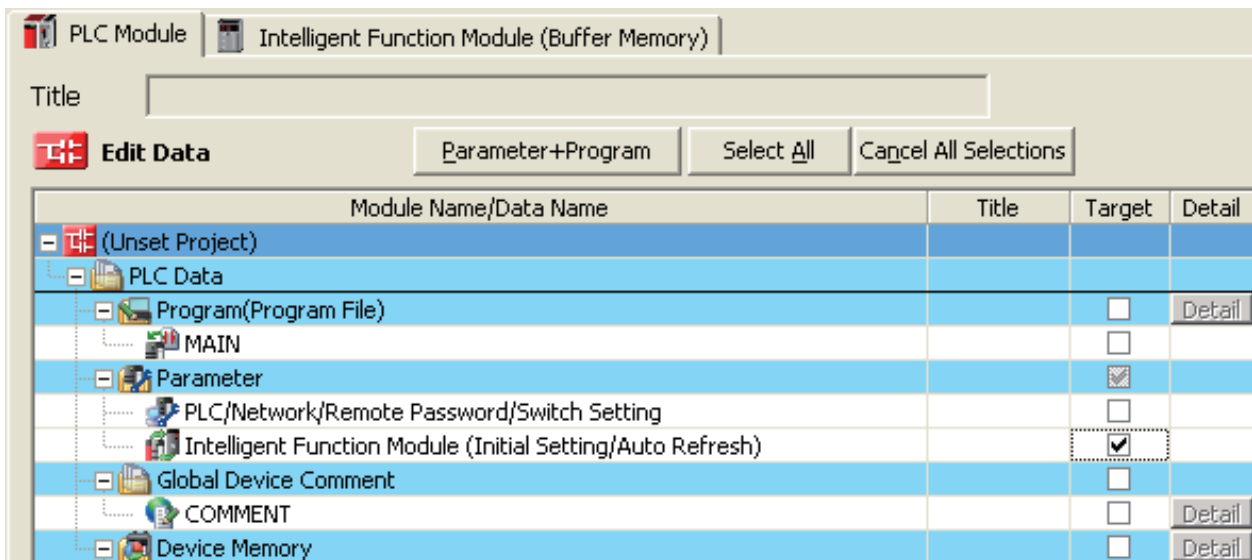

(b) In the "PLC Module" tab, select the "Valid" check box of "LC71C24" and the "Target" check box of "Memory for Read and Write".

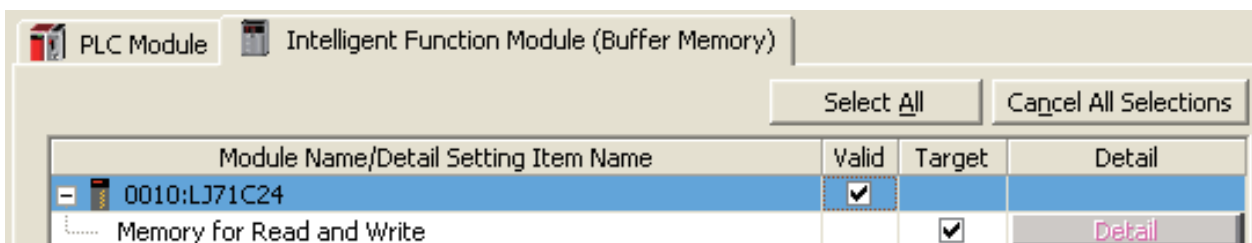

7

7.4 Various Parameter Settings and Writing to the Flash ROM  
7.4.2 Writing to the Flash ROM

### (3) Executing data writing

Click the "Execute" button to write the data.

As the following dialog box appears, click the "Yes" button.

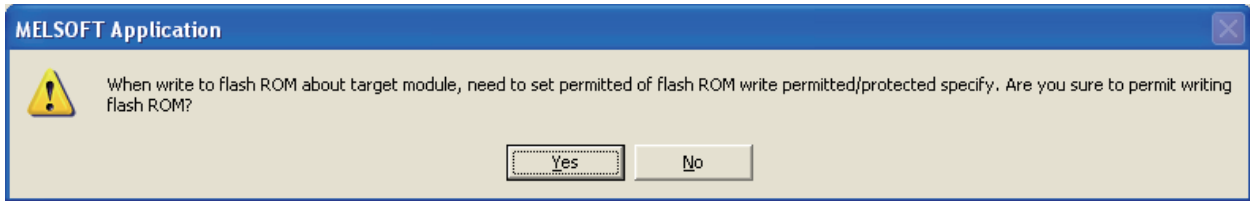

#### *Point*

---

Collectively write data to the flash ROM from GX Works2 before the system is started.

(Writing to the flash ROM normally takes approximately one to three seconds. However, note that sometimes it may take approximately one to two minutes.)

If writing to flash ROM is executed when the system is operating, the following functions are stopped while writing.

- Communication with external devices
  - Execution of dedicated instructions
  - Accessing the C24 from GX Works2
-

## 7.5 Auto Refresh

This section explains the procedures of the auto refresh setting.

The auto refresh settings are used to automatically store information stored in the C24's buffer memory into a specified device of the CPU module.

By setting the auto refresh, the read and write processing of the buffer memories on the program are not necessary.

### 7.5.1 Setting method for auto refresh

#### (1) Displaying the screen for auto refresh

For the method for displaying the screen, refer to  Page 95, Section 7.4.1.

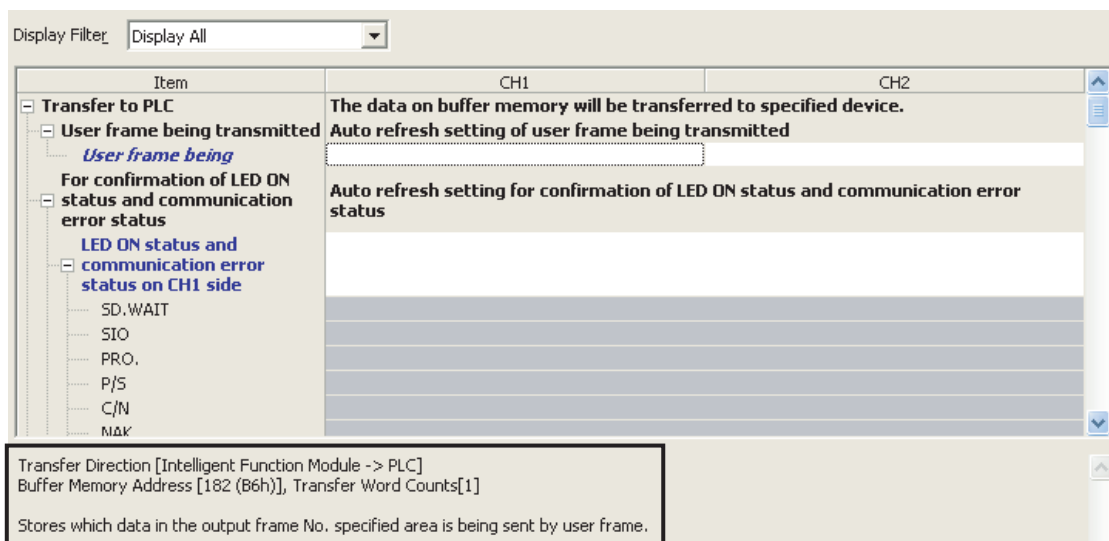

Buffer memory and description of the item selected on the screen are displayed.

#### (2) Setting auto refresh

Set a CPU module device that stores the information in the setting item field.

Applicable devices are any of X, Y, M, L, B, T, C, ST, D, W, R, and ZR.

#### (3) Writing setting values

Execute the writing of auto refresh settings to the CPU module, by Write to PLC.

For details of Write to PLC, refer to  GX Works2 Version1 Operating Manual (Common).

#### (4) Enabling setting values

Enable the auto refresh settings by turning the power OFF → ON or by resetting the CPU module.

## 7.6 Intelligent Function Module Interrupt Pointer Setting

The following explains the interrupt pointer setting with GX Works2 to receive data using an interrupt program. For the method for receiving data using an interrupt program, refer to  User's Manual (Application).

### (1) Setting purpose

The interrupt pointer sets the information to read the receive data with an interrupt program of the CPU module during communication using the nonprocedural/bidirectional protocol. By performing this setting, an interrupt program starts when data is received from an external communicating device, and the reading of data received by the CPU module becomes possible.

### (2) Startup procedure

 Project window ⇒ [Parameter] ⇒ [PLC Parameter] ⇒ [PLC System] ⇒ "Interrupt Pointer Setting" button

### (3) Setting screen

The following example shows the case the start I/O No. of C24 is assigned to 0000 and the C24 uses the interrupt pointer I50 (CH1 side receive data) and I51 (CH2 side receive data).

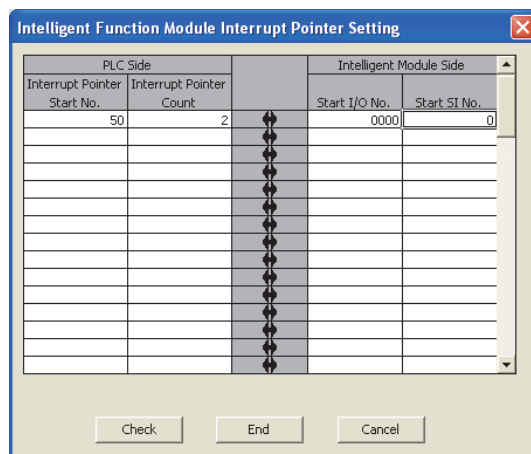

PLC Side		Intelligent Module Side	
Interrupt Pointer Start No.	Interrupt Pointer Count	Start I/O No.	Start SI No.
50	2	0000	0

#### (4) Setting description

Interrupt Pointer Start No.: PLC Side

Set the start number of the interrupt pointer ( $I_{xx}$ ) for use in the sequence program.

The setting range is from 50 to 255.

Interrupt Pointer Count : PLC Side

Set the number of units of interrupt pointers (I) for use in the sequence program.

Start I/O No.: Intelligent Module Side

Set the start I/O No. for the C24.

Start SI No.: Intelligent Module Side

- Assign control numbers (SI) on the C24 side to the interrupt pointers ( $I_{xx}$ ) used in the sequence program.
- Set the start SI No. of the interrupt control numbers.
- The interfaces for data reception corresponding to the interrupt control numbers are as follows:
  - SI No.0: for interface on the CH1 side
  - SI No.1: for interface on the CH2 side

## 7.7 Monitor/Test

---

The "Intelligent Function Module Monitor" screen is used to perform various operations, including the monitoring of the C24's operating status and setting values, and the testing of its output signals.

The monitor/test operations can be performed only via online operation.

For details, refer to  GX Works2 Version1 Operating Manual (Intelligent Function Module).



# CHAPTER 8 DATA COMMUNICATION USING THE MC PROTOCOL

MC protocol is a communication method for the programmable controller. Using this protocol, the external devices can read or write device data and programs from or to the CPU module via a C24.

The C24 automatically returns a response message based on requests from external devices. Thus, sequence programs are not required for response messages.

For details of the MC protocol, refer to  MELSEC Communication Protocol Reference Manual.

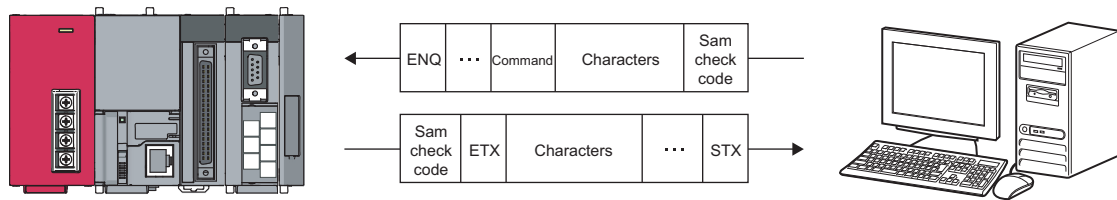

## (1) CPU module device memory read/write

This function reads and writes data from/to the access target CPU module device memory and intelligent function module buffer memory.

For the accessible range, refer to  MELSEC Communication Protocol Reference Manual.

## (2) Sequence programs and parameters read/write

This function reads and writes program files and parameter files stored in the CPU module.

## (3) Remote control of the CPU module

This function performs remote RUN/STOP/PAUSE/latch clear/reset operations.

# 8.1 Data Communication

---

## 8.1.1 Formats and applications of the data communication frames

---

The MC protocol uses the following communication frames for data communication.

The external device must communicate data in the data format appropriate to the MC protocol.

Available communication frame		Code of communication data	Reference
QnA compatible 3C frame	Formats 1 to 4	ASCII code	MELSEC Communication Protocol Reference Manual
QnA compatible 4C frame			
	Format 5	Binary code	
QnA compatible 2C frame	Formats 1 to 4	ASCII code	
A compatible 1C frame			

### (1) QnA compatible 3C and QnA compatible 4C frames

These frames are mainly used to access all devices and files of the Q/L/QnACPU from the external device.

It is also possible to access ACPU devices.

### (2) QnA compatible 2C frame

This frame can access the device memory of LCPUC station (host station) on which the L series C24 is connected and Q/L/QnACPU stations linked by multidrop connection.

### (3) A compatible 1C frame

This frame has the same message structure as when accessing the programmable controller CPU using an A series computer link module.

---

#### *Point*

The message format and control procedure are the same as when accessing the programmable controller using the conventional modules listed below.

- A series computer link module
- QnA series serial communication module
- Q series C24

The external device side can access the L series C24 with a program used for accessing the programmable controller via a conventional module.

---

## 8.1.2 MC protocol system setting

Perform the system setting for data communication using the MC protocol by GX Works2.

### (1) Switch setting

Set the transmission specification, the communication protocol with external devices and others.

Always perform this setting.

For the communication protocol setting, select one from the MC protocols (Formats 1 to 5).

Configure other settings according to the system being used.

For details of the settings, refer to  Page 73, CHAPTER 7.

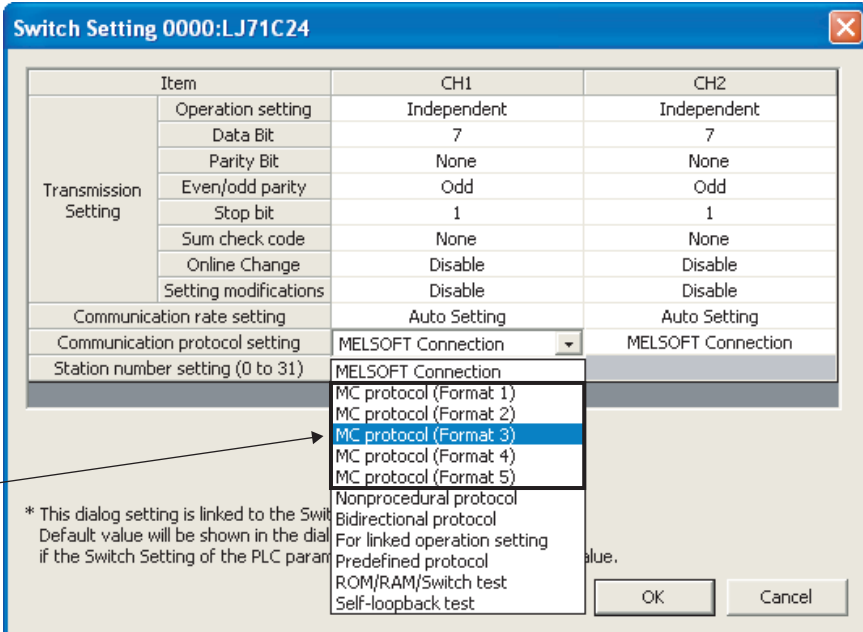

Item	CH1	CH2
Operation setting	Independent	Independent
Data Bit	7	7
Parity Bit	None	None
Even/odd parity	Odd	Odd
Stop bit	1	1
Sum check code	None	None
Online Change	Disable	Disable
Setting modifications	Disable	Disable
Communication rate setting	Auto Setting	Auto Setting
Communication protocol setting	MELSOFT Connection	MELSOFT Connection
Station number setting (0 to 31)	MELSOFT Connection	MELSOFT Connection

Select any of the MC Protocols (Formats 1 to 5)

\* This dialog setting is linked to the Switch Setting of the PLC parameter. Default value will be shown in the dialog box if the Switch Setting of the PLC parameter is set to the default value.

### (2) Parameter settings

Initial values of buffer memory can be changed by setting each parameter and writing to the flash ROM.

Set each parameter to match the system used.

For the items that can be set by MC protocol, refer to  Page 75, Section 7.2.

For the method for displaying the screen, refer to  Page 95, Section 7.4.1.

## 8.1.3 Support for the LCPU remote password function

---

The remote password function prevents unauthorized access to the LCPU.

To enable this function, set the remote password to an LCPU.

For details, refer to  User's Manual (Application).

## 8.2 Utilizing the MX Component

---

MX Component is an ActiveX control library that supports various types of communication paths between IBM-PC/AT-compatible personal computers and programmable controllers.

By using MX Component, the system can be configured for each user. Furthermore, the communication program for the external device can be created without considering the detailed MC protocol (transmission/reception procedures).

For details, refer to  Operating manual and programming manual of MX Component.

For the procedure for creating programs and sample programs using MX Component, refer to  Page 421, Appendix 9.

# CHAPTER 9 DATA COMMUNICATION USING THE PREDEFINED PROTOCOL

Data can be transferred between the CPU module and an external device with a protocol appropriate to the external device (such as a measuring instrument and a barcode reader).

Device or buffer memory data can be taken into communication packets, and thereby this protocol communication is suitable for data that may change every transmission.

The protocol setting required to communicate with the external device is configured in GX Works2.

Protocols can be selected from the predefined protocol library offered or can be arbitrarily created and edited.

### 1) Setting protocols

The setting can be performed simply, by GX Works2 predefined protocol support functions.

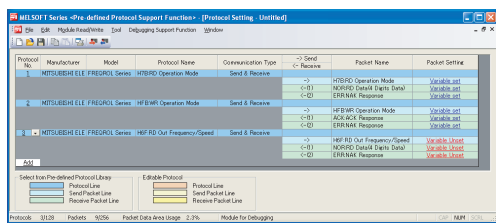

### 2) Writing protocols

The set protocols are written to the flash ROM of the C24.

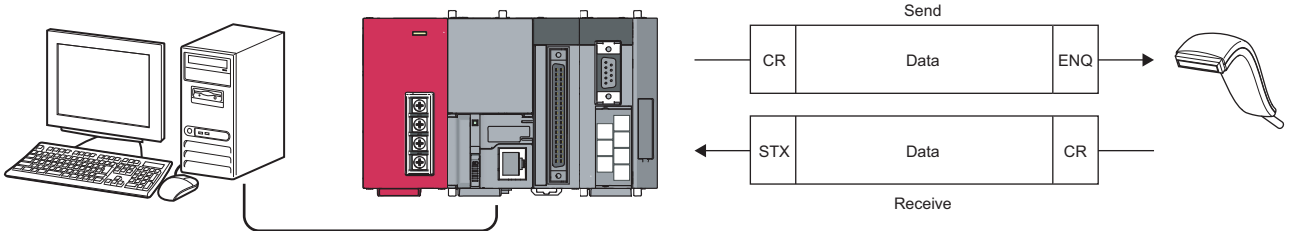
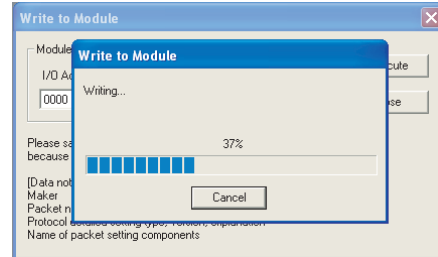

### 3) Executing protocols

Protocols can be executed with a dedicated instruction. One dedicated instruction can execute multiple protocols.

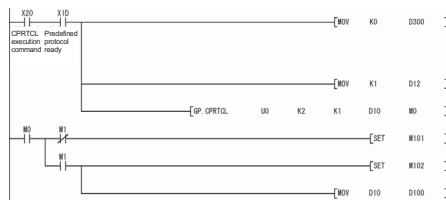

Data communications using protocols corresponding to the external device are available.

For the protocol setting method, refer to the following manual.

GX Works2 Version1 Operating Manual (Intelligent Function Module)

**Point** 

The following are the maximum numbers of protocols and packets that can be registered.

- Protocols: Up to 128
- Packets: Up to 256

However, some packets to be registered may cause capacity shortage. In this case, the maximum numbers of packets above may not be registered.

The usage rate of the packet data area can be confirmed on the "Protocol Setting" screen in GX Works2.

For details, refer to  GX Works2 Version1 Operating Manual (Intelligent Function Module).

# 9.1 Data Communication Procedure

By the following procedure taken in Predefined protocol function, data can be exchanged with an external device.

## 1. Display the "Predefined Protocol Support Function" screen.

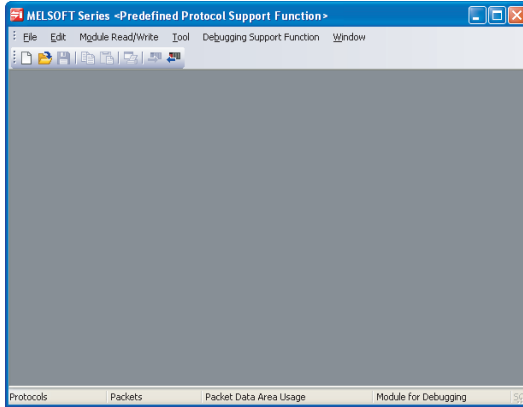

Display the "Predefined Protocol Support Function" screen in the following procedure.  
GX Works2 ⇒ [Tool] ⇒ [Predefined Protocol Support Function] ⇒ [Serial Communication Module]

## 2. Create a new file.

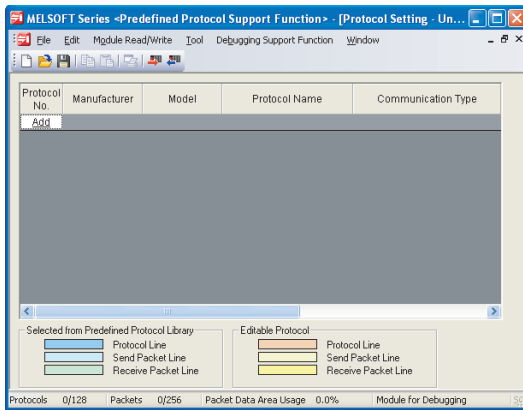

Select [File] ⇒ [New] and click "Add".

## 3. Register the protocol of the external device.

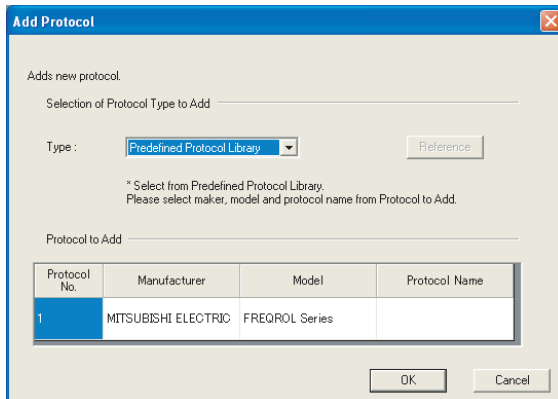

Select "Predefined Protocol Library" or "Add New" on the "Add Protocol" dialog box.

### Point

Selecting "User Protocol Library" on the "Add Protocol" dialog box reads out the protocol saved by the user in advance. For details on User Protocol Library, refer to GX Works2 Version1 Operating Manual (Intelligent Function Module).



4. Set the items required for the data communication.

(a) When selecting "Predefined Protocol Library".

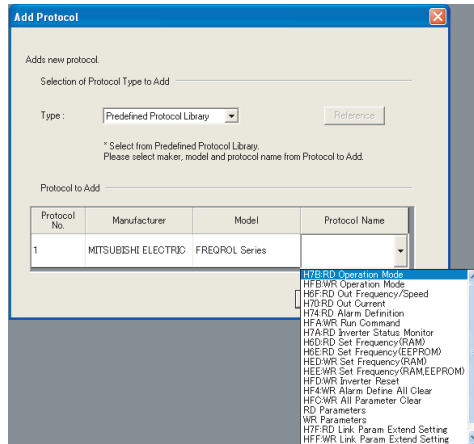

Select a protocol from the predefined protocol library. Specify the send or receive data storage area.

When selecting "Add New"

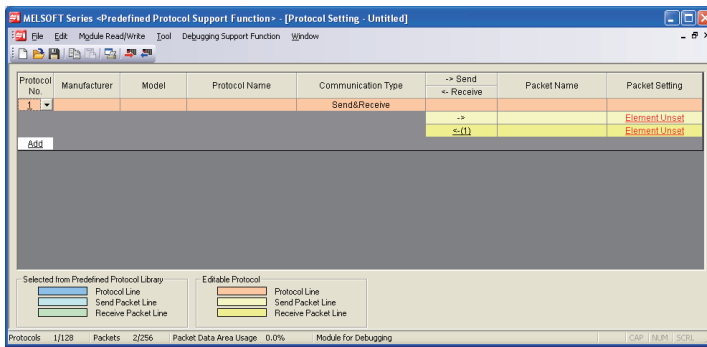

Click "Element Unset" on the "Protocol Setting" screen.

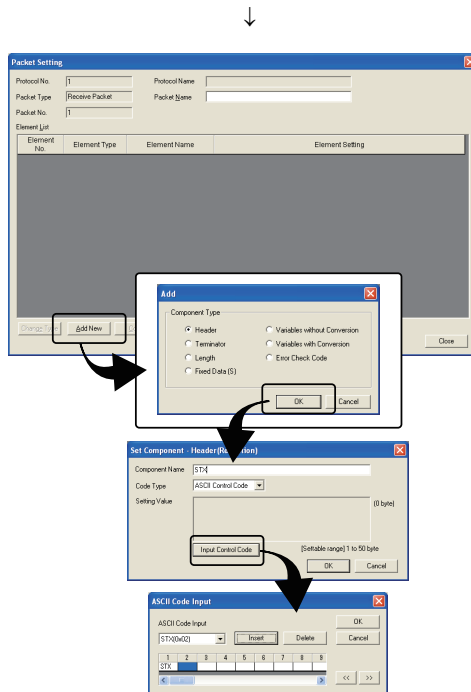

Set the packet configuration to send/receive in the "Packet Setting" screen.

↓

**5. Write the protocol setting data to the flash ROM.**

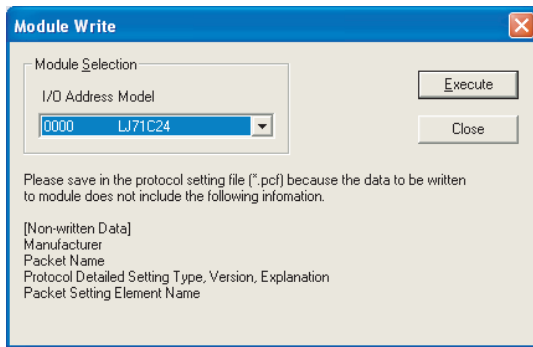

Display the "Module Write" screen in the following procedure.  
 [Module Read/Write] ⇔ [Write to Module]

Select a target module, and write the protocol setting data to the flash ROM.

↓

**6. Execute the protocol with a dedicated instruction.**

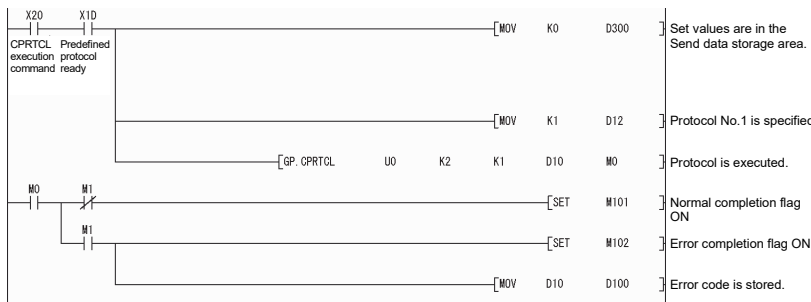

With a dedicated instruction (CPRCTL), execute the protocol that was written to the flash ROM.

↓

**7. Confirm the protocol execution in the protocol execution log.**

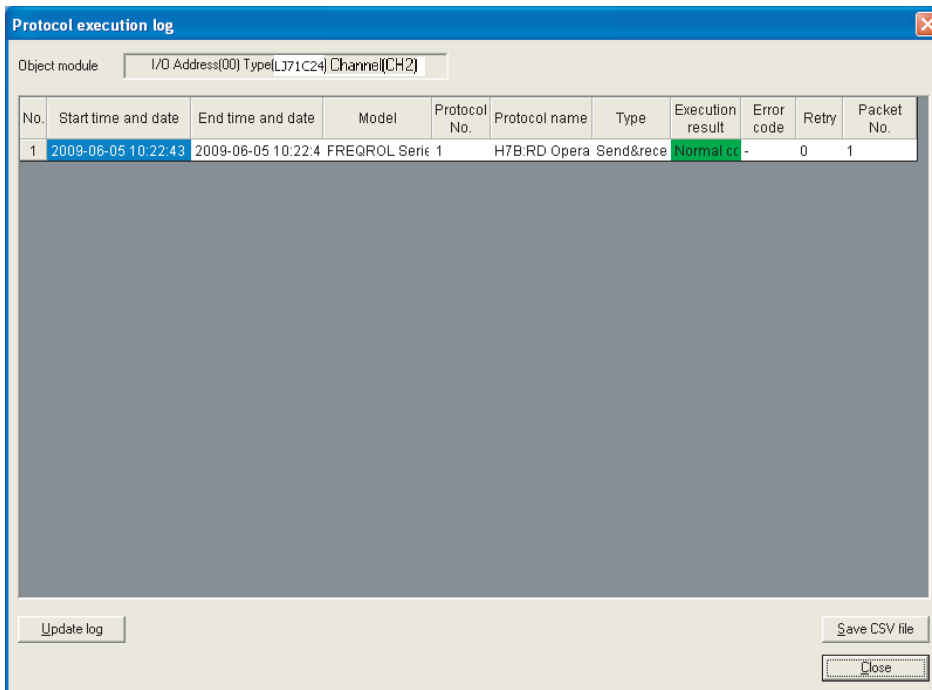

In the Protocol execution log list, information of the executed protocol, such as protocol name, start time and date, end time and date, execution result, can be monitored.

## 9.2 Communication Type of Protocols

Send packets to other devices and receive packets from other devices at the time of process execution are registered in a protocol.

The following shows an example of a packet configuration. For details of packet elements, refer to [Page 114, Section 9.3](#).

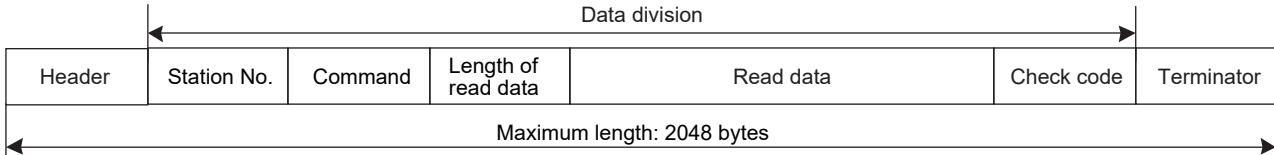

The predefined protocol function communicates with other devices using the following procedures (communication types). For the operation image of each communication type, refer to [Page 372, Appendix 5](#).

Communication type name	Description
Send only	Sends a send packet once. One send packet is required.
Receive only	Receives a packet if it matches any of up to 16 defined receive packets. One or more receive packets are required.
Send & receive	Sends a send packet, and then receives a packet if it matches any of up to 16 defined receive packets. One send packet and one or more receive packets are required.

## 9.3 Packet Elements

A packet consists of packet elements.

Up to 32 elements can be placed in a packet, and the maximum data length is 2048 bytes per packet.

The following shows the details of the packet elements. Also, refer to  Page 379, Appendix 5.3 for an example of packet element data.

### (1) Header

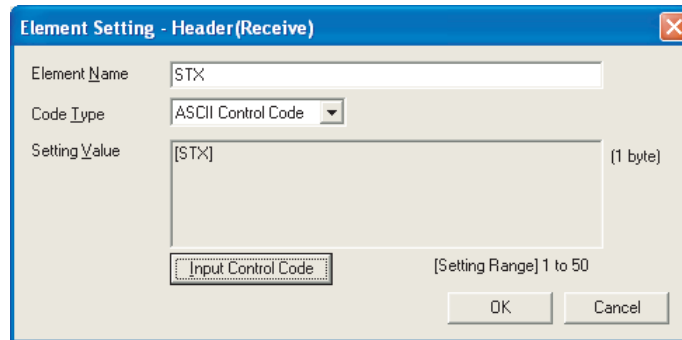

Use this element when a specific code/character string exists at the beginning of a packet.

- When sending: Sends a specified code and character string.
- When receiving: Verifies a header and receive data.

The following table is the items.

Item	Description	Remarks	
Element Name	Set a name of the element.	—	
Code Type	Select a data type of the setting value. ASCII String/ASCII Control Code/HEX	—	
Setting Value	Set data within 1 to 50 bytes.	(Setting example) ASCII String: "ABC" ASCII Control Code: STX HEX: FFFF	
	Code type		Setting range
	ASCII String		20 <sub>H</sub> to 7E <sub>H</sub>
	ASCII Control Code		00 <sub>H</sub> to 1F <sub>H</sub> , and 7F <sub>H</sub> of control code
HEX	00 <sub>H</sub> to FF <sub>H</sub> of hexadecimal data		

### **Point**

- Only one Header can be placed in a packet.
- A Header can be placed only at the beginning of a packet.

(2) Static Data

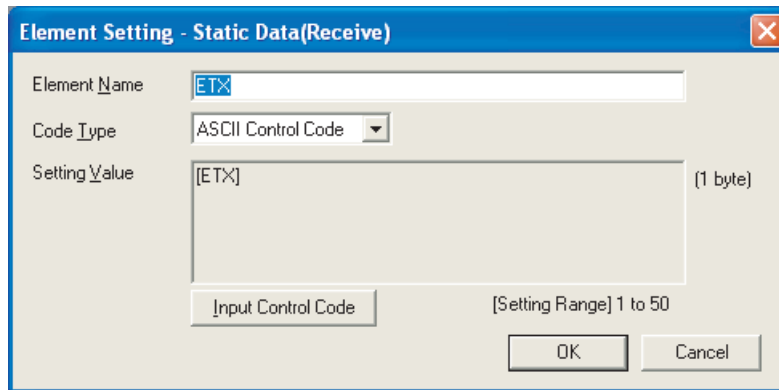

Use this element when a specific code/character string such as command exists in a packet.

- When sending: Sends a specified code and character string.
- When receiving: Verifies the receive data.

Multiple Static Data elements can be placed to desired positions in the data division.

The items are the same as ones explained in Page 114, Section 9.3 (1) in this section.

(3) Terminator

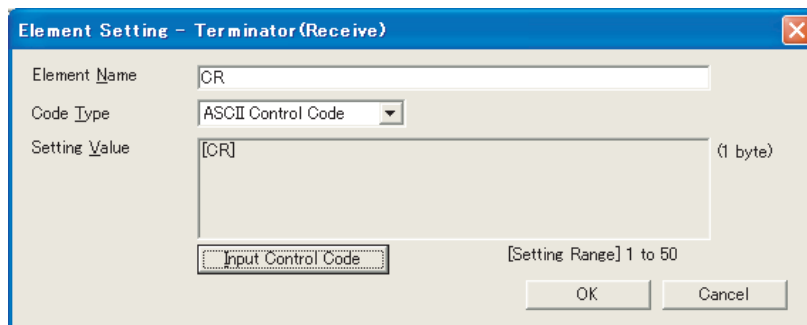

This element indicates the end of a packet. Use this element when a code/character string indicating the end of the packet is included.

The following table lists the items.

Item	Description	Remarks	
Element Name	Set a name of the element.	—	
Code Type	Set a data type of the setting value. ASCII String/ASCII Control Code/HEX	—	
Setting Value	Set data within 1 to 50 bytes.	(Setting example) ASCII String: "ABC" ASCII Control Code: ETX HEX: FFFF	
	Code type		Setting range
	ASCII String		20 <sub>H</sub> to 7E <sub>H</sub>
	ASCII Control Code		00 <sub>H</sub> to 1F <sub>H</sub> , and 7F <sub>H</sub> of control code
	HEX	00 <sub>H</sub> to FF <sub>H</sub> of hexadecimal data	

**Point**

- Only one Terminator can be placed in a packet.
- Only a Check code and Static Data can be placed behind a terminator.

## (4) Length

Use this element when an element indicating the data length is included in a packet.

When sending	Calculates the data length of a specified range, and adds the result to a send packet.
When receiving	Verifies the data (setting value) corresponds to the length in the receive data as the data length of a specified range.

The following table shows the items.

Item	Description		Remarks
Element Name	Set a name of the element.		—
Code Type	Select a format of the data length. ASCII Hexadecimal/ASCII Decimal/HEX		—
Data Length	Select the data length on the line. The range is 1 to 4.		—
Data Flow	Forward Direction (Upper Byte → Lower Byte)	When sending: Sends a calculated length, from the upper byte. When receiving: Receives data, from the upper byte.	Not settable when "Data Length" is 1 byte
	Reverse Direction (Lower Byte → Upper Byte)	When sending: Sends a calculated length, from the lower byte. When receiving: Receives data, from the lower byte.	
	Byte Swap (by Word)	When sending: Sends a calculated length swapping the upper byte and lower byte by word. When receiving: Receives data swapping the upper byte and lower byte by word.	
Calculating Range	Start	Set the starting element number of the calculating range. The range is 1 to 32.	—
	End	Set the ending element number of the calculating range. The range is 1 to 32.	

**Point**

- Only one Length can be placed in a packet.
- When there is no element other than a Length, an element error occurs.
- When the number of digits of calculation result is greater than that specified in "Data Length", digits greater than the specified digit are omitted (ignored).  
Example) When "2 bytes" is specified in "Data Length" and the calculation result is "123 bytes", the data length is considered as "23".
- When any of a Non-conversion variable (Variable length), Conversion variable (Variable number of data), Conversion variable (Fixed number of data/Variable number of digits \*1), and Non-verified reception (Variable number of characters) is placed behind a Length and they are not included in the calculation range of the Length, place any of the following data immediate after the Non-conversion variable (Variable length), Conversion variable (Variable length) or Non-verified reception.  
Static Data  
Terminator  
Check code + Static Data  
Check code + Terminator
- When "Code Type" is "ASCII Hexadecimal", a corresponding packet is regarded as a mismatch packet if a string except for "0"-"9" "A"-"F" "a"-"f" is received.
- When "Code Type" is "ASCII Decimal", a corresponding packet is regarded as a mismatch packet if a string except for "0"-"9" is received.

---

\*1 Excluding a case where "Number of data" is '1' and "Delimiter" is not 'No delimiter'.

## (5) Non-conversion Variable

Use this element to send the data in the device memory of a CPU module or buffer memory as a part of a send packet, or store a part of a receive packet to the device memory of a CPU module device or buffer memory.

The following lists the items.

Item	Description	
Element Name	Set a name of the element.	
Fixed Length/Variable Length	Fixed Length	Sends and receives the data whose length is fixed.
	Variable Length	When sending: Specifies the data length at the time of the protocol execution and sends data. When receiving: Receives data of which the length is variable.
Data Length/ Maximum Data Length	Set the length of data to be sent and received. (For the variable length data, set the maximum data length that can be specified to the data length storage area.) The range is 1 to 2048.	
Unit of Stored Data	Lower Byte + Upper Byte	When sending: Sends each one word (2 bytes) data in the data storage area in the order of the lower byte to the upper byte. When receiving: Stores the receive data to the data storage area in the order of the lower byte to the upper byte.
	Lower Bytes Only	When sending: Sends each lower byte of data in the data storage area. The C24 ignores data in the upper byte. When receiving: Stores the receive data to each lower byte in the data storage area. The C24 stores 00 <sub>H</sub> in the upper byte.



Item	Description		
Byte Swap	<p>Disable (lower → upper)/ Enable (upper → lower)</p> <p>When sending: When "Enable" is selected, sends data swapping the upper byte and lower byte by word (2 bytes). When "Unit of Stored Data" is "Lower Byte + Upper Byte" and "Data Length" is an odd number of bytes, sends the upper byte at transmission of the last byte. When "Unit of Stored Data" is "Lower Bytes Only" and "Data Length" is an odd number of bytes, sends data without any byte swap at transmission of the last byte.</p> <p>When receiving: When 'Enable' is selected, receives data swapping the upper byte and lower byte by word (2 bytes). When "Unit of Stored Data" is "Lower Byte + Upper Byte" and "Data Length" is an odd number of bytes, stores the last byte to the upper byte. When "Unit of Stored Data" is "Lower Bytes Only" and "Data Length" is an odd number of bytes, stores the last byte without any byte swap.</p>		
Data Storage Area Specification	Specify a starting device to store variable value. The following lists the available devices.		
	Classification	Device name	Device symbol
	Internal User <sup>*1*2</sup>	Input Relay	X
		Output Relay	Y
		Internal Relay	M
		Latch Relay	L
		Link Relay	B
		Data Register	D
		Link Register	W
	File Register <sup>*2</sup>	File Register	R
	ZR		
Buffer memory	G device	G	
*1	Do not set local devices.		
*2	Set within the device range specified in the following screen. Project window ⇒ [Parameter] ⇒ [PLC Parameter] ⇒ [Device]		

The following explains the configuration of the data storage area.

**(a) When "Fixed Length/Variable Length" is "Fixed Length"**

An area starting from the device number which is specified on the Element setting screen is considered as the data storage area.

The data storage area to be occupied varies depending on the setting of "Unit of Stored Data".

- When "Lower Byte + Upper Byte" is selected, the same size as the data length is occupied.  
(However, when the data length of a send packet is an odd number, the upper byte (lower byte for "Byte Swap") of the last device is not sent. When the data length of a receive packet is an odd number, the last data is stored with one byte of 00H.)
- When "Lower Bytes Only" is selected, twice the size of the data length is occupied.

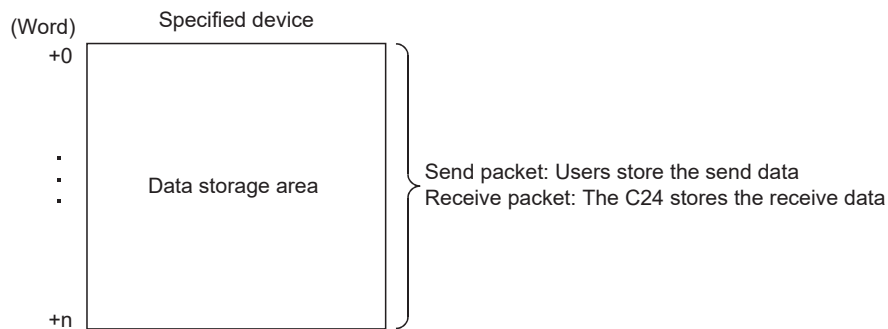

**(b) When "Fixed Length/Variable Length" is "Variable Length"**

An area starting from the device number which is specified on the Element Setting screen +1 is considered as the data storage area.

The data storage area to be occupied varies depending on the setting of "Unit of Stored Data".

- When "Lower Byte + Upper Byte" is selected, the same size as the data length + one word (length for the data length storage area) are occupied.  
(However, when the data length of a send packet is an odd number, the upper byte (lower byte for "Byte Swap") of the last device is not transmitted. When the data length of a receive packet is an odd number, one byte of 00H is added to the last data and stored.)
- When "Lower Bytes Only" is selected, twice size of the data length + one word (length for the data length storage area) are occupied.

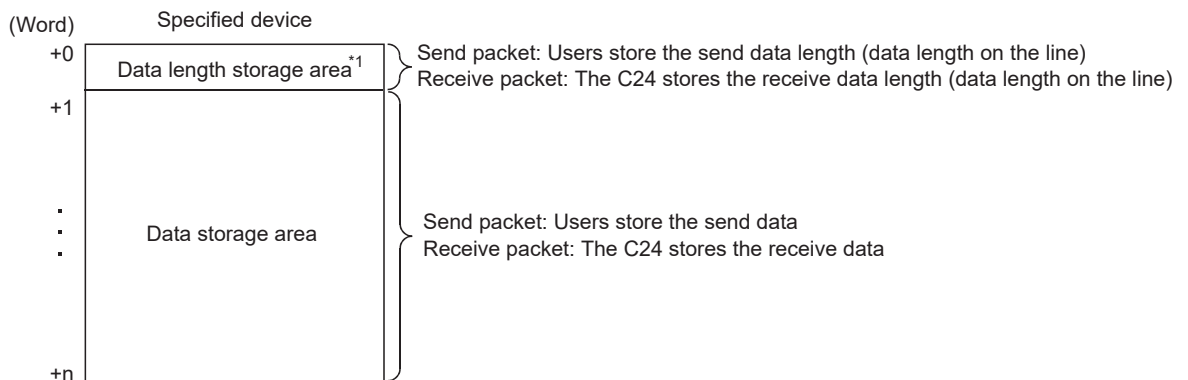

\*1 The unit of data length is byte.

**Point**

- When receiving variable length data whose length exceeds the "Maximum data length", the C24 stores data as long as the maximum data length and omits the rest. (A protocol completes successfully.)
- In receive packet data from other devices, the C24 needs to be able to discriminate data corresponding to a Non-conversion variable from those of a Terminator or a Static Data following a Non-conversion variable. The receive process may not be performed normally if they cannot be classed.

(Example)

When value of a Terminator or value of a Static Data following a Non-conversion variable is used in a Non-conversion variable, the C24 recognizes it as data of a Terminator or a Static Data following a Non-conversion variable and performs the verify/receive process.

- Multiple Non-conversion variable (Fixed length) elements can be placed in a packet, and multiple Non-conversion variable (Variable length) elements can also be placed in a send packet. However, only one Non-conversion variable (Variable length) can be placed in a receive packet, and any of the following requirements need to be met.

- (a) Place any of the following data immediate after a Non-conversion variable

Static Data

Terminator

Check code + Static Data

Check code + Terminator

- (b) Place a Length before a Non-conversion variable and include the Non-conversion variable in the calculation range.

In addition, two or more of the following four elements cannot be placed in the same packet.

Conversion variable (Variable number of data)

Conversion variable (Fixed number of data and Variable number of digits) (Excluding a case where "Number of Data" is '1' and "Delimiter" is not "No Delimiter".)

Non-conversion variable (Variable length)

Non-verified reception (Variable number of characters)

## (6) Conversion Variable

This element converts the numerical data in the device memory of a CPU module or buffer memory to an ASCII string and sends it, or converts the receive data (ASCII string) to the numerical data and stores it to the device memory of a CPU module or buffer memory.

The following lists the items.

Item	Description		Remarks
Element Name	Set a name of the element.		—
Conversion	At sending	HEX → ASCII Decimal	Converts numeric value stored in the data storage area to ASCII decimal.
		HEX → ASCII Hexadecimal	Converts numeric value stored in the data storage area to ASCII hexadecimal.
	At receiving	ASCII Decimal → HEX	Treats receive data as ASCII decimal, converts it to numeric value, and stores it to the data storage area.
		ASCII Hexadecimal → HEX	Treats receive data as ASCII hexadecimal, converts it to numeric value, and stores it to the data storage area.
Fixed Number of Data/ Variable Number of Data	Fixed Number of Data	Fixes the number of data to be sent and received.	—
	Variable Number of Data	When sending: Specifies the number of data at the time of the protocol execution and sends the data. When receiving: Receives data of which the number is variable.	For Variable number of digits, delimiters are required.
Number of Data/ Maximum Number of Data	Set the number of data to be sent and received. (For "Variable Number of Data", set the maximum number of data that can be specified to the data length storage area.) The range is 1 to 256.		—

Item	Description		Remarks
Number of Digits of Data	1 to 10	Set the number of digits per one send and receive data. When the number of digits of data is less than the specified number of digits, upper digits are filled with blank-padded characters.	—
	Variable Number of Digits	When sending: Sends only the data division converted to an ASCII string in variable length. When receiving: Receives only an ASCII string of the data division in variable length. When the maximum data length is set to 2 or greater, blank-padded characters are required.	—
Blank-padded Character	0/Space	Select a character used to fill upper digits when "Number of Digits of Data" is not "Variable Number of Digits" and the number of digits of send/receive data is less than the specified number of digits.	—
Conversion Unit	Select how many words are manipulated as one data in the data storage area. For 'Word', converts data manipulating one word as one data. For 'Double word', converts data manipulating two words as one data.		—
Sign	Unsigned/Signed	Select whether to add signs to data in the data storage area. This item can be set when "Conversion" is "HEX → ASCII Decimal" or "ASCII Decimal → HEX".	—
Sign Character	None/+/0/Space	Select the sign character for positive value on line. This item can be set when "Conversion" is "HEX → ASCII Decimal" or "ASCII Decimal → HEX", and "Sign" is "Signed". The sign character for negative value is fixed to "-".	—
Number of Decimals	No Decimal Point/Variable Point/1 to 9	Select the decimal point position of data on line. This item can be set when "Conversion" is "HEX → ASCII Decimal" or "ASCII Decimal → HEX".	—
Delimiter	No Delimiter/Comma/Space	Select the delimiter inserted after one data. A delimiter is not added to the end of data when the number of data is 2 or more.	—
Data Storage Area Specification	Specify a starting device to store variable value.		—

The following explains the configuration of the data storage area.

**(a) When "Fixed Number of Data/Variable Number of Data" is "Fixed Number of Data"**

An area starting from the device number which is specified on the Element setting screen is considered as the data storage area.

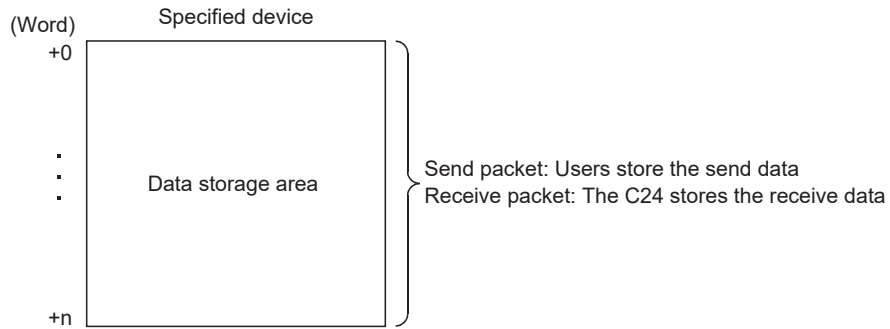

**(b) When "Fixed Number of Data/Variable Number of Data" is "Variable Number of Data"**

An area starting from the device number which is specified on the Element setting screen +1 is considered as the data storage area.

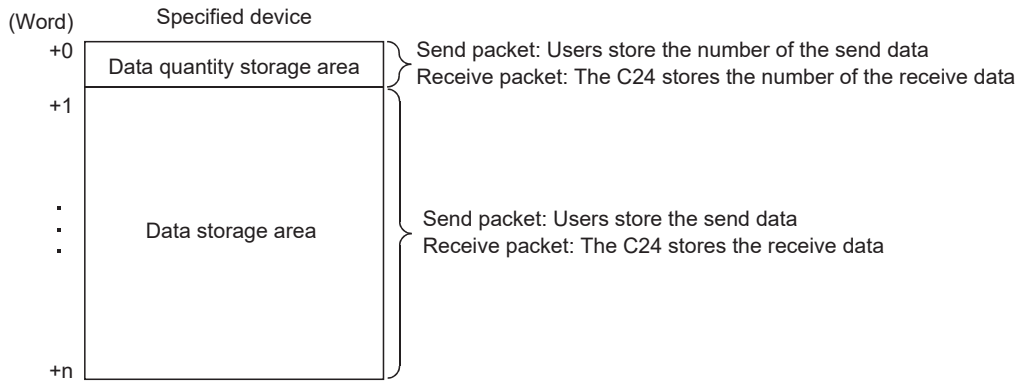

**(c) Occupied size in data storage area**

The size occupied in the data storage area varies depending on the settings of "Conversion Unit" and "Number of Digits of Data".

Setting item		Occupied size in data storage area per one data	Reference for data storage area configuration
Conversion Unit	Number of Decimals		
Word	No Decimal point (fixed point)	1 word	Page 125, Section 9.3 (6) (d)
	Variable point	2 words	Page 125, Section 9.3 (6) (d)
Double Word	No Decimal point (fixed point)	2 words	Page 125, Section 9.3 (6) (d)
	Variable point	4 words	Page 125, Section 9.3 (6) (d)

**(d) Data storage area configuration**

The following shows the data storage area configuration per one data.

- "Conversion Unit": Word, "Number of Decimals": No decimal Point (fixed point) No Decimal Point (fixed point)

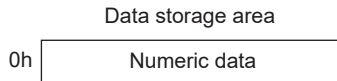

- "Conversion Unit": Word, "Number of Decimals": Variable point  
For "Variable Point", the decimal point position is set in the data storage area.

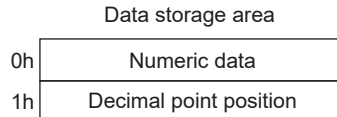

In the decimal point position area, the decimal point position is set as follows.

Send/receive data (number of digits is 10)	Numeric data	Decimal point position
12345	12345 (3039 <sub>H</sub> )	1 (1 <sub>H</sub> )
1234.5	12345 (3039 <sub>H</sub> )	10 (0A <sub>H</sub> )
123.45	12345 (3039 <sub>H</sub> )	100 (64 <sub>H</sub> )
12.345	12345 (3039 <sub>H</sub> )	1000 (3E8 <sub>H</sub> )
1.2345	12345 (3039 <sub>H</sub> )	10000 (2710 <sub>H</sub> )

- "Conversion Unit": Doubleword, "Number of Decimals": No Decimal Point (fixed point) No Decimal Point (fixed point)

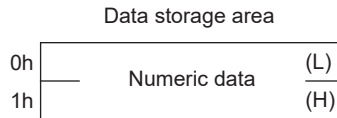

- "Conversion Unit": Doubleword, "Number of Decimals": Variable Point  
For "Variable Point", the decimal point position is set in the data storage area.

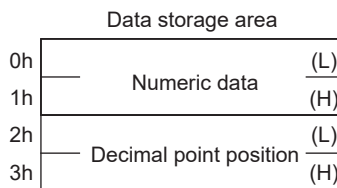

In the decimal point position area, the decimal point position is set as follows.

Send/receive data (number of digits is 10)	Numeric data	Decimal point position
1234567890	1234567890 (499602D2 <sub>H</sub> )	1 (1 <sub>H</sub> )
123456789.0	1234567890 (499602D2 <sub>H</sub> )	10 (0A <sub>H</sub> )
12345678.90	1234567890 (499602D2 <sub>H</sub> )	100 (64 <sub>H</sub> )
1234567.890	1234567890 (499602D2 <sub>H</sub> )	1000 (3E8 <sub>H</sub> )
:	:	:
1.234567890	1234567890 (499602D2 <sub>H</sub> )	1000000000 (3B9ACA00 <sub>H</sub> )

**(e) Range of value that can be used in the data storage area**

The following table shows the range of value that can be used in the data storage area.

Conversion	Sign	Conversion unit	Range of value
HEX → ASCII decimal ASCII decimal → HEX	Unsigned	Word	0 to 65535 (0 <sub>H</sub> to FFFF <sub>H</sub> )
		Double word	0 to 4294967295 (0 <sub>H</sub> to FFFFFFFF <sub>H</sub> )
	Signed	Word	-32768 to 32767 (8000 <sub>H</sub> to FFFF <sub>H</sub> , 0 <sub>H</sub> to 7FFF <sub>H</sub> )
		Double word	-2147483648 to 2147483647 (80000000 <sub>H</sub> to FFFFFFFF <sub>H</sub> , 0 <sub>H</sub> to 7FFFFFFF <sub>H</sub> )
HEX → ASCII hexadecimal ASCII hexadecimal → HEX		Word	0 <sub>H</sub> to FFFF <sub>H</sub>
		Double word	0 <sub>H</sub> to FFFFFFFF <sub>H</sub>

**Point**

An error may occur in any of the following cases.

- When "Conversion" is "ASCII Hexadecimal → HEX", an ASCII → BIN conversion error (7F20<sub>H</sub>) may occur if a string except for '0'-'9' 'A'-'F' 'a'-'f' is received.
- When "Conversion" is "ASCII Decimal → HEX", an ASCII → BIN conversion error (7F20<sub>H</sub>) may occur if a string except for '0'-'9' is received. However, the following are exempt from the ASCII → BIN conversion error.

Item	C24 operation
Sign/Sign Character	When "Signed" is selected, a sign character can be received. However, an ASCII → BIN conversion error (7F20 <sub>H</sub> ) may occur when a sign character which is not at the beginning of a unit of data is received.
Number of Decimals	When any other than "No decimal point" is selected, '.' (a period) can be received. However an ASCII → BIN conversion error (7F20 <sub>H</sub> ) may occur when '.' (a period) which is not at the specified digit is received. An ASCII → BIN conversion error (7F20 <sub>H</sub> ) may also occur when "variable point" is selected and '.' (a period) which is at the beginning or end of a unit of data is received.
Delimiter	When any other than "No delimiter" is selected, a delimiter can be received. However an ASCII → BIN conversion error (7F20 <sub>H</sub> ) may occur when a delimiter which is not at a boundary of data is received.

- When "Number of Digits of Data" is "Variable Number of Digits", an invalid number of digits error (7D19<sub>H</sub>) may occur if the number of digits of receive data exceeds the upper limit shown below.

Conversion unit	Conversion	Upper limit of the number of the receive data
Word	ASCII decimal → HEX	Maximum 5 digits
	ASCII hexadecimal → HEX	Maximum 4 digits
Double word	ASCII decimal → HEX	Maximum 10 digits
	ASCII hexadecimal → HEX	Maximum 8 digits

- When "Number of Decimals" is 'Variable Point' in a send packet, a decimal point position designation error (7D21<sub>H</sub>) may occur if the decimal point position is greater than the number of digits.



**Point**

For the fixed number of data

- When "Number of Digits of Data" is "Variable Number of Digits", an invalid number of digits error (7D19<sub>H</sub>) may occur if the number of digits of receive data is 0.

For the variable number of data

- A too few digits error (7D18<sub>H</sub>) may occur if data of which number of digits are fewer than the digits specified in "Number of Digits of Data" are received.  
(Example for the case that the setting of "Number of Digits of Data" is 4)

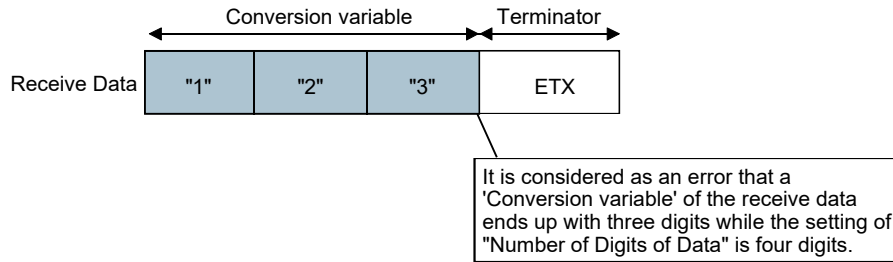

- When receiving data of which the number exceeds the "Maximum number of data", the C24 stores data as many as the maximum number of data and omits the rest. (A protocol completes successfully.)
- In receive packet data from other devices, The C24 needs to be able to discriminate data corresponding to a Conversion variable from those of a Terminator or a Static Data following a Conversion variable. The receive process may not be performed normally if they cannot be classed.  
(Example)  
When a terminator or a fixed data value immediately after the Conversion variable data is used as a Conversion variable, the C24 identifies it as the terminator the fixed data value immediately after the Conversion variable data and executes verification and reception.

To place a Conversion variable in a packet, the following requirements need to be met.

- To place Conversion variable in send packet  
Multiple Conversion variable elements can be placed in one packet, and they can be placed in desired positions in the data division.
- To place Conversion variable in receive packet  
Multiple Conversion variable elements can be placed in one packet in the cases other than [Variable Number of Data] and (a) - 1) of [Fixed Number of Data].

Variable Number of Data

Only one Conversion variable can be placed in one packet, and any of the following 1) and 2) need to be met.

- 1) For discriminating the data length of a Conversion variable, any of the following items is placed immediate after the Conversion variable.
  - Static Data
  - Terminator
  - Check code + Static Data
  - Check code + Terminator
- 2) A "Length" is placed before a Conversion variable. (The Conversion variable needs to be included in the calculating range.)

Fixed number of data

(a) Variable number of digits

- 1) When the number of data is 2 or more, or the number of data is 1 with no delimiter, only one Conversion variable can be placed in a packet and it needs to be placed in the order mentioned in [Variable number of data].
- 2) When a Conversion variable (the number of data is 1, with delimiter, and variable number of digits) and the following four elements are placed in the same packet, these four elements need to be placed behind the Conversion variable (the number of data is 1, with delimiter, and variable number of digits).
  - Conversion variable (variable number of data)
  - Conversion variable (fixed number of data and variable number of digits)
  - (The case of (a) - 1. Excluding a case where "Number of Data" is '1' and "Delimiter" is not "No Delimiter".)
  - Non-conversion variable (variable length)
  - Non-verified reception (variable number of characters)

Note that two or more of these four elements cannot be placed in the same packet.

(b) Fixed number of digits (1 to 10)

- 1) When a Conversion variable (variable decimal point) and the four elements mentioned in (a) - 2), these elements need to be placed behind the Conversion variable (variable decimal point).
  - 2) When a Conversion variable (unsigned) and the four elements mentioned in (a) - 2), these elements need to be placed behind the Conversion variable (unsigned).
-

(7) Check Code

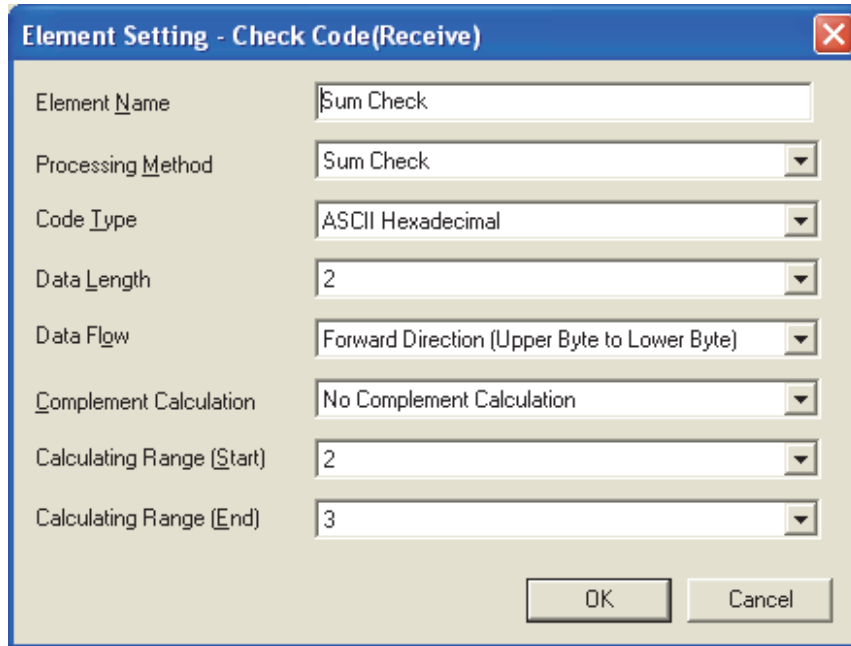

Use this element when an element indicating check code data is included in a packet.

The C24 automatically calculates a specified check code at timing of sending/receiving, and adds it to a send packet or detects an error of a receive packet.

The following table lists the items.

Item	Description		Remarks
Element Name	Set a name of the element.		—
Processing Method	Select a calculating method. Horizontal parity/Sum check/16-bit CRC (for MODBUS)		—
Code Type	ASCII Hexadecimal ASCII Decimal HEX	When sending: Select a format in which a calculated check code is sent. When receiving: Select a format in which data are received.	Not settable when "Processing Method" is "16-bit CRC (for MODBUS)"
Data Length	Select the data length on the line (byte). The range is 1 to 4.		Not settable when "Processing Method" is "16-bit CRC (for MODBUS)"
Data Flow	Forward direction (Upper byte → Lower byte)	When sending: Sends a calculated check code, from the upper byte. When receiving: Manipulates receive data as a check code, from the upper byte.	Not settable when "Processing Method" is "16-bit CRC (for MODBUS)", or when the "Data Length" is set to "1 (byte)".
	Reverse direction (Lower byte → Upper byte)	When sending: Sends a calculated check code, from the upper byte. When receiving: Manipulates receive data as a check code, from the upper byte. Effective only if the data length is 2 to 4 (bytes).	
	Byte swap (by word)	When sending: Sends a calculated check code swapping the upper byte and lower byte by word. When receiving: Manipulates receive data as a check code swapping the upper byte and lower byte by word. Effective only if the data length is 4 bytes.	

9.3 Packet Elements

Item	Description		Remarks
Complement Calculation	Select the complement calculation. No complement calculation/One's complement/Two's complement		Not settable when "Processing Method" is "16-bit CRC (for MODBUS)"
Calculating Range	Start	Select the starting element number of the calculating range. The range is 1 to 32.	—
	End	Select the ending element number of the calculating range. The range is 1 to 32.	

### **Point**

- When "Code Type" is "ASCII Hexadecimal", an ASCII → BIN conversion error (7F20<sub>H</sub>) may occur if a string except for '0'-'9' 'A'-'F' 'a'-'f' is received.
- When "Code Type" is "ASCII Decimal", an ASCII → BIN conversion error (7F20<sub>H</sub>) may occur if a string except for '0'-'9' is received.
- Only one Check code can be placed in a packet.
- Packet elements placed behind a Check code cannot be included in the calculating range.
- A Check code cannot be included in the calculated range.
- When a calculated check code (Sum check/Horizontal parity/16-bit CRC) does not match a received check code, a sum check error (7F24<sub>H</sub>) may occur.
- One or more elements are required before a Check code.

**(8) Non-verified Reception**

Use this element when receive data include data not needed.

The C24 skips characters as many as the specified number if a receive packet includes a Non-verified reception.

The following table lists the items.

Item	Description	Remarks
Element Name	Set a name of the element.	—
Data Length	0 (variable number of characters)	Set this item when the number of characters not to be verified varies in each of communication.
	1 to 2048 (specified number of characters)	Set the number of characters not to be verified.

**Point**

When "Data Length" is '0', the following requirements need to be met.

- Only one Non-verified reception can be placed in a packet.
- Include a Non-verified reception in the calculating range of a Length.  
Otherwise, place any of the following data immediate after a Non-verified reception.  
Static Data  
Terminator  
Check code + Static Data  
Check code + Terminator
- Two or more of the following four elements cannot be placed in the same packet.  
Conversion variable (Variable number of data)  
Conversion variable (Fixed number of data and Variable number of digits) (Excluding a case where "Number of Data" is '1' and "Delimiter" is not "No Delimiter".)  
Non-conversion variable (Variable length)  
Non-verified reception (Variable number of characters)

In receive packet data from other devices, the C24 needs to be able to discriminate data corresponding to a Non-verified reception from those of a Terminator or a Static Data following a Non-verified reception. The receive process may not be performed normally if they cannot be classed.

(Example)

When value of a Terminator or value of a Static Data following a Non-verified reception is used in a Non-verified reception, the C24 recognizes it as data of a Terminator or a Static Data following a Non-verified reception and perform the verify/receive process.

## 9.4 Executing Condition of Predefined Protocol Communication

The predefined protocol communication can be executed when the predefined protocol ready (X1D) is on. Use the signal as an interlock signal when executing the predefined protocol communication in the sequence program.

This signal turns ON only when the communication protocol setting is set to predefined protocol.

### (1) ON/OFF timing of the predefined protocol ready (X1D)

After the protocol setting data is written to a flash ROM, X1D turns off while checking the written data. X1D turns on when the written data are normal.

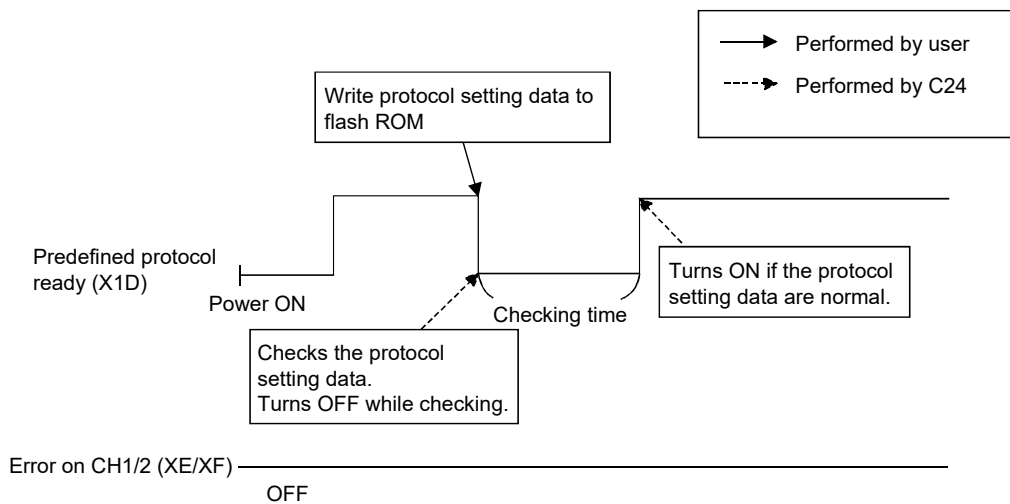

**(2) Timing for executing the UINI instruction or mode switching request signal (Y2/Y9)\*1**

**(a) Timing for executing mode switching request signal (Y2/Y9)**

Communication protocol before change: CH1 and CH2 are other than the predefined protocol mode.

Communication protocol after change: CH1 or CH2 is the predefined protocol mode.

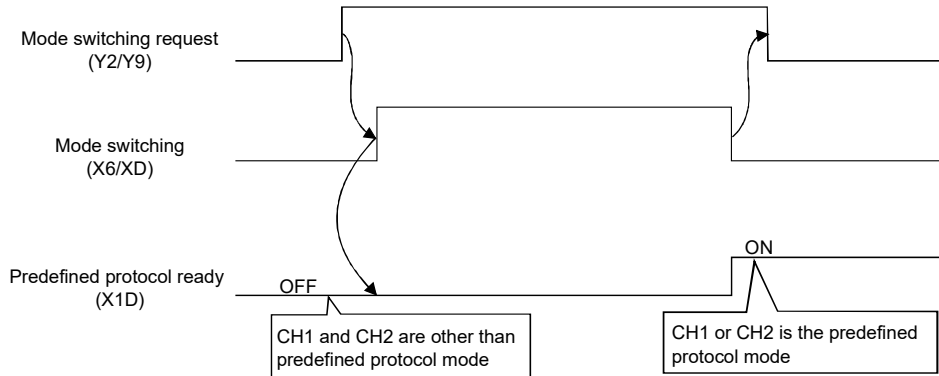

Communication protocol before change: CH1 or CH2 is the predefined protocol mode.

Communication protocol after change: CH1 or CH2 is the predefined protocol mode.

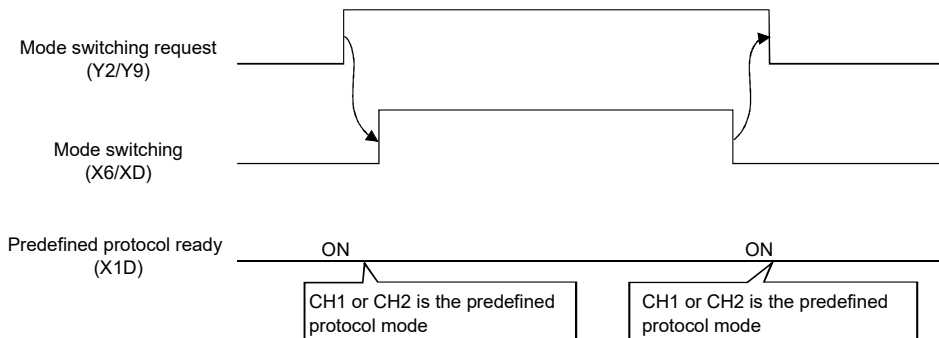

Communication protocol before change: CH1 or CH2 is the predefined protocol mode.

Communication protocol after change: CH1 and CH2 are other than the predefined protocol mode.

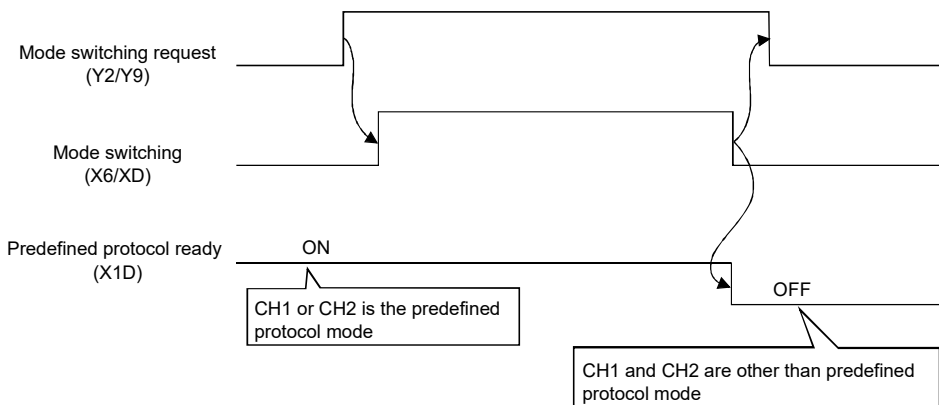

\*1 Based on either of the following condition; the protocol setting data written to the flash ROM are normal, or the protocol setting data are not written to the flash ROM.

**(b) Timing for executing the UINI instruction**

Communication protocol before change: CH1 and CH2 are other than the predefined protocol mode.  
 Communication protocol after change: CH1 or CH2 is the predefined protocol mode.

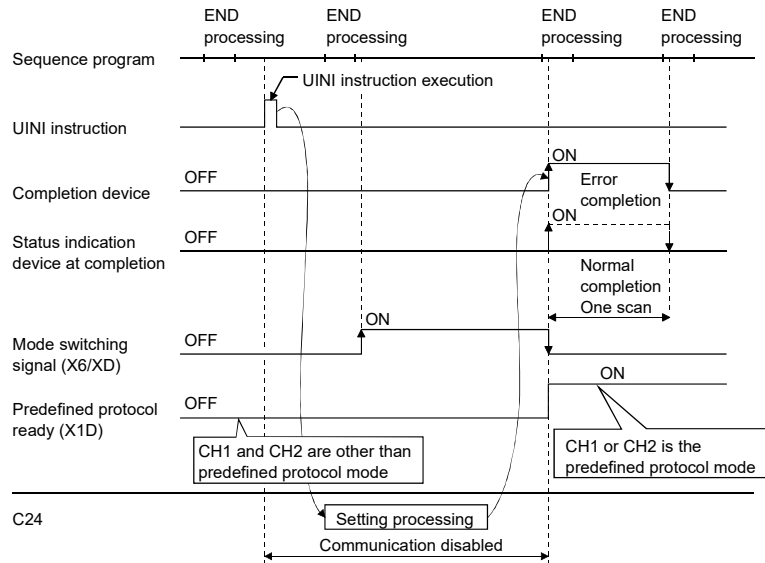

Communication protocol before change: CH1 or CH2 is the predefined protocol mode.  
 Communication protocol after change: CH1 or CH2 is the predefined protocol mode.

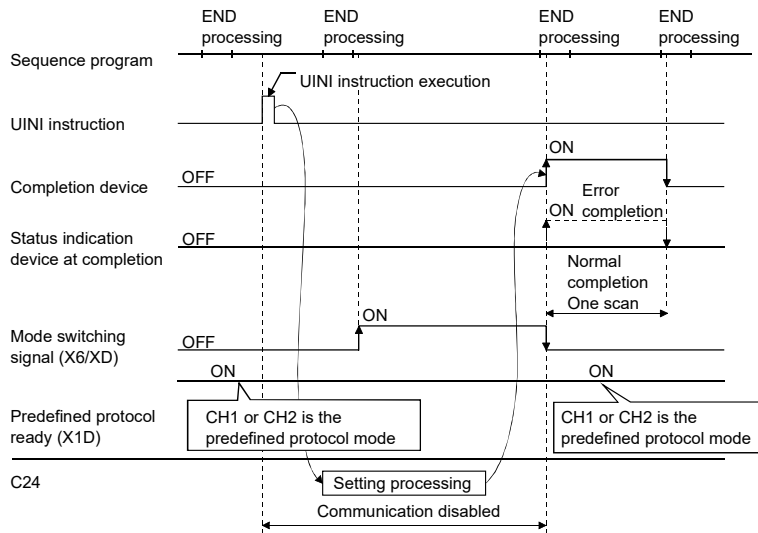



Communication protocol before change: CH1 or CH2 is the predefined protocol mode.

Communication protocol after change: CH1 and CH2 are other than the predefined protocol mode.

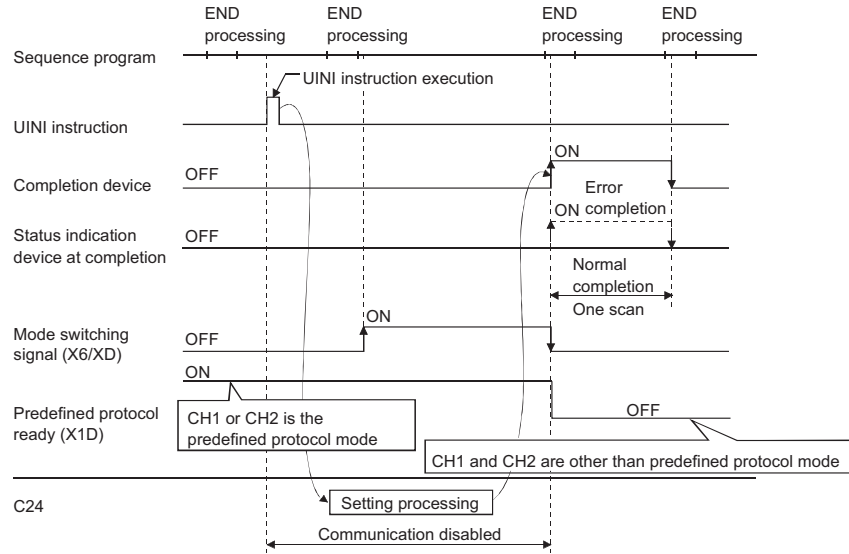

## 9.5 Programming Example

---

This section explains the programming examples and setting examples of the predefined protocol function. GX Works2 is used for the settings. Serial communication module LJ71C24 and Mitsubishi inverter (FREQROL-A700, described as inverter or FR-A700 hereafter) as a connection target device are used in this setting example.

### 9.5.1 System configuration/wiring example

---

The system configuration and wiring example are as follows.

#### (1) System configuration example

In the example, the LJ71C24 is assigned to the I/O numbers X/Y00 to X/Y1F and connected to external device in 1:1 via RS-422/485.

For details of the system configuration, refer to  Page 38, CHAPTER 5.

## 9.5.2 Communication data

In the program example, the predefined protocol communication described below is performed between LJ71C24 and the target device.

### (1) Target device and protocols

Connect the LJ71C24 and the inverter and read out the operation mode values of the inverter.

Set the inverter station number to CPU device (D300) and send it, and store the operation mode value in CPU device (D201).

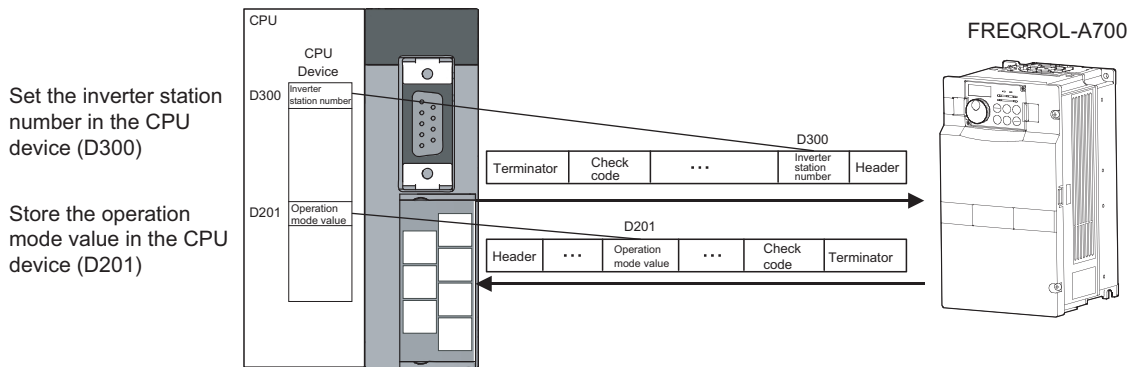

Manufacturer	Mitsubishi Electric
Device name	FR-A700
Protocol name	H7B:RD Operation Mode

### (2) Storage devices for send/receive data, buffer memory assignment

Specify the device memory of a CPU module and buffer memory as the data storage areas as shown in the table below, and send/receive data.

Packet name	Element name	Packet type	Data storage area specification
H7B:RD Operation Mode	Inverter Station Number	Send packet	D300
NOR:RD Data(4 Digits Data)	Inverter Station Number	Receive packet	D200
	Read Data		D201
ERR:NAK Response	Inverter Station Number	Receive packet	D202
	Error Code		D203

## 9.5.3 Communication settings

### (1) Settings on GX Works2

This section explains the settings required for executing the predefined protocol communication on GX Works2. For details, refer to  Page 73, CHAPTER 7.

#### (a) Addition of new modules and I/O assignment

For adding new modules, add an intelligent function module to a project.  
For I/O assignment settings, set each module type and I/O signal range.

##### 1. Display the "New Module" screen.

 Project window ⇒ [Intelligent function module] ⇒ Right click ⇒ [New Module]

##### 2. Set the following items and click the "OK" button.

[Display/Setting screen]

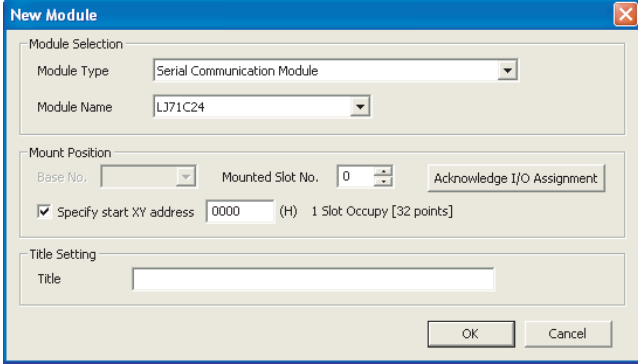

[Display/Setting details]

Item		Setting details
Module Selection	Module Type	Set "Serial communication module".
	Module Name	Set "LJ71C24".
Mount Position	Mounted Slot No.	Set "0".
	Specify start XY address	Set "0000".

##### 3. Display the screen to set the I/O assignment.

 Project window ⇒ [Parameters] ⇒ [PLC parameters] ⇒ [PLC system setting] ⇒ "I/O assignment"

##### 4. Set the start I/O number to "0020", and click the "End setup" button.

For details of setting method for the start I/O number, refer to  MELSEC-L CPU Module User's Manual (Function Explanation, Program Fundamentals).

**(b) Switch settings**

Set the transmission specifications and communication protocols with external devices.

**1. Display the "Switch Setting" screen.**

 Project window ⇒ [Intelligent Function Module] ⇒ Module model name ⇒ [Switch Setting]

**2. Set the following items and click the "OK" button.**

[Display/Setting screen]

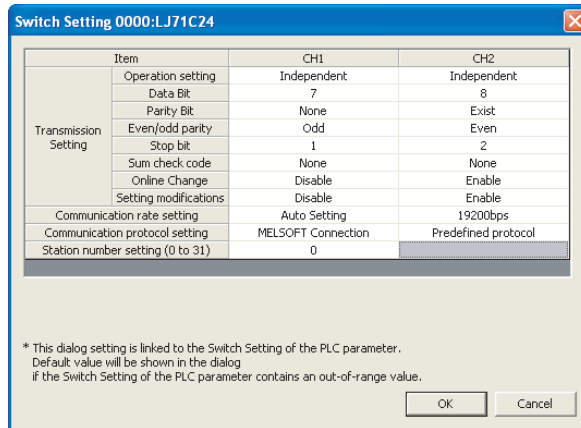

[Display/Setting details]

Configure the settings for CH2 as the screen above.

For CH1, the default values can be used.

## (2) Settings for the predefined protocol support functions

Set the protocol explained in  Page 137, Section 9.5.2.

1. GX Works2 ⇒ [Tool] ⇒ [Intelligent Function Module Tool] ⇒ [Serial Communication Module] ⇒ [Predefined Protocol Support Function]
2. "Predefined Protocol Support Function" screen ⇒ [File] ⇒ [New]

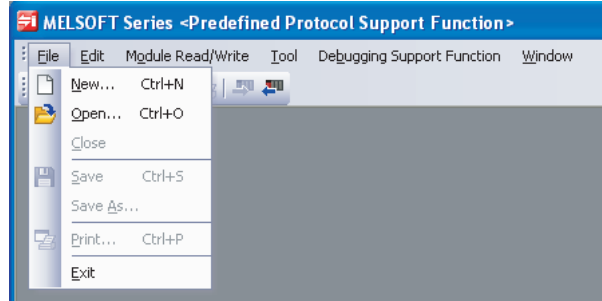

3. Click "Add" for "Protocol No." in the "Protocol Setting" screen.

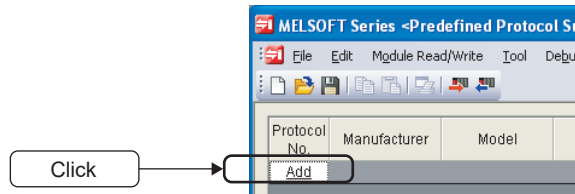

4. The "Add Protocol" screen is displayed.

Select the following protocol, and click the "OK" button.

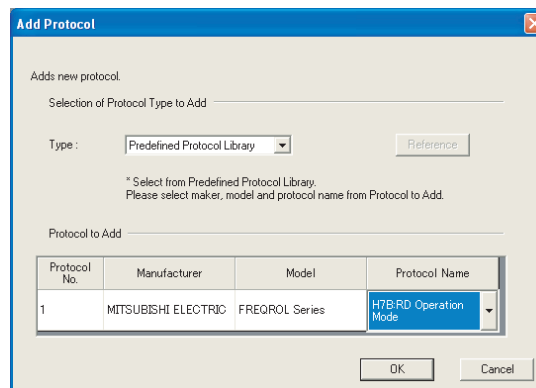

5. The "Protocol Setting" screen is displayed.

Click the cell under "Packet Setting" (displayed in red) of "Packet Name" H7B:RD Operation Mode.

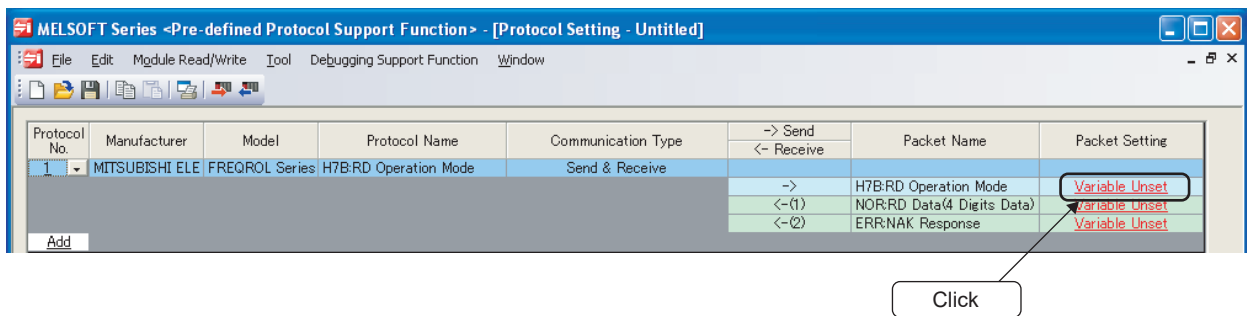

6. In the "Packet Setting" screen, click the cell under "Element Setting" (displayed in red) of "Element No." 2.

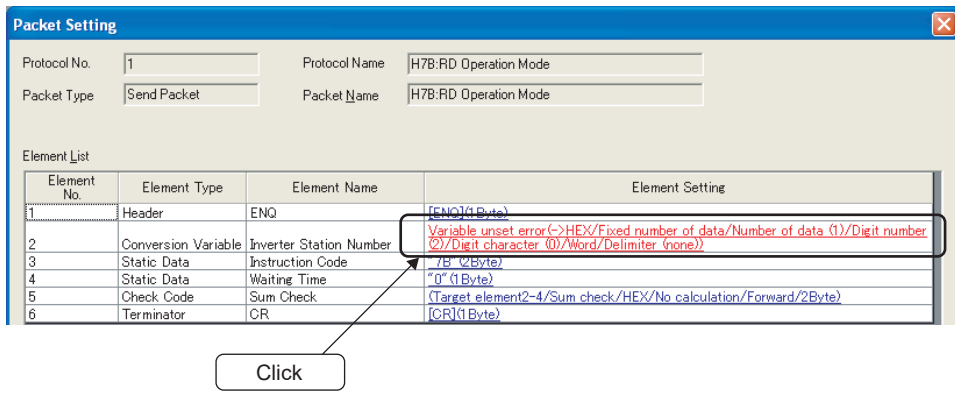

7. In the "Element Setting" (Conversion Variable) screen, enter D300 to "Send Data Storage Area" and click the "OK" button.

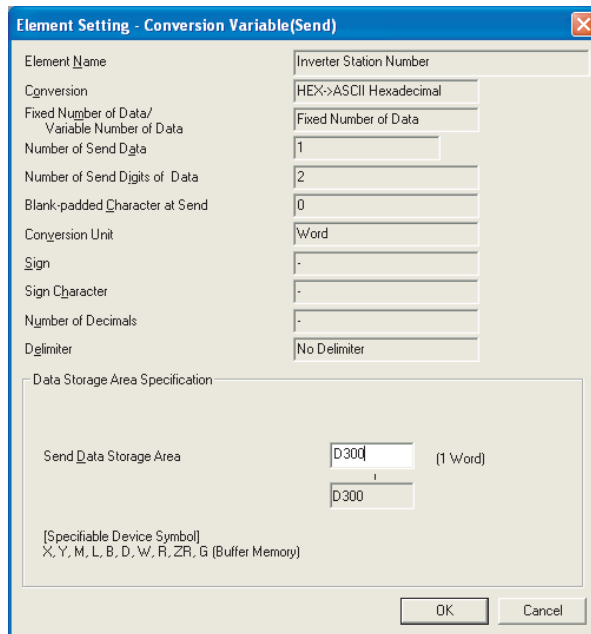

8. The packet setting for "Packet Name" H7B:RD Operation Mode is completed in the "Packet Setting" screen. Click the "Close" button.

**9. Configure the packet settings for "Packet Name" NOR:RD Data (4 Digits Data) and ERR:NAK Response with the same procedure as 5) to 8).**

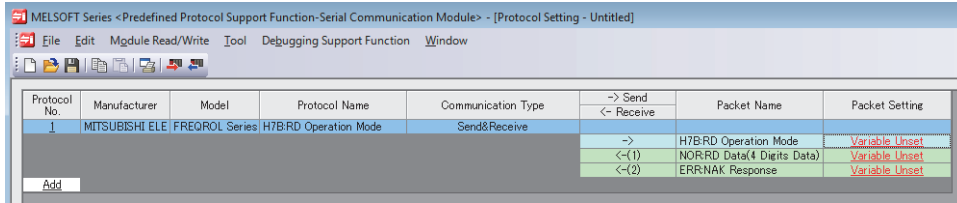

Set the following values for the data storage area.

Packet name	Element number	Element name	Data storage area specification
NOR:RD Data (4 Digits Data)	2	Inverter Station Number	D200
	3	Read Data	D201
ERR:NAK Response	2	Inverter Station Number	D202
	3	Error Code	D203

**(3) Writing data to module**

1. "Predefined Protocol Support Function" screen ⇒ [Module Read/Write] ⇒ [Write to Module]
2. Select the following module and click the "Execute" button.

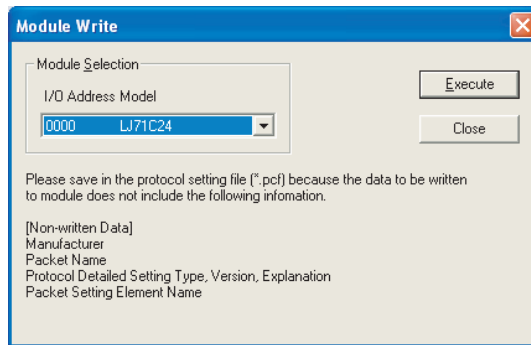

3. The following confirmation message is displayed when writing the protocol setting data to the module is completed.

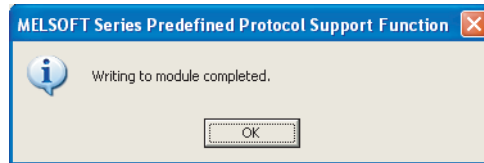



**(4) Executing the protocols (program example)**

Create a program with the dedicated instruction (CPRTCL instruction) using GX Works2.

Switch the CPU to RUN, and execute the registered protocol by the dedicated instruction (CPRTCL instruction).

The following table shows the devices to be used.

**(a) I/O signal of LJ71C24**

Predefined protocol ready: X1D

**(b) Devices used in program example**

Device	Purpose	Device	Purpose
X20	CPRTCL instruction execution command	M1	Status display device at completion
D300	Inverter Station Number designation device	M101	Normal completion flag
D10	Execution result storing device for the CPRTCL instruction	M102	Error completion flag
D12	Execution protocol number designation device	D100	Error code storing device
M0	Completion device	—	—

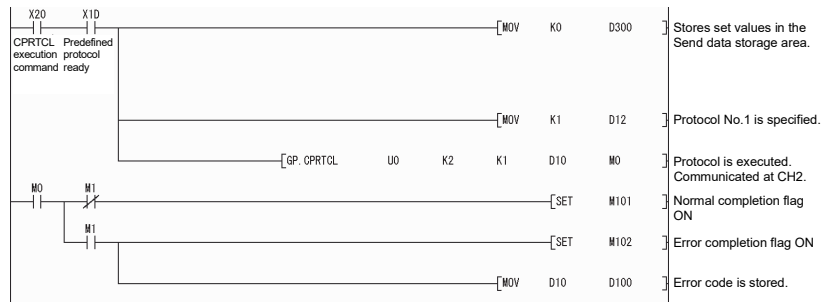

Receive data are stored to the receive data storage area (D200 to D203) that is set to the receive packet.

## (5) Checking protocol execution result

### (a) Check on the "Circuit Trace" screen.

The send/receive packets and communication control signals can be checked from the displayed trace result.  
For details, refer to  Page 243, Section 13.1.

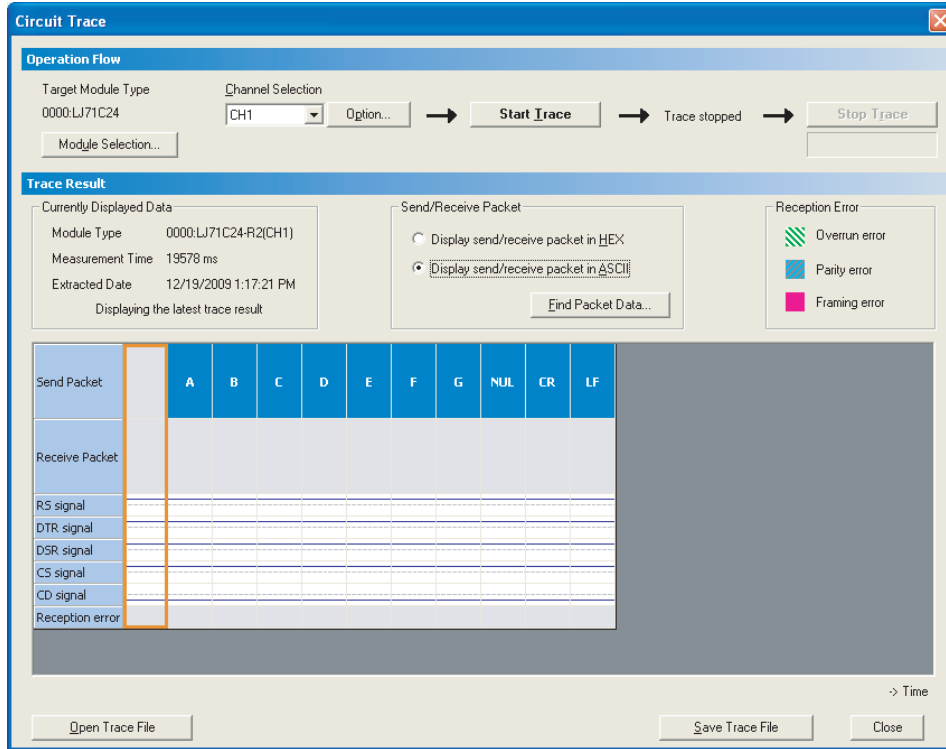

**(b) Check on the "Protocol execution log".****1. Display the "Protocol execution log" screen.**

 "Predefined Protocol Support Function" screen ⇒ [Debugging Support Function] ⇒ [Protocol Execution Log]

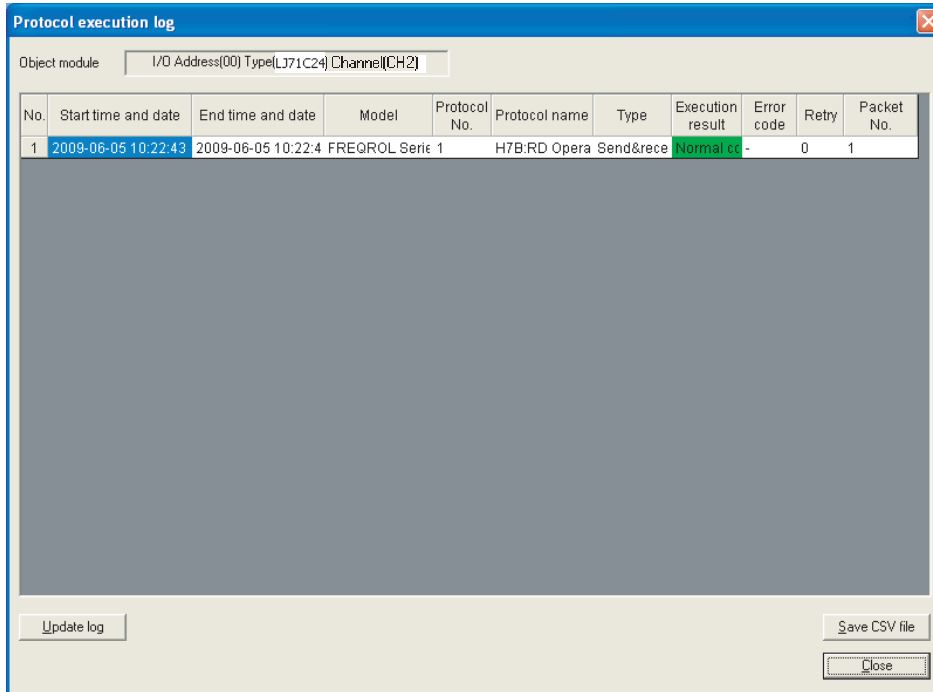
**2. The protocol execution result can be checked.****Point**

The logs displayed in the "Protocol execution log" screen can be selected from the following according to the log registration condition.

- Only the failed protocols are displayed.
- The execution status and log of all protocols are displayed.

For the selecting method of the log registration condition, refer to  Page 254, Section 13.3.

# CHAPTER 10 DATA COMMUNICATION USING THE NONPROCEDURAL PROTOCOL

---

Nonprocedural protocol enables to send and receive data between a CPU module and an external device, using the data format and transmission control procedure set by user.

A sequence program for data communication is required on the CPU module side.

Use this protocol for data communication using any given data format.

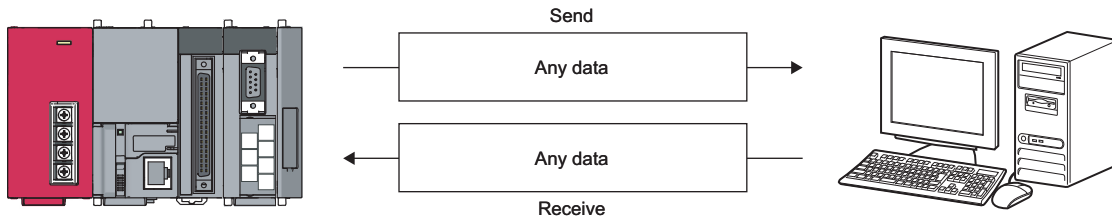

## *Point*

The predefined protocol is recommended for data communication appropriate to the protocol of the external device, such as a measuring instrument or barcode reader.

Communication programs using the nonprocedural protocol can be easily replaced with those of the predefined protocol by the predefined protocol support function of GX Works2.

With the predefined protocol, programs can be run only by starting communication according to the specified protocol, and this can reduce the number of steps considerably.

For the communication using the predefined protocol, refer to  Page 108, CHAPTER 9.

---

# 10.1 Data Reception from the External Device

This section explains the data reception from the external device.

## 10.1.1 Receiving methods

The following shows the methods for receiving data in any format using the nonprocedural protocol. There are three methods for receiving data: the "reception by the receive complete code" for receiving variable length messages, and the "reception by the receive data count" for receiving fixed length messages, and the "reception by a timeout of the no-reception monitoring time (timer 0)" for the case when the receive complete code and receive data count have not been determined. The receive complete code and received data count used for data reception can be changed to any setting values by the user using GX Works2.

Method	Application
Reception by the receive complete code	Receives variable length messages.
Reception by the receive data count	Receives fixed length messages.
Reception by a timeout of the no-reception monitoring time (timer 0)	Receives a message of which the receive complete code and receive data count have not been determined. For a specification of the non-reception monitoring time (timer 0), refer to the following section. ☞ User's Manual (Application)

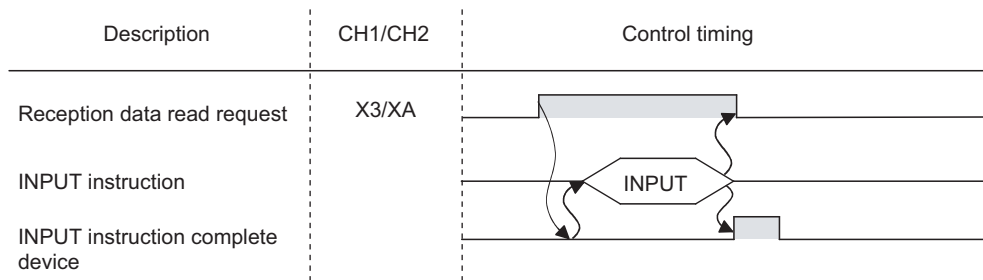
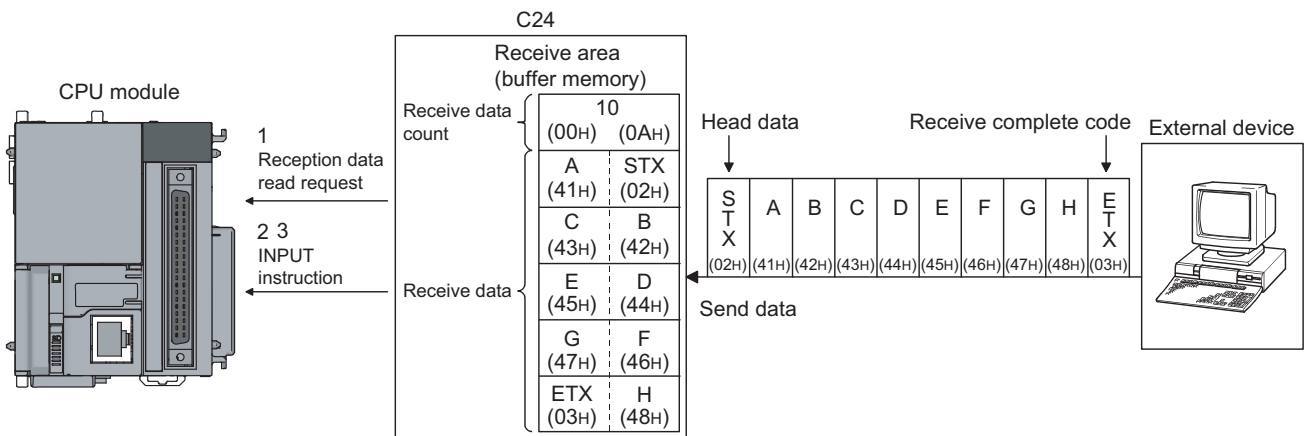

1. When data are received from the external device using either "reception via receive complete code" or "reception via received data count" method, the reception data read request (X3/XA) turns ON.
2. Control data are stored in the device designated with the INPUT instruction.
3. When the INPUT instruction is executed, receive data is read from the reception data storage area of the buffer memory.

## (1) Data reception by receive complete code (for variable length reception)

- This method is used to send data by adding the receive complete code set in the C24 at the completion of setting the message from the external device.
- When the C24 receives the receive complete code data preset in GX Works2 by the user, it sends a receive data read request to the sequence program.
- The read request from the C24 allows the sequence program to read the receive data up to the receive complete code received from the external device.
- The receive complete code can be changed to match the specifications of the external device. An arbitrary 1-character (1-byte) code within the 00<sub>H</sub> to FF<sub>H</sub> range can be designated.
- The C24 issues a receive data read request to the CPU module as follows, according to the set value of the receive complete code.

### (a) When receive complete code not changed (Default value: 0D0A<sub>H</sub>)

(CR+LF is added to the end of the message and sent from the external device.)

- If LF is received within the time set in the no-reception monitoring time (timer 0) after CR is received, the C24 stores the receive data up to CR+LF to the buffer memory receive data storage area and turns on the reception data read request (X3/XA) to the CPU module.

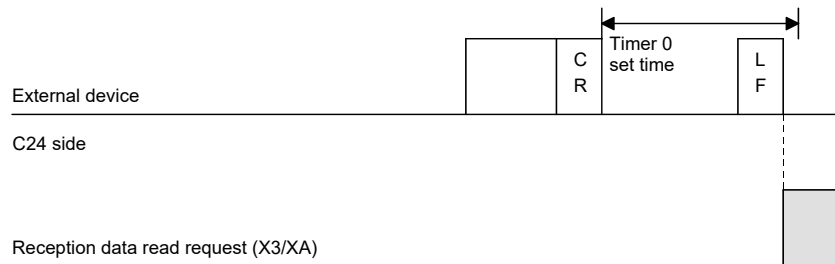

- If LF is not received within the time set in the non reception monitoring time (timer 0) after CR is received, the C24 stores the received data up to CR to the buffer memory receive data storage area and turns on the following signals to the CPU module.

When nonprocedural and non reception monitoring time format is 0: Reception abnormal detection (X4/XB)

When nonprocedural and non reception monitoring time format is 1: Reception data read request (X3/XA)<sup>\*1</sup>

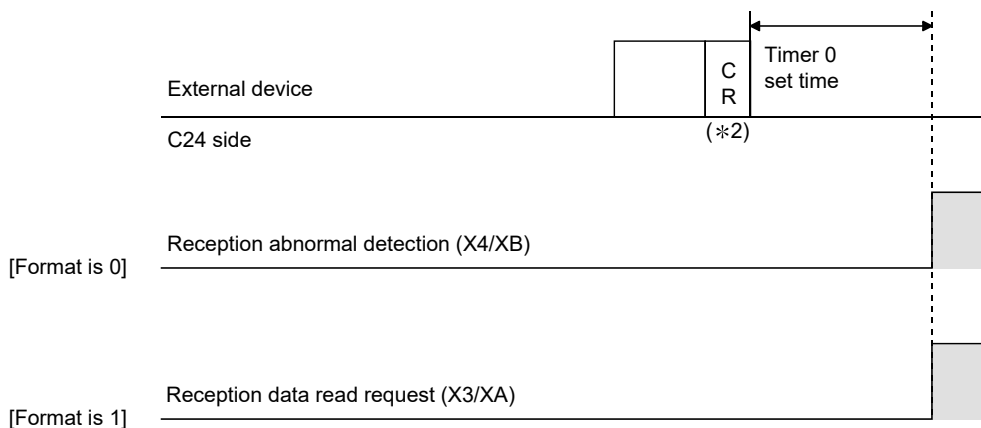

- \*1 In nonprocedural protocol, a message is received by the increase in non reception monitoring time (timer 0) if the received complete code and the received data count are not decided.  
For the nonprocedural protocol at the non reception monitoring time format, refer to User's Manual (Application).
- \*2 CR is handled as 1-byte data in the message.

### (b) When the receive complete code is changed and an arbitrary code is designated (00□□<sub>H</sub> designated)

(User defined receive complete code data is added to the end of the message and sent from the external device).

When the C24 receives the receive complete code data changed by the user, it stores the receive data up to the receive complete code to the buffer memory receive area and turned on the reception data read request (X3/XA) to the CPU module.

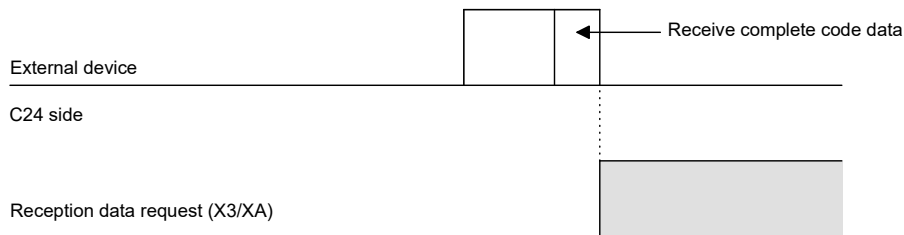

### (c) When the receive complete code is not designated (FFFFH designated)

Reading by the received data count is enabled.

Refer to Page 149, Section 10.1.1 (2) for a description of reading by the received data count.

## (2) Reception by received data count (For fixed length reception)

- This method is used to receive messages of the same length (size) from the external device every time.
- When the C24 receives data of the received data count preset in GX Works2 by the user, it sends a reception data read request to the sequence program.  
Upon a read request by the C24, sequence program data can be read for the amount of the data received from the external device.
- The received data count default value is set to 511 (words). However, it can be changed within the size of the receive data storage area depending on the data contents exchanged with the external device.

### Point

- When the receive complete code and received data count are set to GX Works2, both become valid.  
In this case, if the C24 receives the receive complete code before receiving data that are equivalent to the receive data count, Reception data read request (X3/XA) is set to ON.
- The receive complete code and received data count can be changed in the following items of GX Works2.  
[Various\_Control\_Specification] screen ⇒ "For data reception" ⇒ "Receive complete code designation" or "Received data count designation"  
For details, refer to Page 75, Section 7.2.

## 10.1.2 The receive area and the received data list

The following shows the list of the receive area and the receive data for performing data reception using the nonprocedural protocol.

### (1) Receive area

The receive area is a memory area for storing the data received from the external device and the receive data count in order to read the receive data to the CPU module.

By default, the receive area is assigned to addresses 600<sub>H</sub> to 7FF<sub>H</sub> (CH1 side) and A00<sub>H</sub> to BFF<sub>H</sub> (CH2 side).

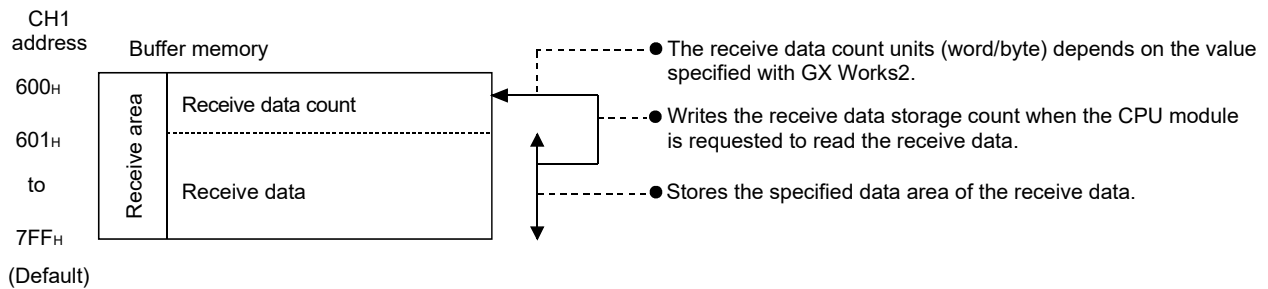

### Point

- The position and size of the receive area in the buffer memory can be changed with the GX Works2 in accordance with the specifications of the external device and the receive data length. (Refer to Page 75, Section 7.2)
  - When changing the position and size of the receive area in the buffer memory with GX Works2, specify as follows:
    - [Various\_Control\_Specification] screen ⇒ "For designation of reception area" ⇒ "Receive buffer memory head address designation"  
Designate the starting address for the area to be used as the receive area in the user setting area (address: 400<sub>H</sub> to 1AFF<sub>H</sub>, 2600<sub>H</sub> to 3FFF<sub>H</sub>).
    - [Various\_Control\_Specification] screen ⇒ "For designation of reception area" ⇒ "Receive buffer memory length designation"  
Designate by address the length of the area (0001<sub>H</sub> to 1A00<sub>H</sub>) to be used as the receive area in the user setting area (address: 400<sub>H</sub> to 1AFF<sub>H</sub>, 2600<sub>H</sub> to 3FFF<sub>H</sub>).
  - When changing the position and size of the receive area in the buffer memory, if any of the functions below are used concurrently, make sure that the addresses of the receive area do not overlap with the buffer memory addresses assigned for storing transmission/receive data with the functions.
    - MC protocol buffer memory read/write function
    - MC protocol on-demand function
    - Predefined protocol function (transmission/reception data storage area)
    - Nonprocedural protocol transmission/receive function
    - Bidirectional protocol transmission/receive function
    - Communication data monitoring function
- Set the size of data per data transmission from the external device to the C24 so that it is equal to or smaller than the size of the receive data storage area in the buffer memory.  
(Receive data storage area) ≥ (Size of data in any data section to be sent from the external device)  
To transmit data whose size is larger than the receive data storage area, increase the receive area, or divide the transmission data before sending.



## (2) Receive data list

The following describes the data list when data received from an external device is stored to the receive area.

- The receive message is stored to the C24 buffer memory (receive data storage area).
- The data is stored to the receive data storage area in the order of low address (L) → (H), next address (L) → (H).

Under the following conditions, when the receive data count is an odd byte, 00<sub>H</sub> is stored in the upper byte of the final data storage position:

- When the unit for the received data count is designated in bytes.
- When data reception is performed using the receive complete code.

**Ex.** When receive data "ABCDEFG123" was stored (The receive area is the default.)

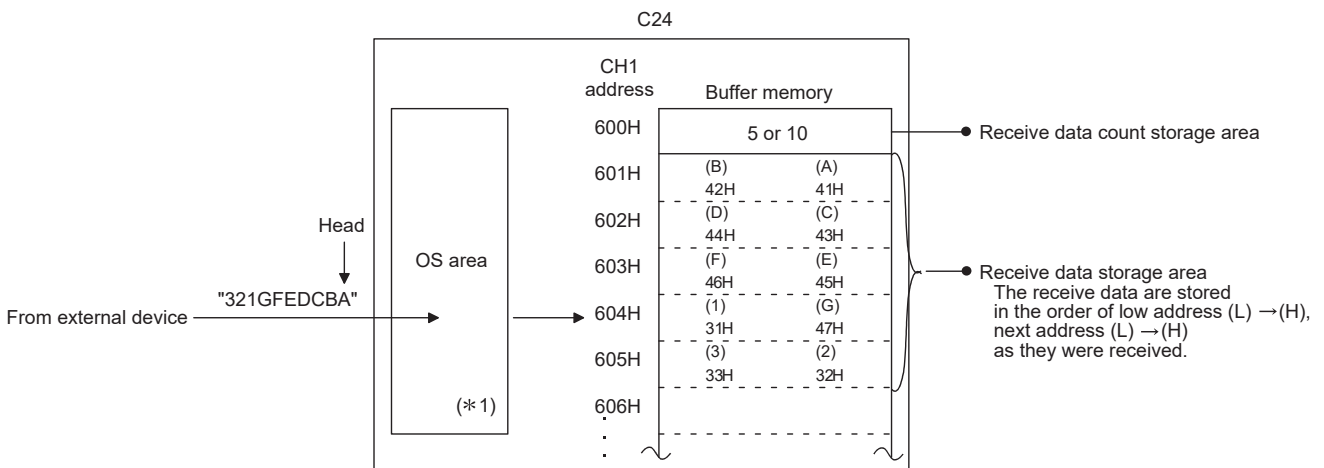

\*1 The OS area of the C24 shown in the above figure is the memory (8448 bytes) that temporarily stores the data to be received while a request for the reading of the receive data is being made to the CPU module. (The user cannot read the receive data in the OS area).

When the sequence program finishes reading the receive data in the buffer memory in response to the read request, the receive data in the OS area, and any succeeding receive data, is stored successively in the receive area of the buffer memory when the next read request is issued.

Also, when the OS area's free space, which stores the receive data, is reduced to 64 bytes default value or less, a request to discontinue data reception from the external device is issued by the following transmission control (the RS(RTS) signal does not turn OFF):

- When DTR control is set, the ER(DTR) signal turns OFF.
- When DC1/DC3 control is set, DC3 is sent.

When there is no more free space in the OS area to store receive data, an SIO error occurs and the SIO information bit in the LED ON status and communication error status (address: 201<sub>H</sub>/202<sub>H</sub>) in the buffer memory turns ON. In that case, succeeding receive data is discarded until a free space becomes available in the OS area.

\* For more details on the transmission control, refer to User's Manual (Application).

**Remark**

- Data reception when: Receive data storage area > Receive data length  
The following control is performed.

**Ex.** When data of 511 words or less is received by the CH1 side interface on the condition that the receive area for the CH1 side interface is at addresses 600<sub>H</sub> to 7FF<sub>H</sub> (default values)

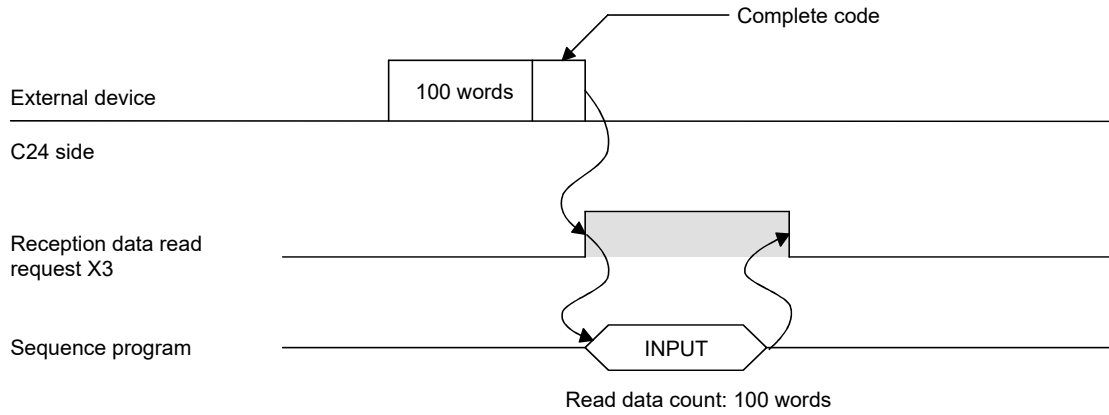

- Data reception when: Receive data storage area < Receive data length  
Since the following control is performed, data link processing is required in the sequence program.
  - Reception using the complete code

**Ex.** When the receive area for the CH1 side interface is at addresses 600<sub>H</sub> to 7FF<sub>H</sub> (default values), and data of 534 words is received by the CH1 side interface.

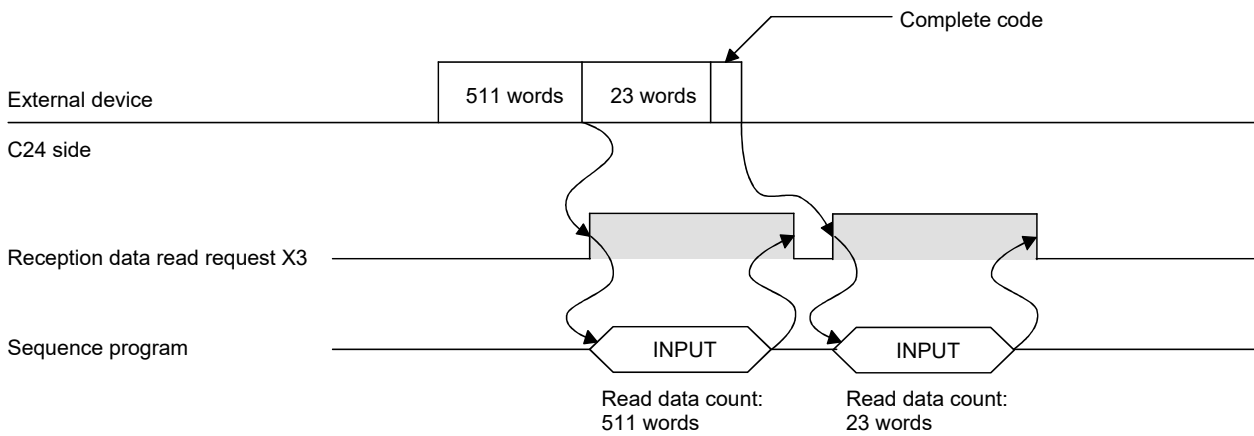

- Reception by received data count  
 If a specified receive data count is too large for the receive data storage area, Receive buffer memory length (address: A7<sub>H</sub>/147<sub>H</sub>, default: 512 words) minus 1 is used as the receive data count instead.  
 (Receive data storage area) > (Data length received from external device)

**Ex.** When 550 words of data is received through the CH1 interface in three parts when the CH1 interface receive area consists of addresses 600<sub>H</sub> to 7FF<sub>H</sub> (default value)

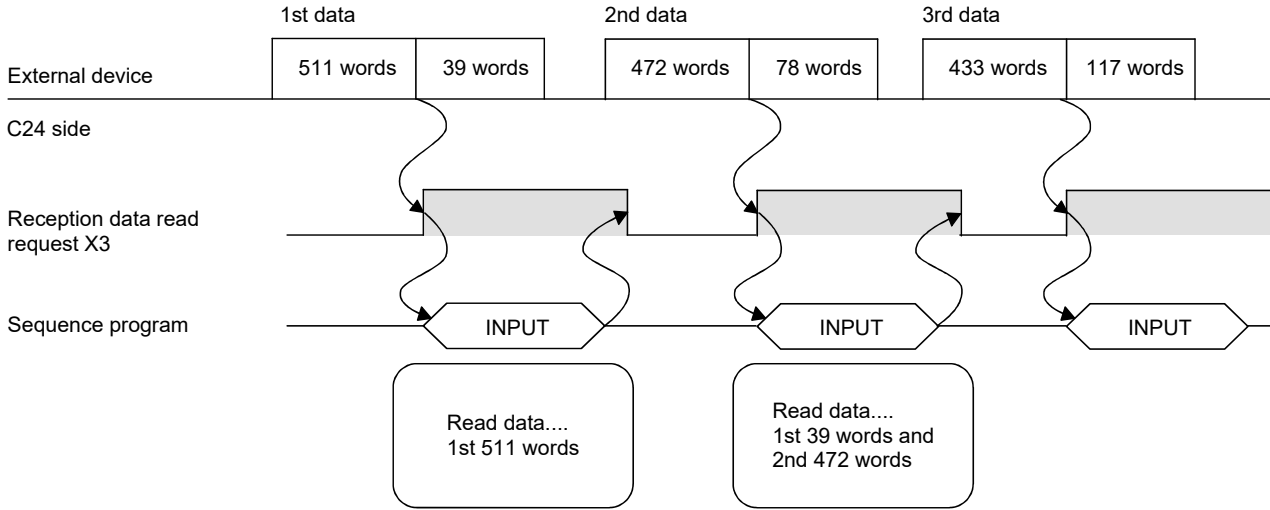

10.1 Data Reception from the External Device  
 10.1.2 The receive area and the received data list

# 10.1.3 Sequence program for data reception

This section explains the sequence program for data reception.

For details on the INPUT instruction for data reception, refer to  Page 206, CHAPTER 12.

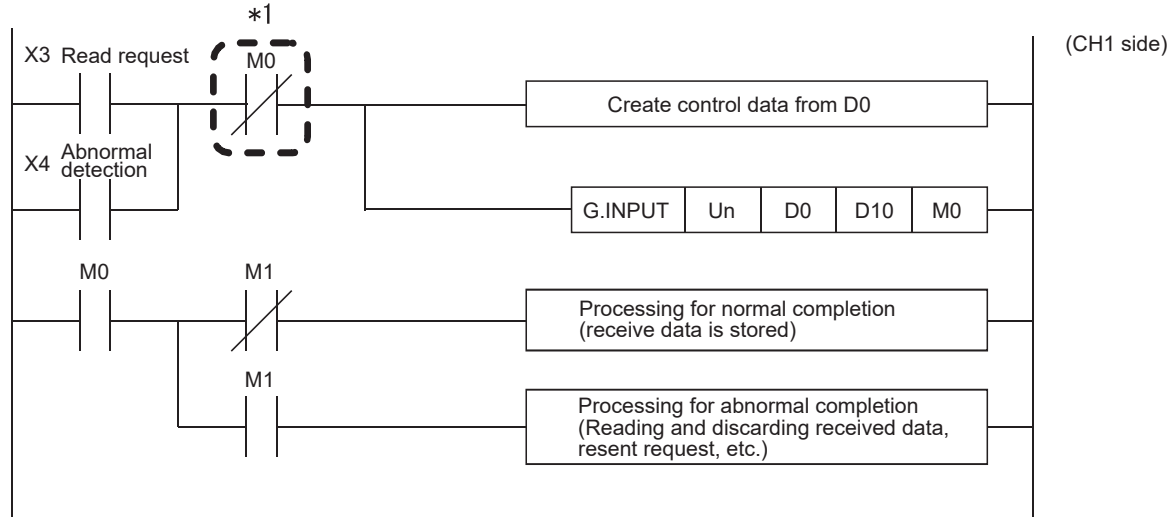

\*1 When the completion device is off, execute the INPUT instruction.  
If the INPUT instruction is executed when the completion device is on, data may not be received properly.

(CH1 side)

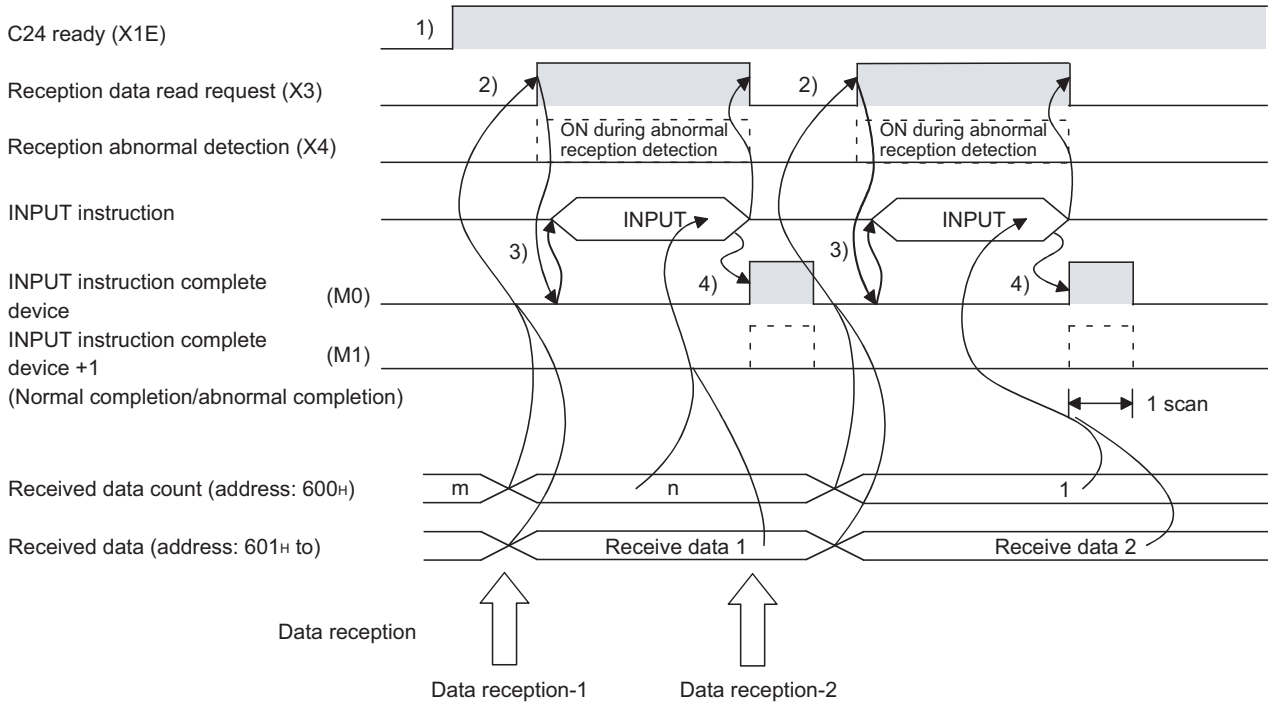

- 1. Start the self-station programmable controller CPU.**  
The values specified with GX Works2 are stored in the C24.
- 2. When the amount of data specified by the received data count or data containing the receive complete code is received from the external device, the reception data read request (X3) turns ON.**
- 3. After the control data for the INPUT instruction is stored in the device, the sequence program executes the INPUT instruction and reads the receive data.**  
Before executing the INPUT instruction, check that the INPUT instruction complete device (M0) is off.
- 4. The INPUT instruction complete device turns ON when the reading of receive data is completed.**  
When the complete device + 1 (abnormal completion signal) turns ON, the error code is stored in the control data completion status (S1 + 1).

(Program example)

When the I/O signals of the C24 are from X/Y00 to X/Y1F:

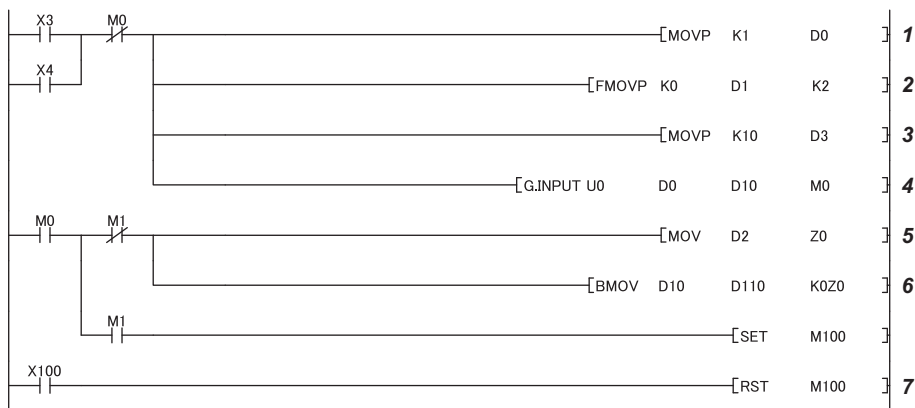

- 1. Specify the receive channel.**
- 2. Clear the reception result and receive data count storage device to 0.**
- 3. Specify the allowable receive data count.**
- 4. Store the receive data in the specified device.**
- 5. After completed, the receive data within the allowable receive data count (user-specified) is read from the receive data storage area in the buffer memory.**  
Once the INPUT instruction is executed, the read completion signal (M0) specified by user turns ON for one scan.
- 6. The receive data of the receive data count is transferred to D110.**
- 7. The abnormal completion flag is reset by an external command.**

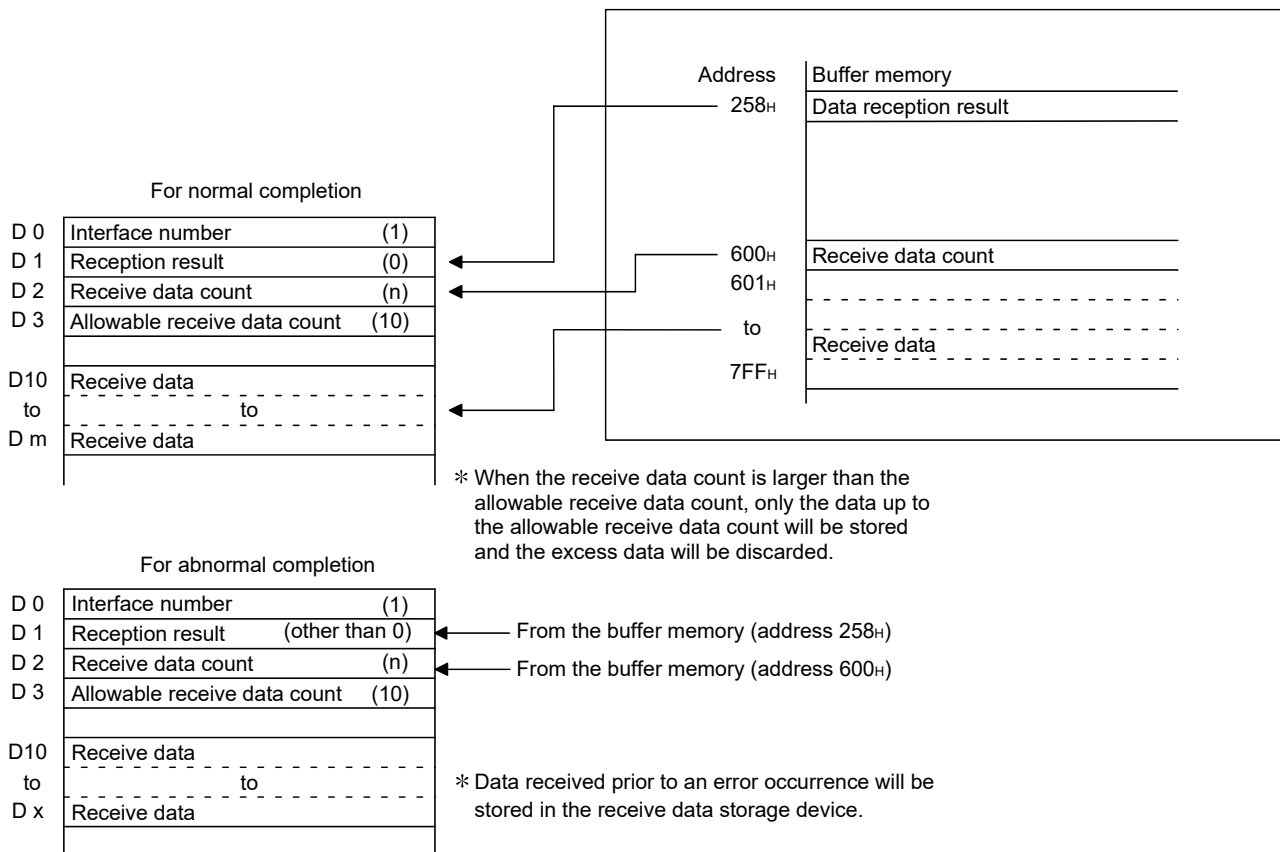

## Point

- Receive data can also be read using interrupt programs.  
For details on reading receive data with interrupt programs, refer to User's Manual (Application).  
Note that if the reading of data received from the same interface is to be performed, it is not possible to combine the reading of data received by the main program and reading of data received by the interrupt program.  
Accordingly, either of the above program to read the data received.
- The SPBUSY instruction is used to read the execution status when using a dedicated instruction. (Refer to Page 206, CHAPTER 12.)
- More than one INPUT instruction cannot be executed simultaneously.  
Execute the next INPUT instruction only after the execution of the first INPUT instruction is completed.
- When the communication data count is set in word units, and if the received data count is an odd byte when requesting the reading of received data to the CPU module, the receive data count is processed as follows:  
Receive data count = Receive data byte count/2...Fractions following the decimal point are rounded up  
Also, 00<sub>H</sub> is stored in the higher byte of the final data storage position in the receive area where receive data is stored.

## 10.1.4 How to detect and check the reception errors

This section explains how to detect and confirm errors that may occur when receiving data from external devices.

The following items are considered as the primary causes of errors that may occur during data reception.

Cause of reception error	Reference
A transmission error occurred due to noise.	Page 46, Section 6.2, Page 54, Section 6.3
A timeout occurred for the no-reception monitoring time (timer 0).	User's Manual (Application)
Data that could not be converted with the ASCII-BIN conversion was detected.	
Received data larger than the size that could be stored in the OS area of the C24.	Page 150, Section 10.1.2

### (1) Confirmation using the sequence program

#### (a) Detecting a reception error

The following device and input signals turn ON.

- INPUT instruction complete device + 1
- Reception abnormal detection (X4/XB)
- ERR. occurrence (XE/XF)

#### (b) Checking a reception error

The reception error code can be checked using the INPUT instruction control data ((S1) + 1).

Or, it can be checked by reading the data reception result (address: 258<sub>H</sub>/268<sub>H</sub>).

#### **Point**

For details on how to check the error code contents and corrective actions, refer to  Page 262, CHAPTER 15.

## (2) Confirmation using GX Works2, display unit, or indicator LED of C24

The following shows how to confirm the errors.

	Item	Reference
GX Works2	"Module's Detailed Information" screen	Page 262, CHAPTER 15
	"Error History" screen	Page 262, CHAPTER 15
	"Intelligent Function Module Monitor" screen	GX Works2 Version 1 Operating Manual (Intelligent Function Module)
Display unit	Buffer memory monitor	MELSEC-L CPU Module User's Manual (Function Explanation, Program Fundamentals)
Indicator LED of C24	ERR LED turns on	Page 262, CHAPTER 15

## (3) Precautions

The following shows the precautions of receive data when a reception error occurs.

### (a) Storing receive data

The receive data for which an error was detected is discarded and only the normally received data is stored in the C24.

Thus, there may be missing data among the data that has been read to the CPU module when a reception error occurs.

### (b) Reading receive data

When receive data is read to the CPU module by turning the reception abnormal detection (X4/XB) ON, the data that was normally received prior to the error detection is read.

Read and discard receive data as needed.



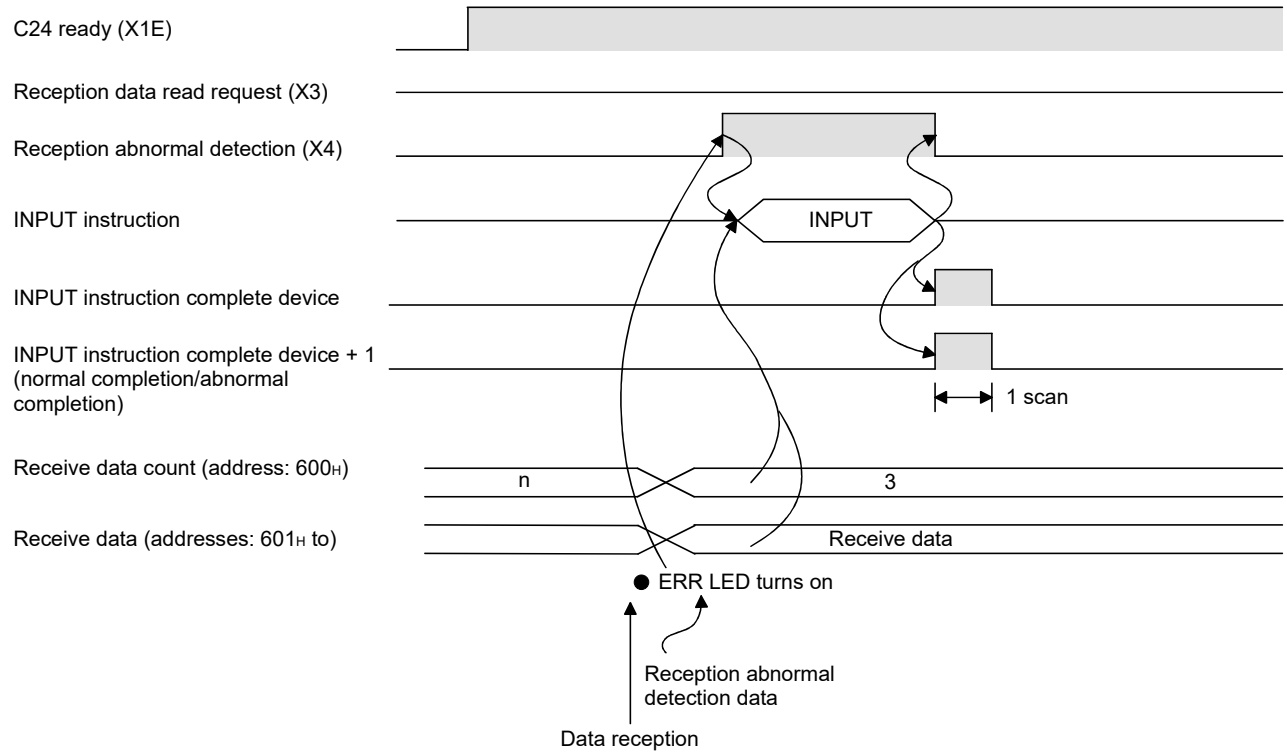
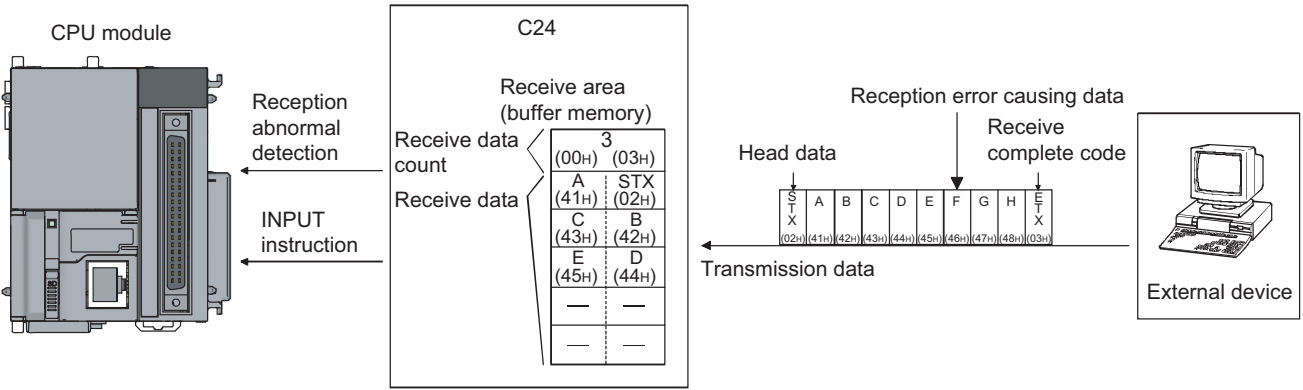

When the data of "G" or later in the reception message shown in the figure above is received normally, the data is stored in the C24 OS area.  
 The receive data stored in the OS area will be read to the CPU module in the next read operation.



## 10.1.5 Receive data clear

---

For the data reception by a nonprocedural protocol, if the transmission of data from a transmitting device is interrupted due to trouble occurring, it may be necessary for the data received up to the present time are cleared in the receiving device and for the data to be received again from the start.

The methods for clearing reception data in the C24 are shown below.

Either method may be used to clear received data as necessary.

- Clear the reception data by the dedicated instruction "CSET.". (Refer to  Page 161, Section 10.1.5 (2).)
- Write to/read from the receive data clear request (address: A8<sub>H</sub>/148<sub>H</sub>).  
(FROM/TO instruction) (Refer to  Page 162, Section 10.1.5 (3).)
- Clear the reception data by GX Works2. (Refer to  Page 165, Section 10.1.5 (4).)

### Remark

When transmitting data to an external device from the C24, do not execute a clear request of the receive data by FROM/TO instruction or GX Works2.

If a receive data clear request is executed when transmitting data to an external device, The C24 stops data transmission and terminates the dedicated instruction for transmission abnormally. (The transmission completed signal does not turn ON.)  
If a receive data clear request is executed during data reception, the data received up to that point are cleared.

### (1) Receive data clear processing

The C24 performs the following processing when the receive data clear is performed.

- The data received up to that point can be ignored.
- The receive data count up to the current point is "0".  
(The receive area in the buffer memory is not initialized).
- Set to the status prior to the start of data reception.

**(2) Procedure for clearing the reception data by the dedicated instruction "CSET"**

This instruction clears the reception data up to the present without interrupting the data transmission processing. (Procedure for clearing)---In the case of the CH1 side interface

- Execute the CSET instruction  
 If the CSET instruction is executed while the reception data read request (X3/XA) or reception abnormal detection signal (X4/XB) is turned on, the CSET instruction is kept waiting until the signal is turned off.
- The receive data clear processing is executed to the OS area of the C24 (Refer to  Page 150, Section 10.1.2).

The following is a program example of clearing the reception data by the dedicated instruction "CSET."

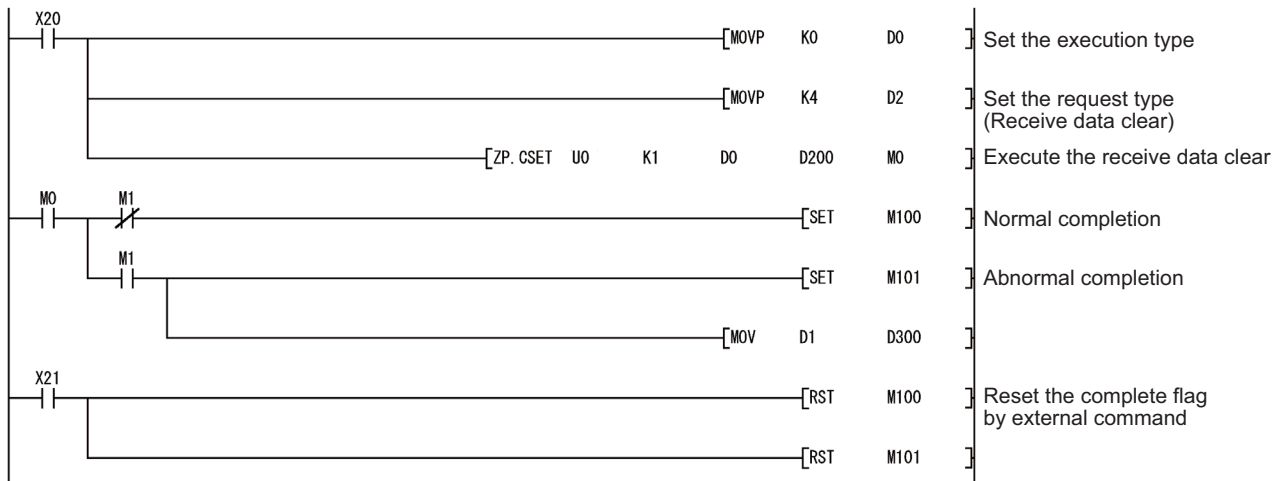

### (3) Receive data clear procedure using FROM/TO instruction

Write and read Receive data clear request (address: A8<sub>H</sub>/148<sub>H</sub>) using the procedure described below.

When resuming data communication with an external device, resume it after completing the receive data clear processing with the C24.

Depending on the data communication system, it may be necessary to restart data communications with the external device after notifying the external device from the CPU module that resumption of communications is possible.

(Clear Procedure)--When the CH1 side interface is used.

1. While none of receiving, sending, and receive data clearing is being performed, with the TO instruction, "1" is written to Receive data clear request (address: A8<sub>H</sub>).
2. Receive data clear processing is performed for the C24's OS area (Refer to  Page 150, Section 10.1.2).
3. When receive data clear processing is completed, Receive data clear request (address: A8<sub>H</sub>) becomes "0".

For an example of a program to clear receive data with the FROM/TO instruction, refer to Page 163, Section 10.1.5 (3) (a).

Create a program that contains the contacts (such as user flags) indicating the following statuses in the TO instruction.

- Contacts indicating that the reception data read request (X3/XA) and reception abnormal detection (X4/XB) are OFF
- Contact indicating that no dedicated instruction (OUTPUT/PRR/INPUT) is currently being executed
- Contact indicating that receive data clear processing is not currently being performed

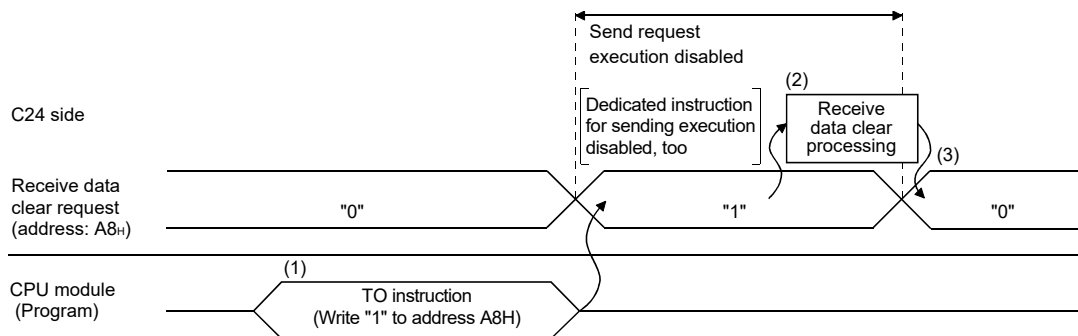

(a) The following is an example program for clearing received data with the FROM/TO instructions while send/receive processing is performed using dedicated instructions (OUTPUT/INPUT).

Ex. (If the C24 input/output signal is X/Y000 to X/Y01F.)

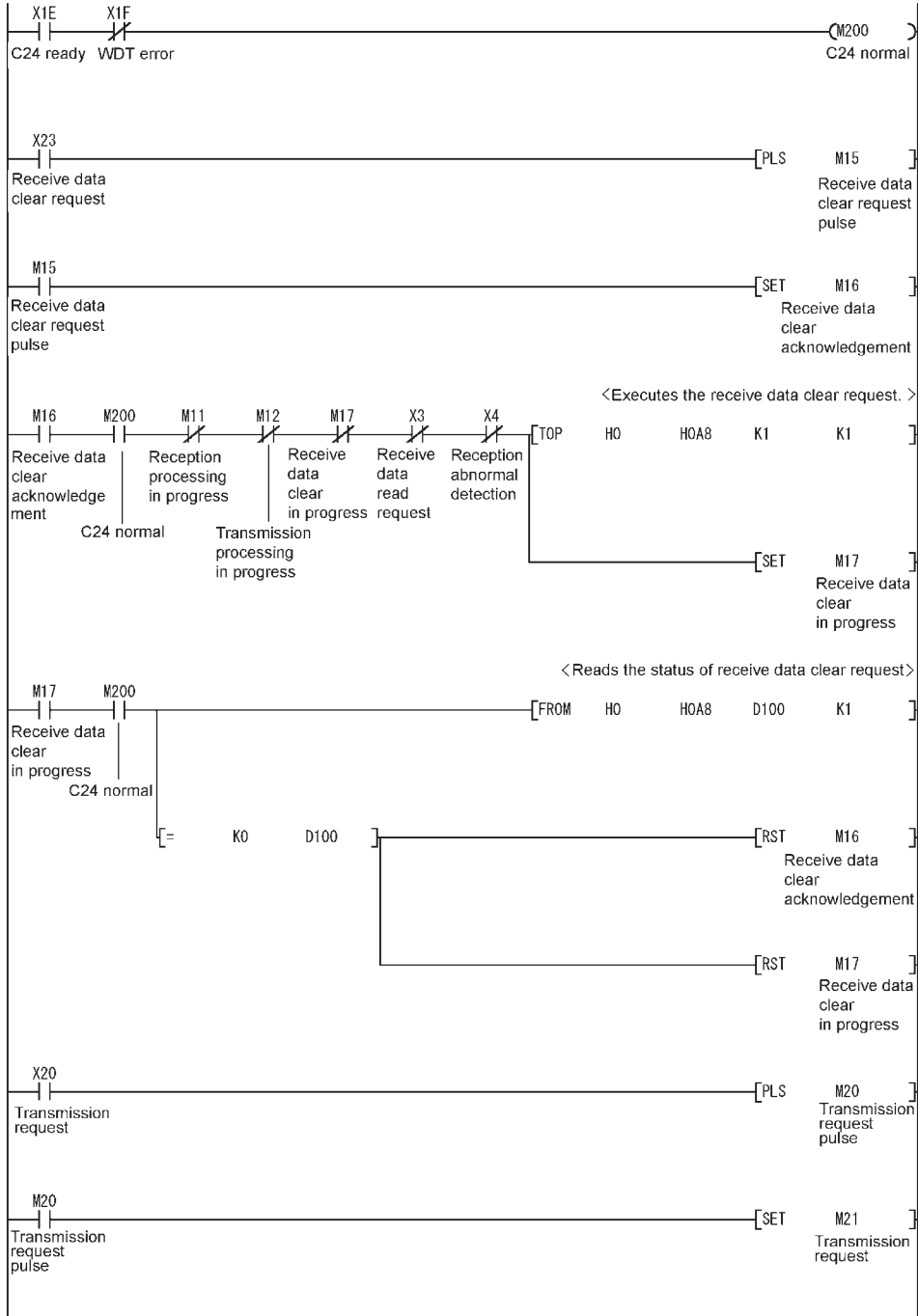

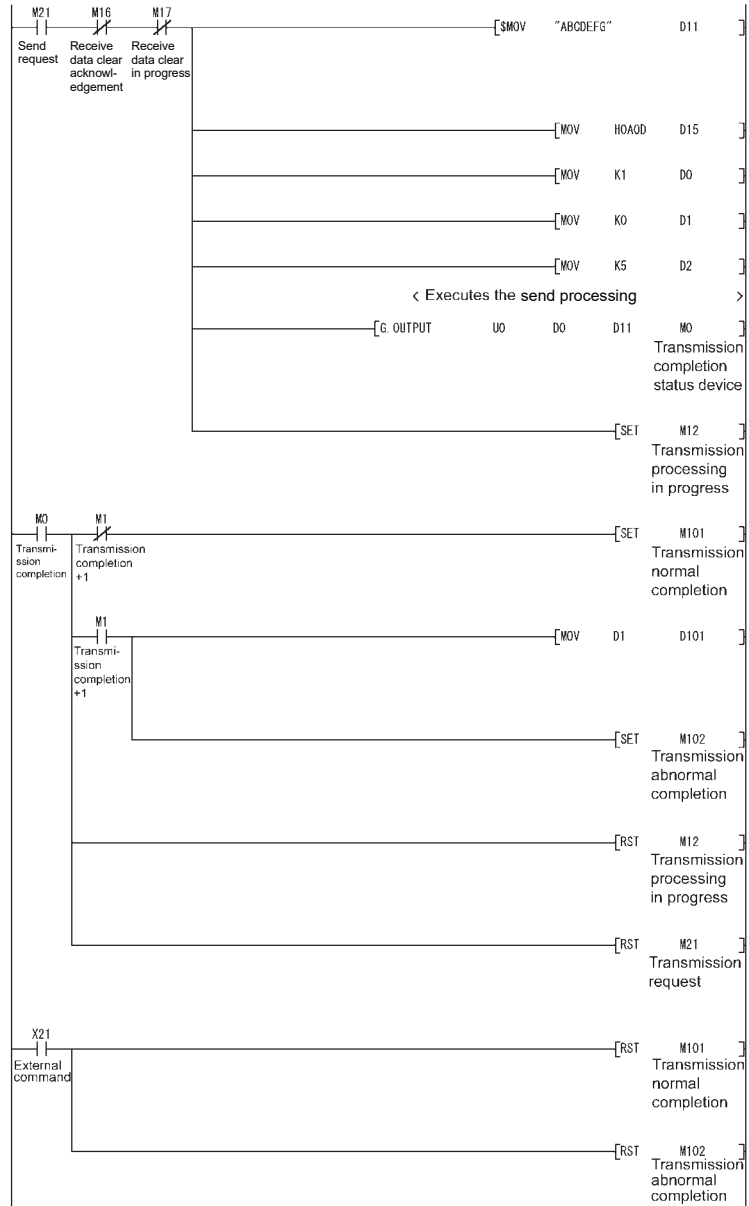

**(4) Receive data clear command procedure using GX Works2****1. Register C24 to "Intelligent Function Module Monitor".**

For the operating method of GX Works2, refer to  GX Works2 Version 1 Operating Manual (Intelligent Function Module).

**2. Set "CH□ Receive data clear request" of "For Data Receiving" to "Requested".****3. The receive data is cleared.**

## 10.1.6 Received data count and receive complete code settings

### (1) Setting method before receiving data

The following default values have been set for the received data count and receive complete code that are used for data reception with the nonprocedural protocol.

The received data count and the receive complete code setting value can be changed by the sequence program before data receive processing. (Refer to  Page 177, Section 10.2.5 (3).)

The default value can be changed in the following items of GX Works2.

[Various\_Control\_Specification] screen → "For data reception" → "Receive complete code designation" or "Received data count designation"

For details, refer to  Page 75, Section 7.2.

Setting data	Default value	Allowable range	Buffer memory address where the setting value is stored	Remarks
Received data count	511 (1FF <sub>H</sub> )	Less than the size of the receive data storage area	A4 <sub>H</sub> /144 <sub>H</sub>	Unit is in accordance with the word/byte units designation
Receive complete code	0D0A <sub>H</sub> (CR+LF)	0000 <sub>H</sub> to 00FF <sub>H</sub>	A5 <sub>H</sub> /145 <sub>H</sub>	When any code is set
		FFFF <sub>H</sub>		When there is no receive complete code



## (2) Setting method after receiving data

Other than through the setting using GX Works2 or the TO instruction at the startup of the C24, the received data count and receive complete code setting values can be changed even after data communication has started if the timing is as shown in the chart below.

The following describes the procedure for changing setting values for data reception via the nonprocedural protocol after the start of data communication, and for the resumption of data reception processing. Specifically, the module restrictions are explained, along with the timing and procedure for changing the setting values.

### (a) How to receive data

Reception using a dedicated instruction (INPUT) or an interrupt program (\*1) cannot be performed.



(Transmission using a dedicated instruction (OUTPUT) can be performed.)

Data must be received using the FROM instruction in the main program.

The following describes the I/O signals.

(A program example is shown on Page 168, Section 10.1 (2) (d).)

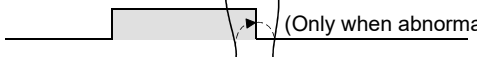
\*1 For details on the data reception using interrupt programs, refer to  User's Manual (Application).

	I/O signal		Signal name	Device that turns ON/OFF		Timing
	CH1 side	CH2 side		CPU module	C24	
Reception	X3	XA	Reception data read request		○	
	X4	XB	Reception abnormal detection		○	
	Y1	Y8	Reception data read completion	○		

### Point

When the reception abnormal detection (X4/XB) turns ON, read the error code from the buffer memory below, and then check the type of error and take corrective action based on the information found in Page 262, CHAPTER 15.

- Data reception result (addresses: 258<sub>H</sub>/268<sub>H</sub>)

**(b) Setting values that can be changed**

Of the initial settings from GX Works2 stored in the buffer memory, only the following setting values can be changed after data communication has started.

- Received data count designation (addresses: A4<sub>H</sub>/144<sub>H</sub>)
- Receive complete code designation (addresses: A5<sub>H</sub>/145<sub>H</sub>)

**(c) Timing and procedure for changing the setting values**

1) Timing of change

To change the receive complete code and received data count after data communication has started, change the setting when the status of the I/O signals relating to the reading of receive data is as follows.

- Reception data read request (X3/XA) or reception abnormal detection (X4/XB): ON
- Reception data read completion (Y1/Y8): OFF

2) Change procedure

When data reception from an external device causes the reception data read request (X3/XA)/reception abnormal detection (X4/XB) to turn ON, turn ON the reception data read completion (Y1/Y8) after performing the following.

- Read the receive data.
- Change the setting values for the receive complete code and the received data count.

**Ex.** When reading data received in the CH1 side interface

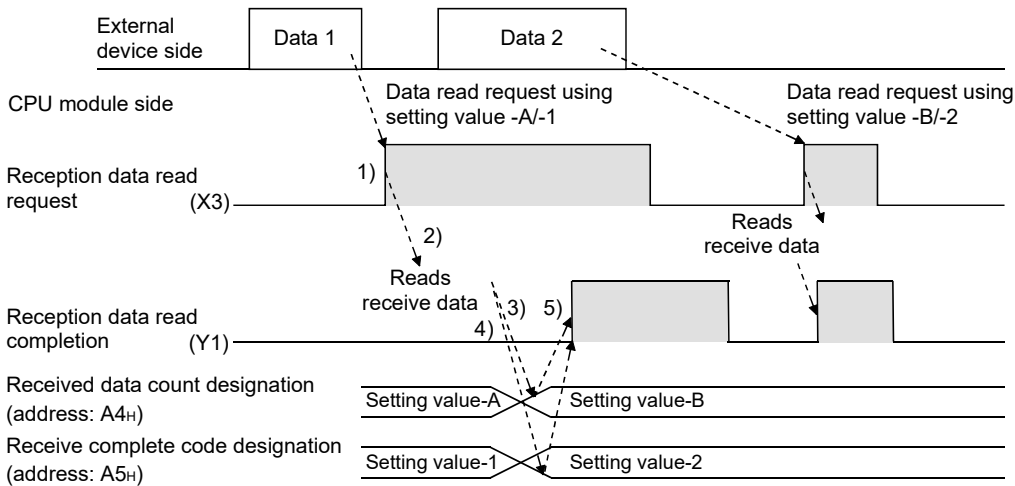

**(d) Program example: I/O signals for the C24 are from X/Y00 to X/Y1F**

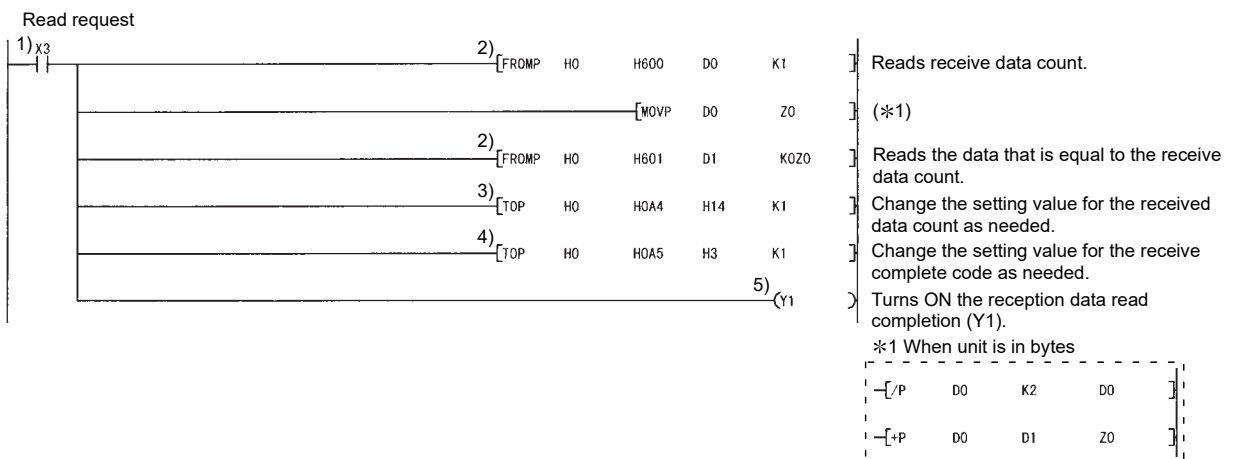

# 10.2 Sending Data to the External Device

This section explains data transmission from the CPU module to the external device.

## 10.2.1 Transmission methods

The following shows how to send data in any format using the nonprocedural protocol.

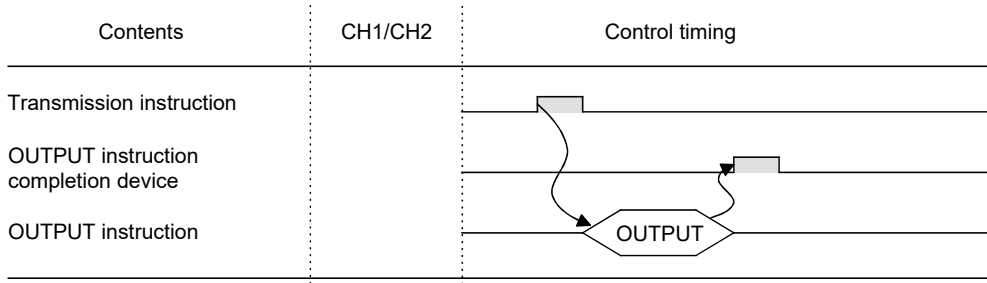
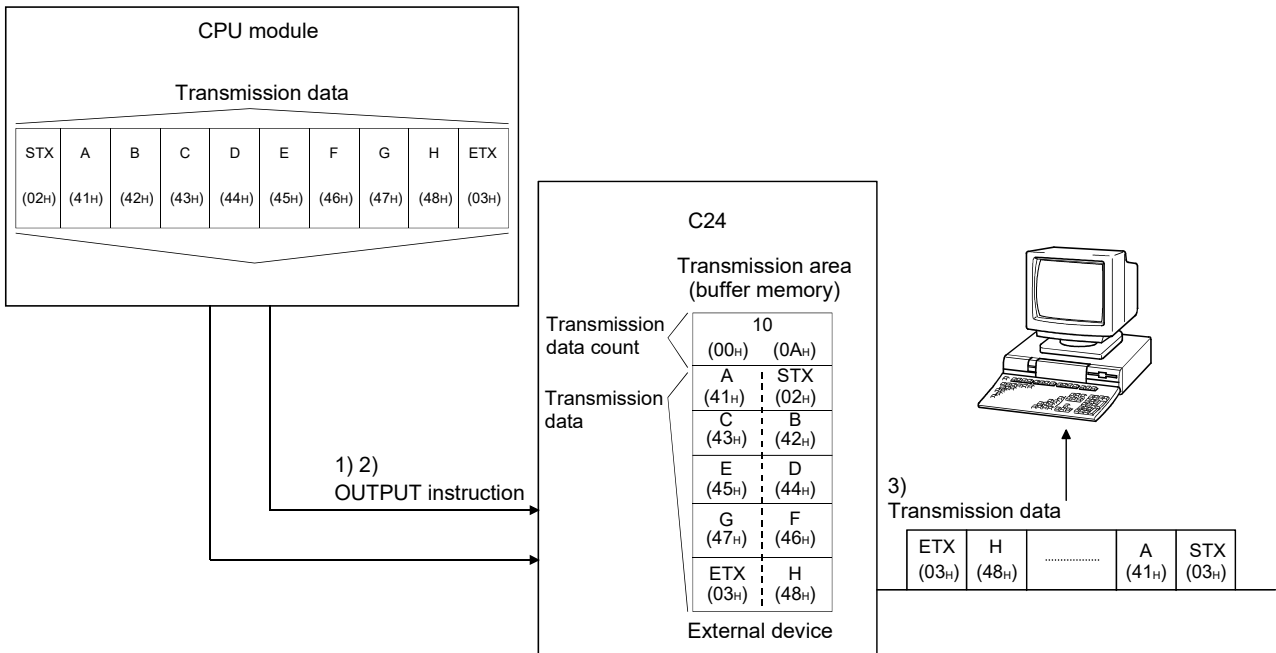

1. Transmission data is stored in the device designated with the OUTPUT instruction.
2. Control data is stored in the device designated with the OUTPUT instruction.
3. When the OUTPUT instruction is executed, the C24 sends the amount of data designated by the transmission data count from the transmission data area to the external device in ascending order of the transmission data area addresses.

## 10.2.2 Arrangement and contents of the transmission area and the transmission data

This section explains the arrangement and contents of the transmission area and the transmission data for performing data transmission using the nonprocedural protocol.

### (1) Transmission area

The transmission area is a memory area for storing the data and the data count that are transmitted from the CPU module to the external device via the C24.

By default, the transmission area is assigned to addresses 400<sub>H</sub> to 5FF<sub>H</sub> (CH1 side) and 800<sub>H</sub> to 9FF<sub>H</sub> (CH2 side).

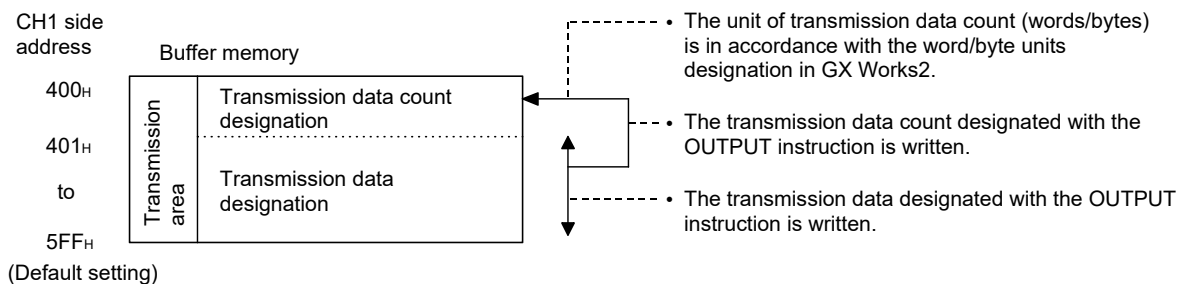

### Point

- The position and size of the transmission area in the buffer memory can be changed with GX Works2 in accordance with the specifications of the external device and the received data length. (Refer to  Page 75, Section 7.2.)
  - When changing the position and size of the transmission area in the buffer memory with GX Works2, specify as follows:
    - [Various\_Control\_Specification] screen → "For designation of transmission area" → "Transmission buffer memory head address designation"  
Designate the starting address for the area to be used as the transmission area in the setting area (address: 400<sub>H</sub> to 1AFF<sub>H</sub>, 2600<sub>H</sub> to 3FFF<sub>H</sub>).
    - [Various\_Control\_Specification] screen → "For designation of transmission area" → "Transmission buffer memory length designation"  
Designate by addresses the length of the area (0001<sub>H</sub> to 1A00<sub>H</sub>) to be used as the transmission area in the setting area (address: 400<sub>H</sub> to 1AFF<sub>H</sub>, 2600<sub>H</sub> to 3FFF<sub>H</sub>).
  - When changing the position and size of the receive area in the buffer memory, if any of the functions below are used concurrently, make sure that the addresses of the transmission area do not overlap with the buffer memory addresses assigned for storing transmission/receive data with the functions.
    - MC protocol buffer memory read/write function
    - MC protocol on-demand function
    - Predefined protocol function (transmission/reception data storage area)
    - Nonprocedural protocol transmission/receive function
    - Bidirectional protocol transmission/receive function
    - Communication data monitoring function
- Set the size of data per data transmission from the CPU module to the external device to be smaller than the size of the transmission data designation area in the buffer memory.

(Transmission data designation area) ≥ (Size of arbitrary data portion to be sent from the CPU module)

To transmit data whose size is larger than the transmission data designation area, increase the transmission area, or divide the transmission data before sending.

## (2) Transmission data arrangement

The following example shows an arrangement of the transmission data to be sent to the external device when storing it in the transmission area.

**Ex.** When transmitting "ABCDEFGH123" (The transmit area is the default value.)

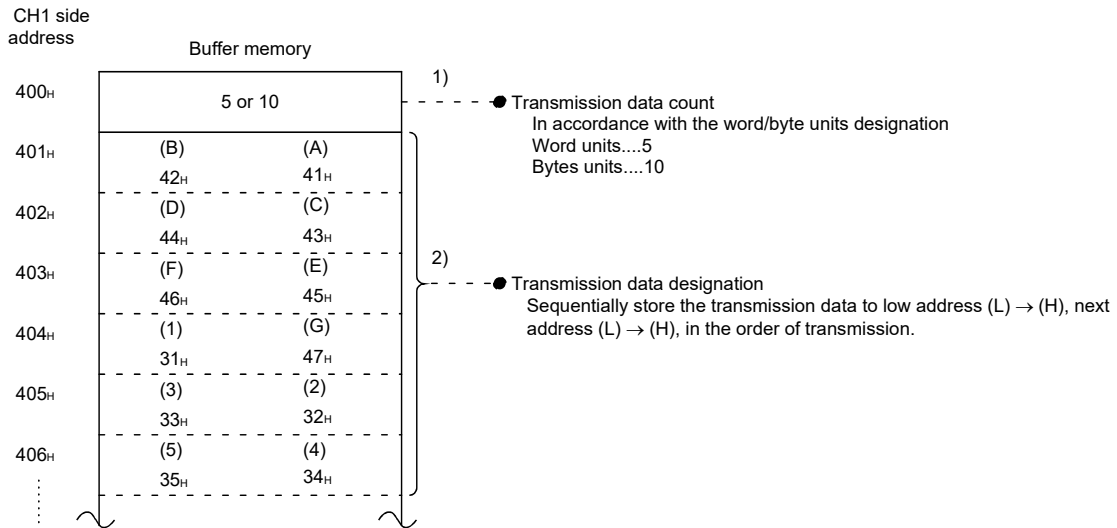

## 10.2.3 Sequence program for transmission data

A sequence program for transmission data is explained below.

For details on the OUTPUT instruction used for data transmission, refer to Page 206, CHAPTER 12.

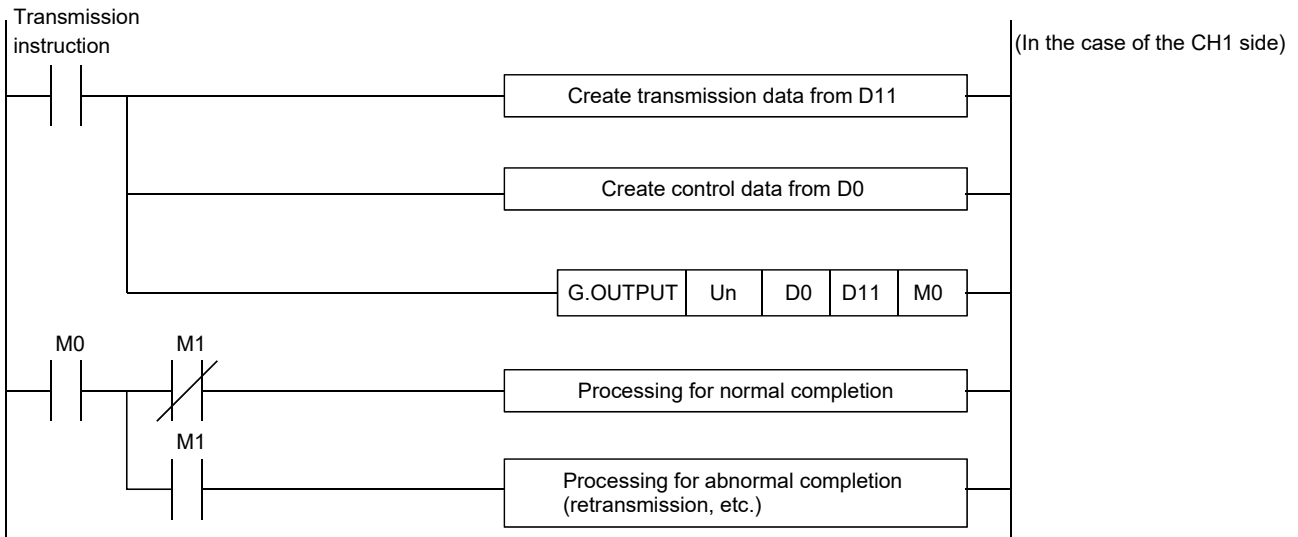

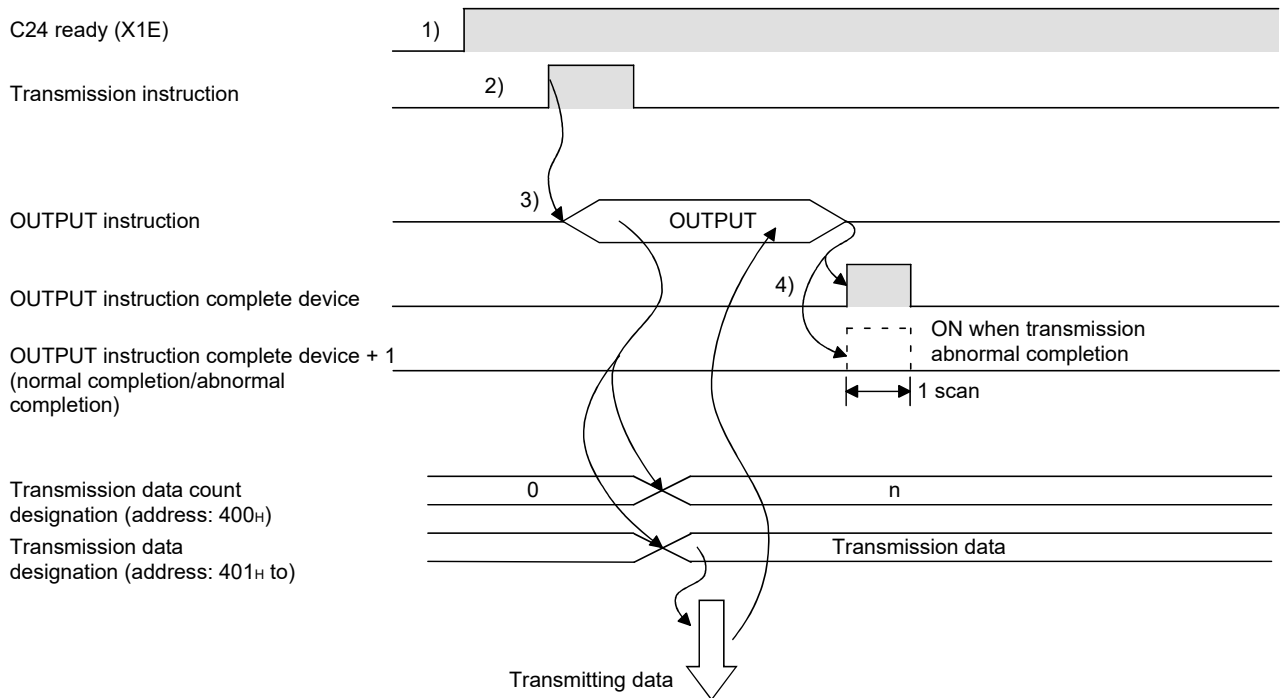

- 1. Starts the host station programmable controller.**  
The setting values in GX Works2 are stored in the C24.
- 2. Inputs the user data transmission command signal.**
- 3. Executes the OUTPUT instruction after storing the transmission data and the control data for the OUTPUT instruction in the device.**  
Data is sent when the OUTPUT instruction is executed.
- 4. When the C24 transmission processing completes, the completion device for the OUTPUT instruction turns ON.**  
When the completion device + 1 (abnormal completion signal) turns ON, the error code is stored in the control data completion status (S1+1).

(Program example)

When the I/O signals of the C24 are from X/Y00 to X/Y1F:

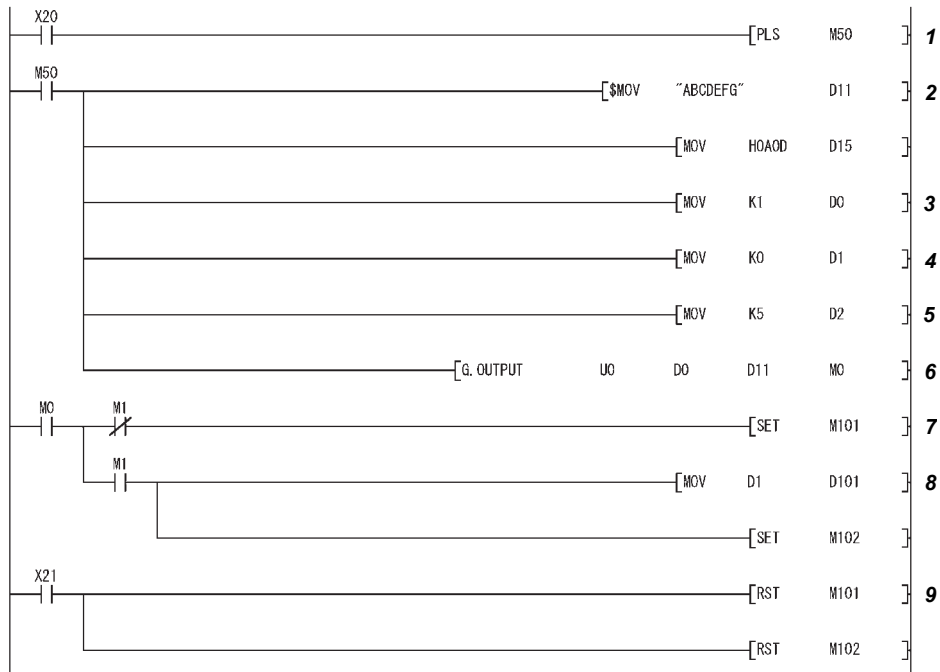

1. Transmission command is converted into pulse.
2. Transmission data is stored.
3. Specify the number of the interface (CH□) that sends the data.
4. Clear the transmission result storage device to 0.
5. Specify the transmission data count in word units. (Specify K10 when the unit is bytes.)
6. The transmission data stored in the specified device is sent.
7. After the OUTPUT instruction is executed, the transmission complete signal (M0) specified by user turns ON for one scan.
8. The error code of the transmission result storage device is saved to D101.
9. The completion flag is reset by an external command.

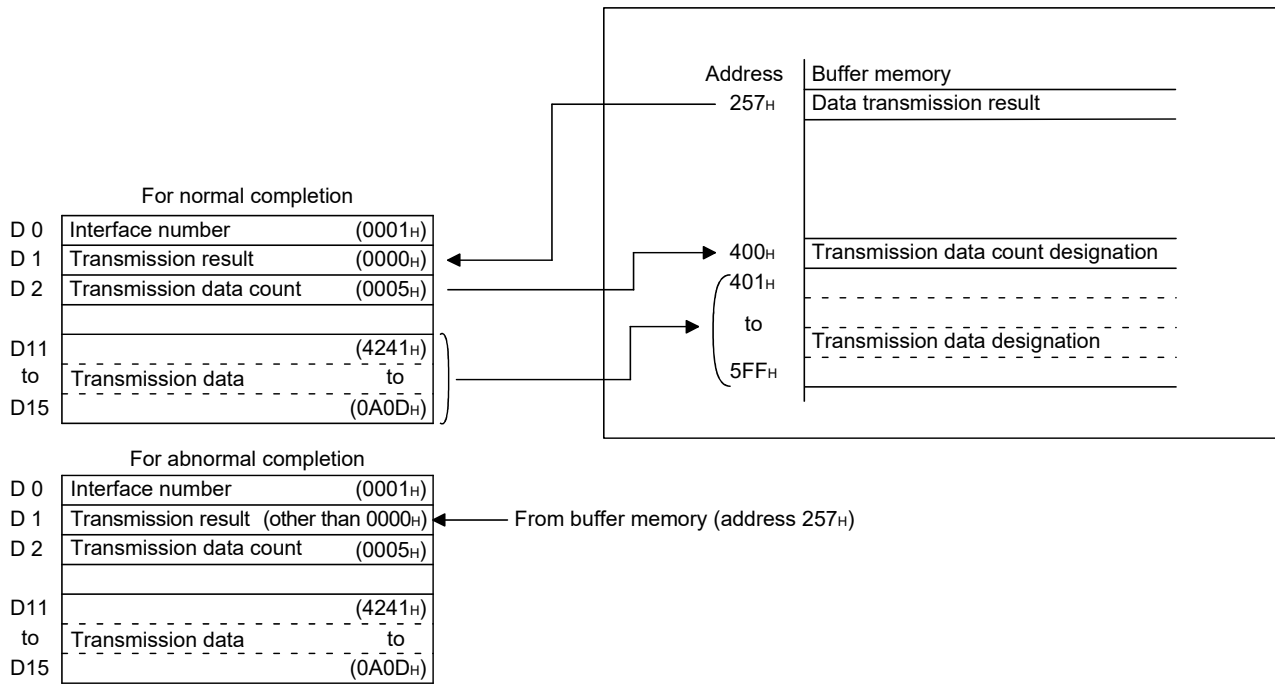

### Point

- The SPBUSY instruction is used to read the execution status when using a dedicated instruction. (Refer to Page 206, CHAPTER 12.)
- More than one OUTPUT instruction cannot be executed simultaneously. Execute the next OUTPUT instruction only after the execution of the first OUTPUT instruction is completed.



## 10.2.4 How to detect and confirm transmission errors

This section explains how to detect and confirm errors that may occur when sending data to external devices.

The following items are considered as the primary causes of errors that may occur during data transmission.

Cause of transmission error	Reference
A timeout occurred for the transmission monitoring time (timer 2).	User's Manual (Application)
Designated number of transmission data was larger than the size that could be stored in the transmission area.	Page 50, Section 6.2.2

### (1) Confirmation using the sequence program

#### (a) Detecting a transmission error

The following device and input signal turn ON.

- OUTPUT instruction complete device + 1
- ERR. occurrence (XE/XF)

#### (b) Confirming a transmission error

The transmission error code can be checked using the OUTPUT instruction control data ((S1) + 1).

Or, it can be checked by reading the data transmission result (address: 257<sub>H</sub>/267<sub>H</sub>).

#### **Point**

For details on how to check the error code contents and corrective actions, refer to  Page 262, CHAPTER 15.

## (2) Confirmation using GX Works2, display unit, or indicator LED of C24

The following shows how to confirm the errors.

	Item	Reference
GX Works2	"Module's Detailed Information" screen	Page 262, CHAPTER 15
	"Error History" screen	Page 262, CHAPTER 15
	"Intelligent Function Module Monitor" screen	GX Works2 Version 1 Operating Manual (Intelligent Function Module)
Display unit	Buffer memory monitor	MELSEC-L CPU Module User's Manual (Function Explanation, Program Fundamentals)
Indicator LED of C24	ERR LED turns on	Page 262, CHAPTER 15

### **Point**

---

When a transmission error occurs, the CPU module may not transmit all the designated data.

It is recommended that data communications be performed by establishing a user arbitrary communication procedure that can check normal transmission by reception of a response to data transmission.

---

## 10.2.5 Data Communications Precautions

The following describes the precautions to be taken during nonprocedural protocol data communications.

### (1) The C24 transmission sequence initialization conditions

The initial status indicates the status where transmission has stopped and receive data has been discarded. The C24 transmission sequence initialization conditions are as follows.

- When the power is turned on, the CPU module is reset, or the C24 mode is switched
- When the receive data was cleared.

### (2) Generation of framing error in external device

When nothing is transmitted from the C24 to the external device through the RS-422/485 interface, a framing error may be generated by the noise etc, in the external device.

Send an arbitrary code to identify the head of the send data from the C24 to the external device.

Before data communication check the C24 interface specifications.

### (3) Data communications with external device over a multidrop link

When the external device and the CPU module are connected by a 1:n multidrop link, each C24 receives the data transmitted by the external device.

With a multidrop link, receive data by user frame (\*1).

If data is not received by user frame, create a sequence program that ignores (discards) the receive data other than the receive data addressed to the host station, including the data indicating the target CPU module in the message.

(Example)

STX (02H)	Space (20H)	Station No. 0 (32H)	Station No. 2 (32H)	Data length (BIN data)	Data	CR (0DH)	LF (0AH)
--------------	----------------	---------------------------	---------------------------	---------------------------	------	-------------	-------------

\*1 For details, refer to  User's Manual (Application).

### (4) Retry processing for data reception errors

The data when reception error occurred is discarded and only the data for the normal reception is taken into the C24.

For this reason, the reception message may be missing data if an error occurs.

To assure the correct transmission and reception of data it is recommended that a normal/error response message is received and a response message reception timeout check is conducted for the data transmitted between the CPU module and the external device and that measures be taken when an error message is received or when an error timeout occurs, such as retransmitting the data (transmission retry).

# CHAPTER 11 DATA COMMUNICATION USING THE BIDIRECTIONAL PROTOCOL

This communication enables data transfer between an external device and a CPU module using the data format and transmission control procedure for the bidirectional protocol.

The feature of this data communication is that a response message is sent from the data receiving side to the data sending side, informing if the communication was completed.

Use this to check if the data communication was completed normally.

Sequence programs for sending and receiving data are required on the CPU module side.

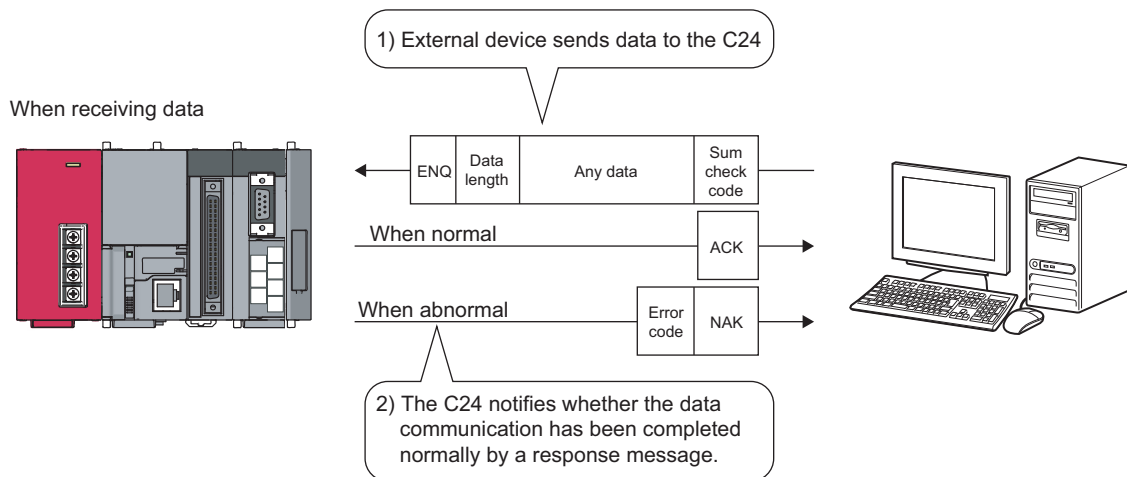

## Point

Communication programs using the bidirectional protocol can be easily replaced with those of the predefined protocol by the predefined protocol support function of GX Works2.

With the predefined protocol, programs can be run only by starting communication according to the specified protocol, and this can reduce the number of steps considerably.

For the communication using the predefined protocol, refer to Page 108, CHAPTER 9.

# 11.1 Data Reception from the External Device

This section explains the data reception from the external device.

## 11.1.1 Receiving methods

The following shows how to receive data sent from the external device using the bidirectional protocol. Since the size of each message received is recognized using the "data length" information contained in the message, messages of any size can be sent from the external device.

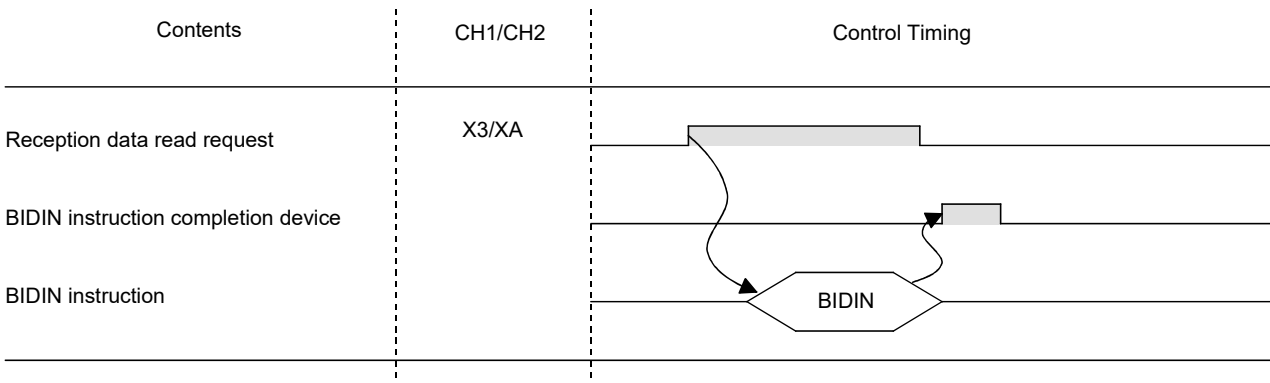
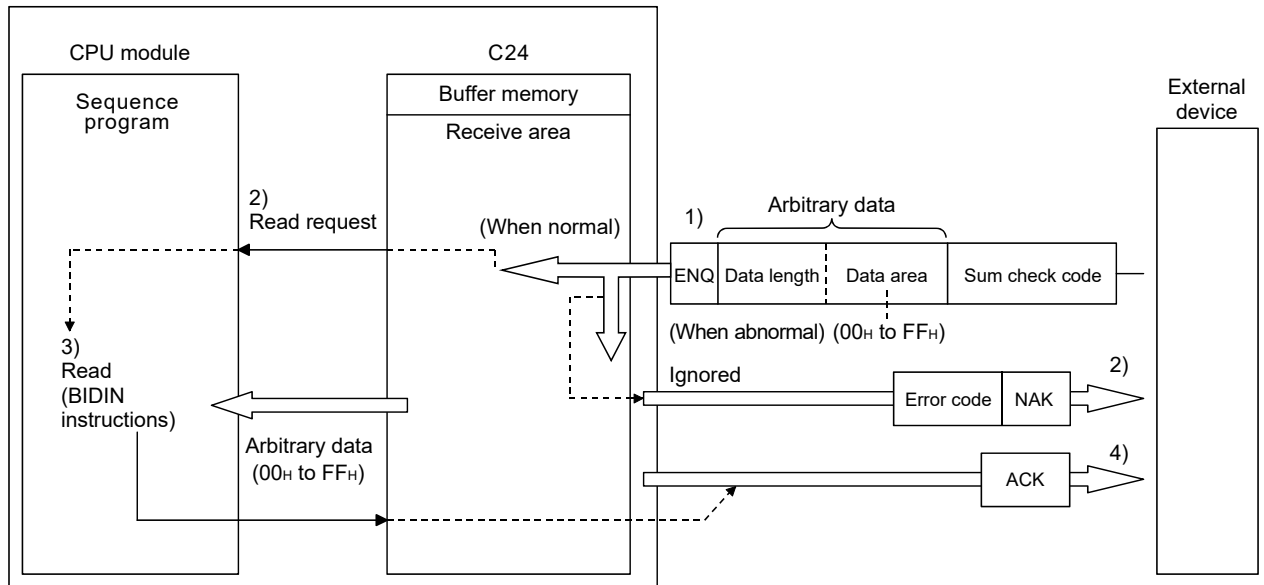

**1. When the control code ENQ is received, the C24 starts data reception processing.**

When the data specified by the data length is received, the C24 ends the reception processing of that data.

When sum check is enabled in the switch setting of GX Works2, the C24 checks whether the message is normal or abnormal using the sum check code received immediately after the message and the sum check code calculated by internal processing.

When sum check is disabled in the switch setting of GX Works2, messages are not checked using the sum check codes.

**2. If the message has normally been received, the reception data read request (X3/XA) turns ON.**

If an error has been detected when receiving the message, the C24 sends an abnormal end response (NAK message) to the external device.

The reception data read request will not be sent to the CPU module. (The reception abnormal detection (X4/XB) does not come on.)

**3. Control data is stored in the device designated with the BIDIN instruction and then the BIDIN instruction is executed.**

Receive data is read from the receive area of the buffer memory.

**4. When the BIDIN instruction has been executed, the C24 sends a normal end response (ACK message) to the external device.**

## 11.1.2 Arrangement and contents of the receive area and the receive data

This section shows the arrangement and contents of the receive area and the receive data for performing data reception using the bidirectional protocol.

### (1) Receive area

The receive area is a memory that stores the received data length (receive data count) and data area received from an external device.

The receive area is assigned to addresses 600<sub>H</sub> to 7FF<sub>H</sub> (CH1 side) and A00<sub>H</sub> to BFF<sub>H</sub> (CH2 side) at initial setting.

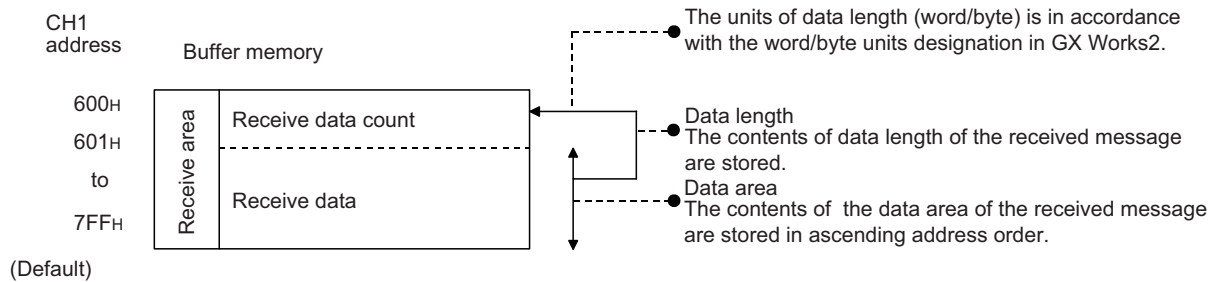

- The position and size of the receive area in the buffer memory can be changed with GX Works2 in accordance with the specifications of the external device and the received data length. (Refer to  Page 75, Section 7.2.)
  - (a) When changing the position and size of the receive area in the buffer memory with GX Works2, specify as follows:
    - [Various\_Control\_Specification] screen → "For designation of reception area" → "Receive buffer memory head address designation"  
Designate the starting address for the area to be used as the receive area in the user setting area (address: 400<sub>H</sub> to 1AFF<sub>H</sub>, 2600<sub>H</sub> to 3FFF<sub>H</sub>).
    - [Various\_Control\_Specification] screen → "For designation of reception area" → "Receive buffer memory length designation"  
Designate by addresses the length of the area (0001<sub>H</sub> to 1A00<sub>H</sub>) to be used as the receive area in the user setting area (address: 400<sub>H</sub> to 1AFF<sub>H</sub>, 2600<sub>H</sub> to 3FFF<sub>H</sub>).
  - (b) When changing the position and size of the receive area in the buffer memory, if any of the functions below are used concurrently, make sure that the addresses of the receive area do not overlap with the buffer memory addresses assigned for storing transmission/receive data with the functions.
    - MC protocol buffer memory read/write function
    - MC protocol on-demand function
    - Predefined protocol function (Transmission/reception data storage area)
    - Nonprocedural protocol transmission/receive function
    - Bidirectional protocol transmission/receive function
    - Communication data monitoring function
- Set the size of data per data transmission from the CPU module to the external device to be smaller than the size of the transmission data designation area in the buffer memory.

(Transmission data designation area) ≥ (Size of data portion to be sent from the CPU module)

To transmit data whose size is larger than the transmission data designation area, increase the transmission area, or divide the transmission data before sending.

---



### (2) Arrangement of receive data

The following example illustrates the arrangement of data received from the external device when it is stored in the receive area.

- The receive message is stored to the C24 buffer memory (receive data storage area).
- The data is stored to the receive data storage area in the order of low address (L) → (H), next address (L) → (H).

If the received data is "ABCDEFG123", it will be stored as shown below (for the CH1 side):

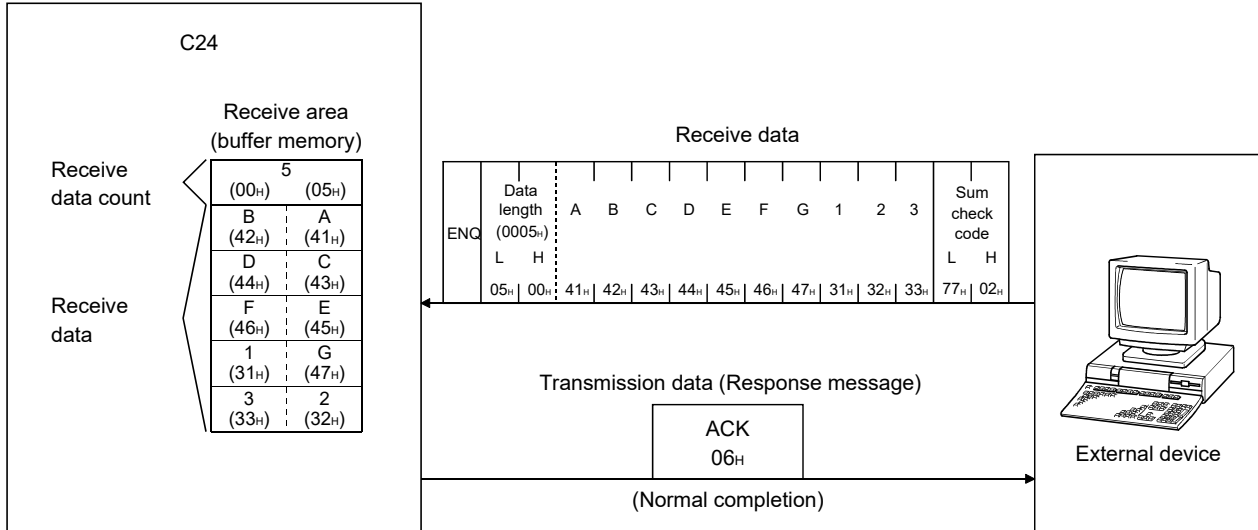

When the data length unit is in bytes, 00<sub>H</sub> is stored in the higher byte of the last data storage position in the receive area when the data length of the message is an even byte.

### (3) Contents of receive data

The contents of receive data, including the receive data as indicated in Page 194, Section 11.2.2, are explained below.

#### (a) Control codes

The types of control codes are shown in the table below.

Signal name	Code (hexadecimal)	Contents	Application
ENQ	05 <sub>H</sub>	Enquiry	Code for starting data transmission.
ACK	06 <sub>H</sub>	Acknowledge	Response code to the opposite side when data was received normally.
NAK	15 <sub>H</sub>	Negative Acknowledge	Response code to the opposite side when data could not be received normally. (Error code is sent immediately after the response code.)

- For data communication from the external device to the C24  
The C24 checks and processes the control code received.  
It cannot be read from the sequence program.
- For data communication from the C24 to the external device  
The control code to be transmitted is added by the C24.

## (b) Data length

This indicates the number of bytes or words for the data portion of the message.

The unit of data length (words/bytes) is in accordance with the word/byte units designation in GX Works2.

- For data communication from the external device to the C24

The C24 checks the length of the data received.

When the reception is normal, the C24 stores the receive data in the receive data storage area of the C24 buffer memory, assigning the first byte as the lower byte (L).

- For data communication from the C24 to the external device

The length of the transmission data is the number of the transmission data designated by the sequence program using the BIDOUT instruction.

The C24 sends this value as is from the lower byte (L).

## (c) Data portion

This consists of an array of original one-byte data to be transmitted to the external device side, which can handle 00<sub>H</sub> to FF<sub>H</sub> code data.

- For data communication from the external device to the C24

If the receive data portion is normal, the C24 takes the codes as is and stores them in the receive data storage area in sequence, beginning with the youngest address.

The storage size is in accordance with the data length in the message (Refer to Page 184, Section 11.1.2 (3) (b)) and the word/byte units designation in GX Works2.

- For data communication from the C24 to the external device

The transmission data portion is the number of the transmission data designated by the sequence program using the BIDOUT instruction.

The C24 sends the transmission data using the existing codes until the transmission data count is reached in accordance with the word/byte units designation in GX Works2 to the transmission data designation area.

**(d) Sum check code**

The sum check code expresses the numeric value for the lower two bytes (16 bits) of the results (sum) from the addition of the data length and the data portion in the message as binary code data.

When "Exist" is specified for "Sum check code" in the Transmission Setting of GX Works2, it is necessary to add a sum check code at the end of the message.

- For data communication from the external device to the C24  
The C24 checks and processes the sum check code received.  
It cannot be read from the sequence program.

When "None" is specified for "Sum check code", once a data portion of message corresponding to the data length is received, the succeeding data received will be ignored up to the control code that follows (Refer to Page 183, Section 11.1.2 (3) (a)).

The following example shows the contents of a sum check code in the message.

- For data communication from the C24 to the external device  
The sum check code to be transmitted is calculated and added by the C24.  
When "None" is specified, no sum check code is transmitted.

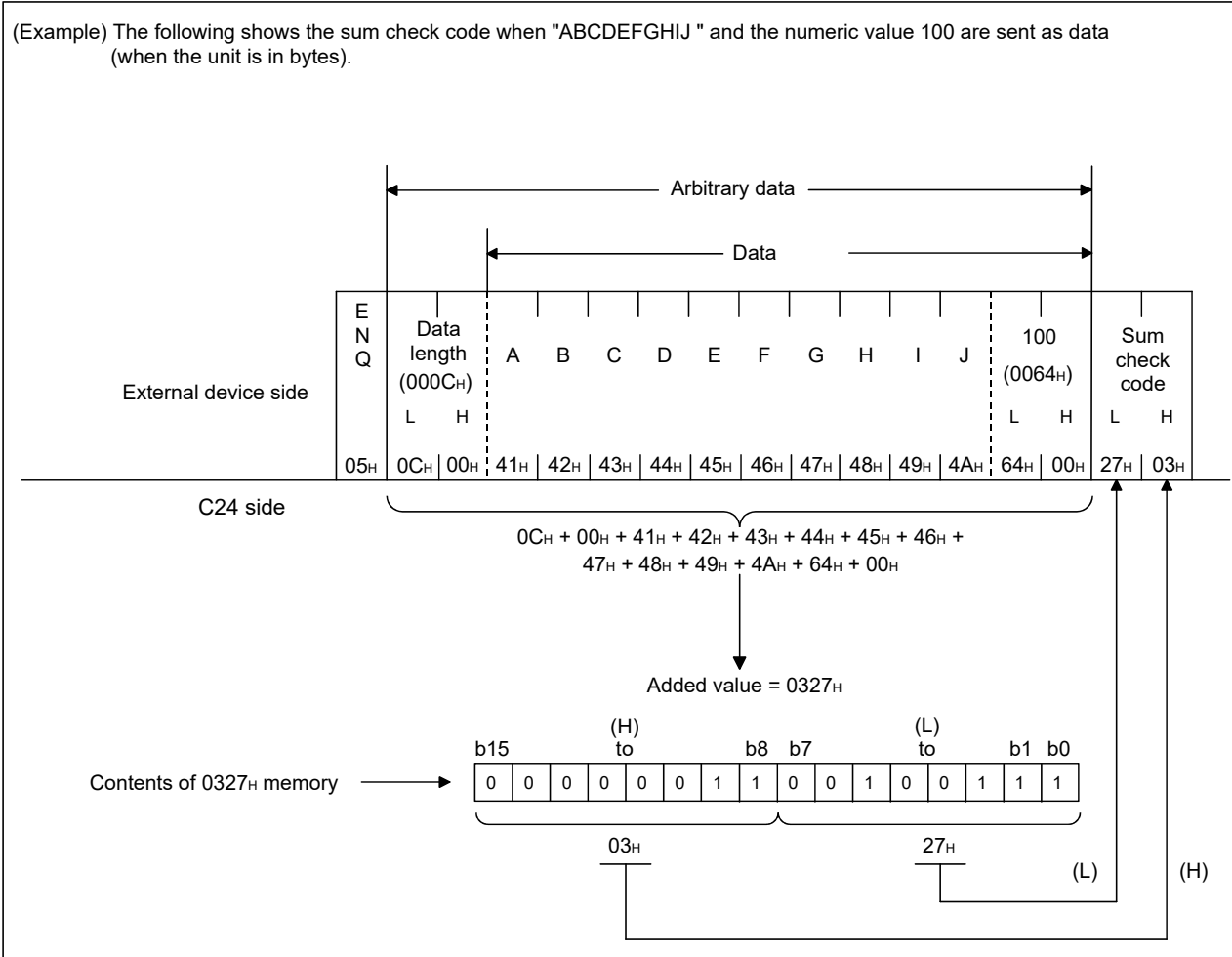

11.1.1 Data Reception from the External Device  
11.1.2 Arrangement and contents of the receive area and the receive data

### (e) Error code

The error code indicates the definition of the error during NAK response.

(For details on the error codes, refer to  Page 262, CHAPTER 15.)

- For data communication from the external device to the C24

For error codes from the external device, transmit the codes specified by the user.

The error codes (0022<sub>H</sub> to 005F<sub>H</sub>) that are not used by the C24 can be used.

The C24 stores the received error codes as a completion status in the control code for the BIDOUT instruction.

They are also stored in Data transmission result (address: 257<sub>H</sub>).

- For data communication from the C24 to the external device

The error codes are added by the C24.

When an error code is transmitted, the C24 writes the same error code in Data reception result (address: 258<sub>H</sub>).

## 11.1.3 Sequence program for data reception

This section explains the sequence program for data reception.

For details on the BIDIN instruction for data reception, refer to  Page 146, CHAPTER 10.

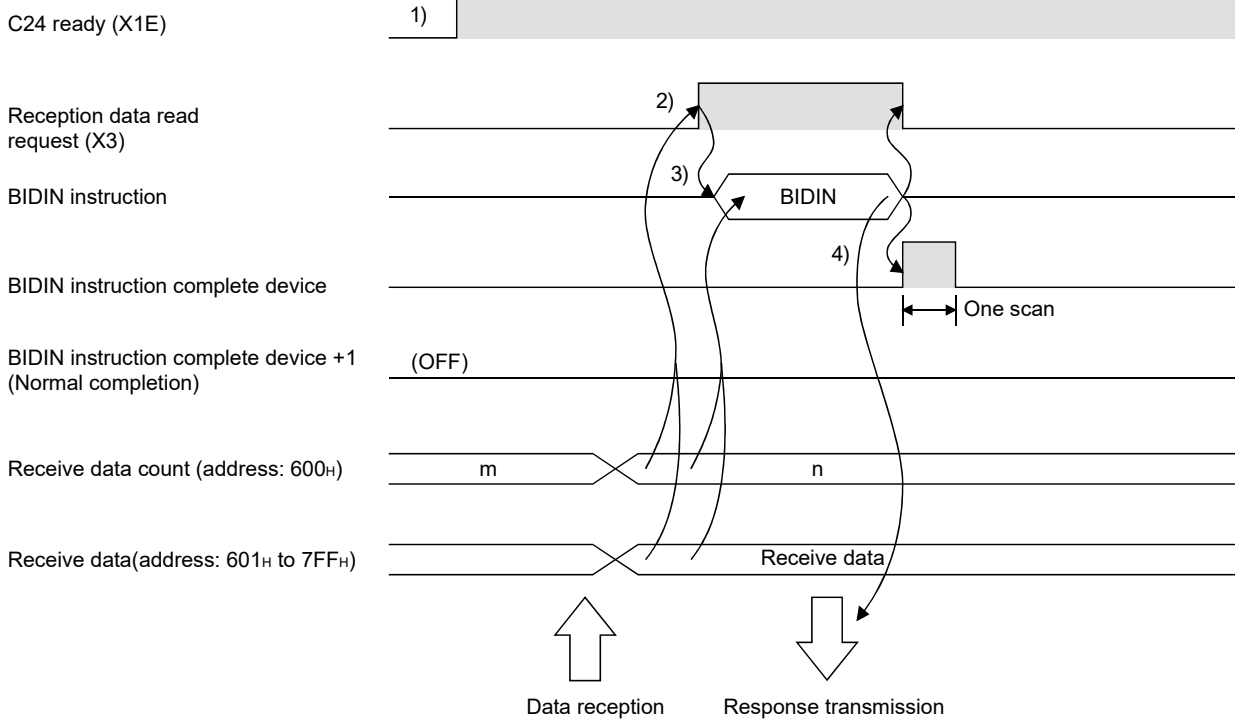
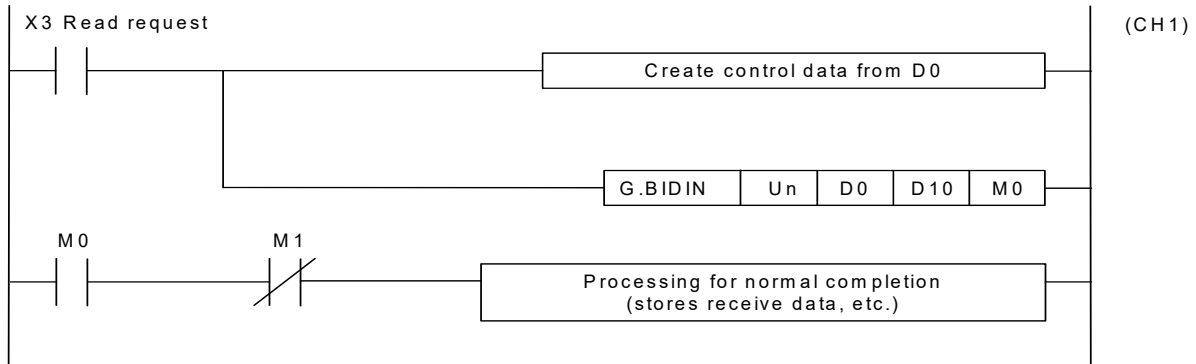

1. **Start the host station programmable controller.**  
The values specified with GX Works2 are stored in the C24.
2. **When data is received from the external device, Reception data read request (X3) turns ON.**
3. **After the control data for the BIDIN instruction is stored in the device, the sequence program executes the BIDIN instruction and reads the receive data.**
4. **When the reading of receive data is completed, a response message (ACK message when the operation was completed normally) is sent and the device that has completed the BIDIN instruction turns ON.**

(Program example)

When C24 I/O signals are from X/Y00 to X/Y1F:

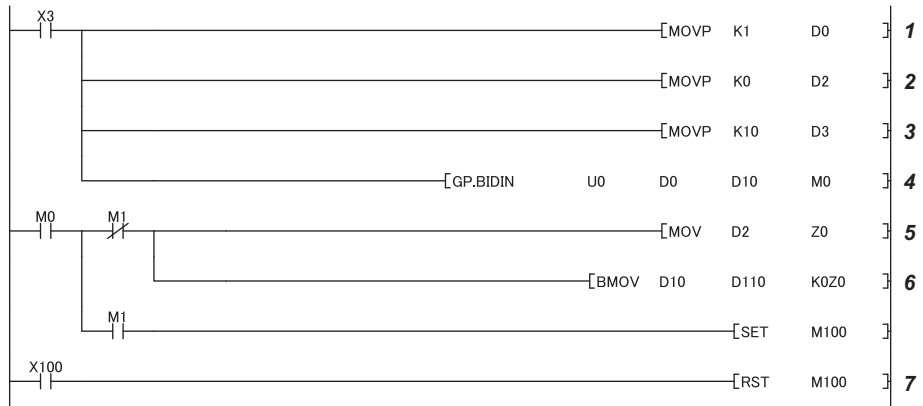

- 1. Specify the receive channel.**
- 2. Clear the receive data count storage device to 0.**
- 3. Specify the allowable receive data count.**
- 4. The receive data within the allowable receive data count (user-specified) is read from the receive data storage area in the buffer memory.**  
Specify the transmission data count in word units. (Specify K10 when the unit is bytes.)
- 5. After the BIDIN instruction execution, the read completion signal (M0) specified by user turns ON for one scan.**
- 6. The receive data of the receive data count is transferred to D110.**
- 7. The completion flag is reset by an external command.**

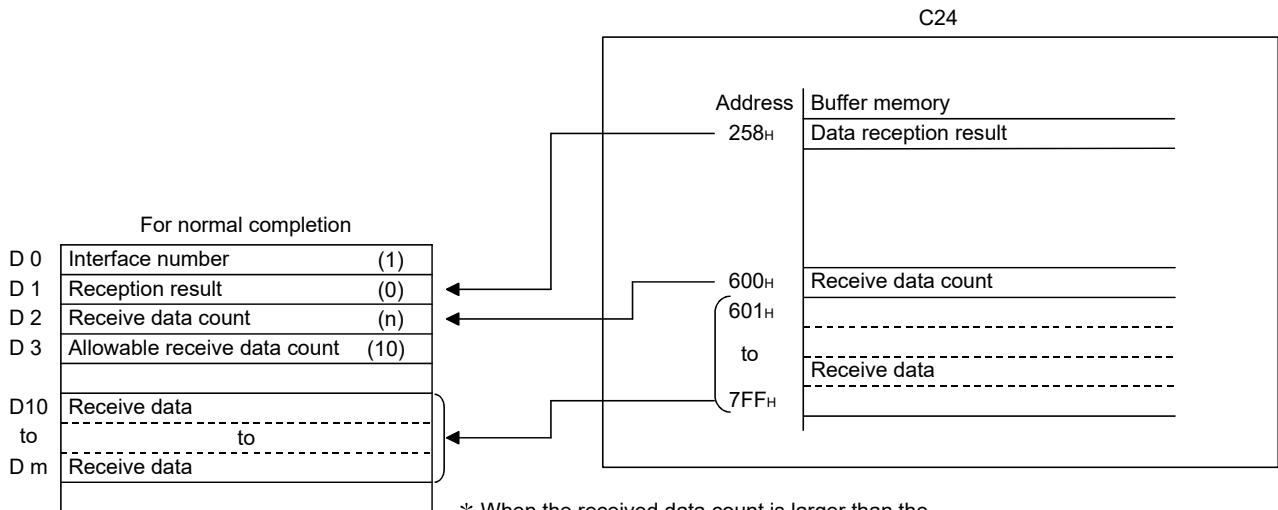

\* When the received data count is larger than the allowable received data count, only the data up to the allowable received data count will be stored and the excess data will be discarded.

**Point**

- Receive data can also be read using interrupt programs.  
For details on reading receive data with interrupt programs, refer to User's Manual (Application).  
Note that if the reading of data received from the same interface is to be performed, it is not possible to combine the reading of data received by the main program and reading of data received by the interrupt program. Accordingly, either of the above program to read the data received.
- The SPBUSY instruction is used to read the execution status when using a dedicated instruction. (Refer to Page 206, CHAPTER 12.)
- More than one BIDIN instruction cannot be executed simultaneously.  
Execute the next BIDIN instruction only after the execution of the first BIDIN instruction is completed.
- If the communication data count is set in byte units and the receive data count is an odd byte when requesting the reading of receive data to the CPU module, 00<sub>H</sub> is stored in the higher byte of the final data storage position in the receive data storage area.

11.1 Data Reception from the External Device  
11.1.3 Sequence program for data reception

## 11.1.4 How to detect and check the reception errors

---

This section explains how to detect and confirm errors that may occur when receiving data from external devices.

The following items are considered as the primary causes of errors that may occur during data reception.

Cause of reception error	Reference
A transmission error occurred due to noise.	Page 46, Section 6.2, Page 54, Section 6.3
A timeout occurred for the no-reception monitoring time (timer 0).	User's Manual (Application)
A timeout occurred for the transmission monitoring time (timer 2).	
Data that could not be converted with the ASCII-BIN conversion was detected.	
Received the data length that was too long to store in the receive area.	Page 181, Section 11.1.2
Simultaneous transmissions occurred.	Page 201, Section 11.3

### (1) Confirmation using the sequence program

#### (a) Detecting the occurrence of a reception error

ERR. occurrence (XE/XF) is on.

#### (b) Confirming a reception error

The receive error code is confirmed and read in data reception result (address: 258<sub>H</sub>/268<sub>H</sub>).



For details of how to check the error code contents and corrective actions, refer to  Page 262, CHAPTER 15.

---



**(2) Confirmation using GX Works2, display unit and indicator LED of C24**

The following shows how to confirm the errors.

	Item	Reference
GX Works2	"Module's Detailed Information" screen	Page 262, CHAPTER 15
	"Error History" screen	Page 262, CHAPTER 15
	"Intelligent Function Module Monitor" screen	GX Works2 Version 1 Operating Manual (Intelligent Function Module)
Display unit	Buffer memory monitor	MELSEC-L CPU Module User's Manual (Function Explanation, Program Fundamentals)
Indicator LED of C24	ERR LED turns on	Page 262, CHAPTER 15

**(3) Precautions**

The following shows the precautions of receive data when a reception error occurs.

- All of the receive data for which an error was detected is ignored and a response message indicating an abnormal completion (NAK message) is sent to the external device.
  - \* If an error has been detected when receiving the message, the C24 does not send the reception data read request to the CPU module.
- The receive area in the buffer memory will contain the data received normally just prior to the error occurrence. (Data will not be rewritten.)

## 11.1.5 Receive data clear

---

Data communications using the bidirectional protocol must be performed after a response message is received in reply to the preceding data transmission.

If the C24 detects an error while receiving data, it sends an NAK message (response message) to the external device after the data reception completion and ignores the data being received when the error was detected.

Therefore, the receive data does not have to be cleared.

## 11.2 Sending Data to the External Device

This section explains the data transmission from the CPU module to an external device.

### 11.2.1 Transmission methods

The following shows the method of sending data to the external device through data communication using the bidirectional protocol.

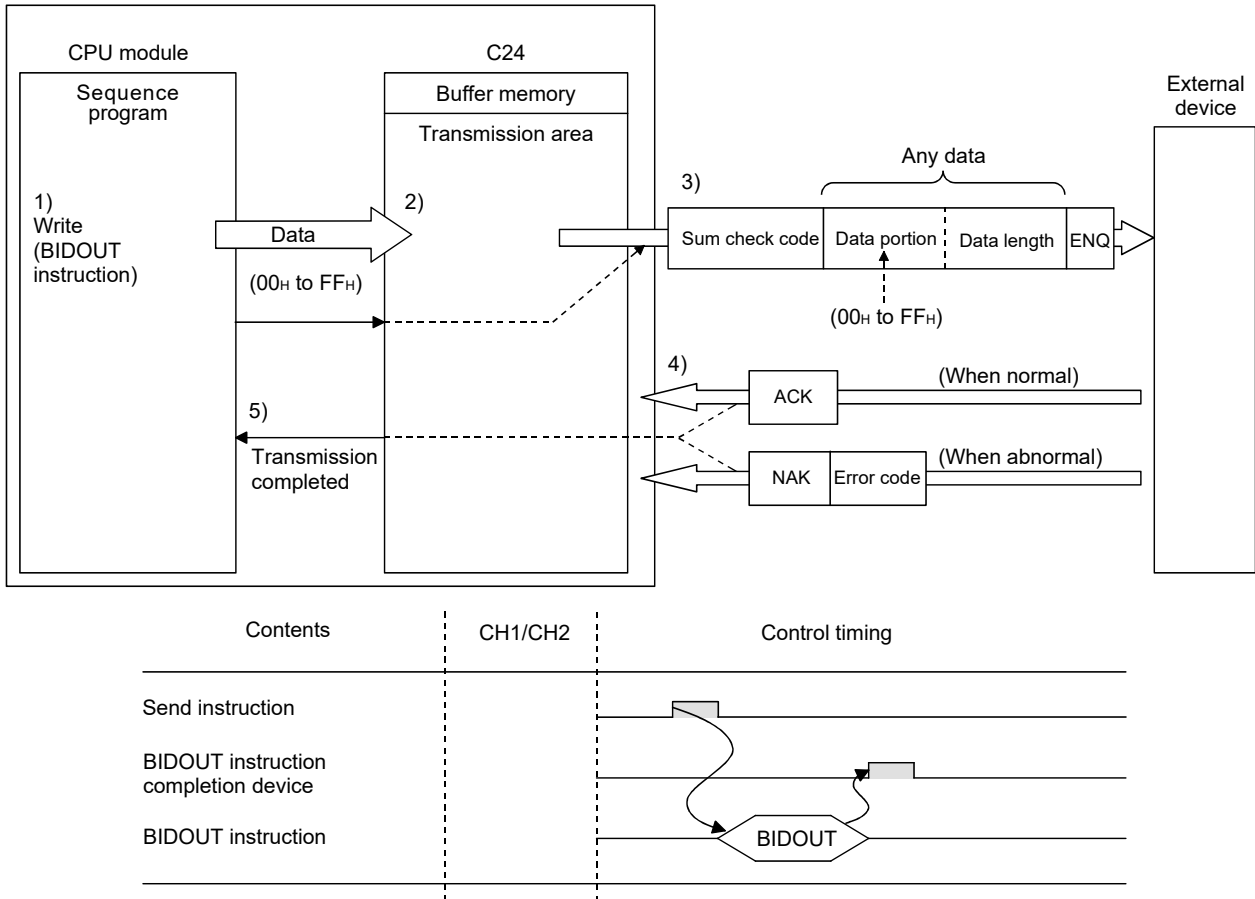

- 1. Data such as control data and transmission data are stored in the device designated with the BIDOUT instruction and then the BIDOUT instruction is executed.**
- 2. The transmission data count and transmission data are written into the transmission area of the buffer memory.**
- 3. The C24 sends data by adding the control code ENQ at the beginning of the data.**  
When "Exist" is specified for "Sum check code" in Switch Setting of GX Works2, the C24 adds the sum check code calculated by internal processing to the end of the message and then transmits the message. When "None" is specified in the Switch Setting of GX Works2, no sum check code is sent.
- 4. A response for the data transmission (for normal completion: ACK message; for abnormal completion: NAK message) is received.**
- 5. The execution of the BIDOUT instruction completes with the transmission processing completion of the C24.**

## 11.2.2 Arrangement and contents of the transmission area and the transmission data

This section explains the arrangement and contents of the transmission area and the transmission data for performing data transmission using the bidirectional protocol.

For details on the contents of transmission data, refer to Page 183, Section 11.1.2 (3).

### (1) Transmission area

The transmission area is a memory area for storing the data and the data count that are transmitted from the CPU module to the external device via the C24.

By default, the transmission area is assigned to addresses 400<sub>H</sub> to 5FF<sub>H</sub> (CH1 side) and 800<sub>H</sub> to 9FF<sub>H</sub> (CH2 side).

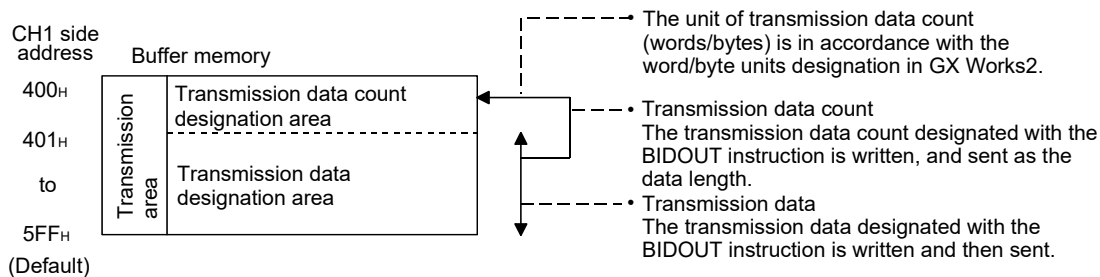

### Point

- The position and size of the transmission area in the buffer memory can be changed with GX Works2 in accordance with the specifications of the external device and the transmission data length. (Refer to  Page 75, Section 7.2.)
  - (a) When changing the position and size of the transmission area in the buffer memory with GX Works2, designate as follows:
    - [Various\_Control\_Specification] screen ⇒ "For designation of transmission area" ⇒ "Transmission buffer memory head address designation"  
Designate the starting address for the area to be used as the transmission area in the user setting area (address: 400<sub>H</sub> to 1AFF<sub>H</sub>, 2600<sub>H</sub> to 3FFF<sub>H</sub>).
    - [Various\_Control\_Specification] screen ⇒ "For designation of transmission area" ⇒ "Transmission buffer memory length designation"  
Designate by addresses the length of the area (0001<sub>H</sub> to 1A00<sub>H</sub>) to be used as the transmission area in the user setting area (address: 400<sub>H</sub> to 1AFF<sub>H</sub>, 2600<sub>H</sub> to 3FFF<sub>H</sub>).
  - (b) When changing the position and size of the receive area in the buffer memory, if any of the functions below are used concurrently, make sure that the addresses of the transmission area do not overlap with the buffer memory addresses assigned for storing transmission/receive data with the functions.
    - MC protocol buffer memory read/write function
    - MC protocol on-demand function
    - Predefined protocol function (transmission/reception data storage area)
    - Nonprocedural protocol transmission/receive function
    - Bidirectional protocol transmission/receive function
    - Communication data monitoring function
- Set the size of data per data transmission from the CPU module to the external device to be smaller than the size of the transmission data designation area in the buffer memory.

$$(\text{Transmission data designation area}) \geq (\text{Size of data portion to be sent from the CPU module})$$

To transmit data whose size is larger than the transmission data designation area, increase the transmission area, or divide the transmission data before sending.

## (2) Transmission data arrangement

The following example shows an arrangement of the transmission data to be sent to the external device when storing it in the transmission area.

**Ex.** When "ABCDEFG123" is sent:

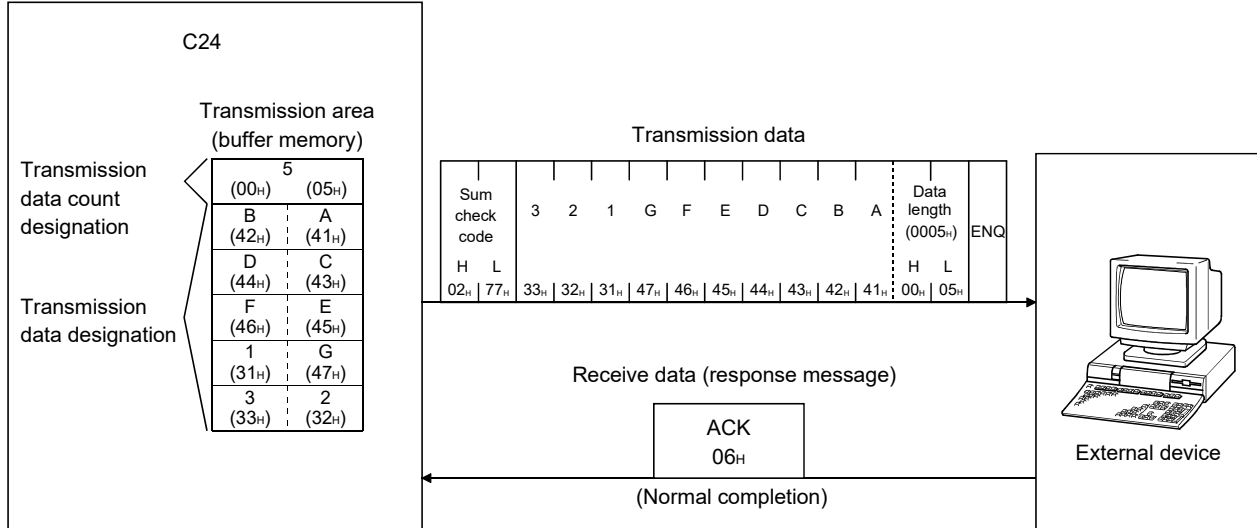

## 11.2.3 Sequence program for data transmission

A sequence program for data transmission is explained below.

For details on the BIDOUT instruction for data transmission, refer to  Page 206, CHAPTER 12.

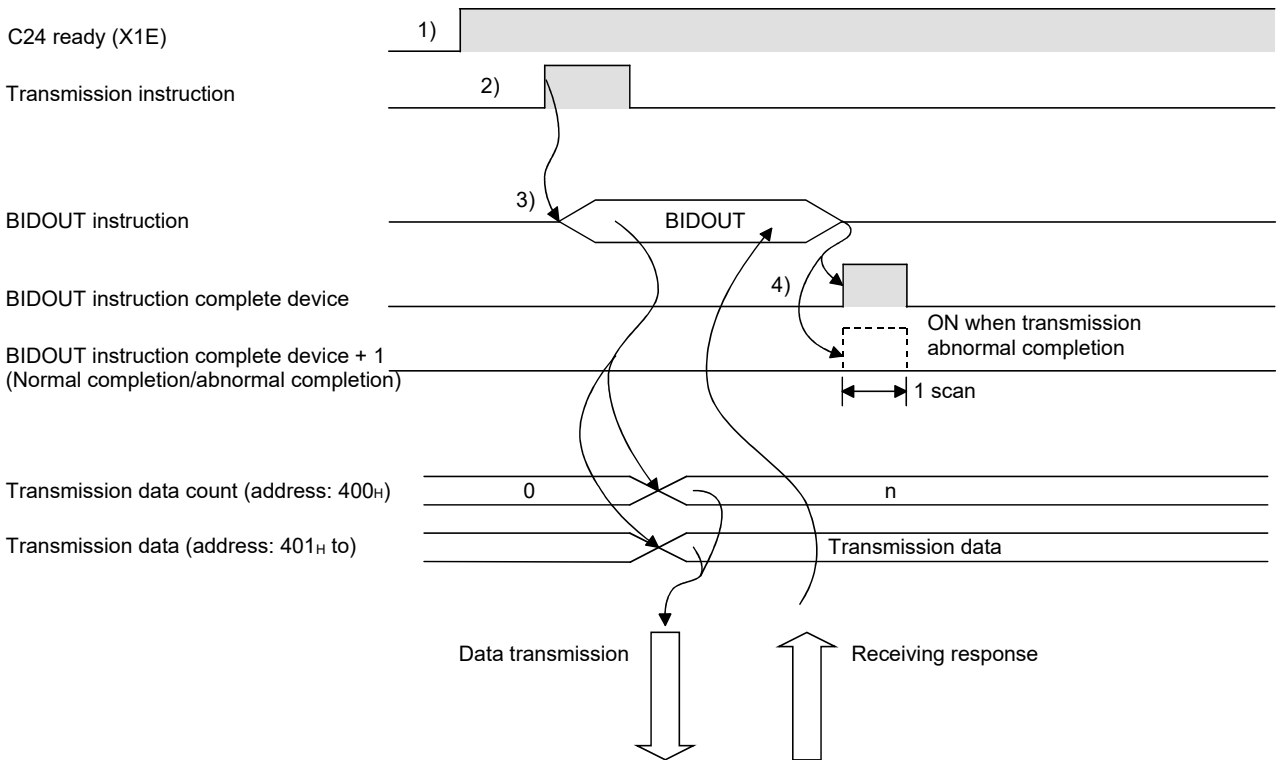
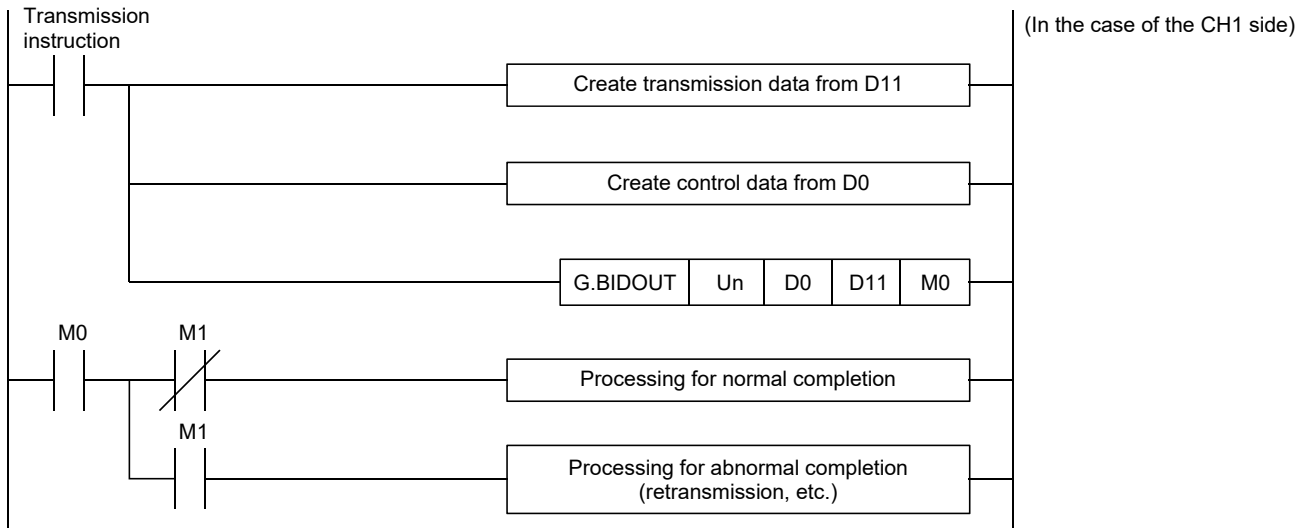

- 1. Starts the host station programmable controller.**  
The setting values in GX Works2 are stored in the C24.
- 2. Inputs the user data transmission instruction signal.**
- 3. Executes the BIDOUT instruction after storing the transmission data and the control data for the BIDOUT instruction in the device.**  
Data is sent when the BIDOUT instruction is executed.
- 4. A response message for the data transmission (for normal completion: ACK message; for abnormal completion: NAK message) is received.**
- 5. When the response is received, the C24 transmission processing completes and the device that has completed the BIDOUT instruction turns ON.**  
When the BIDOUT instruction ends abnormally due to the reception of a NAK message, the complete device +1 (abnormal completion signal) turns ON and the error code is stored in the control data completion status (S1+1).

(Program example)

When C24 I/O signals are from X/Y00 to X/Y1F:

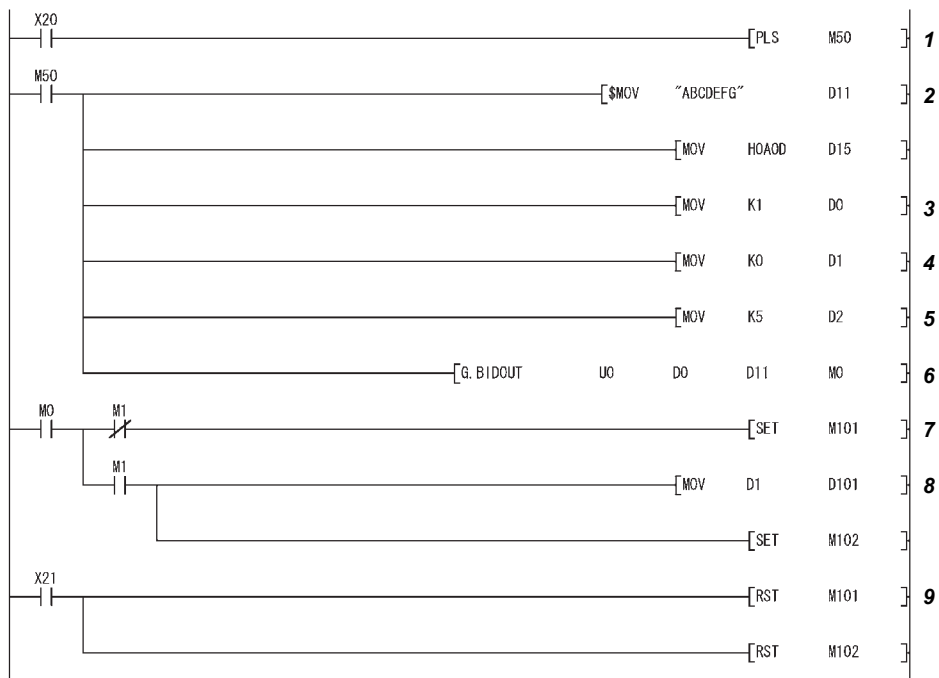

- 1. Transmission command is converted into pulse.**
- 2. Transmission data is stored.**
- 3. Specify the number of the interface (CH□) that sends the data.**
- 4. Clear the transmission result storage device to 0.**
- 5. Specify the transmission data count word units. (Specify K10 when the unit is bytes.)**
- 6. The transmission data stored in the specified device is sent.**
- 7. After the BIDOUT instruction is executed, the transmission complete signal (M0) specified by user turns ON for one scan.**
- 8. The error code of the transmission result storage device is saved to D101.**
- 9. The completion flag is reset by an external command.**

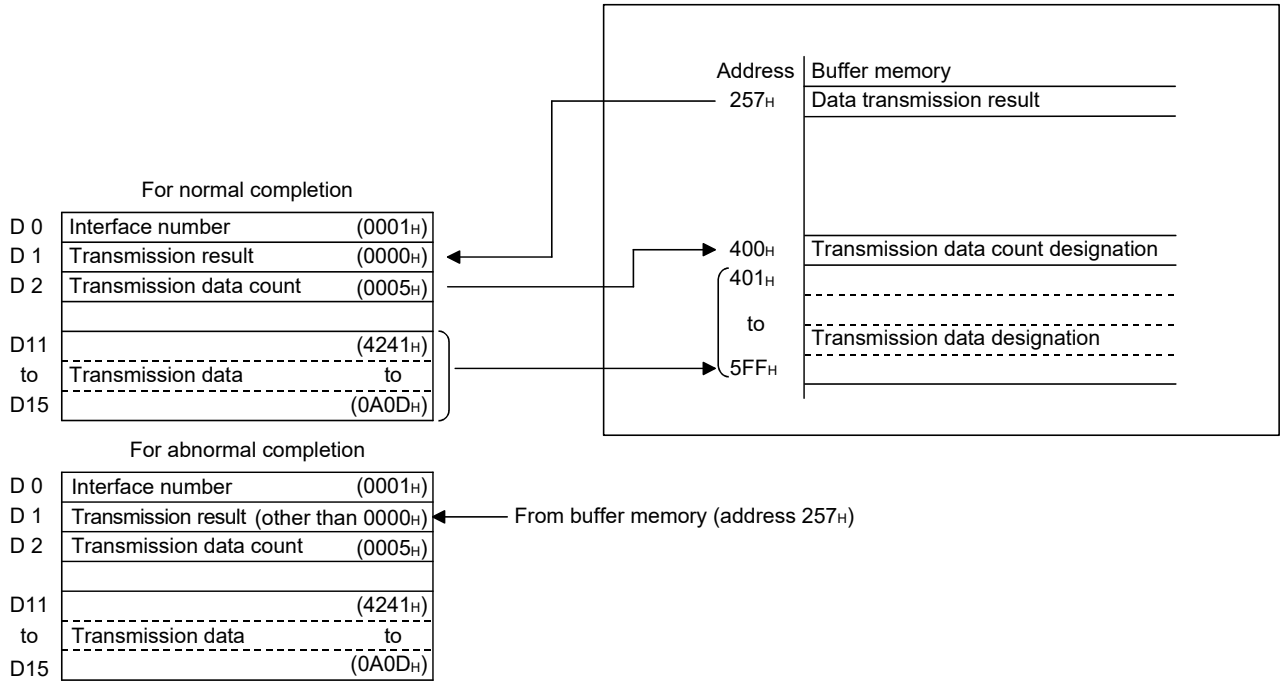

### Point

- The SPBUSY instruction is used to read the execution status when using a dedicated instruction. (Refer to Page 146, CHAPTER 10.)
- More than one BIDOUT instruction cannot be executed simultaneously.  
Execute the next BIDOUT instruction only after the execution of the first BIDOUT instruction is completed.



## 11.2.4 How to detect and confirm transmission errors

This section explains how to detect and confirm errors that may occur when sending data to external devices.

The following items are considered as the primary causes of errors that may occur during data transmission.

Cause of transmission error	Reference
A transmission error occurred due to noise.	Page 46, Section 6.2, Page 54, Section 6.3
A timeout occurred for the no-reception monitoring time (timer 0).	User's Manual (Application)
A timeout occurred for the response monitoring time (timer 1).	
A timeout occurred for the transmission monitoring time (timer 2).	
Data that could not be converted with the ASCII-BIN conversion was detected.	
Designated the transmission data count that exceeded the transmission area size.	Page 194, Section 11.2.2
Simultaneous transmissions occurred.	Page 201, Section 11.3

### (1) Confirmation using the sequence program

#### (a) Detecting a transmission error

The following device and input signal turn ON.

- BIDOUT instruction complete device + 1
- ERR. occurrence (XE/XF)

#### (b) Confirming a transmission error

The transmission error code can be checked using the BIDOUT instruction control data ((S1) + 1).

Or, it can be checked by reading the data transmission result (address: 257<sub>H</sub>/267<sub>H</sub>).

#### **Point**

For details of how to check the error code contents and corrective actions, refer to  Page 262, CHAPTER 15.

## (2) Confirmation using GX Works2, display unit and indicator LED of C24

The following shows how to confirm the errors.



	Item	Reference
GX Works2	"Module's Detailed Information" screen	Page 262, CHAPTER 15
	"Error History" screen	Page 262, CHAPTER 15
	"Intelligent Function Module Monitor" screen	GX Works2 Version 1 Operating Manual (Intelligent Function Module)
Display unit	Buffer memory monitor	MELSEC-L CPU Module User's Manual (Function Explanation, Program Fundamentals)
Indicator LED of C24	ERR LED turns on	Page 262, CHAPTER 15

## 11.3 Processing when Simultaneous Transmission Performed During Full-Duplex Communication

This section explains the processing when simultaneous transmissions occur in full-duplex communication.

### 11.3.1 Processing when simultaneous transmissions occur

This section explains the processing performed by the C24 when the external device and the C24 transmit at the same time during data communications using the bidirectional protocol.

Since the external device and the C24 do not transmit at the same time during half-duplex communications (refer to  User's Manual (Application)),  Page 201, Section 11.3.1 does not have to be read.

When an external device and the C24 transmit at the same time, the C24 processing depends on the setting. The value can be set in the following items of GX Works2.

 "Various\_Control\_Specification" screen ⇨ "For designation of transmission control" ⇨ "Transmission data" or "Receive data"

The values, set to "Receive data" and "Transmission data" are stored in the following areas of the buffer memory. Simultaneous transmission data valid/invalid designation (addresses: 9B<sub>H</sub>/13B<sub>H</sub>)

The C24 communication data processing for each setting is described in  Page 202, Section 11.3.2.

Setting contents with GX Works2	Value set to buffer memory (Address 9B <sub>H</sub> /13B <sub>H</sub> )	C24 processing contents	
		Message transmit processing	Message receive processing
Transmission data: Valid Receive data: Valid	0000 <sub>H</sub>	Waits to receive the response message (1)-2) while checking time-out after data transmission (1)-1) is complete. Posts normal end or abnormal end according to whether or not the CPU module received a response message through the buffer memory.	Transmits a response message (2)-2) after data reception (2)-1) is complete. Posts the receive data and receive result to the CPU module through the buffer memory.
Transmission data: Invalid Receive data: Valid	0100 <sub>H</sub>	Posts a simultaneous transmission error to the CPU module through the buffer memory after data transmission (1)-1). Does not wait for a response message (1)-2) in reply to data transmission (1)-1).	Transmits a response message (2)-2) after data reception (2)-1) is complete. Posts the receive data and receive result to the CPU module through the buffer memory.
Transmission data: Valid Receive data: Invalid	0001 <sub>H</sub>	Waits to receive the response message (1)-2) while checking time-out after data transmission (1)-1) is complete. Posts normal end or abnormal end according to whether or not the CPU module received a response message through the buffer memory.	Ignores data reception (2)-1) and discards the received data. Does not transmit a response message (2)-2). Does not inform the CPU module that data was received.
Transmission data: Invalid Receive data: Invalid	0101 <sub>H</sub>	Posts a simultaneous transmission error to the CPU module through the buffer memory after data transmission (1)-1). Does not wait to a response message (1)-2) in reply to data transmission (1)-1).	Ignored data reception (2)-1) and discards the receive data. Does not transmit a response message (2)-2). Does not inform the CPU module that data was received.

(n)-m) is the number showing the correspondence with the messages in the illustration shown in  Page 202, Section 11.3.2.

## 11.3.2 Communication data processing when simultaneous transmissions occur

Examples of the C24 communication data processing for the "Transmission data" and "Receive data" settings by GX Works2 are explained.

### (1) Transmission: Valid, Receive: Valid

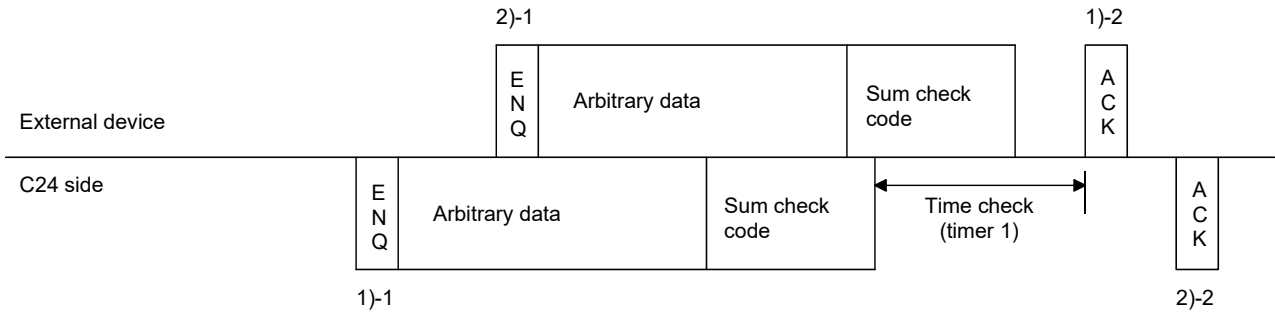

#### Point

When the entire message of 2)-1 was received while transmitting the message of 1)-1 in the illustration:

- The C24 turns ON Receive read request (X3/X4) of 2)-1 after sending all of 1)-1.

### (2) Transmission: Invalid, Receive: Valid

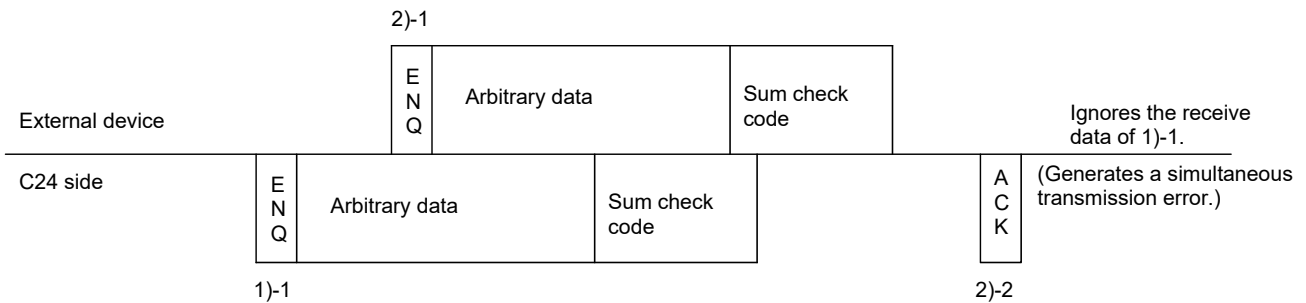

### (3) Transmission: Valid, Receive: Invalid

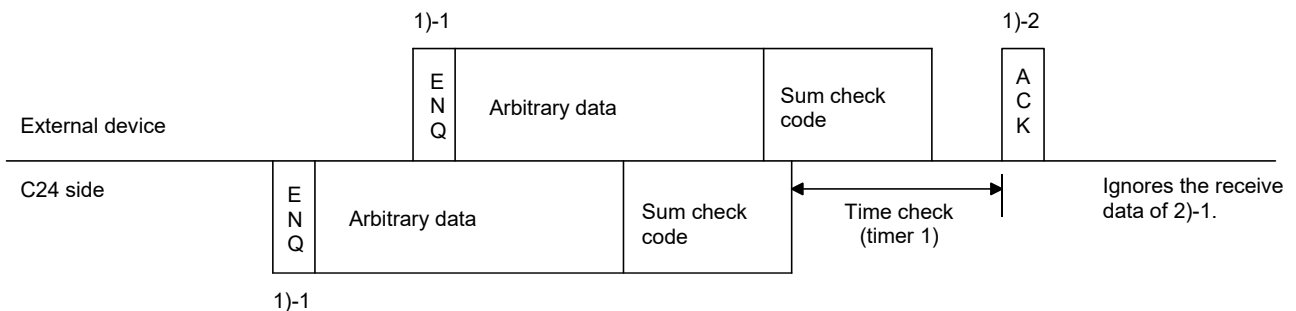

**(4) Transmission: Invalid, Receive: Invalid**

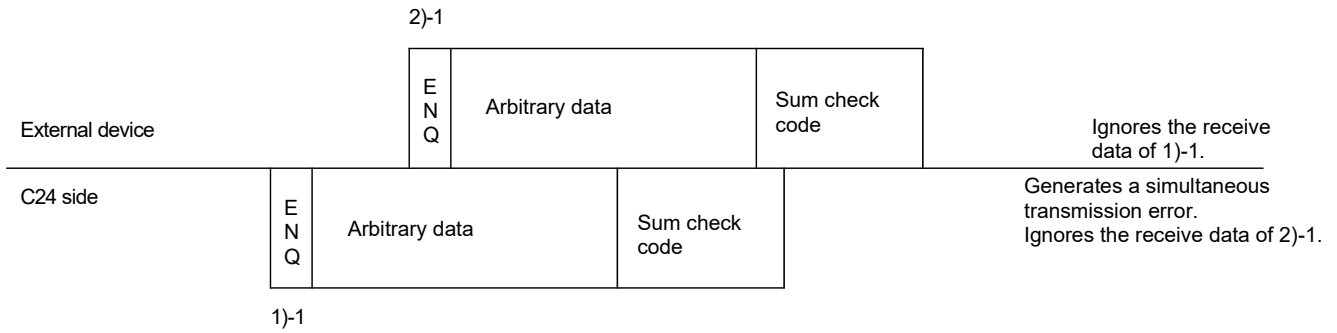

**Remark**

Time-check timer 1 (response monitoring time) shown in the illustration is described in User's Manual (Application).

**Point**

When the transmission control (refer to User's Manual (Application)) is performed with "Transmission data" set to "Valid" and "Receive data" set to "Valid", the C24 performs message transmission and message reception processing as described below.

During message transmission processing, time check by timer 1 (response monitoring time) is performed.

- Message transmission (1)-1 in the illustration)
  - When the C24 receives a terminate transmission request (DC3 received/DR(DSR) signal OFF) from the external device during message transmission, the C24 terminates data transmission.
  - When the C24 receives the ready to send signal (DC1 received/DR(DSR) signal ON), the C24 restarts data transmission.
- Message reception
  - If the C24 cannot send a response message to the external device in response to message reception because the external device issued a terminate transmission request (DC3 received/DR(DSR) signal OFF), the C24 transmits the response message after it receives the ready to send signal (DC1 received/DR(DSR) signal ON) from the external device.

## 11.4 Data Communications Precautions

---

The following shows the precautions when performing data communications using the bidirectional protocol.

**(1) When the transmission sequence is in the initial status, it indicates that data transmission and reception processing has not been started.**

The C24 transmission sequence is initialized in the following cases.

- The power is turned on, the CPU module is reset.
- When operating, or the mode is switched.
- When a response message (ACK, NAK, etc.) was received in reply to data transmission.
- When a response message (ACK, NAK, etc.) was transmitted in reply to data reception.

**(2) As a data transmission procedure, data transmission from the external device or the C24 should be performed after a response for the immediately preceding data transmission has been received.**

**(3) Specify the same units of data length (words/bytes) of the messages to be transmitted between an external device and the CPU module.**

The CPU modules can be set using the GX Works2 word/byte units designation.

Make the length of the data area in the message to be transmitted and received the size of the C24 buffer memory transmission data designation area and receive data storage area, or less.

**(4) NAK code response**

- Response from the C24 to external device  
After the error detection message reception complete, it transmits the NAK code to the external device.
- Response from external device to the C24  
Transmit the error code (0022<sub>H</sub> to 005F<sub>H</sub>) immediately after the NAK response.

---

**Point** 

- Perform error processing according to the error code received immediately after the NAK message at the device that received NAK as the response message after data transmission.  
 Page 262, CHAPTER 15 shows the error codes that are transmitted from the C24.
  - If the C24 receives an NAK response while transmitting data to an external device, it completes data transmission, then reads the NAK, perform abnormal completion.
  - If the C24 detects an error while receiving data, it ignores the receive data corresponding to the data length.  
If the data length is abnormal, the C24 ignores all the data up to the receive message head data (ENQ, etc.) received thereafter.
-

**(5) External device time-out check**

When checking time-out up to reception of the response message at the external device during data transmission from external device to the C24, make the time-out time the time shown below, or longer.

(CPU module maximum scan time × 2) + 100 ms

**(6) External device framing error**

When nothing is transmitted from the C24 to the external device through the RS-422/485 interface, a framing error may be generated in the external device.

Make the external device skip the data up to transmission of the head data (ENQ, NAK, etc.) of the message from the C24.

Before communicating data through the RS-422/485 interface, check C24 specifications given in  Page 54, Section 6.3.

**(7) Data bit settings**

When adding a sum check code to a message, set the data bits to 8 bits using the Transmission Setting of the GX Works2.

For more details on the data bit settings, refer to  Page 86, Section 7.3.1.

# CHAPTER 12 DEDICATED INSTRUCTIONS

Dedicated instructions are used to simplify programming when using intelligent function module functions. This chapter describes the LCPU dedicated instructions used for the C24.

## 12.1 Dedicated Instruction List and Available Devices

### (1) Dedicated instruction list

The following table lists the dedicated instructions explained in this chapter.

Application	Dedicated instruction	Description of function	Reference
On-demand function transmission	ONDEMAND* <sup>1</sup>	Sends data using the on-demand function of the MC protocol.	Page 208, Section 12.2
Predefined protocol communication	CPRTCL	Executes the protocol setting data written to the flash ROM using the predefined protocol support function of GX Works2.	Page 212, Section 12.3
Nonprocedural protocol communication	OUTPUT* <sup>1</sup>	Sends data for the specified data count.	Page 219, Section 12.4
	INPUT* <sup>1</sup>	Reads received data.	Page 223, Section 12.5
Bidirectional protocol communication	BIDOUT* <sup>1</sup>	Sends data for the designated data count.	Page 228, Section 12.6
	BIDIN* <sup>1</sup>	Reads received data.	Page 233, Section 12.7
Communication status confirmation	SPBUSY	Reads the status of data transmission/reception via a dedicated instruction.	Page 237, Section 12.8
Receive data clear	CSET	Perform the receive data clear without stopping the transmission processing during the nonprocedural protocol.	Page 239, Section 12.9

### Point

Do not change data values (control data, request data, etc.) designated by a dedicated instruction until the execution of the dedicated instruction is completed.

- \*1 To change the following values preset in the buffer memory for use of dedicated instructions, use GX Works2 or execute the CSET instruction (Initial setting) before starting data exchange. (Refer to  User's Manual (Application).)
- Word/byte units designation (address: 96<sub>H</sub>/136<sub>H</sub>)
  - Buffer memory head address designation for on-demand function designation (address: A0<sub>H</sub>/140<sub>H</sub>)
  - Transmission buffer memory head address designation (address: A2<sub>H</sub>/ 142<sub>H</sub>)
  - Transmission buffer memory length designation (address: A3<sub>H</sub>/143<sub>H</sub>)
  - Receive buffer memory head address designation (address: A6<sub>H</sub>/146<sub>H</sub>)
  - Receive buffer memory length designation (address: A7<sub>H</sub>/147<sub>H</sub>)

The dedicated instructions are executed based on the values preset in the buffer memory at module startup or those that have been changed by the CSET instruction (Initial setting).



**(2) Available devices**

The following devices are available for the dedicated instructions:

Internal devices		File register	Constant <sup>*2</sup>
Bit <sup>*1</sup>	Word		
X, Y, M, L, F, V, B	T, ST, C, D, W	R, ZR	K, H

- \*1 Word device bit designation can be used as bit data.  
 Word device bit designation is done by designating Word device. Bit No.  
 (Specify the bit number in hexadecimal.)  
 For example, bit 10 of D0 is D0.A.  
 Note that timer (T), retentive timer (ST), and counter (C) cannot be specified with D0.A.
- \*2 Available devices are given in each of the Constant field.

# 12.2 G(P).ONDEMAND

Data can be sent using the on-demand function of the MC protocol.

Setting data	Applicable device								
	Internal device (System, user)		File register	Link direct device J□□□		Intelligent function module device U□□G□□	Index register Zn	Constant	Others
	Bit	Word		Bit	Word				
(S1)	—	○				—			
(S2)	—	○				—			
(D)	○	○				—			

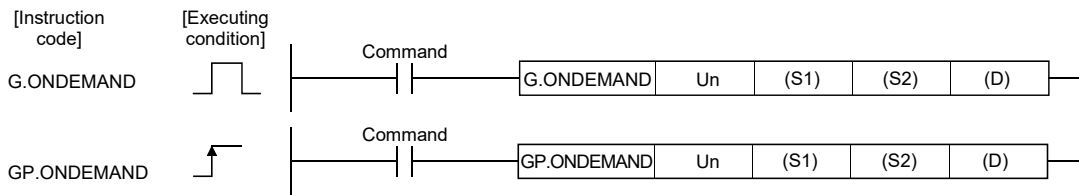

## (1) Setting data

Setting data	Description	Set by	Data type
Un	Start I/O signal of the module (00 to FE: Upper 2 digits when I/O signals are expressed in 3-digit.)	User	BIN16-bit
(S1)	Start number of the devices in which control data is stored.	User, system	Device name
(S2)	Start number of the devices in which transmission data is stored.	User	
(D)	Bit device number to be turned on at completion of execution.	System	Bit

The file register per local device and program cannot be used as the setting data.

## (2) Control data

Device	Item	Setting data	Setting range	Set by <sup>*3</sup>
(S1) + 0	Transmission channel	<ul style="list-style-type: none"> <li>Set transmission channel</li> <li>1: Channel 1 (CH1 side)</li> <li>2: Channel 2 (CH2 side)</li> </ul>	1, 2	User
(S1) + 1	Transmission result	<ul style="list-style-type: none"> <li>Result read by an ONDEMAND instruction is stored.</li> <li>0: Normal</li> <li>Other than 0: Error code<sup>*1</sup></li> </ul>	—	System
(S1) + 2	Transmission data count	<ul style="list-style-type: none"> <li>Set the transmission data count.<sup>*2</sup></li> </ul>	1 or more	User

\*1 For error codes relating to abnormal completion, refer to Page 262, CHAPTER 15.

\*2 When setting "Word/byte units designation" by GX Works2, set the number of bytes when bytes are designated and set the number of words when words are designated.

\*3 The settings are done by either of the following:

- User: Data set by the user before executing the ONDEMAND instructions.
- System: The CPU module stores the execution result of the ONDEMAND instructions.

**(3) Function**

- (a) Data stored in the device designated in (S2) and succeeding devices are sent according to the control data of the device designated in (S1) and succeeding devices, via the on-demand function of the MC protocol of the module designated in Un.

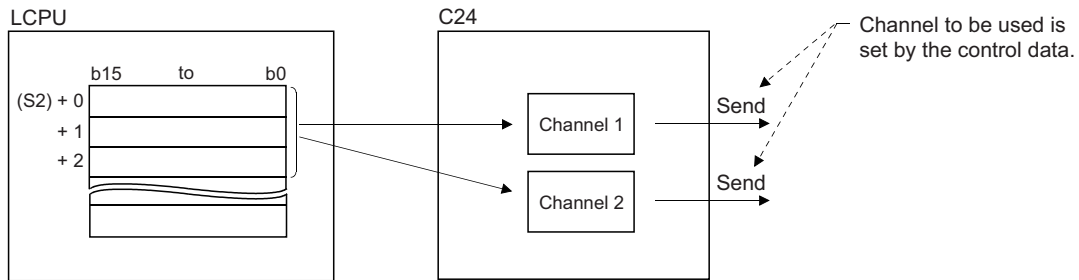

**(b) Simultaneous execution of dedicated instructions**

The following table shows the handling for when executing another instruction during execution of the ONDEMAND instruction or executing the ONDEMAND instruction during execution of another instruction in the same channel.

Instruction*1	Availability of simultaneous execution	Processing of simultaneous execution
ONDEMAND	×	<ul style="list-style-type: none"> <li>The next instruction will be ignored until the active instruction is completed. (However, simultaneous execution is available when channels to be used are not the same.)</li> </ul>
CSET	×	<ul style="list-style-type: none"> <li>Dedicated instructions simultaneous execution error (7FF0<sub>H</sub>) occurs in the dedicated instruction attempted later.</li> <li>(However, simultaneous execution is available when channels to be used are not the same.)</li> </ul>
PUTE	○	—
GETE		
SPBUSY		
UINI	×	<ul style="list-style-type: none"> <li>Dedicated instructions simultaneous execution error (7FF0<sub>H</sub>) occurs in the dedicated instruction attempted later.</li> </ul>

○: Available, ×: Not available

\*1 Since the dedicated instructions shown below use a different communication protocol from that for the ONDEMAND instruction, they are not used in the same channel.

- OUTPUT, PRR, INPUT, BIDOUT, BIDIN, BUFRCVS, CPRTCL

If the dedicated instructions shown above are used in the same channel with the ONDEMAND instruction, the communication protocol setting error (7FF2<sub>H</sub>) occurs. (Except for the BUFRCVS instruction)

**(c) Whether an ONDEMAND instruction was completed or failed can be checked by the completion device ((D)) or status display device at completion ((D)+1).**

Completion device	Turns on at the END processing of the scan where the ONDEMAND instruction is completed, and turns off at the next END processing.
Status display device at completion	Turns on and off depending on the completion status of the ONDEMAND instruction. <ul style="list-style-type: none"> <li>• Normal completion: Remains OFF.</li> <li>• Abnormal completion: Turns on at the END processing of the scan where the ONDEMAND instruction is completed, and turns off at the next END processing.</li> </ul>

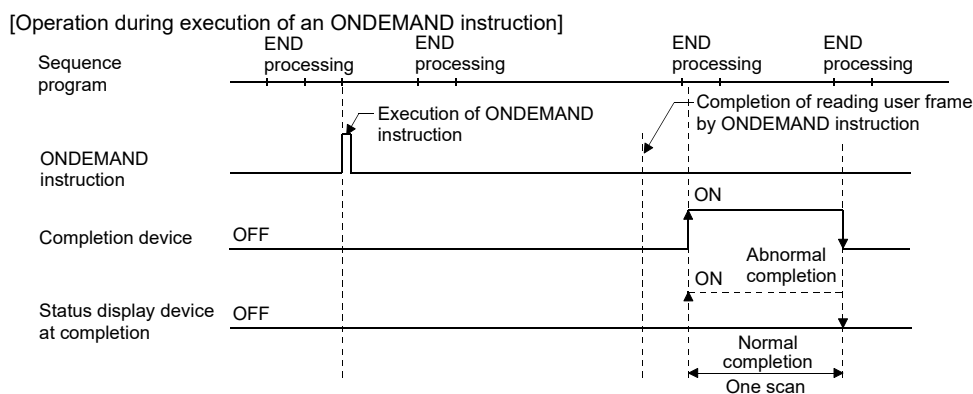

**(4) Error**

**(a) When a dedicated instruction is failed, the abnormal completion signal, (D)+1, turns on and the error code is stored in the transmission result (S1)+1.**

In case of operation errors, Error flag (SM0) turns on and the error code is stored in SD0.

Refer to the following according to the error code, and check and correct the error.

<Error code>

4FFF <sub>H</sub> or less	📖 MELSEC-L CPU Module User's Manual (Hardware Design, Maintenance and Inspection)
7000 <sub>H</sub> or later	📖 Page 277, Section 15.2

**(5) Program example**

A program that sends data stored in D10 to D11 using an on-demand transmission

When input/output signals of the C24 are from X/Y00 to X/Y1F

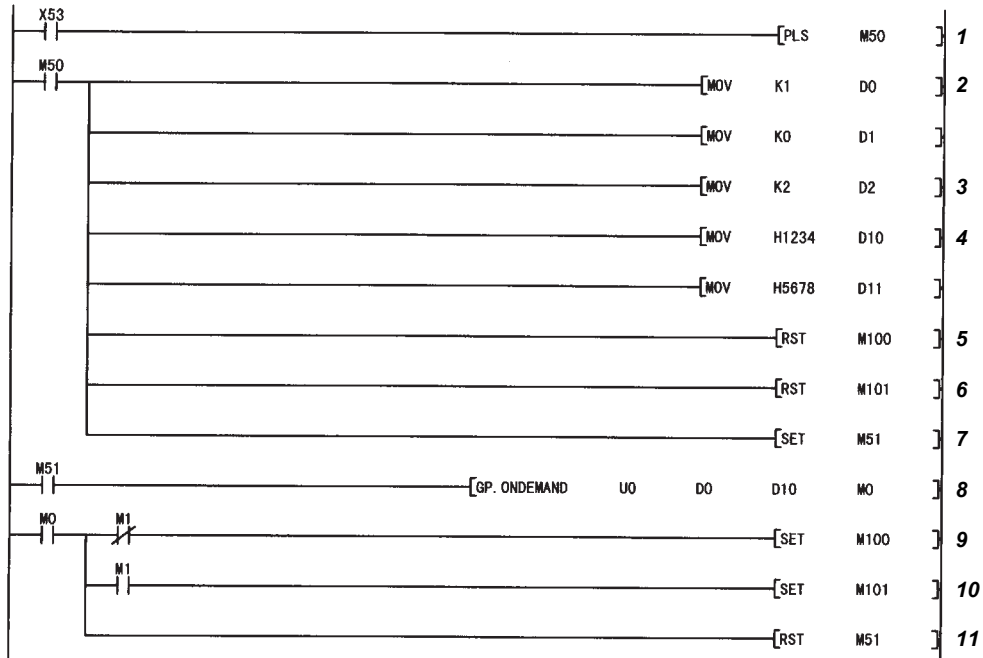

- 1.** On-demand transmission command is converted into pulse.
- 2.** Set the transmission channel to CH1.
- 3.** Set the send data count to 2 words.
- 4.** Set the transmission data to D10 to D11.
- 5.** Reset the normal completion flag.
- 6.** Reset the abnormal completion flag.
- 7.** Set the transmission ready flag.
- 8.** On-demand transmission is executed.
- 9.** Normal completion
- 10.** Abnormal completion
- 11.** Reset the transmission ready flag.

**Point**

- The status of communication via dedicated instructions can be read by the SPBUSY instruction.
- Designate the storage capacity of transmission data (stored in D10 to D11 in the program example above) and data length (stored in D2 in the program example above) within the range of the buffer memory the user has assigned for an on-demand function.

# 12.3 G(P).CPRTCL

Protocols and functional protocols written to the flash ROM with the predefined protocol support function of GX Works2 can be executed.

For details of the functional protocol, refer to  Page 218, Section 12.3.1.

Setting data	Applicable device								
	Internal device (System, user)		File register	Link direct device J□\□		Intelligent function module device U□\G□	Index register Zn	Constant K, H	Others
	Bit	Word		Bit	Word				
n1	—	○				—	○	—	
n2	—	○					○	—	
(S)	—	○					—	—	
(D)	○	○					—	—	

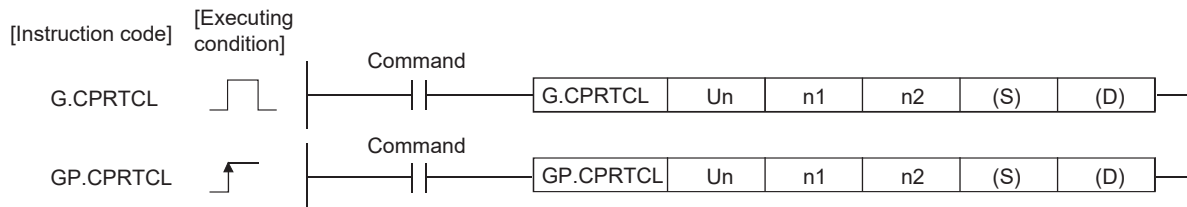

## (1) Setting data

Setting data	Description	Set by	Data type
Un	Start I/O signal of the module (00 to FE: Upper 2 digits when I/O signals are expressed in 3-digit.)	User	BIN16-bit
n1	Channel to communicate with other devices. 1: Channel 1 (CH1 side) 2: Channel 2 (CH2 side)	User	BIN16-bit Device name
n2	Number of consecutive protocol executions (1 to 8)	User	BIN16-bit Device name
(S)	Start number of the devices in which control data is stored.	User, system	Device name
(D)	Bit device number to be turned on at completion of execution.	System	Bit

The file register per local device and program cannot be used as the setting data.

## (2) Control data

Device	Item	Setting data	Setting range	Set by <sup>*1</sup>
(S) + 0	Execution result	<ul style="list-style-type: none"> <li>The execution result of the G(P).CPRTCL instruction is stored.</li> <li>When executing multiple protocols, the execution result of the protocol executed at last is stored.<sup>*2</sup></li> <li>0: Normal</li> <li>Other than 0: Error code<sup>*3</sup></li> </ul>	—	System
(S) + 1	Number of executions	<ul style="list-style-type: none"> <li>The number of executions is stored.</li> <li>Protocols with errors are included in the count.</li> <li>When settings of the setting data and control data contain an error, "0" is stored.</li> </ul>	1 to 8	System
(S) + 2	Execution protocol number designation	<ul style="list-style-type: none"> <li>Set the first protocol number or functional protocol number to be executed.<sup>*4</sup></li> </ul>	1 to 128 201 to 207	User
:		:		
(S) + 9		<ul style="list-style-type: none"> <li>Set the 8th protocol number or functional protocol number to be executed.<sup>*4</sup></li> </ul>		
(S) + 10	Verification match receive packet number	<ul style="list-style-type: none"> <li>When the communication type of the first protocol executed is "Receive only" or "Send &amp; receive", the matched receive packet number is stored.</li> <li>When the communication type is "Send only", "0" is stored.</li> <li>If the error occurs to the first protocol executed, "0" is stored.</li> <li>When the functional protocol is executed, "0" is stored.<sup>*4</sup></li> </ul>	0,1 to 16	System
:		:		
(S) + 17		<ul style="list-style-type: none"> <li>When the communication type of the 8th protocol executed is "Receive only" or "Send &amp; receive", the matched receive packet number is stored.</li> <li>When the communication type is "Send only", "0" is stored.</li> <li>If the error occurs to the 8th protocol executed, "0" is stored.</li> <li>When the number of the executed protocols is less than 8, "0" is stored.</li> <li>When the functional protocol is executed, "0" is stored.<sup>*4</sup></li> </ul>		

\*1 The following are the descriptions of terms in the column.

- User: Data set by the user before executing the CPRTCL instructions.
- System: The CPU module stores the execution result of the CPRTCL instructions.

\*2 When executing multiple protocols, if an error occurs to the nth protocol, the protocols after the nth protocol are not executed.

\*3 For error codes relating to abnormal completion, refer to  Page 262, CHAPTER 15.

\*4 For details of the functional protocol, refer to  Page 218, Section 12.3.1.

### (3) Function

**(a) The protocol setting data written to the flash ROM are executed by the module designated in Un.**

The protocol is executed according to the control data stored in the device designated in (S) and the following devices.

The channel designated in n1 is used.

**(b) Protocols are executed consecutively for the number of times designated in n2 (maximum: 8) in one instruction execution.**

**(c) Simultaneous execution of dedicated instructions**

The following table shows the processing when executing another instruction during execution of the CPRTCL instruction or executing the CPRTCL instruction during execution of another instruction in the same channel.

Instruction <sup>*1</sup>	Availability of simultaneous execution	Processing of simultaneous execution
CPRTCL	×	• The next instruction will be ignored until the active instruction is completed. (However, simultaneous execution is available when channels to be used are not the same.)
PUTE	○	—
GETE		
SPBUSY		
UINI	×	• Dedicated instructions simultaneous execution error (7FF0 <sub>H</sub> ) occurs in the dedicated instruction attempted later.

○: Available, ×: Not available

\*1 Since the dedicated instructions shown below use a different communication protocol from that for the CPRTCL instruction, they are not used in the same channel.

- ONDEMAND, OUTPUT, PRR, BIDOUT, INPUT, BIDIN, BUFRCVS, CSET  
If the dedicated instructions shown above are used in the same channel with the CPRTCL instruction, the communication protocol setting error (7FF2<sub>H</sub>) occurs. (Except for the BUFRCVS instruction)



**(d) Whether a CPRTCL instruction was completed normally or abnormally can be checked by the completion device ((D)) or status display device at completion ((D)+1).**

Completion device	Turns ON at the END processing of the scan where the CPRTCL instruction is completed, and turns OFF at the next END processing.
Status display device at completion	Turns ON and off depending on the completion status of the CPRTCL instruction. <ul style="list-style-type: none"> <li>• Normal completion: OFF with no change.</li> <li>• Error completion: Turns ON at the END processing of the scan where the CPRTCL instruction is completed, and turns OFF at the next END processing.</li> </ul>

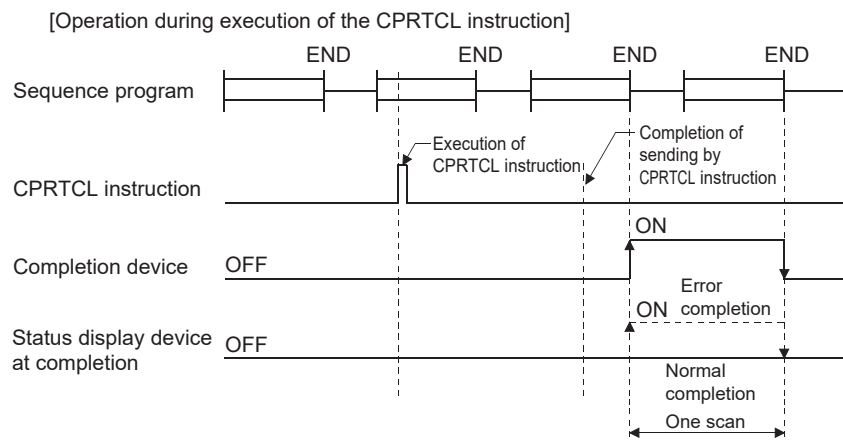

**Point**

The following describes how to check the execution status of protocols.

- Checking with the buffer memory  
Use the protocol execution status (address: 4041<sub>H</sub>/4051<sub>H</sub>).  
For details, refer to Page 331, Appendix 1.
- Checking with GX Works2  
Open the "Predefined Protocol Function" tab in the "State Monitor" screen.  
For details, refer to Page 249, Section 13.2.

**(4) Error**

**(a) When a dedicated instruction is failed, the status display device at completion ((D)+1) turns ON and the error code is stored in the execution result ((S)+0).**

In case of operation errors, Error flag (SM0) turns ON and the error code is stored in SD0.

Refer to the following according to the error code, and check and correct the error.

<Error code>

4FFF <sub>H</sub> or less	MELSEC-L CPU Module User's Manual (Hardware Design, Maintenance and Inspection)
7000 <sub>H</sub> or later	Page 277, Section 15.2

**(5) Program example**

For the program example of the CPRTCL instruction, refer to Page 136, Section 9.5.

## (6) Cancellation of protocol execution

A protocol can be cancelled during its execution.

This function is used to end the protocol execution forcibly when a communication error occurs with the other device.

This function is available for the predefined protocol mode only.

### (a) Execution method for cancellation request

Execute a cancellation request from the sequence program.

The corresponding buffer memories are shown in the following table.

Address Decimal (Hex)		Name	Setting value
CH1	CH2		
16448 (4040 <sub>H</sub> )	16464 (4050 <sub>H</sub> )	Protocol cancellation specification	0: No cancellation specification 1: Cancellation request (Specified by User) 2: Cancel completed (set by C24N)

### (b) Operation after execution of cancellation request

Operation of dedicated instruction (CPRTCL instruction)	<ul style="list-style-type: none"><li>• The operation fails and the error code is stored in the execution result ((S)+0).</li><li>• When executing multiple protocols consecutively, if the cancellation is requested to the nth protocol, the nth protocol is ended forcibly and the protocols after the nth protocol are not executed.</li></ul>
Operation of C24	<ul style="list-style-type: none"><li>• If the cancellation is requested when protocols are not executed, the cancellation is completed in no-operation.</li><li>• If the cancellation is requested when the communication protocol setting is other than the communication protocol mode, the value of the cancellation designation area is ignored.</li></ul>

### **Point**

When the protocol with the communication type of "Send & receive" is cancelled, execute the receive data clear after the cancellation.

When the response from the other device is slow, and data are received after the cancellation, the receive data remains in the OS area (receive data area).

For details of the receive data clear, refer to  Page 160, Section 10.1.5.

When Protocol cancellation specification is "1: Cancellation request", the next CPRTCL instruction cannot be executed.

**(c) Program example**

The following is a program in which a cancellation is requested to the protocol being executed when the start I/O number of the C24 is 0000.

Devices used by user

Device	Purpose
M100	Cancellation request command flag
M101	Cancellation request flag
M110	Turns ON during execution of the CPRTCL instruction.
U0\G16448	Cancellation designation area

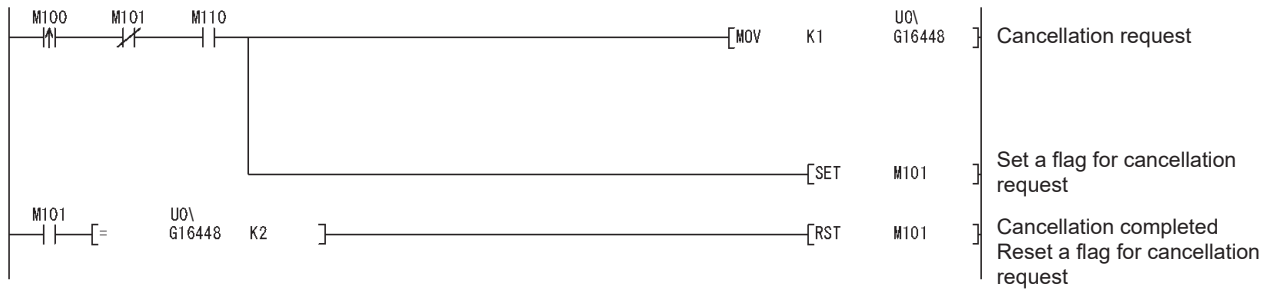

## 12.3.1 Functional protocol

The following functions are available by executing functional protocols with the CPRTCL instruction.

- Receive data clear
- Send/receive data monitoring start/stop
- RS/DTR signal condition designation

### (1) Setting

Specify the functional protocol number of the function to be executed in the control data ((S)+2 to (S)+9) of the CPRTCL instruction.

For details of the CPRTCL instruction, refer to  Page 212, Section 12.3.

### (2) List of functional protocols

The following table shows the list of functional protocols described in this section.

Protocol No.	Protocol type	Keyword <sup>*1</sup>	Reference
201	Receive data clear	Receive Data Clear	Page 218, Section 12.3.1 (2) (a)
202	Send/Receive data monitoring start	Send/Recv Monitor Start	Page 218, Section 12.3.1 (2) (b)
203	Send/Receive data monitoring stop	Send/Recv Monitor Stop	
204	Turns ER (DTR) signal ON	DTR ON	Page 218, Section 12.3.1 (2) (c)
205	Turns ER (DTR) signal OFF	DTR OFF	
206	Turns RS(RTS) signal ON	RS ON	
207	Turns RS(RTS) signal OFF	RS OFF	

\*1 Character strings that are stored to the protocol name of the protocol execution log when functional protocols are executed.

#### (a) Receive data clear

Receive data in the OS area are cleared.

#### (b) Send/Receive data monitoring start/stop

Start or stop of send/receive data monitoring is specified.

When the functional protocol (202, 203) is executed, a monitoring start command (0001<sub>H</sub>) or monitoring stop command (0000<sub>H</sub>) is set for send/receive data monitoring designation (address: 2018<sub>H</sub>/2118<sub>H</sub>) in the C24.

For details of send/receive monitoring, refer to  User's Manual (Application).

#### (c) RS/DTR signal status specification

ON/OFF status of the RS(RTS)/ER(DTR) signal is specified.

When the functional protocol (204 to 207) is executed, corresponding bits of the RS/DTR signal status designation (address: 92<sub>H</sub>/132<sub>H</sub>) are turned ON/OFF in the C24.

For details of RS/DTR signal status designation, refer to  Page 46, Section 6.2.1.

# 12.4 G(P).OUTPUT

Data can be sent in any user-defined message format using the nonprocedural protocol.

Setting data	Applicable device								
	Internal device (System, user)		File register	Link direct device J□□□		Intelligent function module device U□□G□□	Index register Zn	Constant	Others
	Bit	Word		Bit	Word				
(S1)	—	○				—			
(S2)	—	○				—			
(D)	○	○				—			

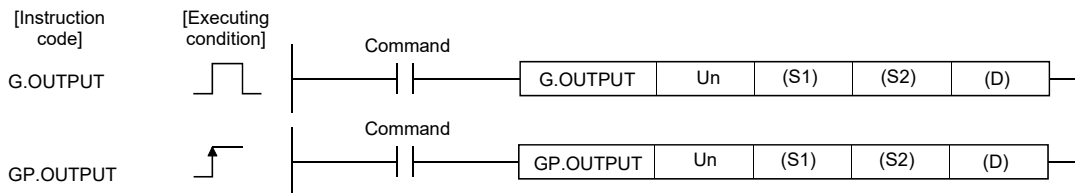

## (1) Setting data

Setting data	Description	Set by	Data type
Un	Start I/O signal of the module (00 to FE: Upper 2 digits when I/O signals are expressed in 3-digit.)	User	BIN16-bit
(S1)	Start number of the devices in which control data is stored.	User, system	Device name
(S2)	Start number of the devices in which transmission data is stored.	User	
(D)	Bit device number to be turned on at completion of execution.	System	Bit

The file register per local device and program cannot be used as the setting data.

## (2) Control data

Device	Item	Setting data	Setting range	Set by <sup>*3</sup>
(S1) + 0	Transmission channel	<ul style="list-style-type: none"> <li>Set transmission channel</li> <li>1: Channel 1 (CH1 side)</li> <li>2: Channel 2 (CH2 side)</li> </ul>	1, 2	User
(S1) + 1	Transmission result	<ul style="list-style-type: none"> <li>Transmission result by an OUTPUT instruction are stored.</li> <li>0: Normal</li> <li>Other than 0: Error code<sup>*1</sup></li> </ul>	—	System
(S1) + 2	Transmission data count	<ul style="list-style-type: none"> <li>Set the transmission data count.<sup>*2</sup></li> </ul>	1 or more	User

\*1 For error codes relating to abnormal completion, refer to Page 262, CHAPTER 15.

\*2 When setting "Word/byte units designation" by GX Works2, set the number of bytes when bytes are designated and set the number of words when words are designated.

\*3 The settings are done by either of the following:

- User: Data set by the user before executing the OUTPUT instructions.
- System: The CPU module stores the execution result of the OUTPUT instructions.

### (3) Function

- (a) Data stored in the device designated in (S2) and succeeding devices are sent according to the control data of the device designated in (S1) and succeeding devices, via the nonprocedural protocol of the module specified in Un.

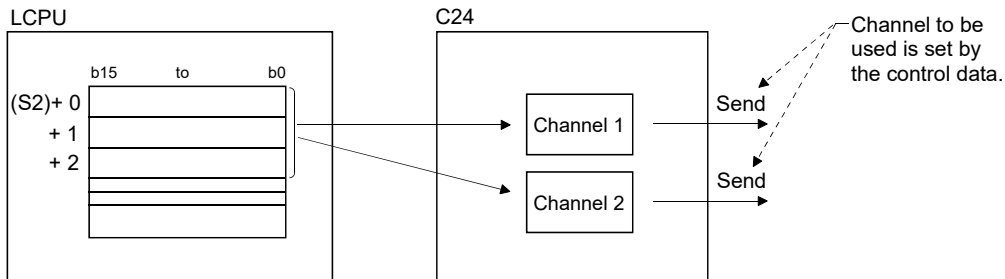

### (b) Simultaneous execution of dedicated instructions

The following table shows the handling for when executing another instruction during execution of the OUTPUT instruction or executing the OUTPUT instruction during execution of another instruction in the same channel.

Instruction *1	Availability of simultaneous execution	Processing of simultaneous execution
OUTPUT	×	• The next instruction will be ignored until the active instruction is completed. (However, simultaneous execution is available when channels to be used are not the same.)
INPUT	○	—
PRR	×	• Dedicated instructions simultaneous execution error (7FF0 <sub>H</sub> ) occurs in the dedicated instruction attempted later. (However, simultaneous execution is available when channels to be used are not the same.)
CSET		
PUTE	○	—
GETE		
BUFRCVS		
SPBUSY		
UINI	×	• Dedicated instructions simultaneous execution error (7FF0 <sub>H</sub> ) occurs in the dedicated instruction attempted later.

○: Available, ×: Not available

- \*1 Since the dedicated instructions shown below use a different communication protocol from that for the OUTPUT instruction, they are not used in the same channel.
- ONDEMAND, BIDOUT, BIDIN, CPRTCL  
If the dedicated instructions shown above are used in the same channel with the OUTPUT instruction, the communication protocol setting error (7FF2<sub>H</sub>) occurs.

**(c) Whether an OUTPUT instruction was completed or failed can be checked by the completion device ((D)) or status display device at completion ((D)+1).**

Completion device	Completion device: Turns on at the END processing of the scan where the OUTPUT instruction is completed, and turns off at the next END processing.
Status display device at completion	Turns on and off depending on the completion status of the OUTPUT instruction. <ul style="list-style-type: none"> <li>• Normal completion: Off with no change.</li> <li>• Abnormal completion: Turns on at the END processing of the scan where the OUTPUT instruction is completed, and turns off at the next END processing.</li> </ul>

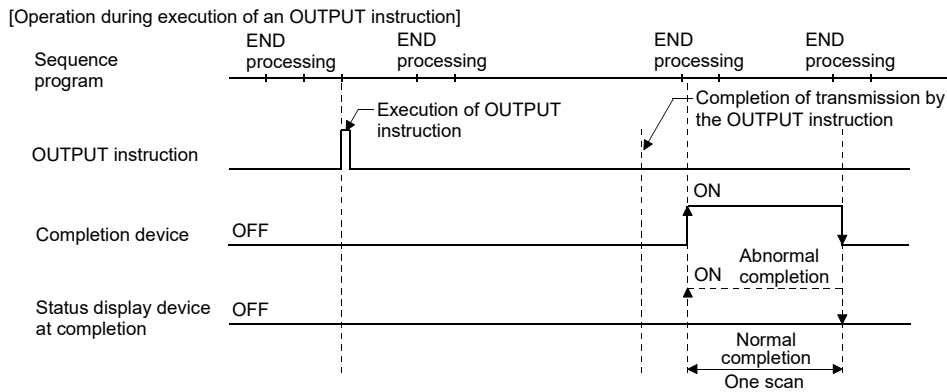

**(4) Error**

**(a) When a dedicated instruction is failed, the abnormal completion signal, (D)+1, turns on and the error code is stored in the transmission result (S1)+1.**

In case of operation errors, Error flag (SM0) turns on and the error code is stored in SD0.

Refer to the following according to the error code, and check and correct the error.

<Error code>

4FFF <sub>H</sub> or less	📖 MELSEC-L CPU Module User's Manual (Hardware Design, Maintenance and Inspection)
7000 <sub>H</sub> or later	📖 Page 277, Section 15.2

## (5) Program example

The following example shows a program that sends any data stored in D11 to D15 using the nonprocedural protocol.

When input/output signals of the C24 are from X/Y00 to X/Y1F:

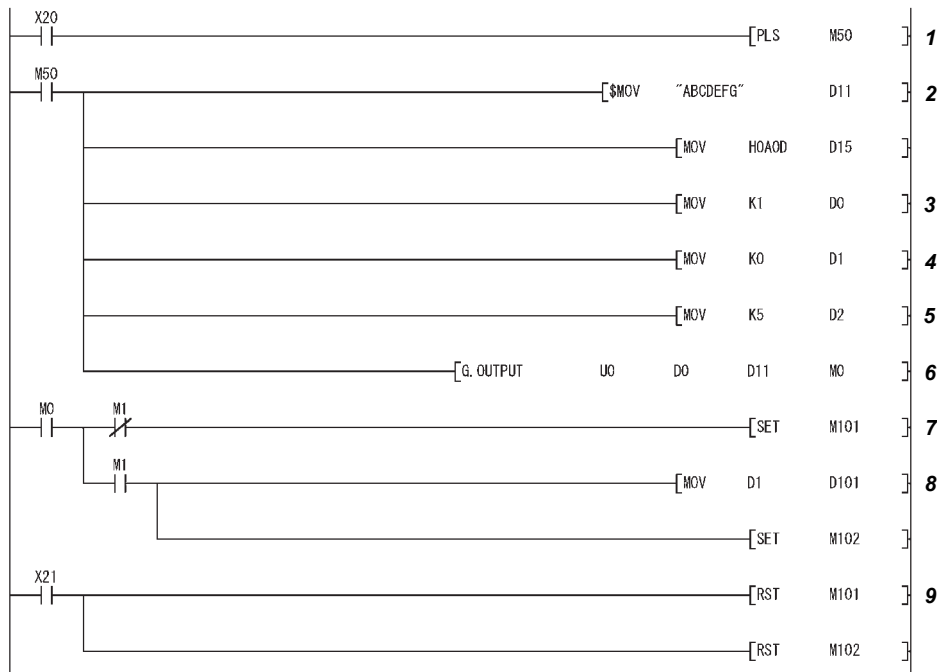

1. Transmission command is converted into pulse.
2. Transmission data is stored.
3. Specify the number of the interface (CH□) that sends the data.
4. Clear the transmission result storage device to 0.
5. Specify the transmission data count in word units. (Specify K10 when the unit is bytes.)
6. The transmission data stored in the specified device is sent.
7. After the OUTPUT instruction is executed, the transmission complete signal (M0) specified by user turns ON for one scan.
8. The error code of the transmission result storage device is saved to D101.
9. The completion flag is reset by an external command.



# 12.5 G.INPUT

Data can be received in any user-defined message format using the nonprocedural protocol.

Setting data	Applicable device								
	Internal device (System, user)		File register	Link direct device J□□□		Intelligent function module device U□\G□	Index register Zn	Constant	Others
	Bit	Word		Bit	Word				
(S)	—	○				—			
(D1)	—	○				—			
(D2)	○	○				—			

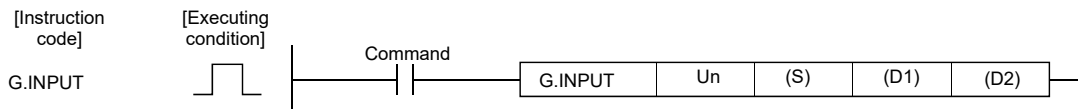

## (1) Setting data

Setting data	Description	Set by	Data type
Un	Start I/O signal of the module (00 to FE: Upper 2 digits when I/O signals are expressed in 3-digit.)	User	BIN16-bit
(S)	Start number of the devices in which control data is stored.	User, system	Device name
(D1)	Start number of the devices in which receive data is stored.	System	
(D2)	Bit device number to be turned on at completion of execution.	System	Bit

The file register per local device and program cannot be used as the setting data.

## (2) Control data

Device	Item	Setting data	Setting range	Set by <sup>*3</sup>
(S) + 0	Receive channel	<ul style="list-style-type: none"> <li>Set receive channel</li> <li>1: Channel 1 (CH1 side)</li> <li>2: Channel 2 (CH2 side)</li> </ul>	1, 2	User
(S) + 1	Reception result	<ul style="list-style-type: none"> <li>Reception result by an INPUT instruction are stored.</li> <li>0: Normal</li> <li>Other than 0: Error code<sup>*1</sup></li> </ul>	—	System
(S) + 2	Receive data count	<ul style="list-style-type: none"> <li>The number of data received is stored.<sup>*2</sup></li> <li>(0 or more)</li> </ul>	—	System
(S) + 3	Allowable number of receive data	<ul style="list-style-type: none"> <li>Set the allowable number of words for received data that can be stored in (D1).</li> </ul>	1 or more	User

## Point

---

- The command of G.INPUT cannot be converted into pulse.
  - G.INPUT should be executed while the read request of the input/output signal is turned on.
- 

- \*1 For error codes relating to abnormal completion, refer to  Page 262, CHAPTER 15.
- \*2 When setting "Word/byte units designation" by GX Works2, set the number of bytes when bytes are designated and set the number of words when words are designated.
- \*3 The settings are done by either of the following:
  - User: Data set by the user before executing the INPUT instructions.
  - System: The CPU module stores the execution result of the INPUT instructions.

**(3) Function**

- (a) The function stores in the device designated in (D1) and succeeding devices the data received with the nonprocedural protocol of the module designated in Un, according to the control data of the device designated in (S) and succeeding devices.
- (b) When the number of data actually received exceeds the allowable receive data count specified by (S)+3, only the receive data within the allowable receive data count is stored, and the remaining receive data is discarded. (The dedicated instructions are completed normally.)

In this case, the allowable receive data count is stored in the receive data count ((S)+2).

**(c) Simultaneous execution of dedicated instructions**

The following table shows the handling for when executing another instruction during execution of the INPUT instruction or executing the INPUT instruction during execution of another instruction in the same channel.

Instruction*1	Availability of simultaneous execution	Processing of simultaneous execution
OUTPUT PRR	○	—
INPUT	×	<ul style="list-style-type: none"> <li>The next instruction will be ignored until the active instruction is completed. (However, simultaneous execution is available when channels to be used are not the same.)</li> </ul>
CSET	(the right column)	[When instructions are executed in order of INPUT → CSET] <ul style="list-style-type: none"> <li>Dedicated instructions simultaneous execution error (7FF0<sub>H</sub>) occurs in the CSET instruction. (However, simultaneous execution is available when channels to be used are not the same.)</li> </ul> [When instructions are executed in order of CSET → INPUT] <ul style="list-style-type: none"> <li>Simultaneous execution is available.</li> </ul>
PUTE GETE	○	—
BUFRCVS	×	INPUT instruction and BUFRCVS instruction cannot be used at the same time. (However, simultaneous execution is available when channels to be used are not the same.)
SPBUSY	○	—
UINI	×	<ul style="list-style-type: none"> <li>Dedicated instructions simultaneous execution error (7FF0<sub>H</sub>) occurs in the dedicated instruction attempted later.</li> </ul>

○: Available, ×: Not available

- \*1 Since the dedicated instructions shown below use a different communication protocol from that for the INPUT instruction, they are not used in the same channel.
- ONDEMAND, BIDOUT, BIDIN, CPRTCL
- If the dedicated instructions shown above are used in the same channel with the INPUT instruction, the communication protocol setting error (7FF2<sub>H</sub>) occurs.

**(d) Whether an INPUT instruction was completed or failed can be checked by the completion device ((D2)) or status display device at completion ((D2)+1).**

Completion device	Turns on at the END processing of the scan where the INPUT instruction is completed, and turns off at the next END processing.
Status display device at completion	Turns on and off depending on the completion status of the INPUT instruction. <ul style="list-style-type: none"> <li>• Normal completion: Off with no change.</li> <li>• Abnormal completion: Turns on at the END processing of the scan where the INPUT instruction is completed, and turns off at the next END processing.</li> </ul>

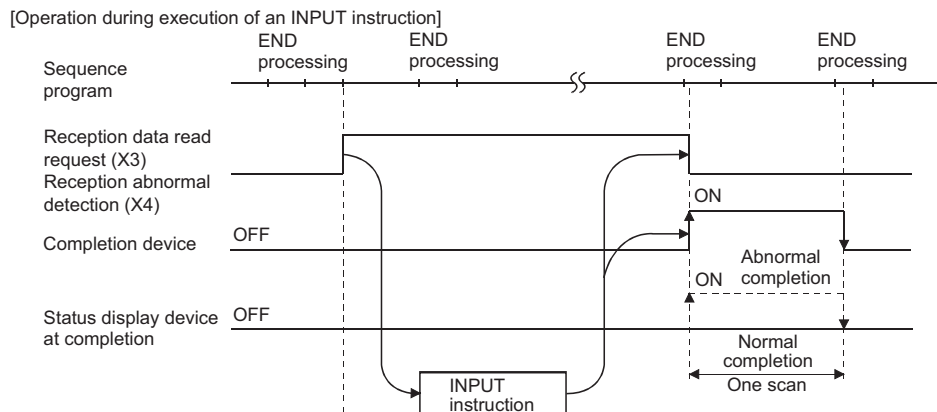

**(4) Error**

**(a) When a dedicated instruction is failed, the abnormal completion signal (D2)+1, turns on and the error code is stored in the reception result (S)+1.**

In case of operation errors, Error flag (SM0) turns on and the error code is stored in SD0.

Refer to the following according to the error code, and check and correct the error.

<Error code>

4FFF <sub>H</sub> or less	📖 MELSEC-L CPU Module User's Manual (Hardware Design, Maintenance and Inspection)
7000 <sub>H</sub> or later	📖 Page 277, Section 15.2

**(5) Program example**

The following example shows a program that stores data received via the nonprocedural protocol in D10 and later.

When the input/output signals of the C24 are from X/Y00 to X/Y1F:

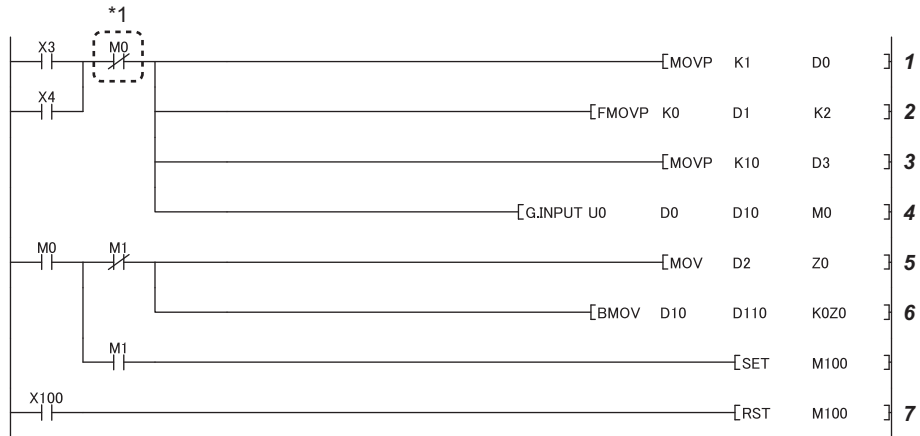

\*1 When the completion device is off, execute the INPUT instruction.  
If the INPUT instruction is executed when the completion device is on, data may not be received properly.

- 1. Specify the receive channel.**
- 2. Clear the reception result and receive data count storage device to 0.**
- 3. Specify the allowable receive data count.**
- 4. Store the receive data in the specified device.**
- 5. After completed, the receive data within the allowable receive data count (user-specified) is read from the receive data storage area in the buffer memory.**  
Once the INPUT instruction is executed, the read completion signal (M0) specified by user turns ON for one scan.
- 6. The receive data of the receive data count is transferred to D110.**
- 7. The abnormal completion flag is reset by an external command.**

# 12.6 G(P).BIDOUT

Data can be sent using the bidirectional protocol.

Setting data	Applicable device								
	Internal device (System, user)		File register	Link direct device J□□□		Intelligent function module device U□□G□□	Index register Zn	Constant	Others
	Bit	Word		Bit	Word				
(S1)	—	○				—			
(S2)	—	○				—			
(D)	○	○				—			

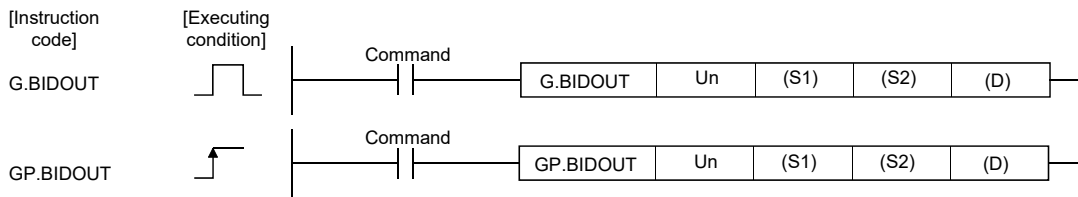

## (1) Setting data

Setting data	Description	Set by	Data type
Un	Start I/O signal of the module (00 to FE: Upper 2 digits when I/O signals are expressed in 3-digit.)	User	BIN16-bit
(S1)	Start number of the devices in which control data is stored.	User, system	Device name
(S2)	Start number of the devices in which transmission data is stored.	User	
(D)	Bit device number to be turned on at completion of execution.	System	Bit

The file register per local device and program cannot be used as the setting data.

## (2) Control data

Device	Item	Setting data	Setting range	Set by <sup>*3</sup>
(S1) + 0	Transmission channel	<ul style="list-style-type: none"> <li>Set transmission channel</li> <li>1: Channel 1 (CH1 side)</li> <li>2: Channel 2 (CH2 side)</li> </ul>	1, 2	User
(S1) + 1	Transmission result	<ul style="list-style-type: none"> <li>Transmission result by a BIDOUT instruction are stored.</li> <li>0: Normal</li> <li>Other than 0: Error code<sup>*1</sup></li> </ul>	—	System
(S1) + 2	Transmission data count	<ul style="list-style-type: none"> <li>Set the transmission data count.<sup>*2</sup></li> </ul>	1 or more	User

\*1 For error codes relating to abnormal completion, refer to Page 262, CHAPTER 15.

\*2 When setting "Word/byte units designation" by GX Works2, set the number of bytes when bytes are designated and set the number of words when words are designated.

\*3 The settings are done by either of the following:

- User: Data set by the user before executing the BIDOUT instructions.
- System: The CPU module stores the execution result of the BIDOUT instructions.

**(3) Function**

**(a) The function sends data stored in the device designated in (S2) and succeeding devices according to the control data of the device designated in (S1) and succeeding devices, via the bidirectional protocol of the module designated in Un.**

**(b) Simultaneous execution of dedicated instructions**

The following table shows the handling for when executing another instruction during execution of the BIDOUT instruction or executing the BIDOUT instruction during execution of another instruction in the same channel.

Instruction*1	Availability of simultaneous execution	Processing of simultaneous execution
BIDOUT	×	• The next instruction will be ignored until the active instruction is completed. (However, simultaneous execution is available when channels to be used are not the same.)
BIDIN	○	—
CSET	×	• Dedicated instructions simultaneous execution error (7FF0 <sub>H</sub> ) occurs in the dedicated instruction attempted later. (However, simultaneous execution is available when channels to be used are not the same.)
PUTE	○	—
GETE		
BUFRCVS		
SPBUSY		
UINI	×	• Dedicated instructions simultaneous execution error (7FF0 <sub>H</sub> ) occurs in the dedicated instruction attempted later.

○: Available, ×: Not available

- \*1 Since the dedicated instructions shown below use a different communication protocol from that for the BIDOUT instruction, they are not used in the same channel.
- ONDEMAND, OUTPUT, PRR, INPUT, CPRTCL  
If the dedicated instructions shown above are used in the same channel with the BIDOUT instruction, the communication protocol setting error (7FF2<sub>H</sub>) occurs.

**(c) Whether a BIDOUT instruction was completed normally or abnormally can be checked by the completion device ((D)) or status display device at completion ((D)+1).**

Completion device	Turns on at the END processing of the scan where the BIDOUT instruction is completed, and turns off at the next END processing.
Status display device at completion	Turns on and off depending on the completion status of the BIDOUT instruction. <ul style="list-style-type: none"> <li>• Normal completion: Off with no change.</li> <li>• Abnormal completion: Turns on at the END processing of the scan where the BIDOUT instruction is completed, and turns off at the next END processing.</li> </ul>

[Operation during execution of a BIDOUT instruction]

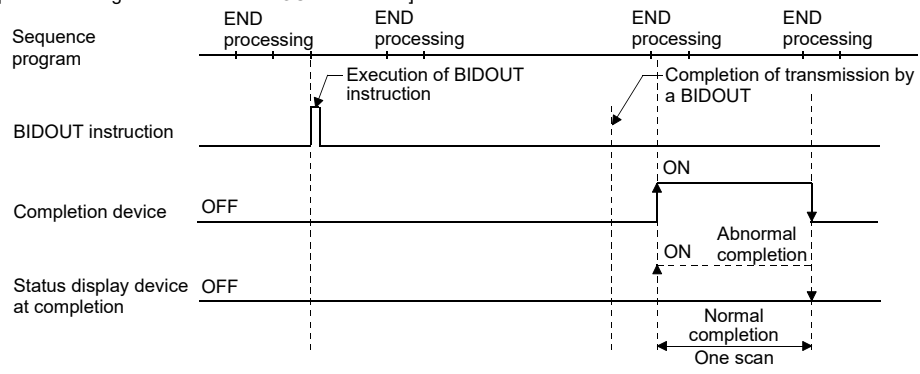





**(4) Error**

- (a) When a dedicated instruction is failed, the abnormal completion signal, (D)+1, turns on and the error code is stored in the transmission result (S1)+1.
- (b) In case of operation errors, Error flag (SM0) turns on and the error code is stored in SD0.

Refer to the following according to the error code, and check and correct the error.

<Error code>

4FFF <sub>H</sub> or less	 MELSEC-L CPU Module User's Manual (Hardware Design, Maintenance and Inspection)
7000 <sub>H</sub> or later	 Page 277, Section 15.2

## (5) Program example

The following example shows a program that sends any data stored in D11 to D15 using the bidirectional protocol.

When the input/output signals of the C24 are from X/Y00 to X/Y1F:

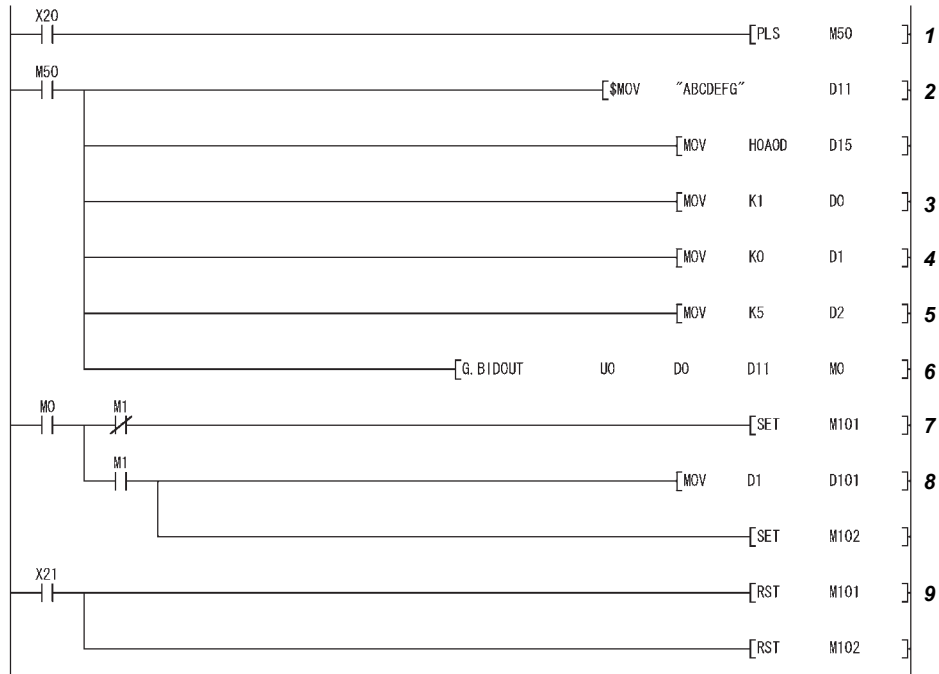

1. Transmission command is converted into pulse.
2. Transmission data is stored.
3. Specify the number of the interface (CH□) that sends the data.
4. Clear the transmission result storage device to 0.
5. Specify the transmission data count in word units. (Specify K10 when the unit is bytes.)
6. The transmission data stored in the specified device is sent.
7. After the BIDOUT instruction is executed, the transmission complete signal (M0) specified by user turns ON for one scan.
8. The error code of the transmission result storage device is saved to D101.
9. The completion flag is reset by an external command.

# 12.7 G(P).BIDIN

Data can be received using the bidirectional protocol.

Setting data	Applicable device								
	Internal device (System, user)		File register	Link direct device J <sub>0</sub> V <sub>0</sub>		Intelligent function module device U <sub>0</sub> IG <sub>0</sub>	Index register Z <sub>n</sub>	Constant	Others
	Bit	Word		Bit	Word				
(S)	—	○				—			
(D1)	—	○				—			
(D2)	○	○				—			

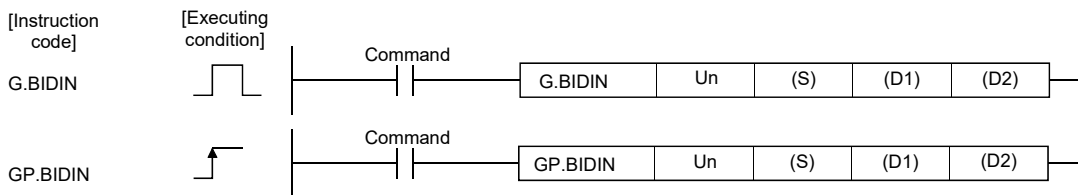

## (1) Setting data

Setting data	Description	Set by	Data type
Un	Start I/O signal of the module (00 to FE: Upper 2 digits when I/O signals are expressed in 3-digit.)	User	BIN16-bit
(S)	Start number of the devices in which control data is stored.	User, system	Device name
(D1)	Start number of the devices in which receive data is stored.	System	
(D2)	Bit device number to be turned on at completion of execution.	System	

The file register per local device and program cannot be used as the setting data.

## (2) Control data

Device	Item	Setting data	Setting range	Set by <sup>*3</sup>
(S) + 0	Receive channel	<ul style="list-style-type: none"> <li>Set receive channel</li> <li>1: Channel 1 (CH1 side)</li> <li>2: Channel 2 (CH2 side)</li> </ul>	1, 2	User
(S) + 1	Reception result	<ul style="list-style-type: none"> <li>Reception result by a BIDIN instruction are stored.</li> <li>0: Normal</li> <li>Other than 0: Error code<sup>*1</sup></li> </ul>	—	System
(S) + 2	Receive data count	<ul style="list-style-type: none"> <li>The number of data received is stored.<sup>*2</sup></li> <li>(1 or more)</li> </ul>	—	System
(S) + 3	Allowable number of receive data	<ul style="list-style-type: none"> <li>Set the allowable number of words for received data that can be stored in (D1).</li> </ul>	1 or more	User

G (P).BIDIN should be executed while the read request of the input/output signal is turned on.

---

- \*1 For error codes relating to abnormal completion, refer to  Page 262, CHAPTER 15.
- \*2 When setting "Word/byte units designation" by GX Works2, set the number of bytes when bytes are designated and set the number of words when words are designated as the unit types.
- \*3 The settings are done by either of the following:
  - User: Data set by the user before executing the BIDIN instructions.
  - System: The CPU module stores the execution result of the BIDIN instructions.

**(3) Function**

(a) The function stores in the device designated in (D1) and succeeding devices the data received via the bidirectional protocol of the module designated in Un, according to the control data of the device designated in (S) and succeeding devices.

**(b) Simultaneous execution of dedicated instructions**

The following table shows the handling for when executing another instruction during execution of the BIDIN instruction or executing the BIDIN instruction during execution of another instruction in the same channel.

Instruction <sup>*1</sup>	Availability of simultaneous execution	Processing of simultaneous execution
BIDOUT	○	—
BIDIN	×	• The next instruction will be ignored until the active instruction is completed. (However, simultaneous execution is available when channels to be used are not the same.)
CSET	×	• Dedicated instructions simultaneous execution error (7FF0 <sub>H</sub> ) occurs in the dedicated instruction attempted later. (However, simultaneous execution is available when channels to be used are not the same.)
PUTE	○	—
GETE		
BUFRCVS	×	BIDIN instruction and BUFRCVS instruction cannot be used at the same time. (However, simultaneous execution is available when channels to be used are not the same.)
SPBUSY	○	—
UINI	×	• Dedicated instructions simultaneous execution error (7FF0 <sub>H</sub> ) occurs in the dedicated instruction attempted later.

○: Available, ×: Not available

\*1 Since the dedicated instructions shown below use a different communication protocol from that for the BIDIN instruction, they are not used in the same channel.  
ONDEMAND, OUTPUT, PRR, INPUT, CPRTCL  
If the dedicated instructions shown above are used in the same channel with the BIDIN instruction, the communication protocol setting error (7FF2<sub>H</sub>) occurs.

**(c) Whether a BIDIN instruction was completed normally can be checked by the completion device ((D2)) or status display device at completion ((D2)+1).**

Completion device	Turns on at the END processing of the scan where the BIDIN instruction is completed normally, and turns off at the next END processing.
Status display device at completion	Does not change when left off.

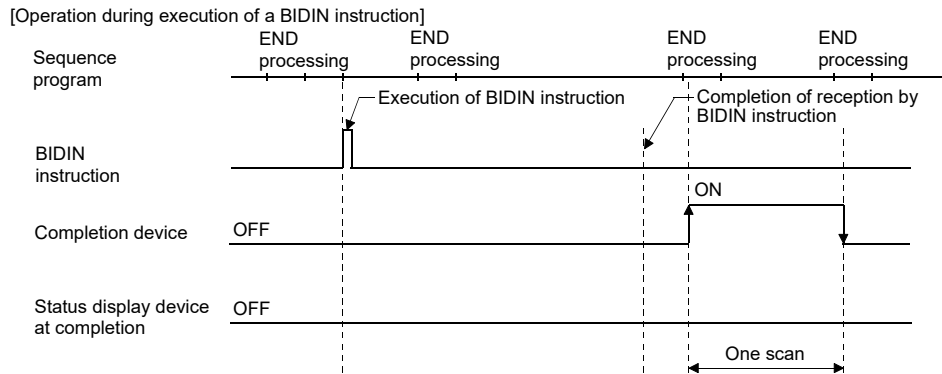

## (4) Error

### (a) In case of operation errors, Error flag (SM0) turns on and the error code is stored in SD0.

Refer to the following according to the error code, and check and correct the error.

<Error code>

4FFF <sub>H</sub> or less	MELSEC-L CPU Module User's Manual (Hardware Design, Maintenance and Inspection)
7000 <sub>H</sub> or later	Page 277, Section 15.2

## (5) Program example

The following example shows a program that receives any data using the bidirectional protocol and stores that data in D10 or later.

The input/output signals of the C24 are from X/Y00 to X/Y1F:

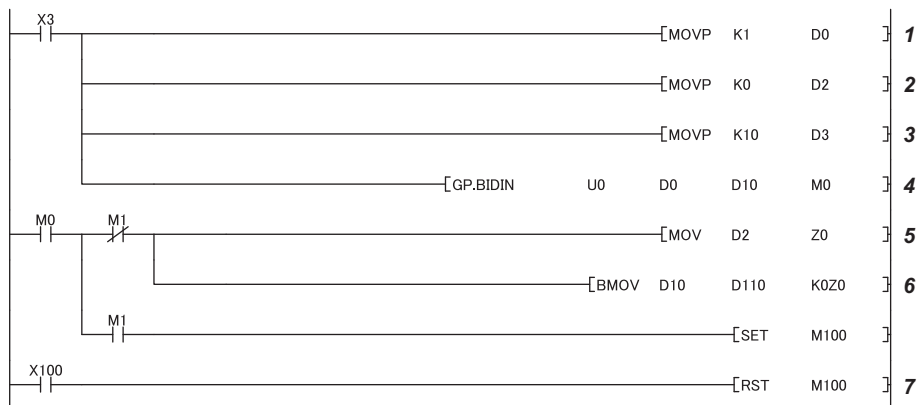

1. Specify the receive channel.
2. Clear the receive data count storage device to 0.
3. Specify the allowable receive data count.
4. Store the receive data in the specified device. After completed, the receive data within the allowable receive data count (user-specified) is read from the receive data storage area in the buffer memory.
5. Once the BIDIN instruction is executed, the read completion signal (M0) specified by user turns ON for one scan.
6. The receive data of the receive data count is transferred to D110.
7. The completion flag is reset by an external command.

# 12.8 G(P).SPBUSY

This instruction reads the status of data transmission and reception executed with dedicated instructions.

Setting data	Applicable device								
	Internal device (System, user)		File register	Link direct device J0V0		Intelligent function module device U0\G0	Index register Zn	Constant	Others
	Bit	Word		Bit	Word				
(D)	○		—						

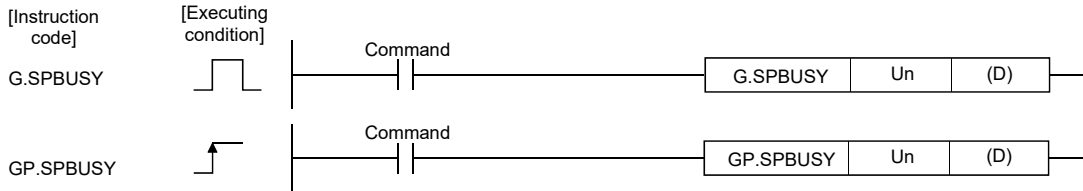

## (1) Setting data

Setting data	Description	Set by	Data type
Un	Start I/O signal of the module (00 to FE: Upper 2 digits when I/O signals are expressed in 3-digit.)	User	BIN16-bit
(D)	Start number of devices in which the read communication status is stored.	System	Device name

## (2) Function

- (a) The function reads the execution status of a dedicated instruction directed to a module designated by the start I/O signal, and stores it in the device designated by (D) or later.
- (b) The execution status is stored in (D) in the form of "1" at the corresponding bit when the processing of each instruction is started, and "0" when the processing is completed.

The processing of each instruction is completed when the completion flag of each instruction is turned from on to off.

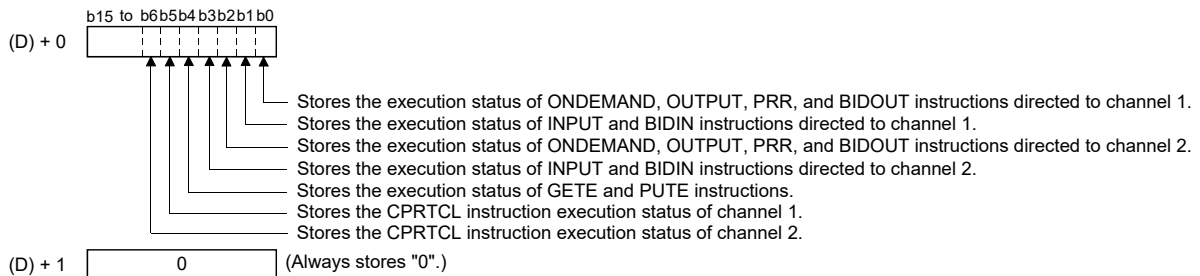

- (c) The SPBUSY instruction is executed for every scan while the read command is ON, if the system is executing during ON. And, the instruction will be executed for a single scan when the read command rises from OFF to ON, if the system is starting up.

#### (d) Simultaneous execution of dedicated instructions



It is possible to execute another instruction during execution of the SPBUSY instruction and to execute the SPBUSY instruction during execution of another instruction.

### (3) Error

#### (a) In case of operation errors, Error flag (SM0) turns on and the error code is stored in SD0.

Refer to the following according to the error code, and check and correct the error.

<Error code>

4FFF <sub>H</sub> or less	 MELSEC-L CPU Module User's Manual (Hardware Design, Maintenance and Inspection)
7000 <sub>H</sub> or later	 Page 277, Section 15.2

### (4) Program example

A program that reads the communication status of a target module.

When input/output signals of the C24 are from X/Y00 to X/Y1F

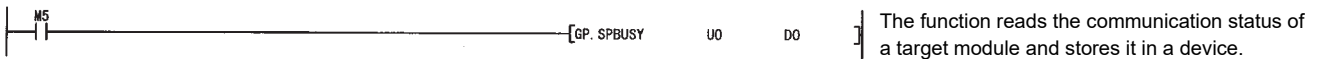



## 12.9 ZP.CSET (Receive data clear)

Setting data	Applicable device								
	Internal device		File register	Link direct device J <small>0</small> AN <small>0</small>		Intelligent function module device U <small>0</small> AG <small>0</small>	Index register Zn	Constant K, H	Others
	Bit	Word		Bit	Word				
(S1)	—		○			—	○	—	
(S2)	—		○			—			
(D1)	—		○			—			
(D2)	○		○			—			

[Instruction code]

[Executing condition]

[Instruction form]

ZP.CSET



### (1) Setting data

Setting data	Description	Set by	Data type
Un	Start I/O signal of the module (00 to FE: Upper 2 digits when I/O signals are expressed in 3-digit.)	User	BIN16-bit
(S1)	Number of the channel that demands to clear receiving data. 1: Channel 1 (CH1 side) 2: Channel 2 (CH2 side)		
(S2)	Start number of the device in which control data is stored.	User, system	Device name
(D1)	Dummy	—	Device name
(D2)	Start number of the bit device at the host station that turns on for one scan at the completion of the instruction. (D2) + 1 also turns on at an abnormal completion.	System	Bit

The file register per local device and program cannot be used as the setting data.

### (2) Control data

Device	Item	Setting data	Setting range	Set by
(S2) + 0	Execution type	Select 0.	0	User
(S2) + 1	Complete status	The execution result at the completion of the instruction is stored. 0: Normal Other than 0: Error code <sup>*1</sup>	—	System
(S2) + 2	Request type	Specify the request. 4: Receive data clear request	4	User
(S2) + 3 to (S2) + 111	For the system	Use prohibited (including for other purposes such as programming)	—	System

\*1 For error codes relating to abnormal completion, refer to Page 262, CHAPTER 15.

**Remark**

- Refer to the "Error" explanation on the following page for details on errors caused by wrong data specifications by the user.
- The setting sides are partitioned as follows:
  - User: Data set by the user before executing the dedicated instruction.
  - System: The CPU module stores the execution result of the dedicated instructions.

**(3) Function**

- (a) This function clears reception data in the OS area. It does not clear the user data reception area in the buffer memory.**
- (b) If the CSET instruction is executed while the reception data read request (X3/XA) or reception abnormal detection signal (X4/XB) is turned on, the CSET instruction is kept waiting until the signal is turned off.**
- (c) Simultaneous execution of dedicated instructions**

The following table shows the handling for when executing another instruction during execution of the CSET instruction or executing the CSET instruction during execution of another instruction in the same channel.

Instruction *1	Availability of simultaneous execution	Processing of simultaneous execution
ONDEMAND OUTPUT PRR BIDOUT BIDIN	×	<ul style="list-style-type: none"> <li>• Dedicated instructions simultaneous execution error (7FF0<sub>H</sub>) occurs in the dedicated instruction attempted later. (However, simultaneous execution is available when channels to be used are not the same.)</li> </ul>
INPUT	(the right column)	<p>[When instructions are executed in order of INPUT → CSET]</p> <ul style="list-style-type: none"> <li>• Dedicated instructions simultaneous execution error (7FF0<sub>H</sub>) occurs in the CSET instruction. (However, simultaneous execution is available when channels to be used are not the same.)</li> </ul> <p>[When instructions are executed in order of CSET → INPUT]</p> <ul style="list-style-type: none"> <li>• Simultaneous execution is available.</li> </ul>
CSET	×	<ul style="list-style-type: none"> <li>• The next instruction will be ignored until the active instruction is completed. (However, simultaneous execution is available when channels to be used are not the same.)</li> </ul>
PUTE GETE BUFRCVS SPBUSY	○	—
UINI	×	<ul style="list-style-type: none"> <li>• Dedicated instructions simultaneous execution error (7FF0<sub>H</sub>) occurs in the dedicated instruction attempted later.</li> </ul>

○: Available, ×: Not available

\*1 The same channel cannot be used for the CPRTCL and CSET instructions because different communication protocols are used for them.  
Using these instructions on the same channel will cause a communication protocol setting error (7FF2<sub>H</sub>).

(d) The status of the CSET instruction, whether it is being executed or completed normally/abnormally, can be checked by the complete device (D2) specified by the setting data.

Complete device ((D2) + 0)	This device turns on at the End processing of the scan at which the CSET instruction is completed and turns off at the next End processing.
Complete device ((D2) + 1)	It turns on/off by the status at which the CSET instruction is completed. <ul style="list-style-type: none"> <li>• At normal completion: It is kept turned off and does not change.</li> <li>• At abnormal completion: It turns on at the END processing of the scan at which the CSET instruction is completed and turns off at the next END processing.</li> </ul>

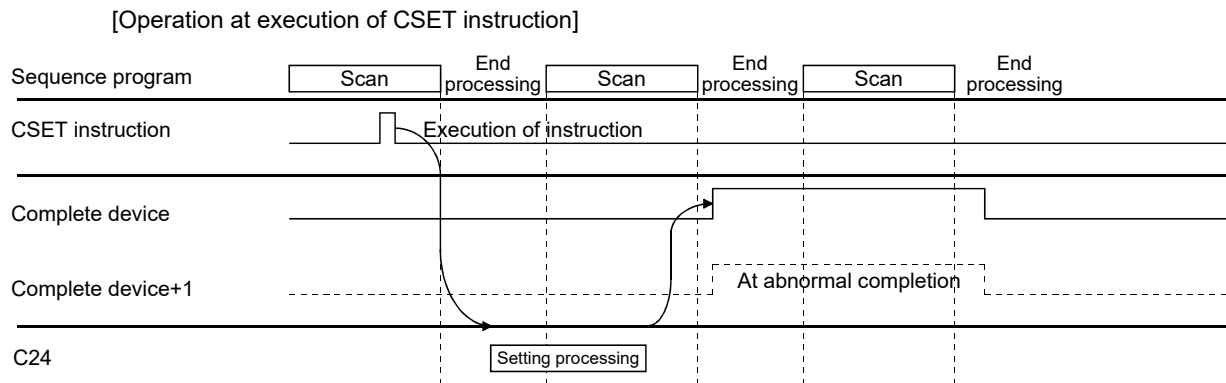

(4) Error

(a) If the dedicated instruction is abnormally completed, the error flag (SM0) turns on and the error code is stored in SD0.

Refer to the following according to the error code, and check/take action according to the error.

<Error code>

4FFF <sub>H</sub> or less	📖 MELSEC-L CPU Module User's Manual (Hardware Design, Maintenance and Inspection)
7000 <sub>H</sub> or later	📖 Page 277, Section 15.2

## (5) Program example

This is an example of a program that clears reception data on the C24 side.

It is assumed that the input/output signals of the C24 are X/Y00 to X/Y1F.

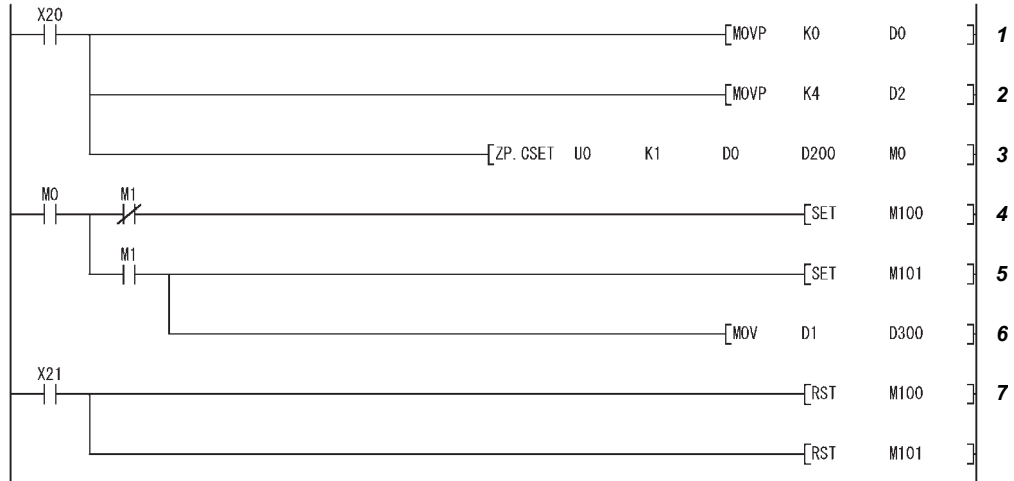

1. Set the execution type.
2. Set the request type (Reception data clear)
3. Execute the reception data clear
4. Normal completion
5. Abnormal completion
6. The error code in the completion status storage device is saved in D300.
7. The completion flag is reset by an external command.

# CHAPTER 13 DEBUG SUPPORT FUNCTION

The debug support functions are designed to support the debugging of communication processing between the C24 and external device. The following functions are available to ease system startup work.

- Circuit trace
- State monitor
- Protocol execution log display storage function (for predefined protocol only)

## 13.1 Circuit Trace

The communication data and communication control signal between the C24 and external device are traced.

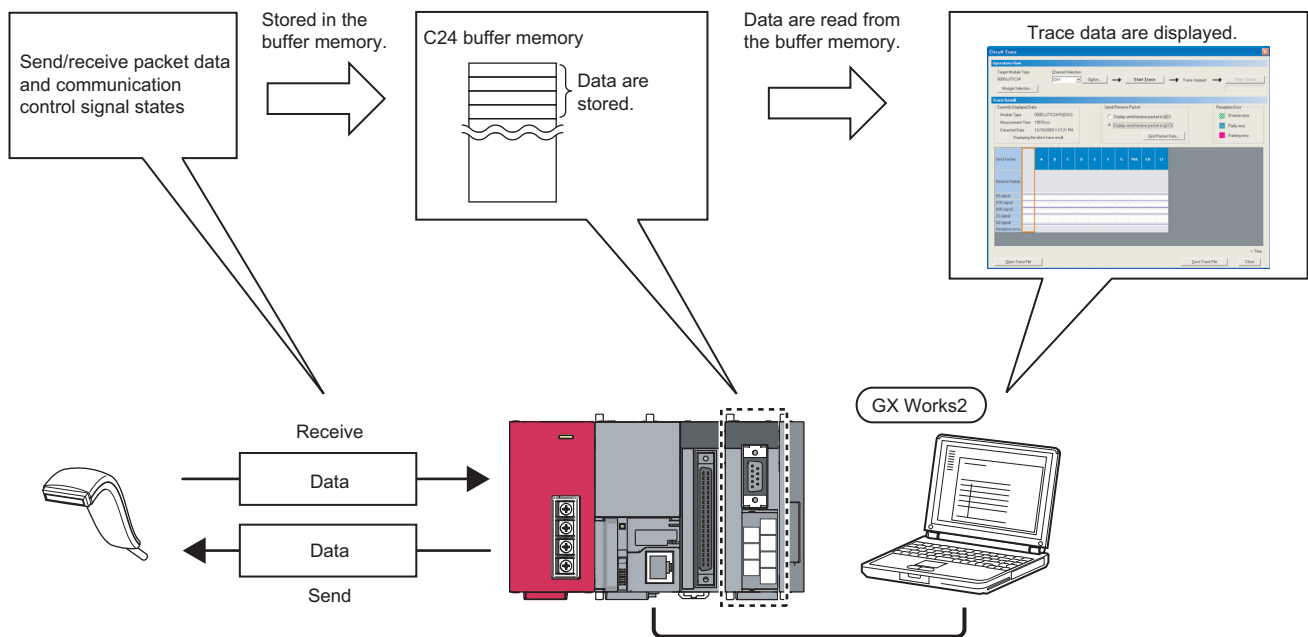

## 13.1.1 Procedure for the circuit trace

---

The following shows the procedure for the circuit trace.

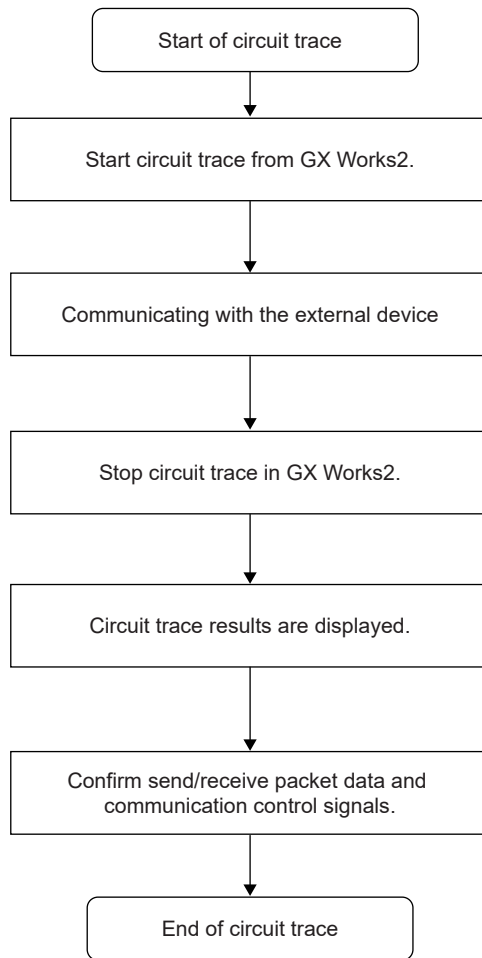

## 13.1.2 Execution of the circuit trace

The trace data is stored in the monitor buffer to trace the communication data and communication signal status.

[Basic operation]

1. GX Works2 ⇒ [Tool] ⇒ [Intelligent Function Module Tool] ⇒ Serial Communication Module] ⇒ [Circuit Trace]
2. Click the "Module Selection" button to select the module to trace in the "Module Selection (Circuit Trace)" screen.  
Click the "OK" button.

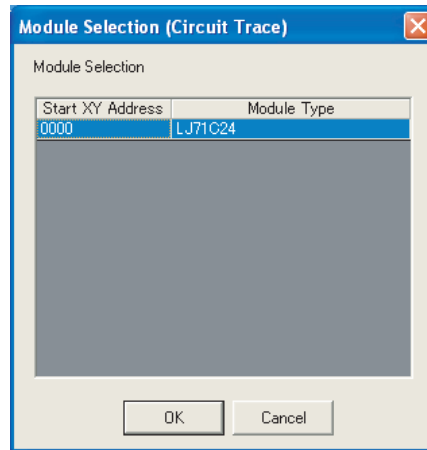

3. Select the channel to trace from "Channel Selection" and click the "Start Trace" button.

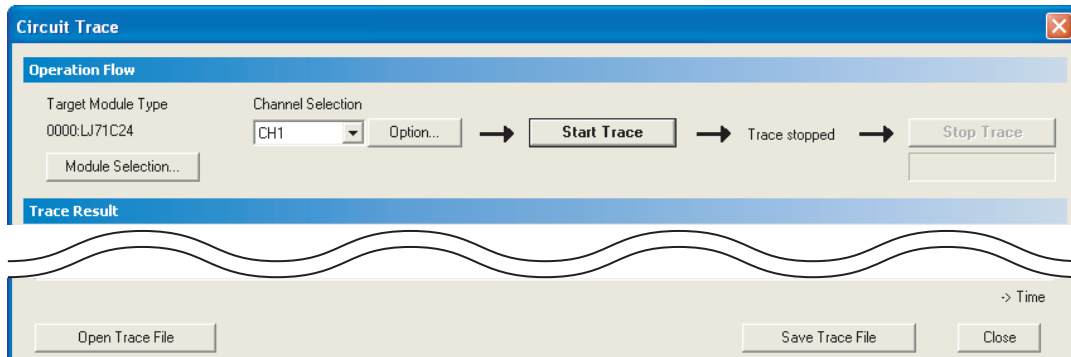



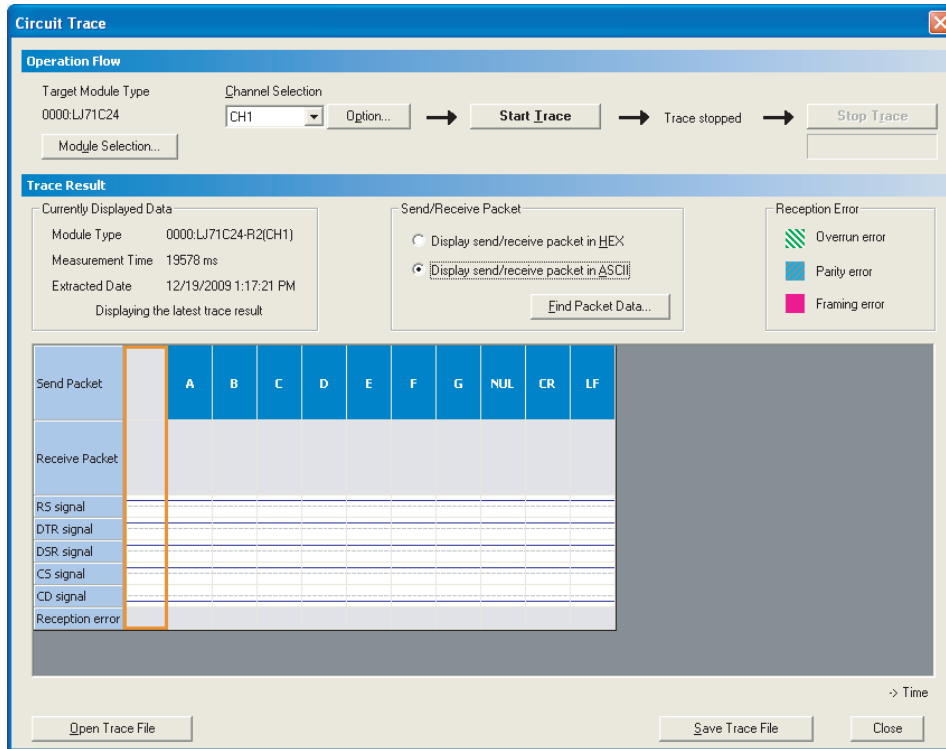

4. When the monitor buffer is full or the "Stop Trace" button is clicked, the trace data are displayed.
5. Confirm the send/receive packets and communication control signals from the displayed trace result.

[Display/Setting screen]



[Display/Setting details]

Item	Display/Setting details
Currently Displayed Data	Displays the model name, measurement time, and extraction date/time of the module on which the circuit trace is executed.
"Find Packet Data..." button	Search the trace data.
Send/Receive Packet	Select the display format of the send/receive packets. The hexadecimal or ASCII code can be selected.
Trace Result  Communication control signals	<p>The RS(RTS), ER(DTR), DR(DSR), CS(CTS), and CD(DCD) signal status and receive error are displayed as described below.</p> <ul style="list-style-type: none"> <li>• RS, ER, DSR, CS and CD signals All signals are displayed with blue lines -.</li> </ul> <p>When signal is ON: </p> <p>When signal is OFF: </p> <p>When the obtained data does not have signal information, the signal is displayed as an OFF status.</p> <ul style="list-style-type: none"> <li>• Receive error Three different errors of overrun error, parity error, and framing error are displayed.</li> </ul> <p>Overrun error:  (Green)</p> <p>Parity error:  (Light Blue)</p> <p>Framing error:  (Purple)</p>
"Open Trace File" button	Reads and displays the trace data saved in the personal computer.
"Save Trace File" button	Saves the trace data obtained by the circuit trace to the personal computer.
"Close" button	Closes the Circuit Trace screen.



## 13.1.3 Circuit trace option setting

In the circuit trace option setting, the following two items can be set.

- The monitor buffer area starting address and size of the C24 that stores the circuit trace data (hereinafter referred to as the monitor buffer area)
- Whether the circuit trace is stopped or continued when the timer 0 time out error occurs

[Basic operation]

### 1. Display the "Circuit trace" screen in the following procedure.

 GX Works2 ⇒ [Tool] ⇒ [Intelligent Function Module Tool] ⇒ [Serial Communication Module] ⇒ [Circuit Trace].

### 2. Click the "Option..." button.

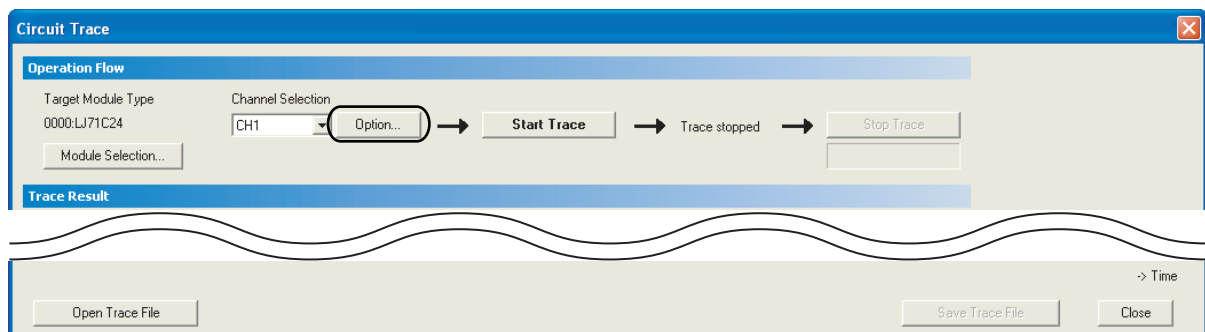

3. In the "Circuit Trace Option" screen, set "Start Address", "Size", and "Stop Setting" of the monitor buffer area, and click the "OK" button.

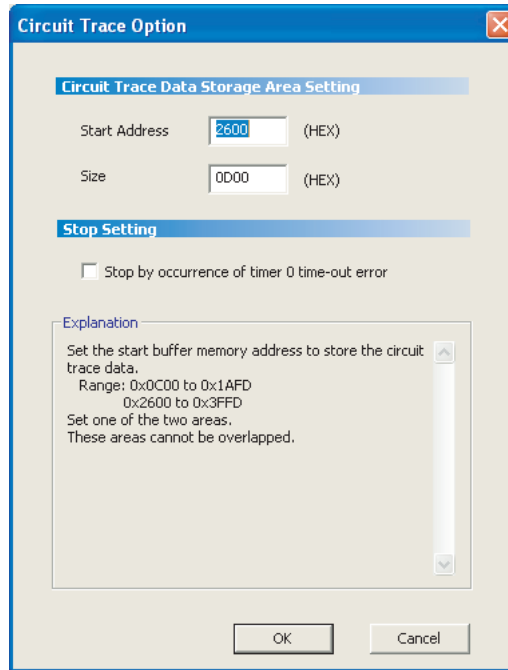

[Display/Setting details]

Item		Display/Setting details
Circuit Trade Data Storage Area Setting	Start Address	Set the starting address of the monitor buffer area. Input the setting in hexadecimal. • Input range CH1/CH2: 2600 <sub>H</sub> to 3FFD <sub>H</sub> (C00 <sub>H</sub> to 1AFD <sub>H</sub> for the user setting area)
	Size	Set the size of the monitor buffer area. Input the setting in hexadecimal. • Input range CH1/CH2: 3 to 1A00 words (3 to F00 words for the user setting area) Set the maximum address <sup>*1</sup> for the trace data storage space to be in the range between 2602 <sub>H</sub> to 3FFF <sub>H</sub> . (C02 <sub>H</sub> to 1AFF <sub>H</sub> for the user setting area) Note that the range of this value is checked at start of the circuit trace when using the user free area.
Stop Setting	Stop by occurrence of timer 0 time-out error	Set whether or not the circuit trace is stopped when the timer 0 time out error occurs.

\*1 The maximum address for the trace data storage space is calculated by the following formula.  
Maximum address for the trace data storage space = "Start Address" + "Size" – 1

## 13.2 State Monitor

The following items are monitored.

- Signals of the C24
- Communication error information
- Operation setting switches
- Protocol execution status during the predefined protocol communication

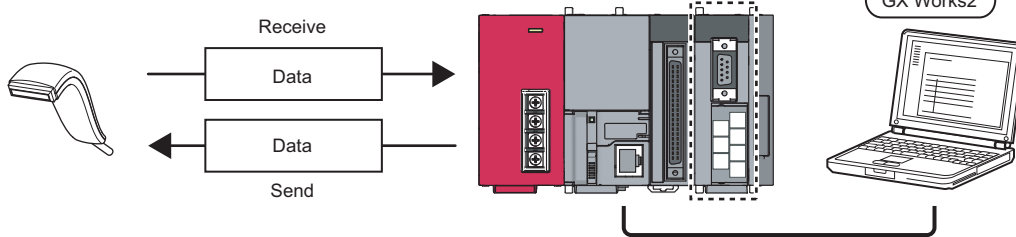
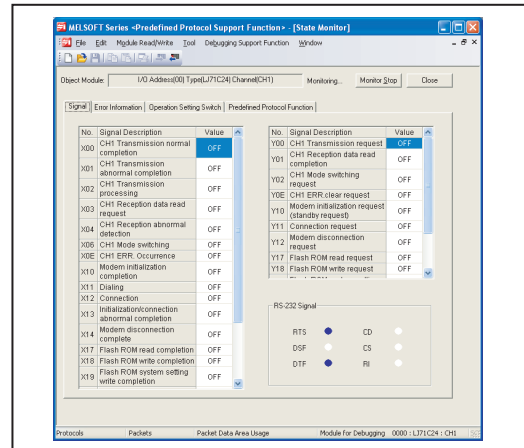

[Basic operation]

**1. Display the "Predefined Protocol Support Function" screen.**

For the method for displaying it, refer to Page 110, Section 9.1.

**2. Display the "Module Selection" screen in the following procedure.**

"Predefined Protocol Support Function" screen ⇒ [Debugging Support Function] ⇒ [Module Selection]

**3. Select the I/O address and channel of the module to be debugged, and click the "Set" button.**

**4. As the "OK" button is clicked, the module information is set.**

**5. Display the "State Monitor" screen in the following procedure.**

"Predefined Protocol Support Function" screen ⇒ [Debugging Support Function] ⇒ [State Monitor]

## (1) "Signal" tab

[Display/Setting screen]

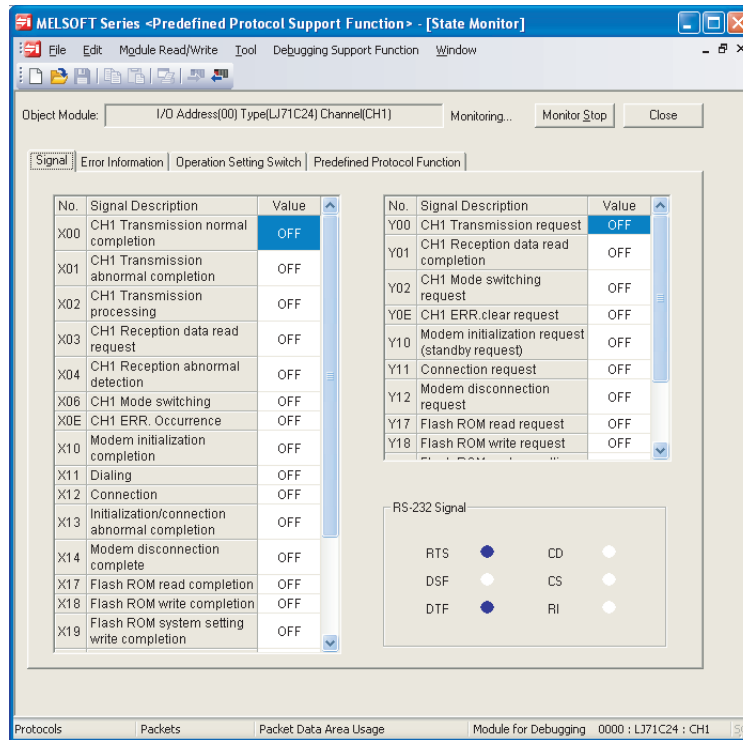

[Display/Setting details]

Item	Display/Setting details
X signal state monitor	Displays the ON/OFF status of the X signals.
Y signal state monitor	Displays the ON/OFF status of the Y signals.
RS-232 signal monitor	Displays the ON/OFF status of the RS-232 control signals.

**(2) "Error Information" tab**

[Display/Setting screen]

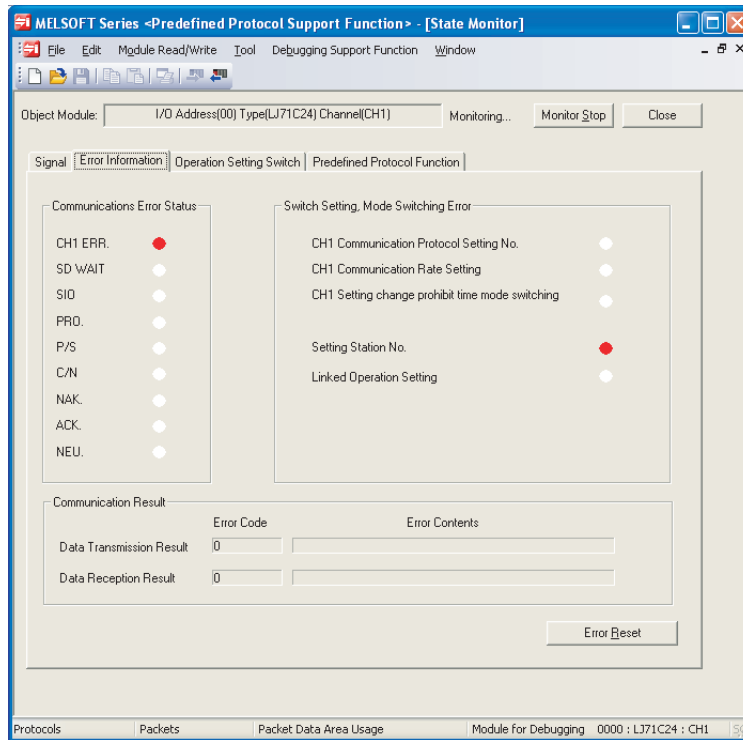

[Display/Setting details]

Item	Display/Setting details
Communications Error Status	Displays the communication error status.
Switch Setting, Mode Switching Error	Displays the switch setting and/or mode selection error status.
Communication Result	Displays the error status of the communication result.
"Error Reset" button	This button is valid when the CH1 ERR. occurrence (XE) or CH2 ERR. occurrence (XF) is ON, and resets the error information.

### (3) "Operation Setting Switch" tab

[Display/Setting screen]

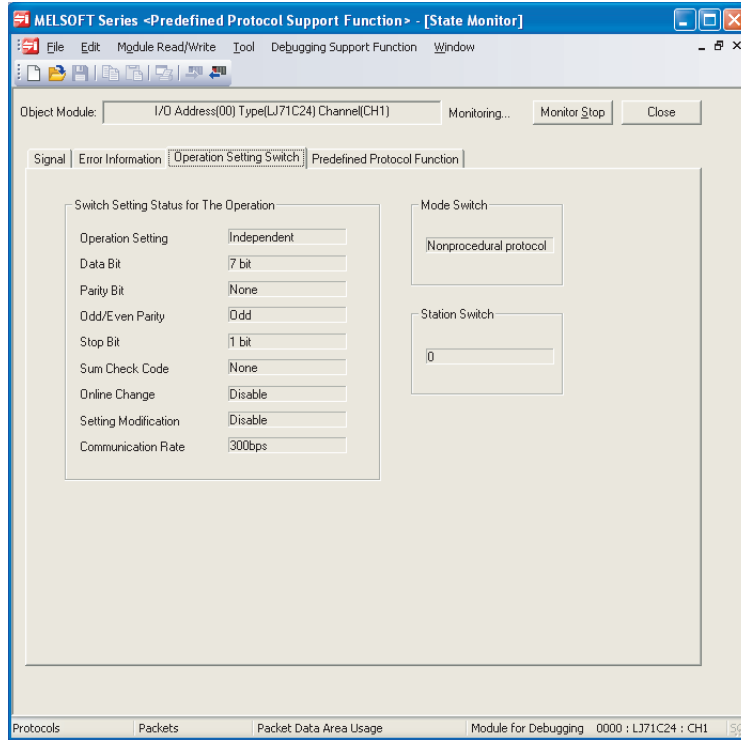

[Display/Setting details]

Item	Display/Setting details
Switch Setting Status for The Operation	Displays the operation switch setting status.
Mode Switch	Displays the predefined protocol setting.
Station Switch	Displays the station number setting.

**(4) "Predefined Protocol Function" tab**

[Display/Setting screen]

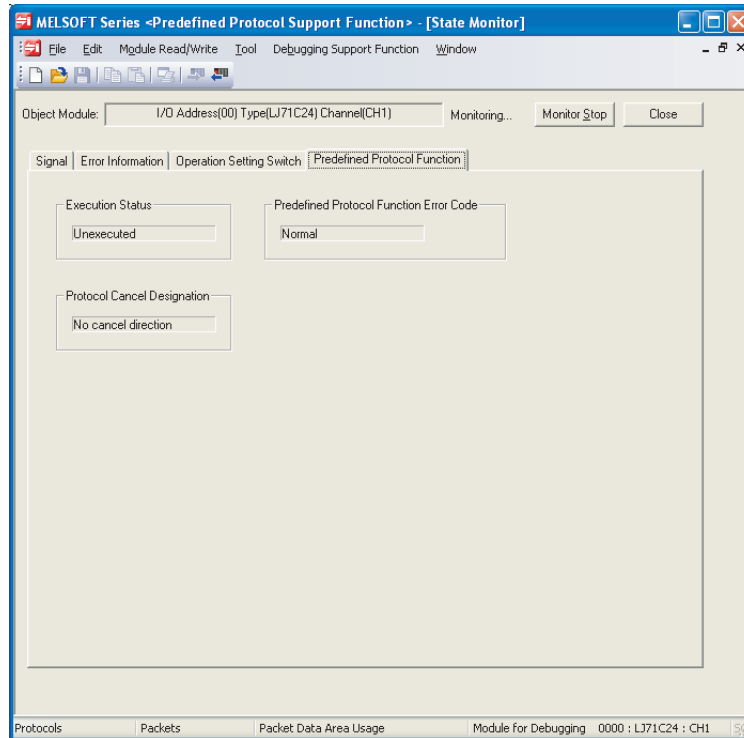

[Display/Setting details]

Item	Display/Setting details
Execution Status	Displays the protocol execution status.
Protocol Cancel Designation	Displays the protocol cancel designation status.
Predefined Protocol Function Error Code	Displays the error code of the result from the error completion.

# 13.3 Protocol Execution Log Display Storage Function (for Predefined Protocol only)

This function checks the detailed predefined protocol execution status and results for each channel. Up to 32 protocol execution logs can be checked.

If the number of the stored logs exceeds 32, the oldest log will be overwritten.

The protocol execution log can be checked in the following method.

- Checking with GX Works2
- Checking with the buffer memory

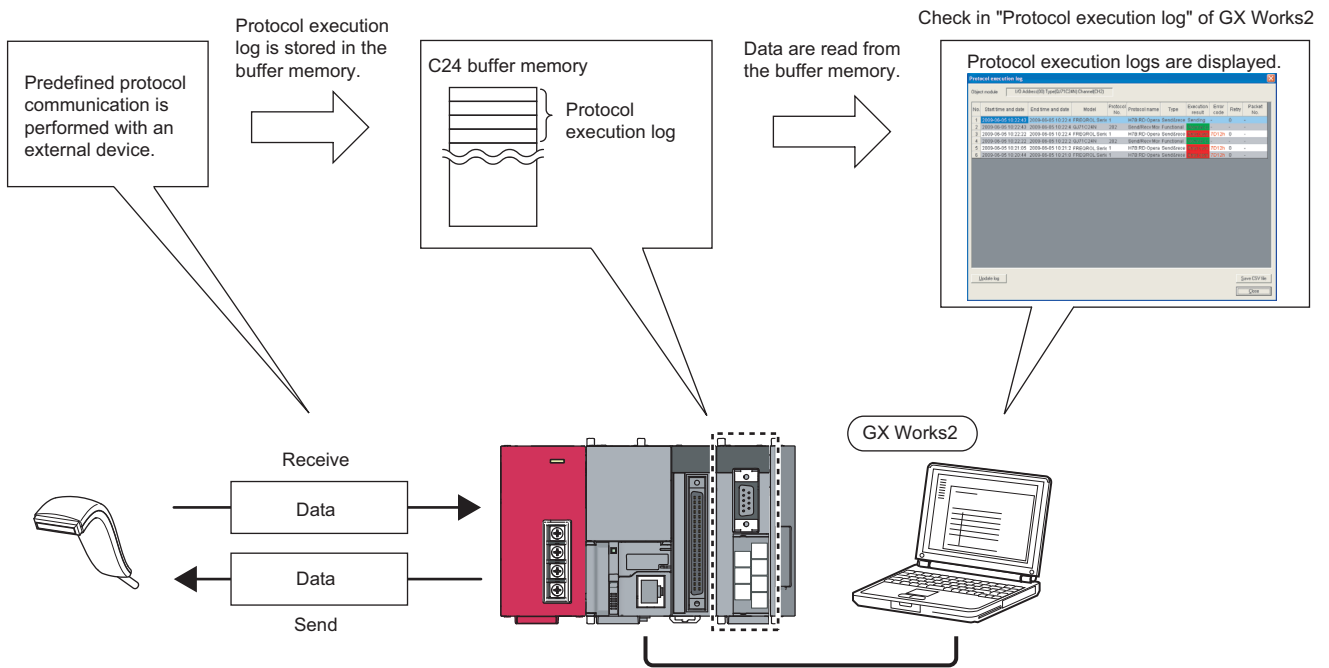

## Point

Do not perform the above two methods at the same time.

The latest execution logs are not in the buffer memory while they are being updated in GX Works2.



## 13.3.1 Checking with GX Works2

Check the protocol execution logs and protocol execution results in the "Protocol execution log" screen of GX Works2.

[Basic operation]

### 1. Select a module to debug.

- 1) Display the "Predefined Protocol Support Function" screen.  
For the method for displaying it, refer to  Page 110, Section 9.1.
- 2) Display the "Module Selection" screen in the following procedure.  
"Predefined Protocol Support Function" screen ⇒ [Debugging Support Function] ⇒ [Module Selection]
- 3) Select the I/O address and channel of the module to be debugged, and click the "Set" button.
- 4) As the "OK" button is clicked, the module information is set.

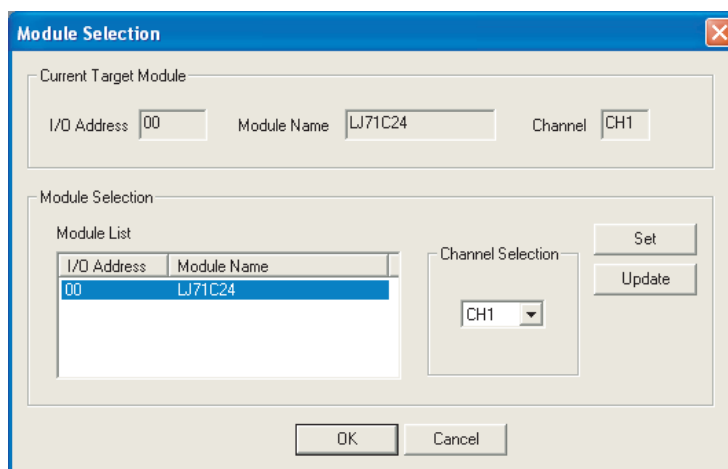

### 2. Execute the CPRTCL instruction.

### 3. Display the "Protocol execution log" screen in the following procedure.

-  "Predefined Protocol Support Function" screen ⇒ [Debugging Support Function] ⇒ [Protocol Execution Log]

[Display/Setting screen]

No.	Start time and date	End time and date	Model	Protocol No.	Protocol name	Type	Execution result	Error code	Retry	Packet No.
1	2009-06-05 10:22:43	2009-06-05 10:22:4	FREQROL Serie 1		H7B:RD Opera	Send&rece	Sending	-	0	-
2	2009-06-05 10:22:43	2009-06-05 10:22:4	LJ71C24	202	Send/Recv Mor	Functional	Normal cc	-	-	-
3	2009-06-05 10:22:22	2009-06-05 10:22:4	FREQROL Serie 1		H7B:RD Opera	Send&rece	Error com	7D12h	0	-
4	2009-06-05 10:22:22	2009-06-05 10:22:2	LJ71C24	202	Send/Recv Mor	Functional	Normal cc	-	-	-
5	2009-06-05 10:21:05	2009-06-05 10:21:2	FREQROL Serie 1		H7B:RD Opera	Send&rece	Error com	7D12h	0	-
6	2009-06-05 10:20:44	2009-06-05 10:21:0	FREQROL Serie 1		H7B:RD Opera	Send&rece	Error com	7D12h	0	-



The logs displayed in the "Protocol execution logs" screen can be selected from the following two, according to the log registration condition.

- Displaying only the failed protocols.
- Displaying all execution statuses and execution logs.

The log registration condition can be set in "Execution log options" in the "Various\_Control\_Specification" screen of GX Works2.

## 13.3.2 Checking with the buffer memory

Check the protocol execution logs in the execution log storage area.

[Basic operation]

1. The log registration condition can be set by the execution log option specification for the buffer memory (address: 40E2<sub>H</sub>/40F2<sub>H</sub>).

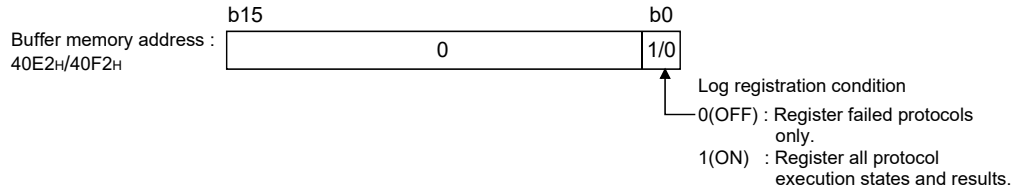

2. Execute the CPRTCL instruction.
3. Check the protocol execution logs stored in the execution log storage area (address: 4102<sub>H</sub> to 4701<sub>H</sub> (CH1), 4802<sub>H</sub> to 4E01<sub>H</sub> (CH2)).

For details, refer to Page 331, Appendix 1.

# CHAPTER 14 MAINTENANCE AND INSPECTION

---

## 14.1 Inspection Items

---

This section explains the inspection items of the C24.

- Check if the terminating resistors and cables are connected securely.
- Verify that the terminal screws and the terminal block installation screws are securely tightened.

For items other than the listed above, perform inspection according to the inspection items listed in the user's manual of the CPU module, in order to always use the system in the optimal condition.

### *Point*

---

Be sure to read through the Safety Precautions in the beginning of this manual regarding the C24 inspection and maintenance.

---

## 14.2 When Replacing Modules

---

When replacing the C24 and LCPU, it becomes necessary to register the following data again for the module to be replaced.

- C24: System setting data in the flash ROM
- LCPU: PLC parameters (I/O assignment, switch setting, etc.)

Please read the following manual before replacing the module, and make sure to pay attention to safety and handle the module properly during the operation.

 MELSEC-L CPU Module User's Manual (Hardware Design, Maintenance and Inspection)

## 14.2.1 Procedure of C24 replacement and re-registration of data

The following shows the procedure of C24 replacement and re-registration of data.

For the method of LCPU replacement and re-registration of data, refer to the following manual.

 MELSEC-L CPU Module User's Manual (Hardware Design, Maintenance and Inspection)

### (1) Reading system setting data of C24

Read the system setting data from the target memory (flash ROM or buffer memory).

#### 1. Display the "Online Data Operation" screen.

 GX Works2 ⇒ [Online] ⇒ [Read from PLC]

#### 2. Select the "Intelligent Function Module (Buffer Memory)" tab.

The following screen is displayed.

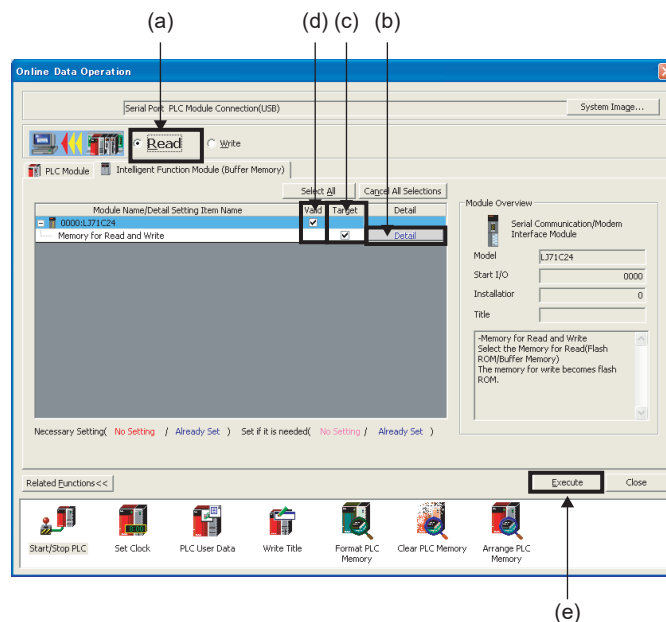

#### 3. Select "Read". ((a) in the illustration)

#### 4. Click the "Detail" button ((b) in the illustration) and select the target memory to read in the "Target to Read and Write Detail Setting" screen.

#### 5. Select the "Target" check box in the "Memory for Read and Write". ((c) in the illustration)

#### 6. Select the "valid" check box of the C24. ((d) in the illustration)

#### 7. Click the "Execute" button. ((e) in the illustration)

#### 8. After reading data from the Programmable controller, save the project.

For the method for saving the project, refer to  GX Works2 Version1 Operating Manual (Common).

**(2) Replacement of the C24**

1. Disconnect the cables and the module itself.
2. Replace the C24 and start up the C24 in accordance with "Chapter 4 PROCEDURES PRIOR TO OPERATION".

**(3) Register the system setting data to the flash ROM of the C24**

1. Read the project saved in (1) 8).  
For the method for reading the project, refer to  GX Works2 Version1 Operating Manual (Common).
2. Display the "Online Data Operation" screen.

 [Online] ⇒ [Write to PLC]

3. Select the "Intelligent Function Module (Buffer Memory)" tab in the "Online Data Operation" screen.

The following screen is displayed.

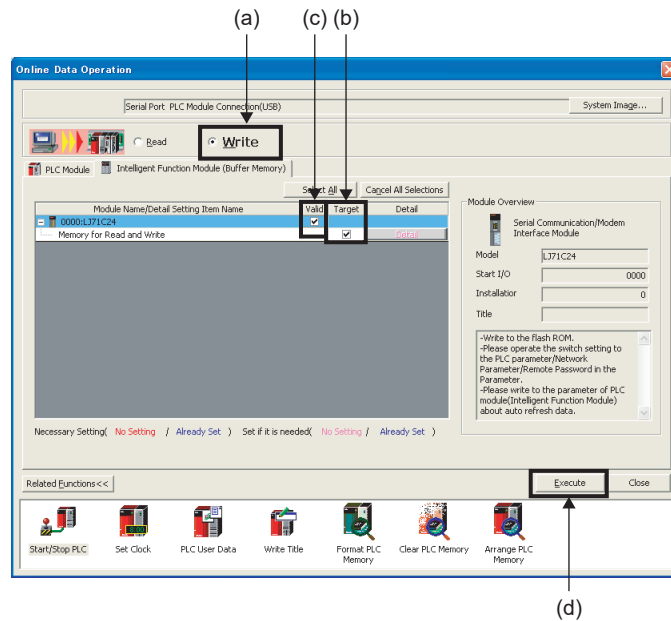

4. Select "Write". ((a) in the illustration)
5. Select the "Target" check box in the "Memory for Read and Write". ((b) in the illustration)
6. Select the "Valid" check box of the C24. ((c) in the illustration)
7. Click the "Execute" button. ((d) in the illustration)

# CHAPTER 15 TROUBLESHOOTING

---

This chapter explains the corrective actions when an error occurs in the C24 and the error codes.

For the trouble shooting from the display unit, refer to  MELSEC-L CPU Module User's Manual (Hardware Design, Maintenance and Inspection).

## 15.1 Checking the Status of the C24

---

This section explains how to check the status of communication between the C24 and external devices, the transmission status, and the switch setting status.

This checking is performed with GX Works2.



# 15.1.1 Checking the H/W LED information

The transmission status and communications error status of the C24 can be checked. (Contents of 201<sub>H</sub>/202<sub>H</sub> of the buffer memory are displayed.)

When a communication error occurs, take corrective action according to Page 301, Section 15.3.

### Point

Each of the communications error status, SIO, PRO., P/S, C/N, CH1 ERR. and CH2 ERR., turns on when an error occurs, and keeps its on-status even after the communication returns to normal. Initialize the error information as necessary. For details, refer to Page 325, Section 15.4.

## (1) Method for displaying

Select [Diagnostics] => [System Monitor...] and click the "H/W Information" button in GX Works2.

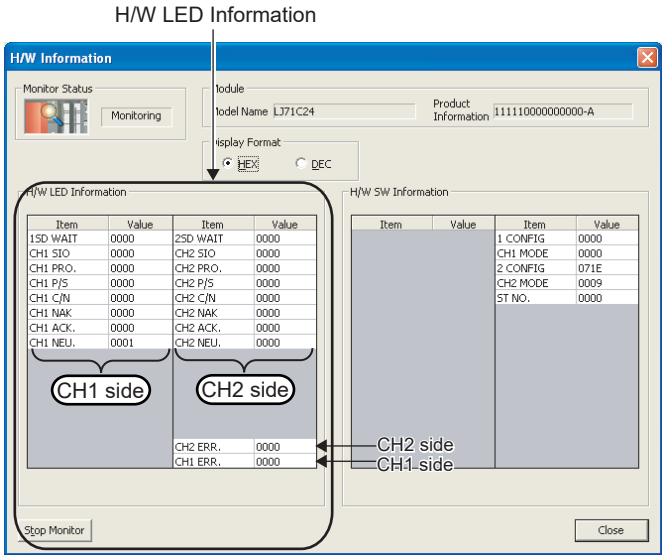

## (2) Screen items



### (a) SD WAIT

Indicates "Transmission wait status".

Value	Status	Description
0001 (ON)	Waiting for data transmission	Data cannot be sent to the external device by the transmission control of the C24 (waiting for data transmission). <ul style="list-style-type: none"><li>• The transmission cannot be started.</li><li>• A terminate transmission request (DC3 received/ DR(DSR) signal off) is received from the external device during message transmission.</li></ul>
0000 (OFF)	Data transmission start	The transmission became available, and the data transmission is started/resumed.

### (b) SIO

Indicates "SIO error status".

Value	Status	Description
0001 (ON)	Overrun or framing error occurred.	Overrun or framing error occurred. Keeps its on-status even after the communication returns to normal. Initialize the error information as necessary. For details, refer to  Page 267, Section 15.1.2.
	OS area is full.	No free space is available in the OS area, and the receive data was discarded. Keeps its on-status even after the communication returns to normal. Initialize the error information as necessary. For details, refer to  Page 267, Section 15.1.2.
0000 (OFF)	Normal	—

**(c) PRO.**

Indicates "Character error status".

Value	Status	Description
0001 (ON)	Error occurred.	Character error occurred. Keeps its on-status even after the communication returns to normal. Initialize the error information as necessary. For details, refer to  Page 267, Section 15.1.2.
0000 (OFF)	Normal	—



**(d) P/S**

Indicates "Status of parity error or sum check error".

Value	Status	Description
0001 (ON)	Error occurred.	Parity error or sum check error occurred. Keeps its on-status even after the communication returns to normal. Initialize the error information as necessary. For details, refer to  Page 267, Section 15.1.2.
0000 (OFF)	Normal	—

**(e) C/N**

Indicates "Access status with the CPU module".

Value	Status	Description
0001 (ON)	Error occurred.	<ul style="list-style-type: none"> <li>An external device issued a data read request to the CPU module when online change is set to prohibit in the switch settings by GX Works2. For functions that cannot be used when online change is set to prohibit, refer to the explanation section in each command list of  MELSEC Communication Protocol Reference Manual.</li> <li>An error has occurred during access between the C24 and the CPU module.</li> </ul> <p>Keeps its on-status even after the communication returns to normal. Initialize the error information as necessary. For details, refer to  Page 267, Section 15.1.2.</p>
0000 (OFF)	Normal	—

**(f) NAK**

Indicates "Abnormal completion status".

Value	Status	Description
0001 (ON)	Abnormal completion transmission	The C24 that could not receive data normally sent a response message (NAK message) to the external device to notice the abnormal completion.
0000 (OFF)	Normal completion transmission	The C24 that could receive data normally sent a response message (ACK message) to the external device to notice the normal completion.

**(g) ACK.**

Indicates "Normal completion status".

Value	Status	Description
0001 (ON)	Normal completion transmission	When the C24 could receive data normally, the C24 sent a response message (ACK message) to the external device to notice the normal completion.
0000 (OFF)	Abnormal completion transmission	When the C24 could not receive data normally, the C24 sent a response message (NAK message) to the external device to notice the abnormal completion.

**(h) NEU.**

Indicates "Neutral status".

NEU. is valid when a communication protocol on CH□ side is set to use the MC protocol.

When the communication protocol is set to other than the MC protocol, the status of NEU. is off.

Value	Status	Description
0001 (ON)	Neutral	Waiting for command message to be received.
0000 (OFF)	Command reception	Command message being received.

**(i) CH2 ERR.**

Indicates "Error occurrence status on CH2 side".

Value	Status	Description
0001 (ON)	<ul style="list-style-type: none"> <li>• Switch setting error</li> <li>• Mode switching error</li> <li>• Transmission error</li> <li>• Reception error</li> <li>• On-demand error</li> <li>• Flash ROM write error</li> <li>• Flash ROM write count over limit error</li> </ul>	<p>The errors in the left column occurred on the CH2 side.</p> <p>Keeps its on-status even after the communication returns to normal. Initialize the error information as necessary.</p> <p>For details, refer to  Page 267, Section 15.1.2.</p>
0000 (OFF)	Normal	—

**(j) CH1 ERR.**

Indicates "Error occurrence status on CH1 side".

Value	Status	Description
0001 (ON)	<ul style="list-style-type: none"> <li>• Switch setting error</li> <li>• Mode switching error</li> <li>• Transmission error</li> <li>• Reception error</li> <li>• On-demand error</li> <li>• Flash ROM write error</li> <li>• Flash ROM write count over limit error</li> </ul>	<p>The errors in the left column occurred on the CH1 side.</p> <p>Keeps its on-status even after the communication returns to normal. Initialize the error information as necessary.</p> <p>For details, refer to  Page 267, Section 15.1.2.</p>
0000 (OFF)	Normal	—

## 15.1.2 Checking the H/W switch information

The details of switch information can be monitored.

### (1) Method for displaying

Select [Diagnostics] ⇒ [System Monitor...] and click the "H/W Information" button in GX Works2.

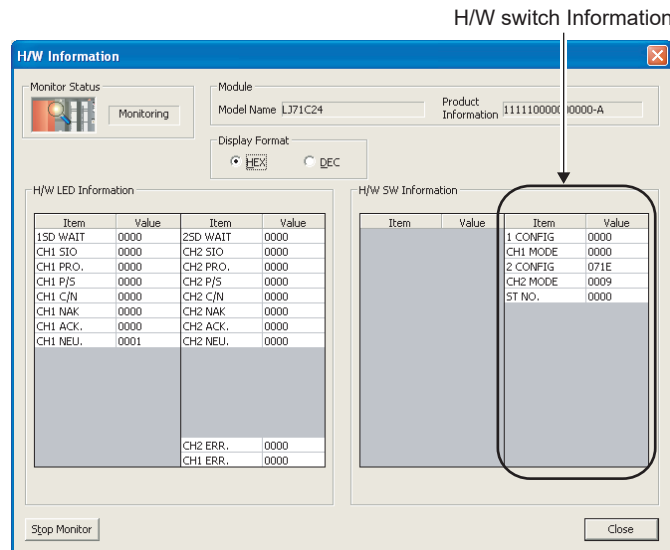

### (2) Screen items

Item	Description	Reference
1 CONFIG	Displays the communication rate setting and transmission setting on the CH1 side.	Page 268, Section 15.1.2 (2) (a)
CH1 MODE	Displays the communication protocol setting on the CH1 side.	Page 269, Section 15.1.2 (2) (b)
2 CONFIG	Displays the communication rate setting and transmission setting on the CH2 side.	Page 268, Section 15.1.2 (2) (a)
CH2 MODE	Displays the communication protocol setting on the CH2 side.	Page 269, Section 15.1.2 (2) (b)
ST NO.	Displays the station number setting.	Page 269, Section 15.1.2 (2) (c)

### (a) 1 CONFIG, 2 CONFIG

The following shows the communication rate setting and transmission setting of the CH1 side (1 CONFIG) and CH2 side (2 CONFIG).

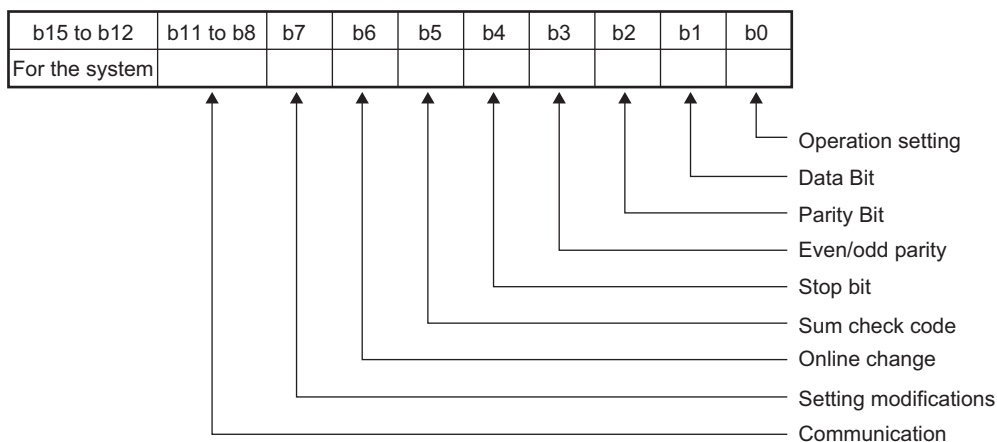

Bit	Item	Description
b0	Operation setting	OFF (0): Independent ON (1): Linked
b1	Data Bit	OFF (0): 7 ON (1): 8
b2	Parity Bit	OFF (0): None ON (1): Exist
b3	Even/odd parity	OFF (0): Odd ON (1): Even
b4	Stop bit	OFF (0): 1 ON (1): 2
b5	Sum check code	OFF (0): None ON (1): Exist
b6	Online Change	OFF (0): Disable ON (1): Enable
b7	Setting modifications	OFF (0): Disable ON (1): Enable
b8 to b11	Communication rate	(unit: bps) 50: F <sub>H</sub> 14400: 6 <sub>H</sub> 300: 0 <sub>H</sub> 19200: 7 <sub>H</sub> 600: 1 <sub>H</sub> 28800: 8 <sub>H</sub> 1200: 2 <sub>H</sub> 38400: 9 <sub>H</sub> 2400: 3 <sub>H</sub> 57600: A <sub>H</sub> 4800: 4 <sub>H</sub> 115200: B <sub>H</sub> 9600: 5 <sub>H</sub> 230400: C <sub>H</sub> (*1)
b12 to b15	For the system	All 0

\*1 230400 bps can be used via CH1 only.

**(b) CH1 MODE, CH2 MODE**

The following shows the communication protocol setting of CH1 side (CH1 MODE) and CH2 side (CH2 MODE).

Setting number	Description	
0 <sub>H</sub>	Communication with MELSOFT Connection	
1 <sub>H</sub>	Communication with MC protocol	Format 1
2 <sub>H</sub>		Format 2
3 <sub>H</sub>		Format 3
4 <sub>H</sub>		Format 4
5 <sub>H</sub>		Format 5
6 <sub>H</sub>	Communication with nonprocedural protocol	
7 <sub>H</sub>	Communication with bidirectional protocol	
8 <sub>H</sub>	For linked operation setting	
9 <sub>H</sub>	Communication with predefined protocol	
E <sub>H</sub>	ROM/RAM/Switch test	
F <sub>H</sub>	Self-loopback test	

**(c) ST NO.**

This number displays the host station number used for MC protocol.

Setting number	Description
0 to 31 (0 <sub>H</sub> to 1F <sub>H</sub> )	Host station number used for MC protocol

# 15.1.3 Reading the RS-232 control signal status

This section explains how to read the control signal status stored in the buffer memory during communication using RS-232 interface.

When using GX Works2, check in the "Intelligent Function Module Monitor" screen. (Refer to GX Works2 Version1 Operating Manual (Intelligent Function Module).)

When a transmission problem occurs, read operation is executed to check the signal on/off status of the RS-232 interface.

## (1) RS-232 control signal status (address: 254<sub>H</sub>/264<sub>H</sub>)

The RS-232 control signal status is stored as follows.

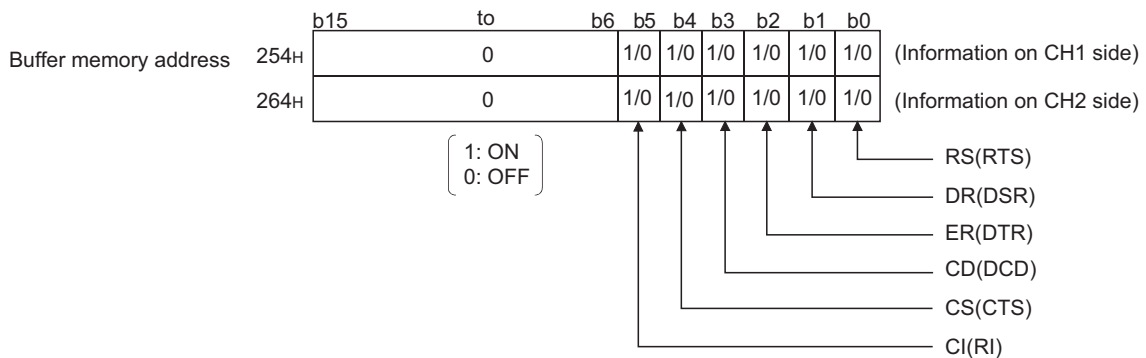

### Remark

- For details on signals for RS-232, refer to Page 46, Section 6.2.1.
- Signals output from the C24 side (RS(RTS) and ER(DTR)) are controlled by the operating system (OS) of the C24. They cannot be directly controlled by the sequence program.
- There is a maximum delay of 100ms in signal status stored in the buffer memory above.

## (2) Example of a program that reads from RS-232 control signal status (address: 254<sub>H</sub>/264<sub>H</sub>)

The following shows an example of a program that reads the RS-232 control signal status. (input/output signals X/Y00 to X/Y1F of the C24)

- Example of FROM instruction

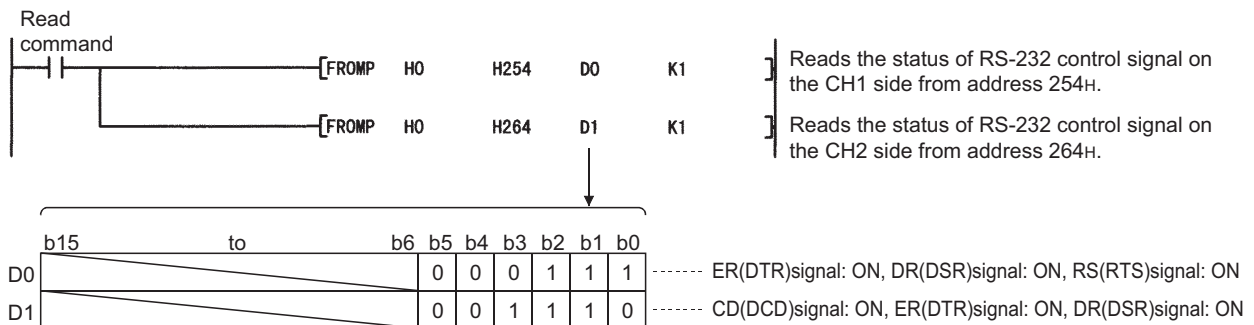



# 15.1.4 Reading the data communication status (Transmission sequence status)

This section explains how to read the current status of the data communication using the MC protocol stored in the buffer memory.

When using GX Works2, check in the "Intelligent Function Module Monitor" screen. (Refer to GX Works2 Version1 Operating Manual (Intelligent Function Module).)

When a transmission problem occurs, read operation is executed to check the status of the data communication using the MC protocol.

## (1) Transmission sequence status (address: 255<sub>H</sub>/265<sub>H</sub>)

The status of data communication using the MC protocol is stored as a numeric value as shown below.

Buffer memory address	255 <sub>H</sub>	b15	to	b0	(Information on the CH1 side)
	265 <sub>H</sub>			0 to 9	(Information on the CH2 side)

The following shows the correspondence between the numerical values in the transmission sequence status storage area and the data communication status.

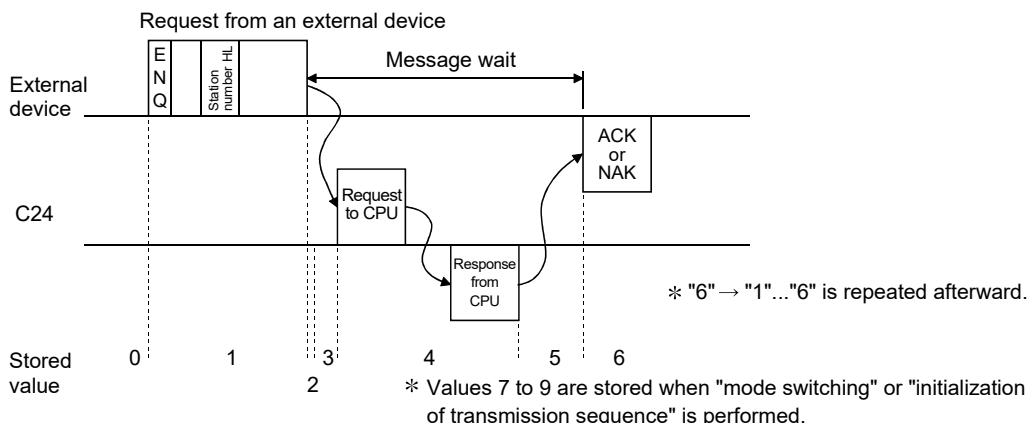

**Remark** .....

When the target interface is not set to use the MC protocol, "0" is stored in the transmission sequence status (address: 255<sub>H</sub>/265<sub>H</sub>).

.....

**(2) Example of a program that reads from transmission sequence status (address: 255<sub>H</sub>/265<sub>H</sub>)**

The following shows an example of a program that reads from the transmission sequence status. (input/output signals X/Y00 to X/Y1F of the C24)

● Example of FROM instruction

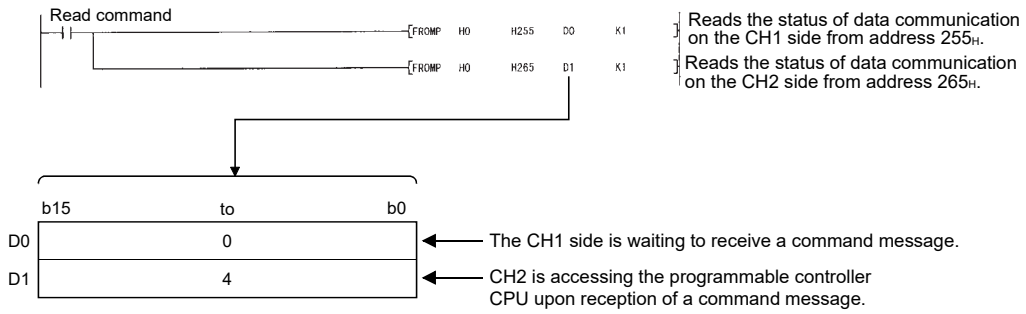

# 15.1.5 Reading the switch setting status

This section explains how to read the switch setting status of the C24.  
 When using GX Works2, check in the "Intelligent Function Module Monitor" screen. (Refer to GX Works2 Version1 Operating Manual (Intelligent Function Module).)

**Remark**

- The switch settings can be changed when the mode is switched or when the UINI instruction is executed. (The station No. setting can be changed only when the UINI instruction is executed.)  
 For details, refer to User's Manual (Application).  
 For how to read the current operating status after the mode is switched or the UINI instruction is completed, refer to Page 275, Section 15.1.6.
- For details of the switch setting, refer to Page 85, Section 7.3 and Page 267, Section 15.1.2.

## (1) Setting status storage area

The switch settings by GX Works2 and setting error information are stored in different areas of the buffer memory shown below.

- Station No. (switch setting) (address: 200<sub>H</sub>)

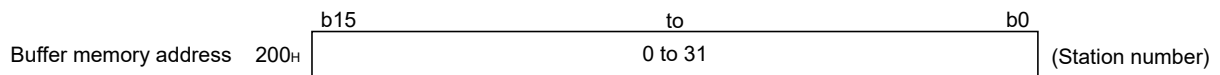

- Switch setting error and mode switching error status (address: 203<sub>H</sub>)

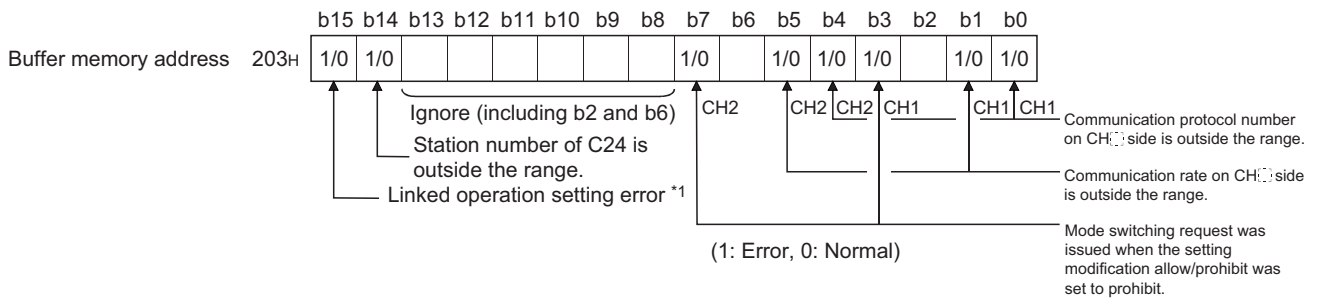

\*1 Page 91, Section 7.3.5

- Communication protocol status (address: 250<sub>H</sub>/260<sub>H</sub>)

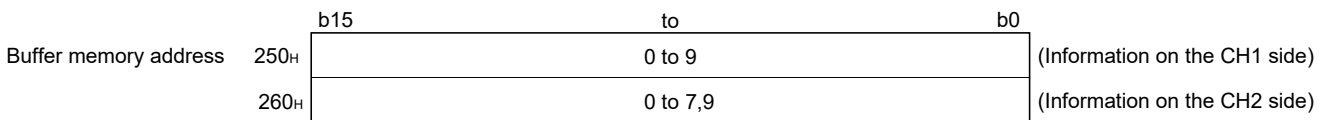

- Transmission setting status (address: 251<sub>H</sub>/261<sub>H</sub>)

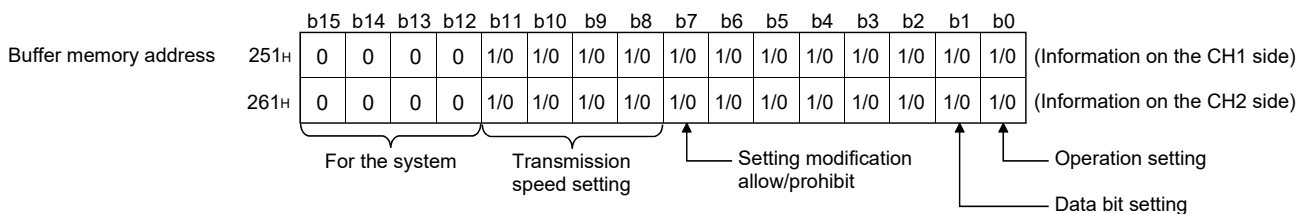

## (2) Example of a program that reads from the setting status storage area

The following shows an example of a program that reads the setting of various switches of the C24 from the setting status.

For details on ERR. occurrence (XE/XF) of the input/output signals used in the program, refer to  Page 325, Section 15.4 (3).

(input/output signals X/Y00 to X/Y1F of the C24)

### ● Example of FROM instruction

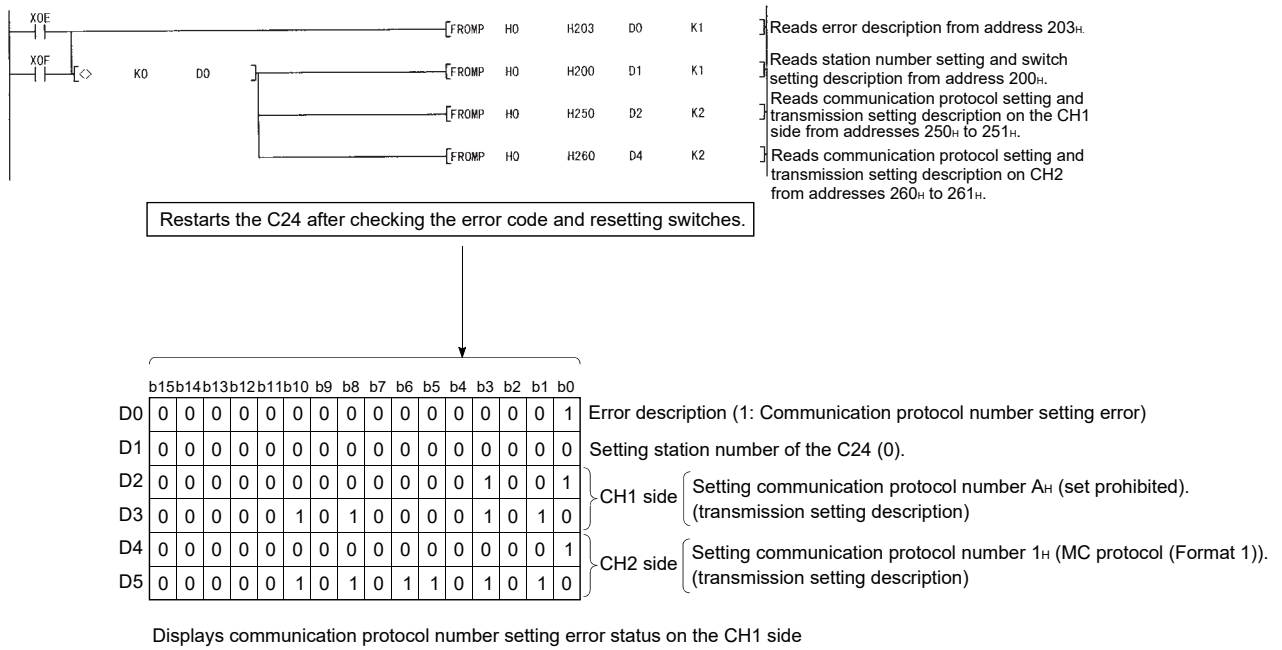

# 15.1.6 How to read the current operation status

This section explains how to read the current operation status of the C24.

When using GX Works2, check in the "Intelligent Function Module Monitor" screen. (Refer to GX Works2 Version1 Operating Manual (Intelligent Function Module).)

**Remark**

- The status of the switch settings by GX Works2 can be checked by performing read operations as described in Page 273, Section 15.1.5.
- Refer to Page 85, Section 7.3 for the switch settings.

## (1) Operation mode status storage area

The current operation status of the C24 is stored into the following buffer memory areas.

- Station No. (instruction setting) (address: 24FH)

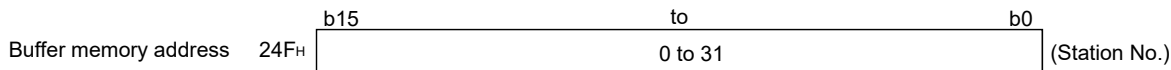

- Communication protocol status (address: 252H/262H)

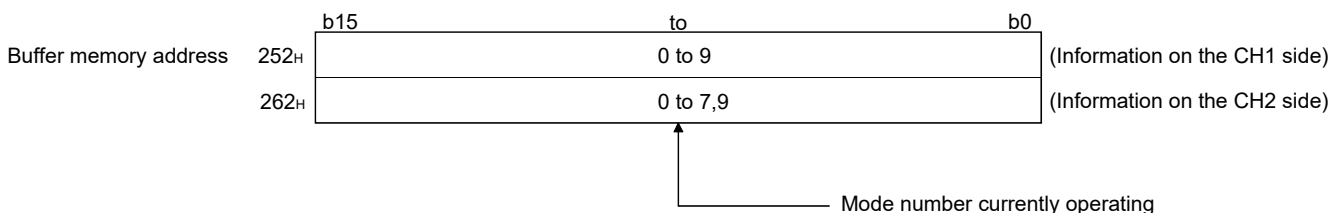

- Transmission status (address: 253H/263H)

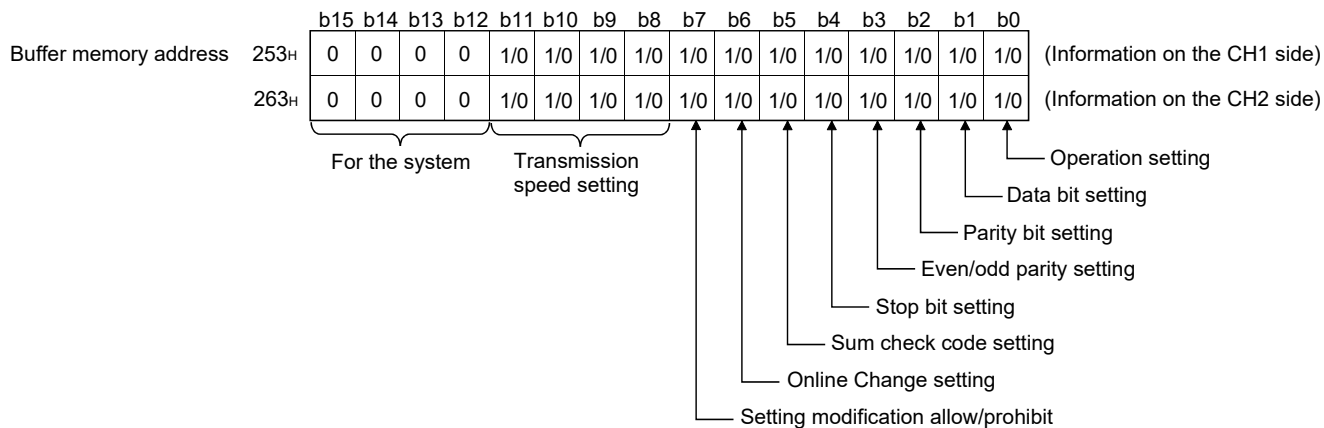

## (2) Example of a program that reads from the current setting status storage area

The following shows an example of a program that reads from the switch setting status for current operation of the C24.

For details on ERR. occurrence (XE/XF) of the input/output signals used in the program, refer to  Page 325, Section 15.4 (3).

(input/output signals X/Y00 to X/Y1F of the C24)

### ● Example of FROM instruction

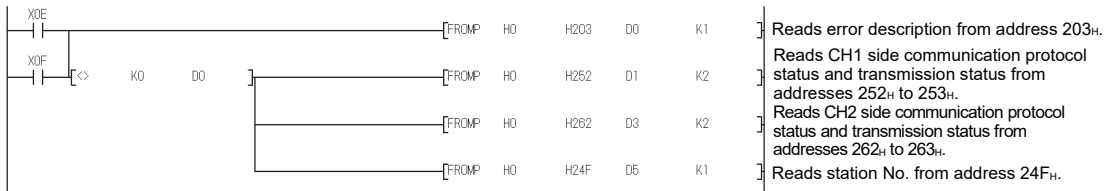

After checking error codes and changed setting values, designate the correct setting values and switch mode.

	b15	b14	b13	b12	b11	b10	b9	b8	b7	b6	b5	b4	b3	b2	b1	b0		
D0	0	0	0	0	0	0	0	0	0	0	0	0	0	0	1	0	Error description (2: Communication rate error)	
D1	0	0	0	0	0	0	0	0	0	0	0	0	0	0	1	1		0
D2	0	0	0	0	0	1	1	1	1	0	0	0	0	1	0	1	0	CH2 side { Setting communication protocol number 1 <sub>H</sub> (MC protocol (Format 1)). (transmission setting description)
D3	0	0	0	0	0	0	0	0	0	0	0	0	0	0	0	0	1	
D4	0	0	0	0	0	1	0	1	0	1	1	0	1	0	1	0		
D5	0	0	0	0	0	0	0	0	0	0	0	0	0	0	0	1		

Indicates the communication rate setting error on the CH1 side.

# 15.2 Error Code

---

When a trouble such as external device communication failure has occurred, the error cause can be identified by an error code.

## 15.2.1 How to check the error codes

---

Error codes can be checked on GX Works2. (Refer to  Page 278, Section 15.2.1 (1).)

**Remark** .....

By using GX Works2, error history of the entire system can be checked even after errors were cleared by turning the power off to on, or by resetting the CPU module or the head module. (Refer to  Page 279, Section 15.2.1 (1) (b).)

.....

## (1) Checking with GX Works2

Error codes that are corresponding to the errors occurred in the C24 can be checked by following either procedure described in Page 278, Section 15.2.1 (1) (a) or Page 279, Section 15.2.1 (1) (b).

### (a) Checking on the "Module's Detailed Information" screen

Error code, error contents, and corrective action are displayed.

On GX Works2, select [Diagnostics] ⇒ [System Monitor] and click the "Detailed Information" button.

Module's Detailed Information

Monitor Status

Monitoring

Module

Model Name L371C24

I/O Address 0000

Mount Position Main block 0th slot

Product Information 11111000000000-A

Production Number ---

Module Information

Module Access Possible

Status of External Power Supply ---

Fuse Blown Status ---

Status of I/O Address Verify Agree

I/O Clear / Hold Setting ---

Noise Filter Setting ---

Input Type ---

Remote Password Setting Status Nothing

H/W Information

Error Information

Latest Error Code 7FEF

Update Error History

Clear Error History

Error Clear

Display Format

HEX

DEC

No.	Error Code
1	7FEF

The error history is sequentially displayed from an old error. The latest error is displayed at the bottom line.

Stop Monitor

Close

Displays the latest error code.

Displays error history.

Displays description of the error code that is currently selected under Error history and corrective action for the error.



(b) Checking on the "Error History" screen

On this screen, errors including those occurred in other modules are displayed in chronological order, and the data can be output in a CSV file.

Error code and date and time of error occurrence can be checked even after powering OFF and then ON the CPU module or after resetting the CPU module or head module.

On GX Works2, select [Diagnostics] => [System Monitor] and click the "System Error History" button.

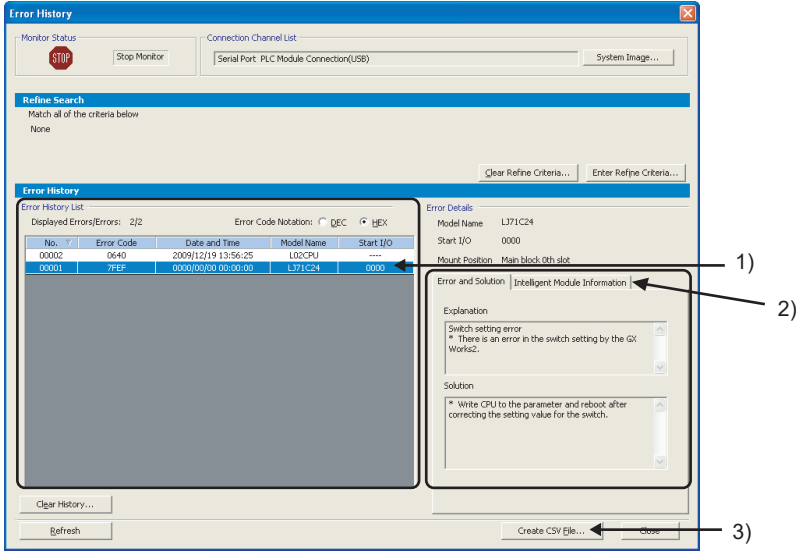

- 1) Error History List
  - Error log of the module is displayed.
  - For errors occurred during initial processing of the CPU module, the date and time will be 0000/00/00 00:00:00, therefore the displayed order under Error history list is not in the order in which the error occurred.
- 2) Error and Solution, Intelligent Module Information
  - Error and Solution
    - The error description and corrective action for the error, which is currently selected under "Error History List", are displayed.

- Intelligent Module Information

The status of the C24 when the error, which is currently selected under "Error History List", had occurred is displayed.

For the C24, the following will be displayed.

Item	Description
Channel where error occurs	Channel on which an error has occurred.
LED ON status, communication error status	Communication error and LED ON status of the channel on which an error has occurred. (Value of the buffer memory address 201 <sub>H</sub> /202 <sub>H</sub> is displayed.)
Communication protocol status	Communication protocol status at the occurrence of the error. (Value of the buffer memory address 252 <sub>H</sub> /262 <sub>H</sub> is displayed.)
Transmission status	Transmission status at the occurrence of the error. (Value of the buffer memory address 253 <sub>H</sub> /263 <sub>H</sub> is displayed.)
Control signal status	RS-232 control signal status at the occurrence of the error. (Value of the buffer memory address 254 <sub>H</sub> /264 <sub>H</sub> is displayed.)
MC protocol transmission sequence status	Transmission sequence status at the occurrence of the error. (Value of the buffer memory address 255 <sub>H</sub> /265 <sub>H</sub> is displayed.)
Nonprocedural protocol Receive user frame	Receive user frame at the occurrence of the error. (Value of the buffer memory address 25B <sub>H</sub> /26B <sub>H</sub> is displayed.)
Predefined protocol Execution status	Protocol execution status at the occurrence of the error. (Value of the buffer memory address 4041 <sub>H</sub> /4051 <sub>H</sub> is displayed.)
Predefined protocol Number of protocol executions	Protocol No. at the occurrence of the error. (Value of the buffer memory address 4103 <sub>H</sub> /4803 <sub>H</sub> is displayed.)

3) "Create CSV File..." button

Click this button to output the module error history in a CSV file.

**Point**

- If errors have frequently occurred in the C24, "\*\*HST.LOSS\*\*" may be displayed instead of error codes in the Error Code column.

(Example)

No.	Error Code	Date and Time	Model Name	Start I/O
00002	*HST.LOSS*	2009/11/18 21:24:33	LJ71C24	0000
00001	7FEF	0000/00/00 00:00:00	LJ71C24	0000

If too many "\*\*HST.LOSS\*\*" are displayed, increase the number of errors to be collected per scan in the "PLC RAS" tab of the "PLC Parameter" dialog box.

For setting, refer to [MELSEC-L CPU Module User's Manual \(Function Explanation, Program Fundamentals\)](#).

- When the same errors consecutively occurred, only the error code for the first occurred is displayed on the "Error History" screen.

## 15.2.2 Error code list



The following shows the error codes, error contents, and corrective actions for errors that are generated during data communication.

The signal name in the following table indicates the CH□ side LED on status or communication error status that is stored into buffer memory address 201<sub>H</sub>/202<sub>H</sub> when an error occurs.

The CH□ side LED on status and communication error status can be confirmed by System monitor and Intelligent function module monitor function of GX Works2. (Refer to  Page 263, Section 15.1.1.)



For errors without a corresponding signal name entered to errors generated with the MC protocol communication, "NAK" comes on.

Error code (Hexadecimal)	Error	Error contents	Signal name	Corrective action	Protocol			
					MC	Nonpr ocedu ral	Bidir ectio nal	Predefi ned
4000 <sub>H</sub> : 4FFF <sub>H</sub>	Error detected by CPU module	—	—	<ul style="list-style-type: none"> <li>Take corrective actions by referring to the User's Manual (Hardware Design, Maintenance and Inspection) for the CPU module used.</li> <li>If this error occurs during CPRTCL instruction execution, identify the CPU module error, and correct the CPU device No. that is specified in the Nonconversion or Conversion variable data storage area.</li> </ul>	○			○
7101 <sub>H</sub> : 7102 <sub>H</sub>	System error	• The OS of the C24 detected some error.	—	*1				
7103 <sub>H</sub>	Programmable controller access error	• Cannot communicate with the CPU module.	C/N	<ul style="list-style-type: none"> <li>Increase the Response monitoring time (timer 1).</li> <li>Perform a Self-loopback test, and check if the data communication with the CPU module can be performed.</li> </ul>	○			
7104 <sub>H</sub> : 7116 <sub>H</sub>	System error	• The OS of the C24 detected some error.	—	*1				
7140 <sub>H</sub> *2	Request data error	<ul style="list-style-type: none"> <li>The request exceeded the limit of processing points that are predetermined for each command and allowed for one transmission.</li> <li>A word device was designated in a bit units command.</li> <li>The requested range exceeded the last device number.</li> </ul> <p>( Last device of CPU module <math>\geq</math> Transmit message head device of external device + The number of device points of which the external device transmit message occupies )</p>	PRO.	<ul style="list-style-type: none"> <li>Check and correct the external device transmit message and restart data communications.</li> <li>If no error is found in the device range, clear the programmable controller CPU information and retry. (Refer to  Page 329, Section 15.5.)</li> </ul>	○			
7141 <sub>H</sub>	System error	• The OS of the C24 detected some error.	—	*1				

Error code (Hexadecimal)	Error	Error contents	Signal name	Corrective action	Protocol			
					MC	Nonprocedural	Bidirectional	Predefined
7142 <sub>H</sub> <sup>*2</sup>	Device name error	<ul style="list-style-type: none"> <li>A device that cannot be designated by the given command was designated.</li> </ul>	PRO.	<ul style="list-style-type: none"> <li>Check and correct the external device transmit message and restart data communications.</li> <li>If no error is found in the device name, clear the programmable controller CPU information and retry. (Refer to  Page 329, Section 15.5.)</li> </ul>	○			
7143 <sub>H</sub> <sup>*2</sup>	Device No. error	<ul style="list-style-type: none"> <li>The head device No. is out of range.</li> </ul>	PRO.	<ul style="list-style-type: none"> <li>Check and correct the external device transmit message and restart data communications.</li> </ul>	○			
7144 <sub>H</sub> <sup>*2</sup>	Monitor data write error	<ul style="list-style-type: none"> <li>Monitoring was requested before the device to be monitored was written.</li> </ul>	PRO.	<ul style="list-style-type: none"> <li>Write the device to be monitored before issuing a monitor request.</li> </ul>	○			
7145 <sub>H</sub> <sup>*2</sup>	Monitor PC No. error	<ul style="list-style-type: none"> <li>The written PC No. and PC No. in the monitor request are different.</li> </ul>	C/N	<ul style="list-style-type: none"> <li>Check the transmit message from the external device, correct it, and restart data communications.</li> <li>Rewrite the monitor data.</li> </ul>	○			
7146 <sub>H</sub> <sup>*2</sup>	Monitor CPU model name error	<ul style="list-style-type: none"> <li>The written CPU model name and the CPU monitor name in the monitor request are different.</li> </ul>	C/N		○			
7147 <sub>H</sub> <sup>*2</sup>	Written number of monitoring points overrun error	<ul style="list-style-type: none"> <li>The written number of monitoring points exceeds the designated range.</li> </ul>	PRO.	<ul style="list-style-type: none"> <li>Check and correct the external device transmit message and restart data communications.</li> </ul>	○			
7148 <sub>H</sub> <sup>*2</sup>	Extension R block No. error	<ul style="list-style-type: none"> <li>A nonexistent extension file register block No. was designated.</li> <li>A block No. being used as an extension comment area, sampling trace area, or status latch area was designated.</li> </ul>	PRO.	<ul style="list-style-type: none"> <li>Check and correct the designated block No. and restart data communications.</li> </ul>	○			
7149 <sub>H</sub>	System error	<ul style="list-style-type: none"> <li>The OS of the C24 detected some error.</li> </ul>	—	*1				
714A <sub>H</sub> <sup>*2</sup>	Cannot execute a command during RUN	<ul style="list-style-type: none"> <li>A write command was designated when disable online change was set.</li> <li>Parameter or sequence program was written during RUN.</li> </ul>	C/N	<ul style="list-style-type: none"> <li>Change the setting to enable online change and restart data communications.</li> <li>Stop the CPU module and restart data communications</li> </ul>	○			
714B <sub>H</sub> 714C <sub>H</sub>	System Error	<ul style="list-style-type: none"> <li>The OS of the C24 detected some error.</li> </ul>	—	*1				
714D <sub>H</sub>	Unusable command error	<ul style="list-style-type: none"> <li>An unusable command is issued to the access target CPU module.</li> </ul>	C/N	<ul style="list-style-type: none"> <li>Check and correct the external device transmit message and restart data communications.</li> <li>If no error is found in the command, clear the programmable controller CPU information and retry. (Refer to  Page 329, Section 15.5.)</li> </ul>	○			
714E <sub>H</sub> <sup>*2</sup>	Monitor network No. error	<ul style="list-style-type: none"> <li>The written monitor network No. and the monitor request network No. are different.</li> </ul>	C/N	<ul style="list-style-type: none"> <li>Check and correct the other station access valid module No. in the network parameters, and restart data communications.</li> <li>Rewrite the monitor data.</li> </ul>	○			
7150 <sub>H</sub>	System error	<ul style="list-style-type: none"> <li>The OS of the C24 detected some error.</li> </ul>	—	*1				

Error code (Hexadecimal)	Error	Error contents	Signal name	Corrective action	Protocol			
					MC	Nonpr ocedu ral	Bidir ectio nal	Predefi ned
7151 <sub>H</sub>	PC No. designation error	• A PC No. other than "FF" or "0 to 120 (00 <sub>H</sub> to 78 <sub>H</sub> )" was designated.	C/N	• Check and correct the external device transmit message and restart data communications.	○			
7152 <sub>H</sub>	System error	• The OS of the C24 detected some error.	—	*1				
7153 <sub>H</sub>	Frame length error	• The request exceeded the limit of the processing points that are predetermined for each command and allowed for one transmission.	CHn ERR.	• Modify the setting of the transmit message from the external device so that the request will not exceed the limit of the processing points that are allowed for one transmission and predetermined for each MC protocol command.	○			
7154 <sub>H</sub>	System error	• The OS of the C24 detected some error.	—	*1				
7155 <sub>H</sub>	Unwritten monitor data error	• Monitoring was requested before monitor data was written.	PRO.	• Write the device to be monitored before issuing a monitor request.	○			
7156 <sub>H</sub>	System error	• The OS of the C24 detected some error.	—	*1				
7160 <sub>H</sub>	Programmable controller access error	• CPU model name cannot be confirmed.	C/N	• If there is an error in the CPU module, remove the CPU module error and restart data communications.	○			
7161 <sub>H</sub> : 7163 <sub>H</sub>	System error	• The OS of the C24 detected some error.	—	*1				
7164 <sub>H</sub>	Request error	• Either the request or the device designation method is wrong.	—	• Check the transmission message/request from the external device, make the necessary corrections, and send again.	○			
7166 <sub>H</sub>	System error	• The OS of the C24 detected some error.	—	*1				
7167 <sub>H</sub>	Cannot execute a command during RUN	• A write command was designated when disable online change was set.	C/N	• Change the setting to enable online change and restart data communications. • Set the CPU module to STOP, and retry communications.	○			
7168 <sub>H</sub>		• A command that cannot be executed during RUN was designated.	C/N	• Stop the CPU module and restart data communications.				
7169 <sub>H</sub>	CPU module error	• Cannot communicate normally with the CPU module.	C/N	• If there is an error in the CPU module, remove the CPU error and restart data communications.	○			
716A <sub>H</sub> : 716C <sub>H</sub>	System error	• The OS of the C24 detected some error.	—	*1				
716D <sub>H</sub>	Monitor data write error	• Monitor data was not written using QnA compatible 2C/3C/4C frame.	PRO.	• Rewrite monitor data.	○			
716E <sub>H</sub>		• Monitor data was not written using A compatible 1C frame.	PRO.		○			

Error code (Hexadecimal)	Error	Error contents	Signal name	Corrective action	Protocol			
					MC	Nonprocedural	Bidirectional	Predefined
716F <sub>H</sub>	Device error	<ul style="list-style-type: none"> <li>A nonexistent device was designated.</li> <li>Device that cannot be specified by the corresponding command was designated.</li> </ul>	PRO.	<ul style="list-style-type: none"> <li>Check and correct the external device transmit message and restart data communications.</li> </ul>	○			
7170 <sub>H</sub>	A compatible 1C frame error	<ul style="list-style-type: none"> <li>Number of access points exceeded the range.</li> </ul>	PRO.		○			
7171 <sub>H</sub>		<ul style="list-style-type: none"> <li>A device that cannot be designated was designated.</li> </ul>	PRO.		○			
7172 <sub>H</sub>		<ul style="list-style-type: none"> <li>Written number of monitoring points is incorrect. For example, [0] was designated.</li> </ul>	PRO.		○	○	○	
7173 <sub>H</sub>	Monitor data write error	<ul style="list-style-type: none"> <li>Monitor data was written for a CPU other than a Q/L/QnACPU using QnA compatible 2C/3C/4C frame.</li> </ul>	PRO.	<ul style="list-style-type: none"> <li>For a CPU other than Q/L/QnACPU, use the A compatible 1C frame to write the monitor data.</li> </ul>	○			
7D00 <sub>H</sub>	Protocol No. setting error	<ul style="list-style-type: none"> <li>In control data of the CPRTCL instruction, the protocol No. is out of range.</li> </ul>	CHn ERR.	<ul style="list-style-type: none"> <li>Protocol No. setting error</li> </ul>				○
7D01 <sub>H</sub>	Continuous protocol execution count setting error	<ul style="list-style-type: none"> <li>The number of protocols to be executed continuously, which is specified with an argument in the CPRTCL instruction, is out of range.</li> </ul>	CHn ERR.	<ul style="list-style-type: none"> <li>Correct the number of protocols to be executed continuously.</li> </ul>				○
7D02 <sub>H</sub>	Protocol not-ready error	<ul style="list-style-type: none"> <li>The CPRTCL instruction was executed while Predefined protocol ready (X1D) is OFF.</li> <li>The CPRTCL instruction was executed during protocol setting data writing.</li> <li>The CPRTCL instruction was executed with abnormal protocol setting data.</li> </ul>	CHn ERR.	<ul style="list-style-type: none"> <li>Confirm Predefined protocol ready (X1D) turned ON before executing the CPRTCL instruction.</li> <li>Do not execute the CPRTCL instruction during writing of protocol setting data. (Set the CPU module to STOP before writing protocol setting data.)</li> <li>Write the protocol setting data again to the C24, and then execute the CPRTCL instruction.</li> <li>If this error persists even after rewriting, replace the module.</li> </ul>				○
7D10 <sub>H</sub>	Protocol unregistered error	<ul style="list-style-type: none"> <li>The protocol No. specified in control data for the CPRTCL instruction is not registered to the C24.</li> <li>The CPRTCL instruction was executed with no protocol setting data written.</li> </ul>	CHn ERR.	<ul style="list-style-type: none"> <li>Check if the specified protocol No. is correct.</li> <li>Check the Protocol registration area (buffer memory: 4091<sub>H</sub> to 4098<sub>H</sub>) to see if the specified protocol No. is registered.</li> <li>Write the protocol setting data, and then execute the CPRTCL instruction.</li> </ul>				○
7D11 <sub>H</sub>	Protocol simultaneous execution error	<ul style="list-style-type: none"> <li>The CPRTCL instruction and CH1 protocol execute request (Y3) or CH2 protocol execute request (YA) were executed simultaneously in the same channel.</li> </ul>	CHn ERR.	<ul style="list-style-type: none"> <li>Correct the program not to execute the CPRTCL instruction and CH1 protocol execute request (Y3)/CH2 protocol execute request (YA) simultaneously in the same channel.</li> </ul>				○

Error code (Hexadecimal)	Error	Error contents	Signal name	Corrective action	Protocol			
					MC	Nonpr ocedu ral	Bidir ectio nal	Predefi ned
7D12 <sub>H</sub>	Transmission monitoring timeout error	<ul style="list-style-type: none"> <li>Transmission monitoring time has timed out. Although the transmission was retried the specified number of times, it did not succeed.</li> </ul>	CHn ERR.	<ul style="list-style-type: none"> <li>Check if the transmission is interrupted due to some reason such as DTR control.</li> <li>Check if the CS signal is ON.</li> <li>Check the cables for disconnection.</li> </ul>				○
7D13 <sub>H</sub>	Receive wait timeout error	<ul style="list-style-type: none"> <li>Receive wait time has timed out.</li> </ul>	CHn ERR.	<ul style="list-style-type: none"> <li>Check if the reception is interrupted due to some reason such as DTR control.</li> <li>Check the cables for disconnection.</li> <li>Check the sending device for an error.</li> <li>Using the circuit trace function (communication data monitoring function), check if:               <ol style="list-style-type: none"> <li>1) Transmissions from the external device are interrupted.</li> <li>2) Any data are missing due to a receive error.</li> <li>3) An error exists in the data (packet) sent from the other device.</li> </ol> </li> </ul>				○
7D14 <sub>H</sub>	Response monitoring timeout error	<ul style="list-style-type: none"> <li>Response monitoring time (timer 1) has timed out during transmission.</li> <li>Data to be sent to the external device were not acquired from the CPU module within the Response monitoring time (timer 1).</li> </ul>	CHn ERR.	<ul style="list-style-type: none"> <li>Increase the Response monitoring time (timer 1) value. (Default: 5 seconds)</li> <li>If an error has occurred in the CPU module, take corrective actions by referring to  User's Manual (Hardware Design, Maintenance and Inspection) for the CPU module used.</li> </ul>				○
7D15 <sub>H</sub>	Response monitoring timeout error	<ul style="list-style-type: none"> <li>Response monitoring time (timer 1) has timed out during reception.</li> <li>Data received from the external device were not stored into the CPU module within the Response monitoring time (timer 1).</li> </ul>	CHn ERR.	<ul style="list-style-type: none"> <li>Increase the Response monitoring time (timer 1) value. (Default: 5 seconds)</li> <li>If an error has occurred in the CPU module, take corrective actions by referring to  User's Manual (Hardware Design, Maintenance and Inspection) for the CPU module used.</li> </ul>				○
7D16 <sub>H</sub>	Protocol cancel request error	<ul style="list-style-type: none"> <li>A cancel request was accepted during protocol execution, and the CPRTCL instruction failed.</li> <li>The CPRTCL instruction failed because protocol setting data were written during CPRTCL instruction execution.</li> </ul>	CHn ERR.	<ul style="list-style-type: none"> <li>Check the cancelled Predefined protocol in the CPRTCL instruction's control data (execution count result), and eliminate the cause of the cancellation.</li> <li>If necessary, clear the error information by error clear request (YE/YF).</li> <li>To prevent coincidental execution of the CPRTCL instruction, set the CPU module to STOP before writing the protocol setting data.</li> </ul>				○

Error code (Hexadecimal)	Error	Error contents	Signal name	Corrective action	Protocol			
					MC	Nonprocedural	Bidirectional	Predefined
7D17 <sub>H</sub>	Packet size error	<ul style="list-style-type: none"> <li>A packet of more than 2048 bytes was received.</li> </ul>	CHn ERR.	<ul style="list-style-type: none"> <li>Check the data length of the packet sent from the device.</li> <li>Divide the packet data into several parts and send them separately.</li> </ul>				○
7D18 <sub>H</sub>	Too few digits error	<ul style="list-style-type: none"> <li>When data are received by the protocol including a packet that contains a conversion variable (variable number of data), the number of digits corresponding to the variable is insufficient.</li> </ul>	CHn ERR.	<ul style="list-style-type: none"> <li>Correct the data sent from the device.</li> <li>Check the packet format of the external device to see if the number of digits is set correctly.</li> </ul>				○
7D19 <sub>H</sub>	Invalid number of digits error	<ul style="list-style-type: none"> <li>When data are received by the protocol including a packet that contains a conversion variable (variable number of data and variable number of digits), the corresponding data is 0 bytes (0 digits) or exceeds the maximum number of digits.</li> </ul>	CHn ERR.	<ul style="list-style-type: none"> <li>Correct the data sent from the device.</li> <li>Check the packet format of the external device to see if the number of digits is set correctly.</li> </ul>				○
7D1A <sub>H</sub>	Data length error	<ul style="list-style-type: none"> <li>In the data received from the external device, the Length value does not match the data length of the conversion variable(s).</li> </ul>	CHn ERR.	<ul style="list-style-type: none"> <li>Check the data sent from the external device to see if:               <ol style="list-style-type: none"> <li>The Length value is correct or not.</li> <li>Any of the data corresponding to the conversion variable is missing or not.</li> </ol> </li> <li>Check the packet format of the external device to see if the conversion variable is set correctly.</li> </ul>				○
7D1B <sub>H</sub>	Value range error	<ul style="list-style-type: none"> <li>When the protocol used for data reception includes a packet that contains a conversion variable, a value of the data for the conversion variable exceeds the range allowed for the C24.</li> </ul>	CHn ERR.	<ul style="list-style-type: none"> <li>Correct the data sent from the device.</li> <li>Check the packet format of the external device to see if the conversion size is set correctly.               <ol style="list-style-type: none"> <li>If it exceeds the range for word data, change the conversion size setting to Double word.</li> <li>If it exceeds the range for double-word data, change the element to Non-conversion variable.</li> </ol> </li> </ul>				○
7D20 <sub>H</sub>	Data length setting error, data quantity setting error	<ul style="list-style-type: none"> <li>The value set in the data length storage area or the data quantity storage area is out of range.</li> </ul>	CHn ERR.	<ul style="list-style-type: none"> <li>Check the maximum allowable data length, and specify the maximum length or less in the data length storage area.</li> <li>Check the maximum allowable data quantity, and specify the maximum quantity or less in the data quantity storage area.</li> </ul>				○
7D21 <sub>H</sub>	Decimal point position error	<ul style="list-style-type: none"> <li>An out-of-range decimal point position is set when the number of decimals is set to Variable point.</li> <li>The number of decimals is larger than the number of digits for each data.</li> </ul>	CHn ERR.	<ul style="list-style-type: none"> <li>Correct the decimal point position.</li> <li>Check the number of digits setting, and set the decimal point position so that the number of decimals is less than the number of digits.</li> </ul>				○



Error code (Hexadecimal)	Error	Error contents	Signal name	Corrective action	Protocol			
					MC	Nonpr ocedu ral	Bidir ectio nal	Predefi ned
7E00 <sub>H</sub> : 7E05 <sub>H</sub>	System error	• The OS of the C24 detected some error.	—	*1				
7E06 <sub>H</sub>	Buffer memory address setting error	• Transmit/receive buffer memory addresses are in the special applications area.	—	• Change the buffer memory addresses so that they are outside the special applications area.				
7E07 <sub>H</sub>	System error	• The OS of the C24 detected some error.	—	*1				
7E08 <sub>H</sub>	Currently inexecutable error	• The UINI instruction was executed during execution of the programmable controller CPU information clear.	—	• Execute the UINI instruction while the programmable controller CPU information clear is not executed.	○	○	○	○
7E09 <sub>H</sub> 7E0A <sub>H</sub>	System error	• The OS of the C24 detected some error.	—	*1				
7E40 <sub>H</sub>	Command error	• A nonexistent command or subcommand was designated.	PRO.	• Check and correct the external device transmit message and restart data communications.	○			
7E41 <sub>H</sub>	Data length error	• A data length exceeding the number of points that can communicate during random read/write was designated.	PRO.	• Check and correct the external device transmit message and restart data communications.	○			
7E42 <sub>H</sub>	Error count error, protocol setting data write error	• Number of processing points exceeds the range allowed for the command. • Protocol setting data were written to the C24 that does not support the predefined protocol function.	PRO.	• Modify the setting of the transmit message from the external device so that the request will not exceed the limit of processing points that are allowed for one transmission and predetermined for each MC protocol command. Then, retry communications. • When using the predefined protocol function, use a C24 that supports the function.	○			
7E43 <sub>H</sub>	Device error	• A nonexistent device was designated. • Device that cannot be specified by the corresponding command was designated. • The head device No. is out of range.	PRO.	• Check and correct the external device transmit message and restart data communications.	○	○		
7E44 <sub>H</sub>	Timer 1 time- out error	• A response message was not returned within the response monitoring time (timer 1) monitoring time.	C/N	• Increase the Response monitoring time (timer 1). • When accessing another station's CPU, check if the routing parameters match.	○			
7E46 <sub>H</sub>	System error	• The OS of the C24 detected some error.	—	*1				
7E47 <sub>H</sub>	Continuous request error	• The next request was received before a response message was returned for the preceding request.	PRO.	• Do not send requests continuously from the external device. • Adjust the Response monitoring time (timer 1) to the timeout time set for the external device.	○			
7E48 <sub>H</sub> : 7E4C <sub>H</sub>	System error	• The OS of the C24 detected some error.	—	*1				

Error code (Hexadecimal)	Error	Error contents	Signal name	Corrective action	Protocol			
					MC	Nonprocedural	Bidirectional	Predefined
7E4D <sub>H</sub>	Error during data transmission	<ul style="list-style-type: none"> <li>Mode switching was executed during data transmission.</li> </ul>	CHn ERR.	<ul style="list-style-type: none"> <li>Make arrangements between the target device and CPU module so that mode switching is not executed during data transmission.</li> </ul>	○	○		
7E4E <sub>H</sub>	System error	<ul style="list-style-type: none"> <li>The OS of the C24 detected some error.</li> </ul>	—	*1				
7E4F <sub>H</sub>	Device point count error	<ul style="list-style-type: none"> <li>Access point count is incorrect.</li> </ul>	PRO.	<ul style="list-style-type: none"> <li>Check and correct the external device transmit message and restart data communications.</li> </ul>	○	○		
7E50 <sub>H</sub>	User frame No. designation error	<ul style="list-style-type: none"> <li>A user frame No. outside the range was designated.</li> </ul>	PRO.	<ul style="list-style-type: none"> <li>Check and correct the external device transmit message and restart data communications.</li> <li>Recheck the frame No.</li> </ul>	○	○		
7E51 <sub>H</sub>	Unwritten user frame error	<ul style="list-style-type: none"> <li>An unwritten user frame No. was designated.</li> </ul>	PRO.	<ul style="list-style-type: none"> <li>Write the frame beforehand.</li> <li>Change the frame No. and restart data communications.</li> <li>Recheck the frame No.</li> </ul>	○	○		
7E52 <sub>H</sub>	User frame overwrite error	<ul style="list-style-type: none"> <li>A written frame No. overwrite request was issued.</li> </ul>	PRO.	<ul style="list-style-type: none"> <li>Change the write destination to an unwritten frame No.</li> <li>When overwriting, delete the given No. beforehand.</li> </ul>	○			
7E53 <sub>H</sub>	User frame access data error	<ul style="list-style-type: none"> <li>A nonexistent command was designated in a subcommand.</li> <li>Byte count exceeding the number of bytes that can be requested was designated.</li> </ul>	PRO.	<ul style="list-style-type: none"> <li>Check and correct the external device transmit message and restart data communications.</li> </ul>	○			
7E54 <sub>H</sub>	Modification allowed error	<ul style="list-style-type: none"> <li>Flash ROM Write Enable/Protection Status is set to Write Enable.</li> <li>In the Switch Setting, Setting Modifications is set to Disable.</li> </ul>	PRO.	<ul style="list-style-type: none"> <li>Select Protection for the Flash ROM Write Enable/Protection Status.</li> <li>Select Enable for the Setting Modifications in the Switch Setting.</li> </ul>	○	○	○	○
7E55 <sub>H</sub>	User frame data error	<ul style="list-style-type: none"> <li>There is an error in the user frame variable data.</li> </ul>	PRO.	<ul style="list-style-type: none"> <li>Check and correct the external device transmit message and restart data communications.</li> </ul>	○	○		
7E56 <sub>H</sub>	System error	<ul style="list-style-type: none"> <li>The OS of the C24 detected some error.</li> </ul>	—	*1				
7E57 <sub>H</sub>	Flash ROM write error	<ul style="list-style-type: none"> <li>Writing to the flash ROM failed.</li> <li>Power is turned off during writing to Flash ROM.</li> </ul>	— or CHn ERR.	<ul style="list-style-type: none"> <li>Re-execute the write operation.</li> <li>If the error occurs after rewriting, replace the module.</li> </ul>	○	○	○	○
7E58 <sub>H</sub>	Mode modification error	<ul style="list-style-type: none"> <li>There is an error in the mode No. or transmission specifications after changing the mode.</li> </ul>	PRO.	<ul style="list-style-type: none"> <li>Check and correct the external device's transmit message and restart data communications.</li> <li>Check the switch setting.</li> </ul>	○	○	○	○
7E59 <sub>H</sub>	Flash ROM write count over limit error	<ul style="list-style-type: none"> <li>Writing to flash ROM was performed 1000 times after power-on.</li> <li>Writing to flash ROM was performed 100,000 times.</li> </ul>	— or CHn ERR.	<ul style="list-style-type: none"> <li>Review the program.</li> <li>Write "0" to the Flash ROM write count area (address: 2401<sub>H</sub>) in the buffer memory and restart data communications.</li> <li>When the number of writes reached 100,000, replace the module.</li> </ul>	○	○	○	○

Error code (Hexadecimal)	Error	Error contents	Signal name	Corrective action	Protocol			
					MC	Nonpr ocedu ral	Bidir ectio nal	Predefi ned
7E5E <sub>H</sub>	Programmable controller CPU monitoring function registration error	<ul style="list-style-type: none"> <li>The programmable controller CPU monitoring function is registered for the communication protocol that does not support the function.</li> </ul>	CHn ERR.	<ul style="list-style-type: none"> <li>Correct the communication protocol setting.</li> </ul>			○	○
7E5F <sub>H</sub>	I/O number error on requested module	<ul style="list-style-type: none"> <li>I/O number of requested module is incorrect.</li> </ul>	—	<ul style="list-style-type: none"> <li>Correct the I/O number of the module to which data is sent.</li> </ul>	○	○		
7E60 <sub>H</sub>	Device monitoring duplicate registration error	<ul style="list-style-type: none"> <li>Programmable controller CPU monitoring registration was performed twice.</li> </ul>	—	<ul style="list-style-type: none"> <li>Cancel the programmable controller CPU monitoring and perform the programmable controller CPU monitoring registration again.</li> </ul>	○	○		
7E61 <sub>H</sub>	Cycle time units range error	<ul style="list-style-type: none"> <li>Cycle time units setting is out of range.</li> </ul>	—	<ul style="list-style-type: none"> <li>Correct the cycle time units setting.</li> </ul>	○	○		
7E62 <sub>H</sub>	Programmable controller CPU monitoring function error	<ul style="list-style-type: none"> <li>Setting of the programmable controller CPU monitoring function is out of range.</li> </ul>	—	<ul style="list-style-type: none"> <li>Correct the setting of the programmable controller CPU monitoring function.</li> </ul>	○	○		
7E63 <sub>H</sub>	Transmission measure setting error	<ul style="list-style-type: none"> <li>Incorrect transmission method is set for the programmable controller CPU monitoring.</li> </ul>	—	<ul style="list-style-type: none"> <li>Correct the setting of the transmission method for the programmable controller CPU monitoring.</li> </ul>	○	○		
7E64 <sub>H</sub>	Registration point range error	<ul style="list-style-type: none"> <li>The total number of word blocks and bit blocks registered for programmable controller CPU monitoring is out of range.</li> </ul>	—	<ul style="list-style-type: none"> <li>Correct the setting value so that the total number of registered word blocks and bit blocks is within 1 to 10.</li> </ul>	○	○		
7E65 <sub>H</sub>	Programmable controller CPU abnormality monitoring number error	<ul style="list-style-type: none"> <li>Setting of the programmable controller CPU abnormality monitoring is out of range.</li> </ul>	—	<ul style="list-style-type: none"> <li>Correct the setting of the programmable controller CPU abnormality monitoring.</li> </ul>	○	○		
7E66 <sub>H</sub>	Monitoring condition error of monitoring device	<ul style="list-style-type: none"> <li>Setting of the monitoring condition is out of range.</li> </ul>	—	<ul style="list-style-type: none"> <li>Correct the monitoring condition.</li> </ul>	○	○		
7E67 <sub>H</sub>	Programmable controller CPU abnormality monitoring error	<ul style="list-style-type: none"> <li>The programmable controller CPU abnormality monitoring setting (fixed value) is out of range.</li> </ul>	—	<ul style="list-style-type: none"> <li>Correct the programmable controller CPU abnormality monitoring setting (fixed value).</li> </ul>	○	○		
7E68 <sub>H</sub>	Transmission condition range error of monitoring device	<ul style="list-style-type: none"> <li>The transmission condition (condition agreement transmission) setting is out of range.</li> </ul>	—	<ul style="list-style-type: none"> <li>Correct the transmission condition (condition agreement transmission).</li> </ul>	○	○		
7E69 <sub>H</sub>	Programmable controller CPU abnormality monitoring error	<ul style="list-style-type: none"> <li>The programmable controller CPU abnormality monitoring setting (fixed value) is out of range.</li> </ul>	—	<ul style="list-style-type: none"> <li>Correct the programmable controller CPU abnormality monitoring setting (fixed value).</li> </ul>	○	○		
7E6A <sub>H</sub>	Monitoring device read point range error	<ul style="list-style-type: none"> <li>Read points of monitoring device is out of range.</li> </ul>	—	<ul style="list-style-type: none"> <li>Correct the monitoring device read points.</li> </ul>	○	○		

Error code (Hexadecimal)	Error	Error contents	Signal name	Corrective action	Protocol			
					MC	Nonprocedural	Bidirectional	Predefined
7E6B <sub>H</sub>	Programmable controller CPU abnormality monitoring error	• The programmable controller CPU abnormality monitoring setting (fixed value) is out of range.	—	• Correct the programmable controller CPU abnormality monitoring setting (fixed value).	○	○		
7E6C <sub>H</sub>					○	○		
7E6D <sub>H</sub>					○	○		
7E6E <sub>H</sub>	System error	• The OS of the C24 detected some error.	—	*1				
7E6F <sub>H</sub>	Modem connection error	• Modem is connected to an incorrect channel.	—	• Correct the setting of the destination channel to which data or notification is sent with the modem function.	○	○		
7E70 <sub>H</sub>	CPU module error	• The communication with the CPU module was not performed normally.	C/N	• If there is an error in the CPU module, eliminate the error on the CPU module side and communicate again.	○	○		○
7E73 <sub>H</sub> , 7E81 <sub>H</sub> ⋮ 7E8E <sub>H</sub>	System error	• The OS of the C24 detected some error.	—	*1				
7EC1 <sub>H</sub>								
7EC2 <sub>H</sub>								
7EC3 <sub>H</sub>	Double send request error	• A send request was sent again during processing of the send request.	—	• Provide an interlock for send requests.		○	○	
7EC4 <sub>H</sub>	Transmission data count error, Transmission/receive buffer setting error	• Data exceeding the transmit buffer memory size was transmitted. • Transmit/receive buffer settings are out of range.	—	• Make the transmission data count smaller than the transmit buffer size. • Increase the transmission buffer memory length designation value. • Designate the first address and size of transmission/receipt buffer in the free area range of the user.	○	○	○	
7EC5 <sub>H</sub>	Flash ROM access error	• Write to flash ROM was requested when the setting modifications is set to disable.	—	• When writing to the flash ROM, set the switch setting described on the left to enable and restart the C24.	○	○	○	○
7EC6 <sub>H</sub>		• There is an error in the Flash ROM read/write request contents.	—	• Check the read/write request data and designate the correct data.	○	○	○	○
7F00 <sub>H</sub>	System error	• The OS of the C24 detected some error.	—	*1				
7F01 <sub>H</sub>	Buffer full error	• The next data was received before processing of the previous data was completed. • Multiple requests was simultaneously issued for one channel.	—	• Perform handshake between the external device and C24. • Do not send requests continuously from the external device.	○	○	○	○
7F02 <sub>H</sub> ⋮ 7F06 <sub>H</sub>	System error	• The OS of the C24 detected some error.	—	*1				

Error code (Hexadecimal)	Error	Error contents	Signal name	Corrective action	Protocol			
					MC	Nonpr ocedu ral	Bidir ectio nal	Predefi ned
7F20 <sub>H</sub>	ASCII → BIN conversion error	<ul style="list-style-type: none"> <li>While nonprocedural or bidirectional protocol is used, an ASCII code that cannot be converted to binary code was received.</li> <li>While nonprocedural or bidirectional protocol is used, an odd number of bytes of data was received during data communications using ASCII ↔ BIN conversion.</li> </ul>	PRO.	<ul style="list-style-type: none"> <li>Check and correct the external device transmit message and restart data communications.</li> <li>While nonprocedural or bidirectional protocol is used and when data are converted between ASCII and binary, always transmit data in units of even bytes.</li> </ul>		○	○	
		<ul style="list-style-type: none"> <li>When data are received by a conversion variable of the predefined protocol function, the data corresponding to the conversion variable cannot be converted to binary numbers.</li> <li>When data are received by an error check code (ASCII hexadecimal or ASCII decimal) of the predefined protocol function, the data corresponding to the error check code cannot be converted to binary numbers.</li> </ul>		<ul style="list-style-type: none"> <li>If the predefined protocol was edited, check if the following values match the packet format of the external device:               <ol style="list-style-type: none"> <li>Conversion variable and sign character</li> <li>Number of decimals</li> <li>Delimiter</li> <li>Number of digits</li> <li>Code type of error check code</li> <li>Data length</li> </ol> </li> </ul>				○
7F21 <sub>H</sub>	Receive header area error	<ul style="list-style-type: none"> <li>There is an error in the command (frame) part.</li> <li>An ASCII code that cannot be converted to binary code was received.</li> </ul>	PRO.	<ul style="list-style-type: none"> <li>Check and correct the external device transmit message and restart data communications.</li> </ul>	○			
7F22 <sub>H</sub>	Command error	<ul style="list-style-type: none"> <li>A nonexistent command, subcommand, or device was designated.</li> <li>The remote password length is wrong.</li> </ul>	PRO.	<ul style="list-style-type: none"> <li>Check and correct the external device transmit message and restart data communications.</li> </ul>	○			
7F23 <sub>H</sub>	MC protocol message error	<ul style="list-style-type: none"> <li>There is no data (ETX, CR-LF, etc.) following the character area, or designation was incorrect.</li> </ul>	PRO.	<ul style="list-style-type: none"> <li>Check and correct the external device transmit message and restart data communications.</li> </ul>	○			
7F24 <sub>H</sub>	Sum check error	<ul style="list-style-type: none"> <li>The sum check code calculated does not match the sum check code received.</li> <li>The horizontal parity code calculated does not match the horizontal parity code received.</li> <li>The calculated error check code does not match the received error check code.</li> </ul>	P/S	<ul style="list-style-type: none"> <li>Check the sum check code of the external device.</li> <li>Check the horizontal parity code calculated of the external device.</li> <li>Check CRC-16 of the external device.</li> <li>If the predefined protocol was edited, check if the following values match the packet format of the external device:               <ol style="list-style-type: none"> <li>Processing method or code type of the error check code</li> <li>Data length</li> <li>Data flow</li> <li>Complement calculation</li> <li>Calculating range</li> </ol> </li> </ul>	○	○		○
7F25 <sub>H</sub>	Data length error	<ul style="list-style-type: none"> <li>The length of the received data exceeds the receive area size.</li> </ul>	CHn ERR.	<ul style="list-style-type: none"> <li>Correct the "data length" that is transmitted from the external device.</li> <li>Change the "word/byte units" setting to "byte units".</li> <li>Increase the receive buffer memory length designation value.</li> </ul>			○	

Error code (Hexadecimal)	Error	Error contents	Signal name	Corrective action	Protocol			
					MC	Nonprocedural	Bidirectional	Predefined
7F26 <sub>H</sub>	Command error	<ul style="list-style-type: none"> <li>Another command was received before an unlock processing while the remote password is registered.</li> </ul>	CHn ERR.	<ul style="list-style-type: none"> <li>Perform the communication after the unlock processing is normally completed.</li> </ul>	○			
7F30 <sub>H</sub>	System error	<ul style="list-style-type: none"> <li>The OS of the C24 detected some error.</li> </ul>	—	*1				
7F31 <sub>H</sub>	Simultaneous transmission error	<ul style="list-style-type: none"> <li>The C24 and an external device started transmissions simultaneously.</li> </ul>	—	<ul style="list-style-type: none"> <li>Perform processing according to the predefined arrangement with the external device. When necessary, change the simultaneous transmission data valid/invalid designation setting. (address: 9B<sub>H</sub>/13B<sub>H</sub>)</li> </ul>			○	
7F32 <sub>H</sub>	System error	<ul style="list-style-type: none"> <li>The OS of the C24 detected some error.</li> </ul>	—	*1				
7F40 <sub>H</sub>	Time-out error	<ul style="list-style-type: none"> <li>No reception watchdog timer (timer 0) time-out occurred.</li> </ul>	PRO.	<ul style="list-style-type: none"> <li>Check if data was dropped from the receive data.</li> <li>Check if DTR control, etc. interrupted reception.</li> </ul>	○	○	○	
7F41 <sub>H</sub>		<ul style="list-style-type: none"> <li>Response watchdog timer (timer 1) time-out occurred.</li> </ul>	—	<ul style="list-style-type: none"> <li>Check the status of the external device, and restart data communications, as required.</li> </ul>	○		○	
7F42 <sub>H</sub>		<ul style="list-style-type: none"> <li>Transmit watchdog timer (timer 2) time-out occurred.</li> </ul>	—	<ul style="list-style-type: none"> <li>Check if DTR control, etc. interrupted transmission.</li> </ul>	○	○	○	
7F50 <sub>H</sub> ⋮ 7F54 <sub>H</sub> 7F60 <sub>H</sub> ⋮ 7F66 <sub>H</sub>	System error	<ul style="list-style-type: none"> <li>The OS of the C24 detected some error.</li> </ul>	—	*1				
7F67 <sub>H</sub>	Overrun error	<ul style="list-style-type: none"> <li>The C24 received the next data before it completed receive processing of the previous data.</li> </ul>	SIO	<ul style="list-style-type: none"> <li>Decrease the data transmission rate and restart data communications.</li> <li>Check whether a temporary stop has occurred in the station to which the C24 is installed. (It can be checked at special register SD1005.) If a temporary stop has occurred, remove its cause.</li> <li>Perform the registration, read, and delete to the flash ROM while the data communication is not performed.</li> </ul>	○	○	○	○

Error code (Hexadecimal)	Error	Error contents	Signal name	Corrective action	Protocol			
					MC	Nonpr ocedu ral	Bidir ectio nal	Predefi ned
7F68 <sub>H</sub>	Framing error	<ul style="list-style-type: none"> <li>Data does not match the stop bit setting.</li> <li>A malfunction occurred in the network because the power source of the partner station was on or off.</li> <li>Noise occurs in the network.</li> <li>When the multidrop was connected, data was transmitted simultaneously by multiple devices.</li> </ul>	SIO	<ul style="list-style-type: none"> <li>Match the C24 and external device settings.</li> <li>Clear the error information according to the ERR. clear request (YE/YF). In addition, when communicating data with the nonprocedural protocol, execute the INPUT instruction, and read and discard the unnecessary data.</li> <li>Measure the noise.</li> <li>When connecting the multidrop, remove the interlock so that data will not be transmitted simultaneously by multiple devices.</li> </ul>	○	○	○	○
7F69 <sub>H</sub>	Parity error	<ul style="list-style-type: none"> <li>Data does not match the parity bit setting.</li> <li>A malfunction occurred in the network because the power source of the partner station was on or off.</li> <li>Noise occurs in the network.</li> <li>When the multidrop was connected, data was transmitted simultaneously by multiple devices.</li> </ul>	P/S	<ul style="list-style-type: none"> <li>Match the C24 and external device settings.</li> <li>Clear the error information according to the ERR. clear request (YE/YF). In addition, when communicating data with the nonprocedural protocol, execute the INPUT instruction, and read and discard the unnecessary data.</li> <li>Measure the noise.</li> <li>When connecting the multidrop, remove the interlock so that data will not be transmitted simultaneously by multiple devices.</li> </ul>	○	○	○	○
7F6A <sub>H</sub>	Buffer full error	<ul style="list-style-type: none"> <li>OS receive buffer overflowed and receive data was skipped.</li> </ul>	SIO	<ul style="list-style-type: none"> <li>Use DTR and DC control and perform data communications so that the buffer does not become full. (Perform RS and CS control when the modem function is used.)</li> <li>If the Reception data read request signal was turned ON, execute reading immediately.</li> </ul>	○	○	○	○
7F6B <sub>H</sub>	CD(DCD) signal control error	<ul style="list-style-type: none"> <li>Data was received when CD(DCD) signal is OFF when "CD terminal check designation" set to "Check".</li> </ul>	CHn ERR.	<ul style="list-style-type: none"> <li>Recheck the CD(DCD) signal control of the external device. (Send while the CD(DCD) signal is ON.)</li> <li>Set "Not check" and perform communication.</li> </ul>	○	○	○	○
7F6C <sub>H</sub>	Transmission error	<ul style="list-style-type: none"> <li>Data cannot be sent because the line is not connected.</li> </ul>	CHn ERR.	<ul style="list-style-type: none"> <li>Transmit data after line connection processing on the interface side that uses the modem function.</li> </ul>	○	○	○	

Error code (Hexadecimal)	Error	Error contents	Signal name	Corrective action	Protocol											
					MC	Nonprocedural	Bidirectional	Predefined								
7F91 <sub>H</sub> ⋮ 7F96 <sub>H</sub>	System error	<ul style="list-style-type: none"> <li>The OS of the C24 detected some error.</li> </ul>	—	*1												
7F98 <sub>H</sub> ⋮ 7F9A <sub>H</sub>																
7F9D <sub>H</sub>																
7F9E <sub>H</sub>																
7FA0 <sub>H</sub> ⋮ 7FA3 <sub>H</sub>																
7FA8 <sub>H</sub>																
7FAA <sub>H</sub> ⋮ 7FAD <sub>H</sub>																
7FAF <sub>H</sub> ⋮ 7FB2 <sub>H</sub>																
7FB5 <sub>H</sub>																
7FB6 <sub>H</sub>																
7FB8 <sub>H</sub> ⋮ 7FBC <sub>H</sub>																
7FC0 <sub>H</sub> ⋮ 7FC4 <sub>H</sub>																
7FC7 <sub>H</sub>																
7FC8 <sub>H</sub>									Protocol setting data error	<ul style="list-style-type: none"> <li>The predefined protocol setting written to the C24 is in any of the following states.</li> <li>1) The predefined protocol has an error.</li> <li>2) Unsupported function is included in the setting.</li> <li>3) Set data is corrupted.</li> </ul>	CHn ERR.	<ul style="list-style-type: none"> <li>Check the predefined protocol in Protocol setting data error information (buffer memory: 4086<sub>H</sub> to 4089<sub>H</sub>), correct and write it again to the C24, and execute the CPRTCL instruction.</li> <li>Check the version of the C24, and use the predefined protocol function within the range of supported functions.</li> <li>If this error persists even after rewriting, replace the module.</li> </ul>				○
7FC9 <sub>H</sub> ⋮ 7FCF <sub>H</sub>									System error	<ul style="list-style-type: none"> <li>The OS of the C24 detected some error.</li> </ul>	—	*1				
7FD0 <sub>H</sub> ⋮ 7FE5 <sub>H</sub>									Refer to the error code list for use of the modem function, and take corrective action. (Refer to  Page 299, Section 15.2.4.)							
7FE6 <sub>H</sub>	Remote password error	<ul style="list-style-type: none"> <li>Remote passwords do not match.</li> </ul>	—	<ul style="list-style-type: none"> <li>Check the remote password and communicate again.</li> </ul>	○											



Error code (Hexadecimal)	Error	Error contents	Signal name	Corrective action	Protocol			
					MC	Nonpr ocedu ral	Bidir ectio nal	Predefi ned
7FE7 <sub>H</sub>	Remote password error	<ul style="list-style-type: none"> <li>The remote password is not registered.</li> <li>The remote password processing command was received on the interface side where the modem function is not used.</li> <li>The MELSOFT Connection is selected in the Communication protocol setting on the corresponding CH.</li> </ul>	CHn ERR.	<ul style="list-style-type: none"> <li>A remote password processing command is not necessary when a remote password is not registered.</li> <li>Unlock the remote password by MELSOFT. Alternatively, change the Communication protocol setting of the corresponding channel to MC protocol.</li> </ul>	○			
7FE8 <sub>H</sub>	Remote password error	<ul style="list-style-type: none"> <li>The number of remote password mismatch exceeded the value designated at the address 200D<sub>H</sub>.</li> </ul>	CHn ERR.	<ul style="list-style-type: none"> <li>Clear the storage area of the accumulated count of unlock process abnormal completion processing (address: 22FC<sub>H</sub>) to 0.</li> </ul>	○			
7FE9 <sub>H</sub>	Refer to the error code list for use of the modem function, and take corrective action. (Refer to  Page 299, Section 15.2.4.)							
7FEF <sub>H</sub>	Switch setting error	<ul style="list-style-type: none"> <li>There is an error in the switch setting by MELSOFT.</li> </ul>	CHn ERR.	<ul style="list-style-type: none"> <li>After correcting the switch setting, write parameters to the CPU module and reboot it.</li> </ul>	○	○	○	○
7FF0 <sub>H</sub>	Dedicated instructions simultaneous execution error	<ul style="list-style-type: none"> <li>Executed dedicated instructions simultaneously.</li> </ul>	—	<ul style="list-style-type: none"> <li>Do not use dedicated instructions simultaneously.</li> </ul>	○	○	○	○
7FF1 <sub>H</sub>	Control data error	<ul style="list-style-type: none"> <li>Setting value is incorrect.</li> <li>Setting value is out of range.</li> </ul>	—	<ul style="list-style-type: none"> <li>Correct the setting value in the control data.</li> </ul>	○	○		
7FF2 <sub>H</sub>	Communication protocol setting error	<ul style="list-style-type: none"> <li>Instruction cannot be executed with the current communication protocol.</li> </ul>	—	<ul style="list-style-type: none"> <li>Correct the setting value of the communication protocol.</li> </ul>	○	○		○
7FF3 <sub>H</sub> : 7FF4 <sub>H</sub>	System error	<ul style="list-style-type: none"> <li>The OS of the C24 detected some error.</li> </ul>	—	*1				
7FF5 <sub>H</sub>	Processing cancelled due to mode switching, transmission sequence initialization, etc.	<ul style="list-style-type: none"> <li>The processing in operation was cancelled due to execution of the following: Mode switching, transmission sequence initialization, receive data clear (by buffer memory), user frame use enable/disable designation, UINI instruction, programmable controller CPU information clear</li> </ul>	—	<ul style="list-style-type: none"> <li>Do not execute these functions during any other processing.</li> </ul>	○	○	○	○
7FF7 <sub>H</sub>	Simultaneous access error	<ul style="list-style-type: none"> <li>Multiple external devices accessed a remote station on the same network at the same time.</li> </ul>	—	<ul style="list-style-type: none"> <li>Multiple external devices must not access a remote station on the same network at the same time.</li> </ul>	○			
7FF8 <sub>H</sub> : 7FFF <sub>H</sub>	System error	<ul style="list-style-type: none"> <li>The OS of the C24 detected some error.</li> </ul>	—	*1				
B000 <sub>H</sub> : BFFF <sub>H</sub>	Errors detected by the CC-Link module	—	—	<ul style="list-style-type: none"> <li>Take corrective action, referring to CC-Link Master/Local Module User's Manual.</li> </ul>	○			
D000 <sub>H</sub> : DFFF <sub>H</sub>	Errors detected by the CC-Link IE Field Network module	—	—	<ul style="list-style-type: none"> <li>Take corrective actions, referring to User's manual of the CC-Link IE Field Network.</li> </ul>	○			

- \*1 Take corrective actions in the following procedure.
- 1) Check whether the C24, power supply module, and CPU module are installed correctly.
  - 2) Check whether the operating environment of the C24 is within the general specifications range of the CPU module.
  - 3) Check whether the power supply capacity is sufficient or not.
  - 4) Check whether the hardware of the C24 and CPU module are normal according to the manuals of the corresponding modules.  
If any module is faulty, please consult your local Mitsubishi service center or representative.
  - 5) If the problem cannot be solved through the above steps, please consult your local Mitsubishi service center or representative, explaining a detailed description of the problem.
- \*2 Error code when the target CPU is MELSEC-A series

## 15.2.3 A compatible 1C frame communications error code list

The following table lists the error code, error contents, and corrective action for errors generated during A compatible 1C frame communications.

Error code (Hexadecimal)	Error	Error contents	Signal name	Corrective action	Protocol			
					MC	Nonprocedural	Bidirectional	Predefined
00 <sub>H</sub>	Disable during RUN	<ul style="list-style-type: none"> <li>A write command was designated when disable online change was set.</li> <li>Parameter or sequence program was written during RUN.</li> </ul>	C/N	<ul style="list-style-type: none"> <li>Change the setting to enable online change and restart data communications.</li> <li>Stop the CPU and restart data communications.</li> </ul>	○			
01 <sub>H</sub>	Parity error	<ul style="list-style-type: none"> <li>Data does not match the parity bit setting.</li> </ul>	P/S	<ul style="list-style-type: none"> <li>Match the C24 and external device settings.</li> </ul>	○			
02 <sub>H</sub>	Sum check error	<ul style="list-style-type: none"> <li>The sum check calculated by the C24 and the transmitted sum check are not the same.</li> </ul>	P/S	<ul style="list-style-type: none"> <li>Check the external device sum check.</li> </ul>	○			
03 <sub>H</sub>	Protocol error	<ul style="list-style-type: none"> <li>Received message that is different from the control procedure with the communication protocol setting.</li> </ul>	PRO.	<ul style="list-style-type: none"> <li>Check and correct the external device transmit message and restart data communications.</li> </ul>	○			
04 <sub>H</sub>	Framing error	<ul style="list-style-type: none"> <li>The data does not match the stop bit setting.</li> </ul>	SIO	<ul style="list-style-type: none"> <li>Match the C24 and external device settings.</li> </ul>	○			
05 <sub>H</sub>	Overrun error	<ul style="list-style-type: none"> <li>The next data was received before the C24 received all the preceding data.</li> </ul>	SIO	<ul style="list-style-type: none"> <li>Decrease the transmission rate and restart data communications.</li> </ul>	○			
06 <sub>H</sub>	Character area error	<ul style="list-style-type: none"> <li>Designation method error in part of a message.</li> <li>A command that does not exist was designated.</li> <li>The number of processing points is outside the range for the command.</li> <li>A device that does not exist was designated.</li> </ul>	PRO.	<ul style="list-style-type: none"> <li>Check and correct the external device transmit message and restart data transmission.</li> </ul>	○			
07 <sub>H</sub>	Character error	<ul style="list-style-type: none"> <li>Received data that cannot be used.</li> </ul>	PRO.		○			
08 <sub>H</sub>	Programmable controller access error	<ul style="list-style-type: none"> <li>The CPU module cannot communicate with the C24.</li> </ul>	C/N	<ul style="list-style-type: none"> <li>Replace the CPU module with a CPU module that can communicate with the C24.</li> </ul>	○			
10 <sub>H</sub>	PC No. error	<ul style="list-style-type: none"> <li>The PC No. is not "FF", or a station No. set in the network parameters.</li> </ul>	C/N	<ul style="list-style-type: none"> <li>Check and correct the external device transmit message and restart data communications.</li> </ul>	○			
11 <sub>H</sub>	Mode error	<ul style="list-style-type: none"> <li>An error was detected upon access to the CPU module.</li> </ul>	—	<ul style="list-style-type: none"> <li>Send again.</li> <li>Conduct Self-loopback test and check the C24.</li> </ul>	○			
12 <sub>H</sub>	Special function module designation error	<ul style="list-style-type: none"> <li>A special function module does not exist at the specified position.</li> </ul>	C/N	<ul style="list-style-type: none"> <li>Check and correct the external device transmit message and restart data communications.</li> </ul>	○			
21 <sub>H</sub>	Special function module bus error	<ul style="list-style-type: none"> <li>An error was detected upon access to a special function module at the specified position.</li> </ul>	C/N	<ul style="list-style-type: none"> <li>Check the error and take corrective action according to the manual of the corresponding module.</li> </ul>	○			
42 <sub>H</sub>	Other errors	* Refer to POINT.			○			

## Point

---

- If an error occurs during A compatible 1C frame communications, the C24 adds a 2-character error code (00<sub>H</sub> to 10<sub>H</sub>, 42<sub>H</sub>) to the "NAK" code and returns the "NAK" code to the external device and stores the error code (equivalent to QnA compatible 2C/3C/4C frame error code) to buffer memory address 25A<sub>H</sub> (CH1) or 26A<sub>H</sub> (CH2).  
The exact error contents can be checked by reading the value stored to the buffer memory. For details of the error codes, refer to  Page 277, Section 15.2.
-

## 15.2.4 Error code list while modem function is used

The following describes the error codes, contents and corrective actions for errors (including errors at the abnormal completion) that may occur while the C24 modem function is used.

The error codes for the modem function are stored in the modem function error code (address: 221<sub>H</sub>(545)).

Error code (Hexadecimal)	Error	Error contents	Signal name	Corrective action	
7FD0 <sub>H</sub>	Modern function error	There is an error in the designation of the notification execution.	CHn ERR.	Set 0 or 1 to the notification execution designation. Check if the C24 supports the notification function.	
7FD1 <sub>H</sub>		There is an error in the designation of the number of connection retries.		Set the number of connection retries in the range of 1 to 5.	
7FD2 <sub>H</sub>		There is an error in the designation of the connection retry interval.		Set the connection retry interval in the range of 90 to 300 (s).	
7FD3 <sub>H</sub>		There is an error in the initialization/connection time-out designation.		Set the initialization/connection time-out in the range of 1 to 60 (s).	
7FD4 <sub>H</sub>		There is an error in the designation of the number of initialization retries.		Set the number of initialization retries in the range of 1 to 5.	
7FD5 <sub>H</sub>		There is an error in the designation of the data number for initialization.		Designate the registered data number for initialization, or 0.	
7FD6 <sub>H</sub>		There is an error in the data for connection designated by the data number for connection.		Recheck the pager receiver designation.	
7FD7 <sub>H</sub>				Recheck the dialing number of the external line.	
7FD8 <sub>H</sub>	System error	The OS of the C24 detected some error.	—	(*1)	
7FD9 <sub>H</sub>	Modern function error	Line connection or notification was performed during communication by the modem function.	CHn ERR.	Complete the communication by the modem function, and then perform line connection or notification.	
7FDA <sub>H</sub>		There is an error in the designation of the data number for connection.		Designate a registered number for the data for connection.	
7FDB <sub>H</sub>		There is an error in the designation of the MELSOFT connection.		Set 0 to 1 to the MELSOFT connection designation.	
7FDC <sub>H</sub>		There is an error in the data for connection designated by the data number for connection.		Recheck the waiting time for the notification-message part of the message transmission.	
7FDD <sub>H</sub>		A connection time-out error occurred.		<ul style="list-style-type: none"> <li>• Recheck the telephone number in the data for connection.</li> <li>• Check if the destination is ready for a connection.</li> <li>• Recheck the set value of the connection time-out.</li> <li>• Recheck the initialization command.</li> </ul>	
7FDE <sub>H</sub>		Connection to the modem/TA was unsuccessful, or the modem/TA is not connected.		<ul style="list-style-type: none"> <li>• Check if there is any problem with the modem/TA by seeing the operation manual of the modem/TA.</li> <li>• Connect the modem/TA to the C24.</li> <li>• Check the connection cable by seeing the operation manual of the modem/TA.</li> <li>• Check if the C24 is faulty or not, following the procedure shown under *1.</li> </ul>	
7FDF <sub>H</sub>		Modem connection channel number is not designated.		—	Set 1 to 2 to the modem connection channel designation.
7FE0 <sub>H</sub>		Designated value of modem connection channel is incorrect.			

Error code (Hexadecimal)	Error	Error contents	Signal name	Corrective action
7FE1 <sub>H</sub>	Modern function error	There is an error in the designation of the user frame number.	CHn ERR.	<ul style="list-style-type: none"> <li>Recheck the user frame number.</li> <li>Designate the registered user frame number.</li> <li>Register the designated data for initialization.</li> </ul>
7FE2 <sub>H</sub>		There is an error in the designation of the output head pointer.		<ul style="list-style-type: none"> <li>Designate the output head pointer in the range of 1 to 100.</li> <li>Designate the position (n-th position) where the data for initialization number is designated.</li> <li>Designate the data for initialization number at the designated position (n-th position).</li> </ul>
7FE3 <sub>H</sub>		There is an error in the designation of the output frame number.		<ul style="list-style-type: none"> <li>Designate a registered data for initialization number within the range of the designated number of outputs from the location of the output head pointer.</li> </ul>
7FE4 <sub>H</sub>		There is an error in the designation of the number of registered data bytes.		<ul style="list-style-type: none"> <li>Designate the data for initialization in the range of 1 to 78.</li> <li>Designate 80 for the data for connection.</li> </ul>
7FE5 <sub>H</sub>		There is an error in the data for connection.		Recheck the message length of the message for notification.
7FE8 <sub>H</sub>		There is an error in the designation of the no-communication interval time.		Designate the no-communication interval time in the range of 0 to 120.
7FE9 <sub>H</sub>		The number of remote password mismatch exceeded the value designated at the address 200D <sub>H</sub> .		Clear the Accumulated count of unlock process abnormal completion processing (address: 22FC <sub>H</sub> ) to 0.
7FE9 <sub>H</sub>		Callback denial exceeded the value designated at the address 2002H.		Clear the callback denial accumulated count (address: 22F1 <sub>H</sub> ) to 0.

- \*1 Take corrective actions in the following procedure.
- 1) Check whether the C24, power supply module, and CPU module are installed correctly.
  - 2) Check whether the operating environment of the C24 is within the general specifications range of the CPU module.
  - 3) Check whether the power supply capacity is sufficient or not.
  - 4) Check whether the hardware of the C24 and CPU module are normal according to the manuals of the corresponding modules.  
If any module is faulty, please consult your local Mitsubishi service center or representative.
  - 5) If the problem cannot be solved through the above steps, please consult your local Mitsubishi service center or representative, explaining a detailed description of the problem.

## 15.3 Troubleshooting by Symptom

This following shows troubleshooting of trouble generated during communications between the C24 and external device according to the trouble symptom.

When trouble occurs, first confirm the status of the C24 and check the relevant item in the table below.

Symptom	Symptom description	Protocol				Dedicated
		MC	Nonprocedural	Bidirectional	Predefined	
LED turns on/off (check according to Page 25, CHAPTER 2)	• "RUN" LED turned off.	<input type="radio"/>	<input type="radio"/>	<input type="radio"/>	<input type="radio"/>	Page 303, Section 15.3.1
	• "RD" does not blink even through an external device is transmitting a message.	<input type="radio"/>	<input type="radio"/>	<input type="radio"/>	<input type="radio"/>	Page 303, Section 15.3.2
	• An external device transmitted a message and "RD" blinked, but the C24 did not return a response message.	<input type="radio"/>		<input type="radio"/>		Page 304, Section 15.3.3
	• "SD" does not blink even after a send request was made.	<input type="radio"/>	<input type="radio"/>	<input type="radio"/>	<input type="radio"/>	Page 305, Section 15.3.4
	• An external device transmitted a message and "RD" blinked, but the C24 did not turn ON the read request.		<input type="radio"/>	<input type="radio"/>		Page 306, Section 15.3.5
	• The CPRTCL instruction is not completed even though "RD" was blinking.				<input type="radio"/>	Page 307, Section 15.3.6
	• "ERR." LED turns on.	<input type="radio"/>	<input type="radio"/>	<input type="radio"/>	<input type="radio"/>	Page 324, Section 15.3.23
Communication errors occurred (check according to  Page 277, Section 15.2.1)	• The "NAK" was turned ON.	<input type="radio"/>				Page 308, Section 15.3.7
	• The "C/N" was turned ON.	<input type="radio"/>	<input type="radio"/>	<input type="radio"/>	<input type="radio"/>	Page 309, Section 15.3.8
	• The "P/S" was turned ON.	<input type="radio"/>	<input type="radio"/>	<input type="radio"/>	<input type="radio"/>	Page 310, Section 15.3.9
	• The "PRO." was turned ON.	<input type="radio"/>				Page 311, Section 15.3.10
	• The "SIO" was turned ON.	<input type="radio"/>	<input type="radio"/>	<input type="radio"/>	<input type="radio"/>	Page 312, Section 15.3.11
	• The "CH1 ERR." or "CH2 ERR." was turned ON.	<input type="radio"/>	<input type="radio"/>	<input type="radio"/>	<input type="radio"/>	Page 313, Section 15.3.12
	• Communications are intermittently established and lost.	<input type="radio"/>	<input type="radio"/>	<input type="radio"/>	<input type="radio"/>	Page 316, Section 15.3.13
	• Data that cannot be decoded was transmitted and received.	<input type="radio"/>	<input type="radio"/>	<input type="radio"/>	<input type="radio"/>	Page 318, Section 15.3.14
• Whether the cause of the communications error is in the C24 or the external device is unknown.	<input type="radio"/>	<input type="radio"/>	<input type="radio"/>	<input type="radio"/>	Page 319, Section 15.3.15	
Cannot communicate via modem (*1)	• Cannot communicate via modem.	<input type="radio"/>	<input type="radio"/>	<input type="radio"/>		Page 320, Section 15.3.16
	• Cannot communicate with ISDN sub-address.	<input type="radio"/>	<input type="radio"/>			Page 321, Section 15.3.17
The programmable controller CPU monitoring function does not operate in the designated cycle time.	• Does not operate in the cycle time designated in the constant cycle transmission setting.	<input type="radio"/>	<input type="radio"/>			Page 321, Section 15.3.18
	• Does not operate in the cycle time designated in condition agreement transmission setting.	<input type="radio"/>	<input type="radio"/>			Page 321, Section 15.3.19
Cannot receive by an interrupt program	• Cannot receive data.		<input type="radio"/>	<input type="radio"/>		Page 321, Section 15.3.20
Cannot perform initial setting	• Cannot write setting value in flash ROM of the C24.	<input type="radio"/>	<input type="radio"/>	<input type="radio"/>	<input type="radio"/>	Page 322, Section 15.3.21

\*1 If an error occurs while performing data exchange using the modem function described in  User's Manual (Application), first check the following items and confirm whether or not the error is caused by the modem/TA connection.

If an error relating to the modem function occurs, take corrective actions according to the following items shown below:

- Check the ON/OFF status of current I/O signals of the C24.
- Check the storage status for error codes related to the modem function.
- Check the ON/OFF status of the DR terminal of the modem/TA. ( the manual for the modem/TA.)



**Remark**

The following are precautionary notes when exchanging data with an external device via one of the C24 interfaces.

- When the power supply to the C24 or external device is started, the remote device that is connected may generate a reception error.
- If the remote device that is connected starts up while data is being transmitted, the remote device side will generate a reception error.
- When the C24 error LED turns on because a reception error has occurred, turn off the light if necessary in accordance with  Page 325, Section 15.4.

Also, if a reception error has occurred on the external device side, handle the error by seeing to the operating manual for the external device.

\* Handle the occurrence of a reception error on the C24 side using the following corrective actions.

- When communicating with the MC protocol  
The C24 will disregard the received data or returns a response message indicating an abnormal termination if it detects a reception error after receiving the head data of the command message in the set format.  
If the reception error is detected before the head data of the command message in the set format is received, the received data will be disregarded.
- When communicating using nonprocedural protocol  
If the C24 detects a reception error, the reception abnormal detection (X4/XB) turns ON.  
Perform procedures such as detection of reception error or clearing received data as required by following the explanations found in  Page 157, Section 10.1.4.
- When communicating using bidirectional protocol  
When the C24 detects a reception error after the head data of a communication message for bidirectional protocol is received, it returns a response message indicating an abnormal termination.  
If the reception error is detected before the head data of the communication message for bidirectional protocol is received, the received data will be disregarded.
- When communicating using the predefined protocol  
If a reception error occurs, an error code is stored in the Data reception result area (address: 258<sub>H</sub>/268<sub>H</sub>) of the C24.  
Reception error codes can be also checked with the communication data monitoring function.  
Take actions such as detecting a reception error or clearing the received data, if necessary.  
For details of the communication data monitoring function, refer to  User's Manual (Application).



## 15.3.1 The "RUN" LED is turned OFF

Symptom	Cause	Corrective action	MC	Nonprocedural	Bidirectional	Predefined
• The C24 "RUN" LED turned off.	• A transmission setting switch is set to an unusable position.	• Set the switch by GX Works2 correctly and after writing to the CPU module reset the CPU.	○	○	○	○
	• CPU module error.	• Remove the cause of the CPU module error and reset the CPU. <u>Remarks</u> • During the C24 and external device loopback test, the minimum parameters file must be written to the CPU module beforehand.	○	○	○	○
	• Power module 5 V current capacity is insufficient.	• Calculate the 5 V current drain of each installed module. If the current capacity is insufficient, check power module selection.	○	○	○	○
	• Extraneous noise caused the C24 to abnormal operation.	• Check if the shielded twisted pair cable is 2-point ground. • When ground is used with other devices, ground the C24 independently.	○	○	○	○
	• The module is not installed properly.	• Check if the module is installed properly. • Lock the module joint lever properly.	○	○	○	○

## 15.3.2 The "RD" LED does not blink even after message transmission from the external device

Symptom	Cause	Corrective action	MC	Nonprocedural	Bidirectional	Predefined
• "RD" does not blink even through an external device is transmitting a message.	• Signal lines are not connected correctly.	• Check if the C24 and external RD(RXD) and SD(TXD) signal lines are cross connected. • Use the external device OPEN statement to check if the opened port and the cable connection port are matched.	○	○	○	○
	• External device transmission control signals are not turned ON.	• Connect the wiring so that the "DR(DSR)", "CS(CTS)", and other transmission control signals are ready. <u>Remarks</u> • Since the control signal specifications depend on the device, connect the wiring by seeing the instruction manual of the device used.	○	○	○	○
	• If the message passes through a modem or others, the signal is interrupted at one of the intervening devices.	• Check the specification of the modem and recheck the settings and wiring	○	○	○	○



## 15.3.3 No response message is returned even though the external device transmitted a message and the "RD" LED blinked

Symptom	Cause	Corrective action	MC	Nonprocedural	Bidirectional	Predefined
• An external device transmitted a message and "RD" blinked, but the C24 did not return a response message. ("NEU." remains on and "SD" does not blink)	• Communication protocol is set incorrectly.	<ul style="list-style-type: none"> <li>• Check if the communication protocol is set correctly.</li> <li>• Check if the mode was switched without using the buffer memory mode switching area.</li> </ul> <u>Remarks</u> <ul style="list-style-type: none"> <li>• The communication protocol setting contents and the communication protocol in the current operation can be checked at communication protocol status (address: 250<sub>H</sub>/260<sub>H</sub>).</li> </ul>	○			
	• When "Check CD terminal" was set, the CD terminal was turned OFF.	<ul style="list-style-type: none"> <li>• Change the wiring so that the terminal status is always ON.</li> </ul>	○		○	
	• The header byte of the message is not data needed by the set protocol and format.	<ul style="list-style-type: none"> <li>• Check if the external device sent a message matched to the protocol and format.</li> <li>• Use the communication monitoring function to check the message from the external device.</li> </ul> <u>Remarks</u> <ul style="list-style-type: none"> <li>• The C24 skips all the messages transmitted until the header byte set for each protocol and format (for example, "ENQ (05H)" for Format 1) is received.</li> </ul>	○		○	
	• The C24 station No. setting and message station No. designation do not match.	<ul style="list-style-type: none"> <li>• Check the C24 station No. setting and message station No. designation.</li> <li>• Use the communication monitoring function to check the message from the external device.</li> </ul> <u>Remarks</u> <ul style="list-style-type: none"> <li>• When the station No. designation is host station after the header byte set for each protocol and format is received, the C24 performs receive processing.</li> </ul>	○			
	• The C24 data communications monitoring time is set to "Infinite wait", or the monitoring time is too long.	<ul style="list-style-type: none"> <li>• Set, or shorten, the monitoring time and retransmit the message from the external device and determine the trouble from the contents of the time-out error.</li> </ul> <u>Remarks</u> Error detection by watchdog timers (timer 0 to timer 2) is possible in the following cases. <ul style="list-style-type: none"> <li>• When part of a message is skipped.</li> <li>• When transmission from an external device is interrupted.</li> <li>• When a link error was generated while accessing another station over a CC-Link IE Controller Network</li> </ul> Refer to  User's Manual (Application) for a detailed description of the monitoring time.	○		○	
	• The path setting of the CPU module to be accessed is incorrect.	Check the path of the CPU module to be accessed and set the path again.	○			

## 15.3.4 Transmission request does not make the "SD" LED blink

Symptom	Cause	Corrective action	MC	Nonprocedural	Bidirectional	Predefined
• Although a transmission request was made, "SD" does not blink.	• Due to the OFF status of the CS(CTS) signal, the C24 cannot transmit data to the external device.	• While the CS(CTS) signal is OFF, the C24 does not transmit data to the external device. It must be ON when the external device is ready to receive data.	○	○	○	○
	• Due to transmission control (DTR or DC control), the external device cannot receive data.	• Wait until the external device is ready to receive data. • When the waiting time is too long, check the external device or cable condition.	○	○	○	○

# 15.3.5 Read request signal does not turn ON even though the external device transmitted a message and the "RD" LED was blinking

Symptom	Cause	Corrective action	MC	Nonprocedural	Bidirectional	Predefined
<ul style="list-style-type: none"> <li>An external device transmitted a message and "RD" blinked, but the read request signal (X3/XA) was not turned ON.</li> </ul>	<ul style="list-style-type: none"> <li>Communication protocol is set incorrect.</li> </ul>	<ul style="list-style-type: none"> <li>Check if the communication protocol is set correctly.</li> <li>Check if the mode was switched without using the buffer memory mode switching area.</li> </ul> <p><u>Remarks</u></p> <ul style="list-style-type: none"> <li>The communication protocol setting contents and the communication protocol in the current operation can be checked at communication protocol status (address: 250<sub>H</sub>/260<sub>H</sub>).</li> </ul>		○	○	
	<ul style="list-style-type: none"> <li>When "Check CD terminal" was set, the CD terminal was turned off.</li> </ul>	<ul style="list-style-type: none"> <li>Change the wiring so that the terminal status is always ON.</li> </ul>		○	○	
	<ul style="list-style-type: none"> <li>When DC control is selected, the necessary DC codes are not transmitted.</li> </ul>	<ul style="list-style-type: none"> <li>Check if a message is transmitted without transmitting "DC1 (11<sub>H</sub>)" after the external device transmits "DC3 (13<sub>H</sub>)" during DC1/DC3 external control.</li> <li>Check if the next message is transmitted without adding "DC2 (12<sub>H</sub>)" after the external device transmits "DC4 (14<sub>H</sub>)" during DC2/DC4 external control.</li> <li>Use the communication monitoring function to check the message from the external device.</li> </ul>		○	○	
	<ul style="list-style-type: none"> <li>The end code was not received, or fixed length data was not received.</li> </ul>	<ul style="list-style-type: none"> <li>Check if the end code set at the C24 and the end code transmitted from the external device are the same.</li> <li>Check if the external device transmitted the fixed length designated at the C24.</li> <li>Check if the trailer frame was transmitted during communications by user frame.</li> <li>Use the communication monitoring function to check the message from the external device.</li> </ul> <p><u>Remarks</u></p> <ul style="list-style-type: none"> <li>When the send data from the external device is correct, take the corrective action described in  Page 312, Section 15.3.11.</li> </ul>		○	○	
	<ul style="list-style-type: none"> <li>The C24 setting and message format do not match.</li> </ul>	<ul style="list-style-type: none"> <li>The data count basics, message format, etc. depend on the following settings. <ul style="list-style-type: none"> <li>· ASCII-BIN conversion enable/disable</li> <li>· Transparent code setting</li> <li>· User frame setting</li> </ul> </li> </ul> <p>For details of the operation according to the set contents and setting of each item, refer to the relevant section.</p>		○	○	
	<ul style="list-style-type: none"> <li>The C24 data communications monitoring time is set to "Infinite wait", or the monitoring time is too long.</li> </ul>	<ul style="list-style-type: none"> <li>Set, or shorten, the monitoring time and retransmit the message from the external device and determine the trouble from the contents of the time-out error.</li> </ul> <p><u>Remarks</u></p> <ul style="list-style-type: none"> <li>Error detection by the watchdog timer (timer 0 to timer 2) is possible in the following cases. <ul style="list-style-type: none"> <li>· When part of a message is skipped.</li> <li>· When transmission from an external device is interrupted.</li> </ul> </li> </ul> <p>For details of the monitoring time, refer to  User's Manual (Application).</p>		○	○	

## 15.3.6 The CPRTCL instruction execution is not completed although the "RD" LED blinked

Symptom	Cause	Corrective action	MC	Nonprocedural	Bidirectional	Predefined
<ul style="list-style-type: none"> <li>When the CPRTCL instruction was executed for the protocol with Communication type set to "Receive Only" or "Send and Receive", "RD" blinked, but the instruction execution was not completed.</li> </ul>	<ul style="list-style-type: none"> <li>Incorrect protocol No. is specified in the control data.</li> </ul>	<ul style="list-style-type: none"> <li>Check the protocol No. specified in the control data for the CPRTCL instruction for an error.</li> </ul>				○
	<ul style="list-style-type: none"> <li>The CD terminal is OFF when "CD terminal check enabled" is set.</li> </ul>	<ul style="list-style-type: none"> <li>Change the wiring so that the terminal status is always ON</li> </ul>				○
	<ul style="list-style-type: none"> <li>The user-edited protocol setting in the predefined protocol support function of GX Works2 is inconsistent with the packet format of the external device.</li> </ul>	<ul style="list-style-type: none"> <li>Check the packet format of the external device, and correct the protocol setting.               <ol style="list-style-type: none"> <li>Check for an error in the element type or element order in the packet setting.</li> <li>Check for an error in each element setting item (Code type, Data length, Data flow, Calculating range, etc.)</li> </ol> </li> </ul>				○
	<ul style="list-style-type: none"> <li>The C24 has not received the expected packet.</li> </ul>	<ul style="list-style-type: none"> <li>Using the circuit trace of the predefined protocol support function of GX Works2, check for the data being transmitted from the external device.</li> <li>When proper data are being transmitted from the external device, take action according to  Page 313, Section 15.3.12 or Page 316, Section 15.3.13.</li> </ul>				○
	<ul style="list-style-type: none"> <li>The C24 has cleared the data received before the protocol execution. (In the "Protocol Detailed Setting" screen of GX Works2 predefined protocol support function, "Clear OS area (receive data area) before protocol execution" is enabled.)</li> </ul>	<ul style="list-style-type: none"> <li>If data could be received before protocol execution, disable the "Clear OS area (receive data area) before protocol execution" setting in the "Protocol Detailed Setting" screen of GX Works2 predefined protocol support function.</li> </ul>				○
	<ul style="list-style-type: none"> <li>The C24 data communications monitoring time is set to "Infinite Wait", or the monitoring time is too long.</li> </ul>	<ul style="list-style-type: none"> <li>Set monitoring time or shorten the specified time, and then transmit data from the external device to find a cause from the timeout error. Part of the messages is not read. Transmission from the external device is interrupted.</li> <li>Perform cancel processing to complete the CPRTCL instruction execution.</li> </ul>				○

## 15.3.7 Communication error "NAK"

Symptom	Cause	Corrective action	MC	Nonprocedural	Bidirectional	Predefined	
<ul style="list-style-type: none"> <li>Communication error signal "NAK" turned on.</li> </ul>	<ul style="list-style-type: none"> <li>Refer to section that describes the communication error signal ("C/N", "P/S", "PRO", "SIO") that are turned on simultaneously when the "NAK" signal is turned on.</li> </ul>	<ul style="list-style-type: none"> <li>Take corrective action corresponding to the contents of the error.</li> </ul>	○				
	<b>Remarks</b> <ul style="list-style-type: none"> <li>Since the error code is added to "NAK" and is transmitted from the C24 to the external device when the "NAK" signal is turned on, take the corrective action described in the error code list (refer to  Page 281, Section 15.2.2). Since the error code added when "NAK" is transmitted is stored to the C24 buffer memory shown below, it can also be checked at the C24.</li> </ul>						
	Error code storage buffer memory address						
		CH1 side	25A <sub>H</sub>				
	CH2 side	26A <sub>H</sub>					

## 15.3.8 Communication error "C/N"

Symptom	Cause	Corrective action	MC	Nonprocedural	Bidirectional	Predefined
• Communication error signal "C/N" turned on.	• PC No. designated local station (FF), or a station other than a station No. set with the network parameters.	• Change the PC No. to local station (FF), or a station No. set with the network parameter and restart data communications.	○			
	• Routing parameters between CPU module with the C24 and communication destination CPU module are not set.	• Check the routing parameters and set them up to the communication destination CPU module.	○			
	• An error was generated on the CC-Link IE Controller Network.	• Check the error contents from the state of SB and SW related to the CC-Link IE Controller Network with the GX Works2 monitor, etc. and perform the checks and take the corrective action described in CC-Link IE Controller Network reference manual.	○			
	• The local station CPU module on the CC-Link IE Controller Network generated an error.					
	• Module installation address designation during communications with intelligent function module is incorrect.	• Change the transmit message designation data.	○			
	• A command that cannot be transmitted during RUN (sequence program, parameters, etc.) was transmitted, or "Online Change" is disabled by setting.	• Stop the CPU module and restart data communications.	○			
• Enable the "Online Change" by command and restart data communications.		○				

## 15.3.9 Communication error "P/S"

Symptom	Cause	Corrective action	MC	Nonprocedural	Bidirectional	Predefined
• Communication error signal "P/S" turned on.	• Data does not match the parity bit setting.	• Check the C24 and external device data format and match the settings.	○	○	○	○
	• Sum check codes do not match.	• Check if the sum check code transmitted from the external device is correct. (Recalculate)	○			
	• When CH1 and CH2 are used in the linked mode, the cable is not connected to one of the interface.	<ul style="list-style-type: none"> <li>• When using CH1 and CH2 independently, check that the C24 is not in the linked mode.</li> <li>• When using CH1 and CH2 in the linked mode, also connect the cable to both of the interfaces.</li> </ul> <u>Remarks</u> <ul style="list-style-type: none"> <li>• If the cable is not connected to one of the interfaces when CH1 and CH2 are used in the linked mode, noise may enter and the data may be destroyed and "Data cannot be decoded" or "Communications error cause" may occur.</li> </ul>	○	○	○	



## 15.3.10 Communication error "PRO."

Symptom	Cause	Corrective action	MC	Nonprocedural	Bidirectional	Predefined
	<ul style="list-style-type: none"> <li>Communications were performed with a control procedure different from the C24 communication protocol setting.</li> </ul>	<ul style="list-style-type: none"> <li>Check the C24 communication protocol setting and the message from the external device and match the settings, or correct the message and restart data communications.</li> <li>Use the communication monitoring function to check the message from the external device.</li> </ul>	○			
	<ul style="list-style-type: none"> <li>Some of the data are different from the control procedure.</li> </ul>					
	<ul style="list-style-type: none"> <li>Designated command does not exist.</li> </ul>					
	<ul style="list-style-type: none"> <li>The device No. designation is not the character count corresponding to the command.</li> </ul>					
<ul style="list-style-type: none"> <li>Communication error signal "PRO." turned on.</li> </ul>	<ul style="list-style-type: none"> <li>The characters in the message include a data other than the "A to Z", "0 to 9", "(SP)", and control data.</li> </ul>	<ul style="list-style-type: none"> <li>Check and correct the external device message and restart data communications.</li> <li>Use the communication monitoring function to check the message from the external device.</li> </ul> <p><u>Remarks</u></p> <ul style="list-style-type: none"> <li>Only the data "0 to 9" and "A to F" can be handled as character area data during communications using an MC protocol (ASCII mode). Therefore, when transmitting a character string as data, convert the ASCII code of each character string to 2-byte binary code.</li> </ul> <p>Examples)</p> <ul style="list-style-type: none"> <li>Transmitting the character "G" The ASCII code for the character "G" is 47<sub>H</sub> and is transmitted as the two bytes 34<sub>H</sub>, 37<sub>H</sub>.</li> <li>Transmitting the character "A" The ASCII code for "A" is 41<sub>H</sub> and is transmitted as the two bytes 34<sub>H</sub>, 31<sub>H</sub>.</li> </ul> <p>( If the ASCII code 41<sub>H</sub> for the character "A" is transmitted unchanged, the C24 ASCII-BIN conversion will convert it to A<sub>H</sub> (10) and pass it to the CPU module. )</p>	○			
	<ul style="list-style-type: none"> <li>A device No. outside the designated range was designated.</li> </ul>	<ul style="list-style-type: none"> <li>When specifying a device, check "Device setting" of the parameters written to the CPU module and correct it to a device No. within the designated range and restart data communications.</li> </ul>	○			
	<ul style="list-style-type: none"> <li>A remote RUN/STOP request was issued while remote STOP was applied from another module.</li> </ul>	<ul style="list-style-type: none"> <li>Check if remote STOP is applied from another module and restart data communications.</li> </ul>	○			

## 15.3.11 Communication error "SIO"

Symptom	Cause	Corrective action	MC	Nonprocedural	Bidirectional	Predefined
• Communication error signal "SIO" turned on.	• Data does not match the stop bit setting.	• Check if the C24 and external device settings are the same.	○	○	○	○
	• Transmission rate is too fast and the next data is transmitted before the C24 completes processing of the receive data.	• Decrease the transmission rate and restart data communications.	○	○	○	○
	• Data larger than the receive buffer size was received.	<ul style="list-style-type: none"> <li>• Use DTR and DC control and interrupt transmission before the buffer becomes full. Perform RS and CS control when the modem function is used.</li> <li>• Increase the transmission interval and provide an ample CPU module read processing time.</li> </ul> <p><u>Remarks</u></p> <ul style="list-style-type: none"> <li>• The nonprocedural protocol stores the data received up to first the end code received, or fixed length data, to the nonprocedural receive buffer memory and turns on the Read Request signal to the CPU module. If the next data is sent while the Read Request signal is ON, the data is temporarily stored to the OS receive buffer. When the OS receive buffer becomes full, the C24 skips the rest of the data and turns on the "SIO" LED.</li> </ul>		○	○	○
	• With a multidrop link, two or more devices transmitted data at the same time.	• Connect the external devices and the C24 in a 1:1 configuration and perform a communications test. Since data is transmitted simultaneously from two or more devices with a multidrop link when normal communications among all the devices is possible, interlock the devices so that cannot transmit simultaneously.	○	○	○	○

## 15.3.12 Communication error "CH1 ERR." or "CH2 ERR."

Symptom	Cause	Corrective action	MC	Nonprocedural	Bidirectional	Predefined
• "ERR." LED turns on.	• There is an error in the communication protocol or transmission setting.	• Read the error code from the buffer memory and check the error contents and change the switch setting to the correct setting.	○	○	○	○
	• There is an error in the on-line mode switching designation.	• Read the error code from the buffer memory and check the error contents and correct the designation contents.	○	○	○	○
	• On-demand execution generated an error.	• Read the error code from the buffer memory and check the error contents and correct the designation contents.	○			
	• The C24 detected an error while transmitting data.	• Read the error code from the buffer memory and take the corrective action corresponding to the error contents.	○	○	○	○
	• The C24 detected an error while receiving data.	• Read the error code from the buffer memory and take the corrective action corresponding to the error contents.	○	○	○	○
	• The receive data clear request is executed during the dedicated instruction execution.	• Read the execution result (error code) of control data of the dedicated instruction for which the abnormal completion signal has turned on, and take the corrective action corresponding the error contents.	○	○	○	○
• When the predefined protocol is executed, the "ERR." LED turns on.	• The communication protocol mode is set to other than "Predefined protocol mode".	• Set the communication protocol mode to "Predefined protocol mode".				○
	• No protocol setting data have been written to the C24.	• Write the protocol setting data from the predefined protocol support function of GX Works2, and then execute the CPRTCL instruction.				○
	• The protocol corresponding to the protocol No. specified in the control data for the CPRTCL instruction is not registered.	• By the predefined protocol support function of GX Works2, read the protocol setting from the C24. On the protocol selection screen, check the registered protocol and protocol No. for an error.				○
	• To the same channel, multiple CPRTCL instructions were concurrently executed.	• Correct the sequence program so that, upon completion of one CPRTCL instruction execution, another is executed.				○
	• Incorrect control data are specified for the CPRTCL instruction.	• Correct the control data for the CPRTCL instruction.				○

Symptom	Cause	Corrective action	MC	Nonprocedural	Bidirectional	Predefined
<ul style="list-style-type: none"> <li>When the predefined protocol is executed, the "ERR." LED turns on.</li> </ul>	<ul style="list-style-type: none"> <li>The user-edited protocol setting in the predefined protocol support function of GX Works2 is inconsistent with the packet format of the external device.</li> </ul>	<ul style="list-style-type: none"> <li>Check the packet format of the external device, and correct the protocol setting.</li> <li>(1) When a conversion variable exists in the receive packet, check for an error in the setting of Conversion, Sign character, Number of decimals, Delimiter, or Number of digits.</li> <li>(2) When an error check code exists in the receive packet, check for an error in the setting of Processing method, Code type, Data length, Data flow, Complement calculation, or Calculating range.</li> <li>(3) When Length exists in the receive packet and a conversion variable is included in the calculating range of the Length, check for an error in Code type, Data length, Data flow, or Calculating range set for the Length.</li> </ul>				○
	<ul style="list-style-type: none"> <li>An expected packet was not received, and a monitoring timeout error occurred.</li> </ul>	<ul style="list-style-type: none"> <li>Using the circuit trace (communication data monitoring function) of the predefined protocol support function of GX Works2, check for the data being transmitted from the external device.</li> </ul>				○
	<ul style="list-style-type: none"> <li>A communication error occurs.</li> </ul>	<ul style="list-style-type: none"> <li>Confirm the error by the system monitor, and remove the cause of the error.</li> </ul>				○

**Remark**



When the "ERR." LED is turned on, an error code is stored in the following buffer memory.

Error cause	Error code storage buffer memory		
	Address		Name
	CH1	CH2	
Switch setting error Mode switching error	203 <sub>H</sub>		Switch setting error and mode switching error status
On-demand execution error	256 <sub>H</sub>	266 <sub>H</sub>	On-demand execution result
Data transmission error	257 <sub>H</sub>	267 <sub>H</sub>	Data transmission result
Data receive error	258 <sub>H</sub>	268 <sub>H</sub>	Data reception result
Modern function error	221 <sub>H</sub>		Modern function error code
MC protocol transmission error	25A <sub>H</sub>	26A <sub>H</sub>	MC protocol transmission error code
Monitoring device error	2205 <sub>H</sub>	2305 <sub>H</sub>	Programmable controller CPU monitoring function execution result
Predefined protocol function error	4042 <sub>H</sub>	4052 <sub>H</sub>	Predefined protocol function error code

\* For details of the error codes, refer to  Page 277, Section 15.2.

## 15.3.13 Communication is intermittent

Symptom	Cause	Corrective action	MC	Nonprocedural	Bidirectional	Predefined
<ul style="list-style-type: none"> <li>Communications are intermittently established and lost. (*1)</li> </ul>	<ul style="list-style-type: none"> <li>With a multidrop link, two or more devices transmitted data at the same time.</li> </ul>	<ul style="list-style-type: none"> <li>Connect the external devices and the C24 in a 1:1 configuration and perform a communications test. Since data is transmitted simultaneously from two or more devices with a multidrop link when normal communications among all the devices is possible, interlock the external devices so that they do not transmit simultaneously.</li> </ul>	○	○	○	○
	<ul style="list-style-type: none"> <li>The signal cable wiring connection is faulty.</li> </ul>	<ul style="list-style-type: none"> <li>Replace the cable, or make the connections firm.</li> </ul>	○	○	○	○
	<ul style="list-style-type: none"> <li>When "Check CD terminal" is set, the CD(DCD) signal is turned on/off repeatedly.</li> </ul>	<ul style="list-style-type: none"> <li>Change the wiring so that the CD(DCD) signal remains ON all the time, or change the setting to "Do not check CD terminal".</li> </ul>	○	○	○	○
	<ul style="list-style-type: none"> <li>When half-duplex communications is selected, the ON/OFF timing of each signal is not matched.</li> </ul>	<ul style="list-style-type: none"> <li>Control the external device so that the ON/OFF timing of each signal is matched. For details, refer to  User's Manual (Application).</li> </ul>		○	○	○
	<ul style="list-style-type: none"> <li>Requested processing of the next transmission before the processing of the current transmission is completed.</li> <li>Requested processing of the next reception before the processing of the current reception is completed.</li> </ul>	<ul style="list-style-type: none"> <li>Make sure to obtain handshake in the sequence program.</li> </ul>	○	○	○	○
	<ul style="list-style-type: none"> <li>Communication via modem is disrupted.</li> </ul>	<ul style="list-style-type: none"> <li>Since communication via modem may be disrupted due to low line quality or instantaneous interruption, create a sequence program for reconnecting the line in case of unexpected line disruption. If this symptom occurs frequently, reduce the communication speed of the modem, and retry the communication.</li> </ul>	○	○	○	
	<ul style="list-style-type: none"> <li>The data sent from the C24 are received back on the RS-422/485 interface (CH2) side.</li> </ul>	<ul style="list-style-type: none"> <li>Disable the echo back in the Echo back enable/disable setting before communication.</li> </ul>	○	○	○	○

- \*1 The following explains how to take corrective actions when a normal exit response message cannot be received upon sending of a command message.
- (a) When a response message of abnormal end is received
    - 1) When an external device sent a command message and received an abnormal end response message, take corrective action with the error according to the error code in the response message (refer to  Page 281, Section 15.2.2).
    - 2) When the following problem occurs at the time of access to other station CPU module, clear the programmable controller CPU information and retry. (Refer to  Page 329, Section 15.5.)
      - Accessible device range is narrowed. (Error code: 7140<sub>H</sub>)
      - Some of commands and/or devices cannot be used. (Error code: 7142<sub>H</sub>, 714D<sub>H</sub>)
  - (b) When response messages cannot be received

Change the setting value for the response monitoring time (timer 1, default value is 5 seconds). (Refer to  User's Manual (Application).)

If response messages still cannot be received after changing the setting value, check the communication protocol setting of the corresponding interface, the ON status of the indicator LED, and the connection cable.
  - (c) When the first part of a response message cannot be received

Increase the setting value of the message wait time (the default value is 0ms). (Refer to  User's Manual (Application).)

If response messages still cannot be received after increasing the setting value, it is necessary to reduce the processing time from the end of transmission processing to the start of reception processing on the external device side.

## 15.3.14 Undecodable data are transmitted or received

Symptom	Cause	Corrective action	MC	Nonprocedural	Bidirectional	Predefined
• Data that cannot be decoded was transmitted and received	• With a multidrop link, two or more devices transmitted data at the same time.	• Connect the external devices and the C24 in a 1:1 configuration and perform a communications test. Since data is transmitted simultaneously from two or more devices with a multidrop link when normal data communications among all the devices is possible, interlock the external devices so that they do not transmit simultaneously.	○	○	○	○
	• Data does not match the parity bit setting.	• Match the C24 and external device settings. <u>Remarks</u> • If the setting of one side is data bit length 7 bits and with parity and the setting of the other side is data length 8 bits and without parity, the number of transmission/receive bits will be the same and the data will sent and receive without generating an error.	○	○	○	○
	• Data does not match the parity bit setting.	• Match the C24 and external device transmission rates.	○	○	○	○
	• Transmission rate settings do not match.	• Check if the terminating resistor (110Ω or 330Ω in the case of the C24) is connected to the stations at both ends of the link.	○	○	○	○
	• With a multidrop link, the terminating resistor is not connected correctly.	• When using CH1 and CH2 independently, check that the C24 is not in the linked mode. • When using CH1 and CH2 in the linked mode, also connect the cable to both of the interfaces. <u>Remarks</u> • If the cable is not connected to one of the interfaces when CH1 and CH2 are used in the linked mode, noise may enter and destroy the data and "Data cannot be decoded" or "Communication error cause" may occur.	○	○	○	○
	• When CH1 and CH2 are used to the linked mode, there is an interface without cable connection.					



# 15.3.15 Whether the communication error is caused on the C24 or external device is unclear

Symptom	Cause	Corrective action	MC	Nonprocedural	Bidirectional	Predefined	
<ul style="list-style-type: none"> <li>Whether the communication error cause is in the C24 or an external device is unclear.</li> </ul>	—	<ul style="list-style-type: none"> <li>Test the C24 as described below to check where the cause is.</li> </ul>	○	○	○	○	
		1) Check the hardware.					<ul style="list-style-type: none"> <li>The C24 must be installed firmly.</li> <li>The pins of the C24 must not be bent or otherwise abnormal.</li> </ul>
		2) Test the C24 alone. (Refer to Page 66, Section 6.4)					<ul style="list-style-type: none"> <li>ROM/RAM/switch test must not generate any errors.</li> <li>Self-loopback test must not generate any errors.</li> </ul>
		3) Check the state of the CPU module.					<ul style="list-style-type: none"> <li>There must not be any errors that stop the CPU module operation.</li> </ul>
		<u>Remarks</u> <ul style="list-style-type: none"> <li>The following methods are available for testing if normal communications are possible with the C24 alone.                             <ol style="list-style-type: none"> <li>With one C24, set CH1 and CH2 to the nonprocedural protocol and connect the wiring the same as for the self-loopback test and transmit data from one channel and receive the transmitted data at the other channel. If the transmitted data and the received data are the same, transmit and receive processing is performed normally.</li> <li>When two C24 are available, set one C24 to the nonprocedural protocol and the other C24 to the MC protocol and transmit an MC protocol message from the nonprocedural protocol station. If the MC protocol station returns the transmit message normally, transmit and receive processing is normal.</li> </ol> </li> </ul>					

## 15.3.16 Communication is not available via the modem

Symptom	Cause	Corrective action	MC	Nonprocedural	Bidirectional	Predefined
• Auto modem initialization cannot be executed.	• A modem initialization error occurs.	• Check the error code and execute processing accordingly.	○	○	○	
	• Modem connection channel designation is not performed.	• Set Modem connection channel designation.	○	○	○	
	• There is an error in the switch settings in GX Works2.	• Review the switch settings. • Set it to match the local station modem and the TA.	○	○	○	
• Data cannot be communicated with GX Works2 supporting the C24.	• Communication protocol setting is incorrect.	• Set the communication protocol to MC protocol, Format 5.	○			
	• Transmission setting does not match the external device.	• Review the transmission setting.	○			
	• Communication rate does not match the external device.	• Review the communication rate setting.	○			
• The GX Works2 does not receive the callback signals from the C24.	• The product is not supported by GX Works2.	• Confirm the GX Works2 S/W version.	○			
	• There was an error in the GX Works2 connection system.	• Check the GX Works2 connection system. • Set the connection system on "callback reception waiting" and connect.	○			
	• There is an error in the GX Works2 side's modem settings.	• Set the modem's settings on "Auto Reception."	○			
• Callback connections from GX Works2 are refused by the C24.	• There is an error in the GX Works2 connection system.	• Check the GX Works2 connection system. • Correct the C24's settings.	○			
	• There is an error in the connection system's telephone No.	• Check the telephone No. • Change the telephone No. to the data for callback.	○			
• When performing Auto (callback: during fixed/ during designated number) from GX Works2, connection to the C24 is refused.	• There is an error in the C24 setting value.	• Set the callback function designation on the setting 1 to 3.	○			
	• There is an error in the GX Works2 connection system.	• Check the GX Works2 connection system. • Check the C24's settings.	○			
	• There is an error in the telephone No. of the connection system.	• Check the telephone No. • Change the telephone No. to the data for callback.	○			
• It is possible to connect from GX Works2, but callback from C24 cannot be performed.	• The timer value for the status of the modem used or the line is short.	• Adjust each of the timer values for the callback function on the GX Works2 side. (Line callback cancel wait time, callback delay time)	○			
	• There is a problem with the modem specifications or settings.	• Check the modem's specifications and settings.	○			

## 15.3.17 Communication is not available with the ISDN sub-address

Symptom	Cause	Corrective action	MC	Nonprocedural	Bidirectional	Predefined
• Data cannot be communicated with ISDN sub-address	• Sub-address is incorrect.	• Review the sub-address.	<input type="radio"/>	<input type="radio"/>		
	• Modem does not support ISDN sub-address.	• Use modem that supports ISDN sub-address.	<input type="radio"/>	<input type="radio"/>		
	• Sub-address is incorrectly partitioned.	• Review how to partition the sub-address using the TA manual.	<input type="radio"/>	<input type="radio"/>		

## 15.3.18 Constant cycle transmission is not performed normally

Symptom	Cause	Corrective action	MC	Nonprocedural	Bidirectional	Predefined
• Does not operate in the cycle time designated in the constant cycle transmission setting	• The setting value of the constant cycle transmission is incorrect.	• Review the constant cycle transmission setting.	<input type="radio"/>	<input type="radio"/>		
	• The cycle time is affected by some causes.	• Remove the causes or designate the cycle time anticipating the causes.	<input type="radio"/>	<input type="radio"/>		

## 15.3.19 Condition agreement transmission is not performed normally

Symptom	Cause	Corrective action	MC	Nonprocedural	Bidirectional	Predefined
• Does not operate in the cycle time designated in condition agreement transmission setting	• The setting value of the condition agreement transmission is incorrect.	• Review the condition agreement transmission setting.	<input type="radio"/>	<input type="radio"/>		
	• The cycle time is affected by some causes.	• Remove the causes or designate the cycle time anticipating the causes.	<input type="radio"/>	<input type="radio"/>		

## 15.3.20 Data cannot be received due to by an interrupt program

Symptom	Cause	Corrective action	MC	Nonprocedural	Bidirectional	Predefined
• Cannot receive data with the interrupt program	• Interrupt issuance was not designated.	• Designate interrupt issuance.		<input type="radio"/>	<input type="radio"/>	
	• Receiving by instruction other than BUFRCVS.	• Use BUFRCVS instruction to receive interrupt data.		<input type="radio"/>	<input type="radio"/>	
	• "PLC Parameter" - "PLC System" - or "Interrupt Pointer Setting" are not set on the CPU module side, or the settings are incorrect.	• Review "L Parameter Setting" - "PC System" - "Interrupt Pointer Setting" on the CPU module side		<input type="radio"/>	<input type="radio"/>	

## 15.3.21 Data cannot be written to the flash ROM

Symptom	Cause	Corrective action	MC	Nonprocedural	Bidirectional	Predefined
• Cannot write data to Flash ROM	• Flash ROM write allow/prohibit was not set to allow.	• Set flash ROM write allow/prohibit to allow.	<input type="radio"/>	<input type="radio"/>	<input type="radio"/>	<input type="radio"/>
	• Setting modification is not enabled in the switch settings by GX Works2.	• Set "Enable" in the switch setting by GX Works2.	<input type="radio"/>	<input type="radio"/>	<input type="radio"/>	<input type="radio"/>
• The data written to the flash ROM are not valid.	• The C24 was turned off during writing to the flash ROM.	• Write the data again to the flash ROM.	<input type="radio"/>	<input type="radio"/>	<input type="radio"/>	<input type="radio"/>
	• Communication with GX Works2 was interrupted during writing to the flash ROM.					
	• When data is written to the Programmable controller, C24 of the "Intelligent Function Module" tab is not set as a target memory on the "Online Data Operation" screen.	• Check the procedure for writing data to the flash ROM, and write the data to the flash ROM again. (Refer to  Page 97, Section 7.4.2.)	<input type="radio"/>	<input type="radio"/>	<input type="radio"/>	<input type="radio"/>

# 15.3.22 Troubleshooting on the protocol setting data reading/writing

Symptom	Cause	Corrective action	MC	Nonprocedural	Bidirectional	Predefined	
<ul style="list-style-type: none"> <li>The "ERR." LED turns on when protocol setting data are written to the C24.</li> </ul>	<ul style="list-style-type: none"> <li>The user-edited protocol setting in the predefined protocol support function of GX Works2 has an error.</li> <li>Or, function data not supported by the C24 are included in the protocol setting data.</li> </ul>	<ul style="list-style-type: none"> <li>In Protocol setting data error information (buffer memory: 4086<sub>H</sub> to 4089<sub>H</sub>), locate the error part (protocol No, packet No, or element No.) and correct it. Check the protocol setting for an error paying attention to the following, and write corrected data to the C24 again.</li> </ul> <p>(1) When an error was detected in the user-edited protocol Check if the following condition for element placement are satisfied in the packet setting or not: If any elements of 1) and 2) are in the same packet, 1) must be placed before 2).</p>					
		1)	<ul style="list-style-type: none"> <li>Conversion variable (fixed number of data, fixed number of digits (1 to 10), no signed character)</li> <li>Conversion variable (fixed number of data, fixed number of digits (1 to 10), variable decimal point)</li> <li>Conversion variable (fixed number of data, variable number of digits, number of data is 1, delimiter set)</li> </ul>				
		2)	<ul style="list-style-type: none"> <li>Non-conversion variable (variable length)</li> <li>Conversion variable (variable number of data)</li> <li>Conversion variable (fixed number of data, variable number of digits, number of data is 1, no delimiter)</li> <li>Conversion variable (fixed number of data, variable number of digits, number of data is 2 or more)</li> <li>Non-verified reception (variable number of characters)</li> </ul> <p>(2) When function data not supported by the C24 are included in the protocol setting data Check the version of the C24 to confirm supported functions. Set the protocol within the range of supported functions if any unsupported function is applied.</p>				

## 15.3.23 The "ERR." LED is lit

Symptom	Cause	Corrective action	MC	Nonprocedural	Bidirectional	Predefined
• "ERR." LED is lit	• A communication error has occurred.	• Check the error and remove the cause according to  Page 277, Section 15.2.	<input type="radio"/>	<input type="radio"/>	<input type="radio"/>	<input type="radio"/>
	• Switch settings of the C24 are incorrect.	• Review the switch settings of the C24.	<input type="radio"/>	<input type="radio"/>	<input type="radio"/>	<input type="radio"/>
	• The communication protocol mode is set to "Predefined protocol mode", and linked operation is set for two interfaces.	For communication in the predefined protocol mode, change the setting to separate operations.				<input type="radio"/>
	• The C24 is powered off while data are written to the flash ROM.	• Write the data to the flash ROM again.	<input type="radio"/>	<input type="radio"/>	<input type="radio"/>	<input type="radio"/>

# 15.4 Initializing Error Information of the Serial Communication Module

This section explains the ERR. LED ON factors and the error code initialization (clear) for the C24.

## (1) ERR. LED ON factors

When any of the following errors occurs, its error code is stored in the buffer memory corresponding to the interface (CH) where the error occurred, and the ERR. LED turns on.

Error cause	Error code storage buffer memory			Protocol			
	Address		Name	MC	Nonprocedural	Bidirectional	Predefined
	CH1	CH2					
Switch setting error Mode switching error	203 <sub>H</sub>		Switch setting error and mode switching error status	○	○	○	○
On-demand execution error	256 <sub>H</sub>	266 <sub>H</sub>	On-demand execution result	○	×	×	×
Data transmission error	257 <sub>H</sub>	267 <sub>H</sub>	Data transmission result	○	○	○	○
Data reception error	258 <sub>H</sub>	268 <sub>H</sub>	Data reception result	○	○	○	○
MC protocol transmission error	25A <sub>H</sub>	26A <sub>H</sub>	MC protocol transmission error code	○	×	×	×
Monitoring device error	2205 <sub>H</sub>	2305 <sub>H</sub>	Programmable controller CPU monitoring function execution result	○	○	○	×
Predefined protocol function error	4042 <sub>H</sub>	4052 <sub>H</sub>	Predefined protocol function error code	×	×	×	○

## (2) Turning off the ERR. LED and initializing the error codes by GX Works2

### (a) When turning off the ERR. LED and initializing the error codes

By turning on the CH□ ERR. clear request in the "Intelligent Function Module Monitor" screen, the ERR. LED of the C24 turns off and the stored error codes are initialized.

### (b) When initializing the communication error information

By making the CH□ LED off, Communication error clear request on the "Intelligent Function Module Monitor" screen, the LEDs (ERR., NEU.) of the C24 turn off and the communication error information is initialized.

## (3) Turning off the ERR. LED and initializing the error codes by sequence program

### (a) Input signals used to notify of error occurrences and output signals used to initialize the error code

I/O signal	Name of status information	Description/function	
Input signal	XE	CH1 ERR. occurrence	Turns on upon error occurrence in CH1 interface.
	XF	CH2 ERR. occurrence	Turns on upon error occurrence in CH2 interface.
Output signal	YE	CH1 ERR. clear request	Turns on when initializing error code of interface on CH1 side.
	YF	CH2 ERR. clear request	Turns on when initializing error code of interface on CH2 side.

Initialization of error code is continuously performed when ERR. clear request (YE/YF) is on.

The CHn side error information can be initialized by the LED off, Communication error clear request (address: 0<sub>H</sub>/1<sub>H</sub>). By using the ERR. clear request (YE/YF), the error codes stored in the above buffer memory can further be initialized (cleared). However, protocol execution logs are not cleared even if the ERR. clear request (YE/YF) is used.

**(b) Initializing communication error information by writing**

Communication error information can be initialized by writing "1" to the corresponding bit in the communication error clear request and to turn LED off (address: 0<sub>H</sub>/1<sub>H</sub>).

- \* The indicator LED and communication error information may be turned on/off in the following cases:
  - NEU. to NAK turn on/off depending on the status.
  - C/N to SIO turn on when errors occur and keep the ON-status even after the operation returns to normal.

1) Communication error clear request and to turn LED off (address: 0<sub>H</sub>/1<sub>H</sub>)

The contents of the error information corresponding to each bit in this request area are the same as those for the LED ON status and communication error status (address: 201<sub>H</sub>/202<sub>H</sub>).

For more details, refer to  Page 263, Section 15.1.1 (1).

The following describes the correspondence between the LED OFF request areas and the LED ON status storage areas:

- Communication error clear request for CH1 and to turn LED off (address: 0<sub>H</sub>) → LED ON status and communication error status on CH1 side (address: 201<sub>H</sub>)
- Communication error clear request for CH1 and to turn LED off (address: 0<sub>H</sub>) → LED ON status and communication error status on CH1 side (address: 201<sub>H</sub>)

2) Example of a program for turning off indicator LED

The following shows an example of a program that issues an initialization request for all the communication error information of CH1 and CH2.

(Input/output signals X/Y00 to X/Y1F of C24)

● Example of TO instruction

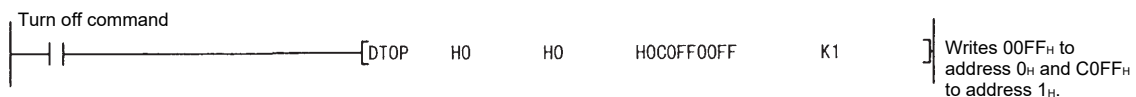

- Initialization requests are valid only when write operation is performed. The initialization requests clear all data in the LED ON status and communication error status (address: 201<sub>H</sub>/202<sub>H</sub>) at the same time. Furthermore, when initialization of error information on the CH1 and CH2 sides is requested, ERR. occurrence (XE/XF) also turns off.
- Data written to the communication error clear request and to turn LED off (address: 0<sub>H</sub>/1<sub>H</sub>) is cleared after initialization processing.
- If errors persist even after completion of the initialization processing, the corresponding communication error information is stored again and the corresponding bit in the LED ON status and communication error status (address: 201<sub>H</sub>/202<sub>H</sub>) turns on (1).



**(c) Examples of programs that initialize indicator LED and communication error information**

The following shows examples of a program that reads error codes when errors described in Page 325, Section 15.4 (1) occur in an interface on the CH1 side and initializes the indicator LED and communication error information.

Incorporate the necessary part of the program.

(Input/output signals X/Y00 to X/Y1F of C24)

- When data is communicated using the MC protocol

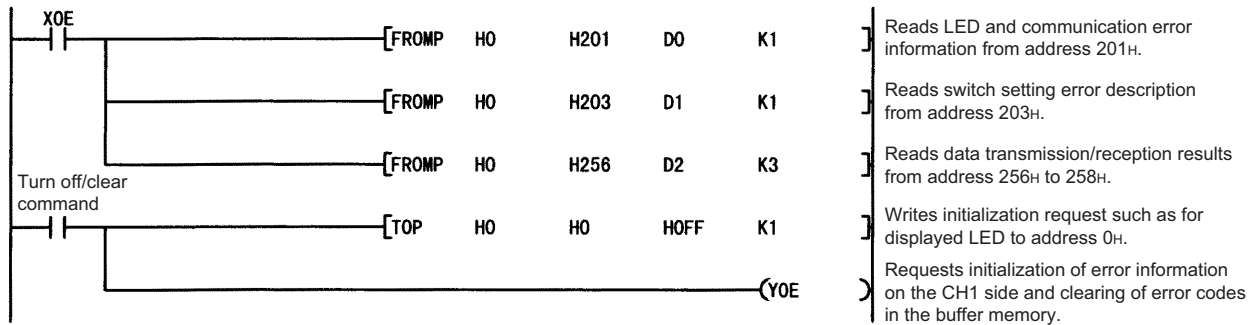

Check the error codes and take corrective actions according to Page 277, Section 15.2.

- When data is communicated using the predefined protocol

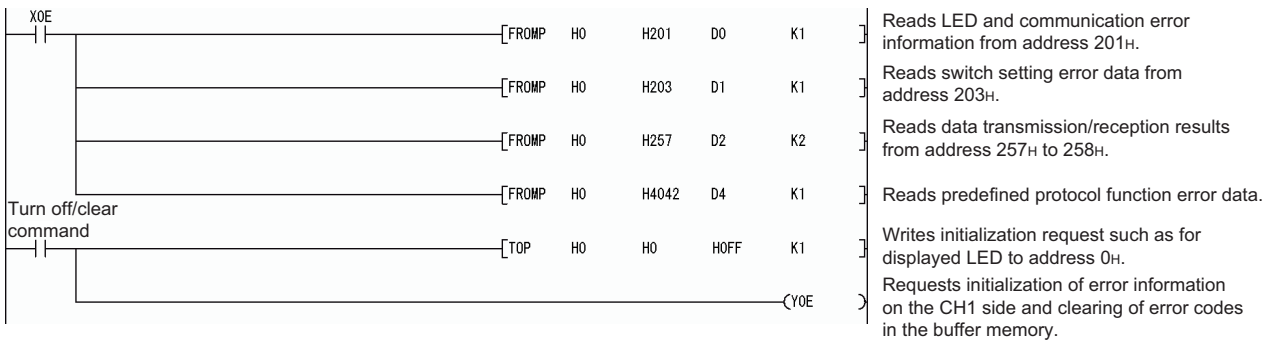

Check the error codes and take corrective actions according to Page 277, Section 15.2.

- When data is communicated using the nonprocedural or bidirectional protocol

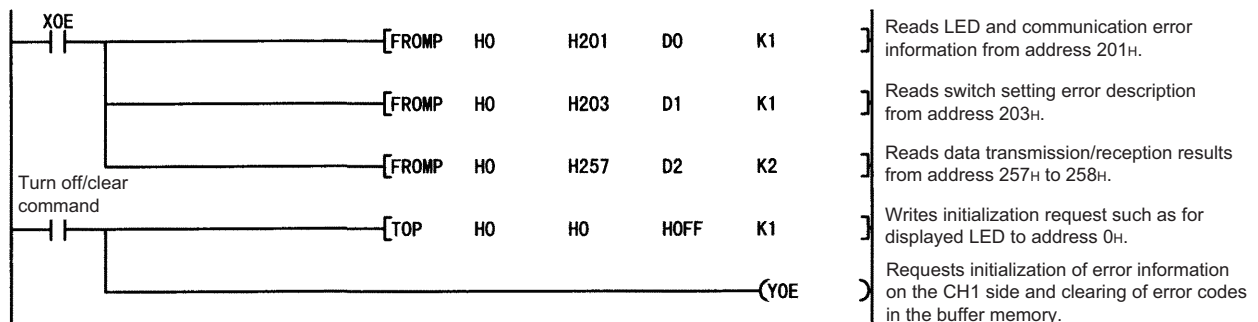

Check the error codes and take corrective actions according to Page 277, Section 15.2.

**Remark**

When data is communicated using the MC protocol, the ERR. LED may not be turned on if the C24 sends an NAK message to the external device in response to the command message.

Error codes corresponding to the error content when the NAK message is sent back to the external device are stored in the following areas. (When communicating with an A compatible 1C frame, the error codes differ from the transmission error code.)

When checking error codes transmitted by the CPU module, incorporate the following program (in the case of the interface on the CH1 side).

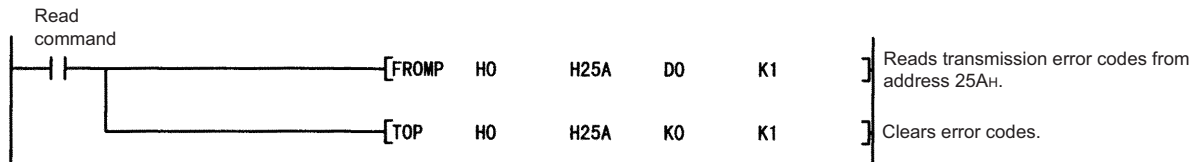

Check the error codes and take corrective actions according to Page 277, Section 15.2.

# 15.5 Clearing the Programmable Controller CPU Information

This section explains how to clear the programmable controller CPU information.

## (1) Programmable controller CPU information

### (a) This is the information about the access target CPU module type used in MC protocol communications.

The C24 obtains this information from the access target CPU module at the time of initial access, and stores it inside the C24.

Since access is made based on this information, the processing speed will be increased from the second access.

### (b) The programmable controller CPU information is cleared in the following cases:

- When the programmable controller is powered OFF and then ON, or when the CPU module is reset
- When the programmable controller CPU information clear request is executed

## (2) If the programmable controller CPU information has not been correctly obtained

The following problems may occur:

- Accessible device range is narrowed. (Error code: 7140<sub>H</sub>)
- Some of commands and/or devices cannot be used. (Error code: 7142<sub>H</sub>, 714D<sub>H</sub>), etc.

In the above case, execute the programmable controller CPU information clear request.

### Point

If initial access is made at startup of the access target CPU module or while the network is unstable, the programmable controller CPU information may not be correctly acquired.

## (3) Operation of the programmable controller CPU information clear request

- Write "4C43<sub>H</sub>" to the programmable controller CPU information clear request (address: 80<sub>H</sub>). (Set by the user)

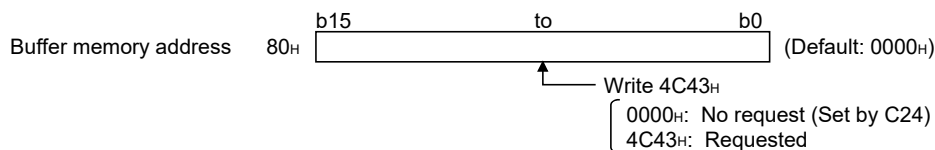

- The programmable controller CPU information clear processing of the C24 is executed. <sup>\*1</sup>
- Upon completion of the clear processing, "0000<sub>H</sub>" is written to the programmable controller CPU information clear request (address: 80<sub>H</sub>). (Set by the C24)

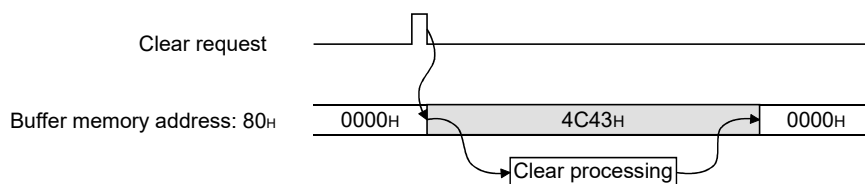

\*1 The transmission sequence status (address: 255<sub>H</sub>/265<sub>H</sub>) is also initialized.

## (4) Executing the programmable controller CPU information clear request

### (a) Executing from GX Works2

- In the "Intelligent Function Module Monitor" screen, set "4C43<sub>H</sub>" to buffer memory address 80<sub>H</sub>.
- In the Buffer Memory Batch monitor screen, check that the value in buffer memory address 80<sub>H</sub> is "0000<sub>H</sub>".

### (b) Executing from sequence program

In the following program, turning on the clear request command clears the programmable controller CPU information of the C24 that is connected in the position corresponding to I/O signal X/Y00 to X/Y1F.

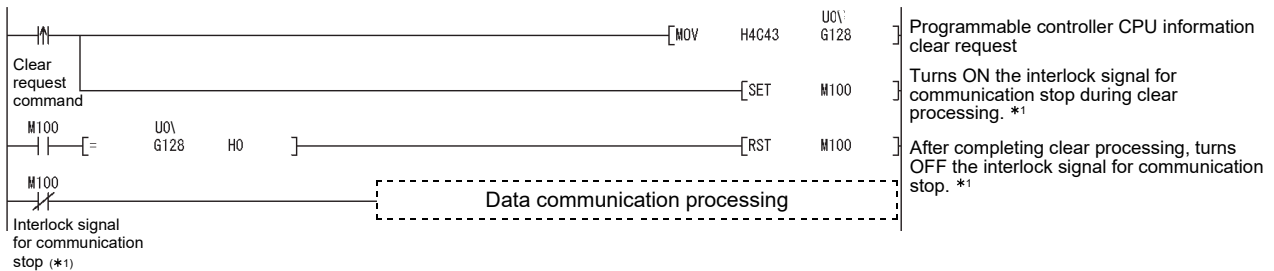

\*1 Create a program in which data communication processing will not be performed while the interlock signal for communication stop (M100) is ON.

## (5) Precautions

### (a) Execute the programmable controller CPU information clear after communication with the external device is stopped.

And, do not perform communication with the external device during the programmable controller CPU information clear processing. (If any data are received from the external device during the clear processing, the data will be discarded.)

### (b) When a modem is connected, cut off the line linked with the external device before executing the programmable controller CPU information clear. (The line is cut off at execution of the programmable controller CPU information clear.)

### (c) Do not execute the UINI instruction during the programmable controller CPU information clear.

If the programmable controller CPU information clear is attempted during execution of the UINI instruction, the clear processing will be executed after completion of the UINI instruction.

# APPENDICES

## Appendix 1 Buffer Memory

The buffer memory is the memory of the C24 used for storing data sent to or received from the CPU module. (Setting values, monitor values, etc.)

Initial values are set to the buffer memory.

When changing the initial values, set the parameters in GX Works2 and write them to the flash ROM.

For details, refer to  Page 332, Appendix 1 (3).

### (1) Structure of the buffer memory

A buffer memory consists of a user area and a system area, as shown below.

#### (a) User area

- This is the area where users write/read data.
- The user area consists of areas for storing setting values for data communication, for actual data communication, and for storing communication status and communication error information.
- Data read/write to the user area should be performed following the instructions in the corresponding detailed reference page.

#### (b) System area

This area is used by the C24 system.

### (2) List of buffer memory assignments

A buffer memory is configured with 16 bits per address.

Name, default value, etc. of each address of the buffer memory is shown in the lists on the following pages.

- Abbreviations in the Protocol column

MC: MC protocol

Pd: Predefined protocol

Non: Nonprocedural protocol

Bi: Bidirectional protocol

- Meaning of symbols shown in the Protocol column

The following symbols are assigned to protocols related to the setting values of a corresponding area and to areas used for controlled with user settings, and indicate what kind of access is allowed to the area in question.

RW: Area where it is possible to read/write from/to the CPU module and an external device.

R: Area where only reading is possible from the CPU module and an external device.

—: System area used by the system or area not used by the corresponding protocol.

- Meaning of symbols shown in the Registration column

Indicates whether or not it is possible to use a value in the corresponding area by registering it to the flash ROM of the C24.

Allowed: Area that can be registered and used.

Not allowed: Area that cannot be registered.

### (3) Procedure for writing the buffer memory to the flash ROM

#### 1. Displaying the screen for writing to the flash ROM

Open the "Flash ROM Operation" screen by the following procedure.

 Parameter setting screen ⇒ [Tool] ⇒ [Flash ROM Operation]

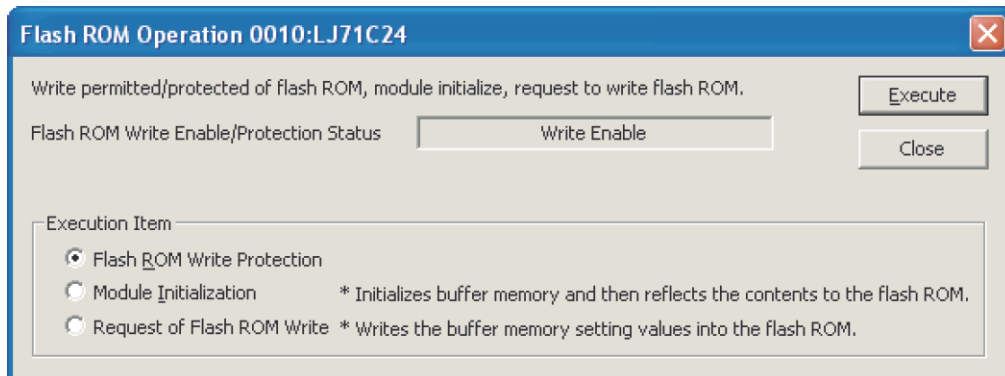

#### 2. Executing the write operation to the flash ROM

Select "Request of Flash ROM Write" in the Execution Item area and click the "Execute" button.

#### *Point*

- Check if "Flash ROM Write Enable/Protection Status" is set to "Write Enable", before executing the write operation to the flash ROM.
- If "Write Protection" is displayed, select "Flash ROM Write Enable" in the Execution Item area and click the "Execute" button.

#### 3. Enabling the set value

Reset the CPU module.

The set values written to the flash ROM is written into the buffer memory of the module.

#### 4. Disabling the write operation to the flash ROM

Set "Flash ROM Write Enable/Protection Status" to "Write Protection" in the "Flash ROM Operation" dialog box or "sequence program", and click the "Execute" button.

**(a) IMPORTANT**

Do not write data in the "System area" of the buffer memory.

If data is written to any of the system areas, the programmable controller system may malfunction.

Some of the user areas are partially system areas. Care must be taken when performing read/write to the buffer memory.

**Point**

To use the dedicated instructions, change the following initial settings (default values) for data communications by registration operation from GX Works2 or by the CSET instruction for the sequence program.

- Initial settings for communication using the MC protocol
  - Setting the unit of data length sent by the on-demand function  
"Word/byte units designation" (addresses: 150 (96<sub>H</sub>)/310 (136<sub>H</sub>))
  - Setting the buffer memory used by the on-demand function  
"Buffer memory head address designation" (addresses: 160 (A0<sub>H</sub>)/320 (140<sub>H</sub>))  
"Transmission buffer memory length designation" (addresses: 163 (A3<sub>H</sub>)/323 (143<sub>H</sub>))
- Initial settings for communication using the nonprocedural/bidirectional protocols
  - Setting the unit of data length to be sent and received  
"Word/byte units designation" (addresses: 150 (96<sub>H</sub>)/310 (136<sub>H</sub>))
  - Setting the transmission area  
"Transmission buffer memory head address designation" (addresses: 162 (A2<sub>H</sub>)/322 (142<sub>H</sub>))  
"Transmission buffer memory length designation" (addresses: 163 (A3<sub>H</sub>)/323 (143<sub>H</sub>))
  - Setting the reception area  
"Receive buffer memory head address designation" (addresses: 166 (A6<sub>H</sub>)/326 (146<sub>H</sub>))  
"Receive buffer memory length designation" (addresses: 167 (A7<sub>H</sub>)/327 (147<sub>H</sub>))

\* For details on the registration operation by GX Works2, refer to  Page 94, Section 7.4.

For details on the CSET instruction, refer to  User's Manual (Application).

#### (4) List of buffer memory addresses

Address Decimal (Hex)		Application	Name	Initial value	Protocol				Registr ation	Reference
CH1	CH2				MC	Non	Bi	Pd		
0 (0 <sub>H</sub> )	—	For LED and communication error clear	Communication error clear request for CH1 and to turn LED off 0: ON, No initialization request 1: OFF, Initialization requested	0	RW			Not allowed	Page 263, Section 15.1.1 Page 325, Section 15.4	
			SD WAIT (b0) SIO (b1)) PRO. (b2) P/S (b3)							C/N (b4) NAK (b5) ACK. (b6) NEU. (b7) For system (b8) to (b15)
—	1 (1 <sub>H</sub> )		Communication error clear request for CH2 and to turn LED off 0: ON, No initialization request 1: OFF, Initialization requested	0	RW			Not allowed		
			SD WAIT (b0) SIO (b1)) PRO. (b2) P/S (b3) C/N (b4)							NAK (b5) ACK. (b6) NEU. (b7) For system (b8) to (b13) CH2 ERR. (b14) CH1 ERR. (b15)
2 (2 <sub>H</sub> )	For Flash ROM access		Register/read/delete instructions 0: No request 1: Register request 2: Read request 3: Delete request	0	RW			Not allowed	—	
3 (3 <sub>H</sub> )			Frame No. direction 0: No designation Other than 0: Frame No.							
4 (4 <sub>H</sub> )			Registration/read/delete result storage 0: Normal completion Other than 0: Abnormal completion							
5 (5 <sub>H</sub> )			Number of data bytes registered designation 0: No designation Other than 0: Number of data bytes registered (maximum 80 bytes)							
6 to 45 (6 <sub>H</sub> to 2D <sub>H</sub> )			User frame 0: No designation Other than 0: Registered data (maximum 80 bytes)							
46 (2E <sub>H</sub> )	For designation of modem function-1	Modem connection channel designation 0: Non 1: CH1 2: CH2	0	RW			Allowed	Page 75, Section 7.2 User's Manual (Application)		
47 (2F <sub>H</sub> )	Use prohibited	System area					—			



Address Decimal (Hex)		Application	Name	Initial value	Protocol				Registr ation	Reference
CH1	CH2				MC	Non	Bi	Pd		
48 (30 <sub>H</sub> )		For designation of modem function-1	Number of connection retries designation 1 to 5: Number of retries	3	RW	—	—	Allowed	Page 75, Section 7.2  User's Manual (Application)	
49 (31 <sub>H</sub> )			Connection retry interval designation 90 to 300: Connection retry interval (unit: s)	180						
50 (32 <sub>H</sub> )			Initialization/connection timeout designation 1 to 60: Timeout (unit: s)	60						
51 (33 <sub>H</sub> )			Number of initialization retries designation 1 to 5: Number of retries	3						
52 (34 <sub>H</sub> )			Data No. for initialization designation 0 <sub>H</sub> : Send initialization data designated by the designated area of the user frame for transmission. 7D0 <sub>H</sub> to 801F <sub>H</sub> : Data No. for initialization	7D0 <sub>H</sub>						
53 (35 <sub>H</sub> )			Data No. for connection designation 0 <sub>H</sub> : No designation BB8 <sub>H</sub> to 801F <sub>H</sub> : Data No. for connection	0						
54 (36 <sub>H</sub> )			MELSOFT connection designation 0: Do not connect. 1: Connect.							
55 (37 <sub>H</sub> )			No - communication interval time designation 0: Wait infinitely 1 to 120: No communication interval (Waiting time for line disconnection) (unit: min.)	30						
56 (38 <sub>H</sub> )			RS · CS control yes/no designation 0: No control 1: Controlled	1						
57 to 127 (39 <sub>H</sub> to 7F <sub>H</sub> )		Use prohibited	System area					—		
128 (80 <sub>H</sub> )		For programmable controller CPU information clear	Programmable controller CPU information clear request 0000 <sub>H</sub> : No request 4C43 <sub>H</sub> : Requested	0	RW			—	Not allowed	Page 329, Section 15.5
129 to 143 (81 <sub>H</sub> to 8F <sub>H</sub> )		Use prohibited	System area					—		

A

Address Decimal (Hex)		Application	Name	Initial value	Protocol				Registr ation	Reference
CH1	CH2				MC	Non	Bi	Pd		
144 (90 <sub>H</sub> )	304 (130 <sub>H</sub> )	For designation of mode switching	Switching mode no. designation (0001 <sub>H</sub> to 0007 <sub>H</sub> , 0009 <sub>H</sub> , 00FF <sub>H</sub> ) 0000 <sub>H</sub> : No designation 0001 <sub>H</sub> : MC protocol (Format 1) 0002 <sub>H</sub> : MC protocol (Format 2) 0003 <sub>H</sub> : MC protocol (Format 3) 0004 <sub>H</sub> : MC protocol (Format 4) 0005 <sub>H</sub> : MC protocol (Format 5) 0006 <sub>H</sub> : Nonprocedural protocol 0007 <sub>H</sub> : Bidirectional protocol 0009 <sub>H</sub> : Predefined protocol 00FF <sub>H</sub> : MELSOFT Connection							
145 (91 <sub>H</sub> )	305 (131 <sub>H</sub> )	For designation of mode switching	Transmission specifications after switching designation Designates transmission specifications (below) after switching when b15 of this area is 1 (ON). • Operation setting (b0) 0: Independent 1: Linked • Data Bit (b1) 0: 7 bit 1: 8 bit • Parity Bit (b2) 0: None 1: Exist • Odd/even parity (b3) 0: Odd 1: Even • Stop bit (b4) 0: 1 bit 1: 2 bit • Sum check code (b5) 0: None 1: Exist • Online Change (b6) 0: Disable 1: Enable • Setting modifications (b7) 0: Disable 1: Enable • Communication rate (b8 to b11) 50 bps to 230400 bps • For system (b12 to b14) All 0 • Transmission specifications after switching (b15) designation 0: Match settings in MELSOFT 1: Match settings in this area	0			RW	Not allowed	Page 85, Section 7.3  User's Manual (Application)	
146 (92 <sub>H</sub> )	306 (132 <sub>H</sub> )	Signal setting	RS and DTR signal status designation 0: Off 1: On RS(RTS) signal (b0) ER(DTR) signal (b2) For system (b1), (b3) to (b15)	0005 <sub>H</sub>				Allowed	Page 46, Section 6.2.1	

Address Decimal (Hex)		Application	Name	Initial value	Protocol				Registr ation	Reference
CH1	CH2				MC	Non	Bi	Pd		
147 (93 <sub>H</sub> )	307 (133 <sub>H</sub> )	For designation of transmission control	DTR/DSR(ER/DR), DC control designation • Transmission control (b0) 0: DTR/DSR control 1: DC code control • DC1/DC3 control (b8) 0: No control 1: Controlled • DC2/DC4 control (b9) 0: No control 1: Controlled	0	RW				Page 75, Section 7.2	
148 (94 <sub>H</sub> )	308 (134 <sub>H</sub> )		DC1/DC3(Xon/Xoff) code designation • DC1 code (b0 to b7) 00 <sub>H</sub> to FF <sub>H</sub> : DC1 code • DC3 code (b8 to b15) 00 <sub>H</sub> to FF <sub>H</sub> : DC3 code	1311 <sub>H</sub>						
149 (95 <sub>H</sub> )	309 (135 <sub>H</sub> )		DC2/DC4 code designation • DC2 code (b0 to b7) 00 <sub>H</sub> to FF <sub>H</sub> : DC2 code • DC4 code (b8 to b15) 00 <sub>H</sub> to FF <sub>H</sub> : DC4 code	1412 <sub>H</sub>						
150 (96 <sub>H</sub> )	310 (136 <sub>H</sub> )	For designation of communication control	Word/byte units designation 0: Word units 1: Byte units	0	RW		—		Page 146, CHAPTER 10 Page 178, CHAPTER 11 Page 75, Section 7.2	
151 (97 <sub>H</sub> )	311 (137 <sub>H</sub> )		CD terminal check designation (for RS-232) 0: Check 1: No check	1	RW				Page 46, Section 6.2.1 Page 75, Section 7.2	
152 (98 <sub>H</sub> )	312 (138 <sub>H</sub> )		Communication system designation (for RS-232) 0: Full duplex communication 1: Half-duplex communication	0						
153 (99 <sub>H</sub> )	313 (139 <sub>H</sub> )	For half- duplex communications control designation (RS-232)	Simultaneous transmission priority/non-priority designation 0: Priority 1 to 125: Non-priority (transmission wait time, unit: 100ms)	0	RW				Page 178, CHAPTER 11 Page 75, Section 7.2	
154 (9A <sub>H</sub> )	314 (13A <sub>H</sub> )		Retransmission time transmission method designation 0: Do not resend. 1: Resend.							
155 (9B <sub>H</sub> )	315 (13B <sub>H</sub> )	For designation of communication control	Simultaneously transmission data valid/invalid designation • Receive data valid/invalid (b0) 0: Valid 1: Invalid • Transmission data valid/invalid (b8) 0: Valid 1: Invalid			—	R W	—	User's Manual (Application)	
156 (9C <sub>H</sub> )	316 (13C <sub>H</sub> )	For designation of data communication time monitoring	No-reception monitoring time (timer 0) designation 0 <sub>H</sub> : Wait infinitely 28 <sub>H</sub> to FA0 <sub>H</sub> : Monitoring time (unit: byte)	0 <sub>H</sub>	RW			—	Page 75, Section 7.2	
157 (9D <sub>H</sub> )	317 (13D <sub>H</sub> )		Response monitoring time (timer 1) designation 0 <sub>H</sub> : Wait infinitely 1 <sub>H</sub> to BB8 <sub>H</sub> : Monitoring time (unit: 100ms)	32 <sub>H</sub> (5s)	RW	—	R W	—		
158 (9E <sub>H</sub> )	318 (13E <sub>H</sub> )		Transmission monitoring time (timer 2) designation 0 <sub>H</sub> : Wait infinitely 1 <sub>H</sub> to BB8 <sub>H</sub> : Monitoring time (unit: 100ms)	708 <sub>H</sub> (3 min.)						RW

Address Decimal (Hex)		Application	Name	Initial value	Protocol				Registr ation	Reference
CH1	CH2				MC	Non	Bi	Pd		
159 (9F <sub>H</sub> )	319 (13F <sub>H</sub> )	Use prohibited	System area						—	
160 (A0 <sub>H</sub> )	320 (140 <sub>H</sub> )	For designation of on-demand function	Buffer memory head address designation (400 <sub>H</sub> to 1AFF <sub>H</sub> , 2600 <sub>H</sub> to 3FFF <sub>H</sub> )	CH1: 400 <sub>H</sub> CH2: 800 <sub>H</sub>	RW	—	—	Allowed	Page 75, Section 7.2	
161 (A1 <sub>H</sub> )	321 (141 <sub>H</sub> )		Data length designation (0000 <sub>H</sub> to 3400 <sub>H</sub> )	0					MELSEC Communicat ion Protocol Reference Manual	
162 (A2 <sub>H</sub> )	322 (142 <sub>H</sub> )	For designation of transmission area	Transmission buffer memory head address designation (400 <sub>H</sub> to 1AFF <sub>H</sub> , 2600 <sub>H</sub> to 3FFF <sub>H</sub> )	CH1: 400 <sub>H</sub> CH2: 800 <sub>H</sub>	—	RW	—	Allowed	Page 146, CHAPTER 10 Page 178, CHAPTER 11 Page 75, Section 7.2 Page 160, Section 10.1.5	
163 (A3 <sub>H</sub> )	323 (143 <sub>H</sub> )		Transmission buffer memory length designation (0001 <sub>H</sub> to 1A00 <sub>H</sub> )	200 <sub>H</sub>						
164 (A4 <sub>H</sub> )	324 (144 <sub>H</sub> )	For data reception	Received data count designation 0001 <sub>H</sub> to 33FE <sub>H</sub> : Received data count	1FF <sub>H</sub>	—	RW	—			
165 (A5 <sub>H</sub> )	325 (145 <sub>H</sub> )		Receive complete code designation FFFF <sub>H</sub> : No designation for receive complete code 0 <sub>H</sub> to FF <sub>H</sub> : Receive complete code	0D0A <sub>H</sub> : (CR+LF)						
166 (A6 <sub>H</sub> )	326 (146 <sub>H</sub> )	For designation of reception area	Receive buffer memory head address designation (400 <sub>H</sub> to 1AFF <sub>H</sub> , 2600 <sub>H</sub> to 3FFF <sub>H</sub> )	CH1: 600 <sub>H</sub> CH2: A00 <sub>H</sub>	—	RW	—	Allowed		
167 (A7 <sub>H</sub> )	327 (147 <sub>H</sub> )		Receive buffer memory length designation (0001 <sub>H</sub> to 1A00 <sub>H</sub> )	200 <sub>H</sub>						
168 (A8 <sub>H</sub> )	328 (148 <sub>H</sub> )	For data reception	Receive data clear request 0: No request 1: Requested	0				Not allowed		

Address Decimal (Hex)		Application	Name	Initial value	Protocol				Registr ation	Reference
CH1	CH2				MC	Non	Bi	Pd		
169 (A9 <sub>H</sub> )	329 (149 <sub>H</sub> )	For designation of on-demand user frame	First frame No. designation 1st 0: No designation Other than 0: Designated	0	RW	—	—	—	Allowed	Page 75, Section 7.2 User's Manual (Application)
170 (AA <sub>H</sub> )	330 (14A <sub>H</sub> )		First frame No. designation 2nd 0: No designation Other than 0: Designated							
171 (AB <sub>H</sub> )	331 (14B <sub>H</sub> )		Last frame No. designation 1st 0: No designation Other than 0: Designated							
172 (AC <sub>H</sub> )	332 (14C <sub>H</sub> )		Last frame No. designation 2nd 0: No designation Other than 0: Designated							
173 (AD <sub>H</sub> )	333 (14D <sub>H</sub> )	For designation of receive user frame	User frame use enable/disable designation 0: Do not use 1: Use 2: Data communication possible (C24 set)	—	—	—	—	—	Allowed	Page 75, Section 7.2 User's Manual (Application)
174 to 177 (AE <sub>H</sub> to B1 <sub>H</sub> )	334 to 337 (14E <sub>H</sub> to 151 <sub>H</sub> )		First frame No. designation 1st (1st to 4th) 0 <sub>H</sub> : No designation 1 <sub>H</sub> or more: First frame No.							
178 to 181 (B2 <sub>H</sub> to B5 <sub>H</sub> )	338 to 341 (152 <sub>H</sub> to 155 <sub>H</sub> )		Last frame No. designation (1st to 4th) 0 <sub>H</sub> : No designation 1 <sub>H</sub> or more: Last frame No.							
182 (B6 <sub>H</sub> )	342 (156 <sub>H</sub> )	User frame being transmitted	User frame being transmitted 0: Not send 1 to 100: User frame being transmitted (nth)	0	—	—	—	—	Not allowed	Page 75, Section 7.2 User's Manual (Application)
183 (B7 <sub>H</sub> )	343 (157 <sub>H</sub> )	For user frame being transmitted designation	CR/LF output designation 0: Do not send. 1: Send.							
184 (B8 <sub>H</sub> )	344 (158 <sub>H</sub> )		Output head pointer designation 0: No designation 1 to 100: Send from nth							
185 (B9 <sub>H</sub> )	345 (159 <sub>H</sub> )		Output count designation 0: No designation 1 to 100: Output n							
186 to 285 (BA <sub>H</sub> to 11D <sub>H</sub> )	346 to 445 (15A <sub>H</sub> to 1BD <sub>H</sub> )		Output frame No. designation (A maximum of 100 can be specified) 0 <sub>H</sub> : No transmission 1 <sub>H</sub> to C01F <sub>H</sub> : Designated							

Address Decimal (Hex)		Application	Name	Initial value	Protocol				Registr ation	Reference
CH1	CH2				MC	Non	Bi	Pd		
286 (11E <sub>H</sub> )	446 (1BE <sub>H</sub> )	For designation of transmission wait time	Message wait time designation 0: No wait time 1 <sub>H</sub> to F <sub>H</sub> : Wait time (unit: 10ms)	0	RW	—		Allowed	Page 75, Section 7.2	
287 (11F <sub>H</sub> )	447 (1BF <sub>H</sub> )	For designation of transparent code	Transmission transparent code designation 1st 0000 <sub>H</sub> : No designation Other than 0000 <sub>H</sub> : Designated (below) • Transparent code (b0 to b7) 00 <sub>H</sub> to FF <sub>H</sub> : Transparent code • Additional code (b8 to b15) 01 <sub>H</sub> to FF <sub>H</sub> : Additional code						Page 75, Section 7.2  User's Manual (Application)	
288 (120 <sub>H</sub> )	448 (1C0 <sub>H</sub> )		Receive transparent code designation 0000 <sub>H</sub> : No designation Other than 0000 <sub>H</sub> : Designated (below) • Transparent code (b0 to b7) 00 <sub>H</sub> to FF <sub>H</sub> : Transparent code • Additional code (b8 to b15) 01 <sub>H</sub> to FF <sub>H</sub> : Additional code		—	RW	—			
289 (121 <sub>H</sub> )	449 (1C1 <sub>H</sub> )	For conversion designation	ASCII-BIN conversion designation 0: No conversion 1: Convert							Page 75, Section 7.2  User's Manual (Application)
290 (122 <sub>H</sub> )	—	For designation of communication control	System area							
—	450 (1C2 <sub>H</sub> )		Echo back enable/disable setting for RS-422/485 interface 0: Enable echo back 1: Disable echo back	0		RW		Allowed	Page 64, Section 6.3.5	
291 to 303 (123 <sub>H</sub> to 12F <sub>H</sub> )	451 to 511 (1C3 <sub>H</sub> to 1FF <sub>H</sub> )	Use prohibited	System area							
512 (200 <sub>H</sub> )		For confirmation of station No. setting status	Station No. (switch setting)	Depends on parameter setting						
513 (201 <sub>H</sub> )		For confirmation of LED ON status and communication error status	LED ON status and communication error status on CH1 side 0: LED OFF, no error 1: LED ON, error	Depends on module status	R		Not allowed	Page 85, Section 7.3 Page 263, Section 15.1.1 Page 273, Section 15.1.5		
			SD WAIT (b0) SIO (b1) PRO. (b2) P/S (b3)						C/N (b4) NAK (b5) ACK. (b6) NEU. (b7) For system (b8) to (b15)	
514 (202 <sub>H</sub> )			LED ON status and communication error status on CH2 side 0: LED OFF, no error 1: LED ON, error							
			SD WAIT (b0) SIO (b1) PRO. (b2) P/S (b3) C/N (b4)	NAK (b5) ACK. (b6) NEU. (b7) For system (b8) to (b13) CH2 ERR. (b14) CH1 ERR. (b15)						

Address Decimal (Hex)		Application	Name	Initial value	Protocol				Registr ation	Reference
CH1	CH2				MC	Non	Bi	Pd		
515 (203 <sub>H</sub> )		For confirmation of switch setting and mode switching	Switch setting error and mode switching error status 0: No error Other than 0: Switch setting error and mode switching error • CH1 Communication protocol setting No. (b0) 0: Normal 1: Error • CH1 Communication rate setting (b1) 0: Normal 1: Error • CH1 Setting change prohibit time mode switching (b3) 0: Normal 1: Error • CH2 Communication protocol setting No. (b4) 0: Normal 1: Error • CH2 Communication rate setting (b5) 0: Normal 1: Error • CH2 Setting change prohibit time mode switching (b7) 0: Normal 1: Error • Setting station No. (b14) 0: Normal 1: Error • Linked operation setting (b15) 0: Normal 1: Error	0		R			Not allowed	Page 85, Section 7.3 Page 263, Section 15.1.1 Page 273, Section 15.1.5
516 (204 <sub>H</sub> )		For confirmation of user frame	Number of registered user frames 0: No registration 1 to 200: Number of registrations	Depends on registration status	R	—			—	
517 to 541 (205 <sub>H</sub> to 21D <sub>H</sub> )	User frame registration status (for confirmation of registration No.) 0: No registration 1: Registered * Bit corresponding to registration No. is 0(OFF)/1(ON). Registration No. 3E8 <sub>H</sub> (1000): Address 205 <sub>H</sub> (b0) to Registration No. 4AF <sub>H</sub> (1199): Address 211 <sub>H</sub> (b7)									
542 (21E <sub>H</sub> )		For confirmation of user frame	Number of registered default registration frames (for system)	Depends on registration status						User's Manual (Application)
543 (21F <sub>H</sub> )		Use prohibited	System area							

Address Decimal (Hex)		Application	Name	Initial value	Protocol				Registr ation	Reference		
CH1	CH2				MC	Non	Bi	Pd				
544 (220 <sub>H</sub> )		For confirmation of flash ROM write result	Flash ROM system parameters write result 0: Normal completion Other than 1 (error code): Abnormal completion		RW					—		
545 (221 <sub>H</sub> )		For confirmation of modem function	Modem function error code (error code when modem function is being used) 0: Normal completion Other than 1 (error code): Abnormal completion	0	RW				Not allowed	User's Manual (Application)		
546 (222 <sub>H</sub> )	Modem function sequence status 0: Idle 1: Waiting for initialization 2: Initializing modem 3: Waiting 4: Checking password 5: Communicating 7: Modem disconnected 8: Callback Request reception waiting 9: Callback Modem disconnect waiting 10: Callback Delay time waiting 11: Callback Reconnecting 12: Callback Rechecking password		—									
547 (223 <sub>H</sub> )	Number of data registration for connection 0: No registration 1 to 30: Number of registrations		R		—						Not allowed	
548 to 549 (224 <sub>H</sub> to 225 <sub>H</sub> )	Data registration status for connection (for confirmation of registration No.) 0: No registration 1: Registered * Bit corresponding to registration No. is 0(OFF)/1(ON). Registration No. BB8 <sub>H</sub> (3000): Address 224 <sub>H</sub> (b0) to Registration No. BD5 <sub>H</sub> (3029): Address 225 <sub>H</sub> (b13)				Depends on registration status	—						
550 (226 <sub>H</sub> )	Number of data registration for initialization 0: No registration 1 to 30: Number of registrations				—							
551 to 552 (227 <sub>H</sub> to 228 <sub>H</sub> )	Data registration status for initialization (for confirmation of registration No.) 0: No registration 1: Registered * Bit corresponding to registration No. is 0(OFF)/1(ON). Registration No. 9C4 <sub>H</sub> (2500): Address 227 <sub>H</sub> (b0) to Registration No. 9E1 <sub>H</sub> (2529): Address 228 <sub>H</sub> (b13)	—										
553 to 590 (229 <sub>H</sub> to 24E <sub>H</sub> )	Use prohibited	System area	—									
591 (24F <sub>H</sub> )	For confirmation of station No. setting status	Station No. (instruction setting) (0 to 31)	Depends on module status	R				Not allowed	Page 85, Section 7.3 Page 275, Section 15.1.6			



Address Decimal (Hex)		Application	Name	Initial value	Protocol				Registr ation	Reference
CH1	CH2				MC	Non	Bi	Pd		
592 (250 <sub>H</sub> )	608 (260 <sub>H</sub> )		Communication protocol status (switch setting)							
			0: MELSOFT Connection 1: MC protocol (Format 1) 2: MC protocol (Format 2) 3: MC protocol (Format 3) 4: MC protocol (Format 4) 5: MC protocol (Format 5) 6: Nonprocedural protocol 7: Bidirectional protocol 8: (For linked operation) 9: Predefined protocol							
593 (251 <sub>H</sub> )	609 (261 <sub>H</sub> )	For confirmation of transmission control status	Transmission setting status (switch setting) • Operation setting (b0) 0: Independent 1: Linked • Data Bit (b1) 0: 7 bit 1: 8 bit • Parity Bit (b2) 0: None 1: Exist • Odd/even parity (b3) 0: Odd 1: Even • Stop bit (b4) 0: 1 bit 1: 2 bit • Sum check code (b5) 0: None 1: Exist • Online Change (b6) 0: Disable 1: Enable • Setting modifications (b7) 0: Disable 1: Enable • Communication rate (b8 to b11) 50 bps to 230400 bps • For system (b12 to b15) All 0	Depends on parameter setting		R	Not allowed	Page 85, Section 7.3 Page 273, Section 15.1.5		

Address Decimal (Hex)		Application	Name	Initial value	Protocol				Registr ation	Reference
CH1	CH2				MC	Non	Bi	Pd		
594 (252 <sub>H</sub> )	610 (262 <sub>H</sub> )		Communication protocol status (current)							
			0: MELSOFT Connection 1: MC protocol (Format 1) 2: MC protocol (Format 2) 3: MC protocol (Format 3) 4: MC protocol (Format 4) 5: MC protocol (Format 5) 6: Nonprocedural protocol 7: Bidirectional protocol 8: (For linked operation) 9: Predefined protocol							
595 (253 <sub>H</sub> )	611 (263 <sub>H</sub> )	For confirmation of transmission control status	Transmission status (current)	Depends on module status		R		Not allowed	Page 85, Section 7.3 Page 275, Section 15.1.6	
			<ul style="list-style-type: none"> <li>• Operation setting (b0) 0: Independent 1: Linked</li> <li>• Data Bit (b1) 0: 7 bit 1: 8 bit</li> <li>• Parity Bit (b2) 0: None 1: Exist</li> <li>• Odd/even parity (b3) 0: Odd 1: Even</li> <li>• Stop bit (b4) 0: 1 bit 1: 2 bit</li> <li>• Sum check code (b5) 0: None 1: Exist</li> <li>• Online Change (b6) 0: Disable 1: Enable</li> <li>• Setting modifications (b7) 0: Disable 1: Enable</li> <li>• Communication rate (b8 to b11) 50 bps to 230400 bps</li> <li>• For system (b12 to b15) All 0</li> </ul>							
596 (254 <sub>H</sub> )	612 (264 <sub>H</sub> )	Control signal status	RS-232 control signal status 0: OFF status 1: ON status RS(RTS) (b0), ER(DTR) (b2), CS(CTS) (b4) DR(DSR) (b1), CD(DCD) (b3), CI(RI) (b5) Not used (b6 to b15) All 0	Depends on signal status					Page 270, Section 15.1.3	

Address Decimal (Hex)		Application	Name	Initial value	Protocol				Registration	Reference
CH1	CH2				MC	Non	Bi	Pd		
597 (255 <sub>H</sub> )	613 (265 <sub>H</sub> )	For confirmation of communication result	Transmission sequence status (For confirmation of MC protocol communication status) 0: Waiting for receiving command message 1: Receiving command message 2: Command message reception complete 3: Waiting to access CPU module 4: Accessing CPU module 5: CPU module access complete 6: Response message transmission	0	R	—			Not allowed	Page 271, Section 15.1.4
598 (256 <sub>H</sub> )	614 (266 <sub>H</sub> )		On-demand execution result 0: Normal completion 1 or more: Abnormal completion (error code)		RW	—				
599 (257 <sub>H</sub> )	615 (267 <sub>H</sub> )		Data transmission result 0: Normal completion 1 or more: Abnormal completion (error code)		RW			Page 146, CHAPTER 10 Page 178, CHAPTER 11		
600 (258 <sub>H</sub> )	616 (268 <sub>H</sub> )		Data reception result 0: Normal completion 1 or more: Abnormal completion (error code)							
601 (259 <sub>H</sub> )	617 (269 <sub>H</sub> )		System area (Use prohibited)	—						
602 (25A <sub>H</sub> )	618 (26A <sub>H</sub> )		MC protocol transmission error code (excludes A compatible 1C frame communication) 0: No error 1 or more: Transmission error code	0	RW	—			Not allowed	—
603 (25B <sub>H</sub> )	619 (26B <sub>H</sub> )		Receive user frame (nth) 0: Not received 1 to 4: Combination of user frame No. designations for reception message		—	R	—			—
604 to 607 (25C <sub>H</sub> to 25F <sub>H</sub> )	620 to 1023 (26C <sub>H</sub> to 3FF <sub>H</sub> )	Use prohibited	System area	—						
1024 (400 <sub>H</sub> )	2048 (800 <sub>H</sub> )	Transmission/receive area (*2)	Transmission data count designation 0: No designation 1 or more: Number of send data	0	RW			Not allowed	Page 146, CHAPTER 10 Page 178, CHAPTER 11	
1025 to 1535 (401 <sub>H</sub> to 5FF <sub>H</sub> )	2049 to 2559 (801 <sub>H</sub> to 9FF <sub>H</sub> )	Transmission/receive area (*2)	Transmission data designation Data to be sent to an external device	0	RW			Not allowed	Page 146, CHAPTER 10 Page 178, CHAPTER 11	
1536 (600 <sub>H</sub> )	2560 (A00 <sub>H</sub> )		Receive data count (Number of data for which read is requested) 0: No receive data 1 or more: Number of receive data							
1537 to 2047 (601 <sub>H</sub> to 7FF <sub>H</sub> )	2561 to 3071 (A01 <sub>H</sub> to BFF <sub>H</sub> )		Receive data Data received from an external device							
3072 to 6911 (C00 <sub>H</sub> to 1AFF <sub>H</sub> )		For user	User setting area (3840 words) * Determined by the user.	0	RW			Not allowed	—	

Address Decimal (Hex)		Application	Name	Initial value	Protocol				Registr ation	Reference
CH1	CH2				MC	Non	Bi	Pd		
6912 to 6952 (1B00 <sub>H</sub> to 1B28 <sub>H</sub> )		For designation of user registration data	For registration No. 8001 <sub>H</sub>	The user registration area has the following combined uses, with data written by the user according to the purpose of use by the TO instruction, etc. Refer to each explanation item concerning the configuration of each area, the data written, etc.  (1) If data communications is being carried out by user registration frame. • User registration frame  (2) If data communications is being carried out by the modem function. • Initialization Data • Connection Data	Not allowed	User's Manual (Application)				
6953 to 6993 (1B29 <sub>H</sub> to 1B51 <sub>H</sub> )	For registration No. 8002 <sub>H</sub>									
6994 to 7034 (1B52 <sub>H</sub> to 1B7A <sub>H</sub> )	For registration No. 8003 <sub>H</sub>									
7035 to 7075 (1B7B <sub>H</sub> to 1BA3 <sub>H</sub> )	For registration No. 8004 <sub>H</sub>									
7076 to 7116 (1BA4 <sub>H</sub> to 1BCC <sub>H</sub> )	For registration No. 8005 <sub>H</sub>									
7117 to 7157 (1BCD <sub>H</sub> to 1BF5 <sub>H</sub> )	For registration No. 8006 <sub>H</sub>									
7158 to 7198 (1BF6 <sub>H</sub> to 1C1E <sub>H</sub> )	For registration No. 8007 <sub>H</sub>									
7199 to 7239 (1C1F <sub>H</sub> to 1C47 <sub>H</sub> )	For registration No. 8008 <sub>H</sub>									
7240 to 7280 (1C48 <sub>H</sub> to 1C70 <sub>H</sub> )	For registration No. 8009 <sub>H</sub>									
7281 to 7321 (1C71 <sub>H</sub> to 1C99 <sub>H</sub> )	For registration No. 800A <sub>H</sub>									
7322 to 7362 (1C9A <sub>H</sub> to 1CC2 <sub>H</sub> )	For registration No. 800B <sub>H</sub>									
7363 to 7403 (1CC3 <sub>H</sub> to 1CEB <sub>H</sub> )	For registration No. 800C <sub>H</sub>									
7404 to 7444 (1CEC <sub>H</sub> to 1D14 <sub>H</sub> )	For registration No. 800D <sub>H</sub>									
7445 to 7485 (1D15 <sub>H</sub> to 1D3D <sub>H</sub> )	For registration No. 800E <sub>H</sub>									
7486 to 7526 (1D3E <sub>H</sub> to 1D66 <sub>H</sub> )	For registration No. 800F <sub>H</sub>									
7527 to 7567 (1D67 <sub>H</sub> to 1D8F <sub>H</sub> )	For registration No. 8010 <sub>H</sub>									
7568 to 7608 (1D90 <sub>H</sub> to 1DB8 <sub>H</sub> )	For registration No. 8011 <sub>H</sub>									
7609 to 7649 (1DB9 <sub>H</sub> to 1DE1 <sub>H</sub> )	For registration No. 8012 <sub>H</sub>									
7650 to 7690 (1DE2 <sub>H</sub> to 1E0A <sub>H</sub> )	For registration No. 8013 <sub>H</sub>									
7691 to 7731 (1E0B <sub>H</sub> to 1E33 <sub>H</sub> )	For registration No. 8014 <sub>H</sub>									
7732 to 7772 (1E34 <sub>H</sub> to 1E5C <sub>H</sub> )	For registration No. 8015 <sub>H</sub>									
7773 to 7813 (1E5D <sub>H</sub> to 1E85 <sub>H</sub> )	For registration No. 8016 <sub>H</sub>									
7814 to 7854 (1E86 <sub>H</sub> to 1EAE <sub>H</sub> )	For registration No. 8017 <sub>H</sub>									
7855 to 7895 (1EAF <sub>H</sub> to 1ED7 <sub>H</sub> )	For registration No. 8018 <sub>H</sub>									
7896 to 7936 (1ED8 <sub>H</sub> to 1F00 <sub>H</sub> )	For registration No. 8019 <sub>H</sub>									

Address Decimal (Hex)		Application	Name	Initial value	Protocol				Registration	Reference
CH1	CH2				MC	Non	Bi	Pd		
7937 to 7977 (1F01 <sub>H</sub> to 1F29 <sub>H</sub> )		For designation of user registration data	For registration No. 801A <sub>H</sub>	The user registration area has the following combined uses, with data written by the user according to the purpose of use by the TO instruction, etc.  Refer to each explanation item concerning the configuration of each area, the data written, etc.  (1) If data communications is being carried out by user registration frame. • User registration frame  (2) If data communications is being carried out by the modem function. • Initialization Data • Connection Data					User's Manual (Application)	
7978 to 8018 (1F2A <sub>H</sub> to 1F52 <sub>H</sub> )			For registration No. 801B <sub>H</sub>							
8019 to 8059 (1F53 <sub>H</sub> to 1F7B <sub>H</sub> )			For registration No. 801C <sub>H</sub>							
8060 to 8100 (1F7C <sub>H</sub> to 1FA4 <sub>H</sub> )			For registration No. 801D <sub>H</sub>							
8101 to 8141 (1FA5 <sub>H</sub> to 1FCD <sub>H</sub> )			For registration No. 801E <sub>H</sub>							
8142 to 8182 (1FCE <sub>H</sub> to 1FF6 <sub>H</sub> )			For registration No. 801F <sub>H</sub>							
8183 to 8191 (1FF7 <sub>H</sub> to 1FFF <sub>H</sub> )		Use prohibited	System area	—						
8192 (2000 <sub>H</sub> )		System designation	Flash ROM write allow/prohibit designation 0: Write prohibited 1: Write allowed	0	RW			Not allowed	Page 97, Section 7.4.2	
8193 (2001 <sub>H</sub> )		For callback function	Callback function designation 0 <sub>H</sub> : Auto 1 <sub>H</sub> : Callback connection (during fixed) (Setting 4) 3 <sub>H</sub> : Callback connection (during designated number) (Setting 5) 7 <sub>H</sub> : Callback connection (during max. designated number is 10) (Setting 6) 9 <sub>H</sub> : Auto/Callback connection (during fixed) (Setting 1) B <sub>H</sub> : Auto/Callback connection (during designated number) (Setting 2) F <sub>H</sub> : Auto/Callback connection (during max. designated number is 10) (Setting 3)	0	RW	—	Allowed		Page 75, Section 7.2 User's Manual (Application)	
8194 (2002 <sub>H</sub> )			Callback denial notification accumulated count designation 0 <sub>H</sub> : Not specified 1 <sub>H</sub> to FFFF <sub>H</sub> : Notification accumulated number count	1						
8195 to 8198 (2003 <sub>H</sub> to 2006 <sub>H</sub> )		Use prohibited	System area	—						
8199 (2007 <sub>H</sub> )		For designation of modem function -2	Auto modem initialization designation 0: Do not auto initialize 1: Auto initialize	0	RW	—	Allowed		Page 75, Section 7.2 User's Manual (Application)	
8200 (2008 <sub>H</sub> )			Modem initialization time DR (DSR) signal valid/invalid designation 0: Do not ignore DR(DSR) signal. 1: Ignore DR(DSR) signal.	1						
8201 (2009 <sub>H</sub> )			Complete signal handling for modem function designation 0: Do not turn on/off X13 to X16. 1: Turn on/off X13 to X16.	1			Not allowed			
8202 to 8203 (200A <sub>H</sub> to 200B <sub>H</sub> )		Use prohibited	System area	—						

Address Decimal (Hex)		Application	Name	Initial value	Protocol				Registration	Reference
CH1	CH2				MC	Non	Bi	Pd		
8204 (200C <sub>H</sub> )		For remote password function	Remote password mismatch notification count designation 0 <sub>H</sub> : No designation 1 <sub>H</sub> to FFFF <sub>H</sub> : Notification times	0	RW	—			Allowed	Page 75, Section 7.2 User's Manual (Application)
8205 (200D <sub>H</sub> )			Remote password mismatch notification accumulated count designation 0 <sub>H</sub> : No designation 1 <sub>H</sub> to FFFF <sub>H</sub> : Cumulative times of notification	1						
8206 (200E <sub>H</sub> )		For designation of modem function -3	Circuit disconnect wait time (programmable controller CPU watch use) 0000 <sub>H</sub> to FFFF <sub>H</sub> : Wait time (unit: s)	0	RW	—				Page 75, Section 7.2 User's Manual (Application)
8207 (200F <sub>H</sub> )	8459 to 8463 (210B <sub>H</sub> to 210F <sub>H</sub> )	Use prohibited	System area	—						
8208 (2010 <sub>H</sub> )	8464 (2110 <sub>H</sub> )	Interrupt designation	Receive interrupt-issued designation 0: Do not issue interrupt. 1: Issue interrupt.	0	—	RW	—	Allowed	User's Manual (Application)	
8209 (2011 <sub>H</sub> )	8465 (2111 <sub>H</sub> )	Use prohibited	System area	—						
8210 (2012 <sub>H</sub> )	8466 (2112 <sub>H</sub> )	For transmission control designation	Transmission control start free area designation 64 to 4,095: transmission control start free area	64	RW			Allowed	User's Manual (Application)	
8211 (2013 <sub>H</sub> )	8467 (2113 <sub>H</sub> )		Transmission control end free area designation 263 to 4096: transmission control end free area	263						
8212 (2014 <sub>H</sub> )	8468 (2114 <sub>H</sub> )		Nonprocedural and non reception monitoring time format designation 0: Format-0 1: Format-1	0	—	RW	—		User's Manual (Application)	
8213 to 8215 (2015 <sub>H</sub> to 2017 <sub>H</sub> )	8469 to 8471 (2115 <sub>H</sub> to 2117 <sub>H</sub> )	Use prohibited	System area	—						
8216 (2018 <sub>H</sub> )	8472 (2118 <sub>H</sub> )	Communication data monitoring function	Communication data monitoring designation 0000 <sub>H</sub> : No monitor/stopped monitor designation 0001 <sub>H</sub> : Monitor start designation 0002 <sub>H</sub> : Monitoring (C24 is a set.) 1002 <sub>H</sub> : Monitoring stopped (C24 is set.) 100F <sub>H</sub> : Monitor setting error (C24 is a set.)	0	RW			Allowed	User's Manual (Application)	
8217 (2019 <sub>H</sub> )	8473 (2119 <sub>H</sub> )		Data optional designation 0: Off 1: On Full stop designation (b0) Timer 0 errors at occurrence stop designation (b2) For system (b1), (b3) to (b15)	0						
8218 (201A <sub>H</sub> )	8474 (211A <sub>H</sub> )		Monitor buffer head address designation (400 <sub>H</sub> to 1AFD <sub>H</sub> , 2600 <sub>H</sub> to 3FFD <sub>H</sub> )	CH1: 2600 <sub>H</sub> CH2: 3300 <sub>H</sub>						
8219 (201B <sub>H</sub> )	8475 (211B <sub>H</sub> )		Monitor buffer size designation (0003 <sub>H</sub> to 1A00 <sub>H</sub> )	0D00 <sub>H</sub>						
8220 to 8223 (201C <sub>H</sub> to 201F <sub>H</sub> )	8476 to 8479 (211C <sub>H</sub> to 211F <sub>H</sub> )	Use prohibited	System area	—						

Address Decimal (Hex)		Application	Name	Initial value	Protocol				Registr ation	Reference
CH1	CH2				MC	Non	Bi	Pd		
8224 to 8227 (2020 <sub>H</sub> to 2023 <sub>H</sub> )	8480 to 8483 (2120 <sub>H</sub> to 2123 <sub>H</sub> )	For designation of user frame receiving method	User frame receive format designation (1st to 4th) 0: Format-0 1: Format-1	0	—	RW	—	Allowed	Page 75, Section 7.2 User's Manual (Application)	
8228 to 8231 (2024 <sub>H</sub> to 2027 <sub>H</sub> )	8484 to 8487 (2124 <sub>H</sub> to 2127 <sub>H</sub> )		Exclusive format-1 received data count (1st to 4th) 0 or more: Exclusive format-1 received data count							
8232 to 8239 (2028 <sub>H</sub> to 202F <sub>H</sub> )	8488 to 8495 (2128 <sub>H</sub> to 212F <sub>H</sub> )	Use prohibited	System area	—						
8240 to 8248 (2030 <sub>H</sub> to 2038 <sub>H</sub> )	8496 to 8504 (2130 <sub>H</sub> to 2138 <sub>H</sub> )	For designation of transparent code	Transmission transparent code designation (2nd to 10th) 0000 <sub>H</sub> : No designation Other than 0000 <sub>H</sub> : Designated (below) • Transparent code (b0 to b7) 00 <sub>H</sub> to FF <sub>H</sub> : Transparent code • Additional code (b8 to b15) 01 <sub>H</sub> to FF <sub>H</sub> : Additional code	0	—	RW	—	Allowed	Page 75, Section 7.2 User's Manual (Application)	
8249 to 8255 (2039 <sub>H</sub> to 203F <sub>H</sub> )	8505 to 8511 (2139 <sub>H</sub> to 213F <sub>H</sub> )	Use prohibited	System area	—						

Address Decimal (Hex)		Application	Name	Initial value	Protocol				Registr ation	Reference				
CH1	CH2				MC	Non	Bi	Pd						
8256 (2040 <sub>H</sub> )	8512 (2140 <sub>H</sub> )	For designation of programmable controller CPU monitoring function	Cycle time units designation 0: 100ms 1: s 2: min	2	R									
8257 (2041 <sub>H</sub> )	8513 (2141 <sub>H</sub> )		Cycle time designation 0 <sub>H</sub> : No designation 1 <sub>H</sub> to FFFF <sub>H</sub> : Programmable controller CPU monitoring cycle time	5 <sub>H</sub>										
8258 (2042 <sub>H</sub> )	8514 (2142 <sub>H</sub> )		Programmable controller CPU monitoring function designation 0: Do not use the function. 1: Fixed cycle transmission 2: Condition agreement transmission											
8259 (2043 <sub>H</sub> )	8515 (2143 <sub>H</sub> )		Programmable controller CPU monitoring transmission measure designation 0: Data transmission (device data and CPU status data)											
8260 (2044 <sub>H</sub> )	8516 (2144 <sub>H</sub> )		Transmission pointer designation (For fixed cycle transmission and data transmission) 0: No designation 1 to 100: Output head point (send from the nth) * Send the user frames designated in the following transmission frame No. designation areas from the designated pointer position. • Address: CH1 side = BA <sub>H</sub> to 11D <sub>H</sub> CH2 side = 15A <sub>H</sub> to 1BD <sub>H</sub>	0						—	R	—	Allowed	User's Manual (Application)
8261 (2045 <sub>H</sub> )	8517 (2145 <sub>H</sub> )		Output count designation (for fixed cycle transmission and data transmission) 0: No designation 1 to 100: Output count (designate the number of frame transmissions.)											
8262 (2046 <sub>H</sub> )	8518 (2146 <sub>H</sub> )		Data No. for connection designation (for fixed cycle transmission) 0: No designation 0BB8 <sub>H</sub> to 0BD5 <sub>H</sub> , 8001 <sub>H</sub> to 801F <sub>H</sub> : Data No. for connection								R			
8263 to 8268 (2047 <sub>H</sub> to 204C <sub>H</sub> )	8519 to 8524 (2147 <sub>H</sub> to 214C <sub>H</sub> )	Use prohibited	System area					—						



Address Decimal (Hex)		Application	Name		Initial value	Protocol				Registr ation	Reference
CH1	CH2					MC	Non	Bi	Pd		
8269 (204D <sub>H</sub> )	8525 (214D <sub>H</sub> )	For designation of programmable controller CPU monitoring function	Number of registered word blocks designation 0: No designation 1 to 10: Number of blocks of word devices	It is possible to designate a maximum of 10 blocks in total.	0	R	—	Allowed	User's Manual (Application)		
8270 (204E <sub>H</sub> )	8526 (214E <sub>H</sub> )		Number of registered bit blocks designation 0: No designation 1 to 10: Number of blocks of bit devices								
8271 (204F <sub>H</sub> )	8527 (214F <sub>H</sub> )		Programmable controller CPU abnormal monitoring designation 0: Do not monitor. 1: Monitor.								
8272 (2050 <sub>H</sub> )	8528 (2150 <sub>H</sub> )		No. 1 block monitoring device	Monitoring device designation 0: No designation 90 <sub>H</sub> to CC <sub>H</sub> : Device code							
8273 to 8274 (2051 <sub>H</sub> to 2052 <sub>H</sub> )	8529 to 8530 (2151 <sub>H</sub> to 2152 <sub>H</sub> )			Head device No. designation 0 or more: Head device No.							

A

Address Decimal (Hex)		Application	Name	Initial value	Protocol				Registr ation	Reference
CH1	CH2				MC	Non	Bi	Pd		
8275 (2053 <sub>H</sub> )	8531 (2153 <sub>H</sub> )	For designation of programmable controller CPU monitoring function	No. 1 block monitoring device	Read point designation 0: No designation 1 or more: Number to read points	0	—	R	Allowed	User's Manual (Application)	
8276 (2054 <sub>H</sub> )	8532 (2154 <sub>H</sub> )			Monitoring condition designation (judgment condition designation) 0: No designation 1 or more: Monitoring condition						
8277 (2055 <sub>H</sub> )	8533 (2155 <sub>H</sub> )			Monitoring condition value designation At bit device 0: OFF 1: ON At word device 0 to FFFF <sub>H</sub> : Monitoring condition value						
8278 (2056 <sub>H</sub> )	8534 (2156 <sub>H</sub> )			Transmission pointer designation (for condition agreement transmission and nonprocedural data transmission) 0: No designation 1 to 100: Output head point (send from nth) * Send the user frames designated in the following transmission frame No. designation areas from the designated pointer position. • Address: CH1 side = BA <sub>H</sub> to 11D <sub>H</sub> , CH2 side = 15A <sub>H</sub> to 1BD <sub>H</sub>	—	R				
8279 (2057 <sub>H</sub> )	8535 (2157 <sub>H</sub> )			Output count designation (for condition agreement transmission and nonprocedural data transmission) 0: No designation 1 to 100: Output count (designate the number of frame transmissions)	—	R				
8280 (2058 <sub>H</sub> )	8536 (2158 <sub>H</sub> )			Data No. for connection designation (for condition agreement transmission) 0: No designation 0BB8 <sub>H</sub> to 0BD5 <sub>H</sub> , 8001 <sub>H</sub> to 801F <sub>H</sub> : Data No. for connection	—	R				
8281 to 8361 (2059 <sub>H</sub> to 20A9 <sub>H</sub> )	8537 to 8617 (2159 <sub>H</sub> to 21A9 <sub>H</sub> )	Block monitoring devices No. 2 to 10	The structure of each area is the same as the first block monitoring device area Refer to *1 for the details of each area.							
8362 to 8421 (20AA <sub>H</sub> to 20E5 <sub>H</sub> )	8618 to 8677 (21AA <sub>H</sub> to 21E5 <sub>H</sub> )	Use prohibited	System area				—			



Address Decimal (Hex)		Application	Name	Initial value	Protocol				Registration	Reference
CH1	CH2				MC	Non	Bi	Pd		
8422 (20E6 <sub>H</sub> )	8678 (21E6 <sub>H</sub> )	For designation of programmable controller CPU monitoring function	Programmable controller CPU abnormal monitoring designation	0	—	R	—	Allowed	User's Manual (Application)	
8423 (20E7 <sub>H</sub> )	8679 (21E7 <sub>H</sub> )		Output count designation (for condition agreement transmission and nonprocedural data transmission) 0: No designation 1 to 100: Output count (designate the number of frame transmissions)							
8424 (20E8 <sub>H</sub> )	8680 (21E8 <sub>H</sub> )		Data No. for connection designation (for condition agreement transmission) 0: No designation 0BB8 <sub>H</sub> to 0BD5 <sub>H</sub> , 8001 <sub>H</sub> to 801F <sub>H</sub> : Data No. for connection							
8425 to 8447 (20E9 <sub>H</sub> to 20FF <sub>H</sub> )	8681 to 8703 (21E9 <sub>H</sub> to 21FF <sub>H</sub> )	Use prohibited	System area				—			
8448 (2100 <sub>H</sub> )		Use prohibited	System area				—			
8449 (2101 <sub>H</sub> )		For callback function	Data No. for callback designation 1 0BB8 <sub>H</sub> to 0BD5 <sub>H</sub> , 8001 <sub>H</sub> to 801F <sub>H</sub> : Data number for callback.	0	RW	—	Allowed	Page 75, Section 7.2 User's Manual (Application)		
8450 (2102 <sub>H</sub> )			Data No. for callback designation 2							
8451 (2103 <sub>H</sub> )			Data No. for callback designation 3							
8452 (2104 <sub>H</sub> )			Data No. for callback designation 4							
8453 (2105 <sub>H</sub> )			Data No. for callback designation 5							
8454 (2106 <sub>H</sub> )			Data No. for callback designation 6							
8455 (2107 <sub>H</sub> )			Data No. for callback designation 7							
8456 (2108 <sub>H</sub> )			Data No. for callback designation 8							
8457 (2109 <sub>H</sub> )			Data No. for callback designation 9							
8458 (210A <sub>H</sub> )			Data No. for callback designation 10							
8704 to 8707 (2200 <sub>H</sub> to 2203 <sub>H</sub> )	8960 to 8963 (2300 <sub>H</sub> to 2303 <sub>H</sub> )	Use prohibited	System area				—			

Appendix 1 Buffer Memory

Address Decimal (Hex)		Application	Name	Initial value	Protocol				Registr ation	Reference
CH1	CH2				MC	Non	Bi	Pd		
8708 (2204 <sub>H</sub> )	8964 (2304 <sub>H</sub> )	Programmable controller CPU monitoring function	Programmable controller CPU monitoring function operation status 0: Not executed (waiting for registration of programmable controller CPU monitoring) 1: Wait for programmable controller CPU monitoring time (Waiting to access CPU module) 2: Accessing CPU module 3: Sending monitoring results	0	R	—	Not allowed	User's Manual (Application)		
8709 (2205 <sub>H</sub> )	8965 (2305 <sub>H</sub> )		Programmable controller CPU monitoring function execution result (current) 0: Normal completion 1 or more: Abnormal completion (error code)							
8710 (2206 <sub>H</sub> )	8966 (2306 <sub>H</sub> )		Programmable controller CPU monitoring function number of transmission 0: Not executed 1 or more: Number of transmissions							
8711 (2207 <sub>H</sub> )	8967 (2307 <sub>H</sub> )		Monitoring condition arrival block No. 0: The monitoring condition is not enabled for any block 1 to 10: Registration order of word/bit block (nth) 4096: CPU abnormal monitoring block * The latest block No. for which monitoring condition is enabled is stored.							
8712 to 8943 (2208 <sub>H</sub> to 22EF <sub>H</sub> )	8968 to 9215 (2308 <sub>H</sub> to 23FF <sub>H</sub> )	Use prohibited	System area	—						
8944 (22F0 <sub>H</sub> )	For callback function	Use prohibited	Callback permit accumulated count 0 or more: Accumulated count	0	RW	—	Not allowed	User's Manual (Application)		
8945 (22F1 <sub>H</sub> )			Callback denial accumulated count 0 or more: Accumulated count							
8946 (22F2 <sub>H</sub> )			Auto (callback) connection permit accumulated count 0 or more: Accumulated count							
8947 (22F3 <sub>H</sub> )			Auto (callback) connection denial accumulated count 0 or more: Accumulated count							
8948 (22F4 <sub>H</sub> )			Accumulated count of callback receive procedure cancel 0 or more: Accumulated count							
8949 to 8954 (22F5 <sub>H</sub> to 22FA <sub>H</sub> )	Use prohibited	System area	—							
8955 (22FB <sub>H</sub> )	For the remote password function	Use prohibited	Accumulated count of unlock process normal completion 0 or more: Accumulated count of normal completion	0	RW	—	Not allowed	User's Manual (Application)		
8956 (22FC <sub>H</sub> )			Accumulated count of unlock process abnormal completion processing 0 or more: Accumulated count of abnormal completion							
8957 to 8958 (22FD <sub>H</sub> to 22FE <sub>H</sub> )	Use prohibited	System area	—							
8959 (22FF <sub>H</sub> )	For the remote password function	Use prohibited	Accumulated count of lock process based on circuit disconnection 0 or more: Accumulated count of lock process based on circuit disconnection	0	RW	—	Not allowed	User's Manual (Application)		
9216 (2400 <sub>H</sub> )	Use prohibited	System area	—							
9217 (2401 <sub>H</sub> )	For flash ROM write count housing	Use prohibited	Flash ROM write count 0 to 1000: Write count	0	R	—	Not allowed	—		

Address Decimal (Hex)		Application	Name	Initial value	Protocol				Registr ation	Reference		
CH1	CH2				MC	Non	Bi	Pd				
9218 to 9727 (2402 <sub>H</sub> to 25FF <sub>H</sub> )		Use prohibited	System area		—							
9728 to 16383 (2600 <sub>H</sub> to 3FFF <sub>H</sub> )		For user	User setting area 2 (6656 words) (Transmission/receiving data monitoring function default buffer) * Usage is determined by the user.	0	RW				Not allowed	—		
16384 (4000 <sub>H</sub> )	16416 (4020 <sub>H</sub> )	Predefined protocol function control data specification	Number of continuous executions 0: Protocol unexecuted 1 to 8: Number of protocols to be executed continuously	0	—		R W	Not allowed	—			
16385 (4001 <sub>H</sub> )		16417 (4021 <sub>H</sub> )	Use prohibited	System area	—							
16386 (4002 <sub>H</sub> )	16418 (4022 <sub>H</sub> )	Predefined protocol function control data specification	Execution result 0: Normal Other than 0: abnormal (error code)	0	—		R	Not allowed	—			
16387 (4003 <sub>H</sub> )	16419 (4023 <sub>H</sub> )		Result of the executions 0: Protocol unexecuted 1 to 8: Number of continuous protocol executions									
16388 (4004 <sub>H</sub> )	16420 (4024 <sub>H</sub> )		Execution protocol No. designation 1 0: No instruction 1 to 128, 201 to 207: Protocol No.	0	—		R W	Not allowed	—			
16389 (4005 <sub>H</sub> )	16421 (4025 <sub>H</sub> )		Execution protocol No. designation 2									
16390 (4006 <sub>H</sub> )	16422 (4026 <sub>H</sub> )		Execution protocol No. designation 3									
16391 (4007 <sub>H</sub> )	16423 (4027 <sub>H</sub> )		Execution protocol No. designation 4									
16392 (4008 <sub>H</sub> )	16424 (4028 <sub>H</sub> )		Execution protocol No. designation 5									
16393 (4009 <sub>H</sub> )	16425 (4029 <sub>H</sub> )		Execution protocol No. designation 6									
16394 (400A <sub>H</sub> )	16426 (402A <sub>H</sub> )		Execution protocol No. designation 7									
16395 (400B <sub>H</sub> )	16427 (402B <sub>H</sub> )		Execution protocol No. designation 8									
16396 (400C <sub>H</sub> )	16428 (402C <sub>H</sub> )		Matched receive packet No. 1 0: No matched receive packet 1 to 16: Matched receive packet No.		0	—				R	Not allowed	—
16397 (400D <sub>H</sub> )	16429 (402D <sub>H</sub> )	Matched receive packet No. 2										
16398 (400E <sub>H</sub> )	16430 (402E <sub>H</sub> )	Matched receive packet No. 3										
16399 (400F <sub>H</sub> )	16431 (402F <sub>H</sub> )	Matched receive packet No. 4										
16400 (4010 <sub>H</sub> )	16432 (4030 <sub>H</sub> )	Matched receive packet No. 5										
16401 (4011 <sub>H</sub> )	16433 (4031 <sub>H</sub> )	Matched receive packet No. 6										
16402 (4012 <sub>H</sub> )	16434 (4032 <sub>H</sub> )	Matched receive packet No. 7										
16403 (4013 <sub>H</sub> )	16435 (4033 <sub>H</sub> )	Matched receive packet No. 8										

Address Decimal (Hex)		Application	Name	Initial value	Protocol				Registr ation	Reference
CH1	CH2				MC	Non	Bi	Pd		
16404 to 16415 (4014 <sub>H</sub> to 401F <sub>H</sub> )	16436 to 16447 (4034 <sub>H</sub> to 403F <sub>H</sub> )	Use prohibited	System area							
16448 (4040 <sub>H</sub> )	16464 (4050 <sub>H</sub> )	Predefined protocol function control data specification	Protocol cancel 0: No cancel instruction 1: Cancel request (set by user) 2: Cancel completed (set by C24)	0	—		R W	Not allowed	GX Works2 Version 1 Operating Manual (Intelligent Function Module)	
16449 (4041 <sub>H</sub> )	16465 (4051 <sub>H</sub> )	Checking predefined protocol function execution status	Execution status 0: Unexecuted 1: Waiting for transmission 2: Sending 3: Waiting for data reception 4: Receiving 5: Completed	0	—		R	Not allowed	Page 249, Section 13.2 Page 277, Section 15.2	
16450 (4042 <sub>H</sub> )	16466 (4052 <sub>H</sub> )		Predefined protocol function error code 0: Normal Other than 0: Error (error code)	0	—		R			
16451 (4043 <sub>H</sub> )	16467 (4053 <sub>H</sub> )		Number of protocol executions 0: No log 1 to 65535: Number of executions	0	—		R			—
16452 to 16463 (4044 <sub>H</sub> to 404F <sub>H</sub> )	16468 to 16479 (4054 <sub>H</sub> to 405F <sub>H</sub> )	Use prohibited	System area							
16480 to 16517 (4060 <sub>H</sub> to 4085 <sub>H</sub> )		Use prohibited	System area							
16518 (4086 <sub>H</sub> )		Protocol setting data error information	Protocol No. 1 to 128: Protocol No. 65535: Unidentified	0	—		R	Not allowed	Page 114, Section 9.3 Page 281, Section 15.2.2	
16519 (4087 <sub>H</sub> )	Setting type 0: Packet setting or element setting 1: Protocol detailed setting 65535: Not specified		0	—		R				
16520 (4088 <sub>H</sub> )	Packet No. 0: Send packet 1 to 16: Receive packet 65535: Unidentified * Valid when the Setting type value is 0.		0	—		R				
16521 (4089 <sub>H</sub> )	Element No. 1 to 32: Element No. 65535: Unidentified * Valid when the Setting type value is 0.		0	—		R				
16522 to 16527 (408A <sub>H</sub> to 408F <sub>H</sub> )		Use prohibited	System area							

Address Decimal (Hex)		Application	Name	Initial value	Protocol				Registration	Reference
CH1	CH2				MC	Non	Bi	Pd		
16528 (4090 <sub>H</sub> )		Checking protocol setting data	Number of registered protocols 0: No registration 1 to 128: Number of registrations	0	—			R	Not allowed	Page 108, CHAPTER 9
16529 to 16536 (4091 <sub>H</sub> to 4098 <sub>H</sub> )			Protocol registration 0: No registration 1: Registered * The bit corresponding to each protocol No. turns on or off.	0	—			R		—
16537 to 16607 (4099 <sub>H</sub> to 40DF <sub>H</sub> )		Use prohibited	System area	—						
16608 to 16609 (40E0 <sub>H</sub> to 40E1 <sub>H</sub> )	16624 to 16625 (40F0 <sub>H</sub> to 40F1 <sub>H</sub> )	Use prohibited	System area	—						
16610 (40E2 <sub>H</sub> )	16626 (40F2 <sub>H</sub> )	Protocol execution log specification	Execution log options 0: Error logs of failed protocol executions are stored. 1: Execution states and logs of all protocols are stored.	0	—			R W	Allowed	Page 254, Section 13.3
16611 to 16623 (40E3 <sub>H</sub> to 40EF <sub>H</sub> )	16627 to 16639 (40F3 <sub>H</sub> to 40FF <sub>H</sub> )	Use prohibited	System area	—						
16640 (4100 <sub>H</sub> )	18432 (4800 <sub>H</sub> )	Checking protocol execution logs	Number of stored protocol execution logs 0: No log 1 to 32: Number of stored logs	0	—			R	Not allowed	Page 254, Section 13.3
16641 (4101 <sub>H</sub> )	18433 (4801 <sub>H</sub> )		Protocol execution log write pointer 0: No log 1 to 32: Latest protocol execution log No.	0	—			R		

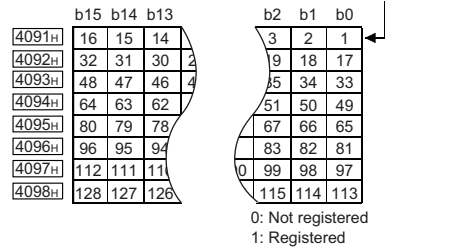

Address Decimal (Hex)		Application	Name	Initial value	Protocol				Registr ation	Reference
CH1	CH2				MC	Non	Bi	Pd		
16642 (4102 <sub>H</sub> )	18434 (4802 <sub>H</sub> )	Checking protocol execution logs	Execution log 1	System area (use prohibited)	—				Not allowed	Page 108, CHAPTER 9 Page 254, Section 13.3 Page 212, Section 12.3
16643 (4103 <sub>H</sub> )	18435 (4803 <sub>H</sub> )			Protocol No. 0: No log 1 to 128: Protocol No. 201 to 207: Functional protocol No.	0	—		R		
16644 to 16659 (4104 <sub>H</sub> to 4113 <sub>H</sub> )	18436 to 18451 (4804 <sub>H</sub> to 4813 <sub>H</sub> )			External device model 0: Protocol unexecuted Other than 0: External device model (Up to 32 bytes are stored in ASCII codes.)	0	—		R		
16660 to 16675 (4114 <sub>H</sub> to 4123 <sub>H</sub> )	18452 to 18467 (4814 <sub>H</sub> to 4823 <sub>H</sub> )			Protocol name 0: No protocol executed Other than 0: Protocol name (Up to 32 bytes in ASCII codes are stored.)	0	—		R		
16676 (4124 <sub>H</sub> )	18468 (4824 <sub>H</sub> )			Communication type 0: Protocol unexecuted 1: Send only 2: Receive only 3: Send and receive 14: Functional protocol 15: Unregistered protocol	0	—		R		
16677 (4125 <sub>H</sub> )	18469 (4825 <sub>H</sub> )			Execution status 0: Unexecuted 1: Waiting for transmission 2: Sending 3: Waiting for reception 4: Receiving 5: Completed	0	—		R		
16678 (4126 <sub>H</sub> )	18470 (4826 <sub>H</sub> )			Execution result 0: Normal Other than 0 (error code): Error	0	—		R		
16679 (4127 <sub>H</sub> )	18471 (4827 <sub>H</sub> )			Matched packet No. 0: Error occurred, or Communication type of the executed protocol is "Send only". 1 to 16: Matched packet No.	0	—		R		
16680 (4128 <sub>H</sub> )	18472 (4828 <sub>H</sub> )			Number of retries 0: No retry 1 to 10: Number of retries	0	—		R		
16681 (4129 <sub>H</sub> )	18473 (4829 <sub>H</sub> )			System area (Use prohibited)	—					





Address Decimal (Hex)		Application	Name		Initial value	Protocol				Registr ation	Reference
CH1	CH2					MC	Non	Bi	Pd		
16682 (412A <sub>H</sub> )	18474 (482A <sub>H</sub> )	Checking protocol execution logs	Execution log 1	Star t time and date	0: No log Upper 8 bits: Month Lower 8 bits: Last 2 digits of year  <small>b15 to b8 b7 to b0 Month (01h to 12h) Year (00h to 99h, last 2 digits)</small>	0	—		R	Not allowed	Page 254, Section 13.3
16683 (412B <sub>H</sub> )	18475 (482B <sub>H</sub> )				0: No log Upper 8 bits: Hour Lower 8 bits: Day  <small>b15 to b8 b7 to b0 Hour (00h to 23h) Day (01h to 31h)</small>	0	—		R		
16684 (412C <sub>H</sub> )	18476 (482C <sub>H</sub> )				0: No log Upper 8 bits: Second Lower 8 bits: Minute  <small>b15 to b8 b7 to b0 Second (00h to 59h) Minute (00h to 59h)</small>	0	—		R		
16685 (412D <sub>H</sub> )	18477 (482D <sub>H</sub> )				0: No log Upper 8 bits: First 2 digits of year Lower 8 bits: Day of week  <small>b15 to b8 b7 to b0 Year (00h to 99h, first 2 digits) Day of week (00h to 06h) 00h (Sunday) to 06h (Saturday)</small>	0	—		R		
16686 (412E <sub>H</sub> )	18478 (482E <sub>H</sub> )	Checking protocol execution log	Execution log 1	End time and date	0: No log Upper 8 bits: Month Lower 8 bits: Last 2 digits of year  <small>b15 to b8 b7 to b0 Month (01h to 12h) Year (00h to 99h, last 2 digits)</small>	0	—		R	Not allowed	Page 254, Section 13.3
16687 (412F <sub>H</sub> )	18479 (482F <sub>H</sub> )				0: No log Upper 8 bits: Hour Lower 8 bits: Day  <small>b15 to b8 b7 to b0 Hour (00h to 23h) Day (01h to 31h)</small>	0	—		R		
16688 (4130 <sub>H</sub> )	18480 (4830 <sub>H</sub> )				0: No log Upper 8 bits: Second Lower 8 bits: Minute  <small>b15 to b8 b7 to b0 Second (00h to 59h) Minute (00h to 59h)</small>	0	—		R		
16689 (4131 <sub>H</sub> )	18481 (4831 <sub>H</sub> )				0: No log Upper 8 bits: First 2 digits of year Lower 8 bits: Day of week  <small>b15 to b8 b7 to b0 Year (00h to 99h, first 2 digits) Day of week (00h to 06h) 00h (Sunday) to 06h (Saturday)</small>	0	—		R		
16690 to 18177 (4132 <sub>H</sub> to 4701 <sub>H</sub> )	18482 to 19969 (4832 <sub>H</sub> to 4E01 <sub>H</sub> )		Execution log 2 to 32		Same as Execution log 1	0	—		R		

Appendix 1 Buffer Memory

Address Decimal (Hex)		Application	Name	Initial value	Protocol				Registr ation	Reference
CH1	CH2				MC	Non	Bi	Pd		
18178 to 18429 (4702 <sub>H</sub> to 47FD <sub>H</sub> )	19970 to 20223 (4E02 <sub>H</sub> to 4EFF <sub>H</sub> )	Use prohibited	System area						—	
20224 to 20479 (4F00 <sub>H</sub> to 4FFF <sub>H</sub> )										
20480 to 24575 (5000 <sub>H</sub> to 5FFF <sub>H</sub> )	Send/receive area for predefined protocol function		Predefined protocol function buffer	0	—		R W	Not allowed	GX Works2 Version 1 Operating Manual (Intelligent Function Module)	
24576 to 32767 (6000 <sub>H</sub> to 7FFF <sub>H</sub> )	Use prohibited		System area						—	

- \*1 (a) and (b) in the following section show assignments of block monitoring device areas No. 1 to No.10 for the programmable controller CPU monitoring function (CH1 side: 8272 to 8361 (2050<sub>H</sub> to 20A9<sub>H</sub>), CH2 side: 8528 to 8617 (2150<sub>H</sub> to 21A9<sub>H</sub>)).
- \*2 The area can be used as a user setting area (the send and receive data storage areas).

**(a) [CH1 side buffer memory address: decimal (hexadecimal)]**

N-th block monitoring device										Name
1	2	3	4	5	6	7	8	9	10	
8272 (2050 <sub>H</sub> )	8281 (2059 <sub>H</sub> )	8290 (2062 <sub>H</sub> )	8299 (206B <sub>H</sub> )	8308 (2074 <sub>H</sub> )	8317 (207D <sub>H</sub> )	8326 (2086 <sub>H</sub> )	8335 (208F <sub>H</sub> )	8344 (2098 <sub>H</sub> )	8353 (20A1 <sub>H</sub> )	Monitoring device designation
8273 to 8274 (2051 <sub>H</sub> to 2052 <sub>H</sub> )	8282 to 8283 (205A <sub>H</sub> to 205B <sub>H</sub> )	8291 to 8292 (2063 <sub>H</sub> to 2064 <sub>H</sub> )	8300 to 8301 (206C <sub>H</sub> to 206D <sub>H</sub> )	8309 to 8310 (2075 <sub>H</sub> to 2076 <sub>H</sub> )	8318 to 8319 (207E <sub>H</sub> to 207F <sub>H</sub> )	8327 to 8328 (2087 <sub>H</sub> to 2088 <sub>H</sub> )	8336 to 8337 (2090 <sub>H</sub> to 2091 <sub>H</sub> )	8345 to 8346 (2099 <sub>H</sub> to 209A <sub>H</sub> )	8354 to 8355 (20A2 <sub>H</sub> to 20A3 <sub>H</sub> )	Head device No. designation
8275 (2053 <sub>H</sub> )	8284 (205C <sub>H</sub> )	8293 (2065 <sub>H</sub> )	8302 (206E <sub>H</sub> )	8311 (2077 <sub>H</sub> )	8320 (2080 <sub>H</sub> )	8329 (2089 <sub>H</sub> )	8338 (2092 <sub>H</sub> )	8347 (209B <sub>H</sub> )	8356 (20A4 <sub>H</sub> )	Designation of number of points read
8276 (2054 <sub>H</sub> )	8285 (205D <sub>H</sub> )	8294 (2066 <sub>H</sub> )	8303 (206F <sub>H</sub> )	8312 (2078 <sub>H</sub> )	8321 (2081 <sub>H</sub> )	8330 (208A <sub>H</sub> )	8339 (2093 <sub>H</sub> )	8348 (209C <sub>H</sub> )	8357 (20A5 <sub>H</sub> )	Monitoring condition designation (Judgment condition designation)
8277 (2055 <sub>H</sub> )	8286 (205E <sub>H</sub> )	8295 (2067 <sub>H</sub> )	8304 (2070 <sub>H</sub> )	8313 (2079 <sub>H</sub> )	8322 (2082 <sub>H</sub> )	8331 (208B <sub>H</sub> )	8340 (2094 <sub>H</sub> )	8349 (209D <sub>H</sub> )	8358 (20A6 <sub>H</sub> )	Monitoring condition value designation
8278 (2056 <sub>H</sub> )	8287 (205F <sub>H</sub> )	8296 (2068 <sub>H</sub> )	8305 (2071 <sub>H</sub> )	8314 (207A <sub>H</sub> )	8323 (2083 <sub>H</sub> )	8332 (208C <sub>H</sub> )	8341 (2095 <sub>H</sub> )	8350 (209E <sub>H</sub> )	8359 (20A7 <sub>H</sub> )	Transmission pointer designation (for conditional transmission, data transmission)
8279 (2057 <sub>H</sub> )	8288 (2060 <sub>H</sub> )	8297 (2069 <sub>H</sub> )	8306 (2072 <sub>H</sub> )	8315 (207B <sub>H</sub> )	8324 (2084 <sub>H</sub> )	8333 (208D <sub>H</sub> )	8342 (2096 <sub>H</sub> )	8351 (209F <sub>H</sub> )	8360 (20A8 <sub>H</sub> )	Designation of number of outputs (for conditional transmission, data transmission)
8280 (2058 <sub>H</sub> )	8289 (2061 <sub>H</sub> )	8298 (206A <sub>H</sub> )	8307 (2073 <sub>H</sub> )	8316 (207C <sub>H</sub> )	8325 (2085 <sub>H</sub> )	8334 (208E <sub>H</sub> )	8343 (2097 <sub>H</sub> )	8352 (20A0 <sub>H</sub> )	8361 (20A9 <sub>H</sub> )	Designation of data No. for connection (for conditional transmission)

**(b) [CH2 side buffer memory address: decimal (hexadecimal)]**

N-th block monitoring device										Name
1	2	3	4	5	6	7	8	9	10	
8528 (2150 <sub>H</sub> )	8537 (2159 <sub>H</sub> )	8546 (2162 <sub>H</sub> )	8555 (216B <sub>H</sub> )	8564 (2174 <sub>H</sub> )	8573 (217D <sub>H</sub> )	8582 (2186 <sub>H</sub> )	8591 (218F <sub>H</sub> )	8600 (2198 <sub>H</sub> )	8609 (21A1 <sub>H</sub> )	Monitoring device designation
8529 to 8530 (2151 <sub>H</sub> to 2152 <sub>H</sub> )	8538 to 8539 (215A <sub>H</sub> to 215B <sub>H</sub> )	8547 to 8548 (2163 <sub>H</sub> to 2164 <sub>H</sub> )	8556 to 8557 (216C <sub>H</sub> to 216D <sub>H</sub> )	8565 to 8566 (2175 <sub>H</sub> to 2176 <sub>H</sub> )	8574 to 8575 (217E <sub>H</sub> to 217F <sub>H</sub> )	8583 to 8584 (2187 <sub>H</sub> to 2188 <sub>H</sub> )	8592 to 8593 (2190 <sub>H</sub> to 2191 <sub>H</sub> )	8601 to 8602 (2199 <sub>H</sub> to 219A <sub>H</sub> )	8610 to 8611 (21A2 <sub>H</sub> to 21A3 <sub>H</sub> )	Head device No. designation
8531 (2153 <sub>H</sub> )	8540 (215C <sub>H</sub> )	8549 (2165 <sub>H</sub> )	8558 (216E <sub>H</sub> )	8567 (2177 <sub>H</sub> )	8576 (2180 <sub>H</sub> )	8585 (2189 <sub>H</sub> )	8594 (2192 <sub>H</sub> )	8603 (219B <sub>H</sub> )	8612 (21A4 <sub>H</sub> )	Designation of number of points read
8532 (2154 <sub>H</sub> )	8541 (215D <sub>H</sub> )	8550 (2166 <sub>H</sub> )	8559 (216F <sub>H</sub> )	8568 (2178 <sub>H</sub> )	8577 (2181 <sub>H</sub> )	8586 (218A <sub>H</sub> )	8595 (2193 <sub>H</sub> )	8604 (219C <sub>H</sub> )	8613 (21A5 <sub>H</sub> )	Monitoring condition designation (Judgment condition designation)
8533 (2155 <sub>H</sub> )	8542 (215E <sub>H</sub> )	8551 (2167 <sub>H</sub> )	8560 (2170 <sub>H</sub> )	8569 (2179 <sub>H</sub> )	8578 (2182 <sub>H</sub> )	8587 (218B <sub>H</sub> )	8596 (2194 <sub>H</sub> )	8605 (219D <sub>H</sub> )	8614 (21A6 <sub>H</sub> )	Monitoring condition value designation
8534 (2156 <sub>H</sub> )	8543 (215F <sub>H</sub> )	8552 (2168 <sub>H</sub> )	8561 (2171 <sub>H</sub> )	8570 (217A <sub>H</sub> )	8579 (2183 <sub>H</sub> )	8588 (218C <sub>H</sub> )	8597 (2195 <sub>H</sub> )	8606 (219E <sub>H</sub> )	8615 (21A7 <sub>H</sub> )	Transmission pointer designation (for conditional transmission, data transmission)
8535 (2157 <sub>H</sub> )	8544 (2160 <sub>H</sub> )	8553 (2169 <sub>H</sub> )	8562 (2172 <sub>H</sub> )	8571 (217B <sub>H</sub> )	8580 (2184 <sub>H</sub> )	8589 (218D <sub>H</sub> )	8598 (2196 <sub>H</sub> )	8607 (219F <sub>H</sub> )	8616 (21A8 <sub>H</sub> )	Designation of number of outputs (for conditional transmission, data transmission)
8536 (2158 <sub>H</sub> )	8545 (2161 <sub>H</sub> )	8554 (216A <sub>H</sub> )	8563 (2173 <sub>H</sub> )	8572 (217C <sub>H</sub> )	8581 (2185 <sub>H</sub> )	8590 (218E <sub>H</sub> )	8599 (2197 <sub>H</sub> )	8608 (21A0 <sub>H</sub> )	8617 (21A9 <sub>H</sub> )	Designation of data No. for connection (for conditional transmission)

## Appendix 2 How to Confirm the Serial No. and Function Version

---

For how to check the serial No. and function version, refer to the following:

 MELSEC-L CPU Module User's Manual (Hardware Design, Maintenance and Inspection)

 MELSEC-L CC-Link IE Field Network Head Module User's Manual

## Appendix 3 Differences between L Series C24 and Q Series C24

A

### Appendix 3.1 Specification comparisons

The following shows the specification comparisons between the L series C24 and Q series C24.

For the function comparisons between LCPU and QnUCPU, refer to the following.

 MELSEC-L CPU Module User's Manual (Hardware Design, Maintenance and Inspection)

Item	Difference	
	L series C24	Q series C24
Notification function	No available	Available

### Appendix 3.2 Precautions for utilizing programs

When utilizing the program used in the Q series system for the L series system, refer to the precautions for utilizing the program described in the following manual.

 MELSEC-L CPU Module User's Manual (Function Explanation, Program Fundamentals)

# Appendix 4 When Using GX Developer or GX Configurator-SC

## Appendix 4.1 Compatible software packages

Refer to the following manual.

📖 MELSEC-L CPU Module User's Manual (Hardware Design, Maintenance and Inspection)

## Appendix 4.2 Specification comparisons

The following shows the specification comparisons between GX Works2 and GX Developer, GX Configurator-SC.

Function	Description	Software package	
		GX Works2	GX Developer, GX Configurator-SC
Protocol FB support function	The man-hours for creating programs can be shortened by converting needed sequence programs for data communication processing to FB (function block). Also, the time to start up programs can be shortened by monitoring and analyzing communication data on the communication circuit. For details, refer to the 📖 GX Configurator-SC Version2 Operating Manual (Protocol FB Support Function).	×	○
System monitor	Detailed information on the intelligent function module can be acquired. That information enables to shorten the recovering process time after error occurrences. For details, refer to the 📖 GX Works2 Version1 Operating Manual (Common).	○	×

○: Can be used, ×: Cannot be used

## Appendix 4.3 Operation comparison

A

### Appendix 4.3.1 Operation of GX Developer

When using GX Developer, the setting and confirmation can be configured in the following screens.

Screen name	Application	Reference
I/O Assignment	Set the type and I/O signal range of each module to be connected.	Page 365, Appendix 4.3 (1)
Switch Setting	Set the transmission specifications and communication protocols with external devices.	Page 366, Appendix 4.3 (2)
Intelligent function module Interrupt pointer setting	Configure the settings to read the receive data using the interrupt program of the CPU module.	Page 368, Appendix 4.3 (3)

#### (1) I/O assignment

 GX Developer ⇒ [PLC Parameter] ⇒ "I/O assignment"

Set "Type", "Model Name", "Points", and "Start XY".

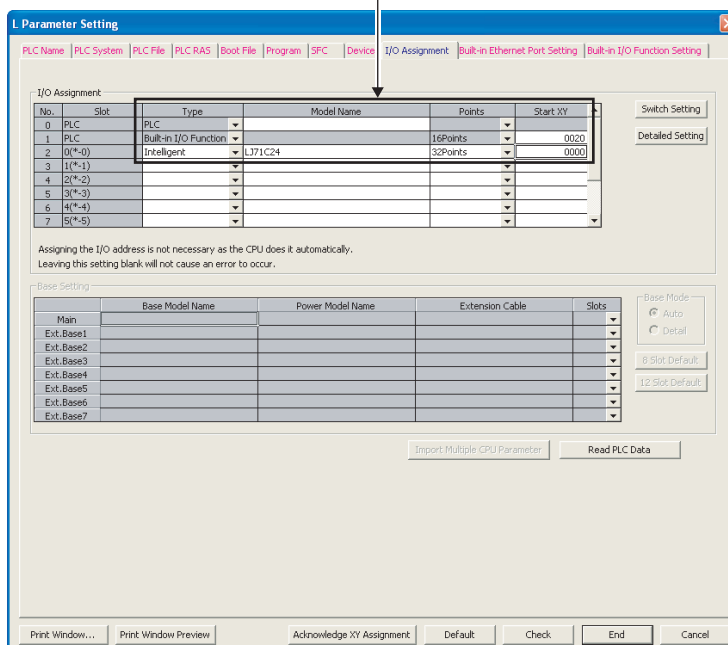

## (2) Switch setting

 GX Developer ⇒ [PLC Parameter] ⇒ [I/O Assignment] ⇒ "Switch Setting" button

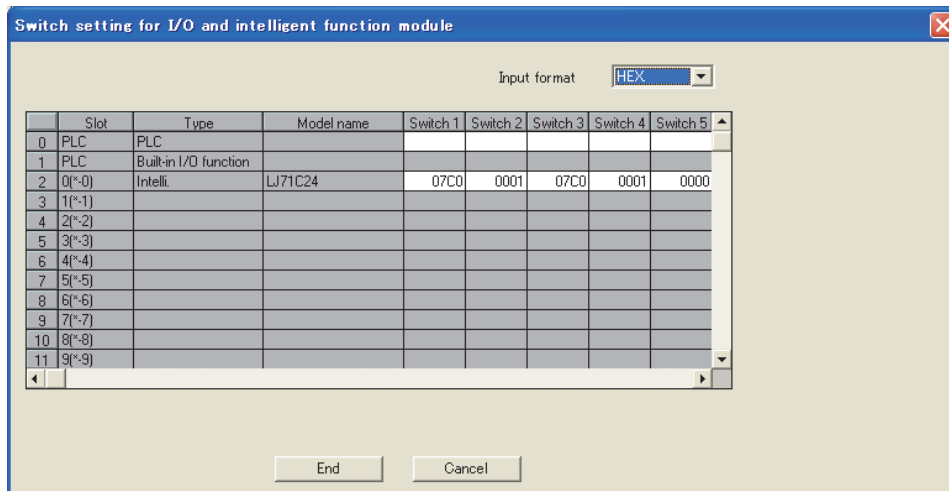

[Setting details]

Set the transmission specifications and communication protocols of each interface.

Switch number	Description	Reference
Switch 1	Communication speed setting and transmission setting on CH1 side	(a)
Switch 2	Communication protocol setting on CH1 side	(b)
Switch 3	Communication speed setting and transmission setting on CH2 side	(a)
Switch 4	Communication protocol setting on CH2 side	(b)
Switch 5	Station number settings on CH1 and CH2 sides	(c)



**(a) Switch 1, Switch 3**

The following shows the communication speed setting and transmission setting of the CH1 side (Switch 1) and CH2 side (Switch 3).

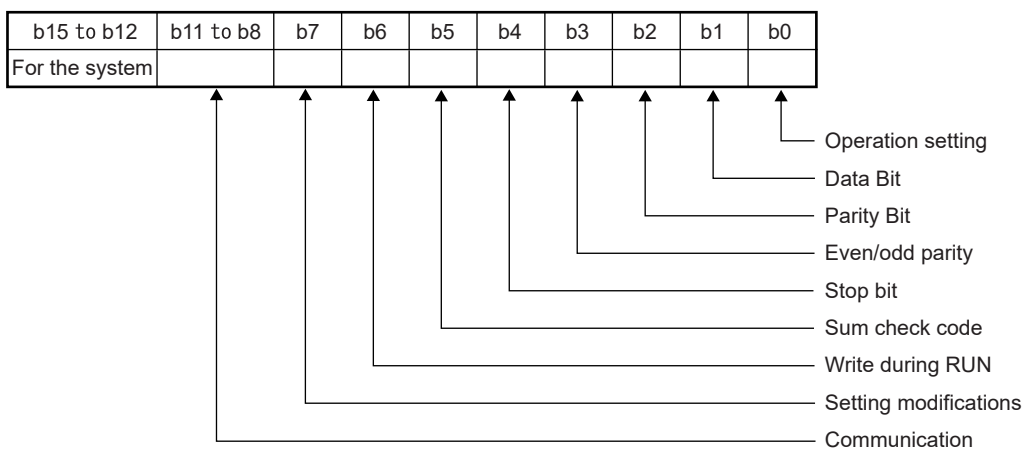

Bit	Item	Description												
b0	Operation setting	OFF (0): Independent ON (1): Linked												
b1	Data Bit	OFF (0): 7 ON (1): 8												
b2	Parity Bit	OFF (0): None ON (1): Exist												
b3	Even/odd parity	OFF (0): Odd ON (1): Even												
b4	Stop bit	OFF (0): 1 ON (1): 2												
b5	Sum check code	OFF (0): None ON (1): Exist												
b6	Online Change	OFF (0): Disable ON (1): Enable												
b7	Setting modifications	OFF (0): Disable ON (1): Enable												
b8 to b11	Communication rate	(unit: bps)												
		<table style="width: 100%; border: none;"> <tr> <td style="width: 50%;">50: F<sub>H</sub></td> <td style="width: 50%;">14400: 6<sub>H</sub></td> </tr> <tr> <td>300: 0<sub>H</sub></td> <td>19200: 7<sub>H</sub></td> </tr> <tr> <td>600: 1<sub>H</sub></td> <td>28800: 8<sub>H</sub></td> </tr> <tr> <td>1200: 2<sub>H</sub></td> <td>38400: 9<sub>H</sub></td> </tr> <tr> <td>2400: 3<sub>H</sub></td> <td>57600: A<sub>H</sub></td> </tr> <tr> <td>4800: 4<sub>H</sub></td> <td>115200: B<sub>H</sub></td> </tr> <tr> <td>9600: 5<sub>H</sub></td> <td>230400: C<sub>H</sub> (*1)</td> </tr> </table>	50: F <sub>H</sub>	14400: 6 <sub>H</sub>	300: 0 <sub>H</sub>	19200: 7 <sub>H</sub>	600: 1 <sub>H</sub>	28800: 8 <sub>H</sub>	1200: 2 <sub>H</sub>	38400: 9 <sub>H</sub>	2400: 3 <sub>H</sub>	57600: A <sub>H</sub>	4800: 4 <sub>H</sub>	115200: B <sub>H</sub>
50: F <sub>H</sub>	14400: 6 <sub>H</sub>													
300: 0 <sub>H</sub>	19200: 7 <sub>H</sub>													
600: 1 <sub>H</sub>	28800: 8 <sub>H</sub>													
1200: 2 <sub>H</sub>	38400: 9 <sub>H</sub>													
2400: 3 <sub>H</sub>	57600: A <sub>H</sub>													
4800: 4 <sub>H</sub>	115200: B <sub>H</sub>													
9600: 5 <sub>H</sub>	230400: C <sub>H</sub> (*1)													
b12 to b15	For the system	All 0												

\*1 230400bps can be used via CH1 only.

**(b) Switch 2, Switch 4**

The following shows the communication protocol setting of CH1 side (Switch 2) and CH2 side (Switch 4).

Setting number	Description	
0 <sub>H</sub>	Communication with MELSOFT Connection	
1 <sub>H</sub>	Communication with MC protocol	Format 1
2 <sub>H</sub>		Format 2
3 <sub>H</sub>		Format 3
4 <sub>H</sub>		Format 4
5 <sub>H</sub>		Format 5
6 <sub>H</sub>	Communication with nonprocedural protocol	
7 <sub>H</sub>	Communication with bidirectional protocol	
8 <sub>H</sub>	For linked operation setting	
9 <sub>H</sub>	Communication with predefined protocol	
E <sub>H</sub>	ROM/RAM/Switch test	
F <sub>H</sub>	Self-loopback test	

**(c) Switch 5**

This number displays the host station number used for MC protocol.

Setting number	Description
0 to 31 (0 <sub>H</sub> to 1F <sub>H</sub> )	Host station number used for MC protocol

**(3) Intelligent function module Interrupt pointer setting**

 GX Developer ⇒ [PLC Parameter] ⇒ [PLC System] ⇒ "Interrupt Pointer Setting"

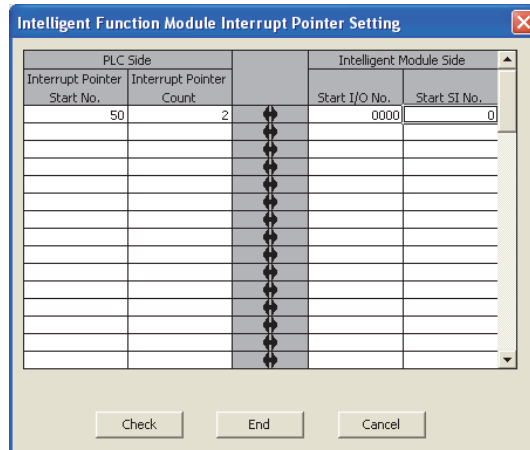

## Appendix 4.3.2 Operation of GX Configurator-SC

When using GX Configurator-SC to set C24 parameters, display methods such as setting screens vary from those of GX Works2.

In this section, the screen displaying methods of GX Configurator-SC are explained.

Also, since the setting contents are the same as GX Works2, refer to  Page 73, CHAPTER 7.

When using GX Configurator-SC, configure the settings in the following screens.

Screen name	Application
Flash ROM setting	Change the initial values of the C24 buffer memory to register them to the flash ROM.
Select monitor/test module	Monitor the operating status and set values of the C24 and test its output signals.
Auto refresh setting	Configure the setting to automatically transfer the data in the C24 buffer memory to the CPU module device.

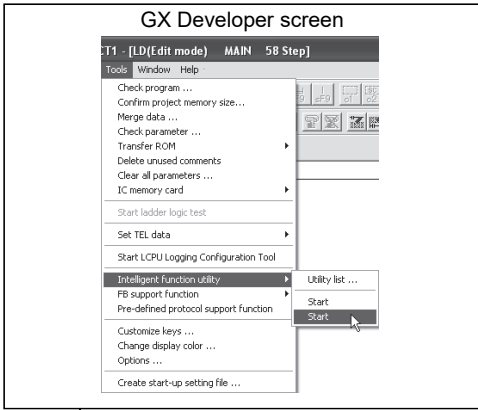

[Tools] – [Intelligent function utility] – [Start]

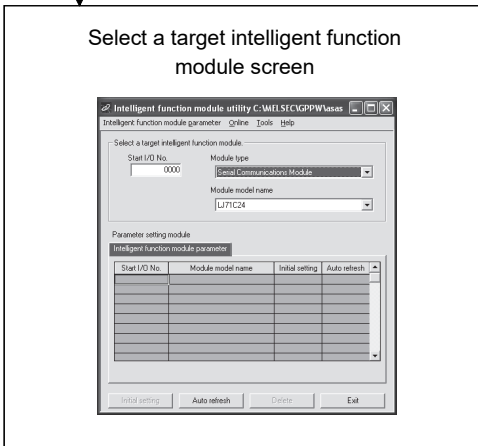

When used via online operation

1) To the next page

When auto refresh is set

2) To the next page

When used via offline operation

Select [Tools] – [Flash ROM setting] from the menu bar.

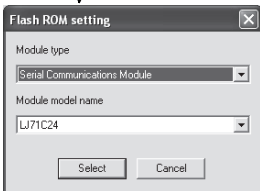

Select the module type and module model name.

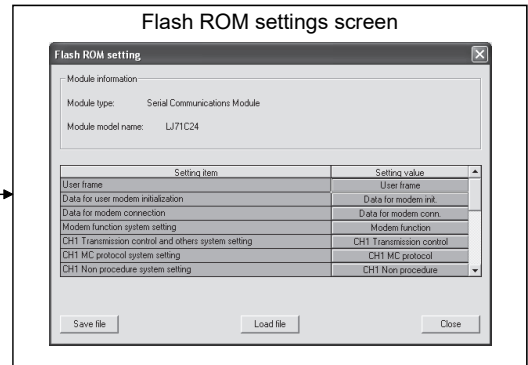

To each setting screen

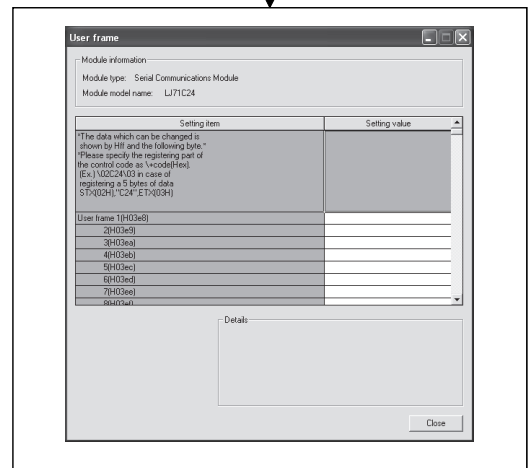



1) When using online operation

Select [Online] – [Monitor/Test] from the menu bar.

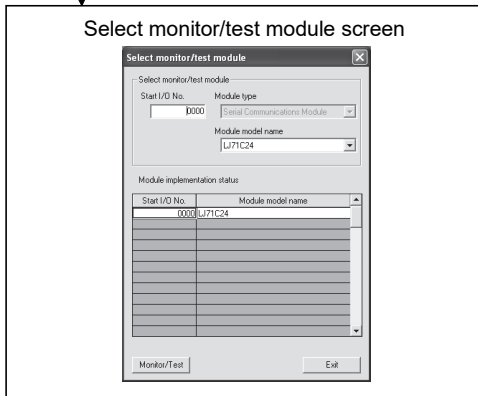

Monitor/Test

Select a module to be monitored/tested.

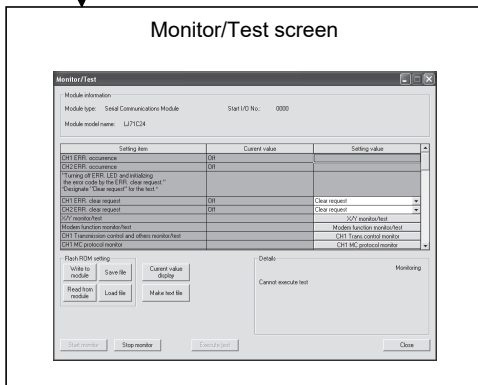

2) When setting auto refresh

Auto refresh

Enter "Start I/O No.", and select "Module type" and "Module model name".

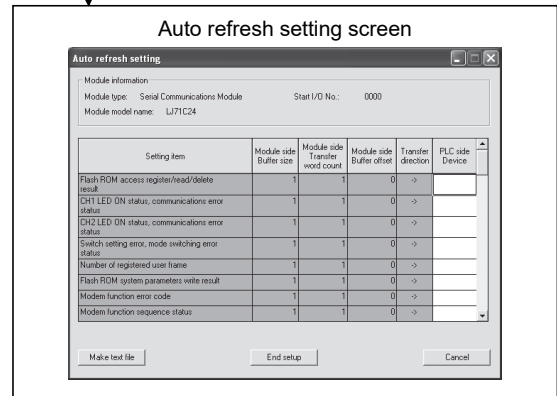

# Appendix 5 Operation Image and Data Structure of Predefined Protocol

## Appendix 5.1 Operation image of each communication type of protocol

In the predefined protocol function, communication with other devices is performed through the communication type 'Send only', 'Receive only', or 'Send & receive'. This section describes the respective operation images.

### Appendix 5.1.1 When communication type is "Send only"

The specified packet is sent once.

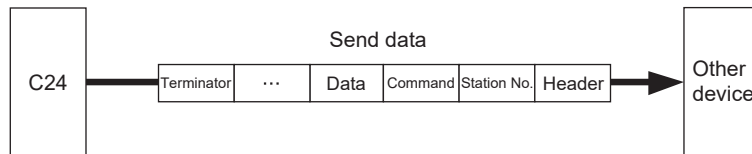

The operation image of "Send only" is as follows.

#### (1) Normal completion

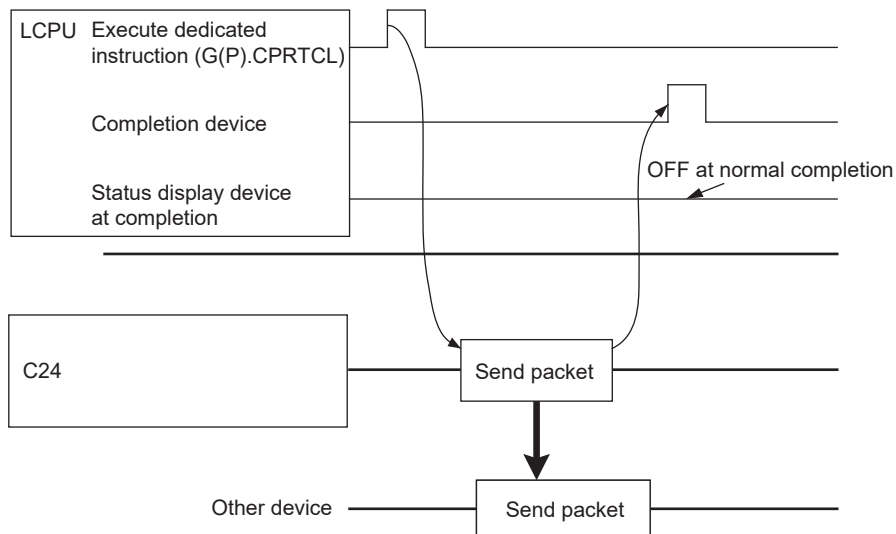

## (2) Error completion (transmission monitoring timeout error)

Example of setting)

Standby time: 0, Number of retries: 0, Monitoring time: other than 0

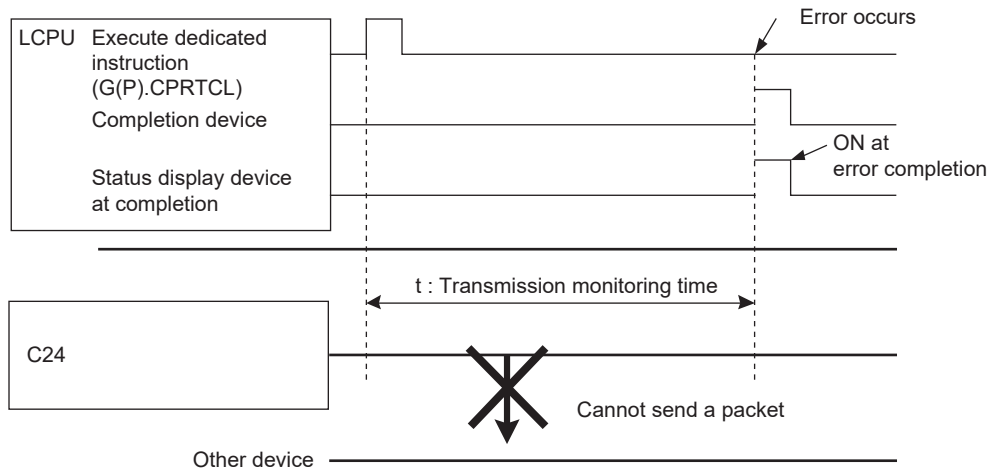

## Appendix 5.1.2 When communication type is "Receive only"

When data are received from other devices, the process completes when the receive data matches the receive packet and the receiving process is performed.

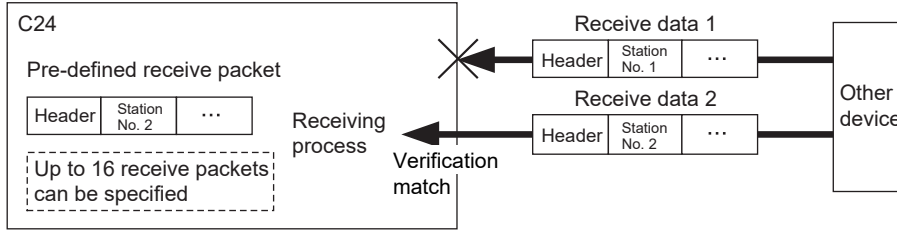

The operation image of "Receive only" is as follows.

### (1) Normal completion

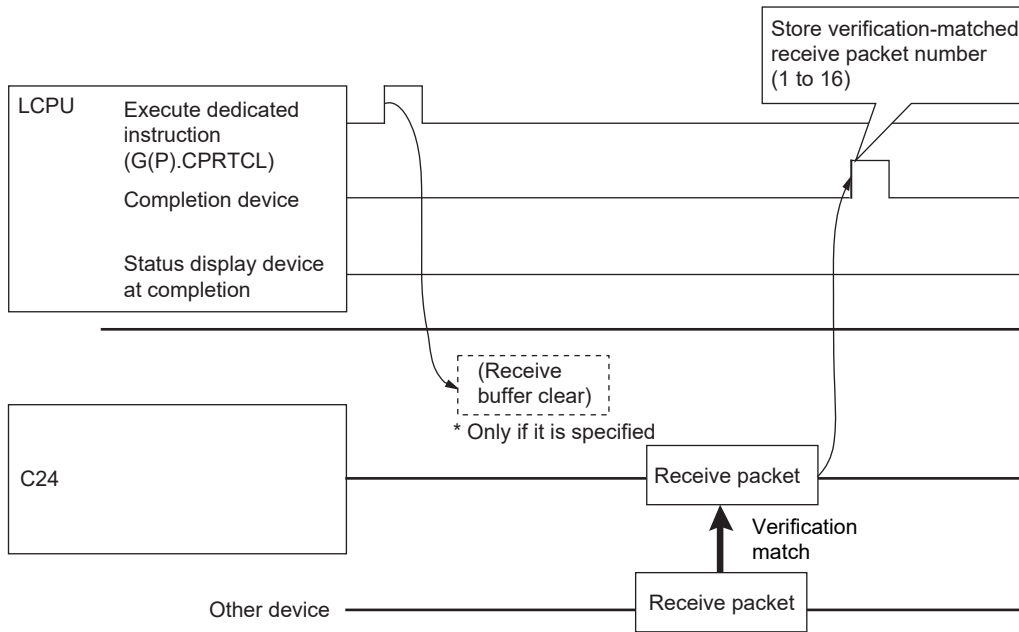



**(2) Error completion (receive wait timeout error)**

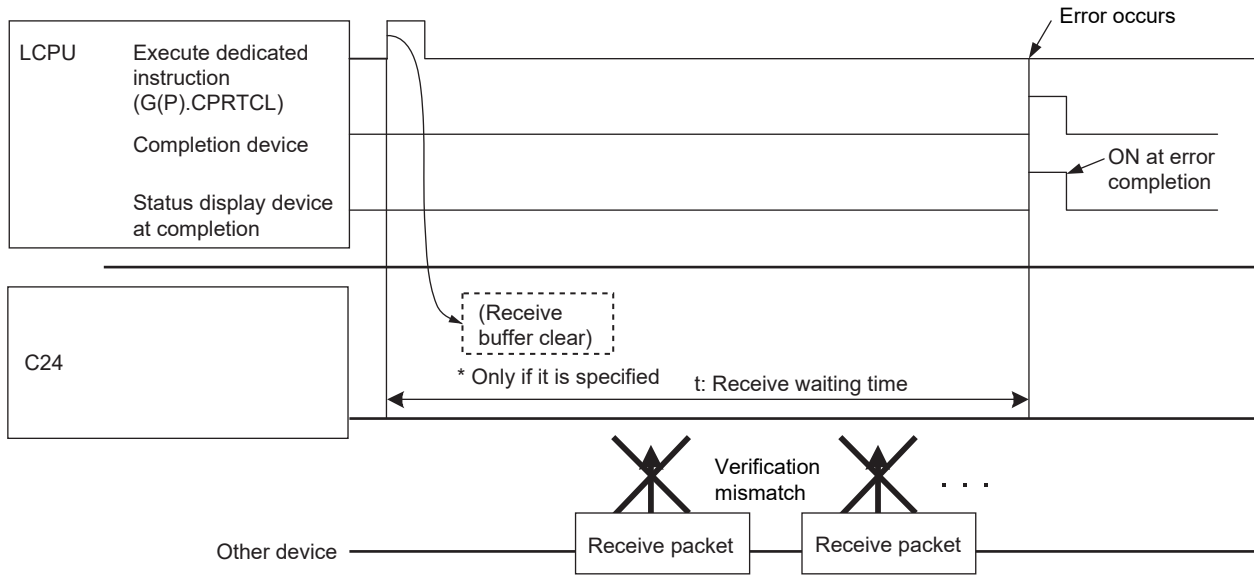

**Point**

- When variables are included in receive packet elements, variable parts are not verified.
- With multiple receive packet specifications, receive data are verified with registered receive packet information starting from information of the first registered packet, in the registration order. Once the receive data match one of them, the receiving process is performed and the following verification is cancelled.
- The number of a receive packet which is matched in the verification is stored in the control data of the dedicated instruction (CPRTCL instruction).

## Appendix 5.1.3 When communication type is "Send & receive"

The specified packet is sent, and the execution status changes to Waiting for receive data status after the sending process completes normally. Then data are received from other devices, and the process completes when the receive data matches the receive packet and the receiving process is performed.

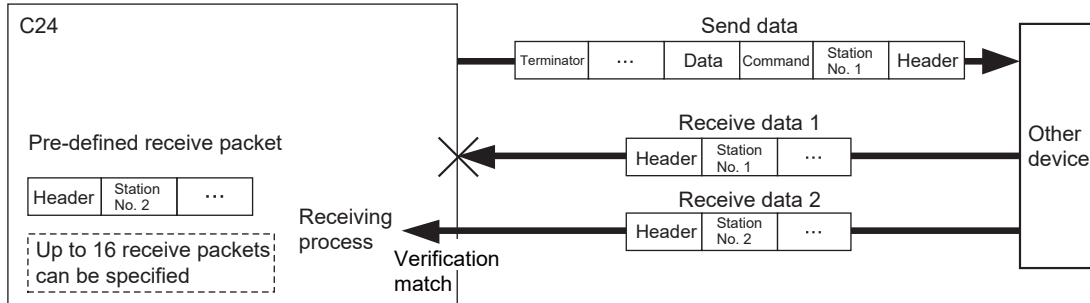

The operation image of "Send & receive" is as follows.

### (1) Normal completion

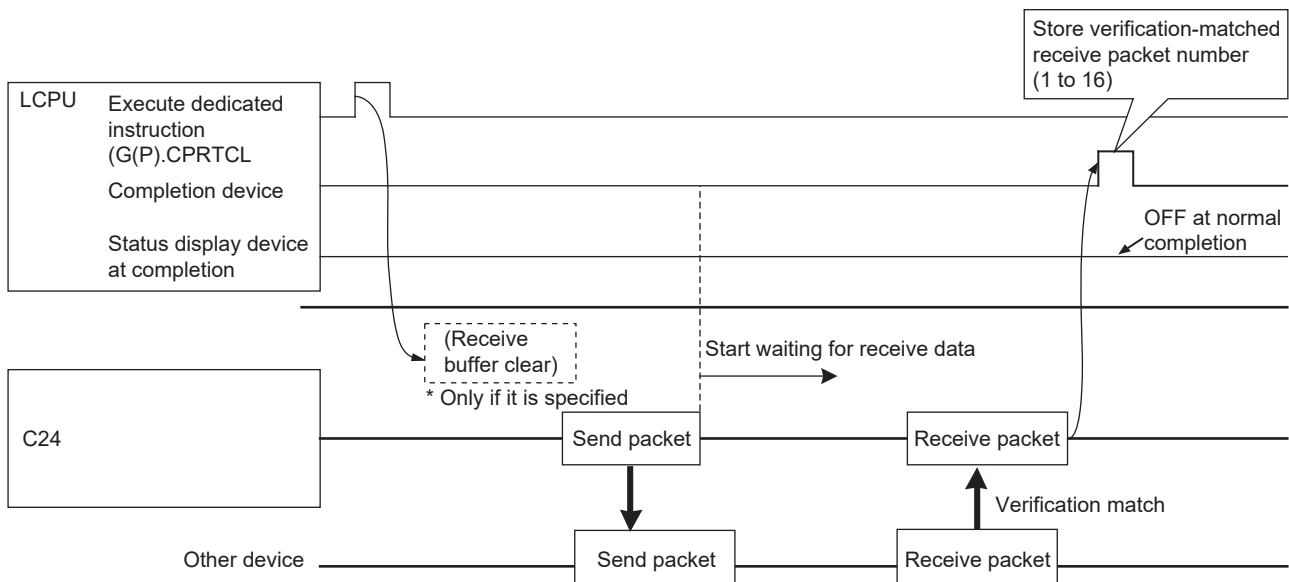

### (2) Error completion (receive wait timeout error)

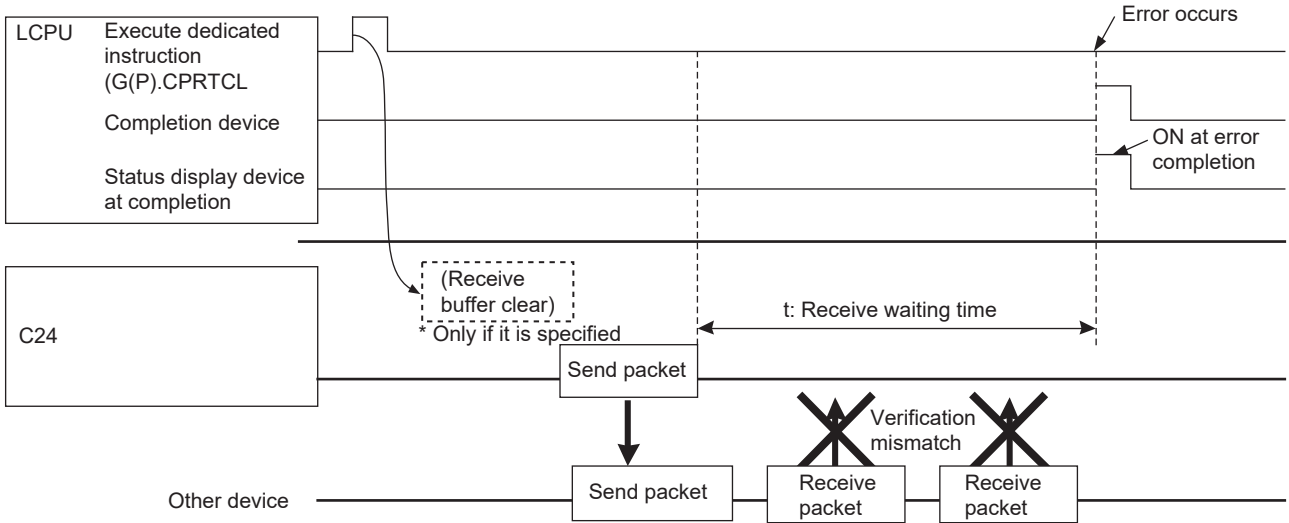

#### Point

- When variables are included in receive packet elements, variable parts are not verified.
- With multiple receive packet specifications, receive data are verified with registered receive packet information starting from information of the first registered packet, in the registration order. Once the receive data match one of them, the receiving process is performed and the following verification is cancelled.
- The number of a receive packet that is matched in the verification is stored in the control data of the dedicated instruction (CPRTCL instruction).

## Appendix 5.2 Verification operation of receive packet

The following shows the C24 operation when data that are different from the specified receive packet are received.

Receive data prior to the different data are discarded. Data are compared again from the start of the receive packet, and once the data are matched with the receive packet, the data receiving operation is processed.

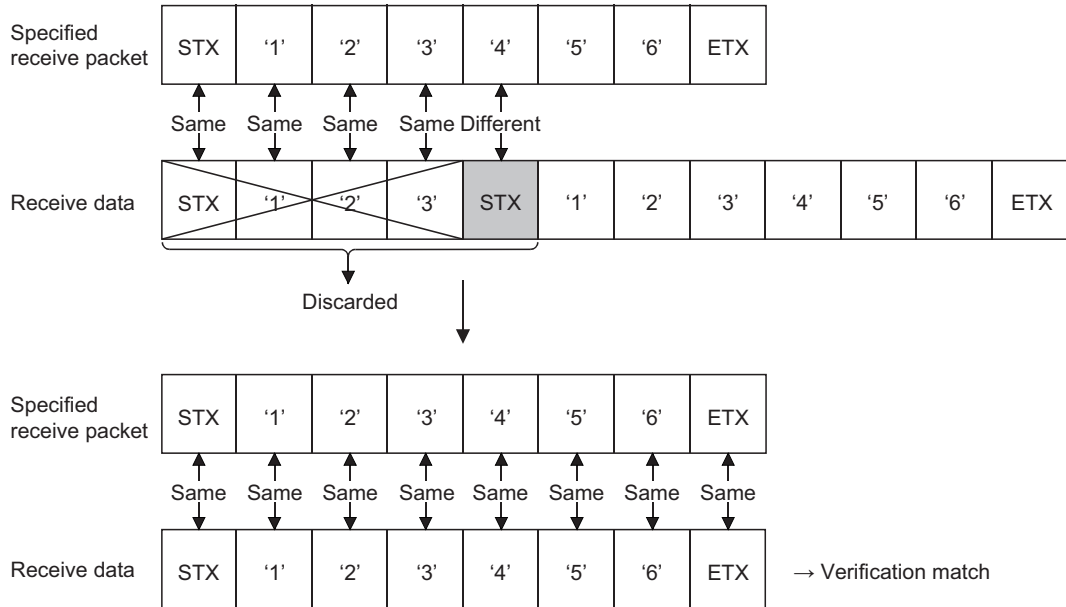

# Appendix 5.3 Data examples of packet elements



This section describes the processing procedures and practical data examples of elements that can be placed in a packet.

## Appendix 5.3.1 Length

### (1) Processing procedure

The C24 processes Length according to the following procedure.

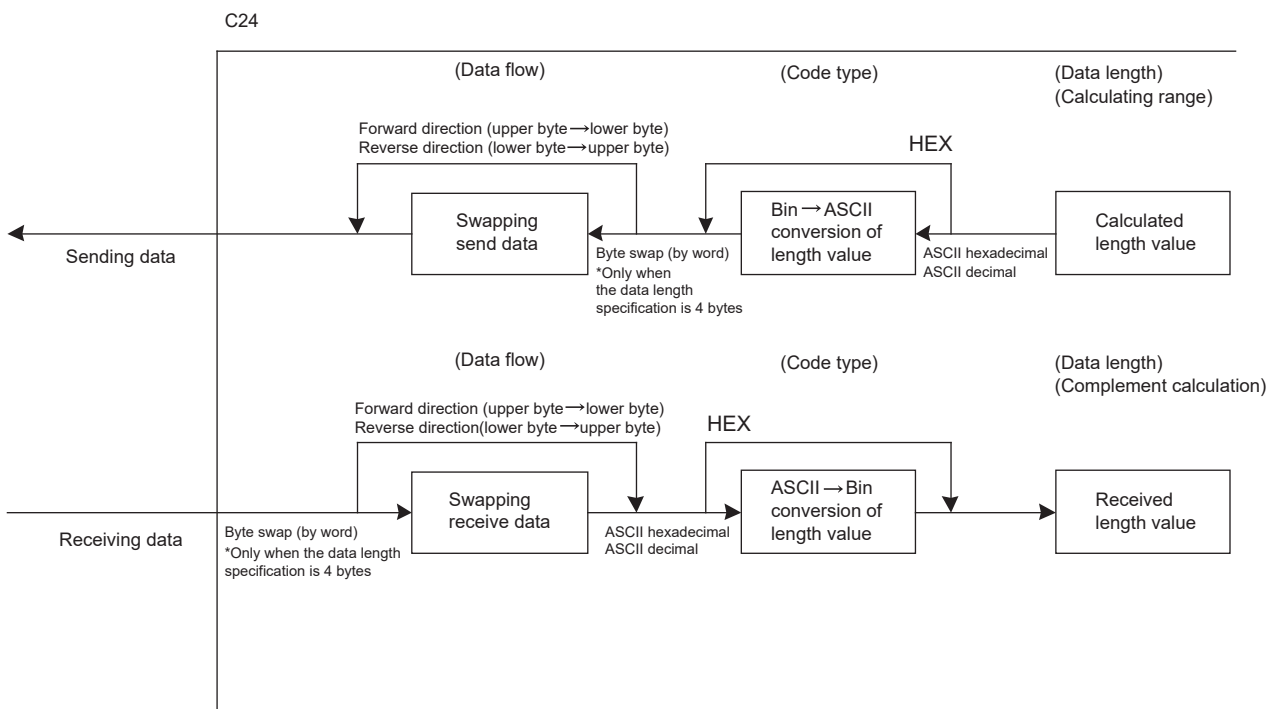

### (2) Data example

The following shows examples in the case where the calculated value of length is 258 bytes in decimal (258 is 102<sub>H</sub> in hexadecimal).

#### (a) Data flow is 'Forward direction'

Code type	Data length			
	1 byte	2 bytes	3 bytes	4 bytes
ASCII hexadecimal	"2" (32 <sub>H</sub> )	"02" (30 <sub>H</sub> 32 <sub>H</sub> )	"102" (31 <sub>H</sub> 30 <sub>H</sub> 32 <sub>H</sub> )	"0102" (30 <sub>H</sub> 31 <sub>H</sub> 30 <sub>H</sub> 32 <sub>H</sub> )
ASCII decimal	"8" (38 <sub>H</sub> )	"58" (35 <sub>H</sub> 38 <sub>H</sub> )	"258" (32 <sub>H</sub> 35 <sub>H</sub> 38 <sub>H</sub> )	"0258" (30 <sub>H</sub> 32 <sub>H</sub> 35 <sub>H</sub> 38 <sub>H</sub> )
HEX	02 <sub>H</sub>	0102 <sub>H</sub>	000102 <sub>H</sub>	00000102 <sub>H</sub>

Appendix 5 Operation Image and Data Structure of Predefined Protocol  
Appendix 5.3 Data examples of packet elements

**(b) Data flow is 'Reverse direction'**

Code type	Data length			
	1 byte	2 bytes	3 bytes	4 bytes
ASCII hexadecimal	—	"20" (32 <sub>H</sub> 30 <sub>H</sub> )	"201" (32 <sub>H</sub> 30 <sub>H</sub> 31 <sub>H</sub> )	"2010" (32 <sub>H</sub> 30 <sub>H</sub> 31 <sub>H</sub> 30 <sub>H</sub> )
ASCII decimal	—	"85" (38 <sub>H</sub> 35 <sub>H</sub> )	"852" (38 <sub>H</sub> 35 <sub>H</sub> 32 <sub>H</sub> )	"8520" (38 <sub>H</sub> 35 <sub>H</sub> 32 <sub>H</sub> 30 <sub>H</sub> )
HEX	—	0201 <sub>H</sub>	020100 <sub>H</sub>	02010000 <sub>H</sub>

**(c) Data flow is 'Byte swap'**

Code type	Data length			
	1 byte	2 bytes	3 bytes	4 bytes
ASCII hexadecimal	—	—	—	"1020" (31 <sub>H</sub> 30 <sub>H</sub> 32 <sub>H</sub> 30 <sub>H</sub> )
ASCII decimal	—	—	—	"2085" (32 <sub>H</sub> 30 <sub>H</sub> 38 <sub>H</sub> 35 <sub>H</sub> )
HEX	—	—	—	00000201 <sub>H</sub>

**(3) Calculating range**

The following shows specification examples of the calculating range of Length.

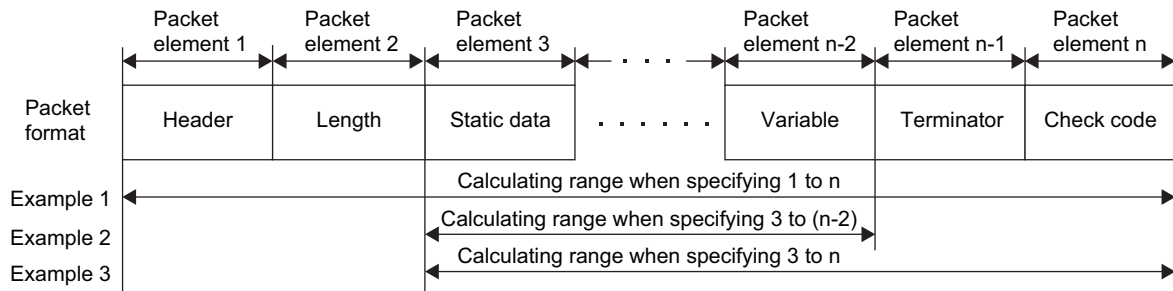

Example 1: Calculating range when its start is 1 and end is n.

Example 2: Calculating range when its start is 3 and end is n-2.

Example 3: Calculating range when its start is 3 and end is n.

## Appendix 5.3.2 Non-conversion variable

### (1) Processing procedure

The C24 processes Non-conversion variable according to the following procedure.

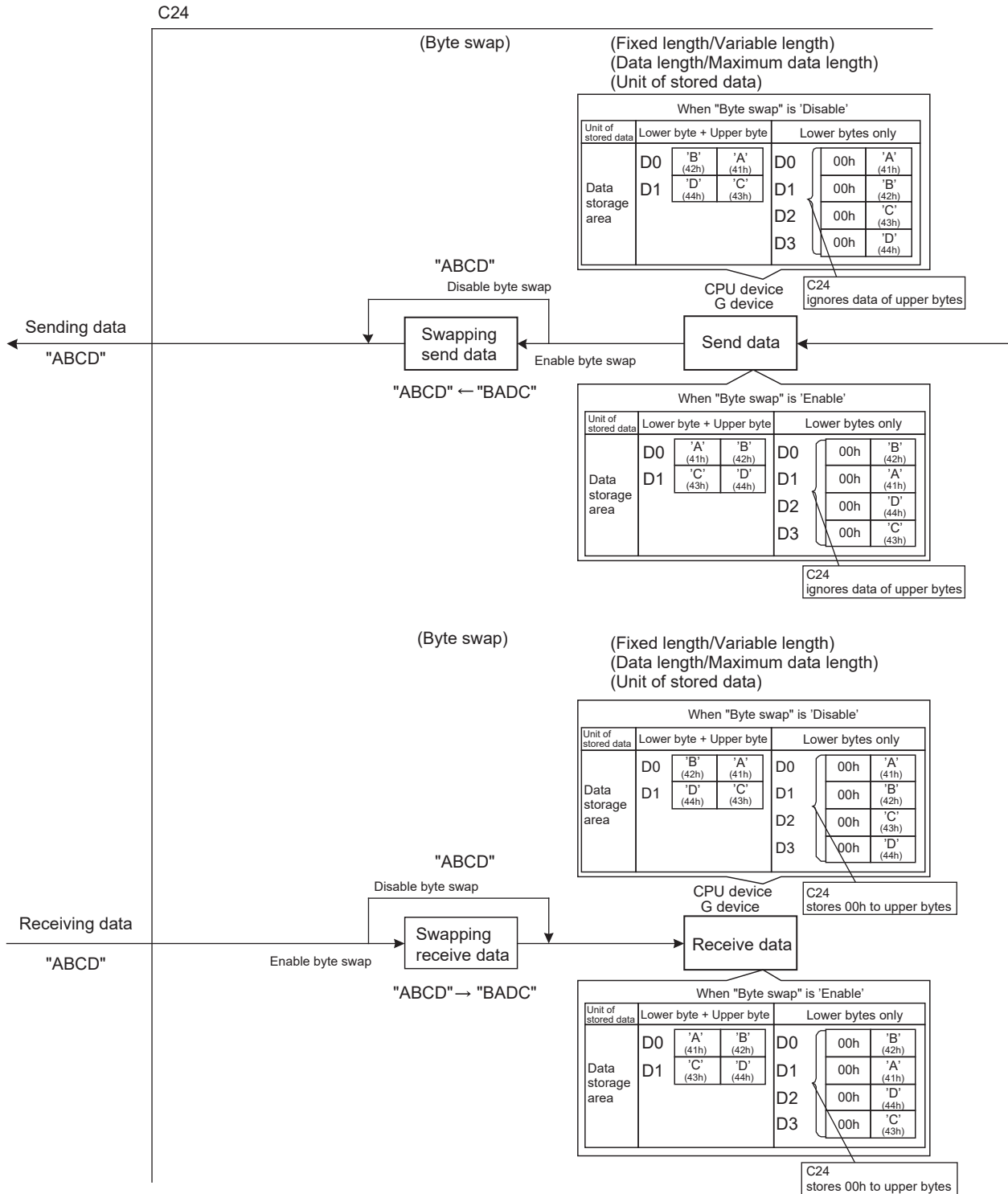

## (2) Data example

(a) The following table shows data to be stored in the data storage area when the string of send data is 'ABCD'

(Reference: A=41<sub>H</sub>, B=42<sub>H</sub>, C=43<sub>H</sub>, and D=44<sub>H</sub> in ASCII code)

Item	Description			
Fixed length/Variable length	Fixed length			
Data length	4 bytes			
Start address of data storage area	D0			
Unit of stored data	Lower byte + Upper byte		Lower bytes only	
Byte swap	Disable	Enable	Disable	Enable
Data to be stored in data storage area	D0 = 4241 <sub>H</sub> D1 = 4443 <sub>H</sub>	D0 = 4142 <sub>H</sub> D1 = 4344 <sub>H</sub>	D0 = 0041 <sub>H</sub> D1 = 0042 <sub>H</sub> D2 = 0043 <sub>H</sub> D3 = 0044 <sub>H</sub>	D0 = 0042 <sub>H</sub> D1 = 0041 <sub>H</sub> D2 = 0044 <sub>H</sub> D3 = 0043 <sub>H</sub>

(b) The following table shows data to be stored in the data storage area when the string of send data is 'EFG'

(Reference: E=45<sub>H</sub>, F=46<sub>H</sub>, and G=47<sub>H</sub> in ASCII code)

Item	Description			
Fixed length/Variable length	Fixed length			
Data length	3 bytes			
Start address of data storage area	D0			
Unit of stored data	Lower byte + Upper byte		Lower bytes only	
Byte swap	Disable	Enable	Disable	Enable
Data to be stored in data storage area	D0 = 4645 <sub>H</sub> D1 = 0047 <sub>H</sub>	D0 = 4546 <sub>H</sub> D1 = 4700 <sub>H</sub>	D0 = 0045 <sub>H</sub> D1 = 0046 <sub>H</sub> D2 = 0047 <sub>H</sub> D3 = (Any data)	D0 = 0046 <sub>H</sub> D1 = 0045 <sub>H</sub> D2 = 0047 <sub>H</sub> D3 = (Any data)



## Appendix 5.3.3 Conversion variable

### (1) Processing procedure

The C24 processes Conversion variable according to the following procedure.

#### (a) When "Conversion" is 'HEX → ASCII hexadecimal' or 'ASCII hexadecimal → HEX'

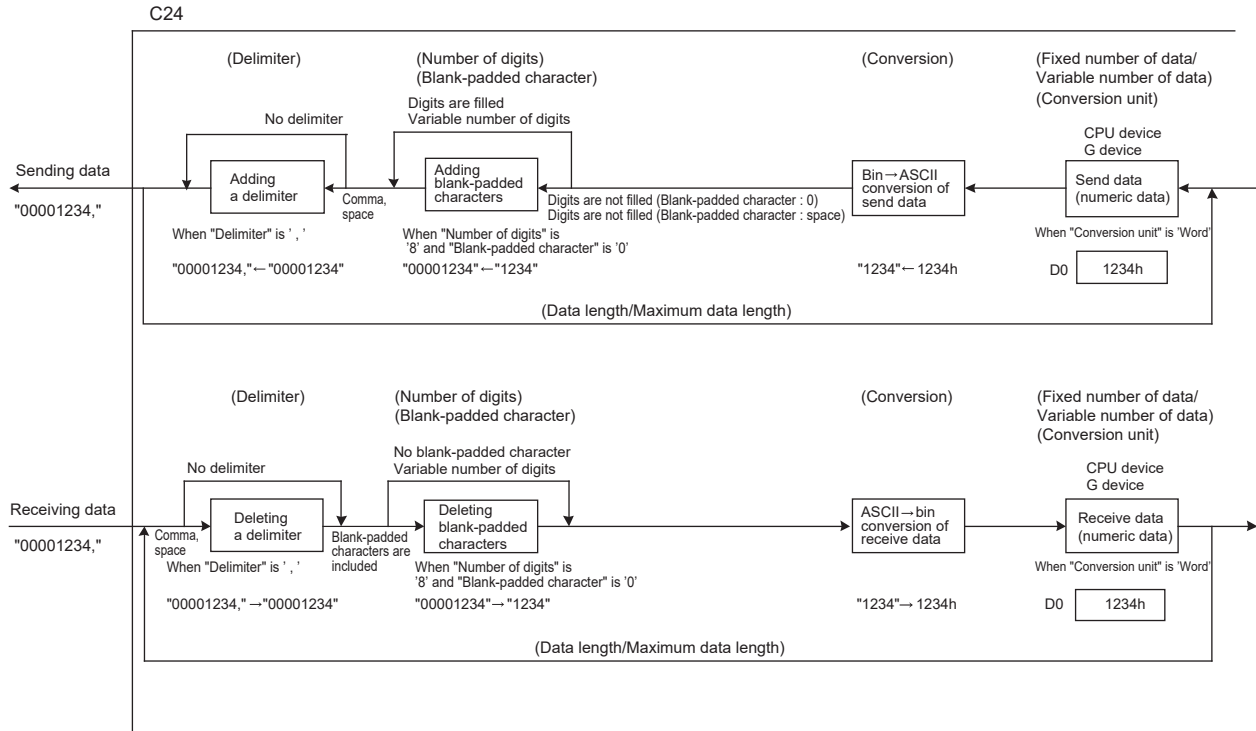

**\* Blank-padded characters**

At data sending, upper digits are filled with data specified in "Blank-padded character" when the number of digits is less than that specified in "Number of send digits of data".

At data receiving, either of '0' or '\_' (space) ' is processed as a blank-padded character, regardless of the setting of "Blank-padded character".

**Ex.** (Example) Setting of "Number of receive digits of data" is '6' ('\_' indicates a space character in the table)

No.	Receive data	Operation of C24
1	000120	Considers its starting 3 digits as blank-padded characters.
2	__ 0120	Considers its starting 3 digits as blank-padded characters.
3	0 _ 0120	Considers its starting 3 digits as blank-padded characters.
4	___ 120	Considers its starting 3 digits as blank-padded characters.
5	00012 _	Considers it to be an ASCII → bin conversion error (7F20 <sub>H</sub> ).
6	___ 12 _	Considers it to be an ASCII → bin conversion error (7F20 <sub>H</sub> ).
7	0001 _ 0	Considers it to be an ASCII → bin conversion error (7F20 <sub>H</sub> ).

**(b) When "Conversion" is 'HEX → ASCII decimal' or 'ASCII decimal → HEX'**

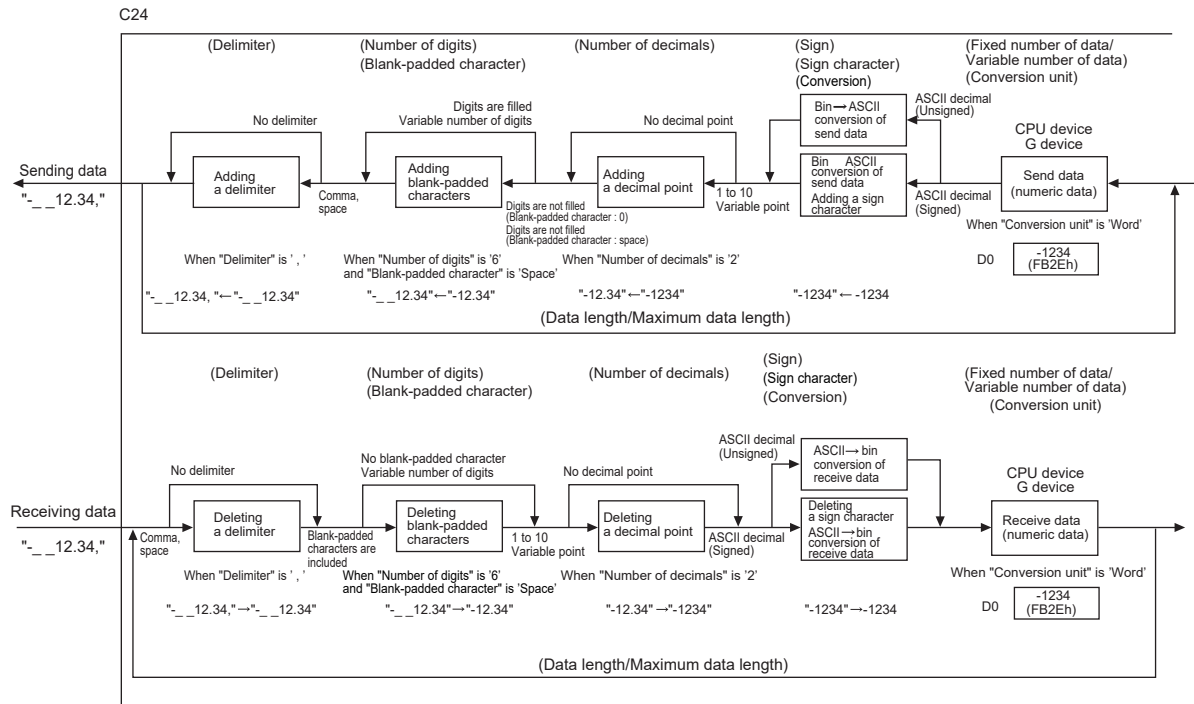

## (2) Data example

The following table shows send data when a packet consists of "Header" "Conversion variable" "Terminator" and data stored in the data storage area is D0=837 (0345<sub>H</sub>), D1=18 (0012<sub>H</sub>).

(Reference: 120345<sub>H</sub> = 1180485 in decimal form)

Item	Setting Details		
Fixed number of data/Variable number of data	Fixed number of data	Fixed number of data	Fixed number of data
Number of data	1	1	1
Start address of data storage area	D0	D0	D0
Conversion unit	Word	Word	Word
Conversion	HEX → ASCII decimal	HEX → ASCII decimal	HEX → ASCII decimal
Number of digits	5	5	Variable number of digits
Blank-padded character	0	Space	-(Not settable)
Sign	Unsigned	Signed	Signed
Sign character	-(Not settable)	+	+
Number of decimals	No decimal point	2	No decimal point
Delimiter	No delimiter	Comma	Comma
Send data *1	"Header" 00837 "Terminator"	"Header" +_ _8.37, "Terminator"	"Header" +837. "Terminator"

Item	Setting Details		
Fixed number of data/Variable number of data	Fixed number of data	Fixed number of data	Fixed number of data
Number of data	1	2	2
Start address of data storage area	D0	D0	D0
Conversion unit	Double word	Word	Word
Conversion	HEX → ASCII decimal	HEX → ASCII decimal	HEX → ASCII decimal
Number of digits	10	5	5
Blank-padded character	0	Space	0
Sign	Signed	Unsigned	Signed
Sign character	+	-(Not settable)	+
Number of decimals	8	No decimal point	2
Delimiter	No delimiter	No delimiter	Comma
Send data *1	"Header" +00.01180485 "Terminator"	"Header" __ 837 __ __ 18 "Terminator"	"Header" +008.37, +000.18 "Terminator"

\*1 " \_ " indicates a blank.

## Appendix 5.3.4 Check code

### (1) Processing procedure

The C24 processes Check code according to the following procedure.

1. Calculates value according to the selection of "Processing method".
2. When "Complement calculation" is 'One's complement' or 'Two's complement', performs a 2-word-wise complement operation on the value calculated in 1).
3. When "Code type" is 'ASCII decimal', extracts the lowest one word from the value calculated in 2) and performs the hexadecimal → decimal conversion.

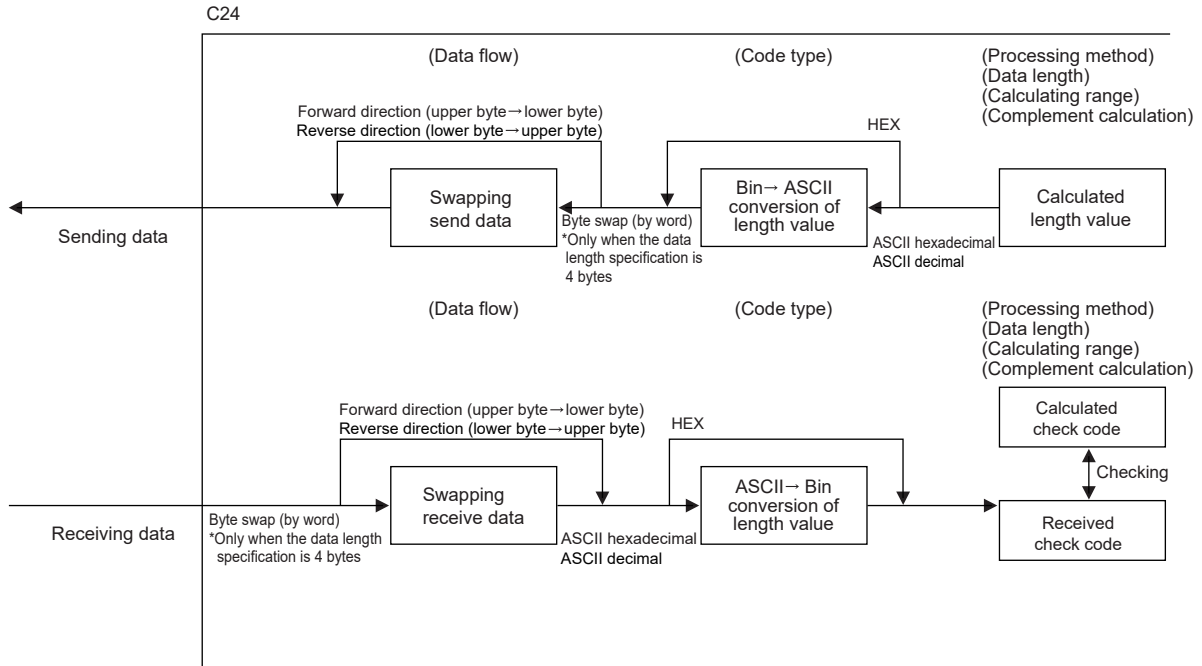

### (2) Procedure for calculating horizontal parity

The following show procedures for calculating horizontal parities using the following sample data.

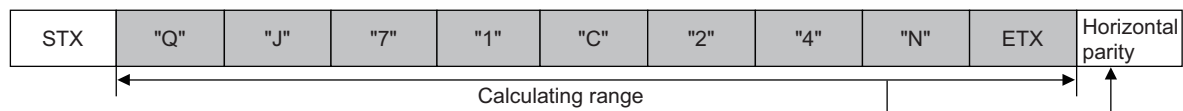

(For the data shown above)

```

"Q" (51+) 0101 0001
           XOR
"J" (4A+) 0100 1010 = 0001 1011
           XOR
"7" (37+)      0011 0111 = 0010 1100
           XOR
"1" (31+)      0011 0001 = 0001 1101
           XOR
"C" (43+)      0100 0011 = 0101 1110
           XOR
"2" (32+)      0011 0010 = 0110 1100
           XOR
"4" (34+)      0011 0100 = 0101 1000
           XOR
"N" (4E+)      0100 1110 = 0001 0110
           XOR
ETX (03+)      0000 0011 = 0001 0101 (Binary)
                                     Horizontal parity = 1 5 (Hexadecimal)
    
```

**(a) Data flow: Forward direction**

- "Complement calculation" is 'No complement calculation' (15<sub>H</sub> in hexadecimal is 21 in decimal)

Code type	Data length			
	1 byte	2 bytes	3 bytes	4 bytes
ASCII hexadecimal	"5" (35 <sub>H</sub> )	"15" (31 <sub>H</sub> 35 <sub>H</sub> )	"015" (30 <sub>H</sub> 31 <sub>H</sub> 35 <sub>H</sub> )	"0015" (30 <sub>H</sub> 30 <sub>H</sub> 31 <sub>H</sub> 35 <sub>H</sub> )
ASCII decimal	"4" (31 <sub>H</sub> )	"21" (32 <sub>H</sub> 31 <sub>H</sub> )	"021" (30 <sub>H</sub> 32 <sub>H</sub> 31 <sub>H</sub> )	"0021" (30 <sub>H</sub> 30 <sub>H</sub> 32 <sub>H</sub> 31 <sub>H</sub> )
HEX	15 <sub>H</sub>	0015 <sub>H</sub>	000015 <sub>H</sub>	00000015 <sub>H</sub>

- "Complement calculation" is 'One's complement' (One's complement of 0000 0015<sub>H</sub> is FFFF FFEA<sub>H</sub>)

When "Code type" is 'ASCII decimal', the last one word is extracted and converted from hexadecimal to decimal. (FFEA<sub>H</sub> in hexadecimal is 65514 in decimal)

Code type	Data length			
	1 byte	2 bytes	3 bytes	4 bytes
ASCII hexadecimal	"A" (41 <sub>H</sub> )	"EA" (45 <sub>H</sub> 41 <sub>H</sub> )	"FEA" (46 <sub>H</sub> 45 <sub>H</sub> 41 <sub>H</sub> )	"FFEA" (46 <sub>H</sub> 46 <sub>H</sub> 45 <sub>H</sub> 41 <sub>H</sub> )
ASCII decimal	"4" (34 <sub>H</sub> )	"14" (31 <sub>H</sub> 34 <sub>H</sub> )	"514" (35 <sub>H</sub> 31 <sub>H</sub> 34 <sub>H</sub> )	"5514" (35 <sub>H</sub> 35 <sub>H</sub> 31 <sub>H</sub> 34 <sub>H</sub> )
HEX	EA <sub>H</sub>	FFEA <sub>H</sub>	FFFEEA <sub>H</sub>	FFFFFEA <sub>H</sub>

- "Complement calculation" is 'Two's complement' (Two's complement of 0000 0015<sub>H</sub> is FFFF FFEB<sub>H</sub>)

When "Code type" is 'ASCII decimal', the last one word is extracted and converted from hexadecimal to decimal. (FFEB<sub>H</sub> in hexadecimal is 65515 in decimal)

Code type	Data length			
	1 byte	2 bytes	3 bytes	4 bytes
ASCII hexadecimal	"B" (42 <sub>H</sub> )	"EB" (45 <sub>H</sub> 42 <sub>H</sub> )	"FEB" (46 <sub>H</sub> 45 <sub>H</sub> 42 <sub>H</sub> )	"FFEB" (46 <sub>H</sub> 46 <sub>H</sub> 45 <sub>H</sub> 42 <sub>H</sub> )
ASCII decimal	"5" (35 <sub>H</sub> )	"15" (31 <sub>H</sub> 35 <sub>H</sub> )	"515" (35 <sub>H</sub> 31 <sub>H</sub> 35 <sub>H</sub> )	"5515" (35 <sub>H</sub> 35 <sub>H</sub> 31 <sub>H</sub> 35 <sub>H</sub> )
HEX	EB <sub>H</sub>	FFEB <sub>H</sub>	FFFEB <sub>H</sub>	FFFFFEB <sub>H</sub>

**(b) Data flow: Reverse direction**

- "Complement calculation" is 'No complement calculation' (15<sub>H</sub> in hexadecimal is 21 in decimal)

Code type	Data length			
	1 byte	2 bytes	3 bytes	4 bytes
ASCII hexadecimal	—	"51" (35 <sub>H</sub> 31 <sub>H</sub> )	"510" (35 <sub>H</sub> 31 <sub>H</sub> 30 <sub>H</sub> )	"5100" (35 <sub>H</sub> 31 <sub>H</sub> 30 <sub>H</sub> 30 <sub>H</sub> )
ASCII decimal	—	"12" (31 <sub>H</sub> 32 <sub>H</sub> )	"120" (31 <sub>H</sub> 32 <sub>H</sub> 30 <sub>H</sub> )	"1200" (31 <sub>H</sub> 32 <sub>H</sub> 30 <sub>H</sub> 30 <sub>H</sub> )
HEX	—	1500 <sub>H</sub>	15000 <sub>H</sub>	1500000 <sub>H</sub>

- "Complement calculation" is 'One's complement' (One's complement of 0000 0015<sub>H</sub> is FFFF FFEA<sub>H</sub>)  
When "Code type" is 'ASCII decimal', the last one word is extracted and converted from hexadecimal to decimal. (FFEA<sub>H</sub> in hexadecimal is 65514 in decimal)

Code type	Data length			
	1 byte	2 bytes	3 bytes	4 bytes
ASCII hexadecimal	—	"AE" (41 <sub>H</sub> 45 <sub>H</sub> )	"AEF" (41 <sub>H</sub> 45 <sub>H</sub> 46 <sub>H</sub> )	"AEFF" (41 <sub>H</sub> 45 <sub>H</sub> 46 <sub>H</sub> 46 <sub>H</sub> )
ASCII decimal	—	"41" (34 <sub>H</sub> 31 <sub>H</sub> )	"415" (34 <sub>H</sub> 31 <sub>H</sub> 35 <sub>H</sub> )	"4155" (35 <sub>H</sub> 35 <sub>H</sub> 31 <sub>H</sub> 34 <sub>H</sub> )
HEX	—	E AFF <sub>H</sub>	E AFFFF <sub>H</sub>	E AFFFFFF <sub>H</sub>

- "Complement calculation" is 'Two's complement' (Two's complement of 0000 0015<sub>H</sub> is FFFF FFEB<sub>H</sub>)  
When "Code type" is 'ASCII decimal', the last one word is extracted and converted from hexadecimal to decimal. (FFEB<sub>H</sub> in hexadecimal is 65515 in decimal)

Code type	Data length			
	1 byte	2 bytes	3 bytes	4 bytes
ASCII hexadecimal	—	"BE" (42 <sub>H</sub> 45 <sub>H</sub> )	"BEF" (42 <sub>H</sub> 45 <sub>H</sub> 46 <sub>H</sub> )	"BEFF" (42 <sub>H</sub> 45 <sub>H</sub> 46 <sub>H</sub> 46 <sub>H</sub> )
ASCII decimal	—	"51" (35 <sub>H</sub> 31 <sub>H</sub> )	"515" (35 <sub>H</sub> 31 <sub>H</sub> 35 <sub>H</sub> )	"5155" (35 <sub>H</sub> 31 <sub>H</sub> 35 <sub>H</sub> 35 <sub>H</sub> )
HEX	—	E BFF <sub>H</sub>	E BFFFF <sub>H</sub>	E BFFFFFF <sub>H</sub>

### (c) Data flow: Byte swap

- "Complement calculation" is 'No complement calculation' (15<sub>H</sub> in hexadecimal is 21 in decimal)

Code type	Data length			
	1 byte	2 bytes	3 bytes	4 bytes
ASCII hexadecimal	—	—	—	"0051" (30 <sub>H</sub> 30 <sub>H</sub> 35 <sub>H</sub> 31 <sub>H</sub> )
ASCII decimal	—	—	—	"0012" (30 <sub>H</sub> 30 <sub>H</sub> 31 <sub>H</sub> 32 <sub>H</sub> )
HEX	—	—	—	00001500 <sub>H</sub>

- "Complement calculation" is 'One's complement' (One's complement of 0000 0015<sub>H</sub> is FFFF FFEA<sub>H</sub>)  
When "Code type" is 'ASCII decimal', the last one word is extracted and converted from hexadecimal to decimal. (FFEA<sub>H</sub> in hexadecimal is 65514 in decimal)

Code type	Data length			
	1 byte	2 bytes	3 bytes	4 bytes
ASCII hexadecimal	—	—	—	"FFAE" (46 <sub>H</sub> 46 <sub>H</sub> 41 <sub>H</sub> 45 <sub>H</sub> )
ASCII decimal	—	—	—	"5541" (35 <sub>H</sub> 35 <sub>H</sub> 34 <sub>H</sub> 31 <sub>H</sub> )
HEX	—	—	—	FFFFE AFF <sub>H</sub>

- "Complement calculation" is 'Two's complement' (Two's complement of 0000 0015<sub>H</sub> is FFFF FFEB<sub>H</sub>)  
When "Code type" is 'ASCII decimal', the last one word is extracted and converted from hexadecimal to decimal. (FFEB<sub>H</sub> in hexadecimal is 65515 in decimal)

Code type	Data length			
	1 byte	2 bytes	3 bytes	4 bytes
ASCII hexadecimal	—	—	—	"FFBE" (46 <sub>H</sub> 46 <sub>H</sub> 42 <sub>H</sub> 45 <sub>H</sub> )
ASCII decimal	—	—	—	"5551" (35 <sub>H</sub> 35 <sub>H</sub> 35 <sub>H</sub> 31 <sub>H</sub> )
HEX	—	—	—	FFFFEBFF <sub>H</sub>

### (3) Procedure for calculating sum check

The following show procedures for calculating sum check codes using the following sample data.

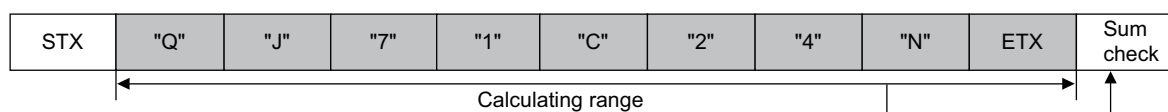

(For the data shown above)

$$\text{Sum check} = 51_{\text{H}} + 4\text{A}_{\text{H}} + 37_{\text{H}} + 31_{\text{H}} + 43_{\text{H}} + 32_{\text{H}} + 34_{\text{H}} + 4\text{E}_{\text{H}} + 03_{\text{H}} = 1\text{FD}_{\text{H}}$$

#### (a) Data flow: Forward direction

- "Complement calculation" is 'No complement calculation' (1FD<sub>H</sub> in hexadecimal is 509 in decimal)

Code type	Data length			
	1 byte	2 bytes	3 bytes	4 bytes
ASCII hexadecimal	"D" (44 <sub>H</sub> )	"FD" (46 <sub>H</sub> 44 <sub>H</sub> )	"1FD" (31 <sub>H</sub> 46 <sub>H</sub> 44 <sub>H</sub> )	"01FD" (30 <sub>H</sub> 31 <sub>H</sub> 46 <sub>H</sub> 44 <sub>H</sub> )
ASCII decimal	"9" (39 <sub>H</sub> )	"09" (30 <sub>H</sub> 39 <sub>H</sub> )	"509" (35 <sub>H</sub> 30 <sub>H</sub> 39 <sub>H</sub> )	"0509" (30 <sub>H</sub> 35 <sub>H</sub> 30 <sub>H</sub> 39 <sub>H</sub> )
HEX	FD <sub>H</sub>	01FD <sub>H</sub>	0001FD <sub>H</sub>	000001FD <sub>H</sub>

- "Complement calculation" is 'One's complement' (One's complement of 0000 01FD<sub>H</sub> is FFFF FE02<sub>H</sub>)  
When "Code type" is 'ASCII decimal', the last one word is extracted and converted from hexadecimal to decimal. (FE02<sub>H</sub> in hexadecimal is 65026 in decimal)

Code type	Data length			
	1 byte	2 bytes	3 bytes	4 bytes
ASCII hexadecimal	"2" (32 <sub>H</sub> )	"02" (30 <sub>H</sub> 32 <sub>H</sub> )	"E02" (45 <sub>H</sub> 30 <sub>H</sub> 32 <sub>H</sub> )	"FE02" (46 <sub>H</sub> 45 <sub>H</sub> 30 <sub>H</sub> 32 <sub>H</sub> )
ASCII decimal	"6" (36 <sub>H</sub> )	"26" (32 <sub>H</sub> 36 <sub>H</sub> )	"026" (30 <sub>H</sub> 32 <sub>H</sub> 36 <sub>H</sub> )	"5026" (35 <sub>H</sub> 30 <sub>H</sub> 32 <sub>H</sub> 36 <sub>H</sub> )
HEX	02 <sub>H</sub>	FE02 <sub>H</sub>	FFFE02 <sub>H</sub>	FFFFFE02 <sub>H</sub>

- "Complement calculation" is 'Two's complement' (Two's complement of 0000 01FD<sub>H</sub> is FFFF FE03<sub>H</sub>)  
When "Code type" is 'ASCII decimal', the last one word is extracted and converted from hexadecimal to decimal. (FE03<sub>H</sub> in hexadecimal is 65027 in decimal)

Code type	Data length			
	1 byte	2 bytes	3 bytes	4 bytes
ASCII hexadecimal	"3" (33 <sub>H</sub> )	"03" (30 <sub>H</sub> 33 <sub>H</sub> )	"E03" (45 <sub>H</sub> 30 <sub>H</sub> 33 <sub>H</sub> )	"FE03" (46 <sub>H</sub> 45 <sub>H</sub> 30 <sub>H</sub> 33 <sub>H</sub> )
ASCII decimal	"7" (37 <sub>H</sub> )	"27" (32 <sub>H</sub> 37 <sub>H</sub> )	"027" (30 <sub>H</sub> 32 <sub>H</sub> 37 <sub>H</sub> )	"5027" (35 <sub>H</sub> 30 <sub>H</sub> 32 <sub>H</sub> 37 <sub>H</sub> )
HEX	03 <sub>H</sub>	FE03 <sub>H</sub>	FFFE03 <sub>H</sub>	FFFFFE03 <sub>H</sub>

**(b) Data flow: Reverse direction**

- "Complement calculation" is 'No complement calculation' (1FD<sub>H</sub> in hexadecimal is 509 in decimal)

Code type	Data length			
	1 byte	2 bytes	3 bytes	4 bytes
ASCII hexadecimal	—	"DF" (44 <sub>H</sub> 46 <sub>H</sub> )	"DF1" (44 <sub>H</sub> 46 <sub>H</sub> 31 <sub>H</sub> )	"DF10" (44 <sub>H</sub> 46 <sub>H</sub> 31 <sub>H</sub> 30 <sub>H</sub> )
ASCII decimal	—	"90" (39 <sub>H</sub> 30 <sub>H</sub> )	"905" (39 <sub>H</sub> 30 <sub>H</sub> 35 <sub>H</sub> )	"9050" (39 <sub>H</sub> 30 <sub>H</sub> 35 <sub>H</sub> 30 <sub>H</sub> )
HEX	—	FD01 <sub>H</sub>	FD0100 <sub>H</sub>	FD010000 <sub>H</sub>

- "Complement calculation" is 'One's complement' (One's complement of 0000 01FD<sub>H</sub> is FFFF FE02<sub>H</sub>)  
When "Code type" is 'ASCII decimal', the last one word is extracted and converted from hexadecimal to decimal. (FE02<sub>H</sub> in hexadecimal is 65026 in decimal)

Code type	Data length			
	1 byte	2 bytes	3 bytes	4 bytes
ASCII hexadecimal	—	"20" (32 <sub>H</sub> 30 <sub>H</sub> )	"20E" (32 <sub>H</sub> 30 <sub>H</sub> 45 <sub>H</sub> )	"20EF" (32 <sub>H</sub> 30 <sub>H</sub> 45 <sub>H</sub> 46 <sub>H</sub> )
ASCII decimal	—	"62" (36 <sub>H</sub> 32 <sub>H</sub> )	"620" (36 <sub>H</sub> 32 <sub>H</sub> 30 <sub>H</sub> )	"6205" (36 <sub>H</sub> 32 <sub>H</sub> 30 <sub>H</sub> 35 <sub>H</sub> )
HEX	—	02FE <sub>H</sub>	02FEFF <sub>H</sub>	02FEFFFF <sub>H</sub>

- "Complement calculation" is 'Two's complement' (Two's complement of 0000 01FD<sub>H</sub> is FFFF FE03<sub>H</sub>)  
When "Code type" is 'ASCII decimal', the last one word is extracted and converted from hexadecimal to decimal. (FE03<sub>H</sub> in hexadecimal is 65027 in decimal)

Code type	Data length			
	1 byte	2 bytes	3 bytes	4 bytes
ASCII hexadecimal	—	"30" (30 <sub>H</sub> 33 <sub>H</sub> )	"30E" (33 <sub>H</sub> 30 <sub>H</sub> 45 <sub>H</sub> )	"30EF" (33 <sub>H</sub> 30 <sub>H</sub> 45 <sub>H</sub> 46 <sub>H</sub> )
ASCII decimal	—	"72" (37 <sub>H</sub> 32 <sub>H</sub> )	"720" (37 <sub>H</sub> 32 <sub>H</sub> 30 <sub>H</sub> )	"7205" (37 <sub>H</sub> 32 <sub>H</sub> 30 <sub>H</sub> 35 <sub>H</sub> )
HEX	—	03FE <sub>H</sub>	03FEFF <sub>H</sub>	03FEFFFF <sub>H</sub>



**(c) Data flow: Byte swap**

- "Complement calculation" is 'No complement calculation' (1FD<sub>H</sub> in hexadecimal is 509 in decimal)

Code type	Data length			
	1 byte	2 bytes	3 bytes	4 bytes
ASCII hexadecimal	—	—	—	"10DF" (31 <sub>H</sub> 30 <sub>H</sub> 44 <sub>H</sub> 46 <sub>H</sub> )
ASCII decimal	—	—	—	"5090" (35 <sub>H</sub> 30 <sub>H</sub> 39 <sub>H</sub> 30 <sub>H</sub> )
HEX	—	—	—	0000FD01 <sub>H</sub>

- "Complement calculation" is 'One's complement' (One's complement of 0000 01FD<sub>H</sub> is FFFF FE02<sub>H</sub>)

When "Code type" is 'ASCII decimal', the last one word is extracted and converted from hexadecimal to decimal. (FE02<sub>H</sub> in hexadecimal is 65026 in decimal)

Code type	Data length			
	1 byte	2 bytes	3 bytes	4 bytes
ASCII hexadecimal	—	—	—	"EF20" (45 <sub>H</sub> 46 <sub>H</sub> 32 <sub>H</sub> 30 <sub>H</sub> )
ASCII decimal	—	—	—	"0562" (30 <sub>H</sub> 35 <sub>H</sub> 36 <sub>H</sub> 32 <sub>H</sub> )
HEX	—	—	—	FFFF02FE <sub>H</sub>

- "Complement calculation" is 'Two's complement' (Two's complement of 0000 01FD<sub>H</sub> is FFFF FE03<sub>H</sub>)

When "Code type" is 'ASCII decimal', the last one word is extracted and converted from hexadecimal to decimal. (FE03<sub>H</sub> in hexadecimal is 65027 in decimal)

Code type	Data length			
	1 byte	2 bytes	3 bytes	4 bytes
ASCII hexadecimal	—	—	—	"EF30" (45 <sub>H</sub> 46 <sub>H</sub> 33 <sub>H</sub> 30 <sub>H</sub> )
ASCII decimal	—	—	—	"0572" (30 <sub>H</sub> 35 <sub>H</sub> 37 <sub>H</sub> 32 <sub>H</sub> )
HEX	—	—	—	FFFF03FE <sub>H</sub>

#### **(4) Procedure for calculating 16-bit CRC (for MODBUS)**

This is a check system that is used only when data are sent/received in the RTU mode of the MODBUS protocol. The data length of CRC is fixed to 2 bytes (16 bits), and the CRC is calculated every 1 byte (8 bits) from the start of the calculating range according to the following procedure.

- 1. Load a 16-bit register whose bits are all '1'.**
- 2. Exclusive OR (XOR) the first 1 byte (8 bits) of the calculating range with bits in above 1).**
- 3. Shift the result of 2) one bit right.**
- 4. If the latest significant bit in above 2) is '1', exclusive OR (XOR) the result of 3) with the generator polynomial (A001<sub>H</sub>). If the last bit is '0', shift the result of 2) one bit right (operation described in 3)) without the exclusive OR (XOR) operation.**
- 5. Repeat steps 3) and 4) until 8 shifts have been performed.**
- 6. Exclusive OR (XOR) the result of 5) with the next 1 byte (8 bits).**
- 7. Repeat step 3) through 6) until all bytes have been processed. The final result is CRC value.**
- 8. When the CRC value is placed in a packet, the lower 8 bits are set first, and then the upper 8 bits are set.**

For the specific example of calculation, refer to the table on the Page 393, Appendix 5 (4) (a).

**(a) The example of 16-bit CRC (for MODBUS) calculation**

The following show the example of 16-bit CRC (for MODBUS) calculation.

Packet example:

Station No.	Function code	16-bit CRC	
02 <sub>H</sub>	07 <sub>H</sub>	41 <sub>H</sub>	12 <sub>H</sub>

Procedure example of 16-bit CRC (for MODBUS) calculation of a packet example above:

CRC error checking procedure	16-bit register (MSB)				Flag	Calculating procedure
(Load a 16-bit register whose bits are all '1')	1111	1111	1111	1111		1) to 2)
02 <sub>H</sub> (Station number)			0000	0010		
Exclusive OR (XOR)	1111	1111	1111	1101		3) to 4)
Shift 1	0111	1111	1111	1110	1	
Generator polynomial	1010	0000	0000	0001		5)
Exclusive OR (XOR)	1101	1111	1111	1111		
Shift 2	0110	1111	1111	1111	1	6)
Generator polynomial	1010	0000	0000	0001		
Exclusive OR (XOR)	1100	1111	1111	1110		5)
Shift 3	0110	0111	1111	1111	0	
Shift 4	0011	0011	1111	1111	1	6)
Generator polynomial	1010	0000	0000	0001		
Exclusive OR (XOR)	1001	0011	1111	1110		5)
Shift 5	0100	1001	1111	1111	0	
Shift 6	0010	0100	1111	1111	1	6)
Generator polynomial	1010	0000	0000	0001		
Exclusive OR (XOR)	1000	0100	1111	1110		5)
Shift 7	0100	0010	0111	1111	0	
Shift 8	0010	0001	0011	1111	1	6)
Generator polynomial	1010	0000	0000	0001		
Exclusive OR (XOR)	1000	0001	0011	1110		5)
07 <sub>H</sub> (Function code)			0000	0111		
Exclusive OR (XOR)	1000	0001	0011	1001		6)

CRC error checking procedure	16-bit register (MSB)				Flag	Calculating procedure
Shift 1	0100	0000	1001	1100	1	7)
Generator polynomial	1010	0000	0000	0001		
Exclusive OR (XOR)	1110	0000	1001	1101		
Shift 2	0111	0000	0100	1110	1	
Generator polynomial	1010	0000	0000	0001		
Exclusive OR (XOR)	1101	0000	0100	1111		
Shift 3	0110	1000	0010	0111	1	
Generator polynomial	1010	0000	0000	0001		
Exclusive OR (XOR)	1100	1000	0010	0110		
Shift 4	0110	0100	0001	0011	0	
Shift 5	0011	0010	0000	1001	1	
Generator polynomial	1010	0000	0000	0001		
Exclusive OR (XOR)	1001	0010	0000	1000		
Shift 6	0100	1001	0000	0100	0	
Shift 7	0010	0100	1000	0010	0	
Shift 8	0001	0010	0100	0001	0	
CRC value	12 <sub>H</sub>		41 <sub>H</sub>			8)

### (5) Calculating range of Check code

The following shows specification examples of the calculating range of Check code.

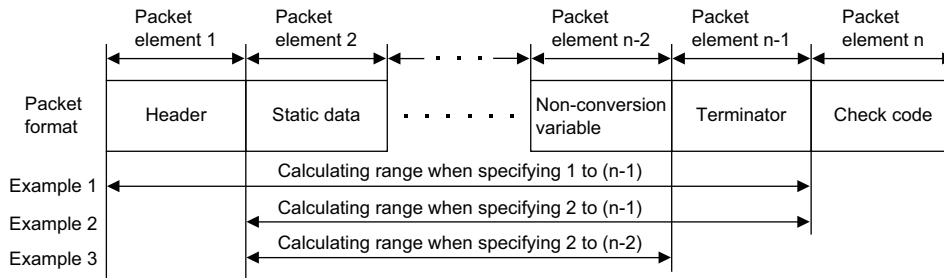

Example 1: Calculating range when its start is 1 and end is n-1.

Example 2: Calculating range when its start is 2 and end is n-1.

Example 3: Calculating range when its start is 2 and end is n-2.

### Appendix 5.3.5 Non-verified reception

The following shows a usage example of Non-verified reception.

• Example of format of packet from other device

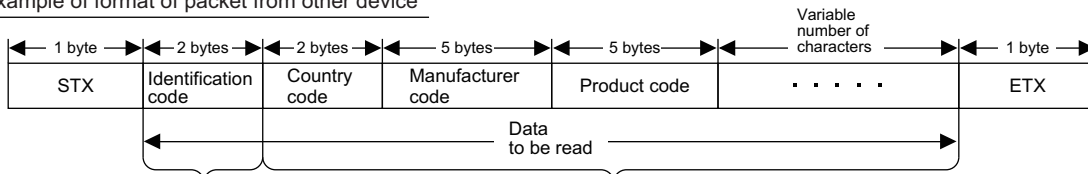

Data needed by the user

Set a Non-verified reception element

When the data are not needed by the user and data contents and/or the number of character vary

• Example of packet setting

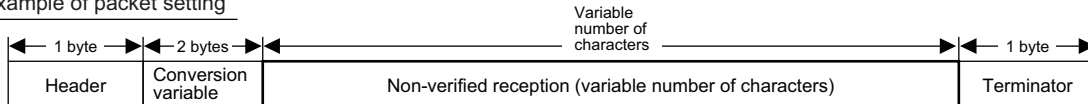

Using a Non-verified reception element has the following advantages in the case of the packet format shown above.

- The only necessary data can be stored in the device memory of a CPU module and buffer memory.
- A single protocol (packet) can handle receive packets that includes data whose contents vary each time.

# Appendix 6 Communication Example when the C24 Is Used Installed to the Head Module

---

This section explains the parameter setting and programming using system configuration examples.  
For the parameter setting of the head module and details on cyclic transmission, refer to the following manual.

 MELSEC-L CC-Link IE Field Network Head Module User's Manual

 MELSEC-Q CC-Link IE Field Network Master/Local Module User's Manual

## Appendix 6.1 Restrictions on programming

---

The following are restrictions when the C24 is used with the head module.

### (1) Restrictions on creating programs

When the C24 is used with the head module, dedicated instructions for the C24 cannot be used. Use the X/Y signals.

### (2) Restrictions on MC protocol communication

The following shows the commands available when accessing the head module using MC protocol.

Available function	Function
Device memory reading/writing *1	Batch read, batch write
	Random read, test (random write)
	Monitor data registration, monitor
	Multiple blocks batch read, multiple blocks batch write
Buffer memory reading/writing	Reading/writing of the C24 buffer memory
Intelligent function module buffer memory reading/writing	Reading/writing of the designated intelligent function module buffer memory

\*1 Devices that can be used are different depending on whether the C24 is connected to a CPU module or head module. For details, refer to the  MELSEC-L CC-Link IE Field Network Head Module User's Manual.

# Appendix 6.2 System configuration example



## (1) System configuration

The following is a system configuration for the program examples in this section.

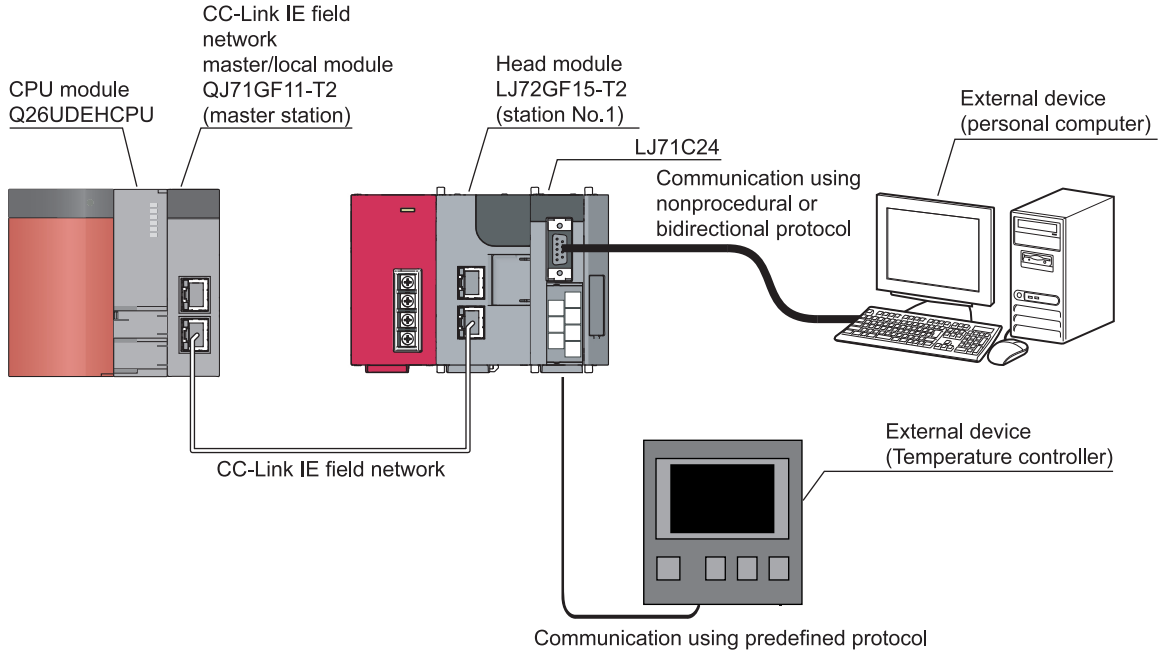

Appendix 6 Communication Example when the C24 is Used Installed to the Head Module  
Appendix 6.2 System configuration example

## **(2) Data communication procedure when the C24 is connected to the head module**

The control is performed using the network parameter setting (refresh parameter setting) of the master station and the C24 auto refresh setting of the intelligent device station (head module).

When the C24 is connected to the head module, dedicated instructions cannot be used.

To communicate with an external device, set data to be sent to the head module device or the C24 buffer memory in advance, and turn on the Y signal.

The following shows the procedure for data communication between the C24 and external devices, based on the system configuration example in  Page 397, Appendix 6.2 (1).



**(a) Data communication using the predefined protocol**

Set send or receive data storage area on the "Predefined Protocol Support Function" screen of the predefined protocol support function in advance. Then, communicate the data in the following procedures.

- 1. Write the send data to the link register W of the CPU module to store the send data in the head module device.**
- 2. Write the number of continuous executions of the protocol and the execution protocol No. to the link register W of the CPU module to write them to the C24 buffer memory.**
- 3. Execute the protocol by receiving the protocol execution request (Y3/YA).**
- 4. The data received from the external device is transferred from the head module device to the link register W of the CPU module.**
- 5. Using the auto refresh function, results and the number of executions of the predefined protocol and cross-checked receive packet number are transferred from the C24 buffer memory to the head module device and then to the CPU module device.**
- 6. After execution of the protocol is completed, the protocol execution completion (X5/XC) turns on.**

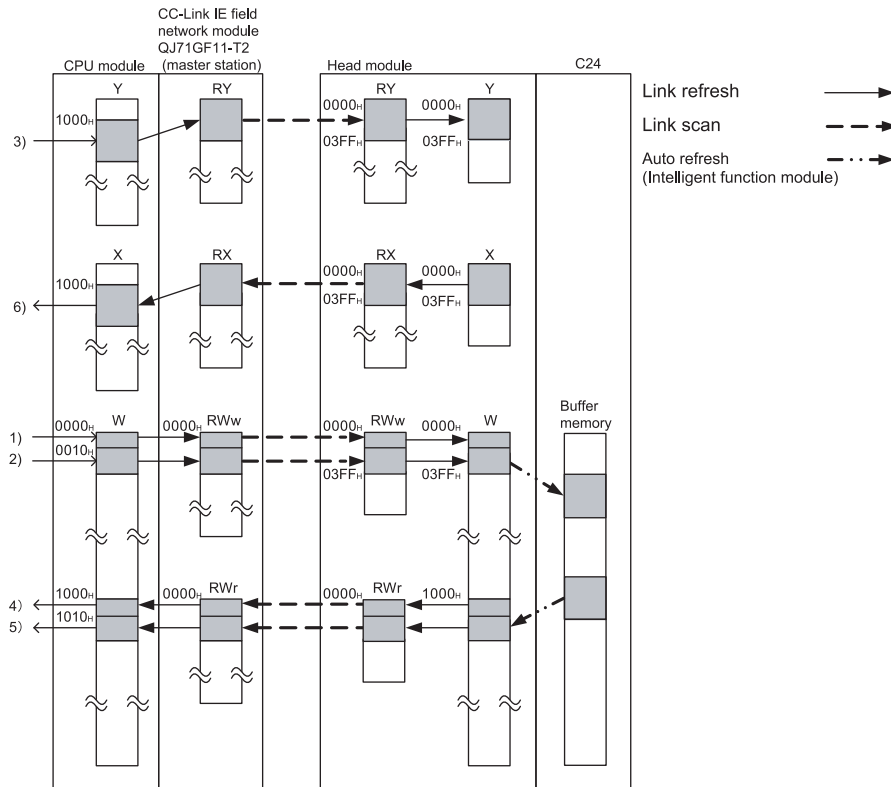

**(b) Data communication using the nonprocedural or bidirectional protocol**

- Sending procedure

- 1. Write the send data to the link register W of the CPU module to write the send data to the C24 buffer memory.**
- 2. Issue a send request by receiving the send request (Y0/Y7).**
- 3. After execution of the send request is completed, the transmission normal completion (X0/X7) turns on.**

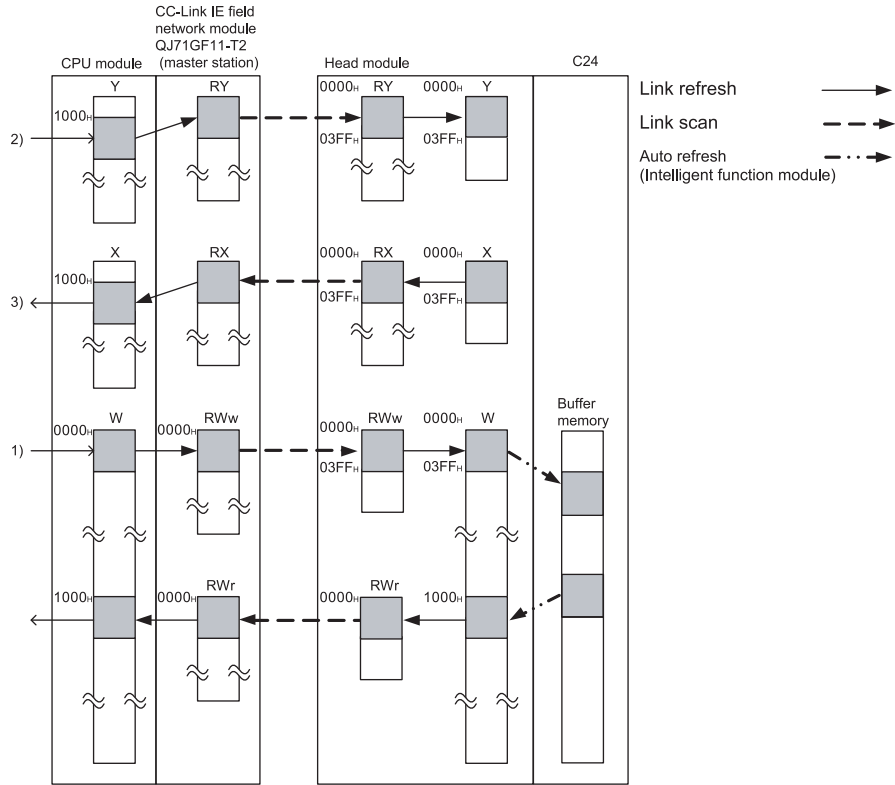

- Receiving procedure
1. Using the auto refresh function, results of execution of the nonprocedural or bidirectional protocol are transferred from the C24 buffer memory to the head module device and then to the link register W of the CPU module.
  2. When the data from the external device is received, the reception data read request (X3/XA) turns on.

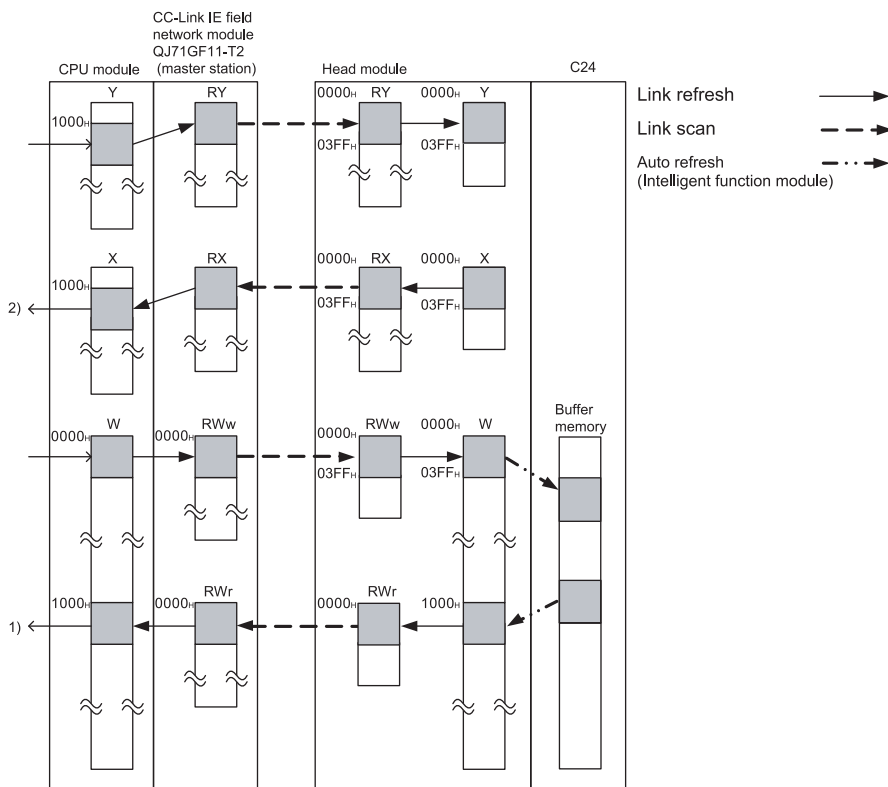

# Appendix 6.3 Parameter setting

## (1) Master station setting

### (a) Network parameter setting

Set the network parameters using GX Works2 as shown below.

For the network configuration setting, refer to Page 402, Appendix 6.3 (1) (b). For the refresh parameters, refer to Page 403, Appendix 6.3 (1) (c).

[Operation procedure]

 Project window ⇒ [Parameter] ⇒ [Network Parameter] ⇒ [Network Parameter Setting the Number of MELSECNET/CC IE/Ethernet Cards]

[Setting screen]

	Module 1	Module 2
Network Type	CC IE Field (Master Station)	None
Start I/O No.	0000	
Network No.	1	
Total Stations	1	
Group No.		
Station No.	0	
Mode	Online (Normal Mode)	
	Network Configuration Setting	*1
	Network Operation Setting	
	Refresh Parameters	*2
	Interrupt Setting	
	Specify Station No. by Parameter	

\*1  Page 402, Appendix 6.3 (1) (b)

\*2  Page 403, Appendix 6.3 (1) (c)

### (b) Network configuration setting

In "Network Configuration Setting", set the following network parameters.

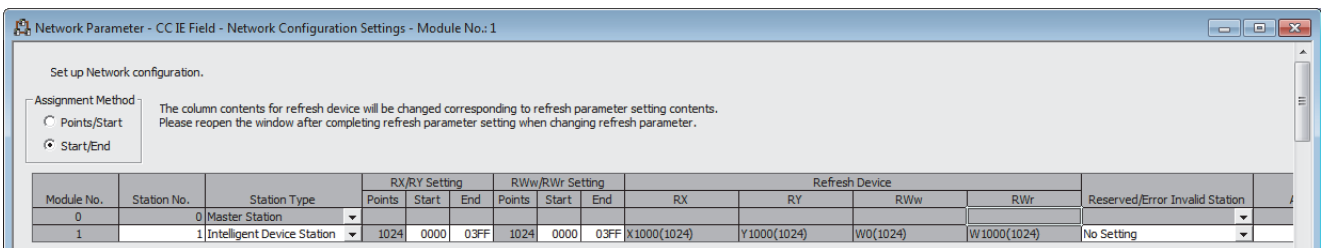

Module No.	Station No.	Station Type	RX/RX Setting			RWw/RWw Setting			Refresh Device				Reserved/Error Invalid Station	
			Points	Start	End	Points	Start	End	RX	RY	RWw	RWr		
0	0	Master Station												
1	1	Intelligent Device Station	1024	0000	03FF	1024	0000	03FF	X1000(1024)	Y1000(1024)	W0(1024)	W1000(1024)	No Setting	

**(c) Refresh parameter setting**

In "Refresh Parameter", set the following network parameters.

Network Parameter CC IE Field Refresh Parameter Module No: 1

Assignment Method  
 Points/Start  
 Start/End

	Link Side					PLC Side			
	Dev. Name	Points	Start	End		Dev. Name	Points	Start	End
Transfer SB	SB	512	0000	01FF	↔	SB	512	0000	01FF
Transfer SW	SW	512	0000	01FF	↔	SW	512	0000	01FF
Transfer 1	RX	1024	0000	03FF	↔	X	1024	1000	13FF
Transfer 2	RY	1024	0000	03FF	↔	Y	1024	1000	13FF
Transfer 3	RWw	1024	0000	03FF	↔	W	1024	000000	0003FF
Transfer 4	RWr	1024	0000	03FF	↔	W	1024	001000	0013FF
Transfer 5					↔				
Transfer 6					↔				

## (2) Head module setting

### (a) PLC parameter setting

Set the PLC parameters using GX Works2 as shown below.

For details on the PLC parameters of the head module and network parameters, refer to the  MELSEC-L CC-Link IE Field Network Head Module User's Manual.

[Operation procedure]

 Project window ⇒ [Parameter] ⇒ [PLC Parameter] ⇒ [CC-Link IE Field Communication Head Parameter Setting] ⇒ "Communication Head Setting"

[Setting screen]

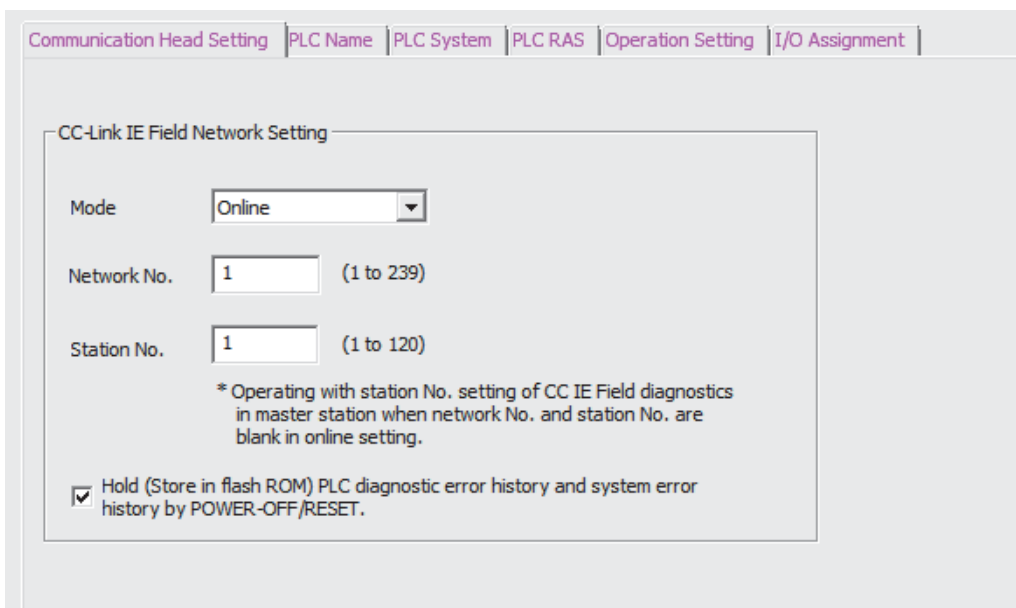

Communication Head Setting | PLC Name | PLC System | PLC RAS | Operation Setting | I/O Assignment

CC-Link IE Field Network Setting

Mode: Online

Network No.: 1 (1 to 239)

Station No.: 1 (1 to 120)

\* Operating with station No. setting of CC IE Field diagnostics in master station when network No. and station No. are blank in online setting.

Hold (Store in flash ROM) PLC diagnostic error history and system error history by POWER-OFF/RESET.

### (b) Adding the C24 to the project

To perform the various C24 settings, the C24 must be added to projects of GX Works2. For details on the adding method, refer to  Page 74, Section 7.1.

### (c) Auto refresh setting

To send or receive the data using the nonprocedural or bidirectional protocol, the auto refresh must be set. For details on the auto refresh setting, refer to  Page 99, Section 7.5.

## Appendix 6.4 Execution program example of the predefined protocol

A

The following shows a program example when connecting an external device (temperature control module) to CH2 of the C24 and executing the pre-defined protocol using the auto refresh function and X/Y signal.

### (1) Setting for the C24 installed to the head module

Configure the switch settings and predefined protocol settings of the C24 to the head module.

To use the program example in this section, set as follows.

#### (a) Switch setting

Set transmission specifications and communication protocols for communication with external devices.

The following is an example of the predefined protocol setting using CH2.

[Operation procedure]

 Project window ⇒ [Intelligent Function Module] ⇒ [LJ71C24] ⇒ [Switch Setting]

[Setting screen]

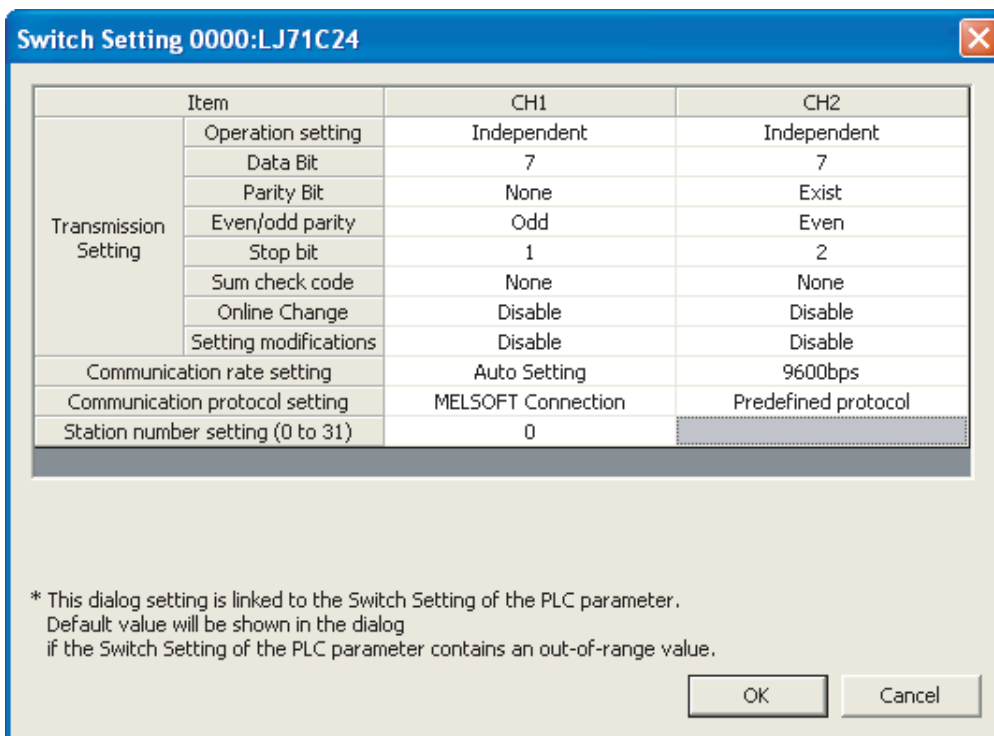

Item	CH1	CH2
Operation setting	Independent	Independent
Data Bit	7	7
Parity Bit	None	Exist
Even/odd parity	Odd	Even
Stop bit	1	2
Sum check code	None	None
Online Change	Disable	Disable
Setting modifications	Disable	Disable
Communication rate setting	Auto Setting	9600bps
Communication protocol setting	MELSOFT Connection	Predefined protocol
Station number setting (0 to 31)	0	

\* This dialog setting is linked to the Switch Setting of the PLC parameter.  
Default value will be shown in the dialog  
if the Switch Setting of the PLC parameter contains an out-of-range value.

OK Cancel

## (b) Various Control Specification

On the "Various\_Control\_Specification" screen, set "1: Prohibited" in "Echo back allow/prohibit designation".  
For details on the echo back allow/prohibit, refer to  Page 64, Section 6.3.5.

[Operation procedure]

 Project window ⇒ [Intelligent Function Module] ⇒ [LJ71C24] ⇒ [Various\_Control\_Specification]

[Setting screen]

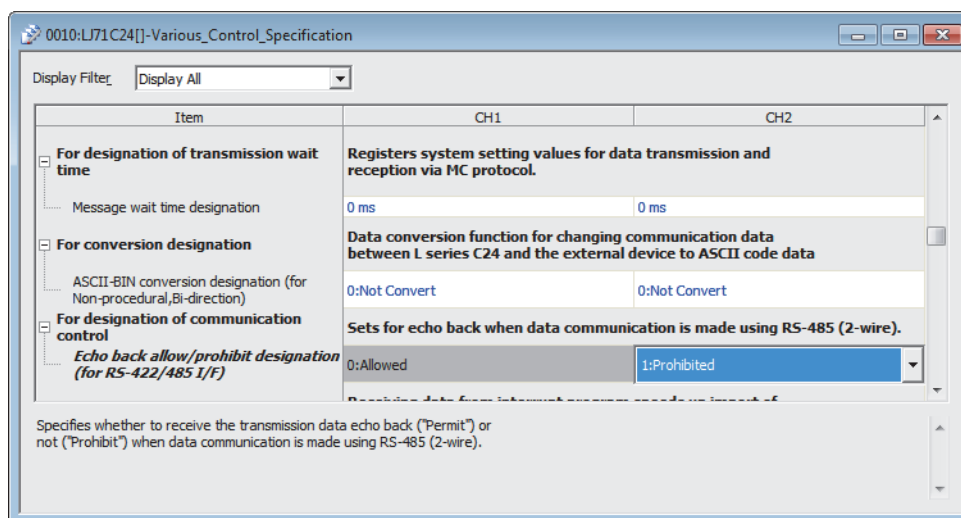





**(c) Auto refresh setting**

Set the auto refresh to transfer the information stored in the C24 buffer memory to the specified device of the head module automatically.

[Operation procedure]

 Project window ⇒ [Intelligent Function Module] ⇒ [LJ71C24] ⇒ [Auto\_Refresh]

[Setting screen]

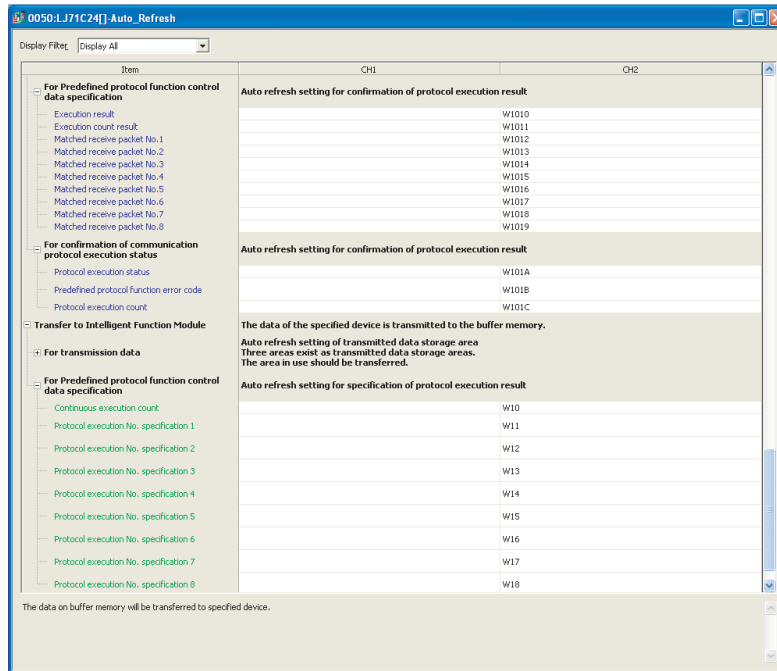

### (d) Predefined protocol setting

Set the predefined protocol as shown below.

(When using the EJ1 0601H:RD Controller Status in the MELSEC predefined protocol library)

For details on predefined protocol support function, refer to  Page 110, Section 9.1.

[Operation procedure]

1. [Tool] ⇒ [Intelligent Function Module Tool] ⇒ [Serial Communication Module] ⇒ [Predefined Protocol Support Function]
2. "Predefined Protocol Support Function" screen ⇒ [File] ⇒ [New]

[Setting screen]

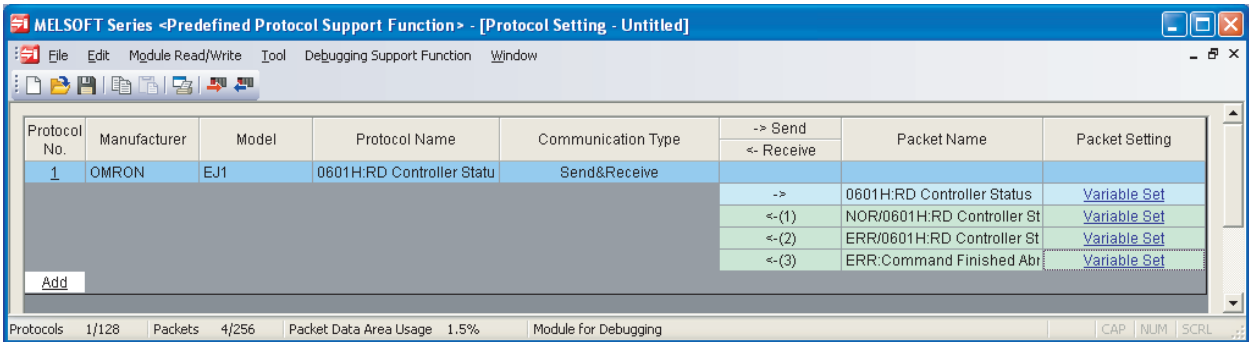

Packet Name	Element No.	Element Name	Data Storage Area Specification
0601H:RD Controller Status	02	Communication Unit No.	Set W0.
NOR/0601H:RD Controller Status	02	Communication Unit No.	Set W1000.
	08	Operation Status	Set W1001.
	09	Related Information	Set W1002.
ERR/0601H:RD Controller Status	02	Communication Unit No.	Set W1000.
	07	Response Code	Set W1003.
ERR: Command Finished Abnormally	02	Communication Unit No.	Set W1000.
	04	End Code	Set W1004.

## (2) Program example

The following shows the program that executes the predefined protocol from CH2 of the C24 when M1000 is turned ON.

[I/O signals of the C24]

Device	Purpose	Device	Purpose
X100C	CH2 protocol execution completion	Y100A	CH2 protocol execution request
X101D	Predefined protocol ready	—	—

[Link special relay (SB), link special register (SW)]

Device	Purpose	Device	Purpose
SB0049	Data link status of host station	SW00B0.0	Data link status of each station (Station number 1)

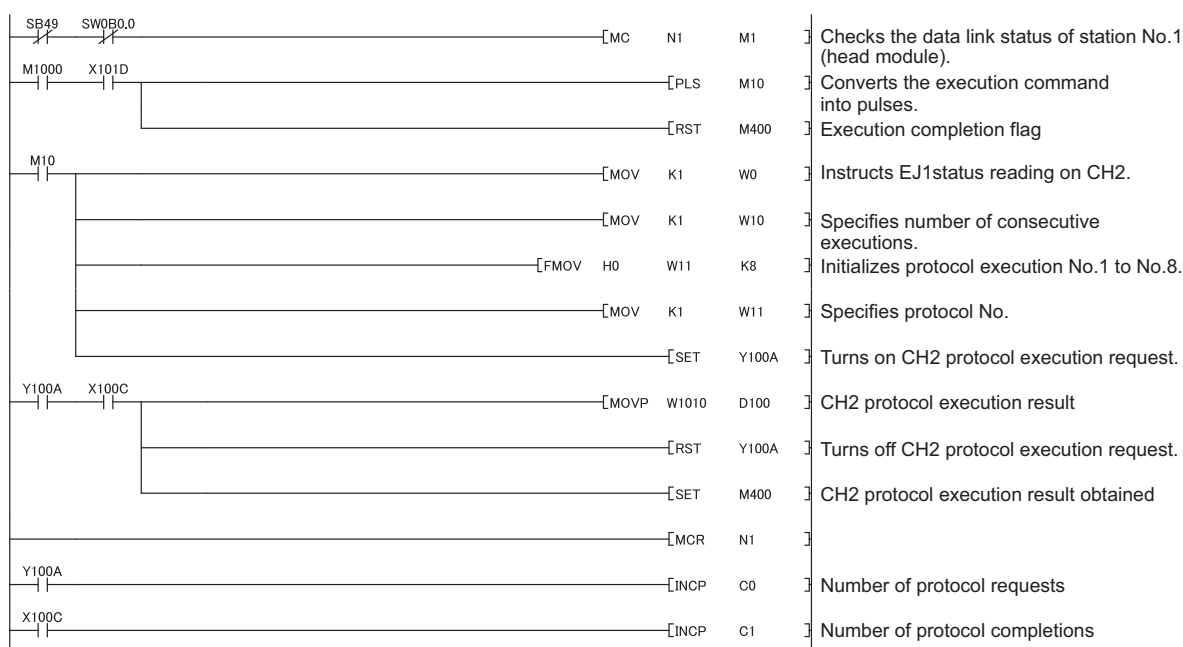

The data in the temperature control module is stored in the following devices in the master station CPU module.

Device	Description
W1000	Communication Unit No.
W1001	Operation Status
W1002	Related Information
W1003	Response Code
W1004	End Code

# Appendix 6.5 Sending/receiving data using the nonprocedural or bidirectional protocol

## Appendix 6.5.1 Receiving data using the nonprocedural or bidirectional protocol

The following shows a program example of connecting an external device (personal computer) to CH1 of the C24 and receiving data by nonprocedural and bidirectional protocols, using auto refresh and X/Y signals.

### (1) Setting of the C24 installed to the head module

Perform the switch setting and communication protocol setting for the C24 to the head module. To use the program example in this section, set as follows.

#### (a) Switch setting

Set the transmission specifications and communication protocols with the external device. The following is an example of the nonprocedural protocol setting using CH1. For the bidirectional protocol, set the communication protocol to the bidirectional protocol.

[Operation procedure]

 Project window ⇒ [Intelligent Function Module] ⇒ [LJ71C24] ⇒ [Switch Setting]

[Setting screen]

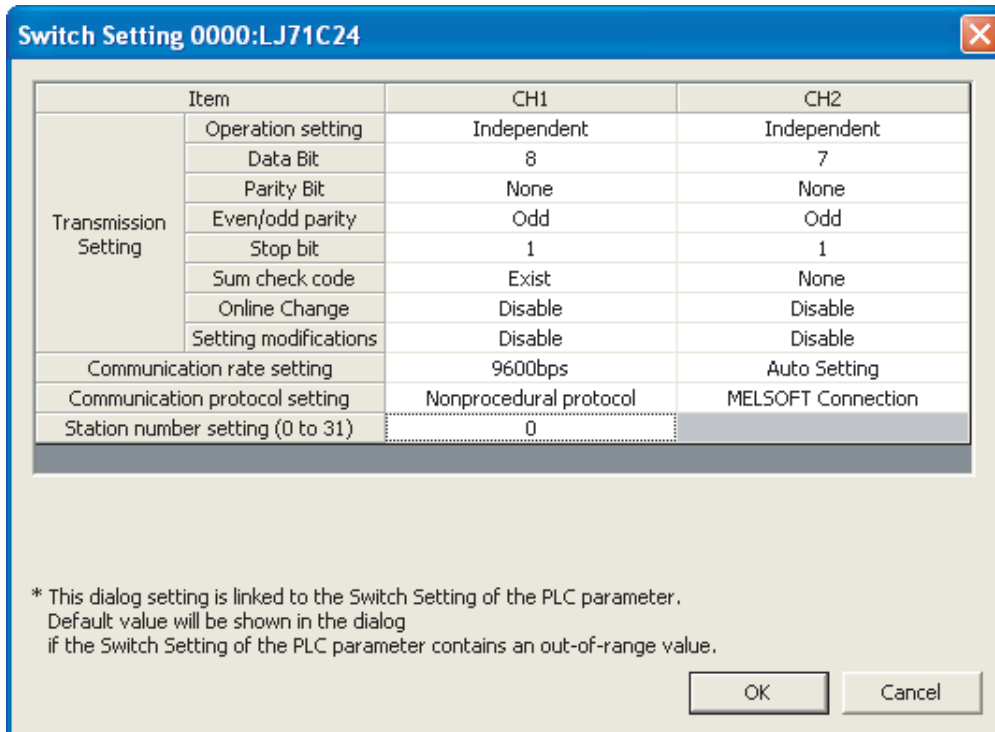

## (b) Auto refresh setting

Configure the auto refresh settings to transfer the information stored in the C24 buffer memory to the specified device in the head module automatically.

For details on the transmission/receive area, refer to  Page 146, CHAPTER 10 or Page 178, CHAPTER 11.

[Operation procedure]

 Project window ⇒ [Intelligent Function Module] ⇒ [LJ71C24] ⇒ [Auto Refresh]

[Setting screen]

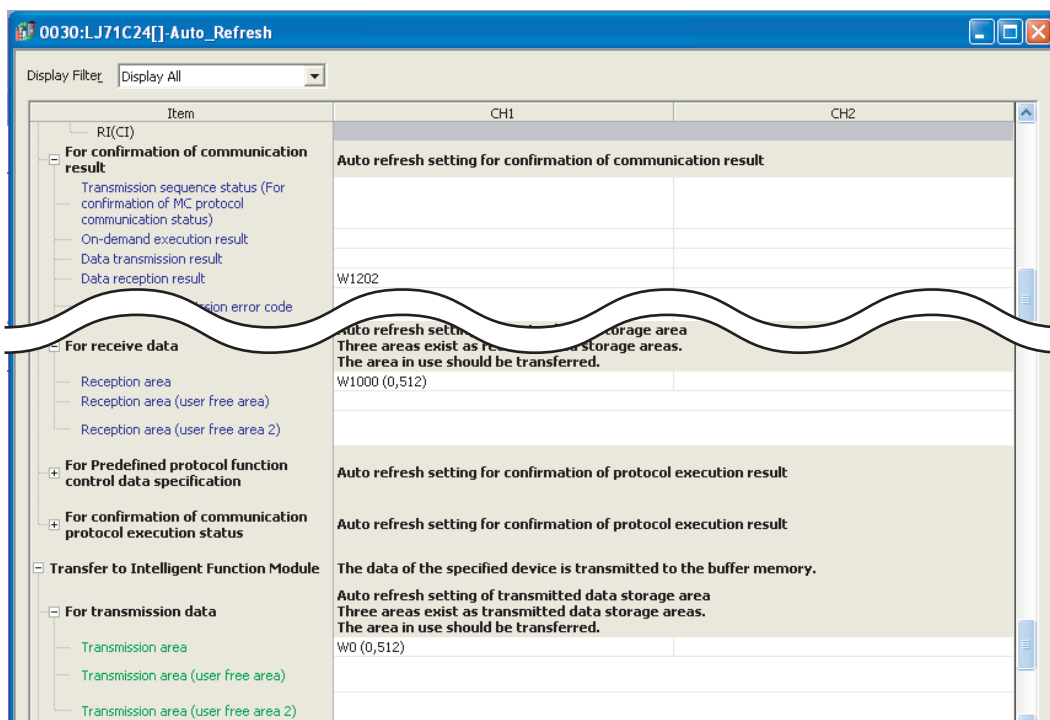

## (2) Program example

The following shows the program example of receiving data using the nonprocedural protocol.

[I/O signals of the C24]

Device	Purpose	Device	Purpose
X1003	CH1 Reception data read request	Y1001	CH1 Reception data read completion
X1004	CH1 Reception error detection	—	—

[Link special relay (SB), link special register (SW)]

Device	Purpose	Device	Purpose
SB0049	Data link status of host station	SW00B0.0	Data link status of each station (Station number 1)

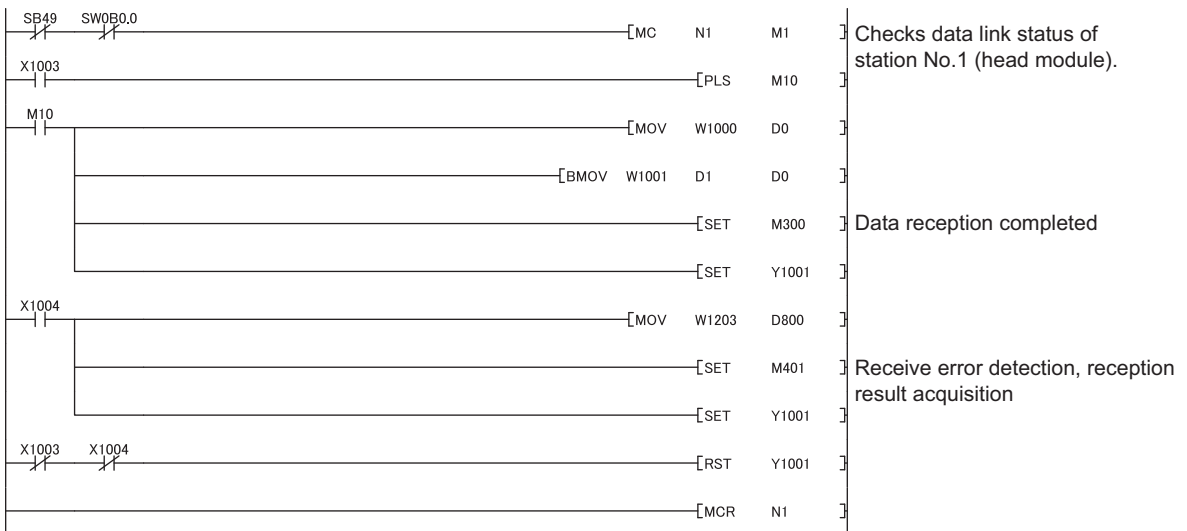

The data received in the C24 is transferred to the master station CPU module and stored in the following devices. (In the program example above, the receive data count is stored in D0, and the receive data corresponding to the receive data count are transferred from W1001 to D1.

Device	Description
W1000	Receive data count
W1001 to W11FF	Receive data

In the example above, data are not read out when a reception error is detected.

For the bidirectional protocol, programs for the reception error detection are not required.

## Appendix 6.5.2 Sending data using the nonprocedural or bidirectional protocol

A

The following shows a program example of connecting an external device (personal computer) to CH1 of the C24 and sending data by nonprocedural and bidirectional protocols, using auto refresh and X/Y signals.

### (1) Setting of the C24 installed to the head module

Perform the switch setting and auto refresh setting for the C24 on the head module.

To use the program example in this section, set as follows.

#### (a) Switch setting

Set switch settings such as transmission specifications and communication protocols with external devices.

The following is an example of the nonprocedural protocol setting using CH1.

For the bidirectional protocol, set the communication protocol to the bidirectional protocol.

[Operation procedure]

 Project window ⇒ [Intelligent Function Module] ⇒ [LJ71C24] ⇒ [Switch Setting]

[Setting screen]

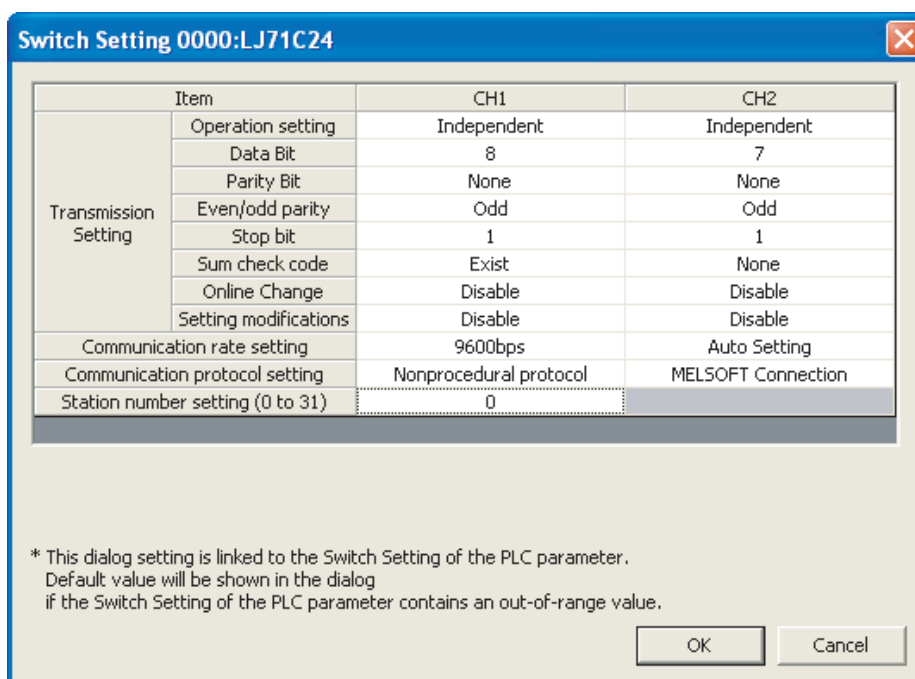

## (b) Auto refresh setting

Configure the auto refresh settings to transfer the information stored in the C24 buffer memory to the specified device in the head module automatically.

For details on the transmission/receive area, refer to  Page 146, CHAPTER 10 or Page 178, CHAPTER 11.

[Operation procedure]

 Project window ⇒ [Intelligent Function Module] ⇒ [LJ71C24] ⇒ [Auto Refresh]

[Setting screen]

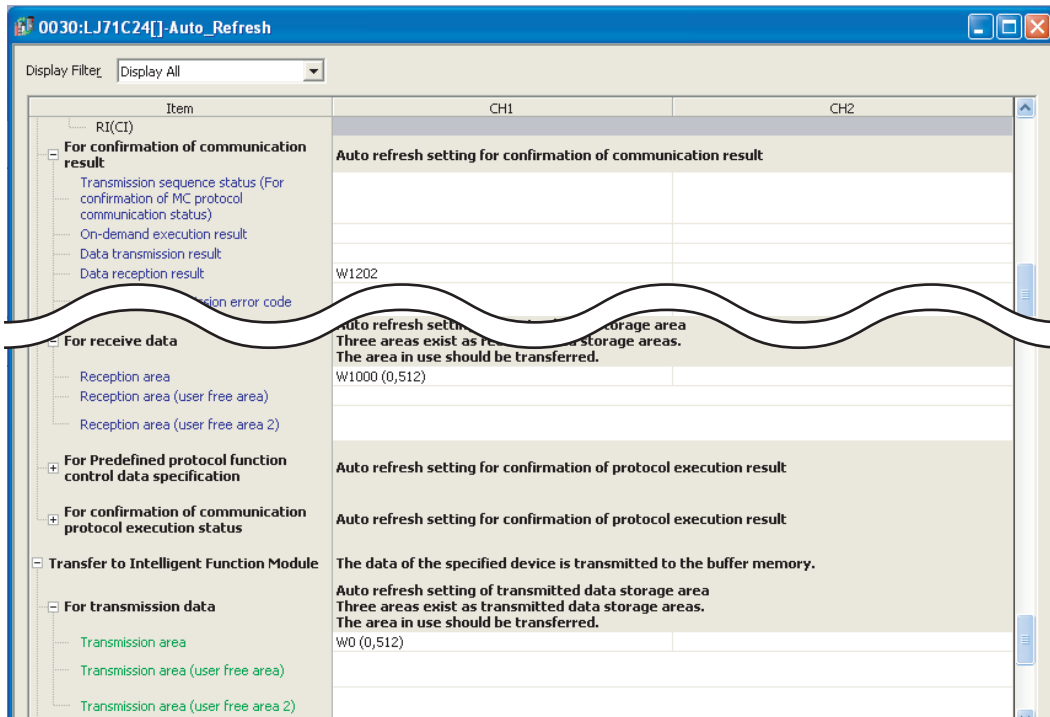



## (2) Program example

The following shows a data transmission image and a program example when sending data using the nonprocedural protocol.

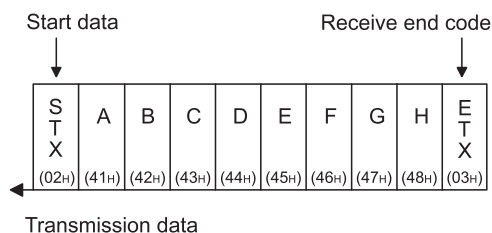

[I/O signals of the C24]

Device	Purpose	Device	Purpose
X1000	CH1 Transmission completion	Y1000	CH1 Transmission request
X1001	CH1 Transmission error	—	—

[Link special relay (SB), link special register (SW)]

Device	Purpose	Device	Purpose
SB0049	Data link status of host station	SW00B0.0	Data link status of each station (Station number 1)

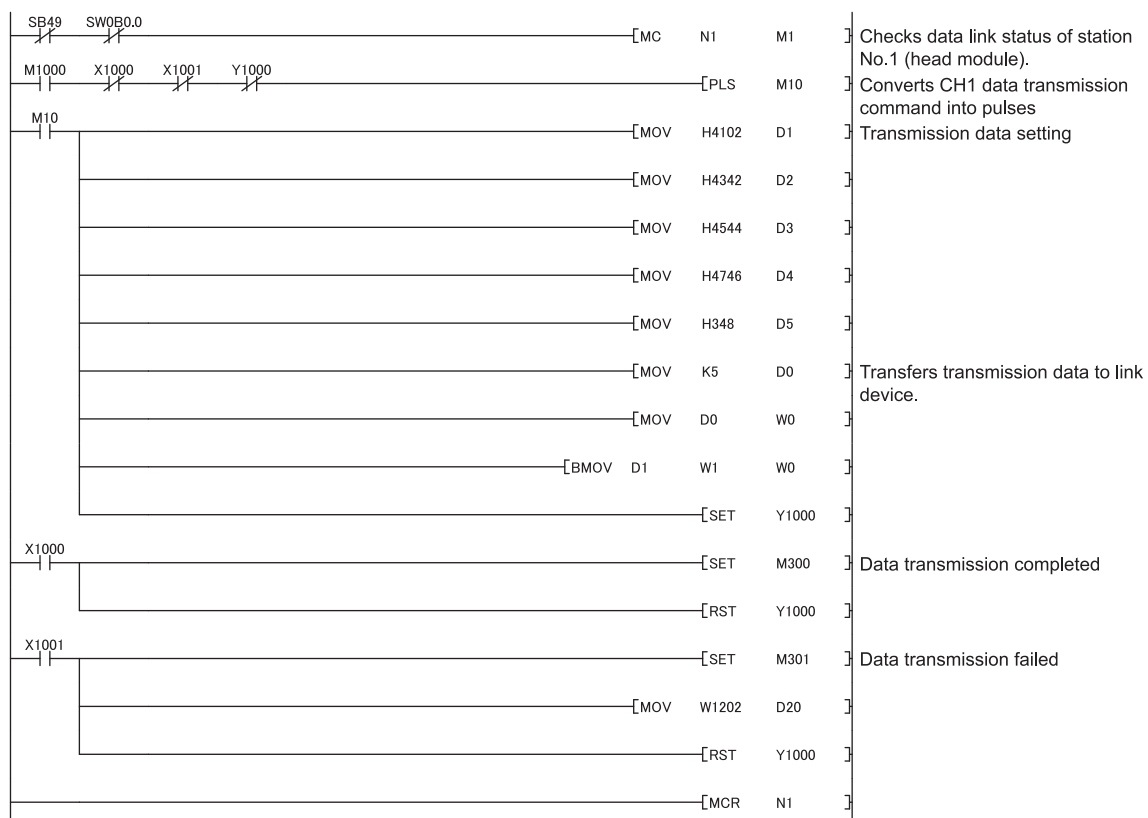

By transferring the send data count to W0 and transferring the send data for the send data count from W1 in the master station CPU module, the data is stored in the C24 device installed to the following head module.

Device	Content
W0	Send data count
W1 to W1FF	Send data

The example in the above does not include a program for turning OFF "M1000: CH1 Data transmission instruction".

Turn OFF "M1000: CH1 Data transmission instruction" when the normal or abnormal transmission signal is turned ON.

# Appendix 7 Processing Time

## (1) Time required to process communication using the nonprocedural protocol (guideline)

The processing time for the Output and Input instructions can be estimated by the following formula.

Note, however, that the processing time may become longer depending on other communication functions (e.g., communication using the MC protocol) and special functions (e.g., ASCII-binary conversion, transmission control) that are used at the same time.

The value obtained from the following formula is considered to be the processing time taken for reception or transmission only when CH1 only is used (RS-232 connection).

### (a) Output instruction

$$T_p = S_t + (D_{le}/C_r \times 1000 + 0.07) \times D_s + T_1$$

$T_p$ (*1)	The time from the start of execution of the Output instruction to the End processing of the sequence scan at the completion of the Output instruction execution (ms)
$S_t$	Scan time
$D_{le}$	Data length of 1 byte at data transmission (number of bits)
$C_r$	Communication rate (bps)
$D_s$	Number of bytes of transmission data
$T_1$	C24 $T_1 = 3.0$

\*1 This stands for the time range of processing ( $T_p$ ).

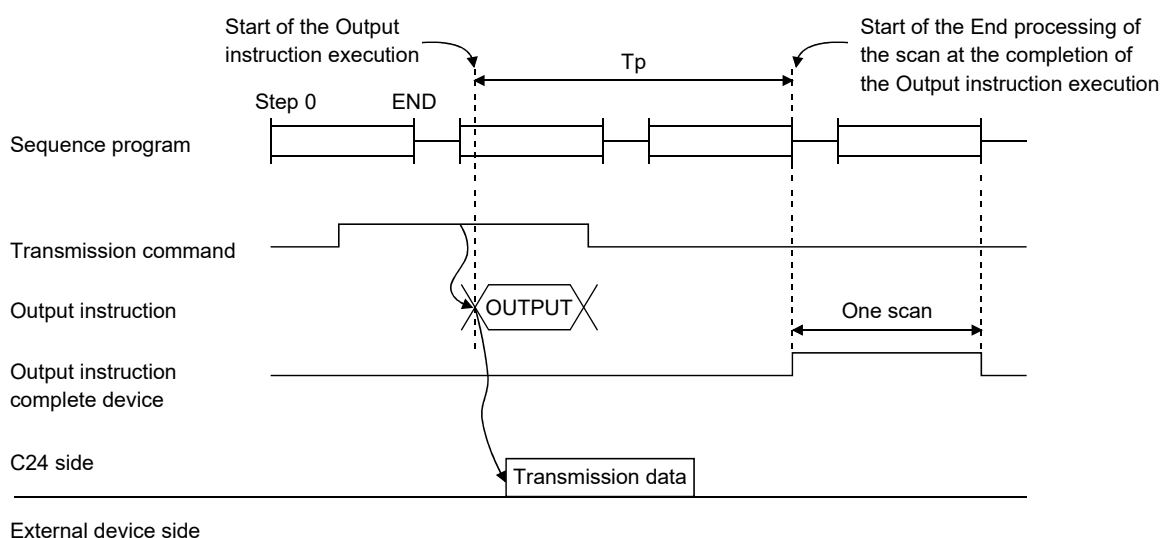

#### [Calculation example]

The time required to process the Output instruction when transmitting 100 bytes of data using the nonprocedural protocol with C24. (Unit: ms)

Scan time	10 ms
Data length	10 bits (1 start bit, 8 data bits, 1 stop bit, no parity bit)
Communication rate	19200 bps

$$10 + (10/19200 \times 1000 + 0.07) \times 100 + 3.0 \approx 72.08 \text{ (ms)}$$

**(b) Input instruction**

$$T_p = S_r + 0.09 \times D_r + T_2$$

$T_p$ (*1)	The time from the start of execution of the Input instruction to the End processing of the sequence scan at the completion of the Input instruction execution (ms)
$S_r$	Scan time
$D_r$	Number of bytes of reception data
$T_2$	C24 $T_2 = 7.0$

\*1 This stands for the time range of processing ( $T_p$ ).

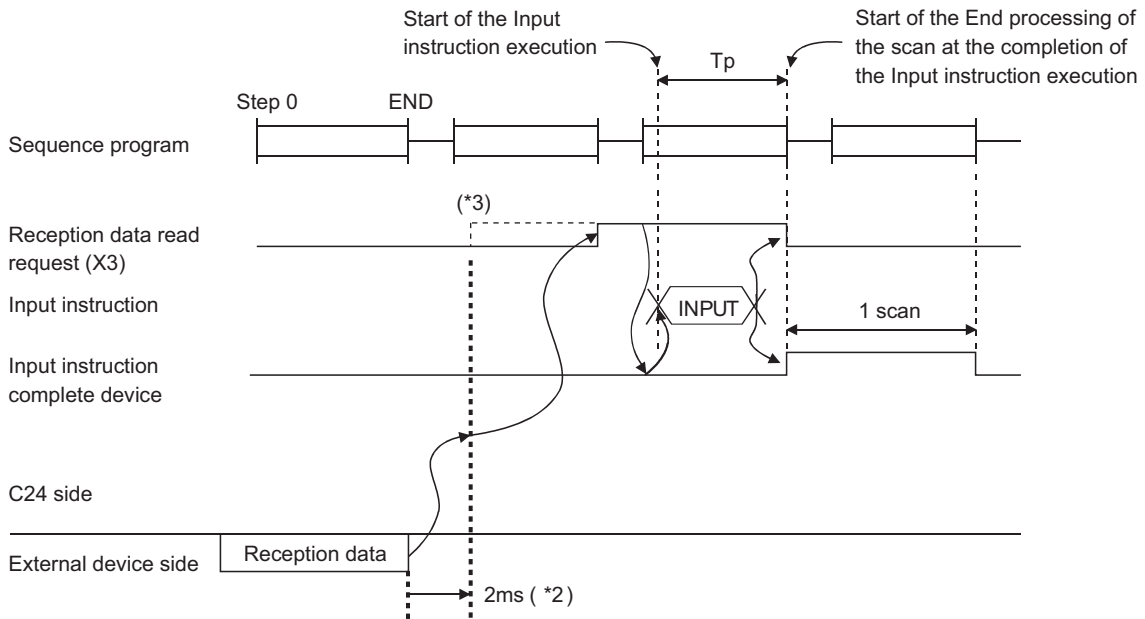

[Calculation example]

The time required to process the Input instruction when receiving 100 bytes of data using the nonprocedural protocol with C24. (Unit: ms)

Scan time	10 ms
-----------	-------

$$10 + 0.09 \times 100 + 7.0 \approx 26.00 \text{ (ms)}$$

- \*2 Indicates the time from when the C24 receives data on the line until Reception data request (X3) turns on, when receiving 30-bytes data at one channel.
- \*3 When DX3 (direct mode) is used, the C24 is accessed at the time of the instruction execution on the sequence program. DX3 speeds up reading input compared to X3 (refresh mode). For differences between modes, refer to the user's manual (function explanation, program fundamentals) of the CPU module used.

## (2) Processing time of dedicated instructions

The following table shows the operation processing time (rough standard) of each dedicated instruction. The operation processing time differs slightly depending on the system configuration and communication protocol.

Instruction name	Processing time (unit: ms)		Instruction execution condition		
	L02CPU, L02CPU-P	L26CPU-BT, L26CPU-PBT	Transmission speed	Transmission/receive (registered) data count	Others
ONDEMAND	48.8	48.3	19200 bps	40 bytes	Send in Format 3
OUTPUT	23.8	23.5	Data length: 8 Stop bit: 1 Parity: none	40 bytes	—
PRR	24.3	23.9		40 bytes * 8 bytes × 5 frames	—
INPUT	1.2	1.2		—	40 bytes
BIDOUT	29.6	29.5	—	40 bytes	—
BIDIN	26.6	26.4	—	40 bytes	—
PUTE	485.7	493.6	—	40 bytes	—
GETE	1.3	1.1	—	40 bytes	—
SPBUSY	0.2	0.2	—	—	—
CSET	1.4	1.2	—	—	Transmission/receive buffer setting
BUFRCVS	0.2	0.2	19200 bps	40 bytes	—
UINI	418.9	413.6	—	—	—
CPRTCL	* Instruction processing time varies by external device and/or protocol.				

# Appendix 8 ASCII-Code List

The ASCII-code list is shown below. (7-bit codes)

LSD		MSD							
		0	1	2	3	4	5	6	7
		000	001	010	011	100	101	110	111
0	0000	NUL <sup>*1</sup>	DLE <sup>*1</sup>	(SP)	0	@	P	,	p
1	0001	SOH	DC1 <sup>*1</sup>	!	1	A	Q	a	q
2	0010	STX <sup>*1</sup>	DC2 <sup>*1</sup>	"	2	B	R	b	r
3	0011	ETX <sup>*1</sup>	DC3 <sup>*1</sup>	#	3	C	S	c	s
4	0100	EOT <sup>*1</sup>	DC4 <sup>*1</sup>	\$	4	D	T	d	t
5	0101	ENQ <sup>*1</sup>	NAK <sup>*1</sup>	%	5	E	U	e	u
6	0110	ACK <sup>*1</sup>	SYN	&	6	F	V	f	v
7	0111	BEL	ETB	/	7	G	W	g	w
8	1000	BS	CAN	(	8	H	X	h	x
9	1001	HT	EM	)	9	I	Y	i	y
A	1010	LF <sup>*1</sup>	SUB	*	:	J	Z	j	z
B	1011	VT	ESC	+	;	K	[	k	{
C	1100	FF <sup>*1*2</sup>	FS	,	<	L	\	l	
D	1101	CR <sup>*1</sup>	GS	—	=	M	]	m	}
E	1110	SO	RS	.	>	N	↑	n	~
F	1111	SI	US	/	?	O	←	o	DEL

\*1 These codes are used as C24 control codes. (DC codes 11H to 14H can be changed by the user.)

\*2 Shown as transmission sequence initialization command (CL) in  MELSEC Communication Protocol Reference Manual

# Appendix 9 Usage Example of MX Component

A

This section explains the procedure for creating programs and sample programs using MX Component.

## (1) Procedure for creating programs

The procedure for creating programs is outlined below.

The usage procedure below uses Visual Basic®.NET 2003 as an example.

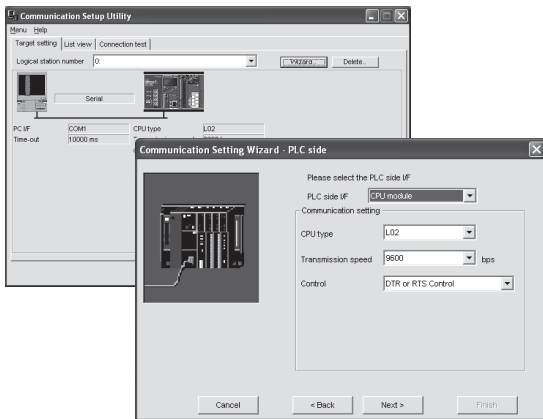

1. Perform the communication settings from a IBM-PC/AT-compatible personal computer to the programmable controller by following the wizard. (Some types of controls are set only by programs without using the wizard.)

The wizard allows the user to perform the settings required for the communication such as logical station number, connected module type, and programmable controller to be connected.

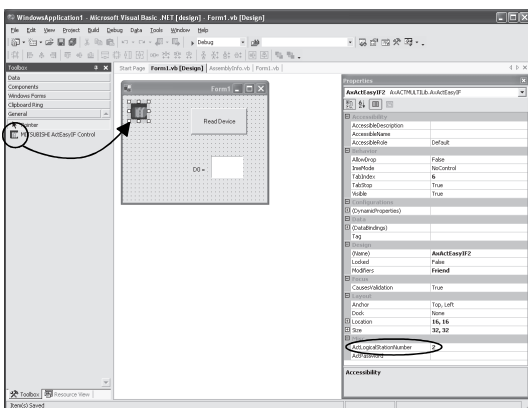

2. Paste the ACT control icon onto the form and assign the logical station number set in step 1 to the property of the pasted control.

```
Private Sub Button1_Click(ByVal sender As System.Object)
    Dim rtn As Integer
    Dim iData As Integer
    rtn = AxActEasyIF1.Open()

    rtn = AxActEasyIF1.GetDevice("D0", iData)
    Label1.Text = iData
End Sub
```

3. Use the functions provided by the software to write a program that reads the device data.

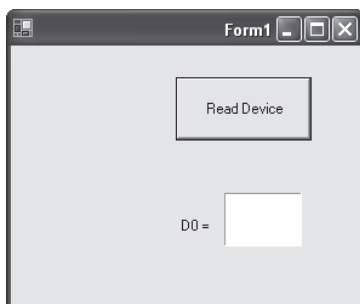

Completed

## (2) Sample program

The following sample program reads D0 to D4 (five points) of the target programmable controller using the logical station number.

### (a) Screen example (Form1)

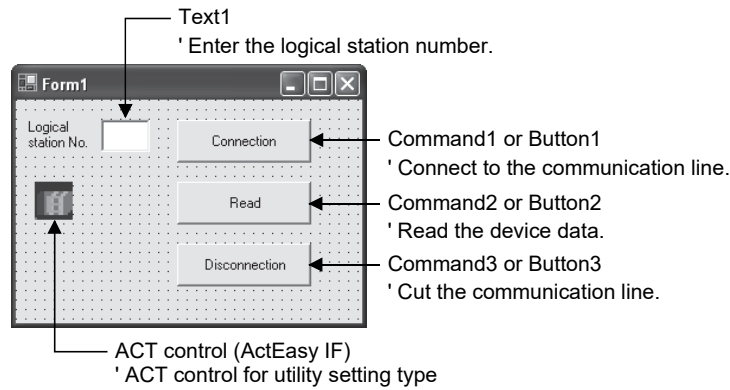

### (b) Program example

For each development software, the program examples are described below.

- 1) Visual Basic®.NET 2003
- 2) Visual C++®.NET 2003
- 3) Visual Basic®6.0
- 4) Visual C++®6.0

- 1) When Visual Basic® .NET 2003 is used

```
Private Sub Command1_Click(ByVal sender As System.Object, ByVal e As System.EventArgs) Handles
Command1.Click
```

```
*****
```

```
' Connection
```

```
*****
```

```
Dim rtn As Integer
```

```
'Get LogicalstationNumber
```

```
AxActEasyIF1.ActLogicalStationNumber = Val(Text1.Text)
```

```
'Connection
```

```
rtn = AxActEasyIF1.Open()
```

```
If rtn = 0 Then
```

```
    MsgBox("The connection was successful")
```

```
Else
```

```
    MsgBox("Connection Error :" & Hex(rtn))
```

```
End If
```

```
End Sub
```



```
Private Sub Command2_Click(ByVal sender As System.Object, ByVal e As System.EventArgs) Handles
Command2.Click
```

```
*****
```

```
' Read
```

```
*****
```

```
Dim rtn As Integer
```

```
Dim idata(5) As Short
```

```
    'D0-D4 are read
```

```
    rtn = AxActEasyIF1.ReadDeviceBlock2("D0", 5, idata(0))
```

```
    If rtn = 0 Then
```

```
        MsgBox("D0-D4 = " & idata(0) & "," & idata(1) & "," & idata(2) & "," & idata(3) & "," & idata(4))
```

```
    Else
```

```
        MsgBox("Read Error :" & Hex(rtn))
```

```
    End If
```

```
End Sub
```

```
Private Sub Command3_Click(ByVal sender As System.Object, ByVal e As System.EventArgs) Handles
Command3.Click
```

```
*****
```

```
' Disconnection
```

```
*****
```

```
Dim rtn As Integer
```

```
    'Disconnection
```

```
    rtn = AxActEasyIF1.Close()
```

```
    If rtn = 0 Then
```

```
        MsgBox("The disconnection was successful")
```

```
    Else
```

```
        MsgBox("Disconnection Error :" & Hex(rtn))
```

```
    End If
```

```
End Sub
```

2) When Visual C++® .NET 2003 is used

```
//*****  
// Connection  
//*****  
private: System::Void button1_Click(System::Object * sender, System::EventArgs * e)  
{  
    int iRet;  
  
    // Get LogicalstationNumber  
    axActEasyIF1->ActLogicalStationNumber=Convert::ToInt32(textBox1->Text);  
  
    // Connection  
    iRet = axActEasyIF1->Open();  
    if( iRet == 0 ){  
        MessageBox::Show( "The connection was successful" );  
    } else {  
        MessageBox::Show( String::Format( "Connection Error:0x{0:x8} [HEX]", __box(iRet) ) );  
    }  
}
```

```
//*****  
// Read  
//*****  
private: System::Void button2_Click(System::Object * sender, System::EventArgs * e)  
{  
    int iRet;  
    short sData[5];  
    String* szMessage= "";  
    String* lpszarrData[];  
    int iNumber;  
    String* szReadData;  
  
    // D0-D4 are read  
    iRet = axActEasyIF1->ReadDeviceBlock2( "D0", 5, sData );  
    if( iRet == 0 ){  
        lpszarrData = new String * [ 5 ];  
        lpszarrData[0] = "D0-D4 = ";  
  
        // Storage of data to display the results  
        for( iNumber = 0 ; iNumber < 5 ; iNumber++ )  
        {  
            lpszarrData[ iNumber ] = sData[ iNumber ].ToString();  
        }  
        szReadData = String::Join(", ", lpszarrData);  
        MessageBox::Show(String::Format("D0-D4 = {0}", szReadData));  
    } else {  
        MessageBox::Show( String::Format( "Read Error:0x{0:x8} [HEX]", __box(iRet) ) );  
    }  
}
```

```

//*****
// Disconnection
//*****
private: System::Void button3_Click(System::Object * sender, System::EventArgs * e)
{
    int iRet;

    // Disconnection
    iRet = axActEasyIF1->Close();
    if( iRet == 0 ){
        MessageBox::Show( "The disconnection was successful" );
    } else {
        MessageBox::Show( String::Format( "Disconnection Error:0x{0:x8} [HEX]", __box(iRet) ) );
    }
}

```

### 3) When Visual Basic® 6.0 is used

```

Private Sub Command1_Click()
*****
' Connection
*****
Dim rtn As Long

'Get LogicalstationNumber
ActEasyIF1.ActLogicalStationNumber = Val(Text1.Text)

'Connection
rtn = ActEasyIF1.Open()
If rtn = 0 Then
    MsgBox "The connection was successful"
Else
    MsgBox "Connection Error :" & Hex(rtn)
End If

End Sub

```

```

Private Sub Command2_Click()
*****
' Read
*****
Dim rtn As Long
Dim idata(5) As Integer

'D0-D4 are read
rtn = ActEasyIF1.ReadDeviceBlock2("D0", 5, idata(0))
If rtn = 0 Then
    MsgBox "D0-D5 = " & idata(0) & "," & idata(1) & "," & idata(2) & "," & idata(3) & "," & idata(4)
Else
    MsgBox "Read Error :" & Hex(rtn)
End If

End Sub

Private Sub Command3_Click()
*****
' Disconnection
*****
Dim rtn As Long

'Disconnection
rtn = ActEasyIF1.Close()
If rtn = 0 Then
    MsgBox "The disconnection was successful"
Else
    MsgBox "Disconnection Error :" & Hex(rtn)
End If

End Sub

```

## 4) When Visual C++® 6.0 is used

```

//*****
// Connection
//*****
void CVCDlg::OnOpen()
    {
        long IRet;
        CString szMessage;

        // Reflects the logical station No. set in the text box to variables.
        UpdateData();

        // Get LogicalstationNumber
        m_actEasyIf.SetActLogicalStationNumber( m_lLogicalStationNumber );

        // Connection
        IRet = m_actEasyIf.Open();
        if( IRet == 0 ){
            MessageBox( "The connection was successful" );
        } else {
            szMessage.Format( "Connection Error : %x", IRet );
            MessageBox( szMessage );
        }
    }

//*****
// Read
//*****
void CVCDlg::OnRead()
{
    long IRet;
    short sData[5];
    CString szMessage;

    // D0-D4 are read
    IRet = m_actEasyIf.ReadDeviceBlock2( "D0", 5, sData );
    if( IRet == 0 ){
        szMessage.Format( "D0-D5 = %d,%d,%d,%d,%d",
            sData[0],sData[1],sData[2],sData[3],sData[4] );
        MessageBox( szMessage );
    } else {
        szMessage.Format( "Read Error : %x", IRet );
        MessageBox( szMessage );
    }
}

```

```
//*****  
// Disconnection  
//*****  
void CVCDlg::OnClose()  
{  
    long lRet;  
    CString szMessage;  
  
    // Disconnection  
    lRet = m_actEasyf.Close();  
    if( lRet == 0 ){  
        MessageBox( "The disconnection was successful" );  
    } else {  
        szMessage.Format( "Disconnection Error : %x", lRet );  
        MessageBox( szMessage );  
    }  
}
```

# Appendix 10 Setting Value Recording Sheet

A

The following sheet is for recording parameter setting values set by GX Works2.  
Use as many copies as needed.

In order to review the setting values of parameters, print them out using the parameter printing function of GX Works2 to use it as the setting value recording sheet.

[Module No.]

Recording sheet 1 (Intelligent function module interrupt pointer setting)

GX Works2 setting screen	Data item name		Setting data	
			Setting value	Remarks
Intelligent Function Module Interrupt Pointer Setting	PLC Side	Interrupt Pointer Start No.		Input format: Decimal
		Interrupt Pointer Count	2 (fixed)	
	Intelligent Module Side	Start I/O No.		Input format: Hexadecimal
		Start SI No.	0 (fixed)	Input format: Decimal

Recording sheet 2 (Remote password setting)

GX Works2 setting screen	Data item name		Setting data	
			Setting value	Remarks
Remote Password Setting	Password Setting	Password		Input format: Character strings
	Password Active Module Setting	Model Name	LJ71C24	Input format: Selection
		Start XY		Input format: Hexadecimal

Appendix 10 Setting Value Recording Sheet

Recording sheet 3 (Switch setting)

GX Works2 setting screen	Data item name		Setting value		Set data			
					CH1 side	CH2 side		
Switch Setting	Transmission Setting	Operation setting <sup>*1</sup>	Independent	Linked	Independent			
		Data Bit <sup>*2</sup>	7	8				
		Parity Bit <sup>*3</sup>	None	Exist				
		Even/odd parity <sup>*4</sup>	Odd	Even				
		Stop bit	1	2				
		Sum check code	None	Exist				
		Online Change	Disable	Enable				
		Setting modifications	Disable	Enable				
	Communication speed setting (unit: bps)			50				
				300				
				600				
				1200				
				2400				
				4800				
				9600				
				14400				
				19200				
				28800				
				38400				
				57600				
				115200				
			230400			—		
	Communication protocol setting			MELSOFT Connection				
		MC protocol			Format 1			
					Format 2			
					Format 3			
					Format 4			
					Format 5			
		Nonprocedural protocol						
		Bidirectional protocol						
		For linked operation setting						
		Predefined protocol						
		ROM/RAM/Switch test						
		Self-loopback test						
Station number setting (Common to CH 1, 2: 0 to 31)								

\*1 Always set to Independent on the CH1 side.

\*2 Do not include parity bit.

\*3 Vertical parity

\*4 Valid only when parity bit is set to Yes.



# Appendix 11 External Dimensions

## (1) LJ71C24

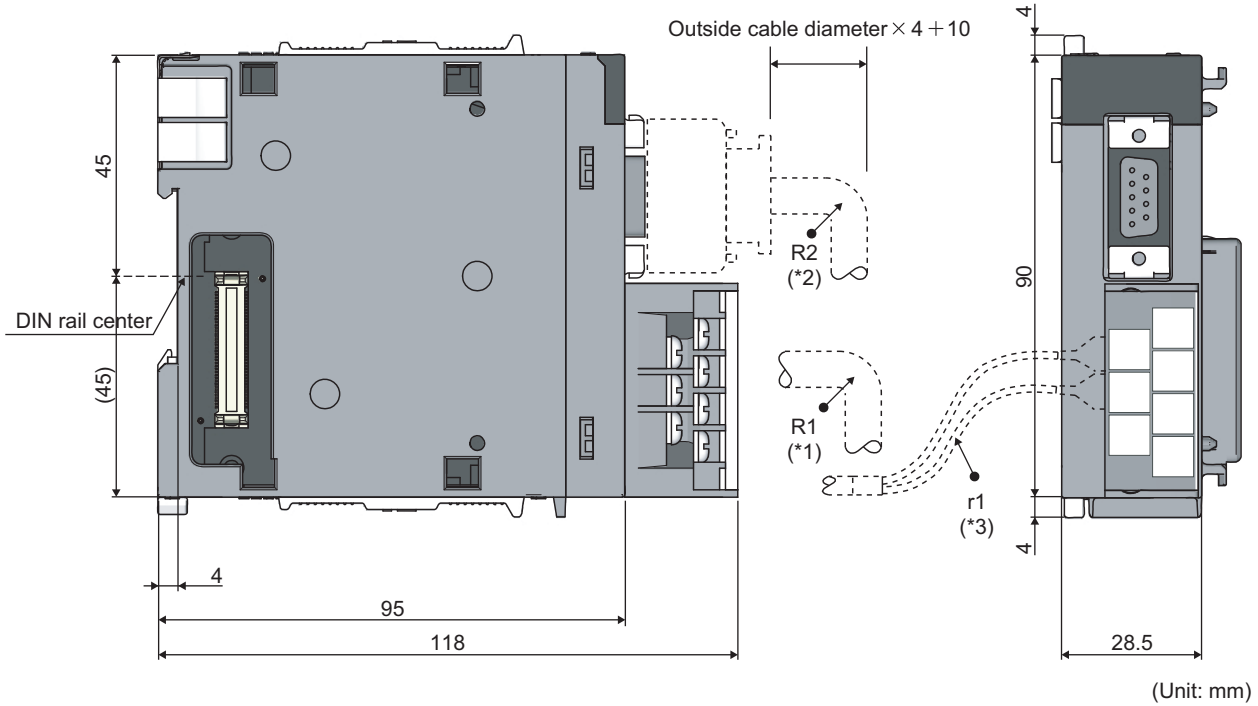

- \*1 R1 (bend radius near the terminal): Cable outside diameter × 4
- \*2 R2 (bend radius near the connector): Cable outside diameter × 4
- \*3 r1 (bend radius near the crimp-on terminal): Connectable without bending excessively

## (2) LJ71C24-R2

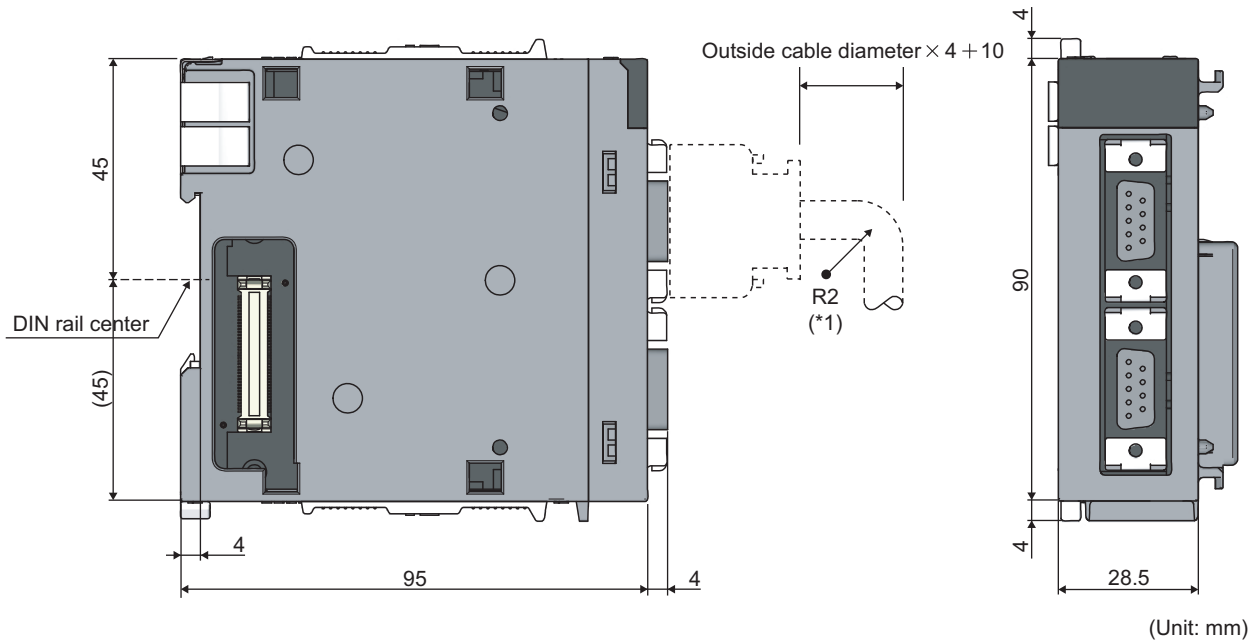

- \*1 R2 (bend radius near the connector): Cable outside diameter × 4

# INDEX

## Symbols

---

"RUN" LED . . . . .	303
"SD" LED . . . . .	305

## 0 to 9

---

1:1 system configuration . . . . .	41
1:n system configuration . . . . .	42

## A

---

A compatible 1C frame . . . . .	104
Additional functions . . . . .	32
Applicable system . . . . .	40
ASCII-code list . . . . .	420
Auto refresh . . . . .	99

## B

---

Basic functions of the C24. . . . .	31
BIDIN . . . . .	233
Bidirectional protocol . . . . .	178
BIDOUT . . . . .	228
Buffer memory . . . . .	331

## C

---

C/N. . . . .	265
CD terminal check designation (for RS-232) . . . . .	46
CH1 ERR., CH2 ERR. . . . .	266
Check code . . . . .	129
Cl. . . . .	47
Circuit trace . . . . .	243
Communication protocol setting . . . . .	89
Communication rate setting . . . . .	88
Communication system . . . . .	27
Connecting the RS-232 interface . . . . .	51
Connection method for the RS-422/485 interface. . . . .	56
Conversion variable . . . . .	122
CPRTCL . . . . .	212
Crimp-on terminals. . . . .	54
CS . . . . .	47
CSET (Receive data clear) . . . . .	239
CTS . . . . .	47

## D

---

Data bit. . . . .	86
Data communication functions. . . . .	43
Data format . . . . .	27
Data reception by receive complete code . . . . .	148
Debug support function. . . . .	243
Dedicated instruction . . . . .	206
DR . . . . .	47
DSR . . . . .	47
DTR . . . . .	47

## E

---

Echo back. . . . .	64
ER. . . . .	47
ERR. LED . . . . .	325
Error code list . . . . .	281
Even/odd parity . . . . .	86
Execution log options (buffer memory) . . . . .	257
Execution log options (GX Works2) . . . . .	256
External dimensions. . . . .	431

## F

---

Full-duplex communication . . . . .	201
Functional protocol . . . . .	218

## H

---

H/W gate OFF time . . . . .	62
Header . . . . .	114
How to detect and confirm reception errors (bidirectional) . . . . .	190
How to detect and confirm transmission errors (bidirectional) . . . . .	199
How to detect and confirm transmission errors (nonprocedural) . . . . .	175
How to detect reception error (nonprocedural) . . . . .	157

## I

---

I/O assignment . . . . .	365
Independent operation . . . . .	86
Indicator LED . . . . .	26
Individual station test . . . . .	66
Initializing error information . . . . .	325
INPUT . . . . .	223
Interrupt pointer setting . . . . .	100

## L

---

LED ON status, communication error status . . . . .	280
Length . . . . .	116
Linked operation . . . . .	91
List of input/output signals . . . . .	34

## M

---

m:n system configuration . . . . .	42
MC protocol . . . . .	103
Modem function. . . . .	80
Module error history. . . . .	279
Monitor/test. . . . .	102
Multidrop connection . . . . .	39

## N

---

n:1 system configuration. . . . .	41
NAK. . . . .	265

Non-conversion variable	118
Nonprocedural protocol	146
Non-verified reception	131
Number of parameter settings	30
Number of protocol executions	356

## O

ONDEMAND	208
Online change	87
Operation of GX Configurator-SC	369
Operation of GX Developer	365
OUTPUT	219

## P

P/S	265
Packet	114
Parity bit	86
Part names	25
PLC monitoring function	78
Predefined protocol	108
Predefined protocol library	111
PRO	265
Procedures before operation	36
Processing time	417
Protocol cancellation specification	216
Protocol execution log display storage function	254

## Q

QnA compatible 2C frame	104
QnA compatible 3C frame	104
QnA compatible 4C frame	104

## R

RD	46
Reading the data communication status	271
Reading the RS-232 control signal status	270
Reading the signal status (RS-232)	270
Reading the switch setting status	273
Receive area (bidirectional)	181
Receive area (nonprocedural)	150
Receive complete code	166
Receive data (bidirectional)	183
Receive data (nonprocedural)	151
Receive data clear (bidirectional)	192
Receive data clear (nonprocedural)	160
Received data count	166
Receiving methods (bidirectional)	179
Receiving methods (nonprocedural)	147
Remote password function	106
RI	47
ROM/RAM/switch test	67
RS	47
RTS	47
RXD	46

## S

SD	46
Self-loopback test	69

Simultaneous transmissions	201
SIO	264
SPBUSY	237
Specifications of RS-232 interface	46
Specifications of RS-422/485	54
State monitor	249
Static data	115
Station number setting	90
Stop bit	86
Sum check code	86
Switch setting	85
System configuration	38
System error history	279

## T

Terminating resistors	57
Terminator	115
Transmission area (bidirectional)	194
Transmission area (nonprocedural)	170
Transmission data (bidirectional)	195
Transmission data (nonprocedural)	171
Transmission methods (bidirectional)	193
Transmission methods (nonprocedural)	169
Transmission setting	86
Transmission specification	27
Troubleshooting	262
TXD	46

## U

Usage example of MX Component	421
User register frame content	81
User register frame specification	81

## V

Various control specification	75
-------------------------------	----

## W

Writing to the flash ROM	97
--------------------------	----

# REVISIONS

\*The manual number is given on the bottom left of the back cover.

Print date	*Manual number	Revision
January, 2010	SH(NA)-080894ENG-A	First edition
April, 2010	SH(NA)-080894ENG-B	[Addition] Section 5.2.1, Appendix 6 [Partial correction] SAFETY PRECAUTIONS, RELEVANT MANUALS, TERMS, Section 3.1, 3.2.1, 3.4, Chapter 4, Section 5.1, 5.2, 6.1, 7.4.2, Chapter 10, 11, Section 15.2.2, Appendix 1, 2 Change Appendix 6 to 10 → Appendix 7 to 11
September, 2010	SH(NA)-080894ENG-C	[Partial correction] Section 7.2, 9.4, 13.2, 15.2.1, 15.3.21, Appendix 6.2, 6.4, 6.5, 6.5.1, 6.5.2
April, 2011	SH(NA)-080894ENG-D	[Partial correction] Section 6.2 to 6.3.2, 9.1, 10.1.1, 10.1.3, 12.5, Appendix 7
April, 2012	SH(NA)-080894ENG-E	[Partial correction] Appendix 4.2, 7
October, 2014	SH(NA)-080894ENG-F	[Partial correction] SAFETY PRECAUTIONS, COMPLIANCE WITH THE EMC AND LOW VOLTAGE DIRECTIVES, RELEVANT MANUALS, Chapter 1, 2, Section 3.1, 3.2, 3.3, 3.4, Chapter 4, Section 5.1, 5.3, 6.2.1, 6.2.2, 6.3.1, 6.3.2, 6.4, 6.5, 7.2, 7.3, Chapter 8, 9, Section 10.1, Chapter 11, 13, Section 15.1.1, 15.1.5, 15.4, Appendix 1, 6.3, 8, 11 Change Appendix 6.3.1 → Appendix 6.3 (1) Appendix 6.3.2 → Appendix 6.3 (2)
December, 2016	SH(NA)-080894ENG-G	[Partial correction] INTRODUCTION, Section 7.3.1, 10.1.1, 12.3, 15.2.2
May, 2022	SH(NA)-080894ENG-H	[Partial correction] CONDITIONS OF USE FOR THE PRODUCT, COMPLIANCE WITH EMC AND LOW VOLTAGE DIRECTIVES, Section 5.3, 5.4, 6.2.1, 10.2.5, 11.4, 15.3.3, 15.3.5, 15.3.6

Japanese manual version SH-080879-H

This manual confers no industrial property rights or any rights of any other kind, nor does it confer any patent licenses. Mitsubishi Electric Corporation cannot be held responsible for any problems involving industrial property rights which may occur as a result of using the contents noted in this manual.

© 2010 MITSUBISHI ELECTRIC CORPORATION

# WARRANTY

Please confirm the following product warranty details before using this product.

## **1. Gratis Warranty Term and Gratis Warranty Range**

If any faults or defects (hereinafter "Failure") found to be the responsibility of Mitsubishi occurs during use of the product within the gratis warranty term, the product shall be repaired at no cost via the sales representative or Mitsubishi Service Company.

However, if repairs are required onsite at domestic or overseas location, expenses to send an engineer will be solely at the customer's discretion. Mitsubishi shall not be held responsible for any re-commissioning, maintenance, or testing on-site that involves replacement of the failed module.

[Gratis Warranty Term]

The gratis warranty term of the product shall be for one year after the date of purchase or delivery to a designated place. Note that after manufacture and shipment from Mitsubishi, the maximum distribution period shall be six (6) months, and the longest gratis warranty term after manufacturing shall be eighteen (18) months. The gratis warranty term of repair parts shall not exceed the gratis warranty term before repairs.

[Gratis Warranty Range]

- (1) The range shall be limited to normal use within the usage state, usage methods and usage environment, etc., which follow the conditions and precautions, etc., given in the instruction manual, user's manual and caution labels on the product.
- (2) Even within the gratis warranty term, repairs shall be charged for in the following cases.
  1. Failure occurring from inappropriate storage or handling, carelessness or negligence by the user. Failure caused by the user's hardware or software design.
  2. Failure caused by unapproved modifications, etc., to the product by the user.
  3. When the Mitsubishi product is assembled into a user's device, Failure that could have been avoided if functions or structures, judged as necessary in the legal safety measures the user's device is subject to or as necessary by industry standards, had been provided.
  4. Failure that could have been avoided if consumable parts (battery, backlight, fuse, etc.) designated in the instruction manual had been correctly serviced or replaced.
  5. Failure caused by external irresistible forces such as fires or abnormal voltages, and Failure caused by force majeure such as earthquakes, lightning, wind and water damage.
  6. Failure caused by reasons unpredictable by scientific technology standards at time of shipment from Mitsubishi.
  7. Any other failure found not to be the responsibility of Mitsubishi or that admitted not to be so by the user.

## **2. Onerous repair term after discontinuation of production**

- (1) Mitsubishi shall accept onerous product repairs for seven (7) years after production of the product is discontinued. Discontinuation of production shall be notified with Mitsubishi Technical Bulletins, etc.
- (2) Product supply (including repair parts) is not available after production is discontinued.

## **3. Overseas service**

Overseas, repairs shall be accepted by Mitsubishi's local overseas FA Center. Note that the repair conditions at each FA Center may differ.

## **4. Exclusion of loss in opportunity and secondary loss from warranty liability**

Regardless of the gratis warranty term, Mitsubishi shall not be liable for compensation to:

- (1) Damages caused by any cause found not to be the responsibility of Mitsubishi.
- (2) Loss in opportunity, lost profits incurred to the user by Failures of Mitsubishi products.
- (3) Special damages and secondary damages whether foreseeable or not, compensation for accidents, and compensation for damages to products other than Mitsubishi products.
- (4) Replacement by the user, maintenance of on-site equipment, start-up test run and other tasks.

## **5. Changes in product specifications**

The specifications given in the catalogs, manuals or technical documents are subject to change without prior notice.

# TRADEMARKS

---

Microsoft, Visual Basic, Visual C++, and Visual Studio are trademarks of the Microsoft group of companies.

The company names, system names and product names mentioned in this manual are either registered trademarks or trademarks of their respective companies.

In some cases, trademark symbols such as <sup>™</sup> or <sup>®</sup> are not specified in this manual.



SH(NA)-080894ENG-H(2205)KWIX

MODEL: LJ71C24-U-KI-E

MODEL CODE: 13JZ40

## **MITSUBISHI ELECTRIC CORPORATION**

HEAD OFFICE : TOKYO BUILDING, 2-7-3 MARUNOUCHI, CHIYODA-KU, TOKYO 100-8310, JAPAN  
NAGOYA WORKS : 1-14, YADA-MINAMI 5-CHOME, HIGASHI-KU, NAGOYA, JAPAN

When exported from Japan, this manual does not require application to the  
Ministry of Economy, Trade and Industry for service transaction permission.

Specifications subject to change without notice.