

MELSEC **WS** series

Safety Controller CC-Link Interface Module User's Manual

-WS0-GCC1

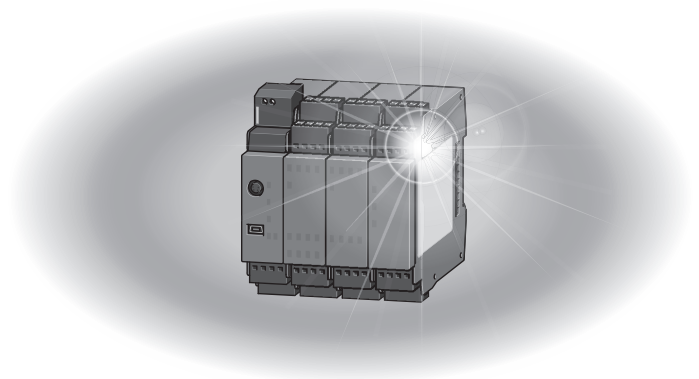

Powered by
SICK

MELSEC-WS series products were jointly developed and manufactured by Mitsubishi Electric and SICK AG, Industrial Safety Systems in Germany.
* Note that the warranty on MELSEC-WS series products differs from that on MELSEC-Q or MELSEC-QS series products.
(Refer to "WARRANTY" written in this manual.)

This document is protected by the law of copyright, whereby all rights established therein remain with the company Mitsubishi Electric Corporation. Reproduction of this document or parts of this document is only permissible within the limits of the legal determination of Copyright Law. Alteration or abridgement of the document is not permitted without the explicit written approval of the company Mitsubishi Electric Corporation.

Precautions regarding warranty and specifications

MELSEC-WS series products are jointly developed and manufactured by Mitsubishi and SICK AG, Industrial Safety Systems, in Germany.

Note that there are some precautions regarding warranty and specifications of MELSEC-WS series products.

<Warranty>

- The gratis warranty term of the product shall be for one (1) year after the date of delivery or for eighteen (18) months after manufacturing, whichever is less.
- The onerous repair term after discontinuation of production shall be for four (4) years.
- Mitsubishi shall mainly replace the product that needs a repair.
- It may take some time to respond to the problem or repair the product depending on the condition and timing.

<Specifications>

- General specifications of the products differ.

	MELSEC-WS	MELSEC-Q	MELSEC-QS
Operating ambient temperature	-25 to 55°C*1	0 to 55°C	0 to 55°C
Operating ambient humidity	10 to 95%RH	5 to 95%RH	5 to 95%RH
Storage ambient temperature	-25 to 70°C	-25 to 75°C	-40 to 75°C
Storage ambient humidity	10 to 95%RH	5 to 95%RH	5 to 95%RH

*1 When the WS0-GCC100202 is included in the system, operating ambient temperature will be 0 to 55 °C.

- EMC standards that are applicable to the products differ.

	MELSEC-WS	MELSEC-Q, MELSEC-QS
EMC standards	EN61000-6-2, EN55011	EN61131-2

● SAFETY PRECAUTIONS ●

(Read these precautions before using this product.)

Before using this product, please read this manual, the relevant manuals, and the safety standards carefully and pay full attention to safety to handle the product correctly.

The precautions given in this manual are concerned with installation of this product and wiring with the external application only.

For the safety precautions of the MELSEC-WS safety controller system, refer to the user's manual for the CPU module used.

In this manual, the safety precautions are classified into two levels: "⚠ WARNING" and "⚠ CAUTION".



Indicates that incorrect handling may cause hazardous conditions, resulting in death or severe injury.



Indicates that incorrect handling may cause hazardous conditions, resulting in minor or moderate injury or property damage.

Under some circumstances, failure to observe the precautions given under "⚠ CAUTION" may lead to serious consequences.

Observe the precautions of both levels because they are important for personal and system safety.

Make sure that the end users read this manual and then keep the manual in a safe place for future reference.

[Design Precautions]

⚠ WARNING

- **The CC-Link interface module is not suitable for operation on a safety fieldbus.**

The CC-Link interface module only generates non-safety-related fieldbus data (status bytes) for control and diagnostics purposes.

- **Do not use non-safe data from a CC-Link interface module for safety related applications.**

With the CC-Link interface module it is possible to integrate non-safe data into the logic editor such that the safety function of the MELSEC-WS safety controller is compromised. Never implement the CC-Link interface module into a MELSEC-WS safety controller without having this danger checked by a safety specialist.

CAUTION

- Do not install the control lines or communication cables together with the main circuit lines or power cables. Keep a distance of 100 mm or more between them.
Failure to do so may result in malfunction due to noise.
- **The MELSEC-WS safety controller fulfils the requirements of Class A (industrial applications) in accordance with the "Interference emission" basic specifications.**
The MELSEC-WS safety controller is therefore only suitable for use in an industrial environment and not for private use.

[Installation Precautions]

CAUTION

- Use the MELSEC-WS safety controller in an environment that meets the general specifications in the user's manual for the CPU module used. Failure to do so may result in electric shock, fire, malfunction, or damage to or deterioration of the product.
- Latch the module onto the DIN rail. Incorrect mounting may cause malfunction, failure or drop of the module.
To ensure full electromagnetic compatibility (EMC), the DIN mounting rail has to be connected to functional earth (FE).
Ensure that the earthing contact is positioned correctly. The earthing spring contact of the module must contact the DIN rail securely to allow electrical conductivity.
Additionally connect all network cable shields directly at the control cabinet entrance to a common FE ground line.
- Tighten the screw within the specified torque range.
Undertightening can cause drop of the screw, short circuit or malfunction.
Overtightening can damage the screw and/or module, resulting in drop, short circuit, or malfunction.
- Shut off the external power supply (all phases) used in the system before mounting or removing the module.
Failure to do so may result in damage to the product.
- Do not directly touch any conductive part of the module.
Doing so can cause malfunction or failure of the module.
- The MELSEC-WS safety controller is only suitable for mounting in a control cabinet with at least IP 54 degree of protection.
Failure to meet the installation method may cause the module to fail or malfunction due to the deposition of dust or the adhesion of water.

CAUTION

- **Make sure that the connection of the CC-Link interface module cannot lead to hazardous situations during installation.**

Ensure that the connection of the CC-Link dedicated cables and power cables cannot lead to a hazardous situation when implementing the unit on to the MELSEC-WS safety controller and CC-Link network. Prevent unintended start-up of equipment during connection of a CC-Link interface module. Failure to do so may cause the system to malfunction.

[Wiring Precautions]

CAUTION

- Switch the entire machine/system off line.
The system could start up unexpectedly while you are connecting the devices.
- Connectors for external devices must be crimped or pressed with the tool specified by the manufacturer, or must be correctly soldered. Incomplete connections could result in short circuit, fire, or malfunction.
- Connect the connectors to the module securely.
Failure to do so may cause malfunction due to poor contact.
- Place the cables in a duct or clamp them.
If not, dangling cable may swing or inadvertently be pulled, resulting in damage to the module or cables or malfunction due to poor contact.
- Tighten the terminal screw within the specified torque range.
Undertightening can cause short circuit or malfunction.
Overtightening can damage the screw and/or module, resulting in drop, short circuit, or malfunction.
- When disconnecting the cable from the module, do not pull the cable by the cable part.
When disconnecting the cable with connector from the module, hold the connector part.
When disconnecting the cable connected to a terminal block, loosen the terminal screws first.
Failure to do so may result in damage to the module or cable or malfunction.
- Prevent foreign matter such as dust or wire chips from entering the module.
Such foreign matter can cause a fire, failure, or malfunction.
- Use dedicated cables as specified by the manufacturer for the CC-Link system. If a cable other than the one specified by the manufacturer is used, the performance of the CC-Link system is not guaranteed.
Also, follow the specifications shown in the Cable Wiring Manual from CC-Link Partner Association for the overall cable distance and the station-to-station cable length. If the wiring does not meet the specifications, accurate data transmission is not guaranteed.
- Do not install the control lines or communication cables together with the main circuit lines or power cables. Failure to do so may result in malfunction due to noise.

● CONDITIONS OF USE FOR THE PRODUCT ●

- (1) Although MELCO has obtained the certification for Product's compliance to the international safety standards IEC61508, ISO13849-1 from TUV Rheinland, this fact does not guarantee that Product will be free from any malfunction or failure. The user of this Product shall comply with any and all applicable safety standard, regulation or law and take appropriate safety measures for the system in which the Product is installed or used and shall take the second or third safety measures other than the Product. MELCO is not liable for damages that could have been prevented by compliance with any applicable safety standard, regulation or law.
- (2) MELCO prohibits the use of Products with or in any application involving, and MELCO shall not be liable for a default, a liability for defect warranty, a quality assurance, negligence or other tort and a product liability in these applications.
- 1) power plants,
 - 2) trains, railway systems, airplanes, airline operations, other transportation systems,
 - 3) hospitals, medical care, dialysis and life support facilities or equipment,
 - 4) amusement equipments,
 - 5) incineration and fuel devices,
 - 6) handling of nuclear or hazardous materials or chemicals,
 - 7) mining and drilling,
 - 8) and other applications where the level of risk to human life, health or property are elevated.

CONTENTS

SAFETY PRECAUTIONS	1
CONDITIONS OF USE FOR THE PRODUCT	4
REVISIONS	5
CONTENTS	6
GENERIC TERMS AND ABBREVIATIONS	9
1. About this document.....	11
1.1 Function of this document	11
1.2 MELSEC-WS manuals	11
1.3 Target group.....	12
1.4 Depth of information	12
1.5 Scope.....	13
1.6 Abbreviations used	13
1.7 Symbols used	13
2. On safety	14
2.1 Qualified safety personnel	14
2.2 Correct use	14
2.3 Environmental protection	16
2.3.1 Disposal	16
2.3.2 Material separation	16
3. System configuration	17
3.1 Overall system configuration	17
3.2 Applicable system.....	17
4. CC-Link interface module	18
4.1 Overview	18
4.1.1 Interfaces and operation	18
4.2 Mounting/Dismantling	21
4.2.1 Steps for mounting the modules	21
4.2.2 Steps for dismantling the modules	23
4.3 Electrical installation	24
4.4 Connecting CC-Link dedicated cables	25
4.5 First configuration steps	26
4.5.1 Station number configuration.....	26
4.5.2 Establishing a connection between MELSEC-WS safety controller and PC	27
4.5.3 Configuration of the number of occupied stations	28
4.5.4 Parameter configuration	29
4.5.5 Transfer of a configuration	30

4.5.6	Verification of a configuration.....	31
4.5.7	Upload of a configuration.....	31
5.	Data sets	32
5.1	Data transmitted into the network (network input data sets (RX, RWr))	33
5.1.1	Logic results.....	33
5.1.2	Module and EFI input and output values	34
5.1.3	Routing of data from a second network.....	34
5.2	Data received from the network (network output data sets) (RY, RWw)	35
5.3	Default settings for the input data set.....	36
5.4	Customizing the input data set (MELSEC-WS to CC-Link).....	37
5.4.1	The toolbar.....	38
5.4.2	Available data area	39
5.4.3	Network Module Data area	40
5.4.4	Tag names area	40
5.5	Default settings for the output data set.....	41
5.6	Tag names for incoming data (CC-Link to MELSEC-WS).....	43
5.6.1	Saving and loading a configuration	44
5.6.2	Importing and exporting a configuration	44
5.7	Monitoring the data set online	45
5.8	Accessible range	46
6.	Troubleshooting.....	47
6.1	When data cannot be normally exchanged	47
6.2	When the L RUN/L ERR. LED does not turn on (green)	48
6.3	When an error occurs in remote input (RX) or remote register (RWr).....	49
6.4	When an error occurs in remote output (RY) or remote register (RWw)	49
7.	Technical specifications	50
7.1	Technical specifications, supply circuit	50
7.2	Technical specifications of CC-Link interface module	50
7.3	General technical specifications	51
7.4	Technical specifications of cables.....	52
7.5	Transmission delay time	52
7.6	Dimensional drawings.....	53
8.	Connecting to a Q series programmable controller.....	54
8.1	Features achieved by the connection.....	54
8.2	Applicable system.....	55

9.	Preparing for operation.....	56
9.1	System configuration and start-up procedure	56
9.2	Wiring.....	57
9.3	Sample program	58
9.3.1	Parameter configuration example.....	59
9.3.2	Sample program	63
10.	Troubleshooting when CC-Link interface module is connected to Q series programmable controller	64

GENERIC TERMS AND ABBREVIATIONS

Generic term/abbreviation	Description
WS0-CPU0	The abbreviation for the WS0-CPU000200 MELSEC-WS safety controller CPU module
WS0-CPU1	The abbreviation for the WS0-CPU130202 MELSEC-WS safety controller CPU module
WS0-CPU3	The abbreviation for the WS0-CPU320202 MELSEC-WS safety controller CPU module
WS0-XTIO	The abbreviation for the WS0-XTIO84202 MELSEC-WS safety controller safety I/O combined module
WS0-XTDI	The abbreviation for the WS0-XTDI80202 MELSEC-WS safety controller safety input module
WS0-4RO	The abbreviation for the WS0-4RO4002 MELSEC-WS safety controller safety relay output module
WS0-GETH	The abbreviation for the WS0-GETH00200 MELSEC-WS safety controller Ethernet interface module
WS0-GCC1	The abbreviation for the WS0-GCC100202 MELSEC-WS safety controller CC-Link interface module
CPU module	A generic term for the WS0-CPU0, WS0-CPU1, and WS0-CPU3
Safety I/O module	A generic term for the WS0-XTIO and WS0-XTDI
Network module	A generic term for the WS0-GETH and WS0-GCC1
CC-Link interface module	Another name for the WS0-GCC1
Q series programmable controller	The abbreviation for the Mitsubishi Electric MELSEC-Q series programmable controller
QJ61BT11N	The abbreviation for the QJ61BT11N CC-Link system master/local module
QS0J61BT12	The abbreviation for the QS0J61BT12 CC-Link Safety system master/local module
QCPU	A generic term for the Q00JCPU, Q00CPU, Q01CPU, Q02CPU, Q02HCPU, Q06HCPU, Q12HCPU, Q25HCPU, Q02PHCPU, Q06PHCPU, Q12PHCPU, Q25PHCPU, Q12PRHCPU, Q25PRHCPU, Q00UJCPU, Q00UCPU, Q01UCPU, Q02UCPU, Q03UDCPU, Q04UDHCPU, Q06UDHCPU, Q10UDHCPU, Q13UDHCPU, Q20UDHCPU, Q26UDHCPU, Q03UDECPU, Q04UDEHCPU, Q06UDEHCPU, Q10UDEHCPU, Q13UDEHCPU, Q20UDEHCPU, Q26UDEHCPU, Q50UDEHCPU and Q100UDEHCPU
QSCPU	The abbreviation for the QS001CPU
GX Developer	The product name of the software package for the MELSEC programmable controllers

Terms

Generic term/abbreviation	Description
Master station	A station that controls the data link system (One master station is required in each system.)
Local station	A station that has a CPU module and communicates data with the master and other local stations
Remote device station	A remote station that exchanges bit data and word data
Remote station	A generic term for a remote I/O station and remote device station (The remote station is controlled by the master station.)
Intelligent device station	A station (including local stations) that can perform transient transmission (example: AJ65BT-R2(N))
Slave station	A generic term for a remote I/O station, remote device station, local station, and intelligent device station
RX	Remote input (area for data to be read) Bit data that is input from a slave station to the master station
RY	Remote output (area for data to be written) Bit data that is output from the master station to a slave station
RWw	Remote register (area for data to be written) 16-bit data that is output from the master station to a slave station
RWr	Remote register (area for data to be read) 16-bit data that is input from a slave station to the master station
Terminating resistor	A resistor that is connected to the terminal of the stations at both ends of a CC-Link dedicated cable
Network input	Data sent from the WS0-GCC1 to the master station (RX, RWr)
Network output	Data sent from the master station to the WS0-GCC1 (RY, RWw)
Input data status	A signal that is output from the WS0-GCC1 to the CPU module. This signal turns on when the WS0-GCC1 receives data from the master station.
Output data status	A signal that is output from the WS0-GCC1 to the CPU module. This signal turns on when data to be sent from the WS0-GCC1 to the master station is ready.

Accessories

The following table shows accessories for the WS0-GCC1.

No.	Item	Amount	Remarks
1	Safety Controller CC-Link Interface Module User's Manual (Hardware)	1	The Japanese manual is included.
2	Terminating resistor 110Ω 1/2W (brown-brown-brown)	1	Bar terminal

Screw terminals (for replacement) (WS0-TBS4) are not available for the CC-Link interface module.

1. About this document

Please read the SAFETY PRECAUTIONS, Chapter 1, and Chapter 2 carefully before working with this documentation and the MELSEC-WS safety controller CC-Link interface module.

1.1 Function of this document

This manual only applies in conjunction with the other MELSEC-WS manuals (see Section 1.2) and instructs the technical staff of the machine manufacturer and/or of the machine operator on safe mounting, adjustment, electrical installation, commissioning as well as operation and maintenance of the CC-Link interface module.

The manual does not provide instructions for operating the machine in which the MELSEC-WS safety controller and CC-Link interface module are, or will be, integrated. Information of this kind will be found in the manuals for the machine.

1.2 MELSEC-WS manuals

For the MELSEC-WS safety controller there are four manuals with clearly distinguished fields of application as well as user's manuals (hardware) for each module.

- This manual describes the CC-Link interface module and its functions in detail.
- The user's manuals (hardware) are enclosed with each MELSEC-WS module. They inform on the basic technical specifications of the modules and contain simple mounting instructions. Use the user's manuals (hardware) when mounting the MELSEC-WS safety controller.
- The Safety Controller User's Manual describes all the MELSEC-WS modules (except for network modules) and their functions in detail. Use the manual in particular to configure the MELSEC-WS safety controller.
- The Safety Controller Setting and Monitoring Tool Operating Manual describes the software-supported configuration and parameterization of the MELSEC-WS safety controller. In addition, the manual contains the description of the diagnostics functions that are important for operation and detailed information for the identification and elimination of errors. Use the manual in particular for the configuration, commissioning and operation of MELSEC-WS safety controllers.

The following shows the relevant manuals.

Table 1:
Overview of disposal by
components

Title	Number
Safety Controller User's Manual	WS-CPU-U-E (13JZ32)
Safety Controller Ethernet Interface Module User's Manual	WS-ET-U-E (13JZ33)
Safety Controller CC-Link Interface User's Manual	WS-CC-U-E (13JZ45)
Safety Controller Setting and Monitoring Tool Operating Manual	SW1DNN-WS0ADR-B-O-E (13JU67)
Safety Controller CPU Module User's Manual (Hardware)	WS-CPU-U-HW (13J200)
Safety Controller Safety I/O Module User's Manual (Hardware)	WS-IO-U-HW (13J201)
Safety Controller Safety Relay Output Module User's Manual (Hardware)	WS-SR-U-HW (13J202)
Safety Controller Ethernet Interface Module User's Manual (Hardware)	WS-ET-U-HW (13J203)
Safety Controller CC-Link Interface Module User's Manual (Hardware)	WS-CC-U-HW (13J209)

1.3 Target group

This manual is addressed to planning engineers, machine designers and the operators of systems in which a MELSEC-WS safety controller is integrated and who want to exchange data with a fieldbus (a controller) via a network module.

It also addresses people who integrate the network module into a machine, commission it initially or who are in charge of servicing and maintaining the unit.

1.4 Depth of information

This manual contains information on the CC-Link interface module in the following subjects:

- mounting
- implementation into a network
- configuration via Setting and Monitoring Tool
- data transfer to and from the network
- status information, planning and related mapping



ATTENTION!

Pay attention to the safety notes and safety measures on the CC-Link interface module!

Note For the acquisition of Setting and Monitoring Tool, please contact your local Mitsubishi representative.

1.5 Scope

This manual applies to the WS0-GCC1 CC-Link interface module.
This document is the original manual.

1.6 Abbreviations used

EFI Enhanced Function Interface

1.7 Symbols used

Note Notes provide special information on the device.

●**Red**, ✱**Red**,
○**Green** LED symbols describe the state of a diagnostics LED. Examples:

●**Red** The red LED is illuminated constantly.

✱**Red** The red LED is flashing.

○**Green** The green LED is off.

⇒ **Action** Instructions for taking action are shown by an arrow. Read carefully and follow the instructions for action.



ATTENTION!

An "ATTENTION" indicates an actual or potential risk or health hazard. They are designed to help you to prevent accidents.

Read carefully and follow the attention notices!

2. On safety

This chapter deals with your own safety and the safety of the equipment operators.

- Please read this chapter carefully before working with a CC-Link interface module.

2.1 Qualified safety personnel

The CC-Link interface module may only be installed, commissioned and serviced by qualified safety personnel.

Qualified safety personnel are defined as persons who...

- have undergone the appropriate technical training
and
- have been instructed by the responsible machine operator in the operation of the machine and the current valid safety guidelines
and
- have access to the manuals of the CC-Link interface module and safety controller and have read and familiarized themselves with them.

2.2 Correct use

The CC-Link interface module can only be operated with a MELSEC-WS safety controller.

The CC-Link interface module does not have a dedicated voltage supply.



The CC-Link interface module is not suitable for operation on a safety fieldbus!

The CC-Link interface module only generates non-safety-related fieldbus data (status bytes) for control and diagnostics purposes.

Do not use non-safe data from a CC-Link interface module for safety related applications!

With the CC-Link interface module it is possible to integrate non-safe data into the logic editor such that the safety function of the MELSEC-WS safety controller is compromised. Never implement the CC-Link interface module into a MELSEC-WS safety controller without having this danger checked by a safety specialist.

The CC-Link interface module may only be used by qualified safety personnel and only on the machine where they have been installed and initialized by qualified safety personnel in accordance with the manual.



Pay attention to the safety notes and safety measures on the CC-Link interface module!

If the device is used for any other purposes or modified in any way - also during mounting and installation - any warranty claim against Mitsubishi Electric Corporation shall become void.

Note

- When mounting, installing and using the CC-Link interface module, observe the standards and directives applicable in your country.
- The national/international rules and regulations apply to the installation, commissioning, use and periodic technical inspection of the MELSEC-WS safety controller, in particular:
 - EMC directive 2004/108/EC,
 - Provision and Use of Work Equipment Directive 89/655/EC,
 - the work safety regulations/safety rules.
- This manual must be made available to the operator of the machine where the MELSEC-WS safety controller is used. The machine operator is to be instructed in the use of the device by qualified safety personnel and must be instructed to read the manual.



The MELSEC-WS safety controller fulfils the requirements of Class A (industrial applications) in accordance with the “Interference emission” basic specifications.

The MELSEC-WS safety controller is therefore only suitable for use in an industrial environment and not for private use.

2.3 Environmental protection

The CC-Link interface module has been designed to minimize environmental impact. It uses only a minimum of power and natural resources.

- At work, always act in an environmentally responsible manner.

2.3.1 Disposal

Disposal of unusable or irreparable devices should always occur in accordance with the applicable country-specific waste-disposal regulations (e.g. European Waste Code 16 02 14).

2.3.2 Material separation



Material separation may only be performed by qualified safety personnel!

Exercise care when disassembling the devices. The danger of injury is present.

Before you can turn over the devices for environmental-friendly recycling, you must separate the different materials of the CC-Link interface module from one another.

- Separate the housing from the remaining components (especially the PCB).
- Send the separated components to the corresponding recycling centers (see the following table).

Component	Disposal
Product Housing PCBs, cables, plugs and electrical connection pieces	Plastic recycling Electronics recycling
Packaging Cardboard, paper	Paper/cardboard recycling

Table 2:
Overview of disposal by components

3. System configuration

3.1 Overall system configuration

The following shows the overall system configuration.

Figure 1:
System configuration

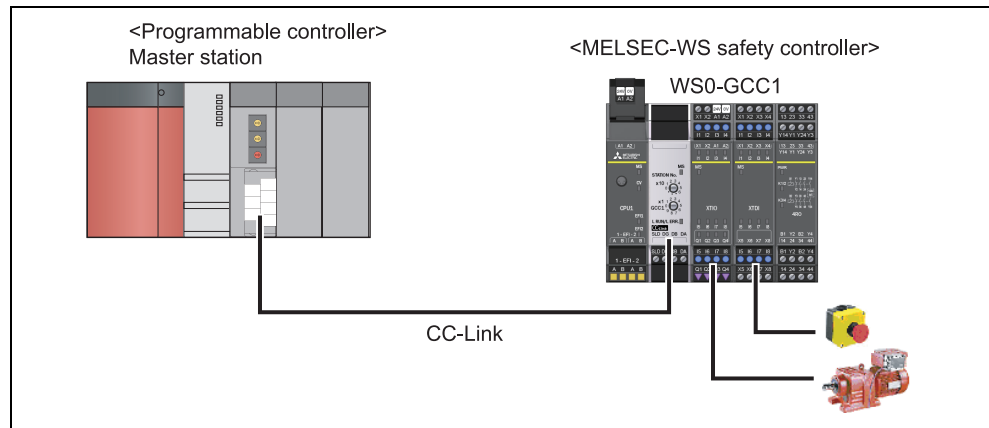

Note Although the WS0-GCC1 can communicate data with the QS0J61BT12 over CC-Link Safety as well, safety communication cannot be performed.

3.2 Applicable system

(1) Applicable modules and the number of connectable modules

The following table shows the applicable CPU modules and the number of connectable WS0-GCC1s.

Table 3:
Applicable modules and the number of connectable modules

CPU module type	Model	Number of connectable WS0-GCC1s	Remarks
MELSEC-WS CPU module	WS0-CPU000200	2*1	-
MELSEC-WS CPU module (with EFI)	WS0-CPU130202	2*1	-
MELSEC-WS CPU module (with Flexi Line and EFI)	WS0-CPU320202	2*1	-

*1 Up to two network modules can be connected.

(2) Compatible software package

The following table shows the software package compatible with the WS0-GCC1.

Table 4:
Compatible software package

Name	Model	Version	Remarks
Setting and Monitoring Tool	SW1DNN-WS0ADR-B	Version1.2.1.0	-

4. CC-Link interface module

This chapter describes the CC-Link interface module (WS0-GCC1).

4.1 Overview

The CC-Link interface module is used to connect a MELSEC-WS safety controller to a Q series programmable controller.

The module can exchange non-safety related data by connecting an external application (e.g. Q series programmable controller) over CC-Link.

4.1.1 Interfaces and operation

The CC-Link interface module is equipped with a terminal block for CC-Link network connection.

Figure 2:
Interfaces and display
elements of the WS0-
GCC1

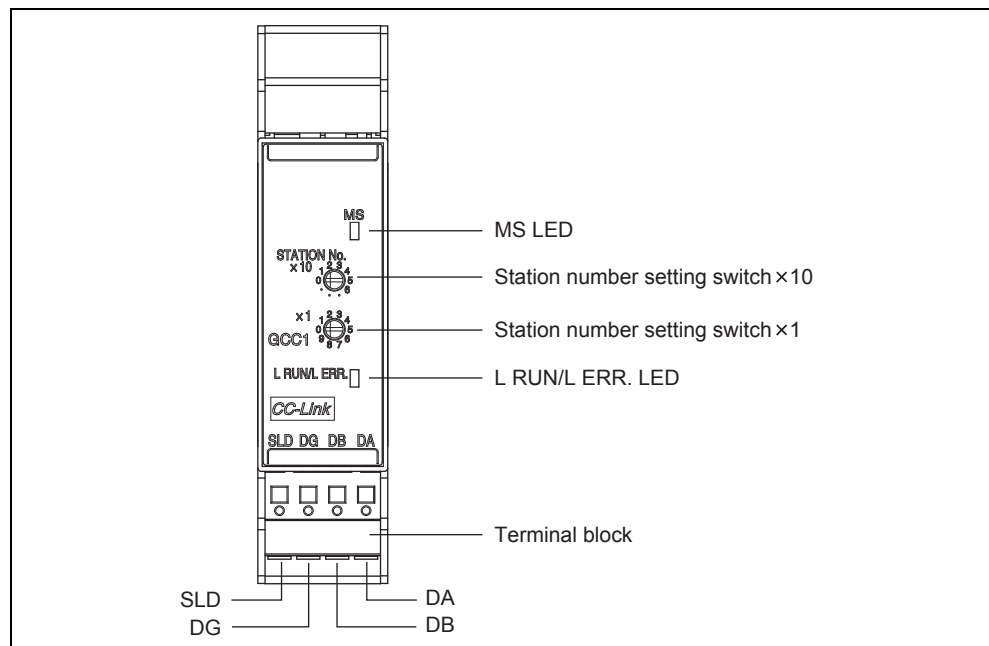

Table 5:
Meaning of the LED
displays

	LED	Meaning
MS	○	No power supply, immediately after the module start or hardware failure
	● Green	Executing (live process data from/to CPU)
	☼ Green	Idle (CPU STOP)
	☼ Green/Red	Executing, but data link stopped or faulty
	☼ Red	1 Hz: Configuring/configuration required 2 Hz: Critical fault on CC-Link interface module
	● Red	Critical fault on another module
L RUN/ L ERR.	○	No power supply or data link stopped
	● Green	Data link active
	☼ Green/Red	One of the following has been detected when data link is active. <ul style="list-style-type: none"> • Configuration change of the station number setting switches • Terminating resistor not connected • Module or CC-Link dedicated cable affected by noise
	☼ Red	One of the following has been detected when data link is stopped. <ul style="list-style-type: none"> • Configuration change of the station number setting switches • Terminating resistor not connected • Module or CC-Link dedicated cable affected by noise
	● Red	Station number setting switches out-of-range

Power-up sequence

On power up, the following LED test sequence is performed:

- LED MS ○ **Off** for 6 s.
- LED MS ● **Red** for 0.25 s.
- LED MS ● **Green** for 0.25 s.
- LED MS ○ **Off**

Table 6:
Station number setting
switches and terminal
block

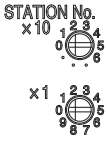
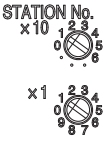
Name	Meaning
<p>Station number setting switches</p> 	<p>A switch for configuring a station number for the module (factory default: 0) 1 to 64: Station number When the number other than 1 to 64 is configured, the MS LED flashes in red and the L RUN/L ERR. LED lights up in red. Example: Setting the station number 11</p> 
<p>Terminal block SLD, DG, DB, DA</p>	<p>CC-Link dedicated cables are connected for data link. For wiring, see Section 4.3 and Section 4.4. The SLD terminal is internally connected to the earthing spring contact. (the connecting part to the DIN rail). This two-piece terminal block allows replacement of a failed module without disconnecting from the CC-Link network. (Before replacement, power off the module to be replaced.) For the crimp tools, see Section 7.4.</p>

4.2 Mounting/Dismantling

This chapter describes the mounting of the CC-Link interface module.



Make sure that the connection of the CC-Link interface module cannot lead to hazardous situations during installation!

Ensure that the connection of the CC-Link dedicated cables and power cables cannot lead to a hazardous situation when implementing the unit on to the MELSEC-WS safety controller and CC-Link network. Prevent unintended start-up of equipment during connection of a CC-Link interface module. Failure to do so may cause the system to malfunction.

4.2.1 Steps for mounting the modules



The MELSEC-WS safety controller is only suitable for mounting in a control cabinet with at least IP 54 degree of protection.

Failure to meet the installation method may cause the module to fail or malfunction due to the deposition of dust or the adhesion of water.

While supply voltage is applied, modules must not be plugged to nor be removed from the MELSEC-WS safety controller.

To ensure full electromagnetic compatibility (EMC), the DIN mounting rail must be connected to functional earth (FE). Additionally connect all network cable shields directly at the control cabinet entrance to a common FE ground line.

- In a MELSEC-WS safety controller, the WS0-CPU0 or WS0-CPU1 module is positioned at the extreme left.
- The two optional network modules follow directly to the right of the CPU module.
- Connect further MELSEC-WS safety I/O modules (e.g. WS0-XTIO or WS0-XTDI) onto the right side of the network modules and any additional safety relay output modules (WS0-4RO) to the extreme right of the entire MELSEC-WS safety controller.
- Mount the modules in accordance with EN 50274.
- The modules are located in a 22.5 mm wide modular system for 35 mm DIN rails according to EN 60715.
- Ensure that suitable ESD protective measures are also taken during mounting. Otherwise the FLEXBUS+ bus may be damaged.
- The connection between the modules is effected by means of the plug connection integrated in the housing. Take into account that, when replacing a module, the MELSEC-WS modules have to be pushed approx. 10 mm apart before the corresponding module can be removed from the DIN rail.
- Take suitable measures to ensure that foreign matter does not penetrate the connector openings, in particular that of the memory plug.

Figure 3:
Mounting the module
onto the DIN rail

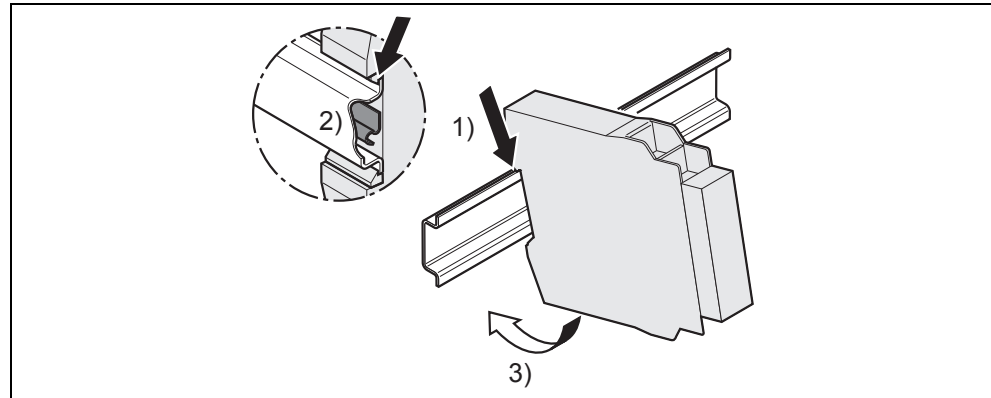

- ⇒ Make sure that the voltage supply of the MELSEC-WS safety controller is switched off.
- ⇒ Hang the device onto the DIN rail (1)).
- ⇒ Connect the CC-Link interface module directly onto the right side of the CPU module of the MELSEC-WS safety controller. Up to two network modules per system are possible.
- ⇒ Ensure that the earthing spring contact is positioned correctly (2)). The earthing spring contact of the module must contact the DIN rail securely to allow electrical conductivity.
- ⇒ Latch the module onto the DIN rail by pressing it lightly in the direction of the arrow (3)).

Figure 4:
Installing the end clips

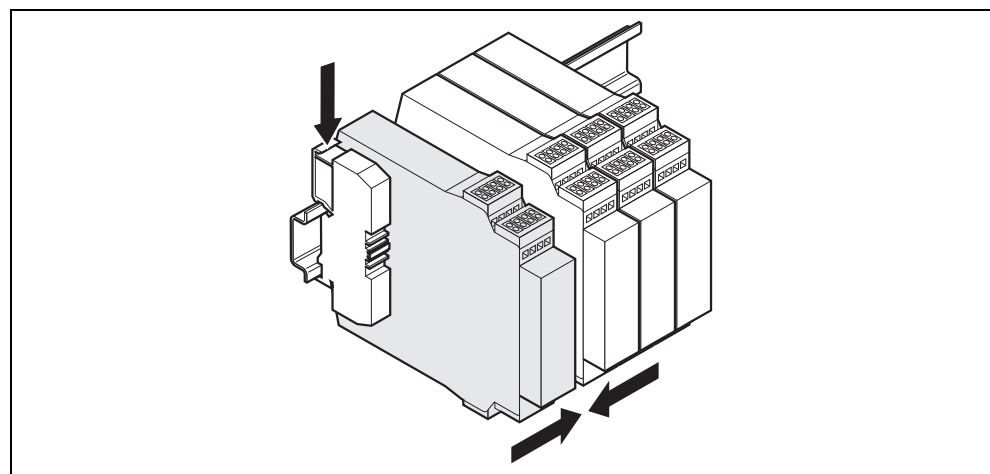

- ⇒ If there are several modules, slide the modules together individually in the direction of the arrow until the side plug connection latches in.
- ⇒ Install the end clips on the right and left.

The following steps are necessary after mounting:

- Complete the electrical connections (See Section 4.3.)
- Configuration (See Section 4.5 and the Safety Controller Setting and Monitoring Tool Operating Manual.)
- Checking the installation (See the Safety Controller User's Manual.)

4.2.2 Steps for dismantling the modules

Figure 5:
Disconnecting the plug
connections

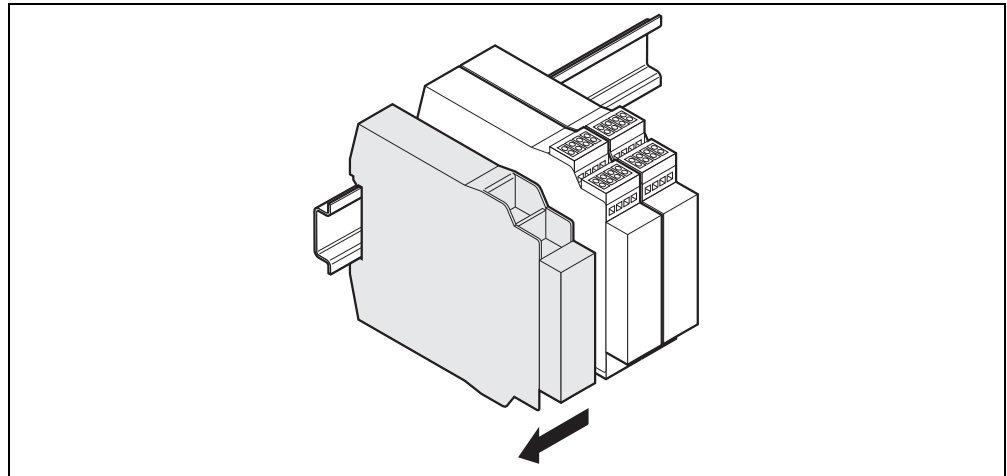

- ⇒ Remove the removable terminals with wiring and the end clips.
- ⇒ If there are several modules, slide the modules away from each other individually in the direction of the arrow until the side plug connection is separated.

Figure 6:
Removing modules
from the DIN rail

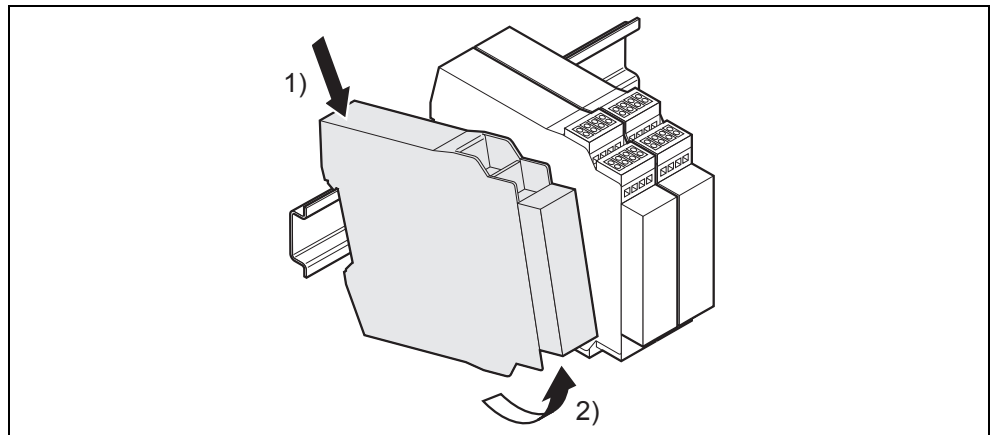

- ⇒ Press the module downwards at the rear (1)) and remove it from the DIN rail in the direction of the arrow while keeping it pressed down (2)).

4.3 Electrical installation



Switch the entire machine/system off line!

The system could start up unexpectedly while you are connecting the devices.

Note

- The CC-Link interface module fulfills the EMC requirements in accordance with the basic specification EN 61000-6-2 for industrial use.
- To ensure full electromagnetic compatibility (EMC), the mounting rail has to be connected to functional earth (FE).
- The control cabinet or assembly casing of the MELSEC-WS safety controller must comply at least with enclosure rating IP 54.
- Mount the modules in accordance with EN 50274.
- Electrical installation in accordance with EN 60204-1
- The voltage supply of the devices must be capable of buffering brief mains voltage failures of 20 ms as specified in EN 60204-1.
- The voltage supply has to fulfill the regulations for extra-low voltages with safe separation (SELV, PELV) in accordance with EN 60664 and DIN 50178 (equipment of electrical power installation with electronic devices).
- Ensure that all the modules of the MELSEC-WS safety controller, the connected protective devices as well as the voltage supplies are connected with the same earth (GND). The GND of the RS-232 interface is connected internally to the GND of the supply of the CPU module (A2).
- Connect all fieldbus and CC-Link cable shields directly at the control cabinet entrance to the functional earth (FE).
- Use dedicated cables as specified by the manufacturer for the CC-Link system. If a cable other than the one specified by the manufacturer is used, the performance of the CC-Link system is not guaranteed.
Also, follow the specifications shown in the Cable Wiring Manual from CC-Link Partner Association for the overall cable distance and the station-to-station cable length. If the wiring does not meet the specifications, accurate data transmission is not guaranteed.
- Do not install the control lines or communication cables together with the main circuit lines or power cables. Failure to do so may result in malfunction due to noise.
- For other details, see the Cable Wiring Manual from CC-Link Partner Association.
CC-Link Partner Association website: www.cc-link.org

4.4 Connecting CC-Link dedicated cables

If the shield of a CC-Link dedicated cable is not properly grounded, the cable does not meet the specifications of noise immunity.

Ground the shield of a cable connected to the CC-Link interface module which is the farthest from the input power inside the control cabinet or any of the stations on the CC-Link network within 30 cm from the module or station.

The CC-Link dedicated cables are shielded cables.

Strip a part of the jacket of the cable as shown in Figure 7 and ground the exposed shield to the ground as much as possible.

Figure 7:
Grounding a CC-Link dedicated cable

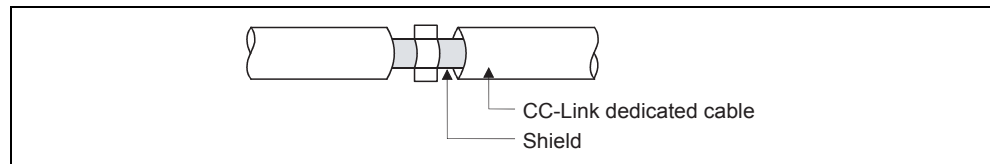

The following shows the connection between the WS0-GCC1 and the master station using a CC-Link dedicated cable.

Figure 8:
Connecting stations to FG line inside the control cabinet

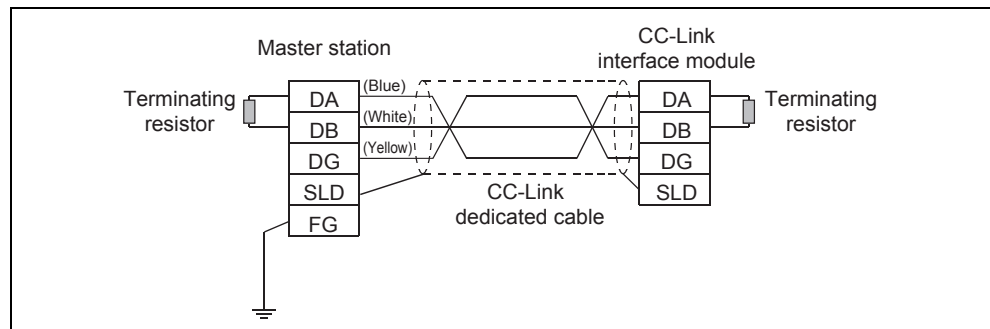

Use a bar terminal to connect the cable to the CC-Link interface module.

For applicable bar terminals, see Section 7.4.

Two poles of each terminal are internally connected. (See below.)

The SLD terminal is connected to the earthing spring contact at inside of the CC-Link interface module.

Figure 9:
Connecting CC-Link interface modules

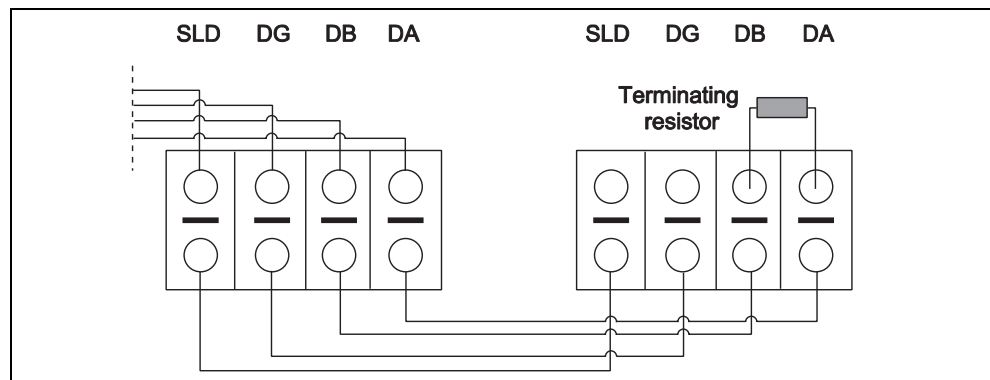

The above figure shows a view from under the module after wiring.

4.5 First configuration steps

This chapter describes the basic steps you have to perform for the configuration of the CC-Link interface module:

- Station number configuration
- Establish a first connection between the MELSEC-WS safety controller and a PC or notebook.
- Configuration of the number of occupied stations
- Upload or transfer of a configuration
- Verification of a configuration

4.5.1 Station number configuration

Configure the station number of the CC-Link interface module.

Since the configured station number becomes valid when the module is powered on, power off the module before configuration.

The following is an example when the station number is set to “11”.

Figure 10:
Station number setting
switches

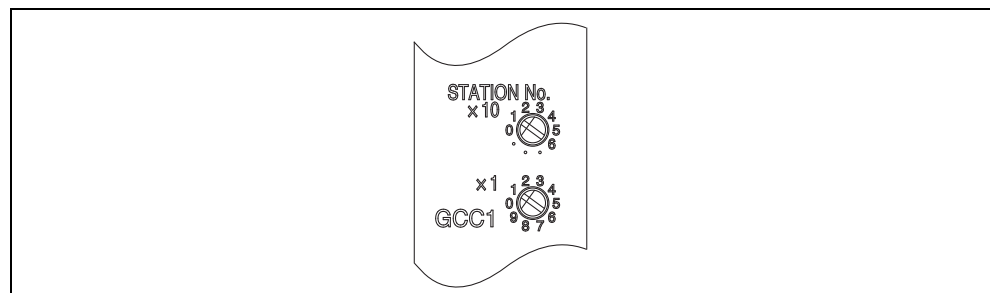

4.5.2 Establishing a connection between MELSEC-WS safety controller and PC

- ⇒ Connect a PC or notebook to the RS-232 interface of the CPU module.
- ⇒ Power on the MELSEC-WS safety controller.
- ⇒ Open the Setting and Monitoring Tool installed on the PC.
- ⇒ Click on **Com settings** to ensure the correct communication interface has been selected. The following dialog appears:

Figure 11:
Connection settings dialog

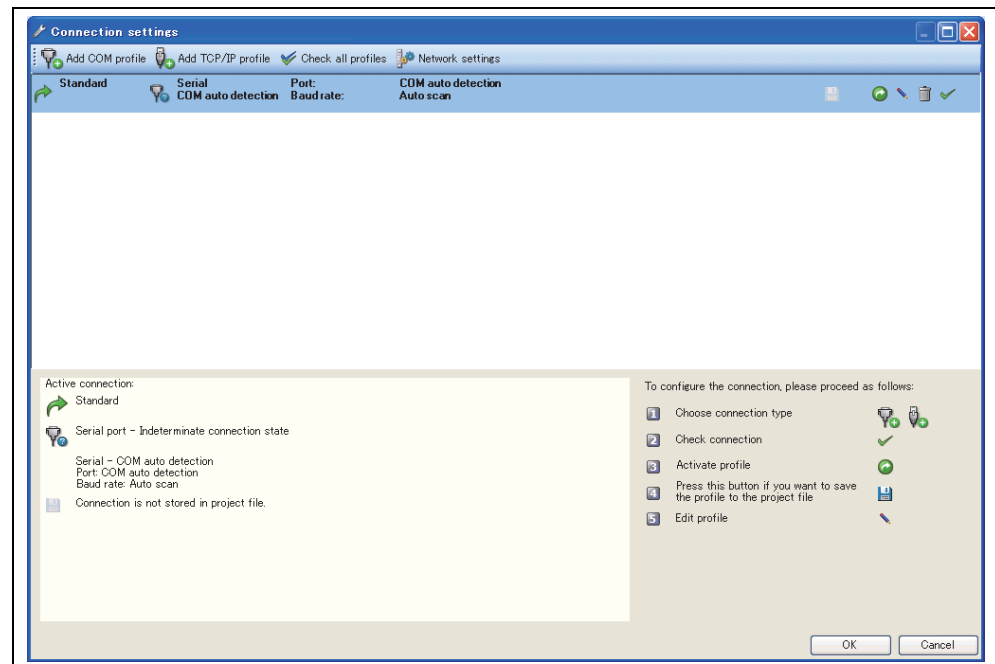

- ⇒ To edit the settings click on the pencil icon to the right. The following dialog appears:

Figure 12:
Modify profile dialog

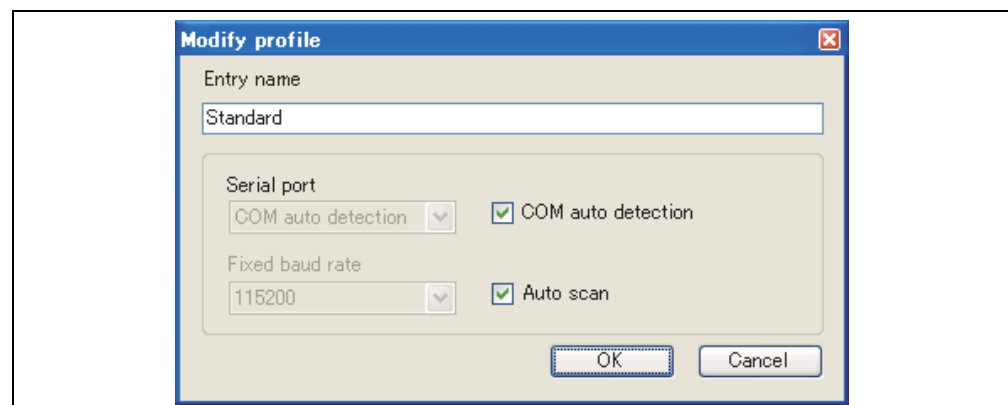

- ⇒ Modify the settings if required.
- ⇒ Click **OK**. The dialog closes.
- ⇒ Click on **Connect**. The Setting and Monitoring Tool will search for connected MELSEC-WS safety controller and load the hardware configuration into the **Hardware configuration** dialog. Once all modules have been identified correctly, the Setting and Monitoring Tool will ask whether the configuration shall be uploaded.
- ⇒ Click **Yes** to upload the configuration.

As an example, the following hardware configuration may appear:

Figure 13:
Hardware configuration dialog

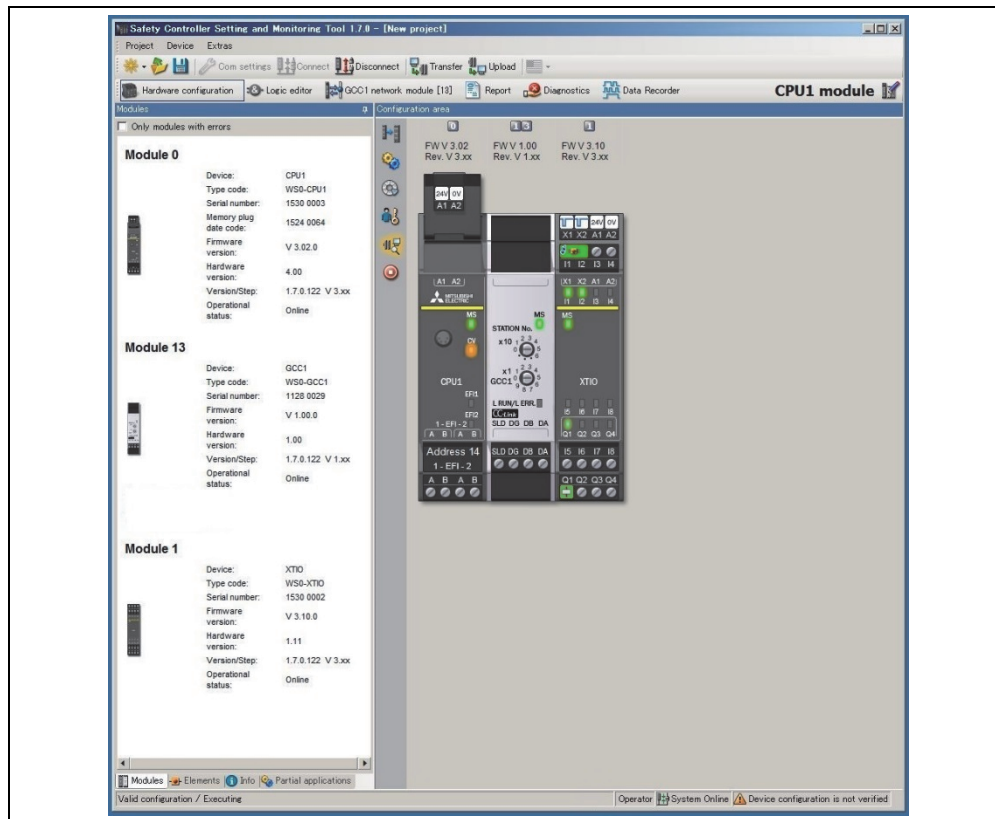

⇒ Click **Disconnect** to go into the offline mode if you want to change the configuration of the MELSEC-WS modules.

4.5.3 Configuration of the number of occupied stations

⇒ Click on **Network module configuration** on the left hand menu.

⇒ Configure the number of occupied stations.

The following is an example when **1 station occupied** has been selected.

Figure 14:
Configuration of the number of occupied stations

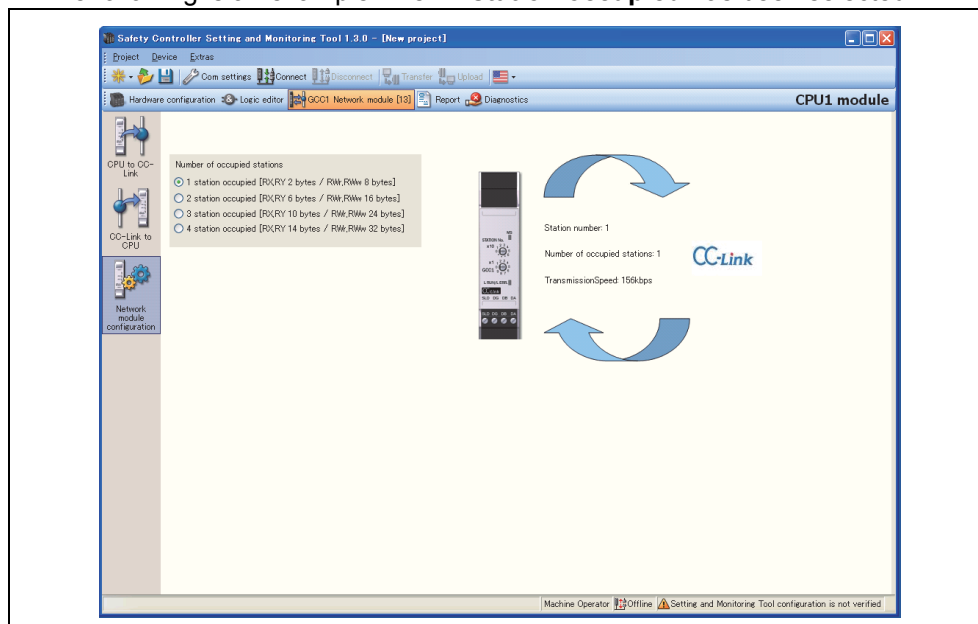

4.5.4 Parameter configuration

The following parameters can be configured with Setting and Monitoring Tool.

Table 7:
Parameter configuration

No.	Option		Description
1	Number of occupied stations		Select the number of stations occupied by the CC-Link interface modules.
2	Data sets for cyclic communication	Input data set (MELSEC-WS to CC-Link)	Customize the input data sets.
3		Output data set (CC-Link to MELSEC-WS)	Define tag names for the output data sets.

(1) Number of occupied stations

According to data size, the number of stations occupied by the CC-Link interface module can be configured by the parameter (1 to 4).

Table 7 shows the data size for each device (remote input (RX), remote output (RY), and remote registers (RWw and RWr)), depending on the number of occupied stations.

Table 8:
Device size depending on the number of occupied stations

Number of occupied stations	Device name			
	RX	RY	RWw	RWr
1 (default)	2 bytes (+ 2 bytes used by the system)	2 bytes (+ 2 bytes used by the system)	8 bytes	8 bytes
2	6 bytes (+ 2 bytes used by the system)	6 bytes (+ 2 bytes used by the system)	16 bytes	16 bytes
3	10 bytes (+ 2 bytes used by the system)	10 bytes (+ 2 bytes used by the system)	24 bytes	24 bytes
4	14 bytes (+ 2 bytes used by the system)	14 bytes (+ 2 bytes used by the system)	32 bytes	32 bytes

(2) Customizing network input/output data sets

For customization of network input and output data sets, see Section 5.4 and Section 5.6.

(3) Transmission speed

Since the transmission speed of the CC-Link interface module is determined according to that of the master station, it does not need to be configured.

When the transmission speed is determined, Remote READY (RX(m+n)B) turns on.

4.5.5 Transfer of a configuration

Once you have finished the configuration, you have to transfer the configuration to your MELSEC-WS safety controller. In order to transfer a configuration, perform the following steps:

- ⇒ Click **Connect** to go online. The Setting and Monitoring Tool connects to the MELSEC-WS safety controller.
- ⇒ Click **Transfer** to transfer the configuration to the MELSEC-WS safety controller.

Note Depending on your current user level, you will be prompted to log on as Administrator to be able to transfer a configuration. For details please see the Safety Controller Setting and Monitoring Tool Operating Manual.

- ⇒ Once the transfer has been completed, you will be asked whether you want to run the CPU module. Depending on your choice, click **Yes** or **No** to leave the dialog.

Note You can also start and stop the application in the **Hardware configuration** view using the **Run application** or **Stop application** buttons while the project is online. More information can be found in the Safety Controller Setting and Monitoring Tool Operating Manual.

4.5.6 Verification of a configuration

After the configuration has been transferred successfully, the MELSEC-WS safety controller can be verified. To this purpose, the downloaded configuration data are read back out from the safety controller and compared with the project data. If they match, the data are displayed in a report. If the user confirms that they are correct, the safety controller is considered to be verified.

- ⇒ In the **Hardware configuration** view, click the icon **Upload and verify configuration** and compare the configuration. The **Upload and verify result** window is opened.
- ⇒ Click **Yes** below at the question **Set device to verified?** if the displayed configuration is the expected configuration. The safety controller is then considered to be verified.

Note

- You have to be logged in as an Administrator in order to mark the device as “verified”.
- If the verification is completed successfully, a “Read in and compare” report that provides the most important project information is created subsequently. You can print out or store this report.
- The status verified/not verified is indicated in the lower right-hand corner of the Setting and Monitoring Tool and by the CV LED of the CPU module turning on.
- Only if the device and the corresponding configuration have been marked as verified, the **Auto RUN Mode** is active in the configuration of the CPU module. If the configuration is not set to verified, the safety controller stays in Idle mode (CV LED on the CPU module flashing) after power up and needs to be set to **Run Mode** using the Setting and Monitoring Tool.
- If differences between the project data and the read-back configuration data are detected, a corresponding message including information about possible actions is displayed. Verification of the configuration is not possible then. Observe the information in the error message for the further procedure. Terminate the dialog box by clicking **Close**.
- If you change a verified configuration, the status is reset to “not verified”.
Exception: If you make only non safety-related changes such as modifying the CC-Link interface module name or the number of occupied stations, the configuration status remains “verified”.

More information can be found in the Safety Controller Setting and Monitoring Tool Operating Manual.

4.5.7 Upload of a configuration

When in online mode, you can upload a configuration from the connected MELSEC-WS safety controller:

- ⇒ Click on **Upload**. The current configuration of the safety controller will be loaded into the Setting and Monitoring Tool and can be edited after going offline.

5. Data sets

The CC-Link interface module allows the MELSEC-WS safety controller to send and receive non-safety related data to and from the external fieldbus system for control and diagnostics purposes.

Note In this manual, the data exchanged between the MELSEC-WS safety controller and the respective network will be considered always from the network master (programmable controller) point of view. Therefore data sent from the MELSEC-WS safety controller into the network (master station) will be referred to as network input while data received from the network (master station) will be referred to as network output.



Do not operate a CC-Link interface module on a safety fieldbus!

The CC-Link interface module is not suitable for operation on a safety fieldbus. It does not support any safety mechanism, which would be mandatory to communicate within a safety network.

Configuration of the CC-Link interface module is performed using the Setting and Monitoring Tool on a PC or notebook connected to the CPU module over RS-232 interface. Configuration data can be exported, imported, and saved.

If the MELSEC-WS safety controller has been configured to integrate non-safe information from the fieldbus into the logic editor, a decoupling of the CC-Link interface module can result in availability problems.

A CC-Link interface module can only be operated on a MELSEC-WS safety controller. It does not have a dedicated voltage supply. It is possible to use two network modules per system.

The CC-Link interface module is fitted in a 22.5 mm wide housing for 35 mm rails in accordance with EN 60715.

5.1 Data transmitted into the network (network input data sets (RX, RWr))

Available data

The CC-Link interface module can provide the following data:

- Operational data
 - **Logic results** from the CPU module (see Section 5.1.1.)
 - **Input values** (Active/Inactive) for all safety I/O modules in the system and EFI devices connected (see Section 5.1.2.)
 - **Output values** (Active/Inactive) for all safety I/O modules and EFI devices connected (see Section 5.1.2.)
 - **Output data** from another network, i.e. data received by a second network module in the safety controller (see Section 5.1.3.)

Data sets

- Input data sets to be sent from the CC-Link interface module to the network consist of logic results, I/O state data, and other data.
- If a CC-Link network is disconnected, data communication will be disabled. To hold input data (RX) in the master station, open the **Operational settings** window from the CC-Link parameter dialog box of GX Developer and check the **Hold input data** checkbox under **Data link disorder station setting**.

Note If a dual-channel element is connected to a safety I/O module, the low-order bit of the redundant I/O signals shows the active I/O state (ON/OFF) of the element.

5.1.1 Logic results

Logic results generated by the logic editor of the CPU module can be sent to the master station. Up to 20 bytes are available where each bit represents one logic result from the logic editor.

Data set containing the logic results can be customized. For detailed information see Section 5.4.

5.1.2 Module and EFI input and output values

The CC-Link interface module can transmit all input and output states of all MELSEC-WS modules and EFI devices connected to the MELSEC-WS safety controller to the master station. Data set containing the input and output values and the EFI information can be customized. For detailed information see Section 5.4.

Module input and output states

The input and output states of the modules are transmitted using one byte for each module's inputs and one byte for each module's outputs where each bit represents the state of one input or output (on/off).

EFI system information

The WS0-CPU1 and WS0-CPU3 have 2 EFI interfaces. An EFI interface is a safe communication interface between SICK devices. It allows to

- read out information from the safety devices (e.g. SICK C4000, S3000)
- transfer commands to the safety devices

The CC-Link interface module allows these EFI devices connected to the WS0-CPU1 and WS0-CPU3 to transmit their data to the master station.

Note

It is only possible to select the EFI data in byte arrays. 4 byte arrays for each connected EFI device are available. Some of the data contents are reserved and can not be used at the programmable controller.

Further information about the properties, functions and benefits of the EFI interfaces can be found in the Safety Controller User's Manual.

5.1.3 Routing of data from a second network

If your MELSEC-WS safety controller contains two network modules, it is possible to route information received by the first network module from one network (e.g. from an HMI) into a second network (e.g. to a programmable controller) via the second network module and vice versa.

5.2 Data received from the network (network output data sets) (RY, RWw))

The data received from the master station are organized in output data sets (max. 46 bytes (RY is 14 bytes and RWw is 32 bytes)).

The contents of the output data blocks can be used within the Setting and Monitoring Tool logic editor and can also be made available to another network via a second network module in the MELSEC-WS safety controller.

- Note**
- In order to make the data from the network available in the logic editor or as input to another network, you will have to define a tag name for each bit that shall be used.
 - Bits without a tag name will not be available in the logic editor nor for routing via another network module. For detailed information on how to define tag names for the data received please see Section 5.6.

These modules may only be used by qualified safety personnel and only on the machine where they have been installed and initialized by qualified safety personnel in accordance with the manual.

The status of the communication to and from the network can be checked by monitoring the input data status (for data received from the master station) and the output data status (for data send to the master station) in the logic editor. When the CC-Link interface module detects a communication error or the STOP status of the CPU module on the master station, the network output data sets will be set to off and the corresponding data status will also be set to off.

Table 9:
Data status

No.	Name	Description	Remarks
1	Input data status	Off: Error On: Normal	This signal turns on when data is normally received from the master station.
2	Output data status	Off: Error On: Normal	This signal turns on when data to be sent from the WS0-GCC1 to the master station is ready. Monitor this signal to check if data is ready for transmission.



Since output data set, input data status, and output data status are non-safety related data, do not use them for safety related applications.

5.3 Default settings for the input data set

In the delivery status, the input data set (RX, RWr) of the CC-Link interface module are pre-configured. The following table shows the default data assignment.

The default byte assignment can be freely customized as will be described in the following section. The "remote READY" and "use prohibited" areas shown in the following table are for system use; therefore, these areas are not displayed on the editing window.

Table 10: Default configuration for the input data set

Data	One station is occupied.	Two stations are occupied.	Three stations are occupied.	Four stations are occupied.				
RX07 - RX00	-	-	-	-				
RX0F - RX08	-	-	-	-				
RX17 - RX10	RX1B: Remote READY Other than RX1B: Use prohibited	-	-	-				
RX1F - RX18		-	-	-				
RX27 - RX20	X	-	-	-				
RX2F - RX28		-	-	-				
RX37 - RX30		RX3B: Remote READY Other than RX3B: Use prohibited	-	-				
RX3F - RX38			-	-				
RX47 - RX40		X	-	-				
RX4F - RX48			-	-				
RX57 - RX50			RX5B: Remote READY Other than RX5B: Use prohibited	-	-			
RX5F - RX58				-	-			
RX67 - RX60			X	X	X	-		
RX6F - RX68						-		
RX77 - RX70	RX7B: Remote READY Other than RX7B: Use prohibited					-		
RX7F - RX78						-		
RWr00 Low	Logic result 0					Logic result 0	Logic result 0	Logic result 0
RWr00 High	Logic result 1					Logic result 1	Logic result 1	Logic result 1
RWr01 Low	Logic result 2	Logic result 2				Logic result 2	Logic result 2	
RWr01 High	Logic result 3	Logic result 3				Logic result 3	Logic result 3	
RWr02 Low	Module 1 input	Module 1 input				Module 1 input	Module 1 input	
RWr02 High	Module 1 output	Module 1 output				Module 1 output	Module 1 output	
RWr03 Low	Module 2 input	Module 2 input	Module 2 input	Module 2 input				
RWr03 High	Module 2 output	Module 2 output	Module 2 output	Module 2 output				
RWr04 Low	X	Module 3 input	Module 3 input	Module 3 input				
RWr04 High		Module 3 output	Module 3 output	Module 3 output				
RWr05 Low		Module 4 input	Module 4 input	Module 4 input				
RWr05 High		Module 4 output	Module 4 output	Module 4 output				
RWr06 Low		Module 5 input	Module 5 input	Module 5 input				
RWr06 High		Module 5 output	Module 5 output	Module 5 output				
RWr07 Low		Module 6 input	Module 6 input	Module 6 input				
RWr07 High		Module 6 output	Module 6 output	Module 6 output				
RWr08 Low		X	X	Module 7 input	Module 7 input			
RWr08 High				Module 7 output	Module 7 output			
RWr09 Low	Module 8 input			Module 8 input				
RWr09 High	Module 8 output			Module 8 output				
RWr0A Low	Module 9 input			Module 9 input				
RWr0A High	Module 9 output			Module 9 output				
RWr0B Low	Module 10 input			Module 10 input				
RWr0B High	Module 10 output			Module 10 output				
RWr0C Low	X			X	Module 11 input	Module 11 input		
RWr0C High					Module 11 output	Module 11 output		
RWr0D Low		Module 12 input	Module 12 input					
RWr0D High		Module 12 output	Module 12 output					
RWr0E Low	-	-	-	-				
RWr0E High	-	-	-	-				
RWr0F Low	-	-	-	-				
RWr0F High	-	-	-	-				

-: Not configured ("0" is sent.)

5.4 Customizing the input data set (MELSEC-WS to CC-Link)

This section outlines briefly how you can customize the input data set that the CC-Link interface module transmits to the network.

In the delivery status, the data routing configuration of the CC-Link interface module is shown in the network module configuration dialog.

- ⇒ Click on the **GCC1 Network module [13]** button (**Network Modules** button when two network modules are used) above the main window and select the desired CC-Link interface module or double click the desired CC-Link interface module in the hardware configuration to open the network module configuration dialog.
- ⇒ Click on the **MELSEC-WS to CC-Link** tab on the left hand menu to display the network module configuration dialog.

The default setting is as follows:

Figure 15:
MELSEC-WS to CC-Link
dialog of the WS0-GCC1

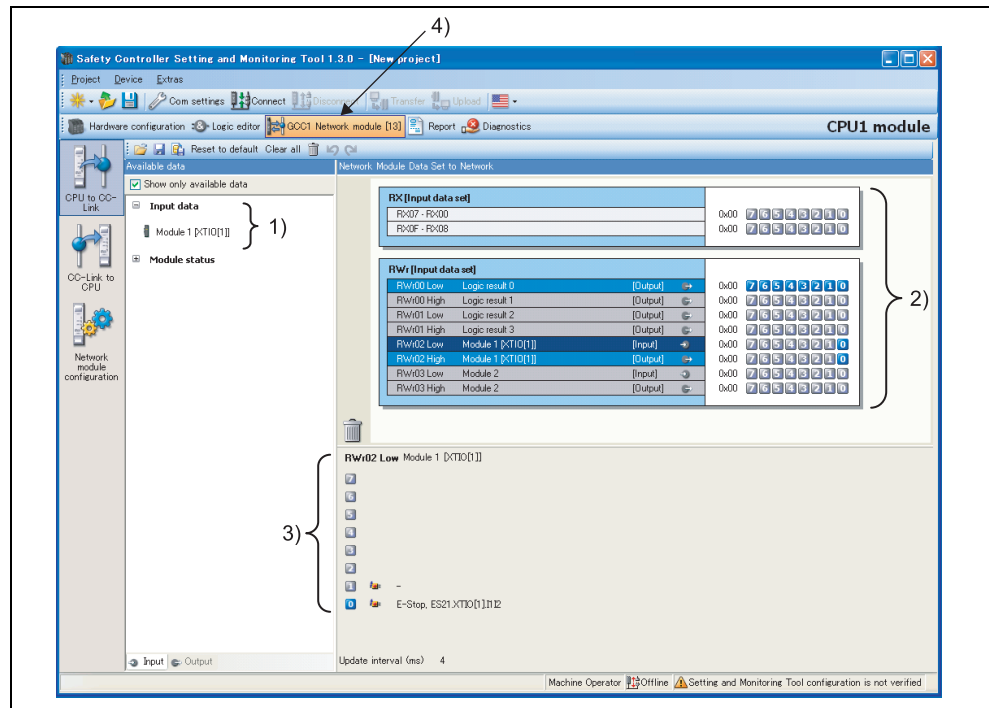

Basically this dialog is divided into three areas: **Available data** (1)), **Network Module Data** (2)) and **Tag names** (3)). The upper left corner of the dialog holds the toolbar (4)).

5.4.1 The toolbar

Figure 16:
Toolbar for the routing
configuration



The toolbar contains buttons for the following actions (from left to right):

- The **Load user configuration** and **Save user configuration** buttons allow you to load and/or save a configuration including the used tag names in XML format. If you load a configuration, all previously made changes that have not been saved will be lost. You can not undo this action.
- With the **Import** and **Export** buttons you can import and export the used tag names used as a CSV (comma separated values) file. This allows you to import and use the assigned tag names in a programmable controller program. To edit the CSV file, use a text editor.

Note When importing the exported network module data after editing the data in a text editor such as Notepad, select **CSV Files - Shift-JIS encoded** for **Files of type** in the **Open** dialog box if the data is saved in ANSI format. If not, characters in the data may get garbled.

Note The **Import** button is only available for the CC-Link to MELSEC-WS routing configuration.

- **Reset to default** restores the default routing configuration. You will be prompted for confirmation. If you click **Yes**, all previously made changes that have not been saved will be lost. You can not undo this action.
- **Clear all** clears the configuration, i.e. deletes all assigned bytes in the **Network Module Data** area. You will be prompted for confirmation.
- **Delete routing** deletes the selected byte from the **Network Module Data** area.
- The **Undo** and **Redo** buttons allow you to undo or redo changes you made to your configuration.

5.4.2 Available data area

This area offers all sources from which data may be routed into the network. It is divided in two views holding the available **Input types** and **Output** data. You can switch between these views using the file cards at the bottom.

- The **Input types** view contains the input values for the connected MELSEC-WS modules and EFI devices. If your MELSEC-WS safety controller contains a second network module, the input data of this network module (i.e. data received from the network the second network module is connected to) will be available here as well.
- The **Output** view offers the output values for the connected MELSEC-WS modules and EFI devices as well as the **Logic results** from the logic editor.

All sources supported by the current configuration are displayed in black:

- connected MELSEC-WS modules
- connected EFI devices
- configured logic results*1
- input data available from another network module in the system

*1 In the default configuration, only the first logic result byte (Logic Result 0) is active and available. You can activate more logic result output bits in the logic editor.

Sources currently not configured will be displayed in grey. Activating the **Show only available data** checkbox in the upper left corner hides the unused sources from the view.

Sources that offer “live” data are marked with a little icon next to the text.

How to add a data byte to the routing table:

⇒ Drag and drop an element (i.e. byte) from the **Available data** area to a free slot in the **Network Module Data** area. If the desired position is not free, you will have to clear it first by deleting or moving the byte currently assigned to it.

Note It is possible to use the same byte several times in the routing table.

5.4.3 Network Module Data area

This area contains the routing table. It shows the current content of the CC-Link interface module's input data modules. Bytes and bits highlighted blue will hold "live" data from the system since the hardware configuration does support the source. Bytes highlighted grey actually do not have data associated with them since the hardware configuration does not support the sources.

How to delete a data byte from the routing table:

⇒ Drag and drop the byte you want to delete to the trashcan icon in the bottom left corner of the **Network Module Data** area.

Or:

⇒ Select the byte you want to delete by clicking it with the left mouse button. Then, click on the **Delete routing** button in the toolbar.

Or:

⇒ Call up the context menu by clicking the respective byte with the right mouse button. In the context menu, select the **Delete routing** command.

How to move a data byte to another place in the routing table:

⇒ Drag and drop the byte you want to move to the desired position. If the desired position is not free, you will have to clear it first by deleting or moving the byte currently assigned to it.

5.4.4 Tag names area

This area shows the tag names associated with each bit of the byte currently selected in the **Available data** or the **Network Module Data** area. You can enter these tag names in the tag name editor.

In the **Tag names** area of the **MELSEC-WS to CC-Link** configuration dialog, you can only edit tag names for unassigned data sets by activating the **Use direct editing** checkbox (with CPU module firmware version V2.01 or higher).

5.5 Default settings for the output data set

In the delivery status, the output data set (RY, RWw) of the CC-Link interface module are pre-configured. The following table shows the default data assignment.

The "reserved" areas shown in the following table are for system use; therefore, these areas are not displayed on the editing window.

Table 11:
Default configuration for
the output data set

Data	One station is occupied.	Two stations are occupied.	Three stations are occupied.	Four stations are occupied.		
RY07 - RY00	Byte 0	Byte 0	Byte 0	Byte 0		
RY0F - RY08	Byte 1	Byte 1	Byte 1	Byte 1		
RY17 - RY10	Use prohibited	Byte 2	Byte 2	Byte 2		
RY1F - RY18		Byte 3	Byte 3	Byte 3		
RY27 - RY20	X	-	-	--		
RY2F - RY28		-	-	-		
RY37 - RY30		Use prohibited	-	-	-	
RY3F - RY38			-	-	-	
RY47 - RY40		X	-	-	-	
RY4F - RY48			-	-	-	
RY57 - RY50			Use prohibited	-	-	-
RY5F - RY58				-	-	-
RY67 - RY60			X	-	-	-
RY6F - RY68				-	-	-
RY77 - RY70	-	-		-		
RY7F - RY78	-	-	-	Use prohibited		

-: Not configured

Data	One station is occupied.	Two stations are occupied.	Three stations are occupied.	Four stations are occupied.	
RWw00 Low	-	-	-	-	
RWw00 High	-	-	-	-	
RWw01 Low	-	-	-	-	
RWw01 High	-	-	-	-	
RWw02 Low	-	-	-	-	
RWw02 High	-	-	-	-	
RWw03 Low	-	-	-	-	
RWw03 High	-	-	-	-	
RWw04 Low	X	-	-	-	
RWw04 High		-	-	-	
RWw05 Low		-	-	-	
RWw05 High		-	-	-	
RWw06 Low		-	-	-	
RWw06 High		-	-	-	
RWw07 Low		-	-	-	
RWw07 High		-	-	-	
RWw08 Low		X	-	-	-
RWw08 High			-	-	-
RWw09 Low			-	-	-
RWw09 High			-	-	-
RWw0A Low			-	-	-
RWw0A High			-	-	-
RWw0B Low			-	-	-
RWw0B High			-	-	-
RWw0C Low	X	-	-	-	
RWw0C High		-	-	-	
RWw0D Low		-	-	-	
RWw0D High		-	-	-	
RWw0E Low		-	-	-	
RWw0E High		-	-	-	
RWw0F Low	-	-	-	-	
RWw0F High	-	-	-	-	

-: Not configured

Remote READY turns on when a transmission speed is determined by the autosensing function.

Check that Remote READY is on before configuring the RY and RWw values using the sequence program.

5.6 Tag names for incoming data (CC-Link to MELSEC-WS)

In order to enable incoming data bits:

- ⇒ Click on **CC-Link to MELSEC-WS** on the left hand menu. The following dialog appears:

Figure 17:
CC-Link to MELSEC-WS dialog of the WS0-GCC1

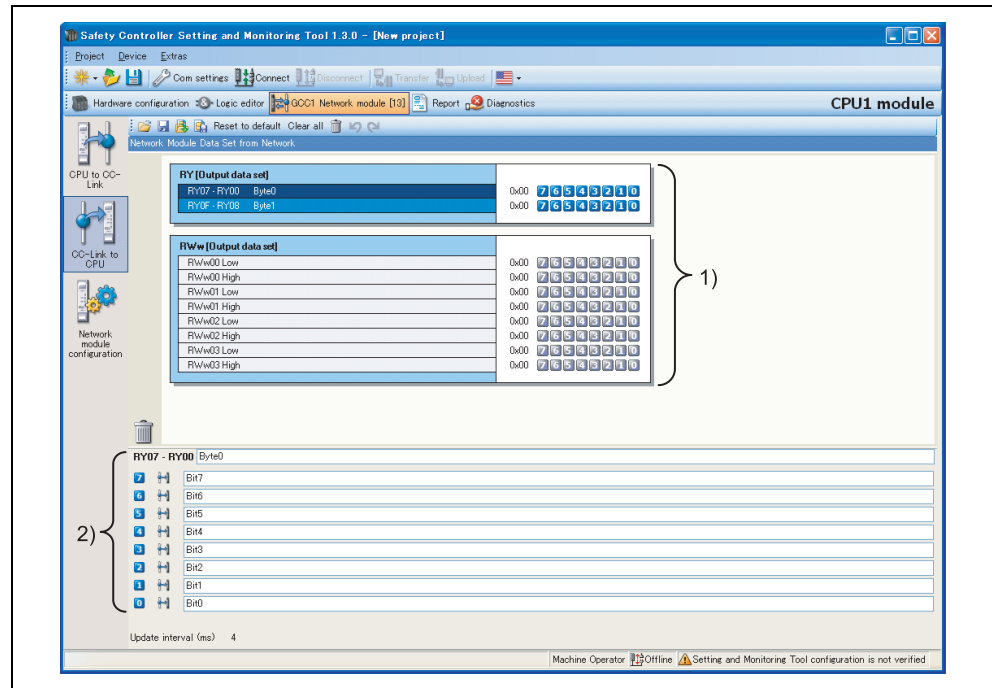

Basically this dialog is divided into two areas: **Network Module Data (1)** and **Tag names (2)**:

The **Network Module Data** area shows the current configuration of the output modules.

The **Tag names** area shows the tag names associated to the byte selected in the **Network Module Data** area.

- ⇒ Select a byte in the **Network Module Data** area.
- ⇒ For each bit of the selected byte that you wish to use, enter a tag name in the **Tag names** area.

Each bit you enter a tag name for here will be available within the logic editor or for the process image of a second network module:

Figure 18:
Tag names of incoming bits of the WS0-GCC1 in the logic editor dialog

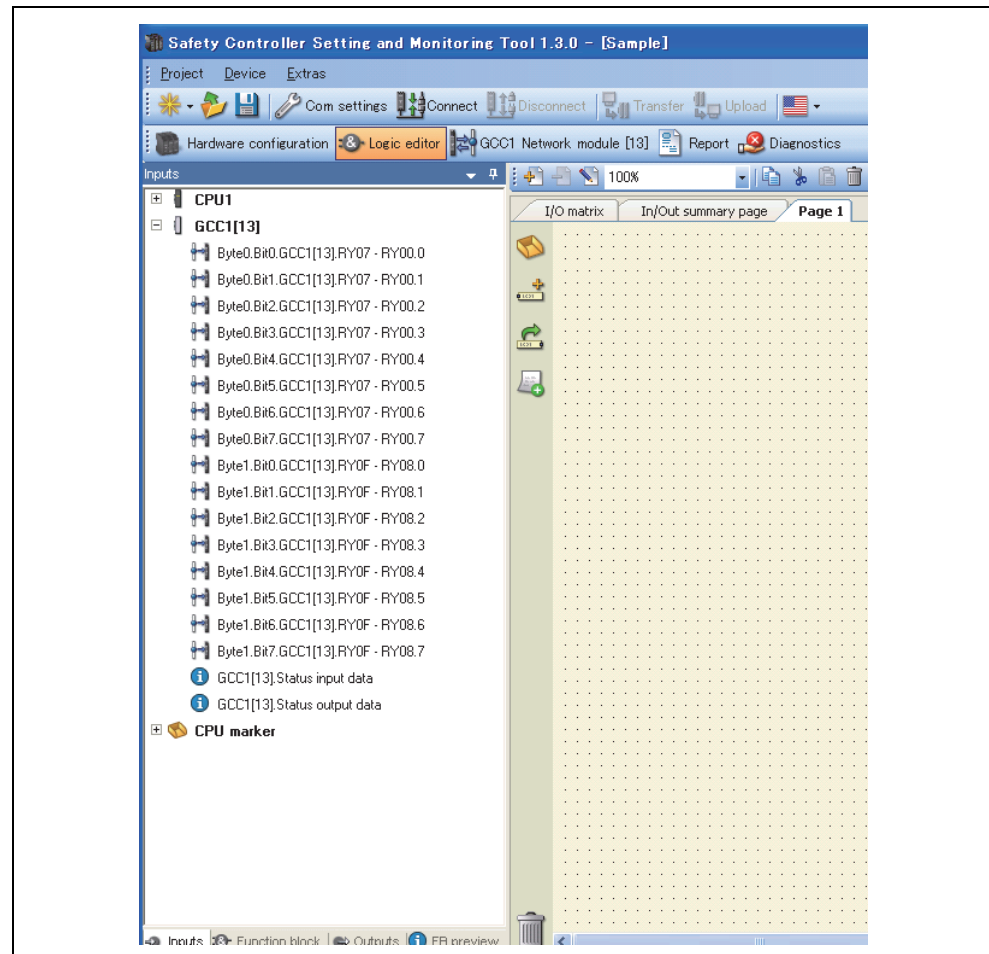

5.6.1 Saving and loading a configuration

Using the buttons **Load user configuration** and **Save user configuration** you can save and load your configuration in XML format. If you load a configuration, all previously made changes that have not been saved will be lost. You can not undo this action.

5.6.2 Importing and exporting a configuration

With the **Import** and **Export** buttons you can import and export a configuration including the tag names used as a CSV (comma separated values) file. This allows you to import and use tag names you have assigned in the MELSEC-WS safety controller project in another programmable controller program and vice versa. To edit the CSV file, use a text editor.

If you import a configuration, all previously made changes that have not been saved will be lost. You can not undo this action.

Note The **Import** button is only available for the CC-Link to MELSEC-WS routing configuration.

5.7 Monitoring the data set online

When the MELSEC-WS safety controller is online and running, you can monitor the data set online in the network module configuration dialog.

- ⇒ Click on the **GCC1 Network module [13]** button (**Network Modules** button when two network modules are used) above the main window and select the desired CC-Link interface module or double click the desired CC-Link interface module in the hardware configuration to open the network module configuration dialog.
- ⇒ Click on the **MELSEC-WS to CC-Link** or the **CC-Link to MELSEC-WS** tab on the left hand menu to display the routing view for the input or output data you want to monitor.

For both directions, **MELSEC-WS to CC-Link** as well as **CC-Link to MELSEC-WS**, inactive bits are displayed grey while active bits are highlighted green:

Figure 19:
Active and inactive bits in the online process image

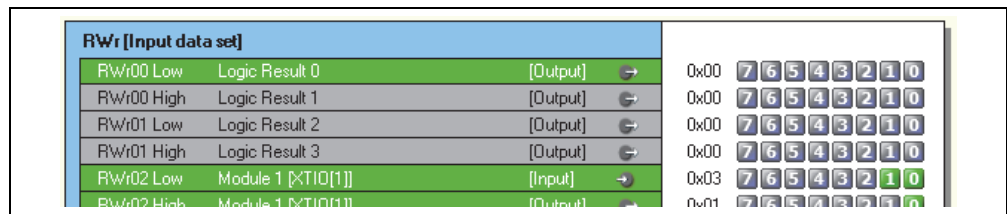

In the **MELSEC-WS to CC-Link** view, bits that are inactive due to an error are displayed red. This could be the case e.g. for the outputs of a WS0-XTIO module if the power supply of this module is faulty:

Figure 20:
Inactive Network input bits as a result of an error

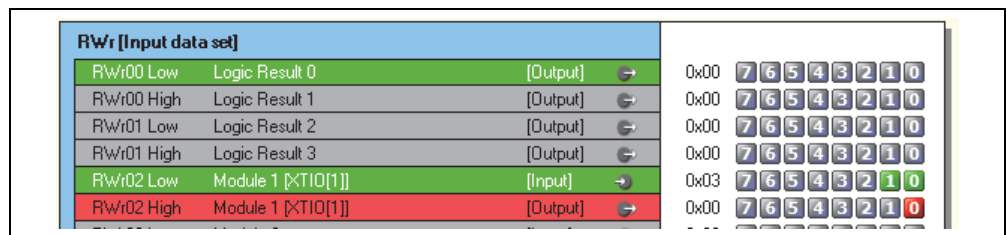

In the **CC-Link to MELSEC-WS** view, bits that have no tag name assigned (so that they can not be used in the logic editor) but which are included in the process image that the CC-Link interface module receives from the programmable controller, are highlighted yellow:

Figure 21:
Network output bits with no tag names assigned in the online process image

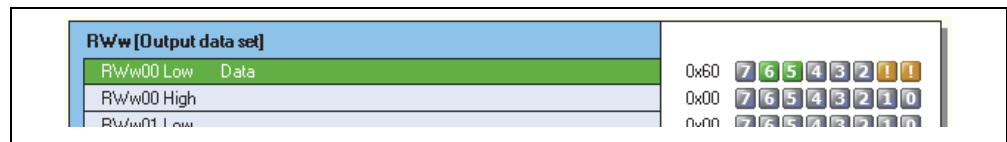

Note The CC-Link interface module always reflects the actual physical status of the inputs and outputs on the connected modules and devices. This means that even when Force mode is active and inputs that are physically **Inactive (Low)** are forced **Active (High)** (or vice versa) the actual physical status of these inputs will be transmitted to the programmable controller instead of the (virtual) forced status. If, however, as a result of forcing of one or several inputs, one or several outputs change their status, the changed status of these outputs will be transmitted to the programmable controller since the actual physical status of the outputs on the devices has changed.

5.8 Accessible range

- Accessible range of Setting and Monitoring Tool
Setting and Monitoring Tool can access the CPU module that is directly connected using an RS-232 cable (cannot access the CPU module over CC-Link).
- Accessibility to network input and network output
The following table shows the accessibility from the station on the CC-Link network to the network input and network output of the WS0-GCC1. The network input can be read from the master stations, local stations, and intelligent device stations. Only the master stations can write the network output.

Figure 22: Reading/writing network input and network output

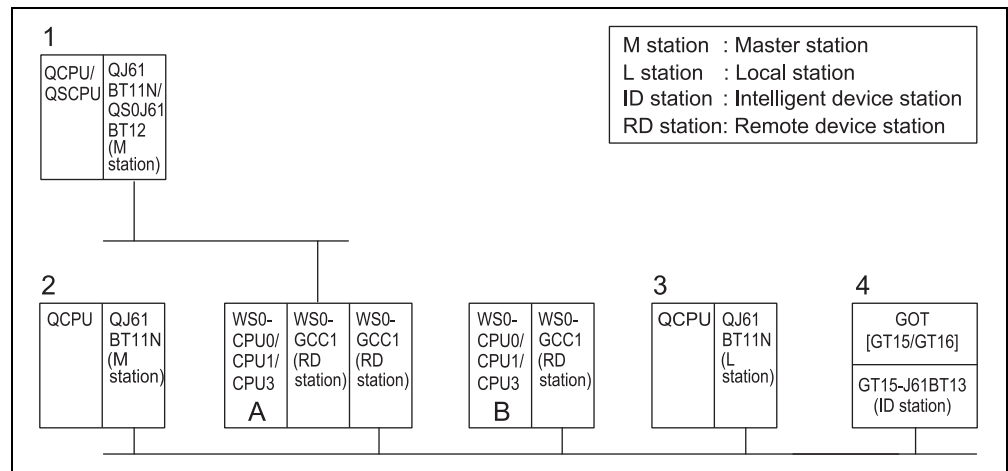

Table 12: Accessibility by cyclic transmission

Access target \ Requesting device	A: WS0-CPU0/CPU1/CPU3	B: WS0-CPU0/CPU1/CPU3
1 QCPU/QSCPU	○	-
2 QCPU	○	○
3 QCPU	△	△
4 GOT (GT15/GT16)	△	△

○: Can be read/written, △: Can be read, -: Cannot be read/written

6. Troubleshooting

Note Check the LEDs of the module during troubleshooting.

6.1 When data cannot be normally exchanged

Refer to the following flowchart when data cannot be normally exchanged.

Figure 23:
Troubleshooting
flowchart: when data
cannot be normally
exchanged

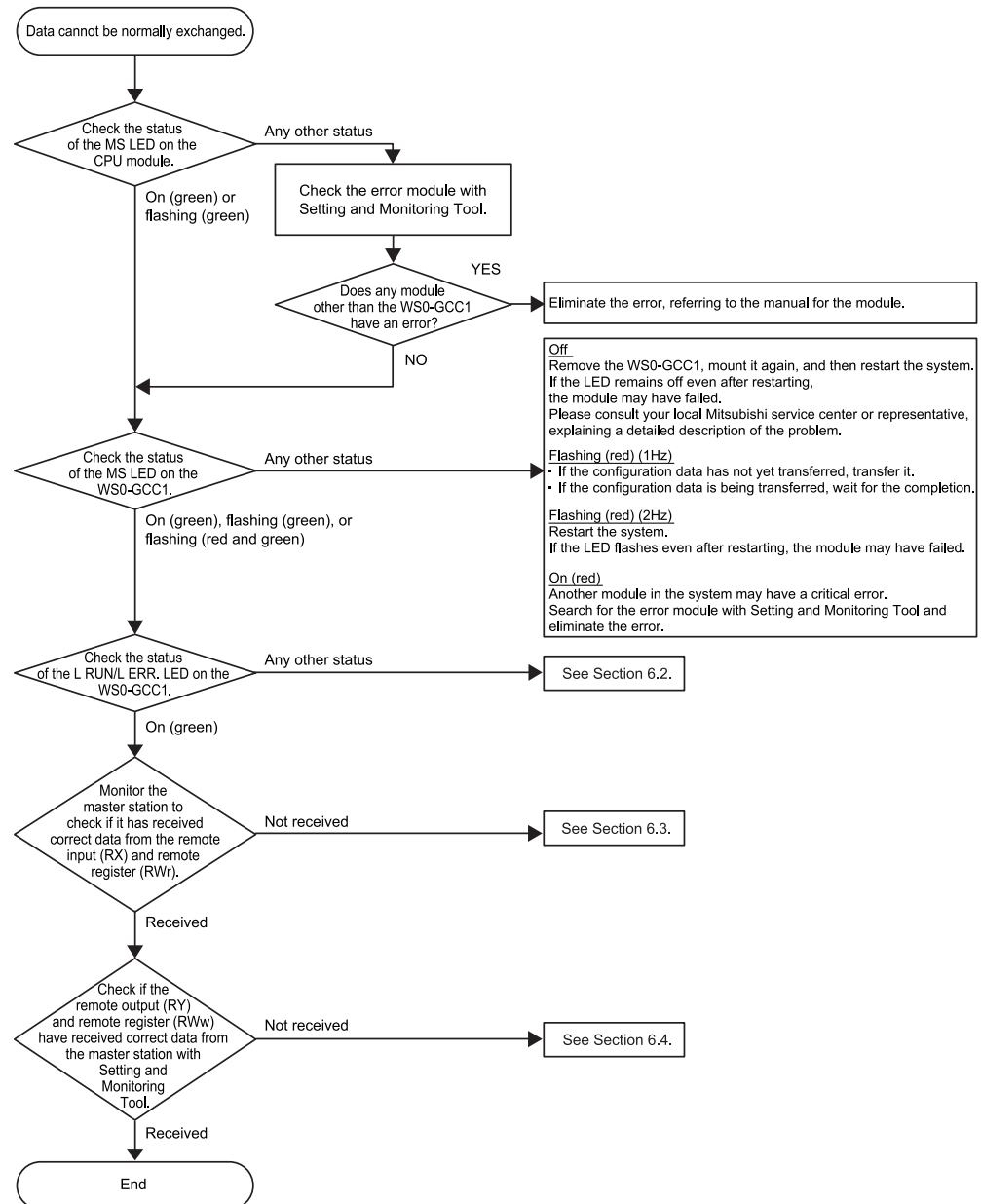

6.2 When the L RUN/L ERR. LED does not turn on (green)

Refer to the following flowchart when the L RUN/L ERR. LED does not turn on (green) at power-on or during RUN of the WS0-GCC1.

Figure 24:
Troubleshooting
flowchart: when the L
RUN/L ERR. does not
turn on (green)

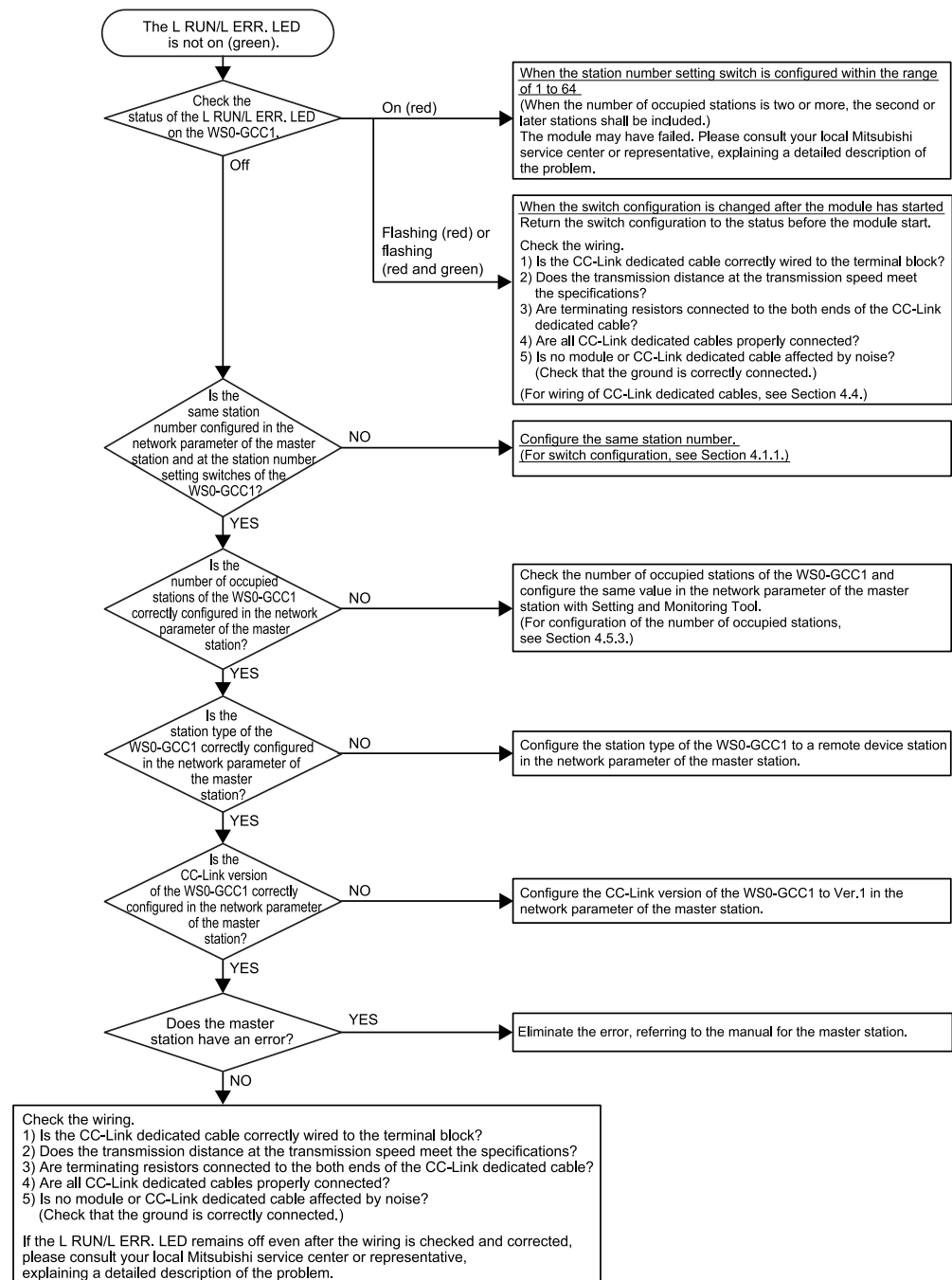

6.3 When an error occurs in remote input (RX) or remote register (RWr)

Refer to the following flowchart when an error occurs in remote input (RX) or remote register (RWr) at power-on or during RUN of the WS0-GCC1.

Figure 25:
Troubleshooting flowchart: when an error occurs in remote input (RX) or remote register (RWr)

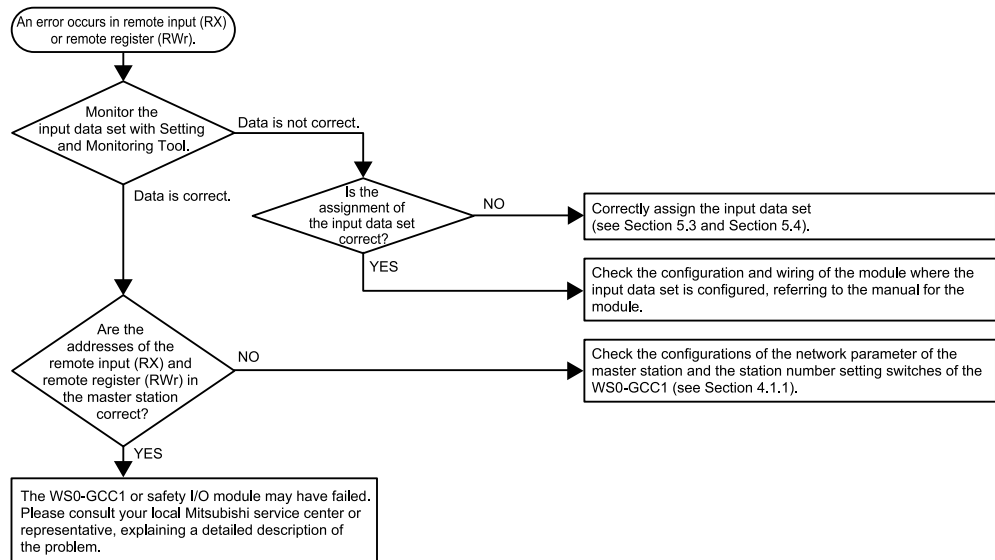

6.4 When an error occurs in remote output (RY) or remote register (RWw)

Refer to the following flowchart when an error occurs in the remote output (RY) or remote register (RWw) at power-on or during RUN of the WS0-GCC1.

Figure 26:
Troubleshooting flowchart: when an error occurs in remote output (RY) or remote register (RWw)

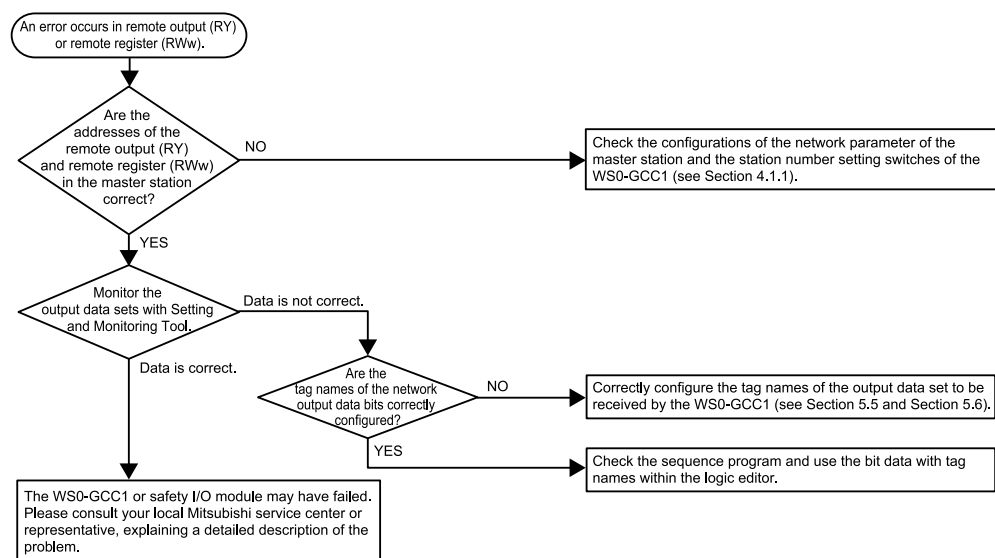

7. Technical specifications

7.1 Technical specifications, supply circuit

Table 13:
Technical specifications, supply circuit

Item	Specifications
Supply voltage	24 V DC (16.8 to 30 V DC)
Power consumption	Max. 1.4 W

7.2 Technical specifications of CC-Link interface module

Table 14:
Technical specifications of CC-Link interface module

Item	Specifications
Fieldbus	CC-Link
CC-Link station type	Remote device station
CC-Link Version	Ver.1.10
Data transmission speed	156kbps/625kbps/2.5Mbps/5Mbps/10Mbps (autosensing)
Station number	1 to 64 (factory default: 0)
Number of occupied stations	1 station (RX/RX 32 points each, RWw/RWr 4 points each)/ 2 stations (RX/RX 64 points each, RWw/RWr 8 points each)/ 3 stations (RX/RX 96 points each, RWw/RWr 12 points each)/ 4 stations (RX/RX 128 points each, RWw/RWr 16 points each) (The last 16 points of RX/RX are for system use (reserved).)
CC-Link interface	1 terminal block at the lower part of the module
Cable	Ver.1.10-compatible CC-Link dedicated cable ^{*1}
Data interface	Backplane bus (FLEXBUS+)

*1 Connect a terminating resistor (110Ω).

7.3 General technical specifications

Table 15:
General technical
specifications

Item	Specifications
Fieldbus	CC-Link
FLEXBUS+	10-pin connector for internal safety bus (plug)
Ambient operating temperature	0°C to +55°C
Storage temperature	-25°C to +70°C
Humidity	10% to 95%, non-condensing
Climatic conditions	According to EN 61131-2
Vibration	Tested in accordance with IEC 61131-2.
Rigidity	Tested in accordance with IEC 61131-2.
Protection class	III
Electromagnetic compatibility	IEC 61000-6-2/EN 55011 Class A
Housing material	Polycarbonate
Housing type	Device for control cabinet installation
Housing enclosure rating/terminals	IP 40/IP 20 according to IEC60529
Housing color	Light grey
Weight	120g
Mounting rail	Mounting rail according to IEC/EN 60715

7.4 Technical specifications of cables

Technical specifications of cables

Table 16:
Technical specifications
of cables

Item	Specifications
Ver1.10-compatible CC-Link dedicated cable	For the specifications and any inquiries on the CC-Link dedicated cables, refer to the following: CC-Link Partner Association website: www.cc-link.org
Cable size	20 AWG
Temperature rating	-15°C to +75°C
Material	Conductor: Annealed copper wire (finely stranded)
Core type	Finely stranded
Solderless terminal (bar terminal) and crimp tool	1) Mitsubishi Electric Engineering Co., Ltd. <ul style="list-style-type: none"> • Bar terminal model: FA-TVC125T9 • Crimp tool : FA-NH65A 2) NICHIFU Co.,Ltd. <ul style="list-style-type: none"> • Bar terminal model: TE0.5-10 (for CC-Link dedicated cable (0.5mm²)), TE1.5-10 (for SLD) • Crimp tool: NH-79 3) PHOENIX CONTACT <ul style="list-style-type: none"> • Bar terminal model: AI0.5-10WH (for CC-Link dedicated cable (0.5mm²)), AI1.5-10BK (for SLD) • Crimp tool: CRIMPFOX UD6, CRIMPFOX UD6-4, CRIMPFOX UD6-6, and CRIMPFOXZA3 *Note: When a shielded cable is excessively crimped to a bar terminal using a tool, CRIMPFOX UD6-4 or CRIMPFOX UD6-6, the bar terminal may not be connected to the terminal block depending on the cross-sectional shape after crimping.
Tightening torque range	No torque range specified since two-tier tension-spring terminal is used.

7.5 Transmission delay time

For transmission delay time, refer to the CC-Link System Master/Local Module User's Manual.

For the processing time of the remote device station that is used to calculate the transmission delay time, see the response time of the MELSEC-WS safety controller given in the Safety Controller User's Manual.

The following shows the response times of field bus sender and receiver that are used to calculate the response time of the safety controller.

Response time field bus sender: 1 ms

Response time field bus receiver: 1 ms

7.6 Dimensional drawings

Figure 27:
Dimensional drawings
of WS0-GCC1 (mm)

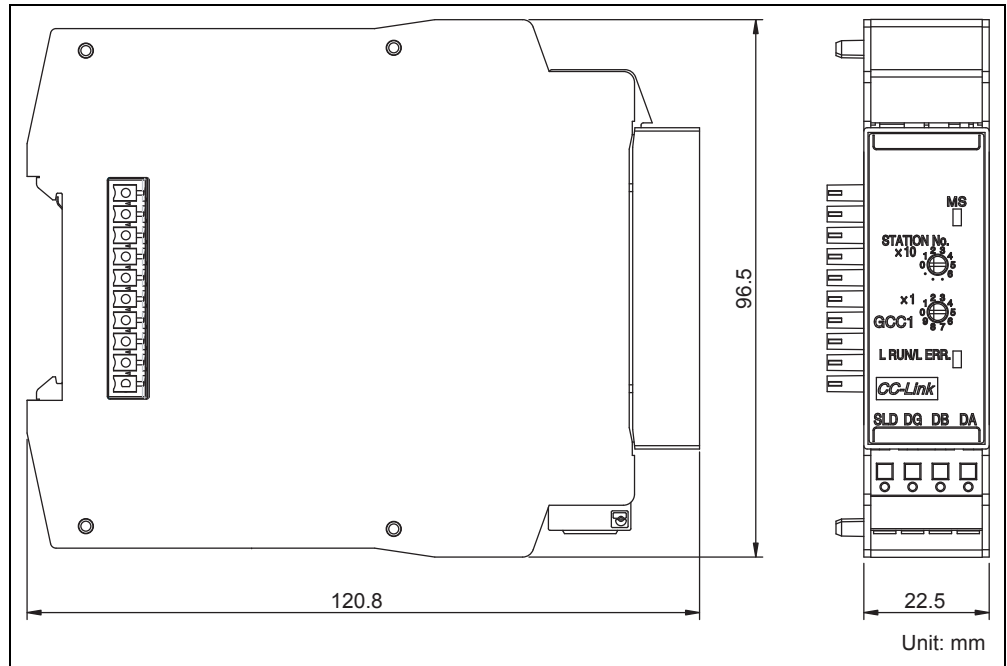

8. Connecting to a Q series programmable controller

This chapter describes the exchange of non-safety related data (transmission data: RX, RWr, reception data: RY, RWw) between a MELSEC-WS safety controller and a Q series programmable controller over CC-Link.

The safety controller can also exchange non-safe data with a QS series programmable controller.

8.1 Features achieved by the connection

The QJ61BT11N or QS0J61BT12 can read the MELSEC-WS safety controller information (e.g. operation results of the CPU module, safety input/output data) by cyclic transmission.

This feature allows you to notify the MELSEC-WS safety controller of device state or other information from a Q series programmable controller.



Do not operate a CC-Link interface module on a safety fieldbus!

The CC-Link interface module is not suitable for operation on a safety fieldbus. It does not support any safety mechanism, which would be mandatory to communicate within a safety network.

Figure 28:
Obtaining information in
a MELSEC-WS safety
controller

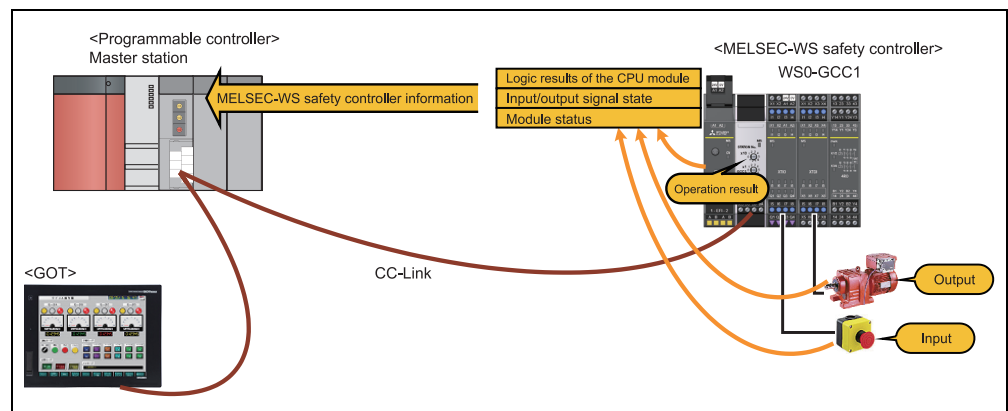
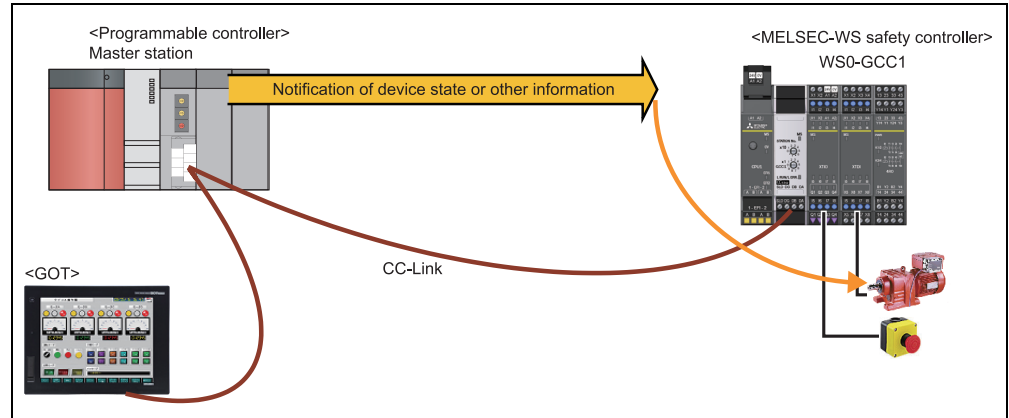

Figure 29:
Notifying information to a
MELSEC-WS safety
controller



8.2 Applicable system

For system configuration of the programmable controller, refer to the following.

- CC-Link System Master/Local Module User's Manual

9. Preparing for operation

9.1 System configuration and start-up procedure

This section provides procedures before operation with the following system configuration example.

Figure 30:
System configuration
example

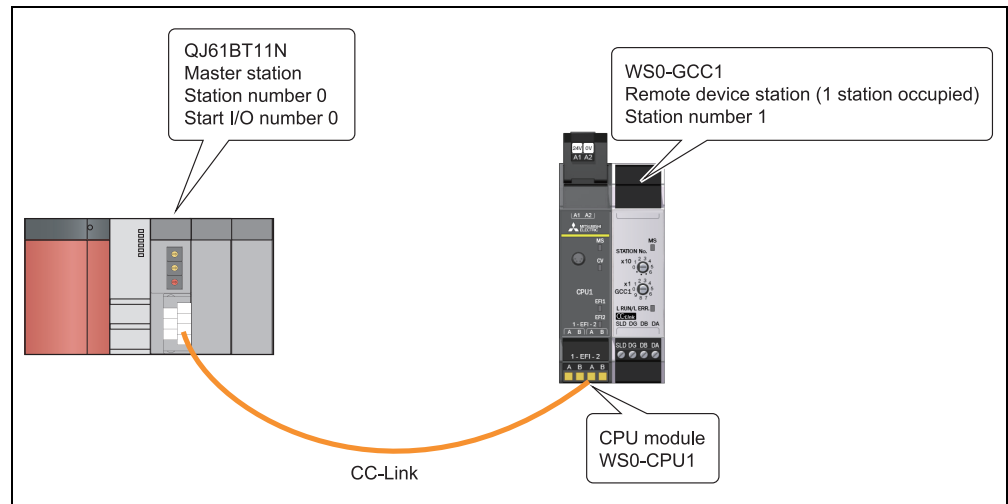
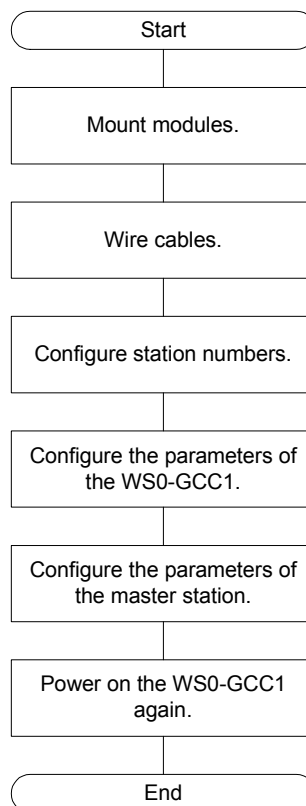

Figure 31:
Procedure before
operation



9.2 Wiring

This section describes wiring of the WS0-GCC1 using CC-Link dedicated cables.

For wiring of the QJ61BT11N, refer to the following.

- CC-Link System Master/Local Module User's Manual

(1) Cables

Use dedicated cables as specified by the manufacturer for the CC-Link system (see Section 7.2).

If a cable other than the one specified by the manufacturer is used, the performance of the CC-Link system is not guaranteed.

For the specifications and any inquiries on the CC-Link dedicated cables, refer to the following:

CC-Link Partner Association website: www.cc-link.org

Wiring precautions

For wiring precautions, refer to SAFETY PRECAUTIONS.

9.3 Sample program

This section describes examples of parameter configuration and a program for communication between the WS0-GCC1 and QJ61BT11N.

For system configuration, refer to the example in Section 9.1.

The WS0-GCC1 exchanges data and signals with the QJ61BT11N by cyclic transmission.

The cyclic transmission automatically exchanges bit data (RX, RY, RWw, and RWr) between the WS0-GCC1 and the QJ61BT11N.

The CPU module periodically sends/receives those bit data to/from the WS0-GCC1.

Figure 32:
Data exchange by cyclic transmission

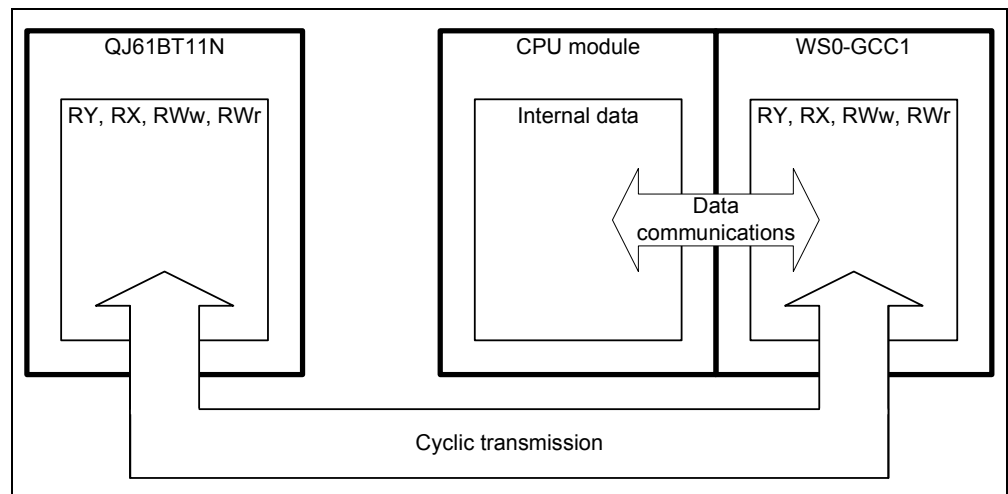

9.3.1 Parameter configuration example

This section describes parameter configuration to output data from the WS0-GCC1 to the QJ61BT11N and to input data from the QJ61BT11N to the WS0-GCC1.

(1) Configuration required for the WS0-GCC1

The following shows the configuration example using the system configuration of Figure 30.

1) Creating a hardware configuration

Read the hardware configuration data from the actual CPU module to Setting and Monitoring Tool or place modules in Setting and Monitoring Tool according to the actual configuration.

Figure 33:
Hardware configuration
dialog

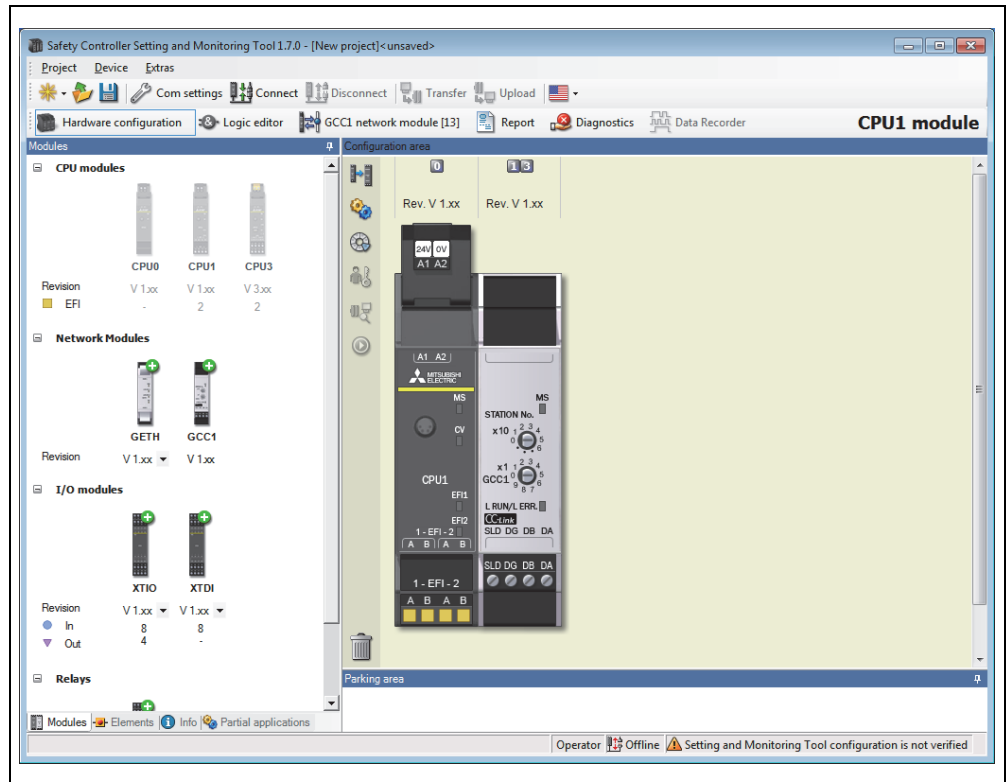

- 2) Configuring the number of occupied stations
 - Configure the number of stations occupied by the WS0-GCC1 in the network module configuration dialog.
 - In this example, **1 station occupied** has been selected.

Figure 34:
Configuring the number of occupied stations

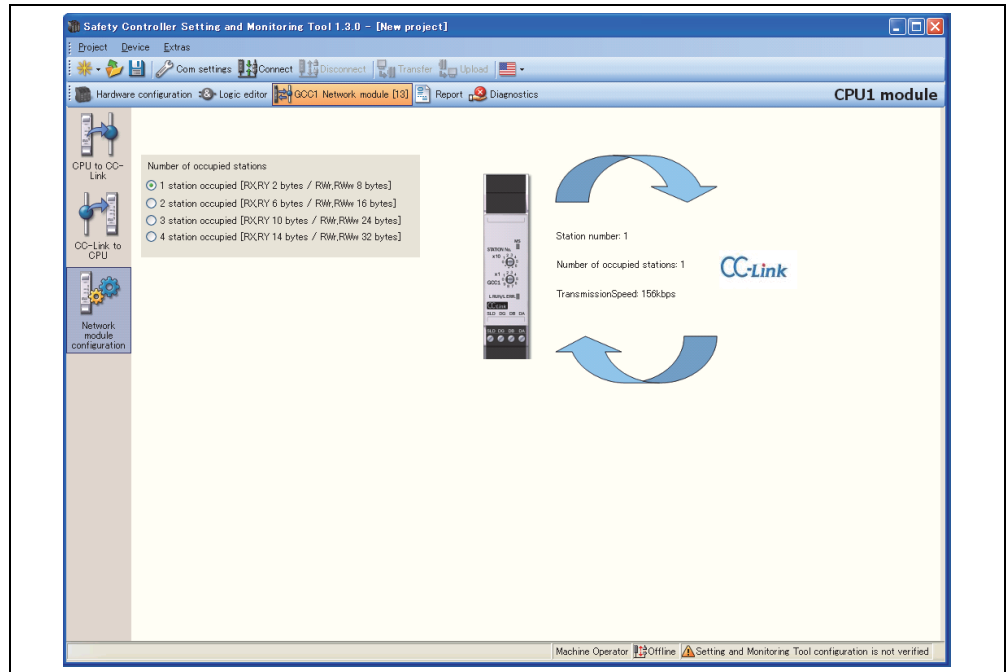

When Setting and Monitoring Tool is connected to the CPU module, the station number, number of occupied stations and transmission speed can be checked in the network module configuration dialog.

Figure 35:
Monitoring the station number, number of occupied stations, and transmission speed

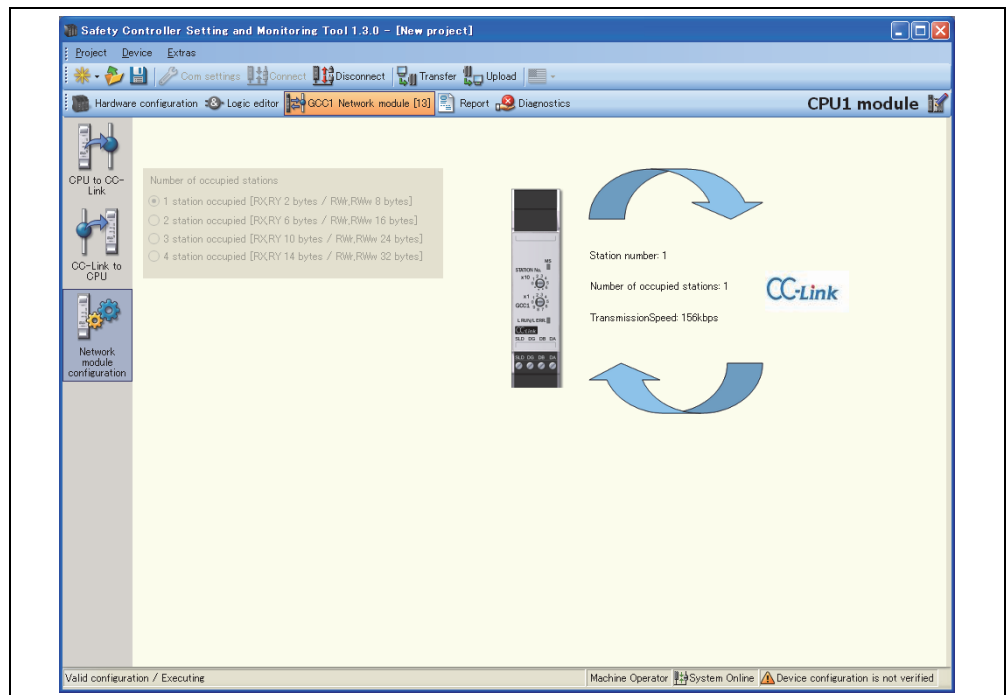

3) Editing data sets

Editing network input data sets

Open the **MELSEC-WS to CC-Link** dialog and edit RX and RWr.

Figure 36:
MELSEC-WS to CC-Link dialog

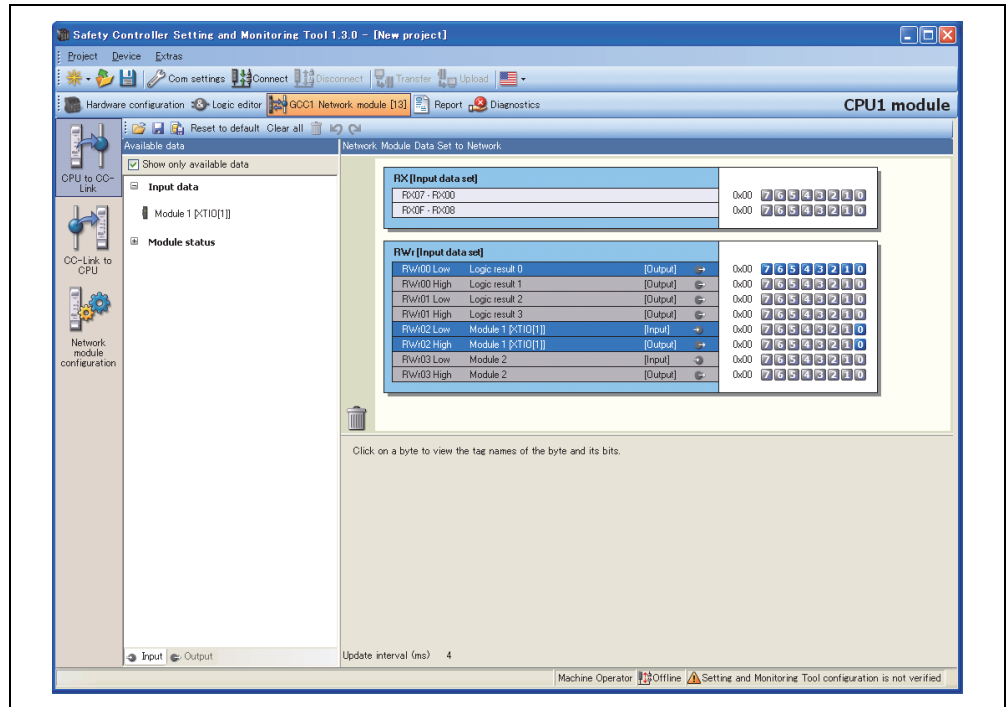

Editing network output data sets

Open the **CC-Link to MELSEC-WS** dialog and configure tag names for each output data set as required.

Figure 37:
CC-Link to MELSEC-WS dialog

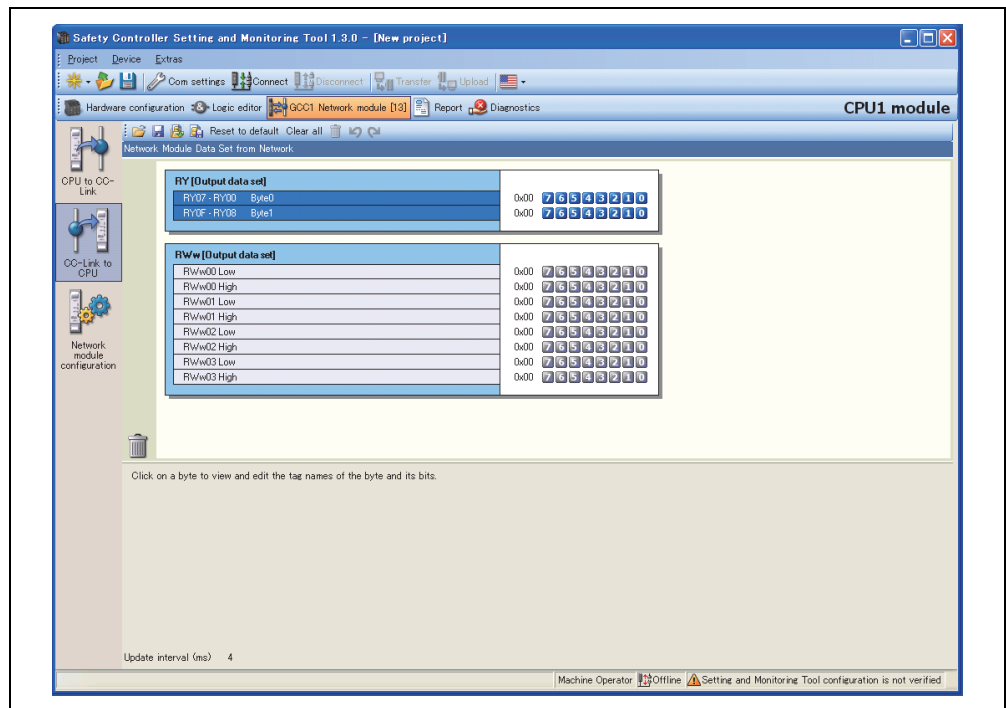

(2) Configuration and program required for the QJ61BT11N

The following shows a network parameter configuration example with GX Developer.

For precautions for parameter configuration and program creation, refer to the following.

- CC-Link System Master/Local Module User's Manual

1) Configuring network parameters with GX Developer

Select **CC-Link** to open the network parameter dialog box and configure the options as follows.

Figure 38:
Network parameter
configuration for CC-
Link

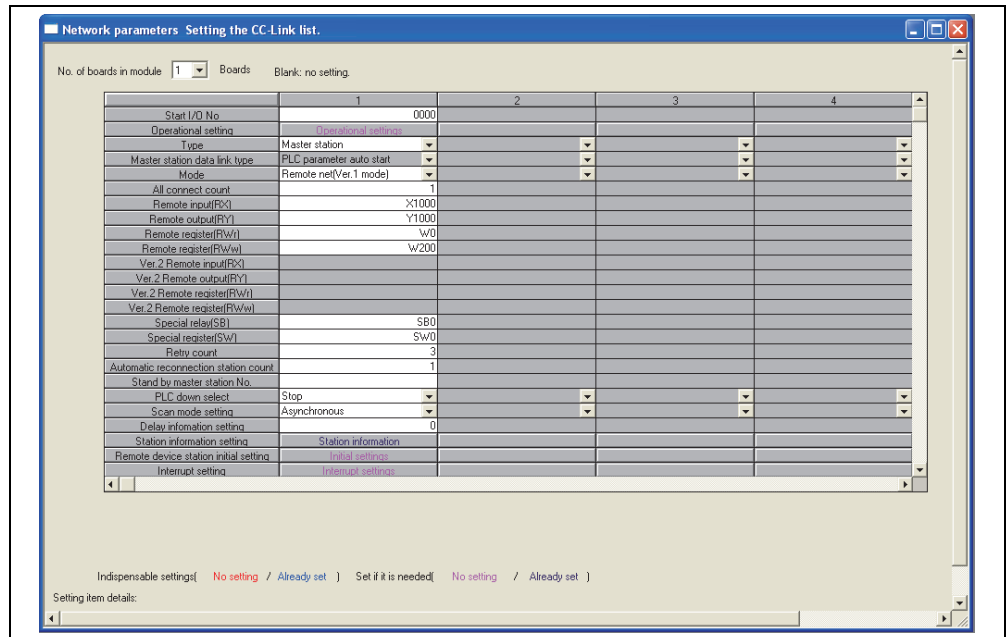

2) Network parameter - Station information setting

Select **Station information** to open the configuration dialog box and configure the options as follows.

Figure 39:
Network parameter -
CC-Link station
information setting
dialog

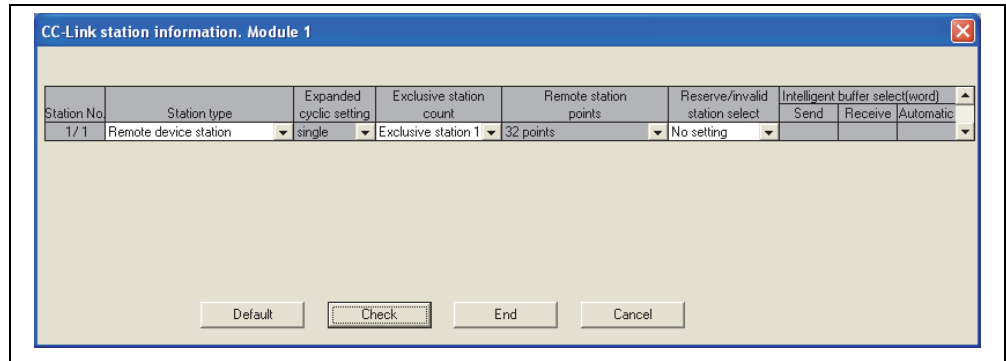

After configuring the parameters of the master station, power on the WS0-GCC1 again.

9.3.2 Sample program

Create a program so that the communication is interlocked according to the data-link status.

Also, create an error-handling program.

Figure 40:
Sample program

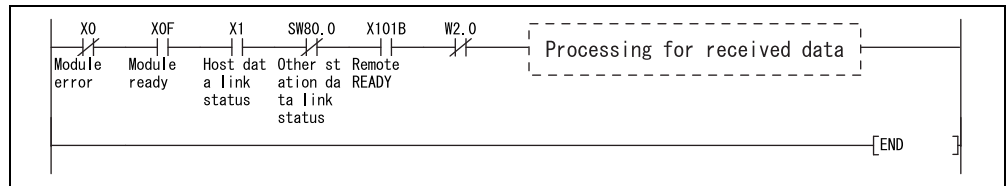

If a CC-Link dedicated cable is disconnected, the line status may become unreliable, resulting in a data link communication error at multiple stations. Configure an interlock circuit in the sequence program to ensure that the entire system will operate safely even if a data link communication error occurs at multiple stations.

10. Troubleshooting when CC-Link interface module is connected to Q series programmable controller

Check the status of each module after all the modules required in the system have been connected using CC-Link dedicated cables, and verify that data link can be performed normally.

For details of GX Developer operations, see the operating manual of GX Developer. Also, see Chapter 5 in this manual.

WARRANTY

1. Limited Warranty and Product Support.

- a. Mitsubishi Electric Company ("MELCO") warrants that for a period of eighteen (18) months after date of delivery from the point of manufacture or one year from date of Customer's purchase, whichever is less, Mitsubishi Safety Controller (the "Products") will be free from defects in material and workmanship.
- b. At MELCO's option, for those Products MELCO determines are not as warranted, MELCO shall either repair or replace them or issue a credit or return the purchase price paid for them.
- c. For this warranty to apply:
 - (1) Customer shall give MELCO (i) notice of a warranty claim to MELCO and the authorized dealer or distributor from whom the Products were purchased, (ii) the notice shall describe in reasonable details the warranty problem, (iii) the notice shall be provided promptly and in no event later than thirty (30) days after the Customer knows or has reason to believe that Products are not as warranted, and (iv) in any event, the notice must be given within the warranty period;
 - (2) Customer shall cooperate with MELCO and MELCO's representatives in MELCO's investigation of the warranty claim, including preserving evidence of the claim and its causes, meaningfully responding to MELCO's questions and investigation of the problem, grant MELCO access to witnesses, personnel, documents, physical evidence and records concerning the warranty problem, and allow MELCO to examine and test the Products in question offsite or at the premises where they are installed or used; and
 - (3) If MELCO requests, Customer shall remove Products it claims are defective and ship them to MELCO or MELCO's authorized representative for examination and, if found defective, for repair or replacement. The costs of removal, shipment to and from MELCO's designated examination point, and reinstallation of repaired or replaced Products shall be at Customer's expense.
 - (4) If Customer requests and MELCO agrees to effect repairs onsite at any domestic or overseas location, the Customer will pay for the costs of sending repair personnel and shipping parts. MELCO is not responsible for any re-commissioning, maintenance, or testing on-site that involves repairs or replacing of the Products.
- d. Repairs of Products located outside of Japan are accepted by MELCO's local authorized service facility centers ("FA Centers"). Terms and conditions on which each FA Center offers repair services for Products that are out of warranty or not covered by MELCO's limited warranty may vary.
- e. Subject to availability of spare parts, MELCO will offer Product repair services for (4) years after each Product model or line is discontinued, at MELCO's or its FA Centers' rates and charges and standard terms in effect at the time of repair. MELCO usually produces and retains sufficient spare parts for repairs of its Products for a period of four (4) years after production is discontinued.
- f. MELCO generally announces discontinuation of Products through MELCO's Technical Bulletins. Products discontinued and repair parts for them may not be available after their production is discontinued.

2. Limits of Warranties.

- a. MELCO does not warrant or guarantee the design, specify, manufacture, construction or installation of the materials, construction criteria, functionality, use, properties or other characteristics of the equipment, systems, or production lines into which the Products may be incorporated, including any safety, fail-safe and shut down systems using the Products.
- b. MELCO is not responsible for determining the suitability of the Products for their intended purpose and use, including determining if the Products provide appropriate safety margins and redundancies for the applications, equipment or systems into which they are incorporated.
- c. Customer acknowledges that qualified and experienced personnel are required to determine the suitability, application, design, construction and proper installation and integration of the Products. MELCO does not supply such personnel.
- d. MELCO is not responsible for designing and conducting tests to determine that the Product functions appropriately and meets application standards and requirements as installed or incorporated into the end-user's equipment, production lines or systems.
- e. MELCO does not warrant any Product:
 - (1) repaired or altered by persons other than MELCO or its authorized engineers or FA Centers;
 - (2) subjected to negligence, carelessness, accident, misuse, or damage;
 - (3) improperly stored, handled, installed or maintained;
 - (4) integrated or used in connection with improperly designed, incompatible or defective hardware or software;
 - (5) that fails because consumable parts such as relay, batteries, backlights, or fuses were not tested, serviced or replaced;
 - (6) operated or used with equipment, production lines or systems that do not meet applicable and commensurate legal, safety and industry-accepted standards;
 - (7) operated or used in abnormal applications;
 - (8) installed, operated or used in contravention of instructions, precautions or warnings contained in MELCO's user, instruction and/or safety manuals, technical bulletins and guidelines for the Products;
 - (9) used with obsolete technologies or technologies not fully tested and widely accepted and in use at the time of the Product's manufacture;
 - (10) subjected to excessive heat or moisture, abnormal voltages, shock, excessive vibration, physical damage or other improper environment; or
 - (11) damaged or malfunctioning due to Acts of God, fires, acts of vandals, criminals or terrorists, communication or power failures, or any other cause or failure that results from circumstances beyond MELCO's control.
- f. All Product information and specifications contained on MELCO's website and in catalogs, manuals, or technical information materials provided by MELCO are subject to change without prior notice.
- g. The Product information and statements contained on MELCO's website and in catalogs, manuals, technical bulletins or other materials provided by MELCO are provided as a guide for Customer's use. They do not constitute warranties and are not incorporated in the contract of sale for the Products.

- h. These terms and conditions constitute the entire agreement between Customer and MELCO with respect to warranties, remedies and damages and supersede any other understandings, whether written or oral, between the parties. Customer expressly acknowledges that any representations or statements made by MELCO or others concerning the Products outside these terms are not part of the basis of the bargain between the parties and are not factored into the pricing of the Products.
- i. THE WARRANTIES AND REMEDIES SET FORTH IN THESE TERMS ARE THE EXCLUSIVE AND ONLY WARRANTIES AND REMEDIES THAT APPLY TO THE PRODUCTS.
- j. MELCO DISCLAIMS THE IMPLIED WARRANTIES OF MERCHANTABILITY AND FITNESS FOR A PARTICULAR PURPOSE.

3. Limits on Damages.

- a. MELCO'S MAXIMUM CUMULATIVE LIABILITY BASED ON ANY CLAIMS FOR BREACH OF WARRANTY OR CONTRACT, NEGLIGENCE, STRICT TORT LIABILITY OR OTHER THEORIES OF RECOVERY REGARDING THE SALE, REPAIR, REPLACEMENT, DELIVERY, PERFORMANCE, CONDITION, SUITABILITY, COMPLIANCE, OR OTHER ASPECTS OF THE PRODUCTS OR THEIR SALE, INSTALLATION OR USE SHALL BE LIMITED TO THE PRICE PAID FOR PRODUCTS NOT AS WARRANTED.
- b. Although MELCO has obtained the certification for Product's compliance to the international safety standards IEC61508 and ISO13849-1 from TUV Rheinland, this fact does not guarantee that Product will be free from any malfunction or failure. The user of this Product shall comply with any and all applicable safety standard, regulation or law and take appropriate safety measures for the system in which the Product is installed or used and shall take the second or third safety measures other than the Product. MELCO is not liable for damages that could have been prevented by compliance with any applicable safety standard, regulation or law.
- c. MELCO prohibits the use of Products with or in any application involving power plants, trains, railway systems, airplanes, airline operations, other transportation systems, amusement equipments, hospitals, medical care, dialysis and life support facilities or equipment, incineration and fuel devices, handling of nuclear or hazardous materials or chemicals, mining and drilling, and other applications where the level of risk to human life, health or property are elevated.
- d. MELCO SHALL NOT BE LIABLE FOR SPECIAL, INCIDENTAL, CONSEQUENTIAL, INDIRECT OR PUNITIVE DAMAGES, FOR LOSS OF PROFITS, SALES, OR REVENUE, FOR INCREASED LABOR OR OVERHEAD COSTS, FOR DOWNTIME OR LOSS OF PRODUCTION, FOR COST OVERRUNS, OR FOR ENVIRONMENTAL OR POLLUTION DAMAGES OR CLEAN-UP COSTS, WHETHER THE LOSS IS BASED ON CLAIMS FOR BREACH OF CONTRACT OR WARRANTY, VIOLATION OF STATUTE, NEGLIGENCE OR OTHER TORT, STRICT LIABILITY OR OTHERWISE.
- e. In the event that any damages which are asserted against MELCO arising out of or relating to the Products or defects in them, consist of personal injury, wrongful death and/or physical property damages as well as damages of a pecuniary nature, the

disclaimers and limitations contained in these terms shall apply to all three types of damages to the fullest extent permitted by law. If, however, the personal injury, wrongful death and/or physical property damages cannot be disclaimed or limited by law or public policy to the extent provided by these terms, then in any such event the disclaimer of and limitations on pecuniary or economic consequential and incidental damages shall nevertheless be enforceable to the fullest extent allowed by law.

- f. In no event shall any cause of action arising out of breach of warranty or otherwise concerning the Products be brought by Customer more than one year after the cause of action accrues.
- g. Each of the limitations on remedies and damages set forth in these terms is separate and independently enforceable, notwithstanding the unenforceability or failure of essential purpose of any warranty, undertaking, damage limitation, other provision of these terms or other terms comprising the contract of sale between Customer and MELCO.

4. Delivery/Force Majeure.

- a. Any delivery date for the Products acknowledged by MELCO is an estimated and not a promised date. MELCO will make all reasonable efforts to meet the delivery schedule set forth in Customer's order or the purchase contract but shall not be liable for failure to do so.
- b. Products stored at the request of Customer or because Customer refuses or delays shipment shall be at the risk and expense of Customer.
- c. MELCO shall not be liable for any damage to or loss of the Products or any delay in or failure to deliver, service, repair or replace the Products arising from shortage of raw materials, failure of suppliers to make timely delivery, labor difficulties of any kind, earthquake, fire, windstorm, flood, theft, criminal or terrorist acts, war, embargoes, governmental acts or rulings, loss or damage or delays in carriage, acts of God, vandals or any other circumstances reasonably beyond MELCO's control.

5. Choice of Law/Jurisdiction.

These terms and any agreement or contract between Customer and MELCO shall be governed by the laws of the State of New York without regard to conflicts of laws. To the extent any action or dispute is not arbitrated, the parties consent to the exclusive jurisdiction and venue of the federal and state courts located in the Southern District of the State of New York. Any judgment there obtained may be enforced in any court of competent jurisdiction.

6. Arbitration.

Any controversy or claim arising out of, or relating to or in connection with the Products, their sale or use or these terms, shall be settled by arbitration conducted in accordance with the Center for Public Resources (CPR) Rules for Non-Administered Arbitration of International Disputes, by a sole arbitrator chosen from the CPR's panels of distinguished neutrals. Judgment upon the award rendered by the Arbitrator shall be final and binding and may be entered by any court having jurisdiction thereof. The place of the arbitration shall be New York City, New York. The language of the arbitration shall be English. The neutral organization designated to perform the functions specified in Rule 6 and Rules 7.7(b), 7.8 and 7.9 shall be the CPR.

The company names, system names and product names mentioned in this manual are either registered trademarks or trademarks of their respective companies.

In some cases, trademark symbols such as '™' or '®' are not specified in this manual.

SICK SICK AG

www.sick.com

SH(NA)-080909ENG-E(1912)MEE

MODEL: WS-CC-U-E

MODEL CODE: 13JZ45

MITSUBISHI ELECTRIC CORPORATION

HEAD OFFICE : TOKYO BUILDING, 2-7-3 MARUNOUCHI, CHIYODA-KU, TOKYO 100-8310, JAPAN
NAGOYA WORKS : 1-14, YADA-MINAMI 5-CHOME, HIGASHI-KU, NAGOYA, JAPAN

When exported from Japan, this manual does not require application to the
Ministry of Economy, Trade and Industry for service transaction permission.

Specifications subject to change without notice.