

Mitsubishi Programmable Controller

MELSEC **Q** series

MELSECWinCPU Module Q-Bus Interface Driver User's Manual (Utility Operation, Programming)

-Q10WCPU-W1-E
-Q10WCPU-W1-CFE
-SW1PNC-WCPU-B

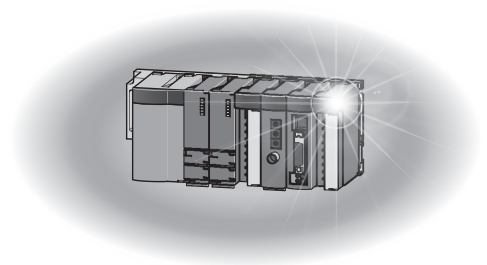

Powered by CONTEC

This product was jointly developed and manufactured by Mitsubishi and CONTEC Corporation.
Note that the warranty on this product differs from that on other programmable controller products.

SAFETY PRECAUTIONS

(Read these precautions before using this product.)

Before using this product, please read this manual and the relevant manuals carefully and pay full attention to safety to handle the product correctly.

The instructions given in this manual are concerned with this product. For the safety instructions of the programmable controller system, please read the programmable controller CPU module user's manual.

In this manual, the safety precautions are classified into two levels: "⚠WARNING" and "⚠CAUTION".

⚠ WARNING	Indicates that incorrect handling may cause hazardous conditions, resulting in death or severe injury.
⚠ CAUTION	Indicates that incorrect handling may cause hazardous conditions, resulting in minor or moderate injury or property damage.

Under some circumstances, failure to observe the precautions given under "⚠CAUTION" may lead to serious consequences.

Observe the precautions of both levels because they are important for personal and system safety.

Make sure that the end users read this manual and then keep the manual in a safe place for future reference.

[Design Instructions]

WARNING

- When changing data and controlling status upon an operating sequencer from the MELSECWinCPU module, safety operation of the total system must always be maintained. For that purpose, configure an interlock circuit externally to the sequencer system.
Countermeasures against communication errors caused by cable connection failure, etc. must be specified by means of on-line operation of programmable controller CPU from the MELSECWinCPU module.

CAUTION

- Read the manual thoroughly and carefully, and verify safety before running the online operations with connected MELSECWinCPU module, and with an operating programmable controller CPU (especially when performing forcible output and changing operation status). Operation error may result in damaging the system or an accident.

[Installation Precautions]

CAUTION

- Shut off the external power supply for the system in all phases before mounting or removing modules. Failing in disconnecting power supply in all phases may lead to damaging the product or out-of-control MELSECWinCPU module.

Notes on operations

(1) Notes on operation on Windows® Embedded Standard 2009 Operating System

- (a) Installation and uninstallation of SW1PNC-WCPU-B *1 and usage of utilities are available only by the administrator's authority.
- (b) When Windows® Embedded Standard 2009 is used, the following new functions cannot be used.
If any of the following new functions is used, this product may not operate properly.
 - Activating the application with Windows® compatible mode
 - Simplified user switch-over
 - Remote desktop
 - Large font size (Advanced setting of Display Properties)
- (c) Under Windows® Embedded Standard 2009, user programs may be executed with a delay due to scheduling by the operating system. You should not use Windows® Embedded Standard 2009 as the platform for applications which require constant periodicity or faster response.

*1: SW1PNC-WCPU-B has already been installed to the main body.

(2) Notes on multiple CPU system configuration

- (a) In a multiple CPU system using a MELSECWinCPU module, available programmable controller CPUs are as follows.
 - Basic model QCPU: function version B or later
 - High performance model QCPU: function version B or later and a serial No. "03051" or later in the first five digits
 - Universal model QCPU: a serial No. "09072" or later in the first five digits
- (b) When a multiple CPU system is configured, a MELSECWinCPU module cannot be mounted to the left of the programmable controller CPU and the motion CPU.
Mount a MELSECWinCPU module to the right of the programmable controller CPU and the motion CPU.
- (c) The multiple CPU parameters set / saved in MELSEC-Q Series Software (e.g. GX Developer and GX Works2) are also available in MELSECWinCPU Setting Utility. For details, refer to "5.3.11. Loading initial setting data file and using multiple CPU parameters".
The multiple CPU parameters set / saved in MELSECWinCPU Setting Utility are not available in MELSEC-Q Series Software (e.g. GX Developer and GX Works2).
- (d) You can not access a MELSECWinCPU module specifying its station No. from MELSEC-Q Series Software (e.g. GX Developer and GX Works2). If you did so, the following message appears: "It could not get the type name of PC because of the limitation of the specified path. Please confirm if you communicate with the PC type your application supports".
- (e) For the reset specifications when a multiple CPU system is configured, refer to "MELSECWinCPU Module User's Manual (Hardware Design, Function Explanation)".

-
- (3) Notes on accessing remote station from a MELSECWinCPU module
Simultaneous remote access to 257 or more station from a MELSECWinCPU module using utilities, user program provided by SW1PNC-WCPU-B, and Mitsubishi- product software package may result in degraded communication performances.
Limit the No. of station to 256 or less for simultaneous remote station access from a MELSECWinCPU module.
When accessing a remote station from the MELSECWinCPU module via a bus interface, MELSECNET/H module, or CC-Link module, second and subsequent communication operations must wait until any previous communication operation completes. Accordingly, a time-out on one communication operation may cause a time-out error on other communication operations also.
- (4) For notes when using I/O modules and intelligent function modules, refer to “MELSECWinCPU Module User's Manual (Hardware Design, Function Explanation)”
- (5) When you use MELSEC or MELSOFT products and refer to their manuals and HELP, the description “PC CPU” should be replaced by “MELSECWinCPU”.

Table of Contents

SAFETY PRECAUTIONS	1
Notes on operations	3
Table of Contents.....	5
About Generic Terms and Abbreviations.....	9
1. Outline	11
1.1 Features.....	11
2. System Configuration	14
2.1 System Configuration.....	14
2.2 Accessible Modules.....	17
2.2.1 CPU module	17
2.2.2 I/O module and intelligent function module.....	18
2.3 Operating Environment.....	18
2.4 S/W Configuration	19
2.4.1 S/W Package Configuration.....	19
2.4.2 Linking with MELSOFT products.....	19
3. Procedures before Starting and Settings	20
4. Installing and Uninstalling the Software Package	29
4.1 Installing the software package.....	29
4.1.1 Installing.....	30
4.2 Icons to be Registered	35
4.3 Uninstalling	35
4.3.1 Uninstalling	36
5. Utility Operations	37
5.1 Utility Common Operations.....	37
5.1.1 Starting a utility.....	37
5.1.2 Ending a utility	38
5.1.3 Displaying the help screen	39
5.1.4 Verifying the version.....	40
5.2 About the Parameter Setup File	41
5.2.1 Status Bar Display Details	42
5.3 MELSECWinCPU Setting Utility	43
5.3.1 MELSECWinCPU Setting Utility Function List.....	43

5.3.2	Operating the Module Information Window.....	44
5.3.3	Operating the Module Monitor Window.....	46
5.3.4	Operating the Online Operation Window.....	49
5.3.5	Operating the System Setting Window.....	50
5.3.6	Operating the I/O Assignment Setting Window.....	54
5.3.7	Operating the Multiple CPU Setting Window.....	58
5.3.8	Operating the Target Setting Window.....	60
5.3.9	Operating the Communication Diagnostics Window.....	61
5.3.10	Operating the System Menu.....	62
5.3.11	Loading initial setting data file and using multiple CPU parameters.....	63
5.4	CC-Link Utility.....	66
5.4.1	CC-Link Utility Function List.....	66
5.4.2	Operating the Module Information Window.....	67
5.4.3	Operating the Other Station Monitor Window.....	73
5.4.4	Operating the Online Operation Window.....	77
5.4.5	Operating on Routing Parameter Setting Window.....	78
5.4.6	Operating the Target Setting Window.....	83
5.4.7	Operating on Network Test Window.....	86
5.4.8	Operating the System Menu.....	89
5.5	MELSECNET/H utility.....	90
5.5.1	Functional List of MELSECNET/H Utility.....	90
5.5.2	Operating the Module Information Window.....	91
5.5.3	Operating Err History Monitor Window.....	98
5.5.4	Operating the Other Station Monitor Window.....	103
5.5.5	Operating the Online Operation Window.....	114
5.5.6	Operating on Routing Parameter Setting Window.....	115
5.5.7	Operating the Target Setting Window.....	126
5.5.8	Operating the System Menu.....	129
5.6	Device Monitor utility.....	130
5.6.1	Functional List of Device Monitor Utility.....	130
5.6.2	Specifying batch monitor.....	131
5.6.3	Specifying 16- point Register Monitor.....	132
5.6.4	Specifying monitor target.....	133
5.6.5	Specifying device to be monitored.....	134
5.6.6	Changing Word Device Values.....	135
5.6.7	Changing Word Device Value Continuously.....	136
5.6.8	Turning ON/OFF Bit Device.....	137
5.6.9	Switching Display Form.....	138
5.6.10	Numerical Pad.....	139
5.6.11	Other Operations.....	140

6. Functions and Programming	142
-------------------------------------	------------

6.1	Outline of Functions.....	142
6.2	Function List.....	143
6.2.1	Bus Interface Function List.....	143

6.2.2	MELSEC Data Link Function List	144
6.3	Settings for Using Functions	145
6.3.1	Using Microsoft® Visual Studio® 2008 Visual Basic.....	145
6.3.2	Using Microsoft® Visual Studio® 2008 Visual C++	146
6.3.3	Using Microsoft® Visual Studio® 2010 Visual Basic.....	151
6.3.4	Using Microsoft® Visual Studio® 2010 Visual C++	152
6.4	Programming Procedures	159
6.4.1	Using Bus Interface Function	160
6.4.2	Using MELSEC data link functions	165
6.5	Channel.....	166
6.6	Sta. No. Setting.....	167
6.7	Device Type	168
6.8	Data Communication via programmable controller Shared Memory	173
6.8.1	CPU Shared Memory Configuration	175
6.8.2	Data Communication When Using Automatic Refresh settings	177
6.8.3	Data Communication Without Using the Automatic Refresh.....	180
6.9	Event Notify Function.....	181
6.10	About Sample Program	184
6.11	About HELP of Bus Interface Function and MELSEC Data Link Function	188

7. Accessible Range and Devices	190
--	------------

7.1	Multiple CPU System Access	190
7.1.1	Accessible Range	190
7.1.2	Accessible Devices.....	191
7.2	Access via CC-Link Utility	196
7.2.1	Accessible Range	196
7.2.2	Accessible Devices.....	197
7.3	Access via MELSECNET/H module	203
7.3.1	Accessible Range	203
7.3.2	Accessible Devices.....	205

8. Actions against Errors	210
----------------------------------	------------

8.1	Basis on Troubleshooting.....	210
8.2	Troubleshooting.....	211
8.2.1	Flow when POWER LED of PSU went out	212
8.2.2	Flow when MELSECWinCPU module does not work properly.....	213
8.2.3	Flow when SW1PNC-WCPU-B cannot be installed.....	215
8.2.4	Flow when ERR.LED lights/blinks	216
8.2.5	Flow for UNIT VERIFY ERR.	218
8.2.6	Flow for CONTROL-BUS.ERR.....	220
8.2.7	Flow for errors on function execution	222
8.2.8	Flow when LED of the output module does not light	223

8.2.9	Flow when the output load of the output module does not turn on	224
8.2.10	Troubleshooting when B.RUN LED continues to blink in the multiple CPU system configuration ..	225
8.2.11	Flow when "Bus I/F driver not activated" is displayed.....	225
8.2.12	Flow for "link refresh time over"	226
8.3	Actions upon Error LED.....	228
8.3.1	How to confirm error information.....	228
8.3.2	Detection timings and operation.....	230
8.3.3	Actions determined from error/alert information and error codes.....	233
8.3.4	Detailed error description and actions.....	236
8.4	List of Error Code, Error Message	248
8.4.1	Actions upon error codes at the time of function execution	248
8.4.2	Corrective Actions for error code on the communication with MELSECWinCPU module	263
8.4.3	Corrective Actions for Each Event ID	265
8.4.4	Corrective Actions for Each Error Message	267

9. Appendix	284
--------------------	------------

9.1	List of Parameter No.....	284
9.2	The difference between MELSECWinCPU and former PC CPU	291
9.2.1	The comparison between MELSECWinCPU and former PC CPU	291
9.2.2	The comparison of supported S/W package.....	293
	REVISIONS	296

About Generic Terms and Abbreviations

Unless otherwise specified, this manual uses the following generic terms and abbreviations to describe the system.

Generic term/Abbreviation	Description
SW1PNC-WCPU-B	Abbreviation for bus interface driver software package of MELSEC- Q series compatible MELSECWinCPU module
MELSECWinCPU module	Abbreviation for MELSEC- Q series compatible MELSECWinCPU module
AnNCPU	Generic term for A0J2HCPU, A1SCPU, A1SCPUC24-R2, A1SHCPU, A1SJCPU, A1SJCPU-S3, A1SJHCPU, A1NCPU, A2CCPU, A2CCPUC24, A2CCPUC24-PRF, A2CJCPU, A2NCPU, A2NCPU-S1, A2SCPU, A2SHCPU, A3NCPU, A1FXCPU.
AnACPU	Generic term for A2ACPU, A2ACPU-S1, A2ACPUP21/R21, A2ACPUP21/R21-S1, A3ACPUP21/R21, A3ACPU.
AnUCPU	Generic term for A2UCPU, A2UCPU-S1, A2USCPU, A2USCPU-S1, A2USHCPU-S1, A3UCPU, A4UCPU.
ACPU	Generic term for AnNCPU, AnACPU, AnUCPU.
QnACPU	Generic term for Q2ACPU, Q2ACPU-S1, Q2ASCPU, Q2ASCPU-S1, Q2ASHCPU, Q2ASHCPU-S1, Q3ACPU, Q4ACPU, Q4ARCPU.
QCPU (A mode)	Generic term for Q02CPU-A, Q02HCPU-A, Q06HCPU-A.
QCPU (Q mode)	Generic term for basic model QCPU (Q00JCPU is excluded), high performance model QCPU, process CPU, universal model QCPU (Q00UJCPU is excluded)
Basic model QCPU	Generic term for Q00JCPU, Q00CPU, Q01CPU.
High performance model QCPU	Generic term for Q02CPU, Q02HCPU, Q06HCPU, Q12HCPU, Q25HCPU.
Process CPU	Generic term for Q02PHCPU, Q06PHCPU, Q12PHCPU, Q25PHCPU.
Universal model QCPU	Generic term for Q00UJCPU, Q00UCPU, Q01UCPU, Q02UCPU, Q03UDCPU, Q04UDHCPU, Q06UDHCPU, Q10UDHCPU, Q13UDHCPU, Q20UDHCPU, Q26UDHCPU, Q03UDECPU, Q04UDEHCPU, Q06UDEHCPU, Q10UDEHCPU, Q13UDEHCPU, Q20UDEHCPU, Q26UDEHCPU, Q50UDEHCPU, Q100UDEHCPU, Q03UDVCPU, Q04UDVCPU, Q06UDVCPU, Q13UDVCPU, Q26UDVCPU.
High-speed Universal model QCPU	Generic term for Q03UDVCPU, Q04UDVCPU, Q06UDVCPU, Q13UDVCPU, Q26UDVCPU.
LCPU	Generic term for L02CPU, L02CPU-P, L26CPU-BT, L26CPU-PBT.
Programmable Controller CPU	Generic term for ACPU, QnACPU, QCPU (A mode) or QCPU (Q mode).
Motion CPU	Generic term for Q172CPUN, Q173CPUN, Q172CPUN-T, Q173CPUN-T, Q172HCPU, Q173HCPU, Q172HCPU-T, Q173HCPU-T, Q172DCPU, Q173DCPU, Q172DSCPU, Q173DSCPU.

Generic term/Abbreviation	Description
MELSECNET/H module	Generic term for QJ71LP21, QJ71LP21-25, QJ71LP21S-25, QJ71LP21G or QJ71BR11.
MELSECNET/H board	Generic term for Q80BD-J71LP21-25, Q80BD-J71LP21S-25, Q80BD-J71LP21G, Q80BD-J71BR11, Q81BD-J71GF11-T2 type MELSECNET/H interface boards.
MELSECNET/H	Abbreviation for Q-compatible MELSECNET/H network system
MELSECNET/10	Abbreviation for AnU-compatible and QnA/Q4AR-compatible MELSECNET/10 network systems
MELSECNET/H mode	Abbreviation for MELSECNET/H module used on MELSECNET/H
MELSECNET/10 mode	Abbreviation for MELSECNET/H module used on MELSECNET/10
CC-Link IE controller network	Abbreviation for CC-Link IE controller network system.
CC-Link IE field network	Abbreviation for CC-Link IE field network system.
CC-Link	Abbreviation for Control & Communication Link system.
CC-Link module	Abbreviation for QJ61BT11N type CC-Link system master & local module, QJ61BT11 type CC-Link system master & local module.
CC-Link board	Generic term for Q81BD-J61BT11, Q80BD-J61BT11N, ECP-CL2BD type CC-Link system master/local interface board
Serial communication module	Generic term for QJ71C24N, QJ71C24N-R2, QJ71C24N-R4, QJ71C24, QJ71C24-R2.
Input module	Generic term for input module that MELSECWinCPU module supports *1
Output module	Generic term for output module that MELSECWinCPU module supports *1
I/O composite module	Generic term for I/O composite module that MELSECWinCPU module supports *1
I/O module	Generic term for input module, output module and I/O composite module
Interrupt module	Generic term for Interrupt module that MELSECWinCPU module supports *1
Intelligent function module	Generic term for Intelligent function module that MELSECWinCPU module supports *1
GX Developer	Generic product name of SW8D5C-GPPW-J, SW8D5C-GPPW-JA, SW8D5C-GPPW-JV, SW8D5C-GPPW-JVA.
GX Works2	Generic product name of SWnDNC-GXW2-J, SWnDNC-GXW2-JA. ("n" means its version)

*1: For the supporting modules, refer to "MELSECWinCPU Module User's Manual (Hardware Design, Function Explanation)".

1. Outline

Thank you for purchasing the MELSEC-Q series compatible MELSECWinCPU module bus interface driver software package.

Before use, please read this document carefully to understand functions and performances of the MELSEC-Q series compatible MELSECWinCPU module bus interface driver software package thoroughly.

1.1 Features

The features of the MELSEC-Q series compatible MELSECWinCPU module bus interface driver software package (it is abbreviated as SW1PNC-WCPU-B in this manual.) are summarized below.

- (1) I/O modules and intelligent function modules are controlled from MELSECWinCPU module.

A user program created with bus interface function is capable of controlling I/O modules and intelligent function modules that are managed on MELSECWinCPU module.

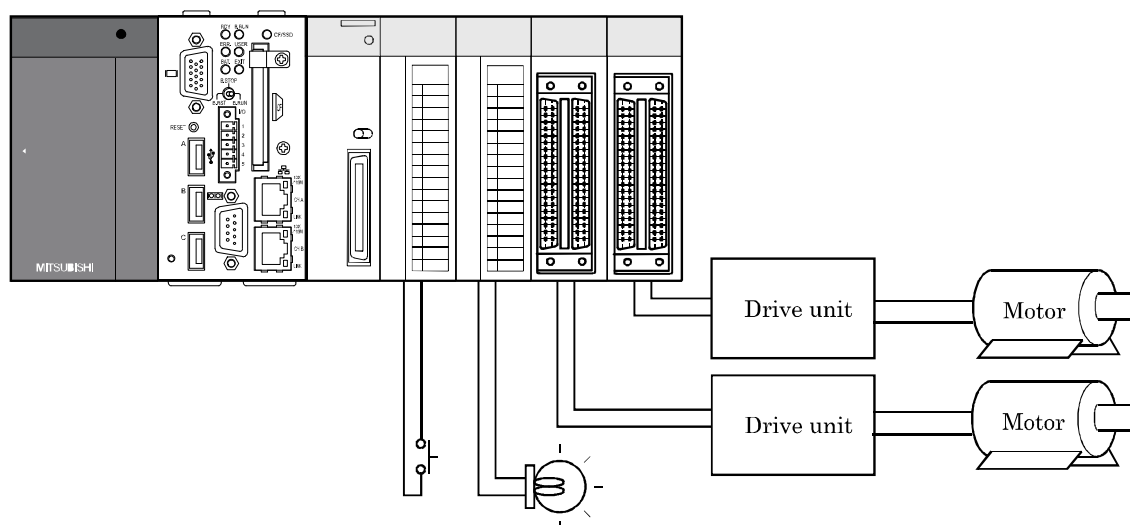

Each unit is controllable from MELSECWinCPU module.

(2) Building multiple CPU system is allowed.

Construction of a multiple CPU system configured of QCPU (Q mode), motion CPU and MELSECWinCPU module is allowed.



Module No.1 : QCPU (Q mode)

Module No.2 through 3 QCPU (Q mode) or motion CPU

Constructing a multiple CPU system with up to 3 modules is allowed

(3) Access from MELSECWinCPU module is allowed via CC- Link and MELSECNET/H.

A user program created with MELSEC data link function is capable of accessing to programmable controller CPU of other station via CC- Link and MELSECNET/H.

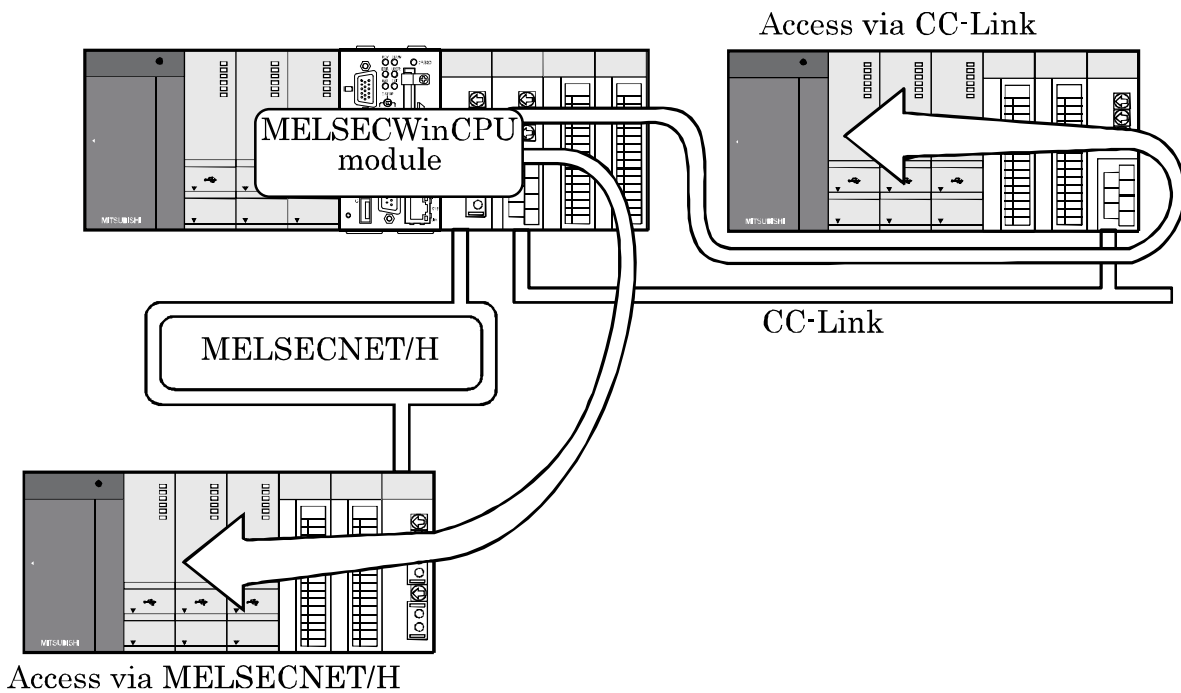

(4) Various settings are specified on utilities.

MELSECWinCPU setting utilities allows easily specifying I/O assignment and multiple CPU settings, etc.

The utilities also allow specifying and executing parameters of CC-Link utility and MELSECNET/H modules and device monitoring of accessing target system.

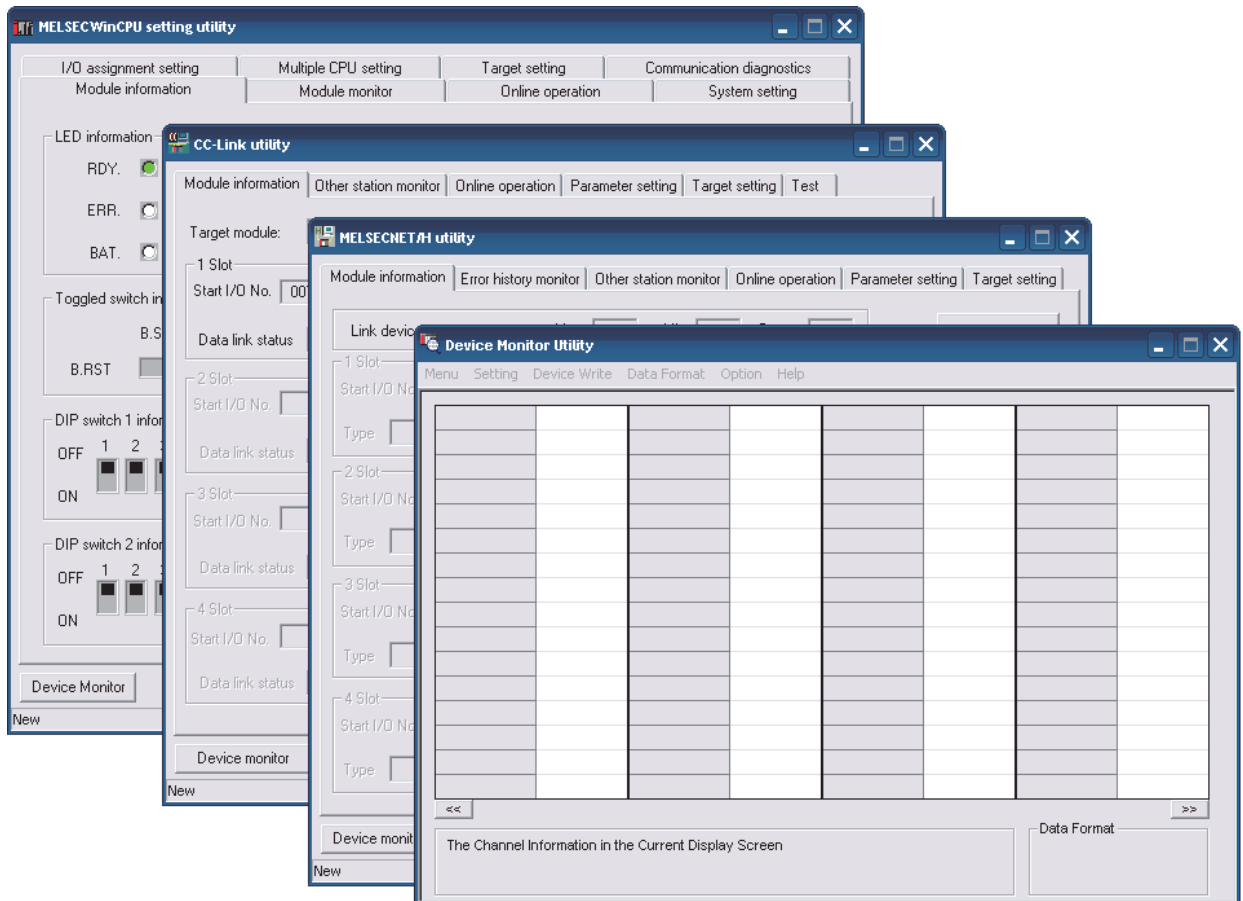

Performs the settings and monitoring by using each utility.

(5) Supports Hyper-Threading function.

Feature	Your benefit
Intel® Atom™ Processor N450 1.66GHz on Q10WCPU-W1 supports Hyper-Threading technology. You can enable the function and use it.	CPU processing performance will get higher and the performance of your application is expected to get higher as well.

2. System Configuration

This section describes system configuration, accessible modules and operating environment.

2.1 System Configuration

(1) System configuration when installing

The following summarizes system configuration required for installation of SW1PNC-WCPU-B

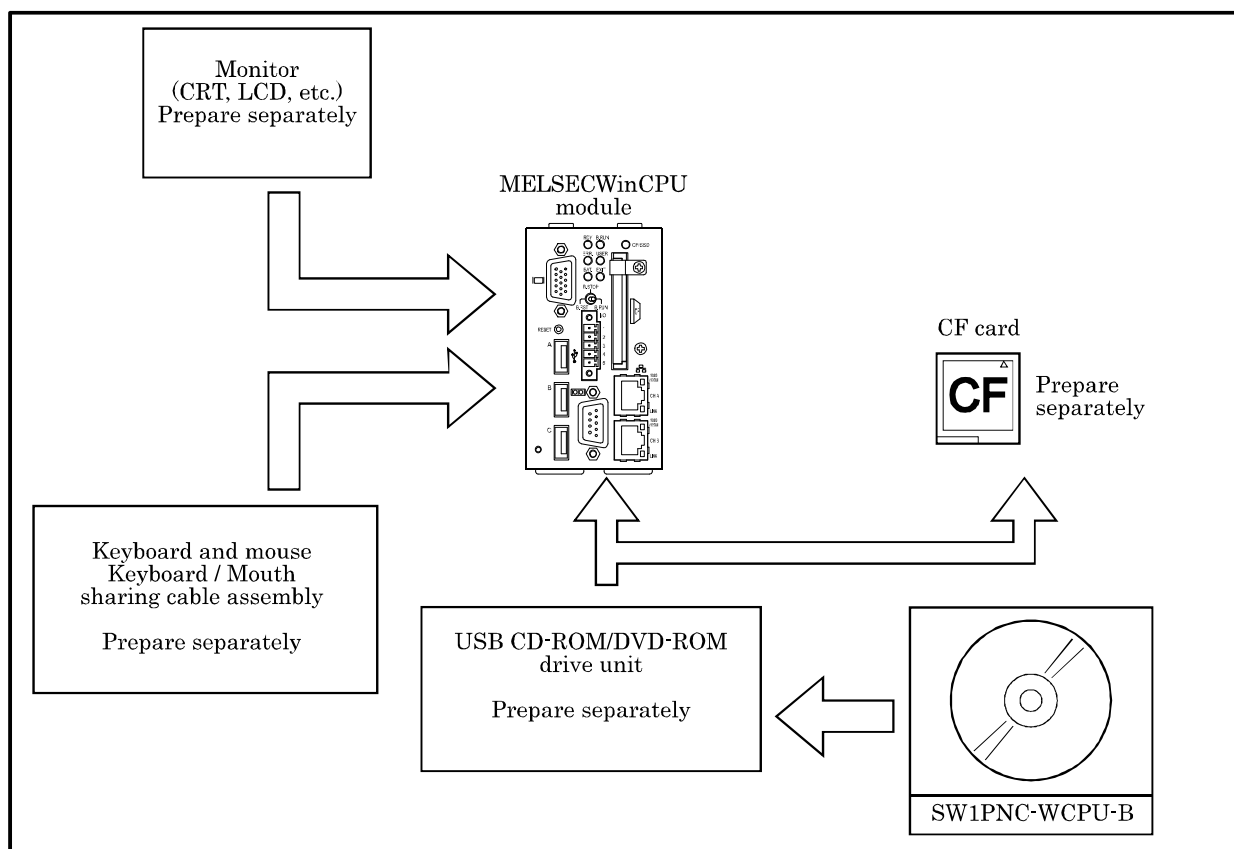

(2) System configuration when developing or debugging

For the development environment and the system configuration needed to develop or debug programs which works on MELSECWinCPU, refer to followings.

The development environment of this product is the cross development environment which regards this product as target system (2) and this product is connected to host system(1), which is your personal computer where you develop programs, via Ethernet.

If you want to debug, remote debugging via Ethernet is recommended.

Use Microsoft® Visual Studio® 2008/2010 provided by Microsoft® in order to develop programs and run remote debugging. But you need the edition which supports remote debugging such as Professional Edition in order to run remote debugging.

For how to run remote debugging, refer to Microsoft's web site or the document of Visual Studio.

Point
When executing user program on MELSECWinCPU, you may have to change the setting of Microsoft® Visual Studio or install Visual C++ library or .NET Framework 4.0 according to your user program. Refer to Microsoft's web site in order to know how to do.

Shows the system configuration when debugging this product as follows.

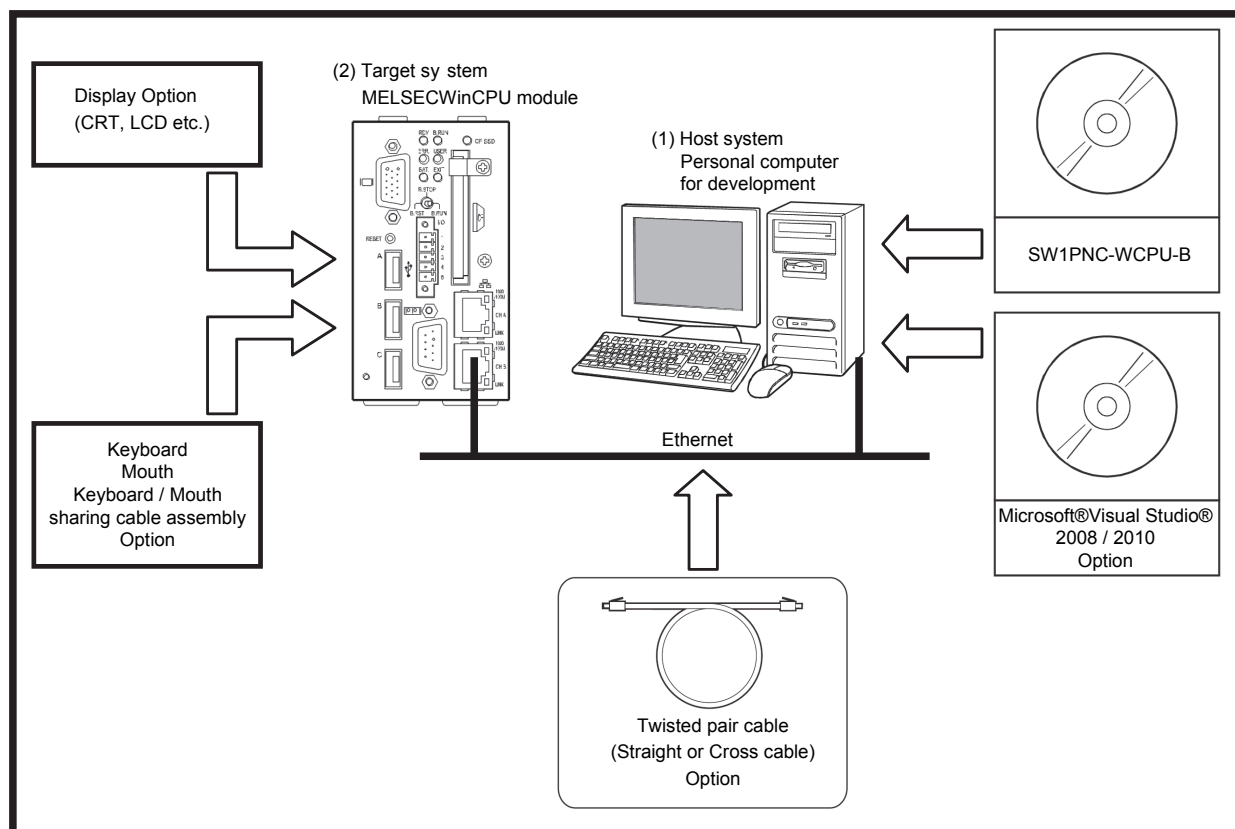

The environment of host system (Personal computer for development)

Item	Content
Programming language *1	Microsoft® Visual Studio® 2008 Visual Basic (Japanese and English editions) Microsoft® Visual Studio® 2008 Visual C++ (Japanese and English editions) Microsoft® Visual Studio® 2010 Visual Basic (Japanese and English editions) Microsoft® Visual Studio® 2010 Visual C++ (Japanese and English editions)
Display	Resolution : 1024 x 768 dots or higher
Ethernet card / board	10BASE-T/100BASE-TX/1000BASE-T

*1: User program created in Japanese environment is not executable in English environment.
User program created in English environment is not executable in Japanese environment.

2.2 Accessible Modules

This section describes the modules accessible from MELSECWinCPU module.

2.2.1 CPU module

The following summarizes CPU modules that are accessible when configuration of multiple CPU module with MELSECWinCPU module is allowed.

For the CPU supporting multiple CPU configuration, refer to “MELSECWinCPU Module User's Manual (Hardware Design, Function Explanation) [Multiple CPU configuration]”.

Type		Model name
Programmable Controller CPU	Basic model QCPU *1*5	Q01CPU, Q00CPU
	High performance model QCPU *2*5	Q02CPU, Q02HCPU, Q06HCPU, Q12HCPU, Q25HCPU
	Process CPU	Q02PHCPU, Q06PHCPU, Q12PHCPU, Q25PHCPU
	Universal model QCPU *3*5	Q00UCPU, Q01UCPU, Q02UCPU, Q03UDCPU, Q04UDHCPU, Q06UDHCPU, Q10UDHCPU, Q13UDHCPU, Q20UDHCPU, Q26UDHCPU, Q03UDECPU, Q04UDEHCPU, Q06UDEHCPU, Q10UDEHCPU, Q13UDEHCPU, Q20UDEHCPU, Q26UDEHCPU, Q50UDEHCPU, Q100UDEHCPU
	High-speed Universal model QCPU *4*5	Q03UDVCPU, Q04UDVCPU, Q06UDVCPU, Q13UDVCPU, Q26UDVCPU
Motion CPU		Q172CPUN, Q173CPUN, Q172CPUN-T, Q173CPUN-T, Q172HCPU, Q173HCPU, Q172HCPU-T, Q173HCPU-T, Q172DCPU, Q173DCPU, Q172DSCPU, Q173DSCPU

*1: When configuring multiple CPU system with MELSECWinCPU module, use products of function version B or later.

*2: When configuring multiple CPU system with MELSECWinCPU module, use products of function version B and of a serial No. having “03051” or later in first 5 digits.

*3: When configuring multiple CPU system with MELSECWinCPU module, use products of a serial No. having “09072” or later in the first 5 digits.

However, if you use a product with a serial No. that has a value between "09072" and "15041" in its first 5 digits, insert modules under the control of a universal model QCPU in a lower slot number than modules under the control of a MELSECWinCPU module.

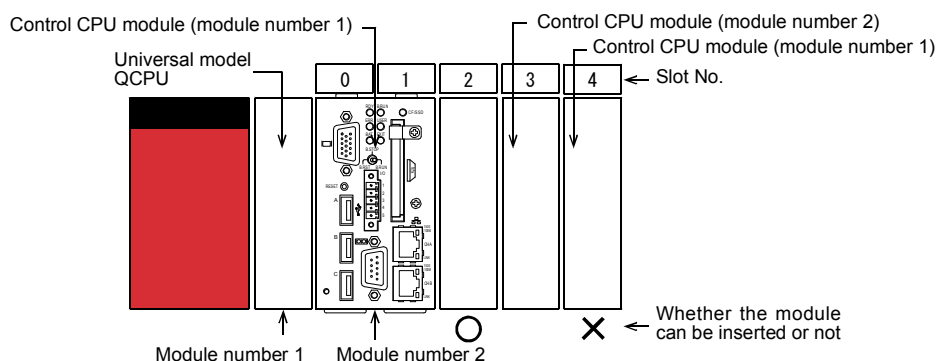

*4: When configuring a multiple CPU system with a MELSECWinCPU module, use products with a serial No. that has a value of "15042" or higher in its first 5 digits.

*5: For checking function version and serial No, refer to manual of QCPU (Q mode) to be used.

2.2.2 I/O module and intelligent function module

(1) Available I/O module and intelligent function module

For available I/O module and intelligent function module, refer to “MELSECWinCPU Module User's Manual (Hardware Design, Function Explanation)”.

(2) Notes on using I/O module and intelligent function module

For notes on using I/O module and intelligent function module, refer to “MELSECWinCPU Module User's Manual (Hardware Design, Function Explanation)”.

2.3 Operating Environment

The following summarizes operating environment of SW1PNC-WCPU-B.

Item	Description
Applicable models	MELSEC-Q series compatible MELSECWinCPU module
Programming language ^{*1*2}	Microsoft® Visual Studio® 2008 Visual Basic (Japanese and English editions) Microsoft® Visual Studio® 2008 Visual C++ (Japanese and English editions) Microsoft® Visual Studio® 2010 Visual Basic (Japanese and English editions) Microsoft® Visual Studio® 2010 Visual C++ (Japanese and English editions)
Display	Resolution: 800 x 600 dots or higher (Recommended: 1024 x 768 dots)

*1: User program created in Japanese environment is not executable in English environment.

User program created in English environment is not executable in Japanese environment.

*2: When developing programs, refer to “Section 2.1. (2) System Configuration when developing and debugging”.

Point
<p>It does not support following functions of Windows® Embedded Standard 2009. If you use these functions, this product may not work in order.</p> <ul style="list-style-type: none"> - Fast User Switching - Remote Desktop - Large Fonts (Detail settings of display properties) - Standby Mode - Languages switching from Regional and Language Options

2.4 S/W Configuration

2.4.1 S/W Package Configuration

S/W package configuration of MELSECWinCPU module bus interface driver, attached to MELSECWinCPU, is as follows.

(1) Folder Configuration in CD-ROM

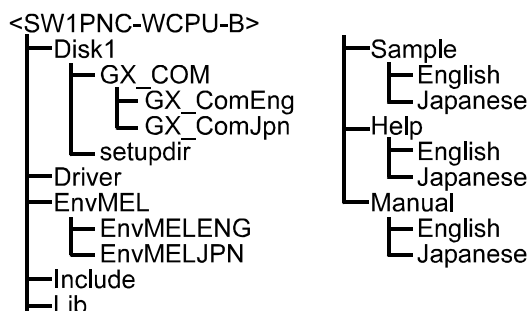

(2) Details of Files in CD-ROM

Name of folder or file	Detailed Explanation	Files
Disk1, Drivers Setup.exe	It provides with install files for utility used on Windows, HELP files, communication function library (DLL), communication function header files, driver files and sample programs.	MELSECWinCPU setting utility, CC-Link utility, device monitor utility, HELP files for each utility, MELSEC data link function library, bus interface function library, driver files, sample programs.

2.4.2 Linking with MELSOFT products

(1) Usable MELSOFT products

Software package name	Supported version
GT SoftGOT1000	Version 3.38Q
GT SoftGOT2000	Version 1.100E
MX Component	Version 4.02C

(2) Notes on using MELSOFT products

- (a) When using the license key for the GT SoftGOT1000/GT SoftGOT2000 USB port
 When using the license key for the USB port, the following screen may be displayed.
 If the following screen is displayed, specify "C:\Program Files\Common Files\SafeNet Sentinel\Sentinel System Driver\sntnlusb.sys" as the source to copy from.

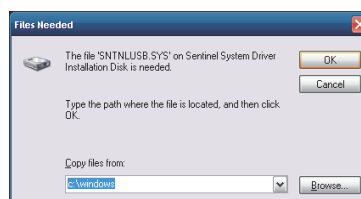

For details, refer to the "GT SoftGOT1000 Version3 Operating Manual for GT Works3" or "GT SoftGOT2000 Version1 Operating Manual".

3. Procedures before Starting and Settings

This chapter describes procedures and settings for operating MELSECWinCPU module.

(1) Caution on use

For how to handle a MELSECWinCPU module as standalone, refer to “MELSECWinCPU Module User's Manual (Hardware Design, Function Explanation)”.

(2) MELSECWinCPU module startup procedure

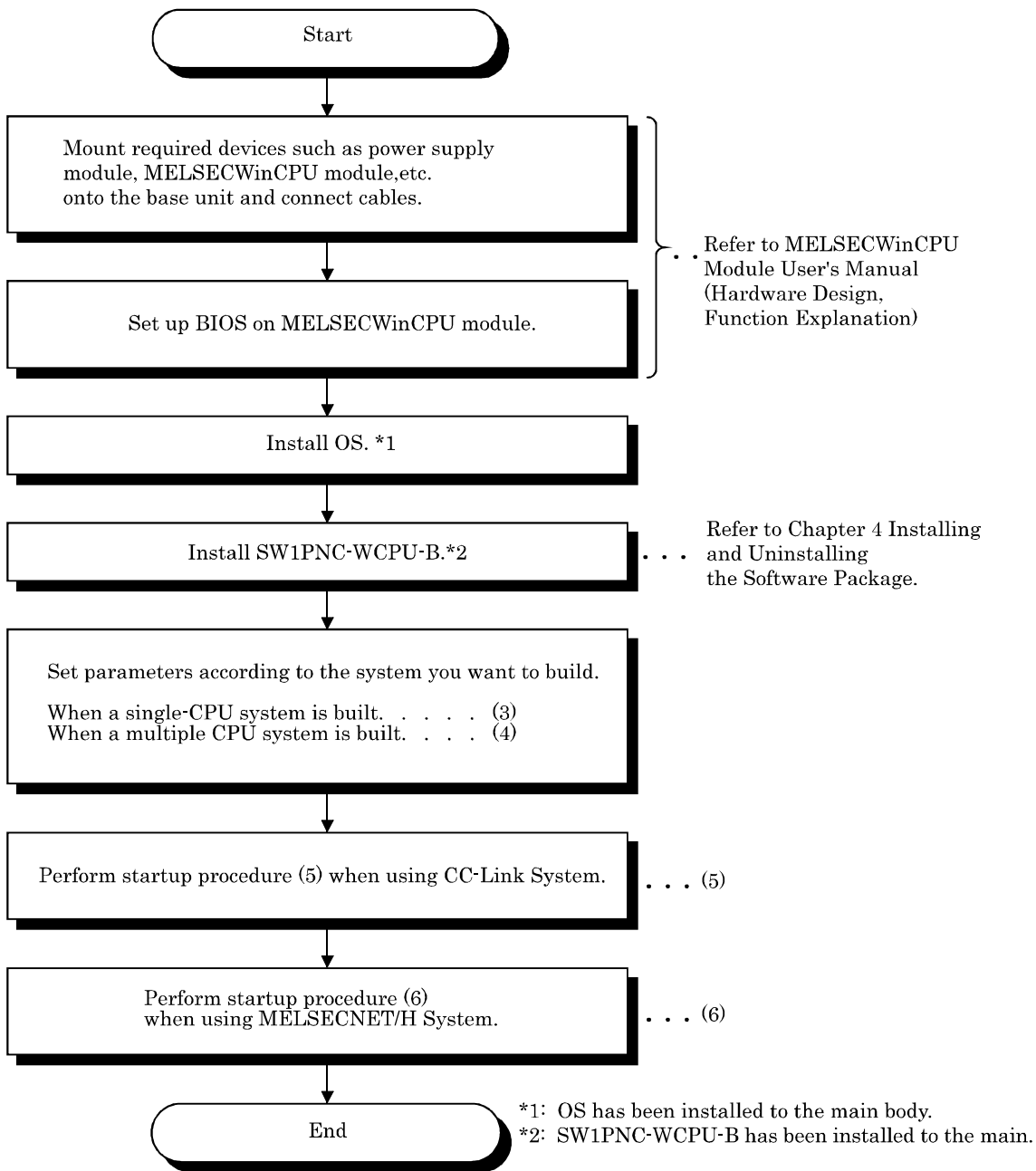

- (3) Startup procedure when a single-CPU system is built.
Perform startup procedure (2) before the following procedure.

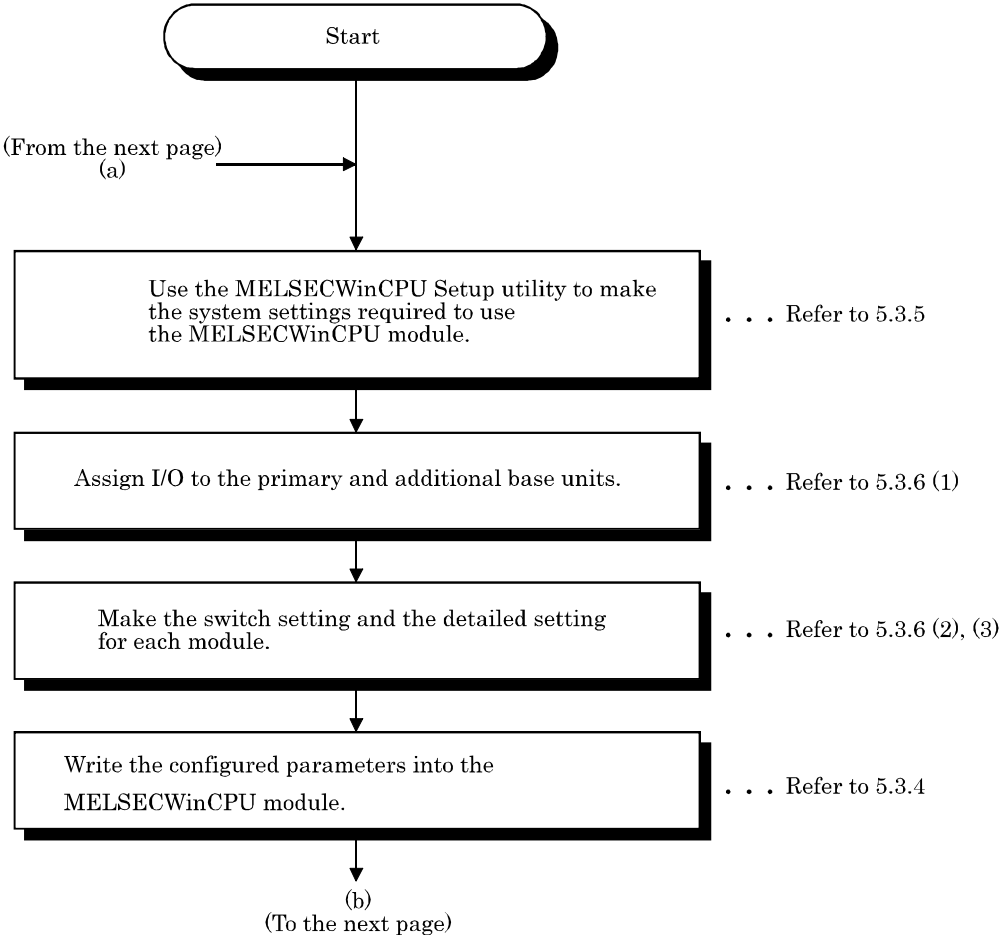
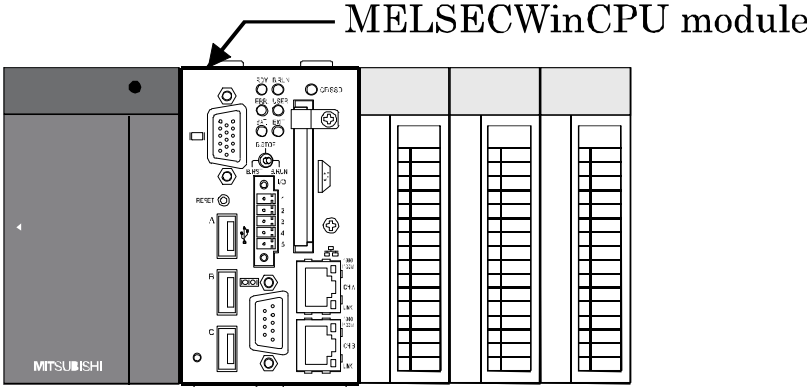

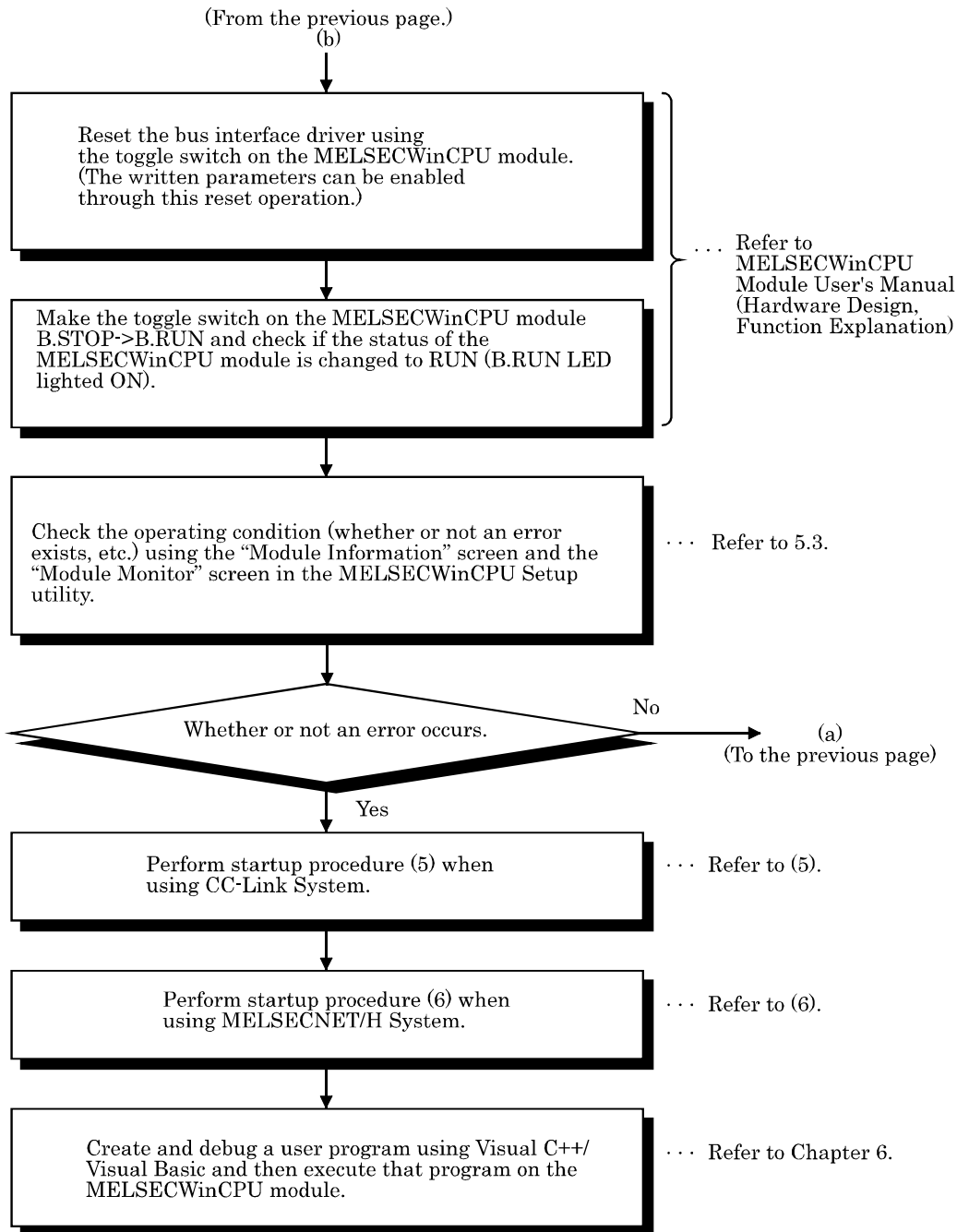

- (4) Startup procedure when a multiple CPU system is built.
Before the following startup procedure, perform the parameter setup for CPU module of a different ID device and perform setup procedure (2).

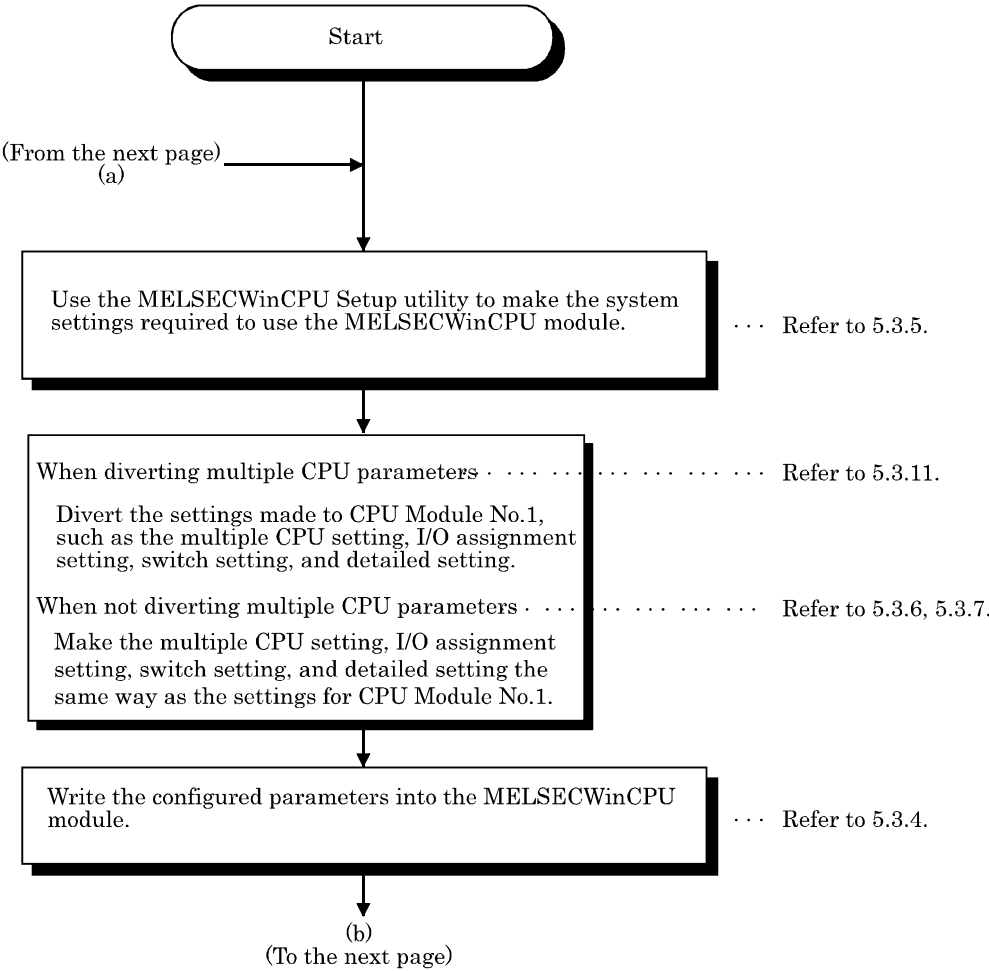
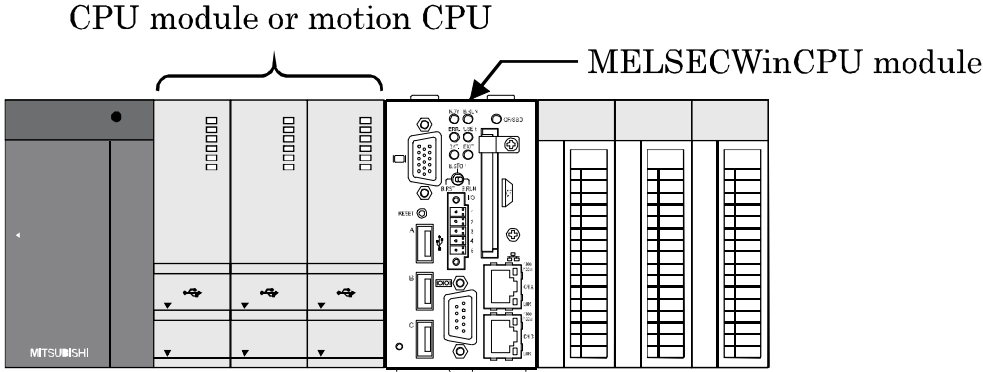

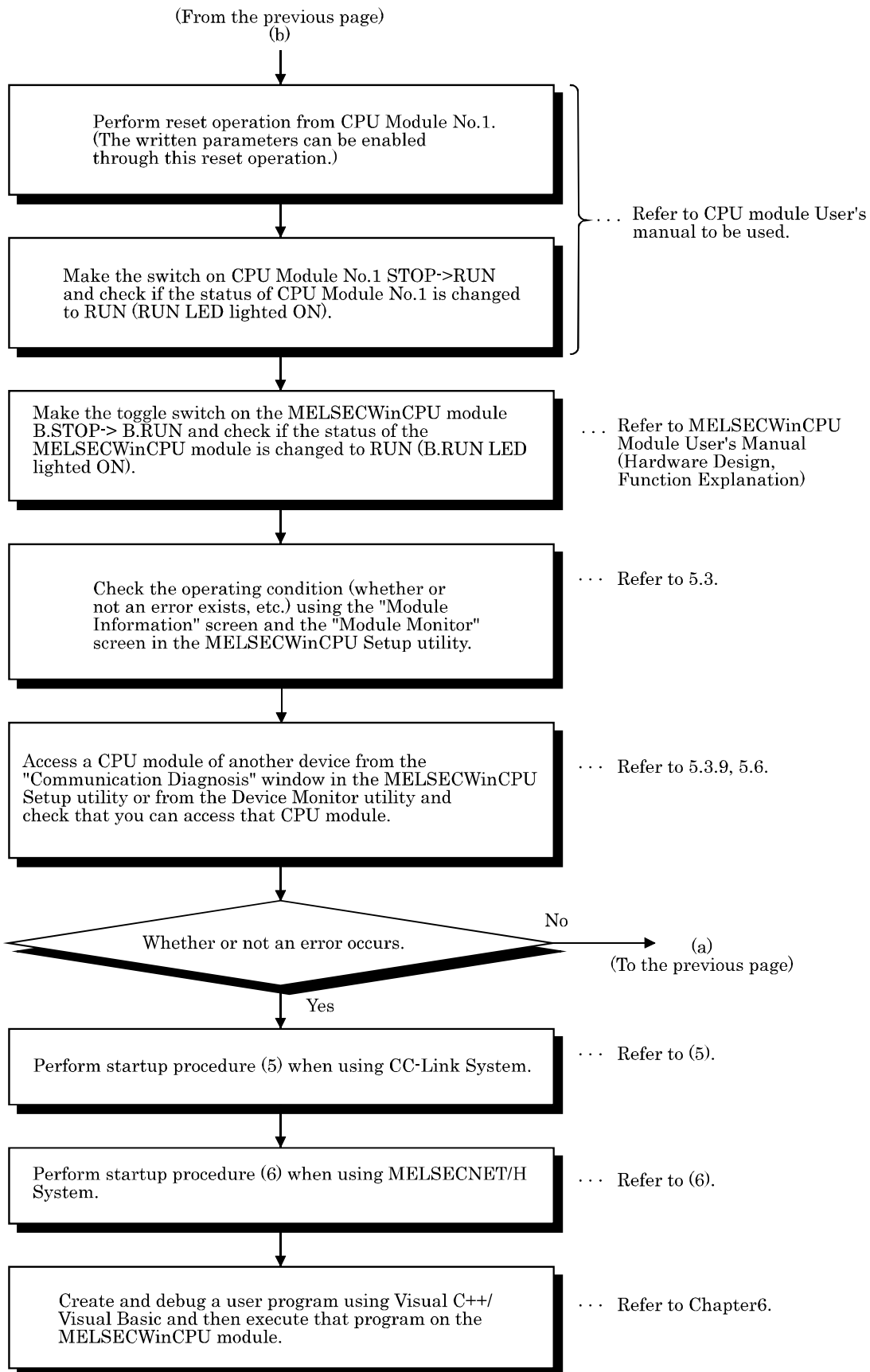

(5) Startup procedure when a CC-Link network system is built.
Before the following startup procedure, perform setup procedure (2).

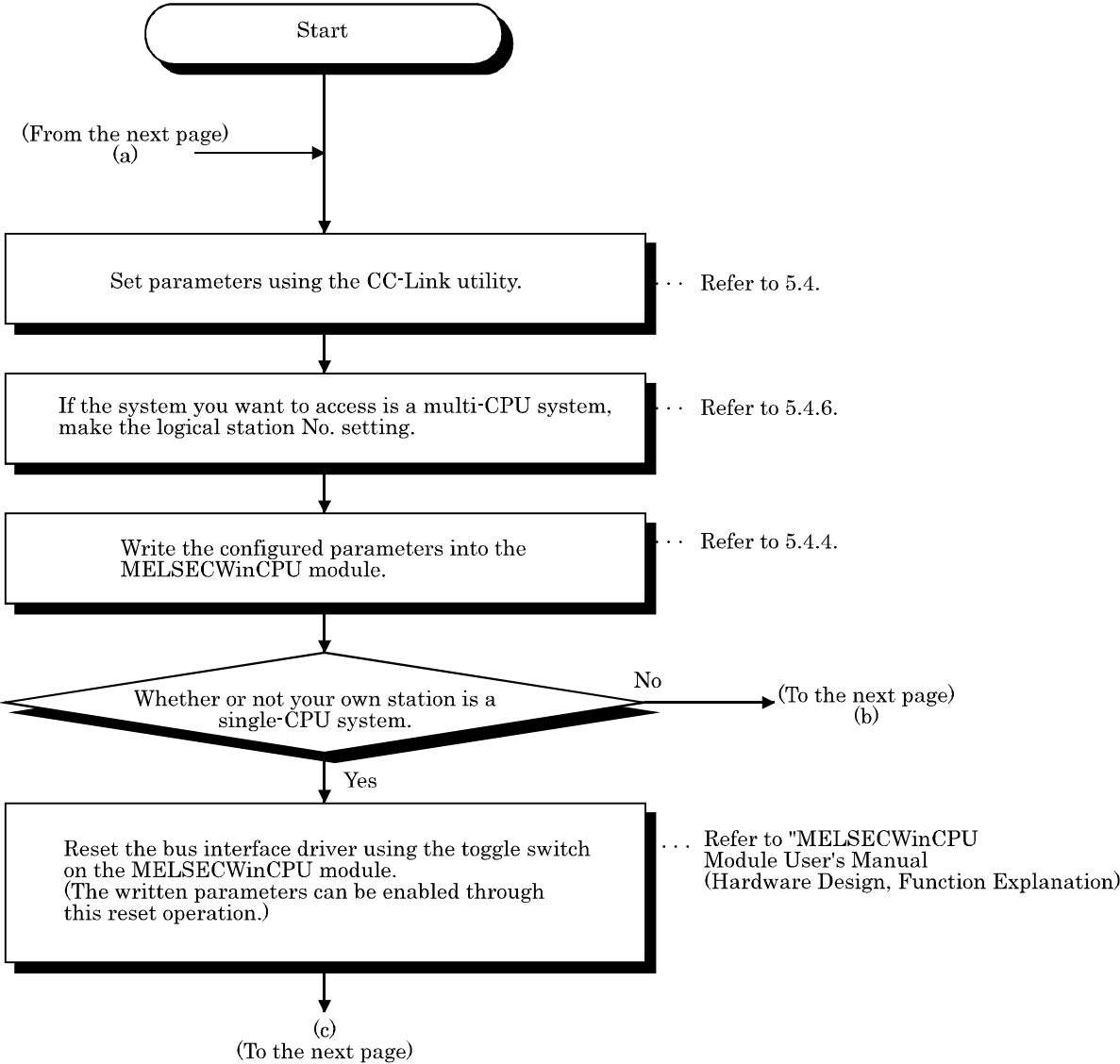
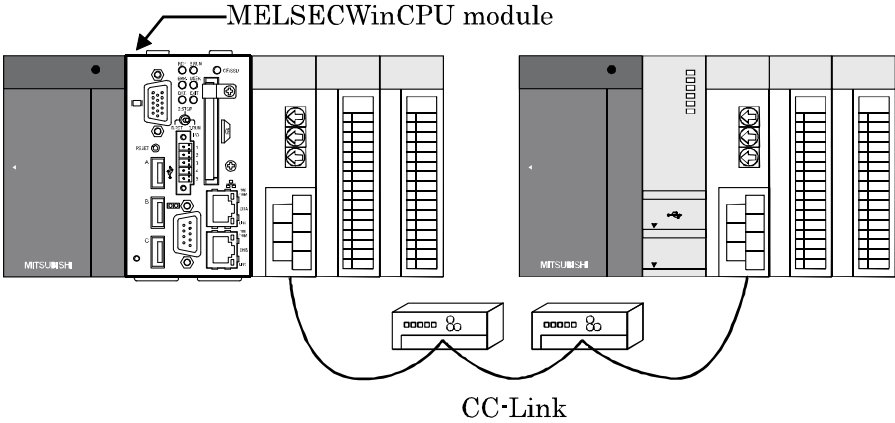

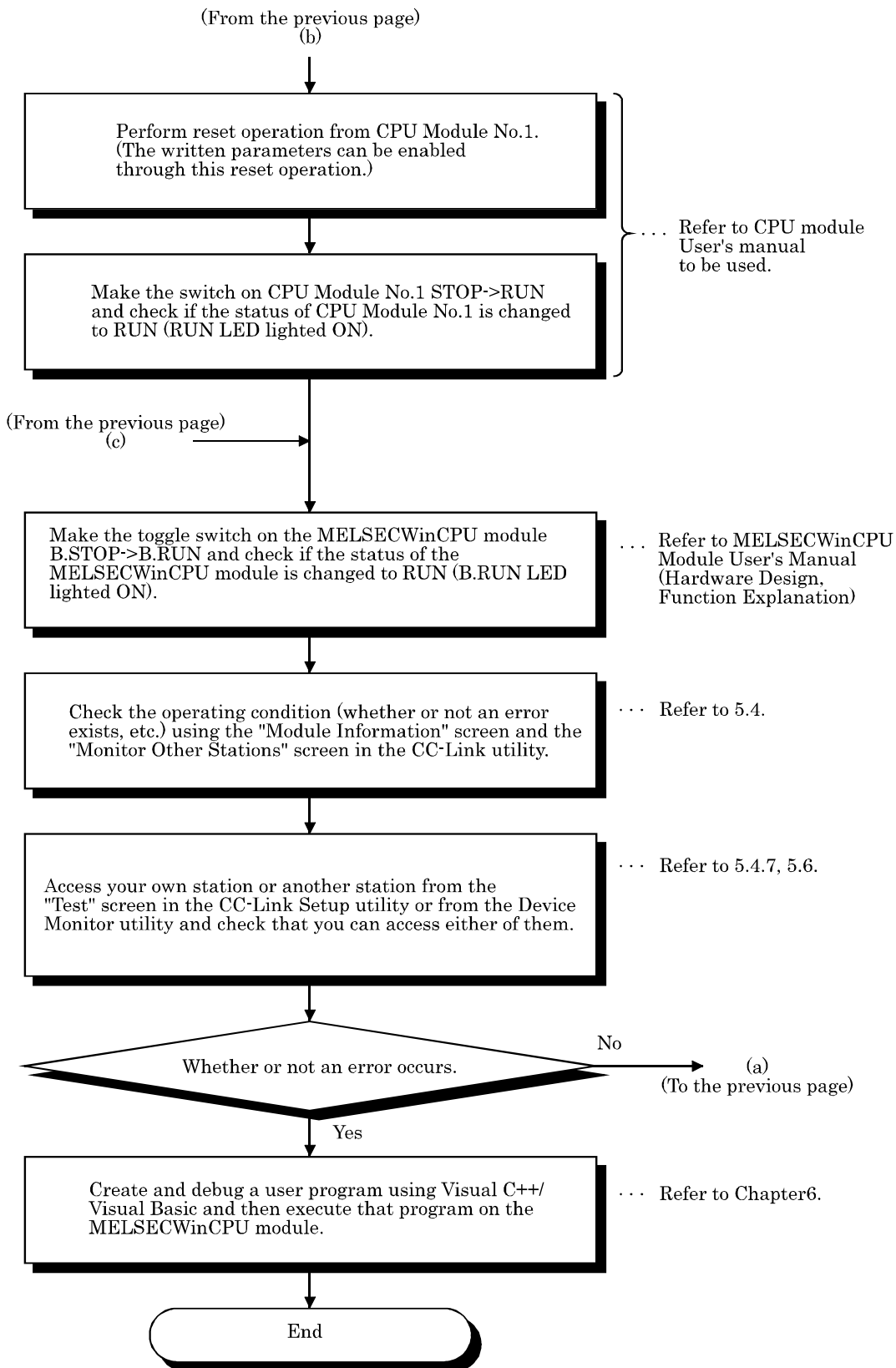

(6) Startup procedure when a MELSECNET/H network system is built.
Perform startup procedure (2) before the following procedure.

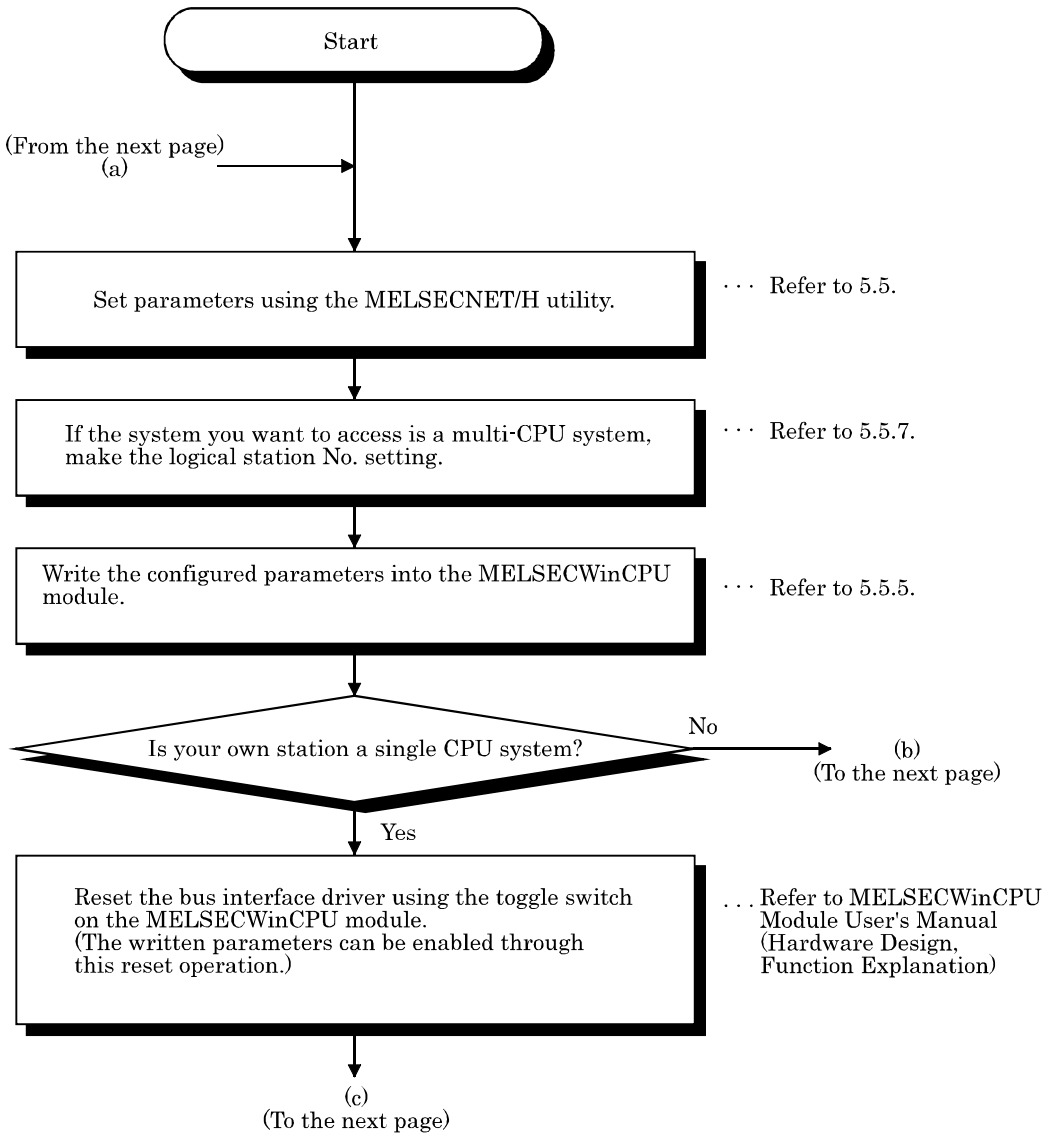
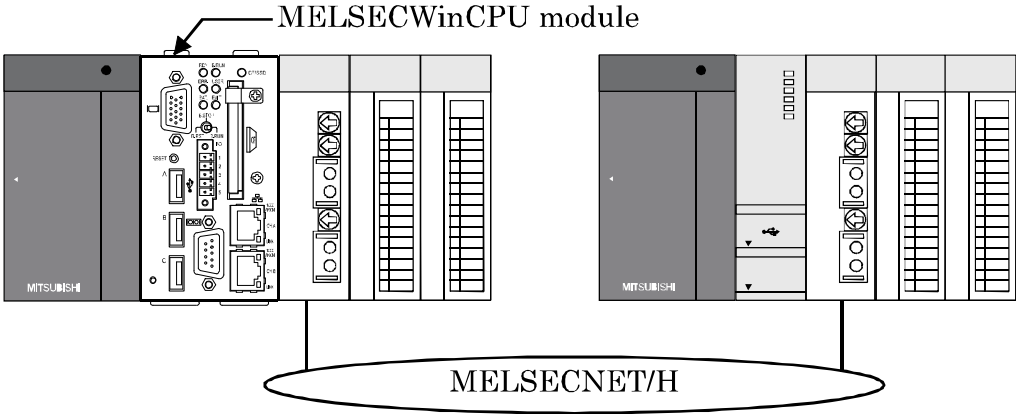

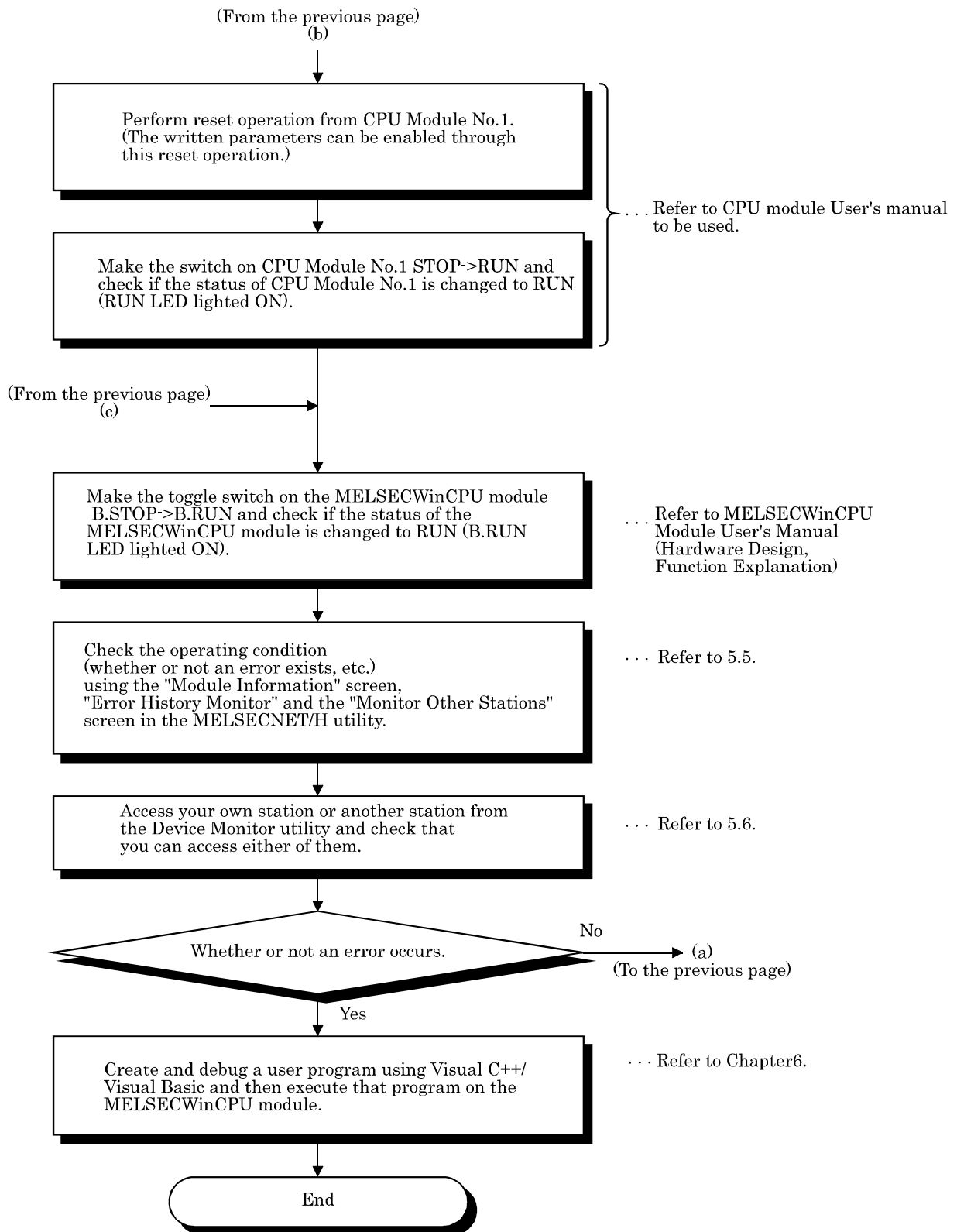

4. Installing and Uninstalling the Software Package

This chapter describes procedures of installing and uninstalling SW1PNC-WCPU-B.

4.1 Installing the software package

This section describes installation of SW1PNC-WCPU-B.

Point	
	SW1PNC-WCPU-B has already been installed after the shipment or after the recovery by an attached recovery media, therefore you have not to install SW1PNC-WCPU-B again in their cases.

4.1.1 Installing

This section describes installation of SW1PNC-WCPU-B.

POINT
(1) When installing the SW1PNC-WCPU-B in the MELSECWinCPU module, log in as a user who has the administrator privilege.
(2) Remove all the applications that are included in the startup, then restart Windows before installing SW1PNC-WCPU-B.
(3) To install SW1PNC-WCPU-B, use "Add or Remove Programs" in "Control Panel". As an alternative method, you can execute "Setup.exe". Double- click "D:\EnvMEL\EnvMELENG\Setup.exe" in CD- ROM, then start the EnvMEL installation from item [6.] - [8.]. And, Double- click "D:\Setup.exe" in CD- ROM, then start the utilities installation from item [12.] - [15.]. ("D:" described in the above means the drive name of a CD-ROM drive. Enter the drive name of a CD-ROM drive you want to use.)
(4) If SW1PNC-WCPU-B has already been installed, you can not additionally install it. First uninstall it and try to install again.
(5) It does not support languages switching from "Regional and Language Options" on "Control Panel". Do not install or uninstall after switching languages.

(1) Installing SW1PNC-WCPU-B

1). Turn on the power to the MELSECWinCPU module and start Windows.

2). Open [Start] - [Control Panel].

Open "Add or Remove Programs" and select "Add New Programs".

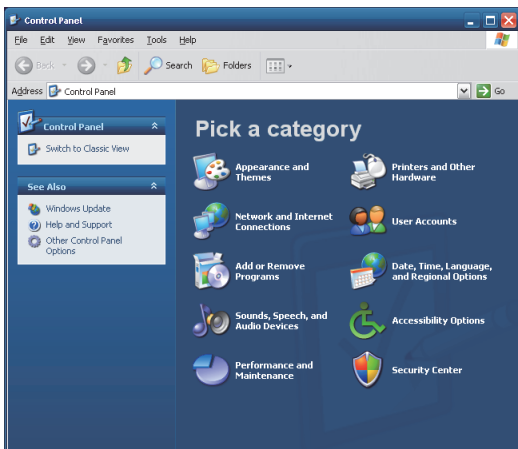

(To the next page)

(From the previous page)

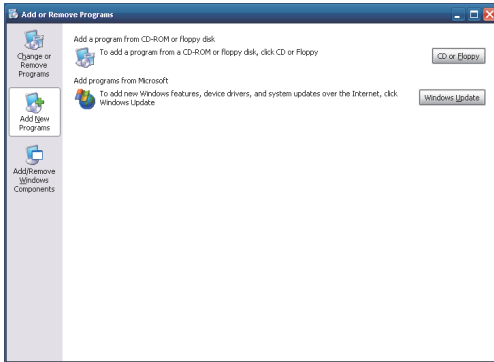

- 3). When the screen shown at the left is displayed, click the **CD or Floppy** button.

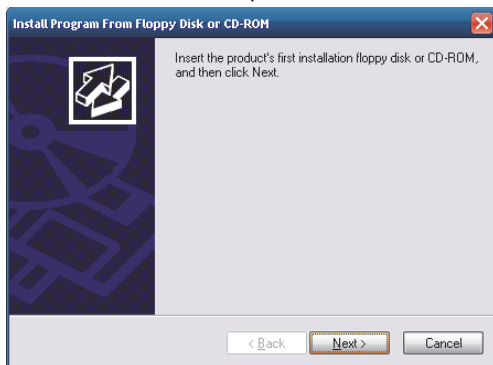

- 4). When the screen shown at the left is displayed, insert CD- ROM into the CD- ROM drive and click the **Next >** button.

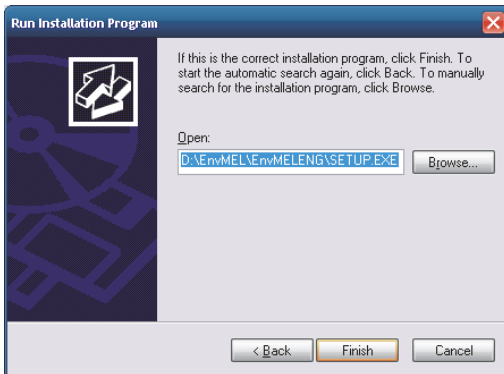

- 5). When the screen shown at the left is displayed, "Setup.exe" has been found. Click the **Browse...** button and change to "D:\EnvMEL\EnvMELENG\Setup.exe". Click the **Finish** button and start the installation. ("D : " described in the above means the drive name of a CD-ROM drive. Enter the drive name of a CD-ROM drive you want to use.)

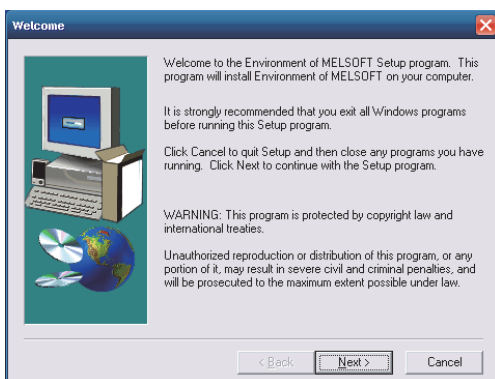

- 6). When the screen shown at the left is displayed, click the **Next >** button.

(To the next page)

(From the previous page)

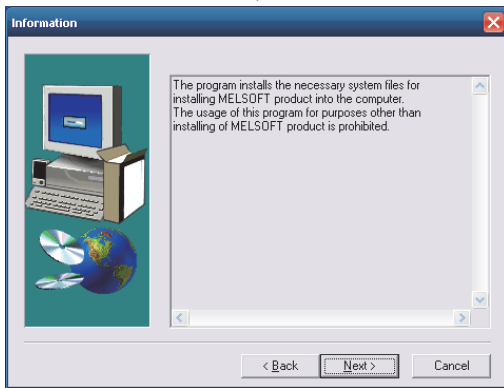

7). When the screen shown at the left is displayed, click the **Next>** button. EnvMEL is installed.

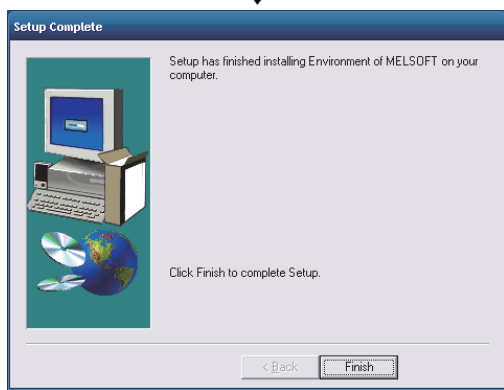

8). The EnvMEL installation is complete when the screen shown at the left is displayed. Click the **Finish** button.

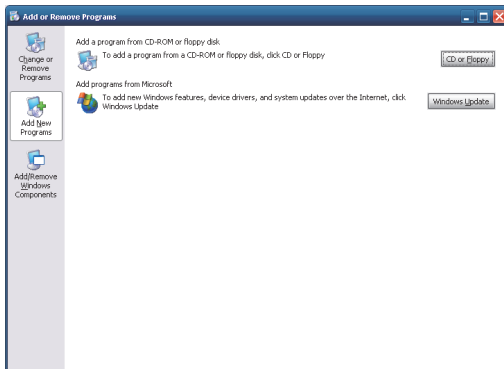

9). When the screen shown at the left is displayed, click the **CD or Floppy** button.

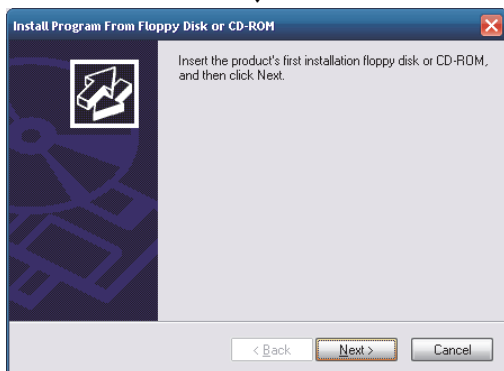

10). When the screen shown at the left is displayed, click the **Next>** button.



(To the next page)

(From the previous page)

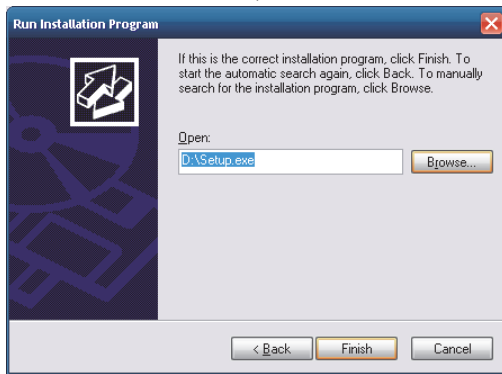

11). When the screen shown at the left is displayed, "Setup.exe" has been found. Click the **Finish** button and start the installation.

If "Setup.exe" was not found, click the **Browse...** button and change to the location where "D:\Setup.exe" exists. ("D:" described in the above means the drive name of a CD-ROM drive. Enter the drive name of a CD-ROM drive you want to use.)

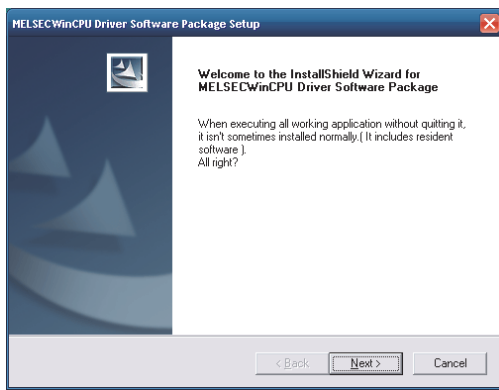

12). When the screen shown at the left is displayed, click the **Next >** button.

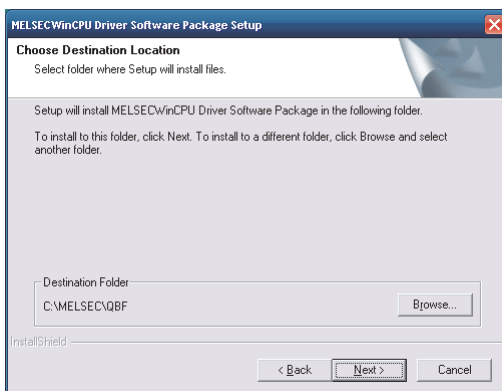

13). Specify the installation destination folder.

The default installation destination folder of SW1PNC-WCPU-B is "C : \MELSEC\QBF".

To accept the default, click the **Next >** button.

To change the installation destination folder, click the **Browse...** button.

(To the next page)

(From the previous page)

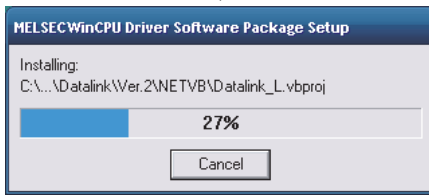

14). The installation will start.

[Remarks]

While installation, following screen may appear.

Click **Yes** and continue installation.

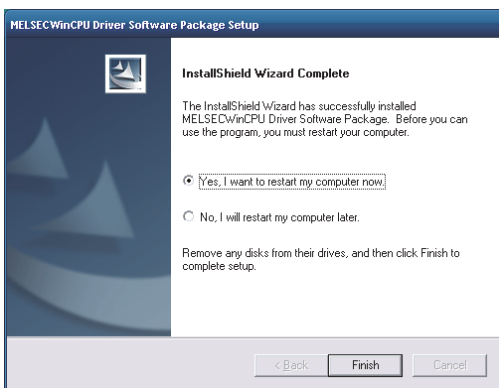
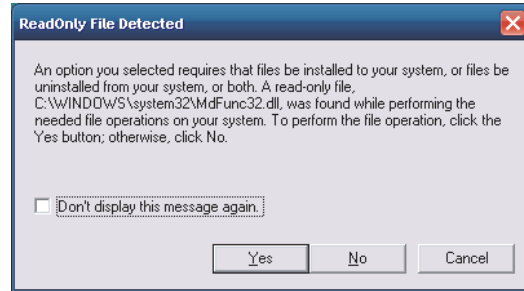

15). The installation is complete when the screen shown at the left is displayed.

To restart, verify that "Yes, I want to restart my computer now" is checked, then click the **Finish** button.

To restart later, check "No, I will restart my computer later, " then click the **Finish** button.









(Complete)

Point

- (1) To reinstall the SW1PNC-WCPU-B after an installation failure in the middle of the installation process, first uninstall the SW1PNC-WCPU-B before trying to reinstall it.
- (2) When reinstalling the software package, first uninstall it, restart the MELSECWinCPU module, and then reinstall the package.

4.2 Icons to be Registered

Upon installation of SW1PNC-WCPU-B, the following icons are registered in [Start] - [Program] - [MELSECWinCPU].

Icon	Utility name	Description
	CC-Link Utility	Start CC-Link Utility.
	MELSECNET_H Utility	Start MELSECNET/H utility.
	MELSEC Data Link Function HELP	Starts MELSEC Data Link Function HELP.
	MELSECWinCPU Setting Utility	Start MELSECWinCPU Setting Utility.
	Device Monitor Utility	Starts device monitor utility.
	Bus Interface Function HELP	Start Bus Interface Function HELP.

4.3 Uninstalling

This section describes uninstallation of SW1PNC-WCPU-B.

Point
<ol style="list-style-type: none"> (1) Always uninstall from Control Panel. (2) Before uninstalling, you should save all the parameters set in MELSECWinCPU to any files. After uninstalling, all the parameters set in MELSECWinCPU will be erased. (3) After uninstalling, you should restart MELSECWinCPU and reinstall SW1PNC-WCPU-B. If you did not reinstall, drivers would not work in order.

4.3.1 Uninstalling

About the uninstallation of SW1PNC-WCPU-B.

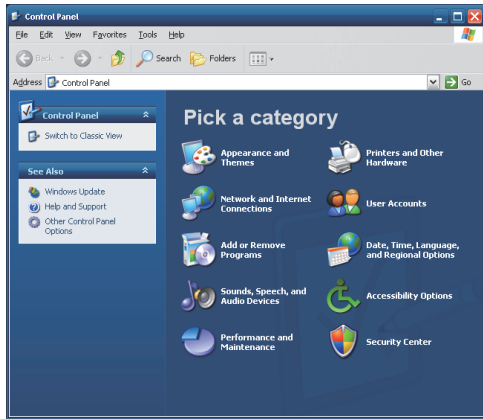

1). Open [Start] - [Control Panel].

Open "Add or Remove Programs" and select "Change or Remove Programs".

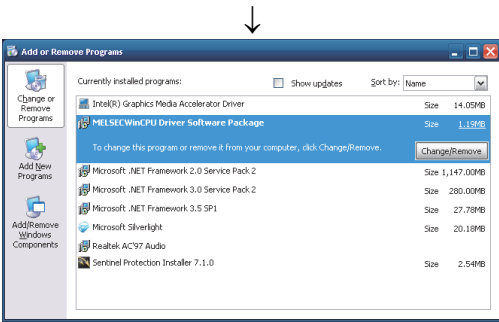

2). When the screen shown at the left is displayed, select "MELSECWinCPU Driver Software Package" and click the **Change/Remove** button.

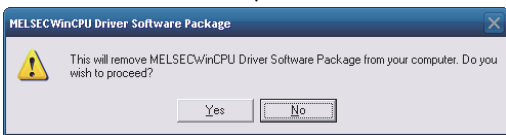

3). When the screen shown at the left is displayed, click **Yes** button and start uninstalling.

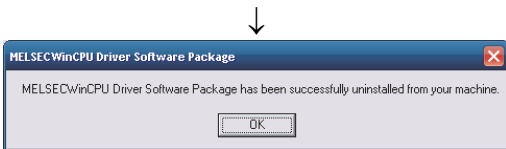

4). When the screen shown at the left is displayed, uninstalling is finished. Click **OK** button.

(Complete)

5. Utility Operations

The following shows a list of utilities included in SW1PNC-WCPU-B.

Utility name	Description	Referring paragraph
MELSECWinCPU setting utility	<p>The MELSECWinCPU setting utility has the following features.</p> <ul style="list-style-type: none"> - Displays module information of the MELSECWinCPU module (LED status, switch status, error information, etc.). - Monitors the statuses (input, output, buffer memory) of mounted modules. - Sets parameters. - Performs online operation directed to the MELSECWinCPU module. 	5.3
CC-Link utility	Sets parameters for the CC-Link utilities managed by the MELSECWinCPU module and monitors the network.	5.4
MELSECNET/H utility	Sets parameters for the MELSECNET/H module managed by the MELSECWinCPU module and monitors the network.	5.5
Device Monitor Utility	Monitors and tests the programmable controller CPU's device data.	5.6

Remarks

If the error dialog box appears while operating any of the utilities, handle the error by referring to “Section 8.4.3 Actions upon the error message.”

5.1 Utility Common Operations

This section explains the common operations for each utility.

5.1.1 Starting a utility

Start a utility by clicking one of the following menus inside [Start] - [Programs] - [MELSECWinCPU module] menu.

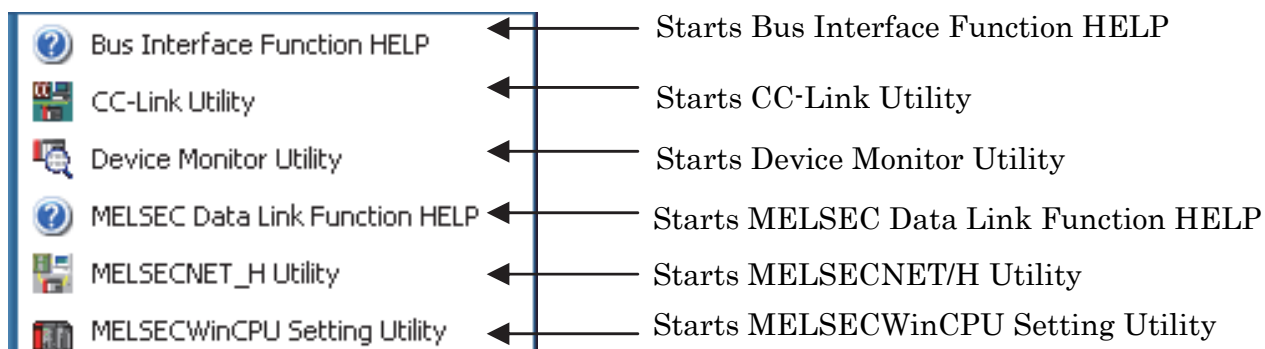

5.1.2 Ending a utility

The following explains how to end a utility.

- (1) To end the MELSECWinCPU Setting Utility, CC-Link Utility and MELSECNET/H Utility, click the **C**lose button at the lower right- hand corner of the utility screen.

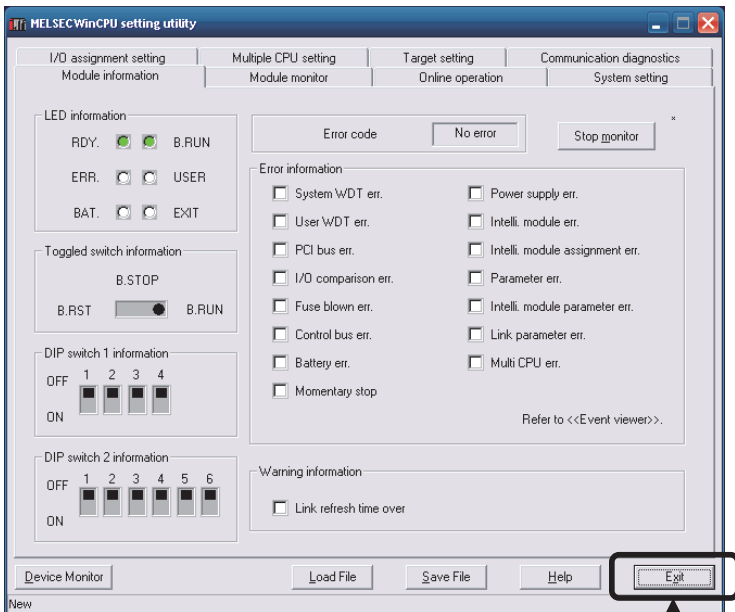

Click!

- (2) To end the Device Monitor Utility, click [Menu] - [Exit] from the menu bar. When a dialog box is displayed, click the **Y**es button.

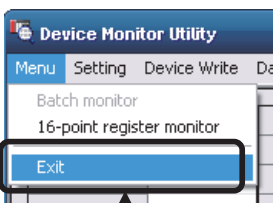

Click!

5.1.3 Displaying the help screen

The following explains how to display the utility's help screen.

- (1) For the MELSECWinCPU Setting Utility, CC-Link Utility, and MELSECNET/H Utility.

To display the help screen of the MELSECWinCPU Setting Utility, CC-Link Utility and MELSECNET/H Utility, click the **[Help]** button at the lower right-hand corner of the utility screen.

Or click on the **[F1]** key while the utility is still active.

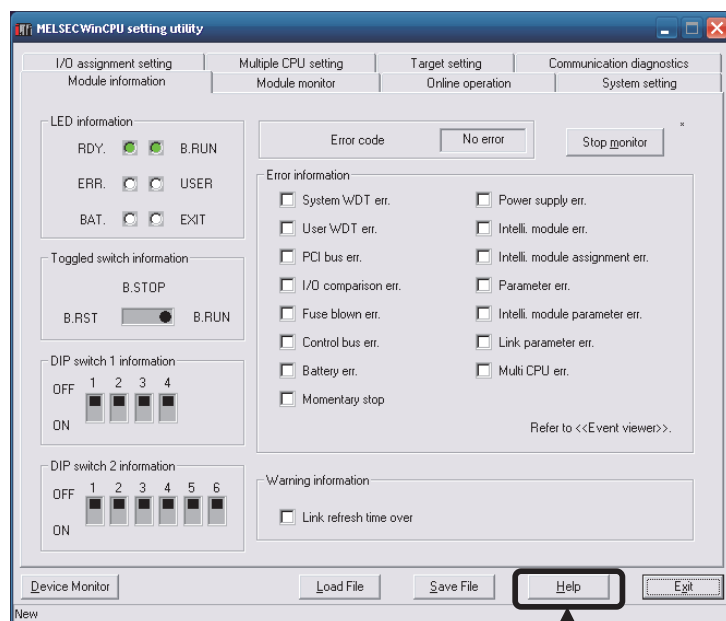

Click!

- (2) Device Monitor Utility

To display the help screen for the Device Monitor Utility, click [Help] - [Help] from the menu bar. Or click on the **[F1]** key while the utility is still active.

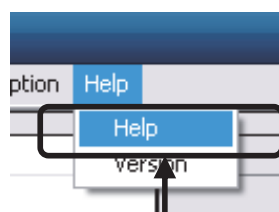

Click!

Remarks

For the help windows of utilities included in SW1PNC-WCPU-B, more than one window cannot be displayed at the same time.

Only one help window can be displayed.

While a help window is displayed, if another help window is started, the one started first shall be closed, so that the one started later can be displayed.

5.1.4 Verifying the version

The following explains how to verify the utility version.

(1) MELSECWinCPU Setting Utility

To verify the version information for the MELSECWinCPU Setting Utility, select [Version] from system menu.

For more details on this, please refer to “5.3.10 Operating the System Menu”.

(2) CC-Link Utility and MELSECNET/H Utility

To verify the version information for the CC-Link Utility and MELSECNET/H Utility, select [Version] from system menu.

For more details on CC-Link Utility, please refer to “5.4.8 Operating the System Menu”.

For more details on MELSECNET/H Utility, please refer to “5.5.8 Operating the System Menu”.

(3) Device Monitor Utility

To check the Device Monitor utility's version.

(a) Operation

Click on [Version] in [Help] on the menu bar to open the “Device Monitor Utility” window.



Click!

(b) Version information window



Item	Description
Device Monitor Utility	Displays the date of the Device Monitor Utility.
OK	Closes the “Version Information” window.

5.2 About the Parameter Setup File

The following explains about the parameter setup files for the MELSECWinCPU Setting Utility, CC-Link Utility and MELSECNET/H Utility.

(1) Reading/saving a parameter setup file.

The following describes how to read/save a parameter setup file.

- 1). Click on the **Load File** button to read a parameter setup file.
Click on the **Save File** button to save a parameter setup file.

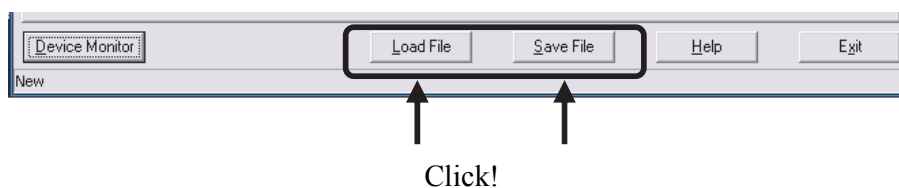

2). Read/save the settings.

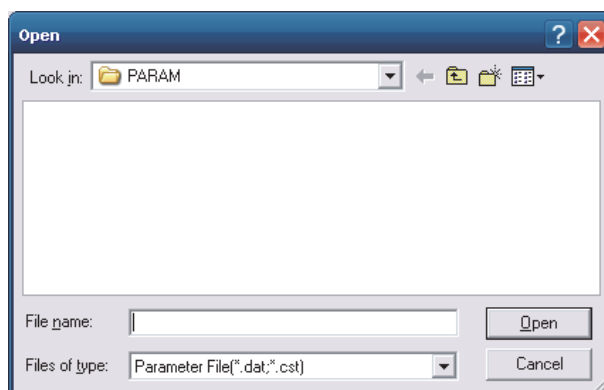

Item	Description
Look in (Place to be saved)	Specify the location from (or to) which it read (or save) parameter setting files. You can not specify the file path which includes 2 bytes character.
File name	Enter the name of a file you want to read (or save). You can not specify the file name which includes 2 byte character.
Open (Save)	Read (or saves) the file whose name has been entered.
Cancel	Close without reading (or saving).

Remarks

- (a) On the status bar of the parameter setup file for the MELSECWinCPU Setting Utility, CC-Link Utility or MELSECNET/H Utility, the name of the currently used parameter file is displayed.
- (b) The following shows the filename extensions of parameter setup files for the MELSECWinCPU Setting Utility, CC-Link Utility, and MELSECNET/H Utility.

Utility name	Parameter setup file filename extensions
MELSECWinCPU Setting Utility	cst (SW1PNC-WCPU-B setting data)
CC-Link Utility	ccl
MELSECNET/H Utility	mnh

- (c) "C : \MELSEC\QBF\PARAM" is the default directory to save the parameter setup files by the MELSECWinCPU setting utility, CC-Link utility, and MELSECNET/H utility.
(When SW1PNC-WCPU-B is installed in "C : \MELSEC\QBF".)

(2) Diverting parameters using a parameter setup file

You can use multiple modules with the same parameter setting by reading a parameter file into multiple MELSECWinCPU modules.

5.2.1 Status Bar Display Details

The status bar for each utility is explained as follows.

The following shows the status bars for the MELSECWinCPU Setting Utility, CC-Link Utility and MELSECNET/H Utility.

- (1) When a parameter setup file has been read/saved.

The filename is displayed on the status bar.

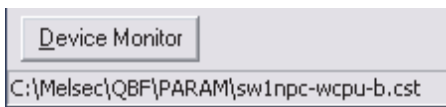

- (2) When a parameter setup file has not been read/saved.

"New..." is displayed on the status bar.



5.3 MELSECWinCPU Setting Utility

The following explains how to operate the MELSECWinCPU Setting Utility.

Notes on the MELSECWinCPU Setting Utility are described as follows.

(1) No. of utilities that can be used at the same time

Multiple MELSECWinCPU Setup utilities cannot run at the same time.

Only one MELSECWinCPU setting utility can be launched.

(2) Notes when parameters have been written.

The parameters written into a MELSECWinCPU module are enabled when that MELSECWinCPU module has been reset.

5.3.1 MELSECWinCPU Setting Utility Function List

The following describes the MELSECWinCPU setting utility 's features.

Name	Description	Reference paragraph
Reading/saving a parameter setup file.	Reads from or saves into a file the parameters that have been set using the MELSECWinCPU Setting Utility.	5.2
Module information	Displays information of the MELSECWinCPU module such as LED status, statuses of switches, error information, and alert information.	5.3.2
Module monitor	Processes the following for the modules mounted on the slots. - Monitors the input (X) status, the output (Y) status, and the buffer memory status. - Can forcibly output the output (Y) and forcibly write to buffer memory.	5.3.3
Online operation	Reads/writes/verifies parameters for the MELSECWinCPU module.	5.3.4
System setting	Sets parameters (system setting) for a MELSECWinCPU module.	5.3.5
I/O assignment setting	Sets parameters (I/O assignment setting) for a MELSECWinCPU module.	5.3.6
Multiple CPU setting	Sets parameters (Multiple CPU setting) for a MELSECWinCPU module.	5.3.7
Target setting	At the time a multiple CPU system is configured, sets a Logical Sta. No. to access a CPU of a different ID device.	5.3.8
Communication diagnostics	When the MELSECWinCPU module is in a multiple CPU configuration, diagnoses the possibility of communication with a CPU of a different ID device.	5.3.9

5.3.2 Operating the Module Information Window



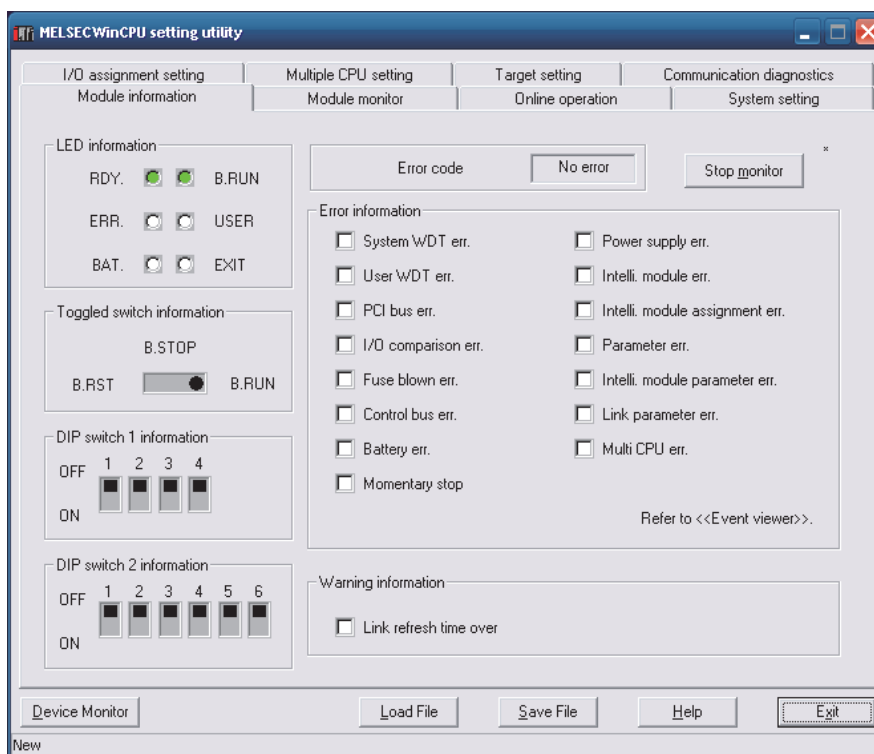

Displays information of the MELSECWinCPU module such as LED status, statuses of switches, error information, and alert information.

Point



- (1) Monitoring stops when the screen switches to another window during monitoring operation. Monitoring resumes the next time the “Module Information” window is opened.
- (2) Monitoring is not possible while the bus interface driver's resetting is in progress. Start monitoring after the reset operation is complete.

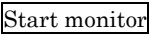
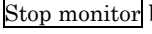
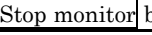
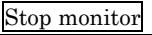
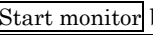

Item	Description
LED information	Displays the LED status of a MELSECWinCPU module. For the details of LED, refer to “MELSECWinCPU Module User's Manual (Hardware Design, Function Explanation)”.
Toggled switch information	Displays the Toggled switch status of MELSECWinCPU module. For the details of Toggled switch, refer to “MELSECWinCPU Module User's Manual (Hardware Design, Function Explanation)”.
DIP switch 1 information	Displays the DIP switch 1 status of MELSECWinCPU module. For the details of DIP switch, refer to “MELSECWinCPU Module User's Manual (Hardware Design, Function Explanation)”.
DIP switch 2 information	Displays the DIP switch 2 status of MELSECWinCPU module. For the details of DIP switch, refer to “MELSECWinCPU Module User's Manual (Hardware Design, Function Explanation)”.

Item	Description
Error code *1	Displays the latest error code for a stop error/continue error occurring. Displays “No error” for the error code “0”.
Error information *2	When a stop error/continue error occurs in the MELSECWinCPU module, the relevant stop error/continue error item becomes :  (white) ->  (red). For the error details and actions to take when LEDs are lighted ON, refer to “Section 8.3 Actions upon Error LED”.
Warning information *2	When an alert occurs in the MELSECWinCPU module, the relevant alert item becomes :  (white)->  (red). For details of warning information and actions to take when LEDs are blinking, refer to “8.3 Actions upon Error LED”.
	Starts monitoring. Changes to the  button when monitoring, with “*” blinking in the upper right of the  button. This button is disabled when in offline mode.
	Stops monitoring. Changes to the  button when monitoring is stopped.

*1: For the details of an error code, refer to the help of MELSECWinCPU setting utility.

*2: Keeps on displaying  (red) in the event of an error or alert, but in the event of a “battery error”, changes to  (red) or  (white) depending on the error condition.

5.3.3 Operating the Module Monitor Window

Monitors the input and output statuses and the buffer memory of a module.

**WARNING**

To perform control (data change) on a MELSECWinCPU module that is running, configure an interlock circuit on a user program so that the entire system can constantly operate on the safety side.

Also to perform other control (operation status change (status control)) on a MELSECWinCPU module that is running, configure an interlock circuit on a user program so that the entire system can constantly operate on the safety side. Note that especially when the above control is performed on a MELSECWinCPU module in a remote location from an external device, you may not immediately respond to trouble on the MELSECWinCPU module side due to a data communication error.

Configure an interlock circuit on the user program, and at the same time, determine the procedure between external device and MELSECWinCPU module for troubleshooting as a system in the event of a data communication error.

(1) Notes on the Module Monitor Window

(a) Window transition when monitoring is in progress.

Monitoring stops when the screen switches to another window during monitoring operation.

Monitoring resumes the next time the “Module Monitor” window is opened.

(b) Monitoring and testing.

For the monitoring and testing of a module performed on this window (output (Y) forcible output and forcible writing to buffer memory), operation is performed on a module mounted to a “Slot No.” set from this window.

Note that a test can be performed only on modules managed by the MELSECWinCPU module.

(c) Notes when the module configuration is changed.

When the module configuration is changed after the launch of the MELSECWinCPU setting utility, perform the following operation to update information up to the state after the module configuration change.

- Click on the **Start monitor** button.

- Open a separate window other than the “Module Monitor” window, and then open the “Module Monitor” window again.

(2) Module monitor window

Monitors the input (X) status, the output (Y) status, and the buffer memory status for the module mounted on the selected slot.

It is possible to forcibly output the output (Y) and forcibly write to buffer memory from this window.

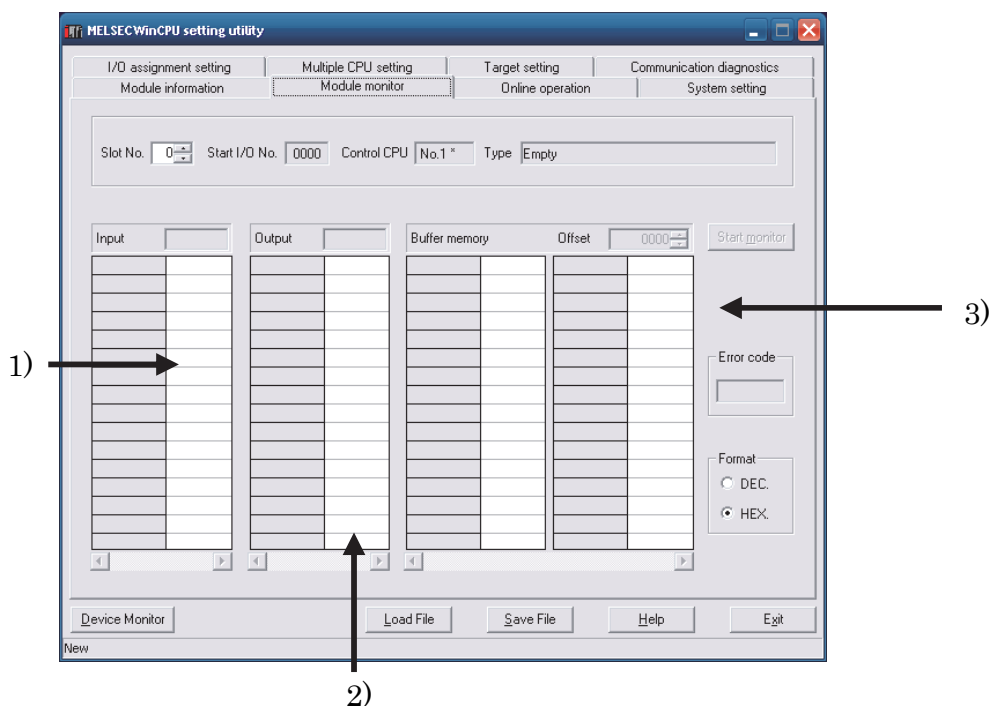

Item	Description
Slot No. *1	Sets Slot No. of a slot to be monitored. (Initial value: 0, setting range: 0 - 63)
Start I/O No.	Displays the start I/O No. of the slot set in the "Slot No." filed.
Control CPU	Displays the device No. of a device that manages the module mounted on the slot set in the "Slot No." filed. (If the MELSECWinCPU module that the MELSECWinCPU Setting Utility is connected to is the control CPU, "*" is displayed to the right of the module No. display.)
Type	Displays the input and output points and type of the module mounted on the slot set in the "Slot No." filed. Displays the "point" value in the parameter setting (I/O assignment setting) in between brackets ().
Start monitor	Starts monitor. Changes to the Stop monitor button when monitoring, with "*" blinking in the upper right of the Stop monitor button. This button is disabled when in offline mode.
Stop monitor	Stops monitoring. Changes to the Start monitor button when monitoring is stopped.
Input *2	Displays the input (X) status of the slot specified in the "Slot No." filed, in units of words.

Item	Description						
1) X area *2*3	<p>Displays the input (X) status of the slot specified by the slot No. in bit units.</p> <table border="1"> <thead> <tr> <th>Display</th> <th>Description</th> </tr> </thead> <tbody> <tr> <td>0</td> <td>OFF</td> </tr> <tr> <td>1</td> <td>ON</td> </tr> </tbody> </table>	Display	Description	0	OFF	1	ON
Display	Description						
0	OFF						
1	ON						
Output *2	<p>Displays the output (Y) status of the slot specified by the slot No. in word units.</p> <p>Double-click on this item to display the "Data Input" window.</p> <p>Enter a value into the "Data Input" window for forcible output. *5</p>						
2) Y area *2*3	<p>Displays the output (Y) status of the slot specified in the "Slot No." filed, in units of bits.</p> <p>Double-click on this item for forcible output.</p> <table border="1"> <thead> <tr> <th>Display</th> <th>Description</th> </tr> </thead> <tbody> <tr> <td>0</td> <td>OFF</td> </tr> <tr> <td>1</td> <td>ON</td> </tr> </tbody> </table>	Display	Description	0	OFF	1	ON
Display	Description						
0	OFF						
1	ON						
Buffer memory address	<p>Specifies the buffer memory address to be monitored for an intelligent function module. *4</p> <p>This setting is not possible for modules other than intelligent function modules.</p> <p>(Initial value: 0, setting range: 0 or more)</p>						
3) Buffer memory area *3	<p>Displays the buffer memory status of the slot specified in the "Slot No." filed.</p> <p>Double-clicking this displays the "Data Change" window.</p> <p>Entering a value on the "Data Change" window executes forced write. *5</p>						
Format	<p>Selects display formats for the input (X) status, output (Y) status, and buffer memory status ("decimal No." or "hexadecimal No.").</p> <p>The selected formats are reflected in the formats of forcible output of words in the output (Y) state and No. value input at the time of buffer memory forcible writing.</p> <p>(Initial value: "hexadecimal", setting range: "decimal" or "hexadecimal")</p>						
Error code	<p>If an intelligent function module is mounted on the slot set in the "Slot No." filed, the latest error code of the intelligent function module is displayed. *6</p> <p>If any module other than intelligent function modules is mounted on the slot set in the "Slot No." filed, "-" is displayed.</p>						

*1: Slot No. cannot be changed when monitoring is in progress.

Change Slot No. after monitoring has been stopped.

*2: The range displaying input data and output data covers just the points assigned by the parameter setting (I/O assignment setting) for the module mounted on the slot of the specified Slot No.

*3: When a multiple CPU system is configured, this item is enabled if the control CPU for the module to be monitored is a MELSECWinCPU module.

*4: For the buffer memory addresses of intelligent function modules, refer to the manual for each module.

*5: The No. input formats for forcible output and forcible writing shall follow the formats selected in "Display Format".

*6: For the details of an error code of intelligent function module, refer to the manual of each module.

Displays "No error" for the error code "0"

5.3.4 Operating the Online Operation Window

Reads/writes/verifies parameters for the MELSECWinCPU module.

Point

Operation on this window is not possible while the bus interface driver's resetting is in progress. Perform operation after the reset operation is complete.

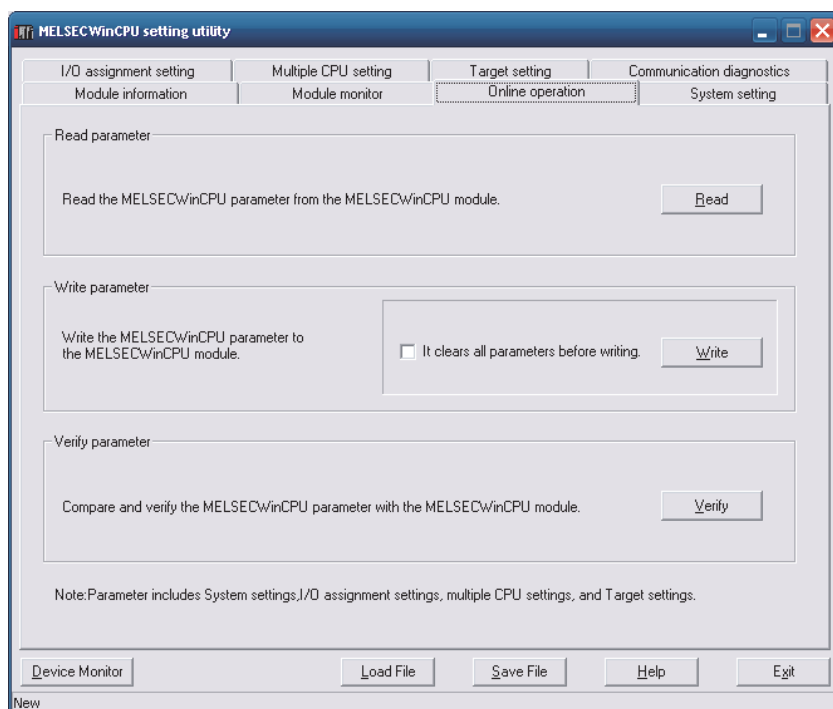

Item		Description
Read parameter Read		Reads the parameters out of the MELSECWinCPU module.
Write parameter *1	Write	Writes the parameters that have been set using the MELSECWinCPU Setting Utility into a MELSECWinCPU module. The parameters written are enabled when that MELSECWinCPU module has been reset.
	“It clears all parameters before writing.” checkbox	When the above Write button is clicked on with this checkbox being marked, clears, before writing new parameters, all the parameters (including CC-Link utility parameters, MELSECNET/H module parameters, and intelligent function module parameters).
Verify parameter Verify		Verify the parameters set to the MELSECWinCPU module against those set to the MELSECWinCPU Setting Utility. The verification result is displayed in the message box.

*1: To write parameters, log on as a user with the Administrator attribute.

5.3.5 Operating the System Setting Window

Makes the parameter setting (system setting) of MELSECWinCPU module.

Sets system-related parameters.

Point

- (1) When a multiple CPU system is configured, divert the multiple CPU parameters set in QCPU (Q mode).
Diverting the multiple CPU parameters can prevent inconsistency between the MELSECWinCPU module settings and the settings of each programmable controller CPU.
- (2) When a multiple CPU system is configured, set up the system after finishing the "Multiple CPU Setting" window setting.
- (3) To reflect the settings in a MELSECWinCPU module, write the parameters using the "Online Operation" window and reset the MELSECWinCPU module.

(1) System setting window

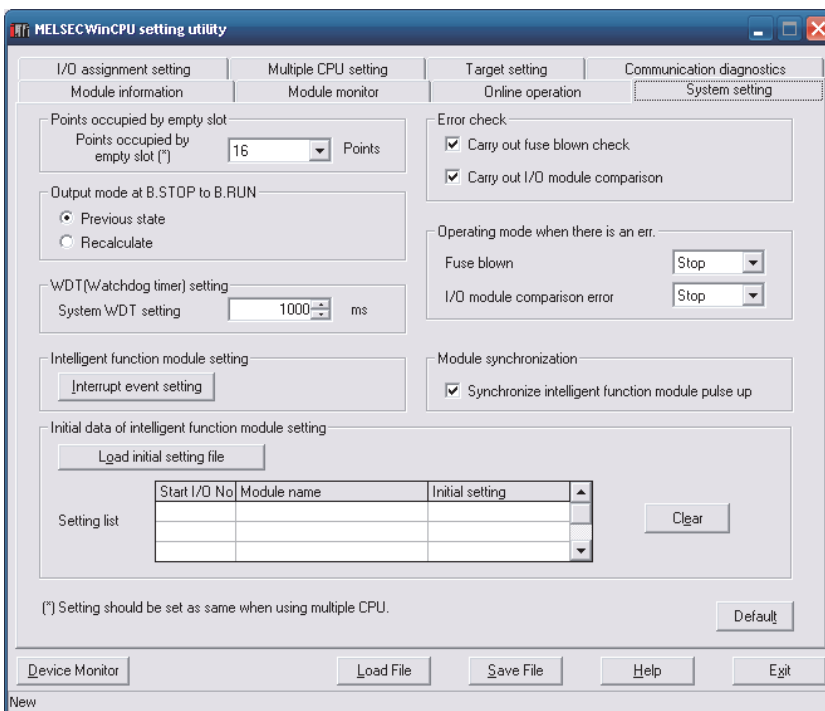

Item	Description	
Points occupied by empty slot [*]	Sets points per slot for vacant slots of the primary and additional base units. (Initial value: 16 points, setting range: 0, 16, 32, 64, 128, 256, 512, 1024 points)	
Output mode at B.STOP to B.RUN	For the output (Y) when the operation status of the MELSECWinCPU module is changed from STOP to RUN, select between “Previous state” and “Recalculate”. (Initial value: “Previous state”)	
WDT [Watchdog timer] setting	Sets the time of WDT [Watchdog timer]. (Initial value: 1000, setting range: 20 – 2000 (10ms unit))	
Intelligent function module setting	When clicking <input type="button" value="Interrupt event setting"/> button, “Intelligent function module interrupt event setting” windows is opened. For details, refer to “(2) Intelligent function module interrupt event setting window”.	
Error check	Sets whether or not to detect errors with respect to the following : - “Carry out fuse blown check”. - “Carry out I/O module comparison”. (Initial value: “Carry out fuse blown check” and “Carry out I/O module comparison” marked. (Errors to be detected.))	
Operating mode when there is an err.	Selects whether to continue or stop the MELSECWinCPU module’s operation if an error is detected with respect to “Fuse blown” or “I/O module comparison error”. (Initial value: “Stop”, setting range: “Stop”, “Continue”)	
Module synchronization	Set whether the startup of the bus interface driver will be synchronized with that of the intelligent function module. *1 (Initial value: Check (Synchronize))	
Initial data of intelligent function module setting *2	<input type="button" value="Load initial setting file"/>	Sets a value to be set to the buffer memory of an intelligent function module when the bus interface driver starts up. Loads initial settings only of parameters of intelligent function module from the file made by GX Developer. For details, refer to “5.3.11. Loading initial setting data file and using multiple CPU parameters”.
	<input type="button" value="Setting list"/>	Displays “I/O address”, “Module name”, and “Initial settings” - the settings that are read using the <input type="button" value="Load initial setting file"/> button for initial setup files.
	<input type="button" value="Clear"/>	Clears the information of setting list.

*1: Set this when synchronizing the MELSECWinCPU module startup with the startup of an intelligent function module (positioning module, etc).

If “Module synchronization” is not made, the MELSECWinCPU module and intelligent function module need to be inter-locked each other.

*2: If setting the initial values of the following devices using “Initial data of intelligent function module setting”, mark “Module synchronization”.

If “Module synchronization” is not marked, the device's initial values may not be set correctly.

- Intelligent function module device (U□\G□)

- Link direct device (J□\W□, J□\SW□)

- (2) Intelligent function module interrupt event setting window
 Sets data for intelligent function module interrupt event *1.

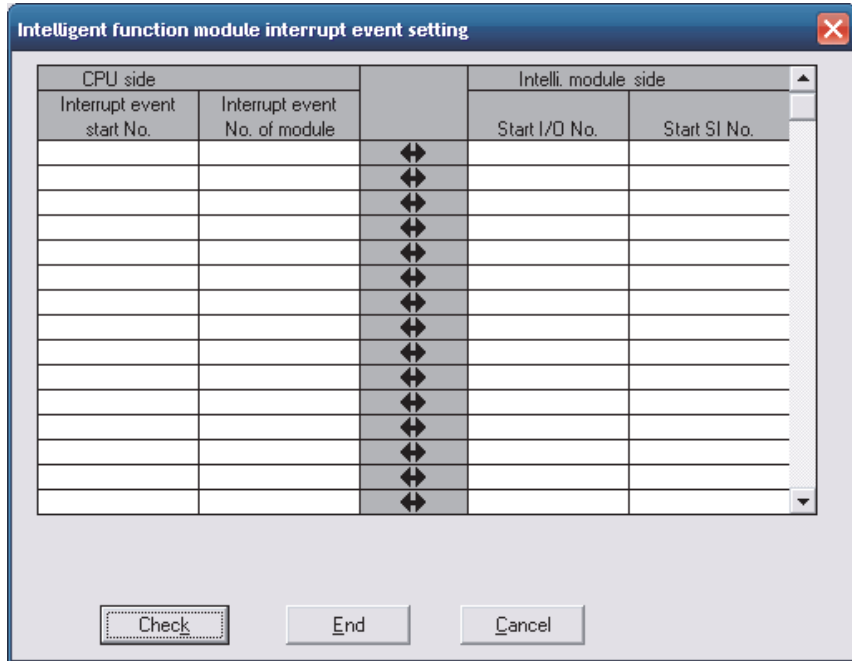

Item	Description
Interrupt event start No.	Sets the start No. of the interrupt notification event to be generated by an interrupt from the intelligent function module. (Initial value: None, setting range: 50 - 255)
Interrupt event No. of module	Sets the No. of the interrupt notification events to be generated by an interrupt from the intelligent function module. (Initial value: None, setting range: 1 - 16)
Start I/O No.	Sets the start I/O No. of the intelligent function module. (Initial value: None, setting range: 0000H - 0FF0H, 3E00H - 3E30H)
Start SI No.	Sets the start SI No. (interrupt factor No.) of the intelligent function module. (Initial value: none, setting range: 0 - 15)
Check	Checks whether or not the setting is correct.
End	Saves the setting and closes the "Intelligent function module interrupt event setting" window.
Cancel	Closes the "Intelligent function module interrupt event setting" window without saving the settings.

*1: An interrupt event is an interrupt notification event generated by an interrupt from the intelligent function module.
 The next page shows interrupt event No. and interrupt factors.

Interrupt event No.	Interrupt factor	
0	Interrupt by QI60	First point
1		Second point
2		Third point
3		Fourth point
4		Fifth point
5		Sixth point
6		Seventh point
7		Eighth point
8		Ninth point
9		Tenth point
10		11th point
11		12th point
12		13th point
13		14th point
14		15th point
15		16th point
16 - 49	Unused	
50 - 255	Intelligent function module interrupt	Use parameters to set which intelligent function module to be used.

Remarks

When multiple interrupts occur simultaneously, it is not possible to specify the order of interruption event notifications to be issued.

5.3.6 Operating the I/O Assignment Setting Window

Makes the parameter setting (I/O assignment setting) of MELSECWinCPU module.

Sets I/O assignment for slots, and sets parameters relating to the base units to which modules are mounted.

Point

- (1) When a multiple CPU system is configured, divert the multiple CPU parameters set in QCPU (Q mode).
Diverting the multiple CPU parameters can prevent inconsistency between the MELSECWinCPU module settings and the settings of each programmable controller CPU.
- (2) When a multiple CPU system is configured, do the I/O assignment setting after finishing the "Multiple CPU Setting" window setting.
- (3) To reflect the settings in a MELSECWinCPU module, write the parameters using the "Online Operation" window and reset the MELSECWinCPU module.

(1) I/O assignment setting window

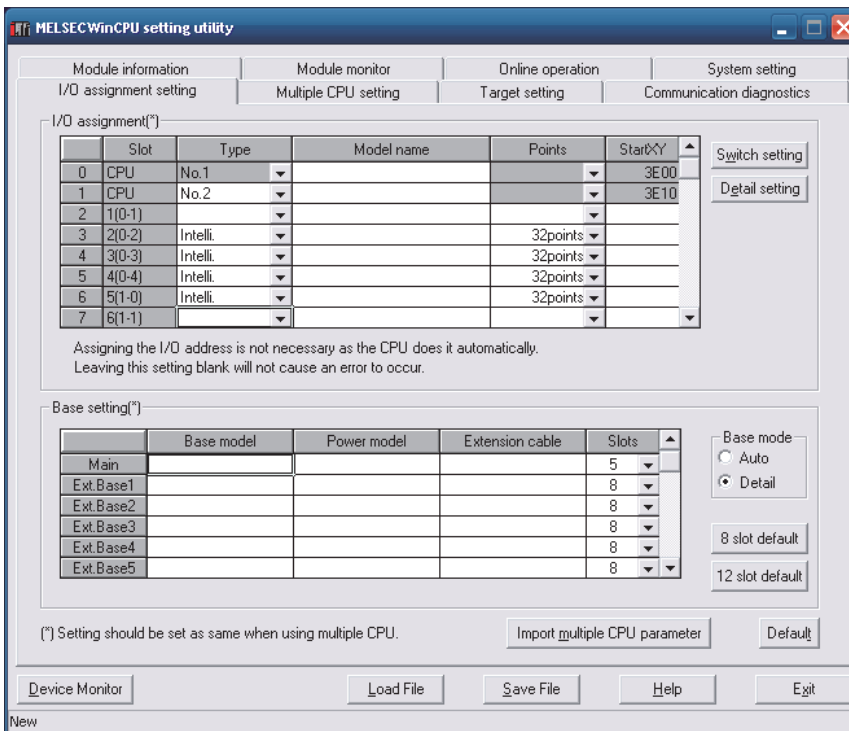

Item		Description
I/O assignment	Slot	Displays "Slot No." of the mounted module, the module No. of the base unit to which the module is mounted, and the mounted position in the base unit.
	Type *1	Sets the module type of the mounted module. At the time a multiple CPU system is configured, if "CPU (vacant)" is set to positions not supported by the MELSECWinCPU module, no error is displayed. Check that the setting is correctly made. (Initial value: " (vacant), setting range: " (vacant), "Empty", "Input", "Hi.input", "Output", "I/O mix", "Intelli.", "Interrupt", "No.1" *2 - "No.4" *2, "CPU (empty)" *2)
	Model name	Enters model name of the mounted module.
	Points *1	Specify I/O points when changing a slot's I/O points. (Initial value: "" (vacant), setting range: 0, 16, 32, 48, 64, 128, 256, 512, 1024)
	Start XY *1	Specify an I/O No. when changing a slot's I/O No.
	<u>Switch setting</u>	Opens the "Switch setting for I/O and intelligent function module" window. For details, refer to "(2) Switch setting for I/O and intelligent function module window".
	<u>Detail setting</u>	Opens the "Intelligent function module detailed setting" window. For details, refer to "(3) Intelligent function module detailed setting window".
Base setting [*]	Base model	Sets base model of the used base unit.
	Power model	Sets power model of the mounted power module.
	Extension cable	Sets type of the used extension cable.
	Slots *1	Specifies "Slot No." of the used base unit. (Initial value: None, setting range: 2, 3, 5, 8, 10, 12)
	Base mode	Selects between "Auto" and "Detail" for the base mode. (Initial value: "Auto", setting range: "Auto", "Detail")
	<u>8 slot default</u> , <u>12 slot default</u>	Collectively sets the specified slot No. to the base units.
	<u>Import multiple CPU parameter</u>	Reads the multiple CPU system parameter part from a file created by "GX Developer," software for MELSEC-Q Series. For details, refer to "5.3.11 Loading initial setting data file and using multiple CPU parameters".
<u>Default</u>	Changes the settings to default.	

*1: When a multiple CPU system is configured, make the settings for the MELSECWinCPU module and the settings for each programmable controller CPU equal.

*2: Can be set only at the time a multiple CPU system is configured

- (2) Switch setting for I/O and intelligent function module window
 Sets the I/O module and intelligent function module switch.

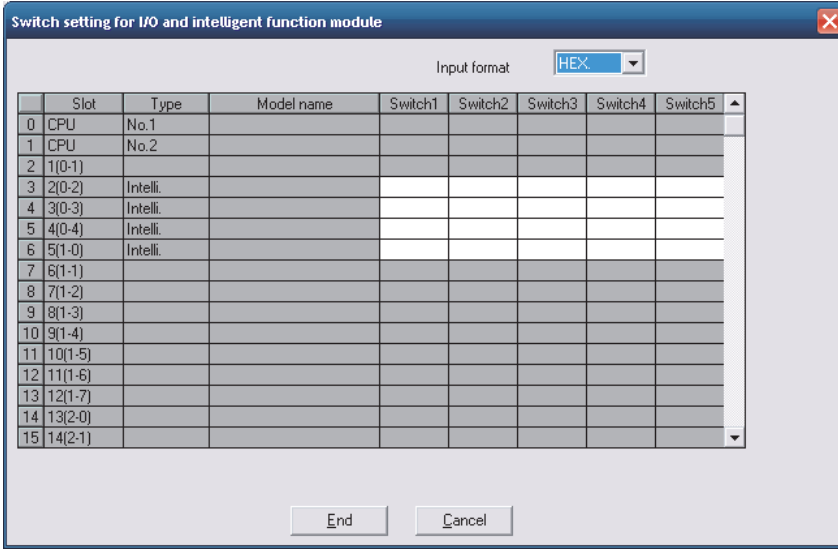

Item	Description
Input format	For the numeric input format, select among binary, decimal, and hexadecimal No. (Initial value: "HEX.", setting range: "BIN.", "DEC.", "HEX.")
Slot, Type, Model name	Displays the "Slot", "Type" and "Model name" set on "I/O assignment setting window".
Switch 1 - Switch 5 *1	Sets the switch of intelligent function module.
End	Saves the settings and closes the "Switch setting for I/O and intelligent function module" window.
Cancel	Closes the "Switch setting for I/O and intelligent function module" window without saving the settings.

*1: In a multiple CPU system, set the same value to the MELSECWinCPU module and that of programmable controller CPU.

(3) Intelligent function module detailed setting window

Makes the detailed setting of the I/O modules and intelligent function modules.

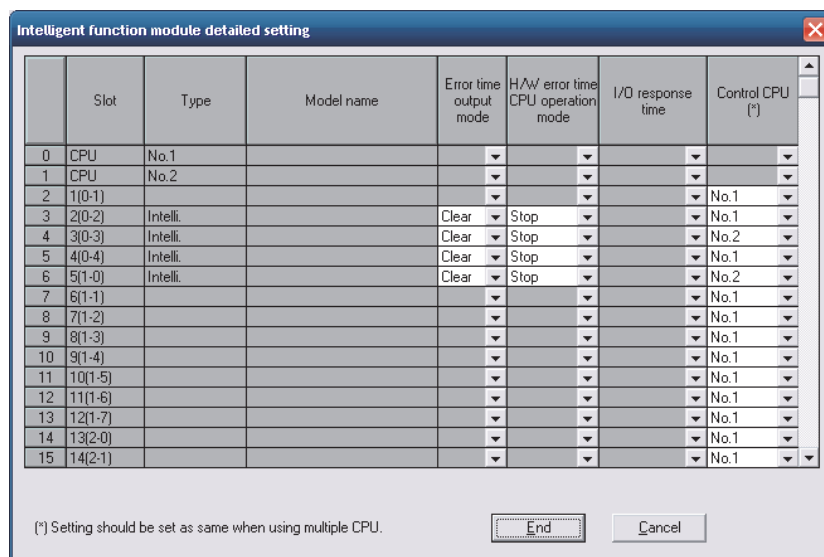

Item	Description									
Slot, Type, Model name	Displays "Slot," "Type," and "Model Name" set from the "I/O Assignment Setup" window.									
Error time output mode	Selects the output mode at the time of error occurring. (Initial value: "Clear", setting range: "Clear", "Hold")									
H/W error time CPU operation mode	Selects the MELSECWinCPU module operation mode at the time of hardware error occurring. (Initial value: "Stop", setting range: "Stop", "Continue")									
I/O response time	Sets the I/O response time. <table border="1" style="margin-left: auto; margin-right: auto;"> <thead> <tr> <th>Modules mounted</th> <th>Initial value</th> <th>Setting range</th> </tr> </thead> <tbody> <tr> <td>High speed inputmodule, Interrupt module</td> <td>0.2</td> <td>0.1, 0.2, 0.4, 0.6, 1</td> </tr> <tr> <td>Input module, Input/output mixed module</td> <td>10</td> <td>1, 5, 10, 20, 70</td> </tr> </tbody> </table> <p style="text-align: right;">(Unit: ms)</p>	Modules mounted	Initial value	Setting range	High speed inputmodule, Interrupt module	0.2	0.1, 0.2, 0.4, 0.6, 1	Input module, Input/output mixed module	10	1, 5, 10, 20, 70
Modules mounted	Initial value	Setting range								
High speed inputmodule, Interrupt module	0.2	0.1, 0.2, 0.4, 0.6, 1								
Input module, Input/output mixed module	10	1, 5, 10, 20, 70								
Control CPU *1	Sets the Control CPU. (Initial value: "No.1", setting range: "No.1" - "No.4" *2)									
End	Saves the settings and closes "I/O module, Intelligent function module detailed setting" window.									
Cancel	Closes the "I/O module, Intelligent function module detailed setting" window without saving the settings.									

*1 : In a multiple CPU system, set the same value to the MELSECWinCPU module and that of programmable controller CPU.

*2 : The setting range depends on the settings made in "No. of CPUs" of the "Multiple CPU Setting" window.

5.3.7 Operating the Multiple CPU Setting Window

Makes the parameter setting (Multiple CPU setting) of MELSECWinCPU module.
Sets the parameters related to the multiple CPUs.

Point

- (1) When a multiple CPU system is configured, divert the multiple CPU parameters set in QCPU (Q mode).
Diverting the multiple CPU parameters can prevent inconsistency between the MELSECWinCPU module settings and the settings of each programmable controller CPU.
- (2) At the time a multiple CPU system is configured, if the multiple CPU parameters of QCPU (Q mode) are not diverted, set I/O assignment after finishing the “Multiple CPU Setting” window setting.
- (3) To reflect the settings in a MELSECWinCPU module, write the parameters using the “Online Operation” window and reset the MELSECWinCPU module.

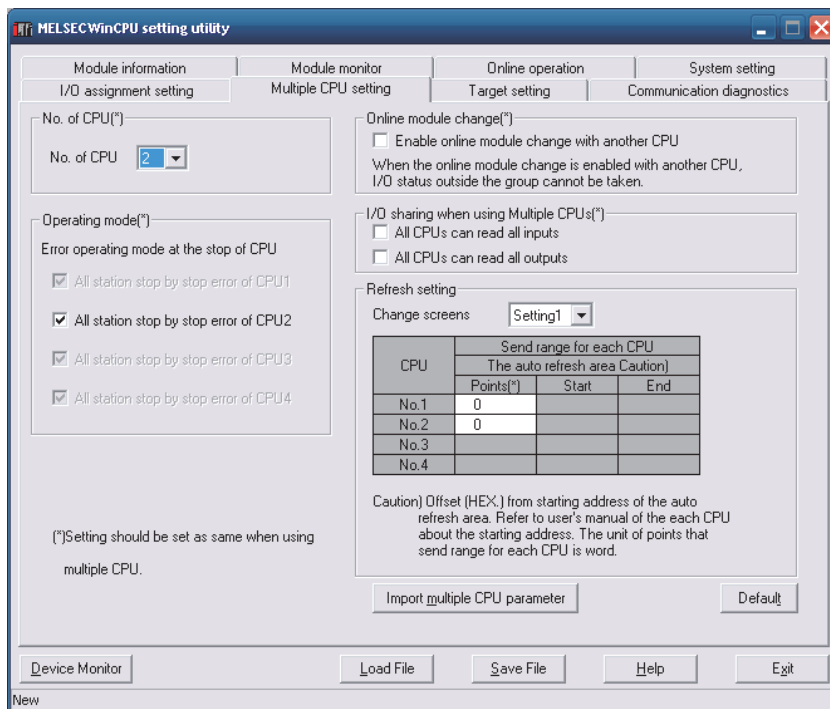

Item		Description
No. of CPU *1		Sets the total No. of programmable controller CPU, MELSECWinCPU and Motion CPU modules that form the multiple CPU system. (Initial value: 1, setting range: 1 - 4)
Operating mode *1		Set the error operating mode at the stop of CPU. (Initial value : Check (All stations stop by stop error of each CPU))
Online module change *1		Enable online module change with another CPU.
I/O sharing when using Multiple CPUs *1		Sets whether or not to import input and output statuses outside the group. (Initial value: Not selected. (Do not import input and output statuses.)) This item can be set when "Online module change" is not marked.
Refresh setting *2	Change screens	Selects the registered refresh setting. (Initial value: "Setting1", setting range: "Setting1" - "Setting4")
	Send range for each CPU *1	Set the points of the shared memory used by each CPU to send data. Displayed by automatically calculating "Start" and "End". (Initial value: 0, setting range: 0 - 2048)
Import multiple CPU parameter		Reads the multiple CPU system parameter part from a file created by GX Developer. For details, refer to "5.3.11 Loading initial setting data file and using multiple CPU parameters".
Default		Changes the settings to default.

*1: In a multiple CPU system, set the same value to the MELSECWinCPU module and that of programmable controller CPU.

*2: When the screen is transitioned to another window, if nothing is set to a No. smaller than the No. to which the refresh setting has already been set, the refresh setting already set is diverted to that No.

5.3.8 Operating the Target Setting Window

Sets the logical Sta. No. for making access to any CPU module in a multiple CPU system configuration.

Point

- (1) To reflect the settings in a MELSECWinCPU module, write the parameters using the “Online Operation” window and reset the MELSECWinCPU module.
- (2) Set a programmable controller CPU as a target CPU.

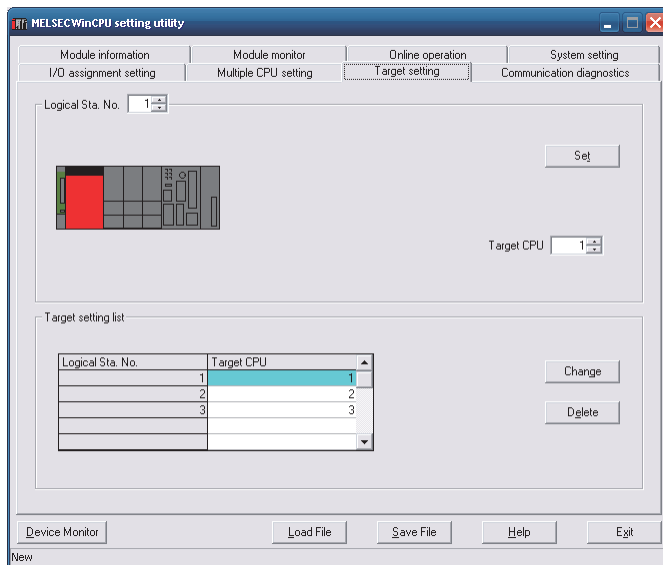

Item	Description
Logical Sta. No. *1 *2	Specifies the Logical Sta. No. to be set or changed. (Initial value: 1, setting range: 1 - 64)
Set	Register the settings and changes (Logical Sta. No., target CPU) to the target setting list.
Target CPU *3	Sets CPUs (CPU module No. in a multiple CPU system) to be accessed. (Initial value: 1, setting range: 1 - 3)
Target setting list	Displays Logical Sta. No. currently set and a list of their corresponding target CPUs.
Change	Displays the setting of the row (Logical Sta. No.) selected from the target setting list, in the Logical Sta. No. field. (You can change the Logical Sta. No. setting by double-clicking on the row that contains the setting you want to change.)
Delete	Deletes the row (Logical Sta. No.) selected from the target setting list.

*1: CPU module No. 1, 2, and 3 are respectively set to Logical Sta. No. 1, 2, and 3.

If there is no need to change Logical Sta. No., the utility can be used with the default Logical Sta. No.

*2: Logical Sta. No. are logical No. specified as “Sta. No.” in the Device Monitor utility and user programs (MELSEC data link function).

Use a Logical Sta. No. when the MELSECWinCPU module accesses a different Sta. CPU (a CPU of a different ID device in a multiple CPU system).

*3: The target CPU field can be set only when, as a CPU module, the MELSECWinCPU module is capable of configuring a multiple CPU system.

5.3.9 Operating the Communication Diagnostics Window

When the MELSECWinCPU module is in a multiple CPU configuration, diagnoses the possibility of communication with a CPU of a different ID device.

Point
Specify the Logical Sta. No. of a different ID device in the Logical Sta. No. field.
If your own device's Logical Sta. No. is specified, the error code “19203” is displayed.
If the Logical Sta. No. of a not-mounted device is specified, the error code “19200” is displayed.

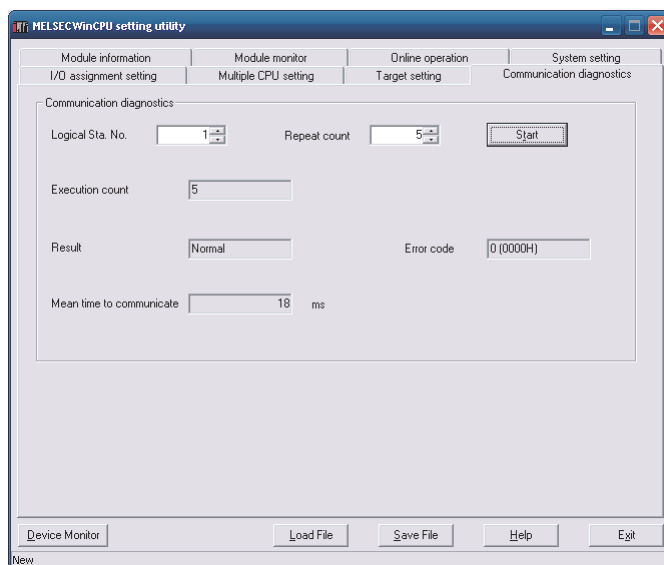



Item	Description	
Communication diagnostics	Logical Sta. No.	Selects a target CPU for diagnostics by its Logical Sta. No. (Initial value: 1, setting range: 1 - 64)
	Repeat count	Specifies the No. of times communication diagnostics is performed. (Initial value: 5, setting range: 1 - 32767)
	Start	Executes communication diagnostics. Changes to the Stop button when diagnostics is in progress.
	Stop	Stops communication diagnostics. Changes to the Start button when diagnostics is not operative.
	Execution count	Displays the No. of times communication diagnostics has been executed.
	Result	Displays “Normal” when the communication diagnostics result is normal. Otherwise, displays “Abnormal”. Displays “Diagnostics in Progress” while communication diagnostics is being executed.
	Error code *1	Displays the error code of the communication diagnostics result.
	Mean time to communicate	Displays the average time expended for communication.

*1: For details, refer to “8.4.1 Actions upon error codes at the time of function execution”.

5.3.10 Operating the System Menu

(1) System Menu

Use the MELSECWinCPU Setting Utility by opening its system menu through any of the following operations.

- Right-click on the title bar.
- Click on the icon () on the title bar.
- Press down the  key immediately after the **Alt** key is pressed down.

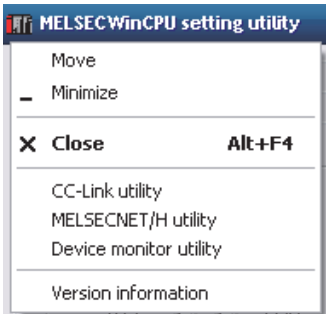

Item	Description
Move, Minimize, Close	Refer to Microsoft Windows manuals.
CC-Link utility	Starts up the CC-Link utility
MELSECNET/H utility	Starts up the MELSECNET/H utility
Device monitor utility	Starts up the Device Monitor utility.
Version information	Opens the “Version Information” window. For details, refer to “(2) Version Information window”.

(2) Version information window

Displays the version of the MELSECWinCPU setting utility.



Item	Description
Software package SW1PNC-WCPU-B	Displays the version of SW1PNC-WCPU-B.
MELSECWinCPU setting utility	Displays the date of the MELSECWinCPU setting utility.
OK	Closes the “Version information” window.

5.3.11 Loading initial setting data file and using multiple CPU parameters

This section describes the procedures for loading initial setting data file and using multiple CPU parameters.

(1) How to display the window

You can open the “Open Project” window through any of the following operations.

- Click on the **Load initial setting file** button on the “System setting” window.
- Click on the **Import multiple CPU parameter** button on the “I/O Assignment Setting” window.
- Click on the **Import multiple CPU parameter** button on the “Multiple CPU Setting” window.

(2) Description of the window

You can select a setup data project.

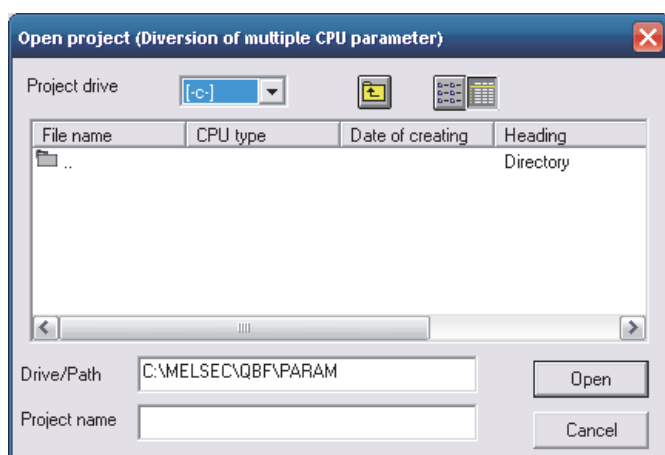

Item	Description
Project drive	Selects a drive that contains project.
Drive/Path	Enters a drive and a path that contains project.
Project name	Enters a name of project to be loaded.
Open	Loads a project.
Cancel	Ends without loading a project.

(3) Notes on using specified data

- (a) When moving setting data of GX Developer that has been specified on a personal computer other than MELSECWinCPU module to a MELSECWinCPU module, move the data to a MELSECWinCPU module with the whole project folder of GX Developer. If files only are moved, specifying a project is disallowed.
- (b) GX Works2 project will not be able to divert the Multiple CPU parameters. Using the features of the GX Works2 "Export to GX Developer Format File", when using a Multiple CPU parameters of GX Works2 project, please save it as a project format GX Developer.

Point
<p>The PLC types shown below cannot be saved in GX Developer format. To reuse projects, use the GX Works2 "Change PLC Type" function to convert the PLC type to "Q26UDEHCPU", and then save the data as a GX Developer format project.</p> <p style="text-align: center;">< PLC types that cannot be saved in GX Developer format ></p> <p style="text-align: center;">Q50UDEHCPU, Q100UDEHCPU Q03UDVCPU, Q04UDVCPU, Q06UDVCPU, Q13UDVCPU, Q26UDVCPU</p>

- (c) After reusing multiple CPU parameters, check that the settings have been configured so that the following functions, which are not supported by the MELSECWinCPU module, are not used.
 - Multiple CPU synchronized start
 - Multiple CPU, high-speed communication function

Point
<ul style="list-style-type: none"> - Multiple CPU, high-speed communication function settings <p>For models other than the MELSECWinCPU module, if you are using a configuration in which the multiple CPU, high-speed communication function can be used, select the "Use multiple CPU high speed transmission" check box, and then set "Points" of the module No. that corresponds to the MELSECWinCPU module to 0.</p>

- (d) Parameters for CC-Link set through GX Configurator-CC cannot be used.
Set parameters using the CC-Link utility provided by SW1PNC-WCPU-B.
- (e) Parameters set through GX Configurator-SC cannot be used.
Write parameters for a serial communication module into buffer memory using the bus interface function (QBF_ToBuf).
- (f) The parameters set through GX Configurator-QP cannot be used.
Write parameters for a positioning module into buffer memory using the bus interface function (QBF_ToBuf).

(g) The following is MELSEC-Q Series software GX Configurator whose MELSECWinCPU setting utility makes it possible to divert initial setup parameters :

- GX Configurator-AD
- GX Configurator-DA
- GX Configurator-CT
- GX Configurator-TC
- GX Configurator-TI
- GX Configurator-PT
- GX Configurator-FL
- GX Configurator-AS

5.4 CC-Link Utility

This section describes operations of CC- Link utility.

Notes on CC- Link utility is as follows :

(1) Details of parameters

For the details of parameters, refer to “CC-Link System Master/Local Module User's Manual”.

(2) Maximum No. of utilities for simultaneous use

More than one CC-Link utility cannot be started at the same time.

Only one can be started at a time.

(3) Note on written parameters

The parameters written to the MELSECWinCPU module are enabled when the module is reset.

5.4.1 CC-Link Utility Function List

This section describes functions of CC- Link utility.

Item	Description	Referring Paragraph
Reading/saving a parameter setup file.	Saves the parameters set by the CC-Link utility into a file and reads them.	5.2
Module information	Displays information of the CC-Link utility (local) managed by the MELSECWinCPU module.	5.4.2
Other station monitor	Displays the line connection conditions of other station. (Station in the CC-Link network).	5.4.3
Online operation	Loads / writes / verifies CC-Link parameter.	5.4.4
Parameter setting	Sets the parameter of CC-Link utility.	5.4.5
Target setting	Sets Logical Sta. No. to access any CPU module in the multiple CPU system to which CC-Link utility are mounted.	5.4.6
Test	Performs a network test and line connection test with respect to mounted CC-Link utility.	5.4.7

5.4.2 Operating the Module Information Window

This window displays various types of information about the CC-Link module (own Sta.) managed by the MELSECWinCPU module.

Point

It cannot be monitored while the bus interface driver is reset.
Start monitoring after the reset is completed.

(1) Module information window

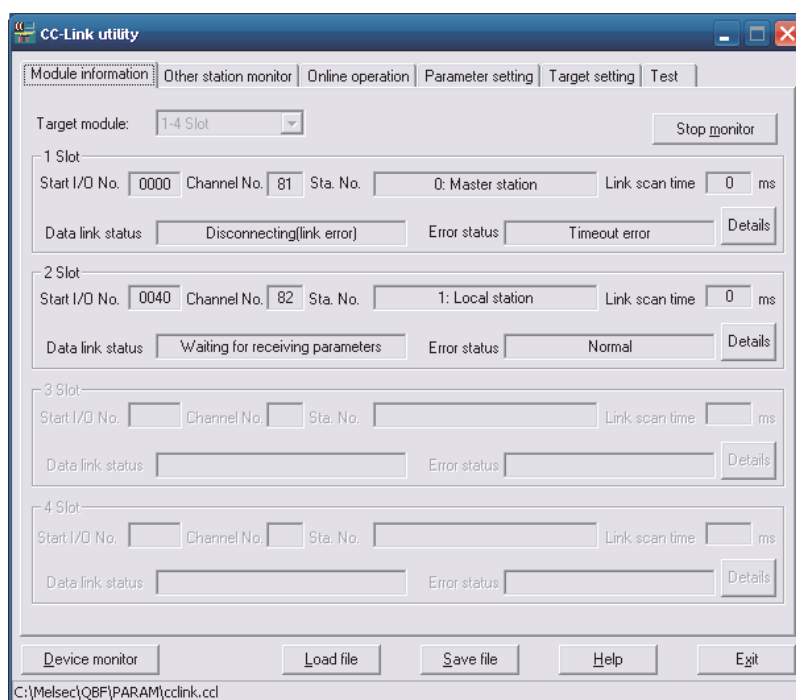

Item		Description
Target module		Select CC-Link utility whose module information you want to display. (Initial value: "1 - 4 Slot", setting range: "1 - 4 Slot", "5 - 8 Slot")
n Slot *1 (n covers the range set in the "Target module" field.)	Start I/O No.	Displays the start I/O No. of a CC-Link utility.
	Channel No.	Displays Channel No. of CC-Link module. *2
	Sta. No.	Displays "<Sta. No.> : <Station type> <Operation mode>". The display range for <Sta. No.> is "0"- "64", and the display range for <Station type> is "Master station" or "Local Station". For the details of <Operation mode>, refer to "(1)(a) Operation mode". (Example of display : "Master station (Ver.2 mode)", "1 : Local station")
	Link scan time	Displays the current link scan time of a CC-Link utility. (ms unit)
	Data link status	Displays the data link activation status of a CC-Link utility. For details, refer to "(1)(b) Data link activation status details".
	Error status	Displays the error status of a CC-Link utility. For details, refer to "(1)(c) Details on error status".
	Details	Opens the "Module detail information" window. For "Module detail information", refer to "(2) Module detail information window". This button cannot be clicked on when monitoring is stopped.

*1 : Module information displayed at one time is displayed in ascending order of start I/O No..

*2 : Channel No. is determined in ascending order of start I/O No. starting from 81.

(a) Operation mode

The details of operation modes are described as follows.

Item	Description
Not displayed	Cyclic point extension not applied. Remote net - Ver.1 mode
(Additional mode)	Both cyclic-point-extension supported and not supported CC-Link utility exist. Remote net - additional mode
(Ver.2 mode)	Cyclic point extension applied. Remote net - Ver. 2 mode

(b) Details on Data link status

Details on data link status is as follows:

Item	Description
In data link	Performs the data link.
Suspend data link	Stops the data link.
Initial states	In the initial state (before parameter update).
Waiting for receiving parameters	Parameters have not been received yet.
Disconnecting (no request polling)	Disconnected from the data link due to no request from the Master station.
Disconnecting (link error)	Disconnected from the data link due to line failure.
Disconnecting (Other)	Disconnected from the data link due to a different cause.
During line test	Line test being performed.
During parameter setting test	Performing a parameter setting test from the Master station.
During Auto-Returning	Processing underway to automatically return to the data link.
During reset	Resetting the CC-Link utility.

(c) Details on error status

Details on error status is as follows:

Item	Description
Normal	Normal status
Transport Error	An error was detected in a communication path.
Parameter Error	An error was detected in a parameter.
CRC Error	A CRC error was detected.
Timeout Error	A timeout error was detected.
Abort Error	An error was detected in the CC- Link utility.
Setting Error	A setting error was detected.
Illegal	An error arising from some other cause was detected.

(2)Module detailed information window

Displays CC-Link module detail information.

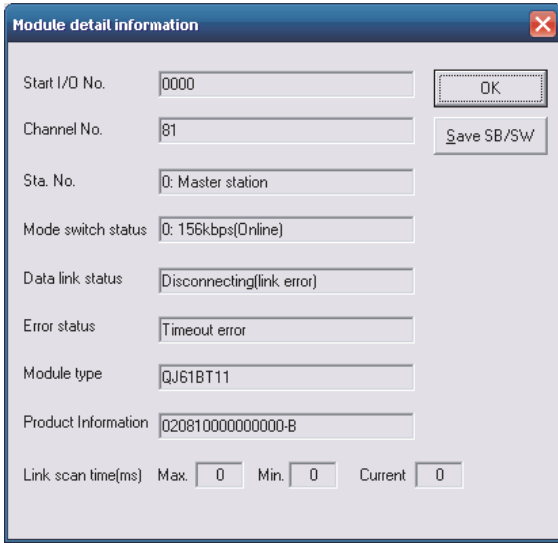

Item	Description
Start I/O No., Channel No., Sta. No.	Displays detailed information of a CC-Link module. For display details, refer to “(1) Module Information window”.
Mode switch status	Displays the mode switch status of a CC-Link module. For details, refer to “(2)(a) Details on mode switch status”.
Data link status	Displays the data link status of a CC-Link module. For details, refer to “(1)(b) Details on data link status”.
Error status	Displays the error status of a CC-Link module. For details, refer to “(1)(c) Details on error status”.
Module type	Displays the model name of a CC-Link module.
Product information	Displays the product information of a CC-Link module. (Serial No. and functionality version).
Link scan time	Displays the maximum/minimum/current link scan time of a CC-Link module. (ms unit)
OK	Closes the “Module detailed information” window.
Save SB/SW	Saves information of a CC-Link utility 's link special relay (SB) and link special register (SW) into a CSV-format file. For details, refer to “(3) Specifications for SB/SW stored files.”

(a) Details on mode switch status

Details on mode switch status is as follows.

Display	Transmission speed	Mode
0: 156kbps (online)	156kbps	Online
1: 625kbps (online)	625kbps	
2: 2.5Mbps (online)	2.5Mbps	
3: 5Mbps (online)	5Mbps	
4: 10Mbps (online)	10Mbps	
5: 156kbps (Line test□)	156kbps	Link test If □ is 1, Sta. No. is 0. If □ is 2, Sta. No. is 1 - 64.
6: 625kbps (Line test□)	625kbps	
7: 2.5Mbps (Line test□)	2.5Mbps	
8: 5Mbps (Line test□)	5Mbps	
9: 10Mbps (Line test□)	10Mbps	
A: 156kbps (hardware test)	156kbps	Hardware test
B: 625kbps (hardware test)	625kbps	
C: 2.5Mbps (hardware test)	2.5Mbps	
D: 5Mbps (hardware test)	5Mbps	
E: 10Mbps (hardware test)	10Mbps	
F: Setting prohibited	-	None

(3) Specifications for SB/SW stored files

The following shows a SB/SW stored file example.

(a) Link special relay (SB) and link special register (SW) saved into a CSV file.

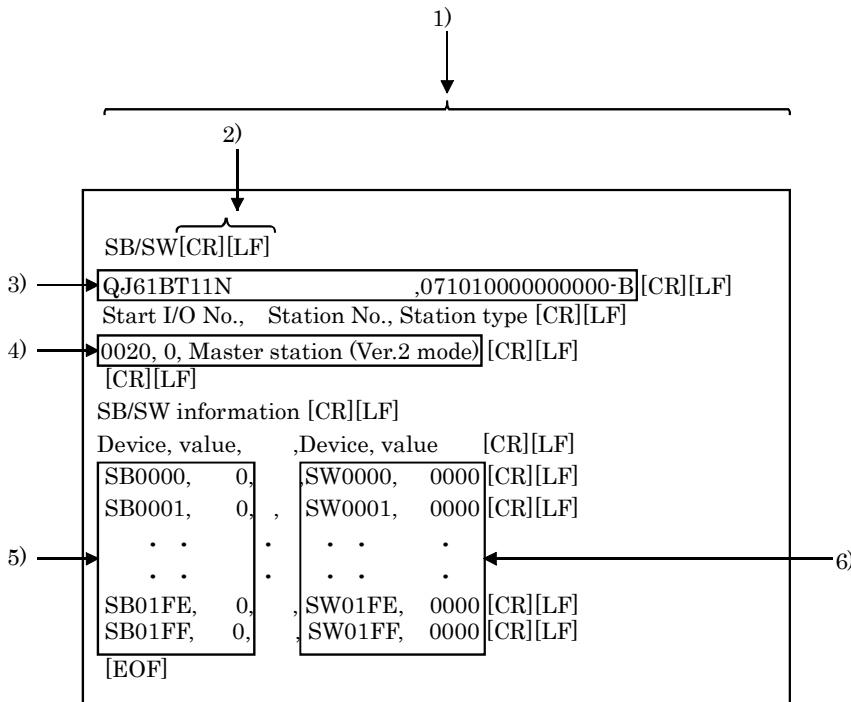

(b) CSV format specifications

A link special relay (SB) and link special register (SW) are stored in the CSV-format shown below.

- 1). “,” (ASCII code : 2CH) is used to separate columns.
- 2). CR/LF is used as linefeed code. (ASCII code : CR=0DH, LF=0AH)
- 3). Stores “Module model name” and “Product information”, starting from the first column.
For the details of “Module model name” and “Product information”, refer to “(2) Module detailed information window”.
- 4). Stores “Start I/O No.”, “Sta. No.”, and “Station type” starting from the first column.
For the details of “Start I/O No.”, “Sta. No.”, and “Station type”, refer to “(2) Module detailed information window”.
- 5). Stores the device name and device value of a link special relay (SB).
- 6). Stores the device name and device value of the link special register (SW).

Remarks

“C : \MELSEC\QBF\PARAM” is the standard directory to save SB/SW stored files.
(When SW1PNC-WCPU-B is installed in "C : \MELSEC\QBF".)

5.4.3 Operating the Other Station Monitor Window

This window displays the line status of the other stations (CC-Link network stations).

Point

- (1) At the time the CC-Link utility is launched, monitoring is not operative.
Click on the **Start monitor** button to start monitoring.
- (2) Other local monitor starts monitoring only when the states of your own station is “In data link”.
- (3) It cannot be monitored while the bus interface driver is reset.
Start monitoring after the reset is completed.

(1) Other station monitor window

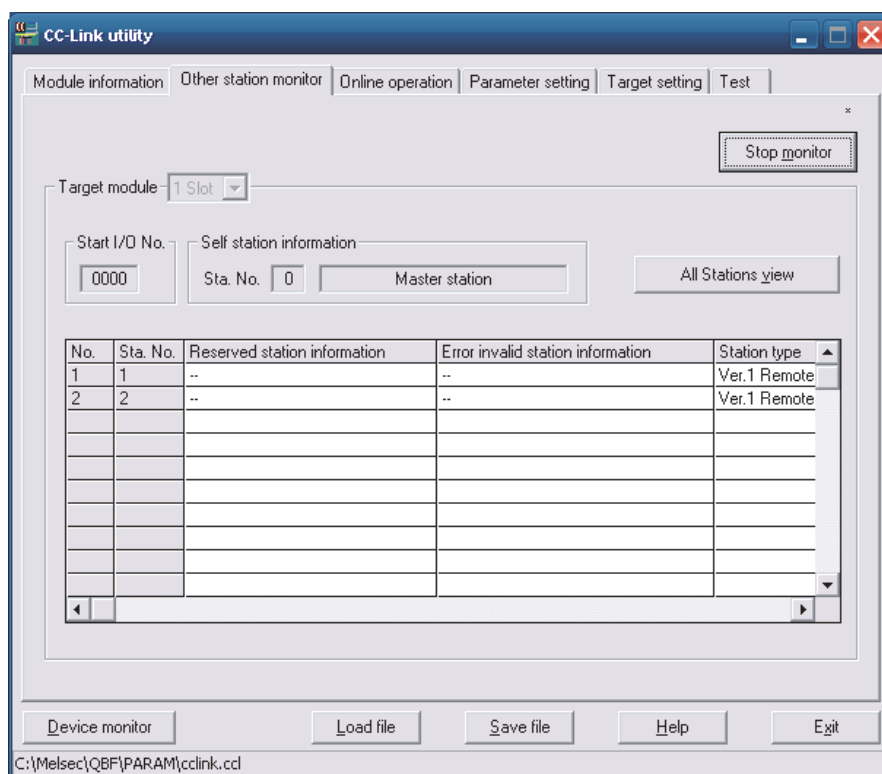

Item	Description
Target module	Selects a target module for other station monitor. (Initial value: "Slot 1", Selecting range: "1 Slot" - "8 Slot".)
Start I/O No.	Displays the start I/O No. of the CC-Link module selected in the "Target module" field.
Self Station information	Displays a Sta. No. ("0" - "64") and station type ("Master station" or "Local station") and operation mode. For the details of Operation mode, refer to "Section 5.4.2 (1)(a) Operation mode".
All Stations view	Opens the "All Stations view" window. For details, refer to "(2) All Stations view window".
No.	Displays the No. of station connected.
Sta. No.	Displays Sta No.
Reserved station information	Displays reserved station information. For details, refer to "(c) Details on reserved station".
Error invalid station information	Displays error invalid station information. For details, refer to "(d) Details on error invalid station".
Station type	Displays station types. For details, refer to "(a) Details on station type".
Occupied No.	Displays the No. of occupied station. (Display range: "1 Station occupied" "4 Station occupied".)
Status	Displays the conditions of a station modules. For details, refer to "(b) Details on states".
Transient error	Displays the status of each module's transient error. For details, refer to "(e) Details on transient error".
Extended cyclic setting *1	Displays Extended cyclic setting. (Display range: "Equimultiple setting", "Twice setting", "Four time setting", "Eight time setting")
Remote station points *1	Displays the No. of remote station points.
Start monitor	Starts monitor. Changes to the Stop monitor button when monitoring, with "*" blinking in the upper right of the Stop monitor button.
Stop monitor	Stops monitor. Changes to the Start monitor button when monitoring is stopped.

*1: Not displayed if "Remote-net Ver.1 Mode" is selected for a target module's operation mode.

(a) Details on the station

Details on the station type is as follows:

Display	Description
Ver.1 Remote I/O station	Remote I/O station without cyclic point extension
Ver.1 Remote device station	Remote device station without cyclic point extension
Ver.1 Intelligent device station	Intelligent device station without cyclic point extension
Ver.2 Remote device station	Remote device station with cyclic point extension
Ver.2 Intelligent device station	Intelligent device station with cyclic point extension

(b) Details on states

Details on states is as follows:

Display	Description
Normal	Normal
Temporary error invalid state	In a temporary error invalid state
Data link error	A link error has occurred.
WDT error	A watchdog timer error has occurred.
Blown fuse confirmation error	There is a station in which a fuse has blown.
Repetition Sta. No.	Duplicate Sta. No. exists.
Switch changing	A switch has been changed.

(c) Details on reserved station

Details on reserved station is as follows:

Display	Description
Reserved station	An error invalid station is set.
-	No setting

(d) Details on error invalid station

Details on error invalid station is as follows:

Display	Description
Error invalid station	An error invalid station is set.
-	No setting

(e) Details on transient error

Details on transient error is as follows:

Display	Description
Transient transmission err	An error invalid station is set.
-	No setting

(2) All Stations view window

A list of the communication status of other Sta. is displayed.



Item	Description
Each station information	Displays station's communication conditions. For details, refer to "(a) Details on each station information".
OK	Closes the "All Stations view" window.

(a) Details on each station information

Details on each station information is as follows:

Display color	Description
White	Normal station
Red	Error station
Green	Error invalid station
Blue	Reserved station
Yellow	Temporary error invalid station

5.4.4 Operating the Online Operation Window

Reads/writes/verifies CC-Link parameters.

Point

Operation on this window is not possible while the bus interface driver's resetting is in progress. Perform operation after the reset operation is complete.

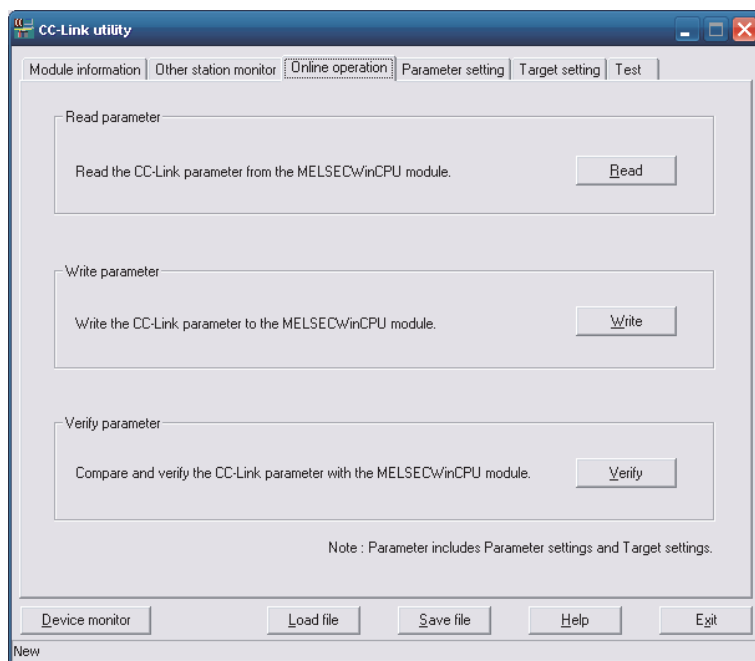

Item	Description
Read parameter Read	Reads CC-Link parameters out of the MELSECWinCPU module.
Write parameter *1 Write	Write the configured CC-Link parameters into the MELSECWinCPU module. The parameters written are enabled when that MELSECWinCPU module has been reset.
Verify parameter Verify	Verify the CC-Link parameters set to the MELSECWinCPU module against the ones set to the CC-Link utility. The verification result is displayed in the message box.

*1: To write parameters, log on as a user with the Administrator attribute.

5.4.5 Operating on Routing Parameter Setting Window

Sets parameters for a CC-Link utility.

Point

- (1) When the window switches to another window, if the entered parameters are mistaken, the warning message is displayed and the window does not switch to another window.
Correct the entered parameters and then transition to another window.
- (2) To reflect the settings in a MELSECWinCPU module, write the parameters using the “Online Operation” window and reset the MELSECWinCPU module.

(1) Parameter setting window

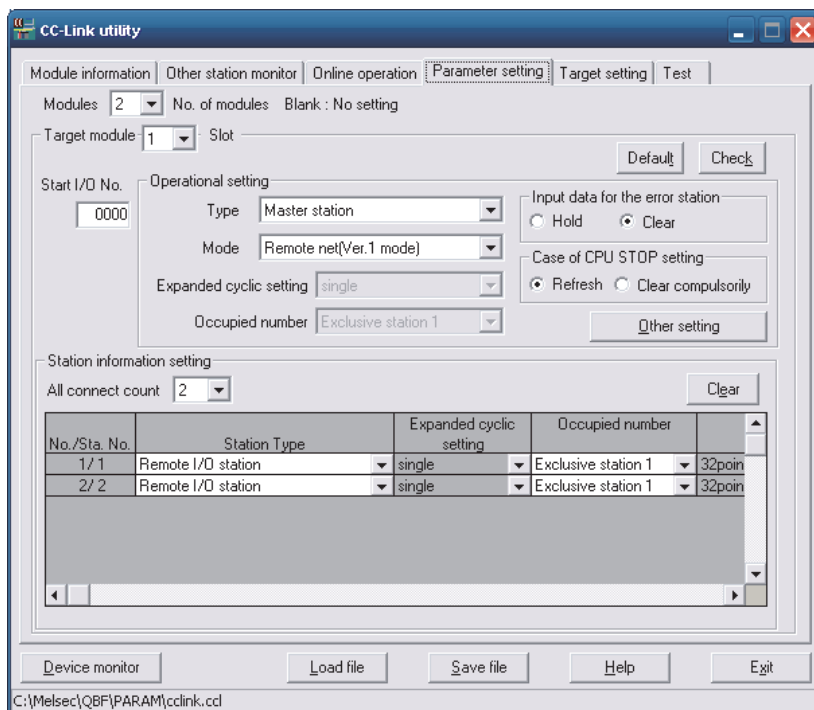

Item	Description
Modules	Sets the No. of CC-Link utility to be managed by the MELSECWinCPU module. If “ (vacant) is selected, none is set (the setting cleared). (Initial value: “ (vacant), setting range: 1 - 8, “ (vacant))
Target module	Selects a target module to be set. (Initial value: 1, setting range: 1 - 8) For the details of No.assigned to this item, refer to “(1)(a) No. to be assigned to target modules”.
Start I/O No.	Sets the start I/O No. of a CC-Link utility. (Setting range: 0000H - 0FE0H (Note that the above start I/O No. cannot overlap the ones set to other CC-Link utility.))

Item	Description
Default	Sets the operation setting and station information setting parameters to default values.
Check	Checks that the settings are correct.
Operational setting	
Type	Sets a type for a CC-Link utility. (Initial value: "Master station", setting range: "Master station", "Local station")
Mode	Sets a mode for a CC-Link utility. (Initial value: "Remote net - Ver.1 mode", setting range: "Remote net - Ver.1 mode", "Remote net - Ver.2 mode", "Remote net additional mode", "Online")
Extended cyclic setting	Configures the extended cyclic setting for a CC-Link utility. This item can be set only when "Local station" is set to "Type" and any mode other than "Remote-net Ver.1" is set to "Mode setting". (Initial value: "One time setting", setting range: "One time setting", "Twice setting", "Four time setting", "Eight time setting")
Occupied number	Sets the No. of stations to be occupied by a CC-Link utility (local). This item can be set when "Local station" is set to "Type." (Initial value: "One station occupied", setting range: "One station occupied" - "Four stations occupied")
Input data for the error station	Sets how to handle input data when a data link error occurs. (Initial value: "Retain", setting range: "Retain", "Clear")
Case of CPU STOP setting	Sets how to handle link data at the time of CPU STOP. This setting can be set for QJ61BT11N. For QJ61BT11, this item is always "Refresh" irrespective of its setting. (Initial value: "Refresh", setting range: "Refresh", "Forced clear")
Other setting	Opens the "Other Settings" window. For details, refer to "(2) Other Settings window". This button can be clicked on only when "Master station" is set to "Type".
Station information setting	
All connect count	Sets the No. of modules to be connected to a CC-Link utility. (Initial value: 64, setting range: 1 - 64)
Station Type	Sets a station type. For the default value and setting range, refer to "(1)(b) Initial value and its setting range by station type".
Extended cyclic setting	Sets extended cyclic points for a CC-Link utility. *1 (Initial value: "One time setting", Setting range: "One time setting", "Twice setting", "Four time setting", "Eight time setting")

*1: This item shall be set when "Remote-net Ver.2 Mode" or "Remote-net Additional Mode" is set to the mode setting, and "Ver.2 remote device station" or "Ver.2 intelligent device station" is set to the station type.

Item		Description
Station information setting		
Occupied No.		Sets the No. of occupied stations. (Initial value : "One station occupied", setting range : "No setting", "One station occupied", "Two stations occupied", "Three stations occupied", "Four stations occupied")
Remote station points		Sets points for a remote station. This item can be set only when "Remote-net Ver.2 mode" is set to "Mode setting". For the default value and setting range, refer to "CC-Link System Master/Local Module User's Manual".
Reserve/invalid station select		Sets a CC-Link utility as a reserved or invalid station. (Initial value: "Not specified", setting range: "No setting", "Local station", "Invalid station")
Intelligent buffer select(word) *2	Send	Specifies a transmission area. (word unit) (Initial value: 64, setting range: 0, 64 - 4096)
	Receive	Specifies a reception area. (word unit) (Initial value: 64, setting range: 0, 64 - 4096)
	Automatic	Specifies an automatic update area. (word unit) (Initial value: 128, setting range: 0, 128 - 4096)
Clear		Clears the parameters in the "Station Information Setup" field and sets initial values.

*2 : This item can be set only when "Intelligent device station", "Ver.1 Intelligent device station" or "Ver.2 intelligent device station" is set to "Station type".

(a) No. to be assigned to target modules

No. assigned to target modules are assigned, starting from 1, in ascending order of “Start I/O No.” obtained when this window is opened or when a parameter setup file is read.

Note that when No. assigned to target modules are reassigned, their parameter settings will not be changed.

1) The “Start I/O No.” “00” position is vacant.

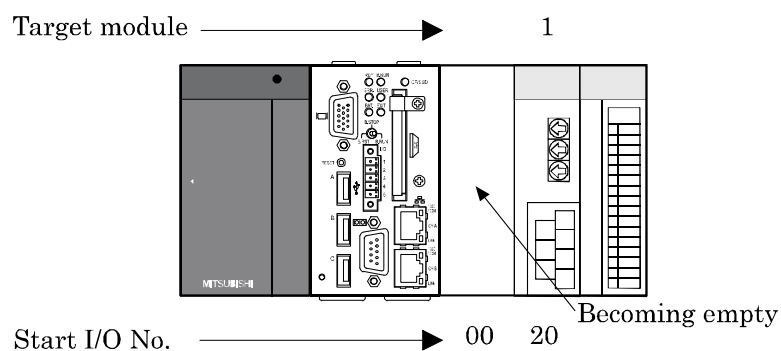

2) Module added to the “Start I/O No.” “00” position.

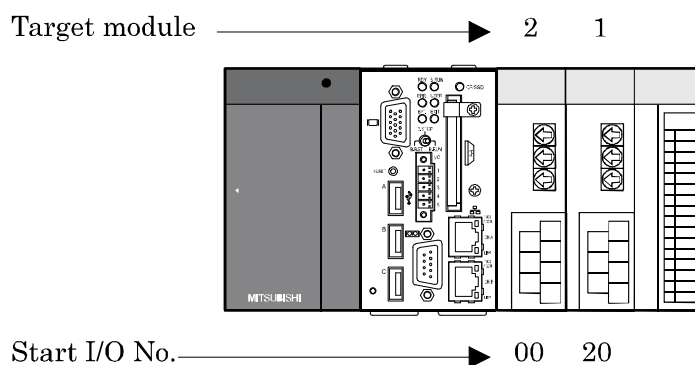

3) Target module reassigned when the screen transitions or when the parameter setup file is saved.

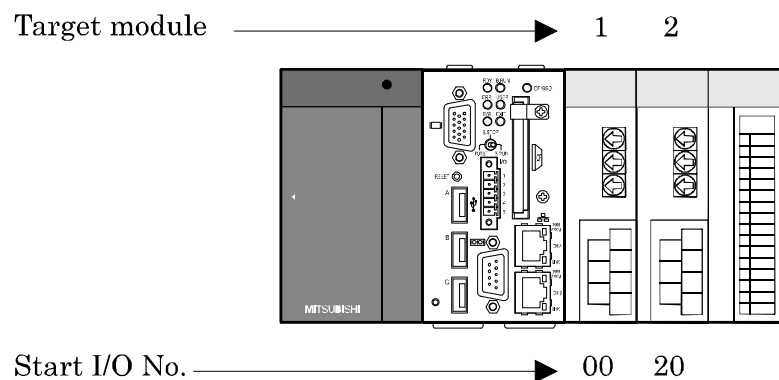

(b) Initial value and its setting range by station type

The initial value and its setting range by station type changes according to the setting in the “Mode setting” field.

Details on this is as follows :

Setting of “Mode setting”	Initial value	Setting range
“Remote net (Ver.1 mode)”	“Remote I/O station”	“No setting”, “Remote I/O station”, “Remote device station”, “Intelligent device station”
“Remote net(Ver.2 mode)”, “Remote net(Add. mode)”	“Ver.1 Remote I/O station”	“No setting”, “Ver.1 Remote I/O station”, “Ver.1 Remote device station”, “Ver.1 Intelligent device station”, “Ver.2 Remote device station”, “Ver.2 Intelligent device station”

(2) The other setting window

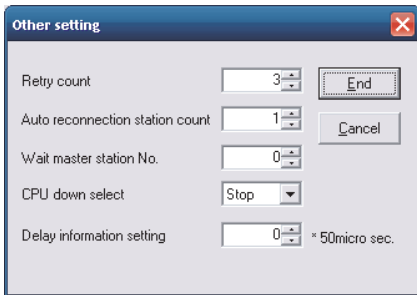

Item	Description
Retry count	Sets the No. of retries in the event of communication failure (when a transient transmission error occurs). (Initial value: 3, setting range: 1 - 7)
Auto reconnection station count	Sets the No. of stations that can automatically return for a one-link scan. (Initial value: 1, setting range: 1 - 10)
Wait master station. No.	Sets a Sta. No. to a standby Master station. (Initial value: 0 (No setting), setting range: 0 - 64)
CPU down select	Sets a data link's state when an error occurs in the MELSECWinCPU module. (Initial value: “Stop”, Setting range: Continue”, “Stop”)
Delay information setting	Set 0 for “Delay time”.
End	Reflects the settings and closes the “Other Settings” window.
Cancel	Closes the “Other Settings” window without reflecting the settings.

5.4.6 Operating the Target Setting Window

Set the logical Sta. No. for making access to any CPU module in a multiple CPU system where the CC-Link module is installed.

Point

- (1) To reflect the settings in a MELSECWinCPU module, write the parameters using the “Online Operation” window and reset the MELSECWinCPU module.
- (2) Set a programmable controller CPU as the Target CPU.

(1) Target window

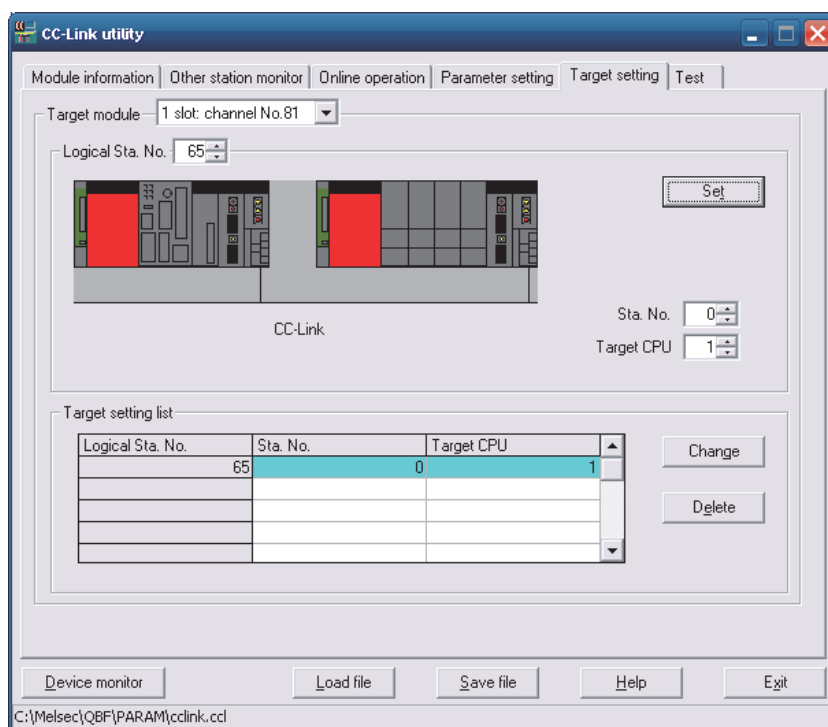

Item	Description
Target module	Select the module to be set. (Initial value: "1 slot", Setting range: "1 slot" - "8 slot")
Logical Sta. No. *1	Specifies a Logical Sta. No. to be set to the module selected in the "Target module" field. (Initial value: 65, setting range: 65 - 239)
Sta. No.	Sets Sta. No. of CC-Link utility managed by the multiple CPU system. (Initial value: 0, setting range: 0 - 63)
Target CPU *2	Sets target CPUs (CPU module No. in a multiple CPU system) to be accessed. (Initial value: 1, setting range: 1 - 4)
Set	Register the settings and changes (Logical Sta. No., Sta. No., target CPU) to the target list.
Target setting list	Displays the Sta. No. that corresponds to the Logical Sta. No. set to the module selected in the "Target module" field, as well as the target CPU list.
Change	Displays the data in the row (Logical Sta. No.) selected in the Target setting list in the Logical Sta. No. area. (Double-clicking the desired row can also change the Logical Sta. No. area setting.)
Delete	Deletes the line (Logical Sta. No.) selected in the Target setting list.

*1: The logical Sta. No. is a Logical No. specified as the "Sta. No." in the Device monitor utility or user program (MELSEC data link function).

Use the Logical Sta. No. when accessing another station CPU (another CPU No. in the multiple CPU system) from the target module (channel No.).

When directly accessing a different station (station 0 - 63) and a CPU module that manages CC-Link utility of a different station use a Sta. No. used for CC-Link, instead of a Logical Sta. No.

*2: The target CPU field can be set only when, as a CPU module, the CPU module set in the "Sta. No." field is capable of configuring a multiple CPU system.

(2) Example of access

By using the Logical Sta. No. “65,” you can access CPU module No.4 through a CC-Link utility (managed by CPU module No.2) from a CC-Link utility managed by the MELSECWinCPU module. From the Device Monitor utility or from a user program (MELSEC data link functions), you can access CPU module No.4 by opening channel No.81 and specifying 65 for a Sta. No.

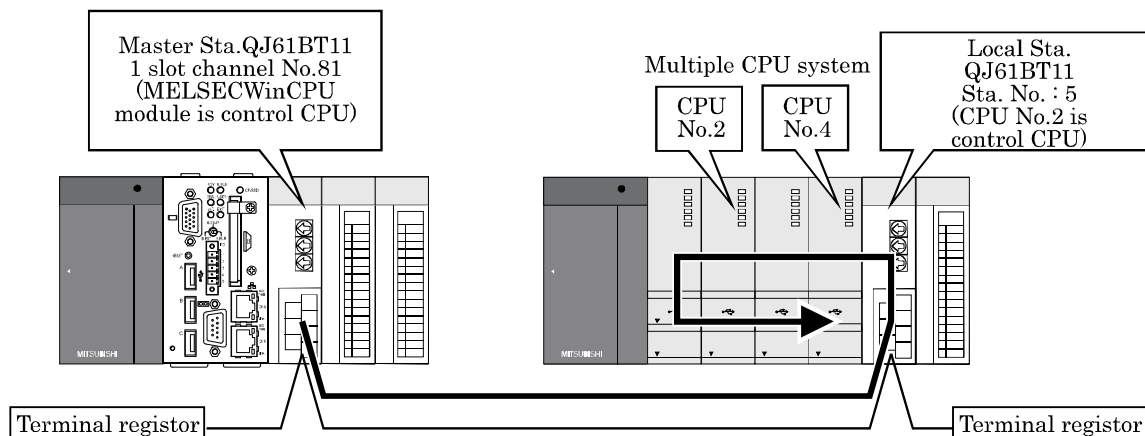

The following window shows the setting for a target to make the above access.

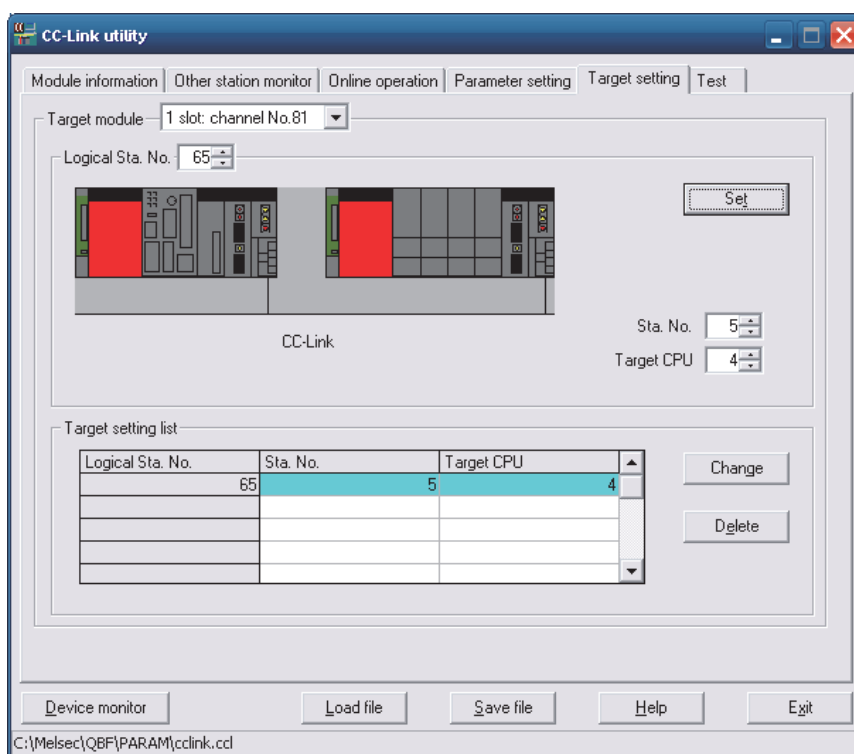

5.4.7 Operating on Network Test Window

This screen executes network test or lining on installed CC- Link utility.

Point
(1) Execute network test and line test when CC- Link is under online status. Executing network test and line test under off- line status of CC- Link utility results in an error. Network tests and line connection tests cannot be performed when in offline.
(2) Line test (station specified) is executed if an error occurred in line test (all stations). If line test (all stations) results in normal status, line test (station specified) is not necessary.

(1) Test Window

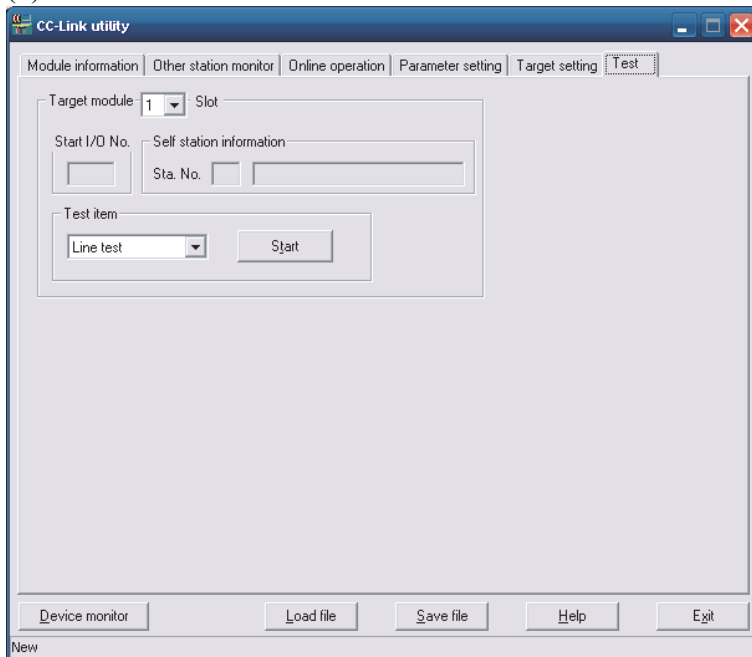

Item	Description						
Target module	Selects the channel to be used. (Initial value: "1 slot", setting range: "1 slot" -"8 slot")						
Start I/O No.	Displays the start I/O No of CC-Link module.						
Self station information	Displays the Sta. No. and station type ("Master station" or "Local station") and operation mode of the CC-Link utility selected in the "Target module" field. For operation modes, refer to "Section 5.4.2 (1)(a) Operation mode."						
Test item	Selects a test to be performed.						
	<table border="1"> <thead> <tr> <th>Display</th> <th>Description</th> </tr> </thead> <tbody> <tr> <td>Network test</td> <td>Test Performs a data link start and stop test.</td> </tr> <tr> <td>Line test</td> <td>Checks whether the connected station is normal or abnormal. (Selectable only on Master station)</td> </tr> </tbody> </table>	Display	Description	Network test	Test Performs a data link start and stop test.	Line test	Checks whether the connected station is normal or abnormal. (Selectable only on Master station)
	Display	Description					
Network test	Test Performs a data link start and stop test.						
Line test	Checks whether the connected station is normal or abnormal. (Selectable only on Master station)						

(2) Operating procedure of test

(a) Line connection test operation procedure

Line connection tests can be performed only when the activation status of a CC-Link utility (refer to “5.4.2 Operating the Module Information Window”) is “Data link connected” or “Processing automatic return”.

1) Setting

Select a line connection test target station and click on the **OK** button to start testing.

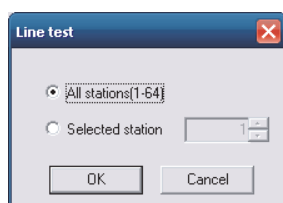

2) Test results

- In step 1) shown above, when a line connection test is performed by selecting “All stations (1 - 64)”, the test results are displayed in the following window.

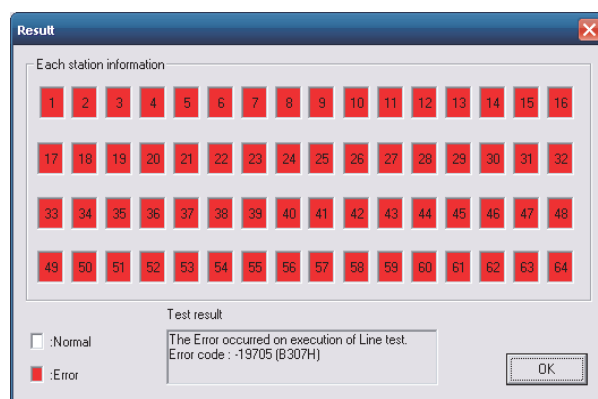

For the details of error codes, refer to “Section 8.4.1 Actions upon error codes at the time of function execution”.

- In step 1) shown above, when a line connection test is performed by selecting “Specified station”, the test results are displayed in the following window.

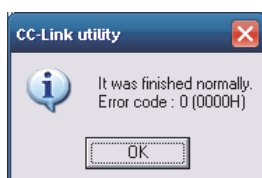

For details of error codes, refer to “8.4.1 Actions upon error codes at the time of function execution”.

(b) Operating procedure of network test

A network test can be performed only when the data link status of the CC-Link module (refer to “5.4.2 Operating the Module Information Window”) is set to “In data link”, “Suspended data link” or “Being automatically reconnected”.

1) Setting

Select either of “Start data link” or “Stop data link” and click on the **OK** button to start a network test.

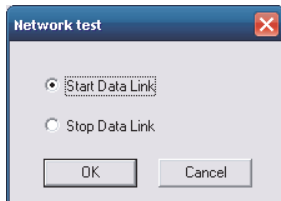

2) Test result

The test results are displayed in the following window.

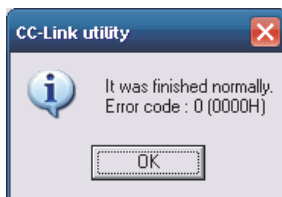



For details of error codes, refer to “8.4.1 Actions upon error codes at the time of function execution”.

5.4.8 Operating the System Menu

(1) System menu

There are three ways, listed below, to open and use the system menu for the CC-Link utility.

- Right-click on the title bar.
- Click icon () on the title bar.
- Press the  key after pressing **[Alt]** key.

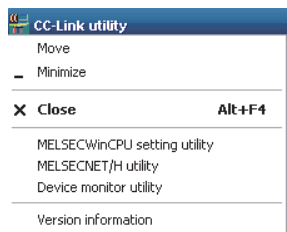

Item	Description
MELSECWinCPU setting utility	Move the MELSECWinCPU setting utility
MELSECNET/H utility	Starts the MELSECNET/H utility.
Device monitor utility	Starts the device monitor utility.
Version information	Opens the “Version information” window. For details on this, refer to “(2) Version information window”.

(2) Version information window

Version information of CC-Link utility is as follows :

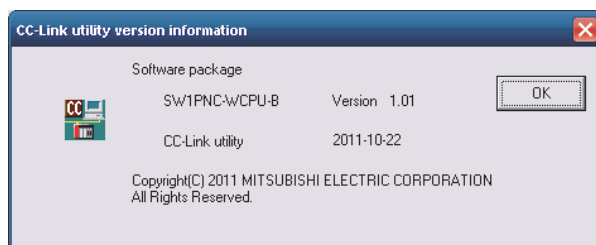

Item	Description
Software package SW1PNC-WCPU-B	Displays SW1PNC-WCPU-B version.
CC-Link utility	Displays the date of CC-Link utility
	Close “Version information” windows.

5.5 MELSECNET/H utility

This section describes operations for MELSECNET/H utility.

Notes on MELSECNET/H utility is as follows :

(1) Details on each parameter

For the details of parameters, refer to “Q Corresponding MELSECNET/H Network System Reference Manual (PLC to PLC network)”.

(2) Maximum No. of utilities for simultaneous use

More than one MELSECNET/H utility cannot be started at the same time.
Only one can be started at a time.

(3) Note on written parameters

The parameters written to the MELSECWinCPU module are enabled when the module is reset.

5.5.1 Functional List of MELSECNET/H Utility

This section describes functions for MELSECNET/H Utility.

Name	Description	Referring Paragraph
Reading/saving a parameter setup file.	Saves the parameters set by MELSECNET/H utility to a file and reads them.	5.2
Displays module information	Displays various types of MELSECNET/H module (own Sta.) information managed by the MELSECWinCPU module.	5.5.2
Err history monitor	Displays a record of errors that have occurred in MELSECNET/H modules.	5.5.3
Other local monitor	This window displays the line status of the other Sta. (MELSECNET/H network stations).	5.5.4
Online operation	Reads, writes and compares MELSECNET/H parameters.	5.5.5
Parameter setting	Performs Parameter setting of MELSECNET/H module	5.5.6
Target setting	Set the Logical Sta. No. for making access to any CPU module in a multiple CPU system where the MELSECNET/H module is installed.	5.5.7

5.5.2 Operating the Module Information Window

This window displays various types of information about the MELSECNET/H module (own Sta.) managed by the MELSECWinCPU module.

Point

It cannot be monitored while the bus interface driver is reset.
Start monitoring after the reset is completed.

(1) Module information window

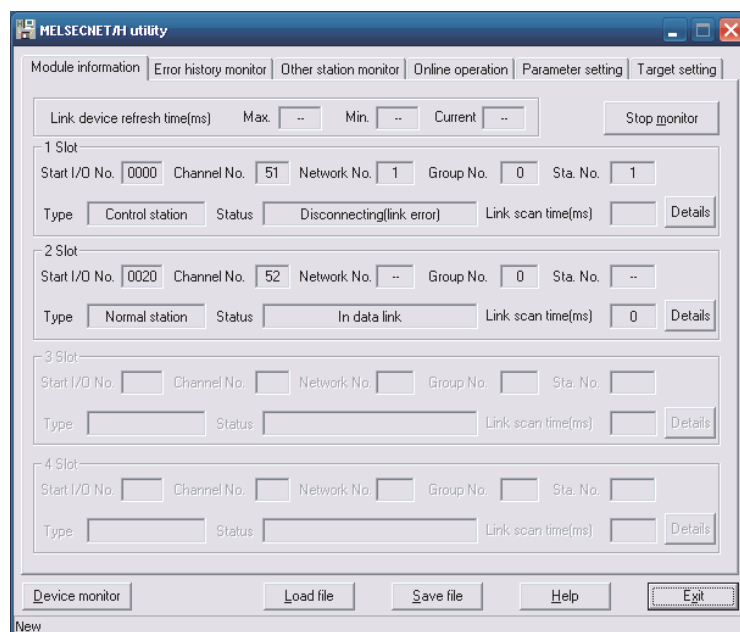

Item		Description	Supported SB	Supported SW
Link device refresh time	Max.	Displays the longest all link devices refresh time recorded, with respect to the MELSECNET/H modules managed by the MELSECWinCPU module (your own device). If the link device refresh cycle *1 is set to 0ms, “-” is displayed.	-	-
	Min.	Displays the shortest all link devices refresh time recorded, with respect to the MELSECNET/H modules managed by the MELSECWinCPU module (your own device). If the link device refresh cycle *1 is set to 0ms, “-” is displayed.	-	-
	Current	Displays the current all link devices refresh time with respect to the MELSECNET/H modules managed by the MELSECWinCPU module (your own device). If the link device refresh cycle *1 is set to 0ms, “-” is displayed.	-	-

*1: For link devices refresh cycle, refer to “Section 5.5.6 Operating the Parameter Setup window”.

Item		Description	Supported SB	Supported SW
1 – 4 Slots *2	Start I/O No.	Displays start I/O No. of MELSECNET/H module.	-	-
	Channel No.	Displays channel No. of MELSECNET/H module. *3	-	-
	Network No.	Displays network No. of MELSECNET/H module.	-	SW0040
	Group No.	Displays group No. of MELSECNET/H module.	-	SW0041
	Sta. No.	Displays Sta.No. of MELSECNET/H module.	-	SW0042
	Type	Displays type of MELSECNET/H module. (Display range: “Control station”, “Normal station”)	-	SW0044
	Status	Displays communication status of MELSECNET/H module. For more details on this, refer to “(1)(a) Details on communication status”	-	SW0047
	Link scan time	Displays the link scan time of a MELSECNET/H module. (ms unit)	-	SW006D
	Details	Opens “Module detail information” window. For details on “Module detail information”, refer to “(2) Module detail information window”. When stopping monitor, Details button cannot be clicked.	-	-
Start monitor	Starts monitoring MELSECNET/H modules. Changes to the Stop monitor button when monitoring, with “*” blinking in the upper right of the Stop monitor button.	-	-	
Stop monitor	Stops monitoring MELSECNET/H modules. Changes to the Start monitor button when monitoring is stopped.	-	-	

*2 : The module information data is displayed at once in ascending order of the start I/O No.

*3 : The channel No. is determined in the ascending order of the start I/O No., starting from 51.

(a) Communication condition details

Details on communication status is as follows :

Display	Description
In data link	In data link.
Suspend data link (Other)	Cyclic transmission stopped by another station.
Suspend data link (Self)	Cyclic transmission stopped by your own Sta..
Baton pass (No area)	No assignment to your own Sta.'s B/W transmission.
Baton pass (Parameter Halt)	Parameters for your own Sta. abnormal.
Baton pass (No Receive)	Unable to receive common parameters.
Disconnecting (no baton)	Sta. No. overlapped, cables not connected.
Disconnecting (link error)	Cables not connected.
In test	In online testing
During reset	Hardware failure
In offline test	In offline testing

(2) Module detail information window

Displays MELSECNET/H module detail information.

Item	Description	Supported SB	Supported SW
Module type	Displays the model name of the MELSECNET/H module.	-	-
Product information	Displays the product information (serial No. and function version) of the MELSECNET/H module.	-	-
OK	Closes "Module detailed information" window.	-	-
Save SB/SW	Saves the link special relay (SB) and link special register (SW) information of the MELSECNET/H module into a CSV format file. For details, refer to "(3) Specification of SB/SW saving file".	-	-
Self station information			
Start I/O No.	Displays the start I/O No. of your own Sta. (Display range: 0000H - 0FE0H)	-	-
Network No.	Displays the network No. of your own Sta. (Display range: 1 - 239)	-	SW0040
Group No.	Displays the group No. of your own Sta. (Display range: 0 - 32)	-	SW0041
Sta. No.	Displays the station No. of your own station. (Display range: 1 - 64, "-")	-	SW0042
Network	Displays the MELSECNET/H module network. (Display range: "MELSECNET/H extension (loop)", "MELSECNET/H extension (bus)", "MELSECNET/H (loop)", "MELSECNET/H (bus)", "MELSECNET/10 (loop)", "MELSECNET/10 (bus)")	SB0057, SB005A	SW0046
Type	Displays the type of your own Sta. (Display range: "Net control station, PLC-PLC", "Net normal station, PLC-PLC")	SB0044	-

Item		Description	Supported SB	Supported SW
Self Station status				
Parameter setting		Displays the parameter setting for your own Sta.. (Display range: "Common parameters only", "Common parameters + inherent parameters", "Default parameters only", and "Default parameters + inherent parameters".)	-	SW0054
Reserved station setting		Displays whether or not reserved stations exist in the network.	SB0064	-
Transmission mode		Displays the communication mode of your own Sta. (Display range : "Normal mode," "Constant link scan XXms" *1)	SB0068	SW0068
Duplex transmission setting		Displays multiplex transmission specified for your own Sta.. (Display range: "Normal transmission","Multiplex transmission", "-" *2)	SB0069	-
Duplex transmission status		Displays the multiplex transmission status of for your own Sta.. (Display range: "Normal transmission in progress", "Multiplex transmission in progress", "-" *2)	SB006A	-
Transmission speed		Displays the transmission speed of your own Sta.. (Display range: "10Mbps", "25Mbps")	-	-
Control station information				
Assign control station		Displays the specified control station in the MELSECNET/H module network. "0" is displayed when the control station does not operate normally.	-	SW0057
Present control station		Displays the current control station in the MELSECNET/H module network. "0" is displayed when the control station does not operate normally.	-	SW0056
Transmission information		Displays communication information of the MELSECNET/H network. (Display range : "Control station communication", "Sub control station communication")	SB0056	-
Sub control station transmission		Displays communication of the sub-control station in the MELSECNET/H network. (Display range: "Have", "None")	SB0058	-
Remote I/O master station number	Block1	Displays the Sta. No. of the remote I/O master station in block 1.	-	SW005C
	Block2	Displays the Sta. No. of the remote I/O master station. in block 2.	-	SW005D

*1: The time set for constant link scan is displayed in XX.

*2: "-" is displayed for a coaxial bus system.

Item	Description	Supported SB	Supported SW
Link information			
Mode	Displays the operation mode of your own Sta. (Display range: "Online", "Offline", "Loop test")	-	SW0043
F loop status	Displays the main loop's status. (Display range: "Normal", "Loopback transmission", "Data link disabled", "-" *2)	SB0091, SB0099	-
Loopback station	Displays the Sta. No. of a station that performs loopback on the main loop side. (Display range: 1 - 64, Not performed, " " (vacant)*3, "-" *2)	-	SW0099
R loop status	Displays the sub-loop's status. (Display range: "normal", "loopback transmission", "data link disabled", "-" *2)	SB0095, SB009A	-
Loopback station	Displays the Sta. No. of a station that performs loopback on the sub-loop side. (Display range: 1 - 64, Not performed, " " (vacant) *3, "-" *2)	-	SW009A
Link scan time	Max. Displays the longest link scan time recorded. " " (vacant) is displayed if data linkage is not possible. (ms unit)	-	SW006B
	Min. Displays the shortest link scan time recorded. " " (vacant) is displayed if data linkage is not possible. (ms unit)	-	SW006C
	Current Displays the current link scan time. " " (vacant) is displayed if data linkage is not possible. (ms unit)	-	SW006D
Data link information			
Total number of linked stations	Displays the total No. of link stations in MELSECNET/H.	-	SW0059
Station of maximum normal transmission	Displays the maximum No. of normal communication stations through MELSECNET/H.	-	SW005A
Station of maximum data link	Displays the maximum No. of data link stations through MELSECNET/H.	-	SW005B
Transmission status	Displays the communication states of MELSECNET/H. For more details on this, refer to "(1)(a) Communication condition details".	-	SW0047
Reason for transmission interruption	Displays the reason for transmission interruption of MELSECNET/H. For more details on this, refer to "(2)(a) Reason for transmission interruption".	-	SW0048
Reason for transmission stop	Displays the cause of MELSECNET/H's data link stoppage. For more details on this, refer to "(2)(a) Reason for transmission interruption".	-	SW0049, SW004A

*2 : The symbol, "-" appears in the case of a coaxial bus system.

*3 : " " (vacant) appears in the case of the data link disabled status.

(a) Reason for transmission interruption

Reason for transmission interruption is as follows:

Display	Description
Normal	In normal communication
Offline	In offline
Offline test	In offline testing
Initial status	Error occurred. (Error code: F101, F102, F105)
Shift control station	Error occurred. (Error code: F104, F106)
Online testing	Error occurred. (Error code: F103, F109, F10A)
Baton disappearance	Error occurred. (Error code: F107)
Baton repetition	Error occurred. (Error code: F108)
Same station present	Error occurred. (Error code: F10B)
Control station repetition	Error occurred. (Error code: F10C)
Reception retry error	Error occurred. (Error code: F10E)
Transmission retry error	Error occurred. (Error code: F10F)
Timeout error	Error occurred. (Error code: F110)
Link Error	Error occurred. (Error code: F112)
Disconnecting	Error occurred. (Error code: F11B)
No baton to local station	Error occurred. (Error code: F11F)
Error code: XXXX	Error occurred. (refer to the displayed error code.)

(b) Details on reason for transmission stop

Reason for transmission stop is as follows:

Display	Description
Normal	In normal communication.
Stop instruction present (All)	Cyclic transmission of all stations stopped by your own Sta. or another Sta.
Stop instruction present (Own)	Cyclic transmission of your own Sta. stopped.
Stop instruction present (□station)	Cyclic transmission of your own Sta. stopped by another Sta. (Sta. No. □).
No parameter	Unable to receive parameters.
Illegal parameter	Configured parameters abnormal.
Error self CPU	A moderate/serious error occurs in the local CPU module.
Suspend communication	A data link error occurs in your own Sta.

(3) Specification of SB/SW saving file

Examples of SB/SW saving file is as follows:

(a) Link special relay (SB) or link special register (SW) which has saved in CSV file

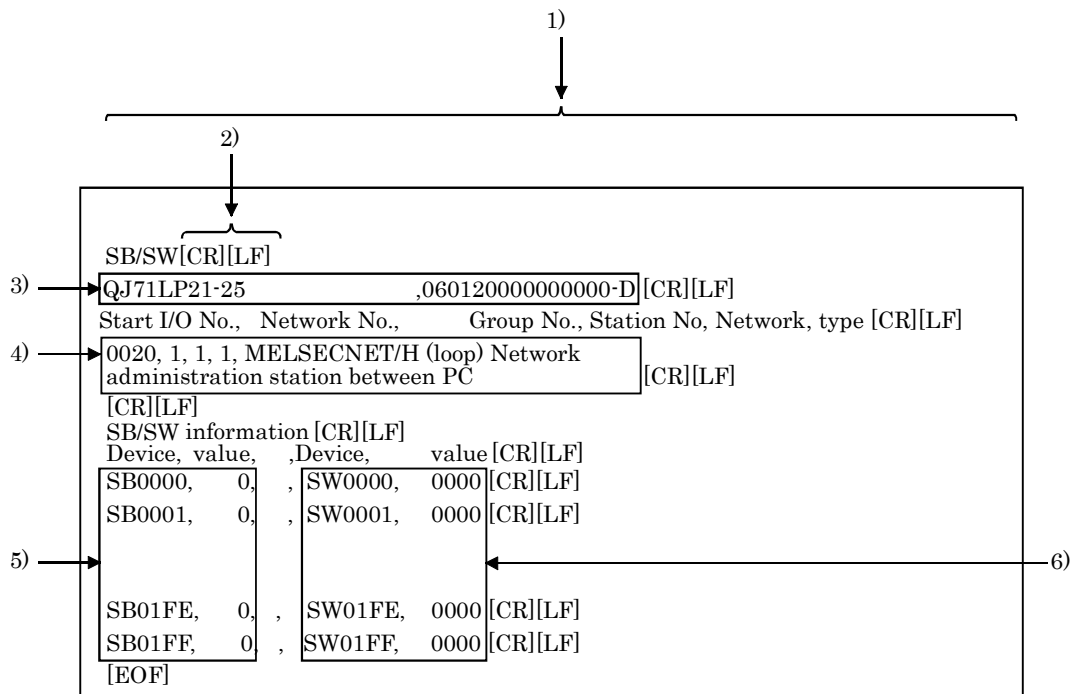

(b) Specification of CSV format

The link special relay (SB) and link special register (SW) are saved in the CSV format, as shown below.

- 1) A comma "," (ASCII code: 2CH) is used to separate columns.
- 2) Line feed code : CR/LF (ASCII code : CR=0DH, LF=0AH)
- 3) Starting from the first string, the "model name of the module" and "product information" are stored in order.
For more details on "model name" and "product information", refer to "(2) Module detail information window".
- 4) Starting from the first string, the "Start I/O No.", "network No.", "group No.", "Sta. No.", "network" and "type" for "Self station information" are stored in order.
For details, refer to "(2) Module detail information window".
- 5) "Device name" and "device value" of the link special relay (SB) are stored.
- 6) "Device name" and "device value" of the link special relay (SW) are stored.

Remarks

"C : \MELSEC\QBF\PARAM" is the standard directory to save SB/SW stored files.
(When SW1PNC-WCPU-B is installed in "C : \MELSEC\QBF".)

5.5.3 Operating Err History Monitor Window

This window displays the history of loop errors, communication errors, and transient transmission errors.

Point
(1) For loop switching errors and transient transmission errors, up to 16 histories can be stored. When there are more than 16 items, items will be erased from the history, starting with the oldest one. (From old to new : No. 1 - No. 16)
(2) For error codes and error types displayed for transient transmission errors, refer to “Q Corresponding MELSECNET/H Network System Reference Manual (PLC to PLC network)”.
(3) It cannot be monitored while the bus interface driver is reset. Start monitoring after the reset is completed.

(1) Err history monitor window

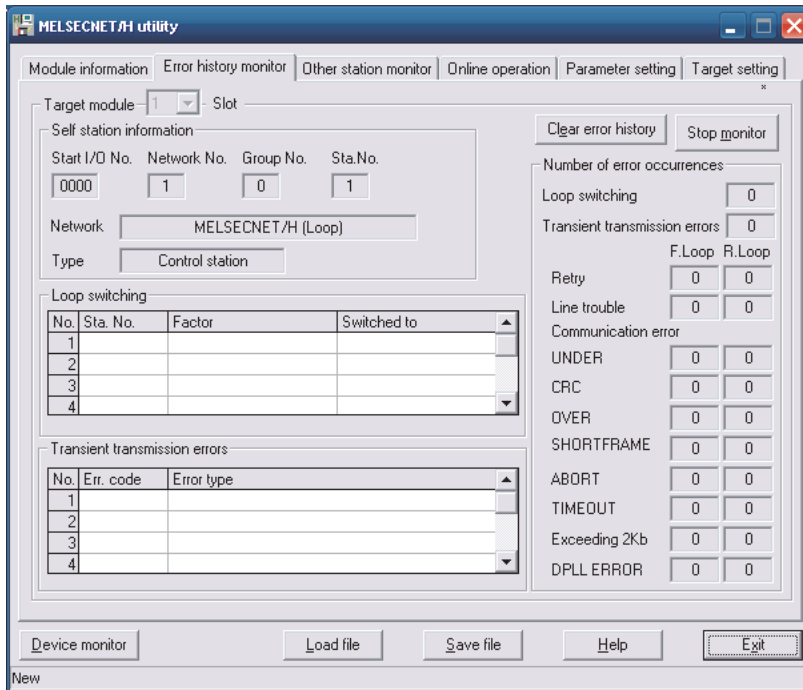

Item	Description	Supported SB	Supported SW
Target module	Selects a target MELSECNET/H module for error history monitoring. (Initial value: 1, setting range: 1 - 4)	-	-
Clear error history	Displays Clear error history window. For more details on this, refer to “(2) Clear of error history window window”.	-	-
Start monitor	Starts monitoring MELSECNET/H modules. Changes to the Stop monitor button when monitoring, with “*” blinking in the upper right of the Stop monitor button.	-	-
Stop monitor	Stops monitoring MELSECNET/H modules. Changes to the Start monitor button when monitoring is stopped.	-	-
Self station information			
Start I/O No.	Displays start I/O No. of your own Sta. (Display range: 0000H - 0FE0H)	-	-
Network No.	Displays network No. of your own Sta. (Display range: 1 - 239)	-	SW0040
Group No.	Displays the group No. of your own Sta. (Display range: 0 - 32)	-	SW0041
Sta. No.	Displays the Sta. No. of your own Sta. (Display range: 1 - 64, “-”)	-	SW0042
Network	Displays network of MELSECNET/H module. (Display range: “MELSECNET/H extension (loop)”, “MELSECNET/H extension (bus)”, “MELSECNET/H (loop)”, “MELSECNET/H (bus)”, “MELSECNET/10 (loop)”, “MELSECNET/10 (bus)”)	SB0057, SB005A	SW0046
Type	Displays type of your own Sta. (Display range: “control station”, “normal station”)	SB0044	-
Loop switching			
Sta. No.	Displays the Sta. No. of a station that requested loop switching or loopback. (Only for optical fiber loops)	-	SW00E0 - SW00E7
Factor	Displays the cause of the loop switching or loopback performed. (Only for optical fiber loops)	-	SW00D0 - SW00DF
Switched to	Displays the data link status after loop switching. (Only for optical fiber loops)	-	SW00D0 - SW00DF
Transient transmission errors			
Err. code	Displays the error code generated in transient transmission *1	-	SW00F0 - SW00FF
Error type	Displays the type of an error that occurred in transient transmission	-	-

*1: For error codes, refer to “Q Corresponding MELSECNET/H Network System Reference Manual (PLC to PLC network)”.

Item		Description	Supported SB	Supported SW
No. of error occurrences *2				
Loop switching		Displays the No. of loop switching occurrences. The symbol, "-" appears in the case of a coaxial bus system.	-	SW00CE
Transient transmission errors		Displays the No. of transient transmission error occurrences.	-	SW00EE
Retry		Displays the No. of retries (re-communication attempts in the event of communication failure).	-	SW00C8, SW00C9
Line trouble		Displays the No. of line connection failure occurrences. “-” is displayed for a coaxial bus system.	-	SW00CC, SW00CD
Communication error	UNDER	Displays the No. of UNDER error occurrences.	-	SW00B8, SW00C0
	CRC	Displays the No. of CRC error occurrences.	-	SW00B9, SW00C1
	OVER	Displays the No. of OVER error occurrences.	-	SW00BA, SW00C2
	SHORT FRAME	Displays the No. of short frame (data message too short) error occurrences.	-	SW00BB, SW00C3
	ABORT	Displays the No. of AB.IF error occurrences.	-	SW00BC, SW00C4
	TIMEOUT	Displays the No. of timeout error occurrences.	-	SW00BD, SW00C5
	Exceeding 2KB	Displays the No. of over-2k-byte reception error occurrences.	-	SW00BE, SW00C6
	DPLL ERROR	Displays the No. of DPLL (unable to recognize data in synchronization/modulation) error occurrences.	-	SW00BF, SW00C7

*2 : For causes of errors and the details of actions, “ refer to “(3) Causes of errors and actions”.

(2) Clear of error history window

Clears (Zero) the No. of error occurrences

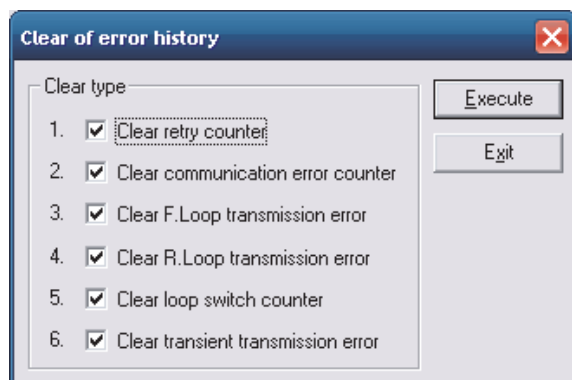

Item	Description	Supported SB	Supported SW
Clear type			
Clear retry counter	Clears (Zero) the No. of retries error occurrences (link special registers SW00C8 and SW00C9). (Initial value: Marked (clear (zero)))	SB0005	-
Clear communication error counter	Clears (Zero) the No. of communication error occurrences (link special registers SW00B8 and SW00C7). (Initial value: Marked (clear (zero)))	SB0006	-
Clear F.Loop transmission error	Clears (Zero) the No. of line connection error occurrences on the main loop side (link special register SW00CC). (Initial value: Marked (clear (zero)))	SB0007	-
Clear R.Loop transmission error	Clears (Zero) the No. of R.Loop transmission error (link special registers SW00CD). (Initial value: Marked (clear (zero)))	SB0008	-
Clear loop switch counter	Clears (Zero) the No. of loop switch error occurrences (link special registers SW00CE and SW00E7). (Initial value: Marked (clear (zero)))	SB0009	-
Clear transient transmission error	Clears (Zero) the No. of transient transmission error (link special registers SW00EE, SW00EF). (Initial value: Not marked (do not clear (zero)))	SB000A	-
Execute	Clears (Zero) the history of the selected Clear item. (Turns from ON to OFF the SB that corresponds to the marked clear item.)	-	-
Exit	Closes the Clear of error history window.	-	-

(3) Causes of errors and actions

The following indicates factors and corrective actions for each error.

Beside the Error History Monitor window, you can check causes from the following link special register (SW). For the details of link special registers (SW), refer to “Q Corresponding MELSECNET/H Network System Reference Manual (PLC to PLC network)”.

Item	Link special register	Factor	Treatment
Loop switching	SW00CE	ON/OFF of a station's power, cable failure, noise, etc.	*1
Transient transmission errors	SW00EE	ON/OFF of a target station's power, a target station's CPU module failure, cable failure, noise, etc.	Check the error code of a transient transmission error and take actions.
Retry	SW00C8, SW00C9	ON/OFF of a station's power, cable failure, noise, etc.	*1
Line trouble	SW00CC, SW00CD	ON/OFF of an adjacent station's power, cable failure, noise, etc.	*1
UNDER	SW00B8, SW00C0	ON/OFF of an adjacent station's power, cable failure, etc.	*1
CRC	SW00B9, SW00C1	Disconnection of a station transmitting data to the relevant station, cable failure, hardware failure, noise, etc.	*1
OVER	SW00BA, SW00C2	Cable failure, hardware failure, noise, etc.	*1
SHORTFRAME	SW00BB, SW00C3		
ABORT	SW00BC, SW00C4	Source station of data transmission was disconnected, cable fault, hardware fault, noise, etc.	*1
TIMEOUT	SW00BD, SW00C5	Data link monitoring time too short, cable failure, noise, etc.	*1
Exceeding 2KB	SW00BE, SW00C6	Cable failure, hardware failure, noise, etc.	*1
DPLL ERROR	SW00BF, SW00C7		

*1: The frequency of occurrence of each error is not a big problem as long as the No. of occurrences does not increase frequently during operation.

If the No. of occurrences increases frequently, perform the following.

- 1) Check the power ON/OFF status of your own Sta. and other Sta.
- 2) Check the conditions of cables and connectors (connectors disconnected or loosened, cables disconnected, cable lengths, etc.)
- 3) Loopback test, internal loopback test, and hardware test.
- 4) Inter-station test, and main loop/sub-loop test.
- 5) Perform cabling once again by referencing the manuals for your network module and MELSECNET/H board.

Perform installation once again by referencing the user manuals for your CPU modules.

5.5.4 Operating the Other Station Monitor Window

This screen displays line status of other stations (each station for MELSECNET/H network).

Point
(1) When the MELSECNET/H utility is started, monitoring is in a stop status. Click the Start monitor button to start monitoring.
(2) It cannot be monitored while the bus interface driver is reset. Start monitoring after the reset is completed.

(1) Other station monitor window

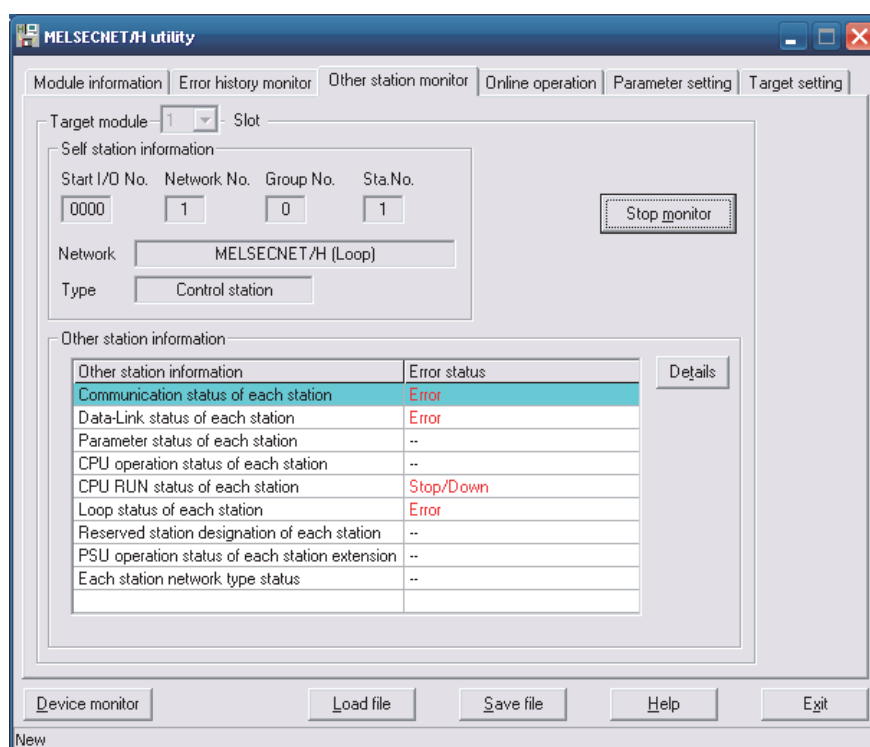

Item	Description	Supported SB	Supported SW
Target module	Selects a target MELSECNET/H module for Other local monitor. (Initial value: 1, setting range: 1 - 4)	-	-
Start monitor	Starts monitoring MELSECNET/H modules. Changes to the Stop monitor button when monitoring, with “*” blinking in the upper right of the Stop monitor button.	-	-
Stop monitor	Stops monitoring MELSECNET/H modules. Changes to the Start monitor button when monitoring is stopped.	-	-

Item		Description	Supported SB	Supported SW
Self station information	Start I/O No.	Displays Start I/O No. of your own Sta. (Display range: 0000H - 0FE0H)	-	-
	Network No.	Displays network No. of your own Sta. (Display range: 1 - 239)	-	SW0040
	Group No.	Displays group No. of your own Sta. (Display range: 0 - 32)	-	SW0041
	Sta. No.	Displays Sta. No. of your own Sta. (Display range: 1 - 64, “-”)	-	SW0042
	Network	Displays network No. of MELSECNET/H module. (Display range: “MELSECNET/H extension (loop)”, “MELSECNET/H extension (bus)”, “MELSECNET/H (loop)”, “MELSECNET/H (bus)”, “MELSECNET/10 (loop)”, “MELSECNET/10(bus)”)	SB0057, SB005A	SW0046
	Type	Displays type of your own Sta. (Display range: “control station”, “normal station”)	SB0044	-
Other station information	<u>Details</u>	Opens the Detail window and displays detailed information of the selected item. For more details on this, refer to “(2) Detailed window”.	-	-
	Other station information	Displays the error conditions for items of “Other stations information” in the “Error condition” column.	-	-
	Error status	Double-click on each item to open its Detail windows and display its detailed information. For more details on this, refer to “(2) Detailed window”.	-	-

(2) Detailed window

Displays detailed information of the item selected on the “Other station monitor” window.

For the detail windows, the following types of window open depending on your choice on the “Other station monitor” window.

Choice on the other station monitor window	Detailed window type	Reference Paragraph
Communication status of each station	“Communication status of each station” window	This section (2)(a)
Data-Link status of each station	“Data Link status of each station” window	This section (2)(b)
Parameter status of each station	“Parameter status of each station” window	This section (2)(c)
CPU operation status of each station	“CPU operation status of each station” window	This section (2)(d)
CPU RUN status of each station	“CPU RUN status of each station” window	This section (2)(e)
Loop status of each station	“Loop status of each station” window	This section (2)(f)
Reserved station designation of each station	“Reserved station destination of each station extension” window	This section (2)(g)
PSU operation status of each station extension	“PSU operation status of each station extension” window	This section (2)(h)
Each station network type status	“Each station network type status” window	This section (2)(i)

(a) Communication status of each station

Displays the baton pass condition (whether transient transmission is possible or not).

The No. of stations to be displayed is the “Total No. of stations” set by the “Parameter Setup” window.

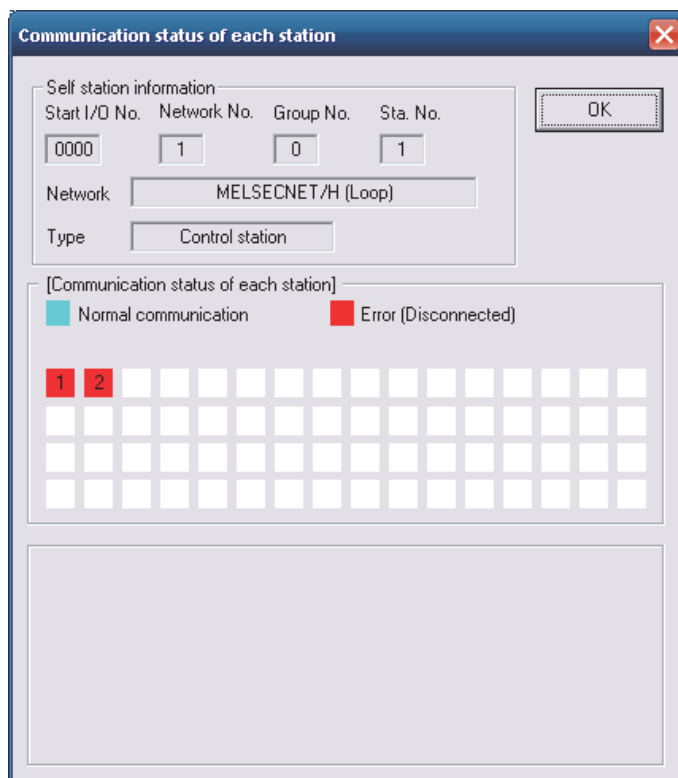

Item	Description	Supported SB	Supported SW
OK	Closes “Communication status of each station”.	-	-
Self station information	Displays local information of a MELSECNET/H module. For details, refer to “(1) Other station monitor window”.	SB0044, SB0057, SB005A	SW0040, SW0041, SW0042, SW0046
Communication status of each station	Displays the baton pass condition (whether transient transmission is possible or not) using the following colors. Light blue : Normal communication station., reserved station Red : Error [Disconnected] (Disconnecting states)	-	SW0070 - SW0073

(b) Data-Link status of each station

Displays the cyclic transmission status.

The No. of stations to be displayed is the “Total No. of stations” set by the “Parameter Setup” window.

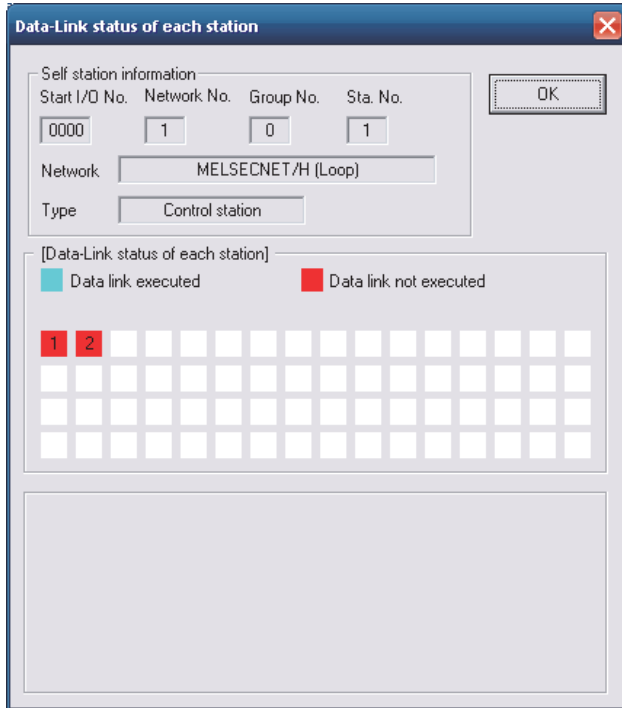

Item	Description	Supported SB	Supported SW
OK	Closes “Data-Link status of each station” window.	-	-
Self station information	Displays self station information of MELSECNET/H module. For details, refer to “(1) Other station monitor window”.	SB0044, SB0057, SB005A	SW0040, SW0041, SW0042, SW0046
Data-Link status of each station	Displays the cyclic transmission status using the following colors. Light blue : Normal station., reserved station Red : Faulty station (data link not executed)	-	SW0074 - SW0077

(c) Parameter status of each station.

Displays a station's parameter communication status and abnormal parameter status.

The No. of stations to be displayed is the "Total No. of stations" set by the "Parameter Setup" window.

Item	Description	Supported SB	Supported SW
OK	Close "Parameter status of each station".	-	-
Self station information	Displays self station information of MELSECNET/H module. For details, refer to "(1) Other station monitor window".	SB0044, SB0057, SB005A	SW0040, SW0041, SW0042, SW0046
Communication status of each station parameter	Displays the communication status of each station parameter using the following colors. Light blue : Other than during parameter communication, reserved station, Not-connected station Red : Parameter communication in progress	-	SW0078 - SW007B
Error status of each station parameter	Displays the error status of each station. parameter using the following colors. Light blue : Parameters normal, reserved station, Not-connected station Red : Parameter error	-	SW007C - SW007F

(d) CPU operation status of each station

Displays the operation status of a CPU.

The No. of stations to be displayed is the “Total No. of stations” set by the “Parameter Setup” window.

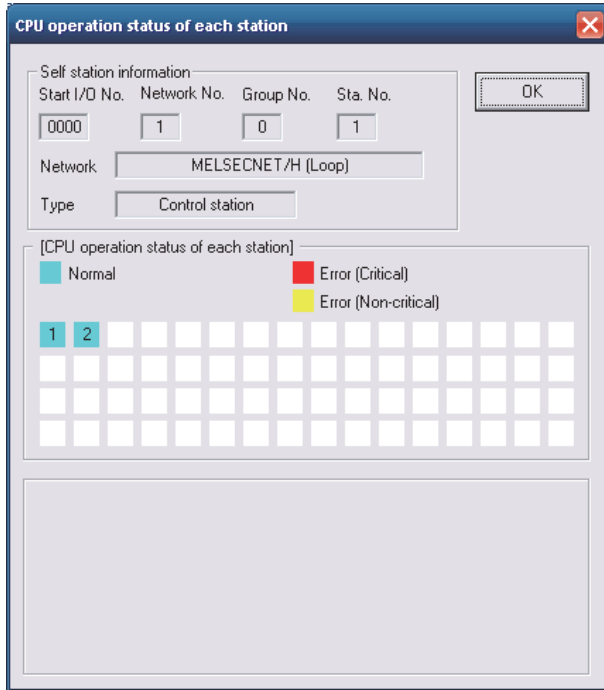

Item	Description	Supported SB	Supported SW
OK	Closes “CPU operation status of each station”.	-	-
Self station information	Displays self station information of MELSECNET/H module. For details, refer to “(1) Other station monitor window”.	SB0044, SB0057, SB005A	SW0040, SW0041, SW0042, SW0046
CPU operation status of each station	Displays the CPU operation status of each station using the following colors. Light blue : CPU normal, reserved station, Not-connected station Red : Moderate CPU error (WDT error, etc), Serious (Hardware error, etc) Yellow : Minor CPU error	-	SW0080 - SW0083, SW0088 - SW008B

(e) CPU RUN status of each station

Displays the RUN/STOP status of CPU

The No. of stations to be displayed is the “Total No. of stations” set by the “Parameter Setup” window.

CPU RUN status of each station

Self station information

Start I/O No. Network No. Group No. Sta. No.

0000 1 0 1

Network: MELSECNET/H (Loop)

Type: Control station

OK

CPU status

1	DOWN	17		33		49	
2	DOWN	18		34		50	
3		19		35		51	
4		20		36		52	
5		21		37		53	
6		22		38		54	
7		23		39		55	
8		24		40		56	
9		25		41		57	
10		26		42		58	
11		27		43		59	
12		28		44		60	
13		29		45		61	
14		30		46		62	
15		31		47		63	
16		32		48		64	

Item	Description	Supported SB	Supported SW
OK	Closes “CPU RUN status of each station” window.	-	-
Self station information	Displays self station information of MELSECNET/H module. For details, refer to “(1) Other station monitor window”.	SB0044, SB0057, SB005A	SW0040, SW0041, SW0042, SW0046
CPU status	Displays the RUN/STOP status of CPU. RUN : RUN, STEPRUN STOP : STOP, PAUSE DOWN : ERROR, Not-connected station Reserved station : Reserved station	-	SW0084 - SW0087

(f) Loop status of each station

Displays the main/sub-loop status in the case of a fiber optical system.

The No. of stations to be displayed is the “Total No. of stations” set by the “Parameter Setup” window.

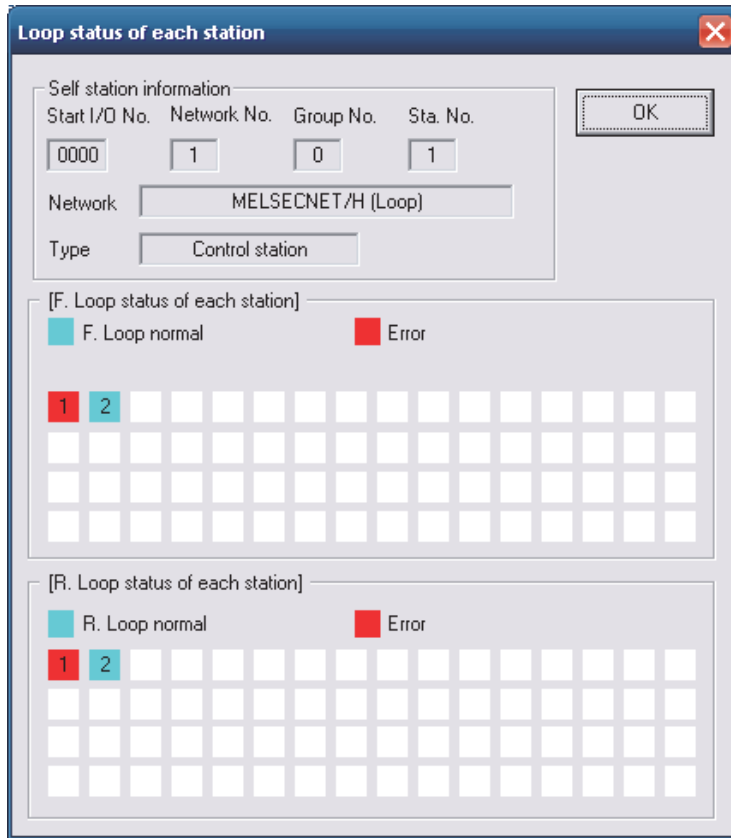

Item	Description	Supported SB	Supported SW
OK	Closes “Loop status of each station” window.	-	-
Self station information	Displays self station information of MELSECNET/H module. For details, refer to “(1) Other station monitor window”.	SB0044, SB0057, SB005A	SW0040, SW0041, SW0042, SW0046
F. Loop status of each station	Displays the main (F) loop condition in the case of a fiber optical system using the following colors. Light blue : Normal, reserved station, Not-connected station Red : Error	-	SW0091 - SW0094
R. Loop status of each station	Displays the sub (F) loop condition in the case of a fiber optical system using the following colors. Light blue : normal, reserved station, Not-connected station Red : Error	-	SW0095 - SW0098

(g) Reserved station designation of each station

Displays the setting status of a reserved station

The No. of stations to be displayed is the “Total No. of stations” set by the “Parameter Setup” window.

Item	Description	Supported SB	Supported SW
OK	Closes “Reserved station designation of each station” window.	-	-
Self station information	Displays self station information of MELSECNET/H module. For details, refer to “(1) Other station monitor window”.	SB0044, SB0057, SB005A	SW0040, SW0041, SW0042, SW0046
Reserved station designation of each station	Displays the Reserved station designation of each station using the following colors. Light blue : Not-reserved station Blue : Reserved station	-	SW0064 - SW0067

(h) PSU operation status of each station extension

Displays the supply status of external 24V DC power supply for a MELSECNET/H module.
The No. of stations to be displayed is the “Total No. of stations” set by the “Parameter Setup” window.

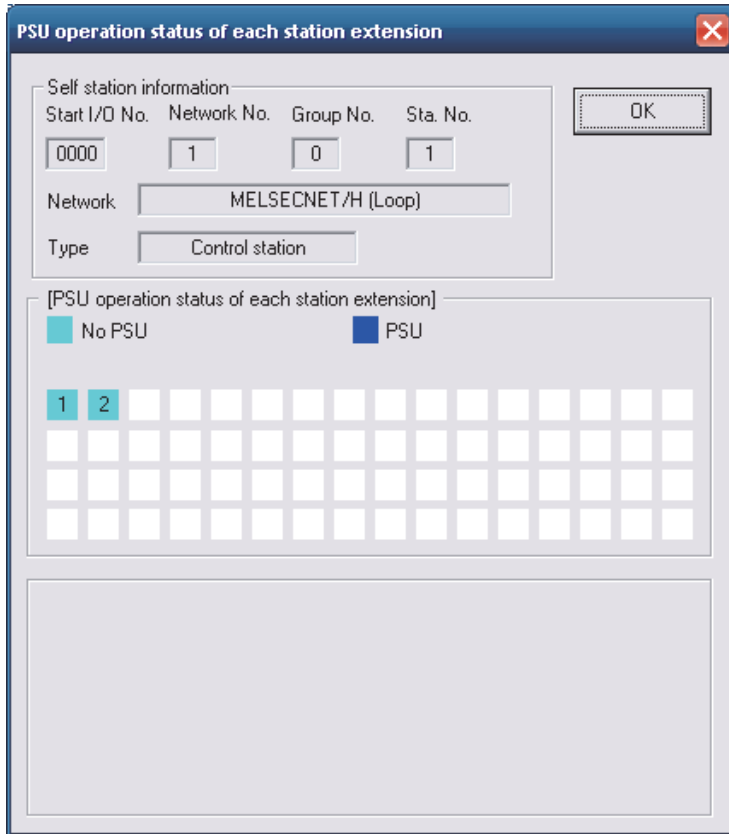

Item	Description	Supported SB	Supported SW
OK	Closes “PSU operation status of each station extension”.	-	-
Self station information	Displays self station information of MELSECNET/H module. For details, refer to “(1) Other station monitor window”.	SB0044, SB0057, SB005A	SW0040, SW0041, SW0042, SW0046
PSU operation status of each station extension	Displays the PSU operation status of each station extension using the following colors. Light blue : No external power supply Blue : External power supply available	-	SW008C - SW008F

(i) Each station network type status

Displays consistency between the network type set to the control station and the one set to normal stations.
The No. of stations to be displayed is the “Total No. of stations” set by the “Parameter Setup” window.

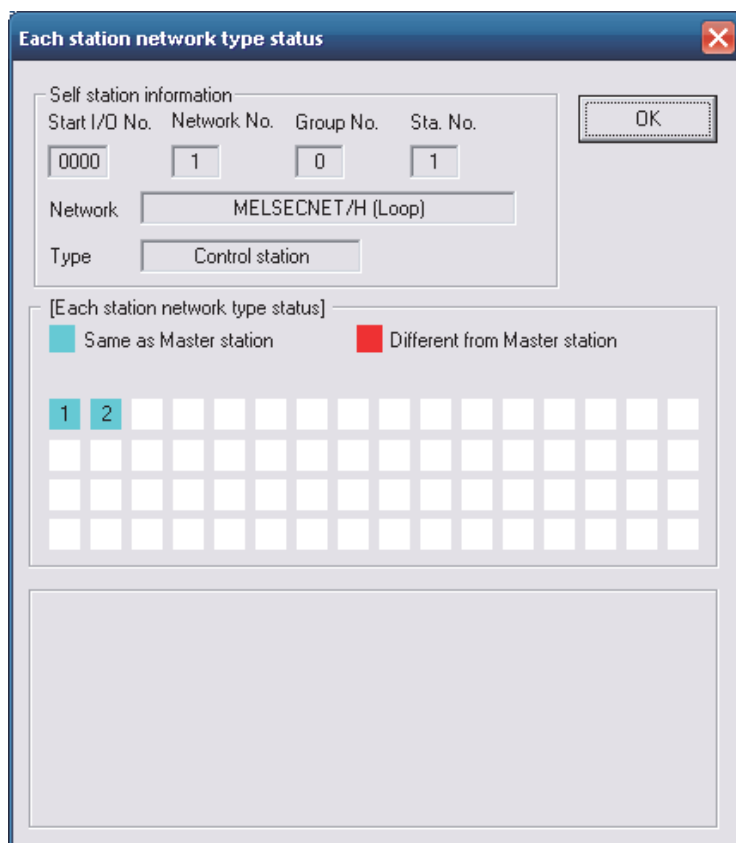

Item	Description	Supported SB	Supported SW
OK	Closes “Each station network type status” window.	-	-
Self station information	Displays self station information of MELSECNET/H module. For details, refer to “(1) Other station monitor window”.	SB0044, SB0057, SB005A	SW0040, SW0041, SW0042, SW0046
Each station network type status	Displays consistency between the network type set to the control station and the one set to normal stations using the following colors. Light blue : Normal station, reserved station and communication fault station, having the same network type as the control station. Red : Normal station having a network type different from that of the control station.	-	SW01E0 - SW01E3

5.5.5 Operating the Online Operation Window

This window is used to read, write and compare MELSECNET/H parameters.

Point

Operation on this window is not possible while the bus interface driver's resetting is in progress.
Perform operation after the reset operation is complete.

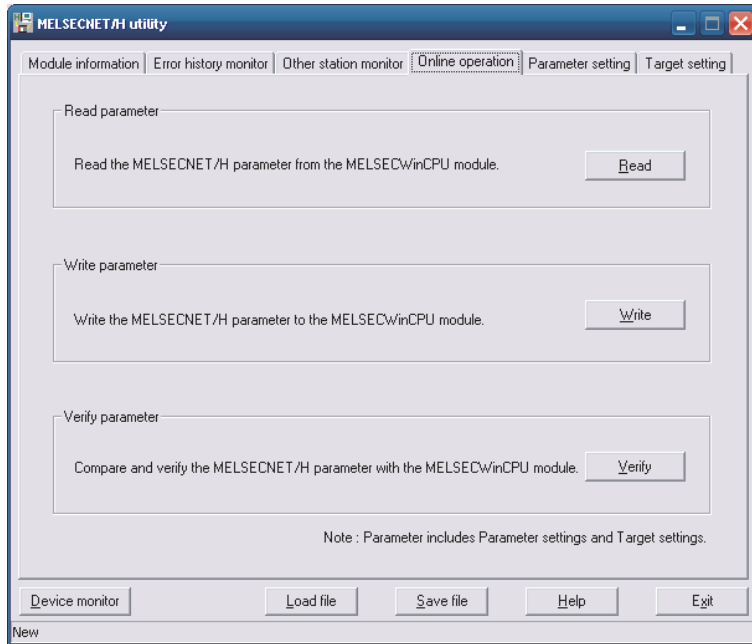

Item	Description
Read parameter Read	Read MELSECNET/H parameter from MELSECWinCPU module.
Write parameter *1 Write	Write MELSECNET/H parameter to MELSECWinCPU module. The written parameter is enabled when MELSECWinCPU module is reset.
Verify parameter Verify	Compares the MELSECNET/H parameter of MELSECWinCPU module with the MELSECNET/H parameter of MELSECNET/H utility. The comparison result appears in a message box.

*1 : Writing of parameters is available only by the administrator's authority.

5.5.6 Operating on Routing Parameter Setting Window

Performs Parameter setting of MELSECNET/H module.

Point

- (1) If the entered parameters are mistaken, the warning message is displayed when the screen transitions to another window, and the screen does not switch to another window. Correct the mistakes in the entered parameters, and then switch over the window.
- (2) To reflect the settings in a MELSECWinCPU module, write the parameters using the “Online Operation” window and reset the MELSECWinCPU module.
- (3) Adjust a link device refresh cycle so that it is always over the maximum value for all links refresh time.
Relational expression:
(Maximum value of all links refresh time) < (link device refresh cycle)
For more details on max. value of total link fresh time refer to “5.5.2 Operating the Module Information Window”.

(1) Parameter setting window

The screenshot shows the 'Parameter setting' window of the MELSECNET/H utility. The window is divided into several sections:

- Module information:** Shows 'Modules: 2', 'No. of modules: Blank : No setting', and 'Link device refresh cycle: 100 ms'. There is a 'Routing parameter' button.
- Operational setting:** Includes 'Target module: 2', 'Slot', 'Start I/O No.: 0070', 'Refresh parameters', 'Check', and 'Default' buttons. It also has 'Network No.: 1', 'Group No.: 0', 'Mode: Online', 'Network type: MNET/H mode (Control station)', and 'Return: Return as control station'.
- Network range assignment:** Shows 'Total stations: 2', 'Assignment method: Start/End', 'Monitoring time: 200 * 10ms', and 'Switch screens: LB/LW setting'.
- Send range for each station table:**

Sta. No.	Send range for each station											
	LB			LW			Low speed LB			Low speed LW		
	Points	Start	End	Points	Start	End	Points	Start	End	Points	Start	End
1	32	0000	001F	32	0000	001F	32	2000	201F	32	2000	201F
2	32	0020	003F	32	0020	003F	32	2020	203F	32	2020	203F
- Buttons:** 'Specify I/O master Sta.', 'Specify reserved Sta.', 'Equal assignment', 'Supplementary setting', and 'Clear'.
- Footer:** 'Device monitor', 'Load file', 'Save file', 'Help', and 'Exit' buttons.

Item	Description
Modules	Sets the No. of MELSECNET/H modules managed by the MELSECWinCPU module. When “ ” (vacant) is selected, no setting is made (setting cleared). (Initial value : “ ” (vacant), setting range : 1 - 4, “ ” (vacant))
Link device refresh cycle *1	Sets a refresh cycle for a link device. (by ms unit) (Initial value : 100, setting range : 0 *2, 10 - 1000)
<u>Routing parameter</u>	Displays the Routing Parameter Setup window. For more details on this, refer to “(2) Routing Parameter setting” window.
Target module	Select the module to be set. (Initial value : 1, setting range : 1 - 4) For details about the number assigned in this item, refer to “5.3.5 (1) (a) No. to be assigned to target modules”.
Start I/O No.	Sets the start I/O No. of MELSECNET/H module. (Setting range : 0000H - 0FE0H (It should be noted that the start I/O No. set to another MELSECNET/H module cannot be duplicated.))
<u>Default</u>	Sets the operation setting and network range assignment parameters to default.
<u>Check</u>	Check for any mistakes in the setting.
<u>Refresh parameters</u>	Displays Refresh Parameter Setting windows. For more details on this, refer to “(3) Refresh parameter setting” window.
Operational setting	
Network type	Sets the type of MELSECNET/H module. (Initial value : “MNET/H mode (control station)”, setting range : “MNET/H mode (control station)”, “MNET/H mode (normal station)”, “MNET/10 mode (control station)”, “MNET/10 mode (normal station)”, “MNET/H extended mode (control station)”, “MNET/H extended mode (normal station)”)
Network No.	Sets a network No. for a MELSECNET/H module. (Initial value : 1, setting range : 1 - 239)
Group No.	Sets Group No. of MELSECNET/H module. (Initial value : 0, setting range : 0 - 32)
Mode	Sets a mode for a MELSECNET/H module. (Initial value : “online”, setting range : “online”, “offline”, “Main loop test”, “Sub-loop test”, “Inter-station test (initiating station)”, “Inter-station test (target station)”)
Return	Sets return for the control station. This item can be set when “MNET/H mode (control station)”, “MNET/10 mode (control station)”, or “MNET/H extended mode (control station)” is selected for “Network type”. (Initial value : “Return as the control station”, setting range : “Return as a control station”, “Return as a normal station”)

*1 : For the link device refresh cycle setting, refer to “Section 8.2.12 (1) Increasing a link device refresh cycle value” or “Section 8.2.12 (2) Reducing a link device refresh cycle value”.

*2 : If 0 is set to the link device refresh cycle setting, refresh will not execute, all the refresh parameter settings will be deleted, and the Refresh parameter button will be disabled.

Item	Description
Network range assignment	
Total stations	Sets the total No. of stations (including the control station) for the target network. (Initial value: 2, setting range: 2 - 64)
Assignment method	Switches the device range input method to points/start, or to start/end. (Initial value : "Start/End", Setting range : point/start, start/end)
Switch screens	Selects a target link device for which you want to set network coverage assignment. "Low-speed LB" and "Low-speed LW" can be set when "MNET/H mode (control station)" or "MNET/H extended mode (control station)" is set to "Network type". (Initial value : "LB/LW setting", Setting range : "LB/LW setting", "LX/LY setting (1)", "LX/LY setting (2)")
Points	Sets link device points to be assigned to a target station. This item can be set when "Points/Start" is set to "Assignment method". (Initial value : " (vacant), setting range : refer to "(1)(a) network coverage assignment setting range".
Start	Sets the first among link devices to be assigned to a target station. (Initial value : " (vacant), setting range : refer to "(1)(a) Network coverage assignment setting range".
End	Sets the last among link devices to be assigned to a target station. This item can be set when "Start/End" is set to "Assignment method". (Initial value: " (vacant), setting range : refer to "(1)(a) Network coverage assignment setting range".
Monitoring time	Sets monitoring time of link scan time. (by 10ms unit) (Initial value : 200, setting range : 1 - 200)
Specify I/O master station	Sets the selected station as the link device (LX/LY) I/O master station, or cancels that setting. This button can be used when "LX/LY setting (1)" or "LX/LY setting (2)" is set to "Window change".
Specify reserved station	Sets the selected station as a reserved station, or cancels the setting.
Equal assignment	Displays Equal assignment window For more details on this, refer to "(4) Equal assignment window".
Supplementary setting	Displays Supplementary setting window. For more details on this, refer to "(5) Supplementary setting window".
Clear	Deletes the settings for "Points", "Start" and "End" and sets "Total No. of stations" and "Monitoring time" to default.

(a) Network coverage assignment setting range

Network coverage assignment setting range is as follows :

Device station		Point/start/end	Setting range
LX		point	16 - 8192 *1
		start	0000 _H - 1FF0 _H *1
		end	000F _H - 1FFF _H *2
LY		point	16 - 8192 *1
		start	0000 _H - 1FF0 _H *1
		end	000F _H - 1FFF _H *2
When “network type” is “MNET/Hmode (control station)”, “MNET/H extended mode (control station)” *3	LB	point	16 - 16384 *1
		start	0000 _H - 3FF0 _H *1
		end	000F _H - 3FFF _H *2
	LW	point	1 - 16384
		start	0000 _H - 3FFF _H
		end	0000 _H - 3FFF _H
	Low Speed LB	point	16 - 8192 *1
		start	2000 _H - 3FF0 _H *1
		end	200F _H - 3FFF _H *2
	Low Speed LW	point	1 - 8192
		start	2000 _H - 3FFF _H
		end	2000 _H - 3FFF _H
When “network type” is “MNET/10 mode (control station)” *3	LB	point	16 - 8192 *1
		start	0000 _H - 1FF0 _H *1
		end	000F _H - 1FFF _H *2
	LW	point	1 - 8192
		start	0000 _H - 1FFF _H
		end	0000 _H - 1FFF _H

*1: Only a multiple of 16 can be set to the “Points” and “Start” of LX, LY, and LB.

*2: Only (a multiple of 16 minus 1) can be set to the “End” of LX, LY, and LB.

*3: “Network type” is set on the “Parameter setting” window.

For more details on this, refer to “(1) Parameter setting window”.

(2) Routing parameter setting window

Set a transfer destination, relay destination network No., and relay destination station No.

Point

MELSECNET/H modules managed by the MELSECWinCPU module cannot be used as relay stations that work as bridges.

For relay stations, use MELSECNET/H modules managed by a programmable controller CPU that can configure a multiple-network system.

Item	Description
Transfer to network No.	Sets Transfer to network No. (Initial value : “ (vacant), setting range : 1 - 239)
Intermediate network No.	Sets Intermediate network No. (Initial value : “ (vacant), setting range : 1 - 239)
Intermediate station No.	Sets Intermediate station No. (Initial value : “ (vacant), setting range : 1 - 64)
Channel No.51 - 54	Sets the maximum transmission size per channel to be conveyed in transient transmission through a MELSECNET/H module to another network No. *1 (Initial value: 480 words, setting range: 960 words, 480 words)
Clear	Clears the settings for “Transfer destination network No.,” “Relay destination network No.,” and “Relay destination station No.”.
Check	Checks setting for “Transfer to network No.,” “Intermediate network No.” and “Intermediate station No.”.
End	Closes Routing parameter setting window with saving the setting description.
Cancel	Closes Routing parameter setting window without saving the setting description.

*1 : Set the value to 960 words only when relay and target stations in transient transmission through another network No. are MELSEC-Q Series supported network modules.

Otherwise set the value to 480 words. If 960 words are set, normal transient transmission may not be possible because data can be cut off.

(3) Refresh parameter setting window

Performs refresh parameter setting window.

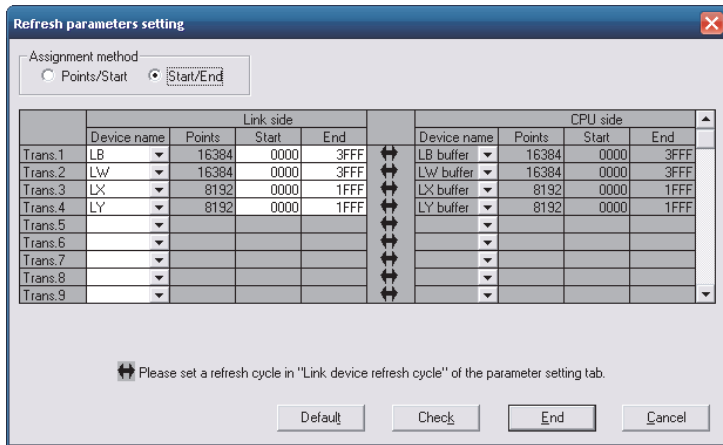

Item		Description
Assignment method		The device range input method can be switched between Points/Start and Start/End. (Initial value : "Start/End")
Link side	Device name	Sets the name of a link device to be refreshed. Refresh parameters can be set to a maximum of 64 devices. Avoid overlapping when setting. Devices cannot overlap one another. (Initial value : Refer to "(3)(a) Initial value of "Device name", "Point", "Start" and "End", Setting range : Refer to "(3)(b) "Device name" on link and CPU side).
	Points	Sets points for a link device to be refreshed. (Initial value : Refer to "(3)(a) Initial value of "Device name", "Point", "Start" and "End", Setting range : Refer to "(3)(c) Setting range of "Point", "Start" and "End" on link side).
	Start	Sets the first among link devices to be refreshed. (Initial value : Refer to "(3)(a) Initial value of "Device name", "Point", "Start" and "End", Setting range : Refer to "(3)(c) Setting range of "Point", "Start" and "End" on link side).
	End	Sets the last among link devices to be refreshed. (Initial value : Refer to "(3)(a) Initial value of "Device name", "Point", "Start" and "End", Setting range : Refer to "(3)(c) Setting range of "Point", "Start" and "End" on link side).
CPU side	Device name	Displays the names of devices to be refreshed by a CPU module in one-to-one correspondence with settings on the "Link side." (Display range : Refer to "(3)(b) "Device name" on link and CPU side).
	Points	Displays the points for devices to be refreshed on the CPU side. Displays the same "Points" as the ones on the "Link side".
	Start	Displays the start for devices to be refreshed on the CPU side. Displays the same "Start No." as the ones on the "Link side".
	End	Displays the end for devices to be refreshed on the CPU side. Displays the same "End No." as the ones on the "Link side".
Default		Changes the settings on both "Link side" and "CPU side" to default.
Check		Performs an error check on the settings on both "Link side" and "CPU side".
End		Close "Refresh Parameter setting" window with saving the setting description.
Cancel		Close "Refresh Parameter setting" window without saving the setting description.

- (a) Initial values for “Device name”, “Points”, “Start” and “End”

Initial values for “Device name”, “Points”, “Start” and “End” is as follows.

Setting item	Device name	Points	Start	End
Transfer 1	LB	16384	0000H	3FFFH
Transfer 2	LW	16384	0000H	3FFFH
Transfer 3	LX	8192	0000H	1FFFH
Transfer 4	LY	8192	0000H	1FFFH
Transfer 5 - transfer 64	“(vacant)”			

- (b) “Device name” on the “Link” and “CPU side”

The following shows the setting ranges for “Device name” on the “link side” and the displays for “Device name” on the “CPU side”.

Setting range on “Link side”	Display on “CPU side”
LX	LX buffer
LY	LY buffer
LB	LB buffer
LW	LW buffer

- (c) Setting ranges for “Points”, “Start” and “End” on the link side.

“Points”, “Start” and “End” on the link side is as follows.

(The same setting range is applied for all : “Transfer 1” - "Transfer 64".)

Device name	Points / Start / End	Setting range
LX	Points	16 - 8192 *1
	Start	0000H - 1FF0H *1
	End	000FH - 1FFFH *2
LY	Point	16 - 8192 *1
	Start	0000H - 1FF0H *1
	End	000FH - 1FFFH *2
LB	Point	16 - 16384 *1
	Start	0000H - 3FF0H *1
	End	000FH - 3FFFH *2
LW	Point	1 - 16384
	Start	0000H - 3FFFH
	End	0000H - 3FFFH

*1 : Only a multiple of 16 can be set to "Points" and "Start" of LX, LY and LB.

*2 : Only a (multiple of 16 -1) can be set to "End" of LX, LY and LB.

(4) Equal assignment window

Equally assigns link device points to all stations.

The start/end stations can be set within the range between the first and last equal assignment station No. (Total No. of links - (first station No. - 1)).

(a) When “LB/LW setting” is set to “Window change” in the “Parameter setting” window.

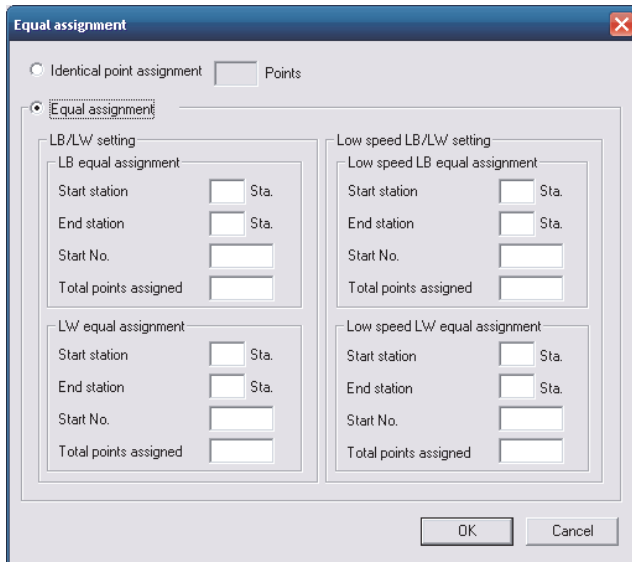

Item	Description	
Identical point assignment	Assigns the same entered points to a station's link devices respectively. (by 16 points) (Initial value : “ (vacant), Setting range : 16 or more)	
OK	Performs equal assignment according to the setting and closes the “Equal assignment” window.	
Cancel	Closes the “Equal assignment” window without performing equal assignment.	
Equal assignment	Divide and assign the entered points to a station's individual link devices so that they are assigned points equally.	
LB equal assignment	Start station	Sets the first among stations to which points are equally assigned. (Initial value : “ (vacant), setting range : 1 - (“Total No. of stations” *1 setting))
	End station	Sets the last among stations to which points are equally assigned. (Initial value : “ (vacant), setting range : (“Start station” setting) - (“Total No. of stations” *1 setting))
	Start No.	Sets the No. of the first among link devices to which points are equally assigned. (Initial value : “ (vacant), setting range : Refer to “(1)(a) network coverage assignment setting range”.)
	Total points assigned	Sets the total No. of points for link devices to which points are equally assigned. (Initial value : “ (vacant), setting range : Refer to “(1)(a) network coverage assignment setting range”.)
LW equal assignment	Sets the method for LW equal assignment. Sets items the same way as in “LB equal assignment”.	
Low speed LB equal assignment	Sets the method for Low speed LB equal assignment. Sets items the same way as in “LB equal assignment”.	
Low speed LW equal assignment	Sets the method for Low speed LW equal assignment. Sets items the same way as in “LB equal assignment”.	

*1 : “Total No. of stations” is set from “Network coverage assignment” on the “Parameter Setup” window.

For more details on this, refer to “(1) Parameter setting window”.

- (b) When “LX/LY setting (1)” or "LX/LY setting (2)" is set to “Window change” in the “Parameter setting” window.

Item	Description	
Identical point assignment	Assigns the same entered points to a station's link devices respectively. (Every 16 points) (Initial value : “ (vacant), setting range : 16 or more)	
OK	Performs equal assignment according to the setting and closes the “Equal assignment” window.	
Cancel	Closes the “Equal assignment” window without performing equal assignment.	
Equal assignment	Divide and assign the entered points to a station's individual link devices so that they are assigned points equally.	
M station -> L station equal assignment	Start station	Sets the first among stations to which points are equally assigned. (Initial value : “ (vacant), setting range : 1 - (“Total No. of stations” *1 setting))
	End station	Sets the last among stations to which points are equally assigned. (Initial value : “ (vacant), setting range : (“Start station” setting) - (“Total No. of stations” *1 setting))
	Start No.	Sets the No. of the first among link devices to which points are equally assigned. (Initial value : “ (vacant), setting range : Refer to “(1)(a) Network coverage assignment setting range”.)
	Total points assigned	Sets the total No. of points for link devices to which points are equally assigned. (Initial value : “ (vacant), setting range : “Refer to (1)(a) Network coverage assignment setting range”.)
M station <- L station equal assignment	Sets the method for LX(1) or LX(2) equal assignment. Sets items the same way as in “M station->L station equal assignment”.	

*1 : “Total No. of stations” is set from “Network coverage assignment” on the “Parameter setting” window.

For more details on this, refer to “(1) Parameter setting window”.

(5) Supplementary setting window

The supplementary setting is used for more detailed operation.
Normally, use it by default.

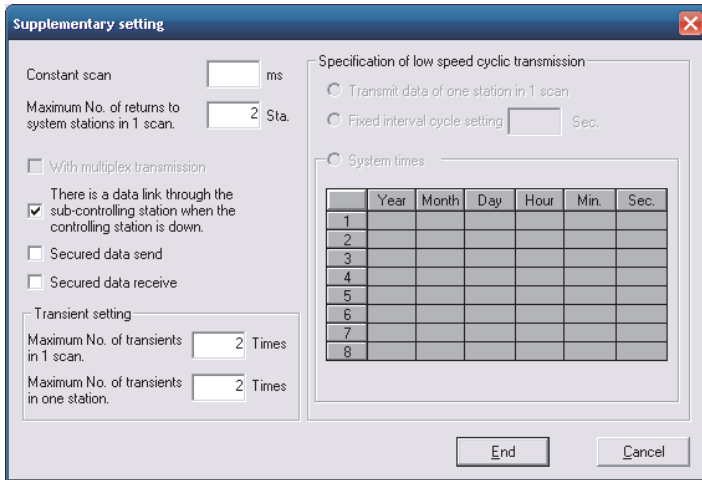

Item	Description
Constant scan	Constant link scan is the function to keep link scan time at a certain level. It shall be set to avoid fluctuations in link scan time. (by ms unit) (Initial value : “ (vacant), setting range : 1 - 500, “ (vacant))
Maximum No. of returns to system stations in 1 scan.	Sets the No. of communication fault stations that can return during a one-link scan. (Initial value : 2, setting range : 1 - 64 (“Total No. of stations” *1 setting))
With multiplex transmission	Sets when performing the multiplex transmission function. Multiplex transmission is the function to increase transmission speed by simultaneously using both main and sub loops, when they operate normally, in a fiber optical loop system. This item can be set only when 4 or over are set to the “total No. of stations” *1 setting. (Initial value : No checking (Do not execute))
There is a data link through the sub-controlling station when the controlling station is down.	This item shall be set when using the control station switchover function - the function to make another normal station in the network continue communication as a substitute (sub control station) if the specified control station is disconnected due to failure, etc. (Initial value : Checking (Use control switchover function))

*1 : “Total No. of stations” is set from “Network coverage assignment” on the “Parameter Setup” window.

For more details on this, refer to “(1) Parameter setting window”.

Item		Description
Secured data send		This item is set to prevent Integrity Loss Prevention*2 (maintain integrity) of a station's link data in cyclic transmission.*3 This makes it possible to manipulate data of multiple words without interlock. Note that the above prevention*2 is effective only for link device refresh processing between MELSECWinCPU module and MELSECNET/H module. (Initial value : refer to “(5) (a) Default values for transmit data with station data integrity assurance specified/receive data with station data integrity assurance specified”).
Secured data receive		
Transient setting	Maximum No. of transients in 1 scan.	Set the No. of transient transmissions (total on a whole network) that can be executed by one network during 1 link scan. (Initial value: 2, setting range: 1 - 255)
	Maximum No. of transients in one station	Set the No. of transient transmissions that can be executed by one station during 1 link scan. (Initial value : 2, setting range : 1 - 10 (Setting for the “maximum No. of transient times per scan”))
Specification of low speed cyclic transmission		Beside normal cyclic transmission, sets the condition for low cycle transmission (low-speed cyclic transmission) of link data (LB, LW). This item can be set only when “Low-speed LB” and “Low-speed LW” of “Network coverage assignment” are set on the “Parameter Setup” window.
Transmit data of one station in 1 scan		Select this item when sending the data of one station to another station in 1 link scan.
Fixed interval cycle setting		Low speed cyclic transmission is performed in the specified cycles. (Initial value : “ (vacant), setting range : 1 sec - 65535 sec)
System times		Low speed cyclic transmission is performed according to the set time. (Initial value : “ (vacant), setting range : 00:00:00 Jan 1, 2000 - 23:59:59 Dec 31, 2099 *4)
End		Close the “Supplementary setting” window with the setting description.
Cancel		Close the “Supplementary setting” window without the setting description.

*2 : Securing consistency means preventing the 2-word (32 bits) link data, such as the current value of the positioning module, from being divided into new and old data in units of 1 word (16 bits) due to the cyclic transmission timing. The link device refresh processing between MELSECWinCPU module and MELSECNET/H module is set on the “Refresh Parameter Setting” window. For more details on this, refer to “(3) Refresh Parameter setting window”.

*3 : If this item is marked for station data integrity assurance, set “Link device refresh cycle” in the “Parameter Setting” window (refer to “(1) Parameter Setting window”) and set “Refresh parameter” in the “Refresh Parameter Setup” window (refer to “(3) Refresh parameter setting window”).

*4 : “Hour,” “Minute,” and “Second” cannot be omitted. If “Year,” “Month,” and “Day” are omitted, transmission is executed at the predetermined time every day. If only “Year” and “Month” are omitted, transmission is executed at the predetermined time every month. If only “Year” is omitted, transmission is executed at the predetermined time every year.

- (a) Default values for transmit data with station data integrity assurance specified/receive data with station data integrity assurance specified

The default values are as follows depending on the network type (refer to “(1) Parameter Setting window”).

Network type	Initial value
MNET/H mode (control station)	“Not specified” for both transmission and reception.
MNET/10 mode (control station)	
MNET/H extended mode (control station)	“Specified” for both transmission and reception.

5.5.7 Operating the Target Setting Window

This operation sets the Logical Sta. No. for access to a multiple CPU system.

Point

- (1) To reflect the settings in a MELSECWinCPU module, write the parameters using the “Online Operation” window and reset the MELSECWinCPU module.
- (2) Set a programmable controller CPU as the Target CPU.

(1) Target setting

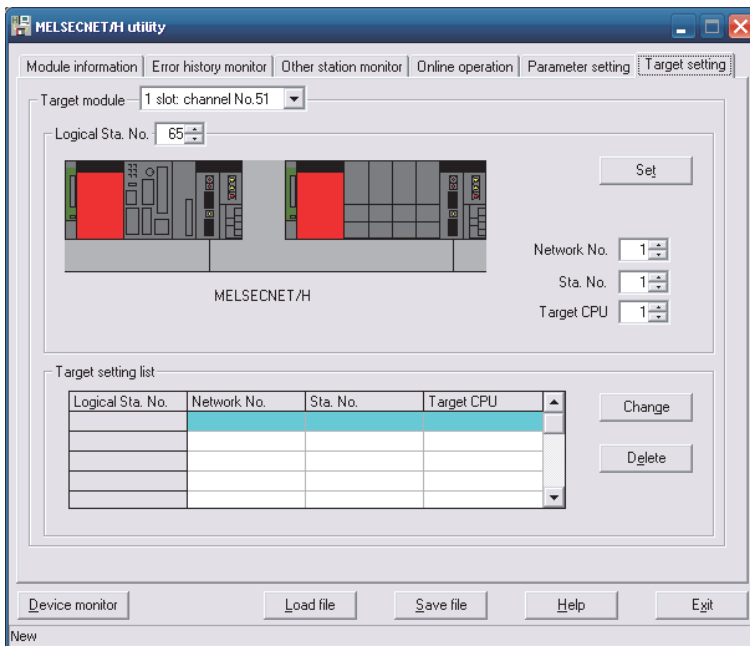

Item	Description
Target module	Select the module to be set. (Initial value : "1 slot", setting range : "1 slot" - 4 slot)
Logical Sta. No. *1	Specify the Logical Sta. No. of the module selected in "Target module". (Initial value : 65, setting range : 65 - 239)
Network No.	Sets the network No. of the MELSECNET/H module controlled by the multiple CPU system. (Initial value : 1, setting range : 1 - 239)
Sta. No.	Sets the Sta. No. of the MELSECNET/H module controlled by the multiple CPU system. (Initial value: 1, setting range: 1 - 120)
Target CPU *2	Sets the target CPU which is being accessed (CPU No. of multiple CPU system). (Initial value : 1, setting range : 1 - 4)
Set	Registers the setting contents (Logical sta., Network No., Sta. No., Target CPU) in the list of external devices.
Target setting list	Displays a list of the Logical Sta. No. set to the module selected in "Target module" and the corresponding Sta. No. and target CPUs.
Change	Displays the data in the row (Logical Sta. No.) selected in the Target setting list in the Logical Sta. No. area. (The same operation is performed when the line being changed is double clicked.)
Delete	Deletes the line (Logical Sta. No.) selected in the Target setting list.

*1 : The Logical Sta. No. is a logical No. specified as the "Sta. No." in the Device monitor utility or user program (MELSEC data link function).

Use the Logical Sta. No. when accessing another station CPU (another CPU No. in the multiple CPU system) from the target module (channel No.).

When accessing a CPU module controlling another station (station 1 to 64) or a MELSECNET/H module of another station, do not use the Logical Sta. No. but a Sta. No. used by MELSECNET/H.

*2 : The target CPU can be set only when the CPU module set to "Sta. No." is the one that can configure a multiple CPU system.

(2) Example of access

When Logical Sta. No. "65" is used, it is possible to access CPU No.4 via a MELSECNET/H module (controlled by CPU No.2, Network No.1) from the MELSECNET/H module controlled by the MELSECWinCPU module.

From the Device monitor utility or user program (MELSEC data link function), CPU No.4 can be accessed by opening Channel No.51 and specifying 65 as the Sta. No.

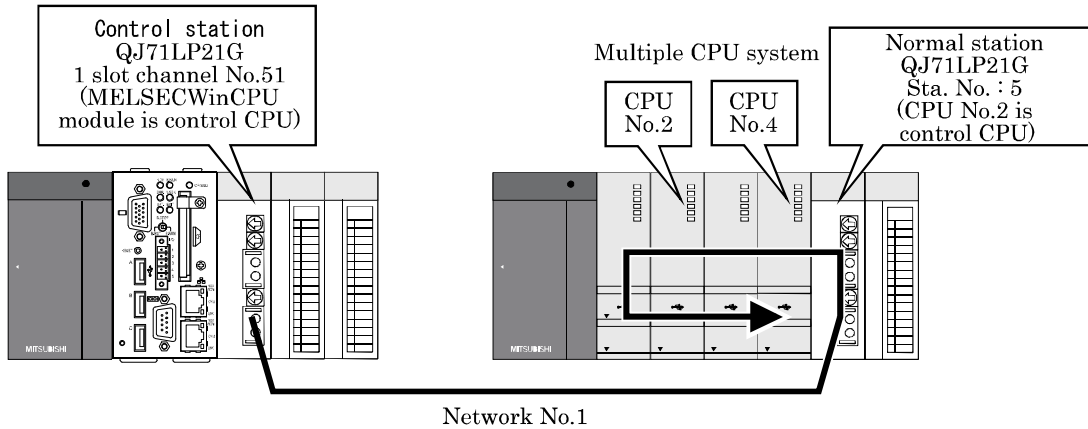

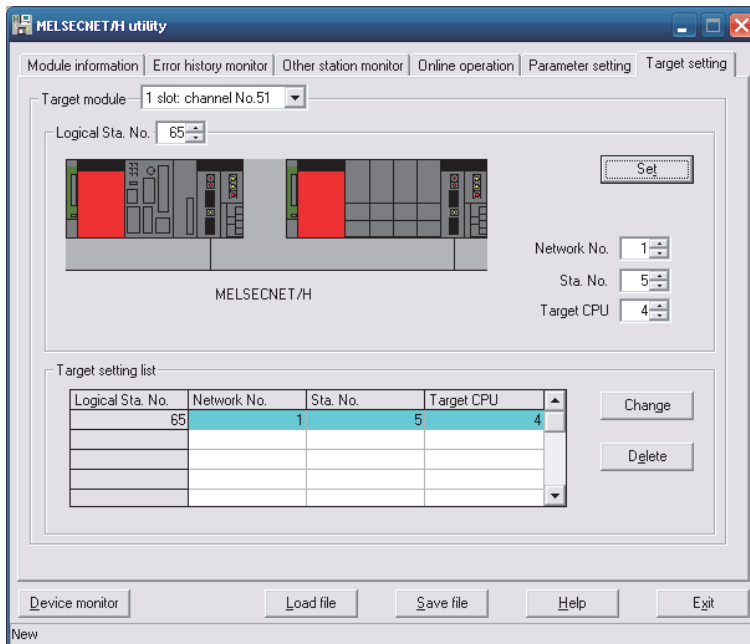

The target window for the above access is shown below.



5.5.8 Operating the System Menu

(1) System menu

There are three ways, listed below, to open and use the system menu for the MELSECNET/H utility.

- Right-click on the title bar.
- Click icon () on the title bar.
- Press the  key after pressing  key.

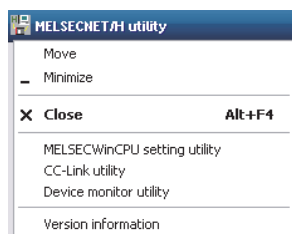

Item	Description
Move, minimize, close	Refer to the Microsoft® Windows®'s manual.
MELSECWinCPU setting utility	Move the MELSECWinCPU setting utility
CC-Link utility	Starts the CC-Link utility.
Device monitor utility	Starts the device monitor utility.
Version information	Opens the "Version information" window. For details on this, refer to "(2) Version information window".

(2) Version information window

Version information of MELSECNET/H utility is as follows :

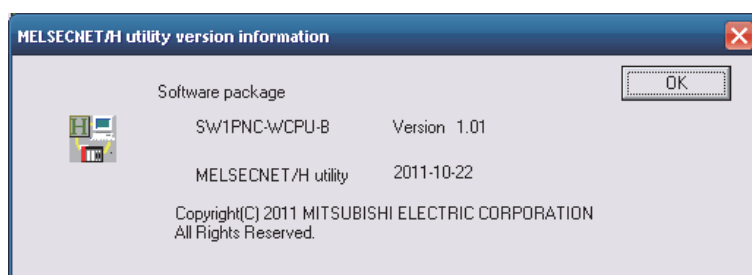

Item	Description
Software package SW1PNC-WCPU-B	Displays SW1PNC-WCPU-B version.
MELSECNET/H utility	Displays the date of MELSECNET/H utility
	Close "Version information" windows.

5.6 Device Monitor utility

This section describes operations for device monitor utility.

5.6.1 Functional List of Device Monitor Utility

A list of the Device Monitor utility's functions is as follows.

Name	Description	Referring Paragraph
Batch monitoring	Monitors only one type of device specified.	5.6.2
16-point mode monitoring	Monitors a maximum of five (5) bit-devices and one (1) word-device simultaneously.	5.6.3
Sets a target to be monitored.	Sets a network for which the Device Monitor utility is used.	5.6.4
Monitored device setting	Selects a target device to be monitored.	5.6.5
Word device value change	Changes the data of the specified word device.	5.6.6
Continuous word device value change	Changes data by the No. of points set to the specified word device.	5.6.7
Bit device ON/OFF	Turns ON/OFF the specified bit device.	5.6.8
Display format change	Changes the display format for device monitoring.	5.6.9
Numeric input pad	Enters a No. through mouse operation.	5.6.10

5.6.2 Specifying batch monitor

Monitors only one device that has been specified.

Point

It cannot be monitored while the bus interface driver is reset.
Start monitoring after the reset is completed.

(1) Selecting the menu

Select [Menu] - [Batch monitor] from the menu bar.

(Selectable for 16- point register monitor only.)

Batch monitoring is displayed immediately after the device monitor is launched.)

Set a device to be monitored from [Settings] - [Device Setup] in the menu bar.

For details, refer to “Section 5.6.5 Specifying device to be monitored”.

(2) Display window

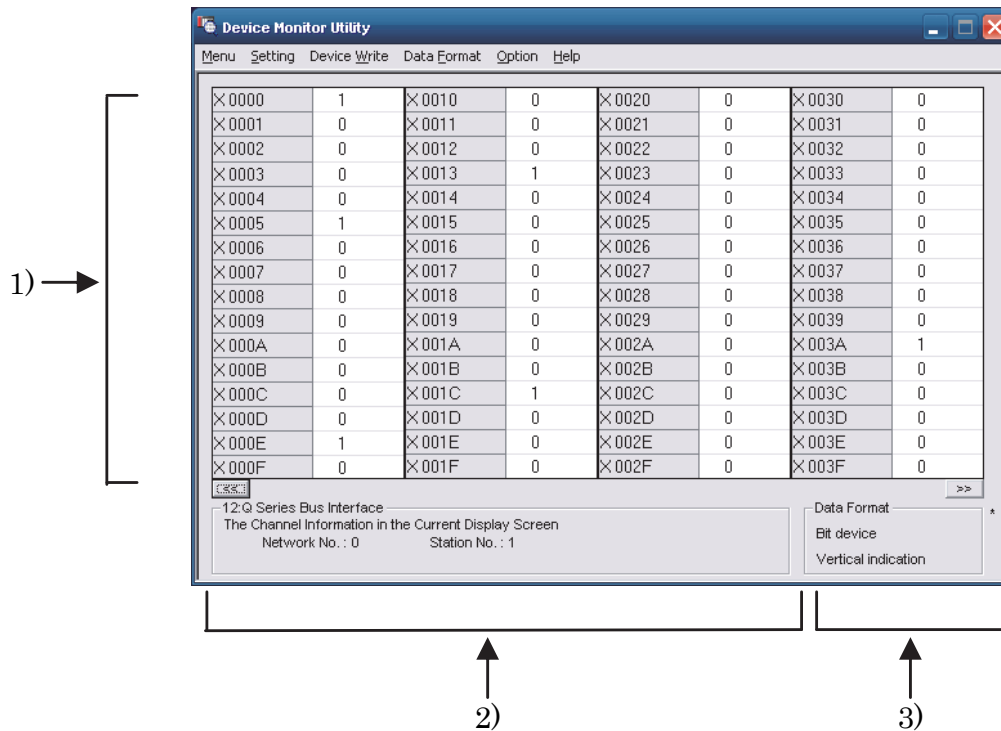

Item	Description
1) Device information	Displays the current device status. For changing the display form, refer to “5.6.9 Switching Display Form”.
2) Network status	Displays the current network status. For setting the network, refer to “5.6.4 Specifying monitor target”.
3) Display method	Displays the device type (word device, bit device) and its form. For changing the device type, refer to “5.6.5 Specifying device to be monitored”. For changing the display form, refer to “5.6.9 Switching Display Form”.

5.6.3 Specifying 16- point Register Monitor

Monitors up to five bit devices and one word device simultaneously.

<p>Point</p>	<p>It cannot be monitored while the bus interface driver is reset. Start monitoring after the reset is completed.</p>
---------------------	---

(1) Selecting the menu

Select [Menu] - [16- point register monitor] from the menu bar.

(Selectable only for batch monitoring)

Sets device to monitor by selecting [Settings] - [Device settings] from the menu bar.

For more details on this, refer to “5.6.5 Specifying device to be monitored”.

(2) Display window

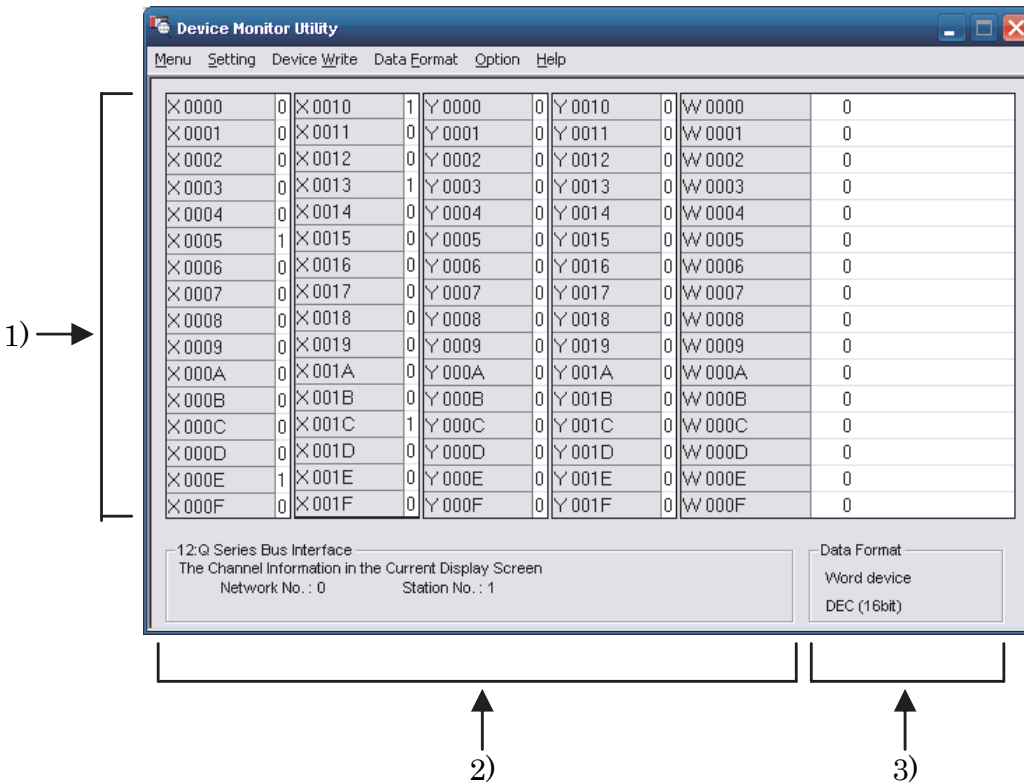

Item	Description
1) Device information	Displays the current device status. For changing the display form, refer to “5.6.9 Switching Display Form”.
2) Network status	Displays the current network status. For setting the network, refer to “5.6.4 Specifying monitor target”.
3) Display method	Displays the device type (word device, bit device) and its form. For changing the device type, refer to “5.6.5 Specifying device to be monitored”. For changing the display form, refer to “5.6.9 Switching Display Form”.

5.6.4 Specifying monitor target

Sets the network to be used for device monitoring.

Set the destination when starting the device monitor utility.

Point
(1) When local is selected in the network setting, as the network status, “0” is displayed in the network No. field, and “255” is displayed in the Sta. No. field.
(2) To access a multiple CPU system, select another station, enter “0” to the network No. field, and enter the value of “Logical Sta. No.” set by each utility.

(1) Selecting the menu

Select [Setting] - [Network Setting] from the menu bar.

(2) Dialog box

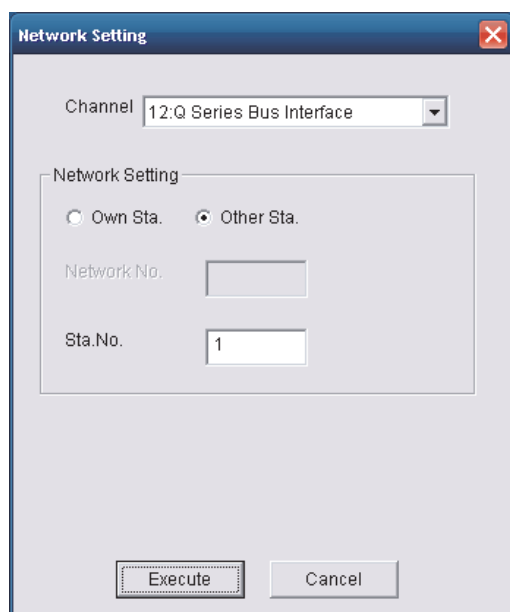

Item	Description
Channel	Set the channel to be used. For more details on this, refer to “6.5 Channel”.
Network Setting	Set the own Sta. and other Sta. along with network No. and Sta. No. For more details on this, refer to “6.6 Sta. No. Setting”.

5.6.5 Specifying device to be monitored

Set the device to be monitored.

Point	<p>Devices that can be monitored through 16-point mode monitoring are devices that can be randomly accessed.</p> <p>If a device that cannot be randomly accessed is specified, a device type error (-3) occurs.</p> <p>For whether or not devices can be randomly accessed, refer to “Chapter 7 Accessible Range - Device”.</p>
--------------	---

(1) Selecting the menu

Select [Setting] - [Device setting] from the menu bar.

(2) Dialog box

Batch monitor

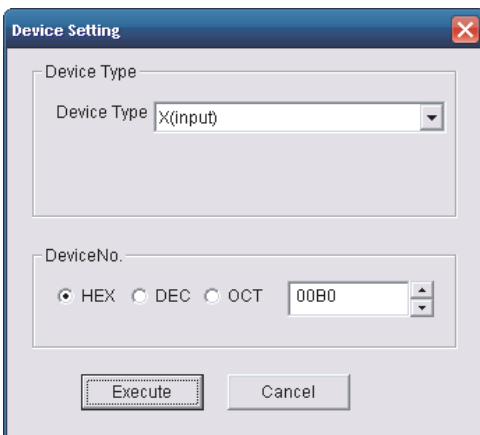

16-point register monitor

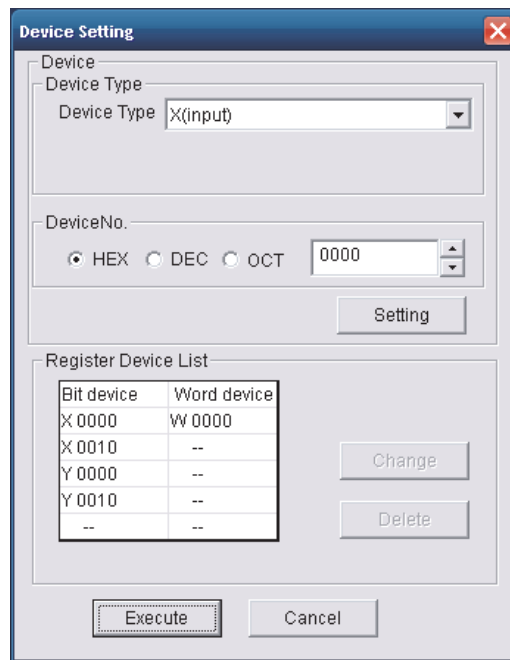

Item	Description
Device Type	Set the type, block No., and network No. for the device to be monitored. For more details on this, refer to “6.7 Device Type”.
DeviceNo.	Set the start No. of the device to be monitored. (HEX: hexadecimal, DEC: decimal, OCT : octal)
Register Device List	Device List Displays a list of the devices entered.
Setting	Enters the item set in Device type and Device No., then adds it to List of devices entered.
Change	Select the device to be changed and click this button to change the entered data.
Delete	Select the device to be deleted and click this button to delete it from List of devices entered.

5.6.6 Changing Word Device Values

Changes the specified word device data.

<p>⚠ WARNING</p>	<p>To perform control (data change) of the MELSECWinCPU module during operation, configure an interlock circuit on the user program so that the whole system runs safely at all times.</p> <p>To perform other control (change in the running status (status control)) of the MELSECWinCPU module during operation, also configure an interlock circuit on the user program so that the whole system runs safely at all times.</p> <p>Especially, when performing the above control of a remote MELSECWinCPU module from an external device, a problem occurring at the MELSECWinCPU module due to abnormal data communication may not be addressed immediately.</p> <p>In addition to configuring an interlock circuit on a user program, determine a system method between the external device and MELSECWinCPU module in case of abnormal data communication.</p>
-------------------------	--

(1) Selecting the menu

Select [Device write] - [Data changing] from the menu bar.

(2) Dialog box

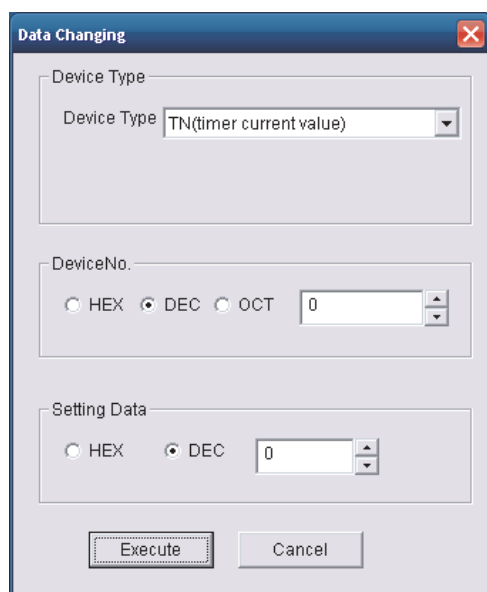

Item	Description
Device Type	Set the type, block No. and network No. for the device for which data is to be changed. For more details on this, refer to "6.7 Device Type".
DeviceNo.	Set the start No. of the device for which data is to be changed. (HEX : hexadecimal, DEC : decimal, OCT : octal)
Setting Data	Set the data to be changed. (HEX : hexadecimal, DEC : decimal)

5.6.7 Changing Word Device Value Continuously

Change the specified word device data for the No. of specified points being set.

<p>⚠ WARNING</p>	<p>To perform control (data change) of the MELSECWinCPU module during operation, configure an interlock circuit on the user program so that the whole system runs safely at all times.</p> <p>To perform other control (change in the running status (status control)) of the MELSECWinCPU module during operation, also configure an interlock circuit on the user program so that the whole system runs safely at all times.</p> <p>Especially, when performing the above control of a remote MELSECWinCPU module from an external device, a problem occurring at the MELSECWinCPU module due to abnormal data communication may not be addressed immediately.</p> <p>In addition to configuring an interlock circuit on a user program, determine a system method between the external device and MELSECWinCPU module in case of abnormal data communication.</p>
-------------------------	--

(1) Selecting the menu

Select [Device write] - [Continuous Change in Data] from the menu bar.

(2) Dialog box

Item	Description
Device Type	Set the type, block No., and network No. of the device for which data is to be changed. For more details on this, refer to “6.7 Device Type”.
DeviceNo	Set the start No. of the device to change data. (HEX : hexadecimal, DEC : decimal, OCT : octal)
Setting Data	Set the data to be continuously changed. (HEX : hexadecimal, DEC : decimal)
Points	Set the No. of points to perform continuous change of data. (HEX : hexadecimal, DEC : decimal, OCT : octal)

5.6.8 Turning ON/OFF Bit Device

Turns on/off the specified bit device.

<p>⚠ WARNING</p>	<p>To perform control (data change) of the MELSECWinCPU module during operation, configure an interlock circuit on the user program so that the whole system runs safely at all times.</p> <p>To perform other control (change in the running status (status control)) of the MELSECWinCPU module during operation, also configure an interlock circuit on the user program so that the whole system runs safely at all times.</p> <p>Especially, when performing the above control of a remote MELSECWinCPU module from an external device, a problem occurring at the MELSECWinCPU module due to abnormal data communication may not be addressed immediately.</p> <p>In addition to configuring an interlock circuit on a user program, determine a system method between the external device and MELSECWinCPU module in case of abnormal data communication.</p>
-------------------------	--

Point

BitDeviceSet (reset) makes it possible to turn ON/OFF devices that can be randomly accessed. If a device that cannot be randomly accessed is turned ON/OFF, a device type error (-3) occurs. For information about the availability of random access support for each device, refer to “Chapter 7 Accessible Range and Devices”.

(1) Selecting the menu

Select [Device write] - [Bit device setting (resetting)] from the menu bar.

(2) Dialog box



Item	Description
Device Type	Sets the type, block No. and network No. of the bit device to be turned on/off. For more details on this, refer to “6.7 Device Type”.
DeviceNo.	Sets the No. of the bit device to be turned on/off. (HEX : hexadecimal, DEC : decimal, OCT : octal)

5.6.9 Switching Display Form

Switches the device monitoring display to the selected form.

The batch monitor and 16- point register monitor have different sets of selectable menus, respectively.

(1) Selecting the menu

Select [Data Format] - [Word(Bit) device] from the menu bar.

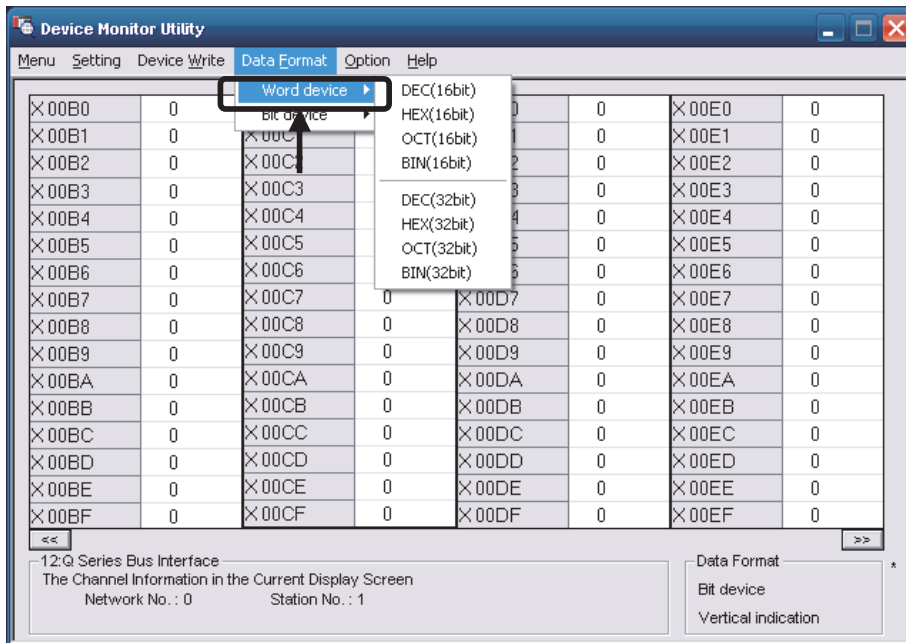

5.6.10 Numerical Pad

A numerical pad is available for setting device values and other numeric parameters. To display the numerical pad, select [Options] - [Numerical Pad] from the menu bar.

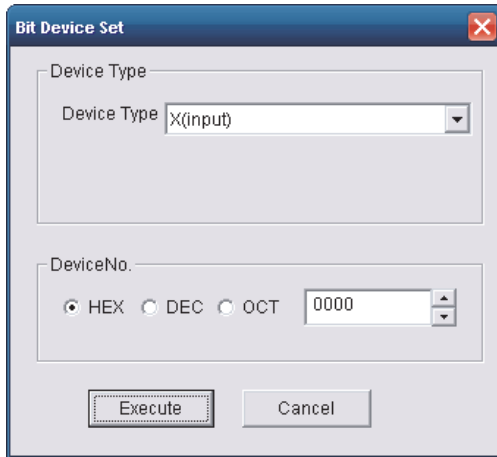

1. Click inside the numeric value input field.

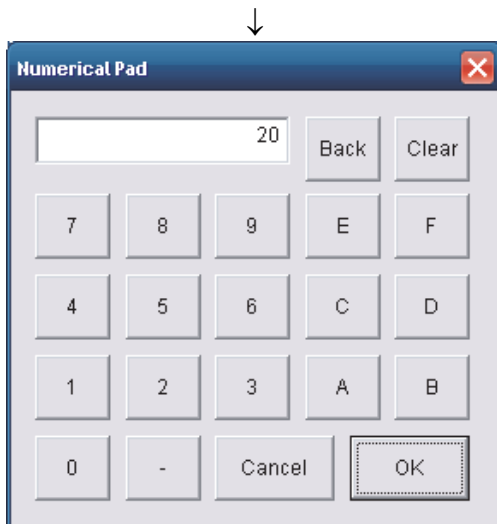

2. The numerical pad is displayed. Use the buttons to enter a desired value and then click the **OK** button.

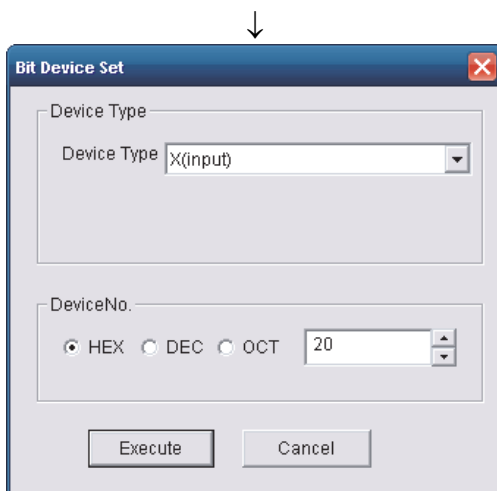

3. The value is entered in the system.

5.6.11 Other Operations

Double-clicking the device No. on the screen while monitoring changes data in word device and turns on/off the bit device.

(1) Word device

The following explains how to change the word device. (Only when the display form is 16 bit.)

 WARNING	To perform control (data change) of the MELSECWinCPU module during operation, configure an interlock circuit on the user program so that the whole system runs safely at all times.
	To perform other control (change in the running status (status control)) of the MELSECWinCPU module during operation, also configure an interlock circuit on the user program so that the whole system runs safely at all times.
	Especially, when performing the above control of a remote MELSECWinCPU module from an external device, a problem occurring at the MELSECWinCPU module due to abnormal data communication may not be addressed immediately.
	In addition to configuring an interlock circuit on a user program, determine a system method between the external device and MELSECWinCPU module in case of abnormal data communication.

W 0000	0
W 0001	0
W 0002	0
W 0003	0

1. Double-click the No. of the word device to be changed.

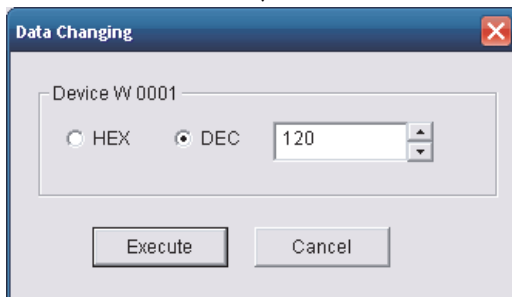

2. The dialog box shown left is displayed. Set a desired value and click the **Execute** button.

*: When the display format is 32bits, "Data change (32 bits)" is displayed on the title.

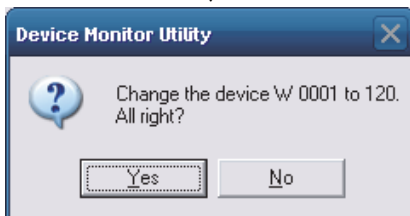

3. The dialog box shown left is displayed. Select **Yes** button if the change is acceptable. Select **No** button to cancel the operation.

(2) Bit device

The following explains how to turn on/off the bit device.

However, this operation is available only when the display orientation is "Vertical Indication".

<p>⚠ WARNING</p>	<p>To perform control (data change) of the MELSECWinCPU module during operation, configure an interlock circuit on the user program so that the whole system runs safely at all times.</p> <p>To perform other control (change in the running status (status control)) of the MELSECWinCPU module during operation, also configure an interlock circuit on the user program so that the whole system runs safely at all times.</p> <p>Especially, when performing the above control of a remote MELSECWinCPU module from an external device, a problem occurring at the MELSECWinCPU module due to abnormal data communication may not be addressed immediately.</p> <p>In addition to configuring an interlock circuit on a user program, determine a system method between the external device and MELSECWinCPU module in case of abnormal data communication.</p>
-------------------------	--

Point

BitDeviceSet (reset) makes it possible to turn ON/OFF devices that can be randomly accessed.

If a device that cannot be randomly accessed is turned ON/OFF, a device type error (-3) occurs.

For information about the availability of random access support for each device, refer to "Chapter 7 Accessible Range and Devices".

X 0000	0
X 0001	0
X 0002	0
X 0003	0

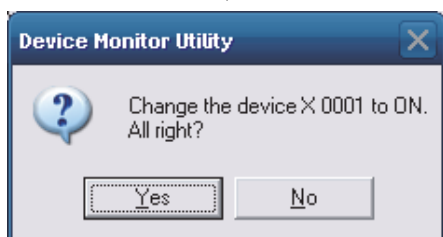

1. Double-click the No. of the bit device to be changed.

2. The dialog box shown left is displayed. Select if the change is acceptable. Select button to cancel.

6. Functions and Programming

This chapter describes bus interface functions and MELSEC data link functions provided by SW1PNC-WCPU-B.

When program examples introduced in this manual are diverted to be used in actual systems, carefully check that there will be no problem with control operation in a target system.

6.1 Outline of Functions

Use of functions provided by SW1PNC-WCPU-B is required to access to and control programmable controller CPU or the modules from the user program. The following summarizes the uses of the functions.

Function type	Use
Bus interface functions	<ul style="list-style-type: none">(1) Input/output control on input and output module controlled by MELSECWinCPU module.(2) Access to the buffer memory of intelligent function module controlled by MELSECWinCPU module.
MELSEC data link functions	<ul style="list-style-type: none">(1) Access to programmable controller CPU on the same system as MELSECWinCPU module.(2) Access to programmable controller CPUs of other Sta. via MELSECNET/H module and CC-Link utility controlled by MELSECWinCPU module.

6.2 Function List

This chapter describes bus interface functions and MELSEC data link functions bundled with SW1PNC-WCPU-B.

6.2.1 Bus Interface Function List

The following lists bus interface functions.

Function name	Function
QBF_Open	Opens the bus.
QBF_Close	Closes the bus.
QBF_X_In_Bit	Performs X 1- point input.
QBF_X_In_Word	Reads X in word unit.
QBF_X_In	Reads specified No. of bits from specified bit position of X.
QBF_Y_Out_Bit	Performs 1- point output for Y.
QBF_Y_Out_Word	Writes Y in word unit.
QBF_Y_Out	Writes specified No. of bits from specified bit position of Y.
QBF_Y_In_Bit	Inputs a Y point. Perform 1- point input for Y.
QBF_Y_In_Word	Reads Y in word unit.
QBF_Y_In	Reads the specified No. of bits from specified bit position of Y.
QBF_ToBuf	Writes to buffer memory of intelligent function module.
QBF_FromBuf	Reads from buffer memory of intelligent function module.
QBF_UnitInfo	Reads the module configuration information.
QBF_StartWDT	Sets the interval of the WDT and start up the WDT.
QBF_ResetWDT	Reset the WDT.
QBF_StopWDT	Stop the WDT.
QBF_ReadStatus	Reads MELSECWinCPU module information (LED, error, etc).
QBF_ReadStatusEx	Reads MELSECWinCPU module information (LED, error, link device refresh time etc).
QBF_ControlLED	Control LED s on MELSECWinCPU module.
QBF_Reset	Reset the bus.
QBF_WaitEvent	Wait for event interrupt from programmable controller program ((P).GINT instruction).
QBF_WaitUnitEvent	Wait for event interrupt from module.
QBF_ControlProgram	Control execution of programmable controller program.

Point

Refer to bus interface function HELP of SW1PNC-WCPU-B for details of bus interface functions.

6.2.2 MELSEC Data Link Function List

MELSEC Data Link Function List as is follows :

Function name	Function	Remarks
mdOpen	Opens communication loop.	
mdClose	Closes communication loop.	
mdSend	Performs batch write of devices.	
mdReceive	Performs batch read of devices.	
mdRandW	Writes device randomly.	
mdRandR	Reads device randomly.	
mdDevSet	Sets bit device.	
mdDevRst	Resets bit device.	
mdTypeRead	Reads the type of programmable controller CPU.	
mdControl	Remotes RUN/STOP/PAUSE.	
mdInit	Refreshes the programmable controller device address table.	
mdBdModSet	Sets mode of network module controlled by MELSECWinCPU module.	
mdBdModRead	Reads mode of network module controlled by MELSECWinCPU module.	
mdBdLedRead	Reads LED information of network module controlled by MELSECWinCPU module.	
mdBdSwRead	Reads switch status of network module controlled by MELSECWinCPU module.	
mdBdVerRead	Reads version information of network module controlled by MELSECWinCPU module.	
mdSendEx	Performs batch write of devices.	*1
mdReceiveEx	Performs batch read of devices.	*1
mdRandWEx	Writes device randomly.	*1
mdRandREx	Reads device randomly.	*1
mdDevSetEx	Sets bit device.	*1
mdDevRstEx	Resets bit device.	*1

*1 The type of argument device No. and the size has been enhanced to short -> long. Please refer to MELSEC Data Link Function HELP for a change detailed point (function specification).

Point
Refer to MELSEC data link function HELP of SW1PNC-WCPU-B for details of MELSEC data link functions.

6.3 Settings for Using Functions

This section describes settings operations for using functions.

6.3.1 Using Microsoft® Visual Studio® 2008 Visual Basic

The following shows setup operation when Visual Studio® 2008 Visual Basic is used.

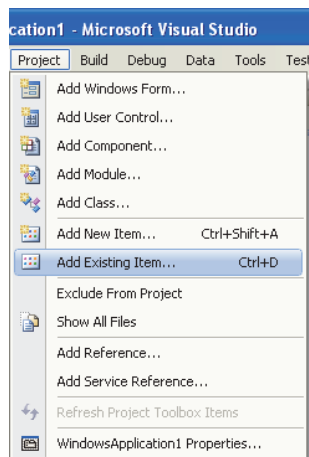

1. Start up Visual Studio® 2008 Visual Basic and select the menu item [Project] - [Add Existing Item].

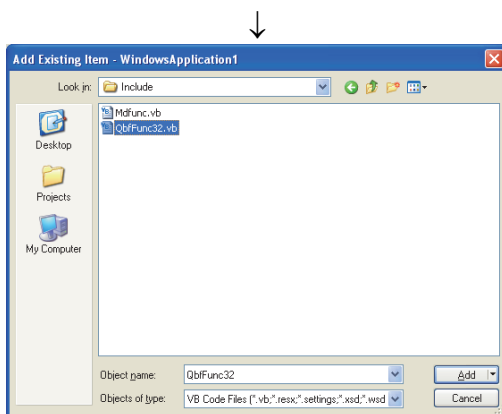

2. Select the files shown as follows.

- 1). When using bus interface function :
Select " QbfFunc32.vb".

" QbfFunc32.vb" is stored under the following folder in CD-ROM drive.

<CD-ROM drive> - <Include>

Copy it to development personal computer and use it.

- 2). When using MELSEC data link function :
Select "Mdfunc.vb".

" Mdfunc.vb " is stored under the following folder in CD-ROM drive.

<CD-ROM drive> - <Include>

Copy it to development personal computer and use it.

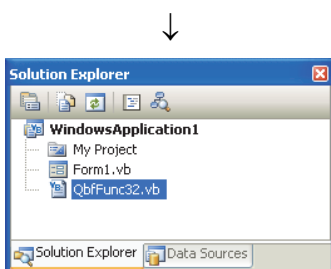

3. The added standard module is displayed in the solution explorer window.

6.3.2 Using Microsoft® Visual Studio® 2008 Visual C++

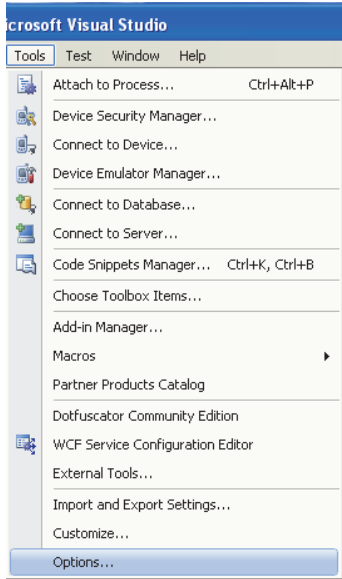

This section describes settings operations for using Visual Studio® 2008 Visual C++.

(1) Setting the include files

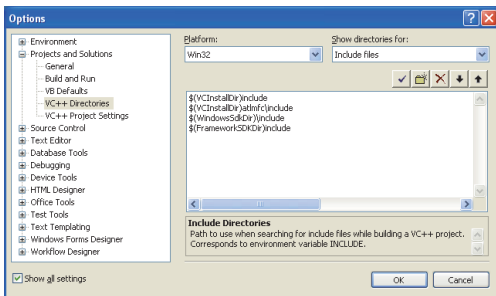

1. Start up Visual Studio® 2008 Visual C++ and select [Tools] - [Options] menu.



2. Select [Projects and Solutions] - [VC++Directries] on the navigation pane on the left, and select  (new row) button while selecting “Include files” in the “Show directories for” field in the upper right. Then clicks the  button.



(To the next page)

(From the previous pages)



3. Reference the folder where the include file is stored.

- 1). When using bus interface function :
Select a folder storing "QbfFunc32.vb"

" QbfFunc32.vb" is stored under the following folder in CD-ROM drive.

<CD-ROM drive> - <Include>

Copy it to development personal computer and use it.

- 2). When using MELSEC data link function :
Select a folder storing "Mdfunc.vb"

"Mbfunc.vb" is stored under the following folder in CD-ROM drive.

<CD-ROM drive> - <Include>

Copy it to development personal computer and use it.



4. Add "#include" at the start of a program.

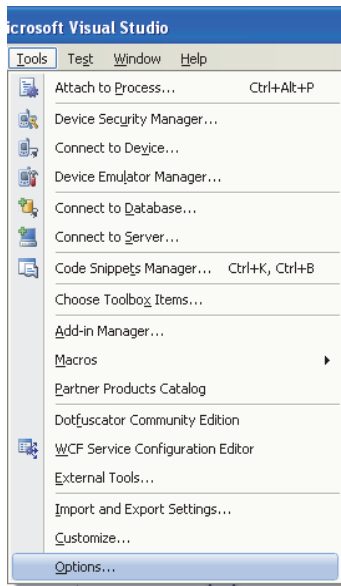

- 1). When bus interface functions are used.
Add "#include <QbfFunc32.h>" at the start of a program.
- 2). When MELSEC data link functions are used.
Add "#include < Mdfunc.h >" at the start of a program.

(2) When specifying library files

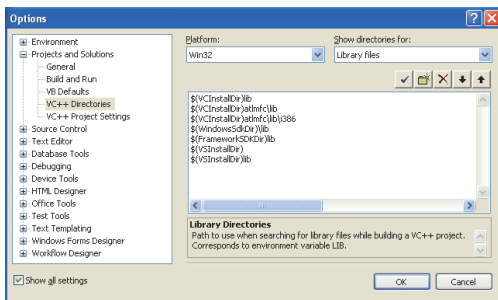

1. Start up Visual Studio® 2008 Visual C++ and select [Tools] - [Options] menu.



2. Select [Projects and solutions] - [VC++Directories] on the navigation pane on the left, and select  button while selecting “Library files” in the “Show directories for” field in the upper right. Then clicks the  button.



(To the next page)

(From the previous page)

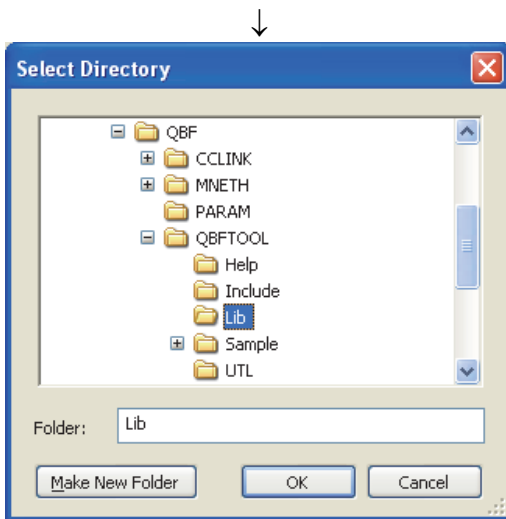

3. Refer to the folder storing the library files.

1). When using bus interface function :

Select a folder storing "QBFFunc32.lib"

" QBFFunc32.lib" is stored under the following folder in CD-ROM drive.

<CD-ROM drive> - <Lib>

Copy it to development personal computer and use it.

2). When using MELSEC data link function :

Select a folder storing "MdFunc32.lib"

" MdFunc32.lib" is stored under the following folder in CD-ROM drive.

<CD-ROM drive> - <Lib>

Copy it to development personal computer and use it.

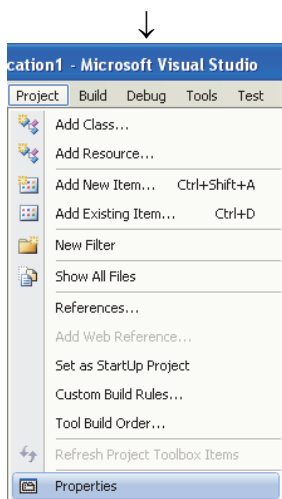

4. Open a project to create and select the menu item [Project] - [Properties].

(To the next page)

(From the previous page)

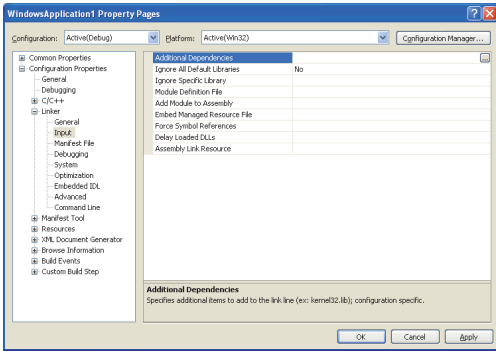

5. Select [Configuration Properties] - [Linker] - [Input] on the navigation pane on the left, and select “Additional Dependencies” and select the  button.

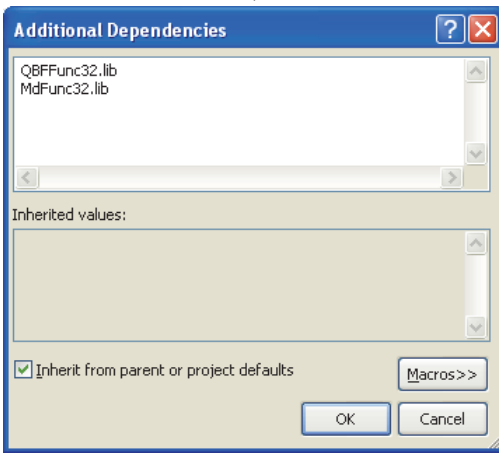

6. Enter the library file names shown as follows.
- When using bus interface function : QBFFunc32.lib
- When using MELSEC data link function : MdFunc32.lib

6.3.3 Using Microsoft® Visual Studio® 2010 Visual Basic

The following shows setup operation when Visual Studio® 2010 Visual Basic is used.

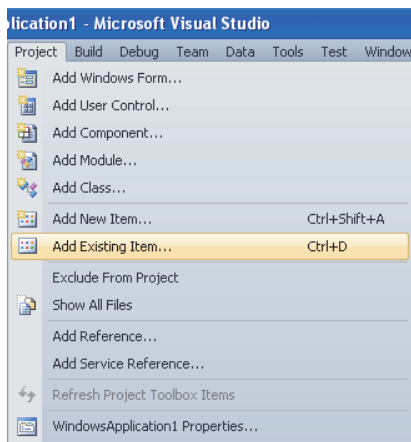

1. Start up Visual Studio® 2010 Visual Basic and select the menu item [Project] - [Add Existing Item].

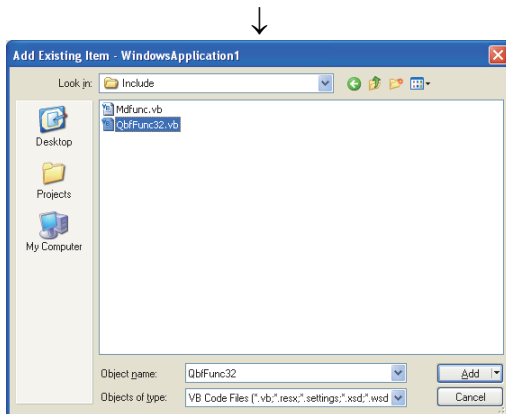

2. Select the files shown as follows.

- 1). When using bus interface function :
Select " QbfFunc32.vb".

" QbfFunc32.vb" is stored under the following folder in CD-ROM drive.

<CD-ROM drive> - <Include>

Copy it to development personal computer and use it.

- 2). When using MELSEC data link function :
Select "Mdfunc.vb".

" Mdfunc.vb " is stored under the following folder in CD-ROM drive.

<CD-ROM drive> - <Include>

Copy it to development personal computer and use it.

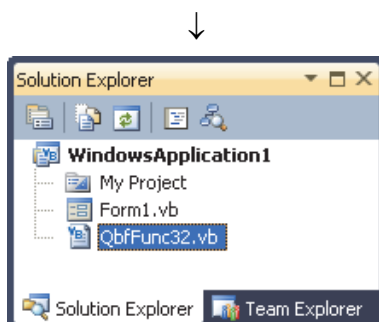

3. The added standard module is displayed in the Solution Explorer window.

6.3.4 Using Microsoft® Visual Studio® 2010 Visual C++

This section describes settings operations for using Visual Studio® 2010 Visual C++.

(1) Setting the include files

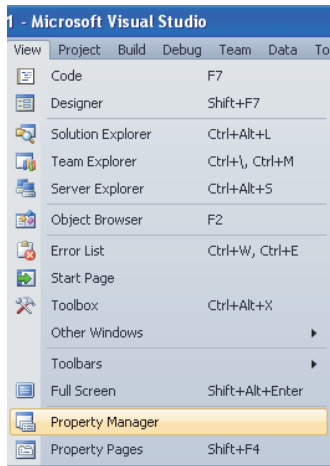

1. Open the project to make and select [View] - [Property Manager] ^{*1} menu.

*1: The configuration of menu may differ depending on development setting and custom setting.

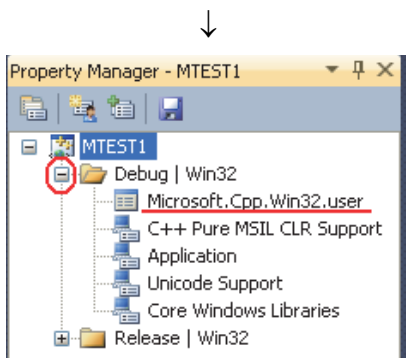

2. In [Property Manager], click the node [+] of the configuration and the platform of [Debug | Win32] and so on.

The node will be opened and the user property sheet such as Microsoft.Cpp.<Platform>.User will be shown.

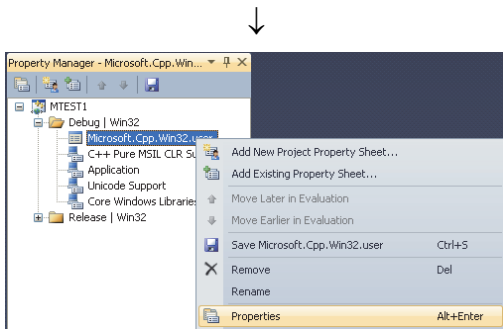

3. Right-click on user property sheet and select [Properties] of short cut menu.

[<User property sheet> Property Pages] dialog box will be shown.

(To the next page)

(From the previous page)

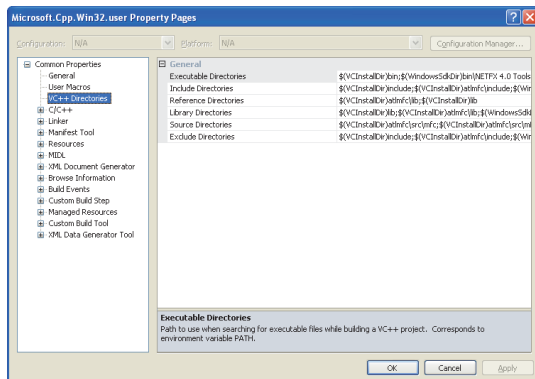

4. In [**<User property sheet> Property Pages**] dialog box, select **<Common properties>** - "**VC++ Directories**".

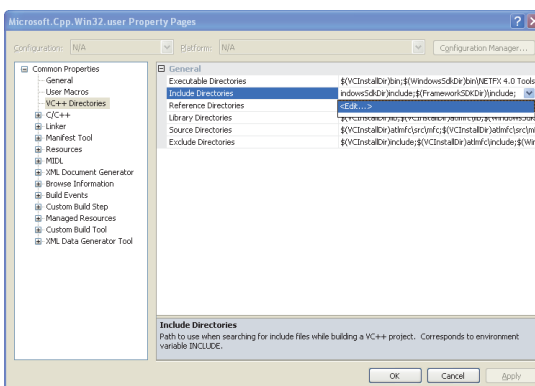

5. Select **Include Directories**. Click  and select **<Edit...>**

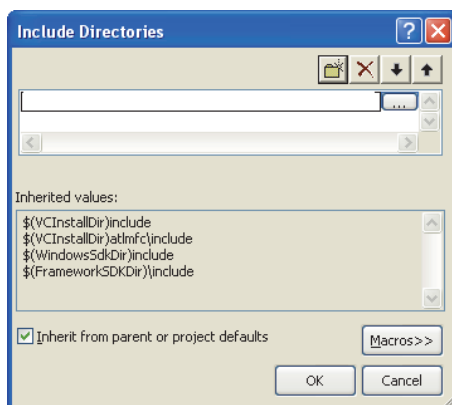

6. In **Include Directories** dialog box, click , then click .



(To the next page)

(From the previous page)

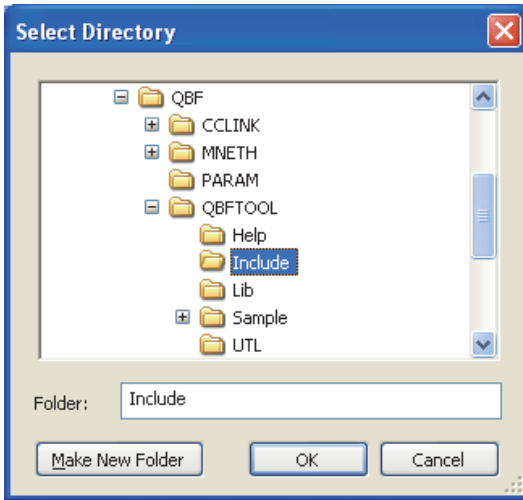

7. Reference the folder where the include file is stored in the dialog box to select a directory.

1). When using bus interface function :
Select a folder storing “QbfFunc32.h”

“ QbfFunc32.h” is stored under the following folder in CD-ROM drive.

<CD-ROM drive> - <Include>

Copy it to development personal computer and use it.

2). When using MELSEC data link function :
Select a folder storing “Mdfunc.h”

“Mbfunc.h” is stored under the following folder in CD-ROM drive.

<CD-ROM drive> - <Include>

Copy it to development personal computer and use it.



8. Add “#include” at the start of a program.

1). When bus interface functions are used.
Add “#include <QbfFunc32.h>” at the start of a program.

2). When MELSEC data link functions are used.
Add “#include < Mdfunc.h >” at the start of a program.

(2) When specifying library files

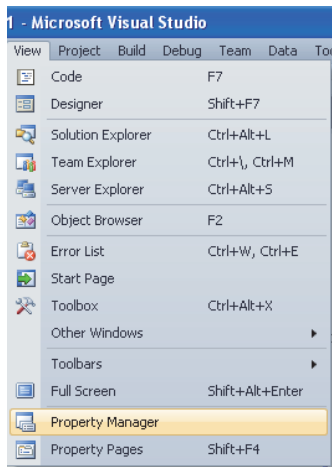

1. Open the project to make and select [View] - [Property Manager] *1 menu.

*1: The configuration of menu may differ depending on development setting and custom setting.

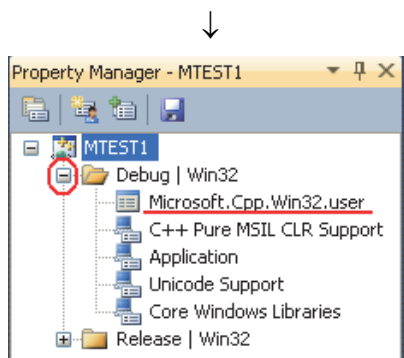

2. In [Property Manager], click the node [+] of the configuration and the platform of [Debug | Win32] and so on.

The node will be opened and the user property sheet such as Microsoft.Cpp. <Platform>.User will be shown.

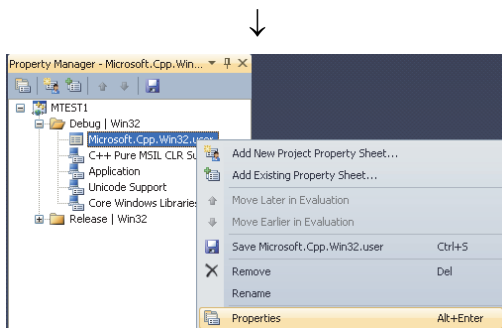

3. Right-click on user property sheet and select [Properties] of short cut menu.

[<User property sheet> Property Pages] dialog box will be shown.

(To the next page)

(From the previous pages)

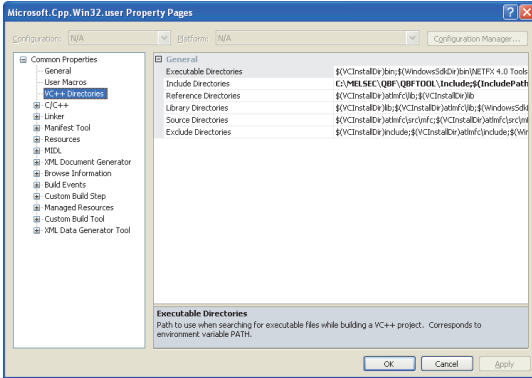

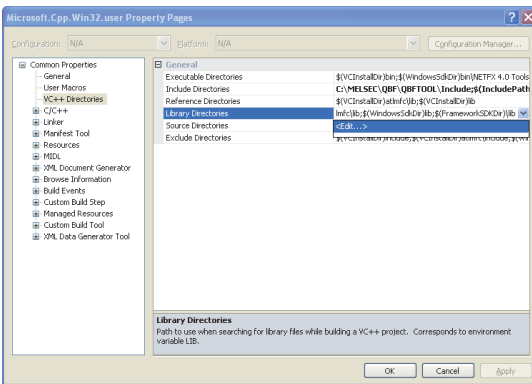

4. In [**User property sheet** Property Pages] dialog box, select **<Common properties>** - “VC++ Directories”.

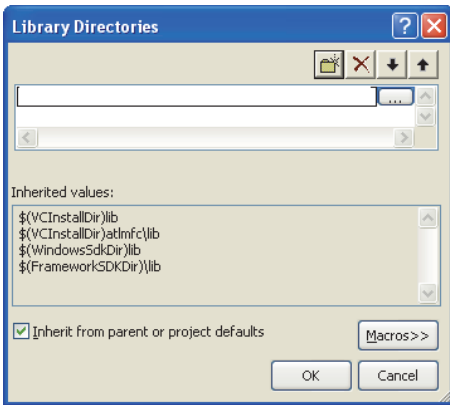

5. Select Library directories. Click  and select [**Edit...>**]



6. In Library Directories dialog box, click , then click .

(To the next page)

(From the previous pages)



7. Reference the folder where the library file is stored in the dialog box to select a directory.

1). When using bus interface function :

Select a folder storing “QBFFunc32.lib”

"QBFFunc32.lib" is stored under the following folder in CD-ROM drive.

<CD-ROM drive> - <Lib>

Copy it to development personal computer and use it.

2). When using MELSEC data link function :

Select a folder storing “MdFunc.lib”

"Mdfunc.lib" is stored under the following folder in CD-ROM drive.

<CD-ROM drive> - <Lib>

Copy it to development personal computer and use it.



(To the next page)

(From the previous pages)

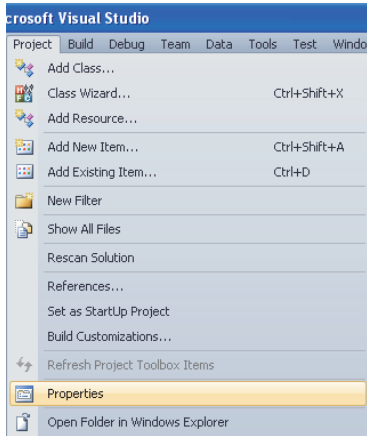

8. Open a project to create and select the menu item [Project] - [Properties].

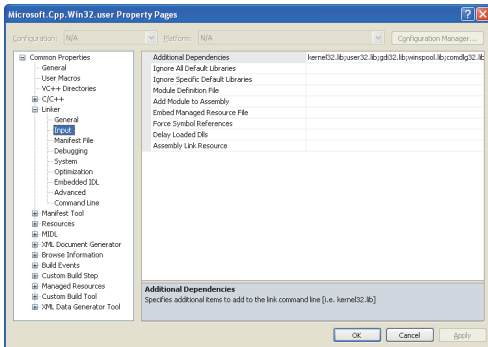

9. In [<Project> Property pages] dialog box, select <Configuration Properties> - <Linker> - “Input”.

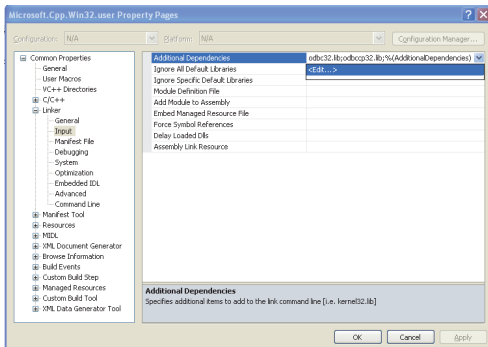

10. Select “Additional Dependencies”. Click  and select [Edit...].

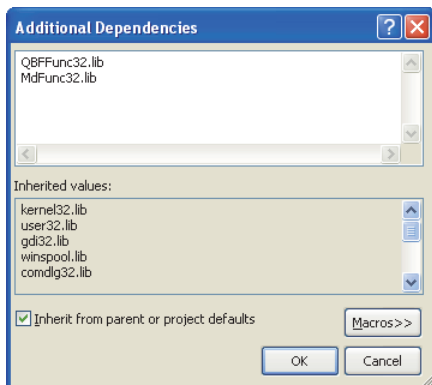

11. In Additional Dependencies dialog box, Enter the library file names shown as follows.

- When using bus interface function : QBFFunc32.lib
- When using MELSEC data link function : MdFunc32.lib

6.4 Programming Procedures

The following shows the procedures of programming with bus interface functions and MELSEC data link functions. The procedures assume that SW1PNC-WCPU-B has already been installed.

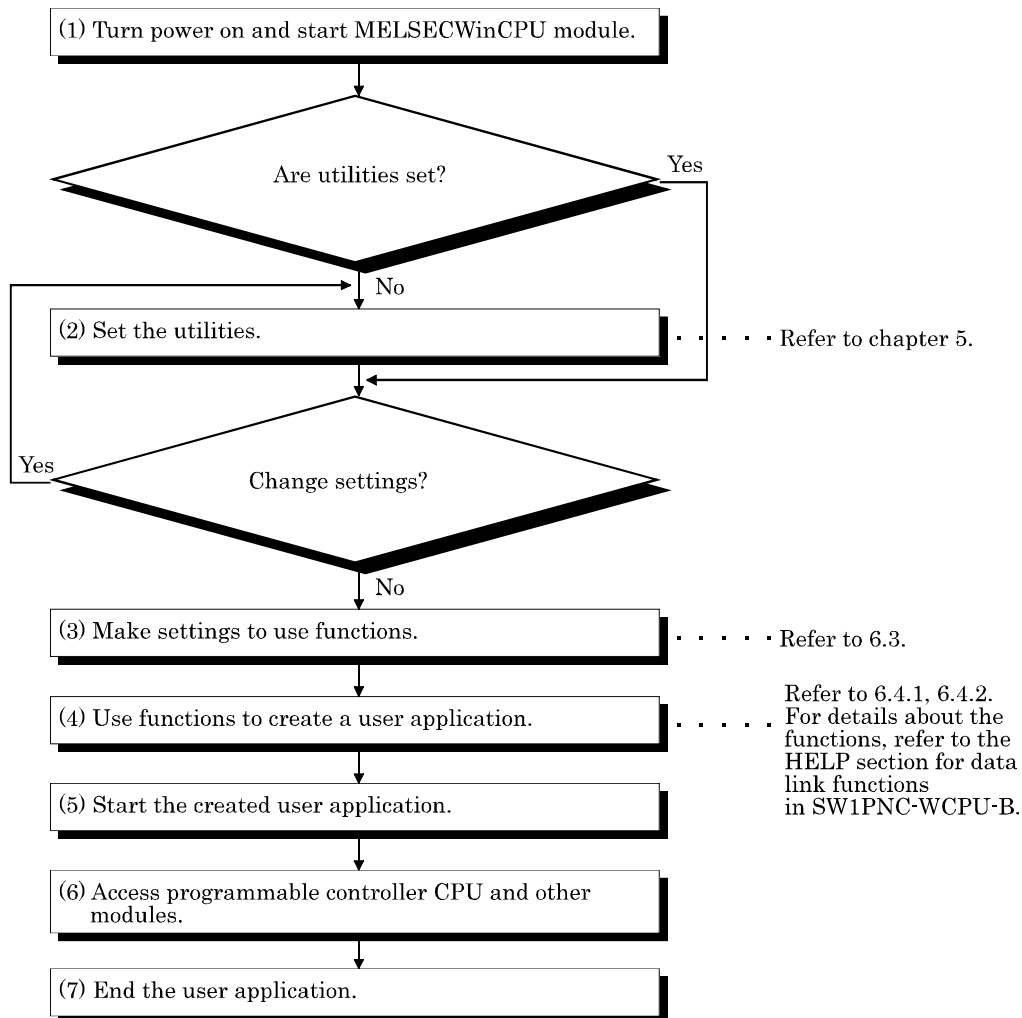

6.4.1 Using Bus Interface Function

The following shows the procedures of programming with bus interface functions.

(1) Programming outline

The following figure shows an outline of programming process using bus interface functions.

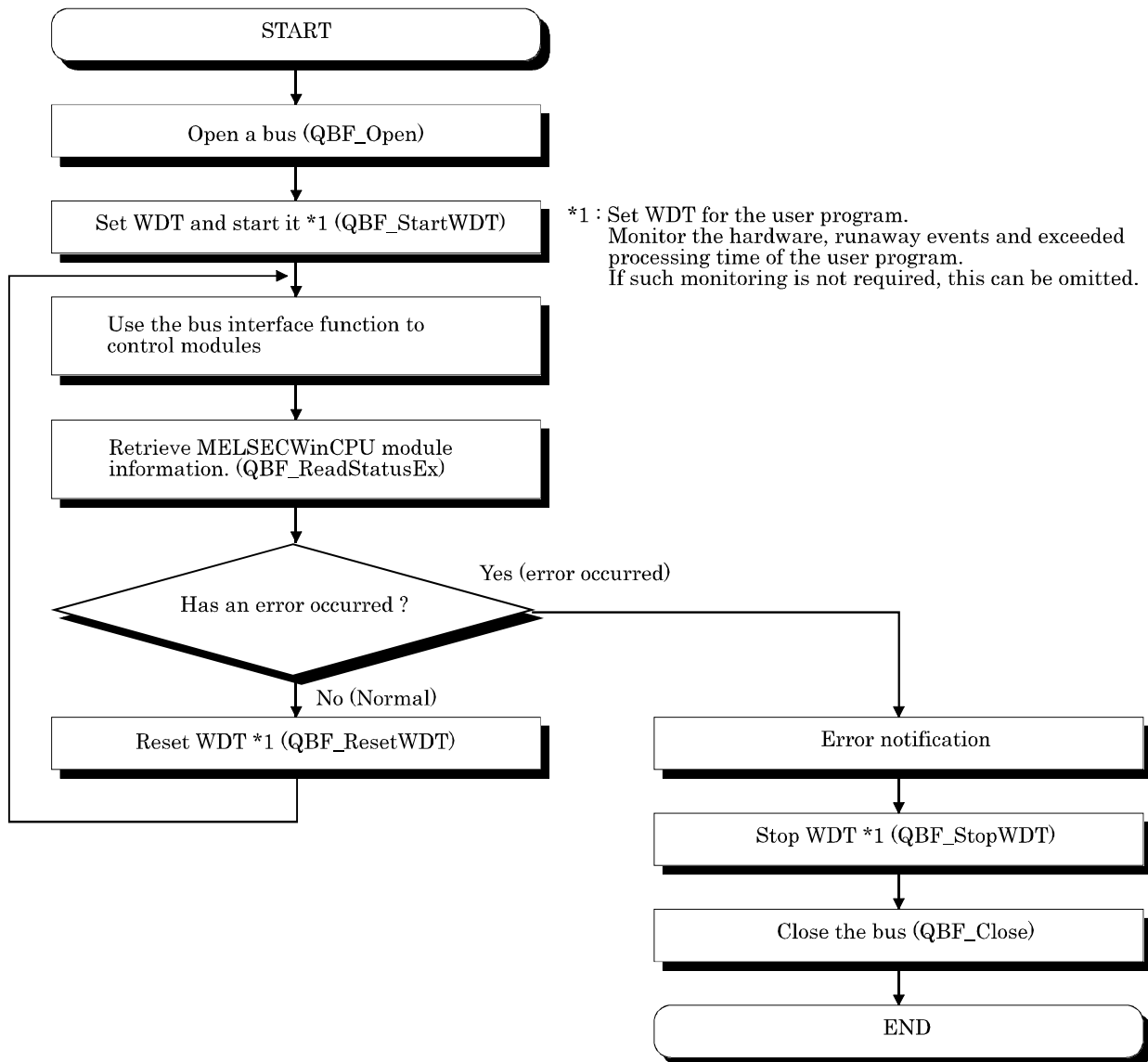

(2) Notes on using bus interface functions

Notes on programming

- a) When you use bus interface functions, you should not use global variable or static variable as the arguments for bus interface functions.

(3) Using the watchdog timer (WDT)



WDT (watchdog timer)

The WDT is used as a timer for an MELSECWinCPU module to detect hardware faults and program errors in the MELSECWinCPU module. The WDTs for MELSECWinCPU modules are divided into two types: system WDT and user WDT.

a) System WDT

The WDT is used as a timer for an MELSECWinCPU module to detect hardware faults and program errors in the personal computer CPU module. The WDTs for MELSECWinCPU modules are divided into two types: system WDT and user WDT.

When the system WDT causes a time-out, the system reacts as follows.



- 1) All the outputs of the MELSECWinCPU module are turned off.
- 2) The RDY LED, B.RUN LED goes out and the ERR. LED blinks on the front panel of the MELSECWinCPU module.
- 3) On the Module Information window of MELSECWinCPU setting utility, the system WDT error of error information turns from  (white) to  (red).

b) User WDT

The WDT is a timer used for monitoring by the user application to detect problems with user applications.

The user WDT time is set and reset by using the QBF function in the user application.

Given below are examples of using the user WDT.

- 1) Turn OFF all the outputs of the MELSECWinCPU module.
- 2) The B.RUN LED goes out and the ERR. LED blinks on the front panel of the MELSECWinCPU module.
- 3) On the Module Information window of MELSECWinCPU setting utility, the system WDT error of error information turns from  (white) to  (red).

[How to use]

Given below are examples of using the user WDT.

1) When the user WDT and communication control consist of a single application

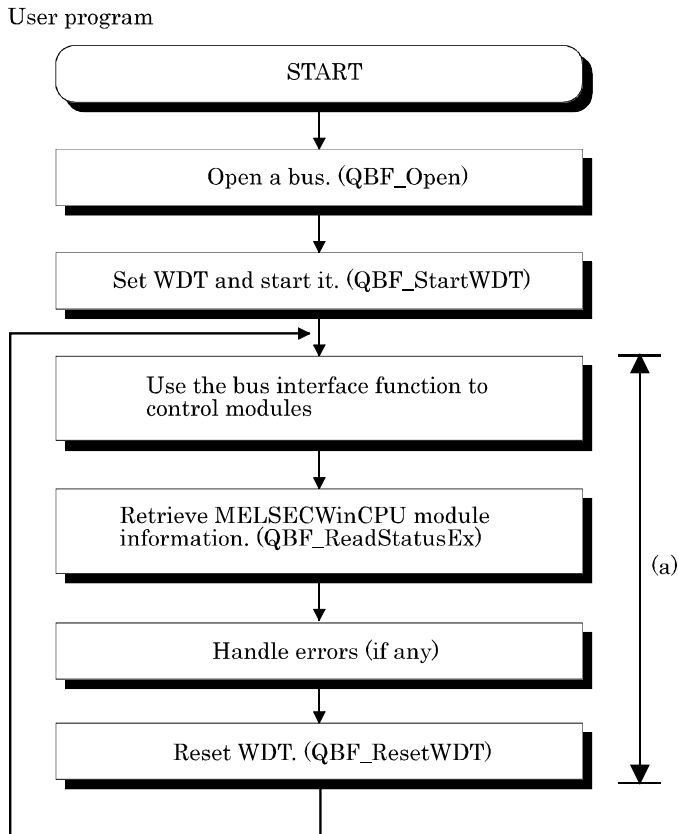

[Caution]

- Set the user WDT time to a value equal to or greater than the maximum value of processing time in (a).
- The processing time in (a) is influenced by the operating states of other applications. Therefore, measure it with all the applications running during test operation of the system. (Refer to the sample program for sample program (2) of time measurement.)
- As the processing time in (a) is influenced by scheduling by the OS, the execution of a user application may be postponed or delayed. To prevent it, raise the priority of the user application. (Refer to the sample program for sample program (2) raising the priority.)

2) When the user WDT and communication control consist of two or more applications

User program 1 (User WDT control)

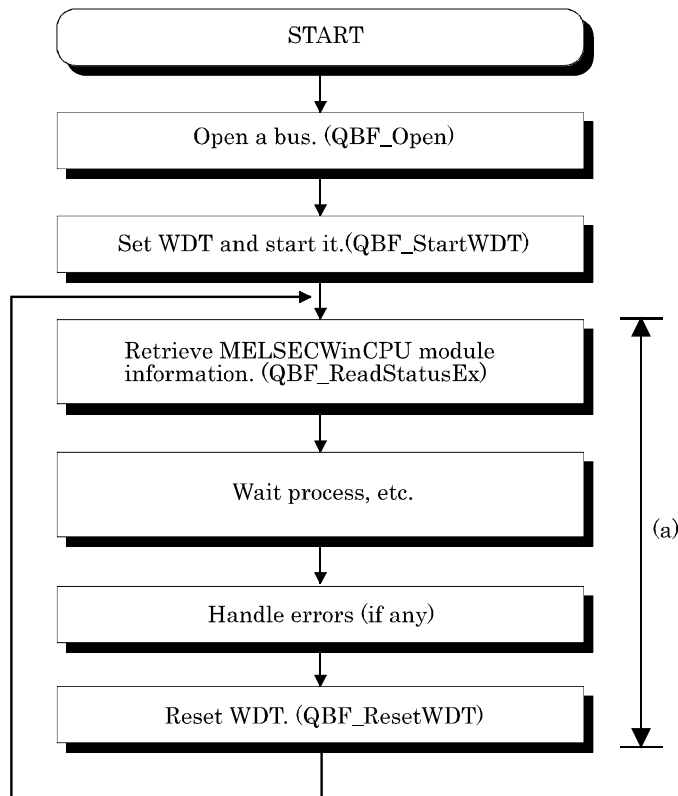

User program 2 (communication control 1)

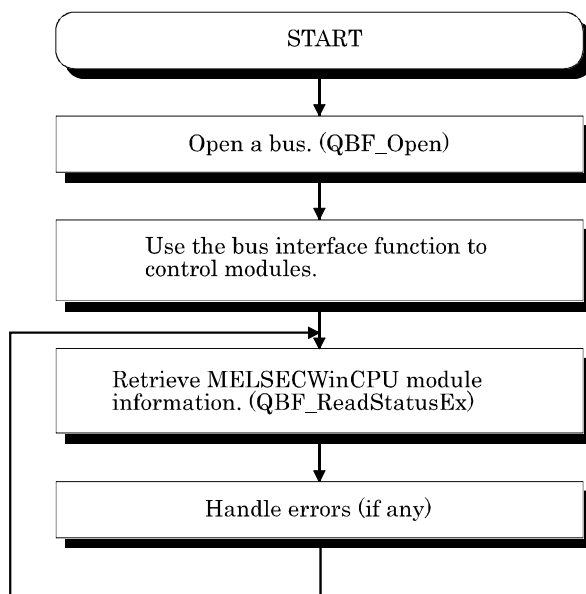

User program 3 (communication control 2)

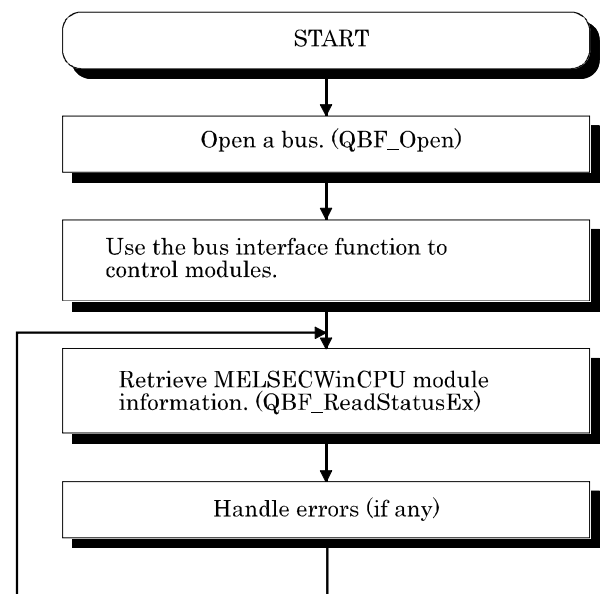

[Caution]

- Set the user WDT time to a value equal to or greater than the maximum value of processing time in (a).
- The processing time in (a) is influenced by the operating states of other applications. Therefore, measure it with all the applications running during test operation of the system. (Refer to the sample program for time measurement.)
- As the processing time in (a) is influenced by scheduling by the OS, the execution of a user application may be postponed or delayed. To prevent it, raise the priority of the user application. (Refer to the sample program for raising the priority.)

[Sample program]

Refer to the sample program for time measurement

```
dispt1=timeGetTime();           // Obtain the system time.  
    Communication control handling  
dispt2=timeGetTime();           // Obtain the system time.  
dispt=dispt2-dispt1;            // Calculation the difference from the previously  
                                obtained system time.
```

Refer to the sample program for raising the priority

```
VOID PriorityChange()  
{  
    UNIT ret ;  
    HANDLE ph;  
        ph=OpenProcess ( (PROCESS_SET_INFORMATION) ,  
                        FALSE,GetCurrentProcessId ( ) );  
                                // Obtain the handle of the current application.  
        ret=SetPriorityClass (ph,HIGH_PRIORITY_CLASS);  
                                // Obtain the priority of the current application.  
}
```

6.4.2 Using MELSEC data link functions

The following shows the procedures of programming with MELSEC data link functions.

(1) Programming procedures

The following shows an outline of creating user program with MELSEC data link functions.

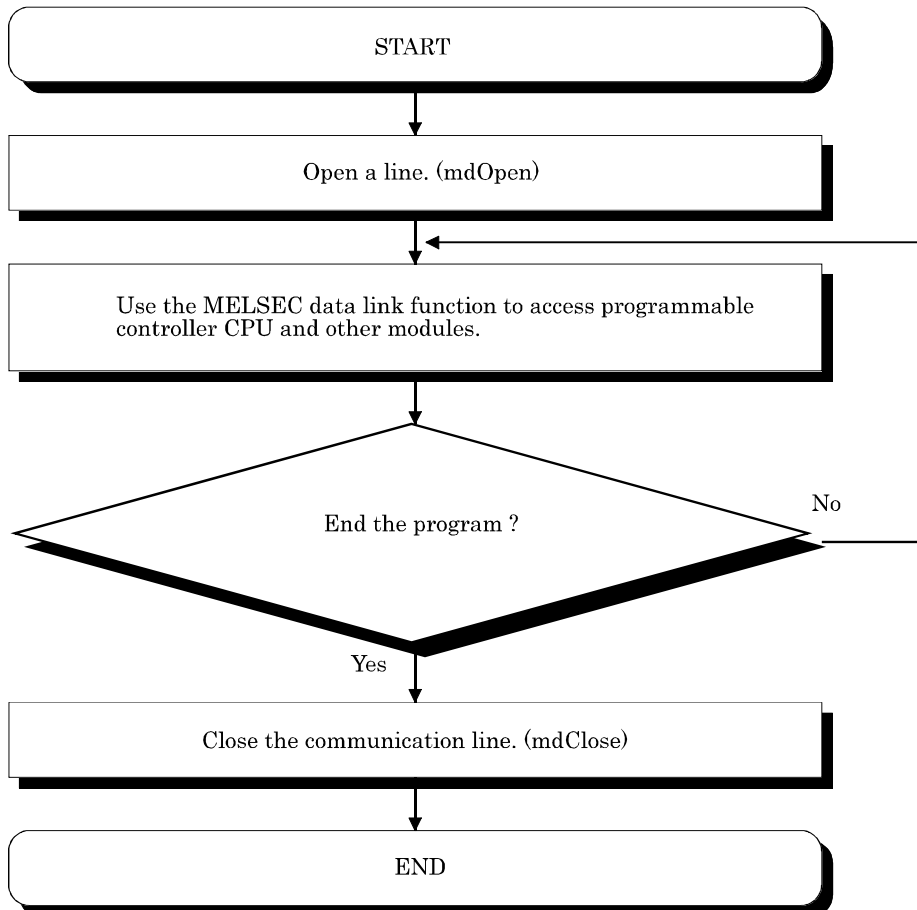

(2) Cautions when using the MELSEC Data Link function.

(a) Cautions when programming

- 1). Perform the processing for opening and closing a data link function (mdOpen, mdClose) only once at the beginning and end of a program. Repeating opening and closing of a communication loop for each transaction will degrade the communication performance.
- 2). When a function is first executed by adding a corresponding device, this acquires programmable controller information in detail. For that reason, the initial function execution time becomes long.
- 3). Simultaneous remote access to 257 or more stations from MELSECWinCPU module using utilities, user program provided by SW1PNC-WCPU-B and Mitsubishi- product software package may result in degraded communication performances. Limit the No. of stations to 256 or less for simultaneous remote station access from MELSECWinCPU module.
- 4). MELSEC data link functions do not support multi-thread programming.
- 5). When you use MELSEC data link functions, you should not use global variable or static variable as the arguments for MELSEC data link functions.

- 6). Random access (mdRandR, mdRandW, mdRandWEx, and mdRandREx) takes longer to execute and uses more memory than batch access (mdSend, mdReceive, mdSendEx, and mdReceiveEx).

Use batch access when the No. of points to access with a single operation is large.

- (b) Cautions when accessing to own Sta. devices and other Sta. programmable controller devices
Depending on link status of own Sta. and other Sta. interlocking is required.
Data is valid only when the following conditions are satisfied.

<For MELSECNET/H>

- 1). Access to a cyclic device (MELSECNET/H module X, Y, B, W)
Writing data to and reading them from the own Sta. cyclic device is valid only if the own Sta.'s handshaking status (SB47H) and the own Sta.'s cyclic status (SB49H) bit goes On (normal communications) and the own Sta.'s module status (SB20H) goes Off (Normal).
However, even if the above conditions are not established, writing and reading processing to the MELSECNET/H module ends normally.
- 2). Other Sta. transient access (remote operation of and device access to other Sta.'s programmable controller CPU.)
In addition to a device which checks the cyclic device's access, access is possible if the accessing station's handshake status (the bits pertaining to the opposite station being communicated with when SW70H - 73H are read by the own Sta.) and the cyclic status (the bits pertaining to the opposite station being communicated with when SW74H - 77H are read by the own Sta.) are Off (normal communications).

6.5 Channel

The following summarizes channels used for MELSEC data link functions.

No.	Channel name	Description
12	Q series bus interface	Used for communication via bus.
51 - 54	MELSECNET/H (1 - 4 slots)	Used for communication via MELSECNET/H module controlled by MELSECWinCPU module. Channel No. are assigned starting from 51 in the order of I/O No.
81 - 88	CC- Link (1 - 8 slots)	Used for communication via CC- Link utility controlled by MELSECWinCPU module. Channel No. are assigned starting from 81 in the order of I/O No.

6.6 Sta. No. Setting

Sta. No. specified by the MELSEC data-link function :

Communication	Sta. No. specification
Q series bus interface	Own Sta. : 255(FFH) Other Sta. : Specified range of Stta. No. 1(1H) - 64(40H) Logical Sta. No. are set from the "Target setting" tab of the MELSECWinCPU setting utility. For details, refer to "5.3.8 Operating the Target Setting Window".
MELSECNET/H	Own Sta. : 255(FFH) Other Sta. : *1
CC-Link	Own Sta. : 255(FFH) Other Sta. : 0(00H) - 63(3FH), 65(41H) - 239(EFH) *2 *3

*1 :
 Network No.
 1(1H) - 239(EFH): When it specifies other Sta. in own network or each Sta. in other networks.
 (in the case it requests the transmission for CC-Link IE controller network, MELSECNET/H or MELSECNET/10)
 Sta No.
 1(1H) - 120(78H): Other Sta

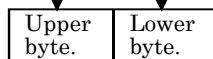

<How to specify a Logical Sta. No.>

Set "0" in the upper byte (network No.) of the above format, and specify a Logical Sta. No. * in the lower byte.

<The setting range of Logical Sta. No.>

It is set from the "Target setting" tab of the MELSECNET/H utility.
 64(41H) - 239(EFH) : MELSECNET/H communication.

For details, refer to "5.4.7 Operating the Target Setting Window".

*2:
 Network No.
 0 : CC-link
 Sta. No.
 0(0H) - 63(3FH) : Other Sta.

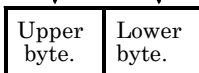

<How to specify a Logical Sta. No.>

Set "0" in the upper byte (network No.) of the above format, and specify a Logical Sta. No. in the lower byte (Sta. No.).

The setting range of Logical Sta. No. is 65(41H) - 239(EFH).

Logical Sta. No. is set from the "Target setting" tab of the CC-Link utility.
 For details, refer to "5.3.6 Operating the Target Setting Window".

*3 : Station #64 cannot be specified in CC-Link communication. And if your own Sta.'s No. is #64, other Sta. cannot be specified. (Access to your own Sta. only is possible.)

6.7 Device Type

Either code No. or device name is allowed for a device type to be used in MELSEC data link function.

This section describes all the device types that can be used for MELSECWinCPU module programs with MELSEC data link functions.

However, there are restraints depending on the connection route and the function used.

For more details on this, refer to “Chapter 7 Accessible Range and Devices”.

(1) Not usable devices

The following devices cannot be used for MELSECWinCPU module programs with MELSEC data link functions.

- Q/QnA SEND function (arrival confirmation available) and RECV function
- Q/QnA SEND function (arrival confirmation not available)
- W (shared device)
- ED (shared device)

(2) shared device type

Device type		Device name specification *1	Device
Code specification			
Decimal	Hexadecimal		
1	1H	DevX	X
2	2H	DevY	Y
3	3H	DevL	L
4	4H	DevM	M
5	5H	DevSM	Special M (SM), SB (MELSECNET/H, MELSECNET/10, link special B for CC-Link)
6	6H	DevF	F
7	7H	DevTT	T (contact)
8	8H	DevTC	T (coil)
9	9H	DevCT	C (contact)
10	AH	DevCC	C (coil)
11	BH	DevTN	T (current value)
12	CH	DevCN	C (current value)
13	DH	DevD	D
14	EH	DevSD	Special D(SD), SW (MELSECNET/H, MELSECNET/10, link special W for CC-Link)
15	FH	DevTM	T (set value main)

*1 : Device name specification (macro) is defined in the modules of MELSEC functions and the include file.

Device type		Device name specification *1	Device
Code specification			
Decimal	Hexadecimal		
16	10H	DevTS	T (set value sub1)
16002	3E82H	DevTS2	T (set value sub2)
16003	3E83H	DevTS3	T (set value sub3)
17	11H	DevCM	C (set value main)
18	12H	DevCS	C (set value sub1)
18002	4652H	DevC2	C (set value sub2)
18003	4653H	DevC3	C (set value sub3)
19	13H	DevA	A
20	14H	DevZ	Z
21	15H	DevV	V(index register)
22	16H	DevR	R(file register)
22000 - 22256	55F0H - 56F0H	DevER(0) - DevER(256)	ER (extended file register) Argument value for device name specification (0 - 256 *3) : Block No.
23	17H	DevB	B
24	18H	DevW	W
25	19H	DevQSB	Q/QnA link special relay (on Q/QnACPU)
26	1AH	DevSTT	Retentive timer (contact)
27	1BH	DevSTC	Retentive timer (coil)
28	1CH	DevQSW	Q/QnA link special register (on Q/QnACPU)
30	1EH	DevQV	Q/QnA edge relay (on Q/QnACPU)
33	21H	DevMRB	Own Sta. random access buffer *2
35	23H	DevSTN	Retentive timer (current value)
36	24H	DevWw	Own Sta. link register (for sending) *2
37	25H	DevWr	Own Sta. link register (for receiving) *2
50	32H	DevSPB	Own Sta. buffer memory *2
220	DC _H	DevZR	ZR (File register)

*1 : Device name specification (macro) is defined in the modules of MELSEC functions and the include file.

*2 : Device dedicated for CC-Link utility (local) buffer memory access

*3 : The mdRandR function ends normally even if an actually not existing device is specified.

(The data read becomes 1.)

Device type		Device name specification *1	Device
Code specification			
Decimal	Hexadecimal		
1001 - 1255	3E9H - 4E7H	DevLX(1) - DevLX(255)	Direct link input (other Sta. side) Argument with a device name specified (1 - 255*3) : network No.
2001 - 2255	7D1H - 8CFH	DevLY(1) - DevLY(255)	Direct link output (other Sta. side) Argument value for device name specification (1 - 255*3) : network No.
23001 - 23255	59D9H - 5AD7H	DevLB(1) - DevLB(255)	Direct link relay (other Sta. side) Argument value for device name specification (1 - 255*3) : network No.
24001 - 24255	5DC1H - 5EBFH	DevLW(1) - DevLW(255)	Direct link register (other Sta. side) Argument value for device name specification (1 - 255*3) : network No.
25001 - 25255	61A9H - 62A7H	DevLSB(1) - DevLSB(255)	Direct link special relay (other Sta. side) Argument value for device name specification (1 - 255*3) : network No.
28001 - 28255	6D61H - 6E5FH	DevLSW(1) - DevLSW(255)	Direct link special register (other Sta. side) Argument value for device name specification (1 - 255*3) : network No.
29000 - 29255	7148H - 7247H	DevSPG(0) - DevSPG(255)	Special direct buffer register Argument value for device name specification (0 - 255*3) : Start I/O No.÷16

*1 : Device name specification (macro) is defined in the modules of MELSEC functions and the include file.

*3 : The mdRandR function ends normally even if an actually not existing device is specified.

(The data read becomes -1.)

(3) Device types dedicated for Q Series bus interface

Device type		Device name specification *1	Device
Code specification			
Decimal	Hexadecimal		
501	1F5H	DevSPB1	CPU shared memory (Machine No.1 area)
502	1F6H	DevSPB2	CPU shared memory (Machine No.2 area)
503	1F7H	DevSPB3	CPU shared memory (Machine No.3 area)
504	1F8H	DevSPB4	CPU shared memory (Machine No.4 area)

*1 : Device name specification (macro) is defined in the modules of MELSEC functions and the include file.

(4) CC-Link dedicated device type

Device type		Device name specification *1	Device
Code specification			
Decimal	Hexadecimal		
1	1H	DevX	Own Sta. RX
2	2H	DevY	Own Sta. RY
5	5H	DevSM	Own Sta. SB (link special B for CC-Link)*2
14	E _H	DevSD	Own Sta. SW (link special W for CC-Link)*3
25	19H	DevQSB	Own Sta. SB (Special B for CC-Link) *2
28	1C _H	DevQSW	Own Sta. SW (link special W for CC-Link) *3
33	21H	DevMRB	Own Sta. random access buffer
36	24H	DevWw	Own Sta. link register (for sending)
37	25H	DevWr	Own Sta. link register (for receiving)
50	32H	DevSPB	Own Sta. buffer memory
-32768	8000H	DevRBM	Other Sta. buffer memory *4
-32736	8020H	DevRAB	Other Sta. random access buffer *4
-32735	8021H	DevRX	Other Sta. RX
-32734	8022H	DevRY	Other Sta. RY
-32732	8024H	DevRW	Other Sta. link register *4
-32669	8063H	DevSB	Other Sta. SB (link special B for CC-Link)
-32668	8064H	DevSW	Other Sta. SW (link special W for CC-Link) *4

*1 : Device name specification (macro) is defined in the modules of MELSEC functions and the include file.

*2 : There are two device type definitions (DevSM, DevQSB) for CC-Link link special relays (local SB). You can specify either of them because they are the same.

*3 : There are two device type definitions (DevSD, DevQSW) for CC-Link link special registers (own SW). You can specify either of them because they are the same.

*4 : Cannot be used for the mdRandR, mdRandW, mdDevSet, and mdDevRst functions.

(5) Device types for MELSECNET/H module access

(a) Internal buffer access

Device type		Device name specification *1	Device
Code specification			
Decimal	Hexadecimal		
1	1H	DevX	Own Sta. link input internal buffer (LX buffer)
2	2H	DevY	Own Sta. link output internal buffer (LX buffer)
23	17H	DevB	Own Sta. link relay internal buffer (LB buffer)
24	18H	DevW	Own Sta. link register internal buffer (LX buffer)

*1 : Device name specification (macro) is defined in the modules of MELSEC functions and the include file.

(b) Direct access

Device type		Device name specification *1	Device
Code specification			
Decimal	Hexadecimal		
5	5H	DevSM	Local direct link special relay (SB)*2
14	EH	DevSD	Own Sta. direct link special register (SW)*3
25	19H	DevQSB	Own Sta. direct link special relay (SB) *2
28	1CH	DevQSW	Own Sta. direct link special register (SW) *3

*1 : Device name specification (macro) is defined in the modules of MELSEC functions and the include file.

*2 : There are two device type definitions (DevSM, DevQSB) for own Sta. direct link special relays (SB). You can specify either of them because they are the same.

*3 : There are two device type definitions (DevSD, DevQSW) for own Sta. direct link special registers (SW). You can specify either of them because they are the same.

6.8 Data Communication via programmable controller Shared Memory

(1) Data Communication Function via programmable controller Shared Memory

This function performs data communication between MELSECWinCPU module and CPU module using CPU shared memory.

Use bus interface functions to create MELSECWinCPU module user programs.

The following shows data communication methods using CPU shared memory as well as method selection.

(a) Data communication using CPU shared memory

The following 2 methods are available for the data communication function using CPU shared memory.

- Data communication using automatic refresh of the programmable controller CPU and motion CPU.
- Data communication without using automatic refresh of the programmable controller CPU.

(b) Data communication method selection

To perform data communication using CPU shared memory, select a data communication method based on the target CPU module.

The following shows whether communication is possible or not according to the data communication type.

Data communication type	Data communication method		Referring item
	Automatic refresh used	Automatic refresh not used	
Programmable Controller CPU <-> MELSECWinCPU module	○	○	6.8.2, 6.8.3
Motion CPU <-> MELSECWinCPU module	○	×	6.8.2

○ : Communication possible × : Communication not possible

(2) CPU Shared Memory Configuration

For CPU shared memory configuration for the MELSECWinCPU module, refer to “Section 6.8.1 CPU Shared Memory Configuration”.

(3) Function

The following shows functions used in the data communication function using CPU shared memory.

Function name	Description
QBF_ToBuf *1	Writes to the CPU shared memory in the specified position of the module and writes to the buffer memory of an intelligent function module.
QBF_FromBuf *2	Reads from the CPU shared memory in the specified position of the module, and reads from the buffer memory of an intelligent function module.

*1 : The mdSend function can be used instead of the QBF_ToBuf function.

*2 : The mdReceive function can be used instead of the QBF_FromBuf.

Point
Only when 2 or more CPUs are specified in the “Multiple CPU setting” tab of the MELSECWinCPU setting utility, it is possible to access CPU shared memory. Otherwise, a CPU No. specification error (return value : -28662) occurs.

6.8.1 CPU Shared Memory Configuration

CPU shared memory configuration and access availability to the memory of MELSECWinCPU module is as follows :

< Access diagram >

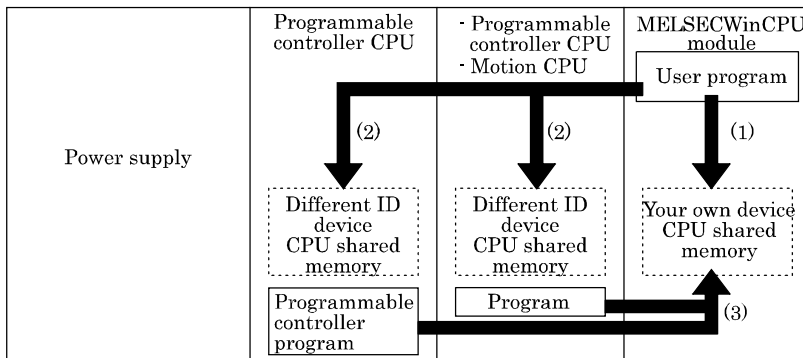

< Accessibility list >

Address *1, *6	Area name	Access from your own device				Access from local device	
		Access to your own device (1)		Access to local device (2)		Access to your own device (3)	
		Write *2	Read *3	Write	Read *4	Write	Read *5
0H(0H) - 1FFH (5FH)	Host CPU operation information area of your own device	Disabled	Enabled	Disabled	Enabled	Disabled	Enabled
200H(60H) - 7FFH (BFH)	System area	Disabled	Disabled	Disabled	Enabled	Disabled	Enabled
800H(C0H) - FFFH (1FFH)	Auto refresh area	Enabled	Enabled	Disabled	Enabled	Disabled	Enabled
	User free area	Enabled	Enabled	Disabled	Enabled	Disabled	Enabled

*1 : Indicates the address of CPU shared memory

*2 : Use the QBF_ToBuf function to write to the automatic refresh area and user free area of your own device (MELSECWinCPU module).

*3 : Use the QBF_FromBuf function to read from the local operation information area, automatic refresh area and user free area of your own device (MELSECWinCPU module).

*4 : Use the QBF_FromBuf function to read from the local operation information area, automatic refresh area and user free area of a different ID device (programmable controller CPU or motion CPU).

*5 : For how to make access from the programmable controller CPU/motion CPU of a different ID device, refer to the manual for each CPU module.

*6 : If the Module No.1 is a basic model QCPU, the address of CPU shared memory is a value in brackets ().

Area name	Description
Own machine operation information area *7	Area storing error information and operating status of own machine (MELSECWinCPU module).
System area	Area used by system.
Automatic refresh area	Area that is automatically refreshed by programmable controller CPU and motion CPU device with automatic refresh settings. The size depends on parameter settings.
User's free area	Area that is freely available. The area size depends on parameter settings of automatic refresh area.

*7 : The details of the local operation information area of a MELSECWinCPU module are shown in the next page.

Shared memory address	Name	Details	Description
0H	Availability of information	Information Availability flag	The area to confirm if information is stored in the own machine's operation information area (1H - 1FH) or not. 0 : None, 1 : Information present
1H	Diagnostic error	Diagnostic error No.	The No. of errors triggered during diagnostics is stored with BIN code. *1
2H	Time the diagnosis error occurred	Time the diagnosis error occurred	The year and month that the error No. was stored in the common programmable controller memory's 1H address is stored with two digits of the BCD code. *1
3H			The day and time that the error No. was stored in the programmable controller shared memory's 1H address is stored with two digits of the BCD code. *1
4H			The minutes and seconds that the error No. was stored in the programmable controller shared memory's 1H address is stored with two digits of the BCD code. *1
5H	Error information identification code	Error information identification code	Stores an identification code to determine what error information has been stored in the common error information and individual error information. *1
6H - 10H	Common error information	Common error information	The common information corresponding with the No. of the error triggered during diagnostic is stored. *1
11H - 1BH	Individual error information	Individual error information	The individual information corresponding with the No. of the error triggered during diagnostic is stored.
1CH	Vacant	-	Cannot be used
1DH	Switch status	MELSECWinCPU switch status	Stores the MELSECWinCPU module's switch status. 0 : RUN, 1 : STOP
1EH	LED status	MELSECWinCPU - LED status	Stores the MELSECWinCPU module's LED bit pattern. (refer to Fig.1 below)
1FH	MELSECWinCPU module operation status	MELSECWinCPU module operation status	Stores the MELSECWinCPU module's operation status. (refer to Fig.2 below)

*1 : Contains 0 if no error occurs.

Fig.1 LED Status

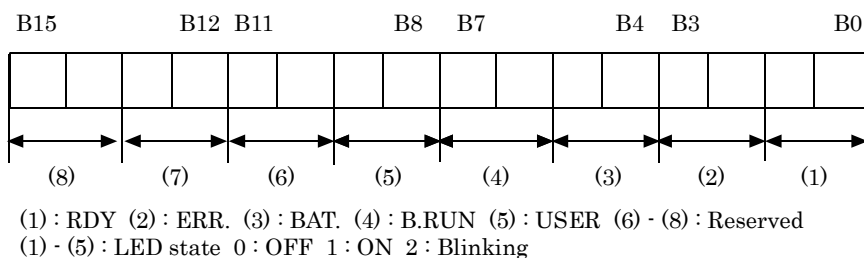
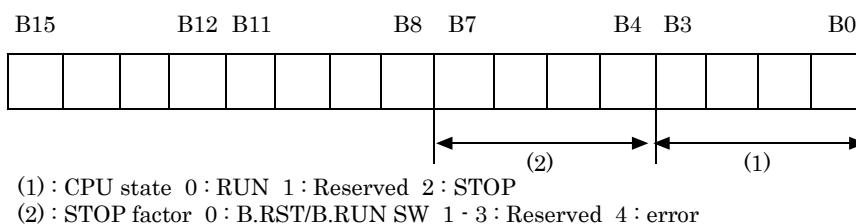

Fig.2 Operation Status



6.8.2 Data Communication When Using Automatic Refresh settings

For data communication functionality using CPU shared memory, the following explains an overview of processing and settings when data communication is performed using the automatic refresh of the programmable controller CPU and motion CPU.

(1) Overview of processing of data communication using automatic refresh

Overview of processing of data communication using automatic refresh is as follows:

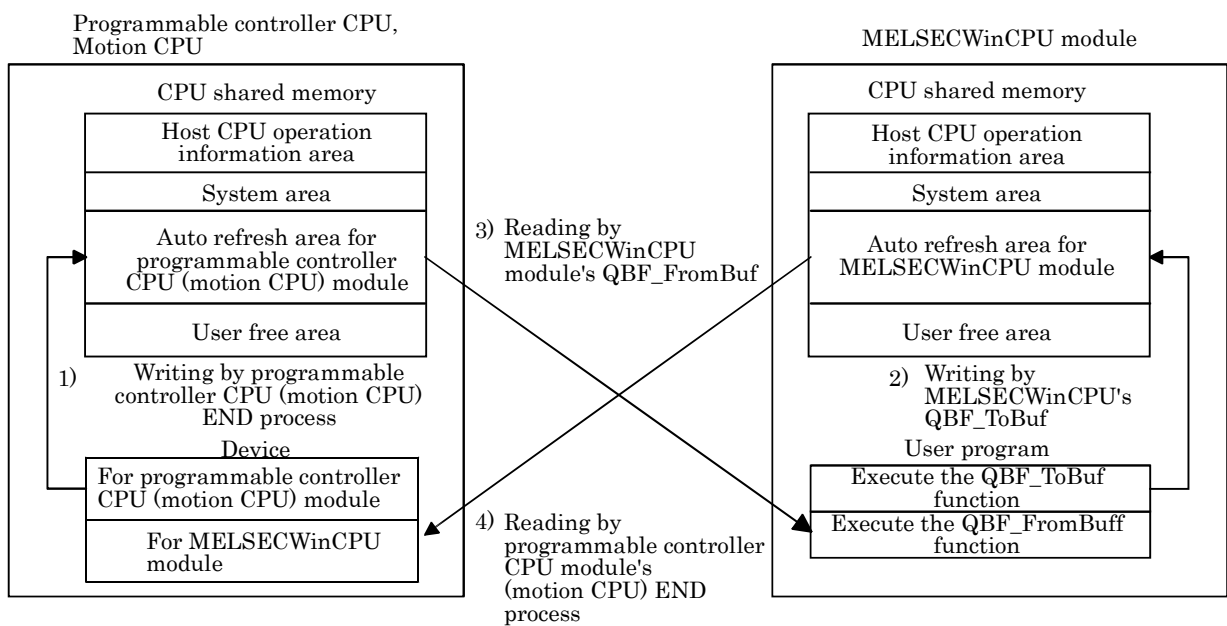

Operation of END process on programmable controller CPU and motion CPU

- 1) : Transfer device memory data for programmable controller CPU (motion CPU) to automatic refresh area of programmable controller CPU (motion CPU) shared memory.
- 4) : Transfer data in automatic refresh area of MELSECWinCPU module to device memory for MELSECWinCPU module of programmable controller CPU (motion CPU)

Operation upon executing bus interface function of MELSECWinCPU module

- 2) : By executing QBF_ToBuf function, transfer the settings of user program to automatic refresh area of MELSECWinCPU module's shared memory.
- 3) : By executing QBF_FromBuf function, data in automatic refresh area of programmable controller CPU (motion CPU) to user program.

Point

Refreshing in 4) above is performed by programmable controller CPU (motion CPU) END process after execution of 2) in the figure, execution of QBF_ToBuf function.

(2) Automatic refresh area setting

To perform data communication using the automatic refresh of the programmable controller CPU and motion CPU, you need to make the automatic refresh area setting.

Make the refresh area setting from “Refresh setting” in the “Multiple CPU setting” tab of the MELSECWinCPU setting utility.

The settings for “Refresh setting” are as follows.

Point

Make the same automatic refresh area setting to all CPUs in a multiple CPU system.
Otherwise, a parameter error occurs.

(a) About “Refresh setting”

The following explains setting items for “Refresh setting” that sets an automatic refresh area.

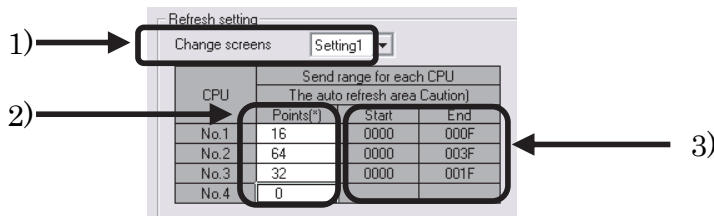

1) About “Setting change”

For “Refresh setting,” 4 ranges can be set by using “Setting change”.

2) About “point”

Set points for the automatic refresh area of each CPU module in units of two points (2 words).

A maximum of 2,048 points (2k words)^{*1} totaling points of 4 ranges (Setting 1 - 4) per CPU module, and a maximum of 8,192 points (8k words)^{*2} totaling points of all CPUs in a multiple CPU system, can be set for an automatic refresh area.

Set “0” to “Points” for CPU modules that do not use refresh areas.

*1: For a basic model QCPU, a maximum of 320 points (320 words) totaling points of 4 ranges (setting 1 - 4) per module can be set.

*2: If the Module No.1 is a basic model QCPU, 4,416 points totaling points of all CPUs in a multiple CPU system can be set.

3) About “Start”, “End”

When a value is set to the “Points” field, the first and last addresses of an automatic refresh area are displayed as offset values in hexadecimal No. for “Start” and “End” respectively.

Remarks

For how to set automatic refresh areas for a programmable controller CPU and motion CPU, refer to the manual for each CPU module.

(b) Example of settings

An automatic refresh area setting example is as follows.

The settings of the following example are made such that a high-performance model QCPU is used as the Module No.1 and that the Module No.4 does not use automatic refresh.

Refresh setting
Change screens: Setting1

CPU	Send range for each CPU The auto refresh area Caution)		
	Points(*)	Start	End
No.1	16	0000	000F
No.2	64	0000	003F
No.3	32	0000	001F
No.4	0		

Caution) Offset (HEX.) from starting address of the auto refresh area. Refer to user's manual of the each CPU about the starting address. The unit of points that send range for each CPU is word.

Refresh setting
Change screens: Setting2

CPU	Send range for each CPU The auto refresh area Caution)		
	Points(*)	Start	End
No.1	32	0010	002F
No.2	0		
No.3	32	0020	003F
No.4	0		

Caution) Offset (HEX.) from starting address of the auto refresh area. Refer to user's manual of the each CPU about the starting address. The unit of points that send range for each CPU is word.



< CPU shared memory of No.1 > < CPU shared memory of No.2 > < CPU shared memory of No.3 > < CPU shared memory of No.4 >

0H	Host CPU operation information area	0H	Host CPU operation information area	0H	Host CPU operation information area	0H	Host CPU operation information area
1FFH		1FFH		1FFH		1FFH	
200H	System area	200H	System area	200H	System area	200H	System area
7FFH		7FFH		7FFH		7FFH	
800H	Auto refresh area	800H	Auto refresh area	800H	Auto refresh area	800H	User free area
800H	Auto refresh area for setting1	800H	Auto refresh area for setting1	800H	Auto refresh area for setting1		
80FH		83FH		81FH			
810H	Auto refresh area for setting2			820H	Auto refresh area for setting2		
82FH				83FH			
82FH		83FH		83FH			
830H	User free area	840H	User free area	840H	User free area		
FFFH		FFFH		FFFH		FFFH	

(3) Notes when data communication is performed using automatic refresh

Depending on the timing of writing to the automatic refresh area from your own Sta. and the timing of reading from a different ID device, data of each device ID device may have old and new data together. Create an interlock program to perform automatic refresh and avoid using data of a different ID device if old data and new one are mixed together.

6.8.3 Data Communication Without Using the Automatic Refresh

For data communication functionality using CPU shared memory, the following explains an overview of processing when data communication is performed without using the automatic refresh of the programmable controller CPU.

(1) Overview of processing of data communication without using automatic refresh

Overview of processing of data communication without using automatic refresh is as follows :

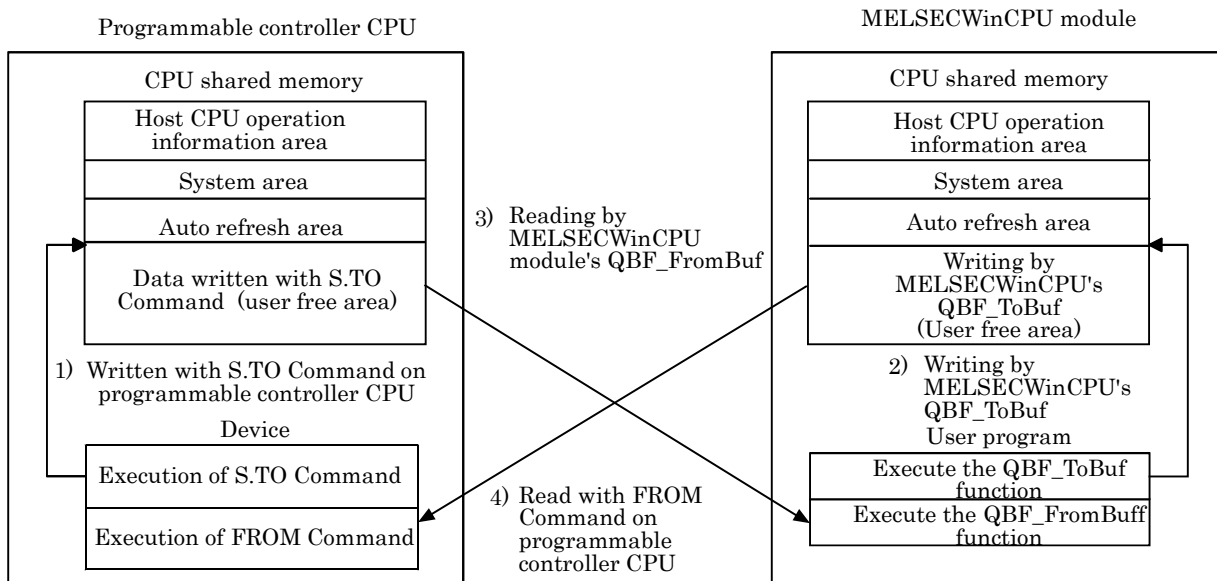

Operation upon executing ladder program on programmable controller CPU

- 1) : Writes data to the user free area in the CPU shared memory of the programmable controller CPU with S.TO Command.
- 4) : Reads data from the user free area in the MELSECWinCPU module into the specified device of the programmable controller CPU with FROM Command.

Operation upon executing bus interface function on MELSECWinCPU module

- 2) : Writes data to the user free area in the CPU shared memory of the MELSECWinCPU by executing the QBF_ToBuf function.
- 3) : Reads data from the user free area in the programmable controller CPU onto a user program by executing the QBF_FromBuf function.

Remarks

The above is an example of operation using S.TO Command and FROM Command in a high-performance model QCPU.

For operations without using the automatic refresh setting on the programmable controller CPU side, refer to the manual for each CPU module.

6.9 Event Notify Function

This section describes a function that notify events from programmable controller CPU to user program on MELSECWinCPU module, using MELSECWinCPU module special instruction (S(P).GINT).

[Special programmable controller instruction for MELSECWinCPU module]

Interrupt instruction on MELSECWinCPU module: S(P).GINT

Setting data	Available devices								
	Internal device (System, user)		File register R, ZR	MELSECNET/10(H) Direct J□\□		Special module U□\G□	Index register Zn	Constant K, H	Others
	Bit	Word		Bit	Word				
n1	-	O *1, *2					O	-	
n2	-	O *2					O	-	

O : Specifiable - : Not specifiable

*1 : For a high-performance model QCPU, indexes can be added.

*2 : For a basic model QCPU, indexes can be added.

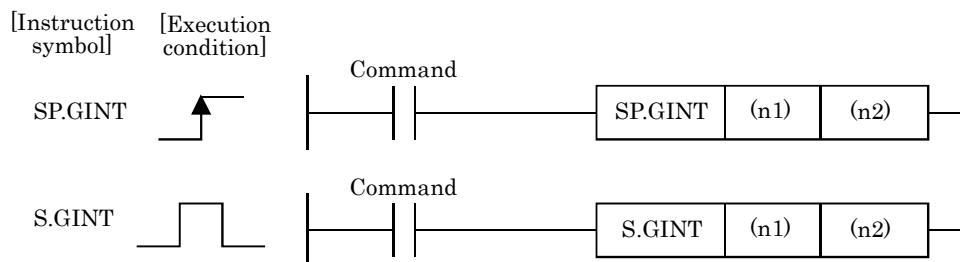

[Setting data]

Setting data	Settings	Data format
(n1)	Start I/O No. of applicable CPU ÷16 Actual values to be specified are as follows: Module No.1: 3E0H, Module No.2: 3E1H, Module No.3: 3E2H, Module No.4: 3E3H	BIN16 bit
(n2)	Interrupt pointer No. (0 - 15)	BIN16 bit

[Available devices]

Dedicated commands can be used for the following devices.

Internal device		File register	Constant *2
Bit	Word *1		
M, L, B	D, W, @□	R, ZR	K, H

*1 : A bit device digit can be specified as word data.

A digit of a bit device shall be specified by digits No. Start No. of bit device.

For example, 16 points from M0 to M15 can be specified as K4M0.

*2 : A device that can be set is described in the constant field of each item.

[Control operation]

The process generates an interrupt to MELSECWinCPU module, upon startup (OFF -> ON) of executing S(P).GINT instruction by ladder program.

The MELSECWinCPU module, upon interrupt from programmable controller CPU, executes a bus interface function (QBF_WaitEvent) that has been programmed in user program.

- (1) Upon completion of transferring instruction to MELSECWinCPU module, SM391 flag (completion of S(P).GINT instruction) of programmable controller CPU is turned on.
- (2) Upon failure of transferring instruction from programmable controller CPU to MELSECWinCPU module, SM391 flag (completion of S(P).GINT instruction) of programmable controller CPU is turned off.

[Operation timing]

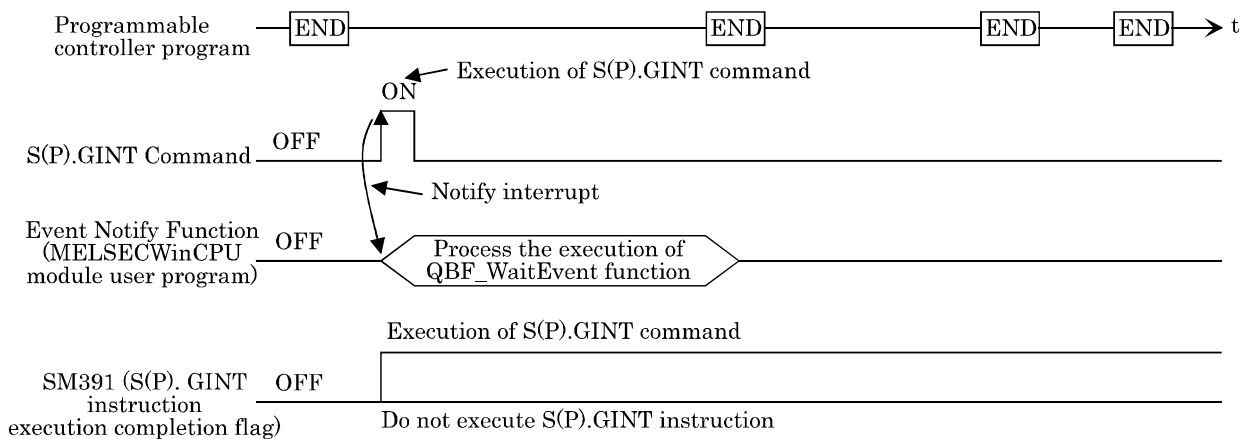

[Errors]

The following cases result in computation error, turning on error flag (SM0) of programmable controller CPU and storing an error code in SD0.

Error code *1	Error cause	Action
2110	Device ID device reserved (CPU vacant setting) by a target device ID device CPU start I/O No. / 16(n1) specified, or no-CPU-module-mounted device ID device specified.	Check program and modify it into a correct ladder program.
2114	Own machine was specified by “applicable CPU start I/O No. ÷ 16(n1)”.	
2117	A module not supporting S(P).GINT instruction was specified by “applicable CPU start I/O No. ÷ 16(n1)”.	
4100	“0 to 3DFH, 3E4H” was specified by “applicable CPU start I/O No. ÷ 16(n1)”.	

*1 : 0000H(normal)

[Program example]

Ladder program that generates interrupt on Module No.4 MELSECWinCPU module.

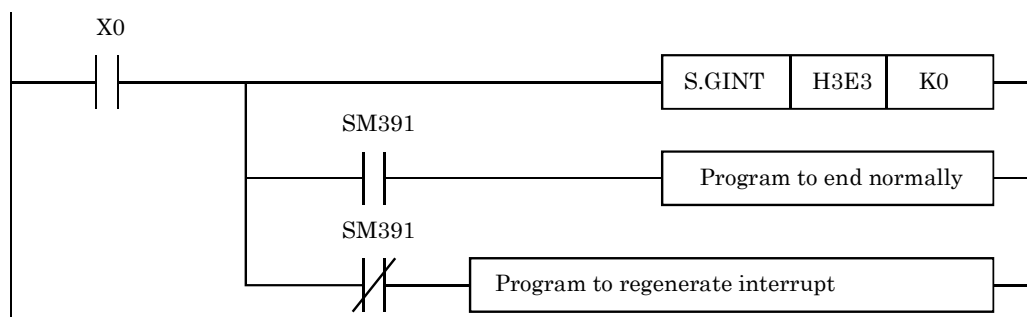

[Notes]

- (1) When the QBF_WaitEvent function is executed, if an interruption event has been already notified from the programmable controller CPU, a user program returns from interruption-event waiting mode immediately when the QBF_WaitEvent function is executed. Also, when the QBF_WaitEvent function is executed, if multiple interruption event notifications have been sent for the same interruption event No., a user program processes them as a single interruption event notification.
- (2) When using the event notification function in multiple user programs, do not set the same device ID device or same interruption event No. for multiple user programs. If the same device ID device or the same interruption event is set in multiple user programs, it becomes uncertain which user program receives an interruption event.

6.10 About Sample Program

Following sample programs are included in CD-ROM.

Installation of SW1PNC-WCPU-B onto MELSECWinCPU module registers the following sample programs. The sample programs are provided for reference purposes that are used when preparing a user program. Use the sample programs on user's own authority.

(1) Sample programs for bus interface functions

Sample programs for bus interface functions are registered in <CD-ROM Drive> - <Sample> - <English> - <QBFTOOL>.

The following describes each folder in Qbftool folder:

(a) NETVB folder (for Visual Basic 2008/2010)

1). QBFTest folder

Sample program for bus interface functions in general

(b) VC folder (for Visual C++ 2008/2010)

1). QBFTest folder

Sample program for bus interface functions in general

2). Shutdown folder

Sample program for shutdown test

3). QC24 folder

Sample program of data communication through the nonprocedural protocol by a serial communication module.

4). CCIEField folder

File name	Description
LocalStation.c	Sample program that uses a CC-Link IE field network to perform cyclic transmission to the master station (for use by a local station)
MasterStation_ LocalStation.c	Sample program that uses a CC-Link IE field network to perform cyclic transmission to a local station (for use by the master station)
MasterStation_ RemoteIO.c	Sample program that uses a CC-Link IE field network to perform cyclic transmission to an intelligent device station (for use by the master station)

(2) Sample programs for MELSECNET/H communication

Sample programs for MELSECNET/H communication are registered in <CD-ROM Drive>-<Sample> - < English > - <MNETH>.

The following describes each folder in Mneth folder:

(a) NETVB folder (for Visual Basic .NET 2008/2010)

1). DEMO folder

Sample program that read D0

2). MTEST folder

Sample program for MELSEC data link functions (mdOpen, mdClose, mdSend, mdReceive) in general

(b) VC folder (for Visual C++ 2008/2010)

1). MTEST folder

File name	Description
Mtest1.c	Sample program for MELSEC data link functions in general
Netsmp1.c	Sample program that read device D of Sta. No.1.

(3) Sample programs for CC- Link communication

Sample programs for CC- Link communication are registered in <CD-ROM Drive>- <Sample> - < English > - <CCLINK>. The following describes each folder in Cclink folder:

(a) Master station folder

1). Datalink folder

Folder name		Description	Programming language
Ver.1	NETVB	Master station↔local station communication sample program	Visual Basic 2008 Visual Basic 2010
	VC		Visual Basic 2008 Visual Basic 2010
Ver.2	NETVB		Visual Basic 2008 Visual Basic 2010
	VC		Visual Basic 2008 Visual Basic 2010

2). PositioningSystem folder

Folder name		Description	Programming language
NETVB		Sample program for initialization, positioning, zero- return and JOG operation on AJ65BT- D75P2- S3.	Visual Basic 2008 Visual Basic 2010
VC	Initialize	Sample program for initialization on AJ65BT- D75P2- S3.	Visual Basic 2008 Visual Basic 2010
	Jog	Sample program for JOG operation on AJ65BT- D75P2- S3.	
	Positioning	Sample program for positioning on AJ65BT- D75P2- S3.	
	ZeroReturn	Sample program for zero- return on AJ65BT- D75P2- S3.	

3). R2 folder

Folder name		Description	Programming language
NETVB		Sample program for initialization, transmission and reception on AJ65BT- R2.	Visual Basic 2008 Visual Basic 2010
VC	Rs2testB	Sample program for initialization of AJ65BT- R2.	Visual Basic 2008 Visual Basic 2010
	Rs2testR	Sample program for reception on AJ65BT- R2.	
	Rs2testS	Sample program for transmission on AJ65BT- R2.	

4). RemoteDevice folder

Folder name		Description	Programming language	
68DAV	Ver.1	NETVB	Visual Basic 2008 Visual Basic 2010	
		VC	Visual Basic 2008 Visual Basic 2010	
	Ver.2	NETVB	Sample program for digital- analog conversion output on AJ65VBTCU-68DAV.	Visual Basic 2008 Visual Basic 2010
		VC		Visual Basic 2008 Visual Basic 2010

5). RemoteIO folder

Folder name	Description	Programming language
NETVB	Sample program for remote I/O reading and writing on remote I/O station	Visual Basic 2008 Visual Basic 2010
VC		Visual Basic 2008 Visual Basic 2010

(b) Local station folder

1). Datalink folder

Folder name	Description	Programming language
Ver.1	NETVB	Visual Basic 2008 Visual Basic 2010
	VC	Visual Basic 2008 Visual Basic 2010
Ver.2	NETVB	Visual Basic 2008 Visual Basic 2010
	VC	Visual Basic 2008 Visual Basic 2010

Master station ← → Sample program for local station communication

(c) MDFunction folder

1). NETVB folder (for Visual Basic 2008/2010)

Sample programs for MELSEC data link functions (mdOpen, mdClose, mdSend, mdReceive)

2). VC folder (for Visual C++ 2008/2010)



File name	Description
Mtest1.c	Sample program for MELSEC data link functions in general
Netsmp1.c	Sample program that read device D of Sta. No.1.

6.11 About HELP of Bus Interface Function and MELSEC Data Link Function

You can refer to the HELP of bus interface function and MELSEC data link function by following procedures.

(1) When referring from a MELSECWinCPU module



Select following icons from [Start] - [All Program] - [MELSECWinCPU].

Icon	Name	Content
	MELSEC Data Link Function HELP	Starts up MELSEC Data Link Function HELP
	Bus Interface Function HELP	Starts up Bus Interface Function HELP

(2) When referring from development personal computer

Bus interface function HELP and MELSEC data link function HELP are contained in <CD-ROM Drive> - <Help> - <English >.

Copy a <Help > folder into any folders of development personal computer and start up the following HELP files contained in a <Help> folder.

Icon	File Name	Content
	MDFUNC.HLP	Starts up MELSEC Data Link Function HELP
	Qbfunc.hlp	Starts up Bus Interface Function HELP

Point

When you start up the HELP, the following screen “Windows HELP and Support” may appear and you may be unable to read the HELP.

In this case, install “WinHlp32.exe”, which is necessary to show the HELP, according to procedures below.

(Notice: You should connect internet)

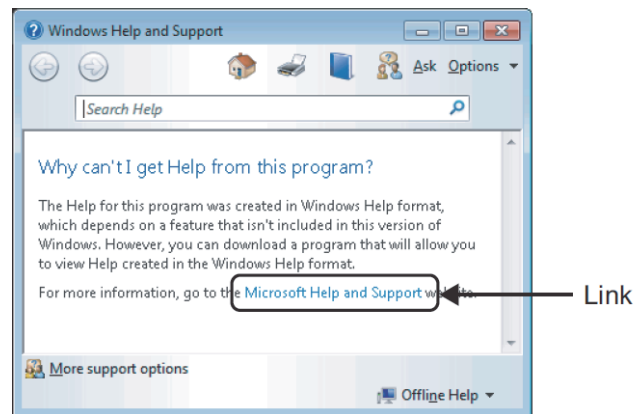
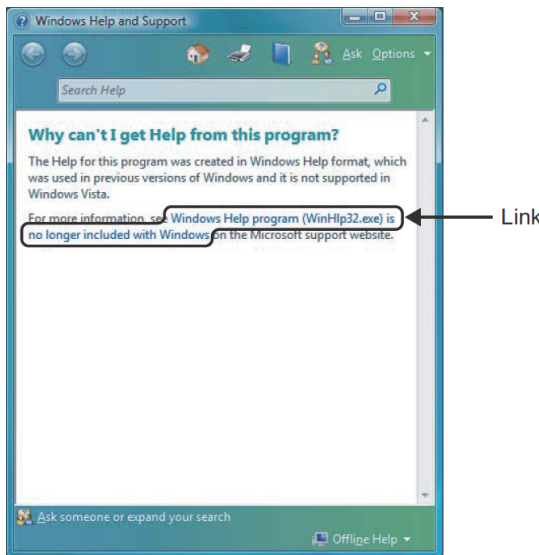

- (1) Click “HELP” button.
- (2) Above screen will appear. Click the link.
- (3) The page of Microsoft Support Technical Information appears.

<http://support.microsoft.com/kb/917607> (as of November 2011)

Follow its explanation and download Windows HELP program (WinHlp32.exe).

- (4) Install the downloaded file.

7. Accessible Range and Devices

This chapter describes accessible range and accessible devices when MELSEC data link functions are used.

When MELSEC data link functions are used in the MELSECWinCPU module, the following devices cannot be accessed.

- Q/QnA SEND function (arrival confirmation available) and RECV function devices
- Q/QnA SEND function (arrival confirmation not available)
- EM (shared device)
- ED (shared device)

7.1 Multiple CPU System Access

This section describes accessible range and accessible devices by operation of multiple CPU system access.

7.1.1 Accessible Range

The accessible range when a multiple CPU system makes access covers only the MELSECWinCPU module (your own device) and programmable controller CPUs (different ID devices) in a multiple CPU system.

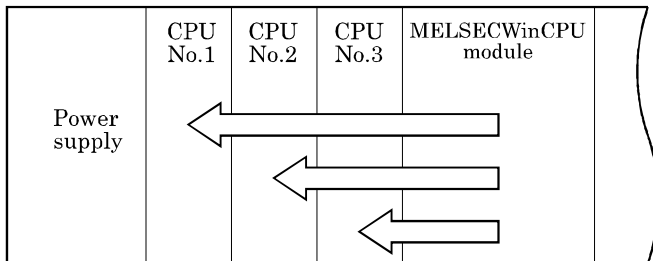

7.1.2 Accessible Devices

This section describes accessible devices under multiple CPU system access operation.

Point
(1) “Batch” and “Random” in the table indicates the following operations: Batch : Batch writing (mdSend), Batch reading (mdReceive) Random : Random writing (mdRandW), Random reading (mdRandR), Bit set (mdDevSet), Bit reset (mdDevRst)
(2) BitSet (mdDevSet function) and BitReset (mdDevRst function) can access bit devices only.
(3) CPU shared memory is accessible only when the multiple CPU setting is made.

(1) Own machine access

Accessible devices at the time of own machine access is as follows :

Device	Device type (Device name specification)	Used function	Access target
			Own machine (MELSECWinCPU module)
CPU shared memory *1	DevSPB1 (No.1 machine), DevSPB2 (No.2 machine), DevSPB3 (No.3 machine), DevSPB4 (No.4 machine)	Batch	O
		Random	×
High-speed communication area between multiple CPU	/	Batch	×
		Random	

O : Accessible, × : Not Accessible

*1 : For more details on Data Communication Via programmable controller Shared Memory, refer to “6.8 Data Communication Via programmable controller Shared Memory”.

(2) Other machine access

Accessible devices at the time of other machine access is as follows :

Device	Device type (Device name specification)	Used function	Access target
			Programmable controller CPU
X	DevX	Batch	O
		Random	
Y	DevY	Batch	O
		Random	
L	DevL	Batch	O
		Random	
M	DevM	Batch	O
		Random	
Special M (SM), SB	DevSM	Batch	O
		Random	
F	DevF	Batch	O
		Random	
T (contact)	DevTT	Batch	O
		Random	
T (coil)	DevTC	Batch	O
		Random	
C (contact)	DevCT	Batch	O
		Random	
C (coil)	DevCC	Batch	O
		Random	
T (current value)	DevTN	Batch	O
		Random	
C (current value)	DevCN	Batch	O
		Random	
D	DevD	Batch	O
		Random	
Special D (SD), SW	DevSD	Batch	O
		Random	

O : Accessible, × : Not Accessible

Device	Device type (Device name specification)	Used function	Access target
			Programmable controller CPU
T (setting value main)	DevTM	Batch	×
		Random	
T (setting value sub 1)	DevTS	Batch	×
		Random	
T (setting value sub 2)	DevTS2	Batch	×
		Random	
T (setting value sub 3)	DevTS3	Batch	×
		Random	
C (setting value main)	DevCM	Batch	×
		Random	
C (setting value sub 1)	DevCS	Batch	×
		Random	
C (setting value sub 2)	DevC2	Batch	×
		Random	
C (setting value sub 3)	DevC3	Batch	×
		Random	
A	DevA	Batch	×
		Random	
Z	DevZ	Batch	O
		Random	
V (index register)	DevV	Batch	×
		Random	
R (file register)	DevR	Batch	O
		Random	
ZR (extension file register)	DevZR	Batch	O
		Random	
ER (extension file register)	DevER(0) - DevER(256)	Batch	O
		Random	
B	DevB	Batch	O
		Random	
W	DevW	Batch	O
		Random	
Q/QnA link special relay (within the Q/QnACPU)	DevQSB	Batch	O
		Random	

O : Accessible, × : Not Accessible

Device	Device type (Device name specification)	Used function	Access target
			Programmable controller CPU
Retentive timer (contact)	DevSTT	Batch	O
		Random	
Retentive timer (coil)	DevSTC	Batch	O
		Random	
Q/QnA link special register (within the Q/QnACPU)	DevQSW	Batch	O
		Random	
Q/QnA edge relay (within the Q/QnACPU)	DevQV	Batch	O
		Random	
Own Sta. random access buffer	DevMRB	Batch	×
		Random	
Retentive timer (current value)	DevSTN	Batch	O
		Random	
Own Sta. link register (for sending)	DevWw	Batch	×
		Random	
Own Sta. link register (for receiving)	DevWr	Batch	×
		Random	
Own Sta. buffer memory	DevSPB	Batch	×
		Random	
Direct link input (other Sta. side)	DevLX(1) - DevLX(255)	Batch	O
		Random	
Direct link output (other Sta. side)	DevLY(1) - DevLY(255)	Batch	O
		Random	
Direct link relay (other Sta. side)	DevLB(1) - DevLB(255)	Batch	O
		Random	
Direct link register (other Sta. side)	DevLW(1) - DevLW(255)	Batch	O
		Random	
Direct link special relay (other Sta. side)	DevLSB(1) - DevLSB(255)	Batch	O
		Random	
Direct link special register (other Sta. side)	DevLSW(1) - DevLSW(255)	Batch	O
		Random	
Special direct buffer register	DevSPG(0) - DevSPG(255)	Batch	O
		Random	
Other Sta. buffer memory	DevRBM	Batch	×
		Random	
Other Sta. random access buffer	DevRAB	Batch	×
		Random	

O : Accessible, × : Not Accessible

Device	Device type (Device name specification)	Used function	Access target
			Programmable controller CPU
Other Sta. RX	DevRX	Batch	×
		Random	
Other Sta. RY	DevRY	Batch	×
		Random	
Other Sta. link register	DevRW	Batch	×
		Random	
Other Sta. SB (link special B for CC-Link)	DevSB	Batch	×
		Random	
Other Sta. SW (link special W for CC-Link)	DevSW	Batch	×
		Random	
CPU shared memory	DevSPB1 (Machine No.1), DevSPB2 (Machine No.2), DevSPB3 (Machine No.3), DevSPB4 (Machine No.4)	Batch	×
		Random	

O : Accessible, × : Not Accessible

7.2 Access via CC-Link Utility

This section describes accessible range and accessible devices via CC- Link utility.

7.2.1 Accessible Range

Devices accessible via CC- Link utility are only CC- Link master station connected with CC- Link utility, Programmable controller CPU of local station, MELSECWinCPU module, intelligent device station and personal computer with CC- Link board installed.

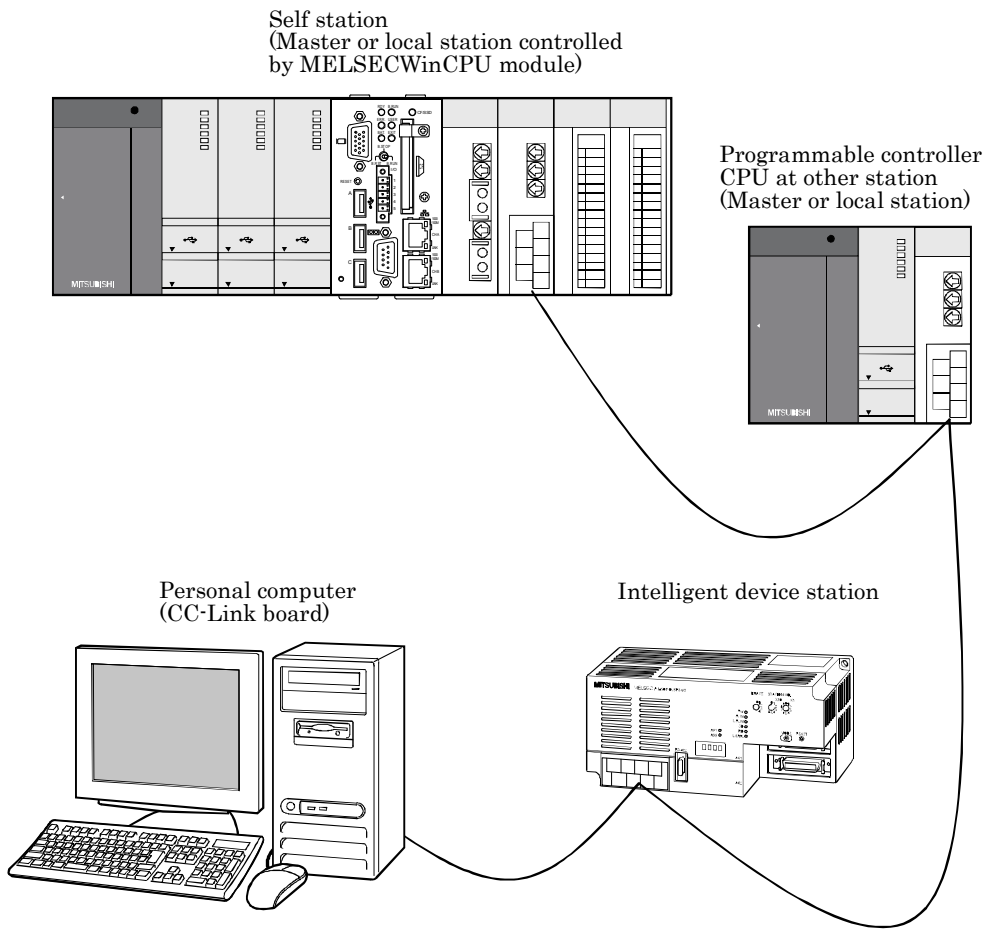

Point

If your own Sta.'s No. is 64, access to other Sta. is not possible.

Accessible for your own Sta.

7.2.2 Accessible Devices

This section describes devices accessible via CC- Link utility.

Point
(1) “Batch” and “Random” in the table indicates the following: Batch : Batch writing (mdSend), Batch reading(mdReceive) Random : Random writing (mdRandW), Random reading(mdRandR), bit setting (mdDevSet), bit resetting(mdDevRst)
(2) BitSet (mdDevSet function) and BitReset (mdDevRst function) can access bit devices only.

(1) Own Sta. accessing

The following lists the devices accessible via the CC- Link utility controlled by MELSECWinCPU module.

Device	Device type (Device name specification)	Used function	Accessibility
Own Sta. RX	DevX	Batch	O
		Random	
Own Sta. RY	DevY	Batch	O
		Random	
Own Sta. SB (link special B for CC-Link)	DevSM, DevQSB	Batch	O
		Random	
Own Sta. SW (link special W for CC-Link)	DevSD, DevQSW	Batch	O
		Random	
Own Sta. link register (for sending)	DevWw	Batch	O
		Random	
Own Sta. link register (for receiving)	DevWr	Batch	O
		Random	
Own Sta. buffer memory	DevSPB	Batch	O
		Random	
Own Sta. random access buffer	DevMRB	Batch	O
		Random	

O : Accessible, × : Not Accessible

(2) Other Sta. access

The following Access target CPUs from (1) to (7) are used for description.

No.	Target CPU
(1)	A1NCPU
(2)	A0J2HCPU, A1S(H)CPU, A1SJ(H)CPU, A2C(J)CPU, A2NCPU(-S1), A2S(H)CPU
(3)	A2ACPU(-S1), A2UCPU(-S1), A2USCPU(-S1), A2USHCPU-S1, Q02(H)CPU-A, Q06HCPU-A
(4)	A3NCPU, A3ACPU, A3UCPU
(5)	A4UCPU
(6)	Q2ACPU(-S1), Q3ACPU, Q4ACPU, Q4ARCPU, Q2ASCPU(-S1), Q2ASHCPU(-S1), Q00JCPU, Q00CPU, Q01CPU, Q02(H)CPU, Q06HCPU, Q12HCPU, Q25HCPU, Q02PHCPU, Q06PHCPU, Q12PHCPU, Q25PHCPU, Q00UJCPU, Q00UCPU, Q01UCPU, Q02UCPU, Q03UDCPU, Q04UDHCPU, Q06UDHCPU, Q10UDHCPU, Q13UDHCPU, Q20UDHCPU, Q26UDHCPU, Q03UDECPU, Q04UDEHCPU, Q06UDEHCPU, Q10UDEHCPU, Q13UDEHCPU, Q20UDEHCPU, Q26UDEHCPU, Q50UDEHCPU, Q100UDEHCPU, Q03UDVCPU, Q04UDVCPU, Q06UDVCPU, Q13UDVCPU, Q26UDVCPU, L02CPU, L02CPU-P, L26CPU-BT, L26CPU-PBT
(7)	Personal computer (CC-Link board), intelligent device station, MELSECWinCPU module (CC-Link module)

Device	Device type (Device name specification)	Used function	Accessibility						
			(1)	(2)	(3)	(4)	(5)	(6)	(7)
X	DevX	Batch	○	○	○	○	○	○	×
		Random	○	○	○	○	○	○	×
Y	DevY	Batch	○	○	○	○	○	○	×
		Random	○	○	○	○	○	○	×
L	DevL	Batch	○	○	○	○	○	○	×
		Random	○	○	○	○	○	○	×
M	DevM	Batch	○	○	○	○	○	○	×
		Random	○	○	○	○	○	○	×
Special M (SM), SB	DevSM	Batch	○	○	○	○	○	○	×
		Random	○	○	○	○	○	○	×
F	DevF	Batch	○	○	○	○	○	○	×
		Random	○	○	○	○	○	○	×
T (contact)	DevTT	Batch	○	○	○	○	○	○	×
		Random	○	○	○	○	○	○	×
T (coil)	DevTC	Batch	○	○	○	○	○	○	×
		Random	○	○	○	○	○	○	×
C (contact)	DevCT	Batch	○	○	○	○	○	○	×
		Random	○	○	○	○	○	○	×
C (coil)	DevCC	Batch	○	○	○	○	○	○	×
		Random	○	○	○	○	○	○	×
T (current value)	DevTN	Batch	○	○	○	○	○	○	×
		Random	○	○	○	○	○	○	×

○ : Accessible, × : Not Accessible

Device	Device type (Device name specification)	Used function	Accessibility						
			(1)	(2)	(3)	(4)	(5)	(6)	(7)
C (current value)	DevCN	Batch							
		Random	O	O	O	O	O	O	×
D	DevD	Batch							
		Random	O	O	O	O	O	O	×
Special D (SD), SW	DevSD	Batch							
		Random	O	O	O	O	O	O	×
T (setting value main)	DevTM	Batch	O	O	O	O	O		
		Random	×	×	×	×	×	×	×
T (setting value sub 1)	DevTS	Batch			O ^{*1}	O	O		
		Random	×	×	×	×	×	×	×
T (setting value sub 2)	DevTS2	Batch					O		
		Random	×	×	×	×	×	×	×
T (setting value sub 3)	DevTS3	Batch					O		
		Random	×	×	×	×	×	×	×
C (setting value main)	DevCM	Batch	O	O	O	O	O		
		Random	×	×	×	×	×	×	×
C (setting value sub 1)	DevCS	Batch			O	O	O		
		Random	×	×	×	×	×	×	×
C (setting value sub 2)	DevC2	Batch					O		
		Random	×	×	×	×	×	×	×
C (setting value sub 3)	DevC3	Batch					O		
		Random	×	×	×	×	×	×	×
A	DevA	Batch							
		Random	O	O	O	O	O	×	×
Z	DevZ	Batch							
		Random	O	O	O	O	O	O	×
V (index register)	DevV	Batch							
		Random	O	O	O	O	O	×	×
R (file register)	DevR	Batch							
		Random	×	O	O	O	O	O ^{*2}	×
ZR (extension file register)	DevZR	Batch							
		Random	×	×	×	×	×	O ^{*2}	×
ER (extension file register)	DevER(0) - DevER(256)	Batch							
		Random	×	O	O	O	O	O ^{*2}	×

O : Accessible, × : Not Accessible

*1 : Cannot access A2ACPU(-S1), A2USHCPU-S1 or Q02(H)CPU-A.

*2 : Cannot access Q00JCPU

Device	Device type (Device name specification)	Used function	Accessibility						
			(1)	(2)	(3)	(4)	(5)	(6)	(7)
B	DevB	Batch							
		Random	O	O	O	O	O	O	×
W	DevW	Batch							
		Random	O	O	O	O	O	O	×
Q/QnA link special relay (within the Q/QnACPU)	DevQSB	Batch	×	×	×	×	×	O	×
		Random	×	×	×	×	×	O	×
Retentive timer (contact)	DevSTT	Batch	×	×	×	×	×	O	×
		Random	×	×	×	×	×	O	×
Retentive timer (coil)	DevSTC	Batch	×	×	×	×	×	O	×
		Random	×	×	×	×	×	O	×
Q/QnA link special register (within the Q/QnACPU)	DevQSW	Batch	×	×	×	×	×	O	×
		Random	×	×	×	×	×	O	×
Q/QnA edge relay (within the Q/QnACPU)	DevQV	Batch	×	×	×	×	×	O	×
		Random	×	×	×	×	×	O	×
Own Sta. random access buffer	DevMRB	Batch	×	×	×	×	×	×	×
		Random	×	×	×	×	×	×	×
Retentive timer (current value)	DevSTN	Batch	×	×	×	×	×	O	×
		Random	×	×	×	×	×	O	×
Own Sta. link register (for sending)	DevWw	Batch	×	×	×	×	×	×	×
		Random	×	×	×	×	×	×	×
Own Sta. link register (for receiving)	DevWr	Batch	×	×	×	×	×	×	×
		Random	×	×	×	×	×	×	×
Own Sta. buffer memory	DevSPB	Batch	×	×	×	×	×	×	×
		Random	×	×	×	×	×	×	×
Direct link input (other Sta. side)	DevLX(1) - DevLX(255)	Batch	×	×	×	×	×	O	×
		Random	×	×	×	×	×	O	×
Direct link output (other Sta. side)	DevLY(1) - DevLY(255)	Batch	×	×	×	×	×	O	×
		Random	×	×	×	×	×	O	×
Direct link relay (other Sta. side)	DevLB(1) - DevLB(255)	Batch	×	×	×	×	×	O	×
		Random	×	×	×	×	×	O	×
Direct link register (other Sta. side)	DevLW(1) - DevLW(255)	Batch	×	×	×	×	×	O	×
		Random	×	×	×	×	×	O	×

O : Accessible, × : Not Accessible

Device	Device type (Device name specification)	Used function	Accessibility						
			(1)	(2)	(3)	(4)	(5)	(6)	(7)
Direct link special relay (other Sta. side)	DevLSB(1) - DevLSB(255)	Batch							
		Random	×	×	×	×	×	○	×
Direct link special register (other Sta. side)	DevLSW(1) - DevLSW(255)	Batch							
		Random	×	×	×	×	×	○	×
Special direct buffer register	DevSPG(0) - DevSPG(255)	Batch							
		Random	×	×	×	×	×	○	×
Other Sta. buffer memory *3	DevRBM	Batch	○	○	○	○	○	○	○
		Random	×	×	×	×	×	×	×
Other Sta. random access buffer *3	DevRAB	Batch	○	○	○	○	○	○	○
		Random	×	×	×	×	×	×	×
Other Sta. RX *3	DevRX	Batch	○	○	○	○	○	○	○
		Random	×	×	×	×	×	×	×
Other Sta. RY *3	DevRY	Batch	○	○	○	○	○	○	○
		Random	×	×	×	×	×	×	×
Other Sta. link register *3	DevRW	Batch	○	○	○	○	○	○	○
		Random	×	×	×	×	×	×	×
Other Sta. SB (Special B for CC-Link) *3	DevSB	Batch	○	○	○	○	○	○	○
		Random	×	×	×	×	×	×	×
Other Sta. SW (link special W for CC-Link) *3	DevSW	Batch	○	○	○	○	○	○	○
		Random	×	×	×	×	×	×	×
CPU shared memory	DevSPB1 (Machine No.1), DevSPB2 (Machine No.2), DevSPB3 (Machine No.3), DevSPB4 (Machine No.4)	Batch							
		Random	×	×	×	×	×	×	×

○ : Accessible, × : Not Accessible

*3 : Access to buffer memory of CC-Link (intelligent device station) modules mounted to each CPU module.
Cannot access a multiple CPU system (when logical Sta. No. are specified).

7.3 Access via MELSECNET/H module

This section describes accessible range and accessible devices via MELSECNET/H module.

7.3.1 Accessible Range

The following describes a system configuration of the accessible range and access possibility according to the destination CPU to be accessed through modules when access is made through MELSECNET/H modules.

(1) Configuration

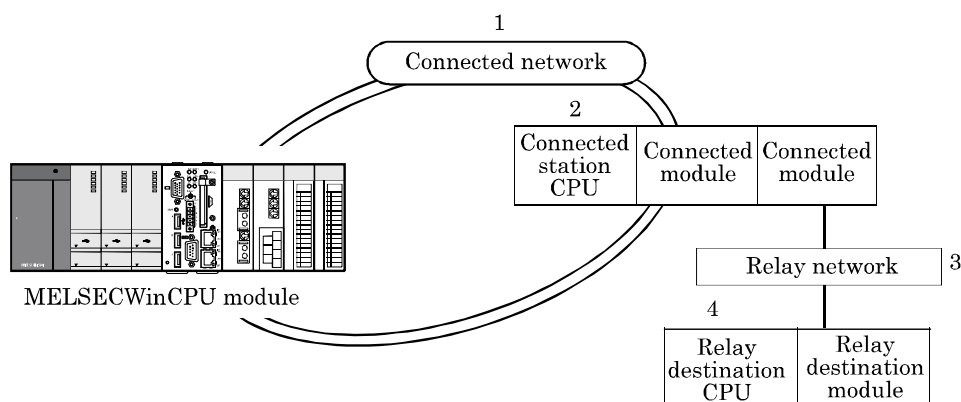

(2) Accessibility table

The following table shows the accessibility.

Own Sta. can be accessed.

1. Connected network	2. Connected station CPU	3. Relay network	4. Relay destination CPU			
			QCPU		QnACPU	ACPU
			Q mode	A mode		
MELSECNET/H	QCPU (Q mode)	CC-Link IE field network	×	×	×	×
		CC-Link IE controller network *1	○	×	×	×
		MELSECNET/H *2	○	×	×	×
		MELSECNET/10 *3	○	○	○	○
		MELSECNET(I)	×	×	×	×
		Ethernet	×	×	×	×
		Computer link	×	×	×	×
		CC-Link	×	×	×	×

○ : Accessible, × : Not Accessible

*1 : It is possible when control CPU of passed network is only entire universal model QCPU since the Sta. No. field 65.

*2 : The MELSECNET/H modules of the connected station can be accessed when in MELSECNET/H mode.

*3 : The MELSECNET/10(H) modules of the connected station can be accessed when in MELSECNET/10 mode.

1. Connected network	2. Connected station CPU	3. Relay network	4. Relay destination CPU			
			QCPU		QnACPU	ACPU
			Q mode	A mode		
MELSECNET/10	QCPU (Q mode)	CC-Link IE field network	×	×	×	×
		CC-Link IE controller network *1	O	×	×	×
		MELSECNET/H	O	×	×	×
		MELSECNET/10	O	O	O	O
		MELSECNET(II)	×	×	×	×
		Ethernet	×	×	×	×
		Computer link	×	×	×	×
	CC-Link	×	×	×	×	
	QnACPU	MELSECNET/H	×	×	×	×
		MELSECNET/10	O	O	O	O
		MELSECNET(II)	×	×	×	×
		Ethernet	×	×	×	×
		Computer link	×	×	×	×
	QCPU (A mode), ACPU	CC-Link	×	×	×	×
		MELSECNET/H	×	×	×	×
		MELSECNET/10	O	O	O	O
		MELSECNET(II)	×	×	×	×
		Ethernet	×	×	×	×
Computer link		×	×	×	×	

O : Accessible, × : Not Accessible

*1 : It is possible when control CPU of passed network is only entire universal model QCPU since the Sta. No. field 65.

7.3.2 Accessible Devices

This section describes devices accessible via MELSECNET/H module.

Point
<p>(1) “Batch” and “Random” in the table indicates the following :</p> <p>Batch : Batch writing (mdSend), Batch reading(mdReceive)</p> <p>Random : Random writing (mdRandW), Random reading(mdRandR), bit setting (mdDevSet), bit resetting (mdDevRst)</p> <p>(2) BitSet (mdDevSet function) and BitReset (mdDevRst function) can access bit devices only.</p>

(1) Own Sta. accessing

The following lists the devices accessible via the MELSECNET/H module controlled by MELSECWinCPU module.

Device	Device type (Device name specification)	Used function	Accessibility
Own Sta. link input internal buffer (LX buffer)	DevX	Batch	O
		Random	
Own Sta. link output internal buffer (LY buffer)	DevY	Batch	O
		Random	
Own Sta. link relay internal buffer (LB buffer)	DevB	Batch	O
		Random	
Own Sta. link register internal buffer (LW buffer)	DevW	Batch	O
		Random	
Own Sta. direct link special relay (SB)	DevSM, DevQSB	Batch	O
		Random	
Own Sta. direct link special register (SW)	DevSD, DevQSW	Batch	O
		Random	

O : Accessible, × : Not Accessible

(2) Other Sta. access

The following Access target CPUs from (1) - (7) are used for description.

No.	Target CPU
(1)	A1NCPU
(2)	A0J2HCPU, A1S(H)CPU, A1SJ(H)CPU, A2C(J)CPU, A2NCPU(-S1), A2S(H)CPU
(3)	A2ACPU(-S1), A2UCPU(-S1), A2USCPU(-S1), A2USHCPU-S1, Q02(H)CPU-A, Q06HCPU-A
(4)	A3NCPU, A3ACPU, A3UCPU
(5)	A4UCPU
(6)	Q2ACPU(-S1), Q3ACPU, Q4ACPU, Q4ARCPU, Q2ASCPU(-S1), Q2ASHCPU(-S1), Q00JCPU, Q00CPU, Q01CPU, Q02(H)CPU, Q06HCPU, Q12HCPU, Q25HCPU, Q02PHCPU, Q06PHCPU, Q12PHCPU, Q25PHCPU, Q00UJCPU, Q00UCPU, Q01UCPU, Q02UCPU, Q03UDCPU, Q04UDHCPU, Q06UDHCPU, Q10UDHCPU, Q13UDHCPU, Q20UDHCPU, Q26UDHCPU, Q03UDECPU, Q04UDEHCPU, Q06UDEHCPU, Q10UDEHCPU, Q13UDEHCPU, Q20UDEHCPU, Q26UDEHCPU, Q50UDEHCPU, Q100UDEHCPU, Q03UDVCPU, Q04UDVCPU, Q06UDVCPU, Q13UDVCPU, Q26UDVCPU
(7)	Personal computer (MELSECNET/H board), MELSECWinCPU module (MELSECNET/H module)

Device	Device type (Device name specification)	Used function	Accessibility						
			(1)	(2)	(3)	(4)	(5)	(6)	(7)
X	DevX	Batch	O	O	O	O	O	O	×
		Random	O	O	O	O	O	O	×
Y	DevY	Batch	O	O	O	O	O	O	×
		Random	O	O	O	O	O	O	×
L	DevL	Batch	O	O	O	O	O	O	×
		Random	O	O	O	O	O	O	×
M	DevM	Batch	O	O	O	O	O	O	×
		Random	O	O	O	O	O	O	×
Special M (SM), SB	DevSM	Batch	O	O	O	O	O	O	×
		Random	O	O	O	O	O	O	×
F	DevF	Batch	O	O	O	O	O	O	×
		Random	O	O	O	O	O	O	×
T (contact)	DevTT	Batch	O	O	O	O	O	O	×
		Random	O	O	O	O	O	O	×
T (coil)	DevTC	Batch	O	O	O	O	O	O	×
		Random	O	O	O	O	O	O	×
C (contact)	DevCT	Batch	O	O	O	O	O	O	×
		Random	O	O	O	O	O	O	×
C (coil)	DevCC	Batch	O	O	O	O	O	O	×
		Random	O	O	O	O	O	O	×
T (current value)	DevTN	Batch	O	O	O	O	O	O	×
		Random	O	O	O	O	O	O	×

O : Accessible, × : Not Accessible

Device	Device type (Device name specification)	Used function	Accessibility						
			(1)	(2)	(3)	(4)	(5)	(6)	(7)
C (current value)	DevCN	Batch	O	O	O	O	O	O	×
		Random	O	O	O	O	O	O	×
D	DevD	Batch	O	O	O	O	O	O	×
		Random	O	O	O	O	O	O	×
Special D (SD), SW	DevSD	Batch	O	O	O	O	O	O	×
		Random	O	O	O	O	O	O	×
T (setting value main)	DevTM	Batch	O	O	O	O	O	×	×
		Random	×	×	×	×	×	×	×
T (setting value sub 1)	DevTS	Batch	×	×	O	O	O	×	×
		Random	×	×	×	×	×	×	×
T (setting value sub 2)	DevTS2	Batch	×	×	×	×	O	×	×
		Random	×	×	×	×	×	×	×
T (setting value sub 3)	DevTS3	Batch	×	×	×	×	O	×	×
		Random	×	×	×	×	×	×	×
C (setting value main)	DevCM	Batch	O	O	O	O	O	×	×
		Random	×	×	×	×	×	×	×
C (setting value sub 1)	DevCS	Batch	×	×	O*1	O	O	×	×
		Random	×	×	×	×	×	×	×
C (setting value sub 2)	DevC2	Batch	×	×	×	×	O	×	×
		Random	×	×	×	×	×	×	×
C (setting value sub 3)	DevC3	Batch	×	×	×	×	O	×	×
		Random	×	×	×	×	×	×	×
A	DevA	Batch	O	O	O	O	O	×	×
		Random	O	O	O	O	O	O	×
Z	DevZ	Batch	O	O	O	O	O	O	×
		Random	O	O	O	O	O	O	×
V (index register)	DevV	Batch	O	O	O	O	O	×	×
		Random	O	O	O	O	O	×	×
R (file register)	DevR	Batch	×	O	O	O	O	O*2	×
		Random	×	O	O	O	O	O*2	×
ZR (extension file register)	DevZR	Batch	×	×	×	×	×	O*2	×
		Random	×	×	×	×	×	O*2	×
ER (extension file register)	DevER(0) - DevER(256)	Batch	×	O	O	O	O	O*2	×
		Random	×	O	O	O	O	O*2	×

O : Accessible, × : Not Accessible

*1 : Cannot access A2ACPU(-S1), A2USHCPU-S1 or Q02(H)CPU-A.

*2 : Cannot access Q00JCPU

Device	Device type (Device name specification)	Used function	Accessibility						
			(1)	(2)	(3)	(4)	(5)	(6)	(7)
B	DevB	Batch							
		Random	O	O	O	O	O	O	×
W	DevW	Batch							
		Random	O	O	O	O	O	O	×
Q/QnA link special relay (within the Q/QnACPU)	DevQSB	Batch	×	×	×	×	×	O	×
		Random	×	×	×	×	×	O	×
Retentive timer (contact)	DevSTT	Batch	×	×	×	×	×	O	×
		Random	×	×	×	×	×	O	×
Retentive timer (coil)	DevSTC	Batch	×	×	×	×	×	O	×
		Random	×	×	×	×	×	O	×
Q/QnA link special register (within the Q/QnACPU)	DevQSW	Batch	×	×	×	×	×	O	×
		Random	×	×	×	×	×	O	×
Q/QnA edge relay (within the Q/QnACPU)	DevQV	Batch	×	×	×	×	×	O	×
		Random	×	×	×	×	×	O	×
Own Sta. random access buffer	DevMRB	Batch	×	×	×	×	×	×	×
		Random	×	×	×	×	×	×	×
Retentive timer (current value)	DevSTN	Batch	×	×	×	×	×	O	×
		Random	×	×	×	×	×	O	×
Own Sta. link register (for sending)	DevWw	Batch	×	×	×	×	×	×	×
		Random	×	×	×	×	×	×	×
Own Sta. link register (for receiving)	DevWr	Batch	×	×	×	×	×	×	×
		Random	×	×	×	×	×	×	×
Own Sta. buffer memory	DevSPB	Batch	×	×	×	×	×	×	×
		Random	×	×	×	×	×	×	×
Direct link input (other Sta. side)	DevLX(1) - DevLX(255)	Batch	×	×	×	×	×	O	×
		Random	×	×	×	×	×	O	×
Direct link output (other Sta. side)	DevLY(1) - DevLY(255)	Batch	×	×	×	×	×	O	×
		Random	×	×	×	×	×	O	×
Direct link relay (other Sta. side)	DevLB(1) - DevLB(255)	Batch	×	×	×	×	×	O	×
		Random	×	×	×	×	×	O	×
Direct link register (other Sta. side)	DevLW(1) - DevLW(255)	Batch	×	×	×	×	×	O	×
		Random	×	×	×	×	×	O	×
Direct link special relay (other Sta. side)	DevLSB(1) - DevLSB(255)	Batch	×	×	×	×	×	O	×
		Random	×	×	×	×	×	O	×
Direct link special register (other Sta. side)	DevLSW(1) - DevLSW(255)	Batch	×	×	×	×	×	O	×
		Random	×	×	×	×	×	O	×

O : Accessible, × : Not Accessible

Device	Device type (Device name specification)	Used function	Accessibility						
			(1)	(2)	(3)	(4)	(5)	(6)	(7)
Special direct buffer register	DevSPG(0) - DevSPG(255)	Batch	×	×	×	×	×	○	×
		Random	×	×	×	×	×	○	×
Other Sta. buffer memory	DevRBM	Batch	×	×	×	×	×	×	×
		Random	×	×	×	×	×	×	×
Other Sta. random access buffer	DevRAB	Batch	×	×	×	×	×	×	×
		Random	×	×	×	×	×	×	×
Other Sta. RX	DevRX	Batch	×	×	×	×	×	×	×
		Random	×	×	×	×	×	×	×
Other Sta. RY	DevRY	Batch	×	×	×	×	×	×	×
		Random	×	×	×	×	×	×	×
Other Sta. link register	DevRW	Batch	×	×	×	×	×	×	×
		Random	×	×	×	×	×	×	×
Other Sta. SB (link special B for CC-Link)	DevSB	Batch	×	×	×	×	×	×	×
		Random	×	×	×	×	×	×	×
Other Sta. SW (link special W for CC-Link)	DevSW	Batch	×	×	×	×	×	×	×
		Random	×	×	×	×	×	×	×
CPU shared memory	DevSPB1 (Machine No.1), DevSPB2 (Machine No.2), DevSPB3 (Machine No.3), DevSPB4 (Machine No.4)	Batch	×	×	×	×	×	×	×
		Random	×	×	×	×	×	×	×

○ : Accessible, × : Not Accessible

8. Actions against Errors

This chapter provides troubleshooting information, including information on various errors, return values (error codes) of bus interface functions and MELSEC data link functions, and available actions.

8.1 Basis on Troubleshooting

Before starting troubleshooting, the following three points must be checked.

(1) Visual check

Check the following :

- 1). The operating state of each external device
- 2). The operating state of each external power supply
- 3). Whether connection cables are correctly connected or not?
- 4). The operating states of the MELSECWinCPU module and the power supply module (determined from such as the states of LEDs)
Ex. : B.RUN LED and ERR.LED of MELSECWinCPU module, POWER LED of power module
- 5). Whether LEDs of the input module and the output module light appropriately according to the states of INPUT (X) and OUTPUT (Y)?
- 6). Whether each module is secured to the base unit?

Once you checked the above items 1) - 6), connect to external devices and check the operation of user programs.

(2) Defect check

Check whether the state of the defect(s) changes or not according to methods :

- 1). Turn INPUT (X) to ON and OFF in order to check whether data can be read on user programs.
- 2). Turn OUTPUT (Y) to ON and OFF in order to check whether the state of each external device properly changes in response to it.

(3) Identification of the cause

The hardware and/or software on which more failures are detected during (1) and (2) is more likely the cause of the problem.

Among the following, identify the cause and perform troubleshooting :

- 1) MELSECWinCPU module
- 2) External device
- 3) Module (Excluding MELSECWinCPU module)
- 4) Connection cable
- 5) User program

8.2 Troubleshooting

Upon occurrence of a trouble, follow the troubleshooting flow on the basis of the table given below :

No.	Trouble description	Referring paragraph
1	Flow when POWER LED of PSU went out	8.2.1
2	Flow when MELSECWinCPU module does not work properly	8.2.2
3	Flow when SW1PNC-WCPU-B cannot be installed	8.2.3
4	Flow when ERR.LED lights/blinks	8.2.4
5	Flow for UNIT VERIFY ERR.	8.2.5
6	Flow for CONTROL-BUS.ERR.	8.2.6
7	Flow for errors on function execution	8.2.7
8	Flow when LED of the output module does not light	8.2.8
9	Flow when the output load of the output module does not turn on	8.2.9
10	Troubleshooting when B.RUN LED continues to blink in the multiple CPU system configuration	8.2.10
11	Flow when "Bus I/F driver not activated" is displayed	8.2.11
12	Flow for "link refresh time over"	8.2.12
13	When BIOS error is displayed at startup of this module	*1
14	When OS does not operate properly	*1

*1 : Please refer to "MELSECWinCPU Module User's Manual (Hardware Design, Function Explanation)".

8.2.1 Flow when POWER LED of PSU went out

The following diagram shows the flow which should be performed when POWER LED goes out at power-on or during operation of the MELSECWinCPU system.

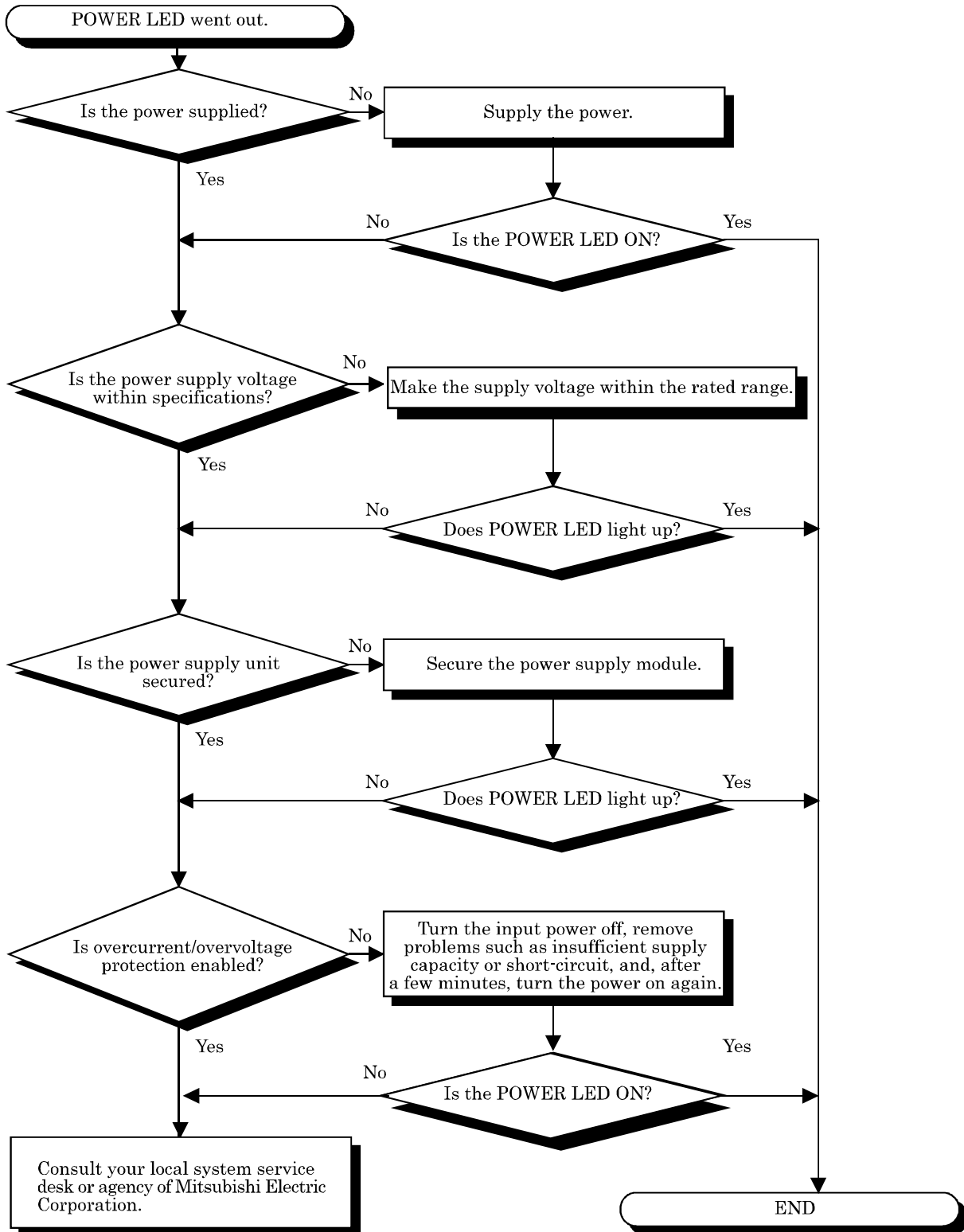

8.2.2 Flow when MELSECWinCPU module does not work properly

The following diagram shows the Flow When MELSECWinCPU Module Does Not Work Properly.

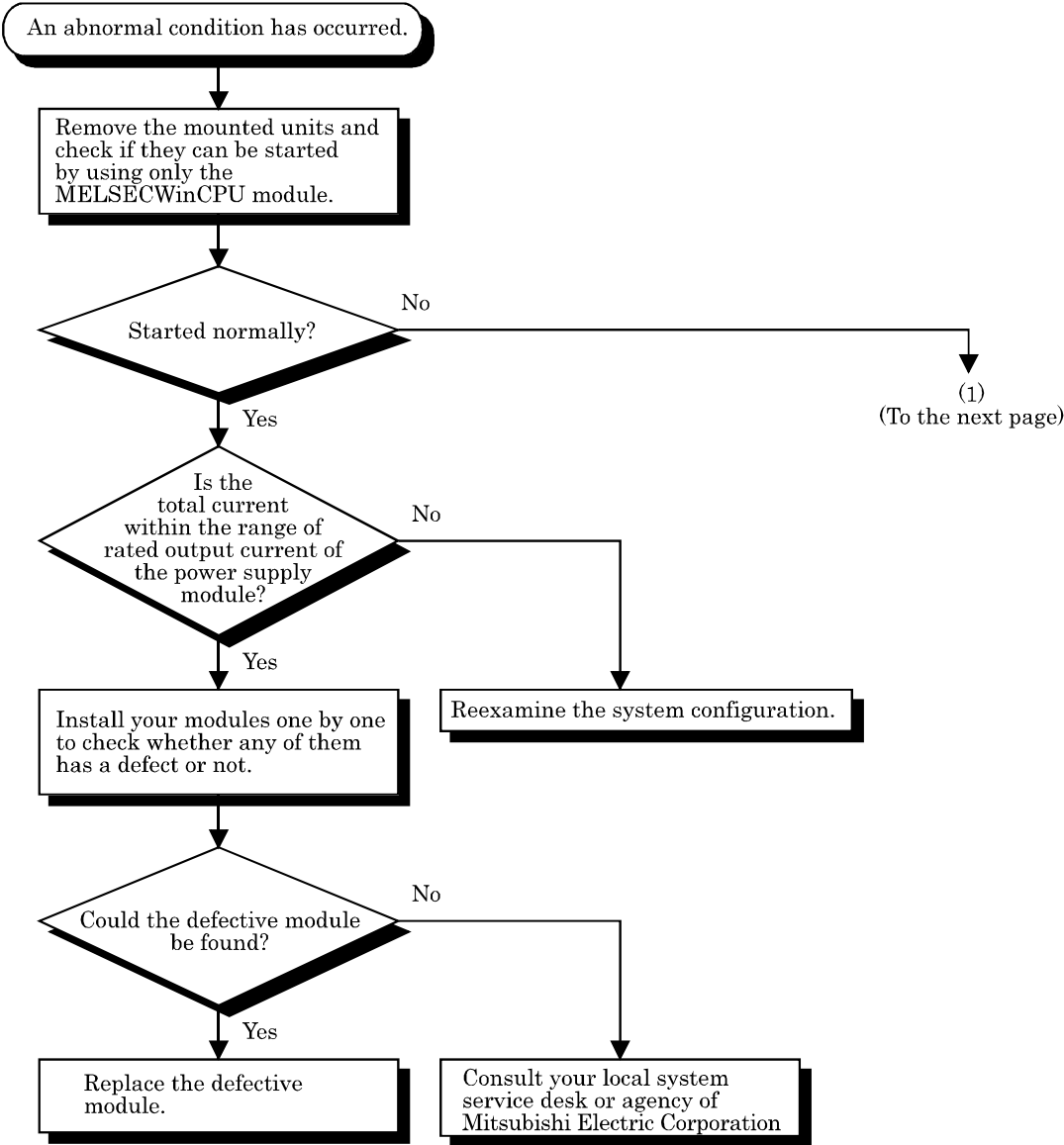

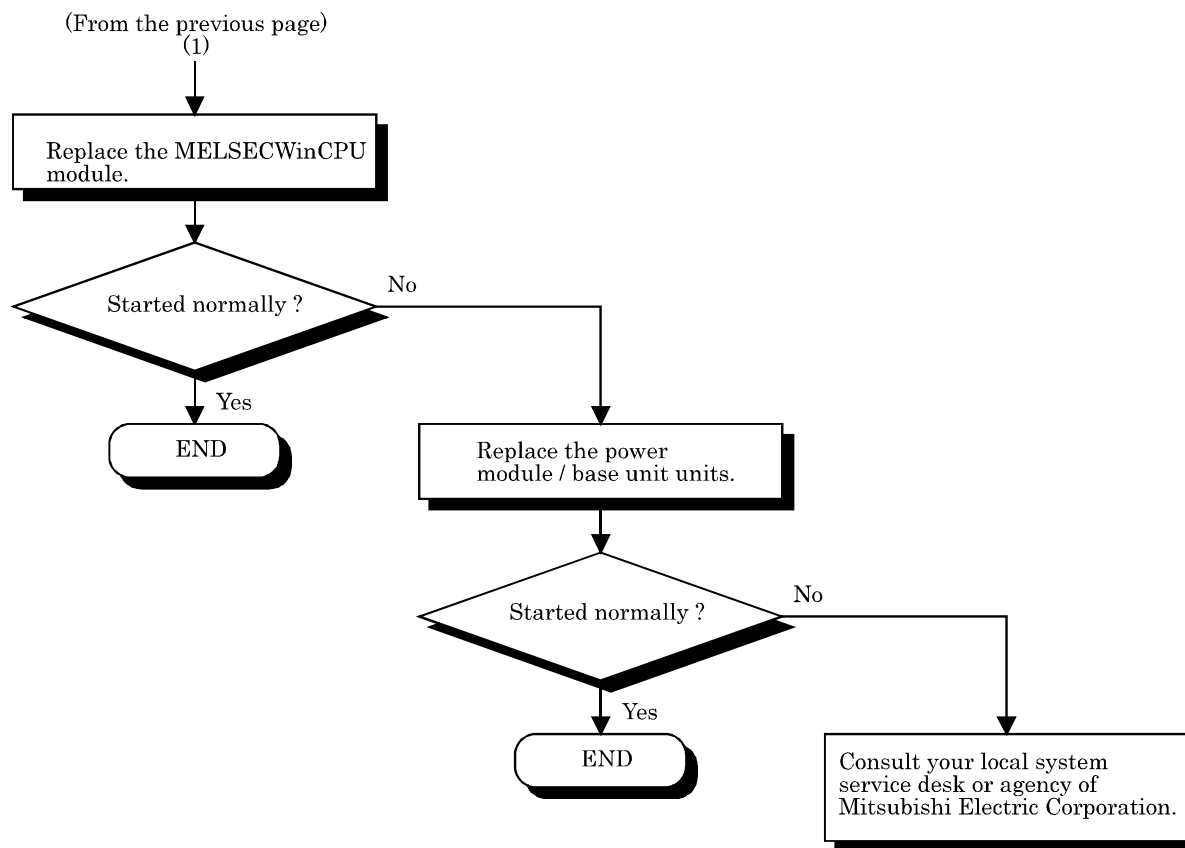

8.2.3 Flow when SW1PNC-WCPU-B cannot be installed

The following diagram shows the flow which should be performed when SW1PNC-WCPU-B cannot be installed.

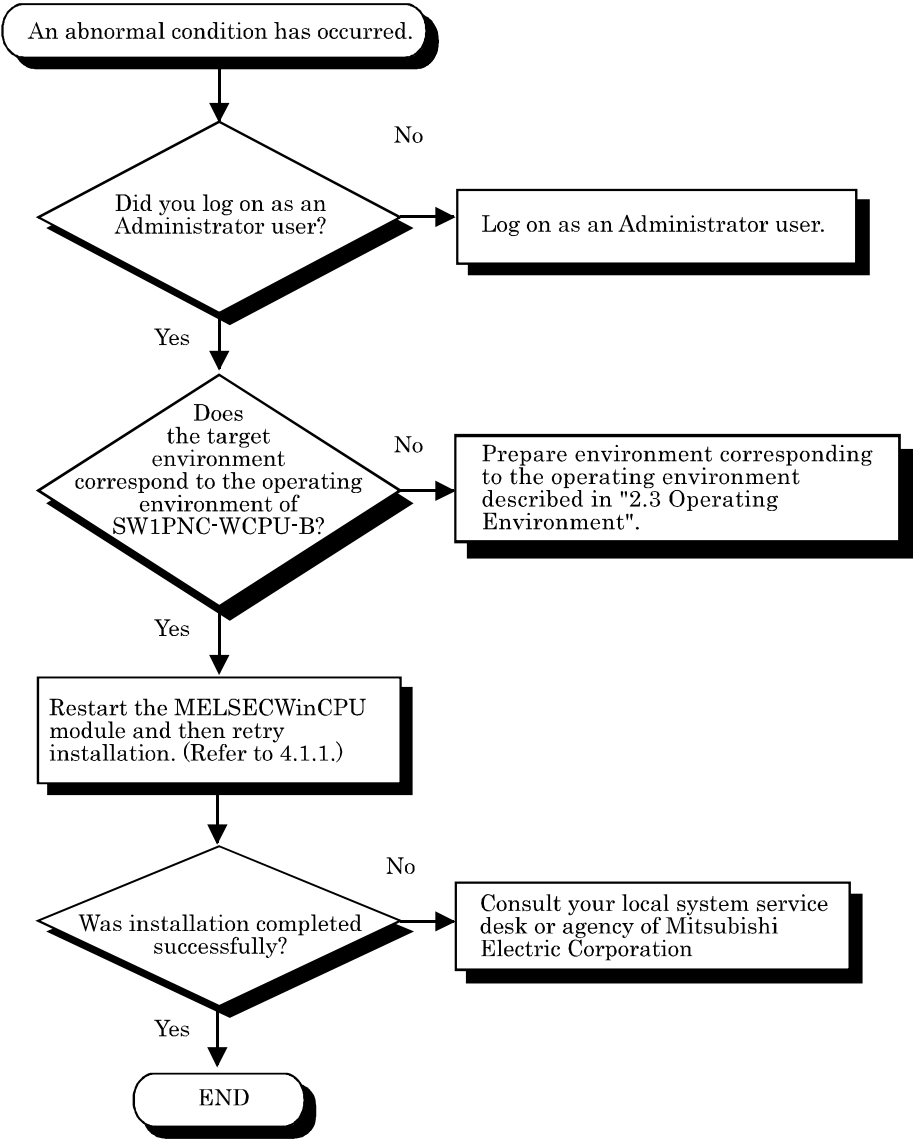

8.2.4 Flow when ERR.LED lights/blinks

This section describes the flow which should be performed when ERR LED lights up or blinks at power-on, starting up of operation or during operation of the MELSECWinCPU system.

(1) Error in the case of the multiple CPU system configuration

On the PC Diagnostic screen of GX Works2 which is connected to the programmable controller CPU or is running on the MELSECWinCPU module, check the module No. of the CPU in which STOP or CONTINUATION error occurred first and information on the error (error code, current error, and date and time).

(2) Error in the MELSECWinCPU module (this module) :

Perform the flow shown below.

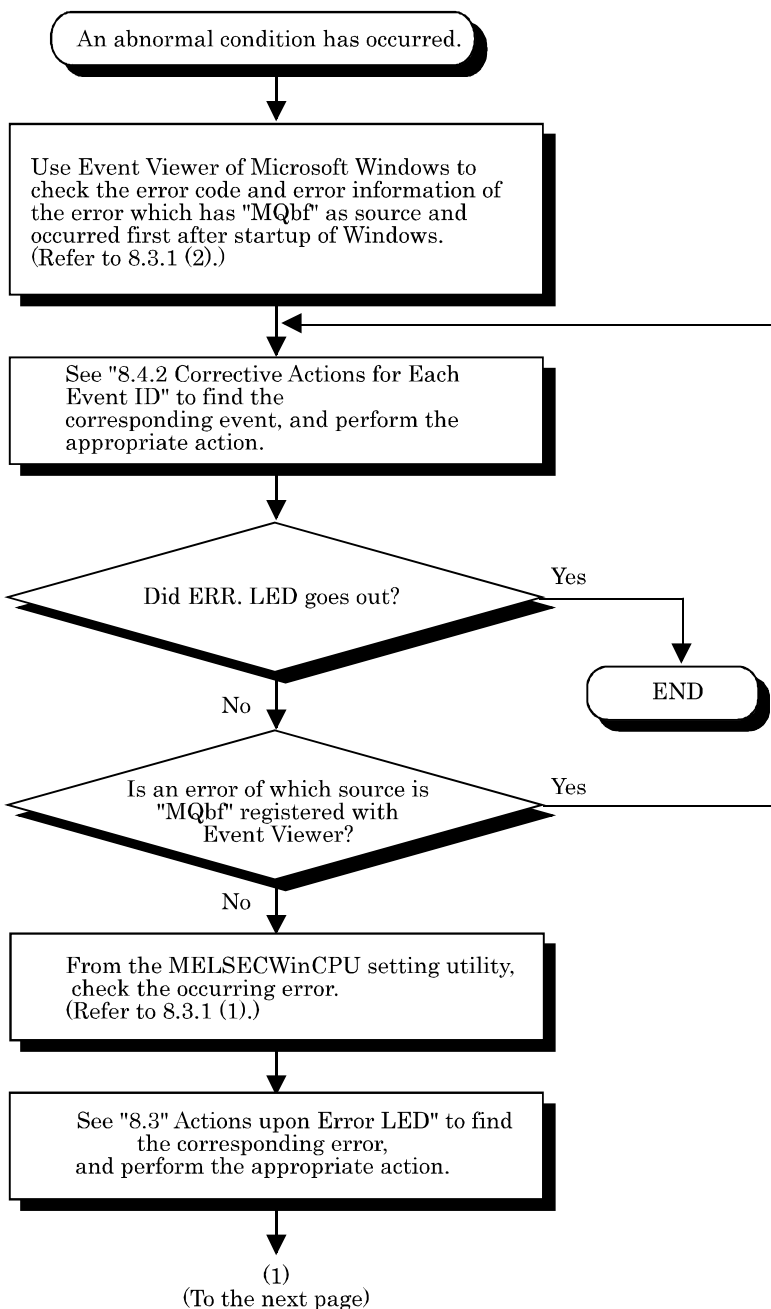

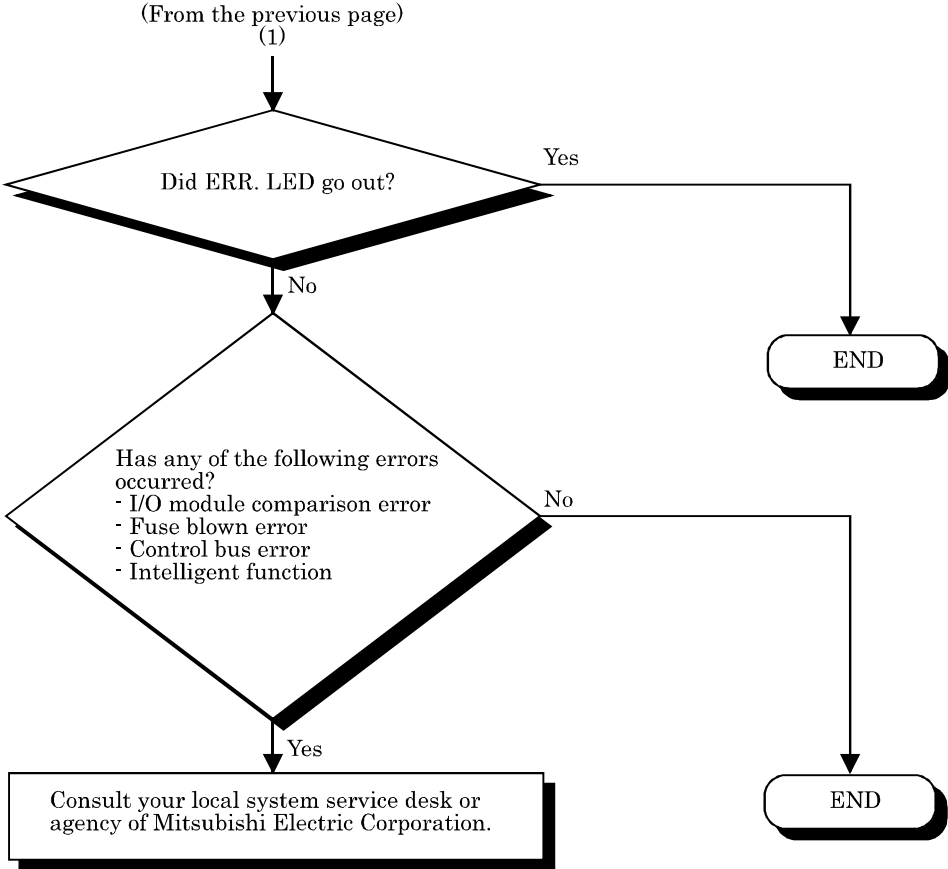

8.2.5 Flow for UNIT VERIFY ERR.

The following diagram shows the flow which should be performed when an I/O module verification error (Error code 2000 : UNIT VERIFY ERR.) occurred at power-on or during operation of the MELSECWinCPU system.

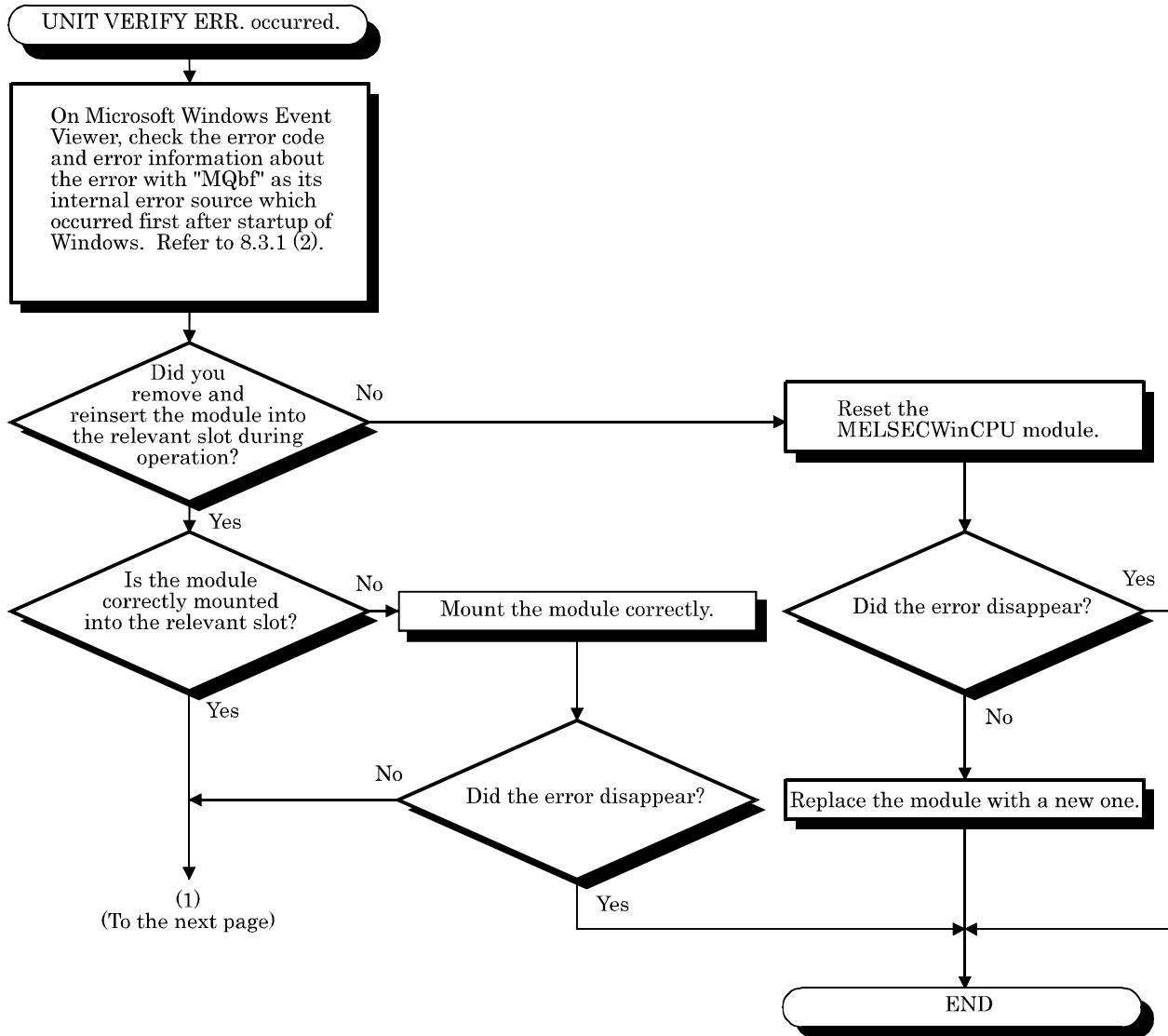

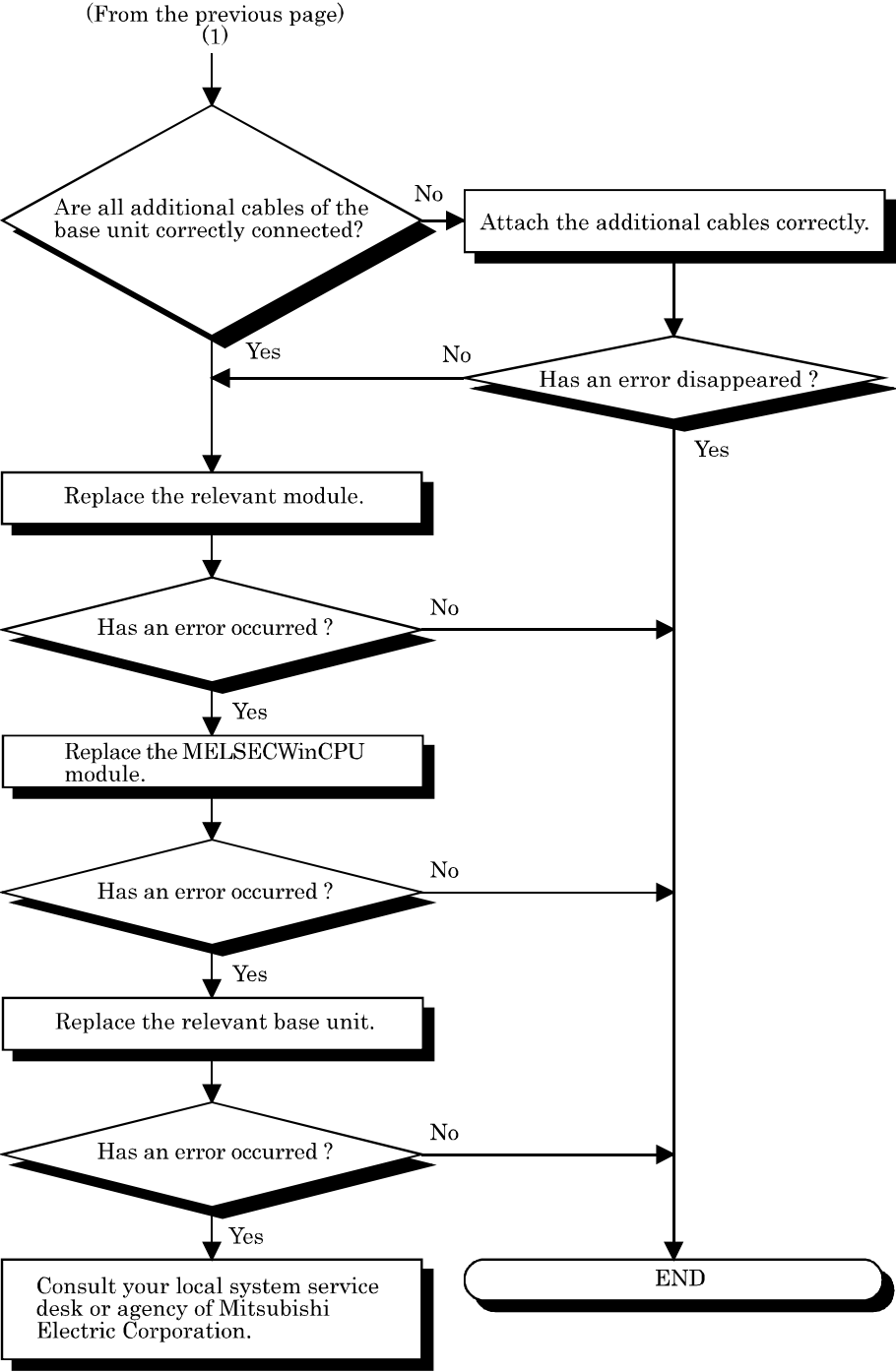

8.2.6 Flow for CONTROL-BUS.ERR.

The following diagram shows the flow which should be performed when a control bus error (Error codes 1412 - 1416 : CONTROL-BUS.ERR) occurs at power-on or during operation of the MELSECWinCPU system.

However, this flow is available only in the case where the faulty slot or base unit can be determined from the error code.

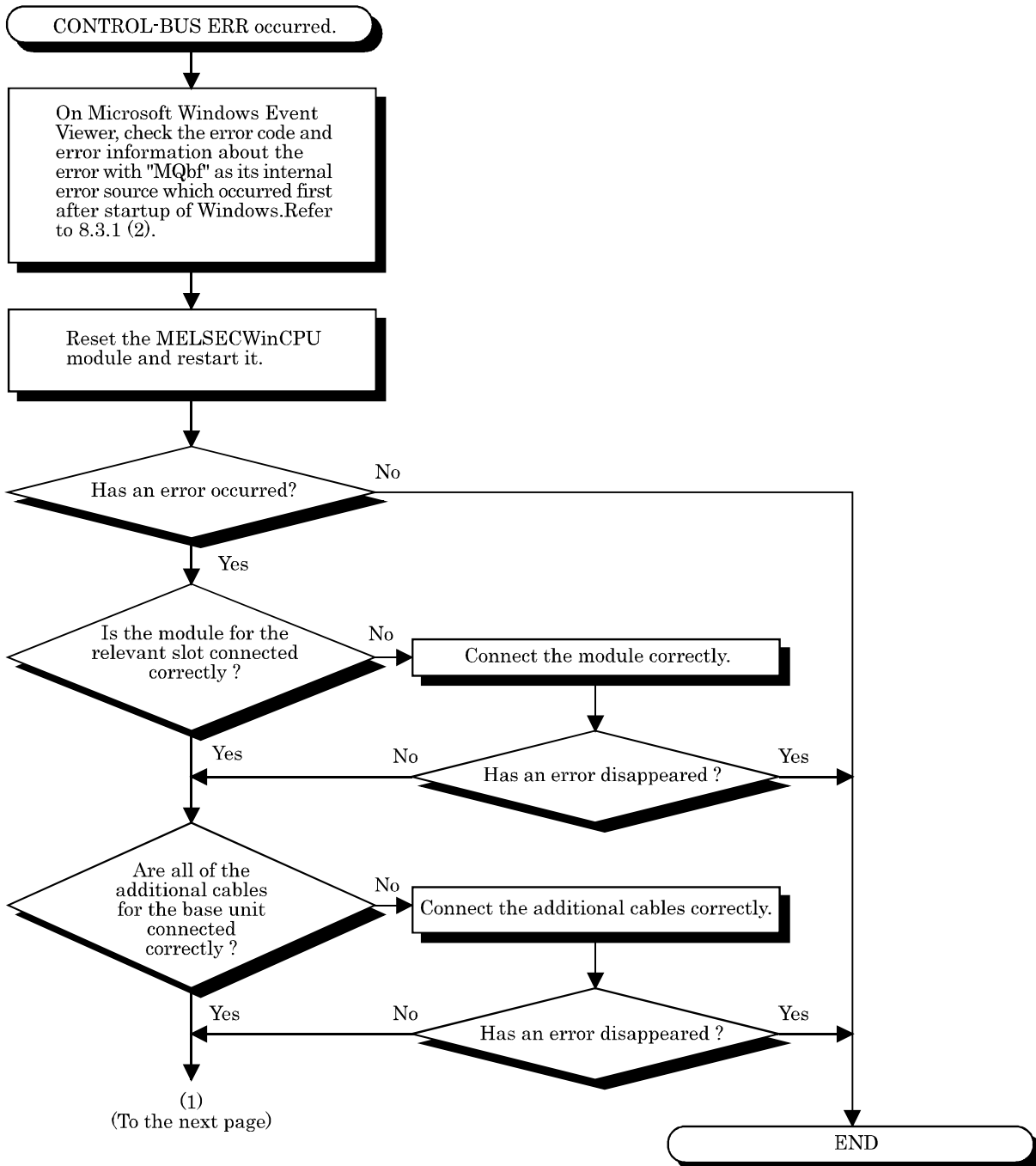

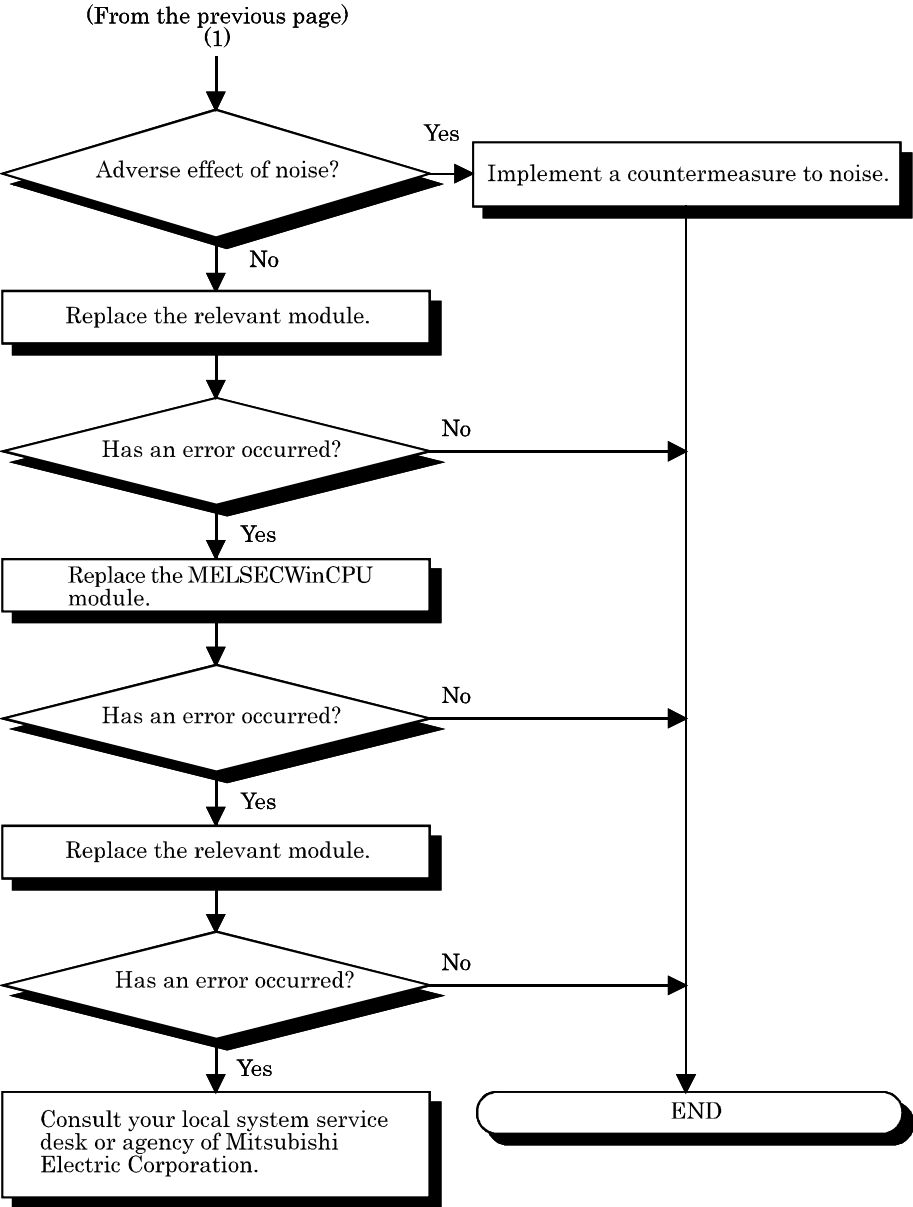

8.2.7 Flow for errors on function execution

The following diagram shows the flow which should be performed when an error occurred on the MELSECWinCPU system during execution of a function.

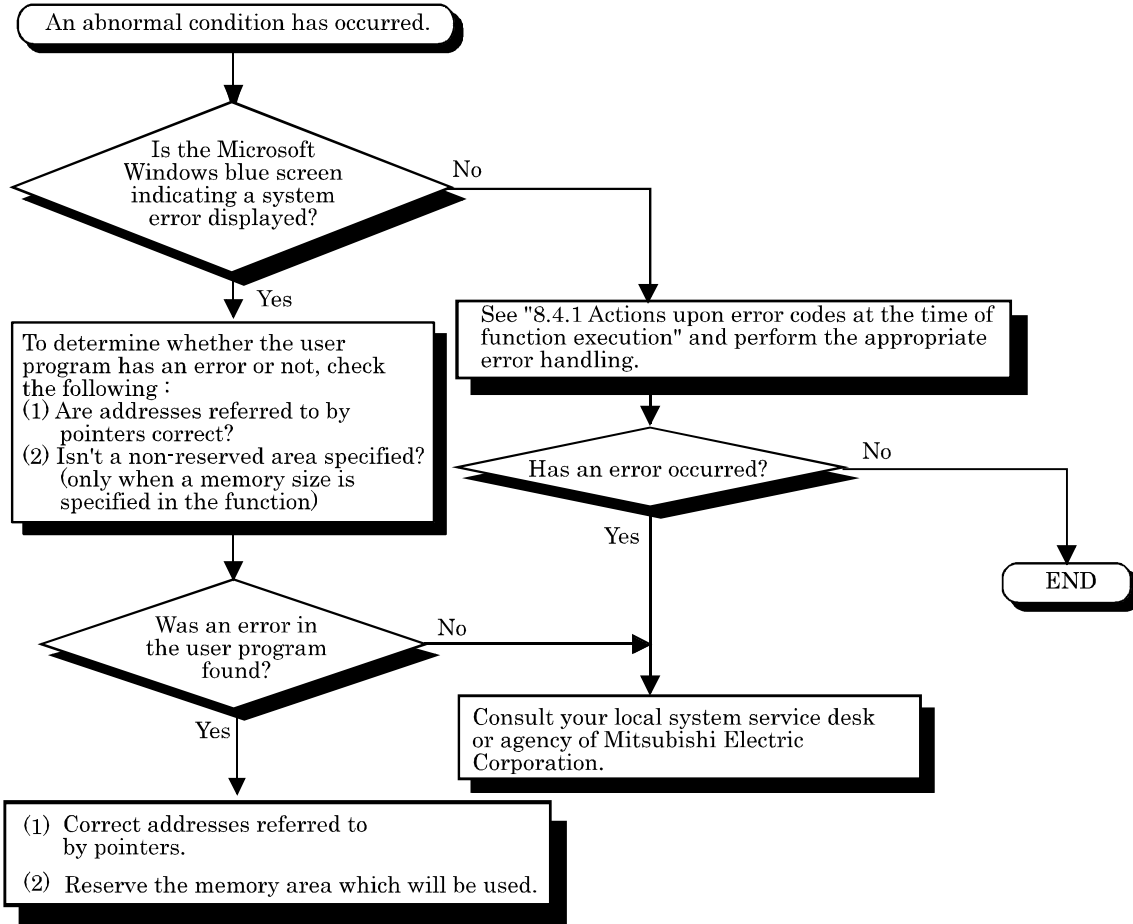

8.2.8 Flow when LED of the output module does not light

The following diagram shows the flow which should be performed when LED of the output module does not light during operation of the MELSECWinCPU system.

Point

Before starting investigation according to the following flow, ensure that B.RUN LED of the MELSECWinCPU module lights.

If it doesn't, put the MELSECWinCPU module into the RUN state to turn B.RUN LED on.

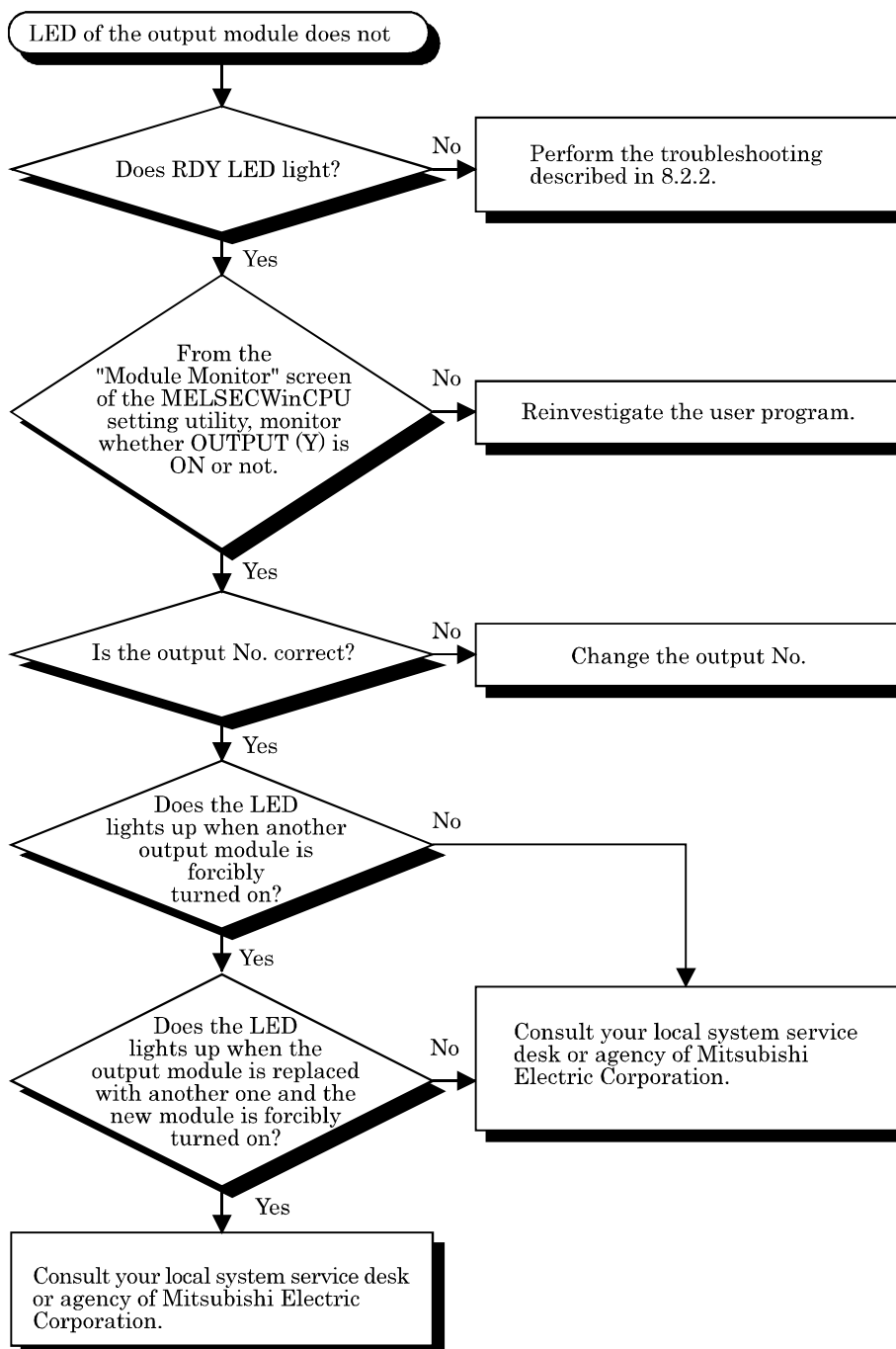

8.2.9 Flow when the output load of the output module does not turn on

The following diagram shows the flow which should be performed when the output load of the output module is not turned on during operation of the MELSECWinCPU system.

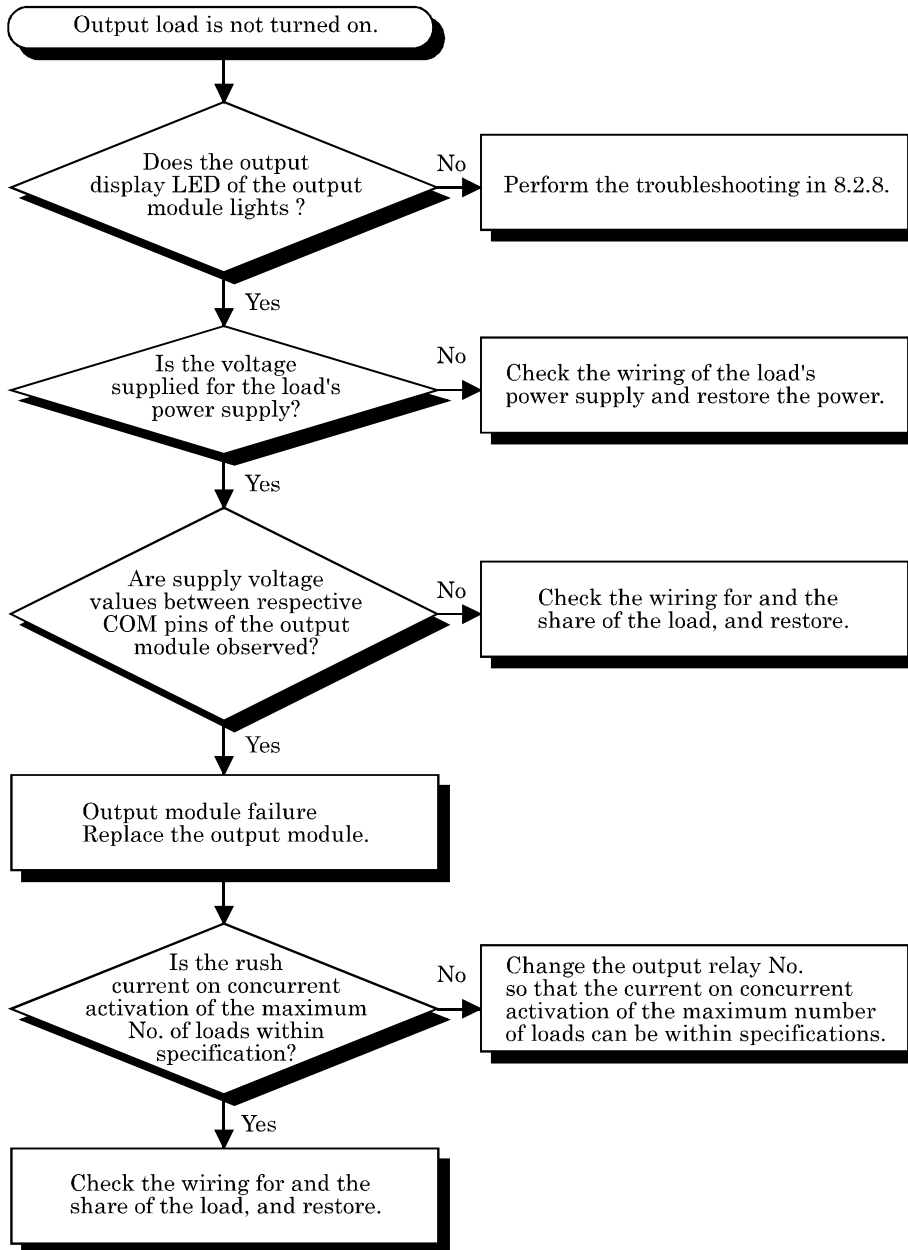

8.2.10 Troubleshooting when B.RUN LED continues to blink in the multiple CPU system configuration

If B.RUN LED continues to blink in the multiple CPU system configuration, clear reset of the CPU module No.1.

For information on how to clear reset of a CPU module, refer to "QCPU User's Manual(Hardware Design, Maintenance and Inspection)".

8.2.11 Flow when "Bus I/F driver not activated" is displayed

The following diagram shows the flow which should be performed when the "Bus I/F driver not activated" message is displayed at startup of the MELSECWinCPU setting utility.

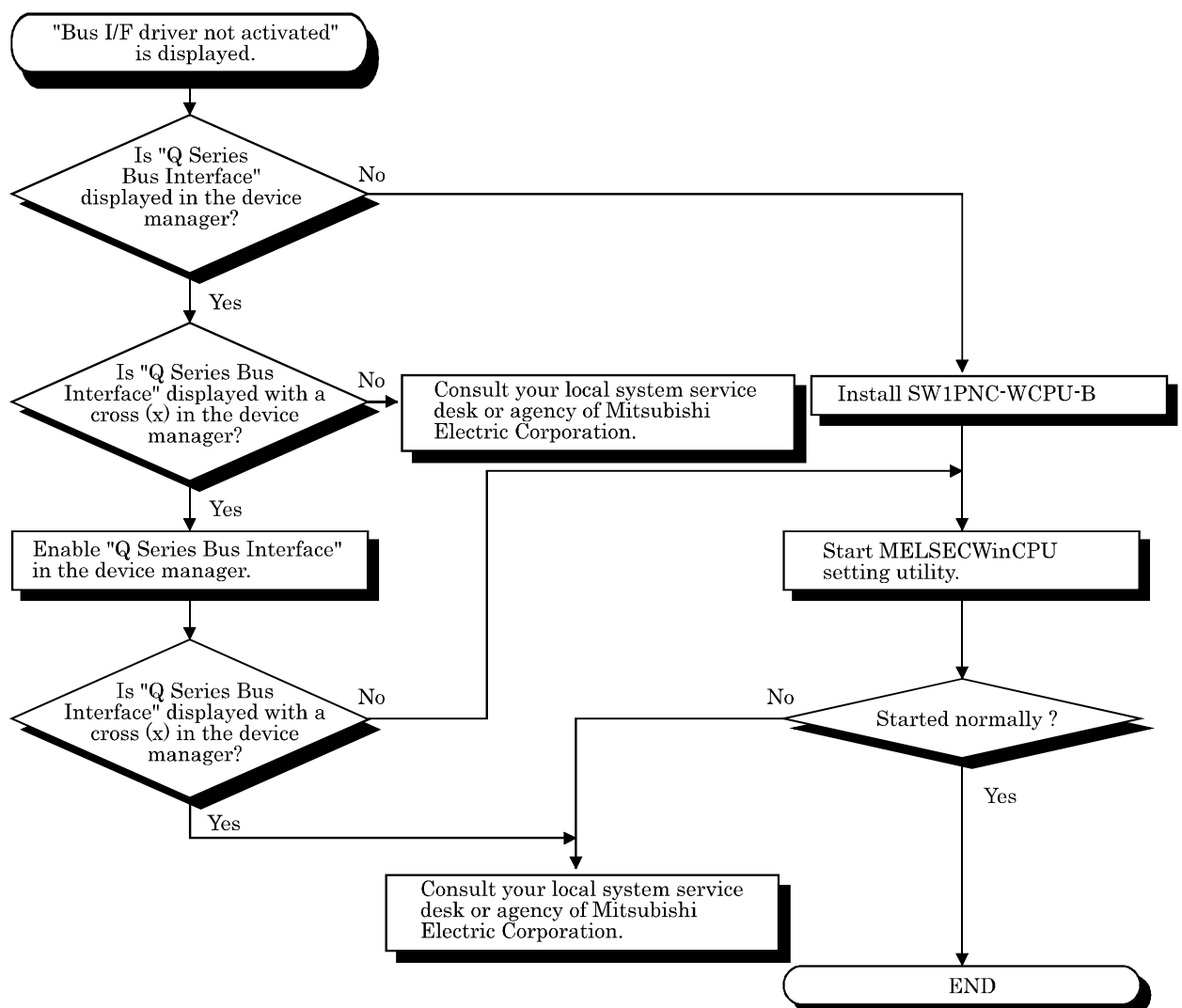

8.2.12 Flow for "link refresh time over"

The following diagram shows the flow which should be performed when "link refresh time over" occurred during operation of the MELSECWinCPU system.

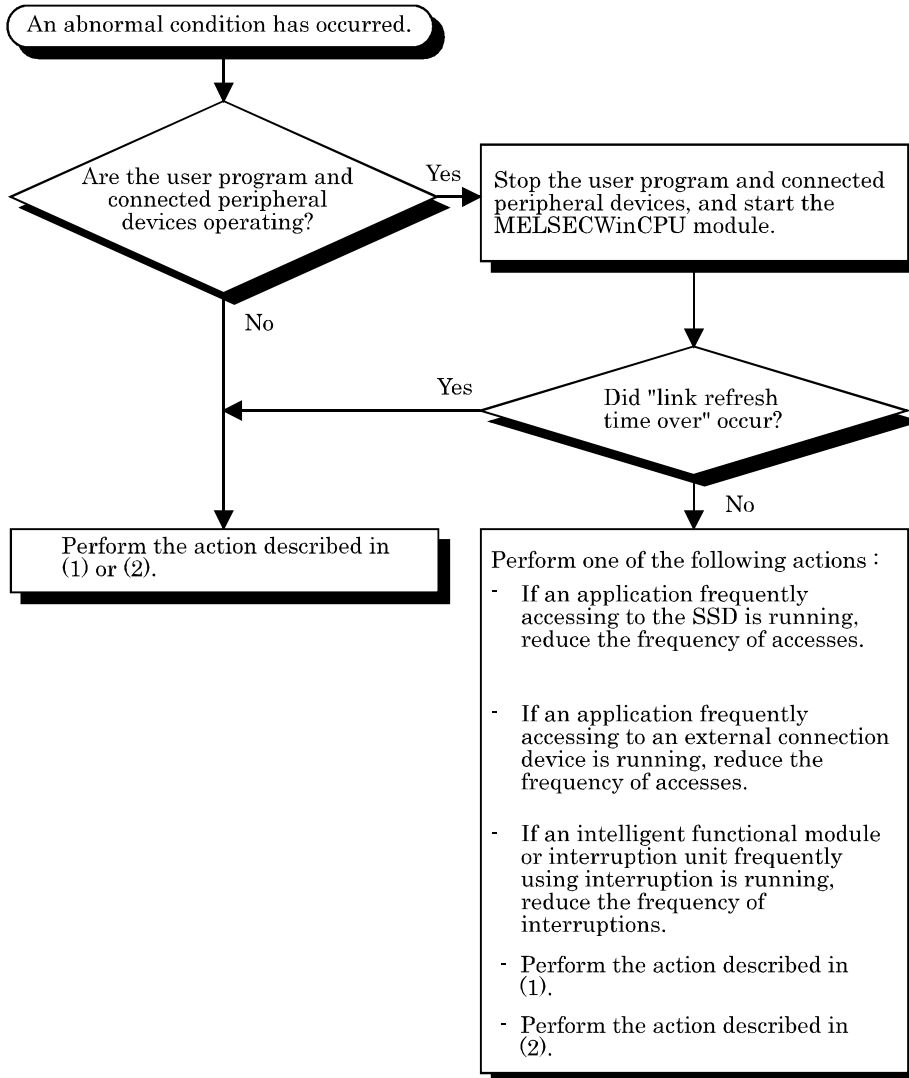

(1) Increasing a link device refresh cycle value

Increase the setting value of the link device refresh cycle to be larger than the actual measurement value of the maximum link device refresh time.

The actual measurement value of the maximum link device refresh time can be confirmed on the "Module Information" screen of the MELSECNET/H utility (refer to 5.4.2) or by using the QBF_ReadStatusEx function (refer to the help information on bus interface functions).

For information about setting the link device refresh cycle, refer to "5.4.6 Operating on Routing Parameter Setting Window".

(2) Reducing a link device refresh cycle value

Reduce the logical value of the total link device refresh time to be smaller than the setting value of the link device refresh cycle by decreasing the No. of points for refresh.

For more details on the setting value of the link device refresh cycle, refer to "5.5.6 Operating on Routing Parameter Setting Window".

The logical value of the total link device refresh time can be calculated by the following formula :

$$B_T, B_R = KM1 + KM2 \times \left\{ \frac{LB + LX + LY + (LW \times 16)}{16} \right\} [\text{ms}]$$

β_T : Total link device refresh time (Sending side)

β_R : Total link device refresh time (Receiving side)

LB : The total No. of link relay (LB) which should be refreshed by the station. *1

LW : Total No. of link registers (LW) refreshed by the station *1

LX : Total No. of link input (LX) refreshed by the station *1

LY : Total No. of link output (LY) refreshed by the station *1

KM1, KM2 : See the constants shown below.

Where to mount MELSECNET/H module	KM1	KM2 (x10 ⁻³)
Main base unit	1.33	0.95
Additional base unit	1.33	1.08

*1 : The total No. of points of areas in which link refresh is actually performed.

In other words, the total No. of points of mounted MELSECNET/H modules managed by the MELSECWinCPU module (including studded unused areas).

8.3 Actions upon Error LED

When a STOP or Continuation error occurs and an alert is issued, the items corresponding to the error and alert are changed from (white) to (red) in "Error Information" and "Alert information," and the relevant error code is displayed in the "Module Information" screen of the MELSECWinCPU setting utility.*¹

*1 : For errors other than STOP and CONTINUATION errors, no information is displayed in "Error Code," "Error Information," and "Alert Information" and therefore, you must check details by Event Viewer.

The action which should be taken when each error item is changed from (white) to (red) is as follows.

8.3.1 How to confirm error information

How to confirm error information when ERR.LED lights or blinks is described below.

(1) MELSECWinCPU setting utility

- 1). Click [Start] - [Program] - [MELSECWinCPU module] - [MELSECWinCPU setting utility].
The MELSECWinCPU setting utility starts.
- 2). Click the "Module Information" tab.
- 3). Click the **Start monitor** button.
- 4). An error code is displayed on the screen (see the following screen diagram).

For details of error codes and corresponding actions, refer to "8.3.4 Detailed error description and actions"

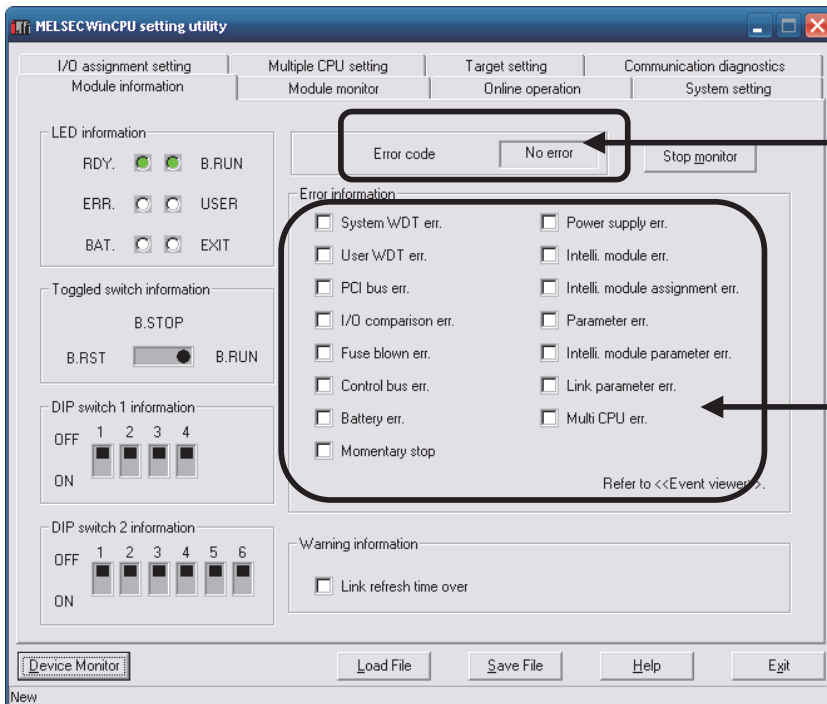

When the error item corresponding to the occurred error is changed from (white) to (red), an error code is displayed. During monitoring, it is always refreshed to the latest error code.

For details of error codes, refer to 8.3.4.

According to the current error and/or alert, the corresponding error item is changed from (white) to (red).

For the mapping between respective error items and errors, refer to 8.3.3.

Point

- (1) To switch to another tab during monitoring, stop the monitoring.
Then, restart monitoring when displaying the "Module Information" tab again.
- (2) It cannot be monitored while the bus interface driver is reset.
Start monitoring after the reset is completed.

(2) Event viewer

When ERR. LED lights up or blinks, error information is registered with Event Viewer.
Refer to "8.3.4 Detailed error description and actions" for details and actions against the error.

1). Starting up event viewer

Start up event viewer by the following procedures :

Select [Start] - [Control Panel] - [Administrative Tools] - [Event Viewer] to display system log.

2). Selecting event

An error registered in event viewer is displayed as "mqbf" in "Source" on event viewer.
Select an event with "mqbf" indication to display details of the event.

Select an event for which "MQbf" is displayed first since the last startup of Windows to view details of the event.

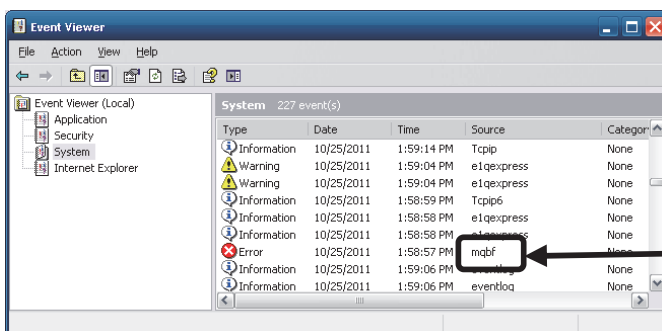

Errors in MELSECWinCPU module are indicated as "mqbf" at "Source".

3). Verifying Error code

An error code is displayed at the portion shown below.

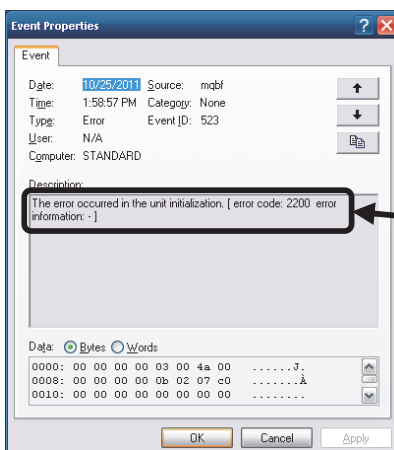

Error code and error information are displayed here.
For more details on this, refer to "8.3.4 Detailed error description and actions".

8.3.2 Detection timings and operation

No	Item	Description	Detection timing	Detection operation			
				Halt output *1	ERR LED Illuminates, blinking *2	Display error in MELSEC WinCPU setting utility / warning *3	Log in event viewer *4
1	System WDT error detected	Detected a system WDT error	Continuous	O	O	O *12	O
2	User WDT error detected	Detected a user WDT error	Continuous	O	O	O *12	O
3	PCI bus error detected	Detected the occurrence of PCI bus parity error, PCI bus target abort error	Continuous	O	O	O *11, *12	O
4	Battery error detected	Detected battery error on MELSECWinCPU module	Periodic monitoring	-	O*5	O *11, *13	-
5	Detection of immediate power outage	An immediate power outage was detected.	Continuous	-	-	O *12	O
6	I/O module comparison error detected *7, *8	Diagnostics of I/O module mounting status	Periodic monitoring	O	O	O *12	O
7	Fuse blown error detected *7, *8	Output module fuse status check	Periodic monitoring	O	O	O *12	O
8	Control bus error detected	Base unit bus status check	Power On, resetting, periodic monitoring, module access	O	O	O *12	O
9	Intelligent function module error detected *9	Detected abnormality in intelligent function module, Detected abnormality in intelligent function module based on card information and X signal An failure in the intelligent function module was detected through handshake (keep alive check).	Power On, resetting, periodic monitoring, module access At occurrence of interruption	O	O	O *12	O



O : Performed - : Not performed

No	Item	Description	Detection timing	Detection operation			
				Halt output *1	ERR LED Illuminates, blinking *2	Display error in MELSEC WinCPU setting utility / warning *3	Log in event viewer *4
10	Intelligent function module assignment error detected	I/O allocation status check for intelligent function module	Power ON, reset	O	O	O *12	O
11	Parameter error detected	Parameter check for system settings, Multiple CPU settings, etc.	Power ON, reset	O	O	O *12	O
12	Intelligent module parameter error detected	Parameter check for intelligent function module	Power ON, reset	O	O	O *12	O
13	Link parameter error detected	Parameter check for link module (CC- Link, MELSECNET/H)	Power ON, reset	O	O	O *12	O
14	Multiple CPU error *10	Detected CPU error on multiple CPU system or multiple CPU consistency error	Periodic monitoring, power ON, reset	O	O	O *12	O
15	Power error *6	A fault in the power supply module or the MELSECWinCPU module was detected.	Periodic monitoring, power ON, reset	O	O	O *12	O
16	link device refresh time over	The link device refresh time with the MELSECNET/H module exceeded the setting value.	Periodic monitoring, power ON, reset	-	-	O *11, *12	-

O : Performed - : Not performed

- *1 : In the "Error time output mode" of the "I/O Module & Intelligent Function Module Detailed Setting" screen (accessible from the "I/O Assignment Setting" screen of the MELSECWinCPU setting utility), you can select whether to clear or keep the output state of each module in the case where a STOP error occurred on the MELSECWinCPU module.
- *2 : ERR.LED lights up for STOP errors and blinks for CONTINUATION errors.
- *3 : When more than one STOP or CONTINUATION errors and alerts are detected, the latest error code is displayed in the "Error Code" area, the items corresponding to the occurred errors and alerts are changed from (white) to (red) in the "Error Information" area and the "Alert information" area of the "Module Information" screen of the MELSECWinCPU setting utility.
For only error items logged by Event Viewer, you can see detailed information in the viewer.
- *4 : Only errors that do not already exist are registered with Event Viewer.
- *5 : BAT. LED on the front panel of the MELSECWinCPU module lights up (not ERR.LED).
- *6 : The No. of times of detection of immediate power outages can be confirmed by the QBF_ReadStatusEx function. "Detection of immediate power outage"(including update of the No. of detection) is not performed while the MELSECWinCPU module is detecting "power supply errors."
- *7 : This detection can be disabled by specifying it in "Error check" of the "System Setting" screen of the MELSECWinCPU setting utility.
- *8 : The operating state of CPU at detection of an error can be changed to "Continue" by specifying it in "Operating mode when there is an error" of the "System Setting" screen of the MELSECWinCPU setting utility.
- *9 : The operating state of CPU at detection of an error can be changed to "Continue" by specifying it in "H/W error time CPU operating mode" of the "I/O Module & Intelligent Function Module Detailed Setting" screen which is accessible from the "I/O Assignment Setting" screen of the MELSECWinCPU setting utility.
- *10 : Whether to stop the multiple CPU system or not can be specified in "Operating mode" of the "Multiple CPU Setting" screen of the MELSECWinCPU setting utility.
- *11 : No error code will be displayed in "Error code" of the "Module Information" screen.
- *12 : Once a STOP or CONTINUATION error or alert occurred, the corresponding item is kept in red in "Error information" or "Alert information" of the "Module Information" screen of the MELSECWinCPU setting utility.
- *13 : According to the state of each STOP or CONTINUATION error, the corresponding item is changed to (red) or (white) in "Error information" of the "Module Information" screen of the MELSECWinCPU setting utility.

8.3.3 Actions determined from error/alert information and error codes

This section describes errors and alerts which are indicated by changing the corresponding items from  (white) to  (red).

For details of self-diagnostic items, refer to "8.3.2 Detection timings and operation".

For detailed error information and actions, refer to "8.3.4 Detailed error description and actions" after confirmation of the error codes shown in the following table.

For detailed information and actions on errors and alerts for which error codes are not displayed, see the following table.

Error item	Self-diagnostic item	Description	Error code
System WDT error	Detection of system WDT error	A system watchdog timer error was detected.	5000
User WDT error	Detection of user WDT error	A user watchdog timer error was detected.	5001
I/O module comparison error	Detection of I/O module comparison error	An error occurred during diagnostic of the mount state of the I/O module.	2000
Fuse blown error	Detection of fuse blown error	An error occurred during diagnostic of the state of the fuse of the I/O module.	1300
Control bus error	Detection of control bus error	An error occurred during diagnostic of the state of buses on the base unit.	1412, 1413, 1414, 1415, 1416
Immediate power outage	Detection of immediate power outage	An immediate power outage was detected.	1500
Power error	Detection of power error	A failure in the power supply module or the MELSECWinCPU module was detected.	1009, 1510, 1520
Intelligent function module error	Detection of intelligent function module error	A failure in the intelligent function module was detected.	1310, 1401, 1403

Error item	Self-diagnostic item	Description	Error code
Intelligent function module assignment error	Detection of intelligent function module assignment error	An error occurred during diagnostic of the I/O assignment state of the intelligent function module.	2100, 2103, 2106, 2107, 2120, 2122, 2124, 2125, 2126, 2150
Parameter error	Detections of parameter error	An error occurred during diagnostic of parameters such as system setting and multiple CPU setting.	2200, 3000, 3001, 3010, 3012, 3014
Intelligent module parameter error	Detections of intelligent module parameter error	Error occurred in parameter checking between intelligent function module.	3300, 3301, 3303
Link parameter error	Detections of link parameter error	An error occurred during diagnostic of parameters for network modules (CC-Link module, MELSECNET/H module).	3100, 3101, 3102, 3103, 3104, 3105, 3107
Multiple CPU error	Detections of Multiple CPU error	For the multiple CPU system configuration, an error in a CPU module other than own or in the multiple CPU system was detected.	7000, 7002, 7010, 7020
PCI bus error	Detections of PCI bus parity error, PCI bus target abort error	Error description : A PCI bus error occurred on the MELSECWinCPU module. Method : The MELSECWinCPU module must be replaced. Consult your local system service desk or agency of Mitsubishi Electric Corporation.	-

Error item	Self-diagnostic item	Description	Error code
Battery error	Detection of MELSECWinCPU module battery error	Error description : The battery voltage of the MELSECWinCPU module body dropped to below the default.	-
		Method : The battery must be replaced. Consult your local system service desk or agency of Mitsubishi Electric Corporation.	
Link refresh time over	Detections of link refresh time over	Error description : The link device refresh time with the MELSECNET/H module exceeded the setting value (link device refresh cycle).	-
		Method : refer to "8.2.12 Flow for "link refresh time over" to take action	
		Method : Move the MELSECWinCPU module to a place which has appropriate temperatures. If the detected abnormal temperature is higher than or equal to 255°C, it may be a failure in the hard disk module and you need to consult your local system service desk or agency of Mitsubishi Electric Corporation.	

8.3.4 Detailed error description and actions

The following summarizes Error descriptions identified by an error code, actions, and error information. If an error code which is not included in the following error code list will be detected, contact Mitsubishi Electric System Service CO., LTD. or a branch or dealer of Mitsubishi Electric Corporation to receive advice on the symptom.

Error code	Error information	Error description	Action
1009	-	A failure in the power supply module, the MELSECWinCPU module, the base unit, an additional base unit, or an additional cable was detected.	Reset and rerun the MELSECWinCPU module. If the same error appears again, it is a failure in the power supply module, the MELSECWinCPU module, the base unit, an additional base unit or an additional cable. Replace the faulty module with a new one. Or, consult your local system service desk or agency of Mitsubishi Electric Corporation.
1300	Module No. *1	Fuse is broken in an output module.	Check ERR.LEDs of the output module and replace the module of which ERR.LED lights. - Check the output module's No. (module No.) in Event Viewer and replace the corresponding fuse. - When GOT is bus-connected to the base unit or an additional base unit, check the connection state of the additional cable and the state of the ground wire of GOT.
1310	-	Into a slot specified as empty by I/O assignment, an interruption module for A is mounted.	Compare I/O assignment with modules which are actually mounted.
		An interrupt occurred when no interrupt module is installed.	Because at least one of the mounted modules has a hardware failure, check these modules and replace the faulty module(s). Consult your local system service desk or agency of Mitsubishi Electric Corporation.

*1 : For example, error information (module No.) will be displayed in "Description" of the Event tab of Event Viewer in the following format :

"Error information : XX-YYY"

XX(decimal) : Slot No. (0 - 63), CPU No. (1 - 4)

YYY (hexadecimal) : Start I/O No.÷16(0000H-00FFH, 03E0H -03E3H)

Error code	Error information	Error description	Action
1401	Module No. *1	- No response is returned from intelligent function module upon updating of initials. - Buffer memory size in intelligent function module is faulty.	Hardware of accessed intelligent function module is faulty. Consult your local system service desk or agency of Mitsubishi Electric Corporation.
1403	Module No. *1	Error was detected in intelligent function module (handshake error).	
1412	Module No. *1	Execution of FROM/TO instruction is impossible due to control bus failure to intelligent function module.	Reset and rerun the MELSECWinCPU module. If the same error appears again, it is a failure in the intelligent function module, the MELSECWinCPU module or the base unit, consult your local system service desk or agency of Mitsubishi Electric Corporation.
1413	-	In the multiple CPU system a module incompatible with the system is mounted.	- Remove the multiple CPU system incompatible module from the basic base unit. Otherwise, replace the incompatible CPU module with a compatible one. Or, move the incompatible CPU module to the CPU slot or one of Slots 0 - 2. - This is a failure in the intelligent function module, the CPU module or the base unit, and consult your local system service desk or agency of Mitsubishi Electric Corporation.
		A failure on the system bus was detected. - System bus self-diagnostic error - CPU module self-diagnostic error	Reset and rerun the MELSECWinCPU module. If the same error appears again, it is a failure in the intelligent function module, the MELSECWinCPU module or the base unit, consult your local system service desk or agency of Mitsubishi Electric Corporation.
		For the multiple CPU configuration, reset of Module No.1 was tried while B.RUN LED was blinking. Or, Windows was restarted only on the MELSECWinCPU.	Retry to reset Module No.1.

*1 : For example, error information (module No.) will be displayed in "Description" of the Event tab of Event Viewer in the following format :

"Error information: XX-YYY", XX (decimal): Slot No.(0 - 63), CPU No. (1 - 4),

YYY(hexadecimal): Start I/O No.+16 (0000H-00FFH, 03E0H -03E3H)

8 Actions against Errors

Error code	Error information	Error description	Action
1414	Module No. *1	Error was detected on installed modules. In a multiple CPU system, a CPU module incompatible with the multiple CPU system is mounted.	<ul style="list-style-type: none"> - Remove the CPU module incompatible with the multiple CPU system from the main base unit. Or, replace the CPU module incompatible with the multiple CPU system with a CPU module compatible with the multiple CPU system. - Reset the MELSECWinCPU module and RUN it again. If the same error is displayed again, the intelligent function module, CPU module or base unit is faulty. Please consult your retailer.
1415	Base No.	Error was detected on main base unit or expansion base unit.	Failure of intelligent function module, MELSECWinCPU module or base unit.
1416	Module No. *1	Bus failure was detected upon turning the power on or upon resetting.	Consult your local system service desk or agency of Mitsubishi Electric Corporation.
		During multiple CPU system operation, Windows was restarted on a MELSECWinCPU module (the MELSECWinCPU module was reset).	<ul style="list-style-type: none"> - Reset Module No.1, and then restart the multiple CPU system. - For the reset specifications when a multiple CPU system is configured, refer to "MELSECWinCPU Module User's Manual (Hardware Design, Function Explanation)".
1500	-	<ul style="list-style-type: none"> - An immediate power outage of the electric supply source was detected. (The No. of times of detection of immediate power outages can be confirmed by the QBF_ReadStatusEx function.) - The electric supply source was turned off. 	Check the electric supply source.
1510	Base No./power No.	On the dual base units, the supply voltage of one side dropped.	Check the electric power supply to the dual power modules mounted on the dual base units.
1520	Base No./power No.	In the dual-power system, a failure was detected in one of the dual power modules.	This is a hardware failure in the dual power modules, and consult your local system service desk or agency of Mitsubishi Electric Corporation.
1600	-	<ul style="list-style-type: none"> - The battery voltage of the MELSECWinCPU module body dropped to below the default. - The lead connector of the battery of the MELSECWinCPU module body is not attached. 	<ul style="list-style-type: none"> - Replace the battery. - Attach the lead connector.

*1 : For example, error information (module No.) will be displayed in "Description" of the Event tab of Event Viewer in the following format :

"Error information: XX-YYY"

XX (decimal) : Slot No.(0 - 63), CPU No.(1 - 4)

YYY (hexadecimal) : Start I/O No.÷16 (0000H - 00FFH, 03E0H - 03E3H)

Error code	Error information	Error description	Action
1601	-	Battery voltage on memory card went down below specified value.	Replace batteries of card mounted on PC card slot.
2000	Module No. *1	In a multiple CPU system, a CPU module incompatible with the multiple CPU system is mounted.	Replace the CPU module incompatible with the multiple CPU system with a CPU module compatible with the multiple CPU system
		I/O module information is different than that upon turning on the power. (Installation status of I/O module was changed during operation, or a module is about to drop off.	<ul style="list-style-type: none"> - Check error information on Event Viewer, and check/replace the module corresponding to the identified numeric value (module No.). - When a GOT is bus-connected to the main base unit or extension base unit, check the connection status of the extension cable and the grounding status of the GOT.
		During multiple CPU system operation, Windows was restarted on a MELSECWinCPU module (the MELSECWinCPU module was reset).	<ul style="list-style-type: none"> - Reset Module No.1, and then restart the multiple CPU system. - For the reset specifications when a multiple CPU system is configured, refer to "MELSECWinCPU Module User's Manual (Hardware Design, Function Explanation)".
2100	Module No. *1	A slot with QI60 was specified for a module other than intelligent function module or interrupt module on parameter I/O assignment.	Specify I/O assignment according to the installation settings.
		<ul style="list-style-type: none"> - On I/O assignment parameters, I/O module was assigned to intelligent function module, or vice versa. - On I/O assignment parameters, CPU module was assigned to other module or specified to idle, or vice versa. - The No. of points of the intelligent function module specified in I/O assignment setting of parameters is smaller than the actual No.. - For a module of which switch setting is not specified in I/O assignment setting of parameters, switch setting was specified. 	<ul style="list-style-type: none"> - Specify I/O assignment according to the installation settings of intelligent function module or CPU module. - Delete the switch setting in I/O assignment setting of parameters.

*1 : For example, error information (module No.) will be displayed in "Description" of the Event tab of Event Viewer in the following format:

"Error information: XX-YYY"

XX (decimal) : Slot No.(0 - 63), CPU No.(1 - 4)

YYY (hexadecimal) : Start I/O No.+16 (0000H - 00FFH, 03E0H - 03E3H)

Error code	Error information	Error description	Action
2103	Module No. *1	<ul style="list-style-type: none"> - Two or more QI60s are mounted on single CPU system. - Two or more QI61/A1SI61 (only programmable controller CPU) are mounted on a same control CPU of multiple CPU system. - Two or more A1SI61s are mounted in the multiple CPU system. 	<ul style="list-style-type: none"> - In the single CPU system, mount only one QI60. - In the multi CPU system, mount only one QI61 for CPUs controlled together. - In the multiple CPU system, mount only one A1SI61. When the interruption module is used for each QCPU in the multiple CPU system, use QI60 (Use one A1SI61 plus the maximum three QI60s, or use only QI60s).
2106	Module No. *1	<ul style="list-style-type: none"> - Five or more MELSECNET/H modules are mounted on multiple CPU system in total. - Five or more Q series Ethernet modules are mounted on multiple CPU system in total. 	<ul style="list-style-type: none"> - Mount a maximum of 4 modules on a total multiple CPU system. - Reduce the No. of Q Series Ethernet modules in the entire multiple CPU system to four or less.
		<ul style="list-style-type: none"> - Five or more MELSECNET/H modules are mounted. - Five or more Q series Ethernet modules are mounted. - In the MELSECNET/H network system, an identical network No. and/or Sta. No. exist. 	<ul style="list-style-type: none"> - Limit the No. of MELSECNET/H module to 4 or less. - Limit the No. of Q series Ethernet modules to 4 or less. - Check network No. and Sta. No..
2107	Module No. *1	Start X/Y specified by I/O assignment parameter overlaps with start X/Y of other modules.	Re- specify I/O assignment parameter according to installation status of intelligent function module.
2108	Module No. *1	<ul style="list-style-type: none"> - Network module for A2UCPU (A1SJ71LP21, A1SJ71BR11, A1SJ71LR21, A1SJ71AP21, A1SJ71AR21, A1SJ71AT21B) is mounted. - Network module for Q2AS (A1SJ71QLP21(S), A1SJ71QBR11, A1SJ71QLR21) is mounted. 	Change network module into MELSECNET/H module.
2120	-	<ul style="list-style-type: none"> - In the single CPU system, QA□B or QA1S□B is used as the base unit. - For the multiple CPU system configuration, the MELSECWinCPU module was specified as the control CPU for modules on QA□B or QA1S□B. 	<ul style="list-style-type: none"> - Change the base unit to Q□B. - Specify a high-performance QCPU as the control CPU for modules on QA□B or QA1S□B.

*1 : For example, error information (module No.) will be displayed in "Description" of the Event tab of Event Viewer in the following format :

“Error information : XX-YYY”

XX (decimal) : Slot No.(0 - 63), CPU No. (1 - 4)

YYY (hexadecimal) : Start I/O No.÷16 (0000H - 00FFH, 03E0H - 03E3H)

Error code	Error information	Error description	Action
2121	-	MELSECWinCPU module is mounted on other slot than CPU slot or slots 0 through 2.	Check installation slot of MELSECWinCPU module, and install the module on a correct slot.
2122	-	QA1S[] B is mounted on main base unit.	Change main base unit into Q[]B
2124	-	<ul style="list-style-type: none"> - A module was mounted on a slot later than 65. - A module was mounted on a slot later than that specified by base allocation. - A module was mounted on later point than I/O point No. 4096. - A module was mounted across the border of I/O point of 4096. 	<ul style="list-style-type: none"> - Remove modules on slot 65 and later. - Remove modules mounted on slots later than the No. specified by base assignment. - Remove modules mounted on point 4096 and later. - Replace a last module with one having points that does not exceed 4096.
2125	Module No. *1	<ul style="list-style-type: none"> - In multi CPU configuration, Windows was restarted only on the MELSECWinCPU module. - An unrecognizable module is mounted. - No response is returned from intelligent function module. 	<ul style="list-style-type: none"> - Reset CPU No.1. - Mount a usable module. - Failure of intelligent function module, programmable controller CPU or base unit. <p>Consult your local system service desk or agency of Mitsubishi Electric Corporation.</p>
2126	Module No. *1	<p>CPU modules on multiple CPU system are configured as the following :</p> <ul style="list-style-type: none"> - There is an empty slot on the left of the CPU module. - On the left in between high-performance model QCPU modules, another type of CPU module is mounted. - On the right of the MELSECWinCPU module, another type of a CPU module is mounted when Module No.1 is the high-performance model QCPU module. - On the right of the MELSECWinCPU module, the programmable controller CPU is mounted when Module No.1 is the MELSECWinCPU module. - On the right of the MELSECWinCPU module, the CPU module is mounted when Module No.1 is the basic model QCPU module. 	<p>Perform an appropriate action among the following.</p> <p>For the places to mount CPU modules in the multiple CPU system, refer to manuals of respective CPU modules.</p> <ul style="list-style-type: none"> - Move a CPU module(s) to fill the empty slot (Make empty slots on the right side of CPU modules.) - Replace the non high-performance model QCPU module mounted on the left in between high-performance model QCPU modules with an additional high-performance QCPU module. - Remove the non MELSECWinCPU module mounted on the right of the MELSECWinCPU module. - Remove the programmable controller CPU module mounted on the right of the MELSECWinCPU module. - Remove the CPU module mounted on the right of the MELSECWinCPU module.

*1 : For example, error information (module No.) will be displayed in "Description" of the Event tab of Event Viewer in the following format :

“Error information: XX-YYY”

XX (decimal) : Slot No.(0 - 63), CPU No. (1 - 4)

YYY (hexadecimal): Start I/O No.±16 (0000H - 00FFH, 03E0H - 03E3H)

Error code	Error information	Error description	Action
2150	Module No. *1	In the multiple CPU system, a module No. other than No.1 is specified for the control CPU of which target is an intelligent function module incompatible with the multiple CPU system.	<ul style="list-style-type: none"> - Change the module to an intelligent function module compatible with the multiple CPU system (functionality module version B or later). - Change the module No. of the control CPU to Module No.1.
2200	-	No parameter file is set.	Set a parameter file.
3000	Parameter No.	On multiple CPU system, an intelligent function module controlled by other machine is specified by interrupt point of parameter.	<ul style="list-style-type: none"> - In interruption event setting of parameters, specify the start I/O No. of the intelligent function module controlled by this MELSECWinCPU module. - Delete interrupt pointer settings of parameter.
		Vacant slot points for parameters are not set within the available range of the MELSECWinCPU module.	<ul style="list-style-type: none"> - See error information in Event Viewer. Check and correct parameter items relevant to the No. (Parameter No.). - If the error remains even after correction of parameters, this may be a failure in the MELSECWinCPU module. Consult your local system service desk or agency of Mitsubishi Electric Corporation.
3001	Parameter No.	Parameter data has been destroyed.	<ul style="list-style-type: none"> - Read detailed information of the error by peripheral device, check parameter corresponding to the value (Parameter No.), and correct the value. - If the error remains even after correction of parameters, this may be a failure in the MELSECWinCPU module. Consult your local system service desk or agency of Mitsubishi Electric Corporation.
3010	Parameter No.	On multiple CPU system, the No. of CPU modules specified by parameter is different from actual No. of mounted modules.	Make the No. of mounted CPUs match (specified No. of modules on multiple CPU system) - (CPU (empty) settings of I/O assignment).
3012	Parameter No.	On multiple CPU system, settings of multiple CPU are different from that of reference machine.	Specify multiple CPU settings and control CPU settings in accordance with reference machine (Module No.1).

*1 : For example, error information (module No.) will be displayed in "Description" of the Event tab of Event Viewer in the following format :

"Error information : XX-YYY"

XX (decimal) : Slot No. (0 - 63), CPU No. (1 - 4)

YYY (hexadecimal): Start I/O No.+16 (0000H - 00FFH, 03E0H - 03E3H)

Error code	Error information	Error description	Action
3014	Parameter No.	For the multiple CPU configuration, a module other than the primary module is specified in the online module replacement parameter (multiple CPU system parameter).	Change the setting of the online module replacement parameter to the primary module (Module No.1).
		For the multiple CPU configuration, online module replacement setting is allowed even though a CPU module which does not support the online module replacement parameter is mounted.	When a CPU module which does not support the online module replacement parameter is mounted, online module replacement setting must be disabled.
3100	Parameter No.	On multiple CPU system, a MELSECNET/H module controlled by other machine is specified as start I/O No. of network setting parameter for MELSECNET/H.	<ul style="list-style-type: none"> - Delete network setting parameters of MELSECNET/H for MELSECNET/H module controlled by other machine. - Change the parameter into start I/O No. of MELSECNET/H module controlled by own machine.
		Link parameters of MELSECNET/H module operating as normal station were changed into "control station" Or, link parameters of MELSECNET/H module operating as control station were changed into "normal station". (Link parameters are reflected on modules upon resetting.)	Reset CPU.
		<ul style="list-style-type: none"> - The No. of modules in the MELSECNET/H module count parameter setting is different from the number of actually mounted modules. - The start I/O No. of the MELSECNET/H network setting parameter is different from the actually mounted start I/O No. - Invalid data exists in parameters. 	<ul style="list-style-type: none"> - Compare network parameters with the actual mount state and if there is a difference, adjust these parameters for the actual state. When you change a network parameter, write it to the CPU module. - Check the setting of the order of addition of additional base units. - Check the connection states of each additional base unit and additional cable. When the GOT is bus-connected to the main base unit and extension base units, check the connection status. - If the error remains even after the checks mentioned above, it is a hardware failure and you must replace the faulty module. Consult your local system service desk or agency of Mitsubishi Electric Corporation.

Error code	Error information	Error description	Action
3101	Parameter No.	<ul style="list-style-type: none"> - PC- PC network parameters are specified when Sta. No. of MELSECNET/H module is "0". - Remote master parameters are specified when Sta. No. of MELSECNET/H module is not "0". 	Correct MELSECNET/H module type or Sta. No. in parameters according to a system to be used.
		<ul style="list-style-type: none"> - Network type specified by parameter is different from actual type. - Network refresh parameter of MELSECNET/H and MELSECNET/10 is out of range. 	<ul style="list-style-type: none"> - Check the connection status of the extension base units and extension cables. When the GOT is bus-connected to the main base unit and extension base units, also check the connection status. - If the error occurs even after performing the above checks, it indicates a hardware fault. Please replace the faulty module. Consult your local system service desk or agency of Mitsubishi Electric Corporation.
3102	Parameter No.	<ul style="list-style-type: none"> - Check of network parameters for the network module resulted in error. - A parameter specific to MELSECNET/H or MELSECNET/10 is not correct. - The network type of the control station is specified as the advanced mode but that of the own Sta. (normal station) is not. - The Sta. No. specified for the own Sta. is larger than the total No. of stations specified by a network parameter on the control station. 	<ul style="list-style-type: none"> - Correct and write network parameters. - If an error occurs even after correction, hardware failure is suspected. Consult your local system service desk or agency of Mitsubishi Electric Corporation. - Specify an identical network type for both. - As the Sta. No. for the own Sta., specify a No. smaller than or equal to the total No. of stations.
3103	Parameter No.	Q series Ethernet module controlled by other machine is specified in start I/O No. of Ethernet networks parameter.	Delete the network parameter of Q series Ethernet module controlled by other machine.
		<ul style="list-style-type: none"> - Although the No. of Ethernet modules was specified as one or more actual No. of module is 0. - Start I/O No. of Ethernet setting parameter is different from actual I/O No.. 	<ul style="list-style-type: none"> - Correct and write network parameters. - If an error occurs even after correction, hardware failure is suspected. Consult your local system service desk or agency of Mitsubishi Electric Corporation.

Error code	Error information	Error description	Action
3104	Parameter No.	<ul style="list-style-type: none"> - An identical network No. is used for Ethernet, MELSECNET/H, and MELSECNET/10. - Network No., Sta. No., or group No. specified by parameter is out of valid range. - I/O No. is out of valid range of used CPU. - Values of Ethernet- specific parameters are invalid. 	<ul style="list-style-type: none"> - Correct and write network parameters. - If an error occurs even after correction, hardware failure is suspected. <p>Consult your local system service desk or agency of Mitsubishi Electric Corporation.</p>
3105	Parameter No.	On multiple CPU system, QJ61BT11 module controlled by other machine is specified as start I/O No. of CC- Link setting parameter	<ul style="list-style-type: none"> - Delete CC- Link setting parameter of QJ61BT11 controlled by other machine. - Change the parameter into start I/O No. of QJ61BT11 module controlled by own machine.
		<ul style="list-style-type: none"> - Although the No. of CC- Link utility was specified as one or more, the actual No. of mounted modules is 0. - Start I/O No. of common parameter setting is different from actual I/O No.. - Different station types are specified in the module count setting parameter for CC-Link. 	<ul style="list-style-type: none"> - Correct and write network parameters. - If an error occurs even after correction, hardware failure is suspected. <p>Consult your local system service desk or agency of Mitsubishi Electric Corporation.</p>
3107	Parameter No.	<ul style="list-style-type: none"> - CC- Link parameters are faulty. - The specified mode is not available for the version of the mounted CC-Link utility. 	Review the setting of the parameter.
3300	Parameter No.	The start I/O No. in the intelligent function module's parameter specified in GX Configurator is different from the actual I/O No.	Check parameter settings.
3301	Parameter No.	The refresh parameter of the intelligent function module is outside the range, or the refresh range exceeded the file register capacity.	Check parameter settings.
3302	Parameter No.	Parameters of intelligent function module are faulty.	Check parameter settings.
3303	Parameter No.	On multiple CPU system, parameters of automatic refresh, etc. have been specified for an intelligent function module controlled by other machine.	<ul style="list-style-type: none"> - Delete parameters of automatic refresh, etc. specified for an intelligent function module controlled by other machine - Change the data into parameters of automatic refresh, etc. specified for an intelligent function module controlled by own machine.

Error code	Error information	Error description	Action
5000	Time (Setting value : ms)	<p>The system watchdog timer managed by the system detected an error. Or, an failure occurred in system software.</p> <ul style="list-style-type: none"> - The time set for the system watchdog timer is too short. - A task with a high CPU usage rate is running. - A program causing a memory or stack failure was executed. 	<ul style="list-style-type: none"> - Increase the system WDT setting time included in the system settings of the MELSECWinCPU setting utility. - Reduce the CPU usage rate of the relevant task. Or, disable the task. - Reexamine the user program. - If the error remains even after implementation of the above actions, it may be a hardware failure and you need to consult your local system service desk or agency of Mitsubishi Electric Corporation.
5001	Time (Setting value : ms)	<p>Because WDT reset had not been performed within the user WDT setting time (specified by the QBF_ResetWDT function), the error was detected on USERWDT (watchdog timer), which is managed by the system. Or, a user program failure occurred.</p> <ul style="list-style-type: none"> - The user WDT setting time is too short. - A task of high CPU utilization rate is running. - A program that will cause an error in the memory, stack, etc. was executed. 	<ul style="list-style-type: none"> - Increase the user WDT setting time specified by the QBF_StartWDT function. - Decrease the CPU utilization rate of a task with a high CPU utilization rate, or do not run that task. - Reexamine the user program. - If the error remains even after the corrective actions are taken, it may be a hardware failure and you need to consult your local system service desk or agency of Mitsubishi Electric Corporation.
7000	Module No.*1	<ul style="list-style-type: none"> - A CPU failure occurred in the CPU in which system halt was selected in the operation mode on multi CPU system. - In a multiple CPU system, a CPU module incompatible with the multiple CPU system is mounted. - When Module No.1 is the basic model QCPU, "CPU (empty)" is specified for the slot on the right of the MELSECWinCPU module. 	<ul style="list-style-type: none"> - Check and remove the error in the CPU module which caused the CPU failure. - A CPU module incompatible with the multiple CPU system is removed from basic module. - Change the setting.
		<p>In the multiple CPU system, Module No.1 has a halt error at powerup and other modules cannot be started. (Modules No.2 - No.4).</p>	<p>Check and remove the error in the CPU module which caused the CPU failure.</p>
		<p>During multiple CPU system operation, Windows was restarted on a MELSECWinCPU module (the MELSECWinCPU module was reset).</p>	<ul style="list-style-type: none"> - Reset Module No.1, and then restart the multiple CPU system. - For the reset specifications when a multiple CPU system is configured, refer to "MELSECWinCPU Module User's Manual (Hardware Design, Function Explanation)".

*1 : For example, error information (module No.) will be displayed in "Description" of the Event tab of Event Viewer in the following format :

"Error information : XX-YYY"

XX (decimal) : Slot No. (0 - 63), CPU No. (1 - 4)

YYY (hexadecimal) : Start I/O No.÷16 (0000H - 0FF0H, 3E00H - 3E30H)

Error code	Error information	Error description	Action
7002	Module No. *1	<ul style="list-style-type: none"> - During initial communication in the multiple CPU system, no response was returned from the destination module. - In a multiple CPU system, a CPU module incompatible with the multiple CPU system is mounted. 	<ul style="list-style-type: none"> - Reset the CPU module and RUN it again. If the same error is displayed again, any of the CPU modules is faulty. Please consult your retailer. - Remove the CPU module incompatible with the multiple CPU system from the main base unit. Or replace the CPU module with a CPU module compatible with the multiple CPU system.
7010	Module No. *1	<ul style="list-style-type: none"> - On multiple CPU system, a faulty CPU is mounted. - In a multiple CPU system, a CPU module incompatible with the multiple CPU system is mounted. (This error is detected by a CPU module compatible with the multiple CPU system.) - On multiple CPU system, Module No.2 to 4 was reset with the power turned on. (This error is detected by a module of which reset was cleared.) 	<ul style="list-style-type: none"> - Replace faulty machines. - Replace it with a CPU module compatible with the multiple CPU system. - Do not reset a high-performance model QCPU of Module No.2 to 4. Reset the CPU module of Module No.1 and relaunch the multiple CPU system.
7020	Module No. *1	<p>CPU failure occurred on CPU of a machine with no "System halt" selected on operation mode of multiple CPU system. (An error was detected on a CPU module which does not actually have any failures.)</p>	<p>Check a CPU error of CPU failure, and remove the error.</p>
-2*2	-	<ul style="list-style-type: none"> - MELSECWinCPU module is shutdown condition. - MELSECWinCPU module was removed from the base unit when working. 	<ul style="list-style-type: none"> - Turn power off -> on. - Reset Module No.1. - Check if MELSECWinCPU module is mounted properly and reboot the system.

*1 : For example, error information (module No.) will be displayed in "Description" of the Event tab of Event Viewer in the following format :

"Error information : XX-YYY"

XX (decimal) : Slot No. (0 - 63), CPU No. (1 - 4)

YYY (hexadecimal) : Start I/O No.÷16 (0000H - 0FF0H, 3E00H - 3E30H)

*2 : This error code is shown only on the error help of PC diagnostics of GX Works2.

8.4 List of Error Code, Error Message

This section describes error codes and error messages returned at the time of error.

Point	<p>For details on the errors that occur when using MX Component, refer to the following sections.</p> <ul style="list-style-type: none"> - 8.4.1 Actions upon error codes at the time of function execution - 8.4.2 Corrective Actions for error code on the communication with MELSECWinCPU module
-------	---

8.4.1 Actions upon error codes at the time of function execution

An error code returned when executing bus interface function or MELSEC data link function is directly returned as a return value.

(1) Error codes common between bus interface functions and MELSEC data link functions

The following table shows description of errors and actions corresponding to error codes which will be returned from both bus interface functions and MELSEC data link functions.

Return value (HEX)	Error description	Actions
0 (0000H)	Normal completion.	-
1 (0001H)	Driver not started. The driver has not been started.	Correct the error occurred when starting the driver.
2 (0002H)	Timeout error. The timeout occurred while waiting for the response of process.	Check the operation status of the access Sta.(s). Retry.
66 (0042H)	Already opened . Selected channel has been already opened.	Open once
67 (0043H)	Already closed . Selected channel has been already closed.	Close once
69 (0045H)	Processing code error. An unsupported processing code was issued.	Use the supported processing code.
70 (0046H)	station specification error. The specified station is incorrect. A process that should have been requested to other station was requested to the own Sta. Or, the Sta. No. corresponds to the own Sta. (0xFF) but the network No. is not 0.	Correct the specification of the Sta. No. in the user program.

Return value (HEX)	Error description	Actions
71 (0047H)	No reception data error (during RECV request). Data has not been received.	Wait until data is received.
77 (004DH)	Memory error/insufficient resource memory error. Enough memory could not be secured.	Terminate other application(s) currently running. Check if the system is operating normally. Reboot the system. *1 Increase the minimum working set area of your computer. *1
85 (0055H)	Network channel No. error (When a SEND / RECV request is issued.) Channel No. error.	Check the specified channel No. when a SEND / RECV request is issued.
102 (0066H)	Data sending error. Data sending has failed.	Retry. Check whether the system is operating properly or not.
103 (0067H)	Data receiving error. Data receiving has failed.	Relaunch the system. *1
130 (0082H)	Device No. error. The specified device No. is out of range. When specifying the bit device, the device No. is not a multiple of 8.	Check the specified device No..
131 (0083H)	Device points error. The specified No. of points is out of device range. When specifying the bit device, the device No. is not a multiple of 8.	Check the size.

*1 : For the single CPU configuration, the MELSECWinCPU module body must be reset.

For the multiple CPU configuration, the CPU Module No.1 must be reset.

Return value (HEX)	Error description	Actions
4110 (100EH)	DLL unload error.	Exit the relevant program and restart your computer. Reinstall your software package. Consult your local system service desk or agency of Mitsubishi Electric Corporation.
8204 (200CH)	Request cancellation.	
8205 (200DH)	Drive name error.	
8206 (200EH)	First step error.	
8207 (200FH)	Parameter type error.	
8208 (2010H)	File name error.	
8209 (2011H)	Registration/reset/setting status error.	
8210 (2012H)	Detailed condition division error.	
8211 (2013H)	Step condition error.	
8212 (2014H)	Bit device condition error.	
8213 (2015H)	Parameter setting error.	
8215 (2017H)	Keyword error.	
8216 (2018H)	Read/write flag error.	
8217 (2019H)	Refresh method error.	
8218 (201AH)	Buffer access method error.	
8219 (201BH)	Start mode/stop mode error.	
8220 (201CH)	Written clock data error.	
8221 (201DH)	Onlineprogram change error.	

Return value (HEX)	Error description	Actions
8223 (201FH)	Trace time error.	Exit the relevant program and restart your computer. Reinstall your software package. Consult your local system service desk or agency of Mitsubishi Electric Corporation.
8224 (2020H)	Start I/O No. error.	
8225 (2021H)	First address error.	
8226 (2022H)	Pattern error.	
8227 (2023H)	SFC block No. error	
8228 (2024H)	SFC step No. error.	
8229 (2025H)	Step No. error.	
8230 (2026H)	Data error.	
8231 (2027H)	System data error.	
8232 (2028H)	TC setting count error.	
8233 (2029H)	Clear mode error.	
8234 (202AH)	Signal flow error.	
8235 (202BH)	Version management error.	
8236 (202CH)	Unregistered monitor error.	
8237 (202DH)	PI type error.	
8238 (202EH)	PI No error.	
8239 (202FH)	PI No. error.	
8240 (2030H)	Shift error.	

8 Actions against Errors

Return value (HEX)	Error description	Actions
8241 (2031H)	File type error.	Exit the relevant program and restart your computer. Reinstall your software package. Consult your local system service desk or agency of Mitsubishi Electric Corporation.
8242 (2032H)	Specified module error.	
8243 (2033H)	Error Check flag error.	
8244 (2034H)	Step RUN-operation error.	
8245 (2035H)	Step RUN data error.	
8246 (2036H)	Step RUN time error.	
8247 (2037H)	Program RUN inside writing error to E2ROM.	
8248 (2038H)	Clock data read/write error.	
8249 (2039H)	Trace non-completion.	
8250 (203AH)	Registration clearness flag error.	
8251 (203BH)	Operation error.	
8252 (203CH)	The No. of station error.	
8253 (203DH)	The No. of repeat error.	
8254 (203EH)	The acquisition data selection error.	
8255 (203FH)	The No. of SFC cycle error.	
8258 (2042H)	The scheduled time setting error.	
8259 (2043H)	Function count error.	
8260 (2044H)	System information error.	

Return value (HEX)	Error description	Actions
8262 (2046H)	Function No. error.	Exit the relevant program and restart your computer. Reinstall your software package. Consult your local system service desk or agency of Mitsubishi Electric Corporation.
8263 (2047H)	RAM operation error.	
8264 (2048H)	Boot former ROM forwarding failure.	
8265 (2049H)	Boot former transfer mode specification error.	
8266 (204AH)	Not enough memory.	
8267 (204BH)	Backup drive (former boot drive) ROM error.	
8268 (204CH)	Block size error.	
8269 (204DH)	RUN-time detaching error.	
8270 (204EH)	Module has already registered.	
8271 (204FH)	Password registration data full error.	
8272 (2050H)	Password unregistration error.	
8273 (2051H)	Remote password error.	
8274 (2052H)	IP address error.	
8275 (2053H)	Error (argument when requesting) outside time-out value range.	
8276 (2054H)	Instruction cast undetection.	
8277 (2055H)	Trace execution type error.	
8278 (2056H)	Version error.	

Return value (HEX)	Error description	Actions
16384-20479 (4000H -4FFFH)	Errors detected by the access target CPU.	Refer to the user's manual of the access target CPU module.
16386 (4002H)	A request that cannot be processed was received.	Change the request destination.
16400 (4010H)	Not executable during running.	Execute when the CPU 's execution status is stop.
16432 (4030H)	The specified device type does not exist.	Check the specified device type.
16433 (4031H)	The specified device No. is out of range. Block No. of the specified device is invalid.	Check the specified device No.. Check the block No. (device type) of the specified device. Check if the specified device and block No. are effective in the target.
16448 (4040H)	The module does not exist.	Do not issue a request that generated an error to the specified special function module.
16449 (4041H)	The No. of device points is out of range.	Check the head address and No. of access points. Access the devices within the existing range.
16450 (4042H)	Corresponding module error	Check if the specified module is operating normally.
16451 (4043H)	The module does not exist at the specified location.	Check the start I/O No. of the specified module.
18944 (4A00H)	Network No., Sta. No. is incorrect. Other network No. was specified, but routing parameter did not exist.	Check the specified network No., Sta. No.. Check the setting of routing parameter.
19200 (4B00H)	The target error was detected.	Review the specified access destination. Check the error occurred on the specified access destination or on the relay station(s) for the access station and take action.
19201 (4B01H)	The target is not the bus master CPU.	If the CPU No. of the C Controller module is not "1", it cannot reset.
19203 (4B03H)	Unsupported path error The request cannot execute through the specified path.	Check the path that the specified request is supported. Do not send a request causing error to MELSECWinCPU module.

Return value (HEX)	Error description	Actions
-475-3839 (FE25H - F101H)	Refer to following manuals. - “Q Corresponding MELSECNET/H Network System Reference Manual (PLC to PLC network)”. - “For QnA/Q4AR MELSECNET/10 Network System Reference Manual” - “Type MELSECNET/10 Network system (PLC to PLC network) Reference Manual”.	Same as the left column
-2174 (F782H)	Destination Sta. No. specification error The destination Sta. No. for the processing request is specifying the own Sta.	Check the specified Sta. No. When issuing a request to the own Sta., specify 255 (0xFF) as the Sta. No.
-16386- -20222 (BFFFH -B102H)	Refer to following manuals. - “CC-Link System Master/Local Module User's Manual”. - “CC-Link System Master/Local Module Type AJ61QBT11/A1SJ61QBT11 User's Manual”. - “CC-Link System Master/Local Module Type AJ61BT11/A1SJ61BT11 User's Manual”.	Same as the left column
-18558 (B782H)	Destination Sta. No. specification error The destination Sta. No. for the processing request is specifying the own Sta..	Check the specified Sta. No. When issuing a request to the own station, specify 255 (0xFF) as the Sta. No.
-18560 (B780H)	Module mode setting error Transient that is remote I/O station is edited.	A demand place Sta. No. is improved.
-18572 (B774H)	Transient unsupported error The target station was not an intelligent device station.	Check the specified Sta. No. Check if the target station is an intelligent device station.
-18575 (B771H)	Other Sta. device was accessed by own Sta..	Confirm the device type.
-25056 (9E20H)	Processing code error The target station can not process the request.	Check the specified Sta. No. and processing codes. Do not execute the function other than mdTypeRead to the other Sta.
-26334 (9922H)	Card reset error During the access to other Sta., other process that is using same channel card reset. Reset operation was executed by the utility during monitor.	Monitor again. Retry it.
-26336 (9920H)	Request error for other loop Routing to other loop was performed.	Change the routing request destination to AnUCPU, QnACPU, QCPU.

8 Actions against Errors

Return value (HEX)	Error description	Actions
-28150 (920AH)	Data link stop error RX / RY / Rww / Rwr device was accessed when data link was stopping.	Restart the data link. Writing the data or reading are done. However, the data is not guaranteed. Access the Own Sta.'s link device when data link not in progress.
-28151 (9209H)	APS No. error Invalid response data was received.	Check the status of the process request destination. Change the module at the process request destination. Retry.
-28158 (9202H)	WDT error Watchdog timer (WDT) error occurred. Watchdog Timer error	Reboot the system. *1 reset the CC-Link card. Restart the personal computer.
-28413 (9103H)	Target CPU down error. The target module is down.	Check the operation state of the target CPU and do troubleshooting of the error.
-28414 (9102H)	Target CPU abnormal start error Processing was requested to a CPU which is not operating properly.	Check the operation state of the target CPU and do troubleshooting of the error.
-28415 (9101H)	Target CPU critical error. Processing was requested to a CPU on which a serious error occurs.	Check the operation state of the target CPU and do troubleshooting of the error.
-28416 (9100H)	Target CPU not mounted error. Processing was requested by specifying the CPU No. of a CPU which is not mounted.	Check the mount state of the target CPU. Change the specified CPU No.
-28625 (902FH)	Intelligent function module offline error. Access was tried to the intelligent function module which is offline.	Check the mode state of the intelligent function module and access in the online mode.
-28626 (902EH)	Control data error The specified control data is out of range.	Check the specified control data.
-28627 (902DH)	Transient unsupported error A transient demand cannot be executed for the specified path and target. (By CC-Link communication, when the Sta. No. of the own Sta. was "64", other Sta. was specified.)	Check the path and target by which the transient demand is supported. Change the Sta. No. of the own Sta..
-28628 (902CH)	Pointer address specification error Pointer address was invalid. An address of a short type pointer is not a multiple of 2. An address of a long pointer is not a multiple of 4.	Check the type of the specified pointer. Check the specified pointer address.
-28629 (902BH)	WDT not running error WDT reset was executed when WDT was not start.	Start the WDT.
-28630 (902AH)	WDT startup impossible error WDT start was executed when WDT was start.	Execute WDT start when WDT was not start.

*1 : In single CPU configuration, reset the MELSECWinCPU module. In multiple CPU configuration, reset CPU No.1.

Return value (HEX)	Error description	Actions
-28631 (9029H)	Buffer access range error The specified offset is out of range. The specified offset + size is out of range.	Check the specified offset. Check the specified offset + size.
-28632 (9028H)	I/O No. error The specified I/O No. is out of range. The module does not exist at the specified I/O No.	Check the specified I/O No..
-28633 (9027H)	Non-controlled module read error The non-controlled module data was read when parameter setting did not allow.	Allow the non-controlled module read by parameter. Check that the control CPU of the specified module is own CPU.
-28634 (9026H)	Intelligent function module down error Intelligent function module down error occurred.	Check the specified intelligent function module. Exchange the intelligent function module or base unit.
-28635 (9025H)	Intelligent function module error The slot where there is no intelligent function module was accessed.	Check the specified I/O No.. Check the specified intelligent function module.
-28636 (9024H)	Control bus error. The control bus to the intelligent function module is not operating properly.	When multiple CPU configuration, check that an error occurred at CPU No.1. Check the specified intelligent function module. Exchange the intelligent function module or base unit.
-28638 (9022H)	Multiple CPU unsupported operation error	Reset CPU No.1.
-28640 (9020H)	CPU STOP error An output request or a buffer memory write request was made while the CPU execution status was "STOP".	Check that the CPU execution status is "RUN".
-28653 (9013H)	I/O assignment error Input data was read from output module. Output data was written to input module. Output data was read from input module.	Check the specified I/O No.
-28654 (9012H)	Non-controlled module write error Own CPU does not control the specified module.	Check that the control CPU of the specified module is own CPU.

Return value (HEX)	Error description	Actions
-28660 (900C _H)	Access size error The specified size is out of range.	Check the specified offset and size.
-28661 (900B _H)	Access impossible error The specified area cannot access.	Check the specified offset and size.
-28662 (900A _H)	CPU No. specification error The specified CPU No. is out of range. The specified CPU No. is invalid.	Check the specified CPU No.. Check the operation status of the specified CPU.
-28663 (9009 _H)	Base No. specification error The specified base No. is out of range.	Check the specified base No..
-28664 (9008 _H)	Data transmission area occupied error.	Retry.
-28665 (9007 _H)	No registration data error	Reboot the system. *1
-28666 (9006 _H)	Data length error.	Reboot the system. *1
-28668 (9004 _H)	Reply data stored error.	Demand once again.
-28669 (9003 _H)	Area No. error The specified area No. or offset address or mode is out of range.	Check the specified area No. or offset address or mode.
-28671 (9001 _H)	Module identification error	Check the parameter. Check the specified module. Reboot the system. *1
-28672 (9000 _H)	Processing code error	Install latest software package again. Reboot the system. *1

*1 : In single CPU configuration, reset the MELSECWinCPU module. In multiple CPU configuration, reset CPU No.1.

(2) Error codes returned from bus interface functions

The following table shows description of errors and actions corresponding to error codes which will be returned from bus interface functions.

For error codes returned from both bus interface functions and MELSEC data link functions, refer to "(1) Error codes common between bus interface functions and MELSEC data link functions".

Return value (HEX)	Error description	Actions
0 (0000H)	Normal completion.	-
-201 (FF37H)	Module identification error The specified module identification is invalid.	Check the specified module identification.
-202 (FF36H)	Path error The specified path is invalid.	Use the path pointer returned with "QBF_Open".
-203 (FF35H)	I/O No. error The specified I/O No. is out of range.	Check the specified I/O No.
-204 (FF34H)	I/O access size error The specified I/O No. + size is out of range.	Check the specified I/O access size. Check the I/O No. + size.
-205 (FF33H)	I/O No. error The specified I/O No. is out of range.	Check the specified I/O No.
-206 (FF32H)	Program execution type error The specified program execution type is out of range.	Check the specified program execution type.
-209 (FF2FH)	Buffer memory size error The specified offset + size is out of range. The address of specified data stored buffer pointer is 0.	Check the specified buffer memory size. Check the offset + size. Check the data stored buffer pointer.
-210 (FF2EH)	Read area size error The read area is too small.	Check the read size and read area size.
-211 (FF2DH)	Time setting error. Time is out of range.	Check the time you specified.
-217 (FF27H)	Driver not started up Driver is not started.	Check the driver is started.
-218 (FF26H)	Bus already opened "QBF_Open" is executed twice.	Check the "QBF_Open" is executed twice.
-219 (FF25H)	Program name error The specified program name is invalid (does not exist on QCPU or is not registered with a parameter).	Check the specified program name.

Return value (HEX)	Error description	Actions
-220 (FF24H)	WDT type error The specified WDT type is out of range.	Check the specified WDT type.
-223 (FF21H)	Memory allocation error Sufficient memory could not be allocated.	Check available size of memory area.
-224 (FF20H)	LED control value error The specified LED control value is out of range.	Check the specified LED control value.
-225 (FF1FH)	Event No. error The specified event No. is out of range. The specified event No. is duplicated.	Check the specified event No.
-227 (FF1DH)	Control code send error Control code sending is failed.	Retry. Check if the system is operating normally. Reboot the system. *1
-231 (FF19H)	Event timeout error The timeout occurred while waiting for the event.	Set timeout value long. Retry.
-232 (FF18H)	CPU No. error The specified CPU No. is wrong.	Change the specified CPU No.
-234 (FF16H)	Event wait error The error except timeout occurred while waiting for the event.	Check if it is not implementing algorithm's compulsion finish etc. Check if the system is operating normally. Reboot system. *1
-235 (FF15H)	Event setting No. error The specified event setting No. is out of range.	Check the specified event setting No.

*1 : In single CPU configuration, reset the MELSECWinCPU module. In multiple CPU configuration, reset CPU No.1.

(3) Error codes returned from MELSEC data link functions

The following table shows description of errors and actions corresponding to error codes which will be returned from MELSEC data link functions.

For error codes returned from both bus interface functions and MELSEC data link functions, refer to "(1) Error codes common between bus interface functions and MELSEC data link functions".

Return value (HEX)	Error description	Actions
0 (0000H)	Normal completion.	-
-1 (FFFFH)	Path error The specified path is invalid.	Check the path pointer that was returned by the mdOpen function.
-2 (FFFEH)	Device No. error The specified device No. is out of range. When specifying the bit device, the device No. is not a multiple of 8. In mdRandR / mdRandW function, the specified device No. + points of the same block is out of range.	Check the head device No. for the specified device. Check the specified device No. + points of the same block.
-3 (FFFDH)	Device type error The specified device type is invalid.	Check if the specified device type is in the device list.
-5 (FFFBH)	Size error The device No. and size are over the device range. Access was attempted using an odd device. The device No. and size are over the range for the same block.	Check the specified device size. Check the device No. and size.
-6 (FFFAH)	No. of block error The No. of blocks specified in dev[0] for device random read/write is out of range.	Check the No. of blocks specified in dev[0].
-8 (FFF8H)	Channel No. error The channel No. specified in the mdOpen function is invalid.	Check the specified channel No.
-11 (FFF5H)	Insufficient buffer area The read area size for read data storage array variables is too small.	Check the read size and the read data storage destination size.
-12 (FFF4H)	Block error The specified block No. of the extension file register is invalid.	Check the block No. (device type) of the extension file register.
-13 (FFF3H)	Write protect error The specified block No. of the extension file register is overlapping with the write protect area of the memory cassette.	Check the block No. (device type) of the extension file register. Check the write protect DIP switch of the accessed memory cassette.

Return value (HEX)	Error description	Actions
-16 (FFF0H)	Sta. No., network No. error Sta. No. and network No. are beyond the range.	Confirm the set Sta. No. and network.
-17 (FFEFH)	All- stations / group No. specification error A function that does not support all- stations / group No. specification was specified.	Check if the function supports all- stations / group No. specification.
-18 (FFEEH)	Remote instruction error An undesignated code was specified.	Check the specified code.
-31 (FFE1H)	Module load error An attempt to load a module, which is necessary to execute the function, has failed.	Check the status of the system ROM drive.
-32 (FFE0H)	Another task/thread is occupying the resource and the resource is not released within 30 seconds.	Retry. There may be a possibility of insufficient memory. Terminate other task(s) currently running. Check if the system is operating normally. Restart the system. *1
-33 (FFDFH)	Invalid access destination error The setting for the communication destination is invalid.	Check if the communication destination is correctly set by the utility.
-34 (FFDEH)	Registry open error An attempt to open the registry has failed.	Check if the communication destination is correctly set by the utility.
-35 (FFDDH)	Registry read error An attempt to read from the registry has failed.	Check if the communication destination is correctly set by the utility.
-36 (FFDCH)	Registry write error An attempt to write to the registry has failed.	Check if the communication destination is correctly set by the utility.
-37 (FFDBH)	Communication initialization setting error An attempt to perform initial setting for communication has failed.	Retry. There may be a possibility of insufficient memory. Terminate other task(s) currently running. Check if the system is operating normally. Restart the system. *1
-42 (FFD6H)	Close error Communication cannot be closed.	Retry. Check if the communication destination is correctly set by the utility.
-43 (FFD5H)	ROM operation error A TC setting value was written to the CPU during ROM operation.	Change the TC setting value during RAM operation.

*1 : In single CPU configuration, reset the MELSECWinCPU module. In multiple CPU configuration, reset CPU No.1.

8.4.2 Corrective Actions for error code on the communication with MELSECWinCPU module

MELSECWinCPU module sends the error code to requester when following modules request to communicate and error happens.

- External peripherals
- Intelligent function module
- network system

If the requester is external peripherals, message or error code will be shown on external peripherals.

If the requester is intelligent function module or network system, it will send back the error code corresponding to requested action to the requester.

The description of error code (4000H - 4FFFH) detected on MELSECWinCPU module and corrective actions are shown as below.

(*) The error codes written in this section is not ones detected by the self-diagnostics function of MELSECWinCPU module. Therefore they will not stored in the special resistor (SD0) indicating diagnostics error.

Error code (HEX)	Error description	Actions
4001H	Unsupported requests were executed	Check the type name of CPU module selected on peripherals.
4002H		
4010H	MELSECWinCPU module is RUN condition and can not execute the request.	Set MELSECWinCPU module to STOP condition and execute again.
4030H	Failed to use the specified device name	- Check the specified device name. - Check the specified device No.
4031H	The specified device No. is out of range.	- Check the specified device No. - Check the device setting of MELSECWinCPU module.
4040H	The specified intelligent function module can not execute the request.	Check if the specified intelligent function module was one with buffer memory or not.
4041H	The range to access was out of the buffer memory range of the specified intelligent function module.	Check the top address and the number of points to access. Then access the range which exists in the intelligent function module.
	Specified the buffer memory address which can not be accessed	Check the address of buffer memory and try again.
4042H	Failed to access the specified intelligent function module.	- Check if the specified intelligent function module worked in order or not. - Check if the hardware of specified module was abnormal or not.
4043H	The specified intelligent function module did not exist.	Check the I/O No. of the specified intelligent function module.
408BH	Failed to execute the remote request.	- Make an MELSECWinCPU module the condition that can execute the remote request and request again. - If you would execute the remote reset operation, set the parameters which permit the remote reset.

Error code (HEX)	Error description	Actions
414AH	Run the operation to the intelligent function module which is out of controlled group among the multiple CPU system.	Execute for the management CPU of the target module again.
414CH	Specified the buffer memory address which can not be accessed	Check the address of buffer memory and try again.
4201H	The online module exchange setting is permitted in the multiple CPU parameters. Therefore could not execute your request.	Stop the request which led to the error. Or forbid the online module exchange setting of multiple CPU parameters and try again.
4A00H	Rooting parameters were not set to the start CPU module and the relay CPU module and could not access the specified station. If you used the relay via multiple CPU system, the management CPU of the network module which relay data did not work. If you constructed duplex system, you started the communication to other stations via a network module when system A / system B had not been decided.	<ul style="list-style-type: none"> - Set the rooting parameter used to access the target station to one of the relational station. - Wait for a while and try again. Or check the startup of the system which relay data and then start communication. - When you constructed duplex system, connect a tracking cable and start system A / system B in order. Then start the communication again.
4A01H	The network with No. set to a rooting parameter is absent.	Check the rooting parameters set to related Sta. and modify them.
4A02H	Failed to access the specified station.	Check the rooting parameter set to a relational station and modify it.
4B00H	The accessed module or the relay station had some problems. Or the specified connection (requested I/O No. of modules) is bad.	<ul style="list-style-type: none"> - Check if network module / link module had some problems or got offline condition. - Check the specified module to access (I/O No. or station number of the target module)
4B01H	The target is not the 1 st module of multiple CPU system.	Execute the request for the 1 st module of multiple CPU system.
4B02H	The request was not for CPU module.	Execute the request for the module which support the specified function.
4B03H	The specified route was not supported for the version of the specified module. The CPU module selected as communication target was not attached.	Check if the specified route was supported one.

8.4.3 Corrective Actions for Each Event ID

When an error occurred in a bus interface function, an event ID and error information are registered with the system log of Event Viewer.

The following table shows description of errors displayed by Event Viewer and corresponding actions on an event ID basis.

Event ID (HEX)	Error description	Actions
2 (0002H)	Failed to register an interrupt.	Replace MELSECWinCPU module.
4 (0004H)	Failed to map the memory address and I/O address.	Reinstall OS.
286 (011EH)	Failed to secure the memory area necessary for starting the driver.	Adds system memory. Reduce the memory used for other programs.
295 (0127H)	SYSTEM WDT ERROR occurred.	Extend the system WDT setting time in the system setting of the MELSECWinCPU setting utility. Decrease the CPU utilization rate of a task with a high CPU utilization rate, or do not run that task. Reexamine the user program.
297 (0129H)	A target abort error occurred.	Replace MELSECWinCPU module.
304 (0130H)	A data parity error occurred.	Replace MELSECWinCPU module.
305 (0131H)	USER WDT ERROR occurred.	Extend the user WDT setting time set with the QBF_StartWDT function. Decrease the CPU utilization rate of a task with a high CPU utilization rate, or do not run that task. Reexamine the user program.
513 (0201H)	AC/DC DOWN occurred.	Perform the action described for the error code 1500. *1
514 (0202H)	CONTROL-BUS.ERR. occurred.	Treats error code 1413, 1414, 1415, 1416. *1
516 (0204H)	MODULE VERIFY ERR. occurred.	Treats error code 2000.
518 (0206H)	FUSE BREAK OFF occurred.	Treats error code 1300.

*1 : For more details on method, refer to "8.3.4 Detailed error description and actions".

Event ID (HEX)	Error description	Actions
519 (0207H)	SP.MODULE DOWN occurred.	Treats error code 1401, 1403. *1
520 (0208H)	CONTROL-BUS.ERR. occurred.	Treats error code 1412. *1
521 (0209H)	SP.MODULE LAY ERR. occurred.	Treats error code 2100, 2103, 2106, 2107, 2108, 2120, 2121, 2122, 2124, 2125, 2126, 2150. *1
522 (020AH)	PARAMETER ERROR occurred.	Treats error code 3000, 3001, 3010, 3012, 3014. *1
523 (020BH)	An error occurred during initialization of the module. *2	Perform an action corresponding to the error code which is indicated in the event information. *1
526 (020EH)	A CPU module built-in battery error occurred.	Treats error code 1600. *1
528 (0210H)	MULTIPLE CPU DOWN occurred.	Treats error code 7000, 7002. *1
529 (0211H)	MULTI EXE.ERROR occurred.	Treats error code 7010. *1
530 (0212H)	MULTIPLE CPU ERROR occurred.	Treats error code 7020. *1
531 (0213H)	SP.PARAMETER ERROR occurred.	Treats error code 3300, 3301, 3302, 3303 *1
532 (0214H)	LINK PARAMETER ERROR occurred.	Treats error code 3100, 3101, 3102, 3103, 3104, 3105, 3107. *1
533 (0215H)	I/O INT.ERROR occurred.	Treats error code 1310. *1
534 (0216H)	PS.ERROR occurred.	Treats error code 1009. *1
535 (0217H)	An immediate power outage was detected.	Treats error code 1503. *1
537 (0219H)	SINGLE PS.DOWN occurred.	Treats error code 1510. *1
538 (021AH)	SINGLE PS.ERROR occurred.	Treats error code 1520. *1
539 (021BH)	A hardware failure was detected.	Replace MELSECWinCPU module.

*1 : For more details on Method, refer to "8.3.4 Detailed error description and actions".

*2 : Only the error code of the error detected first during initialization of the module is displayed.

8.4.4 Corrective Actions for Each Error Message

When an error occurred in each utility, the corresponding error message will be displayed.

This section describes actions on an error message basis.

For errors of which error codes are displayed, refer to "8.4.1 Actions upon error codes at the time of function execution".

(1) Error message for the MELSECWinCPU setting utility

The following table shows error messages and corresponding actions for the MELSECWinCPU setting utility.

Error message	Actions
Failed to start up the CC-Link utility.	Reinstall SW1PNC-WCPU-B because its installation may have been failed.
CPU slot is set as blank. CPU slot must be set as CPU or CPU (Empty).	Specify a CPU module No. or "CPU (empty)" for the CPU slot.
CPU (Empty) is set between CPUs. Do not allow CPU (Empty) setting between CPUs.	Ensure that CPU (empty) is not specified between CPUs.
I/O response time is not set. Please set the I/O response time.	Sets the I/O response time.
Failed to start up the MELSECNET/H utility.	Reinstall SW1PNC-WCPU-B because its installation may have been failed.
The watchdog timer (WDT) value is invalid. Please enter a numeric value.	Reenter using a numeric value.
An error has occurred. Error code: XX(XXXXH)	Perform an action corresponding to the error code. (See the error list in the help information of bus interface functions or MELSEC data link functions.)
A CPU (Empty) that is set up to the control CPU. Please set up a CPU slot.	Check the setting of the type of the control CPU.
I/O assignment exists after base setting. Please set the count of slots.	Sets the slot No.

8 Actions against Errors

Error message	Actions
Blank exists in the base setting. Please the base setting without blank.	Specify the basic settings without vacant (vacant lines).
Failed to save the system information.	<ul style="list-style-type: none"> - Check the available capacity of the save destination. - Check the save destination media. - Check if the file path or the file name you specified might include 2 bytes character.
Parameters were not able to be read from the file. Please create the file again.	Create the parameters again, save to a file, and read the file by GX Developer, GX Works2 or the MELSECWinCPU setting utility.
The specified file cannot be read because the MELSECWinCPU setting utility version is different.	Install the version of the MELSECWinCPU utility by which the file was created.
The specified file is not a parameter file of the MELSECWinCPU setting utility.	Check the specified file.
Unable to open the specified file.	<ul style="list-style-type: none"> - Check the specified file. - Check if the file path or the file name you specified might include 2 bytes character.
This Intelligent function module parameter is not set.	Check whether the specified project has an intelligent function module parameter or not.
This multiple CPU parameter is not set.	Check the contents of the specified project file.
The specified project does not exist. Please specify an existing project path/project name.	Respecify a project path / project name.
Failed to write the output data (Y).	Check whether I/O assignment by parameters matches with the actual state.
Failed to read the output data (Y).	Check whether I/O assignment by parameters matches with the actual state.
Classified CPU (Empty) slots are as follows. - Control CPU for I/O Module, Intelligent function Module detailed setting.	Check whether the slot with the type CPU (empty) is specified for the control CPU in the detailed setting or not.
The allowable No. of characters has been exceeded. Please set to less than 150 characters.	Respecify or select a drive/path name with up to 150 characters.
The switch data value setting is out of range. Please input the switch data with in the range of 0-65535.	Specify a setting value of switch data within the range of 0 - 65535.
The set value of the switch is input excluding the binary number. Please input by the binary number of 0 or 1.	Specify a binary setting value for the switch data.
The slot number is not set. Please set the slot number.	Sets the slot No.
The target MELSECWinCPU module does not support this function. Verify the version of the target MELSECWinCPU module.	Check the version of the connection destination MELSECWinCPU module.
The set value is out of the word data range. Please enter a value within the range of -32768 to 32767.	Specify a value within the range of -32768 - 32767.

Error message	Actions
Unable to select this. Please specify a drive/path using 150 characters or less.	Re-enter or select a drive/path with up to 150 characters.
The start I/O No. is not set. Please input the start I/O No. with in the range of 0000-0FF0.	Specify a hexadecimal value within the range of 0000 - 0FF0.as the start I/O No..
The start I/O No. setting is overlapping. Please correct the settings.	Correct the start I/O No. setting to eliminate duplication.
Illegal start I/O No. setting. Please input the start I/O No. with in the range of 0000-0FF0 in hexadecimals.	Specify a hexadecimal value within the range of 0000 - 0FF0.as the start I/O No..
The start SI No. is not set. Please set the SI No. with in the range of 0 to 15.	Specify a value within the range of 0 - 15 as the start SI No..
The start SI No. is out of range. Please set the SI No. with in the range of 0 to 15.	Specify a value within the range of 0 - 15 as the start SI No..
Illegal value is set as the start SI No.. Please set the SI No. in numbers.	Specify a single-byte numeric value as the start SI No..
The start XY are overlapping. Please set them so that the start XY do not overlap.	Make the setting so that start XY is not duplicated.
The target CPU is own station. Change the target CPU setting.	Specify another CPU as the target of communication diagnostic.
The target CPU does not exist. CPU No. exceeding the one set in the multiple CPU setting may be specified.	Check whether the connection destination MELSECWinCPU module has the multiple CPU configuration or not. Then, specify the module No. of a CPU which is included in the configuration, as the target of communication diagnostic.
The target CPU is not connected. Please change the target CPU setting.	- Check the mount state of the target CPU. Change the specified target CPU No. to another.
The setting in the number of communication diagnostics is out of range. Set a value within the range of 1 to 32767.	Specify a value within the range of 1 - 32767.
This operation is not executable during communication diagnostics. Terminate the communication diagnostics and then retry.	- Wait until communication diagnostic is completed. - Press the Stop Diagnostic button to exit communication diagnostic.
Failed to start up the Device monitor utility.	Reinstall SW1PNC-WCPU-B because its installation may have been failed.
The total of points is out of range. Please set with in the 1000H points.	Make the setting so that the total should be up to 1000H points.

Error message	Actions
Failed to read the input data (X).	Check whether I/O assignment matches with the actual state or not.
Failed to read the version information.	Reinstall SW1PNC-WCPU-B because its installation may have been failed.
Driver is not started. Or it is not a MELSECWinCPU module.	<ul style="list-style-type: none"> - Check whether the connection destination MELSECWinCPU module is operating or not. - Check whether the MELSECWinCPU module is operating properly or not.
Failed to write data to the buffer memory.	<ul style="list-style-type: none"> - Check whether an intelligent function module is mounted to the specified slot or not. - Check whether the intelligent function module mounted to the specified slot has an error or not. - Check whether the MELSECWinCPU module is operating properly or not.
Failed to read data from the buffer memory.	<ul style="list-style-type: none"> - Check whether an intelligent function module is mounted to the specified slot or not. - Check whether the intelligent function module mounted to the specified slot has an error or not. - Check whether the MELSECWinCPU module is operating properly or not.
Failed to obtain the module configuration information due to a WDT error occurred in the MELSECWinCPU module. Check the MELSECWinCPU module of the connection target.	Check whether a watch dog timer error (system user) occurred on the MELSECWinCPU module or not.
Failed to write parameters. The probable causes are: - A Windows logon user does not have administrator authority. - The operating system is faulty.	<ul style="list-style-type: none"> - Check whether you are logging on as a user who has the administrator privilege for Windows or not. - Check whether the MELSECWinCPU module has a hardware failure or not.
Failed to clear the parameters. The probable causes are: - A Windows logon user does not have administrator authority. - The operating system is faulty.	<ul style="list-style-type: none"> - Check whether you are logging on as a user who has the administrator privilege for Windows or not. - Check whether the MELSECWinCPU module has a hardware failure or not.
Failed to read the parameters. No MELSECWinCPU parameters are set. Please set MELSECWinCPU parameters.	Set MELSECWinCPU parameters and write to MELSECWinCPU module.
Failed to read the parameters. The probable causes are: - No MELSECWinCPU parameters are set. - The operating system is faulty.	<ul style="list-style-type: none"> - Set MELSECWinCPU parameters and write to MELSECWinCPU module. - Check whether the MELSECWinCPU module has a hardware failure or not.
Specified file path exceeds 255 characters. Please specify it again.	Specify a file path with up to 255 characters.

Error message	Actions
Failed to save the parameter file. Please confirm the destination to save.	<ul style="list-style-type: none"> - Check the available capacity of the save destination. - Check the save destination media. - Respecify the save destination so that the total characters of the location name and the file name should be up to 128. - Check if the file path or the file name you specified might include 2 bytes character.
The project name has not been entered. Please enter the project name.	Specify the intended project name.
Failed to open the Help file.	Reinstall SW1PNC-WCPU-B because its installation may have been failed.
Parameters are not accessible at the moment since parameter reading/writing is in execution by another utility. Please wait for a while and reexecute.	Retry after that utility (the MELSECWinCPU setting utility, the CC-Link utility or the MELSECNET/H utility) completes reading, writing, and/or verifying parameters.
The Start I/O No. setting of intelligent function module interrupts pointer setting is mismatch because the count of CPU station is changed is multiple CPU setting. Please change the count of CPU in multiple CPU setting or the Start I/O No. of intelligent function.	Change either the No. of CPUs for the multiple CPU setting or the start I/O No. for the intelligent function module interruption event setting.
Failed to reserve space in the memory.	Check whether there is sufficient available memory or not.
Concurrent activations of the MELSECWinCPU setting utility is limited up to 1. One utility have already been activated.	The MELSECWinCPU setting utility is already operating. Retry after exiting the operating MELSECWinCPU setting utility.
The interrupt pointer No. is not set. Please set the interrupt pointer with in the range of 50 - 255.	Specify the setting value of the interruption event within the range of 50 - 255.
The interrupt pointer No. value setting is out of range. Please set the interrupt pointer with in the range of 50 - 255.	Specify the setting value of the interruption event within the range of 50 - 255.
Illegal interrupt pointer No. value setting. Please set the interrupt pointer with in the range of 50 - 255.	Specify the setting value of the interruption event within the range of 50 - 255.
No.of interrupt pointer setting is out of range. Please set the number of interrupt pointers between XX-YY.	Specify the setting value of the No. of interruption events within the prescribed range.
The No.of interrupt pointers is not set. Please set the No.of interrupt pointers with in the range of 1 - 16.	Specify the setting value of the No. of interruption event within the range of 1 - 16.
The No.of interrupt pointers value setting is out of range. Please set the No.of interrupt pointers with in the range of 1 - 16.	Specify the setting value of the No. of interruption event within the range of 1 - 16.
Illegal value is set as No.of interrupt pointers. Please set the No.of interrupt pointers in numbers.	Specify a single-byte numeric value as the setting value of the No. of interruption events.
The interrupt pointer range setting is overlapping. Please correct the settings.	Correct the setting range of interruption events to eliminate duplication.

(2) Error message for the CC-Link utility

The following table shows error messages and corresponding actions for the CC-Link utility.

Error message	Actions
An Error station was detected in 1-64 stations. Error code : XX (XXXXH)	Refer to the manual of the MELSECWinCPU module or the CC-Link utility to see details of the error.
Concurrent activations of the CC-Link utility is limited up to 1. One utility has already been activated.	A CC-Link utility is already operating. End the CC-Link utility that is already operating, and then execute it again.
The parameter of CC-Link module XX slot is not set. Please set a parameter for the number of modules.	Check whether as many parameters as the No. of modules specified on the Parameter Setting screen.
The CC-Link module is not mounted with more than five modules. Please chooses 1-4 modules for the Target module or mounts more than five modules.	Specify the No. of monitored modules as "1st to 4th" or perform monitoring after mounting five or more modules.
A CC-Link module is not mounted. Please execute a test after mounting.	Mount at least one CC-Link utility on the base unit, activate data link properly, and then perform test.
A CC-Link module is not mounted. Please execute a monitor after mounting.	Mount at least one CC-Link utility on the base unit, and then perform monitoring.
There is not a reply from a CC-Link module. The following causes are thought about. There is an error in H/W.	<ul style="list-style-type: none"> - Check if the CC-Link module has any hardware fault. - Retry the request after data link is restored to the normal state.
An error occurred in communication with the CC-Link module. Error code : XX (XXXXH)	Refer to the manual of the MELSECWinCPU module or the CC-Link module to see details of the error.
The CC-Link module is mounted with only to XX slot. Please test it within XX slot.	Change the No. of tested modules within the No. of mounted ones, and perform test.
The CC-Link module is mounted with only to XX slot. Please monitor it within XX slot.	Change the No. of monitored modules within the No. of mounted ones, and perform monitoring.
Failed to start up the MELSECNET/H utility.	Reinstall SW1PNC-WCPU-B because its installation may have been failed.
It failed in the save of the SBSW file. Confirm the end of the save.	<ul style="list-style-type: none"> - Check the available capacity of the save destination. - Check the save destination media. - Check if the file path or the file name you specified might include 2 bytes character.
The station type of Ver.1 (Ver.1 remote I/O station, Ver.1remote device station, Ver.1 intelligent device station) and the station type of Ver.2 (Ver.2remote device station, Ver.2 intelligent device station) are unmixable. Please set up the station type of Ver.1 in the first half and set up the station type of Ver.2 in the second half.	When including both the Ver.1staion type and the Ver.2 station type in the station information setting, specify the Ver.1 station type prior to the Ver.2 station type.

Error message	Actions
<p>The station type of Ver.1 is not set.</p> <p>Please set up the station type of Ver.1 in the first half and set up the station type of Ver.2 in the second half.</p>	<p>In the station information setting, specify the Ver.1 station type prior to the Ver.2 station type.</p>
<p>Setting of the start I/O No. of XX slot and YY slot are overlapping.</p> <p>Please correct the settings.</p>	<p>On the Parameter Setting screen, check the start I/O No. for all of the mounted modules to eliminate duplication.</p>
<p>An error occurred in communication with the CC-Link module of XX slot.</p> <p>Error code : XX (XXXXH)</p>	<p>Refer to the manual of the MELSECWinCPU module or the CC-Link module to see details of the error.</p>
<p>The number of intelligent device stations exceeds the maximum number of set stations.</p> <p>Please set the number within 26 stations.</p>	<p>Change the No. of intelligent device stations specified in the station information setting to be within 26.</p>
<p>The Error occurred on execution of Line test.</p> <p>Error code : XX (XXXXH)</p>	<p>Refer to the manual of the MELSECWinCPU module or the CC-Link module to see details of the error.</p>
<p>Line test can execute data link start state only at the time of the following state.</p> <ul style="list-style-type: none"> - In data link - During Auto-Returning 	<p>Check the state of data link on the "Module Information" screen, and retry.</p>
<p>The station No. setting value is wrong.</p> <p>Please input a value with the range XX-YY.</p>	<p>Specify the Sta. No. within the range of XX-YY.</p>
<p>The station No. setting value is wrong.</p> <p>Please input a value within the range 1-64.</p>	<p>Specify the Sta. No. of the target of circuit test within the range of 1 - 64.</p>
<p>The specified file cannot be read because the CC-Link utility version is different.</p>	<p>Install the version of the CC-Link utility by which the file was created.</p>
<p>The specified file is not a parameter file of the CC-Link utility.</p>	<p>Check the specified file.</p>
<p>Unable to open the specified file.</p>	<ul style="list-style-type: none"> - Check the specified file. - Limit the total No. of characters for the file location and file name to 128. - Check if the file path or the file name you specified might include 2 bytes character.
<p>It is local station.</p> <p>Cannot execute a test from local station.</p>	<p>Change the test target module to the Master station.</p>
<p>The auto buffer size total exceeds 4096 words.</p> <p>Please set it so it is within the maximum value.</p>	<p>In the station information setting, specify a value which is smaller than or equal to 4096 as the total automatic buffer size.</p>
<p>The auto buffer size setting value is wrong.</p> <p>Please input 0 or a value within the range 128-4096 for the auto buffer size.</p>	<p>In the station information setting, specify the automatic buffer size within the range of 0 and 128 - 4096.</p>

8 Actions against Errors

Error message	Actions
<p>The number of auto return to system stations setting value is wrong.</p> <p>Please input a value within the range 1-10.</p>	<p>In the other setting, specify the No. of automatic-parallel-on modules within the range of 1 - 10.</p>
<p>The receive buffer size setting value is wrong.</p> <p>Please input the receive buffer size at 0 or within the range 64-4096.</p>	<p>In the station information setting, specify the receiving buffer size within the range of 0 and 64 - 4096.</p>
<p>The conditions formula ((16×A) + (54×B) + (88×C)) exceeds 2304.</p> <p>Please make settings so the conditions formula satisfy the formula ((16×A) + (54×B) + (88×C)) ≤ 2304 (A: number of I/O stations, B: number of device stations, C: number of intelligent).</p>	<p>In the station information setting, specify a station type which can satisfy the conditional expression $\{(16 \times A) + (54 \times B) + (88 \times C)\} \leq 2304$.</p>
<p>The start I/O No. is not set.</p> <p>Please input the start I/O No. with in the range of 0000H - 0FE0H.</p>	<p>Specify a start I/O No. within the range of 0000H - 0FE0H.</p>
<p>The total of the proportionate number of stations exceeds the maximum number of set stations.</p> <p>Please set it so that the total of the proportionate number of stations is 64 or fewer stations.</p>	<p>In the station information setting, specify a value which is smaller than or equal to 64 as the total No. of occupied stations for connected modules.</p>
<p>Can not set all stations as Reserved stations.</p> <p>Please change any of the station to other than reserved station.</p>	<p>In the station information setting, change the setting of at least one reserved station to "None" or "Disabled station".</p>
<p>The send/receive buffer size total exceeds 4096 words.</p> <p>Please set it so it is within the maximum value.</p>	<p>In the station information setting, set the total transferring / receiving buffer size to 4096 or less.</p>
<p>The send buffer size setting value is wrong.</p> <p>Please input the send buffer size at 0 or within the range 64-4096.</p>	<p>In the station information setting, specify the transferring buffer size within the range of 0 and 64 - 4096.</p>
<p>The station types for the total number of module connected are not set.</p> <p>Please set the station type for the total number of connected module.</p>	<p>Specify the same No. of station types as the total No. of connected modules which is specified in the station information setting.</p>
<p>The proportionate number of stations in the total number of module connected is not set.</p> <p>Please set the proportionate number of stations for the number of module connected.</p>	<p>Specify the same No. of occupied stations as the total No. of connected modules which is specified in the station information setting.</p>
<p>There is no station information for the specified wait master station number.</p> <p>Please specify a station number having station information as the wait master station number.</p>	<p>In the other setting, specify the standby Master station No. within the range of 1 to the total No. of connected modules (the No. specified in the station information setting).</p>

Error message	Actions
Station information specified wait master station number is not a Ver.2Intelligent device station. Please specify a Ver.2Intelligent device station number as the wait master station number.	Change the station type corresponding to the standby Master station No. which was selected in the station information setting, to Ver.2 intelligent device station.
Station information specified wait master station number is not an intelligent device station. Please specify an intelligent device station number as the wait master station number.	Change the station type corresponding to the standby Master station No. which was selected in the station information setting, to intelligent device station.
The wait master station No. setting value is wrong. Please input a value within the range 1-XX.	In the other setting, specify the standby Master station No. within the range of 0 to the No. of connected modules (the No. specified in the station information setting).
The wait master station No. setting value is wrong. Please input it by (there is no setting) or a range of 1.	In the other setting, specify the standby master station number within the range of 0 or 1.
The Target CPU No. setting value is wrong. Please input a value within the range 1-4.	Specify a setting value of target device No. within the range of 1 - 4.
The delay time setting value is wrong. Please input a value within the range 0-100.	In the other setting, specify the delay time within the range of 0 - 100.
Failed to start up the Device monitor utility.	Reinstall SW1PNC-WCPU-B because its installation may have been failed.
Driver is not started. Or it is not a MELSECWinCPU module.	Check whether the driver is active or not.
The Error occurred on execution of Network test. Error code : XX (XXXXH)	Refer to the manual of the MELSECWinCPU module or the CC-Link module to see details of the error.
Network test can execute data link start state only at the time of the following state. - In data link - Suspend data link - During Auto-Returning	Check the state of data link on the "Module Information" tab, and retry.
Failed to read the version information.	Reinstall SW1PNC-WCPU-B because its installation may have been failed.
Failed to start up the MELSECWinCPU setting utility.	Reinstall SW1PNC-WCPU-B because its installation may have been failed.
An error occurred in communication with the MELSECWinCPU module. Error code : XX (XXXXH)	Refer to the manual of the MELSECWinCPU module or the CC-Link module to see details of the error.

Error message	Actions
<p>Failed to write parameters. The probable causes are:</p> <ul style="list-style-type: none"> - A Windows logon user does not have administrator authority. - The operating system is faulty. 	<ul style="list-style-type: none"> - Check whether you are logging on as a user who has the administrator privilege for Windows or not. - Check whether the MELSECWinCPU module has a hardware failure or not.
<p>Failed to read the parameters. No CC-Link parameters are set. Please set CC-Link parameters.</p>	<p>Set CC-Link parameters and write to MELSECWinCPU module.</p>
<p>Failed to read the parameters. The probable causes are:</p> <ul style="list-style-type: none"> - No CC-Link parameters are set. - The operating system is faulty. 	<ul style="list-style-type: none"> - Set CC-Link parameters and write to MELSECWinCPU module. - Check whether the MELSECWinCPU module has a hardware failure or not.
<p>Failed to save the parameter file. Confirm the destination to save.</p>	<ul style="list-style-type: none"> - Check the available capacity of the save destination. - Check the save destination media. - Respecify the save destination so that the total characters of the location name and the file name should be up to 128. - Check if the file path or the file name you specified might include 2 bytes character.
<p>Specified file pass exceeds 255 characters. Please specify it again.</p>	<p>Specify a file path with up to 255 characters.</p>
<p>Failed to open the Help file.</p>	<p>Reinstall SW1PNC-WCPU-B because its installation may have been failed.</p>
<p>Can not open Module detail information screen. There is not the number of modules.</p>	<p>Specify a module No. within the No. of mounted modules.</p>
<p>The number of retries setting value is wrong. Please input a value within the range 1-7.</p>	<p>In the other setting, specify the retry count within the range of 1 - 7.</p>
<p>If there is any 8points Remote station, please set them in pairs.</p>	<p>In the station information setting, specify the value 8 to the No. of points for remote stations as the total for two units.</p>
<p>Please set the total of the Remote station points as becoming to 8192 points or less.</p>	<p>In the station information setting, specify a value which is smaller than or equal to 8192 as the total No. of points for remote station.</p>
<p>The number of remote device stations exceeds the maximum number of set stations. Please set the number within 42 stations.</p>	<p>Change the No. of remote device station modules specified in the station information setting to be within 42.</p>
<p>The logical station No. setting value is wrong. Please input a value within the range 65-239.</p>	<p>Specify a setting value of logical Sta. No. within the range of 65 - 239.</p>

(3) Error message for the MELSECNET/H utility

The following table shows error messages and corresponding actions for the MELSECNET/H utility.

Error message	Actions
The setting value for the maximum number of transients for one station is greater than the setting value for the maximum number of transients in one scan. Please input values so that the setting value for the maximum number of transients for one station is the maximum number of transients in 1 scan.	Correct the setting so that the maximum transient counts per module becomes smaller than or equal to that per scan.
The setting value for the maximum number of transients for one station is outside the range. Please input a value within the range 1-10.	Specify the maximum transient counts per station within the range of 1 - 10.
The setting value for the maximum number of transients in one scan is outside the range. Please input a value within the range 1-255.	Specify the maximum transient counts per scan within the range of 1 - 255.
The setting value for the maximum number of return to system stations in 1 scan is outside the range. Please input a number within the range 1-XX.	Specify the maximum parallel station per scan within the range of 1 - XX.
Failed to start up the CC-Link utility.	Reinstall SW1PNC-WCPU-B because its installation may have been failed.
Two or more stations are selected for the I/O master station set/erase station No. Please select 1 station for the I/O master station set/erase station No.	Select only one Sta. No. and press the Specify I/O master station button.
The I/O master station set/erase station No. is not selected. Please select the I/O master station set/erase station No.	Select only one Sta. No. and press the Specify I/O master station button.
The LB setting are overlapping. Please set them so that they do not overlap.	Correct the LB setting to eliminate duplication.
The LW setting are overlapping. Please set them so that they do not overlap.	Correct the LW setting to eliminate duplication.
The L station to M station setting in LX/LY setting 1 are overlapping. Please set them so that they do not overlap.	Correct the L station->M station of LX/LY setting1 to eliminate duplication.
The M station to L station setting in LX/LY setting 1 are overlapping. Please set them so that they do not overlap.	Correct the M station->L station of LX/LY setting1 to eliminate duplication.
The L station to M station setting in LX/LY setting 2 are overlapping. Please set them so that they do not overlap.	Correct the L station->M station of LX/LY setting2 to eliminate duplication.

8 Actions against Errors

Error message	Actions
The M station to L station setting in LX/LY setting 2 are overlapping. Please set them so that they do not overlap.	Correct the M station->L station of LX/LY setting2 to eliminate duplication.
Concurrent activations of the MELSECNET/H utility is limited up to 1. One utility has already been activated.	MELSECNET/H utility is already operating. End the MELSECNET/H utility that is already operating, and then execute it again.
The parameter of MELSECNET/H module XX slot is not set. Please set a parameter for the number of modules.	Confirm the No. of mounted MELSECNET/H modules, and specify as many parameters as the No.
A MELSECNET/H module is not mounted. Please execute a monitor after mounting.	<ul style="list-style-type: none"> - Check whether the target MELSECNET/H module is mounted or not. - If not, mount the MELSECNET/H module and perform monitoring.
The MELSECNET/H module is mounted with only to XX slot. Please monitor it within XX slot.	Change the No. of monitored modules into that of XX or less and then perform monitoring.
It failed in the save of the SBSW file. Confirm the end of the save.	<ul style="list-style-type: none"> - Check the available capacity of the save destination. - Check the save destination media. - Check if the file path or the file name you specified might include 2 bytes character.
Setting of the start I/O No. of XX slot and YY slot are overlapping. Please correct the settings.	On the Parameter Setting screen, check the start I/O No. for all of the mounted modules to eliminate duplication.
An error occurred in communication with the MELSECNET/H module of XX slot. Error code : XX (XXXXH)	Refer to description of the error code in the help information on bus interface functions or MELSEC data link functions and perform the corresponding action.
The monitoring time setting value is outside the range. Please input the value within the range 1-200.	Specify setting value of monitoring time within the range of 1 - 200.
The station number setting value is outside the range. Please input a value within the range XX-YY.	Specify setting value of Sta. No. within the range of XX - YY.
The equally assigned end station setting value is outside the range. Please input a value within the range XX-YY.	Specify setting value of end station within the range of XX - YY.
The equally assigned start station setting value is outside the range. Please input a value within the range XX-YY.	Specify setting value of start station within the range of XX-YY.
The equally assigned start device No. setting value is outside the range. Please input a value in the range XX-YY.	Specify start device No. of assignment within the range of XX - YY.
The setting value for the number of equally assigned points assigned is outside the range. Please input a value within the range XX-YY.	Specify setting value of assignment point within the range of XX - YY.
An item to clear is not chosen.	Select an item of which error history to be cleared.

Error message	Actions
The group No. setting value is outside the range. Please input the value within the range 0-XX.	Specify setting value of group No. within the range of 0 - XX.
The constant scan setting value is outside the range. Please input a value within the range 1-500. If not setting it, leave this setting blank.	Specify vacant or a value within the range of 1 to 500 for constant link scan.
The end device No. is not set. Please input the number within the range XX-YY.	Specify setting value of end device No. within the range of XX - YY.
The system timer is not set. Please set the system timer.	Sets system timer.
The specified station No. is set as the I/O master station. Please erase the I/O master station and set the reserved station.	Reset the I/O master station setting of the target station and then specify it as a reserved station.
The specified file cannot be read because the MELSECNET/H utility version is different.	Install the version of the MELSECNET/H utility by which the file was created.
The specified file is not a parameter file of the MELSECNET/H utility.	Check the specified file.
Unable to open the specified file.	<ul style="list-style-type: none"> - Check the specified file. - Limit the total No. of characters for the file location and file name to 128. - Check if the file path or the file name you specified might include 2 bytes character.
The hours setting is out of range. Please input with in the range of 0-23.	Within the range of 0 - 23, specify the hour of the system timer.
Can not short hours.	Specify the hour of the system timer.
The start I/O No. is not set. Please input the start I/O No. with in the range of 0-XX.	Specify a setting value of start I/O No. within the range of 0 - XX.
The start device No. setting value is outside the range. Please input the value within the range XX-YY.	Specify a setting value of start device No. within the range of XX - YY.
Can not set all stations as "Reserved stations". Please change any of the station to other than reserved station.	Change at least one reserved station specified for network range assignment to a non-reserved station.
The target CPU No. setting value is outside the range. Please input the value within the range 1-4.	Specify a setting value of target CPU No. within the range of 1 - 4.
The relay destination station No. setting value is outside the range. Please input a value within the range 1-64.	Specify the setting value of the relay destination station No. within the range of 1 - 64.
The relay destination network No. setting value is outside the range. Please input a value within the range 1-239.	Specify the setting value of the relay destination network No. within the range of 1 - 239.

Error message	Actions
<p>The total for B, W and Y exceeds the 2000 bytes which is the ordinary total for one station. Please set the settings so that the total for B, W and Y does not exceed the 2000 byte ordinary total for one station.</p>	<p>Correct the value to be within 2000 bytes.</p>
<p>The total of low speed LB, low speed LW allocated to a normal station exceeds 2000 bytes. Please set the allocations of low speed LB & LW not exceeding 2000 bytes.</p>	<p>Correct the value to be within 2000 bytes.</p>
<p>The month setting is out of range. Please input with in the range of 1-12.</p>	<p>Specify a setting value of the month of the system timer within the range of 1 - 12.</p>
<p>Fixed term cycle interval value setting is out of range. Please input with in the range of 1-65535.</p>	<p>Specify a setting value of the scheduled cycle within the range of 1 - 65535.</p>
<p>The device settings are overlapping. Please set the device numbers so that they do not overlap.</p>	<p>Correct the refresh parameter setting to eliminate duplication.</p>
<p>Failed to start up the Device monitor utility.</p>	<p>Reinstall SW1PNC-WCPU-B because its installation may have been failed.</p>
<p>The number of points setting value is outside the range. Please input the value within the range XX-YY.</p>	<p>Specify a setting value of point within the range of XX - YY.</p>
<p>The send destination network No. are overlapping. Please set them so that they do not overlap.</p>	<p>Correct the Transfer to network No. setting to eliminate duplication.</p>
<p>The send destination network No. setting value is outside the range. Please input a value within the range 1-239.</p>	<p>Specify a setting value of Transfer to network No. within the range of 1 - 239.</p>
<p>The number of identical assigned points setting is outside the range. Changing the number of identical assigned points setting within the range XX-YY.</p>	<p>Specify a setting value of identical point assignment within the range of XX - YY.</p>
<p>Driver is not started. Or it is not a MELSECWinCPU module.</p>	<p>Check the driver is started.</p>
<p>The network No.XX is overlapping. Please correct the settings.</p>	<p>Correct the network No. setting to eliminate duplication.</p>
<p>The network No. setting value is outside the range. Please input the value within the range 1-239.</p>	<p>Specify a setting value of network No. within the range of 1 - 239.</p>
<p>The year setting is out of range. Please input with in the range of 2000-2099.</p>	<p>Within the range of 2000 - 2099, specify the year of the system timer.</p>
<p>Failed to read the version information.</p>	<p>Reinstall SW1PNC-WCPU-B because its installation may have been failed.</p>
<p>Failed to start up the MELSECWinCPU setting utility.</p>	<p>Reinstall SW1PNC-WCPU-B because its installation may have been failed.</p>

Error message	Actions
An error occurred in communication with the MELSECWinCPU module. Error code : XX (XXXXH)	Perform an action corresponding to the error code. (See the error list in the help information of bus interface functions or MELSEC data link functions.)
Failed to write parameters. The probable causes are: - A Windows logon user does not have administrator authority. - The operating system is faulty.	- Check whether you are logging on as a user who has the administrator privilege for Windows or not. - Check whether the MELSECWinCPU module has a hardware failure or not.
Failed to read the parameters. No MELSECNET/H parameters are set. Please set MELSECNET/H parameters.	Set MELSECNET/H parameters and write to MELSECWinCPU module.
Failed to read the parameters. The probable causes are: - No MELSECNET/H parameters are set. - The operating system is faulty.	- Set MELSECNET/H parameters and write to MELSECWinCPU module. - Check whether the MELSECWinCPU module has a hardware failure or not.
Failed to save the parameter file. Confirm the destination to save.	- Check the available capacity of the save destination. - Check the save destination media. - Respecify the save destination so that the total characters of the location name and the file name should be up to 128. - Check if the file path or the file name you specified might include 2 bytes character.
The day setting is out of range. Please input with in the range of 1-XX.	Specify a setting value of the date of the system timer within the range of 1 - XX.
The seconds setting is out of range. Please input with in the range of 0-59.	Specify a setting value of the second of the system timer within the range of 0 - 59.
Can not short seconds.	Specify the second of the system timer.
Specified file pass exceeds 255 characters. Please specify it again.	Specify a file path with up to 255 characters.
The minutes setting is out of range. Please input with in the range of 0-59.	Specify a setting value of the minute of the system timer within the range of 0 - 59.
Can not short minutes.	Specify a setting value of the minute of the system timer.
Failed to open the Help file.	Reinstall SW1PNC-WCPU-B because its installation may have been failed.
Master station 1 is not set. Please set the master station.	Specify I/O Master station 1.
Master station 2 is not set. Please set the master station.	Specify the I/O Master station 2.
Can not open the Module detail information screen. There is not the number of modules.	Specify the module within current pieces.
The reserved station set/erase station No. is not selected. Please select the reserved station set/erase station No.	Select the intended Sta. No. and press the Specify Reserved stations button.

Error message	Actions
The link side end device No. is not set. Please input the number within the range XX-YY.	Specify a setting value of the link-side end device No. within the range of XX - YY.
The link side start device No. setting value is outside the range. Please input the value within the range XX-YY.	Specify a setting value of the link-side start device No. within the range of XX - YY.
The link side number of points setting value is outside the range. Please input the value within the range XX-YY.	Specify a setting value of the link-side point within the range of XX - YY.
The total number of linked stations setting value is outside the range. Please input the value within the range 2-64.	Specify a setting value of the total No. of linked station within the range of 2 - 64.
The link device refresh cycle setting value is outside the range. Please input the value 0 or within the range 10-1000.	Specify a refresh cycle of linked devices within the range of 10 - 1000.
The logical station number setting value is outside the range. Please input a value within the range XX-YY.	Specify a setting value of logical Sta. No. within the range of XX-YY.

(4) Error message for the device monitor utility

The following table shows error messages and corresponding actions for the device monitor utility.

Error message	Actions
DEC input range error. Input 0-9.	Enter a decimal value from 0 to 9.
HEX input range error. Input 0-9,A-F.	Enter a hexadecimal value from 0 to 9, A - F.
Input Error. Input 0-7.	Enter an octal value from 0 to 7.
It cannot communicate XX. Error code :YY	Refer to the error list in the help information on MELSEC data link functions.
Station No. is not input.	Enter a Sta. No.
Station No. is out of the range.	Confirm the range of Sta. No. and enter the intended No.
The device that can use in this function dose not exist.	Select a device which is available for this function.
Setting data are not input.	Enter a setting data.
Setting points are out of the range.	Check the range of setting point and enter it.
"Start I/O No. /16" has not been entered.	Enter the value obtained by dividing the start I/O No. by 16.
"Start I/O No. /16" is out of range.	Check the value of start I/O No.÷16 and enter it.
Channel information is not register.	<ul style="list-style-type: none"> - Update parameters again. - Restart the development environment (computer). - Reinstall SW1PNC-WCPU-B.
It is fail to get the channel information.	<ul style="list-style-type: none"> - Update parameters again. - Restart the development environment (computer). - Reinstall SW1PNC-WCPU-B.
Device No. is not input.	Enter device No.
Device No. is out of the range.	<ul style="list-style-type: none"> - Check the device No., and respecify. - Check the specified device block No. (device type). - Check whether the specified device and block No. are valid for the specified target.
Device data are out of the range.	Check the setting of the device data.
Points are not input.	Enter the intended No. of points.
Network No. is not input.	Enter the network No.
Network No. is out of the range.	Check the range of network No. and enter it.
Block No. has not been entered.	Enter the intended block No.
Block No. is out of range.	Check the range of block No. and enter it.
The necessary information is not found at the time of starting up. Install again.	Reinstall SW1PNC-WCPU-B because its installation may have been failed.

9. Appendix

9.1 List of Parameter No.

Parameter No. are displayed in Microsoft Windows Event Viewer when an error on parameter setting (refer to 8.3) occurred.

The following table shows the mapping between parameter No. and the places to specify parameters.

(1) Description of mn, M and N in the Parameter No. column

Mn, **, M and N in the Parameter No. column indicate :

Mn : The value obtained by dividing the start I/O No. by 16.

** : Any value

N : The No. in the order of modules

M : Network type

(a) Settings for MELSECNET/H

M	Network type
1H	MELSECNET/H mode (control station), MELSECNET/H extended mode (control station)
2H	MELSECNET/H mode (normal station), MELSECNET/H extended mode (normal station)
3H	MELSECNET/10 mode (control station)
4H	MELSECNET/10 mode (normal station)
5H	MELSECNET/H (remote master station)
AH	MELSECNET/H (waiting station)
BH	MELSECNET/H mode multiple remote I/O net master station
DH	MELSECNET/H mode multiple remote I/O net sub master station (No Parameter setting)
EH	MELSECNET/H mode multiple remote I/O net sub master station (Parameter setting)

(b) CC-Link setting

M	Network type
0H	Master station
1H	Local station
2H	Waiting master station

(2) List of Parameter No.

The following table shows the mapping between parameter No. and the places to specify parameters.

Parameter No.	Item		Utility name
0000H	Label		-
0001H	Comment		-
0400H	I/O assignment	Type	MELSECWinCPU Setting Utility (I/O assignment setting window)
		Model name	
		Point	
		Start XY (start I/O No.)	
0401H	Base setting	Base model	MELSECWinCPU Setting Utility (I/O assignment setting window)
		Power model	
		Extension cable	
		Slots	
0403H	Detail setting	Error time output mode	MELSECWinCPU Setting Utility (Intelligent function module detailed setting window)
0405H		I/O response time	MELSECWinCPU Setting Utility (Intelligent function module detailed setting window)
0406H		Control CPU	MELSECWinCPU Setting Utility (Intelligent function module detailed setting window)
0407H	Switch setting		MELSECWinCPU Setting Utility (Switch setting for I/O and intelligent function module window)
05mnH	Switch setting	Group No.	MELSECNET/H Utility
		Mode	
0CmnH	Switch setting	Mode	CC-Link Utility
0D00H	Duplex parameter		-
0E00H	No. of CPU [*]		MELSECWinCPU Setting Utility (Multiple CPU setting window)
0E01H	Operating mode		MELSECWinCPU Setting Utility (Multiple CPU setting)
0E04H	I/O sharing when using Multiple CPUs	All CPUs can read all inputs	MELSECWinCPU Setting Utility (Multiple CPU setting window)
		All CPUs can read all outputs	

Parameter No.	Item			Utility name
1000H	Timer limit setting	Low speed		-
		High speed		
1001H	RUN-PAUSE contact	RUN		-
		PAUSE		
1002H	Remote reset			-
1003H	Output mode at B.STOP to B.RUN			MELSECWinCPU setting utility (system setting window)
1004H	Floating-point operation			-
1005H	Common pointer No.			-
1007H	Points occupied by empty slot			MELSECWinCPU setting utility (system setting window)
1008H	Interrupt / fixed cycle program setting			-
	System interrupt setting	Interrupt counter start No.		
		Interval at fixed cycle (n : 28 - 31)		
100AH	Intelligent function module setting (Interrupt event setting)			MELSECWinCPU Setting Utility (Intelligent function module interrupt event setting window)
100CH	Module synchronization			MELSECWinCPU setting utility (system setting window)
100DH	A series CPU compatible setting			-
100EH	Enablement of serial communication functionality			-
	Transfer speed			
	Sum check			
	Message waiting time			
	Write setting during RUN			
100FH	System interrupt setting	High speed interrupt setting	X input	-
1010H			Y output	-
1011H			Reads buffer	-
1012H			Writes buffer	-
1100H	File register			-
1101H	Comment file used for instruction			-
1102H	Device initial value			-
1103H	File for local device			-
2000H	Device point			-
2001H	Latch (1) start / end			-
2002H	Latch (2) start / end			-
2003H	Local device start / end			-

Parameter No.	Item		Utility name
3000H	WDT (watchdog timer) setting	System WDT setting	MELSECWinCPU setting utility (system setting window)
		Initial execution monitoring time	-
		Low-speed execution monitoring time	
3001H	Error check	Carry out PC battery check.	-
		Carry out fuse blown check.	MELSECWinCPU setting utility (system setting window)
		Carry out I/O module comparison.	
3002H	Operating mode when there is an err.	Calculation error	-
		Advanced instruction error	
		Fuse blown	MELSECWinCPU setting utility (system setting window)
		I/O module comparison error	-
		Intelligent module program execution error	
		Memory card access error	
		Memory card operation error	
External power supply OFF			
3003H	Constant scan	-	
3005H	Failure history	-	
3006H	Low-speed program execution time	-	
3008H	Memory check	Performs program memory check	-
4004H	Detailed setting	H/W error time CPU operation mode	MELSECWinCPU Setting Utility (Intelligent function module interrupt event setting window)
5000H	No. of modules		MELSECNET/H utility
5001H	Effective module on access to another station		-
5002H	Intra-link transfer (intra-data-link transfer parameter)		-
5003H	Routing parameter		MELSECNET/H utility
5NM0H	Start I/O No.		MELSECNET/H utility
	Network No.		
	Total stations		
5NM1H	Refresh parameters		MELSECNET/H utility

Parameter No.	Item		Utility name
5NM2H	Network range assignment	Network range assignment	MELSECNET/H utility
		Monitoring time	
		Specify I/O master Sta.	
		Specify reserved Sta.	
		Supplementary setting	
5NM3H	Station-specific parameter		MELSECNET/H utility
5NM5H	Parameter for sub-master		-
5NMAH	Common parameter 2		MELSECNET/H utility
5NMBH	Station peculiar parameter		MELSECNET/H utility
	Interrupt setting		
7000H	Program setting		-
	Boot option	Program memory clear	-
		Automatic write from memory card to all standard ROM data	-
		Boot file setting	-
8002H	SFC program startup mode		-
8003H	Starting condition		-
8006H	Block-stop-time output mode		-
9000H	Setting of the No. of Ethernet modules		-
9N00H	Start I/O No.		
	Network No.		
	Group No.		
	Sta. No.		
	Operation setting		
9N01H	Initial setting		-
9N02H	Open setting		-
9N03H	Router relay parameter		-
9N04H	Routing parameter		-
9N05H	Sta. No.<->IP related information		-
9N06H	FTP parameter		-
9N07H	E-mail setting		-
9N08H		Information setting	-
9N09H	Interrupt setting		-

Parameter No.	Item	Utility name	
C000H	No. of modules	CC-Link utility	
CNM1H	Remote input (RX) refresh device	-	
	Remote output (RY) refresh device		
	Remote register (RW _r) refresh device		
	Remote register (RW _w) refresh device		
	Ver.2 remote input (RX) refresh device		
	Ver.2 remote output (RY) refresh device		
	Ver.2 remote register (RW _r) refresh device		
	Ver.2 remote register (RW _w) refresh device		
	Special relay (SB) refresh device		
	Special relay (SW) refresh device		
CNM2H	Start I/O No.	CC-Link utility	
	Operational setting		
	All connect count		
	Retry count		
	Auto reconnection station count		
	Wait master station No.	-	
	CPU down select		
	Scan mode setting		
	Delay information setting	CC-Link utility	
	Station information setting		
	Remote device station initial setting	-	
	Interrupt setting		
	D001H	Setting when Power turns on	-
Waiting system monitor setting			
Debug mode setting			
Backup mode setting			
D002H	Tracking transfer mode setting	-	
D003H	Tracking device setting	-	
	Rising/falling execution instruction history (signal flow)		
	Detailed setting on device		Tracking block No.
			Automatically transfer Tracking Block No.1 (Automatic activation of SM1520)
			Device range setting
			File register setting

Parameter No.	Item	Utility name
D004H	Group setting	-
D5**H	Duplex setting	-
D9**H		-
E002H		-
E003H	Refresh setting	MELSECWinCPU setting utility (Multiple CPU setting window)
E006H	Online module change	MELSECWinCPU setting utility (Multiple CPU setting window)

9.2 The difference between MELSECWinCPU and former PC CPU

Limitation and notes when you replace former PC CPU (PC CPU (PPC-CPU852(MS)-512) mfd. By CONTEC) with MELSECWinCPU are written below.

9.2.1 The comparison between MELSECWinCPU and former PC CPU

(1) Functional comparison between MELSECWinCPU and former PC CPU

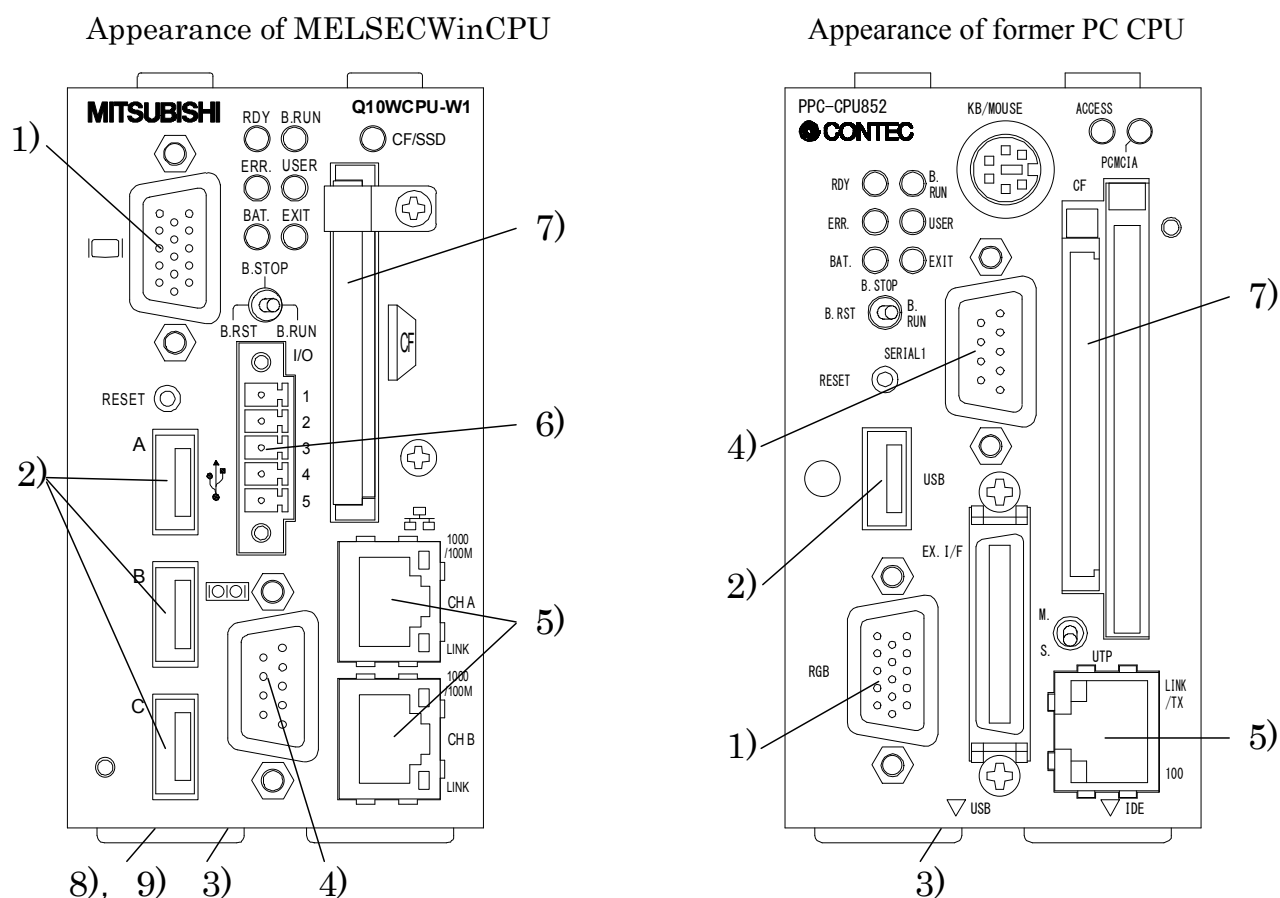

The area colored gray represents major difference.

Item	Description		Figure No.	
	MELSECWinCPU	Former PC CPU		
CPU	Intel®Atom Processor N450 1.66GHz	Intel®Celeron M Processor 600MHz		
System bus	533 MHz	400 MHz		
Cache memory	L2 cache 512KB (CPU built-in)	L1 cache 32KB×2 (CPU built-in)		
		L2 cache 512KB (CPU built-in)		
Main memory	1GB (DDR2-SDRAM 533MHz)	512MB (DDR-SDRAM 266MHz)		
Chipset	Intel®ICH8M	Intel®852GM		
Display function	VideoRAM	MAX 64MB		
	Graphic Controller	CPU built-in	Chipset built-in	
	I/F	Analog-RGB:H-Dsub15pin connector	1)	
Network Function	Controller	Intel®82574L	Intel®82551QM	
	I/F	Ethernet: 1000BASE-T/100BASE-TX/10BASE-T RJ-45 connector 2ch	Ethernet: 100BASE-TX/10BASE-T RJ-45 connector 1ch	5)
Peripherals Connection	Serial (COM1)	RS-232-compliant Dsub9pin connector	4)	
	Serial (COM2)	Not supported USB can replace it (Use commercial conversion peripherals)	RS-232-compliant 36pin composite Half pitch connector (EX. I/F)	
	USB	USB2.0-compliant 5ch (front 3ch, bottom 2ch) I/F: USB Type-A connector Power supply: +5V 0.5A max. per 1ch	USB2.0-compliant 3ch (front 1ch, bottom 2ch)	2)
			I/F: USB Type-A connector Power supply: +5V 0.5A max. per 1ch	3)
	Parallel	Not supported USB can replace it.	1ch 36pin composite Half pitch connector (EX. I/F)	
	PS/2 keyboard	Not supported USB can replace it.	1ch keyboard / mouse composite Mini DIN 6P connector	
	PS/2 mouse	Not supported USB can replace it.	1ch keyboard / mouse composite Mini DIN 6P connector	
	PC card	Not supported USB can replace it.	Type I ,II x 1pcs. Support CardBus card (Controller: RICOH R5C485)	
	CF card	Type1 x 1pcs. Only for a memory card with IDE connection	Type1 x 1pcs. Support card boot. (With the switch to change master/slave) (Only for a memory card)	7)
	Built-in SSD	4GB	Not supported	-
	IDE	Not supported Built-in SSD or a CF card can replace it	Primary IDE 40pin half pitch connector	
	FDD	Not supported USB can replace it.		
	I/O terminal	Photocoupler insulated input 3-point Input to shutdown, Output to notify the completion of shutdown Output to notify the start of WDT.	Connector terminal “PPC-COT-01” for PC CPU module can support it	5)
	Setting switch	DIP switch 6-poles, The bottom of the main body	DIP switch 6-poles, The right of the main body.	8)
DIP switch 4-poles (Built-in SSD setting switch) The bottom of the main body		-	9)	
Extension bus	Q-bus			

(2) H/W limitation

- It does not have a PS/2 port. Therefore you can not connect a PS/2 keyboard / mouse directly to it. USB peripherals can replace it.
- You can not use a HDD with IDE connection. USB peripherals or a CF card can replace it.
- It does not have a PC card slot. USB peripherals can replace it.
- Connector terminal “PPC-COT-01” for PC CPU module is not supported. Therefore you can not use parallel port and RS-232 (36pin composite half pitch connector (EX.I/F) with it. USB peripherals can replace it.
- The performance of MELSECWinCPU is different from that of the former PC CPU because of the difference of the chipset. We suggest that you fully evaluate its operation before utilizing programs from the former PC CPU.

9.2.2 The comparison of supported S/W package

(1) The comparison of supported S/W package is shown below.

Item	Outline	MELSECWin CPU	Former PC CPU
OS	Microsoft®Windows®2000 Professional Operating System (Japanese/English)	×	O
	Microsoft®Windows®XP Professional Operating System (Japanese/English)	×	O
	Microsoft®Windows®XP Embedded Operating System (Japanese/English)	×	O
	Microsoft®Windows®Embedded Standard 2009	O	×
Development environment	Microsoft®Visual C++®Version 6.0 (Japanese/English)	×	O
	Microsoft®Visual Basic®Version 6.0 (Japanese/English)	×	O
	Microsoft®Visual C++®.NET 2003 (Japanese/English)	×	O
	Microsoft®Visual Basic®.NET 2003 (Japanese/English)	×	O
	Microsoft®Visual C++®2005 (Japanese/English)	×	O
	Microsoft®Visual Basic®2005 (Japanese/English)	×	O
	Microsoft®Visual C++®2008 (Japanese/English)	O	×
	Microsoft®Visual Basic®2008 (Japanese/English)	O	×
	Microsoft®Visual C++®2010 (Japanese/English)	O	×
Microsoft®Visual Basic®2010 (Japanese/English)	O	×	
Hyper threading function	Whether it supports the hyper threading function of OS or not	O	×

O :Supported, ×: Not supported

(2) The comparison of the action when an error happens is shown below. (Shows the difference only.)

Item	Outline	MELSECWin CPU	Former PC CPU
Temperature warning of hard disk	Maintain the condition where it detected the abnormal temperature	×	O
PC card battery error	Maintain a PC card battery error.	×	O

O: Supported, ×: Not supported

- (3) For the part which you should change if you divert your program, the comparison of programming specification is shown below. (Shows the difference only.)

Item	Outline	MELSECWin CPU	Former PC CPU
mdBdVerRead	Changed the H/W type name (read data 10h-17h) when reading own board version (mdMdVerRead).	'009PPC-100-DC551'	'009PPC-CPU852'
mdTypeRead	Changed the type name when programmable controller CPU read it (mdTypeRead).	3022 (CONTEC) 3023 (Mitsubishi)	3020
mdBdSwRead	Changed the read data when reading own board switch condition (mdBdSwRead)	-	-
	buf[0] (bit12-9)	Information of DIP switch 1	×
	buf[0] (bit8-3)	Information of DIP switch 2	Information of DIP switch
QBF_ReadStatus QBF_ReadStatusEx	Changed the read data when reading module information of MELSECWinCPU (PC CPU) (QBF_ReadStatus, QBF_ReadStatusEx)	-	-
	plinfo [0](bit12-9)	Information of DIP switch 1	×
	plinfo [0] (bit8-3)	Information of DIP switch 2	Information of DIP switch
	plinfo [2] (bit18)	×	×
	plinfo [2] (bit17)	×	PC card1 Built-in battery error
plinfo [3] (bit11)	×	HDD temperature error	
Processing timing	If the processing of your programs depends on CPU performance, processing timing may change because CPU performance increased.Example) The synchronism with other processing using loop counter.	-	-

O: Supported, ×: Not supported

- (4) The functional comparison of MELSECWinCPU (PC CPU) setting utility is shown below. (Shows the difference only.)

Item	Outline	MELSECWin CPU	Former PC CPU
Information of DIP switch	Shows the information of DIP switch (DIP switch 4-poles).	O	×
	Shows the information of DIP switch (DIP switch 6-poles).	O	O
Error information *1	Shows the temperature warning of hard disk.	×	O
	Shows a PC card battery error.	×	O
The setting of the number of empty slots	Sets the number of empty slots. *1	O	O
The setting of error check item	Check if fuses were cut.	O	O
	Check I/O module collation error.	O	O
	Check a PC card battery error.	×	O
	Check the temperature of hard disk.	×	O

O: Supported, ×: Not supported

*1:MELSECWinCPU module does not need HDD module. Therefore take care of the setting of empty slots.

- (5) The functional comparison of CC-Link utility is shown below. (Shows the difference only.)
- There are no differences.
- (6) The functional comparison of MELSECNET/H utility is shown below. (Shows the difference only.)
- There are no differences.
- (7) The comparison of supported MELSOFT products is shown below.

MELSOFT product	MELSECWin CPU	Former PC CPU
GT SoftGOT1000	O ^{*1}	O ^{*3}
GX Developer	× ^{*2}	O ^{*3}
GX Works2	× ^{*2}	O ^{*3}
MX Component	O ^{*4}	O ^{*3}

O: Supported, ×: Not supported

*1: Use version 3.38Q or later.

*2: Because it does not support Microsoft®Windows®Embedded Standard 2009.

*3: It depends on the OS installed in PC CPU module.

*4: Use version 4.02C or later.

(8) Limitation of S/W

- If you divert the program of former PC CPU, you should change the program to suit the processing speed of the new MELSECWinCPU module, or change the program so that it does not depend on processing speed.
If your program depends on processing speed and you divert the program as it is, the processing timing may change (Example. The synchronism with other processing using loop counter.)
- If you use the program of former PC CPU, build the program again using included files and library files which have been installed by this package. When you build it again, do it under the development environment which MELSECWinCPU module supports. For the development environment which MELSECWinCPU module supports, refer to the operational environment.
- When you use MELSOFT products and commercial software, refer to the manuals and the guides of each product.

REVISIONS

*The manual number is given on the bottom left of the back cover.

Print date	*Manual number	Revision
December 2011	SH(NA)-081054ENG-A	First edition
February 2013	SH(NA)-081054ENG-B	<u>Partial correction</u> About Generic Terms and Abbreviations, 2.2.1, 2.4, 5.3.11, 6.10, 7.2.2, 7.3.2, 9.2.2
August 2013	SH(NA)-081054ENG-C	<u>Partial correction</u> About Generic Terms and Abbreviations, 8.3.4
January 2015	SH(NA)-081054ENG-D	<u>Partial correction</u> 2.4.2, 9.2.1

Japanese manual version SH-081043-E

This manual confers no industrial property rights or any rights of any other kind, nor does it confer any patent licenses. Mitsubishi Electric Corporation cannot be held responsible for any problems involving industrial property rights which may occur as a result of using the contents noted in this manual.

© 2011 MITSUBISHI ELECTRIC CORPORATION

Microsoft, Windows, Windows XP, Windows Embedded are registered trademarks of Microsoft Corporation in the United States and other countries.

Atom is a trademark of Intel Corporation in the United States and other countries.

Ethernet is a trademark of Xerox Corporation.

CompactFlash is a registered trademark of SanDisk Corporation.

All other company names and product names used in this manual are trademarks or registered trademarks of their respective companies.

SH(NA)-081054ENG-D(1501)KWIX

MODEL: SW1PNC-WCPU-B-U-UP-E

MODEL CODE: 13JZ67

mitsubishi electric corporation

HEAD OFFICE : TOKYO BUILDING, 2-7-3 MARUNOUCHI, CHIYODA-KU, TOKYO 100-8310, JAPAN
NAGOYA WORKS : 1-14, YADA-MINAMI 5-CHOME, HIGASHI-KU, NAGOYA, JAPAN

When exported from Japan, this manual does not require application to the
Ministry of Economy, Trade and Industry for service transaction permission.

Specifications subject to change without notice.