

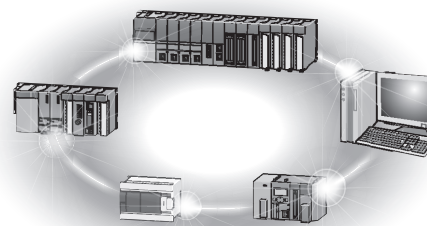

Mitsubishi Programmable Controller

CC-Link IE Field Network Analog-Digital Converter Module User's Manual

-NZ2GF2B-60AD4



● SAFETY PRECAUTIONS ●

(Read these precautions before using this product.)

Before using this product, please read this manual and the relevant manuals carefully and pay full attention to safety to handle the product correctly.

In this manual, the safety precautions are classified into two levels: "⚠ WARNING" and "⚠ CAUTION".

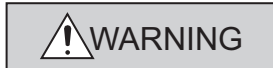

Indicates that incorrect handling may cause hazardous conditions, resulting in death or severe injury.



Indicates that incorrect handling may cause hazardous conditions, resulting in minor or moderate injury or property damage.

Under some circumstances, failure to observe the precautions given under "⚠ CAUTION" may lead to serious consequences.

Observe the precautions of both levels because they are important for personal and system safety. Make sure that the end users read this manual and then keep the manual in a safe place for future reference.

[Design Precautions]

⚠ WARNING

- In the case of a communication failure in the network, data in the master module are held. Check Data link status (each station) (SW00B0 to SW00B7) and configure an interlock circuit in the program to ensure that the entire system will operate safely.
- Do not use any "use prohibited" signals as a remote input or output signal. These signals are reserved for system use. Do not write any data to the "use prohibited" area in the remote register. If these operations are performed, correct operation of the module cannot be guaranteed.

[Design Precautions]

⚠ CAUTION

- Do not install the control lines or communication cables together with the main circuit lines or power cables. Keep a distance of 100mm or more between them. Failure to do so may result in malfunction due to noise.

[Security Precautions]

WARNING

- To maintain the security (confidentiality, integrity, and availability) of the programmable controller and the system against unauthorized access, denial-of-service (DoS) attacks, computer viruses, and other cyberattacks from external devices via the network, take appropriate measures such as firewalls, virtual private networks (VPNs), and antivirus solutions.

[Installation Precautions]

WARNING

- Shut off the external power supply (all phases) used in the system before mounting or removing a module. Failure to do so may result in electric shock or cause the module to fail or malfunction.

[Installation Precautions]

CAUTION

- Use the module in an environment that meets the general specifications in this manual. Failure to do so may result in electric shock, fire, malfunction, or damage to or deterioration of the product.
- Do not directly touch any conductive parts and electronic components of the module. Doing so can cause malfunction or failure of the module.
- Securely fix the module with a DIN rail.
- After the first use of the product (extension module), the number of connections/disconnections is limited to 50 times (IEC 61131-2 compliant).
- To connect an extension module to a main module, engage the respective connectors and securely lock the module joint levers. Incorrect connection may cause malfunction, failure, or drop of the module.
- Securely connect the cable connectors. Poor contact may cause malfunction.

[Wiring Precautions]

WARNING

- Shut off the external power supply (all phases) used in the system before wiring. Failure to do so may result in electric shock or cause the module to fail or malfunction.

[Wiring Precautions]

CAUTION

- Individually ground the FG terminal of the programmable controller with a ground resistance of 100Ω or less. Failure to do so may result in electric shock or malfunction.
- Tighten any unused terminal screws within the specified torque range. Undertightening may cause a short circuit due to contact with a solderless terminal.
- Use applicable solderless terminals and tighten them within the specified torque range. If any spade solderless terminal is used, it may be disconnected when a terminal block screw comes loose, resulting in failure.
- Check the rated voltage and terminal layout before wiring to the module, and connect the cables correctly. Connecting a power supply with a different voltage rating or incorrect wiring may cause a fire or failure.
- Tighten the terminal block screws within the specified torque range. Undertightening can cause short circuit, fire, or malfunction. Overtightening can damage the screw and/or module, resulting in drop, short circuit, fire, or malfunction.

[Wiring Precautions]

CAUTION

- Prevent foreign matter such as dust or wire chips from entering the module. Such foreign matter can cause a fire, failure, or malfunction.
- Place the cables in a duct or clamp them. If not, dangling cable may swing or inadvertently be pulled, resulting in damage to the module or cables or malfunction due to poor contact.
- Do not install the control lines or communication cables together with the main circuit lines or power cables. Keep a distance of 100mm or more between them. Failure to do so may result in malfunction due to noise.
- When disconnecting the cable from the module, do not pull the cable by the cable part. For the cable with connector, hold the connector part of the cable. For the cable connected to the terminal block, loosen the terminal screw. Pulling the cable connected to the module may result in malfunction or damage to the module or cable.
- When an overcurrent caused by an error of an external device or a failure of the programmable controller flows for a long time, it may cause smoke and fire. To prevent this, configure an external safety circuit, such as a fuse.
- Mitsubishi programmable controllers must be installed in control panels. Wiring and replacement of a module must be performed by qualified maintenance personnel with knowledge of protection against electric shock. For wiring methods, refer to "INSTALLATION AND WIRING" in this manual.

[Startup and Maintenance Precautions]

WARNING

- Do not touch any terminal while power is on. Doing so will cause electric shock or malfunction.
- Shut off the external power supply (all phases) used in the system before cleaning the module or retightening the terminal block screws or connector screws. Failure to do so may cause the module to fail or malfunction.

[Startup and Maintenance Precautions]

CAUTION

- Do not disassemble or modify the modules. Doing so may cause failure, malfunction, injury, or a fire.
- Do not drop or apply strong shock to the module. Doing so may damage the module.
- Shut off the external power supply (all phases) used in the system before mounting or removing a module. Failure to do so may cause the module to fail or malfunction.
- After the first use of the product (terminal block), the number of connections/disconnections is limited to 50 times (IEC 61131-2 compliant).
- Before handling the module or the cable to be connected to the module, touch a conducting object such as a grounded metal to discharge the static electricity from the human body. Failure to do so may cause the module to fail or malfunction.
- Startup and maintenance of a control panel must be performed by qualified maintenance personnel with knowledge of protection against electric shock. Lock the control panel so that only qualified maintenance personnel can operate it.

[Disposal Precautions]

CAUTION

- When disposing of this product, treat it as industrial waste.

● CONDITIONS OF USE FOR THE PRODUCT ●

- (1) MELSEC programmable controller ("the PRODUCT") shall be used in conditions;
- i) where any problem, fault or failure occurring in the PRODUCT, if any, shall not lead to any major or serious accident; and
 - ii) where the backup and fail-safe function are systematically or automatically provided outside of the PRODUCT for the case of any problem, fault or failure occurring in the PRODUCT.
- (2) The PRODUCT has been designed and manufactured for the purpose of being used in general industries. MITSUBISHI ELECTRIC SHALL HAVE NO RESPONSIBILITY OR LIABILITY (INCLUDING, BUT NOT LIMITED TO ANY AND ALL RESPONSIBILITY OR LIABILITY BASED ON CONTRACT, WARRANTY, TORT, PRODUCT LIABILITY) FOR ANY INJURY OR DEATH TO PERSONS OR LOSS OR DAMAGE TO PROPERTY CAUSED BY THE PRODUCT THAT ARE OPERATED OR USED IN APPLICATION NOT INTENDED OR EXCLUDED BY INSTRUCTIONS, PRECAUTIONS, OR WARNING CONTAINED IN MITSUBISHI ELECTRIC USER'S, INSTRUCTION AND/OR SAFETY MANUALS, TECHNICAL BULLETINS AND GUIDELINES FOR the PRODUCT.
- ("Prohibited Application")
- Prohibited Applications include, but not limited to, the use of the PRODUCT in;
- Nuclear Power Plants and any other power plants operated by Power companies, and/or any other cases in which the public could be affected if any problem or fault occurs in the PRODUCT.
 - Railway companies or Public service purposes, and/or any other cases in which establishment of a special quality assurance system is required by the Purchaser or End User.
 - Aircraft or Aerospace, Medical applications, Train equipment, transport equipment such as Elevator and Escalator, Incineration and Fuel devices, Vehicles, Manned transportation, Equipment for Recreation and Amusement, and Safety devices, handling of Nuclear or Hazardous Materials or Chemicals, Mining and Drilling, and/or other applications where there is a significant risk of injury to the public or property.
- Notwithstanding the above restrictions, Mitsubishi Electric may in its sole discretion, authorize use of the PRODUCT in one or more of the Prohibited Applications, provided that the usage of the PRODUCT is limited only for the specific applications agreed to by Mitsubishi Electric and provided further that no special quality assurance or fail-safe, redundant or other safety features which exceed the general specifications of the PRODUCTS are required. For details, please contact the Mitsubishi Electric representative in your region.
- (3) Mitsubishi Electric shall have no responsibility or liability for any problems involving programmable controller trouble and system trouble caused by DoS attacks, unauthorized access, computer viruses, and other cyberattacks.

INTRODUCTION

Thank you for purchasing the CC-Link IE Field Network analog-digital converter module (hereafter abbreviated as A/D converter module).

This manual describes the operating procedure, system configuration, parameter settings, functions, and troubleshooting of the A/D converter module.

Before using this product, please read this manual and the relevant manuals carefully and develop familiarity with the functions and performance of the A/D converter module to handle the product correctly.

When applying the program examples introduced in this manual to an actual system, ensure the applicability and confirm that it will not cause system control problems.

■ Target module: NZ2GF2B-60AD4

Remark

Unless otherwise specified, this manual describes the program examples in which the remote I/O signals and remote registers are assigned for an A/D converter module as follows.

- Remote input signal: RX0 to RX1F
- Remote output signal: RY0 to RY1F
- Remote register: RWr0 to RWrF, RWw0 to RWwF

For the assignment of remote I/O signals and remote registers, refer to the following.

 User's manual for the master/local module used

RELEVANT MANUALS

(1) CC-Link IE Field Network (relevant) manuals

When using the CC-Link IE Field Network for the first time, refer to CC-Link IE Field Network Master/Local Module User's Manual or Simple Motion Module User's Manual first. The following shows the structure of the CC-Link IE Field Network manuals.

Manual name <manual number (model code)>	Description
MELSEC-Q CC-Link IE Field Network Master/Local Module User's Manual <SH-080917ENG, 13JZ47>	Overview of the CC-Link IE Field Network, and specifications, procedures before operation, system configuration, installation, wiring, settings, functions, programming, and troubleshooting of the QJ71GF11-T2
MELSEC-L CC-Link IE Field Network Master/Local Module User's Manual <SH-080972ENG, 13JZ54>	Overview of the CC-Link IE Field Network, and specifications, procedures before operation, system configuration, installation, wiring, settings, functions, programming, and troubleshooting of the LJ71GF11-T2
MELSEC-Q QD77GF Simple Motion Module User's Manual (Network) <IB-0300203, 1XB957>	Functions, programming, and troubleshooting for CC-Link IE Field Network of the QD77GF16
MELSEC-Q QD77GF Simple Motion Module User's Manual (Positioning Control) <IB-0300202, 1XB956>	Specifications of the QD77GF16 and information on how to establish a system, maintenance and inspection, and troubleshooting Functions, programming and buffer memory for the positioning control of the QD77GF16

(2) Operating manual

Manual name <manual number (model code)>	Description
GX Works2 Version1 Operating Manual (Common) <SH-080779ENG, 13JU63>	System configuration, parameter settings, and online operations of GX Works2, which are common to Simple projects and Structured projects

CONTENTS

SAFETY PRECAUTIONS	1
CONDITIONS OF USE FOR THE PRODUCT	5
INTRODUCTION	6
RELEVANT MANUALS	7
MANUAL PAGE ORGANIZATION	11
TERM.	12
PACKING LIST	14
<hr/>	
CHAPTER 1 A/D CONVERTER MODULE	15
<hr/>	
1.1 Application	15
1.2 Features	16
<hr/>	
CHAPTER 2 PART NAMES	20
<hr/>	
CHAPTER 3 SPECIFICATIONS	24
<hr/>	
3.1 General Specifications	24
3.2 Performance Specifications	25
3.3 Calculating Current Consumption	27
3.4 Function List	28
3.5 List of Remote I/O Signals	30
3.6 List of Remote Register	32
3.7 List of Remote Buffer Memory	33
<hr/>	
CHAPTER 4 THE PROCEDURE BEFORE OPERATION	43
<hr/>	
CHAPTER 5 SYSTEM CONFIGURATION	45
<hr/>	
5.1 A/D Converter Module System Configuration	45
5.2 Applicable Systems	46
<hr/>	
CHAPTER 6 INSTALLATION AND WIRING	47
<hr/>	
6.1 Station Number Setting	47
6.2 Installation Environment and Installation Position	48
6.2.1 Installation environment	48
6.2.2 Installation position	48
6.2.3 Installation direction	49
6.3 Installation	50
6.3.1 Connecting extension modules	50
6.3.2 Mounting the modules on a DIN rail	52
6.4 Wiring with Terminal Block for Module Power Supply and FG	55
6.5 Wiring of Ethernet Cable	57
6.6 Wiring of External Device and Terminal Block	60

CHAPTER 7 VARIOUS SETTINGS 66

7.1	Parameter Setting	66
7.2	Changing the Parameter	72
7.2.1	Changing the network configuration	72
7.2.2	Changing the parameter without changing the network configuration	76
7.3	Offset/Gain Setting	78

CHAPTER 8 FUNCTIONS 80

8.1	Mode Shift at Power-on	80
8.2	Drive Mode Switch	81
8.3	Processing Each Function	83
8.4	A/D Conversion Enable/Disable Function	84
8.5	A/D Conversion Method	84
8.6	Range Switching Function	89
8.7	Conversion Speed Switch Function	90
8.8	Maximum Value/Minimum Value Hold Function	90
8.9	Input Signal Error Detection Function	91
8.10	Alert Output Function (Process Alarm)	94
8.11	Scaling Function	97
8.12	Shift Function	102
8.13	Digital Clipping Function	106
8.14	Difference Conversion Function	111
8.15	Trigger Conversion Function	115
8.16	CC-Link IE Field Network Synchronous Communication Function	123
8.17	Error Notification Function	127
8.18	Function at the Extension Module Installation	130
8.19	CC-Link IE Field Network Diagnostic Function	135

CHAPTER 9 PROGRAMMING 138

9.1	Precautions for Programming	138
9.2	Procedure for Programming	139
9.3	Program Example	140

CHAPTER 10 MAINTENANCE AND INSPECTION 149

CHAPTER 11 TROUBLESHOOTING 151

11.1	Checking for the Error Codes and the Alarm Codes	151
11.2	Error Code List	154
11.3	Alarm Code List	161
11.4	Checking the LEDs	162
11.5	Unit Test	165
11.6	Troubleshooting for Each Phenomenon	166

APPENDICES **168**

Appendix 1 Details of Remote I/O Signals	168
Appendix 1.1 Remote input signals	168
Appendix 1.2 Remote output signals	175
Appendix 2 Details of Remote Registers	177
Appendix 3 Details of Remote Buffer Memory Addresses	180
Appendix 4 I/O Conversion Characteristics of A/D Conversion	199
Appendix 5 Accuracy of A/D Conversion	202
Appendix 6 Conversion Speed of A/D Conversion	203
Appendix 7 EMC and Low Voltage Directives	204
Appendix 7.1 Measures to comply with the EMC Directive	204
Appendix 7.2 Requirements to compliance with the Low Voltage Directive	210
Appendix 8 Checking Serial Number and Function Version	211
Appendix 9 Addition and Change of Functions	212
Appendix 9.1 Additional function	212
Appendix 9.2 Change of function	212
Appendix 9.3 Operation differences with different serial numbers	213
Appendix 10 External Dimensions	214

INDEX **215**

REVISIONS	218
WARRANTY	219

MANUAL PAGE ORGANIZATION

In this manual, pages are organized and the symbols are used as shown below.

The following illustration is for explanation purpose only, and should not be referred to as an actual documentation.

Annotations on the left side of the manual page:

- "" is used for screen names and items.
- 1. shows operating procedures.
- ☞ shows mouse operations.*1
- [] is used for items in the menu bar and the project window.
- Ex. shows setting or operating examples.
- 📖 shows reference manuals.
- 📄 shows reference pages.

Annotations on the right side of the manual page:

- The chapter of the current page is shown.
- The section of the current page is shown.
- Point shows notes that requires attention.
- Remark shows useful information.

Manual page content (73):

CHAPTER 7 VARIOUS SETTINGS

7.1.1 Setting method

(1) Setting parameters

(a) Operating procedure

1. Open the "PLC Parameter" dialog box.
Project window ⇨ [Parameter] ⇨ [PLC parameter]
2. Select the "IO Assignment" tab.

IO Assignment

Item	Description	Reference
Type	Select the type of the connected module.	Page 74, Section 7.1.2
Model Name	Select the model name of the connected module.	Page 74, Section 7.1.3
Points	Set the number of points assigned to each slot.	Page 74, Section 7.1.4
Start XY	Specify a start I/O number for each slot.	Page 74, Section 7.1.5
Switch setting	Configure the switch setting of the built-in I/O or intelligent function modules.	Page 74, Section 7.1.6
General setting	Set the following: • Error Time Output Mode • PLC Operation Mode at HW Error • I/O Response Time	Page 75, Section 7.1.7

Setting "Start XY" enables modification on the start I/O numbers assigned to connected modules.
 Ex. When "1000" is specified in "Start XY" to the slot where a 16-point module is connected, the assignment range of an input module is changed to X1000 to X100F.

For details, refer to the following:
 MELSEC-L CPU Module User's Manual (Function Explanation, Program Fundamentals)

Point
 Set the type of the connected module in "Type". Setting a different type results in "SP.LIMIT LAV ERR."
 For the intelligent function module, the I/O points must also be the same in addition to the I/O assignment setting.
 Page 30, Section 4.2.2)

Remark
 When an intelligent module is connected, I/O assignment can be omitted by selecting connected modules from "Intelligent Function Module" in the Project window.

*1 The mouse operation example is provided below.

Annotations on the left side of the software interface:

- Menu bar: Ex. ☞ [Online] ⇨ [Write to PLC...]
Select [Online] on the menu bar, and then select [Write to PLC...].
- A window selected in the view selection area is displayed. Ex. ☞ Project window ⇨ [Parameter] ⇨ [PLC Parameter]
Select [Project] from the view selection area to open the Project window. In the Project window, expand [Parameter] and select [PLC Parameter].
- View selection area

Software interface details:

MELSOFT Series GX Works2 (Unset Project) - [[PRG] MAIN]

Menu bar: Project Edit Find/Replace Compile View Online Debug Diagnostics





Navigation:

- Project
 - Parameter
 - Intelligent Function Module
 - Global Device Comment
 - Program Setting
 - POU
 - Program
 - MAIN
 - Local Device Comment
 - Device Memory
 - Device Initial Value
- Project
 - User Library
 - Connection Destination

Unlabeled

TERM

Unless otherwise specified, this manual uses the following terms.

Term	Description
A/D converter module	The abbreviation for the CC-Link IE Field Network analog-digital converter module
CC-Link IE Field Network	A high-speed and large-capacity open field network that is based on Ethernet (1000BASE-T)
GX Works2	The product name of the software package for the MELSEC programmable controllers
REMFR	The abbreviation for ZP.REMFR
REMTO	The abbreviation for ZP.REMTO
Intelligent device station	A station that exchanges I/O signals (bit data) and I/O data (word data) with another station by cyclic transmission. This station responds to a transient transmission request from another station and also issues a transient transmission request to another station.
Cyclic transmission	A function by which data are periodically exchanged among stations on the same network using link devices (RX, RY, RWw, and RWr)
Simple motion module	The abbreviation for the QD77GF CC-Link IE Field Network simple motion module
Slave station	A generic term for stations other than a master station, such as a local station, remote I/O station, remote device station, and intelligent device station
Data link	Generic term for cyclic transmission and transient transmission
Transient transmission	A function of communication with another station, which is used when requested by a dedicated instruction or GX Works2
Network module	A generic term for the following modules: <ul style="list-style-type: none"> • CC-Link IE Field Network module • CC-Link IE Controller Network module • Ethernet interface module • MELSECNET/H module • MELSECNET/10 module
Buffer memory	A memory in an intelligent function module, where data (such as setting values and monitoring values) exchanged with a CPU module are stored
Master/local module	A generic term for the CC-Link IE Field Network master/local module
Master station	A station that controls the entire network. This station can perform cyclic transmission and transient transmission with all stations. Only one master station can be used in a network.
Remote I/O station	A station that exchanges I/O signals (bit data) with the master station by cyclic transmission
Remote device station	A station that exchanges I/O signals (bit data) and I/O data (word data) with another station by cyclic transmission. This station responds to a transient transmission request from another station.
Remote buffer memory	Buffer memory in a remote device station
Remote register (RWr)	Word data input from a slave station to the master station (For some areas in a local station, data are input in the opposite direction.)  User's manual for the master/local module used
Remote register (RWw)	Word data output from the master station to a slave station (For some areas in a local station, data are output in the opposite direction.)  User's manual for the master/local module used
Remote output (RY)	Bit data output from the master station to a slave station (For some areas in a local station, data are output in the opposite direction.)  User's manual for the master/local module used
Remote input (RX)	Bit data input from a slave station to the master station (For some areas in a local station, data are input in the opposite direction.)  User's manual for the master/local module used
Link device	A device (RX, RY, RWr, or RWw) in a module on CC-Link IE Field Network
Link special relay (SB)	Bit data that indicates the operating status and data link status of a module on CC-Link IE Field Network
Link special register (SW)	Word data that indicates the operating status and data link status of a module on CC-Link IE Field Network
Local station	A station that performs cyclic transmission and transient transmission with the master station and other local stations. The station is controlled by programs in the CPU module or other equivalent modules on the station.
Disconnection	A process of stopping data link if a data link error occurs

Term	Description
Main module	A module with the CC-Link IE Field Network communication function, which can be used as a single remote module. Extension modules can be connected to this module.
Dedicated instruction	An instruction that simplifies programming for using functions of intelligent function modules
Extension module	A remote module that does not support the CC-Link IE Field Network communication function. This module cannot be used as a single module. However, connecting the module to the main module will increase the number of I/O points per station.
Extension I/O module	A generic term for extension modules where a digital signal can be input or output
Relay station	A station that includes two or more network modules. Data are passed through this station to stations on other networks.
I/O module	Another term for the CC-Link IE Field Network remote I/O module
Return	Process of restarting data link when a station recovers from an error
Reserved station	A station reserved for future use. This station is not actually connected, but counted as a connected station.

PACKING LIST

The following items are included in the package of this product. Before use, check that all the items are included.

A/D converter module

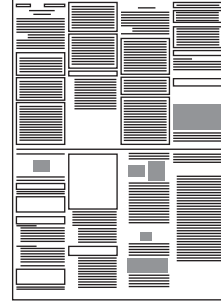
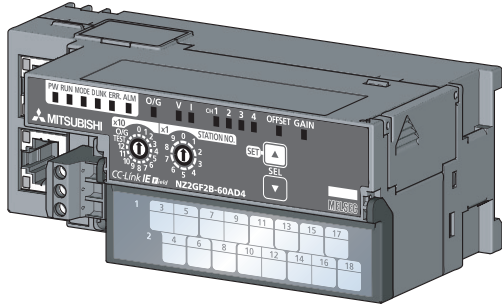

Module

Before Using the Product

CHAPTER 1 A/D CONVERTER MODULE

This chapter describes the applications and features of the A/D converter module.

1.1 Application

This module converts the analog value input from the external devices to the digital operation value.

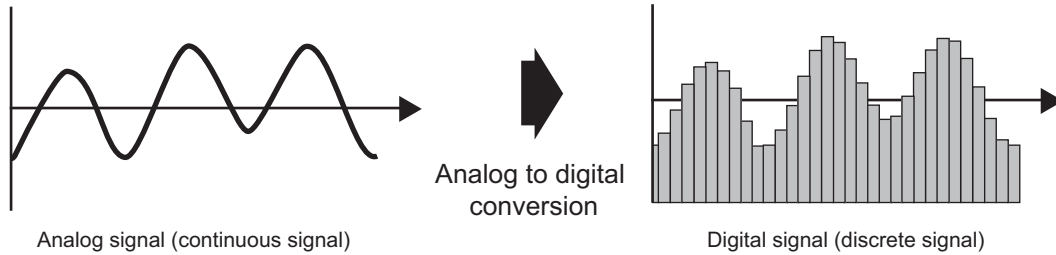

The converted digital operation value can be checked in the master station.
The A/D converter module enables works as follows.

The flow/temperature measured in the A/D converter module can be checked in the master station.

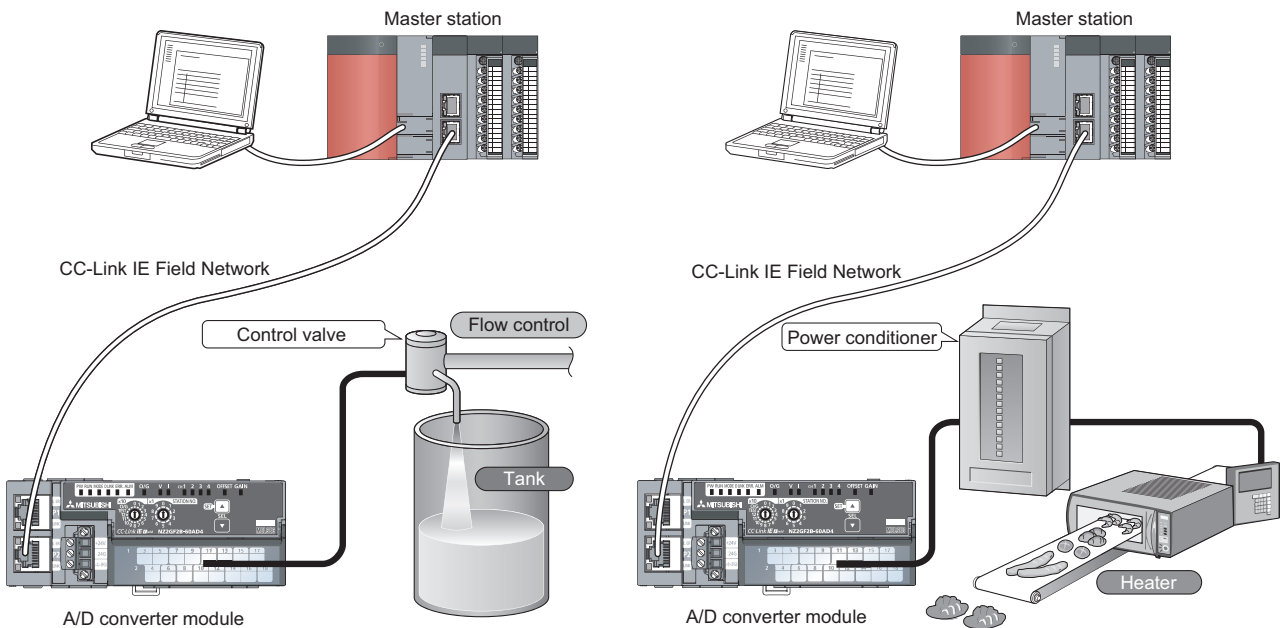

1.2 Features

(1) Available flexible system configuration

Adopting the connection block type enables the combination of the main module and extension module. Because various extension modules can be connected, a flexible configuration can be achieved. In addition, a poor contact of the extension module can be found promptly because the main module always monitors the connection status of the extension module.

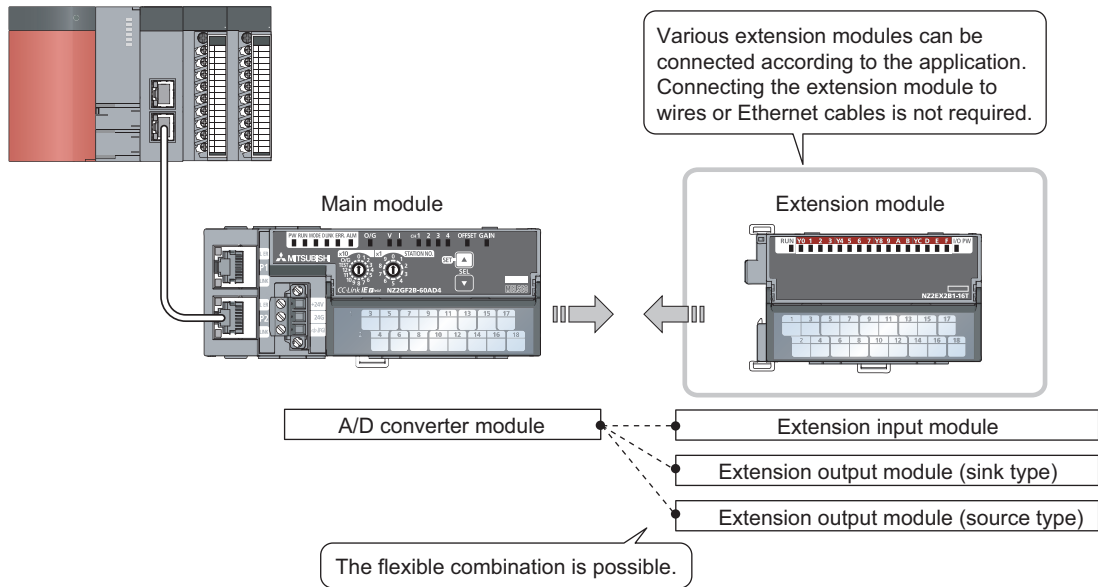

(2) Easy station number setting

Because of the rotary switch on the front of the module, setting and checking the station number are easy.

(3) Selectable conversion speed

When a high-speed conversion is required, the A/D conversion can be performed at 400 μ s/channel. When a noise is easily occurs, switching the conversion speed to 1ms/channel reduces noise influence for the digital operation value. The stability of the digital operation value can be improved.

(4) A/D conversion available at any timing

This function is to perform the A/D conversion one time just after Trigger conversion request is input and acquire the digital operation value.

Combining this function with the external signal assignment function enables the direct input of Trigger conversion request from the extension input module, thus the following advantages are provided.

- The digital operation value can be always acquired at a constant timing without influence from the sequence scan or link scan. The reliability can be improved.
- The digital operation value can be acquired without a program, thus the cost in creating a program can be saved.

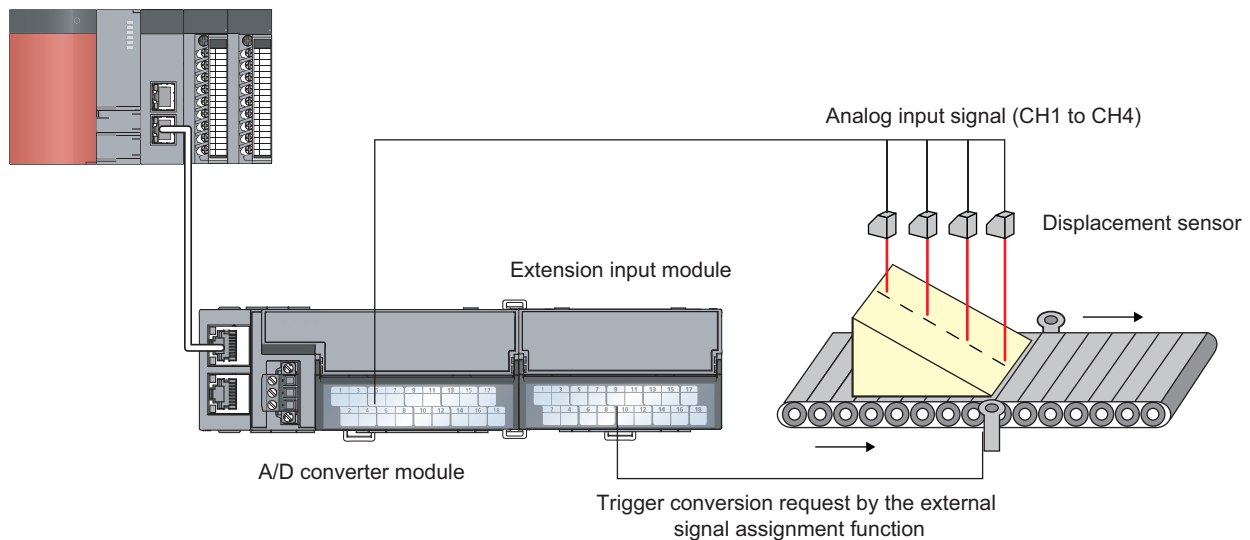

(5) Switching scale available

The A/D conversion value can be scale-converted to any range.

The scale can be converted without a program according to the device that handles the digital operation value, thus the cost can be saved.

(6) Disconnection detection available

Because the disconnection of the analog input can be detected when the input range is 1 to 5V or 4 to 20mA, the cause can be investigated easily when a problem occurs.

With the external signal assignment function combined, a signal (input signal error detection signal) can be output externally from the extension output module without a program when a disconnection is detected. At this time, there is no influence from the sequence scan or link scan.

(7) Input and output available without influence from the sequence scan or link scan

When the external signal assignment function is used, Trigger conversion request can be input from the extension input module. In addition, an error status or alert status can be output from the extension output module when an error or alert occurs.

The sequence scan or link scan does not influence this input and output.

Ex. To turn on the lamp when an error occurs.

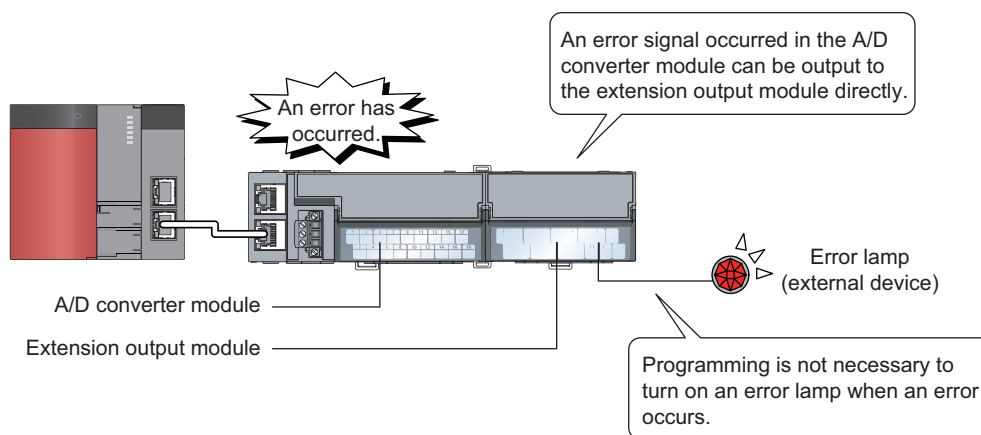

(8) CC-Link IE Field Network synchronous communication function available

With this function, the A/D converter module can perform A/D conversion synchronized with the operation cycle of a simple motion module.

This enables the A/D converter module to operate at the same timing of other slave stations on the same network.

(9) Various installation methods

The module can be installed in six directions using a DIN rail.

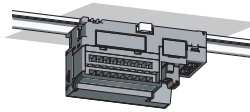

Downward installation

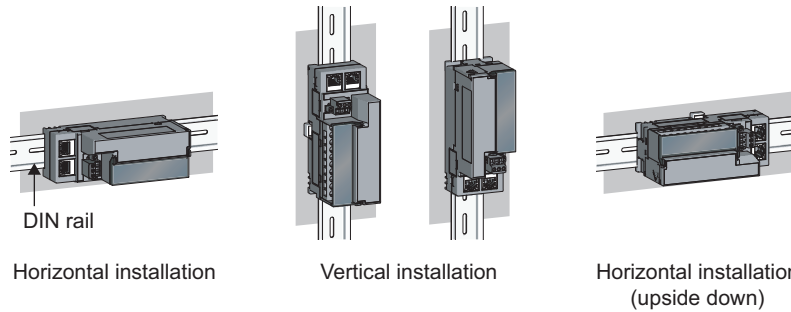

DIN rail

Horizontal installation

Vertical installation

Horizontal installation
(upside down)

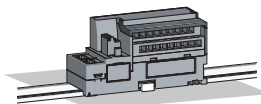

Upward installation

(10) Easy module replacement

Because the 2-piece structure is adopted for the terminal block for module power supply and FG and terminal block for analog input signals, the module can be replaced with the wire connected. In addition, because the terminal block for analog input signals is the lift-up structure, the terminal block can be lifted only by loosening the terminal block mounting screw to be removed easily.

(11) Error history confirmation

The history of 15 errors and occurrence time are stored in the A/D converter module. The error history helps the investigation for the cause when a problem occurs.

(12) Easy setting with CC IE Field configuration of GX Works2

Programming is reduced since the parameter can be configured on the screen with the CC IE Field configuration of GX Works2. In addition, setting status and operation status of modules can be checked easily.

CHAPTER 2 PART NAMES

The section describes part names of the A/D converter module.

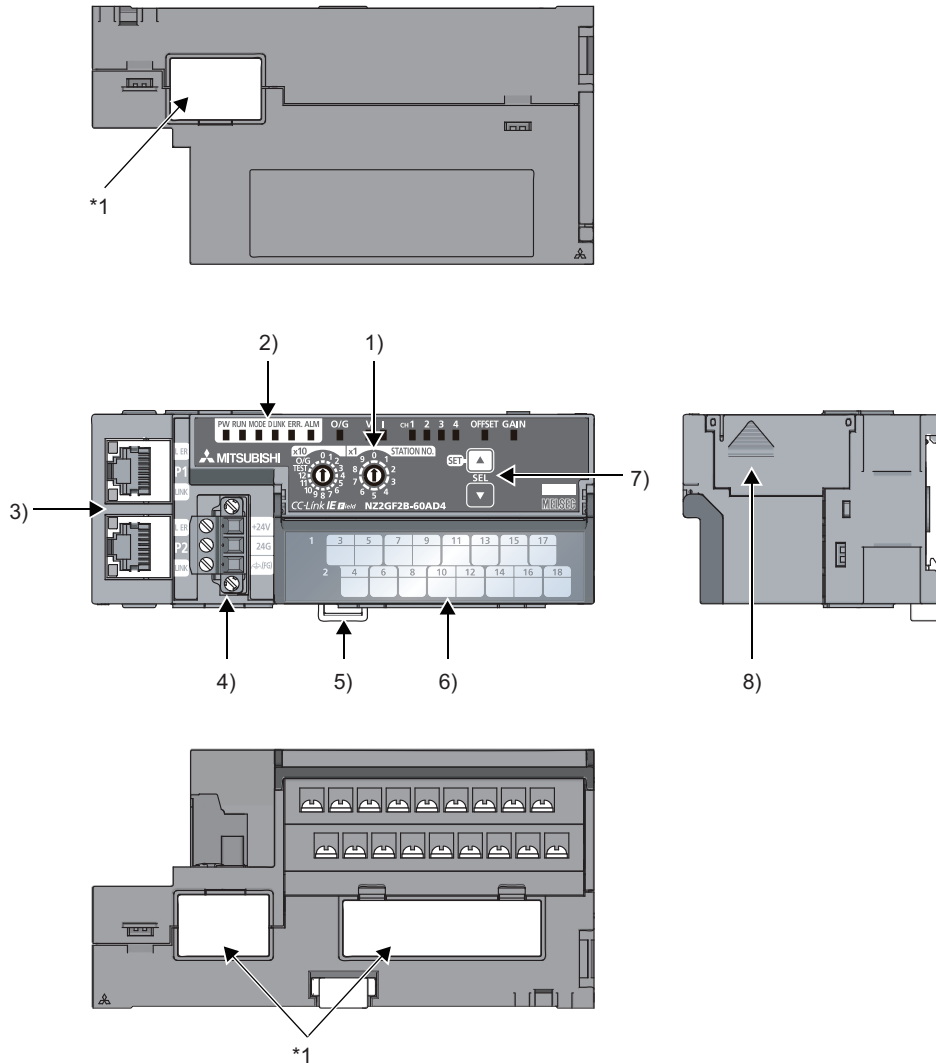

*1 Do not remove this seal because it is used for a maintenance purpose.

No.	Name	Application
1)	Station number setting switch	<p>A rotary switch for the following setting and test.</p> <ul style="list-style-type: none"> • Station Number Setting (☞ Page 47, Section 6.1) • Offset/Gain Setting (☞ Page 78, Section 7.3) • Unit Test (☞ Page 165, Section 11.5) <p>When operating the station number setting switch, use a slotted screwdriver with 3.5mm or less width of the tip.</p>

No.	Name	Application									
	PW LED (green)	Indicates the power supply status of the A/D converter module.									
	ON	Power supply ON									
	OFF	Power supply OFF									
	RUN LED (green)	Indicates the operating status of the A/D converter module.									
	ON	Operating normally. Writing data to the nonvolatile memory in the offset/gain setting mode.									
	OFF	A major error has occurred.									
	MODE LED (green)	Indicates the mode of the A/D converter module.									
	ON	In online mode.									
	Flashing	In unit test mode.									
	OFF	In offset/gain setting mode									
	D LINK LED (green)	Indicates the data link status of the A/D converter module.									
	ON	Data link in operation. (cyclic transmission in progress)									
	Flashing	Data link in operation. (cyclic transmission stopped)									
	OFF	Data link not performed. (disconnected)									
	ERR. LED (red)	Indicates the error status of the A/D converter module.									
	ON	A moderate error or major error has occurred.									
	Flashing	A warning has occurred.									
	OFF	Operating normally.									
2)	ALM LED (red)	Indicates the alert status of the A/D converter module.									
	ON	Alert (process alarm) has occurred.									
	Flashing	An input signal error has been detected.									
	OFF	Operating normally.									
	O/G LED (green)	Indicates the module is in the offset/gain setting mode.									
	ON	In offset/gain setting mode.									
	OFF	In a mode other than the offset/gain setting mode.									
	V LED (green) I LED (green)	Indicates the user range setting for the selected setting in the offset/gain setting mode. <table border="1" data-bbox="587 1272 1410 1391"> <thead> <tr> <th>Setting target</th> <th>V LED</th> <th>I LED</th> </tr> </thead> <tbody> <tr> <td>User range setting 1 (voltage)</td> <td>ON</td> <td>OFF</td> </tr> <tr> <td>User range setting 2 (voltage/current)</td> <td>OFF</td> <td>ON</td> </tr> </tbody> </table>	Setting target	V LED	I LED	User range setting 1 (voltage)	ON	OFF	User range setting 2 (voltage/current)	OFF	ON
Setting target	V LED	I LED									
User range setting 1 (voltage)	ON	OFF									
User range setting 2 (voltage/current)	OFF	ON									
CH1 to CH4 LED (green)		Indicates the channel for the selected setting in the offset/gain setting mode.									
	ON	The channel of the number for which the LED turns on is the setting target.									
	OFF	The channel of the number for which the LED turns off is not the setting target.									
OFFSET LED (green), GAIN LED (green)		Indicates whether the selected setting is offset or gain in the offset/gain setting mode.									
		<table border="1" data-bbox="587 1615 1410 1733"> <thead> <tr> <th>Setting target</th> <th>OFFSET LED</th> <th>GAIN LED</th> </tr> </thead> <tbody> <tr> <td>Offset</td> <td>ON</td> <td>OFF</td> </tr> <tr> <td>Gain</td> <td>OFF</td> <td>ON</td> </tr> </tbody> </table>	Setting target	OFFSET LED	GAIN LED	Offset	ON	OFF	Gain	OFF	ON
	Setting target	OFFSET LED	GAIN LED								
Offset	ON	OFF									
Gain	OFF	ON									

No.	Name	Application	
3)	P1	PORT1 connector for CC-Link IE Field Network (RJ45 connector) Connect an Ethernet cable. (☞ Page 57, Section 6.5) There are no restrictions on the connection order of the cables for the "P1" connector and "P2" connector.	
	L ER LED (red)	ON	<ul style="list-style-type: none"> The module has received abnormal data. The module is performing loopback.
		OFF	<ul style="list-style-type: none"> The module has received normal data. The module is not performing loopback.
	LINK LED (green)	ON	Linkup in progress.
		OFF	Linkdown in progress.
	P2	PORT2 connector for CC-Link IE Field Network (RJ45 connector) Connect an Ethernet cable. (☞ Page 57, Section 6.5) There are no restrictions on the connection order of the cables for the "P1" connector and "P2" connector.	
L ER LED (red) LINK LED (green)	(Same as the "P1" connector)		
4)	Terminal block for module power supply and FG	A terminal block to connect the module power supply (24VDC) and FG.	
5)	DIN rail hook	A hook to mount a module on a DIN rail.	
6)	Terminal block cover	Covers for preventing electric shock while the power is on.	
	Terminal block for analog input signals	A 2-piece screw terminal block for connecting to the external device.	
7)	SET/SEL button	Select the setting target by pressing the ▲ button or ▼ button in the offset/gain setting mode.	
8)	Extension connector cover	A cover to protect a connector of an extension module. Do not remove the cover when an extension module is not connected to the connector.	

(1) Module status and LED status

The following table lists the correspondence between the module status and the LED status.

Module status		Data link status	LED status						
			PW LED	RUN LED	MODE LED	D LINK LED	ERR. LED	ALM LED	O/G LED
Normal mode	Disconnecting	Disconnection	ON	ON	ON	OFF	OFF	OFF	OFF
	Data link in operation	Data link in operation	ON	ON	ON	ON	OFF	OFF	OFF
	Reserved station specification in progress	Cyclic stop	ON	ON	ON	Flashing	OFF	OFF	OFF
	Link stop	Cyclic stop	ON	ON	ON	Flashing	OFF	OFF	OFF
Offset/gain setting mode		-	ON	OFF	OFF	Flashing	OFF	*1	ON
Unit test	In progress	-	ON	ON	Flashing	*1	OFF	OFF	OFF
	Normal completion	-	ON	ON	OFF	OFF	OFF	OFF	OFF
	Abnormal completion	-	ON	ON	OFF	OFF	ON	OFF	OFF
Communication error		Cyclic stop	ON	ON	ON	Flashing	OFF	OFF	OFF
Error	Major error	-	ON	OFF	*2	*1	ON*3	*1	OFF
	Moderate error	-	ON	ON	*2	*1	ON	*1	OFF
Warning	Minor error	-	ON	ON	*2	*1	Flashing	*1	OFF
Alarm	Alert	-	ON	ON	ON	*1	*1	ON	OFF
	Input signal error	-	ON	ON	ON	*1	*1	Flashing	OFF

*1 Either of ON, Flashing, or OFF.

*2 Either of ON or OFF.

*3 When the module is failed, the LED may not turn on.

CHAPTER 3 SPECIFICATIONS

This chapter describes the specifications of the A/D converter module.

3.1 General Specifications

Item	Specifications					
Operating ambient temperature	0 to 55°C					
Storage ambient temperature	-25 to 75°C					
Operating ambient humidity	5 to 95%RH, non-condensing					
Storage ambient humidity						
Vibration resistance	Compliant with JIS B 3502 and IEC 61131-2	Under intermittent vibration	Frequency	Constant acceleration	Half amplitude	Number of sweeps
			5 to 8.4Hz	-	3.5mm	
		Under continuous vibration	8.4 to 150Hz	9.8m/s ²	-	10 times each in X, Y, and Z directions
			5 to 8.4Hz	-	1.75mm	
		8.4 to 150Hz	4.9m/s ²	-	-	
Shock resistance	Compliant with JIS B 3502 and IEC 61131-2 (147m/s ² , 3 times each in X, Y, and Z directions)					
Operating atmosphere	No corrosive gases					
Operating altitude *1	0 to 2000m					
Installation location	Inside a control panel*2					
Overvoltage category*3	II or less					
Pollution degree*4	2 or less					
Equipment class	Class I					

*1 Do not use or store the A/D converter module under pressure higher than the atmospheric pressure of altitude 0m. Doing so may cause malfunction. When using the A/D converter module under pressure, please consult your local Mitsubishi representative.

*2 If the environment satisfies the operating ambient temperature, operating ambient humidity and other conditions, the module can be used even outside the control panel.

*3 This indicates the section of the power supply to which the equipment is assumed to be connected between the public electrical power distribution network and the machinery within premises.
Category II applies to equipment for which electrical power is supplied from fixed facilities. The surge voltage withstand level for the equipment with the rated voltage of 300V or less is 2500V.

*4 This index indicates the degree to which conductive material is generated in terms of the environment in which the equipment is used.
Pollution degree 2 is when only non-conductive pollution occurs. A temporary conductivity caused by condensing must be expected occasionally.

Point

To use the A/D converter module complying with the EMC Directive, refer to "EMC and Low Voltage Directives" in this manual. (Page 204, Appendix 7)

3.2 Performance Specifications

Item		Description																										
Station type		Remote device station																										
Number of analog input points		4 points (4 channels)/module																										
Analog input	Voltage	-10 to 10VDC (input resistance: 1MΩ)																										
	Current	0 to 20mADC (input resistance: 250Ω)																										
Digital output		16-bit signed binary (-16384 to 16383)																										
I/O characteristics, maximum resolution		<table border="1"> <thead> <tr> <th>Input</th> <th>Input range</th> <th>Digital output value</th> <th>Maximum resolution</th> </tr> </thead> <tbody> <tr> <td rowspan="5">Voltage</td> <td>-10 to 10V</td> <td rowspan="3">-16000 to 16000</td> <td>0.625mV</td> </tr> <tr> <td>User range setting 1 (-10 to 10V)</td> <td>0.5mV</td> </tr> <tr> <td>User range setting 2 (-5 to 5V)</td> <td>0.25mV</td> </tr> <tr> <td>0 to 5V</td> <td rowspan="2">0 to 16000</td> <td>0.3125mV</td> </tr> <tr> <td>1 to 5V</td> <td>0.25mV</td> </tr> <tr> <td rowspan="3">Current</td> <td>0 to 20mA</td> <td rowspan="2">0 to 16000</td> <td>1.25μA</td> </tr> <tr> <td>4 to 20mA</td> <td>1μA</td> </tr> <tr> <td>User range setting 2 (-20 to 20mA)</td> <td>-16000 to 16000</td> <td>1μA</td> </tr> </tbody> </table>	Input	Input range	Digital output value	Maximum resolution	Voltage	-10 to 10V	-16000 to 16000	0.625mV	User range setting 1 (-10 to 10V)	0.5mV	User range setting 2 (-5 to 5V)	0.25mV	0 to 5V	0 to 16000	0.3125mV	1 to 5V	0.25mV	Current	0 to 20mA	0 to 16000	1.25μA	4 to 20mA	1μA	User range setting 2 (-20 to 20mA)	-16000 to 16000	1μA
		Input	Input range	Digital output value	Maximum resolution																							
		Voltage	-10 to 10V	-16000 to 16000	0.625mV																							
			User range setting 1 (-10 to 10V)		0.5mV																							
			User range setting 2 (-5 to 5V)		0.25mV																							
			0 to 5V	0 to 16000	0.3125mV																							
			1 to 5V		0.25mV																							
		Current	0 to 20mA	0 to 16000	1.25μA																							
			4 to 20mA		1μA																							
			User range setting 2 (-20 to 20mA)	-16000 to 16000	1μA																							
Conversion accuracy*2	Ambient temperature (0 to 55°C)	±0.2%																										
Conversion speed		400μs/channel 1ms/channel																										
Absolute maximum input		Voltage: ±15V, Current: ±30mA*3																										
Insulation method		Between communication system terminal and all analog input terminals: Photocoupler isolation Between power supply system terminal and all analog input terminals: Transformer insulation Between input channels: Non-insulation																										
Withstand voltage		500VAC for 1 minute between all power supply and communication system terminals and all analog input terminals																										
Noise immunity		Noise voltage 500Vp-p, noise width 1μs, noise frequency 25 to 60Hz (noise simulator condition)																										
External connection system	Communication part	RJ45 connector																										
	Module power supply part	Terminal block for module power supply and FG Tightening torque range for terminal screw (M2.5 screw): 0.5 to 0.6N·m																										
	I/O part	18-point two-piece terminal block (M3 screw) Tightening torque range for terminal screw (M3 screw × 5.2): 0.43 to 0.57N·m																										
Applicable DIN rail		TH35-7.5Fe, TH35-7.5Al (compliant with IEC 60715)																										
Applicable wire size	For power supply	Core: 0.5 to 1.5mm ² (20 to 16 AWG)																										
	For I/O	Core: 0.3 to 2.0mm ² (22 to 14 AWG)																										

Item		Description
Applicable solderless terminal	Terminal block for module power supply and FG ^{*4}	TE 0.5-10 (Nichifu Co., Ltd.) [Applicable wire size: 0.5mm ²] TE 0.75-10 (Nichifu Co., Ltd.) [Applicable wire size: 0.75mm ²] TE 1.0-10 (Nichifu Co., Ltd.) [Applicable wire size: 0.9 to 1.0mm ²] TE 1.5-10 (Nichifu Co., Ltd.) [Applicable wire size: 1.25 to 1.5mm ²] AI 0.5-10WH (Phoenix Contact Co., Ltd.) [Applicable wire size: 0.5mm ²] AI 0.75-10GY (Phoenix Contact Co., Ltd.) [Applicable wire size: 0.75mm ²] AI 1-10RD (Phoenix Contact Co., Ltd.) [Applicable wire size: 1.0mm ²] AI 1.5-10BK (Phoenix Contact Co., Ltd.) [Applicable wire size: 1.5mm ²]
	Terminal block for analog input signals	RAV1.25-3 (compliant with JIS C 2805) [Applicable wire size: 0.3 to 1.25mm ²] V2-MS3 (JST Mfg. Co., Ltd) [Applicable wire size: 1.25 to 2.0mm ²] RAP2-3SL (Nippon Tanshi Co., Ltd.) [Applicable wire size: 1.25 to 2.0mm ²] TGV2-3N (Nichifu Co., Ltd.) [Applicable wire size: 1.25 to 2.0mm ²]
Cyclic transmission	RX/Ry points	32 points + 16 points × number of extension modules
	RWr/RWw points	16 points + points of each extension module
Communication cable	An Ethernet cable that meets the 1000BASE-T standard: Category 5e or higher (double shielded, STP), straight cable	
Availability of connecting extension module	Connectable (Max. one module)	
External power supply	24VDC (20.4 to 28.8VDC) Inrush current: 31.2A (for 1.5ms or shorter) Current consumption: 230mA	
Weight	0.30kg	

*1 For details on the I/O conversion characteristics, refer to the following.

- I/O Conversion Characteristics of A/D Conversion (Page 199, Appendix 4)

*2 Except when receiving noise influence.

*3 This is a momentary current value which does not cause damage to internal resistors of the module. The maximum input current value for constant application is 24mA.



*4 Do not connect two or more wires to the terminal.

3.3 Calculating Current Consumption

The total current consumption of the modules is calculated by summing the module power supply current in the main module and extension module.

The power supply current in the extension module should be within 30mA.

For the value of the module power supply current, refer to the specifications of each module.

- Performance specifications of A/D converter module ( Page 25, Section 3.2)
- Performance specifications of extension I/O module ( CC-Link IE Field Network Remote I/O Module User's Manual)

The value of the module power supply current in the extension module described in the specifications is the value of the module power supply current supplied from the main module.

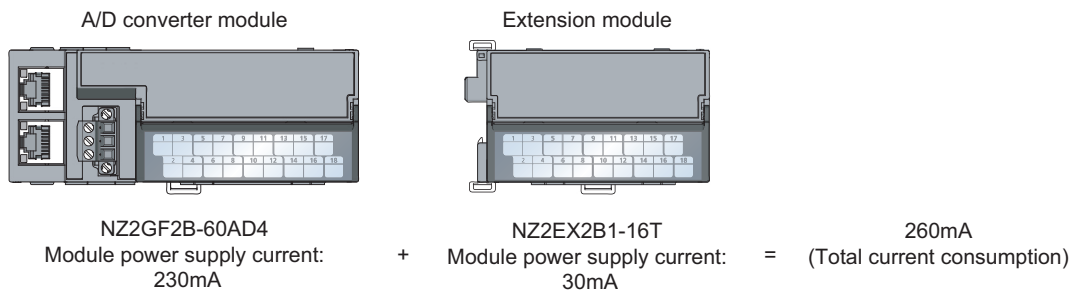

3.4 Function List

Item		Description	Reference	
A/D conversion enable/disable function		Whether to enable or disable A/D conversion can be set for each channel. Disabling the A/D conversion for unused channels reduces the conversion cycles.	Page 84, Section 8.4	
A/D conversion method	Sampling processing	The A/D converter module executes the A/D conversion of the analog input value sequentially and stores the digital operation value to the remote register.	Page 84, Section 8.5 (1)	
	Averaging processing	Time average	The A/D converter module executes the A/D conversion for set time, and stores the average of the total value excluding the maximum and the minimum values to the remote register. The number of processing times within the setting time changes depending on the number of channels used (the number of channels set to A/D conversion enabled).	Page 85, Section 8.5 (2) (a)
		Count average	The A/D converter module executes the A/D conversion for set time, and stores the average of the total value excluding the maximum and the minimum values to the remote register. Time for the count average value stored in the buffer memory changes depending on the used channel numbers (the number of channels specified to A/D conversion enable).	Page 86, Section 8.5 (2) (b)
		Moving average	The A/D converter module averages the set number of digital operation values that are obtained each sampling cycle, and stores them in the remote register. Because the moving average is performed for each sampling, latest digital operation values are obtained.	Page 87, Section 8.5 (2) (c)
Range switching function		The input range can be selected for each channel from the following ranges: <ul style="list-style-type: none"> • Factory default range (4 to 20mA, 0 to 20mA, 1 to 5V, 0 to 5V, -10 to 10V) • User range (user range setting 1, user range setting 2) 	Page 89, Section 8.6	
Offset/gain setting function		This function compensates for errors in digital output value.	Page 78, Section 7.3	
Conversion speed switch function		The conversion speed can be selected from 400μs or 1ms.	Page 90, Section 8.7	
Maximum value/minimum value hold function		The A/D converter module stores the maximum and minimum values of the digital operation values for each channel to the remote buffer memory.	Page 90, Section 8.8	
Input signal error detection function		This function detects a disconnection of the analog input signal.	Page 91, Section 8.9	
Alert output function (process alarm)		This function outputs alert when a digital operation value is in the range set in advance.	Page 94, Section 8.10	
Scaling function		The A/D converter module scale-converts the digital operation value to the set range of the scaling upper limit value and scaling lower limit value.	Page 97, Section 8.11	
Shift function		The A/D converter module adds the set shifting amount to conversion value to the digital operation value and stores in the remote register. Fine adjustment can be performed easily when the system starts.	Page 102, Section 8.12	
Digital clipping function		When the input voltage or current exceeds the input range, the maximum value of the digital operation value can be set to 16000, and the minimum value can be set to 0 or -16000.	Page 106, Section 8.13	

Item	Description	Reference
Difference conversion function	This function subtracts the difference conversion reference value from the digital operation value and stores the acquired value in the remote register.	Page 111, Section 8.14
Trigger conversion function	Using this function, the A/D converter module performs the A/D conversion according to the input of Trigger conversion request. Trigger conversion request from the external device to the extension input module can be used for the A/D conversion.	Page 115, Section 8.15
CC-Link IE Field Network synchronous communication function	Using this function, the A/D converter module performs the A/D conversion synchronized with the operation cycle of a simple motion module. This enables the A/D converter module to operate at the same timing of other slave stations on the same network.	Page 123, Section 8.16
Error notification function	When a moderate error or major error occurs in the A/D converter module, this function notifies the error to the master station with the remote input signal.	Page 127, Section 8.17
Function at the extension module installation	One extension I/O module can be connected to one A/D converter module. Remote input signals of the A/D converter module can be assigned to remote output signals of the connected extension output module. In addition, functions unique to the extension I/O module can be used.	Page 130, Section 8.18
CC-Link IE Field Network diagnostic function	With this function, whether any network error occurs or not can be checked through GX Works2 connected to the CPU module.	Page 135, Section 8.19

3.5 List of Remote I/O Signals

This section lists I/O signals for a master/local module.

In the program example described in this section, the remote I/O signals of the main module are assigned to the I/O numbers of RX0 to RX1F and RY0 to RY1F.

Remote input (RX) indicates the input signal from the A/D converter module to the master/local module.

Remote output (RY) indicates the output signal from the master/local module to the A/D converter module.

The remote I/O signals of the main module and extension module are assigned as shown below.

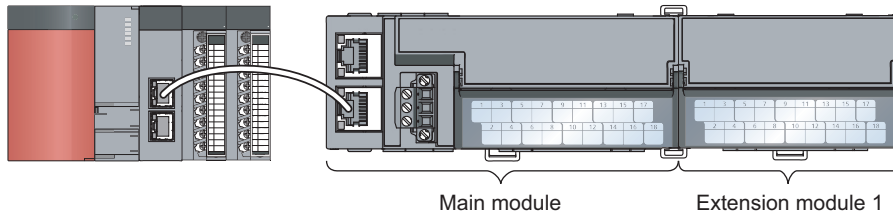

Module	Remote input (RX)	Remote output (RY)
Main module	RX0 to RX1F	RY0 to RY1F
Extension module 1	RX20 to RX2F	RY20 to RY2F

For details on the remote I/O signal, refer to the following.

- Page 168, Appendix 1

Module type	Remote input signal direction: A/D converter module → Master/local module		Remote output signal direction: Master/local module → A/D converter module	
	Device number	Description	Device number	Description
Main module	RX0	Use prohibited	RY0	Use prohibited
	RX1	Use prohibited	RY1	Use prohibited
	RX2	Use prohibited	RY2	Use prohibited
	RX3	Use prohibited	RY3	Use prohibited
	RX4	Use prohibited	RY4	Use prohibited
	RX5	Use prohibited	RY5	Use prohibited
	RX6	Use prohibited	RY6	Use prohibited
	RX7	Warning flag	RY7	Use prohibited
	RX8	Use prohibited	RY8	Use prohibited
	RX9	Initial data setting completion flag	RY9	Initial data setting request flag
	RXA	Error flag	RYA	Error clear request
	RXB	Remote READY	RYB	Use prohibited
	RXC	Use prohibited	RYC	Use prohibited
	RXD	Use prohibited	RYD	Use prohibited
	RXE	Use prohibited	RYE	Use prohibited
	RXF	Use prohibited	RYF	Use prohibited

Module type	Remote input signal direction: A/D converter module → Master/local module		Remote output signal direction: Master/local module → A/D converter module	
	Device number	Description	Device number	Description
Main module	RX10	CH1 A/D conversion completed flag	RY10	Use prohibited
	RX11	CH2 A/D conversion completed flag	RY11	Use prohibited
	RX12	CH3 A/D conversion completed flag	RY12	Use prohibited
	RX13	CH4 A/D conversion completed flag	RY13	Use prohibited
	RX14	CH1 Difference conversion state flag	RY14	CH1 Difference conversion trigger
	RX15	CH2 Difference conversion state flag	RY15	CH2 Difference conversion trigger
	RX16	CH3 Difference conversion state flag	RY16	CH3 Difference conversion trigger
	RX17	CH4 Difference conversion state flag	RY17	CH4 Difference conversion trigger
	RX18	Alert output signal	RY18	Use prohibited
	RX19	Trigger conversion completed flag	RY19	Trigger conversion request
	RX1A	Use prohibited	RY1A	Trigger conversion completed clear request
	RX1B	Use prohibited	RY1B	Use prohibited
	RX1C	Input signal error detection signal	RY1C	Use prohibited
	RX1D	Maximum value/minimum value reset completed flag	RY1D	Maximum value/minimum value reset request
	RX1E	Use prohibited	RY1E	Use prohibited
RX1F	External power supply monitor state flag (for extension output module)	RY1F	External power supply monitor request flag (for extension output module)	
Extension module 1	RX20 to RX2F	Remote input (RX) of the connected extension module is assigned.	RY20 to RY2F	Remote output (RY) of the connected extension module is assigned.

Point

Do not use any "Use prohibited" remote I/O signals. If any of the signals are used, correct operation of the module cannot be guaranteed.

(1) Remote I/O signal of the extension module

The remote I/O signal differs depending on the model of the extension module.

- Extension I/O module

Refer to the following.

 CC-Link IE Field Network Remote I/O Module User's Manual

3.6 List of Remote Register

This section lists remote registers for a master/local module.

In the example of the remote register assignment described in this section, the remote registers of the main module are assigned to the remote registers of RWr0 to RWrF and RWw0 to RWwF.

Remote register (RWr) is the information input from the A/D converter module to the master/local module.

Remote register (RWw) is the information output from the master/local module to the A/D converter module.

For details on the remote register, refer to the following.

-  Page 177, Appendix 2

Remote register (RWr) signal direction: A/D converter module → Master/local module		Remote register (RWw) signal direction: Master/local module → A/D converter module	
Device number	Description	Device number	Description
RWr0	Latest error code	RWw0	Use prohibited
RWr1	Latest warning code	RWw1	Use prohibited
RWr2	CH1 Digital operation value	RWw2	CH1 Shifting amount to conversion value
RWr3	CH2 Digital operation value	RWw3	CH2 Shifting amount to conversion value
RWr4	CH3 Digital operation value	RWw4	CH3 Shifting amount to conversion value
RWr5	CH4 Digital operation value	RWw5	CH4 Shifting amount to conversion value
RWr6	CH1 Difference conversion reference value	RWw6	Use prohibited
RWr7	CH2 Difference conversion reference value	RWw7	Use prohibited
RWr8	CH3 Difference conversion reference value	RWw8	Use prohibited
RWr9	CH4 Difference conversion reference value	RWw9	Use prohibited
RWrA	Input signal error detection flag	RWwA	Use prohibited
RWrB	Alert output flag	RWwB	Use prohibited
RWrC	Use prohibited	RWwC	Use prohibited
RWrD	Use prohibited	RWwD	Use prohibited
RWrE	Use prohibited	RWwE	Use prohibited
RWrF*1	Use prohibited	RWwF*1	Use prohibited

*1 RWrF and RWwF are used for the system in the synchronous communication mode.

Point

Do not read or write the data to/from any "Use prohibited" remote registers. If the data is read or written from/to any of the registers, correct operation of the module cannot be guaranteed.

3.7 List of Remote Buffer Memory

This section lists the remote buffer memory areas of the A/D converter module.

The remote buffer memory areas of the main module and extension module are assigned as shown below.

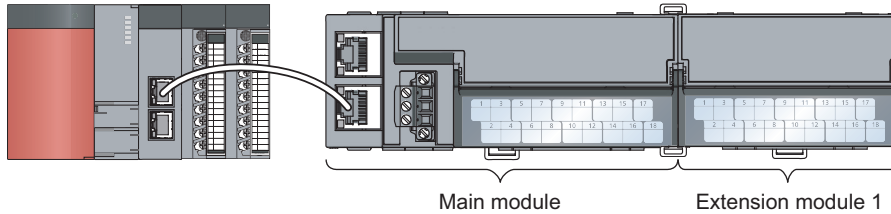

Ex. Example of the remote buffer memory in the manual



For details on the remote buffer memory, refer to the following.

- Page 180, Appendix 3

For details on the remote buffer memory of the connected extension module, refer to the following.

- User's manual for the connected extension module

○: Available ×: Unavailable

Buffer memory address		Area	Target	Access method		
Decimal	Hexadecimal			CC IE Field configuration of GX Works2	REMFR instruction, REMTO instruction*1	
0 to 255	0000 _H to 00FF _H	Parameter area	Station-based parameter data	○*2	○	
256 to 511	0100 _H to 01FF _H		Module-based parameter data			Main module
512 to 767	0200 _H to 02FF _H					Extension module 1
768 to 1279	0300 _H to 04FF _H					System area
1280 to 1535	0500 _H to 05FF _H	Monitoring area	Station-based monitoring data	×	○	
1536 to 1791	0600 _H to 06FF _H		Module-based monitoring data			Main module
1792 to 2047	0700 _H to 07FF _H					Extension module 1
2048 to 2559	0800 _H to 09FF _H					System area
2560 to 4095	0A00 _H to 0FFF _H	Error history area	Station-based error history data	○*2	○	
4096 to 4351	1000 _H to 10FF _H	Module control data area	Station-based control data	×	○	
4352 to 4607	1100 _H to 11FF _H		Module-based control data			Main module
4608 to 4863	1200 _H to 12FF _H					Extension module 1
4864 to 5375	1300 _H to 14FF _H					System area

*1 For the REMFR and REMTO instructions, refer to the following.

User's manual for the master/module used

*2 For the access method, refer to the following.

- Parameter area (Page 66, Section 7.1)
- Error history area (Page 151, Section 11.1)

Do not access the system area using the REMFR or REMTO instruction. Doing so may lead the module to malfunction.

(1) Parameter area (address: 0000_H to 04FF_H)

For the parameter area, parameters can be set using the CC IE Field configuration of GX Works2 or using the REMTO instruction.

The parameter in the parameter area is backed up to the nonvolatile memory.

The parameter backed up to the nonvolatile memory is read to the parameter area when the module power supply is turned off and on or the module returns from remote reset.

If the parameter is written from the parameter setting of the CC IE Field configuration of GX Works2, it is also written to the nonvolatile memory at that time. When the parameter is written using the REMTO instruction, it is written to the nonvolatile memory when Initial data setting request flag (RY9) is turned off and on. At this time, the parameter is written to the nonvolatile memory even though it is incorrect. When the power supply is turned off and on with an incorrect parameter written, the incorrect parameter is read from the nonvolatile memory and an error code is stored to Latest error code (RWr0). Take corrective action according to the error code list. (☞
Page 154, Section 11.2)

Type	Address		Description	Default ^{*1}	Read/ Write ^{*2}
	Decimal	Hexadecimal			
Station-based parameter data	0	0000 _H	Mode switch	0009 _H ^{*3}	R/W
	1	0001 _H	Conversion speed switch	0000 _H	R/W
	2	0002 _H	Trigger conversion signal assignment (for external signal assignment function)	FFFF _H	R/W
	3	0003 _H	Input signal error detection signal assignment (for external signal assignment function)	FFFF _H	R/W
	4	0004 _H	Alert output signal assignment (for external signal assignment function)	FFFF _H	R/W
	5	0005 _H	Error flag assignment (for external signal assignment function)	FFFF _H	R/W
	6	0006 _H	Warning flag assignment (for external signal assignment function)	FFFF _H	R/W
	7	0007 _H	Cyclic data update watch time setting	0000 _H	R/W
	8 to 15	0008 _H to 000F _H	System area	-	-
	16	0010 _H	Input response time setting	0005 _H	R/W
	17	0011 _H	Digital output HOLD/CLEAR setting	0000 _H	R/W
	18 to 255	0012 _H to 00FF _H	System area	-	-

Type	Address		Description	Default ^{*1}	Read/ Write ^{*2}
	Decimal	Hexadecimal			
Module-based parameter data (main module)	256, 257	0100 _H , 0101 _H	System area	-	
	258	0102 _H	A/D conversion enable/disable setting	0000 _H	R/W
	259	0103 _H	Range setting	0000 _H	R/W
	260	0104 _H	Averaging process setting	0000 _H	R/W
	261	0105 _H	CH1 Time average/Count average/Moving average	0	R/W
	262	0106 _H	CH2 Time average/Count average/Moving average	0	R/W
Module-based parameter data (main module)	263	0107 _H	CH3 Time average/Count average/Moving average	0	R/W
	264	0108 _H	CH4 Time average/Count average/Moving average	0	R/W
	265	0109 _H	Input signal error detection setting	0000 _H	R/W
	266 to 269	010A _H to 010D _H	System area	-	-
	270	010E _H	Alert output setting	000F _H	R/W
	271	010F _H	CH1 Process alarm lower lower limit value	0	R/W
	272	0110 _H	CH1 Process alarm lower upper limit value	0	R/W
	273	0111 _H	CH1 Process alarm upper lower limit value	0	R/W
	274	0112 _H	CH1 Process alarm upper upper limit value	0	R/W
	275	0113 _H	CH2 Process alarm lower lower limit value	0	R/W
	276	0114 _H	CH2 Process alarm lower upper limit value	0	R/W
	277	0115 _H	CH2 Process alarm upper lower limit value	0	R/W
	278	0116 _H	CH2 Process alarm upper upper limit value	0	R/W
	279	0117 _H	CH3 Process alarm lower lower limit value	0	R/W
	280	0118 _H	CH3 Process alarm lower upper limit value	0	R/W
	281	0119 _H	CH3 Process alarm upper lower limit value	0	R/W
	282	011A _H	CH3 Process alarm upper upper limit value	0	R/W
	283	011B _H	CH4 Process alarm lower lower limit value	0	R/W
	284	011C _H	CH4 Process alarm lower upper limit value	0	R/W
	285	011D _H	CH4 Process alarm upper lower limit value	0	R/W
	286	011E _H	CH4 Process alarm upper upper limit value	0	R/W
	287	011F _H	Digital clipping enable/disable setting	000F _H	R/W
	288	0120 _H	Scaling enable/disable setting	000F _H	R/W
	289	0121 _H	CH1 Scaling lower limit value	0	R/W
	290	0122 _H	CH1 Scaling upper limit value	0	R/W
	291	0123 _H	CH2 Scaling lower limit value	0	R/W
	292	0124 _H	CH2 Scaling upper limit value	0	R/W
	293	0125 _H	CH3 Scaling lower limit value	0	R/W
	294	0126 _H	CH3 Scaling upper limit value	0	R/W
	295	0127 _H	CH4 Scaling lower limit value	0	R/W
296	0128 _H	CH4 Scaling upper limit value	0	R/W	
297 to 511	0129 _H to 01FF _H	System area	-	-	

Type	Address		Description	Default ^{*1}	Read/ Write ^{*2}
	Decimal	Hexadecimal			
Module-based parameter data (extension module 1)	512 to 767	0200 _H to 02FF _H	The remote buffer memory of the connected extension module is assigned.	-	-
-	768 to 1279	0300 _H to 04FF _H	System area	-	-

*1 This is the value at default or initialization by Parameter area initialization command (address: 1002_H).

*2 This shows whether read or write from programs is possible.

R: Readable

W: Writable

*3 The default value differs depending on the version of the A/D converter module. For details, refer to the following.

- Mode switch (address: 0000_H) (☞ Page 212, Appendix 9.2 (1))

(a) Parameter area of the extension module

The remote buffer memory differs depending on the model of the extension module.

- Extension input module (NZ2EX2B1-16D)

Address		Description	Default ^{*1}	Read/ Write ^{*2}
Decimal	Hexadecimal			
512	0200 _H	Extension module identification code	0000 _H	R/W
513 to 767	0201 _H to 02FF _H	System area	-	-

*1 This is the value at default or initialization by Parameter area initialization command (address: 1002_H).

*2 This shows whether read or write from programs is possible.

R: Readable

W: Writable

- Extension output module (NZ2EX2B1-16T, NZ2EX2B1-16TE)

Address		Description	Default ^{*1}	Read/ Write ^{*2}
Decimal	Hexadecimal			
512	0200 _H	Extension module identification code	0000 _H	R/W
513	0201 _H	System area	-	-
514	0202 _H	Number of ON times integration function enable Y0 to YF	0000 _H	R/W
515 to 767	0203 _H to 02FF _H	System area	-	-

*1 This is the value at default or initialization by Parameter area initialization command (address: 1002_H).

*2 This shows whether read or write from programs is possible.

R: Readable

W: Writable

(2) Monitoring area (address: 0500_H to 09FF_H)

Type	Address		Description	Default ^{*1}	Read/ Write ^{*2}
	Decimal	Hexadecimal			
Station-based monitoring data	1280 to 1535	0500 _H to 05FF _H	System area	-	-
Module-based monitoring data (main module)	1536	0600 _H	System area	-	-
	1537	0601 _H	CH1 Maximum value	0	R
	1538	0602 _H	CH1 Minimum value	0	R
	1539	0603 _H	CH2 Maximum value	0	R
	1540	0604 _H	CH2 Minimum value	0	R
	1541	0605 _H	CH3 Maximum value	0	R
	1542	0606 _H	CH3 Minimum value	0	R
	1543	0607 _H	CH4 Maximum value	0	R
	1544	0608 _H	CH4 Minimum value	0	R
Module-based monitoring data (extension module 1)	1792 to 2047	0700 _H to 07FF _H	The remote buffer memory of the connected extension module is assigned.	-	-
	-	2048 to 2559	0800 _H to 09FF _H	System area	-

*1 This is the value for when the module power supply is turned off and on or at the remote reset.

*2 This shows whether read or write from programs is possible.

R: Readable

W: Writable

(a) Monitoring area of the extension module

The remote buffer memory differs depending on the model of the extension module.

- Extension input module (NZ2EX2B1-16D)

	Address		Description	Default ^{*1}	Read/ Write ^{*2}
	Decimal	Hexadecimal			
1792		0700 _H	Extension module identification code	0000 _H	R
1793 to 2047		0701 _H to 07FF _H	System area	-	-

*1 This is the value for when the module power supply is turned off and on or at the remote reset.

*2 This shows whether read or write from programs is possible.

R: Readable

W: Writable

- Extension output module (NZ2EX2B1-16T, NZ2EX2B1-16TE)

Address		Description	Default*1	Read/ Write*2
Decimal	Hexadecimal			
1792	0700 _H	Extension module identification code	0000 _H	R
1793 to 1807	0701 _H to 070F _H	System area	-	-
1808 to 1809	710 _H to 711 _H	Number of ON times integration value Y0	0	R
1810 to 1811	712 _H to 713 _H	Number of ON times integration value Y1	0	R
1812 to 1813	714 _H to 715 _H	Number of ON times integration value Y2	0	R
1814 to 1815	716 _H to 717 _H	Number of ON times integration value Y3	0	R
1816 to 1817	718 _H to 719 _H	Number of ON times integration value Y4	0	R
1818 to 1819	71A _H to 71B _H	Number of ON times integration value Y5	0	R
1820 to 1821	71C _H to 71D _H	Number of ON times integration value Y6	0	R
1822 to 1823	71E _H to 71F _H	Number of ON times integration value Y7	0	R
1824 to 1825	720 _H to 721 _H	Number of ON times integration value Y8	0	R
1826 to 1827	722 _H to 723 _H	Number of ON times integration value Y9	0	R
1828 to 1829	724 _H to 725 _H	Number of ON times integration value YA	0	R
1830 to 1831	726 _H to 727 _H	Number of ON times integration value YB	0	R
1832 to 1833	728 _H to 729 _H	Number of ON times integration value YC	0	R
1834 to 1835	72A _H to 72B _H	Number of ON times integration value YD	0	R

Address		Description	Default ^{*1}	Read/ Write ^{*2}
Decimal	Hexadecimal			
1836 to 1837	72C _H to 72D _H	Number of ON times integration value YE	0	R
1838 to 1839	72E to 72F	Number of ON times integration value YF	0	R
1840 to 2047	0730 _H to 07FF _H	System area	-	-

*1 This is the value for when the module power supply is turned off and on or at the remote reset.

*2 This shows whether read or write from programs is possible.

R: Readable

W: Writable

(3) Error history area (address: 0A00_H to 0FFF_H)

Type	Address		Description	Default ^{*1}	Read/ Write ^{*2}	
	Decimal	Hexadecimal				
Station-based error history data	2560	0A00 _H	Error history 1	Error code	0000 _H	R
	2561	0A01 _H		Order of generation	0000 _H	R
	2562	0A02 _H		[Error time] First two digits of the year/Last two digits of the year	0000 _H	R
	2563	0A03 _H		[Error time] Month/Day	0000 _H	R
	2564	0A04 _H		[Error time] Hour/Minute	0000 _H	R
	2565	0A05 _H		[Error time] Second/00 _H (Fixed)	0000 _H	R
	2566	0A06 _H		CH1 Digital operation value	0000 _H	R
	2567	0A07 _H		CH2 Digital operation value	0000 _H	R
	2568	0A08 _H		CH3 Digital operation value	0000 _H	R
	2569	0A09 _H		CH4 Digital operation value	0000 _H	R
	2570 to 2575	0A0A _H to 0A0F _H	System area	-	-	
	2576 to 2591	0A10 _H to 0A1F _H	Error history 2	Same as Error history 1.		
	2592 to 2607	0A20 _H to 0A2F _H	Error history 3	Same as Error history 1.		
	2608 to 2623	0A30 _H to 0A3F _H	Error history 4	Same as Error history 1.		
	2624 to 2639	0A40 _H to 0A4F _H	Error history 5	Same as Error history 1.		

Type	Address		Description	Default ^{*1}	Read/ Write ^{*2}
	Decimal	Hexadecimal			
Station-based error history data	2640 to 2655	0A50 _H to 0A5F _H	Error history 6	Same as Error history 1.	
	2656 to 2671	0A60 _H to 0A6F _H	Error history 7	Same as Error history 1.	
	2672 to 2687	0A70 _H to 0A7F _H	Error history 8	Same as Error history 1.	
	2688 to 2703	0A80 _H to 0A8F _H	Error history 9	Same as Error history 1.	
	2704 to 2719	0A90 _H to 0A9F _H	Error history 10	Same as Error history 1.	
	2720 to 2735	0AA0 _H to 0AAF _H	Error history 11	Same as Error history 1.	
	2736 to 2751	0AB0 _H to 0ABF _H	Error history 12	Same as Error history 1.	
	2752 to 2767	0AC0 _H to 0ACF _H	Error history 13	Same as Error history 1.	
	2768 to 2783	0AD0 _H to 0ADF _H	Error history 14	Same as Error history 1.	
	2784 to 2799	0AE0 _H to 0AEF _H	Error history 15	Same as Error history 1.	
	2800 to 4095	0AF0 _H to 0FFF _H	System area	-	-

*1 This is the value at default or initialization by Error history clear command (address: 1000_H).

*2 This shows whether read or write from programs is possible.

R: Readable

W: Writable

(4) Module control data area (address: 1000_H to 14FF_H)

Type	Address		Description	Default ^{*1}	Read/ Write ^{*2}
	Decimal	Hexadecimal			
Station-based control data	4096	1000 _H	Error history clear command	0	R/W
	4097	1001 _H	Error history clear completed	0	R
	4098	1002 _H	Parameter area initialization command	0	R/W
	4099	1003 _H	Parameter area initialization completed	0	R
	4100	1004 _H	Module operation information initialization command	0	R/W
	4101	1005 _H	Module operation information initialization completed	0	R
	4102 to 4351	1006 _H to 10FF _H	System area	-	-
Module-based control data (main module)	4352 to 4607	1100 _H to 11FF _H	System area	-	-
Module-based control data (extension module 1)	4608 to 4863	1200 _H to 12FF _H	The remote buffer memory of the connected extension module is assigned.	-	-
-	4864 to 5375	1300 _H to 14FF _H	System area	-	-

*1 This is the value for when the module power supply is turned off and on or at the remote reset.

*2 This shows whether read or write from programs is possible.

R: Readable

W: Writable

(a) Module control data area of the extension module

The remote buffer memory differs depending on the model of the extension module.

- Extension input module (NZ2EX2B1-16D)

Address		Description	Default ^{*1}	Read/ Write ^{*2}
Decimal	Hexadecimal			
4608 to 4863	1200 _H to 12FF _H	System area	-	-

*1 This is the value for when the module power supply is turned off and on or at the remote reset.

*2 This shows whether read or write from programs is possible.

R: Readable

W: Writable

- Extension output module (NZ2EX2B1-16T, NZ2EX2B1-16TE)

Address		Description	Default ^{*1}	Read/ Write ^{*2}
Decimal	Hexadecimal			
4608	1200 _H	Number of ON times integration value clear Y0 to YF	0000 _H	R/W
4609	1201 _H	Number of ON times integration value clear completed Y0 to YF	0000 _H	R/W
4610 to 4863	1202 _H to 12FF _H	System area	-	-

*1 This is the value for when the module power supply is turned off and on or at the remote reset.

*2 This shows whether read or write from programs is possible.

R: Readable

W: Writable

CHAPTER 4 THE PROCEDURE BEFORE OPERATION

This section describes the procedure before operation.

Check box

Setting a station number

Set the station number for an A/D converter module.

 Page 47, Section 6.1

Connection

When using an extension module, connect the extension module to the A/D converter module.
After that, mount the A/D converter module to a DIN rail.

 Page 48, Section 6.2,
Page 50, Section 6.3

Wiring

Connect the A/D converter module to a power supply, Ethernet cables, and external devices.

 Page 55, Section 6.4,
Page 57, Section 6.5,
Page 60, Section 6.6

Parameter settings and programming

Set parameters and create a program.

 Page 66, Section 7.1,
Page 72, Section 7.2*¹,
Page 138, CHAPTER 9

Offset/gain setting

To use user range settings, configure the offset/gain setting.

 Page 78, Section 7.3

*1 To replace the module, refer to this section.

Point

To replace the module, follow the procedure described below.

- Power off the module and remove the A/D converter module.
- Prepare a new A/D converter module and perform the procedure above from "Setting a station number" to "Parameter settings and programming". (The network parameter of the master station does not need to be set again.)
- When using the user range setting, perform the offset/gain setting.
- After checking the operation, restart the control.

Memo

CHAPTER 5 SYSTEM CONFIGURATION

This chapter describes system configuration using an A/D converter module.
For CC-Link IE Field Network configuration, refer to the following.

 User's manual for the master/local module used

5.1 A/D Converter Module System Configuration

The following shows system configuration using an A/D converter module.

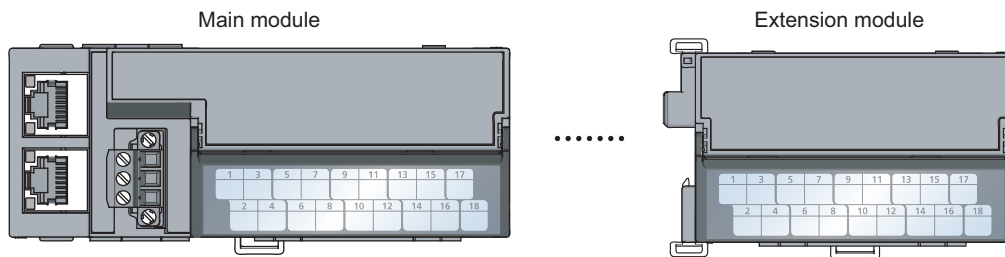

5.2 Applicable Systems

(1) Applicable master station

When using an A/D converter module, use the following products as a master station.

Model	First five digits of serial number
QJ71GF11-T2	"14102" or later
LJ71GF11-T2	
QD77GF16	"14111" or later

When a master station other than the above is used, the A/D converter module cannot be used.

(2) Connectable modules

One extension module can be connected to one A/D converter module.

Module	Model
Extension I/O module	NZ2EX2B1-16D
	NZ2EX2B1-16T
	NZ2EX2B1-16TE

(3) Ethernet cable

For the specifications of the Ethernet cable, refer to the following.

 User's manual for the master/local module used

(4) Software package

GX Works2 is required for setting and diagnosing the A/D converter module. Install GX Works2 with the following version.

A/D converter module	Software version
NZ2GF2B-60AD4	Version 1.91V or later

Extension I/O module	Software version
NZ2EX2B1-16D	Version 1.91V or later
NZ2EX2B1-16T	
NZ2EX2B1-16TE	Version 1.98C or later

CHAPTER 6 INSTALLATION AND WIRING

This chapter describes the installation and wiring of the A/D converter module.

6.1 Station Number Setting

(1) Setting procedure

Set the station number with the rotary switch on the front of the module. The setting value of the station number becomes valid when the module is powered on. Thus, set the station number when the module is powered off.

- The hundreds and tens places of the station number are set with x10.
- The ones place of the station number is set with x1.

Ex. To set the station number to 115, set the switch as shown below.

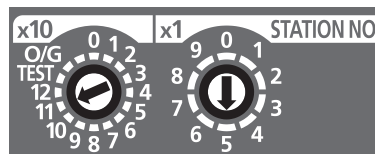

(2) Setting range

Set the station number from 1 to 120. Setting the value other than 1 to 120 causes a communication error and the D LINK LED flashes.

Point

- Changing the station number setting switch while the module is powered on causes a minor error and flashes the ERR. LED.
Returning the station number setting switch to the previous setting eliminates the error after five seconds and turns off the ERR. LED.
- Do not set a station number duplicated with other station numbers. If the station number is duplicated, a communication error occurs and the D LINK LED does not turn on.

6.2 Installation Environment and Installation Position

6.2.1 Installation environment

(1) Installation location

Do not install the A/D converter module to the place where:

- Ambient temperature is outside the range of 0 to 55°C;
- Ambient humidity is outside the range of 5 to 95% RH;
- Condensation occurs due to rapid temperature change;
- Corrosive gas or combustible gas is present;
- Conductive powder such as dust and iron powder, oil mist, salinity, or organic solvent is filled;
- The A/D converter module is exposed to direct sunlight;
- A strong electric field or strong magnetic field is generated; and
- The A/D converter module is subject to vibration and shock.

(2) Installation surface

Install the A/D converter module on the flat surface. When the installation surface is uneven, excessive force is applied to the printed-circuit board and may cause a defect.

6.2.2 Installation position

When installing the A/D converter module in a control panel, provide clearance of 60mm or longer between the module and the sides of control panel or neighboring modules to ensure good ventilation and an easy module change.

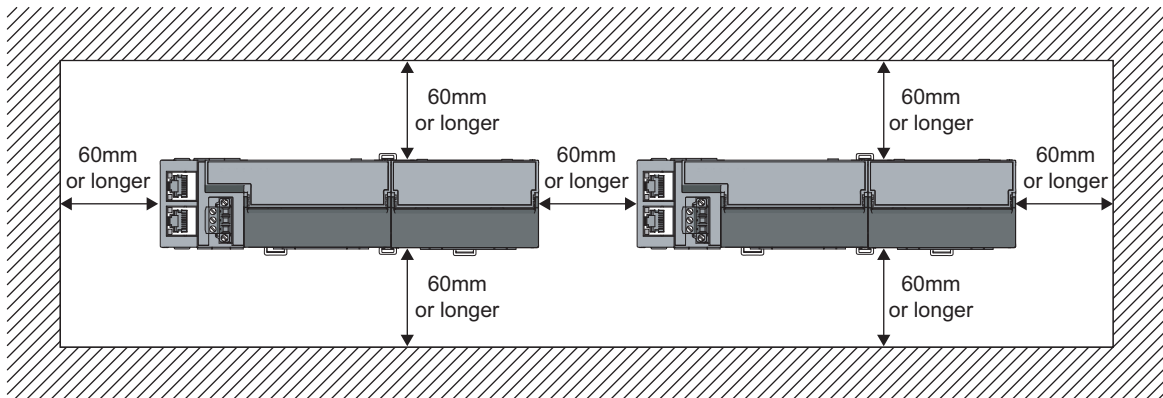

6.2.3 Installation direction

The A/D converter module can be installed in six directions.
Use the DIN rail to install the module.

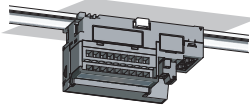

Downward installation

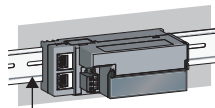

DIN rail

Horizontal installation

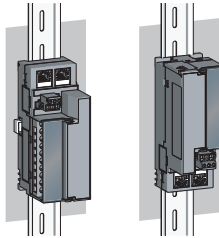

Vertical installation

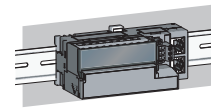

Horizontal installation
(upside down)

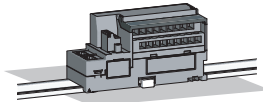

Upward installation

6.3 Installation

6.3.1 Connecting extension modules

(1) Connecting procedure

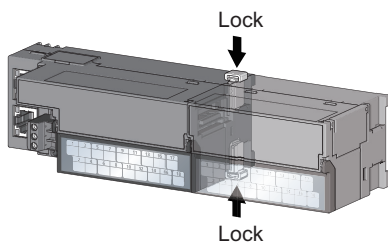
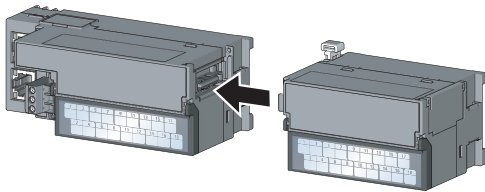
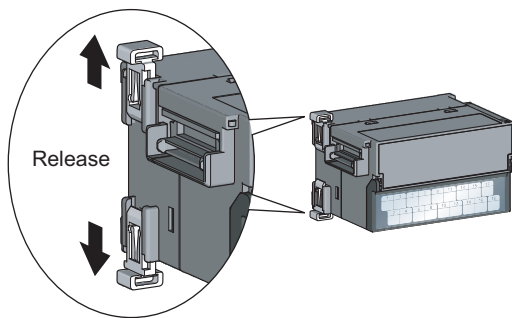
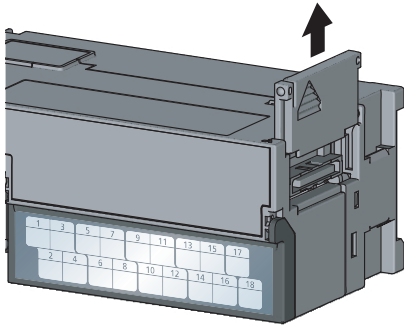

- 1. Remove the cover on the side of the module.**
Do not dispose the removed cover, but store it.
- 2. Release the module joint levers (two points) on the side of the extension module. Slide the levers vertically.**
- 3. Insert the connector of the extension module into that of the A/D converter module so that they are securely engaged.**
- 4. Lock the module joint levers (two points) on the side of the extension module. Slide the levers toward the module.**
Check that the modules are securely connected.

(2) Disconnecting procedure

Disconnect the modules by reversing the procedure above.

Point

-
- Shut off the external power supply for the system in all phases before connecting or disconnecting extension modules.
 - Lock the module joint levers securely. Failure to do so may cause malfunction, failure, or drop of the module.
-

6.3.2 Mounting the modules on a DIN rail

Point

An example of the use of the DIN rail stopper is described in the following procedure. Fix the module according to the manual of the DIN rail stopper used.

(1) Mounting procedure

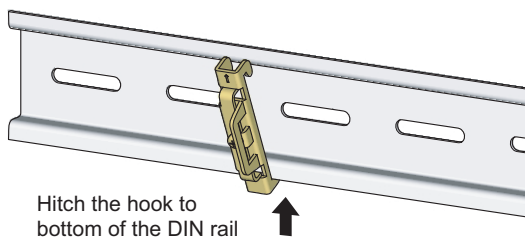
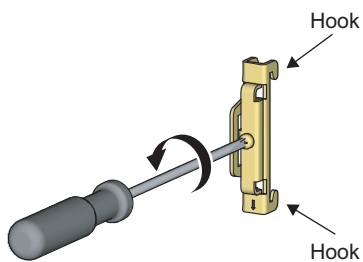
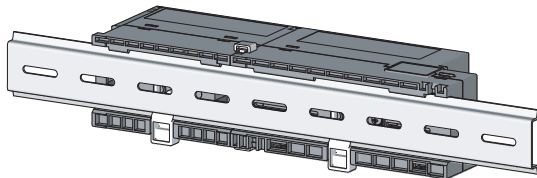
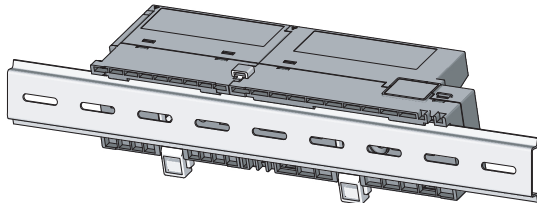
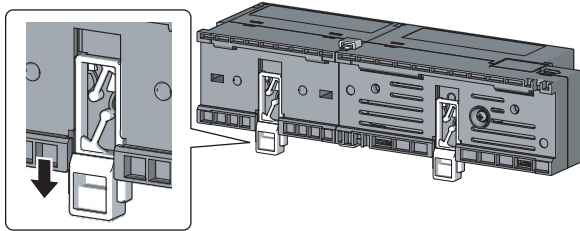

- 1. Pull down all DIN rail hooks on the back of the modules.**

The levers should be pulled down until it clicks.

- 2. Hang the upper tabs of the modules on a DIN rail, and push the modules in position.**

- 3. Lock the DIN rail hooks to the DIN rail to secure the modules in position.**

Push each hook up until it clicks. If the hooks are beyond the reach, use a tool such as a screwdriver.

- 4. Loosen the screw on DIN rail stopper.**

- 5. Hitch the bottom hook of the DIN rail stopper to the bottom of the DIN rail.**

Hitch the hook according to the orientation of the arrow on the front of the stopper.

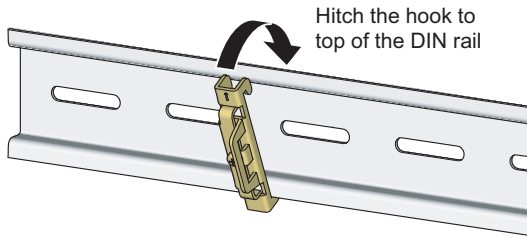

6. Hitch the upper hook of the DIN rail stopper to the top of the DIN rail.

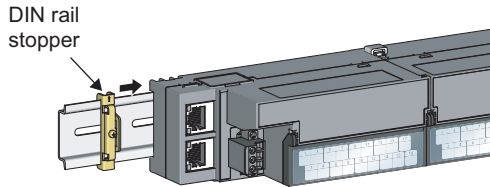

7. Slide the DIN rail stopper up to the left side of the modules.

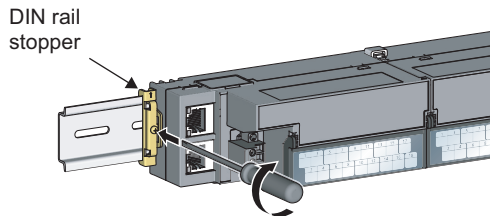

8. Hold the DIN rail stopper in the direction opposite to the arrow on the stopper and tighten the screw with a screwdriver.

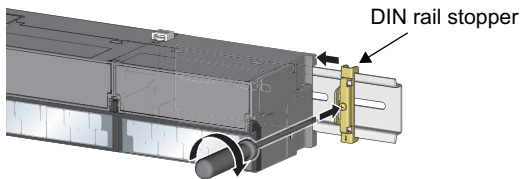

9. Install the DIN rail stopper on the right side of the module in the same procedure. Install the stopper upside down for the right side.

Point!

Do not slide modules from the edge of the DIN rail when mounting them. Doing so may damage the metal part located on the back of the module.

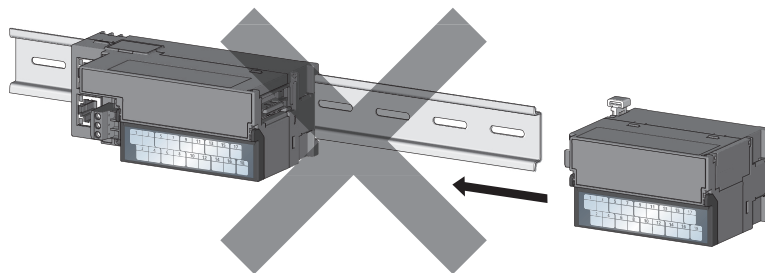

(2) Removal procedure

Remove the modules from the DIN rail by reversing the above procedure.

(3) Applicable DIN rail model (compliant with IEC 60715)

- TH35-7.5Fe
- TH35-7.5Al

(4) Interval between DIN rail mounting screws

Tighten the screws at intervals of 200mm or less.

(5) DIN rail stopper

Use a stopper that is attachable to the DIN rail.

6.4 Wiring with Terminal Block for Module Power Supply and FG

(1) Tightening torque

Tighten the terminal block screws within the following specified torque range.
Tightening the screws too much may damage the module case.

Screw type	Tightening torque range
Terminal block mounting screw (M2.5 screw)	0.2 to 0.3N·m
Terminal screw (M2.5 screw)	0.5 to 0.6N·m

(2) Wire to be used

The following table describes the wire to be connected to the terminal block for module power supply and FG.

Diameter	Type	Material	Temperature rating
20 to 16 AWG	Stranded	Copper	75°C or more

(3) Installing and removing the terminal block

To remove the terminal block, loosen the terminal block fixing screw with a slotted screwdriver.

To install the terminal block, tighten the terminal block fixing screw.

Failure to secure the terminal block may cause drop, short circuit, malfunction.

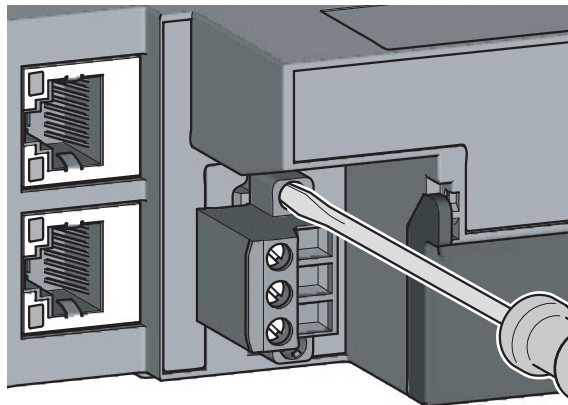

(4) Connecting and disconnecting the cable

To connect the cable, insert the wire with the cable fixing screw loosened and tighten the screw.

To disconnect the cable, pull out the wire with the cable fixing screw loosened with a slotted screwdriver.

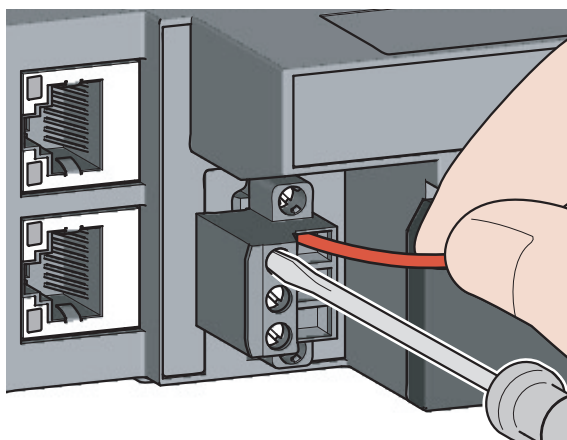

(5) Processing method of the cable terminal

Strip the cable about 10mm from the top.

To use a bar solderless terminal, connect it to the stripped part.

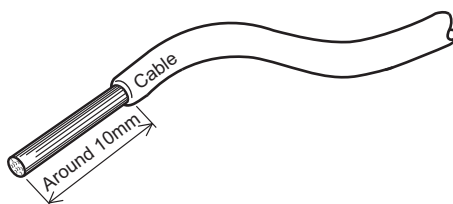

(6) List of bar solderless terminals

The following table lists recommended bar solderless terminals.

Product name	Model name	Applicable wire size	Contact
Bar solderless terminal	TE 0.5-10	0.5 mm ²	Nichifu Co., Ltd.
	TE 0.75-10	0.75 mm ²	
	TE 1.0-10	0.9 to 1.0mm ²	
	TE 1.5-10	1.25 to 1.5 mm ²	
Tool dedicated for bar solderless terminal	NH79	—	
Bar solderless terminal	AI 0.5-10WH	0.5 mm ²	Phoenix Contact Co., Ltd.
	AI 0.75-10GY	0.75 mm ²	
	AI 1-10RD	1.0 mm ²	
	AI 1.5-10BK	1.5 mm ²	
Tool dedicated for bar solderless terminal	CRIMPFOX6	—	

6.5 Wiring of Ethernet Cable

(1) Connecting the Ethernet cable

(a) Connecting

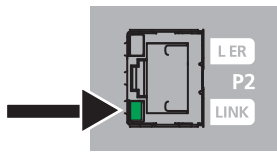
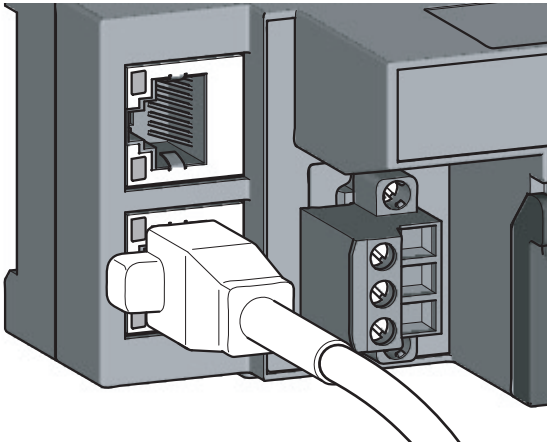

1. Power off the power supplies of the A/D converter module and the external device.
2. Push the Ethernet cable connector into the A/D converter module until it clicks. Pay attention to the connector's direction.
3. Power on the module.
4. Power on the external device.
5. Check if the LINK LED on the port into which the Ethernet cable is connected is on. The LINK LED may take a few seconds to turn on after power-on. If the LINK LED does not turn on, refer to the troubleshooting section and take a corrective action. (👉 Page 162, Section 11.4)

- PORT1 and PORT2 need not to be distinguished. When only one connector is used in star topology, either PORT1 or PORT2 can be connected.

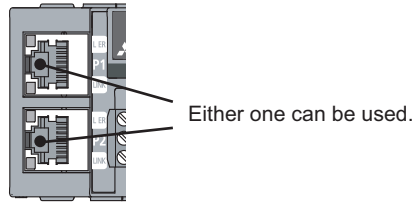

- When two connectors are used in line topology or ring topology, an Ethernet cable can be connected to the connectors in any combination. For example, the cable can be connected between PORT1s and between PORT1 and PORT2.

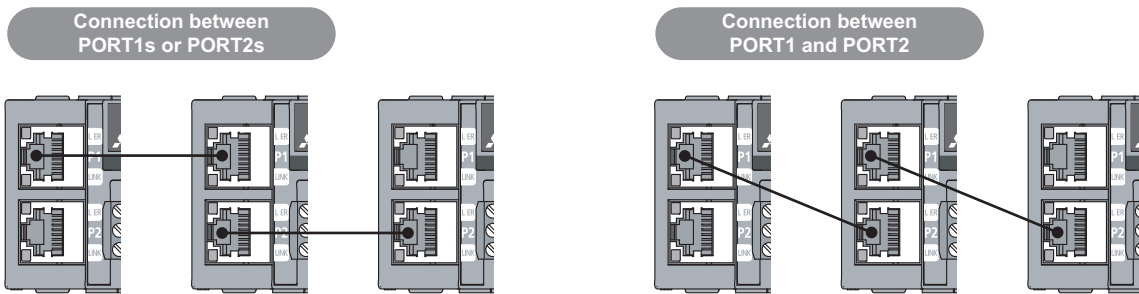

(b) Disconnecting

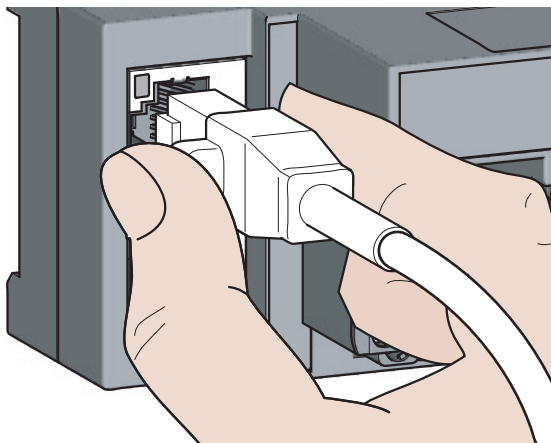

1. Power off the module.
2. Press the latch down and unplug the Ethernet cable.

(2) Precautions

(a) Laying Ethernet cables

- Place the Ethernet cable in a duct or clamp them. If not, dangling cable may swing or inadvertently be pulled, resulting in damage to the module or cables or malfunction due to poor contact.
- Do not touch the core of the connector of the cable or the module, and protect it from dirt and dust. If any oil from your hand, or any dirt or dust sticks to the core, it can increase transmission loss, causing data link to fail.
- Check the following:
 - Is any Ethernet cable disconnected?
 - Does any Ethernet cable short?
 - Are the connectors securely connected?

(b) Broken cable latch

Do not use Ethernet cables with broken latches. Doing so may cause the cable to unplug or malfunction.

(c) Connecting and disconnecting the Ethernet cable

Hold the connector part when connecting and disconnecting the Ethernet cable. Pulling the cable connected to the module may result in damage to the module or cable or malfunction due to poor contact.

(d) Connectors without Ethernet cable

To prevent dust from entering the module, attach the provided connector cover.

(e) Maximum station-to-station distance (Maximum Ethernet cable length)

The maximum station-to-station distance is 100m. However, the distance may be shorter depending on the operating environment of the cable. For details, contact the manufacturer of the cables used.

(f) Bending radius of the Ethernet cable

There are restrictions on the bending radius of the Ethernet cable. Check the bending radius in the specifications of the Ethernet cables used.

6.6 Wiring of External Device and Terminal Block

(1) Tightening torque

Tighten the terminal block screws within the following specified torque range.

Tightening the screws too much may damage the module case.

Screw type	Tightening torque range
Terminal screw (M3 screw)	0.43 to 0.57N•m
Terminal block mounting screw (M3.5 screw)	0.68 to 0.92N•m

The following table shows applicable solderless terminals connected to the terminal block. For wiring, use applicable wires in the following table and an appropriate tightening torque. Use UL-approved solderless terminals. For processing, use a tool recommended by manufacturers of solderless terminals. Sleeved solderless terminals cannot be used.

Solderless terminal		Wire			
Model	Applicable tightening torque	Diameter	Type	Material	Temperature rating
R1.25-3	0.43 to 0.57N•m	22 to 14 AWG	Stranded	Copper	75°C or more
V2-MS3					
RAP2-3SL					
TGV2-3N					

(2) Removing and installing the terminal block

(a) Removal procedure

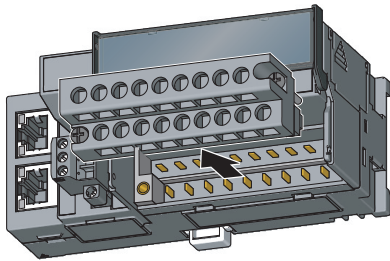
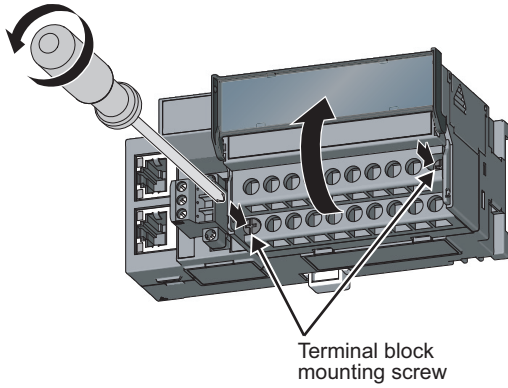

1. Open the terminal block cover and loosen the terminal block mounting screws (two points).

2. When the terminal block mounting screws (two points) are loosened, the 2-piece terminal block can be removed.

(b) Installation procedure

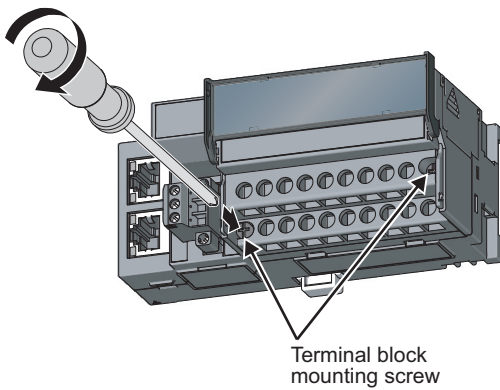
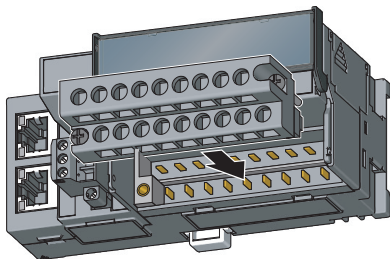

1. Open the terminal block cover to install the 2-piece terminal block.

2. Tighten the terminal block mounting screws.

(3) Wiring of the external device and terminal block

(a) Signal name

The following shows signal names of the terminal block.

1	NC	3	CH1 V+	5	CH1 I+	7	CH2 V+	9	CH2 I+	11	CH3 COM	13	SLD	15	CH4 COM	17	AG
2	NC	4	CH1 COM	6	SLD	8	CH2 COM	10	CH3 V+	12	CH3 I+	14	CH4 V+	16	CH4 I+	18	FG1

Pin number	Signal name	
1	NC	
2	NC	
3	CH1	V+
4		COM
5		I+
6	SLD	
7	CH2	V+
8		COM
9		I+
10	CH3	V+
11		COM
12		I+
13	SLD	
14	CH4	V+
15		COM
16		I+
17	AG	
18	FG1	



Do not wire the NC terminals. Wrong wiring may cause the module to fail or malfunction.

(b) Wiring to a terminal block

The following shows wirings to a terminal block.

- For the voltage input

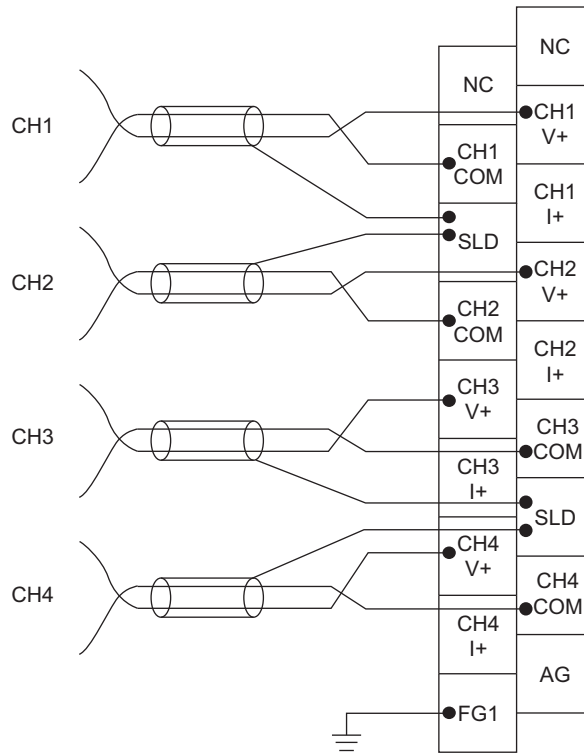

- For the current input

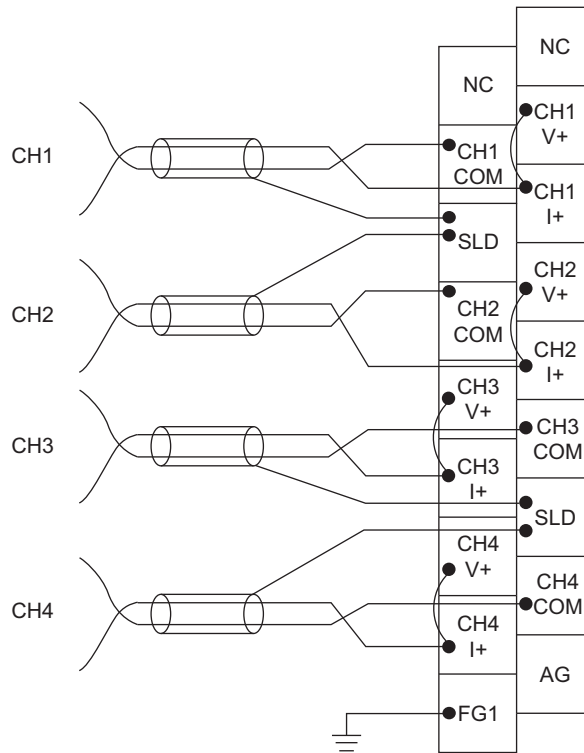

(c) Precautions for external wiring

To obtain the maximum performance from the functions of the A/D converter module and improve the system reliability, an external wiring with high durability against noise is required. Precautions for external wiring are as follows:

- Use separate cables for the AC control circuit and the external input signals of the A/D converter module to avoid the influence of the AC side surges or induction.
- Do not install cables together with the main circuit lines, high voltage lines, or power cables for equipment other than the programmable controller. Noise, surges, or induction may affect the system.
- Ground the shielded wires or shielded cables at one point on the programmable controller side. However, depending on the external noise conditions, it may be better to ground them externally.
- For the voltage input, do not input a value of $\pm 15\text{V}$ or more. This may damage the elements.
- For the current input, do not input a value of $\pm 30\text{mA}$ or more. This may damage the elements.

(d) External wiring

The following describes the external wiring.

- For voltage input
Signal source -10 to 10V

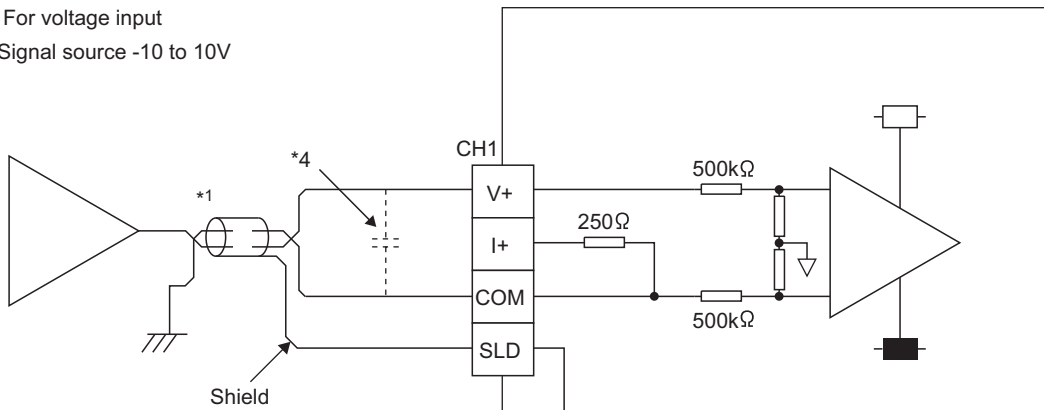

- For current input
Signal source 0 to 20mA

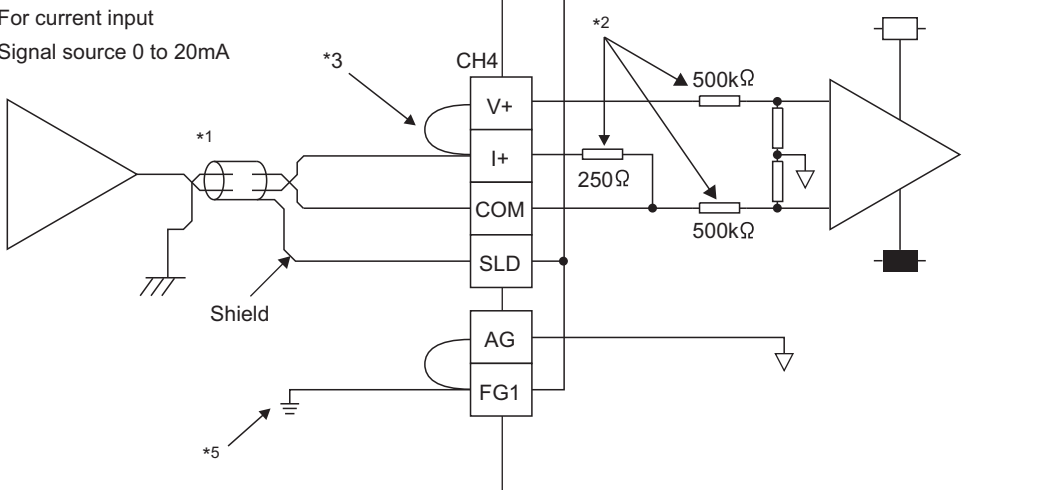

- *1 For the wire, use the shielded twisted pair cable.
- *2 This indicates the input resistance of the A/D converter module.
- *3 For the current input, always connect the terminals (V+) and (I+).
- *4 If there is noise or ripples in the external wiring, connect a 0.1 to 0.47 μF capacitor (25V or higher voltage-resistant product) between the V+ and COM terminals.
- *5 Ground the FG1 terminal without fail. If there is much noise, it may be better to ground the AG terminal as well. If the grounding status of the AG terminal is changed after the offset/gain values are set, set the values again.

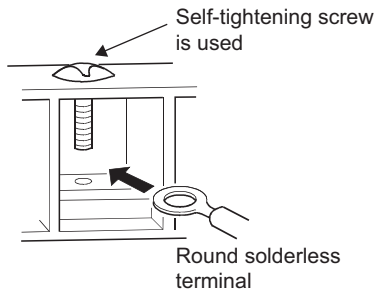
(e) Wiring method

- 1. Loosen the terminal screw. Connect the round solderless terminal as it is.**

Point

- Do not put oil on the terminal and screw. Failure to do so may damage the screw.
- The number of the applicable solderless terminals must be two or less.
When inserting two applicable solderless terminals, insert them back-to-back. Otherwise the screw cannot be tightened and it may damage the screw.
- Tighten the terminal screw with an applicable screwdriver. Tightening with an inapplicable screwdriver may damage the screw.

CHAPTER 7 VARIOUS SETTINGS

This chapter describes the setting procedures of the A/D converter module.

7.1 Parameter Setting

Set the parameter of this module with the network parameter written to the CPU module of the master station. For the setting procedure of the master station, refer to the following.

 User's manual for the master/local module used

Remark

- Check "Set the network configuration settings in CC IE Field configuration window" on the "MELSECNET/CC IE/Ethernet Module Configuration" window in advance.
- To select an extension module in the "CC IE Field Configuration" window, select the following models from the "Module List" window.



Extension module type	Name
Input module	NZ2EX-16(DI)
Output module	NZ2EX-16(DO)

- When points less than the ones of the A/D converter module and extension module are set for the remote I/O signal and remote register, no error occurs. The cyclic transmission is performed for the data of the points set from the start.

(1) Precautions

(a) Before parameter settings

- Read and write the parameter settings of this module with the CPU module in the STOP status. Reading and writing are unavailable in the RUN status.
- Check that the start I/O number of the network parameter of the master station matches that of the PLC parameter. If they differ, the parameter settings cannot be read or written.

(b) Parameter settings

- When using the A/D converter module, enable the block data assurance per station. When it is disabled, correct operation of the A/D converter module cannot be guaranteed.

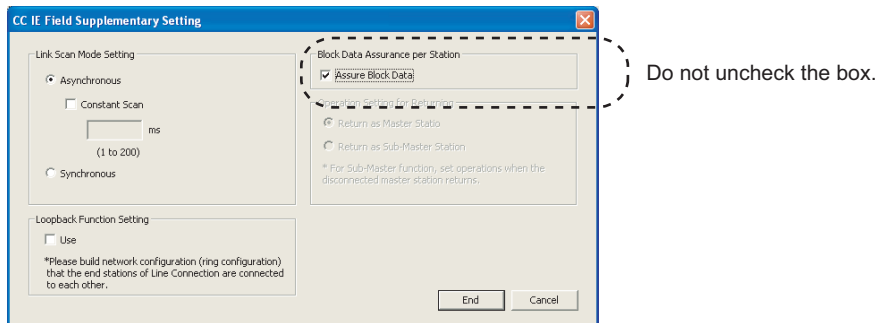

For the block data assurance per station, refer to the following.

User's manual for the master/local module used

- Do not set the parameter using the CCPASET instruction in the master station. When the CCPASET instruction is executed, correct operation of the A/D converter module cannot be guaranteed because the module operates with the block data assurance per station disabled.
- When using the extension module, write the module parameter. (Page 68, Section 7.1 (2)) If the parameter of the extension module has not been written, the error code (1F30_H) is stored in Latest error code (RWr0), Error flag (RXA) turns on, and the ERR. LED turns on.

(2) Setting procedure

1. Display the "CC IE Field Configuration" window.

- When the master/local module is the QJ71GF11-T2

Project window ⇒ [Parameter] ⇒ [Network Parameter] ⇒
[Ethernet/CC IE/MELSECNET] ⇒  button

- When the master/local module is the LJ71GF11-T2

Project window ⇒ [Parameter] ⇒ [Network Parameter] ⇒ [Ethernet/CC IE Field] ⇒
 button

2. Select the A/D converter module in "List of stations" on the "CC IE Field Configuration" window.

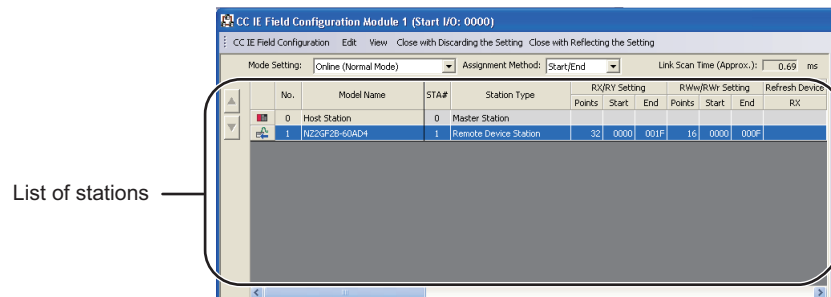

3. Open the "Parameter Processing of Slave Station" window.

 [CC IE Field Configuration] ⇒ [Online] ⇒ [Parameter Processing of Slave Station]

4. Set "Parameter write" for "Method selection".

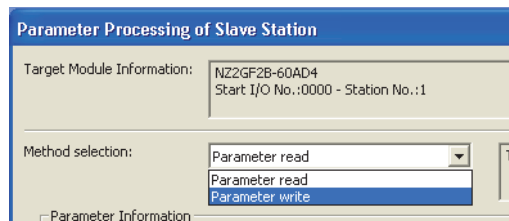

5. Double-click the item to change the setting, and input the setting value.

- Items to input from the pull-down list
Double-click the item to set, to display the pull-down list. Select the item.
- Items to input from the text box
Double-click the item to set, and input the setting value.

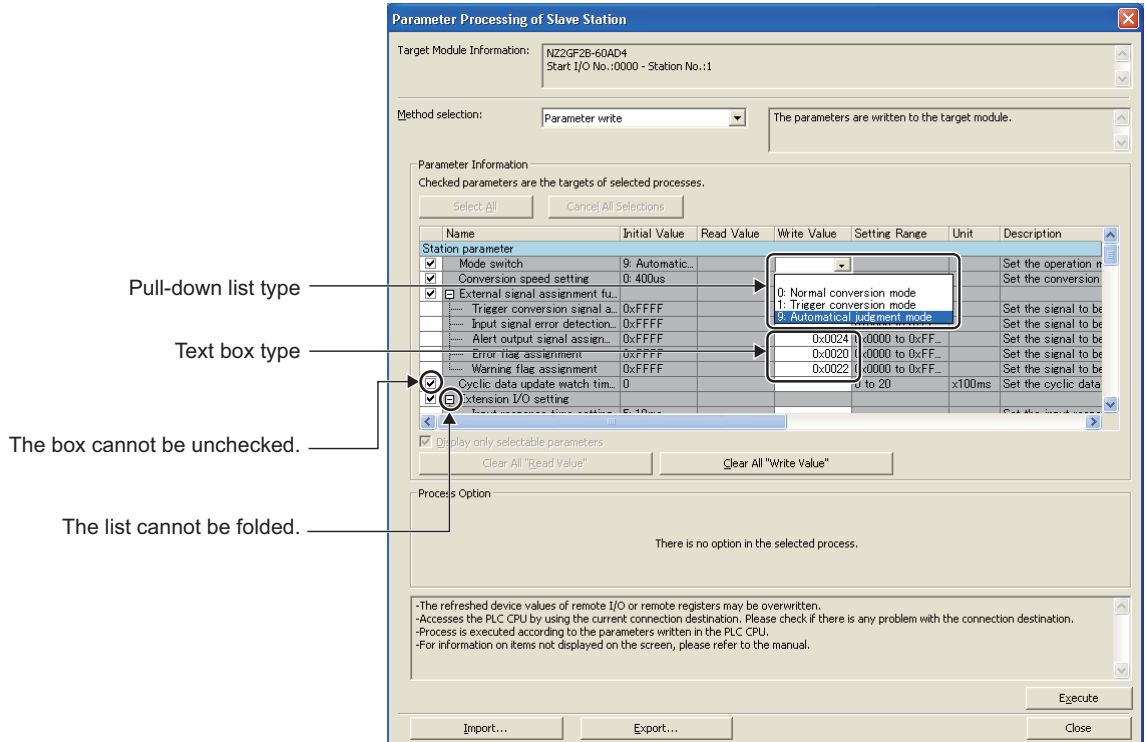



Setting item		Reference
Mode switch		Page 81, Section 8.2
Conversion speed setting		Page 90, Section 8.7
External signal assignment function	Trigger conversion signal assignment	Page 131, Section 8.18 (3)
	Input signal error detection signal assignment	
	Alert output signal assignment	
	Error flag assignment	
	Warning flag assignment	
Cyclic data update watch time setting		
Extension I/O setting	Input response time setting	Page 130, Section 8.18 (1)
	Digital output HOLD/CLEAR setting	
A/D conversion enable/disable setting	CH1 A/D conversion enable/disable setting	Page 84, Section 8.4
	CH2 A/D conversion enable/disable setting	
	CH3 A/D conversion enable/disable setting	
	CH4 A/D conversion enable/disable setting	
Range setting	CH1 Range setting	Page 89, Section 8.6
	CH2 Range setting	
	CH3 Range setting	
	CH4 Range setting	

Setting item		Reference
Averaging process setting	CH1 Averaging process setting	Page 84, Section 8.5
	CH1 Time average/Count average/Moving average	
	CH2 Averaging process setting	
	CH2 Time average/Count average/Moving average	
	CH3 Averaging process setting	
	CH3 Time average/Count average/Moving average	
	CH4 Averaging process setting	
	CH4 Time average/Count average/Moving average	
Input signal error detection function	CH1 Input signal error detection setting	Page 91, Section 8.9
	CH2 Input signal error detection setting	
	CH3 Input signal error detection setting	
	CH4 Input signal error detection setting	
Alert output function	CH1 Alert output setting	Page 94, Section 8.10
	CH1 Process alarm upper upper limit value	
	CH1 Process alarm upper lower limit value	
	CH1 Process alarm lower upper limit value	
	CH1 Process alarm lower lower limit value	
	CH2 Alert output setting	
	CH2 Process alarm upper upper limit value	
	CH2 Process alarm upper lower limit value	
	CH2 Process alarm lower upper limit value	
	CH2 Process alarm lower lower limit value	
	CH3 Alert output setting	
	CH3 Process alarm upper upper limit value	
	CH3 Process alarm upper lower limit value	
	CH3 Process alarm lower upper limit value	
	CH3 Process alarm lower lower limit value	
	CH4 Alert output setting	
CH4 Process alarm upper upper limit value		
CH4 Process alarm upper lower limit value		
CH4 Process alarm lower upper limit value		
CH4 Process alarm lower lower limit value		
Digital clipping function	CH1 Digital clipping enable/disable setting	Page 106, Section 8.13
	CH2 Digital clipping enable/disable setting	
	CH3 Digital clipping enable/disable setting	
	CH4 Digital clipping enable/disable setting	

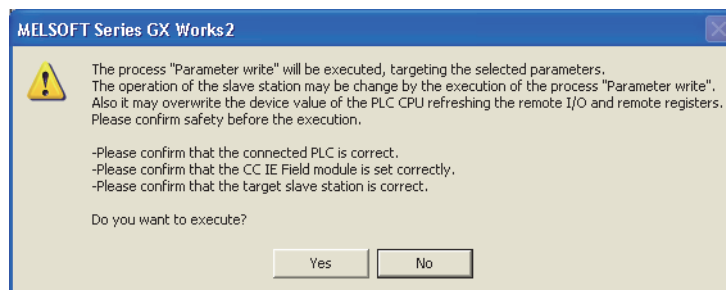

	Setting item	Reference
Scaling function	CH1 Scaling enable/disable setting	Page 97, Section 8.11
	CH1 Scaling upper limit value	
	CH1 Scaling lower limit value	
	CH2 Scaling enable/disable setting	
	CH2 Scaling upper limit value	
	CH2 Scaling lower limit value	
	CH3 Scaling enable/disable setting	
	CH3 Scaling upper limit value	
	CH3 Scaling lower limit value	
	CH4 Scaling enable/disable setting	
	CH4 Scaling upper limit value	
CH4 Scaling lower limit value		

6. Click the  button and the following window is displayed.

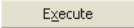

7. Click the  button.
8. The parameter is written to the A/D converter module.

Point

- When using the extension module, also set the parameter of the extension module. For the parameter of the extension module, refer to the following.
 -  Manual for the extension module used
- Set all the items for the parameter. If any blank exists, the parameter cannot be written to the A/D converter module.
- To read the parameter from the A/D converter module, set "Parameter read" for "Method selection" and click the  button.
- The parameter is checked when it is written to the A/D converter module. When the following message is displayed during the writing, take corrective action for the error code in < >. ( Page 154, Section 11.2)

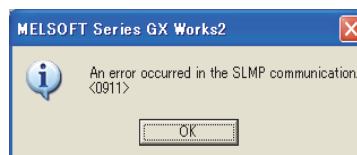

7.2 Changing the Parameter



This section describes the procedures to change the parameter.

The precautions to take when changing the parameter are same as the following.

- Precautions (☞ Page 67, Section 7.1 (1))

7.2.1 Changing the network configuration

When changing the network configuration diverting the created project, set the parameter in the following procedure.

1. Power off the module.
2. Connect the modules again according to the desired network configuration.
3. Power on the module.
4. Display the "CC IE Field Configuration" window.
 - When the master/local module is the QJ71GF11-T2
 - ☞ Project window ⇨ [Parameter] ⇨ [Network Parameter] ⇨ [Ethernet/CC IE/MELSECNET] ⇨  button
 - When the master/local module is the LJ71GF11-T2
 - ☞ Project window ⇨ [Parameter] ⇨ [Network Parameter] ⇨ [Ethernet/CC IE Field] ⇨  button
5. Drag and drop a module to set the slave station. Input a numerical value to set the station number of the station. Change the value as necessary.

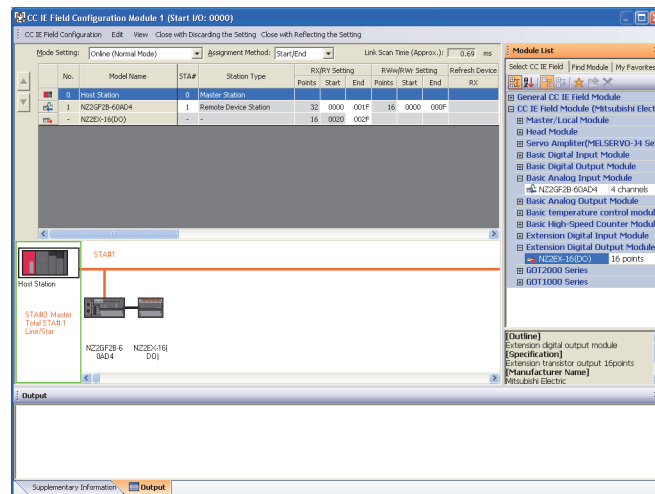

6. Select an A/D converter module in "List of stations" on the "CC IE Field Configuration" window.

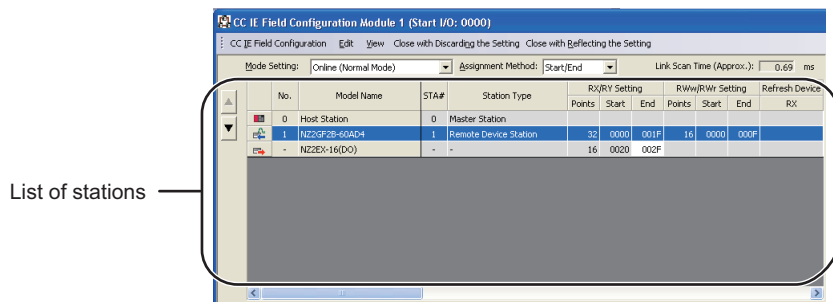

7. Open the "Parameter Processing of Slave Station" window.

[CC IE Field Configuration] ⇨ [Online] ⇨ [Parameter Processing of Slave Station]

8. Set "Parameter read" for "Method selection".

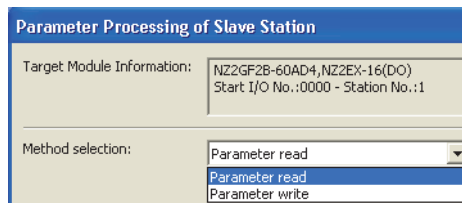

9. Click the button and the following window is displayed.

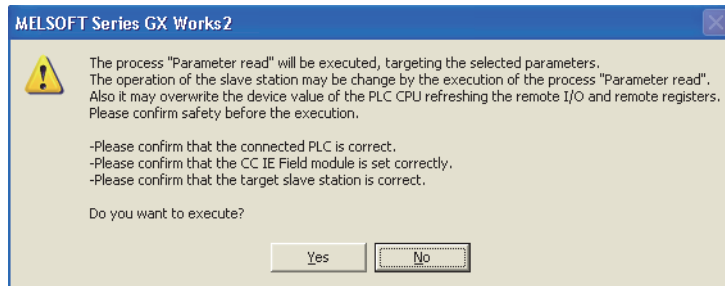

10. Click the button.

11. The parameter is read from the A/D converter module.

Name	Initial Value	Read Value	Write Value	Setting Range
Station parameter				
<input checked="" type="checkbox"/> Mode switch	9: Automatic...	1: Trigger co...		
<input checked="" type="checkbox"/> Conversion speed setting	0: 400us	0: 400us		
<input checked="" type="checkbox"/> External signal assignment fu...				
..... Trigger conversion signal a...	0xFFFF	0xFFFF		0x0000 to 0xFF...
..... Input signal error detection...	0xFFFF	0xFFFF		0x0000 to 0xFF...
..... Alert output signal assign...	0xFFFF	0xFFFF		0x0000 to 0xFF...
..... Error flag assignment	0xFFFF	0xFFFF		0x0000 to 0xFF...
..... Warning flag assignment	0xFFFF	0xFFFF		0x0000 to 0xFF...
<input checked="" type="checkbox"/> Cyclic data update watch tim...	0	0		0 to 20
<input checked="" type="checkbox"/> Extension I/O setting				

12. Set "Parameter write" for "Method selection".

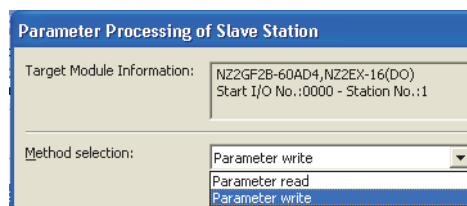

7

7.2 Changing the Parameter
7.2.1 Changing the network configuration

13. Set "Write Value". The following are the procedure.

- Click the title cell of "Read Value" to select all the items and copy them.
- Click the title cell of "Write Value" to select all the items and paste the copy.
- Select the items to be changed, and set new values.

Name	Initial Value	Read Value	Write Value	Setting Range
Station parameter				
<input checked="" type="checkbox"/> Mode switch	9: Automatic	1: Trigger co...	9: Automatic...	
<input checked="" type="checkbox"/> Conversion speed setting	0: 400us	0: 400us	0: 400us	
<input checked="" type="checkbox"/> External signal assignment fu...				
..... Trigger conversion signal a...	0xFFFF	0xFFFF	0xFFFF	0x0000 to 0xFF...
..... Input signal error detection...	0xFFFF	0xFFFF	0xFFFF	0x0000 to 0xFF...
..... Alert output signal assign...	0xFFFF	0xFFFF	0xFFFF	0x0000 to 0xFF...
..... Error flag assignment	0xFFFF	0xFFFF	0xFFFF	0x0000 to 0xFF...
..... Warning flag assignment	0xFFFF	0xFFFF	0xFFFF	0x0000 to 0xFF...
<input checked="" type="checkbox"/> Cyclic data update watch tim...	0	0	0	0 to 20
<input checked="" type="checkbox"/> Extension I/O setting				

14. Click the  button and the following window is displayed.

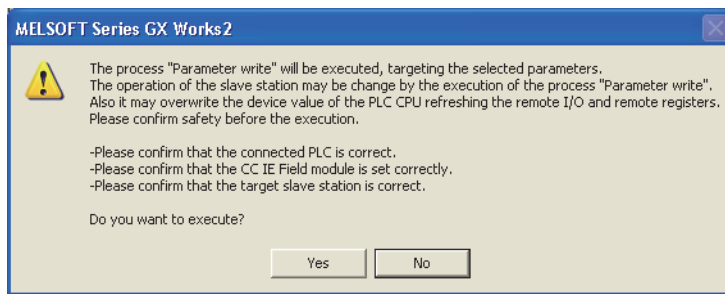

15. Click the  button.

16. The parameter is written to the A/D converter module.

The module parameter setting of the slave station is now completed.

17. Close the "CC IE Field Configuration" window.

 [CC IE Field Configuration] ⇨ [Close with Reflecting the Setting]

18. Click the  button to display the refresh parameter setting window.

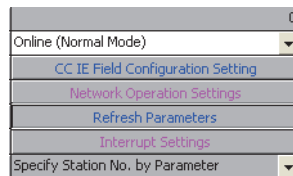

19. Set the refresh parameter. Change the value as necessary.

Assignment Method

Points/Start

Start/End

	Link Side					PLC Side			
	Dev. Name	Points	Start	End		Dev. Name	Points	Start	End
Transfer SB	SB	512	0000	01FF	↔	SB	512	0000	01FF
Transfer SW	SW	512	0000	01FF	↔	SW	512	0000	01FF
Transfer 1	RX	64	0000	003F	↔	X	64	1000	103F
Transfer 2	RY	64	0000	003F	↔	Y	64	1000	103F
Transfer 3	RWw	16	0000	000F	↔	W	16	001000	00100F
Transfer 4	RWr	16	0000	000F	↔	W	16	001100	00110F
Transfer 5					↔				
Transfer 6					↔				
Transfer 7					↔				
Transfer 8					↔				

20. Write the set parameter to the CPU module of the master station and reset the CPU module.

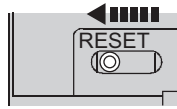

21. Change the status of the CPU module of the master station to RUN.

The network configuration setting is now completed.

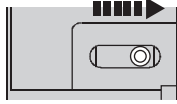

7.2.2 Changing the parameter without changing the network configuration

To change only the created module parameter of the slave station without changing the network configuration, set the parameter in the following procedure.

1. Display the "CC IE Field Configuration" window.

- When the master/local module is the QJ71GF11-T2

Project window ⇨ [Parameter] ⇨ [Network Parameter] ⇨
[Ethernet/CC IE/MELSECNET] ⇨  button

- When the master/local module is the LJ71GF11-T2

Project window ⇨ [Parameter] ⇨ [Network Parameter] ⇨ [Ethernet/CC IE Field] ⇨
 button

2. Select the A/D converter module in "List of stations" on the "CC IE Field Configuration" window.

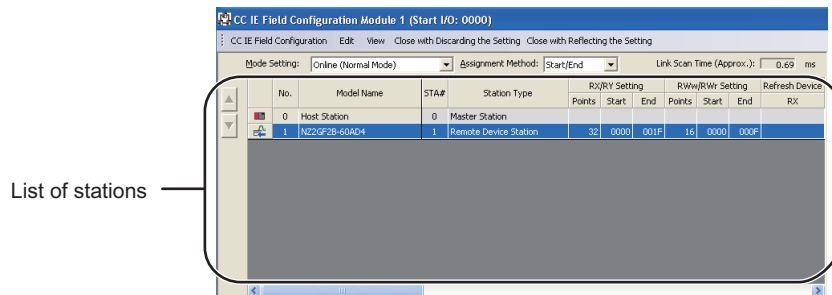

3. Open the "Parameter Processing of Slave Station" window.

 [CC IE Field Configuration] ⇨ [Online] ⇨ [Parameter Processing of Slave Station]

4. Set "Parameter read" for "Method selection".

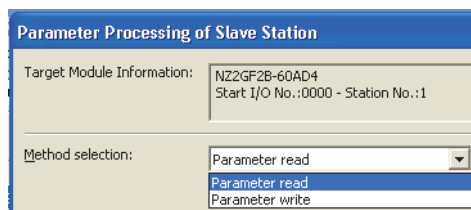

5. Click the button and the following window is displayed.

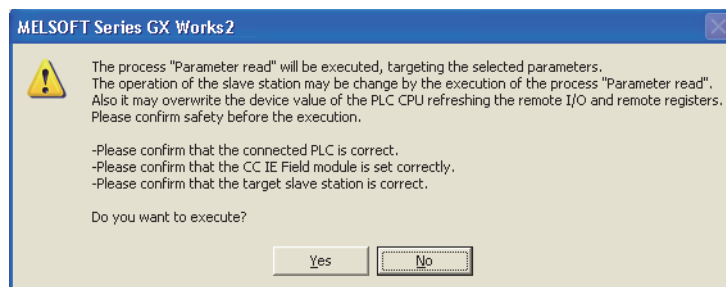

6. Click the button.

7. The parameter is read from the A/D converter module.

Name	Initial Value	Read Value	Write Value	Setting Range
Station parameter				
<input checked="" type="checkbox"/> Mode switch	9: Automatic...	1: Trigger co...		
<input checked="" type="checkbox"/> Conversion speed setting	0: 400us	0: 400us		
<input checked="" type="checkbox"/> External signal assignment fu...				
..... Trigger conversion signal a...	0xFFFF	0xFFFF		0x0000 to 0xFF...
..... Input signal error detection...	0xFFFF	0xFFFF		0x0000 to 0xFF...
..... Alert output signal assign...	0xFFFF	0xFFFF		0x0000 to 0xFF...
..... Error flag assignment	0xFFFF	0xFFFF		0x0000 to 0xFF...
..... Warning flag assignment	0xFFFF	0xFFFF		0x0000 to 0xFF...
<input checked="" type="checkbox"/> Cyclic data update watch tim...	0	0		0 to 20
<input checked="" type="checkbox"/> Extension I/O setting				

8. Set "Parameter write" for "Method selection".

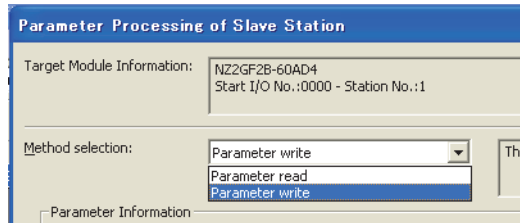

9. Set "Write Value". The following are the procedure.

- Click the title cell of "Read Value" to select all the items and copy them.
- Click the title cell of "Write Value" to select all the items and paste the copy.
- Select the items to be changed, and set new values.

Name	Initial Value	Read Value	Write Value	Setting Range
Station parameter				
<input checked="" type="checkbox"/> Mode switch	9: Automatic...	1: Trigger co...	9: Automatic...	
<input checked="" type="checkbox"/> Conversion speed setting	0: 400us	0: 400us	0: 400us	
<input checked="" type="checkbox"/> External signal assignment fu...				
..... Trigger conversion signal a...	0xFFFF	0xFFFF	0xFFFF	0x0000 to 0xFF...
..... Input signal error detection...	0xFFFF	0xFFFF	0xFFFF	0x0000 to 0xFF...
..... Alert output signal assign...	0xFFFF	0xFFFF	0xFFFF	0x0000 to 0xFF...
..... Error flag assignment	0xFFFF	0xFFFF	0xFFFF	0x0000 to 0xFF...
..... Warning flag assignment	0xFFFF	0xFFFF	0xFFFF	0x0000 to 0xFF...
<input checked="" type="checkbox"/> Cyclic data update watch tim...	0	0	0	0 to 20
<input checked="" type="checkbox"/> Extension I/O setting				

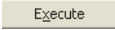
10. Click the  button and the following window is displayed.

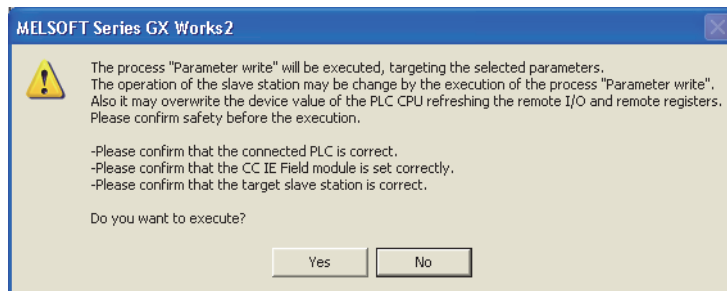

11. Click the  button.

12. The parameter is written to the A/D converter module.

The module parameter setting of the slave station is completed.

7.3 Offset/Gain Setting

When the user range setting is used, configure the offset/gain setting with the following operations.
 When factory default settings are used, the offset/gain setting is not required.

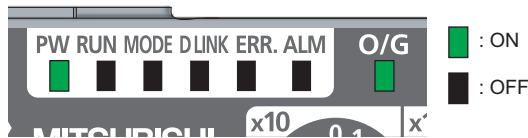

1. Power off the module.
2. Set "O/G" for "x10" of the station number setting switch.
3. Power on the module to check the LED is in the following status.
 RUN LED: OFF
 O/G LED: ON
4. Select the setting target using the SET/SEL button.

[User range setting 1 (-10 to 10V)]

CH1: Offset		Button Button
CH1: Gain		
CH2: Offset		
CH2: Gain		
CH3: Offset		
CH3: Gain		
CH4: Offset		
CH4: Gain		

[User range setting 2 (-5 to 5V, -20 to 20mA)]

CH1: Offset	
CH1: Gain	
CH2: Offset	
CH2: Gain	
CH3: Offset	
CH3: Gain	
CH4: Offset	
CH4: Gain	

5. Apply the offset value or gain value to the selected channel for one second or more.

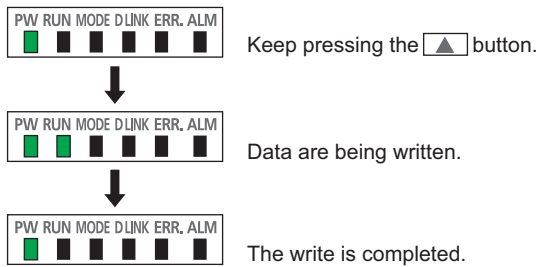

6. Keep pressing the button until the RUN LED turns on.

After the RUN LED turns on, release the button.

While the RUN LED is on, the offset value or gain value is being written to the nonvolatile memory.

After the writing, the RUN LED turns off.

After checking that the RUN LED turns off, go to the next step.

7. When setting another channel, go back to step 4.

8. After setting all the channels to be used, power off the module.

Point

- Configure the offset/gain setting in accordance with the actual use situation. Connection to the CC-Link IE Field Network is not required.
- Configure the offset/gain setting in the range satisfying the following condition. When the setting value out of the range is configured, the maximum resolution and accuracy of the module may not fall within the range shown in the following performance specifications.
 - I/O Conversion Characteristics of A/D Conversion (Page 199, Appendix 4)
- Because the offset value and gain value are written to the nonvolatile memory in the A/D converter module, the set values can be used even after the module is powered on and off.
- Configure the offset/gain setting in the condition of "Offset value < Gain value". For the A/D converter module, the error code (040□_H) is stored to Latest error code (RWr0), Error flag (RXA) is turned on, and the ERR. LED turns on under the following condition: The module is turned on and off after Initial data setting request flag (RY9) is turned on and off with the user range setting 1 or user range setting 2 set to Range setting (address: 0103_H).

CHAPTER 8 FUNCTIONS

This chapter describes the details of the functions available in the A/D converter module, and the setting procedures for those functions.

For details on remote I/O signals, remote registers, and remote buffer memory, refer to the following.

- Details of Remote I/O Signals (☞ Page 168, Appendix 1)
- Details of Remote Registers (☞ Page 177, Appendix 2)
- Details of Remote Buffer Memory Addresses (☞ Page 180, Appendix 3)

8.1 Mode Shift at Power-on

At power-on, the mode of the A/D converter module shifts to any of the following.

- Offset/gain setting mode
- Unit test mode
- Normal mode
- Trigger conversion mode
- Synchronous communication mode

The following table lists conditions where the mode shifts.

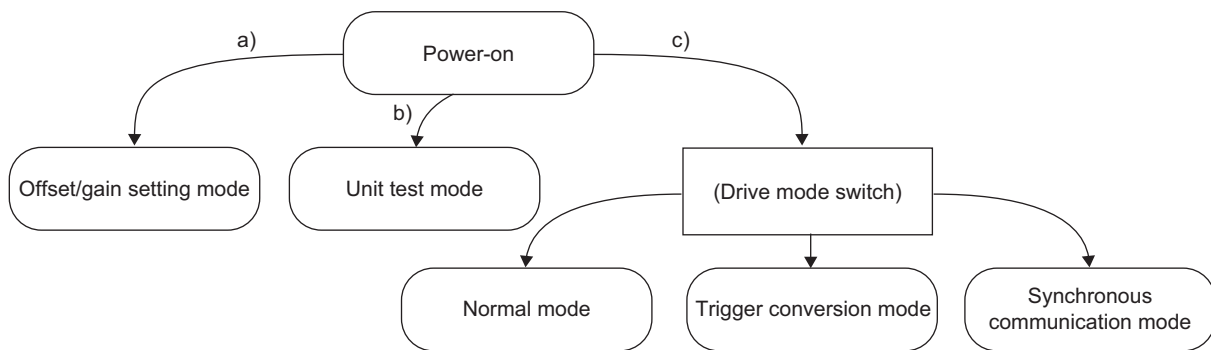

Symbol	Mode	Condition
a)	Offset/gain setting mode	If "X10" of the station number setting switch is set to "O/G", the mode shifts to the offset/gain setting mode. For details, refer to the following. • Offset/Gain Setting (☞ Page 78, Section 7.3)
b)	Unit test mode	If "X10" of the station number setting switch is set to "TEST" and "X1" of the switch is set to "0", the mode shifts to the unit test mode. For details, refer to the following. • Unit Test (☞ Page 165, Section 11.5)
c)	(Drive mode switch)	If the station number setting switch is set to 1 to 120, the mode shifts according to the setting of Mode switch (address: 0000 _H). For details, refer to the following. • Drive Mode Switch (☞ Page 81, Section 8.2)

8.2 Drive Mode Switch

The drive modes of the A/D converter module are the normal mode, trigger conversion mode, and synchronous communication mode.

The following table lists the type and the operation of the mode.

Type	Operation
Normal mode	The A/D conversion is performed based on the internal clock of the A/D converter module.
Trigger conversion mode	The A/D conversion is performed by turning on Trigger conversion request (RY19).
Synchronous communication mode	The A/D conversion is performed synchronized with the operation cycle of a simple motion module.

The drive mode can be selected by setting Mode switch (address: 0000_H). Note that the synchronous communication mode can be used only when the following conditions are met. If the conditions are met, the A/D converter module operates in the synchronous communication mode.

- Mode switch (address: 0000_H) is set to Automatical judgment mode (9_H).
- The A/D converter module is connected to the simple motion module with a serial number (first five digits) of "15092" or later.

(1) Setting procedure

1. Set "Parameter write" for "Method selection".

 "CC IE Field Configuration" window ⇨ Select an A/D converter module in "List of stations".
⇨ [CC IE Field Configuration] ⇨ [Online] ⇨ [Parameter Processing of Slave Station]

2. Set "Mode switch" to "0: Normal conversion mode", "1: Trigger conversion mode", or "9: Automatical judgment mode".

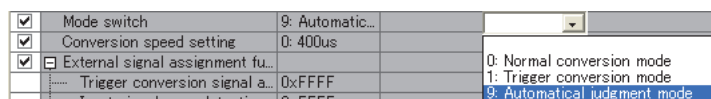

The following table lists the setting value of "Mode switch" and the drive mode.

Setting value of "Mode switch"	Drive mode
"0: Normal conversion mode"	The A/D converter module operates in the normal mode.
"1: Trigger conversion mode"	The A/D converter module operates in the trigger conversion mode.
"9: Automatical judgment mode"	The drive mode is automatically set according to the type of the module that operates as the master station of the A/D converter module.*1

*1 The drive mode varies depending on the module of the master station as shown below.

Master station	Drive mode (when "Mode switch" is set to "9: Automatical judgment mode")
Master/local module	Normal mode
Simple motion module (First five digits of the serial number is "15091" or earlier.)	
Simple motion module (First five digits of the serial number is "15092" or later.)	Synchronous communication mode

3. Click the button to write the parameter to the A/D converter module.

4. Check that "0920H" is stored in Latest warning code (RWr1).

 [Online] ⇨ [Monitor] ⇨ [Device/Buffer Memory Batch]

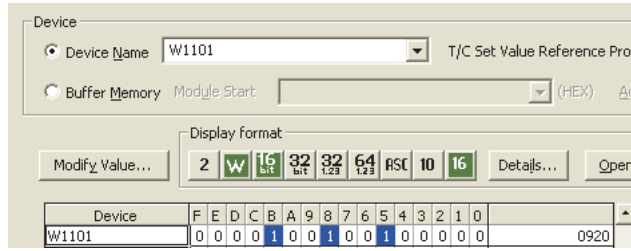

5. The A/D converter module starts operating in the set drive mode by turning off and on the power or performing the remote reset.

Point 

To operate the A/D converter module connected to a simple motion module in the normal mode, set "Mode switch" to "0: Normal conversion mode".

8.3 Processing Each Function

An analog input value and digital operation value are processed by the functions in the order shown below. If multiple functions are enabled, the output of the first-processed function is used as the input of the next function.

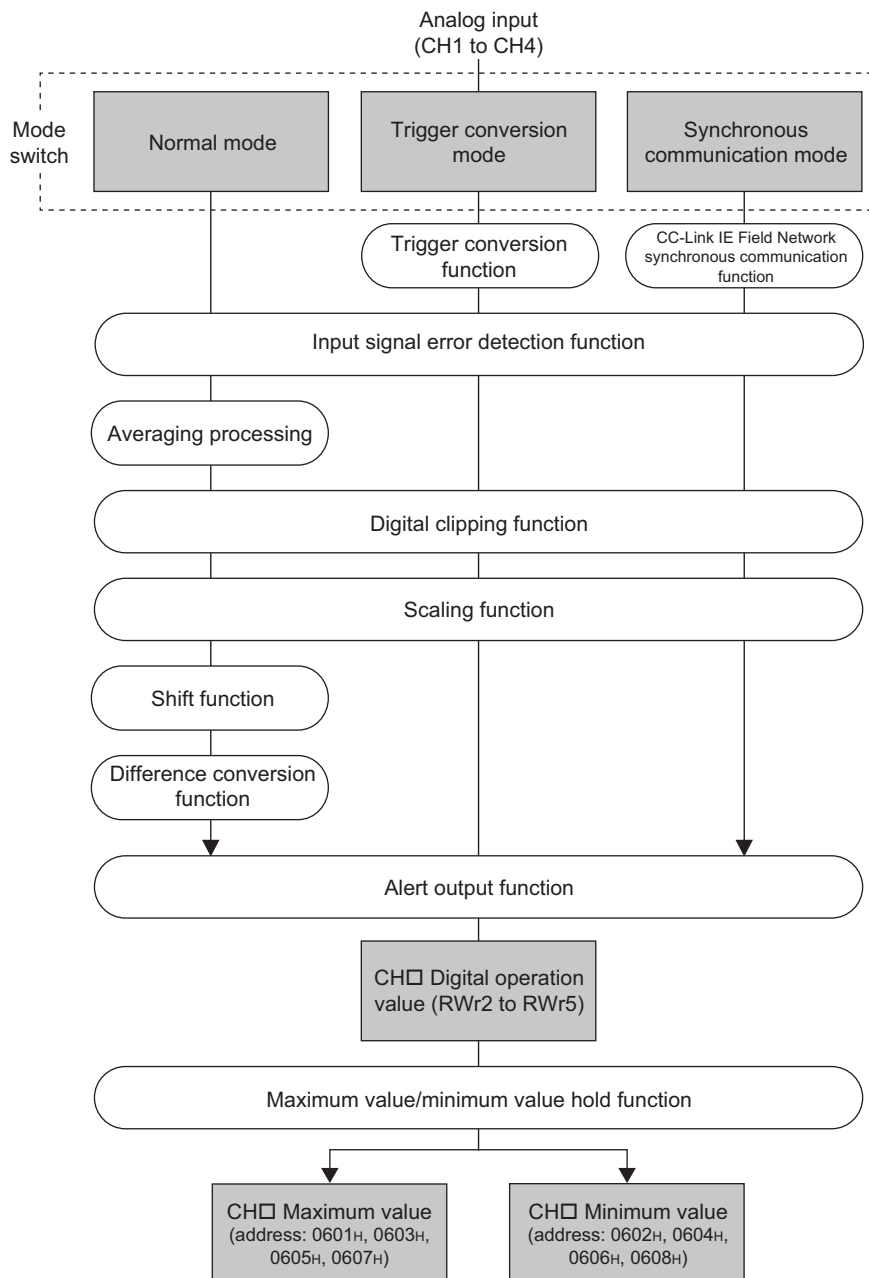

(1) Digital operation value

Digital values after sampling processing or averaging processing have been performed are called digital output values.

The values obtained by operating the digital output value using the digital clipping function, scaling function, shift function, or difference conversion function are stored.

(2) Maximum and minimum values

The maximum and minimum values of the digital operation values are stored.

8.4 A/D Conversion Enable/Disable Function

Sets whether to enable or disable A/D conversion for each channel.

Disabling the A/D conversion for unused channels reduces the conversion cycles.

(1) Setting procedure

1. Set "Parameter write" for "Method selection".

-  "CC IE Field Configuration" window ⇨ Select an A/D converter module in "List of stations".
⇨ [CC IE Field Configuration] ⇨ [Online] ⇨ [Parameter Processing of Slave Station]

2. Set "CH□ A/D conversion enable/disable setting" to "0: Enable".

<input checked="" type="checkbox"/>	A/D conversion enable/disable...			
<input type="checkbox"/>	CH1 A/D conversion enabl.	0: Enable		
<input type="checkbox"/>	CH2 A/D conversion enabl.	0: Enable		
<input type="checkbox"/>	CH3 A/D conversion enabl.	0: Enable	0: Enable	
<input type="checkbox"/>	CH4 A/D conversion enabl.	0: Enable	1: Disable	

8.5 A/D Conversion Method

Sets whether to perform sampling processing or averaging processing for each channel.

(1) Sampling processing

Sequentially performs A/D conversion on the analog input values and stores the digital operation values to CH□ Digital operation value (RWr2 to RWr5).

Point

The conversion cycle is calculated by "Conversion speed × Number of used channels".
Conversion can be enabled or disabled per channel. Disabling A/D conversion for the channels that are not used reduces the conversion cycle.

Ex. Conversion cycle in the following settings

- Number of used channels (where A/D conversion is enabled): CH1 to CH3 (three channels in total)
- Conversion speed: 400μs/channel

$$400 \times 3 = 1200 (\mu\text{s})$$

The conversion cycle is calculated to be 1200μs.

For details on conversion speed setting, refer to the following.

- Conversion Speed Switch Function ( Page 90, Section 8.7)

(2) Averaging processing

Performs averaging processing on the digital operation values for each channel, and stores the average values to CH□ Digital operation value (RWr2 to RWr5).

There are three types of averaging process as follows:

- Time average
- Count average
- Moving average

(a) Time average

Performs A/D conversion for a setting time, averages the total without the maximum and minimum values, and stores the average value to CH□ Digital operation value (RWr2 to RWr5).

The processing times within the setting time varies depending on the number of channels to be used (number of channels for which A/D conversion is enabled).

$$\text{Processing times (Times)} = \frac{\text{Setting time}}{(\text{Number of channels to be used} \times \text{Conversion speed})}$$

Ex. The processing times for the following settings is calculated below:

Item	Setting
Number of channels to be used (number of channels for which A/D conversion is enabled)	4 channels (CH1 to CH4)
Conversion speed	400μs/channel
Setting time	15ms

$$\frac{15}{(4 \times 0.4)} = 9.375 \text{ (times)} \cdot \cdot \cdot \text{ The value after the decimal point is rounded down.}$$

→ 9 times conversion processing are performed and the average value is output.

Point

The valid lower limit setting value for the time average is calculated by "(minimum processing times of 4) × (conversion speed) × (number of channels to be used)".

Ex. If a maximum of four channels are used (conversion speed: 1ms/channel):

$$4 \times 1.0 \times 4 = 16\text{ms}$$

If the processing times becomes less than four due to the setting time, an error occurs (error code: 020□), and a digital operation value comes out to 0 (zero).

(b) Count average

Performs A/D conversion a set number of times, averages the total without the maximum and minimum values, and stores the average value to CH□ Digital operation value (RWr2 to RWr5).

The time required to store the count average value to CH□ Digital operation value (RWr2 to RWr5) varies depending on the number of channels to be used (number of channels for which A/D conversion is enabled).

Processing time = Set number of times × (Number of channels to be used × Conversion speed)

Ex. The processing time for the following settings is calculated below:

Item	Setting
Number of channels to be used (number of channels for which A/D conversion is enabled)	4 channels (CH1 to CH4)
Conversion speed	400μs/channel
Set number of times	20 times

$$20 \times (4 \times 0.4) = 32.0 \text{ (ms)}$$

→ An average value is output every 32.0 ms.

Point

Because the count average requires a sum of at least two counts except the maximum and minimum values, the set number of times should be set to four or more.

(c) Moving average

Averages the set number of digital output values that are obtained each sampling cycle and stores it to CH□ Digital operation value (RWr2 to RWr5).

Because the averaging processing is performed on a moving set of sampling processing, the latest digital operation values can be obtained.

The moving average processing for a set number of times of four is shown below:

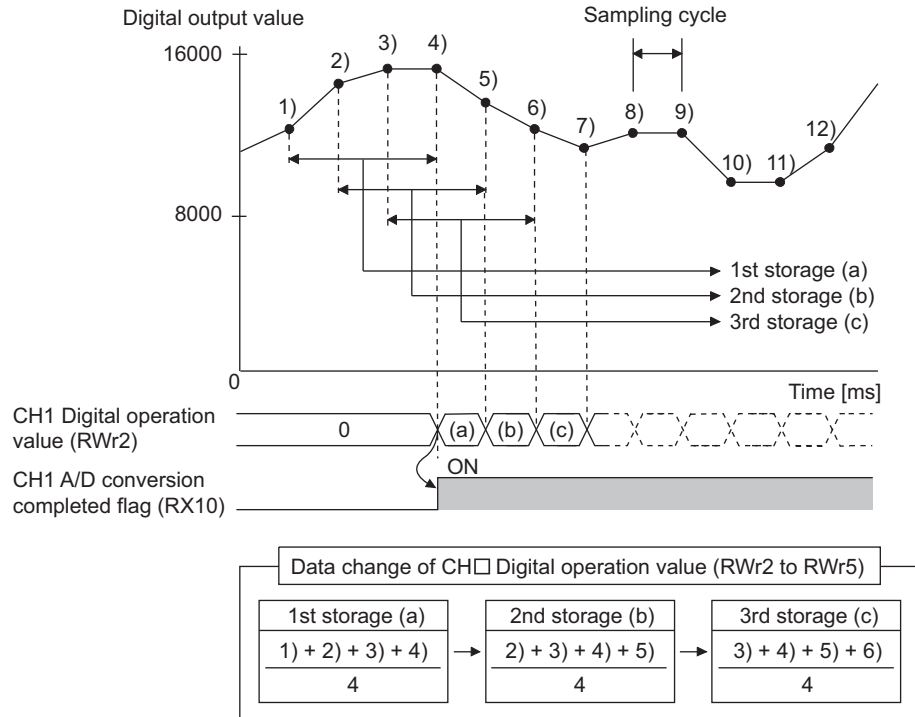

(3) Setting procedure

(a) Sampling processing

1. Set "Parameter write" for "Method selection".

☞ "CC IE Field Configuration" window ⇒ Select an A/D converter module in "List of stations".
 ⇒ [CC IE Field Configuration] ⇒ [Online] ⇒ [Parameter Processing of Slave Station]

2. Set "CH□ A/D conversion enable/disable setting" to "0: Enable".

<input checked="" type="checkbox"/>	A/D conversion enable/disable...			
	CH1 A/D conversion enabl...	0: Enable		
	CH2 A/D conversion enabl...	0: Enable		
	CH3 A/D conversion enabl...	0: Enable		
	CH4 A/D conversion enabl...	0: Enable		

3. For "CH□ Averaging process setting", select "0: Sampling processing".

<input checked="" type="checkbox"/>	Averaging process setting			
	CH1 Averaging process se...	0: Sampling ...		
	CH1 Time average/Count ...	0		
	CH2 Averaging process se...	0: Sampling ...		
	CH2 Time average/Count ...	0		
	CH3 Averaging process se...	0: Sampling ...		
	CH3 Time average/Count ...	0		

(b) Averaging processing

1. Set "Parameter write" for "Method selection".

 "CC IE Field Configuration" window ⇨ Select an A/D converter module in "List of stations".

⇨ [CC IE Field Configuration] ⇨ [Online] ⇨ [Parameter Processing of Slave Station]

2. Set "CH□ A/D conversion enable/disable setting" to "0: Enable".

<input checked="" type="checkbox"/>	A/D conversion enable/disable...			
	CH1 A/D conversion enabl...	0: Enable		
	CH2 A/D conversion enabl...	0: Enable		
	CH3 A/D conversion enabl...	0: Enable		0: Enable
	CH4 A/D conversion enabl...	0: Enable		1: Disable

3. For "CH□ Averaging process setting", select an averaging process method.

<input checked="" type="checkbox"/>	Averaging process setting			
	CH1 Averaging process se...	0: Sampling ...		
	CH1 Time average/Count ...	0		
	CH2 Averaging process se...	0: Sampling ...		
	CH2 Time average/Count ...	0		
	CH3 Averaging process se...	0: Sampling ...		
				0: Sampling processing 1: Time average 2: Count average 3: Moving average

Setting item	Setting range
CH□ Averaging process setting	<ul style="list-style-type: none"> • 1: Time average • 2: Count average • 3: Moving average

4. For "CH□ Time average/Count average/Moving average", enter the following:

<input checked="" type="checkbox"/>	Averaging process setting			
	CH1 Averaging process se...	0: Sampling ...		1: Time aver...
	CH1 Time average/Count ...	0		1000

Setting item	Selection for "CH□ Averaging process setting"	Setting range
CH□ Time average/Count average/Moving average	1: Time average* ¹	2 to 5000 (ms)
	2: Count average	4 to 65000 (times)
	3: Moving average	2 to 128 (times)

*1 For time average, set a value of (4 × Sampling cycle) ms or more. If a shorter value is set, an error occurs. The error code (020□□_μ) is stored in Latest error code (RWr0), Error flag (RXA) turns on, and the ERR. LED turns on. In CH□ Digital operation value (RWr2 to RWr5), 0 is stored.

Point

The following table lists the conversion cycle of each A/D conversion method.

A/D conversion method	Conversion cycle
Sampling processing	Conversion speed × Number of used channels
Time average	$\left(\frac{\text{Time set in "Time average/Count average/Moving average"}^{*1}}{\text{Conversion speed} \times \text{Number of used channels}} \right) \times \text{Conversion speed} \times \text{Number of used channels}$
Count average	Count set in "Time average/Count average/Moving average" × Conversion speed × Number of used channels
Moving average	Conversion speed × Number of used channels

*1 The value after the decimal point is rounded down.

8.6 Range Switching Function

The input range can be selected for each channel from the following ranges:

- Factory default range (4 to 20mA, 0 to 20mA, 1 to 5V, 0 to 5V, -10 to 10V)
- User range (user range setting 1, user range setting 2)

(1) Setting procedure

1. Set "Parameter write" for "Method selection".

-  "CC IE Field Configuration" window ⇒ Select an A/D converter module in "List of stations".
 ⇒ [CC IE Field Configuration] ⇒ [Online] ⇒ [Parameter Processing of Slave Station]

2. Set "CH□ A/D conversion enable/disable setting" to "0: Enable".

<input checked="" type="checkbox"/>	A/D conversion enable/disable...			
	CH1 A/D conversion enabl...	0: Enable		
	CH2 A/D conversion enabl...	0: Enable		
	CH3 A/D conversion enabl...	0: Enable		0: Enable
	CH4 A/D conversion enabl...	0: Enable		1: Disable

3. Set "CH□ Range setting".

<input checked="" type="checkbox"/>	Range setting					
	CH1 Range setting	0: 4 to 20mA		0: 4 to 2...		Set th
	CH2 Range setting	0: 4 to 20mA				
	CH3 Range setting	0: 4 to 20mA		0: 4 to 20mA		
	CH4 Range setting	0: 4 to 20mA		1: 0 to 20mA		
<input checked="" type="checkbox"/>	Averaging process setting			2: 1 to 5V		
	CH1 Averaging process se...	0: Sampling ...		3: 0 to 5V		
	CH1 Time average/Count ...	0		4: -10 to 10V		
	CH2 Averaging process se...	0: Sampling ...		5: User range setting1(-10 to 10V)		
				6: User range setting2(-5 to 5V,-20 to 20mA)		

8.7 Conversion Speed Switch Function

Two conversion speeds are available as follows:

- 400 μ s
- 1ms

(1) Setting procedure

1. Set "Parameter write" for "Method selection".

 "CC IE Field Configuration" window \Rightarrow Select an A/D converter module in "List of stations".
 \Rightarrow [CC IE Field Configuration] \Rightarrow [Online] \Rightarrow [Parameter Processing of Slave Station]

2. Set "CH \square A/D conversion enable/disable setting" to "0: Enable".

<input checked="" type="checkbox"/>	A/D conversion enable/disable...			
	CH1 A/D conversion enabl...	0: Enable		
	CH2 A/D conversion enabl...	0: Enable		
	CH3 A/D conversion enabl...	0: Enable		0: Enable
	CH4 A/D conversion enabl...	0: Enable		1: Disable

3. For "Conversion speed setting", select the appropriate conversion speed.

<input checked="" type="checkbox"/>	Conversion speed setting	0: 400us		
<input checked="" type="checkbox"/>	External signal assignment fu...			
	Trigger conversion signal a...	0xFFFF		0: 400us
	Input signal error detection...	0xFFFF		1: 1ms

8.8 Maximum Value/Minimum Value Hold Function

By using this function, the maximum and minimum digital operation values can be stored to the following remote buffer memory areas for each channel.

- CH \square Maximum value (address: 0601_H, 0603_H, 0605_H, 0607_H)
- CH \square Minimum value (address: 0602_H, 0604_H, 0606_H, 0608_H)

If averaging processing is specified, the values are updated per averaging process cycle. Otherwise they are updated per sampling cycle.

(1) Resetting maximum and minimum values

Switching Maximum value/minimum value reset request (RY1D) or Initial data setting request flag (RY9) on and off updates the maximum and minimum values with the current values.

(2) Targets of the maximum and minimum values

The maximum and minimum digital operation values are stored to the remote buffer memory. For details, refer to the following.

- Processing Each Function ( Page 83, Section 8.3)

8.9 Input Signal Error Detection Function

By using this function, a disconnection of the analog input signal can be detected.

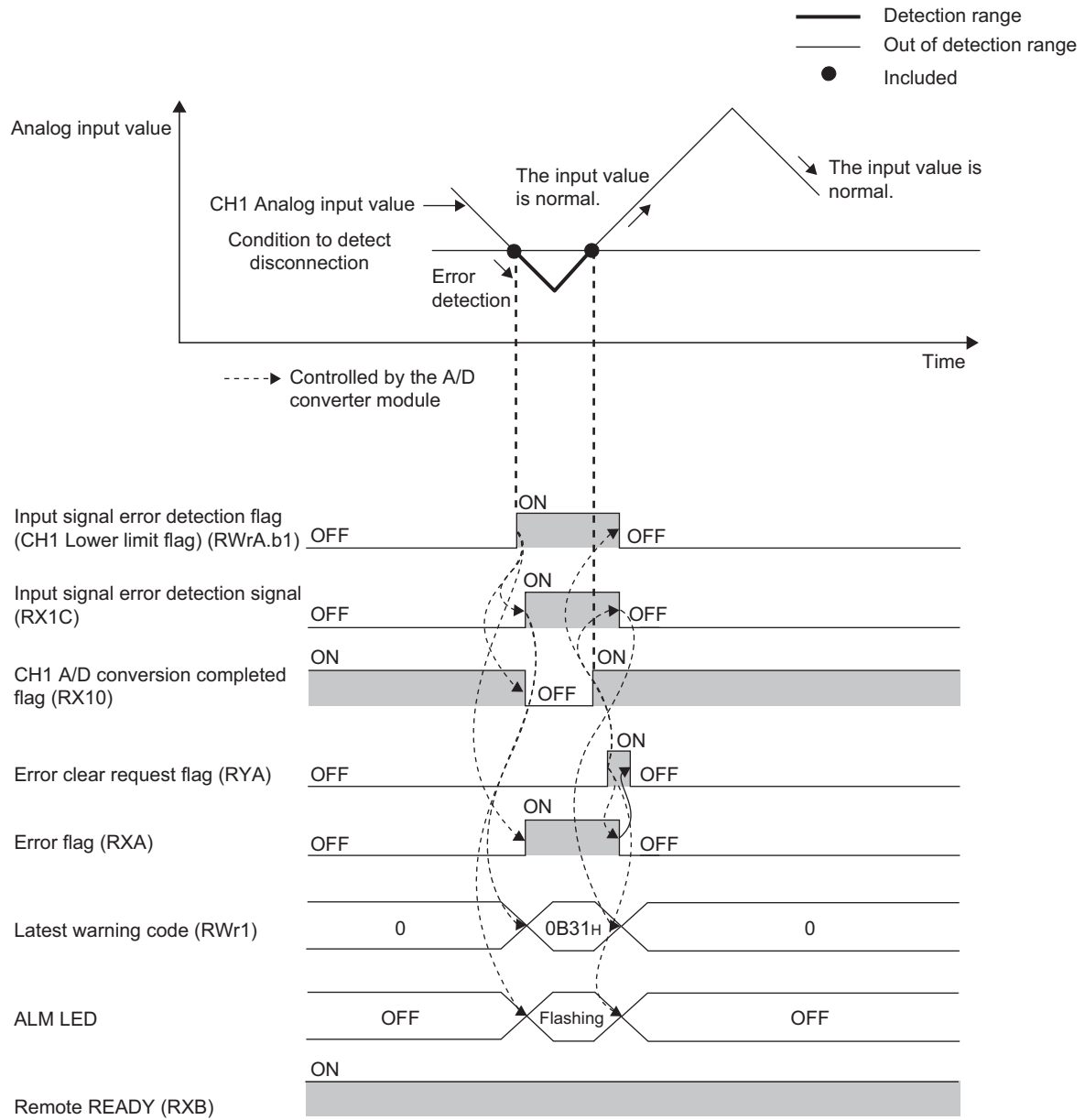

(1) Detection condition

When the following condition is satisfied, a disconnection is detected.

Input range*1	Disconnection detection condition
4 to 20mA	Input analog value \leq 2mA
1 to 5V	Input analog value \leq 0.5V

*1 If an input range other than the table above is set, the error code (082□□) is stored in Latest error code (RWr0), Error flag (RXA) turns on, and the ERR. LED turns on. The operation is performed in the previous setting.

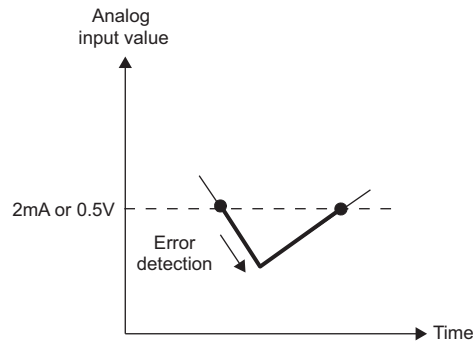

(2) Notification of input signal error

If the analog input value is satisfied the disconnection detection condition, the A/D converter module results in the following state and an error is notified.

- Input signal error detection flag (RWrA): The bit of the corresponding channel is on. (☞ Page 178, Appendix 2 (5))
- Input signal error detection signal (RX1C): ON
- ALM LED: Flashing

In addition, alarm code 0B△□ gets stored in Latest warning code (RWr1).

The alarm code that is stored is shown below:

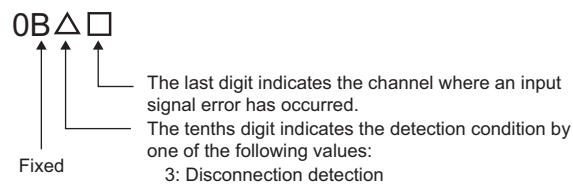

For details on alarm codes, refer to the following.

- Alarm Code List (☞ Page 161, Section 11.3)

(3) Operation of the input signal error detection function

The digital operation value on the channel on which the error was detected is held at the value just before the error was detected, and CH□ A/D conversion completed flag (RX10 to RX13) of the channel turns off.

In addition, once the analog input value is out of the disconnection detection condition, A/D conversion resumes regardless of the reset of Input signal error detection flag (RW_rA) and Input signal error detection signal (RX1C). After the first update, CH□ A/D conversion completed flag (RX10 to RX13) for this channel turns on again. (ALM LED remains flashing.)

Point

The digital operation value is not updated while the input signal error is being detected.
Once the analog input value is out of the disconnection detection condition, updating the digital operation value resumes.

(4) Detection cycle

This function is executed per sampling cycle.

(5) Clearing the input signal error detection

Check that the analog input value is out of the disconnection detection condition and that Error flag (RXA) is off, then turn on and off Error clear request flag (RYA).

When the input signal error is cleared, the A/D converter module results in the following state:

- Input signal error detection flag (RW_rA) is cleared.
- Input signal error detection signal (RX1C) turns off.
- The ALM LED turns off.
- The alarm code stored in Latest warning code (RW_r1) is cleared.

(6) Setting procedure

1. Set "Parameter write" for "Method selection".

- ☞ "CC IE Field Configuration" window ⇒ Select an A/D converter module in "List of stations".
⇒ [CC IE Field Configuration] ⇒ [Online] ⇒ [Parameter Processing of Slave Station]

2. Set "CH□ A/D conversion enable/disable setting" to "0: Enable".

<input checked="" type="checkbox"/>	A/D conversion enable/disable...			
	CH1 A/D conversion enabl...	0: Enable		
	CH2 A/D conversion enabl...	0: Enable		
	CH3 A/D conversion enabl...	0: Enable		
	CH4 A/D conversion enabl...	0: Enable		

3. Set "CH□ Input signal error detection setting" to "4: Disconnection detection".

<input checked="" type="checkbox"/>	Input signal error detection fu...			
	CH1 Input signal error dete...	0: Disable		
	CH2 Input signal error dete...	0: Disable		
	CH3 Input signal error dete...	0: Disable		
	CH4 Input signal error dete...	0: Disable		

8.10 Alert Output Function (Process Alarm)

Outputs an alert when the digital operation value enters a preset range.

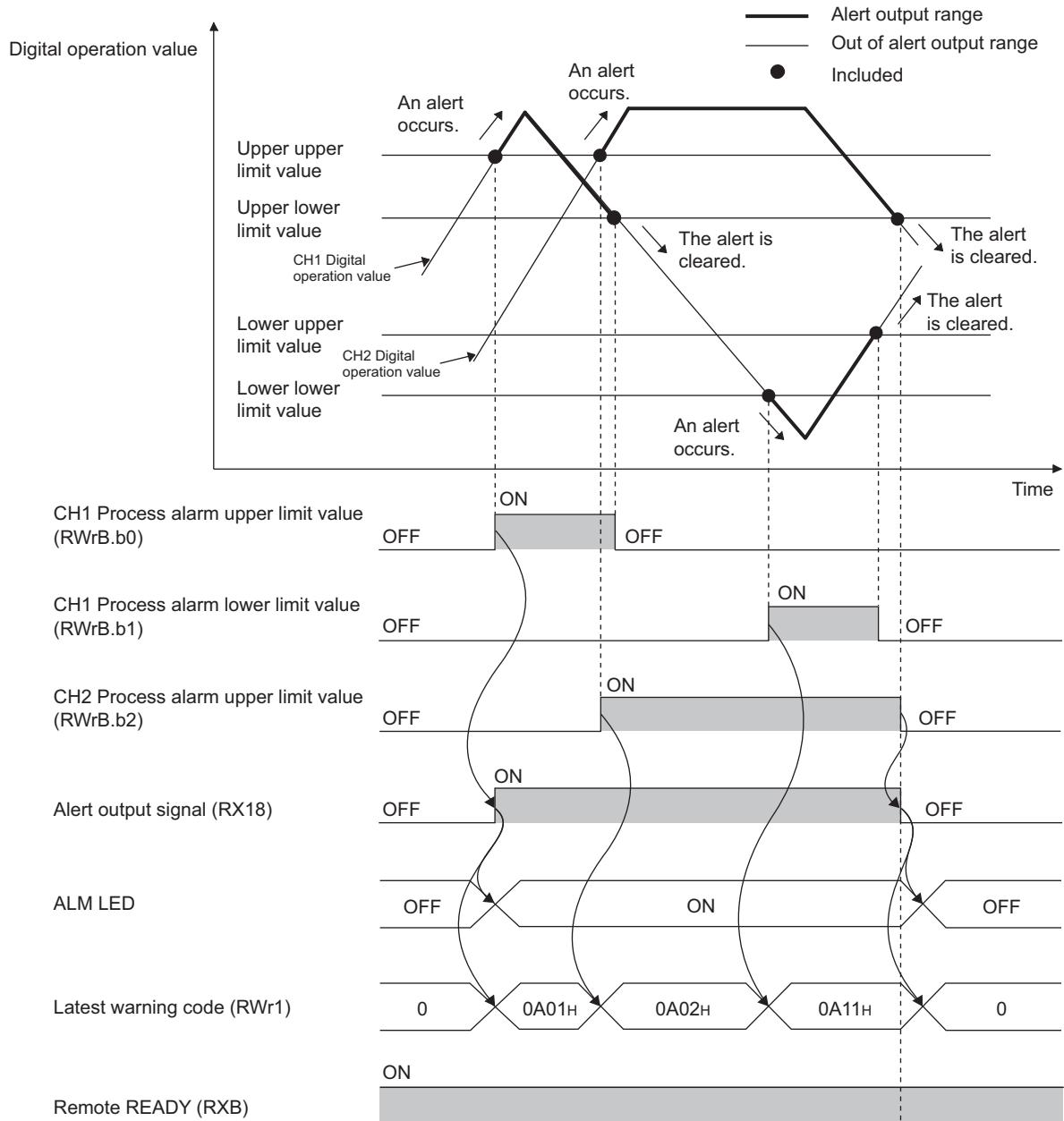

(1) Process alarm notification

When the digital operation value moves on or above the process alarm upper upper limit value, or on or below the process alarm lower lower limit value, thus entering the alert output range, alert notifications are made by Alert output flag (RWrB), Alert output signal (RX18), and the ALM LED turning on.

- Alert output flag (RWrB): The bit corresponding to the alert is on. (☞ Page 179, Appendix 2 (6))
- Alert output signal (RX18): ON
- ALM LED: ON

In addition, alarm code 0A△□ gets stored in Latest warning code (RWr1).

The alarm code that is stored is shown below:

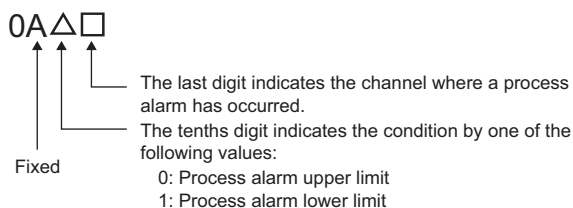

(2) Operation of the alert output function (process alarm)

After the alert is output, once the digital output value returns within the alert output setting range, below the process alarm upper lower limit value and above the process alarm lower upper limit value, a "0" (zero) is stored in the bit position corresponding to the channel number for Alert output flag (RWrB).

Once all channels are within the setting range, Alert output signal (RX18) and the ALM LED turn off.

(3) Detection cycle

When time average is specified, the function is executed per set time (for averaging). When count average is specified, the function is executed per set count (for averaging).

In addition, when sampling processing and moving average are specified, the function is executed per sampling cycle.

(4) Clearing the alarm code

After the digital operation value enters the alert output setting range, turn on and off Initial data setting request flag (RY9).

This clears the alarm code 0A△□, which was stored in Latest warning code (RWr1).

(5) Alert output target

Alert output target is CH□ Digital operation value (RWr2 to RWr5).

When using the digital clipping function, scaling function, shift function, and difference conversion function, set values considering these functions for the process alarm upper upper limit value, upper lower limit value, lower upper limit value, and lower lower limit value.

(6) Setting procedure

1. Set "Parameter write" for "Method selection".

 "CC IE Field Configuration" window ⇨ Select an A/D converter module in "List of stations".
 ⇨ [CC IE Field Configuration] ⇨ [Online] ⇨ [Parameter Processing of Slave Station]

2. Set "CH□ A/D conversion enable/disable setting" to "0: Enable".

<input checked="" type="checkbox"/>	A/D conversion enable/disab...			
	CH1 A/D conversion enabl...	0: Enable		
	CH2 A/D conversion enabl...	0: Enable		
	CH3 A/D conversion enabl...	0: Enable		0: Enable
	CH4 A/D conversion enabl...	0: Enable		1: Disable

3. Set "CH□ Alert output setting" to "0: Enable".

<input checked="" type="checkbox"/>	Alert output function			
	CH1 Alert output setting	1: Disable		
	CH1 Process alarm upper ...	0		
	CH1 Process alarm upper L...	0		0: Enable
	CH1 Process alarm lower ...	0		1: Disable

4. Specify the values for "CH□ Process alarm upper upper limit value", "CH□ Process alarm upper lower limit value", "CH□ Process alarm lower upper limit value", and "CH□ Process alarm lower lower limit value".

<input checked="" type="checkbox"/>	Alert output function			
	CH1 Alert output setting	1: Disable		0: Enable
	CH1 Process alarm upper ...	0		16000
	CH1 Process alarm upper L...	0		10000
	CH1 Process alarm lower ...	0		3000
	CH1 Process alarm lower L...	0		0

Item	Setting range
CH□ Process alarm upper upper limit value	-32768 to 32767
CH□ Process alarm upper lower limit value	
CH□ Process alarm lower upper limit value	
CH□ Process alarm lower lower limit value	

Point

Alert output function must meet the following condition:

Process alarm upper upper limit value ≥ Process alarm upper lower limit value ≥ Process alarm lower upper limit value ≥ Process alarm lower lower limit value

8.11 Scaling Function

By using this function, the digital output value can be scale-converted to the set range of scaling lower limit value and the scaling upper limit value.

The converted values are stored to CH□ Digital operation value (RWr2 to RWr5).

(1) Concept of scaling setting

Ex. If the input range is set to -10 to 10V:

For the scaling lower limit value, set a value corresponding to the lower limit of the input range (-16000), and for the scaling upper limit value, set a value corresponding to the upper limit of the input range (16000).

(2) Calculation of the digital operation value

Scale conversion is performed on the digital values using the following formula:
(Values after the decimal point are rounded down during scale conversion.)

- When the input range is -10 to 10V

$$\text{Digital operation value} = \frac{DX \times (SH - SL)}{32000} + \frac{(SH + SL)}{2}$$

- When the input range is user range setting 1, user range setting 2, 0 to 5V, 1 to 5V, 0 to 20mA, or 4 to 20mA

$$\text{Digital operation value} = \frac{DX \times (SH - SL)}{16000} + SL$$

Item	Description
Dx	Digital output value
SH	Scaling upper limit value
SL	Scaling lower limit value

(3) Setting procedure

1. Set "Parameter write" for "Method selection".

 "CC IE Field Configuration" window ⇨ Select an A/D converter module in "List of stations".
 ⇨ [CC IE Field Configuration] ⇨ [Online] ⇨ [Parameter Processing of Slave Station]

2. Set "CH□ A/D conversion enable/disable setting" to "0: Enable".

<input checked="" type="checkbox"/>	A/D conversion enable/disab..			
	CH1 A/D conversion enabl..	0: Enable		
	CH2 A/D conversion enabl..	0: Enable		
	CH3 A/D conversion enabl..	0: Enable		0: Enable
	CH4 A/D conversion enabl..	0: Enable		1: Disable

3. Set "CH□ Scaling enable/disable setting" to "0: Enable".

<input checked="" type="checkbox"/>	Scaling function			
	CH1 Scaling enable/disabl..	1: Disable		0: Enable
	CH1 Scaling upper limit va..	0		
	CH1 Scaling lower limit va..	0		0: Enable
	CH2 Scaling enable/disabl..	1: Disable		1: Disable

4. Set values for "CH□ Scaling upper limit value" and "CH□ Scaling lower limit value".

<input checked="" type="checkbox"/>	Scaling function			
	CH1 Scaling enable/disabl..	1: Disable		0: Enable
	CH1 Scaling upper limit va..	0		10000
	CH1 Scaling lower limit va..	0		4000

Item	Setting range
CH□ Scaling upper limit value	-32000 to 32000
CH□ Scaling lower limit value	

Point 

- Even if the scaling upper limit value and the scaling lower limit value are set so that the change is larger than the maximum resolution described in the performance specifications, the resolution will not increase.
- Scaling settings must meet the following condition:
 Scaling upper limit value > Scaling lower limit value

(4) Example of scaling setting

Ex. 1: When values are set for a channel with input range of 0 to 5V as follows:

- "CH□ Scaling enable/disable setting": "0: Enable"
- "CH□ Scaling upper limit value": 12000
- "CH□ Scaling lower limit value": 4000

<input checked="" type="checkbox"/>	Scaling function		
	CH1 Scaling enable/disable	1: Disable	0: Enable
	CH1 Scaling upper limit value	0	12000
	CH1 Scaling lower limit value	0	4000

The digital output values and digital operation values are as follows:

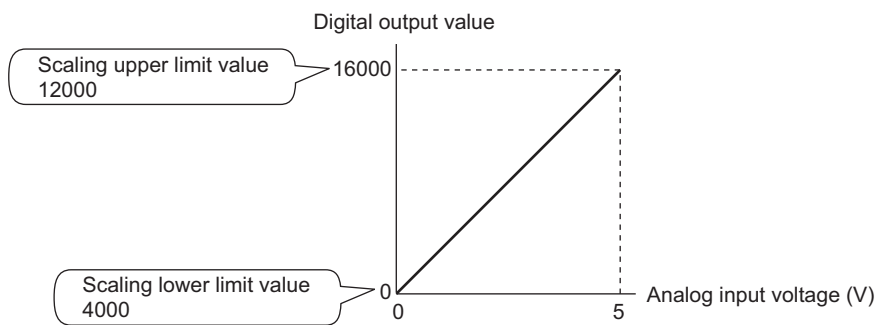

Analog input voltage (V)	Digital output value	Digital operation value
0	0	4000
1	3200	5600
2	6400	7200
3	9600	8800
4	12800	10400
5	16000	12000

Ex. 2: When values are set for a channel with input range of -10 to 10V as follows:

- "CH□ Scaling enable/disable setting": "0: Enable"
- "CH□ Scaling upper limit value": 12000
- "CH□ Scaling lower limit value": 4000

<input checked="" type="checkbox"/>	Scaling function		
	CH1 Scaling enable/disable	1: Disable	0: Enable
	CH1 Scaling upper limit value	0	12000
	CH1 Scaling lower limit value	0	4000

The digital output values and digital operation values are as follows:

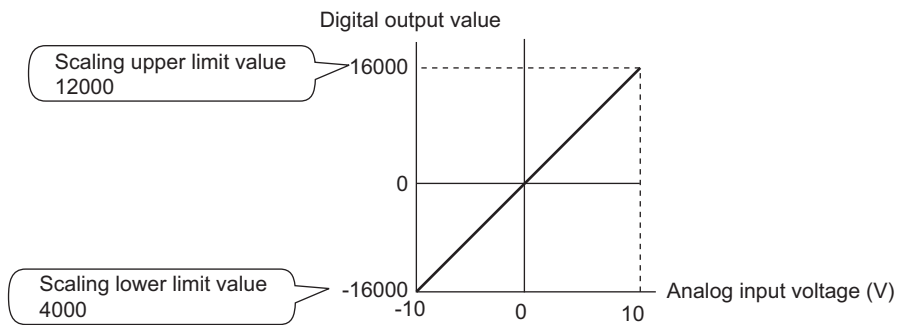

Analog input voltage (V)	Digital output value	Digital operation value
-10	-16000	4000
-5	-8000	6000
0	0	8000
5	8000	10000
10	16000	12000

Ex. 3: When values are set for a channel with the user range of 2 to 10V as follows:

- "CH□ Scaling enable/disable setting": "0: Enable"
- "CH□ Scaling upper limit value": 12000
- "CH□ Scaling lower limit value": 4000

<input checked="" type="checkbox"/>	Scaling function		
	CH1 Scaling enable/disable	1: Disable	0: Enable
	CH1 Scaling upper limit value	0	12000
	CH1 Scaling lower limit value	0	4000

The digital output values and digital operation values are as follows:

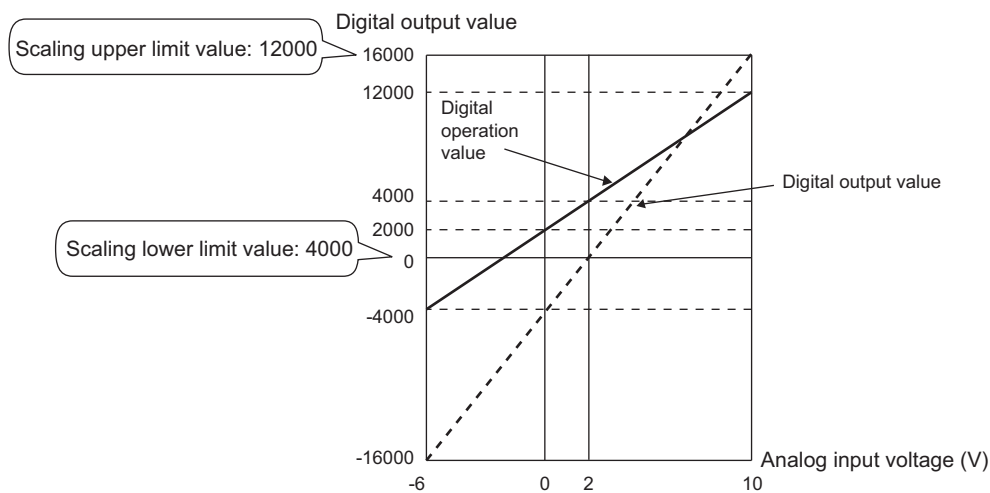

Analog input voltage (V)	Digital output value	Digital operation value
-6	-16000	-4000
-4	-12000	-2000
-2	-8000	0
0	-4000	2000
2	0	4000
4	4000	6000
6	8000	8000
8	12000	10000
10	16000	12000

8.12 Shift Function

By using this function, the set shifting amount to conversion value can be added (shifted) to the digital output value. When the shifting amount to conversion value is changed, it is reflected to the digital operation value in real time. Therefore, fine adjustment can be easily performed when the system starts.

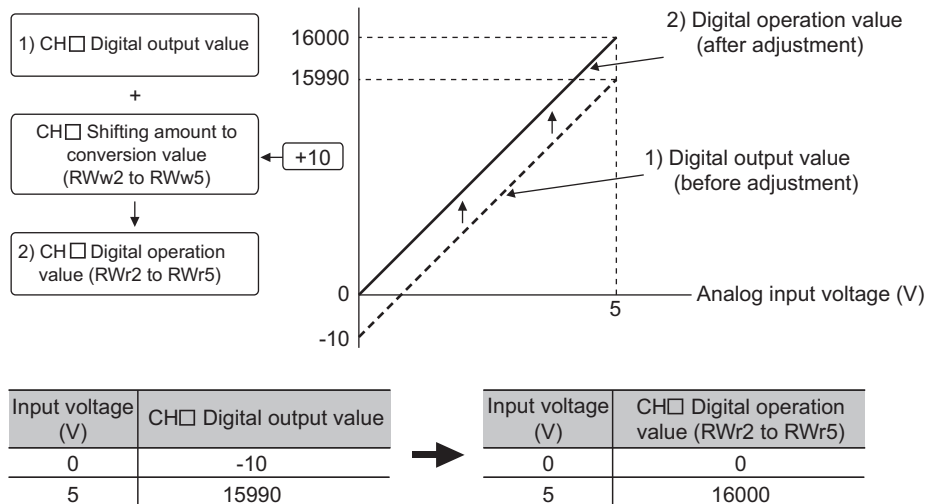

(1) Operation of the shift function

The set shifting amount to conversion value is added to digital output value. Then, the digital operation value with shift addition is stored in CH Digital operation value (RWr2 to RWr5).

When the scaling function is used, the shifting amount to conversion value is added to the value to which the scale-conversion is performed.

The shift amount is added in every sampling cycle for sampling processing, while it is added in every averaging process cycle for averaging processing.

The default value of the shifting amount to conversion value is "0". If some value is set to the shifting amount to conversion value, the shifting amount to conversion value is added regardless of the status change (OFF → ON → OFF) of Initial data setting request flag (RY9).

(2) Setting procedure

1. Set "Parameter write" for "Method selection".

☞ "CC IE Field Configuration" window ⇒ Select an A/D converter module in "List of stations".
 ⇒ [CC IE Field Configuration] ⇒ [Online] ⇒ [Parameter Processing of Slave Station]

2. Set "CH□ A/D conversion enable/disable setting" to "0: Enable".

<input checked="" type="checkbox"/>	A/D conversion enable/disable...			
<input type="checkbox"/>	CH1 A/D conversion enabl...	0: Enable		
<input type="checkbox"/>	CH2 A/D conversion enabl...	0: Enable		
<input type="checkbox"/>	CH3 A/D conversion enabl...	0: Enable		
<input type="checkbox"/>	CH4 A/D conversion enabl...	0: Enable		

3. Set a value to be added for CH□ Shifting amount to conversion value (RWw2 to RWw5).

Item	Setting range
CH□ Shifting amount to conversion value (RWw2 to RWw5)	-32768 to 32767

Point!

If the digital operation value exceeds the range of -32768 to 32767 as a result of shift addition, the digital operation value is fixed to the lower limit value (-32768) or the upper limit value (32767).

(3) Setting example

Ex. When the following settings are used for a channel with input range of -10 to 10V:

- CH□ Shifting amount to conversion value (RWw2 to RWw5): 20000

The digital output values and digital operation values are as follows:

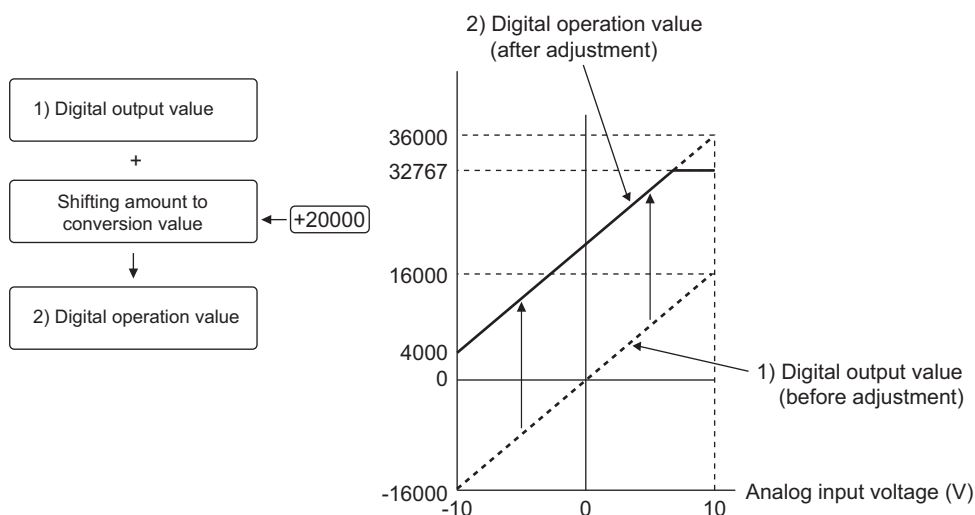

Input voltage (V)	Digital output value	Digital operation value
-10	-16000	4000
-5	-8000	12000
0	0	20000
5	8000	28000
10	16000	32767 ^{*1}

*1 Because the value exceeds the range of -32768 to 32767, it is fixed to 32767 (the upper limit value).

(4) Setting example of when both the scaling function and shift function are used

Ex. When the following settings are used for the A/D converter module with input range of 0 to 5V:

- "CH□ Scaling enable/disable setting": "0: Enable"
- "CH□ Scaling upper limit value": 12000
- "CH□ Scaling lower limit value": 2000
- CH□ Shifting amount to conversion value (RWw2 to RWw5): 2000

The digital output values and digital operation values are as follows:

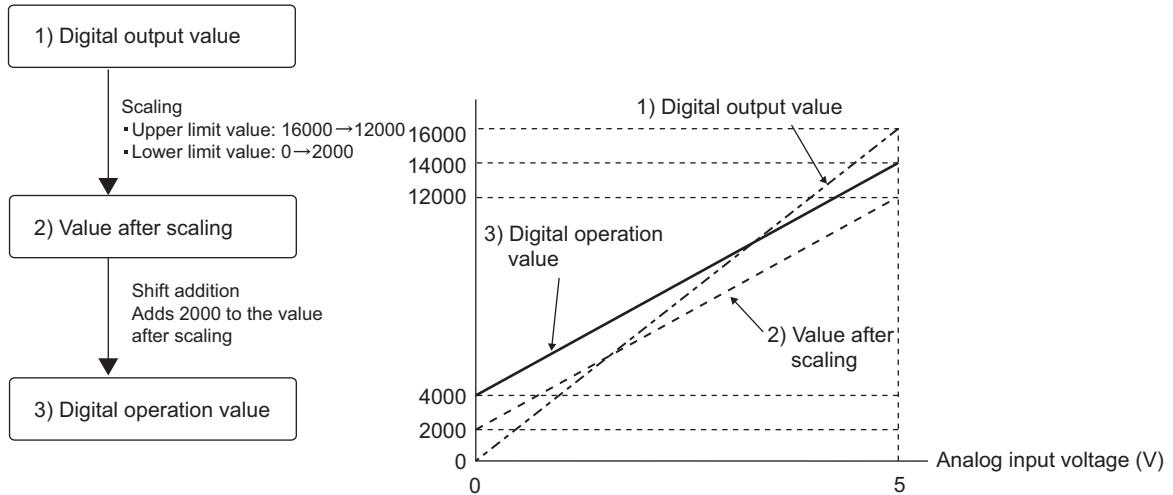

Input voltage (V)	Digital output value	Value after scaling	Digital operation value
0	0	2000	4000
1	3200	4000	6000
2	6400	6000	8000
3	9600	8000	10000
4	12800	10000	12000
5	16000	12000	14000

1. Set "Parameter write" for "Method selection".

☞ "CC IE Field Configuration" window ☞ Select an A/D converter module in "List of stations".

☞ [CC IE Field Configuration] ☞ [Online] ☞ [Parameter Processing of Slave Station]

2. Set "CH□ A/D conversion enable/disable setting" to "0: Enable".

<input checked="" type="checkbox"/>	A/D conversion enable/disable...		
<input type="checkbox"/>	CH1 A/D conversion enabl..	0: Enable	
<input type="checkbox"/>	CH2 A/D conversion enabl..	0: Enable	
<input type="checkbox"/>	CH3 A/D conversion enabl..	0: Enable	0: Enable
<input type="checkbox"/>	CH4 A/D conversion enabl..	0: Enable	1: Disable

3. Set "CH□ Scaling enable/disable setting" to "0: Enable".

<input checked="" type="checkbox"/>	Scaling function			
	CH1 Scaling enable/disabl...	1: Disable		
	CH1 Scaling upper limit va...	0		
	CH1 Scaling lower limit val...	0		0: Enable
	CH2 Scaling enable/disabl...	1: Disable		1: Disable

4. Set values for "CH□ Scaling upper limit value" and "CH□ Scaling lower limit value".

<input checked="" type="checkbox"/>	Scaling function			
	CH1 Scaling enable/disabl...	1: Disable		0: Enable
	CH1 Scaling upper limit va...	0		12000
	CH1 Scaling lower limit val...	0		2000

5. Set "2000" for CH□ Shifting amount to conversion value (RWw2 to RWw5).

Point

When the shift function, digital clipping function, and scaling function are used together, shift addition is executed on the value after digital clipping and scale conversion. In this case, the range of the digital operation value is determined as -32768 to 32767.

For a setting example of when the digital clipping function, scaling function, and shift function are used together, refer to the following.

- Setting example of when the digital clipping function, scaling function, and shift function are used together (☞
Page 109, Section 8.13 (4))

8.13 Digital Clipping Function

The range of the digital operation value for voltage or current over the input range is fixed between the maximum digital output value and the minimum digital output value.

(1) Concept of digital clipping setting

The following table lists the output range of the digital operation value when the digital clipping function is enabled for each range.

Input range	Output range of the digital operation value	
	Digital clipping function disabled	Digital clipping function enabled
4 to 20mA	-384 to 16383	0 to 16000
0 to 20mA		
1 to 5V		
0 to 5V		
-10 to 10V	-16384 to 16383	-16000 to 16000
User range setting 1		
User range setting 2		

(2) Setting procedure

1. Set "Parameter write" for "Method selection".

- ☞ "CC IE Field Configuration" window ⇨ Select an A/D converter module in "List of stations".
- ⇨ [CC IE Field Configuration] ⇨ [Online] ⇨ [Parameter Processing of Slave Station]

2. Set "CH□ A/D conversion enable/disable setting" to "0: Enable".

<input checked="" type="checkbox"/>	<input type="checkbox"/>	A/D conversion enable/disable...		
		CH1 A/D conversion enable...	0: Enable	
		CH2 A/D conversion enable...	0: Enable	
		CH3 A/D conversion enable...	0: Enable	
		CH4 A/D conversion enable...	0: Enable	1: Disable

3. Set "CH□ Digital clipping enable/disable setting" to "0: Enable".

<input checked="" type="checkbox"/>	<input type="checkbox"/>	Digital clipping function		
		CH1 Digital clipping enable...	1: Disable	
		CH2 Digital clipping enable...	1: Disable	
		CH3 Digital clipping enable...	1: Disable	0: Enable
		CH4 Digital clipping enable...	1: Disable	1: Disable

(3) Setting example of when both the digital clipping function and scaling function are used

Ex. When the following settings are used for the A/D converter module with input range of 0 to 5V:

- "CH□ Scaling enable/disable setting": "0: Enable"
- "CH□ Scaling upper limit value": 24000
- "CH□ Scaling lower limit value": 0
- "CH□ Digital clipping enable/disable setting": "0: Enable"

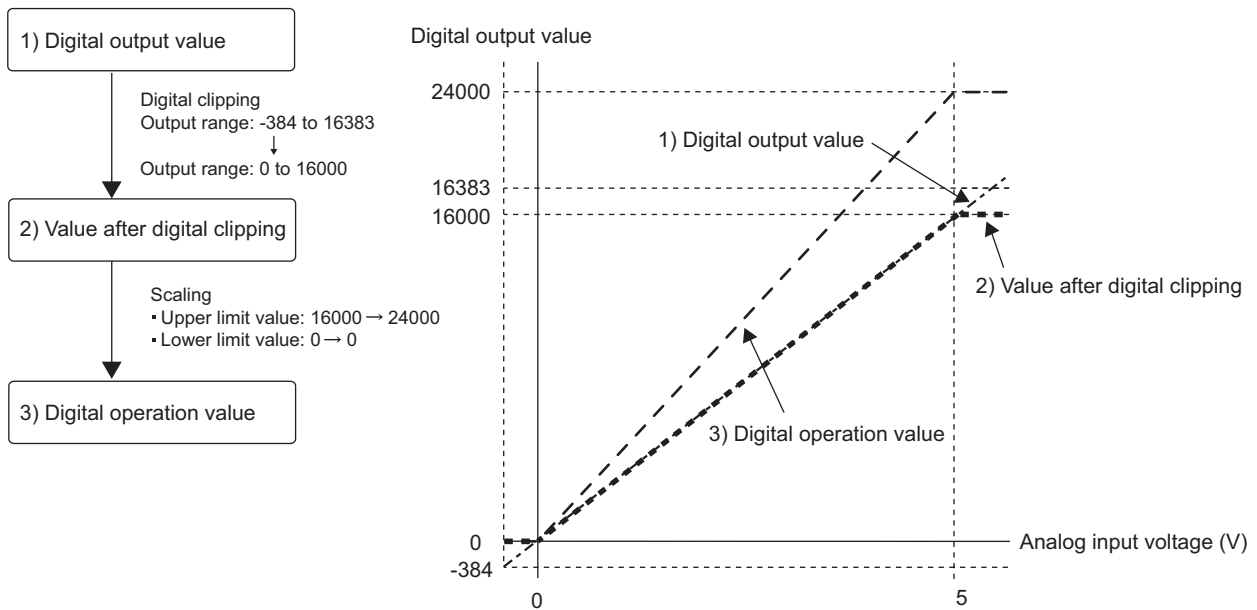

Input voltage (V)	Digital output value	Digital operation value
-0.12	-384	0
0	0	0
1	3200	4800
2	6400	9600
3	9600	14400
4	12800	19200
5	16000	24000
5.12	16383	24000

1. Set "Parameter write" for "Method selection".

- ⇒ "CC IE Field Configuration" window ⇒ Select an A/D converter module in "List of stations".
- ⇒ [CC IE Field Configuration] ⇒ [Online] ⇒ [Parameter Processing of Slave Station]

2. Set "CH□ A/D conversion enable/disable setting" to "0: Enable".

<input checked="" type="checkbox"/>	A/D conversion enable/disable...		
<input type="checkbox"/>	CH1 A/D conversion enabl...	0: Enable	
<input type="checkbox"/>	CH2 A/D conversion enabl...	0: Enable	
<input type="checkbox"/>	CH3 A/D conversion enabl...	0: Enable	0: Enable
<input type="checkbox"/>	CH4 A/D conversion enabl...	0: Enable	1: Disable

3. Set "CH□ Scaling enable/disable setting" to "0: Enable".

<input checked="" type="checkbox"/>	Scaling function			
	CH1 Scaling enable/disable...	1: Disable		
	CH1 Scaling upper limit va...	0		
	CH1 Scaling lower limit va...	0		0: Enable
	CH2 Scaling enable/disable...	1: Disable		1: Disable

4. Set values for "CH□ Scaling upper limit value" and "CH□ Scaling lower limit value".

<input checked="" type="checkbox"/>	Scaling function			
	CH1 Scaling enable/disable...	1: Disable		0: Enable
	CH1 Scaling upper limit va...	0		24000
	CH1 Scaling lower limit va...	0		0

5. Set "CH□ Digital clipping enable/disable setting" to "0: Enable".

<input checked="" type="checkbox"/>	Digital clipping function			
	CH1 Digital clipping enable...	1: Disable		
	CH2 Digital clipping enable...	1: Disable		
	CH3 Digital clipping enable...	1: Disable		0: Enable
	CH4 Digital clipping enable...	1: Disable		1: Disable

(4) Setting example of when the digital clipping function, scaling function, and shift function are used together

Ex. When the following settings are used for the A/D converter module with input range of 0 to 5V:

- "CH□ Scaling enable/disable setting": "0: Enable"
- "CH□ Scaling upper limit value": 12000
- "CH□ Scaling lower limit value": 2000
- "CH□ Digital clipping enable/disable setting": "0: Enable"
- CH□ Shifting amount to conversion value (RWw2 to RWw5): 2000

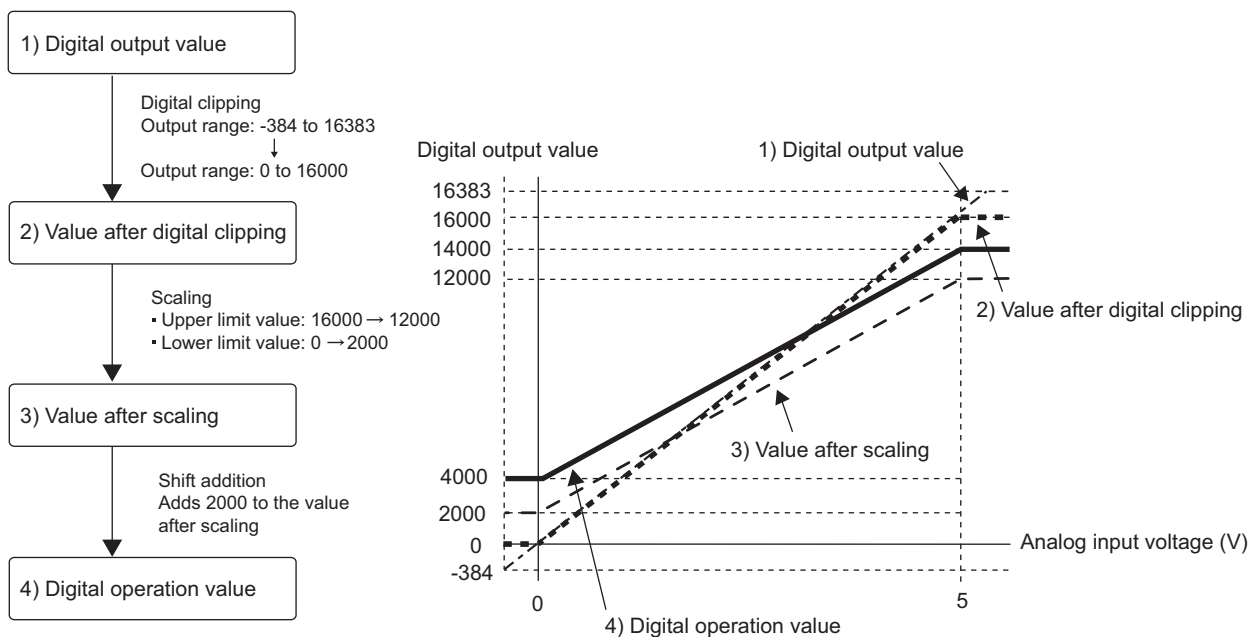

Input voltage (V)	Digital output value	Digital operation value
-0.12	-384	4000
0	0	4000
1	3200	6000
2	6400	8000
3	9600	10000
4	12800	12000
5	16000	14000
5.12	16383	14000

1. Set "Parameter write" for "Method selection".

- ⇒ "CC IE Field Configuration" window ⇒ Select an A/D converter module in "List of stations".
- ⇒ [CC IE Field Configuration] ⇒ [Online] ⇒ [Parameter Processing of Slave Station]

2. Set "CH□ A/D conversion enable/disable setting" to "0: Enable".

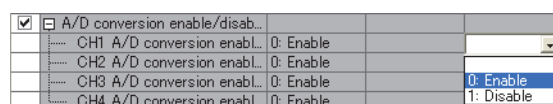

3. Set "CH□ Scaling enable/disable setting" to "0: Enable".

<input checked="" type="checkbox"/>	Scaling function			
	CH1 Scaling enable/disabl...	1: Disable		
	CH1 Scaling upper limit va...	0		
	CH1 Scaling lower limit va...	0		0: Enable
	CH2 Scaling enable/disabl...	1: Disable		1: Disable

4. Set values for "CH□ Scaling upper limit value" and "CH□ Scaling lower limit value".

<input checked="" type="checkbox"/>	Scaling function			
	CH1 Scaling enable/disabl...	1: Disable		0: Enable
	CH1 Scaling upper limit va...	0		12000
	CH1 Scaling lower limit va...	0		2000

5. Set "CH□ Digital clipping enable/disable setting" to "0: Enable".

<input checked="" type="checkbox"/>	Digital clipping function			
	CH1 Digital clipping enable...	1: Disable		
	CH2 Digital clipping enable...	1: Disable		
	CH3 Digital clipping enable...	1: Disable		0: Enable
	CH4 Digital clipping enable...	1: Disable		1: Disable

6. Set "2000" for CH□ Shifting amount to conversion value (RWw2 to RWw5).

Point

When the digital clipping function is used with the scaling function, shift function, and difference conversion function, the scale conversion, shift addition, and difference conversion are executed on the value after digital clipping.

8.14 Difference Conversion Function

The digital operation value at the start of this function is treated as "0" (reference value). Thereafter, the difference between the actual digital operation value and the reference value is stored as the digital operation value.

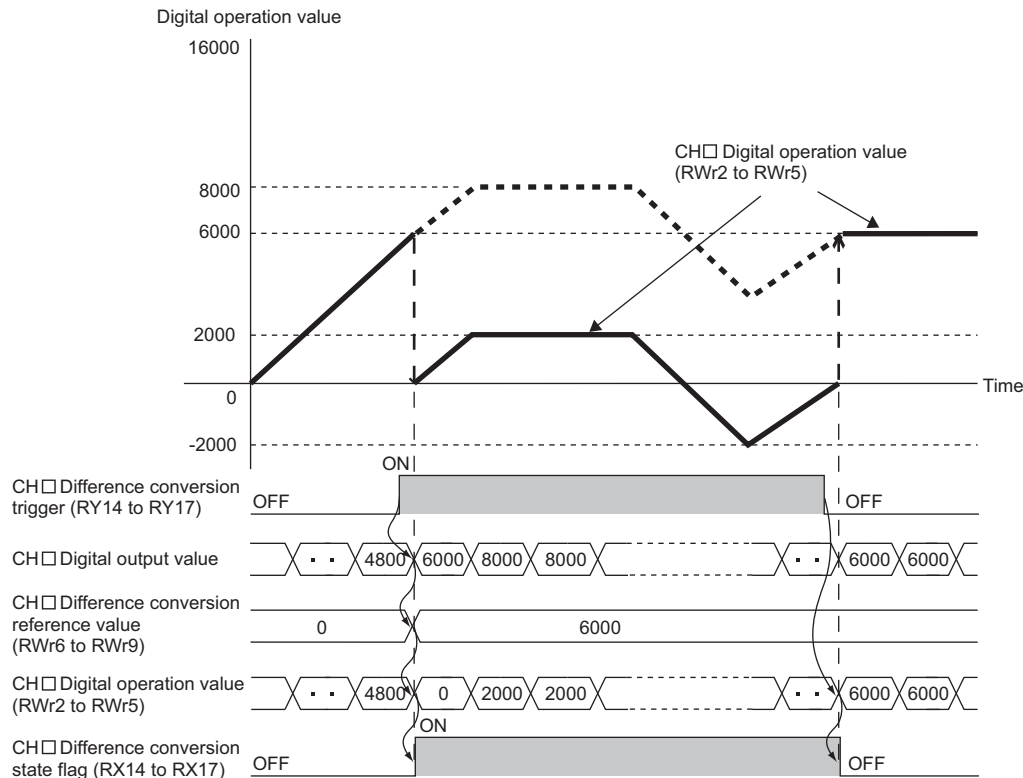

(1) Operation of the difference conversion function

When the difference conversion starts, the digital operation value at that time (the data stored inside the A/D converter module before difference conversion) is determined as the difference conversion reference value. The value acquired by subtracting the difference conversion reference value from the digital operation value is stored in CH□ Digital operation value (RWr2 to RWr5). CH□ Digital operation value (RWr2 to RWr5) at the start of this function is "0" (because the digital operation value equals to the difference conversion reference value at the start).

$$\text{Digital operation value after difference conversion} = \text{Digital operation value} - \text{Difference conversion reference value}$$

(2) How to use difference conversion

(a) Starting difference conversion

1. Change CH□ Difference conversion trigger (RY14 to RY17) from No request (OFF) to Trigger request (ON).

The rise of No request (OFF) to Trigger request (ON) is detected as a trigger. When the trigger is detected, the digital operation value at the start is output to CH□ Difference conversion reference value (RWr6 to RWr9). The value acquired by subtracting the difference conversion reference value from the digital operation value is stored in CH□ Digital operation value (RWr2 to RWr5). After the value is stored, CH□ Difference conversion state flag (RX14 to RX17) changes to Converting difference (ON).

(b) Stopping difference conversion

1. Change CH□ Difference conversion trigger (RY14 to RY17) from Trigger request (ON) to No request (OFF).

When the buffer memory value is changed as above, the difference conversion stops, and CH□ Difference conversion state flag (RX14 to RX17) changes to Not converted (OFF). After that, the digital output value is stored in CH□ Digital operation value (RWr2 to RWr5).

(3) Points for the use of the difference conversion function

(a) Operation of when an input signal error occurs

While an input signal error is occurring, even if Difference conversion trigger (RY14 to RY17) is turned from No request (OFF) to Trigger request (ON), the difference conversion does not start. After the analog input value returns within the setting range, turn CH□ Difference conversion trigger (RY14 to RY17) from No request (OFF) to Trigger request (ON) again. If an input signal error occurs in the status of Trigger request (ON), the difference conversion starts just when the analog input value returns within the setting value, treating the digital output value as the difference conversion reference value.

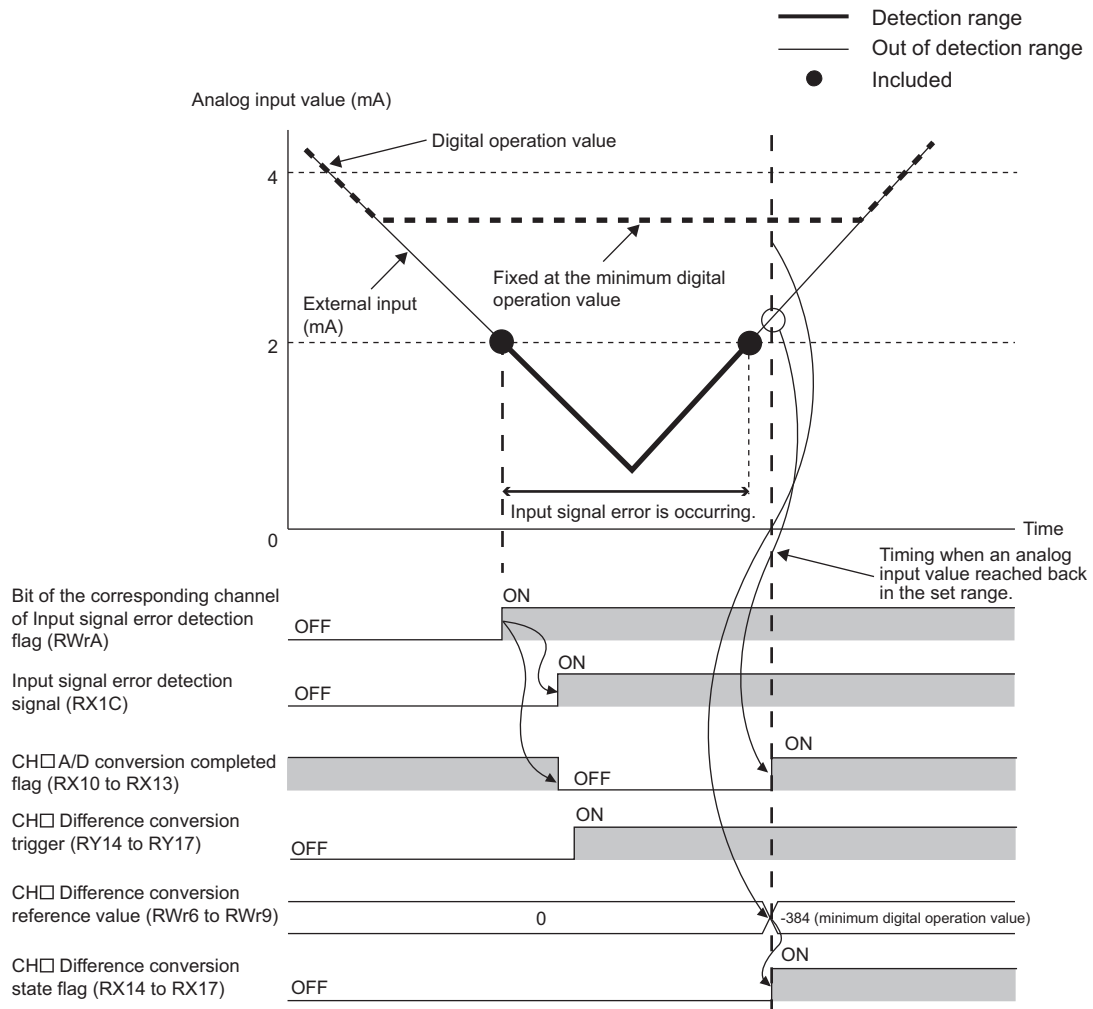

(b) Operation of when Initial data setting request flag (RY9) is switched

- During the difference conversion, even if Initial data setting request flag (RY9) is turned on and off, the difference conversion continues without updating the difference conversion reference value. At this time, even if the digital clipping function, scaling function, and shift function are set valid, the difference conversion reference value is not updated.

To update the difference conversion reference value, restart the difference conversion by changing CH□ Difference conversion trigger (RY14 to RY17) from No request (OFF) to Trigger request (ON) again.

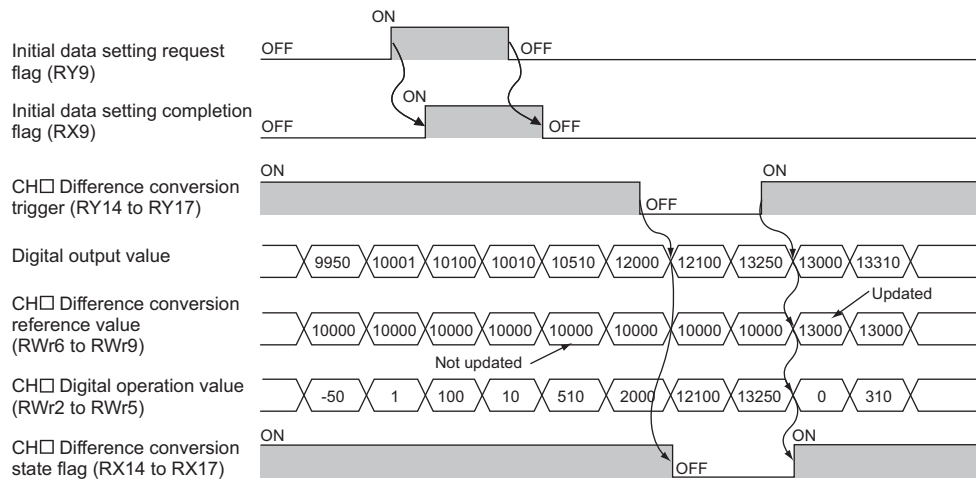

- If CH□ Difference conversion trigger (RY14 to RY17) is turned from No request (OFF) to Trigger request (ON) before CH□ A/D conversion completed flag (RX10 to RX13) turns on after Initial data setting request flag (RY9) is turned on, the digital operation value of when CH□ A/D conversion completed flag (RX10 to RX13) is turned on is determined as the difference conversion reference value.

(c) Operation of the maximum value and the minimum value

When the difference conversion starts, the maximum value and the minimum value of the values acquired by the difference conversion are stored in CH□ Maximum value and CH□ Minimum value. By turning on Maximum value/minimum value reset request (RY1D), the maximum value and the minimum value after the start of the difference conversion can be checked. If Maximum value/minimum value reset request (RY1D) is not turned on, the maximum values and minimum values before and after the difference conversion are mixed up.

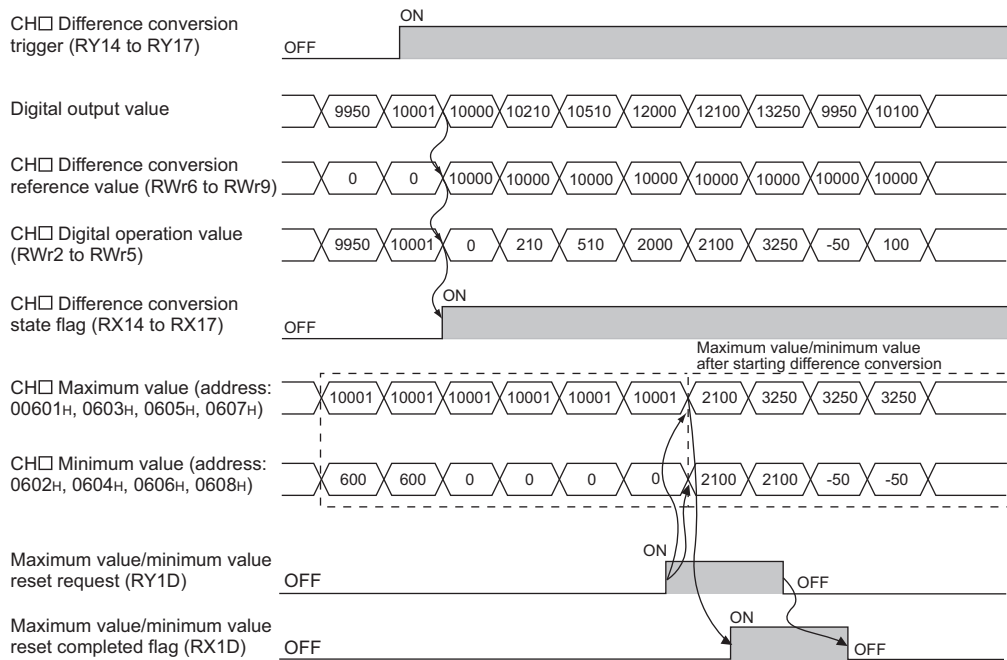

(d) Operation of when the averaging processing is set

If the difference conversion starts while the averaging processing is set, the digital output value at the completion of the averaging processing is determined as the difference conversion reference value. In addition, CH□ Difference conversion state flag (RX14 to RX17) changes to Converting difference (ON).

Point

- The difference conversion function can be started at any timing.
- When the difference conversion function is used with the digital clipping function, scaling function, and shift function, each processed digital operation value is determined as a difference conversion reference value.

8.15 Trigger Conversion Function

By using this function, the A/D converter module performs the A/D conversion according to the input of Trigger conversion request.

Point

- This function can be used only when the drive mode is set to the trigger conversion mode.
- The A/D converter module converts analog values into digital values in all the channels where the A/D conversion is enabled, every time Trigger conversion request (RY19) is turned on.

(1) Combination with the external signal assignment function

Using this function with the external signal assignment function enables the A/D conversion by the trigger conversion request at when the remote input signal is turned on from off on the extension input module.

For the external signal assignment function, refer to the following.

- External signal assignment function (☞ Page 131, Section 8.18 (3))

Point

An extension input module is required when the trigger conversion function is used with the external signal assignment function.

(2) Restrictions

The following table lists the restrictions on the trigger conversion function.

Function name	Restrictions
Averaging processing	Performs the sampling processing. The setting of "Averaging process setting" will be ignored.
Conversion speed switch function	Operates at the conversion speed of 400μs/channel. The setting of "Conversion speed switch" will be ignored. For the conversion timing, refer to the following. • (☞ Page 116, Section 8.15 (3))
Shift function	Cannot be used. The setting of CH□ Shifting amount to conversion value (RWw2 to RWw5) will be ignored.
Difference conversion function	Cannot be used. Turning on CH□ Difference conversion trigger (RY14 to RY17) does not start the difference conversion.

(3) Operation of the trigger conversion function

After the A/D conversion-enabled channel is set and Initial data setting request flag (RY9) is turned on and off, the A/D converter module waits for trigger input.

Once Trigger conversion request (RY19) is turned on from off, the A/D converter module performs the A/D conversion for all the channels where the A/D conversion is enabled.

Ex. The following figure shows the operation until Trigger conversion completed flag (RX19) turns on from off after Trigger conversion request (RY19) is turned on from off under the condition below.

- A/D conversion enabled: CH1, CH2, CH3, CH4

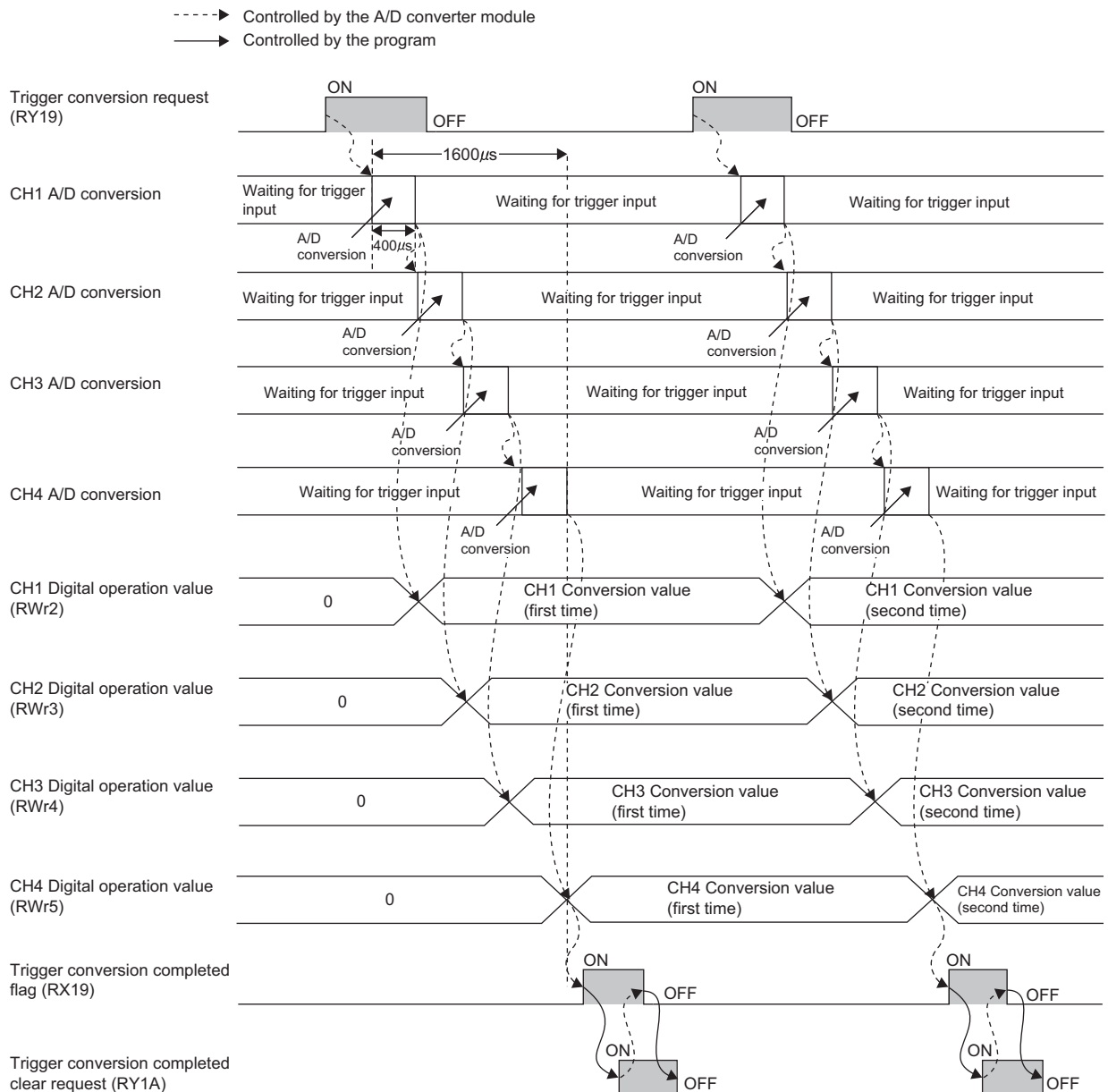

(4) From the start of the trigger conversion to the completion

Set Mode switch (address: 0000_H) to Trigger conversion mode (1_H).

When Initial data setting request flag (RY9) is turned on and off, "0920_H" is stored to Latest warning code (RWr1).

After the module is turned off and on, the A/D converter module results in the following state and waits for trigger input.

- Trigger conversion completed flag (RX19) turns off.
- CH□ A/D conversion completed flag (RX10 to RX13) turns off.

The following figure shows the operation until the A/D conversion is completed after Trigger conversion request (RY19) is turned on from off.

When Trigger conversion request (RY19) is turned on from off, the A/D converter module performs the A/D conversion. When the A/D conversion is completed, Trigger conversion completed flag (RX19) turns on from off.

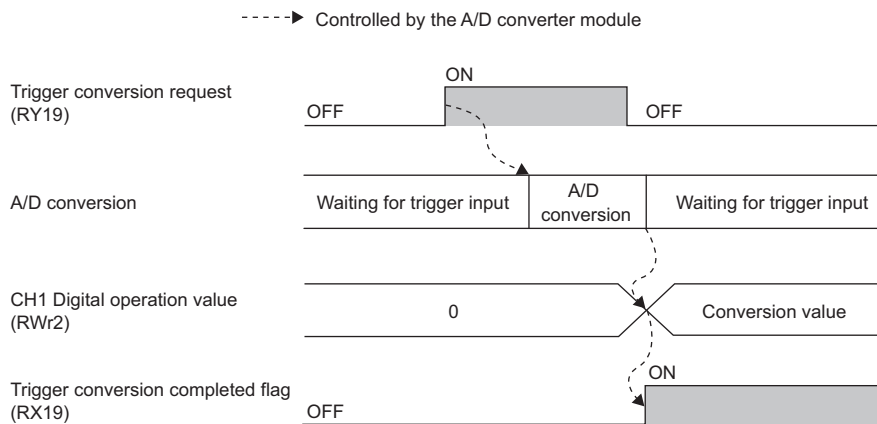

Point

After the trigger conversion starts, each CH□ A/D conversion completed flag (RX10 to RX13) begins to turn on when the corresponding channel completes its A/D conversion.

After turning on, CH□ A/D conversion completed flag (RX10 to RX13) turns off in the following conditions.

- Turning on Initial data setting request flag (RY9)
- Detection of the input signal error

(5) Trigger conversion clear request

The following describes the trigger conversion clear request.

(a) Trigger conversion clear request

The following figure shows the operation where Trigger conversion completed flag (RX19) turns off from on by turning Trigger conversion completed clear request (RY1A) on from off.

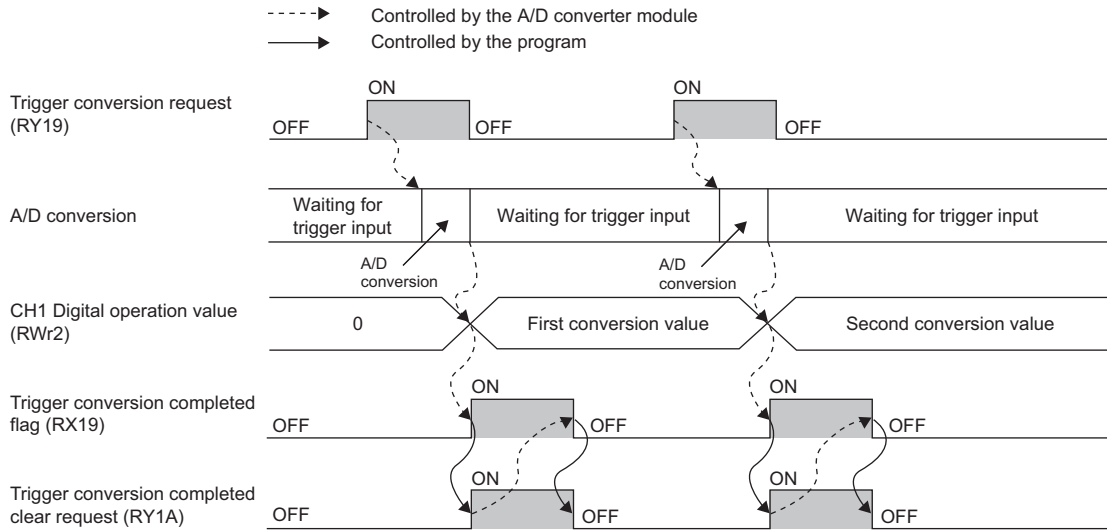

Even when Trigger conversion completed clear request (RY1A) is turned on from off while Trigger conversion completed flag (RX19) is on, the A/D converter module accepts the trigger conversion request and the digital operation value is updated.

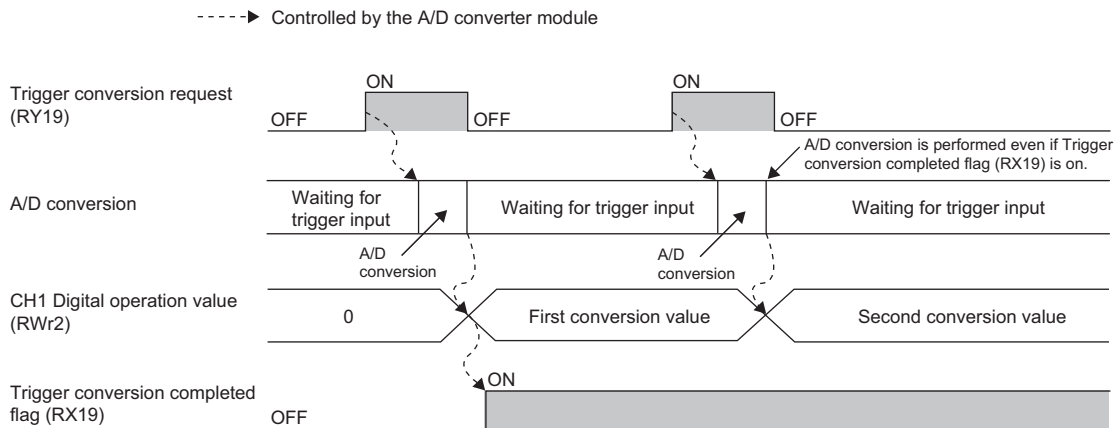

(b) Method for Trigger conversion completed clear request

The time until Trigger conversion completed flag (RX19) turns off from on by Trigger conversion completed clear request (RY1A) depends on the sequence scan time and the link scan time.

To use Trigger conversion completed flag (RX19) as an interlock, turn on from off Trigger conversion request (RY19) after Trigger conversion completed flag (RX19) turns off from on.

Remark

Turning on Trigger conversion completed clear request (RY1A) does not clear CH□ A/D conversion completed flag (RX10 to RX13). To clear CH□ A/D conversion completed flag (RX10 to RX13), turn on Initial data setting request flag (RY9).

(6) Response time

The following describes the response time until Trigger conversion completed flag (RX19) turns on from off after the trigger conversion is requested.



(a) When Trigger conversion request (RY19) is assigned to Remote input (RX) using the external signal assignment function

$(\text{Response time of the A/D converter module})^{*1} + (\text{Response time of the extension input module})^{*2}$ [ms]

- *1 The response time of the A/D converter module is calculated as shown below.
(Number of the channels for which A/D conversion is enabled) × 0.4 [ms]
- *2 The response time of the extension input module is the minimum time period from an input into the module to the notification of the input to the A/D conversion module. The response time of the extension input module is calculated as shown below.
(Input response time setting) + 0.5 [ms]

(b) When Trigger conversion request (RY19) is not assigned to Remote input (RX) using the external signal assignment function

$SM^{*1} + LS^{*2} + (\text{Response time of the A/D converter module})^{*3}$ [ms]

- *1 SM: Sequence scan time [ms] ( User's manual for the CPU module used in the master station)
- *2 LS: Link scan time [ms] ( User's manual for the master/local module used)
- *3 The response time of the A/D converter module is calculated as shown below.
(Number of the channels for which A/D conversion is enabled) × 0.4 [ms]

(7) Input interval and the ON and OFF time of the trigger conversion request

When turning on Trigger conversion request, turn on or off Trigger conversion request satisfying the reference values of the following items.

- Input interval of the trigger conversion request
- ON time of the trigger conversion request
- OFF time of the trigger conversion request

(a) When Trigger conversion request (RY19) is assigned to Remote input (RX) using the external signal assignment function

The following table lists the input interval, ON time, and OFF time of Remote input (RX) to which Trigger conversion request (RY19) is assigned.

Item	Reference value
Input interval of the trigger conversion request	(Response time of the extension input module) ^{*1} [ms] or longer
ON time of the trigger conversion request	
OFF time of the trigger conversion request	

- *1 The response time of the extension input module is the minimum time period from an input into the module to the notification of the input to the A/D conversion module. The response time of the extension input module is calculated as shown below.
(Input response time setting) + 0.5 [ms]

(b) When Trigger conversion request (RY19) is not assigned to Remote input (RX) using the external signal assignment function

The following table lists the input interval, ON time, and OFF time of Trigger conversion request (RY19).

Item	Reference value
Input interval of the trigger conversion request	SM + LS + 0.2 [ms] or longer*1
ON time of the trigger conversion request	
OFF time of the trigger conversion request	

*1 SM: Sequence scan time [ms] (User's manual for the CPU module used in the master station)
 LS: Link scan time [ms] (User's manual for the master/local module used)

-----> Controlled by the A/D converter module

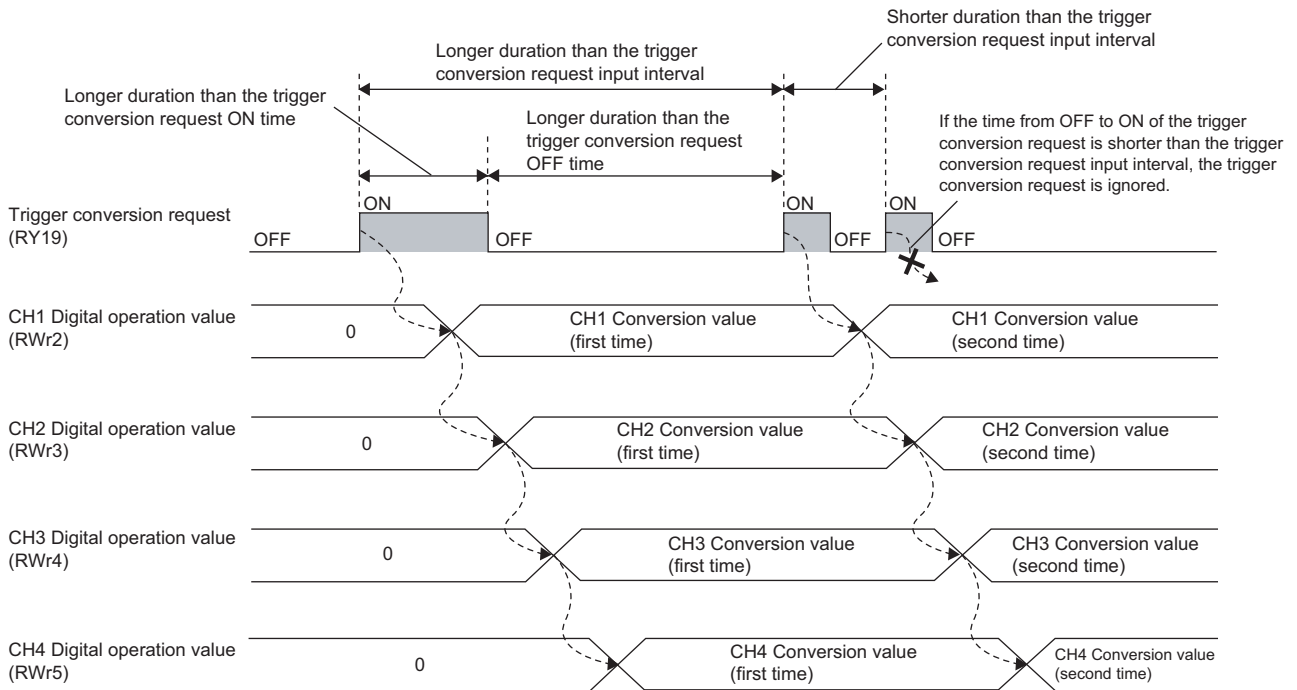

(8) Setting procedure

1. Set "Parameter write" for "Method selection".

☞ "CC IE Field Configuration" window ⇨ Select an A/D converter module in "List of stations".
 ⇨ [CC IE Field Configuration] ⇨ [Online] ⇨ [Parameter Processing of Slave Station]

2. Set "Mode switch" to "1: Trigger conversion mode".

<input checked="" type="checkbox"/>	Mode switch	9: Automatic...		
<input checked="" type="checkbox"/>	Conversion speed setting	0: 400us		
<input checked="" type="checkbox"/>	External signal assignment fu...			0: Normal conversion mode
	Trigger conversion signal a...	0xFFFF		1: Trigger conversion mode
	Test signal error detection	0:FFFF		9: Automatic judgement mode

3. Set "CH□ A/D conversion enable/disable setting" to "0: Enable".

<input checked="" type="checkbox"/>	A/D conversion enable/disable...			
	CH1 A/D conversion enabl...	0: Enable		
	CH2 A/D conversion enabl...	0: Enable		
	CH3 A/D conversion enabl...	0: Enable		0: Enable
	CH4 A/D conversion enabl...	0: Enable		1: Disable

4. Click the button to write the parameter to the A/D converter module.

5. Check that "0920_H" is stored in Latest warning code (RWR1).

☞ [Online] ⇨ [Monitor] ⇨ [Device/Buffer Memory Batch]

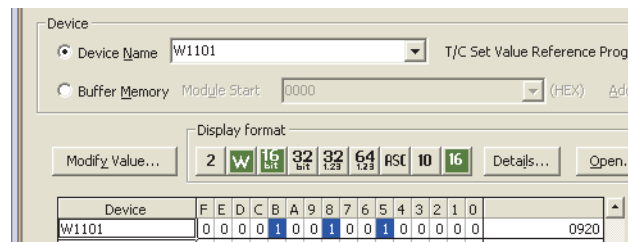

The screenshot shows the "Device" window with "Device Name" set to "W1101". Under "Display Format", the "16 bit" option is selected. The "Details..." button is visible. Below, a table shows the memory contents for device W1101:

Device	F	E	D	C	B	A	9	8	7	6	5	4	3	2	1	0	
W1101	0	0	0	0	1	0	0	1	0	0	1	0	0	0	0	0	0920

6. Turn off and on the module or perform the remote reset to switch the mode of the A/D converter module to the trigger conversion mode.

8.16 CC-Link IE Field Network Synchronous Communication Function

Using this function, the A/D converter module performs the A/D conversion synchronized with the operation cycle of a simple motion module.

This enables the A/D converter module to operate at the same timing of other slave stations on the same network.

Point

This function can be used only when a simple motion module is used for the master station and "Mode switch" is set to "9: Automatical judgment mode".

(1) Applicable module and software

The table below lists modules and software required to use the CC-Link IE Field Network synchronous communication function.

Module and software	Serial number (first five digits)/version of GX Works2
A/D converter module	"15102" or later
Simple motion module	"15092" or later
GX Works2	Version 1.501X or later

(2) Restrictions

This section describes restrictions to use the CC-Link IE Field Network synchronous communication function.

(a) Restrictions to use this function with other functions

Function name	Restrictions
Averaging processing	Cannot be used. The setting of "Averaging process setting" will be ignored.
Conversion speed switch function	Cannot be used. The setting of "Conversion speed switch" will be ignored. The conversion speed of the A/D converter module is synchronized with the operation cycle set in the simple motion module. For the conversion timing, refer to the following. • (Page 124, Section 8.16 (3))
Shift function	Cannot be used. The setting of CH□ Shifting amount to conversion value (RWw2 to RWw5) will be ignored.
Difference conversion function	Cannot be used. Turning on CH□ Difference conversion trigger (RY14 to RY17) does not start the difference conversion.
Extension I/O function	The extension I/O module can be used, but input and output of the extension I/O module is not synchronized with the operation cycle of the simple motion module.
Cyclic data update watch function	The setting of Cyclic data update watch time setting (address: 0007H) will be ignored.

(b) Restrictions on the number of A/D conversion enabled channels

The number of channels where the A/D conversion is enabled vary depending on the operation cycle of the simple motion module.

For details, refer to the following.

(Page 125, Section 8.16 (4))

(c) Restrictions on the network parameter settings (RWw/RWr)

Set the network parameters (RWw/RWr) so that RWwF/RWrF are assigned to use the synchronous communication function.

(3) Operation using the CC-Link IE Field Network synchronous communication function

Every operation cycle of the simple motion module, the A/D conversion is performed for the A/D conversion enabled channels.

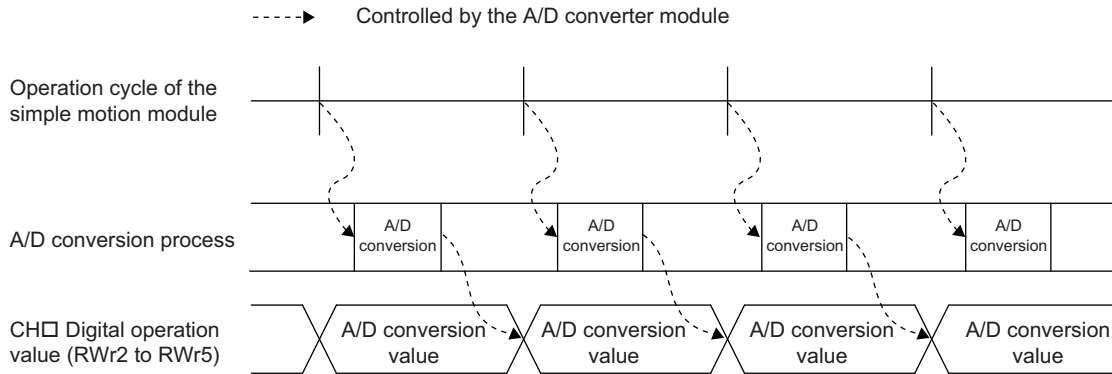

Ex. Operation timing with the following settings

- Operation cycle of the simple motion module: 3.55ms
- Number of A/D conversion enabled channels: 4

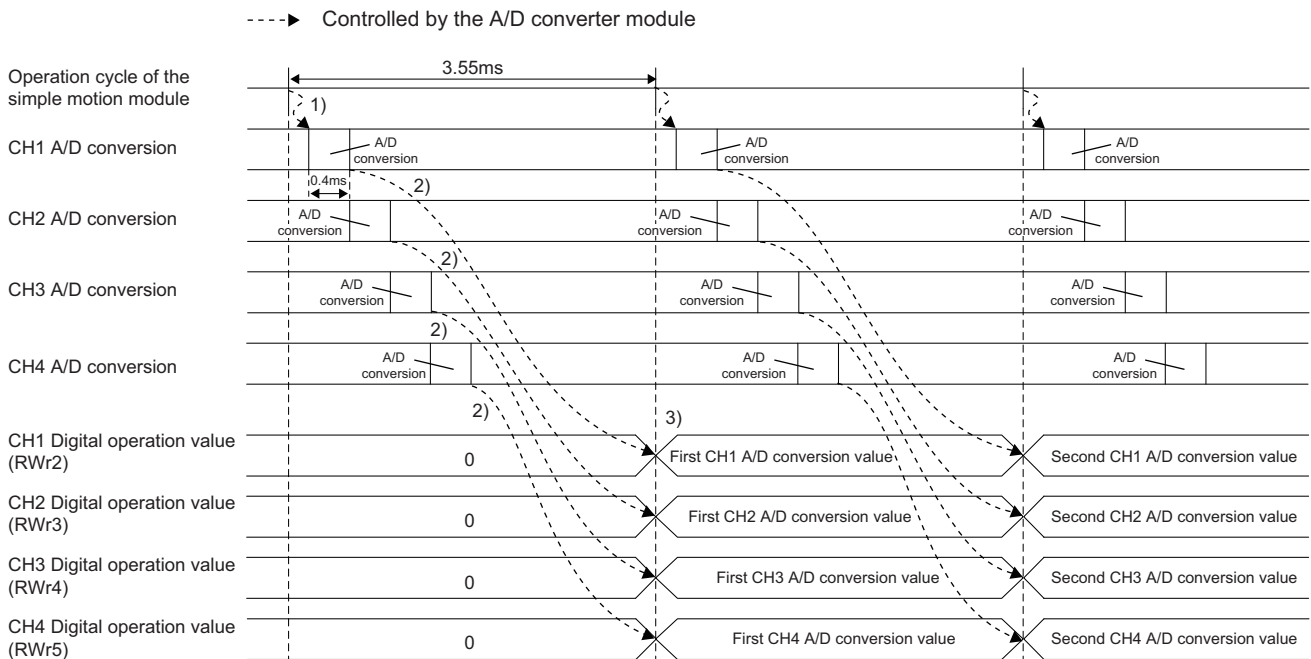

No.	Description
1)	The A/D conversion is started when the operation of the simple motion module shifts to the next cycle.
2)	The A/D conversion is performed for 400µs per channel, from CH1 to CH4.
3)	The converted values are sent to the simple motion module when the operation of the simple motion module shifts to the next cycle.

(a) SB/SW signals used with the CC-Link IE Field Network synchronous communication function

To check the operating status of the A/D converter module (synchronous or asynchronous), use the following link special register (SW) on the master station.

- Synchronous/asynchronous operation status information (each station) (SW01C8 to SW01CF)

For details, refer to the following.

 MELSEC-Q QD77GF Simple Motion Module User's Manual (Network)

When read digital operation values, use the condition of the above mentioned link special register (SW) (the corresponding bit of the register being on) as an interlock.

The following figure shows the program example to read CH1 Digital operation value and CH2 Digital operation value of the A/D converter module with station number 17.



(4) Setting procedure (simple motion module)

1. Set the operation cycle of the simple motion module to any of the following.

- 0.88ms
- 1.77ms
- 3.55ms

For details on the setting procedure, refer to the following.

 MELSEC-Q QD77GF Simple Motion Module User's Manual (Positioning Control)

Point!

Set the operation cycle of the simple motion module and the number of conversion enabled channels of the A/D converter module to meet the following condition.

Operation cycle of simple motion module	Number of conversion enabled channels (maximum)
0.88ms	1
1.77ms	2
3.55ms	4

If the set number of conversion enabled channels does not meet the condition above, the error code (0E40_H) is stored in Latest error code (RWr0), Error flag (RXA) turns on, and the ERR. LED turns on. The A/D conversion is not performed. If an error has occurred (error code: 0E40_H) during operation, the A/D conversion is stopped.

(5) Setting procedure (A/D converter module)

1. Select an A/D converter module in "List of stations" on the "CC IE Field Configuration" window, and set the values as follows.
 - Set 17 or larger number in "STA#".
 - Set 32 in "Points" of "RX/Ry Setting".
 - Set 16 in "Points" of "RWw/RWr Setting".
2. Display the "Parameter Processing of Slave Station" window and set "Parameter write" for "Method selection".

☞ "CC IE Field Configuration" window ⇨ Select an A/D converter module in "List of stations".
 ⇨ [CC IE Field Configuration] ⇨ [Online] ⇨ [Parameter Processing of Slave Station]

3. Set "Mode switch" to "9: Automatical judgment mode".

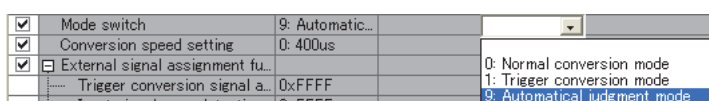

4. Set "CH□ A/D conversion enable/disable setting" to "0: Enable".

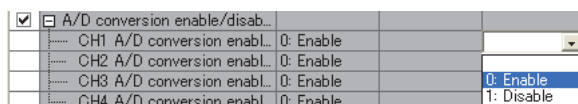

5. Click the **Execute** button to write the parameter to the A/D converter module.
6. Check that "0920_H" is stored in Latest warning code (RWr1).

☞ [Online] ⇨ [Monitor] ⇨ [Device/Buffer Memory Batch]

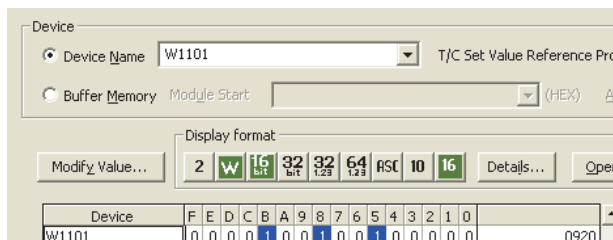

7. The A/D converter module starts operating in the synchronous communication mode by turning off and on the power or performing the remote reset.

8.17 Error Notification Function

When an error, warning, or alarm occurs, the A/D converter module notifies the master station of it using remote input signals and remote registers.

Remark

The notification of the error, warning, or alarm can be checked on the LED on the front of the module.
For details, refer to the following.

- PART NAMES (☞ Page 20, CHAPTER 2)

(1) Notification of an error

The A/D converter module notifies the master station of an error in the following method.

Item	Description	Reference
Error flag (RXA)	Turns on when a moderate error or major error occurs.	Page 170, Appendix 1.1 (3)
Latest error code (RWr0)	An error code is stored when a moderate error or major error occurs.	Page 177, Appendix 2 (1)

(a) Method for clearing an error

The method for clearing an error depends on the error type.

Error type	Clearing an error
Major error	The error cannot be cleared.
Moderate error	Turn on Error clear request flag (RYA) or Initial data setting request flag (RY9) after removing the error cause.

(2) Notification of a warning or alarm

The A/D converter module notifies that a warning or alarm occurs to the master station in the following method.

Item	Description	Reference
Warning flag (RX7)	Turns on when a minor error occurs.	Page 168, Appendix 1.1 (1)
Latest warning code (RWr1)	The error code or alarm code is stored when a minor error occurs.	Page 177, Appendix 2 (2)

(a) Method for clearing a warning or alarm

The method for clearing an error depends on the error type.

Error type		Clearing an error	
Minor error	Warning	A warning is cleared five seconds after the error cause is removed.*1	
	Alarm	Input signal error detection*2	Turn on Error clear request flag (RYA) or Initial data setting request flag (RY9) after the analog input value is out of the disconnection detection condition.
		Alert output	The error is automatically cleared when the digital operation value returns within the set range between the process alarm upper lower limit value and the process alarm lower upper limit value.

*1 A warning results in the following state five seconds after the error cause is removed.

- Warning flag (RX7) turns off.
- Latest warning code (RWr1) is cleared.
- The ERR. LED turns off.

*2 The error of the input signal error detection is not automatically cleared. Latest warning code (RWr1) is cleared when the other minor errors are cleared while an input signal error occurs.

The warning codes can be checked in the error history on GX Works2. For the error history, refer to the following.

- Checking by executing a command of the slave station (☞ Page 151, Section 11.1 (1))
- Error history □ (address: 0A00_H to 0AEF_H) (☞ Page 194, Appendix 3 (22))

Ex. Operation to clear Station number switch changing error (error code: 0940_H)

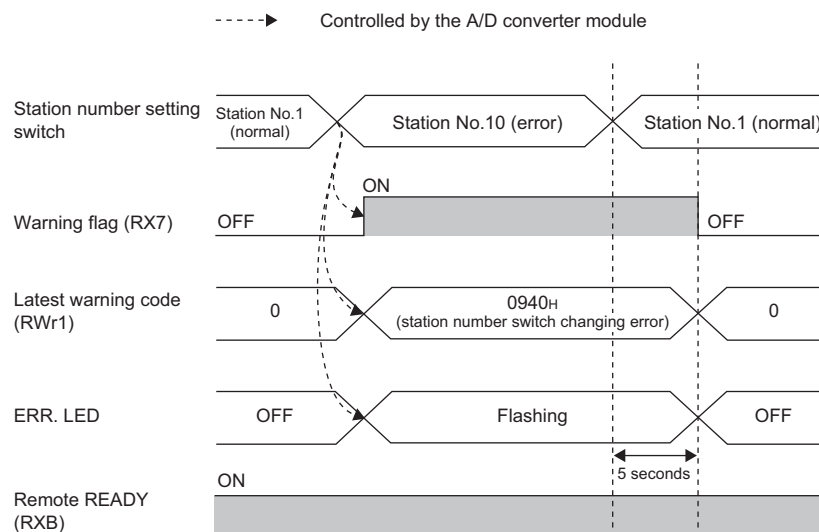

For the method for clearing an alarm, refer to the following.

- Input Signal Error Detection Function (☞ Page 91, Section 8.9)
- Alert Output Function (Process Alarm) (☞ Page 94, Section 8.10)

(3) Method for clearing an error by executing the command of the slave station

The following shows how to clear an error by executing the command of the slave station.

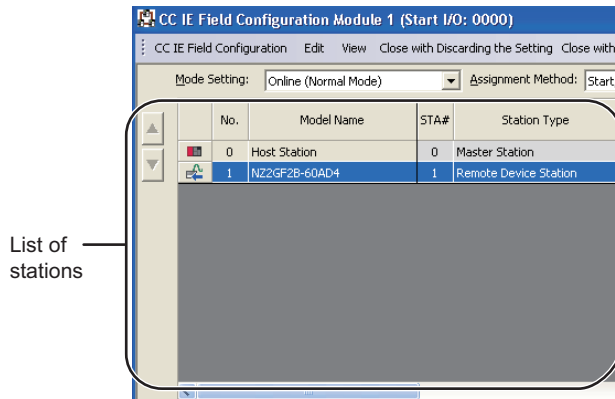

1. Select the A/D converter module in "List of stations" on the "CC IE Field Configuration" window.

2. Open the "Command Execution of Slave Station" window.

 [CC IE Field Configuration] ⇨ [Online] ⇨ [Command Execution of Slave Station]

3. Set "Method selection" to "Error clear request" and click the  button.

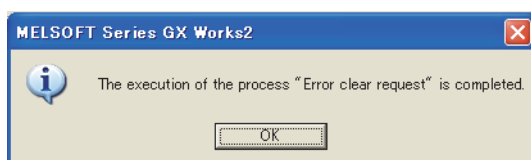
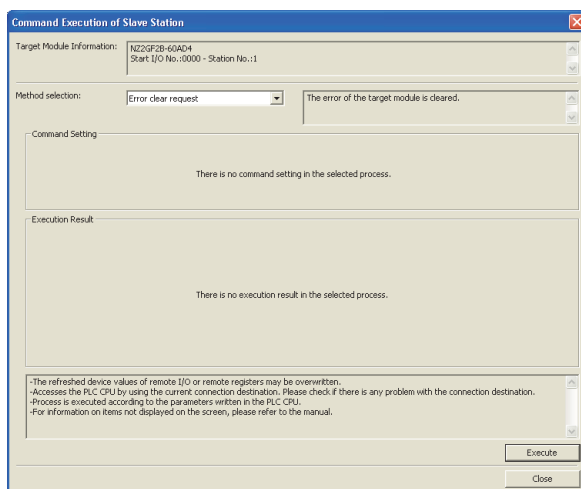

4. When the window shown on the left is displayed, click the  button.

5. The error for the A/D converter module is cleared.

8.18 Function at the Extension Module Installation

An extension I/O module can be connected to the A/D converter module.

Remote I/O signals of the A/D converter module can be assigned to input signals of the connected extension input module or output signals of the connected extension output module. In addition, functions unique to the extension I/O module can be used.

Point

- Turn off the A/D converter module before replacing the extension I/O module. If the extension module is removed when the module power supply is on, the error code (1F00_H) is stored to Latest error code (RWr0), Error flag (RXA) turns on, and the ERR. LED turns on. The main module stops its operation.
- After replacing the extension I/O module, write the parameters again.

(1) Functions available with an extension I/O module connected

Function	Reference
External power supply monitoring function	Page 130, Section 8.18 (2)
External signal assignment function	Page 131, Section 8.18 (3)
Digital output HOLD/CLEAR setting function (Named "Output HOLD/CLEAR setting function" in the I/O module manual.)	CC-Link IE Field Network Remote I/O Module User's Manual
Cyclic data update watch function	
Input response time setting function	
Number of ON times integration function	

(2) External power supply monitoring function

Using this function, the A/D converter module monitors the ON/OFF status of the external power supply and shows it with the I/O PW LED on the extension I/O module.

By using External power supply monitor request flag (RY1F), a moderate error is generated when the external power supply is off. Thus, the ON/OFF status of the external power supply is notified and the extension output module can be stopped.

(a) External power supply monitoring function

When the external power supply is turned off with External power supply monitor request flag (RY1F) on, a moderate error occurs. When using this function, check that the external power supply stabilizes before turning on External power supply monitor request flag (RY1F). When turning off the external power supply, turn off External power supply monitor request flag (RY1F) in advance.

(b) Setting and checking the external power supply monitoring function

Item	Description	Reference
External power supply monitor request flag (RY1F)	Set whether to enable or disable the external power supply monitoring function.	Page 176, Appendix 1.2 (7)
External power supply monitor state flag (RX1F)	Indicates whether the external power supply monitoring function is enabled or disabled.	Page 174, Appendix 1.1 (11)

(3) External signal assignment function

Remote input signals or remote output signals of the A/D converter module can be assigned to remote I/O signals of the connected extension I/O module. Signals can be input from the extension I/O module and error signals can be output to the external at the fixed timing without influence from the sequence scan or link scan.

Target remote I/O signal of external signal assignment	Buffer memory to be set
Trigger conversion request (RY19)	"Trigger conversion signal assignment"
Input signal error detection signal (RX1C)	"Input signal error detection signal assignment"
Alert output signal (RX18)	"Alert output signal assignment"
Error flag (RXA)	"Error flag assignment"
Warning flag (RX7)	"Warning flag assignment"

(a) Operation of the external signal assignment function

Ex. 1: When Trigger conversion request (RY19) of the A/D converter module is assigned to RX2E of the extension input module

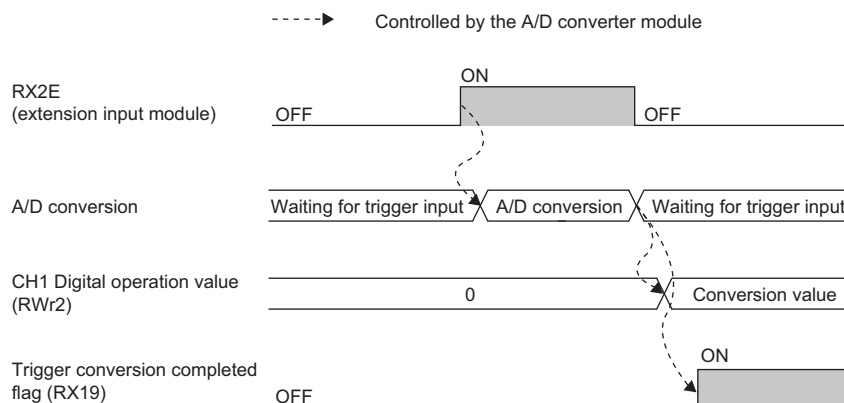
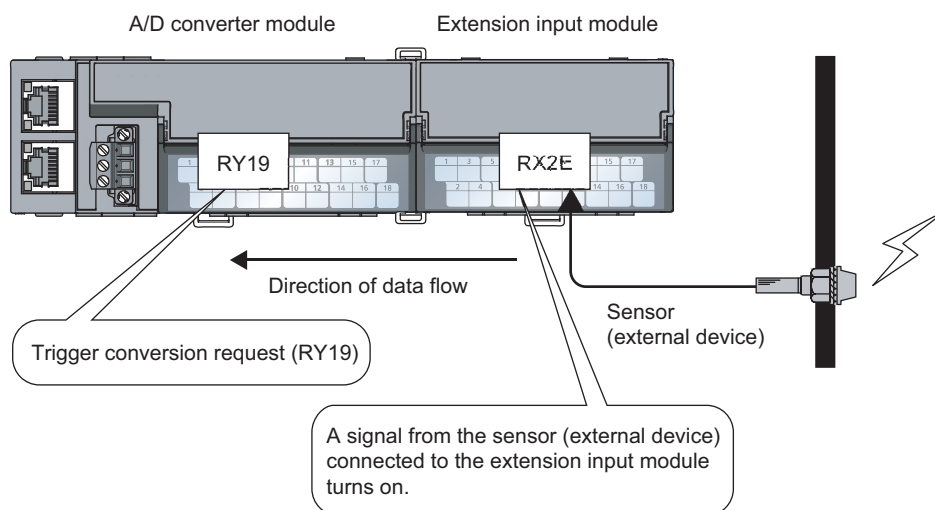

Point

When a remote output signal of the main module is assigned to a remote input signal of the extension input module, the remote output signal before assignment cannot be turned on/off or monitored using the program. Change or monitor the assigned remote input signal of the extension input module. (In the above example, change or monitor RX2E.)

Ex. 2: When Alert output signal (RX18) of the A/D converter module is assigned to RY2A of the extension output module

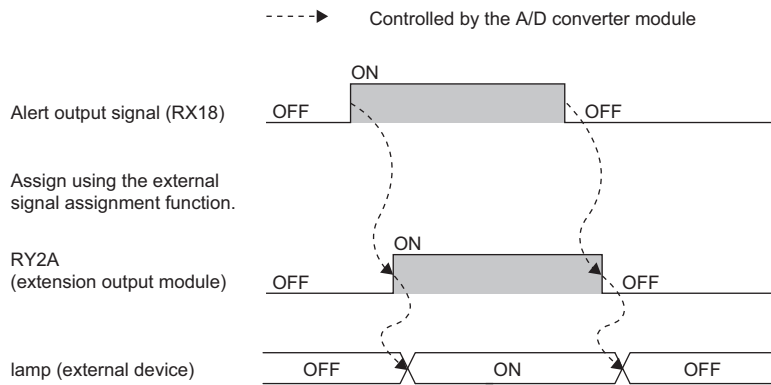
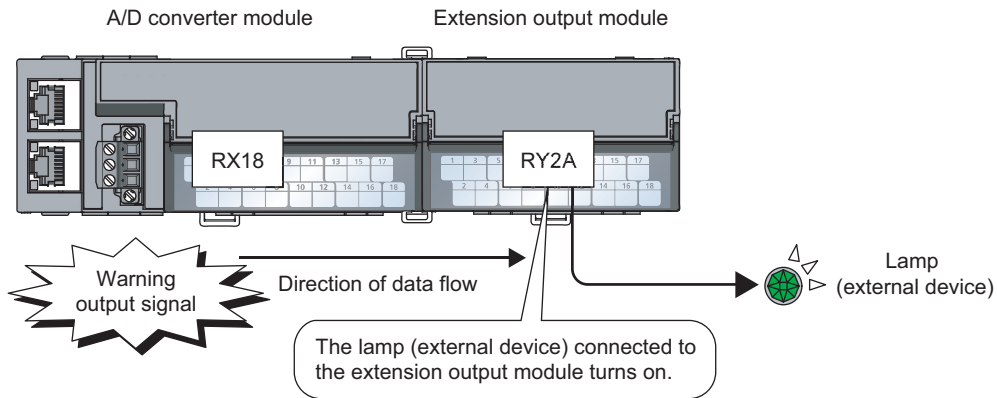

Point

When a remote input signal of the main module is assigned to a remote output signal of the extension output module, the assigned remote output signal cannot be turned on/off or monitored using the program. Change or monitor the remote input signal before assignment of the main module. (In the above example, change or monitor Alert output signal (RX18).)

(b) Setting procedure

Ex. When setting the assignment explained in the previous page

1. Set "Parameter write" for "Method selection".

 "CC IE Field Configuration" window ⇒ Select an A/D converter module in "List of stations".

⇒ [CC IE Field Configuration] ⇒ [Online] ⇒ [Parameter Processing of Slave Station]

2. Set "CH□ A/D conversion enable/disable setting" to "0: Enable".

<input checked="" type="checkbox"/>	A/D conversion enable/disable...			
	CH1 A/D conversion enabl...	0: Enable		
	CH2 A/D conversion enabl...	0: Enable		
	CH3 A/D conversion enabl...	0: Enable		0: Enable
	CH4 A/D conversion enabl...	0: Enable		1: Disable

3. Set "CH□ Alert output setting" to "0: Enable".

<input checked="" type="checkbox"/>	Alert output function			
	CH1 Alert output setting	1: Disable		
	CH1 Process alarm upper ...	0		
	CH1 Process alarm upper L...	0		0: Enable
	CH1 Process alarm lower ...	0		1: Disable

4. Specify the values for "CH□ Process alarm upper upper limit value", "CH□ Process alarm upper lower limit value", "CH□ Process alarm lower upper limit value", and "CH□ Process alarm lower lower limit value".

<input checked="" type="checkbox"/>	Alert output function			
	CH1 Alert output setting	1: Disable		0: Enable
	CH1 Process alarm upper ...	0		16000
	CH1 Process alarm upper L...	0		10000
	CH1 Process alarm lower ...	0		3000
	CH1 Process alarm lower L...	0		0

5. Set 0x002A ("2A" of RY2A) for "Alert output signal assignment".

<input checked="" type="checkbox"/>	External signal assignment fu...			
	Trigger conversion signal a...	0xFFFF		
	Input signal error detection...	0xFFFF		
	Alert output signal assign...	0xFFFF		0x002A

Point 

- Signals other than remote I/O signals assigned to the external module cannot be set with the external signal assignment function.
If the above is set, the error code (017△_H) is stored in Latest error code (RW_r0), Error flag (RXA) turns on, and the ERR. LED turns on.
- Multiple remote I/O signals of the main module cannot be assigned to a remote output signal of the extension module.
If the above is set, the error code (0180_H) is stored in Latest error code (RW_r0), Error flag (RXA) turns on, and the ERR. LED turns on.
- The external signal assignment function cannot be used together with the digital output HOLD/CLEAR function.
When "Digital output HOLD/CLEAR setting" is set to "1: HOLD", the setting is ignored and the A/D converter module operates with "0: CLEAR" set.

(c) Operation of when an error occurs

Depending on whether the remote I/O signals of the extension I/O module are used as general-purpose I/O signals or assigned for the external signal assignment function, the operation of the A/D converter module for an error differs as shown in the following table.

Remote I/O signal		Remote input (RX)		Remote output (RY)			
Digital output HOLD/CLEAR setting function		-		CLEAR		HOLD	
External signal assignment function		Not assigned	Assigned	Not assigned	Assigned	Not assigned	Assigned* ¹
Status of the A/D converter module	Minor error	Same as the normal operation		Same as the normal operation		Same as the normal operation	
	Moderate error	Clear	Same as the normal operation	Clear	Same as the normal operation	Clear	Same as the normal operation
	Major error	Clear		Clear		Clear	
	Disconnecting or CPU STOP	Clear	Same as the normal operation	Clear	Same as the normal operation	Hold* ²	Same as the normal operation

*1 When the external signal assignment function is used, the operation of the A/D converter module is the same as that of when the CLEAR is set for the digital output HOLD/CLEAR setting function, even if HOLD is set.

*2 When "HOLD" is set to Digital output HOLD/CLEAR setting, the Y signal of an extension digital output module is held at the time of disconnection or CPU module STOP.

When different types of errors occur, an error is received in the following priority order.

- Major error > Moderate error > Minor error > the error at the time of Disconnecting or CPU STOP

8.19 CC-Link IE Field Network Diagnostic Function

With this function, whether any network error occurs or not can be checked through GX Works2 connected to the CPU module.

(1) How to use

1. Connect GX Works2 to the CPU module.
2. Start CC-Link IE Field Network diagnostics from the menu of GX Works2.

 [Diagnostics] ⇨ [CC IE Field Diagnostics]

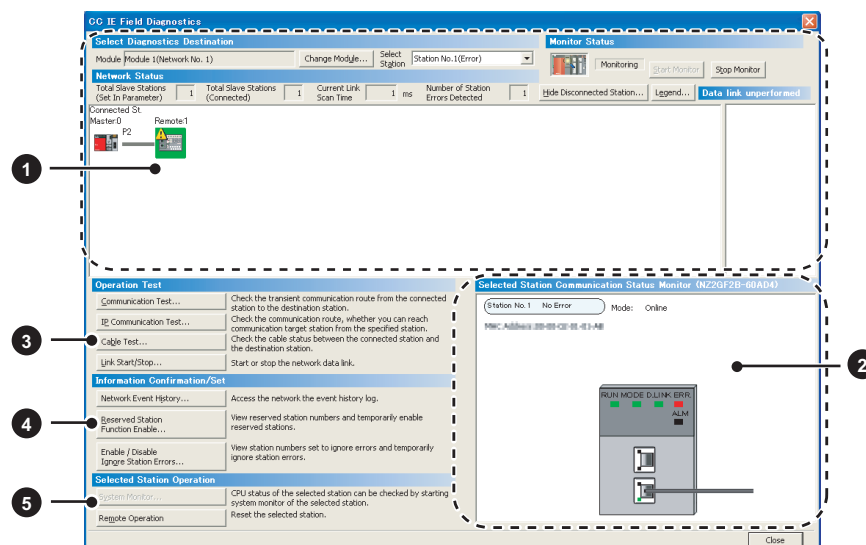



Item to be diagnosed	Description	Reference
① Display of network configuration diagram and error status	The status of the CC-Link IE Field Network can be checked. When an error or a warning for the A/D converter module occurs, the status of the station is indicated on an icon.	
② Display of selected-station status and error details	The communication status of the station selected in "Networks Status" can be checked.*1	
③ Communication Test	The transient communication route and whether the communication is established from the connected station to the destination station can be checked.	User's manual for the master/local module used
③ IP Communication Test	The reaching time and the route of the IP communication from the connected station to the target station can be checked.	
Cable Test	The cable status between the connected station and the destination station can be checked.	
Link Start/Stop	The network data link can be started and stopped.	
④ Network Event History	The history of various events that occurred in the network can be checked.	
④ Reserved Station Function Enable	A reservation for a station can be temporarily cancelled, and the cancellation can be disabled. Also, the station numbers for the modules set as reserved stations can be checked on a list.	
④ Enable/Disable Ignore Station Errors	A station not set as an error invalid station can be temporarily set as an error invalid station, and the error invalid station setting can be disabled. Also, the station numbers for the modules set as (temporarily) error ignore stations can be checked on a list.	
⑤ System Monitor	The system monitor on the selected station is activated and the status of the module can be checked. This function is unavailable for the A/D converter module.	
Remote Operation	The selected station can be reset through the remote operation.	Page 137, Section 8.19 (1) (a)

*1 "Selected Station Communication Status Monitor", which appears at the bottom right in the window, indicates the communication status of the A/D converter module. For the error and alarm for the A/D converter module, refer to the following.

- Checking for the error codes and the alarm codes (👉 Page 151, Section 11.1)

Point

Some of items cannot be diagnosed depending on the master/local module or the simple motion module used. For details, refer to the following.

-  User's manual for the master/local module used
-  MELSEC-Q QD77GF Simple Motion Module User's Manual (Network)

(a) Remote operation

1. Select a slave station to be reset and click the  button.

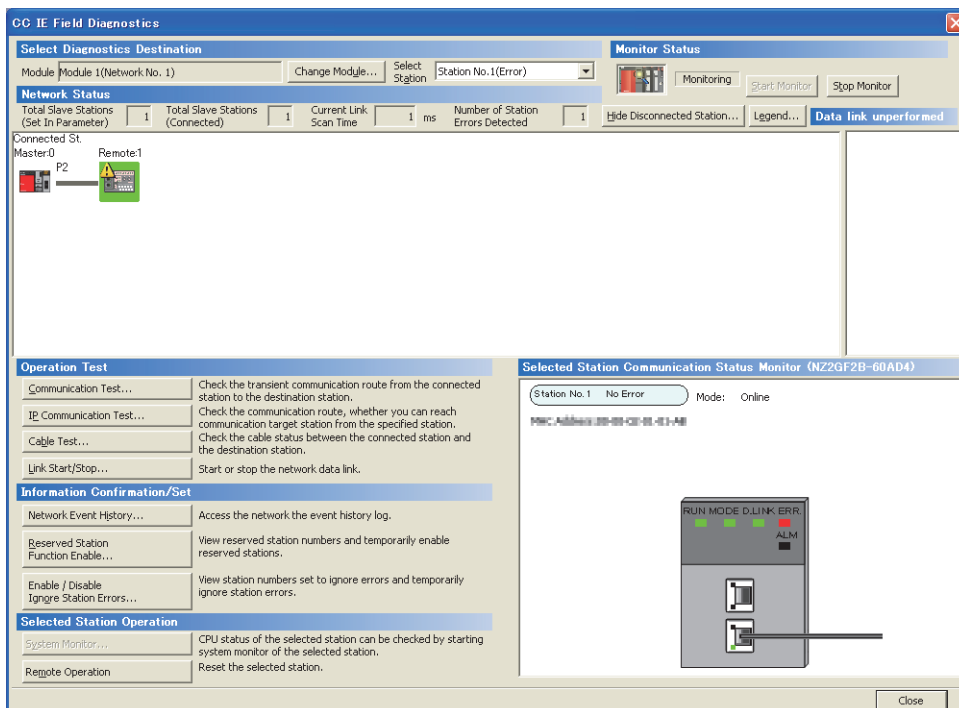

2. Clicking the  button on the following window starts the remote reset.

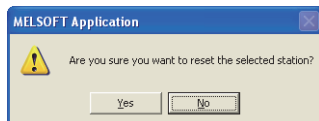

3. Click the  button on the following window.

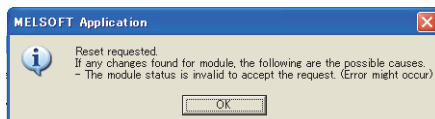

CHAPTER 9 PROGRAMMING

This chapter describes the programming of the A/D converter module.

9.1 Precautions for Programming

This section describes precautions to create CC-Link IE Field Network programs.

(1) Cyclic transmission program

For a cyclic transmission program, interlock with the following link special relay (SB) and link special register (SW).

- Own station data link status (master station) (SB0049)
- Data link status (each station) (SW00B0 to SW00B7)

For the link special relay (SB) and link special register (SW), refer to the following.

 User's manual for the master/local module used

Ex. Interlock example

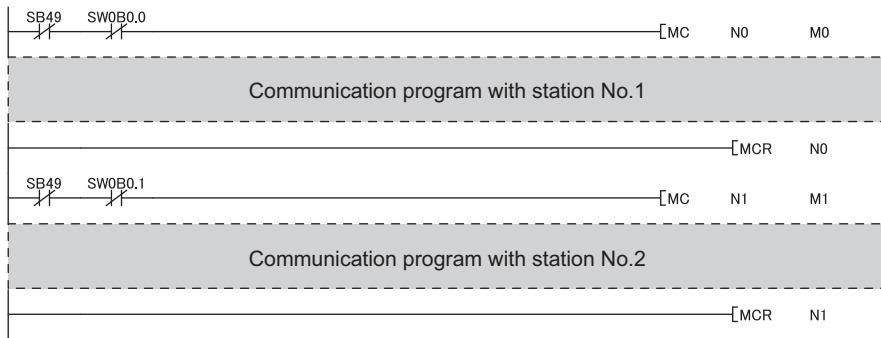

(2) Transient transmission program

For a transient transmission program, interlock with the following link special relay (SB) and link special register (SW).

- Own station baton pass status (master station) (SB0047)
- Baton pass status (each station) (SW00A0 to SW00A7)

For the link special relay (SB) and link special register (SW), refer to the following.

 User's manual for the master/local module used

Ex. Interlock example

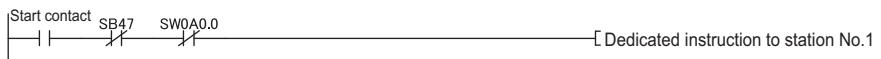

9.2 Procedure for Programming

Create a program to execute A/D conversion, according to the following procedure.

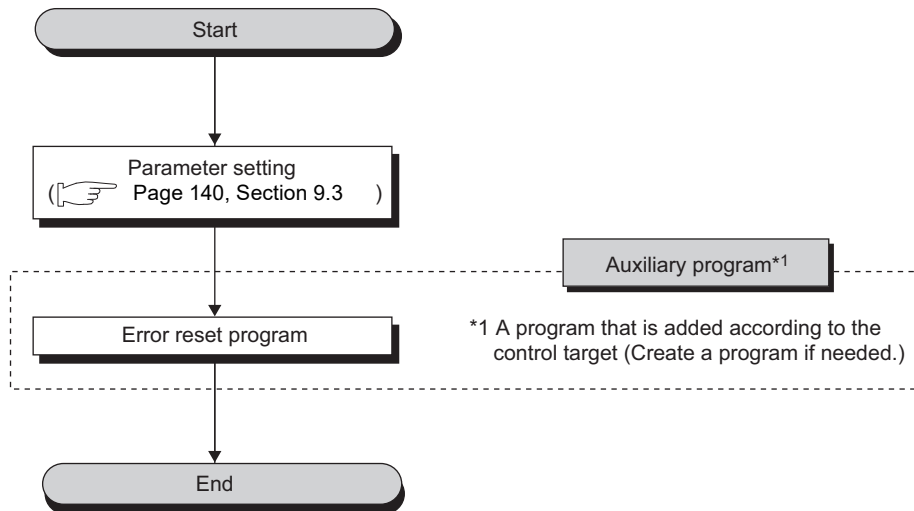

9.3 Program Example

(1) System configuration

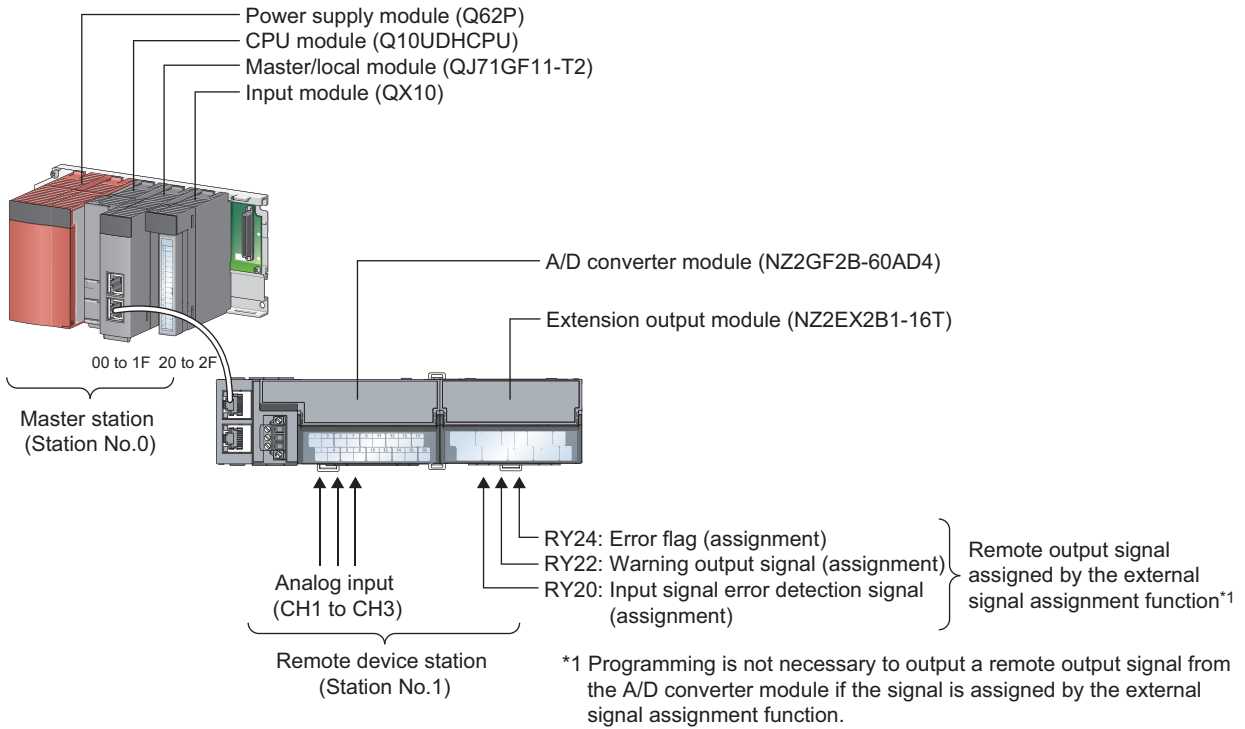

(a) Link device assignment

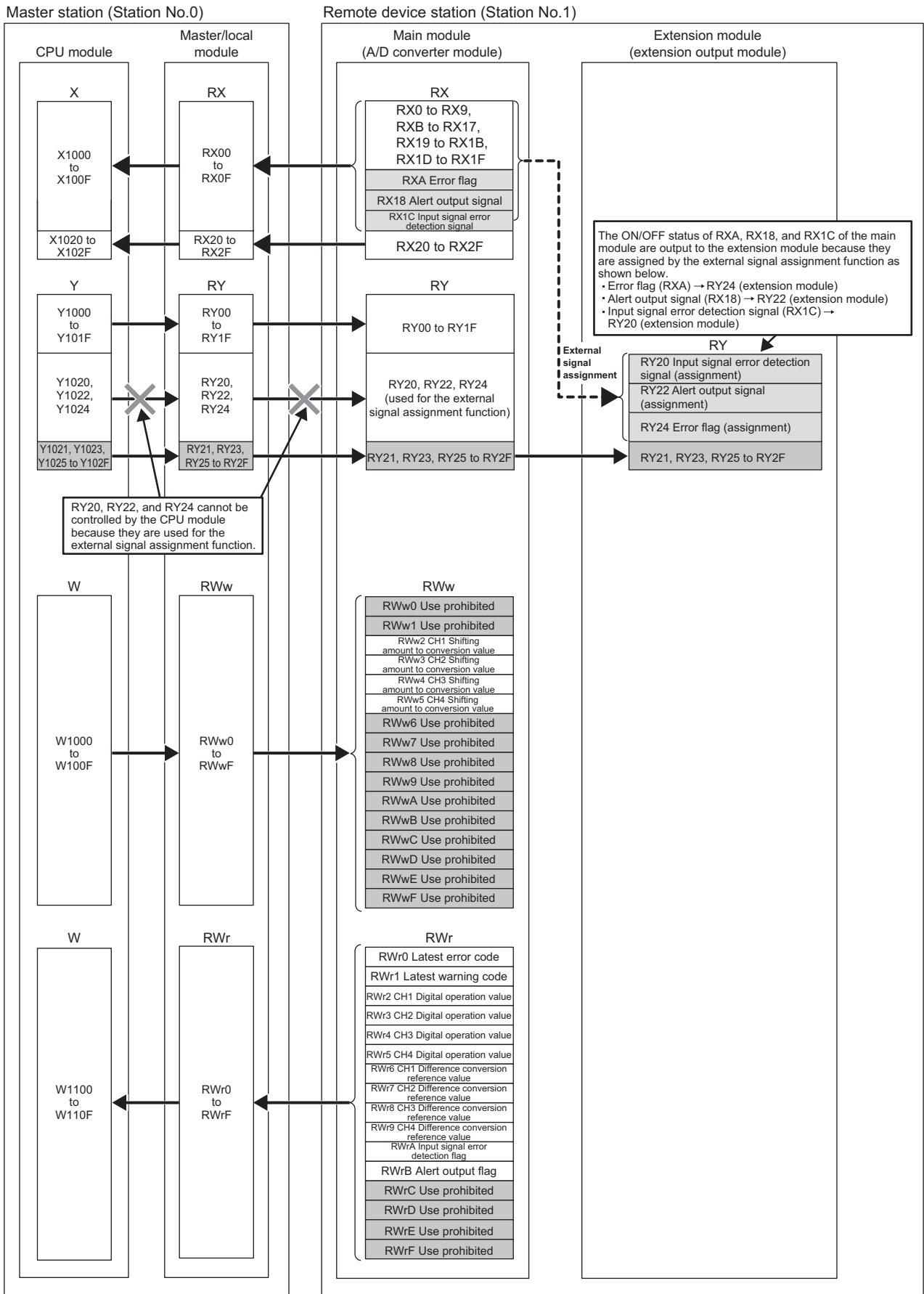

(2) Programming condition

This program reads digital operation values, for which A/D conversion is performed at channel 1 to channel 3 in the A/D converter module, to the master station.

Channel 1 executes sampling processing, channel 2 executes averaging processing every 50 times, and channel 3 executes A/D conversion every 10 moving averages.

If an error or alert occurs or an error of an input signal is detected, a digital signal is output from the extension output module.

(3) Initial setting description

Setting item		Setting value
Conversion speed setting		0: 400 μ s
External signal assignment function	Input signal error detection signal assignment	0x0020
	Alert output signal assignment	0x0022
	Error flag assignment	0x0024
A/D conversion enable/disable setting	CH4 A/D conversion enable/disable setting	1: Disable
Averaging process setting	CH2 Averaging process setting	2: Count average
	CH2 Time average/Count average/Moving average	50
	CH3 Averaging process setting	3: Moving average
	CH3 Time average/Count average/Moving average	10
Input signal error detection function	CH1 Input signal error detection setting	4: Disconnection detection
	CH3 Input signal error detection setting	4: Disconnection detection
Alert output function	CH2 Alert output setting	0: Enable
	CH2 Process alarm upper upper limit value	16000
	CH2 Process alarm upper lower limit value	10000
	CH2 Process alarm lower upper limit value	3000
Digital clipping function	CH2 Digital clipping enable/disable setting	0: Enable
	CH3 Digital clipping enable/disable setting	0: Enable
Scaling function	CH3 Scaling enable/disable setting	0: Enable
	CH3 Scaling upper limit value	32000

Set the initial values for the parameters other than the above.

(4) Device for user

Device	Description	
X20	Digital operation value read command	QX10 (X20 to X2F)
X22	Error reset signal	
X24	Maximum value/minimum value read request	
X26	Maximum value/minimum value reset signal	
X1007	Warning flag	NZ2GF2B-60AD4 (X1000 to X101F)
X1009	Initial data setting completed flag	
X100B	Remote READY	
X100A	Error flag	
X1010	CH1 A/D conversion completed flag	
X1011	CH2 A/D conversion completed flag	
X1012	CH3 A/D conversion completed flag	
X101C	Input signal error detection signal	NZ2GF2B-60AD4 (Y1000 to Y101F)
Y100A	Error clear request flag	
Y101D	Maximum value/minimum value reset request	
D2002	CH1 Digital operation value	
D2003	CH2 Digital operation value	
D2004	CH3 Digital operation value	
D2010 to D2015	CH1 Maximum value to CH3 Minimum value	
D2020	Latest error code	
D2021	Latest warning code	
D2022	Input signal error detection flag	
D2023	Alert output flag	
M300	Maximum value/minimum value read flag	
M310	REMTO instruction completion flag	
M311	REMTO instruction error completion flag	
W1100	Latest error code	Device to be written by link refresh
W1101	Latest warning code	
W1102	CH1 Digital operation value	
W1103	CH2 Digital operation value	
W1104	CH3 Digital operation value	
W110A	Input signal error detection flag	
W110B	Alert output flag	
SM400	Always ON	
SB47	Own station baton pass status (master station)	
SB49	Own station data link status (master station)	
SWA0.0	Baton pass status (each station) (station number 1)	
SWB0.0	Data link status (each station) (station number 1)	
N0	Nesting (station number 1)	

(5) Setting procedure

Connect GX Works2 to the master station to configure the setting.

1. Create a project on GX Works2.

Select "QCPU (Q mode)" for "PLC Series" and select "Q10UDH" for "PLC Type".

 [Project] ⇨ [New...]

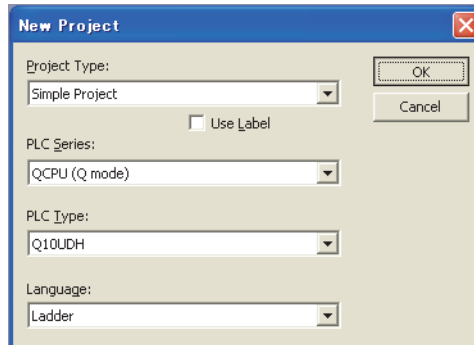

The "New Project" dialog box in GX Works2. It contains the following fields and options:

- Project Type: Simple Project (dropdown menu)
- Use Label:
- PLC Series: QCPU (Q mode) (dropdown menu)
- PLC Type: Q10UDH (dropdown menu)
- Language: Ladder (dropdown menu)
- Buttons: OK, Cancel

2. Display the network parameter setting window and configure the setting as follows.

 Project window ⇨ [Parameter] ⇨ [Network Parameter] ⇨ [Ethernet/CC IE/MELSECNET]

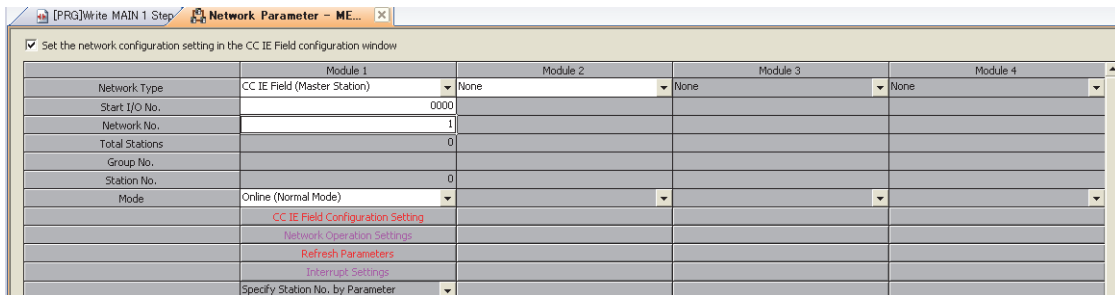

The "Network Parameter - ME..." window showing configuration for four modules. The "Network Type" is set to "CC IE Field (Master Station)".

	Module 1	Module 2	Module 3	Module 4
Network Type	CC IE Field (Master Station)	None	None	None
Start I/O No.	0000			
Network No.	1			
Total Stations	0			
Group No.				
Station No.	0			
Mode	Online (Normal Mode)			
CC IE Field Configuration Setting				
Network Operation Settings				
Refresh Parameters				
Interrupt Settings				
Specify Station No. by Parameter				

3. Display the "CC IE Field Configuration" window and configure the configuration and station number of the slave station as follows.

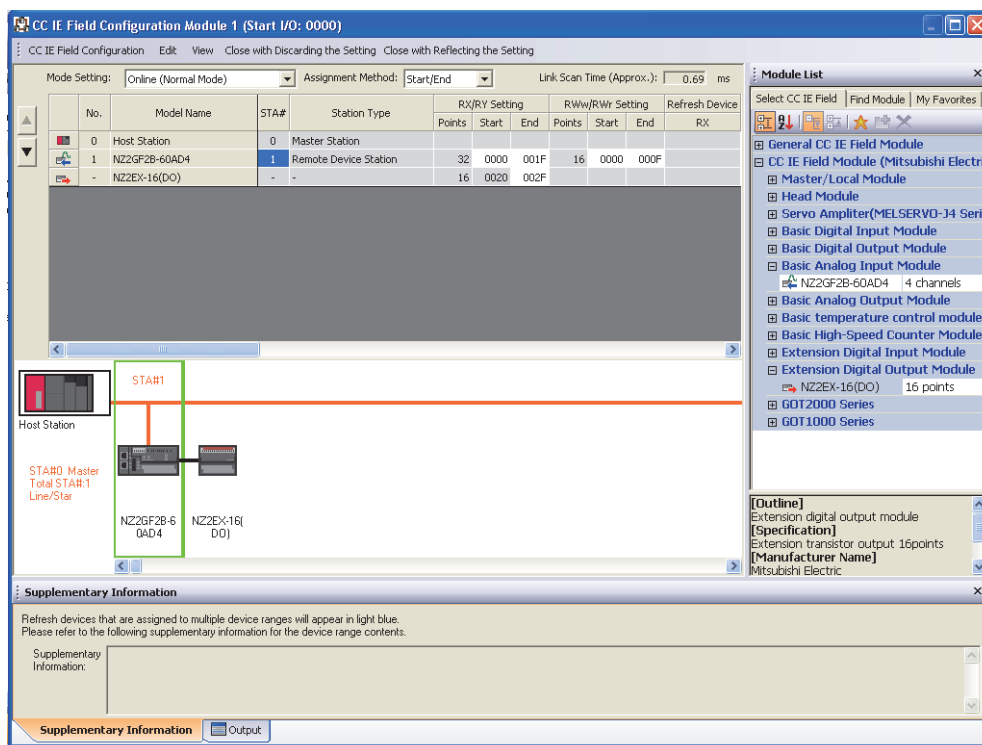

4. Close the "CC IE Field Configuration" window.



5. Display the refresh parameter setting window and configure the setting as follows.

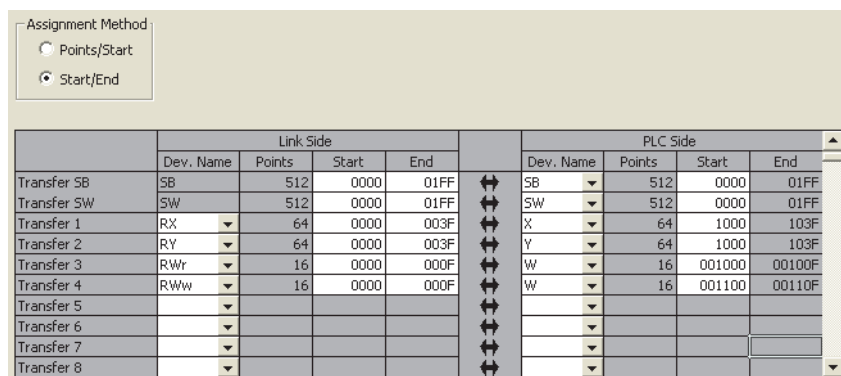

6. Write the set parameter to the CPU module of the master station and reset the CPU module, or turn on from off the power supply.

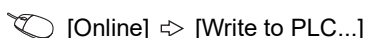

7. Display the "Parameter Processing of Slave Station" window.

Project window ⇨ [Parameter] ⇨ [Network Parameter] ⇨ [Ethernet/CC IE/MELSECNET] ⇨  button ⇨ Select an A/D converter module in "List of stations". ⇨ [CC IE Field Configuration] ⇨ [Online] ⇨ [Parameter Processing of Slave Station]

8. Set "Parameter write" for "Method selection".

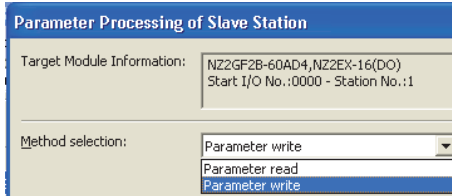

9. Set "Write Value". The following are the procedure.

- Click the title cell of "Initial Value" to select all the items and copy them.
- Click the title cell of "Write Value" to select all the items and paste the copy.
- Select the items to be changed, and set new values according to Initial setting description (👉 Page 142, Section 9.3 (3)).

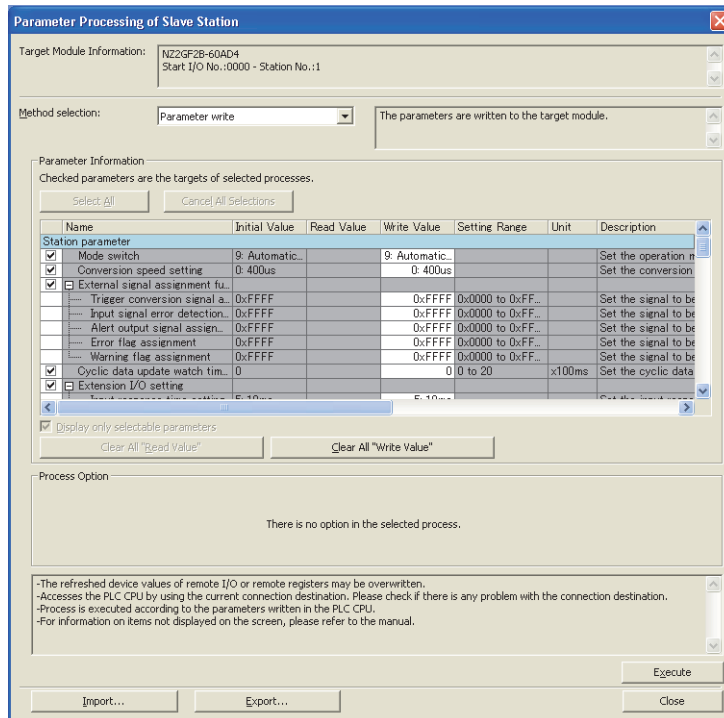

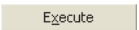
10. Click the  button to write the parameter to the A/D converter module.

(6) Program example

1. Create the following program with GX Works2.

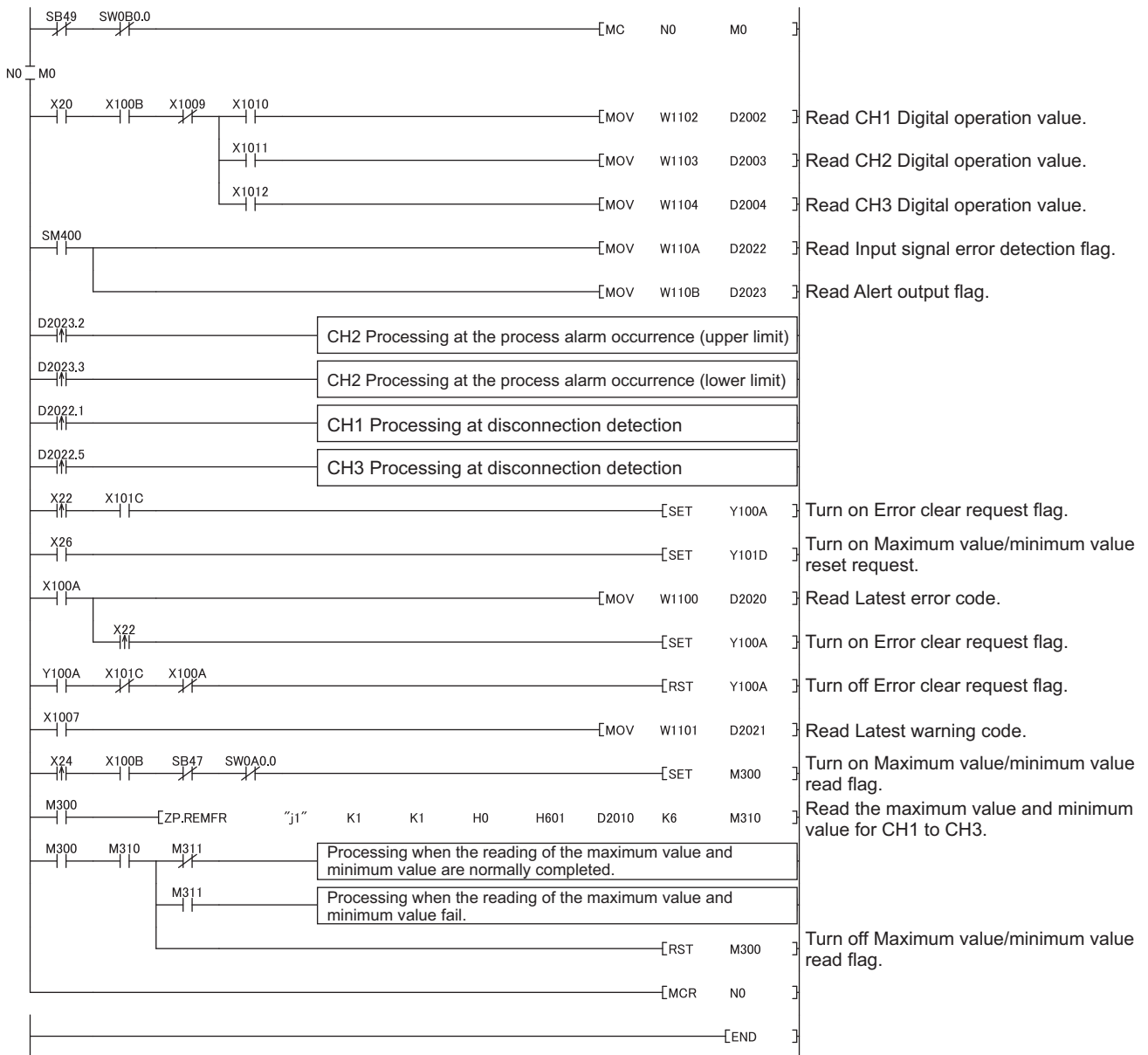

9.3 Program Example

Point!

If the master station does not receive a response for several link scans from the A/D converter module, the A/D converter module is determined as a cyclic transmission faulty station and the corresponding bit of the data link status (each station) (SW0B0 to SW0B7) turns on.

2. Write the program to the CPU module of the master station and reset the CPU module, or turn on from off the power supply.

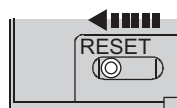

or Power OFF → ON

3. Change the status of the CPU module of the master station to RUN.

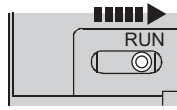

CHAPTER 10 MAINTENANCE AND INSPECTION

The A/D converter module has no special item to be inspected. However, to maintain the best condition of the system, perform the inspection in accordance with the items described in the user's manual of the CPU module used.

Memo

CHAPTER 11 TROUBLESHOOTING

This chapter describes errors that may occur while the A/D converter module is used, and those troubleshooting.

11.1 Checking for the Error Codes and the Alarm Codes

Error codes can be checked by any of the following methods:

- Checking by executing a command of the slave station (☞ Page 151, Section 11.1 (1))
- Checking by Latest error code (RWr0) (☞ Page 153, Section 11.1 (2))
- Checking by Latest warning code (RWr1) (☞ Page 153, Section 11.1 (3))

Alarm codes can be checked by any of the following methods:

- Checking by executing a command of the slave station (☞ Page 151, Section 11.1 (1))
- Checking by Latest warning code (RWr1) (☞ Page 153, Section 11.1 (3))

(1) Checking by executing a command of the slave station

This section describes how to check the errors by executing a command of the slave station.

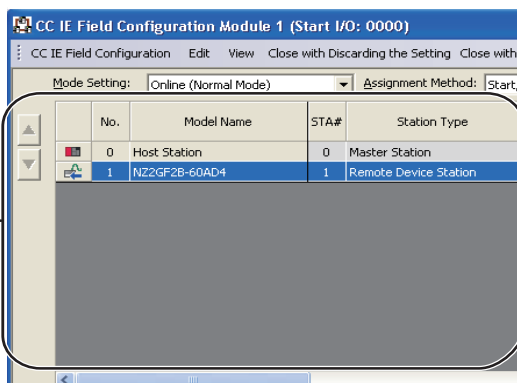

1. Select the A/D converter module in "List of stations" on the "CC IE Field Configuration" window.

2. Open the "Command Execution of Slave Station" window.

☞ [CC IE Field Configuration] ⇨ [Online] ⇨
[Command Execution of Slave Station]

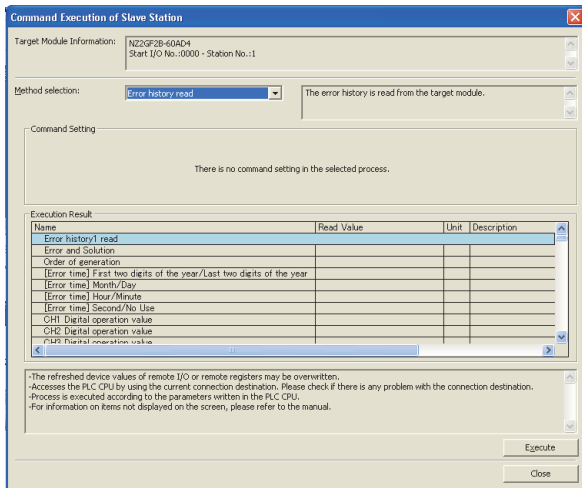

3. Set "Method selection" to "Error history read" and click the **Execute** button.

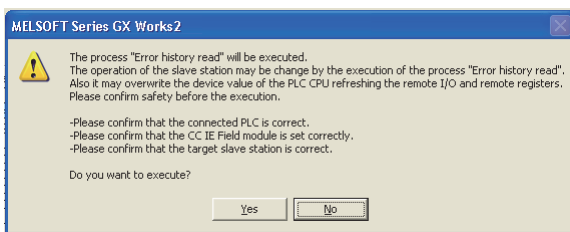

4. When the window shown on the left is displayed, click the **Yes** button.

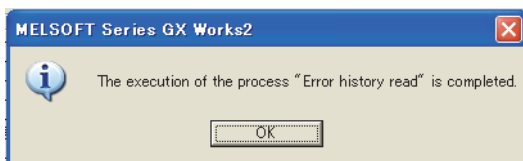

5. When the window shown on the left is displayed, click the **OK** button.

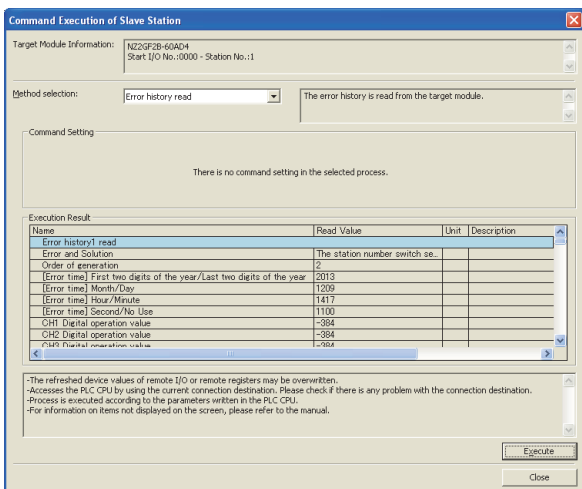

6. The error history of the A/D converter module is displayed in "Execution Result".

Item	Contents
Error and Solution	The action for the error is displayed.
Order of generation	The order of error occurrence is displayed.
[Error time] First two digits of the year/Last two digits of the year	The date and time of error occurrence is displayed. (When the tens place of Month, Hour and Second is "0", the date and time are displayed without "0".)
[Error time] Month/Day	
[Error time] Hour/Minute	
[Error time] Second/No Use	
CH1 Digital operation value	The value in CH□ Digital operation value (RWr2 to RWr5) when an error occurs is stored.
CH2 Digital operation value	
CH3 Digital operation value	
CH4 Digital operation value	

Point

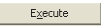
- The error history registers 15 errors at a maximum. If 16 or more errors occur, errors are deleted from the oldest.
- If the same error occurs continuously, only the error that occurred first is stored to the error history.
- Even after the power of the module is turned off and on, the error history remains.
- To initialize the error history, set "Method selection" to "Error history clear request" on the "Command Execution of Slave Station" window and click the  button.

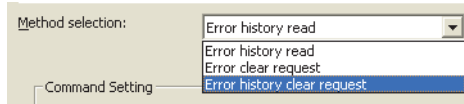

(2) Checking by Latest error code (RWr0)

Check the error with the remote register of the master/local module.

 [Online] ⇔ [Monitor] ⇔ [Device/Buffer Memory Batch]

Ex. When the refresh target device for Latest error code (RWr0) is W1100

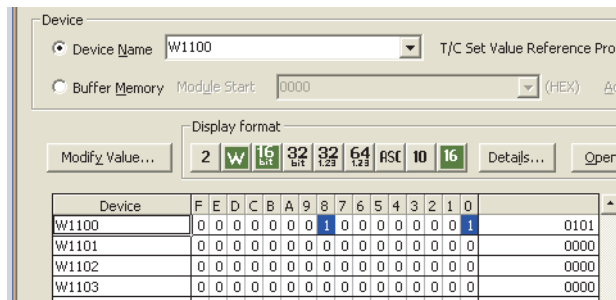

(3) Checking by Latest warning code (RWr1)

Check the warning with the remote register of the master/local module.

 [Online] ⇔ [Monitor] ⇔ [Device/Buffer Memory Batch]

Ex. When the refresh target device for Latest warning code (RWr1) is W1101

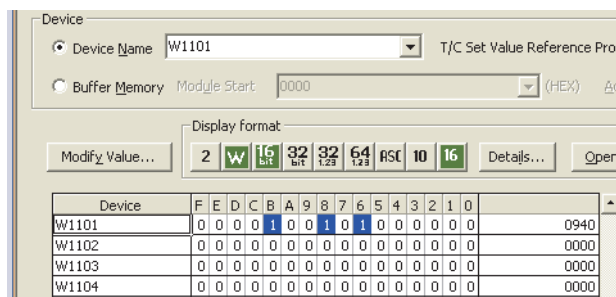

11.2 Error Code List

This section describes error codes.

Error codes are classified by error number as follows.

Error code	Classification	Reference
0000 _H to 3FFF _H , D529 _H , D52B _H	A/D converter module error	Page 154, Section 11.2 (1)
D000 _H to DFFF _H (D529 _H and D52B _H excluded)	CC-Link IE Field Network error (communication system error)	Page 160, Section 11.2 (2)

(1) Error code list (0000_H to 3FFF_H, D529_H, D52B_H)

The errors are classified into the following three types.

Classification	Description
Major error	An error that cannot be recovered. The RUN LED turns off.
Moderate error	An error where the module cannot continue to operate. The ERR. LED turns on.
Minor error	An error where the module can continue to operate. The ERR. LED flashes.

If an error occurs, check that the D LINK LED is on. Then take corrective actions as listed below.

Error code (hexadecimal)	Classification	Error name	Description and cause	Action
0010 _H	Major error	Hardware failure	Module hardware error	Turn off and on the module. If this error persists, the module may be in failure. Please consult your local Mitsubishi representative.
010□ _H	Moderate error	Range setting outside the range	The value set in Range setting (address: 0103 _H) is outside the range. □ represents the channel number mistakenly set.	Set the value of Range setting (address: 0103 _H) within the allowable range.
0110 _H ^{*1}	Moderate error	Non-volatile memory data error (module working information)	The non-volatile memory data are abnormal.	To recover from the error, use the module operation information initialization command. If an error occurs, please consult your local Mitsubishi representative.
0120 _H ^{*1}	Moderate error	User range data damaged (The channel cannot be identified.)	The value set in the offset/gain setting is invalid. The channel where the error has occurred cannot be identified.	Start over the offset/gain setting of all channels where the user range setting is used. If an error occurs, please consult your local Mitsubishi representative.
0130 _H	Moderate error	Non-volatile memory data error (parameter)	The parameter data stored in the non-volatile memory are abnormal.	<ul style="list-style-type: none"> Set no request (0), request (1), and no request (0) in Parameter information clear request (address: 1002_H) and set the parameters of the non-volatile memory to default. Set the parameters again. Take measures against noise with a shielded cable for connection. If this error persists, the module may be in failure. Please consult your local Mitsubishi representative.

Error code (hexadecimal)	Classification	Error name	Description and cause	Action
0140 _H	Minor error	Non-volatile memory data error (error history)	The error history data stored in the non-volatile memory are abnormal.	<ul style="list-style-type: none"> The module will be automatically recovered immediately after the error occurs. Note that the error history of the errors that have occurred will be lost. Take measures against noise with a shielded cable for connection. If this error persists, the module may be in failure. Please consult your local Mitsubishi representative.
0150 _H	Minor error	Incorrect network parameter access error	Access to A/D converter module when network parameter was in the incorrect status	Please reset network parameter correctly.
0160 _H	Minor error	Remote buffer memory access error	A buffer memory area other than the remote buffer memory areas has been accessed using the REMFR/REMTO instruction.	Correct the setting data of the REMFR/REMTO instruction to access the remote buffer memory.
017△ _H	Moderate error	External signal assignment setting error	<p>An address other than those assigned to the extension I/O module for the external signal assignment function has been set.</p> <p>△ represents one of the following error types.</p> <p>0: Trigger conversion function 1: Input signal error detection function 2: Alert output function 3: Error output 4: Warning output</p>	Set an address that has been assigned to the extension I/O module for the external signal assignment function.
0180 _H	Moderate error	Same address for the external signal assignment function	The same address has been set in multiple extension output modules for the external signal assignment function.	Set a unique address.
020□ _H *1	Moderate error	Averaging time setting outside the range	<p>The averaging time value set in CH□ Time average/Count average/Moving average (address: 0105_H to 0108_H) is outside the range of 2 to 5000ms.</p> <p>□ represents the channel number where an error has occurred.</p>	Set the averaging time to a value in the range of 2 to 5000ms.
			<p>The averaging time value set in CH□ Time average/Count average/Moving average (address: 0105_H to 0108_H) is less than "4 x Number of used channels x Conversion speed" (ms).</p> <p>□ represents the channel number where an error has occurred.</p>	Set the averaging time to a value equal to or more than "4 x Number of used channels x Conversion speed" (ms).

Error code (hexadecimal)	Classification	Error name	Description and cause	Action
030□ _H ^{*1}	Moderate error	Count average setting outside the range	The averaging count value set in CH□ Time average/Count average/Moving average (address: 0105 _H to 0108 _H) is outside the range of 4 to 65000. □ represents the channel number where an error has occurred.	Set the averaging count to a value in the range of 4 to 65000.
031□ _H ^{*1}	Moderate error	Moving average setting outside the range	The moving average count value set in CH□ Time average/Count average/Moving average (address: 0105 _H to 0108 _H) is outside the range of 2 to 128. □ represents the channel number where an error has occurred.	Set the moving average count to a value in the range of 2 to 128.
0360 _H ^{*1}	Moderate error	Conversion speed setting outside the range	The value set in Conversion speed setting (address: 0001 _H) is other than 0 and 1.	Set one of the following values in Conversion speed setting (address: 0001 _H). • 400μs/channel (0 _H) • 1ms/channel (1 _H)
040□ _H ^{*1}	Moderate error	Offset/gain setting value inverted	The user range setting value has been set to a value where the offset value is equal to or greater than the gain value. □ represents the channel number where an error has occurred.	Correct the setting so that the offset value is smaller than the gain value.
06△□ _H ^{*1}	Moderate error	Process alarm setting error	The settings in CH1 Process alarm lower lower limit value (address: 010F _H) to CH4 Process alarm upper upper limit value (address: 011E _H) are invalid. □ represents the channel number mistakenly set. △ represents one of the following status. 2: Process alarm lower lower limit value > process alarm lower upper limit value 3: Process alarm lower upper limit value > process alarm upper lower limit value 4: Process alarm upper lower limit value > process alarm upper upper limit value	Correct the settings in CH1 Process alarm lower lower limit value (address: 010F _H) to CH4 Process alarm upper upper limit value (address: 011E _H).

Error code (hexadecimal)	Classification	Error name	Description and cause	Action
0730 _H	Moderate error	Mode switch setting error	The value out of range is set in mode switch (address: 0000 _H).	Reset the mode switch (address: 0000 _H) to either of the followings. <ul style="list-style-type: none"> • Normal Mode (0_H) • Trigger conversion mode (1_H) • Automatic judgment mode (9_H) Please set the module with highest 5 digits of serial No. prior to '15101' to be either of 0 _H or 1 _H .
081□ _H ^{*1}	Moderate error	Input signal error detection setting outside the range	The bit corresponding to a channel of Input signal error detection setting (address: 0109 _H) has been set to a value other than 0 _H to 4 _H . □ represents the channel number where an error has occurred.	Set one of the following values in the channel, where an error has occurred, of Input signal error detection setting (address: 0109 _H). <ul style="list-style-type: none"> • Disable (0_H) • Disconnection detection (4_H)
082□ _H	Moderate error	Disconnection detection setting error	Disconnection detection (4 _H) has been set in Input signal error detection setting (address: 0109 _H), and the input range has been set to a value other than the following values. <ul style="list-style-type: none"> • 4 to 20mA • 1 to 5V □ represents the channel number where an error has occurred.	<ul style="list-style-type: none"> • Set the input range of the channel that detects disconnection within the range of 4 to 20mA or 1 to 5V. • Set Input signal error detection setting (address: 0109_H) of the corresponding channel to a value other than Disconnection detection (4_H).
090□ _H ^{*1}	Moderate error	Scaling setting outside the range	The values set in CH1 Scaling lower limit value (address: 0121 _H) to CH4 Scaling upper limit value (address: 0128 _H) are outside the range of -32000 to 32000. □ represents the channel number where an error has occurred.	Set a value within the range of -32000 to 32000 in CH1 Scaling lower limit value (address: 0121 _H) to CH4 Scaling upper limit value (address: 0128 _H).
091□ _H ^{*1}	Moderate error	Scaling upper/lower limit value inverted	The scaling lower limit value has been set equal to or greater than the scaling upper limit value in CH1 Scaling lower limit value (address: 0121 _H) to CH4 Scaling upper limit value (address: 0128 _H). □ represents the channel number where an error has occurred.	Correct the settings of CH1 Scaling lower limit value (address: 0121 _H) to CH4 Scaling upper limit value (address: 0128 _H) so that the scaling lower limit value is smaller than the scaling upper limit value.
0920 _H ^{*2}	Minor error	Mode switch setting change	The value set in Mode switch (address: 0000 _H) has been changed.	Turn off and on the module so that it operates according to Mode switch (address: 0000 _H).

Error code (hexadecimal)	Classification	Error name	Description and cause	Action
0930 _H	Moderate error	Cyclic data update watch time setting outside the range	The value set in Cyclic data update watch time (address: 0007 _H) is outside the range of 0 to 20.	Set a value within the range of 0 to 20 in Cyclic data update watch time (address: 0007 _H).
0940 _H	Minor error	Station number switch changed error	The station number switch setting has been changed while the module power is on.	While the module power is on, set the switch again to the station number that has been set before.
0950 _H	Moderate error	Clock data outside the range	The clock data acquired from the CPU module is invalid.	There may be an influence from noise or a hardware error. If the same error occurs again even after measures have been taken against noise, please consult your local Mitsubishi representative.
0960 _H	Major error	Network No. changed through the network	The network number has been changed through the network.	Take measures against noise and reset the module. If the same error occurs again, the hardware of the module may be in failure. Please consult your local Mitsubishi representative.
0970 _H	Major error	Station No. changed through the network	The station number has been changed through the network.	Take measures against noise and reset the module. If the same error occurs again, the hardware of the module may be in failure. Please consult your local Mitsubishi representative.
0E00 _H ^{*3}	Moderate error	RWw/RWr setting error	RWwF/RWrF has not been set in RWw/RWr setting when synchronous communication mode is activated.	Reset and turn off and on the power, or execute remote reset to assign RWwF/RWrF in RWw/RWr setting of network parameter.
0E10 _H ^{*3}	Moderate error	Synchronous communication error 1	Synchronous communication with simple motion module did not execute in specified interval.	Execute the followings and turn off and on the power, or execute remote reset. <ul style="list-style-type: none"> • Simple motion module setting/Operation confirmation • Confirmation of transmission path
0E20 _H ^{*3}	Moderate error	Operation cycle setting error	The operation cycle that A/D converter module does not support is set in simple motion module.	Recheck the operation cycle setting of simple motion module and turn off and on the power of A/D converter module, or execute remote reset.
0E30 _H ^{*3}	Moderate error	Synchronous communication error 2	Synchronous communication with simple motion module did not execute in specified interval.	Execute the followings and turn off and on the power, or execute remote reset. <ul style="list-style-type: none"> • Simple motion module setting/Operation confirmation • Confirmation of transmission path
0E40 _H ^{*3}	Moderate error	Excessive number of conversion enabled channels	With the currently set number of A/D conversion enabled channels, the A/D converter module cannot operate in the operation cycle set in the simple motion module.	Execute the followings and turn off and on the power, or execute remote reset. <ul style="list-style-type: none"> • Reduce the number of conversion enabled channels. • Set the operation cycle setting of simple motion module to be a long cycle.
1F00 _H	Major error	Extension module connected error	The extension module is not connected properly or an extension module that is not supported has been connected.	Check whether the extension modules are in contact with each other and whether the extension module is a connectable module. If the same error occurs again, the module may be in failure. Please consult your local Mitsubishi representative.

Error code (hexadecimal)	Classification	Error name	Description and cause	Action
1F20 _H	Moderate error	External power supply OFF error	The external power supply of the extension output module is off with the external power supply monitoring function enabled.	<ul style="list-style-type: none"> Check the external power supply status of the extension output module. If an error occurs when the system is started or stopped, correct the timing to enable the external power supply monitoring function.
1F30 _H	Moderate error	Extension module parameter error	The parameter of the model name that is different from the model name of the connected extension module has been reflected.	Set the same type and number of points in Extension module identification code (address: 0200 _H) as those of the connected extension module.
1F40 _H	Moderate error	Input response time setting error	000b or 001b has been set in the low 3 bits of Input response setting (address: 0010 _H).	Set a value other than 000b and 001b to the low 3 bits of Input response setting (address: 0010 _H).
D529 _H	Major error	Communication error 1	The communication LSI is in failure.	<ul style="list-style-type: none"> A malfunction may have occurred due to noise or others. Check the cable distance or grounding condition of each device. Then take measures against noise. Execute a unit test for the module. If the same error occurs again, the hardware of the module may be in failure. Please consult your local Mitsubishi representative.
D52B _H	Major error	Communication error 2		

- *1 Set a value within the allowable range. Then perform one of the following operations to clear the error.
- Turn on and off Error clear request flag (RYA).
 - Turn on and off Initial data setting request flag (RY9).
- *2 Mode switch setting change (error code: 0920_H) is not cleared even if five seconds have passed after the error occurred. During the error, the A/D converter module keeps operating in the mode before the Mode switch (address: 0000_H) change.
To clear the error in the previous mode, set the previous value to Mode switch (address: 0000_H) and turn on and off Initial data setting request flag (RY9).
- *3 The error cannot be cleared by turning on and off Error clear request flag (RYA) or Initial data setting request flag (RY9). The error is cleared only by the method described in the action.

Point

When multiple errors occur, only the latest error code is stored in Error code (RWr0) or Warning code (RWr1). The errors that have occurred before can be checked with the error history of GX Works2. For error history, refer to the following.

- Checking by executing a command of the slave station (☞ Page 151, Section 11.1 (1))
- Error history data □ (address: 0A00_H to 0AEF_H) (☞ Page 194, Appendix 3 (22))

(2) Error code list (D000_H to DFFF_H (D529_H and D52B_H excluded))

When an error occurs, the ERR. LED does not turn on. The D LINK LED flashes or turns off.

Troubleshoot the problem with the CC-Link IE Field Network diagnostics. (☞ Page 135, Section 8.19)

Error code (hexadecimal)	Error name	Description and cause	Action
D0E0 _H	Station type mismatch	The network parameter is incorrect or outside the range.	In the network configuration settings of the master station, change the station type to that of the remote device station.
D0E1 _H	Own station reserved	The network parameter is incorrect or outside the range.	<ul style="list-style-type: none"> In the network configuration settings of the master station, cancel the reserved station setting. Change the station number of the module to a station number that is not reserved.
D0E2 _H	Station No. already in use (own station)	The network parameter is incorrect or outside the range.	<ul style="list-style-type: none"> Set a unique station number. After taking the above action, turn off and on or reset all the stations where this error has been detected.
D0E3 _H	Own station No. out of range	The network parameter is incorrect or outside the range.	Add the station information of the module in the network configuration settings of the master station.
D217 _H	Transient data command error	The transient data request command is incorrect.	Correct the request command at the request source, and retry the operation.
D2A0 _H	Receive buffer full	The target station is overloaded and cannot receive transient data.	<ul style="list-style-type: none"> Check the network status using the CC-Link IE Field Network diagnostics of GX Works2. When the target station is overloaded and cannot receive transient data, send the data to the target station after a while.
D2A3 _H	Transient data length error	The received transient data is incorrect.	Correct the number of data (frame length) at the request source, and retry the operation.
D72A _H	Station number switch out of range (a value other than 1 to 120)	A station number out of range has been set.	Set the station number within the allowable range.
DF01 _H	Transient data divided error	The divided transient data have been received.	Set the transient data size within the range that can be handled by the module. Then send the transient data that is not divided.

Point

When multiple errors occur, only the latest error code is stored in Error code (RWr0) or Warning code (RWr1).

The errors that have occurred before can be checked with the error history of GX Works2.

For error history, refer to the following.

- Checking by executing a command of the slave station (☞ Page 151, Section 11.1 (1))
- Error history data □ (address: 0A00_H to 0AEF_H) (☞ Page 194, Appendix 3 (22))

11.3 Alarm Code List

This section lists alarm codes.

Alarm code (hexadecimal)	Category	Name	Description and cause of alarm	Action
0A△□ _H	Minor error	Process alarm occurrence	<p>A process alarm is occurring. The channel where the process alarm has occurred fits in □.</p> <p>A value in △ indicates that the alarm status is as follows: 0: Upper limit of a process alarm 1: Lower limit of a process alarm</p>	When the digital operation value falls within the setting range, the corresponding bit of Alert output flag (RWrB) and Alert output signal (RX18) turn off automatically and Latest warning code (RWr1) is cleared.
0B△□ _H	Minor error	Input signal error detection	<p>An input signal error is occurring. The channel where an input signal error has occurred fits in □.</p> <p>A value in △ indicates that the alarm status is as follows: 3: Disconnection detection</p> <p>This alarm code is stored when an input signal error is detected according to the setting of the input signal error detection function.</p>	The corresponding bit of Input signal error detection flag (RWrA) and Input signal error detection signal (RX1C) turn off by turning on and off Error clear request flag (RYA) after the analog input value falls within the setting range.

11.4 Checking the LEDs

This section describes how to troubleshoot the system by the LEDs.

Point

For the troubleshooting using the LEDs of the extension I/O module, refer to the following.

 CC-Link IE Field Network Remote I/O Module User's Manual

(1) When the PW LED does not turn on

Check item	Action
Is any LED other than the PW LED turned on?	When any LED other than the PW LED turns on, the possible cause is a hardware failure. Please consult your local Mitsubishi representative.
Is the module power supply (24VDC) wired?	Wire the module power supply (24VDC).
Is the module power supply (24VDC) turned on?	Turn on the module power supply (24VDC).
Is the voltage of the module power supply (24VDC) within the specified range?	Set the voltage value within the range of performance specifications.

(2) When the RUN LED does not turn on

Check item	Action
Does the voltage of the module power supplied externally reach to the voltage of the performance specifications?	Check that module power supply voltage is within the range of performance specifications.
Does any hardware error occur?	<p>( Page 25, Section 3.2)</p> <p>After the check, power on the module.</p> <p>If the RUN LED does not turn on even after the module power supply is turned from off to on, the possible cause is a module failure. Please consult your local Mitsubishi representative.</p>



(3) When the MODE LED flashes

Check item	Action
Is the A/D converter module in execution of the unit test?	<p>When the A/D converter module is in execution of the unit test, the D LINK LED turns on after the unit test is completed. Take corrective action according to the result of the unit test.</p> <p>( Page 165, Section 11.5)</p>

(4) When the MODE LED turns off

Check item	Action
Is the A/D converter module in the offset/gain setting mode?	When the A/D converter module is in the offset/gain setting, change the mode to the normal mode after the setting is completed.
Does any hardware error occur?	If the MODE LED does not turn on even after the module power supply is turned from off to on, the possible cause is a hardware failure. Please consult your local Mitsubishi representative.



(5) When the D LINK LED turns off

Check item	Action
Does the own station in network operate normally?	Connect GX Works2 to the master station, and check if the own station is performing data link by CC-Link IE Field Network diagnostics. ( User's manual for the master/local module used)
Are 1000BASE-T-compliant Ethernet cables used?	Replace the cable with a 1000BASE-T-compliant Ethernet cable. ( User's manual for the master/local module used)
Is the station-to-station distance 100m or less?	Change the station-to-station distance to 100m or less.
Does the cabling condition (bend radius) meet the specifications?	Refer to the manual for the Ethernet cable used, and correct the bend radius.
Is any Ethernet cable disconnected?	Replace the Ethernet cable.
Do other stations connected to the A/D converter module normally operate?	Check if the power supplies of the other stations are turned on.
Does the switching hub normally operate?	<ul style="list-style-type: none"> • Check if a 1000BASE-T-compliant switching hub is used. ( User's manual for the master/local module used) • Check if the power supply of the switching hub is turned on.
Is the station number of the A/D converter module duplicated with any of other stations?	Two or more duplicated stations exist. Change the setting so that all the station numbers differ.

(6) When the D LINK LED flashes

Check item	Action
Does the station number setting of the A/D converter module match the station number of the A/D converter module set in the network configuration settings of the master station or in the CC IE Field configuration?	Match the station number of the A/D converter module with the station number set in the network configuration settings of the master station or in the CC IE Field configuration.
Is the station type remote device station?	Change the station type of the module to the remote device station in the network configuration settings of the master station.
Is the A/D converter module a reserved station?	Change the setting of reserved/ignored error station to other than the reserved station in the network configuration settings of the master station.
Is stop of the data link checked through CC-Link IE Field Network diagnostics?	Check the link status through CC-Link IE Field Network diagnostics and start the link when the data link is stopped.
Is the station number setting switch set to other than 1 to 120?	The setting range for the station number setting switch is 1 to 120. Set the number between 1 and 120.

(7) When the L ER LED turns on

Check item	Action
Are Ethernet cables normal?	<ul style="list-style-type: none"> • Check if 1000BASE-T-compliant Ethernet cables are used. ( User's manual for the master/local module used) • Check if the station-to-station distance is 100m or less. • Check if the Ethernet cables are not disconnected.
Does the switching hub in the system normally operate?	<ul style="list-style-type: none"> • Check if a 1000BASE-T-compliant switching hub is used. ( User's manual for the master/local module used) • Check if the power supply of the switching hub is turned on.
Do other stations connected to the A/D converter module normally operate?	Check if the power supplies of the other stations are turned on.
Is the mode of the module on the master station set to other than Online?	Change the mode of the module to Online.
Is there any noise affecting the system?	Check the wiring condition of the Ethernet cables.
Is the loopback function enabled for the master station?	When the loopback function is enabled, check if the ring topology is correctly configured for the port where the L ER LED is on. ( User's manual for the master/local module used)

(8) When the LINK LED turns off

Check item	Action
Are Ethernet cables normal?	<ul style="list-style-type: none"> • Check if 1000BASE-T-compliant Ethernet cables are used. ( User's manual for the master/local module used) • Check if the station-to-station distance is 100m or less. • Check if the Ethernet cables are not disconnected.
Do the switching hub and other stations in the system normally operate?	Check if the power supplies of the switching hub and other stations are turned on.

(9) When the ERR. LED turns on

Check item	Action
Does any error occur?	Identify the error cause of the A/D converter module and take corrective action with GX Works2. ( Page 151, Section 11.1)

(10) When the ALM LED turns on or flashes

(a) When the ALM LED turns on

Check item	Action
Is any alert output?	Check Alert output flag (RWrB).

(b) When the ALM LED flashes

Check item	Action
Does any input signal error occur?	Check Input signal error detection flag (RWrA).

11.5 Unit Test

Run a unit test to check if there is any abnormality in the A/D converter module.

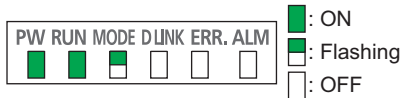
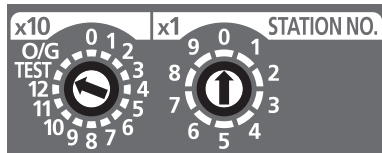
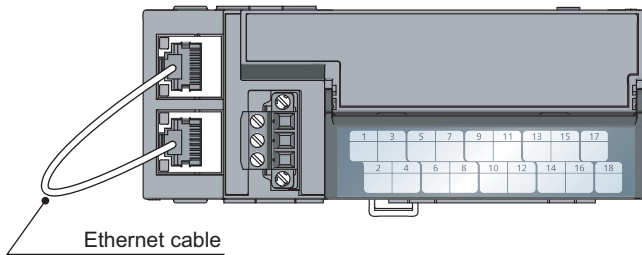

When completed



When failed



1. Power off the module.
2. Connect the PORT1 and PORT2 of the A/D converter module with an Ethernet cable.

3. Set the station number setting switch as follows.
 - x10: TEST
 - x1: 0

4. Power on the module.

5. Unit test begins.

The MODE LED flashes while the unit test is being executed.

6. The MODE LED turns off when the unit test is completed.

- When completed
The ERR. LED does not turn on, but remains off.

- When failed
The ERR. LED turns on.

If the test fails, replace the Ethernet cable and run the test again. If the test fails again, it may be due to a hardware failure in the A/D converter module. Please consult your local Mitsubishi representative.

Remark

When unit test fails, the error details can be checked in the error history.
 To check the error history, set the station number of the A/D converter module and connect the module to the master station with an Ethernet cable.
 For the error history, refer to the following.

- Checking by executing a command of the slave station (Page 151, Section 11.1 (1))
- Error history □ (address: 0A00_H to 0AEF_H) (Page 194, Appendix 3 (22))

11.6 Troubleshooting for Each Phenomenon

This section describes troubleshooting for each phenomenon.

Perform troubleshooting for each phenomenon when the A/D converter module does not operate properly with no error. When an error occurs in the A/D converter module, identify the error cause with GX Works2.

(1) When digital operation value cannot be read

Check item	Action
Is there any problem with wiring, such as off or disconnection of analog signal lines?	Check the faulty area by checking signal line visually or conductively.
Is the CPU module in the STOP status?	Change the status of the CPU module to RUN.
Is the offset/gain setting correct?	Check if the offset/gain setting is correct. When the user range setting is selected, change the input range to the factory default setting. Then check if the A/D conversion is executed. If the A/D conversion is properly executed, configure the offset/gain setting again.
Is the input range setting correct?	Check Range setting (address: 0103 _H) with GX Works2 or the dedicated instruction. When the input range setting is wrong, set the range again with the program or GX Works2.
Is A/D conversion disabled for the channels where the analog value is to be input?	Check A/D conversion enable/disable setting (address: 0102 _H) with GX Works2 or the dedicated instruction. Then, set the A/D conversion enable with the program or GX Works2.
Is Initial data setting request flag (RY9) executed?	Check if the digital operation value is stored in CH□ Digital operation value (RWr2 to RWr5) after turning on and off Initial data setting request flag (RY9) in GX Works2. When the problem has been solved, check the program again.
Are the (V+) and (I+) terminals connected when the current is input?	For the current input, always connect the terminals (V+) and (I+) referring to the following. • Wiring of External Device and Terminal Block ( Page 60, Section 6.6)
Are the setting values of the averaging process setting correct?	When the time average processing is selected, set the values larger than "Four (times) × Conversion speed × Number of channels" as the setting values. If the condition above is not met, digital operation values remain 0.
Is there any potential difference between the AG terminal and the external device GND?	Connect the AG terminal and the external device GND.

Point

If the digital operation value cannot be read even after the above actions are taken, the A/D converter module may be failed. Please consult your local Mitsubishi representative.

(2) When an A/D conversion completed flag does not turn on in the normal mode

Check item	Action
Does any input signal error occur?	Check Input signal error detection flag (RWrA).

(3) When the digital operation value is out of the accuracy range

Check item	Action
Is any measure against noise taken?	Take a measure against noise, such as using a shielded cable for connection.

(4) When the output status of the extension output module differs from the link device status of the master station

Check item	Action
Is the setting of the external signal assignment function correct?	<p>Check that the following assignments are not used in the external signal assignment function.</p> <ul style="list-style-type: none"> • Input signal error detection signal assignment (address: 0003_H) (☞ Page 182, Appendix 3 (4)) • Alert output signal assignment (address: 0004_H) (☞ Page 183, Appendix 3 (5)) • Error flag assignment (address: 0005_H) (☞ Page 184, Appendix 3 (6)) • Warning flag assignment (address: 0006_H) (☞ Page 185, Appendix 3 (7))

(5) When parameters cannot be read or written with GX Works2 and CC-Link IE Field Network diagnostics cannot be performed

Check item	Action
Is the D LINK LED of the main module on?	<p>Check for the D LINK LED of the main module and if it is not on, perform troubleshooting by referring to the following.</p> <ul style="list-style-type: none"> • When the D LINK LED turns off (☞ Page 163, Section 11.4 (5)) • When the D LINK LED flashes (☞ Page 163, Section 11.4 (6)) <p>Check for other LEDs by referring to the following.</p> <ul style="list-style-type: none"> • Checking the LEDs (☞ Page 162, Section 11.4)
Is the version of the module on the master station correct?	<p>Check the serial number (first five digits) of the module on the master station, and if the version is prior to the correct one, replace the module with a module of the applicable version. For the applicable version, refer to the following.</p> <ul style="list-style-type: none"> • Applicable master station (☞ Page 46, Section 5.2 (1))
Is the version of GX Works2 correct?	<p>Check the version of GX Works2, and if the version is prior to the applicable one, update GX Works2. For the applicable version, refer to the following.</p> <ul style="list-style-type: none"> • Software package (☞ Page 46, Section 5.2 (4))
Are network parameter settings same as the settings of the CPU module?	<p>Perform "Verify with PLC" and check that network parameter settings match the settings of the CPU module. If they differ, match the settings by performing "Read from PLC" and "Write to PLC", and write the parameters to modules on slave stations.</p>

APPENDICES

Appendix 1 Details of Remote I/O Signals

This section describes the details of remote I/O signals assigned to the master/local module.

The assignment of each device number is for the case when the remote I/O signals of the main module are assigned as follows.

- Remote input signal: RX0 to RX1F
- Remote output signal: RY0 to RY1F

Appendix 1.1 Remote input signals

(1) Warning flag (RX7)

This signal turns on when a minor error occurs.

Five seconds after the cause of the minor error is eliminated, the value in Latest warning code (RWr1) is cleared (0000_H is stored) and Warning flag (RX7) turns off.

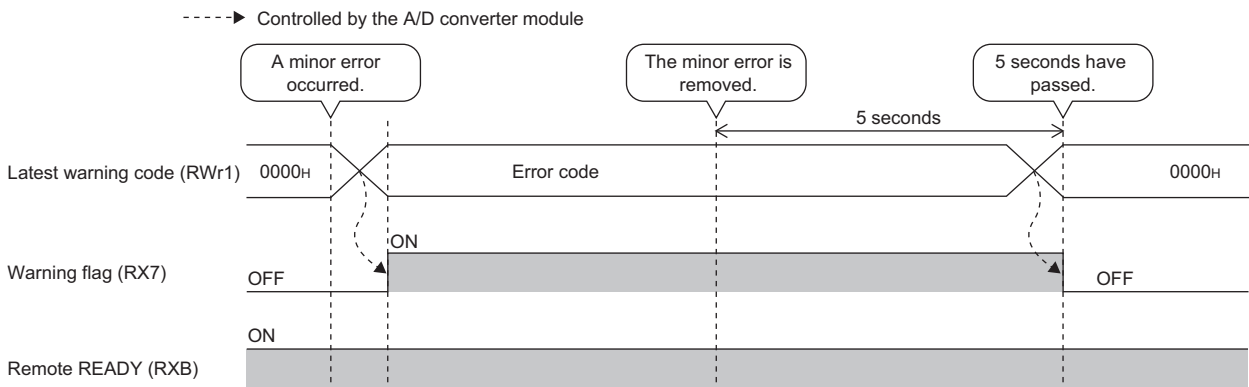

(2) Initial data setting completion flag (RX9)

After writing parameter data to the remote buffer memory using the REMTO instruction, turn on Initial data setting request flag (RY9).

This signal turns on when the operating condition is changed.

When the following settings are changed, the signal is used as an interlock condition to turn Initial data setting request flag (RY9) on and off.

- Mode switch (address: 0000_H)
- Conversion speed switch (address: 0001_H)
- Trigger conversion signal assignment (address: 0002_H)
- Input signal error detection signal assignment (address: 0003_H)
- Alert output signal assignment (address: 0004_H)
- Error flag assignment (address: 0005_H)
- Warning flag assignment (address: 0006_H)
- Cyclic data update watch time setting (address: 0007_H)
- Input response time setting (address: 0010_H)

- Digital output HOLD/CLEAR setting (address: 0011_H)
- A/D conversion enable/disable setting (address: 0102_H)
- Range setting (address: 0103_H)
- Averaging process setting (address: 0104_H)
- CH□ Time average/Count average/Moving average (address: 0105_H to 0108_H)
- Input signal error detection setting (address: 0109_H)
- Alert output setting (address: 010E_H)
- CH□ Process alarm lower lower limit value (address: 010F_H, 0113_H, 0117_H, 011B_H)
- CH□ Process alarm lower upper limit value (address: 0110_H, 0114_H, 0118_H, 011C_H)
- CH□ Process alarm upper lower limit value (address: 0111_H, 0115_H, 0119_H, 011D_H)
- CH□ Process alarm upper upper limit value (address: 0112_H, 0116_H, 011A_H, 011E_H)
- Digital clipping enable/disable setting (address: 011F_H)
- Scaling enable/disable setting (address: 0120_H)
- CH□ Scaling lower limit value (address: 0121_H, 0123_H, 0125_H, 0127_H)
- CH□ Scaling upper limit value (address: 0122_H, 0124_H, 0126_H, 0128_H)

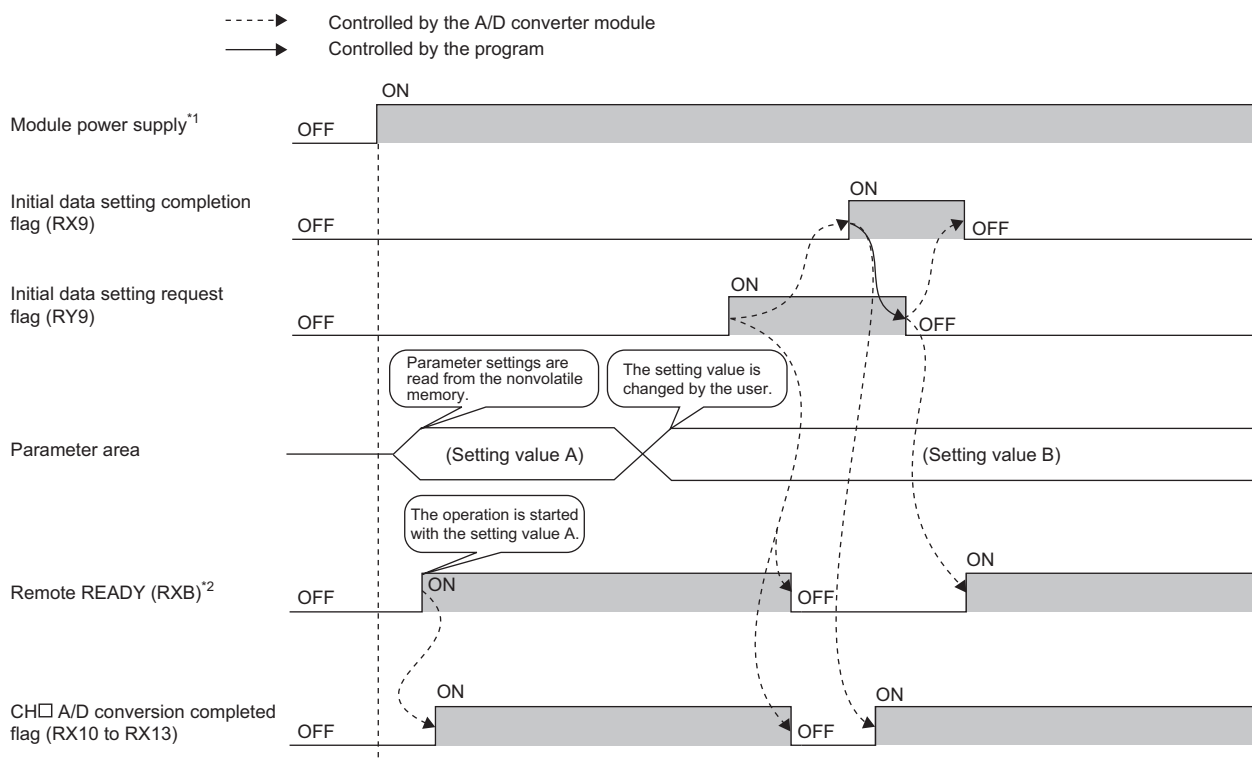

*1 When data link is started at turning on the module power supply

*2 Check that Remote READY (RXB) is turned on, and then start the control when turning on and off Initial data setting request flag (RY9).

(3) Error flag (RXA)

This signal turns on when a moderate or major error occurs.

To clear Latest error code (RWr0), turn on and off Error clear request flag (RYA).

- When a moderate error occurs

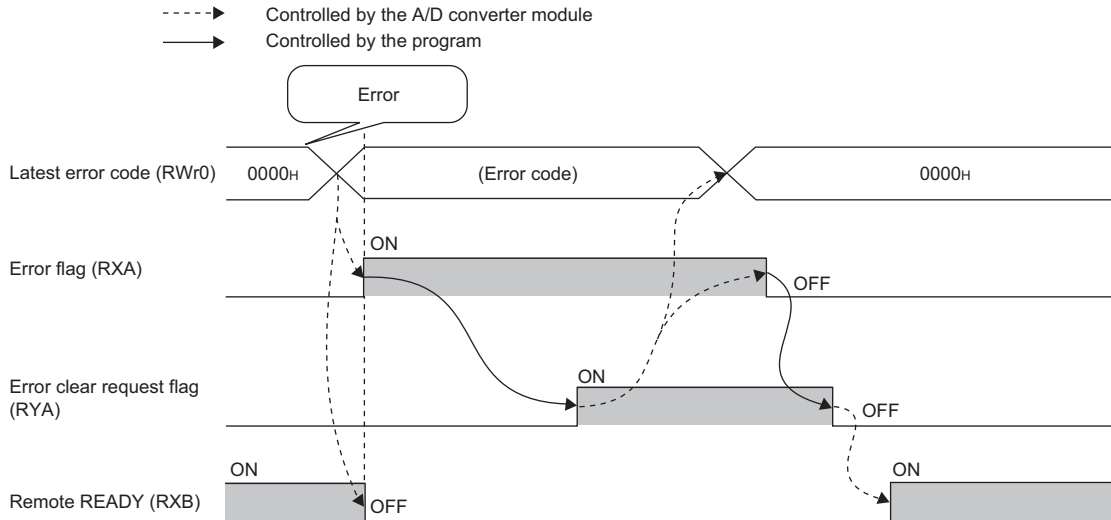

- When a major error occurs

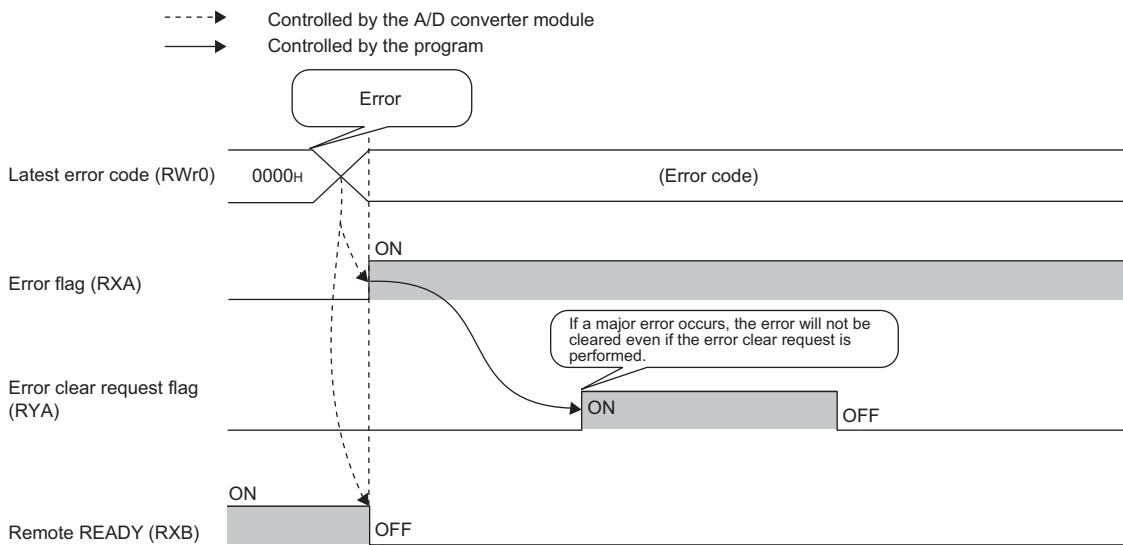

(a) Error history

The error history is not cleared even if Error clear request flag (RYA) is turned on and off.

To clear the error history, set "1" in Error history clear command (address: 1000_H).

For the error history clear, refer to the following.

- Error history clear command (address: 1000_H) (☞ Page 195, Appendix 3 (23))

(4) Remote READY (RXB)

This signal is used as an interlock condition when the master station reads/writes data to/from the remote register or remote buffer memory areas of the A/D converter module.

The signal turns on when the module power supply is turned on.

When Error flag (RXA) turns on, the signal turns off.

(5) CH□ A/D conversion completed flag (RX10 to RX13)

This signal turns on when the A/D conversion of the conversion-enabled channel is completed.
When Initial data setting request flag (RY9) is turned on and off, the signal returns to the default value (off). When the A/D conversion is completed, the signal turns on.

(6) CH□ Difference conversion state flag (RX14 to RX17)

This signal is used to check the difference conversion status.

Difference conversion status	Status of this signal
Not converted	OFF
Converting difference	ON

- When CH□ Difference conversion trigger (RY14 to RY17) is changed from off to on, the signal turns on.
- When CH□ Difference conversion trigger (RY14 to RY17) is changed from on to off, the signal turns off.

(7) Alert output signal (RX18)

This signal turns on when the process alarm is detected.

(a) Process alarm

- The signal turns on when the digital operation value of the conversion-enabled channel exceeds the setting range (the range set from CH1 Process alarm lower lower limit value (address: 010F_H) to CH4 Process alarm upper upper limit value (address: 011E_H)) after enabling the alert output setting (process alarm).
In addition, the corresponding bit in Alert output flag (RW_rB) is set to "1" and the ALM LED turns on.
- When the digital operation values for all the conversion-enabled channels are obtained within the setting range, the corresponding values and status become as follows.

Item	Status
Latest warning code (RW _r 1)	0
Bit corresponding to the channel of Alert output flag (RW _r B)	OFF
Alert output signal (RX18)	OFF
ALM LED	Off

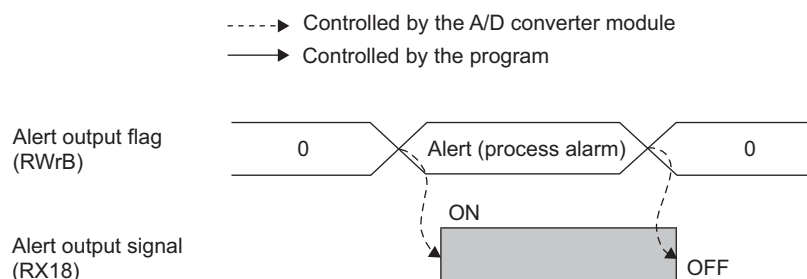

(8) Trigger conversion completed flag (RX19)

- When Trigger conversion request (RY19) is turned on in trigger conversion mode, the A/D converter module performs the A/D conversion to all the conversion-enabled channels and stores the digital operation values in CH□ Digital operation value (RWr2 to RWr5).

When the digital operation values are stored in CH□ Digital operation value (RWr2 to RWr5) of all the conversion-enabled channels, this signal changes from off to on.

- When Trigger conversion completed clear request (RY1A) is changed from on to off while this signal is on, the signal turns off. Check that the signal is off, and turn off Trigger conversion completed clear request (RY1A).
- Even if Trigger conversion request (RY19) is turned on from off while this signal is on, the A/D conversion is performed and the digital operation value is updated.
- When Initial data setting request flag (RY9) is turned on and off, the signal turns off.

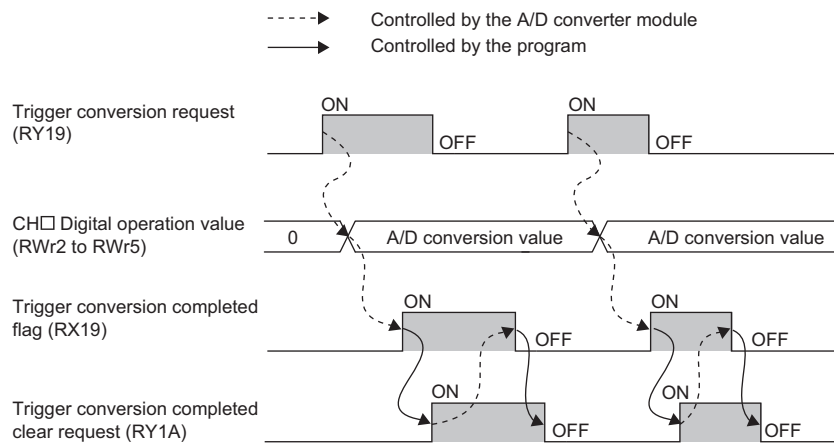

For the trigger conversion function, refer to the following.

- Trigger Conversion Function (☞ Page 115, Section 8.15)

(9) Input signal error detection signal (RX1C)

(a) On status

This signal turns on when Input signal error detection setting (address: 0109_H) is set to Disconnection detection (4_H) and disconnection is detected in any of the conversion-enabled channel.

(b) Off status

The signal turns off when Error clear request flag (RYA) is turned on and off after the analog input value exceeds the disconnection detection condition (2mA or lower, or 0.5V or lower).

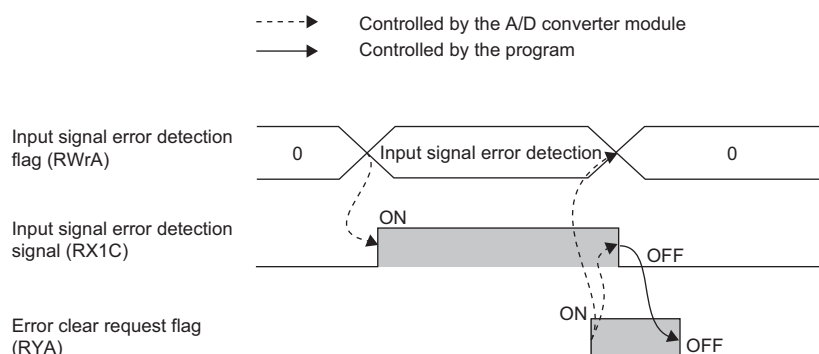

Check that the signal is off before turning off Error clear request flag (RYA). If Error clear request flag (RYA) is turned off earlier, the signal is not cleared.

(c) When the signal turns on

- CH□ A/D conversion completed flag (RX10 to RX13) for the error-detected channel turns off.
- For the error-detected channel, the digital operation value immediately before the error detection is held in the buffer memory.
- The ALM LED flashes.

(d) When the signal turns off

- The ALM LED turns off.
- Latest warning code (RWr1) is cleared.

Point

When the analog input value exceeds the disconnection detection condition (2mA or lower, or 0.5V or lower), A/D conversion resumes regardless of the reset of the signal. When the first A/D conversion after the resumption is completed, CH□ A/D conversion completed flag (RX10 to RX13) for the corresponding channel turns on again. Averaging processing starts over after the A/D conversion resumed.

(10) Maximum value/minimum value reset completed flag (RX1D)

This signal turns on when the maximum value stored in CH□ Maximum value (address: 0601_H, 0603_H, 0605_H, 0607_H) and minimum value stored in CH□ Minimum value (address: 0602_H, 0604_H, 0606_H, 0608_H) are reset by turning on and off Maximum value/minimum value reset request (RY1D).

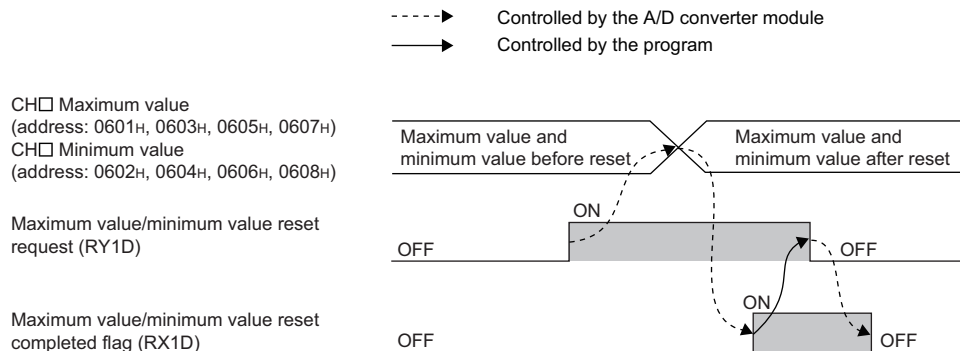

(11) External power supply monitor state flag (RX1F)

This signal turns on when the external power supply monitoring function is being activated by External power supply monitor request flag (RY1F).

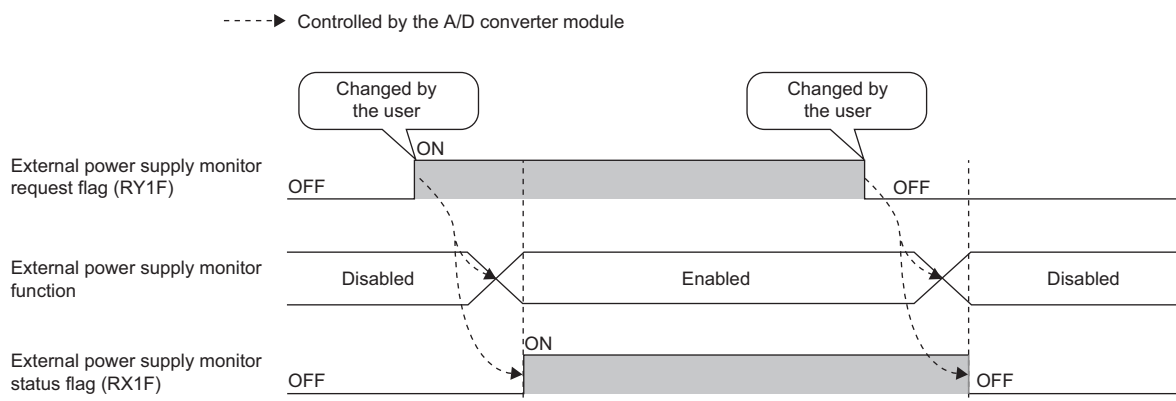

For the external power supply monitoring function, refer to the following.

- External power supply monitoring function (☞ Page 130, Section 8.18 (2))

Appendix 1.2 Remote output signals

(1) Initial data setting request flag (RY9)

Turn on this signal after writing parameter data to the remote buffer memory.

When the operating condition is changed, Initial data setting completion flag (RX9) turns on.

For the on and off timing, refer to the following.

- Initial data setting completion flag (RX9) (☞ Page 168, Appendix 1.1 (2))

(2) Error clear request flag (RYA)

This signal is used to clear Error flag (RXA), Input signal error detection signal (RX1C), and Latest error code (RWr0).

(a) When a moderate error or input signal error detection occurs

When this signal is turned on after the cause of the error is eliminated, the error status is cleared and Error flag (RXA) turns off.

If the signal is turned off before Error flag (RXA) turns off, Error flag (RXA) cannot be turned off.

For the on and off timing, refer to the following.

- Error flag (RXA) (☞ Page 170, Appendix 1.1 (3))
- Input signal error detection signal (RX1C) (☞ Page 173, Appendix 1.1 (9))

(b) When a major error occurs

Error flag (RXA) does not turn off even if Error clear request flag (RYA) is turned on and off.

For the on and off timing, refer to the following.

- Error flag (RXA) (☞ Page 170, Appendix 1.1 (3))

(3) CH□ Difference conversion trigger (RY14 to RY17)

This signal is used as a trigger to start and stop the difference conversion.

For details on the difference conversion function, refer to the following.

- Difference Conversion Function (☞ Page 111, Section 8.14)

Difference conversion trigger	Setting value
No request	OFF
Trigger request	ON

(a) Starting/Stopping the difference conversion

- When CH□ Difference conversion trigger (RY14 to RY17) is turned from No request (OFF) to Trigger request (ON), the difference conversion starts.
- When CH□ Difference conversion trigger (RY14 to RY17) is turned from Trigger request (ON) to No request (OFF), the difference conversion stops.

(4) Trigger conversion request (RY19)

When this signal is turned on in trigger conversion mode, the A/D conversion is performed once using the trigger conversion function for all the conversion-enabled channels.

For the on and off timing, refer to the following.

- Trigger conversion completed flag (RX19) (☞ Page 172, Appendix 1.1 (8))

For the trigger conversion function, refer to the following.

- Trigger Conversion Function (☞ Page 115, Section 8.15)

(5) Trigger conversion completed clear request (RY1A)

- When this signal is turned on while Trigger conversion completed flag (RX19) is on, Trigger conversion completed flag (RX19) changes from on to off.
- Even if the signal is turned on while Trigger conversion completed flag (RX19) is off, Trigger conversion completed flag (RX19) remains off.
- If the signal is not turned on after Trigger conversion completed flag (RX19) is turned on, Trigger conversion completed flag (RX19) remains on.

For the on and off timing, refer to the following.

- Trigger conversion completed flag (RX19) (☞ Page 172, Appendix 1.1 (8))

For the trigger conversion function, refer to the following.

- Trigger Conversion Function (☞ Page 115, Section 8.15)

(6) Maximum value/minimum value reset request (RY1D)

When this signal is turned on and off, CH□ Maximum value (address: 0601_H, 0603_H, 0605_H, 0607_H) and CH□ Minimum value (address: 0602_H, 0604_H, 0606_H, 0608_H) are cleared.

For the on and off timing, refer to the following.

- Maximum value/minimum value reset completed flag (RX1D) (☞ Page 174, Appendix 1.1 (10))

(7) External power supply monitor request flag (RY1F)

Turn on this signal to activate the external power supply monitoring function.

For the on and off timing, refer to the following.

External power supply monitor state flag (RX1F) (☞ Page 174, Appendix 1.1 (11))

Appendix 2 Details of Remote Registers

This section describes details of remote registers for a master/local module.

The assignment of each device number is for the case when the remote registers of the main module are assigned to RWr0 to RWrF and RWw0 to RWwF.

(1) Latest error code (RWr0)

An error code is stored when a moderate error or major error occurs.

Turning on Error clear request flag (RYA) after eliminating the cause of the error clears the error code.

Errors that occurred in the past can be checked with Error history□ (address: 0A00_H to 0AEF_H).

- Error history□ (address: 0A00_H to 0AEF_H) (☞ Page 194, Appendix 3 (22))

(2) Latest warning code (RWr1)

An error code is stored when a minor error occurs. An alarm code is stored when an alarm occurs.

Five seconds after the cause of the occurring minor error is eliminated, the error code or alarm code is automatically cleared.

Errors or alarms that occurred in the past can be checked with Error history□ (address: 0A00_H to 0AEF_H).

- Error history□ (address: 0A00_H to 0AEF_H) (☞ Page 194, Appendix 3 (22))

(3) CH□ Digital operation value (RWr2 to RWr5)

The digital operation value which is obtained by the digital clipping function, scaling function, shift function, and difference conversion function is stored as signed 16-bit binary.

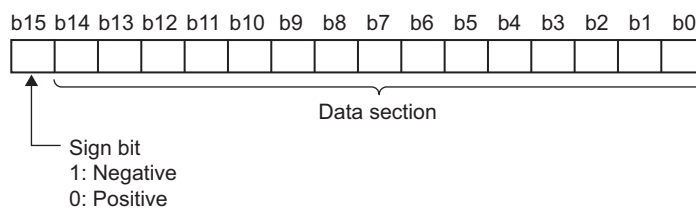

(4) CH□ Difference conversion reference value (RWr6 to RWr9)

The digital operation value at the start of the difference conversion is stored as signed 16-bit binary as the difference conversion reference value.

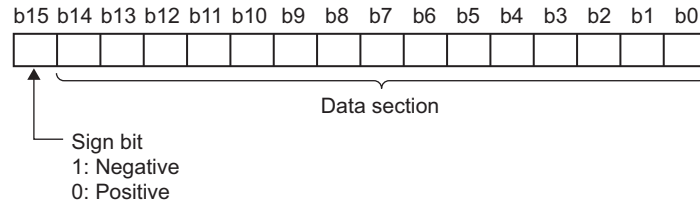

Point

- The difference conversion reference value is updated when CH□ Difference conversion trigger (RY14 to RY17) is turned from No request (OFF) to Trigger request (ON).
- Even if CH□ Difference conversion state flag (RX14 to RX17) is turned from Converting difference (ON) to Not converted (OFF), CH□ Difference conversion reference value (RWr6 to RWr9) is not cleared. For the difference conversion function, refer to the following.
 - Difference conversion function (☞ Page 111, Section 8.14)

(5) Input signal error detection flag (RWrA)

Input signal status can be checked with this flag for each channel.

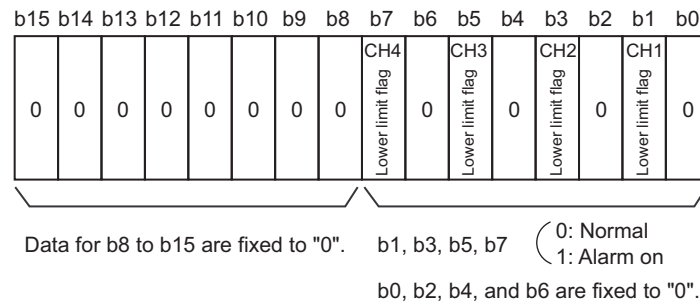

(a) Input signal error detection flag (RWrA) status

- When Input signal error detection setting (address: 0109_H) is set to Disconnection detection (4_H), whether a disconnection occurs or not in the set channel is monitored. When the analog input value satisfies the disconnection detection condition (2mA or 0.5V or less), the bit of the lower limit flag in the corresponding channel turns to Alarm ON (1).
- When an error is detected in any A/D conversion enable channel while the input signal error detection function is used, Input signal error detection signal (RX1C) turns on.

(b) Clearing Input signal error detection flag (RWrA)

- When Error clear request flag (RYA) is turned on and off after the analog input value exceeds the disconnection detection condition (2mA or 0.5V or less), Input signal error detection flag (RWrA) is cleared.
- When Initial data setting request flag (RY9) is turned on and off, Input signal error detection flag (RWrA) is cleared.

(6) Alert output flag (RWrB)

It can be checked whether the alert is for the upper limit value or for the lower limit value for each channel.

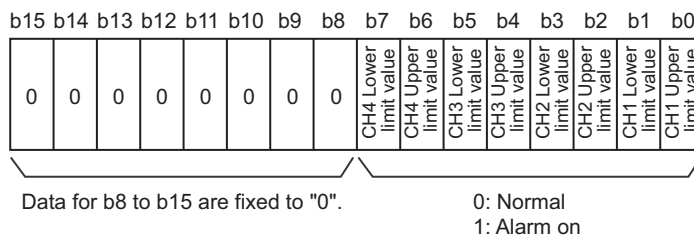

(a) Alert output flag (RWrB) status

- When the value is out of the range specified in CH1 Process alarm lower lower limit value (address: 010F_H) to CH4 Process alarm upper upper limit value (address: 011E_H), Alert output flag (RWrB) corresponding to each channel turns to Alarm ON (1).
- When an error is detected in any A/D conversion enable or alert output enable channels, Alert output signal (RX18) also turns on.

(b) Clearing Alert output flag (RWrB)

- When the digital operation value returns within the setting range, Alert output flag (RWrB) is automatically cleared.
- When Initial data setting request flag (RY9) is turned on and off, Alert output flag (RWrB) is cleared.

(7) CH□ Shifting amount to conversion value (RWw2 to RWw5)

Set the shifting amount to conversion value that is to be used for the shift function in signed 16-bit binary. The digital operation values with shift addition are stored to CH□ Digital operation value (RWw2 to RWw5). For details on the shift function, refer to the following.

- Shift Function (Page 102, Section 8.12)

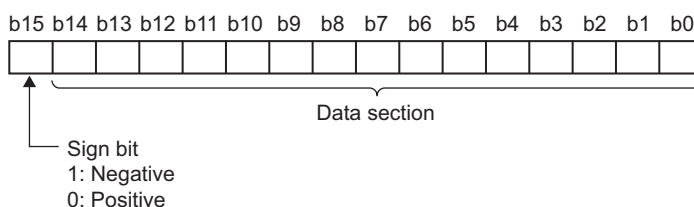

(a) Setting range

Setting range is -32768 to 32767.

(b) Enabling the setting

When the value is set, set shifting amount to conversion value turns valid regardless of turning on and off Initial data setting request flag (RY9).

A

Appendix 2 Details of Remote Registers

Appendix 3 Details of Remote Buffer Memory Addresses

This section describes the details of remote buffer memory addresses.

(1) Mode switch (address: 0000_H)

Set the mode for all channels.

Mode	Setting value
Normal mode	0 _H
Trigger conversion mode	1 _H
Automatic judgment mode	9 _H

When a value other than the above is set, the error code (0730_H) is stored in Latest error code (RWr0), Error flag (RXA) and the ERR. LED turns on, and Automatic judgment mode (9_H) is set to Mode switch (address: 0000_H).

(a) Enabling the setting

1. Turn on and off Initial data setting request flag (RY9).
2. Check that "0920_H" is stored in Latest warning code (RWr1).
3. Turn off and on the power supply.

(b) Default value

The default value is Automatic judgment mode (9_H).

The default value differs depending on the version of the A/D converter module. For details, refer to the following.

- Mode switch (address: 0000_H) (☞ Page 212, Appendix 9.2 (1))

(2) Conversion speed switch (address: 0001_H)

Set the conversion speed for all channels.

Conversion speed	Setting value
400μs/channel	0 _H
1ms/channel	1 _H

In the trigger conversion mode or synchronous communication mode, the above setting is ignored and the A/D converter module operates at the conversion speed of 400μs/channel.

When a value out of the setting range above is set, the error code (0360_H) is stored in Latest error code (RWr0), Error flag (RXA) is turned on, and the ERR. LED turns on.

(a) Enabling the setting

Turn on and off Initial data setting request flag (RY9) to enable the setting.

(b) Default value

The default value is 400μs/channel (0_H).

(3) Trigger conversion signal assignment (address: 0002_H)

Assign Trigger conversion request (RY19) to Remote input (RX) of the extension input module using the external signal assignment function. When assigned Remote input (RX) is turned on, the A/D converter module performs the A/D conversion using the trigger conversion function.

(a) Setting range

Set the number for Remote input (RX) of the extension module, starting from the head number (0000_H) of Remote input (RX) of the main module.

Ex. When Trigger conversion request (RY19) is assigned to 8_H of Remote input (RX) starting from the head number (0_H) of the extension input module

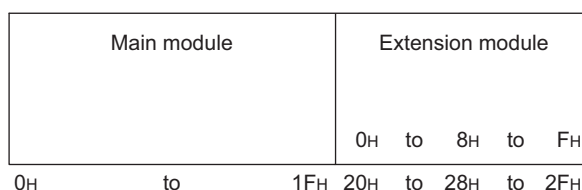

Remote input (RX) of 8_H from the head number of the extension input module corresponds to Remote input (RX) of 28_H from the head number of the main module.

Thus, set 28_H for Trigger conversion signal assignment (address: 0002_H).

(b) Enabling the setting

Turn on and off Initial data setting request flag (RY9) to enable the setting.

(c) Default value

The default value is No assignment (FFFF_H).

Point

- When a value out of the setting range is set, the error code (0170_H) is stored in Latest error code (RWr0), Error flag (RXA) is turned on, and the ERR. LED turns on. The operation is performed in the previous setting.
- When Remote input (RX) of the extension input module is set to Trigger conversion signal assignment (address: 0002_H), the A/D converter module does not perform the A/D conversion even if Trigger conversion request (RY19) is turned on. Turn on Remote input (RX) which is set to Trigger conversion signal assignment (address: 0002_H).

(4) Input signal error detection signal assignment (address: 0003_H)

Assign Input signal error detection signal (RX1C) to Remote output (RY) of the extension output module using the external signal assignment function. When an error of an input signal is detected, assigned Remote output (RY) turns on.

(a) Setting range

Set the number for Remote output (RY) of the extension module, starting from the head number (0000_H) of Remote output (RY) of the main module.

Ex. When Input signal error detection signal (RX1C) is assigned to the first Remote output (RY) of the extension output module

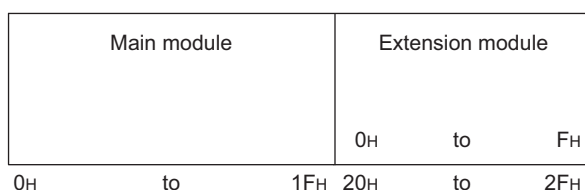

The first Remote output (RY) of the extension output module corresponds to 20_H of Remote output (RY) starting from the head number of the main module.

Thus, set 20_H for Input signal error detection signal assignment (address: 0003_H).

(b) Enabling the setting

Turn on and off Initial data setting request flag (RY9) to enable the setting.

(c) Default value

The default value is No assignment (FFFF_H).

Point

When a value out of the setting range is set, the error code (0171_H) is stored in Latest error code (RWr0), Error flag (RXA) is turned on, and the ERR. LED turns on. The operation is performed in the previous setting.

(5) Alert output signal assignment (address: 0004_H)

Assign Alert output signal (RX18) to Remote output (RY) of the extension output module using the external signal assignment function. When an alarm occurs, assigned Remote output (RY) is turned on.

(a) Setting range

Set the number for Remote output (RY) of the extension module, starting from the head number (0000_H) of Remote output (RY) of the main module.

Ex. When Alert output signal (RX18) is assigned to 2_H of Remote output (RY) starting from the head number (0_H) of the extension output module

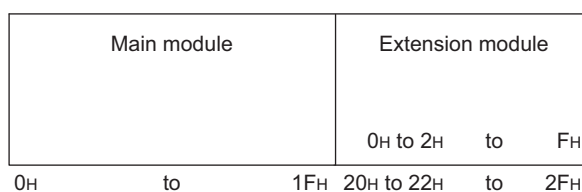

Remote output (RY) of 2_H from the head number of the extension output module corresponds to Remote output (RY) of 22_H from the head number of the main module.

Thus, set 22_H for Alert output signal assignment (address: 0004_H).

(b) Enabling the setting

Turn on and off Initial data setting request flag (RY9) to enable the setting.

(c) Default value

The default value is No assignment (FFFF_H).

Point

When a value out of the setting range is set, the error code (0172_H) is stored in Latest error code (RW_r0), Error flag (RXA) is turned on, and the ERR. LED turns on. The operation is performed in the previous setting.

(6) Error flag assignment (address: 0005_H)

Assign Error flag (RXA) to Remote output (RY) of the extension output module using the external signal assignment function. When a moderate error or major error occurs, assigned Remote output (RY) is turned on.

(a) Setting range

Set the device number for Remote output (RY) of the connected extension module, starting from the head number (0000_H) of Remote output (RY) of the main module.

Ex. When Error flag (RXA) is assigned to 4_H of Remote output (RY) starting from the head number (0_H) of the extension output module

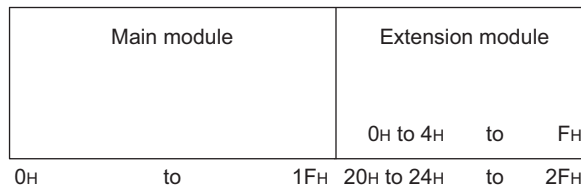

Remote output (RY) of 4_H from the head number of the extension output module corresponds to Remote output (RY) of 24_H from the head number of the main module.

Thus, set 24_H for Alert output signal assignment (address: 0004_H).

(b) Enabling the setting

Turn on and off Initial data setting request flag (RY9) to enable the setting.

(c) Default value

The default value is No assignment (FFFF_H).

Point

When a value out of the setting range is set, the error code (0173_H) is stored in Latest error code (RW_r0), Error flag (RXA) is turned on, and the ERR. LED turns on. The operation is performed in the previous setting.

(7) Warning flag assignment (address: 0006_H)

Assign Warning flag (RX7) to Remote output (RY) of the extension output module using the external signal assignment function. When a minor error occurs, assigned Remote output (RY) is turned on.

(a) Setting range

Set the device number for Remote output (RY) of the connected extension module, starting from the head number (0000_H) of Remote output (RY) of the main module.

Ex. When Warning flag (RX7) is assigned to 6_H of Remote output (RY) starting from the head number (0_H) of the extension output module

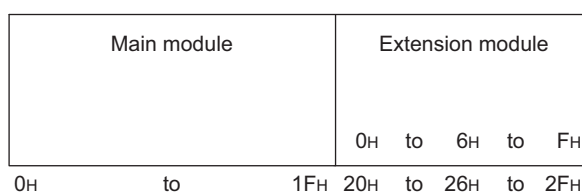

Remote output (RY) of 6_H from the head number of the extension output module corresponds to Remote output (RY) of 26_H from the head number of the main module.

Thus, set 26_H for Warning flag assignment (address: 0006_H).

(b) Enabling the setting

Turn on and off Initial data setting request flag (RY9) to enable the setting.

(c) Default value

The default value is No assignment (FFFF_H).

Point

When a value out of the setting range is set, the error code (0174_H) is stored in Latest error code (RW_r0), Error flag (RXA) is turned on, and the ERR. LED turns on. The operation is performed in the previous setting.

(8) Cyclic data update watch time setting (address: 0007_H)

This signal is used to set the time to monitor the data update interval of the cyclic transmission (watch time). When the cyclic transmission remains to be stopped over the cyclic data update watch time setting, the A/D converter module is regarded as disconnected. Then the output status of the extension output module becomes HOLD (1_H) or CLEAR (0_H) according to Digital output HOLD/CLEAR setting (address: 0011_H). For Digital output HOLD/CLEAR setting (address: 0011_H), refer to the following.

- Digital output HOLD/CLEAR setting (address: 0011_H) (☞ Page 187, Appendix 3 (10))

(a) Setting range

Setting range is Not monitor (0) or 0.1 to 2 seconds (1 to 20). Set the value in increments of 100ms (1).

(b) Enabling the setting

Turn on and off Initial data setting request flag (RY9).

(c) Default value

The default value is set to Not monitor (0).

Point

- If a value out of the setting range is set, the error code (0930_H) is stored in Latest error code (RWr0), Error flag (RXA) turns on, and the ERR. LED turns on. Then the I/O operation stops.
- In the synchronous communication mode, the A/D converter module operates with Not monitor (0) being set even if the other value is set.

(9) Input response time setting (address: 0010_H)

Set the input response time of the extension input module.

Input response time	Setting value
1.0ms	2 _H
1.5ms	3 _H
5ms	4 _H
10ms	5 _H
20ms	6 _H
70ms	7 _H

(a) Enabling the setting

Turn on and off Initial data setting request flag (RY9) to enable the setting.

(b) Default value

The default value is 10ms (5_H).

Point

- If data other than the above is set, the error code (1F40_H) is stored in Latest error code (RWr0), Error flag (RXA) is turned on, and the ERR. LED turns on.
- When no extension input module is connected, the setting of Input response time setting (address: 0010_H) is ignored.

(10) Digital output HOLD/CLEAR setting (address: 0011_H)

Set the output HOLD/CLEAR of the extension output module.

For the output HOLD/CLEAR setting function, refer to the following.

 CC-Link IE Field Network Remote I/O Module User's Manual

Output HOLD/CLEAR setting	Setting value
CLEAR	0 _H
HOLD	1 _H

(a) Enabling the setting

Turn on and off Initial data setting request flag (RY9) to enable the setting.

(b) Default value

The default value is CLEAR (0_H).

Point

- When no extension output module is connected, the setting of Digital output HOLD/CLEAR setting (address: 0011_H) is ignored.
- When the data other than above is set, the A/D converter module operates with the setting value of the lower 1 bit.

(11) A/D conversion enable/disable setting (address: 0102_H)

Set if the A/D conversion is enabled or disabled for each channel.

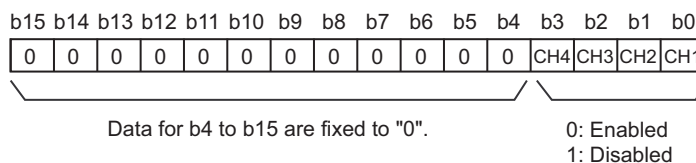
**(a) Enabling the setting**

Turn on and off Initial data setting request flag (RY9) to enable the setting.

(b) Default value

The default value is Enabled (0) for all channels.

(12) Range setting (address: 0103_H)

Set the input range for each channel.

b15 to b12	b11 to b8	b7 to b4	b3 to b0
CH4	CH3	CH2	CH1

Input range	Setting value
4 to 20mA	0 _H
0 to 20mA	1 _H
1 to 5V	2 _H
0 to 5V	3 _H
-10 to 10V	4 _H
User range setting 1	5 _H
User range setting 2	6 _H

(a) Enabling the setting

Turn on and off Initial data setting request flag (RY9) to enable the setting.

(b) Default value

The default value is 4 to 20mA (0_H).

Point

If data other than the above is set, the error code (010□_H) is stored in Latest error code (RWr0), Error flag (RXA) is turned on, and the ERR. LED turns on. In the channel for which data other than the above is set, the A/D converter module operates in the same way as when the A/D conversion is set to disabled.

(13)Averaging process setting (address: 0104_H)

Configure the setting when selecting sampling or averaging processing for each channel.

Averaging processing includes time average, count average and moving average.

b15	to	b12	b11	to	b8	b7	to	b4	b3	to	b0
CH4			CH3			CH2			CH1		

Processing method	Setting value
Sampling processing	0 _H
Time average	1 _H
Count average	2 _H
Moving average	3 _H

(a) Enabling the setting

Turn on and off Initial data setting request flag (RY9) to enable the setting.

(b) Default value

The default value is Sampling processing (0_H) for all channels.

Point

- In the trigger conversion mode or synchronous communication mode, the setting of Averaging process setting (address: 0104_H) is ignored and the sampling processing is performed.
- The channel to which a value out of the above setting range is written performs the operation in the sampling processing.

(14)CH□ Time average/Count average/Moving average (address: 0105_H to 0108_H)

Configure the time/count/moving average setting for each channel to which the averaging processing is specified.

The following shows the setting range.

Processing method	Setting value
Time average ^{*1}	2 to 5000(ms)
Count average ^{*2}	4 to 65000 (times)
Moving average ^{*2}	2 to 128 (times)

*1 For time average, set a value of (4 × Sampling cycle) ms or more. If a value less than the above is set, an error occurs. The error code (020□_H) is stored in Latest error code (RWr0), Error flag (RXA) turns on, and the ERR. LED turns on. In CH□ Digital operation value (RWr2 to RWr5), 0 is stored.

*2 If data other than the above is set, the error code (030□_H or 031□_H) is stored in Latest error code (RWr0), Error flag (RXA) turns on, and the ERR. LED turns on. The A/D conversion is processed in the setting configured before the error occurrence.

(a) Enabling the setting

Turn on and off Initial data setting request flag (RY9) to enable the setting.

(b) Default value

The default value is 0 for all channels.

Point

- Because 0 is set as the default value, change the value according to the processing method.
- When the sampling processing is set to the channel to which the setting value has been set, the setting value is ignored.

(15) Input signal error detection setting (address: 0109_H)

Set the condition for detecting input signal errors for each channel.

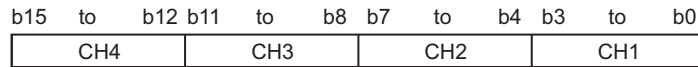

Detection method for input signal error	Setting value
Disable	0 _H
Disconnection detection	4 _H

(a) Enabling the setting

Turn on and off Initial data setting request flag (RY9) to enable the setting.

(b) Default value

The default value is Disable (0_H) for all channels.

Point

Disconnection detection (4_H) is valid only when the input range is 1 to 5V or 4 to 20mA. If Disconnection detection (4_H) is set to the channel for which another input range is set, the disconnection detection setting error (error code: 082□) occurs.

(16) Alert output setting (address: 010E_H)

Set whether the alarm output of process alarm is enabled or disabled for each channel.

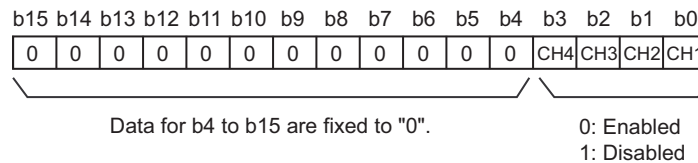

(a) Enabling the setting

Turn on and off Initial data setting request flag (RY9) to enable the setting.

(b) Default value

The default value is Disable (1) for all channels.

- (17)CH□ Process alarm lower lower limit value (address: 010F_H, 0113_H, 0117_H, 011B_H),
- CH□ Process alarm lower upper limit value (address: 0110_H, 0114_H, 0118_H, 011C_H),
- CH□ Process alarm upper lower limit value (address: 0111_H, 0115_H, 0119_H, 011D_H),
- CH□ Process alarm upper upper limit value (address: 0112_H, 0116_H, 011A_H, 011E_H)

Set the digital operation value range for each channel.

For details on Alert output function (process alarm), refer to the following.

- Alert Output Function (Process Alarm) (📖 Page 94, Section 8.10)

(a) Setting range

- Setting range is -32768 to 32767.
- Configure the 4-step setting of process alarm upper upper limit value, process alarm upper lower limit value, process alarm lower upper limit value, and process alarm lower lower limit value.

(b) Enabling the setting

Turn on and off Initial data setting request flag (RY9) to enable the setting.

(c) Default value

The default value is 0.

Point

- When a value out of the setting range above or a value which does not satisfy the formula of process alarm upper upper limit value \geq process alarm upper lower limit value \geq process alarm lower upper limit value \geq process alarm lower lower limit value is set to a channel, an error occurs in the channel. The error code (06△□_H) is stored in Latest error code (RWr0), and Error flag (RXA) turns on. The operation is performed in the setting configured before the error occurrence.
- Because the default value is 0, change the setting value.
- When the following functions are used, alert targets are digital operation values that reflect the operations of each function. Set values considering operation results of each function.
 - Digital clipping function
 - Scaling function
 - Shift function
 - Difference conversion function

(18) Digital clipping enable/disable setting (address: 011F_H)

Set whether the digital clipping function is enabled or disabled, for each channel.
For details on the digital clipping function, refer to the following.

- Digital Clipping Function (☞ Page 106, Section 8.13)

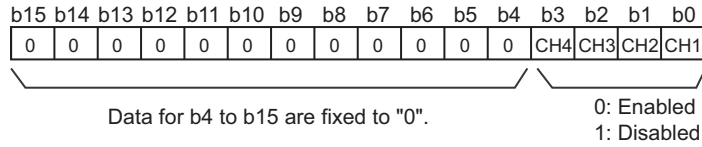

(a) Enabling the setting

Turn on and off Initial data setting request flag (RY9) to enable the setting.

(b) Default value

The default value is Disabled (1) for all channels.

(19) Scaling enable/disable setting (address: 0120_H)

Set whether the scaling is enabled or disabled, for each channel.

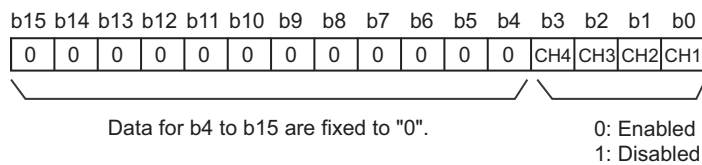

(a) Enabling the setting

Turn on and off Initial data setting request flag (RY9) to enable the setting.

(b) Default value

The default value is Disabled (1) for all channels.

(20)CH□ Scaling lower limit value (address: 0121_H, 0123_H, 0125_H, 0127_H),**CH□ Scaling upper limit value (address: 0122_H, 0124_H, 0126_H, 0128_H)**

Set the range of scale conversion for each channel.

For details on the scaling function, refer to the following.

- Scaling Function (☞ Page 97, Section 8.11)

(a) Setting range

Setting range: -32000 to 32000 (scaling upper limit value > scaling lower limit value)

(b) Enabling the setting

Turn on and off Initial data setting request flag (RY9) to enable the setting.

(c) Default value

The default value 0 for all channels.

Point!

- When a value out of the setting range above or a value which does not satisfy the formula of scaling upper limit value > scaling lower limit value is set to a channel, an error occurs in the channel. The error code (090□_H or 091□_H) is stored in Latest error code (RWr0), and Error flag (RXA) turns on. The operation is performed in the setting configured before the error occurrence.
- Because the default value is 0, change the setting value.
- When Scaling enable/disable setting (0120_H) is set to Disabled (1), the settings for the following areas are ignored.
 - CH□ Scaling lower limit value (address: 0121_H, 0123_H, 0125_H, 0127_H)
 - CH□ Scaling upper limit value (address: 0122_H, 0124_H, 0126_H, 0128_H)

(21)CH□ Maximum value (address: 0601_H, 0603_H, 0605_H, 0607_H),**CH□ Minimum value (address: 0602_H, 0604_H, 0606_H, 0608_H)**

The maximum and minimum values of converted digital operation value are stored as signed 16-bit binary.

In the following cases, CH□ Maximum value (address: 0601_H, 0603_H, 0605_H, 0607_H) and CH□ Minimum value (address: 0602_H, 0604_H, 0606_H, 0608_H) are updated with the current value.

- When Initial data setting request flag (RY9) is turned on and off to change the setting
- When Maximum value/minimum value reset request (RY1D) is turned on and off

Point!

- If averaging processing is specified, the maximum and minimum values are updated per averaging process cycle. Otherwise they are updated per sampling cycle.
- In CH□ Maximum value (address: 0601_H, 0603_H, 0605_H, 0607_H) and CH□ Minimum value (address: 0602_H, 0604_H, 0606_H, 0608_H), the values calculated by each function is stored using the following functions:
 - Digital clipping function
 - Scaling function
 - Shift function
 - Difference conversion function

(22)Error history □ (address: 0A00_H to 0AEF_H)

Up to 15 errors generated in the module are recorded.

The following table and figure show the storage contents for Error history 1 (address: 0A00_H to 0A0F_H).

	b15	to	b8	b7	to	b0
0A00 _H	Error code					
0A01 _H	Order of generation					
0A02 _H	First two digits of the year			Last two digits of the year		
0A03 _H	Month			Date		
0A04 _H	Hour			Minute		
0A05 _H	Second			00 _H (Fixed)		
0A06 _H	CH1 Digital operation value					
0A07 _H	CH2 Digital operation value					
0A08 _H	CH3 Digital operation value					
0A09 _H	CH4 Digital operation value					
0A0A _H to 0A0F _H	System area					

Item	Storage contents	Storage example ^{*1}
Error code	The error code of the error that occurred is stored.	-
Order of generation	The order of error occurrence is stored.	2 _H
First two digits of the year/Last two digits of the year ^{*2}	The items on the left are stored in BCD code.	2012 _H
Month/Date ^{*2}		0829 _H
Hour/Minute ^{*2}		1035 _H
Second/00 _H (Fixed) ^{*2}		40 _H
CH1 Digital operation value	The value in CH□ Digital operation value (RWr2 to RWr5) when an error occurs is stored.	-
CH2 Digital operation value		
CH3 Digital operation value		
CH4 Digital operation value		

*1 Those are values when the second error occurs at 13:30:50, September 1st, 2012.

*2 The clock information of the error that occurred is based on the clock information acquired from the CPU module of the master station.

When an error has occurred before the clock information is acquired from the CPU module, the error time is not recorded.

Error history 2 to Error history 15 (address: 0A10_H to 0AEF_H) are stored in the same format as that of Error history 1 (address: 0A00_H to 0A0F_H).

For the error code, refer to the following.

- Error Code List (☞ Page 154, Section 11.2)

(a) Storage order of the error history

The latest error is stored in Error history 1 (address: 0A00_H to 0A0F_H).

Errors that occurred in the past are stored in Error history 2 to Error history 15 (address: 0A10_H to 0AEF_H) in reverse chronological order.

If 16 or more errors occur, errors are deleted from the oldest.

(23)Error history clear command (address: 1000_H)

This command is used to clear the error history stored in the nonvolatile memory.

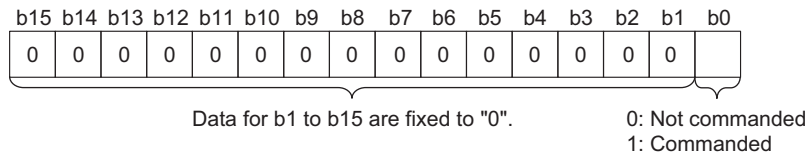

(a) Operation of error history clear

When Error history clear command (address: 1000_H) is set to Commanded (1), an error history is cleared.

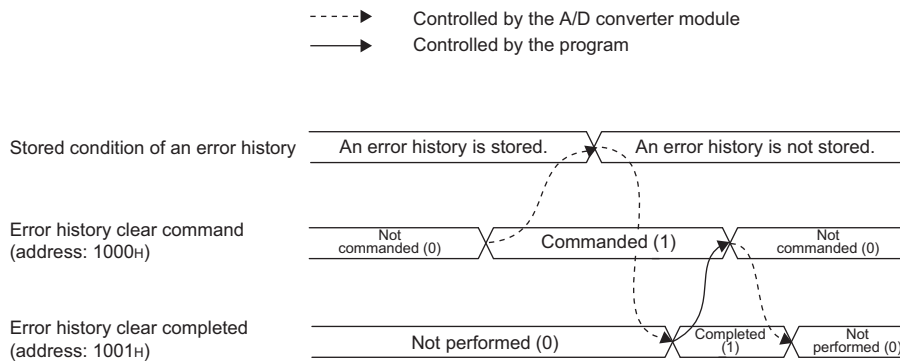

(b) Default value

The default value is Not commanded (0).

(24)Error history clear completed (address: 1001_H)

This remote buffer memory shows the error history clear completed status stored in the nonvolatile memory.

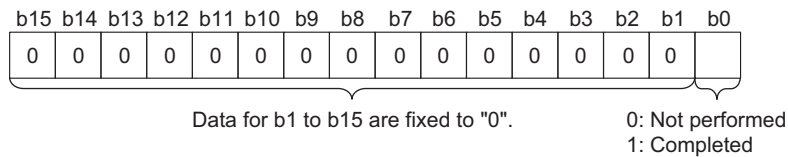

(a) Operation of error history clear

When the error history clear is completed, Error history clear completed (address: 1001_H) is turned to Completed (1).

For the timing of turning the bit Not performed (0)→Completed (1)→Not performed (0), refer to the following.

- Error history clear command (address: 1000_H) (Page 195, Appendix 3 (23))

(b) Default value

The default value is Not performed (0).

A

Appendix 3 Details of Remote Buffer Memory Addresses

(25)Parameter area initialization command (address: 1002_H)

This command is used to set parameters in remote buffer memory areas and non-volatile memory to a default value.

The module can be restored using this command when Nonvolatile memory data error (parameter) (error code: 0130_H) occurs.

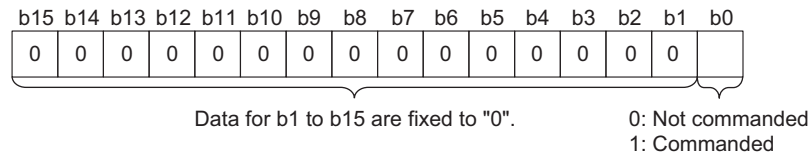

(a) Operation of the parameter area initialization

When Parameter area initialization command (address: 1002_H) is set to Commanded (1), the parameters stored in a nonvolatile memory is set to the default value.

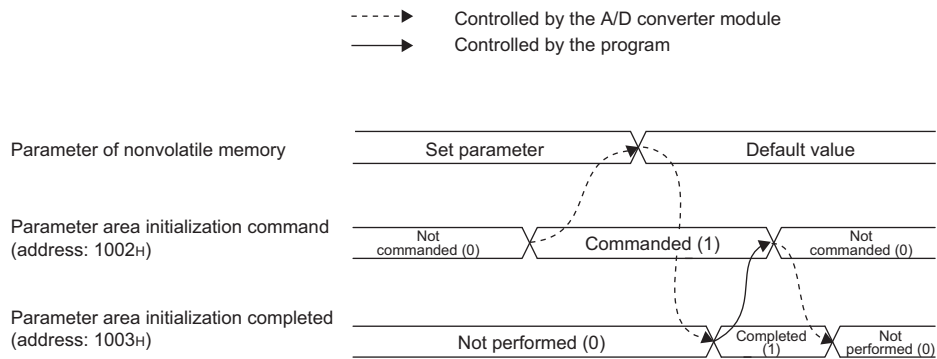

(b) Default value

The default value is Not commanded (0).

Point

Even if Parameter area initialization command (address: 1002_H) is executed, the following remote input signals are not cleared.

- Warning flag (RX7)
- Error flag (RXA)
- Alert output signal (RX18)
- Input signal error detection signal (RX1C)

In addition, Remote READY (RXB) does not turn on.

After Parameter area initialization command (address: 1002_H) is performed, the A/D converter module operates normally by turning off and on the module.

(26)Parameter area initialization completed (address: 1003_H)

This remote buffer memory area shows whether initialization of the parameters stored in a nonvolatile memory is completed or not.

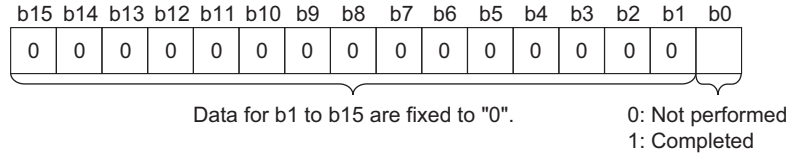

(a) Operation of the parameter area initialization

When setting the parameters stored in a nonvolatile memory is completed, Parameter area initialization completed (address: 1003_H) is turned Completed (1). For the timing of turning the bit Not performed (0)→Completed (1)→Not performed (0), refer to the following.

- Parameter area initialization command (address: 1002_H) (Page 196, Appendix 3 (25))

(b) Default value

The default value is Not performed (0).

(27)Module operation information initialization command (address: 1004_H)

This command is used to clear the module operation information stored in the nonvolatile memory. The module operation information can be initialized only when Nonvolatile memory data error (module operation information) (error code: 0110_H) has occurred.

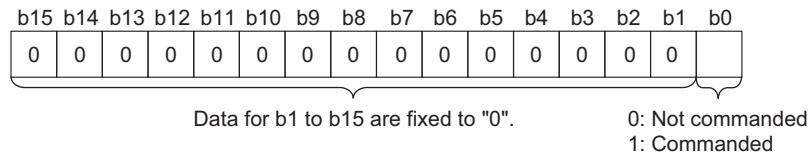

(a) Operation of the module operation information initialization

When Module operation information initialization command (address: 1004_H) is set to Commanded (1), the module operation information is initialized.

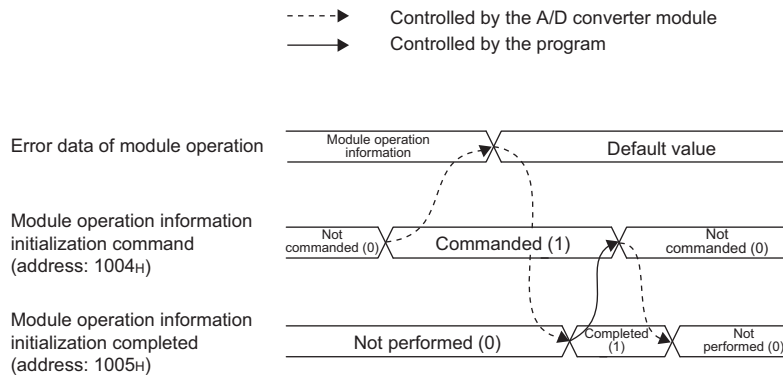

(b) Default value

The default value is Not commanded (0).

A

Appendix 3 Details of Remote Buffer Memory Addresses

(28) Module operation information initialization completed (address: 1005_H)

This remote buffer memory area shows whether initialization of the module operation information stored in a nonvolatile memory is completed or not.

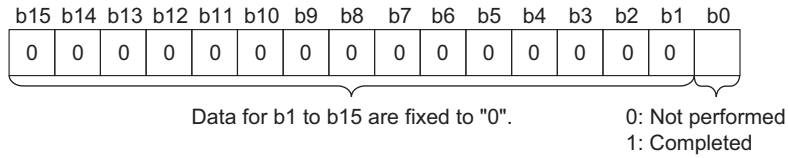

(a) Operation of the module operation information initialization

When initialization of the module operation information is completed, Module operation information initialization completed (address: 1005_H) is turned to Completed (1).

For the timing of turning the bit Not performed (0)→Completed (1)→Not performed (0), refer to the following.

- Module operation information initialization command (address: 1004_H) (☞ Page 197, Appendix 3 (27))

(b) Default value

The default value is Not performed (0).

Appendix 4 I/O Conversion Characteristics of A/D Conversion

The I/O conversion characteristics of A/D conversion are the gradient of a straight line connecting an offset value and a gain value when an analog signal (voltage or current input) from outside the programmable controller is converted to a digital value.

(1) Offset value

An analog input value (voltage or current) which turns 0 as a digital output value after conversion

(2) Gain value

An analog input value (voltage or current) which turns 16000 as a digital output value after conversion

A

(3) Voltage input characteristics

The following graph shows the voltage input characteristics.

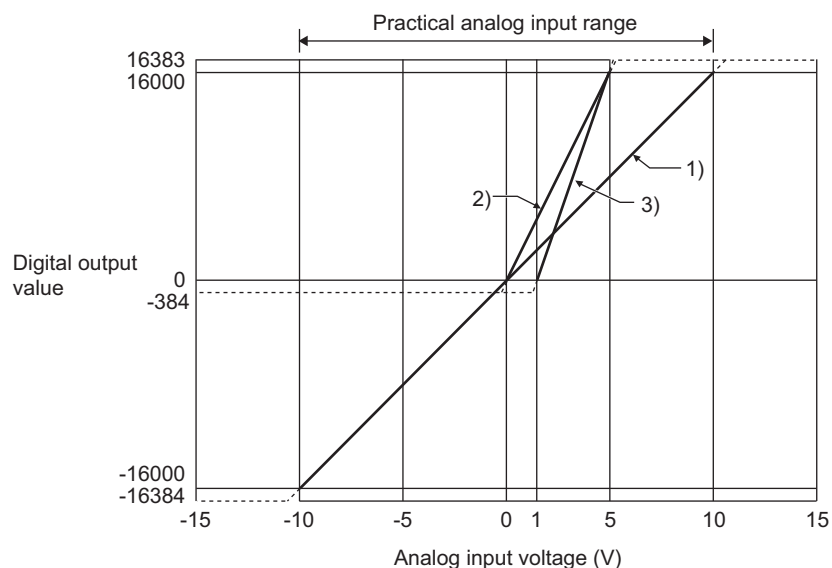

No.	Input range setting	Offset value	Gain value	Digital output value*2	Maximum resolution
1)	-10 to 10V	0V	10V	-16000 to 16000	0.625mV
-	User range setting 1 (-10 to 10V)	*1	*1	-16000 to 16000	0.5mV
-	User range setting 2 (-5V to 5V)	*1	*1	-16000 to 16000	0.25mV
2)	0 to 5V	0V	5V	0 to 16000	0.3125mV
3)	1 to 5V	1V	5V	0 to 16000	0.25mV

*1 Set the offset value and gain value in the user range setting within the range satisfying the following conditions. If the following conditions are not satisfied, A/D conversion may not be properly performed.

<User range setting 1>

- Setting range for offset value and gain value: -10 to 10V
- $((\text{Gain value}) - (\text{Offset value})) \geq 8.0\text{V}$
- $10.433\text{V} \geq (\text{Gain value} - (\text{Offset value} \times 2))$

<User range setting 2>

- Setting range for offset value and gain value: -5 to 5V
- $((\text{Gain value}) - (\text{Offset value})) \geq 4.0\text{V}$
- $5.21\text{V} \geq (\text{Gain value} - (\text{Offset value} \times 2))$

*2 When the analog input value exceeds the range of digital output values, the digital output value is fixed to the maximum or minimum value.

Input range setting	Digital output value	
	Minimum	Maximum
-10 to 10V	-16384	16383
User range 1 (-10 to 10V)		
User range 2 (-5 to 5V)		
0 to 5V	-384	
1 to 5V		

Point

- Use the value within the practical analog input range and practical digital output range. If a value is out of the range, the maximum resolution and accuracy may not fall within the range of performance specifications. (Do not use the value in the dotted line region in the graph of voltage input characteristics.)
- Do not input a value of $\pm 15\text{V}$ or more. This may damage the elements.

(4) Current input characteristics

The following graph shows the current input characteristics.

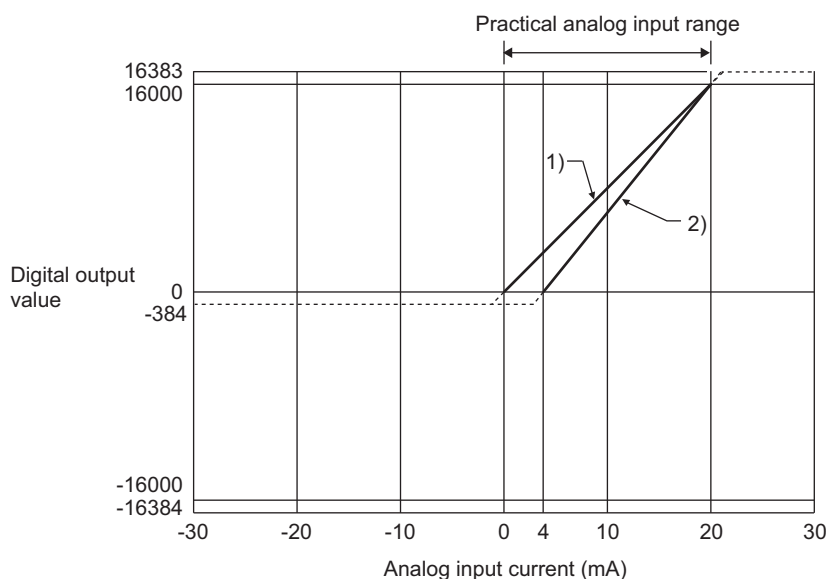

No.	Input range setting	Offset value	Gain value	Digital output value ^{*2}	Maximum resolution
1)	0 to 20mA	0mA	20mA	0 to 16000	1.25μA
2)	4 to 20mA	4mA	20mA		1μA
-	User range setting 2 (-20mA to 20mA)	*1	*1	-16000 to 16000	1μA

*1 Set the offset value and gain value in the user range setting within the range satisfying the following conditions. If the following conditions are not satisfied, A/D conversion may not be properly performed.

- Gain value ≤ 20mA, offset value ≥ -20mA
- ((Gain value) - (Offset value)) ≥ 16mA
- 20.84mA ≥ (Gain value - (Offset value × 2))

*2 When the analog input value exceeds the range of digital output values, the digital output value is fixed to the maximum or minimum value.

Input range setting	Digital output value	
	Minimum	Maximum
0 to 20mA	-384	16383
4 to 20mA		
User range setting 2 (-20mA to 20mA)	-16384	

Point

- Use the value within the practical analog input range and practical digital output range. If a value is out of the range, the maximum resolution and accuracy may not fall within the range of performance specifications. (Do not use the value in the dotted line region in the graph of current input characteristics.)
- Do not input a value of ±30mA or more. This may damage the elements.

A

Appendix 4 I/O Conversion Characteristics of A/D Conversion

Appendix 5 Accuracy of A/D Conversion

The accuracy of A/D conversion is measured for the maximum digital output value.

Even if the offset/gain setting or input range was changed to change input characteristics, the accuracy remains the same, and is kept within the range described in performance specifications.

The following graph shows the variation range of the accuracy for the -10 to 10V range.

When the operating ambient temperature is 0 to 55°C, a digital value is output with the accuracy within $\pm 0.2\%$ (± 32 digit). (Note that this will not apply when the A/D converter module is influenced by noise.)

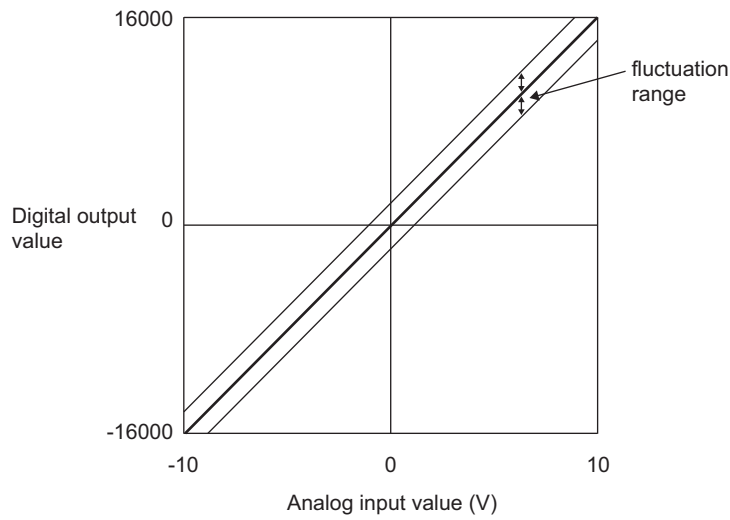

Appendix 6 Conversion Speed of A/D Conversion

The conversion speed is the time for taking in an analog input value and converting it to a digital operation value. However, the CC-Link IE Field Network requires additional time for data link processing. Therefore, the time of the cycle to store the value in CH□ Digital operation value (RWr2 to RWr5) is calculated by the following formula.

Data link processing time = SM + LS + Remote device station processing time [ms]

SM : Scan time of the program in the master station
LS : Link scan time
Remote device station processing time : Conversion speed × Number of conversion-enabled channels

For details on the data link processing time, refer to the following.

 User's manual for the master/local module used

A

Appendix 7 EMC and Low Voltage Directives

In each country, laws and regulations concerning electromagnetic compatibility (EMC) and electrical safety are enacted.

For the products sold in the European countries, compliance with the EU's EMC Directive has been a legal obligation as EMC regulation since 1996, as well as the EU's Low Voltage Directive as electrical safety regulation since 1997. Manufacturers who recognize their products are compliant with the EMC and Low Voltage Directives are required to attach a "CE marking" on their products in European countries.

In some other countries and regions, manufacturers are required to make their products compliant with applicable laws or regulations and attach a certification mark on the products as well (such as UK Conformity Assessed (UKCA) marking in the UK, and Korea Certification (KC) marking in South Korea).

Each country works to make their regulatory requirements consistent across countries based on international standards. When the requirements are consistent, measures to comply with the EMC and electrical safety regulations become common across countries.

The UK and South Korea have enacted EMC regulations whose requirements are consistent with those of the EMC Directive.

The UK has also enacted electrical safety regulations whose requirements are consistent with those of the Low Voltage Directive. In this section, the requirements of the EMC and Low Voltage Directives are described as examples of those of the EMC and electrical safety regulations.

Appendix 7.1 Measures to comply with the EMC Directive

The EMC Directive specifies that "products placed on the market must be so constructed that they do not cause excessive electromagnetic interference (emissions) and are not unduly affected by electromagnetic interference (immunity)".

This section summarizes the precautions on compliance with the EMC Directive of the machinery constructed with the module.

These precautions are based on the requirements and the standards of the regulation, however, it does not guarantee that the entire machinery constructed according to the descriptions will comply with abovementioned directives.

The method and judgement for complying with the EMC Directive must be determined by the person who constructs the entire machinery.

(1) EMC Directive related standards

(a) Emission requirements

Specification	Test item	Test details	Standard value
EN61131-2: 2007	CISPR16-2-3 Radiated emission ^{*2}	Radio waves from the product are measured.	<ul style="list-style-type: none"> • 30M-230MHz QP: 40dBμV/m (10m in measurement range)^{*1} • 230M-1000MHz QP: 47dBμV/m (10m in measurement range)
	CISPR16-2-1, CISPR16-1-2 Conducted emission ^{*2}	Noise from the product to the power line is measured.	<ul style="list-style-type: none"> • 150k-500kHz QP: 79dB, Mean: 66dB^{*1} • 500k-30MHz QP: 73dB, Mean: 60dB

*1 QP: Quasi-peak value, Mean: Average value

*2 The module is an open type device (a device designed to be housed in other equipment) and must be installed inside a conductive control panel. The tests were conducted with the module installed in a control panel.

(b) Immunity requirements

Specification	Test item	Test details	Standard value
EN61131-2: 2007	EN61000-4-2 Electrostatic discharge immunity ^{*1}	Immunity test in which electrostatic is applied to the cabinet of the equipment.	<ul style="list-style-type: none"> • 8kV Air discharge • 4kV Contact discharge
	EN61000-4-3 Radiated, radio-frequency, electromagnetic field immunity ^{*1}	Immunity test in which electric fields are irradiated to the product.	80% AM modulation@1kHz <ul style="list-style-type: none"> • 80M-1000MHz: 10V/m • 1.4G-2.0GHz: 3V/m • 2.0G-2.7GHz: 1V/m
	EN61000-4-4 Electrical fast transient/burst immunity ^{*1}	Immunity test in which burst noise is applied to the power line and signal line.	<ul style="list-style-type: none"> • AC/DC main power, I/O power, AC I/O (unshielded): 2kV • DC I/O, analog, communication: 1kV
	EN61000-4-5 Surge immunity ^{*1}	Immunity test in which lightning surge is applied to the power line and signal line.	<ul style="list-style-type: none"> • AC power line, AC I/O power, AC I/O (unshielded): 2kV CM, 1kV DM • DC power line, DC I/O power: 0.5kV CM, DM • DC I/O, AC I/O (shielded), analog^{*2}, communication: 1kV CM
	EN61000-4-6 Immunity to conducted disturbances, induced by radio-frequency fields ^{*1}	Immunity test in which high frequency noise is applied to the power line and signal line	0.15M-80MHz, 80% AM modulation @1kHz, 10Vrms
	EN61000-4-8 Power-frequency magnetic field immunity ^{*1}	Immunity test in which the product is installed in inductive magnetic field	50Hz/60Hz, 30A/m
	EN61000-4-11 Voltage dips and interruption immunity ^{*1}	Immunity test in which power supply voltage is momentarily interrupted	<ul style="list-style-type: none"> • Apply at 0%, 0.5 cycles and zero-cross point • 0%, 250/300 cycles (50/60Hz) • 40%, 10/12 cycles (50/60Hz) • 70%, 25/30 cycles (50/60Hz)

*1 The module is an open type device (a device designed to be housed in other equipment) and must be installed inside a conductive control panel. The tests were conducted with the programmable controller installed in a control panel.

*2 The accuracy of an analog-digital converter module may temporarily vary within $\pm 10\%$.

A

(2) Installation in a control panel

The module is open type devices and must be installed inside a control panel.

This ensures safety as well as effective shielding of programmable controller-generated electromagnetic noise.

(a) Control panel

- Use a conductive control panel.
- When securing the top or bottom plate using bolts, cover the grounding part on the control panel so that the part will not be painted.
- To ensure electrical contact between the inner plate and control panel, take measures such as covering the bolts so that conductivity can be ensured in the largest possible area.
- Ground the control panel with a thick ground cable so that low impedance can be ensured even at high frequencies.
- Holes in the control panel must be 10cm diameter or less. If the holes are larger than 10cm, radio wave may be emitted. In addition, because radio waves leak through a clearance between the control panel and its door, reduce the clearance as much as possible. The leakage of radio waves can be suppressed by the direct application of an EMI gasket on the paint surface.
Our tests have been carried out on a control panel having the attenuation characteristics of 37dB (max.) and 30dB (mean) (measured by 3m method, 30 to 300MHz).

(b) Wiring of power cables and ground cables

- Near the power supply part, provide a ground point to the control panel. Ground the FG terminal with the thickest and shortest possible ground cable (30cm or shorter).

(3) Cables

Use shielded cables for the cables which are connected to the module and run out from the control panel. If a shielded cable is not used or not grounded correctly, the noise immunity will not meet the specified value.

(a) Cables for the CC-Link IE Field Network

The precautions for using CC-Link IE Field Network cables are described below.

- Shielded cables should be used for the CC-Link IE Field Network. Strip a part of the jacket as shown below and ground the exposed shield in the largest possible area.

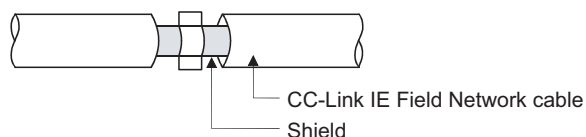

(b) Grounding the cable clamp

Use shielded cables for external wiring and ground the shields of the external wiring cables to the control panel with the AD75CK-type cable clamp (Mitsubishi). (Ground the shield section 20 to 30cm away from the module.)

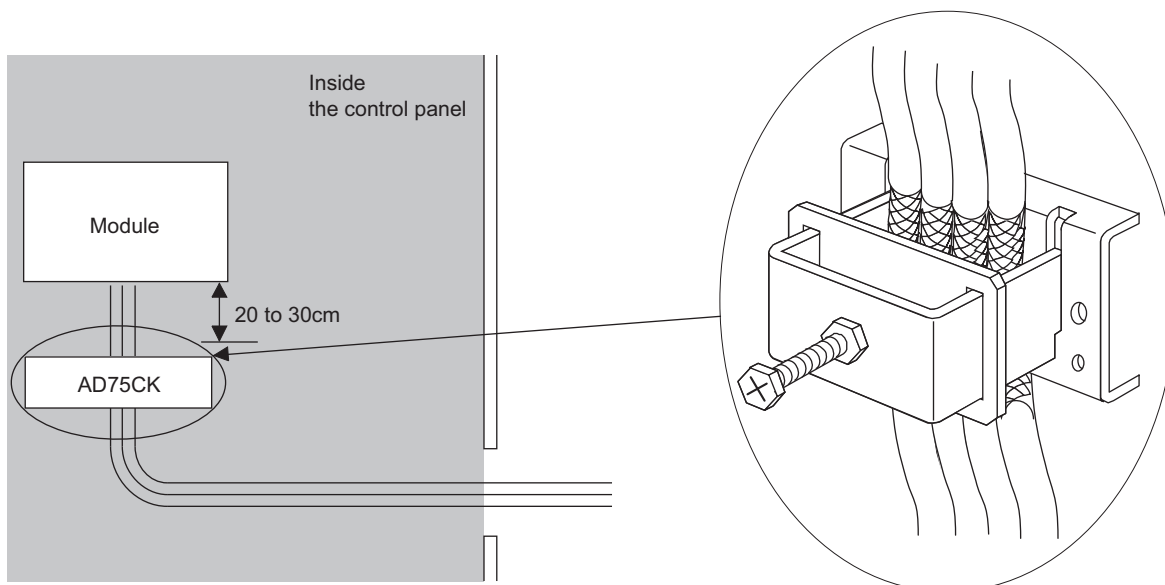

For details of the AD75CK, refer to the following.

 AD75CK-type Cable Clamping Instruction Manual

(c) Analog I/O signal line

Use a signal line of 30m or shorter when connecting it to the analog I/O terminals of the module.

A

(4) External power supply

- Use a CE-marked product for an external power supply and always ground the FG terminal. (External power supply used for the tests conducted by Mitsubishi: TDK-Lambda DLP-120-24-1, IDEC PS5R-SF24, PS5R-F24)
- Use a power cable of 10m or shorter when connecting it to the module power supply terminal.

(5) Others

(a) Ferrite core

A ferrite core has the effect of reducing radiated noise in the 30MHz to 100MHz band.

It is recommended to attach ferrite cores if shielded cables coming out of the control panel do not provide sufficient shielding effects.

Note that the ferrite cores must be attached at the position closest to the cable hole inside the control panel. If attached at an improper position, the ferrite core will not produce any effect.

For the FG terminal on a main module that is connected to the external power supply, the external power supply of an extension module, and CC-Link IE Field Network cables, attach a ferrite core 4cm away from the module.

(Ferrite core used for the tests conducted by Mitsubishi: NEC TOKIN ESD-SR-250, TDK ZCAT3035-1330)

Example

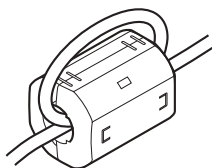

(b) Noise filter (power supply line filter)

A noise filter is a component which has an effect on conducted noise. Attaching the filter can suppress more noise. (The noise filter has the effect of reducing conducted noise of 10MHz or less.)

Connect a noise filter to the external power supply of a main module and the external power supply of an extension module. Use a noise filter with the damping characteristics equivalent to those of MA1206 (manufactured by TDK-Lambda Corporation). Note that a noise filter is not required if the module is used in Zone A defined in EN61131-2.

The precautions for attaching a noise filter are described below.

- Do not bundle the cables on the input side and output side of the noise filter. If bundled, the output side noise will be induced into the input side cables from which the noise was filtered.

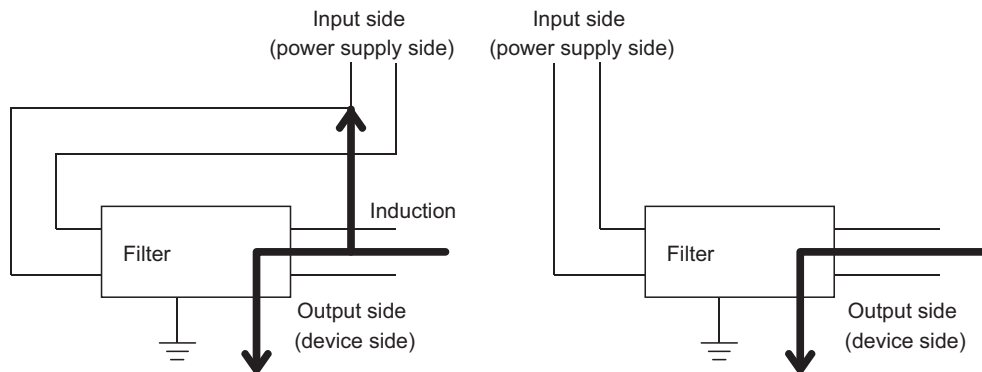

Noise will be induced when the input and output wires are bundled.

Separately install the input and output wires.

- Ground the noise filter grounding terminal to the control panel with the shortest cable possible (approx. 10cm).

A

Appendix 7.2 **Requirements to compliance with the Low Voltage Directive**

The module operates at the rated voltage of 24VDC.

The Low Voltage Directive is not applied to the modules that operate at the rated voltage of less than 50VAC and 75VDC.

Appendix 8 Checking Serial Number and Function Version

The serial number and function version of the A/D converter module can be checked on the rating plate.

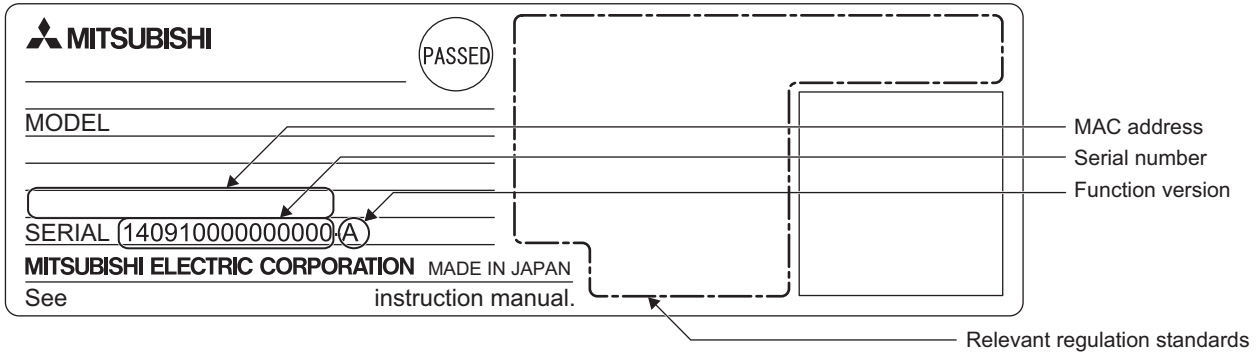

A

Appendix 8 Checking Serial Number and Function Version

Appendix 9 Addition and Change of Functions

Appendix 9.1 Additional function

The following table lists the function added to the A/D converter module and GX Works2 and the serial number and software version of the products that support the additional function.

Additional function	Serial number (first five digits) of A/D converter module	Version of GX Works2	Reference
CC-Link IE Field Network synchronous communication function	15102 or later	Version 1.501X or later	Page 123, Section 8.16

Appendix 9.2 Change of function

The following table lists the changed function of the A/D converter module and GX Works2 and the serial number and software version of the products that support the changed function.

Changed function	Serial number (first five digits) of A/D converter module	Version of GX Works2	Reference
Mode switch (address: 0000 _H)	15102 or later	Version 1.501X or later	Page 180, Appendix 3 (1)

(1) Mode switch (address: 0000_H)

Automatic judgment mode (9_H) was added. The default value is Automatic judgment mode (9_H).

(a) When using the A/D converter module that does not support this function.

- The default value is Normal mode (0_H).
- When Automatic judgment mode (9_H) is set, the error code (0730_H) is stored in Latest error code (RWr0), Error flag (RXA) turns on, and the ERR. LED turns on. The A/D converter module operates in the normal mode.

Appendix 9.3 Operation differences with different serial numbers

The following table lists the changed functions of the A/D converter module and the operation differences between the modules with different serial numbers.

Changed function	Serial number (first five digits) is 15101 or earlier	Serial number (first five digits) is 15102 or later	Reference
External signal assignment function	After power-on, the external signal assignment function starts operating even if communications to the master station are not established.	After power-on, the external signal assignment function does not operate until communications to the master station are established.	Page 131, Section 8.18 (3)
REMFR/REMTO instruction	The REMFR/REMTO instruction is accepted even if the network parameter written to the CPU module is not correct.	The REMFR/REMTO instruction is not accepted if the network parameter written to the CPU module is not correct. Incorrect network parameter access error occurs (minor error, 0150 _H).	—
Following operations on the "CC IE Field Configuration" window <ul style="list-style-type: none"> • [CC IE Field Configuration] ⇨ [Online] ⇨ [Parameter Processing of Slave Station] • [CC IE Field Configuration] ⇨ [Online] ⇨ [Command Execution of Slave Station] 	"Parameter Processing of Slave Station" or "Command Execution of Slave Station" is accepted even if the network parameter written to the CPU module is not correct.	"Parameter Processing of Slave Station" or "Command Execution of Slave Station" is not accepted if the network parameter written to the CPU module is not correct. Incorrect network parameter access error occurs (minor error, 0150 _H).	Page 66, Section 7.1

Point

The following are the conditions when communications to the master station are not established after power-on of the A/D converter module.

- The Ethernet cable is not connected correctly at power-on.
- The network parameter written to the CPU module is not correct.
- Communications to the master station failed because of noise

A

Appendix 10 External Dimensions

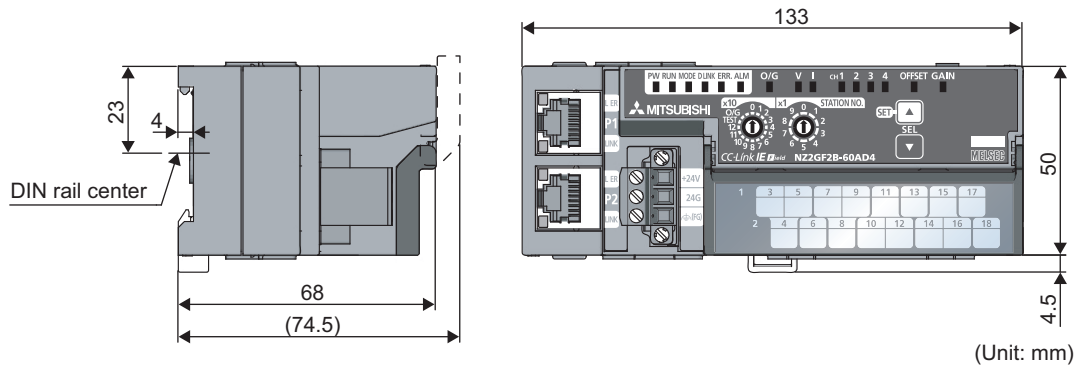

INDEX

A

A/D conversion enable/disable function	84
A/D conversion enable/disable setting (address: 0102 _H)	187
A/D conversion method	84
Averaging processing	84
Sampling processing	84
Alarm code list	161
Alert output flag (RWrB)	179
Alert output function (process alarm)	94
Alert output setting (address: 010E _H)	190
Alert output signal (RX18)	171
Alert output signal assignment (address: 0004 _H)	183
ALM LED	21
Applicable DIN rail model (compliant with IEC 60715)	54
Applicable systems	46
Applicable master station	46
Connectable modules	46
Ethernet cable	46
Software package	46
Application	15
Averaging process setting (address: 0104 _H)	189

B

Bending radius of the Ethernet cable	59
------------------------------------------------	----

C

Calculating current consumption	27
CC-Link IE Field Network diagnostic function	135
CC-Link IE Field Network synchronous communication function	123
CH1 to CH4 LED	21
Checking for the error codes and the alarm codes	151
Checking by executing a command of the slave station	151
Checking by Latest error code (RWr0)	153
Checking by Latest warning code (RWr1)	153
Checking the LEDs	162
CH□ A/D conversion completed flag (RX10 to RX13)	171
CH□ Difference conversion reference value (RWr6 to RWr9)	178
CH□ Difference conversion trigger (RY14 to RY17)	175
CH□ Digital operation value (RWr2 to RWr5)	177
CH□ Maximum value (address: 0601 _H , 0603 _H , 0605 _H , 0607 _H)	193
CH□ Minimum value (address: 0602 _H , 0604 _H , 0606 _H , 0608 _H)	193
CH□ Process alarm lower lower limit value (address: 010F _H , 0113 _H , 0117 _H , 011B _H)	191
CH□ Process alarm lower upper limit value (address: 0110 _H , 0114 _H , 0118 _H , 011C _H)	191
CH□ Process alarm upper lower limit value (address: 0111 _H , 0115 _H , 0119 _H , 011D _H)	191

CH□ Process alarm upper upper limit value (address: 0112 _H , 0116 _H , 011A _H , 011E _H)	191
CH□ Scaling lower limit value (address: 0121 _H , 0123 _H , 0125 _H , 0127 _H)	193
CH□ Scaling upper limit value (address: 0122 _H , 0124 _H , 0126 _H , 0128 _H)	193
CH□ Shifting amount to conversion value (RWr2 to RWr5)	179
CH□ Time average/Count average/Moving average (address: 0105 _H to 0108 _H)	189
Connecting extension modules	50
Connecting the Ethernet cable	57
Conversion speed switch (address: 0001 _H)	180
Conversion speed switch function	90
Count average	86
Current input characteristics	201
Cyclic data update watch function	130
Cyclic data update watch time setting (address: 0007 _H)	186

D

D LINK LED	21
Details of remote I/O signals	168
Difference conversion function	111
Digital clipping enable/disable setting (address: 011F _H)	192
Digital clipping function	106
Digital operation value	83
Digital output HOLD/CLEAR setting (address: 0011 _H)	187
Digital output HOLD/CLEAR setting function	130
DIN rail hook	22
DIN rail stopper	54
Disconnecting	58

E

ERR. LED	21
Error clear request flag (RYA)	175
Error code list	154
Error flag (RXA)	170
Error flag assignment (address: 0005 _H)	184
Error history area (address: 0A00 _H to 0FFF _H)	39
Error history clear command (address: 1000 _H)	195
Error history clear completed (address: 1001 _H)	195
Error history □ (address: 0A00 _H to 0AEF _H)	194
Error notification function	127
Extension connector cover	22
External dimensions	214
External power supply monitor request flag (RY1F)	176
External power supply monitor state flag (RX1F)	174
External power supply monitoring function	130
External signal assignment function	131

F

Features	16
--------------------	----

Function at the extension module installation	130
-------------------------------------------------------	-----

G

GAIN LED	21
Gain value	199
General specifications	24

I

I LED	21
Initial data setting completion flag (RX9)	168
Initial data setting request flag (RY9)	175
Input response time setting (address: 0010 _H)	186
Input response time setting function	130
Input signal error detection flag (RW _r A)	178
Input signal error detection function	91
Input signal error detection setting (address: 0109 _H)	190
Input signal error detection signal (RX1C)	173
Input signal error detection signal assignment (address: 0003 _H)	182
Installation and wiring	47
Installation direction	49
Installation environment	48
Installation environment and installation position	48
Installation position	48

L

L ER LED	22
Latest error code (RW _r 0)	177
Latest warning code (RW _r 1)	177
Laying Ethernet cables	59
LINK LED	22
List of remote buffer memory	33
List of remote I/O signals	30
List of remote register	32

M

Maintenance and inspection	149
Maximum and minimum values	83
Maximum station-to-station distance (Maximum Ethernet cable length)	59
Maximum value/minimum value hold function	90
Maximum value/minimum value reset completed flag (RX1D)	174
Maximum value/minimum value reset request (RY1D)	176
Measures to comply with the EMC Directive	204
Cables	207
EMC Directive related standards	204
External power supply	208
Installation in a control panel	206
Others	208
MODE LED	21
Mode switch (address: 0000 _H)	180
Module control data area (address: 1000 _H to 14FF _H)	41
Module operation information initialization command (address: 1004 _H)	197

Module operation information initialization completed (address: 1005 _H)	198
Monitoring area (address: 0500 _H to 09FF _H)	37
Mounting the modules on a DIN rail	52
Moving average	87

N

Number of ON times integration function	130
---------------------------------------------------	-----

O

O/G LED	21
OFFSET LED	21
Offset value	199
Offset/Gain setting	78

P

P1	22
P2	22
Packing list	14
Parameter area (address: 0000 _H to 04FF _H)	34
Parameter area initialization command (address:1002 _H)	196
Parameter area initialization completed (address: 1003 _H)	197
Parameter setting	66
Part names	20
Performance specifications	25
Programming	138
Precautions for programming	138
Procedure for programming	139
Program example	140
PW LED	21

R

Range setting (address: 0103 _H)	188
Range switching function	89
Remote READY (RXB)	170
Requirements to compliance with the Low Voltage Directive	210
RUN LED	21

S

Scaling enable/disable setting (address: 0120 _H)	192
Scaling function	97
SET/SEL button	22
Shift function	102
Station number setting	47
Station number setting switch	20
System configuration	45

T

Term	12
Terminal block cover	22
Terminal block for analog input signals	22
Terminal block for module power supply and FG	22
The procedure before operation	43
Time average	85

To replace the module	43
Trigger conversion completed clear request (RY1A)	176
Trigger conversion completed flag (RX19)	172
Trigger conversion function	115
Trigger conversion request (RY19)	176
Trigger conversion signal assignment (address: 0002 _H)	181
Troubleshooting	151
Troubleshooting for each phenomenon	166

U

Unit test	165
---------------------	-----

V

V LED	21
Voltage input characteristics.	200

W

Warning flag (RX7)	168
Warning flag assignment (address: 0006 _H)	185
Wiring of Ethernet cable.	57
Wiring of external device and terminal block.	60
Wiring with terminal block for module power supply and FG.	55

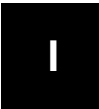

WARRANTY

Please confirm the following product warranty details before using this product.

1. Gratis Warranty Term and Gratis Warranty Range

If any faults or defects (hereinafter "Failure") found to be the responsibility of Mitsubishi occurs during use of the product within the gratis warranty term, the product shall be repaired at no cost via the sales representative or Mitsubishi Service Company.

However, if repairs are required onsite at domestic or overseas location, expenses to send an engineer will be solely at the customer's discretion. Mitsubishi shall not be held responsible for any re-commissioning, maintenance, or testing on-site that involves replacement of the failed module.

[Gratis Warranty Term]

The gratis warranty term of the product shall be for one year after the date of purchase or delivery to a designated place.

Note that after manufacture and shipment from Mitsubishi, the maximum distribution period shall be six (6) months, and the longest gratis warranty term after manufacturing shall be eighteen (18) months. The gratis warranty term of repair parts shall not exceed the gratis warranty term before repairs.

[Gratis Warranty Range]

- (1) The range shall be limited to normal use within the usage state, usage methods and usage environment, etc., which follow the conditions and precautions, etc., given in the instruction manual, user's manual and caution labels on the product.
- (2) Even within the gratis warranty term, repairs shall be charged for in the following cases.
 1. Failure occurring from inappropriate storage or handling, carelessness or negligence by the user. Failure caused by the user's hardware or software design.
 2. Failure caused by unapproved modifications, etc., to the product by the user.
 3. When the Mitsubishi product is assembled into a user's device, Failure that could have been avoided if functions or structures, judged as necessary in the legal safety measures the user's device is subject to or as necessary by industry standards, had been provided.
 4. Failure that could have been avoided if consumable parts (battery, backlight, fuse, etc.) designated in the instruction manual had been correctly serviced or replaced.
 5. Failure caused by external irresistible forces such as fires or abnormal voltages, and Failure caused by force majeure such as earthquakes, lightning, wind and water damage.
 6. Failure caused by reasons unpredictable by scientific technology standards at time of shipment from Mitsubishi.
 7. Any other failure found not to be the responsibility of Mitsubishi or that admitted not to be so by the user.

2. Onerous repair term after discontinuation of production

- (1) Mitsubishi shall accept onerous product repairs for seven (7) years after production of the product is discontinued.
Discontinuation of production shall be notified with Mitsubishi Technical Bulletins, etc.
- (2) Product supply (including repair parts) is not available after production is discontinued.

3. Overseas service

Overseas, repairs shall be accepted by Mitsubishi's local overseas FA Center. Note that the repair conditions at each FA Center may differ.

4. Exclusion of loss in opportunity and secondary loss from warranty liability

Regardless of the gratis warranty term, Mitsubishi shall not be liable for compensation of damages caused by any cause found not to be the responsibility of Mitsubishi, loss in opportunity, lost profits incurred to the user by Failures of Mitsubishi products, special damages and secondary damages whether foreseeable or not, compensation for accidents, and compensation for damages to products other than Mitsubishi products, replacement by the user, maintenance of on-site equipment, start-up test run and other tasks.

5. Changes in product specifications

The specifications given in the catalogs, manuals or technical documents are subject to change without prior notice.

All other company names and product names used in this manual are either trademarks or registered trademarks of their respective companies.

SH(NA)-081110ENG-D(2211)MEE

MODEL: CCIEF-AD-U-E

MODEL CODE: 13JZ80

MITSUBISHI ELECTRIC CORPORATION

HEAD OFFICE : TOKYO BUILDING, 2-7-3 MARUNOUCHI, CHIYODA-KU, TOKYO 100-8310, JAPAN
NAGOYA WORKS : 1-14, YADA-MINAMI 5-CHOME, HIGASHI-KU, NAGOYA, JAPAN

When exported from Japan, this manual does not require application to the Ministry of Economy, Trade and Industry for service transaction permission.

Specifications subject to change without notice.