



PROGRAMMABLE CONTROLLERS
MELSEC-F

FX3S/FX3G/FX3GC/FX3U/FX3UC SERIES PROGRAMMABLE CONTROLLERS

USER'S MANUAL

Positioning Control Edition

Transistor Output

FX3S Main Unit
(Sink Output/Source Output)
FX3G Main Unit
(Sink Output/Source Output)
FX3GC Main Unit
(Sink Output/Source Output)
FX3U Main Unit
(Sink Output/Source Output)
FX3UC Main Unit
(Sink Output/Source Output)

Line Driver Output

FX3U-2HSY-ADP



FX3U FX3UC
FX3G FX3GC
FX3S

Safety Precautions

(Read these precautions before use.)

Before installation, operation, maintenance or inspection of this product, thoroughly read through and understand this manual and all of the associated manuals. Also, take care to handle the module properly and safely.

This manual classifies the safety precautions into two categories: **WARNING** and **CAUTION**.

 WARNING	Indicates that incorrect handling may cause hazardous conditions, resulting in death or severe injury.
 CAUTION	Indicates that incorrect handling may cause hazardous conditions, resulting in medium or slight personal injury or physical damage.

Depending on the circumstances, procedures indicated by **CAUTION** may also cause severe injury. It is important to follow all precautions for personal safety.

Store this manual in a safe place so that it can be taken out and read whenever necessary. Always forward it to the end user.

1. DESIGN PRECAUTIONS

 WARNING	Reference
<ul style="list-style-type: none"> • Make sure to have the following safety circuits outside of the PLC to ensure safe system operation even during external power supply problems or PLC failure. Otherwise, malfunctions may cause serious accidents. <ol style="list-style-type: none"> 1) Most importantly, have the following: an emergency stop circuit, a protection circuit, an interlock circuit for opposite movements (such as normal vs. reverse rotation), and an interlock circuit (to prevent damage to the equipment at the upper and lower positioning limits). 2) Note that when the PLC CPU detects an error, such as a watchdog timer error, during self-diagnosis, all outputs are turned off. Also, when an error that cannot be detected by the PLC CPU occurs in an input/output control block, output control may be disabled. External circuits and mechanisms should be designed to ensure safe machinery operation in such a case. 3) Note that when an error occurs in a relay, triac or transistor output device, the output could be held either on or off. For output signals that may lead to serious accidents, external circuits and mechanisms should be designed to ensure safe machinery operation in such a case. 	B-4 B-16 B-90

 CAUTION	Reference
<ul style="list-style-type: none"> • Do not bundle the control line together with or lay it close to the main circuit or power line. As a guideline, lay the control line at least 100mm (3.94") or more away from the main circuit or power line. Noise may cause malfunctions. • Install module so that excessive force will not be applied to the built-in programming port, power connectors, I/O connectors. Failure to do so may result in wire damage/breakage or PLC failure. 	B-4 B-16 B-90

Safety Precautions

(Read these precautions before use.)

2. WIRING PRECAUTIONS

 WARNING	Reference
<ul style="list-style-type: none"> • Make sure to cut off all phases of the power supply externally before attempting installation or wiring work. Failure to do so may cause electric shock or damage to the product. • Make sure to attach the terminal cover, offered as an accessory, before turning on the power or initiating operation after installation or wiring work. Failure to do so may cause electric shock. 	B-4 B-42 B-90

 CAUTION	Reference
<ul style="list-style-type: none"> • Connect the AC power supply to the dedicated terminals specified in the manual of the PLC main unit. If an AC power supply is connected to a DC input/output terminal or DC power supply terminal, the PLC will burn out. • Connect the DC power supply to the dedicated terminals specified in the manual of the PLC main unit. If an AC power supply is connected to a DC input/output terminal or DC power supply terminal, the PLC will burn out. • Do not wire vacant terminals externally. Doing so may damage the product. • Perform class D grounding (grounding resistance: 100Ω or less) to the grounding terminal on the FX3S/FX3G/FX3U PLC main unit with a wire 2 mm² or thicker. Do not use common grounding with heavy electrical systems (refer to the manual of the PLC main unit). • Perform class D grounding (grounding resistance: 100Ω or less) to the grounding terminal on the FX3GC/FX3UC PLC main unit with a wire as thick as possible. Do not use common grounding with heavy electrical systems (refer to the manual of the PLC main unit). • When drilling screw holes or wiring, make sure cutting or wire debris does not enter the ventilation slits. Failure to do so may cause fire, equipment failures or malfunctions. • Install module so that excessive force will not be applied to I/O connectors. Failure to do so may result in wire damage/breakage or PLC failure. • Connect input/output cables securely to their designated connectors. Loose connections may cause malfunctions. • Make sure to properly wire the terminal block in accordance with the following precautions. Failure to do so may cause electric shock, equipment failures, a short-circuit, wire breakage, malfunctions or damage to the product. <ul style="list-style-type: none"> - The disposal size of the cable end should follow the dimensions described in the manual. - Tightening torque should follow the specifications in the manual. - Tighten the screws using a Phillips-head screwdriver No.2 (shaft diameter 6mm (0.24") or less). Make sure that the screwdriver does not touch the partition part of the terminal block. • Make sure to properly wire to the terminal block (European type) in accordance with the following precautions. Failure to do so may cause electric shock, equipment failures, a short-circuit, wire breakage, malfunctions or damage to the product. <ul style="list-style-type: none"> - The disposal size of the cable end should follow the dimensions described in the manual. - Tightening torque should follow the specifications in the manual. - Twist the end of strand wire and make sure that there are no loose wires. - Do not solder-plate the electric wire ends. - Do not connect more than the specified number of wires or electric wires of unspecified size. - Affix the electric wires so that neither the terminal block nor the connected parts are directly stressed. • Make sure to properly wire to the FX Series terminal blocks in accordance with the following precautions. Failure to do so may cause electric shock, equipment failures, a short-circuit, wire breakage, malfunctions or damage to the product. <ul style="list-style-type: none"> - The disposal size of the cable end should follow the dimensions described in the manual. - Tightening torque should follow the specifications in the manual. - Tighten the screws using a Phillips-head screwdriver No.2 (shaft diameter 6mm (0.24") or less). Make sure that the screwdriver does not touch the partition part of the terminal block. 	B-4 B-5 B-42 B-90 B-91

Safety Precautions

(Read these precautions before use.)

3. STARTUP AND MAINTENANCE PRECAUTIONS

 WARNING	Reference
<ul style="list-style-type: none">• Do not touch any terminal while the PLC's power is on. Doing so may cause electric shock or malfunctions.• Before cleaning or retightening terminals, cut off all phases of the power supply externally. Failure to do so may cause electric shock.• Before modifying or disrupting the program in operation or running the PLC, carefully read through this manual and the associated manuals and ensure the safety of the operation. An operation error may damage the machinery or cause accidents.	B-5 B-91

 CAUTION	Reference
<ul style="list-style-type: none">• Do not disassemble or modify the PLC. Doing so may cause fire, equipment failures, or malfunctions. For repair, contact your local Mitsubishi Electric representative.• Turn off the power to the PLC before connecting or disconnecting any extension cable. Failure to do so may cause equipment failures or malfunctions.• Turn off the power to the PLC before attaching or detaching the following devices. Failure to do so may cause equipment failures or malfunctions.<ul style="list-style-type: none">- Peripheral devices, expansion boards, and special adapters- Input/output extension units/blocks and FX Series terminal blocks	B-5 B-91

4. DISPOSAL PRECAUTIONS

 CAUTION	Reference
<ul style="list-style-type: none">• Please contact a certified electronic waste disposal company for the environmentally safe recycling and disposal of your device.	B-16

5. TRANSPORTATION AND STORAGE PRECAUTIONS

 CAUTION	Reference
<ul style="list-style-type: none">• Before transporting the PLC, turn on the power to the PLC to check that the BATT (BAT) LED is off, and check the battery life. If the PLC is transported with the BATT (BAT) LED on or the battery exhausted, the battery-backed data may be unstable during transportation.• The PLC is a precision instrument. During transportation, avoid impacts larger than those specified in the general specifications of the PLC main unit manual. Failure to do so may cause failures in the PLC. After transportation, verify the operations of the PLC.	B-16

Safety Precautions

(Read these precautions before use.)

MEMO

FX3s/FX3G/FX3GC/FX3U/FX3UC Series Programmable Controllers User's Manual [Positioning Control Edition]

Manual number	JY997D16801
Manual revision	K
Date	4/2015

Foreword

This manual describes the "positioning" functions of the MELSEC-F FX3s/FX3G/FX3GC/FX3U/FX3UC Series PLC and should be read and understood before attempting to install or use the unit.

Store this manual in a safe place so that you can take it out and read it whenever necessary. Always forward it to the end user.

<p>This manual confers no industrial property rights or any rights of any other kind, nor does it confer any patent licenses. Mitsubishi Electric Corporation cannot be held responsible for any problems involving industrial property rights which may occur as a result of using the contents noted in this manual.</p>
--

© 2005 MITSUBISHI ELECTRIC CORPORATION

Outline Precautions

- This manual provides information for the use of the FX3S/FX3G/FX3GC/FX3U/FX3UC Series Programmable Controllers. The manual has been written to be used by trained and competent personnel. The definition of such a person or persons is as follows;
 - 1) Any engineer who is responsible for the planning, design and construction of automatic equipment using the product associated with this manual should be of a competent nature, trained and qualified to the local and national standards required to fulfill that role. These engineers should be fully aware of all aspects of safety with regards to automated equipment.
 - 2) Any commissioning or service engineer must be of a competent nature, trained and qualified to the local and national standards required to fulfill that job. These engineers should also be trained in the use and maintenance of the completed product. This includes being completely familiar with all associated documentation for the said product. All maintenance should be carried out in accordance with established safety practices.
 - 3) All operators of the completed equipment should be trained to use that product in a safe and coordinated manner in compliance to established safety practices. The operators should also be familiar with documentation which is connected with the actual operation of the completed equipment.
- **Note:** The term 'completed equipment' refers to a third party constructed device which contains or uses the product associated with this manual
- This product has been manufactured as a general-purpose part for general industries, and has not been designed or manufactured to be incorporated in a device or system used in purposes related to human life.
- Before using the product for special purposes such as nuclear power, electric power, aerospace, medicine or passenger movement vehicles, consult with Mitsubishi Electric.
- This product has been manufactured under strict quality control. However when installing the product where major accidents or losses could occur if the product fails, install appropriate backup or failsafe functions in the system.
- When combining this product with other products, please confirm the standard and the code, or regulations with which the user should follow. Moreover, please confirm the compatibility of this product to the system, machine, and apparatus with which a user is using.
- If in doubt at any stage during the installation of the product, always consult a professional electrical engineer who is qualified and trained to the local and national standards. If in doubt about the operation or use, please consult your local Mitsubishi Electric representative.
- Since the examples indicated by this manual, technical bulletin, catalog, etc. are used as a reference, please use it after confirming the function and safety of the equipment and system. Mitsubishi Electric will accept no responsibility for actual use of the product based on these illustrative examples.
- This manual content, specification etc. may be changed without a notice for improvement.
- The information in this manual has been carefully checked and is believed to be accurate; however, if you have noticed a doubtful point, a doubtful error, etc., please contact your local Mitsubishi Electric representative.

Registration

- Microsoft® and Windows® are either registered trademarks or trademarks of Microsoft Corporation in the United States and/or other countries.
- Phillips is a registered trademark of Phillips Screw Company.
- The company name and the product name to be described in this manual are the registered trademarks or trademarks of each company.

Table of Contents

SAFETY PRECAUTIONS	(1)
---------------------------------	------------

Functions and Use of This Manual	9
---	----------

Related Manuals	10
------------------------------	-----------

Generic Names and Abbreviations Used in Manuals	13
--	-----------

A. Common Items

Description of Manual (Common Items)	A-2
---	------------

1. Introduction	A-3
------------------------------	------------

1.1 Outline.....	A-3
------------------	-----

1.2 Introduction of Products Needed for Positioning.....	A-4
--	-----

1.2.1 List of Models	A-4
----------------------------	-----

1.2.2 Main Unit (Transistor Output)	A-5
---	-----

1.2.3 Special Adapter (Differential Line Driver Output)	A-6
---	-----

1.2.4 Special Function Unit/Block.....	A-7
--	-----

2. Unit Connection	A-8
---------------------------------	------------

2.1 FX3S PLC.....	A-8
-------------------	-----

2.2 FX3G PLC	A-8
--------------------	-----

2.3 FX3GC PLC.....	A-9
--------------------	-----

2.4 FX3U PLC	A-10
--------------------	------

2.5 FX3UC PLC	A-11
---------------------	------

2.6 Individual Operation of Special Function Unit (FX2N-10GM, FX2N-20GM)	A-12
--	------

3. Comparison of Specifications	A-13
--	-------------

3.1 Comparison of Performance Specifications	A-13
--	------

3.1.1 Built-in Positioning Function [Main Unit (Transistor Output), High-Speed Output Special Adapter (FX3U-2HSY-ADP)]	A-13
---	------

3.1.2 Pulse Output Block [FX3U-1PG, FX2N-1PG(-E), FX2N-10PG].....	A-14
---	------

3.1.3 Positioning Special Function Block [FX3U-20SSC-H]	A-16
---	------

3.1.4 Positioning Special Function Unit [FX2N-10GM, FX2N-20GM].....	A-17
---	------

3.2 Comparison of Operation Modes	A-18
---	------

B. Built-in Positioning Functions

Description of Manual (Built-in Positioning Function)	B-2
--	------------

1. Outline	B-3
-------------------	------------

1.1 Features	B-3
1.2 Setup Procedure for Positioning Control	B-4
1.3 Version Numbers of Compatible PLCs	B-7
1.3.1 Manufacturer's serial number check method	B-7
1.3.2 Version check	B-8
1.3.3 Version upgrade history	B-8
1.4 Version Numbers of Compatible Programming Tools	B-9
1.5 Assignment of Input/Output Numbers	B-10
1.5.1 Assignment of Input Numbers	B-10
1.5.2 Assignment of Output Numbers	B-12
1.5.3 Connection of the High-Speed Output Special Adapter	B-14

2. Specifications	B-16
--------------------------	-------------

2.1 General Specifications	B-17
2.2 Power Supply Specifications	B-17
2.3 Performance Specifications	B-18
2.4 Input Specifications	B-19
2.4.1 FX3S Series main unit (24 V DC Input)	B-19
2.4.2 FX3G Series main unit (24 V DC Input)	B-21
2.4.3 FX3GC Series main unit (24 V DC Input)	B-23
2.4.4 FX3U Series main unit (24 V DC Input)	B-25
2.4.5 FX3UC Series main unit (24 V DC Input)	B-27
2.5 Output Specifications	B-29
2.5.1 FX3S Series main unit (Transistor Output)	B-29
2.5.2 FX3G Series main unit (Transistor Output)	B-31
2.5.3 FX3GC Series main unit (Transistor Output)	B-33
2.5.4 FX3U Series main unit (Transistor Output)	B-35
2.5.5 FX3UC Series main unit (Transistor Output)	B-37
2.5.6 High-Speed Output Special Adapter [FX3U-2HSY-ADP]	B-39
2.6 List of Functions	B-40

3. Connection of Input/Output Lines and Tightening Torques	B-42
---	-------------

3.1 Terminal Board (M3, M3.5)	B-43
3.1.1 Terminal block screw size and tightening torque	B-43
3.1.2 Termination	B-43
3.2 European Terminal Board	B-44
3.2.1 Cable	B-44
3.2.2 Termination of Cable End	B-44
3.2.3 Tool	B-45
3.3 Connector	B-45
3.3.1 Cable Connection To Input/Output Connector	B-45
3.3.2 Setup of Input/Output Connection Connector	B-46

4. Before Programming**B-47**

4.1 List of Related Devices	B-47
4.1.1 Special Auxiliary Relays	B-47
4.1.2 Special Data Registers	B-49
4.2 Setting of Various Items Regarding Speeds	B-50
4.2.1 Setting of Various Items Regarding Instructions and Speeds	B-50
4.2.2 Setting of Output Pulse Frequency (DVIT, PLSV, DRVI, and DRVA Instructions).....	B-52
4.2.3 Setting of Zero Return Speed (DSZR/ZRN Instruction).....	B-53
4.2.4 Setting of Creep Speed (DSZR/ZRN Instruction).....	B-54
4.2.5 Setting of Maximum Speed	B-54
4.2.6 Setting of Bias Speed.....	B-55
4.2.7 Setting of Acceleration Time.....	B-55
4.2.8 Setting of Deceleration Time	B-56
4.3 Various Special Relays for Operation Commands.....	B-57
4.3.1 Forward Rotation Limit and Reverse Rotation Limit	B-57
4.3.2 Immediate Stop of Pulse Output (Pulse Output Stop Command Relay)	B-58
4.3.3 Designation of Zero Return Direction (DSZR/ZRN Instruction).....	B-58
4.3.4 CLEAR Signal Output (DSZR/ZRN Instruction).....	B-60
4.3.5 Change in Logic of Near-Point (DOG) Signal (DSZR Instruction).....	B-61
4.3.6 Change in Logic of Zero-Phase Signal (DSZR Instruction).....	B-61
4.3.7 Designation of Interrupt Input Signal for DVIT Instruction	B-62
4.3.8 Change in Logic of interrupt input Signal (DVIT Instruction)	B-63
4.3.9 Acceleration/Deceleration by PLSV Instruction	B-64
4.4 Current Value and Flag for Monitoring of Operation	B-65
4.4.1 Current Value	B-65
4.4.2 Completion of Instruction Execution ("Instruction execution complete" Flag, "Instruction execution abnormal end" Flag)	B-66
4.4.3 "Pulse Output Monitor" (BUSY/READY) Flag.....	B-66
4.4.4 "Positioning Instruction Activation" Flag	B-66
4.5 Setting of Various Items on PLC Side.....	B-67
4.5.1 Setting of Common Items Using Program.....	B-67
4.5.2 Setting of High-Speed Output Special Adapter	B-71
4.6 Setting of Various Items on Servo Amplifier (Drive Unit) Side	B-73
4.6.1 Setting the Command Pulse Method.....	B-73
4.6.2 Setting of Electronic Gear (For MELSERVO Series).....	B-77
4.6.3 Setting of "Servo Ready" Signal (MELSERVO MR-C Series).....	B-78
4.7 Items To Be Observed in Programming.....	B-79
4.7.1 Positioning Instruction Activation Timing	B-79
4.7.2 STOP instruction	B-81
4.7.3 Correction of Backlash	B-81
4.7.4 "Instruction execution complete" Flag of Positioning Instruction and Completion of Positioning.....	B-81
4.7.5 Operation Error Flag.....	B-84
4.7.6 Write during RUN	B-84
4.8 Items To Be Observed When Using the Main Unit (Transistor Output)	B-85
4.9 Caution for Using the High-Speed Output Special Adapter (FX3U-2HSY-ADP).....	B-86
4.10 Format and Execution of Applied Instruction	B-88

5. Operation Test**B-90**

5.1 Test Procedure.....	B-92
5.2 Creation of Test Program.....	B-96

6. Mechanical Zero Return - DSZR/ZRN Instruction	B-98
6.1 Types of Mechanical Zero Return Instructions.....	B-98
6.2 DOG Search Zero Return (DSZR Instruction).....	B-99
6.2.1 Instruction Format.....	B-99
6.2.2 List of Related devices	B-100
6.2.3 Function and Operation	B-102
6.2.4 Important Points	B-108
6.3 Zero Return (ZRN Instruction).....	B-110
6.3.1 Instruction Format.....	B-110
6.3.2 List of Related devices	B-111
6.3.3 Function and operation.....	B-112
6.3.4 Important Points	B-116
7. Absolute Position Detection System (Absolute Current Value Read) - ABS Instruction	B-117
7.1 Instruction Format	B-117
7.2 List of Related Devices	B-118
7.3 Function and Operation.....	B-118
7.4 Initial Zero Return.....	B-119
7.5 Important Points	B-120
8. 1-Speed Positioning - DRVI/DRVA Instruction	B-121
8.1 Incremental Method and Absolute Method	B-121
8.2 Drive to Increment - DRVI Instruction	B-122
8.2.1 Instruction Format.....	B-122
8.2.2 List of Related Devices.....	B-123
8.2.3 Function and Operation.....	B-125
8.2.4 Important Points	B-126
8.3 Drive To Absolute - DRVA Instruction.....	B-127
8.3.1 Instruction Format.....	B-127
8.3.2 List of Related Devices.....	B-128
8.3.3 Function and Operation.....	B-130
8.3.4 Important Points	B-131
9. One-speed Interrupt constant quantity feed - DVIT Instruction	B-132
9.1 Instruction Format	B-132
9.2 List of Related Devices	B-134
9.3 Function and Operation.....	B-136
9.4 Important Points	B-141
10. Variable Speed Operation (Variable Speed Pulse Output) - PLSV Instruction	B-143
10.1 Instruction Format	B-143
10.2 List of Related Devices	B-144
10.3 Function and Operation.....	B-146
10.3.1 Operation without Acceleration/Deceleration (M8338 = OFF).....	B-146
10.3.2 Operation with Acceleration/Deceleration (M8338 = ON)	B-147
10.4 Important Points	B-149

11. Batch Data Positioning Mode - TBL Instruction	B-150
11.1 Instruction Format	B-150
11.2 List of Related Devices	B-151
11.3 Function and Operation.....	B-153
11.4 Built-in Positioning Parameter Setting.....	B-154
11.4.1 Built-in Positioning Parameter Setting	B-154
11.4.2 Changing of Set Built-in Positioning Parameters (Number of Pulses and Frequency).....	B-160
12. Examples of Programs	B-162
12.1 Input/Output Assignment.....	B-163
12.2 Programs for Forward/Reverse Rotation (Relay Ladder Program).....	B-165
12.2.1 Example Program.....	B-165
12.3 Programs for Forward/Reverse Rotation (Step Ladder (STL) Program).....	B-168
12.3.1 Example Program.....	B-168
12.4 Positioning Using Batch Setting Method	B-172
12.4.1 Setting Using GX Works2.....	B-172
12.4.2 Operation Program.....	B-174
12.5 Program for Reading Current ABS Value Using ABS Instruction	B-177
13. Troubleshooting	B-178
13.1 LED Indicator Lamp Check	B-178
13.1.1 POWER (POW) Indicator Lamp (Statuses: ON, flashing, OFF).....	B-179
13.1.2 RUN Indicator Lamp (Statuses: ON, OFF).....	B-179
13.1.3 BATT (BAT) Indicator Lamp (Statuses: ON, OFF) [FX3U/FX3UC]	B-179
13.1.4 ALM Indicator Lamp (Statuses: ON, OFF) [FX3G/FX3GC]	B-179
13.1.5 ERROR (ERR) indicator lamp (Statuses: ON, flashing, OFF).....	B-180
13.1.6 Pulse Output Destination Device and Rotation Direction Output Indicator Lamp.....	B-181
13.2 Error Check.....	B-183
13.2.1 Error Code Check Method.....	B-183
13.2.2 Error Codes	B-184
13.3 If the Servo Motor or the Stepping Motor Does Not Operate.....	B-185
13.4 If Operation Is Stopped at a Wrong Position.....	B-186

Appendix: Example Connection

Description of Manual (Example of Connection)	Apx.-2
--	---------------

Appendix 1. MELSERVO-J4 Series	Apx.-3
---------------------------------------	---------------

Appendix 1-1 Main Unit (Transistor Output)	Apx.-3
Appendix 1-1-1 Sink Input and Sink Output	Apx.-3
Appendix 1-2 High-Speed Output Special Adapter	Apx.-9
Appendix 1-2-1 Sink Input, Sink Output (Transistor), and Differential Line Driver Output.....	Apx.-9
Appendix 1-3 Absolute Position Detection (Transistor Output)	Apx.-10
Appendix 1-3-1 Sink Input and Sink Output	Apx.-10

Appendix 2. MELSERVO-J3 Series	Apx.-13
---------------------------------------	----------------

Appendix 2-1 Main Unit (Transistor Output)	Apx.-13
Appendix 2-1-1 Sink Input and Sink Output	Apx.-13
Appendix 2-2 High-Speed Output Special Adapter	Apx.-19
Appendix 2-2-1 Sink Input, Sink Output (Transistor), and Differential Line Driver Output.....	Apx.-19
Appendix 2-3 Absolute Position Detection (Transistor Output)	Apx.-20
Appendix 2-3-1 Sink Input and Sink Output	Apx.-20

Appendix 3. MELSERVO-JN Series	Apx.-23
---------------------------------------	----------------

Appendix 3-1 Main Unit (Transistor Output)	Apx.-23
Appendix 3-1-1 Sink Input and Sink Output	Apx.-23
Appendix 3-2 High-Speed Output Special Adapter	Apx.-29
Appendix 3-2-1 Sink Input, Sink Output (Transistor), and Differential Line Driver Output.....	Apx.-29

Appendix 4. MELSERVO-J2 (-Super) Series	Apx.-31
--	----------------

Appendix 4-1 Main Unit (Transistor Output)	Apx.-31
Appendix 4-1-1 Sink Input and Sink Output	Apx.-31
Appendix 4-2 High-Speed Output Special Adapter	Apx.-37
Appendix 4-2-1 Sink Input, Sink Output (Transistor), and Differential Line Driver Output.....	Apx.-37
Appendix 4-3 Absolute Position Detection (Transistor Output)	Apx.-38
Appendix 4-3-1 Sink Input and Sink Output	Apx.-38

Appendix 5. MELSERVO-H Series	Apx.-41
--------------------------------------	----------------

Appendix 5-1 Main Unit (Transistor Output)	Apx.-41
Appendix 5-1-1 Sink Input and Sink Output	Apx.-41
Appendix 5-2 Absolute Position Detection (Transistor Output)	Apx.-42
Appendix 5-2-1 Sink Input and Sink Output	Apx.-42

Appendix 6. MELSERVO-C Series	Apx.-43
--------------------------------------	----------------

Appendix 6-1 Main Unit (Transistor Output)	Apx.-43
Appendix 6-1-1 Sink Input and Sink Output	Apx.-43
Appendix 6-2 High-Speed Output Special Adapter	Apx.-47
Appendix 6-2-1 Sink Input, Sink Output, and Differential Line Driver Output.....	Apx.-47

Warranty	i
-----------------------	----------

Revised History	ii
------------------------------	-----------

Functions and Use of This Manual

The FX3S/FX3G/FX3GC/FX3U/FX3UC PLC outputs transistor signals from the main unit and also outputs pulses from the high-speed output special adapter and the positioning special function unit/block to the servo motor and stepping motor to properly control positioning operations.

PLC

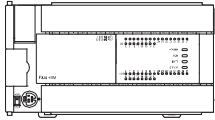
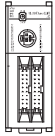
<p>FX3S/FX3G/FX3U Series</p> 	<p><u>Regarding wiring and installation of PLC:</u></p> <ul style="list-style-type: none"> · Hardware manual (The hardware manual is enclosed with the product.) · User's Manual - Hardware Edition <p><u>Regarding sequence program:</u></p> <ul style="list-style-type: none"> · Programming manual <p><u>Regarding positioning function:</u></p> <ul style="list-style-type: none"> · FX3S/FX3G/FX3GC/FX3U/FX3UC Series PLC User's Manual- Positioning Control Edition 	<div style="border: 1px solid #ccc; background-color: #f0f0f0; padding: 5px; margin-bottom: 5px; text-align: center;">Enclosed with the product</div> <div style="border: 1px solid #ccc; background-color: #f0f0f0; padding: 5px; margin-bottom: 5px; text-align: center;">Separate document</div> <div style="border: 1px solid #ccc; background-color: #f0f0f0; padding: 5px; margin-bottom: 5px; text-align: center;">Separate document</div> <div style="border: 1px solid #ccc; background-color: #f0f0f0; padding: 5px; text-align: center;">Separate document</div>
<p>FX3GC/FX3UC Series</p> 		

This document This document describes the built-in positioning function setting method, examples of connection, examples of programs, details for troubleshooting, etc.

Products needed for positioning

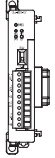
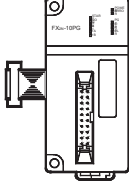
<p>FX3U-2HSY-ADP</p> 	<p>Either "INSTALLATION MANUAL" or "USER'S MANUAL" is enclosed with each product. For the details, refer to User's Manual [Positioning Control] (this document) or the product manual.</p> <p><u>Regarding installation and parts names:</u></p> <ul style="list-style-type: none"> · INSTALLATION MANUAL This manual provides the necessary information. A separate document is needed for programming details. <p><u>Regarding installation, parts names, operation, and programs:</u></p> <ul style="list-style-type: none"> · USER'S MANUAL This manual provides the necessary information. · HARDWARE/PROGRAMMING MANUAL This manual provides the necessary information. 	<div style="border: 1px solid #ccc; background-color: #f0f0f0; padding: 5px; margin-bottom: 5px; text-align: center;">Enclosed with the product</div> <div style="border: 1px solid #ccc; background-color: #f0f0f0; padding: 5px; margin-bottom: 5px; text-align: center;">Supplied with the product</div> <div style="border: 1px solid #ccc; background-color: #f0f0f0; padding: 5px; margin-bottom: 5px; text-align: center;">Separate document</div> <div style="border: 1px solid #ccc; background-color: #f0f0f0; padding: 5px; text-align: center;">Separate document</div>
<p>Special function unit/block</p> 		

Servo motor (stepping motor)

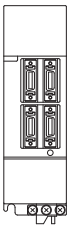
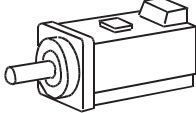
Obtain the instruction manual of the servo motor to be connected to your system. This manual will be needed to set the parameters for the servo amplifier (drive unit) or wire the servo amplifier.

Related Manuals

Refer to this document to perform positioning operations with the FX3s/FX3G/FX3GC/FX3U/FX3UC Series PLC. For hardware information on the PLC and for details on the special function units/blocks, refer to the respective manuals.

⊙ Indispensable manual

✓ Manual that may be indispensable depending on the purpose of use

△ Abbreviated document

		Title of manual	Document number	Description	Model code
Manuals for PLC					
■ FX3s Series PLC					
△	Enclosed with the product	FX3s Series HARDWARE MANUAL	JY997D48301	The input/output specifications and the wiring and installation methods for the FX3s PLC are excerpted from the FX3s Series User's Manual - Hardware Edition. For details, refer to the FX3s Series User's Manual - Hardware Edition.	-
△	Enclosed with the product	FX3s-30M□/E□-2AD HARDWARE MANUAL	JY997D51701	The input/output specifications and the built-in analog specifications and the wiring and installation methods for the FX3s-30M□/E□-2AD PLC are excerpted from the FX3s Series User's Manual - Hardware Edition. For details, refer to the FX3s Series User's Manual - Hardware Edition.	-
⊙	Separate document	FX3s Series User's Manual - Hardware Edition	JY997D48601	Provides detailed information on the hardware, such as the input/output specifications and the detailed wiring, installation, and maintenance methods for the FX3s PLC.	09R535
■ FX3G Series PLC					
△	Enclosed with the product	FX3G Series HARDWARE MANUAL	JY997D46001	The input/output specifications and the wiring and installation methods for the FX3G PLC are excerpted from the FX3G Series User's Manual - Hardware Edition. For details, refer to the FX3G Series User's Manual - Hardware Edition.	-
⊙	Separate document	FX3G Series User's Manual - Hardware Edition	JY997D31301	Provides detailed information on the hardware, such as the input/output specifications and the detailed wiring, installation, and maintenance methods for the FX3G PLC.	09R521
■ FX3GC Series PLC					
△	Enclosed with the product	FX3GC Series HARDWARE MANUAL	JY997D45201	The input/output specifications and the wiring and installation methods for the FX3GC PLC are excerpted from the FX3GC Series User's Manual - Hardware Edition. For details, refer to the FX3GC Series User's Manual - Hardware Edition.	-
⊙	Separate document	FX3GC Series User's Manual - Hardware Edition	JY997D45401	Provides detailed information on the hardware, such as the input/output specifications and the detailed wiring, installation, and maintenance methods for the FX3GC PLC.	09R533

- ⊙ Indispensable manual
 ✓ Manual that may be indispensable depending on the purpose of use
 △ Abbreviated document

		Title of manual	Document number	Description	Model code
■ FX3U Series PLC					
△	Enclosed with the product	FX3U Series HARDWARE MANUAL	JY997D50301	The input/output specifications and the wiring and installation methods for the FX3U PLC are excerpted from the FX3U Series User's Manual - Hardware Edition. For details, refer to the FX3U Series User's Manual - Hardware Edition.	-
⊙	Separate document	FX3U Series User's Manual - Hardware Edition	JY997D16501	Provides detailed information on the hardware, such as the input/output specifications and the detailed wiring, installation, and maintenance methods for the FX3U PLC.	09R516
■ FX3UC Series PLC					
△	Enclosed with the product	FX3UC(D,DS,DSS) Series HARDWARE MANUAL	JY997D50501	The input/output specifications and the wiring and installation methods for the FX3UC(D,DS,DSS) PLC are excerpted from the FX3UC Series User's Manual - Hardware Edition. For details, refer to the FX3UC Series User's Manual - Hardware Edition.	-
△	Enclosed with the product	FX3UC-32MT-LT-2 HARDWARE MANUAL	JY997D31601	The input/output specifications and the wiring and installation methods for the FX3UC-32MT-LT-2 PLC are excerpted from the FX3UC Series User's Manual - Hardware Edition. For details, refer to the FX3UC Series User's Manual - Hardware Edition.	-
⊙	Separate document	FX3UC Series User's Manual - Hardware Edition	JY997D28701	Provides detailed information on the hardware, such as the input/output specifications and the detailed wiring, installation, and maintenance methods for the FX3UC PLC.	09R519
■ Programming					
✓	Separate document	FX3S/FX3G/FX3GC/FX3U/FX3UC Series Programming Manual - Basic & Application Instruction Edition	JY997D16601	Describes the basic instructions, applied instructions, and various devices of the FX3S/FX3G/FX3GC/FX3U/FX3UC PLC to provide detailed information on sequence programming.	09R517
✓	Separate document	MELSEC-Q/L/F Structured Programming Manual (Fundamentals)	SH-080782	Programming methods, specifications, functions, etc. required to create structured programs	13JW06
✓	Separate document	FXCPU Structured Programming Manual [Device & Common]	JY997D26001	Devices, parameters, etc. provided in structured projects of GX Works2	09R925
✓	Separate document	FXCPU Structured Programming Manual [Basic & Applied Instruction]	JY997D34701	Sequence instructions provided in structured projects of GX Works2	09R926
✓	Separate document	FXCPU Structured Programming Manual [Application Functions]	JY997D34801	Application functions provided in structured projects of GX Works2	09R927

- ⊙ Indispensable manual
- ✓ Manual that may be indispensable depending on the purpose of use
- △ Abbreviated document

	Title of manual	Document number	Description	Model code	
Manuals for positioning control					
■ Common					
⊙	Separate document	FX3S/FX3G/FX3GC/ FX3U/FX3UC Series User's Manual - Positioning Control Edition (this document)	JY997D16801	Provides detailed information on the positioning functions incorporated in the FX3S/FX3G/FX3GC/FX3U/FX3UC Series.	09R620
■ Pulse output, positioning					
To use each product, also refer to the user's manual (for hardware) of the PLC to be connected to your system.					
△	Enclosed with the product	FX3U-2HSY-ADP Installation Manual	JY997D16401	Describes how to handle the high-speed output special adapter. To use this adapter, also refer to the User's Manual for FX3S/FX3G/FX3GC/ FX3U/FX3UC Series (for positioning control).	-
△	Enclosed with the product	FX3U-1PG Installation Manual	JY997D47101	Describes how to handle the 1-axis pulse output block. To use this block, also refer to FX3U-1PG USER'S MANUAL.	-
✓	Separate document	FX3U-1PG User's Manual	JY997D47301	Provides detailed information on the 1-axis pulse output block.	09R629
△	Enclosed with the product	FX2N-1PG Installation Manual	JY997D50601	Provides detailed information on the 1-axis pulse output block. To use this block, also refer to FX2N/ FX-1PG USER'S MANUAL.	-
✓	Separate document	FX2N/FX-1PG User's Manual	JY992D65301	Describes how to handle the 1-axis pulse output block.	09R610
△	Enclosed with the product	FX2N-10PG Installation Manual	JY992D91901	Describes how to handle the 1-axis pulse output block. To use this block, also refer to FX2N- 10PG USER'S MANUAL.	-
✓	Separate document	FX2N-10PG User's Manual	JY992D93401	Provides detailed information on the 1-axis pulse output block.	09R611
△	Enclosed with the product	FX2N-10GM User's Guide	JY992D77701	Describes how to handle the 1-axis positioning special function unit. To use this unit, also refer to FX2N- 10GM/FX2N-20GM HARDWARE/ PROGRAMMING MANUAL.	-
△	Enclosed with the product	FX2N-20GM User's Guide	JY992D77601	Describes how to handle the 2-axis positioning special function unit. To use this unit, also refer to FX2N- 10GM/FX2N-20GM HARDWARE/ PROGRAMMING MANUAL.	-
✓	Separate document	FX2N-10GM/FX2N-20GM HARDWARE/ PROGRAMMING MANUAL	JY992D77801	Provides detailed information on the 1-axis/2-axis positioning special function unit.	09R612
✓	Enclosed with the product	FX-PCS-VPS/WIN SOFTWARE MANUAL	JY992D86801	Describes operation details of FX-PCS-VPS/WIN Setting/Monitoring Tool.	09R609
△	Enclosed with the product	FX3U-20SSC-H Installation Manual	JY997D21101	Describes FX3U-20SSC-H positioning block specification for I/O, power supply extracted from the FX3U-20SSC-H User's Manual. For details, refer to FX3U-20SSC-H User's Manual.	-
✓	Separate document	FX3U-20SSC-H User's Manual	JY997D21301	Describes FX3U-20SSC-H Positioning block details.	09R622
✓	Separate document	FX Configurator-FP Operation Manual	JY997D21801	Describes operation details of FX Configurator-FP Setting/Monitoring Tool.	09R916

Generic Names and Abbreviations Used in Manuals

Generic name or abbreviation	Description
PLC	
FX3S series	Generic name for FX3S Series PLC
FX3S PLC or main unit	Generic name for FX3S Series PLC main unit
FX3G series	Generic name for FX3G Series PLC
FX3G PLC or main unit	Generic name for FX3G Series PLC main unit
FX3GC series	Generic name for FX3GC Series PLC
FX3GC PLC or main unit	Generic name for FX3GC Series PLC main unit
FX3U series	Generic name for FX3U Series PLC
FX3U PLC or main unit	Generic name for FX3U Series PLC main unit
FX3UC series	Generic name for FX3UC Series PLC
FX3UC PLC or main unit	Generic name for FX3UC Series PLC main unit
FX2N Series	Generic name for FX2N Series PLC
FX2NC Series	Generic name for FX2NC Series PLC
Expansion board	
Expansion board	Generic name for expansion board The number of connectable units, however, depends on the type of main unit. To check the number of connectable units, refer to the User's Manual - Hardware Edition of the main unit to be used for your system.
Special adapter	
Special adapter	Generic name for high-speed input/output special adapter, communication special adapter, CF card special adapter, and analog special adapter The number of connectable units, however, depends on the type of main unit. To check the number of connectable units, refer to the User's Manual - Hardware Edition of the main unit to be used for your system.
High-speed input/output special adapter	Generic name for high-speed input special adapter and high-speed output special adapter
High-speed output special adapter	Generic name for high-speed output special adapter
2HSY-ADP	FX3U-2HSY-ADP
High-speed input special adapter	Generic name for high-speed input special adapter
Communication special adapter	Generic name for communication special adapter
CF card special adapter	Generic name for CF card special adapter
Analog special adapter	Generic name for analog special adapter
Extension unit	
Extension unit	Generic name for input/output extension unit and special extension unit The number of connectable units, however, depends on the type of main unit. To check the number of connectable units, refer to the User's Manual - Hardware Edition of the main unit to be used for your system.

Generic name or abbreviation	Description
Extension unit	
Input/output extension unit	Generic name for input extension unit and output extension unit The number of connectable units, however, depends on the type of main unit. To check the number of connectable units, refer to the User's Manual - Hardware Edition of the main unit to be used for your system.
Input extension unit	Generic name for FX2N Series input/output powered extension unit, FX2N Series input extension block, FX2NC Series input extension block, and FX0N Series input extension block
Output extension unit	Generic name for FX2N Series input/output powered extension unit, FX2N Series output extension block, FX2NC Series output extension block, and FX0N Series output extension block
Special function unit/block or Special extension unit	Generic name for special function unit and special function block The number of connectable units, however, depends on the type of main unit. To check the number of connectable units, refer to the User's Manual - Hardware Edition of the main unit to be used for your system.
Special function unit	Generic name for special function unit
Special function block	Generic name for special function block
Positioning special function unit	Generic name for the following models: FX2N-10GM, FX2N-20GM
Positioning special function block	Generic name for the following models: FX3U-20SSC-H
Pulse output block	Generic name for the following models: FX3U-1PG, FX2N-1PG-E, FX2N-1PG, FX2N-10PG
FX2N-1PG(-E)	Generic name for the following models: FX2N-1PG-E, FX2N-1PG
Optional unit	
Extension power supply unit	FX3UC-1PS-5V(for FX3GC/FX3UC series), FX3U-1PSU-5V(for FX3G/FX3U series)
Memory cassette	FX3G-EEPROM-32L, FX3U-FLROM-16, FX3U-FLROM-64, FX3U-FLROM-64L, FX3U-FLROM-1M
Battery	FX3U-32BL
FX Series terminal block	FX-16E-TB, FX-32E-TB, FX-16EX-A1-TB, FX-16EYR-TB, FX-16EYS-TB, FX-16EYT-TB
Input/output cable	FX-16E-500CAB-S, FX-16E-□□□CAB, FX-32E-□□□CAB, FX-16E-□□□CAB-R, FX-A32E-□□□CAB □□□ represents 150, 300, or 500.
Input/output connector	FX2C-I/O-CON, FX2C-I/O-CON-S, FX2C-I/O-CON-SA
Power cable	FX2NC-100MPCB, FX2NC-100BPCB, FX2NC-10BPCB1
Peripheral unit	
Peripheral unit	Generic name for programming software, handy programming panel, and HMI
Programming tool	
Programming tool	Generic name for programming software and handy programming panel
Programming software	Generic name for programming software
GX Works2	Generic name for SW□DNC-GXW2-J/SW□DNC-GXW2-E programming software package
GX Developer	Generic name for SW□D5C-GPPW-J/SW□D5C-GPPW-E programming software package
Handy programming panel (HPP)	Generic name for FX-30P, FX-20P(-E)-SET0, FX-20P(-E), FX-10P-SET0, and FX-10P(-E)

Generic name or abbreviation	Description
Setting/Monitoring Tool	
Setting/monitoring tool	Generic name for setting/monitoring tool
FX Configurator-FP	Generic name for SW□D5C-FXSSC-J/SW□D5C-FXSSC-E Setting/monitoring tool
HMI	
GOT1000 series	Generic name for GT16, GT15, GT14, GT11 and GT10
GOT-900 series	Generic name for GOT-A900 series and GOT-F900 series
GOT-A900 series	Generic name for GOT-A900 series
GOT-F900 series	Generic name for GOT-F900 series
ET-940 series	Generic name for ET-940 series Only manuals in Japanese are available for these products
Servo motor/servo amplifier	
Servo motor	Generic name for servo motor or stepping motor Including pulse input type servo amplifier and drive unit.
Servo amplifier (drive unit)	Generic name for pulse input type servo amplifier (drive unit)
MELSERVO series	Generic name for MELSERVO-J4, -J3, -JN, -J2-Super, -J2, -H, and -C series
SSCNET III	Abbreviated name for the high-speed synchronous network communication between the FX3U-20SSC-H and a servo amplifier
Other unit	
Manual pulse generator	Generic name for manual pulse generator (prepared by user)
Manual	
FX3S Hardware Edition	FX3S Series User's Manual - Hardware Edition
FX3G Hardware Edition	FX3G Series User's Manual - Hardware Edition
FX3GC Hardware Edition	FX3GC Series User's Manual - Hardware Edition
FX3U Hardware Edition	FX3U Series User's Manual - Hardware Edition
FX3UC Hardware Edition	FX3UC Series User's Manual - Hardware Edition
Programming manual	FX3S/FX3G/FX3GC/FX3U/FX3UC Series Programming Manual - Basic and Applied Instruction Edition
Communication Control Edition	FX Series User's Manual - Data Communication Edition
Analog Control Edition	FX3S/FX3G/FX3GC/FX3U/FX3UC Series User's Manual - Analog Control Edition
Positioning Control Edition	FX3S/FX3G/FX3GC/FX3U/FX3UC Series User's Manual - Positioning Control Edition

MEMO

FX3s/FX3G/FX3GC/FX3U/FX3UC Series Programmable Controllers User's Manual [Positioning Control Edition]

A. Common Items

Foreword

"Common Items" describes an outline of the "positioning" functions incorporated in the MELSEC-F FX3s/FX3G/FX3GC/FX3U/FX3UC Series PLC and should be read and understood before attempting to install or use the unit.

Store this manual in a safe place so that you can take it out and read it whenever necessary. Always forward it to the end user.

This manual confers no industrial property rights or any rights of any other kind, nor does it confer any patent licenses. Mitsubishi Electric Corporation cannot be held responsible for any problems involving industrial property rights which may occur as a result of using the contents noted in this manual.

© 2005 MITSUBISHI ELECTRIC CORPORATION

Description of Manual (Common Items)

In this manual, the following formats are used for describing the common items:

- Shows the title of the manual and the title of the division.**
 This area shows the title of the manual and the title of the division for the current page.
 1st line: Shows the title of the manual.
 2nd line: Shows the title of the division.
- Shows the title of the chapter and the title of the section.**
 This area shows the title of the chapter and the title of the section for the current page.
- Indexes the title of the division.**
 The right side of each page indexes the title of the division for the current page.

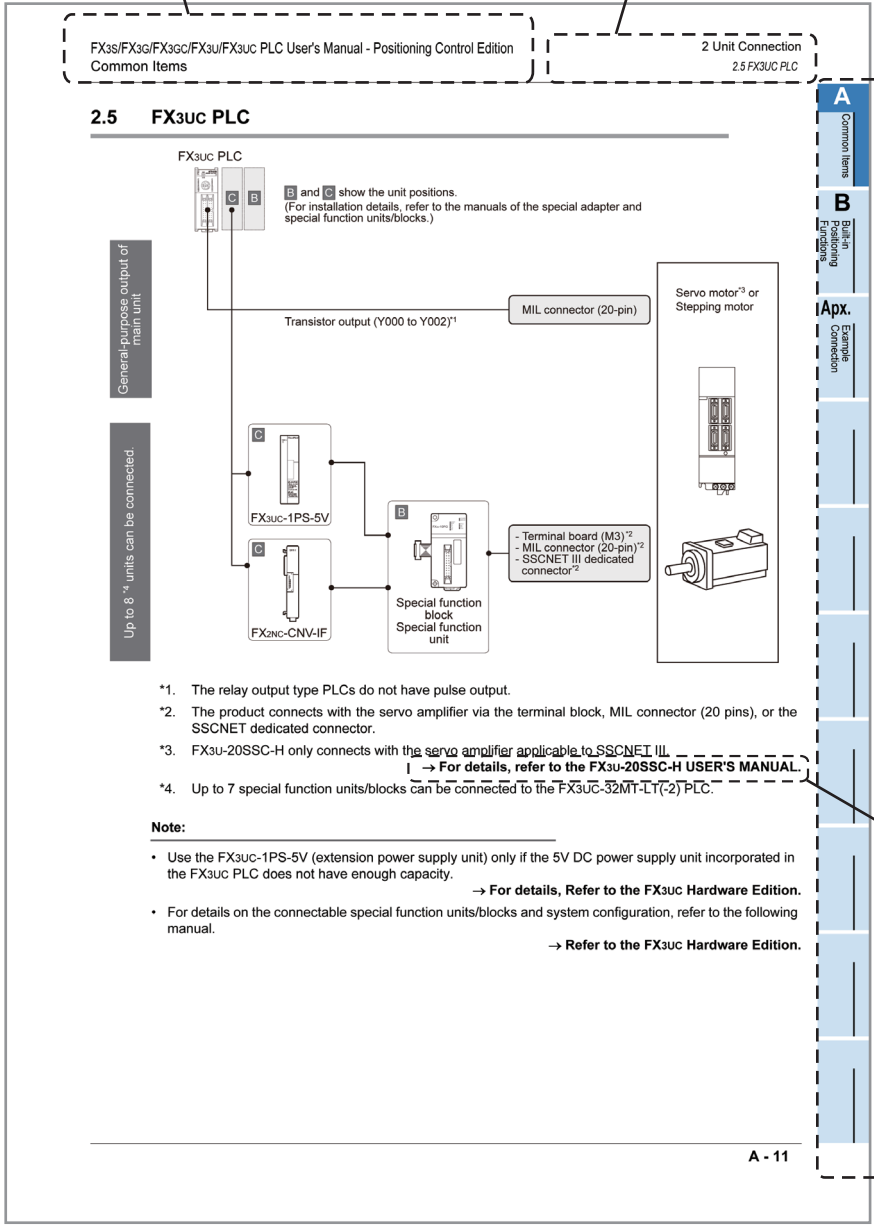

- *1. The relay output type PLCs do not have pulse output.
- *2. The product connects with the servo amplifier via the terminal block, MIL connector (20 pins), or the SSCNET dedicated connector.
- *3. FX3U-20SSC-H only connects with the servo amplifier applicable to SSCNET III.
 → For details, refer to the FX3U-20SSC-H USER'S MANUAL.
- *4. Up to 7 special function units/blocks can be connected to the FX3UC-32MT-LT(-2) PLC.

Note:

- Use the FX3UC-1PS-5V (extension power supply unit) only if the 5V DC power supply unit incorporated in the FX3UC PLC does not have enough capacity.
 → For details, Refer to the FX3UC Hardware Edition.
- For details on the connectable special function units/blocks and system configuration, refer to the following manual.
 → Refer to the FX3UC Hardware Edition.

Shows the reference.
 This area shows the reference document (the reference document is shown next to "→").
 • If the reference is in "A. Common items" division, only the chapter, section, or subsection number only will be shown next to "→".
 • If the reference is in another division, the chapter, section, or subsection number will be shown next to "→" together with the title of the division.

The above is different from the actual page, as it is provided for explanation only.

1. Introduction

This manual describes the positioning control for the FX3S/FX3G/FX3GC/FX3U/FX3UC PLC. In this chapter, a brief description of the positioning products is provided.

1.1 Outline

The FX3S/FX3G/FX3GC/FX3U/FX3UC PLC outputs the pulse signal to the servo motor and the stepping motor to control the positioning operation.

Increase the pulse frequency to increase the motor speed. Increase the number of pulses to increase the number of motor revolutions. In other words, set the pulse frequency to determine the workpiece transfer (positioning) speed.

Set the number of pulses to determine the workpiece transfer distance.

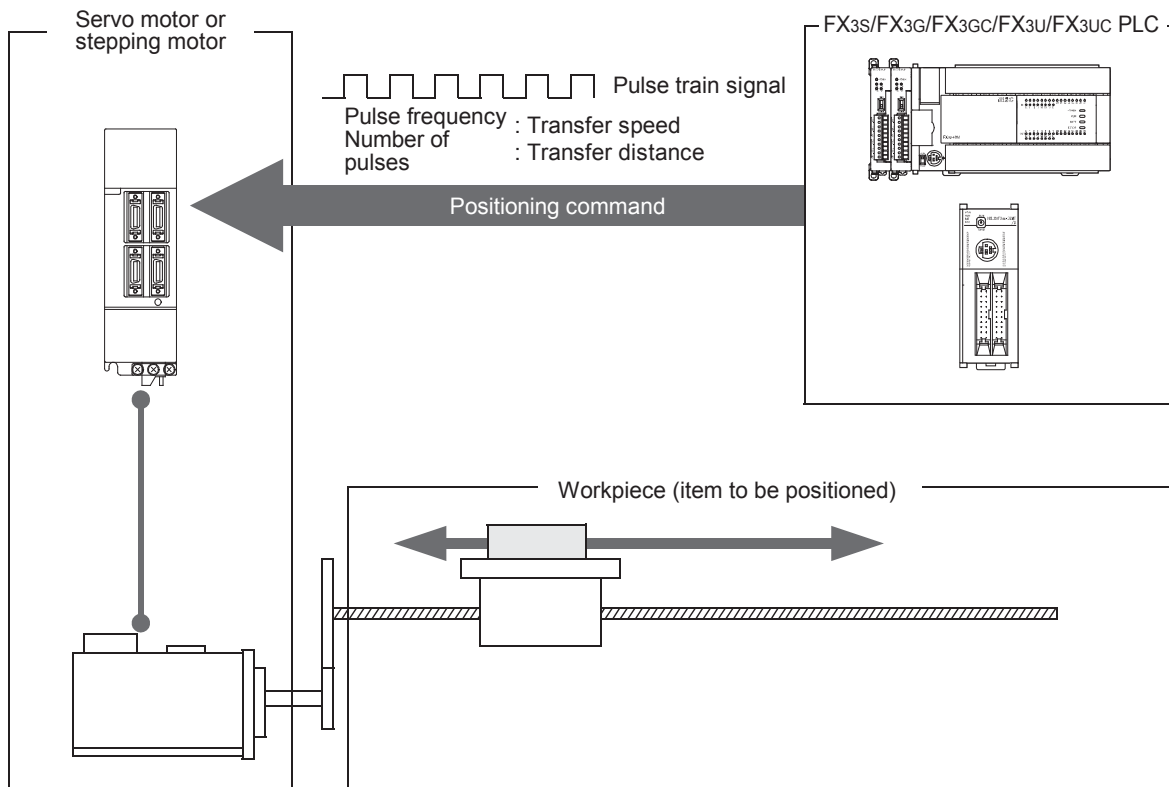

1.2 Introduction of Products Needed for Positioning

To control the positioning operation, use the positioning functions incorporated in the main unit (including the special adapters), and the special functions units/blocks. The functions, however, depend on the product(s) being used. Select the optimum product(s) for the purpose of use.

1.2.1 List of Models

The products needed for positioning are shown in the following table:

1. Main unit (transistor output) and special adapter

Model	Number of axes	Frequency (Hz) ^{*1}	Unit	Output form	Output method	Reference
Main unit (transistor output)						
FX3S PLC	2-axes (independent)	10 ^{*2} to 100,000	pulse	Transistor	"Pulse train + direction" method	B. Built-in Positioning Function
FX3G PLC (14-point, 24-point type)	2-axes (independent)	10 ^{*2} to 100,000	pulse	Transistor	"Pulse train + direction" method	B. Built-in Positioning Function
FX3G PLC (40-point, 60-point type)	3-axes (independent)	10 ^{*2} to 100,000	pulse	Transistor	"Pulse train + direction" method	B. Built-in Positioning Function
FX3GC PLC	2-axes (independent)	10 ^{*2} to 100,000	pulse	Transistor	"Pulse train + direction" method	B. Built-in Positioning Function
FX3U/FX3UC PLC	3-axes (independent)	10 ^{*2} to 100,000	pulse	Transistor	"Pulse train + direction" method	B. Built-in Positioning Function
Special adapter						
FX3U-2HSY-ADP ^{*3}	2-axes ^{*4} (independent)	10 ^{*2} to 200,000	pulse	Differential line driver	"Pulse train + direction" method or "forward/reverse rotation pulse train" method	B. Built-in Positioning Function

*1. Do not exceed the maximum rotation speed of the servo motor or the stepping motor.

*2. The minimum frequency set by the PLSY instruction or PLSV instruction is "1 Hz".

→ For details on the PLSY instruction, refer to the programming manual.

→ For details on the PLSV instruction, refer to Chapter 10.

*3. Can only be connected to the FX3U PLC.

*4. Connection of 1 adapter can control 2 axes. Connection of 2 adapters can control up to 4 axes.

2. Special function block/unit*1

Model	Number of axes	Frequency (Hz)*2	Unit	Output form	Output method
Special function block					
FX3U-1PG	1-axis	1 to 200,000	pulse μm 10 ⁻⁴ inch mdeg	Transistor	"Pulse train + direction" method or "forward/reverse rotation pulse train" method
FX2N-1PG(-E)	1-axis	10 to 100,000	pulse μm 10 ⁻⁴ inch mdeg	Transistor	"Pulse train + direction" method or "forward/reverse rotation pulse train" method
FX2N-10PG	1-axis	1 to 1,000,000	pulse μm 10 ⁻⁴ inch mdeg	Differential line driver	"Pulse train + direction" method or "forward/reverse rotation pulse train" method
FX3U-20SSC-H	2-axes (independent/ interpolation)	1 to 50,000,000	pulse μm 10 ⁻⁴ inch mdeg	SSCNET III	
Special function unit					
FX2N-10GM	1-axis	1 to 200,000	pulse μm 10 ⁻⁴ inch mdeg	Transistor	"Pulse train + direction" method or "forward/reverse rotation pulse train" method
FX2N-20GM	2-axes (independent/ interpolation)	1 to 200,000	pulse μm 10 ⁻⁴ inch mdeg	Transistor	"Pulse train + direction" method or "forward/reverse rotation pulse train" method

*1. Only FX3U and FX3UC PLC can be connected to the above models.
Refer to the manual of each product.

*2. Do not exceed the maximum rotation speed of the servo motor or the stepping motor.

1.2.2 Main Unit (Transistor Output)

The FX3S/FX3G/FX3GC/FX3U/FX3UC PLC incorporates positioning functionality. The PLC can output pulse train of up to 100 kHz from the general-purpose outputs (Y000 to Y002), and it can simultaneously control 3 axes*1.

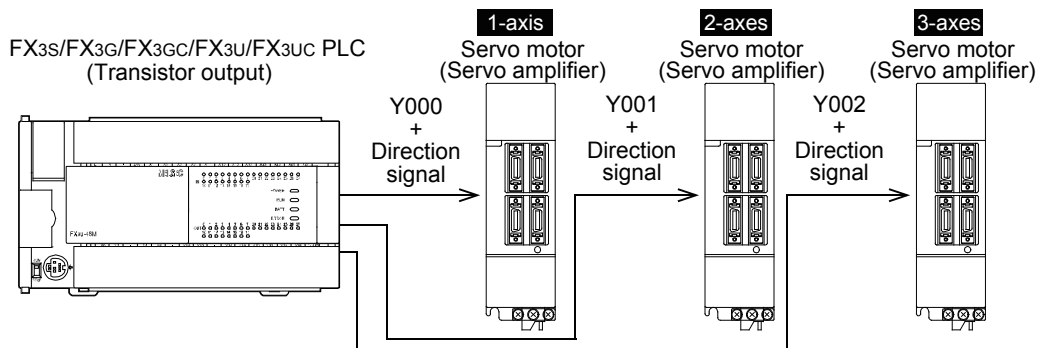

*1. The FX3G PLC (14-point and 24-point type) and FX3S/FX3GC PLC can only control 2 axes.

1.2.3 Special Adapter (Differential Line Driver Output)

The special adapter can output pulse trains of up to 200 kHz using the positioning functionality incorporated in the FX3U PLC, and can simultaneously control up to 4 axes.

Up to 2 high-speed output special adapters (FX3U-2HSY-ADP) can be connected to the FX3U PLC.

- The first FX3U-2HSY-ADP uses Y000 and Y004, and Y001 and Y005.
- The second FX3U-2HSY-ADP uses Y002 and Y006, and Y003 and Y007.

FX3U-2HSY-ADP

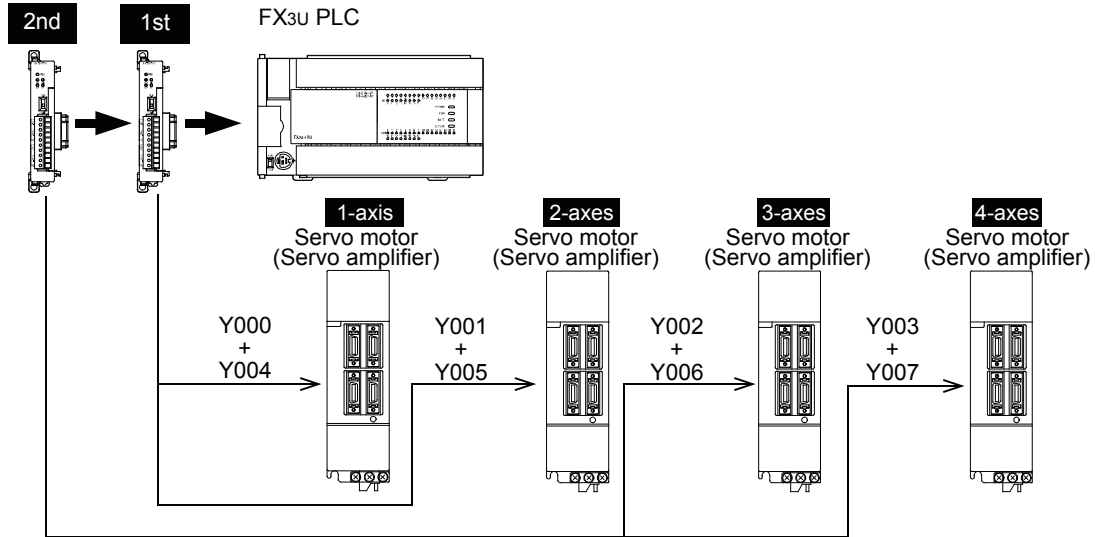

Cautions when connecting special adapters

- To use high-speed output special adapters only (not to use the other special adapters), it is not necessary to connect the expansion board.
- To use the analog, communication, and CF card special adapters, be sure to connect the expansion board.
- To use high-speed output special adapters together with the analog, communication, and/or CF card special adapters, connect the high-speed output special adapters to the expansion board (already connected to the FX3U PLC) first, and then connect the analog special adapters, communication, and/or CF card special adapter(s).

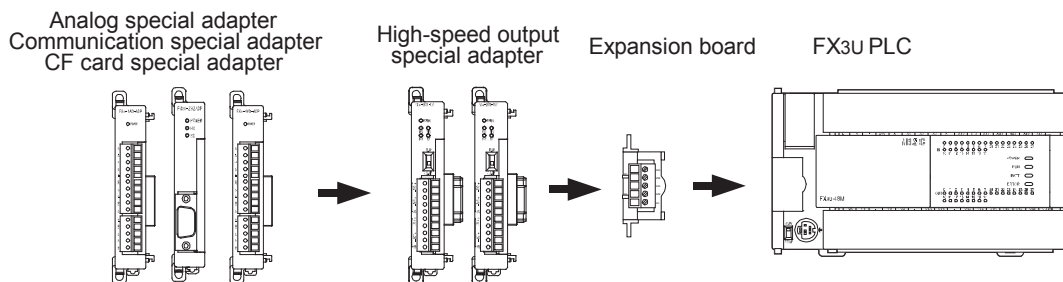

1.2.4 Special Function Unit/Block

Connect a special function unit/block to the FX3U/FX3UC PLC to control positioning operations. Note that a special function unit can individually control positioning operations.

1. System configuration for FX3U PLC

Up to 8 special function units/blocks can be connected to the FX3U PLC.

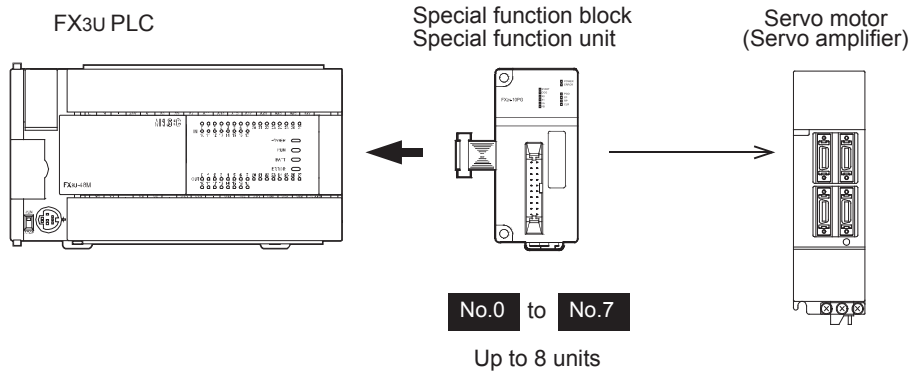

→ For details on system configuration, refer to the FX3U Hardware Edition.

2. System configuration for FX3UC PLC

Up to 8*1 special function units/blocks can be connected to the FX3UC PLC.

FX2NC-CNV-IF or FX3UC-1PS-5V is needed to connect special function units/blocks.

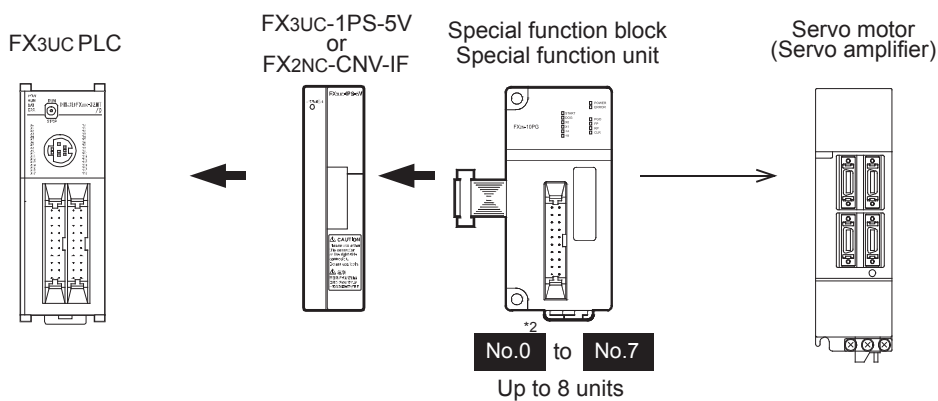

*1. Up to 7 special function units/blocks can be connected to the FX3UC-32MT-LT(-2) PLC.

*2. The unit/block number begins with "No. 1" when special function unit/blocks are connected to the FX3UC-32MT-LT(-2) PLC.

→ For details on system configuration, refer to the FX3UC Hardware Edition.

3. Individual operation (FX2N-10GM, FX2N-20GM)

Without connecting special function units (FX2N-10GM, FX2N-20GM) to the PLC, you can operate them individually.

- FX2N-10GM can control one 1-axis servo motor or stepping motor.
 - FX2N-20GM can control two 1-axis servo motors or stepping motors.
- In addition, up to 48 I/O points can be added.

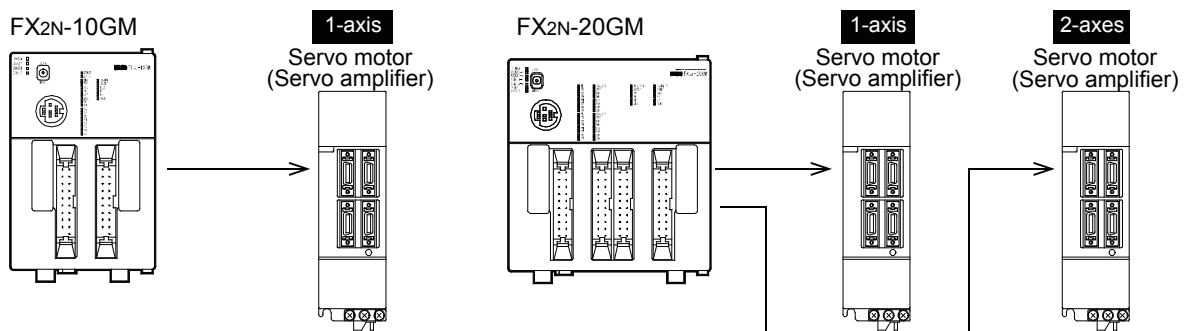

2. Unit Connection

This chapter displays several block diagrams to illustrate the various combinations of units needed for positioning control.

2.1 FX3s PLC

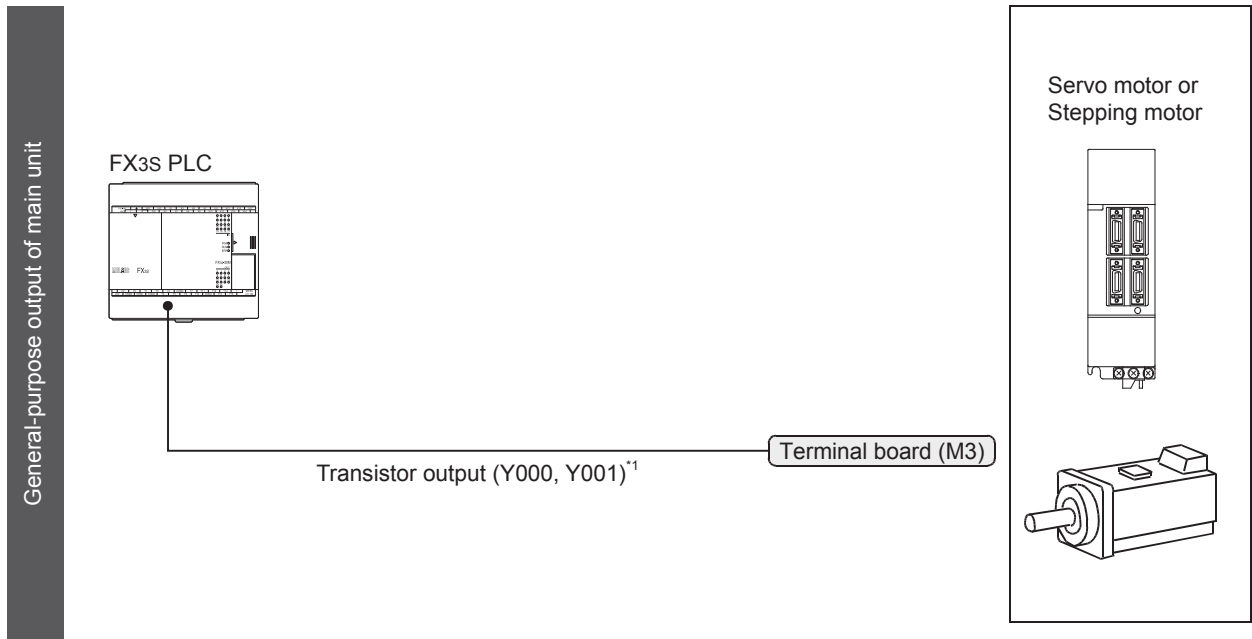

*1. The relay output type PLCs do not have pulse output.

2.2 FX3G PLC

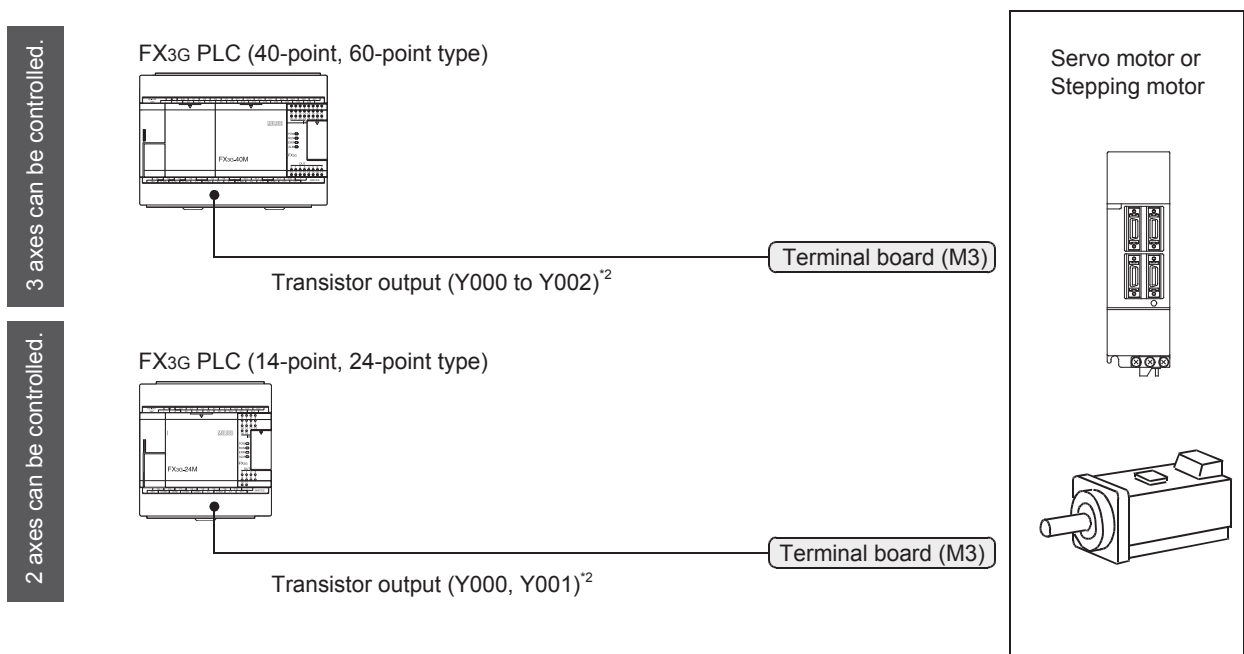

*2. The relay output type PLCs do not have pulse output.

2.3 FX3GC PLC

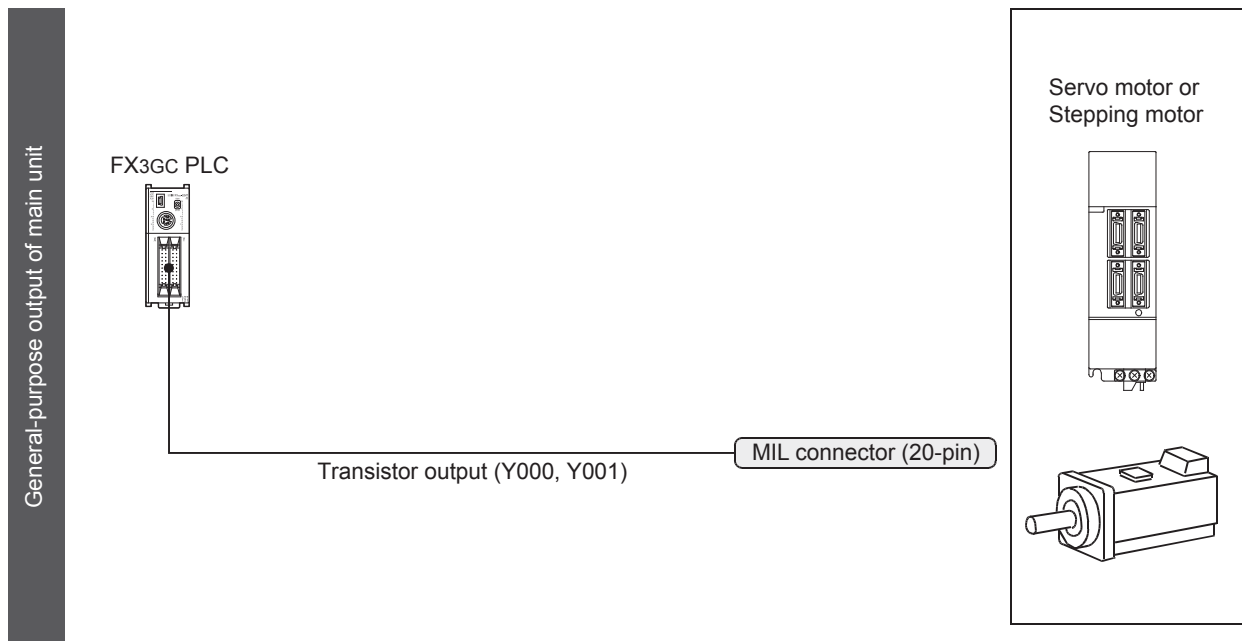

A	Common Items
B	Built-in Positioning Functions
Apx.	Example Connection

2.4 FX3U PLC

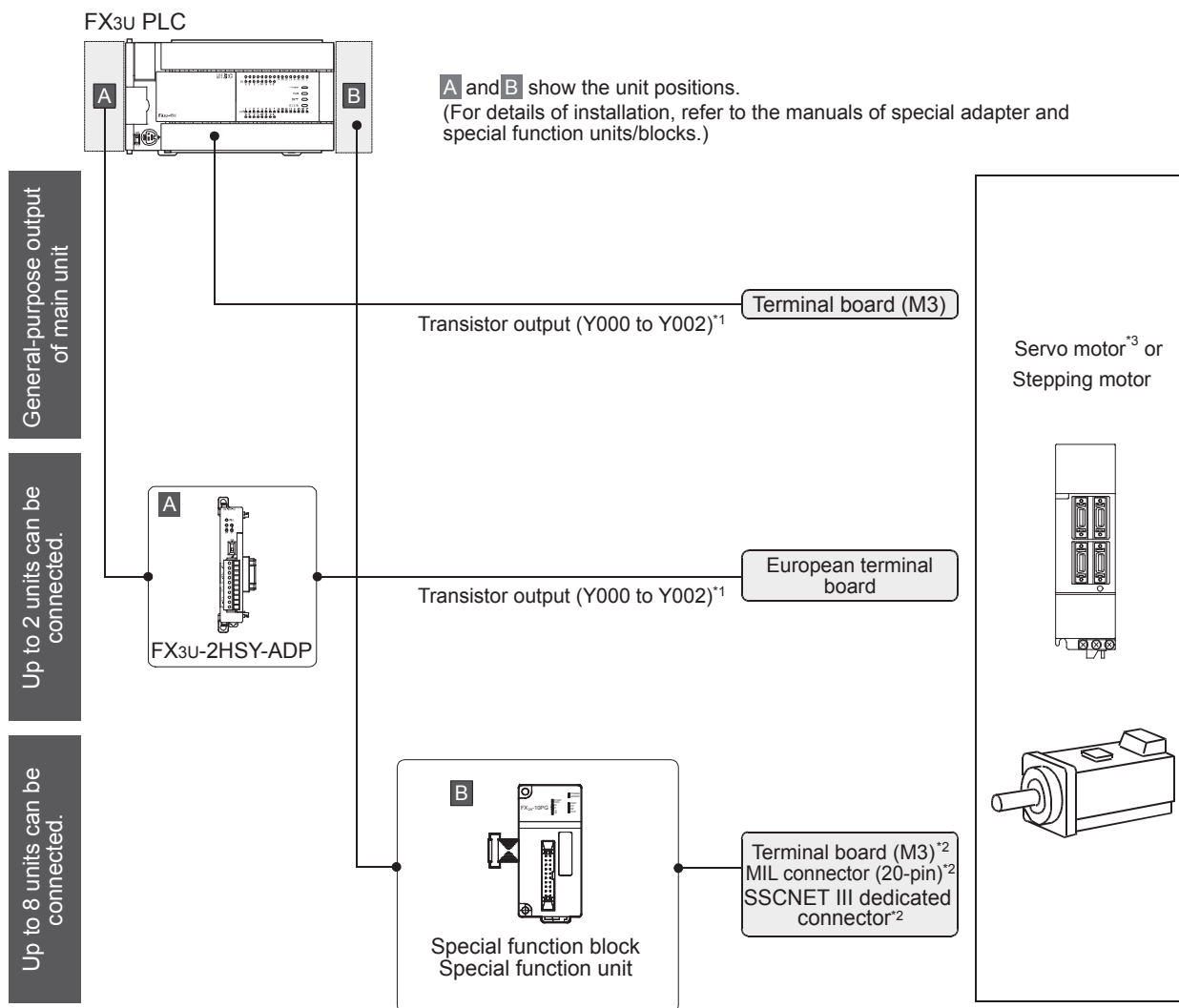

*1. The relay output and triac output type PLCs do not have pulse output.

*2. The product connects with the servo amplifier via the terminal block, MIL connector (20 pins), or the SSCNET dedicated connector.

*3. FX3U-20SSC-H only connects with the servo amplifier applicable to SSCNET III.

→ For details, refer to the **FX3U-20SSC-H USER'S MANUAL**.

Note:

- For details on the connectable special function units/blocks and system configuration, refer to the following manual.

→ Refer to the **FX3U Hardware Edition**.

2.5 FX3UC PLC

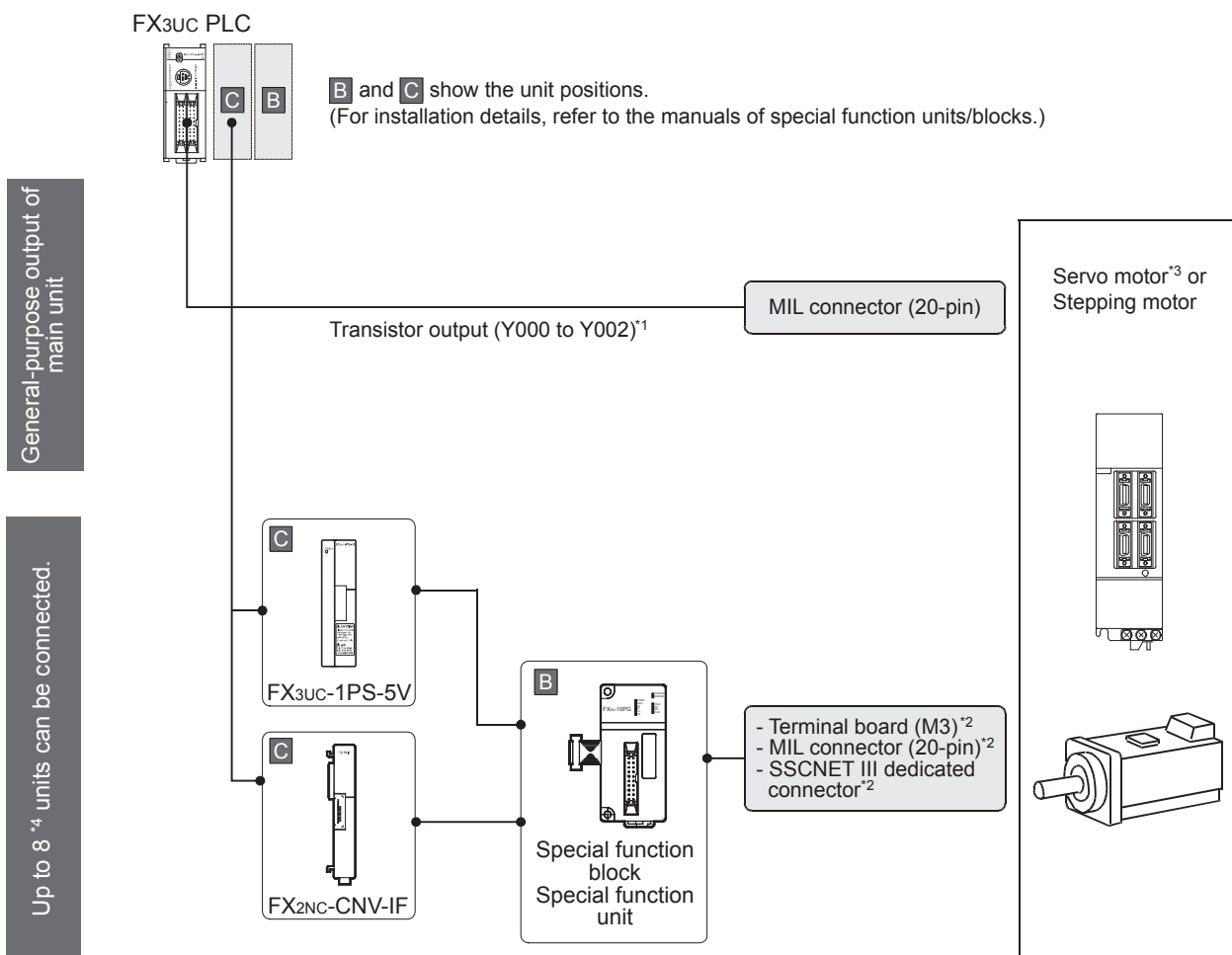

*1. The relay output type PLCs do not have pulse output.

*2. The product connects with the servo amplifier via the terminal block, MIL connector (20 pins), or the SSCNET dedicated connector.

*3. FX3U-20SSC-H only connects with the servo amplifier applicable to SSCNET III.

→ For details, refer to the **FX3U-20SSC-H USER'S MANUAL**.

*4. Up to 7 special function units/blocks can be connected to the FX3UC-32MT-LT(-2) PLC.

Note:

- Use the FX3UC-1PS-5V (extension power supply unit) only if the 5V DC power supply unit incorporated in the FX3UC PLC does not have enough capacity.

→ For details, Refer to the **FX3uc Hardware Edition**.

- For details on the connectable special function units/blocks and system configuration, refer to the following manual.

→ Refer to the **FX3uc Hardware Edition**.

2.6 Individual Operation of Special Function Unit (FX2N-10GM, FX2N-20GM)

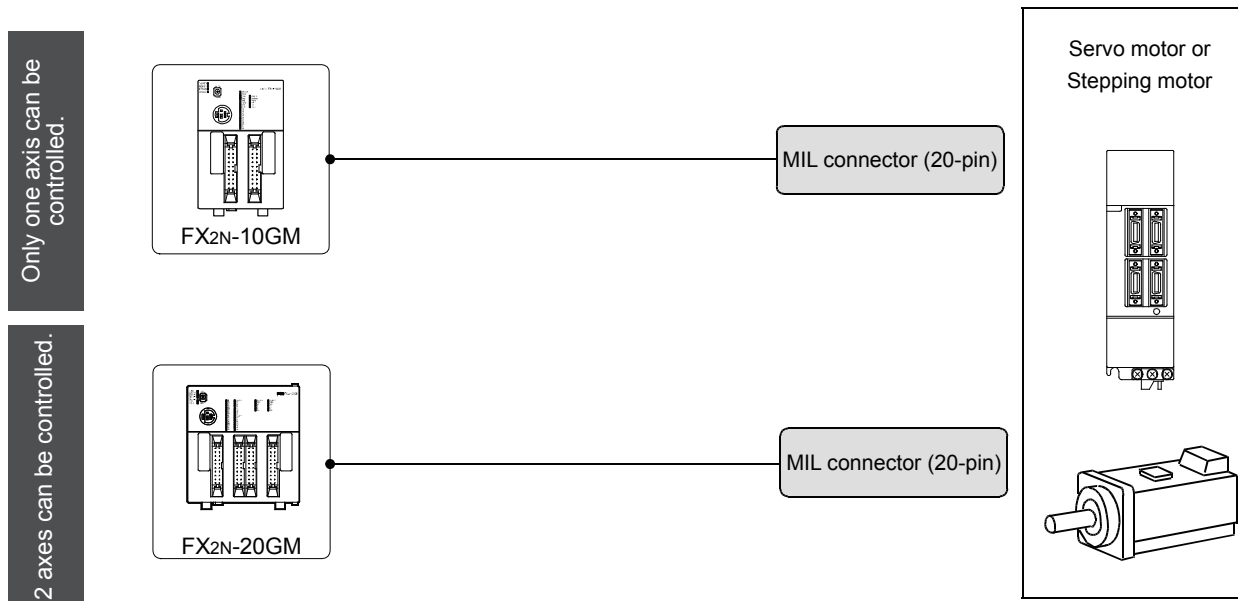

Note:

- For details on the connection of the FX2N-10GM or FX2N-20GM and for system configuration, refer to the following manual.

→ Refer to **FX2N-10GM, FX2N-20GM HARDWARE/PROGRAMMING MANUAL.**

3. Comparison of Specifications

The specifications for each product with positioning functionality are shown below.

3.1 Comparison of Performance Specifications

3.1.1 Built-in Positioning Function [Main Unit (Transistor Output), High-Speed Output Special Adapter (FX3U-2HSY-ADP)]

Model	FX3G PLC (14-point and 24-point type) and FX3S/FX3GC PLC (Main unit, transistor output)	FX3G PLC (40-point and 60-point type) and FX3U/FX3UC PLC (Main unit, transistor output)	FX3U-2HSY-ADP*1
Number of control axes	2 independent axes	3 independent axes	2 independent axes (Connect 2 adapters to the main unit to control 4 axes independently.)
Interpolation	-		
Pulse output form	Transistor		Differential line driver
Pulse output method	"Pulse train + direction" method		"Pulse train + direction" method "Forward/reverse rotation pulse train" method
Maximum frequency*2	100,000Hz		200,000Hz
Acceleration /deceleration type	Trapezoidal acceleration/deceleration		
Unit	pulse		
Positioning range	-999,999 to +999,999 (pulse)		
Program language	Sequence program		
Position data	1 point (set in sequence program)		
Connection of manual pulse generator	-		
Detection of absolute position (Reads out the current value of ABS.)	ABS instruction of the PLC		
Others	Pulses can be output from the general-purpose outputs (Y000 and Y001) of the main unit.	Pulses can be output from the general-purpose outputs (Y000, Y001, and Y002) of the main unit.	<ul style="list-style-type: none"> • To be used when a servo amplifier with a differential line receiver is connected. • To be used when positioning control is performed with a FX3U Series relay output type or triac output type main unit. • Used in place of the general-purpose outputs (Y000 to Y007)*3 of the main unit.

*1. Can only be connected to the FX3U PLC. Up to 2 adapters can be connected.

*2. Do not exceed the maximum rotation speed of the servo motor or the stepping motor.

*3. If 2 adapters are connected, Y000 to Y007 will be used. If only one adapter is connected, Y000, Y001, Y004, and Y005 will be used. The relation between the output of the FX3U-2HSY-ADP and the output of main unit is described in the following sections.

→ For high-speed output special adapters, refer to Subsection 1.5.3 and Section 4.9 of "B. Built-in Positioning Function."

3.1.2 Pulse Output Block [FX3U-1PG, FX2N-1PG(-E), FX2N-10PG]

Model	FX3U-1PG	FX2N-1PG(-E)
Number of control axes	1 independent axis	
Interpolation	-	
Pulse output form	Transistor	
Pulse output method	"Pulse train + direction" method "Forward/reverse rotation pulse train" method	
Maximum frequency*1	200,000Hz	100,000Hz
Acceleration/deceleration type	Trapezoidal acceleration/deceleration, approximate S-shaped acceleration/deceleration	Trapezoidal acceleration/deceleration
Unit	pulse, μm , 10^{-4}inch , mdeg	
Positioning range	-2,147,483,648 to +2,147,483,647 [\times (Position data magnification*2) pulse] -2,147,483,648 to +2,147,483,647 [\times (Position data magnification*2) μm]*3 -2,147,483,648 to +2,147,483,647 [\times (Position data magnification*2) $\times 10^{-4}$ inch]*3 -2,147,483,648 to +2,147,483,647 [\times (Position data magnification*2) mdeg]*3	-999,999 to +999,999 [\times (Position data magnification*2) pulse] -999,999 to +999,999 [\times (Position data magnification*2) μm] -999,999 to +999,999 [\times (Position data magnification*2) $\times 10^{-4}$ inch] -999,999 to +999,999 [\times (Position data magnification*2) mdeg]
Program language	Sequence program (FROM/TO instruction, BFM direct designation)	
Position data	1 point (set in sequence program)	
Connection of manual pulse generator	-	
Detection of absolute position (Reads out the current value of ABS.)	Using the ABS instruction of the PLC	
Others	<ul style="list-style-type: none"> PLC input/output: 8 points occupied (Points can be either input or output points.) During positioning operation, the operation speed and/or target address can be changed. 	PLC input/output: 8 points occupied (Points can be either input or output points.)

*1. Do not exceed the maximum rotation speed of the servo motor or the stepping motor.

*2. The position data magnification sets the 1, 10, 10^2 or 10^3 in parameters.

*3. The positioning range can be set in the range from -2,147,483,648 to +2,147,483,647 pulses.

Model	FX2N-10PG
Number of control axes	1 independent axis
Interpolation	-
Pulse output form	Differential line driver
Pulse output method	"Pulse train + direction" method "Forward/reverse rotation pulse train" method
Maximum frequency ^{*1}	1,000,000Hz
Acceleration/ deceleration type	Trapezoidal acceleration/deceleration, approximate S-pattern acceleration/deceleration
Unit	pulse, μm , 10^{-4}inch , mdeg
Positioning range	-2,147,483,648 to +2,147,483,647 [\times (Position data magnification ^{*2}) pulse] -2,147,483,648 to +2,147,483,647 [\times (Position data magnification ^{*2}) μm] ^{*3} -2,147,483,648 to +2,147,483,647 [\times (Position data magnification ^{*2}) $\times 10^{-4}\text{inch}$] ^{*3} -2,147,483,648 to +2,147,483,647 [\times (Position data magnification ^{*2}) mdeg] ^{*3}
Program language	Sequence program (FROM/TO instruction, BFM direct designation)
Position data	1 point (set in sequence program) ^{*4}
Connection of manual pulse generator	Connectable (Differential line driver, transistor)
Detection of absolute position (Reads out the current value of ABS.)	Using the ABS instruction of the PLC
Others	<ul style="list-style-type: none"> • PLC input/output: 8 points occupied (Points can be either input or output points.) • From the dedicated start, the high-speed start by 1 ms at shortest is enabled. • During positioning operation, the operation speed can be changed.

*1. Do not exceed the maximum rotation speed of the servo motor or the stepping motor.

*2. The position data magnification sets the 1, 10, 10^2 or 10^3 in parameters.

*3. The positioning range can be set in the range from -2,147,483,648 to +2,147,483,647 pulses.

*4. Up to 200 points (table) can be set for the table operation.

A

Common Items

B

Built-in Positioning Functions

Apx.

Example Connection

3.1.3 Positioning Special Function Block [FX3U-20SSC-H]

Model	FX3U-20SSC-H
Number of control axes	2 independent/simultaneous axes
Interpolation	2-axes linear interpolation, 2-axes circular interpolation
Pulse output form	SSCNET III
Pulse output method	
Maximum frequency*1	50,000,000Hz
Acceleration/deceleration type	Trapezoidal acceleration/deceleration, approximate S-pattern acceleration/deceleration
Unit	pulse, μm , 10^{-4}inch , mdeg
Positioning range	-2,147,483,648 to +2,147,483,647 [\times (Position data magnification ^{*2}) pulse] -2,147,483,648 to +2,147,483,647 [\times (Position data magnification ^{*2}) μm] ^{*3} -2,147,483,648 to +2,147,483,647 [\times (Position data magnification ^{*2}) $\times 10^{-4}\text{inch}$] ^{*3} -2,147,483,648 to +2,147,483,647 [\times (Position data magnification ^{*2}) mdeg] ^{*3}
Program language	Sequence program (FROM/TO instruction, BFM direct designation) ^{*4}
Position data	1 point (set in sequence program) ^{*5}
Connection of manual pulse generator	Connectable (Differential line driver)
Detection of absolute position (Reads out the current value of ABS.)	Set in parameters
Others	<ul style="list-style-type: none"> • PLC input/output: 8 points occupied (Points can be either input or output points.) • During positioning operation, the operation speed and/or target address can be changed.

*1. Do not exceed the maximum rotation speed of the servo motor.

*2. The position data magnification sets 1, 10, 10^2 or 10^3 in parameters.

*3. The positioning range can be set in the range from -2,147,483,648 to +2,147,483,647 pulses.

*4. The set data (table information) of the table operation can be set up with FX Configurator-FP Setting/monitor tool.

*5. Up to 300 points (table) can be set for the table operation of the X-/Y-/XY-axis.

3.1.4 Positioning Special Function Unit [FX2N-10GM, FX2N-20GM]

Model	FX2N-10GM	FX2N-20GM
Number of control axes	1 independent axis	2 independent/simultaneous axes
Interpolation	-	2-axes linear interpolation, 2-axes circular interpolation
Pulse output form	Transistor	
Pulse output method	"Pulse train + direction" method "Forward/reverse rotation pulse train" method	
Maximum frequency* ¹	200,000Hz	200,000Hz (100,000Hz during interpolation operation)
Acceleration/ deceleration type	Trapezoidal acceleration/deceleration	
Unit	pulse, mm, 10 ⁻¹ inch, deg	
Positioning range	-999,999 to +999,999 [× (minimum command unit* ²) pulse] -999,999 to +999,999 [× (minimum command unit* ³) mm] -999,999 to +999,999 [× (minimum command unit* ³) ×10 ⁻¹ inch] -999,999 to +999,999 [× (minimum command unit* ³) deg]	
Program language	Cod number system, table system	Cod number system
Position data	Block designation: 0 to 99 (100 blocks)* ⁴	Block designation (X-axis, Y-axis, 2 axes simultaneously): 0 to 99 (100 blocks)
Connection of manual pulse generator	Connectable (Transistor)	
Detection of absolute position (Reads out the current value of ABS.)	Set in parameters	
Others	<ul style="list-style-type: none"> • PLC input/output: 8 points occupied (Points can be either input or output points.) • This unit can perform positioning operations independently, without a main unit. • This unit can perform teaching operation. 	<ul style="list-style-type: none"> • PLC input/output: 8 points occupied (Points can be either input or output points.) • This unit can perform positioning operations independently, without a main unit. • This unit can perform teaching operation. • I/O points can be added (48 points, maximum).

*1. Do not exceed the maximum rotation speed of the servo motor or the stepping motor.

*2. The minimum command unit sets 1, 10, 10² or 10³ in parameters.

*3. The minimum command unit sets 1, 10⁻¹, 10⁻² or 10⁻³ in parameters.

*4. Up to 100 points (table) can be set for the table operation.

A

Common Items

B

Built-in Positioning Functions

Apx.

Example Connection

3.2 Comparison of Operation Modes

Positioning operation pattern	Description	Built-in positioning function FX3s/FX3G/FX3GC/FX3U/ FX3UC PLC (main unit) (Transistor output) FX3U-2HSY-ADP (FX3U)	FX3U-1PG	FX2N-1PG(-E)	FX2N-10PG	FX2N-10GM	FX2N-20GM	FX3U-20SSC-H
Jogging operation 	<p>If the forward/reverse rotation command is input, the motor will rotate in the forward/reverse direction.</p>	✓*1	✓	✓	✓	✓	✓	✓
Mechanical zero return 	<p>The mechanical zero return start command will start the zero return operation at the specified speed. At the completion of the mechanical zero return, CLEAR signal will be output. The DOG search function applies for each unit.</p>	✓	✓	✓	✓	✓	✓	✓
Electric zero return 	<p>The SETR instruction will return the workpiece to the set electric origin at the maximum speed set by the parameters.</p>	—	—	—	—	✓	✓	—
1-speed positioning 	<p>The start command will start the operation at the specified operation speed, and the operation will stop at the target position.</p>	✓*2	✓	✓	✓	✓	✓	✓
2-speed positioning 	<p>The start command will transfer the workpiece to the distance (1) at operation speed (1), and then to the distance (2) at operation speed (2).</p>	—	✓	✓	✓	✓*3	✓*4	✓
Multi-speed operation 	<p>The workpiece will change speed with the specified transfer distance. The figure shows an example of a 3-speed operation.</p>	—	—	—	✓*5	—	—	✓

- *1. Drive to Increment instruction is used.
- *2. Drive to Increment/Absolute instructions are used.
- *3. The pulse train function of the linear interpolation instruction will perform this operation.
- *4. The pulse train function of the linear interpolation instruction will perform this operation. Operation of only one axis is possible.
- *5. The table operation (continuous operation) function will perform this operation.

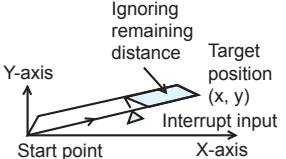
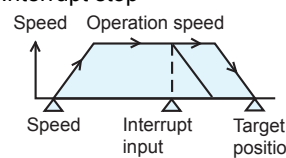
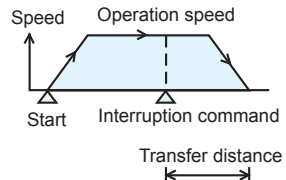
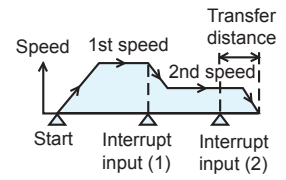
Positioning operation pattern	Description	Built-in positioning function FX3s/FX3G/FX3GC/FX3U/ FX3UC PLC (main unit) (Transistor output) FX3U-2HSY-ADP (FX3U)	FX3U-1PG	FX2N-1PG(-E)	FX2N-10PG	FX2N-10GM	FX2N-20GM	FX3U-20SSC-H
<p>Interrupt stop (linear interpolation [Interrupt stop])</p> 	<p>If an interrupt input turns ON, during a linear interpolation operation to the target position (x, y) at a vector speed, the speed will decelerate and the positioning operation will stop.</p>	-	-	-	-	-	✓	✓
<p>Interrupt stop</p> 	<p>If an interrupt input turns ON, during a positioning operation, the speed will decelerate and the operation will stop.</p>	-	✓	-	✓	✓	-	✓
<p>Interrupt 1-speed positioning (Interrupt 1-speed constant quantity feed)</p> 	<p>If an interrupt input turns ON, the workpiece will travel to the specified transfer distance at the same speed, where it will decelerate and the operation will stop.</p>	✓*6	✓	✓	✓	✓	✓	✓
<p>Interrupt 2-speed positioning (Interrupt 2-speed constant quantity feed)</p> 	<p>If interrupt input (1) turns ON, the speed will be reduced to the 2nd speed. After that, if interrupt input (2) turns ON, the operation will decelerate to stop after moving the specified transfer distance at the 2nd speed.</p>	-	✓	-	✓	✓	✓	✓

*6. Interrupt positioning instruction performs this operation.
Only available for FX3U and FX3UC PLCs.

A

Common Items

B

Built-in Positioning Functions

Apx.

Example Connection

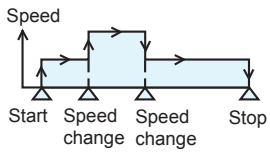
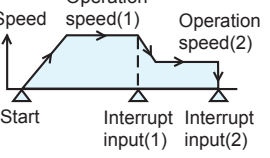
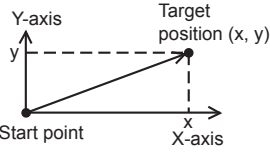
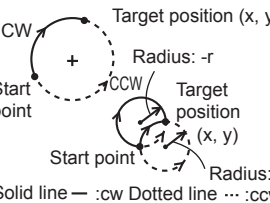
Positioning operation pattern	Description	Built-in positioning function FX3s/FX3G/FX3GC/FX3U/ FX3UC PLC (main unit) (Transistor output) FX3U-2HSY-ADP (FX3U)	FX3U-1PG	FX2N-1PG(-E)	FX2N-10PG	FX2N-10GM	FX2N-20GM	FX3U-20SSC-H																
Variable-speed operation 	The operation will be performed at the operation speed specified by the PLC.	✓*7	✓*8	✓	✓*9	—	—	✓*9																
External Command Positioning Operation 	The operation starts at operation speed (1) by the start command. If interrupt input (1) turns ON during operation, the speed will decelerate to operation speed (2). The operation will continue at operation speed (2) until interrupt input (2) turns ON.	—	✓	✓	—	—	—	—																
Linear interpolation 	The workpiece will travel to the target position at the specified vector speed (interpolation operation).	—	—	—	—	—	—	—																
Circular interpolation 	The workpiece will travel to the specified target position (x, y) along an arc at the specified circumferential speed. The center coordinate or radius can be specified.	—	—	—	—	—	✓*10	✓*11																
Table operation <table border="1" data-bbox="167 1512 422 1646"> <thead> <tr> <th>No.</th> <th>Position</th> <th>Speed</th> <th>...</th> </tr> </thead> <tbody> <tr> <td>0</td> <td>200</td> <td>500</td> <td></td> </tr> <tr> <td>1</td> <td>500</td> <td>1000</td> <td></td> </tr> <tr> <td>2</td> <td>1000</td> <td>2000</td> <td></td> </tr> </tbody> </table>	No.	Position	Speed	...	0	200	500		1	500	1000		2	1000	2000		A positioning control program can be set with the table.	—	—	—	✓ 200 points, maximum	✓ 100 points, maximum	—	✓ X-/Y-/XY-axis: 300 points, maximum
No.	Position	Speed	...																					
0	200	500																						
1	500	1000																						
2	1000	2000																						

- *7. Variable speed pulse output instruction is used to perform this operation. Operations with acceleration/deceleration are supported in the FX3UC PLC Ver. 2.20 or later and FX3s/FX3G/FX3GC/FX3U PLC.
- *8. "Without acceleration/deceleration" or "With acceleration/deceleration" can be selected in the variable-speed operation acceleration/deceleration setting.
- *9. Operates with acceleration/deceleration.
- *10. When interpolation instructions are consecutively set in the program, it will immediately shift to the next operation. (Continuous pass operation)
- *11. When the interpolation operation is continuously set in the table operation, it will immediately shift to the next operation. (Continuation pass function)

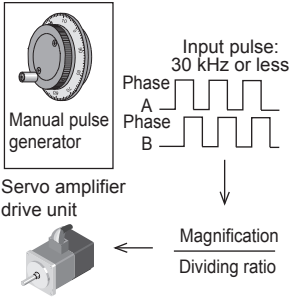
Positioning operation pattern	Description	Built-in positioning function FX3S/FX3G/FX3GC/FX3U/ FX3UC PLC (main unit) (Transistor output) FX3U-2HSY-ADP (FX3U)	FX3U-1PG	FX2N-1PG(-E)	FX2N-10PG	FX2N-10GM	FX2N-20GM	FX3U-20SSC-H
<p>Manual pulse generator operation</p>  <p>Manual operation can be performed with the manual pulse generator.</p>	-	-	-	30 kHz, maximum	2 kHz, maximum	2 kHz, maximum	100 kHz, maximum	

A	Common Items
B	Built-in Positioning Functions
Apx.	Example Connection

MEMO

FX3s/FX3G/FX3GC/FX3U/FX3UC Series Programmable Controllers User's Manual [Positioning Control Edition]

B. Built-in Positioning Functions

Foreword

"B. Built-in Positioning Functions" describes the "positioning" functions incorporated in the MELSEC-F FX3s/FX3G/FX3GC/FX3U/FX3UC Series PLC and should be read and understood before attempting to install or use the unit.

Also, store this manual in a safe place so that you can take it out and read it whenever necessary. Always forward it to the end user.

This manual confers no industrial property rights or any rights of any other kind, nor does it confer any patent licenses. Mitsubishi Electric Corporation cannot be held responsible for any problems involving industrial property rights which may occur as a result of using the contents noted in this manual.

Description of Manual (Built-in Positioning Function)

In this manual, the following formats are used for describing the built-in positioning functions.

Shows the title of the manual and the title of the division.
 This area shows the title of the manual and the title of the division for the current page.
 1st line: Shows the title of the manual.
 2nd line: Shows the title of the division.

Shows the title of the chapter and the title of the section.
 This area shows the title of the chapter and the title of the section for the current page.

Indexes the title of division.
 The right side of each page indexes the title of the division for the current page.

FX3s/FX3G/FX3GC/FX3U/FX3UC PLC User's Manual - Positioning Control Edition
 Built-in Positioning Functions

4 Before Programming
 4.3 Various Special Relays for Operation Commands

4.3.9 Acceleration/Deceleration by PLSV Instruction

Using an FX3uc PLC Ver. 2.20 or later and FX3s/FX3G/FX3GC/FX3U PLC, if acceleration/deceleration operation (M8338) is turned on, the variable speed pulse output (PLSV) instruction will be activated to accelerate/decelerate the operation. This means that if the command value of the output pulse frequency is changed, the operation will be accelerated or decelerated to the changed output pulse frequency depending on the specified acceleration/deceleration time.

→ For operation of PLSV instruction, refer to Chapter 10.

Caution:

- To enable acceleration/deceleration, turn on M8338 first, and then activate the variable speed pulse output (PLSV) instruction.
- If acceleration/deceleration is enabled, the variable speed pulse output (PLSV) instructions of all the pulse output destination devices will accelerate/decelerate with the same time. This means that acceleration/deceleration cannot be specified separately for each pulse output destination device.

A
Common Items

B
Built-in Positioning Functions

Apx.
Example Connection

Shows the version number of the compatible PLC.

Compatible series

Shows the compatible version numbers.

- → Ver. 2.20: Version below 2.20
- Ver.2.20 →: Version 2.20 or later

Shows the reference.

This area shows the reference document (the reference document is shown next to "→").

- If the reference is in the "A. Common items" division, only the chapter, section, or subsection number will be shown next to "→".
- If the reference is in another division, the chapter, section, or subsection number will be shown next to "→" together with the title of the division.

B - 63

The above is different from the actual page, as it is provided for explanation only

1. Outline

This chapter describes a general outline of the positioning modules. Note that the general outputs of the FX3S/FX3G/FX3GC/FX3U/FX3UC PLC (transistor output) and FX3U-2HSY-ADP high-speed output special adapter are needed for positioning control.

1.1 Features

- 1) The general outputs of the FX3S/FX3G/FX3GC/FX3U/FX3UC PLC (transistor output) can control up to 3 axes*1 for positioning operations.
- 2) If one high-speed output special adapter (FX3U-2HSY-ADP) is connected, the adapter can control up to 2 axes for the positioning operation. If 2 high-speed output special adapters are connected, the adapters can control up to 4 axes for the positioning operation.
- 3) The FX3S/FX3G/FX3GC/FX3U/FX3UC PLC positioning instructions (applied instructions) are used for positioning control.
- 4) The general outputs of the FX3S/FX3G/FX3GC/FX3U/FX3UC PLC (transistor output) can output a pulse train of 100 kHz.
- 5) The FX3U-2HSY-ADP high-speed output special adapter (differential line driver system) can output a pulse train of 200 kHz.
- 6) The FX3U-2HSY-ADP high-speed output special adapter can switch the output method between "pulse train + direction" method and "forward/reverse rotation pulse train" method.

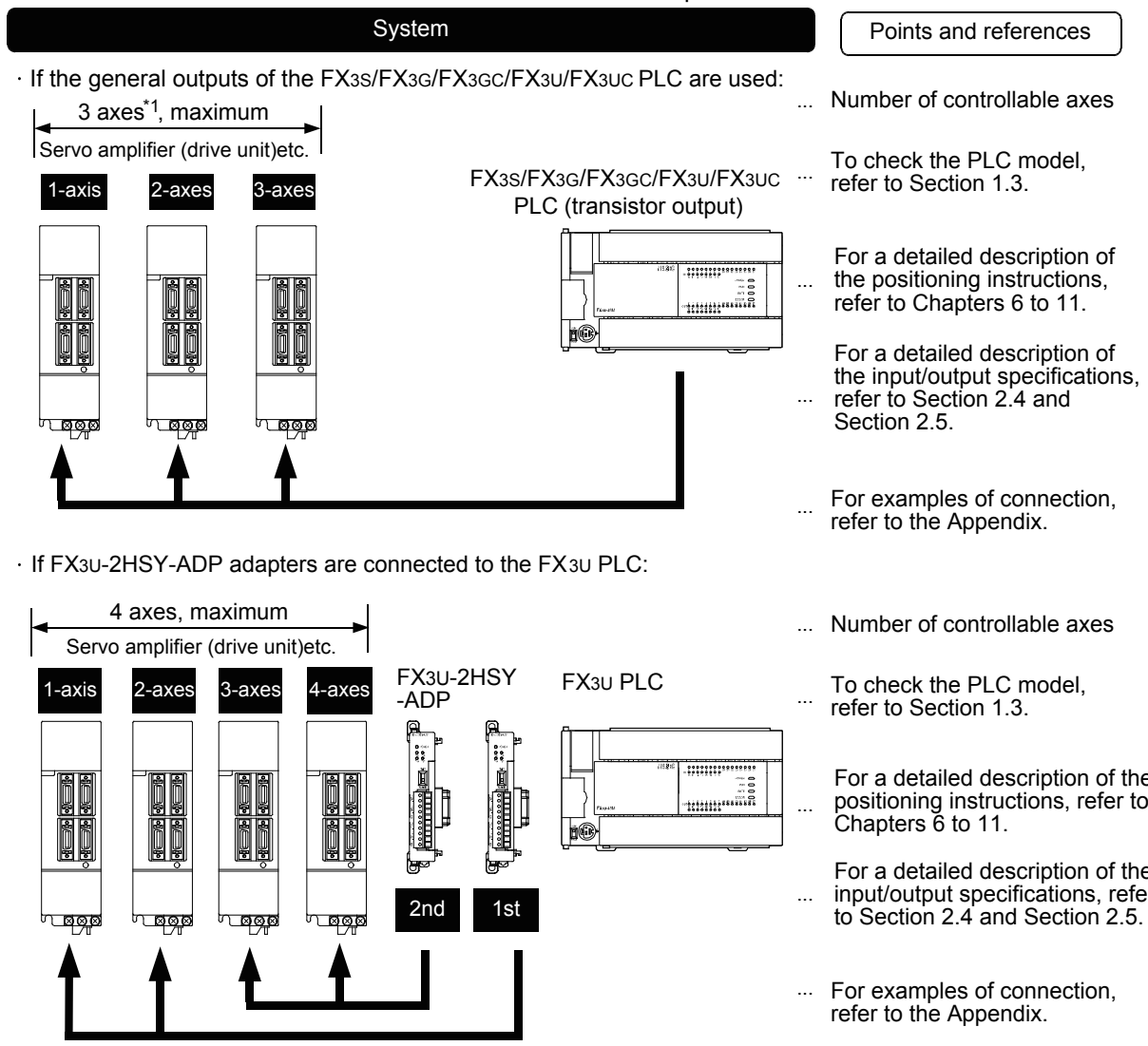

*1. 2 independent axes in the FX3G PLC (14-point and 24-point type) and FX3S/FX3GC PLC.

A Common Items
B Built-in Positioning Functions
Apx. Example Connection

1.2 Setup Procedure for Positioning Control

DESIGN PRECAUTIONS



- Make sure to have the following safety circuits outside of the PLC to ensure safe system operation even during external power supply problems or PLC failure.
Otherwise, malfunctions may cause serious accidents.
 - 1) Most importantly, have the following: an emergency stop circuit, a protection circuit, an interlock circuit for opposite movements (such as normal vs. reverse rotation), and an interlock circuit (to prevent damage to the equipment at the upper and lower positioning limits).
 - 2) Note that when the PLC CPU detects an error, such as a watchdog timer error, during self-diagnosis, all outputs are turned off. Also, when an error that cannot be detected by the PLC CPU occurs in an input/output control block, output control may be disabled.
External circuits and mechanisms should be designed to ensure safe machinery operation in such a case.
 - 3) Note that when an error occurs in a relay, triac or transistor output device, the output could be held either on or off.
For output signals that may lead to serious accidents, external circuits and mechanisms should be designed to ensure safe machinery operation in such a case.

DESIGN PRECAUTIONS



- Do not bundle the control line together with or lay it close to the main circuit or power line. As a guideline, lay the control line at least 100mm (3.94") or more away from the main circuit or power line.
Noise may cause malfunctions.
- Install module so that excessive force will not be applied to the built-in programming port, power connectors, I/O connectors.
Failure to do so may result in wire damage/breakage or PLC failure.

WIRING PRECAUTIONS



- Make sure to cut off all phases of the power supply externally before attempting installation or wiring work.
Failure to do so may cause electric shock or damage to the product.
- Make sure to attach the terminal cover, offered as an accessory, before turning on the power or initiating operation after installation or wiring work.
Failure to do so may cause electric shock.

WIRING PRECAUTIONS



- Connect the AC power supply to the dedicated terminals specified in the manual of the PLC main unit.
If an AC power supply is connected to a DC input/output terminal or DC power supply terminal, the PLC will burn out.
- Connect the DC power supply to the dedicated terminals specified in the manual of the PLC main unit.
If an AC power supply is connected to a DC input/output terminal or DC power supply terminal, the PLC will burn out.
- Do not wire vacant terminals externally.
Doing so may damage the product.
- Perform class D grounding (grounding resistance: 100Ω or less) to the grounding terminal on the FX3S/FX3G/FX3U PLC main unit with a wire 2 mm² or thicker.
Do not use common grounding with heavy electrical systems (refer to the manual of the PLC main unit).
- Perform class D grounding (grounding resistance: 100Ω or less) to the grounding terminal on the FX3GC/FX3UC PLC main unit with a wire as thick as possible.
Do not use common grounding with heavy electrical systems (refer to the manual of the PLC main unit).
- When drilling screw holes or wiring, make sure cutting or wire debris does not enter the ventilation slits.
Failure to do so may cause fire, equipment failures or malfunctions.
- Install module so that excessive force will not be applied to I/O connectors.
Failure to do so may result in wire damage/breakage or PLC failure.

WIRING PRECAUTIONS



- Connect input/output cables securely to their designated connectors. Loose connections may cause malfunctions.
- Make sure to properly wire the terminal block in accordance with the following precautions. Failure to do so may cause electric shock, equipment failures, a short-circuit, wire breakage, malfunctions or damage to the product.
 - The disposal size of the cable end should follow the dimensions described in the manual.
 - Tightening torque should follow the specifications in the manual.
 - Tighten the screws using a Phillips-head screwdriver No.2 (shaft diameter 6mm (0.24") or less). Make sure that the screwdriver does not touch the partition part of the terminal block.
- Make sure to properly wire to the terminal block (European type) in accordance with the following precautions. Failure to do so may cause electric shock, equipment failures, a short-circuit, wire breakage, malfunctions or damage to the product.
 - The disposal size of the cable end should follow the dimensions described in the manual.
 - Tightening torque should follow the specifications in the manual.
 - Twist the end of strand wire and make sure that there are no loose wires.
 - Do not solder-plate the electric wire ends.
 - Do not connect more than the specified number of wires or electric wires of unspecified size.
 - Affix the electric wires so that neither the terminal block nor the connected parts are directly stressed.
- Make sure to properly wire to the FX Series terminal blocks in accordance with the following precautions. Failure to do so may cause electric shock, equipment failures, a short-circuit, wire breakage, malfunctions or damage to the product.
 - The disposal size of the cable end should follow the dimensions described in the manual.
 - Tightening torque should follow the specifications in the manual.
 - Tighten the screws using a Phillips-head screwdriver No.2 (shaft diameter 6mm (0.24") or less). Make sure that the screwdriver does not touch the partition part of the terminal block.

STARTUP AND MAINTENANCE PRECAUTIONS



- Do not touch any terminal while the PLC's power is on. Doing so may cause electric shock or malfunctions.
- Before cleaning or retightening terminals, cut off all phases of the power supply externally. Failure to do so may cause electric shock.
- Before modifying or disrupting the program in operation or running the PLC, carefully read through this manual and the associated manuals and ensure the safety of the operation. An operation error may damage the machinery or cause accidents.

STARTUP AND MAINTENANCE PRECAUTIONS



- Do not disassemble or modify the PLC. Doing so may cause fire, equipment failures, or malfunctions. For repair, contact your local Mitsubishi Electric representative.
- Turn off the power to the PLC before connecting or disconnecting any extension cable. Failure to do so may cause equipment failures or malfunctions.
- Turn off the power to the PLC before attaching or detaching the following devices. Failure to do so may cause equipment failures or malfunctions.
 - Peripheral devices, expansion boards, and special adapters
 - Input/output extension units/blocks and FX Series terminal blocks

A
Common Items

B
Built-in Positioning Functions

Apx.
Example Connection

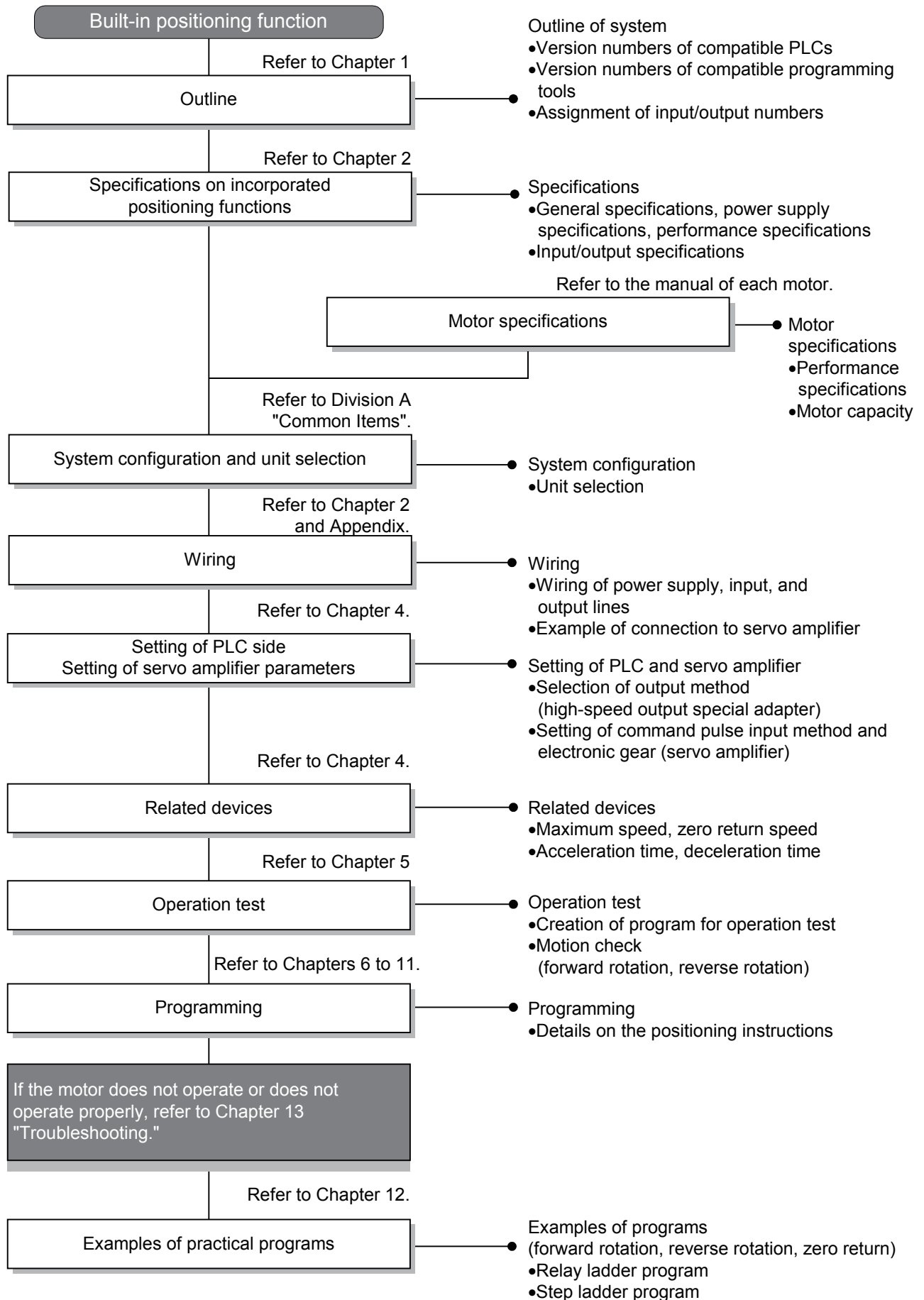

1.3 Version Numbers of Compatible PLCs

1.3.1 Manufacturer's serial number check method

The year and month of production of the product can be checked on the nameplate, and "LOT" indicated on the front of the product.

1. Checking the nameplate

The year and month of production of the product can be checked from the manufacturer's serial number S/N indicated on the label adhered to the right side of the product.

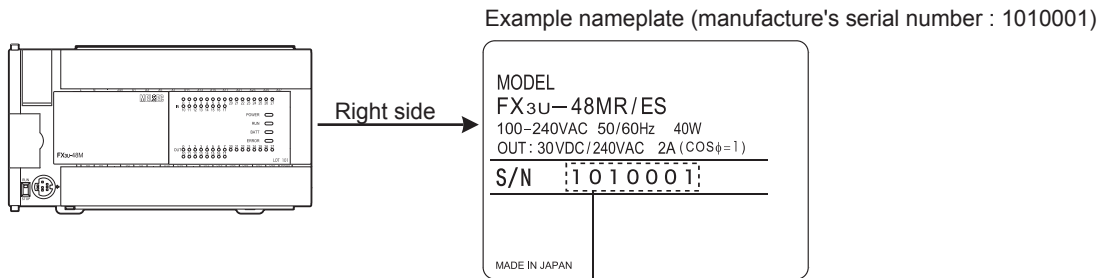

<Product during December, 2009 or earlier>

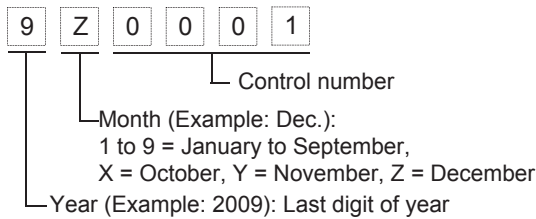

<Product from January, 2010>

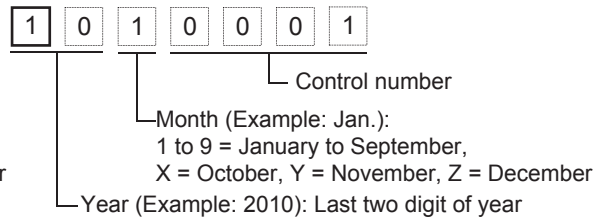

2. Checking the front of the product

The year and month of production of the product can be checked from the manufacturer's serial number "LOT" on the front (at the bottom) of the product.

The "LOT" indication is adopted for products manufactured at the following times.

Main unit	"LOT" indication adoption time
FX3S Series PLC	March 2013 and later (From first product)
FX3G Series PLC	October 2008 and later
FX3GC Series PLC	January 2012 and later (From first product)
FX3U Series PLC	January 2009 and later
FX3UC Series PLC	January 2009 and later

Example: FX3U-48MR/ES

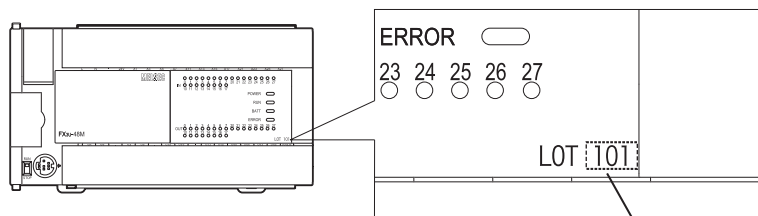

<Product during December, 2009 or earlier>

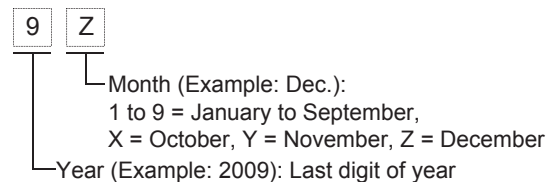

<Product from January, 2010>

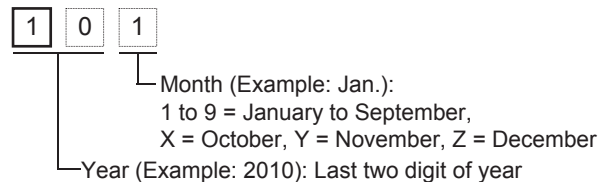

1.3.2 Version check

The PLC version can be checked by reading the last three digits of device D8001/D8101.

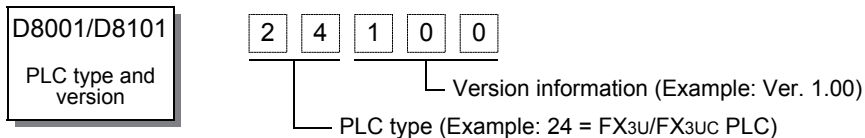

1.3.3 Version upgrade history

Compatible PLC	Compatible version number	Date (month and year) of production	Remarks
FX3S PLC	Ver. 1.00 (initial product) or later	After March 2013	
FX3G PLC	Ver. 1.00 (initial product) or later	After June 2008	
FX3GC PLC	Ver. 1.40 (initial product) or later	After January 2012	
FX3U PLC	Ver. 2.20 (initial product) or later	After May 2005	Equivalent to FX3UC PLC Ver. 2.20 Functions specified as "Ver. 2.20 or later" in this manual are applicable.
	Ver. 1.00 (initial product) or later	After January 2004	
	Ver. 1.30 or later	After August 2004	<ul style="list-style-type: none"> DVIT instruction function is added. - Designation of interrupt input signal
FX3UC PLC	Ver. 2.20 or later	After May 2005	Functions specified as "Ver. 2.20 or later" in this manual are applicable. <ul style="list-style-type: none"> TBL instruction is added. - GX Works2/GX Developer can set the positions using parameters. PLSV instruction function is added. - Acceleration/deceleration function DVIT instruction function is added. - User interruption mode DSZR, ZRN instruction functions are added. - Designation of destination for CLEAR signal to be output

1.4 Version Numbers of Compatible Programming Tools

Use a software version compatible with the used equipment version for programming.

1. GX Works2

- 1) GX Works2 English version (SW□DNC-GXW2-E) is applicable to FX3s/FX3G/FX3GC/FX3U/FX3UC PLCs from the following versions.

Model name	PLC version	Applicable GX Works2 version	Remarks
FX3s PLC	Ver. 1.00 or later	Ver. 1.492N or later	-
FX3G PLC	Ver. 1.00 or later	Ver. 1.08J or later	-
FX3GC PLC	Ver. 1.40 or later	Ver. 1.77F or later	-
FX3U PLC	Ver. 2.20 or later	Ver. 1.08J or later	-
FX3UC PLC	Ver. 1.00 or later	Ver. 1.08J or later	-

- 2) GX Works2 Japanese version (SW□DNC-GXW2-J) is applicable to FX3s/FX3G/FX3GC/FX3U/FX3UC PLCs from the following versions.

Model name	PLC version	Applicable GX Works2 version	Remarks
FX3s PLC	Ver. 1.00 or later	Ver. 1.492N or later	-
FX3G PLC	Ver. 1.00 or later	Ver. 1.07H or later	-
FX3GC PLC	Ver. 1.40 or later	Ver. 1.77F or later	-
FX3U PLC	Ver. 2.20 or later	Ver. 1.07H or later	-
FX3UC PLC	Ver. 1.00 or later	Ver. 1.07H or later	-

2. GX Developer

- 1) GX Developer English version (SW□D5C-GPPW-E) is applicable to FX3G/FX3U/FX3UC PLCs from the following versions.

Model name	PLC version	Applicable GX Developer version	Remarks
FX3G PLC	Ver. 1.00 or later	Ver. 8.72A or later	-
FX3U PLC	Ver. 2.20 or later	Ver. 8.24A or later	-
FX3UC PLC	Ver. 1.00 or later	Ver. 8.18U or later	-
	Ver. 2.20 or later	Ver. 8.24A or later	The built-in positioning setting was added

- 2) GX Developer Japanese version (SW□D5C-GPPW-J) is applicable to FX3G/FX3U/FX3UC PLCs from the following versions.

Model name	PLC version	Applicable GX Developer version	Remarks
FX3G PLC	Ver. 1.00 or later	Ver. 8.72A or later	-
FX3U PLC	Ver. 2.20 or later	Ver. 8.23Z or later	-
FX3UC PLC	Ver. 1.00 or later	Ver. 8.13P or later	-
	Ver. 1.30 or later	Ver. 8.18U or later	-
	Ver. 2.20 or later	Ver. 8.23Z or later	The built-in positioning setting was added

Point:



- It is possible to create programs in FX3GC PLC using programming tools of inapplicable versions by selecting "FX3G" as the alternative model.
- It is possible to create programs in FX3s PLC using programming tools of inapplicable versions by selecting "FX3G" as the alternative model. However, memory capacity setting of the PLC parameter must be set to 4000 steps or less.

1.5 Assignment of Input/Output Numbers

1.5.1 Assignment of Input Numbers

Assign the input numbers of the FX3s/FX3G/FX3GC/FX3U/FX3UC PLC as follows:

Application	Input number	Remarks
Stop command	All input points	Connect a line to any input. If the line-connected input is turned on, turn off the positioning instruction signal must be turned off.
Zero return command	All input points	Connect a line to any input. If the line-connected input is turned on, the DSZR or ZRN instruction must be turned on.
Near-point signal (DOG)	All input points	Connect a line to the input of the near-point signal (DOG) specified by DSZR or ZRN instruction. → For details on the near-point signal of the DSZR instruction, refer to Section 6.2. → For details on the near-point signal of the ZRN instruction, refer to Section 6.3. Point: • To use the ZRN instruction: If X000 to X007*1 of the main unit are set for the near-point signal (DOG), the PLC interruption function will be used for processing of the near-point signal (DOG).
Zero-phase signal	X000 to X007*1	Connect a line to the input specified for the zero-phase signal (this input is specified by DSZR instruction).
ABS read	All input points	Connect a line if it is necessary to use the absolute position detection system. Connect a line to the input specified by the ABS instruction. Use 3 consecutive input points for this function.
JOG command	All input points	Connect a line to any input. If the line-connected input is turned on, the DRVI instruction for the jogging motion must be turned on.

Application	Input number	Remarks										
Interrupt input	X000 to X007	<p>The interrupt input depends on the pulse output destination specified by the DVIT instruction^{*2} as shown in the following table. If the version number of the PLC is 1.30 or higher, the interrupt input can be specified.</p> <table border="1"> <thead> <tr> <th>Pulse output destination</th> <th>Interrupt input</th> </tr> </thead> <tbody> <tr> <td>Y000</td> <td>X000</td> </tr> <tr> <td>Y001</td> <td>X001</td> </tr> <tr> <td>Y002</td> <td>X002</td> </tr> <tr> <td>Y003^{*3}</td> <td>X003</td> </tr> </tbody> </table>	Pulse output destination	Interrupt input	Y000	X000	Y001	X001	Y002	X002	Y003 ^{*3}	X003
		Pulse output destination	Interrupt input									
Y000	X000											
Y001	X001											
Y002	X002											
Y003 ^{*3}	X003											
<p>FX3uc PLC Ver. 1.30 or later</p> <p>If the interrupt input specification function is used, register D8336 (interrupt input specification register) can specify the interrupt input number (X000 - X007) for each pulse output destination.</p> <p>→ For details on the interrupt input specification method, refer to Subsection 4.3.7.</p> 												
<p>FX3u/FX3uc PLC^{*4} Ver. 2.20 or later</p> <p>If the interrupt input specification function is used, register D8336 (interrupt input specification register) can specify the interrupt input number (X000 - X007) for each pulse output destination, or the user interrupt input command can be specified.</p> <p>→ For details on the user interrupt input command, refer to Subsection 4.3.7.</p> <p>The user interrupt input command depends on the pulse output destination as shown in the following table.</p> <table border="1"> <thead> <tr> <th>Pulse output destination</th> <th>User interrupt input command</th> </tr> </thead> <tbody> <tr> <td>Y000</td> <td>M8460</td> </tr> <tr> <td>Y001</td> <td>M8461</td> </tr> <tr> <td>Y002</td> <td>M8462</td> </tr> <tr> <td>Y003^{*3}</td> <td>M8463</td> </tr> </tbody> </table>  		Pulse output destination	User interrupt input command	Y000	M8460	Y001	M8461	Y002	M8462	Y003 ^{*3}	M8463	
Pulse output destination	User interrupt input command											
Y000	M8460											
Y001	M8461											
Y002	M8462											
Y003 ^{*3}	M8463											
Forward rotation limit (LSF)	All input points	<p>Connect a line to any input.</p> <p>If the line-connected input is turned on, the forward limit relay must be turned on. The forward limit relay depends on the pulse output destination as shown in the following table.</p> <table border="1"> <thead> <tr> <th>Pulse output destination</th> <th>Forward limit relay</th> </tr> </thead> <tbody> <tr> <td>Y000</td> <td>M8343</td> </tr> <tr> <td>Y001</td> <td>M8353</td> </tr> <tr> <td>Y002^{*5}</td> <td>M8363</td> </tr> <tr> <td>Y003^{*3}</td> <td>M8373</td> </tr> </tbody> </table>	Pulse output destination	Forward limit relay	Y000	M8343	Y001	M8353	Y002 ^{*5}	M8363	Y003 ^{*3}	M8373
Pulse output destination	Forward limit relay											
Y000	M8343											
Y001	M8353											
Y002 ^{*5}	M8363											
Y003 ^{*3}	M8373											
Reverse rotation limit (LSR)	All input points	<p>Connect a line to any input.</p> <p>If the line-connected input is turned on, the reverse limit relay must be turned on. The reverse limit relay depends on the pulse output destination as shown in the following table:</p> <table border="1"> <thead> <tr> <th>Pulse output destination</th> <th>Reverse limit relay</th> </tr> </thead> <tbody> <tr> <td>Y000</td> <td>M8344</td> </tr> <tr> <td>Y001</td> <td>M8354</td> </tr> <tr> <td>Y002^{*5}</td> <td>M8364</td> </tr> <tr> <td>Y003^{*3}</td> <td>M8374</td> </tr> </tbody> </table>	Pulse output destination	Reverse limit relay	Y000	M8344	Y001	M8354	Y002 ^{*5}	M8364	Y003 ^{*3}	M8374
Pulse output destination	Reverse limit relay											
Y000	M8344											
Y001	M8354											
Y002 ^{*5}	M8364											
Y003 ^{*3}	M8374											

A
Common Items















B
Built-in Positioning Functions

Apx.
Example Connection

- *1. X000 to X005 for FX3S PLC.
- *2. Interrupt outputs are supported only in the FX3U and FX3UC PLC.
- *3. Y003 can be specified as the pulse output destination only if 2 high-speed output special adapters are connected to the FX3U PLC.
- *4. Ver. 2.20 is assigned to the initial product of the FX3U PLC.
- *5. Y002 is not available in FX3G PLC (14-point and 24-point type) and FX3S/FX3GC PLC.

1.5.2 Assignment of Output Numbers

1. FX3S/FX3G/FX3GC/FX3U/FX3UC Series main unit (transistor output)

Application	Output number	Remarks																					
Pulse train signal (Pulse output destination)	Y000 Y001 Y002*1	Connect a line to the output (Y000 - Y002) specified for the pulse output designation (this output is specified by the positioning instruction).																					
Direction signal (Rotational direction signal)	All output points*2	Connect a line to any output. Connect a line to the output specified for the rotation direction signal (this signal is specified by the positioning instruction).																					
CLEAR signal	All output points*2	<p>Connect a line if it is necessary to use DSZR/ZRN instruction to output the CLEAR signal. The CLEAR signal output depends on the pulse output destination specified by the DSZR/ZRN instruction. If the PLC version is later than the following number, the CLEAR signal can be specified.</p> <table border="1"> <thead> <tr> <th>Pulse output destination</th> <th>CLEAR signal</th> </tr> </thead> <tbody> <tr> <td>Y000</td> <td>Y004</td> </tr> <tr> <td>Y001</td> <td>Y005</td> </tr> <tr> <td>Y002*1</td> <td>Y006</td> </tr> </tbody> </table> <div style="border: 1px solid black; padding: 5px;"> <table style="width: 100%; text-align: center;"> <tr> <td></td> <td></td> <td></td> <td></td> <td></td> </tr> </table> <p>FX3UC PLC Ver. 2.20 or later and FX3S/FX3G/FX3GC/FX3U PLC: If the CLEAR signal device specification function is used, the CLEAR signal device specification register can specify an output for each pulse output destination. → For details on the CLEAR signal device specification method, refer to Subsection 4.3.4.</p> <p>The CLEAR signal device specification register depends on the pulse output destination as shown in the following table:</p> <table border="1"> <thead> <tr> <th>Pulse output destination</th> <th>CLEAR signal device specification register</th> </tr> </thead> <tbody> <tr> <td>Y000</td> <td>D8464</td> </tr> <tr> <td>Y001</td> <td>D8465</td> </tr> <tr> <td>Y002*1</td> <td>D8466</td> </tr> </tbody> </table> </div>	Pulse output destination	CLEAR signal	Y000	Y004	Y001	Y005	Y002*1	Y006						Pulse output destination	CLEAR signal device specification register	Y000	D8464	Y001	D8465	Y002*1	D8466
Pulse output destination	CLEAR signal																						
Y000	Y004																						
Y001	Y005																						
Y002*1	Y006																						
																							
Pulse output destination	CLEAR signal device specification register																						
Y000	D8464																						
Y001	D8465																						
Y002*1	D8466																						

- *1. Y002 is not available in FX3G PLC (14-point and 24-point type) and FX3S/FX3GC PLC.
- *2. Specify an output number for transistor output.

2. High-speed output special adapter

Application	Terminal	Output number		Remarks										
		1st	2nd											
Pulse train signal/forward rotation pulse train (pulse output destination)	Y0/2+ Y0/2-	Y000	Y002	Connect a line to determine the pulse train signal or the forward rotation pulse train for the 1st axis of each high-speed output special adapter. For the 1st adapter, specify Y000 as the pulse output destination of the positioning instruction. For the 2nd adapter, specify Y002 as the pulse output destination of the positioning instruction.										
	Y1/3+ Y1/3-	Y001	Y003	Connect a line to determine the pulse train signal or the forward rotation pulse train for the 2nd axis of each high-speed output special adapter. For the 1st adapter, specify Y001 as the pulse output destination of the positioning instruction. For the 2nd adapter, specify Y003 as the pulse output destination of the positioning instruction.										
Direction signal/reverse rotation pulse train (rotation direction signal)	Y4/6+ Y4/6-	Y004	Y006	Connect a line to determine the direction signal or the reverse rotation pulse train for the 1st axis of each high-speed output special adapter. For the 1st adapter, specify Y004 as the rotation direction signal of the positioning instruction. For the 2nd adapter, specify Y006 as the rotation direction signal output of the positioning instruction.										
	Y5/7+ Y5/7-	Y005	Y007	Connect a line to determine the direction signal or the reverse rotation pulse train for the 2nd axis of each high-speed output special adapter. For the 1st adapter, specify Y005 as the rotation direction signal output of the positioning instruction. For the 2nd adapter, specify Y007 as the rotation direction signal output of the positioning instruction.										
CLEAR signal	All output points *1			<p>Connect a line if it is necessary to use the DSZR/ZRN instruction to output the CLEAR signal. Using the CLEAR signal device specification function, specify the output number for the transistor output. In this case, do not specify an output device if the device is already specified for outputting the rotational direction signal.</p> <p>→ For details on the CLEAR signal device specification method, refer to Subsection 4.3.4.</p> <p>The CLEAR signal device specification register depends on the pulse output destination as shown in the following table:</p> <table border="1"> <thead> <tr> <th>Pulse output destination</th> <th>CLEAR signal device specification register</th> </tr> </thead> <tbody> <tr> <td>Y000</td> <td>D8464</td> </tr> <tr> <td>Y001</td> <td>D8465</td> </tr> <tr> <td>Y002</td> <td>D8466</td> </tr> <tr> <td>Y003</td> <td>D8467</td> </tr> </tbody> </table> <p>Point: The CLEAR signal output that is initially set for the DSZR/ZRN instruction is the same output as the direction signal (rotation direction signal, reverse pulse train). Be sure to specify an output number of another transistor output using the CLEAR signal device specification function.</p>	Pulse output destination	CLEAR signal device specification register	Y000	D8464	Y001	D8465	Y002	D8466	Y003	D8467
Pulse output destination	CLEAR signal device specification register													
Y000	D8464													
Y001	D8465													
Y002	D8466													
Y003	D8467													

*1. Specify an output number for transistor output.

1.5.3 Connection of the High-Speed Output Special Adapter

1. When the FX3U-16MR/ES uses an instruction that requires the high-speed input operation, the main unit should have enough input terminals. Before selecting the main unit, be sure to check the number of input points required for the operation.
2. Specify the rotational direction signal of the positioning instruction depending on the setting of each pulse output destination as shown in the following table:

	Pulse output destination	Rotation direction signal
1st	Y000	Y004
	Y001	Y005
2nd	Y002	Y006
	Y003	Y007

3. To output the CLEAR signal using DSZR/ZRN instruction

The CLEAR signal output that is initially set for the DSZR/ZRN instruction is the same output as the direction signal/reverse pulse train (rotation direction signal). Be sure to specify an output number of another transistor output using the CLEAR signal device specification function.

→ For details on the CLEAR signal device specification method, refer to Subsection 4.3.4.

4. If the high-speed output special adapter is connected to the FX3U Series main unit, the output numbers will be assigned in the same way as the main unit.

If an output number assigned to a high-speed output special adapter is turned on by the sequence program, the corresponding output of the main unit will also be turned on. Do not connect a line to both output terminals. Connect a line to only one of the output terminals.

The outputs of the high-speed output special adapter and the main unit will be turned on as shown in the following table:

Unit	Output operation		
	PLSY,PLSR,DSZR, DVIT,TBL,ZRN,PLSV, DRVI,DRVA instruction.	PWM instruction	Other instruction
FX3U Series main unit of relay output type	While instruction is activated, relevant output is ON. (LED is also ON.)	Use of the PWM (FNC 58) instruction is not compatible with a relay type main unit.*2	Operated
FX3U Series main unit of transistor output type	Operated*1	Operated	Operated
FX3U Series main unit of triac output type	While instruction is activated, relevant output is ON. (LED is also ON.)	Use of the PWM (FNC 58) instruction is not compatible with a triac type main unit.*3	Operated
High-speed output special adapter	Operated	Operated The main unit should use the transistor output type.*2	Operated

*1. The output frequency limit of the main unit transistor output is 100 kHz. When operating a load with a pulse frequency exceeding 100 kHz, PLC failure may occur.

*2. Furthermore, use of the PWM (FNC 58) is not recommended with the relay type main unit and the high-speed adapters due to chattering of the relay contacts.

*3. The PWM instruction does not support the triac output due to response delay of outputs.

Block diagram

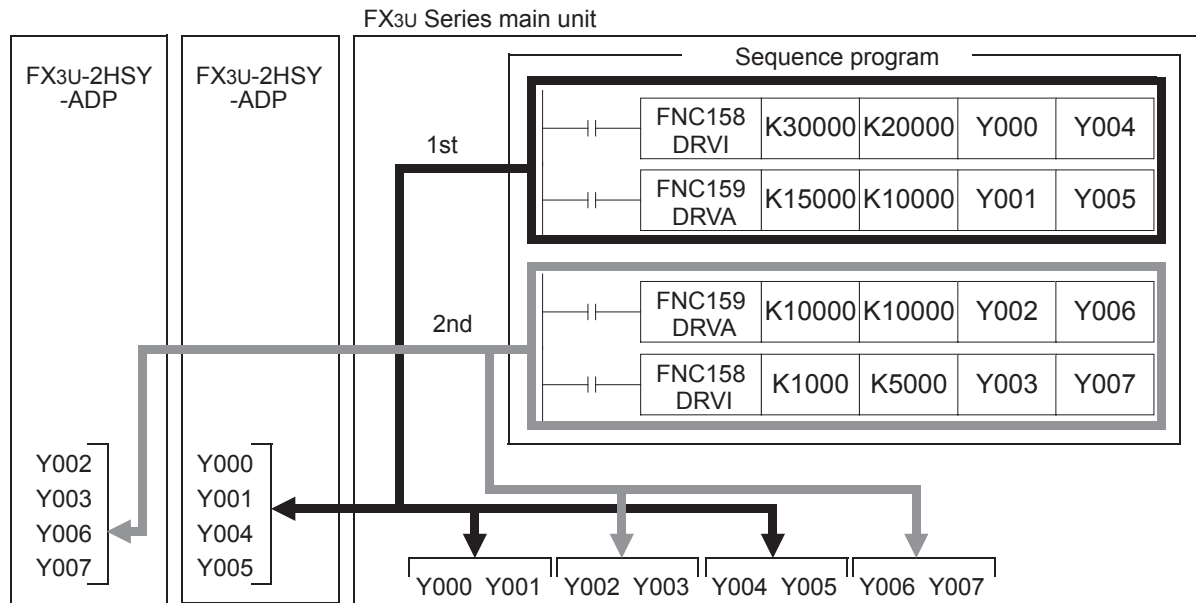

A

Common Items

B

Built-in Positioning Functions

Apx.

Example Connection

2. Specifications

DESIGN PRECAUTIONS



- Make sure to have the following safety circuits outside of the PLC to ensure safe system operation even during external power supply problems or PLC failure.
Otherwise, malfunctions may cause serious accidents.
 - 1) Most importantly, have the following: an emergency stop circuit, a protection circuit, an interlock circuit for opposite movements (such as normal vs. reverse rotation), and an interlock circuit (to prevent damage to the equipment at the upper and lower positioning limits).
 - 2) Note that when the PLC CPU detects an error, such as a watchdog timer error, during self-diagnosis, all outputs are turned off. Also, when an error that cannot be detected by the PLC CPU occurs in an input/output control block, output control may be disabled.
External circuits and mechanisms should be designed to ensure safe machinery operation in such a case.
 - 3) Note that when an error occurs in a relay, triac or transistor output device, the output could be held either on or off.
For output signals that may lead to serious accidents, external circuits and mechanisms should be designed to ensure safe machinery operation in such a case.

DESIGN PRECAUTIONS



- Do not bundle the control line together with or lay it close to the main circuit or power line. As a guideline, lay the control line at least 100mm (3.94") or more away from the main circuit or power line.
Noise may cause malfunctions.
- Install module so that excessive force will not be applied to the built-in programming port, power connectors, I/O connectors.
Failure to do so may result in wire damage/breakage or PLC failure.

DISPOSAL PRECAUTIONS



- Please contact a certified electronic waste disposal company for the environmentally safe recycling and disposal of your device.

TRANSPORTATION AND STORAGE PRECAUTIONS



- Before transporting the PLC, turn on the power to the PLC to check that the BATT (BAT) LED is off, and check the battery life.
If the PLC is transported with the BATT (BAT) LED on or the battery exhausted, the battery-backed data may be unstable during transportation.
- The PLC is a precision instrument. During transportation, avoid impacts larger than those specified in the general specifications of the PLC main unit manual. Failure to do so may cause failures in the PLC. After transportation, verify the operations of the PLC.

2.1 General Specifications

For the FX3S/FX3G/FX3GC/FX3U/FX3UC PLC general specifications, refer to the Hardware Edition manual of each PLC. Note that the high-speed output special adapter general specifications are the same as the PLC excluding the specifications shown in the following table.

Item	Specifications	
Withstand voltage	500V AC, for 1 minute	Between output terminal of high-speed output special adapter and grounding terminal of PLC.
Insulation resistance	5M Ω or more using 500V DC insulation tester	

2.2 Power Supply Specifications

For the FX3S/FX3G/FX3GC/FX3U/FX3UC PLC power supply specifications, refer to the Hardware Edition manual of each PLC. The power supply specifications of the high-speed output special adapter are shown in the following table.

Item	Specifications
Output circuit drive power supply	24V DC, 60 mA The service power of the main unit is supplied internally.
Adapter drive power supply	5V DC, 30 mA The adapter driver power is internally supplied from the 5V DC power supply unit of the main unit.

2.3 Performance Specifications

Model	FX3G (14-point and 24-point type) /FX3s/FX3GC PLC* ¹ (main unit, transistor output)	FX3G (40-point and 60-point type) /FX3U/FX3UC PLC* ¹ (main unit, transistor output)	FX3U-2HSY-ADP* ²
Number of control axes	2 independent axes	3 independent axes	2 independent axes (Connect 2 adapters to the main unit to control 4 axes independently.)
Interpolation	-		-
Pulse output form	Transistor		Differential line driver
Pulse output method	"Pulse train + direction" method		"Pulse train + direction" method "Forward/reverse rotation pulse train" method
Maximum frequency	100,000Hz		200,000Hz
Acceleration/ deceleration type	Trapezoidal acceleration/deceleration		
Unit	pulse		
Positioning range	-999,999 to +999,999 (pulse)		
Program language	Sequence program		
Position data	1 point (set in sequence program)		
Connection of manual pulse generator	-	-	-
Detection of absolute position (Reads out the current value of ABS.)	ABS instruction		
Others	Pulses can be output from the general-purpose outputs (Y000 and Y001) of the main unit.	Pulses can be output from the general-purpose outputs (Y000, Y001 and Y002) of the main unit.	<ul style="list-style-type: none"> To be used when a servo amplifier with a differential line receiver is connected. To be used when positioning control is performed with a FX3U Series relay output type or triac output type main unit. Used in place of the general-purpose outputs (Y000 to Y007)^{*3} of the main unit.

*1. For MELSERVO Series amplifiers, use a sink input/sink output type PLC.

*2. Can only be connected to the FX3U PLC. Up to 2 adapters can be connected.

*3. If 2 adapters are connected, Y000 to Y007 will be used. If only one adapter is connected, Y000, Y001, Y004, and Y005 will be used. The relation between the output of the FX3U-2HSY-ADP and the output of main unit is described in the following sections.

→ To use high-speed output special adapters, refer to Subsection 1.5.3 and Section 4.9 of "B. Built-in Positioning Function".

2.4 Input Specifications

2.4.1 FX3s Series main unit (24 V DC Input)

This section describes the input specifications of the FX3s Series main unit. Note that the simultaneous turning-on rate is restricted for the main unit. For details on this restriction, refer to the following manual:

→ Refer to the FX3s Hardware Edition.

Item		24 V DC input specifications	
Input signal voltage		All inputs	AC power type: 24 V DC $\pm 10\%$ DC power type: 20.4 to 26.4 V DC
Input impedance		X000 to X007	3.3 k Ω
		X010 to X017	4.3 k Ω
Input signal current		X000 to X007	7 mA/24 V DC
		X010 to X017	5 mA/24 V DC
Input sensitivity current	Input ON current	X000 to X007	4.5 mA or more
	Input OFF current	X010 to X017	3.5 mA or more
Input response time		All inputs	Approx. 10 ms ^{*1}
Input signal type		All inputs	No-voltage contact input NPN/PNP open collector transistor
Circuit insulation		All inputs	Photocoupler insulation
Indication of input motion		All inputs	Turning on the input will light the LED indicator lamp

*1. If inputs X000 to X005 are assigned to the zero-phase signal of the DSZR instruction or the near-point signal (DOG) of the ZRN instruction, the input response time will be as shown in the following table.

Input	Input response time
X000, X001	10 μ s
X002 to X005	50 μ s

1. Internal input circuit

1) AC power type

· Sink input type

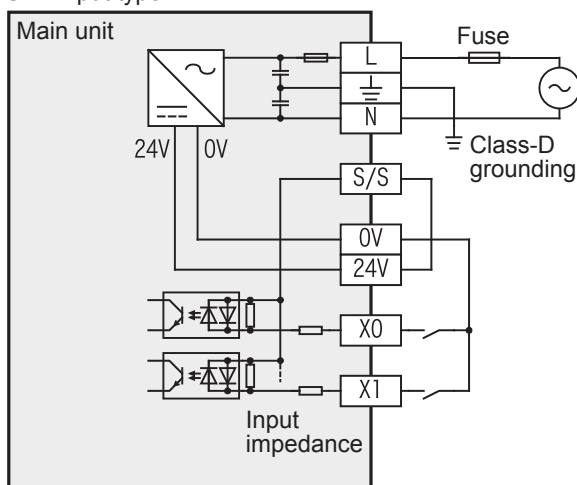

· Source input type

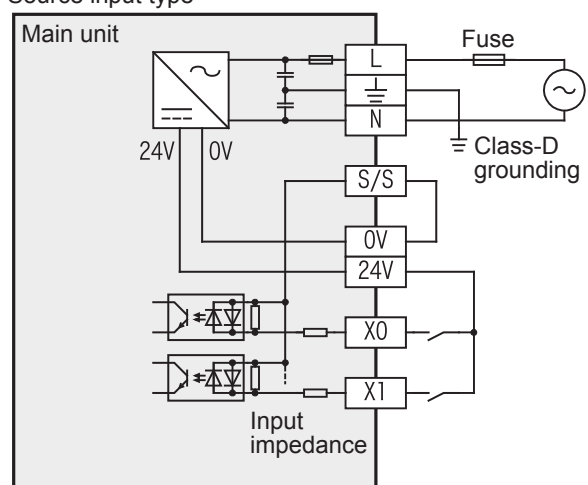

2) DC power type

• Sink input type

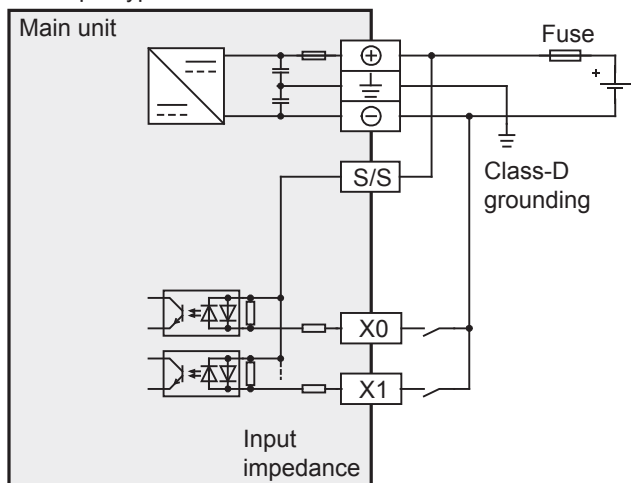

• Source input type

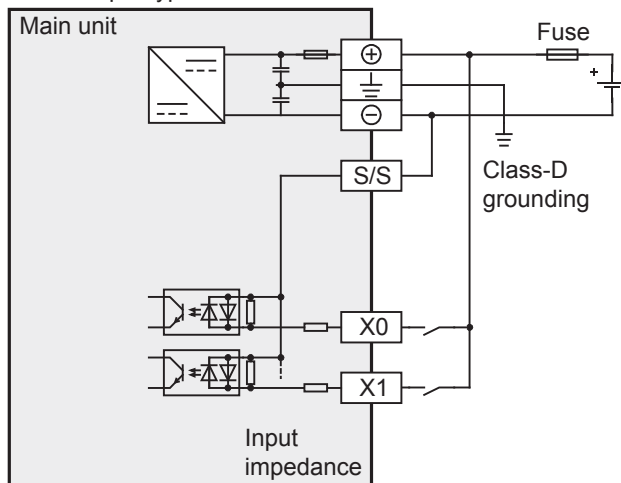

2.4.2 FX3G Series main unit (24 V DC Input)

This section describes the input specifications of the FX3G Series main unit. Note that the simultaneous turning-on rate is restricted for the input extension units and the main unit. For details on this restriction, refer to the following manual:

→ Refer to the FX3G Hardware Edition.

Item		24 V DC input specifications	
Input signal voltage		All inputs	AC power type: 24 V DC $\pm 10\%$ DC power type: 20.4 to 28.8 V DC
Input impedance		X000 to X007	3.3 k Ω
		X010 or more	4.3 k Ω
Input signal current		X000 to X007	7 mA/24 V DC
		X010 or more	5 mA/24 V DC
Input sensitivity current	Input ON current	X000 to X007	4.5 mA or more
		X010 or more	3.5 mA or more
	Input OFF current	All inputs	1.5 mA or less
Input response time		All inputs	Approx. 10 ms ^{*1}
Input signal type		All inputs	No-voltage contact input NPN/PNP open collector transistor
Circuit insulation		All inputs	Photocoupler insulation
Indication of input motion		All inputs	Turning on the input will light the LED indicator lamp

*1. If inputs X000 to X007 are assigned to the zero-phase signal of the DSZR instruction or the near-point signal (DOG) of the ZRN instruction, the input response time will be as shown in the following table.

Input	Input response time
X000, X001, X003, X004	10 μ s
X002, X005 to X007	50 μ s

1. Internal input circuit

1) AC power type

• Sink input type

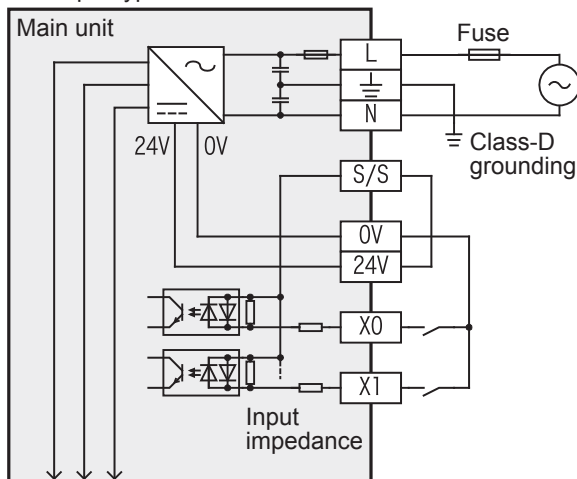

• Source input type

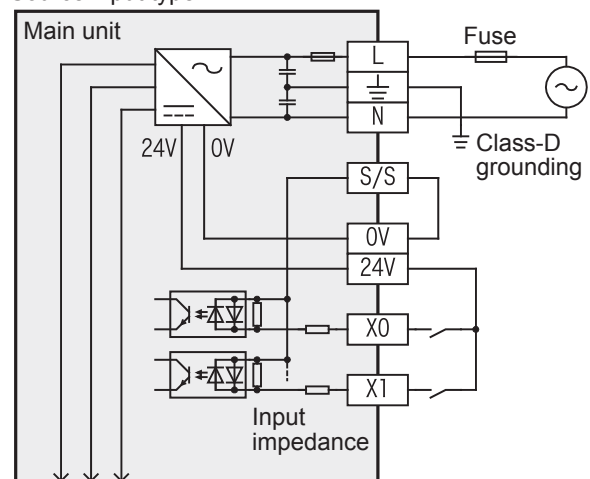

2) DC power type

• Sink input type

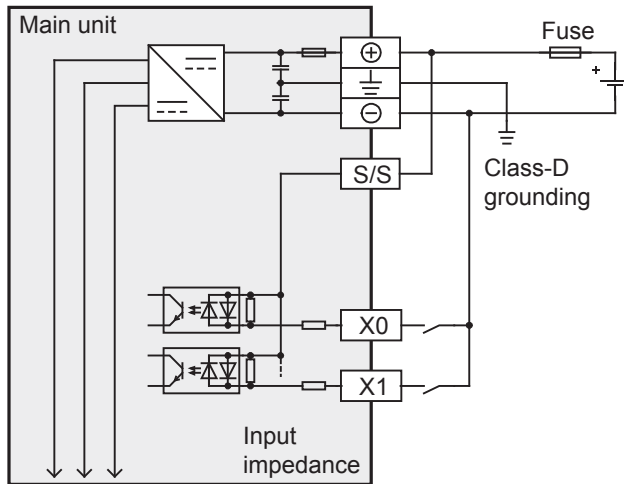

• Source input type

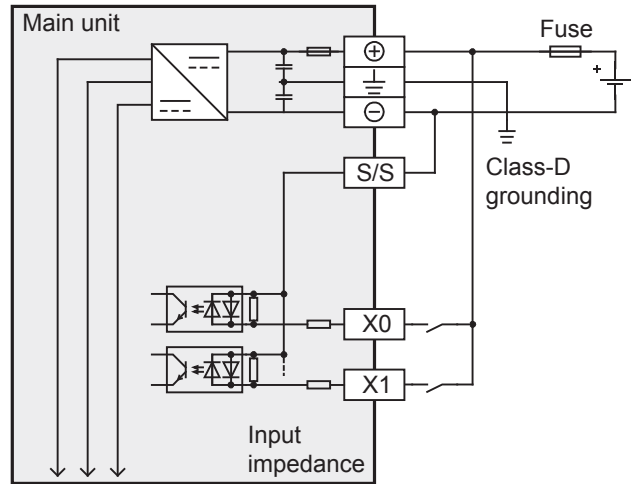

2.4.3 FX3GC Series main unit (24 V DC Input)

This section describes the input specifications of the FX3GC Series main unit. Note that the simultaneous turning-on rate is restricted for the input extension units and the main unit. For details on this restriction, refer to the following manual:

→ Refer to the FX3GC Hardware Edition.

Item		24 V DC input specifications	
Input signal voltage		All inputs	24 V DC +20%, -15%
Input impedance		X000 to X007	3.3 kΩ
		X010 to X017	4.3 kΩ
Input signal current		X000 to X007	7 mA/24 V DC
		X010 to X017	5 mA/24 V DC
Input sensitivity current	Input ON current	X000 to X007	4.5 mA or more
		X010 to X017	3.5 mA or more
	Input OFF current	All inputs	1.5 mA or less
Input response time		All inputs	Approx. 10 ms ^{*1}
Input signal type		All inputs	No-voltage contact input NPN open collector transistor PNP open collector transistor ^{*2}
Circuit insulation		All inputs	Photocoupler insulation
Indication of input motion		All inputs	Turning on the input will light the LED indicator lamp

*1. If inputs X000 to X007 are assigned to the zero-phase signal of the DSZR instruction or the near-point signal (DOG) of the ZRN instruction, the input response time will be as shown in the following table.

Input	Input response time
X000, X001, X003, X004	10 μs
X002, X005 to X007	50 μs

*2. PNP open collector transistors are supported only by the FX3GC-32MT/DSS.

1. Internal input circuit

· Sink input type (FX3GC-32MT/D)

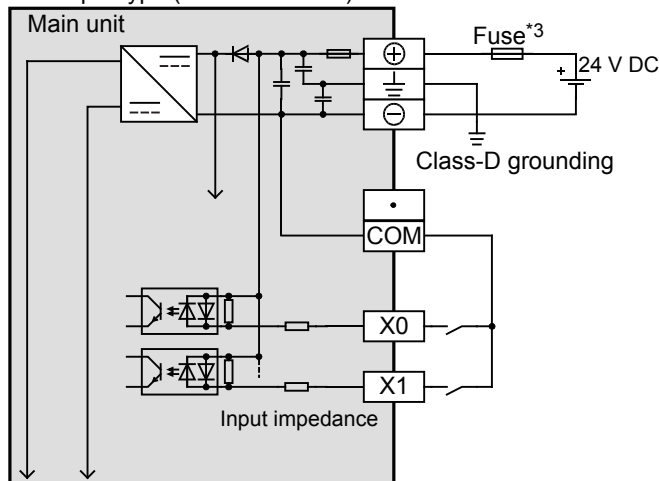

*3. A UL Listed or Recognized fuse rated not higher than 3.47 A must be used with FX3GC.

A
Common Items

B
Built-in Positioning Functions

Apx.
Example Connection

·Sink input type (FX3GC-32MT/DSS)

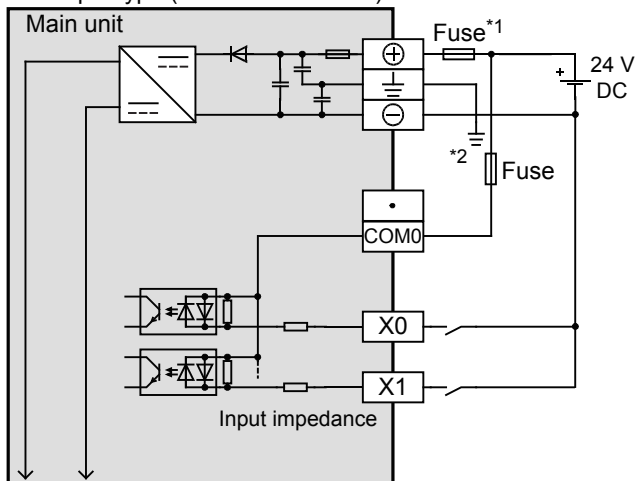

·Source input type (FX3GC-32MT/DSS)

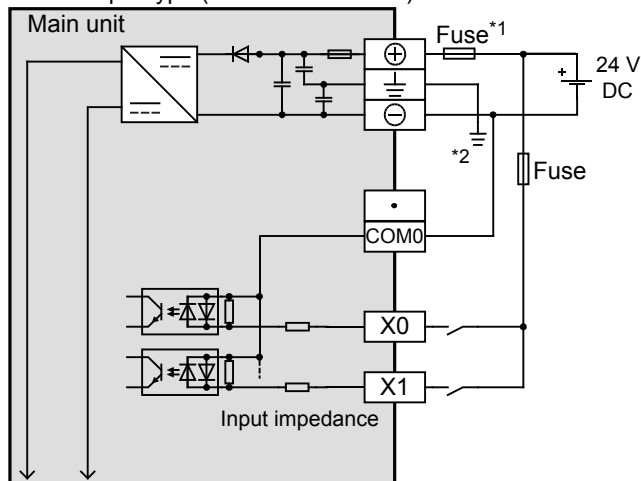

- *1. A UL Listed or Recognized fuse rated not higher than 3.47 A must be used with FX3GC.
- *2. Class-D grounding

2.4.4 FX3U Series main unit (24 V DC Input)

This section describes the input specifications of the FX3U Series main unit. Note that the simultaneous turning-on rate is restricted for the input extension units and the main unit. For details on this restriction, refer to the following manual:

→ Refer to the FX3U Hardware Edition.

Item		24 V DC input specifications	
Input signal voltage		All inputs	AC power type: 24 V DC ±10% DC power type: 16.8 to 28.8 V DC
Input impedance		X000 to X005	3.9 kΩ
		X006, X007	3.3 kΩ
		X010 or more	4.3 kΩ
Input signal current		X000 to X005	6 mA/24 V DC
		X006, X007	7 mA/24 V DC
		X010 or more	5 mA/24 V DC
Input sensitivity current		Input ON current	
		X000 to X005	3.5 mA or more
		X006, X007	4.5 mA or more
Input OFF current		All inputs	1.5 mA or less
Input response time		All inputs	Approx. 10 ms*1
Input signal type		All inputs	No-voltage contact input NPN/PNP open collector transistor
Circuit insulation		All inputs	Photocoupler insulation
Indication of input motion		All inputs	Turning on the input will light the LED indicator lamp.

*1. If inputs X000 to X007 are assigned to the zero-phase signal of DSZR instruction, the near-point signal (DOG) of the ZRN instruction or the interrupt input of the DVIT the instruction, the input response time will be as shown in the following table.

Input	Input response time
X000 to X005	5 μs
X006, X007	50 μs

1. Internal input circuit

1) AC power type

· Sink input type

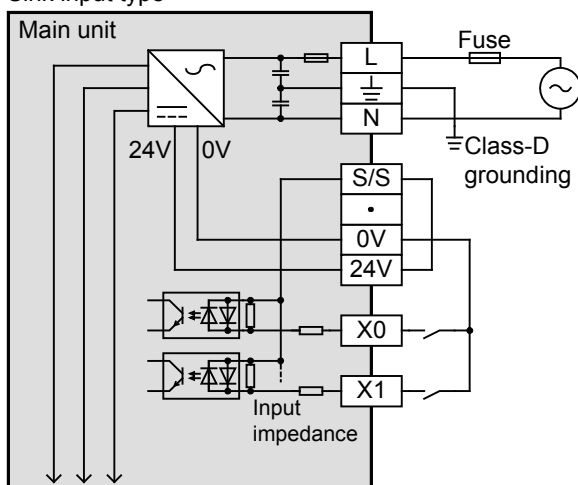

· Source input type

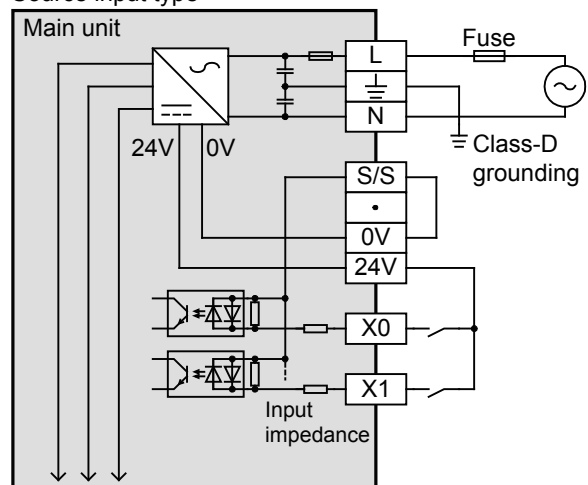

2) DC power type

• Sink input type

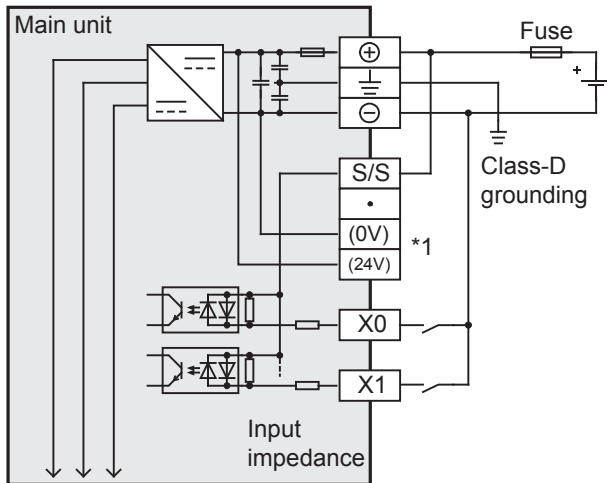

• Source input type

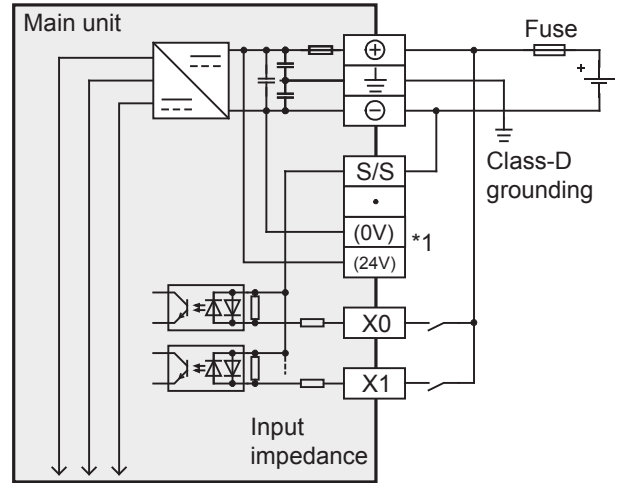

*1. Do not connect with (0V) and (24V) terminals.

2.4.5 FX3uc Series main unit (24 V DC Input)

This section describes the input specifications of the FX3uc Series main unit. Note that the simultaneous turning-on rate is restricted for the input extension units and the main unit. For details on this restriction, refer to the following manual:

→ Refer to the FX3uc Hardware Edition.

Item		24 V DC input specifications	
Input signal voltage		All inputs	24 V DC +20%, -15% / Ripple(p-p): 5 % or less
Input impedance		X000 to X005	3.9 kΩ
		X006, X007	3.3 kΩ
		X010 or more	4.3 kΩ
Input signal current		X000 to X005	6 mA/24 V DC
		X006, X007	7 mA/24 V DC
		X010 or more	5 mA/24 V DC
Input sensitivity current		Input ON current	
		X000 to X005	3.5 mA or more
		X006, X007	4.5 mA or more
Input OFF current		All inputs	1.5 mA or less
		Input response time	
All inputs		Approx. 10 ms ^{*1}	
Input signal type		All inputs	No-voltage contact input NPN open collector transistor PNP open collector transistor ^{*2}
Circuit insulation		All inputs	Photocoupler insulation
Indication of input motion		All inputs	Turning on the input will light the LED indicator lamp ^{*3}

*1. If inputs X000 to X007 are assigned to the zero-phase signal of the DSZR instruction, the near-point signal (DOG) of the ZRN instruction or the interrupt input of the DVIT instruction, the input response time will be as shown in the following table.

Input	Input response time
X000 to X005	5 μs
X006, X007	50 μs

*2. PNP open collector transistors are supported only by the FX3UC-□□MT/DSS.

*3. The FX3UC-32MT-LT(-2) uses the display module for monitoring.

1. Internal input circuit

• Sink input type (FX3uc-□□ MT/D, FX3uc-32MT-LT(-2))

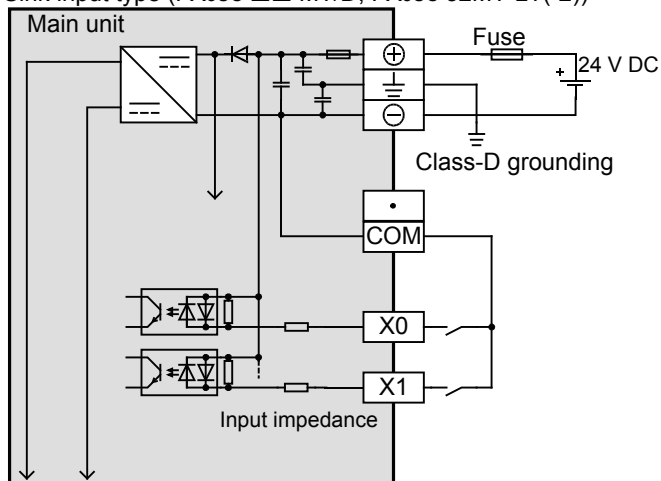

· Sink input type (FX3UC-□□ MT/DSS)

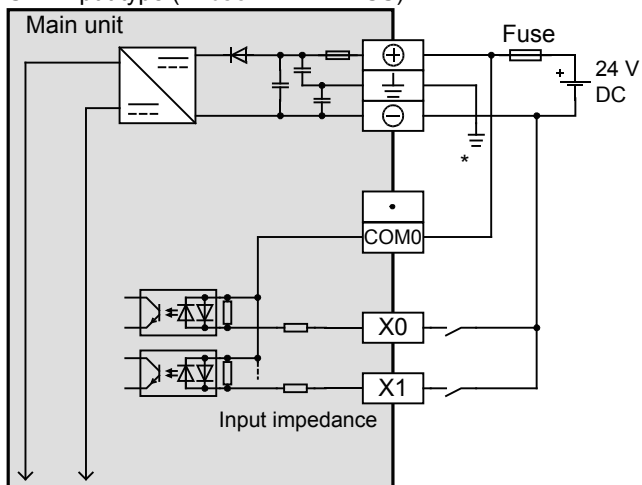

* Class-D grounding

· Source input type (FX3UC-□□ MT/DSS)

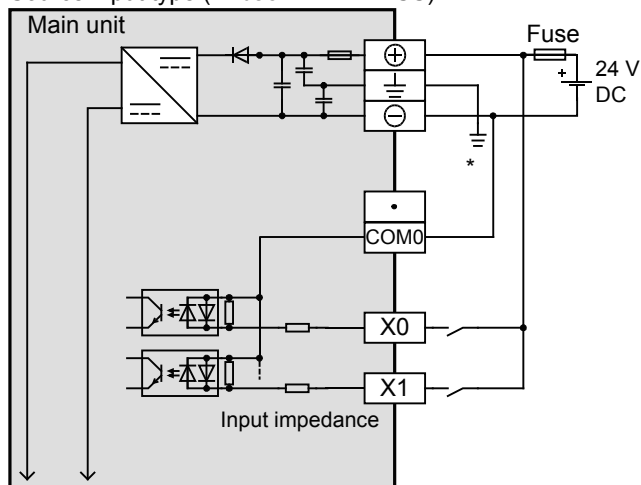

* Class-D grounding

2.5 Output Specifications

2.5.1 FX3s Series main unit (Transistor Output)

This section describes the transistor output specifications of the FX3s Series main unit. Note that the simultaneous turning-on rate is restricted for the main unit. For details on this restriction, refer to the following manual.

→ Refer to the FX3s Hardware Edition.

For MELSERVO Series amplifiers, use a sink input/sink output type PLC.

Item		Transistor output specifications	
External voltage		All outputs	5 to 30 V DC
Maximum load	Resistance load	All outputs	The total load current of resistance loads per common terminal should be the following value or less. - 1 point output common:0.5 A - 4 points output common:0.8 A
	Inductive load	All outputs	The total of inductive loads per common terminal should be the following value or less. - 1 point output common:12 W/24 V DC - 4 points output common:19.2 W/24 V DC
Open-circuit leakage current		All outputs	0.1 mA or less at 30 V DC
ON voltage		All outputs	1.5 V or less
Response time	OFF→ON	Y000, Y001	5 μs or less at 10 mA or more (5 to 24 V DC)
		Y002 to Y015	0.2 ms or less at 200 mA or more (at 24 V DC)
	ON→OFF	Y000, Y001	5 μs or less at 10 mA or more (5 to 24 V DC)
		Y002 to Y015	0.2 ms or less at 200 mA or more (at 24 V DC)
Circuit insulation		All outputs	Photocoupler insulation
Indication of output motion		All outputs	LED is lit when the photocoupler is driven.

Pulse output terminals Y000 and Y001 are high-speed response output terminals.
 To use the positioning instruction, adjust the load current of the NPN open collector to 10 to 100 mA (5 to 24 V DC).

Item	Description
Operation voltage range	5 to 24 V DC
Operation current range	10 to 100 mA
Output frequency	100 kHz or less

1. Sink internal output circuit

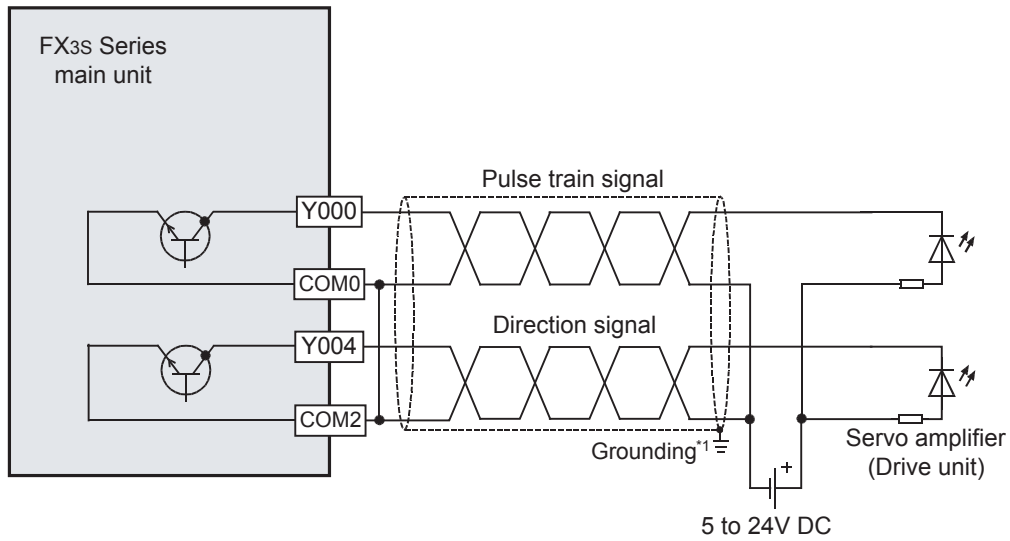

2. Source internal output circuit

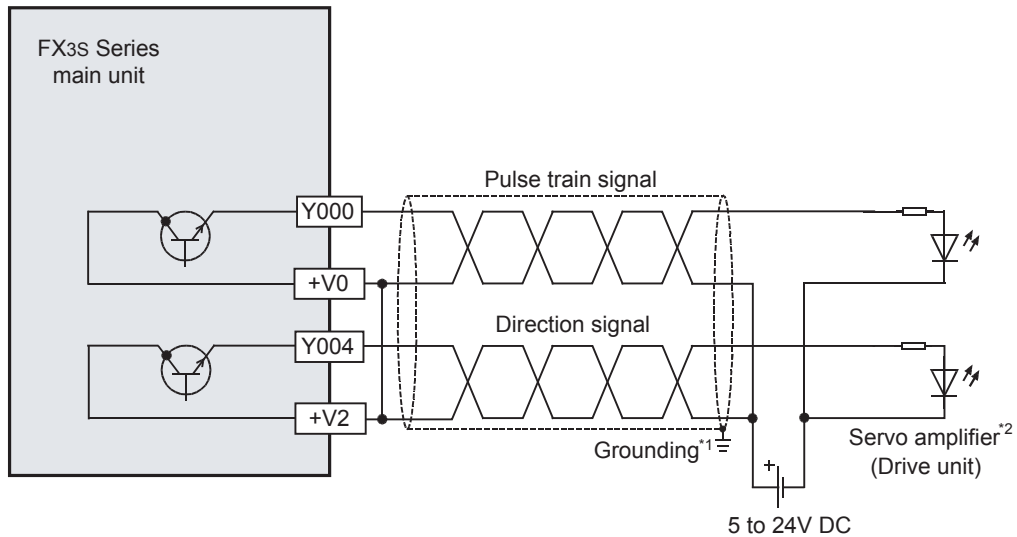

- *1. To ground the unit, refer to the servo amplifier (drive unit) manual. If the grounding method is not specified, carry out class-D grounding.
- *2. For MELSERVO Series amplifiers, use a sink output type FX3s Series main unit.

2.5.2 FX3G Series main unit (Transistor Output)

This section describes the transistor output specifications of the FX3G Series main unit. Note that the simultaneous turning-on rate is restricted for the output extension units and the main unit. For details on this restriction, refer to the following manual.

→ Refer to the FX3G Hardware Edition.

For MELSERVO Series amplifiers, use a sink input/sink output type PLC.

Item		Transistor output specifications		
External voltage		All outputs	5 to 30 V DC	
Maximum load	Resistance load	All outputs	The total load current of resistance loads per common terminal should be the following value or less. - 1 point output common:0.5 A - 4 points output common:0.8 A	
	Inductive load	All outputs	The total of inductive loads per common terminal should be the following value or less. - 1 point output common:12 W/24 V DC - 4 points output common:19.2 W/24 V DC	
Open-circuit leakage current		All outputs	0.1 mA or less at 30 V DC	
ON voltage		All outputs	1.5 V or less	
Response time	14-point, 24-point type	OFF→ON	Y000, Y001	5 μs or less at 10 mA or more (5 to 24 V DC)
			Y002 or more	0.2 ms or less at 200 mA or more (at 24 V DC)
	ON→OFF	Y000, Y001	5 μs or less at 10 mA or more (5 to 24 V DC)	
		Y002 or more	0.2 ms or less at 200 mA or more (at 24 V DC)	
	40-point, 60-point type	OFF→ON	Y000 to Y002	5 μs or less at 10 mA or more (5 to 24 V DC)
			Y003 or more	0.2 ms or less at 200 mA or more (at 24 V DC)
ON→OFF		Y000 to Y002	5 μs or less at 10 mA or more (5 to 24 V DC)	
		Y003 or more	0.2 ms or less at 200 mA or more (at 24 V DC)	
Circuit insulation		All outputs	Photocoupler insulation	
Indication of output motion		All outputs	LED is lit when the photocoupler is driven.	

Pulse output terminals Y000, Y001, and Y002*1 are high-speed response output terminals. To use the positioning instruction, adjust the load current of the NPN open collector to 10 to 100 mA (5 to 24 V DC).

*1. Y002 works as a high-speed response pulse output terminal only in 40-point and 60-point type main units.

Item	Description
Operation voltage range	5 to 24 V DC
Operation current range	10 to 100 mA
Output frequency	100 kHz or less

1. Sink internal output circuit

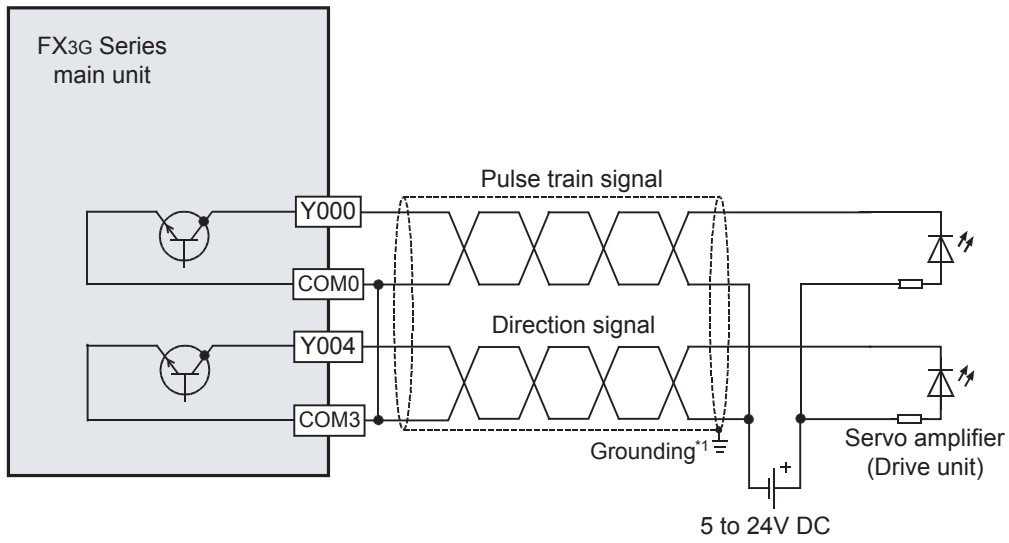

2. Source internal output circuit

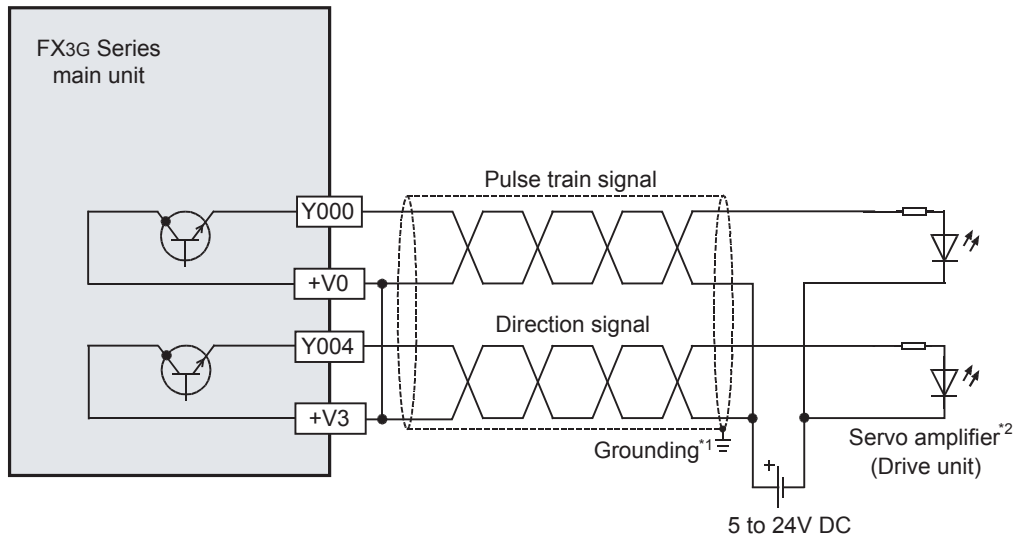

- *1. To ground the unit, refer to the servo amplifier (drive unit) manual. If the grounding method is not specified, carry out class-D grounding.
- *2. For MELSERVO Series amplifiers, use a sink output type FX3G Series main unit.

2.5.3 FX3GC Series main unit (Transistor Output)

This section describes the transistor output specifications of the FX3GC Series main unit. Note that the simultaneous turning-on rate is restricted for the output extension units and the main unit. For details on this restriction, refer to the following manual:

→ Refer to the FX3GC Hardware Edition.

For MELSERVO Series amplifiers, use a sink input/sink output type PLC.

Item		Transistor output specifications		
External voltage		All outputs	5 to 30 V DC	
Maximum load	Resistance load	Y000, Y001	0.3 A/point	The total load current of the common items (8 points) should be 0.8 A* ¹ or less.
		Y002 to Y017	0.1 A/1point	
	Inductive load	Y000, Y001	7.2 W/1point (24 V DC)	The total load of the common items (16 points) should be 38.4 W or less at 24 V DC.
		Y002 to Y017	2.4 W/1point (24 V DC)	
Open-circuit leakage current		All outputs	0.1 mA or less at 30 V DC	
ON voltage		All outputs	1.5 V or less	
Response time	OFF→ON	Y000, Y001	5 μs or less at 10 mA or more (5 to 24 V DC)	
		Y002 to Y017	0.2 ms or less at 100 mA (at 24 V DC)	
	ON→OFF	Y000, Y001	5 μs or less at 10 mA or more (5 to 24 V DC)	
		Y002 to Y017	0.2 ms or less at 100 mA (at 24 V DC)	
Circuit insulation		All outputs	Photocoupler insulation	
Indication of output motion		All outputs	LED is lit when the photocoupler is driven.	

*1. When the two COM1 terminals are connected outside the PLC, resistance load is 1.6 A or less.

Pulse output terminals Y000 and Y001 are high-speed response output terminals. To use the positioning instruction, adjust the load current of the NPN open collector to 10 to 100 mA (5 to 24 V DC).

Item	Description
Operation voltage range	5 to 24 V DC
Operation current range	10 to 100 mA
Output frequency	100 kHz or less

1. Sink internal output circuit

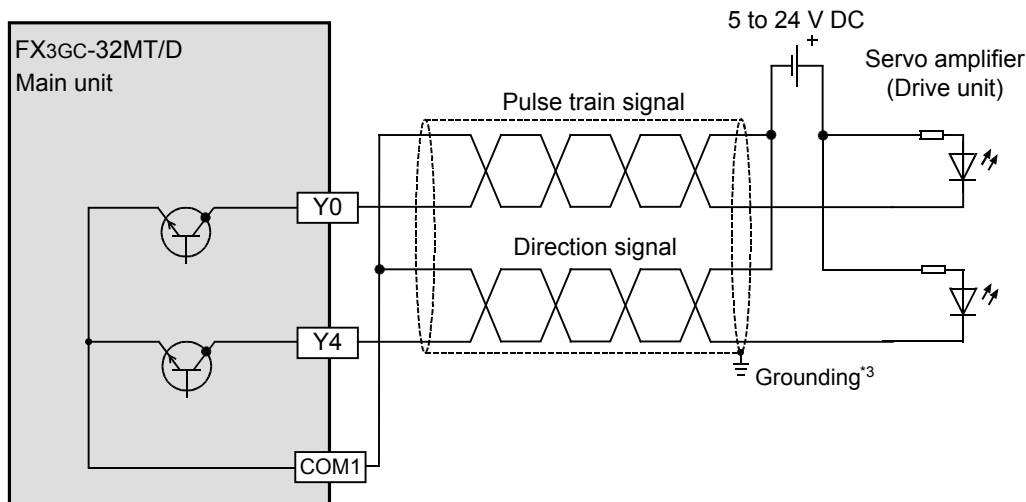

*2. To ground the unit, refer to the servo amplifier (drive unit) manual. If the grounding method is not specified, carry out class-D grounding.

2. Source internal output circuit

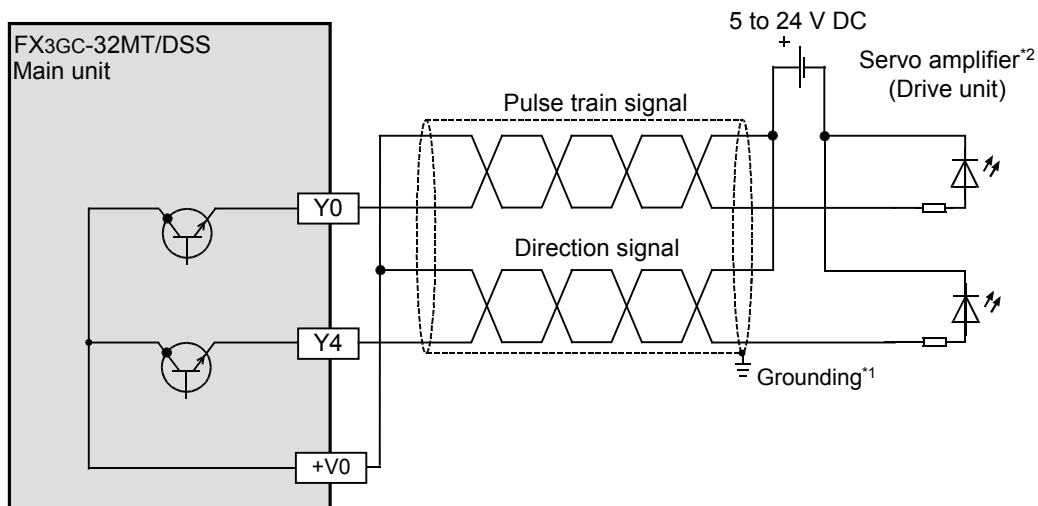

- *1. To ground the unit, refer to the servo amplifier (drive unit) manual. If the grounding method is not specified, carry out class-D grounding.
- *2. For MELSERVO Series amplifiers, use a sink output type FX3GC Series main unit .

2.5.4 FX3U Series main unit (Transistor Output)

This section describes the transistor output specifications of the FX3U Series main unit. Please note that the simultaneous turning-on rate is restricted for the output extension units and the main unit. For details on the restriction, refer to the following manual.

→ Refer to the FX3U Hardware Edition.

For MELSERVO Series amplifiers, use a sink input/sink output type PLC.

Item		Transistor output specifications	
External voltage		All outputs	5 to 30 V DC
Maximum load	Resistance load	All outputs	The total load current of resistance loads per common terminal should be the following value or less. - 1 point output common:0.5 A - 4 points output common:0.8 A - 8 points output common:1.6 A
	Inductive load	All outputs	The total of inductive load per common terminal should be the following value or less. - 1 point output common:12 W/24 V DC - 4 points output common:19.2 W/24 V DC - 8 points output common:38.4 W/24 V DC
Open-circuit leakage current		All outputs	0.1 mA or less at 30 V DC
ON voltage		All outputs	1.5 V or less
Response time	OFF→ON	Y000 to Y002	5 μs or less at 10 mA or more (5 to 24 V DC)
		Y003 or more	0.2 ms or less at 200 mA (at 24 V DC)
	ON→OFF	Y000 to Y002	5 μs or less at 10 mA or more (5 to 24 V DC)
		Y003 or more	0.2 ms or less at 200 mA (at 24 V DC)
Circuit insulation		All outputs	Photocoupler insulation
Indication of output motion		All outputs	LED is lit when the photocoupler is driven.

Pulse output terminals Y000, Y001, and Y002 are high-speed response output terminals.

To use the positioning instruction, adjust the load current of the NPN open collector to 10 to 100 mA (5 to 24 V DC).

Item	Description
Operation voltage range	5 to 24 V DC
Operation current range	10 to 100 mA
Output frequency	100 kHz or less

1. Sink internal output circuit

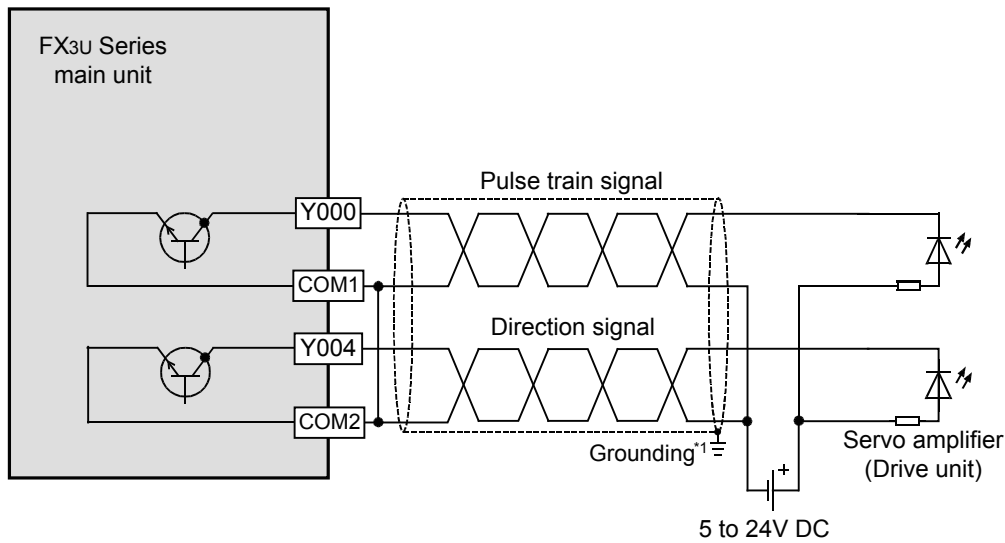

*1. To ground the unit, refer to the servo amplifier (drive unit) manual. If the grounding method is not specified, carry out class-D grounding.

2. Source internal output circuit

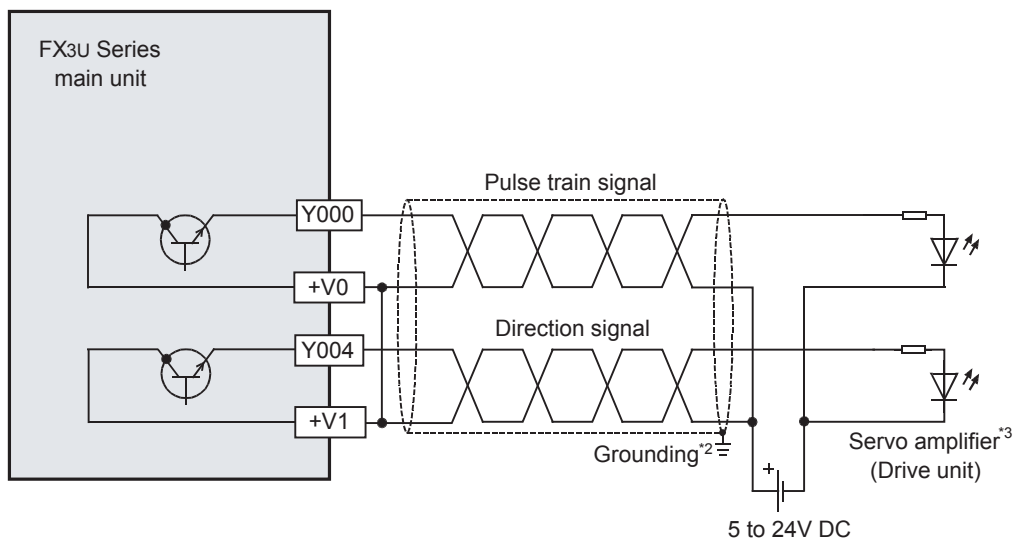

*2. To ground the unit, refer to the servo amplifier (drive unit) manual. If the grounding method is not specified, carry out class-D grounding.

*3. For MELSERVO Series amplifiers, use a sink output type FX3U Series main unit.

2.5.5 FX3uc Series main unit (Transistor Output)

This section describes the transistor output specifications of the FX3uc Series main unit. Note that the simultaneous turning-on rate is restricted for the output extension units and the main unit. For details on this restriction, refer to the following manual:

→ Refer to the FX3uc Hardware Edition.

For MELSERVO Series amplifiers, use a sink input/sink output type PLC.

Item		Transistor output specifications		
External voltage		All outputs	5 to 30 V DC	
Maximum load	Resistance load	Y000 to Y003	0.3 A/point	The total load current of the common items (8 points) should be 0.8 A ^{*1} or less.
		Y004 or more	0.1 A/1point	
	Inductive load	Y000 to Y003	7.2 W/1point (24 V DC)	The total load of the common items (16 points) should be 38.4 W or less at 24 V DC.
		Y004 or more	2.4 W/1point (24 V DC)	
Open-circuit leakage current		All outputs	0.1 mA or less at 30 V DC	
ON voltage		All outputs	1.5 V or less	
Response time	FX3uc-32MT-LT	OFF→ON	Y000 to Y003	5 μs or less at 10 mA or more (5 to 24 V DC)
	FX3uc-32MT-LT-2	ON→OFF	Y004 to Y017	0.2 ms or less at 100 mA (at 24 V DC)
	FX3uc-□□MT/D	OFF→ON	Y000 to Y002	5 μs or less at 10 mA or more (5 to 24 V DC)
	FX3uc-□□MT/DSS	ON→OFF	Y003 or more	0.2 ms or less at 100 mA (at 24 V DC)
Circuit insulation		All outputs	Photocoupler insulation	
Indication of output motion		All outputs	LED is lit when the photocoupler is driven. ^{*2}	

*1. When the two COM1 terminals are connected outside the PLC, resistance load is 1.6 A or less.

*2. The FX3uc-32MT-LT(-2) uses the display module for monitoring.

Pulse output terminals Y000, Y001, and Y002 are high-speed response output terminals.

To use the positioning instruction, adjust the load current of the NPN open collector to 10 to 100 mA (5 to 24 V DC).

Item	Description
Operation voltage range	5 to 24 V DC
Operation current range	10 to 100 mA
Output frequency	100 kHz or less

1. Sink internal output circuit

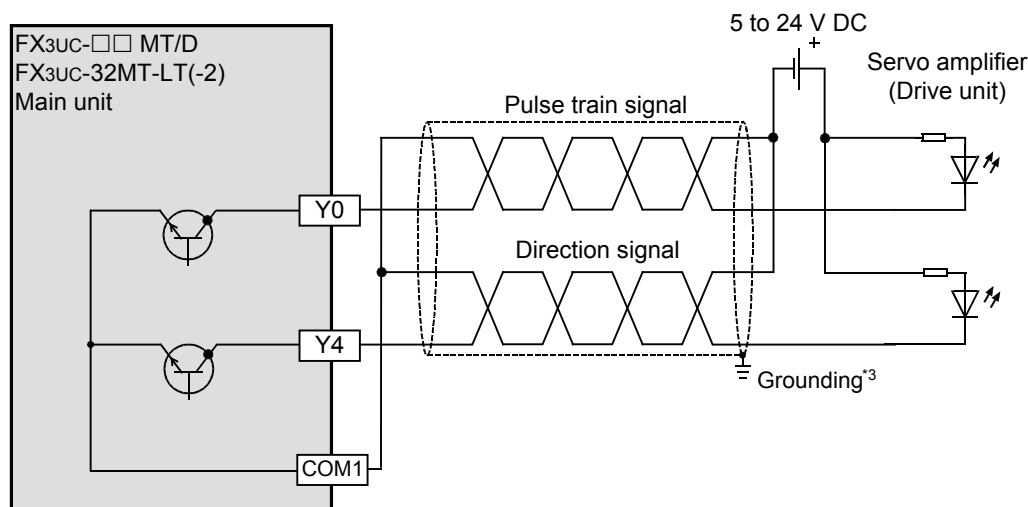

*3. To ground the unit, refer to the servo amplifier (drive unit) manual. If the grounding method is not specified, carry out class-D grounding.

2. Source internal output circuit

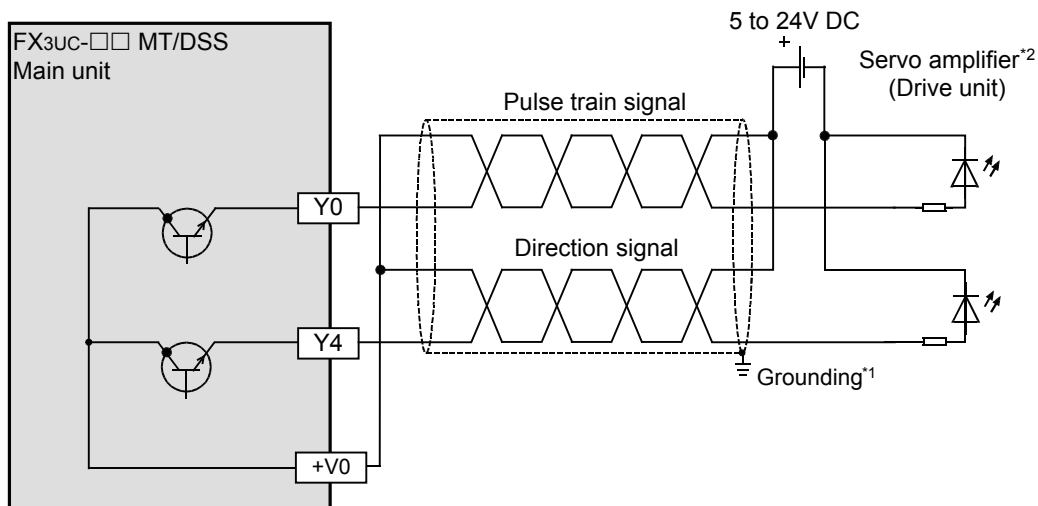

- *1. To ground the unit, refer to the servo amplifier (drive unit) manual. If the grounding method is not specified, carry out class-D grounding.
- *2. For MELSERVO Series amplifiers, use a sink output type FX3UC Series main unit .

2.5.6 High-Speed Output Special Adapter [FX3U-2HSY-ADP]

This section describes the output specifications of the high-speed output special adapter (FX3U-2HSY-ADP).

Item	High-speed output special adapter (FX3U-2HSY-ADP)
Pulse output form	Differential line driver system (equivalent to AM26C31)
Load current	25 mA or less
Maximum output frequency	200KHz
Insulation	Photocoupler and transformer insulate PLC from external lines of its outputs, and transformer insulates each SG.
Cable length	10 m, maximum

1. Internal output circuit

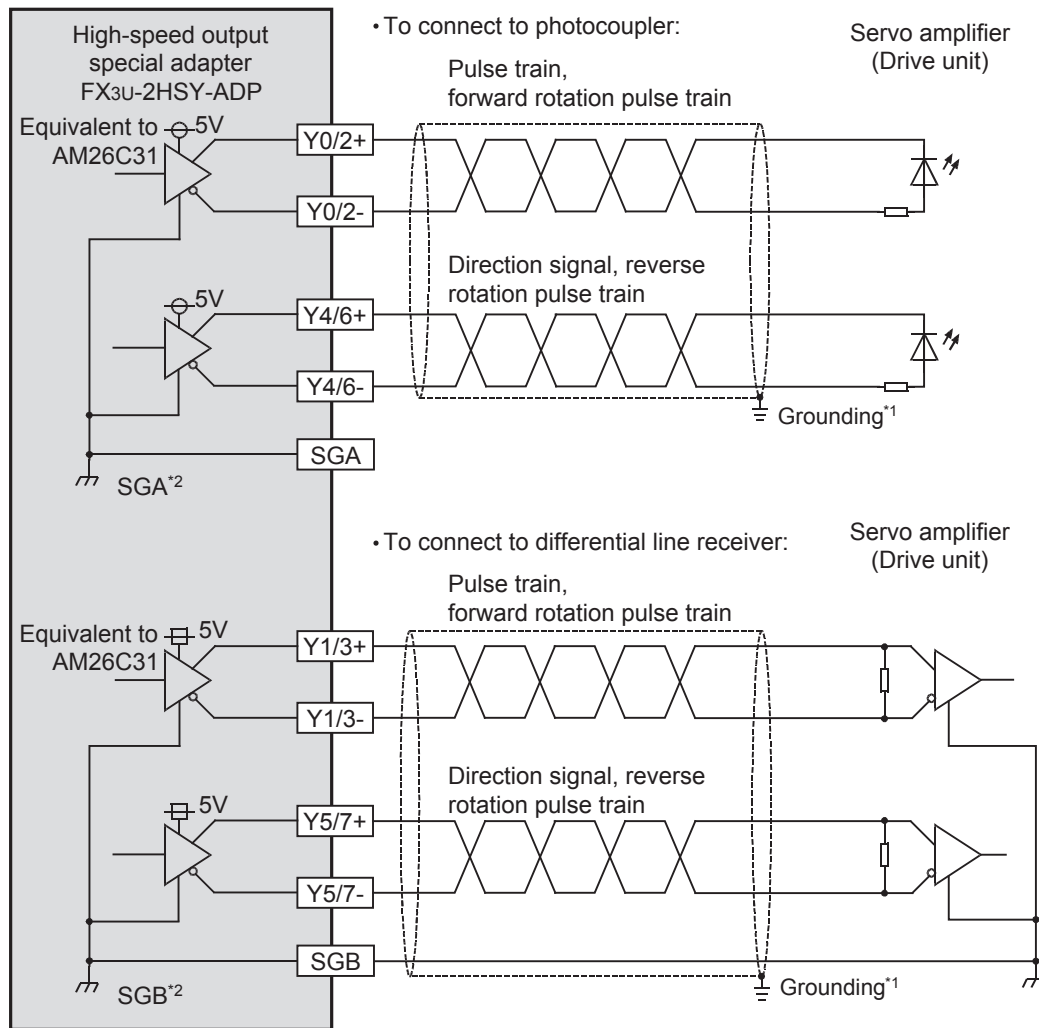

- *1. To ground the unit, refer to the servo amplifier (drive unit) manual. If the grounding method is not specified, carry out class-D grounding.
- *2. The line between the SGA and the SGB is insulated.

2.6 List of Functions

The instructions needed for the FX3S/FX3G/FX3GC/FX3U/FX3UC PLC built-in positioning functions are shown in the following table:

Positioning instruction		Operation	Description	Refer to																								
Mechanical zero return																												
DSZR instruction	zero return with DOG search function	<p>Creep speed Zero return speed</p> <p>Speed</p> <p>Zero-point: ON DOG:ON Start (Dog: OFF when ZRN instruction is used)</p>	If the DSZR/ZRN instruction turns ON, mechanical zero return will be started at the specified zero return speed. If the dog sensor is turned on, the speed will be reduced to the creep speed. If the zero-phase signal is input, the operation will be stopped, and the zero return will be completed. (If the ZRN instruction is used, the dog sensor will be turned off to stop the operation.)	Chapter 6.																								
ZRN instruction	zero return																											
Absolute position detection system																												
ABS instruction	Absolute value detection system (Reading of current ABS value)	<p>Reads out the current value.</p>	If the ABS instruction turns ON, the current motor address will be read out from the servo amplifier.	Chapter 7.																								
1-speed positioning																												
DRVI instruction	Relative positioning	<p>Operation speed</p> <p>Speed</p> <p>Transfer distance</p> <p>Start Target position</p>	If the DRVI/DRVA instruction turns ON, the operation will be started at the operation speed. When the workpiece reaches the target position, the operation will be stopped.	Chapter 8.																								
DRVA instruction	Absolute positioning																											
1-speed positioning with interruption																												
DVIT instruction *1	Interruption positioning	<p>Operation speed</p> <p>Speed</p> <p>Transfer distance</p> <p>Start Interrupt input: ON</p>	If the DVIT instruction turns ON, the operation will be started at the operation speed. If the interrupt input turns ON, the workpiece will go the specified transfer distance, before decelerating to stop.	Chapter 9.																								
Variable speed operation																												
PLSV instruction	Variable positioning (Variable Speed Pulse Output)	<ul style="list-style-type: none"> • Operation without Acceleration/Deceleration <p>Operation speed</p> <p>Speed</p> <p>Start Speed change Speed change Instruction: OFF</p> <ul style="list-style-type: none"> • Operation with Acceleration/Deceleration*2 <p>Operation speed</p> <p>Speed</p> <p>Start Speed change Speed change Instruction: OFF</p>	If the PLSV instruction turns ON, operation will be started at the specified speed. With an operation speed change, the speed changes to the specified speed, and operation continues. At PLSV instruction OFF, the pulse output stops. With acceleration/deceleration operation, the PLC controls acceleration and deceleration.	Chapter 10.																								
Others																												
TBL instruction *3	Positioning using batch setting method	<table border="1"> <thead> <tr> <th>No.</th> <th>Position</th> <th>Speed</th> <th>Instruction</th> </tr> </thead> <tbody> <tr> <td>1</td> <td>1000</td> <td>2000</td> <td>DRVI</td> </tr> <tr> <td>2</td> <td>20000</td> <td>5000</td> <td>DRVA</td> </tr> <tr> <td>3</td> <td>50</td> <td>1000</td> <td>DVIT</td> </tr> <tr> <td>4</td> <td>800</td> <td>10000</td> <td>DRVA</td> </tr> <tr> <td>⋮</td> <td>⋮</td> <td>⋮</td> <td>⋮</td> </tr> </tbody> </table>	No.	Position	Speed	Instruction	1	1000	2000	DRVI	2	20000	5000	DRVA	3	50	1000	DVIT	4	800	10000	DRVA	⋮	⋮	⋮	⋮	Preliminarily set the positioning points using parameters. If the TBL instruction turns ON, the workpiece will be transferred to the specified point.	Chapter 11.
No.	Position	Speed	Instruction																									
1	1000	2000	DRVI																									
2	20000	5000	DRVA																									
3	50	1000	DVIT																									
4	800	10000	DRVA																									
⋮	⋮	⋮	⋮																									

- *1. Only available for FX3U and FX3UC PLCs.
- *2. Only available for FX3UC PLC Ver. 2.20 or later and FX3S/FX3G/FX3GC/FX3U PLC.
- *3. Only available for FX3UC PLC Ver. 2.20 or later and FX3G/FX3GC/FX3U PLC.

A
Common Items

B
Built-in
Positioning
Functions

Apx.
Example
Connection

3. Connection of Input/Output Lines and Tightening Torques

This chapter describes how to connect the input/output lines and the terminal tightening torques.

WIRING PRECAUTIONS



- Make sure to cut off all phases of the power supply externally before attempting installation or wiring work. Failure to do so may cause electric shock or damage to the product.
- Make sure to attach the terminal cover, offered as an accessory, before turning on the power or initiating operation after installation or wiring work. Failure to do so may cause electric shock.

WIRING PRECAUTIONS



- Connect the AC power supply to the dedicated terminals specified in the manual of the PLC main unit. If an AC power supply is connected to a DC input/output terminal or DC power supply terminal, the PLC will burn out.
- Connect the DC power supply to the dedicated terminals specified in the manual of the PLC main unit. If an AC power supply is connected to a DC input/output terminal or DC power supply terminal, the PLC will burn out.
- Do not wire vacant terminals externally. Doing so may damage the product.
- Perform class D grounding (grounding resistance: 100Ω or less) to the grounding terminal on the FX3S/FX3G/FX3U PLC main unit with a wire 2 mm² or thicker. Do not use common grounding with heavy electrical systems (refer to the manual of the PLC main unit).
- Perform class D grounding (grounding resistance: 100Ω or less) to the grounding terminal on the FX3GC/FX3UC PLC main unit with a wire as thick as possible. Do not use common grounding with heavy electrical systems (refer to the manual of the PLC main unit).
- When drilling screw holes or wiring, make sure cutting or wire debris does not enter the ventilation slits. Failure to do so may cause fire, equipment failures or malfunctions.
- Install module so that excessive force will not be applied to I/O connectors. Failure to do so may result in wire damage/breakage or PLC failure.
- Connect input/output cables securely to their designated connectors. Loose connections may cause malfunctions.
- Make sure to properly wire the terminal block in accordance with the following precautions. Failure to do so may cause electric shock, equipment failures, a short-circuit, wire breakage, malfunctions or damage to the product.
 - The disposal size of the cable end should follow the dimensions described in the manual.
 - Tightening torque should follow the specifications in the manual.
 - Tighten the screws using a Phillips-head screwdriver No.2 (shaft diameter 6mm (0.24") or less). Make sure that the screwdriver does not touch the partition part of the terminal block.
- Make sure to properly wire to the terminal block (European type) in accordance with the following precautions. Failure to do so may cause electric shock, equipment failures, a short-circuit, wire breakage, malfunctions or damage to the product.
 - The disposal size of the cable end should follow the dimensions described in the manual.
 - Tightening torque should follow the specifications in the manual.
 - Twist the end of strand wire and make sure that there are no loose wires.
 - Do not solder-plate the electric wire ends.
 - Do not connect more than the specified number of wires or electric wires of unspecified size.
 - Affix the electric wires so that neither the terminal block nor the connected parts are directly stressed.
- Make sure to properly wire to the FX Series terminal blocks in accordance with the following precautions. Failure to do so may cause electric shock, equipment failures, a short-circuit, wire breakage, malfunctions or damage to the product.
 - The disposal size of the cable end should follow the dimensions described in the manual.
 - Tightening torque should follow the specifications in the manual.
 - Tighten the screws using a Phillips-head screwdriver No.2 (shaft diameter 6mm (0.24") or less). Make sure that the screwdriver does not touch the partition part of the terminal block.

3.1 Terminal Board (M3, M3.5)

A terminal board is used for the FX3S/FX3G/FX3U Series main unit, FX2N Series input/output extension unit (excluding some types), and FX0N Series input/output extension block.

3.1.1 Terminal block screw size and tightening torque

The terminal screw size of each product is shown in the following table. For details on the crimp-style terminals, refer to Subsection 3.1.2.

Product	Terminal screw	Tightening torque
FX3S/FX3G/FX3U Series main unit, FX2N Series input/output powered extension unit, FX0N/FX2N Series input/output extension block	M3	0.5 to 0.8 N•m
FX Series terminal block	M3.5	

3.1.2 Termination

The solderless terminal size depends on the terminal screw size and wiring method.

- Use solderless terminals of the following size.
- Tighten the terminals to a torque of 0.5 to 0.8 N•m.
Do not tighten terminal screws with a torque outside the above-mentioned range. Failure to do so may cause equipment failures or malfunctions.

1. In the case of M3 terminal screw

- When one wire is connected to one terminal

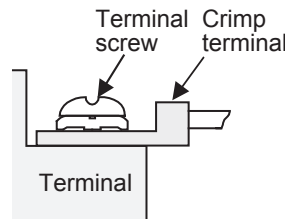
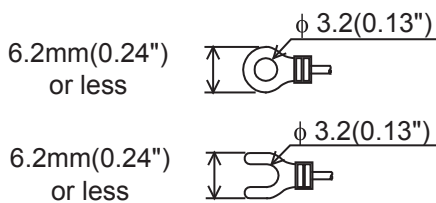

- When two wires are connected to one terminal

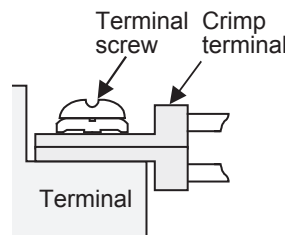
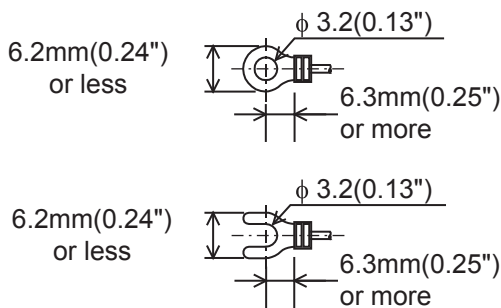

2. In the case of M3.5 terminal screw

- When one wire is connected to one terminal

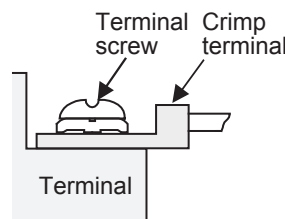
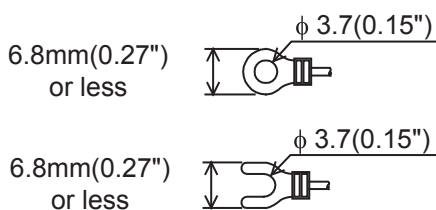

- When two wires are connected to one terminal

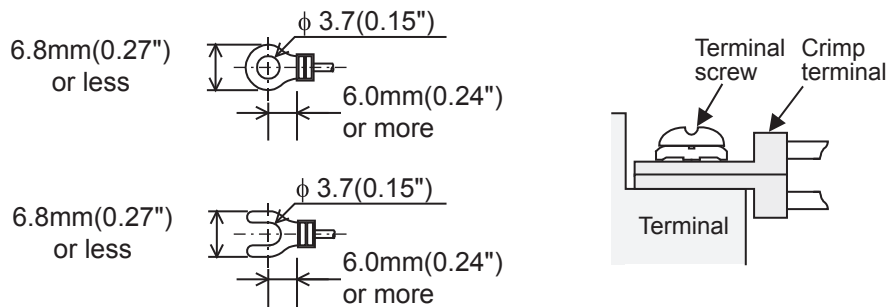

3.2 European Terminal Board

The European terminal board is used for the high-speed output special adapter and the FX2Nc Series input/output extension block.

3.2.1 Cable

Applicable cables and tightening torques

	Wire size (stranded/ single wire)	Tightening torque	Termination
Single-wire	0.3 mm ² to 0.5 mm ² (AWG22 to 20)	0.22 to 0.25 N•m	<ul style="list-style-type: none"> To connect a stranded cable, peel the sheath off the cable, and then twist the core before connection. To connect a single-wire cable, just peel the sheath off the cable before connection. Rod terminal with insulation sleeve (recommended terminal) AI 0.5-8WH: Manufactured by Phoenix Contact Caulking tool: CRIMPFOX 6^{*1}: Manufactured by Phoenix Contact (or CRIMPFOX 6T-F^{*2}: Manufactured by Phoenix Contact)
2-wires	0.3 mm ² (AWG22) ×2		
Rod terminal with insulation sleeve	0.3 mm ² to 0.5 mm ² (AWG22-20) (Refer to the external view of the rod terminal shown in the following figure.)		

*1. Old model name: CRIMPFOX ZA 3

*2. Old model name: CRIMPFOX UD 6

3.2.2 Termination of Cable End

Treat the ends of stranded wires and solid wires without coating or using bar terminals with insulating sleeve. Tighten the terminals to a torque of 0.22 to 0.25 N•m.

Do not tighten terminal screws with a torque outside the above-mentioned range. Failure to do so may cause equipment failures or malfunctions.

- Directly terminate the end of the stranded/single-wire cable:
 - Terminate the end of the stranded cable so that "barbed wires" cannot protrude.
 - Do not solder-plate the end of the cable.
- Terminate the cable end using a rod terminal with insulation sleeve:
 - If the cable sheath is too thick, it may be difficult to insert the cable into the insulation sleeve. For this reason, select an appropriate cable while referring to the external view.
 - <Reference>

- Stranded wire/solid wire

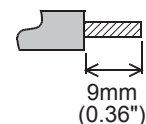

- Bar terminal with insulating sleeve

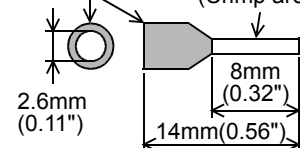

Manufacturer	Model names	Caulking tool
Phoenix Contact	AI 0.5-8WH	CRIMPFOX 6 ^{*3} (or CRIMPFOX 6T-F ^{*4})

*3. Old model name: CRIMPFOX ZA 3

*4. Old model name: CRIMPFOX UD 6

3.2.3 Tool

For tightening the terminal, use a commercially available small screwdriver having a straight form that is not widened toward the end as shown right.

Note:

If the diameter of screwdriver grip is too small, tightening torque will not be able to be achieved. To achieve the appropriate tightening torque shown in the table on the previous page, use the following screwdriver or appropriate replacement (grip diameter : approximately 25 mm (0.98")).
 <Reference>

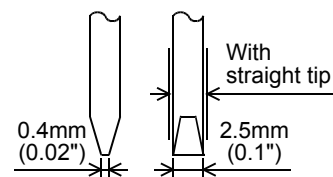

Manufacturer	Model names
Phoenix Contact	SZS 0.4×2.5

3.3 Connector

Connectors conforming to the requirements of the MIL C-83503 are used for the FX3GC/FX3UC Series main unit along with some types of FX2N/FX2NC Series input/output extension blocks.

3.3.1 Cable Connection To Input/Output Connector

Prepare the input/output cables while referring to the next Subsection.

Example : FX3UC-32MT/D Main unit

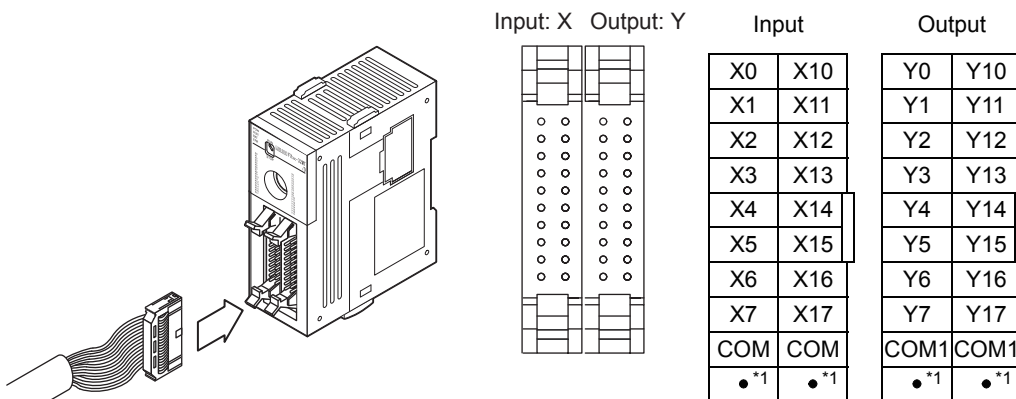

*1: "●" means that the terminal is not used.

3.3.2 Setup of Input/Output Connection Connector

1. Applicable connector (connector purchased at store)

Use a 20-pin (1-key) socket that conforms to the requirements of the MIL C-83503.

Preliminarily check that the peripheral parts, such as the connector cover, will not cause any interference.

2. Input/output cables (optional cables manufactured by our company)

Mitsubishi Electric can provide input/output cables already equipped with a connector.

Model	Length	Description	Connector type
FX-16E-500CAB-S	5m (16' 4")	General-purpose input/output cable	<ul style="list-style-type: none"> Single wire (Wire color: red) PLC side: A 20-pin connector
FX-16E-150CAB	1.5m (4'11")	Cable for connection of FX Series terminal block to input/output connector For details on connection to the FX Series terminal block, refer to the following manuals: →FX3G Hardware Edition →FX3GC Hardware Edition →FX3U Hardware Edition →FX3UC Hardware Edition	<ul style="list-style-type: none"> Flat cables (with tube) A 20-pin connector at both ends
FX-16E-300CAB	3m (9'10")		
FX-16E-500CAB	5m (16' 4")		
FX-16E-150CAB-R	1.5m (4'11")		
FX-16E-300CAB-R	3m (9'10")		
FX-16E-500CAB-R	5m (16' 4")		
FX-16E-500CAB-R	5m (16' 4")		
FX-A32E-150CAB	1.5m (4'11")	Cable for connection of A Series A6TBXY36 connector/terminal board conversion unit to input/output connector type	<ul style="list-style-type: none"> Flat cables (with tube) PLC side: Two 20-pin connectors in 16-point units Terminal block side: A dedicated connector One common terminal covers 32 input/output terminals
FX-A32E-300CAB	3m (9'10")		
FX-A32E-500CAB	5m (16' 4")		

3. Input/output cable connectors prepared by purchaser (optional connectors manufactured by Mitsubishi Electric)

The purchaser should prepare the cables and press-fitting tools.

Input/output connector model and number of connectors included in one set		Applicable cable (recommended cable: UL-1061) and tool		
Our model		Description of parts (Manufactured by Daiichi Denshi Kogyo Co., Ltd.)	Cable size	Crimping tool (Manufactured by Daiichi Denshi Kogyo Co., Ltd.)
FX2c-I/O-CON, for flat cable	Set of 10 parts	Crimp-style connector FRC2-A020-30S	AWG28(0.1mm ²) 1.27 pitch, 20 cores	357J-4674D main unit 357J-4664N attachment
FX2c-I/O-CON-S, for non-stranded cable	5 sets	Housing HU-200S2-001 Crimp-style contact HU-411S	AWG22(0.3mm ²)	357J-5538
FX2c-I/O-CON-SA, for non-stranded cable	5 sets	Housing HU-200S2-001 Crimp-style contact HU-411SA	AWG20(0.5mm ²)	357J-13963
FX-I/O-CON2, for flat cable (40 Pin)	2 sets	Crimp-style connector FRC2-A040-30S	AWG28(0.1mm ²) 1.27 pitch, 40 cores	357J-4674D main unit 357J-4664N attachment
FX-I/O-CON2-S non-stranded cable (40 Pin)	2 sets	Housing HU-400S2-001 Crimp-style contact HU-411S	AWG22(0.3mm ²)	357J-5538
FX-I/O-CON2-SA non-stranded cable (40 Pin)	2 sets	Housing HU-400S2-001 Crimp-style contact HU-411SA	AWG20(0.5mm ²)	357J-13963

4. Connector already confirmed as applicable (available at stores)

Connectors manufactured by Daiichi Denshi Kogyo Co., Ltd. (shown in 3)

4. Before Programming

This chapter describes several items that should be known before programming. They are:

- Operation of related devices, such as output pulse frequency, operation command flag, current value, and operation monitor flag.
- Items to be set on the PLC side
- Items to be set on the servo amplifier (drive unit) side
- Items to be observed in programming

4.1 List of Related Devices

→ For details on related devices, refer to Section 4.2 to Section 4.4.

4.1.1 Special Auxiliary Relays

The following table shows the related special auxiliary relays. Note that Y000, Y001, Y002, and Y003 are devices that determine the pulse output destinations.

→ For details on the PLSY (FNC 57), PWM (FNC 58), and PLSR (FNC 59) instructions, refer to the programming manual.

Device number				Function	Attribute	Corresponding instructions	Refer to
Y000	Y001	Y002*1	Y003*2				
M8029				"Instruction execution complete" flag	Read only	PLSY,PLSR,DSZR, DVIT,ZRN,DRVI, DRVA and so on.	Subsection 4.4.2
M8329				"Instruction execution abnormal end" flag	Read only	PLSY,PLSR,DSZR, DVIT,ZRN,PLSV, DRVI,DRVA	Subsection 4.4.2
M8338				Acceleration/deceleration Operation *3,*4	Drivable	PLSV	Subsection 4.3.9
M8336				Interrupt input specification function enable*4,*5	Drivable	DVIT	Subsection 4.3.7
M8340	M8350	M8360	M8370	"Pulse output monitor" flag (BUSY/READY)	Read only	PLSY,PLSR,DSZR, DVIT,ZRN,PLSV, DRVI,DRVA	Subsection 4.4.3
M8341	M8351	M8361	M8371	CLEAR signal output function enable*4	Drivable	DSZR,ZRN	Subsection 4.3.4
M8342	M8352	M8362	M8372	Zero return direction specification*4	Drivable	DSZR	Subsection 4.3.3
M8343	M8353	M8363	M8373	Forward limit	Drivable	PLSY,PLSR,DSZR, DVIT,ZRN,PLSV, DRVI,DRVA	Subsection 4.3.1
M8344	M8354	M8364	M8374	Reverse limit	Drivable		Subsection 4.3.1
M8345	M8355	M8365	M8375	DOG signal logic reverse*4	Drivable	DSZR	Subsection 4.3.5
M8346	M8356	M8366	M8376	Zero-point signal logic reverse*4	Drivable	DSZR	Subsection 4.3.6
M8347	M8357	M8367	M8377	Interrupt signal logic reverse*4,*6,*7	Drivable	DVIT	Subsection 4.3.8
M8348	M8358	M8368	M8378	Positioning instruction activation	Read only	PLSY,PWM,PLSR, DSZR,DVIT,ZRN, PLSV,DRVI,DRVA	Subsection 4.4.4
M8349	M8359	M8369	M8379	Pulse output stop command*4	Drivable	PLSY,PLSR,DSZR, DVIT,ZRN,PLSV, DRVI,DRVA	Subsection 4.3.2

Device number				Function	Attribute	Corresponding instructions	Refer to
Y000	Y001	Y002 ^{*1}	Y003 ^{*2}				
M8460	M8461	M8462	M8463	User interrupt input command ^{*4,*8}	Drivable	DVIT	Subsection 4.3.7
M8464	M8465	M8466	M8467	CLEAR signal device specification function enable ^{*3,*4}	Drivable	DSZR,ZRN	Subsection 4.3.4

*1. Y002 is not available in FX3G PLC (14-point and 24-point type) and FX3S/FX3GC PLC.

*2. Y003 is available only when two high-speed output special adapters are connected to the FX3U PLC.

*3. Only available for FX3UC PLC Ver. 2.20 or later and FX3S/FX3G/FX3GC/FX3U PLC.

*4. Cleared when PLC switches from RUN to STOP.

*5. Only available for FX3UC PLC Ver. 1.30 or later and FX3U PLC.

*6. Only available for FX3U/FX3UC PLC.

*7. For the user interrupt input command, the logical NOT function will not be activated.

*8. Only available for FX3UC PLC Ver. 2.20 or later and FX3U PLC.

4.1.2 Special Data Registers

The following table shows the related special data registers. Note that Y000, Y001, Y002, and Y003 are devices that determine the pulse output destinations.

Device number								Function	Data length	Initial value	Corresponding instructions	Refer to
Y000	Y001	Y002 ^{*1}	Y003 ^{*2}	D8336								
D8336								interrupt input specification ^{*3}	16-bit	-	DVIT	Subsection 4.3.7
D8340	Low-order	D8350	Low-order	D8360	Low-order	D8370	Low-order	Current value register [PLS]	32-bit	0	DSZR,DVIT, ZRN,PLSV, DRVI,DRVA	Subsection 4.4.1
D8341	High-order	D8351	High-order	D8361	High-order	D8371	High-order					
D8342		D8352		D8362		D8372		Bias speed [Hz]	16-bit	0	DSZR,DVIT, ZRN,PLSV, DRVI,DRVA	Subsection 4.2.6
D8343	Low-order	D8353	Low-order	D8363	Low-order	D8373	Low-order	Maximum speed [Hz]	32-bit	100,000	DSZR,DVIT, ZRN,PLSV, DRVI,DRVA	Subsection 4.2.5
D8344	High-order	D8354	High-order	D8364	High-order	D8374	High-order					
D8345		D8355		D8365		D8375		Creep speed [Hz]	16-bit	1000	DSZR	Subsection 4.2.4
D8346	Low-order	D8356	Low-order	D8366	Low-order	D8376	Low-order	Zero return speed [Hz]	32-bit	50,000	DSZR	Subsection 4.2.3
D8347	High-order	D8357	High-order	D8367	High-order	D8377	High-order					
D8348		D8358		D8368		D8378		Acceleration time [ms]	16-bit	100	DSZR,DVIT, ZRN,PLSV ^{*4} , DRVI,DRVA	Subsection 4.2.7
D8349		D8359		D8369		D8379		Deceleration time [ms]	16-bit	100	DSZR,DVIT, ZRN,PLSV ^{*4} , DRVI,DRVA	Subsection 4.2.8
D8464		D8465		D8466		D8467		CLEAR signal device specification ^{*5}	16-bit	-	DSZR,ZRN	Subsection 4.3.4

*1. Y002 is not available in FX3G PLC (14-point and 24-point type) and FX3S/FX3GC PLC.

*2. Y003 is available only when two high-speed output special adapters are connected to the FX3U PLC.

*3. Only available for FX3UC PLC Ver. 1.30 or later and FX3U PLC. However, the user interrupt input command can be specified only if the FX3U/FX3UC PLC Ver. 2.20 or later is used.

*4. This instruction is valid only during operation with acceleration/deceleration.

*5. Only available for FX3UC PLC Ver. 2.20 or later and FX3S/FX3G/FX3GC/FX3U PLC.

4.2 Setting of Various Items Regarding Speeds

Specify the output pulse frequency using the operand of each instruction or the related device to determine the output pulse frequency, zero return speed, or creep speed.

4.2.1 Setting of Various Items Regarding Instructions and Speeds

1. Interrupt Positioning (DVIT) instruction, drive to increment (DRVI) instruction, and drive to absolute (DRVA) instruction

For these instructions, it is necessary to specify the maximum speed, bias speed, acceleration time, and deceleration time using the related devices in addition to the output pulse frequency specified by the operand of the instruction.

→ For operation of DVIT instruction, refer to Chapter 9.

→ For operation of DRVI or DRVA instruction, refer to Chapter 8.

→ For details on each setting item, refer to Subsection 4.2.2, and Subsection 4.2.5 to Subsection 4.2.8

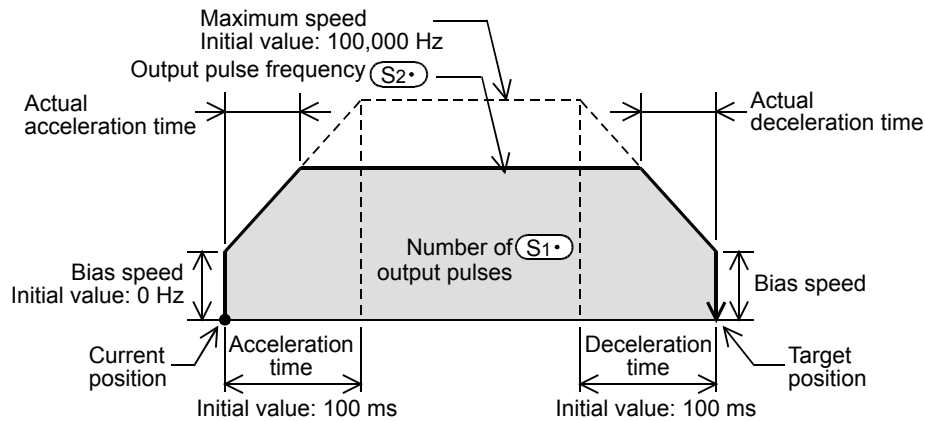

2. Variable speed Pulse Output (PLSV) instruction

For the variable speed pulse output (PLSV) instruction, it is necessary to specify the maximum speed, bias speed, acceleration time, and deceleration time using the related devices in addition to the output pulse frequency specified by the operand of the instruction. However, note that the acceleration time and the deceleration time are only valid during acceleration/deceleration (M8338 = ON).

→ For operation of PLSV instruction, refer to Chapter 10.

→ For details on each setting item, refer to Subsection 4.2.2, and Subsection 4.2.5 to Subsection 4.2.8.

1) When acceleration/deceleration is being performed (M8338 = ON)

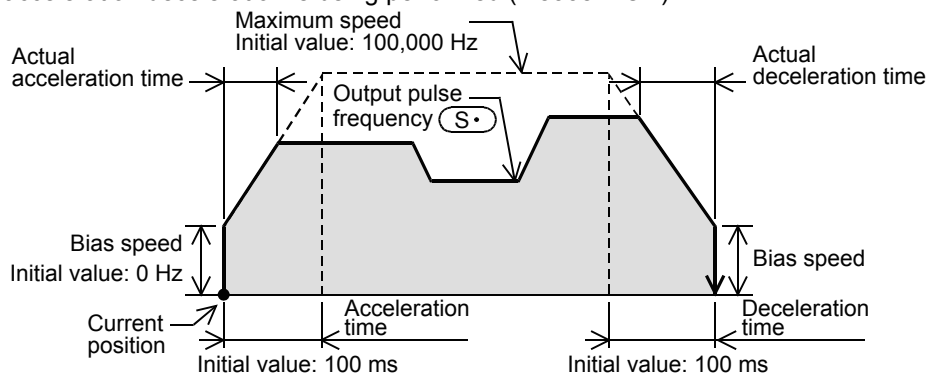

2) When acceleration/deceleration is not performed (M8338 = OFF)

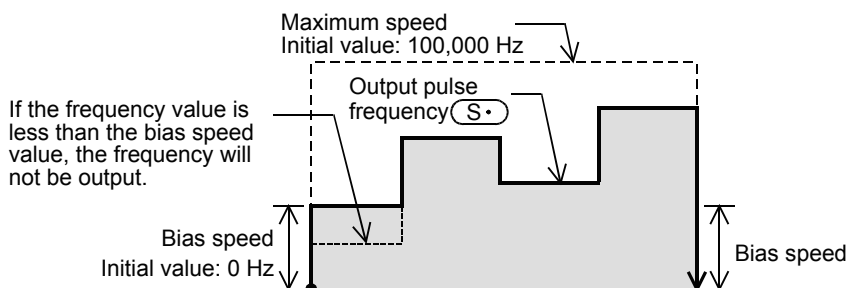

3. Zero return instruction with DOG search function (DSZR)

For this instruction, it is necessary to specify the maximum speed, bias speed, acceleration time, deceleration time, zero return speed, and creep speed using the related devices.

- For operation of DSZR instruction, refer to Section 6.2.
- For details on each setting item, refer to Subsection 4.2.3 to Subsection 4.2.8.

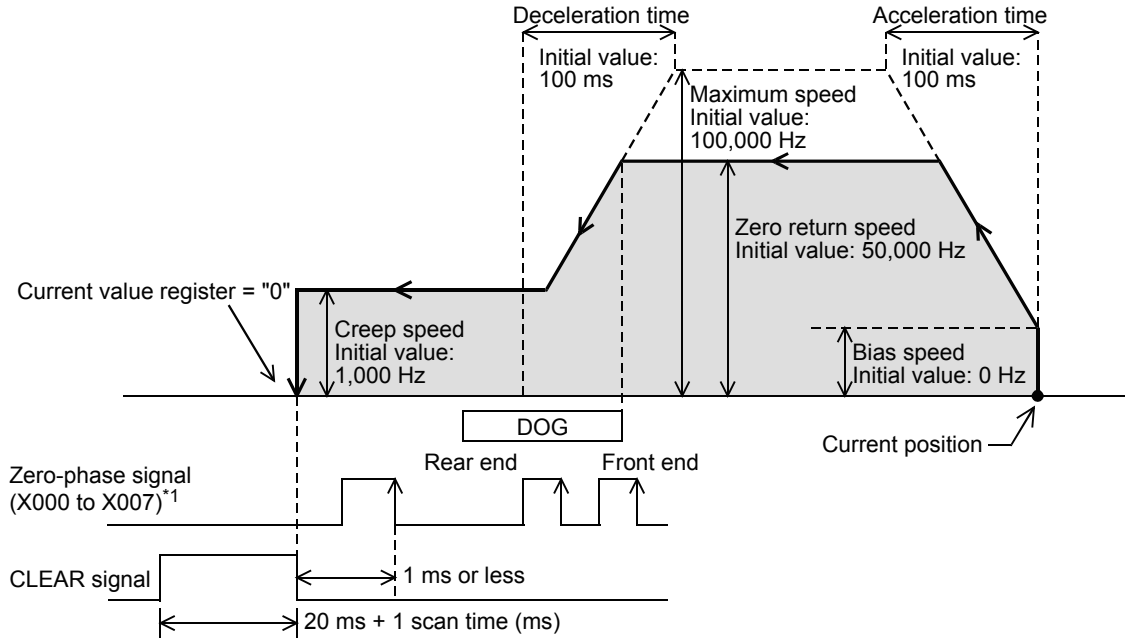

*1. X000 to X005 for FX3s PLC.

4. Zero return (ZRN) instruction

For this instruction, it is necessary to specify the maximum speed, bias speed, acceleration time, and deceleration time using the related devices in addition to the zero return speed and the creep speed specified by the operand of the instruction.

- For operation of ZRN instruction, refer to Section 6.1.
- For details on each setting item, refer to Subsection 4.2.5 to Subsection 4.2.8.

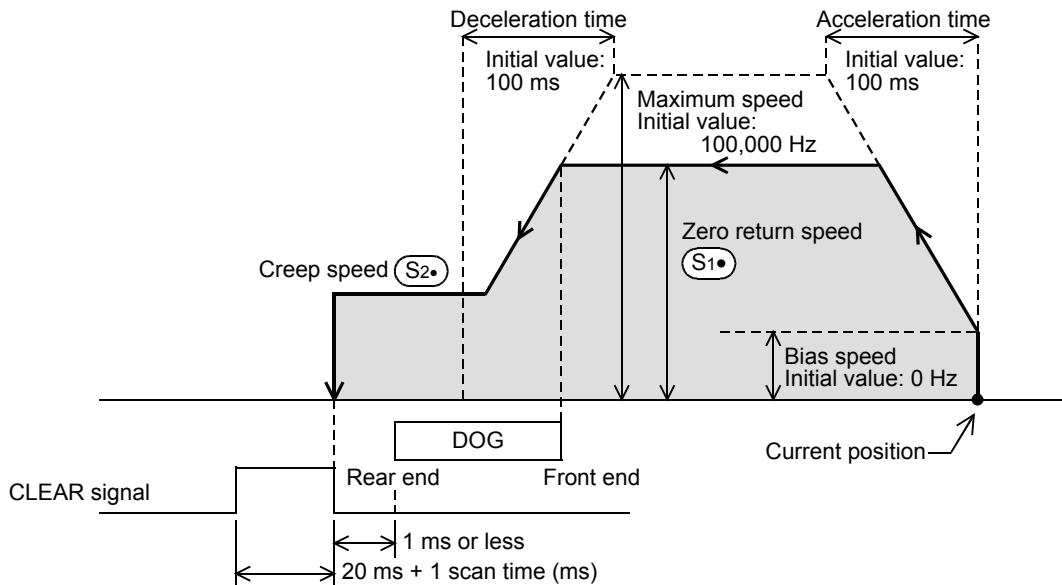

4.2.2 Setting of Output Pulse Frequency (DVIT, PLSV, DRVI, and DRVA Instructions)

Set the output pulse frequency using the operand of each instruction. In this case, the setting range depends on the instruction (see the following table).

However, even in the setting range of each instruction, if the set value of the output pulse frequency is more than the maximum speed value, the operation will be performed at the maximum speed. If the set value of the output pulse frequency is less than the bias speed value, the operation will be performed at the bias speed.

- For operation of DVIT instruction, refer to Chapter 9.
- For operation of PLSV instruction, refer to Chapter 10.
- For operation of DRVI or DRVA instruction, refer to Chapter 8.

Instruction	Operand	Setting range		Instruction format
		16-bit operation (Hz)	32-bit operation (Hz)	
DVIT instruction*3	(S2)	10 to 32767	10 to 200,000*1	
PLSV instruction	(S)	-32768 to -1, +1 to 32767	-200,000*2 to -1, +1 to 200,000*1	
DRVI instruction	(S2)	10 to 32767	10 to 200,000*1	
DRVA instruction	(S2)	10 to 32767	10 to 200,000*1	

*1. If FX3U-2HSY-ADP is not used, note that the frequency value cannot be more than 100,000 Hz.

*2. If FX3U-2HSY-ADP is not used, note that the frequency value cannot be less than -100,000 Hz.

*3. Only available for FX3U/FX3UC PLCs.

Caution:

- To use the main unit (transistor output), set the output pulse frequency (absolute value) to 100,000 Hz or less. If more than 100,000 Hz is output from the transistor output of the main unit to perform operation, it may cause PLC failure.
- Set the output pulse frequency so that the output pulse frequency value is less than the maximum frequency value of the servo amplifier (driver unit).

4.2.3 Setting of Zero Return Speed (DSZR/ZRN Instruction)

Use the related device or the operand of the instruction to set the zero return speed.
 The zero return speed setting range is shown in the following table.

Be sure to set the zero return speed so that the relation with the other speeds can be "bias speed ≤ zero return speed ≤ maximum speed". If the set value of the zero return speed is more than the maximum speed value, operation will be performed at the maximum speed.

- For operation of DSZR instruction, refer to Section 6.2.
- For operation of ZRN instruction, refer to Section 6.3.

Instruction	Operand or related device	Setting range		Instruction format
		16-bit operation (Hz)	32-bit operation (Hz)	
DSZR instruction	(D1) = Y000	D8347, D8346		
	(D1) = Y001	D8357, D8356		
	(D1) = Y002*2	D8367, D8366		
	(D1) = Y003*3	D8377, D8376		
		10 to 200,000*1 Initial value: 50000		
ZRN instruction	(S1)	10 to 32767	10 to 200,000*1	

- *1. If FX3U-2HSY-ADP is not used, note that this value cannot be more than 100,000 Hz.
- *2. Y002 is not available in FX3G PLC (14-point and 24-point type) and FX3s/FX3GC PLC.
- *3. Y003 is available only when two high-speed output special adapters are connected to the FX3U PLC.

Caution:

- When using the transistor outputs of the main unit, set the pulse frequency for the zero return speed to less than 100 kHz.
 If a pulse higher than 100 kHz is output from a transistor output of the main unit to perform an operation, PLC failure may occur.
- Set the zero return speed so that the set value of the zero return speed is less than the maximum frequency value of the servo amplifier (driver unit).

4.2.4 Setting of Creep Speed (DSZR/ZRN Instruction)

Use the related device or the operand of the instruction to set the creep speed.

The creep speed setting range is shown in the following table.

Be sure to set the creep speed so that the relation with the other speeds is "bias speed ≤ creep speed ≤ 32767 Hz^{*1}".

→ For operation of DSZR instruction, refer to Section 6.2.

→ For operation of ZRN instruction, refer to Section 6.3.

Instruction	Operand or related device	Setting range		Instruction format
		16-bit operation (Hz)	32-bit operation (Hz)	
DSZR instruction	(D1•) = Y000	D8345	10 to 32767 Initial value: 1000	
	(D1•) = Y001	D8355		
	(D1•) = Y002 ^{*2}	D8365		
	(D1•) = Y003 ^{*3}	D8375		
ZRN instruction	(S2•)	10 to 32767		

*1. If the maximum speed is set to less than 32767 Hz, note that this value (32767 Hz) will automatically be changed to the maximum speed.

*2. Y002 is not available in FX3G PLC (14-point and 24-point type) and FX3s/FX3GC PLC.

*3. Y003 is available only when two high-speed output special adapters are connected to the FX3U PLC.

4.2.5 Setting of Maximum Speed

Set the maximum speed to determine the upper limit value for the output pulse frequency and the zero return speed.

Use the devices shown in the following table to determine the maximum speed for each pulse output destination device.

Pulse output destination device	Maximum speed	Initial value	Setting range	
			Transistor output of main unit	High-speed output special adapter
Y000	D8344, D8343	100,000Hz	10 to 100,000 Hz: If the value is set to 9 Hz or less, the maximum speed will be automatically set to 10 Hz.	10 to 200,000 Hz: If the value is set to 9 Hz or less, the maximum speed will be automatically set to 10 Hz.
Y001	D8354, D8353			
Y002 ^{*1}	D8364, D8363			
Y003 ^{*2}	D8374, D8373			

*1. Y002 is not available in FX3G PLC (14-point and 24-point type) and FX3s/FX3GC PLC.

*2. Y003 is available only when two high-speed output special adapters are connected to the FX3U PLC.

Caution:

- To use the main unit (transistor output), set the output pulse frequency (absolute value) to 100,000 Hz or less. If more than 100,000 Hz is output from the transistor output of the main unit to perform operation, it may cause PLC failure.
- Set the output pulse frequency so that the output pulse frequency value is less than the maximum frequency value of the servo amplifier (driver unit).

4.2.6 Setting of Bias Speed

To control the stepping motor using each positioning instruction, set the bias speed considering the resonance range of the stepping motor and the self-starting frequency.

Use the devices shown in the following table to determine the bias speed for each pulse output destination device.

Pulse output destination device	Bias speed	Initial value	Setting range
Y000	D8342	0Hz	1/10 or less of maximum speed: If the value is set to more than 1/10 of the maximum speed, the bias speed will be automatically set to 1/10 of the maximum speed.
Y001	D8352		
Y002*1	D8362		
Y003*2	D8372		

*1. Y002 is not available in FX3G PLC (14-point and 24-point type) and FX3s/FX3GC PLC.

*2. Y003 is available only when two high-speed output special adapters are connected to the FX3U PLC.

4.2.7 Setting of Acceleration Time

Set the time required for acceleration from the bias speed to the maximum speed.

If the output pulse frequency is less than the maximum speed, the actual acceleration time will be shorter than the set acceleration time.

If the variable speed pulse output (PLSV) instruction is used, the set acceleration time is only valid during acceleration/deceleration (M8338 = ON)*3.

Use the devices shown in the following table to determine the acceleration time for each pulse output destination device.

Pulse output destination device	Acceleration Time	Initial value	Setting range
Y000	D8348	100ms	50 to 5,000 ms: If the value is set to 49 ms or less, the acceleration time will be automatically set to 50 ms. If the value is set to 5,001 ms or more, the acceleration time will be automatically set to 5,000 ms.
Y001	D8358		
Y002*1	D8368		
Y003*2	D8378		

*1. Y002 is not available in FX3G PLC (14-point and 24-point type) and FX3s/FX3GC PLC.

*2. Y003 is available only when two high-speed output special adapters are connected to the FX3U PLC.

*3. Only available for FX3UC PLC Ver. 2.20 or later and FX3s/FX3G/FX3GC/FX3U PLC.

4.2.8 Setting of Deceleration Time

Set the time required for deceleration from the maximum speed to the bias speed.

If the output pulse frequency is less than the maximum speed, the actual deceleration time will be shorter than the set deceleration time.

If the variable speed pulse output (PLSV) instruction is used, the set deceleration time is only valid during acceleration/deceleration (M8338 = ON)^{*3}.

Use the devices shown in the following table to determine the deceleration time for each pulse output destination device.

Pulse output destination device	Deceleration Time	Initial value	Setting range
Y000	D8349	100ms	50 to 5,000 ms: If the value is set to 49 ms or less, the deceleration time will be automatically set to 50 ms. If the value is set to 5,001 ms or more, the deceleration time will be automatically set to 5,000 ms.
Y001	D8359		
Y002 ^{*1}	D8369		
Y003 ^{*2}	D8379		

*1. Y002 is not available in FX3G PLC (14-point and 24-point type) and FX3S/FX3GC PLC.

*2. Y003 is available only when two high-speed output special adapters are connected to the FX3U PLC.

*3. Only available for FX3UC PLC Ver. 2.20 or later and FX3S/FX3G/FX3GC/FX3U PLC.

4.3 Various Special Relays for Operation Commands

4.3.1 Forward Rotation Limit and Reverse Rotation Limit

When using the servo motor, the forward rotation limit and the reverse rotation limit can be set for the servo amplifier.

To use the DOG search function for zero return, or to set the forward rotation limit or the reverse rotation limit for operations other than zero return using the PLC, set the forward rotation limit 1 (LSF) and reverse rotation limit 1 (LSR) for the PLC so that these limit switches can be activated before the forward rotation limit 2 or reverse rotation limit 2 of the servo amplifier.

As shown in the following figure, interlock the forward rotation limit 1 (LSF) with the forward limit relay, and the reverse rotation limit 1 (LSR) with the reverse limit relay. If the forward limit relay or the reverse limit relay turns ON, the motor will perform operation depending on the output instruction as shown in the following table.

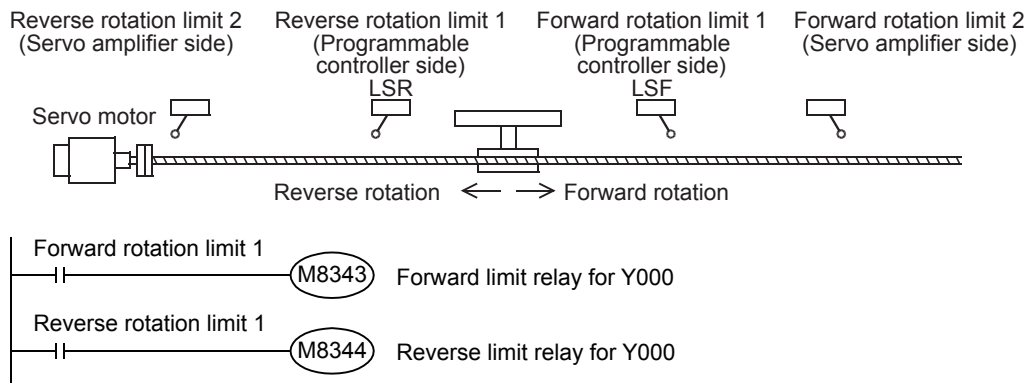

Use the relays shown in the following table to determine the forward rotation limit and the reverse rotation limit for each pulse output destination device (Y000, Y001, Y002, Y003).

Pulse output destination device	Forward limit relay	Reverse limit relay	Corresponding instruction and stop	
			PLSV instruction (M8338 ^{*3} = OFF)	DSZR, DVIT ^{*4} , ZRN, PLSV(M8338 ^{*3} = ON), DRVI, and DRVA instructions
Y000	M8343	M8344	If the corresponding rotation limit relay is turned on, the pulse output (operation) will immediately stop.	If the corresponding rotation limit relay is turned on, the speed will decelerate, and the operation will stop.
Y001	M8353	M8354		
Y002 ^{*1}	M8363	M8364		
Y003 ^{*2}	M8373	M8374		

- *1. Y002 is not available in FX3G PLC (14-point and 24-point type) and FX3S/FX3GC PLC.
- *2. Y003 is available only when two high-speed output special adapters are connected to the FX3U PLC.
- *3. M8338 is supported in the FX3UC PLC Ver. 2.20 or later and FX3S/FX3G/FX3GC/FX3U PLC. If an FX3UC PLC is used and its version is below Ver. 2.20, the PLSV instruction will perform operation in the M8338 = OFF mode (will perform operation without acceleration/deceleration).
- *4. Only available for FX3U and FX3UC PLCs.

Note:

If the forward rotation limit (LSF) and the reverse rotation limit (LSR) cannot be set, observe the following items:

- Even if forward rotation limit 2 or reverse rotation limit 2 turns ON and the servo motor is automatically stopped, the positioning instruction currently being activated cannot recognize the motor being stopped. Therefore, pulses will be continuously output until the instruction is deactivated.
- The DOG search function of the DSZR instruction (zero return instruction with DOG search function) cannot be used.

4.3.2 Immediate Stop of Pulse Output (Pulse Output Stop Command Relay)

During the execution of a positioning instruction, if the pulse output stop command relay is turned on, the pulses being output will immediately stop.

To output pulses again, turn off the pulse output stop command relay, deactivate (turn off) the positioning instruction, and then activate the instruction again (turn it on again).

The following table shows the pulse output stop command relay of each pulse output destination device.

Pulse output destination device	Pulse output stop command relay	Operation
Y000	M8349	During pulse outputting operation, if the pulse output stop command relay of the corresponding pulse output destination device is turned on, the pulse outputting operation will immediately stop.
Y001	M8359	
Y002*1	M8369	
Y003*2	M8379	

*1. Y002 is not available in FX3G PLC (14-point and 24-point type) and FX3s/FX3GC PLC.

*2. Y003 is available only when two high-speed output special adapters are connected to the FX3U PLC.

Note:

Use these relays only if immediate stop is absolutely needed to avoid dangers. Since the motor is immediately stopped, use of these relays may damage the system. For normal STOP operation (decelerate to stop), use the "instruction OFF" function or "forward/reverse limit relay."

However, note that if the PLSV instruction is used together with the "instruction OFF" function or the "forward/reverse limit relay" in the M8338 = OFF mode (operation without acceleration/deceleration), operation will immediately stop.

4.3.3 Designation of Zero Return Direction (DSZR/ZRN Instruction)

Use the DSZR instruction (zero return instruction with DOG search function) or ZRN instruction (zero return instruction) to specify the zero return direction*1. The zero return direction depends on the instruction.

→ For operation of DSZR instruction, refer to Section 6.2.

→ For operation of ZRN instruction, refer to Section 6.3.

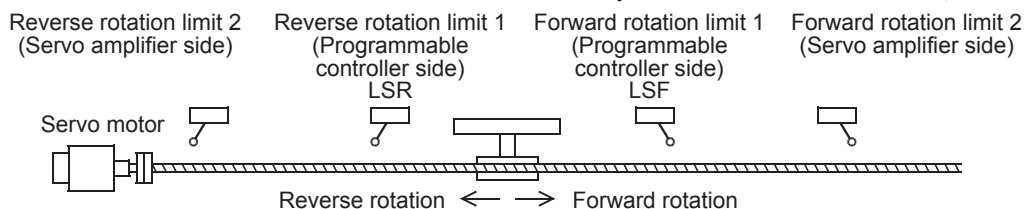

*1. If the DSZR instruction (zero return instruction with DOG search function) is used, zero return will be performed in the direction of the first operation.

1. Zero return instruction with DOG search function (DSZR instruction)

Turn on or off the zero return direction specification relay shown in the following table to specify the zero return direction.

Pulse output destination device	Zero return direction specification relay	Description of setting
Y000	M8342	To perform zero return in the forward rotation direction: Turn on the relay.
Y001	M8352	
Y002*2	M8362	To perform zero return in the reverse rotation direction: Turn off the relay.
Y003*3	M8372	

*2. Y002 is not available in FX3G PLC (14-point and 24-point type) and FX3s/FX3GC PLC.

*3. Y003 is available only when two high-speed output special adapters are connected to the FX3U PLC.

2. Zero return instruction (ZRN instruction)

Zero return will be performed in the reverse rotation direction only.
 (During zero return, the value indicated by the current value register will be decreased.)

To perform zero return in the forward rotation direction using the ZRN instruction (zero return instruction):

To perform zero return in the forward rotation direction, create a program to control the output (Y) relay set as a "rotational direction signal" as follows:

- For details on programming, refer to Section 4.7.
- To use the main unit (transistor output), refer to Section 4.8.
- To use a high-speed output special adapter, refer to Section 4.9.

- a) Turn on Y□□□ (rotational direction signal).
- b) Refresh Y□□□ output using the REF (FNC 50) instruction.
- c) Execute the ZRN instruction (zero return instruction).
- d) Using the execution completion flag (M8029) of the ZRN instruction (zero return instruction), reset Y□□□ (rotational direction signal).

Example program:

The following program uses Y004 as the rotational direction signal for Y000.

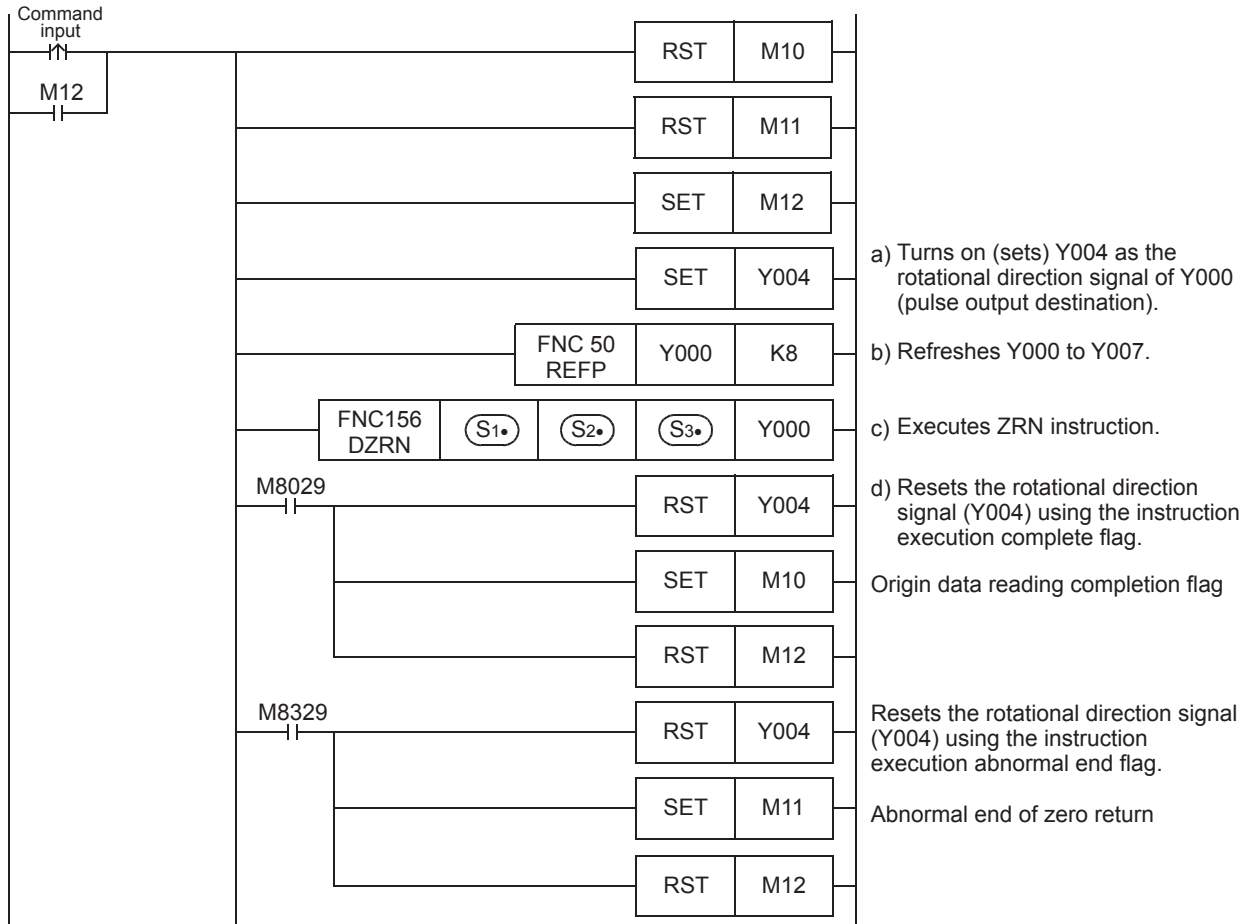

4.3.4 CLEAR Signal Output (DSZR/ZRN Instruction)

The DSZR instruction (zero return instruction with DOG search function) and ZRN instruction (zero return instruction) can stop the workpiece at the origin, and can output the CLEAR signal.

If it is necessary to output the CLEAR signal after zero return, turn on the "CLEAR signal output function enable" relay. The following table shows the "CLEAR signal output function enable" relay of each pulse output destination device (Y000, Y001, Y002 and Y003).

Use an FX3UC PLC Ver. 2.20 or later and FX3S/FX3G/FX3GC/FX3U PLC to specify the CLEAR signal output device.

→ For operation of DSZR instruction, refer to Section 6.2.

→ For operation of ZRN instruction, refer to Section 6.3.

1. If it is not necessary to use the CLEAR signal device specification function, or if an FX3UC PLC below Ver. 2.20 is used:

Pulse output destination device	Status of "CLEAR signal output function enable" relay	Status of "CLEAR signal device specification function enable" relay	CLEAR signal device number
Y000	M8341=ON	M8464=OFF	Y004
Y001	M8351=ON	M8465=OFF	Y005
Y002*1	M8361=ON	M8466=OFF	Y006
Y003*2	M8371=ON	M8467=OFF	Y007

*1. Y002 is not available in FX3G PLC (14-point and 24-point type) and FX3S/FX3GC PLC.

*2. Y003 is available only when two high-speed output special adapters are connected to the FX3U PLC.

2. If it is necessary to use the CLEAR signal device specification function:



Turn on "CLEAR signal device specification function enable" relay to specify the CLEAR signal output device (output Y) for the pulse output destination device using the CLEAR signal device specification register.

Pulse output destination device	Status of "CLEAR signal output function enable" relay	Status of "CLEAR signal device specification function enable" relay	CLEAR signal device number	
			CLEAR signal device specification register	Initial value (CLEAR signal device)
Y000	M8341=ON	M8464=ON	D8464	-
Y001	M8351=ON	M8465=ON	D8465	-
Y002*3	M8361=ON	M8466=ON	D8466	-
Y003*4	M8371=ON	M8467=ON	D8467	-

*3. Y002 is not available in FX3G PLC (14-point and 24-point type) and FX3S/FX3GC PLC.

*4. Y003 is available only when two high-speed output special adapters are connected to the FX3U PLC.

→ For the CLEAR signal device specification method, refer to the next page.

When using a high-speed output special adapter:

The output devices initially set for the CLEAR signal of the DSZR/ZRN instruction are the same output devices as the "direction signal / reverse pulse train (rotation direction signals)" of the high-speed output special adapters. Be sure to specify output numbers of other transistor outputs using the CLEAR signal device specification function.

CLEAR signal device specification method:

- 1) Write the CLEAR signal output (Y) device number in the "CLEAR signal device specification" register with a hexadecimal number (expressed in octal numbers).
 e.g. setting H0010 means Y010. When setting H0008, an operation error occurs because Y008 does not exist.
- 2) Turn on the "CLEAR signal output function enable" relay and "CLEAR signal device specification function enable" relay to specify the CLEAR signal device.
- 3) Execute the DSZR instruction (zero return instruction with DOG search function) or ZRN instruction (zero return instruction).

Example program:

The following figure shows a program that can specify Y010 as the CLEAR signal output device for Y000 (pulse output destination device):

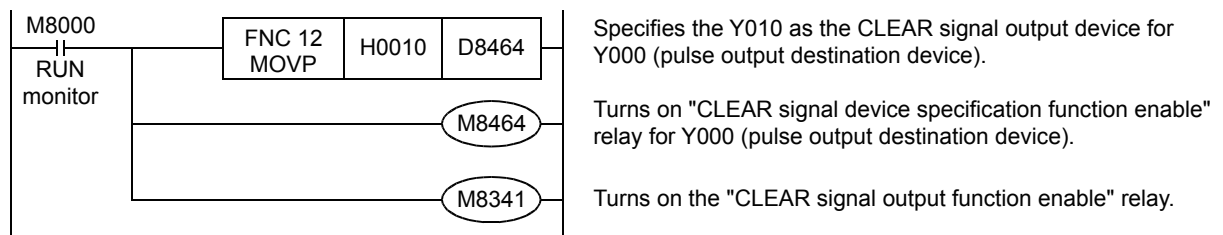

4.3.5 Change in Logic of Near-Point (DOG) Signal (DSZR Instruction)

Turn on or off the "DOG signal logic reverse" relay to specify the logic of the near-point (DOG) signal of the DSZR instruction (zero return instruction with DOG search function). Use the operand ((S1•)) of the instruction to specify the near-point (DOG) signal.

→ For operation of DSZR instruction, refer to Section 6.2.

Pulse output destination device	"DOG signal logic reverse" relay	Description of setting
Y000	M8345	OFF: Positive logic (Turning on the input will turn on the near-point signal.) ON: Negative logic (Turning off the input will turn on the near-point signal.)
Y001	M8355	
Y002*1	M8365	
Y003*2	M8375	

*1. Y002 is not available in FX3G PLC (14-point and 24-point type) and FX3s/FX3GC PLC.

*2. Y003 is available only when two high-speed output special adapters are connected to the FX3U PLC.

4.3.6 Change in Logic of Zero-Phase Signal (DSZR Instruction)

Turn on or off the "Zero-point signal logic reverse" relay to specify the logic of the zero-phase signal of the DSZR instruction (zero return instruction with dog search function). Use the operand ((S2•)) of the instruction to specify the zero-phase signal.

→ For operation of DSZR instruction, refer to Section 6.2.

Pulse output destination device	"Zero-point signal logic reverse" relay	Description of setting
Y000	M8346	OFF: Positive logic (Turning on the input will turn on the zero-phase signal.) ON: Negative logic (Turning off the input will turn on the zero-phase signal.)
Y001	M8356	
Y002*1	M8366	
Y003*2	M8376	

*1. Y002 is not available in FX3G PLC (14-point and 24-point type) and FX3s/FX3GC PLC.

*2. Y003 is available only when two high-speed output special adapters are connected to the FX3U PLC.

4.3.7 Designation of Interrupt Input Signal for DVIT Instruction

The interrupt input signal of the interrupt positioning (DVIT) instruction depends on the pulse output destination device as shown in the following table.

Use an FX3UC PLC Ver. 1.30 or later to use the interrupt input specification function.
 Use an FX3U/FX3UC PLC Ver. 2.20 or later to set the user interrupt input command.

→ For operation of DVIT instruction, refer to Chapter 9.

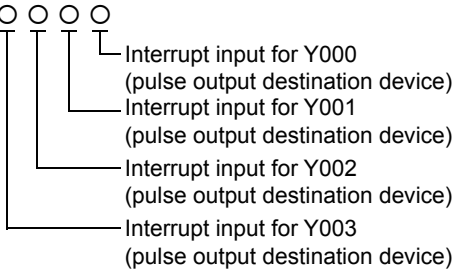
Pulse output destination device	Interrupt input signal	
	If it is not necessary to use the interrupt input specification function (M8336 = OFF), or if an FX3UC PLC below Ver. 1.30 is used	If it is necessary to use the interrupt input specification function (M8336 = ON)
Y000	X000	D8336=H 
Y001	X001	
Y002	X002	
Y003*1	X003	

*1. Y003 is available only when two high-speed output special adapters are connected to the FX3U PLC.

Designation of interrupt input using M8336 interrupt input specification function:

- 1) Turn on M8336.
- 2) Set the interrupt input number (X000 to X007) in D8336, or specify the user interrupt input command*2.
 → For specifying the settings, refer to the following description.

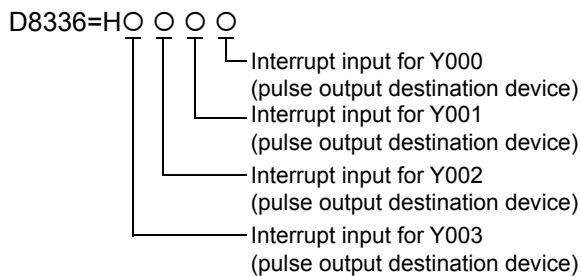

Setting value	Description of setting										
0	Specifies X000 for the interrupt input signal.										
1	Specifies X001 for the interrupt input signal.										
?	?										
7	Specifies X007 for the interrupt input signal.										
8*2	Specifies the user interrupt input command*2 for the interrupt input signal.										
	<table border="1"> <thead> <tr> <th>Pulse output destination device</th> <th>User interrupt input command</th> </tr> </thead> <tbody> <tr> <td>Y000</td> <td>M8460</td> </tr> <tr> <td>Y001</td> <td>M8461</td> </tr> <tr> <td>Y002</td> <td>M8462</td> </tr> <tr> <td>Y003*3</td> <td>M8463</td> </tr> </tbody> </table>	Pulse output destination device	User interrupt input command	Y000	M8460	Y001	M8461	Y002	M8462	Y003*3	M8463
	Pulse output destination device	User interrupt input command									
	Y000	M8460									
	Y001	M8461									
Y002	M8462										
Y003*3	M8463										
9 to E*4	Do not specify these values.										
F	Set "F" for a pulse output destination device if the device is not used for the interrupt positioning (DVIT) instruction.										

- *2. A device can only be specified if an FX3U/FX3UC PLC Ver. 2.20 or later is used. When using an FX3UC PLC below Ver. 2.20, if "8" is set and then the specified interrupt positioning (DVIT) instruction turns ON, an operation error (error code: K6763) will occur, and the instruction will not cause any operation.
- *3. Y003 is available only when two high-speed output special adapters are connected to the FX3U PLC.
- *4. After setting a number in the range of 9 to E for the interrupt input signal, if the corresponding interrupt positioning (DVIT) instruction turns ON, an operation error (error code: K6763) will occur, and the instruction will not cause any operation.

Example program:

The following program specifies the interrupt input signal for each pulse output destination device as shown in the following table.

Pulse output destination device	Interrupt input signal	Setting value
Y000	X003	3
Y001	M8461	8
Y002	Unused	F
Y003 ^{*5}	Unused	F

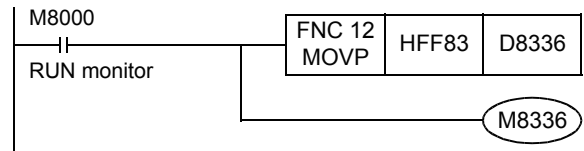

- *5. Y003 is available only when two high-speed output special adapters are connected to the FX3U PLC.

4.3.8 Change in Logic of interrupt input Signal (DVIT Instruction)

Turn the "Interrupt signal logic reverse" relay ON or OFF to specify the logic of the interrupt input signal of the interrupt positioning (DVIT) instruction.

→ For operation of DVIT instruction, refer to Chapter 9.
 → For details on the interrupt input signal designation method, refer to Subsection 4.3.7.

Pulse output destination device	"Interrupt signal logic reverse" relay	Description
Y000	M8347	OFF: Positive logic (Turning the input ON will turn on the interrupt input signal.) ON: Negative logic (Turning the input OFF will turn on the interrupt input signal.)
Y001	M8357	
Y002	M8367	
Y003 ^{*1}	M8377	

- *1. Y003 is available only when two high-speed output special adapters are connected to the FX3U PLC.

Caution:

If a user interrupt input command (M8460 to M8463) is specified in the interrupt input signal, the logic of the user interrupt input command cannot be specified. This is because turning on the user interrupt input command will turn on the interrupt input signal.

4.3.9 Acceleration/Deceleration by PLSV Instruction



Using an FX3UC PLC Ver. 2.20 or later and FX3S/FX3G/FX3GC/FX3U PLC, if acceleration/deceleration operation (M8338) is turned on, the variable speed pulse output (PLSV) instruction will be activated to accelerate/ decelerate the operation.

This means that if the command value of the output pulse frequency is changed, the operation will be accelerated or decelerated to the changed output pulse frequency depending on the specified acceleration/ deceleration time.

→ For operation of PLSV instruction, refer to Chapter 10.

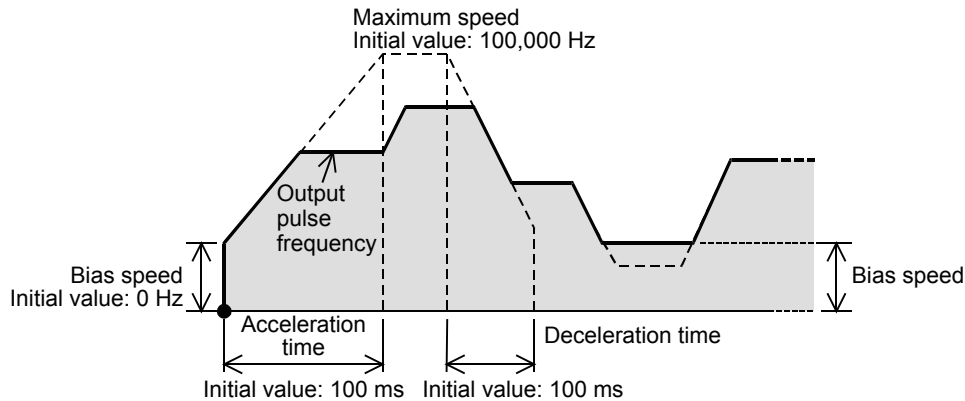

Caution:

- To enable acceleration/deceleration, turn on M8338 first, and then activate the variable speed pulse output (PLSV) instruction.
- If acceleration/deceleration is enabled, the variable speed pulse output (PLSV) instructions of all the pulse output destination devices will accelerate/decelerate with the same time. This means that acceleration/ deceleration cannot be specified separately for each pulse output destination device.

4.4 Current Value and Flag for Monitoring of Operation

4.4.1 Current Value

During positioning operation, use the current value register to check the current value positioning address. The current value will be increased or decreased depending on the rotation direction. The following table shows the current value register (32-bit) of each pulse output destination device.

Pulse output destination device	Current value register (32-bit)
Y000	D8341,D8340
Y001	D8351,D8350
Y002 ^{*1}	D8361,D8360
Y003 ^{*2}	D8371,D8370

*1. Y002 is not available in FX3G PLC (14-point and 24-point type) and FX3s/FX3GC PLC.

*2. Y003 is available only when two high-speed output special adapters are connected to the FX3U PLC.

Caution:

The current value changes between -2,147,483,648 and 2,147,483,647. However, if an overflow or underflow occurs, the value changes as shown below. Check the value carefully.

- If the current value is increased past the maximum value, the minimum value will be indicated.
- If the current value is decreased below the minimum value, the maximum value will be indicated.

Necessity of zero return:

If the specified forward rotation pulse or reverse rotation pulse is output, the current value register will increase or decrease the current value. Upon turning off the power of the PLC, however, the current value stored in the current value register will be erased. For this reason, after turning the power on again, be sure to adjust the current value of the current value register to the current position of the machine. For this adjustment, use the zero return instruction or the Absolute Current Value Read instruction (absolute position detection system) shown below:

→ For details on DSZR instruction, refer to Section 6.2.

→ For details on ZRN instruction, refer to Section 6.3.

→ For details on ABS instruction, refer to Chapter 7.

Instruction	Description
DSZR(FNC150)	Zero return instruction with DOG search function
ZRN(FNC156)	Zero return instruction (without DOG search function)
ABS(FNC155) ^{*3}	Absolute Current Value Read instruction

*3. The absolute position detection function applies for the MR-J4□A, MR-J3□A, MR-J2S□A, MR-J2□A, or MR-H□A servo amplifiers. If one of these servo amplifiers is used and mechanical zero return is performed only once just before turning off the power, the current value will not be erased even after power-off.

After turning on the power again, read out the stored current value using the ABS (FNC155) instruction of the PLC. This means that the current value can be obtained without performing zero return just after turning on the power again.

4.4.2 Completion of Instruction Execution ("Instruction execution complete" Flag, "Instruction execution abnormal end" Flag)

Use the "Instruction execution complete" flag or "Instruction execution abnormal end" flag to check whether execution of the positioning instruction has been completed properly.

The "Instruction execution complete" flag and "Instruction execution abnormal end" flag are turned on or off after each instruction. Use these flags just after the execution of each instruction.

→ For programming details, refer to Subsection 4.7.4.

- "Instruction execution complete" flag (M8029): Will be turned on if the instruction is executed properly.*1
- "Instruction execution abnormal end" flag (M8329): Will be turned on if the instruction is not executed properly.

*1. Will not be turned on for execution of the PLSV instruction.

Caution:

If the "Instruction execution complete" flag or "Instruction execution abnormal end" flag is turned on, then the execution of the instruction (pulse outputting operation, etc.) is complete. However, it is not certain whether the servo motor has stopped or not. Check the "positioning completion" signal of the servo amplifier (drive unit) to determine whether the servo motor has stopped.

4.4.3 "Pulse Output Monitor" (BUSY/READY) Flag

Use the "pulse output monitor" (BUSY/READY) flag to check whether pulses are being output to the pulse output destination device. The following table shows the "pulse output monitor" (BUSY/READY) flag of each pulse output destination device.

Pulse output destination device	"Pulse output monitor" (BUSY/READY) flag	Status of flag and pulse
Y000	M8340	Outputting pulse (BUSY): Flag = ON Pulse outputting stopped (READY): Flag = OFF
Y001	M8350	
Y002*1	M8360	
Y003*2	M8370	

*1. Y002 is not available in FX3G PLC (14-point and 24-point type) and FX3s/FX3GC PLC.

*2. Y003 is available only when two high-speed output special adapters are connected to the FX3U PLC.

4.4.4 "Positioning Instruction Activation" Flag

Use the "positioning instruction activation" flag of each pulse output destination device to check whether or not a positioning instruction is being executed for the pulse output destination device. Use this flag to prevent simultaneous activation of two or more positioning instructions for the same pulse output destination device.

Pulse output destination device	"Positioning instruction Activation" flag	Status of flag and pulse
Y000	M8348	ON: The positioning instruction is being activated for the corresponding pulse output destination. (Even after instruction execution is completed, if the instruction is still being activated, the flag will not be turned off.)
Y001	M8358	
Y002*1	M8368	
Y003*2	M8378	OFF: The positioning instruction is not being activated for the corresponding pulse output destination.

*1. Y002 is not available in FX3G PLC (14-point and 24-point type) and FX3s/FX3GC PLC.

*2. Y003 is available only when two high-speed output special adapters are connected to the FX3U PLC.

4.5 Setting of Various Items on PLC Side

4.5.1 Setting of Common Items Using Program

For each pulse output destination device (Y000, Y001, Y002^{*1}, Y003^{*2}), set the items shown in the following table without using the operand of the instruction.

Setting item	Setting device				Instruction								Refer to
	Y000	Y001	Y002 ^{*1}	Y003 ^{*2}	DSZR	ZRN	ABS	TBL ^{*3}	PLSV	DVIT ^{*4}	DRVI	DRVA	
Items related to speed													
Maximum speed ^{*5}	D8344, D8343	D8354, D8353	D8364, D8363	D8374, D8373	✓	✓	-	✓ ^{*6}	✓	✓	✓	✓	Subsection 4.2.5
Bias speed	D8342	D8352	D8362	D8372	✓	✓	-	✓ ^{*6}	✓	✓	✓	✓	Subsection 4.2.6
Acceleration time ^{*7}	D8348	D8358	D8368	D8378	✓	✓	-	✓ ^{*6}	✓	✓	✓	✓	Subsection 4.2.7
Deceleration time ^{*7}	D8349	D8359	D8369	D8379	✓	✓	-	✓ ^{*6}	✓	✓	✓	✓	Subsection 4.2.8
Zero return speed ^{*5}	D8347, D8346	D8357, D8356	D8367, D8366	D8377, D8376	✓	-	-	-	-	-	-	-	Subsection 4.2.3
Creep speed	D8345	D8355	D8365	D8375	✓	-	-	-	-	-	-	-	Subsection 4.2.4
Items needed for (DSZR) zero return instruction with DOG search function and (ZRN) zero return instruction)													
Zero return direction	M8342	M8352	M8362	M8372	✓	- ^{*8}	-	-	-	-	-	-	Subsection 4.3.3
CLEAR signal output	M8341	M8351	M8361	M8371	✓	✓	-	-	-	-	-	-	Subsection 4.3.4
CLEAR signal device change ^{*9}	M8464 D8464	M8465 D8465	M8466 D8466	M8467 D8467	✓	✓	-	-	-	-	-	-	Subsection 4.3.4
Logic of near-point signal	M8345	M8355	M8365	M8375	✓	-	-	-	-	-	-	-	Subsection 4.3.5
Logic of zero-phase signal	M8346	M8356	M8366	M8376	✓	-	-	-	-	-	-	-	Subsection 4.3.6
Items needed for variable speed pulse output (PLSV) instruction													
Acceleration/ deceleration Operation ^{*7}	M8338				-	-	-	-	✓	-	-	-	Subsection 4.3.9
Items needed for interrupt positioning (DVIT) instruction^{*4}													
Interrupt input signal device change ^{*10}	M8336 D8336				-	-	-	✓ ^{*6}	-	✓	-	-	Subsection 4.3.7

Setting item	Setting device				Instruction								Refer to
	Y000	Y001	Y002*1	Y003*2	DSZR	ZRN	ABS	TBL*3	PLSV	DVIT*4	DRVI	DRVA	
User interrupt input command*10	M8460	M8461	M8462	M8463	-	-	-	✓*6	-	✓	-	-	Subsection 4.3.7
Logic of interrupt input signal	M8347	M8357	M8367	M8377	-	-	-	✓	-	✓	-	-	Subsection 4.3.8
Forward limit, reverse limit, and immediate stop of pulse output													
Forward limit	M8343	M8353	M8363	M8373	✓	✓	-	✓	✓	✓	✓	✓	Subsection 4.3.1
Reverse limit	M8344	M8354	M8364	M8374	✓	✓	-	✓	✓	✓	✓	✓	Subsection 4.3.1
Immediate stop of pulse output*11	M8349	M8359	M8369	M8379	✓	✓	-	✓	✓	✓	✓	✓	Subsection 4.3.2

- *1. Y002 is not available in FX3G PLC (14-point and 24-point type) and FX3S/FX3GC PLC.
- *2. Y003 is available only when two high-speed output special adapters are connected to the FX3U PLC.
- *3. This instruction is not supported in the FX3S PLC.
- *4. Only available for FX3U and FX3UC PLCs.
- *5. 32 bits are used for the maximum speed setting device and the zero return speed setting device.
- *6. Set this item by selecting "PLC Parameter" → "Positioning Instruction Settings" of GX Works2 in the FX3UC PLC Ver. 2.20 or later or FX3G/FX3GC/FX3U PLC.
The data set by the parameter will be stored in the corresponding setting device.
- *7. To accelerate or decelerate the operation using the variable speed pulse output (PLSV) instruction with an FX3UC PLC Ver. 2.20 or later and FX3S/FX3G/FX3GC/FX3U PLC, it is necessary to set this item. If the operation is not accelerated or decelerated, or if an FX3UC PLC below Ver. 2.20 is used, the PLSV instruction will not use this item even if it is set.
- *8. The ZRN instruction will not use any zero return direction setting devices. Using the program, adjust the rotation direction output to the zero return direction.
- *9. This item can be set using an FX3UC PLC Ver. 2.20 or later and FX3S/FX3G/FX3GC/FX3U PLC.
- *10. Only available for FX3UC PLC Ver. 1.30 or later and FX3U PLC.
However, the user interrupt input command can be specified only if the FX3U/FX3UC PLC Ver. 2.20 or later is used.
- *11. Use this function only if immediate stop is absolutely needed to avoid danger.

Example program:

In the following program, the zero return instruction with DOG search function (DSZR), variable speed pulse output (PLSV) instruction, and interrupt positioning (DVIT) instruction are used for the pulse output destination (Y000) under the conditions shown in the following table.

1) Set conditions

Setting item	Description of setting	Related device	Setting value or condition
Items related to speed			
Maximum speed	30000Hz	D8344, D8343 (32-bit)	K30000
Bias speed	10Hz	D8342	K10
Acceleration time	200ms	D8348	K200
Deceleration time	200ms	D8349	K200
Zero return speed	5000Hz	D8347, D8346 (32-bit)	K5000
Creep speed	500Hz	D8345	K500
Items needed for DSZR instruction (zero return instruction with DOG search function)			
Zero return direction	Reverse rotation direction	M8342	OFF
CLEAR signal output	Output to Y010	M8341	ON
CLEAR signal device change		M8464	ON
		D8464	H0010
Logic of near-point signal	Sets the positive logic (turning on the input will turn on the near-point signal).	M8345	OFF
Logic of zero-phase signal	Sets the positive logic (turning on the input will turn on the zero-phase signal).	M8346	OFF
Items needed for variable speed pulse output (PLSV) instruction			
Acceleration/deceleration Operation	If X012 is turned on, the variable speed pulse output (PLSV) instruction will be activated to accelerate or decelerate the operation.	M8338	ON: If X012 = ON
Items needed for interrupt positioning (DVIT) instruction^{*1}			
Interrupt input signal device change	Sets X007 for interrupt inputs. Interrupt positioning (DVIT) instruction will not be used for the pulse output destinations Y001, Y002, and Y003.	M8336	ON
		D8336	HFFF7
User interrupt input command	Do not use.	M8460	-
Logic of interrupt input signal	Sets the negative logic (turning off the input will turn on the interruption signal).	M8347	ON
Forward limit, reverse limit, and immediate stop of pulse output			
Forward limit	If X010 is turned off (if the NC contact is turned on), the limit switch will be activated.	M8343	ON: If X010 = OFF
Reverse limit	If X011 is turned off (if the NC contact is turned on), the limit switch will be activated.	M8344	ON: If X011 = OFF
Immediate stop of pulse output	Do not use.	M8349	-

*1. Only available for FX3U and FX3UC PLCs.

2) Set program

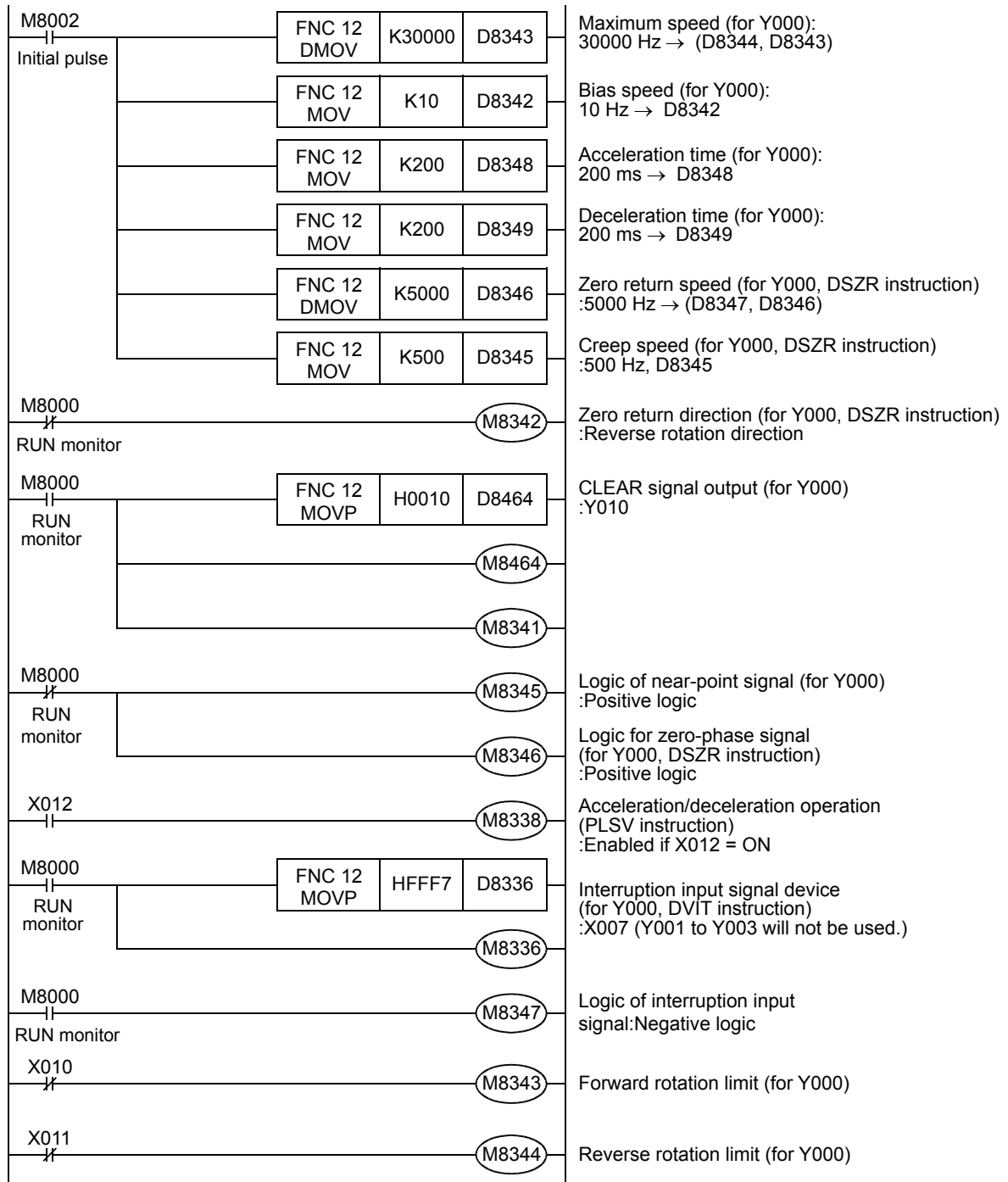

4.5.2 Setting of High-Speed Output Special Adapter

If a high-speed output special adapter (FX3U-2HSY-ADP) is used, the pulse output method can be selected from "pulse train + direction" method and "forward/reverse rotation pulse train" method.

1. Setting of pulse output method

Using the pulse output method setting switch on the high-speed output special adapter (FX3U-2HSY-ADP), set the pulse output method as shown in the following table.

The pulse output method setting should conform to the command pulse input method setting for the servo amplifier (drive unit).

→ For details on the servo amplifier (drive unit), refer to the manual of the product used in your system.

Position of pulse output method setting switch	Pulse output method		Logic of command pulse
FP-RP side	Forward rotation pulse train (FP) Reverse rotation pulse train (RP)		Negative logic
PLS-DIR side	Pulse train + direction		Negative logic

*1. "ON" and "OFF" represent the statuses of the PLC output. "H" and "L" respectively represent the HIGH status and the LOW status of the waveform.

→ For details on the relation between the PLC output and the waveform, refer to Subsection 4.6.1.

Caution:

Use the Output Form Setting Switch while the PLC is in STOP or while the power is OFF. Do not operate the Output Form Setting Switch while a pulse train is being generated.

2. Setting of rotation direction signal for positioning instruction

If a high-speed output special adapter (FX3U-2HSY-ADP) is used, the rotation direction signal will be assigned to each pulse output destination device as shown in the following table. Set the rotation direction signal of the positioning instruction as shown in the following table:

Position of pulse output method setting switch of high-speed output special adapter	Signal	Name of positioning instruction	Output number			
			1st adapter		2nd adapter	
			1st axis	2nd axis	3rd axis	4th axis
FP-RP side	Forward rotation pulse train (FP)	Pulse output destination:	Y000	Y001	Y002	Y003
	Reverse rotation pulse train (RP)	Rotation direction signal	Y004	Y005	Y006	Y007
PLS-DIR side	Pulse train	Pulse output destination:	Y000	Y001	Y002	Y003
	Direction	Rotation direction signal	Y004	Y005	Y006	Y007

3. CLEAR signal and rotation direction signal

If a high-speed output special adapter (FX3U-2HSY-ADP) is used, the same output will be used for both the CLEAR signal and the rotation direction signal of the DSZR (FNC150) or ZRN (FNC156) instruction. For this reason, it is necessary to change the CLEAR signal output device in order to output the CLEAR signal.

→ For details on the CLEAR signal device change method, refer to Subsection 4.3.4.

Pulse output destination device	CLEAR signal device initially set	Rotation direction signal (reverse rotation pulse train / direction)			
		1st adapter		2nd adapter	
		1st axis	2nd axis	3rd axis	4th axis
Y000	Y004	Y004	-	-	-
Y001	Y005	-	Y005	-	-
Y002	Y006	-	-	Y006	-
Y003	Y007	-	-	-	Y007

4.6 Setting of Various Items on Servo Amplifier (Drive Unit) Side

→ For details on the servo amplifier (drive unit), refer to the manual of the product used in your system.

4.6.1 Setting the Command Pulse Method

1. Pulse output method on PLC side

1) Main unit (transistor output (sink output))

If the main unit (transistor output (sink output)) is used, the pulse output signals (pulse output destination and rotation direction) will be as shown in the following figure:

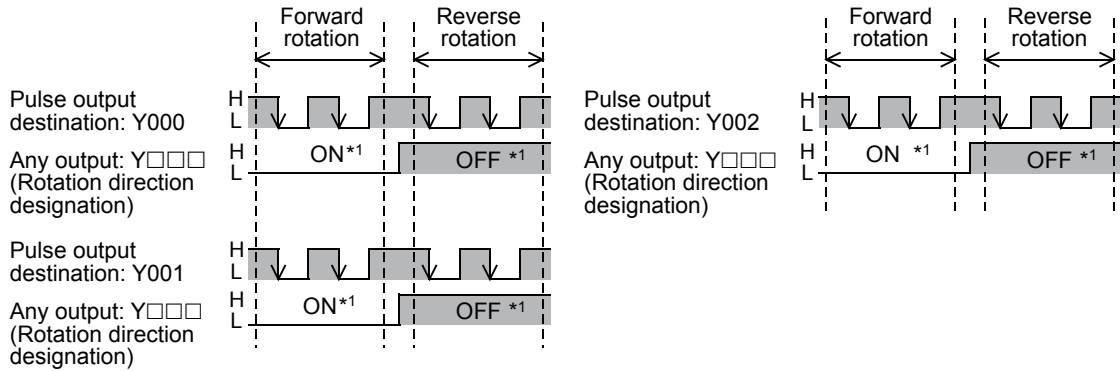

*1. "ON" and "OFF" represent the statuses of the PLC output. "H" and "L" respectively represent the HIGH and LOW status of the waveform.

→ For details on the relationship between the PLC output and the waveform, refer to the following pages.

2) High-speed output special adapter (Pulse train + Direction Setting)

When setting the Output Form Setting Switch of the high speed output special adapter to the "PLS·DIR" position, the pulse output signals (pulse output destination signal and rotation direction signal) will be as shown in the following figure:

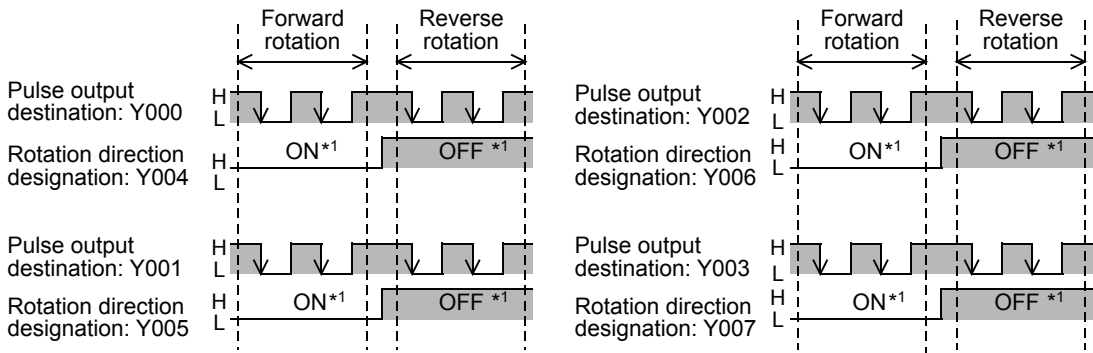

*1. "ON" and "OFF" represent the statuses of the PLC output. "H" and "L" respectively represent the HIGH status and the LOW status of the waveform.

→ For details on the relationship between the high-speed output special adapter output and the waveform, refer to the following pages.

- 3) High-speed output special adapter (Forward/Reverse Pulse Train setting)
 When setting the Output Form Setting Switch of the high speed output special adapter to the "FP·RP" position, the pulse output signals will be as shown in the following figure.

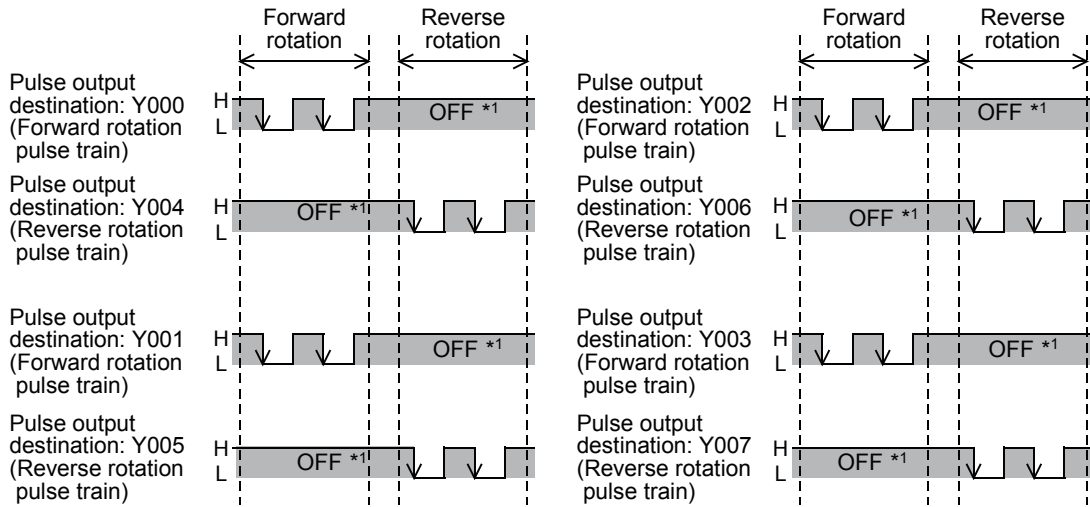

- *1. "ON" and "OFF" represent the statuses of the PLC output. "H" and "L" respectively represent the HIGH status and the LOW status of the waveform.

→ For details on the relationship between high-speed output special adapter output and the waveform, refer to the following pages.

Reference: Image of PLC output and waveform (for MELSERVO-J3 Series servo amplifier)

1) Base unit (transistor output (sink output))

a) Connection of PLC to servo amplifier

When a FX3U Series PLC (sink output) is used, it is connected as shown below.

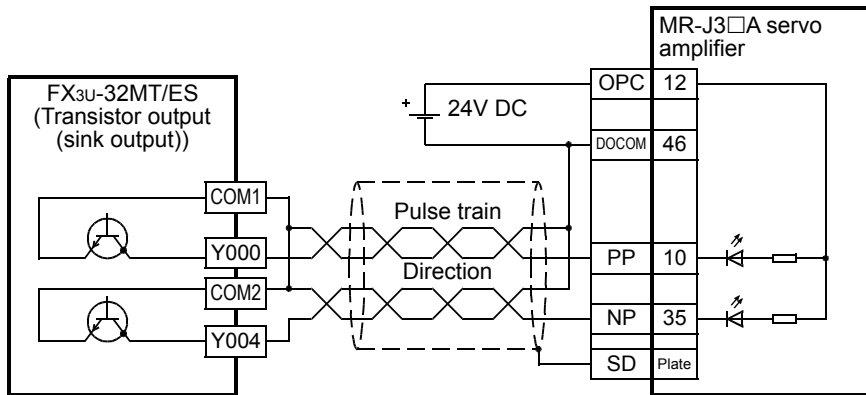

b) Image of PLC output and output waveform

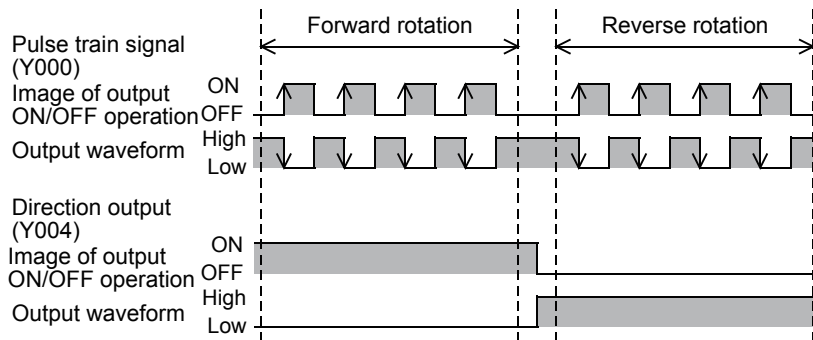

2) High-speed output special adapter (set to "pulse train + direction")

a) Connection of PLC to servo amplifier

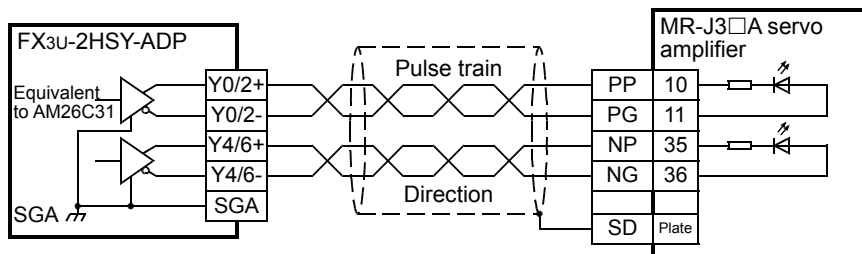

b) Image of PLC output and output waveform

The output waveform shown below is based on the SGA terminal of the high-speed output special adapter. If the SGB side of the high-speed output special adapter is used, the output waveform will be that of the SGB terminal.

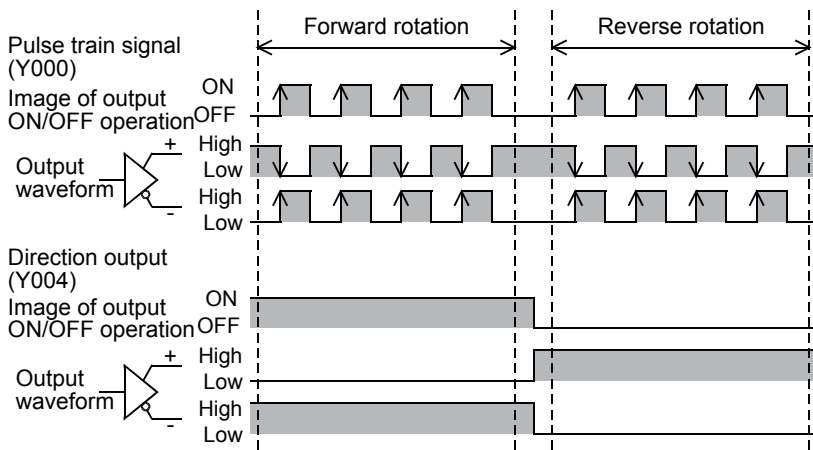

3) High-speed output special adapter (set to "forward/reverse rotation pulse train")

a) Connection of PLC to servo amplifier

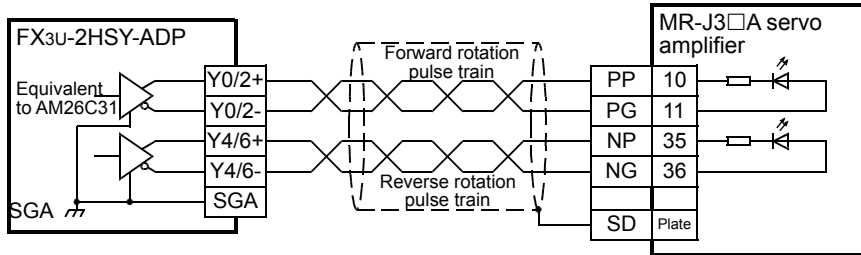

b) Image of PLC output and output waveform

The output waveform shown below is based on the SGA terminal of the high-speed output special adapter. If the SGB side of the high-speed output special adapter is used, the output waveform will be that of the SGB terminal.

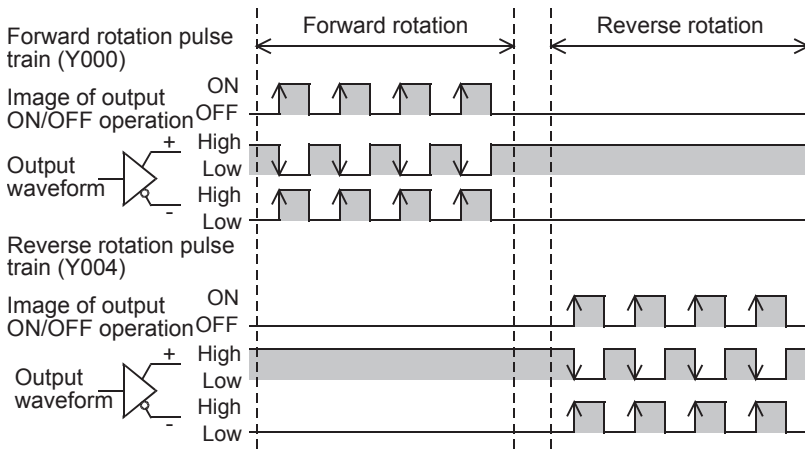

2. Setting of command pulse input method for servo amplifier (drive unit)

Set the following servo amplifier (drive unit) parameter so that the pulse train input method of the servo amplifier (drive unit) matches the pulse output method of the PLC as shown in the following tables.

Servo amplifier (drive unit)	Pulse output from main unit	Pulse output from high-speed output special adapter	
	Transistor output (sink output)	Differential line driver	
	Pulse train + direction	Pulse train + direction	Forward rotation pulse train, reverse rotation pulse train
Command pulse input method	"Pulse train + sign"	"Pulse train + sign"	Forward rotation pulse train, Reverse rotation pulse train
Logic of command pulse	"Negative logic"	"Negative logic"	"Negative logic"

Parameter setting for each series of MELSERVO servo amplifier:

Series	Parameter No.	Set value	
		Pulse train + direction Negative logic	Forward/reverse rotation pulse train Negative logic
MR-J4□A	13	0211	0210
MR-J3□A	13	0011	0010
MR-JN□A	13	□11*1	□10*1
MR-J2□A, MR-J2S□A	21	0011	0010
MR-H□A	21	011□*1	010□*1
MR-C□A	7	011	010
MR-J□A	7	□□□1*1	□□□0*1

*1. □ is for settings other than the command pulse output form.

→ For details, refer to the Servo amplifier manual.

4.6.2 Setting of Electronic Gear (For MELSERVO Series)

Use the electronic gear of the servo motor to set the transfer distance per pulse.
 For details on the electronic gear setting, refer to the manual of the servo motor or servo amplifier, and set an optimum value depending on the application.

Setting example 1:

To set the transfer distance per pulse to 10 μm (if the machine uses a ball screw):

Machine specifications

Servo amplifier	MR-C Series
Rated rotational speed of servo motor	3000r/min
Lead of ball screw (Pb)	10mm (0.4")/rev
Reduction ratio (mechanical gear) (n)	1/2
Resolution of servo motor (Pt)	4000PLS/REV

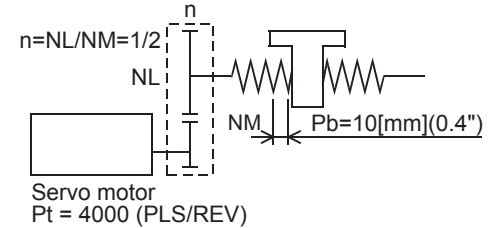

$$\frac{CMX}{CDV} = \Delta l_0 \times \frac{Pt}{n \times Pb} = 10 \times 10^{-3} \times \frac{4000}{1/2 \times 10} = \frac{8}{1}$$

Set the electronic gear as follows:

CMX = 8, CDV = 1

In this case, when the main unit outputs the maximum output pulse frequency (100 kHz), the servo motor rotational speed will be as follows:

$$N_0 = \frac{CMX}{CDV} \times \frac{60}{Pt} \times f_0$$

$$= \frac{8}{1} \times \frac{60}{4000} \times 100000$$

= 12000r/min > 3000r/min (Rated rotational speed of servo motor)

f₀ : Command pulse frequency [Hz]

CMX: Electronic gear

(numerator of command pulse multiplying factor)

CDV: Electronic gear

(denominator of command pulse multiplying factor)

N₀ : Servo motor rotational speed [r/min]

Δl₀ : Transfer distance per pulse [mm]

It is necessary to reduce the pulse frequency on the PLC side in order to reduce the servo motor rotational speed so that it is less than the rated rotational speed.

Pulse output destination device	Maximum speed setting device
Y000	D8344,D8343
Y001	D8354,D8353
Y002*1	D8364,D8363
Y003*2	D8374,D8373

*1. Y002 is not available in FX3G PLC (14-point and 24-point type) and FX3s/FX3GC PLC.

*2. Y003 is available only when two high-speed output special adapters are connected to the FX3U PLC.

Setting example 2:

To set the transfer distance per pulse to 0.01° (if a turntable is used):

Machine specifications

Servo amplifier	MR-J2S Series
Rated rotational speed of servo motor	3000r/min
Turntable	360°/REV
Reduction ratio (mechanical gear) (n) (Timing belt)	8/64
Resolution of servo motor (Pt)	131072PLS/REV

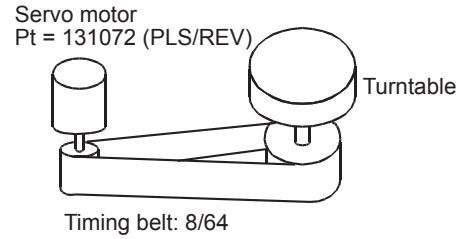

$$\frac{CMX}{CDV} = \Delta l_0 \times \frac{Pt}{n \times 360} = 1 \times 10^{-2} \times \frac{131072}{8/64 \times 360} = \frac{32768}{1125}$$

Set the electronic gear as follows:

$$CMX = 32768, CDV = 1125$$

In this case, when the main unit outputs the maximum output pulse frequency (100 kHz), the servo motor rotational speed will be as follows:

$$\begin{aligned} N_0 &= \frac{CMX}{CDV} \times \frac{60}{Pt} \times f_0 \\ &= \frac{32768}{1125} \times \frac{60}{131072} \times 100000 \\ &\approx 1333.33 \dots \text{r/min} < 3000\text{r/min (Rated rotational speed)} \end{aligned}$$

- f₀ : Command pulse frequency [Hz]
- CMX: Electronic gear
(numerator of command pulse multiplying factor)
- CDV : Electronic gear
(denominator of command pulse multiplying factor)
- N₀ : Servo motor rotational speed [r/min]
- Δl₀ : Transfer distance per pulse [°]

It is not necessary to restrict the maximum speed on the PLC side because the servo motor rotational speed is less than the rated rotational speed.

4.6.3 Setting of "Servo Ready" Signal (MELSERVO MR-C Series)

If the following parameter is set as shown in the following table for the MELSERVO MR-C Series, pin 3 of the CN1 connector of the servo amplifier will be changed to "servo ready" (RD). Note that the following parameter should be set for the example programs shown in Chapter 12.

Series	Parameter No.	Setting value
MR-C	21	020

4.7 Items To Be Observed in Programming

This section describes various programming items that will not be affected by any pulse output destination devices (hardware).

For information on the pulse output destination devices (hardware) that are affected by programming items, refer to the following sections.

- For use of the transistor output of the main unit, refer to Section 4.8.
- For use of the high-speed output special adapter, refer to Section 4.9.

4.7.1 Positioning Instruction Activation Timing

The following positioning instructions can be programmed as many times as needed. However, observe the items shown in the following table to determine the instruction activation timing.

→ For details on the each instructions, refer to Chapter 6 to 11.

	Description	Instruction to be used								
		DSZR	DVIT	TBL	ABS	ZRN	PLSV	DRVI	DRVA	
Instruction to be used	DSZR(FNC150)	Zero return instruction with DOG search function	✓	✓	✓	△	✓	✓	✓	✓
	DVIT(FNC151)	Interrupt Positioning (interruption fixed-feed)	✓	✓	✓	△	✓	✓	✓	✓
	TBL(FNC152)	Positioning by batch setting method	✓	✓	✓	△	✓	✓	✓	✓
	ABS(FNC155)	Current ABS value read-out from servo amplifier	△	△	△	△	△	△	△	△
	ZRN(FNC156)	Zero return (without DOG search function)	✓	✓	✓	△	✓	✓	✓	✓
	PLSV(FNC157)	Variable speed Pulse Output	✓	✓	✓	△	✓	✓	✓	✓
	DRVI(FNC158)	Drive to Increment	✓	✓	✓	△	✓	✓	✓	✓
	DRVA(FNC159)	Drive to Absolute	✓	✓	✓	△	✓	✓	✓	✓

✓: If the pulse output destination device is now outputting pulses, the instruction cannot be activated. Refer to the "Note" below.

△: For the absolute position detection system, activate the ABS (FNC155) instruction after turning the power ON for the servo amplifier. After executing this instruction, the current value will be read out from the servo amplifier only once.

Turning this instruction OFF will turn the servo amplifier OFF.

Caution:

If the "pulse output monitor" (BUSY/READY) flag is on, and if a positioning instruction (excluding the ABS instruction) or pulse output instruction (PLSR, PLSY) specifies the same pulse output destination device as the one being used, the instruction cannot be executed.

Even after turning the instruction activation contact OFF, if the "pulse output monitor" (BUSY/READY) flag is still on, do not execute a positioning instruction (including the PLSR and PLSY instructions) for an output with the same output number.

Before activating such an instruction, check that the "pulse output monitor" (BUSY/READY) flag is off, and then wait until 1 cycle or more of operation has been completed.

→ For examples of programs, refer to Chapter 12.

Pulse output destination device	"Pulse output monitor" flag
Y000	M8340
Y001	M8350
Y002*1	M8360
Y003*2	M8370

*1. Y002 is not available in FX3G PLC (14-point and 24-point type) and FX3S/FX3GC PLC.

*2. Y003 is available only when two high-speed output special adapters are connected to the FX3U PLC.

Use with PLSY (FNC 57) and PLSR (FNC 59) instructions:

Along with the positioning instructions (FNC150 - FNC159), the pulse output instructions (FNC 57 and FNC 59) require hardware for outputting pulses.

- Do not use the same output number for both a positioning instruction (FNC150 - FNC159) and a pulse output instruction (FNC 57 or FNC 59).
- The use of a positioning instruction together with a PLSY or PLSR instruction will complicate the operation of the register that controls the number of output pulses (see the following table). For this reason, it is recommended that a positioning instruction should be used in place of the PLSY or PLSR instruction.

→ For details on the related devices, refer to Section 4.1 to Section 4.4.

Pulse output destination device	Current value register	
	For FNC150 - FNC159 instructions	For FNC 57 and FNC 59 instructions
Y000	D8341,D8340	D8141,D8140
Y001	D8351,D8350	D8143,D8142
Y002*1	D8361,D8360	-
Y003*2	D8371,D8370	-

- *1. Y002 is not available in FX3G PLC (14-point and 24-point type) and FX3S/FX3GC PLC.
- *2. Y003 is available only when two high-speed output special adapters are connected to the FX3U PLC.
- If it is necessary to use a positioning instruction (FNC150 to FNC159) together with a pulse output instruction (FNC 57 or FNC 59), use the following positioning instruction in place of the pulse output instruction:
 - FNC 57(PLSY), FNC 59(PLSR)→FNC158(DRVI)

4.7.2 STOP instruction

For the normal stop of an operation (stop after speed reduction), use the "instruction OFF" function or "forward/reverse limit relay".

If an immediate stop is absolutely needed to avoid danger, use the pulse output stop command relay. During execution of a positioning instruction, however, if the pulse output stop command relay is turned on, the pulse outputting operation will be immediately stopped. This means that the motor will be stopped without deceleration, which may damage the system. For this reason, take caution when using the pulse output stop command relay.

Pulse output destination device	Pulse stop instruction	Operation
Y000	M8349	During pulse outputting operation, if the pulse output stop command relay of the corresponding pulse output destination device is turned on, the pulse outputting operation will immediately stop.
Y001	M8359	
Y002 ^{*1}	M8369	
Y003 ^{*2}	M8379	

*1. Y002 is not available in FX3G PLC (14-point and 24-point type) and FX3s/FX3GC PLC.

*2. Y003 is available only when two high-speed output special adapters are connected to the FX3U PLC.

4.7.3 Correction of Backlash

The built-in positioning function cannot correct the mechanical backlash (clearance/play). If it is necessary to correct the backlash, preliminarily set the number of output pulses considering the backlash that may be caused when reversing the transfer direction.

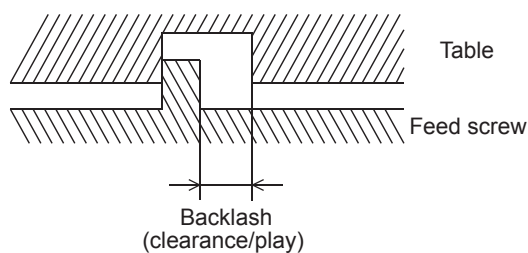

4.7.4 "Instruction execution complete" Flag of Positioning Instruction and Completion of Positioning

If the Instruction execution complete flag (M8029) or the Instruction execution abnormal end flag (M8329) is turned on, the execution of the instruction (pulse outputting operation, etc.) is completed. In this case, however, it is not certain whether the servo motor has stopped. Check the "positioning completion" signal of the servo amplifier (drive unit) to check whether the servo motor is stopped.

→ For details on the "Instruction execution complete" flag and "Instruction execution abnormal end" flag, refer to Subsection 4.4.2.

A
Common Items

B
Built-in Positioning Functions

Apx.
Example Connection

Programming using the "Instruction execution complete" flag and "Instruction execution abnormal end" flag:

- 1) If two or more positioning instructions are used in a program, the "Instruction execution complete" flag (M8029) or "Instruction execution abnormal end" flag (M8329) will be turned on or off after execution of each instruction. However, if the "Instruction execution complete" flag (M8029) and "Instruction execution abnormal end" flag are used together for a program, it is difficult to determine which instruction turns them ON/OFF and the "Instruction execution complete" flag will not be turned on for the intended instruction.
 → **To use a positioning instruction at a position other than just below the instruction, refer to the example shown on the next page.**

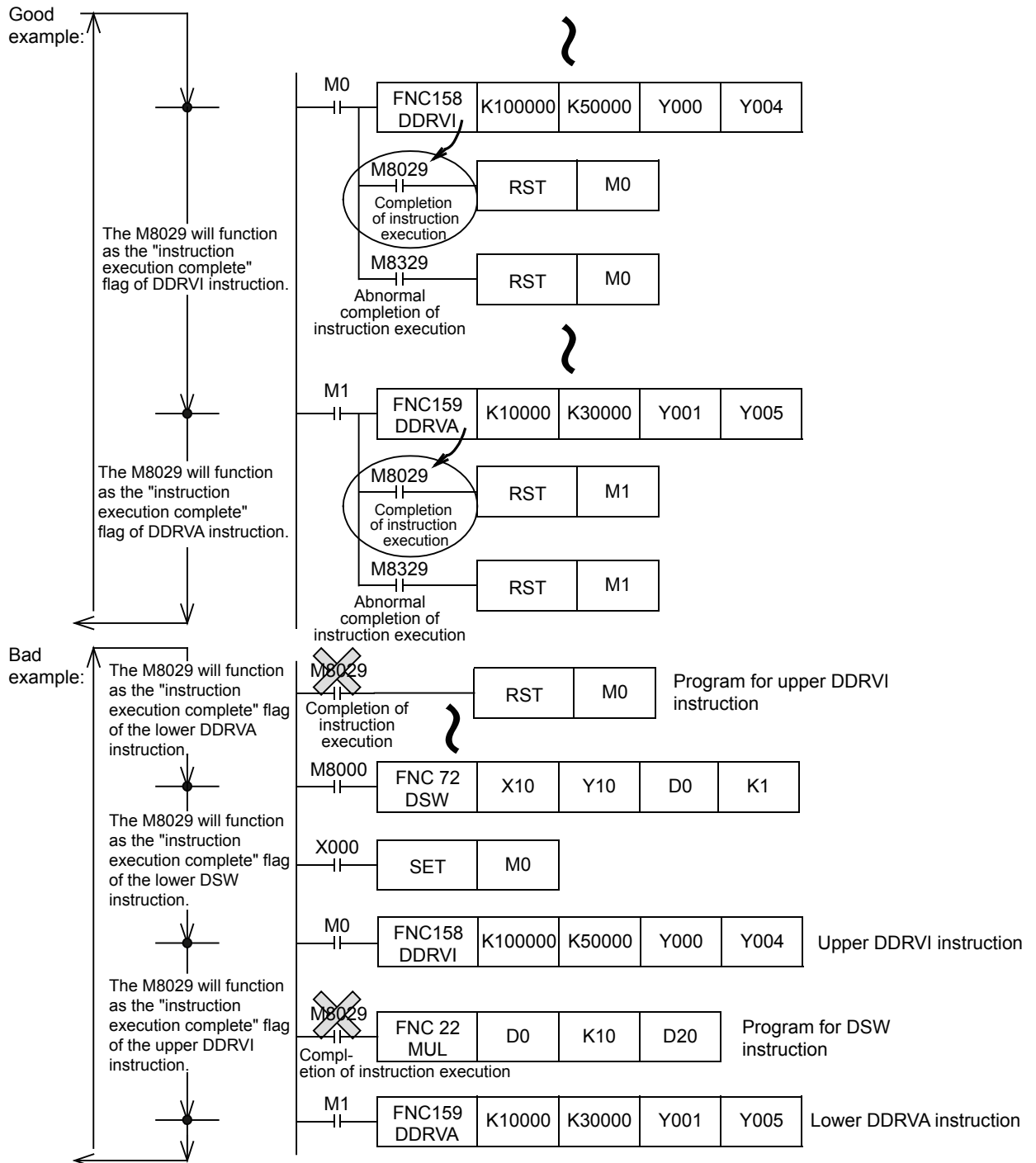

- 2) To use at a position other than just below the positioning instruction:
 If two or more positioning instructions are used in a program, the "Instruction execution complete" flag (M8029) and "Instruction execution abnormal end" flag (M8329) will be turned on or off after execution of each instruction.
 If it is necessary to use the "Instruction execution complete" flag or "Instruction execution abnormal end" flag at a point other than just below the instruction, turn on or off another bit device just below the instruction, and use the contact as the command contact.

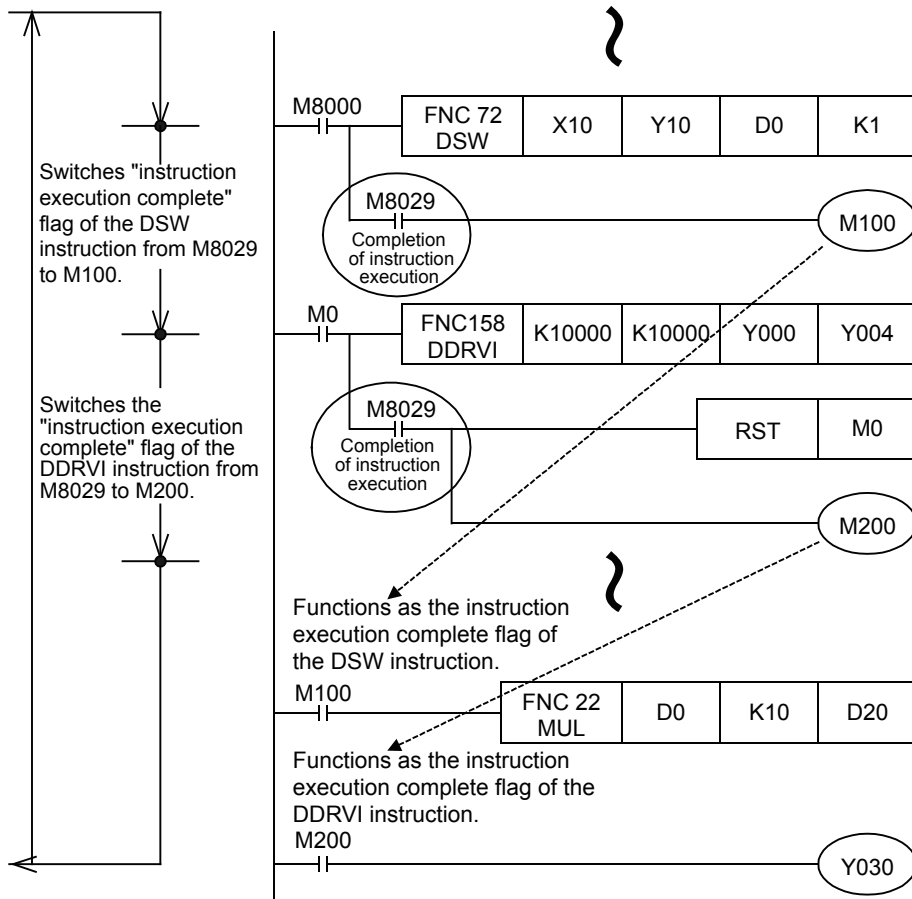

A Common Items
B Built-in Positioning Functions
Apx. Example Connection

4.7.5 Operation Error Flag

When there is an error in the applied instruction configuration, target device or target device number range and an error occurs while operation is executed, the following flag turns ON and the error information is stored.

1. Operation error

Error flag	Error code storage device	Error detected step number storage device	
		FX3U/FX3UC PLC	FX3S/FX3G/FX3GC PLC
M8067	D8067	D8315, D8314 D8069	D8069

- When an operation error has occurred, M8067 is set, D8067 stores the operation error code number in which the error has occurred.
- In the FX3U/FX3UC PLC, D8315 and D8314 (32 bits) store the error occurrence step number. When the error occurrence step is up to the 32767th step, the error occurrence step can be checked in D8069 (16 bits).
- In the FX3S/FX3G/FX3GC PLC, D8069 stores the error occurrence step number.
- If an operation error occurs at another step, the error code and error step number of the instruction will be sequentially updated. (If the error status is canceled, the error flag will be turned off.)
- If the PLC is stopped and restarted without canceling the error status, the error status will be automatically canceled, but immediately after that, the error flag will be turned on again.

2. Operation error latch

Error flag	Error code storage device	Error detected step number storage device	
		FX3U/FX3UC PLC	FX3S/FX3G/FX3GC PLC
M8068	-	D8313, D8312 D8068	D8068

- When an operation error occurs, M8068 is turned on.
- In the FX3U/FX3UC PLC, D8313 and D8312 (32 bits) store the error occurrence step number. When the error occurrence step is up to the 32767th step, the error occurrence step can be checked in D8068 (16 bits).
- In the FX3S/FX3G/FX3GC PLC, D8068 stores the error occurrence step number.
- If a new error is caused by another instruction, the error data will not be updated, and the operation will be continued until the "forced reset" command is input or the power is turned off.

4.7.6 Write during RUN

Do not change the program if a positioning instruction (FNC150, FNC151, FNC156 to FNC159) is being executed (pulses are being output) in the RUN mode. Operations will be performed as shown in the following table if a program is changed during instruction execution in RUN mode.

Also do not change the program if a pulse output instruction (FNC 57, FNC 58 and FNC 59) is being executed (pulses are being output) in RUN mode.

→ For details on the positioning instruction, refer to Chapter 6 to 11.

→ For details on the pulse output instruction (FNC 57, FNC 58 and FNC 59), refer to Programming manual.

Instruction		If program is changed in circuit block including currently-activated instruction
DSZR(FNC150)		Decelerates and stops pulse output.
DVIT(FNC151)		Decelerates and stops pulse output.
TBL(FNC152)		Program cannot be changed in the RUN mode.
ZRN(FNC156)		Decelerates and stops pulse output.
PLSV (FNC157)	During operation with acceleration/deceleration	Decelerates and stops pulse output.
	During operation without acceleration/deceleration	Immediately stops pulse output.
DRVI(FNC158)		Decelerates and stops pulse output.
DRVA(FNC159)		Decelerates and stops pulse output.

4.8 Items To Be Observed When Using the Main Unit (Transistor Output)

1. Pulse output destination devices

Use Y000, Y001, and Y002*¹ transistor outputs of the main unit for the pulse output destination devices. Do not use the transistor output Y003 of the main unit for positioning instructions. If Y003 is used for a positioning instruction, PLC failure may occur.

2. Pulse output method

Adjust the pulse output method of the transistor output of the main unit to conform with the command pulse input method of the servo amplifier (drive unit).

If the pulse output method is not properly adjusted, the servo amplifier (drive unit) may not perform the intended operation.

→ **For details on the servo amplifier (drive unit), refer to the manual of the product used in your system.**

→ **For details on the pulse output method of the main unit, refer to Subsection 4.6.1.**

3. Output pulse frequency (including zero return speed)

If a pulse frequency of more than 100,000 Hz is output from the transistor output terminal of the main unit to perform the operation, it may cause PLC failure.

The output pulse frequency and the zero return speed should be equal to or less than the maximum frequency of the servo amplifier (drive unit).

4. Load current

To use a positioning instruction for the transistor output Y000, Y001, or Y002*¹ of the main unit, adjust the load current of the open collector transistor output to 10 to 100 mA (5 to 24V DC).

Item	Description
Operation voltage range	5 to 24V DC
Operation current range	10 to 100mA
Output pulse frequency	100 kHz or less

*1. Y002 is not available in FX3G PLC (14-point and 24-point type) and FX3s/FX3GC PLC.

4.9 Caution for Using the High-Speed Output Special Adapter (FX3U-2HSY-ADP)

1. Output terminals to be used

If the high-speed output special adapter is connected, output numbers will be assigned in the same way as the main unit as shown in the following table. Use the output terminals of one side (main unit side or high-speed output special adapter side), and do not connect lines to the output terminals of the unused side. The outputs of the high-speed output special adapter and the main will operate as follows.

Assignment of output numbers

Position of pulse output method setting switch of high-speed output special adapter	Signal	Name of positioning instruction	Output number			
			1st adapter		2nd adapter	
			1st axis	2nd axis	3rd axis	4th axis
FP·RP side	Forward rotation pulse train (FP)	Pulse output destination	Y000	Y001	Y002	Y003
	Reverse rotation pulse train (RP)	Rotation direction signal	Y004	Y005	Y006	Y007
PLS·DIR side	Pulse train	Pulse output destination	Y000	Y001	Y002	Y003
	Direction	Rotation direction signal	Y004	Y005	Y006	Y007

Operation of output

Unit	Output operation		
	PLSY,PLSR,DSZR, DVIT,TBL,ZRN,PLSV, DRVI,DRVA instruction.	PWM instruction	Other instruction
FX3U Series main unit of relay output type	While instruction is activated, relevant output is ON. (LED is also ON.)	Use of the PWM (FNC 58) instruction is not compatible with a relay type main unit.*2	Operated
FX3U Series main unit of transistor output type	Operated*1	Operated	Operated
FX3U Series main unit of triac output type	While instruction is activated, relevant output is ON. (LED is also ON.)	Use of the PWM (FNC 58) instruction is not compatible with a triac type main unit.*3	Operated
High-speed output special adapter	Operated	Operated The main unit should use the transistor output type.*2	Operated

*1. The output frequency limit of the main unit transistor output is 100 kHz. When operating a load with a pulse frequency exceeding 100 kHz, PLC failure may occur.

*2. Furthermore, use of the PWM (FNC 58) is not recommended with the relay type main unit and the high-speed adapters due to chattering of the relay contacts.

*3. The PWM instruction does not support the triac output due to response delay of outputs.

- If an output number of the high-speed output special adapter is used (if an output of the high-speed output special adapter is connected), do not use (connect) the corresponding output terminal of the main unit.
- If an output number of the main unit is used (if an output of the main unit is connected), do not use (connect) the corresponding output terminal of the high-speed output special adapter.

2. Rotation direction signal of positioning instruction

If an FX3U-2HSY-ADP high-speed output special adapter is used, the rotational direction signal will be assigned to each pulse output destination device as shown in the following table. Do not assign any other outputs to these devices using positioning instructions, etc.

→ For details, refer to Subsection 4.5.2.

Pulse output destination device	Rotation direction signal (reverse rotation pulse train / direction)				Initial setting of CLEAR signal
	1st adapter		2nd adapter		
	1st axis	2nd axis	3rd axis	4th axis	
Y000	Y004	-	-	-	Y004
Y001	-	Y005	-	-	Y005
Y002	-	-	Y006	-	Y006
Y003	-	-	-	Y007	Y007

3. CLEAR signal and rotation direction signal

If an FX3U-2HSY-ADP high-speed output special adapter is used, outputs for the rotation direction signal of the DSZR (FNC150) or ZRN (FNC156) instruction and the CLEAR signal will overlap as shown in the table above.

For this reason, in order to output the CLEAR signal, change the CLEAR signal device.

→ For details on the CLEAR signal device change method, refer to Subsection 4.3.4.

4. Pulse output method for the high-speed output special adapter

Adjust the pulse output method of the high-speed output special adapter (FX3U-2HSY-ADP) so that the pulse output method conforms to the command pulse input method of the servo amplifier (drive unit).

If the pulse output method is not properly adjusted, the servo amplifier (drive unit) may not perform the intended operation.

→ For details on the servo amplifier (drive unit), refer to the manual of the product to be used for your system.

→ For details on the pulse output method, refer to Subsection 4.6.1 or Subsection 4.5.2.

5. Output pulse frequency (including zero return speed)

Set the output pulse frequency and the zero return speed so that these values can be less than the maximum frequency value of the servo amplifier (driver unit).

4.10 Format and Execution of Applied Instruction

Instruction and operand:

- Function numbers (FNC 00 - FNC□□□) and symbols (mnemonic codes) are assigned to the applied instructions of the PLC. For example, a symbol of "SMOV" (shift) is assigned to FNC 13.
- Some applied instructions consist of the instruction area only, but many applied instructions consist of the instruction area and the operand.

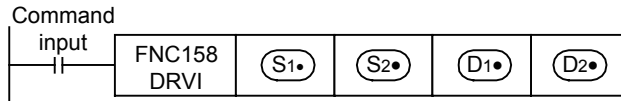

- (S)** : An operand that will not be affected by the execution of the instruction is referred to as a source. This symbol represents a source.
 If the operand device number can be modified by an index register, "•" will be added, and the S will be modified to **(S•)**. If there are two or more sources, the modified sources will become **(S1•)**, **(S2•)**, and so on.
- (D)** : An operand that will be affected by the execution of the instruction is referred to as a destination. This symbol represents a destination.
 If the device numbers can be indexed by index registers, and if there are two or more destinations, the modified destinations will become **(D1•)**, **(D2•)**, and so on.
- m, n** : The operands not corresponding to source and destination are indicated as "m" and "n".
 If the device number can be indexed by index registers, and if there are two or more operands, the modified operands will become m1•, m2•, n1•, n2•, and so on.

- Regarding program steps, the instruction area for each applied instruction is 1 step. The operand of each applied instruction, however, has 2 or 4 steps depending on the number of bits (16 or 32 bits).

Devices for operands:

- Bit devices X, Y, M, and S can be used for the operands, depending on the function.
- Combination of these bit devices, such as KnX, KnY, KnM, and KnS, can be used for numeric data.
 → **Refer to the programming manual.**
- Current value registers, such as data registers D, timers T, and counters C, can be used.
- A data register D consists of 16 bit. Two consecutive data registers (2 points) are used for 32-bit data. For example, if data register D0 is specified for the operand of a 32-bit instruction, D1 and D0 will be used for 32-bit data (D1 for the 16 high-order bits, and D0 for the 16 low-order bits).
 If current value registers T and C are used as general data registers, they will behave the same way as data registers.
 Each 32-bit counter (C200 to C255), however, can use 32-bit data without combining two counters. These counters, however, cannot be specified as the operands of 16-bit instructions.

Format and execution of instruction:

Depending on the sizes of the numeric values to be processed, applied instructions can be classified into two types: 16-bit instructions and 32-bit instructions. In addition, depending on the execution type, these instructions can also be classified into two types: continuous execution type and pulse execution type. Depending on the applied instruction, the instruction may or may not have all the combinations.

1. 16-bit instructions and 32-bit instructions

- Depending on the bit length of the numeric data to be processed, applied instructions can be classified into two types: 16-bit type and 32-bit type.

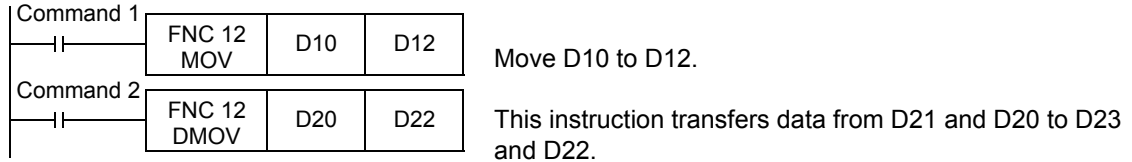

- For the 32-bit instruction, the instruction name will be DMOV ("D" will be added to "MOV").
- Even numbered devices or odd numbered devices can be specified. If a double device is specified, the specified device will be combined with the device with the next number (for the word devices, such as devices T, C, and D).
 To prevent confusion, it is recommended to use even numbered devices to specify the low-order bits of an operand of a 32-bit instruction.
- Each 32-bit counter (C200 to C255) needs only one device to set 32 bits. For this reason, the operand of a 16-bit instruction cannot specify any of the 32-bit counters.

2. Pulse execution type instructions and continuous execution type instructions

Pulse execution type instructions:

The program shown in the right figure shows that when X000 is turned on, the instruction will be executed only once. If X000 is off, the instruction will not be executed. If it is not necessary to execute the instruction frequently, the pulse execution type instruction is recommended. Note that "P" means that the instruction of pulse execution type. This means that DMOVP is a pulse execution type instruction.

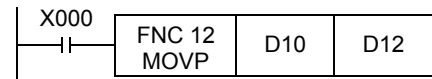

Continuous execution type instructions:

The program shown in the right figure shows that if X001 is on, the continuous execution type MOV instruction will be executed at the start of each operation cycle.

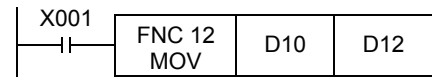

Note that if FNC 24 (INC) or FNC 25 (DEC) is used as a continuous execution type instruction, the destination will be changed at the start of each operation cycle.

To indicate continuous execution type instructions, the symbol "P" will be added to the title of each instruction as shown in the following figure. Use these instructions carefully.

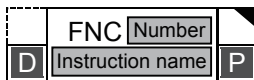

Note that if the activation input X000 or X001 is off, instructions will not be executed. Also note that if the later symbol is not added to the title of an instruction, the destination of the instruction will not be changed.

5. Operation Test

This chapter describes the operation test of positioning instructions. During forward rotation (JOG+) operation and reverse rotation (JOG-) operation, the test checks whether positioning instructions are properly activated.

DESIGN PRECAUTIONS



- Make sure to have the following safety circuits outside of the PLC to ensure safe system operation even during external power supply problems or PLC failure.
Otherwise, malfunctions may cause serious accidents.
 - 1) Most importantly, have the following: an emergency stop circuit, a protection circuit, an interlock circuit for opposite movements (such as normal vs. reverse rotation), and an interlock circuit (to prevent damage to the equipment at the upper and lower positioning limits).
 - 2) Note that when the PLC CPU detects an error, such as a watchdog timer error, during self-diagnosis, all outputs are turned off. Also, when an error that cannot be detected by the PLC CPU occurs in an input/output control block, output control may be disabled.
External circuits and mechanisms should be designed to ensure safe machinery operation in such a case.
 - 3) Note that when an error occurs in a relay, triac or transistor output device, the output could be held either on or off.
For output signals that may lead to serious accidents, external circuits and mechanisms should be designed to ensure safe machinery operation in such a case.

DESIGN PRECAUTIONS



- Do not bundle the control line together with or lay it close to the main circuit or power line. As a guideline, lay the control line at least 100mm (3.94") or more away from the main circuit or power line.
Noise may cause malfunctions.
- Install module so that excessive force will not be applied to the built-in programming port, power connectors, I/O connectors.
Failure to do so may result in wire damage/breakage or PLC failure.

WIRING PRECAUTIONS



- Make sure to cut off all phases of the power supply externally before attempting installation or wiring work.
Failure to do so may cause electric shock or damage to the product.
- Make sure to attach the terminal cover, offered as an accessory, before turning on the power or initiating operation after installation or wiring work.
Failure to do so may cause electric shock.

WIRING PRECAUTIONS



- Connect the AC power supply to the dedicated terminals specified in the manual of the PLC main unit.
If an AC power supply is connected to a DC input/output terminal or DC power supply terminal, the PLC will burn out.
- Connect the DC power supply to the dedicated terminals specified in the manual of the PLC main unit.
If an AC power supply is connected to a DC input/output terminal or DC power supply terminal, the PLC will burn out.
- Do not wire vacant terminals externally.
Doing so may damage the product.
- Perform class D grounding (grounding resistance: 100Ω or less) to the grounding terminal on the FX3S/FX3G/FX3U PLC main unit with a wire 2 mm² or thicker.
Do not use common grounding with heavy electrical systems (refer to the manual of the PLC main unit).
- Perform class D grounding (grounding resistance: 100Ω or less) to the grounding terminal on the FX3GC/FX3UC PLC main unit with a wire as thick as possible.
Do not use common grounding with heavy electrical systems (refer to the manual of the PLC main unit).
- When drilling screw holes or wiring, make sure cutting or wire debris does not enter the ventilation slits.
Failure to do so may cause fire, equipment failures or malfunctions.

WIRING PRECAUTIONS



- Install module so that excessive force will not be applied to I/O connectors. Failure to do so may result in wire damage/breakage or PLC failure.
- Connect input/output cables securely to their designated connectors. Loose connections may cause malfunctions.
- Make sure to properly wire the terminal block in accordance with the following precautions. Failure to do so may cause electric shock, equipment failures, a short-circuit, wire breakage, malfunctions or damage to the product.
 - The disposal size of the cable end should follow the dimensions described in the manual.
 - Tightening torque should follow the specifications in the manual.
 - Tighten the screws using a Phillips-head screwdriver No.2 (shaft diameter 6mm (0.24") or less). Make sure that the screwdriver does not touch the partition part of the terminal block.
- Make sure to properly wire to the terminal block (European type) in accordance with the following precautions. Failure to do so may cause electric shock, equipment failures, a short-circuit, wire breakage, malfunctions or damage to the product.
 - The disposal size of the cable end should follow the dimensions described in the manual.
 - Tightening torque should follow the specifications in the manual.
 - Twist the end of strand wire and make sure that there are no loose wires.
 - Do not solder-plate the electric wire ends.
 - Do not connect more than the specified number of wires or electric wires of unspecified size.
 - Affix the electric wires so that neither the terminal block nor the connected parts are directly stressed.
- Make sure to properly wire to the FX Series terminal blocks in accordance with the following precautions. Failure to do so may cause electric shock, equipment failures, a short-circuit, wire breakage, malfunctions or damage to the product.
 - The disposal size of the cable end should follow the dimensions described in the manual.
 - Tightening torque should follow the specifications in the manual.
 - Tighten the screws using a Phillips-head screwdriver No.2 (shaft diameter 6mm (0.24") or less). Make sure that the screwdriver does not touch the partition part of the terminal block.

STARTUP AND MAINTENANCE PRECAUTIONS



- Do not touch any terminal while the PLC's power is on. Doing so may cause electric shock or malfunctions.
- Before cleaning or retightening terminals, cut off all phases of the power supply externally. Failure to do so may cause electric shock.
- Before modifying or disrupting the program in operation or running the PLC, carefully read through this manual and the associated manuals and ensure the safety of the operation. An operation error may damage the machinery or cause accidents.

STARTUP AND MAINTENANCE PRECAUTIONS



- Do not disassemble or modify the PLC. Doing so may cause fire, equipment failures, or malfunctions. For repair, contact your local Mitsubishi Electric representative.
- Turn off the power to the PLC before connecting or disconnecting any extension cable. Failure to do so may cause equipment failures or malfunctions.
- Turn off the power to the PLC before attaching or detaching the following devices. Failure to do so may cause equipment failures or malfunctions.
 - Peripheral devices, expansion boards, and special adapters
 - Input/output extension units/blocks and FX Series terminal blocks

5.1 Test Procedure

- 1 Turn off the power to the PLC.**
- 2 Temporarily connect the limit switches (forward rotation limit 1, reverse rotation limit 1) and the manual switches (forward rotation, reverse rotation).**

Connect the limit switches and the manual switches to the following input terminals of the PLC.
 Do not connect the servo amplifier (drive unit).

→ For details on connection, refer to Chapter 3 of the Hardware Edition of the PLC.

→ For details on the forward rotation limit and the reverse rotation limit, refer to Subsection 4.3.1.

Signal			Input number
Limit switch	Forward rotation limit 1	NC contact	X010
	Reverse rotation limit 1	NC contact	X011
Manual switch	Forward rotation (JOG+)	NO contact	X012
	Reverse rotation (JOG-)	NO contact	X013

- 3 Create the test program.**
 → For details on the test program, refer to Section 5.2.
- 4 Turn on the power to the PLC.**
- 5 Transfer the test program to the main unit.**
 → For details, refer to the manual of the programming tool.
- 6 Check the input indicator lamp (LED lamp).**

When the programming controller is stopped, activate the temporarily connected input terminals, and check the status of each input indicator lamp (LED lamp).

If an FX3UC-32MT-LT(-2) PLC is used, check the input statuses using the display module.

Signal	Input signal	Status of LED indicator lamp
Forward rotation limit 1	X010	Activation of the forward rotation limit switch 1 will turn off the LED indicator lamp of X010 (turn off X010).
Reverse rotation limit 1	X011	Activation of the reverse rotation limit switch 1 will turn off the LED indicator lamp of X011 (turn off X011).
Forward rotation (JOG+)	X012	Turning on the forward rotation (JOG+) switch will turn on the LED indicator lamp of X012.
Reverse rotation (JOG-)	X013	Turning on the reverse rotation (JOG-) switch will turn on the LED indicator lamp of X013.

- 7 Switch the PLC into RUN mode.**

8 Check the operation in the forward rotation direction.

Check the output indicator lamp (LED lamp) and the current value register to monitor the operation. The status of the LED indicator lamp and the value indicated in the current value register depend on the pulse output destination or rotation direction set by the positioning instruction. However, if the pulse output destination or the rotation direction is changed for the test program, carefully read the status of the output indicator lamp (LED lamp) and the value indicated in the current value register to monitor the change.

1. Operation in forward rotation direction

Turn on the forward rotation (JOG+) switch (X012), and verify that the operation is performed in the forward rotation direction. For this check, set the other inputs as follows:

Input signal	Status
X010	ON
X011	ON
X013	OFF

1) LED indicator lamp check

Check the LED indicator lamps of the PLC or the display module to see whether or not the outputs are turned on. The status of each output should be as shown in the following table:

	Pulse output method	LED lamp of output	Status of LED lamp (output)
If the transistor outputs of the main unit are used	"Pulse train + direction" method	Y000	Turned on and off at high speed.*1
		Y004	Kept ON.
If the high-speed output special adapter is used	"Pulse train + direction" method	Y0/2	Turned on and off at high speed.
		Y4/6	Kept ON.
	Forward rotation pulse train (FP) Reverse rotation pulse train (RP)	Y0/2	Turned on and off at high speed.
		Y4/6	Kept OFF.

*1. The output LED is kept ON in the FX3U PLC.

2) Current value register (D8341, D8340) check

Monitor the current value register (D8341, D8340) of the FX3s/FX3G/FX3GC/FX3U/FX3UC PLC using the programming tool, and confirm that the value is being increased.

→ For details on the current value register, refer to Subsection 4.4.1.

2. Stop of operation

Turn off the forward rotation (JOG+) switch (X012) to stop the operation in the forward rotation direction.

1) LED indicator lamp check

Check the LED indicator lamps of the PLC or the display module to check whether the outputs are turned on. The status of each output should be as shown in the following table:

	Pulse output method	LED lamp of output	Status of LED lamp (output)
If the transistor outputs of the main unit are used	"Pulse train + direction" method	Y000	The LED indicator lamp (turned on and off at high speed) will be turned off.
		Y004	Kept ON.
If the high-speed output special adapter is used	"Pulse train + direction" method	Y0/2	The LED indicator lamp (turned on and off at high speed) will be turned off.
		Y4/6	Kept ON.
	Forward rotation pulse train (FP) Reverse rotation pulse train (RP)	Y0/2	The LED indicator lamp (turned on and off at high speed) will be turned off.
		Y4/6	Kept OFF.

2) Current value register (D8341, D8340) check

Monitor the current value register (D8341, D8340) of the FX3s/FX3G/FX3GC/FX3U/FX3UC PLC using the programming tool, and confirm that the value is not being increased.

→ For details on the current value register, refer to Subsection 4.4.1.

9 Check the operation of the forward rotation limit switch.

During operation in the forward rotation direction (at step 8), turn off the forward rotation limit switch 1 (X010), and confirm that the operation in the forward rotation direction is stopped.

The LED indicator lamps and the current value register (D8341, D8340) will change to the same statuses as the stop statuses described in step 8.

In addition, the "Instruction execution abnormal end" flag (M8329) will turn on.

→ For details on the current value register, refer to Subsection 4.4.1.

10 Check the operation in the reverse rotation direction.

Check the output indicator lamp (LED lamp) and the current value register to monitor the operation. The status of the LED indicator lamp and the value indicated in the current value register depend on the pulse output destination or rotation direction set by the positioning instruction. However, if the pulse output destination or the rotation direction is changed for the test program, carefully read the status of the output indicator lamp (LED lamp) and the value indicated in the current value register to monitor the change.

1. Operation in reverse rotation direction

Turn on the reverse rotation (JOG-) switch (X013), and verify that the operation is performed in the reverse rotation direction. For this check, set the other inputs as follows:

Input signal	Status
X010	ON
X011	ON
X012	OFF

1) LED indicator lamp check

Check the LED indicator lamps of the PLC or the display module to check whether the outputs are turned on. The status of each output should be as shown in the following table:

	Pulse output method	LED lamp of output	Status of LED lamp (output)
If the transistor outputs of the main unit are used	"Pulse train + direction" method	Y000	Turned on and off at high speed. *1
		Y004	Kept OFF.
If the high-speed output special adapter is used	"Pulse train + direction" method	Y0/2	Turned on and off at high speed.
		Y4/6	Kept OFF.
	Forward rotation pulse train (FP) Reverse rotation pulse train (RP)	Y0/2	Kept OFF.
		Y4/6	Turned on and off at high speed.

*1. The output LED is kept ON in the FX3U PLC.

2) Current value register (D8341, D8340) check

Monitor the current value register (D8341, D8340) of the FX3s/FX3G/FX3GC/FX3U/FX3UC PLC using the programming tool, and confirm that the value is being reduced.

→ For details on the current value register, refer to Subsection 4.4.1.

2. Stop of operation

Turn off the reverse rotation (JOG-) switch (X013) to stop the operation in the reverse rotation direction.

1) LED indicator lamp check

Check the LED indicator lamps of the PLC or the display module to check whether or not the outputs are turned on. The status of each output should be as shown in the following table:

	Pulse output method	LED lamp of output	Status of LED lamp (output)
If the transistor outputs of main unit are used	"Pulse train + direction" method	Y000	The LED indicator lamp (turned on and off at high speed) will be turned off.
		Y004	Kept OFF.
If the high-speed output special adapter is used	"Pulse train + direction" method	Y0/2	The LED indicator lamp (turned on and off at high speed) will be turned off.
		Y4/6	Kept OFF.
	Forward rotation pulse train (FP) Reverse rotation pulse train (RP)	Y0/2	Kept OFF.
		Y4/6	The LED indicator lamp (turned on and off at high speed) will be turned off.

2) Current value register (D8341, D8340) check

Monitor the current value register (D8341, D8340) of the FX3S/FX3G/FX3GC/FX3U/FX3UC PLC using the programming tool, and confirm that the value is not being decreased.

→ For details on the current value register, refer to Subsection 4.4.1.

11 Check the operation of the reverse rotation limit switch.

During operation in the reverse rotation direction (at step 10), turn off the reverse rotation limit switch 1 (X011), and confirm that the operation in the reverse rotation direction is stopped.

The LED indicator lamps and the current value register (D8341, D8340) will change to the same statuses as the stop statuses described in step 10.

In addition, the "Instruction execution abnormal end" flag (M8329) will turn on.

→ For details on the current value register, refer to Subsection 4.4.1.

5.2 Creation of Test Program

1. Input/output assignment

Inputs/outputs are assigned as shown in the following table:

Signal			Input/output number
Limit switch	Forward rotation limit 1	NC contact	X010
	Reverse rotation limit 1	NC contact	X011
Manual switch	Forward rotation (JOG+)	NO contact	X012
	Reverse rotation (JOG-)	NO contact	X013
"Pulse train" signal or "forward rotation pulse train" signal (output specified for pulse output destination)			Y000
"Direction" signal or "reverse rotation pulse train" signal (output specified for rotation direction signal)			Y004

2. Setting of related devices

The following related devices depend on the pulse output destination device that is set for the positioning instruction. If the pulse output destination device is changed, it is necessary to change the related devices.

→ For setting items of the related devices, refer to Subsection 4.5.1.

Setting item	Description of setting	Related device	Setting value or condition	
Items related to speed				
Maximum speed	100,000Hz	D8344,D8343 (32-bit)	K100000	Initial value
Bias speed	0Hz	D8342	K0	Initial value
Acceleration time	100ms	D8348	K100	Initial value
Deceleration time	100ms	D8349	K100	Initial value
Forward/reverse rotation speed	30,000Hz	-	K30000	-
Forward limit, reverse limit, and immediate stop of pulse output				
Forward limit	If X010 is turned off (if the NC contact is turned on), the limit switch will be activated.	M8343	ON: If X010 = OFF	
Reverse limit	If X011 is turned off (if the NC contact is turned on), the limit switch will be activated.	M8344	ON: If X011 = OFF	
Status check items				
Positioning (Y000)	Use this device to check whether the positioning instruction is being activated.	M8348	Turns on when the positioning instruction is activated.	
"Instruction execution abnormal end" flag	Use this device to check whether or not the forward/reverse rotation limit switch turns ON.	M8329	Turns on when the limit switch is activated during a positioning operation.	
Current value register (Y000)	Stores the current value of the positioning operation in Y000.	D8341,D8340 (32-bit)	Varies when a positioning instruction turns ON.	

3. Example program

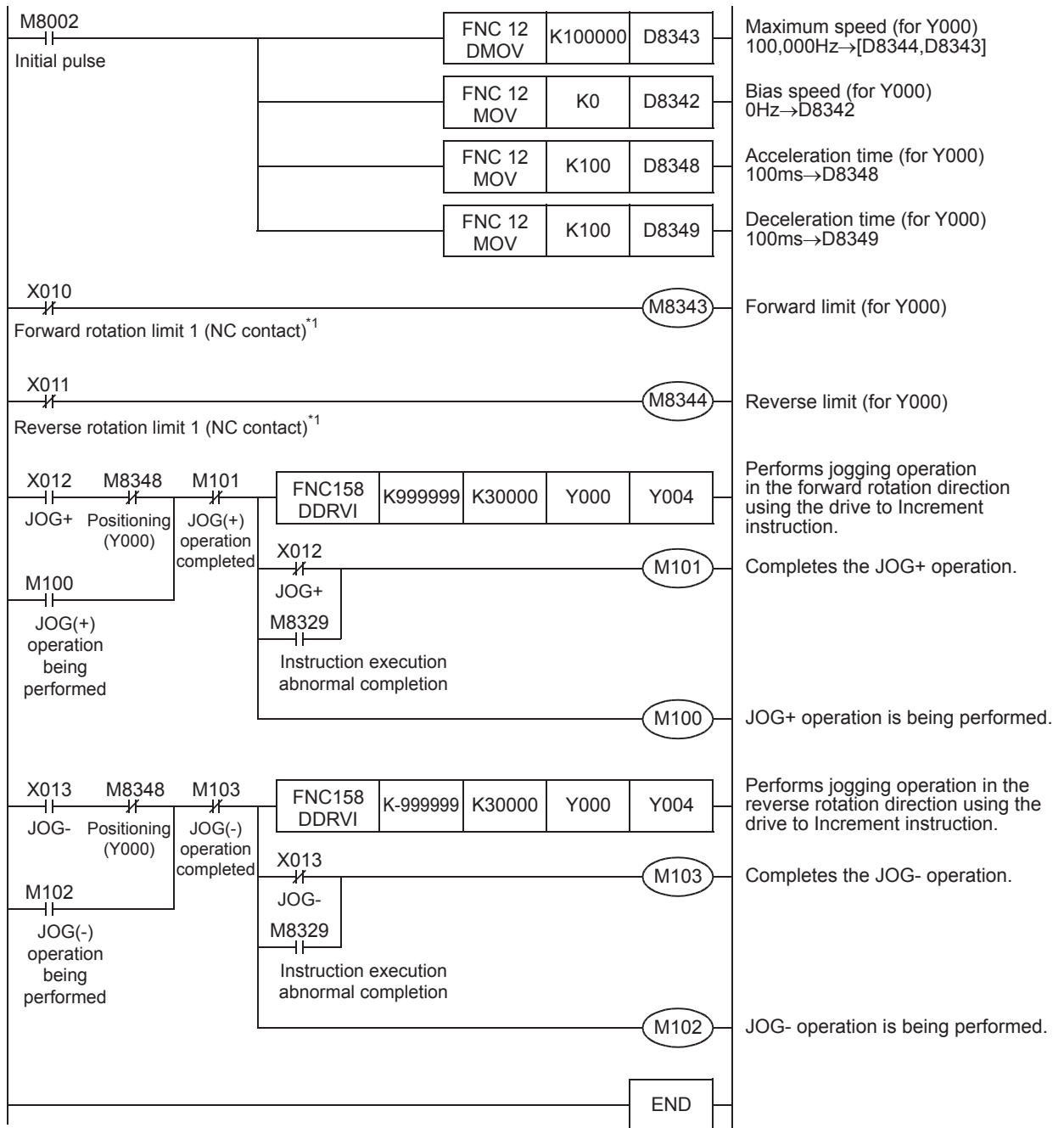

*1. Change contacts in the program to NO contacts when using NO contact type limit switches.

A
Common Items

B
Built-in Positioning Functions

Apx.
Example Connection

6. Mechanical Zero Return - DSZR/ZRN Instruction

6.1 Types of Mechanical Zero Return Instructions

If forward rotation pulses or reverse rotation pulses are being output, the positioning instruction of the PLC will increase or decrease the current value of the current value register.

When turning off the power of the PLC, however, the current value stored in the current value register will be erased. For this reason, after turning on the power again, be sure to adjust the current value of the current value register to the current position of the machine.

The built-in positioning function uses the DSZR/ZRN instruction (zero return instruction) to adjust the value of the current value register to the current mechanical position.

Compared with the ZRN instruction, the DSZR instruction has additional functionality.

	DSZR instruction	ZRN instruction
DOG search function	✓	-
DOG signal logical NOT	✓	-
Zero return using zero-phase signal	✓	-
Zero-point signal logic reverse	✓	-

Absolute position detection system:

If the MR-J4□A, MR-J3□A, MR-J2S□A, MR-J2□A, or MR-H□A servo amplifier (with absolute position detection function) manufactured by Mitsubishi is used, the current position value will be retained even after power-off.

To use the absolute position detection system, zero return is required to be performed only once. The PLC can then read the current position value of the servo motor with the FNC155 (DABS) instruction. With this method, it is not necessary to perform zero return every time after power-on.

6.2 DOG Search Zero Return (DSZR Instruction)

Use this instruction to change the CLEAR signal output destination with an FX3UC PLC Ver. 2.20 or later and FX3S/FX3G/FX3GC/FX3U PLC.

6.2.1 Instruction Format

1. Instruction format

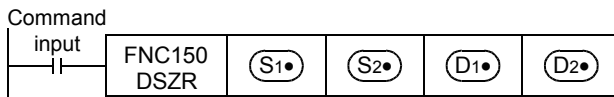
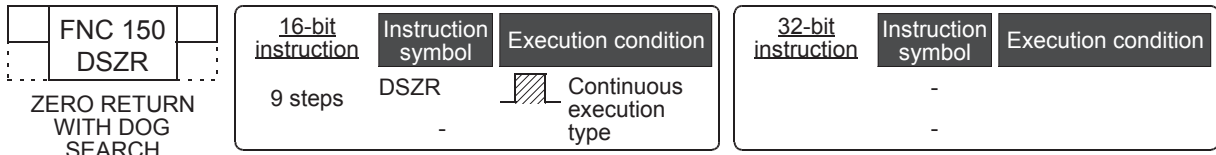

2. Data setting

Operand type	Description	Data type
(S1•)	Specifies the near-point signal (DOG) input device number.	Bit
(S2•)	Specifies the zero-phase signal input number.	
(D1•)	Specifies the pulse output number.	
(D2•)	Specifies the rotation direction signal output destination number.	

3. Devices

Operand type	Bit device							Word device										Others										
	System user							Digit designation				System user				Spe- cial unit	Index		Con- stant	Real num- ber	Char- acter string	Pointer						
	X	Y	M	T	C	S	D□.b	KnX	KnY	KnM	KnS	T	C	D	R	U□\G□	V	Z	Modify	K	H	E	"□"	P				
(S1•)	✓	✓	✓			✓	▲1																					
(S2•)	▲2																											
(D1•)		▲3																										
(D2•)		▲4	✓			✓	▲1																					

▲1 : D□.b is available only in FX3U and FX3UC PLCs. However, index modifiers (V and Z) are not available.

▲2 : Specify X000 to X007 for FX3G/FX3GC/FX3U/FX3UC PLC.
 Specify X000 to X005 for FX3S PLC.

▲3 : Specify Y000, Y001, or Y002*1 transistor output from the main unit, or specify Y000, Y001, Y002*3, or Y003*3 from a high-speed output special adapter*2.

*1. Y002 is not available in FX3G PLC (14-point and 24-point type) and FX3S/FX3GC PLC.

*2. High-speed output special adapters can be connected only to the FX3U PLC.

*3. To use Y002 and Y003 of a high-speed output special adapter, connect a second high-speed output special adapter.

Note:

- To use an FX3U PLC of relay output type or triac output type, be sure to connect a high-speed output special adapter.
- Differential line drive type outputs will be used for the outputs of the high-speed output special adapter.

▲4 : When a high-speed output special adapter is used as a destination for pulse output on a FX3U PLC, use the output shown in the following table for rotation direction signals.
 When a built-in transistor output is used as a destination for pulse output on a FX3s/FX3G/FX3GC/FX3U/FX3UC PLC, use transistor output for signals rotation direction.

→ For the outputs applicable with a High-speed output special adapter, refer to Section 4.9.

High-speed output special adapter connection position	Pulse output	Rotation direction output
1st adapter	(D1•) = Y000	(D2•) = Y004
	(D1•) = Y001	(D2•) = Y005
2nd adapter	(D1•) = Y002	(D2•) = Y006
	(D1•) = Y003	(D2•) = Y007

6.2.2 List of Related devices

1. Special auxiliary relays

The following table shows the related special auxiliary relays. Note that Y000, Y001, Y002, and Y003 are devices that determine the pulse output destinations.

Device number				Function	Attribute	Refer to
Y000	Y001	Y002*1	Y003*2			
M8029				"Instruction execution complete" flag	Read only	Subsection 4.4.2
M8329				"Instruction execution abnormal end" flag	Read only	Subsection 4.4.2
M8340	M8350	M8360	M8370	"Pulse output monitor" (BUSY/READY) flag	Read only	Subsection 4.4.3
M8341	M8351	M8361	M8371	CLEAR signal output function enable*3	Drivable	Subsection 4.3.4
M8342	M8352	M8362	M8372	Zero return direction specification*3	Drivable	Subsection 4.3.3
M8343	M8353	M8363	M8373	Forward limit	Drivable	Subsection 4.3.1
M8344	M8354	M8364	M8374	Reverse limit	Drivable	Subsection 4.3.1
M8345	M8355	M8365	M8375	DOG signal logic reverse*3	Drivable	Subsection 4.3.5
M8346	M8356	M8366	M8376	Zero-point signal logic reverse*3	Drivable	Subsection 4.3.6
M8348	M8358	M8368	M8378	Positioning instruction activation	Read only	Subsection 4.4.4
M8349	M8359	M8369	M8379	Pulse output stop command*3	Drivable	Subsection 4.3.2
M8464	M8465	M8466	M8467	CLEAR signal device specification function enabled*3, *4	Drivable	Subsection 4.3.4

*1. Y002 is not available in FX3G PLC (14-point and 24-point type) and FX3s/FX3GC PLC.

*2. Y003 is available only when two high-speed output special adapters are connected to the FX3U PLC.

*3. Cleared when PLC switches from RUN to STOP.

*4. Only available for FX3UC PLC Ver. 2.20 or later and FX3s/FX3G/FX3GC/FX3U PLC.

2. Special data registers

The following table shows the related special data registers. Note that Y000, Y001, Y002, and Y003 are devices that determine the pulse output destinations.

Device number								Function	Data length	Initial value	Refer to
Y000		Y001		Y002*1		Y003*2					
D8340	Low-order	D8350	Low-order	D8360	Low-order	D8370	Low-order	Current value register (PLS)	32-bit	0	Subsection 4.4.1
D8341	High-order	D8351	High-order	D8361	High-order	D8371	High-order				
D8342		D8352		D8362		D8372		Bias speed (Hz)	16-bit	0	Subsection 4.2.6
D8343	Low-order	D8353	Low-order	D8363	Low-order	D8373	Low-order	Maximum speed (Hz)	32-bit	100,000	Subsection 4.2.5
D8344	High-order	D8354	High-order	D8364	High-order	D8374	High-order				
D8345		D8355		D8365		D8375		Creep speed (Hz)	16-bit	1000	Subsection 4.2.4
D8346	Low-order	D8356	Low-order	D8366	Low-order	D8376	Low-order	Zero return speed (Hz)	32-bit	50,000	Subsection 4.2.3
D8347	High-order	D8357	High-order	D8367	High-order	D8377	High-order				
D8348		D8358		D8368		D8378		Acceleration time (ms)	16-bit	100	Subsection 4.2.7
D8349		D8359		D8369		D8379		Deceleration time (ms)	16-bit	100	Subsection 4.2.8
D8464		D8465		D8466		D8467		CLEAR signal device specification *3	16-bit	-	Subsection 4.3.4

*1. Y002 is not available in FX3G PLC (14-point and 24-point type) and FX3S/FX3GC PLC.

*2. Y003 is available only when two high-speed output special adapters are connected to the FX3U PLC.

*3. Only available for FX3UC PLC Ver. 2.20 or later and FX3S/FX3G/FX3GC/FX3U PLC.

6.2.3 Function and Operation

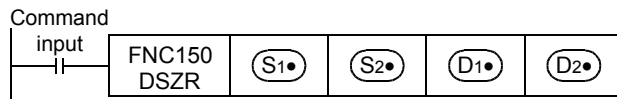

→ For details on the maximum speed, bias speed, acceleration time, and deceleration time, refer to Subsection 4.2.5 to Subsection 4.2.8.

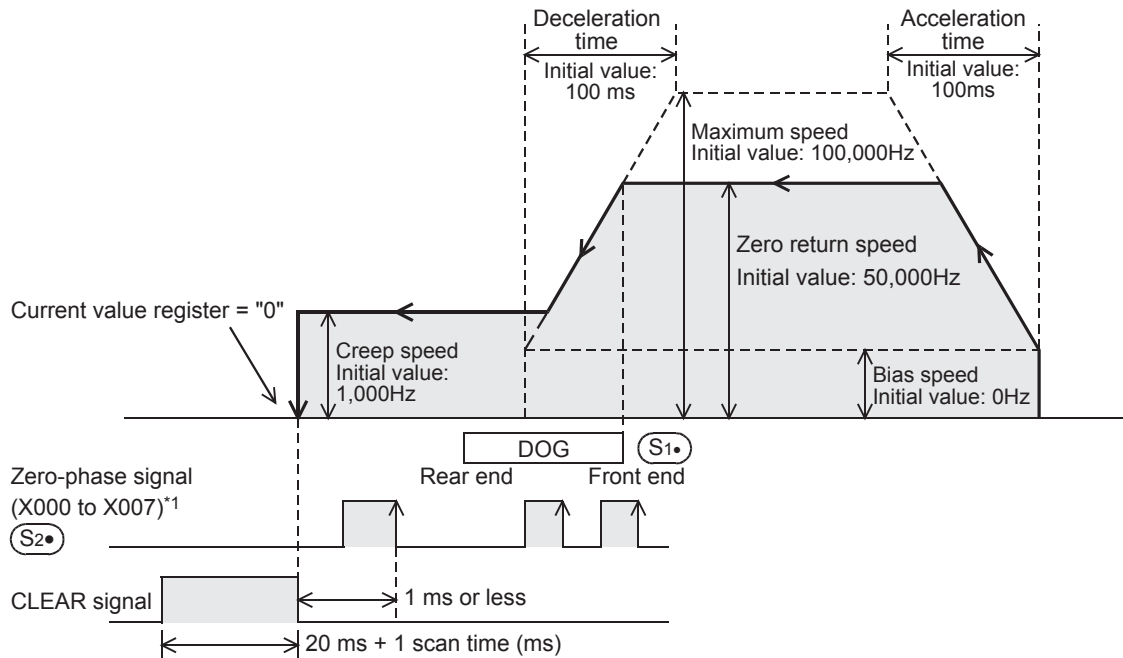

*1. X000 to X005 for FX3s PLC.

- 1) For (S1), specify the near-point signal (DOG) input device number. To specify the logic of this near-point signal (DOG), turn the "DOG signal logic reverse" relay on or off as shown in the following table.

Pulse output destination device	"DOG signal logic reverse" relay	Description
(D1) = Y000	M8345	OFF: Positive logic (Turning on the input will turn on the near-point signal.) ON: Negative logic (Turning off the input will turn on the near-point signal.)
(D1) = Y001	M8355	
(D1) = Y002	M8365	
(D1) = Y003	M8375	

- Detection of (the rear end and the front end of) the near-point signal (DOG) will be affected by the input filter and the scan time of the sequence program.
 Secure 1 scan time or more from the rear end of the DOG to turning ON of the zero-point signal.

- 2) For (S2), specify the zero-phase signal input number in the range of X000 to X007*2. To specify the logic of this zero-phase signal, turn the "Zero-point signal logic reverse" relay on or off as shown in the following table.

If the same input is specified for both the near-point signal and the zero-phase signal, the logic of the zero-phase signal will be specified by the device of the near-point signal (DOG), and not by one of the following devices. In this case, the operation will be performed at the front and rear ends of the near-point signal (DOG) without using the zero-phase signal. This is similar to the operation of the ZRN instruction.

Pulse output destination device	"Zero-point signal logic reverse" flag	Description
(D1) = Y000	M8346	OFF: Positive logic (Turning on the input will turn on the near-point signal.) ON: Negative logic (Turning off the input will turn on the near-point signal.)
(D1) = Y001	M8356	
(D1) = Y002	M8366	
(D1) = Y003	M8376	

*2. X000 to X005 for FX3S PLC.

- 3) For (D1), specify a pulse output number in the range of Y000 to Y003.
- 4) For (D2), specify the rotation direction signal output device number.
 When a high-speed output special adapter is used as a destination for pulse output on a FX3U PLC, use the output shown in the following table for rotation direction signals.
 When a built-in transistor output is used as a destination for pulse output on a FX3S/FX3G/FX3GC/FX3U/FX3UC PLC, use transistor output for signals rotation direction.

High-speed output special adapter connection position	Pulse output	Rotation direction output
1st adapter	(D1) = Y000	(D2) = Y004
	(D1) = Y001	(D2) = Y005
2nd adapter	(D1) = Y002	(D2) = Y006
	(D1) = Y003	(D2) = Y007

The rotation direction ON/OFF status of the specified device is shown in the following table. During instruction execution, however, do not use the output (D2) for other purposes.

ON/OFF status of device specified by (D2)	Rotation direction (increase/decrease current value)
ON	Forward rotation (Outputting pulses from (D1) will increase the current value.)
OFF	Reverse rotation (Outputting pulses from (D1) will decrease the current value.)

- 5) Zero return direction
 To specify the zero return direction, turn "zero return direction specification" relay on or off as shown in the following table.

Pulse output destination device	"Zero return direction specification" relay	Description
(D1) = Y000	M8342	To perform zero return in the forward rotation direction: Turn on the relay.
(D1) = Y001	M8352	
(D1) = Y002	M8362	To perform zero return in the reverse rotation direction: Turn off the relay.
(D1) = Y003	M8372	

6) CLEAR signal output

This instruction can output the CLEAR signal after stopping at the origin.

If it is necessary to output the CLEAR signal at the completion of zero return, turn on the "CLEAR signal output function enable" relay (see the following table).

Use an FX3UC PLC Ver. 2.20 or later and FX3S/FX3G/FX3GC/FX3U PLC to specify the CLEAR signal output device.

- a) If it is not necessary to use the CLEAR signal device specification function, or if an FX3UC PLC below Ver. 2.20 is used.

Pulse output destination device	Status of "CLEAR signal output function enable" relay	Status of "CLEAR signal device specification function enable" relay	CLEAR signal device number
(D1•) = Y000	M8341=ON	M8464=OFF	Y004
(D1•) = Y001	M8351=ON	M8465=OFF	Y005
(D1•) = Y002	M8361=ON	M8466=OFF	Y006
(D1•) = Y003	M8371=ON	M8467=OFF	Y007

- b) If it is necessary to use the CLEAR signal device specification function:

Turn on the "CLEAR signal device specification function enable" relay to specify the CLEAR signal output device (output Y) for the pulse output destination device using the CLEAR signal device specification register.

→ For an example program, refer to Subsection 4.3.4 or Subsection 4.5.1.

Pulse output destination device	Status of "CLEAR signal output function enable" relay	Status of "CLEAR signal device specification function enable" relay*1	CLEAR signal device specification register
(D1•) = Y000	M8341=ON	M8464=ON	D 8464
(D1•) = Y001	M8351=ON	M8465=ON	D 8465
(D1•) = Y002	M8361=ON	M8466=ON	D 8466
(D1•) = Y003	M8371=ON	M8467=ON	D 8467

7) Zero return speed

Use the devices shown in the following table to set the zero return speed. Be sure to set the zero return speed so that the relation with the other speeds is "bias speed ≤ zero return speed ≤ maximum speed".

- If "zero return speed > maximum speed", the operation will be performed at the maximum speed.

Pulse output destination device	Bias speed	Zero return speed	Maximum speed	Initial value
(D1•) = Y000	D8342	D8347,D8346	D8344,D8343	50,000(Hz)
(D1•) = Y001	D8352	D8357,D8356	D8354,D8353	
(D1•) = Y002	D8362	D8367,D8366	D8364,D8363	
(D1•) = Y003	D8372	D8377,D8376	D8374,D8373	

8) Creep speed

Use the devices shown in the following table to set the creep speed. Be sure to set the creep speed so that the relation with the other speeds is "bias speed ≤ creep speed ≤ maximum speed".

Pulse output destination device	Bias speed	Creep speed	Maximum speed	Initial value
(D1•) = Y000	D8342	D8345	D8344,D8343	1,000(Hz)
(D1•) = Y001	D8352	D8355	D8354,D8353	
(D1•) = Y002	D8362	D8365	D8364,D8363	
(D1•) = Y003	D8372	D8375	D8374,D8373	

1. Zero return operation

Zero return operation is described below assuming that Y000 is specified as the pulse output destination device (D1•). If Y001, Y002, or Y003 is specified, it is necessary to change the output number of each related relay (special auxiliary relay, special data register) below.

→ For details on related relays, refer to Section 4.1 to Section 4.4, or Subsection 6.2.2.

- 1) Specify the zero return direction.
 Turn the "zero return direction specification" relay (M8342) on or off to specify the zero return direction.
- 2) Execute the DSZR instruction to perform zero return.
- 3) Transfer operation will be performed in the direction specified by the "zero return direction designation" flag (M8342) at the speed specified by the "zero return speed designation" device (D8347, D8346).
- 4) If the near-point signal (DOG) specified by (S1•) is turned on*1, the speed will be reduced to the creep speed (D8345).
- 5) After turning the near-point signal (DOG) (S1•) OFF*1, if the zero-phase signal specified by (S2•) is turned on*2, the pulse outputting operation will immediately stop.
 If the same input is specified for both the near-point signal and the zero-phase signal, turning the near-point signal (DOG) OFF*1 will immediately stop the pulse outputting operation (just like the ZRN instruction where the zero-phase signal is not used).
- 6) If the CLEAR signal output function (M8341) is enabled (set to ON), the CLEAR signal (Y004) will be turned on within 1 ms after the zero-phase signal is turned ON, and will be kept ON for "20 ms + 1 scan time (ms)".*3
- 7) The current value register (D8341, D8340) will be reset to "0" (will be cleared).
- 8) The "Instruction execution complete" flag (M8029) will turn on, and the zero return operation will be completed.

→ For details on the "Instruction execution complete" flag, refer to Subsection 4.7.4.

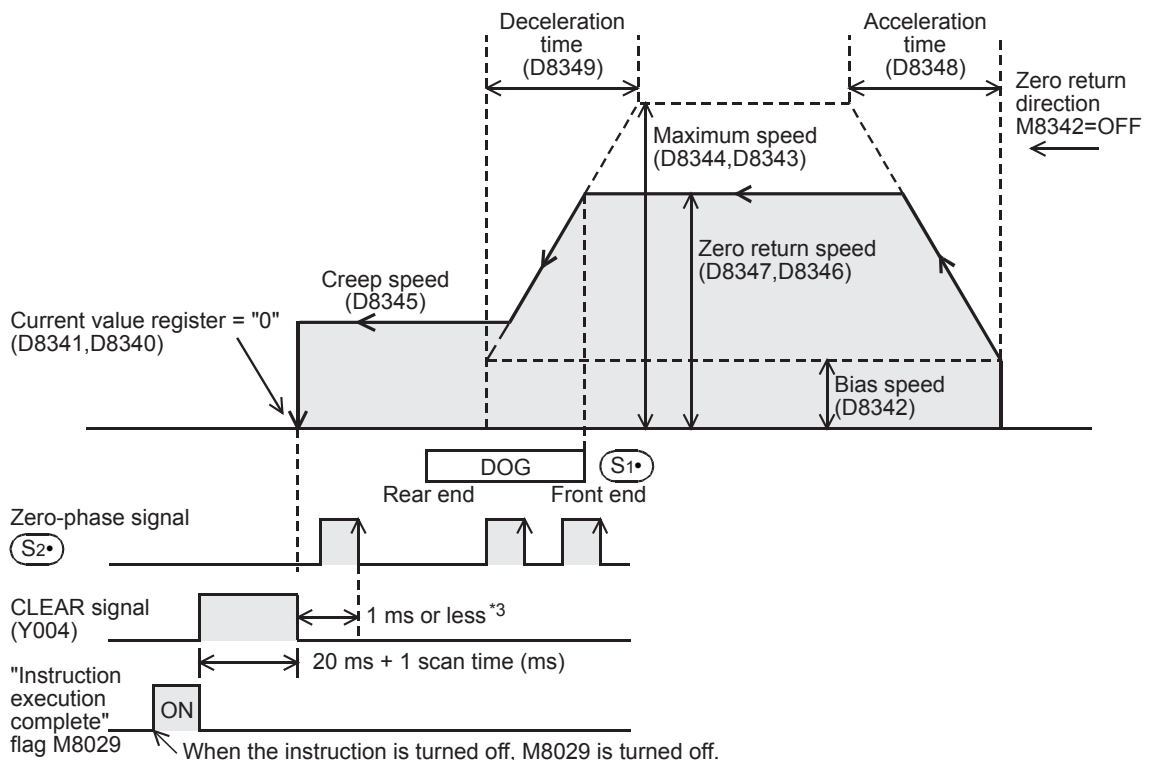

- *1. This step is described assuming that the "DOG signal logic reverse" relay (M8345) is off. If this flag is on, it is necessary to change the expression "on" to "off", and "off" to "on".
- *2. This step is described assuming that the "Zero-point signal logic reverse" relay (M8346) is off. If this flag is on, it is necessary to change the expression "on" to "off", and "off" to "on".
- *3. FX3s/FX3G/FX3GC PLCs operate in the sequence "CLEAR signal output → Pulse output stop".
 Set the CLEAR signal detection to "While on, droop pulses are always cleared" for connected amplifiers (drivers).
 The stop position may deviate if it is set to "Droop pulses are cleared on the leading edge".

2. DOG search function

If the forward rotation limit and the reverse rotation limit are set, the DOG search function can be used for zero return. The zero return operation depends on the zero return start position.

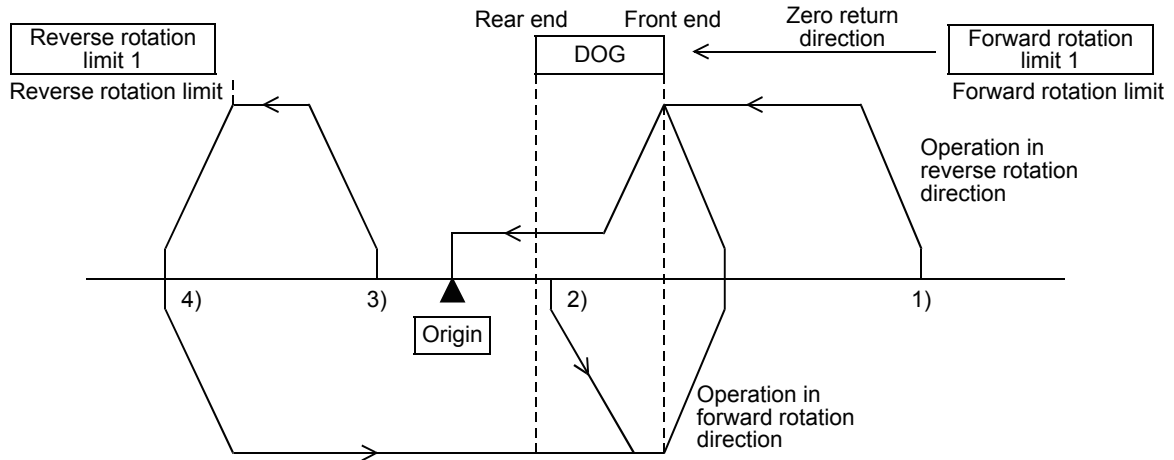

- 1) If the start position is before the DOG:
 - a) When the zero return instruction is executed, zero return will be started.
 - b) Transfer operation will be started in the zero return direction at the zero return speed.
 - c) If the front end of the DOG is detected, the speed will be reduced to the creep speed.
 - d) After detecting the rear end of the DOG, if the first zero-phase signal is detected, the operation will be stopped.
- 2) If the start position is in the DOG area:
 - a) When the zero return instruction is executed, zero return will be started.
 - b) Transfer operation will be started in the opposite direction of the zero return direction at the zero return speed.
 - c) If the front end of the DOG is detected, the speed will decelerate and the operation will stop. (The workpiece will come out of the DOG area.)
 - d) Transfer operation will be restarted in the zero return direction at the zero return speed (and the workpiece will enter the DOG area again).
 - e) If the front end of the DOG is detected, the speed will be reduced to the creep speed.
 - f) After detecting the rear end of the DOG, if the first zero-phase signal is detected, the operation will be stopped.
- 3) If the start position is in the near-point signal OFF area (after the DOG):
 - a) When the zero return instruction is executed, zero return will be started.
 - b) Transfer operation will be started in the zero return direction at the zero return speed.
 - c) If the reverse rotation limit 1 (reverse rotation limit) is detected, the speed will decelerate, and the operation will stop.
 - d) Transfer operation will be started in the opposite direction of the zero return direction at the zero return speed.
 - e) If the front end of the DOG is detected, the speed will be reduced and the operation will be stopped. (The workpiece will detect the DOG and then come out of the DOG area.)
 - f) Transfer operation will be restarted in the zero return direction at the zero return speed. (The workpiece will enter the DOG area again.)
 - g) If the front end of the DOG is detected, the speed will be reduced to the creep speed.
 - h) After detecting the rear end of the DOG, if the first zero-phase signal is detected, the operation will be stopped.

- 4) If the limit switch in the zero return direction turns ON (if the start position is at forward rotation limit 1 or reverse rotation limit 1):
 - a) When the zero return instruction is executed, zero return will be started.
 - b) Transfer operation will be started in the opposite direction of the zero return direction at the zero return speed.
 - c) If the front end of the DOG is detected, the speed will decelerate and the operation will stop. (The workpiece will detect the DOG and then come out of the DOG area.)
 - d) Transfer operation will be restarted in the zero return direction at the zero return speed (and the workpiece will enter the DOG area again).
 - e) If the front end of the DOG is detected, the speed will be reduced to the creep speed.
 - f) After detecting the rear end of the DOG, if the first zero-phase signal is detected, the operation will be stopped.

A

Common Items

B

Built-in
Positioning
Functions

Apx.

Example
Connection

6.2.4 Important Points

→ For important programming points, refer to Section 4.7.

- Detection of (the rear end and the front end of) the near-point signal (DOG) will be affected by the input filter and the scan time of the sequence program.
 Secure 1 scan time or more from the rear end of the DOG to turning ON of the zero-point signal.
- Since the zero-phase signal of the servo motor is used, adjust the relation between the rear end of the DOG and the zero-phase signal as shown in the following figure. If fine adjustment of the origin position is needed, adjust the position of the near-point signal (DOG).

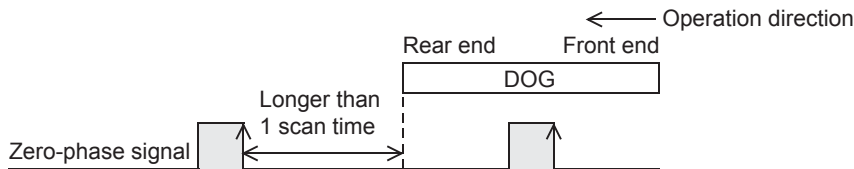

- Properly set the DOG so that the near-point signal (DOG) can be kept at the ON status until the speed is reduced to the creep speed.
 This instruction will start speed reduction at the front end of the DOG, and will stop the operation at the rear end of the DOG or at detection of the first zero-phase signal after passing the rear end of the DOG.
 The current value register will then be cleared (reset to "0").
 If the speed is not reduced to the creep speed before detecting the rear end of the DOG, the operation may not be stopped at the specified position.
- Use the near-point signal (DOG) between the reverse rotation limit 1 (LSR) and the forward rotation limit 1 (LSF).
 The intended operation may not be performed if the relationship among the near-point signal (DOG), reverse rotation limit 1 (LSR) and forward rotation limit 1 (LSF) is not as shown in the figure below.

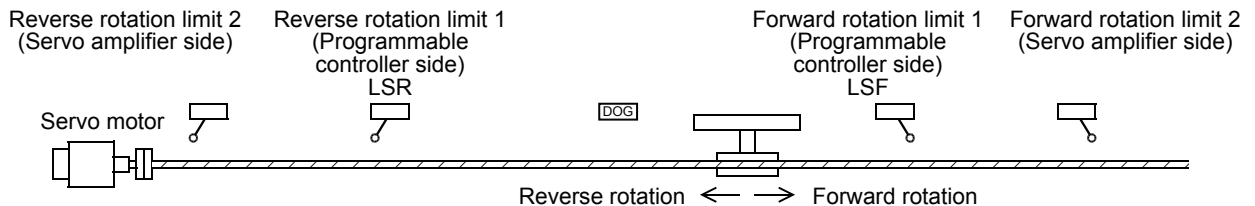

- The input device specified for the near-point signal (S1) or the zero-phase signal (S2) cannot be used for the following items:
 - High-speed counter
 - Input interruption
 - Pulse catch
 - SPD instruction
 - DVIT instruction*1
 - ZRN instruction
- *1. Only available for FX3U and FX3UC PLCs.
- The creep speed should be sufficiently slow.
 The zero return instruction will not decelerate at the stop point. Therefore, if the creep speed is not slow enough, the operation may not stop at the specified position due to inertia.
- If an operand is changed during instruction execution, the change will be ignored and the operation will not be affected. To change the operation, turn off the command contact of the instruction, and then turn it on again.
- If the instruction activation contact is turned off during the zero return operation, the speed will decelerate and the operation will stop. In this case, the "Instruction execution complete" flag (M8029) will not be turned on.
- If the "pulse output monitor" (BUSY/READY) flag is on, a positioning instruction (including PLSR and PLSY) that uses the same output cannot be executed.
 If the "pulse output monitor" (BUSY/READY) flag is still on after the instruction activation contact is turned off, do not execute a positioning instruction (including PLSR and PLSY instructions) that uses the same output number.

- In the following case, the "Instruction execution abnormal end" flag (M8329) will be turned on, and the execution of the instruction will be completed.
 - **For details on the "Instruction execution abnormal end" flag, refer to Subsection 4.7.4.**
- If the DOG search function cannot detect the near-point signal (DOG), the speed will decelerate and the operation will stop.
In this case, "Instruction execution abnormal end" flag (M8329) will be turned on, and the execution of the instruction will be completed.
- FX3S/FX3G/FX3GC PLCs operate in the sequence "CLEAR signal output → Pulse output stop".
Set the CLEAR signal detection to "While on, droop pulses are always cleared" for connected amplifiers (drivers).
The stop position may deviate if it is set to "Droop pulses are cleared on the leading edge".

6.3 Zero Return (ZRN Instruction)

Use this instruction to change the CLEAR signal output destination with an FX3UC PLC Ver. 2.20 or later and FX3S/FX3G/FX3GC/FX3U PLC.

6.3.1 Instruction Format

1. Instruction Format

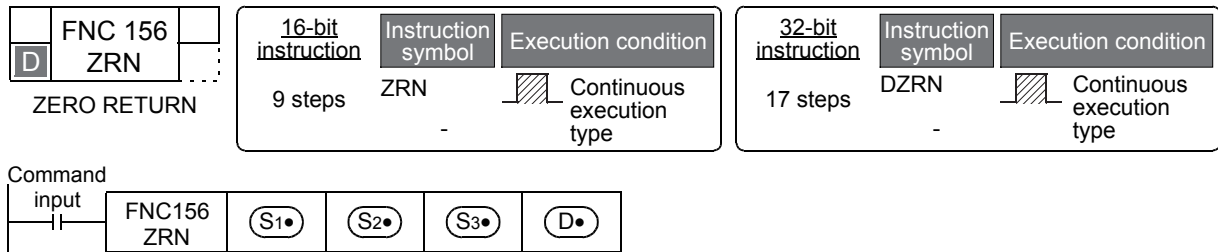

2. Data setting

Operand type	Description	Data type
(S1)	Specifies the zero return speed.*1	BIN16/32-bit
(S2)	Specifies the creep speed. (Setting range: 10 to 32,767 Hz)	
(S3)	Specifies an input number for the near-point signal(DOG).	Bit
(D)	Specifies the pulse output number.	

*1. Setting range : 10 to 32,767 Hz for 16-bit operation
 For 32-bit operation, however, the setting range should be as shown in the following table.

Pulse output destination		Setting range
FX3U PLC	High-speed output special adapter	10 to 200,000(Hz)
FX3S/FX3G/FX3GC/FX3U/FX3UC PLC	Main unit (transistor output)	10 to 100,000(Hz)

3. Devices

Operand type	Bit device							Word device										Others						
	System user							Digit designation				System user				Special unit	Index		Constant	Real number	Character string	Pointer		
	X	Y	M	T	C	S	D□.b	KnX	KnY	KnM	KnS	T	C	D	R	U□/G□	V	Z	Modify	K	H	E	"□"	P
(S1)								✓	✓	✓	✓	✓	✓	✓	▲3	▲4	✓	✓	✓	✓	✓			
(S2)								✓	✓	✓	✓	✓	✓	✓	▲3	▲4	✓	✓	✓	✓	✓			
(S3)	✓	✓	✓			✓	▲1												✓					
(D)		▲2																	✓					

▲1 : D□.b is available only in FX3U and FX3UC PLCs. However, index modifiers (V and Z) are not available.

▲2 : Specify Y000, Y001, or Y002*2 transistor output from the main unit, or specify Y000, Y001, Y002*4, or Y003*4 from a high-speed output special adapter*3.

*2. Y002 is not available in FX3G PLC (14-point and 24-point type) and FX3S/FX3GC PLC.

*3. High-speed output special adapters can be connected only to the FX3U PLC.

*4. To use Y002 and Y003 of a high-speed output special adapter, connect a second high-speed output special adapter.

▲3 : Only available for FX3G/FX3GC/FX3U/FX3UC PLCs.

▲4 : Only available for FX3U and FX3UC PLCs.

Note:

- To use an FX3U PLC of relay output type or triac output type, be sure to connect a high-speed output special adapter.
- Differential line drive type outputs will be used for the outputs of the high-speed output special adapter.

6.3.2 List of Related devices

1. Special auxiliary relays

The following table shows the related special auxiliary relays. Note that Y000, Y001, Y002, and Y003 are devices that determine the pulse output destinations.

Device number				Function	Attribute	Refer to
Y000	Y001	Y002*1	Y003*2			
M8029				"Instruction execution complete" flag	Read only	Subsection 4.4.2
M8329				"Instruction execution abnormal end" flag	Read only	Subsection 4.4.2
M8340	M8350	M8360	M8370	"Pulse output monitor" (BUSY/READY) flag	Read only	Subsection 4.4.3
M8341	M8351	M8361	M8371	CLEAR signal output function enable*3	Drivable	Subsection 4.3.4
M8343	M8353	M8363	M8373	Forward limit	Drivable	Subsection 4.3.1
M8344	M8354	M8364	M8374	Reverse limit	Drivable	Subsection 4.3.1
M8348	M8358	M8368	M8378	Positioning instruction activation	Read only	Subsection 4.4.4
M8349	M8359	M8369	M8379	Pulse output stop command*3	Drivable	Subsection 4.3.2
M8464	M8465	M8466	M8467	CLEAR signal device specification function enable*3, *4	Drivable	Subsection 4.3.4

*1. Y002 is not available in FX3G PLC (14-point and 24-point type) and FX3S/FX3GC PLC.

*2. Y003 is available only when two high-speed output special adapters are connected to the FX3U PLC.

*3. Cleared when PLC switches from RUN to STOP.

*4. Only available for FX3UC PLC Ver. 2.20 or later and FX3S/FX3G/FX3GC/FX3U PLC.

2. Special data registers

The following table shows the related special data registers. Note that Y000, Y001, Y002, and Y003 are devices that determine the pulse output destinations.

Device number								Function	Data length	Initial value	Refer to
Y000		Y001		Y002*5		Y003*6					
D8340	Low-order	D8350	Low-order	D8360	Low-order	D8370	Low-order	Current value register (PLS)	32-bit	0	Subsection 4.4.1
D8341	High-order	D8351	High-order	D8361	High-order	D8371	High-order				
D8342		D8352		D8362		D8372		Bias speed (Hz)	16-bit	0	Subsection 4.2.6
D8343	Low-order	D8353	Low-order	D8363	Low-order	D8373	Low-order	Maximum speed (Hz)	32-bit	100,000	Subsection 4.2.5
D8344	High-order	D8354	High-order	D8364	High-order	D8374	High-order				
D8348		D8358		D8368		D8378		Acceleration time (ms)	16-bit	100	Subsection 4.2.7
D8349		D8359		D8369		D8379		Deceleration time (ms)	16-bit	100	Subsection 4.2.8
D8464		D8465		D8466		D8467		CLEAR signal device specification*7	16-bit	-	Subsection 4.3.4

*5. Y002 is not available in FX3G PLC (14-point and 24-point type) and FX3S/FX3GC PLC.

*6. Y003 is available only when two high-speed output special adapters are connected to the FX3U PLC.

*7. Only available for FX3UC PLC Ver. 2.20 or later and FX3S/FX3G/FX3GC/FX3U PLC.

6.3.3 Function and operation

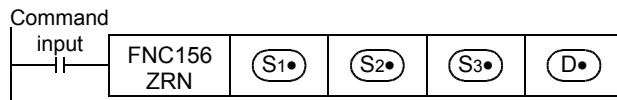

→ For details on the maximum speed, bias speed, acceleration time and deceleration time, refer to Subsection 4.2.5 to Subsection 4.2.8.

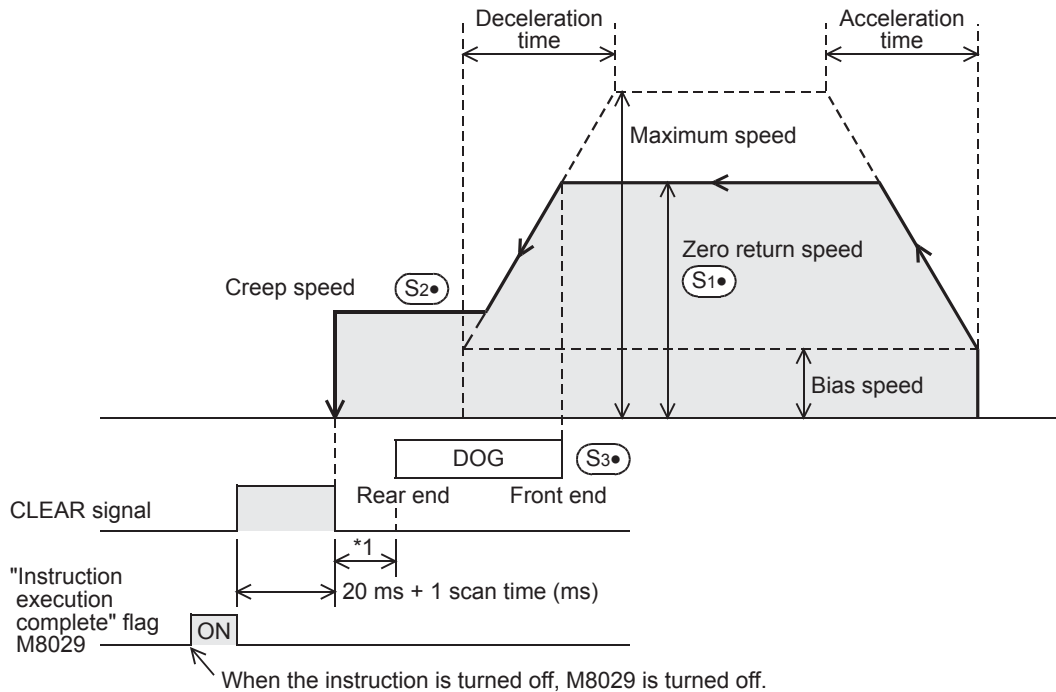

*1. Within 1 ms when X000 to X007 in the main unit (X000 to X005 in the FX3s PLC) is used, and within "1 ms + 1 scan time" when X010 or later (X006 or later in the FX3s PLC) is used.

- For (S1•), specify the zero return speed.
 If the set zero return speed value is more than the maximum speed value, the operation will be performed at the maximum speed.

		Setting range
16-bit operation		10 to 32,767(Hz)
32-bit operation	When a high-speed output special adapter is used	10 to 200,000(Hz)
	When a transistor output from the main unit is used	10 to 100,000(Hz)

Note that the zero return speeds shown in the following table will not apply.

Pulse output destination device	Zero return speed
(D1•) = Y000	D8347,D8346
(D1•) = Y001	D8357,D8356
(D1•) = Y002	D8367,D8366
(D1•) = Y003	D8377,D8376

- For (S2•), specify the creep speed.
 Setting range: 10 to 32,767 Hz

- 3) For (S3•), specify the near-point signal (DOG) input device number (NO contact).
 Turning on the near-point signal will reduce the speed to the creep speed. Turning off the near-point signal will complete the zero return operation.
 → For details, refer to "1. Zero return operation".
- If an input X000 to X007 (X000 to X005 for FX3s PLC) of the main unit is specified for the near-point signal (DOG), the PLC interruption function will be used to stop the operation. (To output the CLEAR signal, turn on the "CLEAR signal output function enable" relay.)
 Under the following condition, however, operation may be affected by the input filter or the scan time of the sequence program, and the operation, therefore, may not be stopped exactly at the origin.
 - An input number of X010 or higher (or other device (auxiliary relay, etc.)) is specified.
 If an input relay X010 or higher (X006 or higher for FX3s PLC) is specified for the near-point signal (DOG), the input filter will be applied.
- 4) For (D•), specify a pulse output number in the range of Y000 to Y003.
- 5) Zero return direction
 For this instruction, the zero return direction is set to the reverse rotation direction.
 (During zero return operation, the value indicated in the current value register will be decreased.)
 To perform zero return in the forward rotation direction, follow the example program below to control the direction output.
 → For programming details, refer to Section 4.7.
 → To use the main unit (transistor output), refer to Section 4.8.
 → To use a high-speed output special adapter, refer to Section 4.9.
- a) Turn on Y□□□ (rotational direction signal).
- b) Refresh Y□□□ output using the REF (FNC 50) instruction.
- c) Execute the ZRN instruction (zero return instruction).
- d) With the execution completion flag (M8029) of the ZRN instruction (zero return instruction), reset Y□□□ (rotational direction signal).

Example program:

In the program shown below, Y004 is specified as the rotation direction signal output device for Y000.

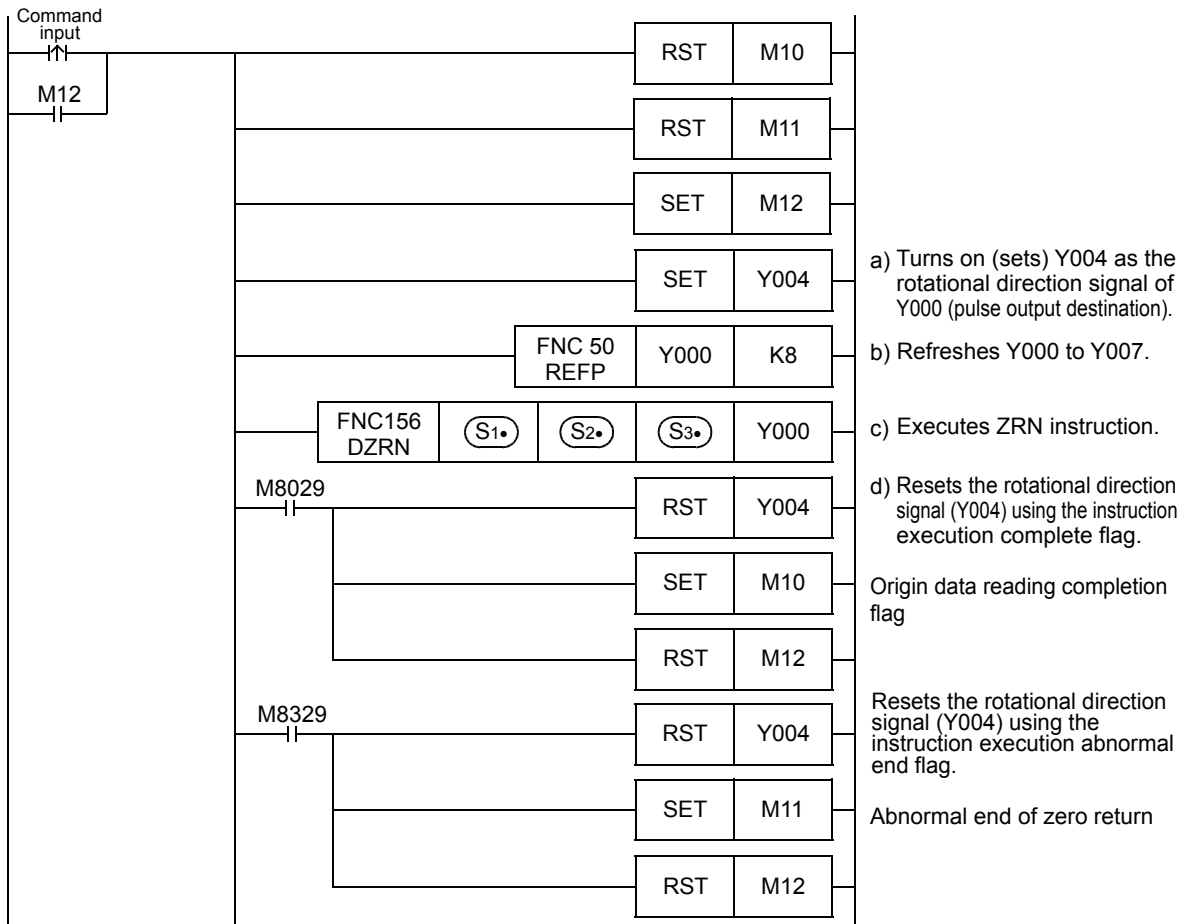

6) CLEAR signal output

This instruction can output the CLEAR signal after stopping at the origin. If it is necessary to output the CLEAR signal at the completion of zero return, turn on the "CLEAR signal output function enable" relay (see the following table). Use an FX3UC PLC Ver. 2.20 or later and FX3S/FX3G/FX3GC/FX3U PLC to specify the CLEAR signal output device.

- a) If it is not necessary to use the CLEAR signal device specification function, or if an FX3UC PLC of below Ver. 2.20 is used:

Pulse output destination device	Status of "CLEAR signal output function enable" relay	Status of "CLEAR signal device specification function enable" relay	CLEAR signal device number
(D1•) = Y000	M8341=ON	M8464=OFF	Y004
(D1•) = Y001	M8351=ON	M8465=OFF	Y005
(D1•) = Y002	M8361=ON	M8466=OFF	Y006
(D1•) = Y003	M8371=ON	M8467=OFF	Y007

- b) If it is necessary to use the CLEAR signal device specification function:

Turn on the "CLEAR signal device specification function enable" relay to specify the CLEAR signal output device (output Y) for the pulse output destination device using the CLEAR signal device specification register.

→ For the example of a program, refer to Subsection 4.3.4 or Subsection 4.5.1.

Pulse output destination device	Status of "CLEAR signal output function enable" relay	Status of "CLEAR signal device specification function enable" relay	CLEAR signal device specification register
(D1•) = Y000	M8341=ON	M8464=ON	D 8464
(D1•) = Y001	M8351=ON	M8465=ON	D 8465
(D1•) = Y002	M8361=ON	M8466=ON	D 8466
(D1•) = Y003	M8371=ON	M8467=ON	D 8467

1. Zero return operation

Zero return operation is described below assuming that Y000 is specified as the pulse output destination device (D•). If Y001, Y002, and Y003 are specified, it is necessary to change the output number of each related relay (special auxiliary relay, special data register) below.

→ For details on related flags, refer to Section 4.1 to Section 4.4, or Subsection 6.2.2.

- 1) Execute the ZRN instruction to carry out zero return.
- 2) Transfer operation will be performed at the zero return speed specified by (S1•).
- 3) If the near-point signal (DOG) specified by (S3•) is turned on, the speed will be reduced to the creep speed specified by (S2•).
- 4) If the near-point signal (DOG) specified by (S3•) is turned off, the pulse outputting operation will be immediately stopped.
- 5) If the CLEAR signal output function (M8341) is enabled (set to ON), the CLEAR signal (Y004) will be turned on within 1 ms*1 after the near-point signal (DOG) is turns from ON to OFF, and will be kept ON for "20 ms + 1 scan time (ms)".*2
- 6) The current value register (D8341, D8340) will be reset to "0" (will be cleared).
- 7) "Instruction execution complete" flag will be turned on, and the zero return operation will be completed.
 → For details on "Instruction execution complete" flag, refer to Subsection 4.7.4.

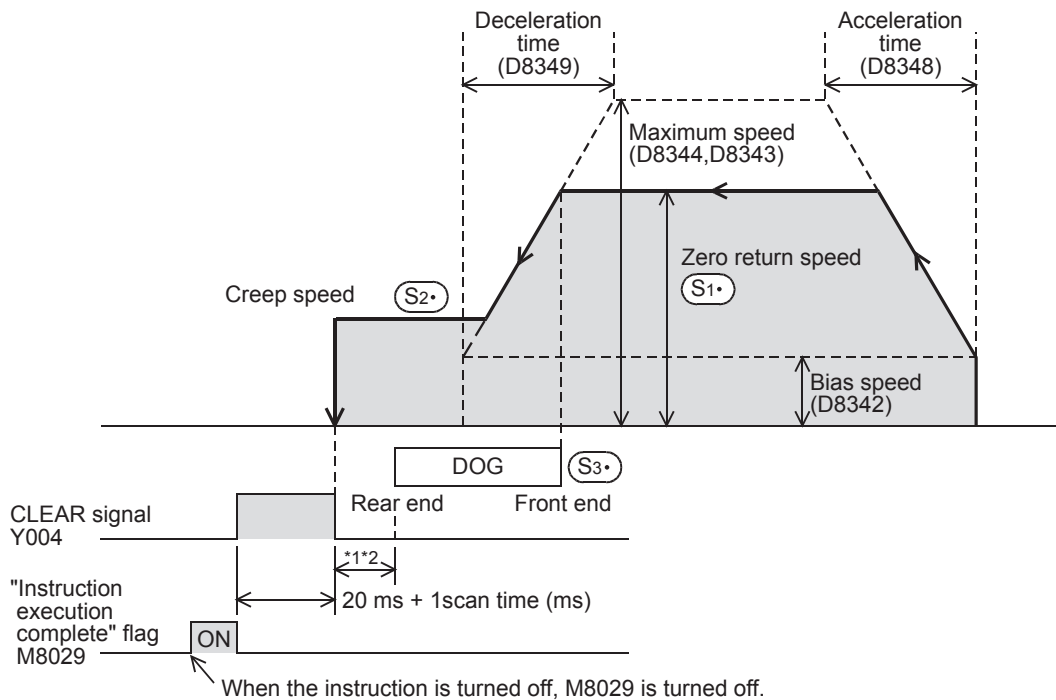

- *1. Within 1 ms when an input X000 to X007 (X000 to X005 in the FX3s PLC) is used for the near-point signal (DOG), and within "1 ms + 1 scan time" when an input X010 or later (X006 or later in the FX3s PLC) is used for the near-point signal (DOG).
- *2. FX3s/FX3G/FX3GC PLCs operate in the sequence "CLEAR signal output → Pulse output stop". Set the CLEAR signal detection to "While on, droop pulses are always cleared" for connected amplifiers (drivers). The stop position may deviate if it is set to "Droop pulses are cleared on the leading edge".

6.3.4 Important Points

→ For important programming points, refer to Section 4.7.

- If an input X000 to X007 (X000 to X005 for FX3S PLC) of the main unit is specified for the near-point signal (DOG), the PLC interruption function will be used to stop the operation.
 Under the following condition, however, operation may be affected by the input filter or the scan time of the sequence program.
 - An input number of X010 or higher (or other device (auxiliary relay, etc.)) is specified.
 If input relay X010 or higher is specified for the near-point signal (DOG), the effects of the input filter will be applied.
 - If an input X000 to X007 (X000 to X005 for FX3S PLC) of the main unit is specified for the near-point signal (DOG), the input cannot be used for the following items:
 - High-speed counter
 - Input interruption
 - Pulse catch
 - SPD instruction
 - DSZR instruction
 - DVIT instruction*1
 - Properly set the DOG so that the near-point signal (DOG) can be kept ON until the speed is reduced to the creep speed.
 This instruction will start speed reduction at the front end of the DOG, and will stop the operation at the rear end of the DOG. The current value register will then be cleared (reset to "0").
 If the speed is not reduced to the creep speed before detecting the rear end of the DOG, the operation may not be stopped at the specified position.
 - The creep speed should be sufficiently slow.
 The zero return instruction will not decelerate at the stop point. Therefore, if the creep speed is not slow enough, the operation may not stop at the specified position due to inertia.
 - The DOG search function does not apply for this instruction. Therefore, start the zero return operation on the front side of the near-point signal. If it is necessary to use the DOG search function, use the DSZR instruction.
 - The zero-phase signal of the servo motor cannot be used. For this reason, if fine adjustment of the origin position is needed, adjust the position of the near-point signal (DOG).
 - If the instruction activation contact is turned off during zero return operation, the speed will decelerate and the operation will stop. In this case, the "Instruction execution complete" flag (M8029) will not turn on.
 - While the "pulse output monitor" (BUSY/READY) flag is on, a positioning instruction (including PLSR and PLSY) that uses the same output cannot be executed.
 If the "pulse output monitor" (BUSY/READY) flag is still on after the instruction activation contact is turned off, do not execute a positioning instruction (including PLSR and PLSY instructions) that uses the same output number.
 - In the following case, the "Instruction execution abnormal end" flag (M8329) will be turned on, and execution of the instruction will be completed.
 - For details on the "Instruction execution abnormal end" flag, refer to Subsection 4.7.4.
 - If the forward limit relay or the reverse limit relay is turned on, the speed will decelerate and the operation will stop. In this case, the "Instruction execution abnormal end" flag (M8329) will be turned on when execution of the instruction is complete.
 - If the limit relay (forward or reverse) on the opposite side of the operation direction is turned on, the speed will decelerate and the operation will stop.
 In this case, the "Instruction execution abnormal end" flag (M8329) will be turned on when execution of the instruction is complete.
 - FX3S/FX3G/FX3GC PLCs operate in the sequence "CLEAR signal output → Pulse output stop".
 Set the CLEAR signal detection to "While on, droop pulses are always cleared" for connected amplifiers (drivers).
 The stop position may deviate if it is set to "Droop pulses are cleared on the leading edge".
- *1. Only available for FX3U and FX3UC PLCs.

7. Absolute Position Detection System (Absolute Current Value Read) - ABS Instruction

With the use of the servo absolute position detection system, the built-in positioning function uses the current ABS value read-out (ABS) instruction to read out the current value (absolute position (ABS) data) from the MR-J4□A, MR-J3□A, MR-J2(S)□A, or MR-H□A servo amplifier.

→ For items to be observed in programming, refer to Section 4.7.

→ For the servo amplifier and connection of the MELSERVO Series, refer to the Appendix and the examples of connection.

7.1 Instruction Format

1. Instruction Format

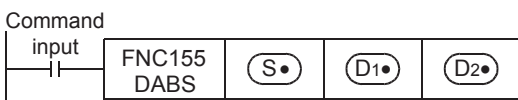
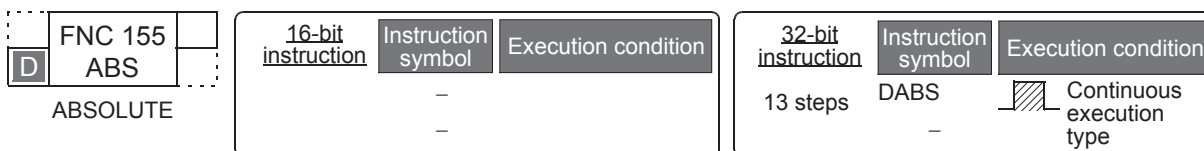

2. Data setting

Operand type	Description	Data type
(S•)	Specifies the first number of the device that inputs the absolute position (ABS) data from the servo amplifier. Number of occupied points: 3 (first point for (S•))	Bit
(D1•)	Specifies the first number of the device that outputs the absolute position (ABS) data control signal to the servo amplifier. Number of occupied points: 3 (first point for (D1•))	
(D2•)	Specifies the absolute position (ABS) data (32-bit value) storage device number.	BIN32-bit

3. Devices

Operand type	Bit device							Word device							Others									
	System user							Digit designation				System user			Special unit	Index		Con-stant	Real number	Char-acter string	Pointer			
	X	Y	M	T	C	S	D□.b	KnX	KnY	KnM	KnS	T	C	D	R	U□/G□	V	Z	Modify	K	H	E	"□"	P
(S•)	✓	✓	✓			✓	▲2												✓					
(D1•)		▲1	✓			✓	▲2												✓					
(D2•)									✓	✓	✓	✓	✓	✓	▲3	▲4			✓	✓				

▲1 : Use a transistor output.

▲2 : D□.b is available only in FX3U and FX3UC PLCs. However, index modifiers (V and Z) are not available.

▲3 : Only available for FX3G/FX3GC/FX3U and FX3UC PLCs.

▲4 : Only available for FX3U and FX3UC PLCs.

7.2 List of Related Devices

→ For details on the related devices, refer to Section 4.1 to Section 4.4.

1. Special auxiliary relays

The following table shows the related special auxiliary relays.

Note that Y000, Y001, Y002, and Y003 are devices that determine the pulse output destinations.

→ For details on PLSY (FNC 57), PWM (FNC 58), and PLSR (FNC 59) instructions, refer to the programming manual.

Device number				Function	Attribute	Refer to
Y000	Y001	Y002*1	Y003*2			
M8029				"Instruction execution complete" flag	Read only	Subsection 4.4.2
M8329				"Instruction execution abnormal end" flag	Read only	Subsection 4.4.2

*1. Y002 is not available in FX3G PLC (14-point and 24-point type) and FX3S/FX3GC PLC.

*2. Y003 is available only when two high-speed output special adapters are connected to the FX3U PLC.

2. Special data registers

The following table shows the related special data registers. Note that Y000, Y001, Y002, and Y003 are devices that determine the pulse output destinations.

Device number								Function	Data length	Initial value	Refer to
Y000		Y001		Y002*3		Y003*4					
D8340	Low-order	D8350	Low-order	D8360	Low-order	D8370	Low-order	Current value register (PLS)	32-bit	0	Subsection 4.4.1
D8341	High-order	D8351	High-order	D8361	High-order	D8371	High-order				

*3. Y002 is not available in FX3G PLC (14-point and 24-point type) and FX3S/FX3GC PLC.

*4. Y003 is available only when two high-speed output special adapters are connected to the FX3U PLC.

7.3 Function and Operation

Connect an MR-J4□A, MR-J3□A, MR-J2(S)□A, or MR-H□A servo amplifier (with absolute position detection function) manufactured by Mitsubishi to your system, and use this instruction to read out the absolute position (ABS) data. The data will be converted into a pulse value before being read out.

Command

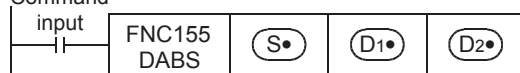

- For (S), specify the first number of the device that inputs the absolute position (ABS) data from the servo amplifier. Number of occupied points: 3 ((S) is ABS (bit 0), (S)+1 is ABS (bit 1), and (S)+2 is the "send data ready" signal.)
- For (D1), specify the first number of the device that outputs the absolute position (ABS) data control signal to the servo amplifier. Be sure to use transistor outputs for the PLC outputs. Number of occupied points: 3 ((D1) is the "servo-ON" signal, (D1)+1 is the ABS data transfer mode, and (D1)+2 is the "ABS data request" signal.)
- For (D2), specify the absolute position (ABS) data (32-bit value) storage device number to store the data read out from the servo amplifier. Handle the absolute position (ABS) data as follows:
 - To use the built-in pulse output function, be sure to specify the following current value registers for the read-out ABS data:

Y000	Y001	Y002*1	Y003*2
D8341,D8340	D8351,D8350	D8361,D8360	D8371, D8370

*1. Y002 is not available in FX3G PLC (14-point and 24-point type) and FX3S/FX3GC PLC.

*2. Y003 is available only when two high-speed output special adapters are connected to the FX3U PLC.

- When using the FX2N-1PG(-E), read out the ABS data to the data register first, and then write the read-out ABS data into the current value register of the FX2N-1PG(-E) using instructions such as the DTO instruction.
 When using the FX3U-1PG or FX2N-10PG, either read out the ABS data to the data register first and write the read-out ABS data into the current value register (value converted into pulse) of the FX3U-1PG or FX2N-10PG using instructions such as the DTO instruction or directly specify the buffer memory (U□\G□) for (D2•) to be written to.

1. Detection of absolute position

- 1) If the DABS (FNC155) instruction turns ON, the PLC will activate the servo-ON output and the ABS transfer mode output.
- 2) 32+6-bit data communication will be performed while mutually checking the data sending/receiving condition using the "send data ready" signal and the "ABS data request" signal.
- 3) The 2-bit line (line for ABS bit 0 and bit 1) will be used for data transmission.
- 4) At the completion of ABS data reading, the "Instruction execution complete" flag (M8029) will turn on.
 → **For details on the "Instruction execution complete" flag, refer to Subsection 4.7.4.**

Example for MR-J3□A

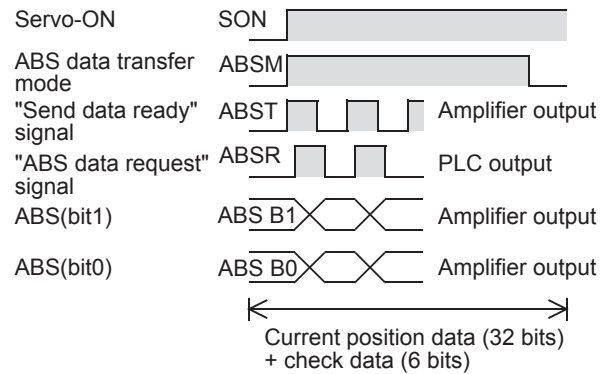

7.4 Initial Zero Return

When your system is established, even if your servo motor is equipped with an absolute position detection function, it is necessary to perform zero return at least once to send the CLEAR signal to the servo motor. Use one of the following methods for the initial zero return:

- 1) Execute DSZR (FNC150) with DOG search zero return instruction or ZRN (FNC156) zero return instruction using the CLEAR signal function to complete zero return.
- 2) Carry out zero return for the machine using the position adjustment method in the jogging operation mode or manual operation mode, and then input the CLEAR signal.
 To input the CLEAR signal, use the output of the PLC or the external switch shown in the following figure.

Example for MR-J2□A

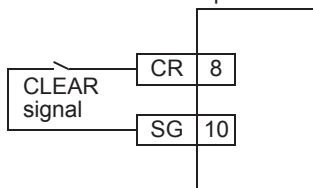

7.5 Important Points

- Set the timing sequence for powering on your system so that the power of the PLC is turned on after the power of the servo amplifier, or that power is turned on at the same time.
- Leave the drive contact of the DABS (FNC155) instruction ON after reading the ABS value. If the instruction activation contact is turned off at the completion of ABS data reading, the servo-ON (SON) signal will be turned off, and the operation will not be performed.
- If the instruction activation contact is turned off during data reading, data reading will be stopped.
- This instruction is for 32-bit data only. Be sure to input this instruction as the DABS instruction.
- Observe the following items to use the FX3U-1PG, FX2N-1PG(-E) or FX2N-10PG:
 - ABS data will be converted into a pulse value before being read out. For this reason, be sure to specify "motor system" when setting the parameters (BFM#3) for the FX2N-1PG(-E).
 - When writing ABS data to the FX2N-10PG, be sure to use the current value register (BFM#40, BFM#39) to store the converted pulse data.
 - When writing the ABS data to the FX3U-1PG, write it to the current value registers (BFM#59 and#58) which store pulse converted values.
- Even if data-communication with the servo amplifier is not performed properly, no error will be detected. For this reason, it is necessary to monitor the handshaking operation using the time-out error detection timer.

→ For the example programs, refer to Section 12.5.
- Set the servo motor rotation direction as described below when using the ABS instruction. Note that the sign (plus or minus) may be different between the current value controlled by the PLC and the current value existing in the servo amplifier after the current value is read by the ABS instruction if another direction is set. In the MR-J2□-A and MR-H□-A, the setting "Forward rotation (CCW) when forward rotation pulses are input, and reverse rotation (CW) when reverse rotation pulses are input" cannot be changed.
 - When using the positioning function built in the FX3S/FX3G/FX3GC/FX3U and FX3UC PLC
 Set the servo amplifier rotation direction to "Forward rotation (CCW) when forward rotation pulses are input, and reverse rotation (CW) when reverse rotation pulses are input".
 → For details, refer to the Servo amplifier manual.
 - When using the FX3U-1PG, FX2N-1PG(-E) or FX2N-10PG with the FX3U or FX3UC PLC
 Achieve the following relationship for the rotation direction setting between the FX3U-1PG, FX2N-1PG or FX2N-10PG and the servo amplifier.

Setting in FX3U-1PG/FX2N-1PG(-E)/ FX2N-10PG	Setting in servo amplifier
Current value is increased by forward rotation pulses.	Servo amplifier rotates forward (CCW) when forward rotation pulses are input. Servo amplifier rotates backward (CW) when reverse rotation pulses are input.
Current value is decreased by forward rotation pulses.	Servo amplifier rotates backward (CW) when forward rotation pulses are input. Servo amplifier rotates forward (CCW) when reverse rotation pulses are input.

8. 1-Speed Positioning - DRVI/DRVA Instruction

The built-in positioning function uses the drive to increment (DRVI) instruction or the drive to absolute (DRVA) instruction to perform 1-speed positioning. Note that these two instructions use different target position setting methods.

Instruction	Target position setting method
Drive to Increment (DRVI) instruction	Incremental method: Uses a relative address to specify the target position.
Drive to Absolute (DRVA) instrument	Absolute method: Uses an absolute address to specify the target position.

→ For important items common to all of the positioning instructions, refer to Section 4.7.
 → For example programs, refer to Chapter 12.

8.1 Incremental Method and Absolute Method

There are two target position setting methods for positioning operations as described below:

1. Incremental method (relative address setting method)

While regarding the current position as the start point, specify the transfer direction and the transfer distance (relative address) to determine the target position.

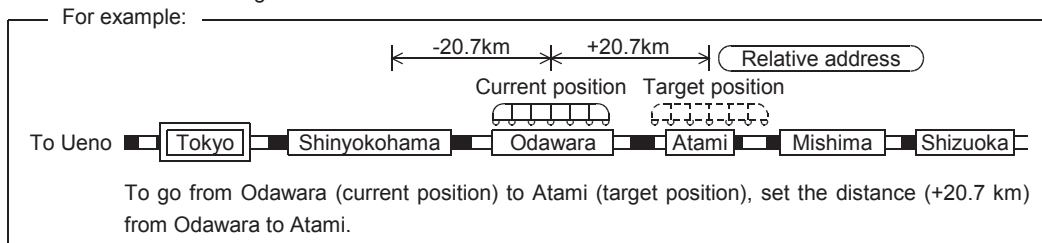
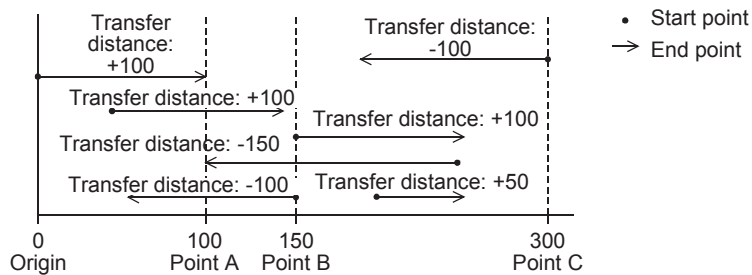

2. Absolute method (absolute address setting method)

Specify the distance (absolute address) from the origin to the target position. In this case, any position can be the start point (current position).

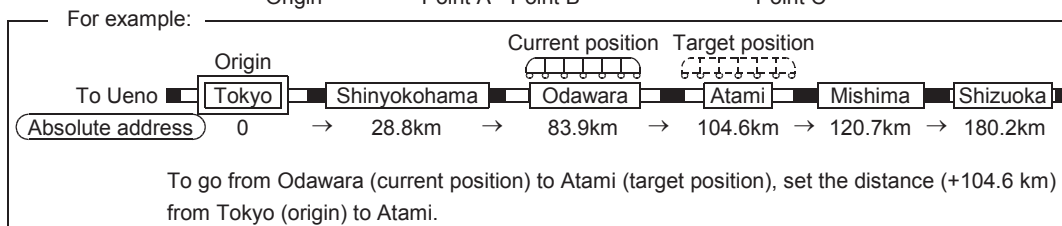
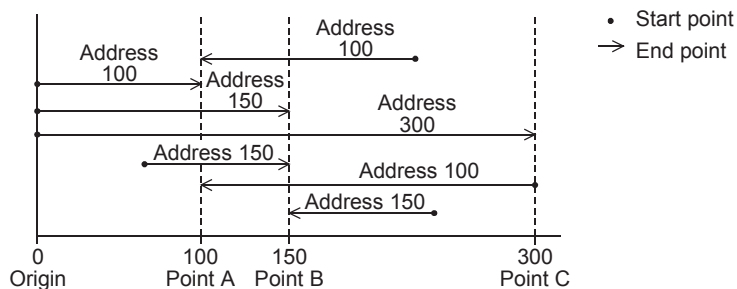

8.2 Drive to Increment - DRVI Instruction

8.2.1 Instruction Format

1. Instruction Format

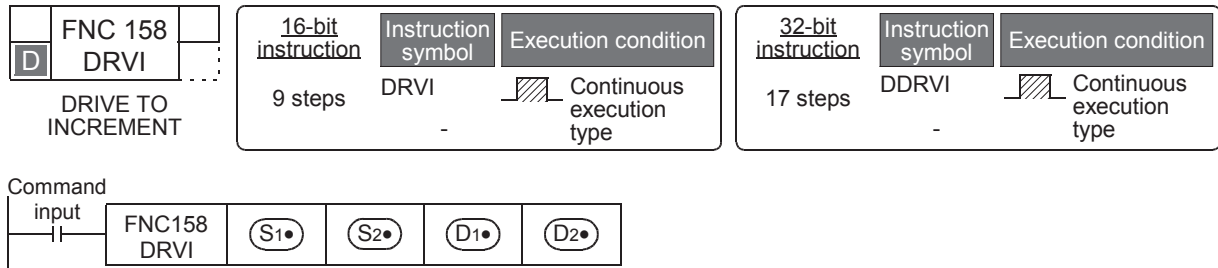

2. Data setting

Operand type	Description	Data type
(S1)	Specifies the number of output pulses (relative address). ^{*1}	BIN16/32-bit
(S2)	Specifies the output pulse frequency. ^{*2}	
(D1)	Specifies the pulse output number.	Bit
(D2)	Specifies the rotation direction signal output destination device number.	

*1. Setting range : -32,768 to +32,767 (excluding 0) for 16-bit operation
 : -999,999 to +999,999 (excluding 0) for 32-bit operation

*2. Setting range : 10 to 32,767 Hz for 16-bit operation
 For 32-bit operation, however, the setting range is as shown in the following table.

Pulse output destination		Setting range
FX3U PLC	High-speed output special adapter	10 to 200,000(Hz)
FX3S/FX3G/FX3GC/FX3U/FX3UC PLC	Main unit (transistor output)	10 to 100,000(Hz)

3. Devices

Operand type	Bit device							Word device										Others						
	System user							Digit designation				System user				Special unit		Index		Constant		Real number	Character string	Pointer
	X	Y	M	T	C	S	D□.b	KnX	KnY	KnM	KnS	T	C	D	R	U□\G□	V	Z	Modify	K	H	E	"□"	P
(S1)								✓	✓	✓	✓	✓	✓	✓	▲4	▲5	✓	✓	✓	✓	✓			
(S2)								✓	✓	✓	✓	✓	✓	✓	▲4	▲5	✓	✓	✓	✓	✓			
(D1)		▲1																	✓					
(D2)		▲2	✓				▲3												✓					

▲1 : Specify Y000, Y001, or Y002^{*3} transistor output from the main unit, or specify Y000, Y001, Y002^{*5}, or Y003^{*5} from a high-speed output special adapter^{*4}.

*3. Y002 is not available in FX3G PLC (14-point and 24-point type) and FX3S/FX3GC PLC.

*4. High-speed output special adapters can be connected only to the FX3U PLC.

*5. To use Y002 and Y003 with a high-speed output special adapter, connect a second high-speed output special adapter.

Note:

- To use an FX3U PLC of relay output type or triac output type, be sure to connect a high-speed output special adapter.
- Differential line drive type outputs will be used for the outputs of the high-speed output special adapter.

- ▲2 : When a high-speed output special adapter is used as a destination for pulse output on a FX3U PLC, use the output shown in the following table for rotation direction signals.
 When a built-in transistor output is used as a destination for pulse output on a FX3S/FX3G/FX3GC/FX3U/FX3UC PLC, use transistor output for signals rotation direction.

→ For the outputs applicable with a High-speed output special adapter, refer to Section 4.9.

High-speed output special adapter connection position	Pulse output	Rotation direction output
1st adapter	(D1•) = Y000	(D2•) = Y004
	(D1•) = Y001	(D2•) = Y005
2nd adapter	(D1•) = Y002	(D2•) = Y006
	(D1•) = Y003	(D2•) = Y007

- ▲3 : D□.b is available only in FX3U and FX3UC PLCs. However, index modifiers (V and Z) are not available.
 ▲4 : Only available for FX3G/FX3GC/FX3U and FX3UC PLCs.
 ▲5 : Only available for FX3U and FX3UC PLCs.

8.2.2 List of Related Devices

1. Special auxiliary relays

The following table shows the related special auxiliary relays. Note that Y000, Y001, Y002, and Y003 are devices that determine the pulse output destinations.

Device number				Function	Attribute	Refer to
Y000	Y001	Y002*1	Y003*2			
M8029				"Instruction execution complete" flag	Read only	Subsection 4.4.2
M8329				"Instruction execution abnormal end" flag	Read only	Subsection 4.4.2
M8340	M8350	M8360	M8370	"Pulse output monitor" (BUSY/READY) flag	Read only	Subsection 4.4.3
M8343	M8353	M8363	M8373	Forward limit	Drivable	Subsection 4.3.1
M8344	M8354	M8364	M8374	Reverse limit	Drivable	Subsection 4.3.1
M8348	M8358	M8368	M8378	Positioning instruction activation	Read only	Subsection 4.4.4
M8349	M8359	M8369	M8379	Pulse output stop command*3	Drivable	Subsection 4.3.2

*1. Y002 is not available in FX3G PLC (14-point and 24-point type) and FX3S/FX3GC PLC.

*2. Y003 is available only when two high-speed output special adapters are connected to the FX3U PLC.

*3. Cleared when the PLC switches from RUN to STOP.

2. Special data registers

The following table shows the related special data registers. Note that Y000, Y001, Y002, and Y003 are devices that determine the pulse output destinations.

Device number								Function	Data length	Initial value	Refer to
Y000		Y001		Y002*1		Y003*2					
D8340	Low-order	D8350	Low-order	D8360	Low-order	D8370	Low-order	Current value register (PLS)	32-bit	0	Subsection 4.4.1
D8341	High-order	D8351	High-order	D8361	High-order	D8371	High-order				
D8342		D8352		D8362		D8372		Bias speed (Hz)	16-bit	0	Subsection 4.2.6
D8343	Low-order	D8353	Low-order	D8363	Low-order	D8373	Low-order	Maximum speed (Hz)	32-bit	100,000	Subsection 4.2.5
D8344	High-order	D8354	High-order	D8364	High-order	D8374	High-order				
D8345		D8355		D8365		D8375		Creep speed (Hz)	16-bit	1000	Subsection 4.2.4
D8346	Low-order	D8356	Low-order	D8366	Low-order	D8376	Low-order	Zero return speed (Hz)	32-bit	50,000	Subsection 4.2.3
D8347	High-order	D8357	High-order	D8367	High-order	D8377	High-order				
D8348		D8358		D8368		D8378		Acceleration time (ms)	16-bit	100	Subsection 4.2.7
D8349		D8359		D8369		D8379		Deceleration time (ms)	16-bit	100	Subsection 4.2.8

*1. Y002 is not available in FX3G PLC (14-point and 24-point type) and FX3s/FX3GC PLC.

*2. Y003 is available only when two high-speed output special adapters are connected to the FX3U PLC.

8.2.3 Function and Operation

This instruction uses a relative drive method to perform a 1-speed positioning instruction. For this instruction, the transfer distance from the current position to the target position should be specified together with a plus or minus sign. This method is also referred to as the incremental (relative) drive method.

→ For details on the "Instruction execution complete" flag, refer to Subsection 4.7.4.

→ For details on the maximum speed, bias speed, acceleration time, and deceleration time, refer to Section 4.2.

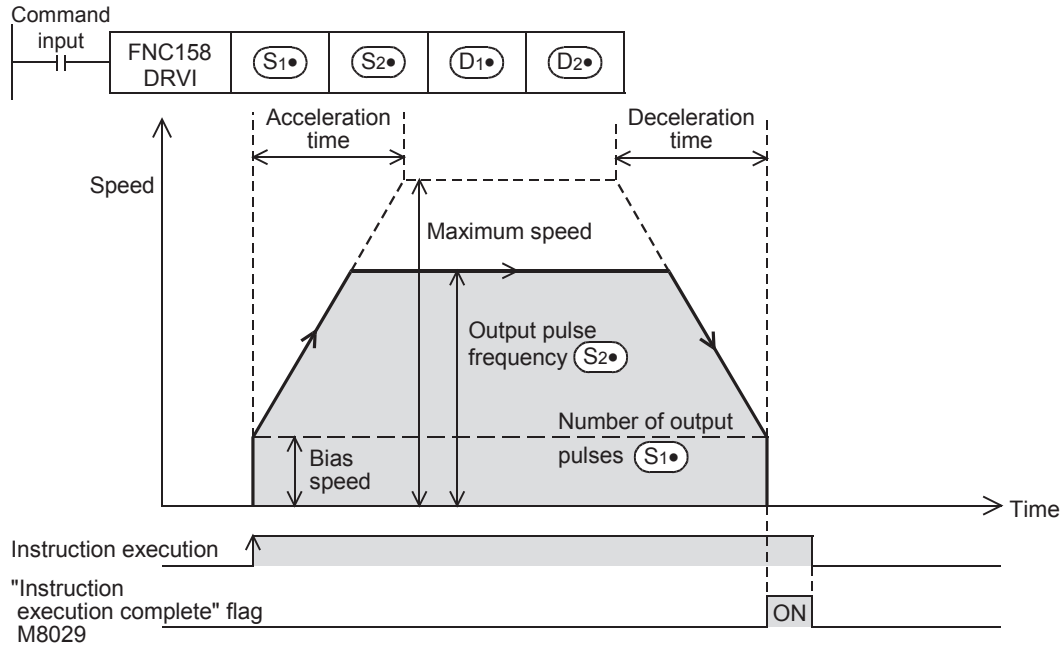

- 1) For (S1), specify the number of output pulses (relative address value).

	Setting range
16-bit operation	-32,768 to +32,767
32-bit operation	-999,999 to +999,999

- 2) For (S2), specify the output pulse frequency.

		Setting range
16-bit operation		10 to 32,767(Hz)
32-bit operation	When a high-speed output special adapter is used	10 to 200,000(Hz)
	When a transistor output from the main unit is used	10 to 100,000(Hz)

- 3) For (D1), specify the pulse output number in the range of Y000 to Y003.

- 4) For (D2), specify the rotation direction signal output device number.

When a high-speed output special adapter is used as a destination for pulse output on a FX3U PLC, use the output shown in the following table for rotation direction signals.

When a built-in transistor output is used as a destination for pulse output on a FX3S/FX3G/FX3GC/FX3U/FX3UC PLC, use transistor output for signals rotation direction.

High-speed output special adapter connection position	Pulse output destination device	Rotation direction output
1st adapter	(D1) = Y000	(D2) = Y004
	(D1) = Y001	(D2) = Y005
2nd adapter	(D1) = Y002	(D2) = Y006
	(D1) = Y003	(D2) = Y007

The rotation direction ON/OFF status of the specified device is shown in the following table.
 During instruction execution, however, do not use the output (D2•) for other purposes.

ON/OFF status of device specified by (D2•)	Rotation direction (increase/decrease current value)
ON	If the number of output pulses specified by (S1•) is a positive number, the operation will be performed in the forward rotation direction. Forward rotation (Outputting pulses from (D1•) will increase the current value.)
OFF	If the number of output pulses specified by (S1•) is a negative number, the operation will be performed in the reverse rotation direction. Reverse rotation (Outputting pulses from (D1•) will decrease the current value.)

8.2.4 Important Points

→ For the important points of programming, refer to Section 4.7.

- If an operand is changed during instruction execution, the change will be ignored and the operation will not be affected.
 Note that the changed operand will be enabled at the next activation of the instruction.
- If the instruction activation contact is turned off during execution of the instruction, the speed will decelerate and the operation will stop.
 In this case, the "Instruction execution complete" flag (M8029) will not be turned on.
- If the limit flag (forward or reverse) in the operation direction is turned on, the speed will decelerate and the operation will stop.
 In this case, the "Instruction execution abnormal end" flag (M8329) will be turned on when execution of the instruction is complete.
 → For details on the "Instruction execution abnormal end" flag, refer to Subsection 4.7.4.
- While the "pulse output monitor" (BUSY/READY) flag is on, a positioning instruction (including PLSR and PLSY) that uses the same output cannot be executed.
 If the "pulse output monitor" (BUSY/READY) flag is still on after the instruction activation contact is turned off, do not execute a positioning instruction (including PLSR and PLSY instructions) that uses the same output number.

8.3 Drive To Absolute - DRVA Instruction

8.3.1 Instruction Format

1. Instruction format

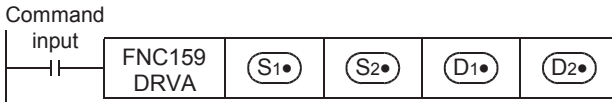
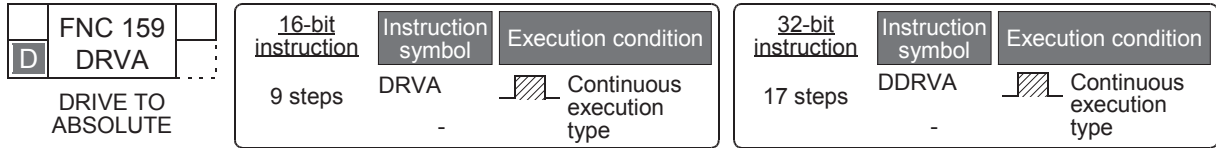

2. Data setting

Operand type	Description	Data type
(S1)	Specifies the number of output pulses (absolute address). ^{*1}	BIN16/32-bit
(S2)	Specifies the output pulse frequency. ^{*2}	
(D1)	Specifies the pulse output number.	Bit
(D2)	Specifies the rotation direction signal output destination device number.	

*1. Setting range : -32,768 to +32,767 for 16-bit operation
 : -999,999 to +999,999 for 32-bit operation

*2. Setting range : 10 to 32,767 Hz for 16-bit operation
 For 32-bit operation, however, the setting range is as shown in the following table.

Pulse output destination		Setting range
FX3U PLC	High-speed output special adapter	10 to 200,000(Hz)
FX3S/FX3G/FX3GC/FX3U/FX3UC PLC	Main unit (transistor output)	10 to 100,000(Hz)

3. Devices

Operand type	Bit device							Word device								Others									
	System user							Digit designation				System user				Special unit	Index	Constant	Real number	Character string	Pointer				
	X	Y	M	T	C	S	D□.b	KnX	KnY	KnM	KnS	T	C	D	R							U□\G□	V	Z	Modify
(S1)								✓	✓	✓	✓	✓	✓	✓	▲4	▲5	✓	✓	✓	✓	✓				
(S2)								✓	✓	✓	✓	✓	✓	✓	▲4	▲5	✓	✓	✓	✓	✓				
(D1)		▲1																	✓						
(D2)		▲2	✓				✓	▲3											✓						

▲1 : Specify Y000, Y001, or Y002^{*3} transistor output from the main unit, or specify Y000, Y001, Y002^{*5}, or Y003^{*5} from a high-speed output special adapter^{*4}.

*3. Y002 is not available in FX3G PLC (14-point and 24-point type) and FX3S/FX3GC PLC.

*4. High-speed output special adapters can be connected only to the FX3U PLC.

*5. To use Y002 and Y003 with a high-speed output special adapter, connect a second high-speed output special adapter.

Caution:

- To use an FX3U PLC of relay output type or triac output type, be sure to connect a high-speed output special adapter.
- Differential line drive type outputs will be used for the outputs of the high-speed output special adapter.

▲2 : When a high-speed output special adapter is used as a destination for pulse output on a FX3U PLC, use the output shown in the following table for rotation direction signals.
 When a built-in transistor output is used as a destination for pulse output on a FX3S/FX3G/FX3GC/FX3U/FX3UC PLC, use transistor output for signals rotation direction.

→ For the outputs applicable with a High-speed output special adapter, refer to Section 4.9.

High-speed output special adapter connection position	Pulse output	Rotation direction output
1st adapter	(D1•) = Y000	(D2•) = Y004
	(D1•) = Y001	(D2•) = Y005
2nd adapter	(D1•) = Y002	(D2•) = Y006
	(D1•) = Y003	(D2•) = Y007

▲3 : D□.b is available only in FX3U and FX3UC PLCs. However, index modifiers (V and Z) are not available.

▲4 : Only available for FX3G/FX3GC/FX3U and FX3UC PLCs.

▲5 : Only available for FX3U and FX3UC PLCs.

8.3.2 List of Related Devices

1. Special auxiliary relays

The following table shows the related special auxiliary relays. Note that Y000, Y001, Y002, and Y003 are devices that determine the pulse output destinations.

Device number				Function	Attribute	Refer to
Y000	Y001	Y002*1	Y003*2			
M8029				"Instruction execution complete" flag	Read only	Subsection 4.4.2
M8329				"Instruction execution abnormal end" flag	Read only	Subsection 4.4.2
M8340	M8350	M8360	M8370	"Pulse output monitor" (BUSY/READY) flag	Read only	Subsection 4.4.3
M8343	M8353	M8363	M8373	Forward limit	Drivable	Subsection 4.3.1
M8344	M8354	M8364	M8374	Reverse limit	Drivable	Subsection 4.3.1
M8348	M8358	M8368	M8378	Positioning instruction activation	Read only	Subsection 4.4.4
M8349	M8359	M8369	M8379	Pulse output stop command*3	Drivable	Subsection 4.3.2

*1. Y002 is not available in FX3G PLC (14-point and 24-point type) and FX3S/FX3GC PLC.

*2. Y003 can be specified as the pulse output destination only if two FX3U-2HSY-ADP are connected to the FX3U PLC.

*3. Cleared when the PLC switches from RUN to STOP.

2. Special data registers

The following table shows the related special data registers. Note that Y000, Y001, Y002, and Y003 are devices that determine the pulse output destinations.

Device number								Function	Data length	Default value	Refer to
Y000		Y001		Y002*1		Y003*2					
D8340	Low-order	D8350	Low-order	D8360	Low-order	D8370	Low-order	Current value register (PLS)	32-bit	0	Subsection 4.4.1
D8341	High-order	D8351	High-order	D8361	High-order	D8371	High-order				
D8342		D8352		D8362		D8372		Bias speed (Hz)	16-bit	0	Subsection 4.2.6
D8343	Low-order	D8353	Low-order	D8363	Low-order	D8373	Low-order	Maximum speed (Hz)	32-bit	100,000	Subsection 4.2.5
D8344	High-order	D8354	High-order	D8364	High-order	D8374	High-order				
D8345		D8355		D8365		D8375		Creep speed (Hz)	16-bit	1000	Subsection 4.2.4
D8346	Low-order	D8356	Low-order	D8366	Low-order	D8376	Low-order	Zero return speed (Hz)	32-bit	50,000	Subsection 4.2.3
D8347	High-order	D8357	High-order	D8367	High-order	D8377	High-order				
D8348		D8358		D8368		D8378		Acceleration time (ms)	16-bit	100	Subsection 4.2.7
D8349		D8359		D8369		D8379		Deceleration time (ms)	16-bit	100	Subsection 4.2.8

*1. Y002 is not available in FX3G PLC (14-point and 24-point type) and FX3S/FX3GC PLC.

*2. Y003 can be specified as the pulse output destination only if two FX3U-2HSY-ADP are connected to the FX3U PLC.

8.3.3 Function and Operation

This instruction uses an absolute drive method to perform a 1-speed positioning instruction.
 For this instruction, the distance from the origin (zero-point) to the target position should be specified.

- For details on the "Instruction execution complete" flag, refer to Subsection 4.7.4.
- For details on the maximum speed, bias speed, acceleration time, and deceleration time, refer to Section 4.2.

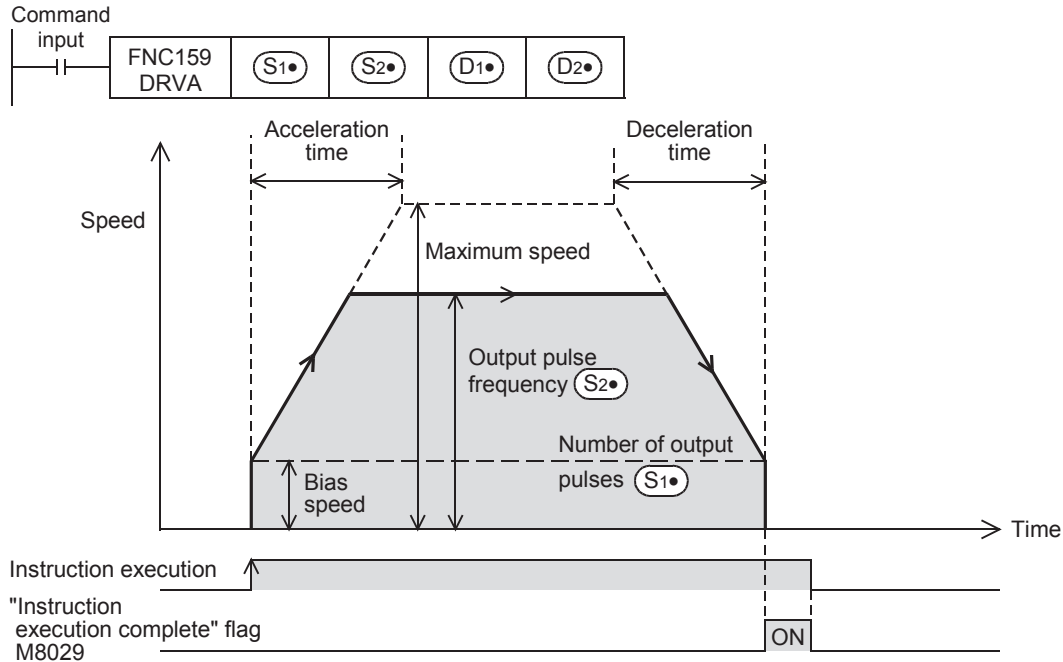

- 1) For (S1), specify the number of output pulses (absolute address value).

	Setting range
16-bit operation	-32,768 to +32,767
32-bit operation	-999,999 to +999,999

- 2) For (S2), specify the output pulse frequency.

		Setting range
16-bit operation		10 to 32,767(Hz)
32-bit operation	When a high-speed output special adapter is used	10 to 200,000(Hz)
	When a transistor output from the main unit is used	10 to 100,000(Hz)

- 3) For (D1), specify the pulse output number in the range of Y000 to Y003.

- 4) For (D2), specify the rotation direction signal output device number.

When a high-speed output special adapter is used as a destination for pulse output on a FX3U PLC, use the output shown in the following table for rotation direction signals.

When a built-in transistor output is used as a destination for pulse output on a FX3S/FX3G/FX3GC/FX3U/FX3UC PLC, use transistor output for signals rotation direction.

High-speed output special adapter connection position	Pulse output destination device	Rotation direction output
1st adapter	(D1) = Y000	(D2) = Y004
	(D1) = Y001	(D2) = Y005
2nd adapter	(D1) = Y002	(D2) = Y006
	(D1) = Y003	(D2) = Y007

The rotation direction ON/OFF status of the specified device is shown in the following table.
 During instruction execution, however, do not use the output (D2•) for other purposes.

ON/OFF status of device specified by (D2•)	Rotation direction (increase/decrease current value)	
ON	Forward rotation (Outputting pulses from (D1•) will increase the current value.)	The rotation direction (normal or reverse rotation) depends on which value is larger; the number of output pulses specified by (S•) (absolute address) or the value indicated in the current value register.
OFF	Reverse rotation (Outputting pulses from (D1•) will reduce the current value.)	

8.3.4 Important Points

→ For the important points of programming, refer to Section 4.7.

- If an the operand is changed during instruction execution, the change will be ignored and the operation will not be affected.
 Note that the changed operand will be enabled at the next activation of the instruction.
- If the instruction activation contact is turned off during execution of the instruction, the speed will decelerate and the operation will stop.
 In this case, the "Instruction execution complete" flag (M8029) will not be turned on.
- If the limit flag (forward or reverse) in the operation direction is turned on, the speed will decelerate and the operation will stop. In this case, the "Instruction execution abnormal end" flag (M8329) will be turned on when execution of the instruction is complete.
 → For details on the "Instruction execution abnormal end" flag, refer to Subsection 4.7.4.
- If the "pulse output monitor" (BUSY/READY) flag is on, a positioning instruction (including PLSR and PLSY) that uses the same output cannot be executed.
 If the "pulse output monitor" (BUSY/READY) flag is still on after the instruction activation contact is turned off, do not execute a positioning instruction (including PLSR and PLSY instructions) that uses the same output number.

9. One-speed Interrupt constant quantity feed - DVIT Instruction

The built-in positioning function uses the Interrupt Positioning (DVIT) instruction to perform one-speed interrupt constant quantity feed. If an FX3UC PLC Ver. 1.30 or later is used, this instruction can change the interruption signal input destination.

If an FX3U/FX3UC PLC Ver. 2.20 or later is used, the interruption signal can be controlled with a user program. The FX3S/FX3G/FX3GC PLC does not support the DVIT instruction (the interrupt positioning).

→ For items to be observed in programming, refer to Section 4.7.

9.1 Instruction Format

1. Instruction Format

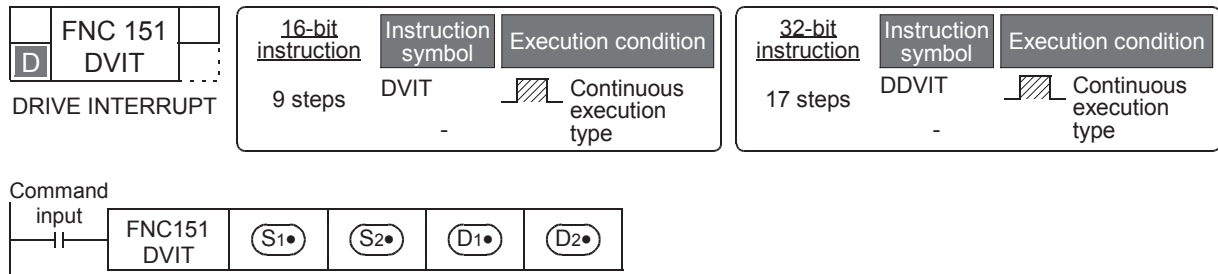

2. Data setting

Operand type	Description	Data type
(S1•)	Specifies the number of pulses (relative address) to be output after interruption. ^{*1}	BIN16/32-bit
(S2•)	Specifies the output pulse frequency. ^{*2}	
(D1•)	Specifies the pulse output number.	Bit
(D2•)	Specifies the rotation direction signal output destination device number.	

*1. Setting range : -32,768 to +32,767 (excluding 0) for 16-bit operation
 : -999,999 to +999,999 (excluding 0) for 32-bit operation

*2. Setting range : 10 to 32,767 Hz for 16-bit operation
 For 32-bit operation, however, the setting range should be as shown in the following table.

Pulse output destination		Setting range
FX3U PLC	High-speed output special adapter	10 to 200,000(Hz)
FX3U/FX3UC PLC	Main unit (transistor output)	10 to 100,000(Hz)

3. Devices

Operand type	Bit device							Word device										Others						
	System user							Digit designation				System user				Special unit	Index			Constant	Real number	Character string	Pointer	
	X	Y	M	T	C	S	D□.b	KnX	KnY	KnM	KnS	T	C	D	R	U□V□G□	V	Z	Modify	K	H	E	"□"	P
(S1•)							✓	✓	✓	✓	✓	✓	✓	✓	✓			✓	✓	✓				
(S2•)							✓	✓	✓	✓	✓	✓	✓	✓	✓			✓	✓	✓				
(D1•)		▲1																✓						
(D2•)		▲2	✓			▲3												✓						

▲1 : Specify Y000, Y001, or Y002 transistor output from the main unit, or specify Y000, Y001, Y002*2, or Y003*2 from a high-speed output special adapter*1.

*1. A high-speed output special adapter cannot be connected to the FX3UC PLC.

*2. To use Y002 and Y003 with a high-speed output special adapter, connect a second high-speed output special adapter.

Point:

- To use an FX3U Series main unit of relay output type or triac output type, be sure to connect a high-speed output special adapter.
- Differential line drive type outputs will be used for the outputs of the high-speed output special adapter.

▲2 : When a high-speed output special adapter is used as a destination for pulse output on a FX3U PLC, use the output shown in the following table for rotation direction signals.
 When a built-in transistor output is used as a destination for pulse output on a FX3U/FX3UC PLC, use transistor output for signals rotation direction.

→ For the outputs applicable with a High-speed output special adapter, refer to Section 4.9.

High-speed output special adapter connection position	Pulse output	Rotation direction output
1st adapter	(D1•) = Y000	(D2•) = Y004
	(D1•) = Y001	(D2•) = Y005
2nd adapter	(D1•) = Y002	(D2•) = Y006
	(D1•) = Y003	(D2•) = Y007

▲3 : D□.b cannot be indexed by index registers (V and Z).

A
Common Items

B
Built-in Positioning Functions

Apx.
Example Connection

9.2 List of Related Devices

1. Special auxiliary relays

The following table shows the related special auxiliary relays. Note that Y000, Y001, Y002, and Y003 are devices that determine the pulse output destinations.

Device number				Function	Attribute	Refer to
Y000	Y001	Y002	Y003*1			
M8029				"Instruction execution complete" flag	Read only	Subsection 4.4.2
M8329				"Instruction execution abnormal end" flag	Read only	Subsection 4.4.2
M8336				Interrupt input specification function enable *2,*3	Drivable	Subsection 4.3.7
M8340	M8350	M8360	M8370	"Pulse output monitor" (BUSY/READY) flag	Read only	Subsection 4.4.3
M8343	M8353	M8363	M8373	Forward limit	Drivable	Subsection 4.3.1
M8344	M8354	M8364	M8374	Reverse limit	Drivable	Subsection 4.3.1
M8347	M8357	M8367	M8377	Interrupt signal logic reverse *3*4	Drivable	Subsection 4.3.8
M8348	M8358	M8368	M8378	Positioning instruction activation	Read only	Subsection 4.4.4
M8349	M8359	M8369	M8379	Pulse output stop command*3	Drivable	Subsection 4.3.2
M8460	M8461	M8462	M8463	User interrupt input command*3,*5	Drivable	Subsection 4.3.7
M8464	M8465	M8466	M8467	CLEAR signal device specification function enable*3,*5	Drivable	Subsection 4.3.4

*1. Y003 is available only when two high-speed output special adapters are connected to the FX3U PLC.

*2. This function is valid for the FX3UC PLC if Ver.1.30 or later is used.

*3. Cleared when the PLC switches from RUN to STOP.

*4. The logical NOT function is not valid for the user interrupt input command.

*5. This function is valid for the FX3UC PLC if Ver.2.20 or later is used.

2. Special data registers

The following table shows the related special data registers. Note that Y000, Y001, Y002, and Y003 are devices that determine the pulse output destinations.

Device number								Function	Data length	Initial value	Refer to
Y000	Y001	Y002	Y003*1								
D8336								Specification of interrupt input.*2	16-bit	-	Subsection 4.3.7
D8340	Low-order	D8350	Low-order	D8360	Low-order	D8370	Low-order	Current value register (PLS)	32-bit	0	Subsection 4.4.1
D8341	High-order	D8351	High-order	D8361	High-order	D8371	High-order				
D8342		D8352		D8362		D8372		Bias speed (Hz)	16-bit	0	Subsection 4.2.6
D8343	Low-order	D8353	Low-order	D8363	Low-order	D8373	Low-order	Maximum speed (Hz)	32-bit	100,000	Subsection 4.2.5
D8344	High-order	D8354	High-order	D8364	High-order	D8374	High-order				
D8348		D8358		D8368		D8378		Acceleration time (ms)	16-bit	100	Subsection 4.2.7
D8349		D8359		D8369		D8379		Deceleration time (ms)	16-bit	100	Subsection 4.2.8
D8464		D8465		D8466		D8467		Specifies the CLEAR signal device.*3	16-bit	-	Subsection 4.3.4

*1. Y003 is available only when two high-speed output special adapters are connected to the FX3U PLC.

*2. This function is valid for the FX3UC PLC if Ver.1.30 or later is used. However, to specify the user interrupt input command, Ver.2.20 or later should be used.

*3. This function is valid for the FX3UC PLC if Ver.2.20 or later is used.

9.3 Function and Operation

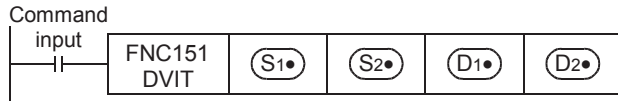

→ For details on the maximum speed, bias speed, acceleration time, and deceleration time, refer to Subsection 4.2.5 to Subsection 4.2.8.

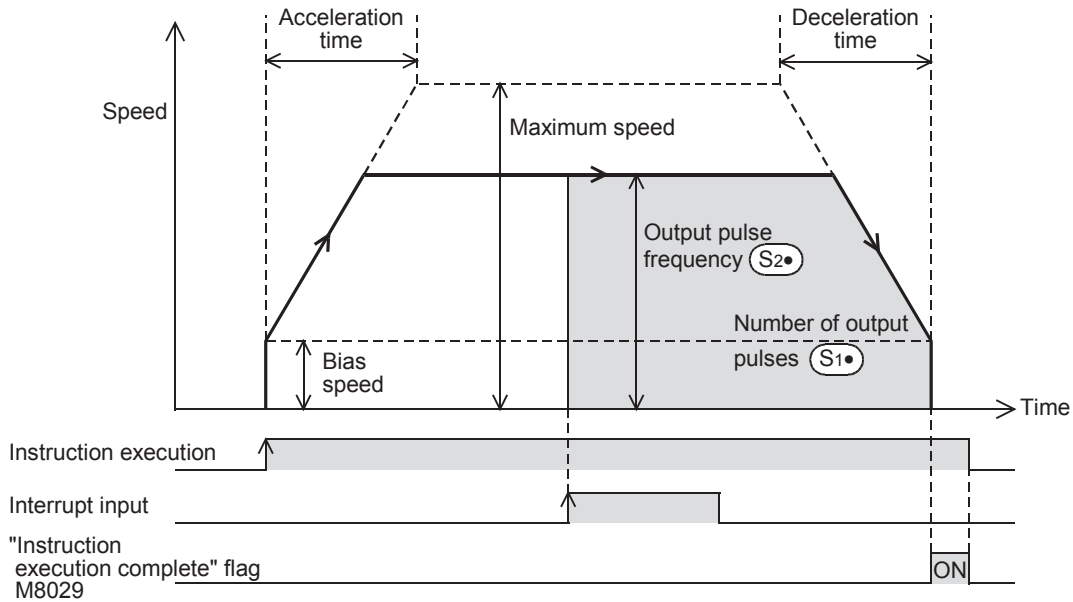

1) For (S1), specify the number of output pulses (relative address value).

	Setting range
16-bit operation	-32,768 to +32,767 (excluding 0)
32-bit operation	-999,999 to +999,999 (excluding 0)

2) For (S2), specify the output pulse frequency.

		Setting range
16-bit operation		10 to 32,767(Hz)
32-bit operation	When a high-speed output special adapter is used	10 to 200,000(Hz)
	When a transistor output from the main unit is used	10 to 100,000(Hz)

3) For (D1), specify the pulse output number in the range of Y000 to Y003.

4) For (D2), specify the rotation direction signal output device number.

When a high-speed output special adapter is used as a destination for pulse output on a FX3U PLC, use the output shown in the following table for rotation direction signals.

When a built-in transistor output is used as a destination for pulse output on a FX3U/FX3UC PLC, use transistor output for signals rotation direction.

High-speed output special adapter number	Pulse output destination device	Rotation direction output
1st adapter	(D1) = Y000	(D2) = Y004
	(D1) = Y001	(D2) = Y005
2nd adapter	(D1) = Y002	(D2) = Y006
	(D1) = Y003	(D2) = Y007

The rotation direction ON/OFF status of the specified device is shown in the following table. During instruction execution, however, do not use the output (D2•) for other purposes.

ON/OFF status of device specified by (D2•)	Rotation direction (increase/decrease current value)
ON	If the number of pulses to be output after interruption (specified by (S1•)) is set to a positive number, the operation will be performed in the forward rotation direction. Forward rotation (Outputting pulses from (D1•)) will increase the current value.)
OFF	If the number of pulses to be output after interruption (specified by (S1•)) is set to a negative number, the operation will be performed in the reverse rotation direction. Reverse rotation (Outputting pulses from (D1•)) will decrease the current value.)

- 5) The interrupt input signal depends on the pulse output of (D1•) as shown in the following table. Use an FX3uc PLC Ver. 1.30 or later to use the interrupt input specification function. Use an FX3u/FX3uc PLC Ver. 2.20 or later to set the user interrupt input command.

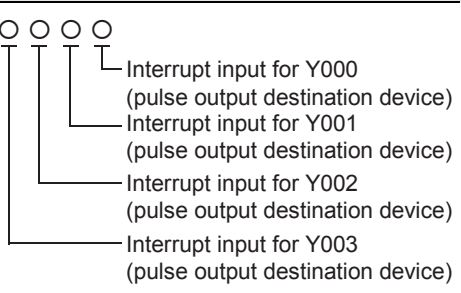
Pulse output destination device	Interrupt input signal	
	If it is not necessary to use the interrupt input specification function (M8336 = OFF), or if the FX3uc PLC below Ver. 1.30 is used	If it is necessary to use the interrupt input specification function (M8336 = ON)
(D1•) = Y000	X000	D8336=H 
(D1•) = Y001	X001	
(D1•) = Y002	X002	
(D1•) = Y003*1	X003	

*1. Y003 is available only when two high-speed output special adapters are connected to the FX3u PLC.

Designation of interrupt input using M8336 interrupt input specification function:

- Turn on the M8336.
- Set the interrupt input number (X000 to X007) in D8336, or specify the user interrupt input command *2.
 → For details on the specification method, refer to Subsection 4.3.7 or Subsection 4.5.1.

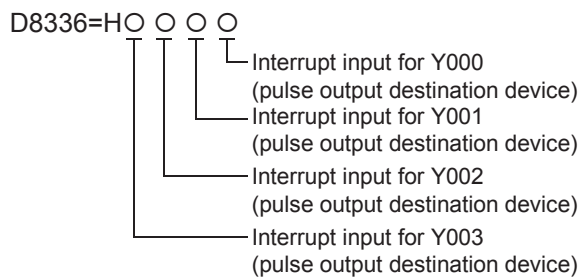

Setting value	Description of setting
0	Specifies X000 for the interrupt input signal.
1	Specifies X001 for the interrupt input signal.
⋮	⋮
7	Specifies X007 for the interrupt input signal.

Setting value	Description of setting										
8 ^{*2}	Specifies a user interrupt input command ^{*2} for the interrupt input signal.										
	<table border="1" style="width: 100%; border-collapse: collapse;"> <thead> <tr> <th style="text-align: center;">Pulse output destination device</th> <th style="text-align: center;">User interrupt input command</th> </tr> </thead> <tbody> <tr> <td style="text-align: center;">Y000</td> <td style="text-align: center;">M8460</td> </tr> <tr> <td style="text-align: center;">Y001</td> <td style="text-align: center;">M8461</td> </tr> <tr> <td style="text-align: center;">Y002</td> <td style="text-align: center;">M8462</td> </tr> <tr> <td style="text-align: center;">Y003^{*3}</td> <td style="text-align: center;">M8463</td> </tr> </tbody> </table>	Pulse output destination device	User interrupt input command	Y000	M8460	Y001	M8461	Y002	M8462	Y003 ^{*3}	M8463
	Pulse output destination device	User interrupt input command									
	Y000	M8460									
	Y001	M8461									
Y002	M8462										
Y003 ^{*3}	M8463										
9 ~ E ^{*4}	Do not specify these values.										
F	Set "F" for a pulse output destination device if the device is not used for the Interrupt Positioning (DVIT) instruction.										

- *2. A device can only be specified if an FX3U/FX3UC PLC Ver. 2.20 or later is used. When using an FX3UC PLC below Ver. 2.20, if "8" is set and then the specified Interrupt Positioning (DVIT) instruction turns ON, an operation error (error code: K6763) will occur, and the instruction will not cause any operation.
- *3. Y003 is available only when two high-speed output special adapters are connected to the FX3U PLC.
- *4. After setting a number in the range of 9 to E for the interrupt input signal, if the corresponding Interrupt Positioning (DVIT) instruction turns ON, an operation error (error code: K6763) will occur, and the instruction will not cause any operation.

Example program:

The following program shows that the interrupt input for Y000 is set using the user interrupt input command (M8460).

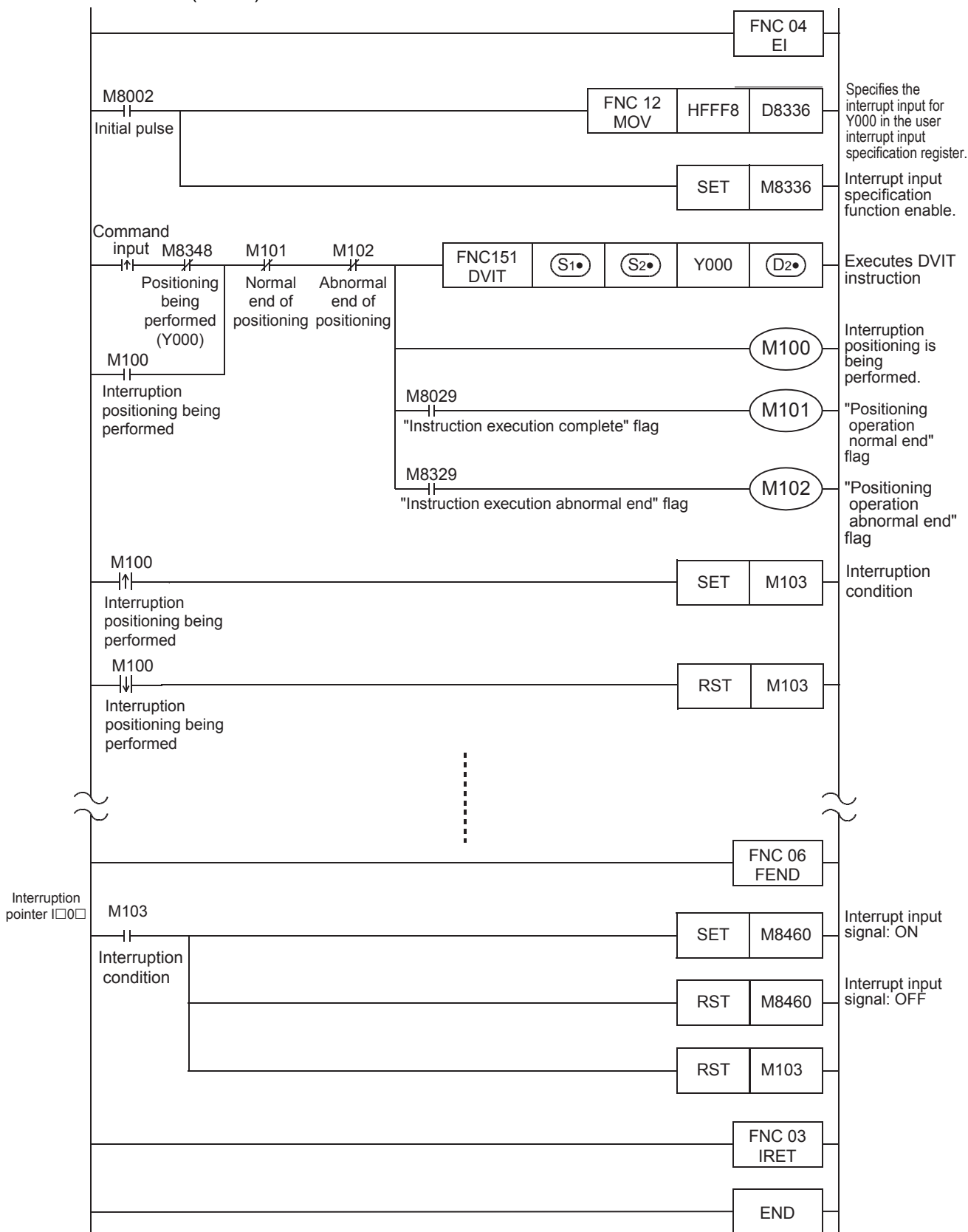

After specifying a user interrupt input command for the interrupt input signal, if the specified device is turned on, the number of pulses specified by (S1) will be output and then the operation will be stopped. Before activating the Interrupt Positioning instruction again, be sure to turn off the user interrupt input command.

A Common Items
B Built-in Positioning Functions
Apx. Example Connection

6) Interrupt input signal logical NOT

Turn the "Interrupt signal logic reverse" relay ON or OFF (see the following table) to specify the logic of the interrupt input signal. However, if the user interrupt input command is set for the pulse output destination device, the interrupt input signal logical NOT function cannot be used.

Pulse output destination device	"Interrupt signal logic reverse" relay	Description
(D1•) = Y000	M8347	OFF: Positive logic (Turning the input ON will turn on the interrupt input signal.) ON: Negative logic (Turning the input OFF will turn on the interrupt input signal.)
(D1•) = Y001	M8357	
(D1•) = Y002	M8367	
(D1•) = Y003*1	M8377	

*1. Y003 is available only when two high-speed output special adapters are connected to the FX3u PLC.

1. Interruption positioning operation

The interruption positioning operation is described below assuming that Y000 is specified as the pulse output destination device by (D1•).

For this reason, if Y001, Y002, or Y003 is specified, it is necessary to change the output number of each related flag.

→ For details on related flags, refer to Section 4.1 to Section 4.4, or Section 9.2.

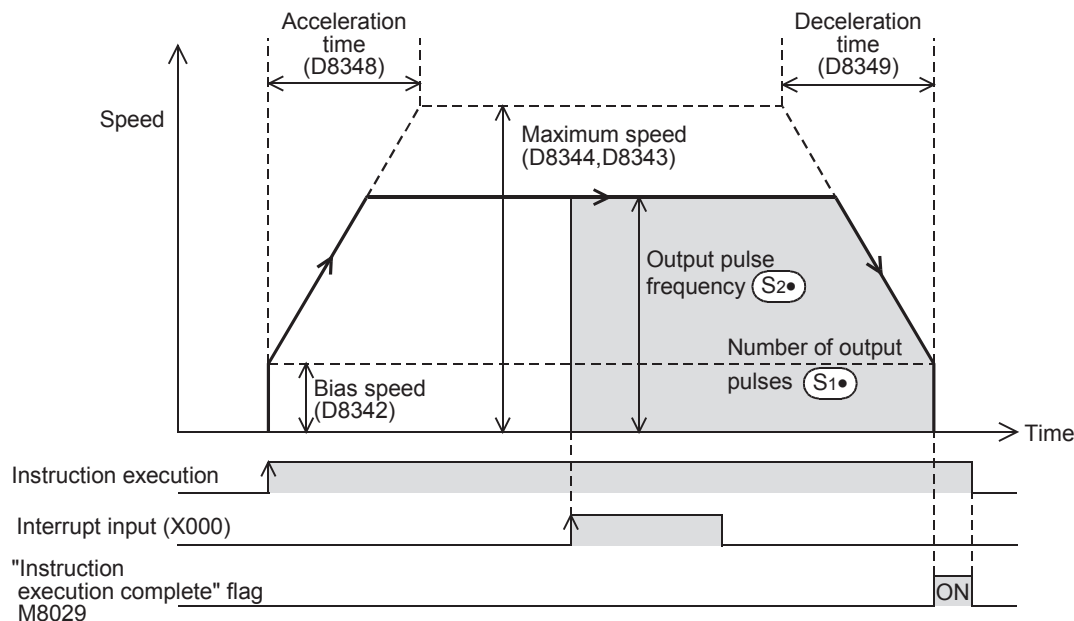

- 1) Execute the Interruption Positioning (DVIT) instruction.
- 2) Transfer operation will be performed in the direction specified by the sign attached to the number of output pulses (specified by (S1•)) at the speed specified by the output pulse frequency (specified by (S2•)).
- 3) If interrupt input X000 is turned on, pulses will be output until the number of output pulses reaches the number specified by (S1•), and then the operation will stop.
- 4) The "instruction execution complete" flag (M8029) will turn on, and the interruption positioning operation will be completed.

→ For details on "Instruction execution complete" flag, refer to Subsection 4.7.4.

9.4 Important Points

→ For details on the instruction activation timing, refer to Section 4.7.

- If the speed is too high for the number of pulses specified by (S1•), the frequency will be reduced so that the speed can be reduced within the specified number of output pulses.

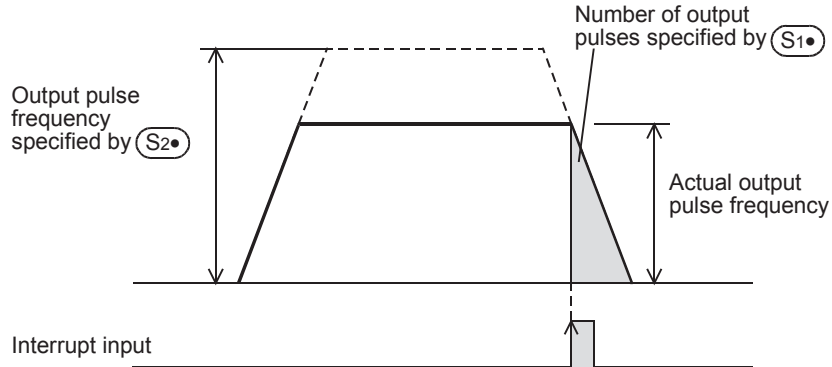

- If there is a possibility for the interrupt input instruction to be turned on during acceleration, specify the number of pulses so that the relation can be set to "number of output pulses \geq number of pulses needed for acceleration + number of pulses needed for deceleration".
 If the relation is set to "number of output pulses $<$ number of pulses needed for acceleration + number of pulses needed for deceleration", the operation will be as shown in the following figure:

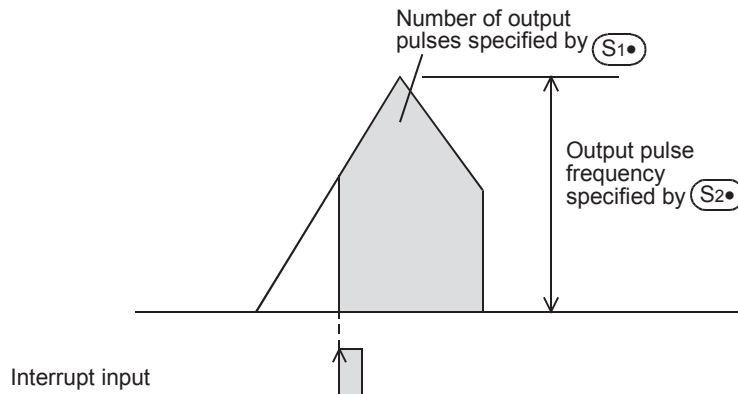

- If the interrupt input turns ON before execution of the instruction, the operation will be performed in the same way as the DRVI instruction.
- If an operand is changed during instruction execution, the change will be ignored and the operation will not be affected. To reflect the change on the operation, turn off the command contact of the instruction, and then turn it on again.
- If the instruction activation contact is turned off during operation, the speed will decelerate and the operation will stop. In this case, the "Instruction execution complete" flag (M8029) will not be turned on.
- Input the interruption signal before the number of output pulses reaches 4,294,967,296. If the number of pulses reaches 4,294,967,296 before inputting the interruption signal, the operation will stop, and the "Instruction execution complete" flag (M8029) will be turned on.
 → For details on "Instruction execution complete" flag, refer to Subsection 4.7.4.
- If the "pulse output monitor" (BUSY/READY) flag is on, a positioning instruction (including PLSR and PLSY) that uses the same output cannot be executed.
 If the "pulse output monitor" (BUSY/READY) flag is still on after the instruction activation contact is turned off, do not execute a positioning instruction (including PLSR and PLSY instructions) that uses the same output number.
- If the forward limit relay or the reverse limit relay in the operation direction is turned on, the speed will decelerate and the operation will stop. In this case, the "Instruction execution abnormal end" flag (M8329) will turn when execution of the instruction is complete.

→ For details on "Instruction execution abnormal end" flag, refer to Subsection 4.7.4.

- The interrupt input cannot be used for the following items:
Interrupt inputs can only be specified when using Ver.1.30 or later.
 - High-speed counter
 - Input interruption
 - Pulse catch
 - SPD instruction
 - DSZR instruction
 - ZRN instruction

10. Variable Speed Operation (Variable Speed Pulse Output) - PLSV Instruction

The built-in positioning function uses the variable speed pulse output (PLSV) instruction equipped with the rotation direction designation function to perform variable speed operation. If an FX3UC PLC Ver. 2.20 or later and FX3S/FX3G/FX3GC/FX3U PLC is used, this instruction can change the speed using the acceleration/ deceleration speed.

10.1 Instruction Format

1. Instruction Format

<table border="1"> <tr><td style="width: 20px; height: 20px;"></td><td style="text-align: center;">FNC 157</td><td style="width: 20px; height: 20px;"></td></tr> <tr><td style="text-align: center;">D</td><td style="text-align: center;">PLSV</td><td style="width: 20px; height: 20px;"></td></tr> </table> <p style="text-align: center;">PULSE V</p>		FNC 157		D	PLSV		<table border="1"> <tr> <td style="text-align: center;">16-bit instruction</td> <td style="text-align: center;">Instruction symbol</td> <td style="text-align: center;">Execution condition</td> </tr> <tr> <td style="text-align: center;">7 steps</td> <td style="text-align: center;">PLSV -</td> <td style="text-align: center;"> Continuous execution type </td> </tr> </table>	16-bit instruction	Instruction symbol	Execution condition	7 steps	PLSV -	Continuous execution type	<table border="1"> <tr> <td style="text-align: center;">32-bit instruction</td> <td style="text-align: center;">Instruction symbol</td> <td style="text-align: center;">Execution condition</td> </tr> <tr> <td style="text-align: center;">13 steps</td> <td style="text-align: center;">DPLSV -</td> <td style="text-align: center;"> Continuous execution type </td> </tr> </table>	32-bit instruction	Instruction symbol	Execution condition	13 steps	DPLSV -	Continuous execution type
	FNC 157																			
D	PLSV																			
16-bit instruction	Instruction symbol	Execution condition																		
7 steps	PLSV -	Continuous execution type																		
32-bit instruction	Instruction symbol	Execution condition																		
13 steps	DPLSV -	Continuous execution type																		

2. Data setting

Operand type	Description	Data type
(S•)	Specifies the output pulse frequency designation device number.*1	BIN 16/32-bit
(D1•)	Specifies the pulse output device number.	Bit
(D2•)	Specifies the rotation direction signal output destination device number.	

*1. Setting range : -32,768 to -1 Hz, +1 to 32,767 Hz*2 for 16-bit operation.
 For the 32-bit operation, however, the setting range should be as shown in the following table.

Pulse output destination		Setting range
FX3U PLC	High-speed output special adapter	-200,000 to -1, +1 to 200,000(Hz)
FX3S/FX3G/FX3GC/ FX3U/FX3UC PLC	Main unit (transistor output)	-100,000 to -1, +1 to 100,000(Hz)*3

- *2. In the case of operation without Acceleration/Deceleration (M8338 = OFF), setting range of FX3S/FX3G/FX3GC PLC is -32,768 to -10 Hz, +10 to 32,767 Hz.
- *3. In the case of operation without Acceleration/Deceleration (M8338 = OFF), setting range of FX3S/FX3G/FX3GC PLC is -100,000 to -10 Hz, +10 to 100,000 Hz.

3. Devices

Operand type	Bit device							Word device								Others								
	System user							Digit designation				System user				Special unit	Index			Con-stant	Real number	Char-acter string	Pointer	
	X	Y	M	T	C	S	D□.b	KnX	KnY	KnM	KnS	T	C	D	R	U□V□	V	Z	Modify	K	H	E	"□"	P
(S•)							✓	✓	✓	✓	✓	✓	✓	▲4	▲5	✓	✓	✓	✓	✓				
(D1•)	▲1																	✓						
(D2•)	▲2	✓				▲3												✓						

- ▲1 : Specify Y000, Y001, or Y002*4 transistor output from the main unit, or specify Y000, Y001, Y002*6, or Y003*6 from a high-speed output special adapter*5.
- *4. Y002 is not available in FX3G PLC (14-point and 24-point type) and FX3S/FX3GC PLC.
- *5. High-speed output special adapters can be connected only to the FX3U PLC.
- *6. To use Y002 and Y003 with a high-speed output special adapter, connect a second high-speed output special adapter.

Point:

- To use an FX3U PLC of relay output type or triac output type, be sure to connect a high-speed output special adapter.
- Differential line drive type outputs will be used for the outputs of the high-speed output special adapter.
- ▲2 : When a high-speed output special adapter is used as a destination for pulse output on a FX3U PLC, use the output shown in the following table for rotation direction signals.
 When a built-in transistor output is used as a destination for pulse output on a FX3S/FX3G/FX3GC/FX3U/FX3UC PLC, use transistor output for signals rotation direction.

High-speed output special adapter connection position	Pulse output	Rotation direction output
1st adapter	(D1•) = Y000	(D2•) = Y004
	(D1•) = Y001	(D2•) = Y005
2nd adapter	(D1•) = Y002	(D2•) = Y006
	(D1•) = Y003	(D2•) = Y007

- ▲3 : D□.b is available only in FX3U and FX3UC PLCs. However, index modifiers (V and Z) are not available.
- ▲4 : Only available for FX3G/FX3GC/FX3U and FX3UC PLCs.
- ▲5 : Only available for FX3U and FX3UC PLCs.

10.2 List of Related Devices

1. Special auxiliary relays

The following table shows the related special auxiliary relays. Note that Y000, Y001, Y002, and Y003 are devices that determine the pulse output destinations.

Device number				Function	Attribute	Refer to
Y000	Y001	Y002*1	Y003*2			
M8329				"Instruction execution abnormal end" flag	Read only	Subsection 4.4.2
M8338				Acceleration/deceleration*3,*4	Drivable	Subsection 4.3.9
M8340	M8350	M8360	M8370	"Pulse output monitor" (BUSY/READY) flag	Read only	Subsection 4.4.3
M8343	M8353	M8363	M8373	Forward limit	Drivable	Subsection 4.3.1
M8344	M8354	M8364	M8374	Reverse limit	Drivable	Subsection 4.3.1
M8348	M8358	M8368	M8378	Positioning instruction activation	Read only	Subsection 4.4.4

- *1. Y002 is not available in FX3G PLC (14-point and 24-point type) and FX3S/FX3GC PLC.
- *2. Y003 is available only when two high-speed output special adapters are connected to the FX3U PLC.
- *3. Only available for FX3UC PLC Ver. 2.20 or later and FX3S/FX3G/FX3GC/FX3U PLC.
- *4. Cleared when the PLC switches from RUN to STOP.

2. Special data registers

The following table shows the related special data registers. Note that Y000, Y001, Y002, and Y003 are devices that determine the pulse output destinations.

Device number								Function	Data length	Initial value	Refer to
Y000		Y001		Y002 ^{*1}		Y003 ^{*2}					
D8340	Low-order	D8350	Low-order	D8360	Low-order	D8370	Low-order	Current value register (PLS)	32-bit	0	Subsection 4.4.1
D8341	High-order	D8351	High-order	D8361	High-order	D8371	High-order				
D8342		D8352		D8362		D8372		Bias speed (Hz)	16-bit	0	Subsection 4.2.6
D8343	Low-order	D8353	Low-order	D8363	Low-order	D8373	Low-order	Maximum speed (Hz)	32-bit	100,000	Subsection 4.2.5
D8344	High-order	D8354	High-order	D8364	High-order	D8374	High-order				
D8348		D8358		D8368		D8378		Acceleration time (ms) ^{*3}	16-bit	100	Subsection 4.2.7
D8349		D8359		D8369		D8379		Deceleration time (ms) ^{*3}	16-bit	100	Subsection 4.2.8

*1. Y002 is not available in FX3G PLC (14-point and 24-point type) and FX3s/FX3GC PLC.

*2. Y003 is available only when two high-speed output special adapters are connected to the FX3U PLC.

*3. This device is valid for the PLSV instruction only when the acceleration/deceleration operation is performed in the FX3UC PLC Ver. 2.20 or later and FX3s/FX3G/FX3GC/FX3U PLC.

10.3 Function and Operation

The variable speed pulse output instruction changes the speed while using the rotation direction output. The acceleration/deceleration function applies for the variable speed pulse output (PLSV) instruction, which makes it possible to specify whether acceleration/deceleration will be used or not. If an FX3UC PLC below Ver. 2.20 is used, operation will be performed without acceleration/deceleration.

10.3.1 Operation without Acceleration/Deceleration (M8338 = OFF)

If the output pulse frequency (S•) value is changed after turning the acceleration/deceleration function (M8338) OFF, the variable speed pulse output (PLSV) instruction will change the output frequency without using acceleration/deceleration.

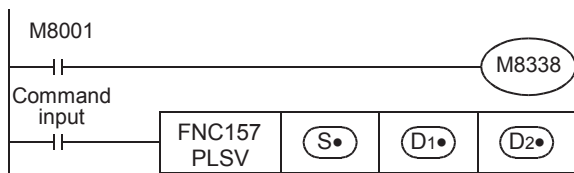

→ For details on the maximum speed and bias speed, refer to Subsection 4.2.5 and Subsection 4.2.6.

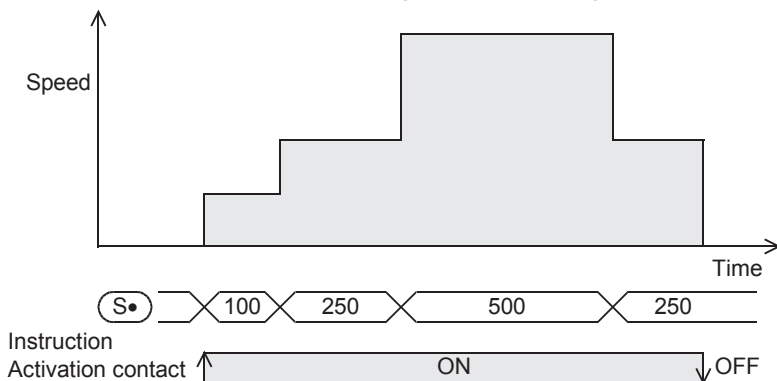

1) For (S•), specify the output pulse frequency.

Even if pulses are being output, the output pulse frequency (S•) can be changed freely. Acceleration/deceleration, however, will not be performed.

		Setting range
16-bit operation		-32,768 to -1 Hz, +1 to 32,767 Hz ^{*1}
32-bit operation	When a high-speed output special adapter is used	-200,000 to -1 Hz, +1 to 200,000 Hz
	When a transistor output from the main unit is used	-100,000 to -1 Hz, +1 to 100,000 Hz ^{*2}

*1. Setting range of FX3S/FX3G/FX3GC PLC is -32,768 to -10 Hz, +10 to 32,767 Hz.

*2. Setting range of FX3S/FX3G/FX3GC PLC is -100,000 to -10 Hz, +10 to 100,000 Hz.

2) For (D1•), specify the pulse output number in the range of Y000 to Y003.

3) For (D2•), specify the rotation direction signal output device number.

When a high-speed output special adapter is used as a destination for pulse output on a FX3U PLC, use the output shown in the following table for rotation direction signals.

When a built-in transistor output is used as a destination for pulse output on a FX3S/FX3G/FX3GC/FX3U/FX3UC PLC, use transistor output for signals rotation direction.

High-speed output special adapter number	Pulse output destination device	Rotation direction output
1st adapter	(D1•) = Y000	(D2•) = Y004
	(D1•) = Y001	(D2•) = Y005
2nd adapter	(D1•) = Y002	(D2•) = Y006
	(D1•) = Y003	(D2•) = Y007

The rotation direction ON/OFF status of the specified device is shown in the following table.
 During instruction execution, however, do not use the output (D2•) for other purposes.

ON/OFF status of device specified by (D2•)	Rotation direction (increase/decrease current value)
ON	If the number of output pulses specified by (S•) is a positive number, the operation will be performed in the forward rotation direction. Forward rotation (Outputting pulses from (D1•) will increase the current value.)
OFF	If the number of output pulses specified by (S•) is a negative number, the operation will be performed in the reverse rotation direction. Reverse rotation (Outputting pulses from (D1•) will decrease the current value.)

10.3.2 Operation with Acceleration/Deceleration (M8338 = ON)

If the output pulse frequency (S•) value is changed after turning the acceleration/deceleration (M8338) ON, the variable speed pulse output (PLSV) instruction will accelerate or decelerate to the changed output. If a FX3UC PLC below Ver. 2.20 is used, operation will be performed without acceleration/deceleration.

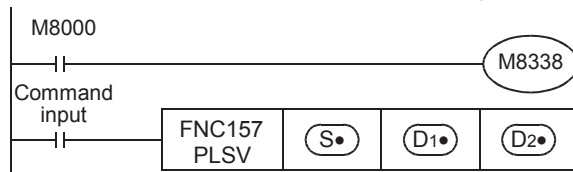

→ For details on the maximum speed, bias speed, acceleration time, and deceleration time, refer to Subsection 4.2.5 to Subsection 4.2.8.

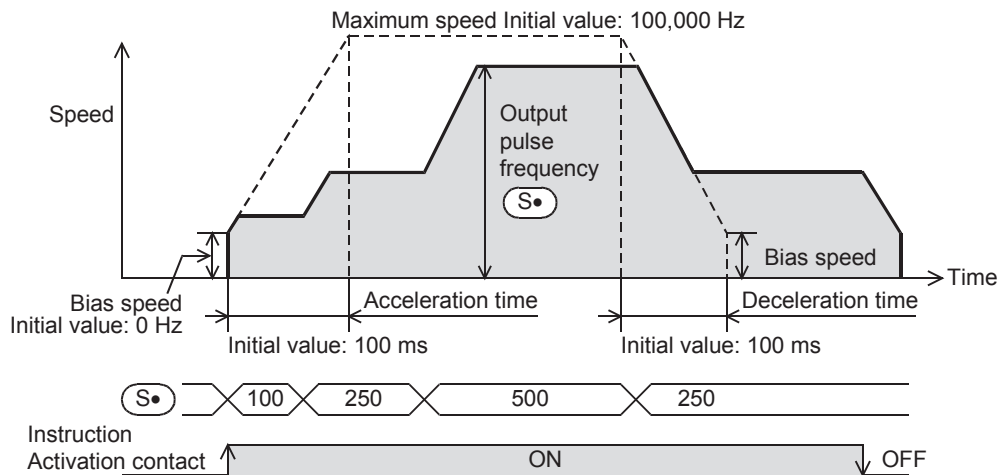

1) For (S•), specify the output pulse frequency.

Even if pulses are being output, the output pulse frequency (S•) can be changed freely. Acceleration/ deceleration will be performed.

		Setting range
16-bit operation		-32,768 to -1 Hz, 1 to 32,767 Hz
32-bit operation	When a high-speed output special adapter is used	-200,000 to -1 Hz, 1 to 200,000 Hz
	When a transistor output from the main unit is used	-100,000 to -1 Hz, 1 to 100,000 Hz

2) For (D1•), specify the pulse output number in the range of Y000 to Y003.

- 3) For (D2•), specify the rotation direction signal output device number.
 When a high-speed output special adapter is used as a destination for pulse output on a FX3U PLC, use the output shown in the following table for rotation direction signals.
 When a built-in transistor output is used as a destination for pulse output on a FX3S/FX3G/FX3GC/FX3U/FX3UC PLC, use transistor output for signals rotation direction.

High-speed output special adapter number	Pulse output destination device	Rotation direction output
1st adapter	(D1•) = Y000	(D2•) = Y004
	(D1•) = Y001	(D2•) = Y005
2nd adapter	(D1•) = Y002	(D2•) = Y006
	(D1•) = Y003	(D2•) = Y007

The rotation direction ON/OFF status of the specified device is shown in the following table.
 During execution of this instruction, however, do not use the output (D2•) for other purposes.

ON/OFF status of device specified by (D2•)	Rotation direction (increase/decrease current value)
ON	If the number of output pulses specified by (S•) is a positive number, the operation will be performed in the forward rotation direction. Forward rotation (Outputting pulses from (D1•) will increase the current value.)
OFF	If the number of output pulses specified by (S•) is a negative number, the operation will be performed in the reverse rotation direction. Reverse rotation (Outputting pulses from (D1•) will decrease the current value.)

10.4 Important Points

→ For important programming points, refer to Section 4.7.

- During pulse output operation, if the output pulse frequency (S•) is changed to "K0", the PLC will reduce the speed and then stop the pulse outputting operation if the acceleration/deceleration function is ON. However, if the acceleration/deceleration function is not activated, the PLC will immediately stop the pulse outputting operation.
 Before outputting pulses again, check that the "pulse output monitor" (BUSY/READY) flag is off, and then wait until 1 or more cycles of operation have been completed. After that, set (change) the output pulse frequency to a value other than "K0".
- During pulse outputting operation, do not change the sign attached to the output pulse frequency value (S•).
 If it is necessary to change the sign, stop the servo motor first by setting the output pulse frequency value (S•) to "K0", and wait for the motor to stop completely after decelerating to stop. And then, change the sign attached to the output pulse frequency value (S•).
 If the sign attached to the output pulse frequency value (S•) is changed during pulse outputting operation, the operation may be changed as follows, and the machine, therefore, may be damaged:
 - 1) The pulse outputting operation may be stopped.
 - 2) "Pulse output monitor" (BUSY/READY) flag may be turned off.
 (The pulse outputting operation may be stopped, but the motor may not be stopped immediately.)
 - 3) Operation may be performed in the specified direction at the frequency specified by the output pulse frequency value (S•).
- If the instruction activation contact is turned off during pulse outputting operation while the acceleration/deceleration function is ON, the speed will decelerate and the operation will stop.
 If the instruction activation contact is turned off during pulse outputting operation while the acceleration/deceleration function is OFF, the operation will stop immediately.
 The "Instruction execution complete" flag (M8029) will not turn on.
- If a limit flag (forward rotation or reverse rotation) in the operation direction is turned ON, the speed will decelerate and the operation will stop in the case that the acceleration/deceleration function is ON, or the operation will stop immediately in the case that the acceleration/deceleration function is OFF. In this case, the "Instruction execution abnormal end" flag (M8329) will turn on when execution of the instruction is complete.
 → For details on the "Instruction execution abnormal end" flag, refer to Subsection 4.7.4.
- If the "pulse output monitor" (BUSY/READY) flag is on, a positioning instruction (including PLSR and PLSY) that uses the same output cannot be executed.
 If the "pulse output monitor" (BUSY/READY) flag is still on after the instruction activation contact is turned off, do not execute a positioning instruction (including PLSR and PLSY instructions) that uses the same output number.
- After executing the instruction, the rotation direction signal output will turn off.

1. Important items for FX3uc PLCs below Ver. 2.20

- Acceleration/deceleration will not be performed when starting or stopping the operation. For this reason, if it is necessary to use the cushion start function or the cushion stop function, increase/decrease the output pulse frequency value (S•) using the FNC 67 (RAMP) instruction, etc.

2. Important items for FX3uc PLC Ver. 2.20 or later and FX3S/FX3G/FX3GC/FX3U PLC

- If acceleration/deceleration is enabled, the variable speed pulse output (PLSV) instructions for all of the pulse output destination devices will use acceleration/deceleration. This means that acceleration/deceleration cannot be specified separately for each pulse output destination device.

11. Batch Data Positioning Mode - TBL Instruction



If GX Works2, for example, is used, the positioning instructions shown below can first be set in the positioning tables. After that, when a table is specified, the positioning operation of the specified table will be performed. The FX3s PLC does not support TBL instruction.

Instruction	Description	
DVIT ^{*1} (FNC151)	One-speed interrupt constant quantity feed (Interrupt positioning)	
PLSV(FNC157)	Variable speed operation (Variable Speed Pulse Output)	
DRVI(FNC158)	1-speed positioning	Drive to Increment
DRVA(FNC159)		Drive to Absolute

*1. Only available for FX3U and FX3UC PLCs.

11.1 Instruction Format

1. Instruction Format

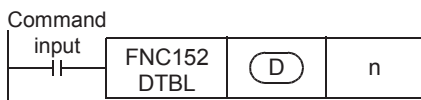
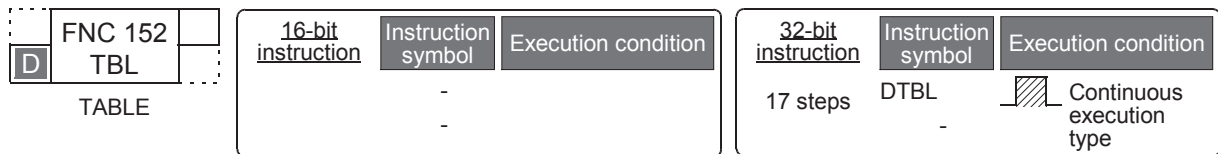

2. Data setting

Operand type	Description	Data type
(D)	Specifies the pulse output number.	Bit
n	Specifies the table number (1 to 100) to be executed.	BIN 32-bit

3. Devices

Operand type	Bit device							Word device								Others								
	System user							Digit designation				System user				Special unit	Index		Constant	Real number	Character string	Pointer		
	X	Y	M	T	C	S	D□.b	KnX	KnY	KnM	KnS	T	C	D	R	U□\G□	V	Z	Modify	K	H	E	"□"	P
(D)		▲1																						
n																				✓	✓			

- ▲1 : Specify Y000, Y001, or Y002^{*1} transistor output from the main unit, or specify Y000, Y001, Y002^{*3}, or Y003^{*3} from a high-speed output special adapter^{*2}.
- *1. Y002 is not available in FX3G PLC (14-point and 24-point type) and FX3GC PLC.
- *2. High-speed output special adapters can be connected only to the FX3U PLC.
- *3. To use Y002 and Y003 with a high-speed output special adapter, connect a second high-speed output special adapter.

Point:

- To use an FX3U PLC of relay output type or triac output type, be sure to connect a high-speed output special adapter.
- Differential line drive type outputs will be used for the outputs of the high-speed output special adapter.

11.2 List of Related Devices

1. Special auxiliary relays

The following table shows the related special auxiliary relays. Note that Y000, Y001, Y002, and Y003 are devices that determine the pulse output destinations.

Device number				Function	Attribute	Refer to
Y000	Y001	Y002*1	Y003*2			
M8029				"Instruction execution complete" flag	Read only	Subsection 4.4.2
M8329				"Instruction execution abnormal end" flag	Read only	Subsection 4.4.2
M8338				Acceleration/deceleration operation *3,*4	Drivable	Subsection 4.3.9
M8336				Interrupt input specification function enable *4, *5	Drivable	Subsection 4.3.7
M8340	M8350	M8360	M8370	"Pulse output monitor" (BUSY/READY) flag	Read only	Subsection 4.4.3
M8343	M8353	M8363	M8373	Forward limit	Drivable	Subsection 4.3.1
M8344	M8354	M8364	M8374	Reverse limit	Drivable	Subsection 4.3.1
M8347	M8357	M8367	M8377	Interrupt signal logic reverse *4,*6,*7	Drivable	Subsection 4.3.8
M8348	M8358	M8368	M8378	Positioning instruction activation	Read only	Subsection 4.4.4
M8349	M8359	M8369	M8379	Pulse output stop command *4	Drivable	Subsection 4.3.2
M8460	M8461	M8462	M8463	User interrupt input command *4,*8	Drivable	Subsection 4.3.7

*1. Y002 is not available in FX3G PLC (14-point and 24-point type) and FX3GC PLC.

*2. Y003 is available only when two high-speed output special adapters are connected to the FX3U PLC.

*3. Only available for FX3UC PLC Ver. 2.20 or later and FX3G/FX3GC/FX3U PLC.

*4. Cleared when the PLC switches from RUN to STOP.

*5. Only available for FX3UC PLC Ver. 1.30 or later and FX3U PLC.

*6. Only available for FX3U/FX3UC PLC.

*7. The logical NOT function is not valid for the user interrupt input command.

*8. Only available for FX3UC PLC Ver. 2.20 or later and FX3U PLC.

2. Special data registers

The following table shows the related special data registers. Note that Y000, Y001, Y002, and Y003 are devices that determine the pulse output destinations. To set the constants shown in the shaded area, set the built-in positioning parameters.

→ For details on the built-in positioning parameters, refer to Section 11.4.

Device number								Function	Data length	Initial value	Refer to
Y000	Y001	Y002* ¹	Y003* ²								
D8336								Specification of interrupt input.* ³	16-bit	-	Subsection 4.3.7
D8340	Low-order	D8350	Low-order	D8360	Low-order	D8370	Low-order	Current value register (PLS)	32-bit	0	Subsection 4.4.1
D8341	High-order	D8351	High-order	D8361	High-order	D8371	High-order				
D8342		D8352		D8362		D8372		Bias speed (Hz)	16-bit	0	Subsection 4.2.6
D8343	Low-order	D8353	Low-order	D8363	Low-order	D8373	Low-order	Maximum speed (Hz)	32-bit	100,000	Subsection 4.2.5
D8344	High-order	D8354	High-order	D8364	High-order	D8374	High-order				
D8345		D8355		D8365		D8375		Creep speed (Hz)	16-bit	1000	Subsection 4.2.4
D8346	Low-order	D8356	Low-order	D8366	Low-order	D8376	Low-order	Zero return speed (Hz)	32-bit	50,000	Subsection 4.2.3
D8347	High-order	D8357	High-order	D8367	High-order	D8377	High-order				
D8348		D8358		D8368		D8378		Acceleration time (ms)* ⁴	16-bit	100	Subsection 4.2.7
D8349		D8359		D8369		D8379		Deceleration time (ms)* ⁴	16-bit	100	Subsection 4.2.8

*1. Y002 is not available in FX3G PLC (14-point and 24-point type) and FX3GC PLC.

*2. Y003 is available only when two high-speed output special adapters are connected to the FX3U PLC.

*3. Only available for FX3UC PLC Ver. 1.30 or later and FX3U PLC.
 However, the user interrupt input command can be specified only if the FX3UC PLC Ver. 2.20 or later and FX3U PLC is used.

*4. For the variable-speed output (PLSV) instruction, the setting is valid only when acceleration/deceleration operation is turned on.

11.3 Function and Operation

Preliminarily set the built-in positioning parameters using GX Works2, and then specify the pulse output destination (D) and the positioning table number (n) for the DTBL instruction in order to carry out positioning.

Use GX Works2 or GX Developer to set the built-in positioning parameters.

The "Pulse" and "Frequency" set by the built-in positioning parameters in each positioning table can be changed using the program, display module, or HMI.

→ For details on built-in positioning parameters, refer to Section 11.4.

→ For details on GX Developer operating procedure, refer to GX Developer Operating Manual.

Specifies the pulse output destination device for the positioning table to be activated.

Specifies the positioning table number to be activated.

Positioning table setting

Constant setting

As shown in the following table, each "Positioning Instruction", "Pulse (Pls)", "Frequency (Hz)", etc. For further information on the operation of each instruction, refer to the description of each instruction.

Positioning Instruction C	Instruction and its operand to be activated				Refer to	
	Instruction word	Operand				
		D Number of output pulses	E Output pulse frequency	A Pulse output destination device		B Rotation direction signal
DDVIT [Interrupt positioning instruction]	DDVIT	(S1)	(S2)	(D1)	(D2)	Chapter 9
DPLSV [Variable speed output pulse instruction]	DPLSV	-	(S)	(D1)	(D2)	Chapter 10
DDRVI [Relative positioning instruction]	DDRVI	(S1)	(S2)	(D1)	(D2)	Section 8.2
DDRVA [Absolute positioning instruction]	DDRVA	(S1)	(S2)	(D1)	(D2)	Section 8.3

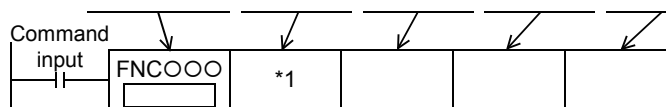

*1. PLSV(FNC157) has only 3 operands. It has no operand of number of output pulses.

11.4 Built-in Positioning Parameter Setting

Use GX Works2 or GX Developer to set the built-in positioning parameters.

The "Pulse" and "Frequency" set by the built-in positioning parameters in a positioning table can be changed using the program, display module, or HMI.

→ To change the set "number of pulses" or "frequency", refer to Subsection 11.4.2.

11.4.1 Built-in Positioning Parameter Setting

Assuming that GX Works2 is used, this section describes how to set the built-in positioning parameters.

→ For details on GX Developer operating procedure, refer to GX Developer Operating Manual.

1 Open the "Parameter Setting" screen.

On the project view of the navigation window displayed, double-click "Parameter" and then "PLC Parameter".

If the navigation window is not displayed, click "View" on the menu bar, and then click "Docking Window", and then click "Navigation".

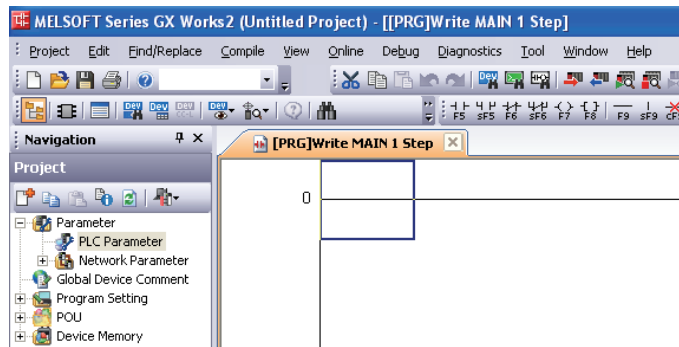

2 Set the memory capacity.

Click on the «Memory Capacity» tab, and then click on the "Positioning Instruction Settings" check box to enter check the box.

9,000 steps are needed to set the built-in positioning data. If there is not enough capacity for programming, set the "Memory capacity" to 16,000 steps or more.

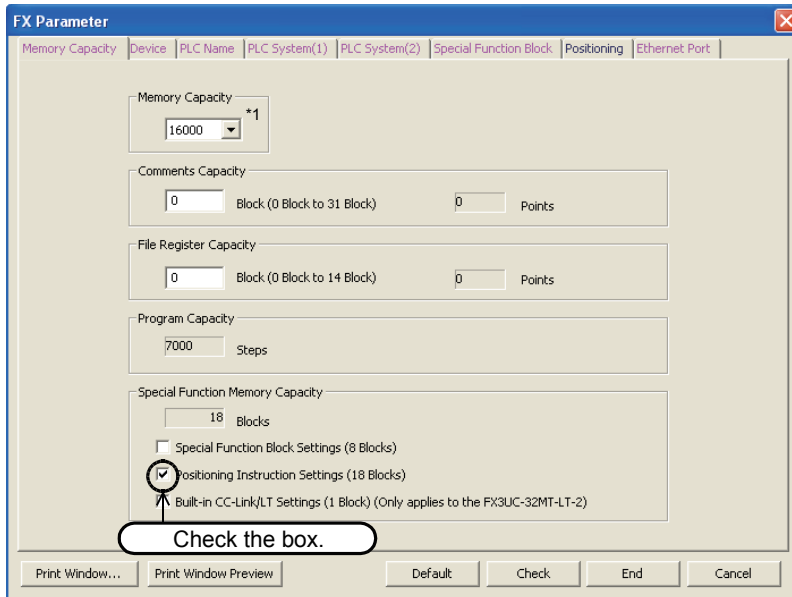

Setting item	Description of setting	Setting range
Memory Capacity	Set the capacity of the program memory. Initial value: 16000*1	Refer to the programming manual.
Comment Capacity	Set the capacity for the comments to be stored in the PLC. Initial value: 0 Device comment: 50 points/block (500 steps)	
File Register Capacity	Set the capacity for the file registers. Initial value: 0 File registers: 500 points/block (500 steps)	
Program Capacity	Displays the number of steps that can be used for the sequence program.	
Special Function Memory Capacity	Set whether "Special Function Block Settings", "Positioning Instruction Settings", "Built-in CC-Link/LT Settings" should be enabled.	-
Special Function Block Settings*2	Check the box to enable the special function unit/block initial data setting function. Use the «Special Function Block» tab to set the initial value of a special block.	-
Positioning Instruction Settings	Check the box to enable the TBL (FNC152) instruction setting function. Use the «Positioning» tab to set the built-in positioning data.	-
Built-in CC-Link/LT Settings*3	Check the box to enable the built-in CC-Link/LT setting function. Use the «Special Function Block» tab to set the built-in CC-Link/LT data.	-

*1. The initial value is 8000 steps in the FX3G/FX3GC PLC.

*2. Only available for FX3U and FX3UC PLCs.

*3. Only available for FX3UC-32MT-LT-2 PLC.

- *1. When the destination for pulse output on a FX3G/FX3GC/FX3U or FX3UC PLC is a built-in transistor output, the setting range is 10 to 100,000 Hz.
 If an FX3U PLC is used, and if the pulse output destination is a high-speed output special adapter, the setting range will be 10 to 200,000 Hz.
- *2. Set the creep speed so that the relation with the other speeds is "bias speed ≤ creep speed ≤ maximum speed."
- *3. The set interrupt input cannot be simultaneously used for a high-speed counter, input interruption, pulse catch input, input for the SPD (FNC 67) instruction, or for other interrupt inputs of the DVIT (FNC151) instruction.
- *4. Y003 is available only when two high-speed output special adapters are connected to the FX3U PLC.
- *5. Only available for FX3U and FX3UC PLCs.
- *6. Y002 is not available in FX3G PLC (14-point and 24-point type) and FX3GC PLC.

3. Click on the "Individual Setting" button to display the positioning instruction settings screen. In this screen, set the positioning table for each pulse output destination device.

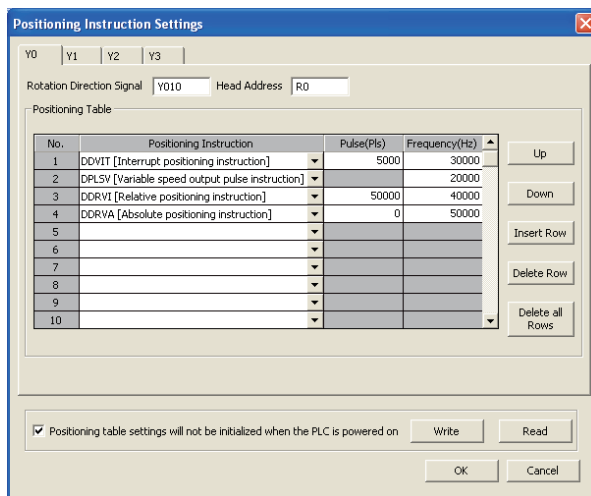

Setting item	Description of setting	Setting range
Y0	Click this tab to set the positioning table for Y000 (pulse output destination).	-
Y1	Click this tab to set the positioning table for Y001 (pulse output destination).	-
Y2*1	Click this tab to set the positioning table for Y002 (pulse output destination).	-
Y3*2	Click this tab to set the positioning table for Y003 (pulse output destination).	-
Rotation Direction Signal	Set the rotation direction output number.*3 Initial setting: Y010 for Y000 (pulse output destination) Y011 for Y001 (pulse output destination) Y012 for Y002 (pulse output destination) Y013 for Y003*2 (pulse output destination)	FX3U/FX3UC: Y000 to Y357 FX3G/FX3GC: Y000 to Y177
Head Address	Set the first device number to store the set data (number of pulses, frequency). Starting from the set device, 1600 points (FX3U/FX3UC) or 1200 points (FX3G/FX3GC) will be occupied. Initial setting: R0	FX3U/FX3UC: D0 to D6400 R0 to R31168 FX3G/FX3GC: D0 to D6800 R0 to R22800
No.	Table number Data can be set for tables 1 to 100.	-
Positioning Instruction	Select a positioning type from the following types: DDVIT [Interrupt positioning instruction]*4, "DPLSV [Variable speed output pulse instruction]", "DDRVI [Relative positioning instruction]", "DDRVA [Absolute positioning instruction]"	-
Pulse (Pls)	Set the number of pulses to be output to perform the specified type of positioning operation (instruction).	*5
Frequency (Hz)	Set the speed (output pulse frequency) to perform the specified type of positioning operation (instruction).	

Setting item	Description of setting	Setting range
"Up" button	Click this button to move the cursor up by 1 line (to select the line just above the cursor-positioned line).	-
"Down" button	Click this button to move the cursor down by 1 line (to select the line just below the cursor-positioned line).	-
"Insert Row" button	Click this button to insert a line at the specified position.	-
"Delete Row" button	Click this button to delete the selected line.	-
"Delete all Rows" button	Click this button to delete all the data from the positioning table of the selected pulse output destination device.	-
Positioning table settings will not be initialized when the PLC is powered on	If this check box is checked, the built-in positioning data will not be initialized when the PLC power is turned ON. Enter a check in this check box to retain the changed data ("Pulse" and "Frequency" changed by the program, display module, or HMI) even after power-off and to use the changed data after turning on the power again. To use this function, set an uninterruptible power supply type device as "Head Address".	-
"Write" button	Click this button to write 1600 points (FX3U/FX3UC) or 1200 points (FX3G/FX3GC) of data ("Pulses" and "Frequency" set on the positioning table using GX Works2) starting from "Head Address" of the PLC.	-
"Read" button	Click this button to read out 1600 points (FX3U/FX3UC) or 1200 points (FX3G/FX3GC) of data ("Pulse" and "Frequency" set on the positioning table currently used) from the PLC starting from Head Address. At the completion of data reading, the data numbers will appear only if "Positioning Instruction" is set for the data.	-

- *1. Y002 is not available in FX3G PLC (14-point and 24-point type) and FX3GC PLC.
- *2. Y003 is available only when two high-speed output special adapters are connected to the FX3U PLC.
- *3. To use an FX3U-2HSY-ADP, set the rotation direction signal depending on the pulse output destination device as shown in the following table.

Pulse output destination device	Rotation direction signal
Y000	Y004
Y001	Y005
Y002	Y006
Y003	Y007

- *4. Only available for FX3U and FX3UC PLCs.
- *5. Refer to the description of the selected instruction (positioning type).

Positioning Instruction	Refer to
DDVIT (Interrupt positioning)	Chapter 9
DPLSV (Variable Speed Pulse Output)	Chapter 10
DDRVI (Drive to Increment)	Section 8.2
DDRVA (Drive to Absolute)	Section 8.3

4 Transfer the parameters (+ sequence program) to the PLC.

1. Select "Online" from the tool menu, and then select "Write to PLC". The online data operation screen will appear.

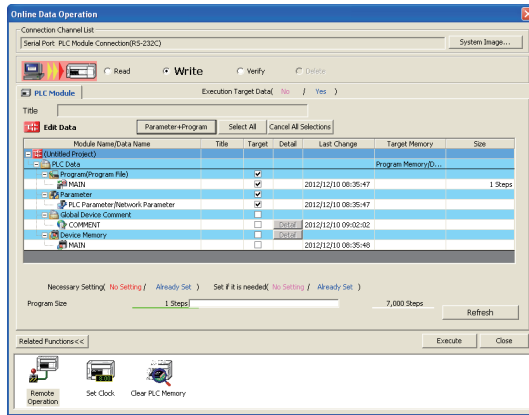

2. Enter a check in the "Parameter" check box, and then click the "Execute" button.
 The selected parameter data will be transferred to the PLC. When the PLC is started (enters the RUN mode), the transferred parameter data will be enabled.

11.4.2 Changing of Set Built-in Positioning Parameters (Number of Pulses and Frequency)

The "Pulse" and "Frequency" set by the built-in positioning parameters in a positioning table will be stored in the devices starting from the specified head address as shown below. The set "Pulse" and "Frequency" can be changed using a display module or HMI.

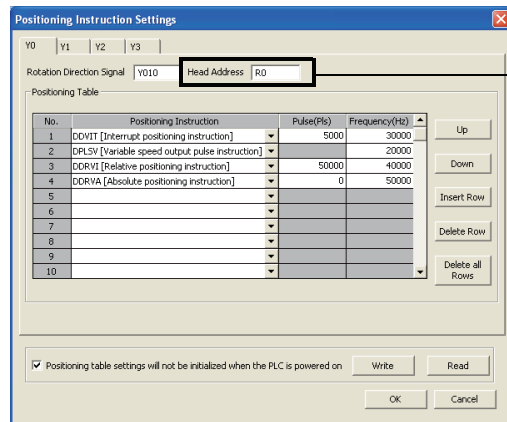

If the Head Address is set to "R0":

Pulse output destination device	Positioning table No.	Pulse	Frequency
Y000	1	R1,R0	R3,R2
	2	R5,R4	R7,R6
	3	R9,R8	R11,R10
	⋮	⋮	⋮
	100	R397,R396	R399,R398
Y001	1	R401,R400	R403,R402
	2	R405,R404	R407,R406
	3	R409,R408	R411,R410
	⋮	⋮	⋮
	100	R797,R796	R799,R798
Y002	1	R801,R800	R803,R802
	2	R805,R804	R807,R806
	3	R809,R808	R811,R810
	⋮	⋮	⋮
	100	R1197,R1196	R1199,R1198
Y003	1	R1201,R1200	R1203,R1202
	2	R1205,R1204	R1207,R1206
	3	R1209,R1208	R1211,R1210
	⋮	⋮	⋮
	100	R1597,R1596	R1599,R1598

Caution:

If "Positioning Instruction" is set to "DPLSV [Variable speed output pulse instruction]", the "Frequency (Hz)" value set on the screen will be stored as the set number of pulses, and the device for "Frequency" will be "K0".

To use the "Pulse" and "Frequency" changed by a display module or HMI even after turning the power OFF and then ON again:

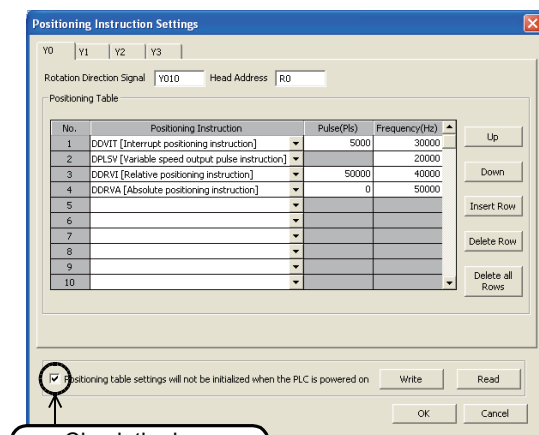

To use the "Pulse" and "Frequency" changed by a display module or HMI even after turning the power OFF and then ON again, check the "Positioning table settings will not be initialized when the PLC is powered on" check box in the "Positioning Instruction Settings" screen of the positioning parameters.

To use this function, use the uninterruptible power supply type devices.

If this function is not set, the data set by the built-in positioning parameters will be initialized.

To read out and store the "Pulse" and "Frequency" changed by a display module or HMI:

- 1) In the "Positioning Instruction Settings" screen of the positioning parameters, check the "Positioning table settings will not be initialized when the PLC is powered on" check box.

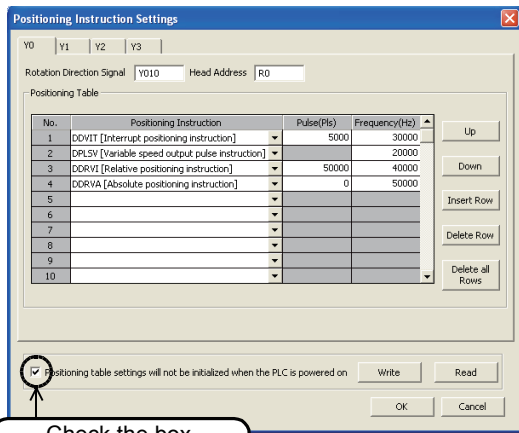

- 2) Click on the "Read" button to read out the set data ("Pulse" and "Frequency") from the connected main unit.
 This is exclusively for the positioning table number with the positioning type specified.

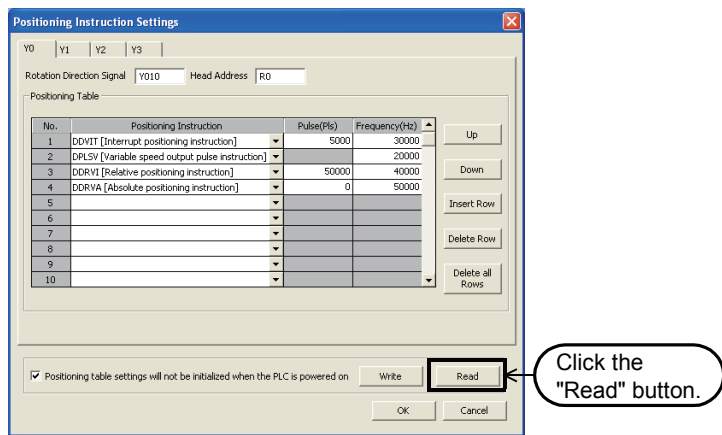

- 3) At the completion of register data reading, the data file will be stored.

12. Examples of Programs

Assuming that the MELSERVO Series 1-axis servo amplifier is used for control, this chapter shows various examples of programs.

For the connection examples of MELSERVO Series, refer to the following chapters and manuals.

→ Refer to Chapter 3 and the examples of connection shown in the Appendix.

→ Refer to the manual of your servo amplifier.

Operation		Instruction	Examples of programs		Description of instruction
			Relay ladder program	Step ladder program	
Mechanical zero return	DOG Search Zero Return	DSZR(FNC150)	Subsection 12.2.1	Subsection 12.3.1	Section 6.2
Absolute position detection	Reading of current ABS value	ABS(FNC155)	Section 12.5	-	Chapter 7
1-speed positioning	Drive to Increment	DRVI(FNC158)	Subsection 12.2.1	Subsection 12.3.1	Section 8.2
	Drive to Absolute	DRVA(FNC159)	Subsection 12.2.1	Subsection 12.3.1	Section 8.3
Batch data positioning mode		TBL(FNC152)	Section 12.4	-	Chapter 11

12.1 Input/Output Assignment

The programs shown in this chapter use 1 axis for Y000 (pulse output destination device). If other pulse output destination devices are used, modify corresponding device numbers shown in the table below when referencing the description.

When the FX3s PLC is used, check the input and output numbers in the connection examples of the appendix, and replace with those devices.

Signal	Input/output number				Connected to	
	Y000	Y001	Y002	Y003		
Pulse train* ¹ (pulse output destination)	Y000	Y001	Y002	Y003	Connected to MELSERVO Series servo amplifier.	
Direction* ^{2, 3} (rotation direction signal)	Y004	Y005	Y006	Y007		
CLEAR signal* ^{3, 4}	Y020	Y024	Y030	Y034		
Zero-phase signal* ^{4, 5}	X004	X005	X006	X007		
"Servo ready" signal* ⁶	X014	X015	X016	X017	Connected to external switches.	
Immediate stop command	X020	X040	X050	X070		
Zero return command	X021	X041	X051	X071		
Jog (+) command	X022	X042	X052	X072		
Jog (-) command	X023	X043	X053	X073		
Forward rotation positioning command	X024	X044	X054	X074		
Reverse rotation positioning command	X025	X045	X055	X075		
Stop command	X030	X034	X060	X064		
Near-point signal (DOG)* ^{4, 5}	X010	X011	X012	X013	Connected to sensors and limit switches.	
Interrupt signal	X000	X001	X002	X003		
Forward rotation limit (LSF)* ⁷	X026	X046	X056	X076		
Reverse rotation limit (LSR)* ⁷	X027	X047	X057	X077		
To use absolute position detection system	ABS (bit0)	X031	X035	X061	X065	Connected to MELSERVO Series servo amplifier (MR-J4□A, MR-J3□A, MR-J2S□A, MR-J2□A, MR-H□A)
	ABS (bit1)	X032	X036	X062	X066	
	"Send data ready" signal	X033	X037	X063	X067	
	Servo-ON signal	Y021	Y025	Y031	Y035	
	"ABS data transfer mode" signal	Y022	Y026	Y032	Y036	
	"ABS data request" signal	Y023	Y027	Y033	Y037	

- *1. To use the "forward rotation pulse train" signal and "reverse rotation pulse train" signal of a FX3U-2HSY-ADP, change the name of this signal to "forward rotation pulse train" signal when reading the description.
- *2. To use the "forward rotation pulse train" signal and "reverse rotation pulse train" signal of a FX3U-2HSY-ADP, change the name of this signal to "reverse rotation pulse train" signal when reading the description.
- *3. If an FX3UC PLC below Ver.2.20 is used, exchange the direction signal output number with the CLEAR signal output number.
- *4. If the absolute position detection system is used, and if the DSZR instruction and ZRN instruction are not used for the first zero return, this signal is not needed. To use the absolute position detection system, refer to the following chapter and manual.
 → **Refer to Chapter 7 and the manual of your servo amplifier.**
- *5. To use the ZRN instruction for zero return, assign the input number of the near-point signal (DOG) to the zero-phase signal. This is needed since the ZRN instruction will not use the zero-phase signal.

- *6. To use pin 3 of the CN1 connector of the MR-C□A servo amplifier for the "servo ready" signal, set parameter 21 as follows:

Series	Parameter number	Setting value
MR-C	21	020

- *7. To ensure safety, use a forward rotation limit switch and reverse rotation limit switch on both sides: the PLC side and the servo amplifier side.
 Note that the limit switches on the PLC side should be activated slightly earlier than the limit switches on the servo amplifier side.

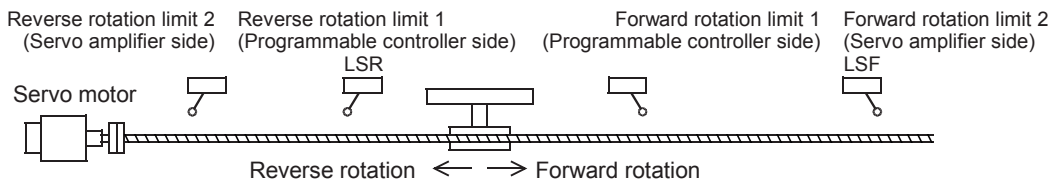

12.2 Programs for Forward/Reverse Rotation (Relay Ladder Program)

12.2.1 Example Program

Positioning operation will be performed using the absolute positioning method shown in the following chart:
 → For details on input/output assignment, refer to Section 12.1.

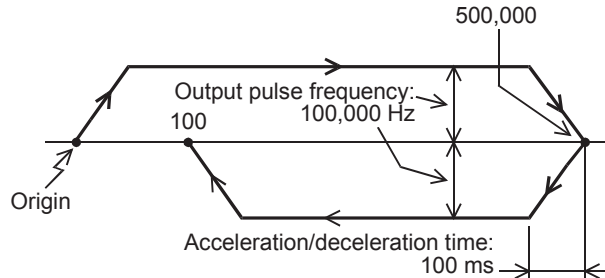

The following program is a relay ladder program.

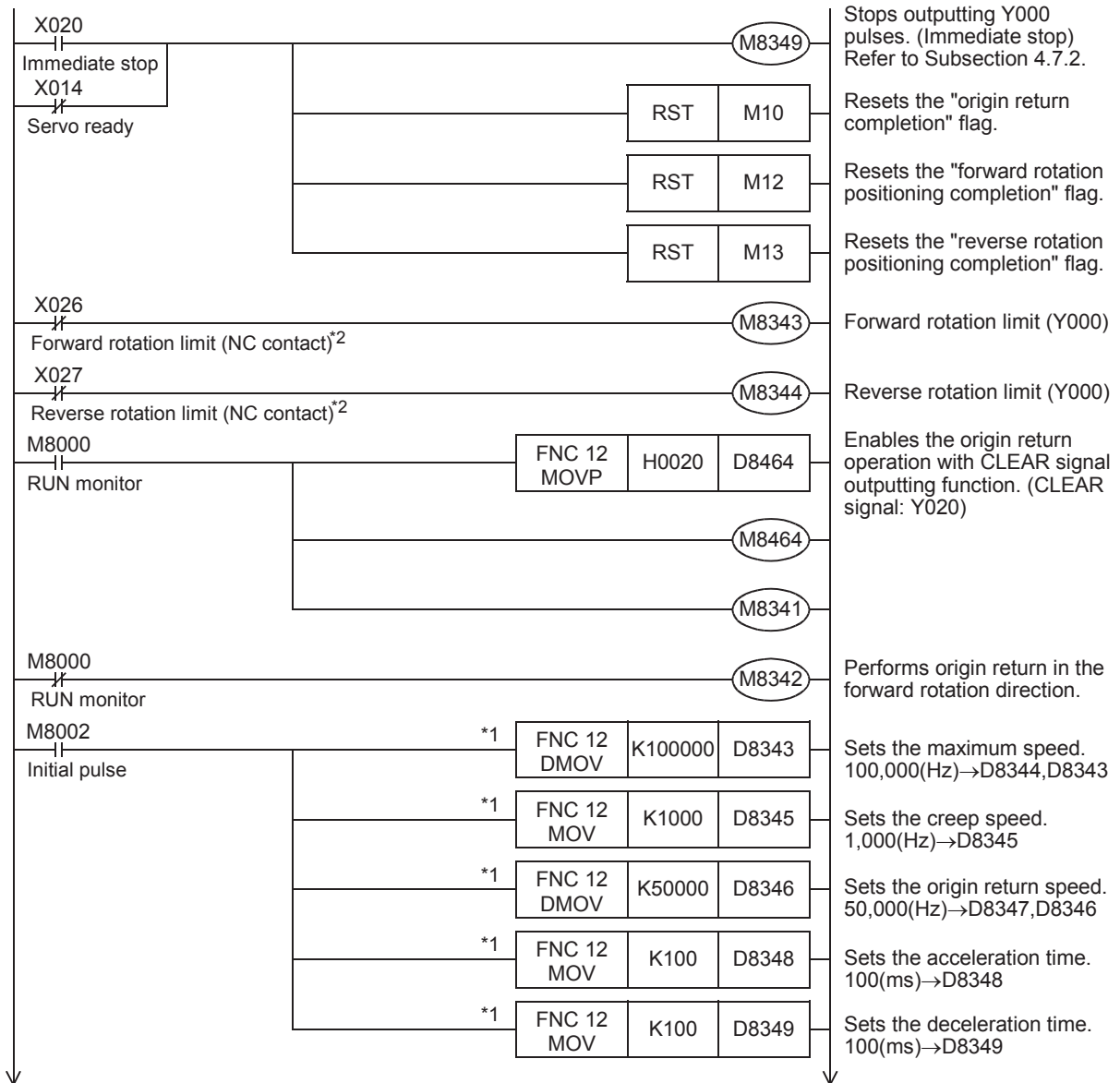

*1. If the initial values (maximum speed, acceleration/deceleration time, zero return speed, creep speed) can be used, it is not necessary to create the program.
 → For the related devices, refer to Section 4.1 to Section 4.4.

*2. Change contacts in the program to NO contacts when using NO contact type limit switches.

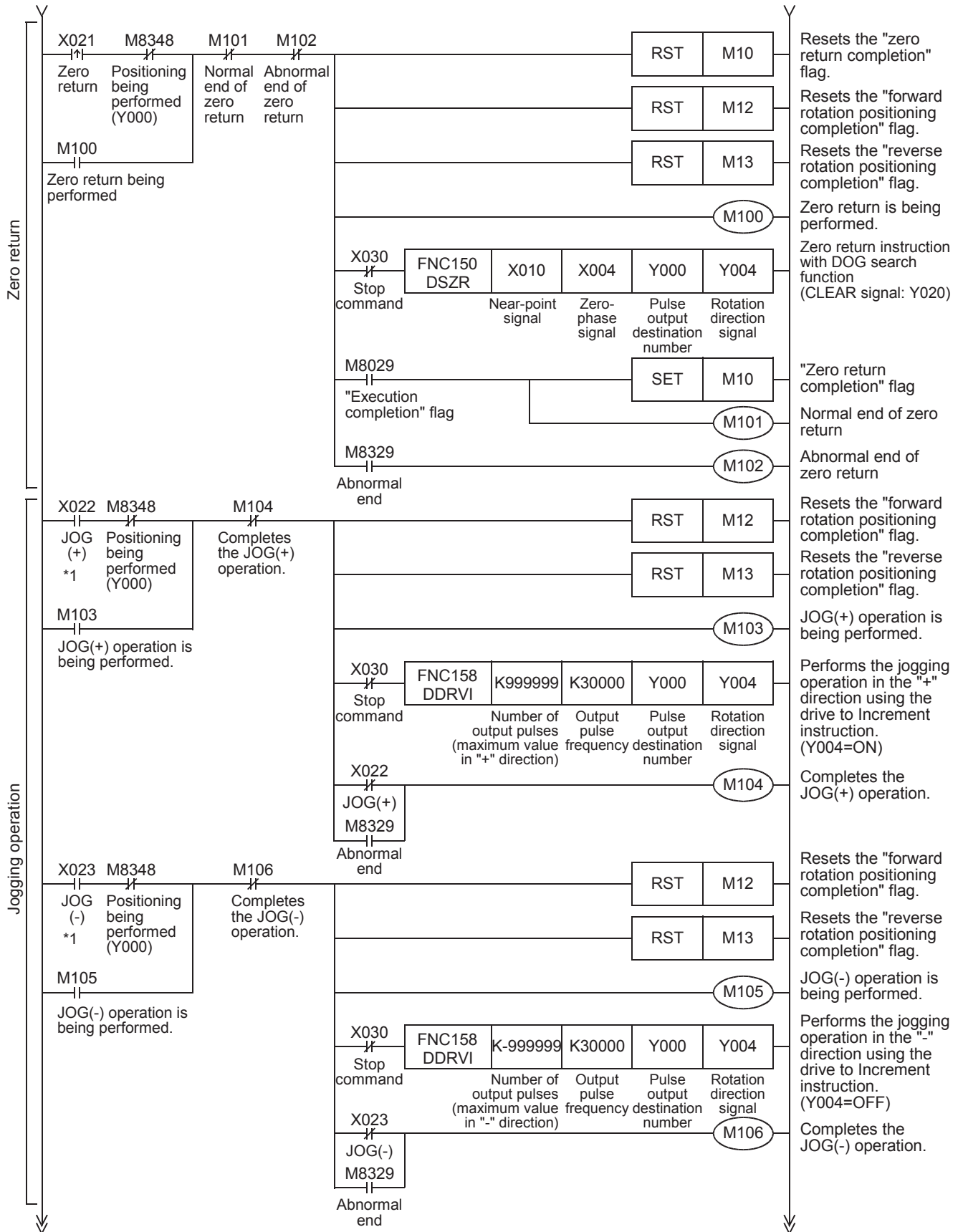

*1. The maximum transfer distance for each jogging operation is ±999,999 pulses (pulse output range of FNC158 (DRVI) instruction). To move the workpiece further, execute the JOG command again.

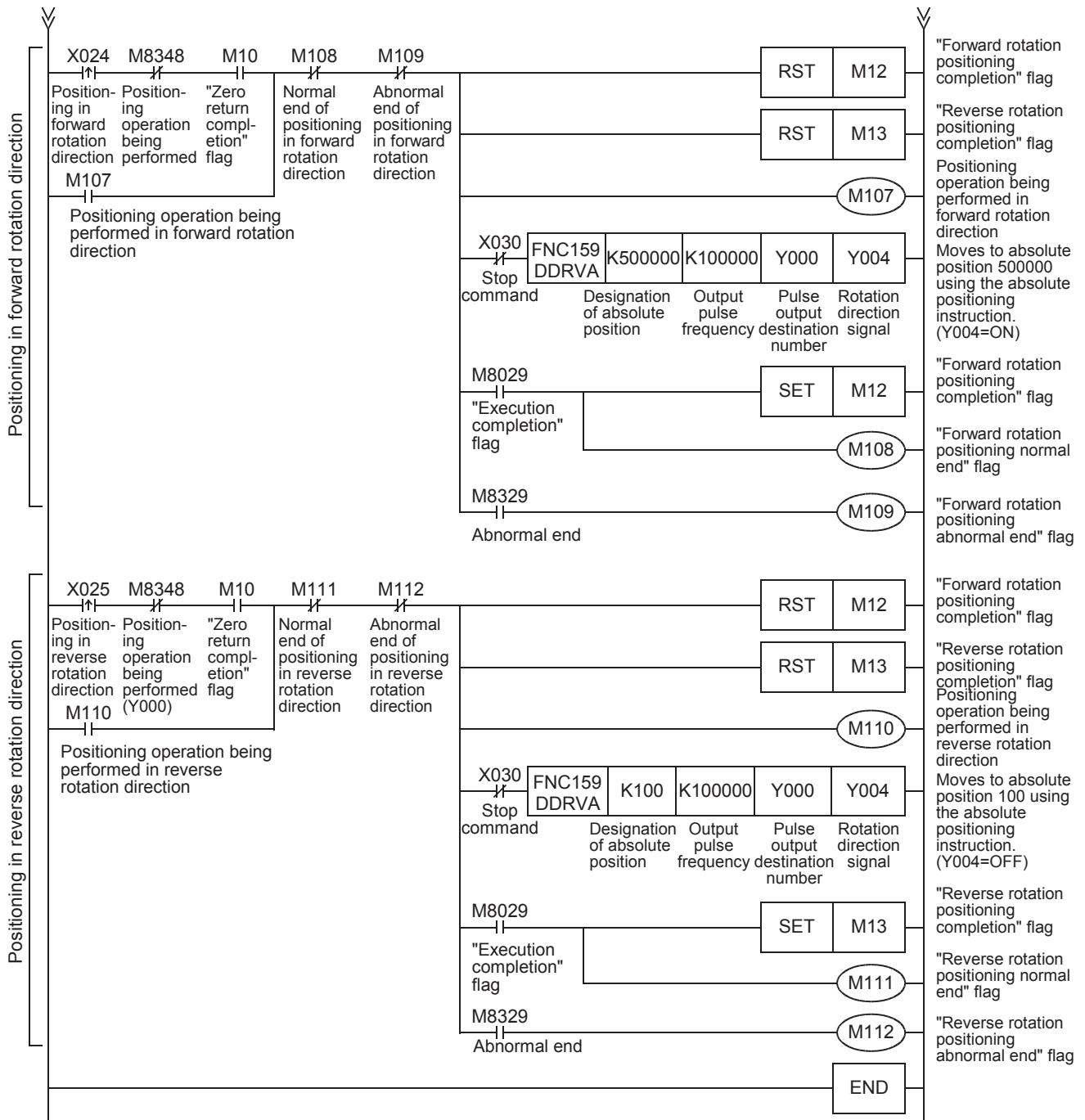

A

Common Items

B

Built-in Positioning Functions

Ap.

Example Connection

12.3 Programs for Forward/Reverse Rotation (Step Ladder (STL) Program)

12.3.1 Example Program

Positioning operation will be performed using the absolute positioning method as shown in the following chart:
 → For details on input/output assignment, refer to Section 12.1.

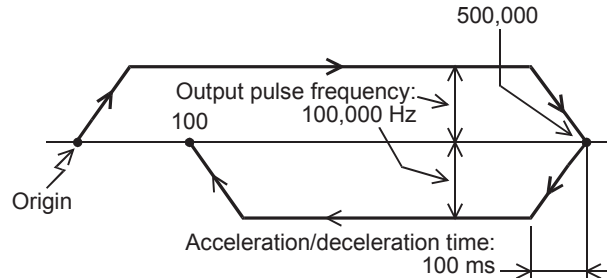

The following program uses the step ladder (STL) instruction.

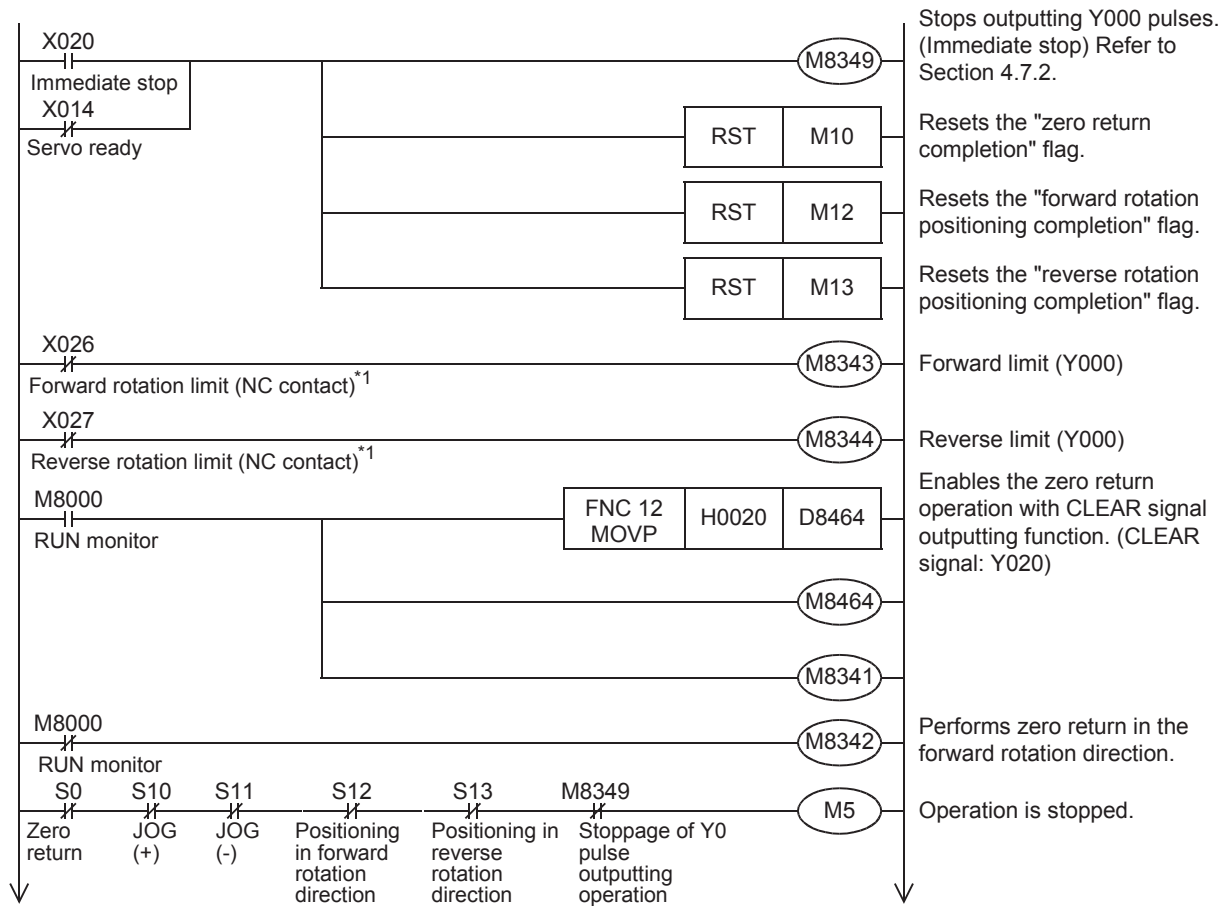

*1. Change contacts in the program to NO contacts when using NO contact type limit switches.

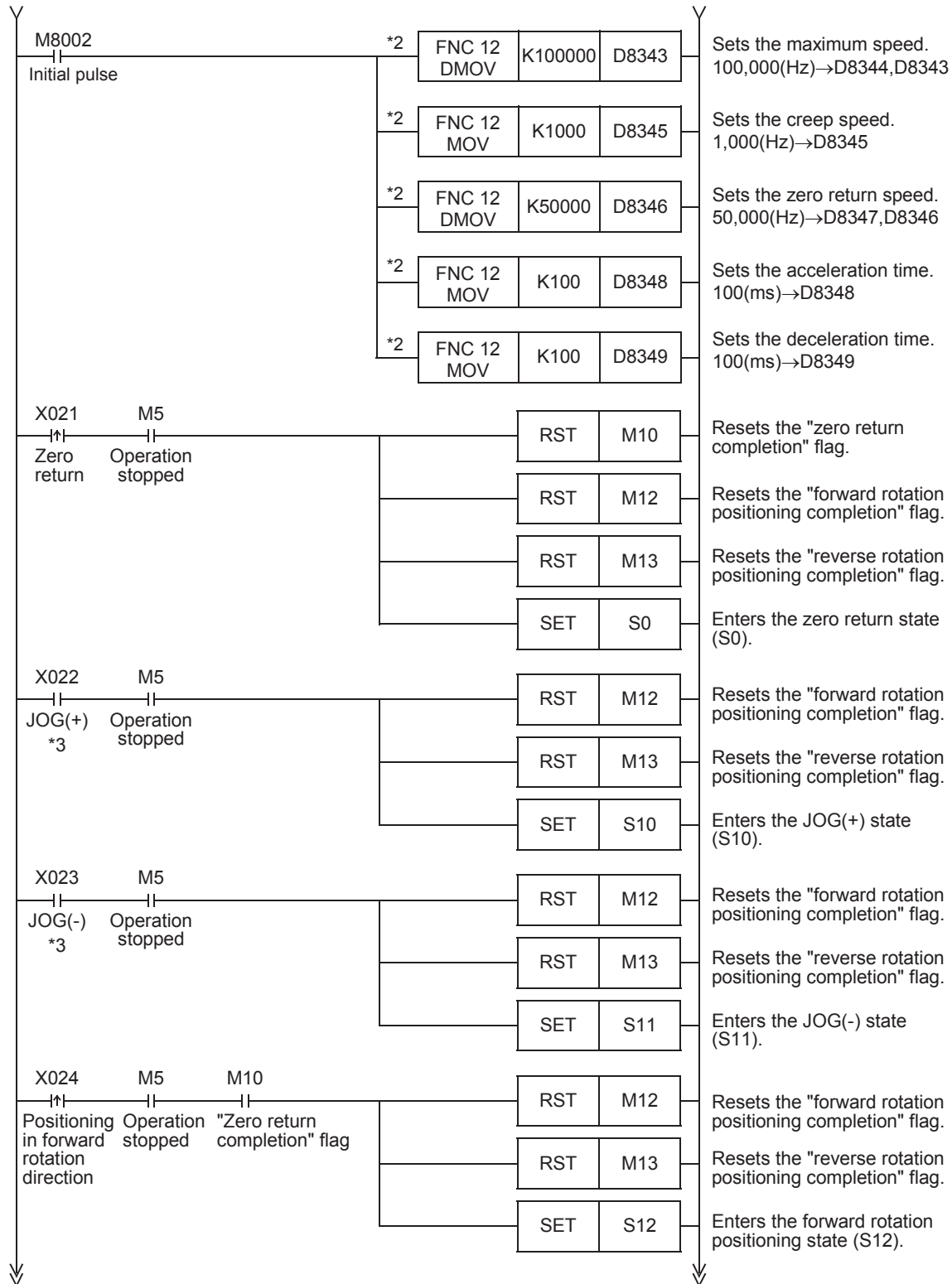

- *2. If the initial values (maximum speed, acceleration/deceleration time, zero return speed, creep speed) can be used, it is not necessary to create the program.
 → For the related devices, refer to Section 4.1 to Section 4.4.
- *3. The maximum transfer distance for each jogging operation is ±999,999 pulses (pulse output range of FNC158 (DRVI) instruction). To move the workpiece further, execute the JOG command again.

A Common Items
B Built-in Positioning Functions
Apx. Example Connection

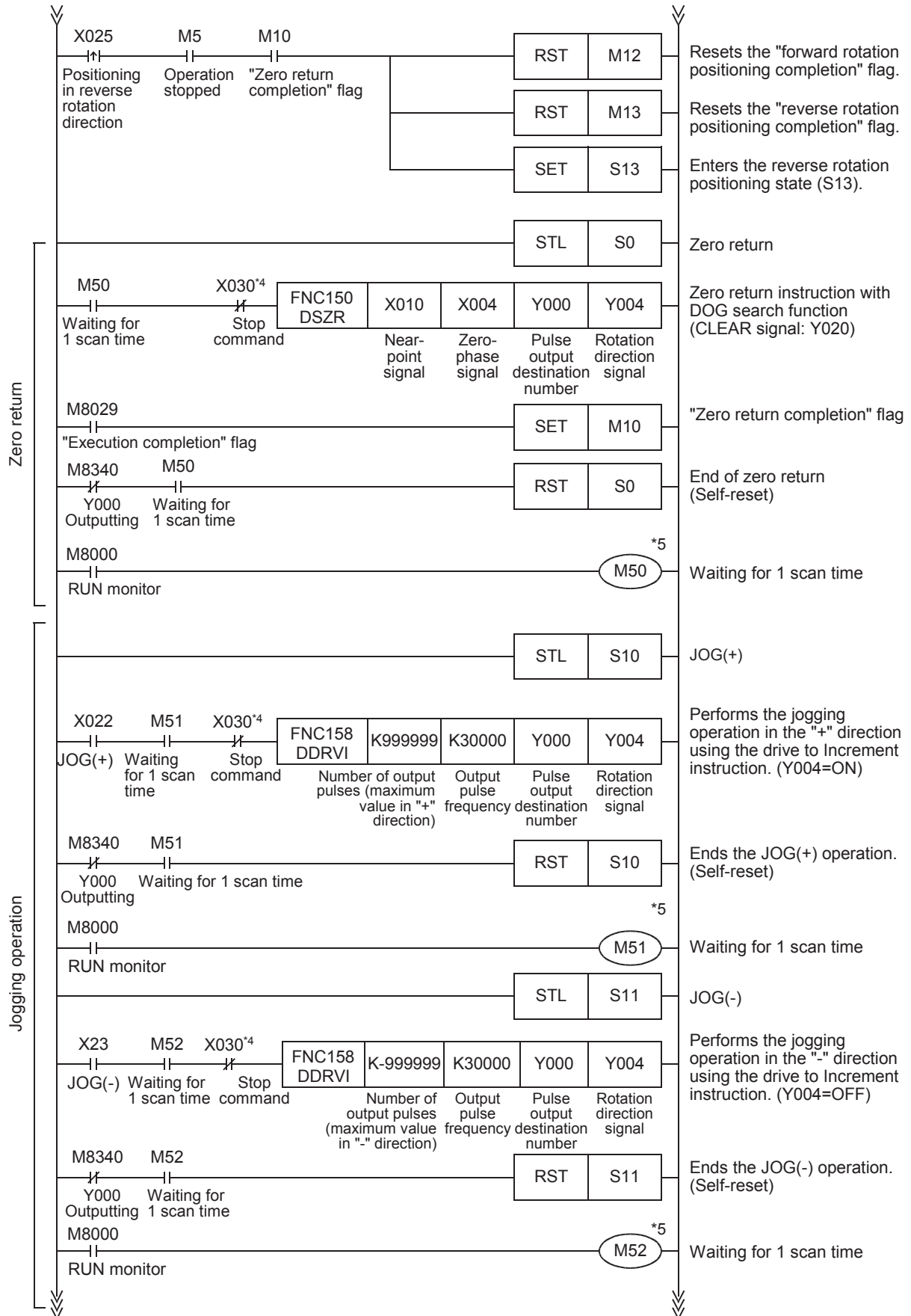

- *4. To stop the positioning operation, be sure to insert the stop contact before the positioning instruction so that STL instruction cannot be turned off (reset) until the "pulse output monitor" flag (M8340 (for Y000)) is turned off.
- *5. To prevent simultaneous activation of positioning instructions, the instruction activation timing should be delayed by 1 scan time.

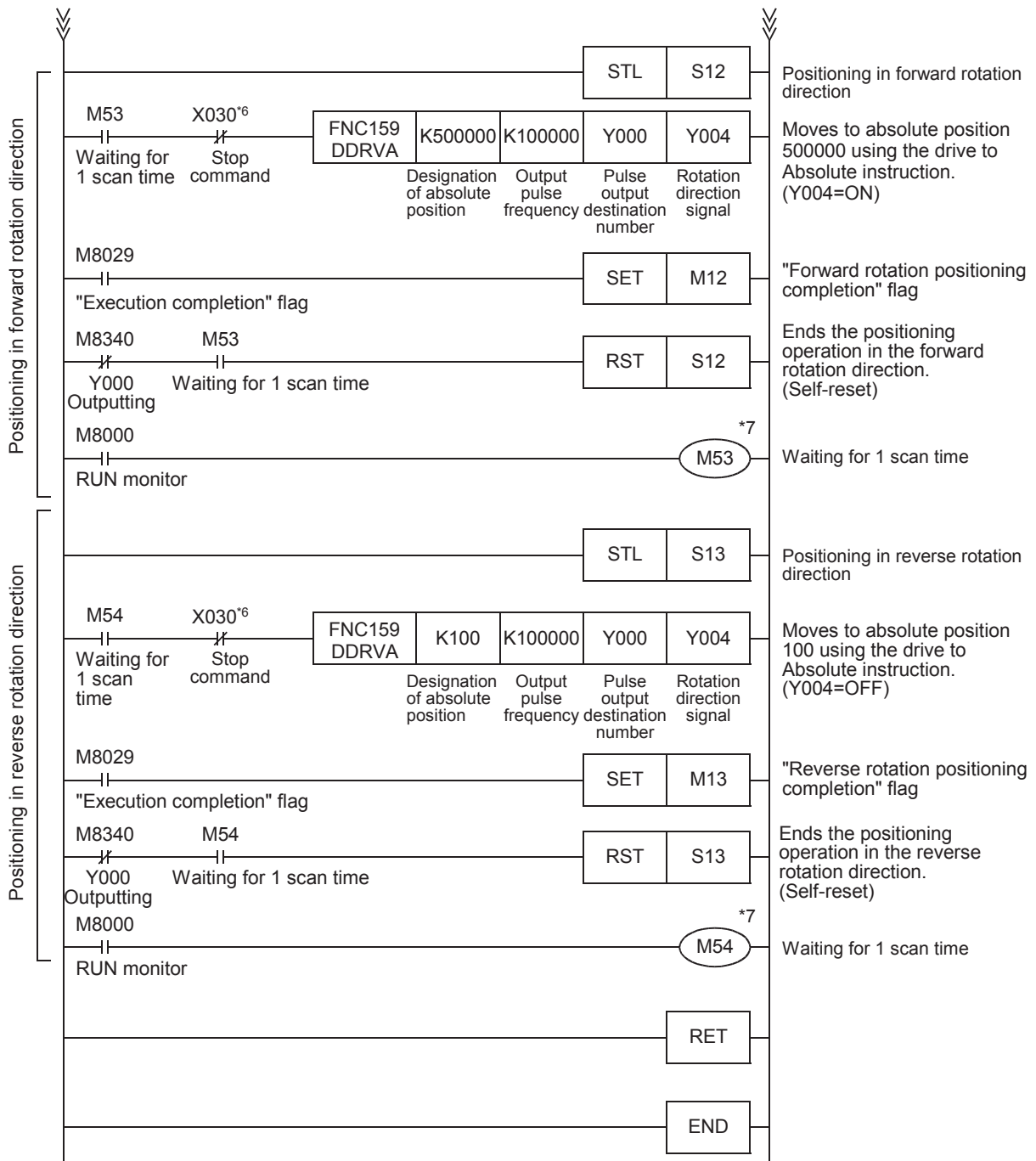

- *6. To stop the positioning operation, be sure to insert the stop contact before the positioning instruction so that the STL instruction cannot be turned off (reset) until the "pulse output monitor" flag (M8340 (for Y000)) is turned off.
- *7. To prevent simultaneous activation of positioning instructions, the instruction activation timing should be delayed by 1 scan time.

A
Common Items

B
Built-in Positioning Functions

Apx.
Example Connection

12.4 Positioning Using Batch Setting Method

Positioning operation will be performed using the absolute positioning method as shown in the following chart:
 → For details on input/output assignment, refer to Section 12.1

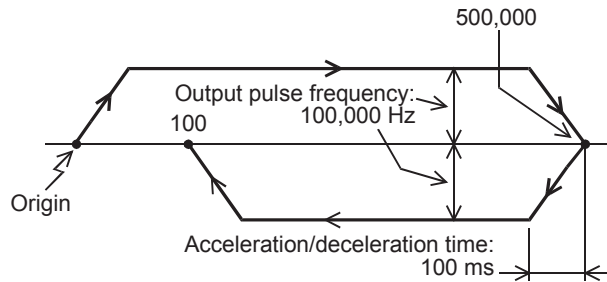

12.4.1 Setting Using GX Works2

This section describes how to set the built-in positioning parameters using GX Works2. The built-in positioning parameters can be specified only if FX3UC PLC Ver. 2.20 or later and FX3G/FX3GC/FX3U PLC is used.

→ For details on GX Developer operating procedure, refer to GX Developer Operating Manual.

1 On the project view displayed, double-click on "Parameter" and then "PLC Parameter".

If the project view is not displayed on the screen, click on "View" in the menu bar, and then click on "Docking Window", and then click "Navigation".

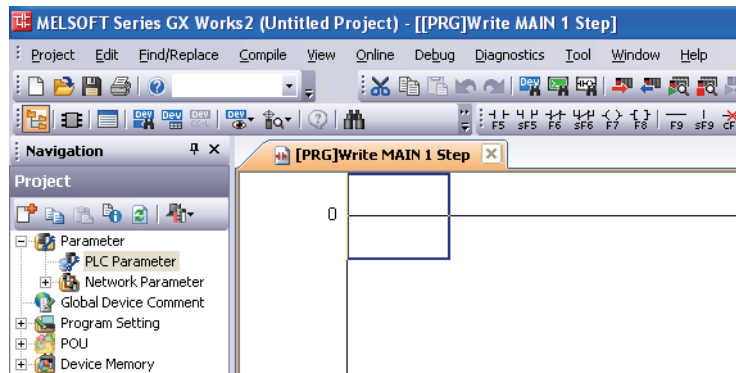

2 Click on the «Memory Capacity» tab, and then check the "Positioning Instruction Settings" check box.

9,000 steps are needed to set the built-in positioning data. If there is not enough capacity for programming, set the "Memory Capacity" to 16,000 steps or more.

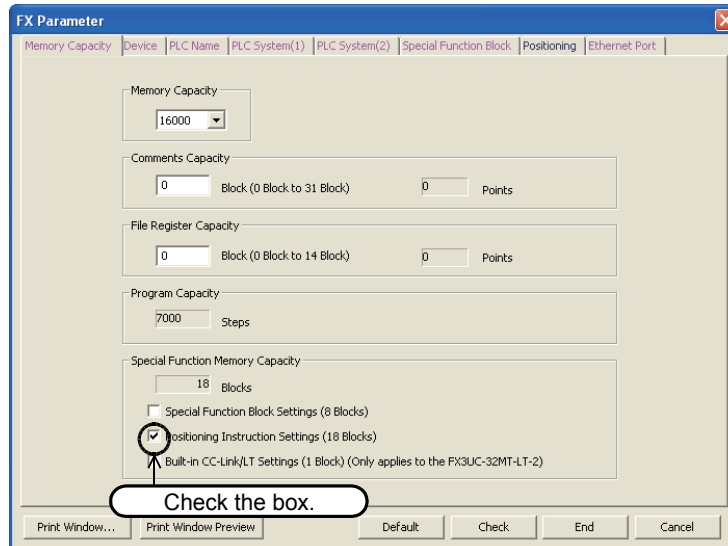

3 Click on the «Positioning» tab, and then set Y000 (pulse output destination) as follows.

Before clicking on the "Positioning" tab, click on the «Memory Capacity» tab, and then enter a check in the "Positioning Instruction Settings" check box. After entering a check, positioning data can be set.

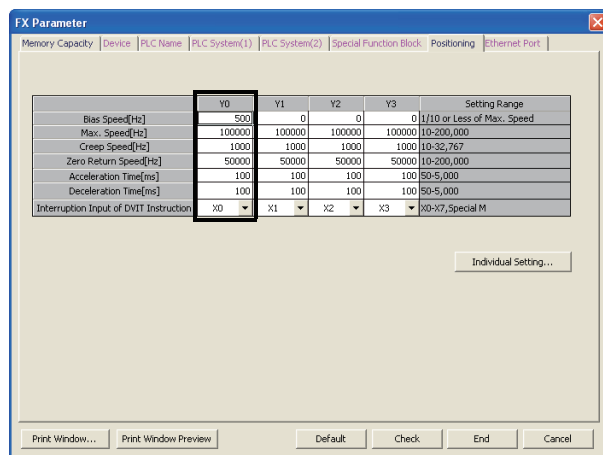

Setting item	Setting value
Bias Speed [Hz]	500
Max. Speed [Hz]	100,000
Creep Speed [Hz]	1000
Zero Return Speed [Hz]	50,000
Acceleration Time [ms]	100
Deceleration Time [ms]	100
Interrupt Input for DVIT Instruction *1	X000

*1. Only available for FX3U and FX3UC PLCs.

4 Click on the "Individual setting" button. The "Positioning Instruction Settings" screen will appear. In this screen, click on the «Y0» tab to display the positioning table for Y000 (pulse output destination). Set the data in the positioning table as follows:

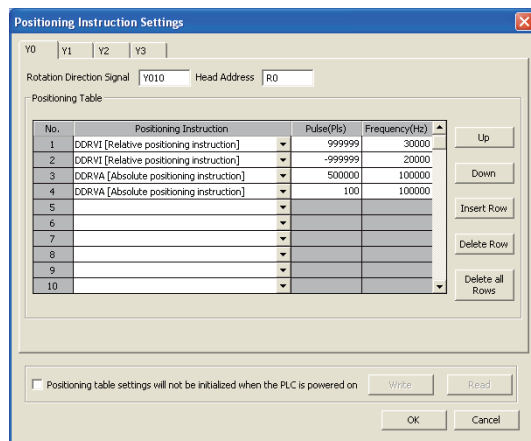

Setting item	Setting value	
Rotation Direction Signal	Y004	
Head Address	R0	
No. 1	Positioning Instruction (drive to increment)	DDRVI
	Pulse (Pls)	999,999
	Frequency (Hz)	30,000
No. 2	Positioning Instruction (drive to increment)	DDRVI
	Pulse (Pls)	-999,999
	Frequency (Hz)	30,000
No. 3	Positioning Instruction (drive to absolute)	DDRVA
	Pulse (Pls)	500,000
	Frequency (Hz)	100,000
No. 4	Positioning Instruction (drive to absolute)	DDRVA
	Pulse (Pls)	100
	Frequency (Hz)	100,000

5 Create a program.

6 On the bar, click on "Online" and then «Write to PLC». The online data operation screen will appear.

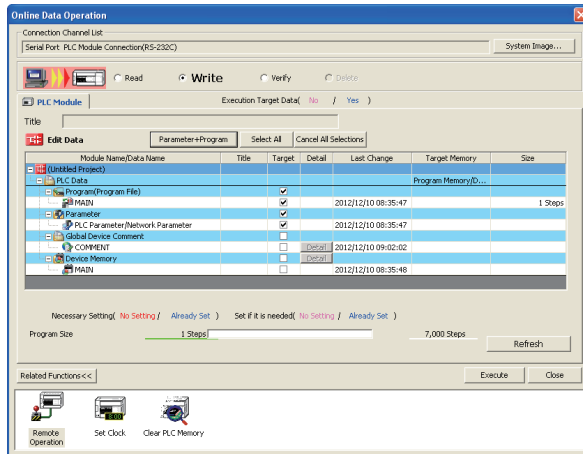

7 Click the "Parameter+Program" buttons, and then click the "Execute" button.

The parameters and the created program will be transferred to the PLC. To enable the transferred parameters, stop the PLC, and then restart it.

12.4.2 Operation Program

An example of a relay ladder program is shown below:

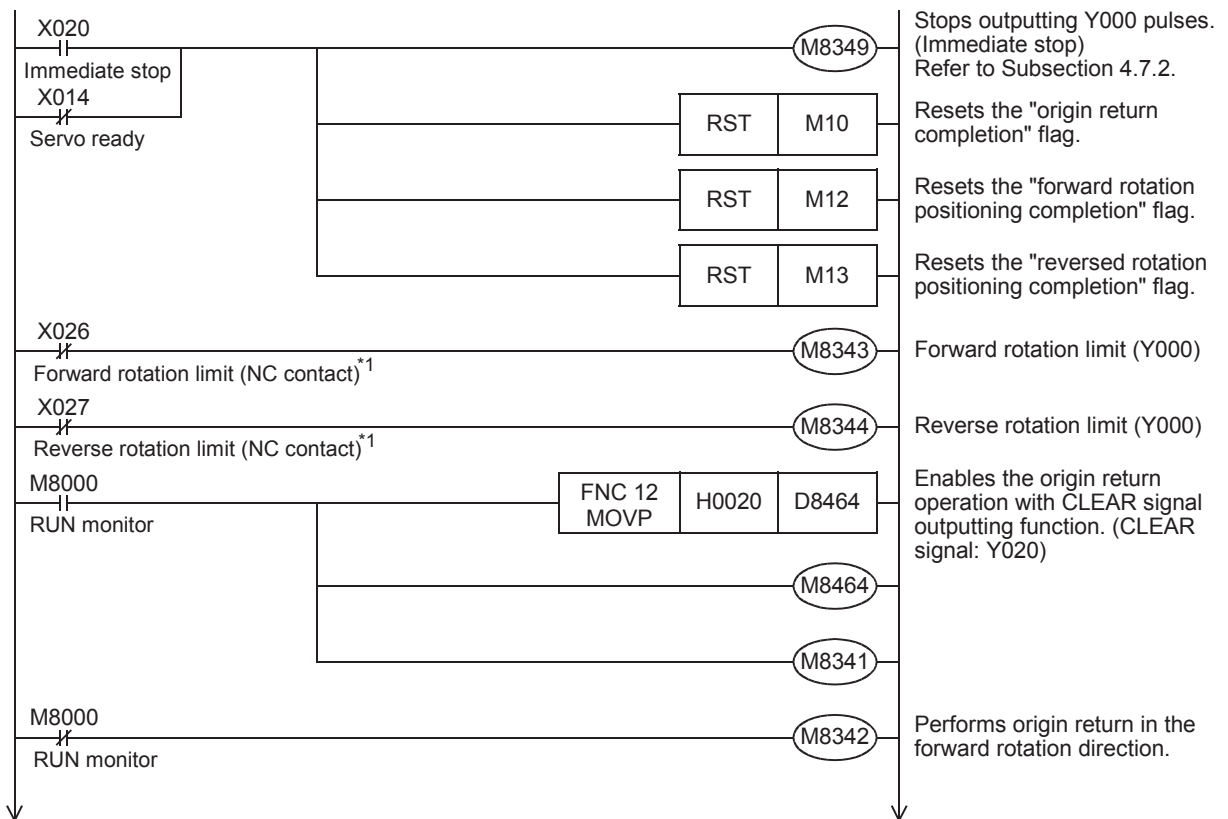

*1. Change contacts in the program to NO contacts when using NO contact type limit switches.

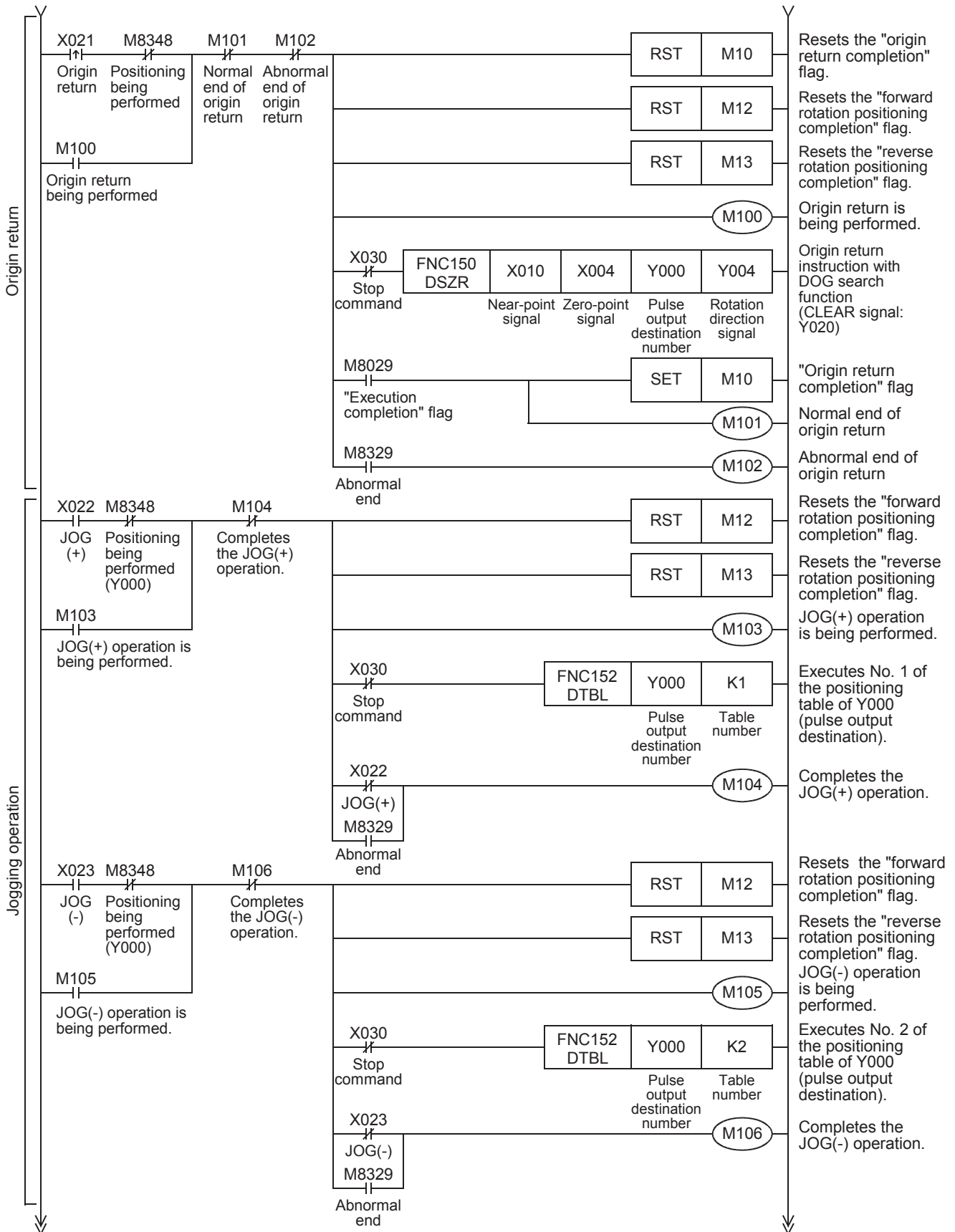

A Common Items
B Built-in Positioning Functions
Apx. Example Connection

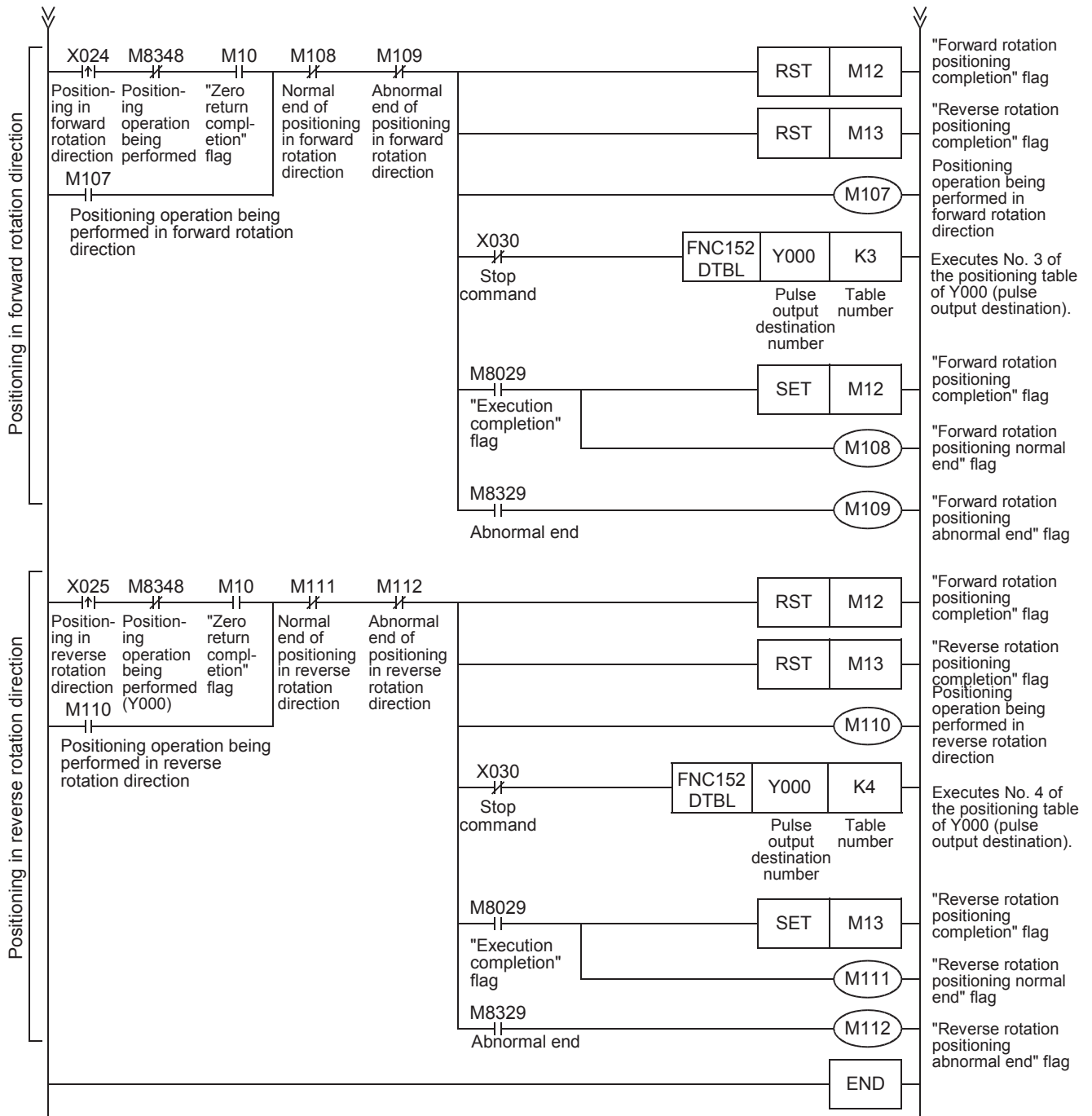

12.5 Program for Reading Current ABS Value Using ABS Instruction

- 1) Program for storing ABS data in current value registers specified by a positioning instruction for Y000 (pulse output destination)

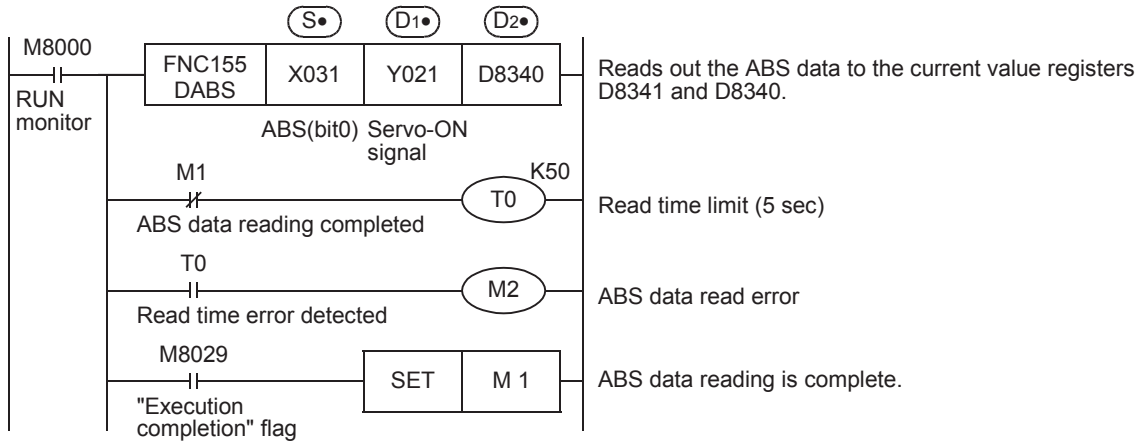

- 2) Program for storing ABS data in the current value registers of the FX3U-1PG, FX2N-1PG(-E) or FX2N-10PG

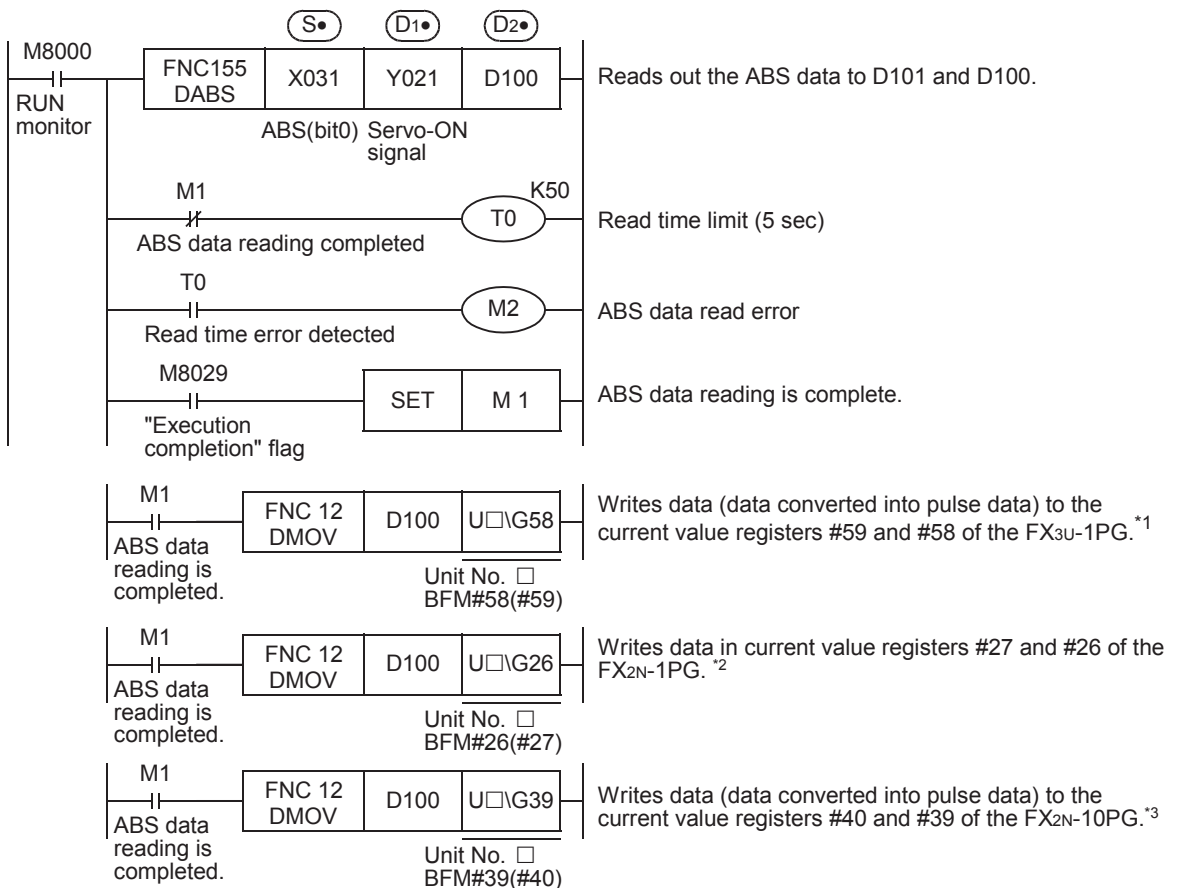

- *1. When writing the ABS data to the FX3U-1PG, be sure to use the current value registers (BFM#59, BFM#58) to store the pulse converted data.
- *2. The ABS data will be read out as a pulse converted value. For this reason, be sure to specify "motor system" when setting parameters (BFM#3) for the FX2N-1PG(-E).
- *3. When writing the ABS data to the FX2N-10PG, be sure to use the current value registers (BFM#40, BFM#39) to store the converted pulse data.

13. Troubleshooting

13.1 LED Indicator Lamp Check

If an error occurs, check the ON/OFF status of the LED indicator lamps on the PLC to assess the general meaning of the error. This section does not describe all the LED indicator lamps of the main unit. For details on the LED indicator lamps, refer to the manual (Hardware Edition) of the PLC main unit.

FX3s PLC

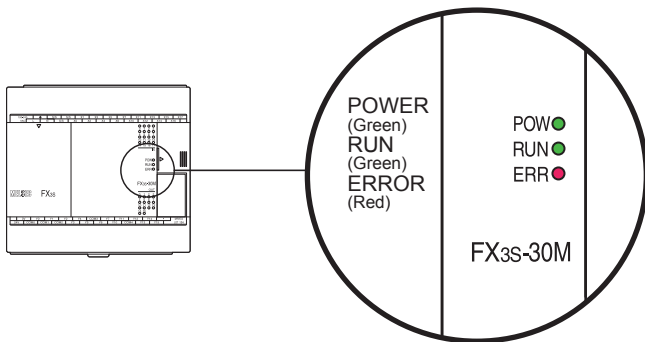

FX3GC PLC

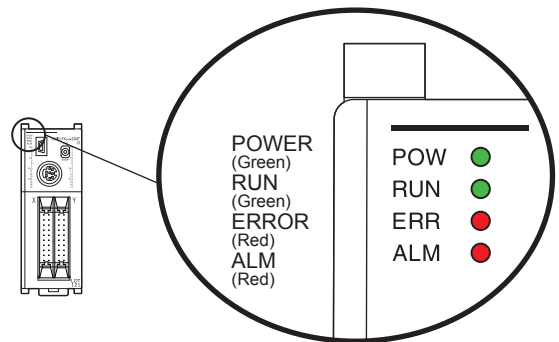

FX3G PLC

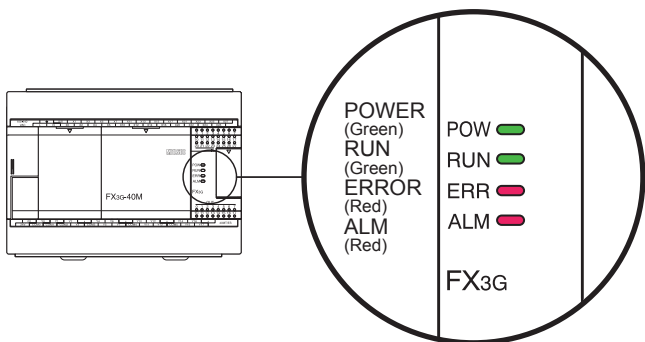

FX3UC (D, DS, DSS) PLC

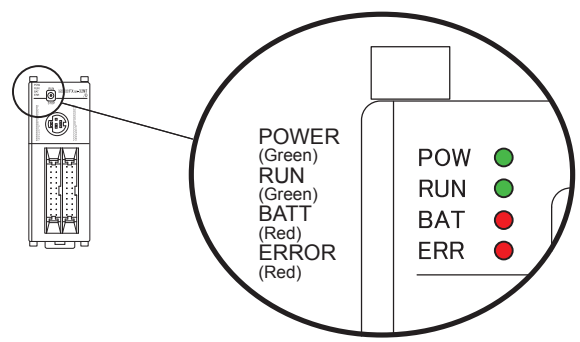

FX3U PLC

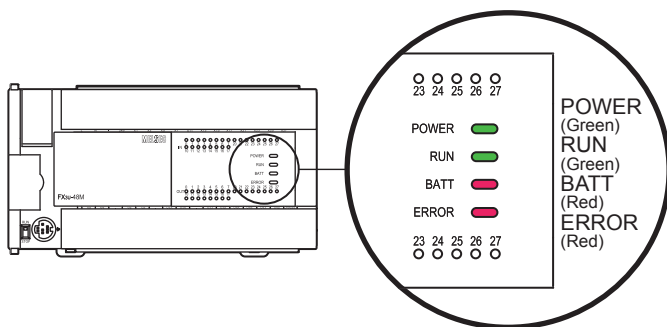

FX3UC-32MT-LT (-2) PLC

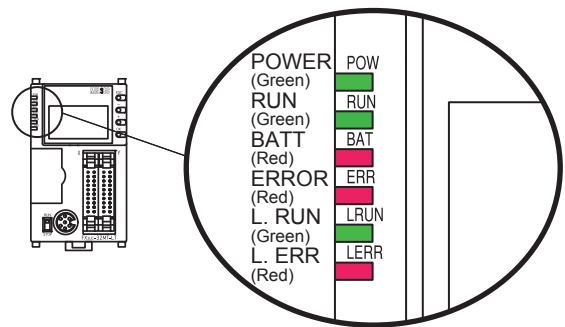

13.1.1 POWER (POW) Indicator Lamp (Statuses: ON, flashing, OFF)

Lamp status	Status of PLC	Troubleshooting
ON	The specified voltage is properly supplied to the power supply terminal.	The power is being supplied properly.
Flashing	The PLC may be at one of the following statuses: <ul style="list-style-type: none"> · The specified voltage/current is not supplied to the power supply terminal. · An external line is not properly connected. · The PLC has a problem. 	<ul style="list-style-type: none"> · Check the power supply voltage. · Excluding the power cable, disconnect all other cables, and then turn the power ON again. Check the lamp status. If the lamp flashes again, please contact your local Mitsubishi Electric representative.
OFF	The PLC may be at one of the following statuses: <ul style="list-style-type: none"> · The power is off. · The specified voltage is not supplied to the power supply terminal. · The power cable is disconnected. 	If the power is on, check the power supply unit and the power supply line. If the power is properly supplied, please contact your local Mitsubishi Electric representative.

13.1.2 RUN Indicator Lamp (Statuses: ON, OFF)

Lamp status	Status of PLC	Troubleshooting
ON	The sequence program is being executed.	The RUN indicator lamp indicates the operation status of the PLC. Note that the RUN indicator lamp will go out depending on the status of the ERROR indicator lamp (refer to Subsection 13.1.4).
OFF	Execution of the sequence program is stopped.	

13.1.3 BATT (BAT) Indicator Lamp (Statuses: ON, OFF) [FX3U/FX3UC]

Lamp status	Status of PLC	Troubleshooting
ON	The voltage of the battery is too low.	Immediately replace the battery (refer to the manual of the PLC).
OFF	The battery supplies enough voltage as specified by D8006.	The PLC has no problems.

13.1.4 ALM Indicator Lamp (Statuses: ON, OFF) [FX3G/FX3GC]

This LED is valid when the optional battery is installed and the battery mode is selected using a parameter.

Lamp status	Status of PLC	Troubleshooting
ON	The voltage of the battery is too low.	Immediately replace the battery (refer to the manual of the PLC).
OFF	The battery supplies enough voltage as specified by D8006.	The PLC has no problems.

13.1.5 ERROR (ERR) indicator lamp (Statuses: ON, flashing, OFF)

Lamp status	Status of PLC	Troubleshooting
ON	A watchdog timer error may have been detected, or the hardware of the PLC may be damaged.	1) Stop the PLC, turn the power OFF, and then turn the power ON again. If the ERROR (ERR) indicator lamp goes out, check to see if a watchdog timer error has been detected, and take one of the following measures. <ul style="list-style-type: none"> - Review the program. The maximum value of the scanning time (D8012) should not be larger than the set value of the watchdog timer (D8000). - The interrupt input and the pulse catch input should not be turned on and off too frequently during 1 scan time. - The frequency of the pulse input to the high-speed counter should not exceed the specified range (duty:50%) - Add several WDT instructions. Set several WDT instructions in the program so that the watchdog timer can be reset several times during 1 scan time. - Change the set value of the watchdog timer. Using the program, change the set value of the watchdog timer (D8000) so that the set value of the watchdog timer (D8000) can be larger than the maximum value of the scanning time (D8012). 2) Remove the PLC, and put it on a workbench. Supply another source of power to the PLC. If the ERROR (ERR) indicator lamp does not light, the cause of the problem may be noise. In this case, take the following measures. <ul style="list-style-type: none"> - Check the grounding line, and change the wiring route and the installation place. - Adopt a noise filter for the power supply line. 3) If measures 1) and 2) do not turn the ERROR indicator lamp OFF, please contact your local Mitsubishi Electric representative.
Flashing	The PLC has one of the following errors: <ul style="list-style-type: none"> · Parameter error · Syntax error · Circuit error 	Diagnose the PLC (PC), or check the programs using the programming tool. For countermeasures, refer to the following manual of the applied PLC. <p style="text-align: right;">→ Programming manual</p>
OFF	Errors that can stop the PLC are not detected.	If an operation error is detected on the PLC, diagnose the PLC (PC), or check the programs using the programming tool. There is a good possibility that an "I/O configuration error", "parallel link/communication error", or "operation error" has been detected.

13.1.6 Pulse Output Destination Device and Rotation Direction Output Indicator Lamp

1. If transistor outputs from the main unit are used for positioning

Signal	LED status during execution of positioning instruction	Description
"Pulse output destination device" (pulse train) signal	Turned on and off at high speed*1	The pulse outputting operation is controlled by the positioning instruction.
	OFF	The PLC may exhibit the following status: 1) The operation of the positioning instruction is completed. 2) The positioning instruction turns ON, but an operation error is detected. The instruction, therefore, is not being executed. To check the error, refer to the following section: → Refer to Subsection 13.2.1 "Error code check method" .
"Rotation direction output" (direction) signal	ON	Operation is being performed in the forward rotation direction.
	OFF	The PLC may exhibit the following status: 1) The positioning instruction turns ON, and operation is being performed in the reverse rotation direction. 2) The positioning instruction turns ON, but an operation error is detected. The instruction, therefore, is not being executed. To check the error, refer to the following section: → Refer to Subsection 13.2.1 "Error Code Check Method" .

*1. The output LED is kept ON in the FX3U PLC.

A
Common Items

B
Built-in Positioning Functions

Apx.
Example Connection

2. If the high-speed output special adapter (FX3U-2HSY-ADP) is used for positioning

Status of pulse output method setting switch	Signal	LED status during execution of positioning instruction	Description
PLS•DIR side	"Pulse output destination device" (pulse train)	Turned on and off at high speed	The pulse output operation is controlled by the positioning instruction.
		OFF	The PLC may exhibit the following status: 1) The operation of the positioning instruction is completed. 2) An operation error occurred during positioning. The instruction, therefore, is not being executed. To check the error, refer to the following section: → Refer to Subsection 13.2.1 "Error Code Check Method" .
	"Rotation direction output" (direction)	ON	Forward operation is in execution.
		OFF	The PLC may exhibit the following status: 1) The positioning instruction turns ON, and operation is being performed in the reverse rotation direction. 2) An operation error occurred during positioning instruction. The instruction, therefore, is not being executed. To check the error, refer to the following section: → Refer to Subsection 13.2.1 "Error Code Check Method" .
FP/RP side	"Pulse output destination device" (Forward pulse train)	Turned on and off at high speed	Forward operation is being executed for a positioning instruction. Reverse pulse train is OFF.
		OFF	The PLC may exhibit the following status: 1) The positioning instruction turns ON, and operation is being performed in the reverse rotation direction. 2) An operation error occurred during positioning. The instruction, therefore, is not being executed. To check the error, refer to the following section: → Refer to Subsection 13.2.1 "Error Code Check Method" .
	"Rotation direction output" (Reverse pulse train)	Turned on and off at high speed	Reverse operation is being executed for a positioning instruction. Forward pulse train is OFF.
		OFF	The PLC may exhibit the following status: 1) The positioning instruction turns ON, and operation is being performed in the forward rotation direction. 2) An operation error occurred during positioning. The instruction, therefore, is not being executed. To check the error, refer to the following section: → Refer to Subsection 13.2.1 "Error Code Check Method" .

13.2 Error Check

13.2.1 Error Code Check Method

This section describes how to check the error codes using GX Works2.

If the display module is being used, use the "error check" function of the display module to check the error codes. For details on the operation of the display module, refer to the following manuals:

- FX3G Hardware Edition.
- FX3U Hardware Edition.
- FX3UC Hardware Edition.

1 Connect a personal computer to the PLC.

2 Diagnose the PLC.

On the tool menu bar, click on "Diagnostics", and then "PLC Diagnostics" to diagnose the cause of the PLC error.

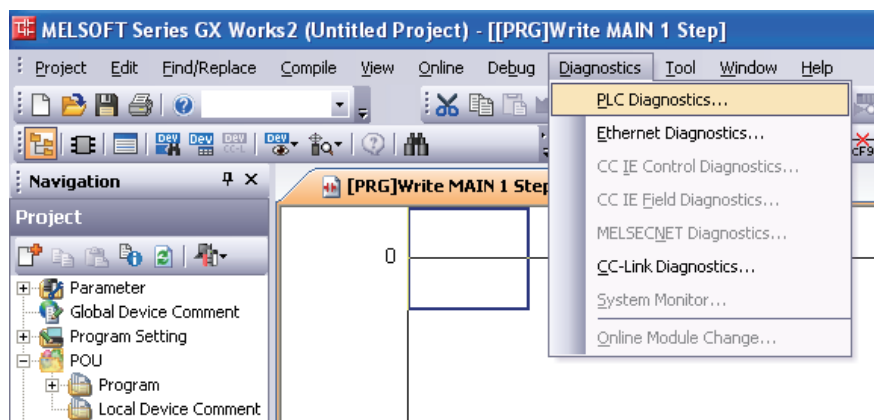

3 Check the diagnosis result.

The following window will appear. Check the details of the error shown on the window.

<Example of error display screen>

The PLC error is displayed.

Displays statuses of LEDs on FX PLC

The help function of GX Works2 opens, and you can check the details of the error code.

Status	No.	Error Step	Current Error	Year/Month/Day	Time
Major Error	6507	1	Syntax Error	2012-12-10	09:12:57

13.2.2 Error Codes

This section describes the error codes related to the positioning instructions. For details on the error codes, refer to the following manual.

→ Refer to the programming manual.

Error code	Operation after detecting error	Description of error	Troubleshooting
Operation error [M8067 (D8067)]			
0000		No error detected	
6705	Operation will be continued.	The device specified by the operand of the applied instruction is a wrong device.	This error occurs during operation. Check the program or the operand of the applied instruction. Even if no syntax error or circuit error is detected, an operation error may occur for the following reason: Example: T500Z is not an error. However, if Z = 100, the result of operation will be T600. This means that the device number is out of the specified range, and an operation error will be detected.
6706		The device number or the data specified by the operand of the applied instruction is out of the specified range.	
6760		Sum error of ABS data sent from servo amplifier	Check the servo amplifier for disconnection. Also check the set data.
6763		1) The input (X) specified by the DSZR, DVIT, or ZRN instruction is already being used for another instruction. 2) The interruption signal device number specified by the DVIT instruction is outside the setting range.	1) Check that the input (X) specified by the DSZR, DVIT, or ZRN instruction is not being used for the following items: - Input interruption (including delay function) - High-speed counter (C235 to C255) - Pulse catch (M8170 to M8177) - SPD instruction 2) Check the data set in D8336 (interruption signal designation device for DVIT instruction).
6764		The pulse output number is already being used for a positioning instruction or pulse output instruction (PLSY, PWM, etc.).	Check that the output specified as the pulse output destination is not being activated by another positioning instruction.

13.3 If the Servo Motor or the Stepping Motor Does Not Operate

If the servo motor or the stepping motor does not operate, check the following items.

- 1) Check the wiring condition.
 - For output specifications, refer to Section 2.5.
 - To connect the MELSERVO Series, refer to the examples of connection shown in the Appendix.
 - For details on the servo amplifier (drive unit), refer to the manual of your unit.
- 2) Execute the positioning instruction, and then check the statuses of the following LED indicator lamps.
 - For details on lamp statuses, refer to Subsection 13.1.5.
 - LED indicator lamp of the output specified as the pulse output destination
 - LED indicator lamp of the output specified as the rotation direction output device
- 3) Verify that the same pulse output method is being applied for both the PLC and the servo amplifier (drive unit).
 - For details on the pulse output method, refer to Subsection 4.6.1.
 - For details on high-speed output special adapter setting method, refer to Subsection 4.5.2.
- 4) Check that the pulse output stop command flag is off.
 - For details on the pulse output stop command flag, refer to Subsection 4.3.2.

The following table shows the pulse output stop command flag of each pulse output destination device (Y000, Y001, Y002, Y003).

Pulse output destination device	Pulse output stop command flag	Operation
Y000	M8349	During pulse outputting operation, if the pulse output stop command flag of a corresponding pulse output destination device is turned on, the pulse outputting operation will be immediately stopped.
Y001	M8359	
Y002	M8369	
Y003	M8379	

- 5) Check that the limit switch (forward or reverse rotation limit switch) is not activated.
 - For details on the normal and reverse rotation limits, refer to Subsection 4.3.1.

The following table shows the forward and reverse limit relays of each pulse output destination device (Y000, Y001, Y002, Y003).

Pulse output destination device	Forward limit relay	Reverse limit relay	Corresponding instruction and stop	
			PLSV instruction (M8338 = OFF)	DSZR, DVIT, ZRN, PLSV (M8338 = ON), DRVI, and DRVA instructions
Y000	M8343	M8344	If the corresponding rotation limit relay is turned on, the pulse output (operation) will immediately stop.	If the corresponding rotation limit relay is turned on, the speed will decelerate, and the operation will stop.
Y001	M8353	M8354		
Y002	M8363	M8364		
Y003	M8373	M8374		

- 6) Check the operation timing of the positioning instruction.
 If the "pulse output monitor" (BUSY/READY) flag is on, and if a positioning instruction (excluding the ABS instruction) or pulse output instruction (PLSR, PLSY) uses the same pulse output destination device, the instruction cannot be executed.

If the "pulse output monitor" (BUSY/READY) flag is still on after the instruction activation contact is turned off, do not execute a positioning instruction (including PLSR and PLSY instructions) that uses the same output number.

Before activating such an instruction, check that the "pulse output monitor" (BUSY/READY) flag is off, and then wait until at least 1 scan time is completed.

Pulse output destination device	Pulse output monitor flag
Y000	M8340
Y001	M8350
Y002	M8360
Y003	M8370

13.4 If Operation Is Stopped at a Wrong Position

If operation is stopped at a wrong position, check the following items.

- 1) Check whether the electronic gear of the servo amplifier (drive unit) is set properly.
 → **For the electronic gear setting method of the MELSERVO Series, refer to Subsection 4.6.2.**
- 2) Check whether the origin is set properly.
 - Properly set the DOG so that the near-point signal (DOG) can be kept ON until the speed is reduced to the creep speed. The zero return instruction will start speed reduction at the front end of the DOG, and will stop the operation at the rear end of the DOG or at detection of the first zero-phase signal after passing the rear end of the DOG. After that, the current value register will be cleared (reset to "0"). If the speed is not reduced to the creep speed before detecting the rear end of the DOG, the operation may not be stopped at the specified position.
 - The creep speed should be sufficiently slow. The zero return instruction will not reduce the speed before stopping. For this reason, if the creep speed is not slow enough, the operation may not be stopped at the specified position due to inertia.
 - Devices for the near-point signal (DOG)
 - DSZR instruction
 Detection of (the rear end and the front end of) the near-point signal (DOG) will be affected by the input filter and the scan time of the sequence program.
 Secure 1 scan time or more from the rear end of the DOG to turning ON of the zero-point signal.
 - ZRN instruction
 If an input X000 to X007 (X000 to X005 for FX3s PLC) of the main unit is specified for the near-point signal (DOG), the PLC interruption function will be used to stop the operation. Under the following condition, however, operation may be affected by the input filter or the scan time of the sequence program, and the operation may not be stopped at the specified position.
 - a) An input number of X010 or higher (X006 or higher for FX3s PLC) (or other device (auxiliary relay, etc.)) is specified. If an input relay X010 or higher (X006 or higher for FX3s PLC) is specified for the near-point signal (DOG), the effects of the input filter will apply.
 - If the DSZR instruction is used:
 Since the zero-phase signal of the servo motor is used, adjust the relation between the rear end of the DOG and the zero-phase signal as shown in the following figure. If fine adjustment of the origin position is needed, adjust the position of the near-point signal (DOG).

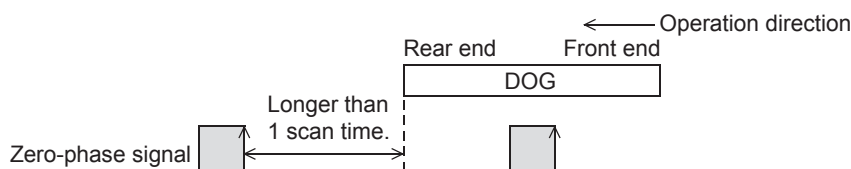

- 3) If reciprocating operation (operation in the forward rotation direction and then reverse rotation direction) is not stopped at the specified position: The built-in positioning function cannot correct the mechanical backlash (clearance/play) during positioning operation. If it is necessary to correct the backlash, preliminarily set the number of output pulses considering the backlash that may be caused when changing the transfer direction.

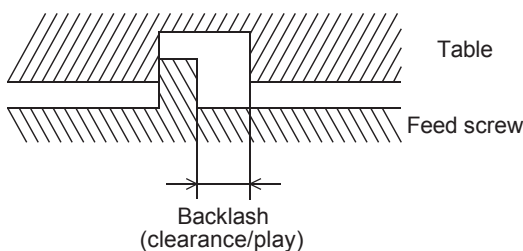

FX3s/FX3G/FX3GC/FX3U/FX3UC Series Programmable Controllers User's Manual [Positioning Control Edition]

Appendix: Example Connection

Foreword

To use the positioning function of the MELSEC-F FX3s/FX3G/FX3GC/FX3U/FX3UC Series PLC described in this manual, the PLC should be connected to a servo amplifier drive unit. The Appendix, therefore, describes how to connect the PLC to a servo amplifier drive unit and should be read and understood before attempting to install or use the unit.

Store this manual in a safe place so that you can take it out and read it whenever necessary. Always forward it to the end user.

This manual confers no industrial property rights or any rights of any other kind, nor does it confer any patent licenses. Mitsubishi Electric Corporation cannot be held responsible for any problems involving industrial property rights which may occur as a result of using the contents noted in this manual.

Description of Manual (Example of Connection)

In this manual, the following formats are used for describing the examples of connection:

- Shows the title of the manual and the title of the division.
 This area shows the title of the manual and the title of the division for the current page.
 1st line: Shows the title of the manual.
 2nd line: Shows the title of the division.
- Shows the title of the chapter and the title of the section.
 This area shows the title of the chapter and the title of the section for the current page.
- Indexes the division titles.
 The right side of each page indexes the title of the division for the current page.

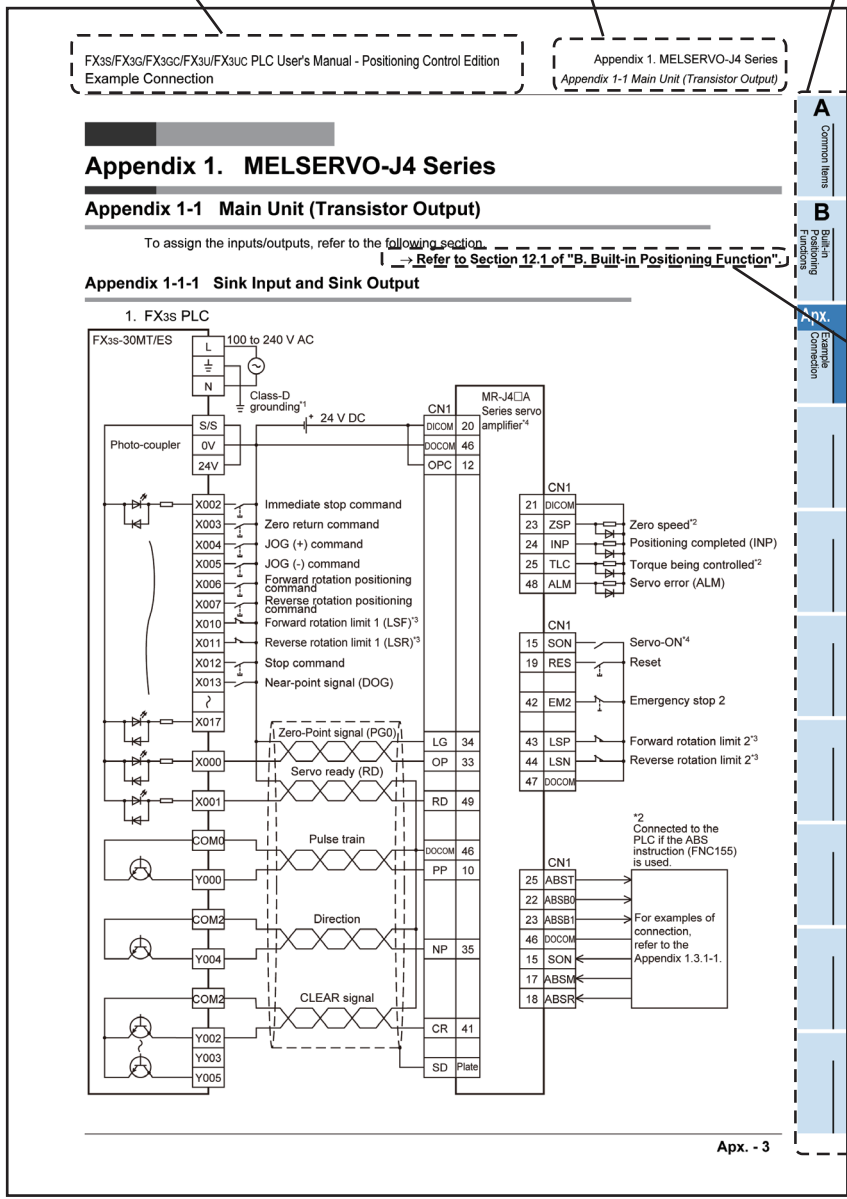

Shows the reference.
 This area shows the reference document (the reference document is shown next to "→"). If the reference is in "Appendix: Examples of Connection", the chapter, section, or item number only will be shown next to "→".

The above is different from the actual page, as it is provided for explanation only.

Appendix 1. MELSERVO-J4 Series

Appendix 1-1 Main Unit (Transistor Output)

To assign the inputs/outputs, refer to the following section.

→ Refer to Section 12.1 of "B. Built-in Positioning Function".

Appendix 1-1-1 Sink Input and Sink Output

1. FX3s PLC

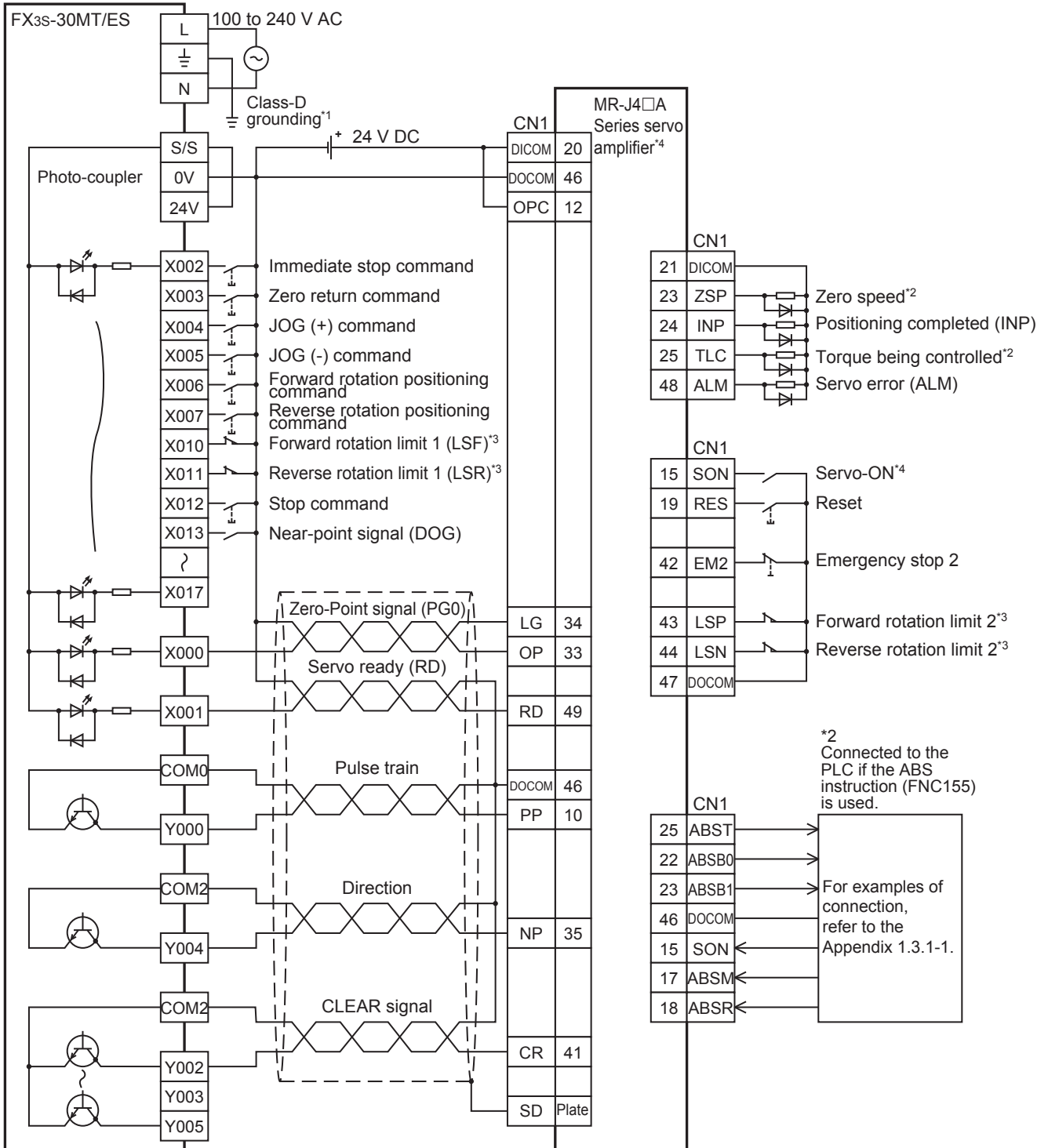

A Common Items
B Built-in Positioning Functions
Apx. Example Connection

- *1. Be sure to use the class-D grounding method (grounding resistance: 100 Ω or less).
- *2. To detect absolute positions, connect this line to the PLC.
- *3. To ensure safety, use the forward rotation limit switch and the reverse rotation limit switch on both sides: the PLC side and the servo amplifier side.
 Note that the limit switches on the PLC side should be activated slightly earlier than the limit switches on the servo amplifier side.

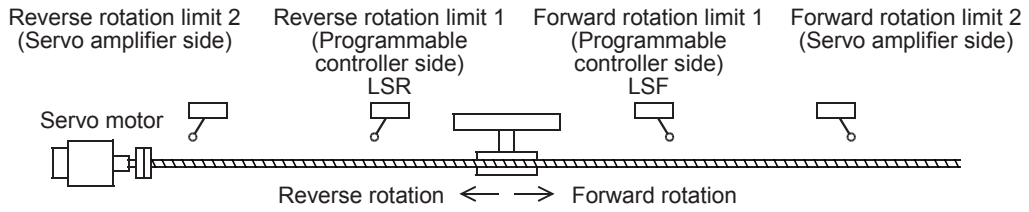

- *4. Set the command pulse input form of the servo amplifier (PA13) MR-J4□A to "0211" (negative logic, command input pulse train filter: 500 kpps or less).

2. FX3G/FX3U PLC

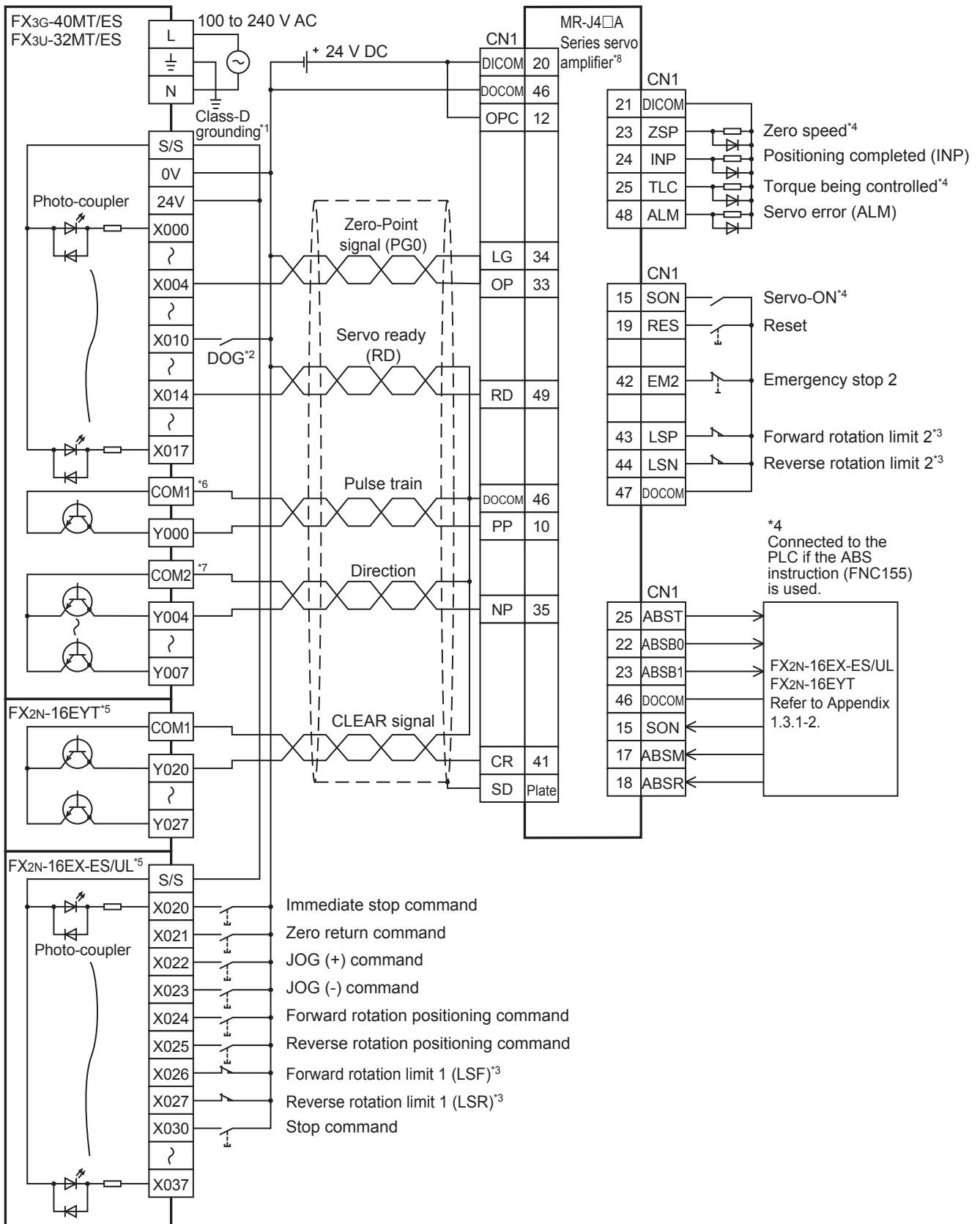

*1. Be sure to use the class-D grounding method (grounding resistance: 100 Ω or less).
 *2. Near-point signal (DOG)

- *3. To ensure safety, use the forward rotation limit switch and the reverse rotation limit switch on both sides: the PLC side and the servo amplifier side.
 Note that the limit switches on the PLC side should be activated slightly earlier than the limit switches on the servo amplifier side.

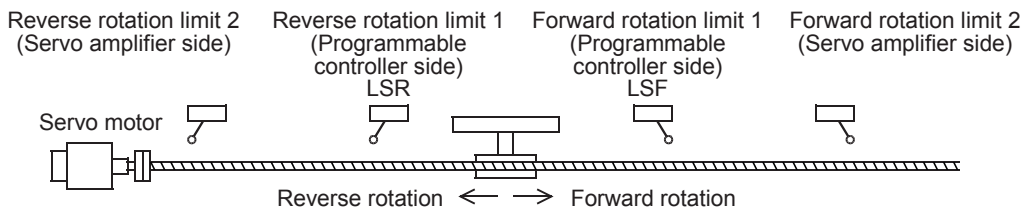

- *4. To detect absolute positions, connect this line to the PLC.
- *5. Extension blocks are used in the connection example.
 Inputs and outputs built into the main unit are available in place of extension blocks.
- *6. COM0 in the FX3G-40MT/ES
- *7. COM3 in the FX3G-40MT/ES
- *8. Set the command pulse input form of the servo amplifier (PA13) MR-J4□A to "0211" (negative logic, command input pulse train filter: 500 kpps or less).

3. FX3GC/FX3UC PLC

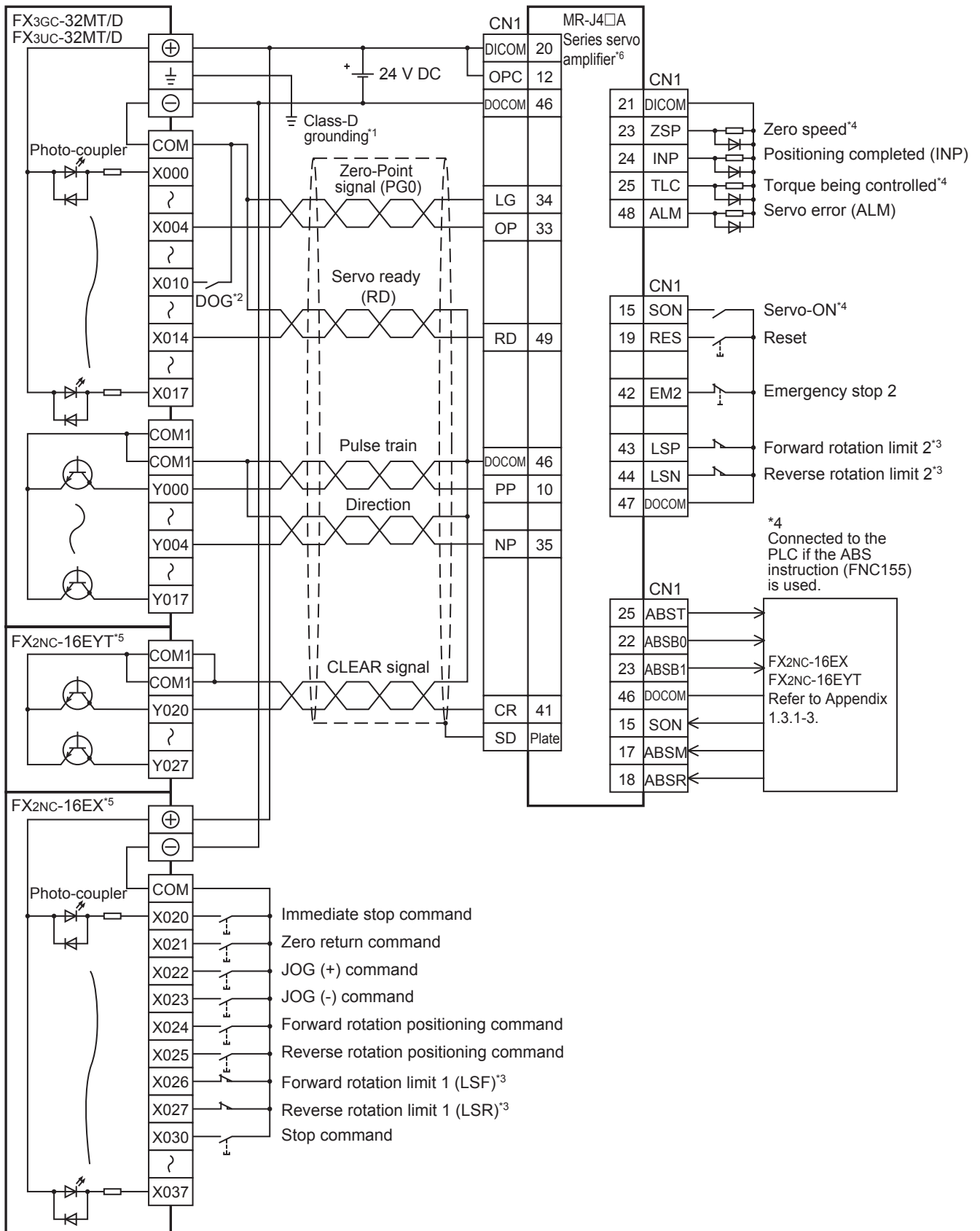

*1. Be sure to use the class-D grounding method (grounding resistance: 100 Ω or less).
 *2. Near-point signal (DOG)

A Common Items
B Built-in Positioning Functions
Apx. Example Connection

*4 Connected to the PLC if the ABS instruction (FNC155) is used.

- *3. To ensure safety, use the forward rotation limit switch and the reverse rotation limit switch on both sides: the PLC side and the servo amplifier side.
 Note that the limit switches on the PLC side should be activated slightly earlier than the limit switches on the servo amplifier side.

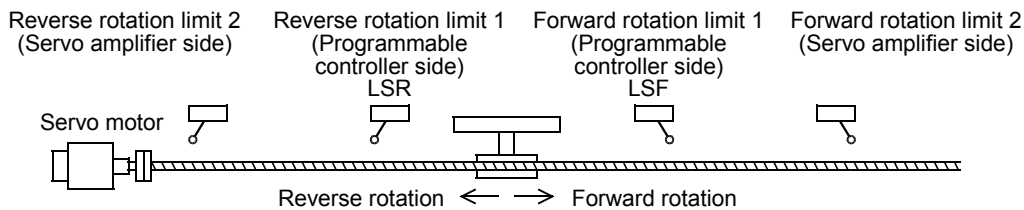

- *4. To detect absolute positions, connect this line to the PLC.
- *5. Extension blocks are used in the connection example.
 Inputs and outputs built into the main unit are available in place of extension blocks.
- *6. Set the command pulse input form of the servo amplifier (PA13) MR-J4□A to "0211" (negative logic, command input pulse train filter: 500 kpps or less).

Appendix 1-2 High-Speed Output Special Adapter

To assign the inputs/outputs, refer to the following section.

→ Refer to Section 12.1 of "B. Built-in Positioning Function".

Appendix 1-2-1 Sink Input, Sink Output (Transistor), and Differential Line Driver Output

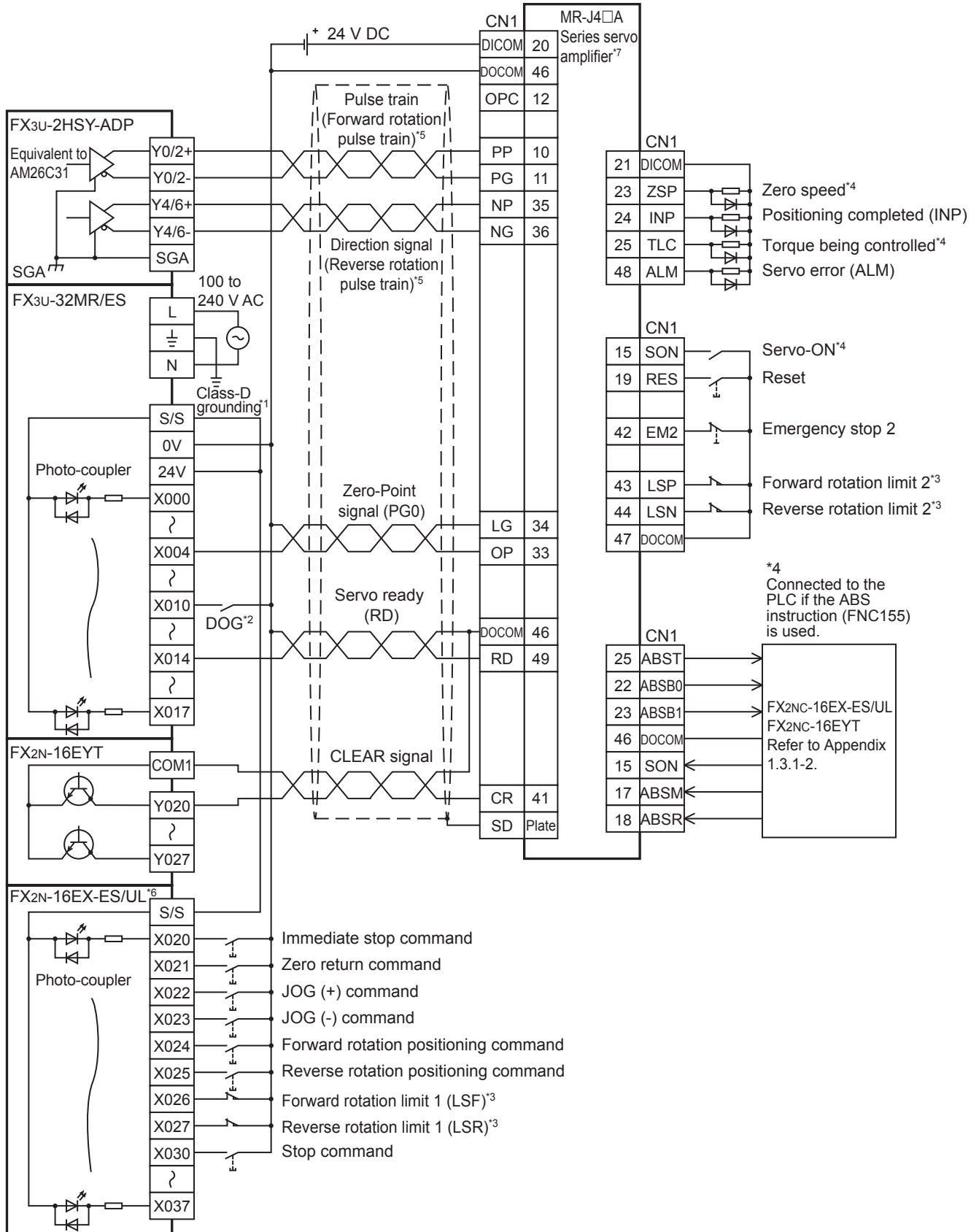

- *1. Be sure to use the class-D grounding method (grounding resistance: 100 Ω or less).
- *2. Near-point signal (DOG)
- *3. To ensure safety, use the forward rotation limit switch and the reverse rotation limit switch on both sides: the PLC side and the servo amplifier side.
 Note that the limit switches on the PLC side should be activated slightly earlier than the limit switches on the servo amplifier side.

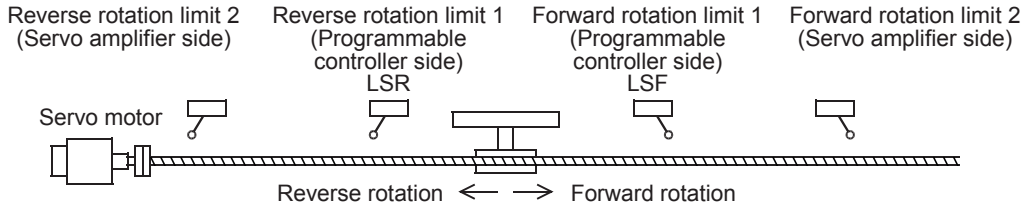

- *4. To detect absolute positions, connect this line to the PLC.
- *5. Set the pulse output form by pulse output form setting switch.

Pulse output method setting switch	Pulse output method
FP·RP side	Forward/reverse pulse train
PLS·DIR side	Pulse train + direction

- *6. Extension blocks are used in the connection example.
 Inputs and outputs built into the main unit are available in place of extension blocks.
- *7. Set the command pulse input form of the servo amplifier (PA13) MR-J4□A to "021*" (negative logic, command input pulse train filter: 500 kpps or less).
 In "*", set "0" when the pulse output type of FX3U-2HSY-ADP is "Forward/reverse pulse train", and set "1" when it is "Pulse train + Direction".

Appendix 1-3 Absolute Position Detection (Transistor Output)

To assign the inputs/outputs, refer to the following section.

→ Refer to Section 12.1 of "B. Built-in Positioning Function"

Appendix 1-3-1 Sink Input and Sink Output

1. FX3s PLC

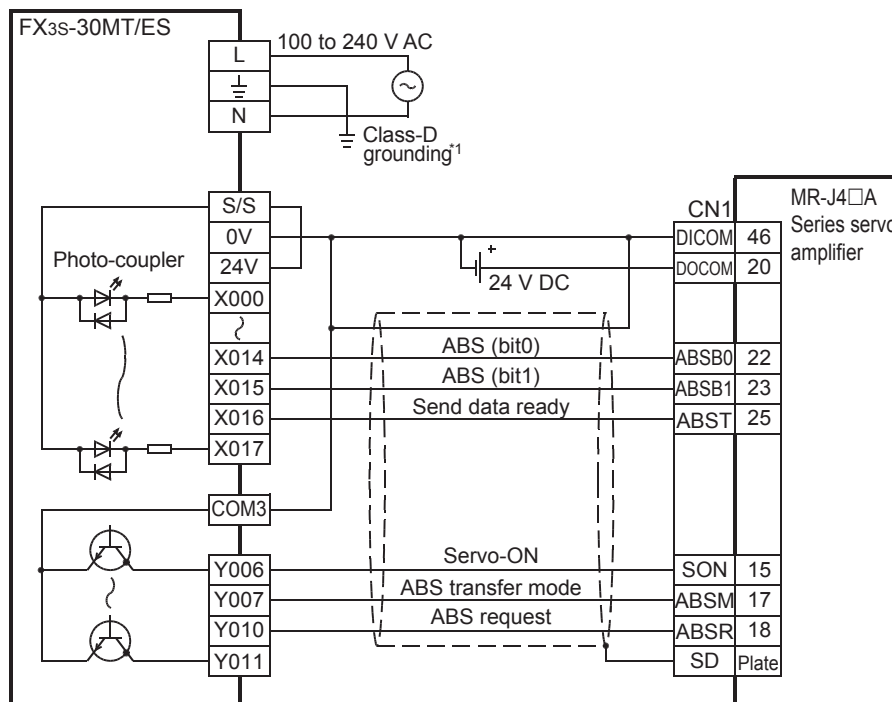

- *1. Be sure to use the class-D grounding method (grounding resistance: 100 Ω or less).

2. FX3G/FX3U PLC

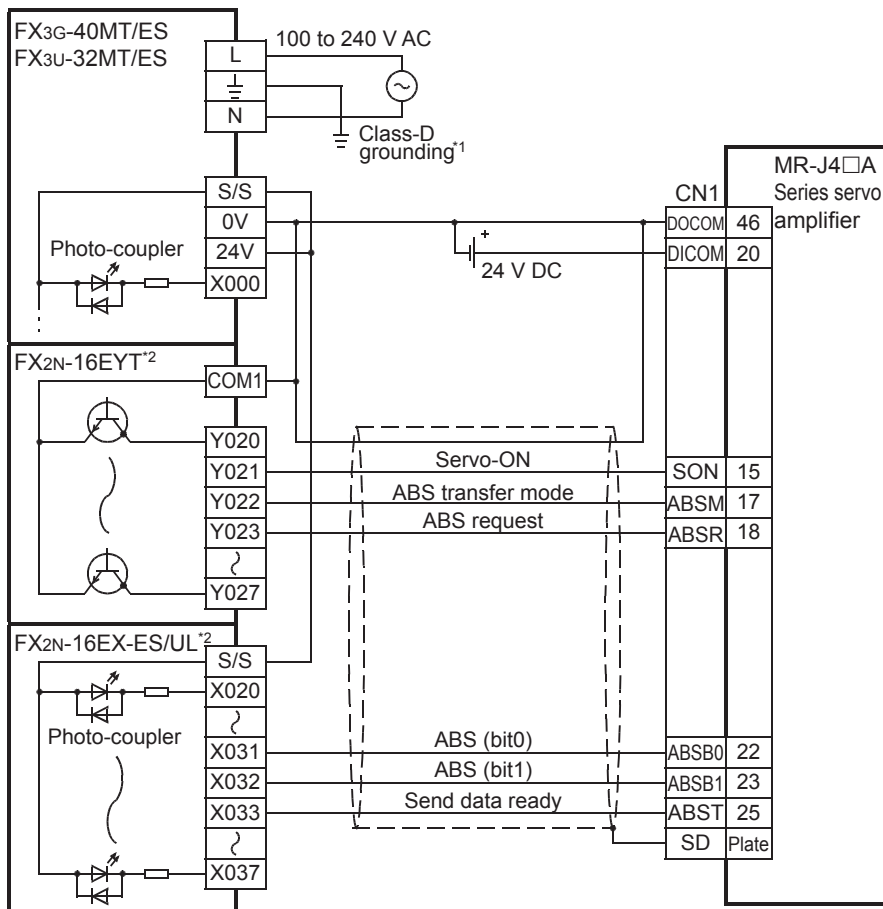

- *1. Be sure to use the class-D grounding method (grounding resistance: 100 Ω or less).
- *2. Extension blocks are used in the connection example.
 Inputs and outputs built into the main unit are available in place of extension blocks.

3. FX3GC/FX3UC PLC

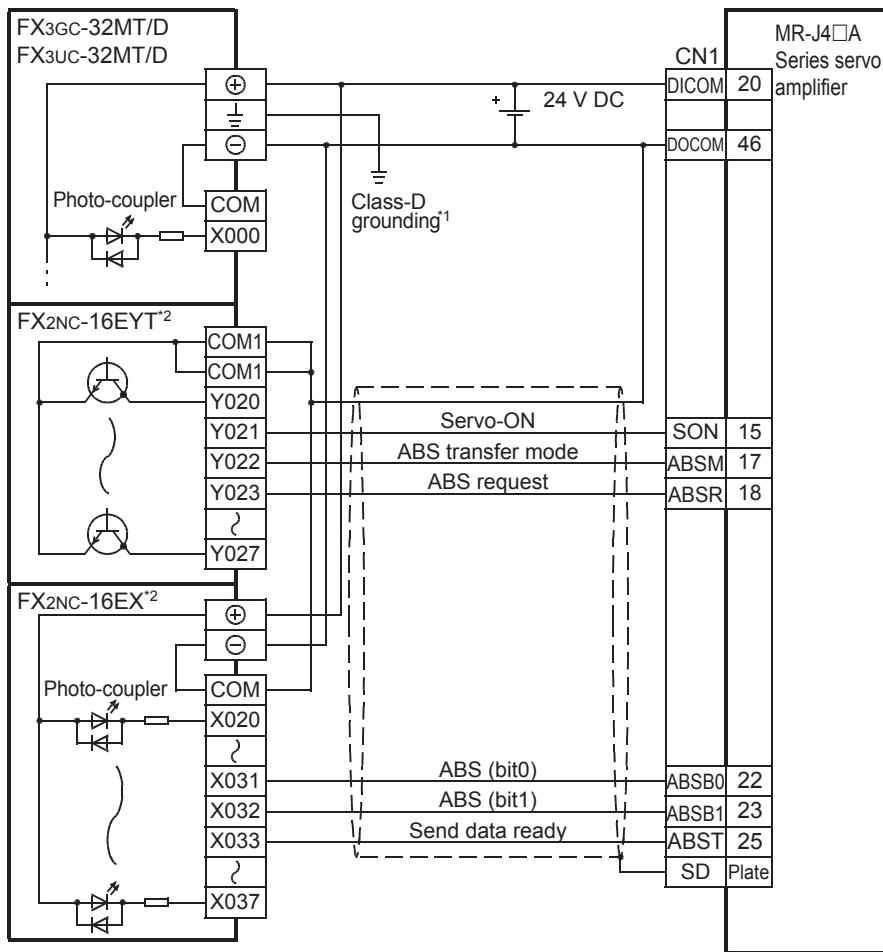

- *1. Be sure to use the class-D grounding method (grounding resistance: 100 Ω or less).
- *2. Extension blocks are used in the connection example.
 Inputs and outputs built into the main unit are available in place of extension blocks.

Appendix 2. MELSERVO-J3 Series

Appendix 2-1 Main Unit (Transistor Output)

To assign the inputs/outputs, refer to the following section.

→ Refer to Section 12.1 of "B. Built-in Positioning Function".

Appendix 2-1-1 Sink Input and Sink Output

1. FX3s PLC

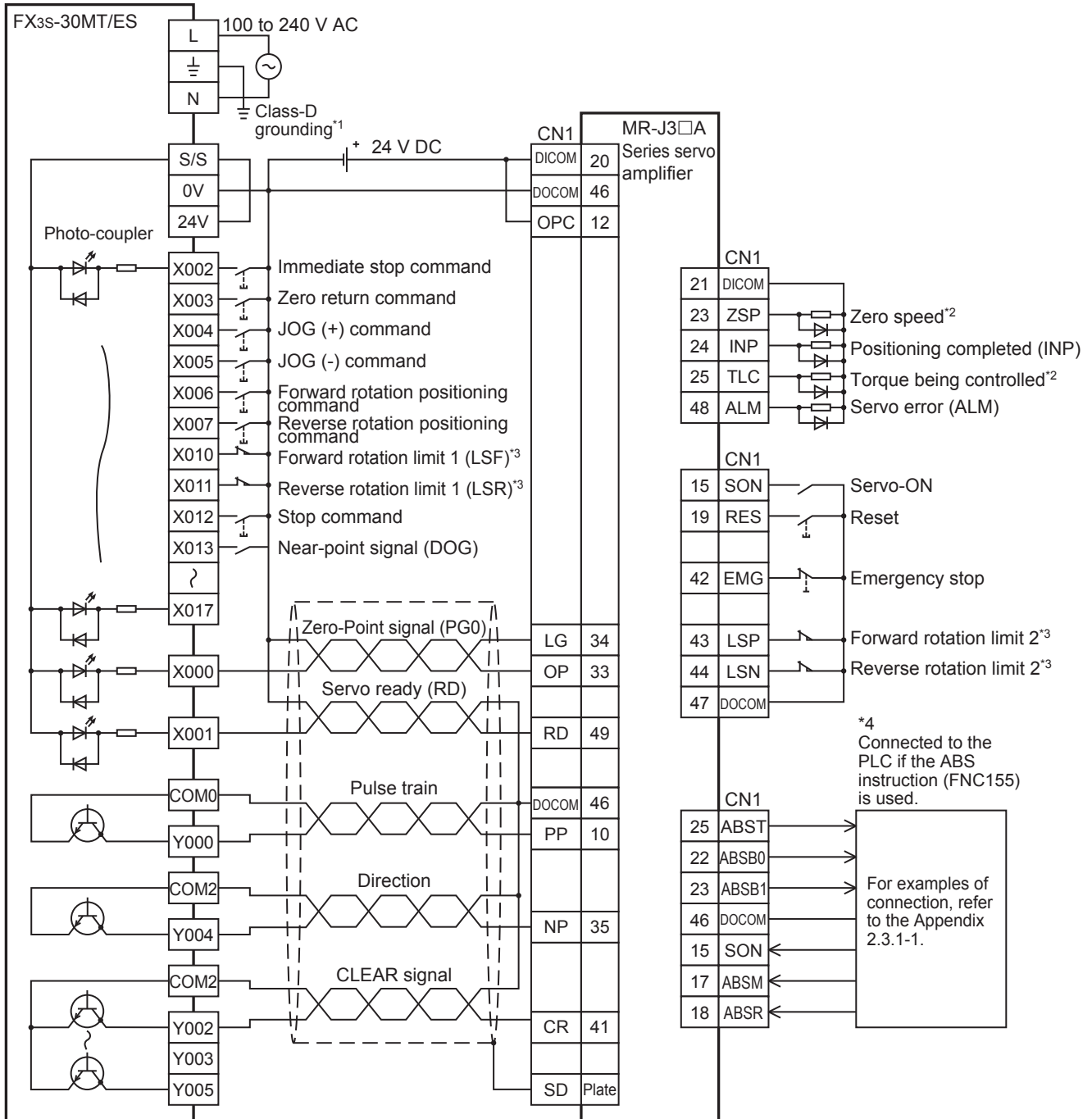

- *1. Be sure to use the class-D grounding method (grounding resistance: 100 Ω or less).
- *2. To detect absolute positions, connect this line to the PLC.
- *3. To ensure safety, use the forward rotation limit switch and the reverse rotation limit switch on both sides: the PLC side and the servo amplifier side. Note that the limit switches on the PLC side should be activated slightly earlier than the limit switches on the servo amplifier side.

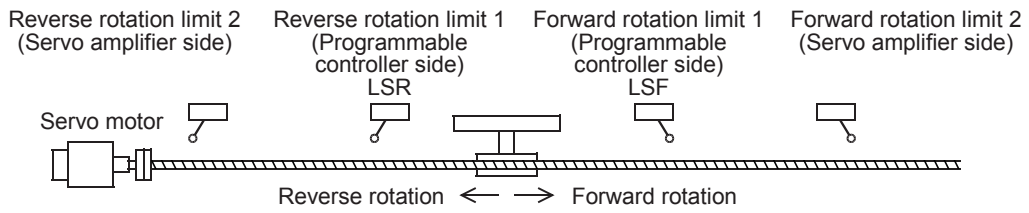

2. FX3G/FX3U PLC

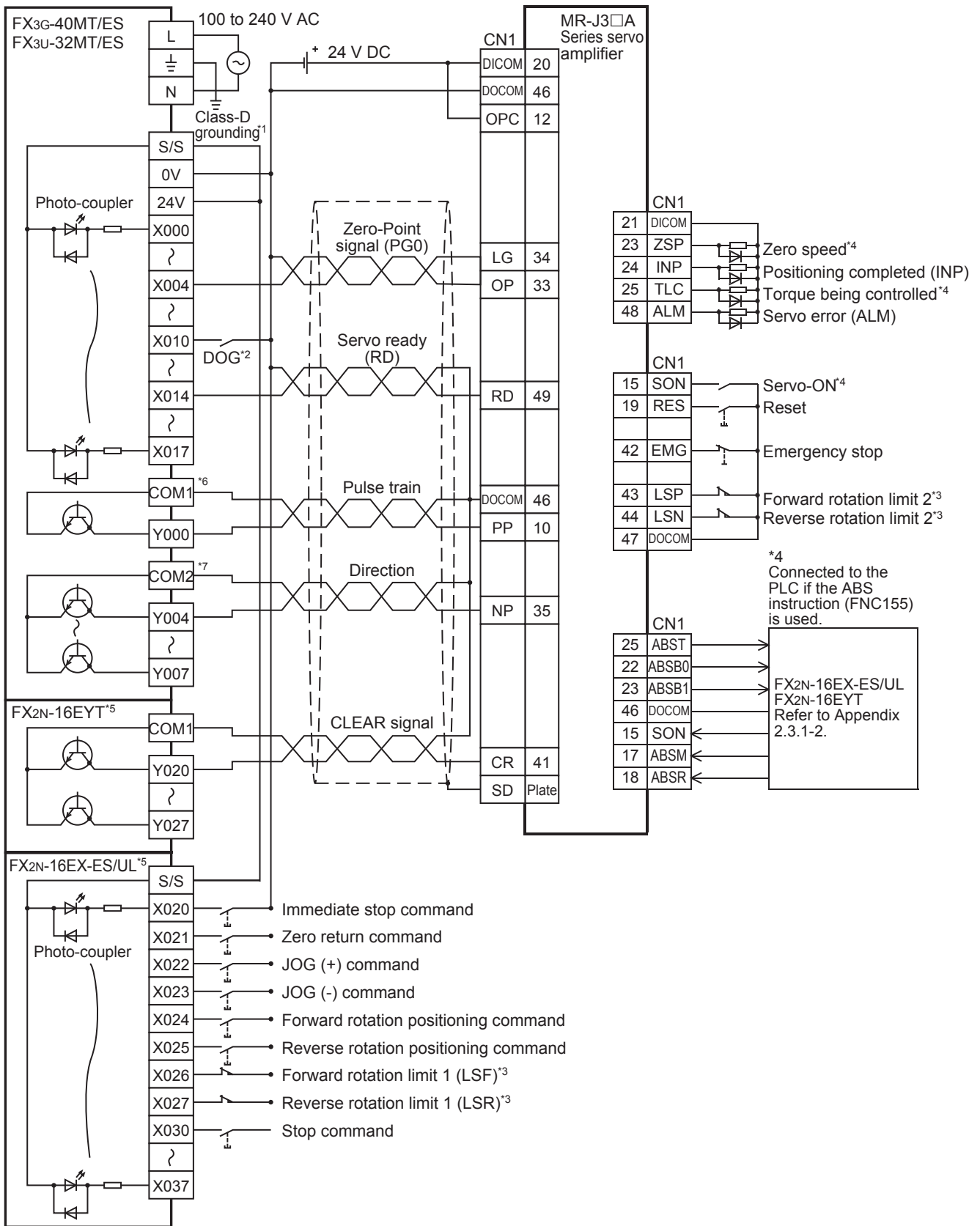

*1. Be sure to use the class-D grounding method (grounding resistance: 100 Ω or less).
 *2. Near-point signal (DOG)

- *3. To ensure safety, use the forward rotation limit switch and the reverse rotation limit switch on both sides: the PLC side and the servo amplifier side.
Note that the limit switches on the PLC side should be activated slightly earlier than the limit switches on the servo amplifier side.

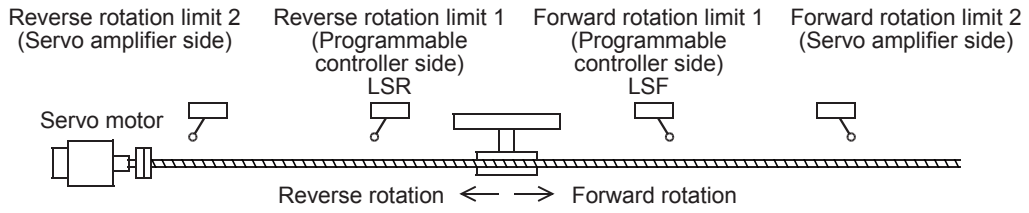

- *4. To detect absolute positions, connect this line to the PLC.
- *5. Extension blocks are used in the connection example.
Inputs and outputs built into the main unit are available in place of extension blocks.
- *6. COM0 in the FX3G-40MT/ES
- *7. COM3 in the FX3G-40MT/ES

3. FX3GC/FX3UC PLC

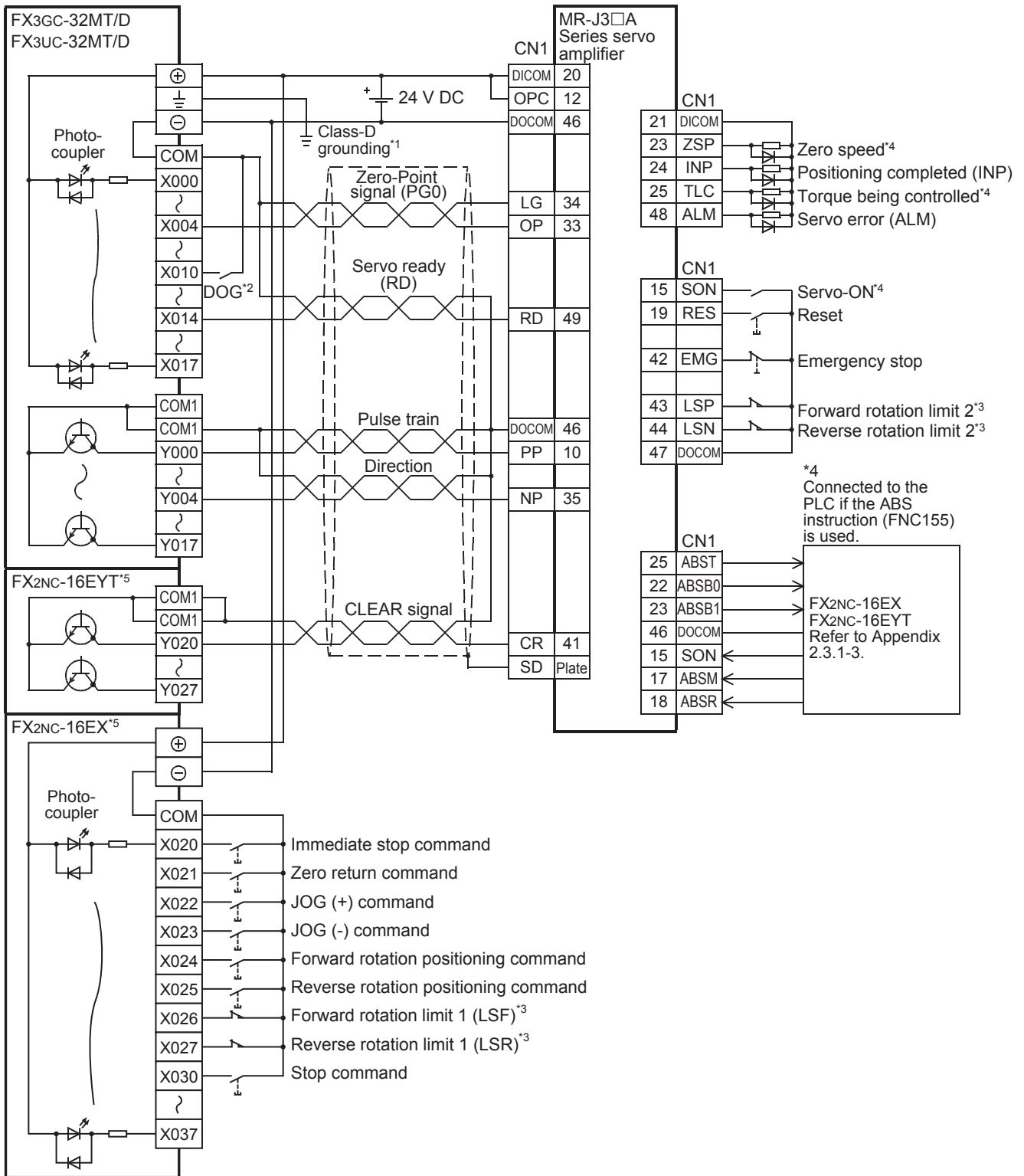

- *1. Be sure to use the class-D grounding method (grounding resistance: 100 Ω or less).
- *2. Near-point signal (DOG)

A

Common Items

B

Built-in Positioning Functions

Apx.

Example Connection

- *3. To ensure safety, use the forward rotation limit switch and the reverse rotation limit switch on both sides: the PLC side and the servo amplifier side.
 Note that the limit switches on the PLC side should be activated slightly earlier than the limit switches on the servo amplifier side.

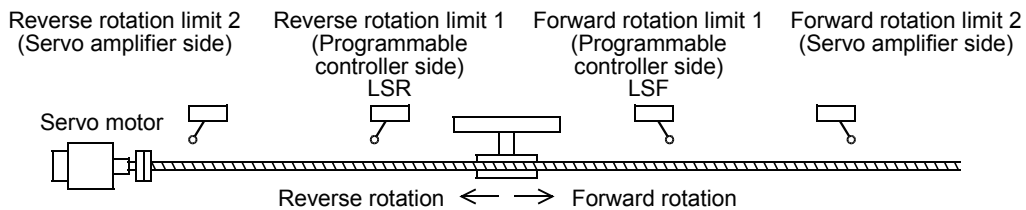

- *4. To detect absolute positions, connect this line to the PLC.
- *5. Extension blocks are used in the connection example.
 Inputs and outputs built into the main unit are available in place of extension blocks.

Appendix 2-2 High-Speed Output Special Adapter

To assign the inputs/outputs, refer to the following section.

→ Refer to Section 12.1 of "B. Built-in Positioning Function".

Appendix 2-2-1 Sink Input, Sink Output (Transistor), and Differential Line Driver Output

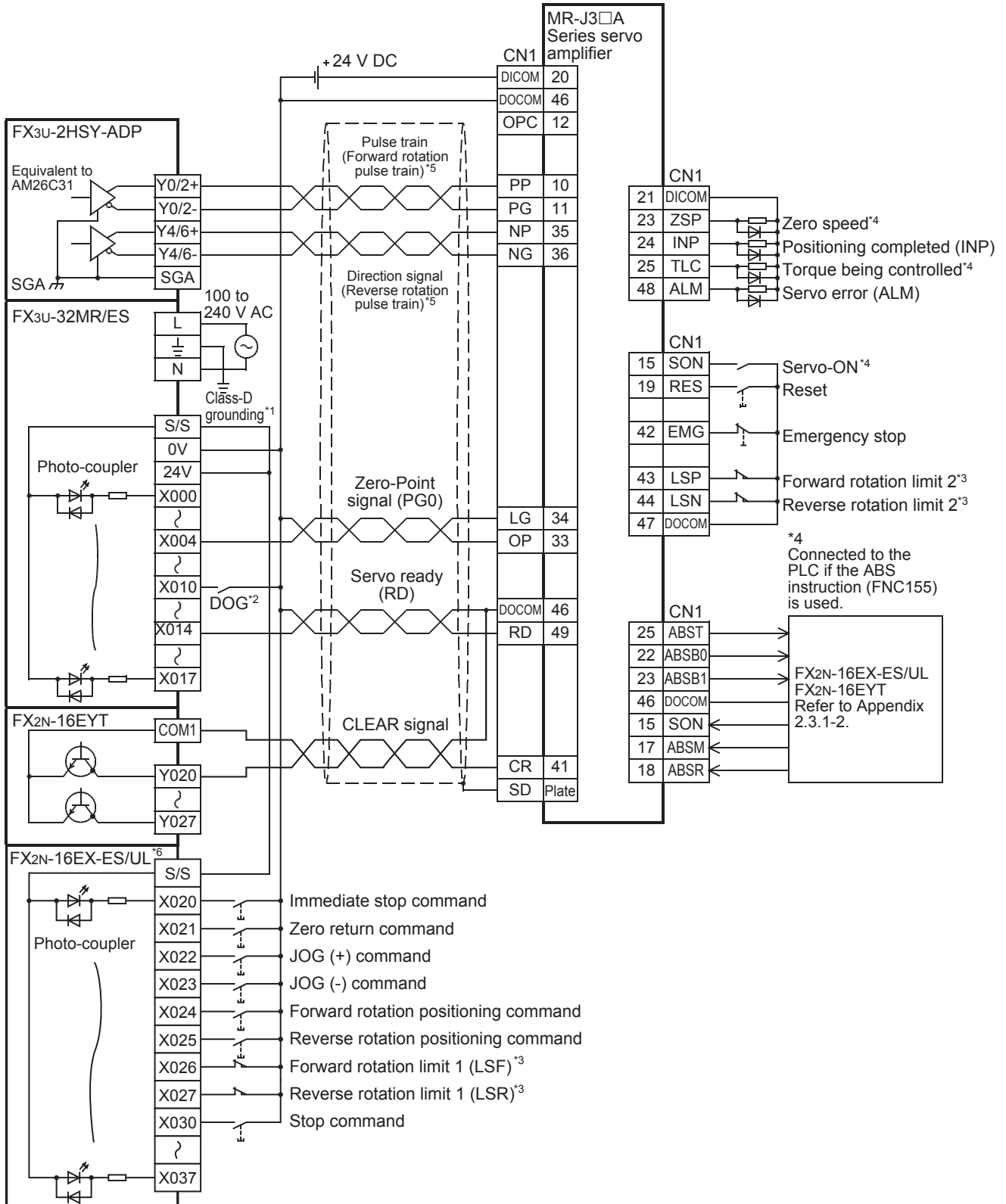

*1. Be sure to use the class-D grounding method (grounding resistance: 100 Ω or less).

*2. Near-point signal (DOG)

- *3. To ensure safety, use the forward rotation limit switch and the reverse rotation limit switch on both sides: the PLC side and the servo amplifier side. Note that the limit switches on the PLC side should be activated slightly earlier than the limit switches on the servo amplifier side.

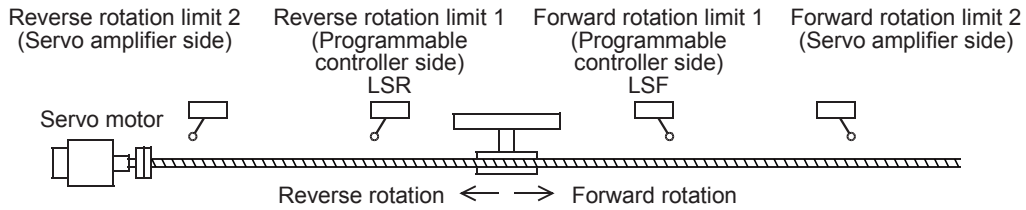

- *4. To detect absolute positions, connect this line to the PLC.
- *5. Set the pulse output form by pulse output form setting switch.

Pulse output method setting switch	Pulse output method
FP·RP side	Forward/reverse pulse train
PLS·DIR side	Pulse train + direction

- *6. Input extension blocks are used in the connection example. Inputs built into the main unit are available in place of extension blocks.

Appendix 2-3 Absolute Position Detection (Transistor Output)

To assign the inputs/outputs, refer to the following section.

→ Refer to Section 12.1 of "B. Built-in Positioning Function"

Appendix 2-3-1 Sink Input and Sink Output

1. FX3S PLC

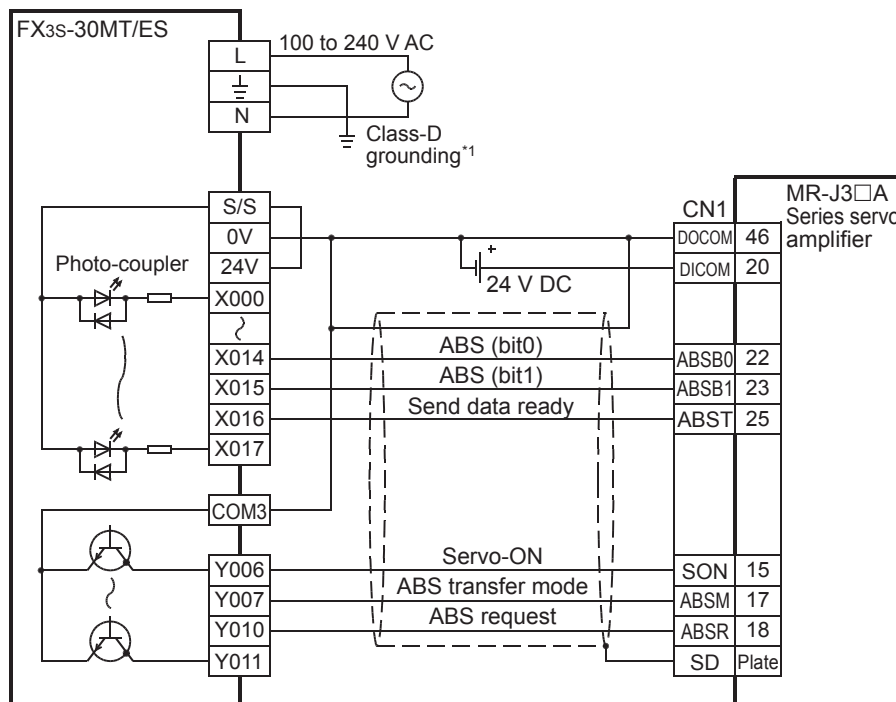

- *1. Be sure to use the class-D grounding method (grounding resistance: 100 Ω or less).

2. FX3G/FX3U PLC

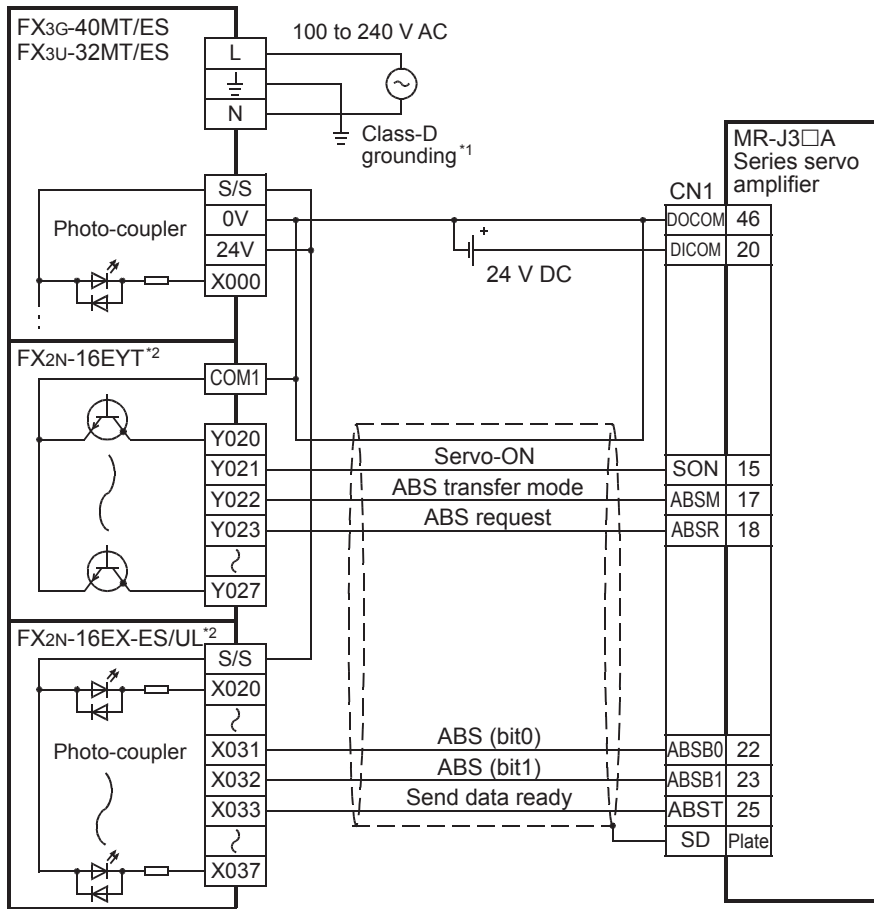

- *1. Be sure to use the class-D grounding method (grounding resistance: 100 Ω or less).
- *2. Extension blocks are used in the connection example.
 Inputs and outputs built into the main unit are available in place of extension blocks.

A Common Items
B Built-in Positioning Functions
Apx. Example Connection

3. FX3GC/FX3UC PLC

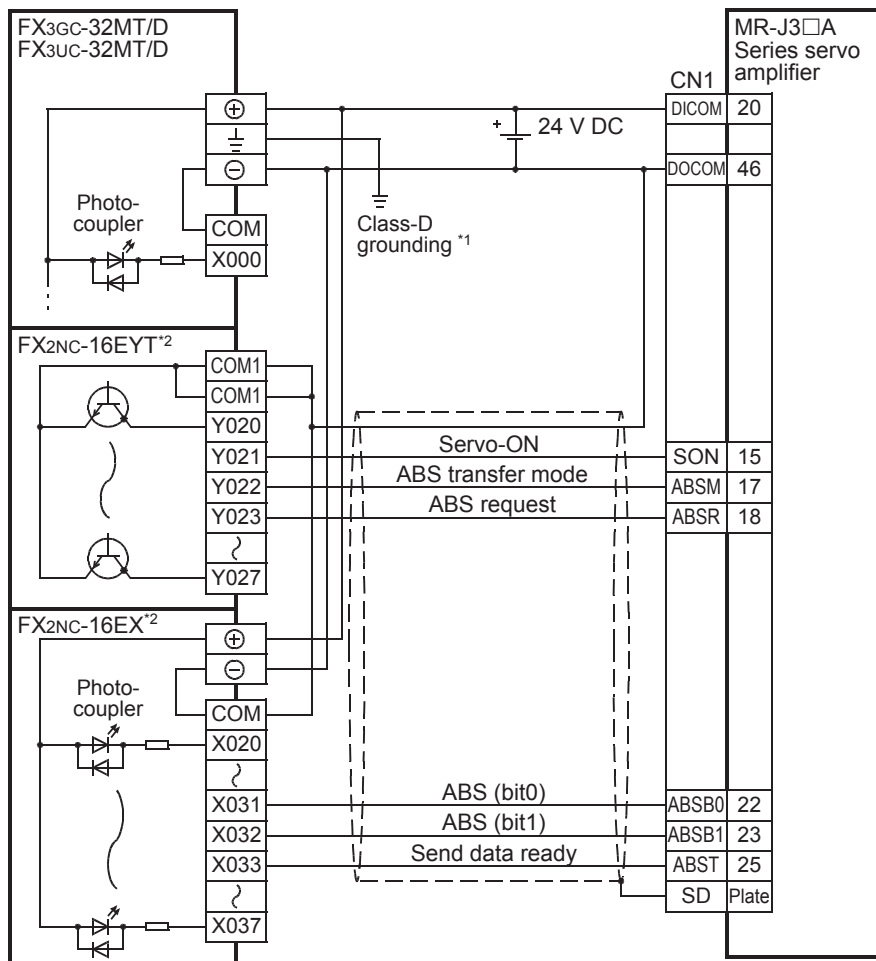

- *1. Be sure to use the class-D grounding method (grounding resistance: 100 Ω or less).
- *2. Extension blocks are used in the connection example.
 Inputs and outputs built into the main unit are available in place of extension blocks.

Appendix 3. MELSERVO-JN Series

Appendix 3-1 Main Unit (Transistor Output)

To assign the inputs/outputs, refer to the following section.

→ Refer to Section 12.1 of "B. Built-in Positioning Function".

Appendix 3-1-1 Sink Input and Sink Output

1. FX3s PLC

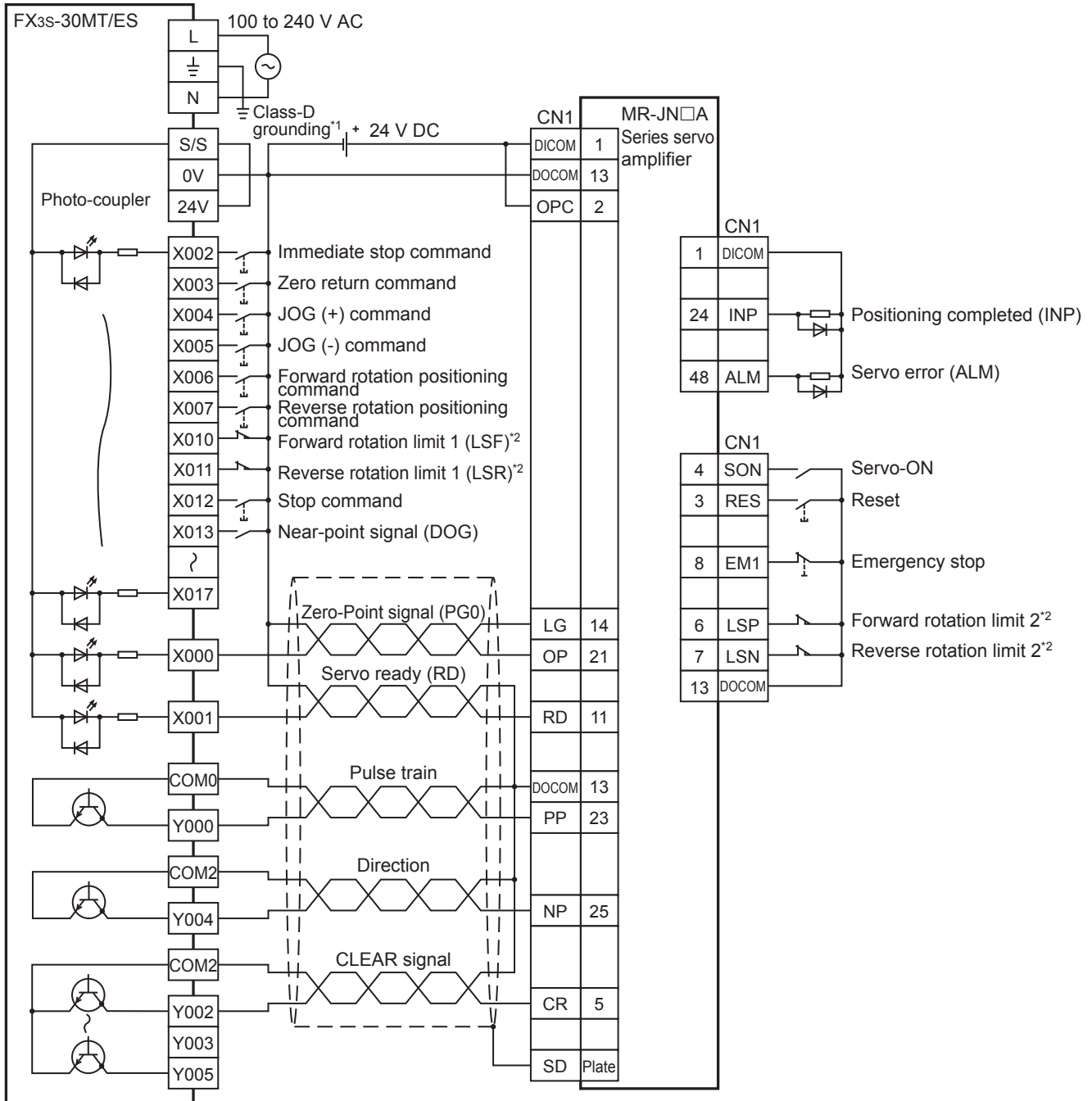

*1. Be sure to use the class-D grounding method (grounding resistance: 100 Ω or less).

- *2. To ensure safety, use the forward rotation limit switch and the reverse rotation limit switch on both sides: the PLC side and the servo amplifier side.
Note that the limit switches on the PLC side should be activated slightly earlier than the limit switches on the servo amplifier side.

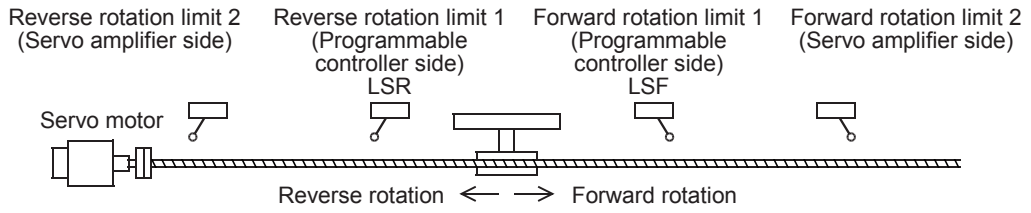

2. FX3G/FX3U PLC

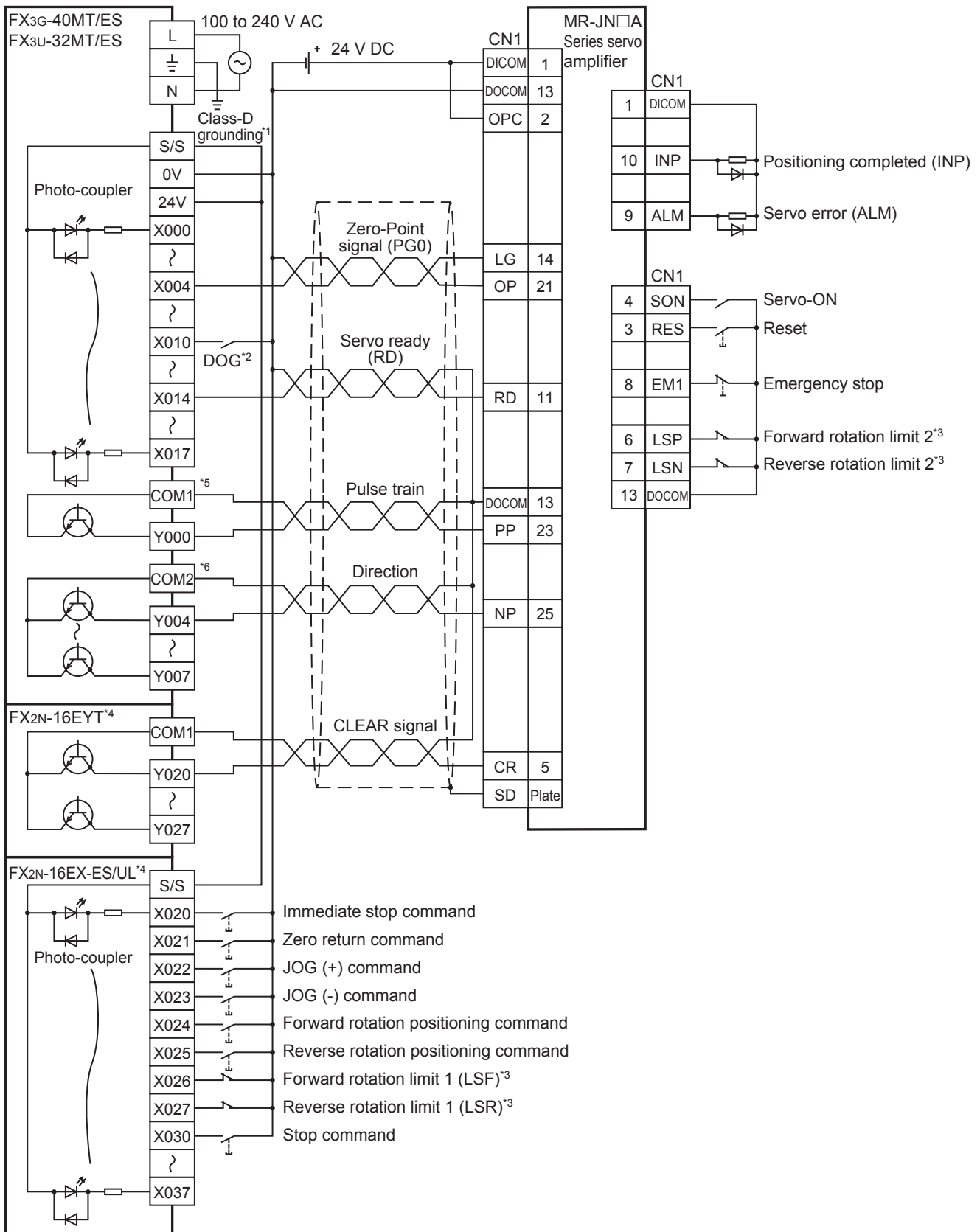

*1. Be sure to use the class-D grounding method (grounding resistance: 100 Ω or less).
 *2. Near-point signal (DOG)

A Common Items
B Built-in Positioning Functions
Apx. Example Connection

- *3. To ensure safety, use the forward rotation limit switch and the reverse rotation limit switch on both sides: the PLC side and the servo amplifier side.
 Note that the limit switches on the PLC side should be activated slightly earlier than the limit switches on the servo amplifier side.

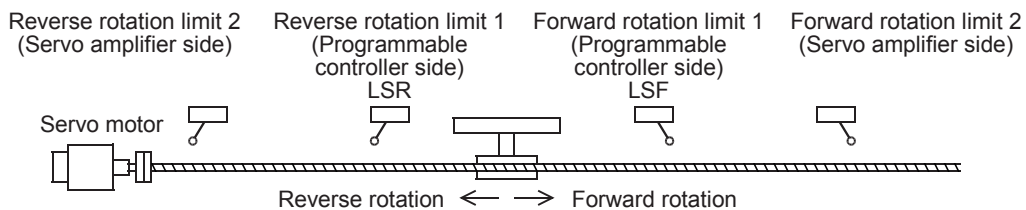

- *4. Extension blocks are used in the connection example.
 Inputs and outputs built into the main unit are available in place of extension blocks.
- *5. COM0 in the FX3G-40MT/ES
- *6. COM3 in the FX3G-40MT/ES

3. FX3GC/FX3UC PLC

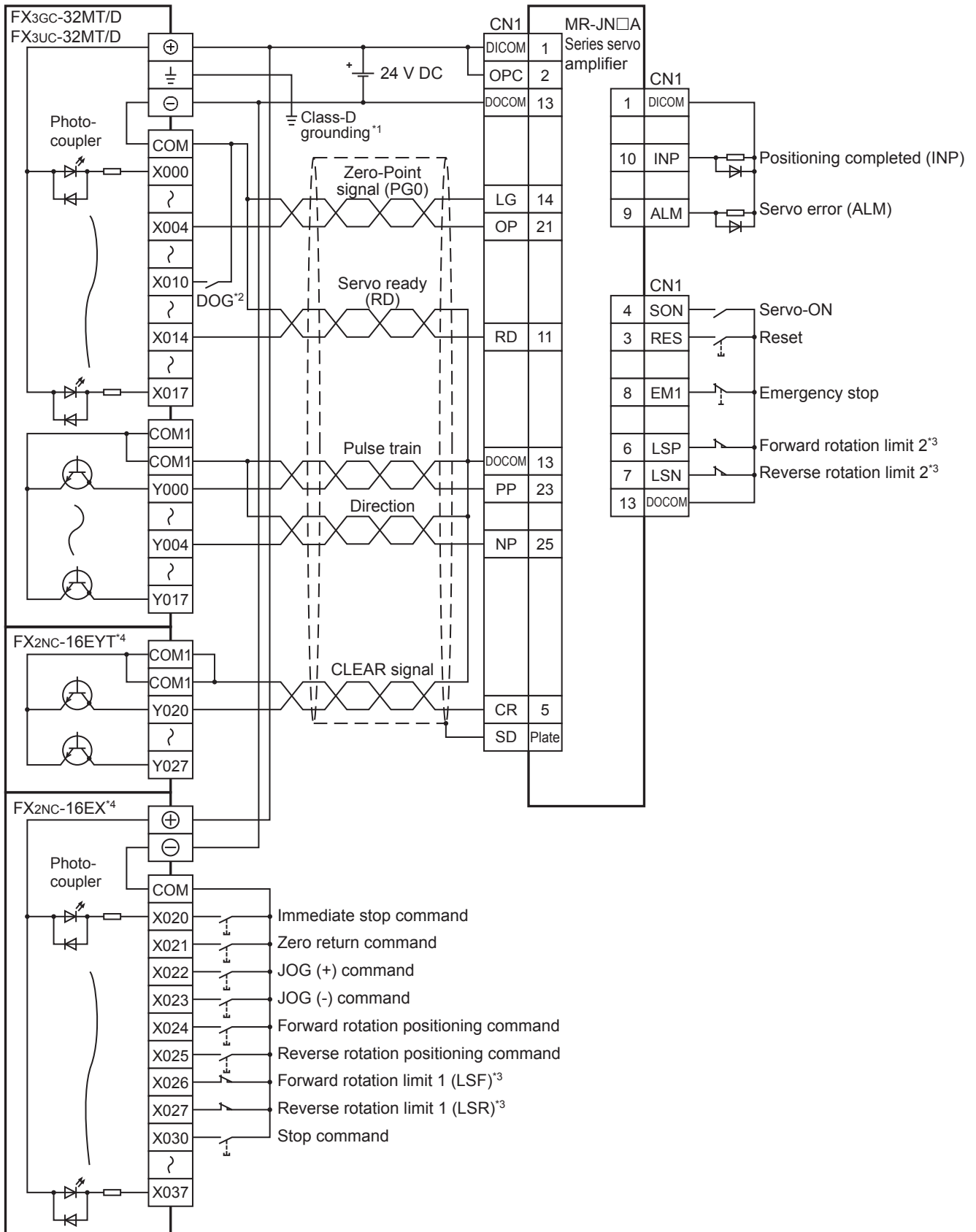

*1. Be sure to use the class-D grounding method (grounding resistance: 100 Ω or less).
 *2. Near-point signal (DOG)

A Common Items
B Built-in Positioning Functions
Apx. Example Connection

- *3. To ensure safety, use the forward rotation limit switch and the reverse rotation limit switch on both sides: the PLC side and the servo amplifier side.
Note that the limit switches on the PLC side should be activated slightly earlier than the limit switches on the servo amplifier side.

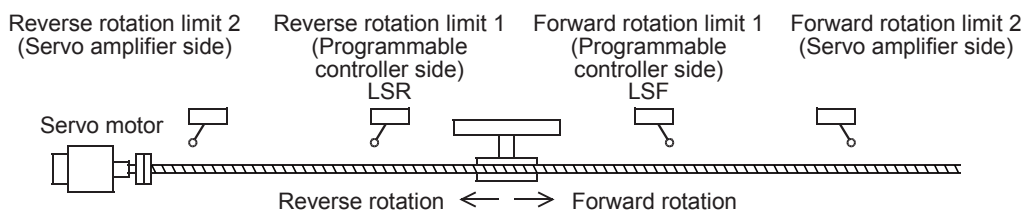

- *4. Extension blocks are used in the connection example.
Inputs and outputs built into the main unit are available in place of extension blocks.

Appendix 3-2 High-Speed Output Special Adapter

To assign the inputs/outputs, refer to the following section.

→ Refer to Section 12.1 of "B. Built-in Positioning Function".

Appendix 3-2-1 Sink Input, Sink Output (Transistor), and Differential Line Driver Output

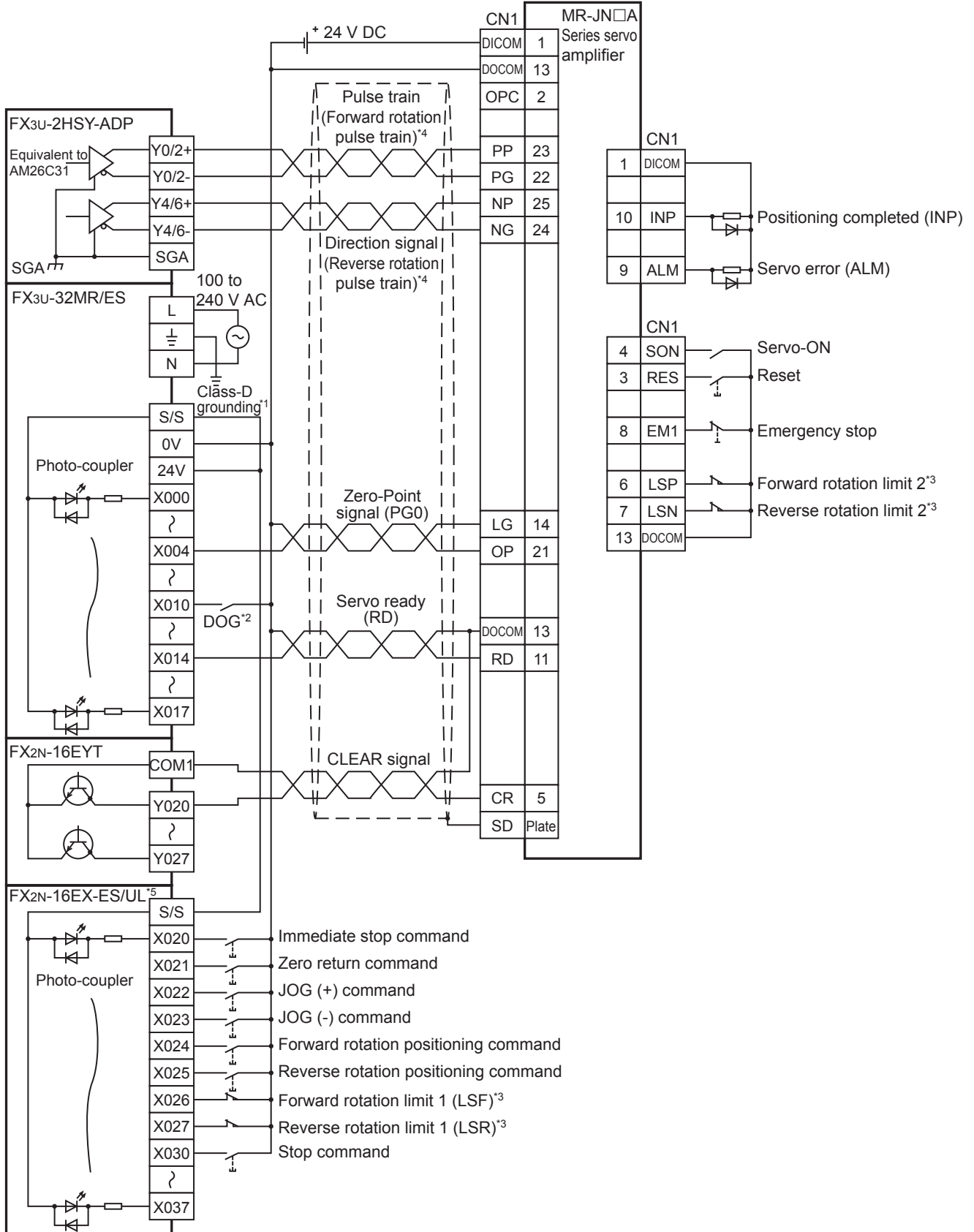

- *1. Be sure to use the class-D grounding method (grounding resistance: 100 Ω or less).
- *2. Near-point signal (DOG)
- *3. To ensure safety, use the forward rotation limit switch and the reverse rotation limit switch on both sides: the PLC side and the servo amplifier side.
 Note that the limit switches on the PLC side should be activated slightly earlier than the limit switches on the servo amplifier side.

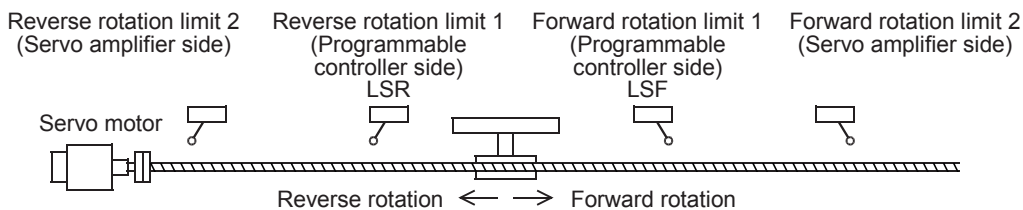

- *4. Set the pulse output form by pulse output form setting switch.

Pulse output method setting switch	Pulse output method
FP·RP side	Forward/reverse pulse train
PLS·DIR side	Pulse train + direction

- *5. Extension blocks are used in the connection example.
 Inputs and outputs built into the main unit are available in place of extension blocks.

Appendix 4. MELSERVO-J2 (-Super) Series

Appendix 4-1 Main Unit (Transistor Output)

To assign the inputs/outputs, refer to the following section.

→ Refer to Section 12.1 of "B. Built-in Positioning Function".

Appendix 4-1-1 Sink Input and Sink Output

1. FX3s PLC

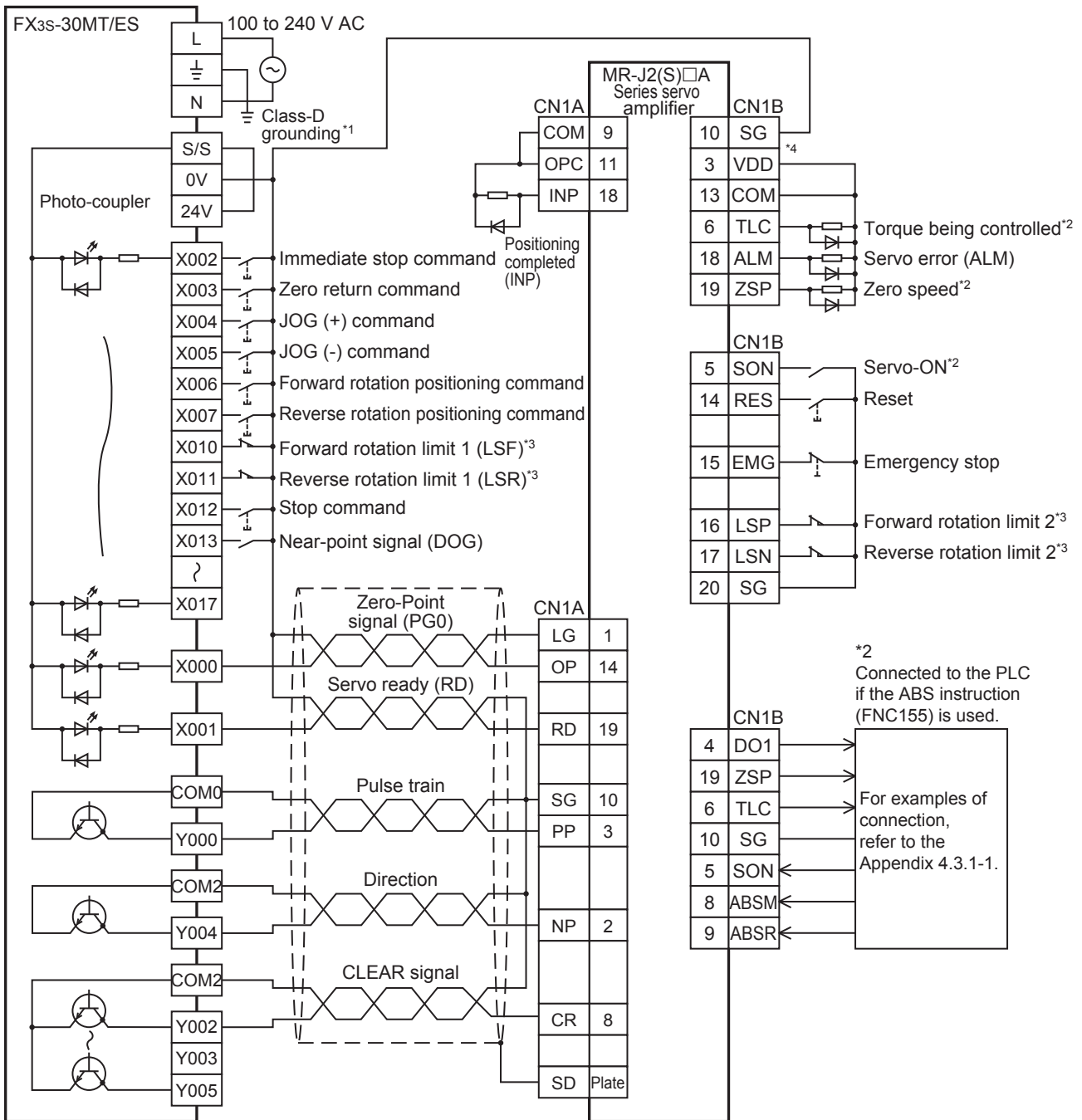

*1. Be sure to use the class-D grounding method (grounding resistance: 100 Ω or less).

*2. To detect absolute positions, connect this line to the PLC.

*2
 Connected to the PLC
 if the ABS instruction
 (FNC155) is used.

For examples of
 connection,
 refer to the
 Appendix 4.3.1-1.

A
 Common Items

B
 Built-in
 Positioning
 Functions

Apx.
 Example
 Connection

- *3. To ensure safety, use the forward rotation limit switch and the reverse rotation limit switch on both sides: the PLC side and the servo amplifier side.
Note that the limit switches on the PLC side should be activated slightly earlier than the limit switches on the servo amplifier side.

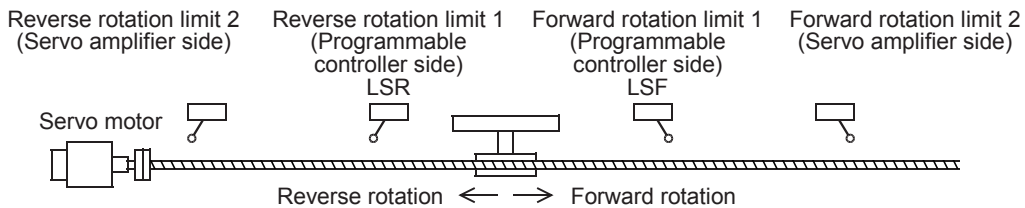

- *4. For details on the internal power supply of MR-J2 (S) servo amplifier, refer to the following manual.
→ **For details, refer to the servo amplifier manual.**

2. FX3G/FX3U PLC

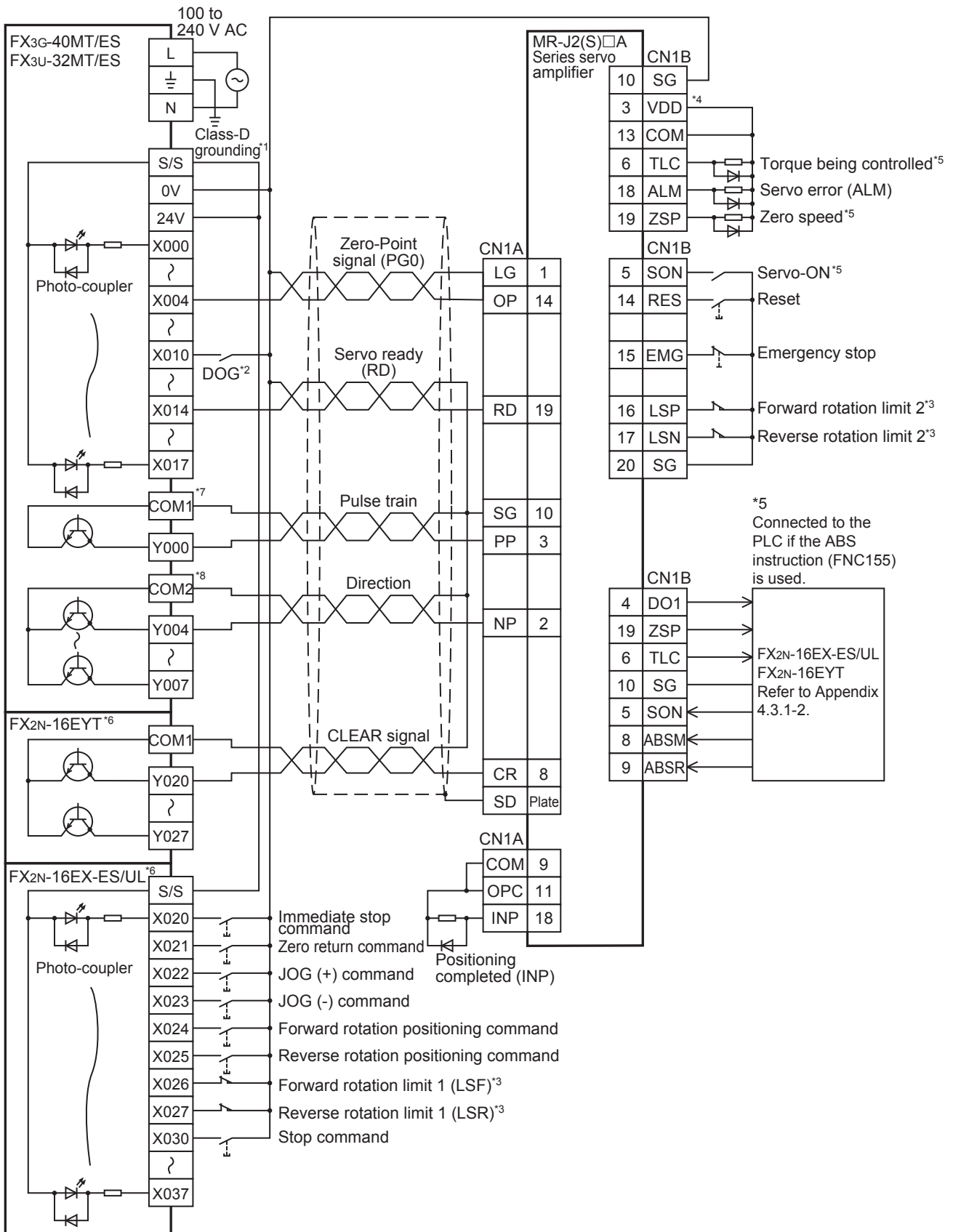

*1. Be sure to use the class-D grounding method (grounding resistance: 100 Ω or less).
 *2. Near-point signal (DOG)

*5 Connected to the PLC if the ABS instruction (FNC155) is used.

A Common Items
 B Built-in Positioning Functions
 Apx. Example Connection

- *3. To ensure safety, use the forward rotation limit switch and the reverse rotation limit switch on both sides: the PLC side and the servo amplifier side. Note that the limit switches on the PLC side should be activated slightly earlier than the limit switches on the servo amplifier side.

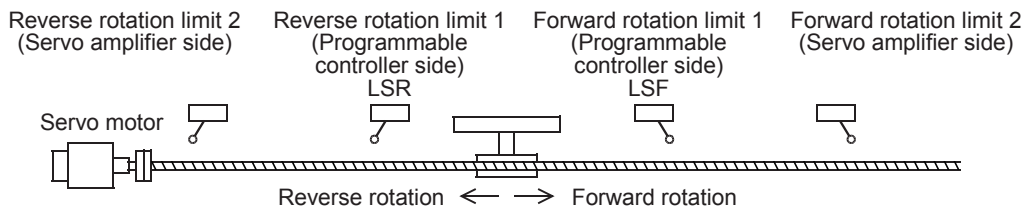

- *4. For details on the internal power supply of MR-J2 (S) servo amplifier, refer to the following manual.
 → **For details, refer to the servo amplifier manual.**
- *5. To detect absolute positions, connect this line to the PLC.
- *6. Extension blocks are used in the connection example.
 Inputs and outputs built into the main unit are available in place of extension blocks.
- *7. COM0 in the FX3G-40MT/ES
- *8. COM3 in the FX3G-40MT/ES

3. FX3GC/FX3UC PLC

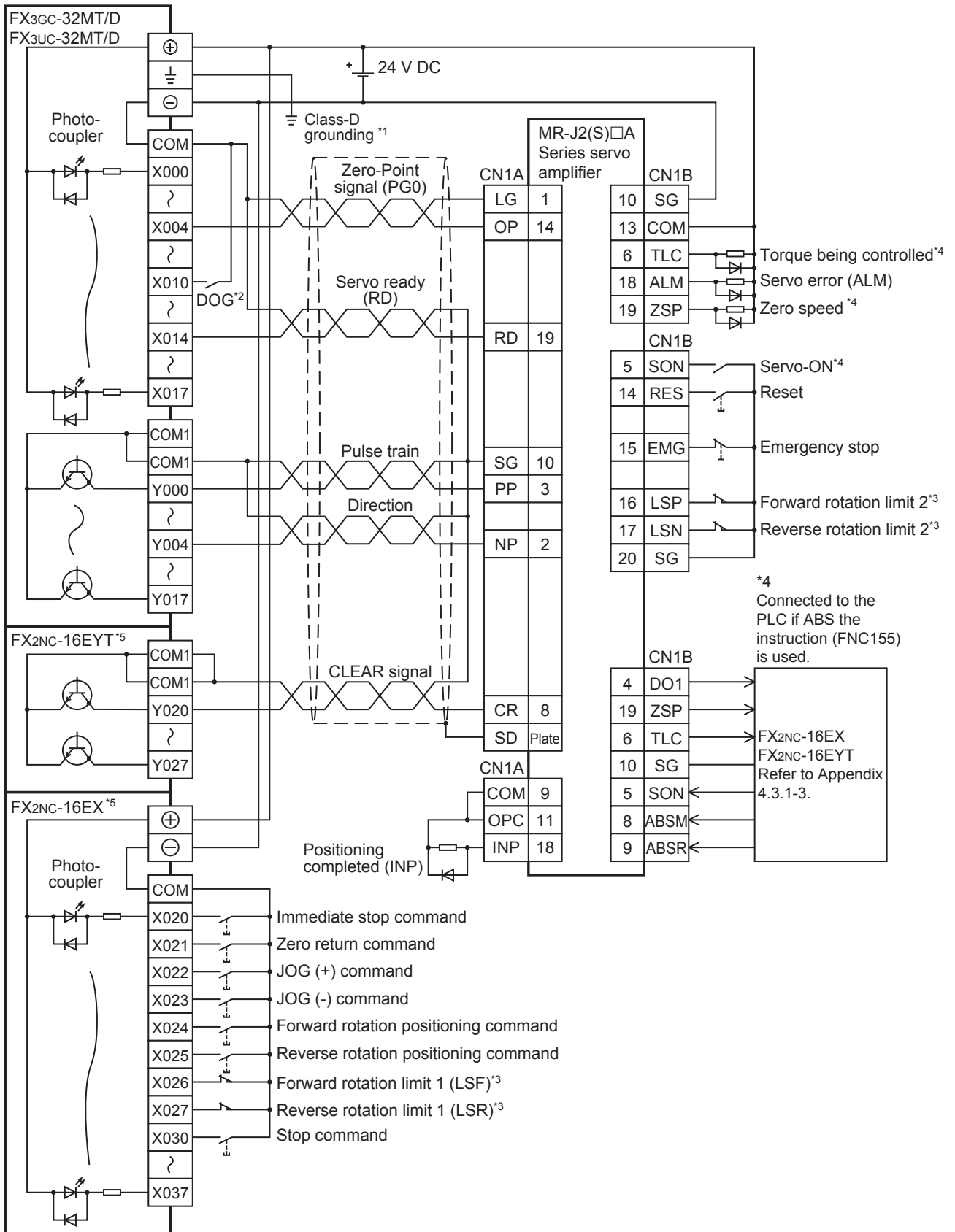

*1. Be sure to use the class-D grounding method (grounding resistance: 100 Ω or less).
 *2. Near-point signal (DOG)

*4 Connected to the PLC if ABS the instruction (FNC155) is used.

- *3. To ensure safety, use the forward rotation limit switch and the reverse rotation limit switch on both sides: the PLC side and the servo amplifier side. Note that the limit switches on the PLC side should be activated slightly earlier than the limit switches on the servo amplifier side.

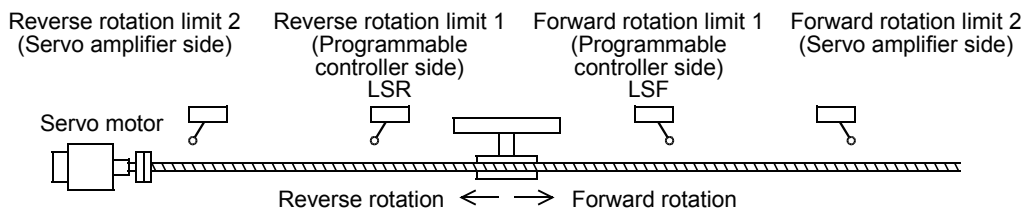

- *4. To detect absolute positions, connect this line to the PLC.
- *5. Extension blocks are used in the connection example. Inputs and outputs built into the main unit are available in place of extension blocks.

Appendix 4-2 High-Speed Output Special Adapter

To assign the inputs/outputs, refer to the following section.

→ Refer to Section 12.1 of "B. Built-in Positioning Function".

Appendix 4-2-1 Sink Input, Sink Output (Transistor), and Differential Line Driver Output

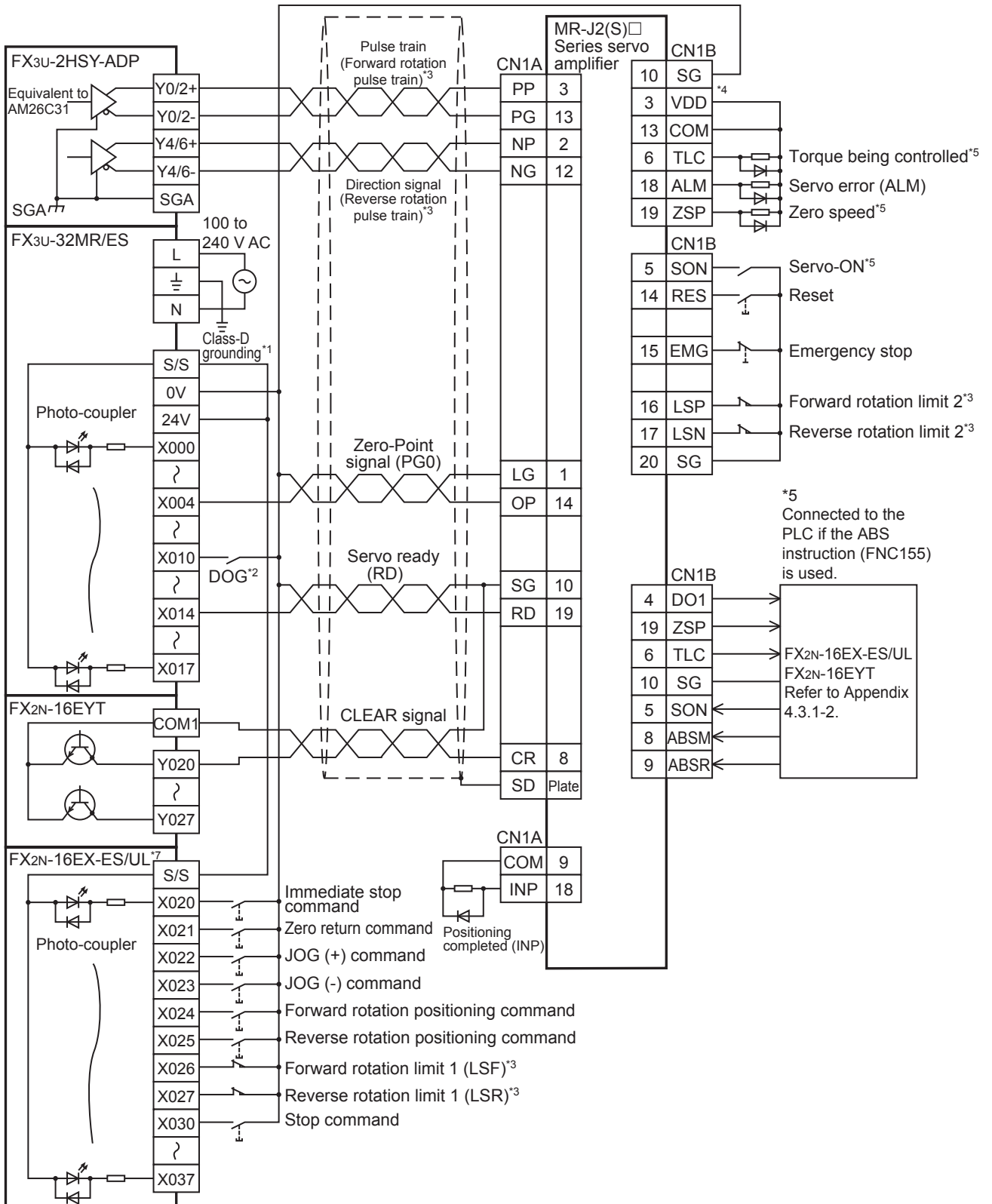

*1. Be sure to use the class-D grounding method (grounding resistance: 100 Ω or less).

*2. Near-point signal (DOG)

- *3. To ensure safety, use the forward rotation limit switch and the reverse rotation limit switch on both sides: the PLC side and the servo amplifier side. Note that the limit switches on the PLC side should be activated slightly earlier than the limit switches on the servo amplifier side.

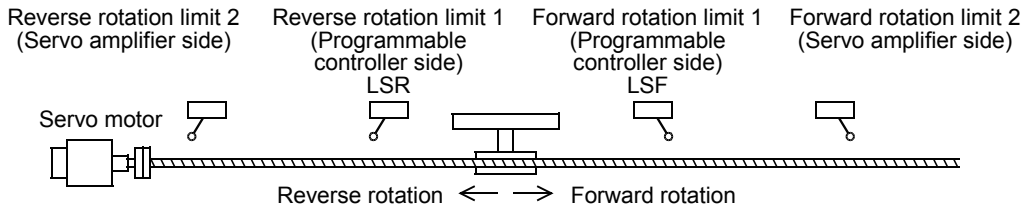

- *4. For details on the MR-J2(S) servo amplifier, such as the tolerance for the internal power and operation of the servo amplifier, refer to the following manual.
 → **For details, refer to the servo amplifier manual.**
- *5. To detect absolute positions, connect this line to the PLC.
- *6. Set the pulse output method using the pulse output method setting switch.

Pulse output method setting switch	Pulse output method
FP·RP side	Forward/reverse pulse train
PLS·DIR side	Pulse train + direction

- *7. Input extension blocks are used in the connection example. Inputs built into the main unit are available in place of extension blocks.

Appendix 4-3 Absolute Position Detection (Transistor Output)

To assign the inputs/outputs, refer to the following section.

→ Refer to Section 12.1 of "B. Built-in Positioning"

Appendix 4-3-1 Sink Input and Sink Output

1. FX3s PLC

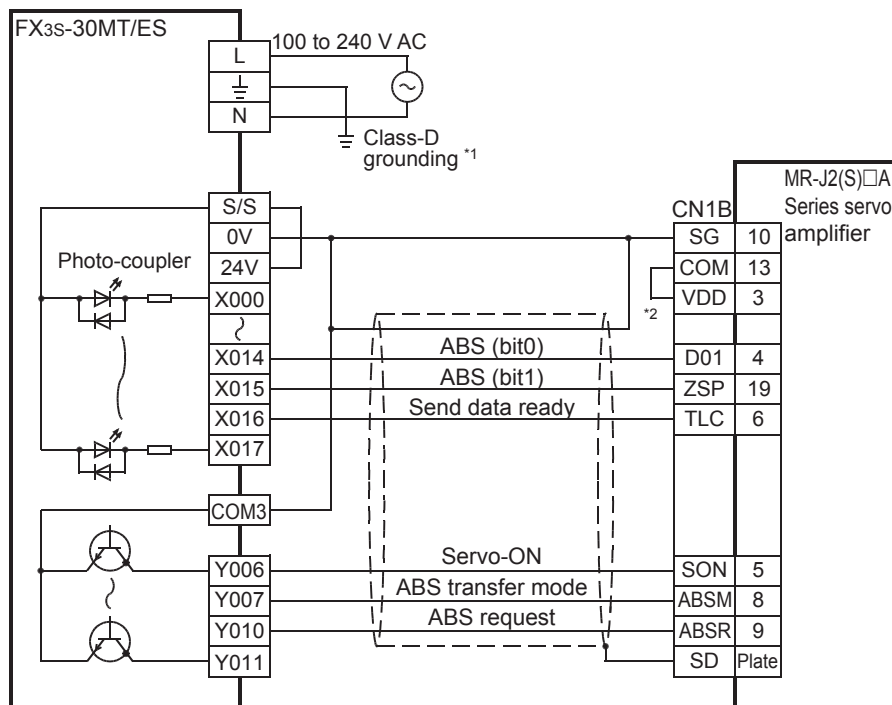

- *1. Be sure to use the class-D grounding method (grounding resistance: 100 Ω or less).
- *2. For details on the internal power supply of MR-J2(S) servo amplifier, refer to the following manual.
 → **For details, refer to the servo amplifier manual.**

2. FX3G/FX3U PLC

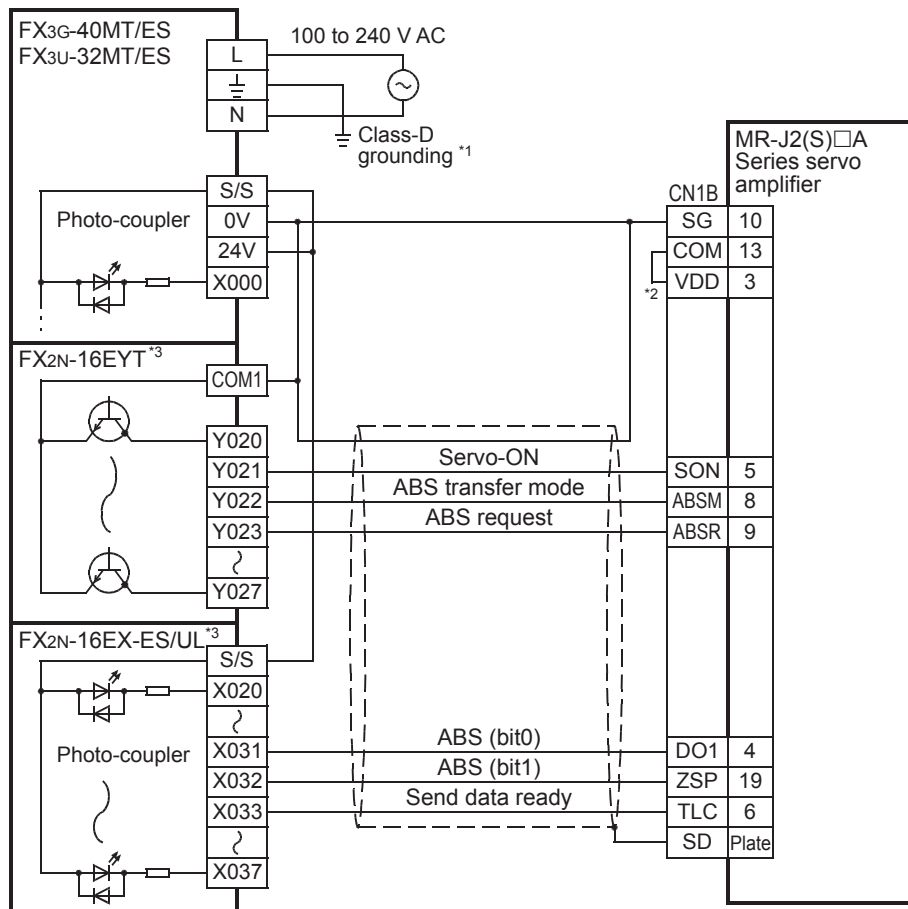

- *1. Be sure to use the class-D grounding method (grounding resistance: 100 Ω or less).
- *2. For details on the MR-J2(S) servo amplifier, such as the tolerance for the internal power and operation of the servo amplifier, refer to the following manual.
 → **For details, refer to the servo amplifier manual.**
- *3. Extension blocks are used in the connection example.
 Inputs and outputs built into the main unit are available in place of extension blocks.

A Common Items
B Built-in Positioning Functions
Apx. Example Connection

3. FX3GC/FX3UC PLC

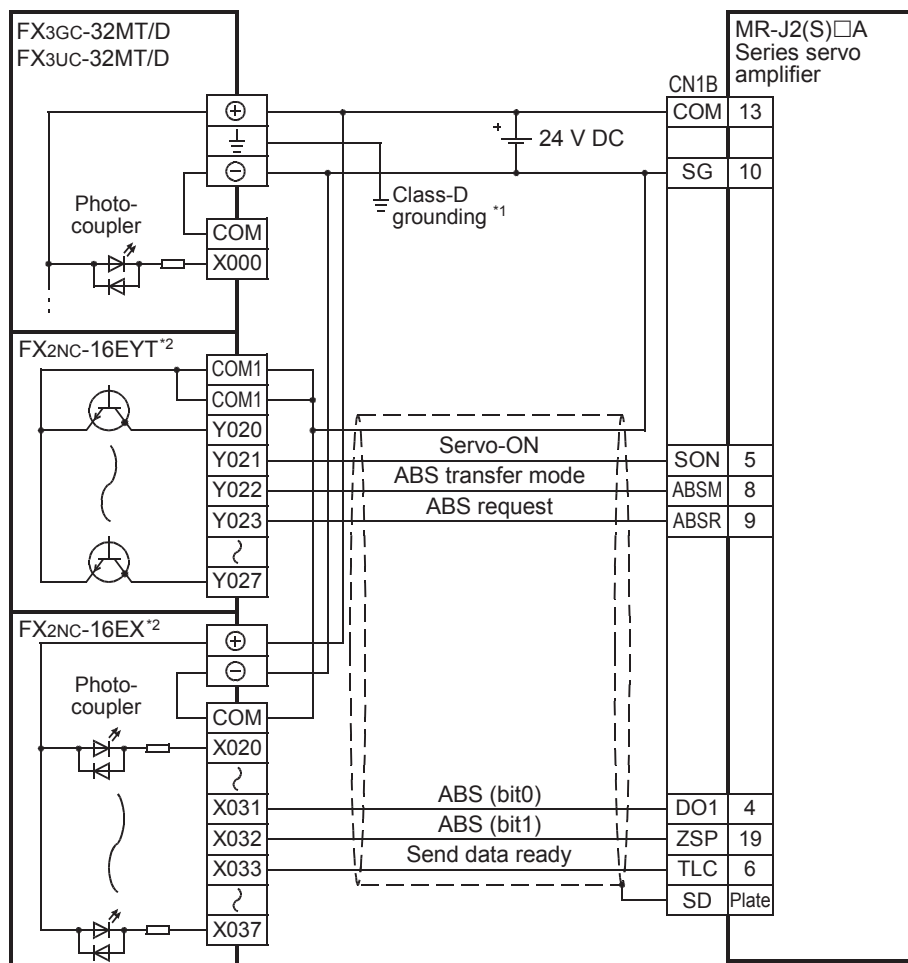

- *1. Be sure to use the class-D grounding method (grounding resistance: 100 Ω or less).
- *2. Extension blocks are used in the connection example.
 Inputs and outputs built into the main unit are available in place of extension blocks.

Appendix 5. MELSERVO-H Series

Appendix 5-1 Main Unit (Transistor Output)

To assign the inputs/outputs, refer to the following section.

→ Refer to Section 12.1 of "B. Built-in Positioning Function".

Appendix 5-1-1 Sink Input and Sink Output

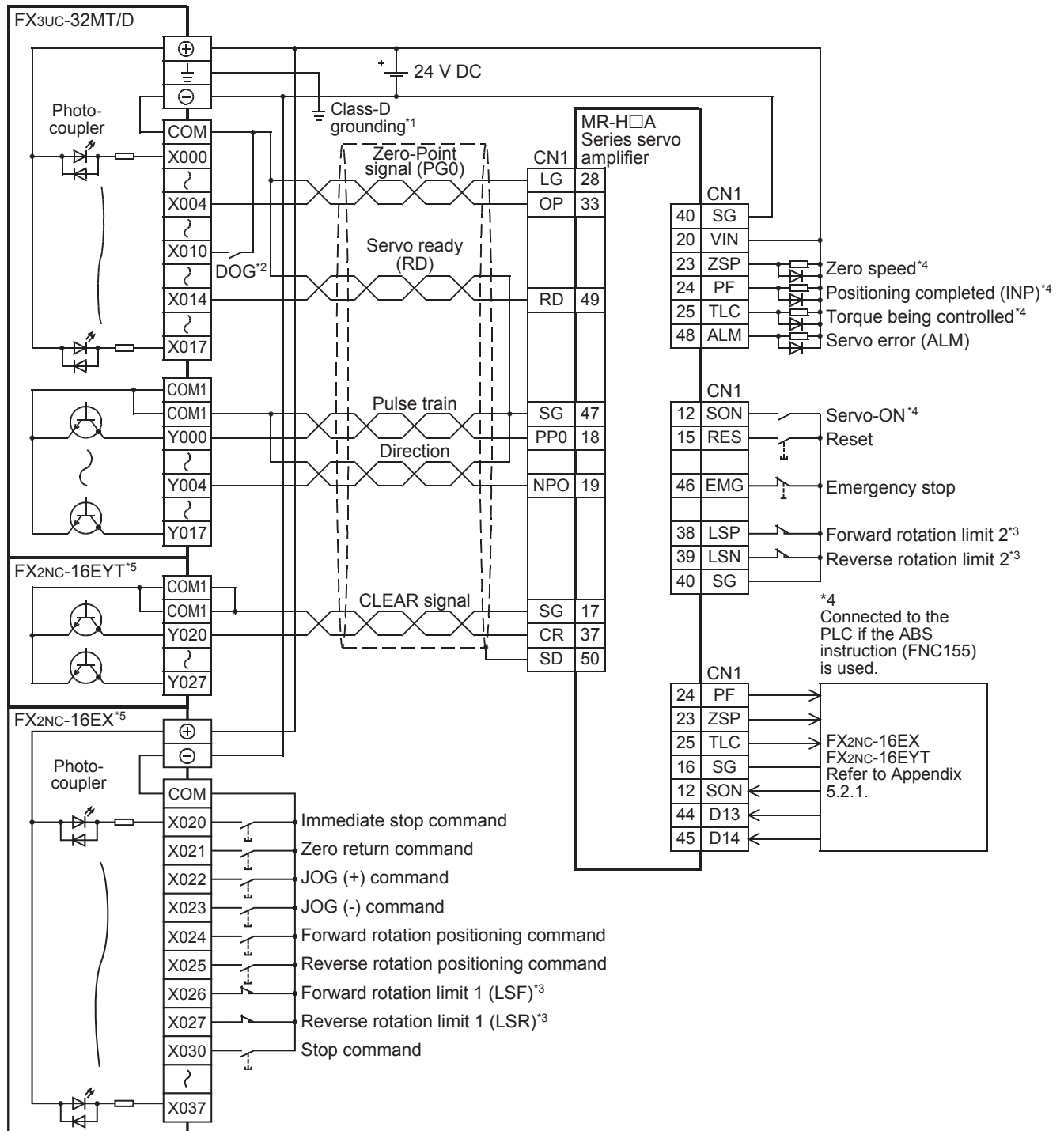

- *1. Be sure to use the class-D grounding method (grounding resistance: 100 Ω or less).
- *2. Near-point signal (DOG)
- *3. To ensure safety, use the forward rotation limit switch and the reverse rotation limit switch on both sides: the PLC side and the servo amplifier side. Note that the limit switches on the PLC side should be activated slightly earlier than the limit switches on the servo amplifier side.

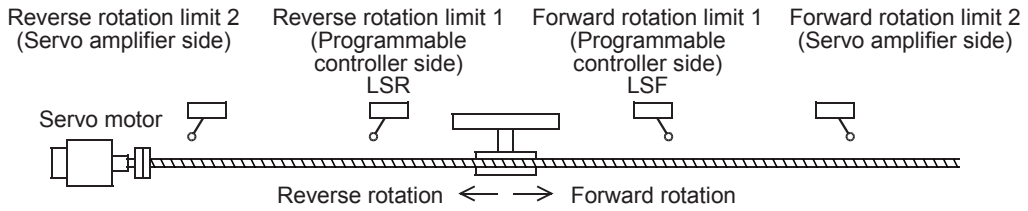

- *4. To detect absolute positions, connect this line to the PLC.
- *5. Extension blocks are used in the connection example. Inputs and outputs built into the main unit are available in place of extension blocks.

Appendix 5-2 Absolute Position Detection (Transistor Output)

To assign the inputs/outputs, refer to the following section.

→ Refer to Section 12.1 of "B. Incorporated Positioning"

Appendix 5-2-1 Sink Input and Sink Output

1. FX3UC PLC

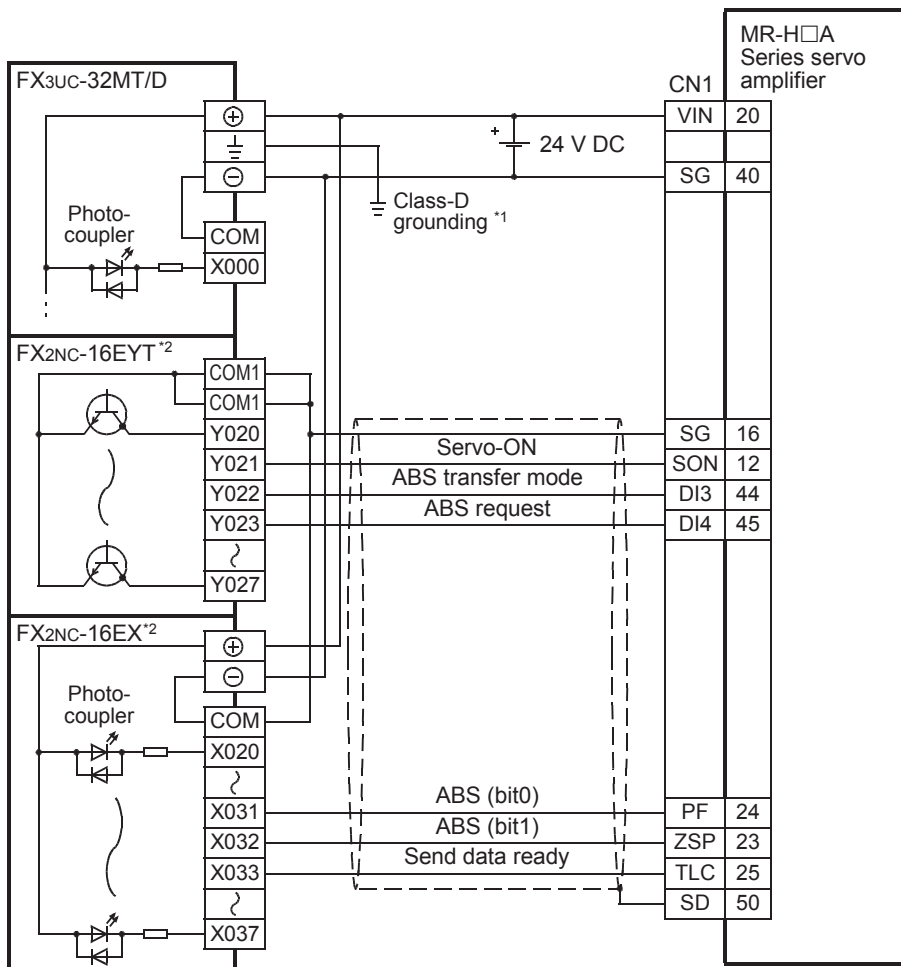

- *1. Be sure to use the class-D grounding method (grounding resistance: 100 Ω or less).
- *2. Extension blocks are used in the connection example. Inputs and outputs built into the main unit are available in place of extension blocks.

Appendix 6. MELSERVO-C Series

Appendix 6-1 Main Unit (Transistor Output)

To assign the inputs/outputs, refer to the following section.

→ Refer to Section 12.1 of "B. Built-in Positioning Function".

Appendix 6-1-1 Sink Input and Sink Output

1. FX3G/FX3U PLC

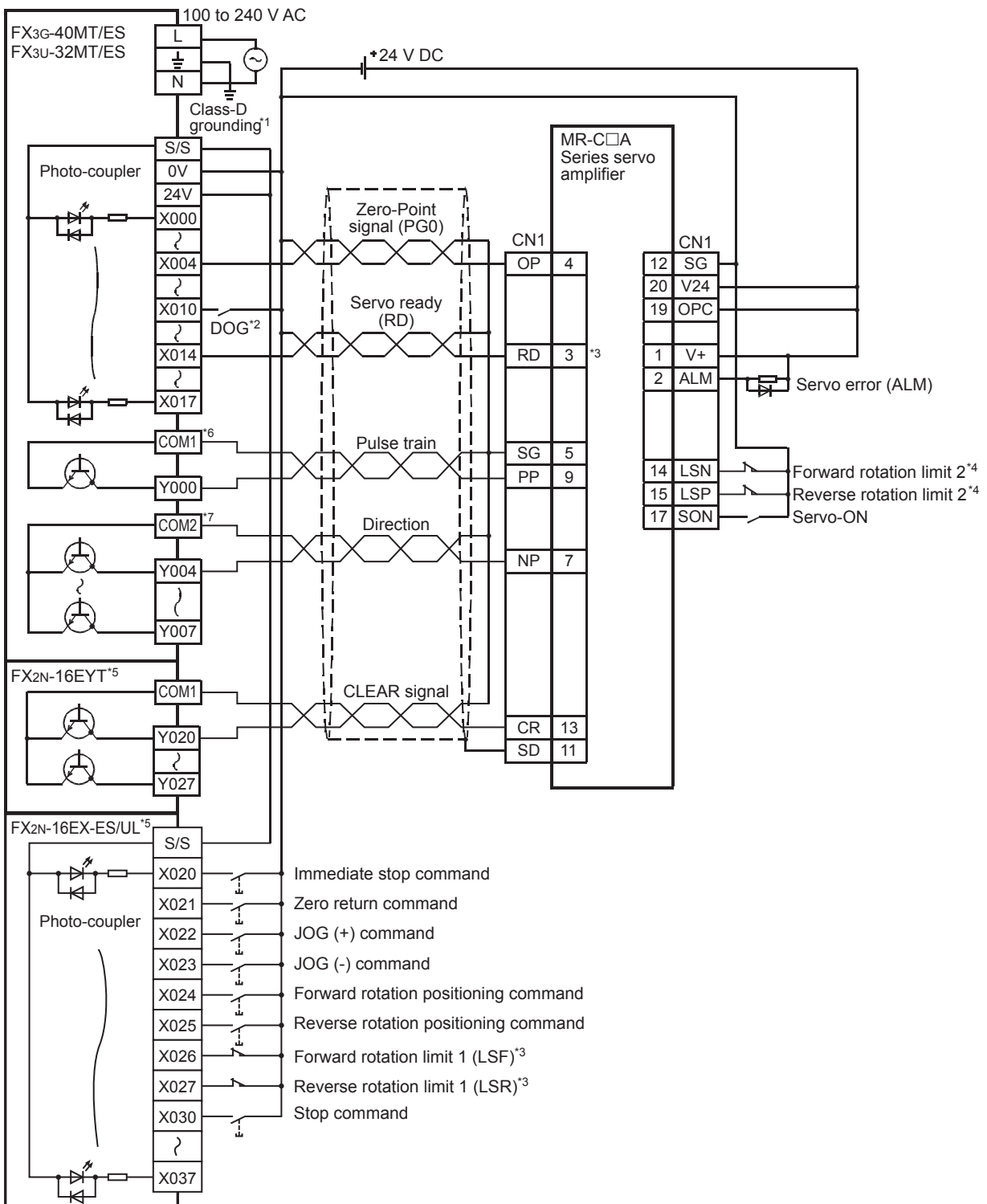

- *1. Be sure to use the class-D grounding method (grounding resistance: 100 Ω or less).
- *2. Near-point signal (DOG)
- *3. Set the servo amplifier parameter No.21 to "020".
- *4. To ensure safety, use the forward rotation limit switch and the reverse rotation limit switch on both sides: the PLC side and the servo amplifier side. Note that the limit switches on the PLC side should be activated slightly earlier than the limit switches on the servo amplifier side.

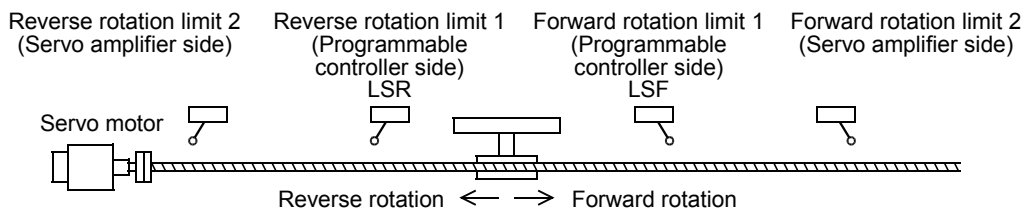

- *5. Extension blocks are used in the connection example. Inputs and outputs built into the main unit are available in place of extension blocks.
- *6. COM0 in the FX3G-40MT/ES
- *7. COM3 in the FX3G-40MT/ES

2. FX3GC/FX3UC PLC

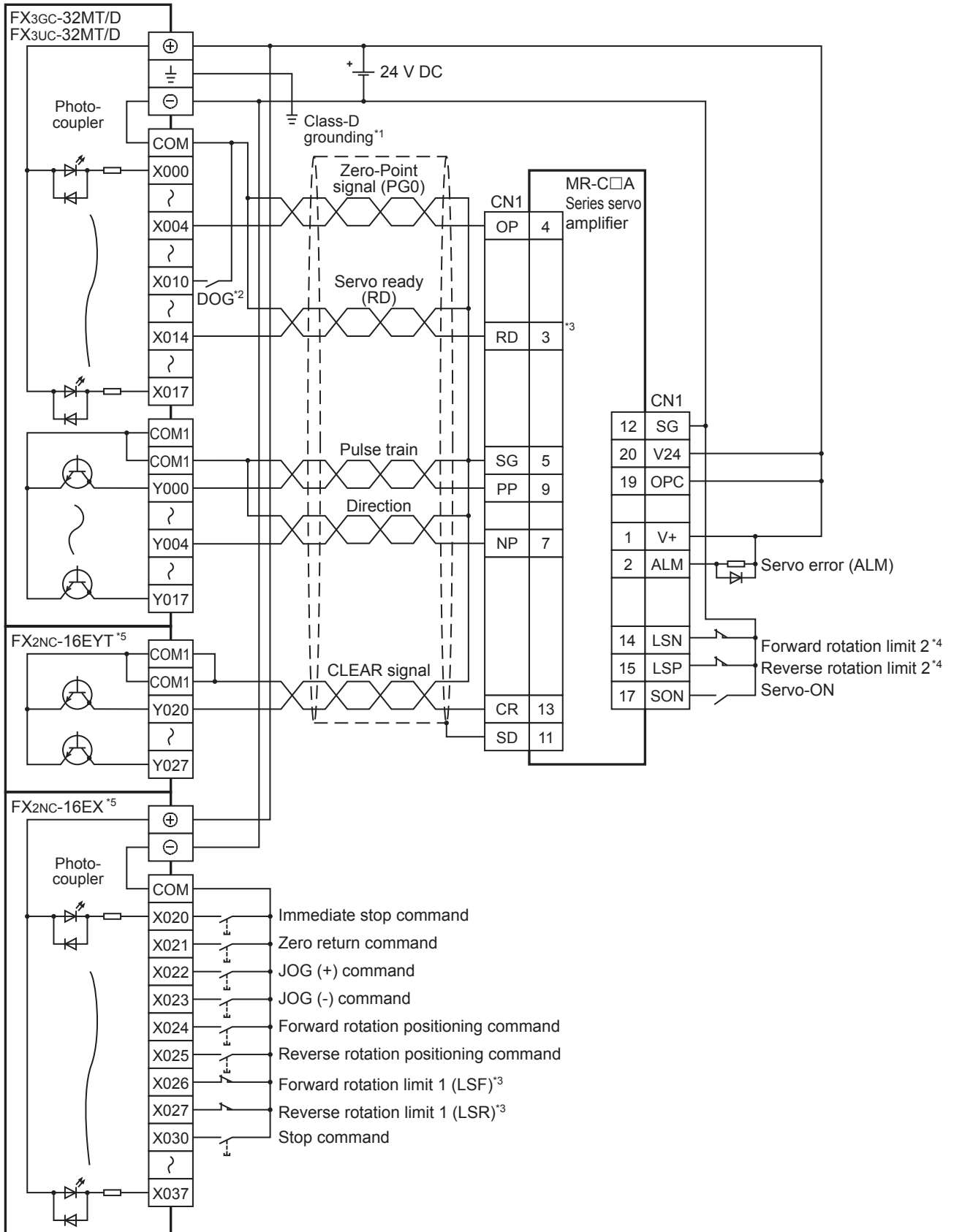

- *1. Be sure to use the class-D grounding method (grounding resistance: 100 Ω or less).
- *2. Near-point signal (DOG)
- *3. Set the servo amplifier parameter No.21 to "020".

A
Common Items

B
Built-in Positioning Functions

Apx.
Example Connection

- *4. To ensure safety, use the forward rotation limit switch and the reverse rotation limit switch on both sides: the PLC side and the servo amplifier side. Note that the limit switches on the PLC side should be activated slightly earlier than the limit switches on the servo amplifier side.

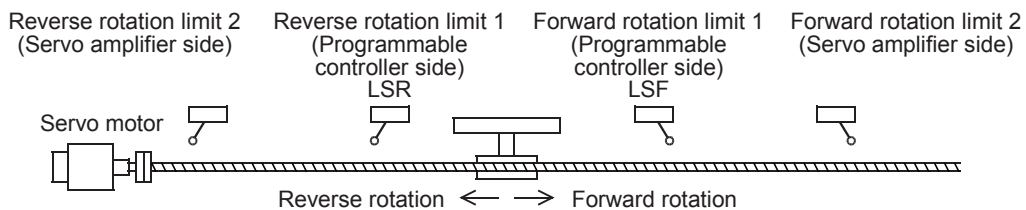

- *5. Extension blocks are used in the connection example. Inputs and outputs built into the main unit are available in place of extension blocks.

Appendix 6-2 High-Speed Output Special Adapter

To assign the inputs/outputs, refer to the following section.

→ Refer to Section 12.1 of "B. Built-in Positioning Function"

Appendix 6-2-1 Sink Input, Sink Output, and Differential Line Driver Output

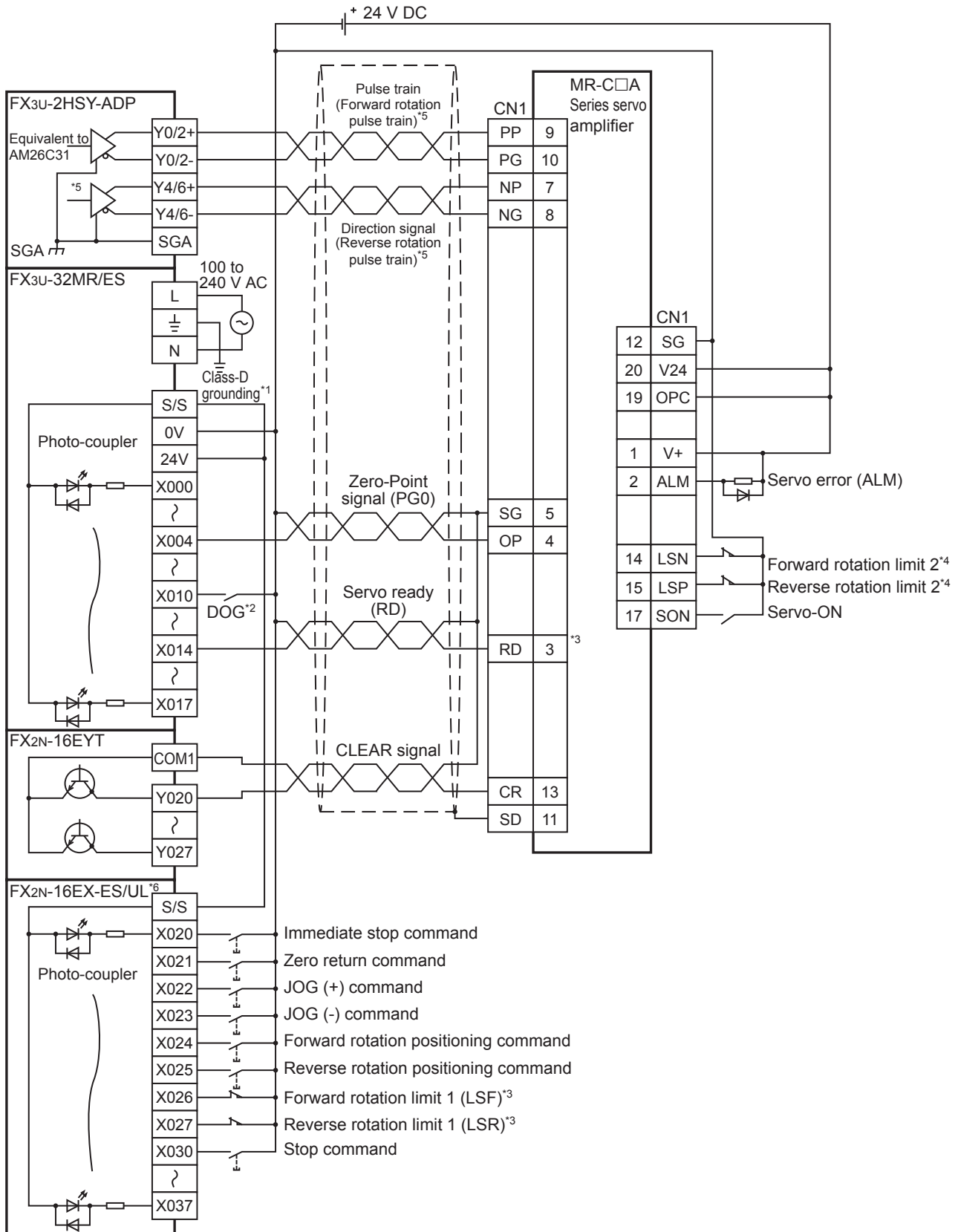

*1. Be sure to use the class-D grounding method (grounding resistance: 100 Ω or less).

- *2. Near-point signal (DOG)
- *3. Set the servo amplifier parameter No.21 to "020".
- *4. To ensure safety, use the forward rotation limit switch and the reverse rotation limit switch on both sides: the PLC side and the servo amplifier side.

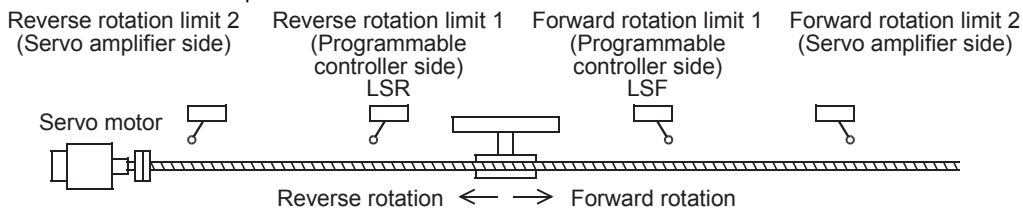

- *5. Set the pulse output method using the pulse output method setting switch.

Pulse output method setting switch	Pulse output method
FP·RP side	Forward/reverse pulse train
PLS·DIR side	Pulse train + direction

- *6. Input extension blocks are used in the connection example. Inputs built into the main unit are available in place of extension blocks.

Warranty

Please confirm the following product warranty details before using this product.

1. Gratis Warranty Term and Gratis Warranty Range

If any faults or defects (hereinafter "Failure") found to be the responsibility of Mitsubishi occurs during use of the product within the gratis warranty term, the product shall be repaired at no cost via the sales representative or Mitsubishi Service Company. However, if repairs are required onsite at domestic or overseas location, expenses to send an engineer will be solely at the customer's discretion. Mitsubishi shall not be held responsible for any re-commissioning, maintenance, or testing on-site that involves replacement of the failed module.

[Gratis Warranty Term]

The gratis warranty term of the product shall be for one year after the date of purchase or delivery to a designated place. Note that after manufacture and shipment from Mitsubishi, the maximum distribution period shall be six (6) months, and the longest gratis warranty term after manufacturing shall be eighteen (18) months. The gratis warranty term of repair parts shall not exceed the gratis warranty term before repairs.

[Gratis Warranty Range]

- 1) The range shall be limited to normal use within the usage state, usage methods and usage environment, etc., which follow the conditions and precautions, etc., given in the instruction manual, user's manual and caution labels on the product.
- 2) Even within the gratis warranty term, repairs shall be charged for in the following cases.
 - a) Failure occurring from inappropriate storage or handling, carelessness or negligence by the user. Failure caused by the user's hardware or software design.
 - b) Failure caused by unapproved modifications, etc., to the product by the user.
 - c) When the Mitsubishi product is assembled into a user's device, Failure that could have been avoided if functions or structures, judged as necessary in the legal safety measures the user's device is subject to or as necessary by industry standards, had been provided.
 - d) Failure that could have been avoided if consumable parts (battery, backlight, fuse, etc.) designated in the instruction manual had been correctly serviced or replaced.
 - e) Relay failure or output contact failure caused by usage beyond the specified Life of contact (cycles).
 - f) Failure caused by external irresistible forces such as fires or abnormal voltages, and failure caused by force majeure such as earthquakes, lightning, wind and water damage.
 - g) Failure caused by reasons unpredictable by scientific technology standards at time of shipment from Mitsubishi.
 - h) Any other failure found not to be the responsibility of Mitsubishi or that admitted not to be so by the user.

2. Onerous repair term after discontinuation of production

- 1) Mitsubishi shall accept onerous product repairs for seven (7) years after production of the product is discontinued.
Discontinuation of production shall be notified with Mitsubishi Technical Bulletins, etc.
- 2) Product supply (including repair parts) is not available after production is discontinued.

3. Overseas service

Overseas, repairs shall be accepted by Mitsubishi's local overseas FA Center. Note that the repair conditions at each FA Center may differ.

4. Exclusion of loss in opportunity and secondary loss from warranty liability

Regardless of the gratis warranty term, Mitsubishi shall not be liable for compensation of damages caused by any cause found not to be the responsibility of Mitsubishi, loss in opportunity, lost profits incurred to the user or third person by Failures of Mitsubishi products, special damages and secondary damages whether foreseeable or not, compensation for accidents, and compensation for damages to products other than Mitsubishi products, replacement by the user, maintenance of on-site equipment, start-up test run and other tasks.

5. Changes in product specifications

The specifications given in the catalogs, manuals or technical documents are subject to change without prior notice.

6. Product application

- 1) In using the Mitsubishi MELSEC programmable logic controller, the usage conditions shall be that the application will not lead to a major accident even if any problem or fault should occur in the programmable logic controller device, and that backup and fail-safe functions are systematically provided outside of the device for any problem or fault.
- 2) The Mitsubishi programmable logic controller has been designed and manufactured for applications in general industries, etc. Thus, applications in which the public could be affected such as in nuclear power plants and other power plants operated by respective power companies, and applications in which a special quality assurance system is required, such as for Railway companies or Public service purposes shall be excluded from the programmable logic controller applications.
In addition, applications in which human life or property that could be greatly affected, such as in aircraft, medical applications, incineration and fuel devices, manned transportation, equipment for recreation and amusement, and safety devices, shall also be excluded from the programmable logic controller range of applications.
However, in certain cases, some applications may be possible, providing the user consults their local Mitsubishi representative outlining the special requirements of the project, and providing that all parties concerned agree to the special circumstances, solely at the users discretion.

Revised History

Date	Revision	Description
7/2005	A	First Edition
2/2006	B	<ul style="list-style-type: none"> • The transistor output for FX3U Series was added. <ul style="list-style-type: none"> - A.Common items (Subsection 1.2.1 and 1.2.2, Section 2.1 and Subsection 3.1.1). - B.Built-in positioning function (Section 1.1, Subsection 1.5.2 and 1.5.3, Section 2.3, Subsection 2.5.1, Section 4.9, Subsection 6.3.1, 8.2.1 and 8.3.1, Section 9.1 and 10.1). - Appendix:Example connection (Appendix 1-1-1, 1-3, 2-1-1 and 4-1-1). • FX3U-20SSC-H was added. <ul style="list-style-type: none"> - A.Common items (Subsection 1.2.1, Section 2.1, Section 2.2, Subsection 3.1.3 and Section 3.2) • Other <ul style="list-style-type: none"> - Section-number changed Revision A (Revision B) A.Common items: Subsection 3.1.3 (3.1.4) B. Built-in positioning function: Subsection 2.5.1 (2.5.2) to 2.5.2 (2.5.3) - Correction of errors
11/2007	C	<ul style="list-style-type: none"> • FX3UC (D, DSS) Series PLC added. • Correction of errors
11/2008	D	<ul style="list-style-type: none"> • FX3G Series PLC added.
3/2009	E	<ul style="list-style-type: none"> • The transistor output (source type) for FX3G Series was added. • Explanation corrections for manufacturer's serial number.
9/2010	F	<ul style="list-style-type: none"> • Note on FX3U Series of triac type was added. • Note on FX3UC Series of relay output type was added. • Note on the zero return operation in FX3G PLCs was added. • Explanation corrections for manufacturer's serial number and lot number. • Correction of errors
2/2012	G	<ul style="list-style-type: none"> • FX3GC Series PLC added. • Correction of errors
5/2013	H	<ul style="list-style-type: none"> • FX3S Series PLC added. • MELSERVO-JN/MELSERVO-J4 Series servo amplifier added. • FX3U-1PG was added. • Description of the programming tool is changed accompanied by change of the programming tool from GX Developer to GX Works2. • Correction of errors
9/2013	J	<ul style="list-style-type: none"> • The DC power type for FX3S Series was added. • Correction of errors
4/2015	K	<ul style="list-style-type: none"> • A part of the cover design is changed.

FX3S/FX3G/FX3GC/FX3U/FX3UC SERIES PROGRAMMABLE CONTROLLERS

USER'S MANUAL

Positioning Control Edition

MITSUBISHI ELECTRIC CORPORATION

HEAD OFFICE: TOKYO BUILDING, 2-7-3 MARUNOUCHI, CHIYODA-KU, TOKYO 100-8310, JAPAN

MODEL	FX3U-U-POS-E
MODEL CODE	09R620