



Programmable Controller
MELSEC-F

FX3U-J1939



USER'S MANUAL



FX3U

Safety Precautions

(Read these precautions before use.)

Before installation, operation, maintenance or inspection of this product, thoroughly read through and understand this manual and all of the associated manuals. Also, take care to handle the module properly and safely.

This manual classifies the safety precautions into two categories:  **WARNING** and  **CAUTION**.

 WARNING	Indicates that incorrect handling may cause hazardous conditions, resulting in death or severe injury.
 CAUTION	Indicates that incorrect handling may cause hazardous conditions, resulting in medium or slight personal injury or physical damage.

Depending on the circumstances, procedures indicated by  **CAUTION** may also cause severe injury.

It is important to follow all precautions for personal safety.

Store this manual in a safe place so that it can be taken out and read whenever necessary. Always forward it to the end user.

1. DESIGN PRECAUTIONS

 WARNING	Reference
<ul style="list-style-type: none"> • Make sure to have the following safety circuits outside of the PLC to ensure safe system operation even during external power supply problems or PLC failure. Otherwise, malfunctions may cause serious accidents. <ol style="list-style-type: none"> 1) Most importantly, have the following: an emergency stop circuit, a protection circuit, an interlock circuit for opposite movements (such as normal vs. reverse rotation), and an interlock circuit (to prevent damage to the equipment at the upper and lower positioning limits). 2) Note that when the PLC CPU detects an error, such as a watchdog timer error, during self-diagnosis, all outputs are turned off. Also, when an error that cannot be detected by the PLC CPU occurs in an input/output control block, output control may be disabled. External circuits and mechanisms should be designed to ensure safe machinery operation in such a case. • For the operating status of each node in the case of a communication error, see the FX3U-J1939 user's manual and the product manual of each node. Erroneous output or malfunctions may cause an accident. • When executing control (data changes) to an operating PLC, construct an interlock circuit in the sequence program so that the entire system operates safely. In addition, when executing control such as program changes and operation status changes (status control) to an operating PLC, carefully read the manual and sufficiently confirm safety in advance. Especially in control from external equipment to a PLC in a remote place, problems in the PLC may not be able to be handled promptly due to abnormality in data transfer. Construct an interlock circuit in the sequence program. At the same time, determine the actions in the system between the external equipment and the PLC for protection against abnormalities in data transfer. <p>[Precautions for using products in a UL/cUL Class I, Division 2 environment]</p> <ul style="list-style-type: none"> • Products*¹ with the Cl. I, DIV.2 mark on the rating plate are suitable for use in Class I, Division 2, Groups A, B, C and D hazardous locations, or nonhazardous locations only.*² This mark indicates that the product is certified for use in the Class I, Division 2 environment where flammable gases, vapors, or liquids exist under abnormal conditions. When using the products in the Class I, Division 2 environment, observe the following to reduce the risk of explosion. <ul style="list-style-type: none"> - This device is open-type and is to be installed in an enclosure suitable for the environment and require a tool or key to open. - Warning - Explosion Hazard - Substitution of any component may impair suitability for Class I, Division 2. - Warning - Explosion Hazard - Do not disconnect equipment while the circuit is live or unless the area is known to be free of ignitable concentrations. - Do not open the cover of the PLC main unit and remove the battery unless the area is known to be nonhazardous. 	20

*1. For details of the products confirming to the UL explosion-proof standard, refer to the following manuals.

→ MELSEC iQ-F FX5U User's Manual (Hardware)
 → MELSEC iQ-F FX5UC User's Manual (Hardware)

*2. Only when connecting to FX5CPU module, FX3U-J1939 are suitable for use in Class I, Division 2 Groups A, B, C, and D.

Safety Precautions

(Read these precautions before use.)

 CAUTION	Reference
<ul style="list-style-type: none">• Make sure to observe the following precautions in order to prevent any damage to the machinery or accidents due to abnormal data written to the PLC under the influence of noise:<ol style="list-style-type: none">1) Do not bundle the main circuit line together with or lay it close to the main circuit, high-voltage line or load line. Otherwise, noise disturbance and/or surge induction are likely to take place. As a guideline, lay the control line at least 100mm (3.94") or more away from the main circuit or high-voltage lines.2) Ground the shield wire or shield of a shielded cable. Do not use common grounding with heavy electrical systems (refer to the manual of the PLC main unit).	20

2. INSTALLATION PRECAUTIONS

 WARNING	Reference
<ul style="list-style-type: none">• Make sure to cut off all phases of the power supply externally before attempting installation or wiring work. Failure to do so may cause electric shock or damage to the product.	23

 CAUTION	Reference
<ul style="list-style-type: none">• Use the product within the generic environment specifications described in PLC main unit manual (Hardware Edition). Never use the product in areas with excessive dust, oily smoke, conductive dusts, corrosive gas (salt air, Cl₂, H₂S, SO₂ or NO₂), flammable gas, vibration or impacts, or expose it to high temperature, condensation, or rain and wind. If the product is used in such conditions, electric shock, fire, malfunctions, deterioration or damage may occur.• Do not touch the conductive parts of the product directly. Doing so may cause device failures or malfunctions.• When drilling screw holes or wiring, make sure that cutting and wiring debris do not enter the ventilation slits. Failure to do so may cause fire, equipment failures or malfunctions.• Be sure to remove the dust proof sheet from the PLC's ventilation port when installation work is completed. Failure to do so may cause fire, equipment failures or malfunctions.• Install the product on a flat surface. If the mounting surface is rough, undue force will be applied to the PC board, thereby causing nonconformities.• Install the product securely using a DIN rail or mounting screws.• Connect extension cables securely to their designated connectors. Loose connections may cause malfunctions.	23

Safety Precautions

(Read these precautions before use.)

3. WIRING PRECAUTIONS

 WARNING	Reference
<ul style="list-style-type: none"> Make sure to cut off all phases of the power supply externally before attempting installation or wiring work. Failure to do so may cause electric shock or damage to the product. 	27

 CAUTION	Reference
<ul style="list-style-type: none"> Perform class D grounding (grounding resistance: 100Ω or less) to the shield of the twisted shield cable (refer to Subsection 4.2.3). Do not use common grounding with heavy electrical systems. When drilling screw holes or wiring, make sure cutting or wire debris does not enter the ventilation slits. Failure to do so may cause fire, equipment failures or malfunctions. Install module so that excessive force will not be applied to communication connectors or communication cables. Failure to do so may result in wire damage/breakage or PLC failure. Make sure to affix the CAN bus connector with fixing screws. Tightening torque should follow the specifications in the manual. Loose connections may cause malfunctions. Make sure to properly wire to the terminal block (CAN bus connector) in accordance with the following precautions. Failure to do so may cause electric shock, equipment failures, a short-circuit, wire breakage, malfunctions, or damage to the product. <ul style="list-style-type: none"> The disposal size of the cable end should follow the dimensions described in the manual. Tightening torque should follow the specifications in the manual. Twist the end of strand wire and make sure that there are no loose wires. Do not solder-plate the electric wire ends. Do not connect more than the specified number of wires or electric wires of unspecified size. Affix the electric wires so that neither the terminal block nor the connected parts are directly stressed. Make sure to observe the following precautions in order to prevent any damage to the machinery or accidents due to abnormal data written to the PLC under the influence of noise: <ol style="list-style-type: none"> Do not bundle the main circuit line together with or lay it close to the main circuit, high-voltage line or load line. Otherwise, noise disturbance and/or surge induction are likely to take place. As a guideline, lay the control line at least 100 mm (3.94") or more away from the main circuit or high-voltage lines. Ground the shield wire or shield of a shielded cable. Do not use common grounding with heavy electrical systems. Place the communication cable in grounded metallic ducts or conduits both inside and outside of the control panel whenever possible. 	27

4. STARTUP AND MAINTENANCE PRECAUTIONS

 WARNING	Reference
<ul style="list-style-type: none"> Do not touch any terminal while the PLC's power is on. Doing so may cause electric shock or malfunctions. Before cleaning or retightening terminals, cut off all phases of the power supply externally. Failure to do so may cause electric shock. Before modifying or disrupting the program in operation or running the PLC, carefully read through this manual and the associated manuals and ensure the safety of the operation. An operation error may damage the machinery or cause accidents. 	79 82 92

 CAUTION	Reference
<ul style="list-style-type: none"> Do not disassemble or modify the PLC. Doing so may cause fire, equipment failures, or malfunctions. For repair, contact your local Mitsubishi Electric representative. Turn off the power to the PLC before connecting or disconnecting any extension cable. Failure to do so may cause equipment failures or malfunctions. Do not drop the product or exert strong impact to it. Doing so may cause damage. Turn off the power to the PLC before attaching or detaching the following devices. Failure to do so may cause equipment failures or malfunctions. <ul style="list-style-type: none"> Peripheral devices, display module, expansion boards, and special adapters Input/output extension units/blocks, FX Series terminal blocks and special function units/blocks Battery and memory cassette 	79 82 92

Safety Precautions

(Read these precautions before use.)

5. DISPOSAL PRECAUTIONS

 CAUTION	Reference
<ul style="list-style-type: none">• Please contact a certified electronic waste disposal company for the environmentally safe recycling and disposal of your device.	20

6. TRANSPORTATION AND STORAGE PRECAUTIONS



 CAUTION	Reference
<ul style="list-style-type: none">• The PLC is a precision instrument. During transportation, avoid impacts larger than those specified in the general specifications of the PLC main unit manual by using dedicated packaging boxes and shock-absorbing palettes. Failure to do so may cause failures in the PLC. After transportation, verify operation of the PLC and check for damage of the mounting part, etc.	20

Précautions de Sécurité

(Lire ces précautions avant toute utilisation.)

Avant l'installation, l'utilisation, la maintenance ou le contrôle de ce produit, lisez entièrement ce manuel ainsi que tous les manuels associés et veillez à bien en comprendre le contenu. Aussi, assurez-vous de manipuler correctement et en toute sécurité le module.

Ce manuel classe les mesures de précautions en deux catégories  **AVERTISSEMENT** et  **ATTENTION** :

 AVERTISSEMENT	Attire l'attention sur le fait qu'une négligence peut créer une situation dangereuse, ce qui entraîne la mort ou des blessures graves.
 ATTENTION	Attire l'attention sur le fait qu'une négligence peut créer une situation dangereuse, ce qui entraîne des blessures légères ou moyennes, ou des dégâts physiques.

Selon les circonstances, les procédures signalées par un  **ATTENTION** peuvent également causer des blessures graves. Il est important de suivre toutes les précautions pour la sécurité personnelle.

Conserver ce manuel dans un lieu sûr de sorte qu'il puisse être accessible et consultable chaque fois que cela est nécessaire. Toujours faire suivre à l'utilisateur final.

1. PRÉCAUTIONS DE CONCEPTION

 AVERTISSEMENT	Référence
<ul style="list-style-type: none"> • Assurez-vous de configurer les circuits de sécurité suivants en dehors du contrôleur programmable afin d'assurer un fonctionnement sûr du système même pendant qu'il y a un problème d'alimentation externe ou une panne du contrôleur programmable. Faute de quoi, des dysfonctionnements peuvent causer des accidents graves. <ol style="list-style-type: none"> 1) Configurez surtout ce qui suit : un circuit d'arrêt d'urgence, un circuit de protection, un circuit de verrouillage pour les mouvements opposés (tels que la rotation normale ou inversée) et un circuit de verrouillage (pour éviter d'endommager l'équipement aux niveaux supérieur et inférieur de limites de positionnement). 2) Notez que lorsque le module CPU du contrôleur programmable détecte une erreur, telle qu'une erreur dans un minuteur de surveillance pendant l'auto-diagnostic, toutes les sorties sont désactivées. En outre, lorsqu'une erreur qui ne peut pas être détectée par le module CPU du contrôleur programmable se produit dans un bloc de contrôle E/S, la commande de sortie peut être désactivée. Les circuits et mécanismes externes devraient être conçus pour assurer le fonctionnement sûr des machines dans un tel cas. • Pour l'état d'opération de chaque nœud dans le cas d'une erreur de communication, consultez le manuel de l'utilisateur FX3U-J1939 et le manuel du produit de chaque nœud. Une sortie erronée ou un dysfonctionnement peut être à l'origine d'un accident. • Lors de l'exécution d'une commande (changement de données) vers un contrôleur programmable en cours de fonctionnement, construire un circuit de verrouillage dans le programme de séquence afin que tout le système fonctionne en toute sécurité. En outre, lors de l'exécution d'une commande tels que les changements de programme et les changements d'état d'opération (commande d'état) vers un contrôleur programmable en cours de fonctionnement, lisez attentivement le manuel et confirmez pleinement la sécurité à l'avance. Particulièrement lors d'effectuer une commande de l'équipement externe vers un contrôleur programmable dans un endroit éloigné, les problèmes dans le contrôleur programmable ne peuvent pas être traités rapidement en raison d'une anomalie dans le transfert de données. Construire un circuit de verrouillage dans le programme de séquence. Dans le même temps, déterminer les actions dans le système entre l'équipement externe et le contrôleur programmable pour la protection contre les anomalies dans le transfert de données. <p>[Précautions d'utilisation des produits en environnement de UL/cUL Class I, Division 2]</p> <ul style="list-style-type: none"> • Les produits^{*1} marques Cl. I, DIV.2 sur la plaque signalétique peuvent être utilisés en Class I, Division 2, local dangereux de groupe A, B, C et D, ou uniquement en local non dangereux.*² Ce logo indique que le produit est homologué pour utilisation en environnement de Class I, Division 2 ou, dans des circonstances anormales, il peut y avoir présence de gaz, vapeurs ou liquides inflammables. Si le produit est utilisé en environnement de Class I, Division 2, observer les précautions suivantes pour réduire le risque d'explosion. <ul style="list-style-type: none"> - Cet appareil est de type ouvert et il doit être installé dans une enceinte appropriée à l'environnement et ne pouvant être ouverte qu'au moyen d'une clef ou d'un outil. - Avertissement - Danger d'explosion - Toute substitution de composant peut compromettre l'aptitude à l'utilisation en Class I, Division 2. - Avertissement - Danger d'explosion - Ne pas déconnecter l'équipement quand le circuit est sous tension, ni avant de s'être assuré de l'absence d'atmosphère inflammable. - Ne pas ouvrir le couvercle de l'unité principale du contrôleur programmable et ne pas retirer la batterie avant d'avoir vérifié que l'atmosphère est sans danger. 	21

*1. Pour les informations sur les produits conformes aux normes UL des produits antidéflagrants, veuillez vous référer aux manuels suivants.

→ MELSEC iQ-F FX5U User's Manual (Hardware)
→ MELSEC iQ-F FX5UC User's Manual (Hardware)

*2. C'est uniquement lors de la connexion au module FX5CPU, que FX3U-J1939 conviennent à une utilisation en Class I, Division 2 Groupes A, B, C, et D.

Précautions de Sécurité

(Lire ces précautions avant toute utilisation.)

 ATTENTION	Référence
<ul style="list-style-type: none">Assurez-vous d'observer les précautions suivantes afin d'éviter tous les endommagements aux machines ou les accidents dus aux données anormales écrites sur le contrôleur programmable sous les effets du bruit :<ol style="list-style-type: none">Ne pas regrouper la ligne du circuit principal, ou ne pas la placer près du circuit principal, de la ligne de haute tension ou de la ligne de charge. Faute de quoi, des perturbations du bruit et/ou des inductions de surtension sont susceptibles d'avoir lieu. À titre indicatif, posez la ligne de commande à au moins 100 mm (3,94") ou plus du circuit principal ou des lignes de haute tension.Mettre à la terre les fils blindés ou le blindage des câbles blindés. Ne pas utiliser la mise à la terre commune pour les systèmes électriques lourds (reportez-vous au manuel de l'unité principale du contrôleur programmable).	21

2. PRÉCAUTIONS D'INSTALLATION

 AVERTISSEMENT	Référence
<ul style="list-style-type: none">Assurez-vous de couper toutes les phases de l'alimentation externe avant d'essayer l'installation ou le câblage. Faute de quoi, il y a risque d'électrocution ou d'endommagement du produit.	23

 ATTENTION	Référence
<ul style="list-style-type: none">Utilisez le produit dans les spécifications d'environnement générique décrites dans le manuel de l'unité principale du contrôleur programmable (Hardware Edition). N'utilisez jamais ce produit dans les zones à poussières excessives, à fumées grasses, à poussières conductrices, à gaz corrosifs (air salé, Cl₂, H₂S, SO₂ ou NO₂), à gaz inflammables, à vibrations ou à impacts, ou ne l'exposer jamais à haute température, à condensation ou à pluie et vent. Si le produit est utilisé dans de telles conditions, des électrocution, des feux, des dysfonctionnements, des détériorations ou des dommages peuvent se produire.Ne pas toucher directement les parties conductrices du produit. Cela pourrait être à l'origine de pannes ou de dysfonctionnements d'équipement.Lors du perçage des trous de vis ou du câblage, assurez-vous que les débris de coupe et de câblage ne pénètrent pas dans les fentes de ventilation. Faute de quoi, il y a risque de départ de feu, de panne ou de dysfonctionnement d'équipement.Assurez-vous d'enlever la feuille anti-poussière du port de ventilation du contrôleur programmable lorsque les travaux d'installation sont terminés. Faute de quoi, il y a risque de départ de feu, de panne ou de dysfonctionnement d'équipement.Installez le produit sur une surface plane. Si la surface de montage est rugueuse, une force excessive sera appliquée à la carte PC, ce qui entraînera des non-conformités.Installez le produit solidement à l'aide d'un rail DIN ou de vis de montage.Connectez les câbles d'extension de manière sécurisée à leurs connecteurs désignés. Les connexions lâches peuvent provoquer des dysfonctionnements.	23

Précautions de Sécurité

(Lire ces précautions avant toute utilisation.)

3. PRÉCAUTIONS DE CABLAGE

 AVERTISSEMENT	Référence
<ul style="list-style-type: none">Assurez-vous de couper toutes les phases de l'alimentation externe avant d'essayer l'installation ou le câblage. Faute de quoi, il y a risque d'électrocution ou d'endommagement du produit.	28

 ATTENTION	Référence
<ul style="list-style-type: none">Effectuer la mise à la terre classe D (résistance à la mise à la terre : 100 Ω ou moins) sur le blindage du câble blindé torsadé (voir la sous-section 4.2.3). Ne pas utiliser le réseau commun de mise à la terre pour les systèmes électriques lourds.Lors du perçage des trous de vis ou du câblage, assurez-vous que les débris de coupe ou de câblage ne pénètrent pas dans les fentes de ventilation. Faute de quoi, il y a risque de départ de feu, de panne ou de dysfonctionnement d'équipement.Installer le module afin que la force excessive ne soit pas appliquée aux connecteurs de communication ou aux câbles de communication. Faute de quoi, il y a risque d'endommagement, de rupture ou de panne du contrôleur programmable.Assurez-vous de fixer le connecteur du bus CAN avec les vis de fixation. Pour le couple de serrage, respecter les spécifications du manuel. Les connexions lâches peuvent provoquer des dysfonctionnements.Assurez-vous de bien câbler le bornier (connecteur du bus CAN) conformément aux précautions suivantes. Faute de quoi, il y a risque d'électrocutions, de pannes d'équipement, de court-circuit, de rupture du fil, de dysfonctionnements ou de dommages au produit.<ul style="list-style-type: none">La taille des extrémités du câble lors de la mise au rebut doit se conformer aux dimensions décrites dans le manuel.Pour le couple de serrage, respecter les spécifications du manuel.Tordre les extrémités des câbles toron et s'assurer qu'il n'y a pas de fils desserrés.Ne pas souder et plaquer les extrémités des fils électriques.Ne pas connecter plus que le nombre indiqué de fils ou des fils électriques ayant une taille non indiquée.Fixez les fils électriques de sorte que ni le bornier ni les pièces connectées ne soient directement soumis à une contrainte.Assurez-vous d'observer les précautions suivantes afin d'éviter tous les endommagements aux machines ou les accidents dus aux données anormales écrites sur le contrôleur programmable sous les effets du bruit :<ol style="list-style-type: none">Ne pas regrouper la ligne du circuit principal, ou ne pas la placer près du circuit principal, de la ligne de haute tension ou de la ligne de charge. Faute de quoi, des perturbations du bruit et/ou des inductions de surtension sont susceptibles d'avoir lieu. À titre indicatif, posez la ligne de commande au moins à 100 mm (3,94") ou plus du circuit principal ou les lignes à haute tension.Mettre à la terre les fils blindés ou le blindage des câbles blindés. Ne pas utiliser le réseau commun de mise à la terre pour les systèmes électriques lourds.Placez le câble de communication dans les conduits métalliques mis à la terre ou dans les conduits mis à la terre à l'intérieur et à l'extérieur du panneau de commande chaque fois que cela est possible.	28

Précautions de Sécurité

(Lire ces précautions avant toute utilisation.)

4. PRÉCAUTIONS DE MISE EN SERVICE ET DE MAINTENANCE

 AVERTISSEMENT	Référence
<ul style="list-style-type: none">• Ne toucher aucune borne quand le contrôleur programmable est sous tension. Cela pourrait être à l'origine d'électrocutions ou de dysfonctionnements.• Avant de nettoyer ou de resserrer les bornes, couper toutes les phases de l'alimentation externe. Faute de quoi, il y a risque d'électrocution.• Avant toute modification ou arrêt du programme en cours ou toute utilisation du contrôleur programmable, lisez attentivement ce manuel ainsi que tous les manuels associés et assurez-vous que le fonctionnement se fera en toute sécurité. Une opération erronée peut endommager la machine ou provoquer des accidents.	79 82 92

 ATTENTION	Référence
<ul style="list-style-type: none">• Ne pas démonter ni modifier le contrôleur programmable. Cela pourrait causer un départ de feu, une panne ou un dysfonctionnement des équipements. Pour réparation, contactez votre représentant local de Mitsubishi Electric.• Coupez l'alimentation du contrôleur programmable avant de connecter ou déconnecter les câbles d'extension. Faute de quoi, il y a risque de panne ou de dysfonctionnement des équipements.• Ne pas laisser tomber le produit ni donner un choc sur lui. Cela pourrait endommager le produit.• Coupez l'alimentation du contrôleur programmable avant d'attacher ou de détacher les appareils suivants. Faute de quoi, il y a risque de panne ou de dysfonctionnement des équipements.<ul style="list-style-type: none">- Appareils périphériques, module d'affichage, cartes d'extension et adaptateurs spéciaux- Blocs/unités d'extension E/S, borniers de série FX et blocs/unités de fonction spéciale- Cassette batterie et mémoire	79 82 92

5. PRÉCAUTIONS DE MISE AU REBUT

 ATTENTION	Référence
<ul style="list-style-type: none">• Veuillez contacter une société certifiée de mise au rebut des déchets électroniques pour le recyclage écologique et la mise au rebut écologique de votre équipement.	21

6. PRECAUTION POUR LE TRANSPORT ET LE STOCKAGE

 ATTENTION	Référence
<ul style="list-style-type: none">• Le contrôleur programmable est un instrument de précision. Pendant le transport, évitez de donner les chocs supérieurs à ceux spécifiés dans les spécifications générales du manuel de l'unité principale du contrôleur programmable en utilisant les boîtes d'emballage dédiées et les palettes amortisseuse. Faute de quoi, il y a risque de panne du contrôleur programmable. Après le transport, vérifiez le bon fonctionnement du contrôleur programmable et contrôlez l'absence de dégâts des pièces de montage, etc.	21

FX3U-J1939

User's Manual

Manual number	JY997D43101
Manual revision	D
Date	10/2017

Foreword

This manual describes the FX3U-J1939 Communication Block and should be read and understood before attempting to install or operate the hardware.
Store this manual in a safe place so that you can take it out and read it whenever necessary. Always forward it to the end user.

This manual confers no industrial property rights or any rights of any other kind, nor does it confer any patent licenses. Mitsubishi Electric Corporation cannot be held responsible for any problems involving industrial property rights which may occur as a result of using the contents noted in this manual.

Outline Precautions

- This manual provides information for the use of the FX3U-J1939 Communication block. The manual has been written to be used by trained and competent personnel. The definition of such a person or persons is as follows;
 - 1) Any engineer who is responsible for the planning, design and construction of automatic equipment using the product associated with this manual should be of a competent nature, trained and qualified to the local and national standards required to fulfill that role. These engineers should be fully aware of all aspects of safety with aspects regarding to automated equipment.
 - 2) Any commissioning or maintenance engineer must be of a competent nature, trained and qualified to the local and national standards required to fulfill the job. These engineers should also be trained in the use and maintenance of the completed product. This includes being familiar with all associated manuals and documentation for the product. All maintenance should be carried out in accordance with established safety practices.
 - 3) All operators of the completed equipment should be trained to use that product in a safe and coordinated manner in compliance with established safety practices. The operators should also be familiar with documentation that is connected with the actual operation of the completed equipment.
- **Note:** The term 'completed equipment' refers to a third party constructed device that contains or uses the product associated with this manual.

- This product has been manufactured as a general-purpose part for general industries, and has not been designed or manufactured to be incorporated in a device or system used in purposes related to human life.
- Before using the product for special purposes such as nuclear power, electric power, aerospace, medicine or passenger movement vehicles, consult with Mitsubishi Electric.
- This product has been manufactured under strict quality control. However when installing the product where major accidents or losses could occur if the product fails, install appropriate backup or failsafe functions into the system.
- When combining this product with other products, please confirm the standards and codes of regulation to which the user should follow. Moreover, please confirm the compatibility of this product with the system, machines, and apparatuses to be used.
- If there is doubt at any stage during installation of the product, always consult a professional electrical engineer who is qualified and trained in the local and national standards. If there is doubt about the operation or use, please consult your local Mitsubishi Electric representative.
- Since the examples within this manual, technical bulletin, catalog, etc. are used as reference; please use it after confirming the function and safety of the equipment and system. Mitsubishi Electric will not accept responsibility for actual use of the product based on these illustrative examples.
- The content, specification etc. of this manual may be changed for improvement without notice.
- The information in this manual has been carefully checked and is believed to be accurate; however, if you notice any doubtful point, error, etc., please contact your local Mitsubishi Electric representative.

Registration

- NMEA[®] and NMEA 2000[®] are registered trademarks of NMEA (National Marine Electronics Association).
- The company name and the product name to be described in this manual are the registered trademarks or trademarks of each company.

Table of Contents

SAFETY PRECAUTIONS	(1)
Standards.....	6
Certification of UL, cUL standards	6
Compliance with EC directive (CE Marking)	6
Associated Manuals.....	8
Generic Names and Abbreviations Used in the Manual	10
Reading the Manual	12

1. Introduction **13**

1.1 Outline.....	13
1.2 External Dimensions and Each Part Name	15
1.2.1 External dimensions and each part name	15
1.2.2 Power and status LEDs	16
1.2.3 Terminal layout	16
1.3 System Configuration.....	17
1.3.1 General configuration	17
1.3.2 Applicable PLC	17
1.3.3 Connection with PLC	18
1.4 System Start-up Procedure.....	19

2. Specifications **20**

2.1 General Specifications	22
2.2 Power Supply Specifications.....	22
2.3 Performance Specifications	22

3. Installation **23**

3.1 Connection with PLC.....	24
3.2 Mounting	25
3.2.1 DIN rail mounting.....	25
3.2.2 Direct Mounting	26

4. Wiring **27**

4.1 Applicable Cable and Connector.....	28
4.1.1 Applicable connector	28
4.1.2 Applicable cable	29
4.1.3 Termination of cable end	29
4.1.4 Removal and installation of CAN bus connector	29
4.2 CAN-Bus Wiring	30
4.2.1 Connecting communication cables.....	30
4.2.2 Module wiring	30
4.2.3 Grounding of twisted pair cable	31
4.2.4 Termination.....	31
4.3 Grounding	31

5. Allocation of Buffer Memories	32
5.1 Buffer Memories (BFM) Lists	32
5.2 How to Read/Write from/to Buffer Memory	34
5.3 [BFM #20] Data Exchange Control	35
5.4 [BFM #21] Function Mode.....	35
5.5 [BFM #22] Save/Restore Configuration	36
5.6 [BFM #24] Baud Rate.....	37
5.7 [BFM #25] Communication Status	37
5.8 [BFM #26] FROM/TO Watchdog.....	38
5.9 [BFM #27] Node Address (Address Claim Start Address)	39
5.10 [BFM #28] Node Address (Current Address)	41
5.11 [BFM #29] Error Status	41
5.12 [BFM #30] Module ID Code.....	41
5.13 [BFM #35] CAN Transmit Message Error Counter.....	41
5.14 [BFM #36] CAN Receive Message Error Counter.....	41
5.15 [BFM #37] Baud Rate Display	41
5.16 [BFM #39] BFM Setting Error Display	42
5.17 [BFM #40 to #48] 64 Bit ECU NAME According to J1939-81	42
5.18 [BFM #100 to #399] Send/Receive Data Buffer	43
5.19 [BFM #401 to #479] Message Specific Error Code List	43
5.20 [BFM #1280 to #1284] Manual Transmit Trigger flags.....	45
5.21 [BFM #1900 to #1927] PLC RUN>STOP Messages	45
5.22 [BFM #3000 to #3879] Configuration of Remote Address to ECU Name Assignment	46
6. J1939 Communication Mode	48
6.1 Send/Receive Data Buffer.....	48
6.1.1 [BFM #100 to #399] Send/receive data buffer for standard messages	48
6.1.2 [BFM #1300 to #1799] Send/receive data buffer for extended messages	49
6.2 [BFM #500 to #973] Configuration Area.....	49
6.2.1 Example configuration setting for J1939 communication mode	58
6.2.2 Example J1939 communication mode use of RUN>STOP messages and remote address to ECU name assignment.....	59
7. Layer 2 Communication Mode (11/29 bit ID)	61
7.1 [BFM #100 to #399] Sending/Receiving Pre-defined Layer 2 Messages.....	61
7.2 [BFM #1100 to #1267] Pre-defined Layer 2 Messages Parameter.....	64
7.2.1 Pre-defined Layer 2 transmit messages.....	65
7.2.2 Pre-defined Layer 2 receive messages	67
7.3 [BFM #1270 to #1272] Layer 2 RTR Flags	69
8. [BFM #1900 to #1927] PLC RUN>STOP Messages	70

9. Command Interface	72
9.1 [BFM #1000 to #1066] Command Interface (CIF)	72
9.2 Sending Layer 2 Message	73
9.3 Send PGN	74
9.4 Request PGN	75
9.5 Setup PLC RUN>STOP Messages	76
9.6 Reset Command Interface	77
9.7 Display Current Parameter	77
9.8 CIF: Error code list	78
10. Communication Settings Procedure	79
10.1 J1939 Communication Mode	80
10.2 Layer 2 communication (11/29 bit ID) mode	81
11. Example Program	82
11.1 System Configuration	83
11.2 Contents of Operation/Setting of FX3U-J1939	83
11.3 J1939 Communication Example Programs	84
12. Diagnostics	92
12.1 Preliminary Checks	93
12.2 Detail Error Check	95
Warranty	97
Revised History	98

Standards

Certification of UL, cUL standards

FX3U-J1939 units comply with the UL standards (UL, cUL).

UL, cUL File number :E95239

Regarding the standards that comply with the main unit, please refer to either the FX series product catalog or consult with your nearest Mitsubishi product provider.

Compliance with EC directive (CE Marking)

This document does not guarantee that a mechanical system including this product will comply with the following standards.

Compliance to EMC directive and LVD directive for the entire mechanical module should be checked by the user / manufacturer. For more information please consult with your nearest Mitsubishi product provider.

Regarding the standards that comply with the main unit, please refer to either the FX series product catalog or consult with your nearest Mitsubishi product provider.

Requirement for Compliance with EMC directive

The following products have shown compliance through direct testing (of the identified standards below) and design analysis (through the creation of a technical construction file) to the European Directive for Electromagnetic Compatibility (2014/30/EU) when used as directed by the appropriate documentation.

Attention

This product is designed for use in industrial applications.

Type: Programmable Controller (Open Type Equipment)

Models: MELSEC FX3U series manufactured

from May 1st, 2012 FX3U-J1939

Standard	Remark
EN61131-2:2007 Programmable controllers - Equipment requirements and tests	Compliance with all relevant aspects of the standard. EMI • Radiated Emission • Conducted Emission EMS • Radiated electromagnetic field • Fast transient burst • Electrostatic discharge • High-energy surge • Voltage drops and interruptions • Conducted RF • Power frequency magnetic field

Caution for Compliance with EC Directive

- 1) Caution for wiring
For noise prevention, please ground at least 35 mm (1.38") of the twisted-pair cable along the grounding plate to which the ground terminal is connected.
→ For details regarding wiring, refer to Section 4.2
 - 2) Installation in Enclosure
→ For details regarding installation in an enclosure of FX3G Series PLC, refer to FX3G User's Manual - Hardware Edition
→ For details regarding installation in an enclosure of FX3GC^{*1} Series PLC, refer to FX3GC User's Manual - Hardware Edition
→ For details regarding installation in an enclosure of FX3U Series PLC, refer to FX3U User's Manual - Hardware Edition
→ For details regarding installation in an enclosure of FX3UC^{*1} Series PLC, refer to FX3UC User's Manual - Hardware Edition
→ For details regarding installation in an enclosure of FX5U^{*2} PLC, refer to MELSEC iQ-F FX5U User's Manual (Hardware)
→ For details regarding installation in an enclosure of FX5UC^{*2} PLC, refer to MELSEC iQ-F FX5UC User's Manual (Hardware)
- *1. An FX2NC-CNV-IF or FX3UC-1PS-5V is necessary to connect the FX3U-J1939 to an FX3GC/FX3UC Series PLC.
- *2. An FX5-CNV-BUS or FX5-CNV-BUSC is necessary to connect the FX3U-J1939 to an FX5U/FX5UC PLC.

Associated Manuals

Only the installation manual is packed together with the FX3U-J1939 Communication Block.

For a detailed explanation of the FX3U-J1939, refer to this manual.

For further information of the hardware information and instructions on the PLC main unit/CPU Module, refer to the respective manuals.

- ⊙ Refer to these manuals
- ✓ Refer to the appropriate equipment manual
- △ For a detailed explanation, refer to an additional manual

		Title of manual	Document number	Description	Model code
Manual for the Main Unit/CPU Module					
FX3G Series PLCs Main Unit					
△	Supplied Manual	FX3G Series Hardware Manual	JY997D46001	Describes FX3G Series PLC specification for I/O, wiring and installation extracted from the FX3G User's Manual - Hardware Edition. For details, refer to FX3G Series User's Manual - Hardware Edition.	-
⊙	Additional Manual	FX3G Series User's Manual - Hardware Edition	JY997D31301	Describes FX3G Series PLC specification details for I/O, wiring, installation and maintenance.	09R521
FX3GC Series PLCs Main Unit					
△	Supplied Manual	FX3GC Series Hardware Manual	JY997D45201	Describes FX3GC Series PLC specification for I/O, wiring and installation extracted from the FX3GC User's Manual - Hardware Edition. For details, refer to FX3GC Series User's Manual - Hardware Edition.	-
⊙	Additional Manual	FX3GC Series User's Manual - Hardware Edition	JY997D45401	Describes FX3GC Series PLC specification details for I/O, wiring, installation and maintenance.	09R533
FX3U Series PLCs Main Unit					
△	Supplied Manual	FX3U Series Hardware Manual	JY997D50301	Describes FX3U Series PLC specification for I/O, wiring and installation extracted from the FX3U User's Manual - Hardware Edition. For details, refer to FX3U Series User's Manual - Hardware Edition.	-
⊙	Additional Manual	FX3U Series User's Manual - Hardware Edition	JY997D16501	Describes FX3U Series PLC specification details for I/O, wiring, installation and maintenance.	09R516
FX3UC Series PLCs Main Unit					
△	Supplied Manual	FX3UC(D,DS,DSS) Series Hardware Manual	JY997D50501	Describes FX3UC(D,DS,DSS) Series PLC specification for I/O, wiring and installation extracted from the FX3UC Series User's Manual - Hardware Edition. For details, refer to FX3UC Series User's Manual - Hardware Edition.	-
△	Supplied Manual	FX3UC-32MT-LT-2 Hardware Manual	JY997D31601	Describes FX3UC-32MT-LT-2 specification for I/O, wiring and installation extracted from the FX3UC User's Manual - Hardware Edition. For details, refer to FX3UC Series User's Manual - Hardware Edition.	-
△	Supplied Manual	FX3UC-32MT-LT Hardware Manual (Only Japanese document)	JY997D12701	Describes FX3UC-32MT-LT specification for I/O, wiring and installation extracted from the FX3UC User's Manual - Hardware Edition. For details, refer to FX3UC Series User's Manual - Hardware Edition.	-
⊙	Additional Manual	FX3UC Series User's Manual - Hardware Edition	JY997D28701	Describes FX3UC Series PLC specification details for I/O, wiring, installation and maintenance.	09R519

		Title of manual	Document number	Description	Model code
FX5U PLCs CPU Module					
△	Supplied Manual	MELSEC iQ-F FX5U CPU Module Hardware Manual	JY997D53401	Describes FX5U PLC specification for I/O, wiring and installation extracted from the FX5U PLC from MELSEC iQ-F FX5U User's Manual (Hardware). For details, refer to FX5U PLC from MELSEC iQ-F FX5U User's Manual (Hardware).	-
⊙	Additional Manual	MELSEC iQ-F FX5U User's Manual (Hardware)	JY997D55301	Describes FX5U PLC specification details for I/O, wiring, installation and maintenance.	09R536
FX5UC PLCs CPU Module					
△	Supplied Manual	MELSEC iQ-F FX5UC CPU Module Hardware Manual	JY997D61001	Describes FX5UC PLC specification for I/O, wiring and installation extracted from the FX5UC PLC from MELSEC iQ-F FX5UC User's Manual (Hardware). For details, refer to FX5UC PLC from MELSEC iQ-F FX5UC User's Manual (Hardware).	-
⊙	Additional Manual	MELSEC iQ-F FX5UC User's Manual (Hardware)	JY997D61401	Describes FX5UC PLC specification details for I/O, wiring, installation and maintenance.	09R558
Programming					
⊙	Additional Manual	FX3S/FX3G/FX3GC/FX3U/FX3UC Series Programming Manual - Basic & Applied Instruction Edition	JY997D16601	Describes FX3S/FX3G/FX3GC/FX3U/FX3UC Series PLC programming for basic/applied instructions and devices.	09R517
✓	Additional Manual	MELSEC-Q/L/F Structured Programming Manual (Fundamentals)	SH-080782	Programming methods, specifications, functions, etc. required to create structured programs.	13JW06
✓	Additional Manual	FX CPU Structured Programming Manual [Device & Common]	JY997D26001	Devices, parameters, etc. provided in structured projects of GX Works2.	09R925
✓	Additional Manual	FX CPU Structured Programming Manual [Basic & Applied Instruction]	JY997D34701	Sequence instructions provided in structured projects of GX Works2.	09R926
✓	Additional Manual	FX CPU Structured Programming Manual [Application Functions]	JY997D34801	Application functions provided in structured projects of GX Works2.	09R927
✓	Additional Manual	MELSEC iQ-F FX5 Programming Manual (Program Design)	JY997D55701	Describes specifications of ladders, ST, FBD/LD, and other programs and labels.	09R538
⊙	Additional Manual	MELSEC iQ-F FX5 Programming Manual (Instructions, Standard Functions/Function Blocks)	JY997D55801	Describes specifications of instructions and functions that can be used in programs.	09R539
Manuals for FX3U-J1939 Communication Block					
△	Supplied Manual	FX3U-J1939 Installation Manual	JY997D43001	Describes some of FX3U-J1939 communication block specifications for installation and wiring extracted from the FX3U-J1939 User's Manual. For details, refer to FX3U-J1939 User's Manual.	-
⊙	Additional Manual	FX3U-J1939 User's Manual (This Manual)	JY997D43101	Describes details of the FX3U-J1939 communication block.	-

Generic Names and Abbreviations Used in the Manual

Generic name or abbreviation	Description
PLC	
FX3G series	Generic name for FX3G Series PLC
FX3G PLC or main unit	Generic name for FX3G Series PLC main unit
FX3GC series	Generic name for FX3GC Series PLC
FX3GC PLC or main unit	Generic name for FX3GC Series PLC main unit
FX3U series	Generic name for FX3U Series PLC
FX3U PLC or main unit	Generic name for FX3U Series PLC main unit
FX3UC series	Generic name for FX3UC Series PLC
FX3UC PLC or main unit	Generic name for FX3UC Series PLC main unit
FX5U	Generic name for FX5U PLC
FX5U PLC or CPU module	Generic name for FX5U PLC CPU module
FX5UC	Generic name for FX5UC PLC
FX5UC PLC or CPU module	Generic name for FX5UC PLC CPU module
Expansion board	Generic name for expansion board The number of connectable units, however, depends on the type of main unit. To check the number of connectable units, refer to the User's Manual - Hardware Edition of the main unit to be used for your system.
Special adapter	Generic name for high-speed input/output special adapter, communication special adapter, analog special adapter, and CF card special adapter. The number of connectable units, however, depends on the type of main unit. To check the number of connectable units, refer to the User's Manual - Hardware Edition of the main unit to be used for your system.
I/O extension unit/block	Generic name for input/output powered extension unit and input/output extension block The number of connectable units, however, depends on the type of main unit. To check the number of connectable units, refer to the User's Manual - Hardware Edition of the main unit to be used for your system.
Special function unit/block or Special extension unit	Generic name for special function unit and special function block The number of connectable units, however, depends on the type of main unit. To check the number of connectable units, refer to the User's Manual - Hardware Edition of the main unit to be used for your system.
Special function unit	Generic name for special function unit
Special function block	Generic name for special function block
FX3U-J1939	Abbreviated name for FX3U-J1939
Memory cassette	Generic name for memory cassette. The number of connectable units, however, depends on the type of main unit. To check the number of connectable units, refer to the User's Manual - Hardware Edition of the main unit to be used for your system.
FX Series terminal block	Generic name for FX Series terminal block. The number of connectable units, however, depends on the type of main unit. To check the number of connectable units, refer to the User's Manual - Hardware Edition of the main unit to be used for your system.
Peripheral unit	
Peripheral unit	Generic name for programming software, handy programming panel, and indicator
Programming tool	
Programming tool	Generic name for programming software and handy programming panel
Programming software	Generic name for programming software
GX Works2	Abbreviation of programming software packages SW□DNC-GXW2-J/SW□DNC-GXW2-E
GX Developer	Abbreviation of programming software packages SW□D5C-GPPW-J/SW□D5C-GPPW-E
Handy programming panel (HPP)	Generic name for FX-30P and FX-20P(-E)
Indicator	
GOT1000 series	Generic name for GT15, GT11 and GT10
GOT-900 series	Generic name for GOT-A900 series and GOT-F900 series
GOT-A900 series	Generic name for GOT-A900 series
GOT-F900 series	Generic name for GOT-F900 series
ET-940 series	Generic name for ET-940 series

Generic name or abbreviation	Description
Manual	
FX3G Hardware Edition	Abbreviation of FX3G Series User's Manual - Hardware Edition
FX3GC Hardware Edition	Abbreviation of FX3GC Series User's Manual - Hardware Edition
FX3U Hardware Edition	Abbreviation of FX3U Series User's Manual - Hardware Edition
FX3UC Hardware Edition	Abbreviation of FX3UC Series User's Manual - Hardware Edition
Programming manual	Generic name for FX3S/FX3G/FX3GC/FX3U/FX3UC Series Programming Manual - Basic and Applied Instruction Edition, MELSEC iQ-F FX5 Programming Manual (Program Design), and MELSEC iQ-F FX5 Programming Manual (Instructions, Standard Functions/Function Blocks)
Communication control Edition	Abbreviation of FX Series User's Manual - Data Communication Edition
Analog control Edition	Abbreviation of FX3S/FX3G/FX3GC/FX3U/FX3UC Series User's Manual - Analog Control Edition
Positioning control Edition	Abbreviation of FX3S/FX3G/FX3GC/FX3U/FX3UC Series User's Manual - Positioning Control Edition
J1939 communication term	
CAN	Controller Area Network
CAN-ID (also ID)	CAN Identifier Identifier for CAN data and remote frames as defined in ISO11898-1
DA	Destination Address (see also PGN and PDU1 Format)
ECU	Electronic Control Unit Is a functional unit that controls one or more systems in a J1939 network/engine application
GE	Group Extension (see also PGN and PDU2 Format)
J1939	Is a CAN based protocol used for communication with a motor, engine or generator.
NMEA 2000®	Is an extension of J1939 especially adjusted to requirements in nautical environments (shipping and offshore applications)
PDU	Protocol Data Unit Is the J1939 term for a 29 bit CAN-ID and the data of a CAN frame
PF	PDU Format The PF byte is located in bits 8 to 15 of the PGN.
PDU 1 Format (also just PDU1)	PDU 1 Format is used in peer to peer communication. In PDU 1 format, the PF field is in the range K0 to K239 (H00 to HEF). The PDU Specific (PS) in the next 8 bits contains the destination address (DA) of the message.
PDU 2 Format (also just PDU2)	PDU 2 Format is used for broadcast messages and transports the group extension (GE) information in the PDU Specific (PS) field.
PGN	Parameter Group Number The PGN assigns a number to a certain group of information. The single data fields within the PGN are called SPN.
PS	PDU Specific This field of the PGN will either contain the Destination address or Group Extension information
RTR	Remote Transmission Request An RTR message can be used to request information from the network (request certain information to be sent in response)
SAE	Society of Automotive Engineers Is an organization that develops standards for automotive environment (like the SAE J1939 standards)
SPN	Suspected Parameter Number The SPN assigns a number to the detailed definition of a data set. This definition includes the description, data length, type and range. e.g. SPN 175 "Engine Oil Temperature" Data length: 2 bytes Resolution: 0.03125 °C/bit, -273 °C offset Data range: -273 to 1735 °C
ttype	transmission type Defines the event that triggers the transmission of a message
DLC	Data Length Count, this value defines how many bytes are transported in a CAN data frame (0 to 8 byte). In this manual, DLC is also used for the total byte count of a user configured data packet, even if the data is transported by more than a single CAN telegram.
RTS/CTS	Request To Send/Clear To Send Handshake mechanism used by J1939 to transport data blocks exceeding 8 data bytes in multiple CAN messages to a certain target node
BAM	Broadcast Announce Message Similar to "RTS/CTS," this is a mechanism to transport data blocks exceeding 8 bytes, but a BAM transmission is broadcast to all nodes and no handshake is executed

Reading the Manual

Shows the manual title.

This area shows the manual title for the current page.

Shows the title of the chapter and the title of the section.

This area shows the title of the chapter and the title of the section for the current page.

Indexes the chapter number.

The right side of each page indexes the chapter number for the page currently opened.

FX3U-J1939 User's Manual

3 Installation
3.2 Mounting

3.2 Mounting

The FX3U-J1939 may be installed in a control cabinet with a 35 mm wide DIN46277 DIN rail mounting or M4 screw direct mounting.

3.2.1 DIN rail mounting

The product may be mounted on a 35 mm wide DIN46277 (DIN rail).

- 1 **Fit the upper edge (A in the figure to the right) of the DIN rail mounting groove onto the DIN rail.**
- 2 **Push the product onto the DIN rail.**
 - An interval space of 1 to 2 mm (0.04" to 0.08") between each unit is necessary.
- 3 **Connect the extension cable.**

Connect the extension cable (B in the figure to the right) to the main unit, I/O extension unit/block or special function unit/block on the left side of the product.
For further information of the extension cable connection procedure, refer to the respective product PLC manual.

 - Refer to FX3G Hardware Edition
 - Refer to FX3GC Hardware Edition
 - Refer to FX3U Hardware Edition
 - Refer to FX3UC Hardware Edition
 - Refer to MELSEC iQ-F FX5U User's Manual (Hardware)
 - Refer to MELSEC iQ-F FX5UC User's Manual (Hardware)

• Example of installation on DIN rail

- In the case of the FX3G/FX3U PLC

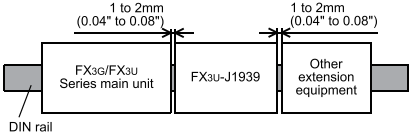

- In the case of the FX3GC/FX3UC PLC

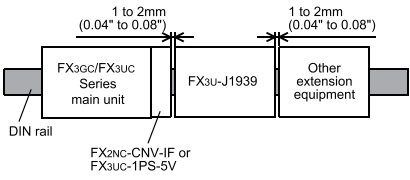

- 1 Introduction
- 2 Specifications
- 3 Installation
- 4 Wiring
- 5 Allocation of Buffer Memories
- 6 FX3U Comms Mode
- 7 Layer 2 Communication Mode
- 8 PLC RUN/STOP Messages
- 9 Command Interface
- 10 Communication Settings Procedure

23

Shows the reference.

The "→" mark indicates a reference destination and reference manual.

The above is different from the actual page, as it is provided for explanation only.

1. Introduction

1.1 Outline

The FX3U-J1939 communication block is an interface block that allows FX3G/FX3GC/FX3U/FX3UC/FX5U/FX5UC PLCs to connect to a J1939 system. FX3U-J1939 can be connected directly to the FX3G/FX3GC^{*1}/FX3U/FX3UC^{*1}/FX5U^{*2}/FX5UC^{*2} PLC's extension port, or to any other extension unit / block's right side extension port.

- *1. An FX2NC-CNV-IF or FX3UC-1PS-5V is necessary to connect the FX3U-J1939 to an FX3GC/FX3UC Series PLC.
- *2. An FX5-CNV-BUS or FX5-CNV-BUSC is necessary to connect the FX3U-J1939 to an FX5U/FX5UC PLC.

For safe use



- This product has been manufactured as a general-purpose part for general industries, and has not been designed or manufactured to be incorporated in a device or system used in purposes related to human life.
- Before using the product for special purposes such as nuclear power, electric power, aerospace, medicine or passenger movement vehicles, consult with Mitsubishi Electric.
- This product has been manufactured under strict quality control. However when installing the product where major accidents or losses could occur if the product fails, install appropriate backup or failsafe functions in the system.

Pour la sécurité d'utilisation



- Ce produit a été fabriqué en tant que composant ordinaire pour des industries en général, et il n'a pas été conçu et fabriqué afin d'être incorporé dans les équipements ou systèmes utilisés en relation avec la vie humaine.
- Avant d'utiliser ce produit pour des applications spéciales comme par exemple dans le domaine de l'énergie nucléaire, de l'énergie électrique, de l'aérospatiale, de la médecine ou du transport de passagers, veuillez consulter le représentant de Mitsubishi Electric.
- Ce produit a été fabriqué sous un contrôle de qualité rigoureux. Cependant, lors de l'installation du produit où des accidents ou des pertes majeurs pourraient survenir si le produit échoue, installez des fonctions de sauvegarde ou de sécurité appropriées dans le système.

1. The maximum send / receive message number

75 messages (8 bytes / message) and 4 extension messages (a maximum of 250 bytes / message) can be sent and received on J1939 communication.

2. CAN Layer 2 communication

FX3U-J1939 (in Layer 2 communication mode) can send and receive up to 42 messages on a CAN network.

Note: Drop of NMEA 2000[®] functions in FX3U-J1939 Version 1.10 and later

Due to changed regulation of supporting and applying of NMEA 2000[®] functions as of August 2012, all NMEA 2000[®] functions have been removed from FX3U-J1939 in version V1.10.

In order to avoid legal trouble with the NMEA[®] organization or network malfunctions, Mitsubishi Electric recommends FX3U-J1939 users:

- Do not use (send/receive) any NMEA 2000[®] reserved PGNs with the FX3U-J1939.
- Do not use the FX3U-J1939 in a NMEA 2000[®] Network or mixed J1939/NMEA 2000[®] network.

1

Introduction

2

Specifications

3

Installation

4

Wiring

5

Allocation of Buffer/Memories

6

J1939 Comms Mode

7

Layer 2 Communication Mode

8

PLC RUN>STOP Messages

9

Command Interface

10

Communication Settings Procedure

3. Support a Command Interface (CIF)

The command interface is a tool to execute asynchronous network services, module configuration and diagnosis features. The following table shows the supported functions.

Command	Function Mode Selection			Reference
	J1939 Communication Mode	Layer 2 Communication (11 bit ID) Mode	Layer 2 Communication (29 bit ID) Mode	
Sending Layer 2 Message	-	✓	✓	Section 9.2
Sending PGN	✓	-	-	Section 9.3
Request PGN* ¹	✓	-	-	Section 9.4
Set up PLC RUN>STOP messages	✓	-	-	Section 9.5
Reset command interface	✓	✓	✓	Section 9.6
Display current Parameter	✓	✓	✓	Section 9.7

*1. FX3U-J1939 firmware Ver. 1.10 or later is applicable.

4. To read and write to the buffer memory

To read and write the buffer memory in the FX3U-J1939, use the FROM/TO instructions or direct specification of the buffer memory. However, only FX3U/FX3UC/FX5U/FX5UC PLC supports direct specification of the buffer memory.

For further information on applied instructions, bit specification of word devices and direct specification of buffer memory, refer to the following manual.

→ Refer to **PROGRAMMING MANUAL**

Note

Buffer memory that is assigned in 32 bits must use 32-bit instructions to read/write.

32-bit data cannot be correctly read/written from/to buffer memory if 16-bit read/write instructions are used.

1.2 External Dimensions and Each Part Name

1.2.1 External dimensions and each part name

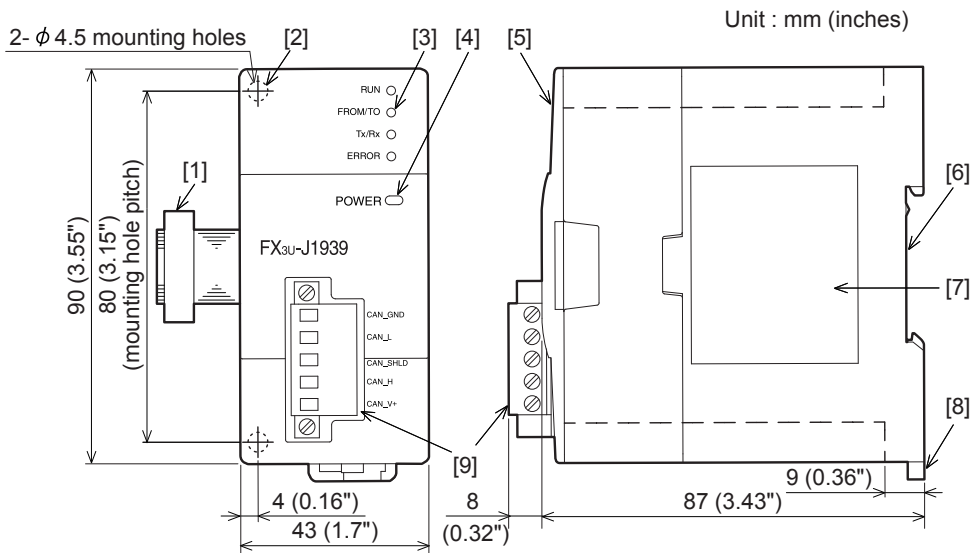

Mass (Weight): Approx. 0.2 kg (0.44 lbs)

Accessories: Label for indication of special function unit/block number, Dust proof protection sheet, Terminating resistor (120 Ω 1/2W), Manual supplied with product

- | | |
|---|---|
| [1] Extension cable | [5] Top cover |
| [2] Direct mounting hole
2 holes of ϕ 4.5 (0.18")
(mounting screw: M4 screw) | [6] DIN rail mounting groove
DIN rail: DIN46277, 35 mm (1.38") width |
| [3] Status LEDs (See Subsection 1.2.2) | [7] Nameplate |
| [4] Power LED (See Subsection 1.2.2) | [8] DIN rail mounting hook |
| | [9] CAN bus connector |

1

Introduction

2

Specifications

3

Installation

4

Wiring

5

Allocation of Buffer/Memories

6

J1939 Comms Mode

7

Layer 2 Communication Mode

8

PLC RUN \rightarrow STOP Messages

9

Command Interface

10

Communication Settings Procedure

1.2.2 Power and status LEDs

LED Name	LED Color	Status	Description
RUN	Green	OFF	Module is offline.
		ON	Module is online.
FROM/TO	Green	OFF	PLC is not accessing BFM's in module.
		ON	PLC is accessing BFM's in module.
Tx/Rx	Green	OFF	Module is not transmitting or receiving messages.
		ON	Module is transmitting or receiving messages.
ERROR	Red	OFF	Normal operation (status)
		SINGLE FLASH*1	Error passive state → For details, refer to Section 12.2
		BLINKING*1	General error → For details, refer to Section 12.2
		ON	BUS-OFF state → For details, refer to Section 12.2
POWER	Green	ON	24V DC power is properly supplied from PLC main unit.

*1. ERROR LED has two kinds of flicker states: single flash, and blinking. This LED flickers as follows.

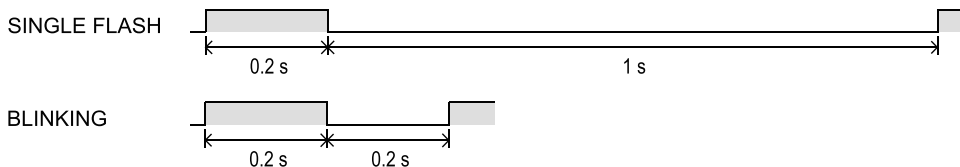

1.2.3 Terminal layout

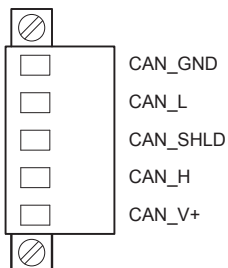

Pin No.	Signal	Description
1	CAN_GND	Ground / 0 V / V-
2	CAN_L	CAN_L bus line (dominant low)
3	(CAN_SHLD)	Optional CAN shield
4	CAN_H	CAN_H bus line (dominant high)
5	(CAN_V+)	Optional CAN external positive supply (not connected internally)

1.3 System Configuration

1.3.1 General configuration

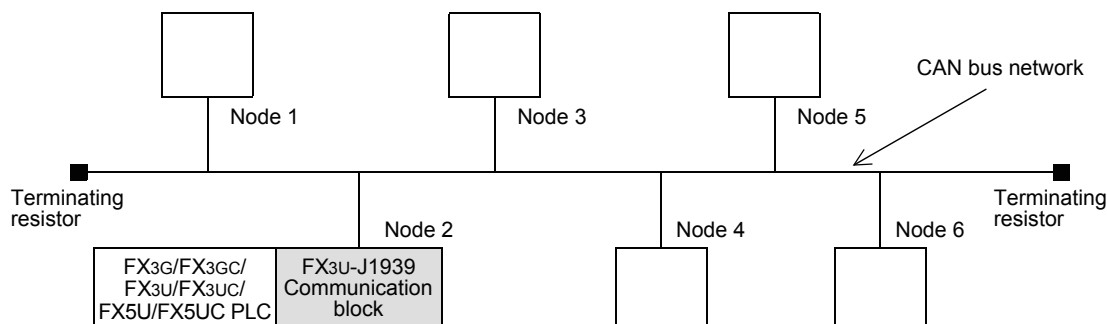

Part Name	Model Name	Remarks
Communication block	FX3U-J1939	
PLC	FX3G/FX3GC/FX3U/ FX3UC/FX5U/FX5UC PLC	An FX2NC-CNV-IF or FX3UC-1PS-5V is necessary to connect the FX3U-J1939 to an FX3GC/FX3UC Series PLC. An FX5-CNV-BUS or FX5-CNV-BUSC is necessary to connect the FX3U-J1939 to an FX5U/FX5UC PLC.
CAN bus network	-	CAN bus network
Node	-	J1939 Node or CAN Layer 2 Node
Terminating resistor	-	The CAN bus network requires terminating resistors for both network ends.
Maximum transmission distance	-	<ul style="list-style-type: none"> SAE J1939-11: 40 m (131'2"), stubs max. 1 m (3'3") at 250 kbps SAE J1939-15: 40 m (131'2"), stubs max. 3 m (9'10") at 250 kbps CAN (Layer 2): 5000 m (16,404'2") at 10 kbps (with repeaters). The transmission distance is reduced to 25 m (82') at the maximum baud rate of 1 Mbps. The maximum distance also depends on the specification of other connected nodes.

1.3.2 Applicable PLC

Model name	Applicability
FX3G Series PLC	Ver. 1.00 and later (Up to 8 blocks can be extended ^{*2})
FX3GC Series PLC ^{*1}	Ver. 1.40 and later (Up to 8 blocks can be extended ^{*2})
FX3U Series PLC	Ver. 2.20 and later (Up to 8 blocks can be extended ^{*2})
FX3UC Series PLC ^{*1}	Ver. 2.20 and later (Up to 8 blocks can be extended ^{*2*3})
FX5U PLC ^{*4*5}	Ver. 1.031 and later (Up to 8 blocks can be extended)
FX5UC PLC ^{*4*5}	Ver. 1.031 and later (Up to 4 blocks can be extended)

The version number can be checked by reading the last three digits of device D8001/D8101.

- *1. An FX2NC-CNV-IF or FX3UC-1PS-5V is necessary to connect the FX3U-J1939 to an FX3GC/FX3UC PLC.
- *2. Check the current consumption of the connected extension blocks and insert extension power supply units if necessary.
- *3. Up to 7 units can be connected to the FX3UC-32MT-LT(-2) PLC.
- *4. An FX5-CNV-BUS or FX5-CNV-BUSC is necessary to connect the FX3U-J1939 to an FX5U/FX5UC PLC.
- *5. Applicable for FX3U-J1939 firmware Ver. 1.11 and later.

1.3.3 Connection with PLC

The FX3U-J1939 connects with a PLC via an extension cable.

The FX3U-J1939 is handled as a special extension block of the PLC. The unit number of the FX3U-J1939 is automatically assigned No. 0 to No. 7*1*2 starting from the special function unit/block closest to the PLC main unit/CPU Module.

(This unit number is used for the designation of a FROM/TO instruction.)

For further information of the assignment of the I/O number and unit number of the PLC, refer to the following manual corresponding to the connected PLC.

*1. Unit No. 1 to No. 7 is assigned when the main unit is an FX3UC-32MT-LT(-2).

*2. Unit No. 2 to No. 16 is assigned when the CPU module is an FX5U/FX5UC.

→ Refer to FX3G Hardware Edition

→ Refer to FX3GC Hardware Edition

→ Refer to FX3U Hardware Edition

→ Refer to FX3UC Hardware Edition

→ Refer to MELSEC iQ-F FX5U User's Manual (Hardware)

→ Refer to MELSEC iQ-F FX5UC User's Manual (Hardware)

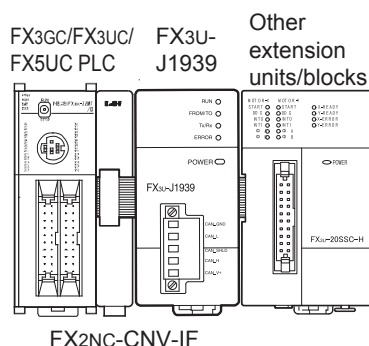
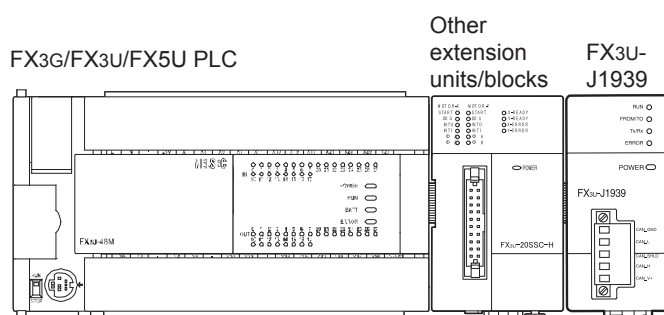

- An FX2NC-CNV-IF or FX3UC-1PS-5V is necessary to connect the FX3U-J1939 to an FX3GC/FX3UC PLC.
- An FX5-CNV-BUS or FX5-CNV-BUSC is necessary to connect the FX3U-J1939 to an FX5U/FX5UC PLC.
- The optional FX0N-65EC (FX0N-30EC) and FX2N-CNV-BC are necessary to lengthen the extension cable. (FX3G/FX3GC/FX3U/FX3UC PLC)
- The optional FX5-65EC (FX5-30EC) and FX5-CNV-BC are necessary to lengthen the extension cable. (FX5U/FX5UC PLC)
- The number of I/O points occupied by the FX3U-J1939 is eight. Make sure that the total number of I/O points (occupied I/O points) of the main unit, extension unit(s), extension block(s) and the number of points occupied by special function blocks does not exceed the maximum number of I/O points of the PLC. For further information of the maximum number of I/O points of the PLC, refer to the respective product manual.

→ Refer to FX3G Hardware Edition

→ Refer to FX3GC Hardware Edition

→ Refer to FX3U Hardware Edition

→ Refer to FX3UC Hardware Edition

→ Refer to MELSEC iQ-F FX5U User's Manual (Hardware)

→ Refer to MELSEC iQ-F FX5UC User's Manual (Hardware)

1.4 System Start-up Procedure

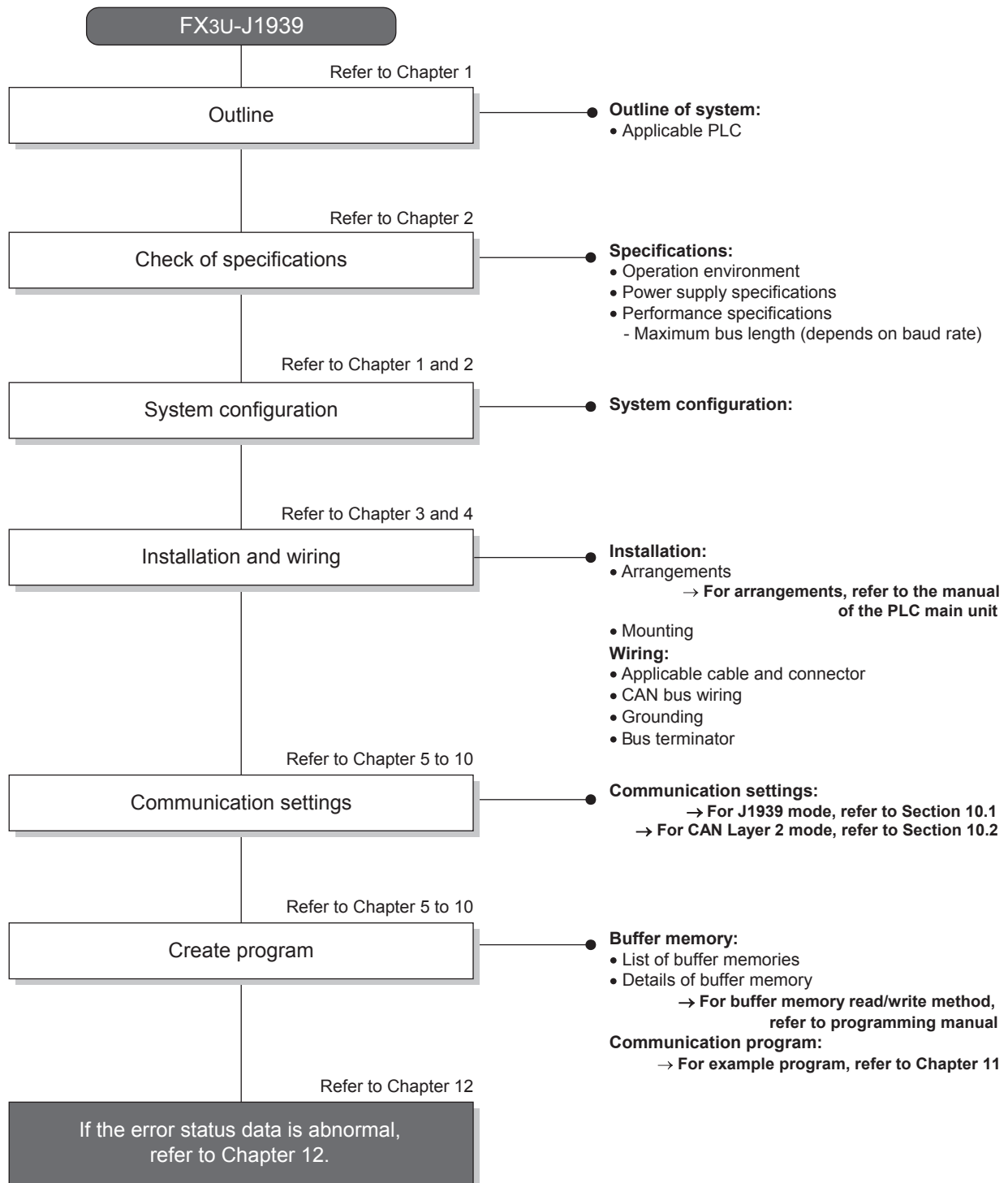

1	Introduction
2	Specifications
3	Installation
4	Wiring
5	Allocation of Buffer Memories
6	J1939 Comms Mode
7	Layer 2 Communication Mode
8	PLC RUN>STOP Messages
9	Command Interface
10	Communication Settings Procedure

2. Specifications

DESIGN PRECAUTIONS	 WARNING
<ul style="list-style-type: none"> • Make sure to have the following safety circuits outside of the PLC to ensure safe system operation even during external power supply problems or PLC failure. Otherwise, malfunctions may cause serious accidents. <ol style="list-style-type: none"> 1) Most importantly, have the following: an emergency stop circuit, a protection circuit, an interlock circuit for opposite movements (such as normal vs. reverse rotation), and an interlock circuit (to prevent damage to the equipment at the upper and lower positioning limits). 2) Note that when the PLC CPU detects an error, such as a watchdog timer error, during self-diagnosis, all outputs are turned off. Also, when an error that cannot be detected by the PLC CPU occurs in an input/output control block, output control may be disabled. External circuits and mechanisms should be designed to ensure safe machinery operation in such a case. • For the operating status of each node in the case of a communication error, see the FX3U-J1939 user's manual and the product manual of each node. Erroneous output or malfunctions may cause an accident. • When executing control (data changes) to an operating PLC, construct an interlock circuit in the sequence program so that the entire system operates safely. In addition, when executing control such as program changes and operation status changes (status control) to an operating PLC, carefully read the manual and sufficiently confirm safety in advance. Especially in control from external equipment to a PLC in a remote place, problems in the PLC may not be able to be handled promptly due to abnormality in data transfer. Construct an interlock circuit in the sequence program. At the same time, determine the actions in the system between the external equipment and the PLC for protection against abnormalities in data transfer. <p>[Precautions for using products in a UL/cUL Class I, Division 2 environment]</p> <ul style="list-style-type: none"> • Products*¹ with the Cl. I, DIV.2 mark on the rating plate are suitable for use in Class I, Division 2, Groups A, B, C and D hazardous locations, or nonhazardous locations only.*² This mark indicates that the product is certified for use in the Class I, Division 2 environment where flammable gases, vapors, or liquids exist under abnormal conditions. When using the products in the Class I, Division 2 environment, observe the following to reduce the risk of explosion. <ul style="list-style-type: none"> - This device is open-type and is to be installed in an enclosure suitable for the environment and require a tool or key to open. - Warning - Explosion Hazard - Substitution of any component may impair suitability for Class I, Division 2. - Warning - Explosion Hazard - Do not disconnect equipment while the circuit is live or unless the area is known to be free of ignitable concentrations. - Do not open the cover of the PLC main unit and remove the battery unless the area is known to be nonhazardous. 	

*1. For details of the products confirming to the UL explosion-proof standard, refer to the following manuals.

→ MELSEC iQ-F FX5U User's Manual (Hardware)
→ MELSEC iQ-F FX5UC User's Manual (Hardware)

*2. Only when connecting to FX5CPU module, FX3U-J1939 are suitable for use in Class I, Division 2 Groups A, B, C, and D.

DESIGN PRECAUTIONS	 CAUTION
<ul style="list-style-type: none"> • Make sure to observe the following precautions in order to prevent any damage to the machinery or accidents due to abnormal data written to the PLC under the influence of noise: <ol style="list-style-type: none"> 1) Do not bundle the main circuit line together with or lay it close to the main circuit, high-voltage line or load line. Otherwise, noise disturbance and/or surge induction are likely to take place. As a guideline, lay the control line at least 100mm (3.94") or more away from the main circuit or high-voltage lines. 2) Ground the shield wire or shield of a shielded cable. Do not use common grounding with heavy electrical systems (refer to the manual of the PLC main unit). 	

DISPOSAL PRECAUTIONS	 CAUTION
<ul style="list-style-type: none"> • Please contact a certified electronic waste disposal company for the environmentally safe recycling and disposal of your device. 	

TRANSPORTATION AND STORAGE PRECAUTIONS	 CAUTION
<ul style="list-style-type: none"> • The PLC is a precision instrument. During transportation, avoid impacts larger than those specified in the general specifications of the PLC main unit manual by using dedicated packaging boxes and shock-absorbing pallettes. Failure to do so may cause failures in the PLC. After transportation, verify operation of the PLC and check for damage of the mounting part, etc. 	

PRÉCAUTIONS DE CONCEPTION AVERTISSEMENT

- Assurez-vous de configurer les circuits de sécurité suivants en dehors du contrôleur programmable afin d'assurer un fonctionnement sûr du système même pendant qu'il y a un problème d'alimentation externe ou une panne du contrôleur programmable. Faute de quoi, des dysfonctionnements peuvent causer des accidents graves.
 - Configurez surtout ce qui suit : un circuit d'arrêt d'urgence, un circuit de protection, un circuit de verrouillage pour les mouvements opposés (tels que la rotation normale ou inversée) et un circuit de verrouillage (pour éviter d'endommager l'équipement aux niveaux supérieur et inférieur de limites de positionnement).
 - Notez que lorsque le module CPU du contrôleur programmable détecte une erreur, telle qu'une erreur dans un minuteur de surveillance pendant l'auto-diagnostic, toutes les sorties sont désactivées. En outre, lorsqu'une erreur qui ne peut pas être détectée par le module CPU du contrôleur programmable se produit dans un bloc de contrôle E/S, la commande de sortie peut être désactivée.

Les circuits et mécanismes externes devraient être conçus pour assurer le fonctionnement sûr des machines dans un tel cas.
 - Pour l'état d'opération de chaque nœud dans le cas d'une erreur de communication, consultez le manuel de l'utilisateur FX3U-J1939 et le manuel du produit de chaque nœud. Une sortie erronée ou un dysfonctionnement peut être à l'origine d'un accident.
 - Lors de l'exécution d'une commande (changement de données) vers un contrôleur programmable en cours de fonctionnement, construire un circuit de verrouillage dans le programme de séquence afin que tout le système fonctionne en toute sécurité. En outre, lors de l'exécution d'une commande tels que les changements de programme et les changements d'état d'opération (commande d'état) vers un contrôleur programmable en cours de fonctionnement, lisez attentivement le manuel et confirmez pleinement la sécurité à l'avance. Particulièrement lors d'effectuer une commande de l'équipement externe vers un contrôleur programmable dans un endroit éloigné, les problèmes dans le contrôleur programmable ne peuvent pas être traités rapidement en raison d'une anomalie dans le transfert de données. Construire un circuit de verrouillage dans le programme de séquence. Dans le même temps, déterminer les actions dans le système entre l'équipement externe et le contrôleur programmable pour la protection contre les anomalies dans le transfert de données.
- [Précautions d'utilisation des produits en environnement de UL/cUL Class I, Division 2]
- Les produits*1 marqués Cl. I, DIV.2 sur la plaque signalétique peuvent être utilisés en Class I, Division 2, local dangereux de groupe A, B, C et D, ou uniquement en local non dangereux.*2
Ce logo indique que le produit est homologué pour utilisation en environnement de Class I, Division 2 ou, dans des circonstances anormales, il peut y avoir présence de gaz, vapeurs ou liquides inflammables.
Si le produit est utilisé en environnement de Class I, Division 2, observer les précautions suivantes pour réduire le risque d'explosion.
 - Cet appareil est de type ouvert et il doit être installé dans une enceinte appropriée à l'environnement et ne pouvant être ouverte qu'au moyen d'une clef ou d'un outil.
 - Avertissement - Danger d'explosion - Toute substitution de composant peut compromettre l'aptitude à l'utilisation en Class I, Division 2.
 - Avertissement - Danger d'explosion - Ne pas déconnecter l'équipement quand le circuit est sous tension, ni avant de s'être assuré de l'absence d'atmosphère inflammable.
 - Ne pas ouvrir le couvercle de l'unité principale du contrôleur programmable et ne pas retirer la batterie avant d'avoir vérifié que l'atmosphère est sans danger.

- *1. Pour les informations sur les produits conformes aux normes UL des produits antidéflagrants, veuillez vous référer aux manuels suivants.
- MELSEC iQ-F FX5U User's Manual (Hardware)
→ MELSEC iQ-F FX5UC User's Manual (Hardware)
- *2. C'est uniquement lors de la connexion au module FX5CPU, que FX3U-J1939 conviennent à une utilisation en Class I, Division 2 Groupes A, B, C, et D.

PRÉCAUTIONS DE CONCEPTION ATTENTION

- Assurez-vous d'observer les précautions suivantes afin d'éviter tous les endommagements aux machines ou les accidents dus aux données anormales écrites sur le contrôleur programmable sous les effets du bruit :
 - Ne pas regrouper la ligne du circuit principal, ou ne pas la placer près du circuit principal, de la ligne de haute tension ou de la ligne de charge. Faute de quoi, des perturbations du bruit et/ou des inductions de surtension sont susceptibles d'avoir lieu. À titre indicatif, posez la ligne de commande à au moins 100 mm (3,94") ou plus du circuit principal ou des lignes de haute tension.
 - Mettre à la terre les fils blindés ou le blindage des câbles blindés.
Ne pas utiliser la mise à la terre commune pour les systèmes électriques lourds (reportez-vous au manuel de l'unité principale du contrôleur programmable).

PRÉCAUTIONS DE MISE AU REBUT ATTENTION

- Veuillez contacter une société certifiée de mise au rebut des déchets électroniques pour le recyclage écologique et la mise au rebut écologique de votre équipement.

PRECAUTION POUR LE TRANSPORT ET LE STOCKAGE ATTENTION

- Le contrôleur programmable est un instrument de précision. Pendant le transport, évitez de donner les chocs supérieurs à ceux spécifiés dans les spécifications générales du manuel de l'unité principale du contrôleur programmable en utilisant les boîtes d'emballage dédiées et les palettes amortisseuse.
Faute de quoi, il y a risque de panne du contrôleur programmable. Après le transport, vérifiez le bon fonctionnement du contrôleur programmable et contrôlez l'absence de dégâts des pièces de montage, etc.

1

Introduction

2

Specifications

3

Installation

4

Wiring

5

Allocation of Buffer/Memoires

6

J1939 Comms Mode

7

Layer 2 Communication Mode

8

PLC RUN>STOP Messages

9

Command Interface

10

Communication Settings Procedure

2.1 General Specifications

Items other than the following table are equivalent to those of the PLC main unit/CPU Module.

For further information of general specifications, refer to the manual of the PLC main unit/CPU Module.

- Refer to FX3G Hardware Edition
- Refer to FX3GC Hardware Edition
- Refer to FX3U Hardware Edition
- Refer to FX3UC Hardware Edition
- Refer to MELSEC iQ-F FX5U User's Manual (Hardware)
- Refer to MELSEC iQ-F FX5UC User's Manual (Hardware)

Item	Specification	
Dielectric Withstand Voltage	500V AC for one minute	Between all terminals and ground terminal
Insulation Resistance	5MΩ or more by 500V DC megger	

2.2 Power Supply Specifications

Item	Specification
Internal Power Supply	24V DC, max 110 mA 24V DC power is supplied internally from the main unit.

For details on the 24V DC power supply of main unit, refer to the manual of the PLC main unit.

2.3 Performance Specifications

Item	Specification	
Transmission Type	CAN bus network	
Applicable Function	J1939 Node or CAN Layer 2 Node	
J1939 Services According to SAE Standards	<ul style="list-style-type: none"> • SAE J1939 (recommended practice for serial communication vehicle networks) • SAE J1939-11 (physical layer) • SAE J1939-15 (reduced physical layer) • SAE J1939-21 (data link layer) • SAE J1939-71 (vehicle application layer) • SAE J1939-73 (application layer - diagnostics) • SAE J1939-75 (application layer -generator sets and industrial) • SAE J1939-81 (network management) 	
Network Size	SAE J1939-11	2 to 30 nodes / segment
	SAE J1939-15	2 to 10 nodes / segment
	CAN (Layer 2)	2 to 127 nodes
Communication Method	Cyclic, acyclic or request driven	
Supported Transmission Speed / Max. Bus Length	SAE J1939-11	250 kbps / 40 m (131'2"), stubs max. 1 m (3'3")
	SAE J1939-15	250 kbps / 40 m (131'2"), stubs max. 3 m (9'10")
	CAN (Layer 2)	1 Mbps / 25 m (82')
		800 kbps / 50 m (164')
		500 kbps / 100 m (328'1")
		250 kbps / 250 m (820'2")
		125 kbps / 500 m (1,640'5")
		100 kbps / 600 m (1,968'6")
		50 kbps / 1000 m (3,280'10")
		20 kbps / 2500 m (8,202'1")
10 kbps / 5000 m (16,404'2")		
Connection Cable	Refer to Subsection 4.1.2.	
Terminating Resistor	120 Ω (Accessory: 120 Ω 1/2W)	
No. of Occupied I/O Points	8 points (taken from either the input or output points of the PLC)	

3. Installation

INSTALLATION PRECAUTIONS  **WARNING**

- Make sure to cut off all phases of the power supply externally before attempting installation or wiring work. Failure to do so may cause electric shock or damage to the product.

INSTALLATION PRECAUTIONS  **CAUTION**

- Use the product within the generic environment specifications described in PLC main unit manual (Hardware Edition). Never use the product in areas with excessive dust, oily smoke, conductive dusts, corrosive gas (salt air, Cl₂, H₂S, SO₂ or NO₂), flammable gas, vibration or impacts, or expose it to high temperature, condensation, or rain and wind. If the product is used in such conditions, electric shock, fire, malfunctions, deterioration or damage may occur.
- Do not touch the conductive parts of the product directly. Doing so may cause device failures or malfunctions.
- When drilling screw holes or wiring, make sure that cutting and wiring debris do not enter the ventilation slits. Failure to do so may cause fire, equipment failures or malfunctions.
- Be sure to remove the dust proof sheet from the PLC's ventilation port when installation work is completed. Failure to do so may cause fire, equipment failures or malfunctions.
- Install the product on a flat surface. If the mounting surface is rough, undue force will be applied to the PC board, thereby causing nonconformities.
- Install the product securely using a DIN rail or mounting screws.
- Connect extension cables securely to their designated connectors. Loose connections may cause malfunctions.

PRÉCAUTIONS D'INSTALLATION  **AVERTISSEMENT**

- Assurez-vous de couper toutes les phases de l'alimentation externe avant d'essayer l'installation ou le câblage. Faute de quoi, il y a risque d'électrocution ou d'endommagement du produit.

PRÉCAUTIONS D'INSTALLATION  **ATTENTION**

- Utilisez le produit dans les spécifications d'environnement générique décrites dans le manuel de l'unité principale du contrôleur programmable (Hardware Edition). N'utilisez jamais ce produit dans les zones à poussières excessives, à fumées grasses, à poussières conductrices, à gaz corrosifs (air salé, Cl₂, H₂S, SO₂ ou NO₂), à gaz inflammables, à vibrations ou à impacts, ou ne l'exposer jamais à haute température, à condensation ou à pluie et vent. Si le produit est utilisé dans de telles conditions, des électrocution, des feux, des dysfonctionnements, des détériorations ou des dommages peuvent se produire.
- Ne pas toucher directement les parties conductrices du produit. Cela pourrait être à l'origine de pannes ou de dysfonctionnements d'équipement.
- Lors du perçage des trous de vis ou du câblage, assurez-vous que les débris de coupe et de câblage ne pénètrent pas dans les fentes de ventilation. Faute de quoi, il y a risque de départ de feu, de panne ou de dysfonctionnement d'équipement.
- Assurez-vous d'enlever la feuille anti-poussière du port de ventilation du contrôleur programmable lorsque les travaux d'installation sont terminés. Faute de quoi, il y a risque de départ de feu, de panne ou de dysfonctionnement d'équipement.
- Installez le produit sur une surface plane. Si la surface de montage est rugueuse, une force excessive sera appliquée à la carte PC, ce qui entraînera des non-conformités.
- Installez le produit solidement à l'aide d'un rail DIN ou de vis de montage.
- Connectez les câbles d'extension de manière sécurisée à leurs connecteurs désignés. Les connexions lâches peuvent provoquer des dysfonctionnements.

- 1** Introduction
- 2** Specifications
- 3** Installation
- 4** Wiring
- 5** Allocation of Buffer Memories
- 6** J1939 Comms Mode
- 7** Layer 2 Communication Mode
- 8** PLC RUN>STOP Messages
- 9** Command Interface
- 10** Communication Settings Procedure

3.1 Connection with PLC

The FX3U-J1939 connects on the right side of a PLC main unit/CPU Module or extension units/blocks (including special function units/blocks).

For connection to an FX3GC/FX3UC Series PLC or FX2NC Series PLC extension block, an FX2NC-CNV-IF or FX3UC-1PS-5V is required.

For connection to an FX5U/FX5UC PLC, an FX5-CNV-BUS or FX5-CNV-BUSC is required.

For further information, refer to the respective PLC manual.

- Refer to FX3G Hardware Edition
- Refer to FX3GC Hardware Edition
- Refer to FX3U Hardware Edition
- Refer to FX3UC Hardware Edition
- Refer to MELSEC iQ-F FX5U User's Manual (Hardware)
- Refer to MELSEC iQ-F FX5UC User's Manual (Hardware)

3.2 Mounting

The FX3U-J1939 may be installed in a control cabinet with a 35 mm wide DIN46277 DIN rail mounting or M4 screw direct mounting.

3.2.1 DIN rail mounting

The product may be mounted on a 35 mm wide DIN46277 (DIN rail).

1 Fit the upper edge (A in the figure to the right) of the DIN rail mounting groove onto the DIN rail.

2 Push the product onto the DIN rail.

- An interval space of 1 to 2 mm (0.04" to 0.08") between each unit is necessary.

3 Connect the extension cable.

Connect the extension cable (B in the figure to the right) to the main unit, I/O extension unit/block or special function unit/block on the left side of the product.

For further information of the extension cable connection procedure, refer to the respective product PLC manual.

- Refer to FX3G Hardware Edition
- Refer to FX3GC Hardware Edition
- Refer to FX3U Hardware Edition
- Refer to FX3UC Hardware Edition
- Refer to MELSEC iQ-F FX5U User's Manual (Hardware)
- Refer to MELSEC iQ-F FX5UC User's Manual (Hardware)

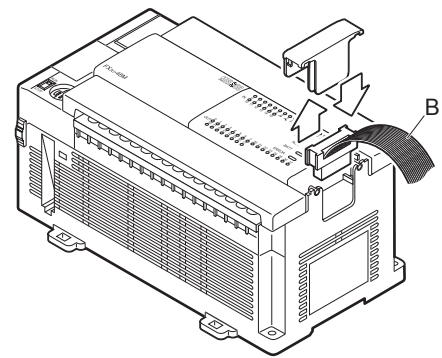
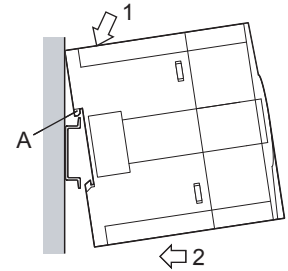

- Example of installation on DIN rail
 - In the case of the FX3G/FX3U PLC

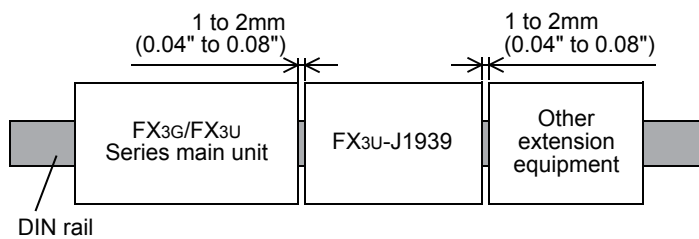

- In the case of the FX3GC/FX3UC PLC

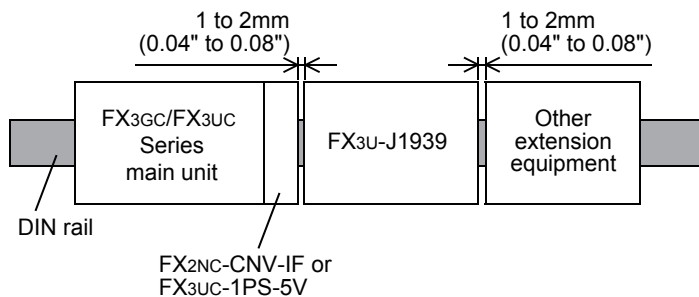

1	Introduction
2	Specifications
3	Installation
4	Wiring
5	Allocation of Buffer Memories
6	J1939 Comms Mode
7	Layer 2 Communication Mode
8	PLC RUN>STOP Messages
9	Command Interface
10	Communication Settings Procedure

3.2.2 Direct Mounting

The product can be installed directly with screws.
An interval space of 1 to 2 mm (0.04" to 0.08") between each unit is necessary.
For further information of installation, refer to the following respective PLC manual.

- For mounting hole pitches, refer to Section 1.2
 - Refer to FX3G Hardware Edition
 - Refer to FX3GC Hardware Edition
 - Refer to FX3U Hardware Edition
 - Refer to FX3UC Hardware Edition
- Refer to MELSEC iQ-F FX5U User's Manual (Hardware)
- Refer to MELSEC iQ-F FX5UC User's Manual (Hardware)

1 Create mounting holes in the mounting surface according to the external dimensions diagram.

2 Fit the FX3U-J1939 (A in the figure to the right) to the mounting holes and tighten with M4 screws (B in the figure to the right).

For further information of the screw position and quantity, refer to the dimensioned drawing specified below.

→ For dimensions, refer to Section 1.2

3 Connect the extension cable.

Connect the extension cable to the main unit, I/O extension unit/block or special function unit/block on the left side of the product.

(Refer to Step 3 in Subsection 3.2.1.)

For further information of the extension cable connection procedure, refer to the respective PLC manual.

- Refer to FX3G Hardware Edition
- Refer to FX3GC Hardware Edition
- Refer to FX3U Hardware Edition
- Refer to FX3UC Hardware Edition
- Refer to MELSEC iQ-F FX5U User's Manual (Hardware)
- Refer to MELSEC iQ-F FX5UC User's Manual (Hardware)

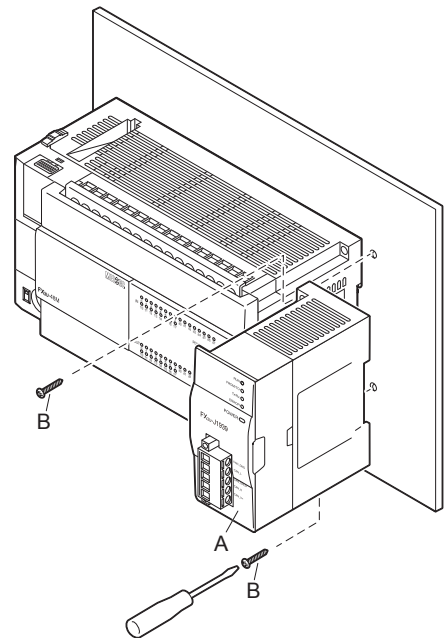

- Example of direct installation

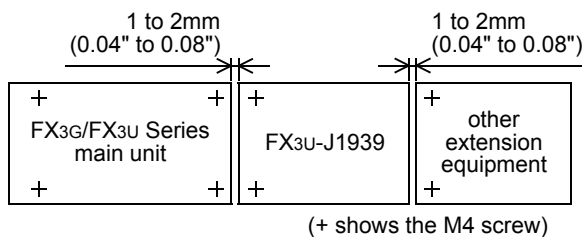

4. Wiring

WIRING PRECAUTIONS



WARNING

- Make sure to cut off all phases of the power supply externally before attempting installation or wiring work. Failure to do so may cause electric shock or damage to the product.

WIRING PRECAUTIONS



CAUTION

- Perform class D grounding (grounding resistance: 100Ω or less) to the shield of the twisted shield cable (refer to Subsection 4.2.3). Do not use common grounding with heavy electrical systems.
- When drilling screw holes or wiring, make sure cutting or wire debris does not enter the ventilation slits. Failure to do so may cause fire, equipment failures or malfunctions.
- Install module so that excessive force will not be applied to communication connectors or communication cables. Failure to do so may result in wire damage/breakage or PLC failure.
- Make sure to affix the CAN bus connector with fixing screws. Tightening torque should follow the specifications in the manual. Loose connections may cause malfunctions.
- Make sure to properly wire to the terminal block (CAN bus connector) in accordance with the following precautions. Failure to do so may cause electric shock, equipment failures, a short-circuit, wire breakage, malfunctions, or damage to the product.
 - The disposal size of the cable end should follow the dimensions described in the manual.
 - Tightening torque should follow the specifications in the manual.
 - Twist the end of strand wire and make sure that there are no loose wires.
 - Do not solder-plate the electric wire ends.
 - Do not connect more than the specified number of wires or electric wires of unspecified size.
 - Affix the electric wires so that neither the terminal block nor the connected parts are directly stressed.
- Make sure to observe the following precautions in order to prevent any damage to the machinery or accidents due to abnormal data written to the PLC under the influence of noise:
 - 1) Do not bundle the main circuit line together with or lay it close to the main circuit, high-voltage line or load line. Otherwise, noise disturbance and/or surge induction are likely to take place. As a guideline, lay the control line at least 100 mm (3.94") or more away from the main circuit or high-voltage lines.
 - 2) Ground the shield wire or shield of a shielded cable. Do not use common grounding with heavy electrical systems.
- Place the communication cable in grounded metallic ducts or conduits both inside and outside of the control panel whenever possible.

1

Introduction

2

Specifications

3

Installation

4

Wiring

5

Allocation of Buffer/Memorries

6

J1939 Comms Mode

7

Layer 2 Communication Mode

8

PLC RUN→STOP Messages

9

Command Interface

10

Communication Settings Procedure

**PRÉCAUTIONS DE
CABLAGE****AVERTISSEMENT**

- Assurez-vous de couper toutes les phases de l'alimentation externe avant d'essayer l'installation ou le câblage. Faute de quoi, il y a risque d'électrocution ou d'endommagement du produit.

**PRÉCAUTIONS DE
CABLAGE****ATTENTION**

- Effectuer la mise à la terre classe D (résistance à la mise à la terre : 100 Ω ou moins) sur le blindage du câble blindé torsadé (voir la sous-section 4.2.3).
Ne pas utiliser le réseau commun de mise à la terre pour les systèmes électriques lourds.
- Lors du perçage des trous de vis ou du câblage, assurez-vous que les débris de coupe ou de câblage ne pénètrent pas dans les fentes de ventilation.
Faute de quoi, il y a risque de départ de feu, de panne ou de dysfonctionnement d'équipement.
- Installer le module afin que la force excessive ne soit pas appliquée aux connecteurs de communication ou aux câbles de communication.
Faute de quoi, il y a risque d'endommagement, de rupture ou de panne du contrôleur programmable.
- Assurez-vous de fixer le connecteur du bus CAN avec les vis de fixation.
Pour le couple de serrage, respecter les spécifications du manuel.
Les connexions lâches peuvent provoquer des dysfonctionnements.
- Assurez-vous de bien câbler le bornier (connecteur du bus CAN) conformément aux précautions suivantes.
Faute de quoi, il y a risque d'électrocutions, de pannes d'équipement, de court-circuit, de rupture du fil, de dysfonctionnements ou de dommages au produit.
 - La taille des extrémités du câble lors de la mise au rebut doit se conformer aux dimensions décrites dans le manuel.
 - Pour le couple de serrage, respecter les spécifications du manuel.
 - Tordre les extrémités des câbles toron et s'assurer qu'il n'y a pas de fils desserrés.
 - Ne pas souder et plaquer les extrémités des fils électriques.
 - Ne pas connecter plus que le nombre indiqué de fils ou des fils électriques ayant une taille non indiquée.
 - Fixez les fils électriques de sorte que ni le bornier ni les pièces connectées ne soient directement soumis à une contrainte.
- Assurez-vous d'observer les précautions suivantes afin d'éviter tous les endommagements aux machines ou les accidents dus aux données anormales écrites sur le contrôleur programmable sous les effets du bruit :
 - 1) Ne pas regrouper la ligne du circuit principal, ou ne pas la placer près du circuit principal, de la ligne de haute tension ou de la ligne de charge. Faute de quoi, des perturbations du bruit et/ou des inductions de surtension sont susceptibles d'avoir lieu. À titre indicatif, posez la ligne de commande au moins à 100 mm (3,94") ou plus du circuit principal ou les lignes à haute tension.
 - 2) Mettre à la terre les fils blindés ou le blindage des câbles blindés.
Ne pas utiliser le réseau commun de mise à la terre pour les systèmes électriques lourds.
- Placez le câble de communication dans les conduits métalliques mis à la terre ou dans les conduits mis à la terre à l'intérieur et à l'extérieur du panneau de commande chaque fois que cela est possible.

4.1 Applicable Cable and Connector

4.1.1 Applicable connector

FX3U-J1939 uses a CAN bus connector. This connector is removable.

For further information of removal and installation of the CAN bus connector, refer to the following section.

→ **Refer to Subsection 4.1.4**

4.1.2 Applicable cable

Item	Applicable Cable	
	SAE J1939-11, CAN (Layer 2)	SAE J1939-15
Cable Type	Twisted pair cable	
Unshielded/ Shielded	Shielded	Unshielded*1
No. of Pairs	2 pair	
Conformance Standard	ISO 11898/1993	
Wire Size	0.3 mm ² to 0.82 mm ² (AWG22 to 18)	
Impedance	120 Ω	

*1. Shielded twisted pair cable is recommended.

Note

The bus length, length related resistance and the cross section of the cable to be used should be related as follows.

Bus Length (m)	Length Related Resistance (mΩ/m)	Cross Section (mm ²)
0 to 40	70	0.3 to 0.34 (AWG 22)
40 to 300	Less than 60	0.34 to 0.60 (AWG 22 to 19)
300 to 600	Less than 40	0.50 to 0.60 (AWG 20 to 19)
600 to 1000	Less than 26	0.75 to 0.80 (AWG 18)

4.1.3 Termination of cable end

Strip 9 mm (0.35") of insulation from the end of the wire. For stranded wires, terminate the end of the wire using a wire ferrule with insulating sleeve.

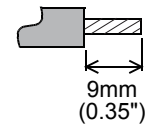

Tighten the terminals to a torque of 0.4 to 0.5 N•m.

Do not tighten terminal screws with a torque outside the above-mentioned range. Failure to do so may cause equipment failures or malfunctions.

- When using stranded wires
It may be difficult to insert the electric wire into the insulating sleeve depending on the thickness of the electric wire sheath. Select the electric wire by referring to the dimensions of the wire ferrule.

<Reference>

Manufacturer	Model names	Caulking tool
Phoenix Contact	AI 0.5-8WH	CRIMPFOX 6*1 (or CRIMPFOX 6T-F*2)
	AI-TWIN 2X 0.5-8WH	

*1. Old model name : CRIMPFOX ZA 3

*2. Old model name : CRIMPFOX UD 6

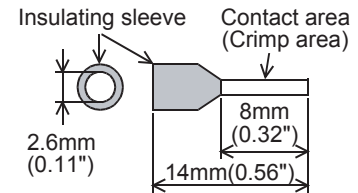

4.1.4 Removal and installation of CAN bus connector

- Removal
Evenly unscrew both CAN connector mounting screws, and remove the CAN connector from the module. If the cable is attached to the connector, hold and pull the connector on the side. Do not pull the cable.
- Installation
Place the CAN connector in the specified position, and evenly tighten both CAN connector mounting screws.
Tightening torque 0.4 to 0.5 N•m
Do not tighten terminal block mounting screws with a torque outside the above-mentioned range. Failure to do so may cause equipment failures or malfunctions.

1	Introduction
2	Specifications
3	Installation
4	Wiring
5	Allocation of Buffer/Memorires
6	J1939 Comms Mode
7	Layer 2 Communication Mode
8	PLC RUN>STOP Messages
9	Command Interface
10	Communication Settings Procedure

4.2 CAN-Bus Wiring

4.2.1 Connecting communication cables

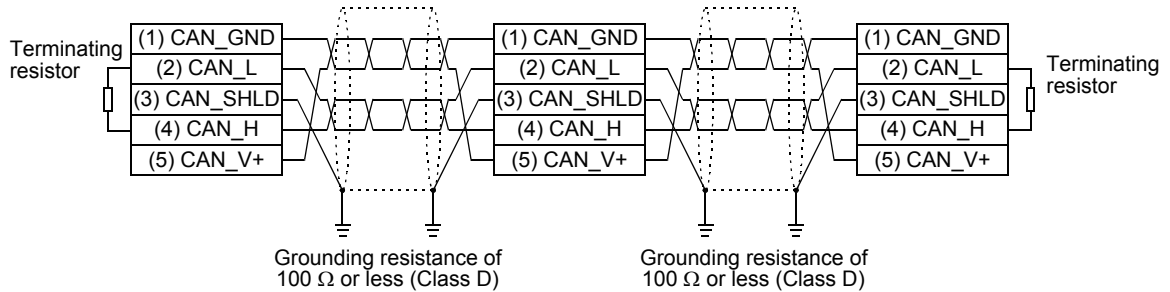

For electromagnetic compatibility (EMC), it is recommended to ground the cable shield at both ends.

Caution

For safety, always check the potential differences between the grounding points. If potential differences are found, proper measures must be taken to avoid damage.

4.2.2 Module wiring

For further information on PLC wiring, refer to the following manual.

- Refer to FX3G Hardware Edition
- Refer to FX3GC Hardware Edition
- Refer to FX3U Hardware Edition
- Refer to FX3UC Hardware Edition
- Refer to MELSEC iQ-F FX5U User's Manual (Hardware)
- Refer to MELSEC iQ-F FX5UC User's Manual (Hardware)

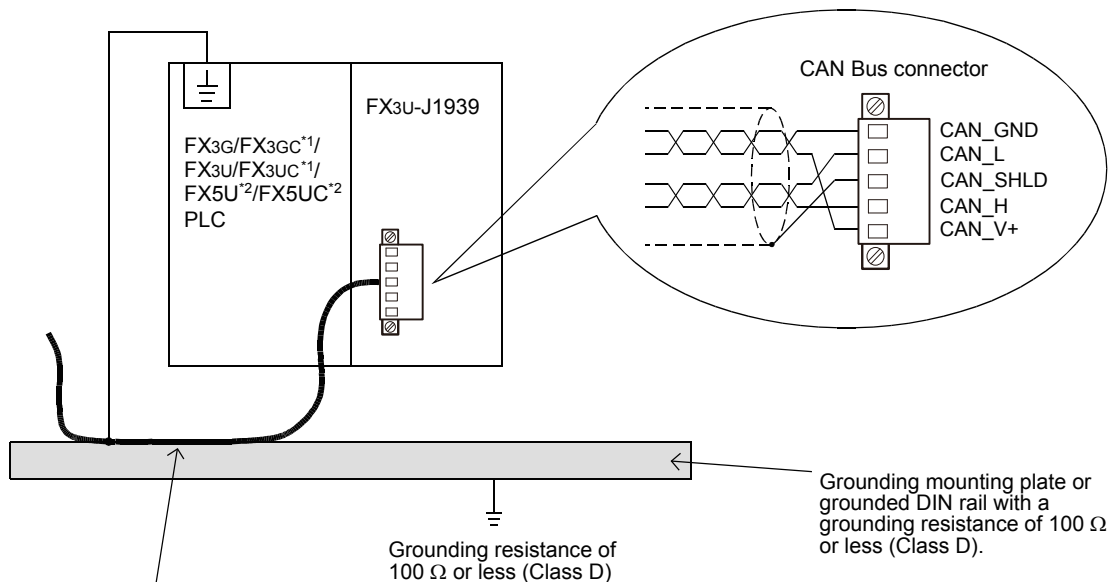

Strip a part of the coating of the shielded twisted pair cable as shown in subsection 4.2.3. Ground the PLCs grounding terminal there.

- *1. An FX2NC-CNV-IF or FX3UC-1PS-5V is necessary to connect the FX3U-J1939 to an FX3GC/FX3UC Series PLC.
- *2. An FX5-CNV-BUS or FX5-CNV-BUSC is necessary to connect the FX3U-J1939 to an FX5U/FX5UC PLC.

4.2.3 Grounding of twisted pair cable

Strip a part of the coating of the shielded twisted pair cable as shown below, and ground at least 35 mm (1.38") of the exposed shield section.

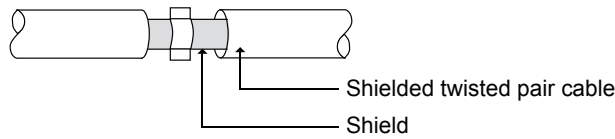

4.2.4 Termination

The J1939 network requires terminating resistors for both network ends. When FX3U-J1939 is the network end, connect the included terminating resistor (120 Ω 1/2W) between pin number 2 (CAN_L) and 4 (CAN_H).

4.3 Grounding

Ground the cables as follows

- The grounding resistance should be 100 Ω or less.
- Independent grounding should be established whenever possible. Independent grounding should be performed for best results. When independent grounding is not configured, perform "shared grounding" as shown in the following figure. For further information, refer to the respective PLC manual.

- Refer to FX3G Hardware Edition
- Refer to FX3GC Hardware Edition
- Refer to FX3U Hardware Edition
- Refer to FX3UC Hardware Edition
- Refer to MELSEC iQ-F FX5U User's Manual (Hardware)
- Refer to MELSEC iQ-F FX5UC User's Manual (Hardware)

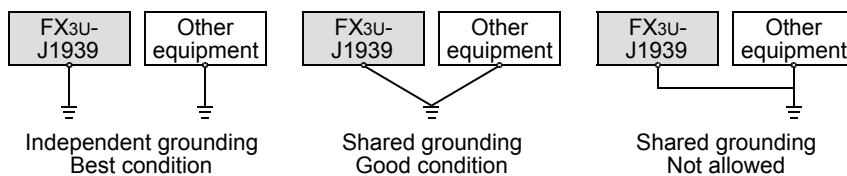

- The grounding point should be close to the FX3U-J1939, and all grounding wires should be as short as possible.

1	Introduction
2	Specifications
3	Installation
4	Wiring
5	Allocation of Buffer Memories
6	J1939 Comms Mode
7	Layer 2 Communication Mode
8	PLC RUN>STOP Messages
9	Command Interface
10	Communication Settings Procedure

5. Allocation of Buffer Memories

5.1 Buffer Memories (BFM) Lists

Caution

- Do not access buffer memory (BFM) that is marked as "not used" (Ex. BFM #0 to #19, #23, #31 to #34, #49 to #99, #400, #480 to #499, etc.) by FROM/TO instructions, etc. Accessing these buffer memories may cause abnormal behavior of the FX3U-J1939.
- When BFM #21, #24, #25 bit 2, #26 or #27 is written to, FX3U-J1939 stores the state of the corresponding BFM in the built-in flash ROM. The maximum number of writes to the built-in flash ROM is 10,000 times. Therefore, when creating a program, do not frequently write to such buffer memories.

Note

- When writing to a BFM that contains any bits marked as "reserved" (Ex. BFM #20 bit 1 to bit 15, BFM #22 bit 3 to bit 15, etc), set such bits to OFF.
Setting these flags to ON may cause abnormal behavior of the FX3U-J1939.
- The state of BFM #40 to #48, #100 to #399, #500 to #973, #1100 to #1267, #1900 to #1927, #3000 to #3879 is stored in the built-in flash ROM by turning ON BFM #22 bit 0. The buffer memories that are stored depend on the function mode (BFM #21).
For further information, refer to the following section.
Therefore, when creating a program, do not frequently switch BFM #22 bit 0 from OFF to ON.

→ Refer to Section 5.5

BFM No.	Description	Default value	Read/Write	Stored to Flash ROM	Reference
BFM #0 to #19	Not used	-	-	-	-
BFM #20	Data exchange control	K0	R/W	-	Section 5.3
BFM #21	Function mode	K1939	R/W	✓	Section 5.4
BFM #22	Save/Restore configuration	K0	R/W	-	Section 5.5
BFM #23	Not used	-	-	-	-
BFM #24	Baud rate	K250	R/W	✓	Section 5.6
BFM #25	Communication status	K4	R/W	✓ ^{*1}	Section 5.7
BFM #26	FROM/TO Watchdog (× 10 ms)	K20	R/W	✓	Section 5.8
BFM #27	Node address (address claim start address)	K128	R/W	✓	Section 5.9
BFM #28	Node address (current address)	K254	R	-	Section 5.10
BFM #29	Error status	K0	R/W	-	Section 12.2
BFM #30	Module ID code	K7180	R	-	Section 5.12
BFM #31 to #34	Not used	-	-	-	-
BFM #35	CAN transmission error counter	K0	R	-	Section 5.13
BFM #36	CAN reception error counter	K0	R	-	Section 5.14
BFM #37	Baud rate display (× 0.1 kbps)	K2500	R	-	Section 5.15
BFM #39	BFM setting error display	K0	R	-	Section 5.16
BFM #40 to #48	64 bit ECU NAME according to J1939-81	-	R/W	✓ ^{*2}	Section 5.17
BFM #49 to #99	Not used	-	-	-	-
BFM #100 to #399	Data (read/write)	K0	R/W	✓ ^{*2}	*3
BFM #400	Not used	-	-	-	-
BFM #401 to #479	Message error code list	K0	R/W	-	Section 5.19
BFM #480 to #499	Not used	-	-	-	-
BFM #500 to #973	J1939 message configuration area	-	R/W	✓ ^{*2}	Section 6.2

BFM No.	Description	Default value	Read/Write	Stored to Flash ROM	Reference
BFM #974 to #999	Not used	-	-	-	-
BFM #1000 to #1066	Command interface	K0	R/W	-	Chapter 9
BFM #1067 to #1099	Not used	-	-	-	-
BFM #1100 to #1267	Pre-defined Layer 2 message configuration	-	R/W	√*2	Section 7.2
BFM #1268 to #1269	Not used	-	-	-	-
BFM #1270 to #1272	Layer 2 RTR flags	K0	R	-	Section 7.3
BFM #1273 to #1279	Not used	-	-	-	-
BFM #1280 to #1284	Manual transmit trigger flags	K0	R/W	-	Section 5.20
BFM #1285 to #1299	Not used	-	-	-	-
BFM #1300 to #1799	Send/receive data buffer for extended messages	K0	R/W	-	Subsection 6.1.2
BFM #1800 to #1899	Not used	-	-	-	-
BFM #1900 to #1927	PLC RUN>STOP messages	-	R/W	√*2	Section 5.21 and Chapter 8
BFM #1956 to #2999	Not used	-	-	-	-
BFM #3000 to #3879	Remote Address to ECU Name assignment	K0	R/W	√*2	Section 5.22

- *1. Only bit 2 in BFM #25 is stored to built-in flash ROM.
- *2. The state of buffer memory is stored in the built-in flash ROM by turning on BFM #22 bit 0. The buffer memories that are stored depend on the function mode (BFM #21).
For further information, refer to the following section.
→ Refer to Section 5.5
- *3. Refer to the following items for each function mode.
→ When using J1939 communication mode, refer to Section 6.1
→ When using the Layer 2 communication (11/29 bit ID) mode, refer to Section 7.1

1	Introduction
2	Specifications
3	Installation
4	Wiring
5	Allocation of Buffer Memories
6	J1939 Comms Mode
7	Layer 2 Communication Mode
8	PLC RUN>STOP Messages
9	Command Interface
10	Communication Settings Procedure

5.2 How to Read/Write from/to Buffer Memory

To read/write from/to buffer memory in the FX3U-J1939, use the FROM/TO instructions or the applied instructions that directly specify the buffer memory.

FX3U/FX3UC/FX5U/FX5UC PLC applicable software is required to perform direct specification of the buffer memory and bit specification of word devices.

For further information on applied instructions, bit specification of word devices, direct specification of buffer memory or special function unit/block unit number, refer to following manual.

→ Refer to Programming manual

1. Direct specification of buffer memory (FX3U/FX3UC/FX5U/FX5UC only)

When directly specifying the buffer memory, specify the following device in the source or destination area of the applied instruction as follows:

$U\boxed{}\backslash G\boxed{}$ $\boxed{}$ is substituted with a number

Unit No. (0 to 7*) Buffer memory No. (0 to 32766)

*1. Unit No. 2 to No. 16 is assigned when the CPU module is an FX5U/FX5UC.

1) Reading out BFM data to PLC (MOV instruction)

If the following program is created, 1 point of data will be read out from buffer memory BFM #30 of unit No.1 to data register D10.

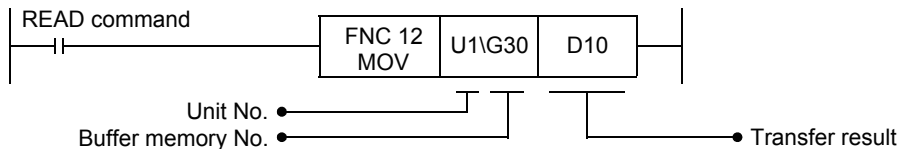

2) Writing PLC data into BFM (MOV instruction)

If the following program is created, 1 point of data (H0001) will be written to buffer memory BFM #20 of unit No.1.

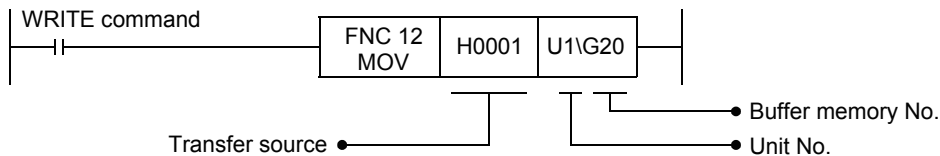

2. FROM/TO instructions

1) FROM instruction (Reading out BFM data to PLC)

Use the FROM instruction to read the data from the buffer memory.

If the following program is created, 1 point of data will be read out from buffer memory BFM #30 of unit No.1 to data register D10.

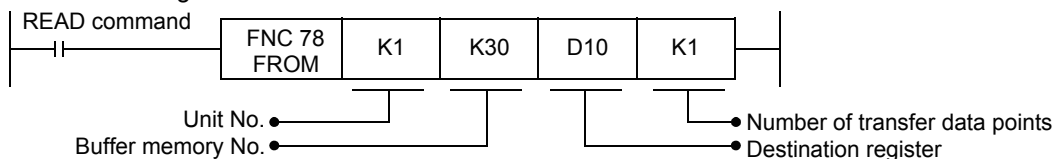

2) TO instruction (Writing PLC data into BFM)

Use the TO instruction to write data to buffer memory.

If the following program is created, 1 point of data (H0001) will be written to buffer memory BFM #20 of unit No.1.

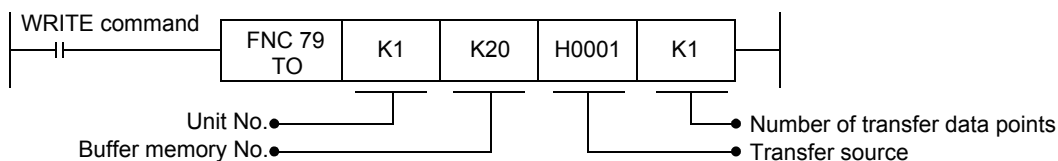

5.3 [BFM #20] Data Exchange Control

This flag is used when data consistency is required for data exchange between data area in BFM #100 to #399 and BFM #1300 to #1799.

Bit	Description
Bit 0	Data consistency flag; To keep data consistency over a certain data area in BFM #100 to #399 and BFM #1300 to #1799, write all data required to be treated consistent to the data BFM's and then set the "Data consistency flag" afterwards. The flag is reset automatically.
Bit 1 to 15	Not used

5.4 [BFM #21] Function Mode

Sets up function mode of FX3U-J1939. FX3U-J1939 chooses a communication mode based on the function mode set in BFM #21.

Caution

A new valid value written to BFM #21, #24, #25 bit 2, #26, #27 is automatically written to flash ROM. The maximum number of writes to the built-in flash ROM is 10,000 times. Therefore, when creating a program, do not frequently write to such buffer memories.

Note

- A change of the function mode requires a restart of the FX3U-J1939 to become effective.
→ **For module restart, refer to Section 5.7**

Set Value	Function Mode
K11	Layer 2 communication (11 bit ID) mode
K29	Layer 2 communication (29 bit ID) mode
K1939 (default)	J1939 communication mode
Other value	Setting prohibited If setting other values, FX3U-J1939 keeps the former value.

1

Introduction

2

Specifications

3

Installation

4

Wiring

5

Allocation of
Buffer Memories

6

J1939 Comms
Mode

7

Layer 2
Communication
Mode

8

PLC RUN→STOP
Messages

9

Command
Interface

10

Communication
Settings
Procedure

5.5 [BFM #22] Save/Restore Configuration

This BFM supports three bits that allow the default configuration of the BFMs to be restored and the configuration from BFMs to be stored into Flash ROM.

Caution

To prevent accidental destruction of the built-in Flash ROM, bit 0 is held ON for 1 s after the save operation is completed. If during the time BFM #22 bit 0 is ON another write access to BFM #22 attempts to set bit 0, 1, or 2 to ON, then the first write operation will be completed, but BFM #29 bit 4 "FLASH memory error" will be set to ON and BFM #22 bits 0, 1, and 2 will not reset to OFF. Any further save operations will be blocked. This state can be cleared by power cycle or BFM #25 bit 0 reset.

Note

If bit 0 and bit 1 or 2 are set simultaneously, the corresponding BFMs and Flash ROM will be reset to factory default settings.

Bit	Description
Bit 0	When this bit is set, configuration is saved to Flash ROM ^{*1} When operation is completed, FX3U-J1939 will automatically reset this bit.
Bit 1	When this bit is set, all BFMs are reset to default values (factory default). After all BFMs are reset, BFM #21, #24, #25 bit 2, #26 and #27 are saved to Flash ROM. Save to Flash ROM is not executed for configuration BFMs. ^{*1} When operation is completed, FX3U-J1939 will automatically reset this bit.
Bit 2	Restore default configuration for current mode (Layer 2 or J1939, not saved to Flash ROM) ^{*1} When only bit 2 is set, corresponding BFM areas are restored to the factory default values but not stored in Flash ROM. To store changes made to the configuration BFMs, set BFM #22 bit 0 after changing the configuration. When operation is completed, FX3U-J1939 will automatically reset this bit.
Bit 3 to 15	Not used

- *1. The BFM areas corresponding to the function mode set in BFM #21 are stored/restored as shown in the table below:

Mode		Description	Reference
J1939 communication mode	Layer 2 communication (11 bit ID) mode/ Layer 2 communication (29 bit ID) mode		
Saved	Not saved	BFM #40 to #48 64 bit ECU NAME according to J1939-81	Section 5.17
Not saved	Saved	BFM #100 to #399 The CAN-ID and data length for Tx messages configured in this data area are stored to Flash ROM.	Section 7.1
Saved	Not saved	BFM #500 to #973	Section 6.2
Not saved	Saved	BFM #1100 to #1267	Section 7.2
Saved	Saved	BFM #1900 to #1927	Section 5.21 and Chapter 8
Saved	Not saved	BFM #3000 to #3879	Section 5.22

5.6 [BFM #24] Baud Rate

Determines the communication speed (baud rate) of the module to the CAN bus. Baud rate change becomes effective after reset or power cycle.

Caution

Any new valid value written to BFM #21, #24, #25 bit 2, #26 or #27 is automatically stored to flash ROM. The maximum number of writes to the built-in flash ROM is 10,000 times. Therefore, when creating a program, do not frequently write to such buffer memories.

Set Value	Baud Rate	
	J1939 Communication Mode	Layer 2 Communication (11 bit ID) Mode/ Layer 2 Communication (29 bit ID) Mode
K10	-	10 kbps
K20	-	20 kbps
K50	-	50 kbps
K100	-	100 kbps
K125	-	125 kbps
K250	250 kbps	250 kbps
K500	-	500 kbps
K800	-	800 kbps
K1000	-	1000 kbps
Other value	Setting prohibited If an invalid baud rate is written to BFM #24, the BFM will keep its former value and BFM #29 bit 11 will be set.	

5.7 [BFM #25] Communication Status

Displays the FX3U-J1939 network communication status and sets different control commands (e.g. Online mode and reset module).

Caution

Any new valid value written to BFM #21, #24, #25 bit 2, #26 or #27 is automatically stored to flash ROM. The maximum number of writes to the built-in flash ROM is 10,000 times. Therefore, when creating a program, do not frequently write to such buffer memories.

Module restart

When restarting the module, set BFM #25 Bit 0 to ON.
In this case, set data that was not saved will be lost.

Bit	Access	
	FROM (Read Access)	TO (Write Access)
Bit 0	OFF: Module offline ON: Module online	OFF: No action ON: Module restart Restart is required: - After changing the baud rate, node ID or function mode - To recover from BUS-OFF state
Bit 1	ON when error counter of the CAN controller has reached its warning level (Error counter 96 to 127)	Not used
Bit 2	OFF: Single address capable*1 ON: Arbitrary address capable	
Bit 3	FX3U-J1939 node address has changed*2	OFF: Clear flag ON: No change

1

Introduction

2

Specifications

3

Installation

4

Wiring

5

Allocation of Buffer Memories

6

J1939 Comms Mode

7

Layer 2 Communication Mode

8

PLC RUN→STOP Messages

9

Command Interface

10

Communication Settings Procedure

Bit	Access	
	FROM (Read Access)	TO (Write Access)
Bit 4	OFF: Request configuration mode ON: Request online mode ^{*3}	
Bit 5, 6	Not used	Not used
Bit 7	Module initialization state ^{*4}	
Bit 8 to 15	Not used	

- *1. If the arbitrary address capability is activated (BFM #25 bit 2 = ON) and the address set in BFM #27/#28 is in the "dynamic" address range, the FX3U-J1939 will start to negotiate with other nodes in the network for a node address. If an address conflict occurs, the FX3U-J1939 will attempt to claim a new address and set BFM #29 bit 9 to ON.
If the module is set to single address capable (arbitrary address capability is de-activated), an address conflict will cause the FX3U-J1939 to send a "can not claim" message and stop exchanging data with the bus.
The status of this bit is stored to Flash ROM.
→ For details on the node address, refer to Section 5.9 and Section 5.10
→ For error status (BFM #29), refer to Section 12.2

- *2. There are two events that might cause the FX3U-J1939 to lose permission to use its current node address:
- The reception of a "commanded address" message
 - A node with higher priority claims the address currently used by the FX3U-J1939
- In such a case, bit 3 is set to ON when a new a node address is claimed successfully by the FX3U-J1939. If no new node address could be claimed, BFM #29 bit 1 is set to ON.
- *3. This bit must be set to ON to start data exchange with other network nodes. The configuration of the module can only be changed while this bit is OFF.

Note

If a configuration BFM was changed during online mode, BFM #29 bit 5 is set ON.

- *4. While this flag is ON, the FX3U-J1939 is initializing.

Note

- During this time, do not write (TO instruction, etc) to any BFMs.
If write access is performed, FX3U-J1939 will cause an error in BFM #29 bit 5.
- During this time, do not read (FROM instruction, etc) any BFMs other than BFM #25, as the current values of the BFM might change during initialization.

5.8 [BFM #26] FROM/TO Watchdog

The FROM/TO Watchdog can be used to monitor if the PLC program cyclically accesses data BFMs #100 to #399 or the extended data area in BFM #1300 to #1799.

After the first FROM/TO on the data BFM, the Watchdog will check if the next access to the data BFMs takes place before the time set in BFM #26 expires.

BFM #26 sets the Watchdog timer in units of 10 ms [default value: K20 (200 ms)].

Note

- Any new valid value written to BFM #21, #24, #25 bit 2, #26 or #27 is automatically stored to flash ROM. The maximum number of writes to the built-in flash ROM is 10,000 times. Therefore, when creating a program, do not frequently write to such buffer memories.
- If the watchdog expires, bit 7 in BFM #29 is set to ON, and the "PLC RUN>STOP messages" defined in BFM #1900 to #1927 are transmitted on the network.
- The FROM/TO watchdog can be restarted by writing the setting value to BFM #26 again, which will also reset the error flag in BFM #29.
- If the watchdog function is not required, it can be deactivated by writing K0 to BFM #26.

5.9 [BFM #27] Node Address (Address Claim Start Address)

Sets the node address within the J1939 network. A node address written by a TO instruction, etc. into BFM #27 will be effective after the next power cycle or BFM #25 bit 0 reset.

The actual node address is always displayed in BFM #28. The address claiming process starts at the address set in BFM #27 after power cycle or BFM #25 bit 0 reset. If the module is set from online to offline and back to online, it will try to acquire the last used address shown in BFM #28.

If this address is not available, another address is claimed. When the address claiming process is successful, BFM #28 will display the address occupied by the FX3U-J1939.

Caution

- The address range K0 to K127 and K208 to K255 is assigned/reserved by SAE J1939. If the user sets one of these addresses, it is their responsibility to ensure proper network behavior.
e.g. It may be useful to set the FX3U-J1939 address to an "engine" address to simulate the motor during programming. But if the "Engine address" is used by the FX3U-J1939 in a real application (including the motor), the network will be adversely affected.
- Any new valid value written to BFM #21, #24, #25 bit 2, #26 or #27 is automatically stored to flash ROM. The maximum number of writes to the built-in flash ROM is 10,000 times.
Therefore, when creating a program, do not frequently write to such buffer memories.

Note

- The node address is not used in Layer 2 mode; any write access to this BFM will be ignored. The value is not changed or stored to non volatile memory as long as the module is in Layer 2 mode.
- If the node address is the result of an address claiming procedure, the address is displayed in BFM #28 but not stored to Flash ROM. After the next power ON or reset (BFM #25 bit 0), the FX3U-J1939 will start to negotiate for a node address again and might obtain another address.
- If an invalid node address is written to BFM #27, the BFM will keep its former value and BFM #29 bit 12 will be set.
- If the address set in BFM #27 is not a dynamic address, bit 2 in BFM #25 is set to OFF.
- If during the address claiming process an "address conflict" occurs (two nodes want to use the same node number), the node address number is assigned to the node with the higher priority. The other node must continue address claiming to find another free address.
The priority of a node depends on the node's "ECU name." If all other fields of the "ECU name" are same, the smaller value of "Function Instance" in the "ECU name" indicates higher priority.
For further information on ECU name, refer to following section.

→ Refer to Section 5.17

When a fix node address is required

Set the node address by using one of the following methods.

- Set BFM #25 bit 2 to OFF, and set an address in BFM #27
- Start the address claim procedure once, when an address is obtained:
 - 1) Read the obtained address from BFM #28
 - 2) Set BFM #25 bit 2 to OFF.
Otherwise, address claiming might start from the new address after the next power on or reset.
 - 3) Write the address read from BFM #28 back to BFM #27.
The address will be stored to Flash ROM.

1

Introduction

2

Specifications

3

Installation

4

Wiring

5

Allocation of Buffer Memories

6

J1939 Comms Mode

7

Layer 2 Communication Mode

8

PLC RUN→STOP Messages

9

Command Interface

10

Communication Settings Procedure

Setting Value	State of BFM #25 bit 2	description
K128 to K206	ON	When the current address of the FX3U-J1939 (displayed in BFM #28) is claimed by a node with a higher priority, the FX3U-J1939 will claim the next higher address. If node address is increased beyond the maximum dynamic address* ¹ , FX3U-J1939 sets BFM #29 bit 1, and stores HFE ("can not claim" address) in BFM #28. If the FX3U-J1939 Industry group is set to 0, BFM #25 bit 2 is forced to OFF.
K128 to K207	OFF	Even if the address is in the "dynamic" address range, the FX3U-J1939 will not try to claim another address if a node with higher priority claims the address set in BFM #27. If the FX3U-J1939 cannot use the address in BFM #27 due to an address claim from a node with higher priority, the FX3U-J1939 will set BFM #29 bit 1, and stores HFE ("can not claim" address) in BFM #28.
K0 to K127	-	FX3U-J1939 uses the address set in BFM #27 for communication.
K208 to K247		However, these node addresses are reserved by SAE or assigned to certain functions within the network. If using these node address, see the Caution in this section.
K248 to K253		
K254	-	"can not claim". Invalid setting.
K255		"broadcast" address. Invalid setting.

- *1. The maximum dynamic address depends on the industry group.
For further information on industry groups, refer to following section.

→ Refer to Section 5.17

Industry Group	Maximum Address
0	Not define any dynamic addresses
1	K160
2 to 5	K207

Node address range, State and Industry group

The relation between Node address range, State, and Industry group is as follows.

Node Address Range	State	Industry Group
128 to 207 (H80 to HCF)	Dynamic	Group 5: Industrial, Process Control, Stationary Equipment* ¹ Group 4: Marine Equipment* ²
208 to 247 (HD0 to HF7)	Assigned/Reserved	Group 3: Construction Equipment* ² Group 2: Agricultural and Forestry Equipment* ²
128 to 160 (H80 to HA0)	Dynamic	Group 1: On-Highway Equipment* ²
161 to 247 (HA1 to HF7)	Assigned/Reserved	
0 to 84 (H00 to H54)	Assigned	Global / Group 0 (for all industry groups)
85 to 127 (H55 to H7F)	Reserved	
248 to 253 (HF8 to HFD)	Assigned/Reserved	
254, 255 (HFE, HFF)	Assigned/Reserved	Global / Group 0 (for all industry groups) "cannot claim" and "broadcast" address are invalid settings for BFM #27.

- *1. Recommended industry group
*2. Other industry groups for reference

States

Dynamic: The address range is available for dynamic node address assignment (arbitrary address assignment)

Assigned: The Address is assigned to a certain application or ECU type

Reserved: The Address is reserved for further use by the SAE

5.10 [BFM #28] Node Address (Current Address)

BFM #28 displays the current node address of the FX3U-J1939. Until the FX3U-J1939 is successfully able to claim an address, BFM #28 shows K254 (HFE).

Note

- No network communication can be executed until the FX3U-J1939 owns a valid address.
- If BFM #25 bit 4 is ON, the address in BFM #28 might change even in a running network when another node with higher priority is added and claims the address currently used by the FX3U-J1939.
- The FX3U-J1939 will also display HFE in BFM #28 if the current node address becomes invalid, due to an address conflict or a commanded address. If the address conflict can be solved or the commanded address is successfully claimed, BFM #28 will show the new address. If the address conflict cannot be solved, BFM #28 remains HFE and BFM #29 bit 9 is set to ON.

5.11 [BFM #29] Error Status

For further information on error status, refer to the following section.

→ Refer to Section 12.2

5.12 [BFM #30] Module ID Code

Shows the module ID code K7180 of the FX3U-J1939 module.

5.13 [BFM #35] CAN Transmit Message Error Counter

Displays the current value of the CAN transmit message error counter. The CAN transmit message error counter counts up to K256.

Value	Description
K0 to K95	Error active status
K96 to K127	Error active status/Warning level
K128 to K255	Error passive status
K256	BUS-OFF status

5.14 [BFM #36] CAN Receive Message Error Counter

Displays the current value of the CAN receive message error counter. The CAN receive message error counter counts up to K128. However, when FX3U-J1939 is in BUS-OFF status, K256 is stored in this BFM.

Value	Description
K0 to K95	Error active status
K96 to K127	Error active status/Warning level
K128	Error passive status
K129 to K255	(The CAN receive message error counter is increased up to K128.)
K256	BUS-OFF status

5.15 [BFM #37] Baud Rate Display

Displays the current baud rate of the CAN Controller in units of 0.1 kbps.

1

Introduction

2

Specifications

3

Installation

4

Wiring

5

Allocation of Buffer Memories

6

J1939 Comms Mode

7

Layer 2 Communication Mode

8

PLC RUN→STOP Messages

9

Command Interface

10

Communication Settings Procedure

5.16 [BFM #39] BFM Setting Error Display

BFM #29 bit 6 is set to ON if an attempt to write an invalid value into a Buffer Memory is detected. BFM #39 displays the address of the target BFM of the invalid write attempt. In case an irregular value was written to more than one BFM, only the address of the first BFM is displayed. When BFM #29 bit 6 is set to OFF, BFM #39 will be reset to K0.

5.17 [BFM #40 to #48] 64 Bit ECU NAME According to J1939-81

The ECU name is unique for every module in the network and is used for identification. The ECU Name contains 64 bits. 62 of those bits are defined as shown in the following table.

The remaining 2 bits are reserved by SAE. FX3U-J1939 sets the reserved bits automatically to OFF.

BFM No.	Field name	Length	Default value	Remarks
BFM #40	Industry Group	3 bit	K5 ^{*1}	SAE defined
BFM #41	Vehicle System	7 bit	K127 (H7F) ^{*2}	SAE defined
BFM #42	Vehicle System Instance	4 bit	K0 ^{*3}	-
BFM #43	Function	8 bit	K255 (HFF) ^{*2}	SAE defined
BFM #44	Function Instance	5 bit	K0 ^{*3}	-
BFM #45	ECU instance	3 bit	K0 ^{*3}	-
BFM #46	Manufacturer Code	11 bit	K2047 (H7FF)	SAE defined
BFM #47	Identity Number (LW)	21 bit	H1FFFFFF	-
BFM #48	Identity Number (HW)			

- *1. FX3U-J1939 sets the Industry Group to group 5 (Industrial, Process Control, Stationary Equipment) by default.
- *2. FX3U-J1939 sets the Vehicle System and Function to "not available" as defined in SAE J1939 specification for undefined/unknown Vehicle Systems and Functions.
- *3. The Vehicle System Instance, Function Instance and ECU Instance should be set to K0 for the first object of this kind or if only one object exists in the whole network.

Industry Group

Defines the application field or general environment. Most applications of the FX3U-J1939 will be in the "Industrial, Process Control, Stationary Equipment" which equals the default K5.

Vehicle System

In combination with the Industry group, the Vehicle system is used to identify a unit with several functions. In the case of Industry Group 5, this could be a generator set. The exact function within the generator set unit will be assigned by the function field. The default value K127 defines the Vehicle System as "Not available" or "Not yet defined".

Vehicle System Instance

The Vehicle System Instance identifies a certain entity of a Vehicle System in case there is more than one in the same network.

Function

The Function field defines the particular task of a certain device more specifically. The Default value K255 defines the Function as "Not available" or "Not yet defined".

A device of Industry group K5, Vehicle System K0, Function K129 would identify the generator set controller (within a generator set system).

Function Instance

The Function Instance identifies a certain entity of a Function in case there is more than one in the same network.

ECU instance

The ECU Instance identifies a certain entity of an ECU in case there is more than one electronic control unit with the same function in the same network.

Manufacturer Code

The manufacturer code identifies the maker of the ECU. The manufacturer code is assigned by the SAE and listed in the SAE J1939 main specification.

Identity Number

The Identity number is a unique code that distinguishes ECUs of the same Manufacturer and Kind (Industry Group, Vehicle System, Vehicle System Instance, Function, Function Instance, ECU instance and Manufacturer Code).

5.18 [BFM #100 to #399] Send/Receive Data Buffer

BFM #100 to #399 in the FX3U-J1939 module are used for data communication to the CAN bus. The configuration for where each data is sent/received is explained in the following chapter.

- When using the J1939 communication mode, refer to Chapter 6
- When using Layer 2 communication (11 bit/29 bit ID) mode, refer to Chapter 7

5.19 [BFM #401 to #479] Message Specific Error Code List

This List contains an error message for each message. FX3U-J1939 has 42 messages for Layer 2 mode and 79 messages for J1939 mode. If several message buffers are combined for messages with more than 8 data bytes in J1939 mode, the error code is stored only in the first related message.
e.g. If message 3, 4 and 5 are combined to transport a message with 24 byte, any errors will be displayed in BFM #403 "message 3 error code."

Note

- Write K0 to clear the error for related message. If all message error codes are cleared to K0, the error flag BFM #29 bit 15 will be reset to OFF.
→ For the error status, refer to Section 12.2
- All error codes in BFM #401 to #479 will be cleared to K0 if BFM #29 bit 15 is set to OFF, or if BFM #25 bit 0 is set to ON for the module reset.
- The abort cause of PGN 60416 "connection abort" is set to HFE (K254) "error indicator" according to ISO 11783-7 in case the FX3U-J1939 detects any protocol errors, e.g. in case the total data count does not match the number of frames in a RTS frame.

BFM No.	Detailed Error Code for Each Message	
	J1939 Mode	Layer 2 Mode
BFM #401		Message 1 error code
BFM #402		Message 2 error code
⋮		⋮
BFM #442		Message 42 error code
BFM #443	Message 43 error code	Not used
⋮	⋮	
BFM #474	Message 74 error code	
BFM #475	Message 75 error code	
BFM #476	Message 76 error code *1	
BFM #477	Message 77 error code *1	
BFM #478	Message 78 error code *1	
BFM #479	Message 79 error code *1	

*1. Messages 76 to 79 are for extended messages 1 to 4.

- For the extended message, refer to Subsection 6.1.2

Message specific error codes:

Error Code	Description
H0000	No error
H10nn	Multi message transmission aborted by remote node. FX3U-J1939 received a connection abort message from remote node, the low-byte shows the abort cause. → For abort cause, refer to documentation of remote node or applicable J1939 specification
H11nn	Multi message transmission aborted by local node. The FX3U-J1939 detected an error condition that requires the termination of the current multi message transmission, the low-byte shows the abort cause. → For abort cause, refer to documentation of remote node or applicable J1939 specification
H12nn	Negative acknowledge received from remote node. The low-byte shows the control byte of the acknowledge message → For control byte, refer to documentation of remote node or applicable J1939 specification
H1300	Total byte count does not match the assigned number of frames. When opening a multi message connection (RTS/CTS or BAM) the first message defines the total byte count and the number of messages required to exchange all data bytes. If these values do not match, error code H1300 is generated.
H1301	Repeated PGN has changed. During RTS/CTS handshake the transported PGN is repeated in each RTS or CTS message. If the PGN does not match to the PGN of an open connection, this error is generated.
H1302	Frame number has changed. During a J1939 Multi message transmission, the included message counter did not have the expected value, which means at least one message was missed.
H1303	Data frame overflowed. When opening an RTS/CTS connection, the two involved nodes negotiate how many data messages can be sent before another CTS is required. If the remote node sends another data frame without waiting for clear to send, this error will occur.
H1304	The received message matches the configured PGN, but the DLC does not match the configured value.
H1305	Message abandoned by remote node. A remote node did not properly terminate a multi message transmission before re-opening the connection to the FX3U-J1939, either with the same or a different PGN.
H1306	The ECU name of each node in the Network must be unique, but the FX3U-J1939 received an address claim message containing the same ECU name as the FX3U-J1939. → For ECU name, refer to Section 5.17
H2000	Receive buffer overflowed. High bus load caused an overflow condition. More messages have been received than buffers available. As it is not possible to detect which message was lost, this error code is written to all RX messages.
H2001	A remote node attempted to open a multi message connection to transmit a data block that exceeds the valid range of the FX3U-J1939. (250 byte for user messages, 122 byte for the CIF)
H2002	Response timed-out. The maximum delay between two subsequent messages of a multi packet message expired.
H2003	BAM data frame lost. At least one data message of a multi message BAM reception was lost.
H2004	A Reception Timeout for this message occurred. The message has not been received for the time set in BFM #500 to #973 after changing to online mode or after last reception of this message.
H3000	Unexpected CTS. The FX3U-J1939 received a CTS handshake message when none was expected.

5.20 [BFM #1280 to #1284] Manual Transmit Trigger flags

The transmission of a message in J1939 or Layer 2 mode can be triggered via the following flags. Transmit requests on receive messages are discarded. When a bit is set to ON, the corresponding transmit message will be sent as soon as a transmit buffer is available. The flags are reset automatically as soon as the message is written into the transmit queue. In case of messages larger than 8 bytes, which need several transmissions, the flag is reset when the last segment is written into a transmit queue. For J1939, messages 1 to 75 are standard 8 bytes messages (BFM #100 to #399), and messages 76 to 79 are extended messages with up to 250 bytes (BFM #1300 to #1799).

BFM No.	Bit No.	Transmit Request Message		Remarks
		J1939 Communication Mode	Layer 2 Communication (11/29 bit ID) Mode	
BFM #1280	Bit 0	Message 1		R/W
	⋮	⋮		R/W
	Bit 15	Message 16		R/W
BFM #1281	Bit 0	Message 17		R/W
	⋮	⋮		R/W
	Bit 15	Message 32		R/W
BFM #1282	Bit 0	Message 33		R/W
	⋮	⋮		R/W
	Bit 9	Message 42		R/W
	Bit 10	Message 43	Not used	R/W
	⋮	⋮		R/W
Bit 15	Message 48	R/W		
BFM #1283	Bit 0	Message 49		R/W
	⋮	⋮		R/W
	Bit 15	Message 64	R/W	
BFM #1284	Bit 0	Message 65	Not used	R/W
	⋮	⋮		R/W
	Bit 10	Message 75		R/W
	Bit 11	Message 76 ^{*1}		R/W
	Bit 12	Message 77 ^{*1}		R/W
	Bit 13	Message 78 ^{*1}		R/W
	Bit 14	Message 79 ^{*1}		R/W
Bit 15	Not used	-		

*1. Messages 76 to 79 are extended messages

→ Refer to Subsection 6.1.2

5.21 [BFM #1900 to #1927] PLC RUN>STOP Messages

If required to inform other nodes about the events "PLC RUN>STOP" of the local node, this function can be used to define up to 4 messages to be transmitted on occurrence of each of the two events.

For setup in J1939 communication mode, the CIF provides the "set up PLC RUN>STOP messages" function.

→ For details on the PLC RUN>STOP Messages, refer to Chapter 8

→ For the setup in J1939 communication mode by CIF, refer to Section 9.5

Note

In J1939 mode, the PLC RUN>STOP messages and the CAN-ID are adjusted according to J1939 Specification:

- The lowest byte of the CAN-ID will always equal the FX3U-J1939 current node address (BFM #28)
- If the PGN is in PDU1 format range (PF = HEF or less), the destination address is adjusted if the target node changes its node address during dynamic address allocation.

→ For the required node address and ECU name definition, refer to Section 5.22

5.22 [BFM #3000 to #3879] Configuration of Remote Address to ECU Name Assignment

When the remote nodes of a J1939 network support dynamic address allocation, it is possible that a remote node changes its current node address due to an address conflict. Additionally, a configuration tool could send a "commanded address" message, which would also cause the remote node to change its address. This could cause a problem if the source/destination node address, configured in the FX3U-J1939, is not used by the expected node anymore.

To avoid this, the FX3U-J1939 supports the following table where the remote source/destination node address used in the FX3U-J1939 configuration can be assigned to the unique ECU name of the Remote node.

If the FX3U-J1939 receives an address claim message from one of the ECUs listed in this ECU Name list, it checks if the node address has changed. The FX3U-J1939 will adjust its internal configuration to ensure that communication will not fail after an address change (the destination address of TX PGNs or the source Address of RX PGNs is adjusted).

→ For the Industry Group, Vehicle System, Vehicle System Instance, Function, Function Instance, ECU instance, Manufacturer Code and Identity Number, refer to Section 5.17

e.g.

- The FX3U-J1939 is configured to exchange PGN 45312 with node 130.
(ECU name HD0FE.FF00.FFFF.FFFF).
- Node address 130 is claimed by a different ECU.
- ECU (ECU name HD0FE.FF00.FFFF.FFFF) claims node address 131.
- Now the FX3U-J1939 checks the Table in BFM #3000 to #3879.
(Where ECU name HD0FE.FF00.FFFF.FFFF is assigned to node address 130)
- The FX3U-J1939 adjusts the configuration to ensure PGN 45312 is from now on exchanged with node 131.

Note

If not using the remote node address to ECU name assignment, set K-1 to Node address.

BFM No.	Description	Bit Length	Default Value	Remote ECU
BFM #3000	Node address*1	8 bit	K-1 (Not used)	1st remote node address to ECU name assignment
BFM #3001	Arbitrary address capable field	1 bit	K0	
BFM #3002	Industry Group	3 bit	K0	
BFM #3003	Vehicle System	7 bit	K0	
BFM #3004	Vehicle System Instance	4 bit	K0	
BFM #3005	Function	8 bit	K0	
BFM #3006	Function Instance	5 bit	K0	
BFM #3007	ECU instance	3 bit	K0	
BFM #3008	Manufacturer Code	11 bit	K0	
BFM #3009	Identity Number (LW)	21 bit	K0	
BFM #3010	Identity Number (HW)		K0	
BFM #3011	Node address*1	8 bit	K-1 (Not used)	2nd remote node address to ECU name assignment
BFM #3012	Arbitrary address capable field	1 bit	K0	
BFM #3013	Industry Group	3 bit	K0	
BFM #3014	Vehicle System	7 bit	K0	
BFM #3015	Vehicle System Instance	4 bit	K0	
BFM #3016	Function	8 bit	K0	
BFM #3017	Function Instance	5 bit	K0	
BFM #3018	ECU instance	3 bit	K0	
BFM #3019	Manufacturer Code	11 bit	K0	
BFM #3020	Identity Number (LW)	21 bit	K0	
BFM #3021	Identity Number (HW)		K0	
⋮	⋮	⋮	⋮	⋮

BFM No.	Description	Bit Length	Default Value	Remote ECU
BFM #3869	Node address ^{*1}	8 bit	K-1 (Not used)	80th remote node address to ECU name assignment
BFM #3870	Arbitrary address capable field	1 bit	K0	
BFM #3871	Industry Group	3 bit	K0	
BFM #3872	Vehicle System	7 bit	K0	
BFM #3873	Vehicle System Instance	4 bit	K0	
BFM #3874	Function	8 bit	K0	
BFM #3875	Function Instance	5 bit	K0	
BFM #3876	ECU instance	3 bit	K0	
BFM #3877	Manufacturer Code	11 bit	K0	
BFM #3878	Identity Number (LW)	21 bit	K0	
BFM #3879	Identity Number (HW)		K0	

- *1. Set the node address used in FX3U-J1939 configuration.
 K-1 or any node address K0 (H00) to K253 (HFD) can be set, except the address set in the BFM #27. Setting K-1 indicates that the node is not used. Broadcast (K255 = HFF) and cannot claim (K254 = HFE) are invalid settings. When the FX3U-J1939 is set to online (BFM #25 bit 4 set to ON), bit 15 of the node address BFM is set to indicate that the address is not yet valid. As soon as a valid Address Claim matching the ECU name defined by the following 10 BFMs is received, bit 15 is reset to OFF and the current node address is displayed.

→ For the configuration of the J1939 message, refer to Section 6.2
 → For node address of FX3U-J1939, refer to Section 5.9 and Section 5.10

1

Introduction

2

Specifications

3

Installation

4

Wiring

5

Allocation of Buffer Memories

6

J1939 Comms Mode

7

Layer 2 Communication Mode

8

PLCRUN>STOP Messages

9

Command Interface

10

Communication Settings Procedure

6. J1939 Communication Mode

6.1 Send/Receive Data Buffer

The FX3U-J1939 supports 75 standard messages (with up to 8 bytes) and 4 extended messages (with up to 250 bytes). It is also possible to combine several standard messages for data packages up to 250 bytes.

6.1.1 [BFM #100 to #399] Send/receive data buffer for standard messages

These BFMs are used to buffer network data.

- For details, see the manual of the source/target module or the corresponding J1939 specification
- For the extended data area, refer to Subsection 6.1.2
- For the Configuration area, refer to Section 6.2

BFM No.	Transmit/Receive Data		Message No.
	High Byte	Low Byte	
BFM #100	2nd data byte	1st data byte	Message 1
BFM #101	4th data byte	3rd data byte	
BFM #102	6th data byte	5th data byte	
BFM #103	8th data byte	7th data byte	
BFM #104	2nd data byte	1st data byte	Message 2
BFM #105	4th data byte	3rd data byte	
BFM #106	6th data byte	5th data byte	
BFM #107	8th data byte	7th data byte	
BFM #108	2nd data byte	1st data byte	Message 3
BFM #109	4th data byte	3rd data byte	
BFM #110	6th data byte	5th data byte	
BFM #111	8th data byte	7th data byte	
⋮	⋮	⋮	⋮
BFM #396	2nd data byte	1st data byte	Message 75
BFM #397	4th data byte	3rd data byte	
BFM #398	6th data byte	5th data byte	
BFM #399	8th data byte	7th data byte	

6.1.2 [BFM #1300 to #1799] Send/receive data buffer for extended messages

These BFM's are used to buffer network data.

- For details, see the manual of the source/target module or the corresponding J1939 specification
- For the Configuration area, refer to Section 6.2

BFM No.	Transmit/Receive data		Message No.
	High Byte	Low Byte	
BFM #1300	2nd data byte	1st data byte	Extended Message 1
BFM #1301	4th data byte	3rd data byte	
⋮			
BFM #1423	248th data byte	247th data byte	
BFM #1424	250th data byte	249th data byte	Extended Message 2
BFM #1425	2nd data byte	1st data byte	
BFM #1426	4th data byte	3rd data byte	
⋮			
BFM #1548	248th data byte	247th data byte	Extended Message 3
BFM #1549	250th data byte	249th data byte	
BFM #1550	2nd data byte	1st data byte	
BFM #1551	4th data byte	3rd data byte	
⋮			Extended Message 4
BFM #1673	248th data byte	247th data byte	
BFM #1674	250th data byte	249th data byte	
BFM #1675	2nd data byte	1st data byte	
BFM #1676	4th data byte	3rd data byte	Extended Message 4
⋮			
BFM #1798	248th data byte	247th data byte	
BFM #1799	250th data byte	249th data byte	

6.2 [BFM #500 to #973] Configuration Area

The following table shows the format of the configuration data.

The differentiation between read and write is specified by the 3rd BFM (ttype) for each message.

BFM No.	Description		Default Value	Assigned Data BFM
	TX (Transmit Data Parameter Settings)	RX (Receive Data Parameter Settings)		
BFM #500, #501	PGN bit 17 to 0 (includes Destination Address)	Filter PGN bit 17 to 0	HFFFFFFF	BFM #100 to #103 Standard 8 byte message 1
BFM #502	ttype	J1939 communication mode K-1 (HFFFF) (receive message)	H0000	
BFM #503	Priority	Filter Source Address	H0000	
BFM #504	Interval [× 10 ms]	Receive Timeout [× 10 ms]	H0000	
BFM #505	DLC	DLC	H0000	
BFM #506, #507	PGN bit 17 to 0 (includes Destination Address)	Filter PGN bit 17 to 0	HFFFFFFF	BFM #104 to #107 Standard 8 byte message 2
BFM #508	ttype	J1939 communication mode K-1 (HFFFF) (receive message)	H0000	
BFM #509	Priority	Filter Source Address	H0000	
BFM #510	Interval [× 10 ms]	Receive Timeout [× 10 ms]	H0000	
BFM #511	DLC	DLC	H0000	
⋮	⋮	⋮	⋮	⋮

- 1 Introduction
- 2 Specifications
- 3 Installation
- 4 Wiring
- 5 Allocation of Buffer/Memories
- 6 J1939 Comms Mode
- 7 Layer 2 Communication Mode
- 8 P/C RUN>STOP Messages
- 9 Command Interface
- 10 Communication Settings Procedure

BFM No.	Description		Default Value	Assigned Data BFM
	TX (Transmit Data Parameter Settings)	RX (Receive Data Parameter Settings)		
BFM #938, #939	PGN bit 17 to 0 (includes Destination Address)	Filter PGN bit 17 to 0	HFFFFFFF	BFM #392 to #395 Standard 8 byte message 74
BFM #940	ttype	J1939 communication mode K-1 (HFFFF) (receive message)	H0000	
BFM #941	Priority	Filter Source Address	H0000	
BFM #942	Interval [\times 10 ms]	Receive Timeout [\times 10 ms]	H0000	
BFM #943	DLC	DLC	H0000	
BFM #944, #945	PGN bit 17 to 0 (includes Destination Address)	Filter PGN bit 17 to 0	HFFFFFFF	BFM #396 to #399 Standard 8 byte message 75
BFM #946	ttype	J1939 communication mode K-1 (HFFFF) (receive message)	H0000	
BFM #947	Priority	Filter Source Address	H0000	
BFM #948	Interval [\times 10 ms]	Receive Timeout [\times 10 ms]	H0000	
BFM #949	DLC	DLC	H0000	
BFM #950, #951	PGN bit 17 to 0 (includes Destination Address)	Filter PGN bit 17 to 0	HFFFFFFF	BFM #1300 to #1424 Extended 0 to 250 byte message 1
BFM #952	ttype	J1939 communication mode K-1 (HFFFF) (receive message)	H0000	
BFM #953	Priority	Filter Source Address	H0000	
BFM #954	Interval [\times 10 ms]	Receive Timeout [\times 10 ms]	H0000	
BFM #955	DLC	DLC	H0000	
⋮	⋮	⋮	⋮	⋮
BFM #968, #969	PGN bit 17 to 0 (includes Destination Address)	Filter PGN bit 17 to 0	HFFFFFFF	BFM #1675 to #1799 Extended 0 to 250 byte message 4
BFM #970	ttype	J1939 communication mode K-1 (HFFFF) (receive message)	H0000	
BFM #971	Priority	Filter Source Address	H0000	
BFM #972	Interval [\times 10 ms]	Receive Timeout [\times 10 ms]	H0000	
BFM #973	DLC	DLC	H0000	

1. PGN bit 17 to 0 (include Destination Address)

PGN to be transmitted is specified by the lower 18 bits (bit 0 to 17) as shown below. The PGN must also include the Destination Address if applicable.

Note

For unused messages, set HFFFFFFF to the PGN.

A PGN contains following four fields information. The PF field decides whether PDU 1 format or PDU 2 format is used. In PDU 1 format (PF = K0 to K239), the PS field contains the destination address for the message. In PDU 2 format (PF = K240 to K255), the PS field contains the group extension.

Bit	31.....18	17	16	15.....8	7.....0
	Not Used (Set bit 2 to 15 to OFF.)	EDP (Extend data page)	DP (Data page)	PDU Format (PF)	PDU specific (PS)

Note

- When a configuration parameter of the FX3U-J1939 requires a PGN (including destination address), the set value must include the target node address if the PGN is using PDU 1 Format. If a PGN is using PDU 2 format, the PGN does not require target address.
e.g. PGN 59904 shall be used to request certain information from the network from node 30. PGN 59904 is shown below.

PGN 59904 (HEA00)

Bit	31.....18	17	16	15.....8	7.....0
	Not Used (Set bits 2 to 15 to OFF.)	EDP = OFF	DP = OFF	PF = EA (hex)	PS = 00 (hex)

As this PGN is PDU 1 format, it requires a destination address. PGN with added target address to PS field is shown below.

Bit	31.....18	17	16	15.....8	7.....0
	Not Used (Set bit 2 to 15 to OFF.)	EDP = OFF	DP = OFF	PF = EA (hex)	PS = 1E (hex)

Therefore, PGN (including destination address) is set to 59934 (HEA1E).

- Some PGNs can not be combined with certain destination addresses.
 - Overview Rx Message valid and invalid settings

Format	Destination	DLC	Mode	Description
PDU1	Any*1	0 to 8	J1939 communication	Setting Valid
PDU1	BFM #27	9 to 250		Setting Valid
	HFF			Setting Valid (receive Broadcast messages)
	Any other address (not BFM #27, not HFF)*1			Setting Invalid. DLC 9 to 250 requires a Point to Point connection. As the "Destination" address is not equal to BFM #27 or Broadcast, the FX3U-J1939 can not participate in the Point to Point communication.
PDU2	-	0 to 250		Setting Valid

*1. Address HFE is an invalid address for all user messages.

1	Introduction
2	Specifications
3	Installation
4	Wiring
5	Allocation of Buffer Memories
6	J1939 Comms Mode
7	Layer 2 Communication Mode
8	PLC RUN>STOP Messages
9	Command Interface
10	Communication Settings Procedure

- Overview Tx Message valid and invalid settings

Format	Destination	DLC	Mode	Description
PDU1	BFM #27	0 to 250	J1939 communication	Setting Invalid
	HFF			Setting Valid (Transmit Broadcast messages)
	Any other address (not BFM #27, not HFF) ^{*1}			Setting Valid
PDU2	-	0 to 250		Setting Valid

*1. Address HFE is an invalid address for all user messages.

- Additional notes for PDU1 format

If the same PDU1 PGN is configured with multiple destination addresses, the following cases need to be taken into account:

- a) Tx user messages can be either addressed to several explicit destination addresses OR to broadcast the address HFF.
- b) In general, a PDU1 PGN in a RX user message should use the FX3U-J1939 address (BFM #27) as the destination.
e.g. BFM #27 = H80, PGN = HB100 >> filter PGN = HB180.
- c) The Destination address of a RX user message can be set to a destination address other than BFM #27. (The FX3U-J1939 is listening to a message targeting a different node.) As mentioned in the table "Overview Rx Message valid and invalid settings" this setting is valid only for messages with max. 8 data bytes.

RX user messages can be addressed to both explicit destination addresses AND to broadcast address HFF at the same time, as long as the DLC is 8 byte or less.

Direction	Configured User Messages (all messages same DLC, e.g. all DLC = 8byte)		Description
TX	HB101, HB102, HB103	valid	Requests from node 1 to 3 will be answered. Requests from any other node will result in a NAK message if PtP, or a timeout if request was sent broadcast.
	HB101, HB102, HB103, HB1FF	invalid	The broadcast message (HB1FF) will overwrite the data written to node 1-3 (HB101 to HB103).
	HB1FF (no other HB1xx message configured)	valid	Only broadcast requests are answered, PtP requests will be answered by NAK.
RX	HB101, HB102, HB103, HB1FF	valid	Messages transporting the specified PGNs are stored, any other (HB104 to HB1FD) are ignored. The first 3 user messages will store the PGNs HB101 to HB103 but no broadcast messages, while the last slot stores only broadcast messages.

2. Priority

Set the priority of the message.

Setting range: K0 to K7 (where K0 is the highest priority)

→ For default priority of each PGN, refer to the related SAE J1939 Specification

3. ttype (transmission type)

The transmission type defines the trigger for messages to be sent on the network. All configured transmit messages will be sent when the module is set from configuration to online mode. After this first transmission, the message will be sent every time the condition of the selected transmission type is satisfied.

ttype	Function Mode [BFM #21]	Description
	K1939	
K0	✓	When BFM #20 bit 0 is set to ON, the message is always transmitted.
K1	✓	When BFM #20 bit 0 is set to ON, the message is transmitted. However, if data has not been changed, it is not transmitted.
K2	✓	When the cycle time set by an interval parameter elapses, the message is always transmitted.
K3	✓	When the cycle time set by an interval parameter elapses, the message is transmitted. However, if data has not been changed, it is not transmitted.
K4	✓	The message transmits on one of the following conditions. <ul style="list-style-type: none"> • PGN Request*2 • Message transmit trigger flags The message transmits when the corresponding message transmit trigger flag in BFM #1280 to #1284 is set to ON. → For the message transmit trigger flag, refer to Section 5.20
K-1	✓	Receive message

The following table describes the relation between ttype and communication method (transmission of data).

ttype	Communication Method	Communication Method	
		DLC ≤ 8	DLC > 8
K-1, K0 to K4	J1939	Single Frame message	Point-to-point or BAM (Multi message)

*2. J1939 communication mode does not use remote transmit request (RTR) frames to request certain information from the network.

The CAN Layer 2 function RTR will not work because although the priority and the source and the destination node address are part of the J1939 CAN-ID, they might not be known by the requesting node. Instead, J1939 uses the PGN 59904 (H0EAxx where xx is the destination node number) to request data from remote nodes:

e.g.
Request PGN 65248 (HFEE0) from the network
PGN 59904 default priority = 06
Requesters node number = nn

CAN-ID Request Message	Data Length (DLC)	Data			Destination Node
		1st Data Byte	2nd Data Byte	3rd Data Byte	
0x06EA18nn	3	0xE0	0xFE	0x00	24 (H18)
0x06EAFFnn	3	0xE0	0xFE	0x00	HFF = BC (Broadcast)

- 1 Introduction
- 2 Specifications
- 3 Installation
- 4 Wiring
- 5 Allocation of Buffer Memories
- 6 J1939 Comms Mode
- 7 Layer 2 Communication Mode
- 8 PLC RUN→STOP Messages
- 9 Command Interface
- 10 Communication Settings Procedure

Remote transmission request

The CAN standard defines a service to request certain information from the network. Upon reception of this kind of request, every node checks if it is the producer of the requested information. The producer node of the requested data will respond with the desired data.

The request differs between Layer 2 and J1939 mode.

Function Mode	Remote Transmit Request Format	Applies To
J1939 communication mode	SAE J1939 defines the PGN 59904 for remote transmit requests. The request message contains 3 data bytes with the requested PGN (low byte first). If the requested PGN is configured as a transmit message of the FX3U-J1939, the module will respond with a data frame.	All configured transmit PGNs.
Layer 2 communication mode	The remote transmit request flag in the CAN message is set, and the CAN-ID of the message matches exactly with the ID of one of the FX3U-J1939 configured transmit message IDs.	A maximum of 28 transmit messages with enabled auto or manual RTR handling. → Refer to Section 7.3

Manual/PLC transmission trigger

The transmission of any configured transmit message can be triggered by setting the corresponding bit in BFM #1280 to #1284.

Transmission Type K0 and K1

Transmission type K0 and K1 are controlled by BFM #20 bit 0.

- Transmission type = K0
When BFM #20 bit 0 is set to ON, the message is always transmitted.
- Transmission type = K1
When BFM #20 bit 0 is set to ON, the message is transmitted. However, if data has not been changed, it is not transmitted.

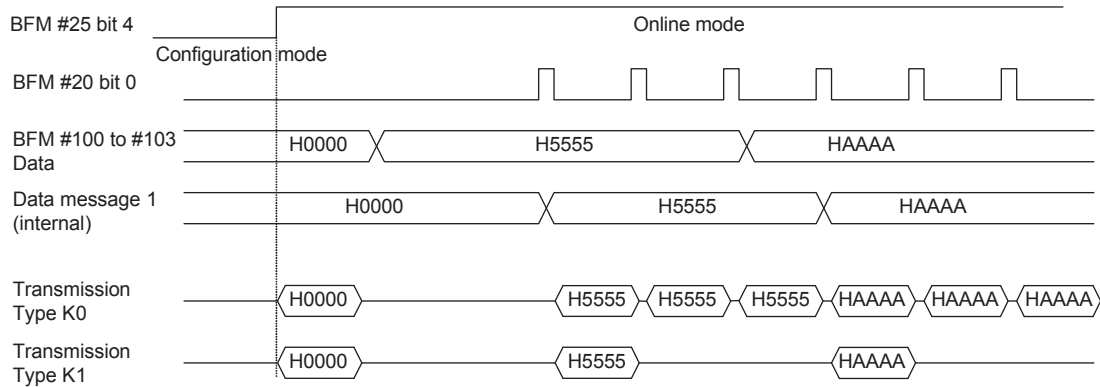

Transmission Type K2 and K3

Transmission type K2 and K3 are time controlled.

If the transmission was triggered by remote request or manual/PLC trigger, the interval timer is restarted, and the next transmission will be suspended for the set interval to avoid unnecessary data traffic caused by remote requests or manual triggers.

- Transmission type = K2
When the time interval elapses, the message is always sent.
- Transmission type = K3
When the time interval elapses, the message is sent. However, if data has not been changed, it is not transmitted.

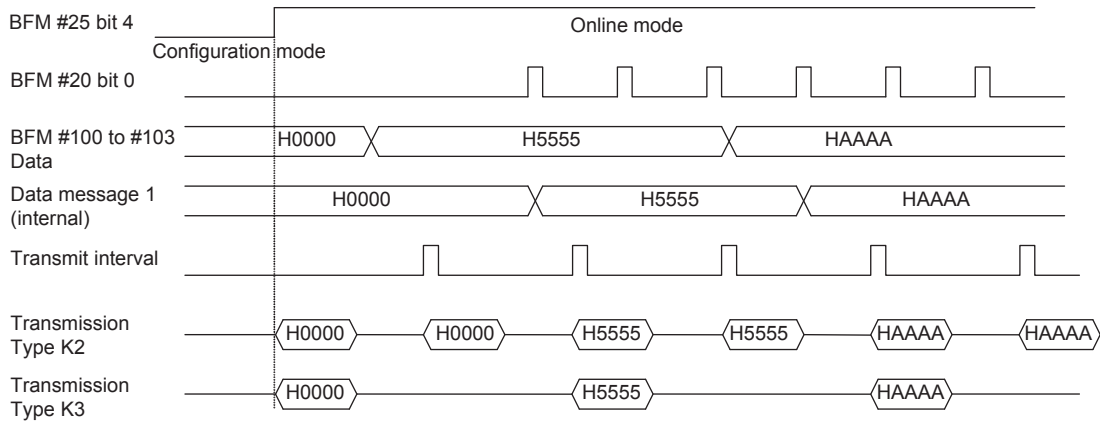

The user interval set for the message is restarted every time the message is transmitted.

In case the transmission is triggered by a request message from the network or manual trigger (BFM #1280 to #1284), the next transmission after externally/manual triggered message will not be sent in the former interval "**1," but in the new interval related to the external/manual trigger event.

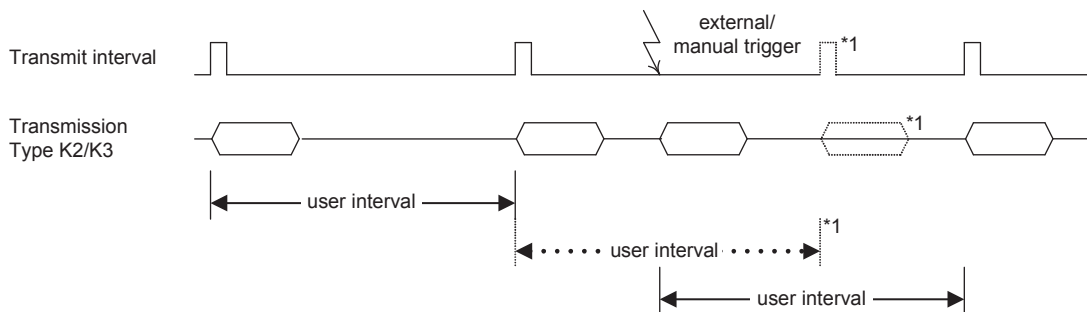

1	Introduction
2	Specifications
3	Installation
4	Wiring
5	Allocation of Buffer Memories
6	J1939 Comms Mode
7	Layer 2 Communication Mode
8	PLC RUN→STOP Messages
9	Command Interface
10	Communication Settings Procedure

Transmission Type K4

Transmission type K4 will trigger the transmission only upon explicit request from the network or PLC/user trigger.

1) Transmission Type K4 (trigger via remote request frame)

When the FX3U-J1939 receives a valid request frame for supported information, it will respond with the most recent internal data that is copied from the BFM every time BFM #20 bit 0 is set to ON.

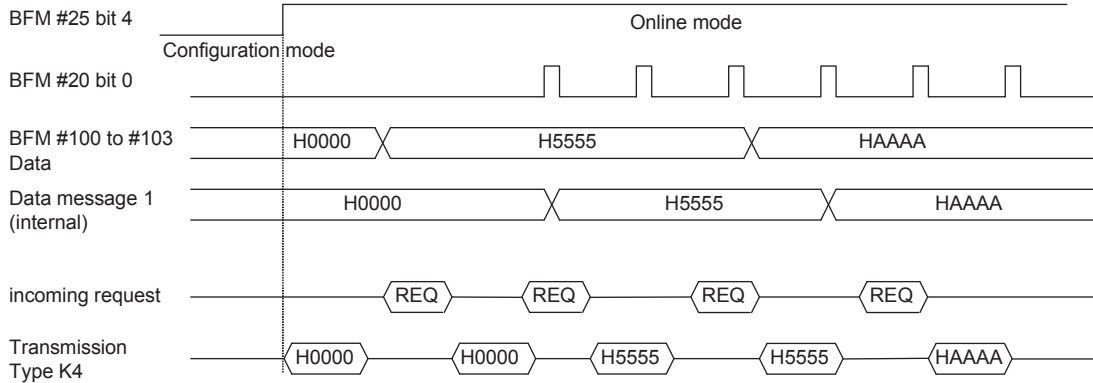

2) Transmission Type K4 (trigger via PLC/user flag)

The message transmits when the corresponding message transmit trigger flag in BFM #1280 to #1284 is set to ON.

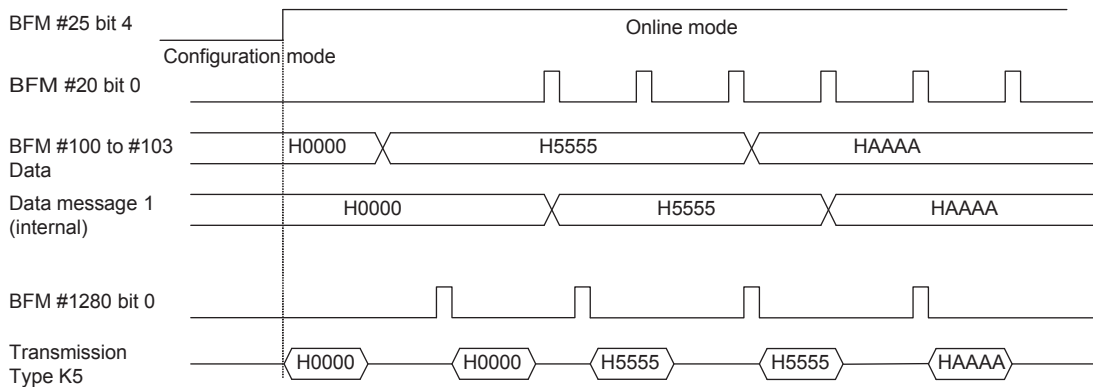

4. Interval [in units of 10 ms]

The Interval setting is used when the transmission type (ttype) is set to K2 or K3. Setting is in units of 10 ms. The maximum value is K65535 (HFFFF) = 655.35 seconds.

The Interval must be longer than the min. interval, which is calculated by the following formula:

$$\text{min.interval} = \text{INT} \left(\frac{\text{DLC} + 13}{7} \right) \times 51 \text{ ms}$$

Example: BFM #505 = K58 (DLC)

$$\text{min.interval} = \text{INT} \left(\frac{58 + 13}{7} \right) \times 51 \text{ ms} = 10 \times 51 \text{ ms} = 510 \text{ ms}$$

⇒ Interval setting: BFM #504 = K52 (K52 x 10 ms > min. interval time)

Note

- The Interval should be set while taking into consideration the PLC scan cycle and communications response time, etc.
- If Interval is set to K0, it is automatically adjusted to K1 and operation at 10 ms.
- Values larger than K32767 will be displayed as negative values by the monitor software.

5. DLC (data length count)

Set the number of bytes to be transmitted to 0 to 8 bytes for standard messages (single frame). For the last four settings (BFM #950 to #973), the DLC can be up to 250. Please keep in mind that the transmission/reception of this amount of data must be segmented and transferred in multiple CAN messages and should be used for non time critical data only (e.g. recipes, configuration or text to be displayed on a HMI.).

Setting range: K0 to K8 [K9 to K250] (standard message 1 to 75), 0 to 250 (extended message 1 to 4)

Note

If the four extended buffers are not sufficient, several standard 8 byte message buffers can be combined to transport messages of up to 250 bytes. If the DLC of a standard message is set to 9 bytes or more, many subsequent messages are occupied to buffer the number of data bytes defined by the DLC. The subsequent configuration BFM's are filled with copies of the parameters set in the first message. If the DLC value occupies more messages than available, an error will be generated for the DLC BFM (BFM #29 bit 6 ON, BFM #39 = DLC BFM address).

e.g.

If the DLC of message 2 is set to 20 (3 standard 8 byte messages are required to transport 20 bytes), the configuration set in message 2 (BFM #506 to #511) is copied into message 3 and 4 (BFM #512 to #523). The message data is located in BFM's #104 to #113 for messages 2 to 4. BFM's #114 and #115 are unused. Message 3 and 4 configuration BFM's (#512 to #523) are write protected and locked as long as the DLC in message 2 remains 20. If message 2 DLC is set back to 8 byte or less, message 3 and 4 are released and can be used independently from message 2 again. If the DLC is increased, further messages will be occupied as required, as long as these messages are not already in use (PGN bit 0 to 17 parameter BFM's are not equal to HFFFF).

It is not possible to combine extended messages with standard 8 byte messages or other extended messages. The max. data block size is 250 bytes.

For a configuration setting example of a message larger than 8 bytes, refer to the following section.

→ **For configuration setting example in J1939 communication mode, refer to Subsection 6.2.1**

6. Filter PGN

Defines the PGN for receive messages. Receive messages are stored to the corresponding location in BFM #100 to #399 (standard 8 byte messages) and BFM #1300 to #1799 (extended messages).

→ **For valid PGN values, refer to the remote devices manual or SAE J1939 Specification**

7. Filter Source Address

Can be used to define a stricter Filter. The PGN is received only if PGN and source Address filter are satisfied. This can be required if a certain PGN/Information is transmitted by several nodes (e.g. PGN 65262 "Engine Temperature 1" received from two independent generator units).

Set the filter source address to H00FF to receive a PGN no matter which node is the source.

Setting range: K0 to K253, K255 (any source).

8. Receive Timeout [in units of 10 ms]

This setting can be used to define a timeout for the message reception. If the value is set to K0, the timeout detection is disabled. If the value is set to a Value different from K0, the FX3U-J1939 is guarding the reception of the user message. If no message is received for the defined time, an error (H2004) is set for the corresponding user message slot.

→ **For Message specific error codes list, refer to Section 5.19**

Note

- If the Timeout time is set too short (e.g. 50 ms for a broadcast message which takes at least 100 ms) an error is generated for this parameter.
- The timer is started when the module is set to online. If the message is not received at all, the reception timeout error is generated "reception timeout" × 10 ms after the module is set to online.
- Values larger than K32767 will be displayed as negative values by the monitor software.

1

Introduction

2

Specifications

3

Installation

4

Wiring

5

Allocation of Buffer Memories

6

J1939 Comms Mode

7

Layer 2 Communication Mode

8

PLC RUN>STOP Messages

9

Command Interface

10

Communication Settings Procedure

6.2.1 Example configuration setting for J1939 communication mode

The configuration setting example of a message of 20 bytes which combines three standard 8 byte message buffers starting at message 4 is shown below.

Transmit data parameter settings case:

PGN bit 17 to 0 (includes Destination Address): K45364 (HB134)
 PGN = K45312 (HB100, "Proprietarily Configurable Message 1"),
 destination node = K52 (H34)
 ttype: K2 (transmission once every 10 seconds, determined by interval setting.)
 Priority: K6 (default)
 Interval: K1000 (1000 × 10 ms = 10 seconds)
 DLC: K20 (Total 20 bytes)

Receive data Parameter settings case:

PGN bit 17 to 0 (includes Destination Address): K45364 (HB134)
 PGN = K45312 (HB100, "Proprietarily Configurable Message 1"), source node = K52 (H34)
 ttype: K-1 (receive message)
 Filter Source Address: H00FF (Any source address)
 DLC: K20 (Total 20 byte)

Message configuration

BFM No.	Description	
	TX (Transmit Data Parameter Settings)	RX (Receive Data Parameter Settings)
BFM #518, #519	K45364 (HB134) (PGN)	K45364 (HB134) (PGN)
BFM #520	K2 (J1939 time triggered tx message)	K-1 (J1939 receive message)
BFM #521	K6 (priority)	H00FF (Any source address)
BFM #522	K100 (1 second interval)	K0 (Receive timeout disable)
BFM #523	K20 (Total DLC)	K20 (Total DLC)
BFM #524, #525	K45364 (HB134) (PGN) ^{*1}	K45364 (HB134) (PGN) ^{*1}
BFM #526	K2 ^{*1}	K-1 ^{*1}
BFM #527	K6 ^{*1}	H00FF ^{*1}
BFM #528	K100 ^{*1}	K0 ^{*1}
BFM #529	K20 ^{*1}	K20 ^{*1}
BFM #530, #531	K45364 (HB134) (PGN) ^{*1}	K45364 (HB134) (PGN) ^{*1}
BFM #532	K2 ^{*1}	K-1 ^{*1}
BFM #533	K6 ^{*1}	H00FF ^{*1}
BFM #534	K100 ^{*1}	K0 ^{*1}
BFM #535	K20 ^{*1}	K20 ^{*1}

*1. Parameters in BFM #524 to #535 are automatically copied from BFM #518 to #523 by the FX3U-J1939.

Message send/receive BFM

BFM No.	Description	Message No.
BFM #112 to #115	20 byte message communication buffer TO: Send data FROM: Receive data	Message 4
BFM #116 to #119		Message 5
BFM #120		Message 6
BFM #121		
BFM #122		
BFM #123		

6.2.2 Example J1939 communication mode use of RUN>STOP messages and remote address to ECU name assignment

These examples show the use of the RUN>STOP Messages in J1939 communication mode. Additionally, the function of the Remote Address to ECU Name assignment and its effect on user Messages and the RUN>STOP Messages is shown.

The two examples show the behaviour for the configuration below. The FX3U-J1939 (node "A") is using node address H80 (BFM #27) and communicates with Remote Node "B." For easier understanding, the ECU Name of node "B" is addressed with "ECU Name Node B" instead of repeating the Values (Arbitrary Address Capable = yes, Industry Group = K5, Vehicle System = K127, Vehicle System Instance = K0, Function = K0, Function Instance = K1, ECU Instance = K0, Manufacturer Code = K2047 and Identity Number = H1F.FFFF). The first User Message (BFM #500 to #505) is configured with a TX Message, the second message (BFM #506 to #511) is configured for reception. Any other user message (BFM #512 to #973) could be used instead with the same effect.

For this example, only the two messages are expected to be present in the user message configuration. If additional messages are configured, the behaviour of the module may differ from the described.

The first RUN>STOP message (BFM #1900 to #1906) is used in this example, but the second to fourth (BFM #1907 to #1927) can be used with the same effect. In this example, only a single RUN>STOP message is expected to be configured. If the other three messages are not disabled, behaviour may be different than described.

Note

- There is no relation between the user message numbers, RUN>STOP messages or Remote Address to ECU Name assignments. These examples would work the same if user message 4 and 30, Run>STOP message 3 and Remote Address to ECU Name assignment 40 are used instead of the messages 1 and 2 used for all functions in these examples.
- Both setups have advantages and disadvantages. Ensure proper behaviour of your network according to your applications behaviour and requirements.
- The RUN>STOP message in example 2 is not transmitted if the node "B" sends a can not claim message (node "B" could not acquire a node address) or does not send an address claim at all. As long as no valid address for node "B" is available (e.g. BFM #1900 "mm" = HFE), the message is not sent!

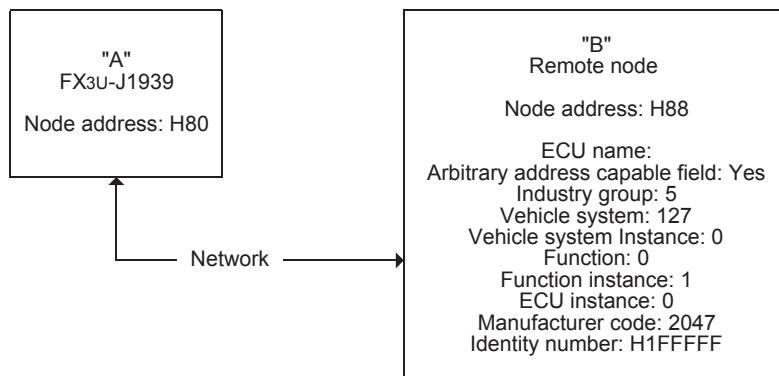

- 1) Tx/Rx User messages and one RUN>STOP message configured, but no Remote Address to ECU Name assignment

BFM No.	Configuration*1	Configuration Effect	Display in Online	Behaviour If Node "B" Sends Address Claim for Address H89
BFM #500, #501	HB188	TX Message PGN HB188 (Target address H88) Sent with priority 6 and 8 data bytes every second.	Same as in Configuration/Offline	No change: !!The target address of the TX message is still H88!! If node "B" expects now to receive PGN HB189 (target address H89), communication fails!
BFM #502	K2			
BFM #503	K6			
BFM #504	K100			
BFM #505	K8			

BFM No.	Configuration* ¹	Configuration Effect	Display in Online	Behaviour If Node "B" Sends Address Claim for Address H89
BFM #506, #507	HB280	RX Message PGN HB280 with 8 data bytes Source must be node H88	Same as in Configuration/Offline	No change: !!The source must still be H88!! Node "B" will transmit any messages with the new node address H89 >> communication fails!
BFM #508	K-1			
BFM #509	H88			
BFM #510	K0			
BFM #511	K8			
BFM #3000	HFFFF	No ECU name assigned		n.a.
BFM #3001 to #3010	H0000			
BFM #1900, #1901	H0CB3.88nn* ²	Run>STOP message PGN HB388 (Target address H88) Sent with priority 6 and 5 data bytes		No change: RUN>STOP message destination is still H88. !!High chance that node "B" will not receive this message!!
BFM #1902	H0005			
BFM #1903 to #1906	Any data			

- *1. The Configuration values equal the Values displayed in Offline.
- *2. The low byte "nn" is replaced by the current node address of the FX3U-J1939. If the FX3U-J1939 does not own a valid address due to an address conflict or if the address claiming was not completed, HFE is shown.
- 2) Tx/Rx User messages and one RUN>STOP message configured and Remote Address to ECU Name assignment for Node B

BFM No.	Configuration* ³	Configuration Effect	Display in Online	Behaviour If Node "B" Sends Address Claim for Address H89
BFM #500, #501	HB188	TX Message PGN HB188 (Target address H88) Sent with priority 6 and 8 data bytes every second.	Same as in Configuration/Offline	Target address is changed from H88 to H89.
BFM #502	K2			
BFM #503	K6			
BFM #504	K100			
BFM #505	K8			
BFM #506, #507	HB280	RX Message PGN HB280 with 8 data bytes Source must be node H88		Source is changed from H88 to H89, messages from Node "B" will still be received.
BFM #508	K-1			
BFM #509	H88			
BFM #510	K0			
BFM #511	K8			
BFM #3000	H88	Node "B" identified by "ECU Name Node B" is assigned to node Address H88 in the configuration: Any TX destination "H88" is assigned to node "B" Any Rx source "H88" is assigned to node "B"	BFM #3000 Displays H8088 until node "B" sends a valid address claim, afterwards the current node address (e.g. H89) is displayed Other BFM's same as in Configuration/Offline	Any address claim using the "ECU Name Node B" is causing an adjustment of all messages exchanged with node "B". All messages sent to address H88 before, are sent to address H89 now. All Messages received from address H88, are expected to be sent from address H89 now.
BFM #3001	K1			
BFM #3002	K5			
BFM #3003	K127			
BFM #3004	K0			
BFM #3005	K0			
BFM #3006	K1			
BFM #3007	K2047			
BFM #3008	K0			
BFM #3009	HFFFF			
BFM #3010	H001F			
BFM #1900, #1901	H0CB3.88nn* ⁴	Run>STOP message PGN HB388 (Target address H88) Sent with priority 6 and 5 data bytes	H0CB3.mmnn* ^{4*5}	New address of node "B" is used as destination Node "B" will receive the RUN>STOP message.
BFM #1902	H0005		H0005	
BFM #1903 to #1906	Any data		Any data	

- *3. The Configuration values equal the Values displayed in Offline.
- *4. The low byte "nn" is replaced by the current node address of the FX3U-J1939. If the FX3U-J1939 does not own a valid address due to an address conflict or if the address claiming was not completed, HFE is shown.
- *5. The 2nd byte "mm" displays the node address currently in use. When the node address becomes invalid (e.g. due to the address change from H88 > H89 in this example), the address is set to HFE.

7. Layer 2 Communication Mode (11/29 bit ID)

This chapter describes the data transfer locations and setting of the Layer 2 communication (11/29 bit ID) mode. In this mode up to 42 predefined messages can be sent/received.

Moreover, Layer 2 messages can be sent via CIF.

In 11 bit ID mode (BFM #21 = K11), the module sends and receives only CAN messages with an 11 bit identifier. In 29 bit ID mode (BFM #21 = K29), the module sends and receives only CAN messages with a 29 bit identifier.

Note

- To ensure that the FX3U-J1939 module can handle the Layer 2 message in a consistent way, it is necessary to set BFM #20 bit 0 to ON before reading the received message (FROM) and after writing the transmitted message (TO) to the module.
→ For BFM #20 bit 0, refer to Section 5.3
- To activate the Layer 2 communication (11/29 bit ID) mode, write into BFM #21 the value K11 or K29, and reset the module.
→ For module reset, refer to Section 5.7
- BFMs (#40 to #48, #500 to #973, #1300 to #1799, and #3000 to #3879), which are active in J1939 communication mode, are not active and not accessible.

7.1 [BFM #100 to #399] Sending/Receiving Pre-defined Layer 2 Messages

The data transfer locations of the Layer 2 communication (11/29 bit ID) mode are as follows.

Note

The following settings of each message have to be defined in request configuration mode, before requesting online mode.

- The CAN-ID LW, CAN-ID HW and transmitting data byte number (in RTR/new/DLC) in the following BFM
- Layer 2 message configuration in BFM #1100 to #1276
Set the parameters (transmitting/receiving message, etc.) for each message.

→ For Layer 2 message configuration in BFM #1100 to #1267, refer to the Section 7.2

BFM No.	Name	Description		Message No.	Initial Value	Read/Write	Stored to Flash ROM
		High Byte	Low Byte				
BFM #100	CAN-ID 1 LW ^{*1}	11/29 bit CAN-ID low word		Layer 2 message 1	HFFFF	R/W	✓ ^{*2}
BFM #101	CAN-ID 1 HW ^{*1}	11/29 bit CAN-ID high word			HFFFF	R/W	✓ ^{*2}
BFM #102	RTR/new/DLC ^{*1}	Status/Control Flags	DLC		H0	R/W	✓ ^{*2}
BFM #103	Data bytes ^{*1}	2nd data byte	1st data byte		H0	R/W	-
BFM #104		4th data byte	3rd data byte		H0	R/W	-
BFM #105		6th data byte	5th data byte		H0	R/W	-
BFM #106		8th data byte	7th data byte		H0	R/W	-
⋮	⋮	⋮	⋮	⋮	⋮	⋮	

BFM No.	Name	Description		Message No.	Initial Value	Read/Write	Stored to Flash ROM
		High Byte	Low Byte				
BFM #387	CAN-ID 42 LW ^{*1}	11/29 bit CAN-ID low word		Layer 2 message 42	HFFFF	R/W	✓ ^{*2}
BFM #388	CAN-ID 42 HW ^{*1}	11/29 bit CAN-ID high word			HFFFF	R/W	✓ ^{*2}
BFM #389	RTR/new/DLC ^{*1}	Status/Control Flags	DLC		H0	R/W	✓ ^{*2}
BFM #390	Data bytes ^{*1}	2nd data byte	1st data byte		H0	R/W	-
BFM #391		4th data byte	3rd data byte		H0	R/W	-
BFM #392		6th data byte	5th data byte		H0	R/W	-
BFM #393		8th data byte	7th data byte		H0	R/W	-
BFM #394 to #399	Reserved				-	-	-

*1. For details, refer to "When transmitting messages" and "When receiving messages" mentioned shortly hereafter.

*2. These BFM will be stored into the Flash ROM when the save command is executed.

→ For save command, refer to Section 5.5

1. When transmitting messages

The CAN-ID, Status/Control Flags and data bytes of each message are as follows.

1) CAN-ID

The destination of the message is specified by the 32 bit CAN-ID parameter. Valid values are as follows:

- 11 bit mode: 0 to H000007FF
- 29 bit mode: 0 to H1FFFFFFF

→ For function mode, refer to Section 5.4

2) Status/Control Flags

Setting is as follows.

High Byte/Low Byte	Description
High byte	Bit 12 ^{*3} ON: Strict DLC check for RTR Bit 15 ^{*4} OFF: Send data frame Bit 15 ^{*4} ON: Send RTR frame
Low byte	Number of data bytes to transmit (K0 to K8) ^{*3*4}

*3. Bit 12 specifies whether strict DLC check is used for RTR frames. If Bit 12 is OFF, only the CAN-ID of an inbound RTR frame is checked for a match with a user message. If Bit 12 is ON, the CAN-ID and the DLC of the RTR frame must match the user message to cause a response. Otherwise, BFM #1270 to #1272 flag to be set. Bit 15 and Bit 12 can not be set ON at the same time.

*4. Bit 15 defines if the message is transmitted as a data frame (Bit 15 OFF) or a Remote Transmit frame (Bit 15 ON). Bit 15 and Bit 12 cannot be set ON at the same time.

3) Data bytes

Store the data to transmit. The data length of the transmit data is set by DLC.

2. When receiving messages

The CAN-ID, status/control flags and data bytes of each message are as follows.

Note

In case more than one ID can pass the filter set in BFM #1100 to #1267, the received CAN-ID might change. The CAN-ID, DLC and data of the latest received message will always be displayed.

→ For Layer 2 message configuration in BFM #1100 to #1267, refer to Section 7.2

1) CAN-ID

The 32 bit source CAN-ID of the received Layer 2 message is stored. Values are as follows:

- 11 bit mode: 0 to H000007FF
- 29 bit mode: 0 to H1FFFFFFF

→ For the function mode, refer to Section 5.4

Function Mode	Description
Layer 2 communication (11 bit ID) mode	CAN-ID is stored in the 11 bits, bit 0 to 10, in the CAN-ID n ^{*1} LW. In this function mode, CAN-ID n ^{*1} HW does not used.
Layer 2 communication (29 bit ID) mode	CAN-ID is stored in the 29 bits, bit 0 to 28, in the CAN-ID n ^{*1} LW and CAN-ID n ^{*1} HW. Handle CAN-ID n ^{*1} LW and CAN-ID n ^{*1} HW by 32 bit instructions.

*1. The "n" corresponds to the Layer 2 message number.

2) Status/Control Flags

High Byte/Low Byte	Description
High byte	H00: New data is not received. Bit 8: ON when new data is received. Bit 9: ON when new frame is received. Bit 10: ON when overflowing.*2
Low byte	Data length count (DLC) of the received CAN frame.

*2. If bit 8 of the Status/Control Flags is ON, a new frame including new data has been received and stored. If bit 9 is ON but bit 8 is OFF, the same message (same ID, DLC and data) has been received. If bit 10 is ON, at least one more frame has been stored in this message buffer while bit 8 was ON which caused an overflow condition.

Status/Control Flags	Receive messages only				
	New frame no new data	New frame new data	New frame no new data overflow occur	New frame new data overflow occur	No data received
New data (bit 8)	OFF	ON	ON	ON	- (Do not care)
New frame (bit 9)	ON	ON	OFF	ON	OFF
Overflow (bit 10)	OFF	OFF	ON	ON	- (Do not care)

3) Data bytes

The data received of length specified by DLC is stored.

In case the received DLC is less than 8, unused data bytes are set to H00.

7.2 [BFM #1100 to #1267] Pre-defined Layer 2 Messages Parameter

This section describes the Pre-defined Layer 2 messages configuration.

The Layer 2 message parameter defines if the corresponding Layer 2 message in BFM #100 to #393 is a transmit or receive message, e.g. Layer 2 message parameter 2 (BFM #1104 to #1107) determines the function of Layer 2 message 2 (BFM #107 to #113).

Note

- The Pre-defined Layer 2 messages configuration can be set in offline mode (set BFM #25 bit 4 OFF and wait for BFM #25 bit 0 OFF).
→ **For the communication status (BFM #25), refer to Section 5.7**
- If an invalid value is written to one of BFM #1100 to #1267, then BFM #29 bit 6 is set, and the BFM address is displayed in BFM #39.
- Set parameter A and B of unused Layer 2 messages to HFFFF.

BFM No.	Name	Description	Default Value	Read/Write
BFM #1100	Layer 2 message 1 parameter A	Layer 2 message 1 parameter	HFFFF	R/W
BFM #1101	Layer 2 message 1 parameter B		HFFFF	R/W
BFM #1102	Layer 2 message 1 parameter C		H0000	R/W
BFM #1103	Layer 2 message 1 parameter D		H0000	R/W
BFM #1104	Layer 2 message 2 parameter A	Layer 2 message 2 parameter	HFFFF	R/W
BFM #1105	Layer 2 message 2 parameter B		HFFFF	R/W
BFM #1106	Layer 2 message 2 parameter C		H0000	R/W
BFM #1107	Layer 2 message 2 parameter D		H0000	R/W
⋮	⋮	⋮	⋮	⋮
BFM #1260	Layer 2 message 41 parameter A	Layer 2 message 41 parameter	HFFFF	R/W
BFM #1261	Layer 2 message 41 parameter B		HFFFF	R/W
BFM #1262	Layer 2 message 41 parameter C		H0000	R/W
BFM #1263	Layer 2 message 41 parameter D		H0000	R/W
BFM #1264	Layer 2 message 42 parameter A	Layer 2 message 42 parameter	HFFFF	R/W
BFM #1265	Layer 2 message 42 parameter B		HFFFF	R/W
BFM #1266	Layer 2 message 42 parameter C		H0000	R/W
BFM #1267	Layer 2 message 42 parameter D		H0000	R/W

7.2.1 Pre-defined Layer 2 transmit messages

This subsection describes parameters A to D for the transmit message.

Parameter	Description	Default Value
Layer 2 message number parameter A	Constant HFFFF	HFFFF
Layer 2 message number parameter B	H7FFF (auto RTR response) H6FFF (manual RTR response) H5FFF (disable RTR handling) HFFFF (message disabled)	HFFFF
Layer 2 message number parameter C	Transmission type	H0000
Layer 2 message number parameter D	Cycle time in [10 ms]	H0000

1. Parameter A and B for each Layer 2 message

A message buffer in BFM #100 to #393 is assigned to a Layer 2 transmit message by writing HFFFF in parameter A, and writing H7FFF, H6FFF or H5FFF in parameter B. For unused Layer 2 messages, set parameter A and B to HFFFF.

Note

The Layer 2 implementation of the FX3U-J1939 can handle up to 28 transmit messages with RTR handling (parameter B = H7FFF or H6FFF). If the configuration violates this rule, the first 28 transmit message configurations remain as they are, and RTR handling is disabled for any further transmit messages as parameter B is forced to H5FFF.

→ For Layer 2 RTR flags, refer to Section 7.3

- When using the auto RTR response
Set H7FFF to parameter B for the Layer 2 message.
The FX3U-J1939 automatically responds to Remote Transmit Requests (RTRs) if the 11/29 bit CAN-ID (e.g. setting in BFM #100 and #101) matches the ID in the RTR message.
Reception of the RTR message is not displayed in the Layer 2 RTR Flags.
→ For Layer 2 RTR flags, refer to Section 7.3
- When using the manual RTR response
Set H6FFF to parameter B for the Layer 2 message.
The FX3U-J1939 will not automatically respond to Remote Transmit Requests, but the reception of the RTR message is displayed by the Layer 2 RTR Flag.
→ For Layer 2 RTR flags, refer to Section 7.3
- When using the disable RTR handling
Set H5FFF to parameter B for the Layer 2 message.
The FX3U-J1939 will discard any incoming RTR telegrams matching the CAN-ID of this Layer 2 message.

2. Parameter C "transmission type" for each Layer 2 message

The transmission type defines the transmit/receive message and transmission trigger event of the message as follows.

→ For transmission type, refer to Section 6.2

Transmission Type value	Message Type	Transmission Trigger Event
K0	Transmit message	When BFM #20 bit 0 is set to ON, the Layer 2 message is always transmitted.
K1		When BFM #20 bit 0 is set to ON, the Layer 2 message is transmitted. However, if data has not been changed, it is not transmitted.
K2		The Layer 2 message transmits with following condition. <ul style="list-style-type: none"> • With a cycle time set by parameter D • BFM #20 bit 0 set to ON
K3		The Layer 2 message transmits with following condition. However, if data has not been changed, it is not transmitted. <ul style="list-style-type: none"> • With a cycle time set by parameter D • BFM #20 bit 0 set to ON
K4		The Layer 2 message transmits with following condition. <ul style="list-style-type: none"> • Request via RTR frames Request via RTR frames works for maximum 28 transmit messages. • Manual transmit trigger flags The Layer 2 message transmits when the corresponding manual transmit trigger flag in BFM #1280 to #1284 is set to ON.

→ For the manual transmit trigger flag, refer to Section 5.20

3. Parameter D "cycle time" for each Layer 2 message

This parameter is used when the transmission type (event) is set to K2 or K3. The cycle time is in units of 10 ms

Note

- The cycle time should be set in consideration of the PLC scan cycle and communications response time, etc.
- If the cycle time is set to K0, the value is automatically corrected to K1. Cycle time is 10 ms in this case.

7.2.2 Pre-defined Layer 2 receive messages

This subsection describes parameters A to D for the receive message.

Parameter	Description	Default Value
Layer 2 message number parameter A	Reception CAN-ID low word	HFFFF
Layer 2 message number parameter B	Reception CAN-ID high word	HFFFF
Layer 2 message number parameter C	Reception ID filter bit mask low word	H0000
Layer 2 message number parameter D	Reception ID filter bit mask high word	H0000

1. Parameter A and B for each Layer 2 message

Set the source CAN ID of the received message to parameter A and B. CAN-ID is as follows, corresponding to the function mode to be used.

Set parameter A and B of unused Layer 2 messages to HFFFF.

→ For function mode, refer to Section 5.4

Function Mode	Description
layer 2 communication (11 bit ID) mode	Store CAN-ID in the lower 11 bits (bit 0 to 10) of parameters A and B by 32 bit instructions.
layer 2 communication (29 Bit ID) mode	Store CAN-ID in the lower 29 bits (bit 0 to 28) of parameters A and B by 32 bit instructions.

2. Parameter C and D for each Layer 2 message

Set the filter for the ID set in parameter A and B. If the filter is set to H00000000, incoming messages are checked for an exact match with the ID set in parameter A and B. Any bit set in the filter will be omitted when comparing received IDs with the ID set in parameter A and B.

Example 1:

Layer 2 message 1 parameter A/B = H00000181

Layer 2 message 1 parameter C = H00000000

BFM #100 to #106 store received messages with the CAN-ID H181 only. Relation between received CAN message, BFM #20 bit 0 and "RTR/new/DLC" high byte is shown below.

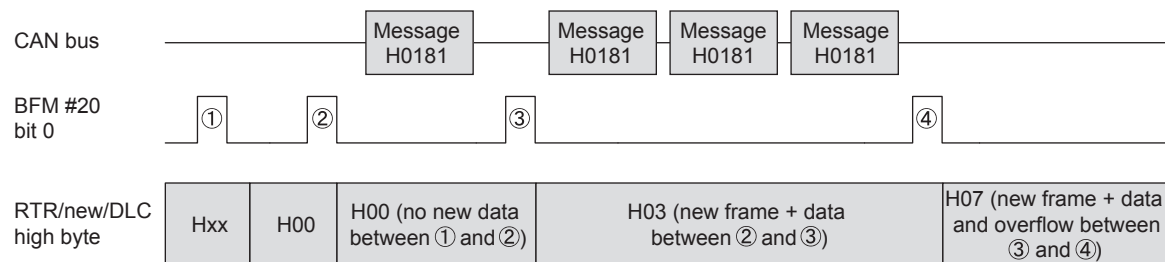

The flags "RTR/new/DLC" are cleared by PLC program after ①. They remain H00 after ②, because there was no message stored between ① and ②. The first received CAN message that matches parameter A/B and C/D is stored into the internal buffers, and as this is the only message between ② and ③, the high byte value is set to H03. The high byte value H07 after ④ shows that the buffer was overwritten at least once (in this sample two times) since ③. The data bytes in the BFM are the data received with the last message.

Note

In this sample it is expected that the PLC program resets the status/command flags after reading the data at ①, ②, ③ and ④.

Example 2:

Layer 2 message 2 parameter A = H00000180

Layer 2 message 1 parameter C = H00000006

BFM #107 to #113 stores received messages with CAN-IDs H180, H182, H184 and H186 because the ID bits 1 and 2 are not evaluated. Relation between received CAN message, BFM #20 bit 0 and "Status/Control Flags" is shown below.

Note

- All four messages are stored in the same location. If more than one of the messages with ID H180, H182, H184 or H186 is received between two write operations (BFM #20 bit 0 = ON), only the last received CAN-ID, DLC, and data is available in BFM #107 to #113.
- In this sample, it is expected that the PLC program resets the status/command flags after reading the data at ①, ②, ③ and ④.

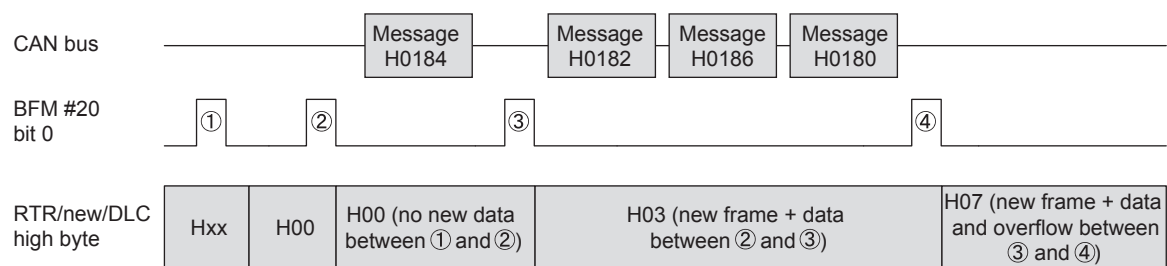

Behavior until ④ is similar to that described in example 1.

Same as in the first example, the high byte value H07 after ④ shows that the buffer was overwritten at least once, since ③ and the data bytes in the BFM are also the data received with the last message.

But this time, it is required to check the 11 bit CAN-ID in the corresponding Layer 2 message (BFM #100 to #399) to determine which message ID was received. In this case the last message is H0180, and the data of this message is stored to the data BFMs. The data of messages H0182 and H0186 are lost.

7.3 [BFM #1270 to #1272] Layer 2 RTR Flags

If the FX3U-J1939 is set to Layer 2 communication mode, an incoming RTR message is indicated in the BFM if the following conditions are satisfied:

- Matching the "CAN-ID n*1" of one of the Layer 2 messages
- The message "n*1" is configured as a transmit message
- The message "n*1" is set to "no auto RTR response" (H6FFF)
 - *1. Where "n" is one of the messages 1 to 42.

The bits in the "Layer 2 RTR flags" are updated independently from BFM #20 bit 0. A bit is set if a valid RTR message has been received. The bit can be evaluated by PLC program and the required changes to the response message data can be made (BFM #20 bit 0 must be set in order to refresh the internal data buffer and trigger the transmission). The flag is automatically reset when a message is transmitted from the message.

BFM No.	Bit No.	Description	Read/Write
BFM #1270	Bit 0	RTR message for Layer 2 message 1 received	R
	⋮	⋮	R
	Bit 15	RTR message for Layer 2 message 16 received	R
BFM #1271	Bit 0	RTR message for Layer 2 message 17 received	R
	⋮	⋮	R
	Bit 15	RTR message for Layer 2 message 32 received	R
BFM #1272	Bit 0	RTR message for Layer 2 message 33 received	R
	⋮	⋮	R
	Bit 9	RTR message for Layer 2 message 42 received	R
	Bit 10	Not Used	-
	⋮		
Bit 15			

- 1 Introduction
- 2 Specifications
- 3 Installation
- 4 Wiring
- 5 Allocation of Buffer/Memories
- 6 J1939 Comms Mode
- 7 Layer 2 Communication Mode
- 8 PLC RUN→STOP Messages
- 9 Command Interface
- 10 Communication Settings Procedure

8. [BFM #1900 to #1927] PLC RUN>STOP Messages

FX3U-J1939 can transmit the message according to its state, if the PLC is in one of the following two states. Up to four transmit messages can each be registered.

- If PLC state changes from RUN to STOP, the message registered into RUN>STOP messages 1 to 4 are transmitted.
- If FROM/TO Watchdog in FX3U-J1939 has timed-out, the message registered in RUN>STOP messages 1 to 4 are transmitted.

Warning

Depending on PLC type and baud rate and bus load, FX3U-J1939 may be unable to send the message. In such a case, additional H/W and/or S/W should be considered for safe system behavior.

If possible, use only one "RUN>STOP message" which will increase the possibility that the information is transmitted in the event "RUN>STOP" occurs.

If more than one message is defined, messages are transmitted in order of priority "message 1" to "message 4."

Note

- In J1939 mode, the CAN-ID of PLC RUN>STOP messages are adjusted to J1939 Specification:
 - The lowest byte of the CAN-ID will always equal the FX3U-J1939 current node address (BFM #28)
 - If the PGN is in PDU1 format range (PF = HEF or less), the destination address is adjusted if the target node changes its node address during dynamic address allocation. In this case, the node address is displayed in BFM #1901/#1900, #1922/#1921 ... as HFE until a valid address claim matching the Remote ECU List entry is received.

→ For the required node address and ECU name definition, refer to Section 5.22

BFM No.	Function	Description		Message No.	Default Value
		High Byte	Low Byte		
BFM #1900	CAN-ID 1 LW	11/29 bit CAN-Identifier low word		RUN>STOP message 1	HFFFF
BFM #1901	CAN-ID 1 HW	29 bit CAN-Identifier high word			HFFFF
BFM #1902	DLC	Data length count			H0
BFM #1903	Data bytes	2nd data byte	1st data byte		H0
BFM #1904		4th data byte	3rd data byte		H0
BFM #1905		6th data byte	5th data byte		H0
BFM #1906		8th data byte	7th data byte		H0
⋮	⋮	⋮			⋮
BFM #1921	CAN-ID 4 LW	11/29 bit CAN-Identifier low word		RUN>STOP message 4	HFFFF
BFM #1922	CAN-ID 4 HW	29 bit CAN-Identifier high word			HFFFF
BFM #1923	DLC	Data length count			H0
BFM #1924	Data bytes	2nd data byte	1st data byte		H0
BFM #1925		4th data byte	3rd data byte		H0
BFM #1926		6th data byte	5th data byte		H0
BFM #1927		8th data byte	7th data byte		H0

BFM Function	Description
11/29 bit CAN-ID n	CAN-ID is used to transmit this message into the network. Sets HFFFF to the CAN-ID n LW and CAN-ID n HW when not using the message.
DLC	High byte H00 = send data frame*1 Low byte = number of data bytes to transmit (K0 to K8)
Data bytes	Data bytes 1 to 8. Number of attached data bytes is defined by DLC.

*1. RTR is prohibited for these messages.

MEMO

1	Introduction
2	Specifications
3	Installation
4	Wiring
5	Allocation of Buffer Memories
6	J1939 Comms Mode
7	Layer 2 Communication Mode
8	PLC RUN>STOP Messages
9	Command Interface
10	Communication Settings Procedure

9. Command Interface

This chapter describes the Command Interface supported by FX3U-J1939.

A function overview of the Command Interface is shown in the following table.

Command	Function Mode Selection			Reference
	J1939 Communication Mode	Layer 2 Communication (11 bit ID) Mode	Layer 2 Communication (29 bit ID) Mode	
Sending Layer 2 Message	-	✓	✓	Section 9.2
Sending PGN	✓	-	-	Section 9.3
Request PGN* ¹	✓	-	-	Section 9.4
Setup PLC RUN>STOP messages	✓	-	-	Section 9.5
Reset command interface	✓	✓	✓	Section 9.6
Display current Parameter	✓	✓	✓	Section 9.7

*1. FX3U-J1939 firmware Ver. 1.10 or later is applicable.

9.1 [BFM #1000 to #1066] Command Interface (CIF)

The CIF can be used for asynchronous services, configuration and diagnosis.

For all commands, the parameter (BFM #1001 to #1066) must be set first. When the command code is written to BFM #1000, the command is executed and BFM #1000 shows HFFFF (CIF busy). BFM #1000 to #1066 must not be changed until a positive or negative acknowledge is displayed in BFM #1000.

For details, refer to descriptions of each CIF command and the error code list of CIF.

→ For the error code list of CIF, refer to Section 9.8

BFM No.	Description	
	TO (Write Access)	FROM (Read Access)
BFM #1000	Command code (trigger for command execution)	Command execution result code
BFM #1001 to #1066	Command parameter	Command parameter read back or detailed error information

9.2 Sending Layer 2 Message

If the FX3U-J1939 is set to Layer 2 communication Mode, this function can be used to send any Layer 2 message to the CAN bus.

This command is prohibited in J1939 communication mode.

→ For the function mode, refer to Section 5.4

BFM No.	Description		
	TO (Write Access)		
	High Byte	Low Byte	
		FROM (Read Access)	
BFM #1000	Command: H000C		H000D: Data written to transmit buffer → For other response codes, refer to Section 9.8
BFM #1001	CAN-ID (low word) ^{*1}		H0000
BFM #1002	CAN-ID (high word) ^{*1}		
BFM #1003	RTR (Remote Transmission Request) ^{*2}		
BFM #1004	DLC (Data Length Count) ^{*3}		
BFM #1005	2nd data byte	1st data byte	Not used
BFM #1006	4th data byte	3rd data byte	
BFM #1007	6th data byte	5th data byte	
BFM #1008	8th data byte	7th data byte	
BFM #1009 to #1066		Not used	

*1. CAN-ID is as follows, corresponding to the function mode used.

→ For the function mode, refer to Section 5.4

Function Mode	Description
Layer 2 Communication (11 bit ID) Mode	Store CAN-ID in the 11 bits, bit 0 to 10, in the CAN-ID (low word) and CAN-ID (high word). Use 32 bit instructions to write CAN-ID data.
Layer 2 Communication (29 bit ID) Mode	Store CAN-ID in the 29 bits, bit 0 to 28, in the CAN-ID (low word) and CAN-ID (high word). Use 32 bit instructions to write CAN-ID data.

- *2. Set this BFM to K0 for normal transmission. If this BFM is set to K1, a request frame is sent. This request makes the producer of the associated CAN-ID specified in BFM #1001 and #1002 send the actual data.
- *3. The data length in bytes (0 to 8).

1	Introduction
2	Specifications
3	Installation
4	Wiring
5	Allocation of Buffer Memories
6	J1939 Comms Mode
7	Layer 2 Communication Mode
8	PLC RUN→STOP Messages
9	Command Interface
10	Communication Settings Procedure

9.3 Send PGN

This command can be used to transmit a J1939 message frame with a certain PGN and destination address. This command is prohibited in Layer 2 communication Mode.

BFM No.	Description	
	TO (Write Access)	
	High Byte	Low Byte
BFM #1000	Command: H1000	
BFM #1001	PGN bit 15 to 0 ^{*1*2}	
BFM #1002	PGN bit 17 and 16 ^{*1*2}	
BFM #1003	Priority ^{*3}	
BFM #1004	Destination address ^{*2*4}	
BFM #1005	DLC (Data Length Count) ^{*5}	
BFM #1006	2nd data byte ^{*6}	1st data byte ^{*6}
BFM #1007	4th data byte ^{*6}	3rd data byte ^{*6}
BFM #1008	6th data byte ^{*6}	5th data byte ^{*6}
BFM #1009	8th data byte ^{*6}	7th data byte ^{*6}
BFM #1010	10th extended data byte ^{*7}	9th extended data byte ^{*7}
⋮	⋮	⋮
BFM #1066	122nd extended data byte ^{*7}	121st extended data byte ^{*7}

*1. PGN to be transmitted is specified in the 18 bits, bit 0 to 17, in BFM #1001 and #1002 as shown below.

	BFM #1002			BFM #1001	
	Bit 2 to 15 (Bit 18 to 31)	Bit 1 (Bit 17)	Bit 0 (Bit 16)	Bit 8 to 15	Bit 0 to 7
PGN	Not Used (Set bit 2 to 15 to OFF.)	EDP (Extend data page)	DP (Data page)	PF	PS

- *2. If a PDU1 formatted PGN (the destination address is included in the PGN low byte) is transmitted:
- The destination address in BFM #1004 must match the address set in the PGN low byte (BFM #1001).
 - The low byte of the PDU1 PGN is set to H00 and the target address is set in BFM #1004. If an invalid value is set, BFM #1004 will display the address to show the mismatch between PGN-destination and BFM #1004 destination. If BFM #1004 is set to H00, and the BFM #1001 low-byte is set to a value other than to H00, BFM #1004 will display HFFFF (instead of H0000).
- *3. The valid range of the message priority, the first three bits in the 29 bit ID, is between K0 to K7. K0 is the highest priority.
- *4. Specifies the destination node address. Valid range of the destination node address is between K0 to K253, K255 (broadcast). Destination address must be different from the FX3U-J1939 address (BFM #28).
- *5. Sum of the data buffer and extended data buffer. Valid range of the number of data bytes to be transmitted is between K0 to K122.
- *6. Data buffer (standard frames up to 8 bytes)
- *7. Extended data buffer
When more than 8 bytes must be transmitted, the first 8 bytes are located in BFM #1006 to #1009, and bytes 9 to 122 are stored in BFM #1010 to #1066. If the data exceeds the standard length of 8 bytes, the data will be segmented and transferred in several frames.

9.4 Request PGN

This command can be used to request a J1939 message frame with a certain PGN from the network. This command is prohibited in Layer 2 communication Mode. This command is supported in the FX3U-J1939 firmware Ver. 1.10 or later.

Note

It is not possible to request PDU1 PGNs with a different DA than the current FX3U-J1939 node address (BFM #28). The PS byte of the requested PDU1 PGN must be set to H00.

e.g. FX3U-J1939 BFM #28 = H80

BFM #1001/#1002	BFM #1004	Description
HB100	H00 to H7F, H81 to HFD	Valid setting, FX3U-J1939 will send a request for PGN HB100, expecting a response with PGN HB180 (HB100 + BFM #28 value).
	HFF	Valid setting, FX3U-J1939 will send a Broadcast request for PGN HB100, expecting a response with PGN HB1FF (HB100 + HFF).
HB101 to HB1FF	x	INVALID setting for PDU1 Format PGN request.

BFM No.	Description		
	TO (Write Access)	FROM (Read Access)	
		High Byte	Low Byte
BFM #1000	Command: H1200	H1201: Reception complete → For other response codes, refer to Section 9.8	
BFM #1001	PGN bit 15 to 0 ^{*1}	Received PGN bit 15 to 0	
BFM #1002	PGN bit 17 and 16 ^{*1}	Received PGN bit 17 and 16	
BFM #1003	Priority ^{*2}	Received priority	
BFM #1004	Destination address ^{*3}	Received source address	
BFM #1005	Not used	DLC (Data Length Count) ^{*4}	
BFM #1006		2nd data byte ^{*5}	1st data byte ^{*5}
BFM #1007		4th data byte ^{*5}	3rd data byte ^{*5}
BFM #1008		6th data byte ^{*5}	5th data byte ^{*5}
BFM #1009		8th data byte ^{*5}	7th data byte ^{*5}
BFM #1010		10th extended data byte ^{*6}	9th extended data byte ^{*6}
BFM #1011		12th extended data byte ^{*6}	11th extended data byte ^{*6}
⋮		⋮	⋮
BFM #1066		122nd extended data byte ^{*6}	121st extended data byte ^{*6}

*1. PGN to be requested is specified in the 18 bits, bit 0 to 17, in BFM #1001 and #1002 as shown below.

	BFM #1002			BFM #1001	
	Bit 2 to 15 (Bit 18 to 31)	Bit 1 (Bit 17)	Bit 0 (Bit 16)	Bit 8 to 15	Bit 0 to 7
PGN	Not Used (Set bit 2 to 15 to OFF.)	EDP (Extend data page)	DP (Data page)	PDU Format (PF)	PDU specific (PS)

*2. The valid range of the message priority, the first three bits in the 29 bit ID, is between K0 to K7. K0 is the highest priority.

*3. Destination node address. Set HFF to this BFM to send a broadcast request. Valid range of the destination node address is K0 to K253, or K255 for broadcast. Destination address must be different from the FX3U-J1939 address (BFM #28).

*4. The number of data bytes received (sum of the data buffer and extended data buffer).

*5. Data buffer (standard frames up to 8 bytes)

*6. Extended data buffer

When more than 8 bytes of data are received, the first 8 bytes are located in BFM #1006 to #1009, and bytes 9 to 122 are stored in BFM #1010 to #1066. If the data exceeds the standard length of 8 bytes, the data will be segmented and received in several frames.

1

Introduction

2

Specifications

3

Installation

4

Wiring

5

Allocation of Buffer Memories

6

J1939 Comms Mode

7

Layer 2 Communication Mode

8

PLC RUN>STOP Messages

9

Command Interface

10

Communication Settings Procedure

9.5 Setup PLC RUN>STOP Messages

This command can be used to set up the Layer 2 "PLC RUN>STOP messages" in a convenient way for the J1939 mode. The Message Buffers in BFM #1900 to #1927 are set up with the Layer 2 messages that result from the given Parameters and the actual node ID.

This command is prohibited in Layer 2 communication Mode.

Note

- BFMs #1900 to #1927 are initialized via this command but not stored to Flash ROM.
Set BFM #22 bit 0 to ON, to save messages to Flash ROM, when setting them by this command.
- For unused messages, set HFFFFFFF to the PGN, and HFFFF to priority and destination address.

BFM No.	Description			
	TO (Write Access)		FROM (Read Access)	
	High Byte	Low Byte		
BFM #1000	Command: H3000		H3001: Execution complete → For other response codes, refer to Section 9.8	
BFM #1001	PGN bit 15 to 0 ^{*1}		Message 1	H0000
BFM #1002	PGN bit 17 and 16 ^{*1}			
BFM #1003	Priority ^{*2}			
BFM #1004	Destination address ^{*3}			
BFM #1005	DLC (Data Length Count) ^{*4}			
BFM #1006	2nd data byte ^{*5}	1st data byte ^{*5}		
BFM #1007	4th data byte ^{*5}	3rd data byte ^{*5}		
BFM #1008	6th data byte ^{*5}	5th data byte ^{*5}		
BFM #1009	8th data byte ^{*5}	7th data byte ^{*5}		
⋮	⋮	⋮		
BFM #1028	PGN bit 15 to 0 ^{*1}		Message 4	H0000
BFM #1029	PGN bit 17 and 16 ^{*1}			
BFM #1030	Priority ^{*2}			
BFM #1031	Destination address ^{*3}			
BFM #1032	DLC (Data Length Count) ^{*4}			
BFM #1033	2nd data byte ^{*5}	1st data byte ^{*5}		
BFM #1034	4th data byte ^{*5}	3rd data byte ^{*5}		
BFM #1035	6th data byte ^{*5}	5th data byte ^{*5}		
BFM #1036	8th data byte ^{*5}	7th data byte ^{*5}		
BFM #1037 to #1066	Not used			

- *1. PGN to be transmitted is specified in the 18 bits, bit 0 to 17, in BFM #1001 and #1002 as shown below.

	BFM #1002			BFM #1001	
	Bit 2 to 15 (Bit 18 to 31)	Bit 1 (Bit 17)	Bit 0 (Bit 16)	Bit 8 to 15	Bit 0 to 7
PGN	Not used (Set bit 2 to 15 to OFF.)	EDP (Extend data page)	DP (Data page)	PDU Format (PF)	PDU specific (PS)

- *2. The valid range of the message priority, the first three bits in the 29 bit ID, is between K0 to K7. K0 is the highest priority.
- *3. Specifies the destination node address. Valid range of the destination node address is between K0 to K253, K255 (broadcast). Destination address must be different from the FX3U-J1939 address (BFM #28).
- *4. Valid range of the number of data bytes to be transmitted is between K0 to K8.
- *5. Data buffer (standard frames up to 8 bytes)

9.6 Reset Command Interface

This command can be used to reset the command interface and clear errors displayed in BFM #1000 to #1066.

BFM No.	Description	
	TO (Write Access)	FROM (Read Access)
BFM #1000	Command: HFFFF (K-1)	H0000: Execution complete
BFM #1001 to #1066	Not used	H0000

9.7 Display Current Parameter

This command can be used to display the parameters in BFM #1001 to #1066 of the last executed CIF command. If a command caused an error, this function allows the parameter which caused the error to be displayed and to make the necessary adjustments to the parameters and the sequence program.

BFM No.	Description	
	TO (Write Access)	FROM (Read Access)
BFM #1000	Command: H0000	H0000: Input buffer is displaying. → For other response codes, refer to Section 9.8
BFM #1001 to #1066	Not used	Parameter values of the last executed CIF command

1

Introduction

2

Specifications

3

Installation

4

Wiring

5

Allocation of
Buffer Memories

6

J1939 Comms
Mode

7

Layer 2
Communication
Mode

8

PLC RUN→STOP
Messages

9

Command
Interface

10

Communication
Settings
Procedure

9.8 CIF: Error code list

If an error occurs during the execution of a command, the CIF will display these errors and no further commands will be accepted. To reset the CIF and clear the error, write HFFFF (K-1) to BFM #1000. While processing a command in CIF, FX3U-J1939 displays HFFFF in the read access area of BFM #1000. The CIF cannot accept write access to BFM #1000 to #1066 during busy status.

1. When the error code is HFFFF or H000F in BFM #1000

Error Code		Description
BFM #1000	BFM #1001	
HFFFF	H0000	CIF is busy processing a command This is the status message during CIF processing, not the error status.
H000F	H0064	The written command to BFM #1000 is an unknown command. Confirm the function mode setting and the executed command.
	H000F	Confirm the Message specific error code which stored is in BFM #1002. → For message specific error codes, refer to Section 5.19
	H0100	Command is not allowed in current mode. Confirm the function mode setting and the executed command.
	H0200	Command is prohibited in online mode.
	H0F0F	The command can not execute when the module is offline. Confirm the communication status. → For communication status, refer to Section 5.7
	HB0FF	The command can not execute when the module is offline. Confirm the communication status and error status. → For communication status, refer to Section 5.7 → For error status, refer to Section 12.2
HFFFF		Write access to CIF while CIF was busy.

2. When other error codes (except HFFFF and H000F) are in BFM #1000

Error Code		Description
BFM #1000	BFM #1001 and following	
HF00C	<ul style="list-style-type: none"> • H0000: The corresponding parameter has no errors. • All other values: The corresponding parameter caused an error. 	At least 1 parameter in BFM #1001 to #1066 is invalid. Invalid values are shown in the corresponding BFMs. BFMs with valid parameters are set to H0000.
H10FF		
H12FF		
H20FF		
H30FF		
H31FF		
H100F	Abort code ^{*1} or negative acknowledge code ^{*1} received from remote node	Negative response: This error is set in case a multi message transmission had to be terminated due to the reception of an abort or negative acknowledge message from a remote node.

*1. For abort codes, refer to remote node's manual or J1939/ISO specification.

10. Communication Settings Procedure

STARTUP AND MAINTENANCE PRECAUTIONS



WARNING

- Do not touch any terminal while the PLC's power is on. Doing so may cause electric shock or malfunctions.
- Before cleaning or retightening terminals, cut off all phases of the power supply externally. Failure to do so may cause electric shock.
- Before modifying or disrupting the program in operation or running the PLC, carefully read through this manual and the associated manuals and ensure the safety of the operation. An operation error may damage the machinery or cause accidents.

STARTUP AND MAINTENANCE PRECAUTIONS



CAUTION

- Do not disassemble or modify the PLC. Doing so may cause fire, equipment failures, or malfunctions. For repair, contact your local Mitsubishi Electric representative.
- Turn off the power to the PLC before connecting or disconnecting any extension cable. Failure to do so may cause equipment failures or malfunctions.
- Do not drop the product or exert strong impact to it. Doing so may cause damage.
- Turn off the power to the PLC before attaching or detaching the following devices. Failure to do so may cause equipment failures or malfunctions.
 - Peripheral devices, display module, expansion boards, and special adapters
 - Input/output extension units/blocks, FX Series terminal blocks and special function units/blocks
 - Battery and memory cassette

PRÉCAUTIONS DE MISE EN SERVICE ET DE MAINTENANCE



AVERTISSEMENT

- Ne toucher aucune borne quand le contrôleur programmable est sous tension. Cela pourrait être à l'origine d'électrocutions ou de dysfonctionnements.
- Avant de nettoyer ou de resserrer les bornes, couper toutes les phases de l'alimentation externe. Faute de quoi, il y a risque d'électrocution.
- Avant toute modification ou arrêt du programme en cours ou toute utilisation du contrôleur programmable, lisez attentivement ce manuel ainsi que tous les manuels associés et assurez-vous que le fonctionnement se fera en toute sécurité. Une opération erronée peut endommager la machine ou provoquer des accidents.

PRÉCAUTIONS DE MISE EN SERVICE ET DE MAINTENANCE



ATTENTION

- Ne pas démonter ni modifier le contrôleur programmable. Cela pourrait causer un départ de feu, une panne ou un dysfonctionnement des équipements. Pour réparation, contactez votre représentant local de Mitsubishi Electric.
- Coupez l'alimentation du contrôleur programmable avant de connecter ou déconnecter les câbles d'extension. Faute de quoi, il y a risque de panne ou de dysfonctionnement des équipements.
- Ne pas laisser tomber le produit ni donner un choc sur lui. Cela pourrait endommager le produit.
- Coupez l'alimentation du contrôleur programmable avant d'attacher ou de détacher les appareils suivants. Faute de quoi, il y a risque de panne ou de dysfonctionnement des équipements.
 - Appareils périphériques, module d'affichage, cartes d'extension et adaptateurs spéciaux
 - Blocs/unités d'extension E/S, borniers de série FX et blocs/unités de fonction spéciale
 - Cassette batterie et mémoire

1

Introduction

2

Specifications

3

Installation

4

Wiring

5

Allocation of Buffer/Memories

6

J1939 Comms Mode

7

Layer 2 Communication Mode

8

PLC RUN>STOP Messages

9

Command Interface

10

Communication Settings Procedure

10.1 J1939 Communication Mode

When using J1939 Communication Mode, the outline of the communication setting procedure is as follows.

- For further information on **BFMs**, refer to **Chapter 5**
- For further information on **data transfer location and configuration**, refer to **Chapter 6**
- For further information on the **CIF**, refer to **Chapter 9**
- For example program, refer to **Chapter 11**

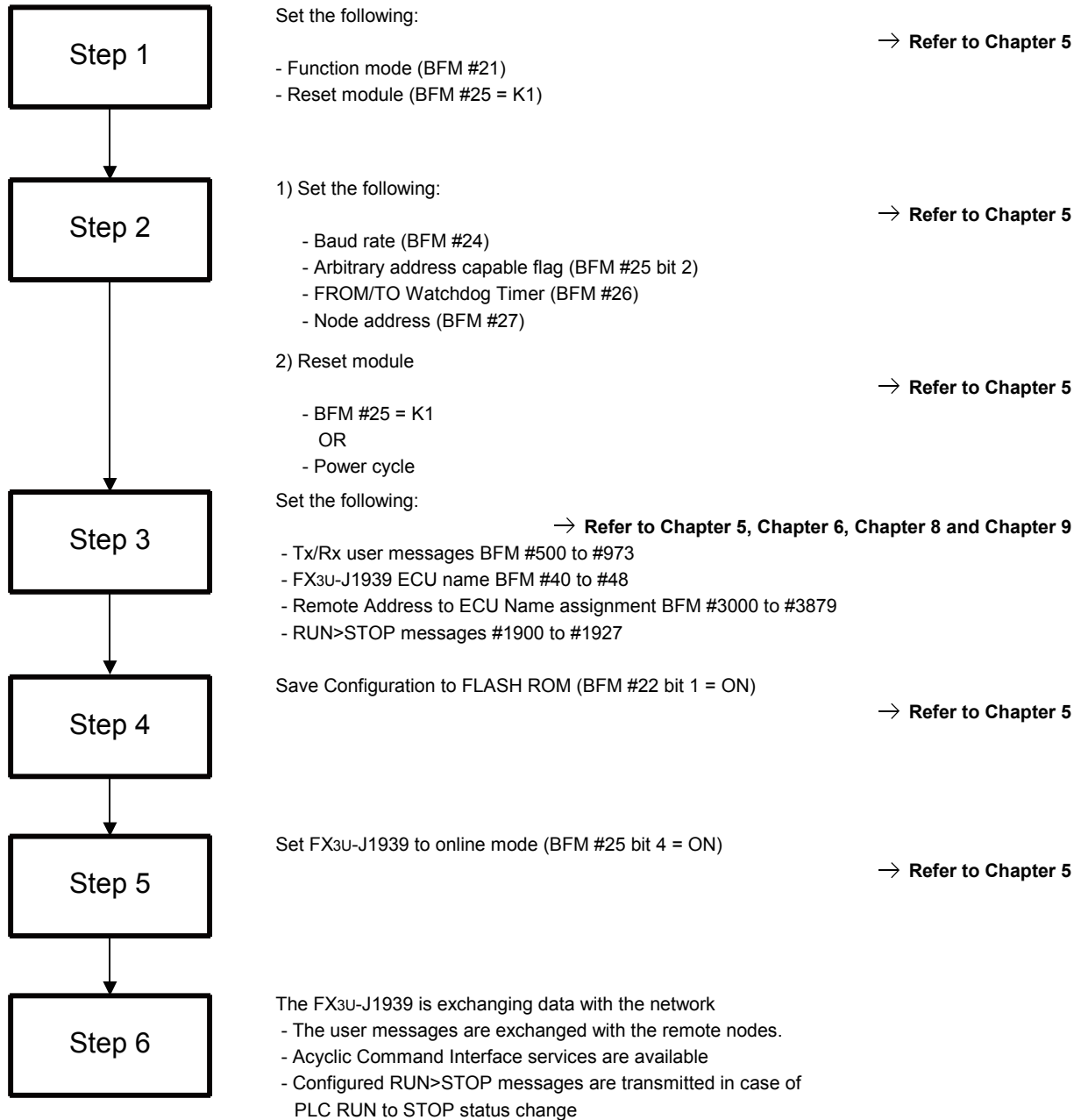

10.2 Layer 2 communication (11/29 bit ID) mode

When using the 11 bit / 29 bit CAN-ID Layer 2 Mode, the outline of the communication setting procedure is as follows.

- For further information on BFM, refer to Chapter 5
- For further information on data transfer location and configuration, refer to Chapter 7
- For further information of the CIF, refer to Chapter 9
- For example program, refer to Chapter 11

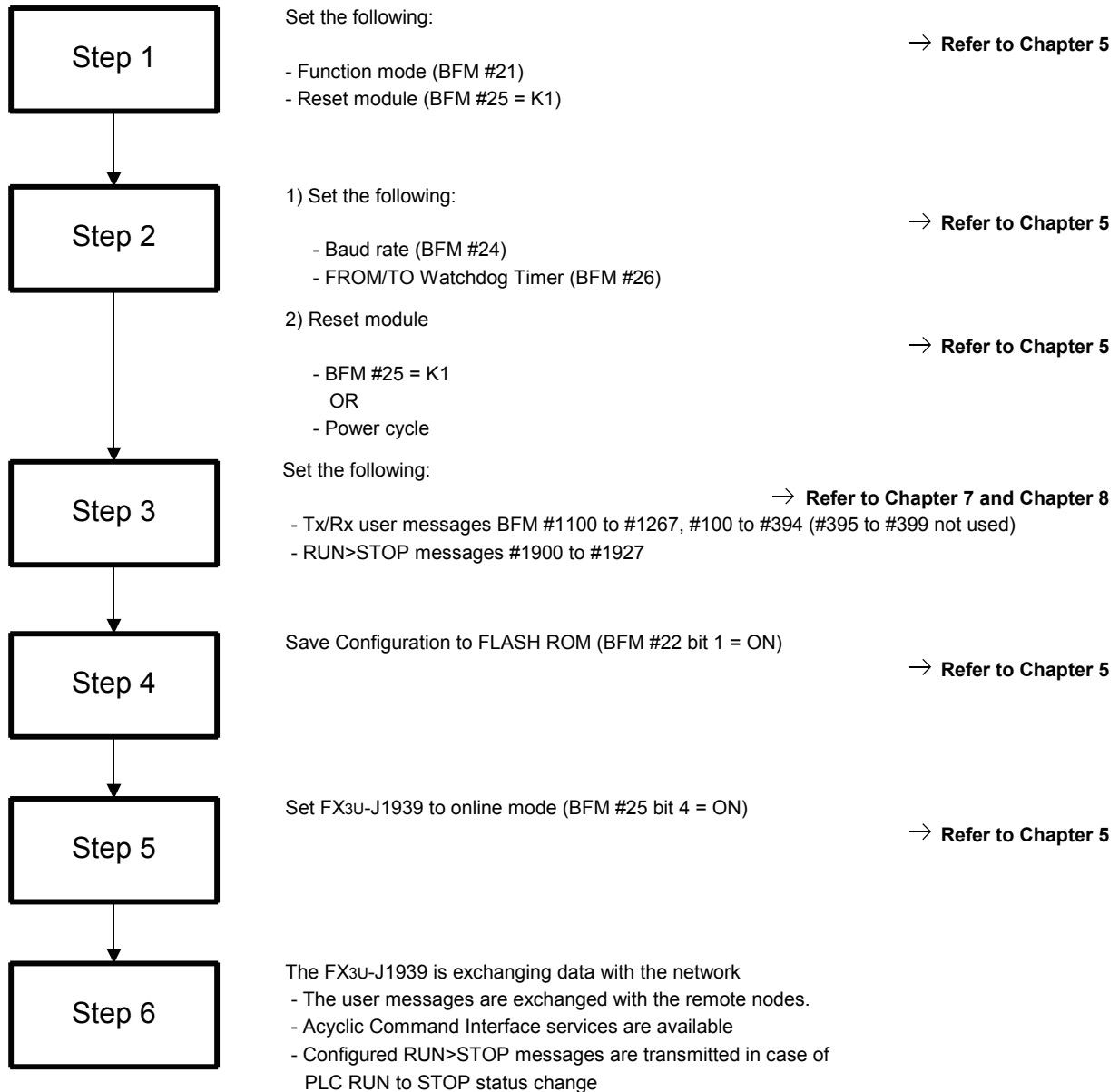

1	Introduction
2	Specifications
3	Installation
4	Wiring
5	Allocation of Buffer/Memories
6	J1939 Comms Mode
7	Layer 2 Communication Mode
8	PLC RUN>STOP Messages
9	Command Interface
10	Communication Settings Procedure

11. Example Program

STARTUP AND MAINTENANCE PRECAUTIONS



- Do not touch any terminal while the PLC's power is on.
Doing so may cause electric shock or malfunctions.
- Before cleaning or retightening terminals, cut off all phases of the power supply externally.
Failure to do so may cause electric shock.
- Before modifying or disrupting the program in operation or running the PLC, carefully read through this manual and the associated manuals and ensure the safety of the operation.
An operation error may damage the machinery or cause accidents.

STARTUP AND MAINTENANCE PRECAUTIONS



- Do not disassemble or modify the PLC.
Doing so may cause fire, equipment failures, or malfunctions.
For repair, contact your local Mitsubishi Electric representative.
- Turn off the power to the PLC before connecting or disconnecting any extension cable.
Failure to do so may cause equipment failures or malfunctions.
- Do not drop the product or exert strong impact to it.
Doing so may cause damage.
- Turn off the power to the PLC before attaching or detaching the following devices.
Failure to do so may cause equipment failures or malfunctions.
 - Peripheral devices, display module, expansion boards, and special adapters
 - Input/output extension units/blocks, FX Series terminal blocks and special function units/blocks
 - Battery and memory cassette

PRÉCAUTIONS DE MISE EN SERVICE ET DE MAINTENANCE



- Ne toucher aucune borne quand le contrôleur programmable est sous tension.
Cela pourrait être à l'origine d'électrocutions ou de dysfonctionnements.
- Avant de nettoyer ou de resserrer les bornes, couper toutes les phases de l'alimentation externe.
Faute de quoi, il y a risque d'électrocution.
- Avant toute modification ou arrêt du programme en cours ou toute utilisation du contrôleur programmable, lisez attentivement ce manuel ainsi que tous les manuels associés et assurez-vous que le fonctionnement se fera en toute sécurité.
Une opération erronée peut endommager la machine ou provoquer des accidents.

PRÉCAUTIONS DE MISE EN SERVICE ET DE MAINTENANCE



- Ne pas démonter ni modifier le contrôleur programmable.
Cela pourrait causer un départ de feu, une panne ou un dysfonctionnement des équipements.
Pour réparation, contactez votre représentant local de Mitsubishi Electric.
- Coupez l'alimentation du contrôleur programmable avant de connecter ou déconnecter les câbles d'extension.
Faute de quoi, il y a risque de panne ou de dysfonctionnement des équipements.
- Ne pas laisser tomber le produit ni donner un choc sur lui.
Cela pourrait endommager le produit.
- Coupez l'alimentation du contrôleur programmable avant d'attacher ou de détacher les appareils suivants.
Faute de quoi, il y a risque de panne ou de dysfonctionnement des équipements.
 - Appareils périphériques, module d'affichage, cartes d'extension et adaptateurs spéciaux
 - Blocs/unités d'extension E/S, borniers de série FX et blocs/unités de fonction spéciale
 - Cassette batterie et mémoire

The programs shown below are examples on how to set local parameters, set up a network and exchange data over the network with FX3U-J1939.

11.1 System Configuration

The system consists of two FX3U-J1939 nodes, Node A and Node B. This system can be used for both the J1939 example programs.

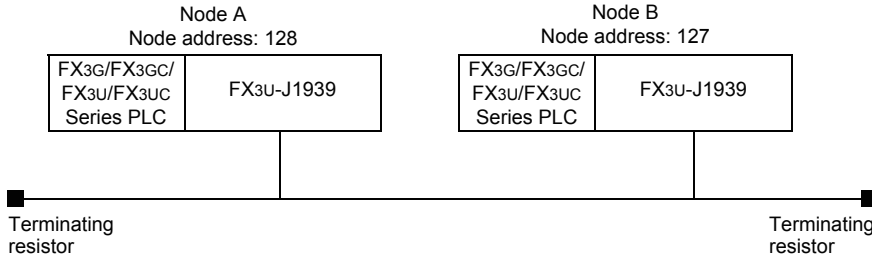

11.2 Contents of Operation/Setting of FX3U-J1939

Node A and Node B exchange data by using one message.

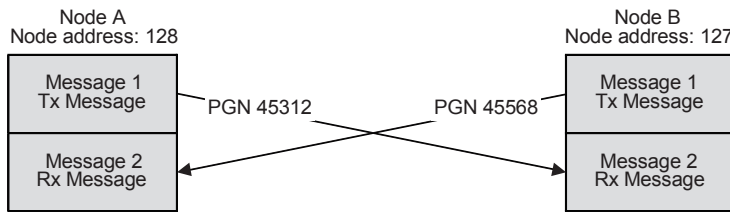

Message 1 of Node A and Node B are configured as transmit (Tx) messages. Node A uses PGN 45312 for its Tx message, Node B uses PGN 45568 for its Tx message.

Message 2 of Node A and Node B are configured as receive (Rx) messages. Node A Rx message receives the Tx message of Node B, and Node B Rx message receives the Tx message of Node A.

The baud rate and node address setting, as well as the configuration of message 1 and message 2, are done in the PLC program.

Node	Setting
A	<ul style="list-style-type: none"> • Node ID = 128, arbitrary address capable OFF (BFM #25 bit 2 OFF) • Message 1 <ul style="list-style-type: none"> - Tx message - PGN 45312 (HB100), Destination address 127 (H7F) - ttype = 1 (event driven), priority = 6, 8 bytes data length • Message 2 <ul style="list-style-type: none"> - Rx message - PGN 45568 (HB200), Destination address 128 (H80) - Source address filter HFF (=> any), 8 bytes data length
B	<ul style="list-style-type: none"> • Node ID = 127, arbitrary address capable OFF (BFM #25 bit 2 OFF) • Message 1 <ul style="list-style-type: none"> - Tx message - PGN 45568 (HB200), Destination address 128 (H80) - ttype = 1 (event driven), priority = 6, 8 bytes data length • Message 2 <ul style="list-style-type: none"> - Rx message - PGN 45312 (HB100), Destination address 127 (H7F) - Source address filter HFF (=> any), 8 bytes data length

11.3 J1939 Communication Example Programs

The example programs for J1939 communication between two FX3U-J1939 modules are written for GX Work2 (simple mode, no labels).

1. Node A program

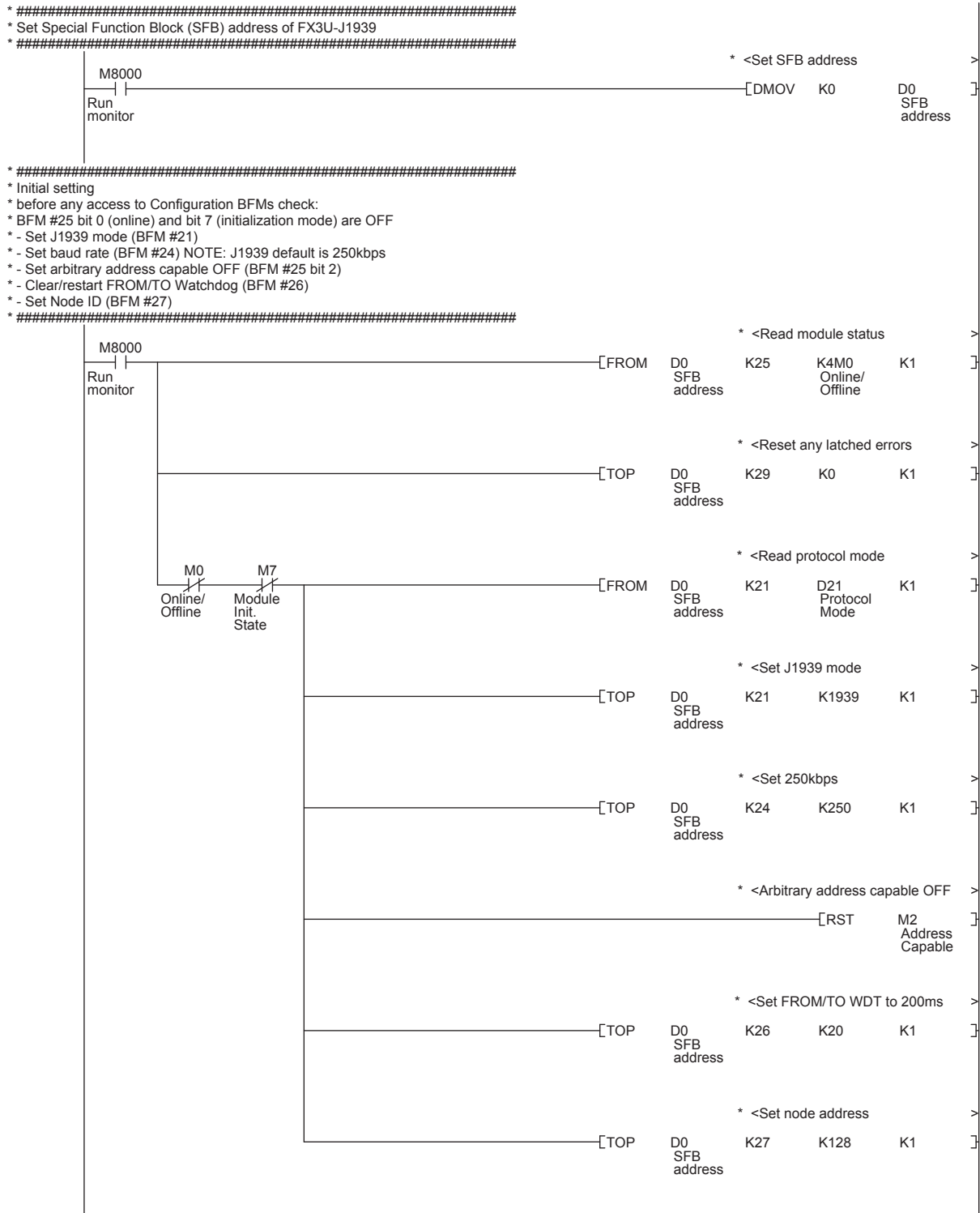

↓
To the next page

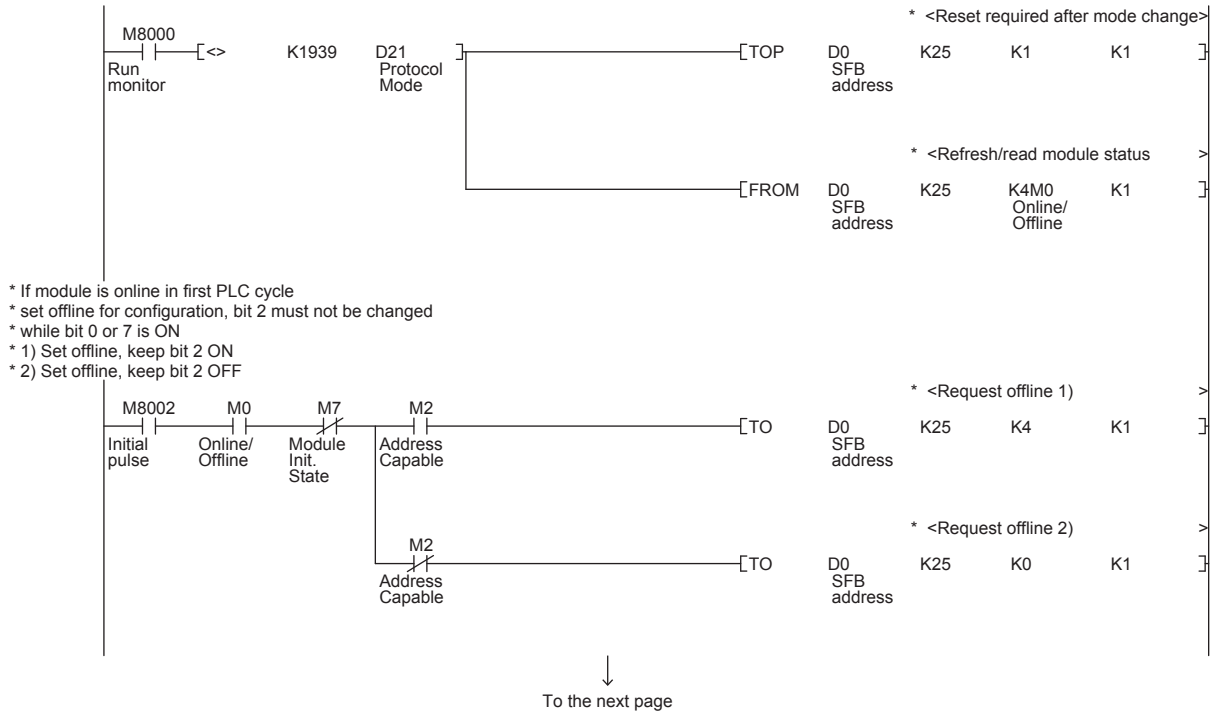

```

* #####
* Message configuration
* Message 1 (Configuration #500 to #505, Data #100 to #103)
* Tx Message
* PGN 45312 (HB100), destination 127 (H7F)
* event oriented transmission type (ttype K1 >> on data change)
* message priority (0 to 7, 6 default, 0 highest)
* interval for time triggered messages (unused) set K100 = 1 sec.
* message data length count = 8 bytes
*
* Message 2 (Configuration #506 to #511, Data #104 to #107)
* Rx Message
* PGN 45568 (HB200), destination 128 (H80) this node
* receive message type
* acceptance filter HFF >> any source address OK
* message data length count = 8 bytes
* #####
    
```

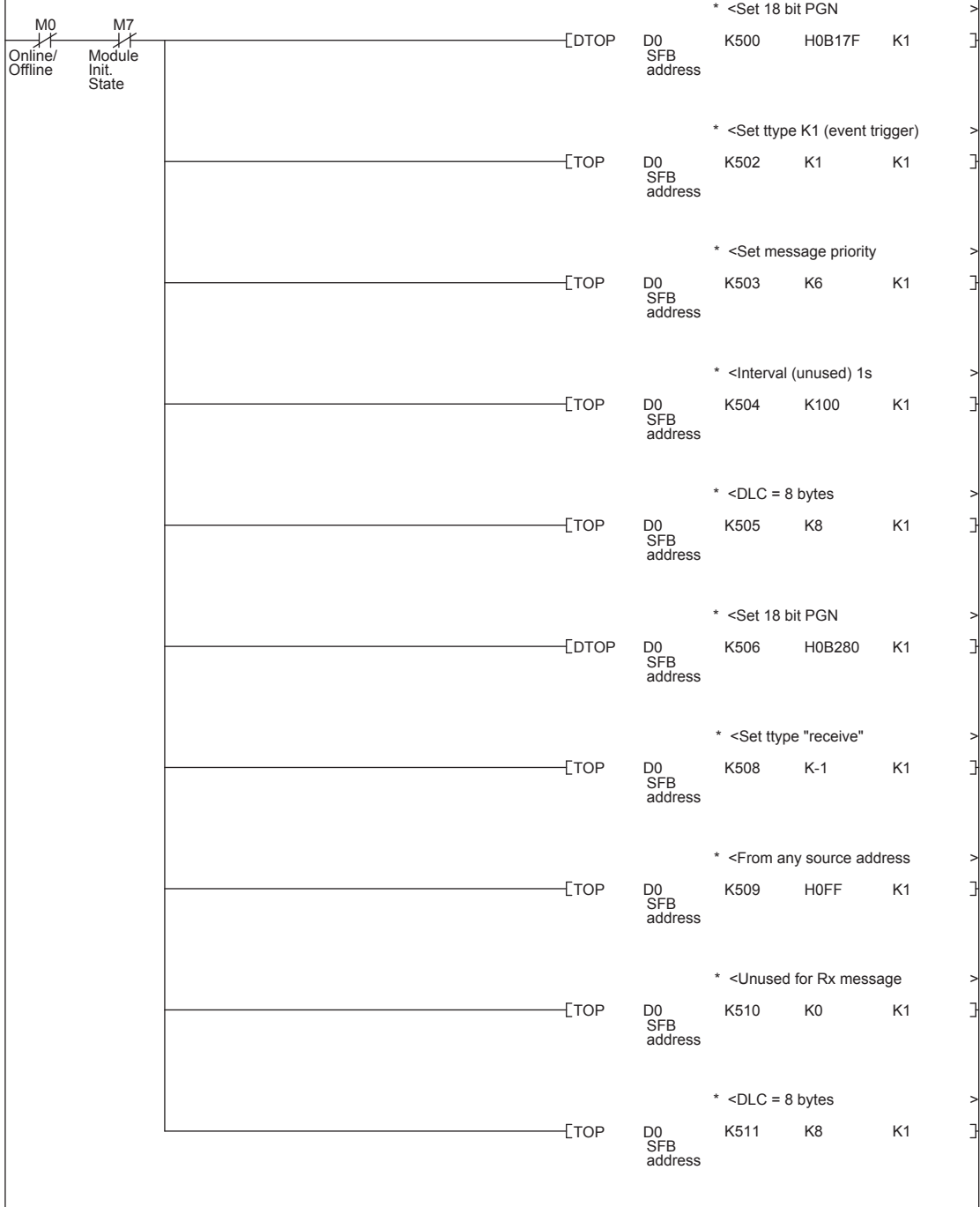

↓
To the next page

2. Node B program

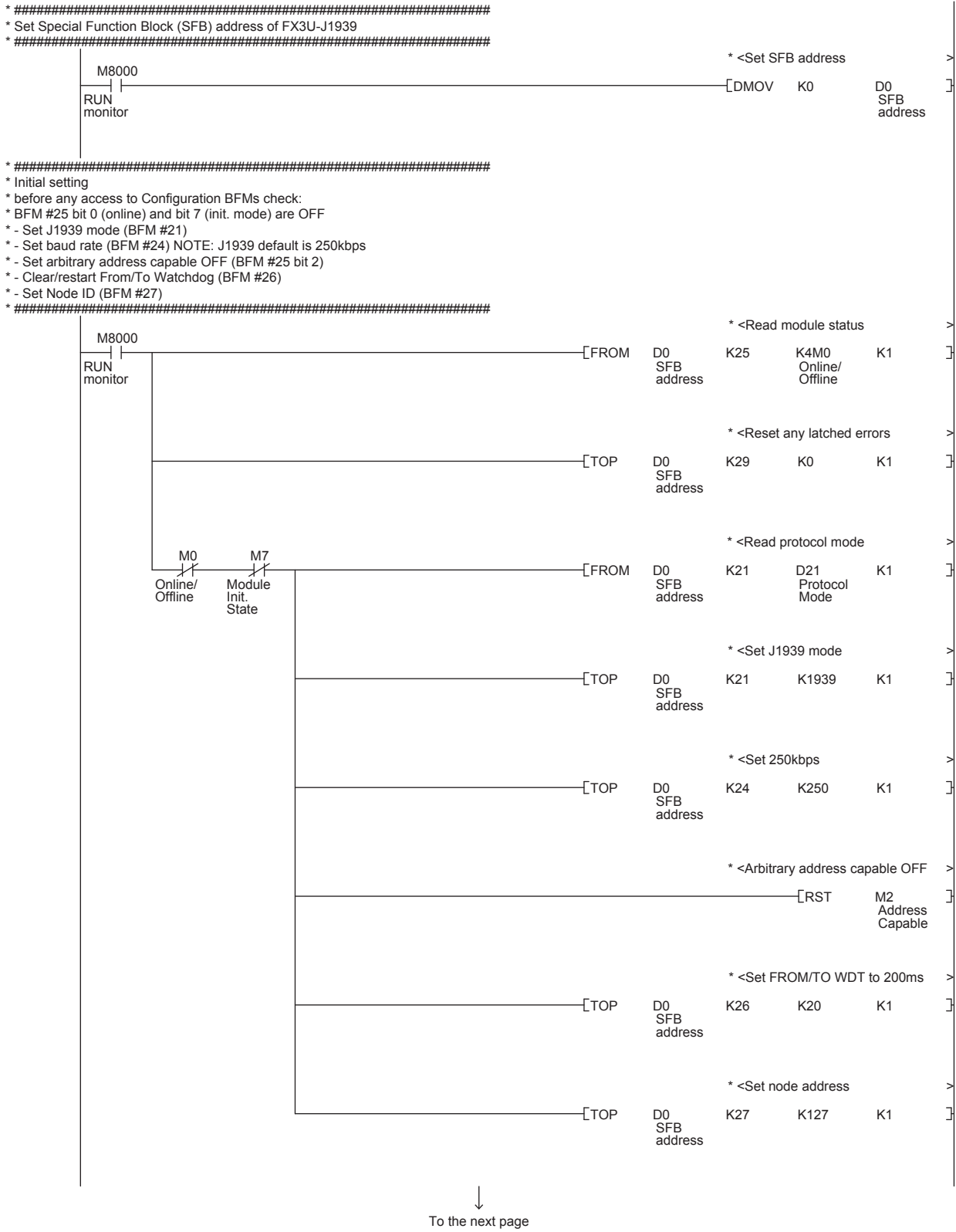

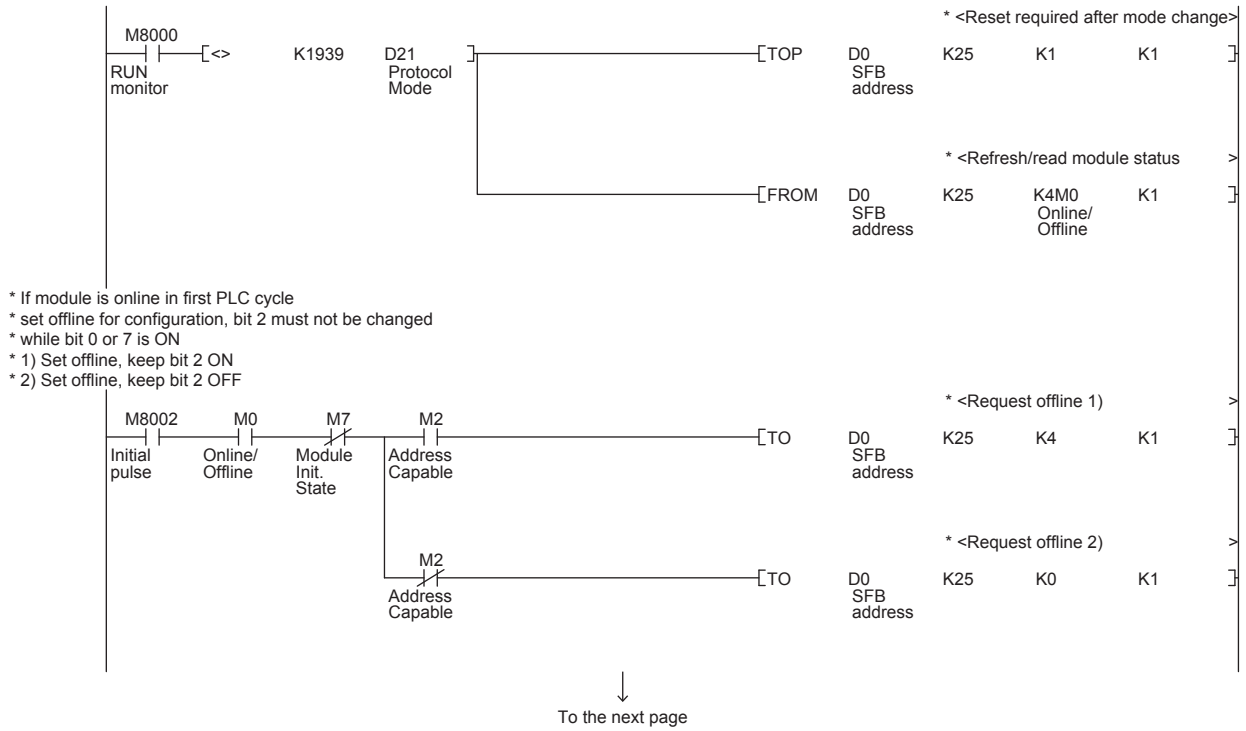

```

* #####
* Message configuration
* Message 1 (Configuration #500 to #505, Data #100 to #103)
* Tx Message
* PGN 45568 (HB200), destination 128 (H80)
* event oriented transmission type (ttype K1 >> on data change)
* message priority (0 to 7, 6 default, 0 highest)
* interval for time triggered messages (unused) set K100 = 1 sec.
* message data length count = 8 bytes
*
* Message 2 (Configuration #506 to #511, Data #104 to #107)
* Rx Message
* PGN 45312 (HB100), destination 127 (H7F) this node
* receive message type
* acceptance filter HFF >> any source address OK
* message data length count = 8 bytes
* #####
    
```

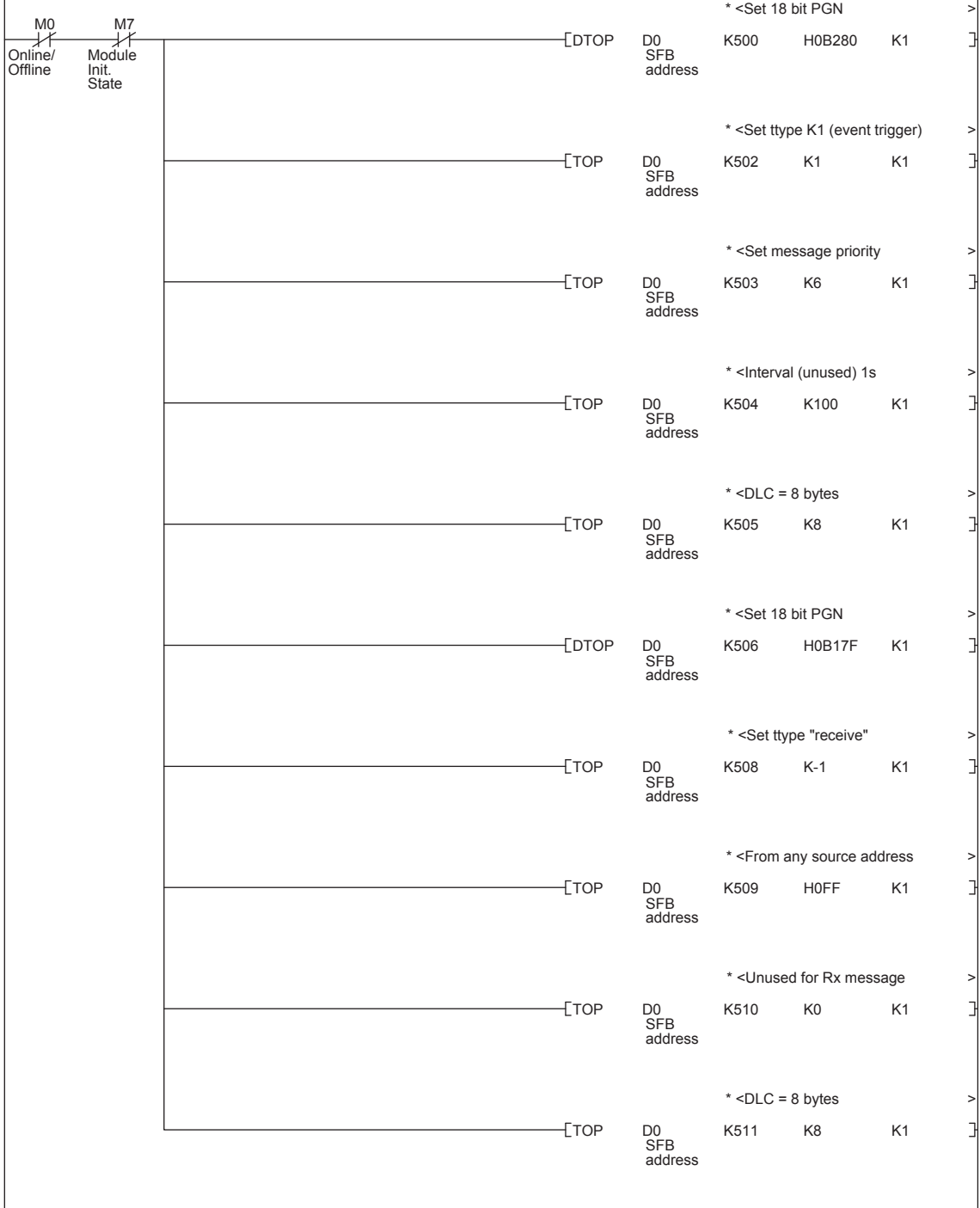

↓
To the next page

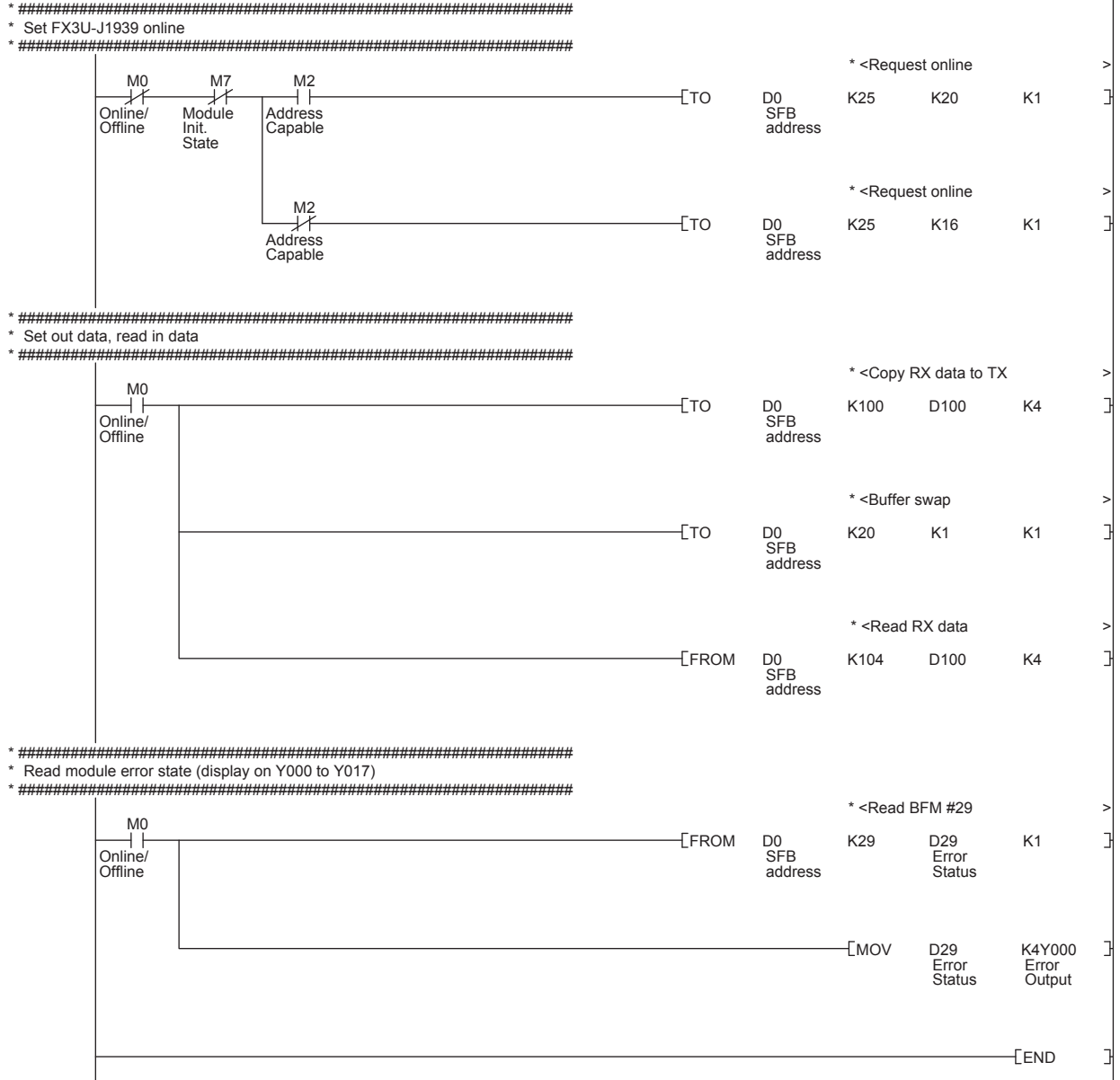

12. Diagnostics

STARTUP AND MAINTENANCE PRECAUTIONS



- Do not touch any terminal while the PLC's power is on.
Doing so may cause electric shock or malfunctions.
- Before cleaning or retightening terminals, cut off all phases of the power supply externally.
Failure to do so may cause electric shock.
- Before modifying or disrupting the program in operation or running the PLC, carefully read through this manual and the associated manuals and ensure the safety of the operation.
An operation error may damage the machinery or cause accidents.

STARTUP AND MAINTENANCE PRECAUTIONS



- Do not disassemble or modify the PLC.
Doing so may cause fire, equipment failures, or malfunctions.
For repair, contact your local Mitsubishi Electric representative.
- Turn off the power to the PLC before connecting or disconnecting any extension cable.
Failure to do so may cause equipment failures or malfunctions.
- Do not drop the product or exert strong impact to it.
Doing so may cause damage.
- Turn off the power to the PLC before attaching or detaching the following devices.
Failure to do so may cause equipment failures or malfunctions.
 - Peripheral devices, display module, expansion boards, and special adapters
 - Input/output extension units/blocks, FX Series terminal blocks and special function units/blocks
 - Battery and memory cassette

PRÉCAUTIONS DE MISE EN SERVICE ET DE MAINTENANCE



- Ne toucher aucune borne quand le contrôleur programmable est sous tension.
Cela pourrait être à l'origine d'électrocutions ou de dysfonctionnements.
- Avant de nettoyer ou de resserrer les bornes, couper toutes les phases de l'alimentation externe.
Faute de quoi, il y a risque d'électrocution.
- Avant toute modification ou arrêt du programme en cours ou toute utilisation du contrôleur programmable, lisez attentivement ce manuel ainsi que tous les manuels associés et assurez-vous que le fonctionnement se fera en toute sécurité.
Une opération erronée peut endommager la machine ou provoquer des accidents.

PRÉCAUTIONS DE MISE EN SERVICE ET DE MAINTENANCE



- Ne pas démonter ni modifier le contrôleur programmable.
Cela pourrait causer un départ de feu, une panne ou un dysfonctionnement des équipements.
Pour réparation, contactez votre représentant local de Mitsubishi Electric.
- Coupez l'alimentation du contrôleur programmable avant de connecter ou déconnecter les câbles d'extension.
Faute de quoi, il y a risque de panne ou de dysfonctionnement des équipements.
- Ne pas laisser tomber le produit ni donner un choc sur lui.
Cela pourrait endommager le produit.
- Coupez l'alimentation du contrôleur programmable avant d'attacher ou de détacher les appareils suivants.
Faute de quoi, il y a risque de panne ou de dysfonctionnement des équipements.
 - Appareils périphériques, module d'affichage, cartes d'extension et adaptateurs spéciaux
 - Blocs/unités d'extension E/S, borniers de série FX et blocs/unités de fonction spéciale
 - Cassette batterie et mémoire

12.1 Preliminary Checks

Check the RUN, FROM/TO, Tx/Rx, ERROR and POWER LED status.

1. RUN LED

LED State	Description
OFF	FX3U-J1939 is in offline.
ON	FX3U-J1939 is in online.

2. FROM/TO LED

LED State	Description
OFF	PLC is not accessing BFM in FX3U-J1939.
ON	PLC is accessing BFM in FX3U-J1939.

3. Tx/Rx LED

LED State	Description
OFF	FX3U-J1939 is not transmitting or receiving messages.
ON	FX3U-J1939 is transmitting or receiving messages.

4. ERROR LED

LED State	Description
OFF	Normal operation (status)
SINGLE FLASH*1	<p>FX3U-J1939 is in error passive state. At least one of the error counters of the module has reached or exceeded the warning level. Check the following points in the network.</p> <ul style="list-style-type: none"> • Check that the terminating resistors at both ends of the network are connected. • Check that all nodes have the same baud rate setting. • Check that all nodes have a unique Node ID setting. • Check that the CAN_H, CAN_L and CAN_GND wires are not broken. • Check that the CAN_H, CAN_L and CAN_GND are wired correctly. • Check that the CAN_SHLD is grounded. • Check that the CAN_SHLD is connected at all nodes. • Check that the CAN cable wires do not short circuit other CAN cable wires.
BLINKING*1	<p>General error has occurred. Check the error status in BFM #29.</p> <p style="text-align: right;">→ Refer to Section 12.2</p>
ON	<p>FX3U-J1939 is in BUS-OFF state, or program/CPU error occurs in PLC main unit. The LED will always be ON if there is a BUS OFF error, a general error (BFM #29, bit 0), or the FROM/TO watchdog is expired.</p> <ul style="list-style-type: none"> • Check the error status in BFM #29. • Check the ERROR LED of the PLC <p style="text-align: right;">→ Refer to Section 12.2</p> <ul style="list-style-type: none"> → For FX3G Series PLC, refer to FX3G Hardware Edition → For FX3GC Series PLC, refer to FX3GC Hardware Edition → For FX3U Series PLC, refer to FX3U Hardware Edition → For FX3UC Series PLC, refer to FX3UC Hardware Edition → For FX5U PLC, refer to MELSEC iQ-F FX5U User's Manual (Hardware) → For FX5UC PLC, refer to MELSEC iQ-F FX5UC User's Manual (Hardware) <p>• Check the sequence program for FROM/TO watchdog.</p> <p style="text-align: right;">→ For the FROM/TO watchdog, refer to Section 5.8</p> <ul style="list-style-type: none"> • Check that the CAN_H, CAN_L and CAN_GND are wired correctly.

*1. ERROR LED has two kinds of flicker states: single flash and blinking. This LED flickers as follows.

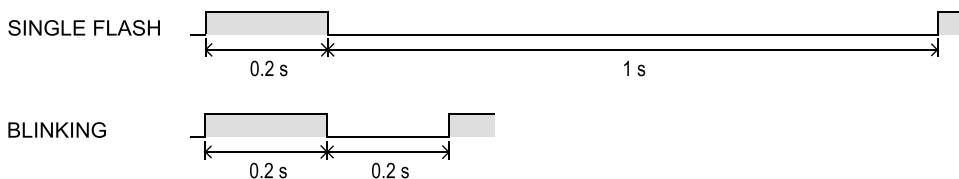

5. POWER LED

LED State	Description
ON	The power is being correctly supplied from FX3G/FX3GC ^{*1} /FX3U/FX3UC ^{*1} /FX5U ^{*2} /FX5UC ^{*2} PLC via the extension cable to FX3U-J1939.
Otherwise	<p>The power is being incorrectly supplied from FX3G/FX3GC^{*1}/FX3U/FX3UC^{*1}/FX5U^{*2}/FX5UC^{*2} PLC via the extension cable to FX3U-J1939.</p> <ul style="list-style-type: none"> • Check the connection of the extension cable to the PLC. • Check the power supply of the FX3G/FX3GC^{*1}/FX3U/FX3UC^{*1}/FX5U^{*2}/FX5UC^{*2} PLC. <ul style="list-style-type: none"> → For FX3G Series PLC, refer to FX3G Hardware Edition → For FX3GC Series PLC, refer to FX3GC Hardware Edition → For FX3U Series PLC, refer to FX3U Hardware Edition → For FX3UC Series PLC, refer to FX3UC Hardware Edition → For FX5U PLC, refer to MELSEC iQ-F FX5U User's Manual (Hardware) → For FX5UC PLC, refer to MELSEC iQ-F FX5UC User's Manual (Hardware) → For power supply specifications for FX3U-J1939, refer to Section 2.2

- *1. An FX2NC-CNV-IF or FX3UC-1PS-5V is necessary to connect the FX3U-J1939 to an FX3GC/FX3UC Series PLC.
- *2. An FX5-CNV-BUS or FX5-CNV-BUSC is necessary to connect the FX3U-J1939 to an FX5U/FX5UC PLC.

12.2 Detail Error Check

Please check the bit status in Error Status BFM #29.

Note

- The error flags bit 5, bit 6, bit 8 and bit 15 in BFM #29 are latched. Write K0 to BFM #29 to clear all latched error flags.
All other bits are reset automatically if the cause for the error is resolved.
 - When BFM #29 bit 6 is set to OFF, BFM #39 will be reset to K0.
 - When BFM #29 bit 15 is set to OFF, all error codes in BFM #401 to #479 will be cleared to H0000.
- In case of a FROM/TO watchdog timer error (bit 7 is ON), the PLC RUN>STOP message will be sent to the network.

→ For the PLC RUN>STOP message, refer to Section 5.21 and Chapter 8

Module failures

The module stays in initial status (Displayed in BFM #25). The configuration may be faulty. Reset the configuration to factory default settings using the BFM #22 bit 1.

→ For restoring configuration to factory default settings, refer to Section 5.5

→ For module restart, refer to Section 5.7

Bit	Description	Action
Bit 0	General error	General error has occurred. This bit is ON if bit 1, 2, 3, 4, 5, 6, 7, 8, 9, 11, 12 or 15 are ON. Check the ON bit.
Bit 1	Hardware error	Please contact your local Mitsubishi Electric Representative.
Bit 2	Internal power supply error	Internal power supply error has occurred. If this error flag is not cleared after a module reset (BFM #25 bit 0) or another power cycle, FX3U-J1939 is probably damaged. Please contact your local Mitsubishi Electric representative. → For module restart, refer to Section 5.7
Bit 3	CAN controller is in BUS OFF state	The FX3U-J1939 is bus OFF. The FX3U-J1939 has too many transmission errors. Check the following points in the network. And then, turn on the power for PLC again or restart the FX3U-J1939. → For module restart, refer to Section 5.7 <ul style="list-style-type: none"> Check that the terminating resistors at both ends of the network are connected. Check that all nodes have the same baud rate setting. Check that all nodes have a unique Node ID setting. Check that the CAN_H, CAN_L and CAN_GND wires are not broken. Check that the CAN_H, CAN_L and CAN_GND are wired correctly. Check that the CAN_SHLD is grounded. Check that the CAN_SHLD is connected at all nodes. Check that the CAN cable wires do not short circuit other CAN cable wires.
Bit 4	FLASH memory error	FLASH memory error has occurred. Invalid data in the Flash memory might be caused by power loss during a write operation to the Flash ROM. If this error flag is not cleared after a module reset (BFM #25 bit 0) or another power cycle, please contact your local Mitsubishi Electric representative. → For module restart, refer to Section 5.7
Bit 5	Invalid write access to configuration BFM while: *1 <ul style="list-style-type: none"> In online mode (BFM #25 bit 0 = ON) Initialization state (BFM #25 bit 7 = ON) Save/restore operation (BFM #22 bit 0, 1 or 2 = ON) 	Do not write to configuration BFM when module is online. Write to configuration BFMs, after switching to configuration mode and off line mode. → For the communication status (BFM #25), refer to Section 5.7
Bit 6	BFM setting error	BFM setting error has occurred. ON when a value that is out of range is written to a BFM. This failure BFM address is displayed in BFM #39. → Refer to Section 5.16

Bit	Description	Action
Bit 7	FROM/TO watchdog timer expired	FROM/TO watchdog timer expired. Please see the above note. This error flag can be reset by writing to BFM #26. → For the FROM/TO watchdog, refer to Section 5.8
Bit 8	Internal data queue overflow	Internal data queue overflowed. Extreme bus load can cause the internal queues to overflow. Decrease the bus load. At a low baud rate, data exchange that is too fast can overflow the CAN Transmit Buffer (Depends also on the bus-load of the CAN). → For Data Exchange Control flag, refer to Section 5.3
Bit 9	J1939 mode: no node address available	Check node address set in BFM #27 and #28. This bit is set if the node address set in BFM #27 is occupied by another node or if no node address could be obtained in the address claiming process. For further information on node address setting, refer to the following section. → Refer to Section 5.9
Bit 10	Not used	
Bit 11	Baud rate change error	Baud rate change error has occurred. ON when an invalid baud rate is written to BFM #24. In this case, the BFM will keep its former value. → For the baud rate setting, refer to Section 5.6
Bit 12	Node address change	Node address change error has occurred. ON when an invalid node address is written to BFM #27. In this case, the BFM will keep its former value. → For the node address setting, refer to Section 5.9
Bit 13	Not used	
Bit 14	Error passive state	This flag shows the CAN error active state/passive state ^{*2} . OFF: Error active state CAN receive message error counter value is in the range of K0 to K127. ON: Error passive state CAN receive message error counter value is K128. This bit will be reset automatically if the internal error counters return back to below K128. → For the CAN reception error counter, refer to Section 5.14
Bit 15	Message specific error exists	Message specific error exists. Check the Message specific error code in BFM #401 to #479. → For the Message specific error code, refer to Section 5.19

*1. The configuration must not be changed while the FX3U-J1939 is set to online or initialization state. Before changing the configuration, set BFM #25 bit 4 to OFF (configuration mode) and wait until BFM #25 bit 7 and 0 are OFF (module offline). Also make sure the Configuration is not being stored/restored to the internal FLASH memory. Check that BFM #22 bit 0 to 2 are OFF before changing the configuration.

The configuration BFM's are #21, #24, #25 (bit 2), #27, #40 to #48, #500 to #973, #1100 to #1267, #1900 to #1927 and #3000 to #3799.

In Layer 2 communication mode, parts of the data BFM #100 to #399 are holding configuration data as well. These BFM's must not be changed during online mode.

After a soft reset is triggered by writing K1 to BFM #25, BFM #25 bit 7 turns ON to indicate that the module is re-initializing the internal buffers. While this flag is on, TO commands on any BFM are prohibited and will cause BFM #29 bit 5 to be set to ON.

*2. Any CAN node will check all CAN messages on the bus for errors. Depending on the error state the action that the node will take is different:

- In error active:
The node will actively mark the frame as invalid.
- In error passive:
The node will not actively mark the frame as invalid to avoid bus disturbance if the node itself has an H/W problem.

Warranty

Please confirm the following product warranty details before using this product.

1. Gratis Warranty Term and Gratis Warranty Range

If any faults or defects (hereinafter "Failure") found to be the responsibility of Mitsubishi occurs during use of the product within the gratis warranty term, the product shall be repaired at no cost via the sales representative or Mitsubishi Service Company. However, if repairs are required onsite at domestic or overseas location, expenses to send an engineer will be solely at the customer's discretion. Mitsubishi shall not be held responsible for any re-commissioning, maintenance, or testing on-site that involves replacement of the failed module.

[Gratis Warranty Term]

The gratis warranty term of the product shall be for one year after the date of purchase or delivery to a designated place. Note that after manufacture and shipment from Mitsubishi, the maximum distribution period shall be six (6) months, and the longest gratis warranty term after manufacturing shall be eighteen (18) months. The gratis warranty term of repair parts shall not exceed the gratis warranty term before repairs.

[Gratis Warranty Range]

- (1) The range shall be limited to normal use within the usage state, usage methods and usage environment, etc., which follow the conditions and precautions, etc., given in the instruction manual, user's manual and caution labels on the product.
- (2) Even within the gratis warranty term, repairs shall be charged for in the following cases.
 1. Failure occurring from inappropriate storage or handling, carelessness or negligence by the user. Failure caused by the user's hardware or software design.
 2. Failure caused by unapproved modifications, etc., to the product by the user.
 3. When the Mitsubishi product is assembled into a user's device, Failure that could have been avoided if functions or structures, judged as necessary in the legal safety measures the user's device is subject to or as necessary by industry standards, had been provided.
 4. Failure that could have been avoided if consumable parts (battery, backlight, fuse, etc.) designated in the instruction manual had been correctly serviced or replaced.
 5. Relay failure or output contact failure caused by usage beyond the specified Life of contact (cycles).
 6. Failure caused by external irresistible forces such as fires or abnormal voltages, and failure caused by force majeure such as earthquakes, lightning, wind and water damage.
 7. Failure caused by reasons unpredictable by scientific technology standards at time of shipment from Mitsubishi.
 8. Any other failure found not to be the responsibility of Mitsubishi or that admitted not to be so by the user.

2. Onerous repair term after discontinuation of production

- (1) Mitsubishi shall accept onerous product repairs for seven (7) years after production of the product is discontinued.
Discontinuation of production shall be notified with Mitsubishi Technical Bulletins, etc.
- (2) Product supply (including repair parts) is not available after production is discontinued.

3. Overseas service

Overseas, repairs shall be accepted by Mitsubishi's local overseas FA Center. Note that the repair conditions at each FA Center may differ.

4. Exclusion of loss in opportunity and secondary loss from warranty liability

Regardless of the gratis warranty term, Mitsubishi shall not be liable for compensation to:

- (1) Damages caused by any cause found not to be the responsibility of Mitsubishi.
- (2) Loss in opportunity, lost profits incurred to the user by Failures of Mitsubishi products.
- (3) Special damages and secondary damages whether foreseeable or not, compensation for accidents, and compensation for damages to products other than Mitsubishi products.
- (4) Replacement by the user, maintenance of on-site equipment, start-up test run and other tasks.

5. Changes in product specifications

The specifications given in the catalogs, manuals or technical documents are subject to change without prior notice.

6. Product application

- (1) In using the Mitsubishi MELSEC programmable logic controller, the usage conditions shall be that the application will not lead to a major accident even if any problem or fault should occur in the programmable logic controller device, and that backup and fail-safe functions are systematically provided outside of the device for any problem or fault.
- (2) The Mitsubishi programmable logic controller has been designed and manufactured for applications in general industries, etc. Thus, applications in which the public could be affected such as in nuclear power plants and other power plants operated by respective power companies, and applications in which a special quality assurance system is required, such as for Railway companies or Public service purposes shall be excluded from the programmable logic controller applications.
In addition, applications in which human life or property that could be greatly affected, such as in aircraft, medical applications, incineration and fuel devices, manned transportation, equipment for recreation and amusement, and safety devices, shall also be excluded from the programmable logic controller range of applications.
However, in certain cases, some applications may be possible, providing the user consults their local Mitsubishi representative outlining the special requirements of the project, and providing that all parties concerned agree to the special circumstances, solely at the users discretion.

Revised History

Date	Revision	Description
5/2012	A	First Edition
3/2014	B	<ul style="list-style-type: none">• Firmware version 1.10 is supported.• Description of NMEA 2000® is deleted.• The following error code is added: H12FF• The explanation of Configuration Area is modified. [Section 6.2]• The contents of Request PGN is added. [Section 9.4]• Partial correction• Errors are corrected.
4/2015	C	<ul style="list-style-type: none">• A part of the cover design is changed.
10/2017	D	<ul style="list-style-type: none">• Firmware version 1.11 is supported.<ul style="list-style-type: none">- Connection to FX5U/FX5UC PLC.• UL explosion-proof standard is added.• The contents of power down message is removed.

FX3U-J1939

USER'S MANUAL

mitsubishi **ELECTRIC CORPORATION**

HEAD OFFICE: TOKYO BUILDING, 2-7-3 MARUNOUCHI, CHIYODA-KU, TOKYO 100-8310, JAPAN