



Programmable Controller  
MELSEC-F

FX2N-32CCL

INSTALLATION MANUAL



Manual Number	JY997D52401
Revision	D
Date	August 2018

This manual describes the part names, dimensions, mounting, and specifications of the product. Before use, read this manual and the manuals of all relevant products fully to acquire proficiency in handling and operating the product. Make sure to learn all the product information, safety information, and precautions. Store this manual in a safe place so that it can be taken out and read whenever necessary. Always forward it to the end user.

Registration:  
The company and product names described in this manual are registered trademarks or the trademarks of their respective companies.

Effective August 2018  
Specifications are subject to change without notice.

© 2013 Mitsubishi Electric Corporation

**Safety Precaution** (Read these precautions before use.)

This manual classifies the safety precautions into two categories:

**WARNING** and **CAUTION**.

<b>WARNING</b>	Indicates that incorrect handling may cause hazardous conditions, resulting in death or severe injury.
<b>CAUTION</b>	Indicates that incorrect handling may cause hazardous conditions, resulting in medium or slight personal injury or physical damage.

Depending on the circumstances, procedures indicated by **CAUTION** may also cause severe injury. It is important to follow all precautions for personal safety.

**Associated Manuals**

Manual name	Manual No.	Description
FX2N-32CCL User's Manual	JY992D71801 MODEL CODE: 09R711	Describes details of the FX2N-32CCL CC-Link Interface block.
FX3G Series User's Manual - Hardware Edition	JY997D31301 MODEL CODE: 09R521	Explains the FX3G Series PLC specifications for I/O, wiring, installation, and maintenance.
FX3GC Series User's Manual - Hardware Edition	JY997D45401 MODEL CODE: 09R533	Explains the FX3GC Series PLC specifications for I/O, wiring, installation, and maintenance.
FX3U Series User's Manual - Hardware Edition	JY997D16501 MODEL CODE: 09R516	Explains the FX3U Series PLC specifications for I/O, wiring, installation, and maintenance.
FX3UC Series User's Manual - Hardware Edition	JY997D28701 MODEL CODE: 09R519	Explains the FX3UC Series PLC specifications for I/O, wiring, installation, and maintenance.
FX2N Series HARDWARE MANUAL	JY992D66301 MODEL CODE: 09R508	Explains FX2N Series PLC specification details for I/O, wiring, installation, and maintenance.
FX2NC (D/UL) Series HARDWARE MANUAL	JY992D87201	Explains FX2NC (D/UL) Series PLC specification details for I/O, wiring, installation, and maintenance.
FX2NC (DSS/DS) Series HARDWARE MANUAL	JY992D76401 MODEL CODE: 09R509	Explains FX2NC (DSS/DS) Series PLC specification details for I/O, wiring, installation, and maintenance.

Manual name	Manual No.	Description
FX1N Series HARDWARE MANUAL	JY992D89301 MODEL CODE: 09R511	Explains FX1N Series PLC specification details for I/O, wiring, installation, and maintenance.
FX0/FX0N Series HARDWARE MANUAL	JY992D47501	Explains FX0/FX0N Series PLC specification details for I/O, wiring, installation, and maintenance.
FX3S/FX3G/FX3GC/FX3U/FX3UC Series Programming Manual - Basic & Applied Instruction Edition	JY997D16601 MODEL CODE: 09R517	Explains basic instructions and applied instructions available in the FX3S/FX3G/FX3GC/FX3U/FX3UC PLC.
FX1S, FX1N, FX2N, FX2NC Series Programming Manual	JY992D88101 MODEL CODE: 09R512	Explains instructions applicable in the FX1S/FX1N/FX2N/FX2NC PLC.

**How to obtain manuals**

For product manuals or documents, consult with the Mitsubishi Electric dealer from who you purchased your product.

**Compliance with EC directive (CE Marking)**

This note does not guarantee that an entire mechanical module produced in accordance with the contents of this note will comply with the following standards. Compliance to EMC directive and LVD directive for the entire mechanical module should be checked by the user / manufacturer. For more information please consult with your nearest Mitsubishi product provider.

Regarding the standards that comply with the main unit, please refer to either the FX Series product catalog or consult with your nearest Mitsubishi product provider.

**Requirement for Compliance with EMC directive**

The following products have shown compliance through direct testing (of the identified standards below) and design analysis (through the creation of a technical construction file) to the European Directive for Electromagnetic Compatibility (2014/30/EU) when used as directed by the appropriate documentation.

**Attention**

This product is designed for use in industrial applications.

Type: Programmable Controller (Open Type Equipment)

Models: MELSEC FX2N series manufactured

from June 1st, 1999 FX2N-32CCL

Standard	Remark
EN61000-6-4:2007 Generic emission standard Industrial environment	Compliance with all relevant aspects of the standard. • Emission-Enclosure port • Emission-Low voltage AC mains port • Emission-Telecommunications/network port
EN61131-2:2007 Programmable controllers - Equipment requirements and tests	Compliance with all relevant aspects of the standard. EMI • Radiated Emission • Conducted Emission EMS • Radiated electromagnetic field • Fast transient burst • Electrostatic discharge • High-energy surge • Voltage drops and interruptions • Conducted RF • Power frequency magnetic field

**1. Introduction**

**1.1 Introduction**

The CC-Link interface block FX2N-32CCL is a special function block to connect the FX0N/FX1N/FX2N/FX2NC/FX3G/FX3GC/FX3U/FX3UC Series PLC to a CC-Link network. → For details, refer to the **FX2N-32CCL User's Manual**.

**1.2 Incorporated Items**

Check to ensure the following product and items are included in the package.

Included Item	
FX2N-32CCL	1 unit
Special unit/block No. label	1 sheet
Dust proof protection sheet	1 sheet
Manuals (Japanese version, English version)	1 manual each

**1.3 External Dimensions and Part Names**

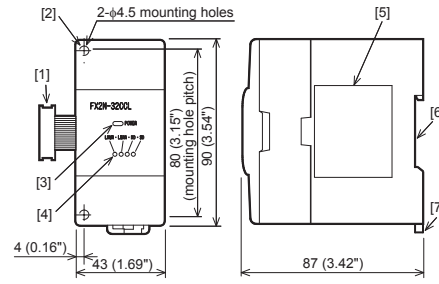

[Without top cover]

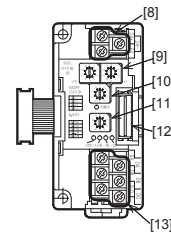

Unit: mm (inches)  
MASS (Weight): Approx. 0.2 kg (0.44 lbs)

- [1] Extension cable
- [2] Direct mounting hole  
2 holes of φ4.5 (0.18") (mounting screw: M4 screw)
- [3] Power LED (green)
- [4] Status LEDs
- [5] Name plate
- [6] DIN rail mounting groove (DIN rail: DIN46277, 35 mm (1.38") width)
- [7] DIN rail mounting hook
- [8] Power supply terminal block
- [9] Station No. set switch
- [10] Number of occupied stations set switch
- [11] Baud rate set switch
- [12] Next step extension connector
- [13] CC-Link connection terminal block

**1.4 Power and status LEDs**

LED display	LED color	Description
POWER	green	Indicates power status of FX2N-32CCL. Lighted when 5 V is supplied from PLC.
L RUN	Red	Lit while communication is performed correctly.
L ERR	Red	Lit when a communication error has occurred. Lit when a rotary switch is incorrectly set. Flickers when setting of a rotary switch is changed while the power is turned on.
RD	Red	Lit while data is received.
SD	Red	Lit while data is sent.

**1.5 Terminal Layout**

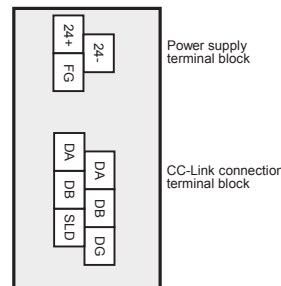

**1.5.1 Terminal screws and tightening torque**

For the terminals of FX2N-32CCL, M3 screws are used. Tighten the screws to a torque of 0.5 to 0.8 N•m. Do not tighten terminal screws with a torque outside the above-mentioned range. Failure to do so may cause equipment failures or malfunctions. For details on the wiring needed to connect to the terminal blocks shown in the figure above, refer to the following manual. → Refer to the **FX2N-32CCL User's Manual**.

**1.6 Switch setting**

The station number, the number of occupied stations and the baud rate can be set using rotary switches provided inside the panel cover of the FX2N-32CCL. The switch settings become valid after FX2N-32CCL startup. If the switch settings are changed after FX2N-32CCL startup, the L ERR LED will flicker. To change the switch setting, power OFF the FX2N-32CCL once, and power it ON again. For details on the switch setting, refer to the following manual. → Refer to the **FX2N-32CCL User's Manual**.

**1.6.1 Station number setting**

One to four FX2N-32CCL units can be used at a time. Pay attention so that the station number set here is not assigned to an other unit.

Setting items	Range	Description
× 10	0 to 6	1 to 64
× 1	0 to 9	0, 65 to 99 is the setting error.

**1.6.2 Baud rate (Transmission speed) setting**

Set the transmission speed in accordance with the specifications of the maximum transmission distance and the transmission speed. → For specifications of the maximum transmission speed and transmission speed, refer to **Section 3.5**.

Setting	Description
0	Transmission speed 156 Kbps
1	Transmission speed 625 Kbps
2	Transmission speed 2.5 Mbps
3	Transmission speed 5 Mbps
4	Transmission speed 10 Mbps
5 to 9	Setting error

**1.6.3 Number of occupied station setting**

The number of remote device points is determined by the number of stations set here. → For specifications of number of occupied station and number of remote points, refer to **Section 3.6**.

Setting	Description
0	1 station
1	2 stations
2	3 stations
3	4 stations
4 to 9	Unusable

**2. Installation**

**INSTALLATION PRECAUTIONS**

**WARNING**

- Make sure to cut off all phases of the power supply externally before attempting installation work. Failure to do so may cause electric shock or damage to the product.

**INSTALLATION PRECAUTIONS**

**CAUTION**

- Use the product within the generic environment specifications described in section 3.2 of this manual. Never use the product in areas with excessive dust, oily smoke, conductive dusts, corrosive gas (salt air, Cl<sub>2</sub>, H<sub>2</sub>S, SO<sub>2</sub>, or NO<sub>2</sub>), flammable gas, vibration or impacts, or expose it to high temperature, condensation, or rain and wind. If the product is used in such conditions, electric shock, fire, malfunctions, deterioration or damage may occur.
- Do not touch the conductive parts of the product directly. Doing so may cause device failures or malfunctions.
- Install the product securely using a DIN rail or mounting screws.

INSTALLATION PRECAUTIONS	CAUTION
<ul style="list-style-type: none"> <li>Install the product on a flat surface. If the mounting surface is rough, undue force will be applied to the PC board, thereby causing nonconformities.</li> <li>When drilling screw holes or wiring, make sure that cutting and wiring debris do not enter the ventilation slits. Failure to do so may cause fire, equipment failures or malfunctions.</li> <li>Be sure to remove the dust proof sheet from the PLC's ventilation port when installation work is completed. Failure to do so may cause fire, equipment failures or malfunctions.</li> <li>Make sure to attach the top cover, offered as an accessory, before turning on the power or initiating operation after installation or wiring work. Failure to do so may cause electric shock.</li> <li>Connect extension cables securely to their designated connectors. Loose connections may cause malfunctions.</li> </ul>	

### 2.1 Connection with PLC

The FX2N-32CCL connects on the right side of an PLC main unit or extension units/blocks (including special function units/blocks).

For connection to the FX2NC Series PLC or an extension block of the FX2NC Series PLC, use an FX2NC-CNV-IF.

For connection to the FX3GC/FX3UC Series PLC or a special function block of the FX3UC Series PLC, use an FX2NC-CNV-IF or FX3UC-1PS-5V.

For details, refer to the respective PLC user's manual hardware edition or hardware manual.

### 2.2 Mounting

The product is mounted by the following method.

- DIN rail mounting
- Direct mounting (mounting screw: M4 screw)

For details, refer to the respective PLC user's manual - hardware edition or hardware manual.

### 3. Specification

For details on specifications, refer to the following manual.

→ Refer to the FX2N-32CCL User's Manual.

DESIGN PRECAUTIONS	WARNING
<ul style="list-style-type: none"> <li>For the status of each station when the main unit stops calculation or when a communication error occurs in the data link, thoroughly read the description of data link processing time in the CC-Link master module manual. Construct an interlock circuit in the sequence program using the communication status information (SB, SW) so that the system always works conservatively. Erroneous outputs and malfunctions may cause accidents.</li> <li>When executing control (data changes) to an operating PLC, construct an interlock circuit in the sequence program so that the entire system operates conservatively.</li> </ul> <p>In addition, when executing control such as program changes and operation status changes (status control) to an operating PLC, thoroughly read the manual and sufficiently confirm safety in advance.</p> <p>Especially in control from external equipment to a PLC in a remote place, problems in the PLC may not be able to be handled promptly due to abnormality in data transfer.</p> <p>Construct an interlock circuit in the sequence program. At the same time, determine the actions in the system between the external equipment and the PLC for protection against abnormalities in data transfer.</p> <ul style="list-style-type: none"> <li>Make sure to include the following safety circuits outside the PLC to ensure safe system operation even during external power supply problems or PLC failure. Otherwise, malfunctions may cause serious accidents.             <ol style="list-style-type: none"> <li>Above all, the following components should be included: an emergency stop circuit, a protection circuit, an interlock circuit for opposite movements (such as normal vs. reverse rotation), and an interlock circuit (to prevent damage to the equipment at the upper and lower positioning limits).</li> <li>Note that when the PLC main unit detects an error during self diagnosis, such as a watchdog timer error, all outputs are turned off. Also, when an error that cannot be detected by the PLC main unit occurs in an input/output control block, output control may be disabled. External circuits and mechanisms should be designed to ensure safe machinery operation in such cases.</li> </ol> </li> </ul>	

DESIGN PRECAUTIONS	CAUTION
<ul style="list-style-type: none"> <li>Observe the following items. Failure to do so may cause incorrect data-writing through noise to the PLC and result in PLC failure, machine damage or other accident.             <ol style="list-style-type: none"> <li>Do not bundle the control line together with or lay it close to the main circuit or power line. As a guideline, lay the control line at least 100 mm (3.94") or more away from the main circuit or power line. Noise may cause malfunctions.</li> <li>Ground the shield wire or shield of a shielded cable. Do not use common grounding with heavy electrical systems.</li> </ol> </li> <li>Do not apply excessive pressure to the power supply terminal block or CC-Link connection terminal block. Excessive pressure may cause damage or error.</li> </ul>	

DISPOSAL PRECAUTIONS	CAUTION
<ul style="list-style-type: none"> <li>Please contact a certified electronic waste disposal company for the environmentally safe recycling and disposal of your device.</li> </ul>	
TRANSPORTATION AND STORAGE PRECAUTIONS	CAUTION
<ul style="list-style-type: none"> <li>The PLC is a precision instrument. During transportation, avoid impacts larger than those specified in the general specifications of the PLC main unit manual by using dedicated packaging boxes and shock-absorbing palletes. Failure to do so may cause failures in the PLC. After transportation, verify operation of the PLC and check for damage of the mounting part, etc.</li> </ul>	

### 3.1 Applicable PLC

Model name	FX0N/FX1N/FX2N/FX2NC/FX3G/FX3GC/FX3U/FX3UC
------------	--

### 3.2 General Specification

Items other than those are equivalent to those of the PLC main unit.

For general specifications, refer to the respective PLC user's manual - hardware edition or hardware manual.

Item	Specification	
Dielectric withstand voltage	500 V AC for one minute	Between external terminals as a whole and ground terminal

### 3.3 Power Supply Specification

Item	Specification	
Drive power supply	Power supply voltage	24 V DC +10% -10%
	Current consumption	50 mA (Supplied from external terminal)
Control power supply	Power supply voltage	5 V DC
	Current consumption	130 mA (Supplied from PLC via extension cable)

### 3.4 Performance Specification

Item	Specification
Station type	Remote device station
CC-Link applicable version	Ver. 1.00
Station number	1 to 64 (set by rotary switch)
Number of occupied stations	1 to 4 (set by rotary switch)
Transmission speed	156 Kbps/625 Kbps/2.5 Mbps/5 Mbps/10 Mbps (set by rotary switch)
Maximum total cable length (maximum transmission distance)	1200 m maximum (varies depending on the transmission speed.) → For details, refer to Section 3.5.
Connection cable	Twisted pair cable For the model name and the specifications of the recommended cable, refer to the FX2N-32CCL User's Manual.
Communication with PLC	By FROM and TO instructions or direct specification*1 of buffer memory via the buffer memory.
Number of I/O occupied points	8 points

\*1 FX3U/FX3UC Series PLC can use direct specification of buffer memory. Refer to the FX3S/FX3G/FX3GC/FX3U/FX3UC Series Programming Manual - Basic & Applied Instruction Edition for details.

### 3.5 Maximum transmission distance and transmission speed

Maximum transmission distance varies depending on the transmission speed.

Transmission speed	1)	2)	Maximum transmission distance
156 Kbps	2 m or more	30 cm or more	1200 m
		60 cm or more	600 m
625 Kbps	2 m or more	30 cm or more	600 m
		60 cm or more	200 m
2.5 Mbps	2 m or more	30 cm or more	200 m
		60 cm or more	150 m
5 Mbps	2 m or more	30 cm or more	150 m
		60 cm or more	110 m

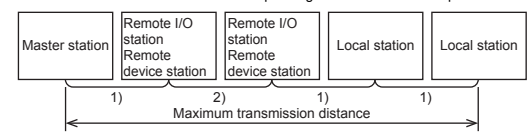

Transmission speed	1)	2)	Maximum transmission distance
10 Mbps	2 m or more	1 m or more	100 m
		60 to 99 cm	80 m
		30 to 59 cm	50 m

1) The cable length between the master/local station and an adjacent station should be 2 m or more without regard to setting of the transmission speed.

2) When the transmission speed is 5 Mbps or 10 Mbps, the maximum transmission distance varies depending on the cable length between remote I/O stations and remote device stations.

### 3.6 Number of occupied station and number of remote points

In the FX2N-32CCL, the number of remote points vary depending on the selected number of stations (1 to 4).

- 32 remote input points and 32 remote output points are available in one station. However, the upper 16 points of the final station are occupied by the CC-Link as the system area.
- 4 read points and 4 write points are available as remote registers in one station.

Number of stations	Type	Remote input	Remote output	Remote register for write	Remote register for read
1	User area	RX00 to 0F (16 points)	RY00 to 0F (16 points)	RW0 to 3 (4 points)	RWw0 to 3 (4 points)
	System area	RX10 to 1F (16 points)	RY10 to 1F (16 points)	-	-
2	User area	RX00 to 2F (48 points)	RY00 to 2F (48 points)	RW0 to 7 (8 points)	RWw0 to 7 (8 points)
	System area	RX30 to 3F (16 points)	RY30 to 3F (16 points)	-	-
3	User area	RX00 to 4F (80 points)	RY00 to 4F (80 points)	RW0 to B (12 points)	RWw0 to B (12 points)
	System area	RX50 to 5F (16 points)	RY50 to 5F (16 points)	-	-
4	User area	RX00 to 6F (112 points)	RY00 to 6F (112 points)	RW0 to F (16 points)	RWw0 to F (16 points)
	System area	RX70 to 7F (16 points)	RY70 to 7F (16 points)	-	-

### Buffer memory

BFM No.	Description	
	Buffer memory dedicated to read	Buffer memory dedicated to write
#0	Remote output RY00 to RY0F (set station)	Remote input RX00 to RX0F (set station)
#1	Remote output RY10 to RY1F (set station)	Remote input RX10 to RX1F (set station)
#2	Remote output RY20 to RY2F (set station+1)	Remote input RX20 to RX2F (set station+1)
#3	Remote output RY30 to RY3F (set station+1)	Remote input RX30 to RX3F (set station+1)
#4	Remote output RY40 to RY4F (set station+2)	Remote input RX40 to RX4F (set station+2)
#5	Remote output RY50 to RY5F (set station+2)	Remote input RX50 to RX5F (set station+2)
#6	Remote output RY60 to RY6F (set station+3)	Remote input RX60 to RX6F (set station+3)
#7	Remote output RY70 to RY7F (set station+3)	Remote input RX70 to RX7F (set station+3)
#8	Remote register RWW0 (set station)	Remote register RWR0 (set station)
#9	Remote register RWW1 (set station)	Remote register RWR1 (set station)
#10	Remote register RWW2 (set station)	Remote register RWR2 (set station)
#11	Remote register RWW3 (set station)	Remote register RWR3 (set station)
#12	Remote register RWW4 (set station+1)	Remote register RWR4 (set station+1)
#13	Remote register RWW5 (set station+1)	Remote register RWR5 (set station+1)
#14	Remote register RWW6 (set station+1)	Remote register RWR6 (set station+1)
#15	Remote register RWW7 (set station+1)	Remote register RWR7 (set station+1)
#16	Remote register RWW8 (set station+2)	Remote register RWR8 (set station+2)
#17	Remote register RWW9 (set station+2)	Remote register RWR9 (set station+2)
#18	Remote register RWWA (set station+2)	Remote register RWRa (set station+2)
#19	Remote register RWWB (set station+2)	Remote register RWRb (set station+2)
#20	Remote register RWWC (set station+3)	Remote register RWRc (set station+3)

BFM No.	Description	
	Buffer memory dedicated to read	Buffer memory dedicated to write
#21	Remote register RWWd (set station+3)	Remote register RWRd (set station+3)
#22	Remote register RWWe (set station+3)	Remote register RWRe (set station+3)
#23	Remote register RWWf (set station+3)	Remote register RWRf (set station+3)
#24	Set value of baud rate	Undefined (Write is disabled.)
#25	Communication status	Undefined (Write is disabled.)
#26	CC-Link model code	Undefined (Write is disabled.)
#27	Set value of its own station No.	Undefined (Write is disabled.)
#28	Set value of number of occupied stations	Undefined (Write is disabled.)
#29	Error code	Undefined (Write is disabled.)
#30	FX Series model code (K7040)	Undefined (Write is disabled.)
#31	Not available	Not available

「电器电子产品有害物质限制使用标识要求」的表示方式



Note: This symbol mark is for China only.

含有有害6物质的名称, 含有量, 含有部品  
本产品中所含有的有害6物质的名称, 含有量, 含有部品如下表所示。

部件名称		产品中有害物质的名称及含量					
		铅 (Pb)	汞 (Hg)	镉 (Cd)	六价铬 (Cr (VI))	多溴联苯 (PBB)	多溴二苯醚 (PBDE)
可编程控制器	外壳	○	○	○	○	○	○
印刷基板	印刷基板	×	○	○	○	○	○

本表格依据SJ/T 11364的规定编制。

○:表示该有害物质在该部件所有均质材料中的含量均在GB/T 26572规定的限量要求以下。

×:表示该有害物质至少在该部件的某一均质材料中的含量超出GB/T 26572规定的限量要求。

基于中国标准法的参考规格:GB/T15969. 2

This manual confers no industrial property rights or any rights of any other kind, nor does it confer any patent licenses. Mitsubishi Electric Corporation cannot be held responsible for any problems involving industrial property rights which may occur as a result of using the contents noted in this manual.

### Warranty

Exclusion of loss in opportunity and secondary loss from warranty liability  
Regardless of the gratis warranty term, Mitsubishi shall not be liable for compensation to:  

- Damages caused by any cause found not to be the responsibility of Mitsubishi.
- Loss in opportunity, lost profits incurred to the user by Failures of Mitsubishi products.
- Special damages and secondary damages whether foreseeable or not, compensation for accidents, and compensation for damages to products other than Mitsubishi products.
- Replacement by the user, maintenance of on-site equipment, start-up test run and other tasks.

For safe use
<ul style="list-style-type: none"> <li>This product has been manufactured as a general-purpose part for general industries, and has not been designed or manufactured to be incorporated in a device or system used in purposes related to human life.</li> <li>Before using the product for special purposes such as nuclear power, electric power, aerospace, medicine or passenger movement vehicles, consult with Mitsubishi Electric.</li> <li>This product has been manufactured under strict quality control. However when installing the product where major accidents or losses could occur if the product fails, install appropriate backup or failsafe functions in the system.</li> </ul>

MITSUBISHI ELECTRIC CORPORATION

HEAD OFFICE : TOKYO BUILDING, 2-7-3 MARUNOUCHI, CHIYODA-KU, TOKYO 100-8310, JAPAN





Side A JAPANESE  
Side B ENGLISH

FX2N-32CCL

INSTALLATION MANUAL



Manual Number	JY997D52401
Revision	D
Date	August 2018

This manual describes the part names, dimensions, mounting, and specifications of the product. Before use, read this manual and the manuals of all relevant products fully to acquire proficiency in handling and operating the product. Make sure to learn all the product information, safety information, and precautions. Store this manual in a safe place so that it can be taken out and read whenever necessary. Always forward it to the end user.

Registration:  
The company and product names described in this manual are registered trademarks or the trademarks of their respective companies.

Effective August 2018  
Specifications are subject to change without notice.

© 2013 Mitsubishi Electric Corporation

Safety Precaution (Read these precautions before use.)

This manual classifies the safety precautions into two categories:

⚠ WARNING and ⚠ CAUTION

<b>WARNING</b>	Indicates that incorrect handling may cause hazardous conditions, resulting in death or severe injury.
<b>CAUTION</b>	Indicates that incorrect handling may cause hazardous conditions, resulting in medium or slight personal injury or physical damage.

Depending on the circumstances, procedures indicated by ⚠ CAUTION may also cause severe injury. It is important to follow all precautions for personal safety.

Associated Manuals

Manual name	Manual No.	Description
FX2N-32CCL User's Manual	JY992D71801 MODEL CODE: 09R711	Describes details of the FX2N-32CCL CC-Link Interface block.
FX3G Series User's Manual - Hardware Edition	JY997D31301 MODEL CODE: 09R521	Explains the FX3G Series PLC specifications for I/O, wiring, installation, and maintenance.
FX3GC Series User's Manual - Hardware Edition	JY997D45401 MODEL CODE: 09R533	Explains the FX3GC Series PLC specifications for I/O, wiring, installation, and maintenance.
FX3U Series User's Manual - Hardware Edition	JY997D16501 MODEL CODE: 09R516	Explains the FX3U Series PLC specifications for I/O, wiring, installation, and maintenance.
FX3UC Series User's Manual - Hardware Edition	JY997D28701 MODEL CODE: 09R519	Explains the FX3UC Series PLC specifications for I/O, wiring, installation, and maintenance.
FX2N Series HARDWARE MANUAL	JY992D66301 MODEL CODE: 09R508	Explains FX2N Series PLC specification details for I/O, wiring, installation, and maintenance.
FX2NC (D/U/L) Series HARDWARE MANUAL	JY992D87201	Explains FX2NC (D/U/L) Series PLC specification details for I/O, wiring, installation, and maintenance.
FX2NC (DSS/DS) Series HARDWARE MANUAL	JY992D76401 MODEL CODE: 09R509	Explains FX2NC (DSS/DS) Series PLC specification details for I/O, wiring, installation, and maintenance.

Manual name	Manual No.	Description
FX1N Series HARDWARE MANUAL	JY992D89301 MODEL CODE: 09R511	Explains FX1N Series PLC specification details for I/O, wiring, installation, and maintenance.
FX0/FX0N Series HARDWARE MANUAL	JY992D47501	Explains FX0/FX0N Series PLC specification details for I/O, wiring, installation, and maintenance.
FX3S/FX3G/FX3GC/FX3U/FX3UC Series Programming Manual - Basic & Applied Instruction Edition	JY997D16601 MODEL CODE: 09R517	Explains basic instructions and applied instructions available in the FX3S/FX3G/FX3GC/FX3U/FX3UC PLC.
FX1S, FX1N, FX2N, FX2NC Series Programming Manual	JY992D88101 MODEL CODE: 09R512	Explains instructions applicable in the FX1S/FX1N/FX2N/FX2NC PLC.

How to obtain manuals

For product manuals or documents, consult with the Mitsubishi Electric dealer from who you purchased your product.

Compliance with EC directive (CE Marking)

This note does not guarantee that an entire mechanical module produced in accordance with the contents of this note will comply with the following standards. Compliance to EMC directive and LVD directive for the entire mechanical module should be checked by the user / manufacturer. For more information please consult with your nearest Mitsubishi product provider. Regarding the standards that comply with the main unit, please refer to either the FX series product catalog or consult with your nearest Mitsubishi product provider.

Requirement for Compliance with EMC directive

The following products have shown compliance through direct testing (of the identified standards below) and design analysis (through the creation of a technical construction file) to the European Directive for Electromagnetic Compatibility (2014/30/EU) when used as directed by the appropriate documentation.

Attention

This product is designed for use in industrial applications.

Type: Programmable Controller (Open Type Equipment)  
Models: MELSEC FX2N series manufactured from June 1st, 1999 FX2N-32CCL

Standard	Remark
EN61000-6-4:2007 Generic emission standard Industrial environment	Compliance with all relevant aspects of the standard. • Emission-Enclosure port • Emission-Low voltage AC mains port • Emission-Telecommunications/network port
EN61131-2:2007 Programmable controllers - Equipment requirements and tests	Compliance with all relevant aspects of the standard. EMI • Radiated Emission • Conducted Emission EMS • Radiated electromagnetic field • Fast transient burst • Electrostatic discharge • High-energy surge • Voltage drops and interruptions • Conducted RF • Power frequency magnetic field

1. Introduction

1.1 Introduction

The CC-Link interface block FX2N-32CCL is a special function block to connect the FX0N/FX1N/FX2N/FX2NC/FX3G/FX3GC/FX3U/FX3UC Series PLC to a CC-Link network. → For details, refer to the FX2N-32CCL User's Manual.

1.2 Incorporated Items

Check to ensure the following product and items are included in the package.

Included Item	Quantity
FX2N-32CCL	1 unit
Special unit/block No. label	1 sheet
Dust proof protection sheet	1 sheet
Manuals (Japanese version, English version)	1 manual each

1.3 External Dimensions and Part Names

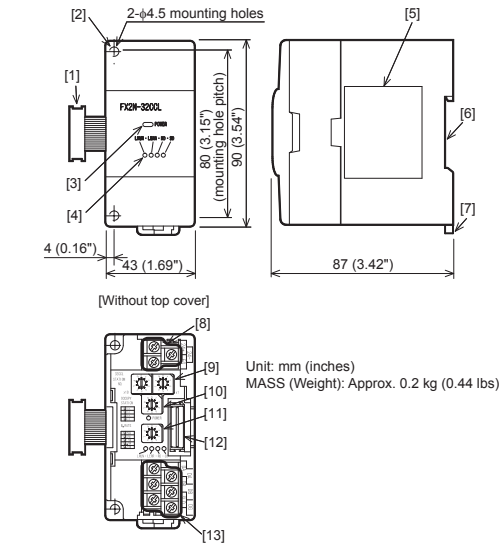

- Extension cable
- Direct mounting hole  
2 holes of  $\phi 4.5$  (0.18") (mounting screw: M4 screw)
- Power LED (green)
- Status LEDs
- Name plate
- DIN rail mounting groove (DIN rail: DIN46277, 35 mm (1.38") width)
- DIN rail mounting hook
- Power supply terminal block
- Station No. set switch
- Number of occupied stations set switch
- Baud rate set switch
- Next step extension connector
- CC-Link connection terminal block

1.4 Power and status LEDs

LED display	LED color	Description
POWER	green	Indicates power status of FX2N-32CCL. Lighted when 5 V is supplied from PLC.
L RUN	Red	Lit while communication is performed correctly.
L ERR	Red	Lit when a communication error has occurred. Lit when a rotary switch is incorrectly set. Flickers when setting of a rotary switch is changed while the power is turned on.
RD	Red	Lit while data is received.
SD	Red	Lit while data is sent.

1.5 Terminal Layout

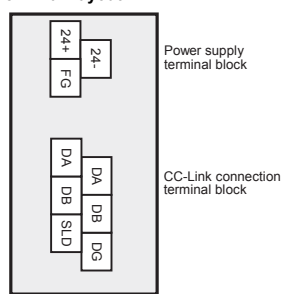

1.5.1 Terminal screws and tightening torque

For the terminals of FX2N-32CCL, M3 screws are used. Tighten the screws to a torque of 0.5 to 0.8 N·m. Do not tighten terminal screws with a torque outside the above-mentioned range. Failure to do so may cause equipment failures or malfunctions. For details on the wiring needed to connect to the terminal blocks shown in the figure above, refer to the following manual.  
→ Refer to the FX2N-32CCL User's Manual.

1.6 Switch setting

The station number, the number of occupied stations and the baud rate can be set using rotary switches provided inside the panel cover of the FX2N-32CCL. The switch settings become valid after FX2N-32CCL startup. If the switch settings are changed after FX2N-32CCL startup, the L ERR LED will flicker. To change the switch setting, power OFF the FX2N-32CCL once, and power it ON again. For details on the switch setting, refer to the following manual.  
→ Refer to the FX2N-32CCL User's Manual.

1.6.1 Station number setting

One to four FX2N-32CCL units can be used at a time. Pay attention so that the station number set here is not assigned to another unit.

Setting items	Range	Description
× 10	0 to 6	1 to 64
× 1	0 to 9	0, 65 to 99 is the setting error.

1.6.2 Baud rate (Transmission speed) setting

Set the transmission speed in accordance with the specifications of the maximum transmission distance and the transmission speed.  
→ For specifications of the maximum transmission distance and transmission speed, refer to Section 3.5.

Setting	Description
0	Transmission speed 156 Kbps
1	Transmission speed 625 Kbps
2	Transmission speed 2.5 Mbps
3	Transmission speed 5 Mbps
4	Transmission speed 10 Mbps
5 to 9	Setting error

1.6.3 Number of occupied station setting

The number of remote device points is determined by the number of stations set here.  
→ For specifications of number of occupied station and number of remote points, refer to Section 3.6.

Setting	Description
0	1 station
1	2 stations
2	3 stations
3	4 stations
4 to 9	Unusable

2. Installation

**INSTALLATION PRECAUTIONS** ⚠ WARNING

- Make sure to cut off all phases of the power supply externally before attempting installation work. Failure to do so may cause electric shock or damage to the product.

**INSTALLATION PRECAUTIONS** ⚠ CAUTION

- Use the product within the generic environment specifications described in section 3.2 of this manual. Never use the product in areas with excessive dust, oily smoke, conductive dusts, corrosive gas (salt air, Cl<sub>2</sub>, H<sub>2</sub>S, SO<sub>2</sub>, or NO<sub>2</sub>), flammable gas, vibration or impacts, or expose it to high temperature, condensation, or rain and wind. If the product is used in such conditions, electric shock, fire, malfunctions, deterioration or damage may occur.
- Do not touch the conductive parts of the product directly. Doing so may cause device failures or malfunctions.
- Install the product securely using a DIN rail or mounting screws.

**INSTALLATION PRECAUTIONS** ⚠ CAUTION

- Install the product on a flat surface. If the mounting surface is rough, undue force will be applied to the PC board, thereby causing nonconformities.
- When drilling screw holes or wiring, make sure that cutting and wiring debris do not enter the ventilation slits. Failure to do so may cause fire, equipment failures or malfunctions.
- Be sure to remove the dust proof sheet from the PLC's ventilation port when installation work is completed. Failure to do so may cause fire, equipment failures or malfunctions.
- Make sure to attach the top cover, offered as an accessory, before turning on the power or initiating operation after installation or wiring work. Failure to do so may cause electric shock.
- Connect extension cables securely to their designated connectors. Loose connections may cause malfunctions.

2.1 Connection with PLC

The FX2N-32CCL connects on the right side of an PLC main unit or extension units/blocks (including special function units/blocks). For connection to the FX2NC Series PLC or an extension block of the FX2NC Series PLC, use an FX2NC-CNV-IF. For connection to the FX3G/FX3UC Series PLC or a special function block of the FX3UC Series PLC, use an FX2NC-CNV-IF or FX3UC-1PS-5V. For details, refer to the respective PLC user's manual hardware edition or hardware manual.

2.2 Mounting

The product is mounted by the following method.

- DIN rail mounting
  - Direct mounting (mounting screw: M4 screw)
- For details, refer to the respective PLC user's manual - hardware edition or hardware manual.

3. Specification

For details on specifications, refer to the following manual.

→ Refer to the FX2N-32CCL User's Manual.

**DESIGN PRECAUTIONS** ⚠ WARNING

- For the status of each station when the main unit stops calculation or when a communication error occurs in the data link, thoroughly read the description of data link processing time in the CC-Link master module manual. Construct an interlock circuit in the sequence program using the communication status information (SB, SW) so that the system always works conservatively. Erroneous outputs and malfunctions may cause accidents.
- When executing control (data changes) to an operating PLC, construct an interlock circuit in the sequence program so that the entire system operates conservatively. In addition, when executing control such as program changes and operation status changes (status control) to an operating PLC, thoroughly read the manual and sufficiently confirm safety in advance. Especially in control from external equipment to a PLC in a remote place, problems in the PLC may not be able to be handled promptly due to abnormality in data transfer. Construct an interlock circuit in the sequence program. At the same time, determine the actions in the system between the external equipment and the PLC for protection against abnormalities in data transfer.
- Make sure to include the following safety circuits outside the PLC to ensure safe system operation even during external power supply problems or PLC failure. Otherwise, malfunctions may cause serious accidents.
  - Above all, the following components should be included: an emergency stop circuit, a protection circuit, an interlock circuit for opposite movements (such as normal vs. reverse rotation), and an interlock circuit to prevent damage to the equipment at the upper and lower positioning limits.
  - Note that when the PLC main unit detects an error during self diagnosis, such as a watchdog timer error, all outputs are turned off. Also, when an error that cannot be detected by the PLC main unit occurs in an input/output control block, output control may be disabled. External circuits and mechanisms should be designed to ensure safe machinery operation in such cases.

**DESIGN PRECAUTIONS** ⚠ CAUTION

- Observe the following items. Failure to do so may cause incorrect data-writing through noise to the PLC and result in PLC failure, machine damage or other accident.
  - Do not bundle the control line together with or lay it close to the main circuit or power line. As a guideline, lay the control line at least 100 mm (3.94") or more away from the main circuit or power line. Noise may cause malfunctions.
  - Ground the shield wire or shield of a shielded cable. Do not use common grounding with heavy electrical systems.
  - Do not apply excessive pressure to the power supply terminal block or CC-Link connection terminal block. Excessive pressure may cause damage or error.

**DISPOSAL PRECAUTIONS** ⚠ CAUTION

- Please contact a certified electronic waste disposal company for the environmentally safe recycling and disposal of your device.

**TRANSPORTATION AND STORAGE PRECAUTIONS** ⚠ CAUTION

- The PLC is a precision instrument. During transportation, avoid impacts larger than those specified in the general specifications of the PLC main unit manual by using dedicated packaging boxes and shock-absorbing pallets. Failure to do so may cause failures in the PLC. After transportation, verify operation of the PLC and check for damage of the mounting part, etc.

3.1 Applicable PLC

Model name	FX0N/FX1N/FX2N/FX2NC/FX3G/FX3GC/FX3U/FX3UC
------------	--

3.2 General Specification

Items other than the following are equivalent to those of the PLC main unit. For general specifications, refer to the respective PLC user's manual - hardware edition or hardware manual.

Item	Specification
Dielectric withstand voltage	500 V AC for one minute Between external terminals as a whole and ground terminal

3.3 Power Supply Specification

Item	Specification
Drive power supply	Power supply voltage: 24 V DC +10% -10% Current consumption: 50 mA (Supplied from external terminal)
Control power supply	Power supply voltage: 5 V DC Current consumption: 130 mA (Supplied from PLC via extension cable)

3.4 Performance Specification

Item	Specification
Station type	Remote device station
CC-Link applicable version	Ver. 1.00
Station number	1 to 64 (set by rotary switch)
Number of occupied stations	1 to 4 (set by rotary switch)
Transmission speed	156 Kbps/625 Kbps/2.5 Mbps/5 Mbps/10 Mbps (set by rotary switch)
Maximum total cable length (maximum transmission distance)	1200 m maximum (varies depending on the transmission speed.) → For details, refer to Section 3.5.
Connection cable	Twisted pair cable For the model name and the specifications of the recommended cable, refer to the FX2N-32CCL User's Manual.
Communication with PLC	By FROM and TO instructions or direct specification*1 of buffer memory via the buffer memory.
Number of I/O occupied points	8 points

\*1 FX3U/FX3UC Series PLC can use direct specification of buffer memory. Refer to the FX3S/FX3G/FX3GC/FX3U/FX3UC Series Programming Manual - Basic & Applied Instruction Edition for details.

3.5 Maximum transmission distance and transmission speed

Maximum transmission distance varies depending on the transmission speed.

Transmission speed	1)	2)	Maximum transmission distance
156 Kbps		30 cm or more	1200 m
625 Kbps		30 cm or more	600 m
2.5 Mbps	2 m or more	30 cm or more	200 m
5 Mbps		60 cm or more	150 m
		30 to 59 cm	110 m

Transmission speed	1)	2)	Maximum transmission distance
10 Mbps	2 m or more	1 m or more	100 m
		60 to 99 cm	80 m
		30 to 59 cm	50 m

- The cable length between the master/local station and an adjacent station should be 2 m or more without regard to setting of the transmission speed.
- When the transmission speed is 5 Mbps or 10 Mbps, the maximum transmission distance varies depending on the cable length between remote I/O stations and remote device stations.

3.6 Number of occupied station and number of remote points

In the FX2N-32CCL, the number of remote points vary depending on the selected number of stations (1 to 4).  
• 32 remote input points and 32 remote output points are available in one station. However, the upper 16 points of the final station are occupied by the CC-Link as the system area.  
• 4 read points and 4 write points are available as remote registers in one station.

Number of stations	Type	Remote input	Remote output	Remote register for write	Remote register for read
1	User area	RX00 to 0F (16 points)	RY00 to 0F (16 points)	RW0 to 3 (4 points)	RW0 to 3 (4 points)
	System area	RX10 to 1F (16 points)	RY10 to 1F (16 points)	-	-
2	User area	RX00 to 2F (48 points)	RY00 to 2F (48 points)	RW0 to 7 (8 points)	RW0 to 7 (8 points)
	System area	RX30 to 3F (16 points)	RY30 to 3F (16 points)	-	-
3	User area	RX00 to 4F (80 points)	RY00 to 4F (80 points)	RW0 to B (12 points)	RW0 to B (12 points)
	System area	RX50 to 5F (16 points)	RY50 to 5F (16 points)	-	-
4	User area	RX00 to 6F (112 points)	RY00 to 6F (112 points)	RW0 to F (16 points)	RW0 to F (16 points)
	System area	RX70 to 7F (16 points)	RY70 to 7F (16 points)	-	-

Buffer memory

BFM No.	Description
#0	Remote output RY00 to RY0F (set station)
#1	Remote output RY10 to RY1F (set station)
#2	Remote output RY20 to RY2F (set station+1)
#3	Remote output RY30 to RY3F (set station+1)
#4	Remote output RY40 to RY4F (set station+2)
#5	Remote output RY50 to RY5F (set station+2)
#6	Remote output RY60 to RY6F (set station+3)
#7	Remote output RY70 to RY7F (set station+3)
#8	Remote register RW0 (set station)
#9	Remote register RW1 (set station)
#10	Remote register RW2 (set station)
#11	Remote register RW3 (set station)
#12	Remote register RW4 (set station+1)
#13	Remote register RW5 (set station+1)
#14	Remote register RW6 (set station+1)
#15	Remote register RW7 (set station+1)
#16	Remote register RW8 (set station+2)
#17	Remote register RW9 (set station+2)
#18	Remote register RWa (set station+2)
#19	Remote register RWb (set station+2)
#20	Remote register RWc (set station+3)

BFM No.	Description
#21	Remote register RWwD (set station+3)
#22	Remote register RWwE (set station+3)
#23	Remote register RWwF (set station+3)
#24	Set value of baud rate
#25	Communication status
#26	CC-Link model code
#27	Set value of its own station No.
#28	Set value of number of occupied stations
#29	Error code
#30	FX Series model code (K7040)
#31	Not available

「电器电子产品有害物质限制使用标识要求」的表示方式

Ⓛ Note: This symbol mark is for China only.

含有有害6物质的名称, 含有量, 含有部品  
本产品中所含有的有害6物质的名称, 含有量, 含有部品如下表所示。

产品名称	产品中有害物质的名称及含量					
	铅 (Pb)	汞 (Hg)	镉 (Cd)	六价铬 (Cr (VI))	多溴联苯 (PBB)	多溴二苯醚 (PBDE)
可编程控制器	○	○	○	○	○	○
印刷基板	×	○	○	○	○	○

本表格依据SJ/T 11364的规定编制。

○: 表示该有害物质在该部件所有均质材料中的含量均在GB/T 26572规定的限量要求以下。  
×: 表示该有害物质至少在该部件的某一均质材料中的含量超出GB/T 26572规定的限量要求。

基于中国标准法的参考规格: GB/T15969.2

This manual confers no industrial property rights or any rights of any other kind, nor does it confer any patent licenses. Mitsubishi Electric Corporation cannot be held responsible for any problems involving industrial property rights which may occur as a result of using the contents noted in this manual.

**Warranty**  
Exclusion of loss in opportunity and secondary loss from warranty liability. Regardless of the gratis warranty term, Mitsubishi shall not be liable for compensation to: (1) Damages caused by any cause found not to be the responsibility of Mitsubishi. (2) Loss in opportunity, lost profits incurred to the user by Failures of Mitsubishi products. (3) Special damages and secondary damages whether foreseeable or not, compensation for accidents, and compensation for damages to products other than Mitsubishi products. (4) Replacement by