



Numerical Protection Relay

*MELPRO*™-D Series

MOTOR PROTECTION RELAY

MODEL

**CMP1-A02D1, CMP1-A02D2**

INSTRUCTION MANUAL

**Request**

Ensure that this Instruction Manual is delivered to  
the end users and the maintenance manager.

— Safety section —

This Safety section should be read before starting any work on the relay. Be sure to read the instruction manuals and other related documents prior to commencing any work on the relay in order to maintain them in a safe condition. Be sure to be familiar with the knowledge, safety information and all caution items of the product prior to use.



**CAUTION**

Caution means that failure to un-observe safety information, incorrect use, or improper use may endanger personnel and equipment and cause personnel injury or physical damage.

Items as classified to the caution may become to occur more sever results according to the circumstance. Therefore, all items described in the safety section are important and to be respected without fail.



**CAUTION**

1. Items concerning transportation
  - (1) Be sure the equipment to be kept in normal direction
  - (2) Avoid the bumps, shock, and vibration, otherwise the product performance /life might be unfavorably affected.
2. Items concerning storage
  - (1) Environment shall be as below, otherwise the product performance/life might be unfavorably affected.
    - Ambient temperature: -20°C~+60°C (with no condensation nor freezing)
    - Relative humidity: 30~80% average of a day
    - Altitude: Less than 2000m
    - Avoid applying unusual shock, vibration or leaning or magnetic field
    - Not expose to harmful smoke, gas, salty air, water, vapor, dust, powder, explosive material or wind, rain.
3. Items concerning mounting/wiring work
  - (1) Mounting and wiring work should be done correctly.  
Otherwise, damage, burning or erroneous operation might occur.
  - (2) Screw terminal should be tightened securely.  
Otherwise, damage and burning might occur.
  - (3) Grounding should be done correctly in case it is required.  
Otherwise, electric shock, damage, burning or erroneous operation might occur.
  - (4) Wiring should be done without mistake especially observing the correct polarity.  
Otherwise, damage, burning or erroneous operation might occur.
  - (5) Wiring should be done without mistake especially observing the phase ordering.  
Otherwise, damage, or erroneous operation might occur.
  - (6) Auxiliary power source, measuring transformer and power source which have enough capacity for correct operation of product should be used.  
Otherwise, an erroneous operation might occur.
  - (7) Be sure to restore the front cover, terminal cover, protection cover, etc to the original position, which have been removed during the mounting/ wiring work.  
Otherwise, electrical shock might occur at the time of checking.
  - (8) Connection should be done correctly using designated and right connectors.  
Otherwise, damage or burning might occur.
  - (9) Fully insert the sub unit into the case until you can hear a click while pressing the handles located on both sides of the sub unit front face.  
Otherwise, incomplete inserting the sub unit might only establish a poor contact with the terminals located on the back side of unit, which might cause erroneous operation or heating.
4. Concerning equipment operation and settings
  - (1) Operational condition should be as below.  
Otherwise, the product performance/life might be unfavorably affected.
    - Deviation of auxiliary power: within +10%~-15% of rated voltage
    - Deviation of frequency: within ±5% of rated frequency
    - Ambient temperature: 0°C~+40°C (-10°C~+50°C is permissible during couples of hour per day, with no condensation nor freezing)
    - Relative humidity: 30~80% average of a day
    - Altitude: Less than 2000m
    - Avoid to be exposed to unusual shock, vibration, leaning or magnetic field

-Not expose to harmful smoke, gas, salty air, water, vapor, dust, powder, explosive material, wind or rain.

- (2) Qualified personnel may work on or operate this product, otherwise, the product performance/life might be unfavorably affected and/or burning or erroneous operation might occur.
- (3) Be sure to read and understand the instruction manuals and other related documents prior to commencing operation and maintenance work on the product. Otherwise, electrical shock, injury, damage, or erroneous operation might occur.
- (4) While energizing product, be sure not to remove any unit or parts without permissible one. Otherwise, damage, or erroneous operation might occur.
- (5) While energizing product, be sure to make short circuit of current transformer secondary circuits before setting change or drawing out the sub unit. Otherwise, secondary circuit of live current transformer might be opened and damage or burning might occur due to the high level voltage.
- (6) While energizing product, be sure to open trip lock terminal before setting change or drawing out the internal unit of product. Otherwise, erroneous operation might occur.
- (7) Be sure to use the product within rated voltage and current.  
Otherwise, damage or mal-operation might be occurred.
- (8) While energizing product, be sure not to clean up the product.  
Only wiping a stain on the front cover of product with a damp waste might be allowable. (Be sure to wring hardly the water out of the waste.)

5. Items concerning maintenance and checking

- (1) Be sure that only qualified personnel might work on or operate this product.  
Otherwise, electrical shock, injury, damage, or erroneous operation might occur.
- (2) Be sure to read and understand the instruction manuals and other related documents prior to commencing operation and maintenance work on the product. Otherwise, electrical shock, injury, damage, or erroneous operation might occur.
- (3) In case of replacing the parts, be sure to use the ones of same type, rating and specifications, etc. If impossible to use above parts, be sure to contact the sales office or distributor nearest you.  
Otherwise, damage or burning might occur.
- (4) Testing shall be done with the following conditions.
  - Ambient temperature:  $20^{\circ}\text{C}\pm 10^{\circ}\text{C}$
  - Relative humidity: Less than 90%
  - Magnetic field: Less than 80A/m
  - Atmospheric pressure:  $86\sim 106\times 10^3\text{ Pa}$
  - Installation angle: Normal direction $\pm 2^{\circ}$
  - Deviation of frequency: within  $\pm 1\%$  of nominal frequency
  - Wave form(in case of AC): Distortion factor less than 2%  
(Distortion factor= $100\%\times$ effective value of harmonics/effective value of fundamental)
  - Ripple (in case of DC): Ripple factor less than 3%  
(Ripple factor= $100\%\times(\text{max}-\text{min})/\text{average of DC}$ )
  - Deviation of auxiliary power: within  $\pm 2\%$  of nominal voltage
  - Be sure not to inject the voltage or current beyond the overload immunity.  
Otherwise, damage or burning might occur.
  - Be careful not to touch the energized parts.  
Otherwise, the electric shock might occur.

6. Items concerning modification and/or repair work

Be sure to ask any modification and/ or repair work for product to the sales office or distributor nearest you.

Unless otherwise, any incidents occurred with modification or repair works (including software) done by any other entity than MITSUBIHI ELECTRIC CORPORATION shall be out of scope on warranty covered by MITSUBISHI ELECTRIC CORPORATION.

7. Items concerning disposal

Particular regulations within the country of operation shall be applied to the disposal.

**- Introduction -**

Thank for your purchasing Mitsubishi Electric **MELPRO**™ – D Series Digital Protection Relay.

Please read this manual carefully to be familiar with the functions and performances enough to use the product properly.

Please note end users are required to be provided with this instruction manual.

For operation of the product, this manual should be used in conjunction with the following materials:

Title of document	Document No.
MELPRO – D Series Protection Relay General Operation Manual	JEP0-IL9416

When the protection relay is used together with a communication card, use the following documents too:

(For CC-Link)

Title of document	Document No.
MELPRO – D Series Protection Relay CC-COM Communication Card (CC-Link) Operation Manual (General information)	JEP0-IL9417
MELPRO – D Series Protection Relay CC-COM Communication Card (CC-Link) Operation Manual (Model-specific information)	JEP0-IL9418

– CONTENTS –

1	Features	6
1.1	General description	6
1.2	Features	6
2	Ratings and specifications	8
2.1	General information	8
2.2	Protective elements	10
2.3	Measurement elements	12
3	Characteristics	14
3.1	Protective elements	14
3.2	Measurement elements	16
3.3	Common technical data	17
4	Description of each function	18
4.1	Protection	18
4.2	Measurement	30
4.3	Self-diagnosis	31
4.4	Communication (option)	32
5	Configuration	34
5.1	Internal configuration	34
5.2	External connection	39
6	Handling	45
6.1	Unpacking	45
6.2	Transportation and storage	45
6.3	Appearance and how to pull sub unit out	45
6.4	How to use front control panel	53
7	Mounting	63
7.1	Mounting dimension	63
7.2	Standard operating environment	63
8	Test	64
8.1	Appearance inspection	64
8.2	Characteristic test	65
9	Maintenance	69
9.1	Daily inspection	69
9.2	Periodical inspection	69
10	Ordering	70
11	Guarantee	70
11.1	Guarantee period	70
11.2	Scope of guarantee	70
11.3	Exclusion of loss in opportunity and secondary loss from warranty liability	71
11.4	Applications of products	71
11.5	Onerous repair term after discontinuation of product	72
11.6	Changes in product specification	72
11.7	Scope of service	72
12	Improvement on the reliability of protection function	72

# 1 Features

## 1.1 General description

Mitsubishi Electric MELPRO-D Series is a digital protection relay product with a microprocessor for protecting high/extra-high-voltage electric power system.

With its improved functions, including operation support using the advanced communication networks, data saving at the power system faults and power system voltage/current measurement, this series of protection relay will allow stable and effective control and monitoring of electric power systems as well as provide high-reliable protection.

## 1.2 Features

### (1) High-reliable protection

- Since "overcurrent instantaneous element", "overcurrent time-delayed element", "negative-sequence overcurrent element", "overload element", "undercurrent element", "limit the number of start-up times" and "earth fault overcurrent element" are built in, protections of an induction motor can be carried out by just this one relay.
- Moreover, since sequence trip is realizable with a main part by taking in an external signal input (for example, undervoltage element) etc. using DI (digital input) in D2 type, it is the best for broad protection.

### (2) The overload operating characteristic united with the thermal withstand characteristic of various motors is built in.

### (3) Communication Network (With the addition of optional communication card)

- With an open field bus system, the relays can be used to build a high-speed, high-performance network system. In addition, the relay's multi-drop serial wiring reduces the amount of labor required for communication wiring.
- Control of measurement values, operation status, as well as setting changes, etc., can be performed from a remote location.
- In consideration of future network system variations and compatibility with communication networks, communication features are mounted in the relay using a replaceable card.

### (4) Measurement & Recording Functions

- Real time monitor of relay input data  
The relay can measure steady state relay input values, supporting energy management.
- Fault Data Monitor  
When a fault occurs, the relay saves the past 5 effective input values and waveform data to assist with fault analysis.

### (5) Programmable Output Configuration

The operating output contacts (DO) can be set by combining the outputs of the protection relay element using 'OR' logic, thereby simplifying sequence design.

### (6) High Accurate Digital Computation

The digital computation using high-speed sampling minimizes the effect of high harmonics, etc., and results in highly accurate protection.

(7) Self-diagnosis

The relay continuously monitors electronic circuits from input to output so that it can detect internal failure before that failure causes damage on the power system, thereby improving reliability.

(8) Easy Replacement

The dimensions of the panel cutout are the same as the prior MULTICAP series. Changing from an existing relay type to this new type is easy.

(9) Easy Maintenance

The relays are adopted as draw-out unit mechanisms with automatic CT shorting at drawing, thereby making maintenance easy.

(10) Easy wiring check

It is possible to carry out forced operation of the output contacts individually. This will allow an easy wiring check.

## 2 Ratings and specifications

### 2.1 General information

Type name		CMP1-A02D1/D2				
Style (CMP1-A02D1)	Without direct communication port	414PMB	415PMB	418PMB	419PMB	
	With direct communication port	605PMB	606PMB	609PMB	610PMB	
Style (CMP1-A02D2)	Without direct communication port	424PMB	425PMB	428PMB	429PMB	
	With direct communication port	611PMB	612PMB	615PMB	616PMB	
Grounding system		Resistance grounding system				
Elements	Protection	Overcurrent instantaneous element (short-circuit element: 50)				
		Overcurrent time-delayed element (locked rotor element: 51LR)				
		Overload element (thermal element: 49)				
		Negative-sequence overcurrent element (open phase element: 46)				
		Undercurrent element (undercurrent element: 37)				
		Limit the number of start-up times (Limit the number of start-up times: 66)				
		Earth fault overcurrent element (Earth fault element: 51G)				
Measurement		Phase current, negative-sequence current, zero-phase current				
Ratings	Frequency		50 Hz	60 Hz	50 Hz	60 Hz
	Phase current		5 A		1 A	
	Zero-phase current		5 A		1 A	
	Photo-coupler input voltage (only type D2)		110VDC (Operative range:77V~143VDC)			
	Auxiliary Power supply *21	Voltage	Common use for 100 ~ 220VDC / 100 ~ 220VAC			
		Operative range	DC : 85 ~ 242 V (Range of 80 ~ 286VDC is allowable temporarily.) AC : 85 ~ 242 V (Range of 85 ~ 253VAC is allowable temporarily.)			
Display	RUN		Indicate the result of self-diagnosis. The lamp is lit for normal conditions and off for abnormal.			
	Unit		Indicate the unit symbol for measurements.			
	Item No., Item data		Display measurement, status, setting and option data selected with an item number.			
	Communication		With a communication card installed: the lamp is lit for normal conditions, blinking during communication and off for abnormal. With a communication card not installed: the lamp is off.			
Self-diagnosis		Monitor the electronic circuit and internal power supply to output signal to the RUN LED and self-diagnosis output (ALARM).				
Output contacts	Configurations	For trip	2 make contacts: X <sub>5</sub> and X <sub>6</sub> (programmable output)			
		For signaling	5 make contacts: X <sub>0</sub> to X <sub>4</sub> (programmable output)			
		For self-diagnosis output	1 break contact: Y (open for normal result of self-diagnosis with power on)			
	Capacity	For trip	Make	110VDC, 15A, 0.5 s (L/R = 0 s)		220VDC, 10A, 0.5 s (L/R = 0 s)
			Break	110VDC, 0.3A (L/R<40 ms)		220VDC, 0.15A (L/R<40 ms)
			Carry	1.5 A, continuously		
		For signaling and self-diagnosis output	Make and Break	500 VA (cosφ= 0.4), 60W (L/R = 0.007 s)		
			Max. current	5 A		
Max. voltage	380VAC, 125VDC					
Communication	Direct communication port		Standard equipment (PC software for direct communication)			
	Remote communication port		Option for CC-Link			
Burden	Phase current circuit		0.5 VA or less (with rated current)			
	Zero-phase current circuit		0.5 VA or less (with rated current)			



	Auxiliary supply circuit	For 100VDC: approx. 4W (approx. 6W including communication card) For 100VAC: approx. 8VA (approx. 10VA including communication card) For 220VDC: approx. 5W (approx. 7W including communication card) For 220VAC: approx. 15VA (approx. 17VA including communication card)
	Mass	Net weight of unit : approx. 2.1 kg (D1 type) Including case : approx. 2.8 kg (D1 type) Net weight of unit : approx. 3.1 kg (D2 type) Including case : approx. 4.3 kg (D2 type)
	Case/cover	Size : D1 type (CMP1-A02D1) D2 type (CMP1-A02D2) Color : N1.5

\*21 When an uninterruptible AC power source is not provided in your system for the auxiliary supply voltage, use the type B-T1 backup power supply or commercially available uninterruptible power supply (UPS).

Type B-T1 back up power supply unit can be applied for DASH series protection relay with 100V~200V auxiliary power supply voltage rating only.

In addition, the power supply duration of the type B-T1 back up power supply is confirmed about 2 seconds in combination with one MELPRO-D series relay. Therefore, in the case that the required power supply duration after power source loss exceeds 2 seconds, please use a suitable commercial uninterruptible power supply.

When the power supply back up for the control power supply of a circuit breaker is required, it is necessary to prepare the backup power supply different from the type B-T1 back up power supply.

## 2.2 Protective elements

Style (CMP1-A02D1)	Without direct communication port	414PMB	415PMB	418PMB	419PMB	
	With direct communication port	605PMB	606PMB	609PMB	610PMB	
Style (CMP1-A02D2)	Without direct communication port	424PMB	425PMB	428PMB	429PMB	
	With direct communication port	611PMB	612PMB	615PMB	616PMB	
Settings *24	Motor rated current (IM)	2 ~ 5A (0.1A step)		0.4 ~ 1A (0.02A step)		
	Overcurrent instantaneous	Operation current	LOCK - 10 ~ 100A (1A step)		LOCK - 2 ~ 20A (0.2A step)	
		Operation time	INST - 0.1 ~ 1.0s (0.1s step)			
	Overcurrent time-delayed	Operation current	LOCK-IM×130~300% (10% step)			
		Operation time Setting (K <sub>oct</sub> )	4-5-6-8-10-12-16-20-24-32-40-48-64-80-96-112-128-160-200-240 (dial)			
		Operation time characteristic equation	$T_{OCT} = 3 \times \frac{K_{OCT}}{I} \text{ (s)}$ <p> <math>K_{OCT}</math> : Operation time setting  <math>I</math> : Phase current (Unit : multiple to IM)                      Selected value of <math>K_{OCT}</math> becomes equal to the time (sec) that will be taken until operation when input I=3.                 </p>			
	Negative-sequence overcurrent	Operation current	LOCK-IM×0.5~8 multiplication (0.5 step)			
		Operation time	0.1~10s (0.1s step)			
	Overload	Operation current	LOCK-IM×105~125% (5% step)			
		Operation time Setting (K <sub>TH</sub> )	8-12-16-20-24-32-40-48-64-80-96-112-128-160-200-240 (dial)			
		Operation time characteristic equation	<p>Operation time for HOT characteristic</p> $T_{TH} = 8.49 \times K_{TH} \times \log_e \frac{(I_1^2 + K \cdot I_2^2) - (I_{P1}^2 + K \cdot I_{P2}^2)}{(I_1^2 + K \cdot I_2^2) - 1} \text{ (s)}$ <p> <math>K_{TH}</math> : Operation time setting  <math>K</math> : Negative-sequence heat multiplying factor  <math>I_1</math> : Positive-sequence current of present input (Unit : multiple to IM)  <math>I_2</math> : Negative-sequence current of present input (Unit : multiple to IM)  <math>I_{P1}</math> : Positive-sequence current before overload (Unit : multiple to IM)  <math>I_{P2}</math> : Negative-sequence current before overload (Unit : multiple to IM)                     </p> <p>Operation time for COLD characteristics, in the above equation, becomes equal to case conditioned as follows :</p> $(I_{P1}^2 + K \cdot I_{P2}^2) = 0$ <p>Selected value of <math>K_{TH}</math>, when input is provided so as to meet the conditions of <math>I_1^2 + K \cdot I_2^2 = 3^2</math> and <math>I_{P1}^2 + K \cdot I_{P2}^2 = 0</math>, becomes equal to the time (sec) that will be taken until operation.</p>			
		Negative-sequence heat multiplying factor	1~10 (1 step) (K: refer to above operation time characteristic)			
		Characteristic changeover	0(COLD) -1(HOT)			
	Undercurrent	Operation current	LOCK - 1.0 ~ 4.0A (0.1A step)		LOCK - 0.2 ~ 0.8A (0.02A step)	
		Operation time	1 ~ 600s (1 s step)			
	Limit the number of start-up times	Number of Start-up times	LOCK-1~5 (1 step)			
		Start-up time	2 ~ 120s (1s step)			
Countdown rate of start-up time counter		2 ~ 250s/h (0.5s/h step)				

Settings *24	Earth fault overcurrent	Operation current	LOCK – 0.05 ~ 2.50A (0.05A step)	LOCK – 0.01 ~ 0.5A (0.01A step)
		Operation time	INST - 0.1 ~ 10s (0.1s step)	
Forced operation		Forced operation is available for any trip or signaling contact individually.		
Operation indication		Operation indicator LED (red) comes on when the relay operates.		

### 2.3 Measurement elements

Style (CMP1-A02D1)	Without direct communication port	414PMB	415PMB	418PMB	419PMB
	With direct communication port	605PMB	606PMB	609PMB	610PMB
Style (CMP1-A02D2)	Without direct communication port	424PMB	425PMB	428PMB	429PMB
	With direct communication port	611PMB	612PMB	615PMB	616PMB
Setup *24	CT primary	Phase current	5-10-12-12.5-15-20-25-30-40-50-60-75-80-100-120-125-150-200-250-300-400-500-600-750-800-1000-1200-1250-1500-2000-2500-3000-4000-5000-6000-7500-8000[A]		1-5-10-12-12.5-15-20-25-30-40-50-60-75-80-100-120-125-150-200-250-300-400-500-600-750-800-1000-1200-1250-1500-2000-2500-3000-4000-5000-6000-7500-8000[A]
		Zero-phase current			
Display	Phase current	Real time	Conversion	Indication value = Relay input value ×CT primary setting / 5	Indication value = Relay input value ×CT primary setting
			Range *22	0.00 ~ CT primary setting ×2 [A]	
			Update	Approx. 200 ms	
		Max. records	Conversion	Indication value = Relay input value ×CT primary setting / 5	Indication value = Relay input value ×CT primary setting
			Range *22	0.00 ~ CT primary setting ×30 [A]	
		Fault records *23	Conversion	Indication value = Relay input value ×CT primary setting / 5	Indication value = Relay input value ×CT primary setting
	Range *22		0.00 ~ CT primary setting ×30 [A]		
	Zero-phase current	Real time	Conversion	Indication value = Relay input value ×CT primary setting / 5	Indication value = Relay input value ×CT primary setting
			Range *22	0.00 ~ CT primary setting ×2 [A]	
			Update	Approx. 200 ms	
		Max. records	Conversion	Indication value = Relay input value ×CT primary setting / 5	Indication value = Relay input value ×CT primary setting
			Range *22	0.00 ~ CT primary setting ×2 [A]	
		Fault records *23	Conversion	Indication value = Relay input value ×CT primary setting / 5	Indication value = Relay input value ×CT primary setting
	Range *22		0.00 ~ CT primary setting ×2 [A]		
	Negative sequence current	Real time	Conversion	Indication value = Relay input value ×CT primary setting / 5	Indication value = Relay input value ×CT primary setting
			Range *22	0.00 ~ CT primary setting ×2 [A]	
			Update	Approx. 200 ms	
		Fault records *23	Conversion	Indication value = Relay input value ×CT primary setting / 5	Indication value = Relay input value ×CT primary setting
Range *22			0.00 ~ CT primary setting ×30 [A]		

\*22 The form of display depends on value range as shown in the tables below:

CT primary setting value and EVT primary setting value determine the minimum number of digits to be displayed on each measurement display.

When a value to be displayed exceeds the max. value of the display range, the max. value will blink.

(1) Display of current

CT primary setting		1[A]	5 ~ 40[A]	50 ~ 400[A]	500 ~ 4000[A]	5000 ~ 8000[A]
Form of display	0.00 ~ 9.99[A]	□.□□[A]	□.□[A]	□[A]	-	-
	10.0 ~ 99.9[A]	□□.□[A]	□□.□[A]	□□[A]	□.□□[kA]	-
	100 ~ 999[A]	□□□[A]	□□□[A]	□□□[A]	□.□□[kA]	□.□[kA]
	1.00 ~ 9.99[kA]	□.□□[kA]	□.□□[kA]	□.□□[kA]	□.□□[kA]	□.□[kA]
	10.0 ~ 99.9[kA]	□□.□[kA]	□□.□[kA]	□□.□[kA]	□□.□[kA]	□□.□[kA]
	100 ~ 999[kA]	□□□[kA]	□□□[kA]	□□□[kA]	□□□[kA]	□□□[kA]

\*23 When a communication card is connected, wave form data in the event of system fault can be read.

(See the section 4 “Function”).

\*24 When the product is shipped from the factory, each setting value is “Lock” (With lock setting element) of “minimum setting value” (Without lock setting element).

### 3 Characteristics

Common conditions	(1) Rated frequency: $\pm 1\%$ (2) Ambient temperature: $20^{\circ}\text{C} \pm 10^{\circ}\text{C}$ (3) Aux. supply voltage: Rated voltage $\pm 2\%$	The conditions shown on the left should be applied unless otherwise specified.
-------------------	--	--

#### 3.1 Protective elements

Items		Conditions	Guaranteed performance
Operation value	Overload	Positive-sequence current	Setting value $\pm 5\%$
	Overcurrent time-delayed	(Common conditions)	
	Overcurrent instantaneous		
	Undercurrent		
	Earth fault overcurrent		
	Negative-sequence overcurrent	Negative-sequence current	
Reset value	Overload	(Common conditions)	Operation value $\times 95\%$ or more
	Overcurrent time-delayed		
	Overcurrent instantaneous		
	Negative-sequence overcurrent		
	Earth fault over-current		
	Undercurrent	(Common conditions)	Operation value $\times 105\%$ or less

Items		Conditions	Guaranteed performance																	
Operation time	Overload	Operation time setting ( $K_{TH}$ ): 8 Positive sequence current: 0A→150% and 300% of motor current rating(IM)	<table border="1"> <tr> <td></td> <td>Current (%)</td> <td>Error against normal (within)</td> </tr> <tr> <td rowspan="2">Over-Load element</td> <td>150</td> <td>±17%</td> </tr> <tr> <td>300</td> <td>±12%</td> </tr> <tr> <td rowspan="3">Over-current time-delayed element</td> <td>300</td> <td>±12%</td> </tr> <tr> <td>500</td> <td>±7%</td> </tr> <tr> <td>1000</td> <td>±7%</td> </tr> </table>		Current (%)	Error against normal (within)	Over-Load element	150	±17%	300	±12%	Over-current time-delayed element	300	±12%	500	±7%	1000	±7%		
		Current (%)		Error against normal (within)																
	Over-Load element	150		±17%																
		300		±12%																
	Over-current time-delayed element	300		±12%																
		500		±7%																
		1000	±7%																	
Overcurrent time-delayed	Operation time setting ( $K_{OCT}$ ): 4 Phase current: 0A→300%, 500% and 1000% of motor current rating(IM)																			
Overcurrent instantaneous	Operation setting: Minimum Input: 0→200% of setting	- For INST setting 40ms or less - For setting of 0.1 ~ 0.4s setting value ± 25ms - For setting of 0.5 ~ 1s setting value ± 5%																		
Undercurrent	Operation setting: Maximum 300% of setting→12% of IM	Setting value ±5%																		
Negative-sequence over-current	Operation setting: Minimum Input: negative sequence current 0→200% of setting	- For setting of 0.1 ~ 0.4s setting value ± 25ms - For setting of 0.5 ~ 10s setting value ±5%																		
Earth fault overcurrent	Operation setting: Minimum Input: negative sequence current 0→200% of setting	- For INST setting 40ms or less - For setting of 0.1 ~ 0.4s setting value ± 25ms - For setting of 0.5 ~ 10s operation value ± 5%																		
Reset time	Overload	Operation time setting ( $K_{TH}$ ): 8 Positive sequence current: 300% of motor current rating(IM)→0 [A]	HOT characteristics (300% input is applied for 5 minutes or more and then input is turned zero.) : 149.2 sec ± 15%																	
	Overcurrent time-delayed	Operation setting: Minimum 300% of setting→0 [A]	COLD characteristics : 200 ± 25ms																	
	Overcurrent instantaneous		200 ± 25ms																	
	Undercurrent	Operation setting: Maximum 12% of IM → 200% of setting																		
	Negative-sequence over-current	Operation setting: Minimum Input: negative sequence current 300% of setting→0 [A]																		
	Earth fault over-current	Operation setting: Minimum Input: negative sequence current 300% of setting→0 [A]																		

Items	Conditions		Guaranteed performance
Restriction * start time	Limit of the number of start-up times element	Setting : Number of start-up times = 1 Start-up time = 2 s Countdown rate of start-up time counter = 2 s/h Input : A-phase current = 0 A → IM × 300 %	1s±5%
Restriction * end time		Setting : Number of start-up times = 1 Start-up time = 2 s Countdown rate of start-up time counter = 250 s/h Input : A-phase current = 0 A → IM × 300 % (for 2 s) → 0 A	14.4s <sup>+10%</sup> <sub>0%</sub>

\* The measurement conditions of limit of the number of start-up times element.

(1) Restriction start time

(2) Restriction end time

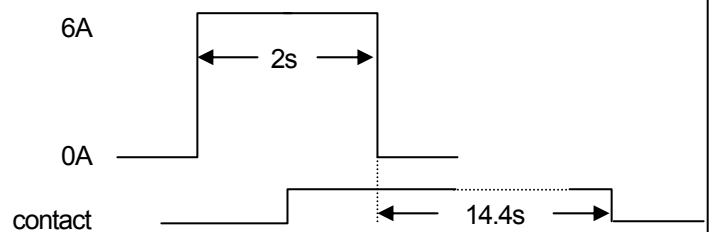
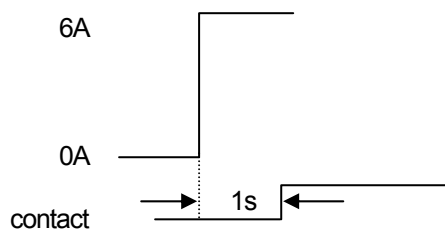

### 3.2 Measurement elements

Items	Condition		Guaranteed performance
Real time	Phase current	CT primary setting ×2	±1%
	Zero-phase current	CT primary setting ×2	±1%
	Negative-sequence current	CT primary setting ×2	±1%
Max. records	Phase current	CT primary setting ×2	±1%
	Zero-phase current	CT primary setting ×2	±1%



### 3.3 Common technical data

		DESCRIPTION	CONDITION	STANDARD
Environment	Ambient operating temperature	-10°C to +55°C		IEC60255-6
	Ambient storage and transport temperature	-25°C to +70°C		IEC60255-6
	Damp heat	+40°C, 95%RH, 4 days		IEC60068-2-3
Thermal withstand	VT	1.15Vn, 3h		
	CT	40In, 1s		
Dielectric test	Circuit of 60V or below	500VAC, 1min.	1) Between each circuit and the exposed conductive parts, the terminals of each independent circuit being connected together 2) Between independent circuits, the terminals of each independent circuit being connected together	IEC60255-5
	Circuit of more than 60V and 500v or below	2000VAC 1min.		
	Open contact	1000VAC, 1min.	Between open contact poles	
Impulse voltage test		5kV, 1.2µs/50µs	1) Between each circuit and the exposed conductive parts, the terminals of each independent circuit being connected together 2) Between independent circuits, the terminals of each independent circuit being connected together	IEC60255-5
High-frequency disturbance test	Common mode	2.5kV peak, 1MHz with 200Ω source impedance for 2s	Between independent circuits, and between independent circuit and earth	IEC60255-22-1 class 3
	Differential mode	1.0kV peak, 1MHz with 200Ω source impedance for 2s	Across terminals of the same circuit	
Electrostatic discharge test		8kV	Contact discharge	IEC60255-22-2 Class 4
		15kV	Air discharge	
Radiated electromagnetic field disturbance test		68 to 87Mhz 146 to 174MHz 420 to 470MHz		IEC60255-22-3 class 3
Fast transient disturbance test		2.0kV, 5ns/50ns, 1min		IEC60255-22-4
Vibration test		Refer to class 1		IEC60255-21-1 Class 1
Shock response		Refer to class 2		IEC60255-21-2 Class 2
Shock withstand		Refer to class 1		IEC60255-21-2 Class 1
Bump		Refer to class 1		IEC60255-21-2 Class 1
Enclosure protection		IP51		IEC60529

Vn: Rated voltage, In: Rated current

## 4 Description of each function

### 4.1 Protection

#### 4.1.1 Motor current rating ( $I_M$ )

Motor's rated current  $I_M$  can be set by 0.1 A steps within a range of 2.0 to 5.0 (A) when CT's rated current is 5 (A), and by 0.02 A steps within a range of 0.4 to 1.0 (A) when CT's rated current is 1 (A).

Each element of overload, overcurrent time-delayed and negative-sequence overcurrent is based on this motor rated current ( $I_M$ ).

#### 4.1.2 Overload element

This element provides protection against deterioration of insulation, breakdown, etc. caused by heat that is generated when the motor is overloaded. Output of overload current depends on the amount of positive-sequence current and negative-sequence current which are calculated from each  $I_A$ ,  $I_B$  and  $I_C$  phase current.

##### (1) Operating current setting

Operating current value of the overload element is set as a multiple of motor's rated current, so it is found by motor current rating  $I_M$  (A)  $\times$  operating current setting value  $I_L$  (%).

For example, where CT rating = 5 (A), motor current rating  $I_M = 3.0$  (A) and operating value  $I_L = 120$  (%), the current value of the overload element becomes:

$$I_M \times I_L = 3.0 \text{ A} \times 120 \% = 3.6 \text{ A}$$

If LOCK position is selected, the selected element does not operate.

##### (2) Operating time characteristic of overload element

Operating time characteristic is expressed in the following equation. (Refer to clause 2.2)

$$T_{TH} = 8.49 \times K_{TH} \times \log_e \frac{(I_1^2 + K \cdot I_2^2) - (I_{P1}^2 + K \cdot I_{P2}^2)}{(I_1^2 + K \cdot I_2^2) - 1} \text{ (s)}$$

$$K = \frac{\text{Heating effect by negative - sequence current}}{\text{Heating effect by positive - sequence current}}$$

(K: Heat multiplying factor of negative-sequence current)

Note) Value of K is determined by the structure of motor (particularly, secondary winding), slip and so on.

If there is no data for determining K, refer to the following value as a standard.

- a. K=6 or so, if the heating effect by negative sequence is taken into account.
- b. K=1, if protection is provided almost for positive-sequence current alone.

For example, where  $K_{TH}=8$ , positive-sequence current ( $I_1$ )=300%, negative-sequence current ( $I_2$ )=100%, K=1 and for COLD characteristic,

$$T_{TH} = 8.49 \times 8 \times \log_e \frac{(3^2 + 1 \times 1^2)}{(3^2 + 1 \times 1^2) - 1} = 7.16 \text{ s}$$

(3) Operating characteristic of overload element

A relay element starts from (1) at the time of (Input value)  $\geq$  (Operating value  $I_L$ ).

And, from (2) relay calculation value is set to  $\theta_n \geq 1$ ,

$$\theta_n = (\theta_{nm} - \theta_{n0}) \cdot (1 - e^{-t/T}) + \theta_{n0}$$

$$T = 8.49 \times K_{TH} \quad (\text{Thermal time constant})$$

$$\theta_{nm} = I_1^2 + K \cdot I_2^2$$

$I_1$  : Positive - sequence current

$I_2$  : Negative - sequence current

$$\theta_{n0} = I_{P1}^2 + K \cdot I_{P2}^2$$

$I_{P1}$  : Positive - sequence current before overload

$I_{P2}$  : Negative - sequence current before overload

At the time the both conditions are formed an overload element is operated.

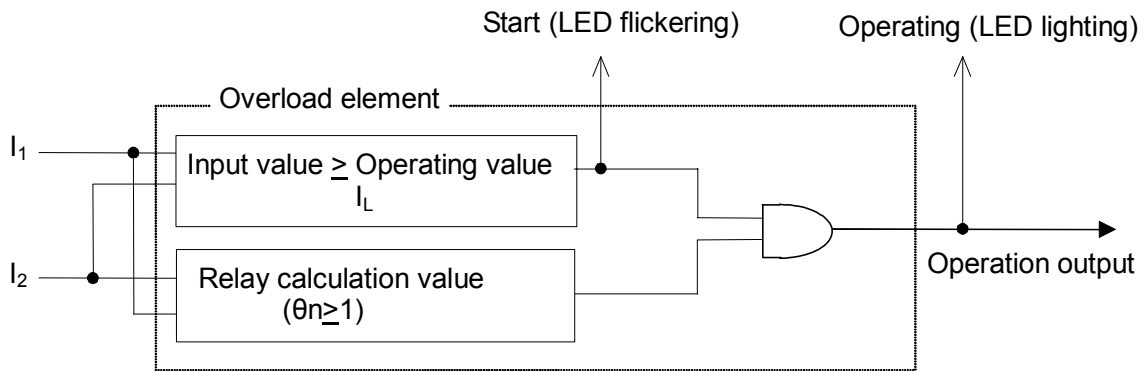

**Fig4.1 Overload element Internal function diagram**

(4) COLD and HOT characteristics

- COLD characteristic

For COLD characteristic, calculation is started when input increases above the operating value.

After operation output is provided, if input decrease below the operating value, resetting is made in 200 msec and the calculation is reset. Even after input exceeds the operating value, if it decreases below the operating value in the state not resulting in operation output, the calculation value becomes reduced.

- HOT characteristic

Hot characteristic is always calculated in view of heat reserve, even when input is below the operating value.

(5) Operating time and resetting time

Please push "RESET" button, when calculation was made to reset after measuring operating time at the time of operating time test

In the resetting time test, if you want to start the test with 300% input for overload element, in HOT characteristic, firstly turn input 300% and then put the overload element into operation forcibly, whereby the state of 300% input is brought about. From this state, change input from 300% to zero and measure the resetting time.

The resetting time of overload element in COLD characteristic is set to 200 msec by the internal timer.

Fig. 4.2 shows an example of relay calculation value, operating time and resetting time.

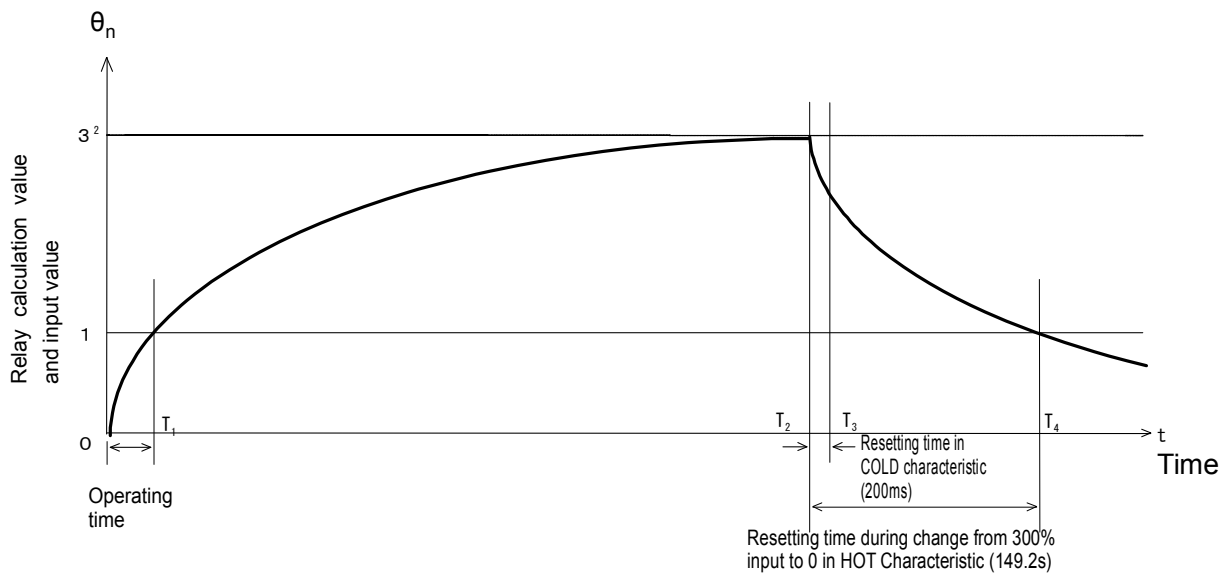

0 ~  $T_1$ : Operating time during change from input 0 to 300%

$T_1$  ~  $T_3$ : Output relay contact closing time in COLD characteristic

$T_1$  ~  $T_4$ : Output relay contact closing time in HOT characteristic

$T_2$  ~  $T_3$ : Resetting time in COLD characteristic

$T_2$  ~  $T_4$ : Resetting time during change from continuous 300% input to zero input in HOT characteristic

$T_1$ : Time at relay calculation value ( $\theta_n$ )  $\geq 1$

$T_2$ : Time for change of relay input from 300% to zero

$T_4$ : Time at relay calculation value ( $\theta_n$ )  $< 1$

**Fig.4.2 Relay calculation value, operating time, and resetting time(example)**

#### (6) Display of Load Factor

The load factor is shown by choosing item number 330. The value to be displayed is the past maximum load factor (%) of the overload element after the auxiliary power supply is turned ON, or after completing the “reset” operation.

$$\text{Load factor} = \sqrt{\frac{\text{Past maximum computed value}}{\text{Computed value during operation}}} \times 100 \%$$

The load factor may be used for grasping the past load status, or as a reference for setting.

Realize the “Reset” operation to reset the load factor. The load factor is reset also when the auxiliary power supply is switched OFF.

### 4.1.3 Overcurrent element

The overcurrent time-delayed element and overcurrent instantaneous element detect each phase current  $I_A$ ,  $I_B$  and  $I_C$  and a signal of operation is outputted.

The time-delayed element compares input currents with the operation setting in each phase. If an input current is larger than the specified operation level, the element outputs an operation signal when the time-delayed timer expires. The expiring time depends on the input current amount and the setting in the operation time characteristic.

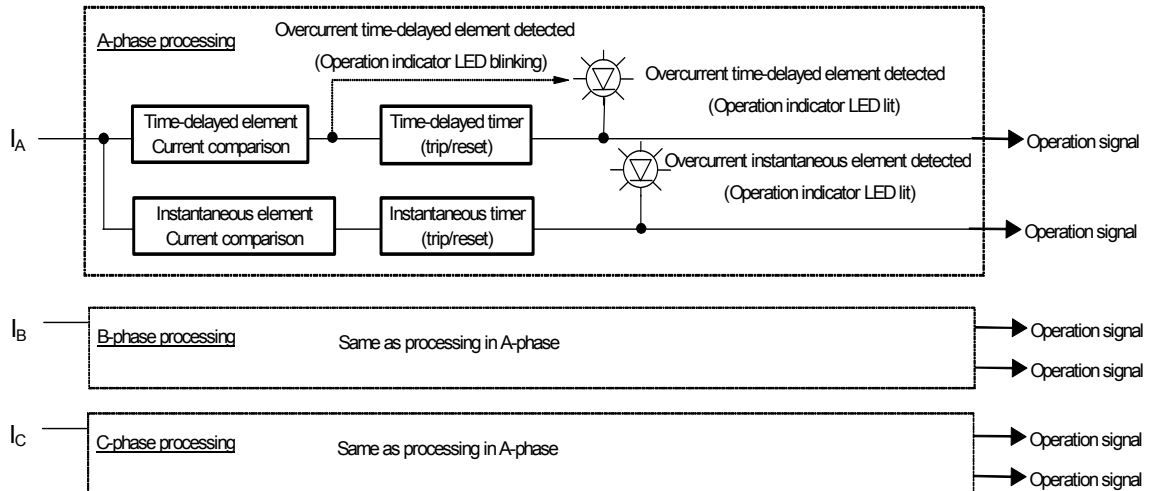

**Fig 4.3 Overcurrent element internal function diagram**

Like the time-delayed element, the instantaneous element also compares the input current with the operation setting to output an operation signal when a period of time set in the instantaneous timer has elapsed.

#### (1) Operating current setting

Operating current value of the time-delayed element is set as a multiple of motor's rated current, so it is found by motor's rated current:  $I_M$  (A)  $\times$  time-delayed element operating current setting value (%).

(Ex.) Where CT rating = 5 (A), motor rated current  $I_M = 3.0$  (A) and overcurrent time-delayed element setting value = 150 (%), the operating value of the overcurrent time-delayed element becomes:

$$3.0A \times 150\% = 4.5A$$

If LOCK position is selected, the selected element does not operate.

#### (2) Operating time characteristic of time-delayed element

The operating time characteristic of the time-delayed element is expressed in the following equation.

$$T_{OCT} = 3 \times \frac{K_{OCT}}{I} \text{ (s)}$$

where,  $I$  = Phase current (Unit: multiple to  $I_M$ )

$K_{OCT}$  = Operating time setting value (Value at  $I = 3$ )

(Ex.) Where CT rating = 5 (A), motor rated current  $I_M = 3.0$  (A) and overcurrent time-delayed operating time ( $K_{OCT}$ ) = 240, and input current = 300%,

$$T_{OCT} = 3 \times \frac{240}{3.0} = 240 \text{ s}$$

#### (3) Display of elapsed time of time-delayed timer

With item number 320 elapsed time of time-delayed timer is indicated. For the time-delayed elements, the elapsed time of the internal operation timer is indicated in the display. As the elapsed time is counted,

operators may imagine the then current status of the electromagnetic mechanical induction disc, which will help detect the starting value.

When an input current is detected to have reached the operation setting or more, "0" will appear in the display. Counting will be made by dividing the operation time equally into ten parts and starting from "1", "2" to "9" and "10". An operation signal will be output as soon as the counter reaches "10".

#### 4.1.4 Negative-sequence overcurrent element

This is a negative-sequence overcurrent element with a definite operating time characteristic which realizes the protections against open-phase at start-up, or large negative-phase current during operation. In case that a relatively small negative-phase current exists for a long time, protection is realized by the overload protection.

(Ex.) CT rated current = 5 (A), motor rated current  $I_M = 3.0$  (A), and negative-phase overcurrent element setting = 0.5 (times)

The operating value of the negative-phase overcurrent element is:

$$3.0 \text{ A} \times 0.5 \text{ (times)} = 1.5 \text{ A}$$

By "locking" the setting, the relevant element attains the operation lock status.

#### 4.1.5 Undercurrent element

This is a undercurrent element with a definite operating time characteristic which protects the motor when the load suddenly disappears (load loss becomes a failure).

It is so designed as not to function at 10% or less of the motor rated current  $I_M$  in order to prevent the undercurrent element operation for the motor which is not running.

If LOCK position is selected, the selected element does not operate.

#### 4.1.6 Limit the number of start-up times element

##### (1) Operation characteristics of Limit the number of start-up times

For each motor, the motor specifications, etc. show how many times the motor can be restarted within a certain period of time. This element is designed to issue an operation signal if the specified number of restarts is exceeded. By combining this element with an external sequence (start-up sequence), it is possible to control excessive restart. When the phase current input  $I_A$  satisfies the following conditions, it is regarded as start-up; and, relay computation (integration) is realized with the time between start-up conditions and start-up end conditions as the start-up time.

Start-up conditions: If the current reaches from 10% or less of the motor rated current to 150% or more of the motor rated current within about 60 ms.

Start-up end conditions: If the current continues the status of 125% or less of the motor rated current from the above-mentioned condition for nearly 100 ms.

(Ex.) For a motor that can accept 4 start-ups each with 10 second start-up time:

The setting is done as follows:

Start-up times: 4

Start-up time: 10 s

Countdown rate of start-up time counter:  $[10 \text{ s (start-up time)} - 1] / 2 \text{ hr (permissible time)} = 4.5 \text{ s/hr}$ .

The operation signal is issued at the integrated count value of 31 s or more  $[= (\text{Start-up times} - 1) \times \text{Start-up time} + 1\text{s}]$ , and the operation signal is canceled at 31 s or less.

For making the explanation easier, if the motor is started up four consecutive times, the integrated count value becomes 40, and will decrease by 9 s in two hours at the countdown rate of 4.5 s/hr; therefore, the integrated value after two hours will be 31 s, and the operation signal is canceled.

If LOCK position is selected, this element does not operate.

#### (2) Start-up time lapse display

The start-up time lapse is shown by choosing item number 340. The integrated count value is shown by unit of second. Realize "reset" operation to reset the start-up time. The start-up time is also reset when the auxiliary power supply is switched OFF.

#### 4.1.7 Earth fault overcurrent element

About the earth fault overcurrent element with definite time characteristic, it operates through comparing the zero-phase current value with operating setting value. If the zero-phase current was over than the setting value, an operation signal outputs when the operation timer expires.

#### 4.1.8 Control function by external control input ( DI (1), DI (2) ) (D2 type only)

It is possible to get the equipment fault signal, the operation signal (undervoltage, etc.) of external protection relay, etc. as external input; and the operation signal is outputted from this input to output the related contact.

[See 4.1.10 (2): Output contact.]

#### 4.1.9 Cooperation between elements

The overload element (49 in Fig. 4.4) reaches saturation of operating time at the operating value of the overcurrent time-delayed element (51 in Fig. 4.4).

When you constitute a system, please take this fully into consideration.

Fig. 4.4 (a) and (b) indicate examples of cooperation where output is provided by the contacts of the overload element and the overcurrent time-delayed element each independently.

Fig. 4.4 (c) indicates an example of cooperation where the overload element and the overcurrent time-delayed (instantaneous) element are externally subject to OR condition.

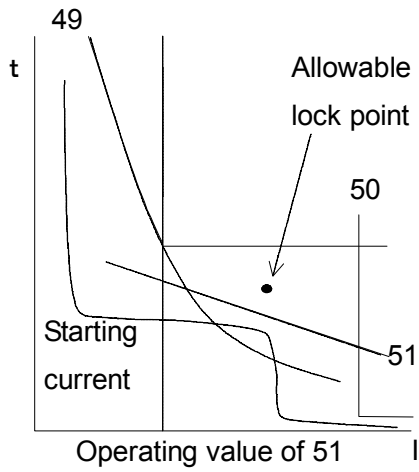

**Fig. 4.4(a)**

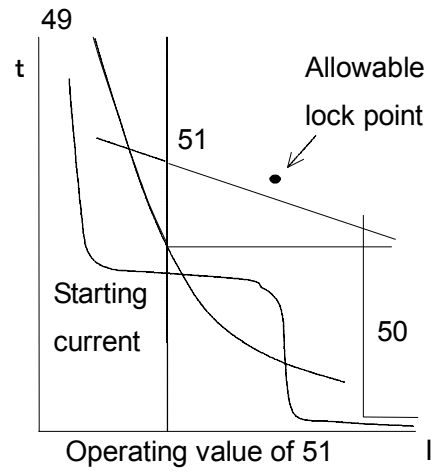

**Fig. 4.4(b)**

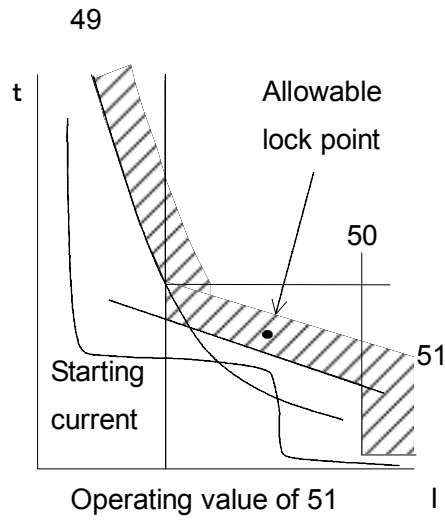

**Fig. 4.4(c)**



## Overload operating time characteristic

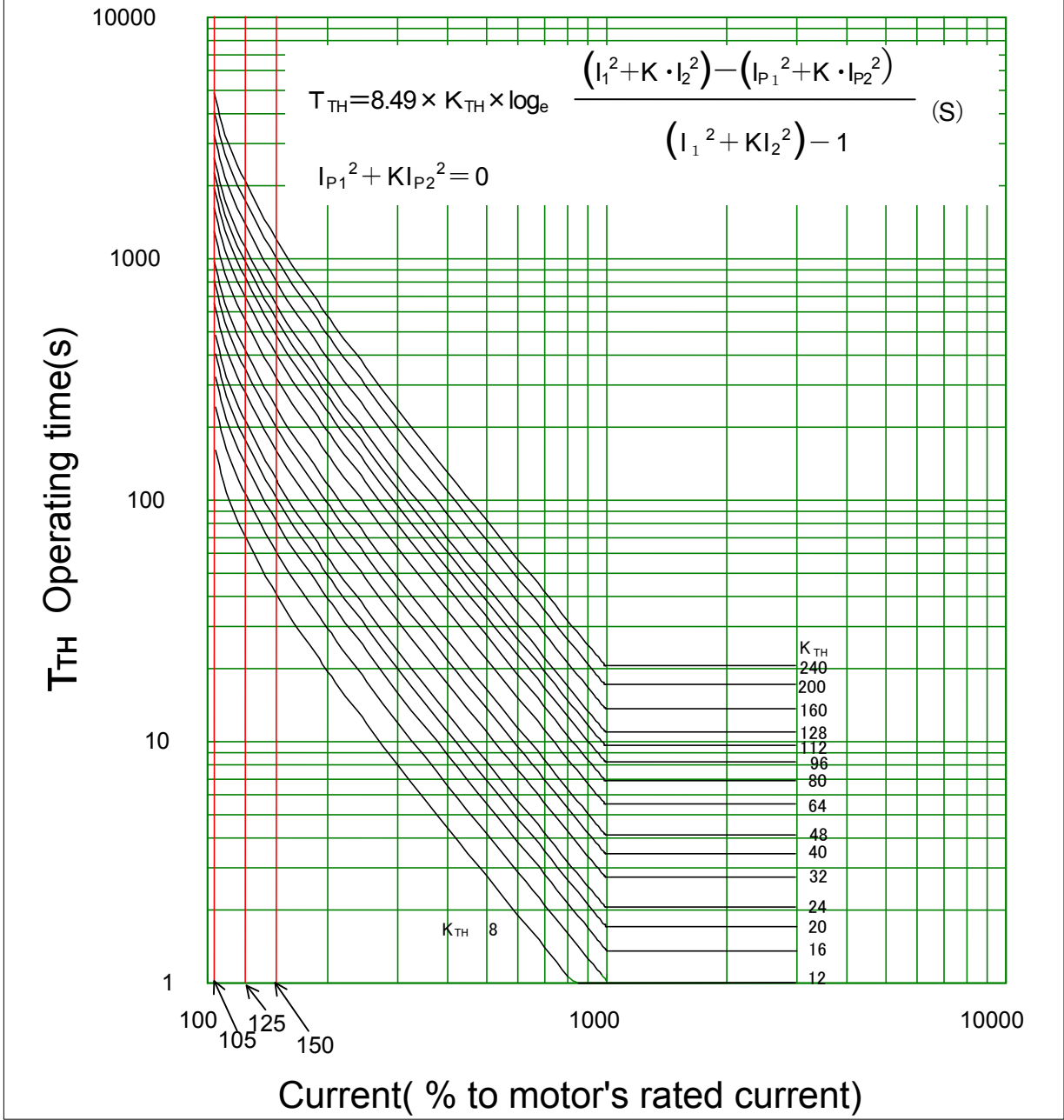
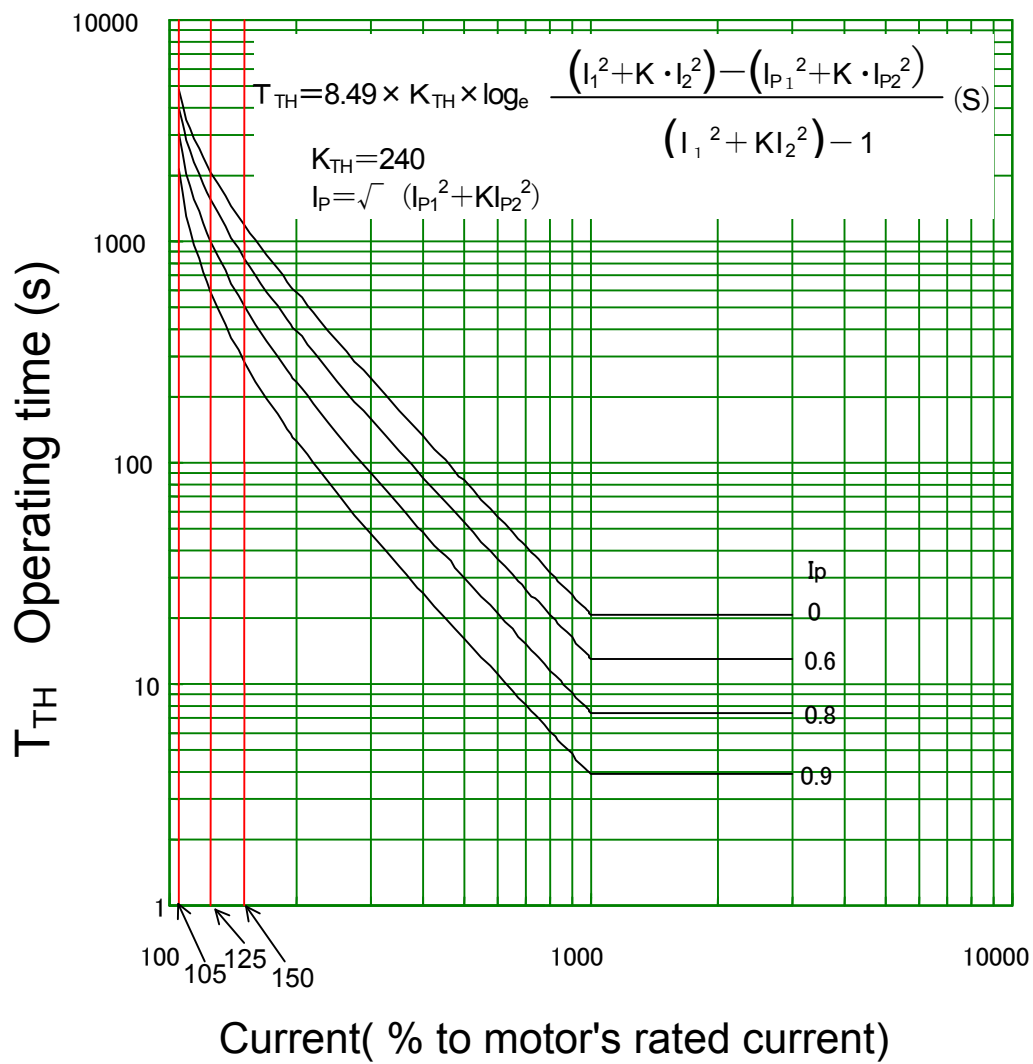

Figure 4.5 Overload element operating time characteristic

## Overload element operating time characteristic (Including the effect of prior current value)



**Figure 4.6 Overload element operating time characteristic**  
(Variation dependent on prior current value in HOT characteristic)

# Overcurrent time delayed element 1 operating time characteristic

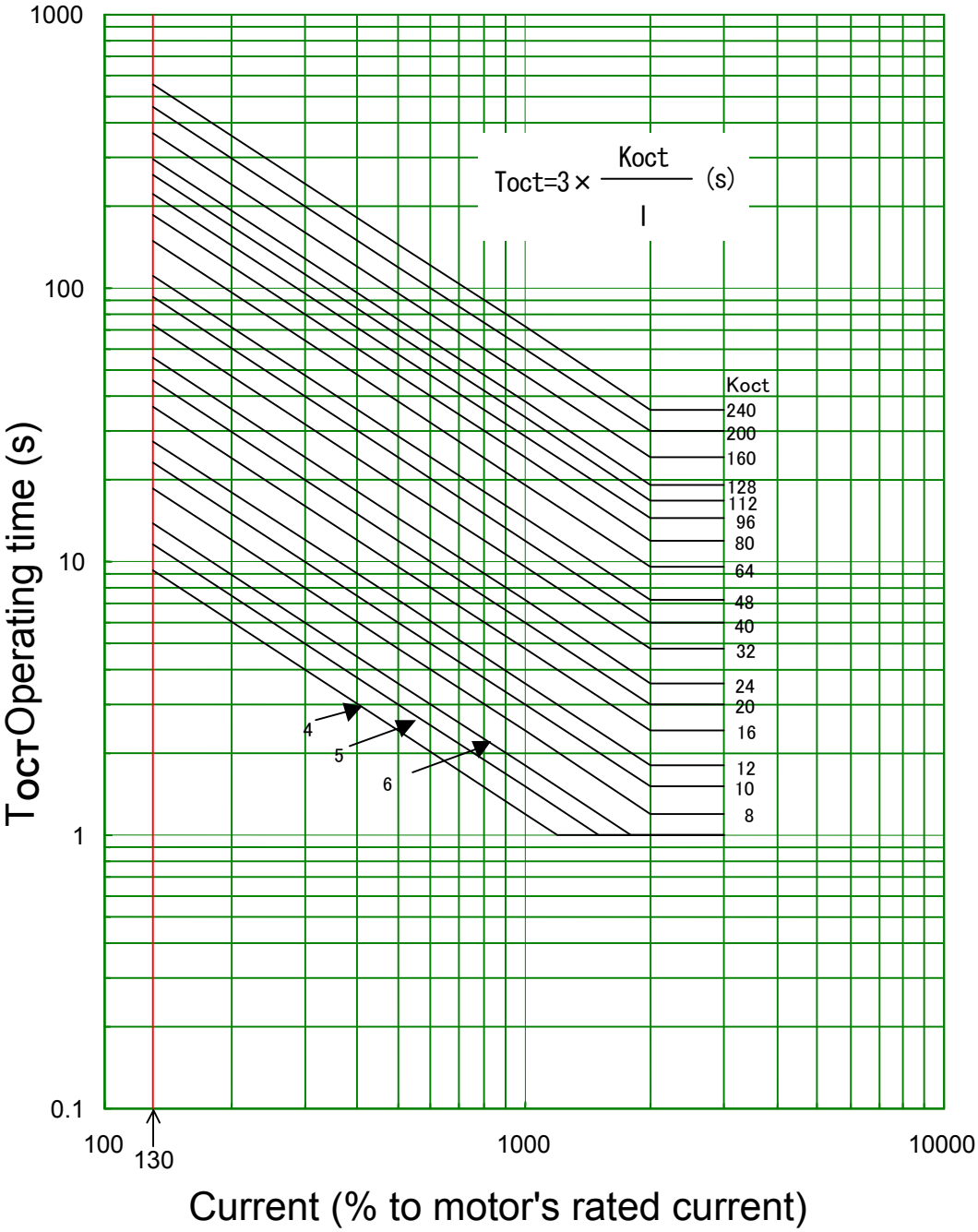

Figure 4.7 Time-delayed element operating time characteristic

#### 4.1.10 General functions

##### (1) Operation display

For the time-delayed element, when the input current becomes larger than the operation setting, the corresponding operation indicator LED will blink to allow you check the starting value.

The LED lamp will come on as soon as an operation output is made when a period of operation time has elapsed.

For the instantaneous element in turn, the LED lamp will come on at the same time when an operation output is made.

The operation indicator LED has been set to “self-hold” in the factory. This setting can be freely changed to “auto reset”.

With the “self-hold” setting, data of the latest operation indication will be stored in the internal memory even if the auxiliary power supply runs down.

The data stored will be cleared when the “indicator reset” switch is pressed.

Up to latest five phenomena can be stored and displayed as a history record. (Older data than the latest five phenomena will automatically be cleared).

Item No.	History	Sequence of recording
311	1 <sup>st</sup> phenomena	Latest fault record data ↓ ↓ ↓ Oldest fault record data
312	2 <sup>nd</sup> phenomena	
313	3 <sup>rd</sup> phenomena	
314	4 <sup>th</sup> phenomena	
315	5 <sup>th</sup> phenomena	

##### (2) Output contacts

The signaling outputs  $X_0$  to  $X_3$  and trip outputs  $X_4$  and  $X_5$  are all programmable type.

The factory default setting of the arrangement of these outputs is as shown in the internal function block diagram of Figure 5.2. This setting can be freely changed by specifying outputs of the internal elements based on the OR logic.

All the outputs have been set to “auto reset” in the factory. Any of them can be changed to “self hold”.

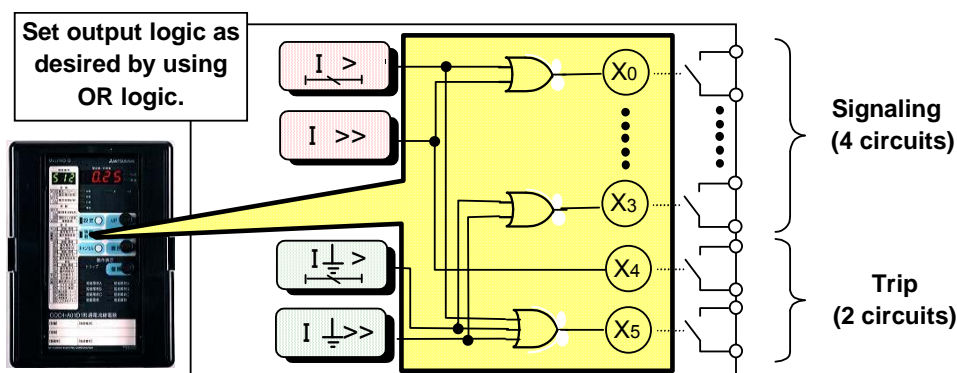

**Figure 4.8 Schematic image of Programmable Outputs (example: COC4-A01)**

##### (3) Forced operation

It is possible to carry out forced operation of any of the signaling outputs  $X_0$  to  $X_3$  and trip outputs  $X_4$  and  $X_5$  independently. Forced operation is useful for checking the wiring.

When forced operation is carried out, the corresponding LED lamps will come on to show the current status of the programmable outputs. Checking the lamp status will be useful not only for wiring check but also to check the programmable outputs arrangement.

## 4.2 Measurement

Currents input to the relay are measured and converted into freely set CT primary currents, then indicated on the display.

(1) Real time measurement

The effective values of input current are displayed for each phase.

(2) Max. record

The maximum effective current value is recorded and stored for each phase.

The max. record will be all cleared when “aux. power supply OFF” or “max. record reset” operation is made.

(3) Fault record

In the event of system fault, the effective current value and waveform data that have been measured at the time when one of the protection elements operates to issue an output signal are stored. Data of up to five phenomena can be stored and displayed for each phase.

With “aux. power supply OFF”, only the waveform data will be cleared and the effective current data will remain.

With “fault record reset” operation, however, both of the data items will be all cleared.

(Records older than the 5<sup>th</sup> phenomenon will automatically be cleared.)

Item No.	History	Sequence of recording
211	1 <sup>st</sup> phenomena	Latest fault record data ↓ ↓ ↓ ↓ Oldest fault record data
212	2 <sup>nd</sup> phenomena	
213	3 <sup>rd</sup> phenomena	
214	4 <sup>th</sup> phenomena	
215	5 <sup>th</sup> phenomena	

The following fault wave form data can be collected if a communication card is installed:

Item	Specification
Data sampling cycle	Fixed to the electric angle of 30° of rated frequency
Data storing capacity (for a phenomenon)	224 cycles of rated frequency (Data point: $224 \times 360^\circ / 30^\circ = 2688$ points)
Permissible setting range	224 cycles before trip ~ 224 cycles after trip
Collected data	The range for data collection can be set by cycle within the “data storing capacity” in the “permissible set range”.

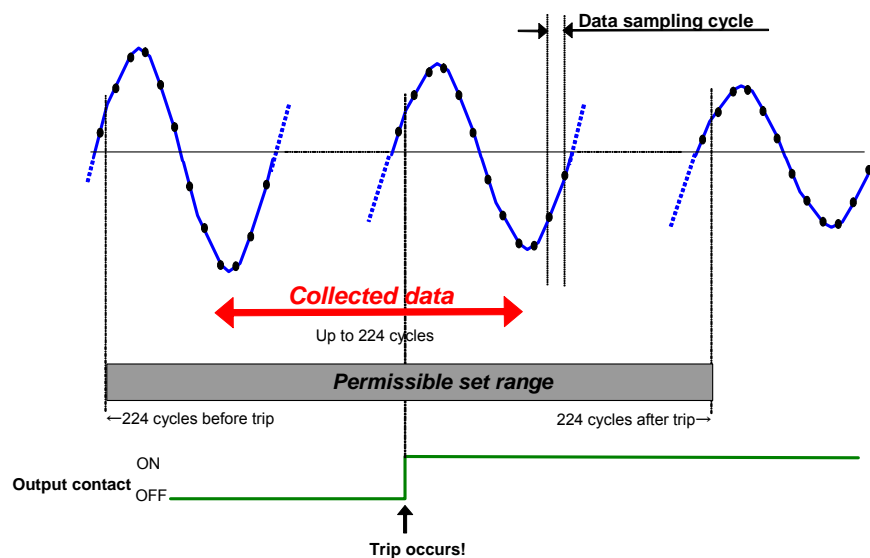

Figure 4.9 Concept of recording fault waveform

### 4.3 Self-diagnosis

The self-diagnosis function monitors the electronic circuit and built-in power source continuously. If an abnormal condition occurs, the protection elements will be locked for operation. Also, the RUN LED lamp will go off and the self-diagnosis output contact (break contact) will be closed.

(1) Checking defect code at failure detection

When a failure is detected, the defect code will be recorded. This defect code can be checked through the self-diagnosis (ALARM) status indication.

(2) Resetting self-diagnosis output

If a failure is detected, **the failure status may be reset by turning off/on the power.**

In this case, **be sure to lock the trip circuit on the external wiring of the relay** before resetting. (If the failure persists, an erroneous output may be caused).

(3) Clearing the defect code

The defect code data stored at failure detection can not be cleared only by carrying out the power on/off procedure in the item (2) above. All the defect code numbers that have been detected since the previous "self-diagnosis reset" (RESET ALARM) operation was made are accumulated in the memory.

**To clear the record data, carry out "self-diagnosis reset" (RESET ALARM) operation.**

**Table 4.1 Output for protection relay failures**

Status	Detected items	Output			
		Display		ALARM (break contact)	Operation output lock
		RUN	Defect code		
Normal	-	On		Open	Not locked
Power circuit failure	-	Off	No display	Closed	Locked
CPU failure	-		*45		
Monitor error	ROM check		0001		
	RAM check		0002		
	A/D accuracy check		0003		
	A/I check		0004		
	A/D check		0005		
	SRAM check		0006		
	D/O status check		0008		
	D/O operation check		0009		
	Analog filter check		0010		
	A/I double check		0011		
	D/I check *41		0012		
	E <sup>2</sup> PROM check		0013		
	Computing function check		0014		
	WDT check		0015		
	Data transfer check *42		0016		
	Differential current check *43		0017		
	Communication card check *44		0028		
Communication card channel No. switch setting error *44	0029				
Communication card baud rate switch setting error *44	0030				
Communication card channel No. switch change error *44	0031				
Communication card baud rate switch change error *44	0032	On	Open	Not locked	

\*41 Monitored only in the models with built-in D/I function. \*42 Monitored only in the models with D2 unit.

\*43 Monitored only the biased differential relay.

\*44 Monitored only when the relay is installed with communication card.

\*45 Not necessary to lock the output as any output would not be possible during CPU failure.

#### 4.4 Communication (option)

Figure 4.13 shows an example of network system configuration.

For more information on the communication facilities, see the materials shown in the introduction (page 2):

#### Central Control System

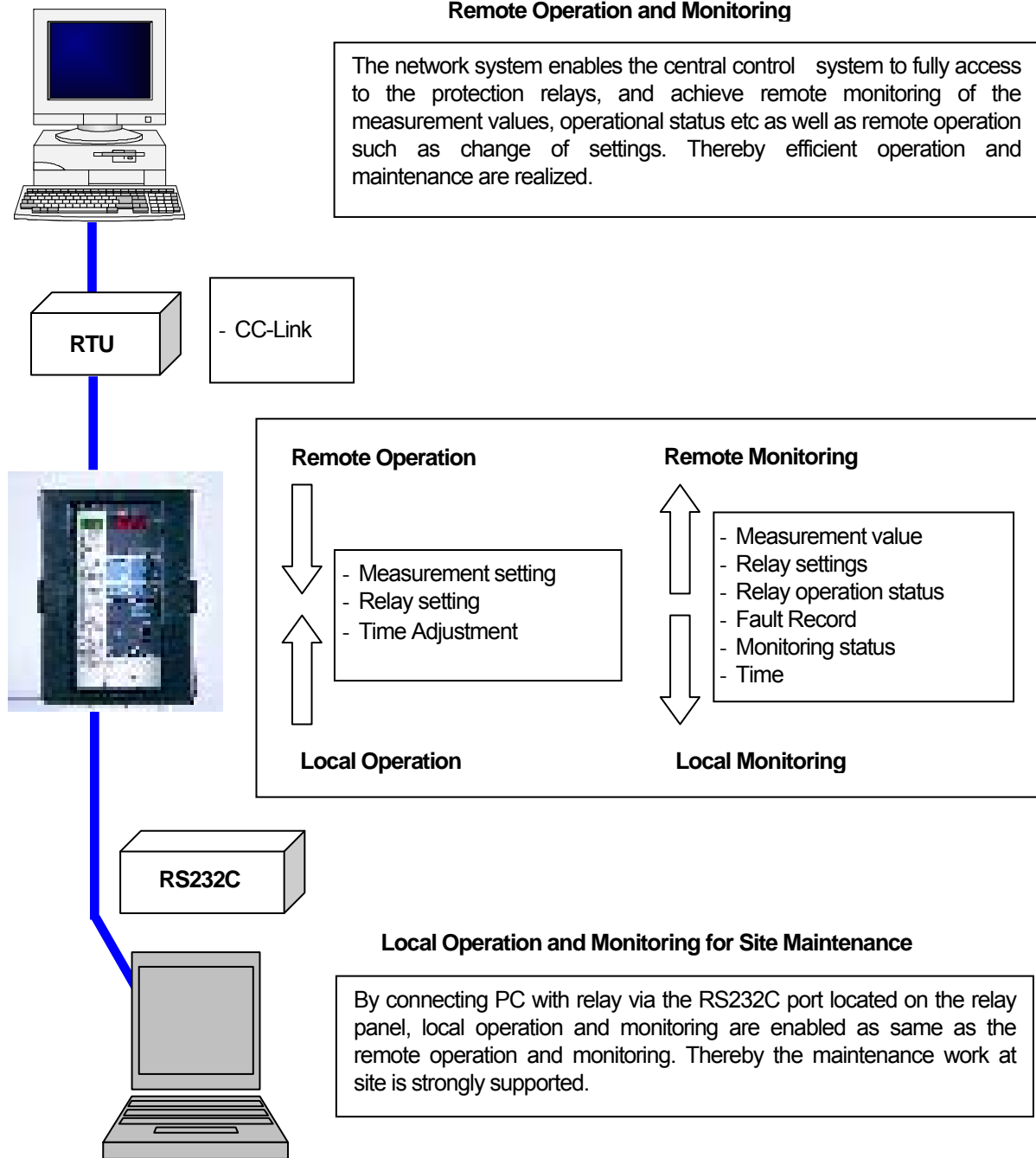

**Figure 4.10 Example of communication network system configuration**

By connecting PC with relay via the direct communication port (as standard equipment located on the relay front panel, local operation and monitoring are enabled as same as the remote operation and monitoring.

Please note that optional HMI software for PC is needed local operation and monitoring.

Using the communication facilities, it is possible to perform Remote Monitoring and Remote Operation with the various useful functions shown in Table 4.2.



**Table 4.2 Outline of functions enabled by communication network**

Direction of communication	Item	Description
<b>Remote Monitoring</b> RTU ← Protection relay	Setting	Read the settings stored in the protection relay.
	Measurement	Read the measurements stored in the protection relay.
	Max. value	Read the max. values stored in the protection relay.
	Fault record	Read the measurements at the time of trip.
	Self-diagnosis (ALARM)	Read the result of self-diagnosis.
	Operation element	Read the elements that operated at the time of trip.
	Operation time	Read the time at the time of trip.
	Current time	Read the internal time of the communication card.
	Waveform record	Read the wave form at the time of trip.
<b>Remote Operation</b> RTU → Protection relay	Setting	Change the setting of the protection relay.
	Indicator reset	Reset the LED lamp that came on at the time of trip.
	Self-diagnosis (ALARM) reset	Clear the result of self-diagnosis.
	Fault record reset	Clear the fault record, operation elements and operation time data.
	Max. record reset	Clear the max. record.
	Forced operation	Carry out forced operation of output contact.
	Time	Set time of communicate card.

## 5 Configuration

### 5.1 Internal configuration

#### (1) I/O and CPU circuits

The internal block diagram of type CMP1-A02D1 and type CMP1-A02D2 relay are shown in Fig. 5.1, 5.2 respectively.

Current and voltage inputs are converted into AC signals at the electronic circuit level via the auxiliary transformer and filter circuits. These signals are retained as a form of DC signal in the sample hold circuit on each channel sharing a same time. The multiplexer selects a channel to take the signal and sends it to an A/D converter. The signals are converted to digital signals sequentially in the converter to be sent to the CPU.

The setting circuit is used to input setting data into the CPU.

These inputs will be used to carry out the functions shown in Fig. 5.3 and Fig. 5.4 “Internal function block diagram”, then issue output signals to the display and output relay.

#### (2) Self-diagnosis circuit

When the self-diagnosis function detects that the electronic and power circuits are normal, the output relay will be energized to open the self-diagnosis output contact (break contact).

The self-diagnosis output contact (break contact) will be closed when a failure occurs in the circuits above or when the built-in power fuse burns.

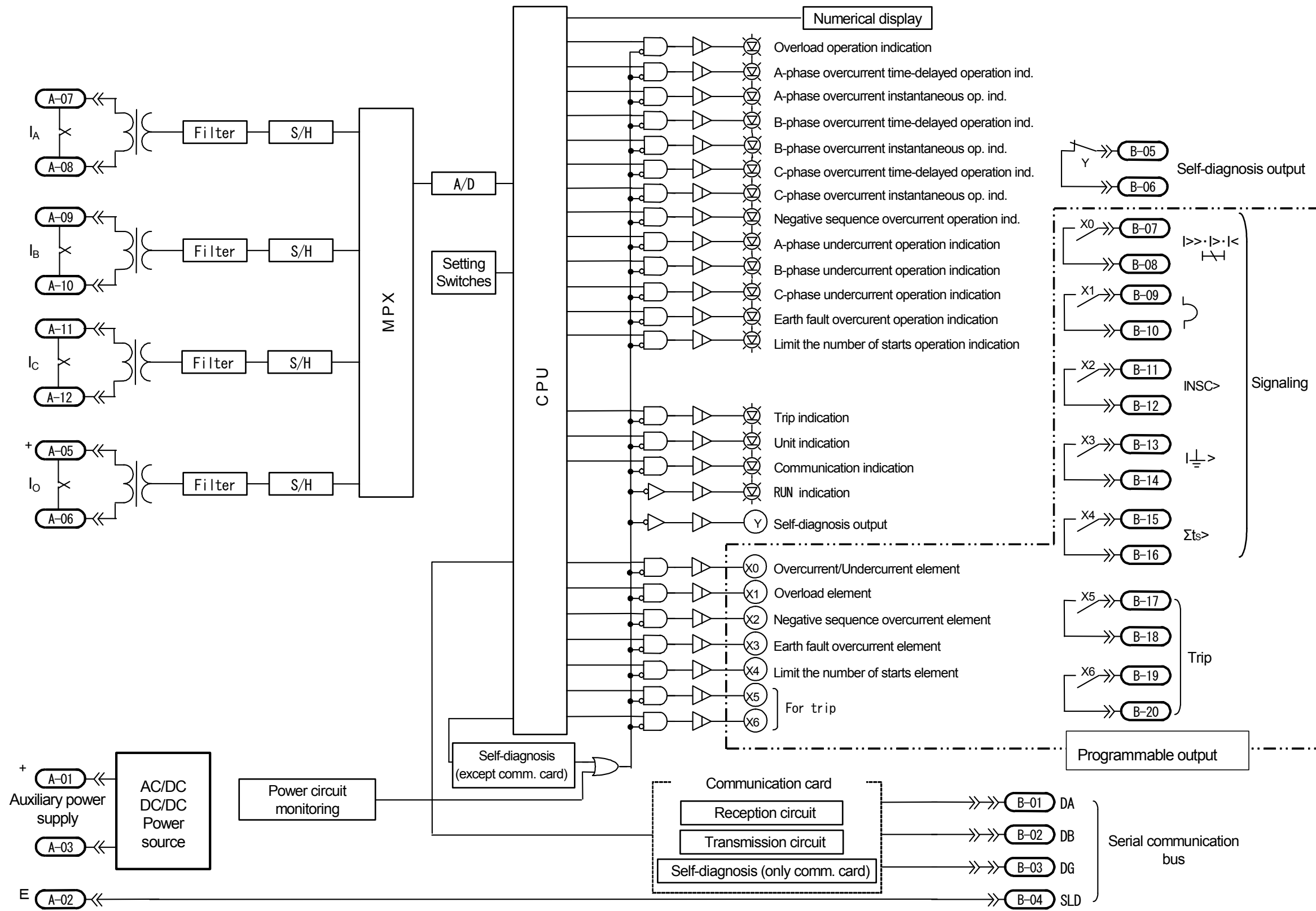

Fig. 5.1 Internal block diagram of Type CMP1-A02D1 relay

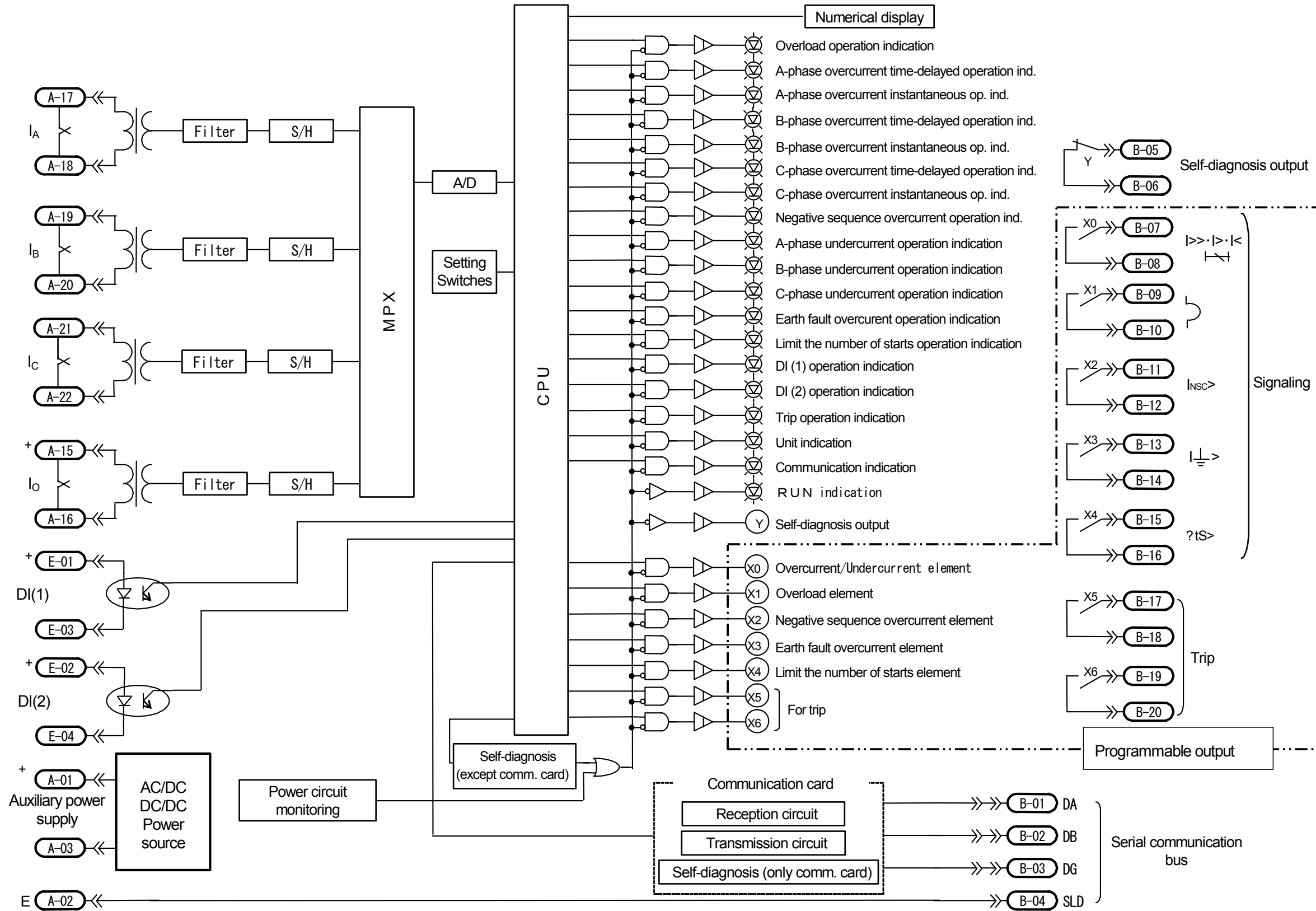

Fig. 5.2 Internal block diagram of Type CMP1-A02D2 relay

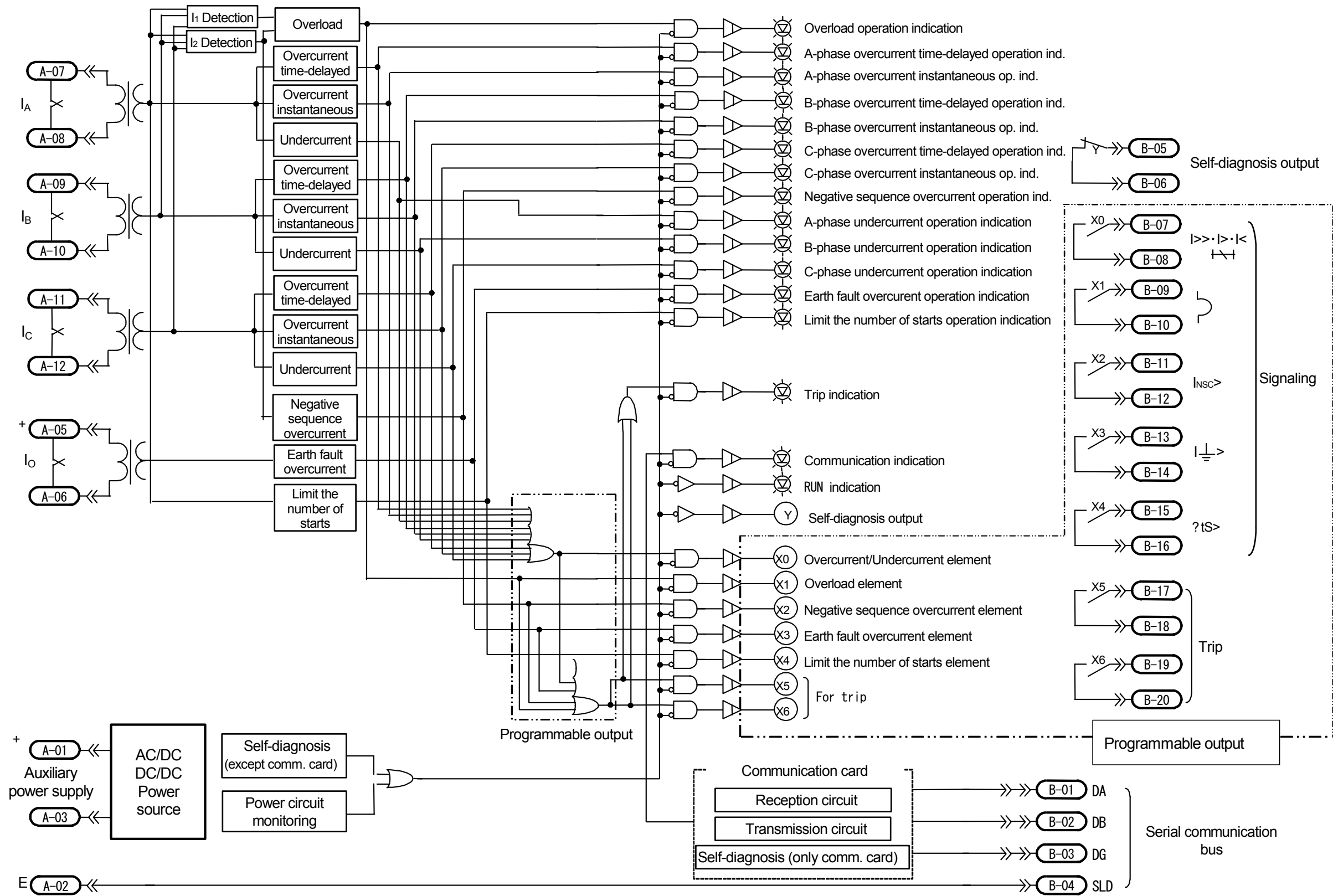

Fig. 5.3 Internal function block diagram of Type CMP1-A02D1 relay

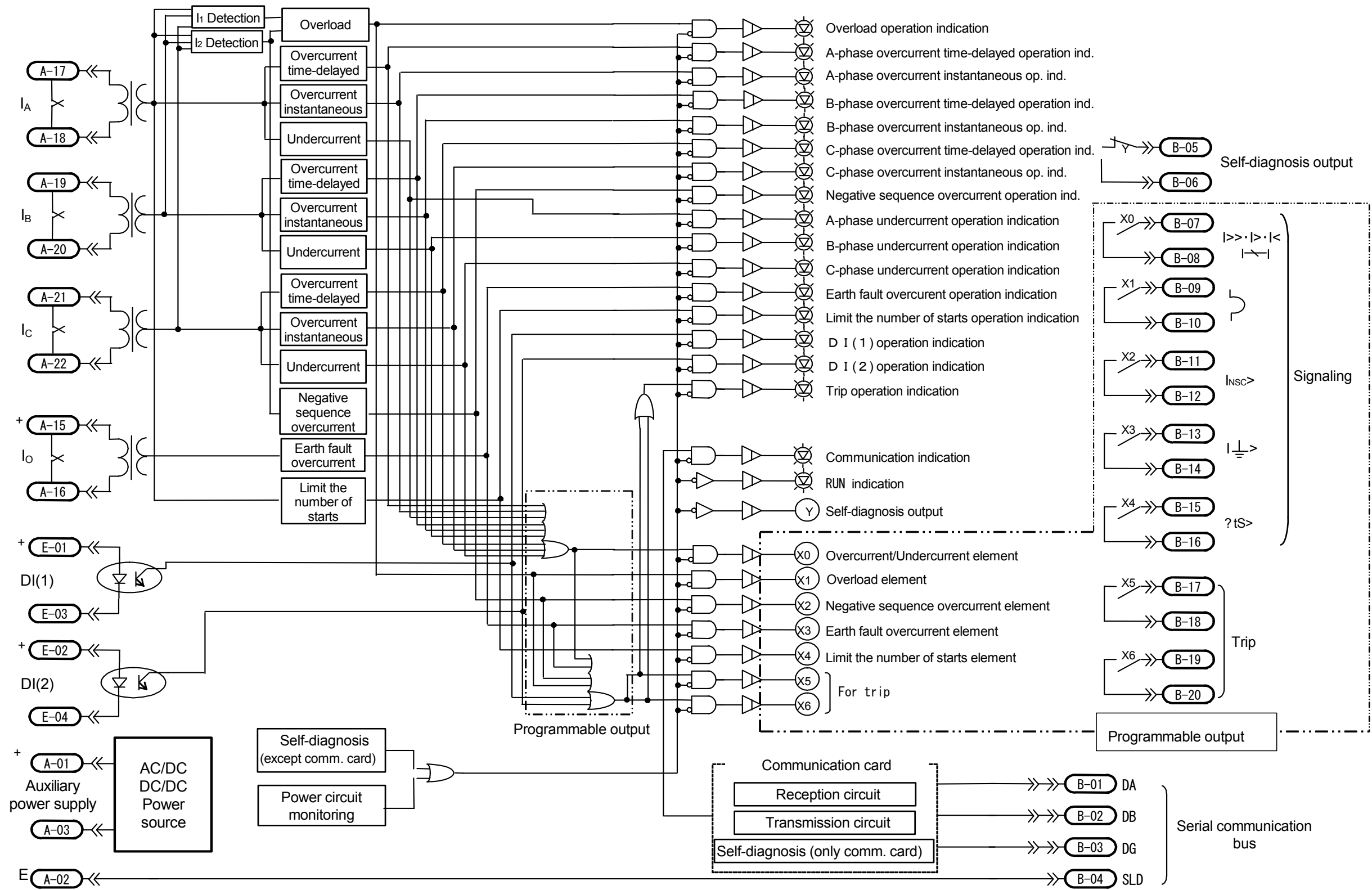

Fig. 5.4 Internal function block diagram of Type CMP1-A02D2 relay

## 5.2 External connection

### (1) Connection diagram

Figures 5.6 and 5.7 show examples of input circuit (AC circuit) connection, Figure 5.8 an example of control circuit (DC circuit) connection and Figure 5.9 and Figure 5.10 a terminal arrangement.

In the terminals, M3.5 screws should be used and wires of 2 mm<sup>2</sup> or less are recommended using.

### (2) Precautions for wiring work

a. For important facilities, fail safe countermeasures such as dual system should be provided to improve reliability of the facilities.

b. Effects of external surge

Some type of surge with a certain condition may inversely affect the relay. If so, take it into account to install

**MF type surge absorbers made by Mitsubishi Electric.**

c. Guarantee of AC auxiliary power supply against power interruption

The AC auxiliary power supply of the relay is not **guaranteed against power interruption**. When you do not have an uninterruptible AC power source, use the **type B-T1 back up power supply manufactured by Mitsubishi Electric** or uninterruptible power source (UPS) that is commercially available.

d. Inrush current of auxiliary supply

Since **inrush current may flow** in the relay when the auxiliary power supply is turned on as shown in the figure below, make consideration of this point when selecting the breaker for the auxiliary supply power circuit.

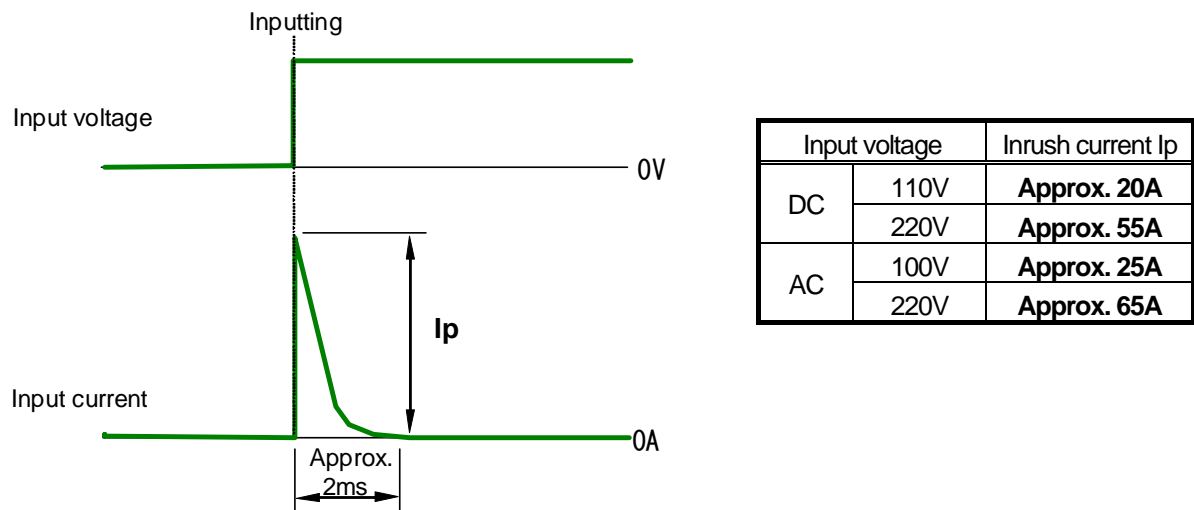

**Figure 5.5 Inrush current of auxiliary power supply**

e. Trip circuit

Only the contacts X<sub>4</sub> and X<sub>5</sub> can be used for the trip circuit. Please keep in mind that the contacts X<sub>0</sub> to X<sub>3</sub> can not be used for the trip circuit. (If used, the contact may burn).

Connect the pallet contact (52a) of the circuit breaker to the trip coil circuit in series.

f. Self-diagnosis output circuit

The self-diagnosis output contact is so configured that the auxiliary relay can be energized (break contact) with normal result of monitoring, in order to be able to continue monitoring even if the built-in power fuse burns. Therefore, connect the timer to the external wiring. (See Fig. 5.8 "DC circuit connection diagram")

g. Earth circuit

Be sure to earth the earth terminal located on the back of the relay according to the Class D earth wiring method.



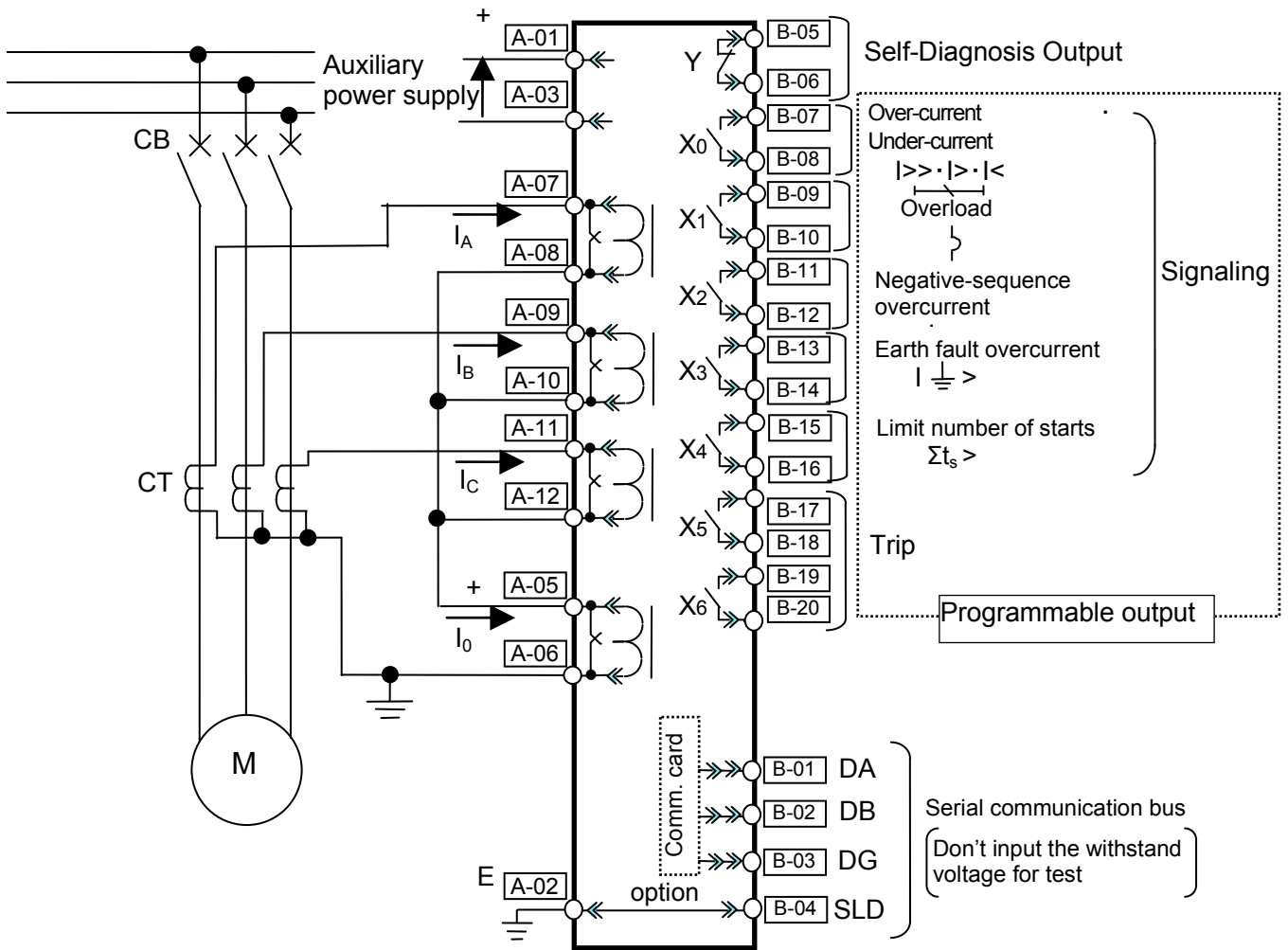

Figure 5.6 External connection diagram for CMP1-A02D1 relay

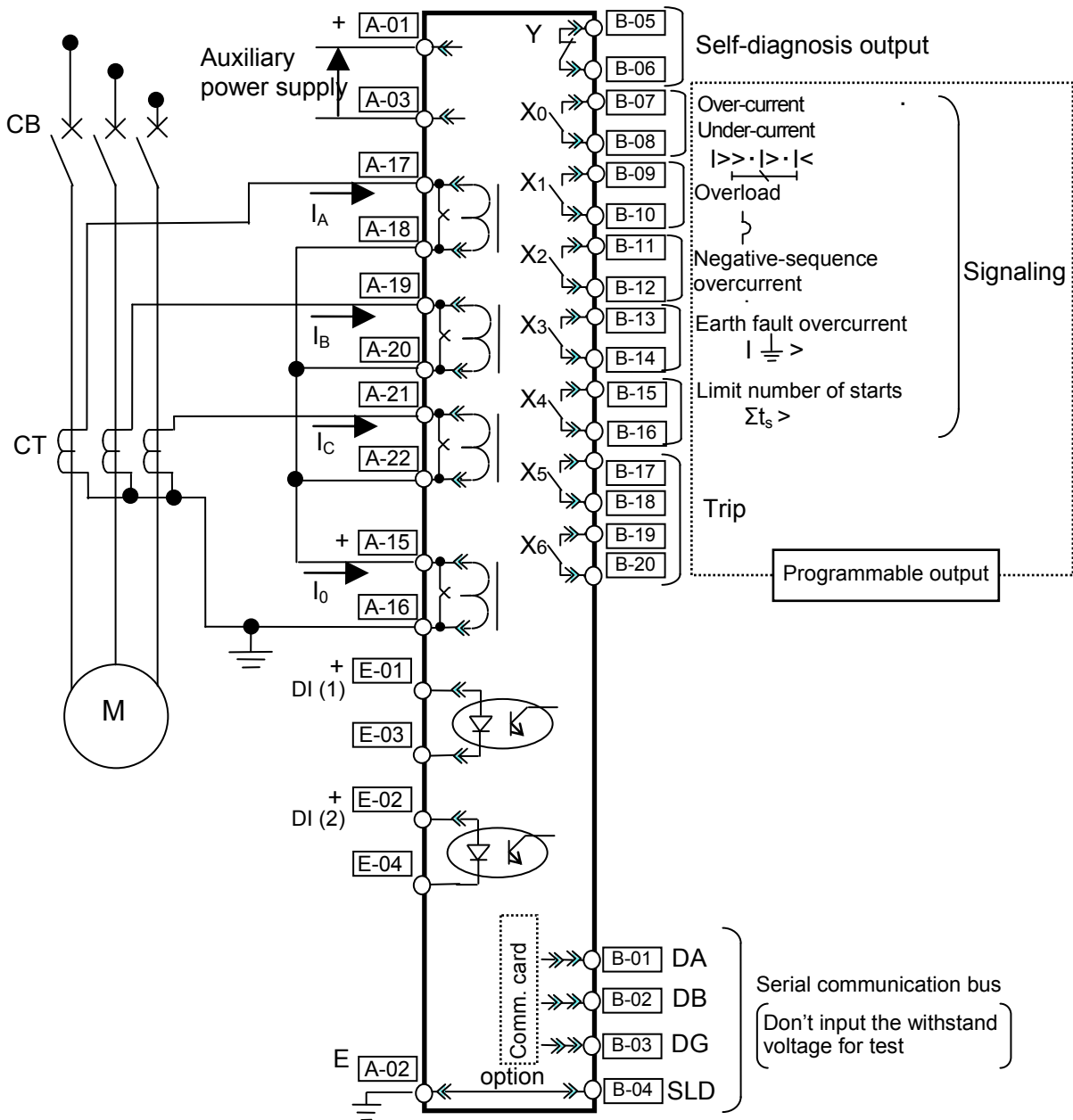
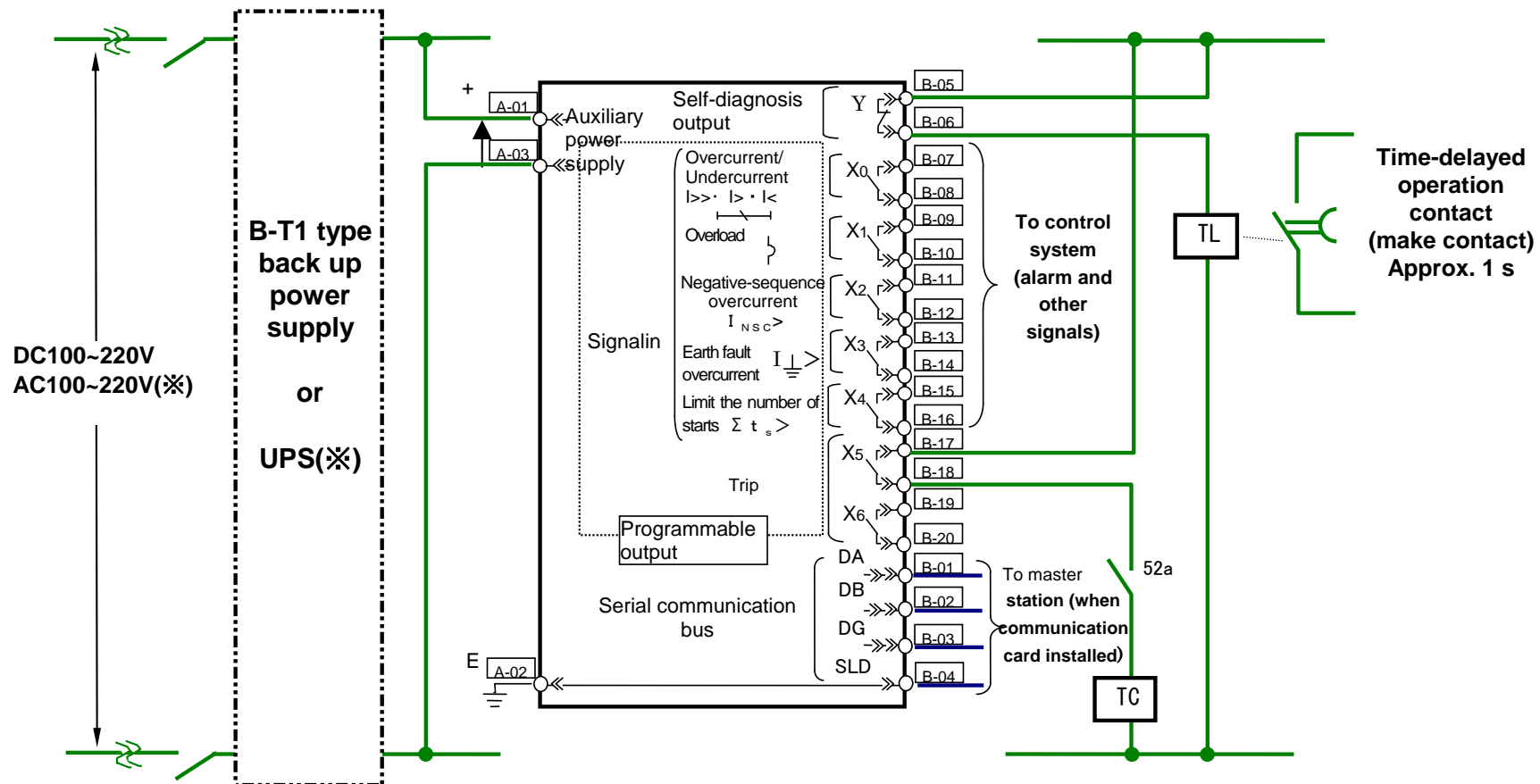

Figure 5.7 External connection diagram for CMP1-A02D2 relay



Note 1) The self-diagnosis output contact is so configured as below mentioned that alarm can be issued even after the built-in power fuse burns. This type of auxiliary relay circuit configured such that relay will be energized ("break contact" opened) when normal result of self-diagnosis is received. Therefore, the "break contact" is closed when the power is applied and will be opened after about 50ms. If the auxiliary power supply of the relay and the self-diagnosis output contact shares a same power source, the "break contact" will be closed temporarily after the auxiliary power supply is turned on. In the case where the phenomenon stated in the above would conflict with your system requirement, it is recommended that the self-diagnosis output contact should be **connected via the time-delayed timer** as shown in the left of the figure.

Note 2) Regarding to the type CPS1 AC/DC converter or commercially available uninterruptible power supply (UPS), refer to the note \*21 in the section 2.1 General information.

(※) Refer to the page 39, 5.2 External connection (2) Precautions for wiring work C. Guarantee of AC auxiliary power supply against power interruption.

Figure 5.8 Auxiliary supply circuit (DC circuit) connection example of CMP1-A02D1 and CMP1-A02D2 relay

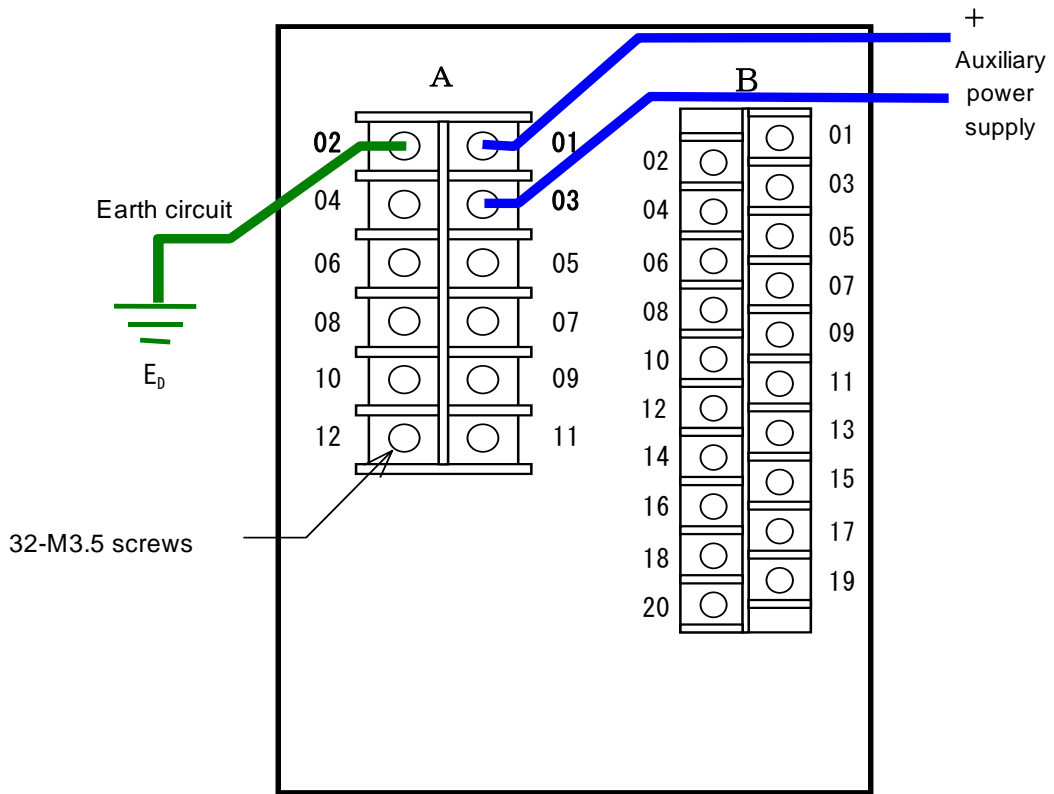

Figure 5.9 Rear view of type CMP1-A02D1 relay (terminal arrangement)

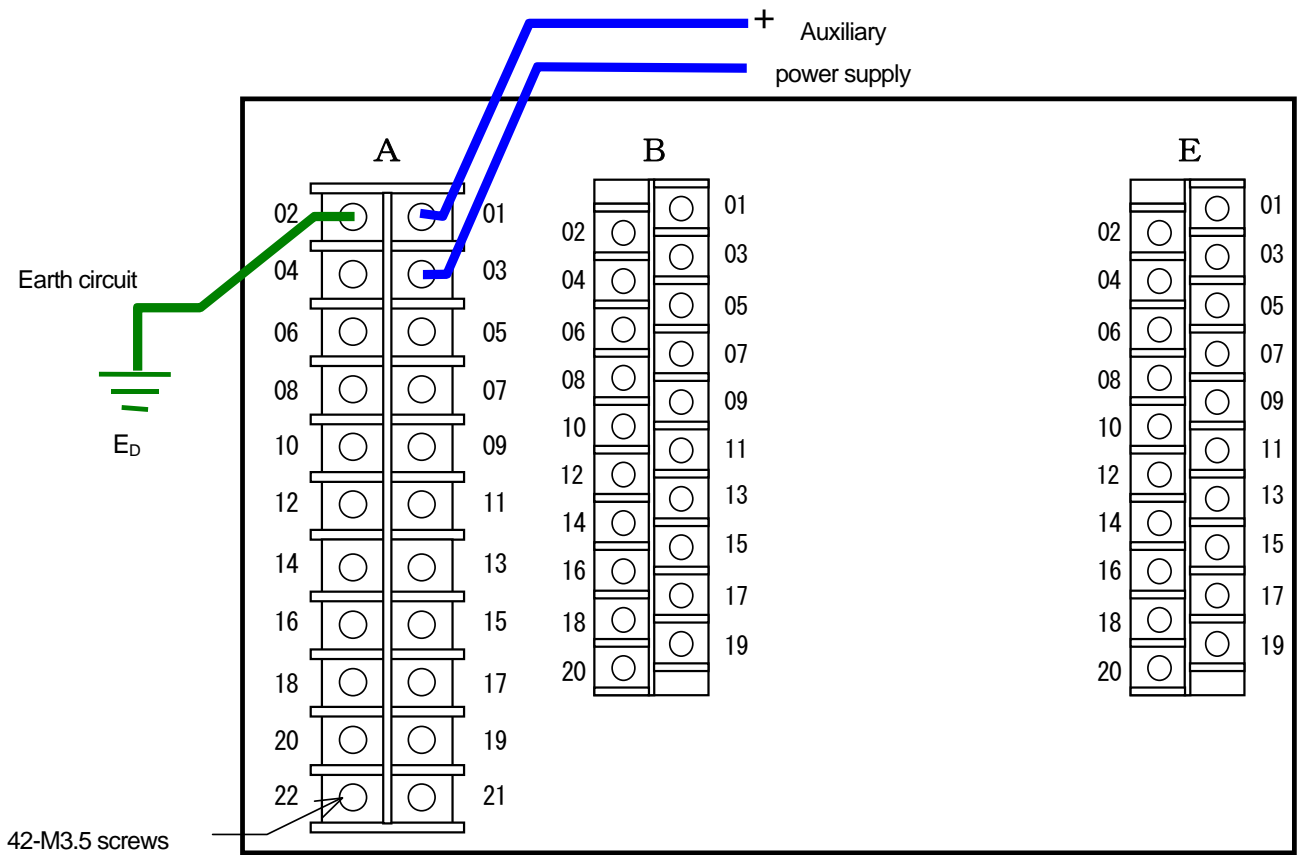

Figure 5.10 Rear view of type CMP1-A02D2 relay (terminal arrangement)

## 6 Handling

### 6.1 Unpacking

Usually this relay is packed in a D1 case (CMP1-A01D1 type) or a D2 case (CMP1-A01D2 type) for transportation. However, it may occur that only the sub unit is transported independently for the convenience at repair. In such a case, fully brush off the dust, dirt, etc. adhered to the sub unit after completion of unpacking, and further visually check that the parts mounted on the front panel or built in the sub unit are not damaged.

### 6.2 Transportation and storage

To carry the equipment within the place of use, handle it carefully so that the parts installed on the front panel of the sub unit or built-in parts cannot be deformed or broken.

### 6.3 Appearance and how to pull sub unit out

The relay is so constructed that the sub unit can be drawn out, in order to facilitate inspection or test. It is possible to pull the sub unit out without disconnecting the external wiring.

Note that the sub unit should not be drawn out with the line hot. Before drawing out, be sure to take the following actions.

- Lock the tripping circuit including breakers.
- Stop the main circuit.
- Shorten and isolate the CT circuit.
- Open the auxiliary power supply circuit.

Bear in mind that careless opening of circuits may result in opening the other control circuits too to impair the protective function. Be sure to only shut off the concerned circuit.

The CT circuit is provided with an automatic short circuit mechanism. In case that you have pulled the sub unit out without isolating the CT circuit by mistake, the automatic short circuit mechanism will work to prevent the CT secondary circuit from opening.

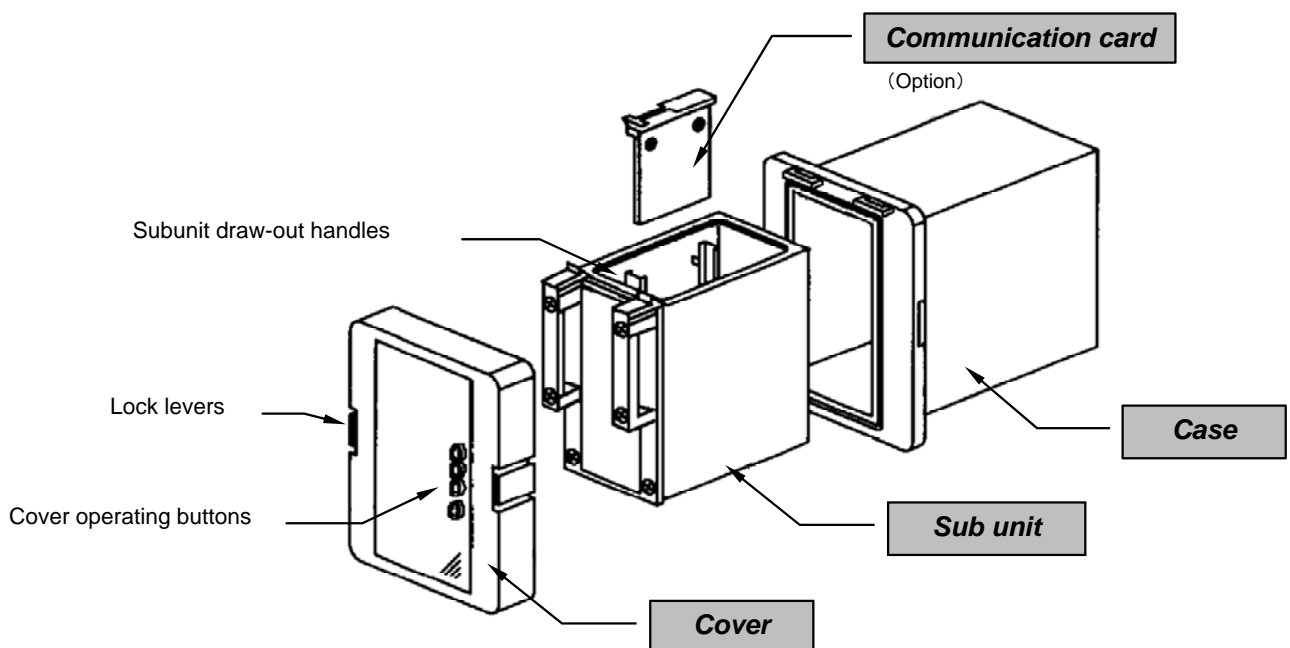
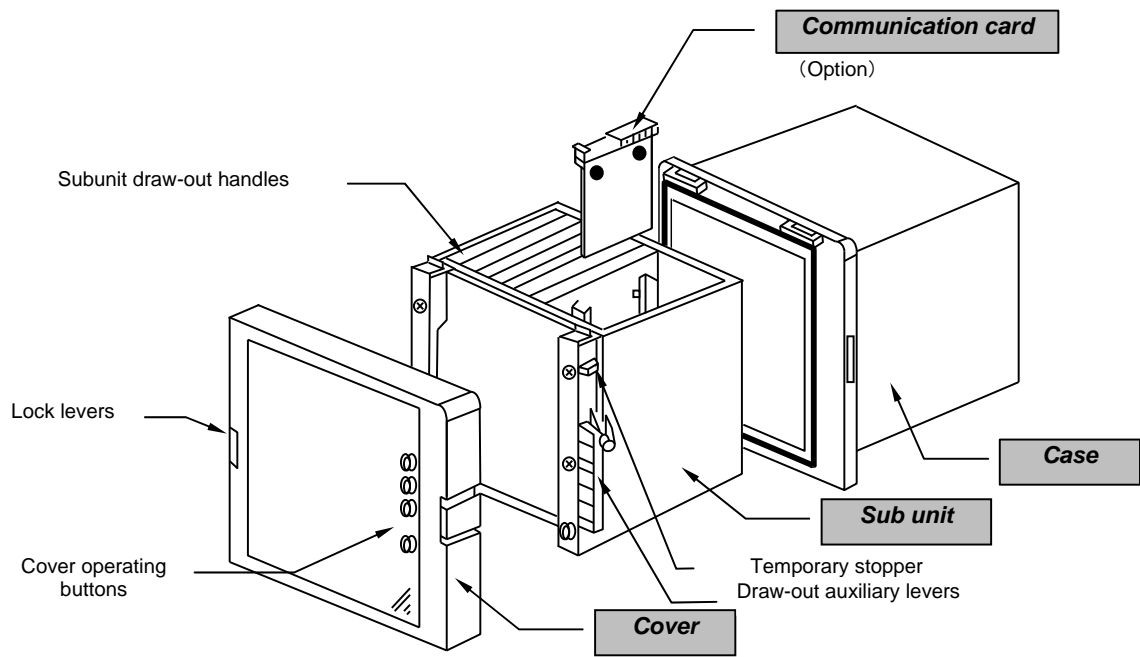

Figure 6.1 Outside view of type CMP1-A02D1 relay



**Figure 6.2 Outside view of type CMP1-A02D2 relay**

### 6.3.1 How to draw sub unit out

#### (1) Removing the cover

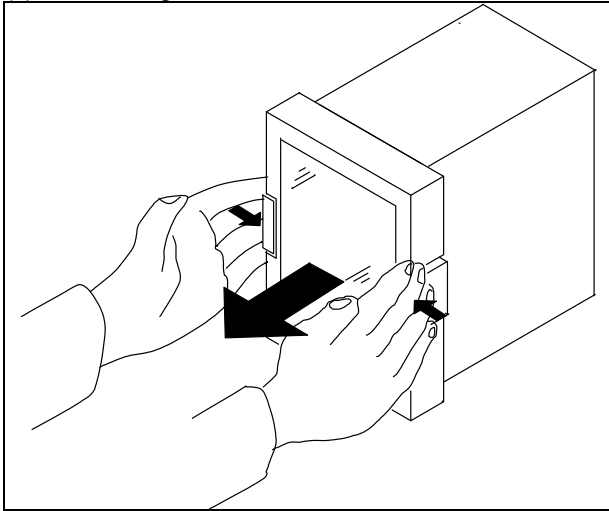

Hold the **lock levers**, which are located at both sides of the cover, on their front sections. Take off the cover **straight toward you** while pushing the levers **inwards**.

#### (2) Drawing the sub unit

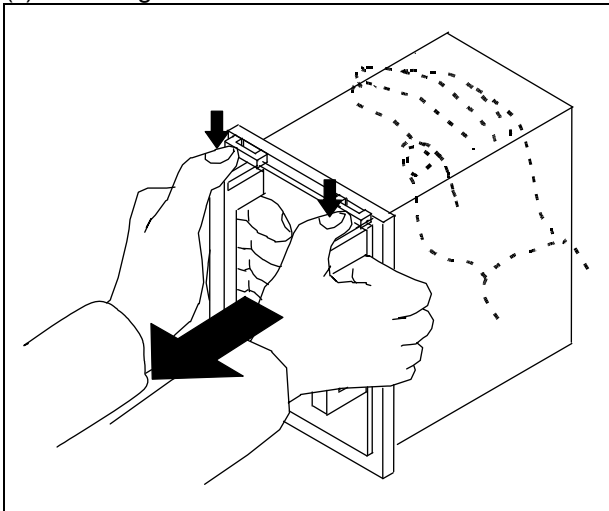

Grip the draw-out handles (located at both sides of the front of the sub unit). **Press the locking pieces installed in the upper portion of the draw-out handles with your thumbs to pull the sub unit towards you.**

Note) The sub unit is so designed that it can not be removed unless it is pulled out with a relatively strong force, in consideration of quake-proof measures. When the relay unit is to be removed independently, it is recommended to draw it out with the case held by other operator.

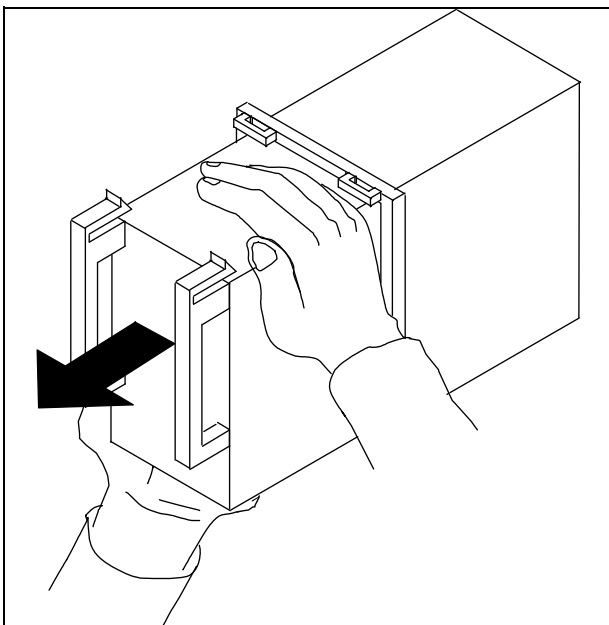

When about a half portion of the sub unit is pulled out of the case, just stop the drawing motion. Then, **hold the top and bottom of the sub unit to pull it out completely**, in order to prevent the unit from falling.

Note) Be careful not to touch the printed circuit board and parts inside the sub unit.

## 6.3.2 Housing the sub unit

### (1) Housing the sub unit

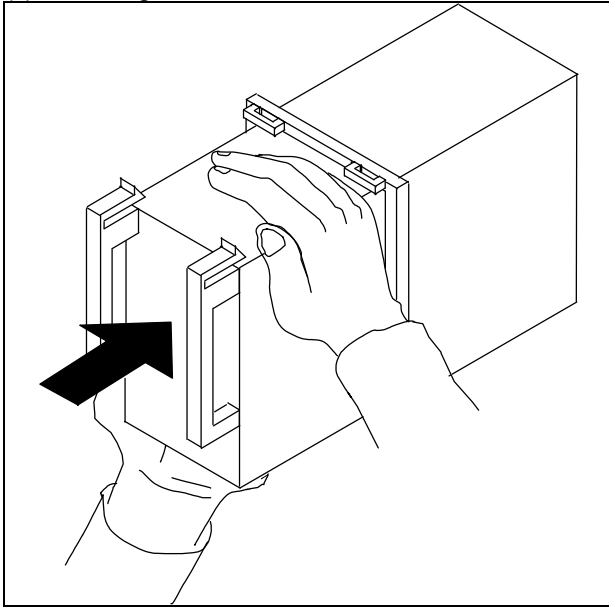

Hold the sub unit on the top and bottom to push the unit into the case approx. a half of the unit.

Note)

- Be careful not to touch the PCB and parts inside the sub unit.
- The sub unit is so constructed that it can not be housed in the case upside down.

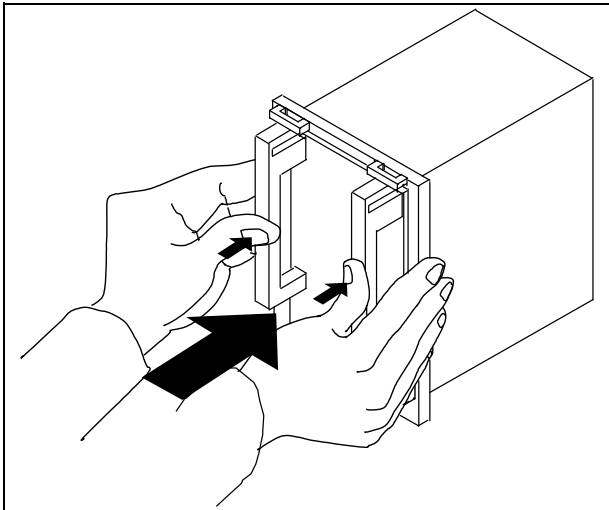

**Fully insert the sub unit into the case until you hear a click** while pressing the handles located on both sides of the front of the sub unit, **and also the front face of subunit (ie, 4 corners of front face) is becoming flush with the vertical surface of the case.**

Note) Please note that inserting the sub-unit incompletely may only establish a poor contact of the terminals located on the back of the unit, which may cause operational failure or heating.

### (2) Attaching the cover

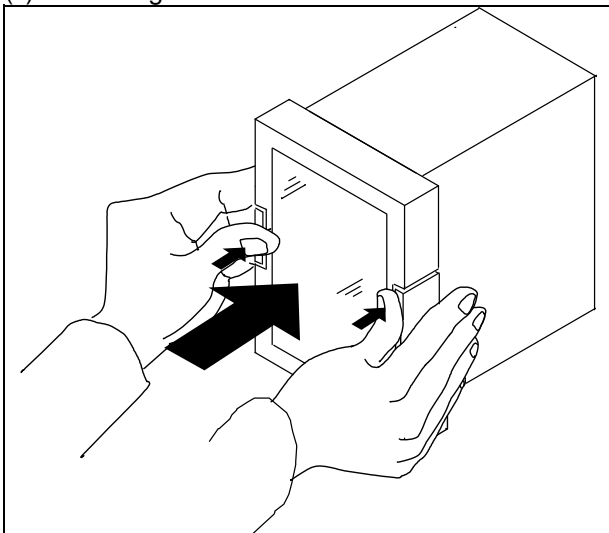

**Fit the cover straight** to the case. Hold the cover frame to **fully push the lock levers, located both side of the cover, to case side until it is clicked and locked.**

Note) After setting the cover, check if the buttons can be smoothly pressed from over the cover.



### 6.3.3 How to draw sub unit out

#### (1) Removing the cover

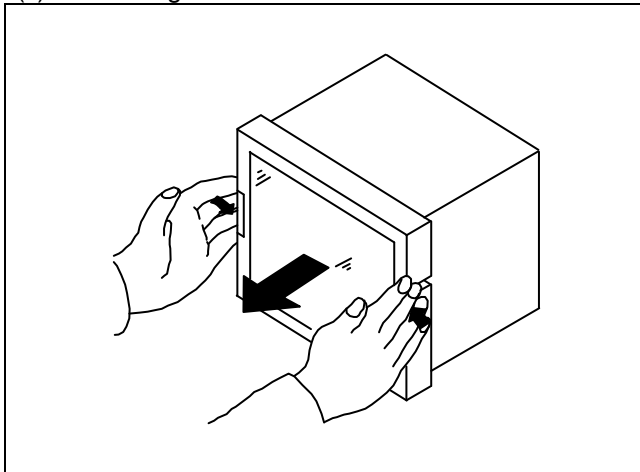

Hold the **lock levers**, which are located at both sides of the cover, on their front sections. Take off the cover **straight toward you** while pushing the levers **inwards**.

#### (2) Drawing the sub unit

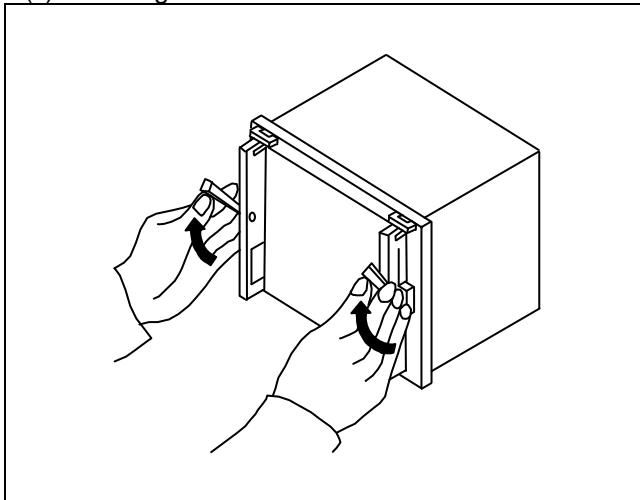

**Please from under to upper direction turn round the draw-out auxiliary levers** located on both sides of the front of the sub unit until the levers touch the metallic parts located on both sides of draw-out handles completely.

**(Rotated angle is approx. 120°)**

Note) Be careful not to put your fingers into the space between drawing-out auxiliary levers and the case.

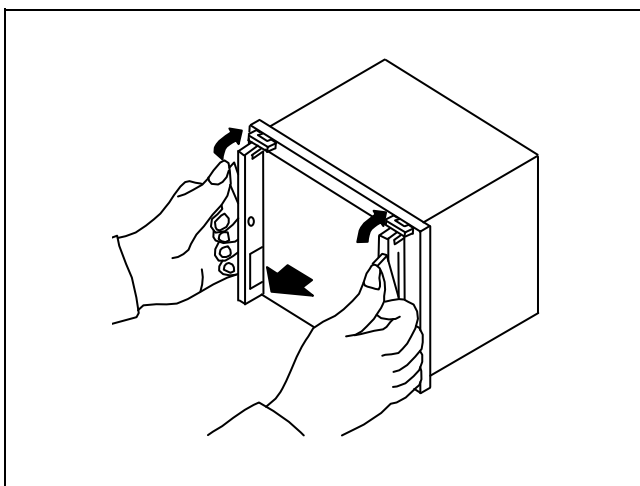

With the draw-out auxiliary levers touching the metallic parts, **exert your strength to turn round the levers** continuously, the sub unit will be drawn out a little from the case.

Then be careful not to let the draw-out auxiliary levers fall down and to **make the draw-out auxiliary levers into a locked status by the with-holders** located on the both sides upper the auxiliary levers please.

**(Rotated angle is from approx. 120° to 180°)**

Note) Be careful not to put your fingers into the space between drawing-out auxiliary levers and the case.

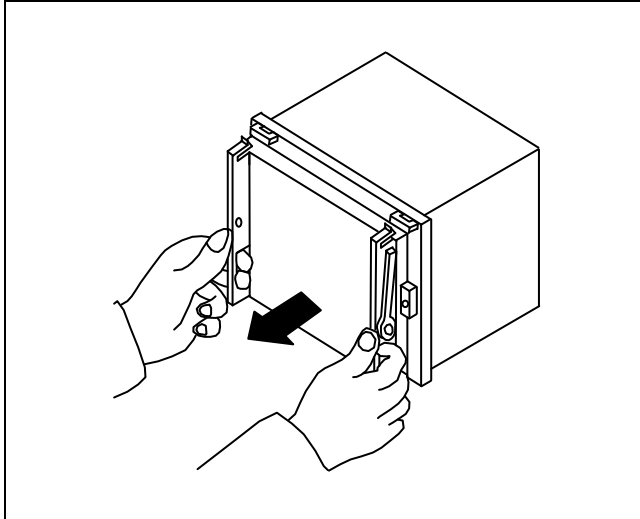

Grip the draw-out handles (located at both sides of the front of the sub unit), and **pull the subunit towards you** until about a half portion of the sub unit is pulled out of the case.

Note) Be careful not to pull out the sub unit too much in order to prevent the sub unit falling.

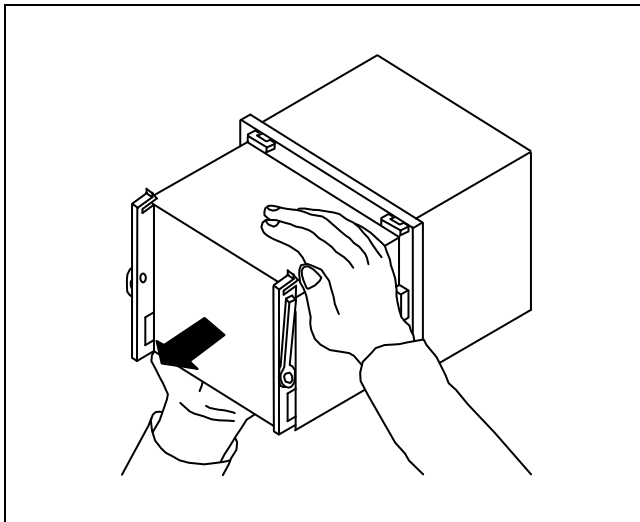

When about a half portion of the sub unit is pulled out of the case, just stop the drawing motion. Then, **hold the top and bottom of the sub unit to pull it out completely**, in order to prevent the unit from falling.

Note) Be careful not to touch the printed circuit board and parts inside the sub unit.

### 6.3.4 Housing the sub unit

#### (1) Housing the sub unit

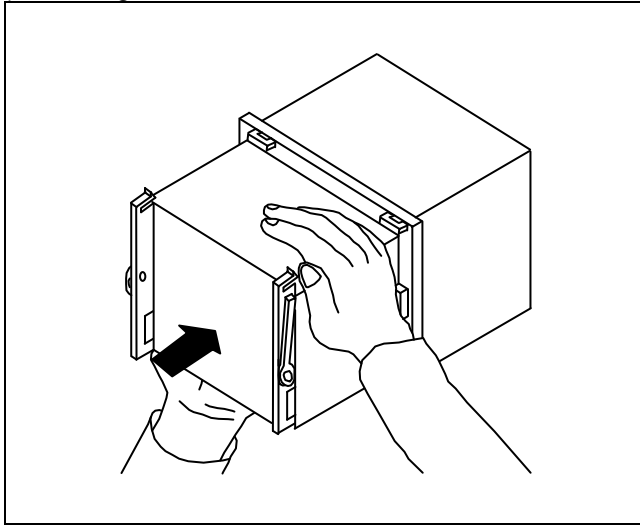

Hold the sub unit on the top and bottom to push the unit into the case approx. a half of the unit.

Note)

- Be careful not to touch the PCB and parts inside the sub unit.
- The sub unit is so constructed that it can not be housed in the case upside down.

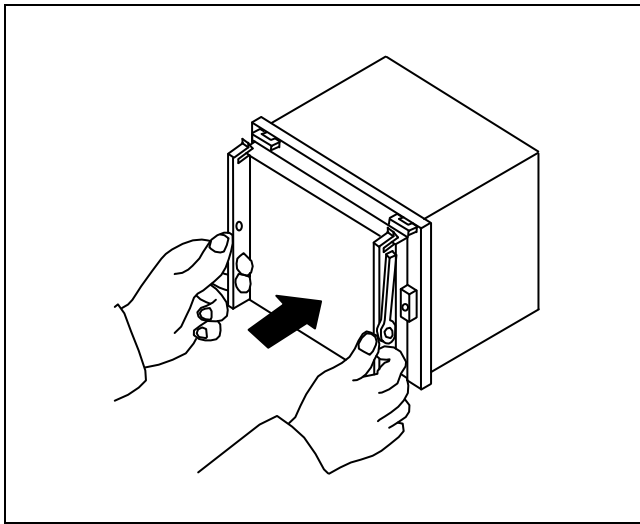

**Under holding the auxiliary levers locked status** by the with-holder (not to let the draw-out auxiliary levers fall down), **Insert the sub unit into the case until the auxiliary levers touch the metallic parts** while pressing the handles located on both sides of the front of the sub unit.

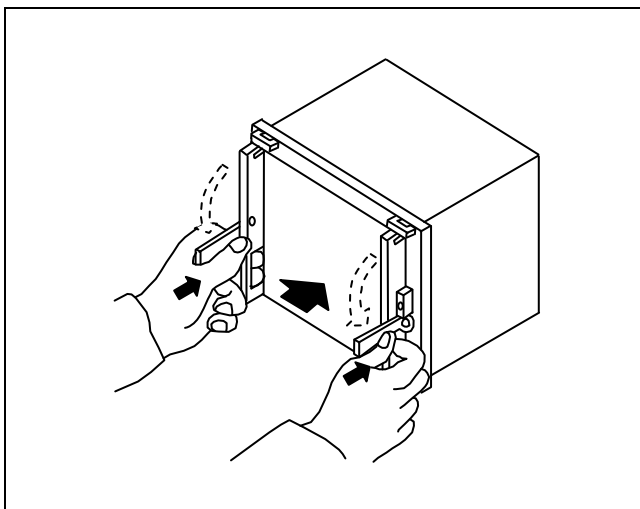

**More fully insert the sub unit into the case until** the auxiliary levers fall down automatically and catch the metal holes inside with its hooks.

**(Rotating angle is from 180° to approx. 45°)**

Note)

If the auxiliary levers are not available to complement the wanted operation automatically, operate the auxiliary levers and make it achieve the above status please.

At this time be also careful that do not injure your fingers.

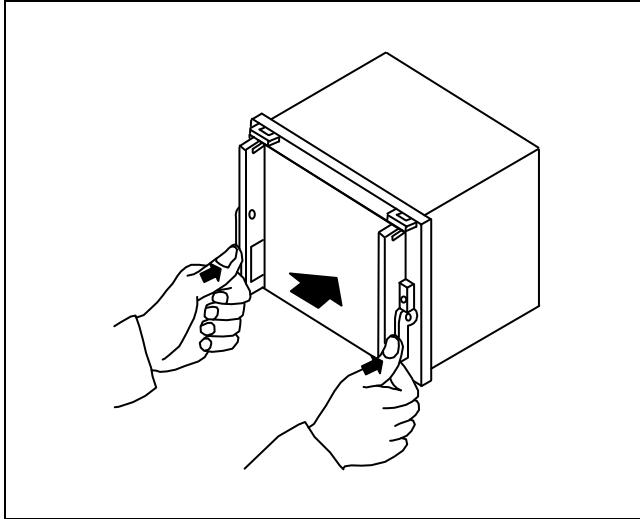

**Exert your strength to press the lower parts of the auxiliary levers to fully insert the sub unit into the case until you hear a click.**

**(Rotated angle is from 45° to approx. 0°)**

Note) Please note that inserting the sub-unit incompletely may only establish a poor contact of the terminals located on the back of the unit, which may cause operational failure or heating.

(2) Attaching the cover

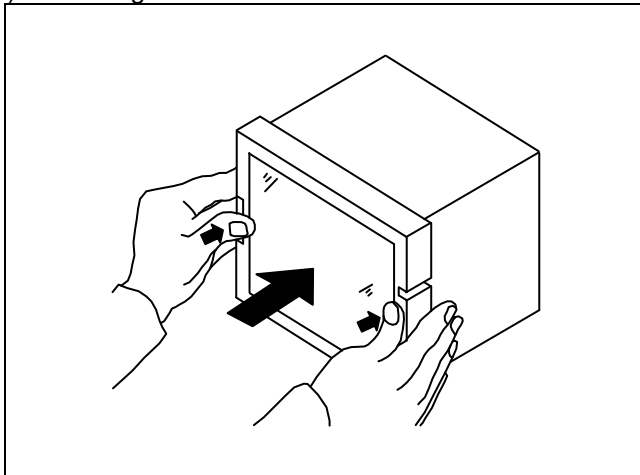

**Fit the cover straight** to the case. Hold the cover frame to **fully push the lock levers, located both side of the cover, to case side until it is clicked and locked.**

Note) After setting the cover, check if the buttons can be smoothly pressed from over the cover.

6.4 How to use front control panel

6.4.1 How to use front control panel

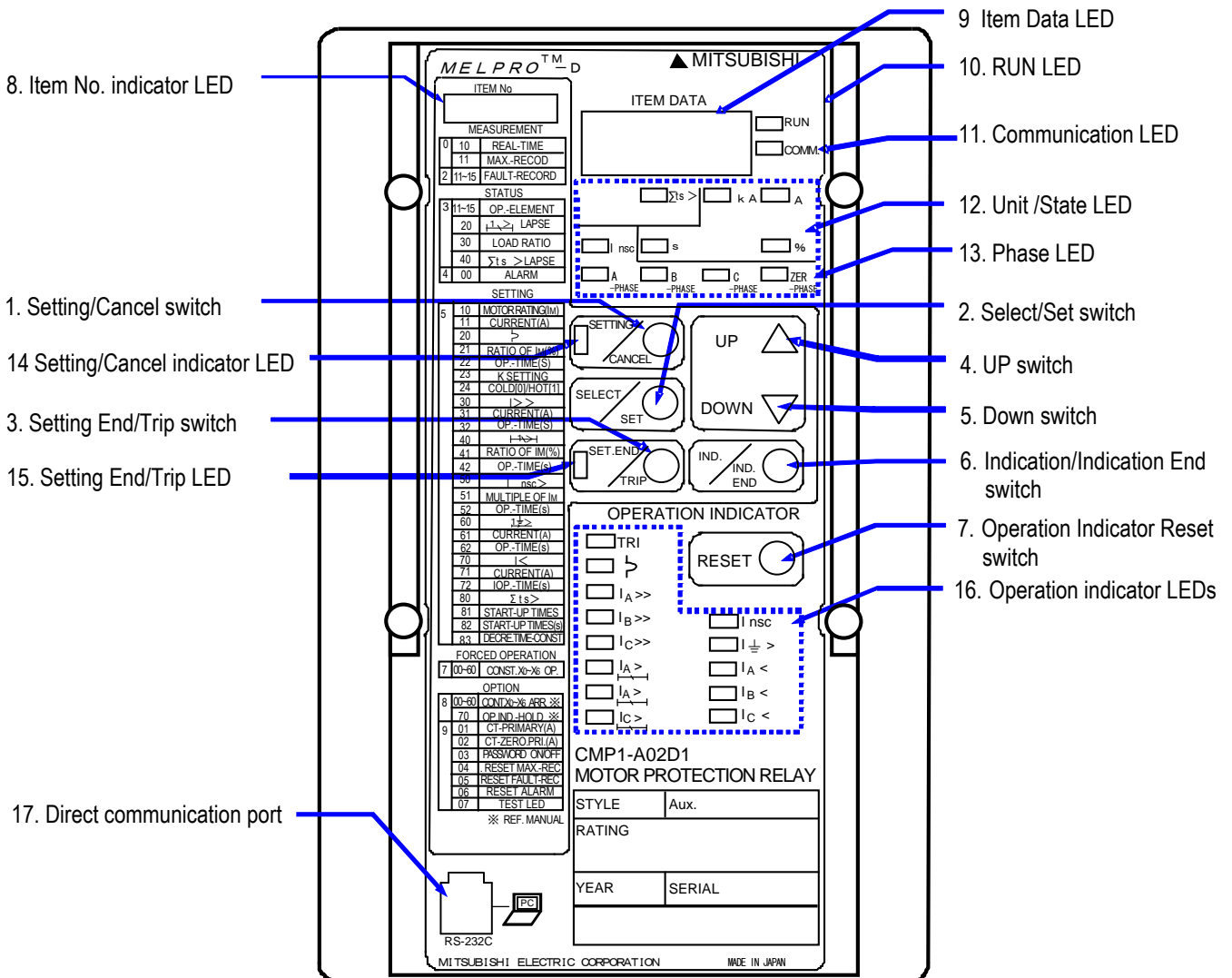

Fig 6.3 Front view of type CMP1-A02D1 relay

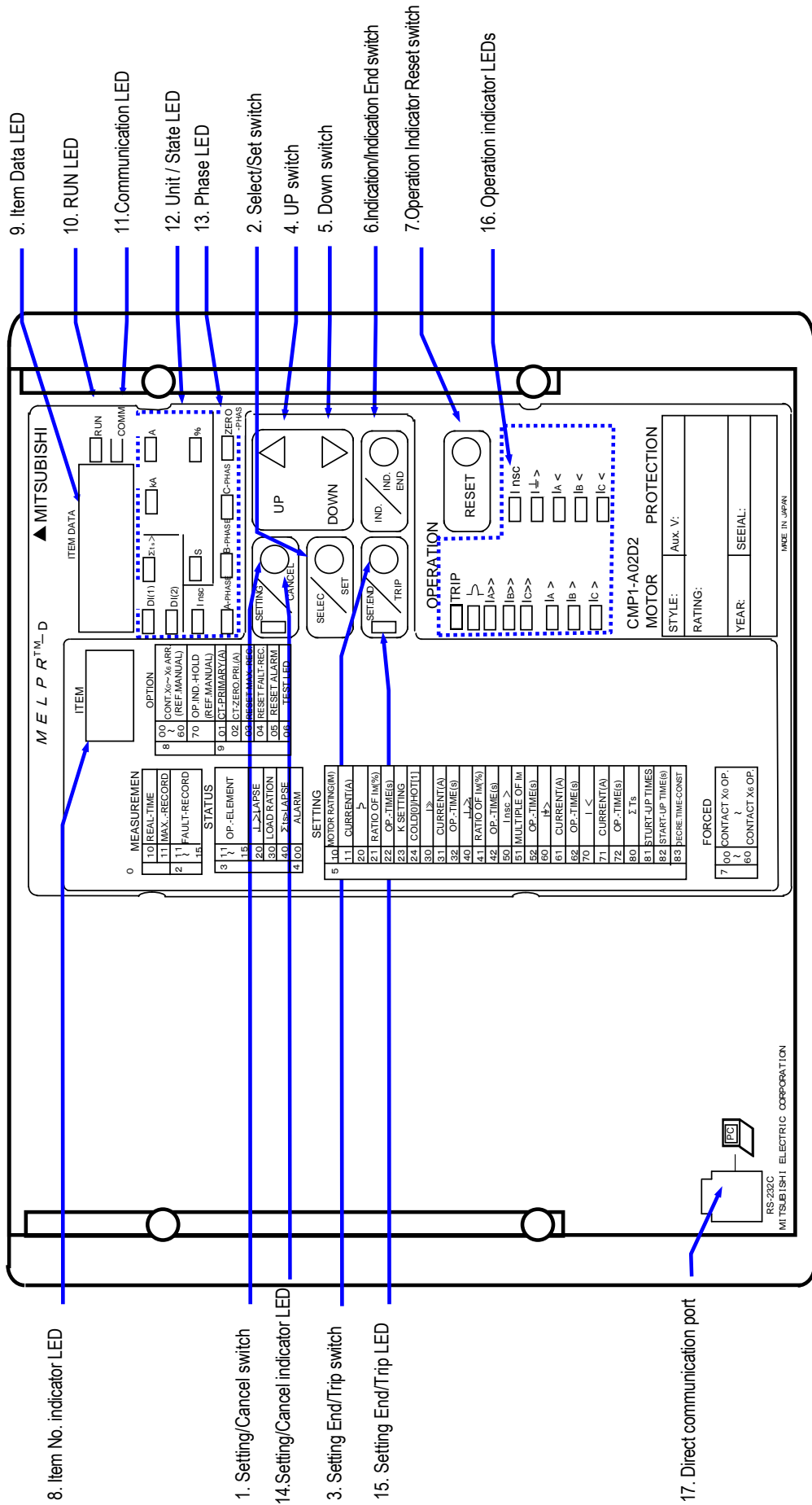



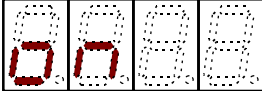
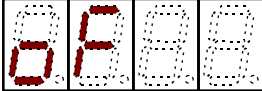
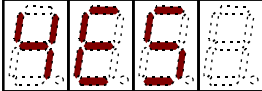
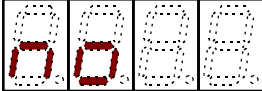
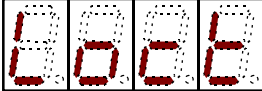
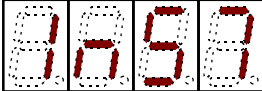

Fig 6.4 Front view of type CMP1-A02D2 relay

Table 6.1 Front control panel guide

No.	Designation		Symbol	Description
1	Setting / Cancel			Pressing this switch will start the procedure for setting, forced operation or option. When this switch is pressed again instead of the  switch, data that has been programmed will be all cleared to terminate the selected procedure. The SETTING/CANCEL indicator LED is lit during the procedure.
2	Select / Set			This switch is used to select an item number and to program item data during setting, forced operation or option procedure. When data is programmed to be ready for replacing the currently used setting, the SET.END/TRIP LED will blink.
3	Setting End / Trip			When the SET.END/TRIP switch is pressed with its LED blinking during setting, forced operation or option procedure, the currently enabled setting will be replaced by data given by programming. The new setting will be thus enabled.
4	UP select			These switches are used for selecting data elements. Pressing these switches for a while will allow fast forwarding. With the cover operating buttons, you can use the switches without removing the cover.
5	DOWN select			
6	Indication / Indication End			Pressing this switch will start or end the display of settings and measurements. With the cover operating button, you can use the switch without removing the cover.
7	Reset			Pressing this switch will reset output contacts after the relay operated and extinguish the operation indicator LEDs. With the cover operating button, you can use the switch without removing the cover.
8	Item No.	Green	-	A number allocated to the selected setting, forced operation or option item is indicated here.
9	Item Data	Red	-	Data that corresponds to the item number selected is displayed here. For the indication of individual letters, see the Table 6.2.
10	RUN	Green	-	Indicate the result of the automatic self-check. The lamp will be lit for normal results while off for abnormal.
11	Communication	Green	-	Indicate the operational status of the communication card. - With a communication card installed: the lamp will be lit for normal conditions, blinking during communication and off for abnormal conditions. - With a communication card not installed: the lamp will be off.
12	Unit	Yellow	-	Indicate the unit used for the item data.
13	Phase	Yellow	-	Indicate the phase that corresponds to the item data.
14	Setting / Cancel	Yellow	-	This lamp will be lit during setting, forced operation or option procedure.
15	Setting End / Trip	Yellow	-	This lamp will blink when new data is programmed to be ready for replacing the currently enabled setting.
16	Operation	Red	-	Indicate the corresponding operation elements and phases of the relay.
17	Direct communication port [current editions]		-	By connecting PC installed dedicated software with relay, local operation and monitoring are enabled.

**Table 6.2 Letter representation of item data indicator LEDs**

Item		Display in item data box
Designation	Letters	
On	ON	
Off	OFF	
Yes	YES	
No	NO	
Operation lock	LOCK	
Instantaneous	INST	



6.4.2 Operational procedure

For more information about the operational procedure shown below, see the MELPRO-D Series General Operation Manual (JEP0-IL9416).

6.4.2.1 Relay without RS232C communication I/F

**Table 6.3 Operational procedure**

Item			Corresponding section of general operation manual		
No.	Designation	Description	Indication mode	Setting / forced operation / option mode	
010	Real time	Measure and display effective value currents input to the relay all the time.	A-1		
011	Max. record	Display the max. effective value current.	A-2		
211	Measurement Fault record	1 <sup>st</sup> phenomena	A-3		
212		2 <sup>nd</sup> phenomena			
213		3 <sup>rd</sup> phenomena			
214		4 <sup>th</sup> phenomena			
215		5 <sup>th</sup> phenomena			
311	Operation elements	1 <sup>st</sup> phenomena	A-4		
312		2 <sup>nd</sup> phenomena			
313		3 <sup>rd</sup> phenomena			
314		4 <sup>th</sup> phenomena			
315		5 <sup>th</sup> phenomena			
320	Elapse of time-delayed timer (LAPSE)	Display the count of the elapsed time of operation of time-delayed elements.	A-5		
330	Status Load factor	The percent display of the greatest ever rate of load of overload element is carried out. Please refer to (6) Display of Load Factor of 4.1.2 Overload element for details.			
340		Start-up time lapse			The integrated count value of limit the number of start-up times is display. Please refer to (2) Start-up time Display of Load Factor of 4.1.2 Overload element for details.
400	Self-diagnosis (ALARM)	Keep in record and display defect codes in the case where an abnormal condition is detected by the self-diagnosis.	A-6		
511	Motor rating	Motor current rating [A]	A-7	B-1	
521	Over load	Operation current [%]			
522		Operation time setting			
523		Negative-sequence heat multiplying factor			
524		Characteristic changeover			
531	Setting Over current	Instantaneous			Operation current[A]
532		Time-delayed			Operation time[s]
541		Operation current[%]			Set and display settings.
542		Operation time setting			
551	Negative-phase over current	Operation current			
552		Operation time[s]			
561	Earth fault overcurrent	Operation current [mA]			
562		Operation time[s]			
571	Undercurrent	Operation current[A]			
572		Operation time[s]			
581	Limit the number of starts	Start-up times			
582		Start-up time[s]			
583		Decrement time constant			
700	Forced operation	Contact X <sub>0</sub> operation	C-1		
710		Contact X <sub>1</sub> operation			
720		Contact X <sub>2</sub> operation			
730		Contact X <sub>3</sub> operation			
740		Contact X <sub>4</sub> operation			
750		Contact X <sub>5</sub> operation			
760		Contact X <sub>6</sub> operation			

Item			Corresponding section of general operation manual	
No.	Designation	Description	Indication mode	Setting / forced operation / option mode
800	Contact arrangement	Contact X <sub>0</sub>	A-7	D-1
810		Contact X <sub>1</sub>		
820		Contact X <sub>2</sub>		
830		Contact X <sub>3</sub>		
840		Contact X <sub>4</sub>		
850		Contact X <sub>5</sub>		
860		Contact X <sub>6</sub>		
870	Option	Operation indicator LED hold	A-7	D-2
901		CT primary side [A]		D-3
902		CT zero-phase primary side [A]		
903		Max. record reset		D-4
904		Fault record reset		
905		Self-diagnosis (ALARM) reset		
906		LED lamp test		

#### 6.4.2.2 Relay with RS232C communication I/F

Item			Corresponding section of general operation manual	
No.	Designation	Description	Indication mode	Setting / forced operation / option mode
As the same as Table 6.3 described in item 6.4.2.1 about the No. 010-870.				
901	Option	CT primary side [A]	A-7	D-3
902		CT zero-phase primary side [A]		
903		Relay password enable/disable option		
904		Max. record reset		D-4
905		Fault record reset		
906		Self-diagnosis (ALARM) reset		
907		LED lamp test		

6.4.2.3 Guide for option function

(1)-1 Setting of contact arrangement data of output contacts (CMP1-A02D1)

The table below shows the setting guide table. See the section [D-1] of the general operation manual for the detailed procedure.

Digit No.	Setting item	Input		
		0	1	
0	Self hold / auto reset upon reset judgment	Reset	Hold	
1	OR element combination	Overlord	Off	On
2		Overcurrent instantaneous A-phase	Off	On
3		Overcurrent instantaneous B-phase	Off	On
4		Overcurrent instantaneous C-phase	Off	On
5		Overcurrent time-delayed A-phase	Off	On
6		Overcurrent time-delayed B-phase	Off	On
7		Overcurrent time-delayed C-phase	Off	On
8		Negative-sequence over-current	Off	On
9		Earth fault overcurrent	Off	On
10		Undercurrent A-phase	Off	On
11		Undercurrent B-phase	Off	On
12		Undercurrent C-phase	Off	On
13		Limit the number of starts	Off	On
14		Not used	X	
15		Not used	X	

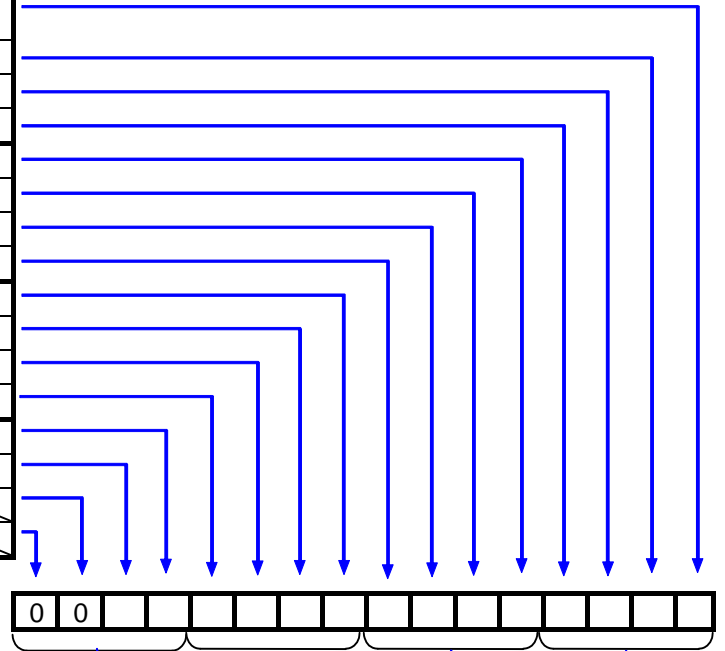

**Conversion from binary number to hexadecimal**

Binary	→ Hexadecimal	Binary	→ Hexadecimal	Binary	→ Hexadecimal
0 0 0 0	→ 0	0 1 1 0	→ 6	1 1 0 0	→ C
0 0 0 1	→ 1	0 1 1 1	→ 7	1 1 0 1	→ D
0 0 1 0	→ 2	1 0 0 0	→ 8	1 1 1 0	→ E
0 0 1 1	→ 3	1 0 0 1	→ 9	1 1 1 1	→ F
0 1 0 0	→ 4	1 0 1 0	→ A		
0 1 0 1	→ 5	1 0 1 1	→ B		

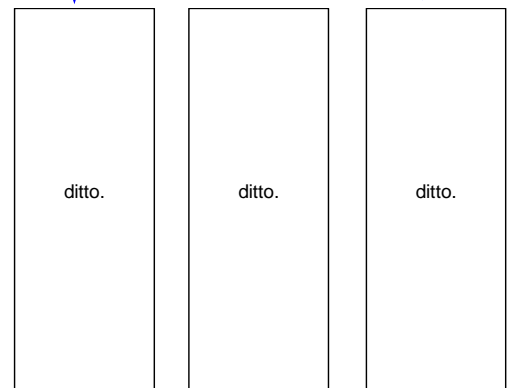

**Contact arrangement data**



When the product is shipped from the factory, above setting is following.

Contact	Item number	Contact Arrangement data	Setting element
X0	800	1CFC	Overcurrent instantaneous, Overcurrent time-delayed, Undercurrent
X1	810	0002	Overlord
X2	820	0100	Negative-sequence overcurrent
X3	830	0200	Earth fault overcurrent
X4	840	2000	Limit number of starts
X5	850	1FFE	"OR" of all the elements except Limit the number of starts.
X6	860	1FFE	"OR" of all the elements except Limit the number of starts.

\*The "Self hold/auto reset upon reset judgment" setting of all the contacts are "Reset".

(1)-2 Setting of contact arrangement data of output contacts (CMP1-A02D2)

The table below shows the setting guide table. See the section **D-1** of the general operation manual for the detailed procedure.

Digit No.	Setting item	Input	
		0	1
0	Self hold / auto reset upon reset judgement	Reset	Hold
1	OR element combination	Overlord	Off / On
2		Overcurrent instantaneous A-phase	Off / On
3		Overcurrent instantaneous B-phase	Off / On
4		Overcurrent instantaneous C-phase	Off / On
5		Overcurrent time-delayed A-phase	Off / On
6		Overcurrent time-delayed B-phase	Off / On
7		Overcurrent time-delayed C-phase	Off / On
8		Negative-sequence overcurrent	Off / On
9		Earth fault overcurrent	Off / On
10		Undercurrent A-phase	Off / On
11		Undercurrent B-phase	Off / On
12		Undercurrent C-phase	Off / On
13		Limit the number of starts	Off / On
14		DI(1)	Off / On
15		DI(2)	Off / On

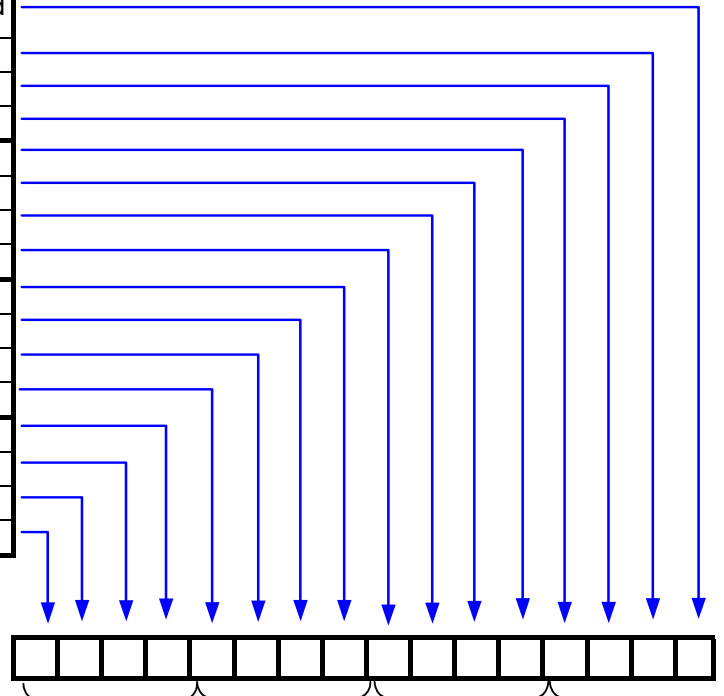

**Conversion from binary number to hexadecimal**

Binary	Hexadecimal	Binary	Hexadecimal	Binary	Hexadecimal
0 0 0 0	0	0 1 1 0	6	1 1 0 0	C
0 0 0 1	1	0 1 1 1	7	1 1 0 1	D
0 0 1 0	2	1 0 0 0	8	1 1 1 0	E
0 0 1 1	3	1 0 0 1	9	1 1 1 1	F
0 1 0 0	4	1 0 1 0	A		
0 1 0 1	5	1 0 1 1	B		

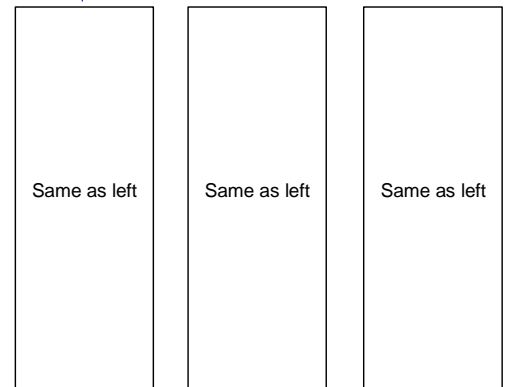

**Contact arrangement data**

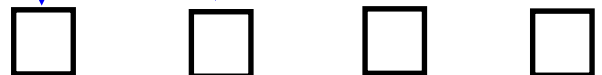

When the product is shipped from the factory, above setting is following.

Contact	Item number	Contact Arrangement data	Setting element
X0	800	1CFC	Overcurrent instantaneous, Overcurrent time-delayed, Undercurrent
X1	810	0002	Overlord
X2	820	0100	Negative-sequence overcurrent
X3	830	0200	Earth fault overcurrent
X4	840	2000	Limit the number of starts
X5	850	DFFE	“OR” of all the elements except Limit the number of starts.
X6	860	DFFE	“OR” of all the elements except Limit the number of starts.

\*The “Self hold/auto reset upon reset judgement” setting of all the contacts are “Reset”.

(2)-1 Setting of operation indicator LED hold data (CMP1-A02D1)

The table below shows the setting guide table. See the section D-2 in the general operation manual for the detailed procedure.

Digit No.	Setting item	Input	
		0	1
0	Trip	Reset	Hold
1	Overlord	Reset	Hold
2	Overcurrent instantaneous A-phase	Reset	Hold
3	Overcurrent instantaneous B-phase	Reset	Hold
4	Overcurrent instantaneous C-phase	Reset	Hold
5	Overcurrent time-delayed A-phase	Reset	Hold
6	Overcurrent time-delayed B-phase	Reset	Hold
7	Overcurrent time-delayed C-phase	Reset	Hold
8	Negative-sequence overcurrent	Reset	Hold
9	Earth fault overcurrent	Reset	Hold
10	Undercurrent A-phase	Reset	Hold
11	Undercurrent A-phase	Reset	Hold
12	Undercurrent C-phase	Reset	Hold
13	Limit the number of starts	Reset	Hold
14	Not used	X	
15	Not used	X	

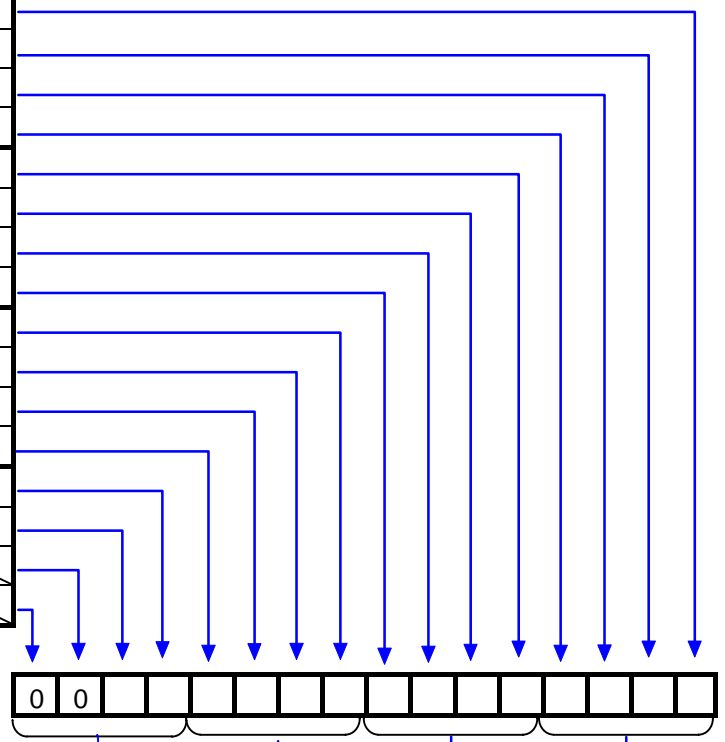

**Conversion from binary number to hexadecimal**

Binary	→ Hexadecimal	Binary	→ Hexadecimal	Binary	→ Hexadecimal
0 0 0 0	→ 0	0 1 1 0	→ 6	1 1 0 0	→ C
0 0 0 1	→ 1	0 1 1 1	→ 7	1 1 0 1	→ D
0 0 1 0	→ 2	1 0 0 0	→ 8	1 1 1 0	→ E
0 0 1 1	→ 3	1 0 0 1	→ 9	1 1 1 1	→ F
0 1 0 0	→ 4	1 0 1 0	→ A		
0 1 0 1	→ 5	1 0 1 1	→ B		

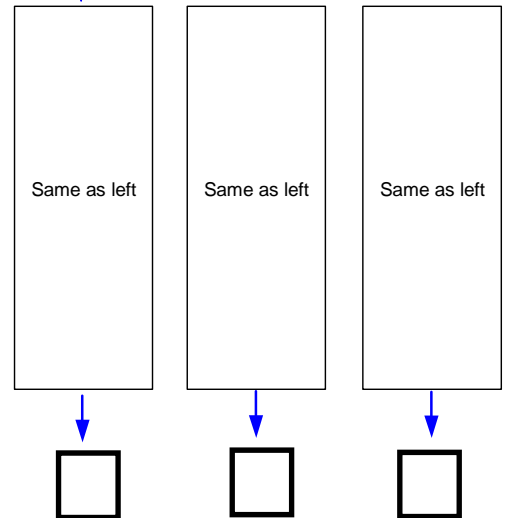

**Operation indicator LED**  
**hold data**

When the product is shipped from the factory, all LEDs are self-hold.

Item number	Operation indicator LED hold data
870	1FFF

(2)-2 Setting of operation indicator LED hold data (CMP1-A02D2)

The table below shows the setting guide table. See the section **D-2** in the general operation manual for the detailed procedure.

Digit No.	Setting item	Input	
		0	1
0	Trip	Reset	Hold
1	Overlord	Reset	Hold
2	Overcurrent instantaneous A-phase	Reset	Hold
3	Overcurrent instantaneous B-phase	Reset	Hold
4	Overcurrent instantaneous C-phase	Reset	Hold
5	Overcurrent time-delayed A-phase	Reset	Hold
6	Overcurrent time-delayed B-phase	Reset	Hold
7	Overcurrent time-delayed C-phase	Reset	Hold
8	Negative-sequence overcurrent	Reset	Hold
9	Earth fault overcurrent	Reset	Hold
10	Undercurrent A-phase	Reset	Hold
11	Undercurrent B-phase	Reset	Hold
12	Undercurrent C-phase	Reset	Hold
13	Limit the number of starts	Reset	Hold
14	DI(1)	Reset	Hold
15	DI(2)	Reset	Hold

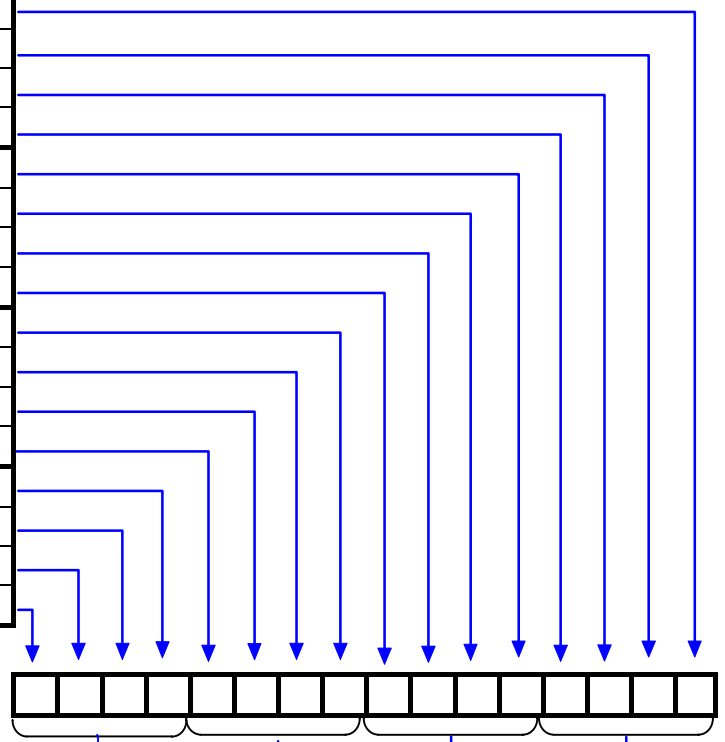

**Conversion from binary number to hexadecimal**

Binary	→ Hexadecimal	Binary	→ Hexadecimal	Binary	→ Hexadecimal
0 0 0 0	→ 0	0 1 1 0	→ 6	1 1 0 0	→ C
0 0 0 1	→ 1	0 1 1 1	→ 7	1 1 0 1	→ D
0 0 1 0	→ 2	1 0 0 0	→ 8	1 1 1 0	→ E
0 0 1 1	→ 3	1 0 0 1	→ 9	1 1 1 1	→ F
0 1 0 0	→ 4	1 0 1 0	→ A		
0 1 0 1	→ 5	1 0 1 1	→ B		

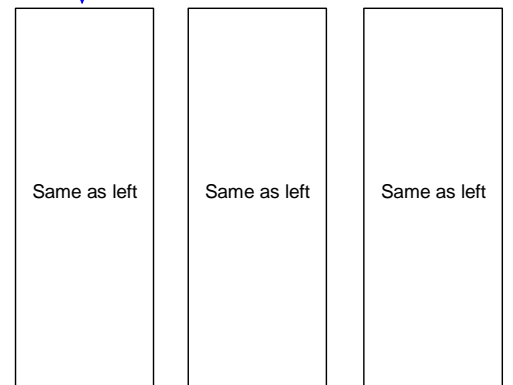

**Operation indicator LED hold data**



When the product is shipped from the factory, all LEDs are self-hold.

Item number	Operation indicator LED hold data
870	DFFF

## 7 Mounting

### 7.1 Mounting dimension

Mount the case to the panel according to Fig. 7.1 and Fig. 7.2 "Mounting dimension".

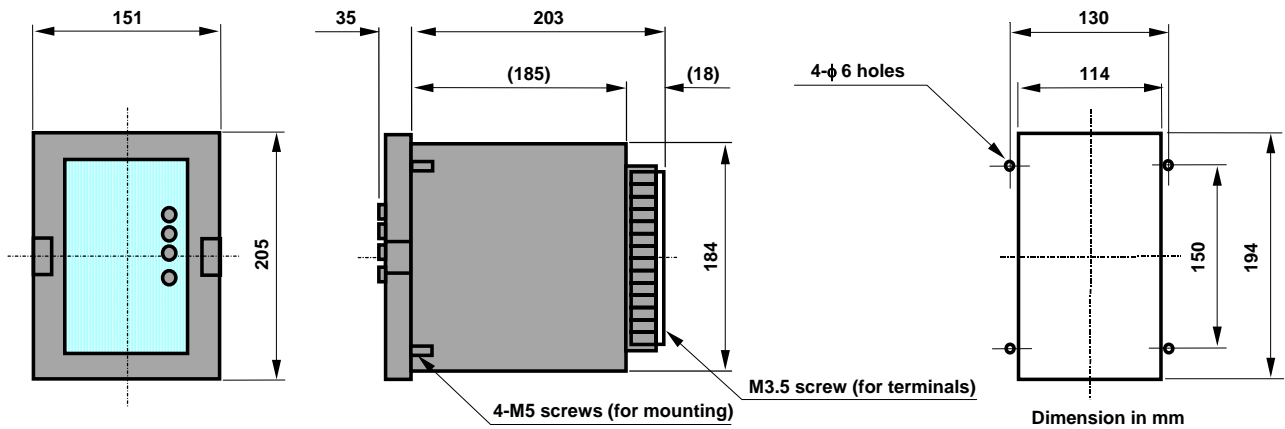

Figure 7.1 Outside dimension /drilling drawing (type D1)

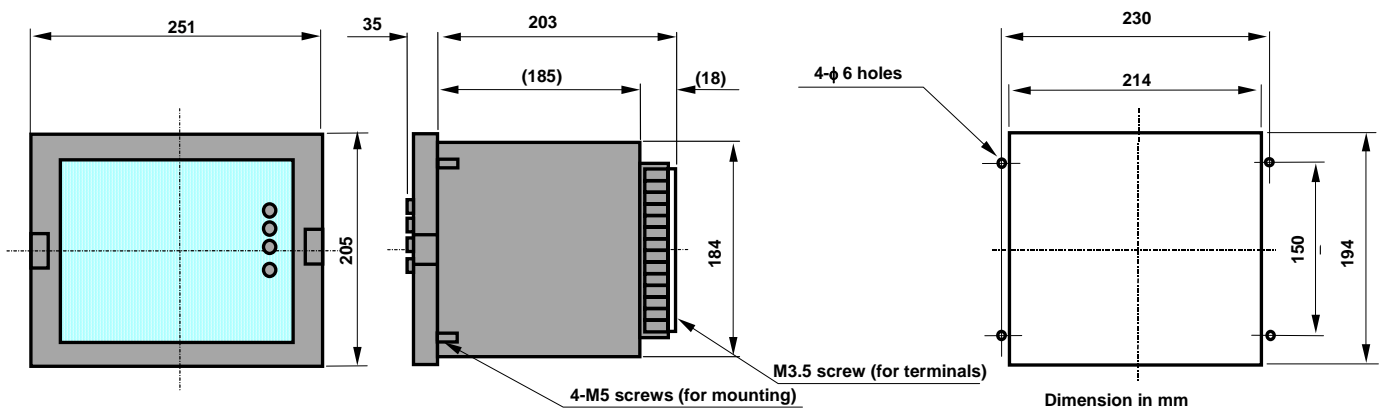

Figure 7.2 Outside dimension /drilling drawing (type D2)

### 7.2 Standard operating environment

Install the relay in the environment described in section 3.3 Common technical data. In addition, the following conditions should be kept:

- Abnormal vibration, shock, inclination or magnetic field should be avoided.
- Harmful smoke or gas, salt gas, excessive humidity, water drop or vapor, excessive dust or fine powder, rain and wind should be avoided.

## 8 Test

The relay has been fully tested prior to shipment. However, it is recommended to carry out a test again by referring to the following test guide before use.

### 8.1 Appearance inspection

Check the relay for appearance according to the following procedure:

Objects		Check points
Unit	Coil/conductor	(1) Discoloring and burning due to overheat. (2) Abnormal conditions including loosened screws.
	Printed card	(1) Discoloring of the printed card due to overheated parts. (2) Contact between the printed card and connector
	Mechanism	(1) Deformation (2) Operation of the operating key switches. (3) Damage of the draw-out lever of the sub unit. (4) Discoloring and deformation of the name plate on the front panel. (5) Damage of the terminal section.
Case/cover		(1) Damage of the cover. (2) Stain of the cover. (3) Clouding of the cover. (4) Damage of the lock lever of the cover. (5) Damage of the operating buttons of the cover. (6) Operation of the operating buttons of the cover. (7) Damage of the terminal section.
Others		Invasion of foreign matters including dust and iron chips.



## 8.2 Characteristic test

### 8.2.1 Precautions in testing

#### (1) Standard test conditions

Ensure the following test conditions whenever possible:

Note that carrying out a test under an environment that significantly differs from the following conditions may produce an incorrect result.

- Ambient temperature :  $20^{\circ}\text{C}\pm 10^{\circ}\text{C}$
- Rated frequency :  $\pm 5\%$
- Waveform (AC) : 2% (distortion ratio)
- Auxiliary power supply voltage : rated voltage  $\pm 2\%$

#### (2) Characteristic control point

See the section 3 "Characteristics".

The characteristic control point refers to the characteristic of a relay unit only. Note that, when a characteristic test is carried out on a relay system connected with external equipment such as CT and ZCT, the result obtained would be a combined characteristic added with the fluctuation of the external equipment.

For special control in terms of a specific control point (for instance, using the operation setting), first carry out a test at "Characteristic control point" at the time when the relay is received or put in service to determine the acceptance/rejection. Thereafter, perform another test at each control point, so that the data obtained can be used for future reference.

#### (3) Changing setting

Change the setting according to the section 6 "Handling".

#### (4) Operation judgment

Determine the operation currents and time and other values of the relay unit basically by turning on and off the corresponding output relay contact of each element.

To determine the starting value of the time-delayed elements of overcurrent relay, which cannot be checked through the output contact, read the display of "elapsed time of time-delayed timer".

#### (5) Communication card

Whatever the communication card is inside or not, for the test of withstand voltage and lightning impulse withstand voltage, please avoid inputting test voltage to the serial communication network circuit (DA, DB, DG, SLD terminals).

Note: Any test can be done without removing the communication card.

8.2.2 Characteristic test

(1) Test circuit

Connect the external wiring referring to the AC input circuit diagram shown below:

a. Overload element

Apply as far as possible the positive-sequence current with optimum balance in 3 phases. If the balance is not completely achieved, the test results may be affected by the ratio of positive-and negative-sequence components, thus making the evaluation harder.

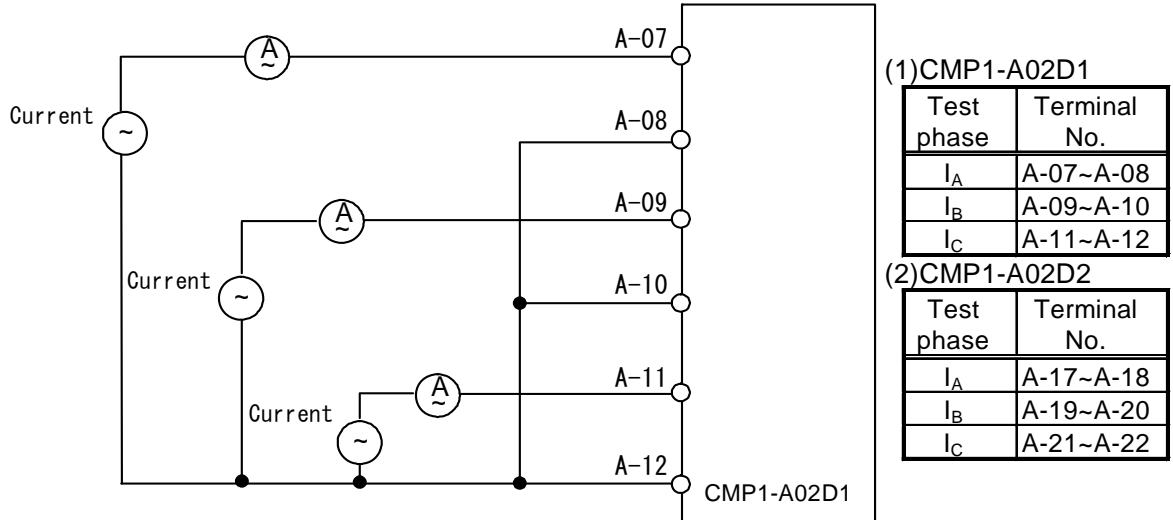

If the 3-phase test power source is not available, test may also be conducted by applying the current shown in the following equation to the circuit shown below by using the single-phase power source:

Provided  $I_B = -I_A$ , and  $I_C = 0$ ,

$$I_1^2 = I_2^2 = \frac{1}{3} I_A^2 = \frac{1}{3} I_B^2$$

Therefore, in order to apply a current that allows establishing

$I_1^2 + K \cdot I_2^2 = I_{OP}^2$ , it is enough to apply the following current:

$$I_A = \sqrt{\frac{3}{1+K}} \cdot I_{OP}$$

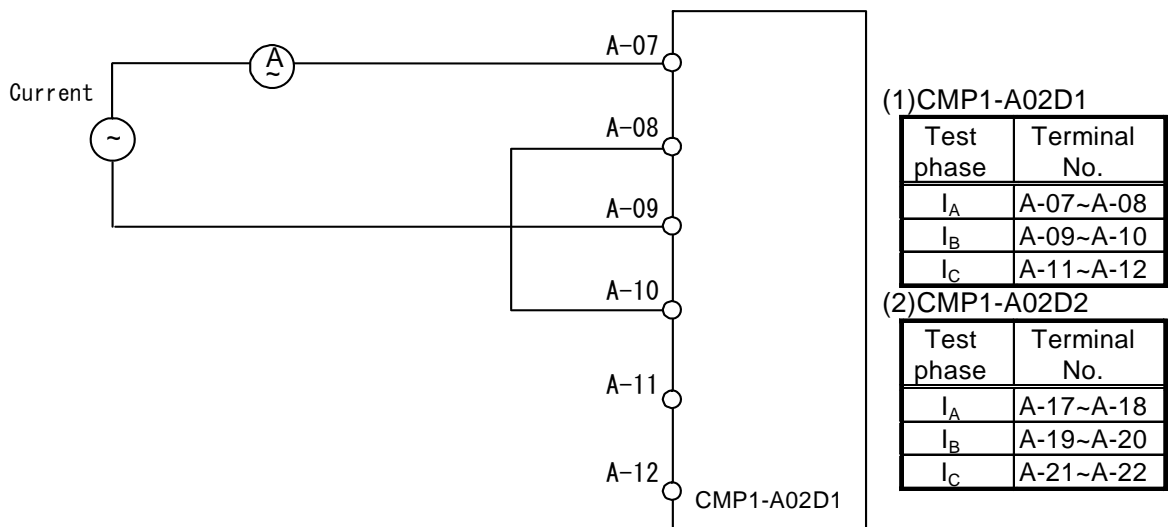

The test also can be done under the condition that  $I_C = -I_B$ , and  $I_A = 0$ , etc.

- b. Overcurrent instantaneous element, overcurrent time-delayed element, undercurrent element, earth fault overcurrent element and limit the number of starts element

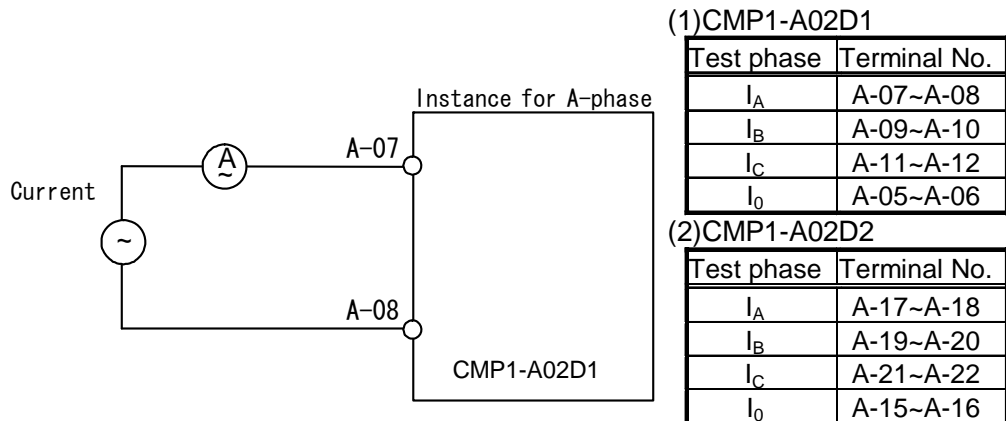

Only  $I_A$  is used for limit the number of starts element.

- c. Negative-sequence current element

Apply as far as possible the negative-sequence current with optimum balance in 3 phases.

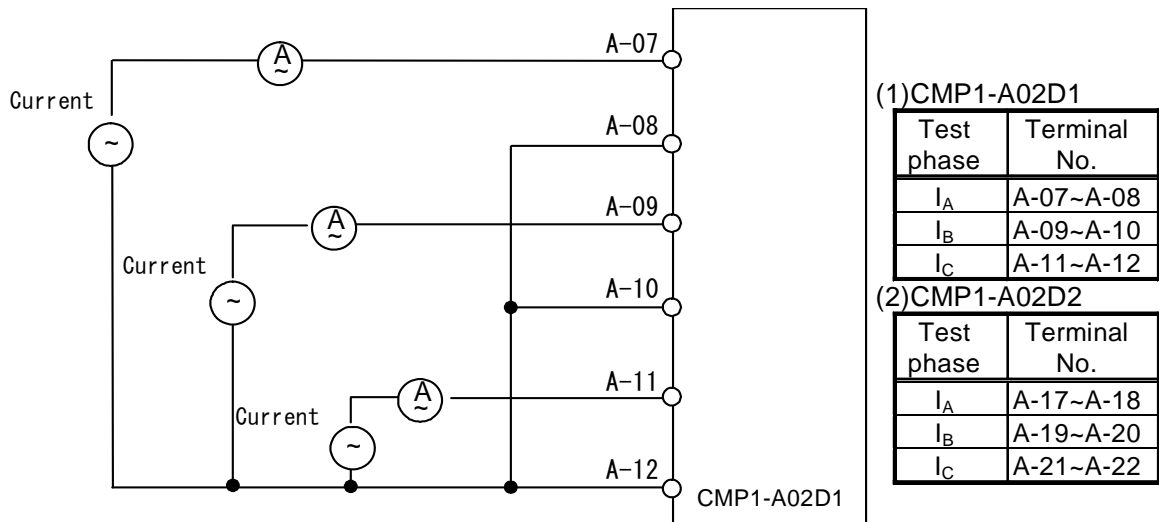

If the 3-phase test power source is not available, test may also be conducted by applying the current shown in the following equation to the circuit shown below by using the single-phase power source as for the overload element:

Provided  $I_B = -I_A$ , and  $I_C = 0$ , in order to apply the operating current that allows establishing  $I_2 = I_{OP}$ ,

and  $I_2^2 = (1/3)I_A^2$ , it is enough to apply the following current:

$$I_A = \sqrt{3} \cdot I_{OP}$$

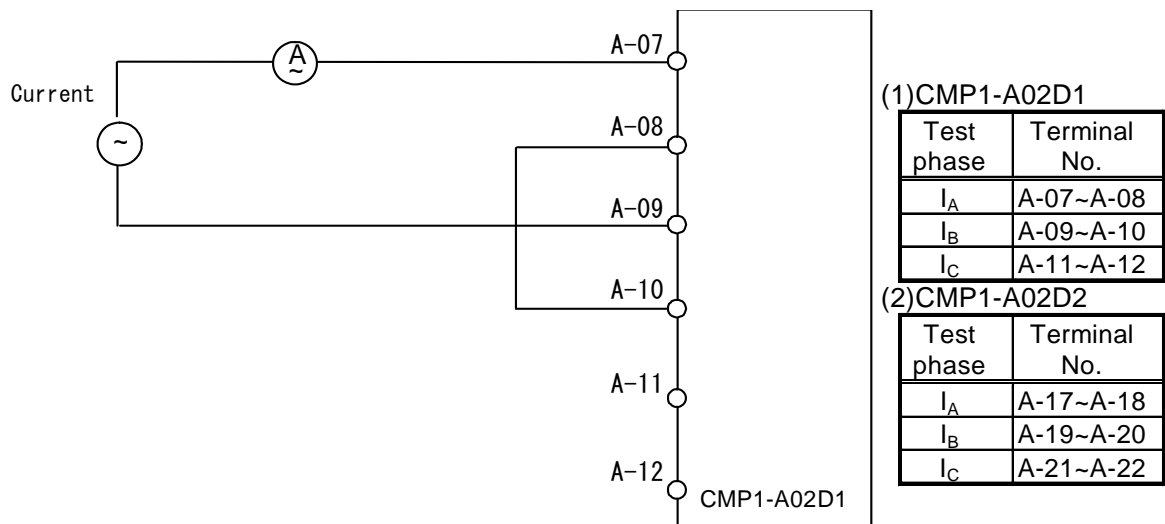

The test also can be done under the condition that  $I_C = -I_B$ , and  $I_A = 0$ , etc.

(2) Test items and characteristic control point

a. Forced operation test

See "Front control panel operational procedure" in the section 6 "Handling".

b. Operation value test

See "Operation and reset values" in the section 3 "Characteristics".

c. Operation time test

See "Operation time" in the section 3 "Characteristics".

d. Reset time test

See "Reset time" in the section 3 "Characteristics".

e. Phase test

See "Phase" in the section 3 "Characteristics".

## 9 Maintenance

### 9.1 Daily inspection

Take every opportunity to carry out the following inspection:

- Check that the cover is not damaged and is attached properly.
- Check that no dust or iron chips have invaded into the unit.
- Check that the cover is not clouded notably.
- Check that abnormal noise is not generated.
- Check that the RUN LED lamp is lit.
- 

### 9.2 Periodical inspection

It is recommended to carry out periodic inspections to check the relay for proper function.

For periodical inspections, perform the appearance inspection and characteristic test in accordance with the section 8 "Test".

## 10 Ordering

The product and specification shown in this manual may subject to changes (including specification change and production suspend) without notice. It is advisory to inquire the nearest Mitsubishi Electric's branch or sales office, if required, to confirm that the latest information is given in the manual, prior to placing an order.

Notify the following items when placing an order.

Item	Example of order	Remarks
Model	CMP1-A02D1	For more information, see the section 2 "Rating and specification".
Frequency	50Hz	Select 50Hz or 60Hz.
Rating	Phase current : 5A Zero-phase current: 5A	For more information, see the section 2 "Rating and specification".
Setting range		For more information, see the section 2 "Rating and specification".
Communication card	One of the followings can be selected: a. CC-Link communication card (Manual No.: JEP0-IL9417, JEP0-IL9418) b. No communication card	Only purchasing a communication card separately will allow customer to add the communication facilities. If customer does not need the communication facilities at the time of introducing the system, just purchase the relay unit without communication card. Customer can add the communication facilities whenever he/she needs to introduce them. This will help decrease the initial cost and upgrade the system in stages.
Direct communication application	PC-DISW HMI software	By connecting PC with relay via the direct communication port (as standard equipment located on the relay front panel, local operation and monitoring are enabled as same as the remote operation and monitoring.

## 11 Guarantee

### 11.1 Guarantee period

The guarantee period of this product should be one year after delivery, unless otherwise specified by both parties.

### 11.2 Scope of guarantee

When any fault or defect is detected during the period of guarantee and such fault or defect is proved to be caused apparently at the responsibility of MITSUBISHI ELECTRIC CORPORATION, the defective unit concerned will be repaired or replaced with substitute with free of charge.

However, the fee for our engineer dispatching to site has to be covered by the user.

Also, site retesting or trial operation caused along with replacing the defect units should be out of scope of our responsibilities.

It is to be acknowledged that the following faults and defects should be out of this guarantee.

- ① When the faults or defects are resulted from the use of the equipment at the range exceeding the condition/environment requirements stated in the catalogue and manual.
- ② When the faults or defects are resulted from the reason concerning without our products.

- ③When the faults or defects are resulted from the modification or repair carried out by any other entity than MITSUBISHI ELECTRIC CORPORATION.
- ④When the faults or defects are resulted from a phenomenon which can not be predicted with the science and technology put into practical use at the time of purchase or contract
- ⑤In case of integrating our products into your equipment, when damages can be hedged by the proper function or structure in the possession of your equipment which should be completed according to the concept of the de facto standard of industry.
- ⑥In case of that the faults or defects are resulted from un-proper application being out of instruction of MITSUBISHI ELECTRIC CORPORATION.
- ⑦In case that the faults or defects are resulted from force majeure such a fire or abnormal voltage and as an act of God such as natural calamity or disaster.

### 11.3 Exclusion of loss in opportunity and secondary loss from warranty liability

Regardless of the gratis warranty term, MITSUBISHI ELECTRIC CORPORATION shall not be liable for compensation of damages caused by any cause found not be the responsibility of MITSUBISHI ELECTRIC CORPORATION, loss in opportunity, lost profits incurred to the user by failures of MITSUBISHI ELECTRIC CORPORATION products, special damages and secondary damages whether foreseeable or not, compensation for accidents, and compensation for damages to products other than MITSUBISHI ELECTRIC CORPORATION products and other tasks

### 11.4 Applications of products

- ①The user is requested to confirm the standards, the regulations and the restrictions which should be applied, in case of utilizing products described in this catalogue and another one in combination.

Also, the user is requested to confirm the suitability of our products to your applied system or equipment or apparatus by yourself.

MITSUBISHI ELECTRIC CORPORATION shall not be liable for any suitability of our products to your utilization.

- ②This MITSUBISHI ELECTRIC CORPORATION products described in the catalogue have been designed and manufactured for application in general industries, etc. Thus, application in which the life or an asset could be affected by special application such as medical system for life-sustaining, in nuclear power plants, power plants, aerospace, transportation devices(automobile, train, ship, etc )shall be excluded from the application. In addition to above, application in which the life or an asset could be affected by potentially chemical contamination or electrical interference and also in which the circumstances and condition are not mentioned in this catalogue shall be excluded from the application.

Note even if the user wants to use for these applications with user's responsibility, the user to be requested to approve the specification of MITSUBISHI ELECTRIC CORPORATION products and to contact to the technical section of MITSUBISHI ELECTRIC CORPORATION prior to such applications.

If the user applies MITSUBISHI ELECTRIC CORPORATION products to such applications without any contact to our technical section, MITSUBISHI ELECTRIC CORPORATION shall not be liable for any items and not be insured, independently from mentioned in this clause.

- ③In using MITSUBISHI ELECTRIC CORPORATION product, the working conditions shall be that the application will not lead to a major accident even if any problem or fault occur, and that backup or duplicate system built in externally which should be decided depend on the importance of facility, is recommended.
- ④The application examples given in this catalogue are reference only and you are requested to confirm

function and precaution for equipment and apparatus and then, use our products

- ⑤The user is requested to understand and to respect completely all warning and caution items so that unexpected damages of the user or the third party arising out of un-correct application of our products would not be resulted.

#### 11.5 Onerous repair term after discontinuation of product

- ①MITSUBISHI ELECTRIC CORPORATION shall accept onerous product repairs for 7(seven) years after production of the product is discontinued. (However, please consider the replacement of products after 15 years have been passed from ex-work of products.)

- ②Product supply (including repair parts) is not available after production is discontinued.

#### 11.6 Changes in product specification

The specification given in the catalogue, manuals or technical documents are subject to change without prior to notice.

#### 11.7 Scope of service

The technical service fee such as engineer dispatching fee is excluded in the price of our products.

Please contact to our agents if you have such a requirement.

## 12 Improvement on the reliability of protection function

Any parts and materials applied to the protection relay have limited life time which will bring the degradation to the relay.

The degree of degradation will be variable and depend on the purpose, period in use, applied circumstance and unevenness on the performance of each part.

MITSUBISHI ELECTRIC CORPORATION design the relay so as to realize that the recommended replaced duration is more them 15 years.

However, there may be some possibilities to occur some defects before reaching 15 years due to above mentioned the degree of degradation of parts and materials being depended on the condition in use.

To prevent unwanted operation or no operation of relay due to above reasons, it is recommended to apply the relay with self-diagnosis function and/or multiplexing relay system such as dual or duplex scheme.



# **mitsubishi electric corporation**

HEAD OFFICE : 7-3 MARUNOUCHI 2-CHOME, CHIYODA-KU TOKYO, 100-8310, JAPAN

Revised in Mar. 2012