



# Numerical Relay MELPRO™-S Series

MODEL



**CBV2 - A02S1**

INSTRUCTION MANUAL

## - Safety precautions -

Before installation, operation, maintenance, and inspection, please be sure to read this instruction manual and all other attached documents thoroughly in order to work safely with the equipment. Please ensure that you fully understand the equipment, safety information, and precautions that need to be taken before working with the equipment.

Safety precautions are classified as "Danger" and "Caution."

 <b>Danger</b>	The case where a dangerous situation can arise and there is the possibility that death or seriously injury can occur if the equipment is handled incorrectly.
 <b>Caution</b>	The case where a dangerous situation can arise and there is the possibility that moderate or minor injuries can occur, or property damage can take place if the equipment is handled incorrectly.

Furthermore, even with items described as  Caution, there is the possibility of serious consequences depending on the situation. All of the described contents are important. Therefore, be sure to comply with them.

### [Transportation]

 <b>Caution</b>
<ul style="list-style-type: none"><li>● Transport the equipment in the correct orientation.</li><li>● Do not apply excessive shock and/or vibration as this could affect the performance and life of the product.</li></ul>

### [Storage]

 <b>Caution</b>
<ul style="list-style-type: none"><li>● The storage environment shall comply with the following conditions. Otherwise, there is a risk of reducing the performance and life of the product.<ul style="list-style-type: none"><li>- Ambient temperature                      -25 to +70°C The state where dew condensation or freezing does not occur.</li><li>• Frequency variation                      Within ±5% of the rated frequency</li><li>- Altitude    2000 m or lower</li><li>- The equipment must not be exposed to abnormal vibration, shock, inclination, or magnetic fields.</li><li>- The equipment must not be exposed to harmful smoke/gas, saline gas, water droplets or vapour, excessive dust or fine powder, explosive gas or fine powder, wind &amp; rain.</li></ul></li></ul>

## [Installation, wiring work]



**Danger**

- The equipment must be correctly grounded using the designated grounding terminals where they exist. Failure to do so may lead to the risk of electric shock, equipment failure, malfunction or failure to operate.
- Be sure to return all terminal covers, protection covers to their original positions once any work is complete. If they remain uncovered there is a risk of electrical shock.



**Caution**

- Ensure that the equipment is mounted and connected correctly. Otherwise, there are risks of failure, burning, or mal-operation.
- Securely tighten the terminal connection screws. Otherwise, there are risks of failure and burning.
- Ensure that the equipment is connected correctly in accordance with the details shown on the connection terminals. Otherwise, there is the risk of failure, burning, malfunction, or maloperation.
- Ensure that the equipment is connected correctly in accordance with the phase sequence details shown on the connection terminals. Otherwise, there is the risk of failure, burning, malfunction, or maloperation.
- All power supplies to the equipment must be of suitable capacity and rated load to avoid the risk of malfunction and maloperation.
- The appropriate connectors must be used to ensure compatibility with the connector terminals to avoid the risks of failure or fire.

## [Operating and Setting the equipment]



**Danger**

- The equipment must only be operated and handled by qualified personnel. Otherwise, there are risks of electric shock, injury, failure, malfunction, and maloperation.
- Handling and maintenance of the equipment must only be carried out after gaining a thorough understanding of the instruction manual. Otherwise, there is the risk of electric shock, injury, failure, malfunction, or maloperation.



**Caution**

- The equipment must be used within the following range limits. Otherwise, there is a risk of reducing the performance and life of the product.
  - Variation range of control power supply voltage      Within  $-15\%$  to  $+10\%$  of the rated voltage
  - Frequency variation      Within  $\pm 5\%$  of the rated frequency
  - Ambient temperature       $-10$  to  $+55^{\circ}\text{C}$   
( $-10$  to  $50^{\circ}\text{C}$  is allowable temporarily within few hours a day, but use under the state where dew condensation or freezing does not occur.)
  - Altitude      2000 m or lower
  - The state where abnormal vibration, shock, inclination, magnetic field are not applied
  - The state where it is not exposed to harmful smoke/gas, saline gas, water droplet or vapor, excessive dust or fine powder, explosive gas or fine powder, wind & rain.
- While energized, do not tamper with or remove any components other than those which have been designated. Otherwise, there is a risk of failure, malfunction, or maloperation.
- When changing the setting value during the energized state, ensure that all trip circuits are locked in order not to operate. Otherwise, there is a risk of malfunction.

## [Maintenance and Inspection]



### Danger

- The equipment must only be operated and handled by qualified personnel. Otherwise, there are risks of electric shock, injury, failure, malfunction, and maloperation.
- Handling and maintenance of the equipment must only be carried out after gaining a thorough understanding of the instruction manual. Otherwise, there is the risk of electric shock, injury, failure, malfunction, or maloperation.
- Do not touch any live parts, such as terminals, etc. Otherwise, there is a risk of electric shock.



### Caution

- When replacing the equipment, use a product of same model, rating, and specifications. Otherwise, there is the risk of failure or fire. If any other product is to be used, the manufacturer must be consulted.
- We recommend that any tests or inspections are carried out under the following conditions, as well as any additional conditions described in the instruction manual.
  - Ambient temperature  $20 \pm 10^{\circ}\text{C}$
  - Relative humidity 90% or less
  - External magnetic field 80 A/m or less
  - Atmospheric pressure  $86 \text{ to } 106 \times 10^3 \text{ Pa}$
  - Mounting angle Regular direction  $\pm 2^{\circ}$
  - Frequency Rated frequency  $\pm 1\%$
  - Waveform (in the case of AC) Distortion factor 2% or less  

$$\text{Distortion factor} = \frac{\text{Effective value of higher harmonics only}}{\text{Effective value of fundamental wave}} \times 100 (\%)$$
  - AC component (in the case of DC) Ripple factor 3% or less  

$$\text{Ripple factor} = \frac{\text{Max. value} - \text{Min. value}}{\text{Average value of DC}} \times 100 (\%)$$
  - Control power supply voltage Rated voltage  $\pm 2\%$
- Do not exceed the overload capacity for voltage and current. Otherwise, equipment failure or fire could occur.
- Do not clean the equipment while energised. When the cover needs to be cleaned, make use of a damp cloth.

## [Repair and modification]



### Caution

- When carrying out repair and/or modification, please consult with the manufacturer in advance of carrying out the work. We will not take any responsibility for any repair and/or modification (including software) which has been carried out without prior consent.

## [Disposal]



### Caution

- Disposal must take place in accordance with the applicable legislation

## - Guarantee -

### 1. Guarantee period

The guarantee period of this product should be one year after delivery, unless otherwise specified by both parties.

### 2. Scope of guarantee

When any fault or defect is detected during the period of guarantee and such fault or defect is proved to be caused apparently at the responsibility of MITSUBISHI ELECTRIC CORPORATION, the defective unit concerned will be repaired or replaced with substitute with free of charge.

However, the fee for our engineer dispatching to site has to be covered by the user.

Also, site retesting or trial operation caused along with replacing the defect units should be out of scope of our responsibilities.

It is to be acknowledged that the following faults and defects should be out of this guarantee.

(1) When the faults or defects are resulted from the use of the equipment at the range exceeding the condition/environment requirements stated in the catalogue and manual.

(2) When the faults or defects are resulted from the reason concerning without our products.

(3) When the faults or defects are resulted from the modification or repair carried out by any other entity than MITSUBISHI ELECTRIC CORPORATION.

(4) When the faults or defects are resulted from a phenomenon which cannot be predicted with the science and technology put into practical use at the time of purchase or contract

(5) In case of integrating our products into your equipment, when damages can be hedged by the proper function or structure in the possession of your equipment which should be completed according to the concept of the de fact standard of industry.

(6) In case of that the faults or defects are resulted from un-proper application being out of instruction of MITSUBISHI ELECTRIC CORPORATION.

(7) In case that the faults or defects are resulted from force majeure such a fire or abnormal voltage and as an act of God such as natural calamity or disaster.

### 3. Exclusion of loss in opportunity and secondary loss from warranty liability

Regardless of the gratis warranty term, MITSUBISHI ELECTRIC CORPORATION shall not be liable for compensation of damages caused by any cause found not be the responsibility of MITSUBISHI ELECTRIC CORPORATION, loss in opportunity, lost profits incurred to the user by failures of MITSUBISHI ELECTRIC CORPORATION products, special damages and secondary damages whether foreseeable or not, compensation for accidents, and compensation for damages to products other than MITSUBISHI ELECTRIC CORPORATION products and other tasks.

### 4. Applications of products

(1) The user is requested to confirm the standards, the regulations and the restrictions which should be applied, in case of utilizing products described in this catalogue and another one in combination.

Also, the user is requested to confirm the suitability of our products to your applied system or equipment or apparatus by yourself.

MITSUBISHI ELECTRIC CORPORATION shall not be liable for any suitability of our products to your utilization.

(2) This MITSUBISHI ELECTRIC CORPORATION products described in the catalogue have been designed and manufactured for application in general industries, etc. Thus, application in which the life or an asset could be affected by special application such as medical system for life-sustaining, in nuclear power plants, power plants, aerospace, transportation devices(automobile, train, ship, etc.) shall be excluded from the application. In addition to above, application in which the life or an asset could be affected by potentially chemical contamination or electrical interference and also in which the circumstances and condition are not mentioned in this catalogue shall be excluded from the application.

Note even if the user wants to use for these applications with user's responsibility, the user to be requested to approve the specification of MITSUBISHI ELECTRIC CORPORATION products and to contact to the technical section of MITSUBISHI ELECTRIC CORPORATION prior to such applications.

If the user applies MITSUBISHI ELECTRIC CORPORATION products to such applications without any contact to our technical section, MITSUBISHI ELECTRIC CORPORATION shall not be liable for any items and not be insured, independently from mentioned in this clause.

(3) In using MITSUBISHI ELECTRIC CORPORATION product, the working conditions shall be that the application will not lead to a major accident even if any problem or fault occur, and that backup or duplicate system built in externally which should be decided depend on the importance of facility, is recommended.

(4) The application examples given in this catalogue are reference only and you are requested to confirm function and precaution for equipment and apparatus and then, use our products.

(5) The user is requested to understand and to respect completely all warning and caution items so that unexpected damages of the user or the third party arising out of un-correct application of our products would

not be resulted.

5. Onerous repair term after discontinuation of product

(1) MITSUBISHI ELECTRIC CORPORATION shall accept onerous product repairs for 7 (seven) years after production of the product is discontinued. (However, please consider the replacement of products after 15 years have been passed from ex-work of products.)

(2) Product supply (including repair parts) is not available after production is discontinued.

6. Changes in product specification

The specification given in the catalogue, manuals or technical documents are subject to change without prior to notice.

7. Scope of service

The technical service fee such as engineer dispatching fee is excluded in the price of our products. Please contact to our agents if you have such a requirement.

## - Introduction -

Thank for your purchasing MITSUBISHI ELECTRIC **MELPRO**<sup>™</sup> – S Series Digital Protection Relay.  
Please read this instruction manual carefully to be familiar with the functions and performances enough to use the product properly.

It is necessary to forward this instruction manual to end users and a person in charge of maintenance.

This “INSTRUCTION MANUAL” explains general specifications, relay elements, functions, configurations, mounting, test and maintenance.

The details of each function –such as front panel operation, MODBUS communication– should be read each functional instruction manual.

- Table of contents -

<b>1. Features</b> .....	<b>9</b>
<b>2. Relay Specification</b> .....	<b>10</b>
2.1. General specification (CBV2-A02S1).....	10
2.2. Main Function.....	11
<b>3. Characteristics</b> .....	<b>12</b>
3.1. Protective Elements .....	12
3.2. Common Technical Data .....	13
<b>4. Functions</b> .....	<b>14</b>
4.1. Protection Functions.....	14
4.1.1. Undervoltage Element .....	14
4.1.2. Overvoltage Elements.....	14
4.1.3. General Functions.....	15
4.2. Automatic Self-Diagnosis .....	16
<b>5. Configuration</b> .....	<b>18</b>
5.1. Internal Configuration .....	18
5.2. External Connection .....	19
5.2.1. Connection Diagram .....	19
5.2.2. Precautions for Wiring Work .....	21
<b>6. Handling</b> .....	<b>22</b>
6.1. Transportation and Storage .....	22
6.2. Front Panel Operation .....	22
6.2.1. Front Panel Layout.....	22
6.2.2. Rotary Switch Items.....	23
6.2.3. Display Specification.....	25
<b>7. Mounting</b> .....	<b>27</b>
7.1. Mounting Dimension.....	27
7.2. Environment for Installed Condition .....	27
<b>8. Test</b> .....	<b>28</b>
8.1. Appearance Test .....	28
8.2. Characteristic Test.....	28
8.2.1. Precautions in Testing.....	28
8.2.2. Characteristic Test .....	29
<b>9. Maintenance</b> .....	<b>30</b>
9.1. Daily inspection .....	30
9.2. Periodical inspection .....	30
<b>10. Ordering</b> .....	<b>30</b>



## 1. Features

### Flexible and reliable protection functions

- Fine setting step of protection elements enables flexible use for various applications.
- 16 kinds of operation time characteristics and wide setting range of time multiplier is available for overcurrent protection element.
- Fault record function (10 records at a maximum) is provided for fault analysis.
- Modbus interface using RS-485 is provided for remote communication.
- Password-protected human-machine interface enables secured operation.

### Highly Accurate Digital Computation

- The digital computation using high-speed sampling minimizes the effect of harmonics, etc., and provides highly accurate protection.

### Self-diagnosis

- The continuously monitoring of electronic circuits from input to output can detect internal failure before the failure causes damage on the power system.

### Compact size

- The compact relay designed for space-saving is suitable for replacement of existing ones.

### Energy saving

- Low power consumption of the relay is effective in miniaturization of CT and VT as well as energy saving.



Fig. 1-1 Front view of MELPRO-S Series

## 2. Relay Specification

In this section, the relay specification such as the rating and relay element is explained.

### 2.1. General specification (CBV2-A02S1)

Table 2-1 General specification (CBV2-A02S1)

Name		Over/Undervoltage Relay	
Relay Model		CBV2-A02S1	
Style		563PQB	
Elements	Protection	Undervoltage element (27)	
		Overvoltage (59)	
Rating	Frequency		50Hz / 60Hz (selectable)
	Voltage		AC110V
	Aux. power supply	Voltage	AC100V – 110 V DC100V – 125 V *1
		Operative range	AC: 85–126.5 V (–15% to +10%, Temporary –15% to +15%) DC: 85-143 V (–15% to +10%, Temporary –15% to +30%) *1
Setting	Undervoltage element	Operation value	LOCK – 60~120 V (1 V step) *2
		Operation time	INST (50 ms or less) - 0.1~ 5.0 s (0.1 s step)
		TEST MODE	OFF – AB – BC – CA
	Overvoltage element	Operation value	LOCK – 120~165 V (1 V step) *2
Operation time		INST (50 ms or less) - 0.1~ 5.0 s (0.1 s step)	
Forced operation	Trip and control (annunciator) contacts can be forced to operate.		
Operation indication	Operation indicator LED comes on when the relay element operates. LED indication: Undervoltage element, Overvoltage element, AB-Phase, BC-Phase, CA-Phase		
Display	RUN LED (green)		Indicate the result of automatic self-diagnosis. This LED is turned on for normal and turned off for abnormal.
	ALARM LED (red)		Indicate the result of automatic self-diagnosis. This LED is turned off for normal and turned on for abnormal.
Self-diagnosis (ALARM)	An electronic circuit and a built-in power supply are always supervised, and it outputs to the RUN/ALARM LED and an ALARM contact.		
Burden	Voltage Circuit		0.5 VA or less (with 110VAC)
	Auxiliary supply		For 110 VDC : approx. 1.6W For 110 VAC : approx. 1.9VA
Output Contact	Configuration	For trip	Normally open contact
		For control	Normally open contact (for 27 and 59)
		For alarm	Normally close contact
	Capacity	For trip	Make: 110 VDC, 15 A, 0.5 s (L/R=0 s) 220 VDC, 10 A, 0.5 s (L/R=0 s) Brake: 110 VDC, 0.3 A (L/R ≤ 40 ms) 220 VDC, 0.15 A (L/R ≤ 40 ms) Continuation : 1.5 A
For control and alarm		Make: 10 VA (cos φ = 0.4) 10 W (L/R = 0.007 s)	
Case/Cover	Color : N1.5		
Mass	approx. 1.2kg		

\*1: When DC125V is used, please note that the maximum voltage of operation range is still 143V.  
(A maximum is not 125V x 30%.)

\*2: If it sets to LOCK, the protection element will be in a lock state of operation.

## 2.2. Main Function

The main functions of this protection relay is shown in Table 2-2.

The “Protectable items by password” column means that the password input is required for operating if password function is activated.

Table 2-2 Main functions

No.	CBV2-A02S1	Description	Protectable items by password
1	MEASURE	Real-Time Measurement	-
2	RECORD(RMS)	Fault Record – Measurement Value	-
3	RECORD (ELE.)	Fault Record – Relay Element	-
4	PICK UP	Relay Element Detection before Trip	-
5	DISP. (SET.)	Display Relay Element Setting	-
6	-	No assigned	
7	SETTING	Change Relay Element Setting	○
8	FORCED OP.(TRIP)	Forced Operation for Trip Digital Output	○
9	FORCED OP.( $U<$ )	Forced Operation for Relay Element (Undervoltage)	○
10	FORCED OP.( $U>$ )	Forced Operation for Relay Element (Overvoltage)	○
11	-	No assigned	
12	-	No assigned	
13	RECORD RESET	Clear Fault Record Data	○
14	DISP.(ERR.CODE)	Display Error Code by Self-Diagnosis	-
15	ERR.CODE RESET	Clear Error Code	○
16	-	No assigned	

### 3. Characteristics

Table 3-1 Common condition

Common conditions	(1) Rated frequency: $\pm 1\%$ (2) Ambient temperature: $20^{\circ}\text{C} \pm 10^{\circ}\text{C}$ (3) Aux. supply voltage: Rated voltage $\pm 2\%$	The conditions shown on the left should be applied unless otherwise specified.
-------------------	--	--

#### 3.1. Protective Elements

Table 3-2 Characteristic of protective elements

Items		Conditions	Guaranteed performance
Operation value	Undervoltage element	(Common conditions)	Setting value $\pm 5\%$
	Overvoltage element		
Reset value	Undervoltage element	(Common conditions)	Operation value $\times 105\%$ or less
	Overvoltage element		Operation value $\times 95\%$ or more
Operation time	Undervoltage element	Rated voltage $\rightarrow$ Setting $\times 70\%$	For setting of INST 50ms or less For setting of 0.4s or less Setting value $\pm 25\text{ms}$ For setting of 0.5s or more Setting value $\pm 5\%$
	Overvoltage element	0 $\rightarrow$ Setting $\times 120\%$	For setting of INST 50ms or less For setting of 0.4s or less Setting value $\pm 25\text{ms}$ For setting of 0.5s or more Setting value $\pm 5\%$
Reset time	Undervoltage element	Setting $\times 70\% \rightarrow$ Rated voltage	60ms or less
	Overvoltage element	Setting $\times 120\% \rightarrow$ 0	

### 3.2. Common Technical Data

Table 3-3 Common technical data

ITEM		DESCRIPTION	CONDITION	STANDARD
Environment	Ambient operating temperature	-10°C to +55°C		IEC60255-6
	Ambient storage and transport temperature	-25°C to +70°C		IEC60255-6
	Damp heat	+40°C, 95%RH, 4 days		IEC60068-2-78
Thermal withstand	VT	1.15Vn, 3h		
	CT	40In, 1s		
Dielectric test	Circuit of 60V or below	500VAC, 1min.	1) Between each circuit and the exposed conductive parts, the terminals of each independent circuit being connected together 2) Between independent circuits, the terminals of each independent circuit being connected together	IEC60255-5
	Circuit of more than 60V and 500V or below	2000VAC, 1min.		
	Open contact	1000VAC, 1min.	Between open contact poles	
Impulse voltage test		5kV, 1.2µs/50µs	1) Between each circuit and the exposed conductive parts, the terminals of each independent circuit being connected together 2) Between independent circuits, the terminals of each independent circuit being connected together	IEC60255-5
High-frequency disturbance test	Common mode	2.5kV peak, 1MHz with 200Ω source impedance for 2s	Between independent circuits, and between independent circuit and earth	IEC60255-22-1 class 3
	Differential mode	1.0kV peak, 1MHz with 200Ω source impedance for 2s	Across terminals of the same circuit	
Electrostatic discharge test		8 kV	Contact discharge	IEC60255-22-2 Class 3
		8 kV	Air discharge	
Fast transient disturbance test		2.0kV, 5ns/50ns, 1min		IEC60255-22-4
Vibration test		Refer to class 1		IEC60255-21-1 Class 1
Shock response		Refer to class 2		IEC60255-21-2 Class 2
Enclosure protection		IP51		IEC60529

Vn: Rated voltage, In: Rated current

## 4. Functions

### 4.1. Protection Functions

#### 4.1.1. Undervoltage Element

The sequence diagram of Undervoltage element is shown in Fig. 4-1.

Undervoltage element compares input voltages of voltage circuit with the operation setting. If an input voltage is less than the specified operation level, the element outputs an operation signal when the timer expires.

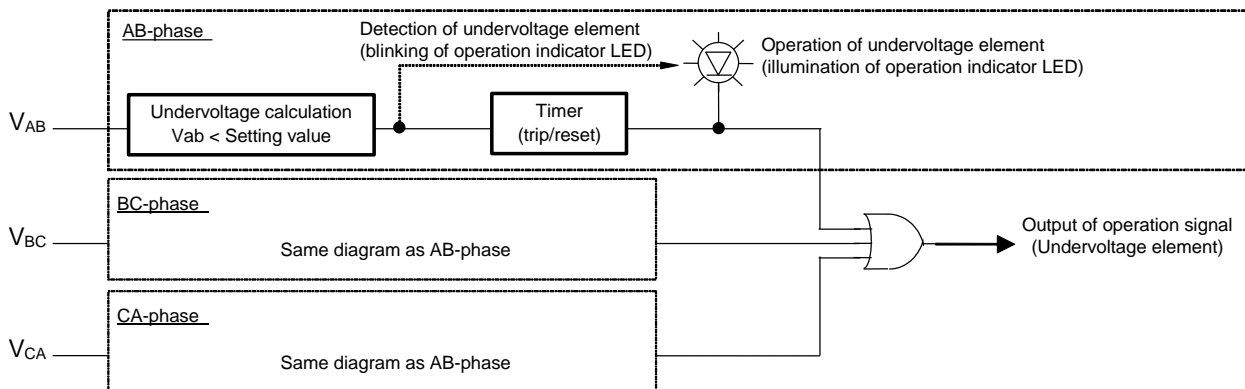

Fig. 4-1 Sequence diagram of Undervoltage element

#### 4.1.2. Overvoltage Elements

The sequence diagram of Overvoltage element is shown in Fig. 4-2.

Overvoltage element compares input voltages of voltage circuit with the operation setting. If an input voltage is larger than the specified operation level, the element outputs an operation signal when the timer expires.

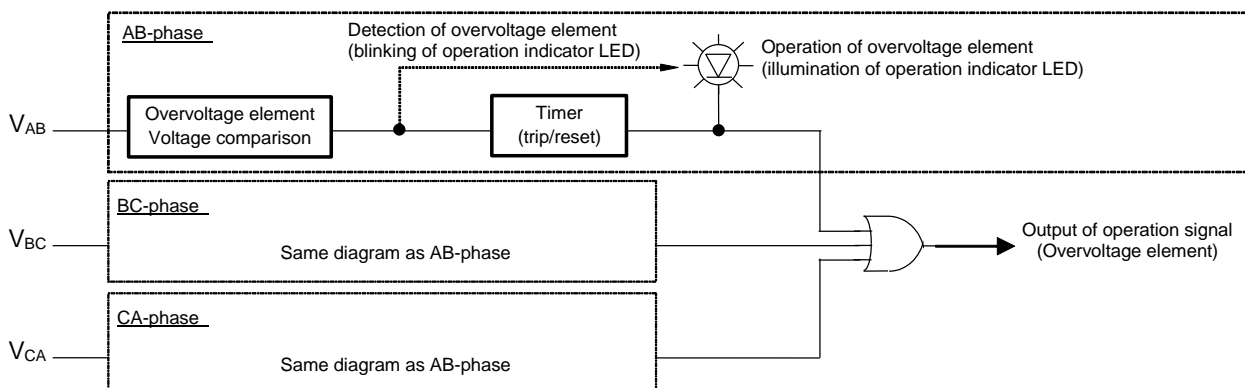

Fig. 4-2 Sequence diagram of Overvoltage element

### 4.1.3. General Functions

#### (1) Setting of Operation Voltage

The operation voltage settings [V] for Undervoltage and Overvoltage elements are indicated in 7-seg. LED. When the setting "Lock", the elements selected are locked for operation.

#### (2) UV-TEST

The UV-TEST setting including in the Undervoltage element is used to UV test with single phase voltage application. That is, only selected phase can operate and others will be in lock status. Please note that UV-TEST must be set to OFF during in service condition.

#### (3) Frequency Setting

According to the frequency to be used, rated frequency (50Hz or 60Hz) is set up. Since a relay is initialized when it changes in service condition, an output is reset and a display is switched off during initialized terms.

#### (4) Forced Operation

The element of a forced operation can be chosen with a selection switch, and the forced operation for each contact can be individually carried out by pushing a forced operation button. (A forced operation will be continued during pushing a forced operation button, and will be returned by detaching button) A forced operation operates regardless of operation setting value of an element, or time of operation (even if it is LOCK setting).

Moreover, the display LED of a corresponding element of operation lights up.

In addition, when having set no selection of a forced operation with a selection switch, even if it pushes a forced operation button, it does not operate.

#### (5) Operation Indicator

When Overvoltage element or Undervoltage element operates, the operated element LED lights up, and also, according to the phase which operated, LED of AB phase, BC phase, and CA phase lights up. The self-hold of the LED lighting at the time of operation is carried out. (Although it will disappear if a power supply is shut off, it will restore to the original state by the power supply switching on again.)

Release of the self-hold of a display is performed by pushing an indicator-reset button.

Regarding the element with timer, the LED of corresponding item is blinked in the state where the input exceeds a setting value. (The self-hold of the blinking display is not carried out.)

#### (6) Indicator Reset

By pushing the indicator reset button, if relay operation is released, self-hold of the operation indicator will be released and if relay operation is not released, the operation indicator is turned off during only the term of button pushing.

Also ALARMS in a self-diagnosis indication will be released if ALARMS condition is reset and if ALARMS condition is not reset, the ALARMS indication will be turned on again after detaching reset button.

#### (7) Digital Output Contact

As digital outputs, there are for trip contact and for annunciator contacts.

The digital output contacts are depended on the relay element operation. When the relay elements goes to reset, the digital output contacts are open. (The contacts don't keep a close condition.)

## 4.2. Automatic Self-Diagnosis

The automatic self-diagnosis function monitors the electric circuit and built-in power source continuously. If an abnormal condition occurs, the protection elements will be locked for operation while RUN indicator will go off and the automatic self-diagnosis output contact will be closed.

In case of WDT error occurrence due to CPU failure, RUN indicator is lit off, ALARM indicator is lit on, alarm contact is closed and the operation output contact is locked.

At the same time, reset of hardware is carried out to attempt the restart of relay.

If CPU failure is caused by transient faults, the relay can return to normal state by the reset of hardware. In this case, please note that the alarm will be coming up temporarily and after that automatically alarm will be turned off.

It is selectable depending on the alarm items if the automatic self-diagnosis contact is hold or not hold. Regarding the automatic self-diagnosis items –which is suggested by Note 1 in Table 4-1–, it is possible to automatically return to normal condition according to the setting with the condition of eliminating the cause of faults.

### (1) Holding/Un-Holding Setting for Self-Diagnosis Contact

The automatic self-diagnosis function continues the checking even after acceptance of failure condition.

In case of any failure are not detected by the automatic self-diagnosis function, there are two kind of indication scheme which are selectable by the setting.

- In case of no HOLD setting: Automatically self-diagnosis contact is released, locking of output contact is released and RUN indicator is lit on.
- In case of HOLD setting: The self-diagnosis contact is not released, locking of output is continued and RUN indicator is lit off continuously.

Regarding no marked up items in the following table, the status of the self-diagnosis contact after acceptance of failure condition is keeping without any change (then never return to normal automatically).

The auxiliary power supply off or pushing the reset button is effective to return the relay to normal status (no indication of automatic self-diagnosis) with the condition of eliminating the cause of faults.

If no eliminating the cause of faults, the fault status will continue.

<NOTE>

The factory setting of ALARM HOLD setting is ON (holding).

### (2) Confirm Error Code

When the self-diagnosis function detects something to error, the error code relating a cause are saved. This error codes are needed to investigate the error cause and assuming the defective parts.

The error code is not erased even after reset operation of indication or automatically reset.

The erasing of error code can be done by the selector switch setting to error code reset.

When the selector switch set to “ERR. CODE. RESET”, the clear process is started. On the 7-seg. LED, the bars are appeared at the same time.

<NOTE>

- The error code clear process is completed successfully when the three (3) bars are appeared. When you would like to CANCEL the error code clear, please change the position of the selector switch to other position until appearing three (3) bars.
- Please pay attention on this regards that next error code can be memorized and indicated after above erasing.



Table 4-1 Protection relay behavior in alarm condition

Items	Error Details	Error code	RUN LED (green)	ALARM LED (red)	Alarm Contact Output	Protection element
Normal condition	–	–	ON	OFF	Open	Enable
Power circuit failure	–	–	OFF	OFF	Close	Lock (disable)
CPU failure	WDT	–	OFF	ON	ON	Lock (disable)
Self-diagnosis error	ROM check	01				
	RAM check	02				
	Analog input (A/I) check (Note 1)	03				
	A/D operating check	04				
	Digital output (D/O) condition check	05				
	Digital output (D/O) operation check	06				
	Analogue filter check	07				
	Watch dog timer (WDT) check	10				
A/D accuracy check (Note 1)	12					

Note 1: In this error code, the error condition are selected from the holding or the un-holding by setting.

## 5. Configuration

### 5.1. Internal Configuration

Fig. 5-1 shows the internal block diagram. The voltage values from power lines go through the voltage transformer (VT), filter circuits and sample hold (S/H) circuits. The multiplexer selects a channel to take the signal and sends it to an A/D converter. The signals are converted to digital signals sequentially in the converter to be sent to the CPU.

Fig. 5-2 shows sequence diagram. The relay behavior would be clarified by this diagram.

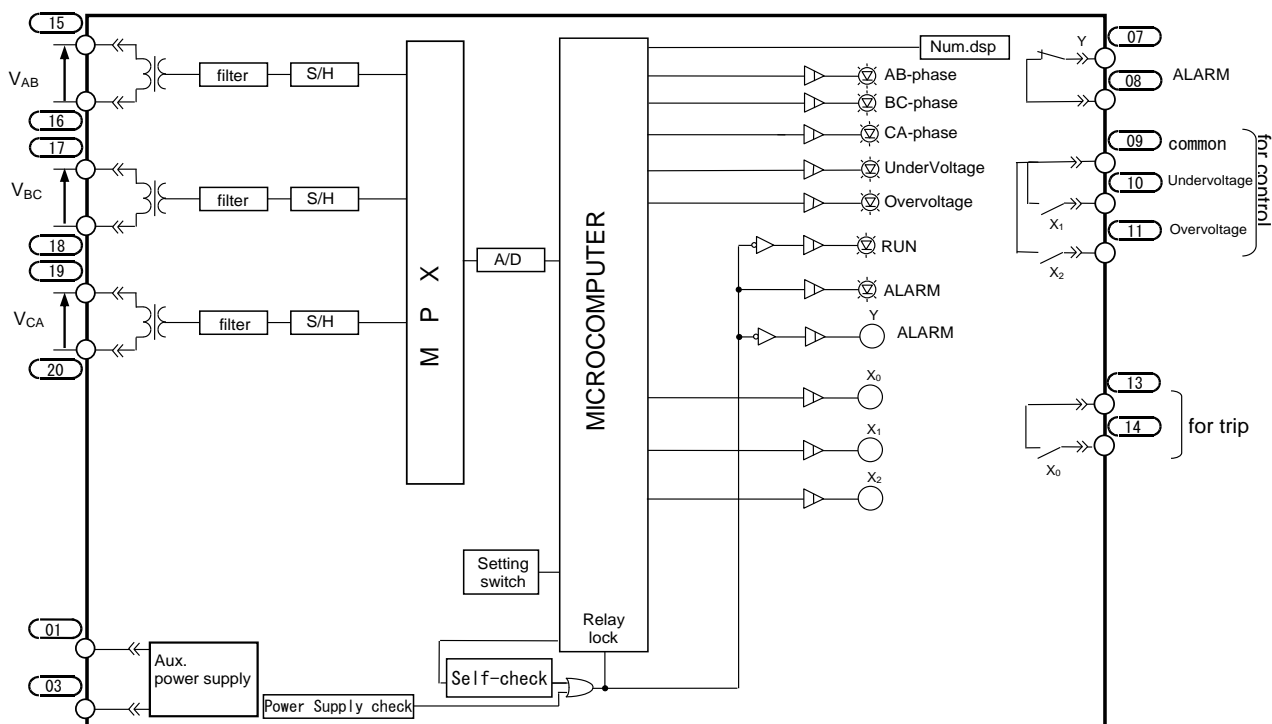

Fig. 5-1 Internal block diagram for CBV2 relay

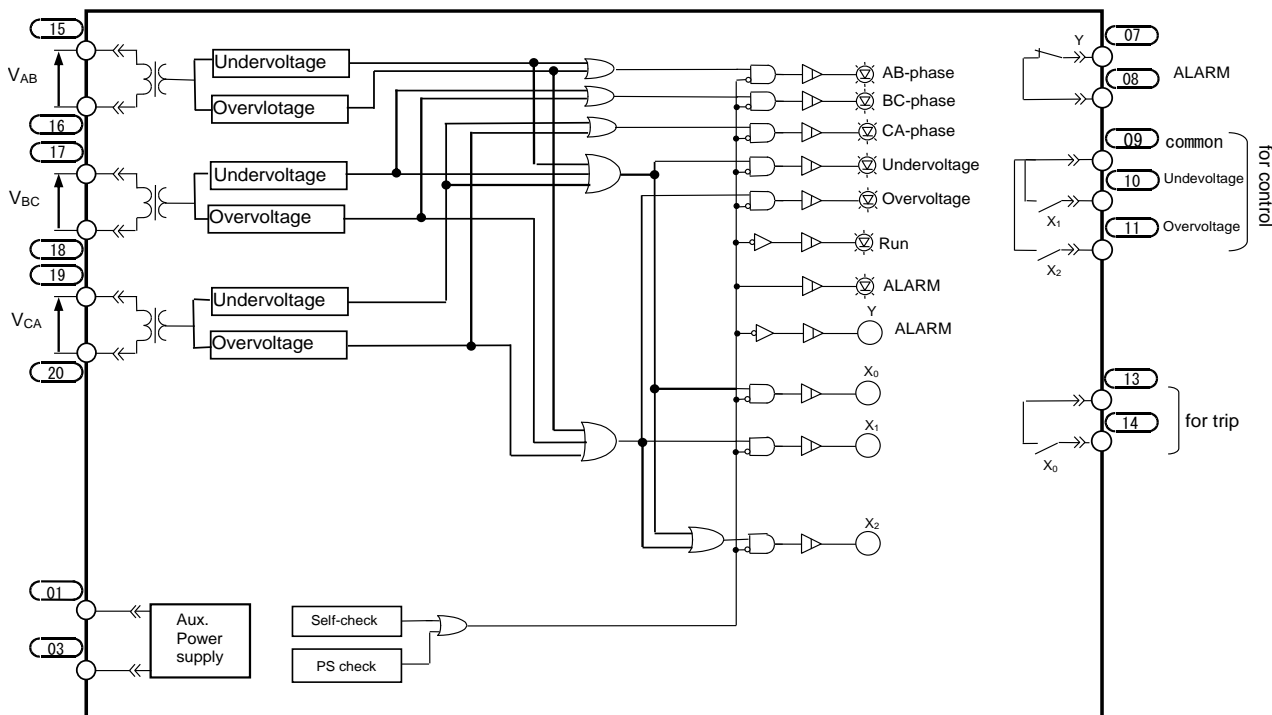

Fig. 5-2 Sequence diagram for CBV2 relay

## 5.2. External Connection

### 5.2.1. Connection Diagram

Fig. 5-3 and Fig. 5-4 shows example of input circuit (AC circuit) connection.

Fig. 5-6 shows example of control circuit (DC circuit) connection.

Fig. 5-5 shows the terminal assigned.

The terminals screw size is M3.5. The wire size is recommended that 2 mm<sup>2</sup> or less.

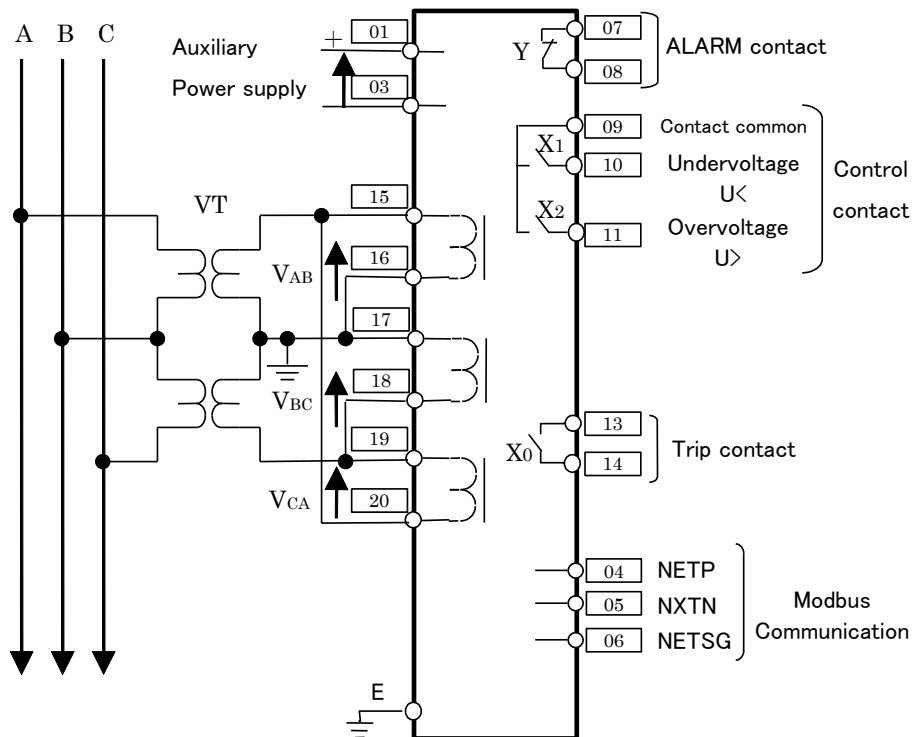

Fig. 5-3 Connection diagram (example of 2 X VT)

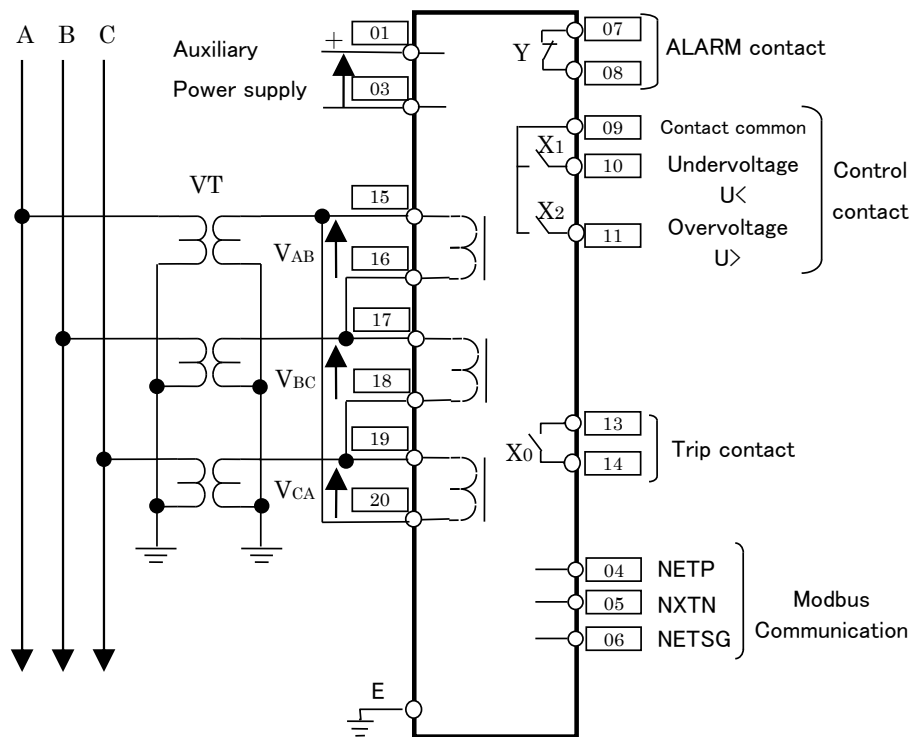

Fig. 5-4 Connection diagram (example of 3 X VT)

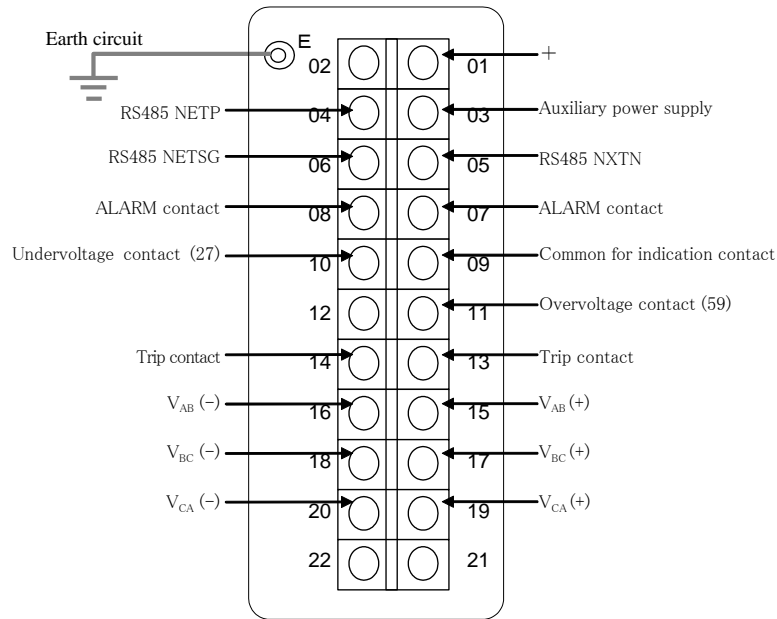

Fig. 5-5 Rear view and terminal assigned

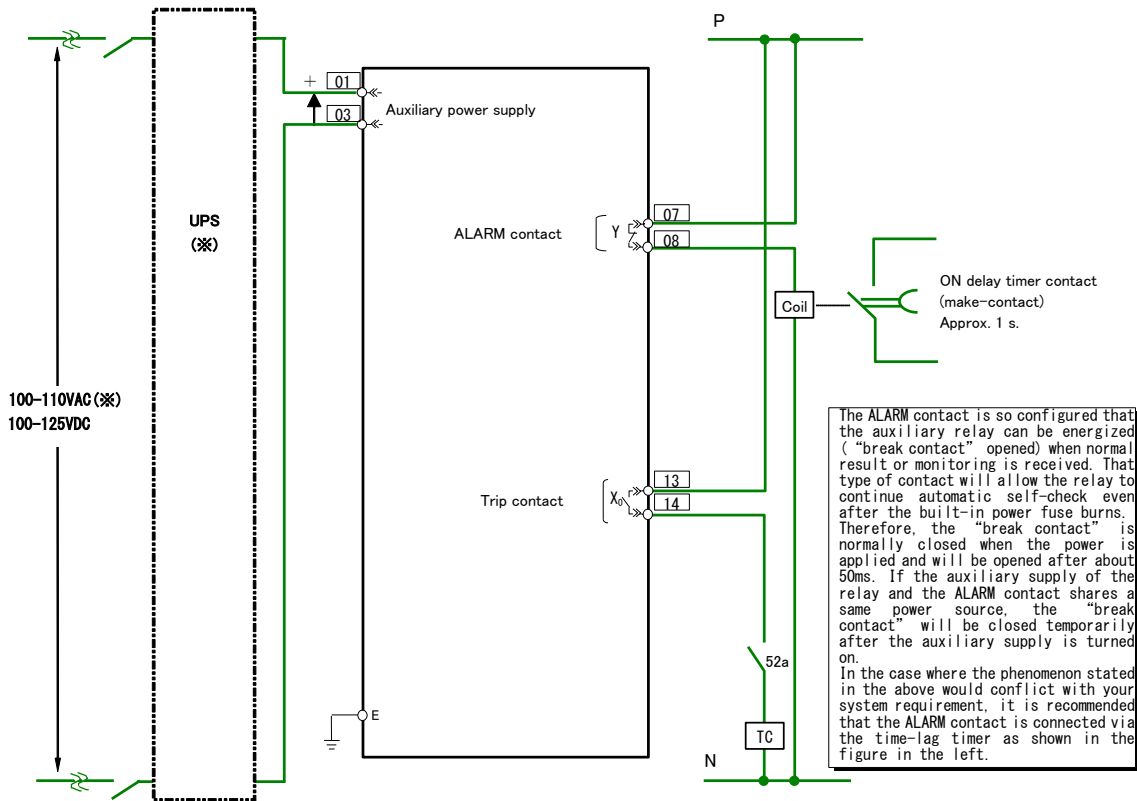

Fig. 5-6 DC circuit connection diagram  
Please also refer to clause 5.2.2(3) and 5.2.2(6).

**5.2.2. Precautions for Wiring Work**

**(1) Fail-Safe Construction**

Important facilities should be provided with fail safe measures such as dual system to improve reliability of the facilities.

**(2) Effects of external surge**

Some type of surge with a certain condition may inversely affect the relay. Under such situation, it is recommended that install surge absorbers as a countermeasure.

**(3) Auxiliary Power Supply and Black Out**

This protection relay does not guarantee correct operation in blackout of AC auxiliary power supply. A stabilized power source equipment (such as UPS) should be applied to stabilize the auxiliary power line.

**(4) Inrush Current of Auxiliary Supply**

At the turn-on to start up the protection relay, the inrush current would be appeared. Please select breakers or fuses for the auxiliary power circuit, considering this inrush current.

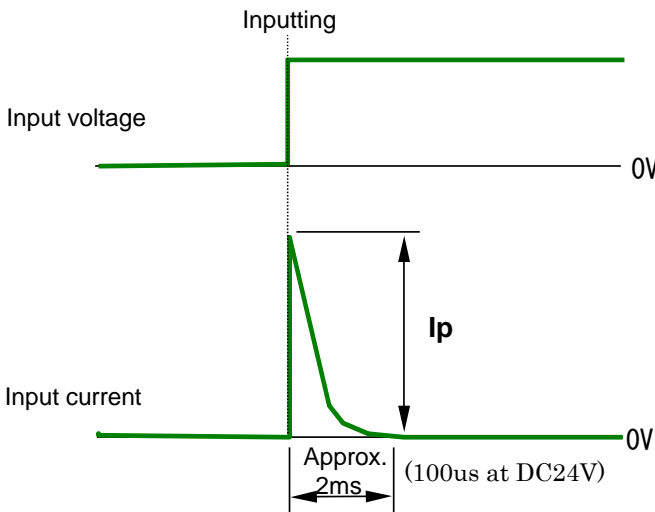

Input voltage	Inrush current Ip
DC 110V	<b>Approx. 6A</b>
AC 220V	<b>Approx. 5A</b>

Fig. 5-7 Inrush current of auxiliary power supply

**(5) Trip Circuit**

Digital output contacts (X<sub>0</sub>) can be used for the trip circuit.  
 Digital output contacts (X<sub>1</sub> to X<sub>2</sub>) can be used for the annunciator circuit, only.  
 To connect the pallet contact (52a) of the circuit breaker, the trip contact X<sub>0</sub> should be used.

**(6) ALARM Output Circuit**

The ALARM output contact (Y) is adopted b-contact. In healthy condition, this contact keeps open. Normally, this alarm contact opens after 50 ms from the injection of auxiliary power for protection relay.

<NOTE>

In the case of the starting up both the protection relay and the annunciator panel at same time, the annunciator regarding of this alarm contact (Y) on the protection relay would be indicated during a few milliseconds.  
 When user would like to avoid this behavior, the ON delay timer contact should be used for the annunciator circuit. (See Fig. 5-6 DC circuit connection diagram)

**(7) Grounding and Earth Terminal**

To make sure of the grounding, the earth terminal located on the back side should be connect with the Class D earth wiring method (grounding resistance less than 100 ohm).

## 6. Handling

### 6.1. Transportation and Storage

To carry the equipment within the place of use, handle it carefully so that the parts installed on the front panel of the sub unit or built-in parts cannot be deformed or broken.

### 6.2. Front Panel Operation

#### 6.2.1. Front Panel Layout

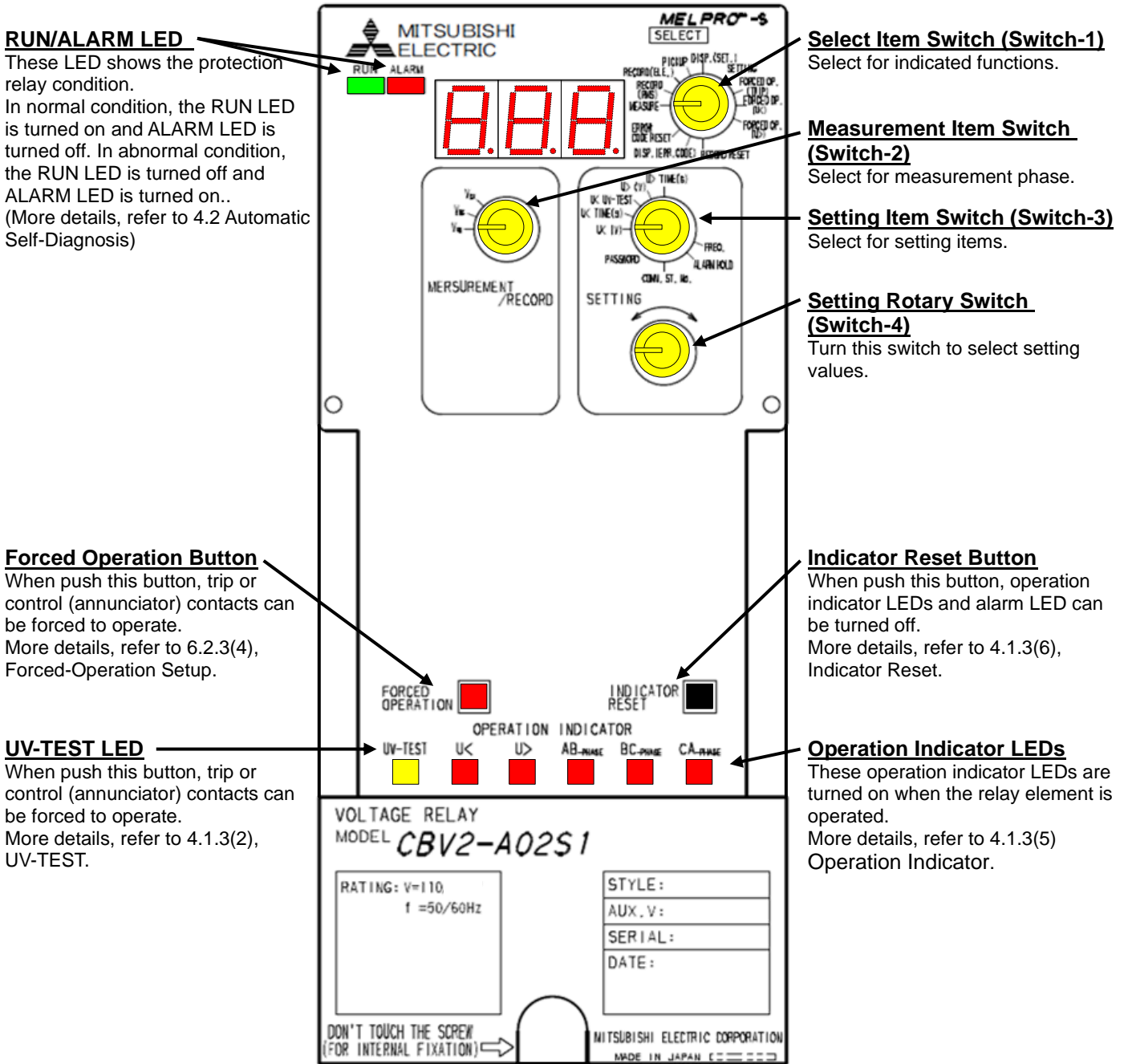

Fig. 6-1 Front view

## 6.2.2. Rotary Switch Items

### (1) Switch-1: Select Switch

There is "Select Item Switch" which is assigned by following tables.

Table 6-1 Select Switch (Switch-1)

Rotary position of Switch-1	CBV2-A02S1	Description
1	MEASURE	Real-Time Measurement
2	RECORD(RMS)	Fault Record – Measurement Value
3	RECORD (ELE.)	Fault Record – Relay Element
4	PICK UP	Relay Element Detection before Trip
5	DISP. (SET.)	Display Relay Element Setting
6	–	No assigned
7	SETTING	Change Relay Element Setting
8	FORCED OP.(TRIP)	Forced Operation for Trip Digital Output
9	FORCED OP.( $U<$ )	Forced Operation for Relay Element (Undervoltage)
10	FORCED OP.( $U>$ )	Forced Operation for Relay Element (Overvoltage)
11	–	No assigned
12	–	No assigned
13	RECORD RESET	Clear Fault Record Data
14	DISP.(ERR.CODE)	Display Error Code by Self-Diagnosis
15	ERR.CODE RESET	Clear Error Code
16	–	No assigned

### (2) Switch-2: Measurement Item Switch

There is "Measurement Item Switch" which is assigned by following tables.

By this rotary switch, the value or condition of selected phase are displayed.

Table 6-2 Measurement items of Switch-2

Rotary position of Switch-2	CBV2-A02S1	Description
1	$V_{AB}$	RMS value of phase-phase voltage
2	$V_{BC}$	
3	$V_{CA}$	

**(3) Switch-3: Setting Item Switch**

There is "Setting Item Switch" which is assigned by following tables.  
These values are enabled when Switch-1 is set "DISP. (SET.)" or "SETTING".

Table 6-3 Setting Item of Switch-3

Rotary position of Switch-3	CBV2-A02S1	Description
1	U< (V)	Undervoltage operating value
2	U< TIME (s)	Undervoltage operating time
3	U< UV-TEST	Undervoltage test mode
4	U> (V)	Overvoltage operating value
5	U> TIME (s)	Overvoltage operating time
6	–	
7	–	
8	–	
9	–	
10	FREQ.	Frequency setting
11	ALARM HOLD	Alarm digital output condition (hold / auto-reset)
12	–	
13	COMM. ST. No.	Slave address of Modbus
14	–	
15	PASSWORD	Set password
16	–	



**6.2.3. Display Specification**

This clause describes simplified how to operation. More details, please refer to HMI operation manual of MELPRO-S series.

**(1) Relay Setting and Display**

The setting value is indicated depending on each elements (undervoltage element, overvoltage element, frequency and ALARM hold etc.).

Indicated as "Lo." means that the relay element is set no use (LOCK).

Indicated as "0.05" in the operation time setting means instantaneous operation (INST).

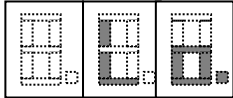

No use setting

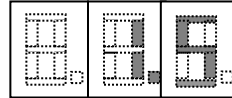

Other setting  
(for example)

Following figures show FREQUENCY setting.

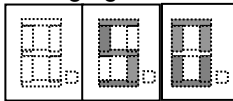

When set 50 Hz

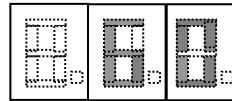

When set 60 Hz

Following figures show ALARM HOLD setting.

To set hold on, ON is indicated. To set hold off (un-holding), OFF is indicated.

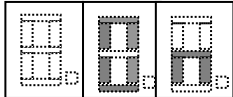

When set ON

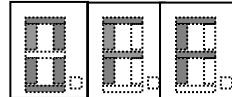

When set OFF

**(2) Real-Time Measurement [MEASURE]**

Relay input voltage value for every phase is calculated with using analog input value.

The display range is up to 250V from 1V and for more than 250V, the overflow (O. F.) is indicated.

Input under 1V : zero is displayed

Inputs 1V~250V : 1V step

Input More than 250V : O.F. is displayed

**(3) Starting Display**

It is made for the detection situation of each element to be known.

In below a setting value, the light is put out. "U" lights up at the time of detection starting.

**(4) Forced-Operation Setup**

The element (contact) which carries out a forced operation is chosen. An actual forced operation is performed on the conditions which pushed the forced-operation button.

The correspondence with the sign and element (contact) which are displayed is as follows.

Table 6-4 Forced operation menu

Displayed characters on 7-seg LED	Rotary position of Switch-1	Displayed name on rotary Switch-1
EL1	8	Forced operation for trip digital output.
EL2	9	Forced operation for relay element (undervoltage, 27).
EL3	10	Forced operation for relay element (overvoltage, 59).

**(5) Error Code**

The error code when the ALARM occur is memorized, and the code number is displayed.

More details, refer to clause 4.2.

**(6) Error Code Reset**

In case of eliminating the memorized error code when the ALARMS occur, the selection switch put to error code reset.

The check time for about 5 seconds is prepared so that error code may not be eliminated, even if makes it

this position temporarily.

If the error code memorized first is displayed and a display disappears after about 5 seconds, it will be the completion of elimination.

More details, refer to clause 4.2.

## 7. Mounting

### 7.1. Mounting Dimension

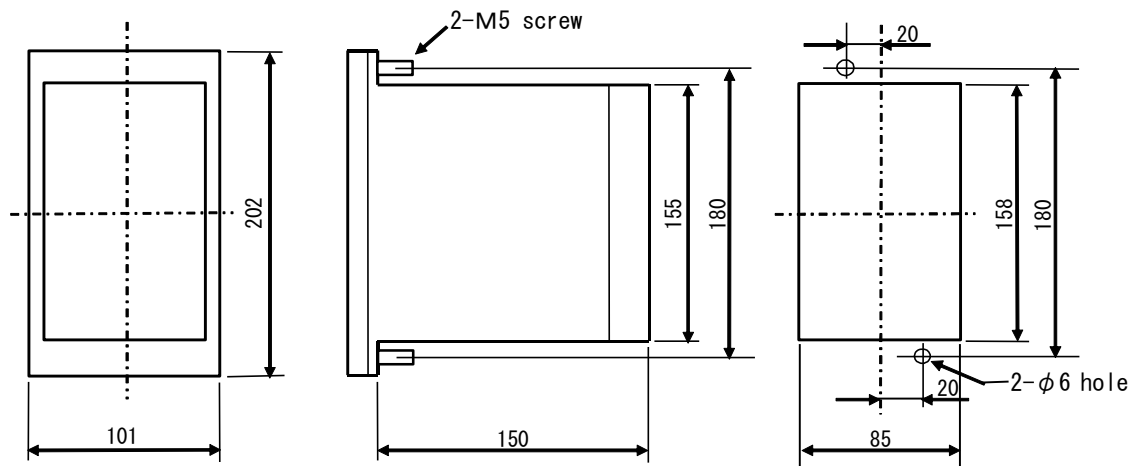

Fig. 7-1 Outside dimension /drilling drawing

### 7.2. Environment for Installed Condition

Install the relay in the environment described in Table 3-3 of chapter 3. In addition, the following conditions should be kept:

- Abnormal vibration, shock, inclination or magnetic field should be avoided.
- Harmful smoke or gas, salt gas, excessive humidity, water drop or vapor, excessive dust or fine powder, rain and wind should be avoided.

## 8. Test

The relay has been fully tested before shipment.

However, it is recommended to carry out a test again by referring to the following test guide before use.

### 8.1. Appearance Test

Check the relay for appearance according to the following procedure:

Objects		Check points
Unit	Coil/conductor	Discoloring and burning due to overheat. Abnormal conditions including loosened screws.
	Printed card	Discoloring of the printed card due to overheated parts. Contact between the printed card and connector
	Mechanism	Deformation Operation of the operating key switches. Damage of the draw-out lever of the sub unit. Discoloring and deformation of the name plate on the front panel. Damage of the terminal section.
Case/cover		Damage of the cover. Stain of the cover. Clouding of the cover. Damage of the lock lever of the cover. Damage of the operating buttons of the cover. Operation of the operating buttons of the cover. Damage of the terminal section.
Others		Invasion of foreign matters including dust and iron chips.

### 8.2. Characteristic Test

#### 8.2.1. Precautions in Testing

(1) Standard test conditions

Ensure the following test conditions whenever possible:

Note that carrying out a test under an environment that significantly differs from the following conditions may produce an incorrect result.

- Ambient temperature :  $20^{\circ}\text{C}\pm 10^{\circ}\text{C}$
- Rated frequency :  $\pm 5\%$
- Waveform (AC) : 2% (distortion ratio)
- Auxiliary power supply voltage : rated voltage  $\pm 2\%$

(2) Characteristic control point

See the chapter 3 "Characteristics".

The characteristic control point refers to the characteristic of a relay unit only. Note that, when a characteristic test is carried out on a relay system connected with external equipment such as VT, the result obtained would be a combined characteristic added with the fluctuation of the external equipment.

For special control in terms of a specific control point (for instance, using the operation setting), first carry out a test at "Characteristic control point" at the time when the relay is received or put in service to determine the acceptance/rejection. Thereafter, perform another test at each control point, so that the data obtained can be used for future reference.

(3) Changing setting

Change the setting according to the chapter 6 "Handling".

(4) Operation judgment

Determine the operation voltage and time and other values of the relay unit basically by turning on and off the corresponding output relay contact of each element.

## 8.2.2. Characteristic Test

### (1) Test Circuit

For the characteristic test, a voltage source, a voltage meter and a protection relay are connected as shown in below figure.

Please change the terminals which connected to voltage source to match the protection element under testing.

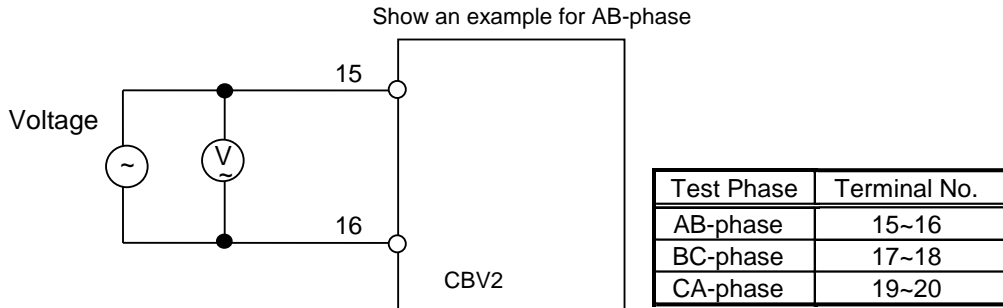

Fig. 8-1 Testing connection

### (2) Test Items and Accuracies

Table 8-1 Test items and accuracies

Test Items	Descriptions
Forced operation test	See section 6.2 "Front Panel Operation".
Operation value test	See item "Operation and reset values" in the section 3 "Characteristic".
Operation time test	See item "Operation time" in the section 3 "Characteristic".
Reset time test	See item "Reset time" in the section 3 "Characteristic".

## 9. Maintenance

### 9.1. Daily inspection

Take every opportunity to carry out the following inspection:

- Check that the cover is not damaged and is attached properly.
- Check that no dust or iron chips have invaded into the unit.
- Check that the cover is not clouded notably.
- Check that abnormal noise is not generated.
- Check that the RUN LED lamp is lit.

### 9.2. Periodical inspection

It is recommended to carry out periodic inspections to check the relay for proper function.

For periodical inspections, perform the appearance inspection and characteristic test in accordance with the clause 8.

## 10. Ordering

The product and specification shown in this manual may subject to changes (including specification change and production suspend) without notice.

It is advisory to inquire the nearest Mitsubishi Electric's branch or sales office, if required, to confirm that the latest information is given in the manual, prior to placing an order.

Notify the following items when placing an order.

Table 10-1 Example of ordering

Item	Example of order	Remarks
Model and style number	CBV2-A02S1 563PQB	For more information, see the section 2.1.
Rating	Votage: 110V	Same as above

# **mitsubishi electric corporation**

HEAD OFFICE: 7-3 MARUNOUCHI 2-CHOME, CHIYODA-KU TOKYO, 100-8310, JAPAN

Revised in Apr. 2019