



General-Purpose AC Servo

MITSUBISHI SERVO AMPLIFIERS & MOTORS
MELSERV/o-J4

CC-Link IE Field Network Interface
Servo Amplifier Instruction Manual
(Motion Mode)



-MR-J4- _GF_
-MR-J4- _GF_-RJ

SAFETY PRECAUTIONS

Please read the instructions carefully before using the equipment.

To use the equipment correctly, do not attempt to install, operate, maintain, or inspect the equipment until you have read through this Instruction Manual, Installation guide, and appended documents carefully. Do not use the equipment until you have a full knowledge of the equipment, safety information and instructions.





In this Instruction Manual, the safety instruction levels are classified into "WARNING" and "CAUTION".

 WARNING	Indicates that incorrect handling may cause hazardous conditions, resulting in death or severe injury.
 CAUTION	Indicates that incorrect handling may cause hazardous conditions, resulting in minor or moderate injury or property damage.

Note that the CAUTION level may lead to a serious consequence according to conditions.

Please follow the instructions of both levels because they are important to personnel safety.

What must not be done and what must be done are indicated by the following diagrammatic symbols.

	Indicates what must not be done. For example, "No Fire" is indicated by  .
	Indicates what must be done. For example, grounding is indicated by  .

In this Instruction Manual, instructions at a lower level than the above, instructions for other functions, and so on are classified into "POINT".

After reading this Instruction Manual, keep it accessible to the operator.

[To prevent electric shock, note the following]

WARNING

- Before wiring and inspections, turn off the power and wait for 15 minutes or more until the charge lamp turns off. Then, confirm that the voltage between P+ and N- is safe with a voltage tester and others. Otherwise, an electric shock may occur. In addition, when confirming whether the charge lamp is off or not, always confirm it from the front of the servo amplifier.
 - Ground the servo amplifier and servo motor securely.
 - Any person who is involved in wiring and inspection should be fully competent to do the work.
 - Do not attempt to wire the servo amplifier and servo motor until they have been installed. Otherwise, it may cause an electric shock.
 - Do not operate switches with wet hands. Otherwise, it may cause an electric shock.
 - The cables should not be damaged, stressed, loaded, or pinched. Otherwise, it may cause an electric shock.
 - During power-on or operation, do not open the front cover of the servo amplifier. Otherwise, it may cause an electric shock.
 - Do not operate the servo amplifier with the front cover removed. High-voltage terminals and charging area are exposed and you may get an electric shock.
 - Except for wiring and periodic inspection, do not remove the front cover of the servo amplifier even if the power is off. The servo amplifier is charged and you may get an electric shock.
 - To prevent an electric shock, always connect the protective earth (PE) terminal (marked \oplus) of the servo amplifier to the protective earth (PE) of the cabinet.
 - To avoid an electric shock, insulate the connections of the power supply terminals.
-

[To prevent fire, note the following]

CAUTION

- Install the servo amplifier, servo motor, and regenerative resistor on incombustible material. Installing them directly or close to combustibles will lead to smoke or a fire.
 - Always connect a magnetic contactor between the power supply and the main circuit power supply (L1/L2/L3) of the servo amplifier, in order to configure a circuit that shuts down the power supply on the side of the servo amplifier's power supply. If a magnetic contactor is not connected, continuous flow of a large current may cause smoke or a fire when the servo amplifier malfunctions.
 - Always connect a molded-case circuit breaker, or a fuse to each servo amplifier between the power supply and the main circuit power supply (L1/L2/L3) of the servo amplifier, in order to configure a circuit that shuts down the power supply on the side of the servo amplifier's power supply. If a moldedcase circuit breaker or fuse is not connected, continuous flow of a large current may cause smoke or a fire when the servo amplifier malfunctions.
 - When using the regenerative resistor, switch power off with the alarm signal. Otherwise, a regenerative transistor malfunction or the like may overheat the regenerative resistor, causing smoke or a fire.
 - Provide adequate protection to prevent screws and other conductive matter, oil and other combustible matter from entering the servo amplifier and servo motor.
-

[To prevent injury, note the following]

 **CAUTION**

- Only the power/signal specified in the Instruction Manual should be applied to each terminal. Otherwise, it may cause an electric shock, fire, injury, etc.
 - Connect cables to the correct terminals. Otherwise, a burst, damage, etc., may occur.
 - Ensure that polarity (+/-) is correct. Otherwise, a burst, damage, etc., may occur.
 - The servo amplifier heat sink, regenerative resistor, servo motor, etc., may be hot while the power is on and for some time after power-off. Take safety measures such as providing covers to avoid accidentally touching them by hands and parts such as cables.
-

[Additional instructions]

The following instructions should also be fully noted. Incorrect handling may cause a malfunction, injury, electric shock, fire, etc.

[Transportation and installation]

CAUTION

- Transport the products correctly according to their mass.
- Stacking in excess of the specified number of product packages is not allowed.
- Do not hold the front cover, cables, or connectors when carrying the servo amplifier. Otherwise, it may drop.
- Install the servo amplifier and the servo motor in a load-bearing place in accordance with the Instruction Manual.
- Do not get on or put heavy load on the equipment. Otherwise, it may cause injury.
- The equipment must be installed in the specified direction.
- Maintain specified clearances between the servo amplifier and the inner surfaces of a control cabinet or other equipment.
- Do not install or operate the servo amplifier and servo motor which have been damaged or have any parts missing.
- Do not block the intake and exhaust areas of the servo amplifier. Otherwise, it may cause a malfunction.
- Do not drop or apply heavy impact on the servo amplifiers and the servo motors. Otherwise, it may cause injury, malfunction, etc.
- Do not strike the connector. Otherwise, it may cause a connection failure, malfunction, etc.
- When you keep or use the equipment, please fulfill the following environment.

Item		Environment
Ambient temperature	Operation	0 °C to 55 °C (non-freezing)
	Storage	-20 °C to 65 °C (non-freezing)
Ambient humidity	Operation	5 %RH to 90 %RH (non-condensing)
	Storage	
Ambience		Indoors (no direct sunlight), free from corrosive gas, flammable gas, oil mist, dust, and dirt
Altitude		2000 m or less above sea level (Contact your local sales office for the altitude for options.)
Vibration resistance		5.9 m/s ² , at 10 Hz to 55 Hz (X, Y, Z axes)

- When the product has been stored for an extended period of time, contact your local sales office.
- When handling the servo motor, be careful with the sharp edges of the servo motor.
- The servo amplifier must be installed in a metal cabinet.
- When fumigants that contain halogen materials, such as fluorine, chlorine, bromine, and iodine, are used for disinfecting and protecting wooden packaging from insects, they cause a malfunction when entering our products. Please take necessary precautions to ensure that remaining materials from fumigant do not enter our products, or treat packaging with methods other than fumigation, such as heat treatment. Additionally, disinfect and protect wood from insects before packing the products.
- To prevent a fire or injury in case of an earthquake or other natural disasters, securely install, mount, and wire the servo motor in accordance with the Instruction Manual.

[Wiring]

CAUTION

- Wire the equipment correctly and securely. Otherwise, the servo motor may operate unexpectedly.
- Make sure to connect the cables and connectors by using the fixing screws and the locking mechanism. Otherwise, the cables and connectors may be disconnected during operation.
- Do not install a power capacitor, surge killer, or radio noise filter (optional FR-BIF(-H)) on the servo amplifier output side.
- To avoid a malfunction, connect the wires to the correct phase terminals (U/V/W) of the servo amplifier and servo motor.
- Connect the servo amplifier power output (U/V/W) to the servo motor power input (U/V/W) directly. Do not connect a magnetic contactor and others between them. Otherwise, it may cause a malfunction.

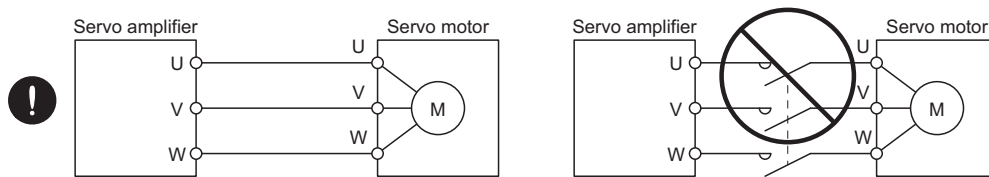

- The connection diagrams in this Instruction Manual are shown for sink interfaces, unless stated otherwise.
- The surge absorbing diode installed to the DC relay for control output should be fitted in the specified direction. Otherwise, the converter unit and the drive unit will malfunction and will not output signals, disabling the emergency stop and other protective circuits.

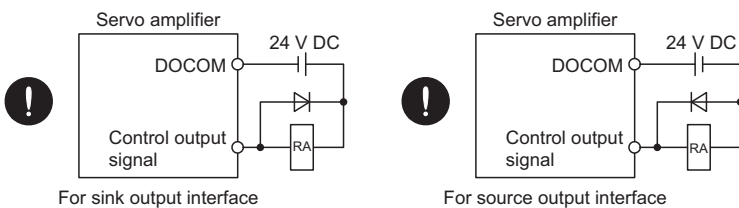

- When the wires are not tightened enough to the terminal block, the wires or terminal block may generate heat because of the poor contact. Be sure to tighten the wires with specified torque.
- Connecting a servo motor of the wrong axis to U, V, W, or CN2 of the servo amplifier may cause a malfunction.
- Configure a circuit to turn off EM2 or EM1 when the main circuit power supply is turned off to prevent an unexpected restart of the servo amplifier.
- To prevent malfunction, avoid bundling power lines (input/output) and signal cables together or running them in parallel to each other. Separate the power lines from the signal cables.

[Test run and adjustment]

CAUTION

- When executing a test run, follow the notice and procedures in this instruction manual. Otherwise, it may cause a malfunction, damage to the machine, or injury.
 - Before operation, check and adjust the parameter settings. Improper settings may cause some machines to operate unexpectedly.
 - Never make a drastic adjustment or change to the parameter values as doing so will make the operation unstable.
 - Do not get close to moving parts during the servo-on status.
-

[Usage]

CAUTION

- Provide an external emergency stop circuit to stop the operation and shut the power off immediately.
 - For equipment in which the moving part of the machine may collide against the load side, install a limit switch or stopper to the end of the moving part. The machine may be damaged due to a collision.
 - Do not disassemble, repair, or modify the product. Otherwise, it may cause an electric shock, fire, injury, etc. Disassembled, repaired, and/or modified products are not covered under warranty.
 - Before resetting an alarm, make sure that the run signal of the servo amplifier is off in order to prevent a sudden restart. Otherwise, it may cause an accident.
 - Use a noise filter, etc., to minimize the influence of electromagnetic interference. Electromagnetic interference may affect the electronic equipment used near the servo amplifier.
 - Do not burn or destroy the servo amplifier. Doing so may generate a toxic gas.
 - Use the servo amplifier with the specified servo motor.
 - Wire options and peripheral equipment, etc. correctly in the specified combination. Otherwise, it may cause an electric shock, fire, injury, etc.
 - The electromagnetic brake on the servo motor is designed to hold the motor shaft and should not be used for ordinary braking.
 - For such reasons as incorrect wiring, service life, and mechanical structure (e.g. where a ball screw and the servo motor are coupled via a timing belt), the electromagnetic brake may not hold the motor shaft. To ensure safety, install a stopper on the machine side.
 - If the dynamic brake is activated at power-off, alarm occurrence, etc., do not rotate the servo motor by an external force. Otherwise, it may cause a malfunction of the dynamic brake or a fire.
-

[Corrective actions]

CAUTION

- Ensure safety by confirming the power off, etc. before performing corrective actions. Otherwise, it may cause an accident.
- If it is assumed that a power failure, machine stoppage, or product malfunction may result in a hazardous situation, use a servo motor with an electromagnetic brake or provide an external brake system for holding purpose to prevent such hazard.
- Configure an electromagnetic brake circuit which is interlocked with an external emergency stop switch.

Shut off when ALM (Malfunction) or MBR (Electromagnetic brake interlock) turns off. Shut off with the emergency stop switch.

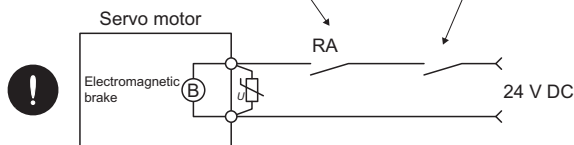

- When an alarm occurs, eliminate its cause, ensure safety, and deactivate the alarm to restart operation.
- If the molded-case circuit breaker or fuse is activated, be sure to remove the cause and secure safety before switching the power on. If necessary, replace the servo amplifier and recheck the wiring. Otherwise, it may cause smoke, fire, or an electric shock.
- Provide an adequate protection to prevent unexpected restart after an instantaneous power failure.
- After an earthquake or other natural disasters, ensure safety by checking the conditions of the installation, mounting, wiring, and equipment before switching the power on to prevent an electric shock, injury, or fire.

[Maintenance, inspection and parts replacement]

CAUTION

- Make sure that the emergency stop circuit operates properly such that an operation can be stopped immediately and a power is shut off by the emergency stop switch.
- It is recommended that the servo amplifier be replaced every 10 years when it is used in general environment.
- When using the servo amplifier that has not been energized for an extended period of time, contact your local sales office.

[General instruction]

- To illustrate details, the equipment in the diagrams of this Instruction Manual may have been drawn without covers and safety guards. When the equipment is operated, the covers and safety guards must be installed as specified. Operation must be performed in accordance with this Instruction Manual.

DISPOSAL OF WASTE

Please dispose a servo amplifier, battery (primary battery) and other options according to your local laws and regulations.

EEP-ROM LIFE

The number of write times to the EEPROM, which stores parameter settings, etc., is limited to 100,000. If the total number of the following operations exceeds 100,000, the servo amplifier may malfunction when the EEPROM reaches the end of its useful life.

- Write to the EEPROM due to parameter setting changes
- Write to the EEPROM due to device changes

STO FUNCTION OF THE SERVO AMPLIFIER

When using the STO function of the servo amplifier, refer to the following.

☞ Page 469 USING STO FUNCTION

For the MR-J3-D05 safety logic unit, refer to the following.

☞ Page 609 MR-J3-D05 Safety logic unit

COMPLIANCE WITH GLOBAL STANDARDS

For the compliance with global standards, refer to the following.

☞ Page 595 Compliance with global standards

ABOUT THE MANUALS

You must have this Instruction Manual and the following manuals to use this servo. Ensure to prepare them to use the servo safely.

Relevant manuals

Manual name	Manual No.
MELSERVO MR-J4-_GF_(-RJ) Servo Amplifier Instruction Manual (I/O Mode)	SH(NA)030221ENG
MELSERVO MR-J4-_GF_(-RJ) Servo Amplifier Instruction Manual (CC-Link IE Field Network Basic)	SH(NA)030273ENG
MELSERVO-J4 Servo Amplifier Instruction Manual (Troubleshooting)	SH(NA)030109ENG
MELSERVO MR-D30 Instruction Manual ^{*1}	SH(NA)030132ENG
MELSERVO Servo Motor Instruction Manual (Vol. 3) ^{*2}	SH(NA)030113ENG
MELSERVO Linear Servo Motor Instruction Manual ^{*3}	SH(NA)030110ENG
MELSERVO Direct Drive Motor Instruction Manual ^{*4}	SH(NA)030112ENG
MELSERVO Linear Encoder Instruction Manual ^{*3*5}	SH(NA)030111ENG
MELSERVO EMC Installation Guidelines	IB(NA)67310ENG

*1 It is necessary for using an MR-D30 functional safety unit.

*2 It is necessary for using a rotary servo motor.

*3 It is necessary for using a linear servo motor.

*4 It is necessary for using a direct drive motor.

*5 It is necessary for using a fully closed loop system.

WIRING

Wires mentioned in this Instruction Manual are selected based on the ambient temperature of 40 °C.

U.S. CUSTOMARY UNITS

U.S. customary units are not shown in this manual. Convert the values if necessary according to the following table.

Quantity	SI (metric) unit	U.S. customary unit
Mass	1 [kg]	2.2046 [lb]
Length	1 [mm]	0.03937 [inch]
Torque	1 [N.m]	141.6 [oz.inch]
Moment of inertia	1 [($\times 10^{-4}$ kg.m ²)]	5.4675 [oz.inch ²]
Load (thrust load/axial load)	1 [N]	0.2248 [lbf]
Temperature	N [°C] \times 9/5 + 32	N [°F]

CONTENTS

SAFETY PRECAUTIONS	1
DISPOSAL OF WASTE	8
EEP-ROM LIFE	8
STO FUNCTION OF THE SERVO AMPLIFIER	8
COMPLIANCE WITH GLOBAL STANDARDS	8
ABOUT THE MANUALS	9
WIRING	9
U.S. CUSTOMARY UNITS	9
CHAPTER 1 FUNCTIONS AND CONFIGURATION	18
1.1 Summary	18
1.2 Function block diagram	19
1.3 Servo amplifier standard specifications	30
1.4 Combinations of servo amplifiers and servo motors	36
1.5 Function list	38
1.6 Model designation	41
1.7 Structure	42
Parts identification	42
Removal and reinstallation of the front cover	56
1.8 Configuration including peripheral equipment	58
CHAPTER 2 INSTALLATION	76
2.1 Installation direction and clearances	77
2.2 Keeping out of foreign materials	79
2.3 Encoder cable stress	79
2.4 Inspection items	79
2.5 Parts having service life	80
2.6 Restrictions when using the servo amplifiers at altitude exceeding 1000 m and up to 2000 m above sea level	81
CHAPTER 3 SIGNALS AND WIRING	82
3.1 Connection example of power circuit	83
200 V class	84
400 V class	90
100 V class	94
3.2 I/O signal connection example	95
For sink I/O interface	95
For source I/O interface	97
3.3 Explanation of power supply system	98
Signal explanations	98
Power-on sequence	99
Wiring CNP1, CNP2, and CNP3	100
3.4 Connectors and pin assignment	103
3.5 Signal (device) explanations	104
Input device	104
Output device	107
Output signal	109
Power supply	109

3.6	Forced stop deceleration function	110
	Forced stop deceleration function	111
	Base circuit shut-off delay time function	112
	Vertical axis freefall prevention function	113
	Residual risks of the forced stop function (EM2)	113
3.7	Alarm occurrence timing chart	114
	When you use the forced stop deceleration function	114
	When you do not use the forced stop deceleration function	115
3.8	Interfaces	116
	Internal connection diagram	116
	Detailed explanation of interfaces	117
	Source I/O interface	119
3.9	Servo motor with an electromagnetic brake	120
	Safety precautions	120
	Timing chart	121
3.10	Grounding	127
CHAPTER 4 STARTUP		128
4.1	Switching power on for the first time	129
	Startup procedure	129
	Wiring check	130
	Surrounding environment	134
	Settings of GX Works	134
4.2	Startup	135
4.3	Switch setting and display of the servo amplifier	137
	Switches	137
	Scrolling display	138
	Status display of a station	139
	CC-Link IE Field status display LED	140
4.4	Test operation	141
4.5	Test operation mode	142
	Test operation mode in MR Configurator2	142
	Motor-less operation in controller	145
4.6	Home position return mode	146
	Outline of home position return	146
	CiA 402-type homing method	151
	Operation example of Manufacturer-specific Homing method	163
CHAPTER 5 PARAMETERS		172
5.1	Parameter list	172
	Basic setting parameters ([Pr. PA_ _])	173
	Gain/filter setting parameters ([Pr. PB_ _])	174
	Extension setting parameters ([Pr. PC_ _])	176
	I/O setting parameters ([Pr. PD_ _])	178
	Extension setting 2 parameters ([Pr. PE_ _])	179
	Extension setting 3 parameters ([Pr. PF_ _])	180
	Linear servo motor/DD motor setting parameters ([Pr. PL_ _])	182
	Positioning control parameters ([Pr. PT_ _])	183
	Network setting parameters ([Pr. PN_ _])	185
5.2	Detailed list of parameters	186

Basic setting parameters ([Pr. PA_ _])	186
Gain/filter setting parameters ([Pr. PB_ _])	195
Extension setting parameters ([Pr. PC_ _])	205
I/O setting parameters ([Pr. PD_ _])	211
Extension setting 2 parameters ([Pr. PE_ _])	215
Extension setting 3 parameters ([Pr. PF_ _])	217
Linear servo motor/DD motor setting parameters ([Pr. PL_ _])	221
Positioning control parameters ([Pr. PT_ _])	223
Network setting parameters ([Pr. PN_ _])	227
5.3 Software limit	229

CHAPTER 6 NORMAL GAIN ADJUSTMENT 230

6.1 Different adjustment methods	230
Adjustment on a single servo amplifier	230
Adjustment using MR Configurator2	231
6.2 One-touch tuning	232
One-touch tuning flowchart	233
Display transition and operation procedure of one-touch tuning	234
Caution for one-touch tuning	237
One-touch tuning via a network	238
6.3 Auto tuning	240
Auto tuning mode	240
Auto tuning mode basis	241
Adjustment procedure by auto tuning	242
Response level setting in auto tuning mode	243
6.4 Manual mode	245
6.5 2 gain adjustment mode	248

CHAPTER 7 SPECIAL ADJUSTMENT FUNCTIONS 250

7.1 Filter setting	250
Machine resonance suppression filter	250
Adaptive filter II	253
Shaft resonance suppression filter	255
Low-pass filter	256
Advanced vibration suppression control II	257
Command notch filter	260
7.2 Gain switching function	262
Applications	262
Function block diagram	263
Parameter	264
Gain switching procedure	267
7.3 Tough drive function	270
Vibration tough drive function	270
Instantaneous power failure tough drive function	272
7.4 Compliance with SEMI-F47 standard	276
7.5 Model adaptive control disabled	278
7.6 Lost motion compensation function	279
7.7 Super trace control	282

CHAPTER 8 TROUBLESHOOTING 283

8.1	Explanation for the lists	283
8.2	Alarm list	284
8.3	Warning list	292
8.4	Troubleshooting at power on	294
CHAPTER 9 DIMENSIONS		295
9.1	Servo amplifier	296
9.2	Connector	312
CHAPTER 10 CHARACTERISTICS		314
10.1	Overload protection characteristics	314
10.2	Power supply capacity and generated loss	318
10.3	Dynamic brake characteristics	321
	Dynamic brake operation	321
	Permissible load to motor inertia when the dynamic brake is used	325
10.4	Cable bending life	327
10.5	Inrush currents at power-on of main circuit and control circuit	328
CHAPTER 11 OPTIONS AND PERIPHERAL EQUIPMENT		330
11.1	Cable/connector sets	330
	Combinations of cable/connector sets	331
	MR-D05UDL3M-B STO cable	335
	Battery cable/junction battery cable	336
	Ethernet cable	337
11.2	Regenerative options	338
	Combination and regenerative power	338
	Selection of the regenerative option	340
	Parameter setting	344
	Connection of regenerative option	344
	Mounting direction	349
	Dimensions	350
11.3	FR-BU2-(H) brake unit	357
	Selection	357
	Brake unit parameter setting	358
	Connection example	359
	Dimensions	367
11.4	FR-RC-(H) power regeneration converter	370
11.5	FR-CV-(H) power regeneration common converter	374
	Model designation	374
	Selection	375
11.6	Junction terminal block PS7DW-20V14B-F (recommended)	383
11.7	MR Configurator2	385
	Engineering software	385
	Precautions for using USB communication function	385
11.8	Battery	386
	Selection of battery	386
	MR-BAT6V1SET-A battery	387
	MR-BAT6V1BJ battery for junction battery cable	391
	MR-BT6VCASE battery case	395
	MR-BAT6V1 battery	401

11.9	Selection example of wires	402
11.10	Molded-case circuit breakers, fuses, magnetic contactors	406
11.11	Power factor improving DC reactors	409
11.12	Power factor improving AC reactors	414
11.13	Relay (recommended)	419
11.14	Noise reduction techniques	420
11.15	Earth-leakage current breaker	429
11.16	EMC filter (recommended)	432
11.17	External dynamic brake	439
	Selection of external dynamic brake	439
	Connection example	440
	Timing chart	442
	Dimensions	447
11.18	Panel through attachment (MR-J4ACN15K/MR-J3ACN)	449
11.19	Multifunction regeneration converter FR-XC-(H)	454
	Multifunction regeneration converter and dedicated stand-alone reactor	454
	Safety precautions	454
	Servo amplifier setting	454
	Capacity selection	455
	Connection diagram	457
	Wires and peripheral options	459
CHAPTER 12 ABSOLUTE POSITION DETECTION SYSTEM		462
12.1	Summary	464
	Features	464
	Structure	464
	Parameter setting	464
	Confirmation of absolute position detection data	465
12.2	Battery	466
	Using MR-BAT6V1SET-A battery	466
	Using MR-BAT6V1BJ battery for junction battery cable	467
	Using MR-BT6VCASE battery case	468
CHAPTER 13 USING STO FUNCTION		469
13.1	Introduction	469
	Summary	469
	Terms related to safety	469
	Cautions	469
	Residual risks of the STO function	470
	Specifications	470
	Maintenance	471
13.2	STO I/O signal connector (CN8) and pin assignment	472
	Pin assignment	472
	Signal (device) explanations	472
	How to pull out the STO cable	473
13.3	Connection example	474
	Connection example for CN8 connector	474
	External I/O signal connection example using an MR-J3-D05 safety logic unit	475
	External I/O signal connection example using an external safety relay unit	478
13.4	Detailed explanation of interfaces	479

Sink I/O interface	479
Source I/O interface	480

CHAPTER 14 USING A LINEAR SERVO MOTOR 481

14.1 Functions and configuration	481
Summary	481
Configuration including peripheral equipment	482
14.2 Signals and wiring	486
14.3 Operation and functions	487
Startup	487
Magnetic pole detection	489
Home position return	497
Test operation mode in MR Configurator2	503
Operation from controller	505
Function	505
Absolute position detection system	507
14.4 Characteristics	508
Overload protection characteristics	508
Power supply capacity and generated loss	509
Dynamic brake characteristics	510
Permissible load to motor mass ratio when the dynamic brake is used	511

CHAPTER 15 USING A DIRECT DRIVE MOTOR 512

15.1 Functions and configuration	512
Summary	512
Configuration including peripheral equipment	513
15.2 Signals and wiring	515
15.3 Operation and functions	517
Startup procedure	517
Magnetic pole detection	518
Home position return	525
Operation from controller	525
Function	526
15.4 Characteristics	528
Overload protection characteristics	528
Power supply capacity and generated loss	529
Dynamic brake characteristics	529

CHAPTER 16 FULLY CLOSED LOOP SYSTEM 533

16.1 Functions and configuration	533
Function block diagram	533
Selecting procedure of control mode	534
System configuration	536
16.2 Load-side encoder	538
Linear encoder	538
Rotary encoder	538
Configuration diagram of encoder cable	539
MR-J4FCCBL03M branch cable	541
16.3 Operation and functions	542
Startup	542

Home position return	549
Operation from controller	553
Fully closed loop control error detection functions	554
Auto tuning function	555
Machine analyzer function	555
Test operation mode	555
Absolute position detection system under fully closed loop system	556
About MR Configurator2	557

CHAPTER 17 APPLICATION OF FUNCTIONS 559

17.1 Scale measurement function	559
Functions and configuration	559
Scale measurement encoder	562
How to use scale measurement function	565
Controller setting of the scale measurement function	567
17.2 Touch probe	568
17.3 Backup/restoration function	572
17.4 Parameter object	573
Definition of parameter objects	573
Enabling parameters	574
17.5 Machine diagnosis function	575
Function summary	575
How to set the function	575
Friction vibration estimation function	578
Failure prediction function	580

APPENDICES 586

Appendix 1 When using the servo amplifier with the DC power supply input	586
Connection example	586
Power supply capacity	589
Selection example of wires	589
Molded-case circuit breakers, fuses, magnetic contactors	590
Appendix 2 Handling of AC servo amplifier batteries for the United Nations Recommendations on the Transport of Dangerous Goods	592
Appendix 3 Symbol for the new EU Battery Directive	594
Appendix 4 Compliance with global standards	595
Terms related to safety (IEC 61800-5-2 Stop function)	595
About safety	595
Installation direction and clearances	601
Electrical Installation and configuration diagram	601
Signal	603
Maintenance and service	604
Transportation and storage	605
Technical data	606
Check list for user documentation	608
Appendix 5 MR-J3-D05 Safety logic unit	609
Contents of the package	609
Terms related to safety	609
Cautions	610
Residual risk	610

Block diagram and timing chart	611
Maintenance and disposal	611
Functions and configuration	612
Signal	615
LED display	621
Rotary switch setting	622
Troubleshooting	622
Dimensions	623
Installation	624
Combinations of cable/connector	625
Appendix 6 EC declaration of conformity	626
Appendix 7 How to replace servo amplifier without magnetic pole detection	628
Appendix 8 Two-wire type encoder cable for HG-MR/HG-KR	630
Configuration diagram	630
Connector set	630
Internal wiring diagram	631
Appendix 9 Analog monitor	632
Setting	632
Details of the setting	633
Analog monitor block diagram	637
Maximum current command (maximum torque) for analog monitor ± 8 V	638
Appendix 10 Special specification	645
Amplifiers without dynamic brake	645
Without regenerative resistor	646
Special coating-specification product (IEC 60721-3-3 Class 3C2)	647
Appendix 11 Driving on/off of main circuit power supply with DC power supply	649
Connection example	649
Magnetic contactor	650
Appendix 12 List of registration objects	651
Servo cyclic transmission function	651
Servo transient transmission function	653
Appendix 13 Status of general-purpose AC servo products for compliance with the China RoHS directive	656
Appendix 14 Encoder output pulse setting method	659
Appendix 15 Adjustment method for error excessive alarm level	660
REVISIONS	662
WARRANTY	667
TRADEMARKS	668

1 FUNCTIONS AND CONFIGURATION

1.1 Summary

The Mitsubishi Electric general-purpose AC servo MELSERVO-J4 series have further higher performance and higher functions compared to the previous MELSERVO-J3 series.

MR-J4-_GF_ servo amplifier can be connected to controllers, such as a simple motion module on CC-Link IE Field Network. CC-Link IE Field Network is an open network using Ethernet (1000BASE-T), allowing high-speed and large-capacity communication. A communication speed of 1 Gbps achieves high-speed control of field devices and high-speed communication between facilities, thus shortening operating cycle.

MELSERVO-J4 series compatible rotary servo motor is equipped with 22-bit (4194304 pulses/rev) high-resolution absolute encoder. In addition, speed frequency response is increased to 2.5 kHz. Thus, faster and more accurate control is enabled as compared to MELSERVO-J3 series.

MR-J4-_GF_ servo amplifier operates MELSERVO-J4 series compatible rotary servo motors, linear servo motors, and direct drive motors as standard.

With one-touch tuning and real-time auto tuning, you can easily adjust the servo gains according to the machine.

The tough drive function and the drive recorder function, which are well-received in the MELSERVO-JN series, have been improved. The MR-J4 servo amplifier supports the improved functions. Additionally, the preventive maintenance support function detects an error in the machine parts. This function provides strong support for the machine maintenance and inspection.

MR-J4-_GF_ servo amplifier supports the Safe Torque Off (STO) function. By combining with optional MR-J3-D05, the servo amplifier supports Safe stop 1 (SS1) function.

The servo amplifier has a USB communication interface. Therefore, you can connect the servo amplifier to the personal computer with MR Configurator2 installed to perform the parameter setting, test operation, gain adjustment, and others.

In the MELSERVO-J4 series, servo amplifiers with the CN2L connector are also available as MR-J4-_GF_-RJ.

By using the CN2L connector, an A/B/Z-phase differential output type external encoder can be connected to the servo amplifier. In a fully closed loop system, a four-wire type external encoder is connectable as well. The following table indicates the communication method of the external encoder compatible with MR-J4-_GF_ and MR-J4-_GF_-RJ servo amplifiers.

Operation mode	External encoder communication method	Connector	
		MR-J4-_GF_	MR-J4-_GF_-RJ
Linear servo system ^{*5}	Two-wire type	CN2 ^{*1}	CN2 ^{*1}
	Four-wire type		
	A/B/Z-phase differential output method	—	CN2L ^{*4}
Fully closed loop system ^{*5}	Two-wire type	CN2 ^{*2*3}	CN2L
	Four-wire type		
	A/B/Z-phase differential output method	—	
Scale measurement function ^{*5}	Two-wire type	CN2 ^{*2*3}	CN2L
	Four-wire type		
	A/B/Z-phase differential output method	—	

*1 The MR-J4THCBL03M branch cable is necessary.

*2 The MR-J4FCCBL03M branch cable is necessary.

*3 When the communication method of the servo motor encoder is four-wire type, MR-J4-_GF_ cannot be used. Use an MR-J4-_GF_-RJ.

*4 Connect a thermistor to CN2.

*5 This is used with servo amplifiers with software version A1 or later.

1.2 Function block diagram

The function block diagram of this servo is shown below.



The diagram shows for MR-J4-GF-RJ as an example. MR-J4-GF servo amplifier does not have CN2L connector.

200 V class

MR-J4-500GF(-RJ) or less

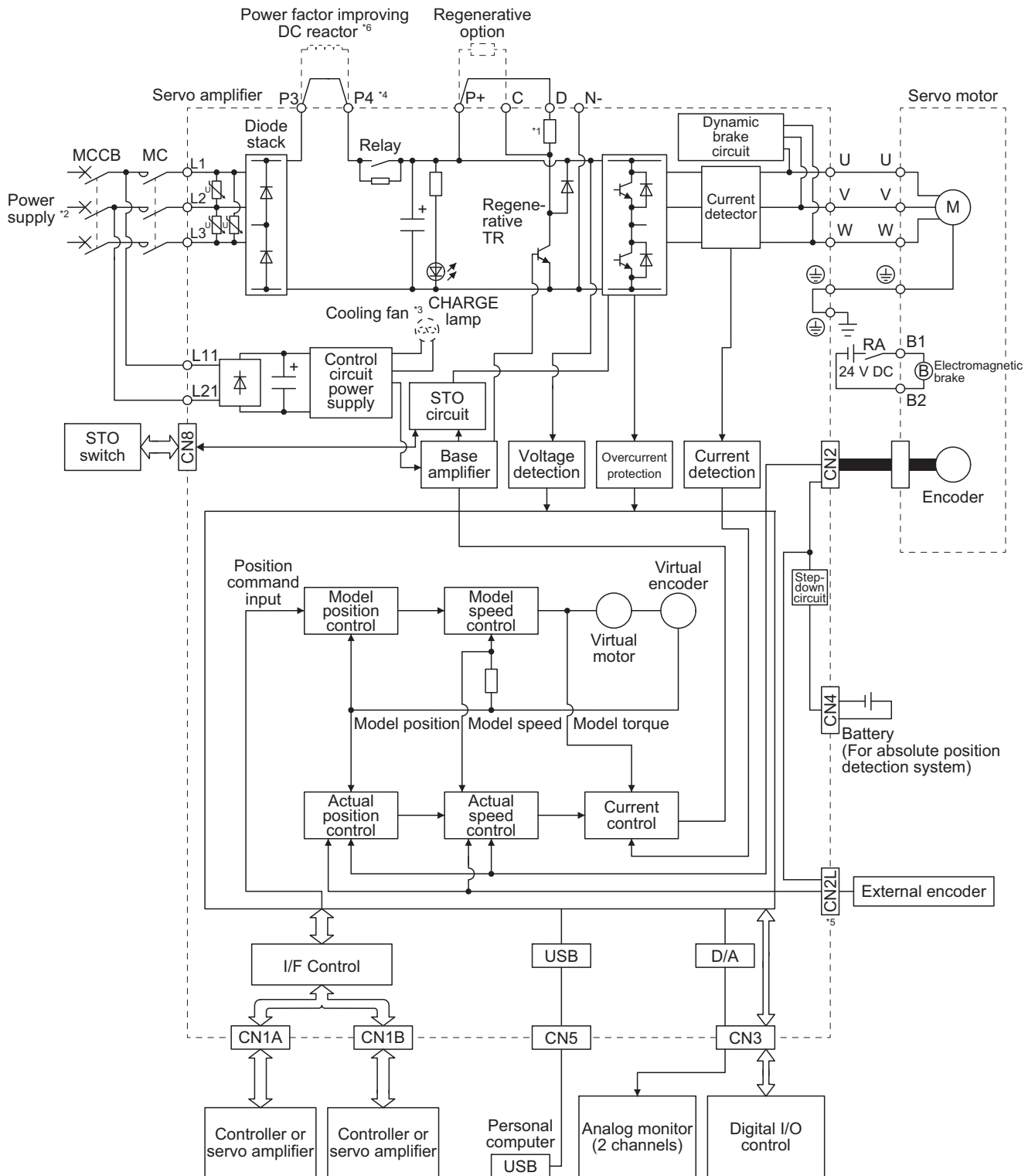

- *1 The built-in regenerative resistor is not provided for MR-J4-10GF(-RJ).
- *2 For 1-phase 200 V AC to 240 V AC, connect the power supply to L1 and L3. Leave L2 open. Refer to the following for the power supply specifications.
 Page 30 Servo amplifier standard specifications
- *3 Servo amplifiers MR-J4-70GF(-RJ) or more have a cooling fan.
- *4 MR-J4 servo amplifier has P3 and P4 in the upstream of the inrush current suppression circuit. They are different from P1 and P2 of MR-J3 servo amplifiers.
- *5 This is for MR-J4-_GF-RJ servo amplifier. MR-J4-_GF servo amplifier does not have CN2L connector.
- *6 The power factor improving AC reactor can also be used. In this case, the power factor improving DC reactor cannot be used. When not using the power factor improving DC reactor, short P3 and P4.

MR-J4-700GF(-RJ)

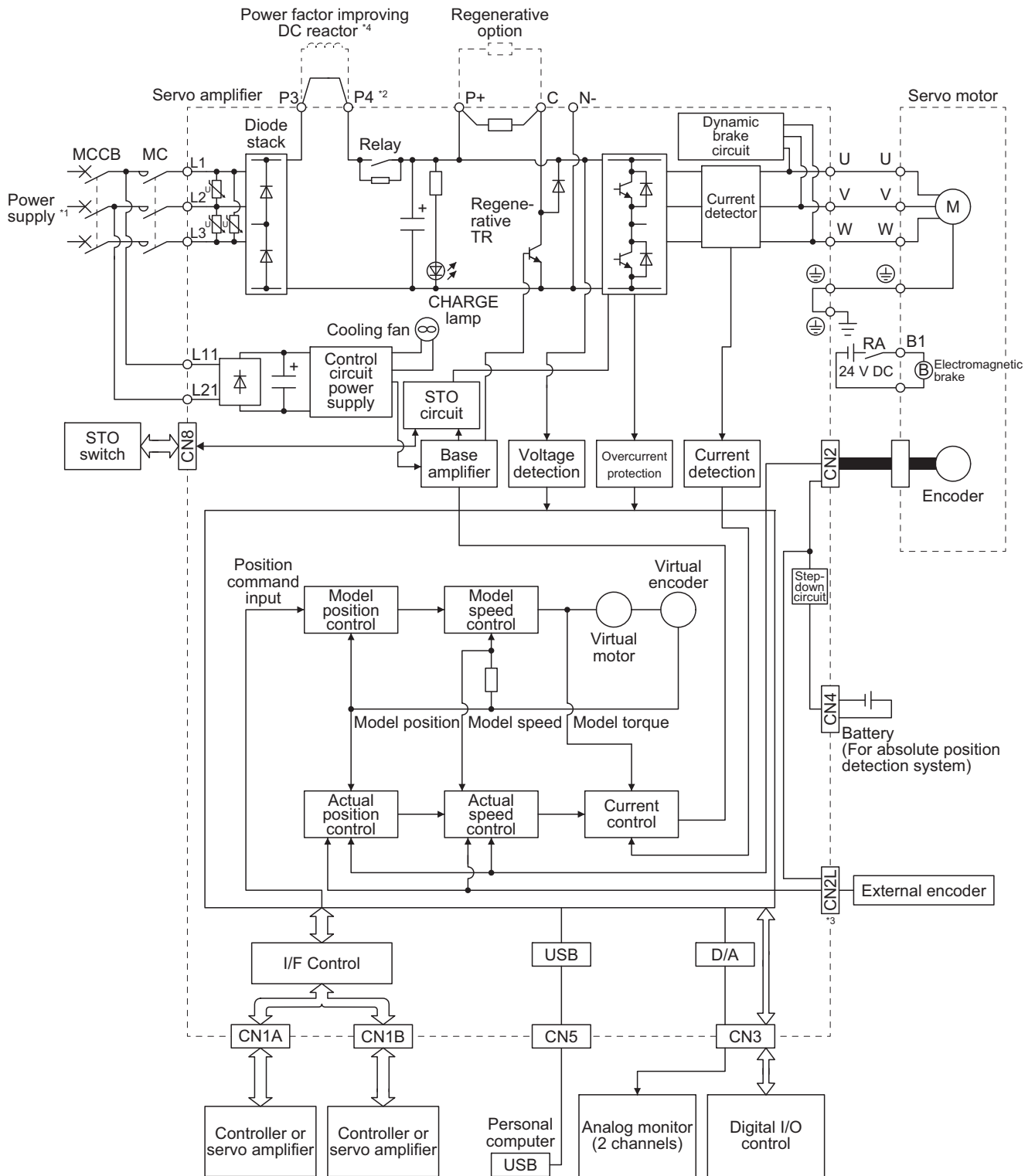

*1 Refer to the following for the power supply specifications.

☞ Page 30 Servo amplifier standard specifications

*2 MR-J4 servo amplifier has P3 and P4 in the upstream of the inrush current suppression circuit. They are different from P1 and P2 of MR-J3 servo amplifiers.

*3 This is for MR-J4_GF-RJ servo amplifier. MR-J4_GF servo amplifier does not have CN2L connector.

*4 The power factor improving AC reactor can also be used. In this case, the power factor improving DC reactor cannot be used. When not using the power factor improving DC reactor, short P3 and P4.

■MR-J4-11KGF(-RJ)/MR-J4-15KGF(-RJ)/MR-J4-22KGF(-RJ)

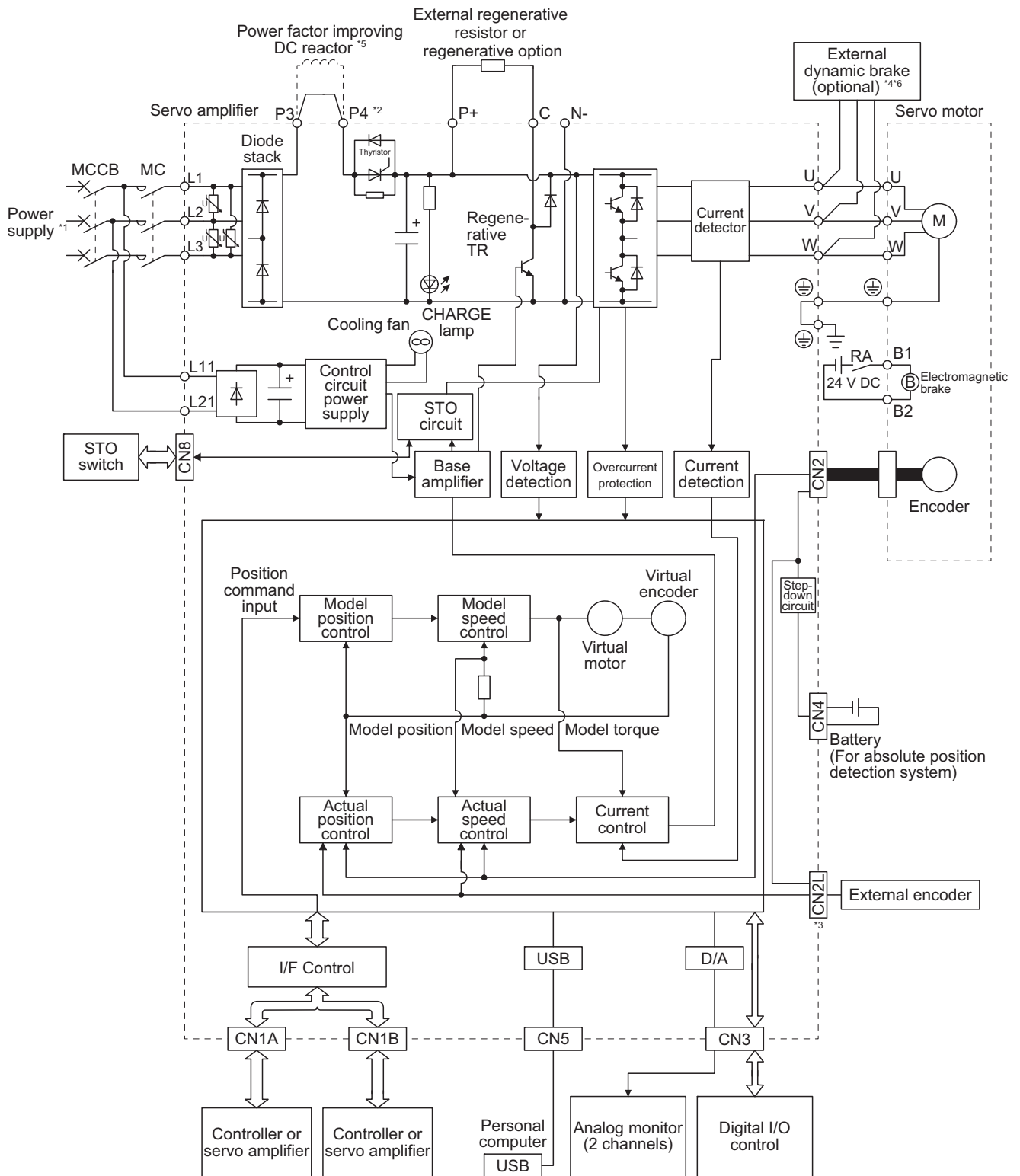

- *1 Refer to the following for the power supply specifications.
☞ Page 30 Servo amplifier standard specifications
- *2 MR-J4 servo amplifier has P3 and P4 in the upstream of the inrush current suppression circuit. They are different from P1 and P2 of MR-J3 servo amplifiers.
- *3 This is for MR-J4-_GF-RJ servo amplifier. MR-J4-_GF servo amplifier does not have CN2L connector.
- *4 Use an external dynamic brake for this servo amplifier. Failure to do so will cause an accident because the servo motor does not stop immediately but coasts at an alarm occurrence for which the servo motor does not decelerate to stop. Ensure the safety in the entire equipment. For alarms for which the servo motor does not decelerate to stop, refer to the following.
☞ Page 283 TROUBLESHOOTING
- *5 The power factor improving AC reactor can also be used. In this case, the power factor improving DC reactor cannot be used. When not using the power factor improving DC reactor, short P3 and P4.
- *6 The external dynamic brake cannot be used for compliance with SEMI-F47 standard. Do not assign DB (Dynamic brake interlock) in [Pr. PD07] to [Pr. PD09]. Failure to do so will cause the servo amplifier to become servo-off when an instantaneous power failure occurs.

■MR-J4-350GF4(-RJ) or less

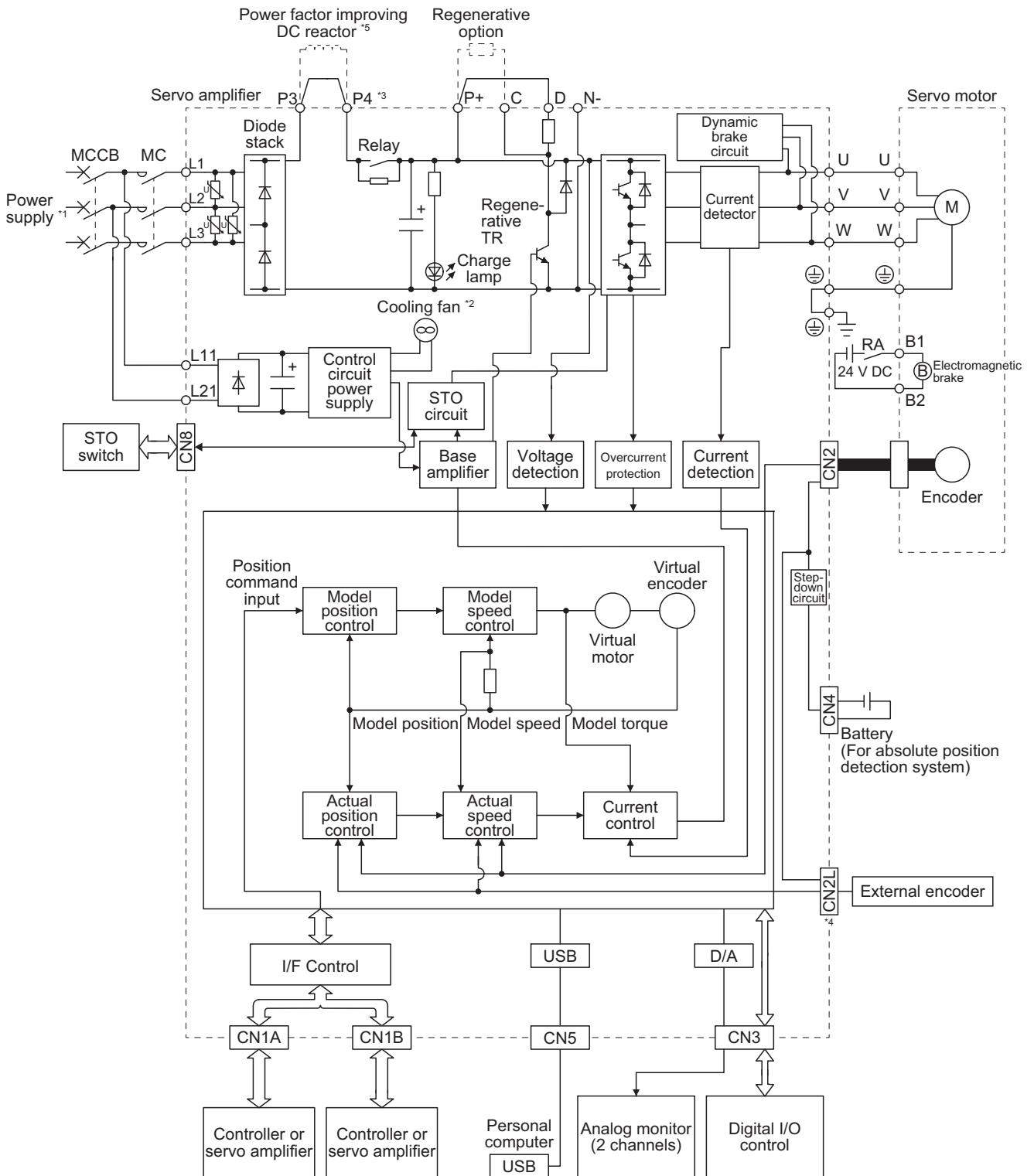

- *1 Refer to the following for the power supply specifications.
☞ Page 30 Servo amplifier standard specifications
- *2 Servo amplifiers MR-J4-200GF4(-RJ) or more have a cooling fan.
- *3 MR-J4 servo amplifier has P3 and P4 in the upstream of the inrush current suppression circuit. They are different from P1 and P2 of MR-J3 servo amplifiers.
- *4 This is for MR-J4-GF4-RJ servo amplifier. MR-J4-GF4 servo amplifier does not have CN2L connector.
- *5 The power factor improving AC reactor can also be used. In this case, the power factor improving DC reactor cannot be used. When not using the power factor improving DC reactor, short P3 and P4.

MR-J4-500GF4(-RJ)/MR-J4-700GF4(-RJ)

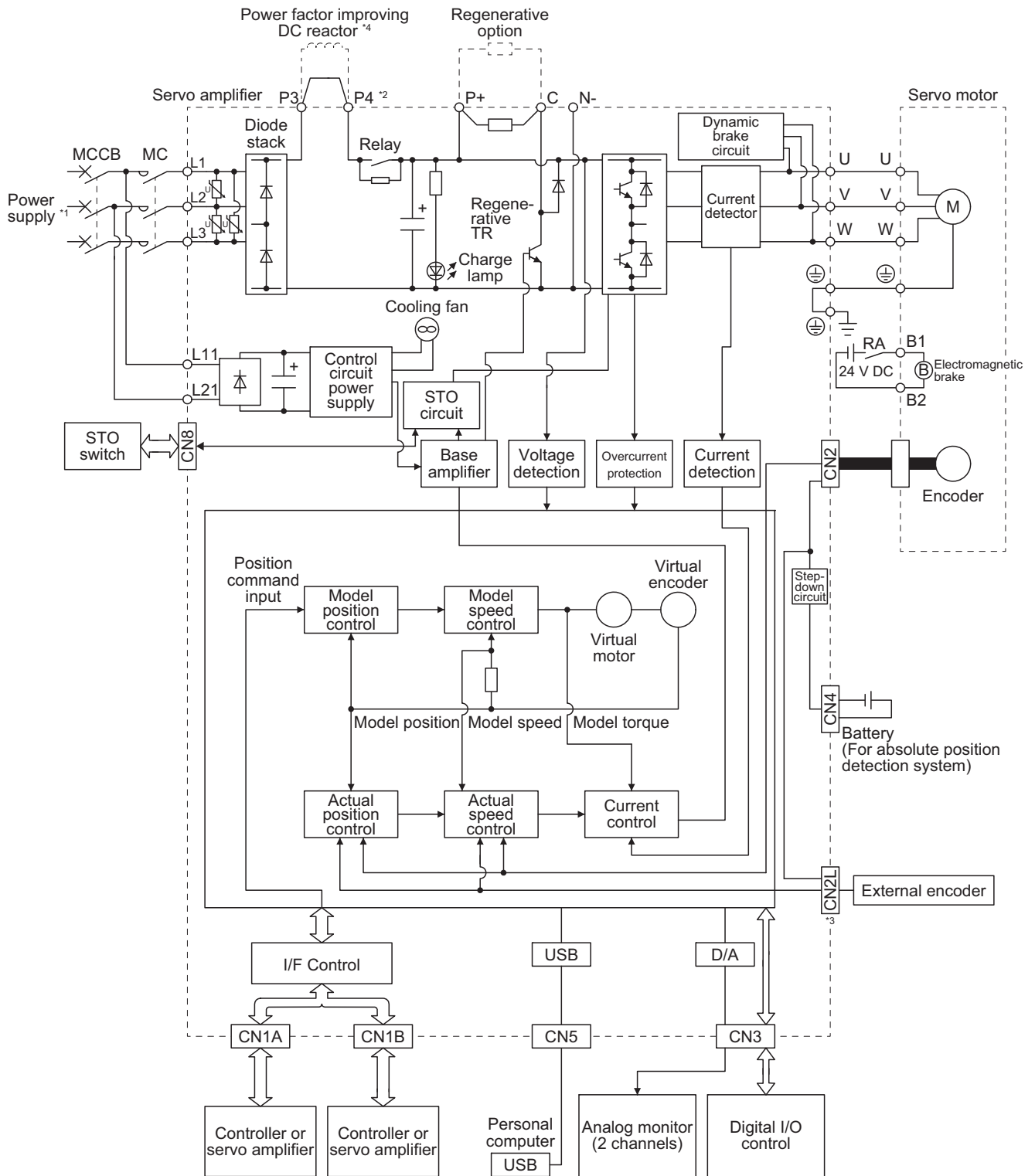

*1 Refer to the following for the power supply specifications.

☞ Page 30 Servo amplifier standard specifications

*2 MR-J4 servo amplifier has P3 and P4 in the upstream of the inrush current suppression circuit. They are different from P1 and P2 of MR-J3 servo amplifiers.

*3 This is for MR-J4-GF4-RJ servo amplifier. MR-J4-GF4 servo amplifier does not have CN2L connector.

*4 The power factor improving AC reactor can also be used. In this case, the power factor improving DC reactor cannot be used. When not using the power factor improving DC reactor, short P3 and P4.

■MR-J4-11KGF4(-RJ)/MR-J4-15KGF4(-RJ)/MR-J4-22KGF4(-RJ)

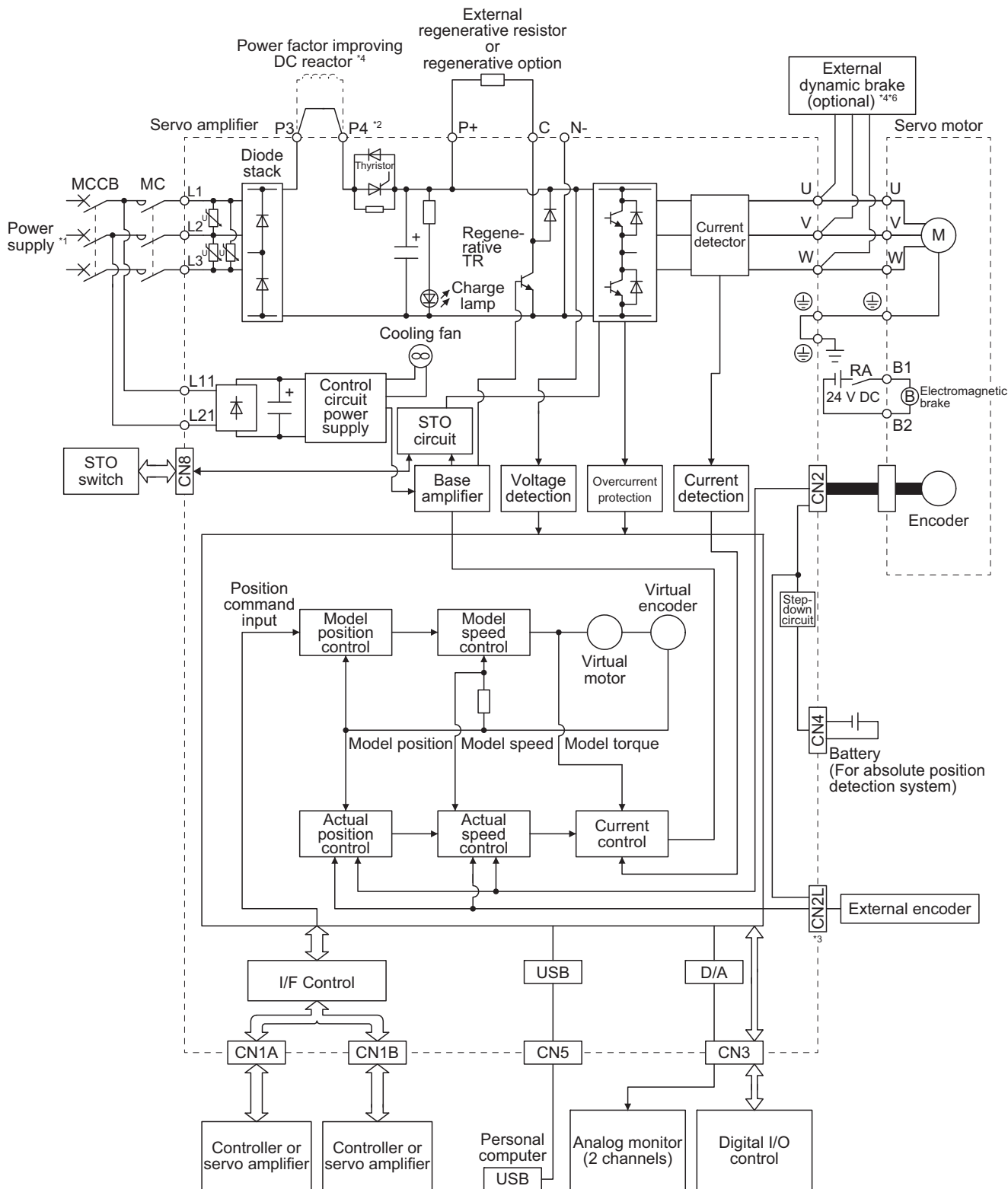

- *1 Refer to the following for the power supply specifications.
☞ Page 30 Servo amplifier standard specifications
- *2 MR-J4 servo amplifier has P3 and P4 in the upstream of the inrush current suppression circuit. They are different from P1 and P2 of MR-J3 servo amplifiers.
- *3 This is for MR-J4-_GF4-RJ servo amplifier. MR-J4-_GF4 servo amplifier does not have CN2L connector.
- *4 Use an external dynamic brake for this servo amplifier. Failure to do so will cause an accident because the servo motor does not stop immediately but coasts at an alarm occurrence for which the servo motor does not decelerate to stop. Ensure the safety in the entire equipment. For alarms for which the servo motor does not decelerate to stop, refer to the following.
☞ Page 283 TROUBLESHOOTING
- *5 The power factor improving AC reactor can also be used. In this case, the power factor improving DC reactor cannot be used. When not using the power factor improving DC reactor, short P3 and P4.
- *6 The external dynamic brake cannot be used for compliance with SEMI-F47 standard. Do not assign DB (Dynamic brake interlock) in [Pr. PD07] to [Pr. PD09]. Failure to do so will cause the servo amplifier to become servo-off when an instantaneous power failure occurs.

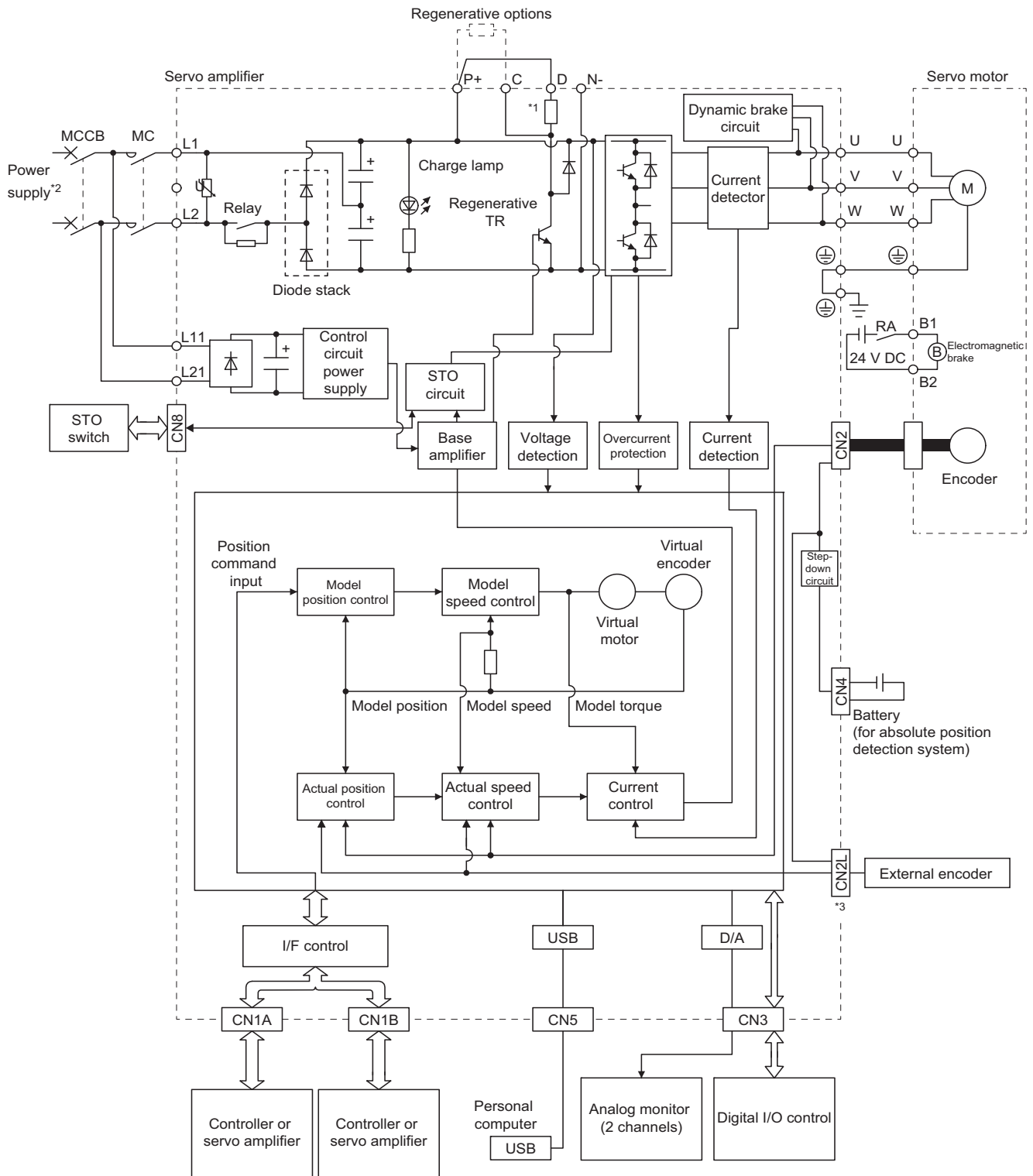

*1 The built-in regenerative resistor is not provided for MR-J4-10GF1(-RJ).

*2 Refer to the following for the power supply specifications.

*3 This is for MR-J4- GF1-RJ servo amplifier. MR-J4- GF1 servo amplifier does not have CN2L connector.

1.3 Servo amplifier standard specifications

200 V class

Model: MR-J4-_-(-RJ)		10GF	20GF	40GF	60GF	70GF	100GF	200GF	350GF	500GF	700GF	11KGF	15KGF	22KGF	
Output	Rated voltage	3-phase 170 V AC													
	Rated current [A]	1.1	1.5	2.8	3.2	5.8	6.0	11.0	17.0	28.0	37.0	68.0	87.0	126.0	
	Output frequency	Less than 590 Hz													
	Output frequency accuracy	±0.01%													
Main circuit power supply input	Voltage/ Frequency	At AC input	3-phase or 1-phase 200 V AC to 240 V AC, 50 Hz/60 Hz				3-phase or 1-phase 200 V AC to 240 V AC, 50 Hz/60 Hz ^{*7}			3-phase 200 V AC to 240 V AC, 50 Hz/60 Hz					
		At DC input ^{*8}	283 V DC to 340 V DC												
	Rated current ^{*5} [A]	0.9	1.5	2.6	3.2 ^{*6}	3.8	5.0	10.5	16.0	21.7	28.9	46.0	64.0	95.0	
	Permissible voltage fluctuation	At AC input	3-phase or 1-phase 170 V AC to 264 V AC				3-phase or 1-phase 170 V AC to 264 V AC ^{*7}			3-phase 170 V AC to 264 V AC					
		At DC input ^{*8}	241 V DC to 374 V DC												
	Permissible frequency fluctuation	±Within ±5%													
	Power supply capacity [kVA]	☞ Page 318 Power supply capacity and generated loss													
	Inrush current [A]	☞ Page 328 Inrush currents at power-on of main circuit and control circuit													
Control circuit power supply input	Voltage/ Frequency	At AC input	1-phase 200 V AC to 240 V AC, 50 Hz/60 Hz												
		At DC input ^{*8}	283 V DC to 340 V DC												
	Rated current [A]	0.2									0.3				
	Permissible voltage fluctuation	At AC input	1-phase 170 V AC to 264 V AC												
		At DC input ^{*8}	241 V DC to 374 V DC												
	Permissible frequency fluctuation	±Within ±5%													
	Power consumption [W]	30									45				
Inrush current [A]	☞ Page 328 Inrush currents at power-on of main circuit and control circuit														
Interface power supply	Voltage	24 V DC ± 10%													
	Current capacity [A]	0.3 (including CN8 connector signals) ^{*1}													
Control method	Sine-wave PWM control, current control method														
Dynamic brake	Built-in										External option ^{*13*14}				
CC-Link IE Field communication cycle ^{*12}	0.5 ms, 1.0 ms, 2.0 ms, 4.0 ms														
Fully closed loop control	Compatible ^{*15}														
Scale measurement function	Compatible ^{*15}														
Load-side encoder interface ^{*11}	Mitsubishi Electric serial interface														
Communication function	USB: connection to a personal computer or others (MR Configurator2-compatible)														
Encoder output pulses	Compatible (A/B/Z-phase pulse)														
Analog monitor	Two channels														
Protective functions	Overcurrent shut-off, regenerative overvoltage shut-off, overload shut-off (electronic thermal), servo motor overheat protection, encoder error protection, regenerative error protection, undervoltage protection, instantaneous power failure protection, overspeed protection, error excessive protection, magnetic pole detection protection, and linear servo control fault protection														
Functional safety	STO (IEC/EN 61800-5-2)														



Model: MR-J4_-(-RJ)		10GF	20GF	40GF	60GF	70GF	100GF	200GF	350GF	500GF	700GF	11KGF	15KGF	22KGF	
Safety performance	Standards certified by CB ^{*10}	EN ISO 13849-1:2015 Category 3 PL e, IEC 61508 SIL 3, EN 62061 SIL CL3, EN 61800-5-2													
	Response performance	8 ms or less (STO input off → energy shut off)													
	Test pulse input (STO) ^{*3}	Test pulse interval: 1 Hz to 25 Hz Test pulse off time: Up to 1 ms													
	Mean time to dangerous failure (MTTFd)	MTTFd ≥ 100 [years] (314a)													
	Diagnostic coverage (DC)	DC = Medium, 97.6 [%]													
	Probability of dangerous Failure per Hour (PFH)	PFH = 6.4 × 10 ⁻⁹ [1/h]													
Compliance to global standards	CE marking	LVD: EN 61800-5-1 EMC: EN 61800-3 MD: EN ISO 13849-1:2015, EN 61800-5-2, EN 62061													
	UL standard	UL 508C													
Structure (IP rating)	Natural cooling, open (IP20)			Force cooling, open (IP20)				Force cooling, open (IP20) ^{*4}							
Close mounting ^{*2}	3-phase power supply input	Possible						Impossible							
	1-phase power supply input	Possible				Impossible		—							
Environment	Ambient temperature	Operation	0 °C to 55 °C (non-freezing)												
		Storage	-20 °C to 65 °C (non-freezing)												
	Ambient humidity	Operation	5 %RH to 90 %RH (non-condensing)												
		Storage													
	Ambience	Indoors (no direct sunlight); no corrosive gas, inflammable gas, oil mist or dust													
	Altitude	2000 m or less above sea level ^{*9}													
Vibration resistance	5.9 m/s ² , at 10 Hz to 55 Hz (directions of X, Y and Z axes)														
Mass [kg]	1.0			1.4		2.1	2.3	4.0	6.2	13.4	13.4	18.2			

- *1 0.3 A is the value applicable when all I/O signals are used. The current capacity can be decreased by reducing the number of I/O points.
- *2 When closely mounting the servo amplifier, operate it at an ambient temperature of 0 °C to 45 °C or at 75% or smaller effective load ratio.
- *3 Test pulse is a signal which instantaneously turns off a signal to the servo amplifier at a constant period for external circuit to self-diagnose.
- *4 Except for the terminal block.
- *5 This value is applicable when a 3-phase power supply is used.
- *6 The rated current is 2.9 A when the servo amplifier is used with a UL or CSA compliant servo motor.
- *7 When using 1-phase 200 V AC to 240 V AC power supply, operate the servo amplifier at 75% or smaller effective load ratio.
- *8 The DC power supply input is available only with MR-J4_-GF-RJ servo amplifiers. For the connection example of the power circuit when a DC input is used, refer to the following.
☞ Page 586 When using the servo amplifier with the DC power supply input
- *9 Follow the restrictions below when using the servo amplifiers at altitude exceeding 1000 m and up to 2000 m above sea level.
☞ Page 81 Restrictions when using the servo amplifiers at altitude exceeding 1000 m and up to 2000 m above sea level
- *10 The safety level depends on the setting value of [Pr. PF18 STO diagnosis error detection time] and whether STO input diagnosis by TOFB output is performed or not. For details, refer to the Function column of [Pr. PF18] below.
☞ Page 217 Extension setting 3 parameters ([Pr. PF_ _])
- *11 The MR-J4_-GF servo amplifier is compatible only with the two-wire type. The MR-J4_-GF-RJ servo amplifier is compatible with the two-wire type, four-wire type, and A/B/Z-phase differential output method.
☞ Page 18 Summary
- *12 The communication cycle depends on the controller specifications and the number of axes connected.
- *13 Use an external dynamic brake for this servo amplifier. Failure to do so will cause an accident because the servo motor does not stop immediately but coasts at emergency stop. Ensure the safety in the entire equipment.
- *14 The external dynamic brake cannot be used for compliance with SEMI-F47 standard. Do not assign DB (Dynamic brake interlock) in [Pr. PD07] to [Pr. PD09]. Failure to do so will cause the servo amplifier to become servo-off when an instantaneous power failure occurs.
- *15 This is used with servo amplifiers with software version A1 or later.

400 V class

Model: MR-J4_(-RJ)		60GF4	100GF4	200GF4	350GF4	500GF4	700GF4	11KGF4	15KGF4	22KGF4
Output	Rated voltage	3-phase 323 V AC								
	Rated current [A]	1.5	2.8	5.4	8.6	14.0	17.0	32.0	41.0	63.0
	Output frequency	Less than 590 Hz								
	Output frequency accuracy	±0.01%								
Main circuit power supply input	Voltage/Frequency	3-phase 380 V AC to 480 V AC, 50 Hz/60 Hz								
	Rated current [A]	1.4	2.5	5.1	7.9	10.8	14.4	23.1	31.8	47.6
	Permissible voltage fluctuation	3-phase 323 V AC to 528 V AC								
	Permissible frequency fluctuation	±Within ±5%								
	Power supply capacity [kVA]	☞ Page 318 Power supply capacity and generated loss								
Inrush current [A]	☞ Page 328 Inrush currents at power-on of main circuit and control circuit									
Control circuit power supply input	Voltage/Frequency	1-phase 380 V AC to 480 V AC, 50 Hz/60 Hz								
	Rated current [A]	0.1			0.2					
	Permissible voltage fluctuation	1-phase 323 V AC to 528 V AC								
	Permissible frequency fluctuation	±Within ±5%								
	Power consumption [W]	30			45					
	Inrush current [A]	☞ Page 328 Inrush currents at power-on of main circuit and control circuit								
Interface power supply	Voltage	24 V DC ± 10%								
	Current capacity [A]	0.3 (including CN8 connector signals)*1								
Control method	Sine-wave PWM control, current control method									
Dynamic brake	Built-in						External option*8*9			
CC-Link IE Field communication cycle*7	0.5 ms, 1.0 ms, 2.0 ms, 4.0 ms									
Fully closed loop control	Compatible*10									
Scale measurement function	Compatible*10									
Load-side encoder interface*6	Mitsubishi Electric serial interface									
Communication function	USB: connection to a personal computer or others (MR Configurator2-compatible)									
Encoder output pulses	Compatible (A/B/Z-phase pulse)									
Analog monitor	Two channels									
Protective functions	Overcurrent shut-off, regenerative overvoltage shut-off, overload shut-off (electronic thermal), servo motor overheat protection, encoder error protection, regenerative error protection, undervoltage protection, instantaneous power failure protection, overspeed protection, error excessive protection, magnetic pole detection protection, and linear servo control fault protection									
Functional safety	STO (IEC/EN 61800-5-2)									
Safety performance	Standards certified by CB*5	EN ISO 13849-1:2015 Category 3 PL e, IEC 61508 SIL 3, EN 62061 SIL CL3, EN 61800-5-2								
	Response performance	8 ms or less (STO input off → energy shut off)								
	Test pulse input (STO)*2	Test pulse interval: 1 Hz to 25 Hz Test pulse off time: Up to 1 ms								
	Mean time to dangerous failure (MTTFd)	MTTFd ≥ 100 [years] (314a)								
	Diagnostic coverage (DC)	DC = Medium, 97.6 [%]								
	Probability of dangerous Failure per Hour (PFH)	PFH = 6.4 × 10 ⁻⁹ [1/h]								



Model: MR-J4-_-(-RJ)			60GF4	100GF4	200GF4	350GF4	500GF4	700GF4	11KGF4	15KGF4	22KGF4	
Compliance to global standards	CE marking	LVD: EN 61800-5-1 EMC: EN 61800-3 MD: EN ISO 13849-1:2015, EN 61800-5-2, EN 62061										
	UL standard	UL 508C										
Close mounting		Impossible										
Structure (IP rating)		Natural cooling, open (IP20)			Force cooling, open (IP20)		Force cooling, open (IP20) ^{*3}					
Environment	Ambient temperature	Operation	0 °C to 55 °C (non-freezing)									
		Storage	-20 °C to 65 °C (non-freezing)									
	Ambient humidity	Operation	5 %RH to 90 %RH (non-condensing)									
		Storage										
	Ambience		Indoors (no direct sunlight); no corrosive gas, inflammable gas, oil mist or dust									
	Altitude		2000 m or less above sea level ^{*4}									
Vibration resistance		5.9 m/s ² , at 10 Hz to 55 Hz (directions of X, Y and Z axes)										
Mass [kg]		1.7	2.1	3.6	4.3	6.5	13.4	13.4	18.2			

- *1 0.3 A is the value applicable when all I/O signals are used. The current capacity can be decreased by reducing the number of I/O points.
- *2 Test pulse is a signal which instantaneously turns off a signal to the servo amplifier at a constant period for external circuit to self-diagnose.
- *3 Except for the terminal block.
- *4 Follow the restrictions below when using the servo amplifiers at altitude exceeding 1000 m and up to 2000 m above sea level.
 Page 81 Restrictions when using the servo amplifiers at altitude exceeding 1000 m and up to 2000 m above sea level
- *5 The safety level depends on the setting value of [Pr. PF18 STO diagnosis error detection time] and whether STO input diagnosis by TOFB output is performed or not. For details, refer to the Function column of [Pr. PF18] below.
 Page 217 Extension setting 3 parameters ([Pr. PF__])
- *6 The MR-J4-_-GF servo amplifier is compatible only with the two-wire type. The MR-J4-_-GF-RJ servo amplifier is compatible with the two-wire type, four-wire type, and A/B/Z-phase differential output method.
 Page 18 Summary
- *7 The communication cycle depends on the controller specifications and the number of axes connected.
- *8 Use an external dynamic brake for this servo amplifier. Failure to do so will cause an accident because the servo motor does not stop immediately but coasts at emergency stop. Ensure the safety in the entire equipment.
- *9 The external dynamic brake cannot be used for compliance with SEMI-F47 standard. Do not assign DB (Dynamic brake interlock) in [Pr. PD07] to [Pr. PD09]. Failure to do so will cause the servo amplifier to become servo-off when an instantaneous power failure occurs.
- *10 This is used with servo amplifiers with software version A1 or later.

100 V class

Model: MR-J4_-(-RJ)		10GF1	20GF1	40GF1
Output	Rated voltage	3-phase 170 V AC		
	Rated current [A]	1.1	1.5	2.8
	Output frequency	Less than 590 Hz		
	Output frequency accuracy	±0.01%		
Main circuit power supply input	Voltage/Frequency	1-phase 100 V AC to 120 V AC, 50 Hz/60 Hz		
	Rated current [A]	3.0	5.0	9.0
	Permissible voltage fluctuation	1-phase 85 V AC to 132 V AC		
	Permissible frequency fluctuation	±Within ±5%		
	Power supply capacity [kVA]	☞ Page 318 Power supply capacity and generated loss		
	Inrush current [A]	☞ Page 328 Inrush currents at power-on of main circuit and control circuit		
Control circuit power supply input	Voltage/Frequency	1-phase 100 V AC to 120 V AC, 50 Hz/60 Hz		
	Rated current [A]	0.4		
	Permissible voltage fluctuation	1-phase 85 V AC to 132 V AC		
	Permissible frequency fluctuation	±Within ±5%		
	Power consumption [W]	30		
	Inrush current [A]	☞ Page 328 Inrush currents at power-on of main circuit and control circuit		
Interface power supply	Voltage	24 V DC ± 10%		
	Current capacity [A]	0.3 (including CN8 connector signals) *1		
Control method	Sine-wave PWM control, current control method			
Dynamic brake	Built-in			
CC-Link IE Field communication cycle *7	0.5 ms, 1.0 ms, 2.0 ms, 4.0 ms			
Fully closed loop control	Compatible			
Scale measurement function	Compatible			
Load-side encoder interface *6	Mitsubishi Electric serial interface			
Communication function	USB: connection to a personal computer or others (MR Configurator2-compatible)			
Encoder output pulses	Compatible (A/B/Z-phase pulse)			
Analog monitor	Two channels			
Protective functions	Overcurrent shut-off, regenerative overvoltage shut-off, overload shut-off (electronic thermal), servo motor overheat protection, encoder error protection, regenerative error protection, undervoltage protection, instantaneous power failure protection, overspeed protection, error excessive protection, magnetic pole detection protection, and linear servo control fault protection			
Functional safety	STO (IEC/EN 61800-5-2)			
Safety performance	Standards certified by CB *5	EN ISO 13849-1:2015 Category 3 PL e, IEC 61508 SIL 3, EN 62061 SIL CL3, EN 61800-5-2		
	Response performance	8 ms or less (STO input off → energy shut off)		
	Test pulse input (STO) *3	Test pulse interval: 1 Hz to 25 Hz Test pulse off time: Up to 1 ms		
	Mean time to dangerous failure (MTTFd)	MTTFd ≥ 100 [years] (314a)		
	Diagnostic coverage (DC)	DC = Medium, 97.6 [%]		
	Probability of dangerous Failure per Hour (PFH)	PFH = 6.4×10^{-9} [1/h]		
Compliance to global standards	CE marking	LVD: EN 61800-5-1 EMC: EN 61800-3 MD: EN ISO 13849-1:2015, EN 61800-5-2, EN 62061		
	UL standard	UL 508C		
Structure (IP rating)	Natural cooling, open (IP20)			
Close mounting *2	Possible			

Model: MR-J4-_-(-RJ)		10GF1	20GF1	40GF1
Environment	Ambient temperature	Operation	0 °C to 55 °C (non-freezing)	
		Storage	-20 °C to 65 °C (non-freezing)	
	Ambient humidity	Operation	5 %RH to 90 %RH (non-condensing)	
		Storage		
	Ambience		Indoors (no direct sunlight); no corrosive gas, inflammable gas, oil mist or dust	
	Altitude		2000 m or less above sea level *4	
	Vibration resistance		5.9 m/s ² , at 10 Hz to 55 Hz (directions of X, Y and Z axes)	
Mass [kg]		1.0		

- *1 0.3 A is the value applicable when all I/O signals are used. The current capacity can be decreased by reducing the number of I/O points.
- *2 When closely mounting the servo amplifier, operate it at an ambient temperature of 0 °C to 45 °C or at 75% or smaller effective load ratio.
- *3 Test pulse is a signal which instantaneously turns off a signal to the servo amplifier at a constant period for external circuit to self-diagnose.
- *4 Follow the restrictions below when using the servo amplifiers at altitude exceeding 1000 m and up to 2000 m above sea level.
 Page 81 Restrictions when using the servo amplifiers at altitude exceeding 1000 m and up to 2000 m above sea level
- *5 The safety level depends on the setting value of [Pr. PF18 STO diagnosis error detection time] and whether STO input diagnosis by TOFB output is performed or not. For details, refer to the Function column of [Pr. PF18] below.
 Page 217 Extension setting 3 parameters ([Pr. PF__])
- *6 The MR-J4-_GF1 servo amplifier is compatible only with the two-wire type. The MR-J4-_GF1-RJ servo amplifier is compatible with the two-wire type, four-wire type, and A/B/Z-phase differential output method.
 Page 18 Summary
- *7 The communication cycle depends on the controller specifications and the number of axes connected.

1.4 Combinations of servo amplifiers and servo motors

Point

- When a 1-phase 200 V AC input is used, the maximum torque of 400% cannot be achieved with HG-JR series servo motor.
- When you use the MR-J4-100GF(-RJ) or MR-J4-200GF(-RJ) with the 1-phase 200 V AC input, contact your local sales office for the torque characteristics of the HG-UR series and HG-RR series servo motors.

200 V class

Servo amplifier	Rotary servo motor						Linear servo motor (primary side) *1	Direct drive motor *1
	HG-KR	HG-MR	HG-SR	HG-UR	HG-RR	HG-JR		
MR-J4-10GF(-RJ)	053 13	053 13	—	—	—	—	—	—
MR-J4-20GF(-RJ)	23	23	—	—	—	—	LM-U2PAB-05M-0SS0 LM-U2PBB-07M-1SS0	TM-RFM002C20 TM-RG2M002C30*2 TM-RU2M002C30*2 TM-RG2M004E30*2 TM-RU2M004E30*2
MR-J4-40GF(-RJ)	43	43	—	—	—	—	LM-H3P2A-07P-BSS0 LM-H3P3A-12P-CSS0 LM-K2P1A-01M-2SS1 LM-U2PAD-10M-0SS0 LM-U2PAF-15M-0SS0	TM-RFM004C20 TM-RG2M004E30*2,4 TM-RU2M004E30*2,4 TM-RG2M009G30*2 TM-RU2M009G30*2
MR-J4-60GF(-RJ)	—	—	51 52	—	—	53	LM-U2PBD-15M-1SS0	TM-RFM006C20 TM-RFM006E20
MR-J4-70GF(-RJ)	73	73	—	72	—	73	LM-H3P3B-24P-CSS0 LM-H3P3C-36P-CSS0 LM-H3P7A-24P-ASS0 LM-K2P2A-02M-1SS1 LM-U2PBF-22M-1SS0	TM-RFM012E20 TM-RFM012G20 TM-RFM040J10
MR-J4-100GF(-RJ)	—	—	81 102	—	—	53*3 103	—	TM-RFM018E20
MR-J4-200GF(-RJ)	—	—	121 201 152 202	152	103 153	73*3 103*3 153 203	LM-H3P3D-48P-CSS0 LM-H3P7B-48P-ASS0 LM-H3P7C-72P-ASS0 LM-FP2B-06M-1SS0 LM-K2P1C-03M-2SS1 LM-U2P2B-40M-2SS0	—
MR-J4-350GF(-RJ)	—	—	301 352	202	203	153*3 203*3 353	LM-H3P7D-96P-ASS0 LM-K2P2C-07M-1SS1 LM-K2P3C-14M-1SS1 LM-U2P2C-60M-2SS0	TM-RFM048G20 TM-RFM072G20 TM-RFM120J10
MR-J4-500GF(-RJ)	—	—	421 502	352 502	353 503	353*3 503	LM-FP2D-12M-1SS0 LM-FP4B-12M-1SS0 LM-K2P2E-12M-1SS1 LM-K2P3E-24M-1SS1 LM-U2P2D-80M-2SS0	TM-RFM240J10
MR-J4-700GF(-RJ)	—	—	702	—	—	503*3 601 701M 703	LM-FP2F-18M-1SS0 LM-FP4D-24M-1SS0	—
MR-J4-11KGF(-RJ)	—	—	—	—	—	801 12K1 11K1M 903	LM-FP4F-36M-1SS0	—
MR-J4-15KGF(-RJ)	—	—	—	—	—	15K1 15K1M	LM-FP4F-48M-1SS0	—

Servo amplifier	Rotary servo motor						Linear servo motor (primary side) ^{*1}	Direct drive motor ^{*1}
	HG-KR	HG-MR	HG-SR	HG-UR	HG-RR	HG-JR		
MR-J4-22KGF(-RJ)	—	—	—	—	—	20K1 25K1 22K1M	—	—

- *1 This is used with servo amplifiers with software version A1 or later.
- *2 This is used with servo amplifiers with software version A5 or later.
- *3 This combination increases the maximum torque of the servo motor to 400%.
- *4 The combination increases the rated torque and the maximum torque.

400 V class

Servo amplifier	Rotary servo motor		Linear servo motor (primary side) ^{*1}
	HG-SR	HG-JR	
MR-J4-60GF4(-RJ)	524	534	—
MR-J4-100GF4(-RJ)	1024	534 ^{*2} 734 1034	—
MR-J4-200GF4(-RJ)	1524 2024	734 ^{*2} 1034 ^{*2} 1534 2034	—
MR-J4-350GF4(-RJ)	3524	1534 ^{*2} 2034 ^{*2} 3534	—
MR-J4-500GF4(-RJ)	5024	3534 ^{*2} 5034	—
MR-J4-700GF4(-RJ)	7024	5034 ^{*2} 6014 701M4 7034	—
MR-J4-11KGF4(-RJ)	—	8014 12K14 11K1M4 9034	—
MR-J4-15KGF4(-RJ)	—	15K14 15K1M4	—
MR-J4-22KGF4(-RJ)	—	20K14 25K14 22K1M4	LM-FP5H-60M-1SS0

- *1 This is used with servo amplifiers with software version A1 or later.
- *2 The combination is for increasing the maximum torque of the servo motor to 400%.

100 V class

Servo amplifier	Rotary servo motor		Linear servo motor (primary side)	Direct drive motor
	HG-KR	HG-MR		
MR-J4-10GF1(-RJ)	053 13	053 13	—	—
MR-J4-20GF1(-RJ)	23	23	LM-U2PAB-05M-0SS0 LM-U2PBB-07M-1SS0	TM-RFM002C20 TM-RG2M002C30 TM-RU2M002C30 TM-RG2M004E30 TM-RU2M004E30
MR-J4-40GF1(-RJ)	43	43	LM-H3P2A-07P-BSS0 LM-H3P3A-12P-CSS0 LM-K2P1A-01M-2SS1 LM-U2PAD-10M-0SS0 LM-U2PAF-15M-0SS0	TM-RFM004C20 TM-RG2M004E30 ^{*1} TM-RU2M004E30 ^{*1} TM-RG2M009G30 TM-RU2M009G30

- *1 The combination increases the rated torque and the maximum torque.

1.5 Function list

The following table lists the functions of this servo. For details of the functions, refer to each section of the detailed explanation field.

Function	Description	Detailed explanation
Model adaptive control	This realizes a high response and stable control following the ideal model. The two-degrees-of-freedom-model model adaptive control enables you to set a response to the command and response to the disturbance separately. Additionally, this function can be disabled. Refer to the following for disabling this function. ☞ Page 278 Model adaptive control disabled	—
Cyclic synchronous position mode (CSP)	Operation is performed in the cyclic synchronous position mode.	—
Cyclic synchronous velocity mode (CSV)	Operation is performed in the cyclic synchronous velocity mode.	—
Cyclic synchronous torque mode (CST)	Operation is performed in the cyclic synchronous torque mode.	—
Touch probe	When the touch probe signal is turned on, the current position is latched. This is used with servo amplifiers with software version A1 or later.	☞ Page 568 Touch probe
High-resolution encoder	High-resolution encoder of 4194304 pulses/rev is used as the encoder of the rotary servo motor compatible with the MELSERVO-J4 series.	—
Absolute position detection system	Merely setting a home position once makes home position return unnecessary at every power-on.	☞ Page 462 ABSOLUTE POSITION DETECTION SYSTEM
Gain switching function	You can switch gains during rotation and during stop, and can use an input device to switch gains during operation.	☞ Page 262 Gain switching function
Advanced vibration suppression control II	This function suppresses vibration at the arm end or residual vibration.	☞ Page 257 Advanced vibration suppression control II
Machine resonance suppression filter	This is a filter function (notch filter) which decreases the gain of the specific frequency to suppress the resonance of the mechanical system.	☞ Page 250 Machine resonance suppression filter
Shaft resonance suppression filter	When a load is mounted to the servo motor shaft, resonance by shaft torsion during driving may generate a mechanical vibration at high frequency. The shaft resonance suppression filter suppresses the vibration.	☞ Page 255 Shaft resonance suppression filter
Adaptive filter II	Servo amplifier detects mechanical resonance and sets filter characteristics automatically to suppress mechanical vibration.	☞ Page 253 Adaptive filter II
Low-pass filter	Suppresses high-frequency resonance which occurs as servo system response is increased.	☞ Page 256 Low-pass filter
Machine analyzer function	Analyzes the frequency characteristic of the mechanical system by simply connecting a MR Configurator2 installed personal computer and servo amplifier. MR Configurator2 is necessary for this function.	—
Robust filter	This function provides better disturbance response in case low response level that load to motor inertia ratio is high for such as roll send axes.	[Pr. PE41]
Slight vibration suppression control	Suppresses vibration of ± 1 pulse produced at a servo motor stop.	[Pr. PB24]
Auto tuning	Automatically adjusts the gain to optimum value if load applied to the servo motor shaft varies.	☞ Page 240 Auto tuning
Brake unit	Used when the regenerative option cannot provide enough regenerative power. Can be used for the 5 kW or more servo amplifier.	☞ Page 357 FR-BU2-(H) brake unit
Power regeneration converter	Used when the regenerative option cannot provide enough regenerative power. Can be used for the 5 kW or more servo amplifier.	☞ Page 370 FR-RC-(H) power regeneration converter

Function	Description	Detailed explanation
Multifunction regeneration converter	Use the brake unit when the regenerative option cannot provide sufficient regenerative capability.	☞ Page 454 Multifunction regeneration converter FR-XC-(H)
Regenerative option	Used when the built-in regenerative resistor of the servo amplifier does not have sufficient regenerative capability for the regenerative power generated.	☞ Page 338 Regenerative options
Alarm history clear	Alarm history is cleared.	[Pr. PC21]
Input signal selection (device settings)	The input devices including LSP (Forward rotation stroke end) and LSN (Reverse rotation stroke end) can be assigned to certain pins of the CN3 connector.	[Pr. PD03] to [Pr. PD05]
Output signal selection (device settings)	The output devices including MBR (Electromagnetic brake interlock) can be assigned to certain pins of the CN3 connector.	[Pr. PD07] to [Pr. PD09]
Output signal (DO) forced output	Output signal can be forced on/off independently of the servo status. Use this function for checking output signal wiring, etc.	☞ Page 143 Output signal (DO) forced output
Torque limit	Servo motor torque can be limited to any value.	[Pr. PA11] [Pr. PA12]
Speed limit	Servo motor speed can be limited to any value.	[Pr. PT67]
Test operation mode	Jog operation, positioning operation, motor-less operation, DO forced output, and program operation can be performed. MR Configurator2 is necessary for this function.	☞ Page 142 Test operation mode
Analog monitor output	Servo status is output in terms of voltage in real time.	[Pr. PC09], [Pr. PC10]
MR Configurator2	Using a personal computer, you can perform the parameter setting, test operation, monitoring, and others.	☞ Page 385 MR Configurator2
Linear servo system	Linear servo system can be configured using a linear servo motor and linear encoder. For the software version of the servo amplifier that is compatible, refer to the following. ☞ Page 36 Combinations of servo amplifiers and servo motors	☞ Page 481 USING A LINEAR SERVO MOTOR
Direct drive servo system	Direct drive servo system can be configured to drive a direct drive motor. For the software version of the servo amplifier that is compatible, refer to the following. ☞ Page 36 Combinations of servo amplifiers and servo motors	☞ Page 512 USING A DIRECT DRIVE MOTOR
Fully closed loop system	Fully closed loop system can be configured using the load-side encoder. This is used with servo amplifiers with software version A1 or later.	☞ Page 533 FULLY CLOSED LOOP SYSTEM
One-touch tuning	Gain adjustment is performed just by one click on a certain button on MR Configurator2. Also, the one-touch tuning can be used through network.	☞ Page 232 One-touch tuning
SEMI-F47 function	Enables to avoid triggering [AL. 10 Undervoltage] using the electrical energy charged in the capacitor in case that an instantaneous power failure occurs during operation. Use a 3-phase for the input power supply of the servo amplifier. Using a 1-phase 100 V AC/200 V AC for the input power supply will not comply with SEMI-F47 standard.	[Pr. PA20] [Pr. PF25] ☞ Page 276 Compliance with SEMI-F47 standard
Tough drive function	This function makes the equipment continue operating even under the condition that an alarm occurs. The tough drive function includes two types: the vibration tough drive and the instantaneous power failure tough drive.	☞ Page 270 Tough drive function
Drive recorder function	This function continuously monitors the servo status and records the status transition before and after an alarm for a fixed period of time. You can check the recorded data on the drive recorder window on MR Configurator2 by clicking the "Graph" button. However, the drive recorder will not operate on the following conditions. <ul style="list-style-type: none"> • You are using the graph function of MR Configurator2. • You are using the machine analyzer function. • [Pr. PF21] is set to "-1". • The controller is not connected (except the test operation mode). • An alarm related to the controller is occurring. 	[Pr. PA23]
STO function	This function is a functional safety that complies with IEC/EN 61800-5-2. You can create a safety system for the equipment easily.	☞ Page 469 USING STO FUNCTION

Function	Description	Detailed explanation
Servo amplifier life diagnosis function	You can check the cumulative energization time and the number of on/off times of the inrush relay. This function gives an indication of the replacement time for parts of the servo amplifier including a capacitor and a relay before they malfunction. MR Configurator2 is necessary for this function. Also, the servo amplifier life diagnosis function can be used through network. ☞ Page 651 List of registration objects	—
Power monitoring function	This function calculates the power running energy and the regenerative power from the data in the servo amplifier such as speed and current. Power consumption and others are displayed on MR Configurator2.	—
Machine diagnosis function	From the data in the servo amplifier, this function estimates the friction and vibrational component of the drive system in the equipment and recognizes an error in the machine parts, including a ball screw and bearing. This function automatically sets the threshold used for detecting the error of machine parts such as ball screws and bearings based on the estimated friction, vibrational component, and servo motor total travel distance. It outputs the warning when the friction, vibrational component, and servo motor total travel distance are out of the set threshold. The error in the machine parts such as ball screws and bearings can be detected automatically with this function. MR Configurator2 is necessary for this function. Also, the machine diagnosis function can be used through network. ☞ Page 651 List of registration objects	☞ Page 575 Machine diagnosis function
Limit switch	External limit switches can be used to limit travel intervals of the servo motor.	—
Software limit	Limits travel intervals by address using parameters. Enables the same function with the limit switch by setting parameters.	☞ Page 229 Software limit
Scale measurement function	The function transmits position information of a scale measurement encoder to the controller by connecting the scale measurement encoder in semi closed loop control. This is used with servo amplifiers with software version A1 or later.	☞ Page 559 Scale measurement function
Home position return mode	The servo amplifier operates in the home position return mode.	☞ Page 146 Home position return mode
Lost motion compensation function	This function improves the response delay occurred when the machine moving direction is reversed.	☞ Page 279 Lost motion compensation function
Super trace control	This function sets constant and uniform acceleration/deceleration droop pulses to almost 0.	☞ Page 282 Super trace control
SLMP	SLMP (SeamLess Message Protocol) is a protocol to access SLMP-compatible devices from external devices (such as a personal computer and an HMI) or programmable controller CPU via Ethernet. The parameters of servo amplifiers can be set (read or written) and monitored.	—
Backup/restoration function	This function is to back up and restore all parameter data and point table data in the servo amplifier to GOT using SLMP. This is used with servo amplifiers with software version A1 or later.	☞ Page 572 Backup/restoration function
Functional safety unit	MR-D30 can be used to expand the safety observation function. This is available with servo amplifiers with software version A3 or later.	—
CC-Link IE Field diagnosis	"Selected Station Communication Status Monitor" is available. This is available with servo amplifiers with software version A3 or later. "Operation Test", "Information Confirmation/Set", and "Selected Station Operation" are not available.	—

1.6 Model designation

Rating plate

The following shows an example of rating plate for explanation of each item.

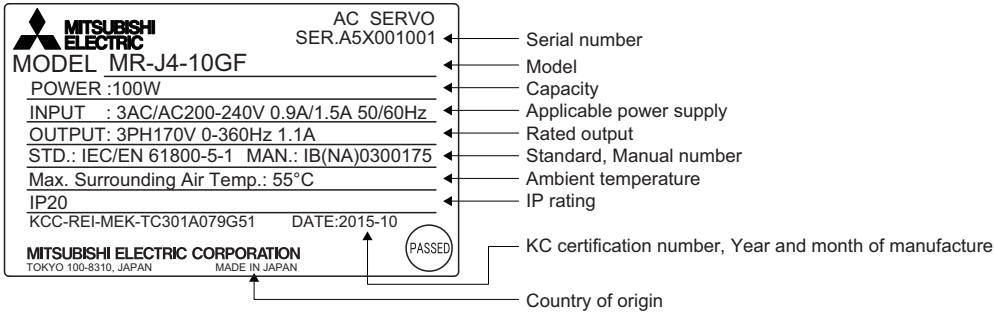

Model

The following describes what each block of a model name indicates. Not all combinations of the symbols are available.

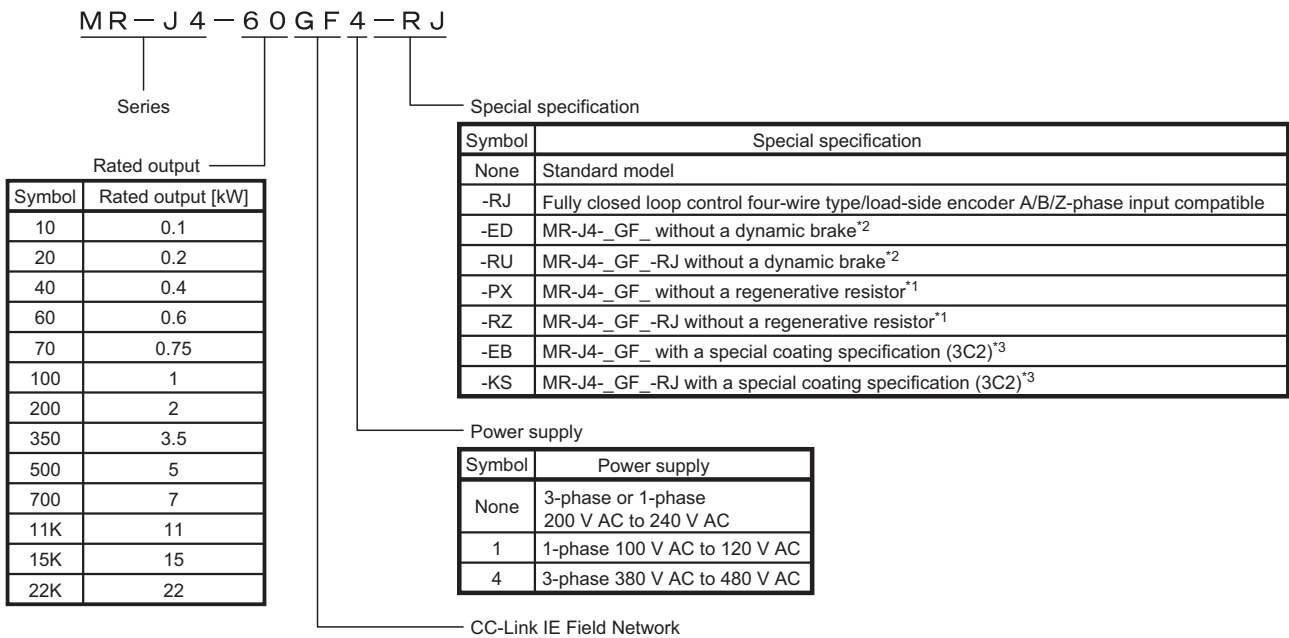

*1 Indicates a servo amplifier of 11 kW to 22 kW that does not use a regenerative resistor as standard accessory.

☞ Page 646 Without regenerative resistor

*2 Dynamic brake which is built in 7 kW or smaller servo amplifiers is removed.

☞ Page 645 Amplifiers without dynamic brake

*3 Type with a specially-coated servo amplifier board (IEC 60721-3-3 Class 3C2).

☞ Page 647 Special coating-specification product (IEC 60721-3-3 Class 3C2)

1.7 Structure

Parts identification

⚠ CAUTION

- When the servo amplifier is used for CC-Link IE Field Network, use the CN1A connector and CN1B connector. Do not connect these connectors to other than CC-Link IE Field Network. Otherwise, a malfunction may occur.
- When the servo amplifier is used for CC-Link IE Field Network Basic, use the CN1A connector only. Do not connect this connector to other than CC-Link IE Field Network Basic. Otherwise, a malfunction may occur.

200 V class

■MR-J4-200GF(-RJ) or less

The diagram shows MR-J4-10GF-RJ.

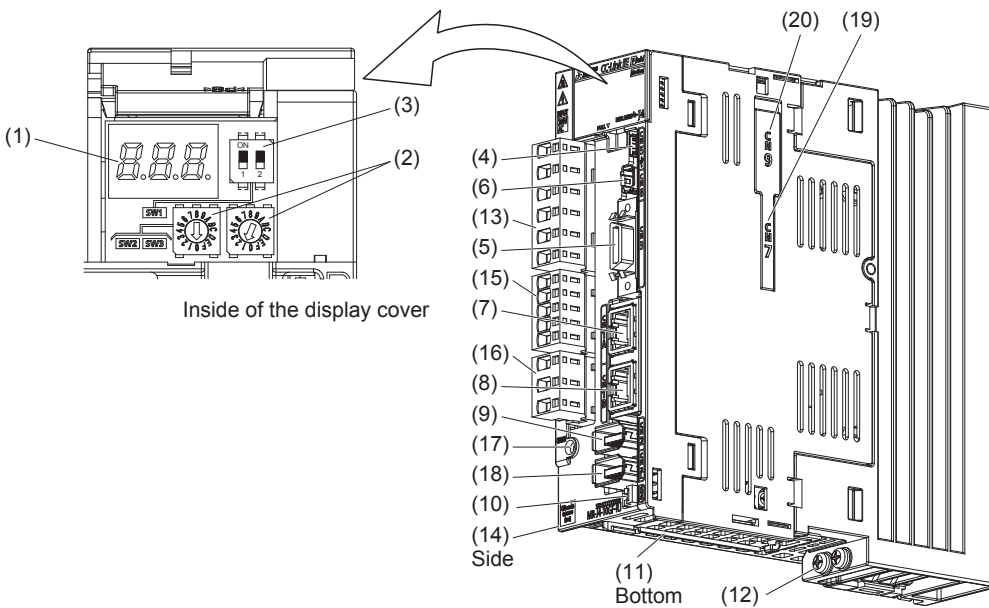

No.	Name/Application	Detailed explanation
(1)	Display The 3-digit, 7-segment LED shows the servo status and the alarm number.	☞ Page 137 Switch setting and display of the servo amplifier
(2)	Station number setting rotary switch (SW2/SW3) Used to set the station number of the servo amplifier.	
(3)	Mode select switch (SW1) To change mode to the test operation mode, set the switch. (SW1-1)	
(4)	USB communication connector (CN5) Used to connect a personal computer.	☞ Page 385 MR Configurator2
(5)	I/O signal connector (CN3) Used to connect digital I/O signals.	☞ Page 95 I/O signal connection example ☞ Page 103 Connectors and pin assignment
(6)	STO input signal connector (CN8) Used to connect the MR-J3-D05 safety logic unit and external safety relay.	☞ Page 469 USING STO FUNCTION ☞ Page 609 MR-J3-D05 Safety logic unit
(7)	Ethernet cable connector (CN1A) Used to connect the controller or the servo amplifier.	☞ Page 58 Configuration including peripheral equipment
(8)	Ethernet cable connector (CN1B) Used to connect the controller or the servo amplifier.	☞ Page 140 CC-Link IE Field status display LED
(9)*2	Encoder connector (CN2) Used to connect the servo motor encoder or external encoder. Refer to the following for the compatible external encoders. ☞ Page 18 Summary	☞ Page 103 Connectors and pin assignment "Servo Motor Instruction Manual (Vol. 3)"
(10)	Battery connector (CN4) Used to connect the battery for absolute position data backup.	☞ Page 466 Battery

No.	Name/Application	Detailed explanation
(11)	Battery holder Used to house the battery for absolute position data backup.	☞ Page 386 Battery
(12)	Protective earth (PE) terminal	☞ Page 83 Connection example of power circuit
(13)	Main circuit power connector (CNP1) Used to connect the input power supply.	☞ Page 98 Explanation of power supply system
(14)	Rating plate	☞ Page 41 Model designation
(15)	Control circuit power connector (CNP2) Used to connect the control circuit power supply and regenerative option.	☞ Page 83 Connection example of power circuit
(16)	Servo motor power output connector (CNP3) Used to connect the servo motor.	☞ Page 98 Explanation of power supply system
(17)	Charge lamp When the main circuit is charged, this will light up. While this lamp is lit, do not reconnect the cables.	—
(18) ^{*1*2}	External encoder connector (CN2L) Used to connect the external encoder. Refer to the following for the compatible external encoders. ☞ Page 18 Summary	☞ Page 103 Connectors and pin assignment "Linear Encoder Instruction Manual"
(19)	Optional unit connector 1 (CN7) This connector is used for connection with an optional unit. The connector is attached only on MR-J4-_GF_-RJ.	—
(20)	Optional unit connector 2 (CN9) This connector is used for connection with an optional unit. The connector is attached only on MR-J4-_GF_-RJ.	—

*1 This is for MR-J4-_GF_-RJ servo amplifier. MR-J4-_GF_ servo amplifier does not have CN2L connector.

*2 "External encoder" is a term for linear encoder used in the linear servo system, load-side encoder used in the fully closed loop system, and scale measurement encoder used with the scale measurement function in this manual.

■MR-J4-350GF(-RJ)

The diagram shows MR-J4-350GF-RJ.

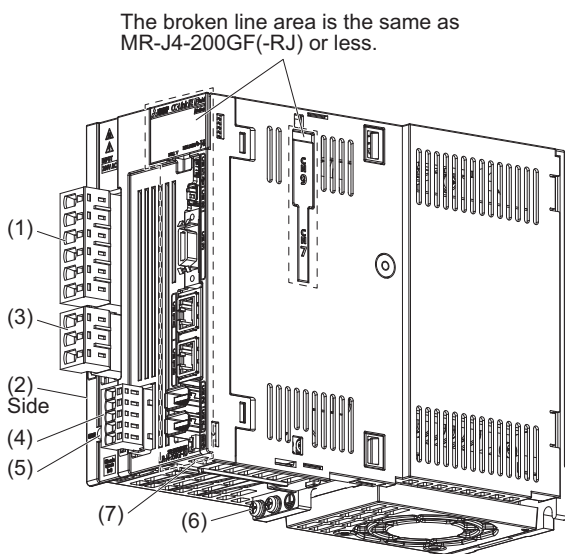

No.	Name/Application	Detailed explanation
(1)	Main circuit power connector (CNP1) Used to connect the input power supply.	☞ Page 83 Connection example of power circuit ☞ Page 98 Explanation of power supply system
(2)	Rating plate	☞ Page 41 Model designation
(3)	Servo motor power output connector (CNP3) Used to connect the servo motor.	☞ Page 83 Connection example of power circuit ☞ Page 98 Explanation of power supply system
(4)	Control circuit power connector (CNP2) Used to connect the control circuit power supply and regenerative option.	—
(5)	Charge lamp When the main circuit is charged, this will light up. While this lamp is lit, do not reconnect the cables.	—
(6)	Protective earth (PE) terminal	☞ Page 83 Connection example of power circuit ☞ Page 98 Explanation of power supply system
(7)	Battery holder Used to house the battery for absolute position data backup.	☞ Page 386 Battery

MR-J4-500GF(-RJ)

Point

The servo amplifier is shown with the front cover open. The front cover cannot be removed.

The diagram shows MR-J4-500GF-RJ.

The broken line area is the same as MR-J4-200GF(-RJ) or less.

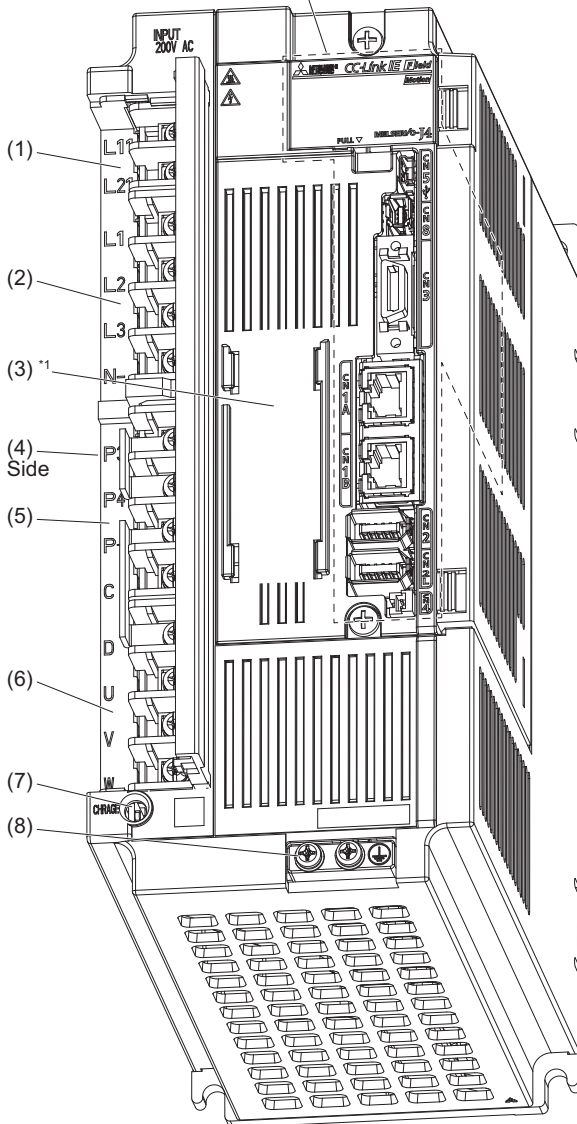

*1 Lines for slots around the battery holder are omitted from the illustration.

No.	Name/Application	Detailed explanation
(1)	Control circuit terminal block (TE2) Used to connect the control circuit power supply.	Page 83 Connection example of power circuit Page 98 Explanation of power supply system
(2)	Main circuit terminal block (TE1) Used to connect the input power supply.	
(3)	Battery holder Used to house the battery for absolute position data backup.	Page 386 Battery
(4)	Rating plate	Page 41 Model designation
(5)	Regenerative option/power factor improving reactor terminal block (TE3) Used to a connect a regenerative option and a power factor improving DC reactor.	Page 83 Connection example of power circuit Page 98 Explanation of power supply system
(6)	Servo motor power output terminal block (TE4) Used to connect the servo motor.	
(7)	Charge lamp When the main circuit is charged, this will light up. While this lamp is lit, do not reconnect the cables.	—

No.	Name/Application	Detailed explanation
(8)	Protective earth (PE) terminal	Page 83 Connection example of power circuit Page 98 Explanation of power supply system

■MR-J4-700GF(-RJ)

Point

The servo amplifier is shown without the front cover. For removal of the front cover, refer to the following.

[Page 56 Removal and reinstallation of the front cover](#)

The diagram shows MR-J4-700GF-RJ.

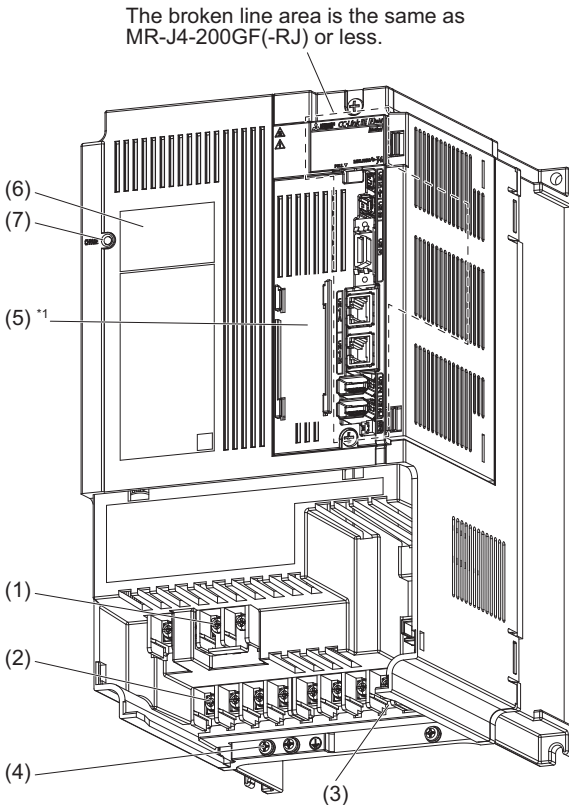

*1 Lines for slots around the battery holder are omitted from the illustration.

No.	Name/Application	Detailed explanation
(1)	Power factor improving reactor terminal block (TE3) Used to connect a power factor improving DC reactor.	Page 83 Connection example of power circuit Page 98 Explanation of power supply system
(2)	Main circuit terminal block (TE1) Used to connect the input power supply, regenerative option, and servo motor.	
(3)	Control circuit terminal block (TE2) Used to connect the control circuit power supply.	
(4)	Protective earth (PE) terminal	
(5)	Battery holder Used to house the battery for absolute position data backup.	Page 386 Battery
(6)	Rating plate	Page 41 Model designation
(7)	Charge lamp When the main circuit is charged, this will light up. While this lamp is lit, do not reconnect the cables.	—

■MR-J4-11KGF(-RJ)/MR-J4-15KGF(-RJ)

Point

The servo amplifier is shown without the front cover. For removal of the front cover, refer to the following.
 ☞ Page 56 Removal and reinstallation of the front cover

The diagram is for MR-J4-11KGF-RJ and MR-J4-15KGF-RJ.

The broken line area is the same as MR-J4-200GF(-RJ) or less.

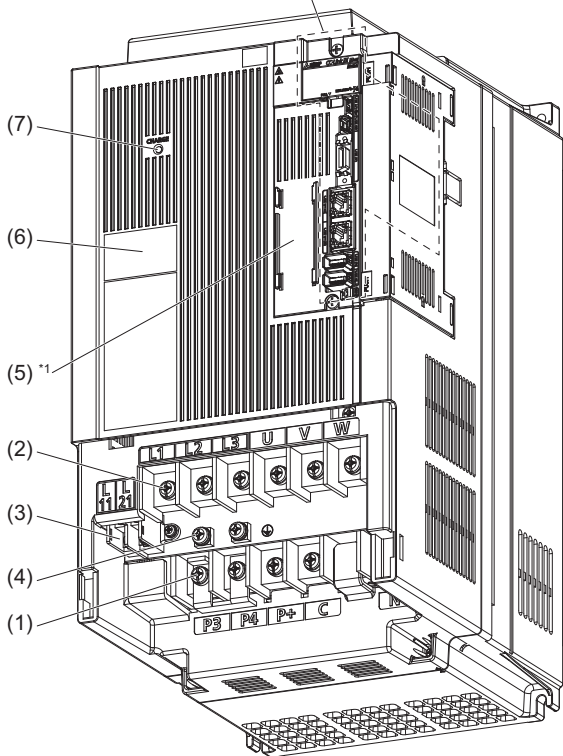

*1 Lines for slots around the battery holder are omitted from the illustration.

No.	Name/Application	Detailed explanation
(1)	Power factor improving reactor terminal block (TE1-2) Used to connect a power factor improving DC reactor and a regenerative option.	☞ Page 83 Connection example of power circuit ☞ Page 98 Explanation of power supply system
(2)	Main circuit terminal block (TE1-1) Used to connect input power and servo motor.	
(3)	Control circuit terminal block (TE2) Used to connect the control circuit power supply.	
(4)	Protective earth (PE) terminal	
(5)	Battery holder Used to house the battery for absolute position data backup.	☞ Page 386 Battery
(6)	Rating plate	☞ Page 41 Model designation
(7)	Charge lamp When the main circuit is charged, this will light up. While this lamp is lit, do not reconnect the cables.	—

MR-J4-22KGF(-RJ)

Point

The servo amplifier is shown without the front cover. For removal of the front cover, refer to the following.
 Page 56 Removal and reinstallation of the front cover

The diagram shows MR-J4-22KGF-RJ.

The broken line area is the same as MR-J4-200GF(-RJ) or less.

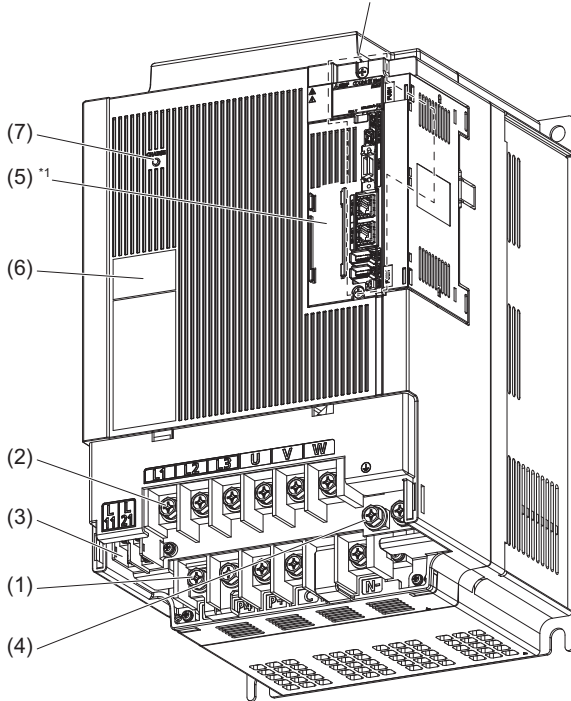

*1 Lines for slots around the battery holder are omitted from the illustration.

No.	Name/Application	Detailed explanation
(1)	Power factor improving reactor terminal block (TE1-2) Used to connect a power factor improving DC reactor and a regenerative option.	Page 83 Connection example of power circuit Page 98 Explanation of power supply system
(2)	Main circuit terminal block (TE1-1) Used to connect input power and servo motor.	
(3)	Control circuit terminal block (TE2) Used to connect the control circuit power supply.	
(4)	Protective earth (PE) terminal	
(5)	Battery holder Used to house the battery for absolute position data backup.	Page 386 Battery
(6)	Rating plate	Page 41 Model designation
(7)	Charge lamp When the main circuit is charged, this will light up. While this lamp is lit, do not reconnect the cables.	—

400 V class

■MR-J4-200GF4(-RJ) or less

The diagram shows MR-J4-60GF4-RJ.

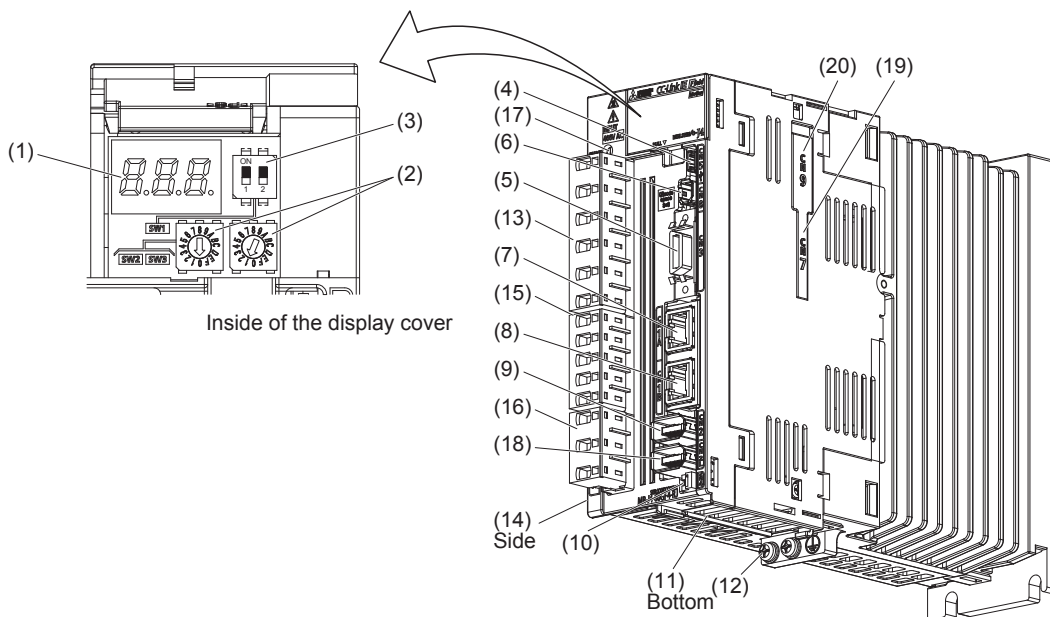

No.	Name/Application	Detailed explanation
(1)	Display The 3-digit, 7-segment LED shows the servo status and the alarm number.	☞ Page 137 Switch setting and display of the servo amplifier
(2)	Station number setting rotary switch (SW2/SW3) Used to set the station number of the servo amplifier.	
(3)	Mode select switch (SW1) To change mode to the test operation mode, set the switch. (SW1-1)	
(4)	USB communication connector (CN5) Used to connect a personal computer.	☞ Page 385 MR Configurator2
(5)	I/O signal connector (CN3) Used to connect digital I/O signals.	☞ Page 95 I/O signal connection example ☞ Page 103 Connectors and pin assignment
(6)	STO input signal connector (CN8) Used to connect the MR-J3-D05 safety logic unit and external safety relay.	☞ Page 469 USING STO FUNCTION ☞ Page 609 MR-J3-D05 Safety logic unit
(7)	Ethernet cable connector (CN1A) Used to connect the controller or the servo amplifier.	☞ Page 58 Configuration including peripheral equipment
(8)	Ethernet cable connector (CN1B) Used to connect the controller or the servo amplifier.	☞ Page 140 CC-Link IE Field status display LED
(9)*2	Encoder connector (CN2) Used to connect the servo motor encoder or external encoder. Refer to the following for the compatible external encoders. ☞ Page 18 Summary	☞ Page 103 Connectors and pin assignment "Servo Motor Instruction Manual (Vol. 3)"
(10)	Battery connector (CN4) Used to connect the battery for absolute position data backup.	☞ Page 466 Battery
(11)	Battery holder Used to house the battery for absolute position data backup.	☞ Page 386 Battery
(12)	Protective earth (PE) terminal	☞ Page 83 Connection example of power circuit ☞ Page 98 Explanation of power supply system
(13)	Main circuit power connector (CNP1) Used to connect the input power supply.	
(14)	Rating plate	☞ Page 41 Model designation
(15)	Control circuit power connector (CNP2) Used to connect the control circuit power supply and regenerative option.	☞ Page 83 Connection example of power circuit ☞ Page 98 Explanation of power supply system
(16)	Servo motor power output connector (CNP3) Used to connect the servo motor.	
(17)	Charge lamp When the main circuit is charged, this will light up. While this lamp is lit, do not reconnect the cables.	—

No.	Name/Application	Detailed explanation
(18) ^{*1,2}	External encoder connector (CN2L) Used to connect the external encoder. Refer to the following for the compatible external encoders. ☞ Page 18 Summary	☞ Page 103 Connectors and pin assignment "Linear Encoder Instruction Manual"
(19)	Optional unit connector 1 (CN7) This connector is used for connection with an optional unit. The connector is attached only on MR-J4-_GF_-RJ.	—
(20)	Optional unit connector 2 (CN9) This connector is used for connection with an optional unit. The connector is attached only on MR-J4-_GF_-RJ.	—

*1 This is for MR-J4-_GF4_-RJ servo amplifier. MR-J4-_GF4_ servo amplifier does not have CN2L connector.

*2 "External encoder" is a term for linear encoder used in the linear servo system, load-side encoder used in the fully closed loop system, and scale measurement encoder used with the scale measurement function in this manual.

■MR-J4-350GF4(-RJ)

The diagram shows MR-J4-350GF4-RJ.

The broken line area is the same as MR-J4-200GF4(-RJ) or less.

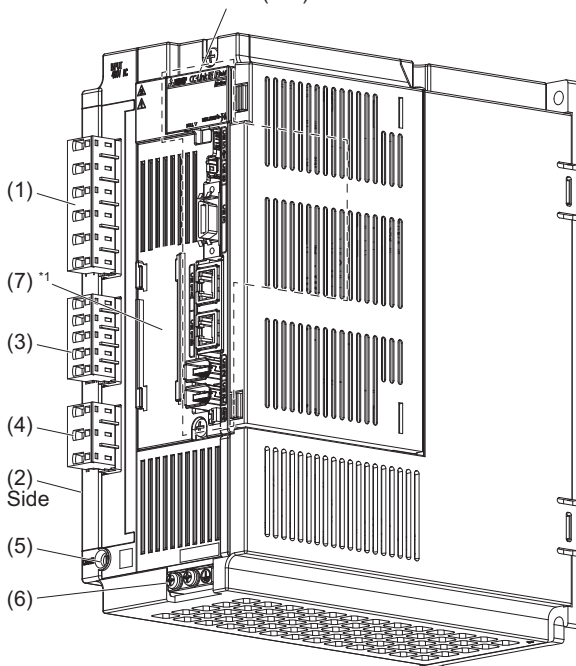

*1 Lines for slots around the battery holder are omitted from the illustration.

No.	Name/Application	Detailed explanation
(1)	Main circuit power connector (CNP1) Used to connect the input power supply.	☞ Page 83 Connection example of power circuit ☞ Page 98 Explanation of power supply system
(2)	Rating plate	☞ Page 41 Model designation
(3)	Control circuit power connector (CNP2) Used to connect the control circuit power supply and regenerative option.	☞ Page 83 Connection example of power circuit ☞ Page 98 Explanation of power supply system
(4)	Servo motor power output connector (CNP3) Used to connect the servo motor.	—
(5)	Charge lamp When the main circuit is charged, this will light up. While this lamp is lit, do not reconnect the cables.	—
(6)	Protective earth (PE) terminal	☞ Page 83 Connection example of power circuit ☞ Page 98 Explanation of power supply system
(7)	Battery holder Used to house the battery for absolute position data backup.	☞ Page 386 Battery

MR-J4-500GF4(-RJ)

Point

The servo amplifier is shown without the front cover. For removal of the front cover, refer to the following.

☞ Page 56 Removal and reinstallation of the front cover

The diagram shows MR-J4-500GF4-RJ.

The broken line area is the same as MR-J4-200GF4(-RJ) or less.

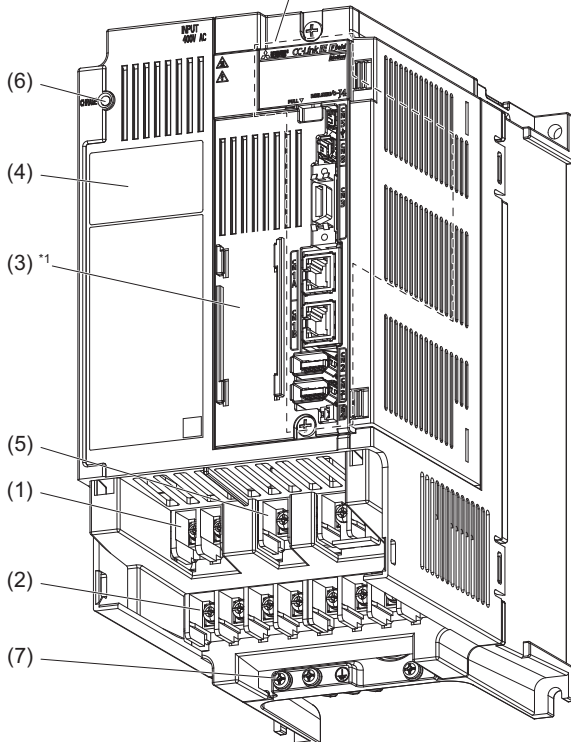

*1 Lines for slots around the battery holder are omitted from the illustration.

No.	Name/Application	Detailed explanation
(1)	Control circuit terminal block (TE2) Used to connect the control circuit power supply.	☞ Page 83 Connection example of power circuit ☞ Page 98 Explanation of power supply system
(2)	Main circuit terminal block (TE1) Used to connect the input power supply, regenerative option, and servo motor.	
(3)	Battery holder Used to house the battery for absolute position data backup.	☞ Page 386 Battery
(4)	Rating plate	☞ Page 41 Model designation
(5)	Power factor improving reactor terminal block (TE3) Used to connect a power factor improving DC reactor.	☞ Page 83 Connection example of power circuit ☞ Page 98 Explanation of power supply system
(6)	Charge lamp When the main circuit is charged, this will light up. While this lamp is lit, do not reconnect the cables.	—
(7)	Protective earth (PE) terminal	☞ Page 83 Connection example of power circuit ☞ Page 98 Explanation of power supply system

MR-J4-700GF4(-RJ)

Point

The servo amplifier is shown without the front cover. For removal of the front cover, refer to the following.
 Page 56 Removal and reinstallation of the front cover

The diagram shows MR-J4-700GF4-RJ.

The broken line area is the same as MR-J4-200GF4(-RJ) or less.

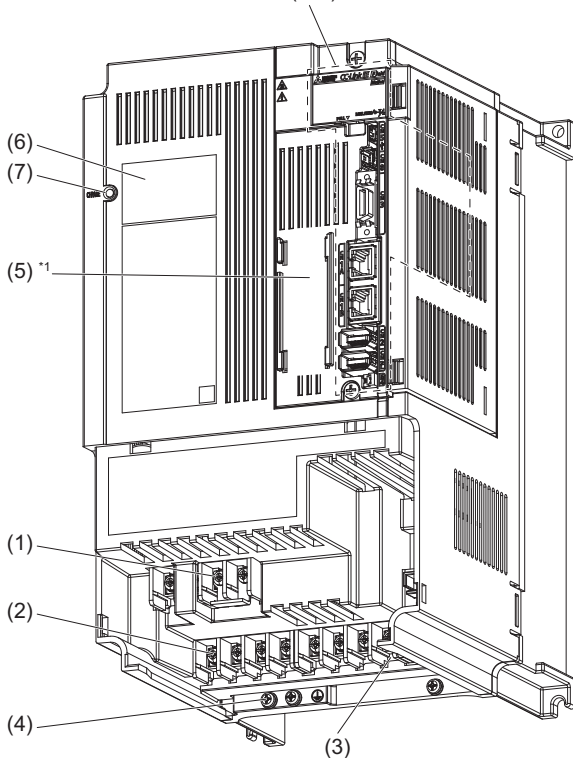

*1 Lines for slots around the battery holder are omitted from the illustration.

No.	Name/Application	Detailed explanation
(1)	Power factor improving reactor terminal block (TE3) Used to connect a power factor improving DC reactor.	Page 83 Connection example of power circuit Page 98 Explanation of power supply system
(2)	Main circuit terminal block (TE1) Used to connect the input power supply, regenerative option, and servo motor.	
(3)	Control circuit terminal block (TE2) Used to connect the control circuit power supply.	
(4)	Protective earth (PE) terminal	
(5)	Battery holder Used to house the battery for absolute position data backup.	Page 386 Battery
(6)	Rating plate	Page 41 Model designation
(7)	Charge lamp When the main circuit is charged, this will light up. While this lamp is lit, do not reconnect the cables.	—

MR-J4-11KGF4(-RJ)/MR-J4-15KGF4(-RJ)

Point

The servo amplifier is shown without the front cover. For removal of the front cover, refer to the following.
 ☞ Page 56 Removal and reinstallation of the front cover

The diagram is for MR-J4-11KGF4-RJ and MR-J4-15KGF4-RJ.

The broken line area is the same as MR-J4-200GF4(-RJ) or less.

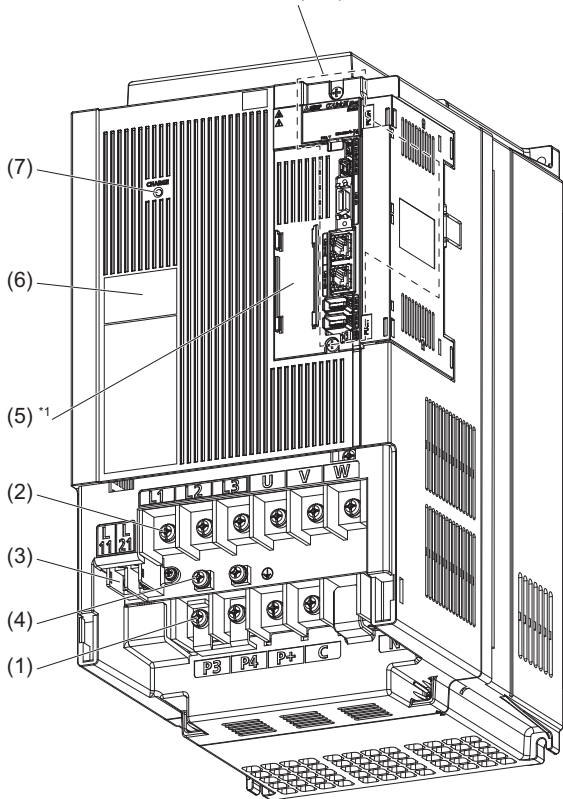

*1 Lines for slots around the battery holder are omitted from the illustration.

No.	Name/Application	Detailed explanation
(1)	Power factor improving reactor terminal block (TE1-2) Used to connect a power factor improving DC reactor and a regenerative option.	☞ Page 83 Connection example of power circuit ☞ Page 98 Explanation of power supply system
(2)	Main circuit terminal block (TE1-1) Used to connect input power and servo motor.	
(3)	Control circuit terminal block (TE2) Used to connect the control circuit power supply.	
(4)	Protective earth (PE) terminal	
(5)	Battery holder Used to house the battery for absolute position data backup.	☞ Page 386 Battery
(6)	Rating plate	☞ Page 41 Model designation
(7)	Charge lamp When the main circuit is charged, this will light up. While this lamp is lit, do not reconnect the cables.	—

MR-J4-22KGF4(-RJ)

Point

The servo amplifier is shown without the front cover. For removal of the front cover, refer to the following.
 ➔ Page 56 Removal and reinstallation of the front cover

The diagram shows MR-J4-22KGF4-RJ.

The broken line area is the same as MR-J4-200GF4(-RJ) or less.

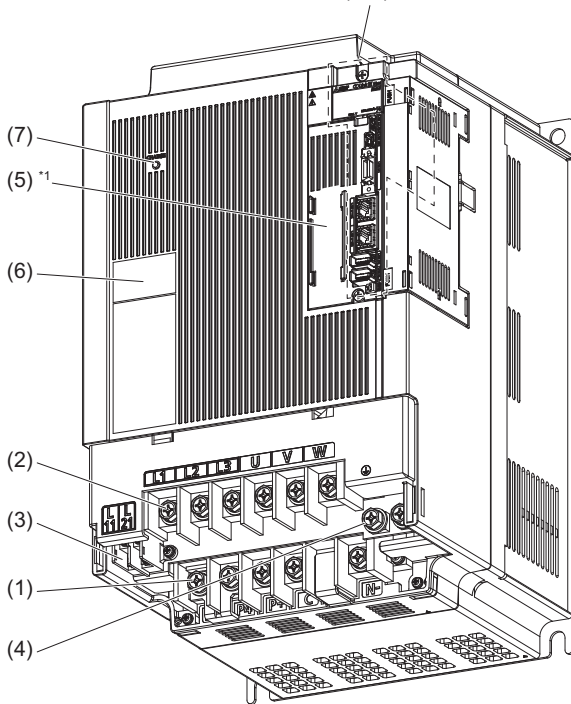

*1 Lines for slots around the battery holder are omitted from the illustration.



No.	Name/Application	Detailed explanation
(1)	Power factor improving reactor terminal block (TE1-2) Used to connect a power factor improving DC reactor and a regenerative option.	➔ Page 83 Connection example of power circuit ➔ Page 98 Explanation of power supply system
(2)	Main circuit terminal block (TE1-1) Used to connect input power and servo motor.	
(3)	Control circuit terminal block (TE2) Used to connect the control circuit power supply.	
(4)	Protective earth (PE) terminal	
(5)	Battery holder Used to house the battery for absolute position data backup.	➔ Page 386 Battery
(6)	Rating plate	➔ Page 41 Model designation
(7)	Charge lamp When the main circuit is charged, this will light up. While this lamp is lit, do not reconnect the cables.	—

100 V class

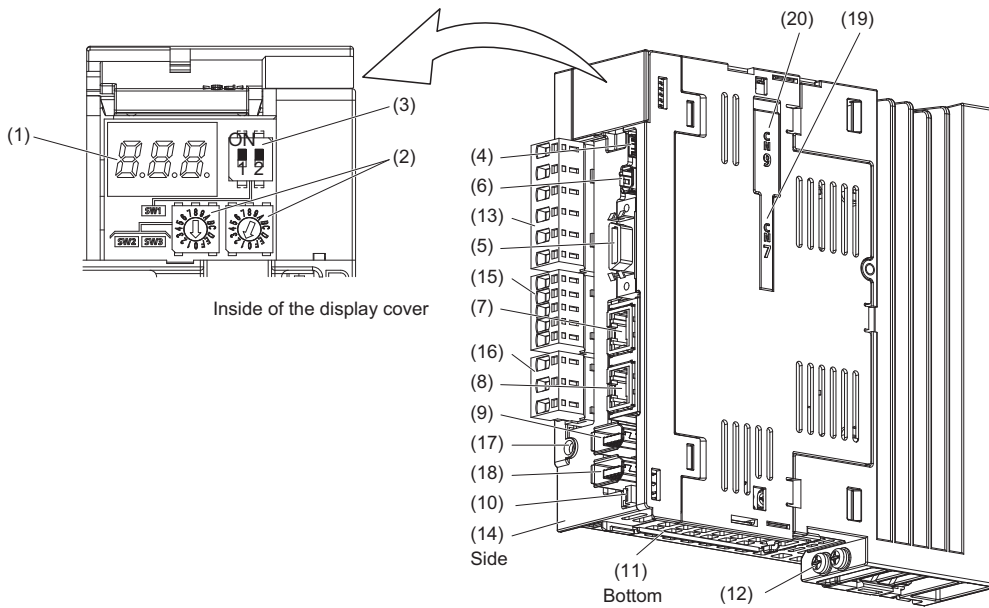
The diagram shows MR-J4-10GF1-RJ.



No.	Name/Application	Detailed explanation
(1)	Display The 3-digit, 7-segment LED shows the servo status and the alarm number.	☞ Page 137 Switch setting and display of the servo amplifier
(2)	Station number setting rotary switch (SW2/SW3) Used to set the station number of the servo amplifier.	
(3)	Mode select switch (SW1) To change mode to the test operation mode, set the switch. (SW1-1)	
(4)	USB communication connector (CN5) Used to connect a personal computer.	☞ Page 385 MR Configurator2
(5)	I/O signal connector (CN3) Used to connect digital I/O signals.	☞ Page 95 I/O signal connection example ☞ Page 103 Connectors and pin assignment
(6)	STO input signal connector (CN8) Used to connect the MR-J3-D05 safety logic unit and external safety relay.	☞ Page 469 USING STO FUNCTION ☞ Page 609 MR-J3-D05 Safety logic unit
(7)	Ethernet cable connector (CN1A) Used to connect the controller or the servo amplifier.	☞ Page 58 Configuration including peripheral equipment
(8)	Ethernet cable connector (CN1B) Used to connect the controller or the servo amplifier.	☞ Page 140 CC-Link IE Field status display LED
(9)*2	Encoder connector (CN2) Used to connect the servo motor encoder or external encoder. Refer to the following for the compatible external encoders. ☞ Page 18 Summary	☞ Page 103 Connectors and pin assignment "Servo Motor Instruction Manual (Vol. 3)"
(10)	Battery connector (CN4) Used to connect the battery for absolute position data backup.	☞ Page 462 ABSOLUTE POSITION DETECTION SYSTEM
(11)	Battery holder Used to house the battery for absolute position data backup.	☞ Page 386 Battery
(12)	Protective earth (PE) terminal	☞ Page 83 Connection example of power circuit ☞ Page 98 Explanation of power supply system
(13)	Main circuit power connector (CNP1) Used to connect the input power supply.	
(14)	Rating plate	☞ Page 41 Model designation
(15)	Control circuit power connector (CNP2) Used to connect the control circuit power supply and regenerative option.	☞ Page 83 Connection example of power circuit ☞ Page 98 Explanation of power supply system
(16)	Servo motor power output connector (CNP3) Used to connect the servo motor.	
(17)	Charge lamp When the main circuit is charged, this will light up. While this lamp is lit, do not reconnect the cables.	

No.	Name/Application	Detailed explanation
(18) ^{*1*2}	External encoder connector (CN2L) Used to connect the external encoder. Refer to the following for the compatible external encoders.  Page 18 Summary	 Page 103 Connectors and pin assignment "Linear Encoder Instruction Manual"
(19)	Optional unit connector 1 (CN7) This connector is used for connection with an optional unit. The connector is attached only on MR-J4-_GF1_-RJ.	—
(20)	Optional unit connector 2 (CN9) This connector is used for connection with an optional unit. The connector is attached only on MR-J4-_GF1_-RJ.	—

*1 This is for MR-J4-_GF1_-RJ servo amplifier. MR-J4-_GF1_ servo amplifier does not have CN2L connector.

*2 "External encoder" is a term for linear encoder used in the linear servo system, load-side encoder used in the fully closed loop system, and scale measurement encoder used with the scale measurement function in this manual.

Removal and reinstallation of the front cover

WARNING

- Before removing or installing the front cover, turn off the power and wait for 15 minutes or more until the charge lamp turns off. Then, confirm that the voltage between P+ and N- is safe with a voltage tester and others. Otherwise, an electric shock may occur. In addition, when confirming whether the charge lamp is off or not, be sure to look at the lamp from the front of the servo amplifier.

The following shows how to remove and reinstall the front cover of MR-J4-700GF(-RJ) to MR-J4-22KGF(-RJ) and MR-J4-500GF4(-RJ) to MR-J4-22KGF4(-RJ).

The diagram shows MR-J4-700GF-RJ.

Removal of the front cover

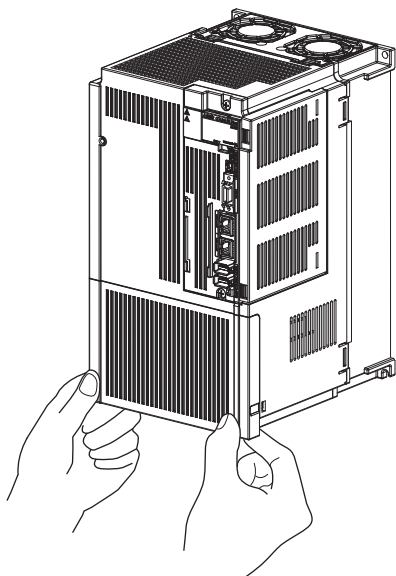

1) Hold the ends of lower side of the front cover with both hands.

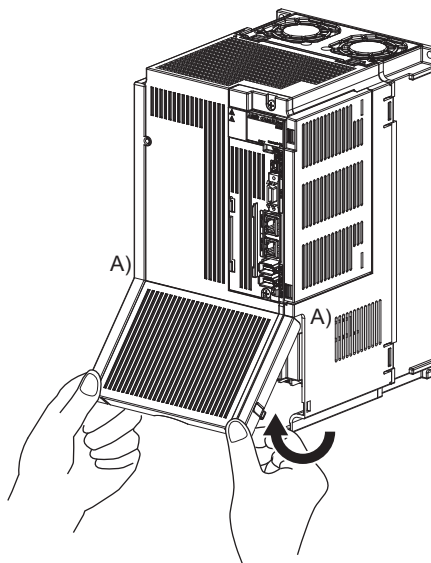

2) Pull up the cover, supporting at point A).

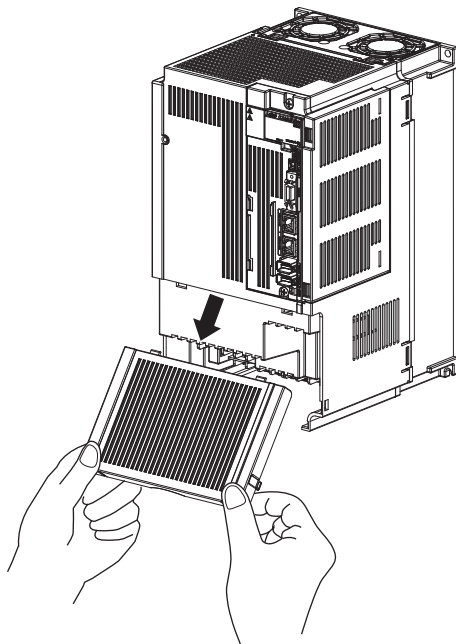

3) Pull out the front cover to remove.

Reinstallation of the front cover

1

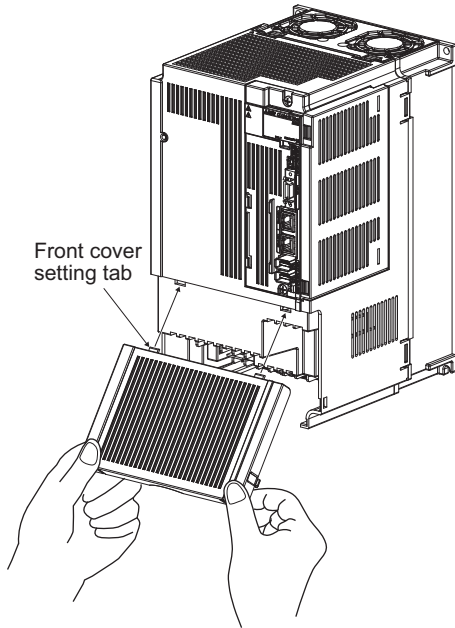

1) Insert the front cover setting tabs into the sockets of servo amplifier (2 places).

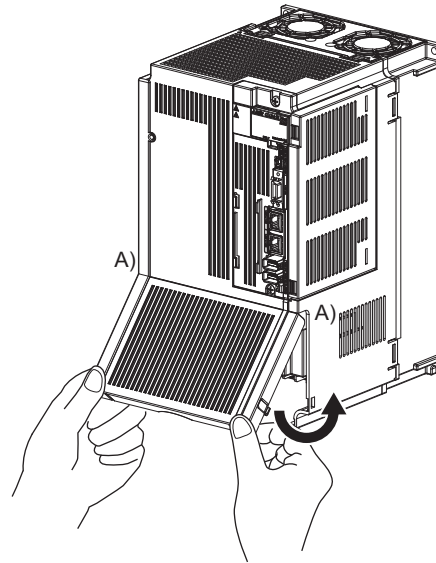

2) Push down the cover, supporting at point A).

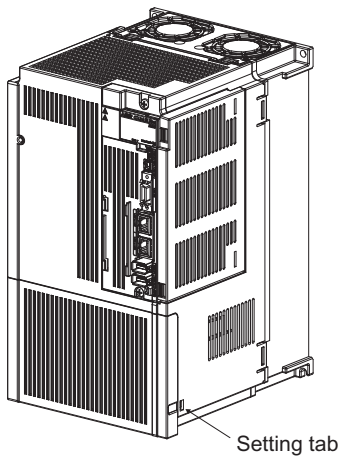

3) Press the cover against the terminal box until the installing knobs click.

1.8 Configuration including peripheral equipment

CAUTION

- Connecting a servo motor of the wrong axis to U, V, W, or CN2 of the servo amplifier may cause a malfunction.
- The CN1A and CN1B connectors are designed for CC-Link IE Field Network only. Do not connect these connectors to other than CC-Link IE Field Network. Otherwise, a malfunction may occur.

Point



- Equipment other than the servo amplifier and servo motor are optional or recommended products.
- When using the MR-J4-GF-RJ servo amplifier with the DC power supply input, refer to the following.
 Page 586 When using the servo amplifier with the DC power supply input

200 V class

MR-J4-200GF(-RJ) or less

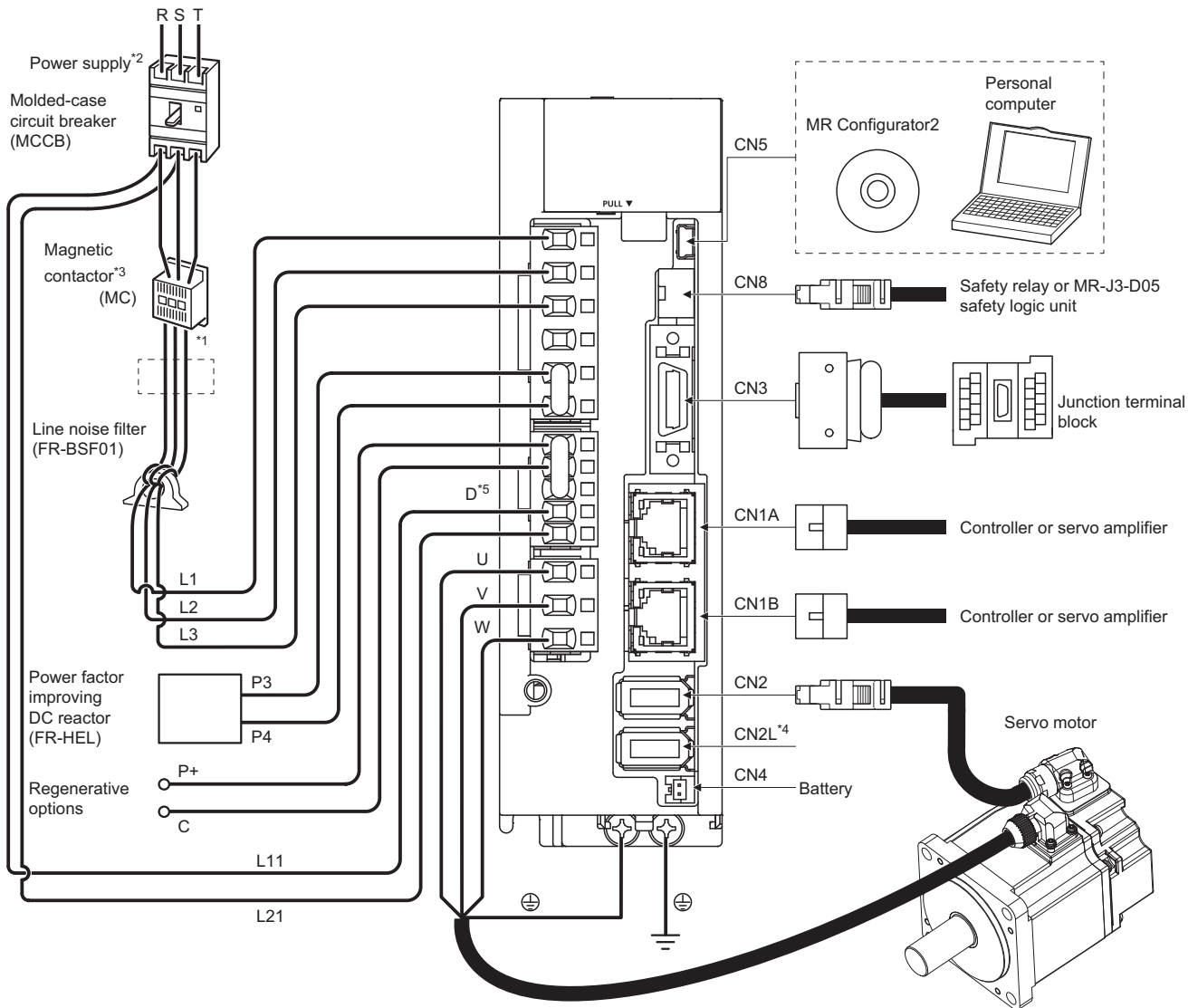
The diagram shows MR-J4-20GF-RJ.



- *1 The power factor improving AC reactor can also be used. In this case, the power factor improving DC reactor cannot be used. When not using the power factor improving DC reactor, short P3 and P4.
- *2 For 1-phase 200 V AC to 240 V AC, connect the power supply to L1 and L3. Leave L2 open. Refer to the following for the power supply specifications.
 Page 30 Servo amplifier standard specifications
- *3 Depending on the main circuit voltage and operation pattern, bus voltage decreases, and that may cause the forced stop deceleration to shift to the dynamic brake deceleration. When dynamic brake deceleration is not required, slow the time to turn off the magnetic contactor.
- *4 This is for MR-J4-_GF-RJ servo amplifier. MR-J4-_GF servo amplifier does not have CN2L connector. When using MR-J4-_GF-RJ servo amplifier in the linear servo system or in the fully closed loop system, connect an external encoder to this connector. Refer to the following and "Linear Encoder Instruction Manual" for the compatible external encoders.
 Page 18 Summary
- *5 Always connect between P+ and D terminals. When using the regenerative option, refer to the following.
 Page 338 Regenerative options

MR-J4-350GF(-RJ)

The diagram shows MR-J4-350GF-RJ.

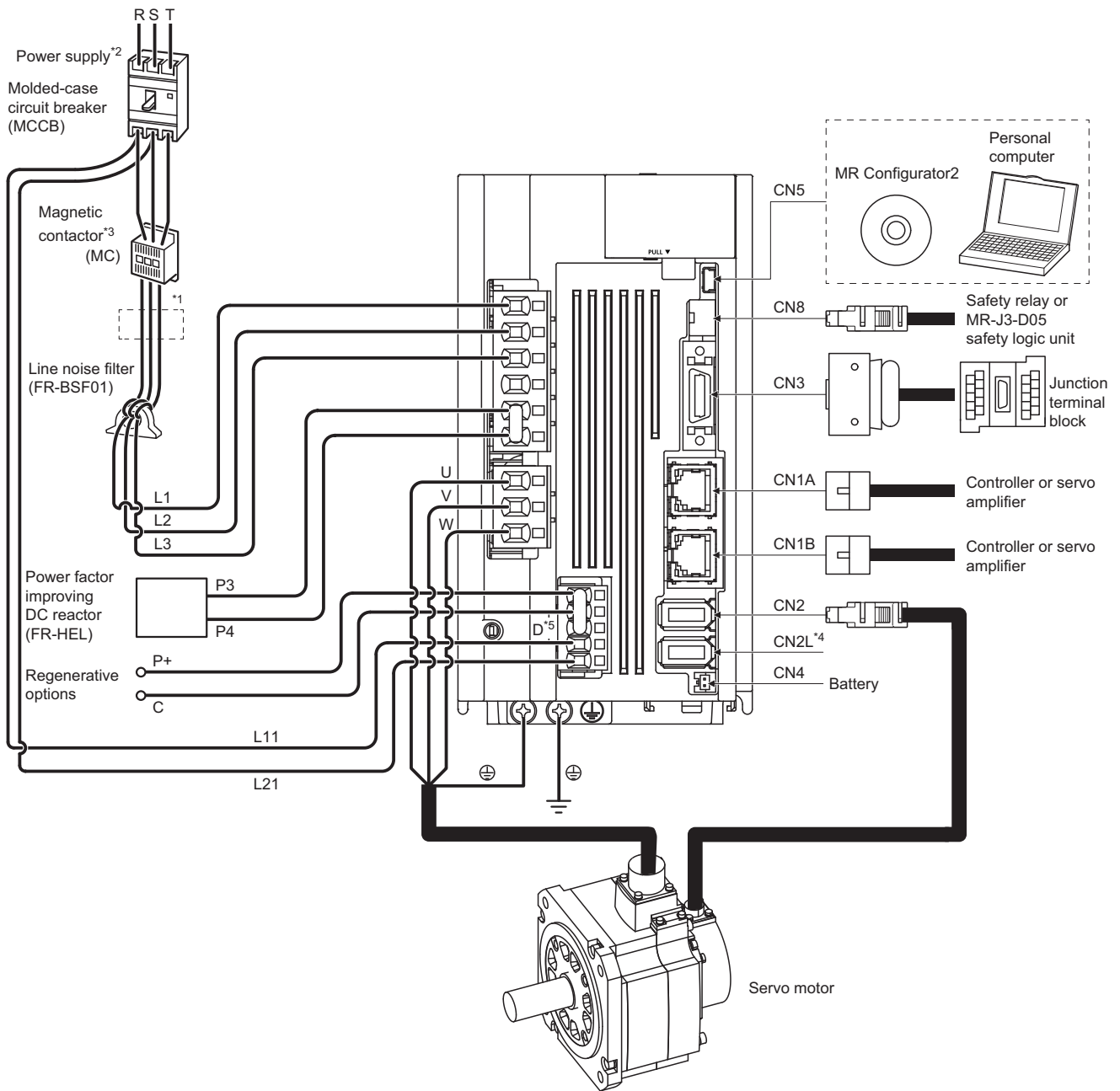

*1 The power factor improving AC reactor can also be used. In this case, the power factor improving DC reactor cannot be used. When not using the power factor improving DC reactor, short P3 and P4.

*2 Refer to the following for the power supply specifications.

☞ Page 30 Servo amplifier standard specifications

*3 Depending on the main circuit voltage and operation pattern, bus voltage decreases, and that may cause the forced stop deceleration to shift to the dynamic brake deceleration. When dynamic brake deceleration is not required, slow the time to turn off the magnetic contactor.

*4 This is for MR-J4-_GF-RJ servo amplifier. MR-J4-_GF servo amplifier does not have CN2L connector. When using MR-J4-_GF-RJ servo amplifier in the linear servo system or in the fully closed loop system, connect an external encoder to this connector. Refer to the following and "Linear Encoder Instruction Manual" for the compatible external encoders.

☞ Page 18 Summary

*5 Always connect between P+ and D terminals. When using the regenerative option, refer to the following.

☞ Page 338 Regenerative options

MR-J4-500GF(-RJ)

The diagram shows MR-J4-500GF-RJ.

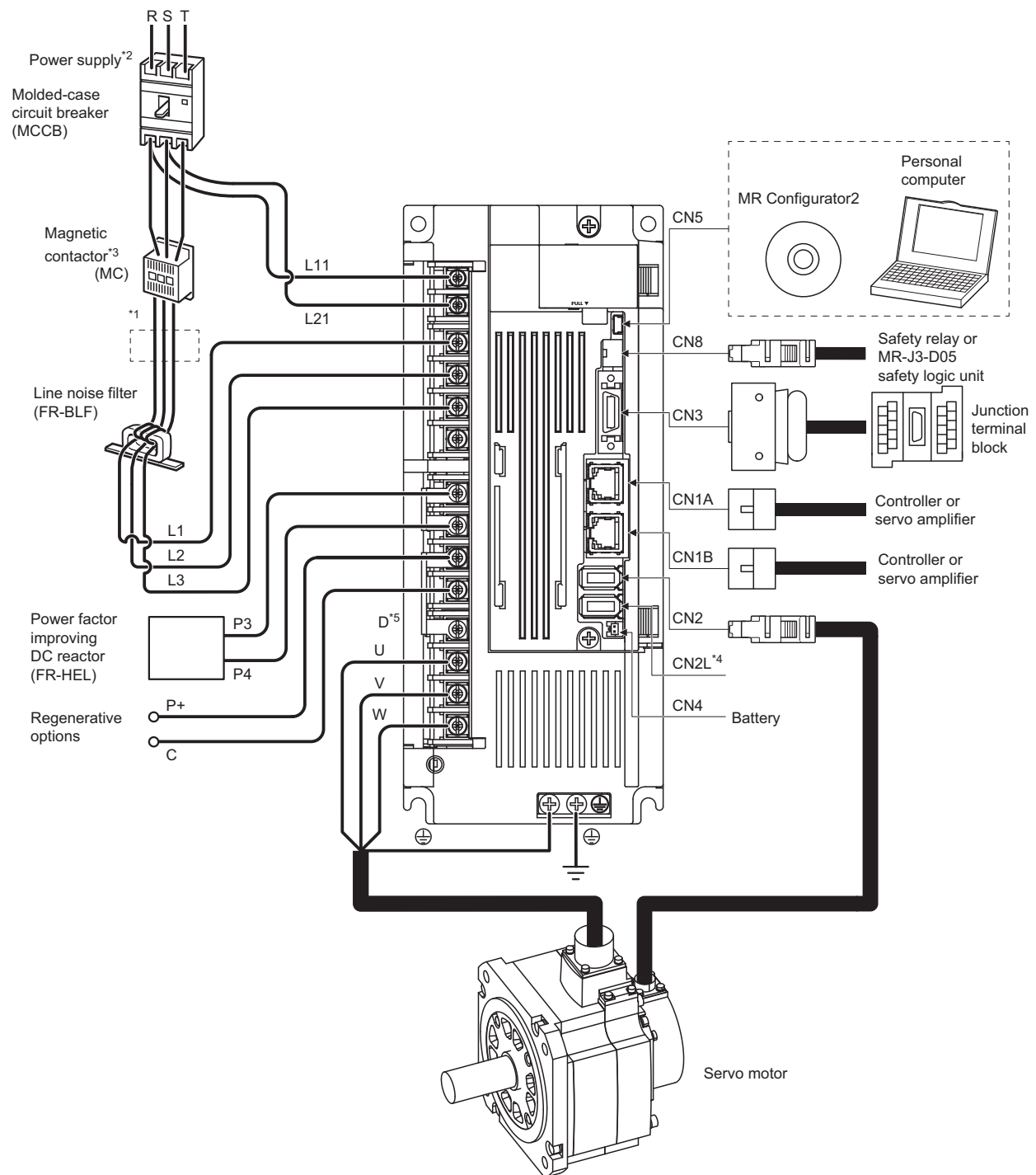

- *1 The power factor improving AC reactor can also be used. In this case, the power factor improving DC reactor cannot be used. When not using the power factor improving DC reactor, short P3 and P4.
- *2 Refer to the following for the power supply specifications.
☞ Page 30 Servo amplifier standard specifications
- *3 Depending on the main circuit voltage and operation pattern, bus voltage decreases, and that may cause the forced stop deceleration to shift to the dynamic brake deceleration. When dynamic brake deceleration is not required, slow the time to turn off the magnetic contactor.
- *4 This is for MR-J4-GF-RJ servo amplifier. MR-J4-GF servo amplifier does not have CN2L connector. When using MR-J4-GF-RJ servo amplifier in the linear servo system or in the fully closed loop system, connect an external encoder to this connector. Refer to the following and "Linear Encoder Instruction Manual" for the compatible external encoders.
☞ Page 18 Summary
- *5 Always connect between P+ and D terminals. When using the regenerative option, refer to the following.
☞ Page 338 Regenerative options

MR-J4-700GF(-RJ)

The diagram shows MR-J4-700GF-RJ.

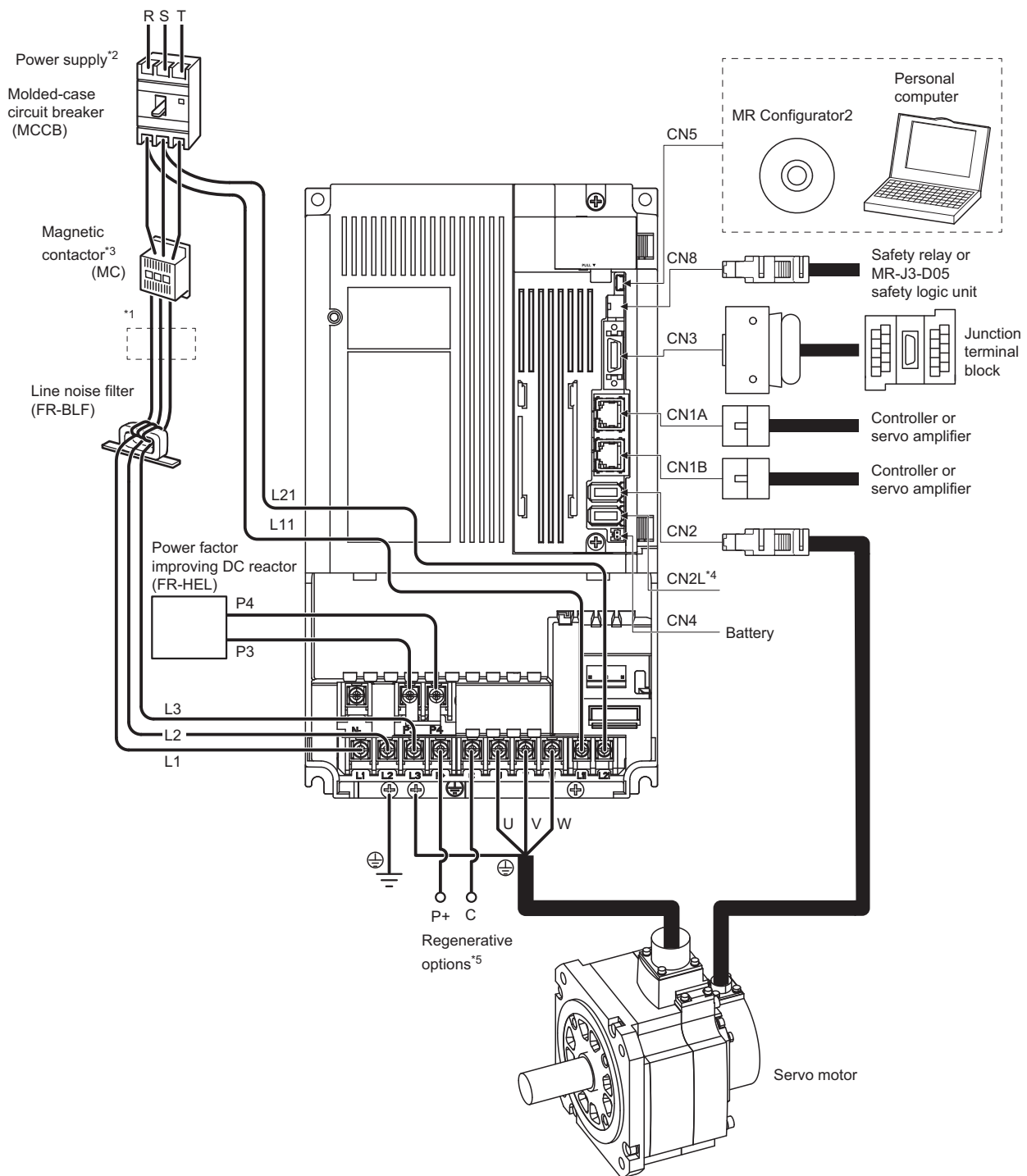

*1 The power factor improving AC reactor can also be used. In this case, the power factor improving DC reactor cannot be used. When not using the power factor improving DC reactor, short P3 and P4.

*2 Refer to the following for the power supply specifications.

☞ Page 30 Servo amplifier standard specifications

*3 Depending on the main circuit voltage and operation pattern, bus voltage decreases, and that may cause the forced stop deceleration to shift to the dynamic brake deceleration. When dynamic brake deceleration is not required, slow the time to turn off the magnetic contactor.

*4 This is for MR-J4-_GF-RJ servo amplifier. MR-J4-_GF servo amplifier does not have CN2L connector. When using MR-J4-_GF-RJ servo amplifier in the linear servo system or in the fully closed loop system, connect an external encoder to this connector. Refer to the following and "Linear Encoder Instruction Manual" for the compatible external encoders.

☞ Page 18 Summary

*5 When using the regenerative option, refer to the following.

☞ Page 338 Regenerative options

MR-J4-11KGF(-RJ)/MR-J4-15KGF(-RJ)

The diagram is for MR-J4-11KGF-RJ and MR-J4-15KGF-RJ.

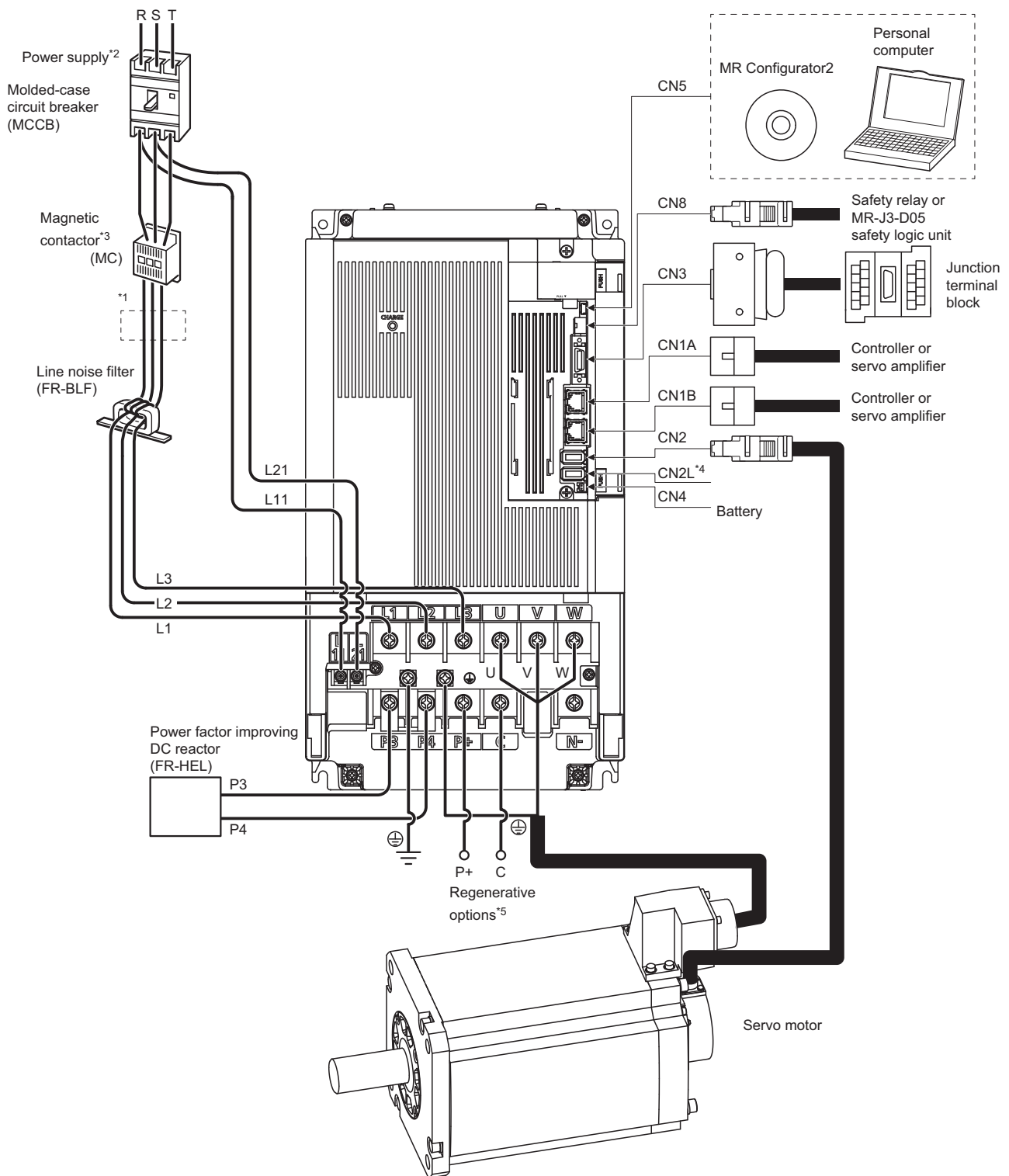

- *1 The power factor improving AC reactor can also be used. In this case, the power factor improving DC reactor cannot be used. When not using the power factor improving DC reactor, short P3 and P4.
- *2 Refer to the following for the power supply specifications.
 - ☞ Page 30 Servo amplifier standard specifications
- *3 Depending on the main circuit voltage and operation pattern, bus voltage decreases, and that may cause the forced stop deceleration to shift to the dynamic brake deceleration. When dynamic brake deceleration is not required, slow the time to turn off the magnetic contactor.
- *4 This is for MR-J4-_GF-RJ servo amplifier. MR-J4-_GF servo amplifier does not have CN2L connector. When using MR-J4-_GF-RJ servo amplifier in the linear servo system or in the fully closed loop system, connect an external encoder to this connector. Refer to the following and "Linear Encoder Instruction Manual" for the compatible external encoders.
 - ☞ Page 18 Summary
- *5 When using the regenerative option, refer to the following.
 - ☞ Page 338 Regenerative options

MR-J4-22KGF(-RJ)

The diagram shows MR-J4-22KGF-RJ.

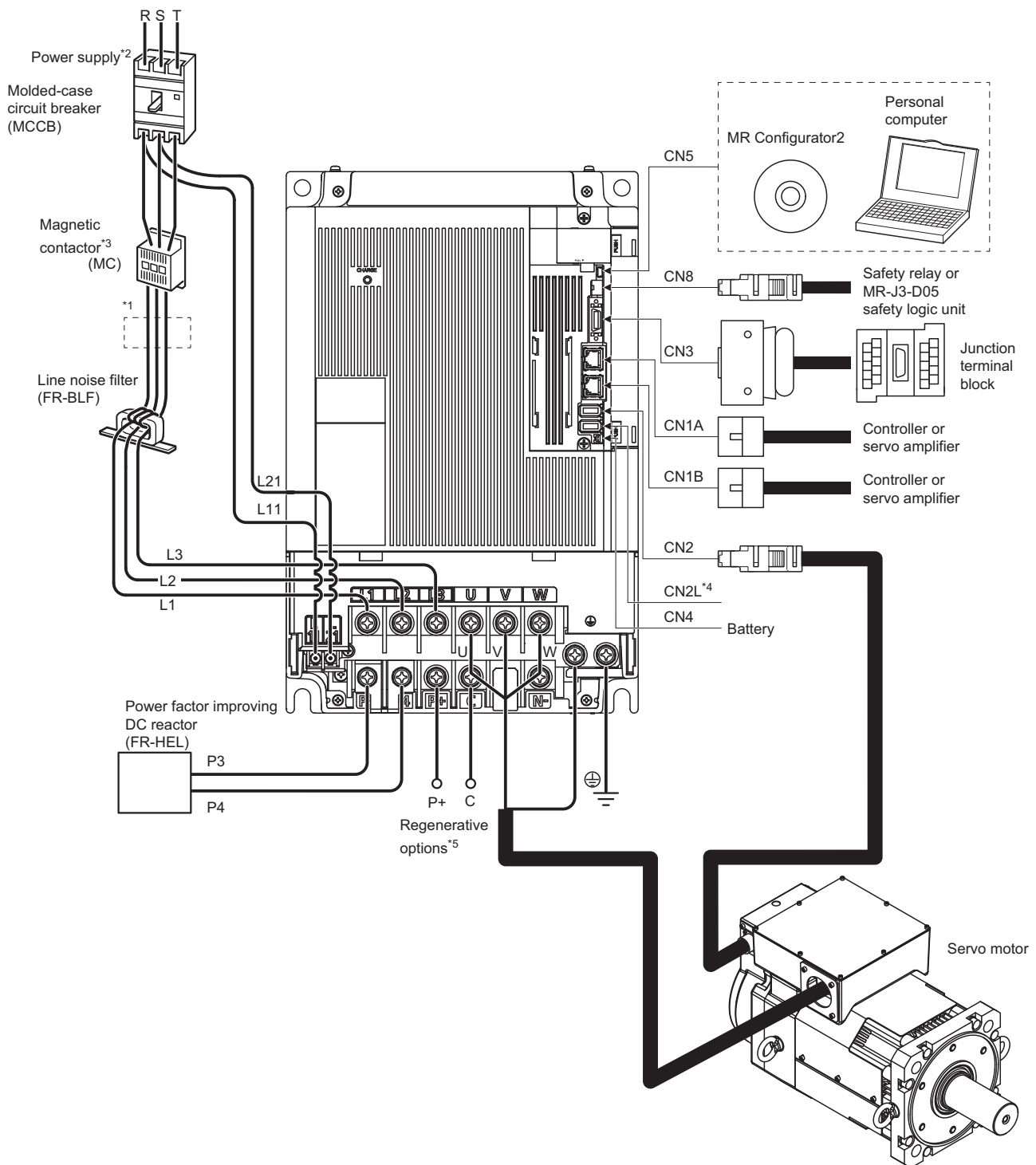

*1 The power factor improving AC reactor can also be used. In this case, the power factor improving DC reactor cannot be used. When not using the power factor improving DC reactor, short P3 and P4.

*2 Refer to the following for the power supply specifications.

☞ Page 30 Servo amplifier standard specifications

*3 Depending on the main circuit voltage and operation pattern, bus voltage decreases, and that may cause the forced stop deceleration to shift to the dynamic brake deceleration. When dynamic brake deceleration is not required, slow the time to turn off the magnetic contactor.

*4 This is for MR-J4- GF-RJ servo amplifier. MR-J4- GF servo amplifier does not have CN2L connector. When using MR-J4- GF-RJ servo amplifier in the linear servo system or in the fully closed loop system, connect an external encoder to this connector. Refer to the following and "Linear Encoder Instruction Manual" for the compatible external encoders.

☞ Page 18 Summary

*5 When using the regenerative option, refer to the following.

☞ Page 338 Regenerative options

400 V class

■MR-J4-200GF4(-RJ) or less

The diagram is for MR-J4-60GF4-RJ and MR-J4-100GF4-RJ.

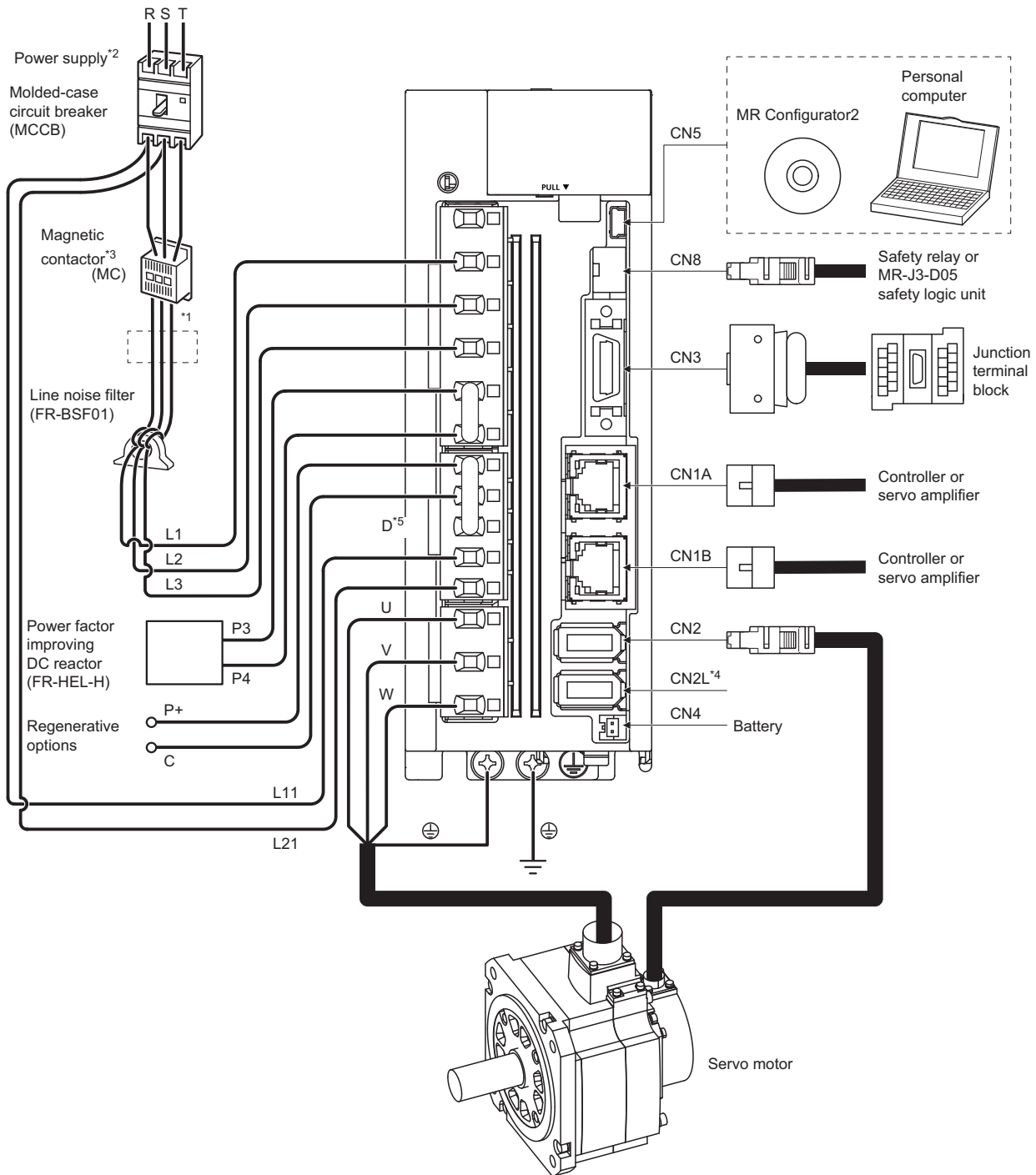

- *1 The power factor improving AC reactor can also be used. In this case, the power factor improving DC reactor cannot be used. When not using the power factor improving DC reactor, short P3 and P4.
- *2 Refer to the following for the power supply specifications.
☞ Page 30 Servo amplifier standard specifications
- *3 Depending on the main circuit voltage and operation pattern, bus voltage decreases, and that may cause the forced stop deceleration to shift to the dynamic brake deceleration. When dynamic brake deceleration is not required, slow the time to turn off the magnetic contactor.
- *4 This is for MR-J4-_GF4-RJ servo amplifier. MR-J4-_GF4 servo amplifier does not have CN2L connector. When using MR-J4-_GF4-RJ servo amplifier in the linear servo system or in the fully closed loop system, connect an external encoder to this connector. Refer to the following and "Linear Encoder Instruction Manual" for the compatible external encoders.
☞ Page 18 Summary
- *5 Always connect between P+ and D terminals. When using the regenerative option, refer to the following.
☞ Page 338 Regenerative options

MR-J4-350GF4(-RJ)

The diagram shows MR-J4-350GF4-RJ.

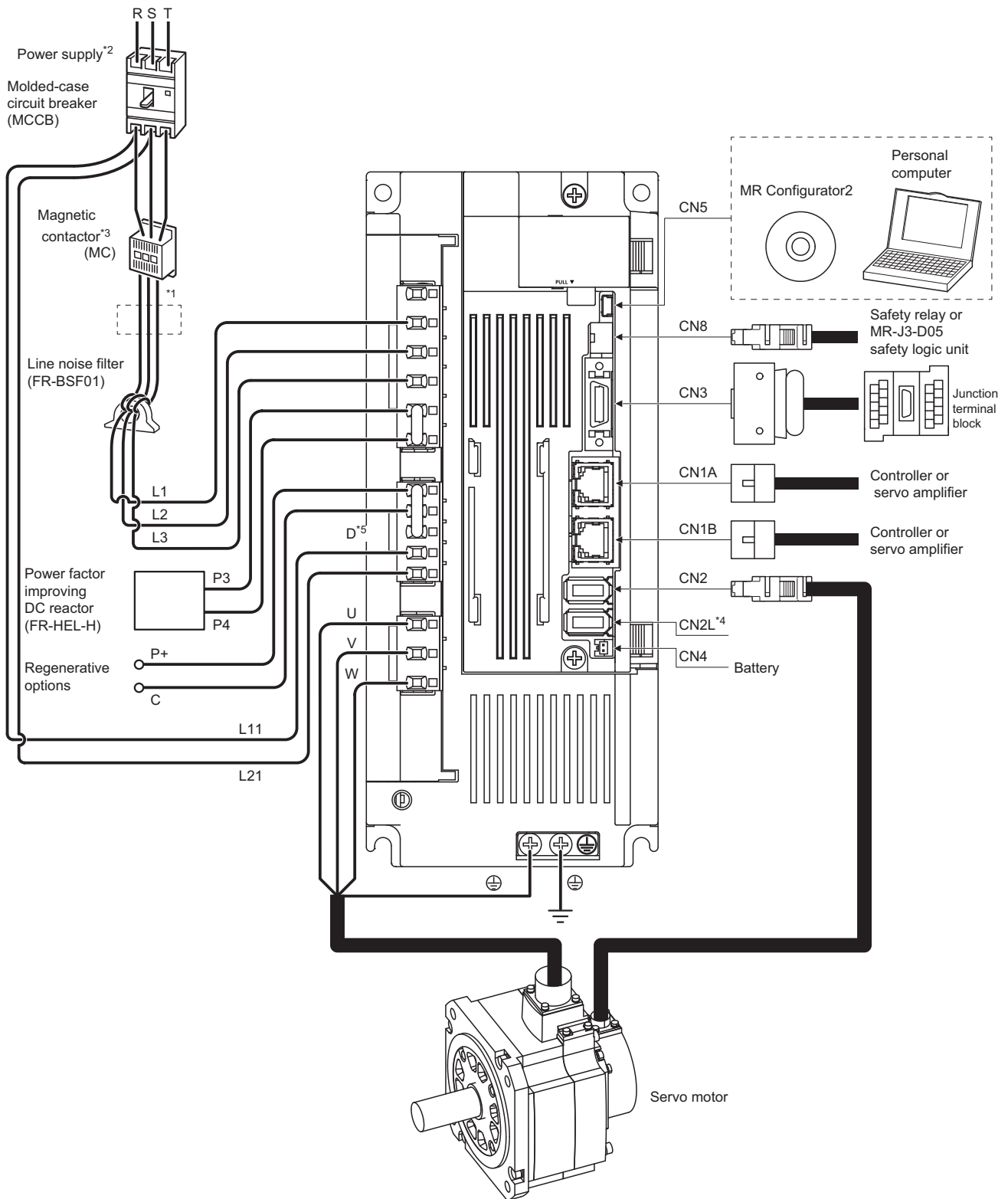

- *1 The power factor improving AC reactor can also be used. In this case, the power factor improving DC reactor cannot be used. When not using the power factor improving DC reactor, short P3 and P4.
- *2 Refer to the following for the power supply specifications.
☞ Page 30 Servo amplifier standard specifications
- *3 Depending on the main circuit voltage and operation pattern, bus voltage decreases, and that may cause the forced stop deceleration to shift to the dynamic brake deceleration. When dynamic brake deceleration is not required, slow the time to turn off the magnetic contactor.
- *4 This is for MR-J4-_GF4-RJ servo amplifier. MR-J4-_GF4 servo amplifier does not have CN2L connector. When using MR-J4-_GF4-RJ servo amplifier in the linear servo system or in the fully closed loop system, connect an external encoder to this connector. Refer to the following and "Linear Encoder Instruction Manual" for the compatible external encoders.
☞ Page 18 Summary
- *5 Always connect between P+ and D terminals. When using the regenerative option, refer to the following.
☞ Page 338 Regenerative options

MR-J4-500GF4(-RJ)

The diagram shows MR-J4-500GF4-RJ.

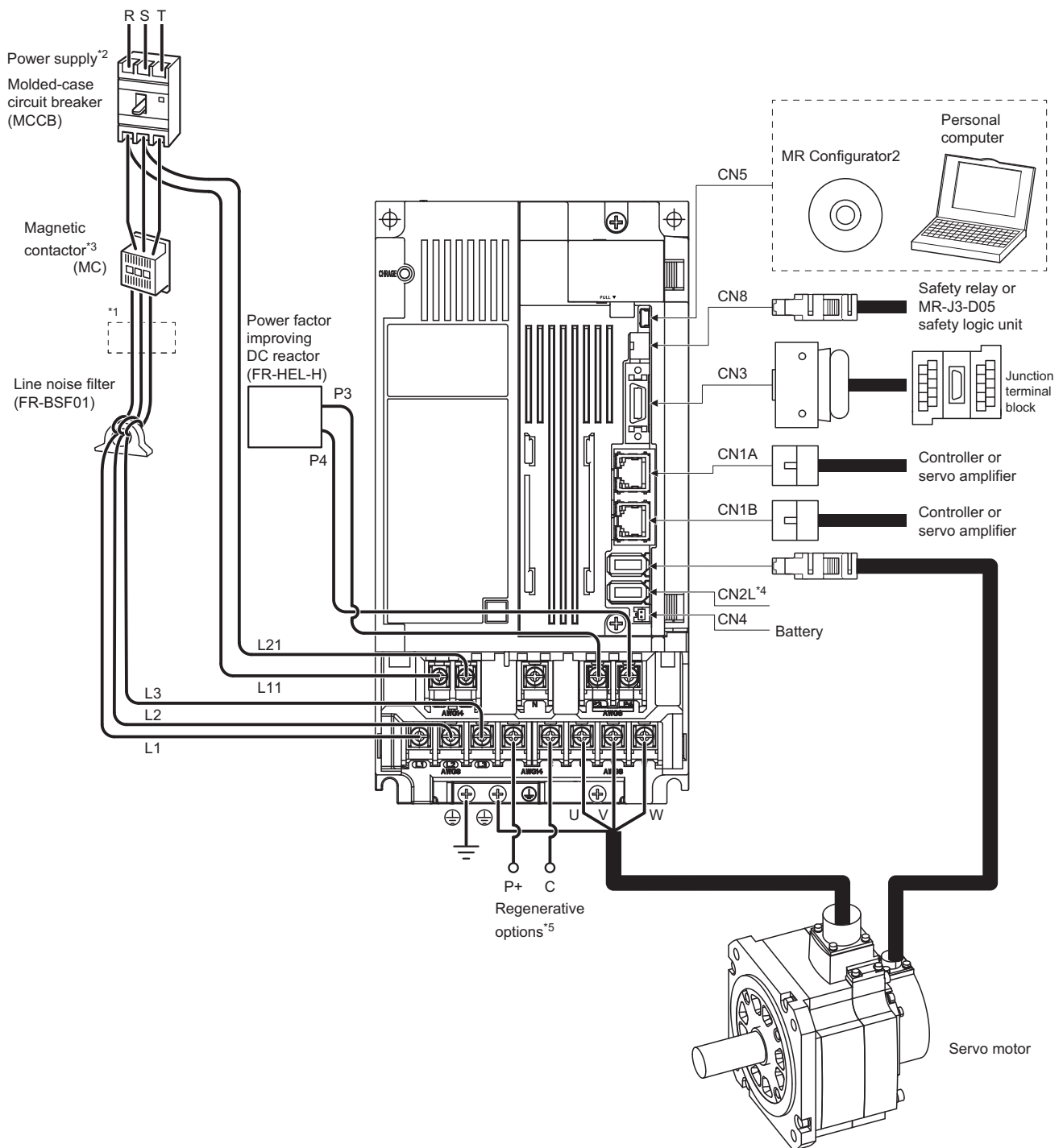

- *1 The power factor improving AC reactor can also be used. In this case, the power factor improving DC reactor cannot be used. When not using the power factor improving DC reactor, short P3 and P4.
- *2 Refer to the following for the power supply specifications.
☞ Page 30 Servo amplifier standard specifications
- *3 Depending on the main circuit voltage and operation pattern, bus voltage decreases, and that may cause the forced stop deceleration to shift to the dynamic brake deceleration. When dynamic brake deceleration is not required, slow the time to turn off the magnetic contactor.
- *4 This is for MR-J4-_GF4-RJ servo amplifier. MR-J4-_GF4 servo amplifier does not have CN2L connector. When using MR-J4-_GF4-RJ servo amplifier in the linear servo system or in the fully closed loop system, connect an external encoder to this connector. Refer to the following and "Linear Encoder Instruction Manual" for the compatible external encoders.
☞ Page 18 Summary
- *5 When using the regenerative option, refer to the following.
☞ Page 338 Regenerative options

MR-J4-700GF4(-RJ)

The diagram shows MR-J4-700GF4-RJ.

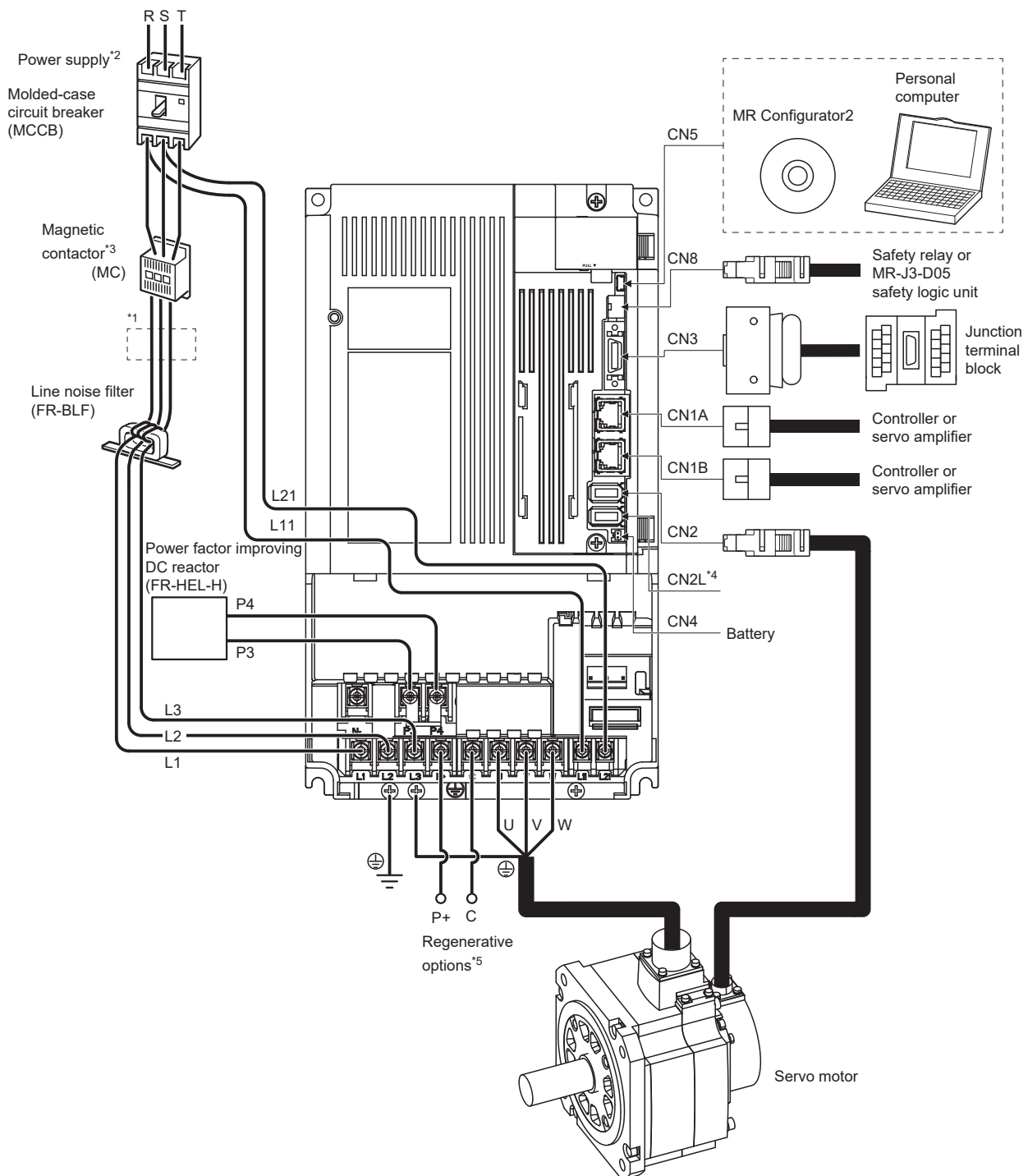

*1 The power factor improving AC reactor can also be used. In this case, the power factor improving DC reactor cannot be used. When not using the power factor improving DC reactor, short P3 and P4.

*2 Refer to the following for the power supply specifications.

☞ Page 30 Servo amplifier standard specifications

*3 Depending on the main circuit voltage and operation pattern, bus voltage decreases, and that may cause the forced stop deceleration to shift to the dynamic brake deceleration. When dynamic brake deceleration is not required, slow the time to turn off the magnetic contactor.

*4 This is for MR-J4-GF4-RJ servo amplifier. MR-J4-GF4 servo amplifier does not have CN2L connector. When using MR-J4-GF4-RJ servo amplifier in the linear servo system or in the fully closed loop system, connect an external encoder to this connector. Refer to the following and "Linear Encoder Instruction Manual" for the compatible external encoders.

☞ Page 18 Summary

*5 When using the regenerative option, refer to the following.

☞ Page 338 Regenerative options

MR-J4-11KGF4(-RJ)/MR-J4-15KGF4(-RJ)

The diagram is for MR-J4-11KGF-RJ and MR-J4-15KGF-RJ.

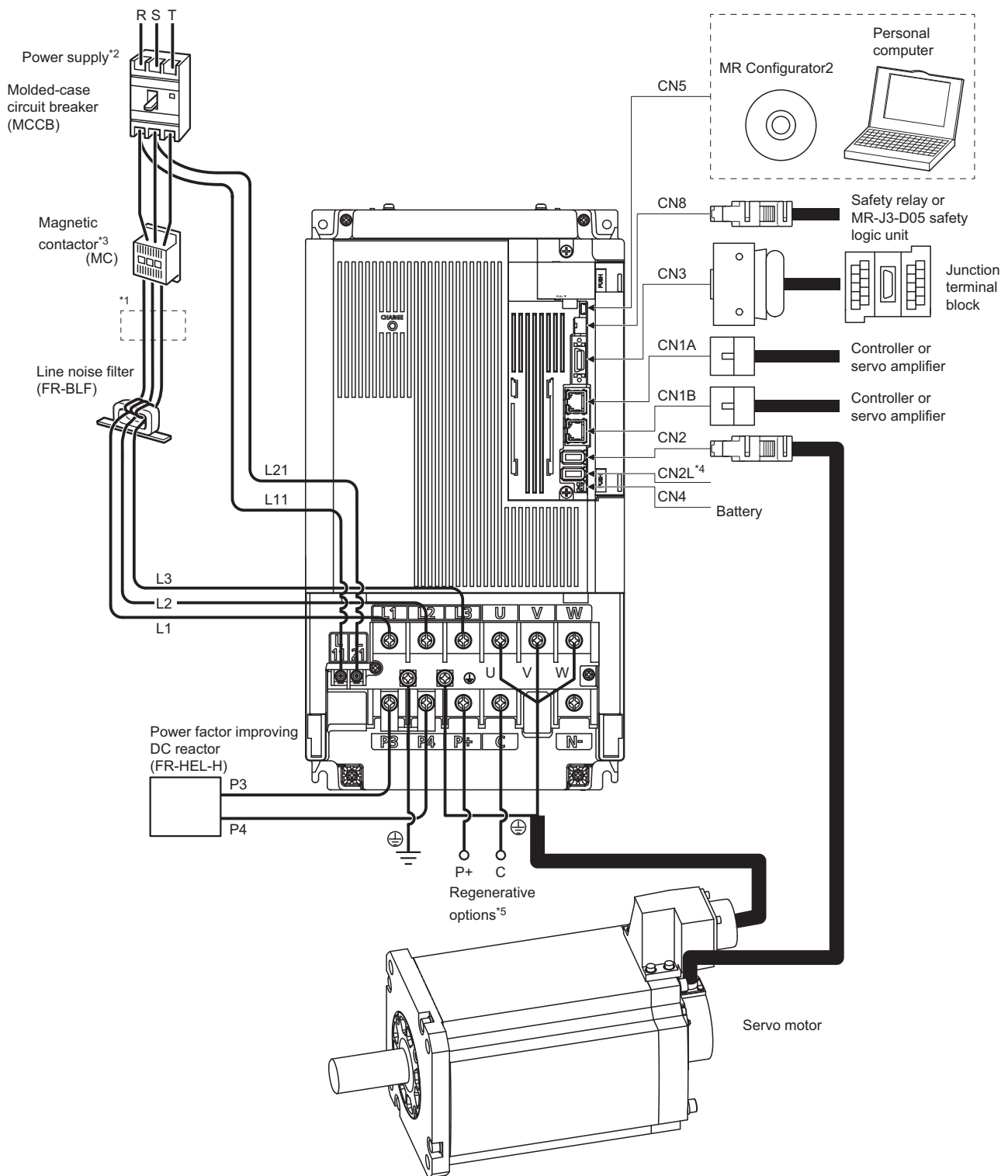

- *1 The power factor improving AC reactor can also be used. In this case, the power factor improving DC reactor cannot be used. When not using the power factor improving DC reactor, short P3 and P4.
- *2 Refer to the following for the power supply specifications.
 - ☞ Page 30 Servo amplifier standard specifications
- *3 Depending on the main circuit voltage and operation pattern, bus voltage decreases, and that may cause the forced stop deceleration to shift to the dynamic brake deceleration. When dynamic brake deceleration is not required, slow the time to turn off the magnetic contactor.
- *4 This is for MR-J4-_GF4-RJ servo amplifier. MR-J4-_GF4 servo amplifier does not have CN2L connector. When using MR-J4-_GF4-RJ servo amplifier in the linear servo system or in the fully closed loop system, connect an external encoder to this connector. Refer to the following and "Linear Encoder Instruction Manual" for the compatible external encoders.
 - ☞ Page 18 Summary
- *5 When using the regenerative option, refer to the following.
 - ☞ Page 338 Regenerative options

MR-J4-22KGF4(-RJ)

The diagram shows MR-J4-22KGF4-RJ.

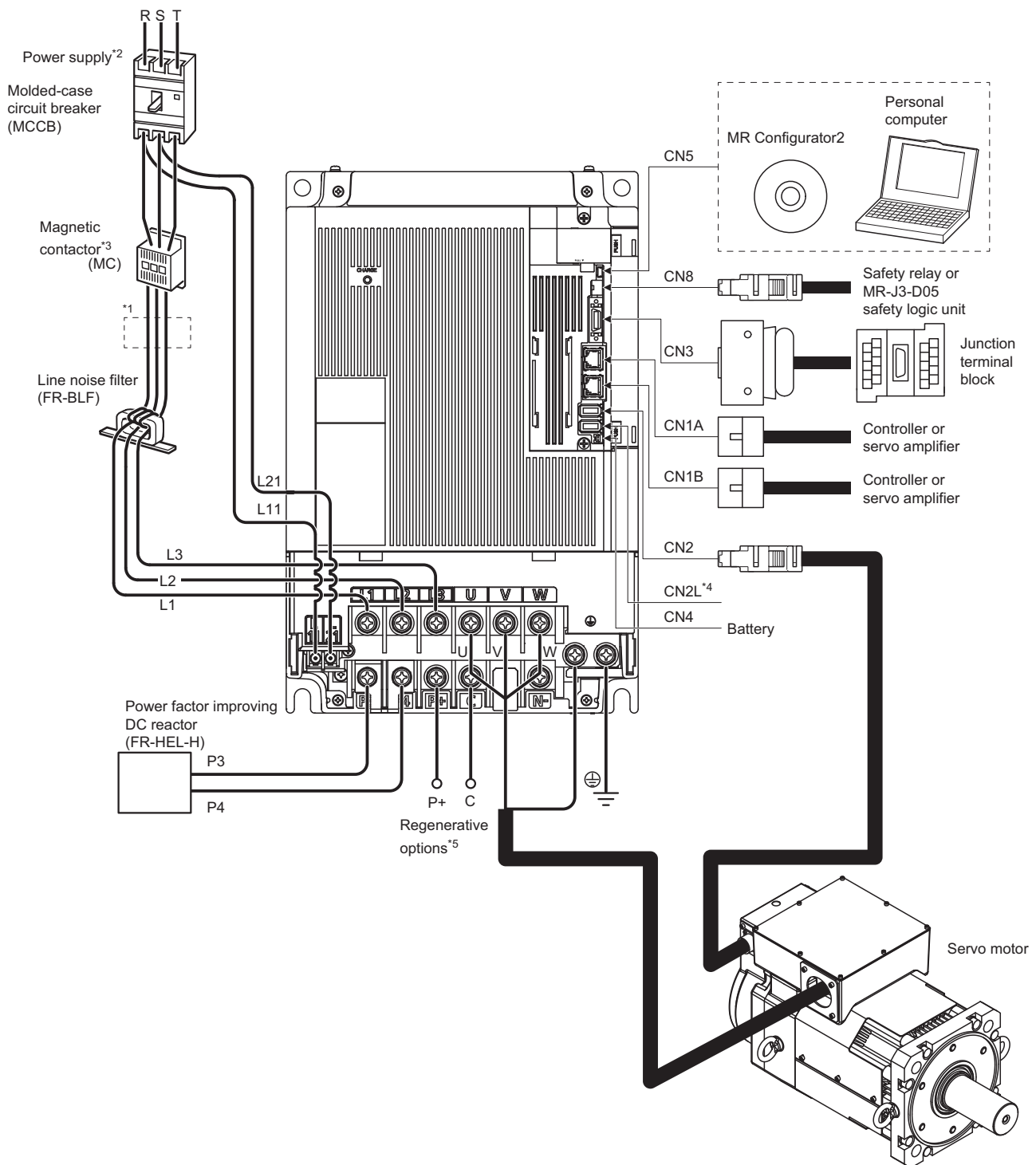

*1 The power factor improving AC reactor can also be used. In this case, the power factor improving DC reactor cannot be used. When not using the power factor improving DC reactor, short P3 and P4.

*2 Refer to the following for the power supply specifications.

☞ Page 30 Servo amplifier standard specifications

*3 Depending on the main circuit voltage and operation pattern, bus voltage decreases, and that may cause the forced stop deceleration to shift to the dynamic brake deceleration. When dynamic brake deceleration is not required, slow the time to turn off the magnetic contactor.

*4 This is for MR-J4- _GF4-RJ servo amplifier. MR-J4- _GF4 servo amplifier does not have CN2L connector. When using MR-J4- _GF4-RJ servo amplifier in the linear servo system or in the fully closed loop system, connect an external encoder to this connector. Refer to the following and "Linear Encoder Instruction Manual" for the compatible external encoders.

☞ Page 18 Summary

*5 When using the regenerative option, refer to the following.

☞ Page 338 Regenerative options

100 V class

The diagram shows MR-J4-20GF1-RJ.

1

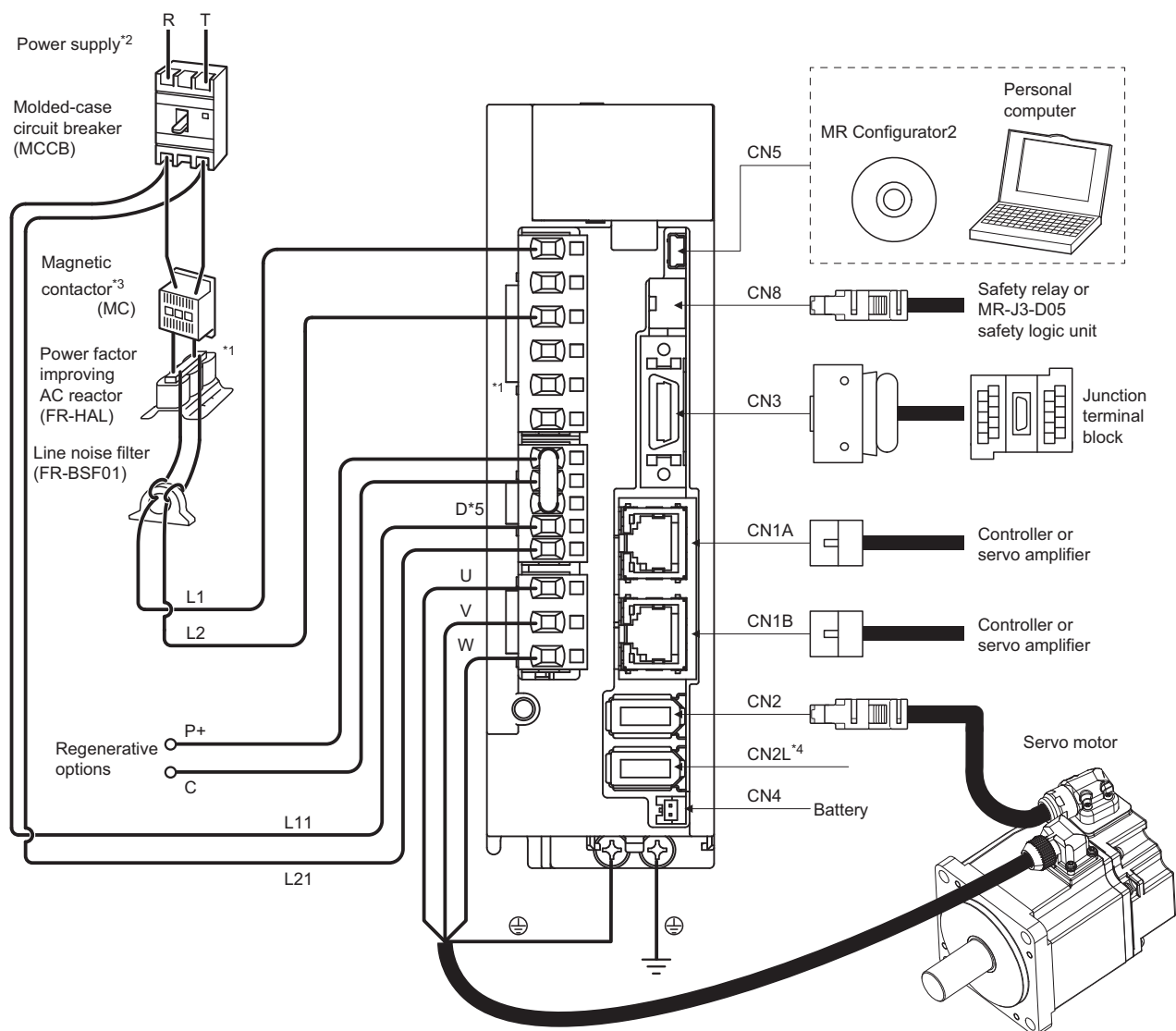

*1 The power factor improving DC reactor cannot be used.

*2 Refer to the following for the power supply specifications.

☞ Page 30 Servo amplifier standard specifications

*3 Depending on the main circuit voltage and operation pattern, bus voltage decreases, and that may cause the forced stop deceleration to shift to the dynamic brake deceleration. When dynamic brake deceleration is not required, slow the time to turn off the magnetic contactor.

*4 When this is used as a fully closed loop system, the external encoder status is returned. Refer to the following and "Linear Encoder Instruction Manual" for the compatible external encoders.

☞ Page 18 Summary

*5 Always connect between P+ and D terminals. When using the regenerative option, refer to the following.

☞ Page 338 Regenerative options

2 INSTALLATION

WARNING

- To prevent electric shock, ground each equipment securely.
-

CAUTION

- Stacking in excess of the specified number of product packages is not allowed.
 - Do not hold the front cover, cables, or connectors when carrying the servo amplifier. Otherwise, it may drop.
 - Install the equipment on incombustible material. Installing it directly or close to combustibles will lead to a fire.
 - Install the servo amplifier and the servo motor in a load-bearing place in accordance with the Instruction Manual.
 - Do not get on or put heavy load on the equipment. Otherwise, it may cause injury.
 - Use the equipment within the specified environment. For the environment, refer to the following.  Page 30 Servo amplifier standard specifications
 - Provide an adequate protection to prevent screws and other conductive matter, oil and other combustible matter from entering the servo amplifier.
 - Do not block the intake and exhaust areas of the servo amplifier. Otherwise, it may cause a malfunction.
 - Do not drop or apply heavy impact on the servo amplifiers and the servo motors. Otherwise, it may cause injury, malfunction, etc.
 - Do not drop or strike the servo amplifier. Isolate it from all impact loads.
 - Do not install or operate the servo amplifier which have been damaged or have any parts missing.
 - When the product has been stored for an extended period of time, contact your local sales office.
 - When handling the servo motor, be careful with the sharp edges of the servo motor.
 - The servo amplifier must be installed in a metal cabinet.
 - When fumigants that contain halogen materials, such as fluorine, chlorine, bromine, and iodine, are used for disinfecting and protecting wooden packaging from insects, they cause a malfunction when entering our products. Please take necessary precautions to ensure that remaining materials from fumigant do not enter our products, or treat packaging with methods other than fumigation, such as heat treatment. Additionally, disinfect and protect wood from insects before packing the products.
-

2.1 Installation direction and clearances

⚠ CAUTION

- The equipment must be installed in the specified direction. Otherwise, it may cause a malfunction.
- Leave specified clearances between the servo amplifier and the cabinet walls or other equipment. Otherwise, it may cause a malfunction.

Installation clearances of the servo amplifier

■ Installation of one servo amplifier

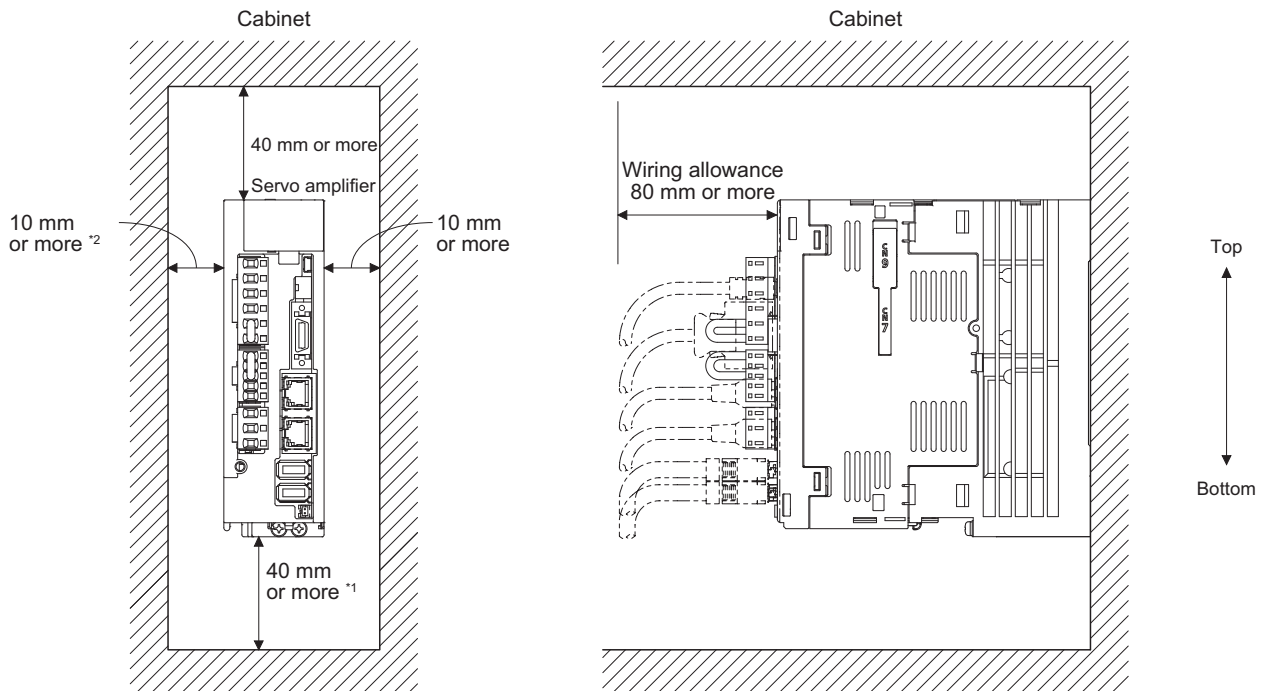

*1 For 11 kW to 22 kW servo amplifiers, the clearance between the bottom and ground will be 120 mm or more.

*2 When mounting MR-J4-500GF(-RJ), maintain a minimum clearance of 25 mm on the left side.

■ Installation of two or more servo amplifiers

Point

- Close mounting is possible depending on the capacity of the servo amplifier. Refer to the following for availability of close mounting. [☞ Page 30 Servo amplifier standard specifications](#)
- When closely mounting multiple servo amplifiers, the servo amplifier on the right must have a larger depth than that on the left. Otherwise, the CNP1, CNP2, and CNP3 connectors cannot be removed.

Leave a large clearance between the top of the servo amplifier and the cabinet walls, and install a cooling fan to prevent the internal temperature of the cabinet from exceeding the environment.

When mounting the servo amplifiers closely, leave a clearance of 1 mm between the adjacent servo amplifiers in consideration of mounting tolerances. In this case, keep the ambient temperature within 0 °C to 45 °C or use the servo amplifier with 75% or less of the effective load ratio.

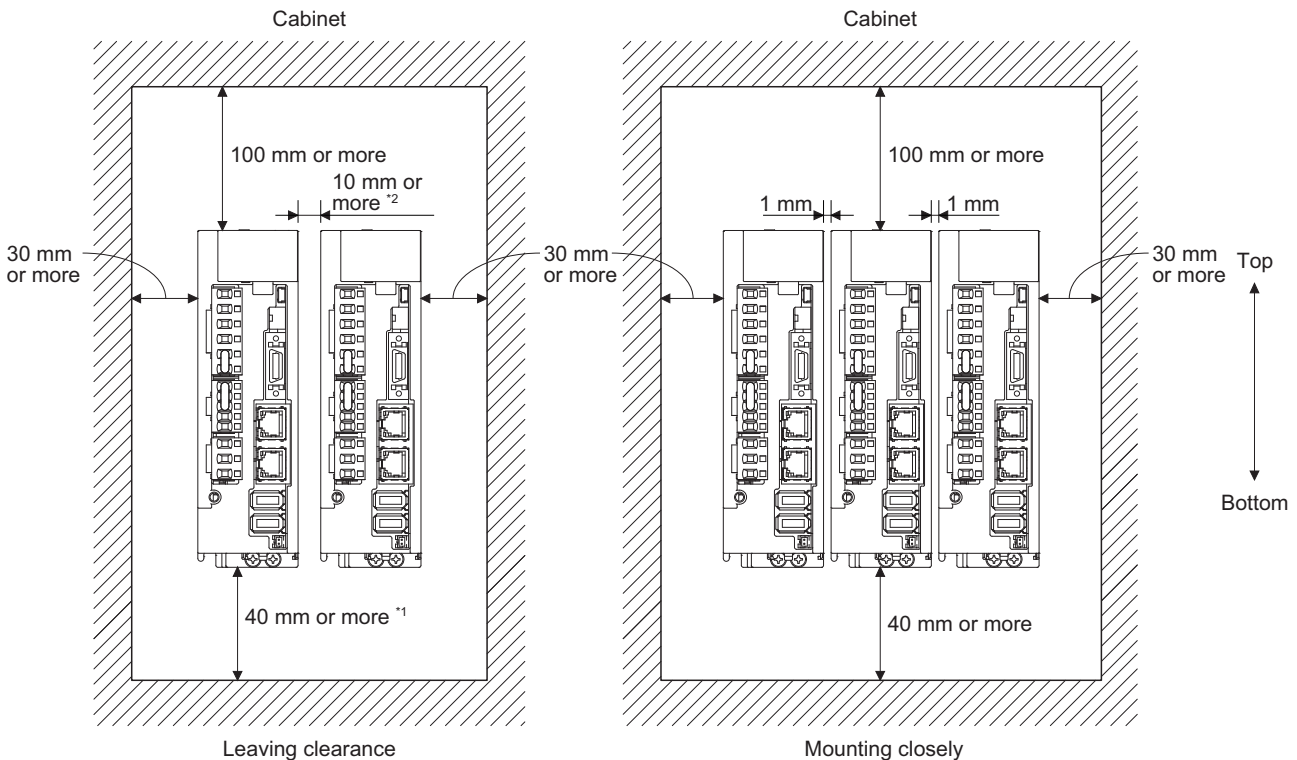

*1 For 11 kW to 22 kW servo amplifiers, the clearance between the bottom and ground will be 120 mm or more.

*2 When mounting MR-J4-500GF(-RJ), maintain a minimum clearance of 25 mm between the MR-J4-500GF(-RJ) and a servo amplifier mounted on the left side.

Others

When using heat generating equipment such as the regenerative option, install them with full consideration of heat generation so that the servo amplifier is not affected.

Install the servo amplifier on a perpendicular wall in the correct vertical direction.

2.2 Keeping out of foreign materials

- When drilling in the cabinet, prevent drill chips and wire fragments from entering the servo amplifier.
- Prevent oil, water, metallic dust, etc. from entering the servo amplifier through openings in the cabinet or a cooling fan installed on the ceiling.
- When installing the cabinet in a place where toxic gas, dirt and dust exist, conduct an air purge (force clean air into the cabinet from outside to make the internal pressure higher than the external pressure) to prevent such materials from entering the cabinet.

2.3 Encoder cable stress

- The way of clamping the cable must be fully examined so that bending stress and cable's own weight stress are not applied to the cable connection.
- For use in any application where the servo motor moves, fix the cables (encoder, power supply, and brake) with having some slack from the connector connection part of the servo motor to avoid putting stress on the connector connection part. Use the optional encoder cable within the bending life range. Use the power supply and brake wiring cables within the bending life of the cables.
- Avoid any probability that the cable insulator might be cut by sharp chips, rubbed by a machine corner, or stamped by workers or vehicles.
- For installation on a machine where the servo motor moves, the bending radius should be made as large as possible. Refer to the following for the bending life.  Page 327 Cable bending life

2.4 Inspection items

WARNING

- Before starting maintenance and/or inspection, turn off the power and wait for 15 minutes or more until the charge lamp turns off. Then, confirm that the voltage between P+ and N- is safe with a voltage tester and others. Otherwise, an electric shock may occur. In addition, when confirming whether the charge lamp is off or not, always confirm it from the front of the servo amplifier.
- To avoid an electric shock, only qualified personnel should attempt inspections. For repair and parts replacement, contact your local sales office.

CAUTION

- Do not perform insulation resistance test on the servo amplifier. Otherwise, it may cause a malfunction.
- Do not disassemble and/or repair the equipment on customer side.

It is recommended that the following points periodically be checked.

- Check for loose terminal block screws. Retighten any loose screws.
- Check the cables and the like for scratches or cracks. Inspect them periodically according to operating conditions especially when the servo motor is movable.
- Check that the connector is securely connected to the servo amplifier.
- Check that the wires are not coming out from the connector.
- Check for dust accumulation on the servo amplifier.
- Check for unusual noise generated from the servo amplifier.
- Make sure that the emergency stop circuit operates properly such that an operation can be stopped immediately and a power is shut off by the emergency stop switch.

2.5 Parts having service life

Service life of the following parts is listed below. However, the service life varies depending on operation and environment. If any fault is found in the parts, they must be replaced immediately regardless of their service life. For parts replacement, please contact your local sales office.

Part name	Life guideline
Smoothing capacitor	10 years
Relay	Number of power-on, forced stop by EM1 (Forced stop 1), and sudden stop command from controller: 100,000 times Number of on and off for STO: 1,000,000 times
Cooling fan	10,000 hours to 30,000 hours (2 years to 3 years)
Absolute position battery	 Page 466 Battery

Smoothing capacitor

The characteristic of smoothing capacitor is deteriorated due to ripple currents, etc. The life of the capacitor greatly depends on ambient temperature and operating conditions. The capacitor will be the end of its life in 10 years of continuous operation in air-conditioned environment (ambient temperature of 40 °C or less for use at the maximum 1000 m above sea level, 30 °C or less for over 1000 m to 2000 m).

Relays

Contact faults will occur due to contact wear arisen from switching currents. Relays reach the end of their lives when the power has been turned on, forced stop by EM1 (Forced stop 1) has occurred, and sudden stop command from controller has been executed 100,000 times in total, or when the STO has been turned on and off 1,000,000 times while the servo motor is stopped under servo-off state. However, the lives of relays may depend on the power supply capacity.

Servo amplifier cooling fan

The cooling fan bearings reach the end of their life in 10,000 hours to 30,000 hours. Normally, therefore, the cooling fan must be replaced in a few years of continuous operation as a guideline. It must also be changed if unusual noise or vibration is found during inspection.

The life indicates under the yearly average ambient temperature of 40 °C, free from corrosive gas, flammable gas, oil mist, dust and dirt.

2.6 Restrictions when using the servo amplifiers at altitude exceeding 1000 m and up to 2000 m above sea level

Effective load ratio and regenerative load ratio

Heat dissipation effects decrease in proportion to decreasing air density, and hence use the servo amplifiers with the effective load ratio and the regenerative load ratio within the following range.

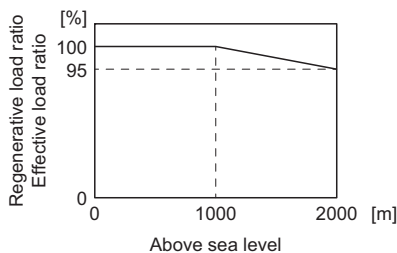

When closely mounting the servo amplifiers, operate them at the ambient temperatures of 0 °C to 45 °C or at 75% or smaller effective load ratio.

☞ Page 77 Installation direction and clearances

Input voltage

Generally, withstand voltage decreases as altitude increases; however, there is no restriction on the withstand voltage. Use in the same manner as in 1000 m or less.

☞ Page 30 Servo amplifier standard specifications

Parts having service life

■Smoothing capacitor

The capacitor will reach the end of its life in 10 years of continuous operation in air-conditioned environment (30 °C ambient temperature or less).

■Relays

There is no restriction. Use in the same manner as in 1000 m or less.

☞ Page 80 Parts having service life

■Servo amplifier cooling fan

There is no restriction. Use in the same manner as in 1000 m or less.

☞ Page 80 Parts having service life

3 SIGNALS AND WIRING

⚠ WARNING

- Any person who is involved in wiring should be fully competent to do the work.
- Before wiring, turn off the power and wait for 15 minutes or more until the charge lamp turns off. Then, confirm that the voltage between P+ and N- is safe with a voltage tester and others. Otherwise, an electric shock may occur. In addition, when confirming whether the charge lamp is off or not, always confirm it from the front of the servo amplifier.
- Ground the servo amplifier and servo motor securely.
- Do not attempt to wire the servo amplifier and servo motor until they have been installed. Otherwise, it may cause an electric shock.
- The cables should not be damaged, stressed, loaded, or pinched. Otherwise, it may cause an electric shock.
- To avoid an electric shock, insulate the connections of the power supply terminals.

⚠ CAUTION

- Wire the equipment correctly and securely. Otherwise, the servo motor may operate unexpectedly, resulting in injury.
- Connect cables to the correct terminals. Otherwise, a burst, damage, etc., may occur.
- Ensure that polarity (+/-) is correct. Otherwise, a burst, damage, etc., may occur.
- The surge absorbing diode installed to the DC relay for control output should be fitted in the specified direction. Otherwise, the converter unit and the drive unit will malfunction and will not output signals, disabling the emergency stop and other protective circuits.

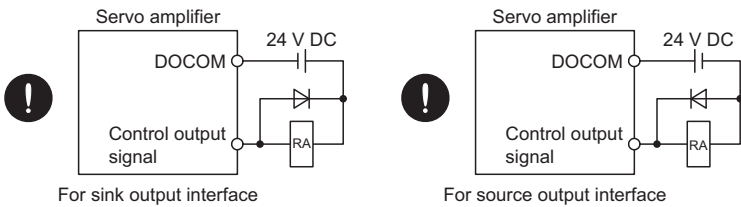

- Use a noise filter, etc., to minimize the influence of electromagnetic interference. Electromagnetic interference may affect the electronic equipment used near the servo amplifier.
- Do not install a power capacitor, surge killer or radio noise filter (optional FR-BIF(-H)) with the power line of the servo motor.
- When using the regenerative resistor, switch power off with the alarm signal. Otherwise, a transistor fault or the like may overheat the regenerative resistor, causing a fire.
- Do not modify the equipment.
- Connect the servo amplifier power output (U/V/W) to the servo motor power input (U/V/W) directly. Do not connect a magnetic contactor and others between them. Otherwise, it may cause a malfunction.

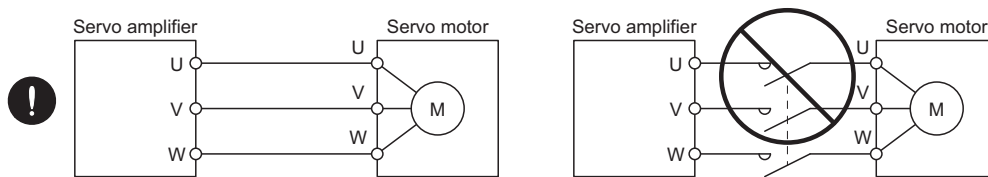

- Connecting a servo motor of the wrong axis to U, V, W, or CN2 of the servo amplifier may cause a malfunction.
- Before wiring, switch operation, etc., eliminate static electricity. Otherwise, it may cause a malfunction.

When you use a linear servo motor, replace the following left words to the right words.

Load to motor inertia ratio → Load mass

Torque → Thrust

3.1 Connection example of power circuit

CAUTION

- Always connect a magnetic contactor between the power supply and the main circuit power supply (L1/L2/L3) of the servo amplifier, in order to configure a circuit that shuts down the power supply on the side of the servo amplifier's power supply. If a magnetic contactor is not connected, continuous flow of a large current may cause a fire when the servo amplifier malfunctions.
- Use ALM (Malfunction) to switch main circuit power supply off. Not doing so may cause a fire when a regenerative transistor malfunctions or the like may overheat the regenerative resistor.
- Check the servo amplifier model, and then input proper voltage to the servo amplifier power supply. If input voltage exceeds the upper limit, the servo amplifier will break down.
- The servo amplifier has a built-in surge absorber (varistor) to reduce exogenous noise and to suppress lightning surge. Exogenous noise or lightning surge deteriorates the varistor characteristics, and the varistor may be damaged. To prevent a fire, use a molded-case circuit breaker or fuse for input power supply.
- Connecting a servo motor of the wrong axis to U, V, W, or CN2 of the servo amplifier may cause a malfunction.
- The N- terminal is not a neutral point of the power supply. Incorrect wiring will cause a burst, damage, etc.

- Even if alarm has occurred, do not switch off the control circuit power supply. When the control circuit power supply has been switched off, network communication is interrupted. Therefore, the next servo amplifier displays "AA" at the indicator and turns into base circuit shut-off. The servo motor stops with starting dynamic brake.
- EM2 has the same function as EM1 in the torque mode.
- When using the MR-J4-_GF-RJ servo amplifier with the DC power supply input, refer to the following.
 Page 586 When using the servo amplifier with the DC power supply input

Configure the wiring so that the main circuit power supply is shut off and the servo-on command turns off after deceleration to a stop due to an alarm occurring, an enabled servo forced stop, or a sudden stop command from controller. A molded-case circuit breaker (MCCB) must be used with the input cables of the main circuit power supply.

200 V class

For 3-phase 200 V AC to 240 V AC power supply of MR-J4-10GF(-RJ) to MR-J4-350GF(-RJ)

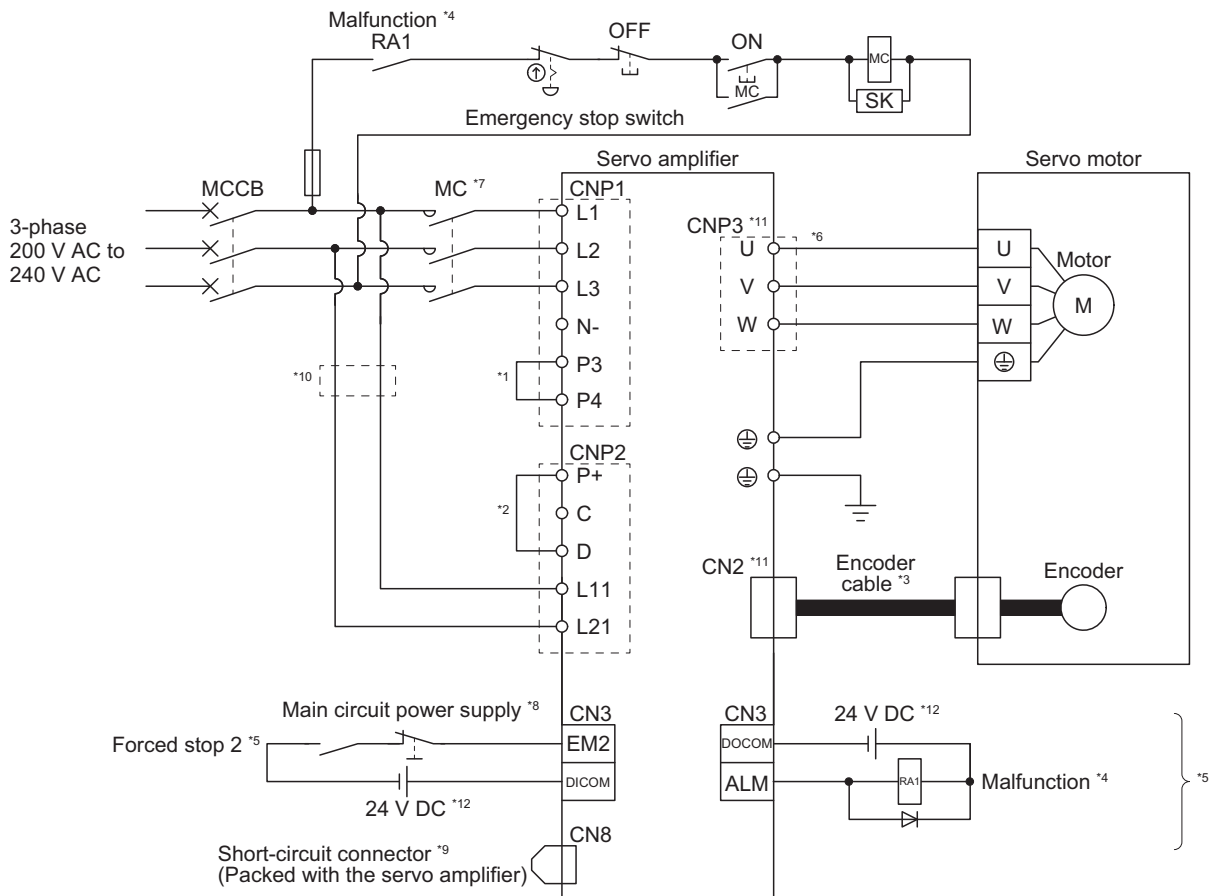

- *1 Between P3 and P4 is connected by default. When using the power factor improving DC reactor, remove the short bar between P3 and P4. Additionally, a power factor improving DC reactor and power factor improving AC reactor cannot be used simultaneously.
 ☞ Page 409 Power factor improving DC reactors
- *2 Always connect between P+ and D terminals. (factory-wired) When using the regenerative option, refer to the following.
 ☞ Page 338 Regenerative options
- *3 For the encoder cable, use of the option cable is recommended. For selecting cables, refer to "Servo Motor Instruction Manual (Vol. 3)".
- *4 If disabling ALM (Malfunction) output with the parameter, configure up the power supply circuit which switches off the magnetic contactor after detection of alarm occurrence on the controller side.
- *5 This diagram shows sink I/O interface. For source I/O interface, refer to the following.
 ☞ Page 119 Source I/O interface
- *6 For connecting servo motor power wires, refer to "Servo Motor Instruction Manual (Vol. 3)".
- *7 Use a magnetic contactor with an operation delay time (interval between current being applied to the coil until closure of contacts) of 80 ms or less. Depending on the main circuit voltage and operation pattern, bus voltage decreases, and that may cause the forced stop deceleration to shift to the dynamic brake deceleration. When dynamic brake deceleration is not required, slow the time to turn off the magnetic contactor.
- *8 Configure a circuit to turn off EM2 when the main circuit power is turned off to prevent an unexpected restart of the servo amplifier.
- *9 When not using the STO function, attach the short-circuit connector came with a servo amplifier.
- *10 When wires used for L11 and L21 are thinner than wires used for L1, L2, and L3, use a molded-case circuit breaker.
 ☞ Page 406 Molded-case circuit breakers, fuses, magnetic contactors
- *11 Connecting a servo motor of the wrong axis to U, V, W, or CN2 of the servo amplifier may cause a malfunction.
- *12 The illustration of the 24 V DC power supply is divided between input signal and output signal for convenience. However, they can be configured by one.

For 1-phase 200 V AC to 240 V AC power supply of MR-J4-10GF(-RJ) to MR-J4-200GF(-RJ)

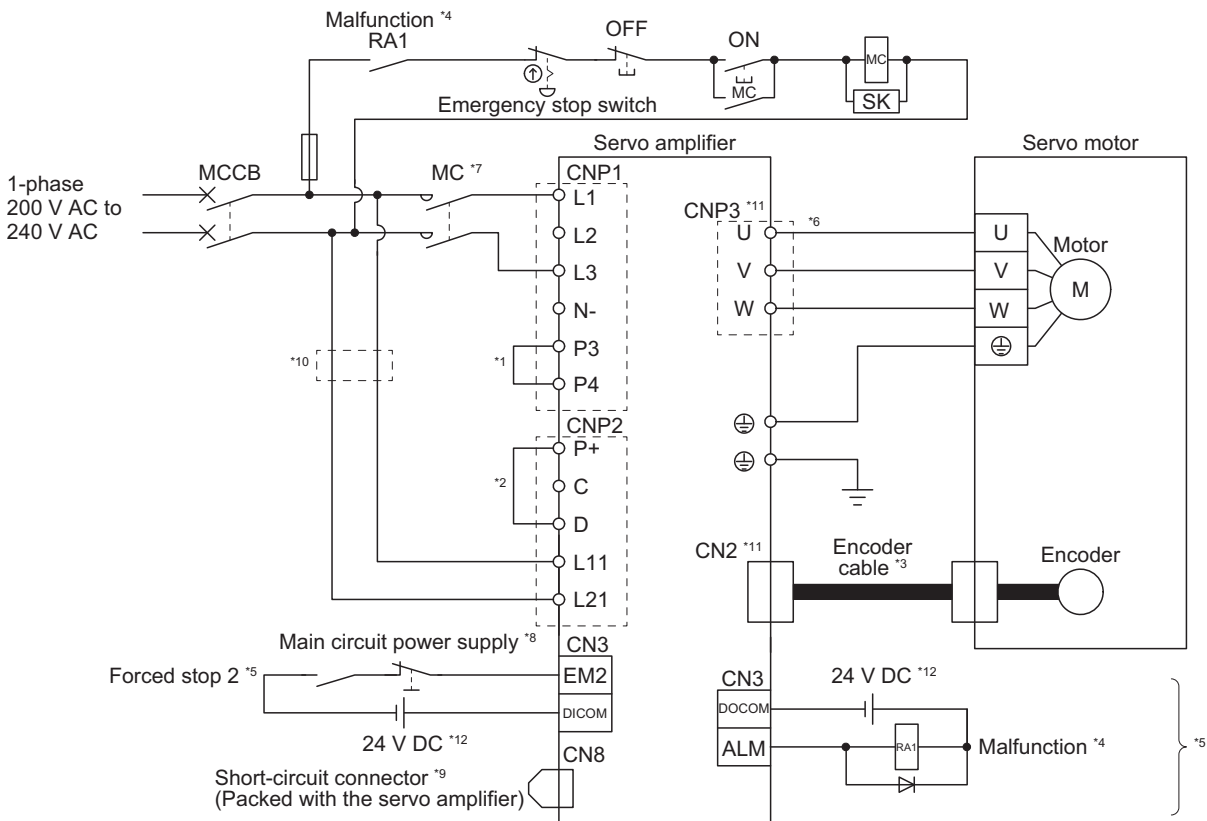

- *1 Between P3 and P4 is connected by default. When using the power factor improving DC reactor, remove the short bar between P3 and P4. Additionally, a power factor improving DC reactor and power factor improving AC reactor cannot be used simultaneously.
☞ Page 409 Power factor improving DC reactors
- *2 Always connect between P+ and D terminals. (factory-wired) When using the regenerative option, refer to the following.
☞ Page 338 Regenerative options
- *3 For the encoder cable, use of the option cable is recommended. For selecting cables, refer to "Servo Motor Instruction Manual (Vol. 3)".
- *4 If disabling ALM (Malfunction) output with the parameter, configure up the power supply circuit which switches off the magnetic contactor after detection of alarm occurrence on the controller side.
- *5 This diagram shows sink I/O interface. For source I/O interface, refer to the following.
☞ Page 119 Source I/O interface
- *6 For connecting servo motor power wires, refer to "Servo Motor Instruction Manual (Vol. 3)".
- *7 Use a magnetic contactor with an operation delay time (interval between current being applied to the coil until closure of contacts) of 80 ms or less. Depending on the main circuit voltage and operation pattern, bus voltage decreases, and that may cause the forced stop deceleration to shift to the dynamic brake deceleration. When dynamic brake deceleration is not required, slow the time to turn off the magnetic contactor.
- *8 Configure a circuit to turn off EM2 when the main circuit power is turned off to prevent an unexpected restart of the servo amplifier.
- *9 When not using the STO function, attach the short-circuit connector came with a servo amplifier.
- *10 When wires used for L11 and L21 are thinner than wires used for L1, and L3, use a molded-case circuit breaker.
☞ Page 406 Molded-case circuit breakers, fuses, magnetic contactors
- *11 Connecting a servo motor of the wrong axis to U, V, W, or CN2 of the servo amplifier may cause a malfunction.
- *12 The illustration of the 24 V DC power supply is divided between input signal and output signal for convenience. However, they can be configured by one.

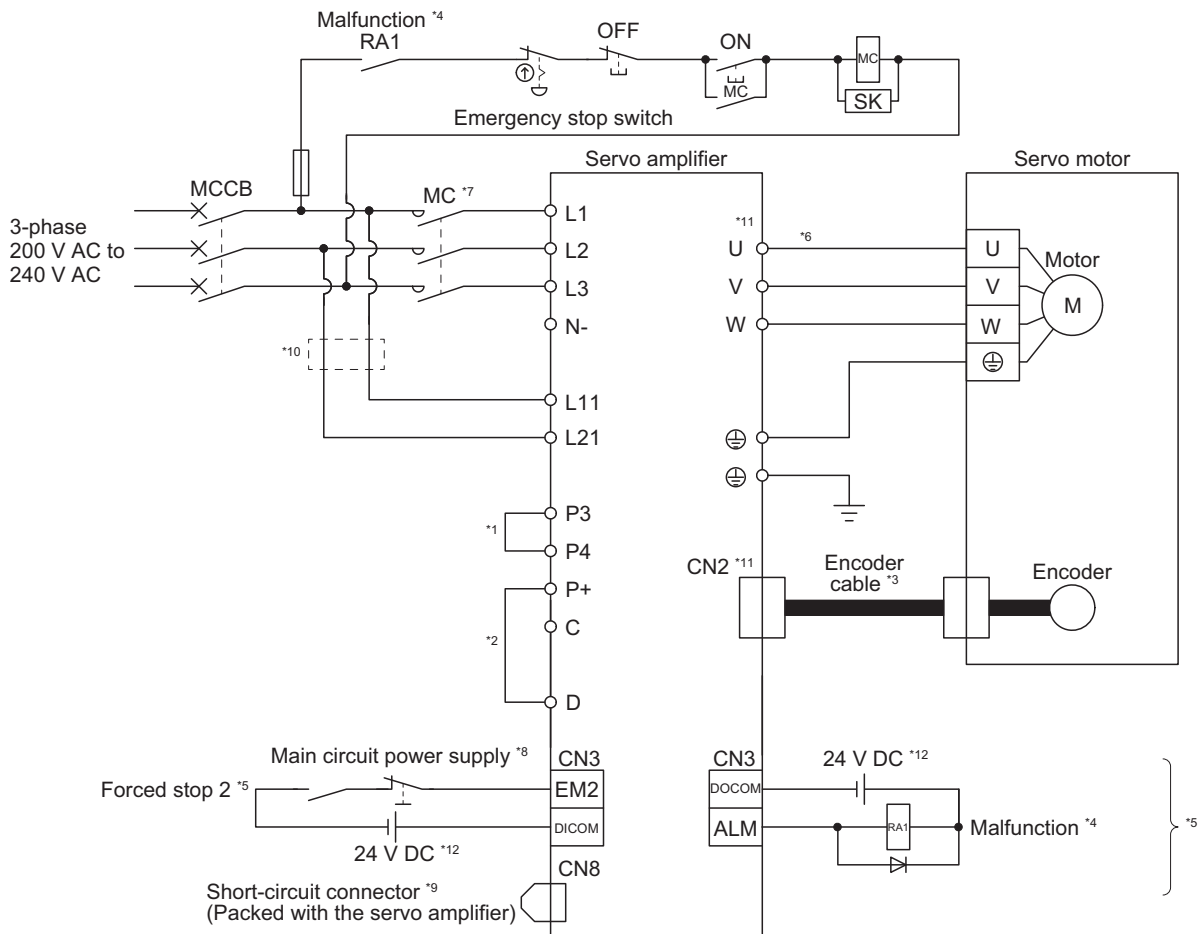

- *1 Between P3 and P4 is connected by default. When using the power factor improving DC reactor, remove the short bar between P3 and P4. Additionally, a power factor improving DC reactor and power factor improving AC reactor cannot be used simultaneously.
[☞ Page 409 Power factor improving DC reactors](#)
- *2 Always connect between P+ and D terminals. (factory-wired) When using the regenerative option, refer to the following.
[☞ Page 338 Regenerative options](#)
- *3 For the encoder cable, use of the option cable is recommended. For selecting cables, refer to "Servo Motor Instruction Manual (Vol. 3)".
- *4 If disabling ALM (Malfunction) output with the parameter, configure up the power supply circuit which switches off the magnetic contactor after detection of alarm occurrence on the controller side.
- *5 This diagram shows sink I/O interface. For source I/O interface, refer to the following.
[☞ Page 119 Source I/O interface](#)
- *6 For connecting servo motor power wires, refer to "Servo Motor Instruction Manual (Vol. 3)".
- *7 Use a magnetic contactor with an operation delay time (interval between current being applied to the coil until closure of contacts) of 80 ms or less. Depending on the main circuit voltage and operation pattern, bus voltage decreases, and that may cause the forced stop deceleration to shift to the dynamic brake deceleration. When dynamic brake deceleration is not required, slow the time to turn off the magnetic contactor.
- *8 Configure a circuit to turn off EM2 when the main circuit power is turned off to prevent an unexpected restart of the servo amplifier.
- *9 When not using the STO function, attach the short-circuit connector came with a servo amplifier.
- *10 When wires used for L11 and L21 are thinner than wires used for L1, L2, and L3, use a molded-case circuit breaker.
[☞ Page 406 Molded-case circuit breakers, fuses, magnetic contactors](#)
- *11 Connecting a servo motor of the wrong axis to U, V, W, or CN2 of the servo amplifier may cause a malfunction.
- *12 The illustration of the 24 V DC power supply is divided between input signal and output signal for convenience. However, they can be configured by one.

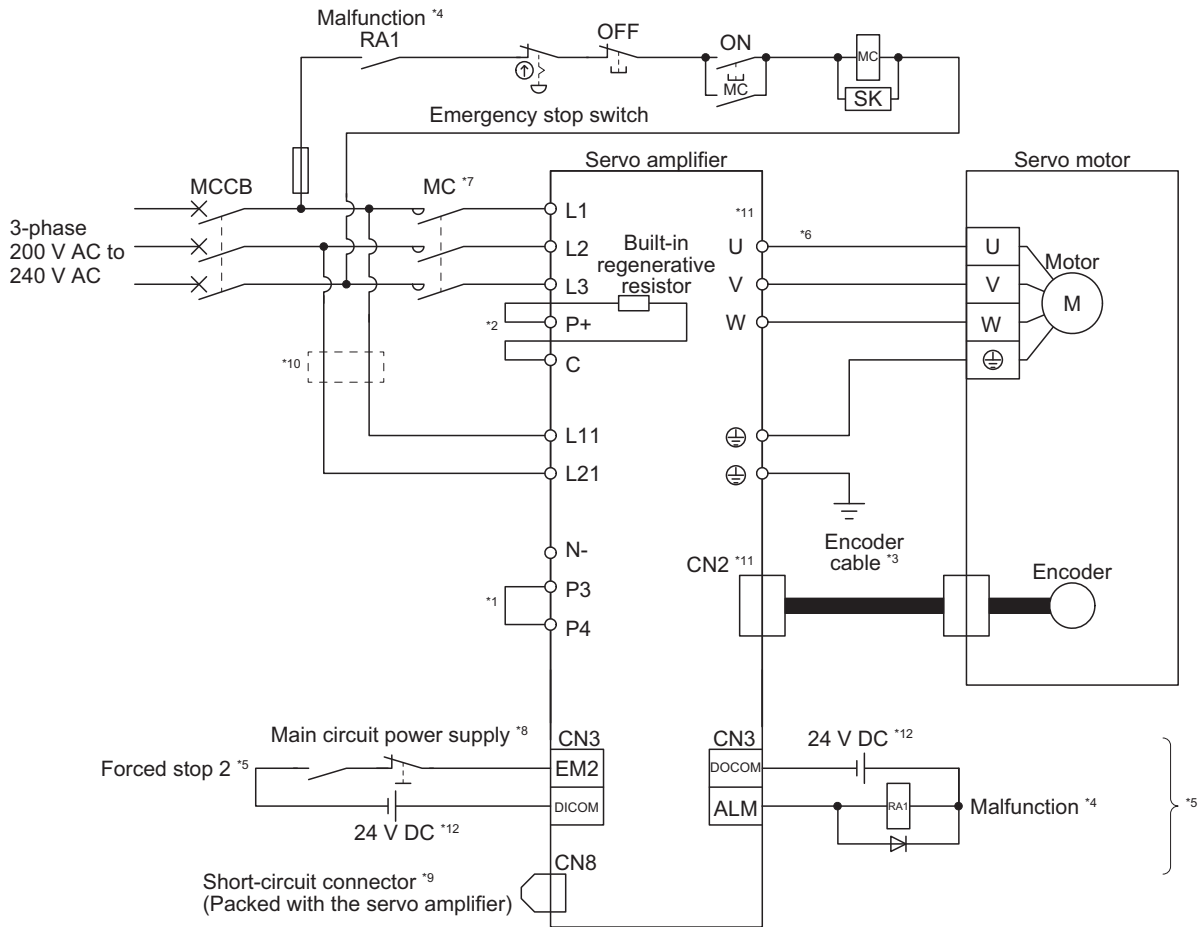

- *1 Between P3 and P4 is connected by default. When using the power factor improving DC reactor, remove the short bar between P3 and P4. Additionally, a power factor improving DC reactor and power factor improving AC reactor cannot be used simultaneously.
 ☞ Page 409 Power factor improving DC reactors
- *2 When using the regenerative option, refer to the following.
 ☞ Page 338 Regenerative options
- *3 For the encoder cable, use of the option cable is recommended. For selecting cables, refer to "Servo Motor Instruction Manual (Vol. 3)".
- *4 If disabling ALM (Malfunction) output with the parameter, configure up the power supply circuit which switches off the magnetic contactor after detection of alarm occurrence on the controller side.
- *5 This diagram shows sink I/O interface. For source I/O interface, refer to the following.
 ☞ Page 119 Source I/O interface
- *6 For connecting servo motor power wires, refer to "Servo Motor Instruction Manual (Vol. 3)".
- *7 Use a magnetic contactor with an operation delay time (interval between current being applied to the coil until closure of contacts) of 80 ms or less. Depending on the main circuit voltage and operation pattern, bus voltage decreases, and that may cause the forced stop deceleration to shift to the dynamic brake deceleration. When dynamic brake deceleration is not required, slow the time to turn off the magnetic contactor.
- *8 Configure a circuit to turn off EM2 when the main circuit power is turned off to prevent an unexpected restart of the servo amplifier.
- *9 When not using the STO function, attach the short-circuit connector came with a servo amplifier.
- *10 When wires used for L11 and L21 are thinner than wires used for L1, L2, and L3, use a molded-case circuit breaker.
 ☞ Page 406 Molded-case circuit breakers, fuses, magnetic contactors
- *11 Connecting a servo motor of the wrong axis to U, V, W, or CN2 of the servo amplifier may cause a malfunction.
- *12 The illustration of the 24 V DC power supply is divided between input signal and output signal for convenience. However, they can be configured by one.

MR-J4-11KGF(-RJ)/MR-J4-15KGF(-RJ)/MR-J4-22KGF(-RJ)

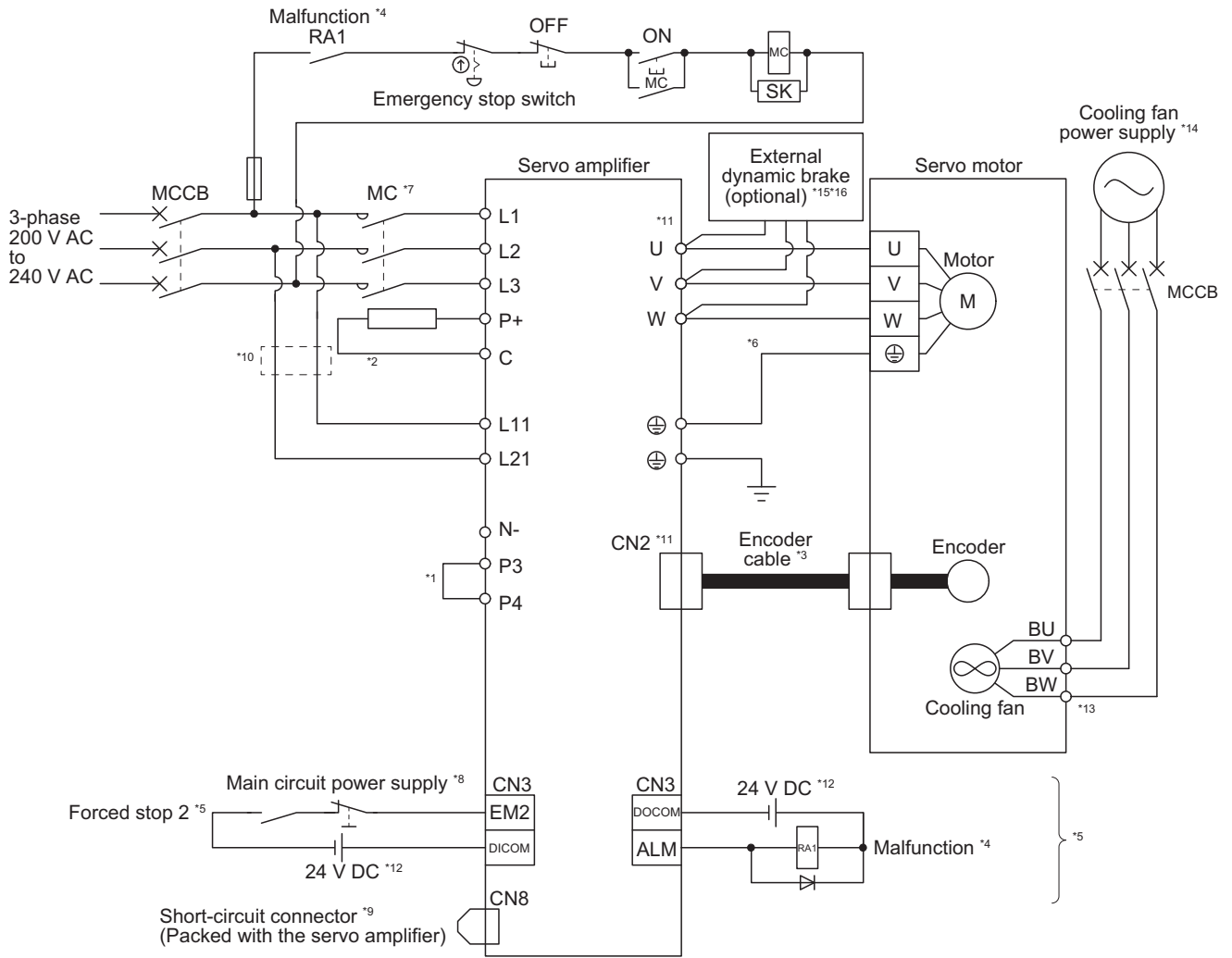

- *1 Between P3 and P4 is connected by default. When using the power factor improving DC reactor, remove the short bar between P3 and P4. Additionally, a power factor improving DC reactor and power factor improving AC reactor cannot be used simultaneously.
☞ Page 409 Power factor improving DC reactors
- *2 When using the regenerative option, refer to the following.
☞ Page 338 Regenerative options
- *3 For the encoder cable, use of the option cable is recommended. For selecting cables, refer to "Servo Motor Instruction Manual (Vol. 3)".
- *4 If disabling ALM (Malfunction) output with the parameter, configure up the power supply circuit which switches off the magnetic contactor after detection of alarm occurrence on the controller side.
- *5 This diagram shows sink I/O interface. For source I/O interface, refer to the following.
☞ Page 119 Source I/O interface
- *6 For connecting servo motor power wires, refer to "Servo Motor Instruction Manual (Vol. 3)".
- *7 Use a magnetic contactor with an operation delay time (interval between current being applied to the coil until closure of contacts) of 80 ms or less. Depending on the main circuit voltage and operation pattern, bus voltage decreases, and that may cause the forced stop deceleration to shift to the dynamic brake deceleration. When dynamic brake deceleration is not required, slow the time to turn off the magnetic contactor.
- *8 Configure a circuit to turn off EM2 when the main circuit power is turned off to prevent an unexpected restart of the servo amplifier.
- *9 When not using the STO function, attach the short-circuit connector came with a servo amplifier.
- *10 When wires used for L11 and L21 are thinner than wires used for L1, L2, and L3, use a molded-case circuit breaker.
☞ Page 406 Molded-case circuit breakers, fuses, magnetic contactors
- *11 Connecting a servo motor of the wrong axis to U, V, W, or CN2 of the servo amplifier may cause a malfunction.
- *12 The illustration of the 24 V DC power supply is divided between input signal and output signal for convenience. However, they can be configured by one.
- *13 For the servo motor with a cooling fan.
- *14 For the cooling fan power supply, refer to "Servo Motor Instruction Manual (Vol. 3)".
- *15 Use an external dynamic brake for this servo amplifier. Failure to do so will cause an accident because the servo motor does not stop immediately but coasts at an alarm occurrence for which the servo motor does not decelerate to stop. Ensure the safety in the entire equipment. For alarms for which the servo motor does not decelerate to stop, refer to the following.
☞ Page 283 TROUBLESHOOTING
For wiring of the external dynamic brake, refer to the following.
☞ Page 439 External dynamic brake
- *16 The external dynamic brake cannot be used for compliance with SEMI-F47 standard. Do not assign DB (Dynamic brake interlock) in [Pr. PD07] to [Pr. PD09]. Failure to do so will cause the servo amplifier to become servo-off when an instantaneous power failure occurs.

400 V class

MR-J4-60GF4(-RJ) to MR-J4-350GF4(-RJ)

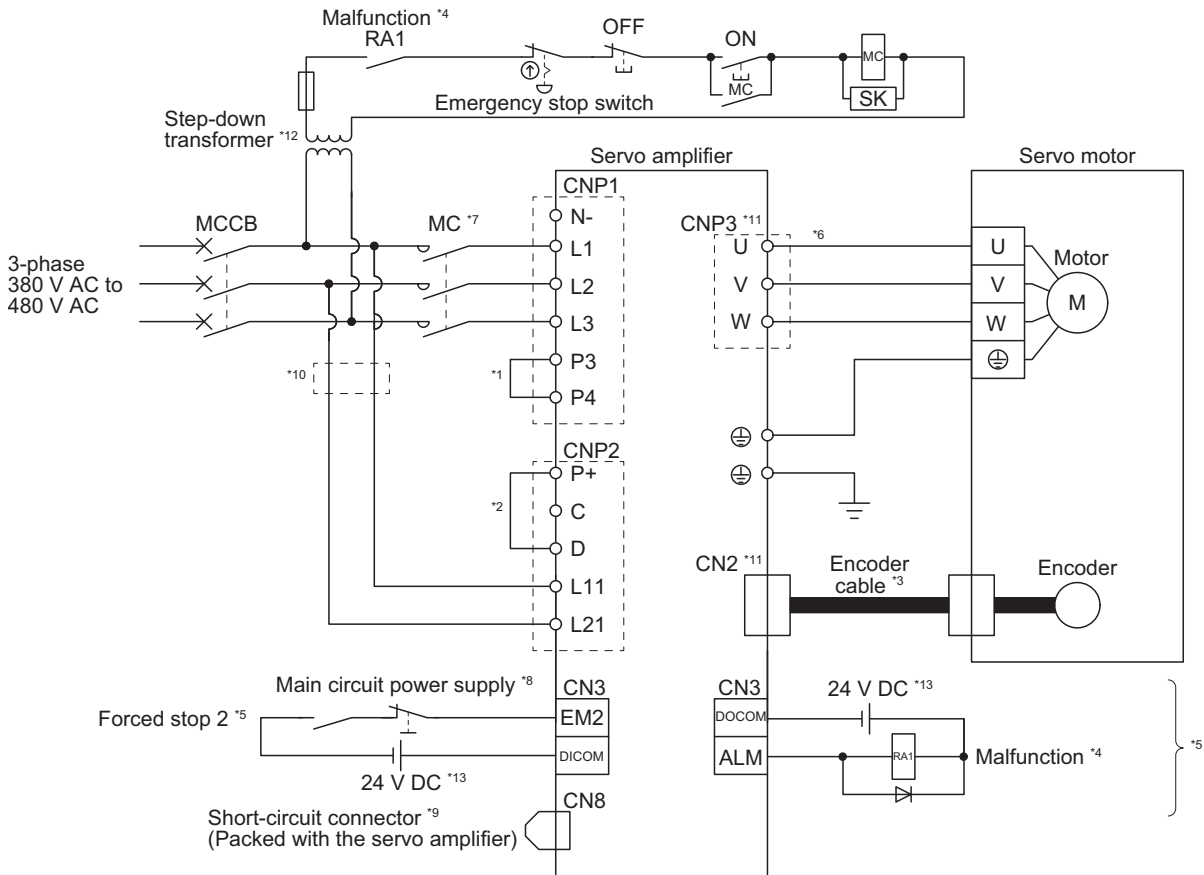

- *1 Between P3 and P4 is connected by default. When using the power factor improving DC reactor, remove the short bar between P3 and P4. Additionally, a power factor improving DC reactor and power factor improving AC reactor cannot be used simultaneously.
[☞ Page 409 Power factor improving DC reactors](#)
- *2 Always connect between P+ and D terminals. (factory-wired) When using the regenerative option, refer to the following.
[☞ Page 338 Regenerative options](#)
- *3 For the encoder cable, use of the option cable is recommended. For selecting cables, refer to "Servo Motor Instruction Manual (Vol. 3)".
- *4 If disabling ALM (Malfunction) output with the parameter, configure up the power supply circuit which switches off the magnetic contactor after detection of alarm occurrence on the controller side.
- *5 This diagram shows sink I/O interface. For source I/O interface, refer to the following.
[☞ Page 119 Source I/O interface](#)
- *6 For connecting servo motor power wires, refer to "Servo Motor Instruction Manual (Vol. 3)".
- *7 Use a magnetic contactor with an operation delay time (interval between current being applied to the coil until closure of contacts) of 80 ms or less. Depending on the main circuit voltage and operation pattern, bus voltage decreases, and that may cause the forced stop deceleration to shift to the dynamic brake deceleration. When dynamic brake deceleration is not required, slow the time to turn off the magnetic contactor.
- *8 Configure a circuit to turn off EM2 when the main circuit power is turned off to prevent an unexpected restart of the servo amplifier.
- *9 When not using the STO function, attach the short-circuit connector came with a servo amplifier.
- *10 When wires used for L11 and L21 are thinner than wires used for L1, L2, and L3, use a molded-case circuit breaker.
[☞ Page 406 Molded-case circuit breakers, fuses, magnetic contactors](#)
- *11 Connecting a servo motor of the wrong axis to U, V, W, or CN2 of the servo amplifier may cause a malfunction.
- *12 Stepdown transformer is required when the coil voltage of the magnetic contactor is 200 V class.
- *13 The illustration of the 24 V DC power supply is divided between input signal and output signal for convenience. However, they can be configured by one.

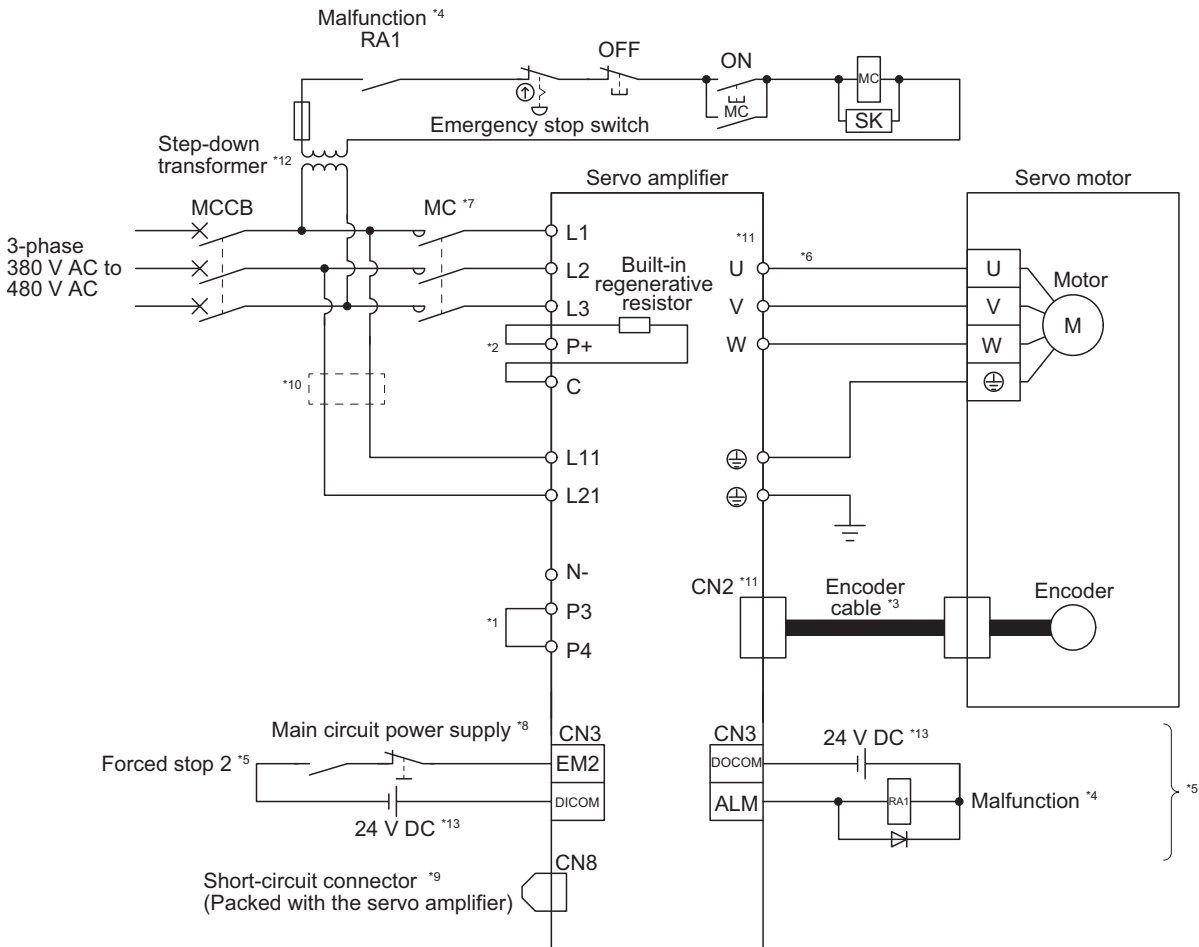

- *1 Between P3 and P4 is connected by default. When using the power factor improving DC reactor, remove the short bar between P3 and P4. Additionally, a power factor improving DC reactor and power factor improving AC reactor cannot be used simultaneously.
 ☞ Page 409 Power factor improving DC reactors
- *2 When using the regenerative option, refer to the following.
 ☞ Page 338 Regenerative options
- *3 For the encoder cable, use of the option cable is recommended. For selecting cables, refer to "Servo Motor Instruction Manual (Vol. 3)".
- *4 If disabling ALM (Malfunction) output with the parameter, configure up the power supply circuit which switches off the magnetic contactor after detection of alarm occurrence on the controller side.
- *5 This diagram shows sink I/O interface. For source I/O interface, refer to the following.
 ☞ Page 119 Source I/O interface
- *6 For connecting servo motor power wires, refer to "Servo Motor Instruction Manual (Vol. 3)".
- *7 Use a magnetic contactor with an operation delay time (interval between current being applied to the coil until closure of contacts) of 80 ms or less. Depending on the main circuit voltage and operation pattern, bus voltage decreases, and that may cause the forced stop deceleration to shift to the dynamic brake deceleration. When dynamic brake deceleration is not required, slow the time to turn off the magnetic contactor.
- *8 Configure a circuit to turn off EM2 when the main circuit power is turned off to prevent an unexpected restart of the servo amplifier.
- *9 When not using the STO function, attach the short-circuit connector came with a servo amplifier.
- *10 When wires used for L11 and L21 are thinner than wires used for L1, L2, and L3, use a molded-case circuit breaker.
 ☞ Page 406 Molded-case circuit breakers, fuses, magnetic contactors
- *11 Connecting a servo motor of the wrong axis to U, V, W, or CN2 of the servo amplifier may cause a malfunction.
- *12 Stepdown transformer is required when the coil voltage of the magnetic contactor is 200 V class.
- *13 The illustration of the 24 V DC power supply is divided between input signal and output signal for convenience. However, they can be configured by one.

MR-J4-11KGF4(-RJ) to MR-J4-22KGF4(-RJ)

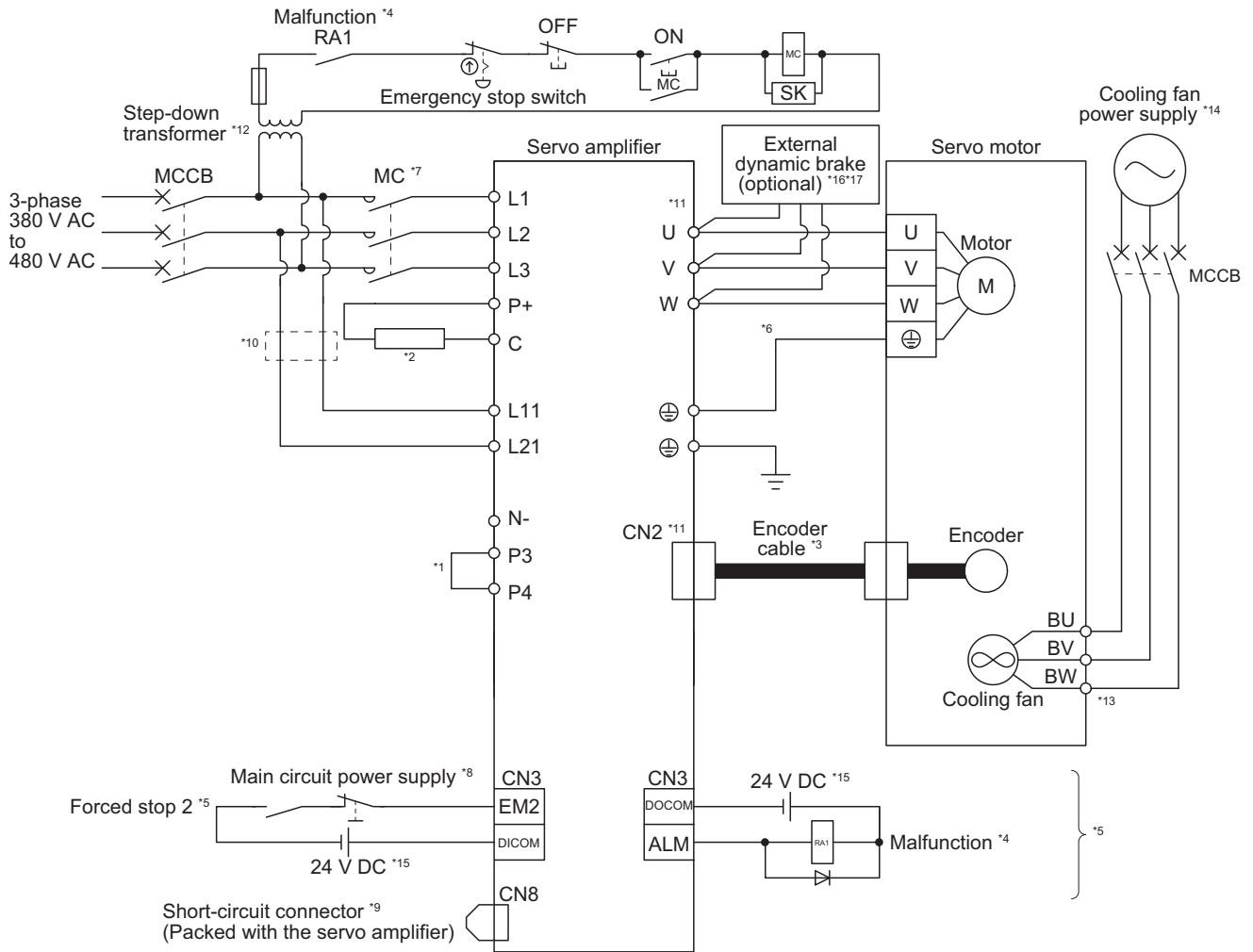

- *1 Between P3 and P4 is connected by default. When using the power factor improving DC reactor, remove the short bar between P3 and P4. Additionally, a power factor improving DC reactor and power factor improving AC reactor cannot be used simultaneously.
☞ Page 409 Power factor improving DC reactors
- *2 When using the regenerative option, refer to the following.
☞ Page 338 Regenerative options
- *3 For the encoder cable, use of the option cable is recommended. For selecting cables, refer to "Servo Motor Instruction Manual (Vol. 3)".
- *4 If disabling ALM (Malfunction) output with the parameter, configure up the power supply circuit which switches off the magnetic contactor after detection of alarm occurrence on the controller side.
- *5 This diagram shows sink I/O interface. For source I/O interface, refer to the following.
☞ Page 119 Source I/O interface
- *6 For connecting servo motor power wires, refer to "Servo Motor Instruction Manual (Vol. 3)".
- *7 Use a magnetic contactor with an operation delay time (interval between current being applied to the coil until closure of contacts) of 80 ms or less.
Depending on the main circuit voltage and operation pattern, bus voltage decreases, and that may cause the forced stop deceleration to shift to the dynamic brake deceleration. When dynamic brake deceleration is not required, slow the time to turn off the magnetic contactor.
- *8 Configure a circuit to turn off EM2 when the main circuit power is turned off to prevent an unexpected restart of the servo amplifier.
- *9 When not using the STO function, attach the short-circuit connector came with a servo amplifier.
- *10 When wires used for L11 and L21 are thinner than wires used for L1, L2, and L3, use a molded-case circuit breaker.
☞ Page 406 Molded-case circuit breakers, fuses, magnetic contactors
- *11 Connecting a servo motor of the wrong axis to U, V, W, or CN2 of the servo amplifier may cause a malfunction.
- *12 Stepdown transformer is required when the coil voltage of the magnetic contactor is 200 V class.
- *13 For the servo motor with a cooling fan.
- *14 For the cooling fan power supply, refer to "Servo Motor Instruction Manual (Vol. 3)".
- *15 The illustration of the 24 V DC power supply is divided between input signal and output signal for convenience. However, they can be configured by one.
- *16 Use an external dynamic brake for this servo amplifier. Failure to do so will cause an accident because the servo motor does not stop immediately but coasts at an alarm occurrence for which the servo motor does not decelerate to stop. Ensure the safety in the entire equipment. For alarms for which the servo motor does not decelerate to stop, refer to the following.
☞ Page 283 TROUBLESHOOTING
For wiring of the external dynamic brake, refer to the following.
☞ Page 439 External dynamic brake
- *17 The external dynamic brake cannot be used for compliance with SEMI-F47 standard. Do not assign DB (Dynamic brake interlock) in [Pr. PD07] to [Pr. PD09]. Failure to do so will cause the servo amplifier to become servo-off when an instantaneous power failure occurs.

100 V class

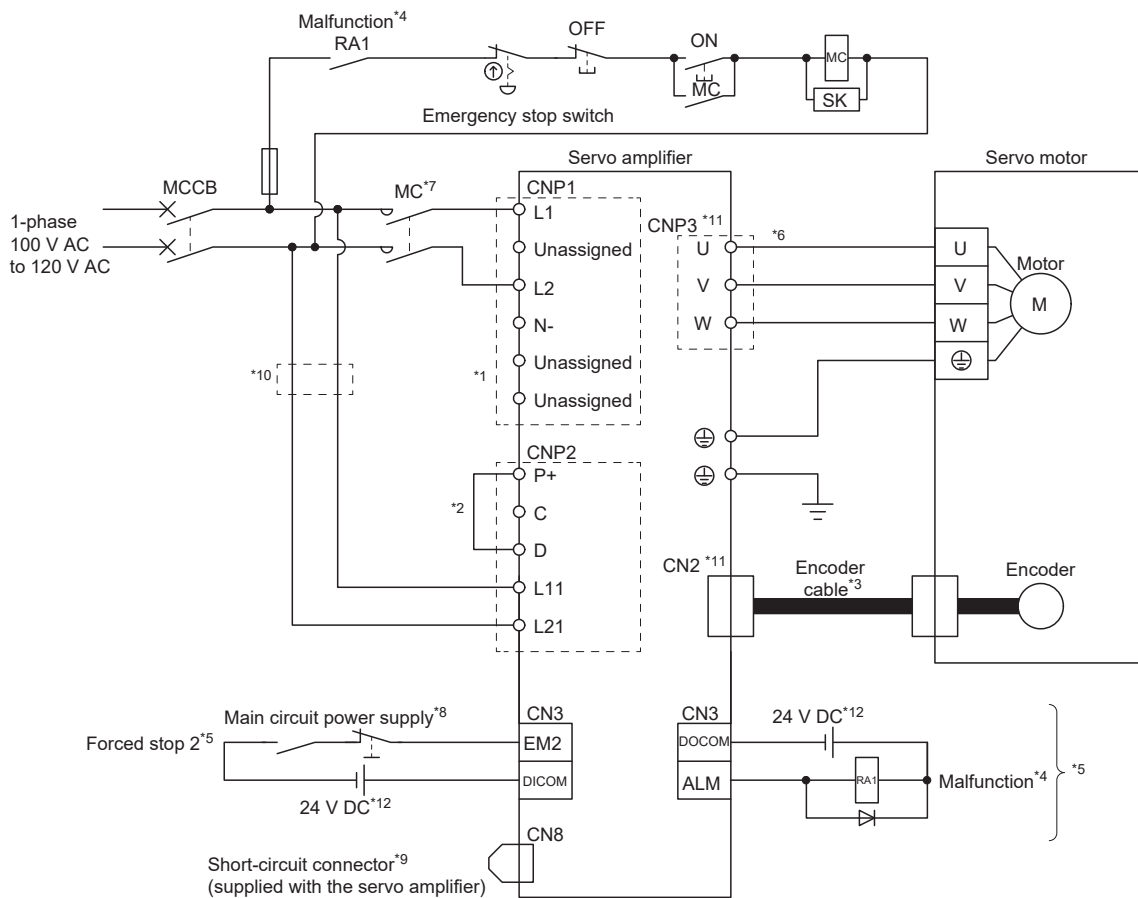

- *1 The power factor improving DC reactor cannot be used.
- *2 Always connect between P+ and D terminals. (factory-wired) When using the regenerative option, refer to the following.
☞ Page 338 Regenerative options
- *3 For the encoder cable, use of the option cable is recommended. For selecting cables, refer to "Servo Motor Instruction Manual (Vol. 3)".
- *4 If disabling ALM (Malfunction) output with the parameter, configure up the power supply circuit which switches off the magnetic contactor after detection of alarm occurrence on the controller side.
- *5 This diagram shows sink I/O interface. For source I/O interface, refer to the following.
☞ Page 119 Source I/O interface
- *6 For connecting servo motor power wires, refer to "Servo Motor Instruction Manual (Vol. 3)".
- *7 Use a magnetic contactor with an operation delay time (interval between current being applied to the coil until closure of contacts) of 80 ms or less. Depending on the main circuit voltage and operation pattern, bus voltage decreases, and that may cause the forced stop deceleration to shift to the dynamic brake deceleration. When dynamic brake deceleration is not required, slow the time to turn off the magnetic contactor.
- *8 Configure a circuit to turn off EM2 when the main circuit power is turned off to prevent an unexpected restart of the servo amplifier.
- *9 When not using the STO function, attach the short-circuit connector came with a servo amplifier.
- *10 When wires used for L11 and L21 are thinner than wires used for L1, and L2, use a molded-case circuit breaker.
☞ Page 406 Molded-case circuit breakers, fuses, magnetic contactors
- *11 Connecting a servo motor of the wrong axis to U, V, W, or CN2 of the servo amplifier may cause a malfunction.
- *12 The illustration of the 24 V DC power supply is divided between input signal and output signal for convenience. However, they can be configured by one.

3.2 I/O signal connection example

CAUTION



- The CN1A and CN1B connectors are designed for CC-Link IE Field Network only. Do not connect these connectors to other than CC-Link IE Field Network. Otherwise, a malfunction may occur.

Point

- EM2 has the same function as EM1 in the torque mode.
- When the servo amplifier is used in the motion mode, use the switching hub DT135TX (Mitsubishi Electric System & Service) to branch a CC-Link IE Field Network.

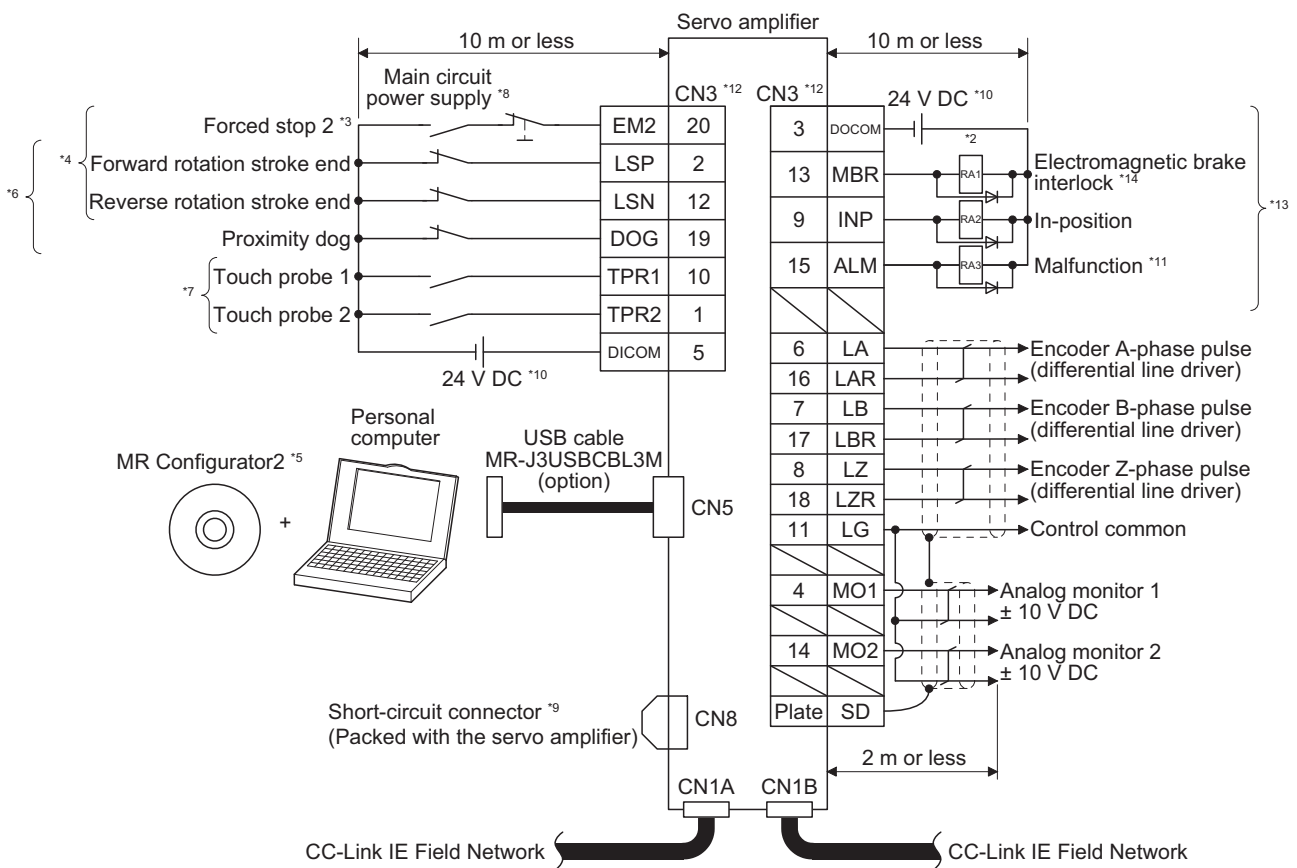
For sink I/O interface



- *1 To prevent an electric shock, always connect the protective earth (PE) terminal (marked \oplus) of the servo amplifier to the protective earth (PE) of the cabinet.
- *2 Connect the diode in the correct direction. If it is connected reversely, the servo amplifier will malfunction and will not output signals, disabling EM2 (Forced stop 2) and other protective circuits.
- *3 If the controller does not have forced stop function, always install the forced stop 2 switch (normally closed contact).
- *4 When starting operation, always turn on EM2 (Forced stop 2), LSP (Forward rotation stroke end) and LSN (Reverse rotation stroke end). (Normally closed contact)
When C_FLS (Upper stroke limit) and C_RLS (Lower stroke limit) are used through a controller, wiring LSP and LSN is unnecessary. In that case, set [Pr. PD41].
- *5 Use SW1DNC-MRC2-_.
 Page 385 MR Configurator2
- *6 You can change devices of these pins with [Pr. PD03], [Pr. PD05], and [Pr. PD06].
- *7 The device is available only with MR-J4-_GF_-RJ.
- *8 Configure a circuit to turn off EM2 when the main circuit power is turned off to prevent an unexpected restart of the servo amplifier.
- *9 When not using the STO function, attach the short-circuit connector came with a servo amplifier.
- *10 Supply 24 V DC \pm 10% for interfaces from outside. Set the total current capacity to 300 mA. 300 mA is the value applicable when all I/O signals are used. The current capacity can be decreased by reducing the number of I/O points. Refer to the following for the current value necessary for the interface.
 Page 117 Digital input interface DI-1
The illustration of the 24 V DC power supply is divided between input signal and output signal for convenience. However, they can be configured by one.
- *11 ALM (Malfunction) turns on in normal alarm-free condition. (Normally closed contact)
- *12 The pins with the same signal name are connected in the servo amplifier.
- *13 You can change devices of these pins with [Pr. PD07], [Pr. PD08], and [Pr. PD09].
- *14 When you use a linear servo motor or direct drive motor, use MBR (Electromagnetic brake interlock) for an external brake mechanism.

For source I/O interface



For notes, refer to the following.

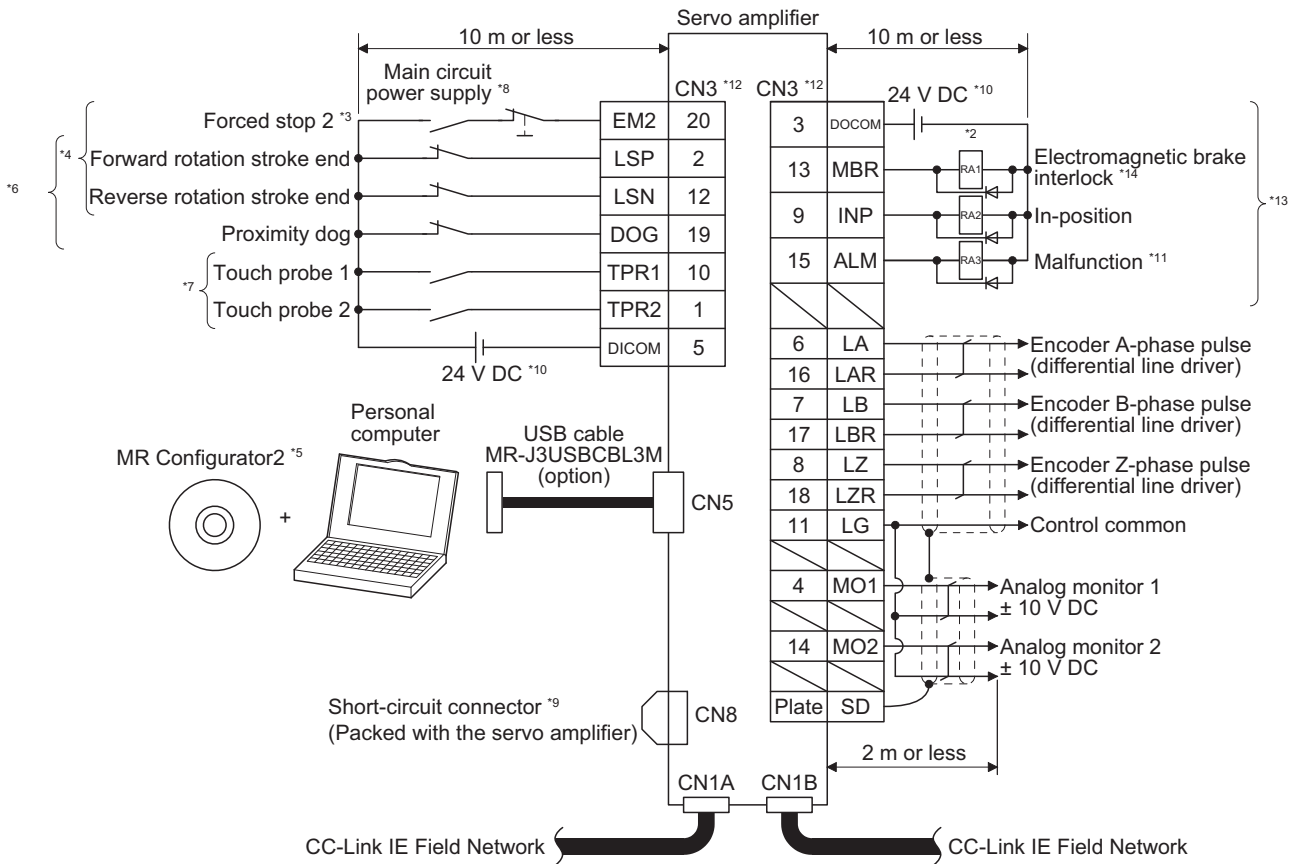

Page 95 For sink I/O interface





3.3 Explanation of power supply system

Signal explanations

Point

- For the layout of connector and terminal block, refer to the following.  Page 295 DIMENSIONS
- When using the MR-J4-_GF-RJ servo amplifier with the DC power supply input, refer to the following.  Page 586 When using the servo amplifier with the DC power supply input

Symbol	Connection target (application)	Description																													
L1/L2/L3	Main circuit power supply	<p>Supply the following power to L1, L2, and L3. For 1-phase 200 V AC to 240 V AC, connect the power supply to L1 and L3. Leave L2 open.</p> <table border="1"> <thead> <tr> <th rowspan="2">Power supply</th> <th colspan="4">Servo amplifier</th> </tr> <tr> <th>MR-J4-10GF(-RJ) to MR-J4-200GF(-RJ)</th> <th>MR-J4-350GF(-RJ) to MR-J4-22KGF(-RJ)</th> <th>MR-J4-60GF4(-RJ) to MR-J4-22KGF4(-RJ)</th> <th>MR-J4-10GF1(-RJ) to MR-J4-40GF1(-RJ)</th> </tr> </thead> <tbody> <tr> <td>3-phase 200 V AC to 240 V AC, 50 Hz/60 Hz</td> <td>L1/L2/L3</td> <td>-</td> <td>-</td> <td>-</td> </tr> <tr> <td>1-phase 200 V AC to 240 V AC, 50 Hz/60 Hz</td> <td>L1/L3</td> <td>-</td> <td>-</td> <td>-</td> </tr> <tr> <td>3-phase 380 V AC to 480 V AC, 50 Hz/60 Hz</td> <td>-</td> <td>-</td> <td>L1/L2/L3</td> <td>-</td> </tr> <tr> <td>1-phase 100 V AC to 120 V AC, 50 Hz/60 Hz</td> <td>-</td> <td>-</td> <td>-</td> <td>L1/L2</td> </tr> </tbody> </table>	Power supply	Servo amplifier				MR-J4-10GF(-RJ) to MR-J4-200GF(-RJ)	MR-J4-350GF(-RJ) to MR-J4-22KGF(-RJ)	MR-J4-60GF4(-RJ) to MR-J4-22KGF4(-RJ)	MR-J4-10GF1(-RJ) to MR-J4-40GF1(-RJ)	3-phase 200 V AC to 240 V AC, 50 Hz/60 Hz	L1/L2/L3	-	-	-	1-phase 200 V AC to 240 V AC, 50 Hz/60 Hz	L1/L3	-	-	-	3-phase 380 V AC to 480 V AC, 50 Hz/60 Hz	-	-	L1/L2/L3	-	1-phase 100 V AC to 120 V AC, 50 Hz/60 Hz	-	-	-	L1/L2
Power supply	Servo amplifier																														
	MR-J4-10GF(-RJ) to MR-J4-200GF(-RJ)	MR-J4-350GF(-RJ) to MR-J4-22KGF(-RJ)	MR-J4-60GF4(-RJ) to MR-J4-22KGF4(-RJ)	MR-J4-10GF1(-RJ) to MR-J4-40GF1(-RJ)																											
3-phase 200 V AC to 240 V AC, 50 Hz/60 Hz	L1/L2/L3	-	-	-																											
1-phase 200 V AC to 240 V AC, 50 Hz/60 Hz	L1/L3	-	-	-																											
3-phase 380 V AC to 480 V AC, 50 Hz/60 Hz	-	-	L1/L2/L3	-																											
1-phase 100 V AC to 120 V AC, 50 Hz/60 Hz	-	-	-	L1/L2																											
P3/P4	Power factor improving DC reactor	<p>When not using the power factor improving DC reactor, connect P3 and P4. (factory-wired)</p> <p>When using the power factor improving DC reactor, disconnect P3 and P4, and connect the power factor improving DC reactor to P3 and P4.</p> <p> Page 409 Power factor improving DC reactors</p>																													
P+/C/D	Regenerative option	<p>■200 V class/100 V class</p> <ul style="list-style-type: none"> • MR-J4-500GF(-RJ) or less and MR-J4-40GF1(-RJ) or less <p>When using a servo amplifier built-in regenerative resistor, connect P+ and D. (factory-wired)</p> <p>When using a regenerative option, disconnect P+ and D, and connect the regenerative option to P+ and C.</p> <ul style="list-style-type: none"> • MR-J4-700GF(-RJ) to MR-J4-22KGF(-RJ) <p>These servo amplifiers do not have D.</p> <p>When using a servo amplifier built-in regenerative resistor, connect P+ and C. (factory-wired)</p> <p>When using a regenerative option, disconnect wires of P+ and C for the built-in regenerative resistor. And then connect wires of the regenerative option to P+ and C.</p> <p> Page 338 Regenerative options</p> <p>■400 V class</p> <ul style="list-style-type: none"> • MR-J4-350GF4(-RJ) or less <p>When using a servo amplifier built-in regenerative resistor, connect P+ and D. (factory-wired)</p> <p>When using a regenerative option, disconnect P+ and D, and connect the regenerative option to P+ and C.</p> <ul style="list-style-type: none"> • MR-J4-500GF4(-RJ) to MR-J4-22KGF4(-RJ) <p>These servo amplifiers do not have D.</p> <p>When using a servo amplifier built-in regenerative resistor, connect P+ and C. (factory-wired)</p> <p>When using a regenerative option, disconnect wires of P+ and C for the built-in regenerative resistor. And then connect wires of the regenerative option to P+ and C.</p> <p> Page 338 Regenerative options</p>																													
L11/L21	Control circuit power supply	<p>Supply the following power to L11 and L21.</p> <table border="1"> <thead> <tr> <th rowspan="2">Power supply</th> <th colspan="3">Servo amplifier</th> </tr> <tr> <th>MR-J4-10GF(-RJ) to MR-J4-22KGF(-RJ)</th> <th>MR-J4-60GF4(-RJ) to MR-J4-22KGF4(-RJ)</th> <th>MR-J4-10GF1(-RJ) to MR-J4-40GF1(-RJ)</th> </tr> </thead> <tbody> <tr> <td>1-phase 200 V AC to 240 V AC, 50 Hz/60 Hz</td> <td>L11/L21</td> <td>-</td> <td>-</td> </tr> <tr> <td>1-phase 380 V AC to 480 V AC, 50 Hz/60 Hz</td> <td>-</td> <td>L11/L21</td> <td>-</td> </tr> <tr> <td>1-phase 100 V AC to 120 V AC, 50 Hz/60 Hz</td> <td>-</td> <td>-</td> <td>L11/L21</td> </tr> </tbody> </table>	Power supply	Servo amplifier			MR-J4-10GF(-RJ) to MR-J4-22KGF(-RJ)	MR-J4-60GF4(-RJ) to MR-J4-22KGF4(-RJ)	MR-J4-10GF1(-RJ) to MR-J4-40GF1(-RJ)	1-phase 200 V AC to 240 V AC, 50 Hz/60 Hz	L11/L21	-	-	1-phase 380 V AC to 480 V AC, 50 Hz/60 Hz	-	L11/L21	-	1-phase 100 V AC to 120 V AC, 50 Hz/60 Hz	-	-	L11/L21										
Power supply	Servo amplifier																														
	MR-J4-10GF(-RJ) to MR-J4-22KGF(-RJ)	MR-J4-60GF4(-RJ) to MR-J4-22KGF4(-RJ)	MR-J4-10GF1(-RJ) to MR-J4-40GF1(-RJ)																												
1-phase 200 V AC to 240 V AC, 50 Hz/60 Hz	L11/L21	-	-																												
1-phase 380 V AC to 480 V AC, 50 Hz/60 Hz	-	L11/L21	-																												
1-phase 100 V AC to 120 V AC, 50 Hz/60 Hz	-	-	L11/L21																												

Symbol	Connection target (application)	Description
U/V/W	Servo motor power supply	Connect the servo amplifier power output (U/V/W) to the servo motor power input (U/V/W) directly. Do not connect a magnetic contactor and others between them. Otherwise, it may cause a malfunction.
N-	Power regeneration converter Power regeneration common converter Brake unit Multifunction regeneration converter	This terminal is used for a power regeneration converter, power regeneration common converter, multifunction regeneration converter, and brake unit. ☞ Page 357 FR-BU2-(H) brake unit ☞ Page 370 FR-RC-(H) power regeneration converter ☞ Page 374 FR-CV-(H) power regeneration common converter ☞ Page 454 Multifunction regeneration converter FR-XC-(H)
⊕	Protective earth (PE)	Connect it to the grounding terminal of the servo motor and to the protective earth (PE) of the cabinet for grounding.

Power-on sequence

Point

The output signal, etc. may be unstable at power-on.

Power-on procedure

1. Always wire the power supply as shown in the following section using the magnetic contactor with the main circuit power supply (L1/L2/L3). Configure up an external sequence to switch off the magnetic contactor as soon as an alarm occurs.
☞ Page 83 Connection example of power circuit
2. Switch on the control circuit power supply (L11/L21) simultaneously with the main circuit power supply or before switching on the main circuit power supply. If the control circuit power supply is turned on with the main circuit power supply off, and then the servo-on command is transmitted, [AL. E9 Main circuit off warning] will occur. Turning on the main circuit power supply stops the warning and starts the normal operation.
3. The servo amplifier receives the servo-on command in 3 s to 4 s + network initial communication time after the main circuit power supply is switched on. ☞ Page 99 Timing chart

Timing chart

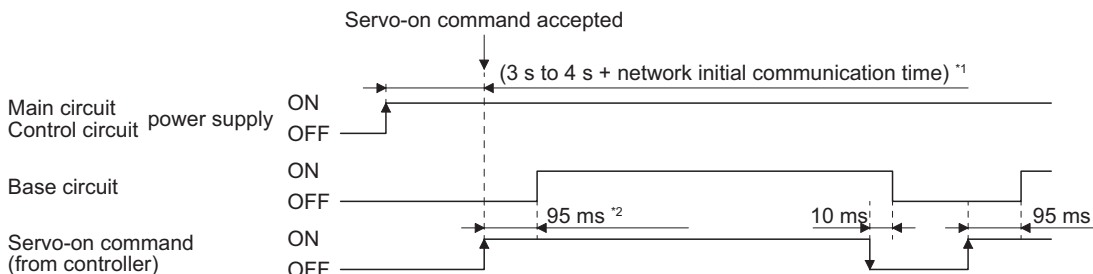

*1 This range will be "5 s to 6 s + network initial communication time" for the linear servo system and fully closed loop system.

*2 The time will be longer during the magnetic pole detection of a linear servo motor and direct drive motor.

Wiring CNP1, CNP2, and CNP3

Point

- For the wire sizes used for wiring, refer to the following. Page 402 Selection example of wires
- When wiring, remove the power connectors from the servo amplifier.
- Insert only one wire or ferrule to each wire insertion hole.
- MR-J4-500GF(-RJ) or more and MR-J4-500GF4(-RJ) or more do not have these connectors.

Use the servo amplifier power connector for wiring CNP1, CNP2, and CNP3.

Connector

■MR-J4-10GF(-RJ) to MR-J4-100GF(-RJ)

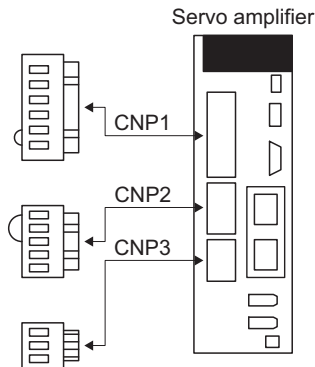

Connector	Receptacle assembly	Applicable wire		Stripped length [mm]	Open tool	Manufacturer
		Size	Insulator OD			
CNP1	06JFAT-SAXGDK-H7.5	AWG 18 to 14	3.9 mm or shorter	9	J-FAT-OT (N) or J-FAT-OT	JST
CNP2	05JFAT-SAXGDK-H5.0					
CNP3	03JFAT-SAXGDK-H7.5					

■MR-J4-200GF(-RJ)/MR-J4-350GF(-RJ)

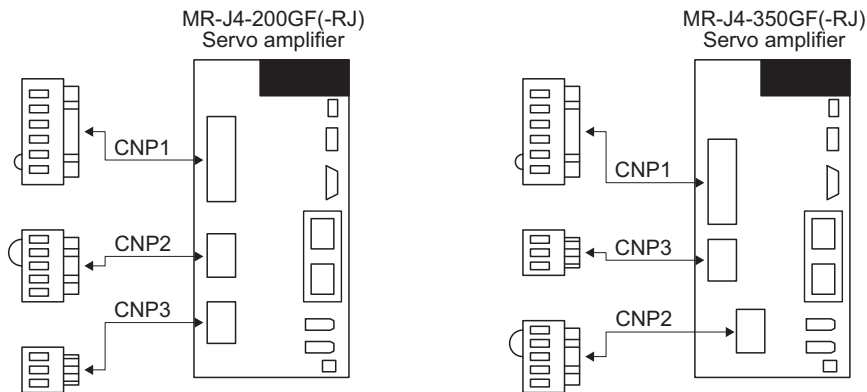

Connector	Receptacle assembly	Applicable wire		Stripped length [mm]	Open tool	Manufacturer
		Size	Insulator OD			
CNP1	06JFAT-SAXGFK-XL	AWG 16 to 10	4.7 mm or shorter	11.5	J-FAT-OT-EXL	JST
CNP3	03JFAT-SAXGFK-XL					
CNP2	05JFAT-SAXGDK-H5.0	AWG 18 to 14	3.9 mm or shorter	9		

■MR-J4-60GF4(-RJ) to MR-J4-350GF4(-RJ)

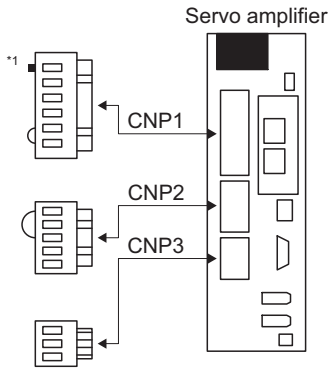

*1 A pin for preventing improper connection is inserted to N- of CNP1 connector.

Connector	Receptacle assembly	Applicable wire		Stripped length [mm]	Open tool	Manufacturer
		Size	Insulator OD			
CNP1	06JFAT-SAXGDK-HT10.5	AWG 16 to 14	3.9 mm or shorter	10	J-FAT-OT-XL	JST
CNP2	05JFAT-SAXGDK-HT7.5					
CNP3	03JFAT-SAXGDK-HT10.5					

■MR-J4-10GF1(-RJ) to MR-J4-40GF1(-RJ)

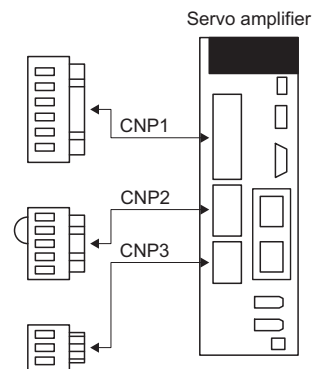

Connector	Receptacle assembly	Applicable wire		Stripped length [mm]	Open tool	Manufacturer
		Size	Insulator OD			
CNP1	06JFAT-SAXGDK-H7.5	AWG 18 to 14	3.9 mm or shorter	9	J-FAT-OT (N) or J-FAT-OT	JST
CNP2	05JFAT-SAXGDK-H5.0					
CNP3	03JFAT-SAXGDK-H7.5					

Cable connection procedure

■Fabrication on cable insulator

Refer to the following for stripped length of cable insulator. The appropriate stripped length of cables depends on their type, etc. Set the length considering their status.

☞ Page 100 Connector

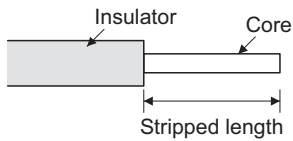

Twist strands lightly and straighten them as follows.

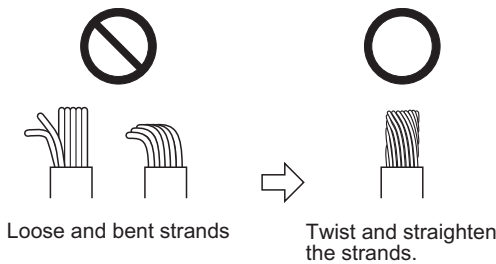

You can also use a ferrule to connect with the connectors. When using a ferrule, select a ferrule and crimping tool listed in the table below.

Servo amplifier	Wire size	Ferrule model (Phoenix Contact)		Crimping tool (Phoenix Contact)
		For one	For two	
MR-J4-10GF(-RJ) to MR-J4-100GF(-RJ)	AWG 16	AI1.5-10BK	AI-TWIN2 × 1.5-10BK	CRIMPFOX-ZA3
	AWG 14	AI2.5-10BU	—	
MR-J4-200GF(-RJ) to MR-J4-350GF(-RJ)	AWG 16	AI1.5-10BK	AI-TWIN2 × 1.5-10BK	
	AWG 14	AI2.5-10BU	AI-TWIN2 × 2.5-10BU	
	AWG 12	AI4-10GY	—	
MR-J4-60GF4(-RJ) to MR-J4-350GF4(-RJ)	AWG 16	AI1.5-10BK	AI-TWIN2 × 1.5-10BK	
	AWG 14	AI2.5-10BU	—	
MR-J4-10GF1(-RJ) to MR-J4-40GF1(-RJ)	AWG 16	AI1.5-10BK	AI-TWIN2 × 1.5-10BK	
	AWG 14	AI2.5-10BU	—	

■Inserting wire

Insert only one wire or ferrule to each wire insertion hole.

Insert the open tool as follows and push it down to open the spring.

While the open tool is pushed down, insert the stripped wire into the wire insertion hole. Check the wire insertion depth, and make sure that the cable insulator will not be caught by the spring and that the conductive part of the stripped wire will not be exposed.

Release the open tool to fix the wire. Pull the wire lightly to confirm that the wire is surely connected. In addition, make sure that no conductor wire sticks out of the connector.

The following shows a connection example of the CNP3 connector for MR-J4-200GF(-RJ) and MR-J4-350GF(-RJ).

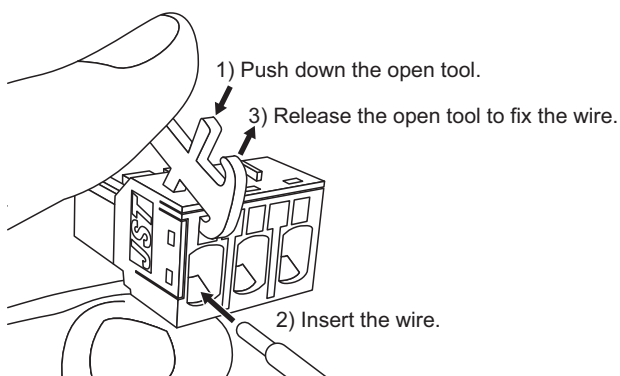

3.4 Connectors and pin assignment

Point

- The pin assignment of the connectors is as viewed from the cable connector wiring section.
- For the STO I/O signal connector (CN8), refer to the following. Page 469 USING STO FUNCTION
- For the CN3 connector, securely connect the shielded external conductor of the cable to the ground plate and fix it to the connector shell.

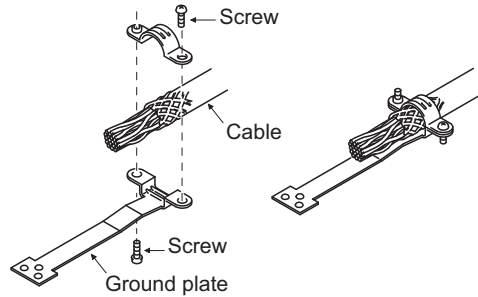

The servo amplifier front view shown is that of the MR-J4-60GF-RJ or less. Refer to the following for the appearances and connector layouts of the other servo amplifiers.

Page 295 DIMENSIONS

The frames of the CN2, CN2L, and CN3 connectors are connected to the protective earth terminal in the servo amplifier.

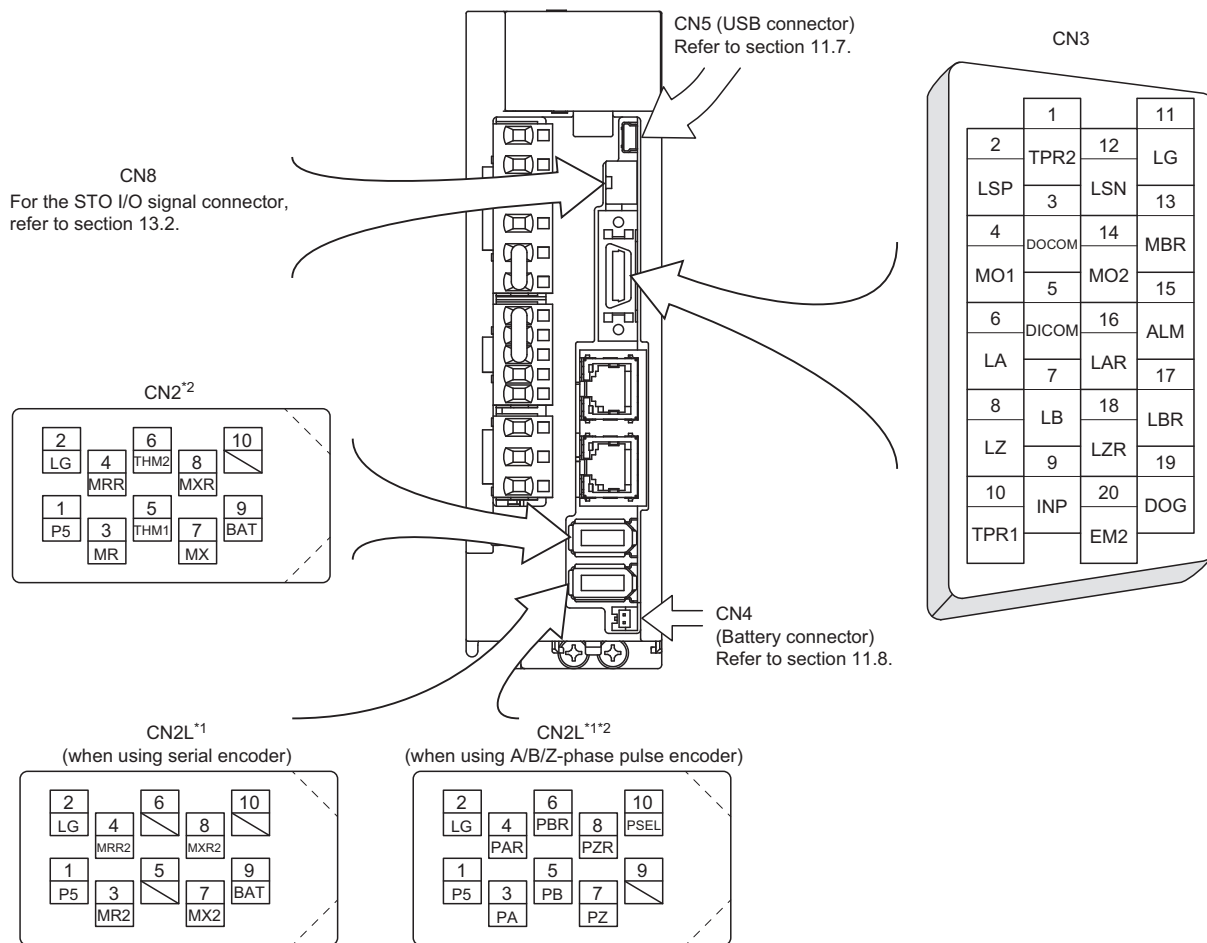

*1 The MR-J4-_GF_ servo amplifier does not have CN2L connector.

*2 This is a connector of 3M. Refer to the following and "Linear Encoder Instruction Manual" for connection of the external encoders.

Page 18 Summary

3.5 Signal (device) explanations

For the I/O interfaces (symbols in I/O division column in the table), refer to the following.

☞ Page 117 Detailed explanation of interfaces

The pin numbers in the connector pin No. column are those in the initial status.

Input device

Input device pin



The following shows the input device pins and parameters for setting devices.

Connector pin No.	Parameter	Initial device	I/O division
CN3-2	[Pr. PD03]	LSP	DI-1
CN3-12	[Pr. PD04]	LSN	
CN3-19	[Pr. PD05]	DOG	
CN3-20	[Pr. PA04]	EM2	

Input device explanations

Device	Symbol	Connector pin No.	Function and application	I/O division																						
Forced stop 2	EM2	CN3-20	<p>Turn off EM2 (open between commons) to decelerate the servo motor to a stop with commands.</p> <p>Turn EM2 on (short between commons) in the forced stop state to reset that state.</p> <p>Set [Pr. PA04] to "2 1 __" to disable EM2.</p> <p>The following shows the setting of [Pr. PA04].</p> <table border="1"> <thead> <tr> <th rowspan="2">[Pr. PA04] setting</th> <th rowspan="2">EM2/EM1</th> <th colspan="2">Deceleration method</th> </tr> <tr> <th>EM2 or EM1 is off</th> <th>Alarm occurred</th> </tr> </thead> <tbody> <tr> <td>0 0 __</td> <td>EM1</td> <td>MBR (Electromagnetic brake interlock) turns off without the forced stop deceleration.</td> <td>MBR (Electromagnetic brake interlock) turns off without the forced stop deceleration.</td> </tr> <tr> <td>2 0 __</td> <td>EM2</td> <td>MBR (Electromagnetic brake interlock) turns off after the forced stop deceleration.</td> <td>MBR (Electromagnetic brake interlock) turns off after the forced stop deceleration.</td> </tr> <tr> <td>0 1 __</td> <td>Not using EM2 or EM1</td> <td>—</td> <td>MBR (Electromagnetic brake interlock) turns off without the forced stop deceleration.</td> </tr> <tr> <td>2 1 __</td> <td>Not using EM2 or EM1</td> <td>—</td> <td>MBR (Electromagnetic brake interlock) turns off after the forced stop deceleration.</td> </tr> </tbody> </table> <p>EM2 and EM1 are mutually exclusive. EM2 has the same function as EM1 in the torque mode.</p>	[Pr. PA04] setting	EM2/EM1	Deceleration method		EM2 or EM1 is off	Alarm occurred	0 0 __	EM1	MBR (Electromagnetic brake interlock) turns off without the forced stop deceleration.	MBR (Electromagnetic brake interlock) turns off without the forced stop deceleration.	2 0 __	EM2	MBR (Electromagnetic brake interlock) turns off after the forced stop deceleration.	MBR (Electromagnetic brake interlock) turns off after the forced stop deceleration.	0 1 __	Not using EM2 or EM1	—	MBR (Electromagnetic brake interlock) turns off without the forced stop deceleration.	2 1 __	Not using EM2 or EM1	—	MBR (Electromagnetic brake interlock) turns off after the forced stop deceleration.	DI-1
[Pr. PA04] setting	EM2/EM1	Deceleration method																								
		EM2 or EM1 is off	Alarm occurred																							
0 0 __	EM1	MBR (Electromagnetic brake interlock) turns off without the forced stop deceleration.	MBR (Electromagnetic brake interlock) turns off without the forced stop deceleration.																							
2 0 __	EM2	MBR (Electromagnetic brake interlock) turns off after the forced stop deceleration.	MBR (Electromagnetic brake interlock) turns off after the forced stop deceleration.																							
0 1 __	Not using EM2 or EM1	—	MBR (Electromagnetic brake interlock) turns off without the forced stop deceleration.																							
2 1 __	Not using EM2 or EM1	—	MBR (Electromagnetic brake interlock) turns off after the forced stop deceleration.																							
Forced stop 1	EM1	(CN3-20)	<p>When using EM1, set [Pr. PA04] to "0 0 __" to enable EM1.</p> <p>When EM1 is turned off (open between commons), the base circuit shuts off, and the dynamic brake operates to decelerate the servo motor to a stop.</p> <p>The forced stop will be reset when EM1 is turned on (short between commons).</p> <p>Set [Pr. PA04] to "0 1 __" to disable EM1.</p>	DI-1																						
Touch probe 1	TPR1	CN3-10	<p>The device is available only with MR-J4- _GF_ _RJ.</p> <p>The touch probe function is available to latch the current position by sensor input. Turn it on to latch the current position. Refer to the following for the touch probe function.</p>	DI-1																						
Touch probe 2	TPR2	CN3-1	<p>☞ Page 568 Touch probe</p>	DI-1																						

Device	Symbol	Connector pin No.	Function and application	I/O division																								
Forward rotation stroke end	LSP	CN3-2	To start the operation, turn on LSP and LSN. Turn it off to bring the servo motor to a slow stop and make it servo-locked.	DI-1																								
Reverse rotation stroke end	LSN	CN3-12	<table border="1"> <thead> <tr> <th colspan="2">Input device *1</th> <th colspan="2">Operation</th> </tr> <tr> <th>LSP</th> <th>LSN</th> <th>CCW direction Positive direction</th> <th>CW direction Negative direction</th> </tr> </thead> <tbody> <tr> <td>1</td> <td>1</td> <td>○</td> <td>○</td> </tr> <tr> <td>0</td> <td>1</td> <td>—</td> <td>○</td> </tr> <tr> <td>1</td> <td>0</td> <td>○</td> <td>—</td> </tr> <tr> <td>0</td> <td>0</td> <td>—</td> <td>—</td> </tr> </tbody> </table>	Input device *1		Operation		LSP	LSN	CCW direction Positive direction	CW direction Negative direction	1	1	○	○	0	1	—	○	1	0	○	—	0	0	—	—	DI-1
			Input device *1		Operation																							
			LSP	LSN	CCW direction Positive direction	CW direction Negative direction																						
			1	1	○	○																						
			0	1	—	○																						
1	0	○	—																									
0	0	—	—																									
*1 0: Off 1: On		Setting [Pr. PD01] as follows turns the signals on automatically (always connected) in the servo amplifier.																										
<table border="1"> <thead> <tr> <th rowspan="2">[Pr. PD01]</th> <th colspan="2">Status</th> </tr> <tr> <th>LSP</th> <th>LSN</th> </tr> </thead> <tbody> <tr> <td>_ 4 _ _</td> <td>Automatic on</td> <td>—</td> </tr> <tr> <td>_ 8 _ _</td> <td>—</td> <td>Automatic on</td> </tr> <tr> <td>_ C _ _</td> <td>Automatic on</td> <td>Automatic on</td> </tr> </tbody> </table>		[Pr. PD01]	Status		LSP	LSN	_ 4 _ _	Automatic on	—	_ 8 _ _	—	Automatic on	_ C _ _	Automatic on	Automatic on													
[Pr. PD01]	Status																											
	LSP	LSN																										
_ 4 _ _	Automatic on	—																										
_ 8 _ _	—	Automatic on																										
_ C _ _	Automatic on	Automatic on																										
When LSP or LSN is turned off, [AL. 99 Stroke limit warning] occurs. In the torque mode, this device cannot be used during normal operation. It can be used during the magnetic pole detection in the linear servo motor control mode and the DD motor control mode. Also, when the magnetic pole detection in the torque mode is completed, this signal will be disabled.																												
Proximity dog	DOG	CN3-19	Turning off DOG will detect a proximity dog. The polarity for dog detection can be changed with [Pr. PT29].	DI-1																								
		<table border="1"> <thead> <tr> <th>[Pr. PT29]</th> <th>Polarity for proximity dog detection</th> </tr> </thead> <tbody> <tr> <td>_ _ _ 0</td> <td>Detection with off</td> </tr> <tr> <td>_ _ _ 1</td> <td>Detection with on</td> </tr> </tbody> </table>		[Pr. PT29]	Polarity for proximity dog detection	_ _ _ 0	Detection with off	_ _ _ 1	Detection with on																			
[Pr. PT29]	Polarity for proximity dog detection																											
_ _ _ 0	Detection with off																											
_ _ _ 1	Detection with on																											
Proportional control (PID control)	PC	—	<p>Turn PC on to switch the speed amplifier from the proportional integral type to the proportional type.</p> <p>If the servo motor at a stop is rotated even one pulse due to any external factor, it generates torque to compensate for a position shift. When the servo motor shaft is to be locked mechanically after positioning completion (stop), switching on the PC (Proportion control) upon positioning completion will suppress the unnecessary torque generated to compensate for a position shift.</p> <p>When the shaft is to be locked for a long time, switch on the PC (Proportion control) at the same time to make the torque less than the rated one.</p> <p>Do not use PC (Proportional control) in the torque mode. When PC (Proportional control) is used in the torque mode, operation may be performed at a speed exceeding the speed limit value.</p> <p>This is used when "PI control enabled (_ _ _ 0)" is selected for "PI-PID switching control selection" of [Pr. PB24].</p>	DI-1																								
Gain switching	CDP	—	Turn on CDP to use the values of [Pr. PB29] to [Pr. PB36] and [Pr. PB56] to [Pr. PB60] as the load to motor inertia ratio and gain values.	DI-1																								
Fully closed loop selection	CLD	—	<p>This is used when the semi closed loop control/fully closed loop control switching is enabled with [Pr. PE01].</p> <p>Turn off CLD to select the semi closed loop control, and turn on CLD to select the fully closed loop control.</p> <p>This is used with servo amplifiers with software version A1 or later.</p>	DI-1																								
Reset	RES	—	<p>Turn on RES to reset the alarm.</p> <p>Some alarms cannot be deactivated by RES (Reset). Refer to the following for details.</p> <p>📖 MELSERVO-J4 Servo Amplifier Instruction Manual (Troubleshooting)</p> <p>This is available with servo amplifiers with software version A7 or later.</p>	DI-1																								

Device	Symbol	Connector pin No.	Function and application	I/O division
Internal torque limit selection	CTL	—	<p>Turning on CTL compares torque limit values of [Pr. PA11 Forward rotation torque limit], [Pr. PA12 Reverse rotation torque limit], and [Pr. PC77 Internal torque limit] and enables the lowest one.</p> <p>Refer to the following for details.</p> <p>  MELSERVO MR-J4- _GF_(-RJ) Servo Amplifier Instruction Manual (I/O Mode)  MELSERVO MR-J4- _GF_(-RJ) Servo Amplifier Instruction Manual (CC-Link IE Field Network Basic) </p> <p>This is available with servo amplifiers with software version A7 or later.</p>	DI-1
Clear	CR	—	<p>Turning on CR clears the droop pulses in the position control counter and the command remaining distance at the rising edge. The pulse width should be 10 ms or longer.</p> <p>When [Pr. PD42] is set to "___1", the pulses are always cleared while CR is on.</p> <p>This can be used with the point table method and the indexer method.</p> <p>This is available with servo amplifiers with software version A7 or later.</p>	DI-1

Output device

Output device pin

The following shows the output device pins and parameters for assigning devices.

Connector pin No.	Parameter	Initial device	I/O division
CN3-13	[Pr. PD07]	MBR	DO-1
CN3-9	[Pr. PD08]	INP	
CN3-15	[Pr. PD09]	ALM	

Output device explanations

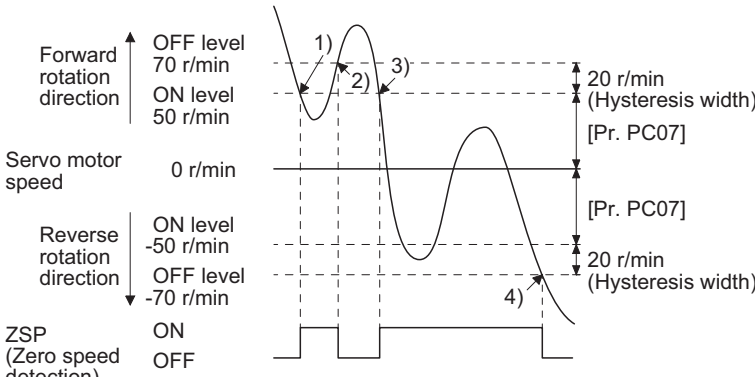
Device	Symbol	Function and application
Electromagnetic brake interlock	MBR	When using the device, set operation delay time of the electromagnetic brake in [Pr. PC02]. When a servo-off status or alarm occurs, MBR will turn off.
Malfunction	ALM	When the protective circuit is activated to shut off the base circuit, ALM will turn off. When an alarm does not occur, ALM will turn on after 2.5 s to 3.5 s after power-on.
In-position	INP	When the number of droop pulses is in the in-position range, INP will turn on. The in-position range can be changed using [Pr. PA10]. When the in-position range is increased, INP may be on during low-speed rotation. The device cannot be used in the velocity mode and torque mode.
Dynamic brake interlock	DB	When using the signal, enable it by the setting of [Pr. PD07] to [Pr. PD09]. DB turns off when the dynamic brake needs to operate. When using the external dynamic brake on the servo amplifier of 11 kW or more, this device is required. ☞ Page 439 External dynamic brake For the servo amplifier of 7 kW or less, it is not necessary to use this device. The external dynamic brake cannot be used with 11 kW or more servo amplifier for compliance with SEMI-F47 standard. Do not assign DB (Dynamic brake interlock) in [Pr. PD07] to [Pr. PD09]. Failure to do so will cause the servo amplifier to become servo-off when an instantaneous power failure occurs.
Ready	RD	Enabling servo-on to make the servo amplifier ready to operate will turn on RD.
Speed reached	SA	SA will turn off during servo-off. When the servo motor speed reaches the following range, SA will turn on. Set speed $\pm ((\text{Set speed} \times 0.05) + 20)$ r/min When the preset speed is 20 r/min or less, SA always turns on. The device cannot be used in the position mode and torque mode.
Limiting speed	VLC	When the speed reaches the speed limit value in the torque mode, VLC will turn on. When the servo is off, VLC will be turned off. The device cannot be used in the position mode and velocity mode.
Zero speed detection	ZSP	ZSP turns on when the servo motor speed is zero speed (50 r/min) or less. Zero speed can be changed with [Pr. PC07].  <p>Forward rotation direction OFF level 70 r/min ON level 50 r/min</p> <p>Servo motor speed 0 r/min</p> <p>Reverse rotation direction ON level -50 r/min OFF level -70 r/min</p> <p>ZSP (Zero speed detection) ON OFF</p> <p>20 r/min (Hysteresis width) [Pr. PC07]</p> <p>20 r/min (Hysteresis width) [Pr. PC07]</p> <p>ZSP will turn on when the servo motor is decelerated to 50 r/min (at 1), and will turn off when the servo motor is accelerated to 70 r/min again (at 2)). ZSP will turn on when the servo motor is decelerated again to 50 r/min (at 3)), and will turn off when the servo motor speed has reached -70 r/min (at 4)). The range from the point when the servo motor speed has reached on level, and ZSP turns on, to the point when it is accelerated again and has reached off level is called hysteresis width. Hysteresis width is 20 r/min for this servo amplifier. When you use a linear servo motor, [r/min] explained above will be [mm/s].</p>
Limiting torque	TLC	When the torque reaches the torque limit value during torque generation, TLC will turn on. When the servo is off, VLC will be turned off. This device cannot be used in the torque mode.

Device	Symbol	Function and application
Warning	WNG	When warning has occurred, WNG turns on. When a warning is not occurring, turning on the power will turn off WNG after 2.5 s to 3.5 s.
Battery warning	BWNG	BWNG turns on when [AL. 92 Battery cable disconnection warning] or [AL. 9F Battery warning] has occurred. When the battery warning is not occurring, turning on the power will turn off BWNG after 2.5 s to 3.5 s.
Variable gain selection	CDPS	CDPS will turn on during variable gain.
Absolute position undetermined	ABSV	ABSV turns on when the absolute position is undetermined. The device cannot be used in the velocity mode and torque mode.
During tough drive	MTTR	When a tough drive is enabled in [Pr. PA20], activating the instantaneous power failure tough drive will turn on MTTR.
During fully closed loop control	CLDS	CLDS turns on during fully closed loop control. This is used with servo amplifiers with software version A1 or later.
Home position return completion 2	ZP2	<p>1. When the incremental system is set When home position return finishes successfully, ZP2 turns on. When home position return starts or [AL. 69 Command error] occurs, ZP2 turns off. Also, when [Pr. PT01] is set to incremental value command method while in positioning mode (point table method and indexer method) and the following conditions are met, ZP2 turns off.</p> <p>1) Servo-off status (The servo is off, EM1 or EM2 is off, an alarm occurs, STO is off, or [AL. E9 Main circuit off warning] occurs.) 2) Stroke limit is off. 3) Software limit is detected.</p> <p>2. When the absolute position detection system is set When home position return finishes successfully, ZP2 turns on. When home position return starts or [AL. 69 Command error] occurs, ZP2 turns off. Also, ZP2 turns off when any of the following conditions is met.</p> <p>1) [AL. 25 Absolute position erased] occurs. 2) [AL. E3 Absolute position counter warning] occurs. 3) [Pr. PA01], [Pr. PA06], [Pr. PA07], [Pr. PA14], [Pr. PT01 (_ x _)], [Pr. PT08], [Pr. PT28], and [Pr. PT47] are changed.</p> <p>However, when [Pr. PT01] is set to incremental value command method while in positioning mode (point table method and indexer method), the absolute position detection system cannot be configured. Review the parameter setting values. ZP2 is always off in the positioning mode (speed control mode). This is available with servo amplifiers with software version A8 or later.</p>
Rough match	CPO	When the command remaining distance is lower than the value of the rough match output range set in [Pr. PT12], CPO turns on. This is not outputted during base circuit shut-off. CPO turns on at servo-on. This is available with servo amplifiers with software version A8 or later. This can be used with the point table method and the indexer method.
Position range output	POT	When the current position is within the range set with [Pr. PT19], [Pr. PT20], [Pr. PT21], and [Pr. PT22], POT turns on. This will be off when a home position return is not completed or base circuit shut-off is in progress. This is available with servo amplifiers with software version A8 or later. This can be used only with the point table method.
During a temporary stop	PUS	For the use in the I/O mode When a deceleration for a stop is started by turning on RYn7 (Temporary stop/restart), PUS turns on. When the operation is restarted by turning on RYn7 (Temporary stop/restart) again, PUS turns off. For the use on CC-Link IE Field Network Basic When a deceleration for a stop is started by turning on Halt (Temporary stop/restart), PUS turns on. When the operation is restarted by turning on Halt (Temporary stop/restart), PUS turns off. This is available with servo amplifiers with software version A8 or later. This can be used only with the point table method.
Travel completion	MEND	When the number of droop pulses is within the in-position output range set with [Pr. PA10] and the command remaining distance is "0", MEND turns on. MEND turns on at servo-on. MEND is off at servo-off status. However, MEND is not off in the indexer method, even at servo-off status. This is available with servo amplifiers with software version A8 or later. This can be used with the point table method and the indexer method.
Wait for enabling parameters	PRMWR	When a parameter is changed but not enabled, PRMWR turns on. It turns off when the changed parameter is enabled. When changing a parameter whose symbol is preceded by *, then after the change, cycle the power or reset the controller to turn off PRMWR. When changing a parameter whose symbol is preceded by **, then after the change, cycle the power to turn off PRMWR. This does not turn on when a parameter whose symbol is not preceded by * is changed. This is available with servo amplifiers with software version A6 or later.

Output signal

Signal name	Symbol	Connector pin No.	Function and application
Encoder A-phase pulse (differential line driver)	LA LAR	CN3-6 CN3-16	These devices output pulses of encoder output set in [Pr. PA15] and [Pr. PA16] in the differential line driver type. In CCW rotation of the servo motor, the encoder B-phase pulse lags the encoder A-phase pulse by a phase angle of $\pi/2$.
Encoder B-phase pulse (differential line driver)	LB LBR	CN3-7 CN3-17	The relation between rotation direction and phase difference of the A-phase and B-phase pulses can be changed with [Pr. PC03]. Output pulse specification, dividing ratio setting, and electronic gear setting can be selected.
Encoder Z-phase pulse (differential line driver)	LZ LZR	CN3-8 CN3-18	The encoder zero-point signal is output in the differential line driver type. One pulse is output per servo motor revolution. This turns on when the zero-point position is reached. (negative logic) The minimum pulse width is about 400 μ s. For home position return using this pulse, set the creep speed to 100 r/min or less.
Analog monitor 1	MO1	CN3-4	This is used to output the data set in [Pr. PC09] to between MO1 and LG in terms of voltage. Resolution: 10 bits or equivalent
Analog monitor 2	MO2	CN3-14	This signal outputs the data set in [Pr. PC10] to between MO2 and LG in terms of voltage. Resolution: 10 bits or equivalent

Power supply

Signal name	Symbol	Connector pin No.	Function and application
Digital I/F power supply input	DICOM	CN3-5	Input 24 V DC (24 V DC \pm 10% 300 mA) for I/O interface. The power supply capacity changes depending on the number of I/O interface points to be used. For sink interface, connect + of 24 V DC external power supply. For source interface, connect - of 24 V DC external power supply.
Digital I/F common	DOCOM	CN3-3	Common terminal of input signal such as EM2 of the servo amplifier. This is separated from LG. For sink interface, connect - of 24 V DC external power supply. For source interface, connect + of 24 V DC external power supply.
Monitor common	LG	CN3-11	Common terminal of MO1 and MO2.
Shield	SD	Plate	Connect the external conductor of the shielded wire.

3.6 Forced stop deceleration function

Point

- When alarms not related to the forced stop function occur, control of motor deceleration cannot be guaranteed.
 - ☞ Page 283 TROUBLESHOOTING
 - When network communication is shut-off, forced stop deceleration will operate.
 - ☞ Page 115 When network communication is shut-off
 - In the torque mode, the forced stop deceleration function is not available.
 - Disable the forced stop deceleration function for a machine in which multiple axes are connected together, such as a tandem structure. If an alarm occurs with the forced stop deceleration function disabled, the servo motor will stop with the dynamic brake.
 - Keep the servo-on command (from controller) and ready-on command (from controller) on while EM2 (Forced stop 2) is off. When the servo-on command (from controller) or ready-on command (from controller) is off, forced stop deceleration, base circuit shut-off delay time, and vertical axis freefall prevention do not function.
-

Forced stop deceleration function

When EM2 is turned off, dynamic brake will start to stop the servo motor after forced stop deceleration. During this sequence, the display shows [AL. E6 Servo forced stop warning].

During normal operation, do not use EM2 (Forced stop 2) to alternate stop and drive. The servo amplifier life may be shortened.

Connection diagram

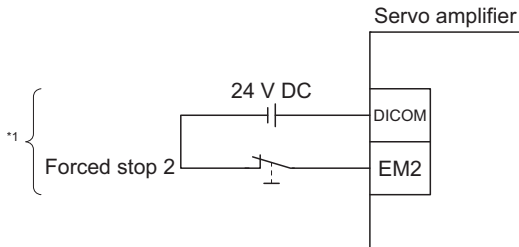

*1 This diagram shows sink I/O interface. For source I/O interface, refer to the following.

☞ Page 119 Source I/O interface

Timing chart

When EM2 (Forced stop 2) is turned off, the motor will decelerate according to [Pr. PC24 Forced stop deceleration time constant]. Once the motor speed is below [Pr. PC07 Zero speed] after completion of the deceleration command, base power is cut and the dynamic brake activates.

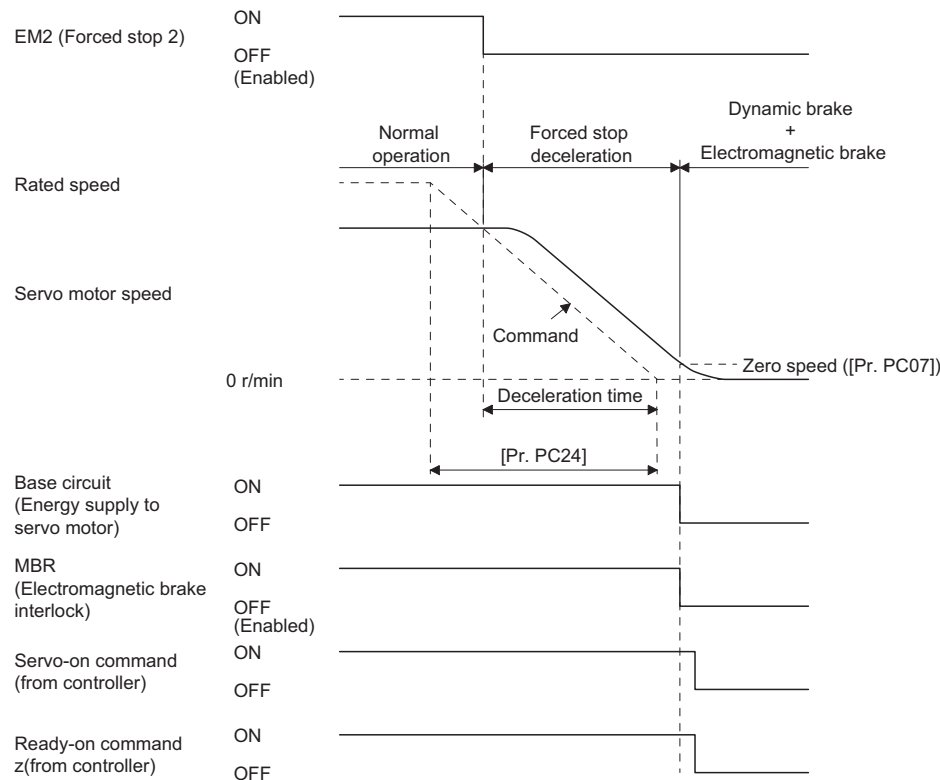

Base circuit shut-off delay time function

The base circuit shut-off delay time function is used to prevent vertical axis from dropping at a forced stop (EM2 goes off), alarm occurrence, or network communication shut-off due to delay time of the electromagnetic brake. Set the time from MBR (Electromagnetic brake interlock) off to base circuit shut-off with [Pr. PC02].

Timing chart

When EM2 (Forced stop 2) turns off or an alarm occurs during driving, the servo motor will decelerate based on the deceleration time constant. MBR (Electromagnetic brake interlock) will turn off, and then after the delay time set in [Pr. PC02], the servo amplifier will be base circuit shut-off status.

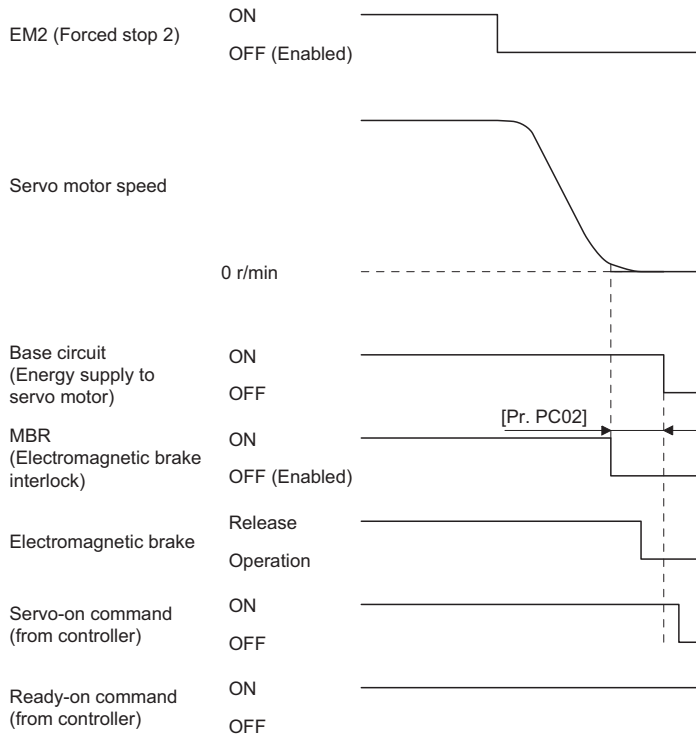

Adjustment

While the servo motor is stopped, turn off EM2 (Forced stop 2), adjust the base circuit shut-off delay time in [Pr. PC02], and set the value to approximately 1.5 times of the smallest delay time in which the servo motor shaft does not freefall.

Vertical axis freefall prevention function

The vertical axis freefall prevention function avoids machine damage by pulling up the shaft slightly like the following case. When the servo motor is used for operating vertical axis, the servo motor electromagnetic brake and the base circuit shut-off delay time function avoid dropping axis at forced stop. However, the functions may not avoid dropping axis a few μm due to the backlash of the servo motor electromagnetic brake.

The vertical axis freefall prevention function is performed when all of the following conditions are met.

- The position control mode is set.
- The setting value for [Pr. PC31 Vertical axis freefall prevention compensation amount] is other than "0".
- "Forced stop deceleration function selection" of [Pr. PA04] is set to "Forced stop deceleration function enabled (2 ___)".
- EM2 (Forced stop 2) turned off, an alarm occurred, or network communication shut-off occurred while the servo motor speed is zero speed or less.
- MBR (Electromagnetic brake interlock) is enabled in [Pr. PD07] to [Pr. PD09], and the base circuit shut-off delay time is set in [Pr. PC02].

Timing chart

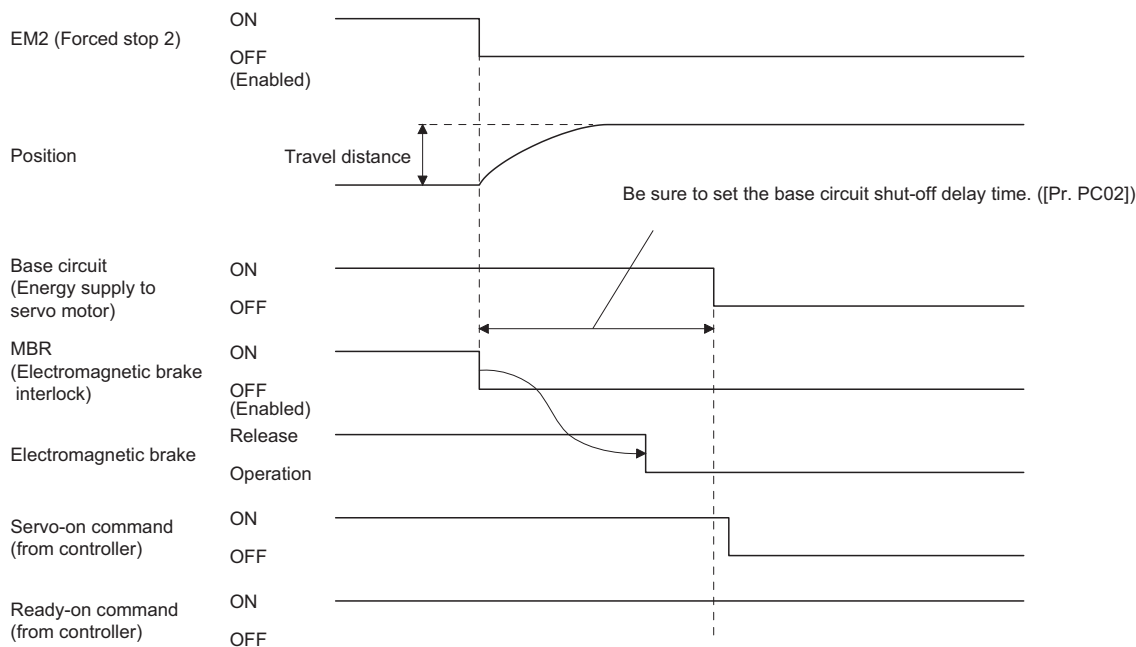

Adjustment

- Set the freefall prevention compensation amount in [Pr. PC31].
- While the servo motor is stopped, turn off the EM2 (Forced stop 2). Adjust the base circuit shut-off delay time in [Pr. PC02] in accordance with the travel distance ([Pr. PC31]). Adjust it considering the freefall prevention compensation amount by checking the servo motor speed, torque ripple, etc.

Residual risks of the forced stop function (EM2)

- The forced stop function is not available for alarms that activate the dynamic brake when the alarms occur.
- When an alarm that activates the dynamic brake during forced stop deceleration occurs, the braking distance until the servo motor stops will be longer than that of normal forced stop deceleration without the dynamic brake.
- If STO is turned off during forced stop deceleration, [AL.63 STO timing error] will occur.

3.7 Alarm occurrence timing chart

CAUTION

- When an alarm has occurred, remove its cause, make sure that the operation signal is not being input, ensure safety, and reset the alarm before restarting operation.

Point

In the torque mode, the forced stop deceleration function is not available.

To deactivate the alarm, cycle the control circuit power, give the error reset command from the controller, or perform network communication reset. However, the alarm cannot be deactivated unless its cause is removed.

When you use the forced stop deceleration function

Point

- To enable the function, set "2 ___ (initial value)" in [Pr. PA04].
- Disable the forced stop deceleration function for a machine in which multiple axes are connected together, such as a tandem structure. If an alarm occurs with the forced stop deceleration function disabled, the servo motor will stop with the dynamic brake.

When the forced stop deceleration function is enabled

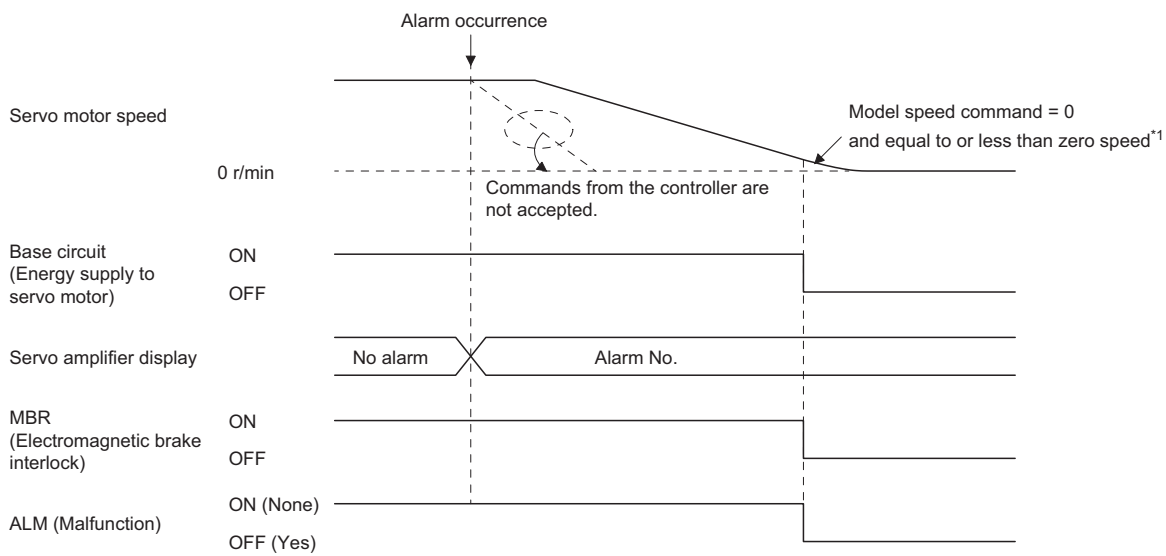

*1 The model speed command is a speed command generated in the servo amplifier for forced stop deceleration of the servo motor.

When the forced stop deceleration function is not enabled

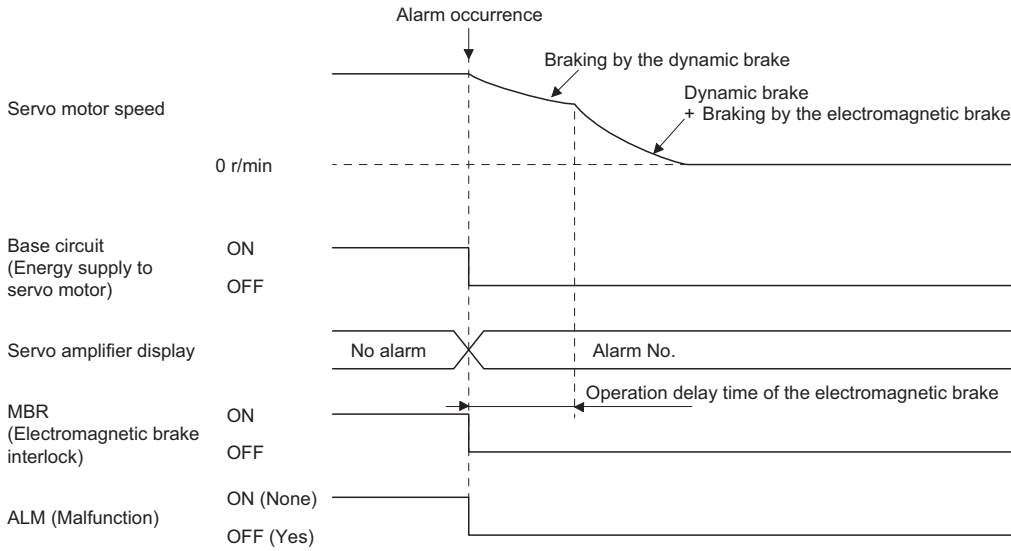

When network communication is shut-off

The dynamic brake may operate depending on the communication shut-off status.

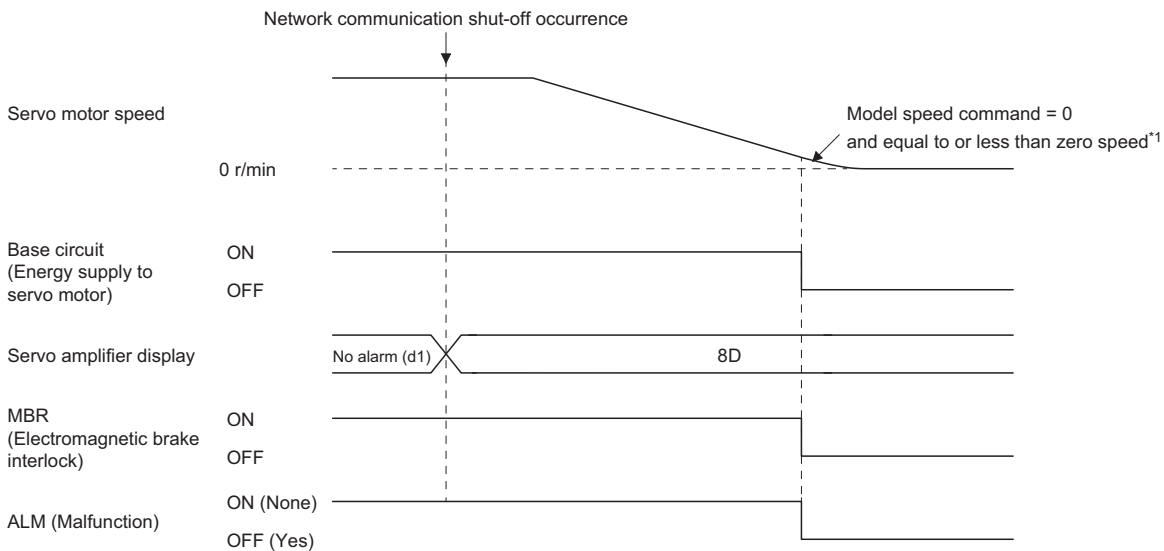

*1 The model speed command is a speed command generated in the servo amplifier for forced stop deceleration of the servo motor.

When you do not use the forced stop deceleration function

Point

To disable the function, set "0 _ _ _" in [Pr. PA04].

The timing chart that shows the servo motor condition when an alarm or network communication shut-off occurs is the same as the following section.

Page 115 When the forced stop deceleration function is not enabled

3.8 Interfaces

Internal connection diagram



Refer to the following for the CN8 connector.

Page 474 Connection example for CN8 connector

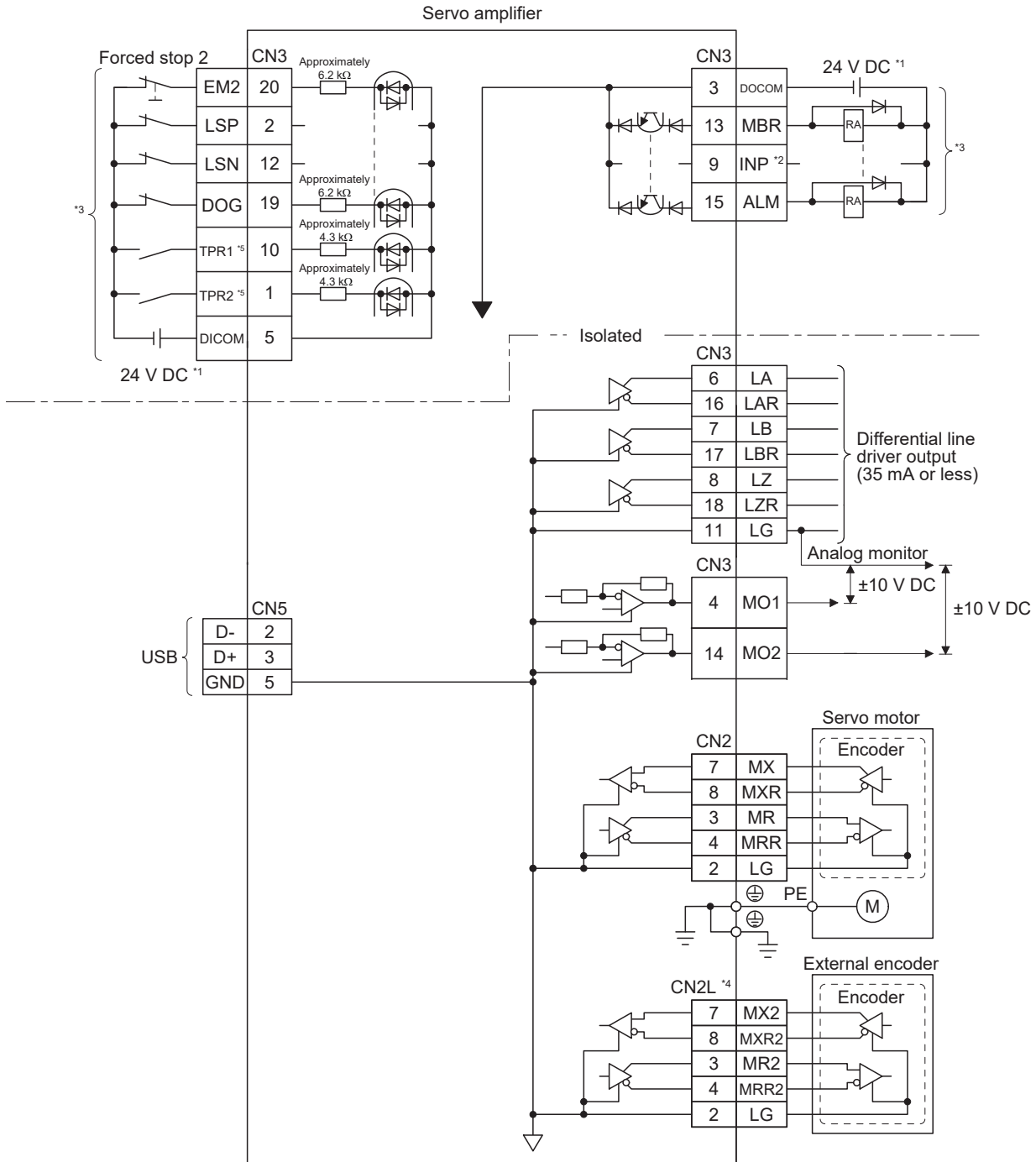

- *1 The illustration of the 24 V DC power supply is divided between input signal and output signal for convenience. However, they can be configured by one.
- *2 The signal cannot be used in the velocity mode and torque mode.
- *3 This diagram shows sink I/O interface. For source I/O interface, refer to the following.
☞ Page 119 Source I/O interface
- *4 Refer to the following for connections of external encoders.
☞ Page 18 Summary
- *5 The device is available only with MR-J4-_GF_-RJ.

Detailed explanation of interfaces

This section provides the details of the I/O signal interfaces (refer to the I/O division in the table) given in the following section. Refer to this section and make connection with the external device.

☞ Page 104 Signal (device) explanations

Digital input interface DI-1

This is an input circuit whose photocoupler cathode side is input terminal. Transmit signals from sink (open-collector) type transistor output, relay switch, etc. The following is a connection diagram for sink input. Refer to the following for source input.

☞ Page 119 Source I/O interface

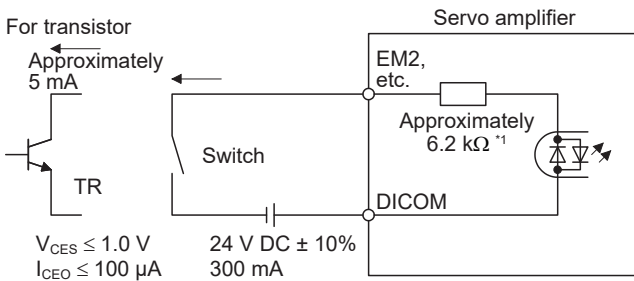

- *1 It will be approximately 4.3 kΩ for interface of CN3-1 and CN3-10 pins.

Digital output interface DO-1

This is a circuit in which the collector of the output transistor is the output terminal. When the output transistor is turned on, the current will flow to the collector terminal.

A lamp, relay or photocoupler can be driven. Install a diode (D) for an inductive load, or install an inrush current suppressing resistor (R) for a lamp load.

(Rated current: 40 mA or less, maximum current: 50 mA or less, inrush current: 100 mA or less) A maximum of 2.6 V voltage drop occurs in the servo amplifier. The following shows a connection diagram for sink output. Refer to the following for source output.

☞ Page 119 Source I/O interface

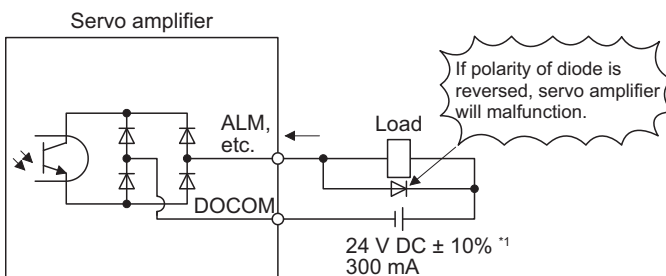

- *1 If the voltage drop (maximum of 2.6 V) interferes with the relay operation, apply high voltage (maximum of 26.4 V) from external source.

Encoder output pulses DO-2 (differential line driver type)

■ Interfaces

Maximum output current: 35 mA

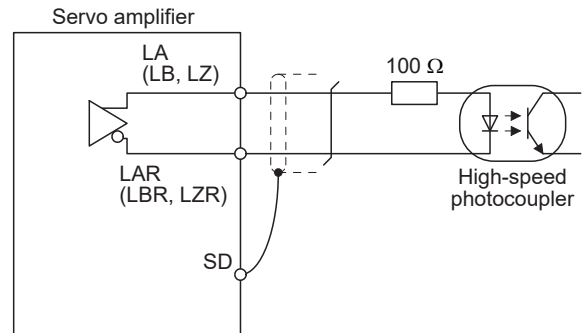
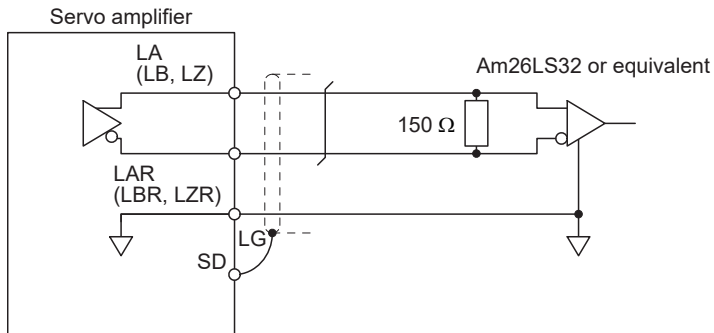

■ Output pulse

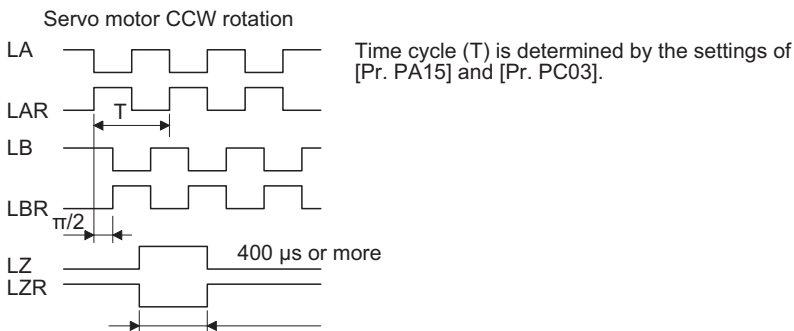

Analog output

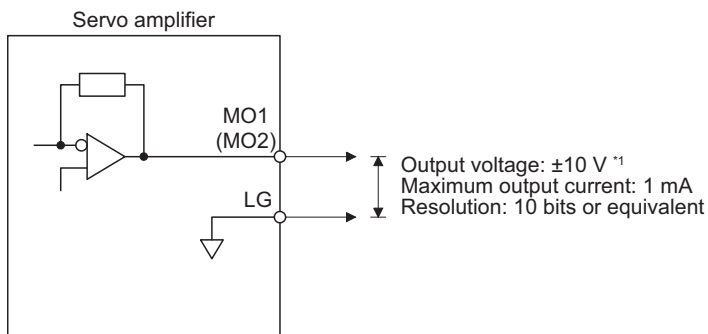

*1 Output voltage range varies depending on the output contents.

Source I/O interface

In this servo amplifier, source type I/O interfaces can be used.

Digital input interface DI-1

This is an input circuit whose photocoupler anode side is input terminal. Transmit signals from source (open-collector) type transistor output, relay switch, etc.

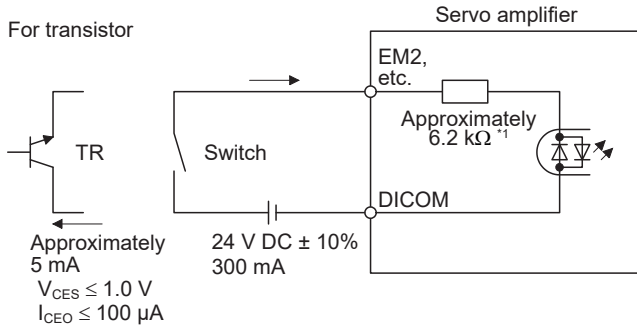

*1 It will be approximately 4.3 kΩ for interface of CN3-1 and CN3-10 pins.

Digital output interface DO-1

This is a circuit in which the emitter of the output transistor is the output terminal. When the output transistor is turned on, the current will flow from the output terminal to a load.

A maximum of 2.6 V voltage drop occurs in the servo amplifier.

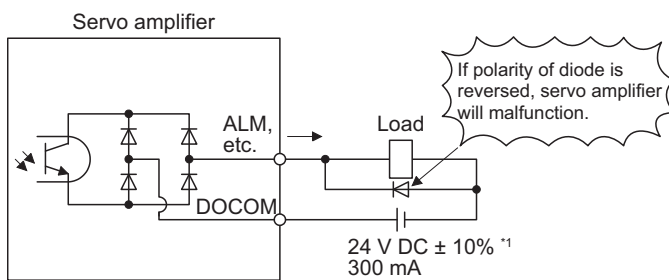

*1 If the voltage drop (maximum of 2.6 V) interferes with the relay operation, apply high voltage (maximum of 26.4 V) from external source.

3.9 Servo motor with an electromagnetic brake

Safety precautions

CAUTION

- Configure an electromagnetic brake circuit which is interlocked with an external emergency stop switch.

Shut off when ALM (Malfunction) or MBR (Electromagnetic brake interlock) turns off. Shut off with the emergency stop switch.

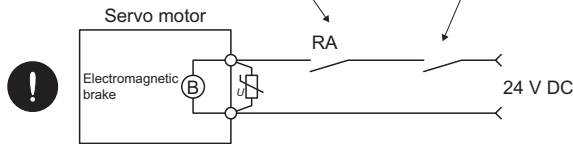

- The electromagnetic brake is provided for holding purpose and must not be used for ordinary braking.
- Before operating the servo motor, be sure to confirm that the electromagnetic brake operates properly.
- Do not use the 24 V DC interface power supply for the electromagnetic brake. Always use the power supply designed exclusively for the electromagnetic brake. Otherwise, it may cause a malfunction.
- When using EM2 (Forced stop 2), use MBR (Electromagnetic brake interlock) for operating the electromagnetic brake. Operating the electromagnetic brake without using MBR during deceleration to a stop will saturate servo motor torques at the maximum value due to brake torque of the electromagnetic brake. This can result in delay of the deceleration to a stop from a set value.

Point

- Refer to "Servo Motor Instruction Manual (Vol. 3)" for specifications such as the power supply capacity and operation delay time of the electromagnetic brake.
- Refer to "Servo Motor Instruction Manual (Vol. 3)" for the selection of a surge absorber for the electromagnetic brake.

Note the following when the servo motor with an electromagnetic brake is used.

- The electromagnetic brake will operate when the power (24 V DC) turns off.
- Turn off the servo-on command after the servo motor stopped.

Connection diagram

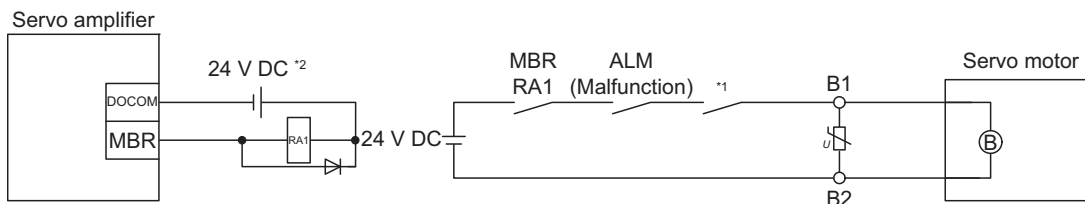

- *1 Create the circuit in order to shut off by interlocking with the emergency stop switch.
- *2 Do not use the 24 V DC interface power supply for the electromagnetic brake.

Setting

In [Pr. PC02 Electromagnetic brake sequence output], set a delay time (T_b) from MBR (Electromagnetic brake interlock) off to base circuit shut-off at a servo-off as in the timing chart in the following section.

Page 121 Timing chart

Timing chart

When you use the forced stop deceleration function



To enable the function, set "2 ___" (initial value) in [Pr. PA04].

■ Servo-on command (from controller) on/off



Keep the ready-on command (from controller) on while the servo-on command (from controller) is off. When the ready-off command (from controller) is off, Tb [Pr. PC02 Electromagnetic brake sequence output] does not function.

When servo-on command is turned off, the servo lock will be released after Tb [ms], and the servo motor will coast. If the electromagnetic brake is enabled during servo-lock, the brake life may be shorter. Therefore, set Tb about 1.5 times of the minimum delay time where the moving part will not drop down for a vertical axis system, etc.

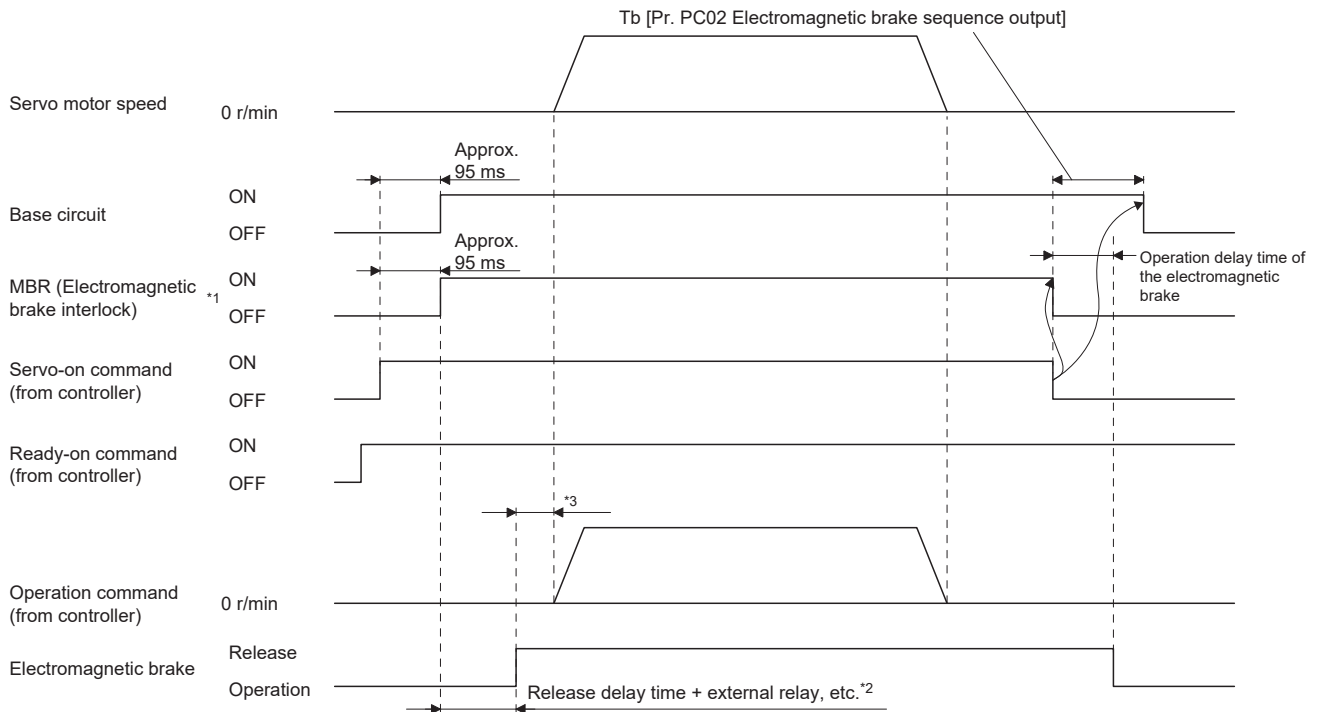

*1 ON: Electromagnetic brake is not activated.
OFF: Electromagnetic brake is activated.

*2 Electromagnetic brake is released after the release delay time of electromagnetic brake and operation time of external circuit relay, etc. For the release delay time of electromagnetic brake, refer to "Servo Motor Instruction Manual (Vol. 3)".

*3 Give the operation command from the controller after the electromagnetic brake is released.

■ Off/on of the quick stop command (from controller) or EM2 (Forced stop 2)

Point

- In the torque mode, the forced stop deceleration function is not available.
- Keep the ready-on command (from controller) on while the quick stop command (from controller) or the EM2 (Forced stop 2) is off. When the ready-off command (from controller) is off, Tb [Pr. PC02 Electromagnetic brake sequence output] does not function.

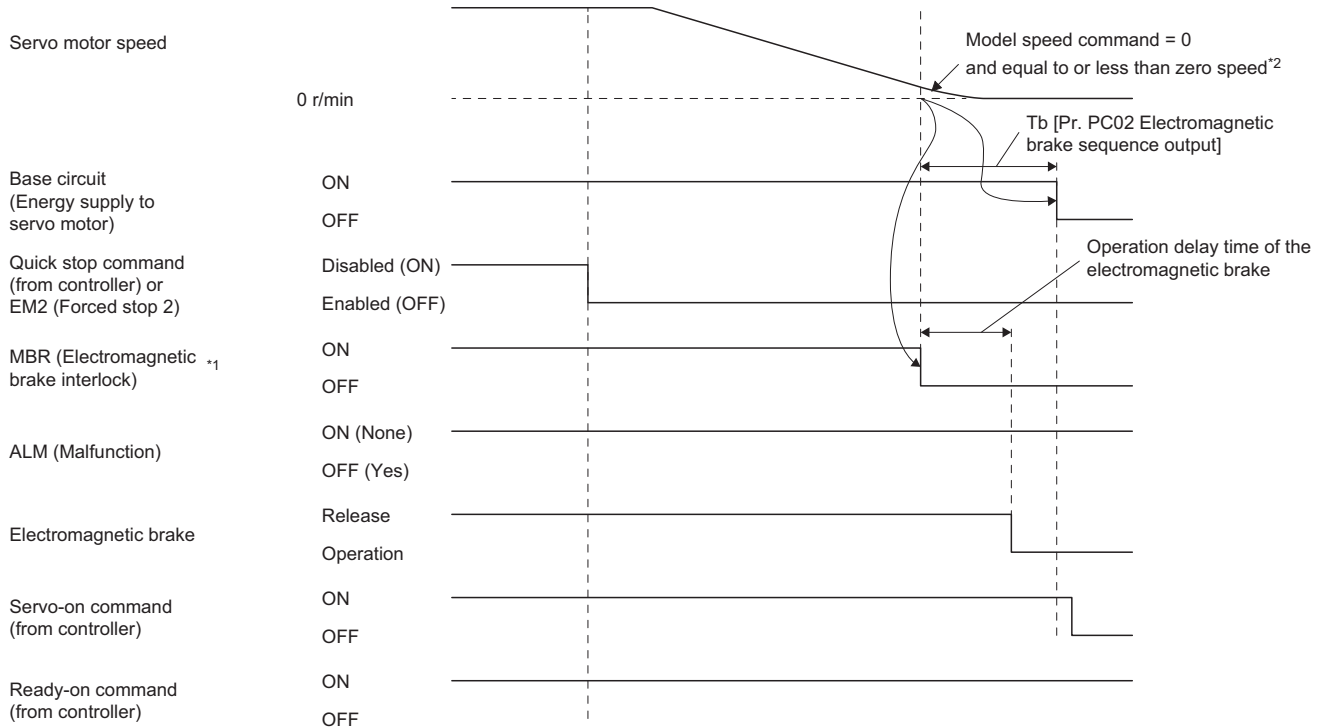

*1 ON: Electromagnetic brake is not activated.
 OFF: Electromagnetic brake is activated.

*2 The model speed command is a speed command generated in the servo amplifier for forced stop deceleration of the servo motor.

■ Alarm occurrence

- When the forced stop deceleration function is enabled

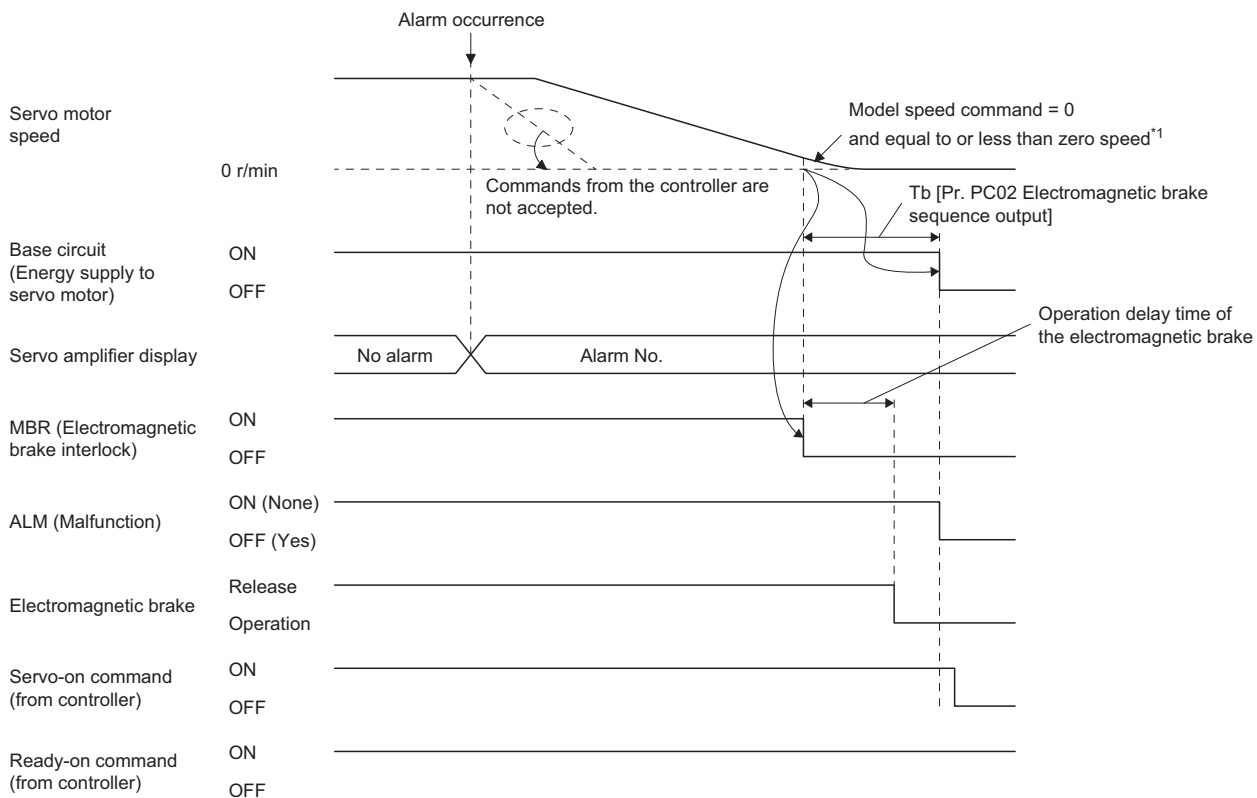

*1 The model speed command is a speed command generated in the servo amplifier for forced stop deceleration of the servo motor.

- When the forced stop deceleration function is disabled
The operation status of the servo motor is the same as in the following.
☞ Page 115 When you use the forced stop deceleration function
- The dynamic brake may operate depending on the communication shut-off status.

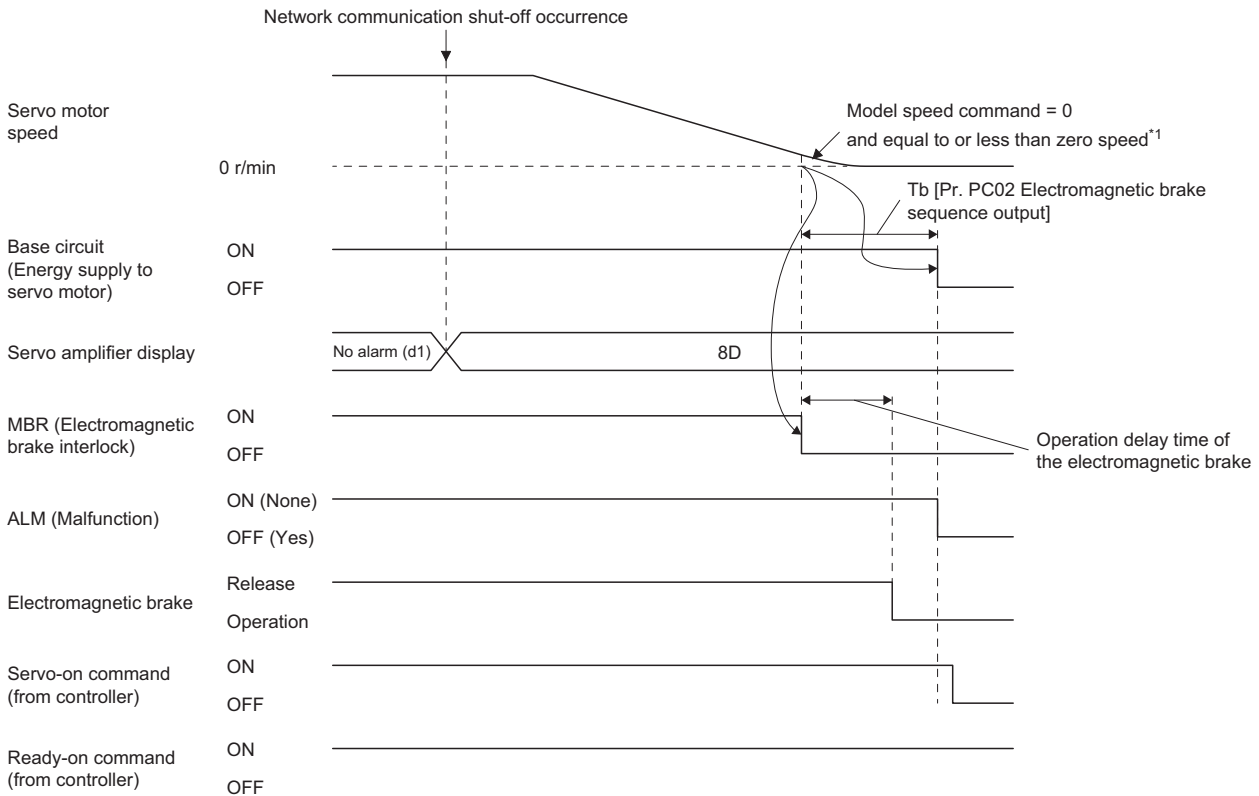

*1 The model speed command is a speed command generated in the servo amplifier for forced stop deceleration of the servo motor.

■ Both main and control circuit power supplies off

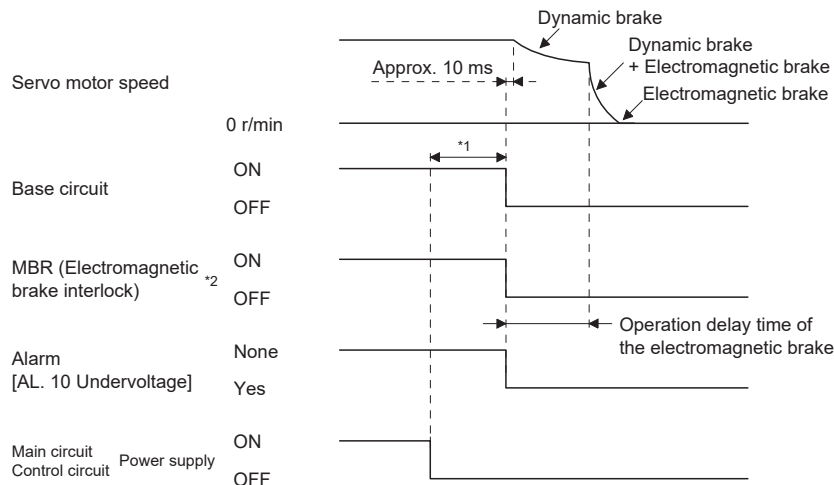

*1 Variable according to the operation status.

*2 ON: Electromagnetic brake is not activated.

OFF: Electromagnetic brake is activated.

■ Main circuit power supply off with control circuit power supply on

Point

In the torque mode, the forced stop deceleration function is not available.

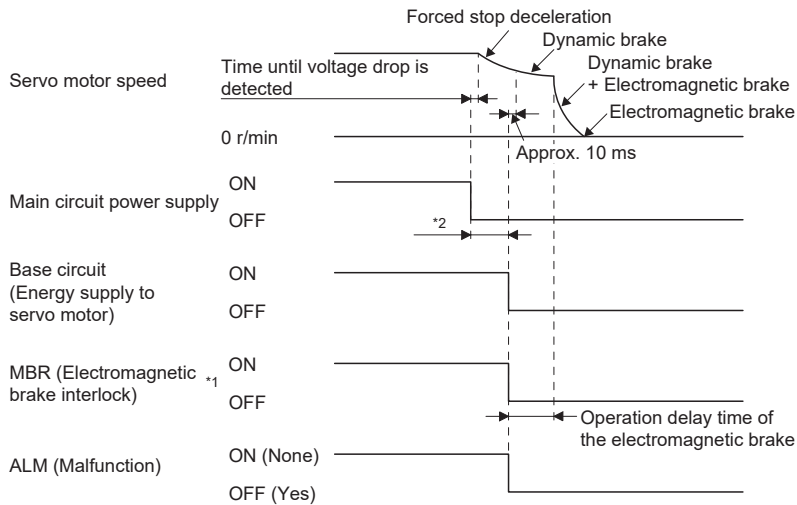

*1 ON: Electromagnetic brake is not activated.

OFF: Electromagnetic brake is activated.

*2 Variable according to the operation status.

■ Ready-off command from controller

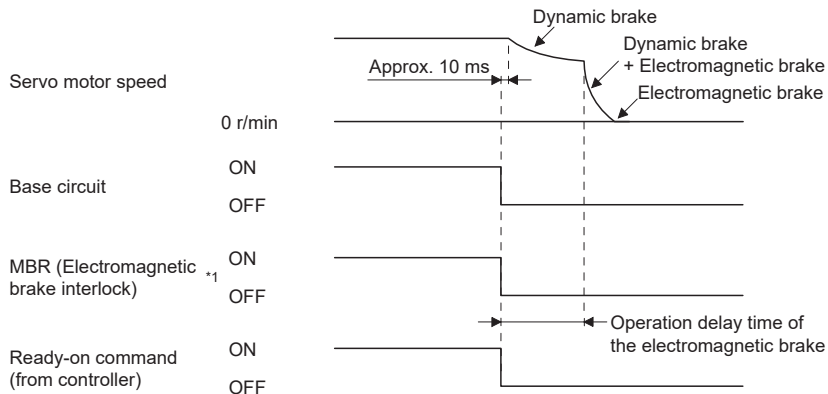

*1 ON: Electromagnetic brake is not activated.

OFF: Electromagnetic brake is activated.

When you do not use the forced stop deceleration function

Point

To disable the function, set "0 ___" in [Pr. PA04].

■ Servo-on command (from controller) on/off

It is the same as the following section.

☞ Page 121 Servo-on command (from controller) on/off

■ Off/on of the sudden stop command (from controller) or EM1 (Forced stop 1)

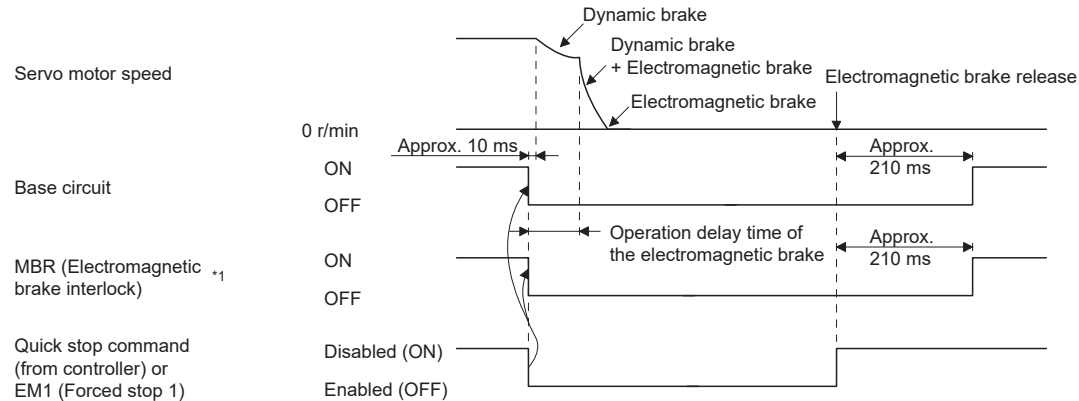

*1 ON: Electromagnetic brake is not activated.
OFF: Electromagnetic brake is activated.

■ Alarm occurrence

The operation status during an alarm is the same as the following section.

☞ Page 115 When you do not use the forced stop deceleration function

■ Both main and control circuit power supplies off

It is the same as the following section.

☞ Page 124 Both main and control circuit power supplies off

■ Main circuit power supply off with control circuit power supply on

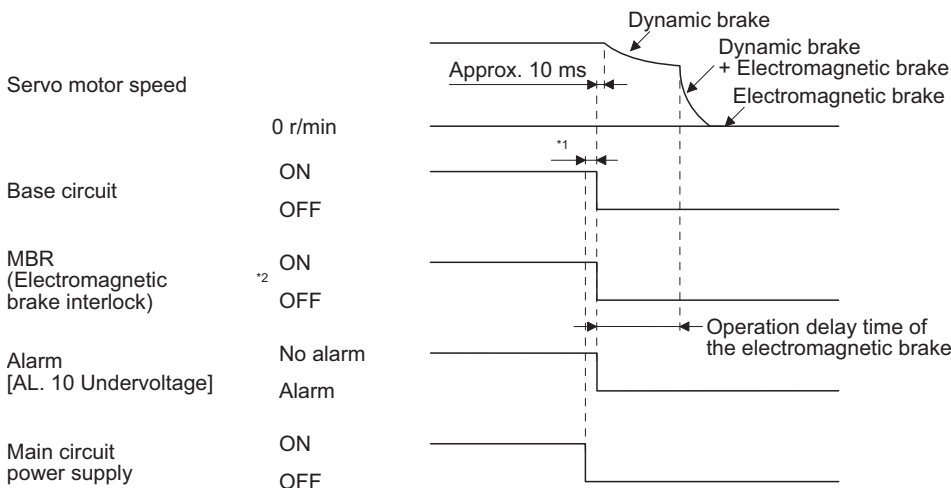

*1 Variable according to the operation status.
*2 ON: Electromagnetic brake is not activated.
OFF: Electromagnetic brake is activated.

■ Ready-off command from controller

It is the same as the following section.

☞ Page 125 Ready-off command from controller

3.10 Grounding

! WARNING

- Ground the servo amplifier and servo motor securely.
- To prevent an electric shock, always connect the protective earth (PE) terminal (marked ⊕) of the servo amplifier to the protective earth (PE) of the cabinet.

The servo amplifier switches the power transistor on-off to supply power to the servo motor. Depending on the wiring and ground cable routing, the servo amplifier may be affected by the switching noise (due to di/dt and dv/dt) of the transistor. To prevent such a fault, refer to the following diagram and always ground.

To conform to the EMC Directive, refer to "EMC Installation Guidelines".

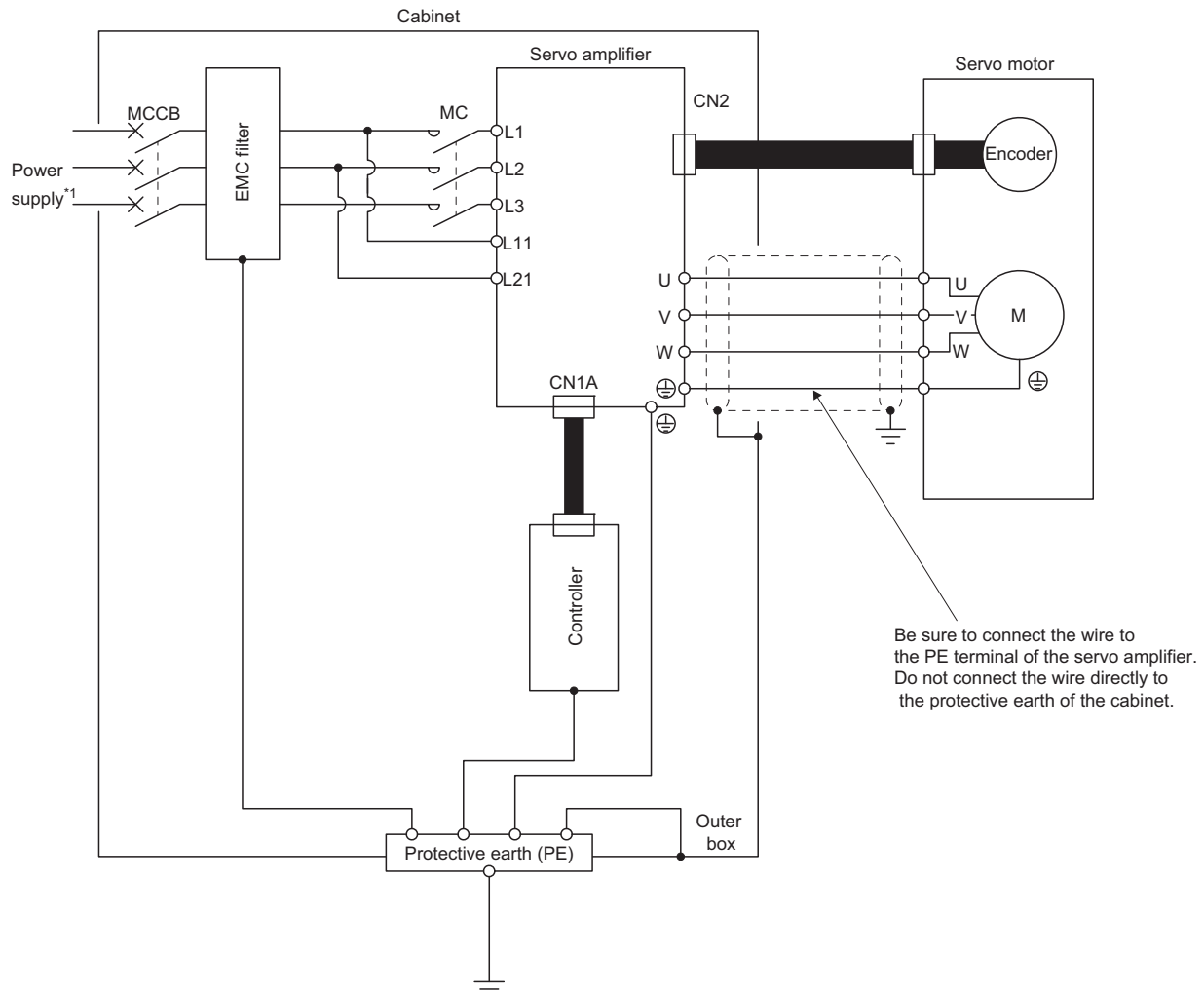

*1 For the power supply specifications, refer to the following.

☞ Page 30 Servo amplifier standard specifications

4 STARTUP

WARNING

- Do not operate the switches with wet hands. Otherwise, it may cause an electric shock.
 - When executing a test run, follow the notice and procedures in this instruction manual. Otherwise, it may cause a malfunction, damage to the machine, or injury.
-

CAUTION

- Before starting operation, check the parameters. Improper settings may cause some machines to operate unexpectedly.
 - The servo amplifier heat sink, regenerative resistor, servo motor, etc., may be hot while the power is on and for some time after power-off. Take safety measures such as providing covers to avoid accidentally touching them by hands and parts such as cables.
 - During operation, never touch the rotor of the servo motor. Otherwise, it may cause injury.
 - Before wiring, switch operation, etc., eliminate static electricity. Otherwise, it may cause a malfunction.
-

Point

When you use a linear servo motor, replace the following left words to the right words.

Load to motor inertia ratio → Load to motor mass ratio

Torque → Thrust

4.1 Switching power on for the first time

Point

- To use the servo amplifier in the motion mode, set [Pr. PN03] to "___0" (initial value).
- To use the servo amplifier in the motion mode changed from the I/O mode, settings must be configured on GX Works. Refer to the following for settings with GX Works.
 - ☞ Page 134 Settings of GX Works

When switching power on for the first time, follow this section to make a startup.

Startup procedure

1. Wiring check

Check whether the servo amplifier and servo motor are wired correctly by performing a visual check, using DO forced output function, etc.

☞ Page 130 Wiring check

☞ Page 142 Test operation mode in MR Configurator2

2. Surrounding environment check

Check the surrounding environment of the servo amplifier and servo motor.

☞ Page 134 Surrounding environment

3. Station No. setting

Set the station number with the station number setting rotary switch (SW2/SW3).

☞ Page 137 Station number setting rotary switch (SW2/SW3)

4. Parameter setting

Set the parameters as necessary, such as the used operation mode and regenerative option selection.

☞ Page 172 PARAMETERS

When a simple motion module QD77GF_ or RD77GF_ or simple motion board MR-EM340GF is used as a controller, set [Pr. PD41] to "_ 1 _" (enabled only for home position return mode).

5. Test operation of the servo motor alone in test operation mode

For the test operation, with the servo motor disconnected from the machine and operated at the speed as low as possible, check whether the servo motor rotates correctly.

☞ Page 142 Test operation mode

6. Test operation of the servo motor alone by commands

For the test operation with the servo motor disconnected from the machine and operated at the speed as low as possible, give commands to the servo amplifier and check whether the servo motor rotates correctly.

7. Test operation with the servo motor and machine connected

After connecting the servo motor with the machine, check machine motions with sending operation commands from the controller.

8. Gain adjustment

Make gain adjustment to optimize the machine motions.

☞ Page 230 NORMAL GAIN ADJUSTMENT

9. Actual operation

10. Stop

Stop giving commands and stop operation.

Wiring check

Before switching on the main circuit and control circuit power supplies, check the following items.

Power supply system

- The power supplied to the power input terminals (L1/L2/L3/L11/L21) of the servo amplifier should satisfy the defined specifications.

☞ Page 30 Servo amplifier standard specifications

- When the power factor improving DC reactor is not used, between P3 and P4 should be connected.

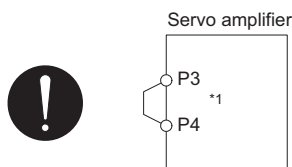

*1 The 100 V class servo amplifiers do not have P3 and P4.

Connection of servo amplifier and servo motor

- The servo amplifier power output (U/V/W) should match in phase with the servo motor power input terminals (U/V/W).

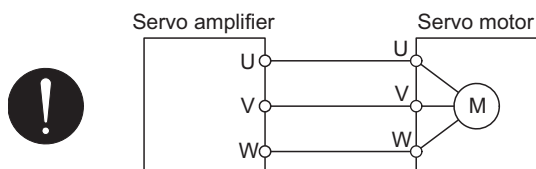

- The power supplied to the servo amplifier should not be connected to the servo motor power terminals (U/V/W). Doing so will fail the servo amplifier and servo motor.

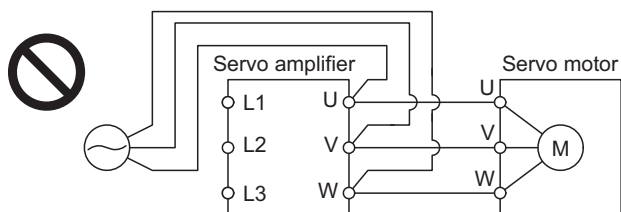

- The grounding terminal of the servo motor is connected to the PE terminal of the servo amplifier.

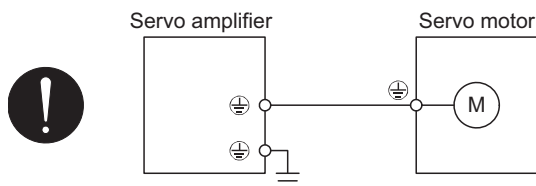

- The CN2 connector of the servo amplifier should be connected to the encoder of the servo motor securely using the encoder cable.

When you use an option and peripheral equipment (200 V class)

■When you use a regenerative option for 5 kW or less servo amplifiers

- The lead wire between P+ terminal and D terminal should not be connected.
- The regenerative option wire should be connected between P+ and C terminal.
- Twisted wires should be used.

☞ Page 344 Connection of regenerative option

■When you use a regenerative option for 7 kW or more servo amplifiers

- For 7 kW servo amplifiers, the lead wire of the built-in regenerative resistor connected to P+ terminal and C terminal should not be connected.
- The regenerative option wire should be connected between P+ and C terminal.
- Twisted wires should be used.

☞ Page 344 Connection of regenerative option

■When you use a brake unit and power regeneration converter for 5 kW or more servo amplifiers

- For 5 kW servo amplifiers, the lead wire between P+ terminal and D terminal should not be connected.
- For 7 kW servo amplifiers, the lead wire of the built-in regenerative resistor connected to P+ terminal and C terminal should not be connected.
- Wires of a brake unit or power regeneration converter should be connected to P+ terminal and N- terminal.

☞ Page 357 FR-BU2-(H) brake unit

☞ Page 370 FR-RC-(H) power regeneration converter

- Twisted wires should be used when wiring is over 5 m and equal to or less than 10 m using a brake unit.

☞ Page 357 FR-BU2-(H) brake unit

■When you use a power regeneration common converter

- For 5 kW or less servo amplifiers, the lead wire between P+ terminal and D terminal should not be connected.
- For 7 kW servo amplifiers, the lead wire of the built-in regenerative resistor connected to P+ terminal and C terminal should not be connected.
- The wire of power regeneration common converter should be connected to P4 terminal and N- terminal.

☞ Page 374 FR-CV-(H) power regeneration common converter

■When you use a multifunction regeneration converter

- For 5 kW or less servo amplifiers, the lead wire between P+ terminal and D terminal should be connected. (factory-wired)
- For 7 kW servo amplifiers, the lead wire of the built-in regenerative resistor connected to P+ terminal and C terminal should be connected. (factory-wired)
- The wire of multifunction regeneration converter should be connected to P4 terminal and N- terminal.

☞ Page 454 Multifunction regeneration converter FR-XC-(H)

■When you use a power factor improving DC reactor

- The power factor improving DC reactor should be connected between P3 and P4.

☞ Page 409 Power factor improving DC reactors

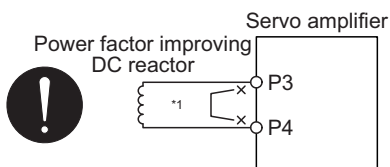

*1 Always disconnect between P3 and P4 terminals.

When you use an option and peripheral equipment (400 V class)

■When you use a regenerative option for 3.5 kW or less servo amplifiers

- The lead wire between P+ terminal and D terminal should not be connected.
- The regenerative option wire should be connected between P+ and C terminal.
- Twisted wires should be used.

☞ Page 344 Connection of regenerative option

■When you use a regenerative option for 5 kW or more servo amplifiers

- For 5 kW or 7 kW servo amplifiers, the lead wire of the built-in regenerative resistor connected to P+ terminal and C terminal should not be connected.
- The regenerative option wire should be connected between P+ and C terminal.
- Twisted wires should be used.

☞ Page 344 Connection of regenerative option

■When you use a brake unit and power regeneration converter for 5 kW or more servo amplifiers

- For 5 kW or 7 kW servo amplifiers, the lead wire of the built-in regenerative resistor connected to P+ terminal and C terminal should not be connected.
- Wires of a brake unit or power regeneration converter should be connected to P+ terminal and N- terminal.
 - ☞ Page 357 FR-BU2-(H) brake unit
 - ☞ Page 370 FR-RC-(H) power regeneration converter
- Twisted wires should be used when wiring is over 5 m and equal to or less than 10 m using a brake unit.
 - ☞ Page 357 FR-BU2-(H) brake unit

■When you use a power regeneration common converter

- The wire of power regeneration common converter should be connected to P4 terminal and N- terminal.
 - ☞ Page 374 FR-CV-(H) power regeneration common converter

■When you use a multifunction regeneration converter

- For 5 kW or 7 kW servo amplifiers, the lead wire of the built-in regenerative resistor connected to P+ terminal and C terminal should be connected. (factory-wired)
- The wire of multifunction regeneration converter should be connected to P4 terminal and N- terminal.
 - ☞ Page 454 Multifunction regeneration converter FR-XC-(H)

■When you use a power factor improving DC reactor

- The power factor improving DC reactor should be connected between P3 and P4.
 - ☞ Page 409 Power factor improving DC reactors

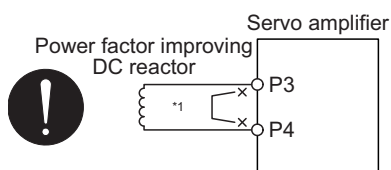

*1 Always disconnect between P3 and P4 terminals.

When you use an option and peripheral equipment (100 V class)

■When you use a regenerative option

- The lead wire between P+ terminal and D terminal should not be connected.
- The regenerative option wire should be connected between P+ and C terminal.
- Twisted wires should be used.

☞ Page 344 Connection of regenerative option

I/O signal

- The I/O signals should be connected correctly. Use DO forced output to forcibly turn on/off the pins of the CN3 connector. You can use the function to check the wiring. In this case, switch on the control circuit power supply only. Refer to the following for details of I/O signal connection.
 - ➔ Page 95 I/O signal connection example
- 24 V DC or higher voltage is not applied to the pins of the CN3 connector.
- Plate and DOCOM of the CN3 connector is not shorted.

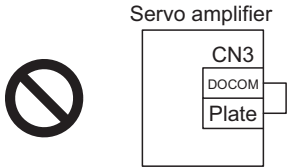

Surrounding environment

Cable routing

- The wiring cables should not be stressed.
- The encoder cable should not be used in excess of its bending life.
 - ☞ Page 327 Cable bending life
- The connector of the servo motor should not be stressed.

Environment

Signal cables and power cables are not shorted by wire offcuts, metallic dust or the like.

Settings of GX Works

To use GX Works2 or GX Works3, make settings as indicated in this section.

Station-specific mode setting

Make "Station-specific mode setting" in the "CC IE Field Configuration" window according to the operation mode to be used.

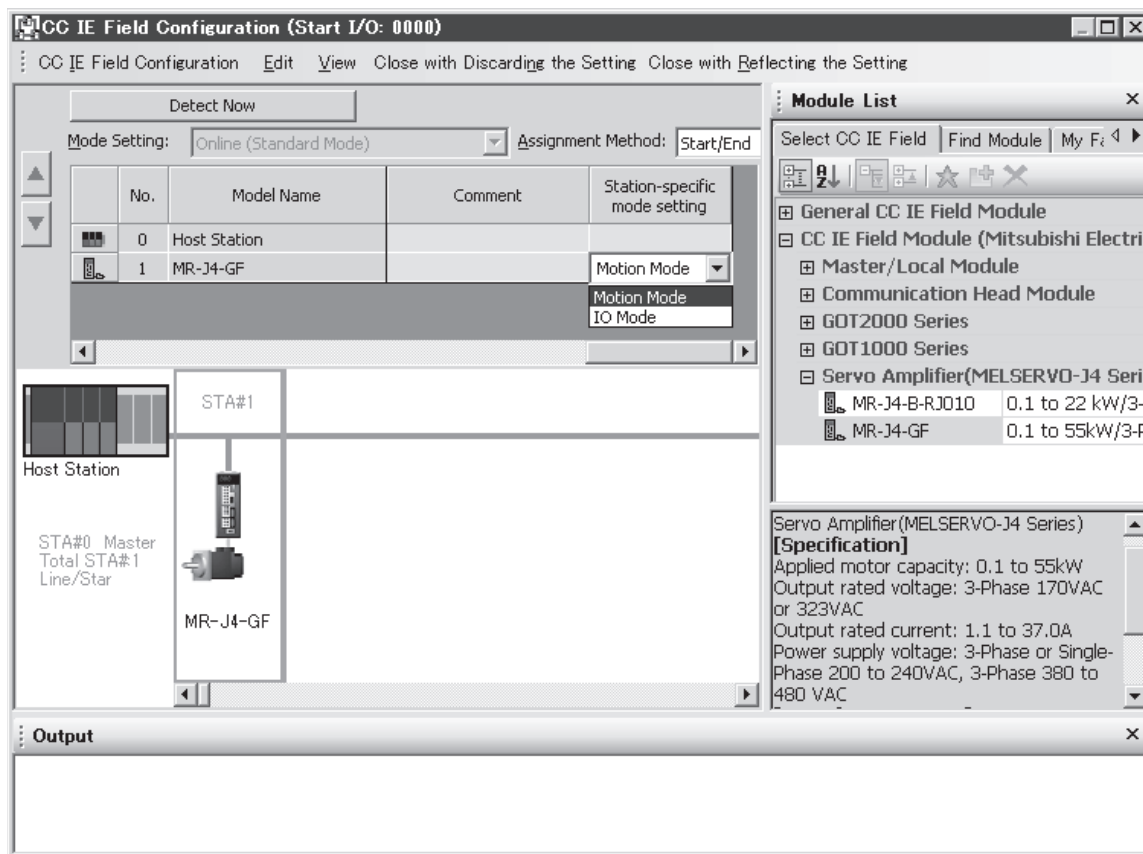

Precautions for "Detect Now"

With GX Works, connected devices can be automatically configured by performing "Detect Now" in the "CC IE Field Configuration" window. However, the contents of "Station-specific mode setting" in [Pr. PN03] and the operation mode setting cannot be discriminated. Make "Station-specific mode setting" according to the section above.

4.2 Startup

Confirm that the servo motor operates properly before connecting with a machine.

Power on

When the main and control circuit power supplies are turned on, "b01" (for the first station) appears on the servo amplifier display.

When the absolute position detection system is used in a rotary servo motor, first power-on results in [AL. 25 Absolute position erased] and the servo-on cannot be ready. The alarm can be deactivated by then switching power off once and on again.

Also, if power is switched on at the servo motor speed of 3000 r/min or higher, position mismatch may occur due to external force or the like. Power must therefore be switched on when the servo motor is at a stop.

Parameter setting

Point

The following encoder cables are of four-wire type. When using any of these encoder cables, set [Pr. PC04] to "1 _ _ _" to select the four-wire type. Incorrect setting will result in [AL. 16 Encoder initial communication error 1].

MR-EKCBL30M-L

MR-EKCBL30M-H

MR-EKCBL40M-H

MR-EKCBL50M-H

Set the parameters according to the structure and specifications of the machine.

 Page 172 PARAMETERS

After setting the above parameters, turn power off as necessary. Then switch power on again to enable the parameter values.

Servo-on

Enable the servo-on with the following procedure.

1. Switch on main circuit power supply and control circuit power supply.
2. Transmit the servo-on command with the controller.

When the servo-on status is enabled, the servo amplifier is ready to operate and the servo motor is locked.

Home position return

Always perform home position return before starting positioning operation.

 Page 146 Home position return mode

Stop

Turn off the servo-on command after the servo motor has stopped, and then switch the power off.

If any of the following situations occurs, the servo amplifier suspends the running of the servo motor and brings it to a stop.

Refer to the following for the servo motor with an electromagnetic brake.

☞ Page 120 Servo motor with an electromagnetic brake

Unit	Operation/command	Stopping condition
Controller	Servo-off command	The base circuit is shut off and the servo motor coasts.
	Ready-off command	The base circuit is shut off and the dynamic brake operates to bring the servo motor to a stop.
	Quick stop command	The servo motor decelerates to a stop with the command.
Servo amplifier	Alarm occurrence	The servo motor decelerates to a stop with the command. With some alarms, however, the dynamic brake operates to bring the servo motor to a stop. ☞ Page 283 TROUBLESHOOTING*1
	EM2 (Forced stop 2) off	The servo motor decelerates to a stop with the command. [AL. E6 Servo forced stop warning] occurs. EM2 has the same function as EM1 in the torque mode.
	STO (STO1, STO2) off	The base circuit is shut off and the dynamic brake operates to bring the servo motor to a stop.

*1 Only a list of alarms and warnings is listed in chapter 8. Refer to the following for details of alarms and warnings. ☞ MELSERVO-J4 Servo Amplifier Instruction Manual (Troubleshooting)

CC-Link IE Field Network connection

■Network disconnection procedure

Always make the servo-off status before turning off the system power and disconnecting the servo amplifier from the network. Otherwise, [AL. 8D] may occur. For the detection conditions of [AL. 8D], refer to [Pr. PN06].

■Network configuration change

If the network configuration in the same network as the servo amplifier is changed, such as adding or disconnecting a slave station, and adding a hub, all connected slave stations may be disconnected. Always make the servo-off status before changing the network configuration. Otherwise, [AL. 8D] may occur or the servo amplifier may not be reconnected.

■Restrictions on CC-Link IE Field diagnosis

The following shows restrictions on CC-Link IE Field diagnosis.

Diagnosis item	Restrictions	
Operation Test	Communication Test	Not compatible.
	IP Communication Test	Not compatible.
	Cable Test	Not compatible.
	Link Start/Stop	Not compatible. If the link start/stop function is used, [AL. 8D] may occur.
Information Confirmation/Set	Reserved Station Function Enable	When the servo amplifier is set as a reserved station, [AL. 8D] will occur.
	Enable/Disable Ignore Station Errors	Even if the servo amplifier is set as a temporary error invalid station, [AL. 8D] may occur when the servo amplifier is disconnected from the network. When setting the servo amplifier as a temporary error invalid station, make the servo-off status.
Selected Station Operation	Remote Operation	Not compatible.

■Model code

The following shows the vendor code and model code.

Vendor code	Model code	Model
0002	1002	MR-J4-_GF

4.3 Switch setting and display of the servo amplifier

Switching to the test operation mode and setting station No. are enabled with switches on the servo amplifier. On the servo amplifier display (three-digit, seven-segment LED), check the status of communication with the controller at power-on, and the station number, and diagnose a malfunction at occurrence of an alarm. The communication status of the CN1A connector and CN1B connector can be checked with the LED.

Switches

WARNING

- When switching the station number setting rotary switch (SW2/SW3) and mode select switch (SW1), use insulated screw driver. Do not use a metal screw driver. Touching patterns on electronic boards, lead of electronic parts, etc. may cause an electric shock.

Point

- Turning "ON (up)" all the mode select switches (SW1) enables an operation mode for manufacturer setting and displays "off". The mode is not available. Set the mode select switches (SW1) correctly according to this section.
- Cycling the main circuit power supply and control circuit power supply enables the setting of each switch.

The following explains the mode select switches and the station number setting rotary switch.

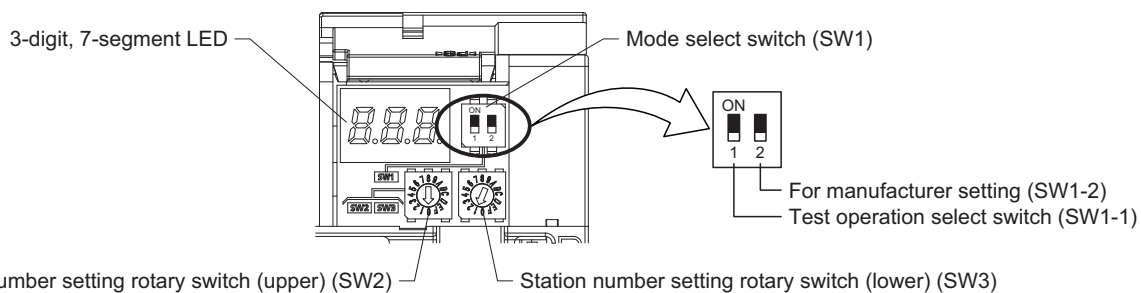

Test operation select switch (SW1-1)

To use the test operation mode, turn "ON (up)" the switch. Turning "ON (up)" the switch enables the test operation mode. In the test operation mode, the functions such as JOG operation, positioning operation, and machine analyzer are available with MR Configurator2.

Station number setting rotary switch (SW2/SW3)

Set the station number of the servo amplifier in hexadecimal. When the station number is set to a value other than "01h (1)" to "78h (120)", [AL. 11.1 Station number setting error] will occur.

Scrolling display

Station number will be displayed in hexadecimal.

Normal display

When there is no alarm, the station No. is displayed.

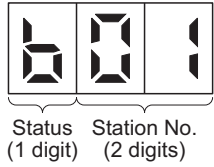

"b": Indicates ready-off and servo-off status.
 "C": Indicates ready-on and servo-off status.
 "d": Indicates ready-on and servo-on status.

Alarm display

When an alarm occurs, the alarm number (two digits) and the alarm detail (one digit) are displayed following the status display. For example, the following shows when [AL. 32 Overcurrent] is occurring.

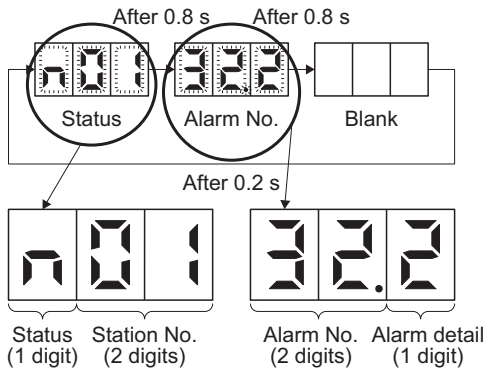

"n": Indicates that an alarm is occurring.

If an alarm occurs during initial communication through a network, the status, the alarm number (two digits) and alarm detail (one digit), and the network initial communication status are displayed, in that order. For example, the following shows when [AL. 16.1 Encoder initial communication - Receive data error 1] is occurring.

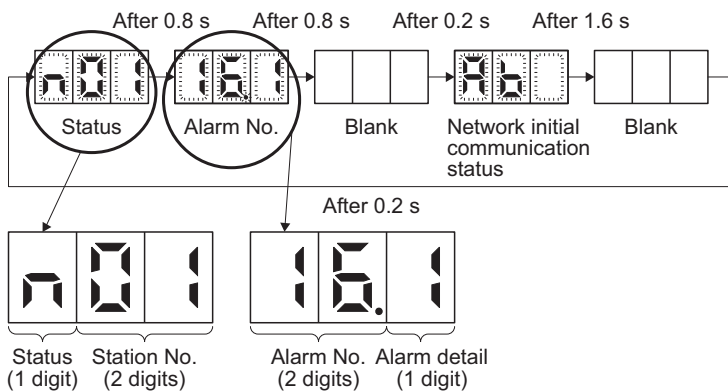

"n": Indicates that an alarm is occurring.

Status display of a station

Display sequence

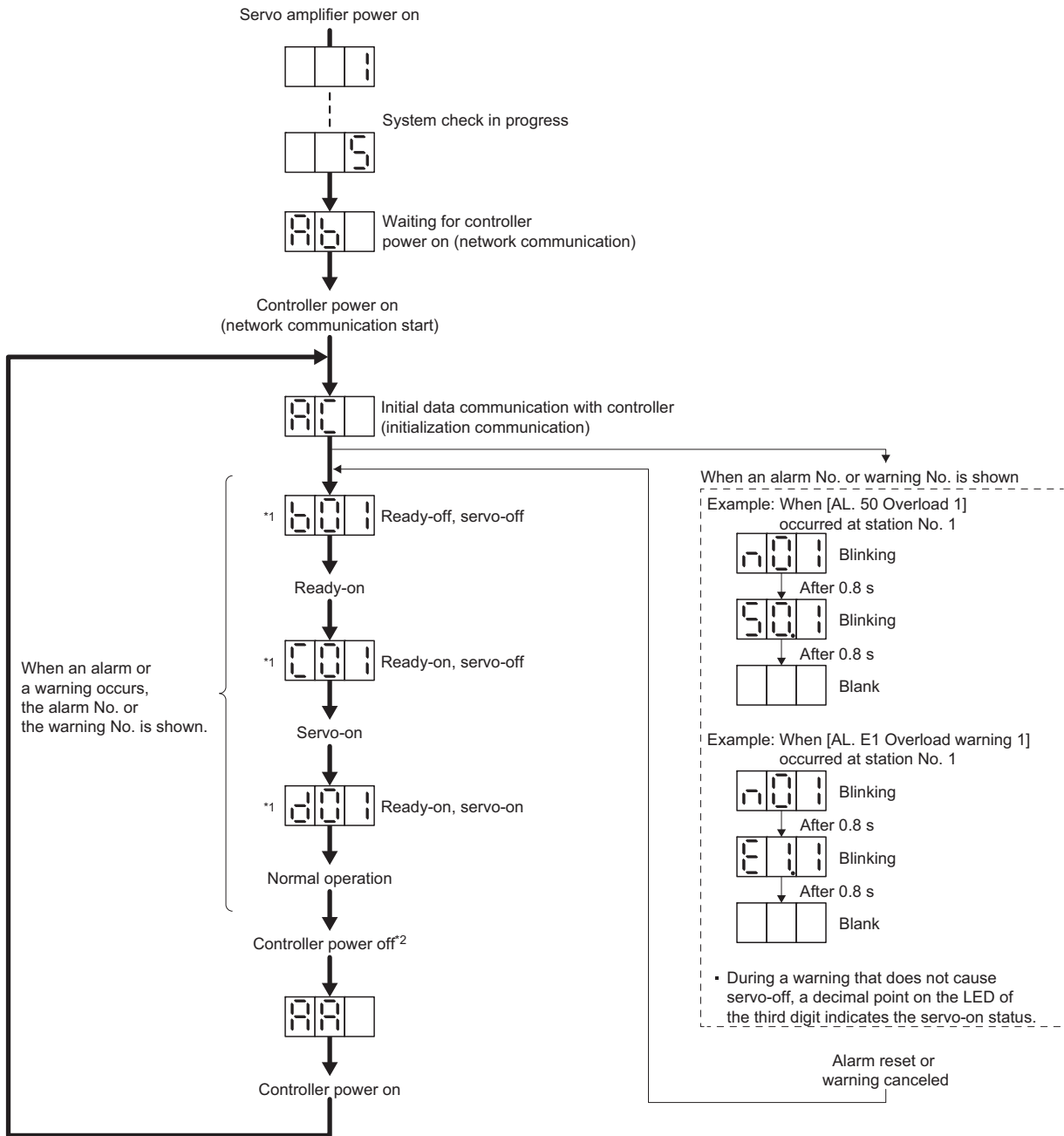

*1









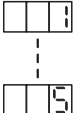

01	02
----	----

 ... The segment of the last 2 digits shows the station number.

Station No. 1	Station No. 2
---------------	---------------

*2 Always make the servo-off status before turning off the controller power. Otherwise, [AL. 8D] may occur.

Indication list

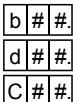
Indication	Status	Description
	Initializing	System check in progress
	Initializing	No connection with the controller
	Initializing	During initial communication with the controller
	Initializing standby	Communication disconnection with the controller
	Ready-off	The ready-off command from the controller was received.
	Servo-on	The servo-on command from the controller was received.
	Servo-off	The servo-off command from the controller was received.
	Alarm occurring	An alarm or warning has occurred in the servo amplifier.
	Alarm and warning	The alarm No. and the warning No. that occurred are displayed. ☞ Page 283 TROUBLESHOOTING ^{*4}
	CPU error	CPU watchdog error has occurred.
	Test operation mode ^{*3}	JOG operation, positioning operation, program operation, output signal (DO) forced output, or motorless operation was set.

*1 ## is displayed in hexadecimal. The following table shows the description.

##	Description
01	Station No. 1
⋮	⋮
78	Station No. 120

*2 *** indicates the alarm No. and the warning No.

*3 Requires the MR Configurator2.

*4 Only a list of alarms and warnings is listed in chapter 8. Refer to the following for details of alarms and warnings.

☞ MELSERVO-J4 Servo Amplifier Instruction Manual (Troubleshooting)

CC-Link IE Field status display LED

The following shows the CC-Link IE Field status display LED.

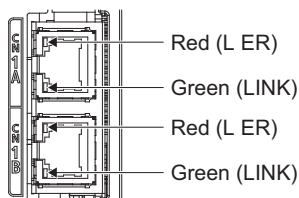

LED	Name	Lighting status	Description
L ER (CN1A/CN1B)	Line error status	Lit	Erroneous data is being received.
LINK (CN1A/CN1B)	Link status	Lit	Linking up

4.4 Test operation

Before starting actual operation, perform test operation to make sure that the machine operates normally. Refer to the following for the power on and off methods of the servo amplifier.

☞ Page 135 Startup

Point

If necessary, verify controller program by using motor-less operation. Refer to the following for the motor-less operation.

☞ Page 145 Motor-less operation in controller

1. Test operation of the servo motor alone in JOG operation of test operation mode

In this step, confirm that the servo amplifier and servo motor operate normally. With the servo motor disconnected from the machine, use the test operation mode and check whether the servo motor rotates correctly. Refer to the following for the test operation mode.

☞ Page 142 Test operation mode

2. Test operation of the servo motor alone by commands

In this step, confirm that the servo motor rotates correctly under the commands from the controller.

Give a low speed command at first and check the rotation direction, etc. of the servo motor. If the machine does not operate in the intended direction, check the input signal.

3. Test operation with the servo motor and machine connected

In this step, connect the servo motor with the machine and confirm that the machine operates normally under the commands from the controller.

Give a low speed command at first and check the operation direction, etc. of the machine. If the machine does not operate in the intended direction, check the input signal.

Check any problems with the servo motor speed, load ratio, and other status display items with MR Configurator2.

Then, check automatic operation with the program of the controller.

4.5 Test operation mode

CAUTION

- The test operation mode is designed for checking servo operation. It is not for checking machine operation. Do not use this mode with the machine. Always use the servo motor alone.
- If the servo motor operates abnormally, use EM2 (Forced stop 2) to stop it.

Point

The content described in this section indicates that the servo amplifier and a personal computer are directly connected.

By using a personal computer and MR Configurator2, you can execute JOG operation, positioning operation, output signal forced output, and program operation.

Test operation mode in MR Configurator2

Point

When the test operation mode is selected with the test operation select switch (SW1-1), the Network communication for the servo amplifier in the test operation mode and the following servo amplifiers is blocked.

Test operation mode

■Jog operation

Jog operation can be performed without using the controller. Use this operation with the forced stop reset. This operation may be used independently of whether the servo is on or off and whether the controller is connected or not.

Exercise control on the jog operation screen of MR Configurator2.

- Operation pattern

Item	Initial value	Setting range
Motor speed [r/min]	200	0 to max. speed
Acceleration/deceleration time constant [ms]	1000	0 to 50000

- Operation method

When the check box of "Rotation only while the CCW or CW button is being pushed." is checked.

Operation	Screen control
Forward rotation start	Keep pressing "Forward CCW".
Reverse rotation start	Keep pressing "Reverse CW".
Stop	Release "Forward CCW" or "Reverse CW".
Forced stop	Click "Forced stop".

When the check box of "Rotation only while the CCW or CW button is being pushed." is not checked.

Operation	Screen control
Forward rotation start	Click "Forward CCW".
Reverse rotation start	Click "Reverse CW".
Stop	Click "Stop".
Forced stop	Click "Forced stop".

■ Positioning operation

Positioning operation can be performed without using the controller. Use this operation with the forced stop reset. This operation may be used independently of whether the servo is on or off and whether the controller is connected or not. Exercise control on the positioning operation screen of MR Configurator2.

• Operation pattern

Item	Initial value	Setting range
Travel distance [pulse]	4000	0 to 99999999
Motor speed [r/min]	200	0 to max. speed
Acceleration/deceleration time constant [ms]	1000	0 to 50000
Repeat pattern	Fwd. rot. (CCW) to rev. rot. (CW)	Fwd. rot. (CCW) to rev. rot. (CW) Fwd. rot. (CCW) to fwd. rot. (CCW) Rev. rot. (CW) to fwd. rot. (CCW) Rev. rot. (CW) to rev. rot. (CW)
Dwell time [s]	2.0	0.1 to 50.0
Number of repeats [time]	1	1 to 9999

• Operation method

Operation	Screen control
Forward rotation start	Click "Forward CCW".
Reverse rotation start	Click "Reverse CW".
Pause	Click "Pause".
Stop	Click "Stop".
Forced stop	Click "Forced stop".

■ Program operation

Positioning operation can be performed in two or more operation patterns combined, without using the controller. Use this operation with the forced stop reset. This operation may be used independently of whether the servo is on or off and whether the controller is connected or not.

Exercise control on the program operation screen of MR Configurator2. For full information, refer to Help of MR Configurator2.

Operation	Screen control
Start	Click "Start".
Pause	Click "Pause".
Stop	Click "Stop".
Forced stop	Click "Forced stop".

■ Output signal (DO) forced output

Output signals can be switched on/off forcibly independently of the servo status. Use this function for output signal wiring check, etc. Exercise control on the DO forced output screen of MR Configurator2.

Operation procedure

1. Turn off the power.
2. Turn "ON (up)" SW1-1.

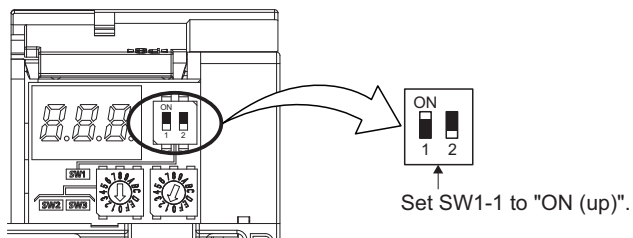

Turning "ON (up)" SW1-1 during power-on will not start the test operation mode.

3. Turn on the servo amplifier.

When initialization is completed, the decimal point on the first digit will blink.

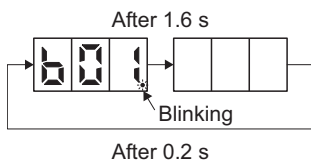

When an alarm or warning also occurs during the test operation, the decimal point on the first digit will blink as follows.

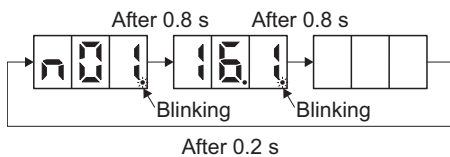

4. Start operation with the personal computer.

Motor-less operation in controller

Point

- Connect the controller to the servo amplifier before the motor-less operation.
- The motor-less operation cannot be used in the fully closed loop control mode, linear servo motor control mode, or DD motor control mode.

Motor-less operation

Without connecting the servo motor to the servo amplifier, output signals or status displays can be provided in response to the controller commands as if the servo motor is actually running. This operation may be used to check the controller sequence. Use this operation with the forced stop reset. Use this operation with the servo amplifier connected to the controller.

To stop the motor-less operation, set "Disabled (_ _ _ 0)" of "Motor-less operation selection" in [Pr. PC05]. The motor-less operation will be disabled from the next power-on.

Load conditions

Load item	Condition
Load torque	0
Load to motor inertia ratio	[Pr. PB06 Load to motor inertia ratio/load to motor mass ratio]

Alarms

The following alarms and warning do not occur. However, the other alarms and warnings occur as when the servo motor is connected.

- [AL. 16 Encoder initial communication error 1]
- [AL. 1E Encoder initial communication error 2]
- [AL. 1F Encoder initial communication error 3]
- [AL. 20 Encoder normal communication error 1]
- [AL. 21 Encoder normal communication error 2]
- [AL. 25 Absolute position erased]
- [AL. 92 Battery cable disconnection warning]
- [AL. 9F Battery warning]

Operation procedure

1. Set the servo amplifier to the servo-off status.
2. Set [Pr. PC05] to " _ _ _ 1", turn "OFF (down)" the test operation select switch (SW1-1), and then turn on the power supply.

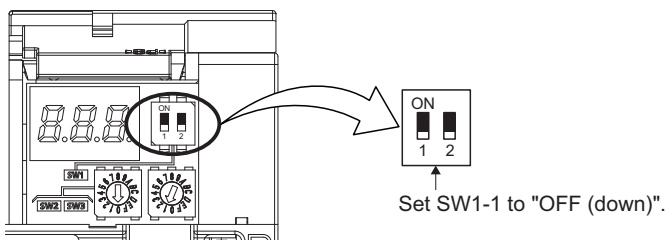

3. Start the motor-less operation with the controller.

The display shows the following screen.

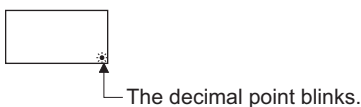

4.6 Home position return mode

Point

Before performing the home position return, make sure that the limit switch operates.

Check the home position return direction. An incorrect setting will cause a reverse running.

Check the input polarity of the proximity dog. Otherwise, it may cause an unexpected operation.

To execute a home position return securely, start a home position return after moving the servo motor to the opposite stroke end.

For the home position return used in the linear servo motor control mode, refer to the following.

☞ Page 497 Home position return

For the home position return used in the direct drive motor control mode, refer to the following.

☞ Page 525 Home position return

For the home position return used in the fully closed loop control mode, refer to the following.

☞ Page 549 Home position return

Outline of home position return

A home position return is performed to match the command coordinates and the machine coordinates. Under the incremental method, each power-on of the input power supply requires the home position return. Contrastingly, in the absolute position detection system, once you have performed the home position return at machine installation, the current position will be retained even if the power supply is shut off. Therefore, the home position return is unnecessary when the power supply is switched on again.

This section shows the home position return types of the servo amplifier. Select the optimum method according to the configuration and uses of the machine.

When a home position return is started with the controller, Controlword bit 4 will turn on. For details of the home position return, refer to the controller instruction manual.

Home position return types

Select the optimum home position return type according to the machine type or others.

Method No.	Home position return type	Home position return direction	Description
-1	Dog type (Rear end detection, Z-phase reference)	Forward rotation (CCW) or positive direction	Deceleration starts at the front end of the proximity dog. After the rear end is passed, the position specified by the first Z-phase signal, or the position of the first Z-phase signal shifted by the specified home position shift distance is used as the home position.
-33		Reverse rotation (CW) or negative direction	
-4	Stopper type (Stopper position reference)	Forward rotation (CCW) or positive direction	A workpiece is pressed against a mechanical stopper, and the position where it is stopped is set as the home position.
-36		Reverse rotation (CW) or negative direction	
-2	Count type (Front end detection, Z-phase reference)	Forward rotation (CCW) or positive direction	At the front end of the proximity dog, deceleration starts. After the front end is passed, the position specified by the first Z-phase signal after the set distance or the position of the Z-phase signal shifted by the set home position shift distance is set as a home position.
-34		Reverse rotation (CW) or negative direction	
-6	Dog type (Rear end detection, rear end reference)	Forward rotation (CCW) or positive direction	Deceleration starts from the front end of the proximity dog. After the rear end is passed, the position is shifted by the travel distance after proximity dog and the home position shift distance. The position after the shifts is set as the home position.
-38		Reverse rotation (CW) or negative direction	
-7	Count type (Front end detection, front end reference)	Forward rotation (CCW) or positive direction	Deceleration starts from the front end of the proximity dog. The position is shifted by the travel distance after proximity dog and the home position shift distance. The position after the shifts is set as the home position.
-39		Reverse rotation (CW) or negative direction	
-8	Dog cradle type	Forward rotation (CCW) or positive direction	A position, which is specified by the first Z-phase signal after the front end of the proximity dog is detected, is set as the home position.
-40		Reverse rotation (CW) or negative direction	

Method No.	Home position return type	Home position return direction	Description
-9	Dog type last Z-phase reference	Forward rotation (CCW) or positive direction	After the front end of the proximity dog is detected, the position is shifted away from the proximity dog in the reverse direction. Then, the position specified by the first Z-phase signal or the position of the first Z-phase signal shifted by the home position shift distance is used as the home position.
-41		Reverse rotation (CW) or negative direction	
-10	Dog type front end reference	Forward rotation (CCW) or positive direction	Starting from the front end of the proximity dog, the position is shifted by the travel distance after proximity dog and the home position shift distance. The position after the shifts is set as the home position.
-42		Reverse rotation (CW) or negative direction	
-11	Dogless Z-phase reference	Forward rotation (CCW) or positive direction	The position specified by the first Z-phase signal, or the position of the first Zphase signal shifted by the home position shift distance is used as the home position.
-43		Reverse rotation (CW) or negative direction	
3	Homing on positive home switch and index pulse	Forward rotation (CCW) or positive direction	Same as the dog type last Z-phase reference home position return. Note that if the stroke end is detected during home position return, [AL. 90 Home position return incomplete warning] occurs.
4	Homing on positive home switch and index pulse	Forward rotation (CCW) or positive direction	Same as the dog cradle type home position return. Note that if the stroke end is detected during home position return, [AL. 90 Home position return incomplete warning] occurs.
5	Homing on negative home switch and index pulse	Reverse rotation (CW) or negative direction	Same as the dog type last Z-phase reference home position return. Note that if the stroke end is detected during home position return, [AL. 90 Home position return incomplete warning] occurs.
6	Homing on negative home switch and index pulse	Reverse rotation (CW) or negative direction	Same as the dog cradle type home position return. Note that if the stroke end is detected during home position return, [AL. 90 Home position return incomplete warning] occurs.
7	Homing on home switch and index pulse	Forward rotation (CCW) or positive direction	Same as the dog type last Z-phase reference home position return.
8	Homing on home switch and index pulse	Forward rotation (CCW) or positive direction	Same as the dog cradle type home position return.
11	Homing on home switch and index pulse	Reverse rotation (CW) or negative direction	Same as the dog type last Z-phase reference home position return.
12	Homing on home switch and index pulse	Reverse rotation (CW) or negative direction	Same as the dog cradle type home position return.
19	Homing without index pulse	Forward rotation (CCW) or positive direction	Same as the dog type front end reference home position return. Note that if the stroke end is detected during home position return, [AL. 90 Home position return incomplete warning] occurs.
20	Homing without index pulse	Forward rotation (CCW) or positive direction	Although this type is the same as the dog cradle type home position return, the stop position is not on the Z-phase. Starting from the front end of the dog, the position is shifted by the travel distance after proximity dog and the home position shift distance. The position after the shifts is set as the home position. If the stroke end is detected during home position return, [AL. 90 Home position return incomplete warning] occurs.
21	Homing without index pulse	Reverse rotation (CW) or negative direction	Same as the dog type front end reference home position return. Note that if the stroke end is detected during home position return, [AL. 90 Home position return incomplete warning] occurs.
22	Homing without index pulse	Reverse rotation (CW) or negative direction	Although this type is the same as the dog cradle type home position return, the stop position is not on the Z-phase. Starting from the front end of the dog, the position is shifted by the travel distance after proximity dog and the home position shift distance. The position after the shifts is set as the home position. If the stroke end is detected during home position return, [AL. 90 Home position return incomplete warning] occurs.
23	Homing without index pulse	Forward rotation (CCW) or positive direction	Same as the dog type front end reference home position return.
24	Homing without index pulse	Forward rotation (CCW) or positive direction	Although this type is the same as the dog cradle type home position return, the stop position is not on the Z-phase. Starting from the front end of the dog, the position is shifted by the travel distance after proximity dog and the home position shift distance. The position after the shifts is set as the home position.
27	Homing without index pulse	Reverse rotation (CW) or negative direction	Same as the dog type front end reference home position return.
28	Homing without index pulse	Reverse rotation (CW) or negative direction	Although this type is the same as the dog cradle type home position return, the stop position is not on the Z-phase. Starting from the front end of the dog, the position is shifted by the travel distance after proximity dog and the home position shift distance. The position after the shifts is set as the home position.

Method No.	Home position return type	Home position return direction	Description
33	Homing on index pulse	Reverse rotation (CW) or negative direction	Although this type is the same as the dogless Z-phase reference home position return, the creep speed is applied as the movement start speed.
34	Homing on index pulse	Forward rotation (CCW) or positive direction	Although this type is the same as the dogless Z-phase reference home position return, the creep speed is applied as the movement start speed.
35	Homing on current position	—	The current position is set as the home position. This type can be executed not in the Operational enabled state.
37	Homing on current position	—	The current position is set as the home position. This type can be executed not in the Operational enabled state.

Parameters for home position return

To perform the home position return, set each parameter as follows.

■[Pr. PT45 Home position return type]

Select the home position return type and home position return direction.

Setting value	Home position return direction	Home position return type	
-1	Forward rotation (CCW) or positive direction	Dog type (rear end detection, Z-phase reference)	
-2		Count type (front end detection, Z-phase reference)	
-4		Stopper type (stopper position reference)	
-6		Dog type (rear end detection, rear end reference)	
-7		Count type (front end detection, front end reference)	
-8		Dog cradle type	
-9		Dog type last Z-phase reference	
-10		Dog type front end reference	
-11		Dogless Z-phase reference	
-33		Reverse rotation (CW) or negative direction	Dog type (rear end detection, Z-phase reference)
-34			Count type (front end detection, Z-phase reference)
-36	Stopper type (stopper position reference)		
-38	Dog type (rear end detection, rear end reference)		
-39	Count type (front end detection, front end reference)		
-40	Dog cradle type		
-41	Dog type last Z-phase reference		
-42	Dog type front end reference		
-43	Dogless Z-phase reference		
3	Forward rotation (CCW) or positive direction		Method 3
4			Method 4
5	Reverse rotation (CW) or negative direction	Method 5	
6		Method 6	
7	Forward rotation (CCW) or positive direction	Method 7	
8		Method 8	
11	Reverse rotation (CW) or negative direction	Method 11	
12		Method 12	
19	Forward rotation (CCW) or positive direction	Method 19	
20		Method 20	
21	Reverse rotation (CW) or negative direction	Method 21	
22		Method 22	
23	Forward rotation (CCW) or positive direction	Method 23	
24		Method 24	
27	Reverse rotation (CW) or negative direction	Method 27	
28		Method 28	
33		Method 33	
34	Forward rotation (CCW) or positive direction	Method 34	
35	—	Method 35	
37	—	Method 37 (Data set type)	

■[Pr. PT29 Function selection T-3]

Select the polarity where the proximity dog is detected with the DOG (Proximity dog) polarity selection.

Setting "0" detects a proximity dog when DOG (Proximity dog) is switched off. Setting "1" detects a proximity dog when DOG (Proximity dog) is switched on.

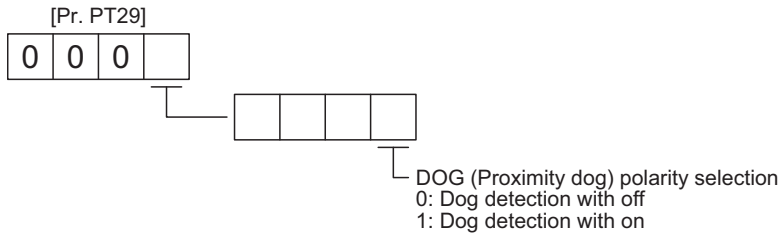

Precautions when using a proximity dog

■Length of proximity dog

Set the length of the proximity dog to satisfy the following, so that the servo motor speed changes from the home position return speed to the creep speed during detection of the proximity dog.

$$L_1 \geq \frac{V}{60} \cdot \frac{td}{2}$$

L_1 : Length of the proximity dog [mm]

V : Home position return speed [mm/min]

td : Time to change from the home position return speed to the creep speed [s]

■Adjustment of proximity dog position

To eliminate variations in the home position return completion position, adjust the proximity dog detection position to be near the center between the positions specified by a Z-phase signal and the next Z-phase signal.

The generated position of the Z-phase signals can be checked with "Position within one-revolution" of "Status display" on MR Configurator2.

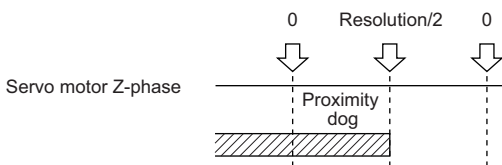

CiA 402-type homing method

Home position return type in CiA 402 type

The following shows the CiA 402-type home position return.

Method 3 and 4: Homing on positive home switch and index pulse

These home position return types use the front end of the proximity dog as reference and set the Z-phase right before and right after the dog as a home position.

Method 3 has the operation of the dog type last Z-phase reference home position return, and Method 4 has the operation of the dog cradle type home position return at a forward rotation start. However, if the stroke end is detected during home position return, [AL. 90] occurs.

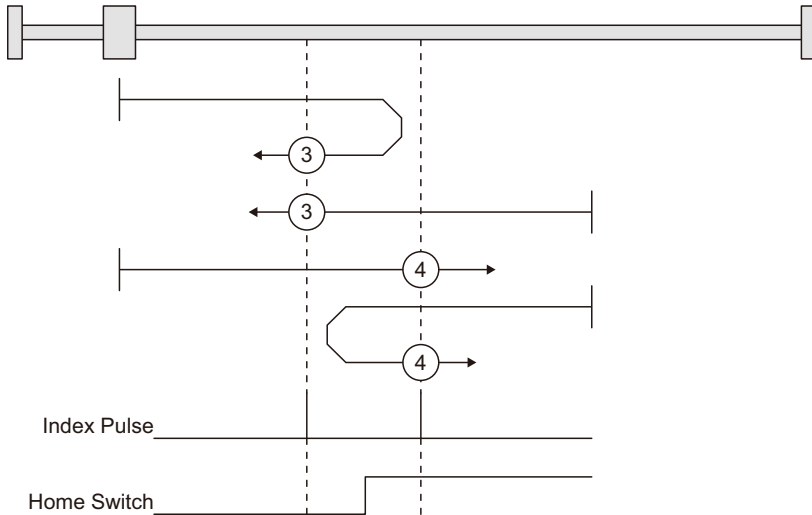

Method 5 and 6: Homing on negative home switch and index pulse

These home position return types use the front end of the proximity dog as reference and set the Z-phase right before and right after the dog as a home position. Method 5 and 6 differ from Method 3 and Method 4 in the starting direction: the starting direction of Method 5 and 6 is the reversed direction.

Method 7, 8, 11, 12: Homing on home switch and index pulse

These types include the operation at stroke end detection in addition to the operation of Method 3 to Method 6. Thus, the home position is the same as that of Method 3 to Method 6. Method 7 has the operation of the dog type last Z-phase reference home position return. Method 8 has the operation of the dog cradle type home position return at a forward rotation start. Method 11 and 12 differ from Method 7 and Method 8 only in the starting direction: the starting direction of Method 11 and 12 is the reversed direction.

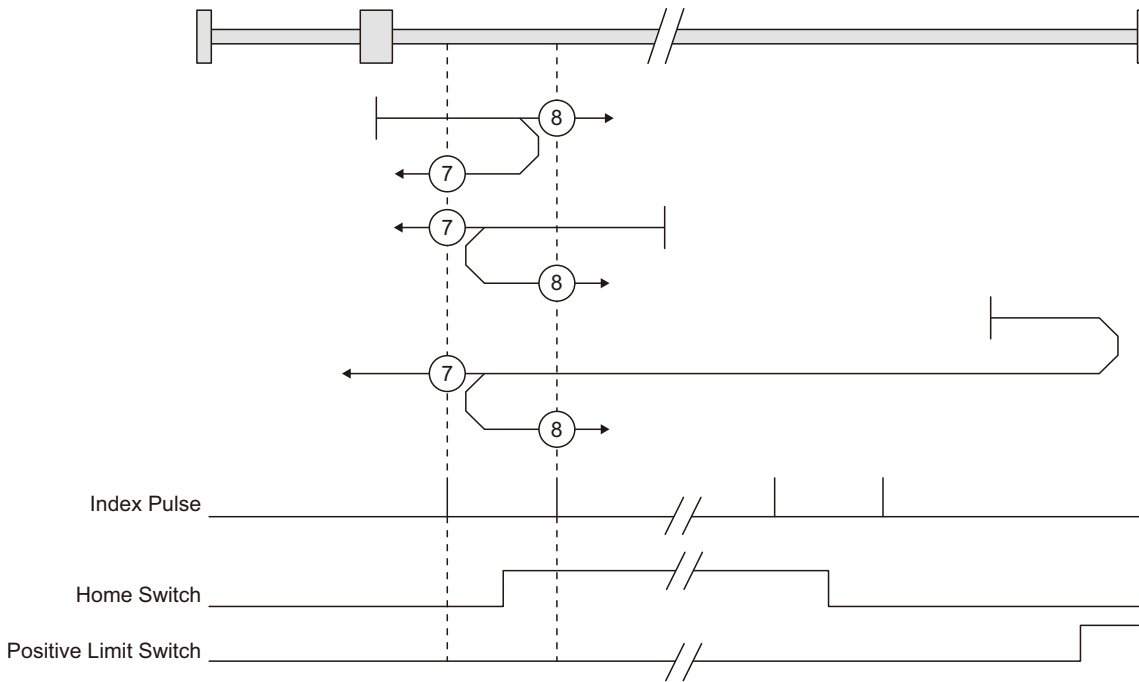

Method 17 to 30: Homing without index pulse

Method 17 to 30 have the operation of Method 1 to Method 14; however, these types set the home position not on the Z-phase but on the dog. The following figure shows the operation of the home position return type of Method 19 and Method 20. Method 19 and Method 20 have the operation of Method 3 and Method 4; however, these types set the home position not on the Z-phase but on the dog. Method 19 has the operation of the dog type front end reference home position return. Method 20 has the operation of the dog cradle type home position return; however, the stop position is not on the Z-phase but on the dog.

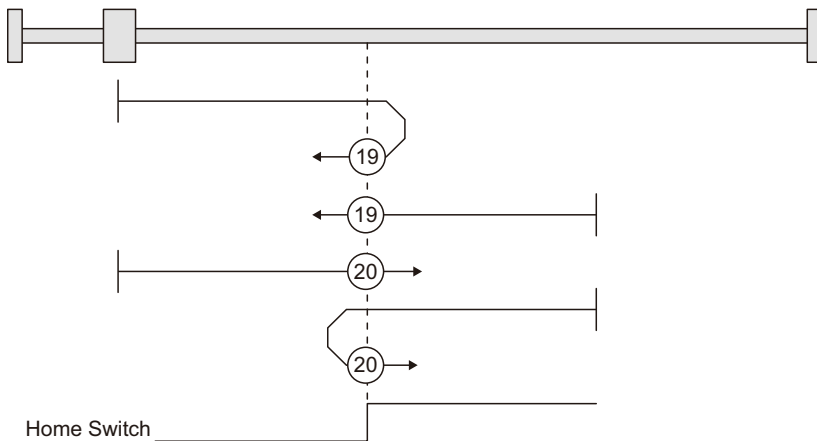

■Method 33 and 34: Homing on index pulse

These home position return types set the Z-phase detected first as a home position. The operation is the same as that of the dogless Z-phase reference home position return except that the creep speed is applied at the start.

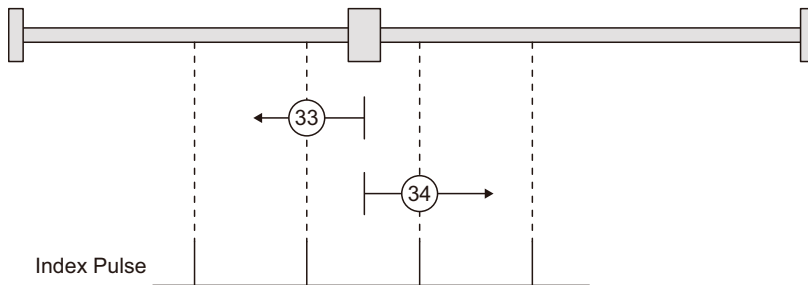

■Method 35 and 37: Homing on current position

These home position return types set the current position as a home position. These methods can be performed even while the servo is off.

When a simple motion module QD77GF_ or RD77GF_ or simple motion board MR-EM340GF is used, these methods cannot be performed while the servo is off.

☞ Page 162 Method 35 and Method 37 (Homing on current position)

Operation example of the CiA 402-type Homing method

The following shows an operation example of the home position return in the CiA 402-type Homing method.

Method 3 (Homing on positive home switch and index pulse) and Method 5 (Homing on negative home switch and index pulse)

The following figure shows the operation of Homing method 3. The operation direction of Homing method 5 is opposite to that of Homing method 3.

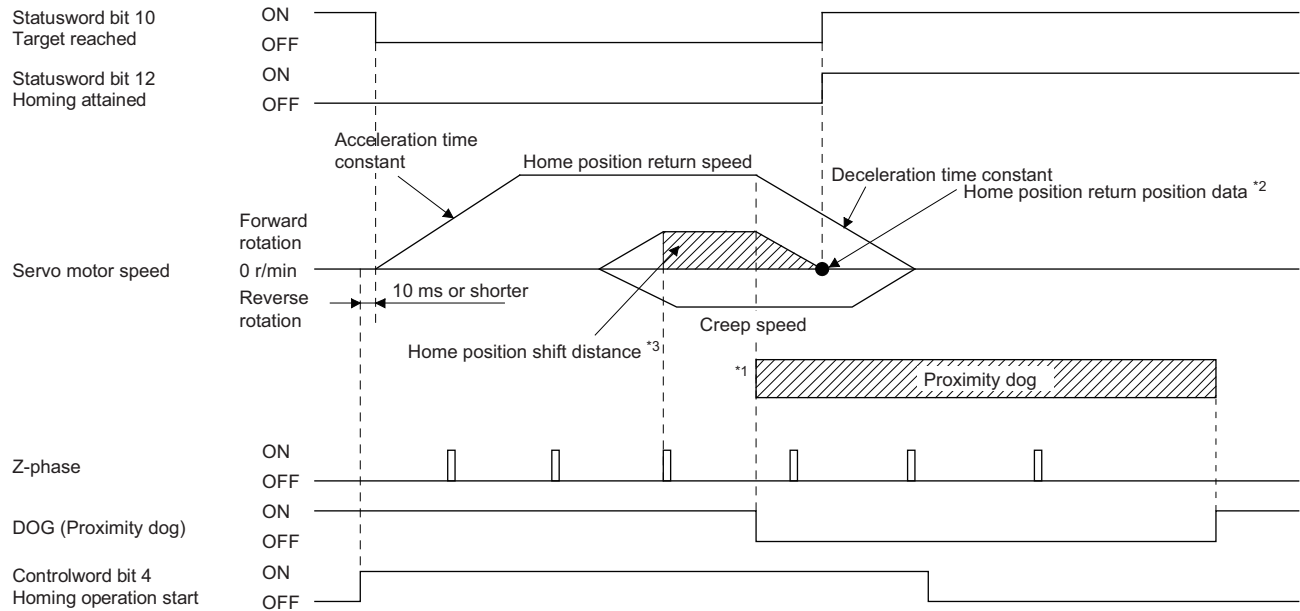

- *1 After the front end of the proximity dog is detected, if the rear end of the proximity dog is detected without stop, [AL. 90] occurs. Check the length of the proximity dog or check the home position return speed and creep speed.
- *2 Home position return position data can be changed with [Pr. PT08] and [Pr. PT47]. Home position return position data is the current position at the time of home position return completion. (I/O mode only)
- *3 Home position shift distance can be changed with [Pr. PT07] and [Pr. PT69].
- When a home position return is started from the proximity dog

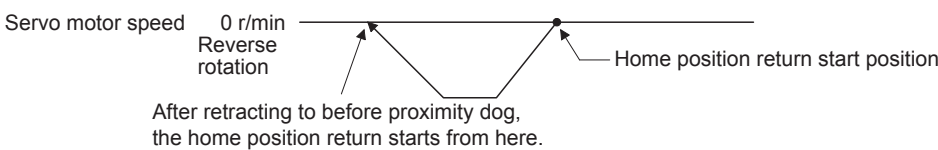

- When the stroke end is detected

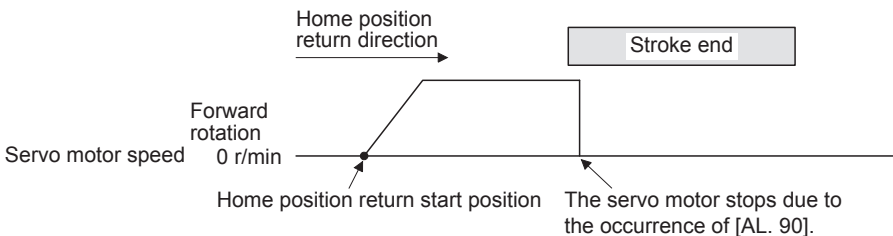

Method 4 (Homing on positive home switch and index pulse) and Method 6 (Homing on negative home switch and index pulse)

The following figure shows the operation of Homing method 4. The operation direction of Homing method 6 is opposite to that of Homing method 4.

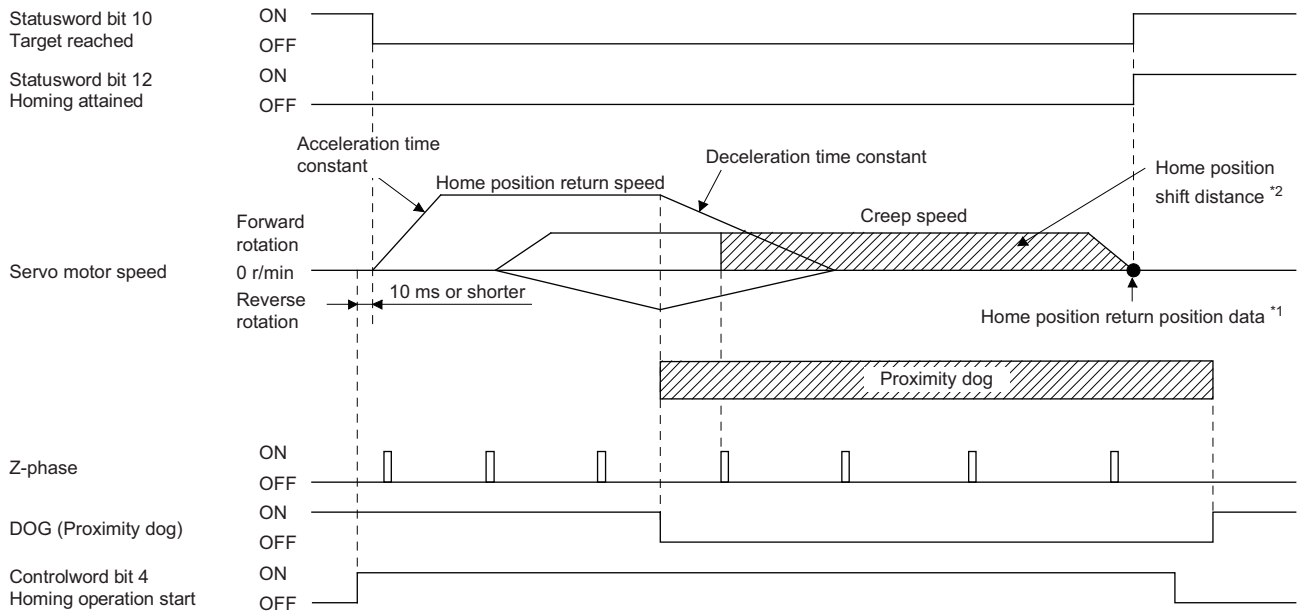

*1 Home position return position data can be changed with [Pr. PT08] and [Pr. PT47]. Home position return position data is the current position at the time of home position return completion. (I/O mode only)

*2 Home position shift distance can be changed with [Pr. PT07] and [Pr. PT69].

- When a home position return is started from the proximity dog

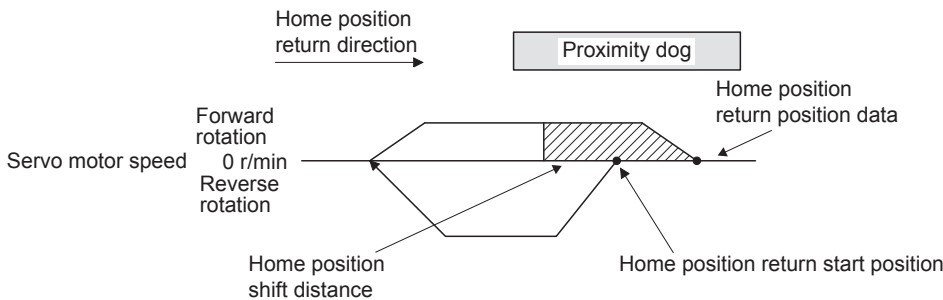

- When the stroke end is detected

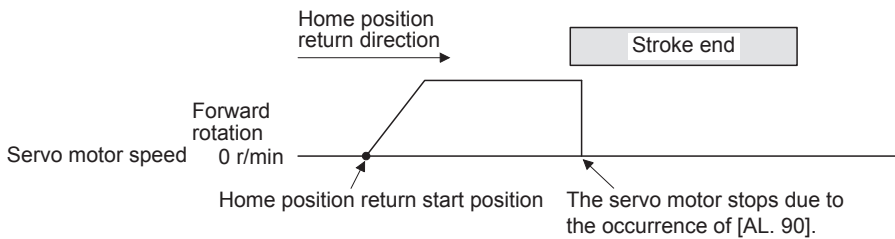

Method 7 and Method 11 (Homing on home switch and index pulse)

The following figure shows the operation of Homing method 7. The operation direction of Homing method 11 is opposite to that of Homing method 7.

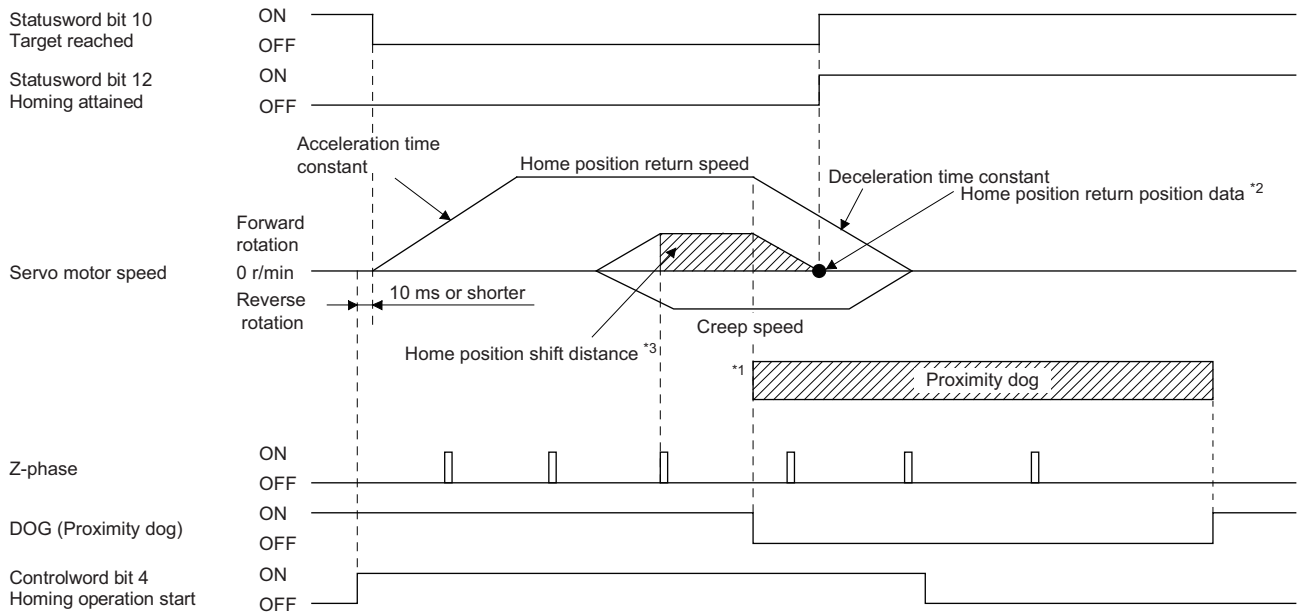

*1 After the front end of the proximity dog is detected, if the rear end of the proximity dog is detected without stop, [AL. 90] occurs. Check the length of the proximity dog or check the home position return speed and creep speed.

*2 Home position return position data can be changed with [Pr. PT08] and [Pr. PT47]. Home position return position data is the current position at the time of home position return completion. (I/O mode only)

*3 Home position shift distance can be changed with [Pr. PT07] and [Pr. PT69].

- When a home position return is started from the proximity dog

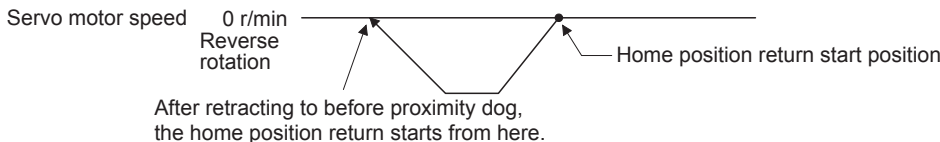

- When the movement is returned at the stroke end

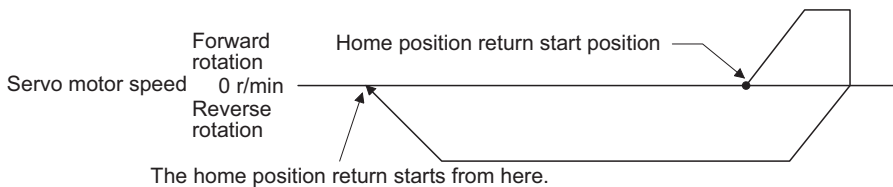

*1 This is not available with the software limit.

Method 8 and Method 12 (Homing on home switch and index pulse)

The following figure shows the operation of Homing method 8. The operation direction of Homing method 12 is opposite to that of Homing method 8.

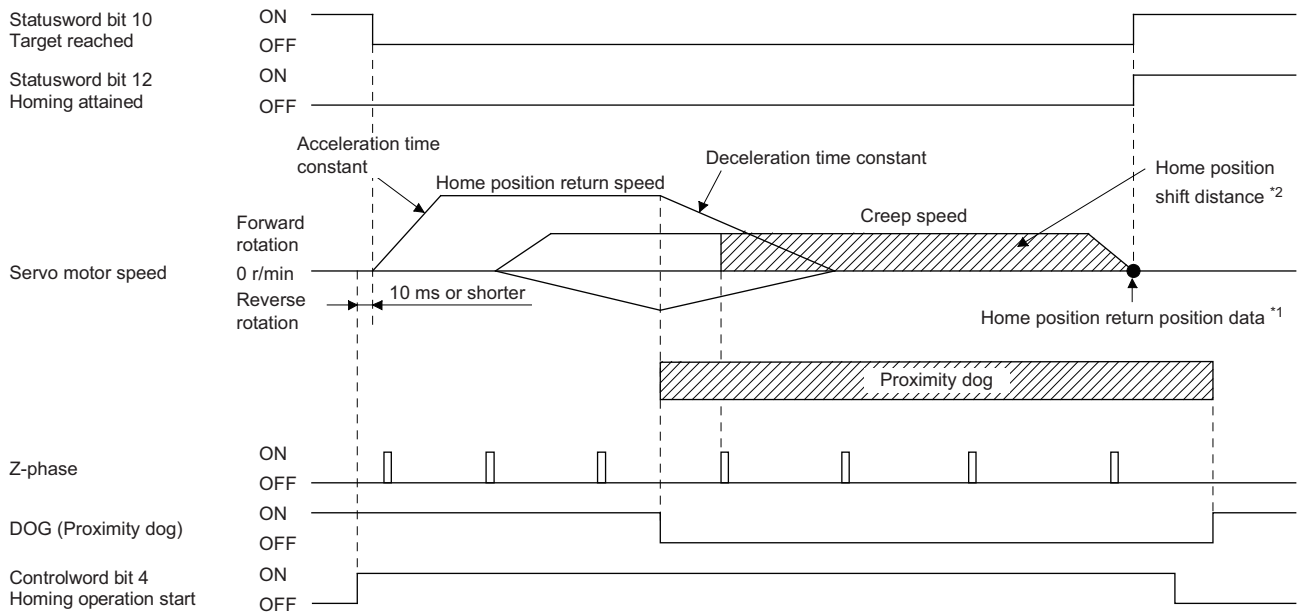

*1 Home position return position data can be changed with [Pr. PT08] and [Pr. PT47]. Home position return position data is the current position at the time of home position return completion. (I/O mode only)

*2 Home position shift distance can be changed with [Pr. PT07] and [Pr. PT69].

- When a home position return is started from the proximity dog

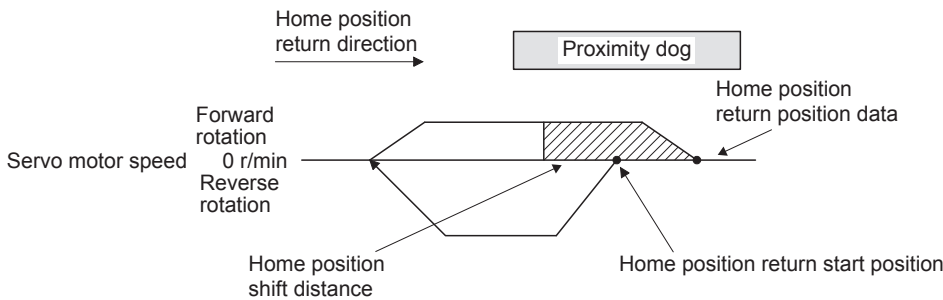

- When the movement is returned at the stroke end

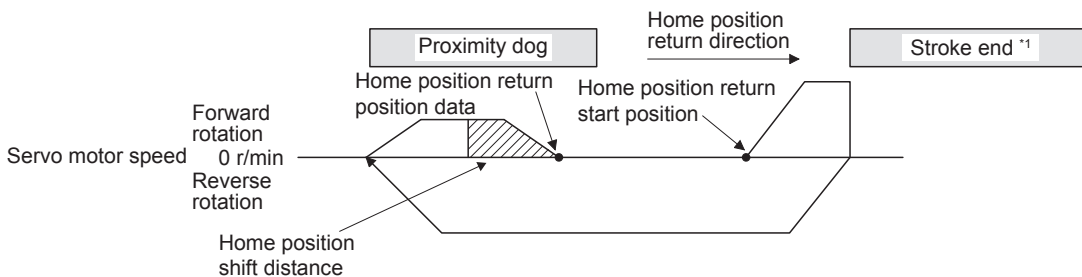

*1 This is not available with the software limit.

Method 19 and Method 21 (Homing without index pulse)

The following figure shows the operation of Homing method 19. The operation direction of Homing method 21 is opposite to that of Homing method 19.

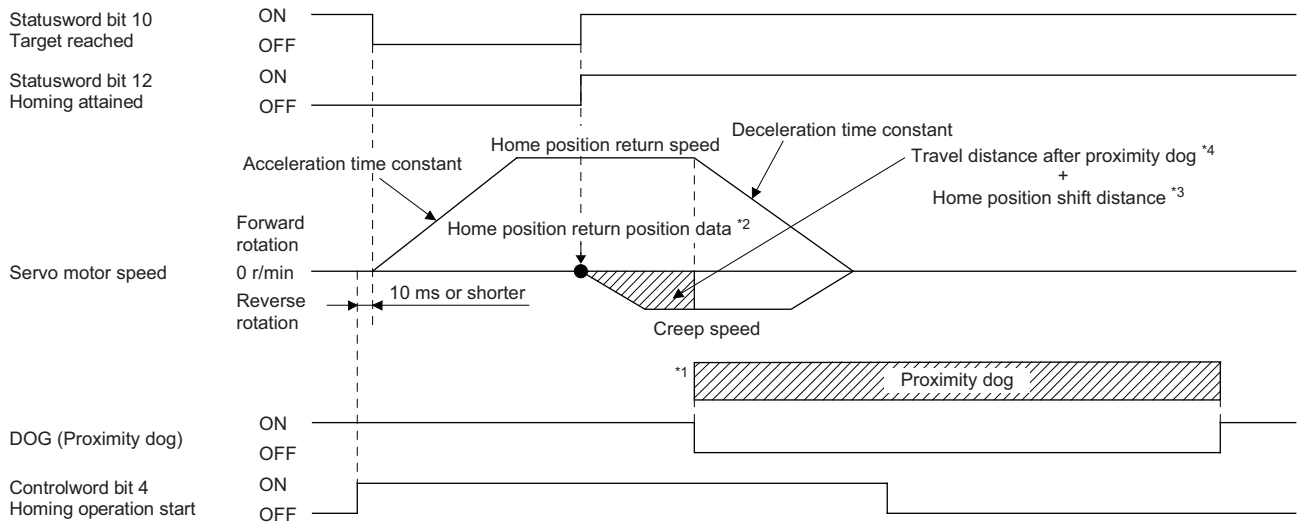

- *1 After the front end of the proximity dog is detected, if the rear end of the proximity dog is detected without reaching the creep speed, [AL. 90] occurs. Check the length of the proximity dog or check the home position return speed and creep speed.
 - *2 Home position return position data can be changed with [Pr. PT08] and [Pr. PT47]. Home position return position data is the current position at the time of home position return completion. (I/O mode only)
 - *3 Home position shift distance can be changed with [Pr. PT07] and [Pr. PT69].
 - *4 Travel distance after proximity dog can be changed with [Pr. PT09] and [Pr. PT71].
- When a home position return is started from the proximity dog

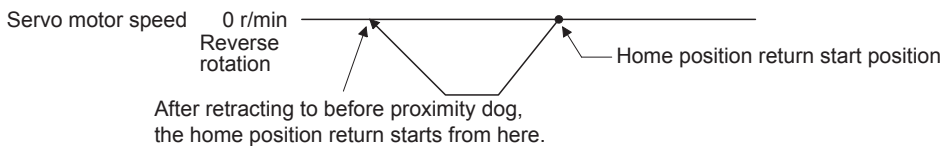

- When the stroke end is detected

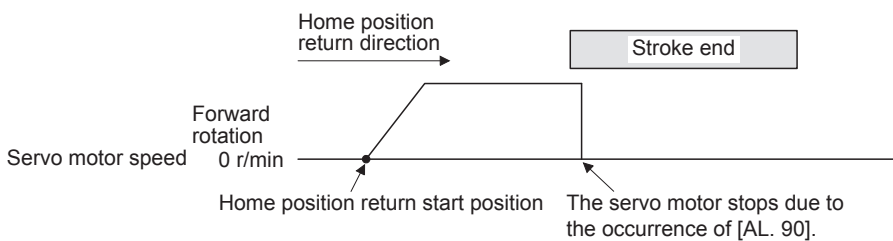

Method 20 and Method 22 (Homing without index pulse)

The following figure shows the operation of Homing method 20. The operation direction of Homing method 22 is opposite to that of Homing method 20.

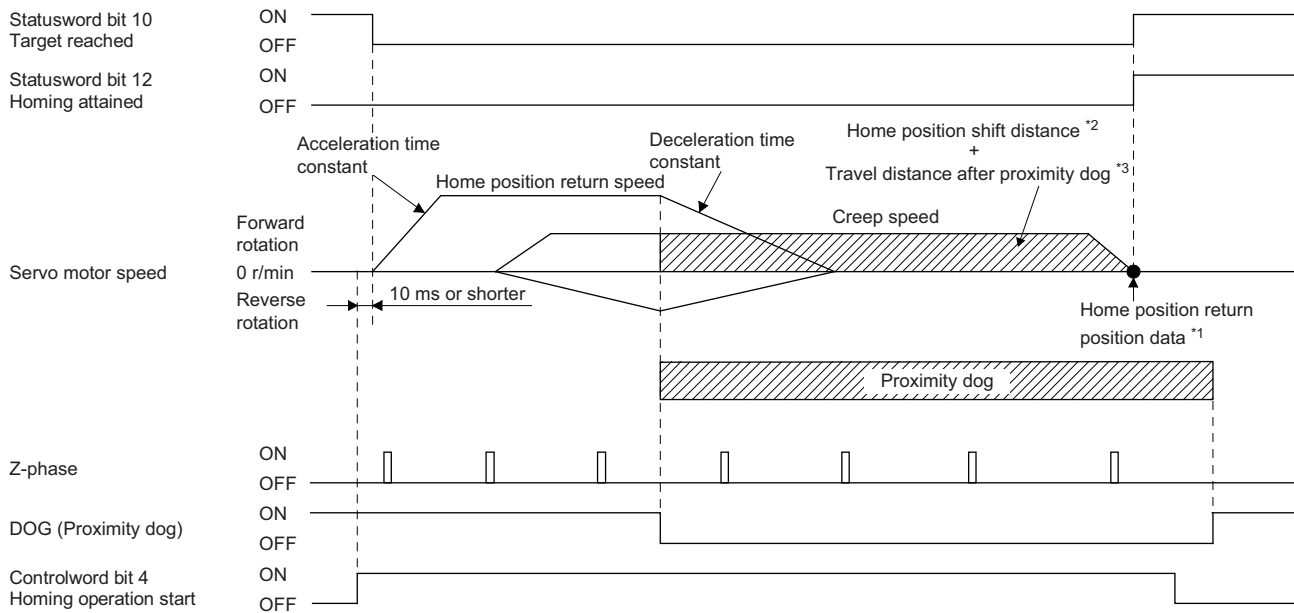

*1 Home position return position data can be changed with [Pr. PT08] and [Pr. PT47]. Home position return position data is the current position at the time of home position return completion. (I/O mode only)

*2 Home position shift distance can be changed with [Pr. PT07] and [Pr. PT69].

*3 Travel distance after proximity dog can be changed with [Pr. PT09] and [Pr. PT71].

- When a home position return is started from the proximity dog

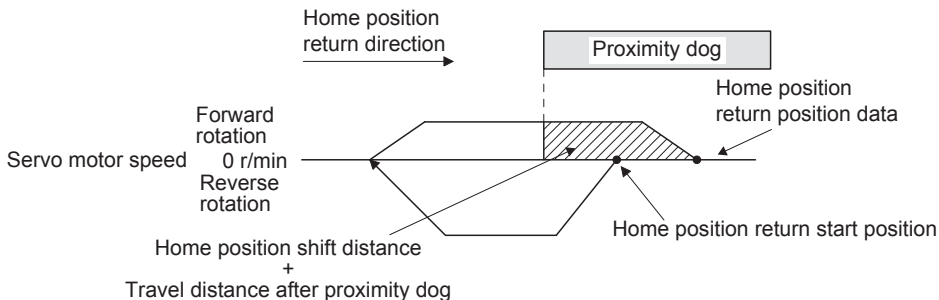

- When the stroke end is detected

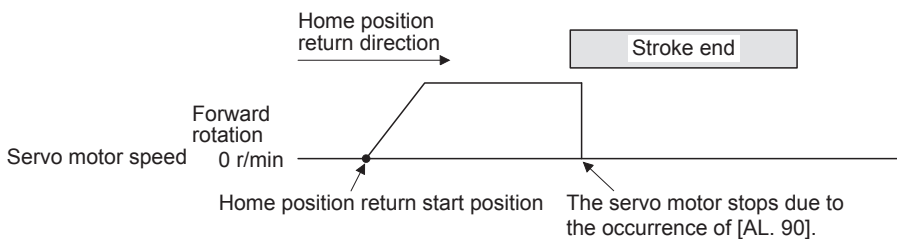

Method 23 and Method 27 (Homing without index pulse)

The following figure shows the operation of Homing method 23. The operation direction of Homing method 27 is opposite to that of Homing method 23.

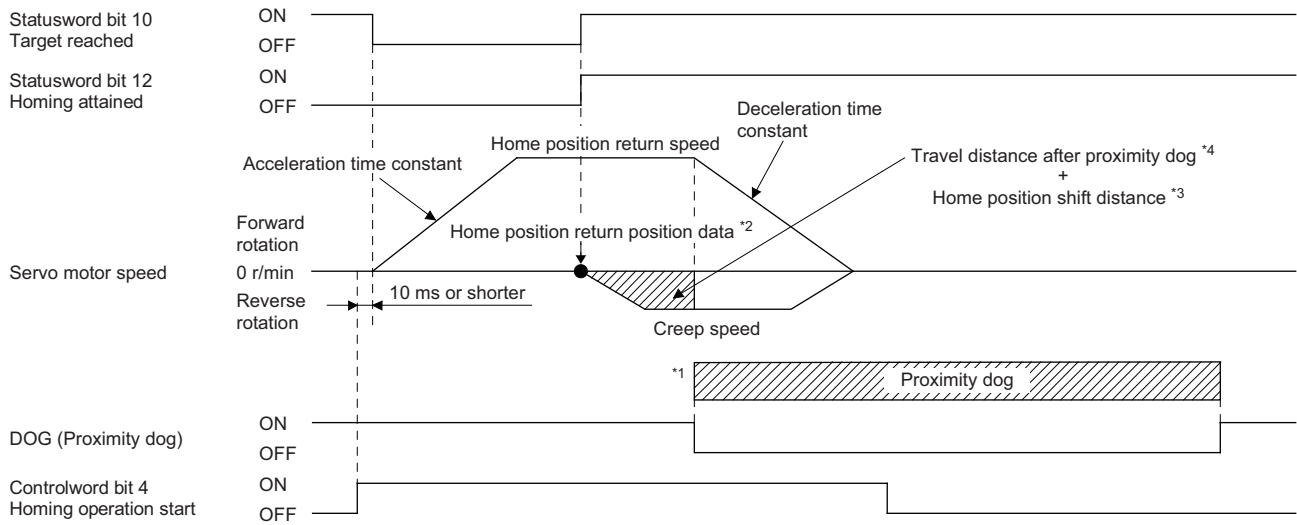

*1 After the front end of the proximity dog is detected, if the rear end of the proximity dog is detected without reaching the creep speed, [AL. 90] occurs. Check the length of the proximity dog or check the home position return speed and creep speed.

*2 Home position return position data can be changed with [Pr. PT08] and [Pr. PT47]. Home position return position data is the current position at the time of home position return completion. (I/O mode only)

*3 Home position shift distance can be changed with [Pr. PT07] and [Pr. PT69].

*4 Travel distance after proximity dog can be changed with [Pr. PT09] and [Pr. PT71].

- When a home position return is started from the proximity dog

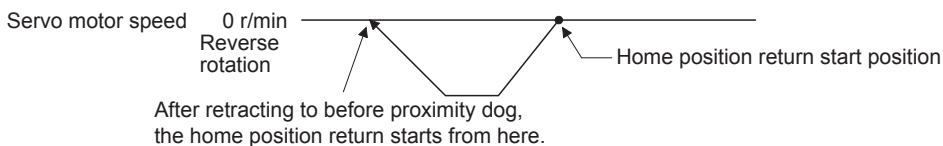

- When the movement is returned at the stroke end

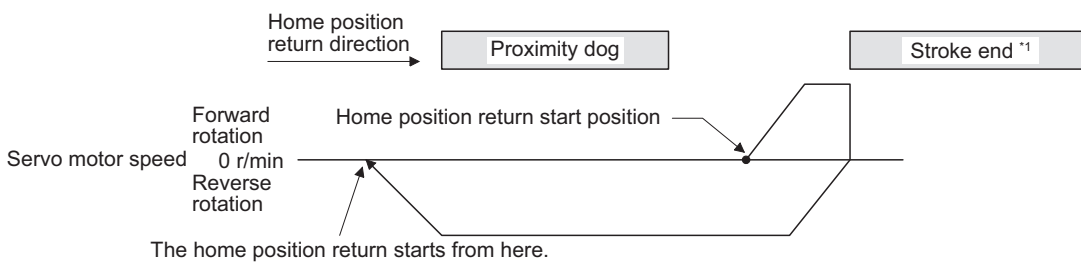

*1 This is not available with the software limit.

Method 24 and Method 28 (Homing without index pulse)

The following figure shows the operation of Homing method 24. The operation direction of Homing method 28 is opposite to that of Homing method 24.

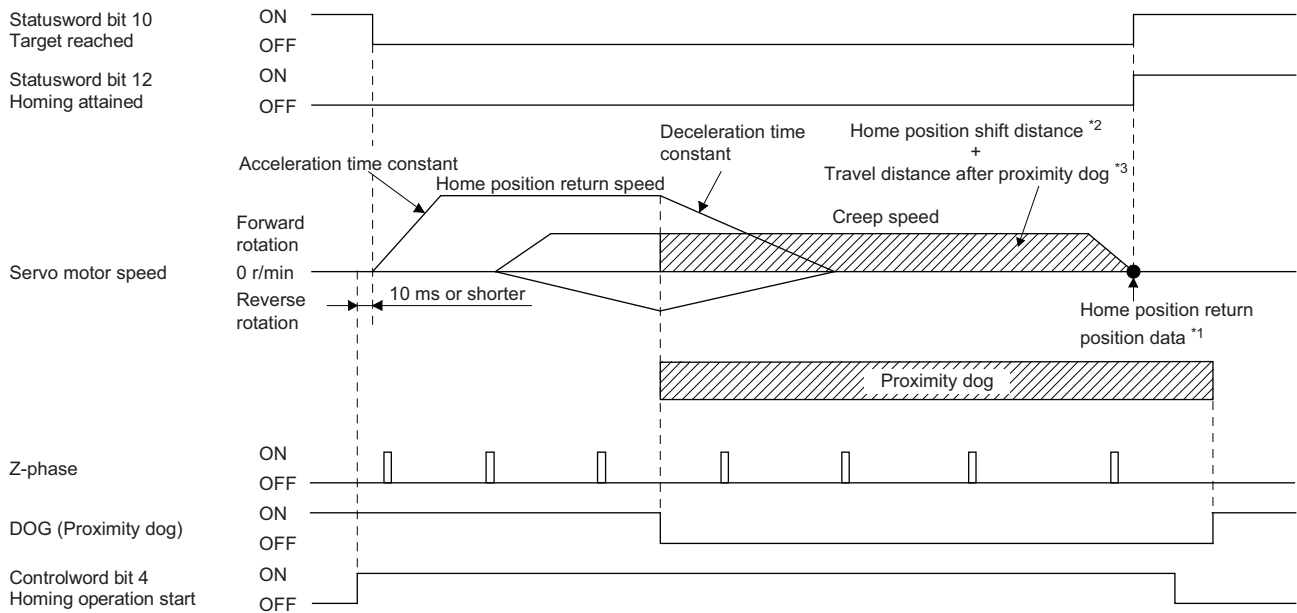

*1 Home position return position data can be changed with [Pr. PT08] and [Pr. PT47]. Home position return position data is the current position at the time of home position return completion. (I/O mode only)

*2 Home position shift distance can be changed with [Pr. PT07] and [Pr. PT69].

*3 Travel distance after proximity dog can be changed with [Pr. PT09] and [Pr. PT71].

- When a home position return is started from the proximity dog

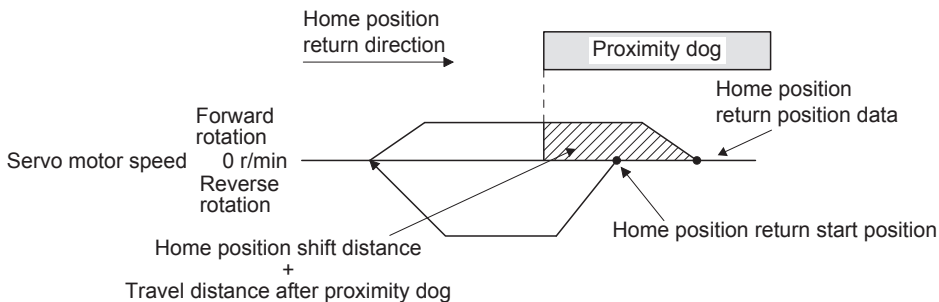

- When the movement is returned at the stroke end

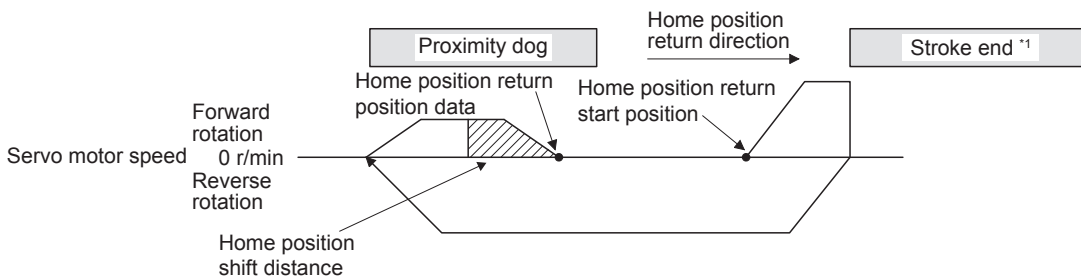

*1 This is not available with the software limit.

Method 33 and Method 34 (Homing on index pulse)

The following figure shows the operation of Homing method 34. The operation direction of Homing method 33 is opposite to that of Homing method 34.

Point

When home position return is performed from near the Z-phase, the home position return completion position varies. The recommended start position for home position return can be found by rotating the servo motor about a half-turn away from the home position return direction.

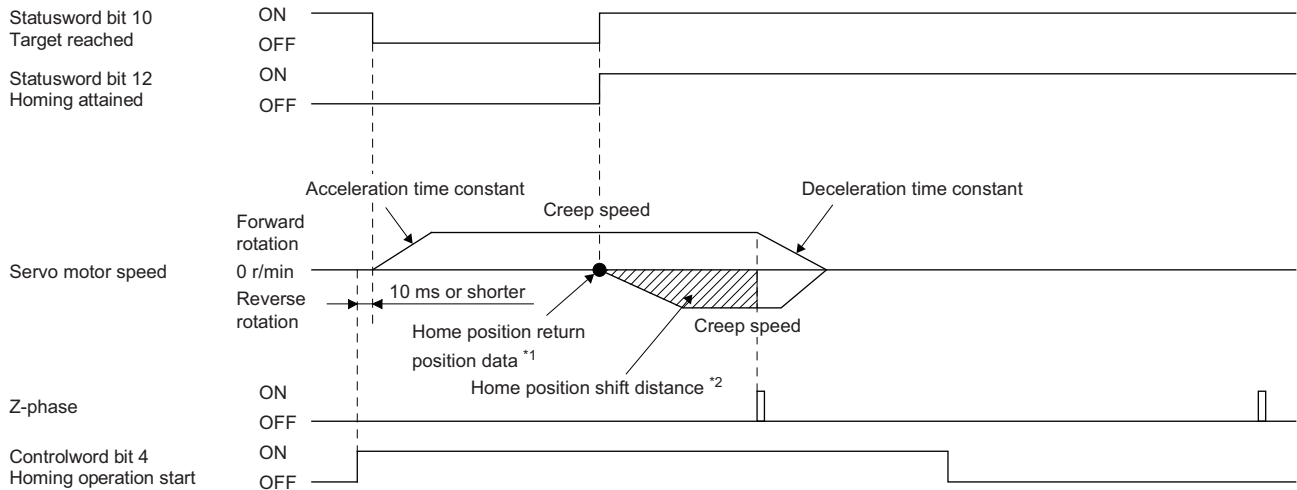

*1 Home position return position data can be changed with [Pr. PT08] and [Pr. PT47]. Home position return position data is the current position at the time of home position return completion. (I/O mode only)

*2 Home position shift distance can be changed with [Pr. PT07] and [Pr. PT69].

- When the stroke end is detected

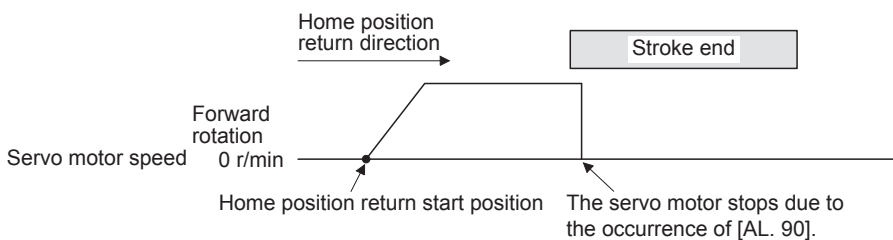

Method 35 and Method 37 (Homing on current position)

The following figure shows the operation of Homing method 35 and Homing method 37. These methods can be performed in the servo-off status.

When a simple motion module QD77GF_ or RD77GF_ or simple motion board MR-EM340GF is used, these methods cannot be performed while the servo is off.

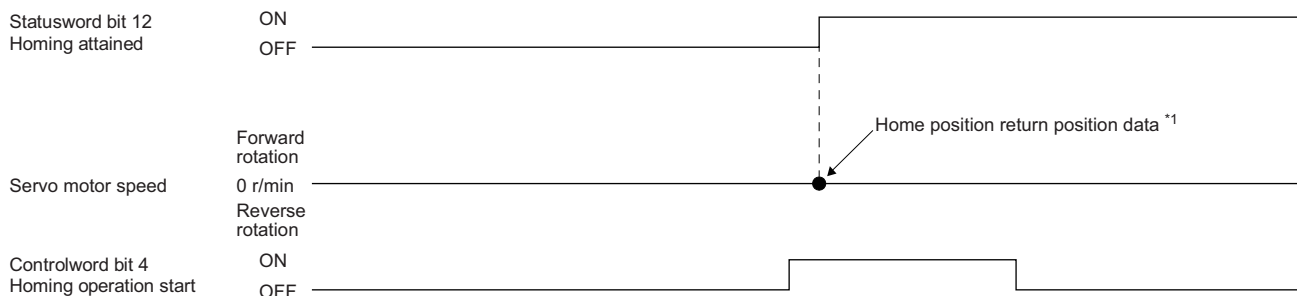

*1 Home position return position data can be changed with [Pr. PT08] and [Pr. PT47]. Home position return position data is the current position at the time of home position return completion. (I/O mode only)

Operation example of Manufacturer-specific Homing method

The following shows an operation example of the Manufacturer-specific home position return.

Method -1 and -33 (Dog type home position return)

The following figure shows the operation of Homing method -1. operation direction of Homing method -33 is opposite to that of Homing method -1.

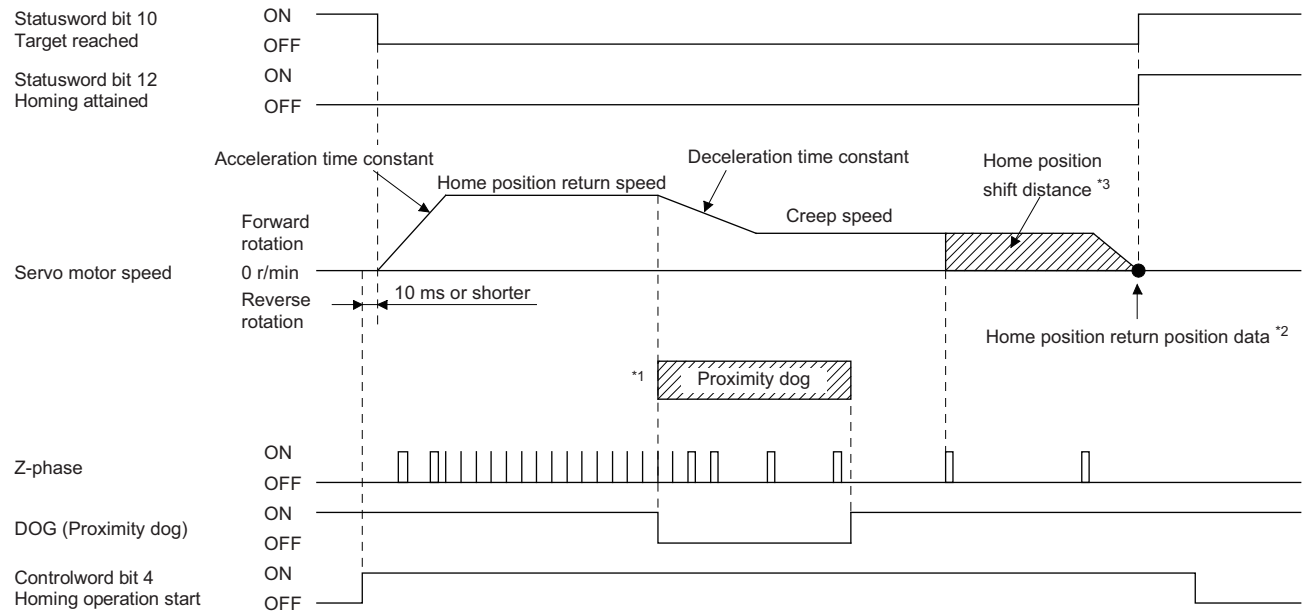

- *1 After the front end of the proximity dog is detected, if the rear end of the proximity dog is detected without reaching the creep speed, [AL. 90] occurs. Check the length of the proximity dog or check the home position return speed and creep speed.
- *2 Home position return position data can be changed with [Pr. PT08] and [Pr. PT47]. Home position return position data is the current position at the time of home position return completion. (I/O mode only)
- *3 Home position shift distance can be changed with [Pr. PT07] and [Pr. PT69].
- When a home position return is started from the proximity dog

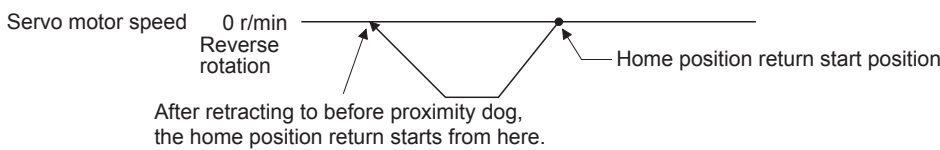

- When the movement is returned at the stroke end

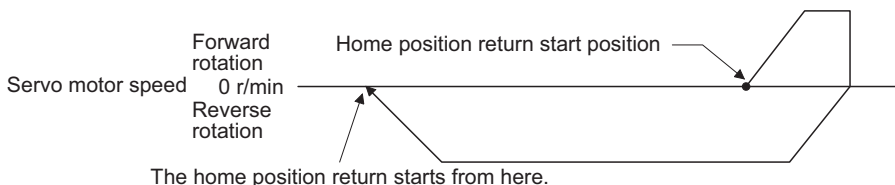

- *1 This is not available with the software limit.

Method -2 and -34 (Count type home position return)

Point

For the count type home position return, after the front end of the proximity dog is detected, the position is shifted by the distance set in the travel distance after proximity dog. Then, the first Z-phase is set as the home position. Therefore, when the on-time of the proximity dog is 10 ms or more, the length of the proximity dog has no restrictions. Use this home position return type when the dog type home position return cannot be used because the length of the proximity dog cannot be reserved or other cases.

The following figure shows the operation of Homing method -2. The operation direction of Homing method -34 is opposite to that of Homing method -2.

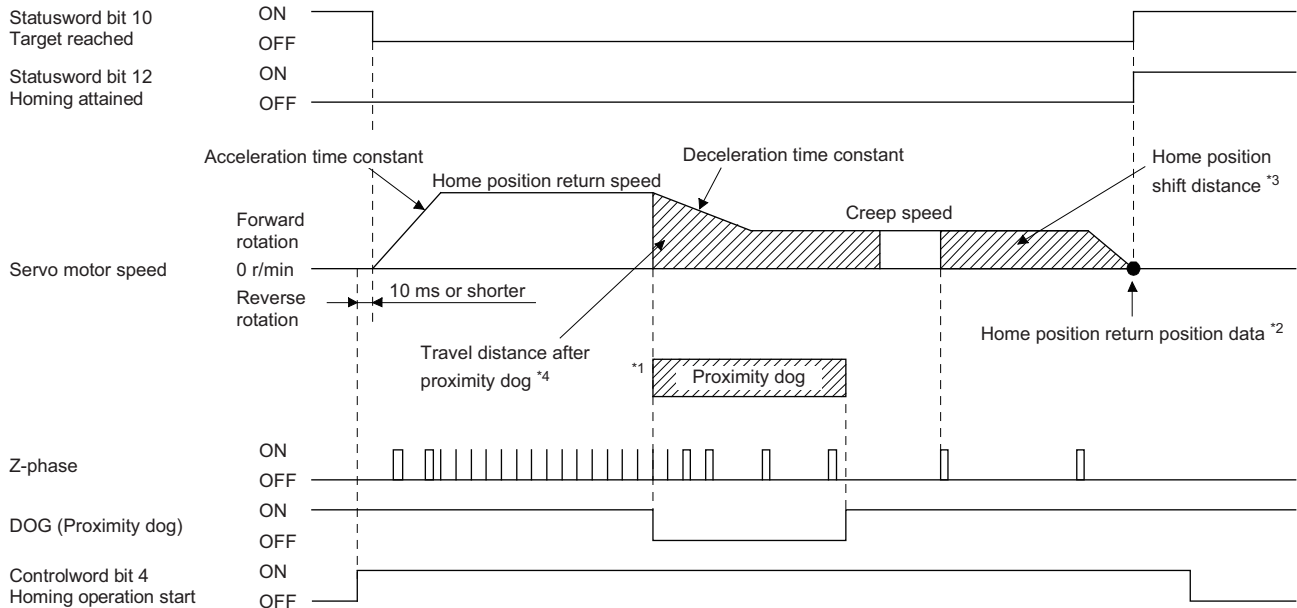

- *1 After the front end of the proximity dog is detected, if the distance after proximity dog is traveled without reaching the creep speed, [AL. 90] occurs. Set the travel distance after proximity dog enough for deceleration from the home position return speed to the creep speed.
 - *2 Home position return position data can be changed with [Pr. PT08] and [Pr. PT47]. Home position return position data is the current position at the time of home position return completion. (I/O mode only)
 - *3 Home position shift distance can be changed with [Pr. PT07] and [Pr. PT69].
 - *4 Travel distance after proximity dog can be changed with [Pr. PT09] and [Pr. PT71].
- When a home position return is started from the proximity dog

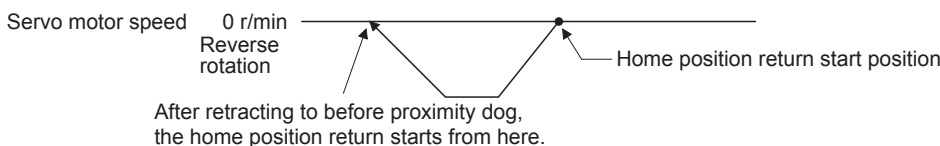

- When the movement is returned at the stroke end

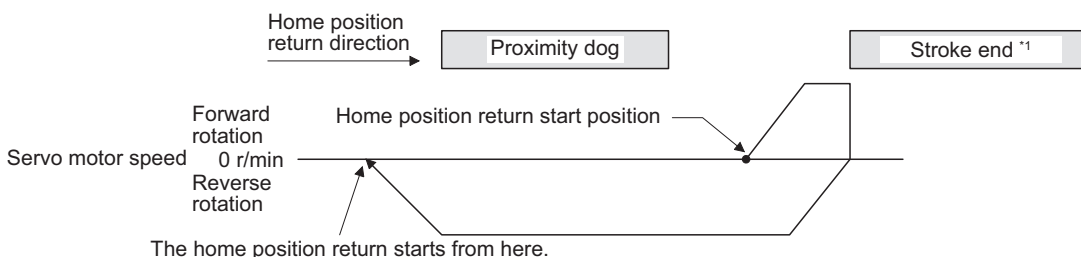

- *1 This is not available with the software limit.

Method -4 and -36 (stopper type home position return)



Since the workpiece collides with the mechanical stopper, the home position return speed must be low enough.

The following figure shows the operation of Homing method -4. The operation direction of Homing method -36 is opposite to that of Homing method -4.

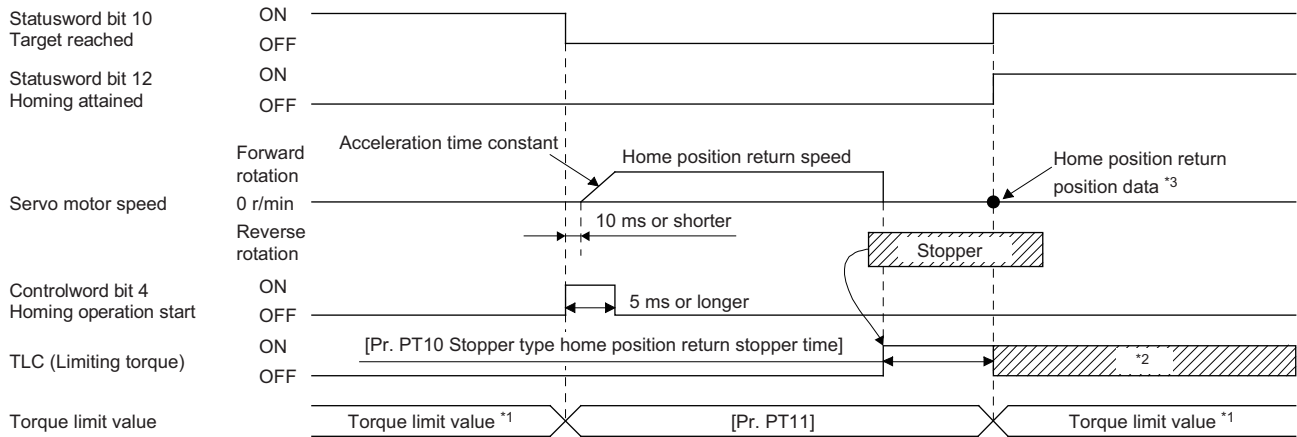

*1 When Method -4 is set, the torque limit value (Positive torque limit value (60E0h)) is applied. When Method -36 is set, the torque limit value (Negative torque limit value (60E1h)) is applied.

*2 If the torque limit value is reached, TLC remains on after the home position return is completed.

*3 Home position return position data can be changed with [Pr. PT08] and [Pr. PT47]. Home position return position data is the current position at the time of home position return completion. (I/O mode only)

- When the stroke end is detected

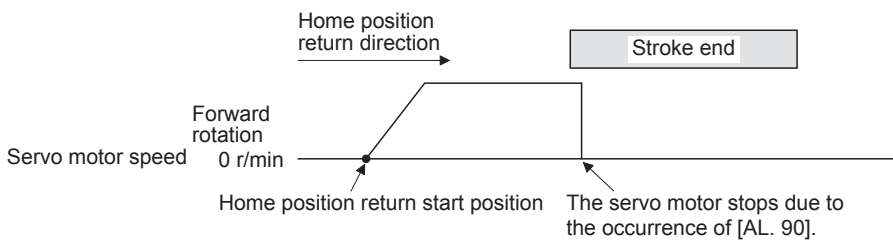

Method -6 and -38 (dog type rear end reference home position return)

Point

This home position return type depends on the timing of reading DOG (Proximity dog) that has detected the rear end of the proximity dog. Therefore, when the creep speed is set to 100 r/min and a home position return is performed, the home position has an error calculated by the following expression.

$$\pm (\text{Encoder resolution}) \times 100/65536 [\text{pulse}]$$

The higher the creep speed, the greater the error of the home position.

The following figure shows the operation of Homing method -6. The operation direction of Homing method -38 is opposite to that of Homing method -6.

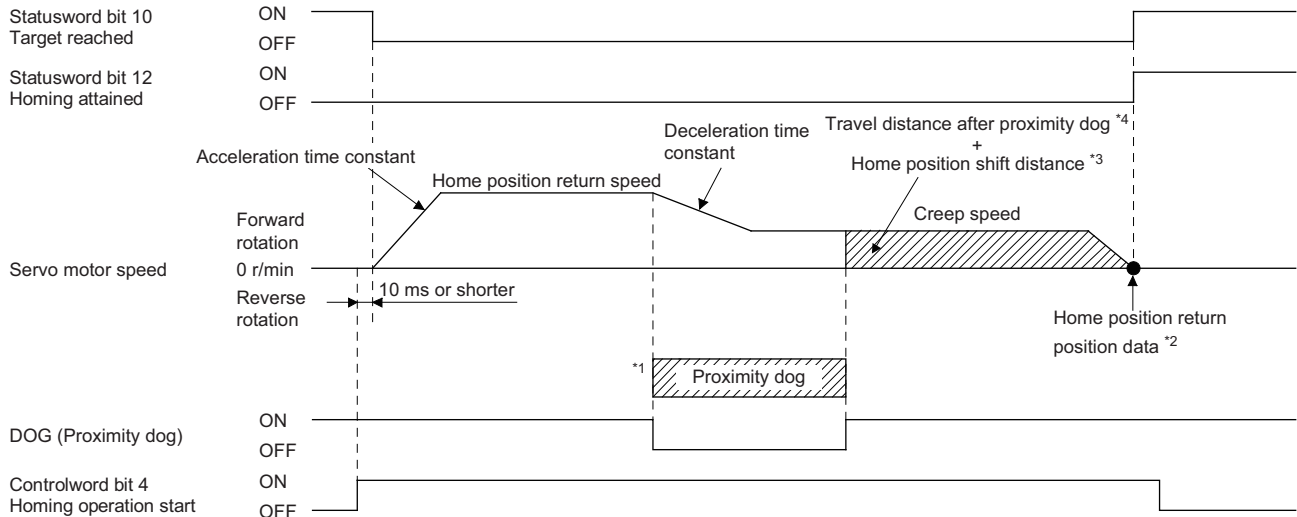

*1 After the front end of the proximity dog is detected, if the rear end of the proximity dog is detected without reaching the creep speed, [AL. 90] occurs. Check the length of the proximity dog or check the home position return speed and creep speed.

*2 Home position return position data can be changed with [Pr. PT08] and [Pr. PT47]. Home position return position data is the current position at the time of home position return completion. (I/O mode only)

*3 Home position shift distance can be changed with [Pr. PT07] and [Pr. PT69].

*4 Travel distance after proximity dog can be changed with [Pr. PT09] and [Pr. PT71].

• When a home position return is started from the proximity dog

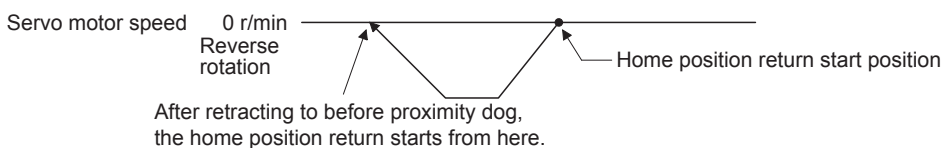

• When the movement is returned at the stroke end

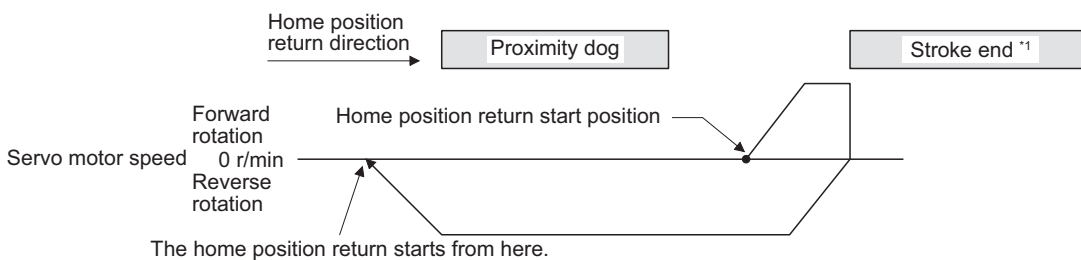

*1 This is not available with the software limit.

Method -7 and -39 (count type front end reference home position return)

Point

This home position return type depends on the timing of reading DOG (Proximity dog) that has detected the front end of the proximity dog. Therefore, when the creep speed is set to 100 r/min and a home position return is performed, the home position has an error calculated by the following expression.

$$\pm (\text{Encoder resolution}) \times 100/65536 [\text{pulse}]$$

The faster home position return speed sets a larger error in the home position.

The following figure shows the operation of Homing method -7. The operation direction of Homing method -39 is opposite to that of Homing method -7.

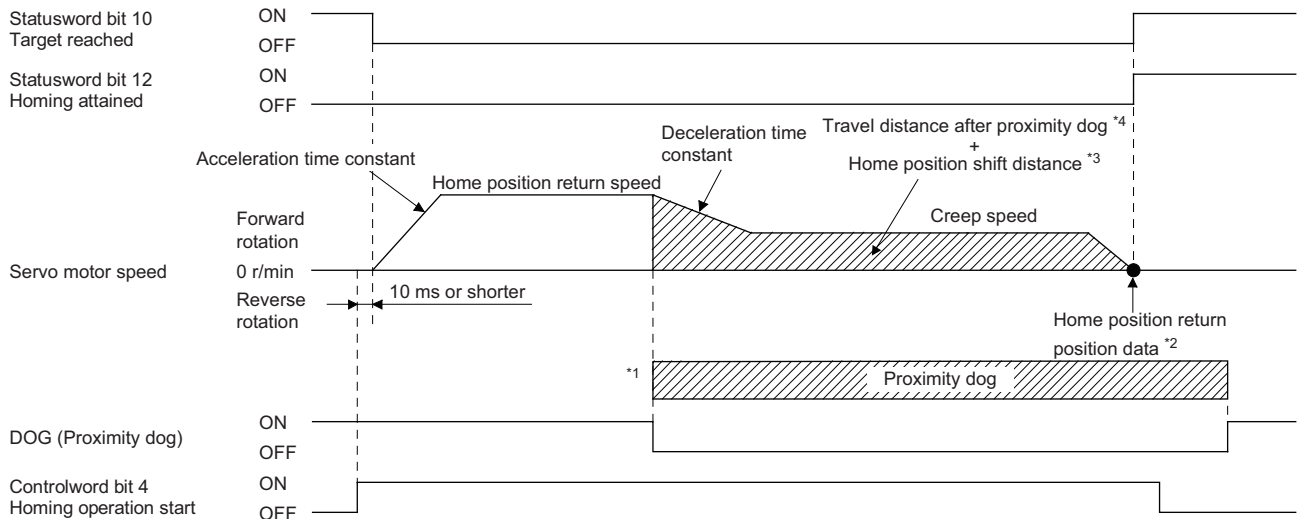

*1 After the front end of the proximity dog is detected, if the distance after proximity dog is traveled without reaching the creep speed, [AL. 90] occurs. Set the travel distance after proximity dog and the home position shift distance large enough for deceleration from the home position return speed to the creep speed.

*2 Home position return position data can be changed with [Pr. PT08] and [Pr. PT47]. Home position return position data is the current position at the time of home position return completion. (I/O mode only)

*3 Home position shift distance can be changed with [Pr. PT07] and [Pr. PT69].

*4 Travel distance after proximity dog can be changed with [Pr. PT09] and [Pr. PT71].

- When a home position return is started from the proximity dog

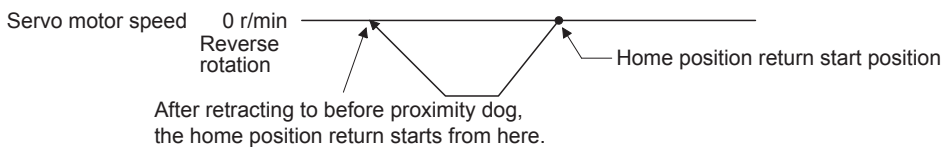

- When the movement is returned at the stroke end

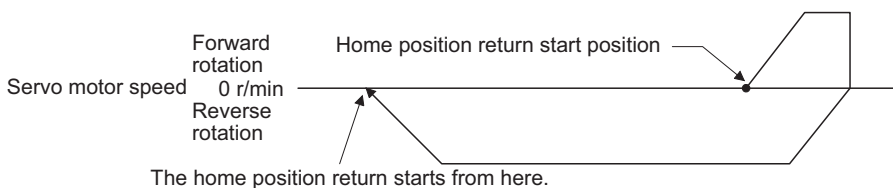

*1 This is not available with the software limit.

Method -8 and -40 (dog cradle type home position return)

The following figure shows the operation of Homing method -8. The operation direction of Homing method -40 is opposite to that of Homing method -8.

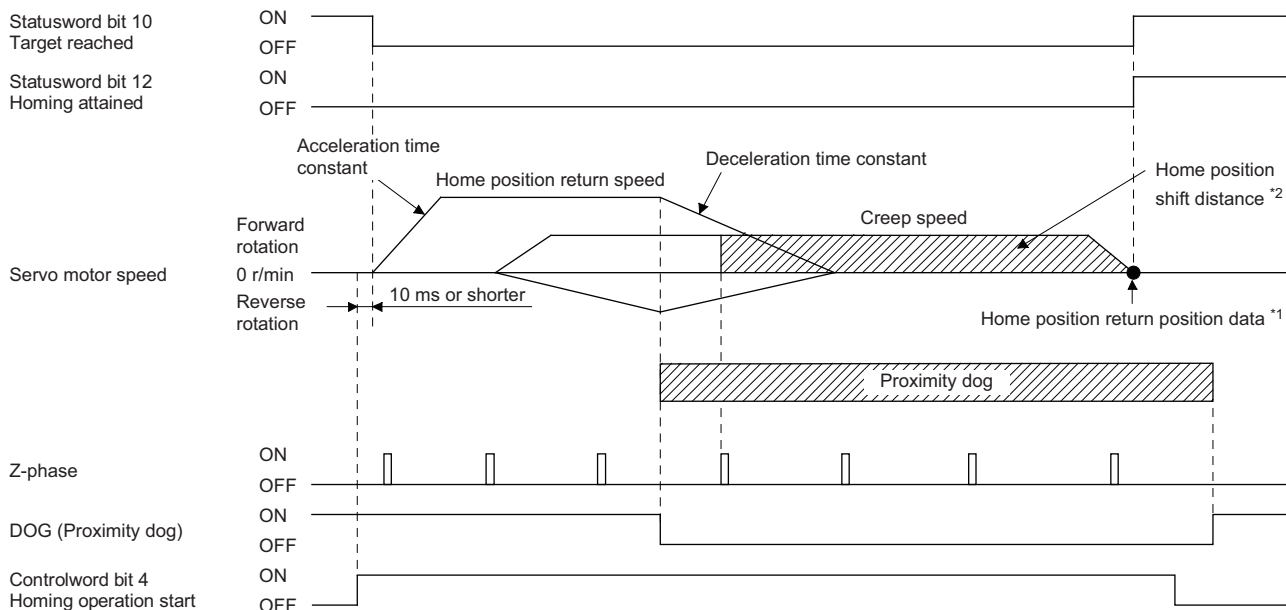

*1 Home position return position data can be changed with [Pr. PT08] and [Pr. PT47]. Home position return position data is the current position at the time of home position return completion. (I/O mode only)

*2 Home position shift distance can be changed with [Pr. PT07] and [Pr. PT69].

- When a home position return is started from the proximity dog

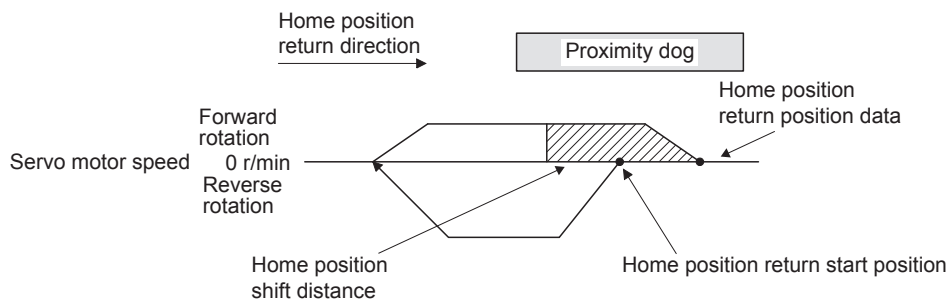

- When the movement is returned at the stroke end

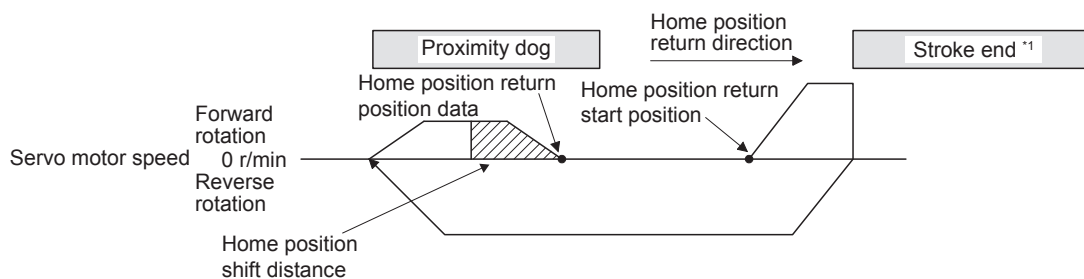

*1 This is not available with the software limit.

Method -9 and -41 (dog type last Z-phase reference home position return)

The following figure shows the operation of Homing method -9. The operation direction of Homing method -41 is opposite to that of Homing method -9.

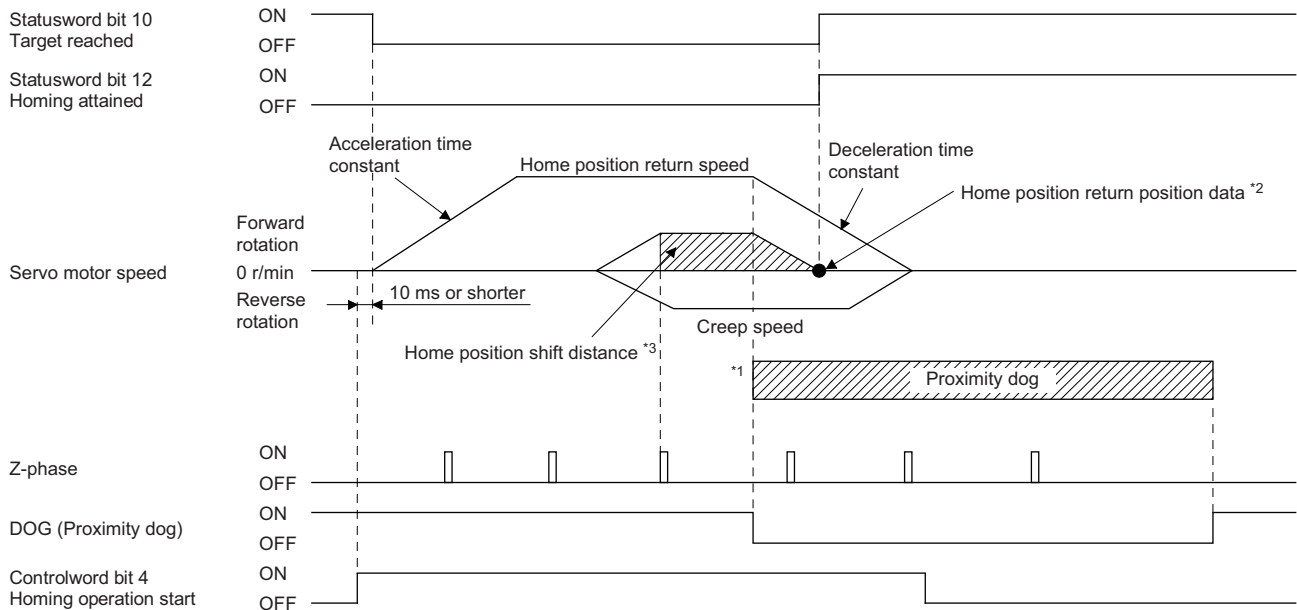

*1 After the front end of the proximity dog is detected, if the rear end of the proximity dog is detected without stop, [AL. 90] occurs. Check the length of the proximity dog or check the home position return speed and creep speed.

*2 Home position return position data can be changed with [Pr. PT08] and [Pr. PT47]. Home position return position data is the current position at the time of home position return completion. (I/O mode only)

*3 Home position shift distance can be changed with [Pr. PT07] and [Pr. PT69].

- When a home position return is started from the proximity dog

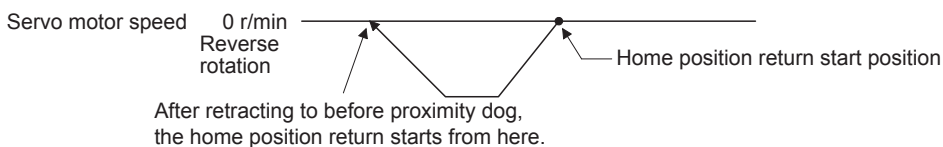

- When the movement is returned at the stroke end

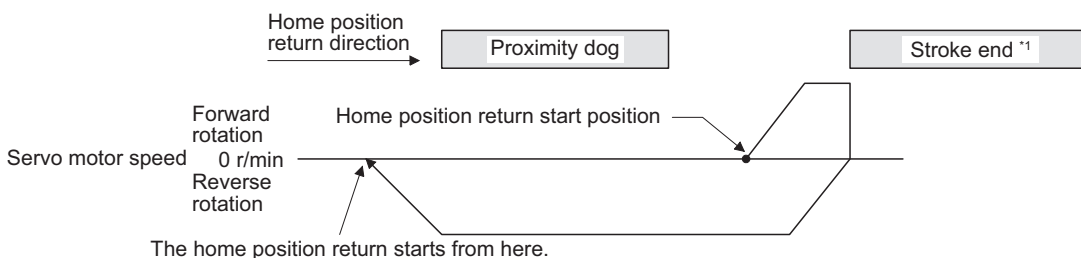

*1 This is not available with the software limit.

Method -10 and -42 (dog type front end reference home position return)

The following figure shows the operation of Homing method -10. The operation direction of Homing method -42 is opposite to that of Homing method -10.

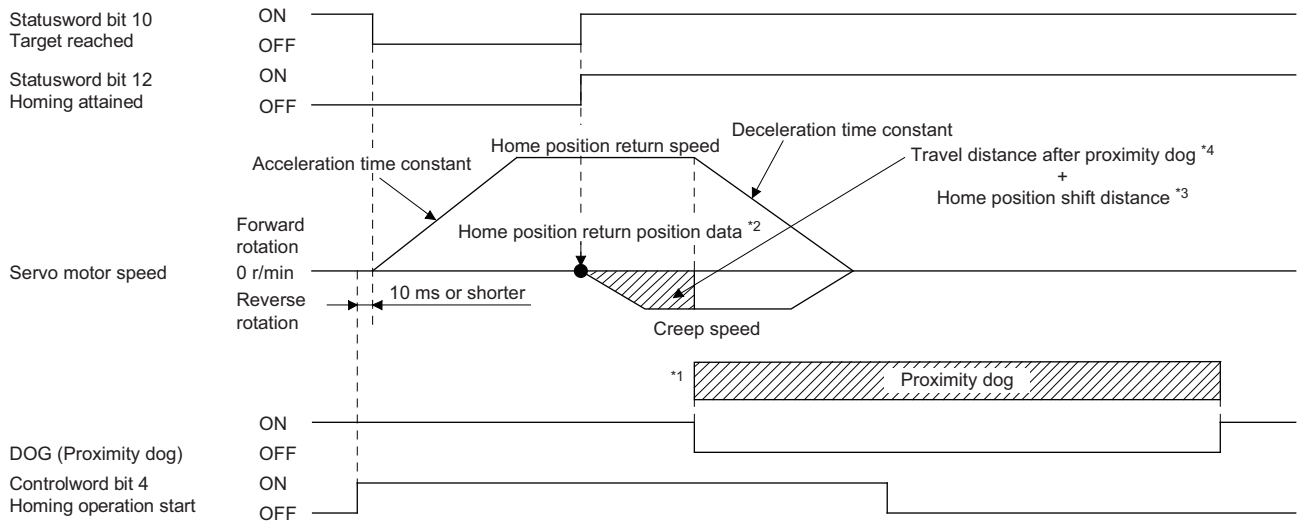

- *1 After the front end of the proximity dog is detected, if the rear end of the proximity dog is detected without reaching the creep speed, [AL. 90] occurs. Check the length of the proximity dog or check the home position return speed and creep speed.
- *2 Home position return position data can be changed with [Pr. PT08] and [Pr. PT47]. Home position return position data is the current position at the time of home position return completion. (I/O mode only)
- *3 Home position shift distance can be changed with [Pr. PT07] and [Pr. PT69].
- *4 Travel distance after proximity dog can be changed with [Pr. PT09] and [Pr. PT71].
- When a home position return is started from the proximity dog

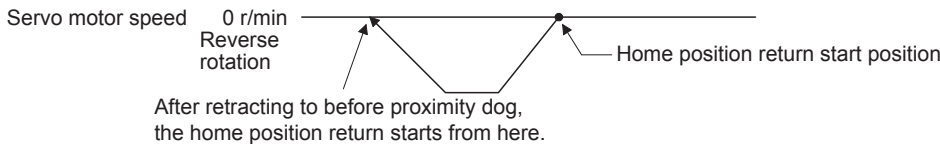

- When the movement is returned at the stroke end

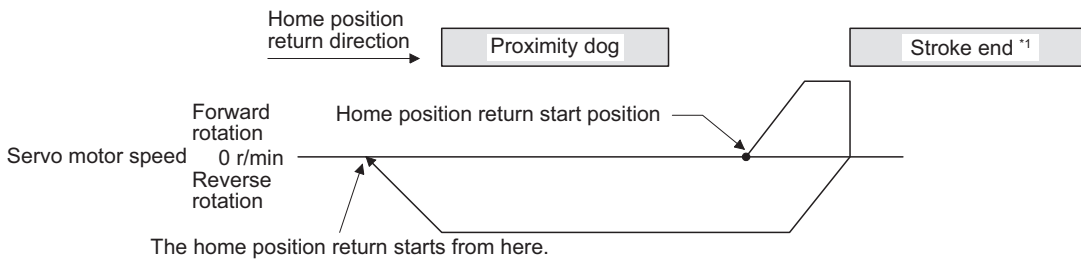

- *1 This is not available with the software limit.

Method -11 and -43 (dogless Z-phase reference home position return)

The following figure shows the operation of Homing method -11. The operation direction of Homing method -43 is opposite to that of Homing method -11.

Point

When home position return is performed from near the Z-phase, the home position return completion position varies. The recommended start position for home position return can be found by rotating the servo motor about a half-turn away from the home position return direction.

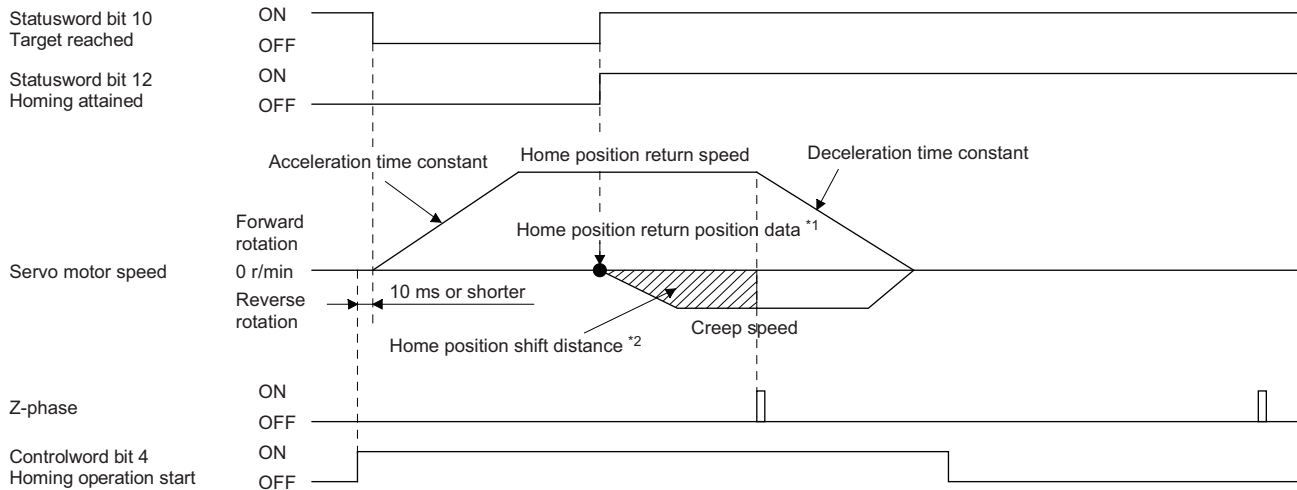

*1 Home position return position data can be changed with [Pr. PT08] and [Pr. PT47]. Home position return position data is the current position at the time of home position return completion. (I/O mode only)

*2 Home position shift distance can be changed with [Pr. PT07] and [Pr. PT69].

- When the stroke end is detected

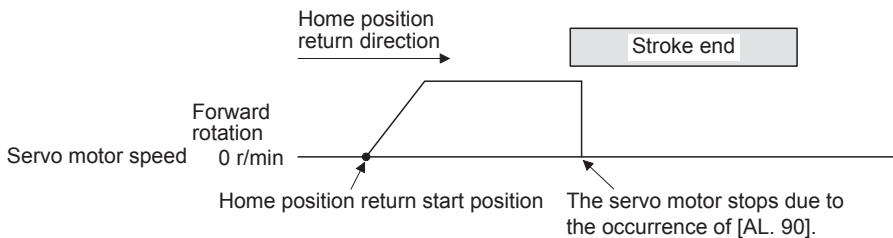

5 PARAMETERS

CAUTION

- Never make a drastic adjustment or change to the parameter values as doing so will make the operation unstable.
 - Do not change the parameter settings as described below. Doing so may cause an unexpected condition, such as failing to start up the servo amplifier.
 - Changing the values of the parameters for manufacturer setting
 - Setting a value out of the range
 - Changing the fixed values in the digits of a parameter
 - When you write parameters with the controller, make sure that the station No. of the servo amplifier is set correctly. Otherwise, the parameter settings of another station may be written, possibly causing the servo amplifier to be an unexpected condition.
-

5.1 Parameter list

Point

The parameter whose symbol is preceded by * is enabled with the following conditions:

- *: After setting the parameter, cycle the power or reset the controller.
- **: After setting the parameter, cycle the power.

Abbreviations of operation modes indicate the following. Operation modes other than the standard mode is used with servo amplifiers with software version A1 or later.

- Standard: use of rotary servo motors in semi closed loop system
 - Full.: use of rotary servo motors in fully closed loop system
 - Lin.: use of linear servo motors
 - DD: use of direct drive motors
-

Basic setting parameters ([Pr. PA_ _])

No.	Symbol	Name	Initial value	Unit	Operation mode			
					Standard	Full.	Lin.	DD
PA01	**STY	Operation mode	1000h	—	○	○	○	○
PA02	**REG	Regenerative option	0000h	—	○	○	○	○
PA03	*ABS	Absolute position detection system	0000h	—	○	○	○	○
PA04	*AOP1	Function selection A-1	2000h	—	○	○	○	○
PA05	—	For manufacturer setting	10000	—	—	—	—	—
PA06			1					
PA07			1					
PA08	ATU	Auto tuning mode	0001h	—	○	○	○	○
PA09	RSP	Auto tuning response	16	—	○	○	○	○
PA10	INP	In-position range	1600	[pulse]	○	○	○	○
PA11	TLP	Forward rotation torque limit/positive direction thrust limit	1000.0	[%]	○	○	○	○
PA12	TLN	Reverse rotation torque limit/negative direction thrust limit	1000.0	[%]	○	○	○	○
PA13	—	For manufacturer setting	0000h	—	—	—	—	—
PA14	*POL	Rotation direction selection/travel direction selection	0	—	○	○	○	○
PA15	*ENR	Encoder output pulses	4000	[pulse/rev]	○	○	○	○
PA16	*ENR2	Encoder output pulses 2	1	—	○	○	○	○
PA17	**MSR	Servo motor series setting	0000h	—	—	—	○	—
PA18	**MTY	Servo motor type setting	0000h	—	—	—	○	—
PA19	*BLK	Parameter writing inhibit	00ABh	—	○	○	○	○
PA20	*TDS	Tough drive setting	0000h	—	○	○	○	○
PA21	*AOP3	Function selection A-3	0001h	—	○	○	○	○
PA22	**PCS	Position control composition selection	0000h	—	○	○	○	○
PA23	DRAT	Drive recorder arbitrary alarm trigger setting	0000h	—	○	○	○	○
PA24	AOP4	Function selection A-4	0000h	—	○	○	○	○
PA25	OTHOV	One-touch tuning - Overshoot permissible level	0	[%]	○	○	○	○
PA26	*AOP5	Function selection A-5	0000h	—	○	○	○	○
PA27	—	For manufacturer setting	0000h	—	—	—	—	—
PA28			0000h					
PA29			0000h					
PA30			0000h					
PA31			0000h					
PA32			0000h					

Gain/filter setting parameters ([Pr. PB_ _])

No.	Symbol	Name	Initial value	Unit	Operation mode			
					Standard	Full.	Lin.	DD
PB01	FILT	Adaptive tuning mode (adaptive filter II)	0000h	—	<input type="radio"/>	<input type="radio"/>	<input type="radio"/>	<input type="radio"/>
PB02	VRFT	Vibration suppression control tuning mode (advanced vibration suppression control II)	0000h	—	<input type="radio"/>	<input type="radio"/>	<input type="radio"/>	<input type="radio"/>
PB03	—	For manufacturer setting	18000	—	—	—	—	—
PB04	FFC	Feed forward gain	0	[%]	<input type="radio"/>	<input type="radio"/>	<input type="radio"/>	<input type="radio"/>
PB05	—	For manufacturer setting	500	—	—	—	—	—
PB06	GD2	Load to motor inertia ratio/load to motor mass ratio	7.00	[Multiplier]	<input type="radio"/>	<input type="radio"/>	<input type="radio"/>	<input type="radio"/>
PB07	PG1	Model loop gain	15.0	[rad/s]	<input type="radio"/>	<input type="radio"/>	<input type="radio"/>	<input type="radio"/>
PB08	PG2	Position loop gain	37.0	[rad/s]	<input type="radio"/>	<input type="radio"/>	<input type="radio"/>	<input type="radio"/>
PB09	VG2	Speed loop gain	823	[rad/s]	<input type="radio"/>	<input type="radio"/>	<input type="radio"/>	<input type="radio"/>
PB10	VIC	Speed integral compensation	33.7	[ms]	<input type="radio"/>	<input type="radio"/>	<input type="radio"/>	<input type="radio"/>
PB11	VDC	Speed differential compensation	980	—	<input type="radio"/>	<input type="radio"/>	<input type="radio"/>	<input type="radio"/>
PB12	OVA	Overshoot amount compensation	0	[%]	<input type="radio"/>	<input type="radio"/>	<input type="radio"/>	<input type="radio"/>
PB13	NH1	Machine resonance suppression filter 1	4500	[Hz]	<input type="radio"/>	<input type="radio"/>	<input type="radio"/>	<input type="radio"/>
PB14	NHQ1	Notch shape selection 1	0000h	—	<input type="radio"/>	<input type="radio"/>	<input type="radio"/>	<input type="radio"/>
PB15	NH2	Machine resonance suppression filter 2	4500	[Hz]	<input type="radio"/>	<input type="radio"/>	<input type="radio"/>	<input type="radio"/>
PB16	NHQ2	Notch shape selection 2	0000h	—	<input type="radio"/>	<input type="radio"/>	<input type="radio"/>	<input type="radio"/>
PB17	NHF	Shaft resonance suppression filter	0000h	—	<input type="radio"/>	<input type="radio"/>	<input type="radio"/>	<input type="radio"/>
PB18	LPF	Low-pass filter setting	3141	[rad/s]	<input type="radio"/>	<input type="radio"/>	<input type="radio"/>	<input type="radio"/>
PB19	VRF11	Vibration suppression control 1 - Vibration frequency	100.0	[Hz]	<input type="radio"/>	<input type="radio"/>	<input type="radio"/>	<input type="radio"/>
PB20	VRF12	Vibration suppression control 1 - Resonance frequency	100.0	[Hz]	<input type="radio"/>	<input type="radio"/>	<input type="radio"/>	<input type="radio"/>
PB21	VRF13	Vibration suppression control 1 - Vibration frequency damping	0.00	—	<input type="radio"/>	<input type="radio"/>	<input type="radio"/>	<input type="radio"/>
PB22	VRF14	Vibration suppression control 1 - Resonance frequency damping	0.00	—	<input type="radio"/>	<input type="radio"/>	<input type="radio"/>	<input type="radio"/>
PB23	VFBF	Low-pass filter selection	0000h	—	<input type="radio"/>	<input type="radio"/>	<input type="radio"/>	<input type="radio"/>
PB24	*MVS	Slight vibration suppression control	0000h	—	<input type="radio"/>	<input type="radio"/>	<input type="radio"/>	<input type="radio"/>
PB25	*BOP1	Function selection B-1	0000h	—	<input type="radio"/>	<input type="radio"/>	<input type="radio"/>	<input type="radio"/>
PB26	*CDP	Gain switching function	0000h	—	<input type="radio"/>	<input type="radio"/>	<input type="radio"/>	<input type="radio"/>
PB27	CDL	Gain switching condition	10	[kpulse/s]/ [pulse]/[r/min]	<input type="radio"/>	<input type="radio"/>	<input type="radio"/>	<input type="radio"/>
PB28	CDT	Gain switching time constant	1	[ms]	<input type="radio"/>	<input type="radio"/>	<input type="radio"/>	<input type="radio"/>
PB29	GD2B	Load to motor inertia ratio/load to motor mass ratio after gain switching	7.00	[Multiplier]	<input type="radio"/>	<input type="radio"/>	<input type="radio"/>	<input type="radio"/>
PB30	PG2B	Position loop gain after gain switching	0.0	[rad/s]	<input type="radio"/>	<input type="radio"/>	<input type="radio"/>	<input type="radio"/>
PB31	VG2B	Speed loop gain after gain switching	0	[rad/s]	<input type="radio"/>	<input type="radio"/>	<input type="radio"/>	<input type="radio"/>
PB32	VICB	Speed integral compensation after gain switching	0.0	[ms]	<input type="radio"/>	<input type="radio"/>	<input type="radio"/>	<input type="radio"/>
PB33	VRF11B	Vibration suppression control 1 - Vibration frequency after gain switching	0.0	[Hz]	<input type="radio"/>	<input type="radio"/>	<input type="radio"/>	<input type="radio"/>
PB34	VRF12B	Vibration suppression control 1 - Resonance frequency after gain switching	0.0	[Hz]	<input type="radio"/>	<input type="radio"/>	<input type="radio"/>	<input type="radio"/>
PB35	VRF13B	Vibration suppression control 1 - Vibration frequency damping after gain switching	0.00	—	<input type="radio"/>	<input type="radio"/>	<input type="radio"/>	<input type="radio"/>
PB36	VRF14B	Vibration suppression control 1 - Resonance frequency damping after gain switching	0.00	—	<input type="radio"/>	<input type="radio"/>	<input type="radio"/>	<input type="radio"/>

No.	Symbol	Name	Initial value	Unit	Operation mode			
					Standard	Full.	Lin.	DD
PB37	—	For manufacturer setting	1600	—	—	—	—	—
PB38			0.00					
PB39			0.00					
PB40			0.00					
PB41			0000h					
PB42			0000h					
PB43			0000h					
PB44			0.00					
PB45	CNHF	Command notch filter	0000h	—	○	○	○	○
PB46	NH3	Machine resonance suppression filter 3	4500	[Hz]	○	○	○	○
PB47	NHQ3	Notch shape selection 3	0000h	—	○	○	○	○
PB48	NH4	Machine resonance suppression filter 4	4500	[Hz]	○	○	○	○
PB49	NHQ4	Notch shape selection 4	0000h	—	○	○	○	○
PB50	NH5	Machine resonance suppression filter 5	4500	[Hz]	○	○	○	○
PB51	NHQ5	Notch shape selection 5	0000h	—	○	○	○	○
PB52	VRF21	Vibration suppression control 2 - Vibration frequency	100.0	[Hz]	○	○	○	○
PB53	VRF22	Vibration suppression control 2 - Resonance frequency	100.0	[Hz]	○	○	○	○
PB54	VRF23	Vibration suppression control 2 - Vibration frequency damping	0.00	—	○	○	○	○
PB55	VRF24	Vibration suppression control 2 - Resonance frequency damping	0.00	—	○	○	○	○
PB56	VRF21B	Vibration suppression control 2 - Vibration frequency after gain switching	0.0	[Hz]	○	○	○	○
PB57	VRF22B	Vibration suppression control 2 - Resonance frequency after gain switching	0.0	[Hz]	○	○	○	○
PB58	VRF23B	Vibration suppression control 2 - Vibration frequency damping after gain switching	0.00	—	○	○	○	○
PB59	VRF24B	Vibration suppression control 2 - Resonance frequency damping after gain switching	0.00	—	○	○	○	○
PB60	PG1B	Model loop gain after gain switching	0.0	[rad/s]	○	○	○	○
PB61	—	For manufacturer setting	0.0	—	—	—	—	—
PB62			0000h					
PB63			0000h					
PB64			0000h					

Extension setting parameters ([Pr. PC_ _])

No.	Symbol	Name	Initial value	Unit	Operation mode			
					Standard	Full.	Lin.	DD
PC01	ERZ	Error excessive alarm level	0	[rev]/[mm]	○	○	○	○
PC02	MBR	Electromagnetic brake sequence output	0	[ms]	○	○	○	○
PC03	*ENRS	Encoder output pulse selection	0000h	—	○	○	○	○
PC04	**COP1	Function selection C-1	0000h	—	○	○	○	○
PC05	**COP2	Function selection C-2	0000h	—	○	—	—	—
PC06	*COP3	Function selection C-3	0000h	—	○	○	○	○
PC07	ZSP	Zero speed	50	[r/min]/[mm/s]	○	○	○	○
PC08	OSL	Overspeed alarm detection level	0	[r/min]/[mm/s]	○	○	○	○
PC09	MOD1	Analog monitor 1 output	0000h	—	○	○	○	○
PC10	MOD2	Analog monitor 2 output	0001h	—	○	○	○	○
PC11	MO1	Analog monitor 1 offset	0	[mV]	○	○	○	○
PC12	MO2	Analog monitor 2 offset	0	[mV]	○	○	○	○
PC13	—	For manufacturer setting	0	—	—	—	—	—
PC14	0							
PC15	0							
PC16	0000h							
PC17	**COP4	Function selection C-4	0000h	—	—	—	○	—
PC18	*COP5	Function selection C-5	0010h	—	○	○	○	○
PC19	*COP6	Function selection C-6	0000h	—	○	○	○	○
PC20	*COP7	Function selection C-7	0000h	—	○	○	○	○
PC21	*BPS	Alarm history clear	0000h	—	○	○	○	○
PC22	—	For manufacturer setting	0	—	—	—	—	—
PC23	0000h							
PC24	RSBR	Forced stop deceleration time constant	100	[ms]	○	○	○	○
PC25	—	For manufacturer setting	0	—	—	—	—	—
PC26	**COP8	Function selection C-8	0000h	—	○ ^{*1}	○	○	○
PC27	**COP9	Function selection C-9	0000h	—	○ ^{*1}	○	○	—
PC28	—	For manufacturer setting	0000h	—	—	—	—	—
PC29	*COPB	Function selection C-B	1000h	—	○	○	○	○
PC30	—	For manufacturer setting	0	—	—	—	—	—
PC31	RSUP1	Vertical axis freefall prevention compensation amount	0	[0.0001 rev]/ [0.01 mm]	○	○	○	○
PC32	—	For manufacturer setting	0000h	—	—	—	—	—
PC33	0							
PC34	100							
PC35	0000h							
PC36	0000h							
PC37	0000h							
PC38	ERW	Error excessive warning level	0	[rev]/[mm]	○	○	○	○

No.	Symbol	Name	Initial value	Unit	Operation mode			
					Standard	Full.	Lin.	DD
PC39	—	For manufacturer setting	0000h	—	—	—	—	—
PC40								
PC41								
PC42								
PC43								
PC44								
PC45								
PC46								
PC47								
PC48								
PC49								
PC50								
PC51								
PC52								
PC53								
PC54								
PC55								
PC56								
PC57								
PC58								
PC59								
PC60								
PC61								
PC62								
PC63								
PC64								
PC65								
PC66								
PC67	FEWL	Following error output level	0000h	[pulse]	○	○	○	○
PC68	FEWH		00C0h					
PC69	FEWF	Following error output filtering time	10	[ms]	○	○	○	○
PC70	—	For manufacturer setting	100	—	—	—	—	—
PC71								
PC72								
PC73								
PC74								
PC75								
PC76	*COPE		Function selection C-E					
PC77	—	For manufacturer setting	0.0	—	—	—	—	—
PC78								
PC79								
PC80								

*1 It is available when the scale measurement function is enabled ([Pr. PA22] is "1 ___" or "2 ___").

I/O setting parameters ([Pr. PD_ _])

No.	Symbol	Name	Initial value	Unit	Operation mode			
					Standard	Full.	Lin.	DD
PD01	*DIA1	Input signal automatic on selection 1	0000h	—	○	○	○	○
PD02	—	For manufacturer setting	0000h	—	—	—	—	—
PD03	*DI1	Input device selection 1	000Ah	—	○	○	○	○
PD04	*DI2	Input device selection 2	000Bh	—	○	○	○	○
PD05	*DI3	Input device selection 3	0022h	—	○	○	○	○
PD06	—	For manufacturer setting	0000h	—	—	—	—	—
PD07	*DO1	Output device selection 1	0005h	—	○	○	○	○
PD08	*DO2	Output device selection 2	0004h	—	○	○	○	○
PD09	*DO3	Output device selection 3	0003h	—	○	○	○	○
PD10	—	For manufacturer setting	0000h	—	—	—	—	—
PD11	*DIF	Input filter setting	0004h	—	○	○	○	○
PD12	*DOP1	Function selection D-1	0101h	—	○	○	○	○
PD13	*DOP2	Function selection D-2	0000h	—	○	○	○	○
PD14	*DOP3	Function selection D-3	0000h	—	○	○	○	○
PD15	—	For manufacturer setting	0000h	—	—	—	—	—
PD16			0000h					
PD17			0000h					
PD18			0000h					
PD19			0000h					
PD20			0					
PD21			0					
PD22			0					
PD23			0					
PD24			0000h					
PD25			0000h					
PD26			0000h					
PD27	0000h							
PD28	0000h							
PD29	0000h							
PD30	0							
PD31	0							
PD32	0							
PD33	0000h							
PD34	0000h							
PD35	0000h							
PD36	0000h							
PD37	*TPOP	Touch probe function selection	0000h	—	○	○	○	○
PD38	—	For manufacturer setting	002Ch	—	—	—	—	—
PD39			002Dh					
PD40			0					
PD41	*DOP4	Function selection D-4	0000h	—	○	○	○	○
PD42	—	For manufacturer setting	0000h	—	—	—	—	—
PD43			0000h					
PD44			0000h					
PD45			0000h					
PD46			0000h					
PD47			0000h					
PD48			0000h					

Extension setting 2 parameters ([Pr. PE_ _])

No.	Symbol	Name	Initial value	Unit	Operation mode			
					Standard	Full.	Lin.	DD
PE01	**FCT1	Fully closed loop function selection 1	0000h	—	—	○	—	—
PE02	—	For manufacturer setting	0000h	—	—	—	—	—
PE03	*FCT2	Fully closed loop function selection 2	0003h	—	—	○	—	—
PE04	**FBN	Fully closed loop control - Feedback pulse electronic gear 1 - Numerator	1	—	—	○	—	—
PE05	**FBD	Fully closed loop control - Feedback pulse electronic gear 1 - Denominator	1	—	—	○	—	—
PE06	BC1	Fully closed loop control - Speed deviation error detection level	400	[r/min]	—	○	—	—
PE07	BC2	Fully closed loop control - Position deviation error detection level	100	[kpulse]	—	○	—	—
PE08	DUF	Fully closed loop dual feedback filter	10	[rad/s]	—	○	—	—
PE09	—	For manufacturer setting	0000h	—	—	—	—	—
PE10	FCT3	Fully closed loop function selection 3	0000h	—	—	○	—	—
PE11	—	For manufacturer setting	0000h	—	—	—	—	—
PE12			0000h					
PE13			0000h					
PE14			0111h					
PE15			20					
PE16			0000h					
PE17			0000h					
PE18			0000h					
PE19			0000h					
PE20			0000h					
PE21			0000h					
PE22			0000h					
PE23			0000h					
PE24			0000h					
PE25	0000h							
PE26	0000h							
PE27	0000h							
PE28	0000h							
PE29	0000h							
PE30	0000h							
PE31	0000h							
PE32	0000h							
PE33	0000h							
PE34	**FBN2	Fully closed loop control - Feedback pulse electronic gear 2 - Numerator	1	—	—	○	—	—
PE35	**FBD2	Fully closed loop control - Feedback pulse electronic gear 2 - Denominator	1	—	—	○	—	—
PE36	—	For manufacturer setting	0.0	—	—	—	—	—
PE37			0.00					
PE38			0.00					
PE39			20					
PE40			0000h					
PE41	EOP3	Function selection E-3	0000h	—	○	○	○	○
PE42	—	For manufacturer setting	0	—	—	—	—	—
PE43			0.0					
PE44	LMCP	Lost motion compensation positive-side compensation value selection	0	[0.01%]	○	○	○	○

No.	Symbol	Name	Initial value	Unit	Operation mode			
					Standard	Full.	Lin.	DD
PE45	LMCN	Lost motion compensation negative-side compensation value selection	0	[0.01%]	○	○	○	○
PE46	LMFLT	Lost motion filter setting	0	[0.1 ms]	○	○	○	○
PE47	TOF	Torque offset	0	[0.01%]	○	○	—	—
PE48	*LMOP	Lost motion compensation function selection	0000h	—	○	○	○	○
PE49	LMCD	Lost motion compensation timing	0	[0.1 ms]	○	○	○	○
PE50	LMCT	Lost motion compensation non-sensitive band	0	[pulse]/[kpulse]	○	○	○	○
PE51	—	For manufacturer setting	0000h	—	—	—	—	—
PE52			0000h					
PE53			0000h					
PE54			0000h					
PE55			0000h					
PE56			0000h					
PE57			0000h					
PE58			0000h					
PE59			0000h					
PE60			0000h					
PE61			0.00					
PE62			0.00					
PE63			0.00					
PE64			0.00					

Extension setting 3 parameters ([Pr. PF_ _])

No.	Symbol	Name	Initial value	Unit	Operation mode			
					Standard	Full.	Lin.	DD
PF01	—	For manufacturer setting	0000h	—	—	—	—	—
PF02			0000h					
PF03			0000h					
PF04			0					
PF05			0000h					
PF06	*FOP5	Function selection F-5	0000h	—	○	○	—	—
PF07	—	For manufacturer setting	0000h	—	—	—	—	—
PF08			0000h					
PF09			0					
PF10			0					
PF11			0					
PF12	DBT	Electronic dynamic brake operating time	2000	[ms]	○	○	—	—
PF13	—	For manufacturer setting	0000h	—	—	—	—	—
PF14			10					
PF15			0000h					
PF16			0000h					
PF17			0000h					
PF18	**STOD	STO diagnosis error detection time	10	[s]	○	○	○	○
PF19	TSL	Friction failure prediction - Compensation coefficient 1	0	[0.001%/°C]	○	○	○	○
PF20	TIC	Friction failure prediction - Compensation coefficient 2	0	[0.1%]	○	○	○	○
PF21	DRT	Drive recorder switching time setting	0	[s]	○	○	○	○
PF22	—	For manufacturer setting	200	—	—	—	—	—
PF23	OSCL1	Vibration tough drive - Oscillation detection level	50	[%]	○	○	○	○
PF24	*OSCL2	Vibration tough drive function selection	0000h	—	○	○	○	○
PF25	CVAT	SEMI-F47 function - Instantaneous power failure detection time	200	[ms]	○	○	○	○

No.	Symbol	Name	Initial value	Unit	Operation mode			
					Standard	Full.	Lin.	DD
PF26	—	For manufacturer setting	0	—	—	—	—	—
PF27			0					
PF28			0					
PF29			0000h					
PF30			0					
PF31	FRIC	Machine diagnosis function - Friction judgment speed	0	[r/min]/[mm/s]	○	○	○	○
PF32	—	For manufacturer setting	50	—	—	—	—	—
PF33			0000h					
PF34	*MFP	Machine diagnosis function selection	0000h	—	○	○	○	○
PF35	—	For manufacturer setting	0000h	—	—	—	—	—
PF36			0000h					
PF37			0000h					
PF38			0000h					
PF39			0000h					
PF40	MFPP	Machine failure prediction parameter	0000h	—	○	○	○	○
PF41	FPMT	Failure prediction - Servo motor total travel distance	0	[rev]/[m]	○	○	○	○
PF42	PAV	Friction failure prediction - Average characteristic	0	[0.1%]	○	○	○	○
PF43	PSD	Friction failure prediction - Standard deviation	0	[0.1%]	○	○	○	○
PF44	—	For manufacturer setting	0	—	—	—	—	—
PF45	VAV	Vibration failure prediction - Average characteristic	0	[0.1%]	○	○	○	○
PF46	VSD	Vibration failure prediction - Standard deviation	0	[0.1%]	○	○	○	○
PF47	—	For manufacturer setting	0000h	—	—	—	—	—
PF48			0000h					
PF49			100					
PF50			100					
PF51			0000h					
PF52			0000h					
PF53			0					
PF54			0					
PF55			0					
PF56			0					
PF57			0000h					
PF58			0000h					
PF59			0000h					
PF60			0000h					
PF61			0000h					
PF62			0000h					
PF63			0000h					
PF64		0000h						

Linear servo motor/DD motor setting parameters ([Pr. PL_ _])

No.	Symbol	Name	Initial value	Unit	Operation mode			
					Standard	Full.	Lin.	DD
PL01	**LIT1	Linear servo motor/DD motor function selection 1	0301h	—	—	—	○	○
PL02	**LIM	Linear encoder resolution - Numerator	1000	[μm]	—	—	○	—
PL03	**LID	Linear encoder resolution - Denominator	1000	[μm]	—	—	○	—
PL04	*LIT2	Linear servo motor/DD motor function selection 2	0003h	—	—	—	○	○
PL05	LB1	Position deviation error detection level	0	[mm]/[0.01 rev]	—	—	○	○
PL06	LB2	Speed deviation error detection level	0	[mm/s]/[r/min]	—	—	○	○
PL07	LB3	Torque/thrust deviation error detection level	100	[%]	—	—	○	○
PL08	*LIT3	Linear servo motor/DD motor function selection 3	0010h	—	—	—	○	○
PL09	LPWM	Magnetic pole detection voltage level	30	[%]	—	—	○	○
PL10	—	For manufacturer setting	5	—	—	—	—	—
PL11			100					
PL12			500					
PL13			0000h					
PL14			0000h					
PL15			20					
PL16			0					
PL17	LTSTS	Magnetic pole detection - Minute position detection method - Function selection	0000h	—	—	—	○	○
PL18	IDLV	Magnetic pole detection - Minute position detection method - Identification signal amplitude	0	[%]	—	—	○	○
PL19	—	For manufacturer setting	0	—	—	—	—	—
PL20			0					
PL21			0					
PL22			0					
PL23			0000h					
PL24			0					
PL25			0000h					
PL26			0000h					
PL27			0000h					
PL28			0000h					
PL29			0000h					
PL30			0000h					
PL31			0000h					
PL32			0000h					
PL33			0000h					
PL34			0000h					
PL35			0000h					
PL36			0000h					
PL37			0000h					
PL38			0000h					
PL39			0000h					
PL40			0000h					
PL41			0000h					
PL42			0000h					
PL43			0000h					
PL44			0000h					
PL45			0000h					
PL46			0000h					
PL47			0000h					
PL48			0000h					

Positioning control parameters ([Pr. PT_ _])

No.	Symbol	Name	Initial value	Unit	Operation mode			
					Standard	Full.	Lin.	DD
PT01	—	For manufacturer setting	0300h	—	—	—	—	—
PT02			0001h					
PT03			0000h					
PT04			0000h					
PT05	ZRF	Home position return speed	100.00	[r/min]/[mm/s]	○	○	○	○
PT06	CRF	Creep speed	10.00	[r/min]/[mm/s]	○	○	○	○
PT07	ZST	Home position shift distance	0	[pulse]	○	○	○	○
PT08	—	For manufacturer setting	0	—	—	—	—	—
PT09	DCT	Travel distance after proximity dog	0	[pulse]	○	○	○	○
PT10	ZTM	Stopper type home position return stopper time	100	[ms]	○	○	○	○
PT11	ZTT	Stopper type home position return torque limit value	15.0	[%]	○	○	○	○
PT12	—	For manufacturer setting	0	—	—	—	—	—
PT13			100					
PT14			0					
PT15	LMPL	Software limit +	0000h	[pulse]	○	○	○	○
PT16	LMPH		0000h					
PT17	LMNL	Software limit -	0000h	[pulse]	○	○	○	○
PT18	LMNH		0000h					
PT19	—	For manufacturer setting	0000h	—	—	—	—	—
PT20			0000h					
PT21			0000h					
PT22			0000h					
PT23			0					
PT24			0					
PT25			0					
PT26			0000h					
PT27			0000h					
PT28			8					
PT29	*TOP3	Function selection T-3	0000h	—	○	○	○	○
PT30	—	For manufacturer setting	0000h	—	—	—	—	—
PT31			0000h					
PT32			0000h					
PT33			0000h					
PT34			0000h					
PT35			0000h					
PT36			0000h					
PT37			10					
PT38			0000h					
PT39			100					
PT40			0					
PT41	ORP	Home position return inhibit function selection	0000h	—	○	○	○	○
PT42	—	For manufacturer setting	0	—	—	—	—	—
PT43			0					
PT44			0000h					
PT45	HMM	Home position return type	37	—	○	○	○	○

No.	Symbol	Name	Initial value	Unit	Operation mode			
					Standard	Full.	Lin.	DD
PT46	—	For manufacturer setting	0000h	—	—	—	—	—
PT47			0000h					
PT48			0000h					
PT49			0					
PT50			0					
PT51			0					
PT52			0					
PT53			0.0					
PT54			0					
PT55			*TOP8					
PT56	HMA	Home position return acceleration time constant	0	[ms]	○	○	○	○
PT57	HMB	Home position return deceleration time constant	0	[ms]	○	○	○	○
PT58	—	For manufacturer setting	100.00	—	—	—	—	—
PT59			500.00					
PT60			1000.00					
PT61			200.00					
PT62			0000h					
PT63			0000h					
PT64			0000h					
PT65			100.00					
PT66			20000.00					
PT67	VLMT	Speed limit	500.00	[r/min]/[mm/s]	○	○	○	○
PT68	—	For manufacturer setting	0102h	—	—	—	—	—
PT69	ZSTH	Home position shift distance (extension parameter)	0	[pulse]	○	○	○	○
PT70	—	For manufacturer setting	0000h	—	—	—	—	—
PT71	DCTH	Travel distance after proximity dog (extension parameter)	0	[pulse]	○	○	○	○
PT72	—	For manufacturer setting	0000h	—	—	—	—	—
PT73			0000h					
PT74			0000h					
PT75			0000h					
PT76			0000h					
PT77			0000h					
PT78			0000h					
PT79			0000h					
PT80			0000h					

Network setting parameters ([Pr. PN_ _])

No.	Symbol	Name	Initial value	Unit	Operation mode			
					Standard	Full.	Lin.	DD
PN01	—	For manufacturer setting	0	—	—	—	—	—
PN02	CERT	Communication error detection time	0	[ms]	○	○	○	○
PN03	**NWMD	Communication mode setting for CC-Link IE communication	0000h	—	○	○	○	○
PN04	**NWNO	CC-Link IE communication network number	0	—	○	○	○	○
PN05	CERI	Communication error detection frequency setting	0	[%]	○	○	○	○
PN06	NOP1	Function selection N-1	0000h	—	○	○	○	○
PN07	—	For manufacturer setting	0000h	—	—	—	—	—
PN08			0000h					
PN09			0000h					
PN10			0000h					
PN11			0000h					
PN12			0000h					
PN13			0000h					
PN14			0000h					
PN15			0000h					
PN16			0000h					
PN17			0000h					
PN18			0000h					
PN19			0000h					
PN20			0000h					
PN21			0000h					
PN22			0000h					
PN23			0000h					
PN24			0000h					
PN25			0000h					
PN26			0000h					
PN27			0000h					
PN28			0000h					
PN29			0000h					
PN30			0000h					
PN31			0000h					
PN32			0000h					

5.2 Detailed list of parameters



Set a value to each "x" in the "Setting digit" columns.

Basic setting parameters ([Pr. PA_ _])

No./symbol/ name	Setting digit	Function	Initial value [unit]						
PA01 **STY Operation mode	___x	Control mode selection Select a control mode. 0: Automatic selection 8: Positioning mode (indexer method) B: Speed control mode (point table method) When "0" is set, the control mode selected with [Pr. PN03] is set. <table border="1"> <thead> <tr> <th>[Pr. PN03]</th> <th>Control mode</th> </tr> </thead> <tbody> <tr> <td>___0 (motion mode)</td> <td>Cyclic synchronous mode (position/velocity/torque)</td> </tr> <tr> <td>___1 (I/O mode)</td> <td>Positioning mode (point table method)</td> </tr> </tbody> </table> When other than "0" is set, if [Pr. PN03] is set to "___0", [AL. 37] will occur. Refer to the following for details of the positioning mode. MR-J4-_GF_(-RJ) Servo Amplifier Instruction Manual (I/O Mode) This digit is available with servo amplifier with software version A3 or later. The setting value "B" is available with servo amplifiers with software version A6 or later.	[Pr. PN03]	Control mode	___0 (motion mode)	Cyclic synchronous mode (position/velocity/torque)	___1 (I/O mode)	Positioning mode (point table method)	0h
	[Pr. PN03]	Control mode							
	___0 (motion mode)	Cyclic synchronous mode (position/velocity/torque)							
	___1 (I/O mode)	Positioning mode (point table method)							
__x_	Operation mode selection 0: Standard control mode 1: Fully closed loop control mode 4: Linear servo motor control mode 6: DD motor control mode Setting other than above will trigger [AL. 37 Parameter error]. The setting of this digit is used by servo amplifier with software version A1 or later.	0h							
_x__	For manufacturer setting	0h							
x___		1h							

No./symbol/ name	Setting digit	Function	Initial value [unit]
PA02 **REG Regenerative option	__ x x	<p>Regenerative option Select a regenerative option. Incorrect setting may cause the regenerative option to burn. If a selected regenerative option is not for use with the servo amplifier, [AL. 37 Parameter error] occurs.</p> <p>00: Regenerative option is not used.</p> <ul style="list-style-type: none"> For the servo amplifiers of 100 W, a regenerative resistor is not used. For servo amplifier of 0.2 kW to 7 kW, built-in regenerative resistor is used. Supplied regenerative resistors or regenerative option is used with the servo amplifier of 11 kW to 22 kW. <p>01: FR-RC-(H)/FR-CV-(H)/FR-BU2-(H)/FR-XC-(H)</p> <ul style="list-style-type: none"> When FR-RC-(H), FR-CV-(H), or FR-XC-(H) is used, select "1" for "[AL. 10 Undervoltage] detection method selection" in [Pr. PC20]. <p>02: MR-RB032 03: MR-RB12 04: MR-RB32 05: MR-RB30 06: MR-RB50 (Cooling fan is required.) 08: MR-RB31 09: MR-RB51 (Cooling fan is required.) 0B: MR-RB3N 0C: MR-RB5N (Cooling fan is required.) 80: MR-RB1H-4 81: MR-RB3M-4 (Cooling fan is required.) 82: MR-RB3G-4 (Cooling fan is required.) 83: MR-RB5G-4 (Cooling fan is required.) 84: MR-RB34-4 (Cooling fan is required.) 85: MR-RB54-4 (Cooling fan is required.) 91: MR-RB3U-4 (Cooling fan is required.) 92: MR-RB5U-4 (Cooling fan is required.) FA: When the supplied regenerative resistors or the regenerative option is cooled by the cooling fan to increase the ability with the servo amplifier of 11 kW to 22 kW.</p>	00h
	_ x _ _	For manufacturer setting	0h
	x _ _ _		0h
PA03 *ABS Absolute position detection system	__ _ x	<p>Absolute position detection system selection Set this digit when using the absolute position detection system. 0: Disabled (incremental system) 1: Enabled (absolute position detection system)</p> <p>The absolute position detection system cannot be used when an incremental type linear encoder is used or the semi closed loop/fully closed loop switching is enabled. Enabling the absolute position detection system will trigger [AL. 37]. Restrictions apply when an absolute position detection system is configured.  Page 463 Restrictions</p>	0h
	_ _ x _	For manufacturer setting	0h
	_ x _ _		0h
	x _ _ _		0h

No./symbol/ name	Setting digit	Function	Initial value [unit]																						
PA04 *AOP1 Function selection A-1	___x	For manufacturer setting	0h																						
	__x_		0h																						
	_x__	Servo forced stop selection 0: Enabled (The forced stop input EM2 or EM1 is used.) 1: Disabled (The forced stop input EM2 and EM1 are not used.) Refer to the following table for details.	0h																						
	x___	Forced stop deceleration function selection 0: Forced stop deceleration function disabled (EM1) 2: Forced stop deceleration function enabled (EM2) Refer to the following table for details.	2h																						
Deceleration method																									
<table border="1"> <thead> <tr> <th rowspan="2">Setting value</th> <th rowspan="2">EM2/EM1</th> <th colspan="2">Deceleration method</th> </tr> <tr> <th>EM2 or EM1 is off</th> <th>Alarm occurred</th> </tr> </thead> <tbody> <tr> <td>00__</td> <td>EM1</td> <td>MBR (Electromagnetic brake interlock) turns off without the forced stop deceleration.</td> <td>MBR (Electromagnetic brake interlock) turns off without the forced stop deceleration.</td> </tr> <tr> <td>20__</td> <td>EM2</td> <td>MBR (Electromagnetic brake interlock) turns off after the forced stop deceleration.</td> <td>MBR (Electromagnetic brake interlock) turns off after the forced stop deceleration.</td> </tr> <tr> <td>01__</td> <td>Neither is used.</td> <td>—</td> <td>MBR (Electromagnetic brake interlock) turns off without the forced stop deceleration.</td> </tr> <tr> <td>21__</td> <td>Neither is used.</td> <td>—</td> <td>MBR (Electromagnetic brake interlock) turns off after the forced stop deceleration.</td> </tr> </tbody> </table>				Setting value	EM2/EM1	Deceleration method		EM2 or EM1 is off	Alarm occurred	00__	EM1	MBR (Electromagnetic brake interlock) turns off without the forced stop deceleration.	MBR (Electromagnetic brake interlock) turns off without the forced stop deceleration.	20__	EM2	MBR (Electromagnetic brake interlock) turns off after the forced stop deceleration.	MBR (Electromagnetic brake interlock) turns off after the forced stop deceleration.	01__	Neither is used.	—	MBR (Electromagnetic brake interlock) turns off without the forced stop deceleration.	21__	Neither is used.	—	MBR (Electromagnetic brake interlock) turns off after the forced stop deceleration.
Setting value	EM2/EM1	Deceleration method																							
		EM2 or EM1 is off	Alarm occurred																						
00__	EM1	MBR (Electromagnetic brake interlock) turns off without the forced stop deceleration.	MBR (Electromagnetic brake interlock) turns off without the forced stop deceleration.																						
20__	EM2	MBR (Electromagnetic brake interlock) turns off after the forced stop deceleration.	MBR (Electromagnetic brake interlock) turns off after the forced stop deceleration.																						
01__	Neither is used.	—	MBR (Electromagnetic brake interlock) turns off without the forced stop deceleration.																						
21__	Neither is used.	—	MBR (Electromagnetic brake interlock) turns off after the forced stop deceleration.																						
PA08 ATU Auto tuning mode	___x	Gain adjustment mode selection Select the gain adjustment mode. 0: 2 gain adjustment mode 1 (interpolation mode) 1: Auto tuning mode 1 2: Auto tuning mode 2 3: Manual mode 4: 2 gain adjustment mode 2 Refer to the following table for details.	1h																						
	__x_	For manufacturer setting	0h																						
	_x__		0h																						
	x___		0h																						
<table border="1"> <thead> <tr> <th>Setting value</th> <th>Gain adjustment mode</th> <th>Automatically adjusted parameter</th> </tr> </thead> <tbody> <tr> <td>___0</td> <td>2 gain adjustment mode 1 (interpolation mode)</td> <td>[Pr. PB06 Load to motor inertia ratio/load to motor mass ratio] [Pr. PB08 Position loop gain] [Pr. PB09 Speed loop gain] [Pr. PB10 Speed integral compensation]</td> </tr> <tr> <td>___1</td> <td>Auto tuning mode 1</td> <td>[Pr. PB06 Load to motor inertia ratio/load to motor mass ratio] [Pr. PB07 Model loop gain] [Pr. PB08 Position loop gain] [Pr. PB09 Speed loop gain] [Pr. PB10 Speed integral compensation]</td> </tr> <tr> <td>___2</td> <td>Auto tuning mode 2</td> <td>[Pr. PB07 Model loop gain] [Pr. PB08 Position loop gain] [Pr. PB09 Speed loop gain] [Pr. PB10 Speed integral compensation]</td> </tr> <tr> <td>___3</td> <td>Manual mode</td> <td>—</td> </tr> <tr> <td>___4</td> <td>2 gain adjustment mode 2</td> <td>[Pr. PB08 Position loop gain] [Pr. PB09 Speed loop gain] [Pr. PB10 Speed integral compensation]</td> </tr> </tbody> </table>				Setting value	Gain adjustment mode	Automatically adjusted parameter	___0	2 gain adjustment mode 1 (interpolation mode)	[Pr. PB06 Load to motor inertia ratio/load to motor mass ratio] [Pr. PB08 Position loop gain] [Pr. PB09 Speed loop gain] [Pr. PB10 Speed integral compensation]	___1	Auto tuning mode 1	[Pr. PB06 Load to motor inertia ratio/load to motor mass ratio] [Pr. PB07 Model loop gain] [Pr. PB08 Position loop gain] [Pr. PB09 Speed loop gain] [Pr. PB10 Speed integral compensation]	___2	Auto tuning mode 2	[Pr. PB07 Model loop gain] [Pr. PB08 Position loop gain] [Pr. PB09 Speed loop gain] [Pr. PB10 Speed integral compensation]	___3	Manual mode	—	___4	2 gain adjustment mode 2	[Pr. PB08 Position loop gain] [Pr. PB09 Speed loop gain] [Pr. PB10 Speed integral compensation]				
Setting value	Gain adjustment mode	Automatically adjusted parameter																							
___0	2 gain adjustment mode 1 (interpolation mode)	[Pr. PB06 Load to motor inertia ratio/load to motor mass ratio] [Pr. PB08 Position loop gain] [Pr. PB09 Speed loop gain] [Pr. PB10 Speed integral compensation]																							
___1	Auto tuning mode 1	[Pr. PB06 Load to motor inertia ratio/load to motor mass ratio] [Pr. PB07 Model loop gain] [Pr. PB08 Position loop gain] [Pr. PB09 Speed loop gain] [Pr. PB10 Speed integral compensation]																							
___2	Auto tuning mode 2	[Pr. PB07 Model loop gain] [Pr. PB08 Position loop gain] [Pr. PB09 Speed loop gain] [Pr. PB10 Speed integral compensation]																							
___3	Manual mode	—																							
___4	2 gain adjustment mode 2	[Pr. PB08 Position loop gain] [Pr. PB09 Speed loop gain] [Pr. PB10 Speed integral compensation]																							

No./symbol/ name	Setting digit	Function	Initial value [unit]																																																																																														
PA09 RSP Auto tuning response		<p>Set the auto tuning response.</p> <table border="1" data-bbox="333 275 1329 1104"> <thead> <tr> <th rowspan="2">Setting value</th> <th colspan="2">Machine characteristic</th> <th rowspan="2">Setting value</th> <th colspan="2">Machine characteristic</th> </tr> <tr> <th>Response</th> <th>Guideline for machine resonance frequency [Hz]</th> <th>Response</th> <th>Guideline for machine resonance frequency [Hz]</th> </tr> </thead> <tbody> <tr><td>1</td><td rowspan="20">Low response ↑</td><td>2.7</td><td>21</td><td rowspan="20">Middle response ↑</td><td>67.1</td></tr> <tr><td>2</td><td>3.6</td><td>22</td><td>75.6</td></tr> <tr><td>3</td><td>4.9</td><td>23</td><td>85.2</td></tr> <tr><td>4</td><td>6.6</td><td>24</td><td>95.9</td></tr> <tr><td>5</td><td>10.0</td><td>25</td><td>108.0</td></tr> <tr><td>6</td><td>11.3</td><td>26</td><td>121.7</td></tr> <tr><td>7</td><td>12.7</td><td>27</td><td>137.1</td></tr> <tr><td>8</td><td>14.3</td><td>28</td><td>154.4</td></tr> <tr><td>9</td><td>16.1</td><td>29</td><td>173.9</td></tr> <tr><td>10</td><td>18.1</td><td>30</td><td>195.9</td></tr> <tr><td>11</td><td>20.4</td><td>31</td><td>220.6</td></tr> <tr><td>12</td><td>23.0</td><td>32</td><td>248.5</td></tr> <tr><td>13</td><td>25.9</td><td>33</td><td>279.9</td></tr> <tr><td>14</td><td>29.2</td><td>34</td><td>315.3</td></tr> <tr><td>15</td><td>32.9</td><td>35</td><td>355.1</td></tr> <tr><td>16</td><td>37.0</td><td>36</td><td>400.0</td></tr> <tr><td>17</td><td>41.7</td><td>37</td><td>446.6</td></tr> <tr><td>18</td><td>47.0</td><td>38</td><td>501.2</td></tr> <tr><td>19</td><td>52.9</td><td>39</td><td>571.5</td></tr> <tr><td>20</td><td>Middle response ↓</td><td>59.6</td><td>40</td><td>High response ↓</td><td>642.7</td></tr> </tbody> </table> <p>Setting range: 1 to 40</p>	Setting value	Machine characteristic		Setting value	Machine characteristic		Response	Guideline for machine resonance frequency [Hz]	Response	Guideline for machine resonance frequency [Hz]	1	Low response ↑	2.7	21	Middle response ↑	67.1	2	3.6	22	75.6	3	4.9	23	85.2	4	6.6	24	95.9	5	10.0	25	108.0	6	11.3	26	121.7	7	12.7	27	137.1	8	14.3	28	154.4	9	16.1	29	173.9	10	18.1	30	195.9	11	20.4	31	220.6	12	23.0	32	248.5	13	25.9	33	279.9	14	29.2	34	315.3	15	32.9	35	355.1	16	37.0	36	400.0	17	41.7	37	446.6	18	47.0	38	501.2	19	52.9	39	571.5	20	Middle response ↓	59.6	40	High response ↓	642.7	16
Setting value	Machine characteristic			Setting value	Machine characteristic																																																																																												
	Response	Guideline for machine resonance frequency [Hz]	Response		Guideline for machine resonance frequency [Hz]																																																																																												
1	Low response ↑	2.7	21	Middle response ↑	67.1																																																																																												
2		3.6	22		75.6																																																																																												
3		4.9	23		85.2																																																																																												
4		6.6	24		95.9																																																																																												
5		10.0	25		108.0																																																																																												
6		11.3	26		121.7																																																																																												
7		12.7	27		137.1																																																																																												
8		14.3	28		154.4																																																																																												
9		16.1	29		173.9																																																																																												
10		18.1	30		195.9																																																																																												
11		20.4	31		220.6																																																																																												
12		23.0	32		248.5																																																																																												
13		25.9	33		279.9																																																																																												
14		29.2	34		315.3																																																																																												
15		32.9	35		355.1																																																																																												
16		37.0	36		400.0																																																																																												
17		41.7	37		446.6																																																																																												
18		47.0	38		501.2																																																																																												
19		52.9	39		571.5																																																																																												
20		Middle response ↓	59.6		40	High response ↓	642.7																																																																																										
PA10 INP In-position range	—	<p>Set an in-position range per command pulse. To change it to the servo motor encoder pulse unit, set [Pr. PC06]. In the motion mode, the in-position range is the range where INP is outputted. The unit is fixed to [pulse]. Setting range: 0 to 65535</p>	1600 [pulse]																																																																																														
PA11 TLP Forward rotation torque limit/positive direction thrust limit	—	<p>You can limit the torque or thrust generated by the servo motor. Set the parameter on the assumption that the rated torque or continuous thrust is 100.0 [%]. The parameter is for limiting the torque of the servo motor in the CCW power running or CW regeneration, or limiting the thrust of the linear servo motor in the positive direction power running or negative direction regeneration. Set this parameter to "0.0" to generate no torque or thrust. With equipment for the simple motion connected, writing from MR Configurator2 may not be reflected since this parameter is updated by the simple motion. The polarity of torque limit can be changed depending on the setting values of [Pr. PA14 Rotation direction selection/travel direction selection] and [Pr. PC29 POL reflection selection at torque mode]. Setting range: 0.0 to 1000.0</p>	1000.0 [%]																																																																																														
PA12 TLN Reverse rotation torque limit/negative direction thrust limit	—	<p>You can limit the torque or thrust generated by the servo motor. Set the parameter on the assumption that the rated torque or continuous thrust is 100.0 [%]. The parameter is for limiting the torque of the servo motor in the CW power running or CCW regeneration, or limiting the thrust of the linear servo motor in the negative direction power running or positive direction regeneration. Set this parameter to "0.0" to generate no torque or thrust. With equipment for the simple motion connected, writing from MR Configurator2 may not be reflected since this parameter is updated by the simple motion. The polarity of torque limit can be changed depending on the setting values of [Pr. PA14 Rotation direction selection/travel direction selection] and [Pr. PC29 POL reflection selection at torque mode]. Setting range: 0.0 to 1000.0</p>	1000.0 [%]																																																																																														

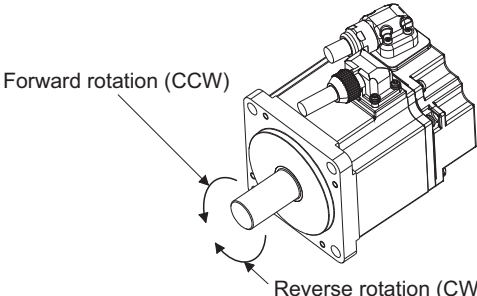
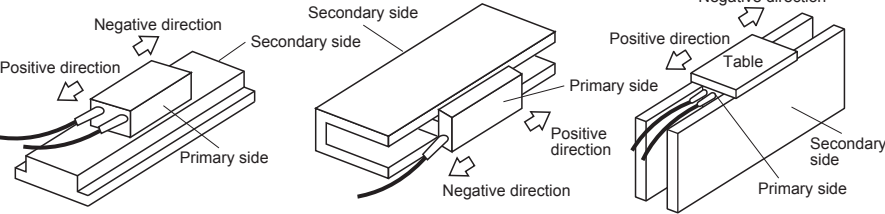
No./symbol/ name	Setting digit	Function	Initial value [unit]																																				
PA14 *POL Rotation direction selection/travel direction selection	—	<p>Select a rotation direction or travel direction for the command input pulse. The torque polarity can be changed with the combination of this parameter and [Pr. PC29 Torque POL reflection selection].</p> <ul style="list-style-type: none"> At position mode/velocity mode <table border="1"> <thead> <tr> <th rowspan="2">Setting value</th> <th colspan="2">Servo motor rotation direction/linear servo motor travel direction</th> </tr> <tr> <th>Position mode Positioning address increase/ Velocity mode Speed command: Positive</th> <th>Position mode Positioning address decrease/ Velocity mode Speed command: Negative</th> </tr> </thead> <tbody> <tr> <td>0</td> <td>CCW or positive direction</td> <td>CW or negative direction</td> </tr> <tr> <td>1</td> <td>CW or negative direction</td> <td>CCW or positive direction</td> </tr> </tbody> </table> <ul style="list-style-type: none"> At torque mode <table border="1"> <thead> <tr> <th rowspan="2">Setting value</th> <th colspan="2">Servo motor rotation direction/travel direction</th> </tr> <tr> <th>[Pr. PA14]</th> <th>[Pr. PC29]</th> <th>Torque mode Torque command: Positive</th> <th>Torque mode Torque command: Negative</th> </tr> </thead> <tbody> <tr> <td rowspan="2">0</td> <td>0 ___ : Enabled</td> <td></td> <td>CCW or positive direction</td> <td>CW or negative direction</td> </tr> <tr> <td>1 ___ : Disabled</td> <td></td> <td>CCW or positive direction</td> <td>CW or negative direction</td> </tr> <tr> <td rowspan="2">1</td> <td>0 ___ : Enabled</td> <td></td> <td>CW or negative direction</td> <td>CCW or positive direction</td> </tr> <tr> <td>1 ___ : Disabled</td> <td></td> <td>CCW or positive direction</td> <td>CW or negative direction</td> </tr> </tbody> </table> <p>The following shows the servo motor rotation directions.</p>  <p>The positive/negative directions of the linear servo motor are as follows.</p>  <p>LM-H3/LM-F series LM-U2 series LM-K2 series</p> <p>Setting range: 0, 1</p>	Setting value	Servo motor rotation direction/linear servo motor travel direction		Position mode Positioning address increase/ Velocity mode Speed command: Positive	Position mode Positioning address decrease/ Velocity mode Speed command: Negative	0	CCW or positive direction	CW or negative direction	1	CW or negative direction	CCW or positive direction	Setting value	Servo motor rotation direction/travel direction		[Pr. PA14]	[Pr. PC29]	Torque mode Torque command: Positive	Torque mode Torque command: Negative	0	0 ___ : Enabled		CCW or positive direction	CW or negative direction	1 ___ : Disabled		CCW or positive direction	CW or negative direction	1	0 ___ : Enabled		CW or negative direction	CCW or positive direction	1 ___ : Disabled		CCW or positive direction	CW or negative direction	0
Setting value	Servo motor rotation direction/linear servo motor travel direction																																						
	Position mode Positioning address increase/ Velocity mode Speed command: Positive	Position mode Positioning address decrease/ Velocity mode Speed command: Negative																																					
0	CCW or positive direction	CW or negative direction																																					
1	CW or negative direction	CCW or positive direction																																					
Setting value	Servo motor rotation direction/travel direction																																						
	[Pr. PA14]	[Pr. PC29]	Torque mode Torque command: Positive	Torque mode Torque command: Negative																																			
0	0 ___ : Enabled		CCW or positive direction	CW or negative direction																																			
	1 ___ : Disabled		CCW or positive direction	CW or negative direction																																			
1	0 ___ : Enabled		CW or negative direction	CCW or positive direction																																			
	1 ___ : Disabled		CCW or positive direction	CW or negative direction																																			
PA15 *ENR Encoder output pulses	—	<p>Set the encoder output pulses from the servo amplifier by using the number of output pulses per revolution, dividing ratio, or electronic gear ratio. (after multiplication by 4)</p> <p>Selecting "Dividing ratio setting (_ _ 1 _)" of "Encoder output pulse setting selection" in [Pr. PC03] will divide the travel distance [pulse] of the linear encoder by the setting value.</p> <p>Set a numerator of the electronic gear for the A/B-phase pulse output when selecting "A-phase/B-phase pulse electronic gear setting (_ _ 3 _)" of "Encoder output pulse setting selection" in [Pr. PC03].</p> <p>Refer to the following for details.</p> <p>☞ Page 659 Encoder output pulse setting method</p> <p>The maximum output frequency is 4.6 Mpulses/s. Set the parameter within this range.</p> <p>Setting range: 1 to 4194304</p>	4000 [pulse/rev]																																				

No./symbol/ name	Setting digit	Function	Initial value [unit]
PA16 *ENR2 Encoder output pulses 2	—	<p>Set a denominator of the electronic gear for the A/B-phase pulse output.</p> <p>Set a denominator of the electronic gear when selecting "A-phase/B-phase pulse electronic gear setting (_ _ 3 _)" of "Encoder output pulse setting selection" in [Pr. PC03].</p> <p>Refer to the following for details.</p> <p> Page 659 Encoder output pulse setting method</p> <p>The maximum output frequency is 4.6 Mpulses/s. Set the parameter within this range.</p> <p>Selecting "Dividing ratio setting (_ _ 1 _)" of "Encoder output pulse setting selection" in [Pr. PC03] will disable the setting value.</p> <p>Setting range: 1 to 4194304</p>	1

No./symbol/ name	Setting digit	Function	Initial value [unit]																																																																																																
PA17 **MSR Servo motor series setting	—	When using a linear servo motor, select any linear servo motor with [Pr. PA17] and [Pr. PA18]. Set this and [Pr. PA18] at a time. Refer to the following table for settings.	0000h																																																																																																
		<table border="1"> <thead> <tr> <th rowspan="2">Linear servo motor series</th> <th rowspan="2">Linear servo motor (Primary side)</th> <th colspan="2">Parameter</th> </tr> <tr> <th>[Pr. PA17] setting</th> <th>[Pr. PA18] setting</th> </tr> </thead> <tbody> <tr> <td rowspan="9">LM-H3</td> <td>LM-H3P2A-07P-BSS0</td> <td rowspan="9">00BBh</td> <td>2101h</td> </tr> <tr> <td>LM-H3P3A-12P-CSS0</td> <td>3101h</td> </tr> <tr> <td>LM-H3P3B-24P-CSS0</td> <td>3201h</td> </tr> <tr> <td>LM-H3P3C-36P-CSS0</td> <td>3301h</td> </tr> <tr> <td>LM-H3P3D-48P-CSS0</td> <td>3401h</td> </tr> <tr> <td>LM-H3P7A-24P-ASS0</td> <td>7101h</td> </tr> <tr> <td>LM-H3P7B-48P-ASS0</td> <td>7201h</td> </tr> <tr> <td>LM-H3P7C-72P-ASS0</td> <td>7301h</td> </tr> <tr> <td>LM-H3P7D-96P-ASS0</td> <td>7401h</td> </tr> <tr> <td rowspan="10">LM-U2</td> <td>LM-U2PAB-05M-0SS0</td> <td rowspan="10">00B4h</td> <td>A201h</td> </tr> <tr> <td>LM-U2PAD-10M-0SS0</td> <td>A401h</td> </tr> <tr> <td>LM-U2PAF-15M-0SS0</td> <td>A601h</td> </tr> <tr> <td>LM-U2PBB-07M-1SS0</td> <td>B201h</td> </tr> <tr> <td>LM-U2PBD-15M-1SS0</td> <td>B401h</td> </tr> <tr> <td>LM-U2PBF-22M-1SS0</td> <td>2601h</td> </tr> <tr> <td>LM-U2P2B-40M-2SS0</td> <td>2201h</td> </tr> <tr> <td>LM-U2P2C-60M-2SS0</td> <td>2301h</td> </tr> <tr> <td>LM-U2P2D-80M-2SS0</td> <td>2401h</td> </tr> <tr> <td rowspan="18">LM-F</td> <td>LM-FP2B-06M-1SS0 (natural cooling)</td> <td rowspan="18">00B2h</td> <td>2201h</td> </tr> <tr> <td>LM-FP2D-12M-1SS0 (natural cooling)</td> <td>2401h</td> </tr> <tr> <td>LM-FP2F-18M-1SS0 (natural cooling)</td> <td>2601h</td> </tr> <tr> <td>LM-FP4B-12M-1SS0 (natural cooling)</td> <td>4201h</td> </tr> <tr> <td>LM-FP4D-24M-1SS0 (natural cooling)</td> <td>4401h</td> </tr> <tr> <td>LM-FP4F-36M-1SS0 (natural cooling)</td> <td>4601h</td> </tr> <tr> <td>LM-FP4H-48M-1SS0 (natural cooling)</td> <td>4801h</td> </tr> <tr> <td>LM-FP5H-60M-1SS0 (natural cooling)</td> <td>5801h</td> </tr> <tr> <td>LM-FP2B-06M-1SS0 (liquid-cooling)</td> <td>2202h</td> </tr> <tr> <td>LM-FP2D-12M-1SS0 (liquid-cooling)</td> <td>2402h</td> </tr> <tr> <td>LM-FP2F-18M-1SS0 (liquid-cooling)</td> <td>2602h</td> </tr> <tr> <td>LM-FP4B-12M-1SS0 (liquid-cooling)</td> <td>4202h</td> </tr> <tr> <td>LM-FP4D-24M-1SS0 (liquid-cooling)</td> <td>4402h</td> </tr> <tr> <td>LM-FP4F-36M-1SS0 (liquid-cooling)</td> <td>4602h</td> </tr> <tr> <td>LM-FP4H-48M-1SS0 (liquid-cooling)</td> <td>4802h</td> </tr> <tr> <td>LM-FP5H-60M-1SS0 (liquid-cooling)</td> <td>5802h</td> </tr> <tr> <td rowspan="7">LM-K2</td> <td>LM-K2P1A-01M-2SS1</td> <td rowspan="7">00B8h</td> <td>1101h</td> </tr> <tr> <td>LM-K2P1C-03M-2SS1</td> <td>1301h</td> </tr> <tr> <td>LM-K2P2A-02M-1SS1</td> <td>2101h</td> </tr> <tr> <td>LM-K2P2C-07M-1SS1</td> <td>2301h</td> </tr> <tr> <td>LM-K2P2E-12M-1SS1</td> <td>2501h</td> </tr> <tr> <td>LM-K2P3C-14M-1SS1</td> <td>3301h</td> </tr> <tr> <td>LM-K2P3E-24M-1SS1</td> <td>3501h</td> </tr> </tbody> </table>		Linear servo motor series	Linear servo motor (Primary side)	Parameter		[Pr. PA17] setting	[Pr. PA18] setting	LM-H3	LM-H3P2A-07P-BSS0	00BBh	2101h	LM-H3P3A-12P-CSS0	3101h	LM-H3P3B-24P-CSS0	3201h	LM-H3P3C-36P-CSS0	3301h	LM-H3P3D-48P-CSS0	3401h	LM-H3P7A-24P-ASS0	7101h	LM-H3P7B-48P-ASS0	7201h	LM-H3P7C-72P-ASS0	7301h	LM-H3P7D-96P-ASS0	7401h	LM-U2	LM-U2PAB-05M-0SS0	00B4h	A201h	LM-U2PAD-10M-0SS0	A401h	LM-U2PAF-15M-0SS0	A601h	LM-U2PBB-07M-1SS0	B201h	LM-U2PBD-15M-1SS0	B401h	LM-U2PBF-22M-1SS0	2601h	LM-U2P2B-40M-2SS0	2201h	LM-U2P2C-60M-2SS0	2301h	LM-U2P2D-80M-2SS0	2401h	LM-F	LM-FP2B-06M-1SS0 (natural cooling)	00B2h	2201h	LM-FP2D-12M-1SS0 (natural cooling)	2401h	LM-FP2F-18M-1SS0 (natural cooling)	2601h	LM-FP4B-12M-1SS0 (natural cooling)	4201h	LM-FP4D-24M-1SS0 (natural cooling)	4401h	LM-FP4F-36M-1SS0 (natural cooling)	4601h	LM-FP4H-48M-1SS0 (natural cooling)	4801h	LM-FP5H-60M-1SS0 (natural cooling)	5801h	LM-FP2B-06M-1SS0 (liquid-cooling)	2202h	LM-FP2D-12M-1SS0 (liquid-cooling)	2402h	LM-FP2F-18M-1SS0 (liquid-cooling)	2602h	LM-FP4B-12M-1SS0 (liquid-cooling)	4202h	LM-FP4D-24M-1SS0 (liquid-cooling)	4402h	LM-FP4F-36M-1SS0 (liquid-cooling)	4602h	LM-FP4H-48M-1SS0 (liquid-cooling)	4802h	LM-FP5H-60M-1SS0 (liquid-cooling)	5802h	LM-K2	LM-K2P1A-01M-2SS1	00B8h	1101h	LM-K2P1C-03M-2SS1	1301h	LM-K2P2A-02M-1SS1	2101h	LM-K2P2C-07M-1SS1	2301h	LM-K2P2E-12M-1SS1	2501h	LM-K2P3C-14M-1SS1	3301h	LM-K2P3E-24M-1SS1	3501h
		Linear servo motor series				Linear servo motor (Primary side)	Parameter																																																																																												
				[Pr. PA17] setting	[Pr. PA18] setting																																																																																														
		LM-H3		LM-H3P2A-07P-BSS0	00BBh	2101h																																																																																													
				LM-H3P3A-12P-CSS0		3101h																																																																																													
				LM-H3P3B-24P-CSS0		3201h																																																																																													
				LM-H3P3C-36P-CSS0		3301h																																																																																													
				LM-H3P3D-48P-CSS0		3401h																																																																																													
				LM-H3P7A-24P-ASS0		7101h																																																																																													
				LM-H3P7B-48P-ASS0		7201h																																																																																													
				LM-H3P7C-72P-ASS0		7301h																																																																																													
				LM-H3P7D-96P-ASS0		7401h																																																																																													
		LM-U2		LM-U2PAB-05M-0SS0	00B4h	A201h																																																																																													
				LM-U2PAD-10M-0SS0		A401h																																																																																													
				LM-U2PAF-15M-0SS0		A601h																																																																																													
				LM-U2PBB-07M-1SS0		B201h																																																																																													
				LM-U2PBD-15M-1SS0		B401h																																																																																													
				LM-U2PBF-22M-1SS0		2601h																																																																																													
				LM-U2P2B-40M-2SS0		2201h																																																																																													
				LM-U2P2C-60M-2SS0		2301h																																																																																													
				LM-U2P2D-80M-2SS0		2401h																																																																																													
				LM-F		LM-FP2B-06M-1SS0 (natural cooling)	00B2h	2201h																																																																																											
		LM-FP2D-12M-1SS0 (natural cooling)			2401h																																																																																														
		LM-FP2F-18M-1SS0 (natural cooling)			2601h																																																																																														
		LM-FP4B-12M-1SS0 (natural cooling)			4201h																																																																																														
		LM-FP4D-24M-1SS0 (natural cooling)			4401h																																																																																														
		LM-FP4F-36M-1SS0 (natural cooling)			4601h																																																																																														
		LM-FP4H-48M-1SS0 (natural cooling)			4801h																																																																																														
		LM-FP5H-60M-1SS0 (natural cooling)			5801h																																																																																														
		LM-FP2B-06M-1SS0 (liquid-cooling)			2202h																																																																																														
		LM-FP2D-12M-1SS0 (liquid-cooling)			2402h																																																																																														
		LM-FP2F-18M-1SS0 (liquid-cooling)			2602h																																																																																														
		LM-FP4B-12M-1SS0 (liquid-cooling)			4202h																																																																																														
		LM-FP4D-24M-1SS0 (liquid-cooling)			4402h																																																																																														
		LM-FP4F-36M-1SS0 (liquid-cooling)			4602h																																																																																														
		LM-FP4H-48M-1SS0 (liquid-cooling)			4802h																																																																																														
		LM-FP5H-60M-1SS0 (liquid-cooling)			5802h																																																																																														
		LM-K2			LM-K2P1A-01M-2SS1	00B8h		1101h																																																																																											
					LM-K2P1C-03M-2SS1			1301h																																																																																											
LM-K2P2A-02M-1SS1	2101h																																																																																																		
LM-K2P2C-07M-1SS1	2301h																																																																																																		
LM-K2P2E-12M-1SS1	2501h																																																																																																		
LM-K2P3C-14M-1SS1	3301h																																																																																																		
LM-K2P3E-24M-1SS1	3501h																																																																																																		
PA18 **MTY Servo motor type setting	—	When using a linear servo motor, select any linear servo motor with [Pr. PA17] and [Pr. PA18]. Set this and [Pr. PA17] at a time. Refer to the table of [Pr. PA17] for settings.	0000h																																																																																																

No./symbol/ name	Setting digit	Function	Initial value [unit]									
PA19 *BLK Parameter writing inhibit	—	Select a reference range and writing range of the parameter. Refer to the following table for settings.	00ABh									
	PA19	Setting operation	PA	PB	PC	PD	PE	PF	PL	PT	PN	
	Other than below	Reading	○	—	—	—	—	—	—	—	—	—
		Writing	○	—	—	—	—	—	—	—	—	—
	000Ah	Reading	Only 19	—	—	—	—	—	—	—	—	—
		Writing	Only 19	—	—	—	—	—	—	—	—	—
	000Bh	Reading	○	○	○	—	—	—	—	—	—	—
		Writing	○	○	○	—	—	—	—	—	—	—
	000Ch	Reading	○	○	○	○	—	—	—	—	—	—
		Writing	○	○	○	○	—	—	—	—	—	—
	000Fh	Reading	○	○	○	○	○	—	○	—	—	—
		Writing	○	○	○	○	○	—	○	—	—	—
	00AAh	Reading	○	○	○	○	○	○	—	—	—	—
		Writing	○	○	○	○	○	○	—	—	—	—
	00ABh (initial value)	Reading	○	○	○	○	○	○	○	○	○	○
		Writing	○	○	○	○	○	○	○	○	○	○
	100Bh	Reading	○	—	—	—	—	—	—	—	—	—
		Writing	Only 19	—	—	—	—	—	—	—	—	—
	100Ch	Reading	○	○	○	○	—	—	—	—	—	—
		Writing	Only 19	—	—	—	—	—	—	—	—	—
	100Fh	Reading	○	○	○	○	○	—	○	—	—	—
		Writing	Only 19	—	—	—	—	—	—	—	—	—
	10AAh	Reading	○	○	○	○	○	○	—	—	—	—
		Writing	Only 19	—	—	—	—	—	—	—	—	—
10ABh	Reading	○	○	○	○	○	○	○	○	○	○	
	Writing	Only 19	—	—	—	—	—	—	—	—	—	
PA20 *TDS Tough drive setting	—	Alarms may not be avoided with the tough drive function depending on the situations of the power supply and load fluctuation. You can assign MTRR (During tough drive) to pins CN3-9, CN3-13, and CN3-15 with [Pr. PD07] to [Pr. PD09].										
	___x	For manufacturer setting	0h									
	__x_	Vibration tough drive selection 0: Disabled 1: Enabled Selecting "1" enables to suppress vibrations by automatically changing the setting values of [Pr. PB13 Machine resonance suppression filter 1] and [Pr. PB15 Machine resonance suppression filter 2] in case that the vibration exceeds the value of the oscillation level set in [Pr. PF23]. The parameter will operate when [Pr. PB13 Machine resonance suppression filter 1] and [Pr. PB15 Machine resonance suppression filter 2] are enabled. ☞ Page 270 Tough drive function	0h									
	_x__	SEMI-F47 function selection 0: Disabled 1: Enabled Selecting "1" enables to avoid triggering [AL. 10 Undervoltage] using the electrical energy charged in the capacitor in case that an instantaneous power failure occurs during operation. In [Pr. PF25 SEMI-F47 function - Instantaneous power failure detection time], set the time until the occurrence of [AL. 10.1 Voltage drop in the control circuit power].	0h									
x___	For manufacturer setting	0h										

No./symbol/ name	Setting digit	Function	Initial value [unit]
PA21 *AOP3 Function selection A-3	___x	One-touch tuning function selection 0: Disabled 1: Enabled When the digit is "0", the one-touch tuning with MR Configurator2 will be disabled.	1h
	__x_	For manufacturer setting	0h
	_x__		0h
	x___		0h
PA22 **PCS Position control composition selection	___x	For manufacturer setting	0h
	__x_	Super trace control selection 0: Disabled 2: Enabled	0h
	_x__	For manufacturer setting	0h
	x___	Scale measurement function selection 0: Disabled 1: Used in absolute position detection system 2: Used in incremental system The absolute position detection system cannot be used while an incremental type encoder is used. Enabling absolute position detection system will trigger [AL. 37 Parameter error]. Additionally, the setting is enabled only in the standard control mode. Setting other than "0" in other operation modes triggers [AL. 37 Parameter error]. The setting of this digit is used by servo amplifier with software version A1 or later.	0h
PA23 DRAT Drive recorder arbitrary alarm trigger setting	__xx	Alarm detail No. setting Set the digits when you execute the trigger with arbitrary alarm detail No. for the drive recorder function. When these digits are "0 0", only the arbitrary alarm No. setting will be enabled.	00h
	xx__	Alarm No. setting Set the digits when you execute the trigger with arbitrary alarm No. for the drive recorder function. When "0 0" are set, arbitrary alarm trigger of the drive recorder will be disabled.	00h
	Setting example: To activate the drive recorder when [AL. 50 Overload 1] occurs, set "5 0 0 0". To activate the drive recorder when [AL. 50.3 Thermal overload error 4 during operation] occurs, set "5 0 0 3".		
PA24 AOP4 Function selection A-4	___x	Vibration suppression mode selection 0: Standard mode 1: 3 inertia mode 2: Low response mode When you select the standard mode or low response mode, "Vibration suppression control 2" is not available. When you select the 3 inertia mode, the feed forward gain is not available. Before changing the control mode during the 3 inertia mode or low response mode, stop the motor.	0h
	__x_	For manufacturer setting	0h
	_x__		0h
	x___		0h
PA25 OTHOV One-touch tuning - Overshoot permissible level	—	Set a permissible value of overshoot amount for one-touch tuning as a percentage of the in-position range. Note that setting "0" will be 50%. Setting range: 0 to 100	0 [%]
PA26 *AOP5 Function selection A-5	___x	Torque limit function selection at instantaneous power failure 0: Disabled 1: Enabled When an instantaneous power failure occurs during operation, you can save electric energy charged in the capacitor in the servo amplifier by limiting torque at acceleration. You can also delay the time until [AL. 10.2 Voltage drop in the main circuit power] occurs with instantaneous power failure tough drive function. Doing this will enable you to set a longer time in [Pr. PF25 SEMI-F47 function - Instantaneous power failure detection time]. The torque limit function at instantaneous power failure is enabled when "SEMI-F47 function selection" in [Pr. PA20] is "Enabled (_ 1 _)".	0h
	__x_	For manufacturer setting	0h
	_x__		0h
	x___		0h

Gain/filter setting parameters ([Pr. PB_ _])

No./symbol/ name	Setting digit	Function	Initial value [unit]
PB01 FILT Adaptive tuning mode (adaptive filter II)	___x	Filter tuning mode selection Set the adaptive tuning. Select the adjustment mode of the machine resonance suppression filter 1. ☞ Page 253 Adaptive filter II 0: Disabled 1: Automatic setting 2: Manual setting	0h
	__x_	For manufacturer setting	0h
	_x__		0h
	x___		0h
PB02 VRFT Vibration suppression control tuning mode (advanced vibration suppression control II)	___x	Vibration suppression control 1 tuning mode selection Select the tuning mode of the vibration suppression control 1. ☞ Page 257 Advanced vibration suppression control II 0: Disabled 1: Automatic setting 2: Manual setting	0h
	__x_	Vibration suppression control 2 tuning mode selection Select the tuning mode of the vibration suppression control 2. To enable the digit, set "Vibration suppression mode selection" to "3 inertia mode (___ 1)" in [Pr. PA24]. ☞ Page 257 Advanced vibration suppression control II 0: Disabled 1: Automatic setting 2: Manual setting	0h
	_x__	For manufacturer setting	0h
	x___		0h
PB04 FFC Feed forward gain	—	Set the feed forward gain. When the setting is 100%, the droop pulses during operation at constant speed will be almost 0. When the super trace control is enabled, constant speed and uniform acceleration/deceleration droop pulses will be almost 0. However, sudden acceleration/deceleration will increase the overshoot. As a guideline, when the feed forward gain setting is 100%, set 1 s or more for the acceleration time constant to the rated speed. Setting range: 0 to 100	0 [%]
PB06 GD2 Load to motor inertia ratio/load to motor mass ratio	—	Set a load to motor inertia ratio or load to motor mass ratio. Setting a value considerably different from the actual load moment of inertia or load mass may cause an unexpected operation such as an overshoot. The setting of this parameter will be automatic or manual depending on the setting of [Pr. PA08]. Refer to the following table for details. When the parameter is set to automatic, the value will vary between 0.00 and 100.00. Setting range: 0.00 to 300.00	7.00 [times]
	Pr. PA08		This parameter
	___ 0 (2 gain adjustment mode 1 (interpolation mode))		Automatic setting
	___ 1: (Auto tuning mode 1)		
	___ 2: (Auto tuning mode 2)		Manual setting
	___ 3 (Manual mode)		
___ 4: (2 gain adjustment mode 2)			

No./symbol/ name	Setting digit	Function	Initial value [unit]	
PB07 PG1 Model loop gain	—	Set the response gain to the target position. Increasing the setting value will also increase the response level to the position command but will be liable to generate vibration and noise. When the vibration suppression control is used, the setting range of [Pr. PB07] is limited. Refer to the following for details. ☞ Page 259 Vibration suppression control manual mode The setting of this parameter will be automatic or manual depending on the setting of [Pr. PA08]. Refer to the following table for details. Setting range: 1.0 to 2000.0	15.0 [rad/s]	
		Pr. PA08		This parameter
		___ 0 (2 gain adjustment mode 1 (interpolation mode))		Manual setting
		___ 1: (Auto tuning mode 1)		Automatic setting
		___ 2: (Auto tuning mode 2)		
___ 3 (Manual mode)	Manual setting			
___ 4: (2 gain adjustment mode 2)				
PB08 PG2 Position loop gain	—	Set the gain of the position loop. Set this parameter to increase the position response to level load disturbance. Increasing the setting value will also increase the response level to the load disturbance but will be liable to generate vibration and noise. The setting of this parameter will be automatic or manual depending on the setting of [Pr. PA08]. Refer to the following table for details. Setting range: 1.0 to 2000.0	37.0 [rad/s]	
		Pr. PA08		This parameter
		___ 0 (2 gain adjustment mode 1 (interpolation mode))		Automatic setting
		___ 1 (Auto tuning mode 1)		
		___ 2: (Auto tuning mode 2)		
___ 3 (Manual mode)	Manual setting			
___ 4: (2 gain adjustment mode 2)	Automatic setting			
PB09 VG2 Speed loop gain	—	Set the gain of the speed loop. Set this parameter when vibration occurs on machines of low rigidity or with large backlash. Increasing the setting value will also increase the response level but will be liable to generate vibration and noise. The setting of this parameter will be automatic or manual depending on the setting of [Pr. PA08]. Refer to the table of [Pr. PB08] for details. Setting range: 20 to 65535	823 [rad/s]	
PB10 VIC Speed integral compensation	—	Set the integral time constant of the speed loop. Decreasing the setting value will increase the response level but will be liable to generate vibration and noise. The setting of this parameter will be automatic or manual depending on the setting of [Pr. PA08]. Refer to the table of [Pr. PB08] for details. Setting range: 0.1 to 1000.0	33.7 [ms]	
PB11 VDC Speed differential compensation	—	Set the differential compensation. To enable the parameter at all times, select "Continuous PID control enabled (___ 3 ___)" of "PI-PID switching control selection" in [Pr. PB24]. To enable it, turn on PC (Proportional control) or PID switching signal from controller. Setting range: 0 to 1000	980	
PB12 OVA Overshoot amount compensation	—	Set a dynamic friction torque in percentage to the rated torque at servo motor rated speed. Alternatively, set a dynamic friction force in percentage to the continuous thrust at linear servo motor rated speed. When the response level is low or when the torque/thrust is limited, the efficiency of the parameter may be lower. Setting range: 0 to 100	0 [%]	
PB13 NH1 Machine resonance suppression filter 1	—	Set the notch frequency of the machine resonance suppression filter 1. When "Filter tuning mode selection" is set to "Automatic setting (___ 1)" in [Pr. PB01], this parameter will be adjusted automatically by adaptive tuning. When "Filter tuning mode selection" is set to "Manual setting (___ 2)" in [Pr. PB01], the setting value will be enabled. Setting range: 10 to 4500	4500 [Hz]	

No./symbol/ name	Setting digit	Function	Initial value [unit]
PB14 NHQ1 Notch shape selection 1		Set forms of the machine resonance suppression filter 1. When "Filter tuning mode selection" is set to "Automatic setting (___ 1)" in [Pr. PB01], this parameter will be adjusted automatically by adaptive tuning. When "Filter tuning mode selection" is set to "Manual setting (___ 2)" in [Pr. PB01], the setting value will be enabled.	
	___ x	For manufacturer setting	0h
	__ x _	Notch depth selection 0: -40 dB 1: -14 dB 2: -8 dB 3: -4 dB	0h
	_ x _ _	Notch width selection 0: $\alpha = 2$ 1: $\alpha = 3$ 2: $\alpha = 4$ 3: $\alpha = 5$	0h
	x _ _ _	For manufacturer setting	0h
PB15 NH2 Machine resonance suppression filter 2	—	Set the notch frequency of the machine resonance suppression filter 2. To enable the setting value, select "Enabled (___ 1)" of "Machine resonance suppression filter 2 selection" in [Pr. PB16]. Setting range: 10 to 4500	4500 [Hz]
PB16 NHQ2 Notch shape selection 2		Set forms of the machine resonance suppression filter 2.	
	___ x	Machine resonance suppression filter 2 selection 0: Disabled 1: Enabled	0h
	__ x _	Notch depth selection 0: -40 dB 1: -14 dB 2: -8 dB 3: -4 dB	0h
	_ x _ _	Notch width selection 0: $\alpha = 2$ 1: $\alpha = 3$ 2: $\alpha = 4$ 3: $\alpha = 5$	0h
	x _ _ _	For manufacturer setting	0h

No./symbol/ name	Setting digit	Function	Initial value [unit]																																																																				
PB17 NHF Shaft resonance suppression filter		Set the shaft resonance suppression filter. Use this to suppress a high-frequency machine vibration. When you select "Automatic setting (_ _ _ 0)" of "Shaft resonance suppression filter selection" in [Pr. PB23], the value will be calculated automatically from the servo motor you use and load to motor inertia ratio. It will not be automatically calculated for the linear servo motor. When "Manual setting (_ _ _ 1)" is selected, the setting written to the parameter is used. When "Shaft resonance suppression filter selection" is set to "Disabled (_ _ _ 2)" in [Pr. PB23], the setting value of this parameter will be disabled. When "Machine resonance suppression filter 4 selection" is set to "Enabled (_ _ _ 1)" in [Pr. PB49], the shaft resonance suppression filter is not available. When "Shaft resonance suppression filter selection" is set to "Disabled (_ _ _ 2)" in [Pr. PB23], the performance may be reduced.																																																																					
	_ _ x x	Shaft resonance suppression filter setting frequency selection Refer to the following table for settings. Set the value closest to the frequency you need.	00h																																																																				
	_ x _ _	Notch depth selection 0: -40 dB 1: -14 dB 2: -8 dB 3: -4 dB	0h																																																																				
	x _ _ _	For manufacturer setting	0h																																																																				
<table border="1"> <thead> <tr> <th>Setting value</th> <th>Frequency [Hz]</th> <th>Setting value</th> <th>Frequency [Hz]</th> </tr> </thead> <tbody> <tr><td>_ _ _ 0 0</td><td>Disabled</td><td>_ _ _ 1 0</td><td>562</td></tr> <tr><td>_ _ _ 0 1</td><td>Disabled</td><td>_ _ _ 1 1</td><td>529</td></tr> <tr><td>_ _ _ 0 2</td><td>4500</td><td>_ _ _ 1 2</td><td>500</td></tr> <tr><td>_ _ _ 0 3</td><td>3000</td><td>_ _ _ 1 3</td><td>473</td></tr> <tr><td>_ _ _ 0 4</td><td>2250</td><td>_ _ _ 1 4</td><td>450</td></tr> <tr><td>_ _ _ 0 5</td><td>1800</td><td>_ _ _ 1 5</td><td>428</td></tr> <tr><td>_ _ _ 0 6</td><td>1500</td><td>_ _ _ 1 6</td><td>409</td></tr> <tr><td>_ _ _ 0 7</td><td>1285</td><td>_ _ _ 1 7</td><td>391</td></tr> <tr><td>_ _ _ 0 8</td><td>1125</td><td>_ _ _ 1 8</td><td>375</td></tr> <tr><td>_ _ _ 0 9</td><td>1000</td><td>_ _ _ 1 9</td><td>360</td></tr> <tr><td>_ _ _ 0 A</td><td>900</td><td>_ _ _ 1 A</td><td>346</td></tr> <tr><td>_ _ _ 0 B</td><td>818</td><td>_ _ _ 1 B</td><td>333</td></tr> <tr><td>_ _ _ 0 C</td><td>750</td><td>_ _ _ 1 C</td><td>321</td></tr> <tr><td>_ _ _ 0 D</td><td>692</td><td>_ _ _ 1 D</td><td>310</td></tr> <tr><td>_ _ _ 0 E</td><td>642</td><td>_ _ _ 1 E</td><td>300</td></tr> <tr><td>_ _ _ 0 F</td><td>600</td><td>_ _ _ 1 F</td><td>290</td></tr> </tbody> </table>				Setting value	Frequency [Hz]	Setting value	Frequency [Hz]	_ _ _ 0 0	Disabled	_ _ _ 1 0	562	_ _ _ 0 1	Disabled	_ _ _ 1 1	529	_ _ _ 0 2	4500	_ _ _ 1 2	500	_ _ _ 0 3	3000	_ _ _ 1 3	473	_ _ _ 0 4	2250	_ _ _ 1 4	450	_ _ _ 0 5	1800	_ _ _ 1 5	428	_ _ _ 0 6	1500	_ _ _ 1 6	409	_ _ _ 0 7	1285	_ _ _ 1 7	391	_ _ _ 0 8	1125	_ _ _ 1 8	375	_ _ _ 0 9	1000	_ _ _ 1 9	360	_ _ _ 0 A	900	_ _ _ 1 A	346	_ _ _ 0 B	818	_ _ _ 1 B	333	_ _ _ 0 C	750	_ _ _ 1 C	321	_ _ _ 0 D	692	_ _ _ 1 D	310	_ _ _ 0 E	642	_ _ _ 1 E	300	_ _ _ 0 F	600	_ _ _ 1 F	290
Setting value	Frequency [Hz]	Setting value	Frequency [Hz]																																																																				
_ _ _ 0 0	Disabled	_ _ _ 1 0	562																																																																				
_ _ _ 0 1	Disabled	_ _ _ 1 1	529																																																																				
_ _ _ 0 2	4500	_ _ _ 1 2	500																																																																				
_ _ _ 0 3	3000	_ _ _ 1 3	473																																																																				
_ _ _ 0 4	2250	_ _ _ 1 4	450																																																																				
_ _ _ 0 5	1800	_ _ _ 1 5	428																																																																				
_ _ _ 0 6	1500	_ _ _ 1 6	409																																																																				
_ _ _ 0 7	1285	_ _ _ 1 7	391																																																																				
_ _ _ 0 8	1125	_ _ _ 1 8	375																																																																				
_ _ _ 0 9	1000	_ _ _ 1 9	360																																																																				
_ _ _ 0 A	900	_ _ _ 1 A	346																																																																				
_ _ _ 0 B	818	_ _ _ 1 B	333																																																																				
_ _ _ 0 C	750	_ _ _ 1 C	321																																																																				
_ _ _ 0 D	692	_ _ _ 1 D	310																																																																				
_ _ _ 0 E	642	_ _ _ 1 E	300																																																																				
_ _ _ 0 F	600	_ _ _ 1 F	290																																																																				
PB18 LPF Low-pass filter setting	—	Set the low-pass filter. Refer to the following table for the relation of setting values for the related parameter to the status of this parameter. Setting range: 100 to 18000	3141 [rad/s]																																																																				
		<table border="1"> <thead> <tr> <th>[Pr. PB23]</th> <th>[Pr. PB18]</th> </tr> </thead> <tbody> <tr> <td>_ _ _ 0 _ (Initial value)</td> <td>Automatic setting</td> </tr> <tr> <td>_ _ _ 1 _</td> <td>Setting value enabled</td> </tr> <tr> <td>_ _ _ 2 _</td> <td>Setting value disabled</td> </tr> </tbody> </table>	[Pr. PB23]	[Pr. PB18]	_ _ _ 0 _ (Initial value)	Automatic setting	_ _ _ 1 _	Setting value enabled	_ _ _ 2 _	Setting value disabled																																																													
	[Pr. PB23]	[Pr. PB18]																																																																					
_ _ _ 0 _ (Initial value)	Automatic setting																																																																						
_ _ _ 1 _	Setting value enabled																																																																						
_ _ _ 2 _	Setting value disabled																																																																						
PB19 VRF11 Vibration suppression control 1 - Vibration frequency	—	Set the vibration frequency for vibration suppression control 1 to suppress low-frequency machine vibration. When "Vibration suppression control 1 tuning mode selection" is set to "Automatic setting (_ _ _ 1)" in [Pr. PB02], this parameter will be set automatically. When "Manual setting (_ _ _ 2)" is selected, the setting written to the parameter is used. The setting range of this parameter varies, depending on the value in [Pr. PB07]. If a value out of the range is set, the vibration suppression control is disabled.  Page 257 Advanced vibration suppression control II Setting range: 0.1 to 300.0	100.0 [Hz]																																																																				

No./symbol/ name	Setting digit	Function	Initial value [unit]
PB20 VRF12 Vibration suppression control 1 - Resonance frequency	—	Set the resonance frequency for vibration suppression control 1 to suppress low-frequency machine vibration. When "Vibration suppression control 1 tuning mode selection" is set to "Automatic setting (_ _ _ 1)" in [Pr. PB02], this parameter will be set automatically. When "Manual setting (_ _ _ 2)" is selected, the setting written to the parameter is used. The setting range of this parameter varies, depending on the value in [Pr. PB07]. If a value out of the range is set, the vibration suppression control is disabled. ☞ Page 257 Advanced vibration suppression control II Setting range: 0.1 to 300.0	100.0 [Hz]
PB21 VRF13 Vibration suppression control 1 - Vibration frequency damping	—	Set a damping of the vibration frequency for vibration suppression control 1 to suppress low-frequency machine vibration. When "Vibration suppression control 1 tuning mode selection" is set to "Automatic setting (_ _ _ 1)" in [Pr. PB02], this parameter will be set automatically. When "Manual setting (_ _ _ 2)" is selected, the setting written to the parameter is used. ☞ Page 257 Advanced vibration suppression control II Setting range: 0.00 to 0.30	0.00
PB22 VRF14 Vibration suppression control 1 - Resonance frequency damping	—	Set a damping of the resonance frequency for vibration suppression control 1 to suppress low-frequency machine vibration. When "Vibration suppression control 1 tuning mode selection" is set to "Automatic setting (_ _ _ 1)" in [Pr. PB02], this parameter will be set automatically. When "Manual setting (_ _ _ 2)" is selected, the setting written to the parameter is used. ☞ Page 257 Advanced vibration suppression control II Setting range: 0.00 to 0.30	0.00
PB23 VFBF Low-pass filter selection	— — — x	Shaft resonance suppression filter selection Select the shaft resonance suppression filter. 0: Automatic setting 1: Manual setting 2: Disabled When "Machine resonance suppression filter 4 selection" is set to "Enabled (_ _ _ 1)" in [Pr. PB49], the shaft resonance suppression filter is not available.	0h
	— — x —	Low-pass filter selection Select the low-pass filter. 0: Automatic setting 1: Manual setting 2: Disabled	0h
	— x — —	For manufacturer setting	0h
	x — — —		0h
PB24 *MVS Slight vibration suppression control	— — — x	Slight vibration suppression control selection Select the slight vibration suppression control. 0: Disabled 1: Enabled To enable the slight vibration suppression control, set "Gain adjustment mode selection" to "Manual mode (_ _ _ 3)" in [Pr. PA08]. Slight vibration suppression control selection cannot be used in the velocity mode.	0h
	— — x —	PI-PID switching control selection 0: PI control enabled (Switching to PID control (Proportional control) is enabled by PID switching signal (C_PC) from controller and Input device PC (Proportional control).) 3: Continuous PID control (Proportional control) enabled If the servo motor at a stop is rotated even one pulse due to any external factor, it generates torque to compensate for a position shift. When the servo motor shaft is to be locked mechanically after positioning completion (stop), enabling PID control and completing positioning simultaneously will suppress the unnecessary torque generated to compensate for a position shift.	0h
	— x — —	For manufacturer setting	0h
	x — — —		0h
PB25 *BOP1 Function selection B-1	— — — x	Model adaptive control selection 0: Enabled (model adaptive control) 2: Disabled (PID control) ☞ Page 278 Model adaptive control disabled	0h
	— — x —	For manufacturer setting	0h
	— x — —		0h
	x — — —		0h

No./symbol/ name	Setting digit	Function	Initial value [unit]
PB26 *CDP Gain switching function		Select a gain switching condition. Set conditions to enable the gain switching values set in [Pr. PB29] to [Pr. PB36] and [Pr. PB56] to [Pr. PB60].	
	___x	Gain switching selection 0: Disabled 1: Switching is enabled by control command from controller and Input device CDP (Gain switching). 2: Command frequency 3: Droop pulses 4: Servo motor speed	0h
	__x_	Gain switching condition selection 0: Gain after switching is enabled with gain switching condition or more 1: Gain after switching is enabled with gain switching condition or less	0h
	_x__	Gain switching time constant disabling condition selection 0: Switching time constant enabled 1: Switching time constant disabled 2: Return time constant disabled ☞ Page 267 Gain switching procedure	0h
	x___	For manufacturer setting	0h
PB27 CDL Gain switching condition	—	Set the value of the gain switching (command frequency, droop pulses, or servo motor speed) selected in [Pr. PB26]. The set value unit differs depending on the switching condition item. ☞ Page 264 Parameter The unit "r/min" will be "mm/s" for linear servo motors. Setting range: 0 to 65535	10 [kpulse/s]/ [pulse]/ [r/min]
PB28 CDT Gain switching time constant	—	Set the time constant at which the gains will change in response to the conditions set in [Pr. PB26] and [Pr. PB27]. Setting range: 0 to 100	1 [ms]
PB29 GD2B Load to motor inertia ratio/load to motor mass ratio after gain switching	—	Set a load to motor inertia ratio/load to motor mass ratio for when gain switching is enabled. This parameter is enabled only when "Gain adjustment mode selection" is set to "Manual mode (___3)" in [Pr. PA08]. Setting range: 0.00 to 300.00	7.00 [times]
PB30 PG2B Position loop gain after gain switching	—	Set the position loop gain for when the gain switching is enabled. When a value less than 1.0 rad/s is set, the value will be the same as that of [Pr. PB08]. This parameter is enabled only when "Gain adjustment mode selection" is set to "Manual mode (___3)" in [Pr. PA08]. Setting range: 0.0 to 2000.0	0.0 [rad/s]
PB31 VG2B Speed loop gain after gain switching	—	Set the speed loop gain for when the gain switching is enabled. When a value less than 20 rad/s is set, the value will be the same as that of [Pr. PB09]. This parameter is enabled only when "Gain adjustment mode selection" is set to "Manual mode (___3)" in [Pr. PA08]. Setting range: 0 to 65535	0 [rad/s]
PB32 VICB Speed integral compensation after gain switching	—	Set the speed integral compensation for when the gain switching is enabled. When a value less than 0.1 ms is set, the value will be the same as that of [Pr. PB10]. This parameter is enabled only when "Gain adjustment mode selection" is set to "Manual mode (___3)" in [Pr. PA08]. Setting range: 0.0 to 5000.0	0.0 [ms]
PB33 VRF11B Vibration suppression control 1 - Vibration frequency after gain switching	—	Set the vibration frequency for vibration suppression control 1 for when the gain switching is enabled. When a value less than 0.1 Hz is set, the value will be the same as that of [Pr. PB19]. This parameter will be enabled only when the following conditions are fulfilled. • "Gain adjustment mode selection" is set to "Manual mode (___3)" in [Pr. PA08]. • "Vibration suppression control 1 tuning mode selection" is set to "Manual setting (___2)" in [Pr. PB02]. • "Gain switching selection" is set to "Switching is enabled by control command from controller and Input device CDP (Gain switching) (___1)" in [Pr. PB26]. Switching during driving may cause a shock. Be sure to switch them after the servo motor stops. Setting range: 0.0 to 300.0	0.0 [Hz]

No./symbol/ name	Setting digit	Function	Initial value [unit]
PB34 VRF12B Vibration suppression control 1 - Resonance frequency after gain switching	—	<p>Set the resonance frequency for vibration suppression control 1 for when the gain switching is enabled. When a value less than 0.1 Hz is set, the value will be the same as that of [Pr. PB20].</p> <p>This parameter will be enabled only when the following conditions are fulfilled.</p> <ul style="list-style-type: none"> • "Gain adjustment mode selection" is set to "Manual mode (_ _ _ 3)" in [Pr. PA08]. • "Vibration suppression control 1 tuning mode selection" is set to "Manual setting (_ _ _ 2)" in [Pr. PB02]. • "Gain switching selection" is set to "Switching is enabled by control command from controller and Input device CDP (Gain switching) (_ _ _ 1)" in [Pr. PB26]. <p>Switching during driving may cause a shock. Be sure to switch them after the servo motor stops.</p> <p>Setting range: 0.0 to 300.0</p>	0.0 [Hz]
PB35 VRF13B Vibration suppression control 1 - Vibration frequency damping after gain switching	—	<p>Set a damping of the vibration frequency for vibration suppression control 1 when the gain switching is enabled.</p> <p>This parameter will be enabled only when the following conditions are fulfilled.</p> <ul style="list-style-type: none"> • "Gain adjustment mode selection" is set to "Manual mode (_ _ _ 3)" in [Pr. PA08]. • "Vibration suppression control 1 tuning mode selection" is set to "Manual setting (_ _ _ 2)" in [Pr. PB02]. • "Gain switching selection" is set to "Switching is enabled by control command from controller and Input device CDP (Gain switching) (_ _ _ 1)" in [Pr. PB26]. <p>Switching during driving may cause a shock. Be sure to switch them after the servo motor stops.</p> <p>Setting range: 0.00 to 0.30</p>	0.00
PB36 VRF14B Vibration suppression control 1 - Resonance frequency damping after gain switching	—	<p>Set a damping of the resonance frequency for vibration suppression control 1 when the gain switching is enabled.</p> <p>This parameter will be enabled only when the following conditions are fulfilled.</p> <ul style="list-style-type: none"> • "Gain adjustment mode selection" is set to "Manual mode (_ _ _ 3)" in [Pr. PA08]. • "Vibration suppression control 1 tuning mode selection" is set to "Manual setting (_ _ _ 2)" in [Pr. PB02]. • "Gain switching selection" is set to "Switching is enabled by control command from controller and Input device CDP (Gain switching) (_ _ _ 1)" in [Pr. PB26]. <p>Switching during driving may cause a shock. Be sure to switch them after the servo motor stops.</p> <p>Setting range: 0.00 to 0.30</p>	0.00

No./symbol/ name	Setting digit	Function	Initial value [unit]																																																																																																																																																																																																					
PB45 CNHF Command notch filter		Set the command notch filter.																																																																																																																																																																																																						
	__ x x	Command notch filter setting frequency selection Refer to the following table (command notch filter setting frequency selection) for the relation of setting values to frequency.	00h																																																																																																																																																																																																					
	_ x __	Notch depth selection Refer to the following table (notch depth selection) for details.	0h																																																																																																																																																																																																					
	x ___	For manufacturer setting	0h																																																																																																																																																																																																					
Command notch filter setting frequency selection																																																																																																																																																																																																								
	<table border="1"> <thead> <tr> <th>Setting value</th> <th>Frequency [Hz]</th> <th>Setting value</th> <th>Frequency [Hz]</th> <th>Setting value</th> <th>Frequency [Hz]</th> </tr> </thead> <tbody> <tr><td>__ 0 0</td><td>Disabled</td><td>__ 2 0</td><td>70</td><td>__ 4 0</td><td>17.6</td></tr> <tr><td>__ 0 1</td><td>2250</td><td>__ 2 1</td><td>66</td><td>__ 4 1</td><td>16.5</td></tr> <tr><td>__ 0 2</td><td>1125</td><td>__ 2 2</td><td>62</td><td>__ 4 2</td><td>15.6</td></tr> <tr><td>__ 0 3</td><td>750</td><td>__ 2 3</td><td>59</td><td>__ 4 3</td><td>14.8</td></tr> <tr><td>__ 0 4</td><td>562</td><td>__ 2 4</td><td>56</td><td>__ 4 4</td><td>14.1</td></tr> <tr><td>__ 0 5</td><td>450</td><td>__ 2 5</td><td>53</td><td>__ 4 5</td><td>13.4</td></tr> <tr><td>__ 0 6</td><td>375</td><td>__ 2 6</td><td>51</td><td>__ 4 6</td><td>12.8</td></tr> <tr><td>__ 0 7</td><td>321</td><td>__ 2 7</td><td>48</td><td>__ 4 7</td><td>12.2</td></tr> <tr><td>__ 0 8</td><td>281</td><td>__ 2 8</td><td>46</td><td>__ 4 8</td><td>11.7</td></tr> <tr><td>__ 0 9</td><td>250</td><td>__ 2 9</td><td>45</td><td>__ 4 9</td><td>11.3</td></tr> <tr><td>__ 0 A</td><td>225</td><td>__ 2 A</td><td>43</td><td>__ 4 A</td><td>10.8</td></tr> <tr><td>__ 0 B</td><td>204</td><td>__ 2 B</td><td>41</td><td>__ 4 B</td><td>10.4</td></tr> <tr><td>__ 0 C</td><td>187</td><td>__ 2 C</td><td>40</td><td>__ 4 C</td><td>10</td></tr> <tr><td>__ 0 D</td><td>173</td><td>__ 2 D</td><td>38</td><td>__ 4 D</td><td>9.7</td></tr> <tr><td>__ 0 E</td><td>160</td><td>__ 2 E</td><td>37</td><td>__ 4 E</td><td>9.4</td></tr> <tr><td>__ 0 F</td><td>150</td><td>__ 2 F</td><td>36</td><td>__ 4 F</td><td>9.1</td></tr> <tr><td>__ 1 0</td><td>140</td><td>__ 3 0</td><td>35.2</td><td>__ 5 0</td><td>8.8</td></tr> <tr><td>__ 1 1</td><td>132</td><td>__ 3 1</td><td>33.1</td><td>__ 5 1</td><td>8.3</td></tr> <tr><td>__ 1 2</td><td>125</td><td>__ 3 2</td><td>31.3</td><td>__ 5 2</td><td>7.8</td></tr> <tr><td>__ 1 3</td><td>118</td><td>__ 3 3</td><td>29.6</td><td>__ 5 3</td><td>7.4</td></tr> <tr><td>__ 1 4</td><td>112</td><td>__ 3 4</td><td>28.1</td><td>__ 5 4</td><td>7.0</td></tr> <tr><td>__ 1 5</td><td>107</td><td>__ 3 5</td><td>26.8</td><td>__ 5 5</td><td>6.7</td></tr> <tr><td>__ 1 6</td><td>102</td><td>__ 3 6</td><td>25.6</td><td>__ 5 6</td><td>6.4</td></tr> <tr><td>__ 1 7</td><td>97</td><td>__ 3 7</td><td>24.5</td><td>__ 5 7</td><td>6.1</td></tr> <tr><td>__ 1 8</td><td>93</td><td>__ 3 8</td><td>23.4</td><td>__ 5 8</td><td>5.9</td></tr> <tr><td>__ 1 9</td><td>90</td><td>__ 3 9</td><td>22.5</td><td>__ 5 9</td><td>5.6</td></tr> <tr><td>__ 1 A</td><td>86</td><td>__ 3 A</td><td>21.6</td><td>__ 5 A</td><td>5.4</td></tr> <tr><td>__ 1 B</td><td>83</td><td>__ 3 B</td><td>20.8</td><td>__ 5 B</td><td>5.2</td></tr> <tr><td>__ 1 C</td><td>80</td><td>__ 3 C</td><td>20.1</td><td>__ 5 C</td><td>5.0</td></tr> <tr><td>__ 1 D</td><td>77</td><td>__ 3 D</td><td>19.4</td><td>__ 5 D</td><td>4.9</td></tr> <tr><td>__ 1 E</td><td>75</td><td>__ 3 E</td><td>18.8</td><td>__ 5 E</td><td>4.7</td></tr> <tr><td>__ 1 F</td><td>72</td><td>__ 3 F</td><td>18.2</td><td>__ 5 F</td><td>4.5</td></tr> </tbody> </table>	Setting value	Frequency [Hz]	Setting value	Frequency [Hz]	Setting value	Frequency [Hz]	__ 0 0	Disabled	__ 2 0	70	__ 4 0	17.6	__ 0 1	2250	__ 2 1	66	__ 4 1	16.5	__ 0 2	1125	__ 2 2	62	__ 4 2	15.6	__ 0 3	750	__ 2 3	59	__ 4 3	14.8	__ 0 4	562	__ 2 4	56	__ 4 4	14.1	__ 0 5	450	__ 2 5	53	__ 4 5	13.4	__ 0 6	375	__ 2 6	51	__ 4 6	12.8	__ 0 7	321	__ 2 7	48	__ 4 7	12.2	__ 0 8	281	__ 2 8	46	__ 4 8	11.7	__ 0 9	250	__ 2 9	45	__ 4 9	11.3	__ 0 A	225	__ 2 A	43	__ 4 A	10.8	__ 0 B	204	__ 2 B	41	__ 4 B	10.4	__ 0 C	187	__ 2 C	40	__ 4 C	10	__ 0 D	173	__ 2 D	38	__ 4 D	9.7	__ 0 E	160	__ 2 E	37	__ 4 E	9.4	__ 0 F	150	__ 2 F	36	__ 4 F	9.1	__ 1 0	140	__ 3 0	35.2	__ 5 0	8.8	__ 1 1	132	__ 3 1	33.1	__ 5 1	8.3	__ 1 2	125	__ 3 2	31.3	__ 5 2	7.8	__ 1 3	118	__ 3 3	29.6	__ 5 3	7.4	__ 1 4	112	__ 3 4	28.1	__ 5 4	7.0	__ 1 5	107	__ 3 5	26.8	__ 5 5	6.7	__ 1 6	102	__ 3 6	25.6	__ 5 6	6.4	__ 1 7	97	__ 3 7	24.5	__ 5 7	6.1	__ 1 8	93	__ 3 8	23.4	__ 5 8	5.9	__ 1 9	90	__ 3 9	22.5	__ 5 9	5.6	__ 1 A	86	__ 3 A	21.6	__ 5 A	5.4	__ 1 B	83	__ 3 B	20.8	__ 5 B	5.2	__ 1 C	80	__ 3 C	20.1	__ 5 C	5.0	__ 1 D	77	__ 3 D	19.4	__ 5 D	4.9	__ 1 E	75	__ 3 E	18.8	__ 5 E	4.7	__ 1 F	72	__ 3 F	18.2	__ 5 F	4.5	
Setting value	Frequency [Hz]	Setting value	Frequency [Hz]	Setting value	Frequency [Hz]																																																																																																																																																																																																			
__ 0 0	Disabled	__ 2 0	70	__ 4 0	17.6																																																																																																																																																																																																			
__ 0 1	2250	__ 2 1	66	__ 4 1	16.5																																																																																																																																																																																																			
__ 0 2	1125	__ 2 2	62	__ 4 2	15.6																																																																																																																																																																																																			
__ 0 3	750	__ 2 3	59	__ 4 3	14.8																																																																																																																																																																																																			
__ 0 4	562	__ 2 4	56	__ 4 4	14.1																																																																																																																																																																																																			
__ 0 5	450	__ 2 5	53	__ 4 5	13.4																																																																																																																																																																																																			
__ 0 6	375	__ 2 6	51	__ 4 6	12.8																																																																																																																																																																																																			
__ 0 7	321	__ 2 7	48	__ 4 7	12.2																																																																																																																																																																																																			
__ 0 8	281	__ 2 8	46	__ 4 8	11.7																																																																																																																																																																																																			
__ 0 9	250	__ 2 9	45	__ 4 9	11.3																																																																																																																																																																																																			
__ 0 A	225	__ 2 A	43	__ 4 A	10.8																																																																																																																																																																																																			
__ 0 B	204	__ 2 B	41	__ 4 B	10.4																																																																																																																																																																																																			
__ 0 C	187	__ 2 C	40	__ 4 C	10																																																																																																																																																																																																			
__ 0 D	173	__ 2 D	38	__ 4 D	9.7																																																																																																																																																																																																			
__ 0 E	160	__ 2 E	37	__ 4 E	9.4																																																																																																																																																																																																			
__ 0 F	150	__ 2 F	36	__ 4 F	9.1																																																																																																																																																																																																			
__ 1 0	140	__ 3 0	35.2	__ 5 0	8.8																																																																																																																																																																																																			
__ 1 1	132	__ 3 1	33.1	__ 5 1	8.3																																																																																																																																																																																																			
__ 1 2	125	__ 3 2	31.3	__ 5 2	7.8																																																																																																																																																																																																			
__ 1 3	118	__ 3 3	29.6	__ 5 3	7.4																																																																																																																																																																																																			
__ 1 4	112	__ 3 4	28.1	__ 5 4	7.0																																																																																																																																																																																																			
__ 1 5	107	__ 3 5	26.8	__ 5 5	6.7																																																																																																																																																																																																			
__ 1 6	102	__ 3 6	25.6	__ 5 6	6.4																																																																																																																																																																																																			
__ 1 7	97	__ 3 7	24.5	__ 5 7	6.1																																																																																																																																																																																																			
__ 1 8	93	__ 3 8	23.4	__ 5 8	5.9																																																																																																																																																																																																			
__ 1 9	90	__ 3 9	22.5	__ 5 9	5.6																																																																																																																																																																																																			
__ 1 A	86	__ 3 A	21.6	__ 5 A	5.4																																																																																																																																																																																																			
__ 1 B	83	__ 3 B	20.8	__ 5 B	5.2																																																																																																																																																																																																			
__ 1 C	80	__ 3 C	20.1	__ 5 C	5.0																																																																																																																																																																																																			
__ 1 D	77	__ 3 D	19.4	__ 5 D	4.9																																																																																																																																																																																																			
__ 1 E	75	__ 3 E	18.8	__ 5 E	4.7																																																																																																																																																																																																			
__ 1 F	72	__ 3 F	18.2	__ 5 F	4.5																																																																																																																																																																																																			
Notch depth selection																																																																																																																																																																																																								
	<table border="1"> <thead> <tr> <th>Setting value</th> <th>Depth [dB]</th> <th>Setting value</th> <th>Depth [dB]</th> </tr> </thead> <tbody> <tr><td>_ 0 __</td><td>-40.0</td><td>_ 8 __</td><td>-6.0</td></tr> <tr><td>_ 1 __</td><td>-24.1</td><td>_ 9 __</td><td>-5.0</td></tr> <tr><td>_ 2 __</td><td>-18.1</td><td>_ A __</td><td>-4.1</td></tr> <tr><td>_ 3 __</td><td>-14.5</td><td>_ B __</td><td>-3.3</td></tr> <tr><td>_ 4 __</td><td>-12.0</td><td>_ C __</td><td>-2.5</td></tr> <tr><td>_ 5 __</td><td>-10.1</td><td>_ D __</td><td>-1.8</td></tr> <tr><td>_ 6 __</td><td>-8.5</td><td>_ E __</td><td>-1.2</td></tr> <tr><td>_ 7 __</td><td>-7.2</td><td>_ F __</td><td>-0.6</td></tr> </tbody> </table>	Setting value	Depth [dB]	Setting value	Depth [dB]	_ 0 __	-40.0	_ 8 __	-6.0	_ 1 __	-24.1	_ 9 __	-5.0	_ 2 __	-18.1	_ A __	-4.1	_ 3 __	-14.5	_ B __	-3.3	_ 4 __	-12.0	_ C __	-2.5	_ 5 __	-10.1	_ D __	-1.8	_ 6 __	-8.5	_ E __	-1.2	_ 7 __	-7.2	_ F __	-0.6																																																																																																																																																																			
Setting value	Depth [dB]	Setting value	Depth [dB]																																																																																																																																																																																																					
_ 0 __	-40.0	_ 8 __	-6.0																																																																																																																																																																																																					
_ 1 __	-24.1	_ 9 __	-5.0																																																																																																																																																																																																					
_ 2 __	-18.1	_ A __	-4.1																																																																																																																																																																																																					
_ 3 __	-14.5	_ B __	-3.3																																																																																																																																																																																																					
_ 4 __	-12.0	_ C __	-2.5																																																																																																																																																																																																					
_ 5 __	-10.1	_ D __	-1.8																																																																																																																																																																																																					
_ 6 __	-8.5	_ E __	-1.2																																																																																																																																																																																																					
_ 7 __	-7.2	_ F __	-0.6																																																																																																																																																																																																					











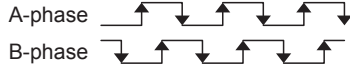

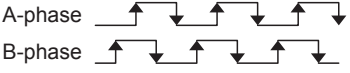
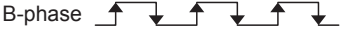
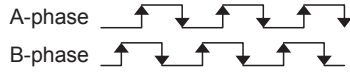

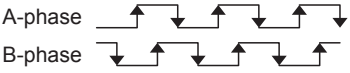

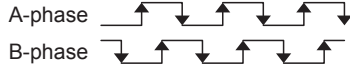

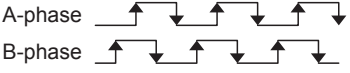
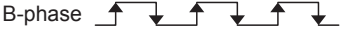
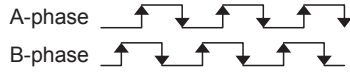
No./symbol/ name	Setting digit	Function	Initial value [unit]
PB46 NH3 Machine resonance suppression filter 3	—	Set the notch frequency of the machine resonance suppression filter 3. To enable the setting value, set "Machine resonance suppression filter 3 selection" to "Enabled (_ _ _ 1)" in [Pr. PB47]. Setting range: 10 to 4500	4500 [Hz]
PB47 NHQ3 Notch shape selection 3	Set forms of the machine resonance suppression filter 3.		
	_ _ _ x	Machine resonance suppression filter 3 selection 0: Disabled 1: Enabled	0h
	_ _ x _	Notch depth selection 0: -40 dB 1: -14 dB 2: -8 dB 3: -4 dB	0h
	_ x _ _	Notch width selection 0: $\alpha = 2$ 1: $\alpha = 3$ 2: $\alpha = 4$ 3: $\alpha = 5$	0h
	x _ _ _	For manufacturer setting	0h
PB48 NH4 Machine resonance suppression filter 4	—	Set the notch frequency of the machine resonance suppression filter 4. To enable the setting value, set "Machine resonance suppression filter 4 selection" to "Enabled (_ _ _ 1)" in [Pr. PB49]. Setting range: 10 to 4500	4500 [Hz]
PB49 NHQ4 Notch shape selection 4	Set forms of the machine resonance suppression filter 4.		
	_ _ _ x	Machine resonance suppression filter 4 selection 0: Disabled 1: Enabled When "Enabled" is set, [Pr. PB17 Shaft resonance suppression filter] is not available.	0h
	_ _ x _	Notch depth selection 0: -40 dB 1: -14 dB 2: -8 dB 3: -4 dB	0h
	_ x _ _	Notch width selection 0: $\alpha = 2$ 1: $\alpha = 3$ 2: $\alpha = 4$ 3: $\alpha = 5$	0h
	x _ _ _	For manufacturer setting	0h
PB50 NH5 Machine resonance suppression filter 5	—	Set the notch frequency of the machine resonance suppression filter 5. To enable the setting value, set "Machine resonance suppression filter 5 selection" to "Enabled (_ _ _ 1)" in [Pr. PB51]. Setting range: 10 to 4500	4500 [Hz]
PB51 NHQ5 Notch shape selection 5	Set forms of the machine resonance suppression filter 5. When "Robust filter selection" is set to "Enabled (_ _ _ 1)" in [Pr. PE41], the machine resonance suppression filter 5 is not available.		
	_ _ _ x	Machine resonance suppression filter 5 selection 0: Disabled 1: Enabled	0h
	_ _ x _	Notch depth selection 0: -40 dB 1: -14 dB 2: -8 dB 3: -4 dB	0h
	_ x _ _	Notch width selection 0: $\alpha = 2$ 1: $\alpha = 3$ 2: $\alpha = 4$ 3: $\alpha = 5$	0h
	x _ _ _	For manufacturer setting	0h

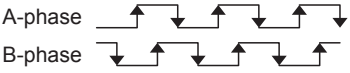

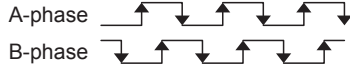
No./symbol/ name	Setting digit	Function	Initial value [unit]
PB52 VRF21 Vibration suppression control 2 - Vibration frequency	—	<p>Set the vibration frequency for vibration suppression control 2 to suppress low-frequency machine vibration. When "Vibration suppression control 2 tuning mode selection" is set to "Automatic setting (_ _ 1 _)" in [Pr. PB02], this parameter will be set automatically. When "Manual setting (_ _ 2 _)" is selected, the setting written to the parameter is used.</p> <p>To enable the setting value, set "Vibration suppression mode selection" to "3 inertia mode (_ _ _ 1)" in [Pr. PA24]. The setting range of this parameter varies, depending on the value in [Pr. PB07]. If a value out of the range is set, the vibration suppression control is disabled.</p> <p>☞ Page 257 Advanced vibration suppression control II</p> <p>Setting range: 0.1 to 300.0</p>	100.0 [Hz]
PB53 VRF22 Vibration suppression control 2 - Resonance frequency	—	<p>Set the resonance frequency for vibration suppression control 2 to suppress low-frequency machine vibration. When "Vibration suppression control 2 tuning mode selection" is set to "Automatic setting (_ _ 1 _)" in [Pr. PB02], this parameter will be set automatically. When "Manual setting (_ _ 2 _)" is selected, the setting written to the parameter is used.</p> <p>To enable the setting value, set "Vibration suppression mode selection" to "3 inertia mode (_ _ _ 1)" in [Pr. PA24]. The setting range of this parameter varies, depending on the value in [Pr. PB07]. If a value out of the range is set, the vibration suppression control is disabled.</p> <p>☞ Page 257 Advanced vibration suppression control II</p> <p>Setting range: 0.1 to 300.0</p>	100.0 [Hz]
PB54 VRF23 Vibration suppression control 2 - Vibration frequency damping	—	<p>Set a damping of the vibration frequency for vibration suppression control 2 to suppress low-frequency machine vibration. When "Vibration suppression control 2 tuning mode selection" is set to "Automatic setting (_ _ 1 _)" in [Pr. PB02], this parameter will be set automatically. When "Manual setting (_ _ 2 _)" is selected, the setting written to the parameter is used.</p> <p>To enable the setting value, set "Vibration suppression mode selection" to "3 inertia mode (_ _ _ 1)" in [Pr. PA24].</p> <p>☞ Page 257 Advanced vibration suppression control II</p> <p>Setting range: 0.00 to 0.30</p>	0.00
PB55 VRF24 Vibration suppression control 2 - Resonance frequency damping	—	<p>Set a damping of the resonance frequency for vibration suppression control 2 to suppress low-frequency machine vibration. When "Vibration suppression control 2 tuning mode selection" is set to "Automatic setting (_ _ 1 _)" in [Pr. PB02], this parameter will be set automatically. When "Manual setting (_ _ 2 _)" is selected, the setting written to the parameter is used.</p> <p>To enable the setting value, set "Vibration suppression mode selection" to "3 inertia mode (_ _ _ 1)" in [Pr. PA24].</p> <p>☞ Page 257 Advanced vibration suppression control II</p> <p>Setting range: 0.00 to 0.30</p>	0.00
PB56 VRF21B Vibration suppression control 2 - Vibration frequency after gain switching	—	<p>Set the vibration frequency for vibration suppression control 2 for when the gain switching is enabled. When a value less than 0.1 Hz is set, the value will be the same as that of [Pr. PB52]. This parameter will be enabled only when the following conditions are fulfilled.</p> <ul style="list-style-type: none"> • "Gain adjustment mode selection" is set to "Manual mode (_ _ _ 3)" in [Pr. PA08]. • "Vibration suppression mode selection" is set to "3 inertia mode (_ _ _ 1)" in [Pr. PA24]. • "Vibration suppression control 2 tuning mode selection" is set to "Manual setting (_ _ 2 _)" in [Pr. PB02]. • "Gain switching selection" is set to "Switching is enabled by control command from controller and Input device CDP (Gain switching) (_ _ _ 1)" in [Pr. PB26]. <p>Switching during driving may cause a shock. Be sure to switch them after the servo motor stops.</p> <p>Setting range: 0.0 to 300.0</p>	0.0 [Hz]
PB57 VRF22B Vibration suppression control 2 - Resonance frequency after gain switching	—	<p>Set the resonance frequency for vibration suppression control 2 for when the gain switching is enabled. When a value less than 0.1 Hz is set, the value will be the same as that of [Pr. PB53]. This parameter will be enabled only when the following conditions are fulfilled.</p> <ul style="list-style-type: none"> • "Gain adjustment mode selection" is set to "Manual mode (_ _ _ 3)" in [Pr. PA08]. • "Vibration suppression mode selection" is set to "3 inertia mode (_ _ _ 1)" in [Pr. PA24]. • "Vibration suppression control 2 tuning mode selection" is set to "Manual setting (_ _ 2 _)" in [Pr. PB02]. • "Gain switching selection" is set to "Switching is enabled by control command from controller and Input device CDP (Gain switching) (_ _ _ 1)" in [Pr. PB26]. <p>Switching during driving may cause a shock. Be sure to switch them after the servo motor stops.</p> <p>Setting range: 0.0 to 300.0</p>	0.0 [Hz]
PB58 VRF23B Vibration suppression control 2 - Vibration frequency damping after gain switching	—	<p>Set a damping of the vibration frequency for vibration suppression control 2 when the gain switching is enabled. This parameter will be enabled only when the following conditions are fulfilled.</p> <ul style="list-style-type: none"> • "Gain adjustment mode selection" is set to "Manual mode (_ _ _ 3)" in [Pr. PA08]. • "Vibration suppression mode selection" is set to "3 inertia mode (_ _ _ 1)" in [Pr. PA24]. • "Vibration suppression control 2 tuning mode selection" is set to "Manual setting (_ _ 2 _)" in [Pr. PB02]. • "Gain switching selection" is set to "Switching is enabled by control command from controller and Input device CDP (Gain switching) (_ _ _ 1)" in [Pr. PB26]. <p>Switching during driving may cause a shock. Be sure to switch them after the servo motor stops.</p> <p>Setting range: 0.00 to 0.30</p>	0.00

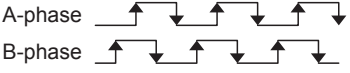
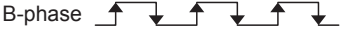
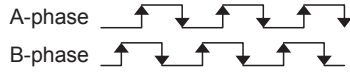
No./symbol/ name	Setting digit	Function	Initial value [unit]
PB59 VRF24B Vibration suppression control 2 - Resonance frequency damping after gain switching	—	<p>Set a damping of the resonance frequency for vibration suppression control 2 when the gain switching is enabled.</p> <p>This parameter will be enabled only when the following conditions are fulfilled.</p> <ul style="list-style-type: none"> • "Gain adjustment mode selection" is set to "Manual mode (_ _ _ 3)" in [Pr. PA08]. • "Vibration suppression mode selection" is set to "3 inertia mode (_ _ _ 1)" in [Pr. PA24]. • "Vibration suppression control 2 tuning mode selection" is set to "Manual setting (_ _ 2 _)" in [Pr. PB02]. • "Gain switching selection" is set to "Switching is enabled by control command from controller and Input device CDP (Gain switching) (_ _ _ 1)" in [Pr. PB26]. <p>Switching during driving may cause a shock. Be sure to switch them after the servo motor stops. Setting range: 0.00 to 0.30</p>	0.00
PB60 PG1B Model loop gain after gain switching	—	<p>Set the model loop gain for when the gain switching is enabled.</p> <p>When a value less than 1.0 rad/s is set, the value will be the same as that of [Pr. PB07].</p> <p>This parameter will be enabled only when the following conditions are fulfilled.</p> <ul style="list-style-type: none"> • "Gain adjustment mode selection" is set to "Manual mode (_ _ _ 3)" in [Pr. PA08]. • "Gain switching selection" is set to "Switching is enabled by control command from controller and Input device CDP (Gain switching) (_ _ _ 1)" in [Pr. PB26]. <p>Switching during driving may cause a shock. Be sure to switch them after the servo motor stops. Setting range: 0.0 to 2000.0</p>	0.0 [rad/s]

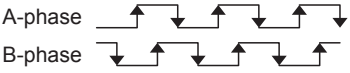
Extension setting parameters ([Pr. PC _ _])

No./symbol/ name	Setting digit	Function	Initial value [unit]
PC01 ERZ Error excessive alarm level	—	<p>Set an error excessive alarm level.</p> <p>The setting unit can be changed with "Error excessive alarm/error excessive warning level unit selection" in [Pr. PC06].</p> <p>Set this per rev. for rotary servo motors and direct drive motors. When "0" is set, 3 rev will be applied. Setting over 200 rev will be clamped to 200 rev. Set this per mm for linear servo motors. Setting "0" will be 100 mm. Refer to the following for the adjustment methods.</p> <p>☞ Page 660 Adjustment method for error excessive alarm level</p> <p>Setting range: 0 to 1000</p>	0 [rev]/[mm]
PC02 MBR Electromagnetic brake sequence output	—	<p>Set the delay time from when MBR (Electromagnetic brake interlock) turns off till when the base drive circuit is shut-off.</p> <p>For the timing chart of when the servo motor with an electromagnetic brake is used, refer to the following.</p> <p>☞ Page 121 Timing chart</p> <p>Setting range: 0 to 1000</p>	0 [ms]

No./symbol/ name	Setting digit	Function	Initial value [unit]											
PC03 *ENRS Encoder output pulse selection	___x	Encoder output pulse phase selection Select an encoder pulse direction. 0: Increasing A-phase 90° in CCW or positive direction 1: Increasing A-phase 90° in CW or negative direction	0h											
		<table border="1"> <thead> <tr> <th rowspan="2">Setting value</th> <th colspan="2">Servo motor rotation direction/linear servo motor travel direction</th> </tr> <tr> <th>CCW or positive direction</th> <th>CW or negative direction</th> </tr> </thead> <tbody> <tr> <td>0</td> <td>A-phase  B-phase </td> <td>A-phase  B-phase </td> </tr> <tr> <td>1</td> <td>A-phase  B-phase </td> <td>A-phase  B-phase </td> </tr> </tbody> </table>	Setting value	Servo motor rotation direction/linear servo motor travel direction		CCW or positive direction	CW or negative direction	0	A-phase  B-phase 	A-phase  B-phase 	1	A-phase  B-phase 	A-phase  B-phase 	
	Setting value	Servo motor rotation direction/linear servo motor travel direction												
		CCW or positive direction	CW or negative direction											
0	A-phase  B-phase 	A-phase  B-phase 												
1	A-phase  B-phase 	A-phase  B-phase 												
__x_	Encoder output pulse setting selection 0: Output pulse setting 1: Dividing ratio setting The setting of [Pr. PA16 Encoder output pulses 2] will be disabled. 3: A-phase/B-phase pulse electronic gear setting 4: A/B-phase pulse through output setting The setting value is available with servo amplifiers with software version A1 or later.  Page 659 Encoder output pulse setting method When another encoder is connected, [AL. 37 Parameter error] will occur. Setting "Standard control mode (___0_)" in [Pr. PA01] will trigger [AL. 37 Parameter error].	0h												
_x__	Selection of the encoders for encoder output pulse Select an encoder used for the encoder output pulses which the servo amplifier outputs. This is only for the fully closed loop system. If "1" is set in other systems than the fully closed loop system, [AL. 37 Parameter error] will occur. The setting of this digit is used by servo amplifier with software version A1 or later. 0: Servo motor encoder 1: Load-side encoder When "_ 1 0_" is set to this parameter, [AL. 37 Parameter error] will occur.	0h												
	x___	For manufacturer setting	0h											
PC04 **COP1 Function selection C-1	___x	For manufacturer setting	0h											
	__x_		0h											
	_x__		0h											
	x___	Encoder cable communication method selection Select an encoder cable communication method. 0: Two-wire type 1: Four-wire type When using an encoder of A/B/Z-phase differential output method, set "0". If the setting is incorrect, [AL. 16 Encoder initial communication error 1] or [AL. 20 Encoder normal communication error 1] occurs.	0h											
PC05 **COP2 Function selection C-2	___x	Motor-less operation selection Set the motor-less operation. The motor-less operation cannot be used in the fully closed loop control mode, linear servo motor control mode, or DD motor control mode. 0: Disabled 1: Enabled	0h											
	__x_	For manufacturer setting	0h											
	_x__		0h											
	x___		0h											
PC06 *COP3 Function selection C-3	___x	In-position range unit selection Select a unit of in-position range. 0: Command input pulse unit 1: Servo motor encoder pulse unit	0h											
	__x_	For manufacturer setting	0h											
	_x__		0h											
	x___	Error excessive alarm/error excessive warning level unit selection Select units for error excessive alarm level setting with [Pr. PC01] and for error excessive warning level setting with [Pr. PC38]. 0: Per 1 rev or 1 mm 1: Per 0.1 rev or 0.1 mm 2: Per 0.01 rev or 0.01 mm 3: Per 0.001 rev or 0.001 mm	0h											

No./symbol/ name	Setting digit	Function	Initial value [unit]																																																																																																																																		
PC07 ZSP Zero speed	—	Set an output range of ZSP (Zero speed detection). ZSP (Zero speed detection) has hysteresis of 20 r/min or 20 mm/s. Setting range: 0 to 10000	50 [r/min]/ [mm/s]																																																																																																																																		
PC08 OSL Overspeed alarm detection level	—	Set an overspeed alarm detection level. When you set a value more than "servo motor maximum speed × 120%", the set value will be clamped. When you set "0", the value of "servo motor maximum speed × 120%" will be set. Setting range: 0 to 20000	0 [r/min]/ [mm/s]																																																																																																																																		
PC09 MOD1 Analog monitor 1 output	__ x x	Analog monitor 1 output selection Select a signal to output to MO1 (Analog monitor 1). Refer to the following for detection point of output selection.  Page 637 Analog monitor block diagram Refer to the following table for settings.	00h																																																																																																																																		
	_ x _ _	For manufacturer setting	0h																																																																																																																																		
	x _ _ _		0h																																																																																																																																		
		<table border="1"> <thead> <tr> <th rowspan="2">Setting value</th> <th rowspan="2">Item</th> <th colspan="4">Operation mode^{*1}</th> </tr> <tr> <th>Standard</th> <th>Full.</th> <th>Lin.</th> <th>DD</th> </tr> </thead> <tbody> <tr> <td>__ 0 0</td> <td>Servo motor speed (±8 V/max. speed)</td> <td><input type="radio"/></td> <td><input type="radio"/></td> <td><input type="radio"/></td> <td><input type="radio"/></td> </tr> <tr> <td>__ 0 1</td> <td>Torque or thrust (±8 V/max. torque or max. thrust)^{*3}</td> <td><input type="radio"/></td> <td><input type="radio"/></td> <td><input type="radio"/></td> <td><input type="radio"/></td> </tr> <tr> <td>__ 0 2</td> <td>Servo motor speed (+8 V/max. speed)</td> <td><input type="radio"/></td> <td><input type="radio"/></td> <td><input type="radio"/></td> <td><input type="radio"/></td> </tr> <tr> <td>__ 0 3</td> <td>Torque or thrust (+8 V/max. torque or max. thrust)^{*3}</td> <td><input type="radio"/></td> <td><input type="radio"/></td> <td><input type="radio"/></td> <td><input type="radio"/></td> </tr> <tr> <td>__ 0 4</td> <td>Current command (±8 V/max. current command)</td> <td><input type="radio"/></td> <td><input type="radio"/></td> <td><input type="radio"/></td> <td><input type="radio"/></td> </tr> <tr> <td>__ 0 5</td> <td>Speed command (±8 V/max. speed)</td> <td><input type="radio"/></td> <td><input type="radio"/></td> <td><input type="radio"/></td> <td><input type="radio"/></td> </tr> <tr> <td>__ 0 6</td> <td>Servo motor-side droop pulses (±10 V/100 pulses)^{*2}</td> <td><input type="radio"/></td> <td><input type="radio"/></td> <td><input type="radio"/></td> <td><input type="radio"/></td> </tr> <tr> <td>__ 0 7</td> <td>Servo motor-side droop pulses (±10 V/1000 pulses)^{*2}</td> <td><input type="radio"/></td> <td><input type="radio"/></td> <td><input type="radio"/></td> <td><input type="radio"/></td> </tr> <tr> <td>__ 0 8</td> <td>Servo motor-side droop pulses (±10 V/10000 pulses)^{*2}</td> <td><input type="radio"/></td> <td><input type="radio"/></td> <td><input type="radio"/></td> <td><input type="radio"/></td> </tr> <tr> <td>__ 0 9</td> <td>Servo motor-side droop pulses (±10 V/100000 pulses)^{*2}</td> <td><input type="radio"/></td> <td><input type="radio"/></td> <td><input type="radio"/></td> <td><input type="radio"/></td> </tr> <tr> <td>__ 0 D</td> <td>Bus voltage (200 V class or 100 V class: +8 V/400 V, 400 V class: +8 V/800 V)</td> <td><input type="radio"/></td> <td><input type="radio"/></td> <td><input type="radio"/></td> <td><input type="radio"/></td> </tr> <tr> <td>__ 0 E</td> <td>Speed command 2 (±8 V/max. speed)</td> <td><input type="radio"/></td> <td><input type="radio"/></td> <td><input type="radio"/></td> <td><input type="radio"/></td> </tr> <tr> <td>__ 1 0</td> <td>Load-side droop pulses (±10 V/100 pulses)^{*2}</td> <td>-</td> <td><input type="radio"/></td> <td>-</td> <td>-</td> </tr> <tr> <td>__ 1 1</td> <td>Load-side droop pulses (±10 V/1000 pulses)^{*2}</td> <td>-</td> <td><input type="radio"/></td> <td>-</td> <td>-</td> </tr> <tr> <td>__ 1 2</td> <td>Load-side droop pulses (±10 V/10000 pulses)^{*2}</td> <td>-</td> <td><input type="radio"/></td> <td>-</td> <td>-</td> </tr> <tr> <td>__ 1 3</td> <td>Load-side droop pulses (±10 V/100000 pulses)^{*2}</td> <td>-</td> <td><input type="radio"/></td> <td>-</td> <td>-</td> </tr> <tr> <td>__ 1 4</td> <td>Load-side droop pulses (±10 V/1 Mpulse)^{*2}</td> <td>-</td> <td><input type="radio"/></td> <td>-</td> <td>-</td> </tr> <tr> <td>__ 1 5</td> <td>Motor/load side position deviation (±10 V/100000 pulses)</td> <td>-</td> <td><input type="radio"/></td> <td>-</td> <td>-</td> </tr> <tr> <td>__ 1 6</td> <td>Motor/load side speed deviation (±8 V/max. speed)</td> <td>-</td> <td><input type="radio"/></td> <td>-</td> <td>-</td> </tr> <tr> <td>__ 1 7</td> <td>Internal temperature of encoder (±10 V/±128 °C)</td> <td><input type="radio"/></td> <td><input type="radio"/></td> <td>-</td> <td><input type="radio"/></td> </tr> </tbody> </table>	Setting value	Item	Operation mode ^{*1}				Standard	Full.	Lin.	DD	__ 0 0	Servo motor speed (±8 V/max. speed)	<input type="radio"/>	<input type="radio"/>	<input type="radio"/>	<input type="radio"/>	__ 0 1	Torque or thrust (±8 V/max. torque or max. thrust) ^{*3}	<input type="radio"/>	<input type="radio"/>	<input type="radio"/>	<input type="radio"/>	__ 0 2	Servo motor speed (+8 V/max. speed)	<input type="radio"/>	<input type="radio"/>	<input type="radio"/>	<input type="radio"/>	__ 0 3	Torque or thrust (+8 V/max. torque or max. thrust) ^{*3}	<input type="radio"/>	<input type="radio"/>	<input type="radio"/>	<input type="radio"/>	__ 0 4	Current command (±8 V/max. current command)	<input type="radio"/>	<input type="radio"/>	<input type="radio"/>	<input type="radio"/>	__ 0 5	Speed command (±8 V/max. speed)	<input type="radio"/>	<input type="radio"/>	<input type="radio"/>	<input type="radio"/>	__ 0 6	Servo motor-side droop pulses (±10 V/100 pulses) ^{*2}	<input type="radio"/>	<input type="radio"/>	<input type="radio"/>	<input type="radio"/>	__ 0 7	Servo motor-side droop pulses (±10 V/1000 pulses) ^{*2}	<input type="radio"/>	<input type="radio"/>	<input type="radio"/>	<input type="radio"/>	__ 0 8	Servo motor-side droop pulses (±10 V/10000 pulses) ^{*2}	<input type="radio"/>	<input type="radio"/>	<input type="radio"/>	<input type="radio"/>	__ 0 9	Servo motor-side droop pulses (±10 V/100000 pulses) ^{*2}	<input type="radio"/>	<input type="radio"/>	<input type="radio"/>	<input type="radio"/>	__ 0 D	Bus voltage (200 V class or 100 V class: +8 V/400 V, 400 V class: +8 V/800 V)	<input type="radio"/>	<input type="radio"/>	<input type="radio"/>	<input type="radio"/>	__ 0 E	Speed command 2 (±8 V/max. speed)	<input type="radio"/>	<input type="radio"/>	<input type="radio"/>	<input type="radio"/>	__ 1 0	Load-side droop pulses (±10 V/100 pulses) ^{*2}	-	<input type="radio"/>	-	-	__ 1 1	Load-side droop pulses (±10 V/1000 pulses) ^{*2}	-	<input type="radio"/>	-	-	__ 1 2	Load-side droop pulses (±10 V/10000 pulses) ^{*2}	-	<input type="radio"/>	-	-	__ 1 3	Load-side droop pulses (±10 V/100000 pulses) ^{*2}	-	<input type="radio"/>	-	-	__ 1 4	Load-side droop pulses (±10 V/1 Mpulse) ^{*2}	-	<input type="radio"/>	-	-	__ 1 5	Motor/load side position deviation (±10 V/100000 pulses)	-	<input type="radio"/>	-	-	__ 1 6	Motor/load side speed deviation (±8 V/max. speed)	-	<input type="radio"/>	-	-	__ 1 7	Internal temperature of encoder (±10 V/±128 °C)	<input type="radio"/>	<input type="radio"/>	-	<input type="radio"/>	
Setting value	Item	Operation mode ^{*1}																																																																																																																																			
		Standard	Full.	Lin.	DD																																																																																																																																
__ 0 0	Servo motor speed (±8 V/max. speed)	<input type="radio"/>	<input type="radio"/>	<input type="radio"/>	<input type="radio"/>																																																																																																																																
__ 0 1	Torque or thrust (±8 V/max. torque or max. thrust) ^{*3}	<input type="radio"/>	<input type="radio"/>	<input type="radio"/>	<input type="radio"/>																																																																																																																																
__ 0 2	Servo motor speed (+8 V/max. speed)	<input type="radio"/>	<input type="radio"/>	<input type="radio"/>	<input type="radio"/>																																																																																																																																
__ 0 3	Torque or thrust (+8 V/max. torque or max. thrust) ^{*3}	<input type="radio"/>	<input type="radio"/>	<input type="radio"/>	<input type="radio"/>																																																																																																																																
__ 0 4	Current command (±8 V/max. current command)	<input type="radio"/>	<input type="radio"/>	<input type="radio"/>	<input type="radio"/>																																																																																																																																
__ 0 5	Speed command (±8 V/max. speed)	<input type="radio"/>	<input type="radio"/>	<input type="radio"/>	<input type="radio"/>																																																																																																																																
__ 0 6	Servo motor-side droop pulses (±10 V/100 pulses) ^{*2}	<input type="radio"/>	<input type="radio"/>	<input type="radio"/>	<input type="radio"/>																																																																																																																																
__ 0 7	Servo motor-side droop pulses (±10 V/1000 pulses) ^{*2}	<input type="radio"/>	<input type="radio"/>	<input type="radio"/>	<input type="radio"/>																																																																																																																																
__ 0 8	Servo motor-side droop pulses (±10 V/10000 pulses) ^{*2}	<input type="radio"/>	<input type="radio"/>	<input type="radio"/>	<input type="radio"/>																																																																																																																																
__ 0 9	Servo motor-side droop pulses (±10 V/100000 pulses) ^{*2}	<input type="radio"/>	<input type="radio"/>	<input type="radio"/>	<input type="radio"/>																																																																																																																																
__ 0 D	Bus voltage (200 V class or 100 V class: +8 V/400 V, 400 V class: +8 V/800 V)	<input type="radio"/>	<input type="radio"/>	<input type="radio"/>	<input type="radio"/>																																																																																																																																
__ 0 E	Speed command 2 (±8 V/max. speed)	<input type="radio"/>	<input type="radio"/>	<input type="radio"/>	<input type="radio"/>																																																																																																																																
__ 1 0	Load-side droop pulses (±10 V/100 pulses) ^{*2}	-	<input type="radio"/>	-	-																																																																																																																																
__ 1 1	Load-side droop pulses (±10 V/1000 pulses) ^{*2}	-	<input type="radio"/>	-	-																																																																																																																																
__ 1 2	Load-side droop pulses (±10 V/10000 pulses) ^{*2}	-	<input type="radio"/>	-	-																																																																																																																																
__ 1 3	Load-side droop pulses (±10 V/100000 pulses) ^{*2}	-	<input type="radio"/>	-	-																																																																																																																																
__ 1 4	Load-side droop pulses (±10 V/1 Mpulse) ^{*2}	-	<input type="radio"/>	-	-																																																																																																																																
__ 1 5	Motor/load side position deviation (±10 V/100000 pulses)	-	<input type="radio"/>	-	-																																																																																																																																
__ 1 6	Motor/load side speed deviation (±8 V/max. speed)	-	<input type="radio"/>	-	-																																																																																																																																
__ 1 7	Internal temperature of encoder (±10 V/±128 °C)	<input type="radio"/>	<input type="radio"/>	-	<input type="radio"/>																																																																																																																																
		<p>*1 Items with <input type="radio"/> are available for each operation mode. Operation modes other than the standard mode are available for servo amplifiers with software version A1 or later. Standard: use of rotary servo motors in semi closed loop system Full.: Fully closed loop system use of the rotary servo motor Lin.: Linear servo motor use DD: use of direct drive motors</p> <p>*2 Encoder pulse unit.</p> <p>*3 The value to [Pr. PA11] or to [Pr. PA12], whichever is higher, is applied to the maximum torque or maximum thrust.</p>																																																																																																																																			
PC10 MOD2 Analog monitor 2 output	__ x x	Analog monitor 2 output selection Select a signal to output to MO2 (Analog monitor 2). Refer to the following for detection point of output selection.  Page 637 Analog monitor block diagram Refer to [Pr. PC09] for settings.	01h																																																																																																																																		
	_ x _ _	For manufacturer setting	0h																																																																																																																																		
	x _ _ _		0h																																																																																																																																		

No./symbol/ name	Setting digit	Function	Initial value [unit]
PC11 MO1 Analog monitor 1 offset	—	Set the offset voltage of MO1 (Analog monitor 1). Setting range: -999 to 999	0 [mV]
PC12 MO2 Analog monitor 2 offset	—	Set the offset voltage of MO2 (Analog monitor 2). Setting range: -999 to 999	0 [mV]
PC17 **COP4 Function selection C-4	___x	For manufacturer setting	0h
	__x_	Linear scale multipoint Z-phase input function selection When two or more reference marks exist during the full stroke of the linear encoder, set "1". 0: Disabled 1: Enabled The setting of this digit is used by servo amplifier with software version A1 or later.	0h
	_x__	For manufacturer setting	0h
	x___	For manufacturer setting	0h
PC18 *COP5 Function selection C-5	___x	For manufacturer setting	0h
	__x_	[AL. E3 Absolute position counter warning] selection 0: Disabled 1: Enabled When "Disabled" is selected, [AL. E3 Absolute position counter warning] does not occur even if the travel distance from the home position is over 32767 rev. In the motion mode, select "0" only when configuring an absolute position detection system by using a simple motion module QD77GF_ or RD77GF_ or simple motion board MR-EM340GF.	1h
	_x__	For manufacturer setting	0h
	x___	[AL. E9 Main circuit off warning] selection Select an occurring condition of [AL. E9 Main circuit off warning]. 0: Detection with ready-on and servo-on command 1: Detection with servo-on command	0h
PC19 *COP6 Function selection C-6	___x	[AL. 99 Stroke limit warning] selection Enable or disable [AL. 99 Stroke limit warning]. 0: Enabled 1: Disabled When "Disabled" is selected, [AL. 99 Stroke limit warning] will not occur while LSP (Forward rotation stroke end) or LSN (Reverse rotation stroke end) is off, but the operation will be stopped with the stroke limit.	0h
	__x_	For manufacturer setting	0h
	_x__	For manufacturer setting	0h
	x___	For manufacturer setting	0h
PC20 *COP7 Function selection C-7	___x	[AL. 10 Undervoltage] detection method selection Set this parameter when [AL. 10 Undervoltage] has occurred due to distorted power supply voltage waveform while using FR-RC-(H), FR-CV-(H), or FR-XC-(H). 0: [AL. 10] has not occurred 1: [AL. 10] has occurred	0h
	__x_	For manufacturer setting	0h
	_x__	Undervoltage alarm selection Select the alarm and warning that occurs when the bus voltage drops to the undervoltage alarm level. 0: [AL. 10] regardless of servo motor speed 1: [AL. E9] at servo motor speed 50 r/min (50 mm/s) or less, [AL. 10] at over 50 r/min (50 mm/s)	0h
	x___	For manufacturer setting	0h
PC21 *BPS Alarm history clear	___x	Alarm history clear selection This parameter is used to clear the alarm history. 0: Disabled 1: Enabled When "Enabled" is set, the alarm history will be cleared at the next power-on. After the alarm history is cleared, the setting is automatically disabled.	0h
	__x_	For manufacturer setting	0h
	_x__	For manufacturer setting	0h
	x___	For manufacturer setting	0h

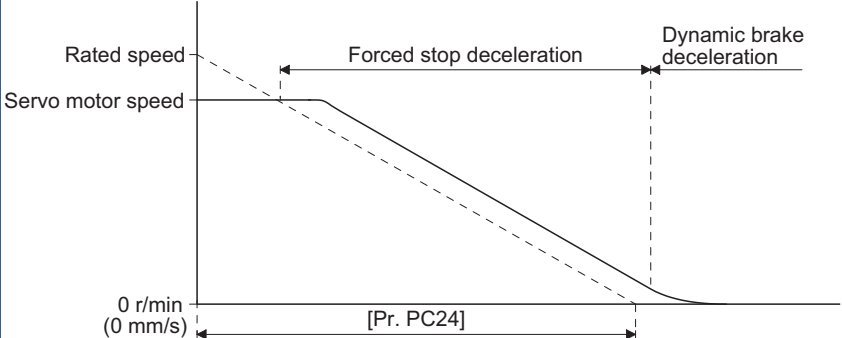
No./symbol/ name	Setting digit	Function	Initial value [unit]																		
PC24 RSBR Forced stop deceleration time constant	—	<p>Set a deceleration time constant for the forced stop deceleration function. Set the time per ms from the rated speed to 0 r/min or 0 mm/s. Setting "0" will be 100 ms.</p>  <p>[Precautions]</p> <ul style="list-style-type: none"> • If the servo motor torque or linear servo motor thrust is saturated at the maximum value during forced stop deceleration because the set time is too short, the time to stop will be longer than the set time constant. • [AL. 50 Overload 1] or [AL. 51 Overload 2] may occur during forced stop deceleration, depending on the set value. • After an alarm that leads to a forced stop deceleration, if an alarm that does not lead to a forced stop deceleration occurs or if the control circuit power supply is cut, dynamic braking will start regardless of the deceleration time constant setting. <p>Setting range: 0 to 20000</p>	100 [ms]																		
PC26 **COP8 Function selection C-8	___x	For manufacturer setting	0h																		
	__x_		0h																		
	_x__		0h																		
	x___	<p>Load-side encoder cable communication method selection Select an encoder cable to be connected to the CN2L connector. 0: Two-wire type 1: Four-wire type When using a load-side encoder of A/B/Z-phase differential output method, set "0". Incorrect setting will trigger [AL. 70] and [AL. 71]. The setting of this digit is used by servo amplifier with software version A1 or later.</p>	0h																		
PC27 **COP9 Function selection C-9	___x	<p>Encoder pulse count polarity selection Select a polarity of the linear encoder or load-side encoder. 0: Encoder pulse increasing direction in the servo motor CCW or positive direction 1: Encoder pulse decreasing direction in the servo motor CCW or positive direction The setting of this digit is used by servo amplifier with software version A1 or later.</p>	0h																		
	__x_	For manufacturer setting	0h																		
	_x__	<p>Selection of A/B/Z-phase input interface encoder Z-phase connection judgment function Select the non-signal detection status for the pulse train signal from the A/B/Z-phase input interface encoder used as a linear encoder or load-side encoder. This function is enabled only when you use an A/B/Z-phase input interface encoder. The setting of this digit is used by servo amplifier with software version A1 or later.</p> <table border="1" data-bbox="427 1523 1332 1780"> <thead> <tr> <th rowspan="2">Setting value</th> <th rowspan="2">Detection of disconnection Z-phase-side non-signal</th> <th colspan="3">Alarm status</th> </tr> <tr> <th>Standard (scale measurement function enabled)</th> <th>Full.</th> <th>Lin.</th> </tr> </thead> <tbody> <tr> <td>0</td> <td>Enabled</td> <td>[AL. 71.6] (Z-phase)</td> <td>[AL. 71.6] (Z-phase)</td> <td>[AL. 20.6] (Z-phase)</td> </tr> <tr> <td>1</td> <td>Disabled</td> <td>—</td> <td>—</td> <td>—</td> </tr> </tbody> </table>	Setting value	Detection of disconnection Z-phase-side non-signal	Alarm status			Standard (scale measurement function enabled)	Full.	Lin.	0	Enabled	[AL. 71.6] (Z-phase)	[AL. 71.6] (Z-phase)	[AL. 20.6] (Z-phase)	1	Disabled	—	—	—	0h
	Setting value	Detection of disconnection Z-phase-side non-signal			Alarm status																
			Standard (scale measurement function enabled)	Full.	Lin.																
0	Enabled	[AL. 71.6] (Z-phase)	[AL. 71.6] (Z-phase)	[AL. 20.6] (Z-phase)																	
1	Disabled	—	—	—																	
x___	For manufacturer setting	0h																			

No./symbol/ name	Setting digit	Function	Initial value [unit]																					
PC29 *COPB Function selection C-B	___x	For manufacturer setting	0h																					
	__x_		0h																					
	_x__		0h																					
	x___	<p>Torque POL reflection selection</p> <p>The torque polarity can be changed with the combination of this parameter and [Pr. PA14 Rotation direction selection/travel direction selection].</p> <p>0: Enabled 1: Disabled</p> <table border="1"> <thead> <tr> <th colspan="2">Setting value</th> <th colspan="2">Servo motor rotation direction/travel direction</th> </tr> <tr> <th>[Pr. PA14]</th> <th>[Pr. PC29]</th> <th>Torque mode Torque command: Positive</th> <th>Torque mode Torque command: Negative</th> </tr> </thead> <tbody> <tr> <td rowspan="2">0</td> <td>0___: Enabled</td> <td>CCW or positive direction</td> <td>CW or negative direction</td> </tr> <tr> <td>1___: Disabled</td> <td>CCW or positive direction</td> <td>CW or negative direction</td> </tr> <tr> <td rowspan="2">1</td> <td>0___: Enabled</td> <td>CW or negative direction</td> <td>CCW or positive direction</td> </tr> <tr> <td>1___: Disabled</td> <td>CCW or positive direction</td> <td>CW or negative direction</td> </tr> </tbody> </table> <p>The torque command polarity can be changed only when [Pr. PA14] is set to "1", and "0" is set to this digit.</p>	Setting value		Servo motor rotation direction/travel direction		[Pr. PA14]	[Pr. PC29]	Torque mode Torque command: Positive	Torque mode Torque command: Negative	0	0___: Enabled	CCW or positive direction	CW or negative direction	1___: Disabled	CCW or positive direction	CW or negative direction	1	0___: Enabled	CW or negative direction	CCW or positive direction	1___: Disabled	CCW or positive direction	CW or negative direction
Setting value		Servo motor rotation direction/travel direction																						
[Pr. PA14]	[Pr. PC29]	Torque mode Torque command: Positive	Torque mode Torque command: Negative																					
0	0___: Enabled	CCW or positive direction	CW or negative direction																					
	1___: Disabled	CCW or positive direction	CW or negative direction																					
1	0___: Enabled	CW or negative direction	CCW or positive direction																					
	1___: Disabled	CCW or positive direction	CW or negative direction																					
PC31 RSUP1 Vertical axis freefall prevention compensation amount	—	<p>Set the compensation amount of the vertical axis freefall prevention function.</p> <p>Set it per servo motor rotation amount or linear servo motor travel distance.</p> <p>This function pulls up the vertical axis in increments of rotation amount of the rotary servo motor and travel distance of the liner servo motor toward the rotation/travel direction of the forward pulse input for a positive value, and of the reverse pulse input for a negative value.</p> <p>For example, when [Pr. PA14 Rotation direction selection/travel direction selection] is set to "1" and a positive value is set for the compensation amount, the servo motor pulls up in the CW direction.</p> <p>The vertical axis freefall prevention function is performed when all of the following conditions are met.</p> <ol style="list-style-type: none"> 1) The control mode is set to the position mode. 2) The setting value of this parameter is other than "0". 3) "Forced stop deceleration function selection" of [Pr. PA04] is set to "Forced stop deceleration function enabled (2___)". 4) EM2 (Forced stop 2) turned off, an alarm occurred, or network communication shut-off occurred while the servo motor speed was zero speed or less. 5) MBR (Electromagnetic brake interlock) is enabled in [Pr. PD07] to [Pr. PD09], and the base circuit shut-off delay time is set in [Pr. PC02]. <p>Setting range: -25000 to 25000</p>	0 [0.0001 rev]/ [0.01 mm]																					
PC38 ERW Error excessive warning level	—	<p>Set an error excessive warning level.</p> <p>The setting unit can be changed with "Error excessive alarm/error excessive warning level unit selection" in [Pr. PC06].</p> <p>Set this per rev. for rotary servo motors and direct drive motors. Setting over 200 rev will be clamped with 200 rev. Set this per mm for linear servo motors. However, setting "0" will not trigger [AL. 9B Error excessive warning].</p> <p>When an error reaches the set value, [AL. 9B Error excessive warning] will occur. When the error decreases lower than the set value, the warning will be canceled automatically. The minimum pulse width of the warning signal is 100 [ms].</p> <p>Set as follows.: [Pr. PC38 Error excessive warning level] < [Pr. PC01 Error excessive alarm level] When you set as follows, [AL. 52 Error excessive] will occur earlier than the warning.: [Pr. PC38 Error excessive warning level] ≥ [Pr. PC01 Error excessive alarm level]</p> <p>Setting range: 0 to 1000</p>	0 [rev]/[mm]																					
PC67 FEWL Following error output level (lower four digits)	—	<p>Set a following error output level.</p> <p>Upper and lower are a set.</p> <p>When the state in which droop pulses ≥ the parameter setting value continues for the time set in [Pr. PC69 Following error output filtering time], "Statusword bit 13 Following error" will be turned on. However, setting "FFFFh FFFFh" will disable it.</p> <p>Set the setting value in hexadecimal.</p> <div style="text-align: center;"> </div> <p>Setting range: 00000000h to FFFFFFFFh (0 to 4294967295)</p>	0000h [pulse]																					
PC68 FEWH Following error output level (upper four digits)			00C0h [pulse]																					

No./symbol/ name	Setting digit	Function	Initial value [unit]
PC69 FEWF Following error output filtering time	—	Set the time until the following error output turns on. When the state in which droop pulses \geq [Pr. PC67/Pr. PC 68 Following error output level] continues for the time set in the parameter setting value, "Statusword bit 13 Following error" will be turned on. The following error output will be disabled when both [Pr. PC67] and [Pr. PC 68] are "FFFFh". Setting range: 0 to 65535	10 [ms]
PC76 *COPE Function selection C-E	___x	For manufacturer setting	1h
	__x_	ZSP disabled selection at control switching Select whether control mode switching from or to the position mode is performed within the range of ZSP. 0: Enabled (control mode switching within the range of ZSP) 1: Disabled (control mode switching regardless of the range of ZSP) When "1" is set, a shock may occur at switching control mode.	0h
	_x__	For manufacturer setting	0h
	x___		0h

I/O setting parameters ([Pr. PD__])

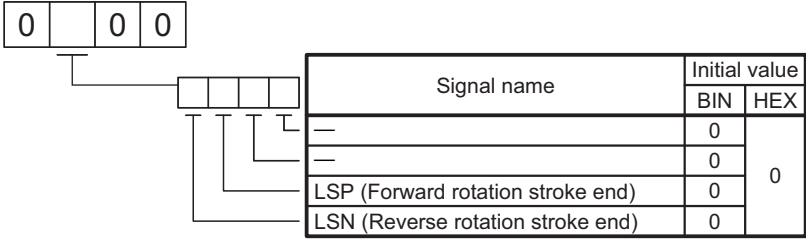
No./symbol/ name	Setting digit	Function	Initial value [unit]														
PD01 *DIA1 Input signal automatic on selection 1		Select input devices to turn on automatically.															
	___x	For manufacturer setting	0h														
	__x_		0h														
	_x__ (HEX)	___x (BIN): For manufacturer setting		0h													
		__x_ (BIN): For manufacturer setting															
		_x__ (BIN): LSP (Forward rotation stroke end) 0: Disabled (Use for an external input signal.) 1: Enabled (automatic on)															
x___ (BIN): LSN (Reverse rotation stroke end) 0: Disabled (Use for an external input signal.) 1: Enabled (automatic on)																	
x___	For manufacturer setting	0h															
Convert the setting value into hexadecimal as follows.																	
 <table border="1" style="margin-left: auto; margin-right: auto;"> <thead> <tr> <th rowspan="2">Signal name</th> <th colspan="2">Initial value</th> </tr> <tr> <th>BIN</th> <th>HEX</th> </tr> </thead> <tbody> <tr> <td>—</td> <td>0</td> <td rowspan="4">0</td> </tr> <tr> <td>—</td> <td>0</td> </tr> <tr> <td>LSP (Forward rotation stroke end)</td> <td>0</td> </tr> <tr> <td>LSN (Reverse rotation stroke end)</td> <td>0</td> </tr> </tbody> </table> <p>BIN 0: Use for an external input signal. BIN 1: Automatic on</p>				Signal name	Initial value		BIN	HEX	—	0	0	—	0	LSP (Forward rotation stroke end)	0	LSN (Reverse rotation stroke end)	0
Signal name	Initial value																
	BIN	HEX															
—	0	0															
—	0																
LSP (Forward rotation stroke end)	0																
LSN (Reverse rotation stroke end)	0																
When you perform a magnetic pole detection without using LSP (Forward rotation stroke end) and LSN (Reverse rotation stroke end), setting [Pr. PL08 Linear servo motor/DD motor function selection 3] to "_ 1 _" allows you to disable LSP and LSN. The linear servo motor control mode and DD motor control mode are available for servo amplifiers with software version A1 or later.																	



No./symbol/ name	Setting digit	Function	Initial value [unit]																																						
PD03 *DI1 Input device selection 1	Any input device can be assigned to the CN3-2 pin.																																								
	__ x x	Device selection Refer to the following table for settings.	0Ah																																						
	_ x __	For manufacturer setting	0h																																						
	x ___		0h																																						
	<table border="1"> <thead> <tr> <th>Setting value</th> <th>Input device</th> </tr> </thead> <tbody> <tr> <td>__ 0 0</td> <td>—</td> </tr> <tr> <td>__ 0 3</td> <td>RES (Reset) *2</td> </tr> <tr> <td>__ 0 4</td> <td>PC (Proportional control)</td> </tr> <tr> <td>__ 0 A</td> <td>LSP (Forward rotation stroke end)</td> </tr> <tr> <td>__ 0 B</td> <td>LSN (Reverse rotation stroke end)</td> </tr> <tr> <td>__ 0 D</td> <td>CDP (Gain switching)</td> </tr> <tr> <td>__ 0 E</td> <td>CLD (Fully closed loop selection) *1</td> </tr> <tr> <td>__ 2 2</td> <td>DOG (Proximity dog)</td> </tr> </tbody> </table>		Setting value	Input device	__ 0 0	—	__ 0 3	RES (Reset) *2	__ 0 4	PC (Proportional control)	__ 0 A	LSP (Forward rotation stroke end)	__ 0 B	LSN (Reverse rotation stroke end)	__ 0 D	CDP (Gain switching)	__ 0 E	CLD (Fully closed loop selection) *1	__ 2 2	DOG (Proximity dog)																					
	Setting value	Input device																																							
	__ 0 0	—																																							
	__ 0 3	RES (Reset) *2																																							
	__ 0 4	PC (Proportional control)																																							
	__ 0 A	LSP (Forward rotation stroke end)																																							
__ 0 B	LSN (Reverse rotation stroke end)																																								
__ 0 D	CDP (Gain switching)																																								
__ 0 E	CLD (Fully closed loop selection) *1																																								
__ 2 2	DOG (Proximity dog)																																								
*1 This is available with servo amplifiers with software version A1 or later.																																									
*2 This is available with servo amplifiers with software version A7 or later.																																									
PD04 *DI2 Input device selection 2	Any input device can be assigned to the CN3-12 pin.																																								
	__ x x	Device selection Refer to the table in [Pr. PD03] for settings.	0Bh																																						
	_ x __	For manufacturer setting	0h																																						
x ___	0h																																								
PD05 *DI3 Input device selection 3	Any input device can be assigned to the CN3-19 pin.																																								
	__ x x	Device selection Refer to the table in [Pr. PD03] for settings.	22h																																						
	_ x __	For manufacturer setting	0h																																						
x ___	0h																																								
PD07 *DO1 Output device selection 1	Any output device can be assigned to the CN3-13 pin. As the initial value, MBR (Electromagnetic brake interlock) is assigned to the pin. Refer to the following table for settings.																																								
	__ x x	Device selection Refer to the following table for settings.	05h																																						
	_ x __	For manufacturer setting	0h																																						
	x ___		0h																																						
	<table border="1"> <thead> <tr> <th>Setting value</th> <th>Output device</th> </tr> </thead> <tbody> <tr> <td>__ 0 0</td> <td>Always off</td> </tr> <tr> <td>__ 0 2</td> <td>RD (Ready)</td> </tr> <tr> <td>__ 0 3</td> <td>ALM (Malfunction)</td> </tr> <tr> <td>__ 0 4</td> <td>INP (In-position)</td> </tr> <tr> <td>__ 0 5</td> <td>MBR (Electromagnetic brake interlock)</td> </tr> <tr> <td>__ 0 6</td> <td>DB (Dynamic brake interlock)</td> </tr> <tr> <td>__ 0 7</td> <td>TLC (Limiting torque)</td> </tr> <tr> <td>__ 0 8</td> <td>WNG (Warning)</td> </tr> <tr> <td>__ 0 9</td> <td>BWNG (Battery warning)</td> </tr> <tr> <td>__ 0 A</td> <td>SA (Speed reached)</td> </tr> <tr> <td>__ 0 B</td> <td>VLC (Limiting speed)</td> </tr> <tr> <td>__ 0 C</td> <td>ZSP (Zero speed detection)</td> </tr> <tr> <td>__ 0 E</td> <td>PRMWR (Wait for enabling parameters) *2</td> </tr> <tr> <td>__ 0 F</td> <td>CDPS (Variable gain selection)</td> </tr> <tr> <td>__ 1 0</td> <td>CLDS (During fully closed loop control) *1</td> </tr> <tr> <td>__ 1 1</td> <td>ABSV (Absolute position undetermined)</td> </tr> <tr> <td>__ 1 7</td> <td>MTTR (During tough drive)</td> </tr> <tr> <td>__ 3 5</td> <td>ZP2 (Home position return completion 2) *3</td> </tr> </tbody> </table>		Setting value	Output device	__ 0 0	Always off	__ 0 2	RD (Ready)	__ 0 3	ALM (Malfunction)	__ 0 4	INP (In-position)	__ 0 5	MBR (Electromagnetic brake interlock)	__ 0 6	DB (Dynamic brake interlock)	__ 0 7	TLC (Limiting torque)	__ 0 8	WNG (Warning)	__ 0 9	BWNG (Battery warning)	__ 0 A	SA (Speed reached)	__ 0 B	VLC (Limiting speed)	__ 0 C	ZSP (Zero speed detection)	__ 0 E	PRMWR (Wait for enabling parameters) *2	__ 0 F	CDPS (Variable gain selection)	__ 1 0	CLDS (During fully closed loop control) *1	__ 1 1	ABSV (Absolute position undetermined)	__ 1 7	MTTR (During tough drive)	__ 3 5	ZP2 (Home position return completion 2) *3	
	Setting value	Output device																																							
	__ 0 0	Always off																																							
	__ 0 2	RD (Ready)																																							
	__ 0 3	ALM (Malfunction)																																							
	__ 0 4	INP (In-position)																																							
__ 0 5	MBR (Electromagnetic brake interlock)																																								
__ 0 6	DB (Dynamic brake interlock)																																								
__ 0 7	TLC (Limiting torque)																																								
__ 0 8	WNG (Warning)																																								
__ 0 9	BWNG (Battery warning)																																								
__ 0 A	SA (Speed reached)																																								
__ 0 B	VLC (Limiting speed)																																								
__ 0 C	ZSP (Zero speed detection)																																								
__ 0 E	PRMWR (Wait for enabling parameters) *2																																								
__ 0 F	CDPS (Variable gain selection)																																								
__ 1 0	CLDS (During fully closed loop control) *1																																								
__ 1 1	ABSV (Absolute position undetermined)																																								
__ 1 7	MTTR (During tough drive)																																								
__ 3 5	ZP2 (Home position return completion 2) *3																																								
*1 This is available with servo amplifiers with software version A1 or later.																																									
*2 This is available with servo amplifiers with software version A6 or later.																																									
*3 This is available with servo amplifiers with software version A8 or later.																																									

No./symbol/ name	Setting digit	Function	Initial value [unit]
PD08 *DO2 Output device selection 2	__ x x	Device selection Any output device can be assigned to the CN3-9 pin. INP (In-position) is assigned as the initial value. Refer to the table in [Pr. PD07] for settings.	04h
	_ x __	For manufacturer setting	0h
	x ___		0h
PD09 *DO3 Output device selection 3	__ x x	Device selection Any output device can be assigned to the CN3-15 pin. ALM (Malfunction) is assigned as the initial value. Refer to the table in [Pr. PD07] for settings.	03h
	_ x __	For manufacturer setting	0h
	x ___		0h
PD11 *DIF Input filter setting	Select a filter for the input signal.		
	___ x	Input signal filter selection If external input signal causes chattering due to noise, etc., input filter is used to suppress it. 0: None 1: 0.888 [ms] 2: 1.777 [ms] 3: 2.666 [ms] 4: 3.555 [ms] 5: 4.444 [ms] *1 6: 5.333 [ms] *1 *1 This is available with servo amplifiers with software version A7 or later.	4h
	__ x _	RES (Reset) dedicated filter selection 0: Disabled 1: Enabled (50 [ms]) The setting of this digit is used by servo amplifiers with software version A7 or later.	0h
	_ x __	For manufacturer setting	0h
x ___	0h		
PD12 *DOP1 Function selection D-1	___ x	For manufacturer setting	1h
	__ x _		0h
	_ x __		1h
	x ___	Servo motor thermistor enabled/disabled selection 0: Enabled 1: Disabled For servo motors without thermistor, the setting will be disabled.	0h
PD13 *DOP2 Function selection D-2	___ x	For manufacturer setting	0h
	__ x _		0h
	_ x __	INP (In-position) on condition selection Select a condition for turning on INP (In-position). 0: Within the in-position range 1: Within the in-position range and at the completion of command output	0h
	x ___	For manufacturer setting	0h

No./symbol/ name	Setting digit	Function	Initial value [unit]						
PD14 *DOP3 Function selection D-3	___x	For manufacturer setting	0h						
	__x_	Selection of output device at warning occurrence Select WNG (Warning) and ALM (Malfunction) output status at warning occurrence.	0h						
		<table border="1"> <thead> <tr> <th>Setting value</th> <th>Device status *1</th> </tr> </thead> <tbody> <tr> <td>0</td> <td> </td> </tr> <tr> <td>1</td> <td> </td> </tr> </tbody> </table>	Setting value	Device status *1	0		1		
	Setting value	Device status *1							
	0								
1									
	*1 0: Off 1: On *2 Although ALM is turned off upon occurrence of the warning, the forced stop deceleration is performed.								
	_x__	For manufacturer setting	0h						
	x___		0h						
PD37 *TPOP Touch probe function selection	___x	Touch probe higher precision selection Latches the rising of TPR2 correctly, and detects it accurate to 2 μs. 0: Disabled 1: Enabled When "Enabled" is selected, encoder output pulses are disabled. The setting of this digit is used by servo amplifier with software version A1 or later.	0h						
	__x_	For manufacturer setting	0h						
	_x__		0h						
	x___		0h						
PD41 *DOP4 Function selection D-4	___x	For manufacturer setting	0h						
	__x_		0h						
	_x__	Stroke limit enabling condition selection 0: Stroke limit always enabled 1: Enabled only for home position return mode When "1" is selected, stroke limit is disabled. Do not select "1" when the stroke limit is not detected with the controller. Otherwise, it may cause a collision. The stroke limit is always enabled at the test operation and magnetic pole detection. When a simple motion module QD77GF_ or RD77GF_ or simple motion board MR-EM340GF is used, set "1" to this digit.	0h						
	x___	Sensor input type selection Select an input type for proximity dog and stroke limit. 0: Input from servo amplifier (LSP/LSN/DOG) 1: Input from controller (C_FLS/C_RLS/C_DOG) When selecting "0", wire the limit switch installed in CCW direction to LSP, and the limit switch installed in CW direction to LSN. If wired in reverse, the limit switches do not stop the servo motor. When selecting "1", wire the limit switch installed in position address increasing direction to C_FLS, and the limit switch installed in decreasing direction to C_RLS. Then, input the signals from the controller. If wired in reverse, the limit switches do not stop the servo motor. For details, refer to the controller user's manual.	0h						

Extension setting 2 parameters ([Pr. PE_ _])

No./symbol/ name	Setting digit	Function	Initial value [unit]																																					
PE01 **FCT1 Fully closed loop function selection 1	___x	Fully closed loop function selection Select the fully closed loop function. 0: Always enabled 1: Switching by fully closed loop selection command from controller and Input device CLD (Fully closed loop selection)	0h																																					
		<table border="1"> <thead> <tr> <th colspan="2">Fully closed loop selection</th> <th rowspan="2">Control method</th> </tr> <tr> <th>Command from controller</th> <th>CLD (Fully closed loop selection)^{*1}</th> </tr> </thead> <tbody> <tr> <td>Off</td> <td>Off</td> <td>Semi closed loop control</td> </tr> <tr> <td>On</td> <td>Off</td> <td rowspan="3">Fully closed loop control</td> </tr> <tr> <td>Off</td> <td>On</td> </tr> <tr> <td>On</td> <td>On</td> </tr> </tbody> </table>	Fully closed loop selection		Control method	Command from controller	CLD (Fully closed loop selection) ^{*1}	Off	Off	Semi closed loop control	On	Off	Fully closed loop control	Off	On	On	On																							
	Fully closed loop selection		Control method																																					
	Command from controller	CLD (Fully closed loop selection) ^{*1}																																						
Off	Off	Semi closed loop control																																						
On	Off	Fully closed loop control																																						
Off	On																																							
On	On																																							
		<p>*1 It is always off when CLD (Fully closed loop selection) is not assigned in [Pr. PD03] to [Pr. PD05].</p> <p>To enable the setting, select "Fully closed loop control mode (_ _ 1 _)" of "operation mode selection" in [Pr. PA01].</p> <p>When "Absolute position detection system" is "Enabled (_ _ _ 1)" in [Pr. PA03], setting "1" will trigger [AL. 37 Parameter error].</p> <p>The setting of this digit is used by servo amplifier with software version A1 or later.</p>																																						
	__x_	For manufacturer setting	0h																																					
	_x__		0h																																					
	x___		0h																																					
PE03 *FCT2 Fully closed loop function selection 2	___x	Fully closed loop control error detection function selection 0: Disabled 1: Speed deviation error detection 2: Position deviation error detection 3: Speed deviation error/position deviation error detection Refer to the following table for settings. The setting of this digit is used by servo amplifier with software version A1 or later.	3h																																					
	__x_	Position deviation error detection system selection 0: Continuous detection system 1: Detection system at stop (detected with command set to "0") Refer to the following table for settings. The setting of this digit is used by servo amplifier with software version A1 or later.	0h																																					
	_x__	For manufacturer setting	0h																																					
	x___	Fully closed loop control error reset selection 0: Reset disabled (reset by powering off/on enabled) 1: Reset enabled The setting of this digit is used by servo amplifier with software version A1 or later.	0h																																					
		<table border="1"> <thead> <tr> <th rowspan="2">Setting value</th> <th rowspan="2">Speed deviation error</th> <th colspan="2">Position deviation error</th> </tr> <tr> <th>With command</th> <th>0 command</th> </tr> </thead> <tbody> <tr> <td>__00</td> <td>—</td> <td>—</td> <td>—</td> </tr> <tr> <td>__01</td> <td>○</td> <td>—</td> <td>—</td> </tr> <tr> <td>__02</td> <td>—</td> <td>○</td> <td>○</td> </tr> <tr> <td>__03</td> <td>○</td> <td>○</td> <td>○</td> </tr> <tr> <td>__10</td> <td>—</td> <td>—</td> <td>—</td> </tr> <tr> <td>__11</td> <td>○</td> <td>—</td> <td>—</td> </tr> <tr> <td>__12</td> <td>—</td> <td>—</td> <td>○</td> </tr> <tr> <td>__13</td> <td>○</td> <td>—</td> <td>○</td> </tr> </tbody> </table> <p style="text-align: right;">○: Abnormal detection enabled —: Abnormal detection disabled</p>	Setting value	Speed deviation error	Position deviation error		With command	0 command	__00	—	—	—	__01	○	—	—	__02	—	○	○	__03	○	○	○	__10	—	—	—	__11	○	—	—	__12	—	—	○	__13	○	—	○
Setting value	Speed deviation error	Position deviation error																																						
		With command	0 command																																					
__00	—	—	—																																					
__01	○	—	—																																					
__02	—	○	○																																					
__03	○	○	○																																					
__10	—	—	—																																					
__11	○	—	—																																					
__12	—	—	○																																					
__13	○	—	○																																					
PE04 **FBN Fully closed loop control - Feedback pulse electronic gear 1 - Numerator	—	Set a numerator of electronic gear for the servo motor encoder pulse at the fully closed loop control. Set the electronic gear so that the number of servo motor encoder pulses for one servo motor revolution is converted to the resolution of the load-side encoder. This parameter is supported with software version A1 or later. Setting range: 1 to 65535	1																																					

No./symbol/ name	Setting digit	Function	Initial value [unit]
PE05 **FBD Fully closed loop control - Feedback pulse electronic gear 1 - Denominator	—	Set a denominator of electronic gear for the servo motor encoder pulse at the fully closed loop control. Set the electronic gear so that the number of servo motor encoder pulses for one servo motor revolution is converted to the resolution of the load-side encoder. This parameter is supported with software version A1 or later. Setting range: 1 to 65535	1
PE06 BC1 Fully closed loop control - Speed deviation error detection level	—	Set [AL. 42.9 Fully closed loop control error by speed deviation] of the fully closed loop control error detection. When the speed deviation between the servo motor encoder and load-side encoder becomes larger than the setting value, the alarm will occur. This parameter is supported with software version A1 or later. Setting range: 1 to 50000	400 [r/min]
PE07 BC2 Fully closed loop control - Position deviation error detection level	—	Set [AL. 42.8 Fully closed loop control error by position deviation] of the fully closed loop control error detection. When the position deviation between the servo motor encoder and load-side encoder becomes larger than the setting value, the alarm will occur. This parameter is supported with software version A1 or later. Setting range: 1 to 20000	100 [kpulse]
PE08 DUF Fully closed loop dual feedback filter	—	Set a dual feedback filter band.  Page 548 Setting of fully closed loop dual feedback filter This parameter is supported with software version A1 or later. Setting range: 1 to 4500	10 [rad/s]
PE10 FCT3 Fully closed loop function selection 3	— x	For manufacturer setting	0h
	— x —	Fully closed loop control - Position deviation error detection level - Unit selection 0: 1 kpulse unit 1: 1 pulse unit The setting of this digit is used by servo amplifier with software version A1 or later.	0h
	— x —	For manufacturer setting	0h
	x — —		0h
PE34 **FBN2 Fully closed loop control - Feedback pulse electronic gear 2 - Numerator	—	Set a numerator of electronic gear for the servo motor encoder pulse at the fully closed loop control. Set the electronic gear so that the number of servo motor encoder pulses for one servo motor revolution is converted to the resolution of the load-side encoder.  Page 545 Setting of feedback pulse electronic gear This parameter is supported with software version A1 or later. Setting range: 1 to 65535	1
PE35 **FBD2 Fully closed loop control - Feedback pulse electronic gear 2 - Denominator	—	Set a denominator of electronic gear for the servo motor encoder pulse at the fully closed loop control. Set the electronic gear so that the number of servo motor encoder pulses for one servo motor revolution is converted to the resolution of the load-side encoder.  Page 545 Setting of feedback pulse electronic gear This parameter is supported with software version A1 or later. Setting range: 1 to 65535	1
PE41 EOP3 Function selection E-3	— x	Robust filter selection 0: Disabled 1: Enabled When "Enabled" is set, the machine resonance suppression filter 5 that is set in [Pr. PB51] is not available.	0h
	— x —	For manufacturer setting	0h
	— x —		0h
	x — —		0h
PE44 LMCP Lost motion compensation positive-side compensation value selection	—	Set the lost motion compensation for when reverse rotation (CW) switches to forward rotation (CCW) in increments of 0.01% assuming the rated torque as 100%. Setting range: 0 to 30000	0 [0.01%]
PE45 LMCN Lost motion compensation negative-side compensation value selection	—	Set the lost motion compensation for when forward rotation (CCW) switches to reverse rotation (CW) in increments of 0.01% assuming the rated torque as 100%. Setting range: 0 to 30000	0 [0.01%]

No./symbol/ name	Setting digit	Function	Initial value [unit]
PE46 LMFLT Lost motion filter setting	—	Set the time constant of the lost motion compensation filter in increments of 0.1 ms. If the time constant is "0", the torque is compensated with the value set in [Pr. PE44] and [Pr. PE45]. If the time constant is other than "0", the torque is compensated with the high-pass filter output value of the set time constant, and the lost motion compensation will continue. Setting range: 0 to 30000	0 [0.1 ms]
PE47 TOF Torque offset	—	Set this when canceling unbalanced torque of vertical axis. Set this assuming the rated torque of the servo motor as 100%. The torque offset does not need to be set for a machine not generating unbalanced torque. The torque offset cannot be used for linear servo motors and direct drive motors. Set 0.00%. The torque offset set with this parameter will be enabled in the position mode, velocity mode, and torque mode. Input commands assuming torque offset for the torque mode. Setting range: -10000 to 10000	0 [0.01%]
PE48 *LMOP Lost motion compensation function selection	___x	Lost motion compensation selection 0: Disabled 1: Enabled	0h
	__x_	Unit setting of lost motion compensation non-sensitive band 0: 1 pulse unit 1: 1 kpulse unit	0h
	_x__	For manufacturer setting	0h
	x___		0h
PE49 LMCD Lost motion compensation timing	—	Set the lost motion compensation timing in increments of 0.1 ms. The timing to perform the lost motion compensation function can be delayed for the set time. Setting range: 0 to 30000	0 [0.1 ms]
PE50 LMCT Lost motion compensation non- sensitive band	—	Set the lost motion compensation non-sensitive band. When the fluctuation of droop pulses is equal to or less than the setting value, the speed will be "0". Setting can be changed in [Pr. PE48]. Set the parameter per encoder unit. Setting range: 0 to 65535	0 [pulse]/ [kpulse]

Extension setting 3 parameters ([Pr. PF__])

No./symbol/ name	Setting digit	Function	Initial value [unit]								
PF06 *FOP5 Function selection F-5	___x	Electronic dynamic brake selection 0: Automatic (enabled only for specified servo motors) 2: Disabled Refer to the following table for the specified servo motors.	0h								
		<table border="1"> <thead> <tr> <th>Series</th> <th>Servo motor</th> </tr> </thead> <tbody> <tr> <td>HG-KR</td> <td>HG-KR053/HG-KR13/HG-KR23/HG-KR43</td> </tr> <tr> <td>HG-MR</td> <td>HG-MR053/HG-MR13/HG-MR23/HG-MR43</td> </tr> <tr> <td>HG-SR</td> <td>HG-SR51/HG-SR52</td> </tr> </tbody> </table>	Series	Servo motor	HG-KR	HG-KR053/HG-KR13/HG-KR23/HG-KR43	HG-MR	HG-MR053/HG-MR13/HG-MR23/HG-MR43	HG-SR	HG-SR51/HG-SR52	
	Series	Servo motor									
	HG-KR	HG-KR053/HG-KR13/HG-KR23/HG-KR43									
	HG-MR	HG-MR053/HG-MR13/HG-MR23/HG-MR43									
HG-SR	HG-SR51/HG-SR52										
__x_	For manufacturer setting	0h									
_x__		0h									
x___		0h									
PF12 DBT Electronic dynamic brake operating time	—	Set an operating time for the electronic dynamic brake. Setting range: 0 to 10000	2000 [ms]								

No./symbol/ name	Setting digit	Function	Initial value [unit]													
PF18 **STOD STO diagnosis error detection time	—	<p>Set the time from when the error of the STO input or STO circuit is detected until the occurrence of [AL. 68.1 Mismatched STO signal error].</p> <p>When "0" is set, [AL. 68.1 Mismatched STO signal error] is not detected.</p> <p>The safety level depends on the setting values as follows.</p> <table border="1"> <thead> <tr> <th>Setting value</th> <th>STO input diagnosis by TOFB output</th> <th>Safety level</th> </tr> </thead> <tbody> <tr> <td rowspan="2">0</td> <td>Execute</td> <td>EN ISO 13849-1:2015 Category 3 PL d, IEC 61508 SIL 2, EN 62061 SIL CL2</td> </tr> <tr> <td>Do not execute</td> <td></td> </tr> <tr> <td rowspan="2">1 to 60</td> <td>Execute</td> <td>EN ISO 13849-1:2015 Category 3 PL e, IEC 61508 SIL 3, EN 62061 SIL CL3</td> </tr> <tr> <td>Do not execute</td> <td>EN ISO 13849-1:2015 Category 3 PL d, IEC 61508 SIL 2, EN 62061 SIL CL2</td> </tr> </tbody> </table> <p>When you do not use the STO function with the short-circuit connector connected to the CN8 connector, setting the parameter will not change the safety level. When MR-D30 functional safety unit is used, the parameter is not available. For safety levels with MR-D30, refer to "MR-D30 Instruction Manual". MR-D30 is used with servo amplifiers with software version A3 or later.</p>	Setting value	STO input diagnosis by TOFB output	Safety level	0	Execute	EN ISO 13849-1:2015 Category 3 PL d, IEC 61508 SIL 2, EN 62061 SIL CL2	Do not execute		1 to 60	Execute	EN ISO 13849-1:2015 Category 3 PL e, IEC 61508 SIL 3, EN 62061 SIL CL3	Do not execute	EN ISO 13849-1:2015 Category 3 PL d, IEC 61508 SIL 2, EN 62061 SIL CL2	10 [s]
Setting value	STO input diagnosis by TOFB output	Safety level														
0	Execute	EN ISO 13849-1:2015 Category 3 PL d, IEC 61508 SIL 2, EN 62061 SIL CL2														
	Do not execute															
1 to 60	Execute	EN ISO 13849-1:2015 Category 3 PL e, IEC 61508 SIL 3, EN 62061 SIL CL3														
	Do not execute	EN ISO 13849-1:2015 Category 3 PL d, IEC 61508 SIL 2, EN 62061 SIL CL2														
PF19 TSL Friction failure prediction - Compensation coefficient 1	—	<p>As the compensation coefficient 1 for friction failure prediction, set a compensation coefficient for compensating the friction torque at rated speed. When the friction failure prediction warning selection is set to the automatic threshold setting, the value will be calculated automatically from the estimated friction torque at rated speed.</p> <p>This parameter is available with servo amplifiers with software version A3 or later.</p> <p>Setting range: -32768 to 32767</p>	0 [0.001%/°C]													
PF20 TIC Friction failure prediction - Compensation coefficient 2	—	<p>As the compensation coefficient 2 for friction failure prediction, set a compensation coefficient for compensating the friction torque at rated speed. When the friction failure prediction warning selection is set to the automatic threshold setting, the value will be calculated automatically from the estimated friction torque at rated speed.</p> <p>This parameter is available with servo amplifiers with software version A3 or later.</p> <p>Setting range: -10000 to 10000</p>	0 [0.1%]													
PF21 DRT Drive recorder switching time setting	—	<p>Set a drive recorder switching time.</p> <p>When a USB communication is cut during using a graph function, the function will be changed to the drive recorder function after the setting time of this parameter.</p> <p>When a value from "1" to "32767" is set, the function will be switched to the drive recorder function after the set time.</p> <p>However, when "0" is set, it will be switched after 600 s.</p> <p>When "-1" is set, the drive recorder function is disabled.</p> <p>Setting range: -1 to 32767</p>	0 [s]													
PF23 OSCL1 Vibration tough drive - Oscillation detection level	—	<p>Set a filter readjustment sensitivity of [Pr. PB13 Machine resonance suppression filter 1] and [Pr. PB15 Machine resonance suppression filter 2] while the vibration tough drive is enabled.</p> <p>Note that setting "0" will be 50%.</p> <p>Example: When you set "50" to the parameter, the filter will be readjusted at the time of 50% or more oscillation level.</p> <p>Setting range: 0 to 100</p>	50 [%]													
PF24 *OSCL2 Vibration tough drive function selection	___x	<p>Oscillation detection alarm selection</p> <p>Select whether to generate an alarm or a warning when an oscillation continues at a filter readjustment sensitivity level of [Pr. PF23].</p> <p>The setting is always enabled regardless of the vibration tough drive in [Pr. PA20].</p> <p>0: [AL. 54 Oscillation detection] will occur at oscillation detection.</p> <p>1: [AL. F3.1 Oscillation detection warning] will occur at oscillation detection.</p> <p>2: Oscillation detection function disabled</p>	0h													
	__x_	For manufacturer setting	0h													
	_x__		0h													
	x___		0h													
PF25 CVAT SEMI-F47 function - Instantaneous power failure detection time	—	<p>Set the time of the [AL. 10.1 Voltage drop in the control circuit power] occurrence.</p> <p>To comply with SEMI-F47 standard, it is unnecessary to change the initial value (200 ms).</p> <p>When the instantaneous power failure time exceeds 200 ms, and the instantaneous power failure voltage is less than 70% of the rated input voltage, the power may be normally turned off even if a value larger than 200 ms is set in the parameter.</p> <p>To disable the parameter setting value, select "Disabled (_ 0 _)" of "SEMI-F47 function selection" in [Pr. PA20].</p> <p>Setting range: 30 to 500</p>	200 [ms]													

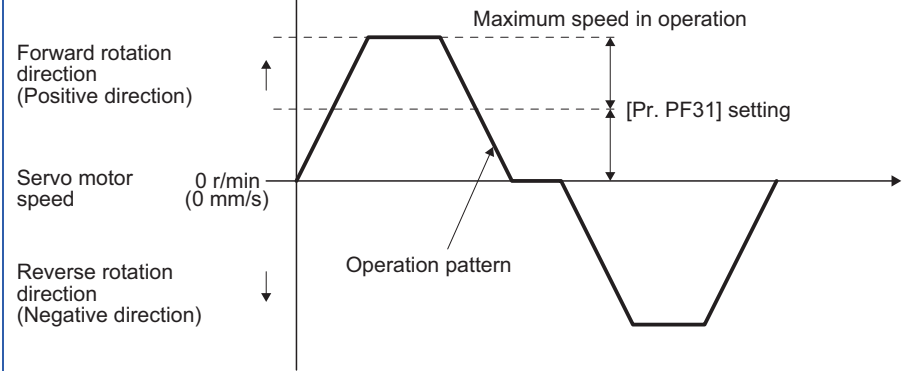
No./symbol/ name	Setting digit	Function	Initial value [unit]
PF31 FRIC Machine diagnosis function - Friction judgment speed	—	<p>Set a servo motor speed that divides a friction estimation area into high and low during the friction estimation process of the machine diagnosis.</p> <p>However, setting "0" will be the value half of the rated speed.</p> <p>When the maximum operation speed is under the rated speed, it is recommended that you set half the value of the maximum operation speed.</p> <p>Set a value larger than the value of [Pr. PC07 Zero speed] to this parameter. The friction estimation process does not function at zero speed or less.</p>  <p>Setting range: 0 to instantaneous permissible speed</p>	0 [r/min]/ [mm/s]
PF34 *MFP Machine diagnosis function selection	_ _ _ x	<p>Friction failure prediction warning selection</p> <p>0: Disabled 1: Enabled (Automatic threshold setting) 2: Enabled (Manual threshold setting) 3: Threshold reset</p> <p>When "2" is set to this digit, if the friction torque exceeds the set threshold, [AL. F7.2 Friction failure prediction warning] will occur.</p> <p>When the threshold is reset by setting "3" to this digit, "1" will be automatically set after the reset.</p> <p>This digit is available with servo amplifier with software version A3 or later.</p>	0h
	_ _ x _	<p>Vibration failure prediction warning selection</p> <p>0: Disabled 1: Enabled (Automatic threshold setting) 2: Enabled (Manual threshold setting) 3: Threshold reset</p> <p>When "2" is set to this digit, if the vibration level exceeds the set threshold, [AL. F7.1 Vibration failure prediction warning] will occur.</p> <p>When the threshold is reset by setting "3" to this digit, "1" will be automatically set after the reset.</p> <p>This digit is available with servo amplifier with software version A3 or later.</p>	0h
	_ x _ _	<p>Servo motor total travel distance failure prediction warning selection</p> <p>0: Disabled 1: Enabled 2: Servo motor total travel distance reset</p> <p>When "1" is set to this digit, if the servo motor total travel distance exceeds the value of "Failure prediction - Servo motor total travel distance unit × Failure prediction - Servo motor total travel distance", [AL. F7.3 Total travel distance failure prediction warning] will occur.</p> <p>When the total travel distance is reset by setting "2" to this digit, "1" will be automatically set after the reset.</p> <p>This digit is available with servo amplifier with software version A3 or later.</p>	0h
	x _ _ _	<p>Failure prediction - Servo motor total travel distance multiplication selection</p> <p>0: × 1 1: × 100 2: × 10000 3: × 1000000 4: × 100000000</p> <p>This digit is available with servo amplifier with software version A3 or later.</p>	0h

No./symbol/ name	Setting digit	Function	Initial value [unit]
PF40 MFPP Machine failure prediction parameter	___x	Friction failure prediction - Threshold multiplication Set a multiplication for calculating the threshold used in the friction failure prediction function. Setting a small threshold multiplication for friction failure prediction will decrease the threshold used for friction failure prediction. Thus, this will enable the prediction of a failure at an early stage, but will increase the possibility of erroneously detecting a failure. When "0" is set to this digit, the multiplication will be the same as when "5" is set. This digit is available with servo amplifier with software version A3 or later.	0h
	__x_	Vibration failure prediction - Threshold multiplication Set a multiplication for calculating the threshold used in the vibration failure prediction function. Setting a small threshold multiplication for vibration failure prediction will decrease the threshold used for vibration failure prediction. Thus, this will enable the prediction of a failure at an early stage, but will increase the possibility of erroneously detecting a failure. When "0" is set to this digit, the multiplication will be the same as when "5" is set. This digit is available with servo amplifier with software version A3 or later.	0h
	_x__	Friction failure prediction - Dynamic friction selection Select a dynamic friction setting used for friction failure prediction. 0: Automatic setting 1: Dynamic friction at forward rotation torque (at rated speed) 2: Dynamic friction at reverse rotation torque (at rated speed) 3: Absolute value average at forward rotation/reverse rotation torque When "0" is set to this digit, any of "1" to "3" is set depending on the operation pattern. This digit is available with servo amplifier with software version A3 or later.	0h
	x___	For manufacturer setting	0h
PF41 FPMT Failure prediction - Servo motor total travel distance	—	Set a servo motor total travel distance required for determining the threshold used in the friction failure prediction function and the servo motor total travel distance failure prediction function. The setting unit can be changed with "Failure prediction - Servo motor total travel distance unit selection" in [Pr. PF34]. When the servo motor total travel distance exceeds 1/2 of "Failure prediction - Servo motor total travel distance unit × Failure prediction - Servo motor total travel distance", the threshold will be automatically calculated for the friction failure prediction function. When [Pr. PF34 Servo motor total travel distance failure prediction warning selection] is enabled, if the servo motor total travel distance exceeds the value of "Failure prediction - Servo motor total travel distance unit × Failure prediction - Servo motor total travel distance", [AL. F7.3 Total travel distance failure prediction warning] will occur. This parameter is available with servo amplifiers with software version A3 or later. Setting range: 0 to 9999	0 [rev]/[m]
PF42 PAV Friction failure prediction - Average characteristic	—	Set a friction torque average at rated speed. This parameter is enabled only when "Manual threshold setting (___2)" is set in [Pr. PF34 Friction failure prediction warning selection]. When "Automatic threshold setting (___1)" is set in [Pr. PF34 Friction failure prediction warning selection], the value will be calculated automatically from the estimated friction torque at rated speed. This parameter is available with servo amplifiers with software version A3 or later. Setting range: -10000 to 10000	0 [0.1%]
PF43 PSD Friction failure prediction - Standard deviation	—	Set a friction torque standard deviation at rated speed. This parameter is enabled only when "Manual threshold setting (___2)" is set in [Pr. PF34 Friction failure prediction warning selection]. When "Automatic threshold setting (___1)" is set in [Pr. PF34 Friction failure prediction warning selection], the value will be calculated automatically from the estimated friction torque at rated speed. This parameter is available with servo amplifiers with software version A3 or later. Setting range: 0 to 20000	0 [0.1%]
PF45 VAV Vibration failure prediction - Average characteristic	—	Set a vibration level average during servo motor operation. This parameter is enabled only when "Manual threshold setting (___2)" is set in [Pr. PF34 Friction failure prediction warning selection]. When "Automatic threshold setting (___1)" is set in [Pr. PF34 Friction failure prediction warning selection], the value will be calculated automatically from the estimated friction torque at rated speed. This parameter is available with servo amplifiers with software version A3 or later. Setting range: 0 to 10000	0 [0.1%]
PF46 VSD Vibration failure prediction - Standard deviation	—	Set a vibration level standard deviation during servo motor operation. This parameter is enabled only when "Manual threshold setting (___2)" is set in [Pr. PF34 Friction failure prediction warning selection]. When "Automatic threshold setting (___1)" is set in [Pr. PF34 Friction failure prediction warning selection], the value will be calculated automatically from the estimated friction torque at rated speed. This parameter is available with servo amplifiers with software version A3 or later. Setting range: 0 to 20000	0 [0.1%]

Linear servo motor/DD motor setting parameters ([Pr. PL_ _])



The linear servo motor control mode and DD motor control mode are available for servo amplifiers with software version A1 or later.

No./symbol/ name	Setting digit	Function	Initial value [unit]																												
PL01 **LIT1 Linear servo motor/ DD motor function selection 1	___x	Linear servo motor/DD motor magnetic pole detection selection The setting value "0" will be enabled only with absolute position linear encoders. 0: Magnetic pole detection disabled 1: Magnetic pole detection at first servo-on 5: Magnetic pole detection at every servo-on	1h																												
	__x_	For manufacturer setting	0h																												
	_x__	Stop interval selection at the home position return Set a stop interval for the dog type home position return. The digit is enabled only for linear servo motors. 0: 2 ¹³ (= 8192) pulses 1: 2 ¹⁷ (= 131072) pulses 2: 2 ¹⁸ (= 262144) pulses 3: 2 ²⁰ (= 1048576) pulses 4: 2 ²² (= 4194304) pulses 5: 2 ²⁴ (= 16777216) pulses 6: 2 ²⁶ (= 67108864) pulses	3h																												
	x___	For manufacturer setting	0h																												
PL02 **LIM Linear encoder resolution - Numerator	—	Set a linear encoder resolution with the settings of [Pr. PL02] and [Pr. PL03]. Set a numerator to [Pr. PL02]. This is enabled only for linear servo motors. Setting range: 1 to 65535	1000 [μm]																												
PL03 **LID Linear encoder resolution - Denominator	—	Set a linear encoder resolution with the settings of [Pr. PL02] and [Pr. PL03]. Set a denominator to [Pr. PL03]. This is enabled only for linear servo motors. Setting range: 1 to 65535	1000 [μm]																												
PL04 *LIT2 Linear servo motor/ DD motor function selection 2	___x	[AL. 42 Servo control error] detection function selection Refer to the following table.	3h																												
		<table border="1"> <thead> <tr> <th>Setting value</th> <th>Thrust/torque deviation error *1</th> <th>Speed deviation error *1</th> <th>Position deviation error *1</th> </tr> </thead> <tbody> <tr> <td>0</td> <td rowspan="3">Disabled</td> <td>Disabled</td> <td>Disabled</td> </tr> <tr> <td>1</td> <td>Enabled</td> </tr> <tr> <td>2</td> <td>Enabled</td> <td>Disabled</td> </tr> <tr> <td>3</td> <td rowspan="4">Enabled</td> <td>Enabled</td> <td>Enabled</td> </tr> <tr> <td>4</td> <td>Disabled</td> <td>Disabled</td> </tr> <tr> <td>5</td> <td>Enabled</td> </tr> <tr> <td>6</td> <td>Enabled</td> <td>Disabled</td> </tr> <tr> <td>7</td> <td>Enabled</td> <td>Enabled</td> </tr> </tbody> </table>		Setting value	Thrust/torque deviation error *1	Speed deviation error *1	Position deviation error *1	0	Disabled	Disabled	Disabled	1	Enabled	2	Enabled	Disabled	3	Enabled	Enabled	Enabled	4	Disabled	Disabled	5	Enabled	6	Enabled	Disabled	7	Enabled	Enabled
		Setting value		Thrust/torque deviation error *1	Speed deviation error *1	Position deviation error *1																									
		0		Disabled	Disabled	Disabled																									
		1			Enabled																										
		2			Enabled	Disabled																									
		3		Enabled	Enabled	Enabled																									
		4			Disabled	Disabled																									
	5	Enabled																													
	6	Enabled	Disabled																												
7	Enabled	Enabled																													
*1 Refer to chapter 15 and 16 for details of each deviation error.																															
📖 Page 505 Linear servo control error detection function																															
📖 Page 526 Servo control error detection function																															
__x_	For manufacturer setting	0h																													
_x__		0h																													
x___	[AL. 42 Servo control error] detection function controller reset condition selection 0: Reset disabled (reset by powering off/on enabled) 1: Reset enabled	0h																													

No./symbol/ name	Setting digit	Function	Initial value [unit]
PL05 LB1 Position deviation error detection level	—	Set a position deviation error detection level of the servo control error detection. When the deviation between a model feedback position and actual feedback position is larger than the setting value, [AL. 42 Servo control error] will occur. However, when "0" is set, the level varies depending on the operation mode in [Pr. PA01]. Linear servo motor: 50 mm Direct drive motor: 0.09 rev Setting range: 0 to 1000	0 [mm]/ [0.01 rev]
PL06 LB2 Speed deviation error detection level	—	Set a speed deviation error detection level of the servo control error detection. When the deviation between a model feedback speed and actual feedback speed is larger than the setting value, [AL. 42 Servo control error] will occur. However, when "0" is set, the level varies depending on the operation mode in [Pr. PA01]. Linear servo motor: 1000 mm/s Direct drive motor: 100 r/min Setting range: 0 to 5000	0 [mm/s]/ [r/min]
PL07 LB3 Torque/thrust deviation error detection level	—	Set a torque/thrust deviation error detection level of the servo control error detection. When the deviation between a current command and current feedback is larger than the setting value, [AL. 42.3 Servo control error by torque/thrust deviation] will occur. Setting range: 0 to 1000	100 [%]
PL08 *LIT3 Linear servo motor/ DD motor function selection 3	___x	Magnetic pole detection method selection 0: Position detection method 4: Minute position detection method	0h
	__x_	For manufacturer setting	1h
	_x__	Magnetic pole detection - Stroke limit enabled/disabled selection 0: Enabled 1: Disabled	0h
	x___	Minute position detection method - High-resolution encoder selection 0: Disabled 1: Enabled The digit will be enabled when "Minute position detection method" is selected in [Pr. PL08 (___x)]. If a linear encoder whose resolution is smaller than 0.05 μm is used and also [AL. 27 Initial magnetic pole detection error] occurs because the travel distance at magnetic pole detection is too large or vibration occurs, set "1" (enabled). The setting of this digit is used by servo amplifier with software version A1 or later.	0h
PL09 LPWM Magnetic pole detection voltage level	—	Set a direct current exciting voltage level during the magnetic pole detection. If [AL. 32 Overcurrent], [AL. 50 Overload 1], or [AL. 51 Overload 2] occurs during the magnetic pole detection, decrease the setting value. If [AL. 27 Initial magnetic pole detection error] occurs during the magnetic pole detection, increase the setting value. Setting range: 0 to 100	30 [%]

No./symbol/ name	Setting digit	Function	Initial value [unit]																																				
PL17 LTSTS Magnetic pole detection - Minute position detection method - Function selection	___x	Response selection The digit will be enabled when "Minute position detection method" is selected in [Pr. PL08]. Set a response of the minute position detection method. When reducing a travel distance at the magnetic pole detection, increase the setting value. For settings, refer to the following tables (Response of minute position detection method at magnetic pole detection) for the setting value.	0h																																				
	__x_	Load to motor mass ratio/load to motor inertia ratio selection The digit will be enabled when "Minute position detection method" is selected in [Pr. PL08]. Select a load to mass of the linear servo motor primary-side ratio or load to mass of the direct drive motor inertia ratio used at the minute position detection method. Set a closest value to the actual load. For settings, refer to the load to following tables (Load to motor mass ratio/load to motor inertia ratio) for the setting value.	0h																																				
	_x__	For manufacturer setting	0h																																				
	x___		0h																																				
Response of minute position detection method at magnetic pole detection																																							
<table border="1"> <thead> <tr> <th>Setting value</th> <th>Response</th> </tr> </thead> <tbody> <tr><td>___0</td><td rowspan="7">Low response ↑ ↓ Middle response</td></tr> <tr><td>___1</td></tr> <tr><td>___2</td></tr> <tr><td>___3</td></tr> <tr><td>___4</td></tr> <tr><td>___5</td></tr> <tr><td>___6</td></tr> <tr><td>___7</td></tr> </tbody> </table>		Setting value	Response	___0	Low response ↑ ↓ Middle response	___1	___2	___3	___4	___5	___6	___7	<table border="1"> <thead> <tr> <th>Setting value</th> <th>Response</th> </tr> </thead> <tbody> <tr><td>___8</td><td rowspan="7">Middle response ↑ ↓ High response</td></tr> <tr><td>___9</td></tr> <tr><td>___A</td></tr> <tr><td>___B</td></tr> <tr><td>___C</td></tr> <tr><td>___D</td></tr> <tr><td>___E</td></tr> <tr><td>___F</td></tr> </tbody> </table>		Setting value	Response	___8	Middle response ↑ ↓ High response	___9	___A	___B	___C	___D	___E	___F														
Setting value	Response																																						
___0	Low response ↑ ↓ Middle response																																						
___1																																							
___2																																							
___3																																							
___4																																							
___5																																							
___6																																							
___7																																							
Setting value	Response																																						
___8	Middle response ↑ ↓ High response																																						
___9																																							
___A																																							
___B																																							
___C																																							
___D																																							
___E																																							
___F																																							
Load to motor mass ratio/load to motor inertia ratio																																							
<table border="1"> <thead> <tr> <th>Setting value</th> <th>Load to motor mass ratio/load to motor inertia ratio</th> </tr> </thead> <tbody> <tr><td>__0_</td><td>10 times or less</td></tr> <tr><td>__1_</td><td>10 times</td></tr> <tr><td>__2_</td><td>20 times</td></tr> <tr><td>__3_</td><td>30 times</td></tr> <tr><td>__4_</td><td>40 times</td></tr> <tr><td>__5_</td><td>50 times</td></tr> <tr><td>__6_</td><td>60 times</td></tr> <tr><td>__7_</td><td>70 times</td></tr> </tbody> </table>		Setting value	Load to motor mass ratio/load to motor inertia ratio	__0_	10 times or less	__1_	10 times	__2_	20 times	__3_	30 times	__4_	40 times	__5_	50 times	__6_	60 times	__7_	70 times	<table border="1"> <thead> <tr> <th>Setting value</th> <th>Load to motor mass ratio/load to motor inertia ratio</th> </tr> </thead> <tbody> <tr><td>__8_</td><td>80 times</td></tr> <tr><td>__9_</td><td>90 times</td></tr> <tr><td>__A_</td><td>100 times</td></tr> <tr><td>__B_</td><td>110 times</td></tr> <tr><td>__C_</td><td>120 times</td></tr> <tr><td>__D_</td><td>130 times</td></tr> <tr><td>__E_</td><td>140 times</td></tr> <tr><td>__F_</td><td>150 times or more</td></tr> </tbody> </table>		Setting value	Load to motor mass ratio/load to motor inertia ratio	__8_	80 times	__9_	90 times	__A_	100 times	__B_	110 times	__C_	120 times	__D_	130 times	__E_	140 times	__F_	150 times or more
Setting value	Load to motor mass ratio/load to motor inertia ratio																																						
__0_	10 times or less																																						
__1_	10 times																																						
__2_	20 times																																						
__3_	30 times																																						
__4_	40 times																																						
__5_	50 times																																						
__6_	60 times																																						
__7_	70 times																																						
Setting value	Load to motor mass ratio/load to motor inertia ratio																																						
__8_	80 times																																						
__9_	90 times																																						
__A_	100 times																																						
__B_	110 times																																						
__C_	120 times																																						
__D_	130 times																																						
__E_	140 times																																						
__F_	150 times or more																																						
PL18 IDLV Magnetic pole detection - Minute position detection method - Identification signal amplitude	—	Set an identification signal amplitude used in the minute position detection method. This parameter is enabled only when the magnetic pole detection is the minute position detection method. However, when "0" is set, the amplitude will be 100%. Setting range: 0 to 100	0 [%]																																				

Positioning control parameters ([Pr. PT__])

No./symbol/ name	Setting digit	Function	Initial value [unit]
PT05 ZRF Home position return speed	—	Set a servo motor speed at home position return. The fractional portion of the parameter will be rounded down. Setting range: 0.00 to instantaneous permissible speed	100.00 [r/min]/[mm/s]
PT06 CRF Creep speed	—	Set a creep speed after proximity dog at home position return. The fractional portion of the parameter will be rounded down. Setting range: 0.00 to instantaneous permissible speed	10.00 [r/min]/[mm/s]

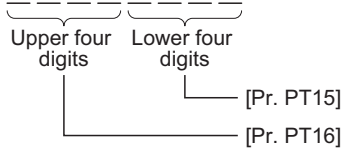
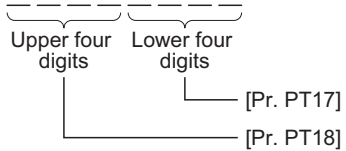
No./symbol/ name	Setting digit	Function	Initial value [unit]
PT07 ZST Home position shift distance	—	Set a shift distance from the Z-phase pulse detection position in the encoder. Up to "2 ³¹ -1" can be set with [Pr. PT69]. Refer to the following for the home position shift direction. ☞ Page 154 Operation example of the CiA 402-type Homing method ☞ Page 163 Operation example of Manufacturer-specific Homing method Setting range: 0 to 65535	0 [pulse]
PT09 DCT Travel distance after proximity dog	—	Set a travel distance after proximity dog for the count type home position return (front end detection, Z-phase reference) (Homing method -2, -34) and the following dog reference home position returns. • Dog type rear end reference home position return (Homing method -6, -38) • Count type home position return (Front end reference) (Homing method -7, -39) • Dog type front end reference home position return (Homing method -10, -42) • Homing without index pulse (Homing method 19, 20, 21, 22, 23, 24, 27, 28) Up to 2 ³¹ can be set with [Pr. PT71]. Setting range: 0 to 65535	0 [pulse]
PT10 ZTM Stopper type home position return stopper time	—	Set a time from a moving part touches the stopper and torques reaches to the torque limit of [Pr. PT11 Stopper type home position return - Torque limit value] to a home position is set for the stopper type home position return. Setting range: 5 to 1000	100 [ms]
PT11 ZTT Stopper type home position return torque limit value	—	Set a torque limit value with [%] to the maximum torque at stopper type home position return. Setting range: 0.1 to 100.0	15.0 [%]
PT15 LMPL Software limit + (lower four digits)	—	Set an address increasing side of the software stroke limit. Upper and lower are a set. Set the setting address in hexadecimal. 	0000h [pulse]
PT16 LMPH Software limit + (upper four digits)	—	Setting a value larger than "Software limit +" to "Software limit -" will disable the software limit. ☞ Page 229 Software limit When setting this parameter with MR Configurator2, change the status to servo-off or the mode to the home position return mode, velocity mode, or torque mode. In the position mode during servo-on, changing the setting by a certain order may trigger [AL. 35], [AL. 69], or [AL. 98]. Setting range: 80000000h to 7FFFFFFFh (-2147483648 to 2147483647)	0000h [pulse]
PT17 LMNL Software limit - (lower four digits)	—	Set an address decreasing side of the software stroke limit. Upper and lower are a set. Set the setting address in hexadecimal. 	0000h [pulse]
PT18 LMNH Software limit - (upper four digits)	—	Setting a value larger than "Software limit +" to "Software limit -" will disable the software limit. ☞ Page 229 Software limit When setting this parameter with MR Configurator2, change the status to servo-off or the mode to the home position return mode, velocity mode, or torque mode. In the position mode during servo-on, changing the setting by a certain order may trigger [AL. 35], [AL. 69], or [AL. 98]. Setting range: 80000000h to 7FFFFFFFh (-2147483648 to 2147483647)	0000h [pulse]

No./symbol/ name	Setting digit	Function	Initial value [unit]														
PT29 *TOP3 Function selection T-3	Set the DOG polarity.																
	----x (HEX)	----x (BIN): DOG (Proximity dog) polarity selection 0: Dog detection with off 1: Dog detection with on This setting is applied to both the input by a servo amplifier and by a controller.	0h														
		--x_ (BIN): For manufacturer setting															
		_x__ (BIN): For manufacturer setting															
		x___ (BIN): For manufacturer setting															
	--x_	For manufacturer setting	0h														
	_x__		0h														
	x___		0h														
	Convert the setting value into hexadecimal as follows.																
	<table border="1" style="margin-left: auto; margin-right: auto;"> <thead> <tr> <th rowspan="2">Setting</th> <th colspan="2">Initial value</th> </tr> <tr> <th>BIN</th> <th>HEX</th> </tr> </thead> <tbody> <tr> <td>DOG (Proximity dog) polarity selection</td> <td>0</td> <td rowspan="4">0</td> </tr> <tr> <td>---</td> <td>0</td> </tr> <tr> <td>---</td> <td>0</td> </tr> <tr> <td>---</td> <td>0</td> </tr> </tbody> </table>			Setting	Initial value		BIN	HEX	DOG (Proximity dog) polarity selection	0	0	---	0	---	0	---	0
Setting	Initial value																
	BIN	HEX															
DOG (Proximity dog) polarity selection	0	0															
---	0																
---	0																
---	0																
PT41 ORP Home position return inhibit function selection	----x	Home position return inhibit selection 0: Disabled (home position return allowed) 1: Enabled (home position return inhibited)	0h														
	--x_	Stop position selection at home position return Select the stop position at home position return for Homing methods 33, 34, -11, and -43. This parameter is enabled when an incremental linear encoder compatible with a serial interface is used. 0: Reference home position 1: Linear encoder home position (reference mark) When a linear servo motor is used, the reference home position is the position per 1048576 pulses (can be changed with the third digit of [Pr. PL01]) to the linear encoder home position (reference mark) passed through first after a home position return start. When a fully closed loop system is used, the reference home position is the position per servo motor revolution to the linear encoder home position (reference mark) passed through first after a home position return start. The setting of this digit is used by servo amplifiers with software version A6 or later.	0h														
	_x__	For manufacturer setting	0h														
	x___		0h														

No./symbol/ name	Setting digit	Function	Initial value [unit]																																																																
PT45 HMM Home position return type	—	Set the home position return method. Refer to the following table for details. Setting a value other than the setting values in the following tables will trigger [AL. 37].	37																																																																
		<table border="1"> <thead> <tr> <th>Setting value</th> <th>Home position return direction</th> <th>Home position return type</th> <th>Setting value</th> <th>Home position return direction</th> <th>Home position return type</th> </tr> </thead> <tbody> <tr> <td>-1</td> <td rowspan="11">Forward rotation (CCW) or positive direction</td> <td>Dog type (rear end detection, Z-phase reference)</td> <td>-33</td> <td rowspan="11">Reverse rotation (CW) or negative direction</td> <td>Dog type (rear end detection, Z-phase reference)</td> </tr> <tr> <td>-2</td> <td>Count type (front end detection, Z-phase reference)</td> <td>-34</td> <td>Count type (front end detection, Z-phase reference)</td> </tr> <tr> <td>-4</td> <td>Stopper type (stopper position reference)</td> <td>-36</td> <td>Stopper type (stopper position reference)</td> </tr> <tr> <td>-6</td> <td>Dog type (rear end detection, rear end reference)</td> <td>-38</td> <td>Dog type (rear end detection, rear end reference)</td> </tr> <tr> <td>-7</td> <td>Count type (front end detection, front end reference)</td> <td>-39</td> <td>Count type (front end detection, front end reference)</td> </tr> <tr> <td>-8</td> <td>Dog cradle type</td> <td>-40</td> <td>Dog cradle type</td> </tr> <tr> <td>-9</td> <td>Dog type last Z-phase reference</td> <td>-41</td> <td>Dog type last Z-phase reference</td> </tr> <tr> <td>-10</td> <td>Dog type front end reference</td> <td>-42</td> <td>Dog type front end reference</td> </tr> <tr> <td>-11</td> <td>Dogless Z-phase reference *1</td> <td>-43</td> <td>Dogless Z-phase reference *1</td> </tr> </tbody> </table>	Setting value	Home position return direction	Home position return type	Setting value	Home position return direction	Home position return type	-1	Forward rotation (CCW) or positive direction	Dog type (rear end detection, Z-phase reference)	-33	Reverse rotation (CW) or negative direction	Dog type (rear end detection, Z-phase reference)	-2	Count type (front end detection, Z-phase reference)	-34	Count type (front end detection, Z-phase reference)	-4	Stopper type (stopper position reference)	-36	Stopper type (stopper position reference)	-6	Dog type (rear end detection, rear end reference)	-38	Dog type (rear end detection, rear end reference)	-7	Count type (front end detection, front end reference)	-39	Count type (front end detection, front end reference)	-8	Dog cradle type	-40	Dog cradle type	-9	Dog type last Z-phase reference	-41	Dog type last Z-phase reference	-10	Dog type front end reference	-42	Dog type front end reference	-11	Dogless Z-phase reference *1	-43	Dogless Z-phase reference *1																					
	Setting value	Home position return direction	Home position return type	Setting value	Home position return direction	Home position return type																																																													
	-1	Forward rotation (CCW) or positive direction	Dog type (rear end detection, Z-phase reference)	-33	Reverse rotation (CW) or negative direction	Dog type (rear end detection, Z-phase reference)																																																													
	-2		Count type (front end detection, Z-phase reference)	-34		Count type (front end detection, Z-phase reference)																																																													
	-4		Stopper type (stopper position reference)	-36		Stopper type (stopper position reference)																																																													
	-6		Dog type (rear end detection, rear end reference)	-38		Dog type (rear end detection, rear end reference)																																																													
	-7		Count type (front end detection, front end reference)	-39		Count type (front end detection, front end reference)																																																													
	-8		Dog cradle type	-40		Dog cradle type																																																													
	-9		Dog type last Z-phase reference	-41		Dog type last Z-phase reference																																																													
	-10		Dog type front end reference	-42		Dog type front end reference																																																													
	-11		Dogless Z-phase reference *1	-43		Dogless Z-phase reference *1																																																													
*1 When an incremental linear encoder compatible with a serial interface is used, the stop position at dogless Z-phase reference home position return can be selected with the second digit (Stop position selection at home position return) of [Pr. PT41].																																																																			
			<table border="1"> <thead> <tr> <th>Setting value</th> <th>Home position return direction</th> <th>Home position return type</th> <th>Setting value</th> <th>Home position return direction</th> <th>Home position return type</th> </tr> </thead> <tbody> <tr> <td>3</td> <td rowspan="2">Forward rotation (CCW) or positive direction</td> <td>Method 3</td> <td>21</td> <td rowspan="2">Reverse rotation (CW) or negative direction</td> <td>Method 21</td> </tr> <tr> <td>4</td> <td>Method 4</td> <td>22</td> <td>Method 22</td> </tr> <tr> <td>5</td> <td>Reverse rotation (CW) or negative direction</td> <td>Method 5</td> <td>23</td> <td>Forward rotation (CCW) or positive direction</td> <td>Method 23</td> </tr> <tr> <td>6</td> <td>Reverse rotation (CW) or negative direction</td> <td>Method 6</td> <td>24</td> <td>Forward rotation (CCW) or positive direction</td> <td>Method 24</td> </tr> <tr> <td>7</td> <td>Forward rotation (CCW) or positive direction</td> <td>Method 7</td> <td>27</td> <td>Reverse rotation (CW) or negative direction</td> <td>Method 27</td> </tr> <tr> <td>8</td> <td>Forward rotation (CCW) or positive direction</td> <td>Method 8</td> <td>28</td> <td>Reverse rotation (CW) or negative direction</td> <td>Method 28</td> </tr> <tr> <td>11</td> <td>Reverse rotation (CW) or negative direction</td> <td>Method 11</td> <td>33</td> <td>Reverse rotation (CW) or negative direction</td> <td>Method 33 *1</td> </tr> <tr> <td>12</td> <td>Reverse rotation (CW) or negative direction</td> <td>Method 12</td> <td>34</td> <td>Forward rotation (CCW) or positive direction</td> <td>Method 34 *1</td> </tr> <tr> <td>19</td> <td>Forward rotation (CCW) or positive direction</td> <td>Method 19</td> <td>35</td> <td>-</td> <td>Method 35</td> </tr> <tr> <td>20</td> <td>Forward rotation (CCW) or positive direction</td> <td>Method 20</td> <td>37</td> <td>-</td> <td>Method 37 (Data set type)</td> </tr> </tbody> </table>	Setting value		Home position return direction	Home position return type	Setting value	Home position return direction	Home position return type	3	Forward rotation (CCW) or positive direction	Method 3	21	Reverse rotation (CW) or negative direction	Method 21	4	Method 4	22	Method 22	5	Reverse rotation (CW) or negative direction	Method 5	23	Forward rotation (CCW) or positive direction	Method 23	6	Reverse rotation (CW) or negative direction	Method 6	24	Forward rotation (CCW) or positive direction	Method 24	7	Forward rotation (CCW) or positive direction	Method 7	27	Reverse rotation (CW) or negative direction	Method 27	8	Forward rotation (CCW) or positive direction	Method 8	28	Reverse rotation (CW) or negative direction	Method 28	11	Reverse rotation (CW) or negative direction	Method 11	33	Reverse rotation (CW) or negative direction	Method 33 *1	12	Reverse rotation (CW) or negative direction	Method 12	34	Forward rotation (CCW) or positive direction	Method 34 *1	19	Forward rotation (CCW) or positive direction	Method 19	35	-	Method 35	20	Forward rotation (CCW) or positive direction	Method 20	37	-
Setting value	Home position return direction	Home position return type	Setting value	Home position return direction	Home position return type																																																														
3	Forward rotation (CCW) or positive direction	Method 3	21	Reverse rotation (CW) or negative direction	Method 21																																																														
4		Method 4	22		Method 22																																																														
5	Reverse rotation (CW) or negative direction	Method 5	23	Forward rotation (CCW) or positive direction	Method 23																																																														
6	Reverse rotation (CW) or negative direction	Method 6	24	Forward rotation (CCW) or positive direction	Method 24																																																														
7	Forward rotation (CCW) or positive direction	Method 7	27	Reverse rotation (CW) or negative direction	Method 27																																																														
8	Forward rotation (CCW) or positive direction	Method 8	28	Reverse rotation (CW) or negative direction	Method 28																																																														
11	Reverse rotation (CW) or negative direction	Method 11	33	Reverse rotation (CW) or negative direction	Method 33 *1																																																														
12	Reverse rotation (CW) or negative direction	Method 12	34	Forward rotation (CCW) or positive direction	Method 34 *1																																																														
19	Forward rotation (CCW) or positive direction	Method 19	35	-	Method 35																																																														
20	Forward rotation (CCW) or positive direction	Method 20	37	-	Method 37 (Data set type)																																																														
*1 When an incremental linear encoder compatible with a serial interface is used, the stop position at dogless Z-phase reference home position return can be selected with the second digit (Stop position selection at home position return) of [Pr. PT41].																																																																			
PT55 *TOP8 Function selection T-8	___x	Home position return - Deceleration time constant selection Select a parameter used for the acceleration time constant and deceleration time constant at home position return. 0: Using [Pr. PT56] for both acceleration time constant and deceleration time constant 1: Using [Pr. PT56] for acceleration time constant, and [Pr. PT57] for deceleration time constant	0h																																																																
	__x_	For manufacturer setting	0h																																																																
	_x__		0h																																																																
	x___		0h																																																																
PT56 HMA Home position return acceleration time constant	—	Set the acceleration time constant for the home position return. Set an acceleration time from 0 r/min or 0 mm/s to the rated speed. When "Using [Pr. PT56] for both acceleration time constant and deceleration time constant (___0)" is selected in [Pr. PT55] Home position return - Deceleration time constant selection, the value set in this parameter is used as a deceleration time constant at home position return. Setting range: 0 to 20000	0 [ms]																																																																

No./symbol/ name	Setting digit	Function	Initial value [unit]
PT57 HMB Home position return deceleration time constant	—	Set the deceleration time constant at the home position return. Set a deceleration time from the rated speed to 0 r/min or 0 mm/s. The parameter will be enabled when you select "Using [Pr. PT56] for acceleration time constant, and [Pr. PT57] for deceleration time constant (_ _ _ 1)" in [Pr. PT55] Home position return - Deceleration time constant selection. Setting range: 0 to 20000	0 [ms]
PT67 VLMT Speed limit	—	Set a maximum speed for the torque mode. With equipment for the simple motion connected, writing from MR Configurator2 may not be reflected since this parameter is updated by the simple motion. Setting range: 0.00 to instantaneous permissible speed	500.00 [r/min]/[mm/s]
PT69 ZSTH Home position shift distance (extension parameter)	—	Set the extension parameter of [Pr. PT07]. When [Pr. PT69] is used, the home position shift distance can be calculated as follows. Home position shift distance = [Pr. PT07] + ([Pr. PT69] × 65536) Refer to the following for the home position shift direction. ☞ Page 154 Operation example of the CiA 402-type Homing method ☞ Page 163 Operation example of Manufacturer-specific Homing method This parameter is supported with software version A1 or later. Setting range: 0 to 32767	0 [pulse]
PT71 DCTH Travel distance after proximity dog (extension parameter)	—	Set the extension parameter of [Pr. PT09]. When [Pr. PT71] is used, the travel distance after proximity dog can be calculated as follows. Travel distance after proximity dog = [Pr. PT09] + ([Pr. PT71] × 65536) This parameter is supported with software version A1 or later. Setting range: 0 to 32767	0 [pulse]

Network setting parameters ([Pr. PN_ _])

No./symbol/ name	Setting digit	Function	Initial value [unit]															
PN02 CERT Communication error detection time	—	Set the time until the detection of [AL. 8D.1 CC-Link IE communication error 1], [AL. 8D.6 CC-Link IE communication error 3], or [AL. 86.1 Network communication error 1]. When the parameter is set to "0", the detection time varies depending on the setting value of [Pr. PN03] as shown in the following table. When [Pr. PD41] is set to "_ 1 _ _" or "1 _ _ _", if this parameter setting value is increased, the servo motor cannot be stopped at the occurrence of a communication error. Be careful when changing the setting value, because there is a danger of collision. <table border="1" data-bbox="427 1263 1334 1480"> <thead> <tr> <th>[Pr. PN03]</th> <th>Communication cycle [ms]</th> <th>Detection time [ms]</th> </tr> </thead> <tbody> <tr> <td rowspan="4">0</td> <td>0.5</td> <td>8.5</td> </tr> <tr> <td>1.0</td> <td>9.0</td> </tr> <tr> <td>2.0</td> <td>10.0</td> </tr> <tr> <td>4.0</td> <td>12.0</td> </tr> <tr> <td>1</td> <td>—</td> <td>10.0</td> </tr> </tbody> </table> Setting range: 0 to 1000	[Pr. PN03]	Communication cycle [ms]	Detection time [ms]	0	0.5	8.5	1.0	9.0	2.0	10.0	4.0	12.0	1	—	10.0	0 [ms]
[Pr. PN03]	Communication cycle [ms]	Detection time [ms]																
0	0.5	8.5																
	1.0	9.0																
	2.0	10.0																
	4.0	12.0																
1	—	10.0																
PN03 **NWMD Communication mode setting for CC-Link IE communication	___x __x_ _x__ x___	Station-specific mode setting Select the motion mode for connection with a simple motion module or the I/O mode for connection with a master/local module. 0: Motion mode 1: I/O mode For the correspondence with the control modes, refer to [Pr. PA01]. The setting of this digit is used by servo amplifier with software version A1 or later.	0h 0h 0h															
PN04 **NWNO CC-Link IE communication network number	—	Set the network number of the servo amplifier. When "0" is selected, use the network number transmitted from the master station. Setting range: 0 to 239	0															

No./symbol/ name	Setting digit	Function	Initial value [unit]
PN05 CER1 Communication error detection frequency setting	—	Set the frequency of communication error detection until the detection of [AL. 8D.7 CC-Link IE communication error 4] or [AL. 8D.8 CC-Link IE communication error 5]. When the parameter is set to "0", the frequency will be 8%. Setting range: 0 to 100	0 [%]
PN06 NOP1 Function selection N-1	— — — x	Communication error alarm history writing selection Select whether [AL. 8D.1 CC-Link IE communication error 1] and [AL. 8D.2 CC-Link IE communication error 2] are recorded in the alarm history at their occurrence. 0: Disabled 1: Enabled When the parameter is set to "1", follow the correct procedure for turning off the power to prevent the occurrence of [AL. 8D.1] or [AL. 8D.2] at power supply shut-off (network disconnection). For details, refer to [Pr. PN06 Communication error detection method selection].	0h
	— — x —	Communication error detection method selection Select the condition for detecting the occurrences of [AL. 8D.1 CC-Link IE communication error 1] and [AL. 8D.2 CC-Link IE communication error 2]. 0: Detected only at servo-on. 1: Continuously detected. When the parameter is set to "0", [AL. 8D.1] and [AL. 8D.2] are detected only at the input of servo-on command. When turning off the power, set the servo amplifier to the servo-off status with commands and then turn off the power. When the parameter is set to "1", [AL. 8D.1] and [AL. 8D.2] are continuously detected while data is being linked. When turning off the power, turn off the servo amplifier first and then the controller.	0h
	— x — —	For manufacturer setting	0h
	x — — —		0h

5.3 Software limit

The limit stop with the software limit ([Pr. PT15] to [Pr. PT18]) is the same as the motion of the stroke end. Exceeding a setting range will stop and servo-lock the shaft. This will be enabled at power-on and will be disabled in the velocity mode, torque mode, and homing mode. Setting a same value to "Software limit +" and "Software limit -" will disable this function. Setting a larger value to "Software limit -" than "Software limit +" will disable this function.

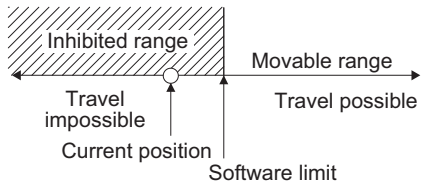

6 NORMAL GAIN ADJUSTMENT

Point

- In the torque mode, you do not need to make gain adjustment.
- Before making gain adjustment, check that your machine is not being operated at maximum torque of the servo motor. If operated over maximum torque, the machine may vibrate and may operate unexpectedly. In addition, make gain adjustment with a safety margin considering characteristic differences of each machine. It is recommended that generated torque during operation is under 90% of the maximum torque of the servo motor.
- When you use a linear servo motor, replace the following left words to the right words. Load to motor inertia ratio → Load to motor mass ratio
Torque → Thrust
- For the vibration suppression control tuning mode, the setting range of [Pr. PB07] is limited. Refer to the following for details.

☞ Page 259 Vibration suppression control manual mode

6.1 Different adjustment methods

Adjustment on a single servo amplifier

The following table shows the gain adjustment modes that can be set on a single servo amplifier. For gain adjustment, first execute "Auto tuning mode 1". If you are not satisfied with the result of the adjustment, execute "Auto tuning mode 2" and "Manual mode" in this order.

Gain adjustment mode explanation

Gain adjustment mode	[Pr. PA08] setting	Estimation of load to motor inertia ratio	Automatically set parameters	Manually set parameters
Auto tuning mode 1 (initial value)	___ 1	Always estimated	GD2 ([Pr. PB06]) PG1 ([Pr. PB07]) PG2 ([Pr. PB08]) VG2 ([Pr. PB09]) VIC ([Pr. PB10])	RSP ([Pr. PA09])
Auto tuning mode 2	___ 2	Fixed to [Pr. PB06] value	PG1 ([Pr. PB07]) PG2 ([Pr. PB08]) VG2 ([Pr. PB09]) VIC ([Pr. PB10])	GD2 ([Pr. PB06]) RSP ([Pr. PA09])
Manual mode	___ 3		—	GD2 ([Pr. PB06]) PG1 ([Pr. PB07]) PG2 ([Pr. PB08]) VG2 ([Pr. PB09]) VIC ([Pr. PB10])
2 gain adjustment mode 1 (interpolation mode)	___ 0	Always estimated	GD2 ([Pr. PB06]) PG2 ([Pr. PB08]) VG2 ([Pr. PB09]) VIC ([Pr. PB10])	PG1 ([Pr. PB07]) RSP ([Pr. PA09])
2 gain adjustment mode 2	___ 4	Fixed to [Pr. PB06] value	PG2 ([Pr. PB08]) VG2 ([Pr. PB09]) VIC ([Pr. PB10])	GD2 ([Pr. PB06]) PG1 ([Pr. PB07]) RSP ([Pr. PA09])

Adjustment sequence and mode usage

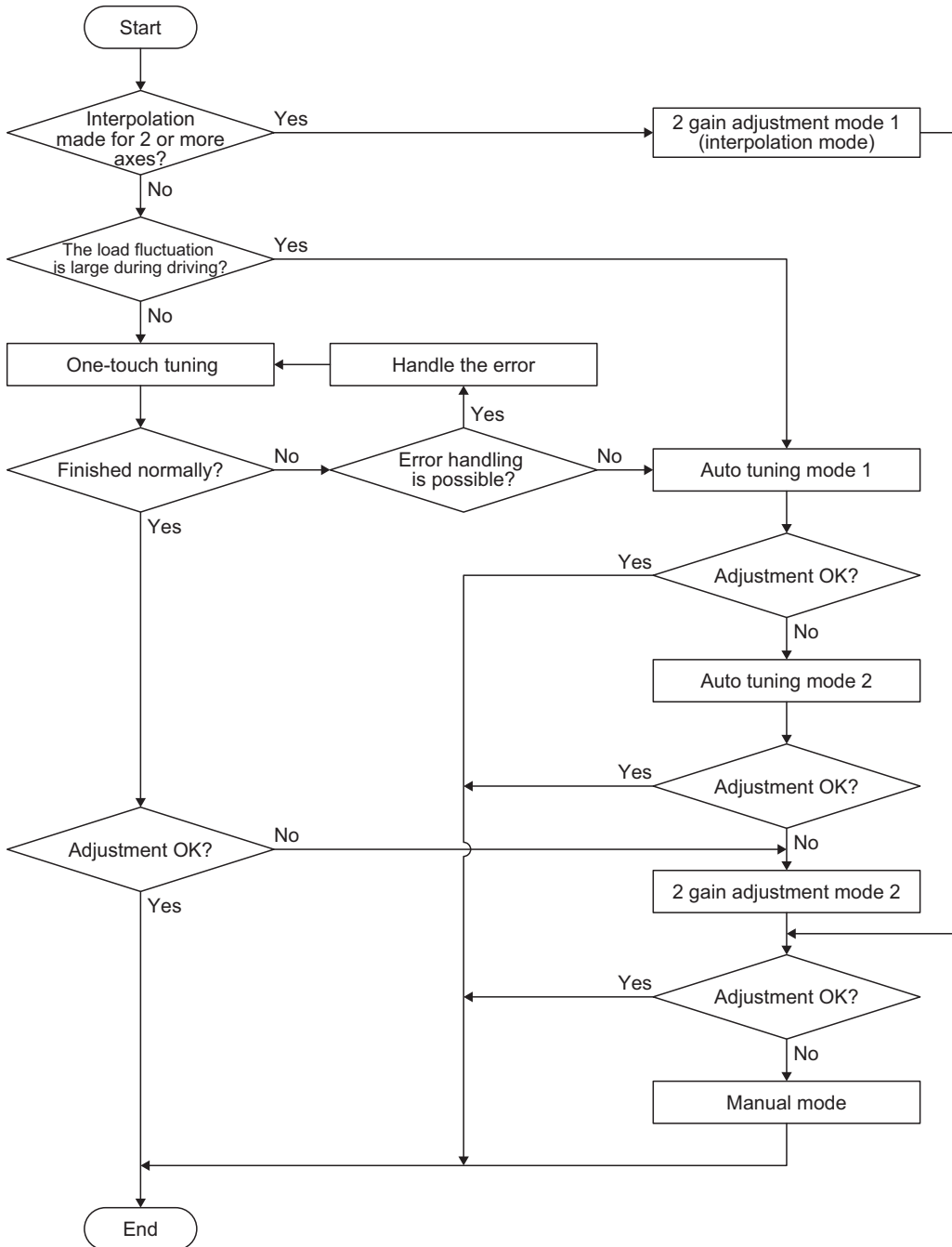

Adjustment using MR Configurator2

This section explains the functions and adjustment using the servo amplifier with MR Configurator2.

Function	Description	Adjustment
Machine analyzer	With the machine and servo motor coupled, the characteristic of the mechanical system can be measured by giving a random vibration command from a personal computer to the servo and measuring the machine response.	You can grasp the machine resonance frequency and determine the notch frequency of the machine resonance suppression filter.

6.2 One-touch tuning

Point

- When executing the one-touch tuning, check the [Pr. PA21 One-touch tuning function selection] is " _ _ _ 1" (initial value).
- Refer to the following for one-touch tuning via a network.
 Page 238 One-touch tuning via a network

Connect MR Configurator2 and open the one-touch tuning window, and you can use the function. The following parameters are set automatically with one-touch tuning.

Parameter	Symbol	Name
PA08	ATU	Auto tuning mode
PA09	RSP	Auto tuning response
PB01	FILT	Adaptive tuning mode (adaptive filter II)
PB02	VRFT	Vibration suppression control tuning mode (advanced vibration suppression control II)
PB06	GD2	Load to motor inertia ratio/load to motor mass ratio
PB07	PG1	Model loop gain
PB08	PG2	Position loop gain
PB09	VG2	Speed loop gain
PB10	VIC	Speed integral compensation
PB12	OVA	Overshoot amount compensation
PB13	NH1	Machine resonance suppression filter 1
PB14	NHQ1	Notch shape selection 1
PB15	NH2	Machine resonance suppression filter 2
PB16	NHQ2	Notch shape selection 2
PB18	LPF	Low-pass filter setting
PB19	VRF11	Vibration suppression control 1 - Vibration frequency
PB20	VRF12	Vibration suppression control 1 - Resonance frequency
PB21	VRF13	Vibration suppression control 1 - Vibration frequency damping
PB22	VRF14	Vibration suppression control 1 - Resonance frequency damping
PB23	VFBF	Low-pass filter selection
PB47	NHQ3	Notch shape selection 3
PB48	NH4	Machine resonance suppression filter 4
PB49	NHQ4	Notch shape selection 4
PB51	NHQ5	Notch shape selection 5
PE41	EOP3	Function selection E-3

One-touch tuning flowchart

Make one-touch tuning as follows.

1. Startup of the system

Start a system referring to the following.

☞ Page 128 STARTUP

2. Operation

Rotate the servo motor by an external controller, etc. (The one-touch tuning cannot be performed if the servo motor is not operating.)

3. One-touch tuning start

Start one-touch tuning of MR Configurator2.

4. Response mode selection

Select a response mode (high mode, basic mode, and low mode) in the one-touch tuning window of MR Configurator2.

5. One-touch tuning execution

Push the start button to start one-touch tuning. Push it during servo motor driving.

When one-touch tuning is completed normally, the parameters described in the following section will be set automatically.

☞ Page 232 One-touch tuning

Display transition and operation procedure of one-touch tuning

Response mode selection

Select a response mode from 3 modes in the one-touch tuning window of MR Configurator2.

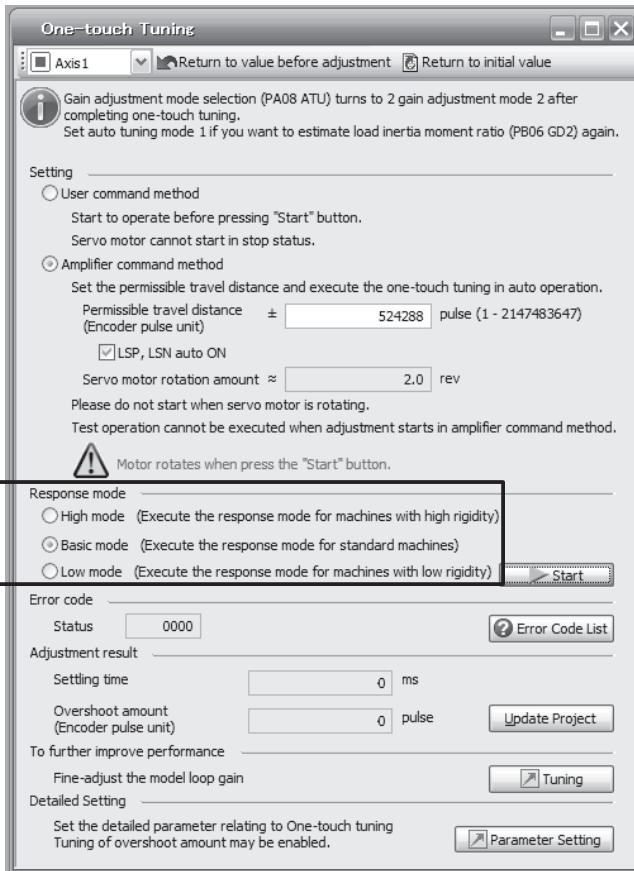

Response mode	Explanation
High mode	This mode is for high rigid system.*1
Basic mode	This mode is for standard system.
Low mode	This mode is for low rigid system.

*1 When the communication cycle of the controller is 2 ms or more, a higher gain may be applied. In this case, use the basic mode or low mode to readjust the gain.

Refer to the following table for selecting a response mode.

Response mode			Response	Machine characteristic
Low mode	Basic mode	High mode		Guideline of corresponding machine
↑ ↓	↑ ↓	↑ ↓	Low response ↑ ↓ High response	

One-touch tuning execution

Point

For equipment in which overshoot during one-touch tuning is in the permissible level of the in-position range, changing the value of [Pr. PA25 One-touch tuning - Overshoot permissible level] will shorten the settling time and improve the response.

After the response mode is selected in the following section, pushing the start button during driving will start one-touch tuning.

☞ Page 234 Response mode selection

If the start button is pushed while the servo motor stops, "C 0 0 2" or "C 0 0 4" will be displayed at status in error code. (Refer to the following for error codes.)

☞ Page 236 If an error occurs

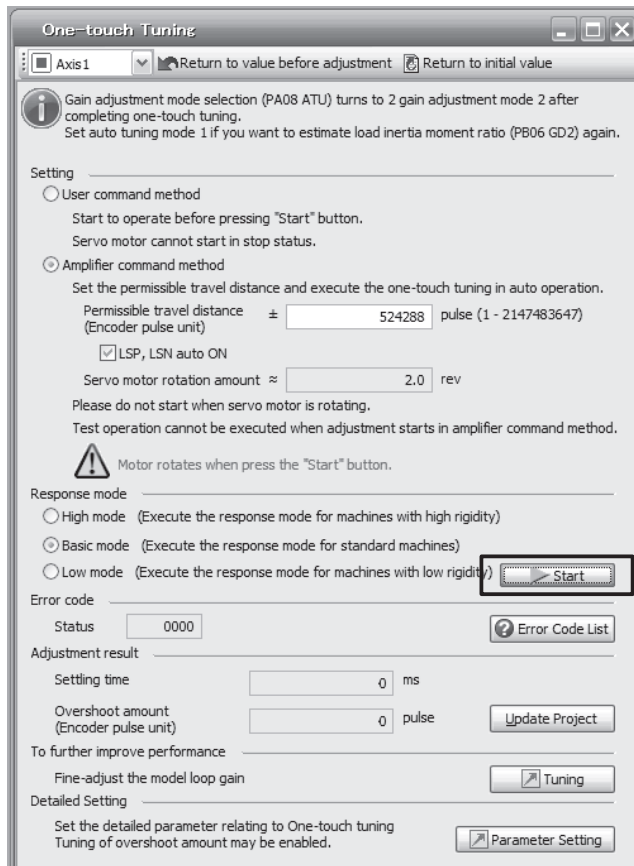

During processing of one-touch tuning, the status will be displayed in the progress window as follows. One-touch tuning will be finished at 100%.

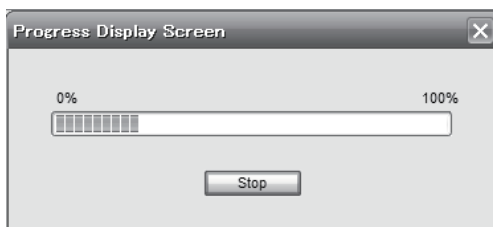

Completing the one-touch tuning starts writing tuning parameters to the servo amplifier. "0 0 0 0" is displayed at status in error code. In addition, settling time and overshoot amount will be displayed in "Adjustment result" after adjustment.

Stop of one-touch tuning

During one-touch tuning, pushing the stop button stops one-touch tuning.

If the one-touch tuning is stopped, "C 0 0 0" will be displayed at status in error code.

If an error occurs

If a tuning error occurs during tuning, one-touch tuning will be forcibly terminated. With that, the following error code will be displayed in status. Check the cause of tuning error.

Error code	Name	Description	Action
C000	Tuning canceled	The stop button was pushed during one-touch tuning.	—
C001	Overshoot exceeded	The overshoot amount is larger than the value set in [Pr. PA10 In-position range].	Increase the in-position range.
C002	Servo-off during tuning	The one-touch tuning was attempted during servo-off.	Perform the one-touch tuning after servo-on.
C003	Control mode error	The one-touch tuning was attempted while the torque mode was selected in the control modes.	Select the position mode or velocity mode for the control mode from the controller, and then make one-touch tuning.
C004	Time-out	1. 1 cycle time during the operation has been over 30 s.	Set the 1 cycle time during the operation to 30 s or less.
		2. The command speed is low.	Set the servo motor speed to 100 r/min or higher.
		3. The operation interval of the continuous operation is short.	Maintain approximately 200 ms of the operation interval during motor driving.
C005	Load to motor inertia ratio misestimated	1. The estimation of the load to motor inertia ratio at one-touch tuning was a failure.	Drive the motor with meeting conditions as follows. <ul style="list-style-type: none"> • The acceleration/deceleration time constant to reach 2000 r/min (mm/s) is 5 s or less. • Servo motor speed is 150 r/min (mm/s) or higher. • The load to servo motor (mass of linear servo motor's primary side or direct drive motor) inertia ratio is 100 times or less. • The acceleration/deceleration torque is 10% or more of the rated torque.
		2. The load to motor inertia ratio was not estimated due to such as an oscillation.	Set to the auto tuning mode that does not estimate the load to motor inertia ratio as follows, and then execute the one-touch tuning. <ul style="list-style-type: none"> • Select "Auto tuning mode 2 (_ _ _ 2)", "Manual mode (_ _ _ 3)", or "2 gain adjustment mode 2 (_ _ _ 4)" of "Gain adjustment mode selection" in [Pr. PA08]. • Set [Pr. PB06 Load to motor inertia ratio/load to motor mass ratio] properly with manual setting.
C00F	One-touch tuning disabled	"One-touch tuning function selection" in [Pr. PA21] is "Disabled (_ _ _ 0)".	Select "Enabled (_ _ _ 1)".

If an alarm occurs

If an alarm occurs during tuning, one-touch tuning will be forcibly terminated.

Remove the cause of the alarm and execute one-touch tuning again.

If a warning occurs

If a warning which continue the motor driving occurs during the tuning, one-touch tuning will be continued.

If a warning which does not continue the motor driving occurs during the tuning, one-touch tuning will be stopped.

Clearing one-touch tuning

You can clear the parameter values set with one-touch tuning.
Refer to the following for the parameters which you can clear.

☞ Page 232 One-touch tuning

Pushing "Return to value before adjustment" in the one-touch tuning window of MR Configurator2 enables to rewrite the parameter to the value before pushing the start button

In addition, pushing "Return to initial value" in the one-touch tuning window enables to rewrite the parameter to the initial value.

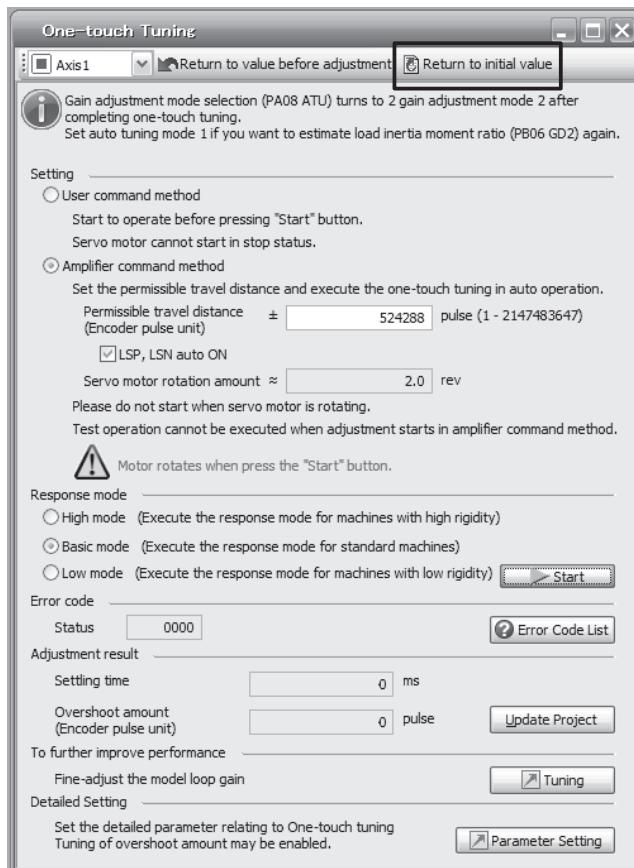

Clearing one-touch tuning is completed, the following window will be displayed. (returning to initial value)

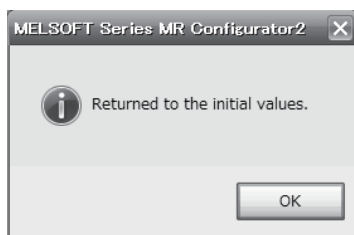

Caution for one-touch tuning

- The tuning is not available in the torque mode.
- The one-touch tuning cannot be executed while an alarm or warning which does not continue the motor driving is occurring.
- The tuning is not available during the following test operation mode.
 - Output signal (DO) forced output
 - Motor-less operation
- If one-touch tuning is performed when the gain switching function is enabled, vibration and/or unusual noise may occur during the tuning.

One-touch tuning via a network



One-touch tuning via a network is available with servo amplifiers with software version A3 or later.

Using One-touch tuning mode (2D50h) allows one-touch tuning from a controller.

When a simple motion module RD77GF or simple motion board MR-EM340GF is used, the one-touch tuning is available with the servo transient transmission function. For settings of the servo transient transmission function, refer to the controller instruction manual.

Related object (servo transient transmission function)

Index	Sub	Object	Name	Data Type	Access	Default	Description
2D50h	0	VAR	One-touch tuning mode	U8	rw	0	One-touch tuning command Setting a value of "1" to "3" starts one-touch tuning. After one-touch tuning is completed, the setting value automatically changes to "0". 0: During one-touch tuning stop 1: Basic mode 2: High mode 3: Low mode
2D51h	0	VAR	One-touch tuning status	I8	ro	0	One-touch tuning status Regardless of whether one-touch tuning is properly completed or not, the setting value changes to 100% at the completion. Unit: %
2D52h	0	VAR	One-touch tuning Stop	U16	wo	0	One-touch tuning stop command Writing "1EA5h" stops one-touch tuning.
2D53h	0	VAR	One-touch tuning Clear	U16	wo	0	The parameter changed in one-touch tuning can be returned to the value before the change. 0000h: Restores the initial value. 0001h: Restores the value before one-touch tuning. The setting value of the restored parameter is stored to the EEPROM.
2D54h	0	VAR	One-touch tuning Error Code	U16	ro	0	One-touch tuning error code 0000h: Finished normally C000h: Tuning canceled C001h: Overshoot exceeded C002h: Servo-off during tuning C003h: Control mode error C004h: Time-out C005h: Load to motor inertia ratio misestimated C00Fh: One-touch tuning disabled

Procedure of one-touch tuning via a network

Perform one-touch tuning via a network in the following procedure.

1. Startup of the system

Start a system referring to the following.

☞ Page 128 STARTUP

2. Operation

Rotate the servo motor with a controller. (One-touch tuning cannot be performed if the servo motor is not operating.)

3. One-touch tuning execution

Write a value corresponding to the response mode (High mode, basic mode, or Low mode) to perform in One-touch tuning mode (2D50h) during servo motor driving to perform one-touch tuning.

4. One-touch tuning in progress

Gains and filters will be adjusted automatically. During one-touch tuning, the progress can be checked with One-touch tuning status (2D51h).

5. One-touch tuning completion

Check whether one-touch tuning is completed normally with One-touch tuning Error Code (2D54h). When one-touch tuning is completed normally, the parameters will be set automatically. Refer to the following for the parameters that are set automatically.

☞ Page 232 One-touch tuning

After a tuning error is returned, take the appropriate action according to the following section.

☞ Page 236 If an error occurs

6. Tuning result check

Check the tuning result.

If the tuning result is not satisfactory, you can return the parameter to the value before the one-touch tuning or the initial value using One-touch tuning Clear (2D53h).

6.3 Auto tuning

Auto tuning mode

The servo amplifier has a real-time auto tuning function which estimates the machine characteristic (load to motor inertia ratio) in real time and automatically sets the optimum gains according to that value. This function permits ease of gain adjustment of the servo amplifier.

Auto tuning mode 1

The servo amplifier is factory-set to the auto tuning mode 1.

In this mode, the load to motor inertia ratio of a machine is always estimated to set the optimum gains automatically.

The following parameters are automatically adjusted in the auto tuning mode 1.

Parameter	Symbol	Name
PB06	GD2	Load to motor inertia ratio/load to motor mass ratio
PB07	PG1	Model loop gain
PB08	PG2	Position loop gain
PB09	VG2	Speed loop gain
PB10	VIC	Speed integral compensation

Point

The auto tuning mode 1 may not be performed properly if all of the following conditions are not satisfied.

- The acceleration/deceleration time constant to reach 2000 r/min (mm/s) is 5 s or less.
- Servo motor speed is 150 r/min (mm/s) or higher.
- The load to servo motor (mass of linear servo motor's primary side or direct drive motor) inertia ratio is 100 times or less.
- The acceleration/deceleration torque is 10% or more of the rated torque.

Under operating conditions which will impose sudden disturbance torque during acceleration/deceleration or on a machine which is extremely loose, auto tuning may not function properly, either. In such cases, use the auto tuning mode 2 or manual mode to make gain adjustment.

Auto tuning mode 2

Use the auto tuning mode 2 when proper gain adjustment cannot be made by auto tuning mode 1. Since the load to motor inertia ratio is not estimated in this mode, set the value of a correct load to motor inertia ratio in [Pr. PB06].

The following parameters are automatically adjusted in the auto tuning mode 2.

Parameter	Symbol	Name
PB07	PG1	Model loop gain
PB08	PG2	Position loop gain
PB09	VG2	Speed loop gain
PB10	VIC	Speed integral compensation

Auto tuning mode basis

The block diagram of real-time auto tuning is shown below.

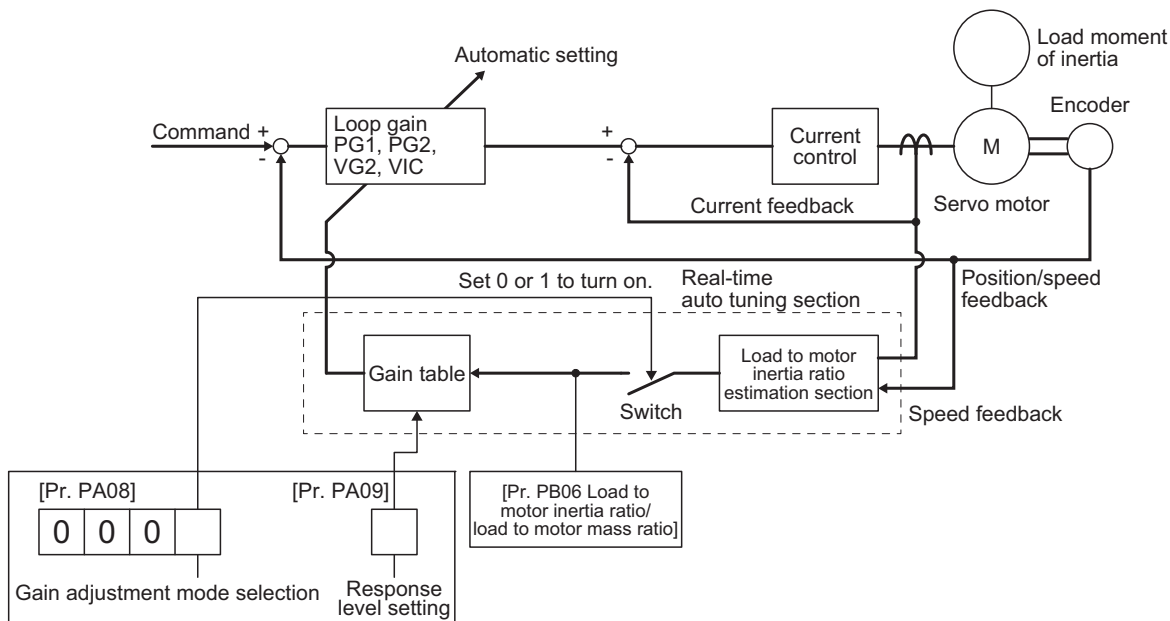

When a servo motor is accelerated/decelerated, the load to motor inertia ratio estimation section always estimates the load to motor inertia ratio from the current and speed of the servo motor. The results of estimation are written to [Pr. PB06 Load to motor inertia ratio/load to motor mass ratio]. These results can be confirmed on the status display screen of the MR Configurator2.

If you have already known the value of the load to motor inertia ratio or failed to estimate, set "Gain adjustment mode selection" to "Auto tuning mode 2 (_ _ 2)" in [Pr. PA08] to stop the estimation (turning off the switch in above diagram), and set the load to motor inertia ratio ([Pr. PB06]) manually.

From the preset load to motor inertia ratio ([Pr. PB06]) value and response ([Pr. PA09]), the optimum loop gains are automatically set on the basis of the internal gain table.

The auto tuning results are saved in the EEPROM of the servo amplifier every 60 minutes since power-on. At power-on, auto tuning is performed with the value of each loop gain saved in the EEPROM being used as an initial value.

Point

- If sudden disturbance torque is imposed during operation, the load to motor inertia ratio may be misestimated temporarily. In such a case, set "Gain adjustment mode selection" to "Auto tuning mode 2 (_ _ 2)" in [Pr. PA08] and then set the correct load to motor inertia ratio in [Pr. PB06].
- When any of the auto tuning mode 1 and auto tuning mode settings is changed to the manual mode 2 setting, the current loop gains and load to motor inertia ratio estimation value are saved in the EEPROM.

Adjustment procedure by auto tuning

Since auto tuning is enabled before shipment from the factory, simply running the servo motor automatically sets the optimum gains that match the machine. Merely changing the response level setting value as required completes the adjustment. The adjustment procedure is as follows.

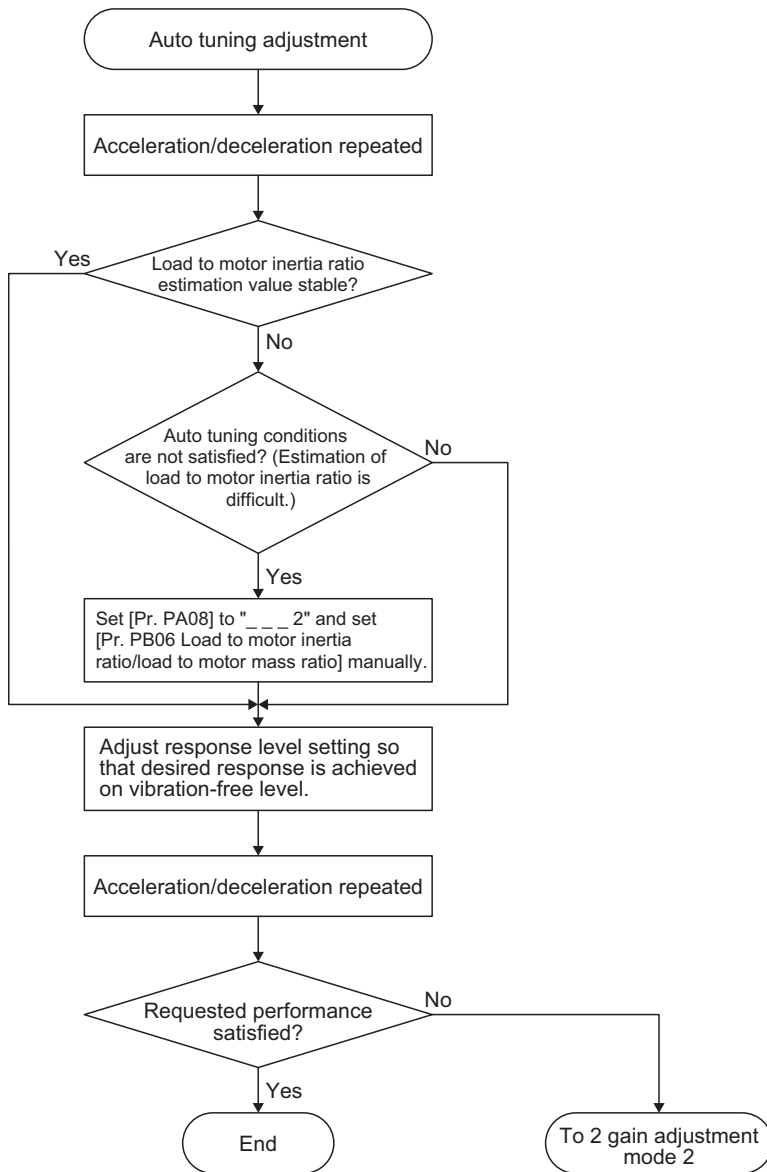

Response level setting in auto tuning mode

Set the response of the whole servo system by [Pr. PA09]. As the response level setting is increased, the trackability and settling time for a command decreases, but a too high response level will generate vibration. Hence, make setting until desired response is obtained within the vibration-free range.

If the response level setting cannot be increased up to the desired response because of machine resonance beyond 100 Hz, filter tuning mode selection in [Pr. PB01] or machine resonance suppression filter in [Pr. PB13] to [Pr. PB16], [Pr. PB46] to [Pr. PB51] may be used to suppress machine resonance. Suppressing machine resonance may allow the response level setting to increase. Refer to the following for settings of the adaptive tuning mode and machine resonance suppression filter.

☞ Page 250 Machine resonance suppression filter, ☞ Page 253 Adaptive filter II

[Pr. PA09]

Setting value	Machine characteristic		Reference (setting value of MR-J3)
	Response	Guideline for machine resonance frequency [Hz]	
1	Increasing the setting value also increases the response level.	2.7	—
2		3.6	—
3		4.9	—
4		6.6	—
5		10.0	1
6		11.3	2
7		12.7	3
8		14.3	4
9		16.1	5
10		18.1	6
11		20.4	7
12		23.0	8
13		25.9	9
14		29.2	10
15		32.9	11
16		37.0	12
17		41.7	13
18		47.0	14
19		52.9	15
20		59.6	16
21		67.1	17
22		75.6	18
23		85.2	19
24		95.9	20
25		108.0	21
26		121.7	22
27		137.1	23
28		154.4	24
29		173.9	25
30		195.9	26
31		220.6	27
32		248.5	28
33		279.9	29
34		315.3	30
35		355.1	31
36		400.0	32
37		446.6	—
38		501.2	—
39		571.5	—
40		642.7	—

6.4 Manual mode

If you are not satisfied with the adjustment of auto tuning, you can adjust all gains manually.

Point 

If machine resonance occurs, filter tuning mode selection in [Pr. PB01] or machine resonance suppression filter in [Pr. PB13] to [Pr. PB16] and [Pr. PB46] to [Pr. PB51] may be used to suppress machine resonance.

 Page 250 Machine resonance suppression filter

 Page 253 Adaptive filter II



For speed control

Parameter

The following parameters are used for gain adjustment.

Parameter	Symbol	Name
PB06	GD2	Load to motor inertia ratio/load to motor mass ratio
PB07	PG1	Model loop gain
PB09	VG2	Speed loop gain
PB10	VIC	Speed integral compensation

Adjustment procedure

Step	Operation	Description
1	Brief-adjust with auto tuning. Refer to the following.  Page 242 Adjustment procedure by auto tuning	—
2	Change the setting of auto tuning to the manual mode ([Pr. PA08]: ___ 3).	—
3	Set the estimated value to the load to motor inertia ratio/load to motor mass ratio. (If the estimate value with auto tuning is correct, setting change is not required.)	—
4	Decrease the model loop gain. Increase the speed integral compensation.	—
5	Increase the speed loop gain within the vibration- and unusual noise-free range, and return slightly if vibration takes place.	Increase the speed loop gain.
6	Decrease the speed integral compensation within the vibration-free range, and return slightly if vibration takes place.	Decrease the time constant of the speed integral compensation.
7	Increase the model loop gain, and return slightly if overshoot takes place.	Increase the model loop gain.
8	If the gains cannot be increased due to mechanical system resonance or the like and the desired response cannot be achieved, response may be increased by suppressing resonance with the adaptive tuning mode or machine resonance suppression filter and then executing steps 3 to 7.	Suppression of machine resonance  Page 250 Machine resonance suppression filter  Page 253 Adaptive filter II
9	While checking the motor status, fine-adjust each gain.	Fine adjustment

Parameter adjustment

- [Pr. PB09 Speed loop gain]

This parameter determines the response level of the speed control loop. Increasing this value enhances response but a too high value will make the mechanical system liable to vibrate. The actual response frequency of the speed loop is as indicated in the following expression.

$$\text{Speed loop response frequency [Hz]} = \frac{\text{Speed loop gain}}{(1 + \text{Load to motor inertia ratio}) \times 2\pi}$$

- [Pr. PB10 Speed integral compensation]

To eliminate stationary deviation against a command, the speed control loop is under proportional integral control. For the speed integral compensation, set the time constant of this integral control. Increasing the setting lowers the response level. However, if the load to motor inertia ratio is large or the mechanical system has any vibratory element, the mechanical system is liable to vibrate unless the setting is increased to some degree. The guideline is as indicated in the following expression.

$$\text{Speed integral compensation setting [ms]} \geq \frac{2000 \text{ to } 3000}{\text{Speed loop gain}/(1 + \text{Load to motor inertia ratio})}$$

- [Pr. PB07 Model loop gain]

This parameter determines the response level to a speed command. Increasing the value improves trackability to a speed command, but a too high value will make overshoot liable to occur at settling.

$$\text{Model loop gain guideline} \leq \frac{\text{Speed loop gain}}{(1 + \text{Load to motor inertia ratio})} \times \left(\frac{1}{4} \text{ to } \frac{1}{8} \right)$$

For position control

Parameter

The following parameters are used for gain adjustment.

Parameter	Symbol	Name
PB06	GD2	Load to motor inertia ratio/load to motor mass ratio
PB07	PG1	Model loop gain
PB08	PG2	Position loop gain
PB09	VG2	Speed loop gain
PB10	VIC	Speed integral compensation

Adjustment procedure

Step	Operation	Description
1	Brief-adjust with auto tuning. Refer to the following. ☞ Page 242 Adjustment procedure by auto tuning	—
2	Change the setting of auto tuning to the manual mode ([Pr. PA08]: ___ 3).	—
3	Set the estimated value to the load to motor inertia ratio/load to motor mass ratio. (If the estimate value with auto tuning is correct, setting change is not required.)	—
4	Set a small value to the model loop gain and the position loop gain. Set a large value to the speed integral compensation.	—
5	Increase the speed loop gain within the vibration- and unusual noise-free range, and return slightly if vibration takes place.	Increase the speed loop gain.
6	Decrease the speed integral compensation within the vibration-free range, and return slightly if vibration takes place.	Decrease the time constant of the speed integral compensation.
7	Increase the position loop gain, and return slightly if vibration takes place.	Increase the position loop gain.
8	Increase the model loop gain, and return slightly if overshoot takes place.	Increase the model loop gain.
9	If the gains cannot be increased due to mechanical system resonance or the like and the desired response cannot be achieved, response may be increased by suppressing resonance with the adaptive tuning mode or machine resonance suppression filter and then executing steps 3 to 8.	Suppression of machine resonance ☞ Page 250 Machine resonance suppression filter ☞ Page 253 Adaptive filter II
10	While checking the settling characteristic and motor status, fine-adjust each gain.	Fine adjustment

■Parameter adjustment

- [Pr. PB09 Speed loop gain]

This parameter determines the response level of the speed control loop. Increasing this value enhances response but a too high value will make the mechanical system liable to vibrate. The actual response frequency of the speed loop is as indicated in the following expression.

$$\text{Speed loop response frequency [Hz]} = \frac{\text{Speed loop gain}}{(1 + \text{Load to motor inertia ratio}) \times 2\pi}$$

- [Pr. PB10 Speed integral compensation]

To eliminate stationary deviation against a command, the speed control loop is under proportional integral control. For the speed integral compensation, set the time constant of this integral control. Increasing the setting lowers the response level. However, if the load to motor inertia ratio is large or the mechanical system has any vibratory element, the mechanical system is liable to vibrate unless the setting is increased to some degree. The guideline is as indicated in the following expression.

$$\text{Speed integral compensation setting [ms]} \geq \frac{2000 \text{ to } 3000}{\text{Speed loop gain}/(1 + \text{Load to motor inertia ratio})}$$

- [Pr. PB08 Position loop gain]

This parameter determines the response level to a disturbance to the position control loop. Increasing the value increases the response level to the disturbance, but a too high value will increase vibration of the mechanical system.

$$\text{Position loop gain guideline} \leq \frac{\text{Speed loop gain}}{(1 + \text{Load to motor inertia ratio})} \times \left(\frac{1}{4} \text{ to } \frac{1}{8} \right)$$

- [Pr. PB07 Model loop gain]

This parameter determines the response level to a position command. Increasing the value improves trackability to a position command, but a too high value will make overshoot liable to occur at settling.

$$\text{Model loop gain guideline} \leq \frac{\text{Speed loop gain}}{(1 + \text{Load to motor inertia ratio})} \times \left(\frac{1}{4} \text{ to } \frac{1}{8} \right)$$

6.5 2 gain adjustment mode

The 2 gain adjustment mode is used to match the position loop gains of the axes when performing the interpolation operation of servo motors of two or more axes for an X-Y table or the like. In this mode, manually set the model loop gain that determines command trackability. Other parameters for gain adjustment are set automatically.

2 gain adjustment mode 1

The 2 gain adjustment mode 1 manually set the model loop gain that determines command trackability. The mode constantly estimates the load to motor inertia ratio, and automatically set other parameters for gain adjustment to optimum gains using auto tuning response.

The following parameters are used for 2 gain adjustment mode 1.

■Automatically adjusted parameter

The following parameters are automatically adjusted by auto tuning.

Parameter	Symbol	Name
PB06	GD2	Load to motor inertia ratio/load to motor mass ratio
PB08	PG2	Position loop gain
PB09	VG2	Speed loop gain
PB10	VIC	Speed integral compensation

■Manually adjusted parameter

The following parameters are adjustable manually.

Parameter	Symbol	Name
PA09	RSP	Auto tuning response
PB07	PG1	Model loop gain

2 gain adjustment mode 2

Use 2 gain adjustment mode 2 when proper gain adjustment cannot be made with 2 gain adjustment mode 1. Since the load to motor inertia ratio is not estimated in this mode, set the value of a proper load to motor inertia ratio in [Pr. PB06].

The following parameters are used for 2 gain adjustment mode 2.

■Automatically adjusted parameter

The following parameters are automatically adjusted by auto tuning.

Parameter	Symbol	Name
PB08	PG2	Position loop gain
PB09	VG2	Speed loop gain
PB10	VIC	Speed integral compensation

■Manually adjusted parameter

The following parameters are adjustable manually.

Parameter	Symbol	Name
PA09	RSP	Auto tuning response
PB06	GD2	Load to motor inertia ratio/load to motor mass ratio
PB07	PG1	Model loop gain

Adjustment procedure of 2 gain adjustment mode



Set the same value in [Pr. PB07 Model loop gain] for the axis used in 2 gain adjustment mode.

Step	Operation	Description
1	Set to the auto tuning mode.	Select the auto tuning mode 1.
2	During operation, increase the response level setting value in [Pr. PA09], and return the setting if vibration occurs.	Adjustment in auto tuning mode 1
3	Check value of the model loop gain and the load to motor inertia ratio in advance.	Check the upper setting limits.
4	Set the 2 gain adjustment mode 1 ([Pr. PA08]: ___ 0).	Select the 2 gain adjustment mode 1 (interpolation mode).
5	When the load to motor inertia ratio is different from the design value, select the 2 gain adjustment mode 2 ([Pr. PA08]: ___ 4) and then set the load to motor inertia ratio manually in [Pr. PB06].	Check the load to motor inertia ratio.
6	Set the model loop gain of all the axes to be interpolated to the same value. At that time, adjust to the setting value of the axis, which has the smallest model loop gain.	Set model loop gain.
7	Considering the interpolation characteristic and motor status, fine-adjust the model loop gain and response level setting.	Fine adjustment

Parameter adjustment

[Pr. PB07 Model loop gain]

This parameter determines the response level of the position control loop. Increasing the value improves trackability to a position command, but a too high value will make overshoot liable to occur at settling. The droop pulses value is determined by the following expression.

$$\text{Number of droop pulses [pulse]} = \frac{\text{Position command frequency [pulse/s]}}{\text{Model loop gain setting}}$$

Position command frequency differs depending on the operation mode.

Rotary servo motor and direct drive motor:

Position command frequency

$$= \frac{\text{Servo motor speed [r/min]}}{60} \times \text{Encoder resolution (number of pulses per servo motor revolution)}$$

Linear servo motor:

$$\text{Position command frequency} = \text{Speed [mm/s]} \div \text{Encoder resolution (travel distance per pulse)}$$

7 SPECIAL ADJUSTMENT FUNCTIONS

Point

- The functions given in this chapter need not be used normally. Use them if you are not satisfied with the machine status after making adjustment in the methods in the following chapter.  Page 230 NORMAL GAIN ADJUSTMENT
- When you use a linear servo motor, replace the following left words to the right words. Load to motor inertia ratio → Load to motor mass ratio
Torque → Thrust

7.1 Filter setting

The following filters are available with MR-J4 servo amplifiers.

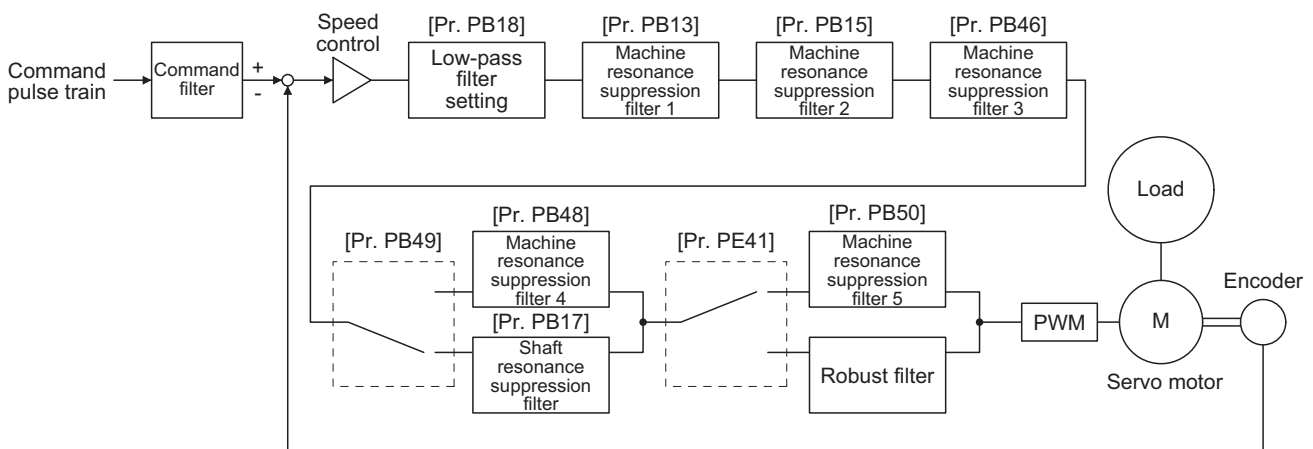

Machine resonance suppression filter

Point

- The machine resonance suppression filter is a delay factor for the servo system. Therefore, vibration may increase if you set an incorrect resonance frequency or set notch characteristics too deep or too wide.
- If the frequency of machine resonance is unknown, decrease the notch frequency from higher to lower ones in order. The optimum notch frequency is set at the point where vibration is minimal.
- A deeper notch has a higher effect on machine resonance suppression but increases a phase delay and may increase vibration.
- A wider notch has a higher effect on machine resonance suppression but increases a phase delay and may increase vibration.
- The machine characteristic can be grasped beforehand by the machine analyzer on MR Configurator2. This allows the required notch frequency and notch characteristics to be determined.

If a mechanical system has a natural resonance point, increasing the servo system response level may cause the mechanical system to produce resonance (vibration or unusual noise) at that resonance frequency. Using the machine resonance suppression filter and adaptive tuning can suppress the resonance of the mechanical system. The setting range is 10 Hz to 4500 Hz.

Function

The machine resonance suppression filter is a filter function (notch filter) which decreases the gain of the specific frequency to suppress the resonance of the mechanical system. You can set the frequency (notch frequency) at which the gain is decreased, and the notch depth and width.

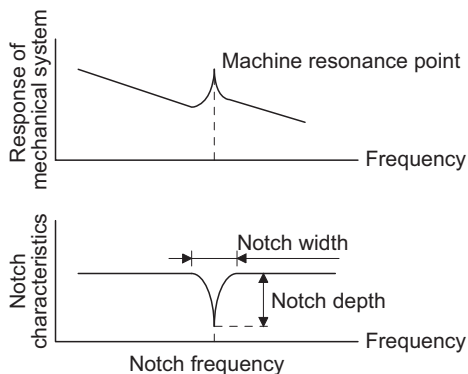

You can set five machine resonance suppression filters at most.

Filter	Setting parameter	Precaution	Parameter that is reset with vibration tough drive function	Parameter automatically adjusted with one-touch tuning
Machine resonance suppression filter 1	PB01/PB13/PB14	The filter can be set automatically with "Filter tuning mode selection" in [Pr. PB01].	PB13	PB01/PB13/PB14
Machine resonance suppression filter 2	PB15/PB16	—	PB15	PB15/PB16
Machine resonance suppression filter 3	PB46/PB47	—	—	PB47
Machine resonance suppression filter 4	PB48/PB49	Enabling the machine resonance suppression filter 4 disables the shaft resonance suppression filter. Using the shaft resonance suppression filter is recommended because it is adjusted properly depending on the usage situation. The shaft resonance suppression filter is enabled for the initial setting.	—	PB48/PB49
Machine resonance suppression filter 5	PB50/PB51	Enabling the robust filter disables the machine resonance suppression filter 5. The robust filter is disabled for the initial setting.	—	PB51

Parameter

■ Machine resonance suppression filter 1 ([Pr. PB13] and [Pr. PB14])

Set the notch frequency, notch depth and notch width of the machine resonance suppression filter 1 ([Pr. PB13] and [Pr. PB14]).

When you select "Manual setting (_ _ _ 2)" of "Filter tuning mode selection" in [Pr. PB01], the setting of the machine resonance suppression filter 1 is enabled.

■ Machine resonance suppression filter 2 ([Pr. PB15] and [Pr. PB16])

To use this filter, select "Enabled (_ _ _ 1)" of "Machine resonance suppression filter 2 selection" in [Pr. PB16].

How to set the machine resonance suppression filter 2 ([Pr. PB15] and [Pr. PB16]) is the same as for the machine resonance suppression filter 1 ([Pr. PB13] and [Pr. PB14]).

■ Machine resonance suppression filter 3 ([Pr. PB46] and [Pr. PB47])

To use this filter, select "Enabled (_ _ _ 1)" of "Machine resonance suppression filter 3 selection" in [Pr. PB47].

How to set the machine resonance suppression filter 3 ([Pr. PB46] and [Pr. PB47]) is the same as for the machine resonance suppression filter 1 ([Pr. PB13] and [Pr. PB14]).

■Machine resonance suppression filter 4 ([Pr. PB48] and [Pr. PB49])

To use this filter, select "Enabled (___ 1)" of "Machine resonance suppression filter 4 selection" in [Pr. PB49]. However, enabling the machine resonance suppression filter 4 disables the shaft resonance suppression filter.

How to set the machine resonance suppression filter 4 ([Pr. PB48] and [Pr. PB49]) is the same as for the machine resonance suppression filter 1 ([Pr. PB13] and [Pr. PB14]).

■Machine resonance suppression filter 5 ([Pr. PB50] and [Pr. PB51])

To use this filter, select "Enabled (___ 1)" of "Machine resonance suppression filter 5 selection" in [Pr. PB51]. However, enabling the robust filter ([Pr. PE41: ___ 1]) disables the machine resonance suppression filter 5.

How to set the machine resonance suppression filter 5 ([Pr. PB50] and [Pr. PB51]) is the same as for the machine resonance suppression filter 1 ([Pr. PB13] and [Pr. PB14]).

Adaptive filter II

Point

- The machine resonance frequency which adaptive filter II (adaptive tuning) can respond to is about 100 Hz to 2.25 kHz. As for the resonance frequency out of the range, set manually.
- When adaptive tuning is executed, vibration sound increases as an excitation signal is forcibly applied for several seconds.
- When adaptive tuning is executed, machine resonance is detected for a maximum of 10 seconds and a filter is generated. After filter generation, the adaptive tuning mode automatically shifts to the manual setting.
- Adaptive tuning generates the optimum filter with the currently set control gains. If vibration occurs when the response setting is increased, execute adaptive tuning again.
- During adaptive tuning, a filter having the best notch depth at the set control gain is generated. To allow a filter margin against machine resonance, increase the notch depth in the manual setting.
- Adaptive vibration suppression control may provide no effect on a mechanical system which has complex resonance characteristics.

Function

Adaptive filter II (adaptive tuning) is a function in which the servo amplifier detects machine resonance for a predetermined period of time and sets the filter characteristics automatically to suppress mechanical system vibration. Since the filter characteristics (frequency, depth) are set automatically, you need not be conscious of the resonance frequency of a mechanical system.

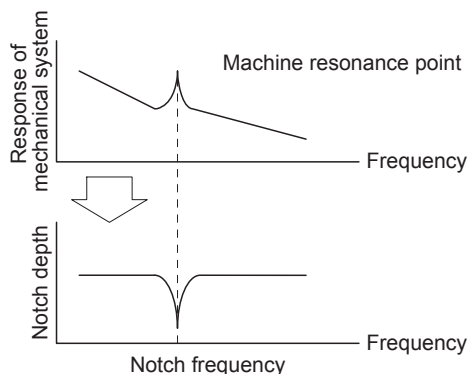

When machine resonance is large and frequency is low

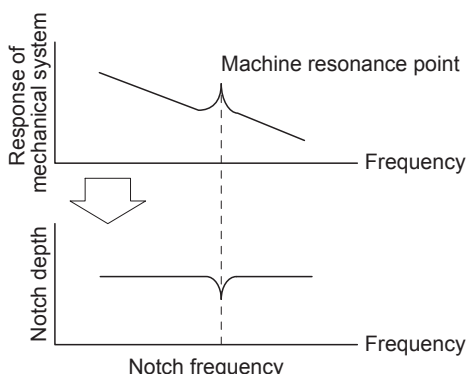

When machine resonance is small and frequency is high

Parameter

Select how to set the filter tuning in [Pr. PB01 Adaptive tuning mode (adaptive filter II)].

[Pr. PB01]

0	0	0	
---	---	---	--

Filter tuning mode selection

Setting value	Filter tuning mode selection	Automatically set parameter
0	Disabled	—
1	Automatic setting	PB13/PB14
2	Manual setting	—

Adaptive tuning procedure

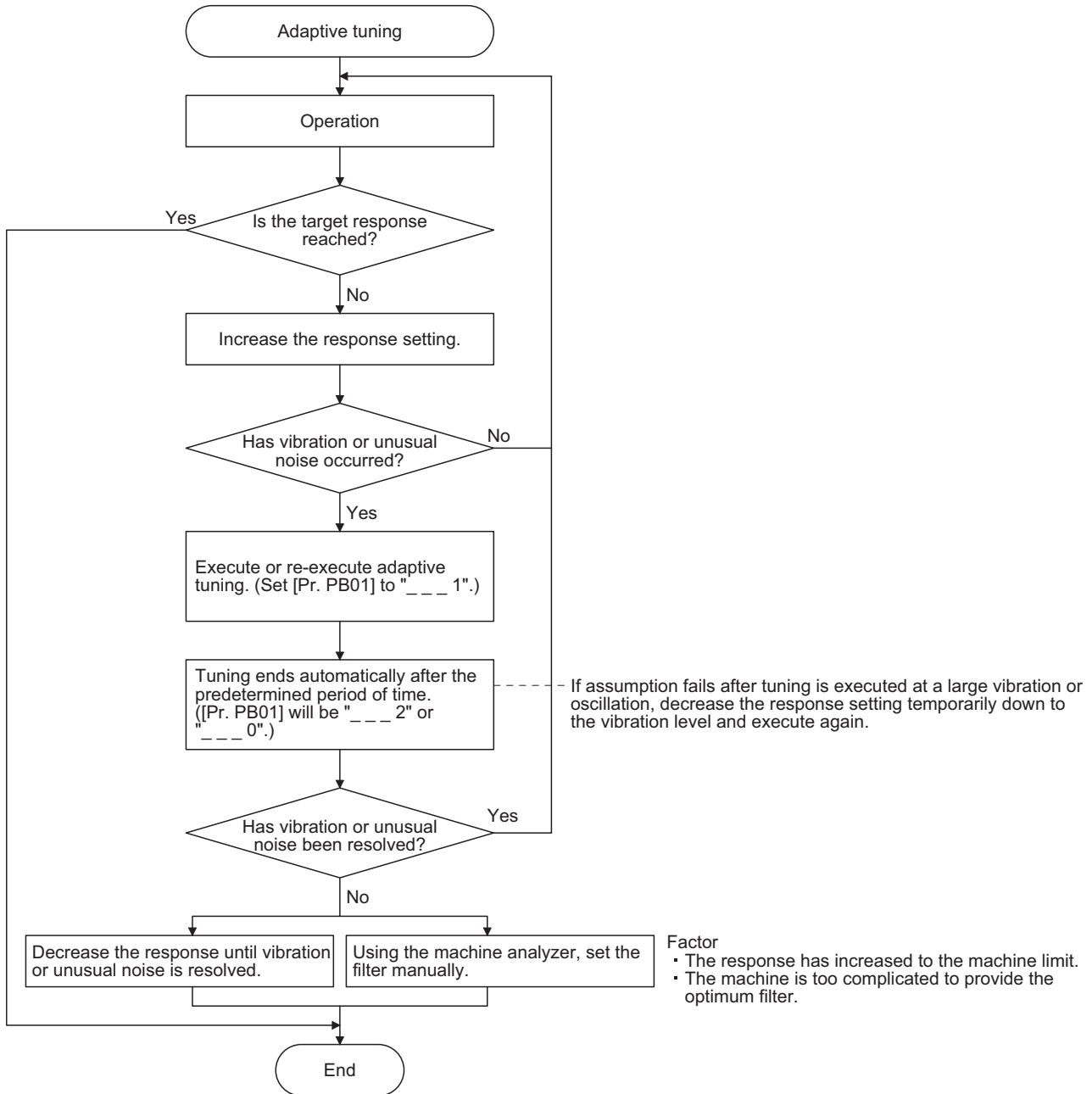

Shaft resonance suppression filter

Point

This filter is set properly by default according to servo motor you use and load moment of inertia. It is recommended that [Pr. PB23] be set to " __ _ 0" (automatic setting) because changing "Shaft resonance suppression filter selection" in [Pr. PB23] or [Pr. PB17 Shaft resonance suppression filter] may lower the performance.

Function

When a load is mounted to the servo motor shaft, resonance by shaft torsion during driving may generate a mechanical vibration at high frequency. The shaft resonance suppression filter suppresses the vibration.

When you select "Automatic setting", the filter will be set automatically on the basis of the motor you use and the load to servo motor inertia ratio. The disabled setting increases the response of the servo amplifier for high resonance frequency.

Parameter

Set "Shaft resonance suppression filter selection" in [Pr. PB23].

[Pr. PB23]

0	0	0	
---	---	---	--

Shaft resonance suppression filter selection
 0: Automatic setting
 1: Manual setting
 2: Disabled

To set [Pr. PB17 Shaft resonance suppression filter] automatically, select "Automatic setting".

To set [Pr. PB17 Shaft resonance suppression filter] manually, select "Manual setting". The setting values are as follows.

Setting value	Frequency [Hz]	Setting value	Frequency [Hz]
__ 0 0	Disabled	__ 1 0	562
__ 0 1	Disabled	__ 1 1	529
__ 0 2	4500	__ 1 2	500
__ 0 3	3000	__ 1 3	473
__ 0 4	2250	__ 1 4	450
__ 0 5	1800	__ 1 5	428
__ 0 6	1500	__ 1 6	409
__ 0 7	1285	__ 1 7	391
__ 0 8	1125	__ 1 8	375
__ 0 9	1000	__ 1 9	360
__ 0 A	900	__ 1 A	346
__ 0 B	818	__ 1 B	333
__ 0 C	750	__ 1 C	321
__ 0 D	692	__ 1 D	310
__ 0 E	642	__ 1 E	300
__ 0 F	600	__ 1 F	290

Low-pass filter

Function

When a ball screw or the like is used, resonance of high frequency may occur as the response level of the servo system is increased. To prevent this, the low-pass filter is enabled for a torque command as a default. The filter frequency of the low-pass filter is automatically adjusted to the value in the following equation.

$$\text{Filter frequency ([rad/s])} = \frac{VG2}{1 + GD2} \times 10$$

However, when an automatically adjusted value is smaller than VG2, the filter frequency will be the VG2 value.

To set [Pr. PB18] manually, select "Manual setting (_ _ 1 _)" of "Low-pass filter selection" in [Pr. PB23].

Parameter

Set "Low-pass filter selection" in [Pr. PB23].

[Pr. PB23]

0	0		0
---	---	--	---

Low-pass filter selection

0: Automatic setting

1: Manual setting

2: Disabled

Advanced vibration suppression control II

Point

- The function is enabled when "Gain adjustment mode selection" in [Pr. PA08] is "Auto tuning mode 2 (_ _ _ 2)", "Manual mode (_ _ _ 3)", or "2 gain adjustment mode 2 (_ _ _ 4)".
- The machine resonance frequency supported in the vibration suppression control tuning mode is 1.0 Hz to 100.0 Hz. As for the vibration out of the range, set manually.
- Stop the servo motor before changing the vibration suppression control-related parameters. Otherwise, it may cause an unexpected operation.
- For positioning operation during execution of vibration suppression control tuning, provide a stop time to ensure a stop after vibration damping.
- Vibration suppression control tuning may not make normal estimation if the residual vibration at the servo motor side is small.
- Vibration suppression control tuning sets the optimum parameter with the currently set control gains. When the response setting is increased, set vibration suppression control tuning again.
- When using the vibration suppression control 2, set " _ _ _ 1" in [Pr. PA24].

Function

Vibration suppression control is used to further suppress load-side vibration, such as work-side vibration and base shake. The servo motor-side operation is adjusted for positioning so that the machine does not vibrate.

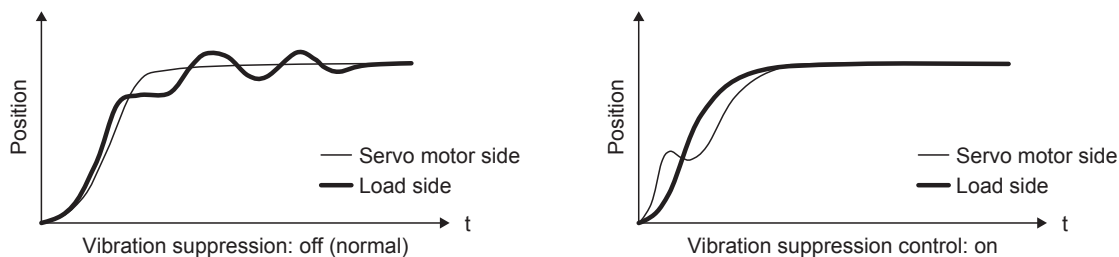

When the advanced vibration suppression control II ([Pr. PB02 Vibration suppression control tuning mode]) is executed, the vibration frequency at load side is automatically estimated to suppress load-side vibration two times at most.

In the vibration suppression control tuning mode, this mode shifts to the manual setting after the positioning operation is performed the predetermined number of times. For manual setting, adjust the vibration suppression control 1 with [Pr. PB19] to [Pr. PB22] and vibration suppression control 2 with [Pr. PB52] to [Pr. PB55].

Parameter

Set [Pr. PB02 Vibration suppression control tuning mode (advanced vibration suppression control II)].

When you use a vibration suppression control, set "Vibration suppression control 1 tuning mode selection". When you use two vibration suppression controls, set "Vibration suppression control 2 tuning mode selection" in addition.

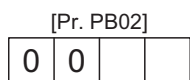

Vibration suppression control 1 tuning mode

Setting value	Vibration suppression control 1 tuning mode selection	Automatically set parameter
_ _ _ 0	Disabled	—
_ _ _ 1	Automatic setting	PB19/PB20/PB21/PB22
_ _ _ 2	Manual setting	—

Vibration suppression control 2 tuning mode

Setting value	Vibration suppression control 2 tuning mode selection	Automatically set parameter
_ _ 0 _	Disabled	—
_ _ 1 _	Automatic setting	PB52/PB53/PB54/PB55
_ _ 2 _	Manual setting	—

Vibration suppression control tuning procedure

The following flow chart is for the vibration suppression control 1. For the vibration suppression control 2, set " __ 1 _ " in [Pr. PB02] to execute the vibration suppression control tuning.

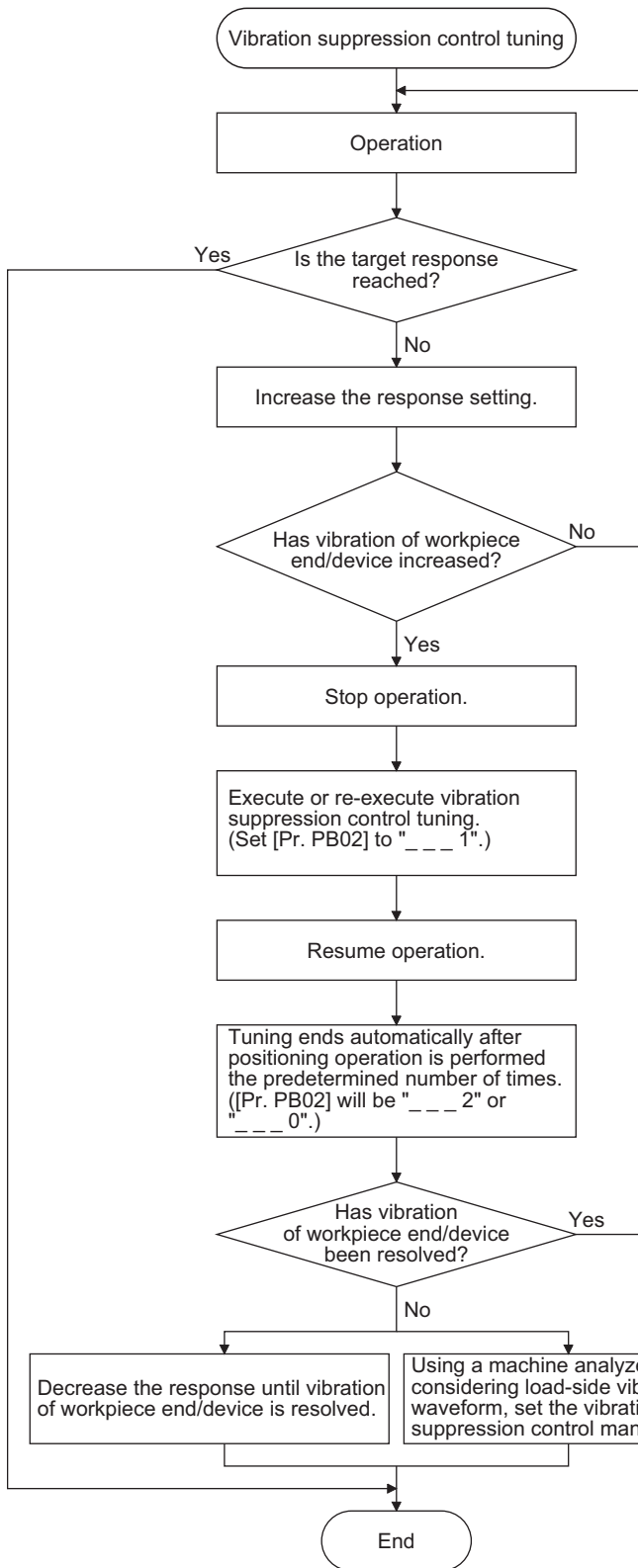

Factor

- Estimation cannot be made as load-side vibration has not been transmitted to the servo motor side.
- The response of the model loop gain has increased to the load-side vibration frequency (vibration suppression control limit).

Vibration suppression control manual mode

Point

- When load-side vibration does not show up in servo motor-side vibration, the setting of the servo motor-side vibration frequency does not produce an effect.
- When the anti-resonance frequency and resonance frequency can be confirmed using the machine analyzer or external equipment, do not set the same value but set different values to improve the vibration suppression performance.
- The setting ranges of [Pr. PB19], [Pr. PB20], [Pr. PB52], and [Pr. PB53] vary depending on the value in [Pr. PB07]. If a value out of the range is set, the vibration suppression control is disabled.

Measure work-side vibration and device shake with the machine analyzer or external measuring instrument, and set the following parameters to adjust vibration suppression control manually.

Setting item	Vibration suppression control 1	Vibration suppression control 2
Vibration suppression control - Vibration frequency	[Pr. PB19]	[Pr. PB52]
Vibration suppression control - Resonance frequency	[Pr. PB20]	[Pr. PB53]
Vibration suppression control - Vibration frequency damping	[Pr. PB21]	[Pr. PB54]
Vibration suppression control - Resonance frequency damping	[Pr. PB22]	[Pr. PB55]

1. Select "Manual setting (_ _ _ 2)" of "Vibration suppression control 1 tuning mode selection" or "Manual setting (_ _ 2 _)" of "Vibration suppression control 2 tuning mode selection" in [Pr. PB02].
2. Set "Vibration suppression control - Vibration frequency" and "Vibration suppression control - Resonance frequency" as follows.

However, the value of [Pr. PB07 Model loop gain], vibration frequency, and resonance frequency have the following usable range and recommended range.

Vibration suppression control	Usable range	Recommended setting range
Vibration suppression control 1	[Pr. PB19] > $1/2\pi \times (0.9 \times [\text{Pr. PB07}])$ [Pr. PB20] > $1/2\pi \times (0.9 \times [\text{Pr. PB07}])$	[Pr. PB19] > $1/2\pi \times (1.5 \times [\text{Pr. PB07}])$ [Pr. PB20] > $1/2\pi \times (1.5 \times [\text{Pr. PB07}])$
Vibration suppression control 2	When [Pr. PB19] < [Pr. PB52], [Pr. PB52] > $(5.0 + 0.1 \times [\text{Pr. PB07}])$ [Pr. PB53] > $(5.0 + 0.1 \times [\text{Pr. PB07}])$ $1.1 < [\text{Pr. PB52}]/[\text{Pr. PB19}] < 5.5$ [Pr. PB07] < $2\pi (0.3 \times [\text{Pr. PB19}] + 1/8 \times [\text{Pr. PB52}])$	When [Pr. PB19] < [Pr. PB52], [Pr. PB52], [Pr. PB53] > 6.25 Hz $1.1 < [\text{Pr. PB52}]/[\text{Pr. PB19}] < 4$ [Pr. PB07] < $1/3 \times (4 \times [\text{Pr. PB19}] + 2 \times [\text{Pr. PB52}])$

- When a vibration peak can be confirmed with machine analyzer using MR Configurator2, or external equipment.

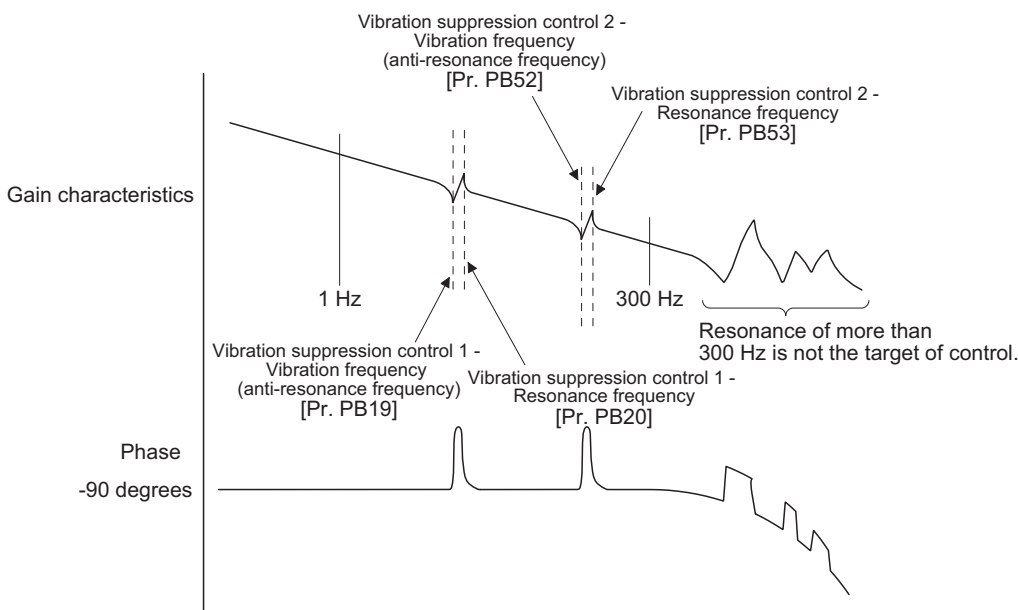

- When vibration can be confirmed using monitor signal or external sensor

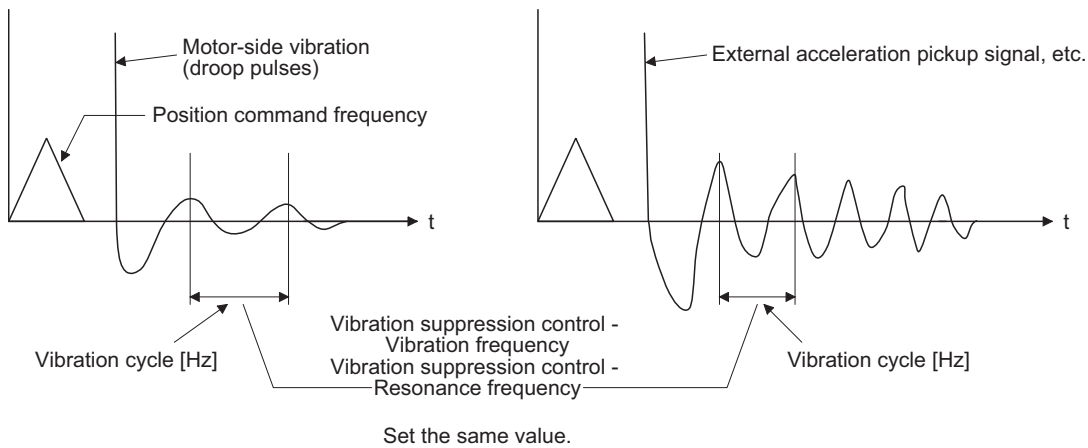

3. Fine-adjust "Vibration suppression control - Vibration frequency damping" and "Vibration suppression control - Resonance frequency damping".

Command notch filter

Point

- By using the advanced vibration suppression control II and the command notch filter, the load-side vibration of three frequencies can be suppressed.
- The frequency range of machine vibration, which can be supported by the command notch filter, is between 4.5 Hz and 2250 Hz. Set a frequency close to the machine vibration frequency and within the range.
- When [Pr. PB45 Command notch filter] is changed during the positioning operation, the changed setting is not reflected. The setting is reflected approximately 150 ms after the servo motor stops (after servo-lock).

Function

Command notch filter has a function that lowers the gain of the specified frequency contained in a position command. By lowering the gain, load-side vibration, such as work-side vibration and base shake, can be suppressed. Which frequency to lower the gain and how deep to lower the gain can be set.

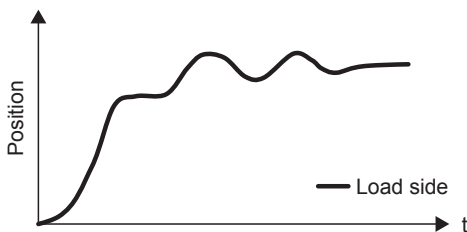

Command notch filter: disabled

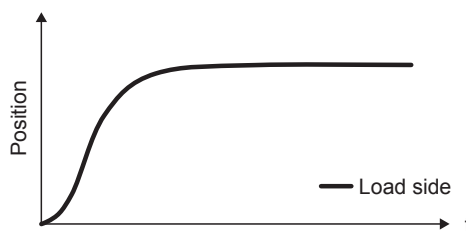

Command notch filter: enabled

Parameter

Set [Pr. PB45 Command notch filter] as shown below. For the command notch filter setting frequency, set the closest value to the vibration frequency [Hz] at the load side.

[Pr. PB45]

0			
---	--	--	--

Notch depth

Command notch filter setting frequency

Setting value	Depth [dB]
0	-40.0
1	-24.1
2	-18.1
3	-14.5
4	-12.0
5	-10.1
6	-8.5
7	-7.2
8	-6.0
9	-5.0
A	-4.1
B	-3.3
C	-2.5
D	-1.8
E	-1.2
F	-0.6

Setting value	Frequency [Hz]
00	Disabled
01	2250
02	1125
03	750
04	562
05	450
06	375
07	321
08	281
09	250
0A	225
0B	204
0C	187
0D	173
0E	160
0F	150
10	140
11	132
12	125
13	118
14	112
15	107
16	102
17	97
18	93
19	90
1A	86
1B	83
1C	80
1D	77
1E	75
1F	72

Setting value	Frequency [Hz]
20	70
21	66
22	62
23	59
24	56
25	53
26	51
27	48
28	46
29	45
2A	43
2B	41
2C	40
2D	38
2E	37
2F	36
30	35.2
31	33.1
32	31.3
33	29.6
34	28.1
35	26.8
36	25.6
37	24.5
38	23.4
39	22.5
3A	21.6
3B	20.8
3C	20.1
3D	19.4
3E	18.8
3F	18.2

Setting value	Frequency [Hz]
40	17.6
41	16.5
42	15.6
43	14.8
44	14.1
45	13.4
46	12.8
47	12.2
48	11.7
49	11.3
4A	10.8
4B	10.4
4C	10.0
4D	9.7
4E	9.4
4F	9.1
50	8.8
51	8.3
52	7.8
53	7.4
54	7.0
55	6.7
56	6.4
57	6.1
58	5.9
59	5.6
5A	5.4
5B	5.2
5C	5.0
5D	4.9
5E	4.7
5F	4.5

7.2 Gain switching function

You can switch gains with the function. You can switch gains during rotation and during stop, and can use a control command from a controller to switch gains during operation.

Applications

The following shows when you use the function.

- You want to increase the gains during servo-lock but decrease the gains to reduce noise during rotation.
- You want to increase the gains during settling to shorten the stop settling time.
- You want to change the gains using a control command from a controller to ensure stability of the servo system since the load to motor inertia ratio varies greatly during a stop (e.g. a large load is mounted on a carrier).

Function block diagram

The control gains, load to motor inertia ratio, and vibration suppression control settings are changed according to the conditions selected by [Pr. PB26 Gain switching function] and [Pr. PB27 Gain switching condition].

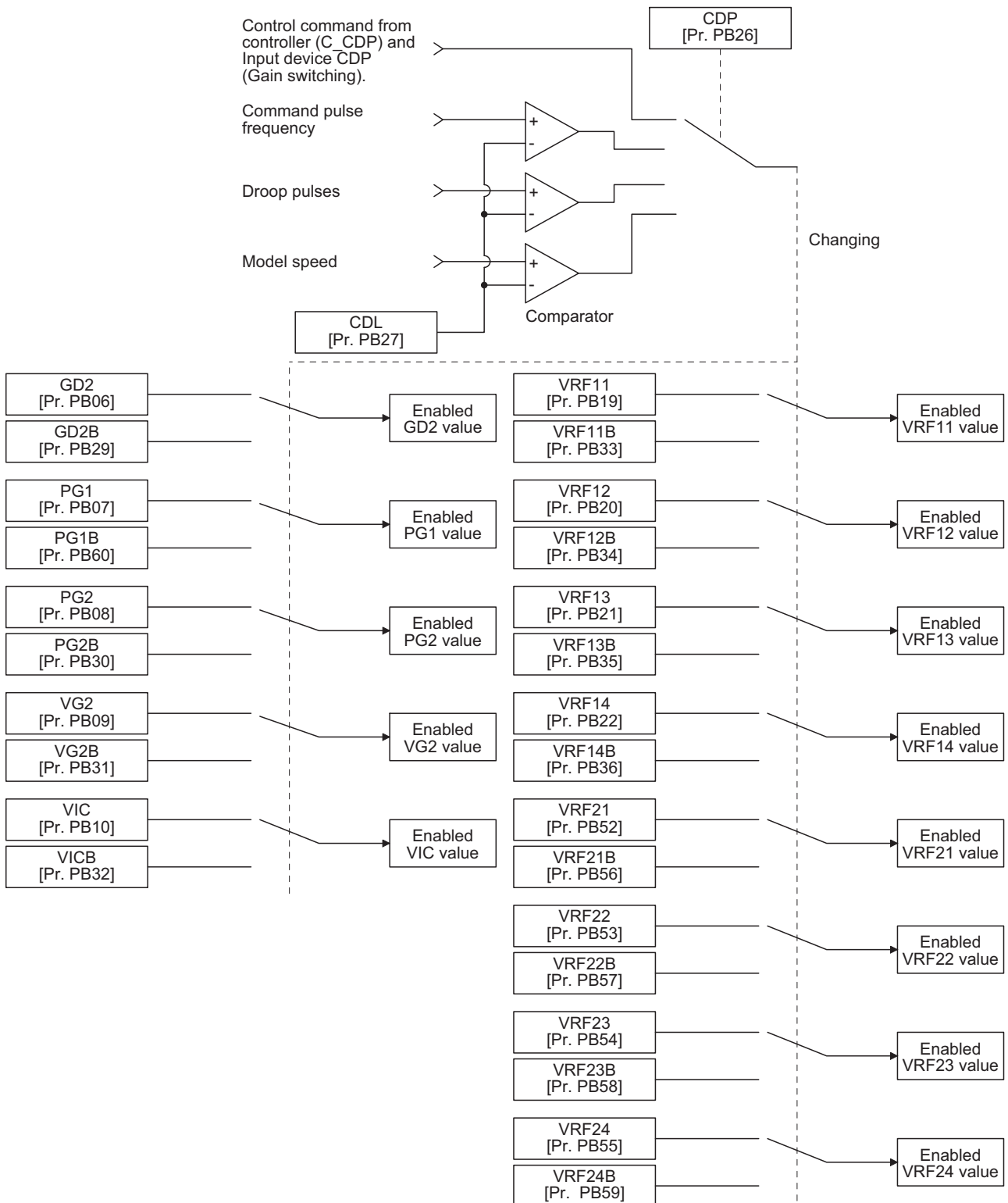

Parameter

When using the gain switching function, always select "Manual mode (_ _ _ 3)" of "Gain adjustment mode selection" in [Pr. PA08 Auto tuning mode]. The gain switching function cannot be used in the auto tuning mode.

Parameter for setting gain switching condition

Parameter	Symbol	Name	Unit	Description
PB26	CDP	Gain switching function	—	Used to select the changing condition.
PB27	CDL	Gain switching condition	[kpulse/s]/[pulse]/[r/min]	Used to set the changing condition values.
PB28	CDT	Gain switching time constant	[ms]	Set the filter time constant for a gain change at changing.

■[Pr. PB26 Gain switching function]

Used to set the gain switching condition. Select the switching condition in the first to third digits.

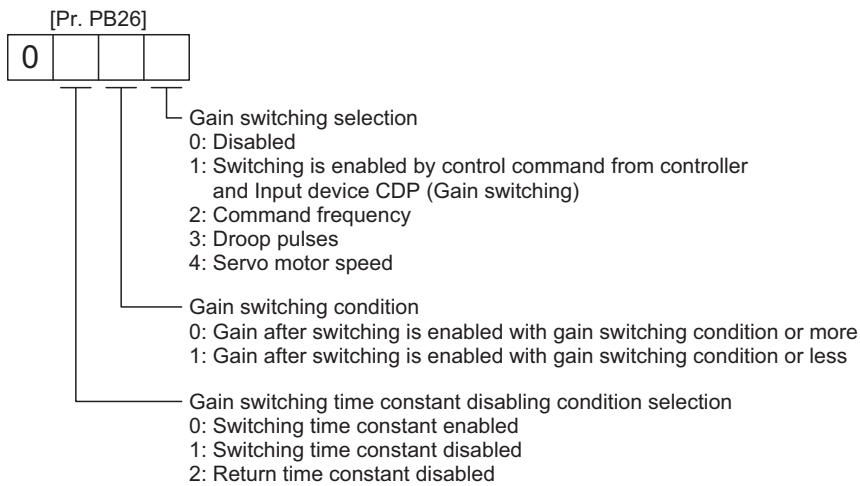

■[Pr. PB27 Gain switching condition]

Set a level to switch gains with [Pr. PB27] after you select "Command frequency", "Droop pulses", or "Servo motor speed" with the gain switching selection in [Pr. PB26 Gain switching function].

The setting unit is as follows.

Gain switching condition	Unit
Command frequency	[kpulse/s]
Droop pulses	[pulse]
Servo motor speed	[r/min]/[mm/s]

■[Pr. PB28 Gain switching time constant]

You can set the primary delay filter to each gain at gain switching. This parameter is used to suppress shock given to the machine if the gain difference is large at gain switching, for example.

Switchable gain parameter

Loop gain	Before switching			After switching		
	Parameter	Symbol	Name	Parameter	Symbol	Name
Load to motor inertia ratio/ load to motor mass ratio	PB06	GD2	Load to motor inertia ratio/load to motor mass ratio	PB29	GD2B	Load to motor inertia ratio/load to motor mass ratio after gain switching
Model loop gain	PB07	PG1	Model loop gain	PB60	PG1B	Model loop gain after gain switching
Position loop gain	PB08	PG2	Position loop gain	PB30	PG2B	Position loop gain after gain switching
Speed loop gain	PB09	VG2	Speed loop gain	PB31	VG2B	Speed loop gain after gain switching
Speed integral compensation	PB10	VIC	Speed integral compensation	PB32	VICB	Speed integral compensation after gain switching
Vibration suppression control 1 - Vibration frequency	PB19	VRF11	Vibration suppression control 1 - Vibration frequency	PB33	VRF11B	Vibration suppression control 1 - Vibration frequency after gain switching
Vibration suppression control 1 - Resonance frequency	PB20	VRF12	Vibration suppression control 1 - Resonance frequency	PB34	VRF12B	Vibration suppression control 1 - Resonance frequency after gain switching
Vibration suppression control 1 - Vibration frequency damping	PB21	VRF13	Vibration suppression control 1 - Vibration frequency damping	PB35	VRF13B	Vibration suppression control 1 - Vibration frequency damping after gain switching
Vibration suppression control 1 - Resonance frequency damping	PB22	VRF14	Vibration suppression control 1 - Resonance frequency damping	PB36	VRF14B	Vibration suppression control 1 - Resonance frequency damping after gain switching
Vibration suppression control 2 - Vibration frequency	PB52	VRF21	Vibration suppression control 2 - Vibration frequency	PB56	VRF21B	Vibration suppression control 2 - Vibration frequency after gain switching
Vibration suppression control 2 - Resonance frequency	PB53	VRF22	Vibration suppression control 2 - Resonance frequency	PB57	VRF22B	Vibration suppression control 2 - Resonance frequency after gain switching
Vibration suppression control 2 - Vibration frequency damping	PB54	VRF23	Vibration suppression control 2 - Vibration frequency damping	PB58	VRF23B	Vibration suppression control 2 - Vibration frequency damping after gain switching
Vibration suppression control 2 - Resonance frequency damping	PB55	VRF24	Vibration suppression control 2 - Resonance frequency damping	PB59	VRF24B	Vibration suppression control 2 - Resonance frequency damping after gain switching

■[Pr. PB06] to [Pr. PB10]

These parameters are the same as in ordinary manual adjustment. Gain switching allows the values of load to motor inertia ratio/load to motor mass ratio, position loop gain, model loop gain, speed loop gain, and speed integral compensation to be switched.

■[Pr. PB19] to [Pr. PB22]/[Pr. PB52] to [Pr. PB55]

These parameters are the same as in ordinary manual adjustment. Executing gain switching while the servo motor stops, you can change vibration frequency, resonance frequency, vibration frequency damping, and resonance frequency damping.

■[Pr. PB29 Load to motor inertia ratio/load to motor mass ratio after gain switching]

Set the load to motor inertia ratio or load to motor mass ratio after gain switching. If the load to motor inertia ratio does not change, set it to the same value as [Pr. PB06 Load to motor inertia ratio/load to motor mass ratio].

■[Pr. PB30 Position loop gain after gain switching], [Pr. PB31 Speed loop gain after gain switching], and [Pr. PB32 Speed integral compensation after gain switching]

Set the values of after switching position loop gain, speed loop gain and speed integral compensation.

■ **Vibration suppression control after gain switching ([Pr. PB33] to [Pr. PB36]/[Pr. PB56] to [Pr. PB59]), and [Pr. PB60 Model loop gain after gain switching]**

The gain switching vibration suppression control and gain switching model loop gain are used only with control command from the controller.

You can switch the vibration frequency, resonance frequency, vibration frequency damping, resonance frequency damping, and model loop gain of the vibration suppression control 1 and vibration suppression control 2.

Gain switching procedure

This operation will be described by way of setting examples.

When you choose switching by control command from the controller

■Setting example

Parameter	Symbol	Name	Setting value	Unit
PB06	GD2	Load to motor inertia ratio/load to motor mass ratio	4.00	[Multiplier]
PB07	PG1	Model loop gain	100	[rad/s]
PB08	PG2	Position loop gain	120	[rad/s]
PB09	VG2	Speed loop gain	3000	[rad/s]
PB10	VIC	Speed integral compensation	20	[ms]
PB19	VRF11	Vibration suppression control 1 - Vibration frequency	50	[Hz]
PB20	VRF12	Vibration suppression control 1 - Resonance frequency	50	[Hz]
PB21	VRF13	Vibration suppression control 1 - Vibration frequency damping	0.20	—
PB22	VRF14	Vibration suppression control 1 - Resonance frequency damping	0.20	—
PB52	VRF21	Vibration suppression control 2 - Vibration frequency	20	[Hz]
PB53	VRF22	Vibration suppression control 2 - Resonance frequency	20	[Hz]
PB54	VRF23	Vibration suppression control 2 - Vibration frequency damping	0.10	—
PB55	VRF24	Vibration suppression control 2 - Resonance frequency damping	0.10	—
PB29	GD2B	Load to motor inertia ratio/load to motor mass ratio after gain switching	10.00	[Multiplier]
PB60	PG1B	Model loop gain after gain switching	50	[rad/s]
PB30	PG2B	Position loop gain after gain switching	84	[rad/s]
PB31	VG2B	Speed loop gain after gain switching	4000	[rad/s]
PB32	VICB	Speed integral compensation after gain switching	50	[ms]
PB26	CDP	Gain switching function	0001 (Switch by control command from the controller and Input device CDP (Gain switching).)	—
PB28	CDT	Gain switching time constant	100	[ms]
PB33	VRF11B	Vibration suppression control 1 - Vibration frequency after gain switching	60	[Hz]
PB34	VRF12B	Vibration suppression control 1 - Resonance frequency after gain switching	60	[Hz]
PB35	VRF13B	Vibration suppression control 1 - Vibration frequency damping after gain switching	0.15	—
PB36	VRF14B	Vibration suppression control 1 - Resonance frequency damping after gain switching	0.15	—
PB56	VRF21B	Vibration suppression control 2 - Vibration frequency after gain switching	30	[Hz]
PB57	VRF22B	Vibration suppression control 2 - Resonance frequency after gain switching	30	[Hz]
PB58	VRF23B	Vibration suppression control 2 - Vibration frequency damping after gain switching	0.05	—
PB59	VRF24B	Vibration suppression control 2 - Resonance frequency damping after gain switching	0.05	—

■ Switching timing chart

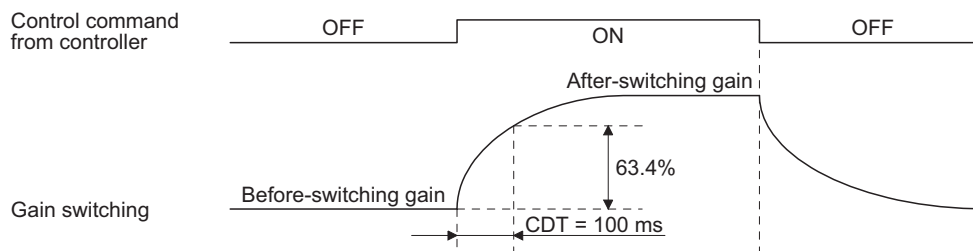

Model loop gain	100	→	50	→	100
Load to motor inertia ratio/load to motor mass ratio	4.00	→	10.00	→	4.00
Position loop gain	120	→	84	→	120
Speed loop gain	3000	→	4000	→	3000
Speed integral compensation	20	→	50	→	20
Vibration suppression control 1 - Vibration frequency	50	→	60	→	50
Vibration suppression control 1 - Resonance frequency	50	→	60	→	50
Vibration suppression control 1 - Vibration frequency damping	0.20	→	0.15	→	0.20
Vibration suppression control 1 - Resonance frequency damping	0.20	→	0.15	→	0.20
Vibration suppression control 2 - Vibration frequency	20	→	30	→	20
Vibration suppression control 2 - Resonance frequency	20	→	30	→	20
Vibration suppression control 2 - Vibration frequency damping	0.10	→	0.05	→	0.10
Vibration suppression control 2 - Resonance frequency damping	0.10	→	0.05	→	0.10

When you choose switching by droop pulses

The vibration suppression control after gain switching and model loop gain after gain switching cannot be used.

■ Setting example

Parameter	Symbol	Name	Setting value	Unit
PB06	GD2	Load to motor inertia ratio/load to motor mass ratio	4.00	[Multiplier]
PB08	PG2	Position loop gain	120	[rad/s]
PB09	VG2	Speed loop gain	3000	[rad/s]
PB10	VIC	Speed integral compensation	20	[ms]
PB29	GD2B	Load to motor inertia ratio/load to motor mass ratio after gain switching	10.00	[Multiplier]
PB30	PG2B	Position loop gain after gain switching	84	[rad/s]
PB31	VG2B	Speed loop gain after gain switching	4000	[rad/s]
PB32	VICB	Speed integral compensation after gain switching	50	[ms]
PB26	CDP	Gain switching selection	0003 (switching by droop pulses)	—
PB27	CDL	Gain switching condition	50	[pulse]
PB28	CDT	Gain switching time constant	100	[ms]

■ Switching timing chart

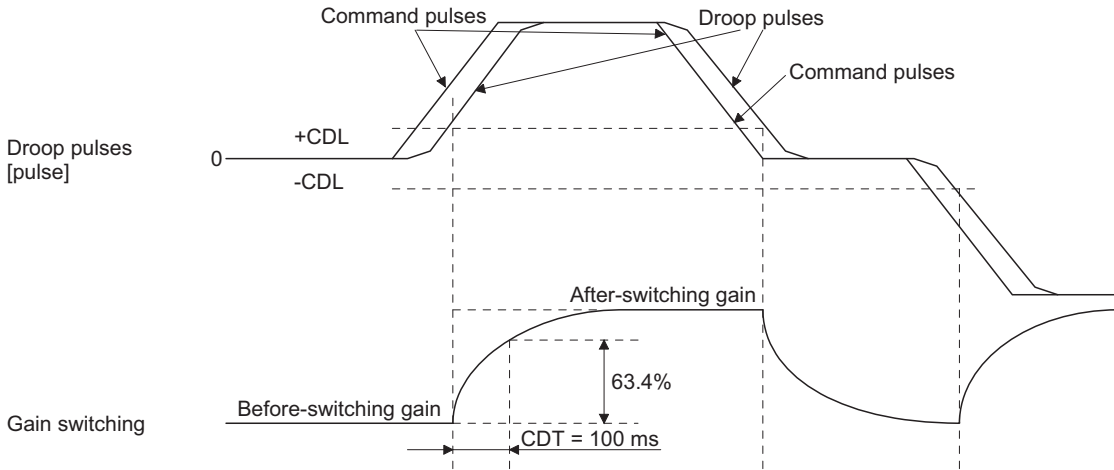

Load to motor inertia ratio/load to motor mass ratio	4.00	→	10.00	→	4.00	→	10.00
Position loop gain	120	→	84	→	120	→	84
Speed loop gain	3000	→	4000	→	3000	→	4000
Speed integral compensation	20	→	50	→	20	→	50

When the gain switching time constant is disabled

■ Time constant disabled at switching

The gain switching time constant is disabled. The time constant is enabled at gain return.

The following example shows for [Pr. PB26 (CDP)] = 0103, [Pr. PB27 (CDL)] = 100 [pulse], and [Pr. PB28 (CDT)] = 100 [ms].

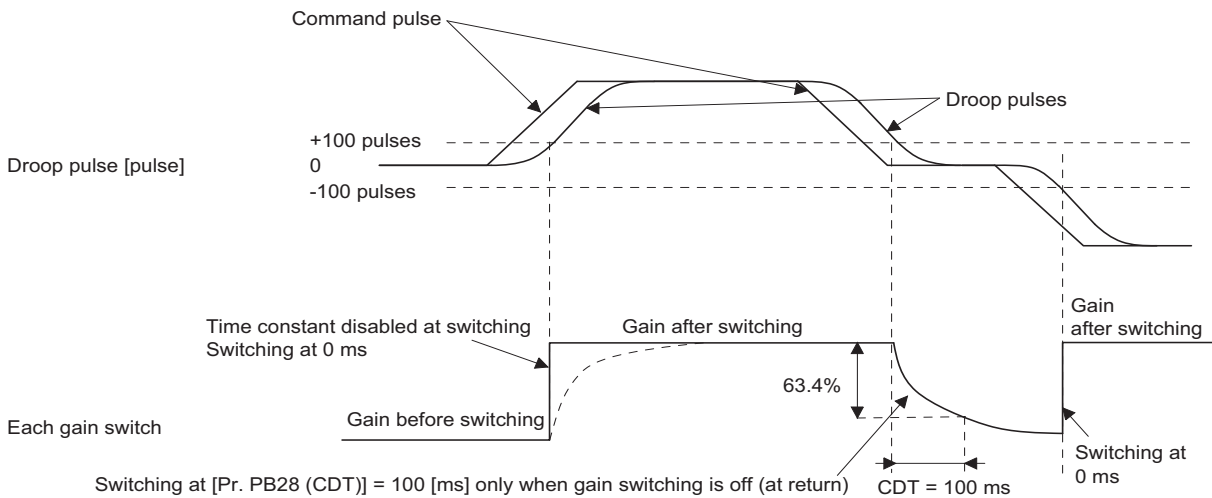

■ Time constant disabled at returning

The gain switching time constant is enabled. The time constant is disabled at gain return.

The following example shows for [Pr. PB26 (CDP)] = 0201, [Pr. PB27 (CDL)] = 0, and [Pr. PB28 (CDT)] = 100 [ms].

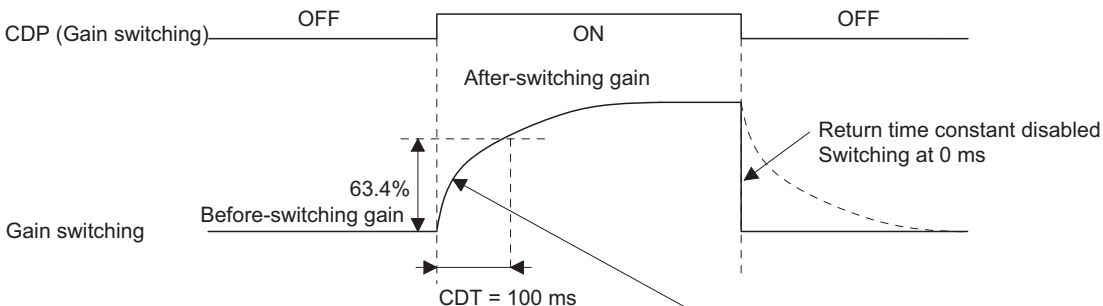

Switching at [Pr. PB28 (CDT)] = 100 [ms] only when gain switching on (when switching)

7.3 Tough drive function

Point

Set enable/disable of the tough drive function with [Pr. PA20 Tough drive setting].

 Page 186 Basic setting parameters ([Pr. PA_ _])

This function makes the equipment continue operating even under the condition that an alarm occurs. The tough drive functions are the vibration tough drive and the instantaneous power failure tough drive.

Vibration tough drive function

This function prevents vibration by resetting a filter instantaneously when machine resonance occurs due to varied vibration frequency caused by machine aging.

To reset the machine resonance suppression filters with the function, [Pr. PB13 Machine resonance suppression filter 1] and [Pr. PB15 Machine resonance suppression filter 2] should be set in advance.

Set [Pr. PB13] and [Pr. PB15] as follows.

- One-touch tuning execution  Page 232 One-touch tuning
- Manual setting  Page 195 Gain/filter setting parameters ([Pr. PB_ _])

The vibration tough drive function operates when a detected machine resonance frequency is within $\pm 30\%$ for a value set in [Pr. PB13 Machine resonance suppression filter 1] or [Pr. PB15 Machine resonance suppression filter 2].

To set a detection level of the function, set sensitivity in [Pr. PF23 Vibration tough drive - Oscillation detection level].

Point

- Resetting [Pr. PB13] and [Pr. PB15] by the vibration tough drive function is performed constantly. However, the number of write times to the EEPROM is limited to once per hour.
 - The vibration tough drive function does not reset [Pr. PB46 Machine resonance suppression filter 3], [Pr. PB48 Machine resonance suppression filter 4], and [Pr. PB50 Machine resonance suppression filter 5].
 - The vibration tough drive function does not detect a vibration of 100 Hz or less.
-

The following shows the function block diagram of the vibration tough drive function.

This function compares the detected machine resonance frequency with the setting values of [Pr. PB13 Machine resonance suppression filter 1] and [Pr. PB15 Machine resonance suppression filter 2], and resets the setting value closer to the detected machine resonance frequency.

Filter	Setting parameter	Precaution	Parameter that is reset with vibration tough drive function
Machine resonance suppression filter 1	PB01/PB13/PB14	The filter can be set automatically with "Filter tuning mode selection" in [Pr. PB01].	PB13
Machine resonance suppression filter 2	PB15/PB16	—	PB15
Machine resonance suppression filter 3	PB46/PB47	—	—
Machine resonance suppression filter 4	PB48/PB49	Enabling the machine resonance suppression filter 4 disables the shaft resonance suppression filter. Using the shaft resonance suppression filter is recommended because it is adjusted properly depending on the usage situation. The shaft resonance suppression filter is enabled for the initial setting.	—
Machine resonance suppression filter 5	PB50/PB51	Enabling the robust filter disables the machine resonance suppression filter 5. The robust filter is disabled for the initial setting.	—

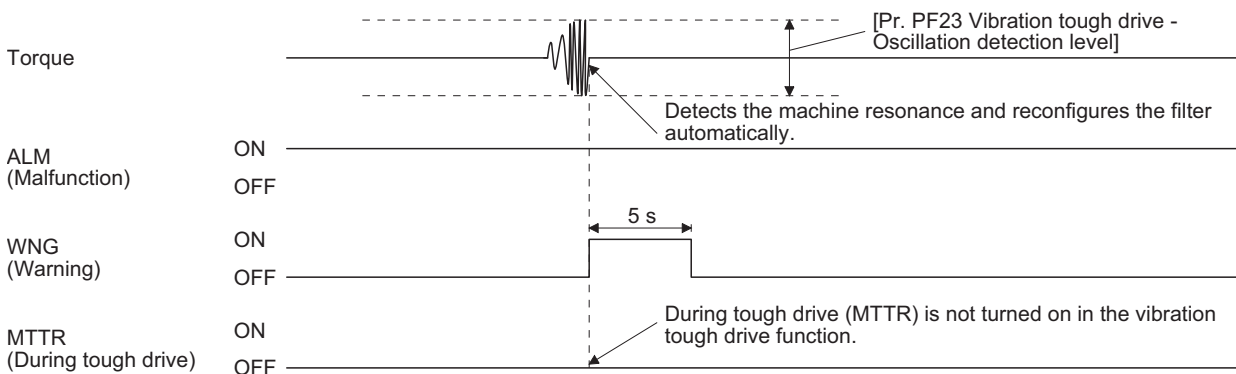
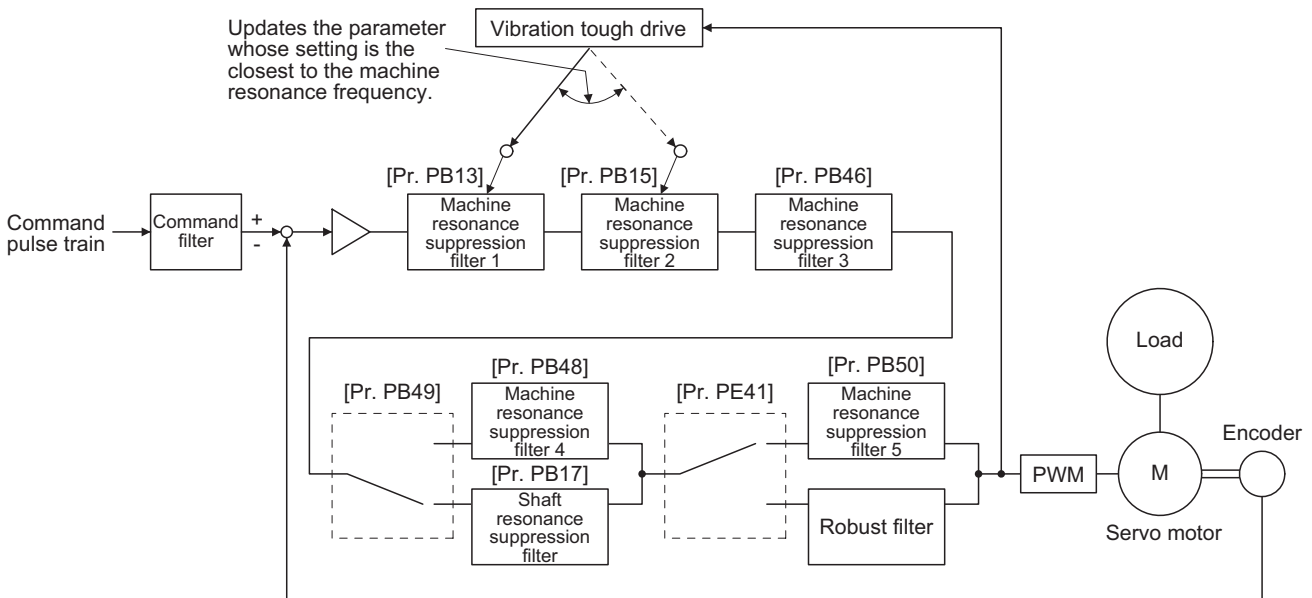

Instantaneous power failure tough drive function

The instantaneous power failure tough drive function avoids [AL. 10 Undervoltage] even when an instantaneous power failure occurs during operation. When the instantaneous power failure tough drive activates, the function will increase the tolerance against instantaneous power failure using the electrical energy charged in the capacitor in the servo amplifier and will change an alarm level of [AL. 10 Undervoltage] simultaneously. The [AL. 10.1 Voltage drop in the control circuit power] detection time for the control circuit power supply can be changed by [Pr. PF25 SEMI-F47 function - Instantaneous power failure detection time]. In addition, [AL. 10.2 Voltage drop in the main circuit power] detection level for the bus voltage is changed automatically.

Point

- MBR (Electromagnetic brake interlock) will not turn off during the instantaneous power failure tough drive.
 - When selecting "Enabled (_ _ _ 1)" for "Torque limit function selection at instantaneous power failure" in [Pr. PA26], if an instantaneous power failure occurs during operation, you can save electric energy charged in the capacitor in the servo amplifier by limiting torque at acceleration. You can also delay the time until the occurrence of [AL. 10.2 Voltage drop in the main circuit power]. Doing this will enable you to set a longer time in [Pr. PF25 SEMI-F47 function - Instantaneous power failure detection time].
 - When the load of instantaneous power failure is large, [AL. 10.2] caused by the bus voltage drop may occur regardless of the set value of [Pr. PF25 SEMI-F47 function - Instantaneous power failure detection time].
 - The external dynamic brake cannot be used for compliance with SEMI-F47 standard. Do not assign DB (Dynamic brake interlock) in [Pr. PD07] to [Pr. PD09]. Failure to do so will cause the servo amplifier to become servo-off when an instantaneous power failure occurs.
 - To comply with SEMI-F47 standard, it is unnecessary to change the initial value (200 ms) in [Pr. PF25 SEMI-F47 function - Instantaneous power failure detection time]. When the instantaneous power failure time exceeds 200 ms, and the instantaneous power failure voltage is less than 70% of the rated input voltage, the power may be normally turned off even if a value larger than 200 ms is set in the parameter.
-

Instantaneous power failure time of the control circuit power supply > [Pr. PF25 SEMI-F47 function - Instantaneous power failure detection time]

The alarm occurs when the instantaneous power failure time of the control circuit power supply exceeds [Pr. PF25 SEMI-F47 function - Instantaneous power failure detection time].

MTTR (During tough drive) turns on after detecting the instantaneous power failure.

MBR (Electromagnetic brake interlock) turns off when the alarm occurs.

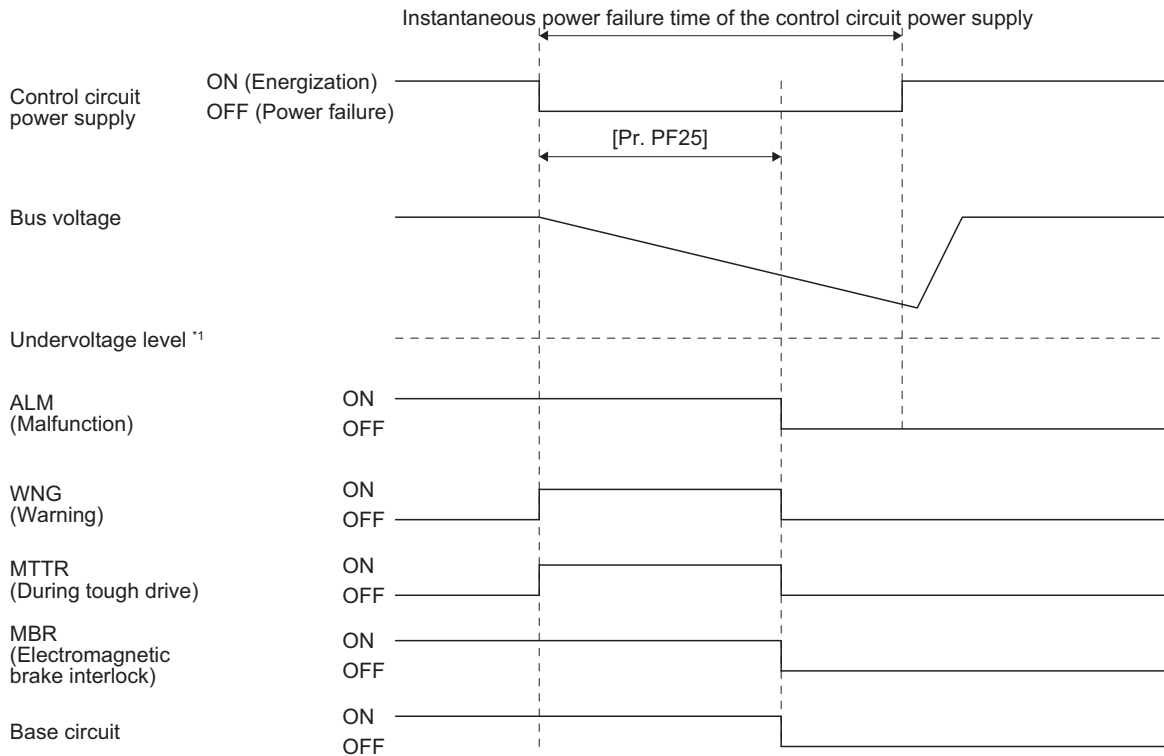

*1 For the undervoltage level, refer to "[AL. 10.2 Voltage drop in the main circuit power] will occur when bus voltage is as follows." in "Parameter setting" below.

☞ Page 276 Parameter setting

Instantaneous power failure time of the control circuit power supply < [Pr. PF25 SEMI-F47 function - Instantaneous power failure detection time]

Operation status differs depending on how bus voltage decreases.

■When the bus voltage decreases to the undervoltage level or lower within instantaneous power failure time of control circuit power supply

[AL. 10 Undervoltage] occurs when the bus voltage decreases to the undervoltage level or lower regardless of the enabled instantaneous power failure tough drive.

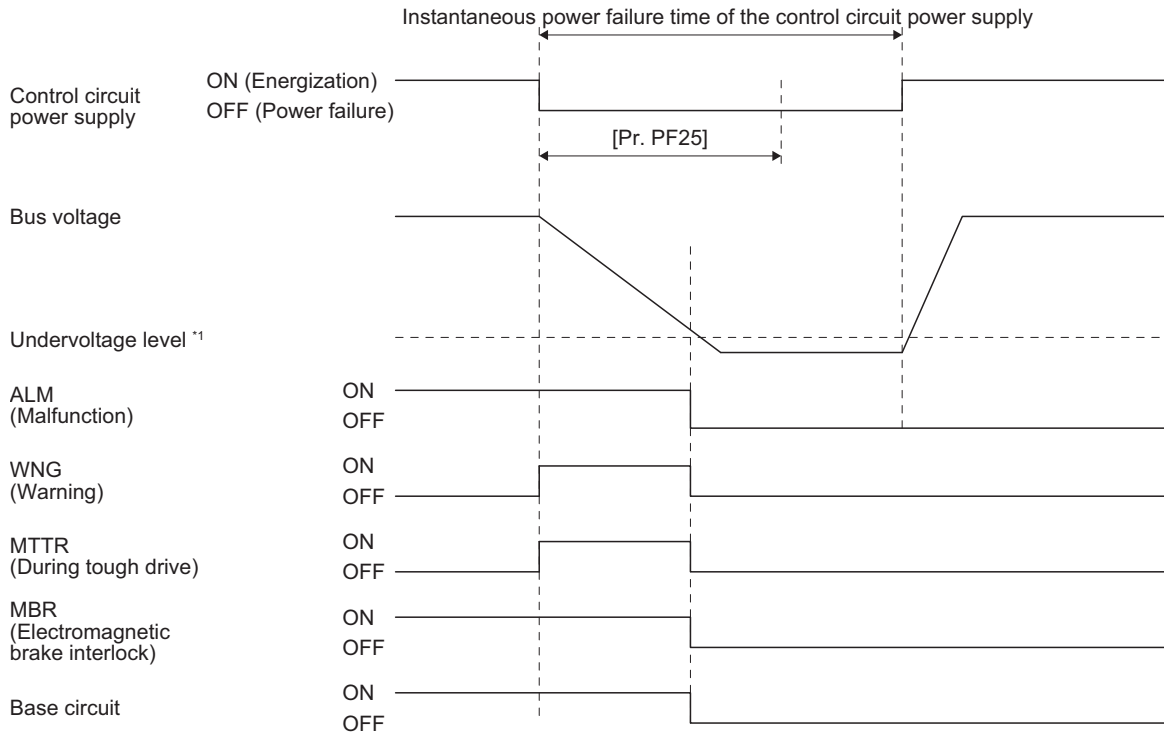

*1 For the undervoltage level, refer to "[AL. 10.2 Voltage drop in the main circuit power] will occur when bus voltage is as follows." in "Parameter setting" below.

☞ Page 276 Parameter setting

■ When the bus voltage does not decrease to the undervoltage level or lower within instantaneous power failure time of control circuit power supply

The operation continues without alarming.

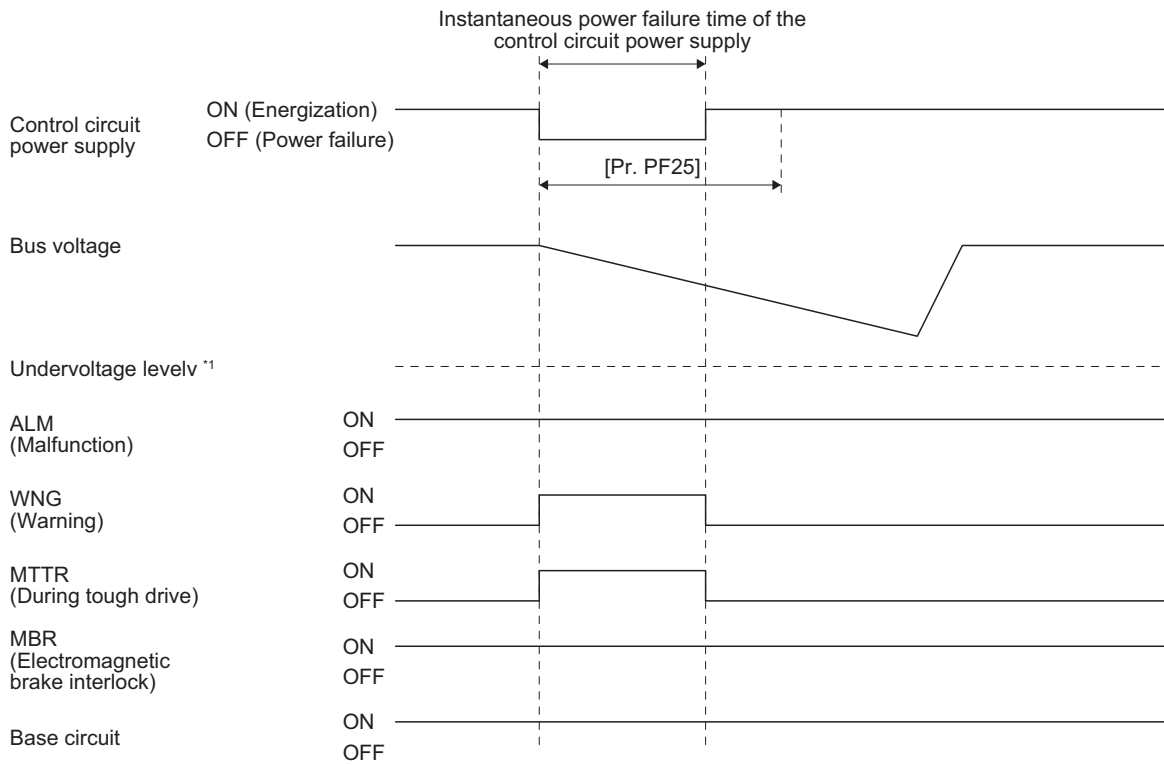

*1 For the undervoltage level, refer to "[AL. 10.2 Voltage drop in the main circuit power] will occur when bus voltage is as follows." in "Parameter setting" below.

Page 276 Parameter setting

7.4 Compliance with SEMI-F47 standard

Point

- The control circuit power supply of the servo amplifier can be possible to comply with SEMI-F47 standard. However, a back-up capacitor may be necessary for instantaneous power failure in the main circuit power supply depending on the power supply impedance and operating situation.
- Use a 3-phase for the input power supply of the servo amplifier. Using a 1-phase 100 V AC/200 V AC for the input power supply will not comply with SEMI-F47 standard.
- The external dynamic brake cannot be used for compliance with SEMI-F47 standard. Do not assign DB (Dynamic brake interlock) in [Pr. PD07] to [Pr. PD09]. Failure to do so will cause the servo amplifier to become servo-off when an instantaneous power failure occurs.
- Be sure to perform actual machine tests and detail checks for power supply instantaneous power failure of SEMI-F47 standard with your equipment.

The following explains the compliance with "SEMI-F47 semiconductor process equipment voltage sag immunity test" of MR-J4 series.

This function enables to avoid triggering [AL. 10 Undervoltage] using the electrical energy charged in the capacitor in case that an instantaneous power failure occurs during operation.

Parameter setting

Setting [Pr. PA20] and [Pr. PF25] as follows will enable SEMI-F47 function.

Parameter	Setting value	Description
PA20	_ 1 _ _	Enable SEMI-F47 function selection.
PF25	200	Set the time [ms] of the [AL. 10.1 Voltage drop in the control circuit power] occurrence.

Enabling SEMI-F47 function will change operation as follows.

- The voltage will drop in the control circuit power at "Rated voltage × 50% or less". After 200 ms, [AL. 10.1 Voltage drop in the control circuit power] will occur.
- [AL. 10.2 Voltage drop in the main circuit power] will occur when bus voltage is as follows.

Servo amplifier	Bus voltage which triggers alarm
MR-J4-10GF(-RJ) to MR-J4-700GF(-RJ)	158 V DC
MR-J4-11KGF(-RJ) to MR-J4-22KGF(-RJ)	200 V DC
MR-J4-60GF4(-RJ) to MR-J4-22KGF4(-RJ)	380 V DC

- MBR (Electromagnetic brake interlock) will turn off when [AL. 10.1 Voltage drop in the control circuit power] occurs.

Requirement of SEMI-F47 standard

The following shows the requirement of SEMI-F47 standard for the instantaneous power failure voltage and permissible time of instantaneous power failure.

Instantaneous power failure voltage	Permissible time of instantaneous power failure [s]
Rated voltage × 80%	1
Rated voltage × 70%	0.5
Rated voltage × 50%	0.2

Calculation of tolerance against instantaneous power failure

The following shows tolerance against instantaneous power failure when instantaneous power failure voltage is "rated voltage × 50%" and instantaneous power failure time is 200 ms.

Servo amplifier	Instantaneous maximum output [W]	Tolerance against instantaneous power failure [W] (voltage drop between lines)
MR-J4-10GF(-RJ)	350	250
MR-J4-20GF(-RJ)	700	420
MR-J4-40GF(-RJ)	1400	630
MR-J4-60GF(-RJ)	2100	410
MR-J4-70GF(-RJ)	2625	1150
MR-J4-100GF(-RJ)	3000	1190
MR-J4-200GF(-RJ)	5400	2040
MR-J4-350GF(-RJ)	10500	2600
MR-J4-500GF(-RJ)	15000	4100
MR-J4-700GF(-RJ)	21000	5900
MR-J4-11KGF(-RJ)	40000	2600
MR-J4-15KGF(-RJ)	50000	3500
MR-J4-22KGF(-RJ)	56000	4300
MR-J4-60GF4(-RJ)	1900	190
MR-J4-100GF4(-RJ)	3500	200
MR-J4-200GF4(-RJ)	5400	350
MR-J4-350GF4(-RJ)	10500	730
MR-J4-500GF4(-RJ)	15000	890
MR-J4-700GF4(-RJ)	21000	1500
MR-J4-11KGF4(-RJ)	40000	2400
MR-J4-15KGF4(-RJ)	50000	3200
MR-J4-22KGF4(-RJ)	56000	4200

Instantaneous maximum output means power which servo amplifier can output in maximum torque at rated speed. You can examine margins to compare the values of following conditions and instantaneous maximum output.

Even if driving at maximum torque with low speed in actual operation, the motor will not drive with the maximum output. This can be handled as a margin.

The following shows the conditions of tolerance against instantaneous power failure.

■Delta connection

For the 3-phase (L1/L2/L3) delta connection, an instantaneous power failure occurs in the voltage between a pair of lines (e.g. between L1 and L2) among voltages between three pairs of lines (between L1 and L2, L2 and L3, or L3 and L1).

■Star connection

For the 3-phase (L1/L2/L3/neutral point N) star connection, an instantaneous power failure occurs in the voltage between a pair of lines (e.g. between L1 and N) among voltages at six locations, between three pairs of lines (between L1 and L2, L2 and L3, or L3 and L1) and between one of the lines and the neutral point (between L1 and N, L2 and N, or L3 and N).

7.5 Model adaptive control disabled

Point

- Change the parameters while the servo motor stops.
- When setting auto tuning response ([Pr. PA09]), change the setting value one by one to adjust it while checking operation status of the servo motor.

Summary

The servo amplifier has a model adaptive control. The servo amplifier has a virtual motor model and drives the servo motor following the output of the motor model in the model adaptive control. At model adaptive control disabled, the servo amplifier drives the motor with PID control without using the model adaptive control.

The following shows the available parameters at model adaptive control disabled.

Parameter	Symbol	Name
PB08	PG2	Position loop gain
PB09	VG2	Speed loop gain
PB10	VIC	Speed integral compensation

Parameter setting

Set [Pr. PB25] to " _ _ _ 2".

Restrictions

The following functions are not available at model adaptive control disabled.

Function	Explanation
Forced stop deceleration function ([Pr. PA04])	Disabling the model adaptive control while the forced stop deceleration function is enabled, [AL. 37] will occur. The forced stop deceleration function is enabled at factory setting. Set [Pr. PA04] to "0 _ _ _" (Forced stop deceleration function disabled).
Vibration suppression control 1 ([Pr. PB02]/[Pr. PB19]/[Pr. PB20]) Vibration suppression control 2 ([Pr. PB02]/[Pr. PB52]/[Pr. PB53])	The vibration suppression control uses the model adaptive control. Disabling the model adaptive control will also disable the vibration suppression control.
Overshoot amount compensation ([Pr. PB12])	The overshoot amount compensation uses data used by the model adaptive control. Disabling the model adaptive control will also disable the overshoot amount compensation.
Super trace control ([Pr. PA22])	The super trace control uses the model adaptive control. Disabling the model adaptive control will also disable the super trace control.

7.6 Lost motion compensation function



The lost motion compensation function is enabled only in the position mode.

The lost motion compensation function corrects response delays (caused by a non-sensitive band due to friction, twist, expansion, and backlash) caused when the machine travel direction is reversed. This function contributes to improvement for protrusions that occur at a quadrant change and streaks that occur at a quadrant change during circular cutting. This function is effective when a high follow-up performance is required such as drawing an arc with an X-Y table.

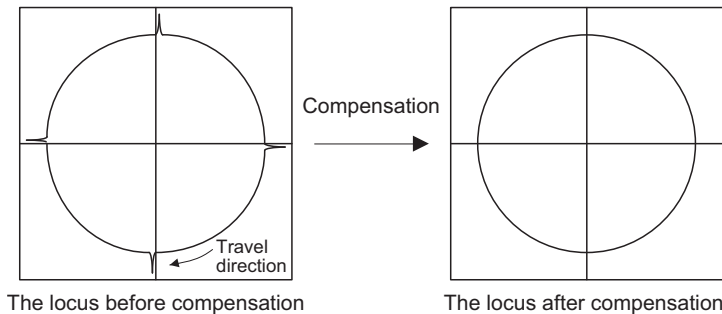

Parameter setting

Setting [Pr. PE44] to [Pr. PE50] enables the lost motion compensation function.

■Lost motion compensation function selection ([Pr. PE48])

Select the lost motion compensation function.

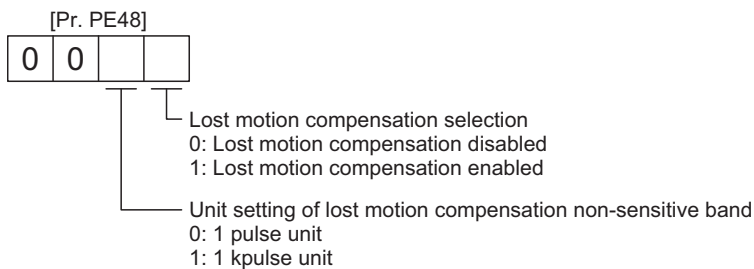

■Lost motion compensation ([Pr. PE44]/[Pr. PE45])

Set the same value for the lost motion compensation for each of when the forward rotation switches to the reverse rotation and when the reverse rotation switches to the forward rotation. When the size of protrusions differ depending on the travel direction, set the different compensation for each travel direction. Set a value twice the usual friction torque and adjust the value while checking protrusions.

■Torque offset ([Pr. PE47])

For a vertical axis, unbalanced torque occurs due to the gravity. Although setting the torque offset is usually unnecessary, setting unbalanced torque of a machine as a torque offset cancels the unbalanced torque. The torque offset does not need to be set for a machine not generating unbalanced torque. The torque offset cannot be used for linear servo motors and direct drive motors. Set 0.00%.

■Lost motion compensation timing ([Pr. PE49])

You can set the delay time of the lost motion compensation start timing with this parameter. When a protrusion occurs belatedly, set the lost motion compensation timing corresponding to the protrusion occurrence timing.

■Lost motion compensation non-sensitive band ([Pr. PE50])

When the travel direction reverses frequently around the zero speed, unnecessary lost motion compensation is triggered by the travel direction switching. By setting the lost motion compensation non-sensitive band, the speed is recognized as 0 when the fluctuation of the droop pulse is the setting value or less. This prevents unnecessary lost motion compensation. When the value of this parameter is changed, the compensation timing is changed. Adjust the value of Lost motion compensation timing ([Pr. PE49]).

■Lost motion filter setting ([Pr. PE46])

Changing the value of this parameter is usually unnecessary. When a value other than 0.0 ms is set in this parameter, the high-pass filter output value of the set time constant is applied to the compensation and lost motion compensation continues.

Adjustment procedure of the lost motion compensation function

The following shows the adjustment procedure of the lost motion compensation function.

■Measuring the load current

Measure the load currents during the forward direction feed and reverse direction feed with MR Configurator2.

■Setting the lost motion compensation

Calculate the friction torque from the measurement result of the section below and set a value twice the friction torque in [Pr. PE44] and [Pr. PE45] as lost motion compensation.

☞ Page 280 Measuring the load current

$$\text{Friction torque [\%]} = \frac{|\text{(load current during feed in the forward rotation direction [\%])} - \text{(load current during feed in the reverse rotation direction [\%])}|}{2}$$

■Checking protrusions

Drive the servo motor and check that the protrusions are corrected.

■Adjusting the lost motion compensation

When protrusions still occur, the compensation is insufficient. Increase the lost motion compensation by approximately 0.5% until the protrusions are eliminated. When notches occur, the compensation is excessive. Decrease the lost motion compensation by approximately 0.5% until the notches are eliminated. Different values can be set as the compensation for each of when the forward rotation (CCW) switches to the reverse rotation (CW) and when the reverse rotation (CW) switches to the forward rotation (CCW).

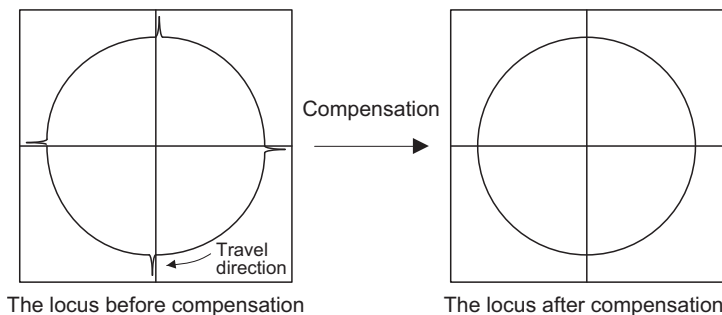

■Adjusting the lost motion compensation timing

When the machine has low rigidity, the speed loop gain is set lower than the standard setting value, or the servo motor is rotating at high speed, quadrant projections may occur behind the quadrant change points. In this case, you can suppress the quadrant projections by delaying the lost motion compensation timing with [Pr. PE49 Lost motion compensation timing]. Increase the setting value of [Pr. PE49] from 0 ms (Initial value) by approximately 0.5 ms to adjust the compensation timing.

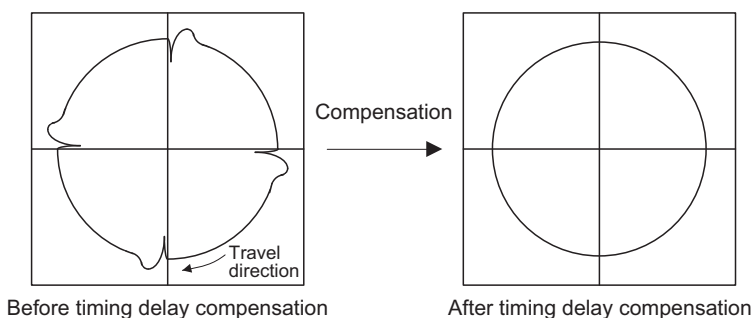

■ Adjusting the lost motion compensation non-sensitive band

When the lost motion is compensated twice around a quadrant change point, set [Pr. PE50 Lost motion compensation nonsensitive band]. Increase the setting value so that the lost motion is not compensated twice. Setting [Pr. PE50] may change the compensation timing. Adjust the lost motion compensation timing in the following section.

☞ Page 280 Adjusting the lost motion compensation timing

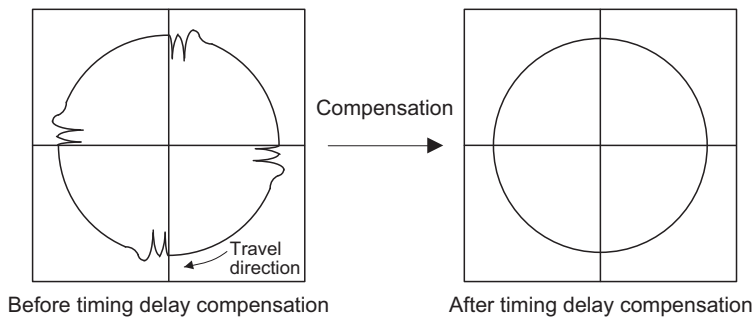

7.7 Super trace control

Summary

In the normal position control, droop pulses are generated against the position control command from the controller. Using the feed forward gain sets droop pulses at a constant speed to almost 0. However, droop pulses generated during acceleration/deceleration cannot be suppressed.

With the ideal model in the servo amplifier, the super trace control enables to set constant speed and uniform acceleration/deceleration droop pulses to almost 0 that cannot be coped with by the feed forward gain.

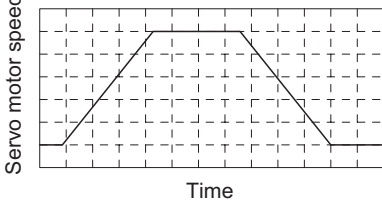
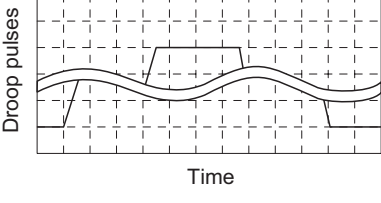
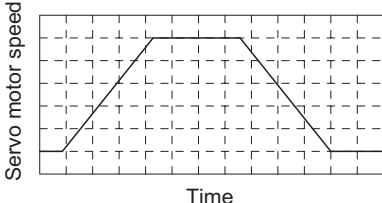
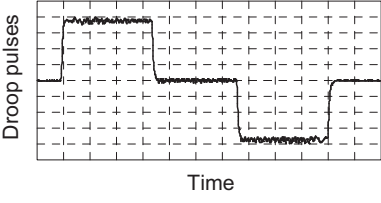
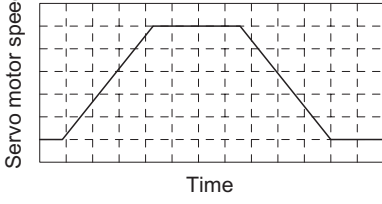
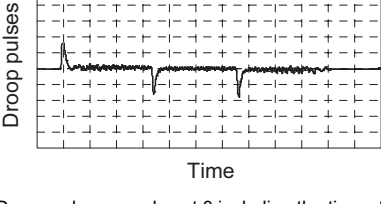
Control	Position command (the same command)	Droop pulses
Normal control		 Droop pulses are always generated.
Feed forward gain		 Droop pulses are generated during acceleration/deceleration.
Super trace control		 Droop pulses are almost 0 including the time of acceleration or deceleration.

Adjustment procedure

Point

- In the super trace control, droop pulses are near 0 during the servo motor control. Thus, the normal INP (In-position) may always be turned on. Be sure to set "INP (In-position) on condition selection" in [Pr. PD13] to "_ 1 _".
- When you use the super trace control, it is recommended that the acceleration time constant up to the rated speed be set to 1 s or more.

The following shows the adjustment procedure.

Step	Operation
1	Execute the gain adjustment with one-touch tuning, auto tuning, etc. ☞ Page 230 NORMAL GAIN ADJUSTMENT
2	Change the setting of auto tuning mode to the manual mode ([Pr. PA08]: ___ 3).
3	Change the setting of feed forward gain ([Pr. PB04]), and adjust that droop pulses will be 0 at a constant speed.
4	Set the setting of INP (In-position) on condition selection ([Pr. PD13]) to "_ 1 _".
5	Enable the super trace control. ([Pr. PA22]: __ 2 _)
6	Change the setting of model loop gain ([Pr. PB07]), and adjust droop pulses during acceleration/deceleration.

8 TROUBLESHOOTING

Point

- Refer to the following for details of alarms and warnings.
 MELSERVO-J4 Servo Amplifier Instruction Manual (Troubleshooting)
- As soon as an alarm occurs, make the Servo-off status and interrupt the main circuit power.
- [AL. 37 Parameter error] and warnings (except [AL. F0 Tough drive warning]) are not recorded in the alarm history.
- In the initial setting, [AL. 8D.1 CC-Link IE communication error 1] and [AL. 8D.2 CC-Link IE communication error 2] are not recorded in the alarm history. The alarms are recorded by setting [Pr. PN06] to "___ 1".

When an error occurs during operation, the corresponding alarm and warning are displayed. When an alarm or warning is displayed, refer to the following to remove the failure.

 MELSERVO-J4 Servo Amplifier Instruction Manual (Troubleshooting)

When an alarm occurs, ALM (Malfunction) will turn off.

8.1 Explanation for the lists

No./Name/Detail No./Detail name

Indicates each No./Name/Detail No./Detail name of alarms or warnings.

Stop method

For the alarms and warnings in which "SD" is written in the stop method column, the servo motor stops with the dynamic brake after forced stop deceleration. For the alarms and warnings in which "DB" or "EDB" is written in the stop method column, the servo motor stops with the dynamic brake without forced stop deceleration.

Alarm deactivation

After its cause has been removed, the alarm can be deactivated in any of the methods marked ○ in the alarm deactivation column. Warnings are automatically canceled after the cause of occurrence is removed. Alarms are deactivated with alarm reset, CPU reset, or cycling the power.

Alarm deactivation	Explanation
Alarm reset	<ul style="list-style-type: none"> • Error reset command from the controller • Click "Occurring Alarm Reset" in the "Alarm Display" window of MR Configurator2 • Turn on RES (Reset) with an input device *1
CPU reset	Resetting the controller itself
Cycling the power	Turning off the power and on again

*1 This is available with servo amplifiers with software version A7 or later.

8.2 Alarm list

No.	Name	Detail No.	Detail name	Stop method *2*3	Alarm deactivation		
					Alarm reset	CPU reset	Cycling the power
10	Undervoltage	10.1	Voltage drop in the control circuit power	EDB	○	○	○
		10.2	Voltage drop in the main circuit power	SD	○	○	○
11	Switch setting error	11.1	Axis number setting error/Station number setting error	DB	—	—	○
		11.2	Disabling control axis setting error	DB	—	—	○
12	Memory error 1 (RAM)	12.1	RAM error 1	DB	—	—	○
		12.2	RAM error 2	DB	—	—	○
		12.3	RAM error 3	DB	—	—	○
		12.4	RAM error 4	DB	—	—	○
		12.5	RAM error 5	DB	—	—	○
		12.6	RAM error 6	DB	—	—	○
13	Clock error	13.1	Clock error 1	DB	—	—	○
		13.2	Clock error 2	DB	—	—	○
		13.3	Clock error 3	DB	—	—	○
14	Control process error	14.1	Control process error 1	DB	—	—	○
		14.2	Control process error 2	DB	—	—	○
		14.3	Control process error 3	DB	—	—	○
		14.4	Control process error 4	DB	—	—	○
		14.5	Control process error 5	DB	—	—	○
		14.6	Control process error 6	DB	—	—	○
		14.7	Control process error 7	DB	—	—	○
		14.8	Control process error 8	DB	—	—	○
		14.9	Control process error 9	DB	—	—	○
		14.A	Control process error 10	DB	—	—	○
		14.B	Control process error 11	DB	—	—	○
		14.C	Control process error 12	DB	—	—	○
		14.D	Control process error 13	DB	—	—	○
		15	Memory error 2 (EEP-ROM)	15.1	EEP-ROM error at power on	DB	—
15.2	EEP-ROM error during operation			DB	—	—	○
15.4	Home position information read error			DB	—	—	○
16	Encoder initial communication error 1	16.1	Encoder initial communication - Receive data error 1	DB	—	—	○
		16.2	Encoder initial communication - Receive data error 2	DB	—	—	○
		16.3	Encoder initial communication - Receive data error 3	DB	—	—	○
		16.4	Encoder initial communication - Encoder malfunction *6	DB	—	—	○
		16.5	Encoder initial communication - Transmission data error 1	DB	—	—	○
		16.6	Encoder initial communication - Transmission data error 2	DB	—	—	○
		16.7	Encoder initial communication - Transmission data error 3	DB	—	—	○
		16.8	Encoder initial communication - Incompatible encoder *6	DB	—	—	○
		16.A	Encoder initial communication - Process error 1	DB	—	—	○
		16.B	Encoder initial communication - Process error 2	DB	—	—	○
		16.C	Encoder initial communication - Process error 3	DB	—	—	○
		16.D	Encoder initial communication - Process error 4	DB	—	—	○
		16.E	Encoder initial communication - Process error 5	DB	—	—	○
		16.F	Encoder initial communication - Process error 6	DB	—	—	○

No.	Name	Detail No.	Detail name	Stop method *2*3	Alarm deactivation		
					Alarm reset	CPU reset	Cycling the power
17	Board error	17.1	Board error 1	DB	—	—	○
		17.3	Board error 2	DB	—	—	○
		17.4	Board error 3	DB	—	—	○
		17.5	Board error 4	DB	—	—	○
		17.6	Board error 5	DB	—	—	○
		17.7	Board error 7	DB	—	—	○
		17.8	Board error 6 *6	EDB	—	—	○
		17.9	Board error 8	DB	—	—	○
19	Memory error 3 (Flash-ROM)	19.1	Flash-ROM error 1	DB	—	—	○
		19.2	Flash-ROM error 2	DB	—	—	○
		19.3	Flash-ROM error 3	DB	—	—	○
1A	Servo motor combination error	1A.1	Servo motor combination error 1	DB	—	—	○
		1A.2	Servo motor control mode combination error	DB	—	—	○
		1A.4	Servo motor combination error 2	DB	—	—	○
1B	Converter error	1B.1	Converter unit error	DB	—	—	○
1E	Encoder initial communication error 2	1E.1	Encoder malfunction	DB	—	—	○
		1E.2	Load-side encoder malfunction	DB	—	—	○
1F	Encoder initial communication error 3	1F.1	Incompatible encoder	DB	—	—	○
		1F.2	Incompatible load-side encoder	DB	—	—	○
20	Encoder normal communication error 1	20.1	Encoder normal communication - Receive data error 1	EDB	—	—	○
		20.2	Encoder normal communication - Receive data error 2	EDB	—	—	○
		20.3	Encoder normal communication - Receive data error 3	EDB	—	—	○
		20.5	Encoder normal communication - Transmission data error 1	EDB	—	—	○
		20.6	Encoder normal communication - Transmission data error 2	EDB	—	—	○
		20.7	Encoder normal communication - Transmission data error 3	EDB	—	—	○
		20.9	Encoder normal communication - Receive data error 4	EDB	—	—	○
		20.A	Encoder normal communication - Receive data error 5	EDB	—	—	○
21	Encoder normal communication error 2	21.1	Encoder data error 1	EDB	—	—	○
		21.2	Encoder data update error	EDB	—	—	○
		21.3	Encoder data waveform error	EDB	—	—	○
		21.4	Encoder non-signal error	EDB	—	—	○
		21.5	Encoder hardware error 1	EDB	—	—	○
		21.6	Encoder hardware error 2	EDB	—	—	○
		21.9	Encoder data error 2	EDB	—	—	○
24	Main circuit error	24.1	Ground fault detected by hardware detection circuit	DB	—	—	○
		24.2	Ground fault detected by software detection function	DB	○	○	○
25	Absolute position erased	25.1	Servo motor encoder - Absolute position erased	DB	—	—	○
		25.2	Scale measurement encoder - Absolute position erased	DB	—	—	○

No.	Name	Detail No.	Detail name	Stop method *2*3	Alarm deactivation		
					Alarm reset	CPU reset	Cycling the power
27	Initial magnetic pole detection error	27.1	Initial magnetic pole detection - Abnormal termination	DB	○	—	○
		27.2	Initial magnetic pole detection - Time out error	DB	○	—	○
		27.3	Initial magnetic pole detection - Limit switch error	DB	○	—	○
		27.4	Initial magnetic pole detection - Estimated error	DB	○	—	○
		27.5	Initial magnetic pole detection - Speed deviation error	DB	○	—	○
		27.6	Initial magnetic pole detection - Position deviation error	DB	○	—	○
		27.7	Initial magnetic pole detection - Current error	DB	○	—	○
28	Linear encoder error 2	28.1	Linear encoder - Environment error	EDB	—	—	○
2A	Linear encoder error 1	2A.1	Linear encoder error 1-1	EDB	—	—	○
		2A.2	Linear encoder error 1-2	EDB	—	—	○
		2A.3	Linear encoder error 1-3	EDB	—	—	○
		2A.4	Linear encoder error 1-4	EDB	—	—	○
		2A.5	Linear encoder error 1-5	EDB	—	—	○
		2A.6	Linear encoder error 1-6	EDB	—	—	○
		2A.7	Linear encoder error 1-7	EDB	—	—	○
		2A.8	Linear encoder error 1-8	EDB	—	—	○
2B	Encoder counter error	2B.1	Encoder counter error 1	EDB	—	—	○
		2B.2	Encoder counter error 2	EDB	—	—	○
30	Regenerative error	30.1	Regeneration heat error	DB	○*1	○*1	○*1
		30.2	Regeneration signal error	DB	○*1	○*1	○*1
		30.3	Regeneration feedback signal error	DB	○*1	○*1	○*1
31	Overspeed	31.1	Abnormal motor speed	SD	○	○	○
32	Overcurrent	32.1	Overcurrent detected at hardware detection circuit (during operation)	DB	—	—	○
		32.2	Overcurrent detected at software detection function (during operation)	DB	○	○	○
		32.3	Overcurrent detected at hardware detection circuit (during a stop)	DB	—	—	○
		32.4	Overcurrent detected at software detection function (during a stop)	DB	○	○	○
33	Overvoltage	33.1	Main circuit voltage error	EDB	○	○	○
34	SSCNET receive error 1	34.1	SSCNET receive data error	SD ⁸	○	○*5	○
		34.2	SSCNET connector connection error	SD ⁸	○	○	○
		34.3	SSCNET communication data error	SD ⁸	○	○	○
		34.4	Hardware error signal detection	SD ⁸	○	○	○
		34.5	SSCNET receive data error (safety observation function)	SD ⁸	○	○	○
		34.6	SSCNET communication data error (safety observation function)	SD ⁸	○	○	○
35	Command frequency error	35.1	Command frequency error	SD	○	○	○
36	SSCNET receive error 2	36.1	Continuous communication data error	SD ⁸	○	○	○
		36.2	Continuous communication data error (safety observation function)	SD ⁸	○	○	○
37	Parameter error	37.1	Parameter setting range error	DB	—	○	○
		37.2	Parameter combination error	DB	—	○	○
		37.3	Point table setting error	DB	—	—	○
39	Program error	39.1	Program error	DB	—	—	○
		39.2	Instruction argument external error	DB	—	—	○
		39.3	Register No. error	DB	—	—	○
		39.4	Non-correspondence instruction error	DB	—	—	○

No.	Name	Detail No.	Detail name	Stop method *2*3	Alarm deactivation		
					Alarm reset	CPU reset	Cycling the power
3A	Inrush current suppression circuit error	3A.1	Inrush current suppression circuit error	EDB	—	—	○
3D	Parameter setting error for driver communication	3D.1	Parameter combination error for driver communication on slave	DB	—	—	○
		3D.2	Parameter combination error for driver communication on master	DB	—	—	○
3E	Operation mode error	3E.1	Operation mode error	DB	—	○	○
		3E.6	Operation mode switch error	DB	—	—	○
		3E.8	MR-D30 combination error	DB	—	○	○
42	Servo control error (for linear servo motor and direct drive motor)	42.1	Servo control error by position deviation	EDB	*4	*4	○
		42.2	Servo control error by speed deviation	EDB	*4	*4	○
		42.3	Servo control error by torque/thrust deviation	EDB	*4	*4	○
	Fully closed loop control error (for fully closed loop control)	42.8	Fully closed loop control error by position deviation	EDB	*4	*4	○
		42.9	Fully closed loop control error by speed deviation	EDB	*4	*4	○
		42.A	Fully closed loop control error by position deviation during command stop	EDB	*4	*4	○
45	Main circuit device overheat	45.1	Main circuit device overheat error 1	SD	○*1	○*1	○*1
		45.2	Main circuit device overheat error 2	SD	○*1	○*1	○*1
46	Servo motor overheat	46.1	Abnormal temperature of servo motor 1	SD	○*1	○*1	○*1
		46.2	Abnormal temperature of servo motor 2	SD	○*1	○*1	○*1
		46.3	Thermistor disconnected error	SD	○*1	○*1	○*1
		46.4	Thermistor circuit error	SD	○*1	○*1	○*1
		46.5	Abnormal temperature of servo motor 3	DB	○*1	○*1	○*1
		46.6	Abnormal temperature of servo motor 4	DB	○*1	○*1	○*1
47	Cooling fan error	47.1	Cooling fan stop error	SD	—	—	○
		47.2	Cooling fan speed reduction error	SD	—	—	○
50	Overload 1	50.1	Thermal overload error 1 during operation	SD	○*1	○*1	○*1
		50.2	Thermal overload error 2 during operation	SD	○*1	○*1	○*1
		50.3	Thermal overload error 4 during operation	SD	○*1	○*1	○*1
		50.4	Thermal overload error 1 during a stop	SD	○*1	○*1	○*1
		50.5	Thermal overload error 2 during a stop	SD	○*1	○*1	○*1
		50.6	Thermal overload error 4 during a stop	SD	○*1	○*1	○*1
51	Overload 2	51.1	Thermal overload error 3 during operation	DB	○*1	○*1	○*1
		51.2	Thermal overload error 3 during a stop	DB	○*1	○*1	○*1
52	Error excessive	52.1	Excess droop pulse 1	SD	○	○	○
		52.3	Excess droop pulse 2	SD	○	○	○
		52.4	Error excessive during 0 torque limit	SD	○	○	○
		52.5	Excess droop pulse 3	EDB	○	○	○
		52.6	Excess droop pulse during servo-off	SD	○	○	○
54	Oscillation detection	54.1	Oscillation detection error	EDB	○	○	○
56	Forced stop error	56.2	Over speed during forced stop	EDB	○	○	○
		56.3	Estimated distance over during forced stop	EDB	○	○	○
		56.4	Forced stop start error	EDB	○	○	○
61	Operation error	61.1	Point table setting range error	DB	○	—	○
63	STO timing error	63.1	STO1 off	DB	○	○	○
		63.2	STO2 off	DB	○	○	○
		63.5	STO by functional safety unit	DB	○	○	○
64	Functional safety unit setting error	64.1	STO input error	DB	—	—	○
		64.2	Compatibility mode setting error	DB	—	—	○
		64.3	Operation mode setting error	DB	—	—	○

No.	Name	Detail No.	Detail name	Stop method *2*3	Alarm deactivation		
					Alarm reset	CPU reset	Cycling the power
65	Functional safety unit connection error	65.1	Functional safety unit communication error 1	SD	—	—	○
		65.2	Functional safety unit communication error 2	SD	—	—	○
		65.3	Functional safety unit communication error 3	SD	—	—	○
		65.4	Functional safety unit communication error 4	SD	—	—	○
		65.5	Functional safety unit communication error 5	SD	—	—	○
		65.6	Functional safety unit communication error 6	SD	—	—	○
		65.7	Functional safety unit communication error 7	SD	—	—	○
		65.8	Functional safety unit shut-off signal error 1	DB	—	—	○
		65.9	Functional safety unit shut-off signal error 2	DB	—	—	○
66	Encoder initial communication error (safety observation function)	66.1	Encoder initial communication - Receive data error 1 (safety observation function)	DB	—	—	○
		66.2	Encoder initial communication - Receive data error 2 (safety observation function)	DB	—	—	○
		66.3	Encoder initial communication - Receive data error 3 (safety observation function)	DB	—	—	○
		66.7	Encoder initial communication - Transmission data error 1 (safety observation function)	DB	—	—	○
		66.9	Encoder initial communication - Process error 1 (safety observation function)	DB	—	—	○
67	Encoder normal communication error 1 (safety observation function)	67.1	Encoder normal communication - Receive data error 1 (safety observation function)	DB	—	—	○
		67.2	Encoder normal communication - Receive data error 2 (safety observation function)	DB	—	—	○
		67.3	Encoder normal communication - Receive data error 3 (safety observation function)	DB	—	—	○
		67.4	Encoder normal communication - Receive data error 4 (safety observation function)	DB	—	—	○
		67.7	Encoder normal communication - Transmission data error 1 (safety observation function)	DB	—	—	○
68	STO diagnosis error	68.1	Mismatched STO signal error	DB	—	—	○
69	Command error	69.1	Forward rotation-side software limit detection - Command excess error	SD	○	○	○
		69.2	Reverse rotation-side software limit detection - Command excess error	SD	○	○	○
		69.3	Forward rotation stroke end detection - Command excess error	SD	○	○	○
		69.4	Reverse rotation stroke end detection - Command excess error	SD	○	○	○
		69.5	Upper stroke limit detection - Command excess error	SD	○	○	○
		69.6	Lower stroke limit detection - Command excess error	SD	○	○	○

No.	Name	Detail No.	Detail name	Stop method *2*3	Alarm deactivation		
					Alarm reset	CPU reset	Cycling the power
70	Load-side encoder initial communication error 1	70.1	Load-side encoder initial communication - Receive data error 1	DB	—	—	○
		70.2	Load-side encoder initial communication - Receive data error 2	DB	—	—	○
		70.3	Load-side encoder initial communication - Receive data error 3	DB	—	—	○
		70.4	Load-side encoder initial communication - Encoder malfunction*6	DB	—	—	○
		70.5	Load-side encoder initial communication - Transmission data error 1	DB	—	—	○
		70.6	Load-side encoder initial communication - Transmission data error 2	DB	—	—	○
		70.7	Load-side encoder initial communication - Transmission data error 3	DB	—	—	○
		70.8	Load-side encoder initial communication - Incompatible encoder*6	DB	—	—	○
		70.A	Load-side encoder initial communication - Process error 1	DB	—	—	○
		70.B	Load-side encoder initial communication - Process error 2	DB	—	—	○
		70.C	Load-side encoder initial communication - Process error 3	DB	—	—	○
		70.D	Load-side encoder initial communication - Process error 4	DB	—	—	○
		70.E	Load-side encoder initial communication - Process error 5	DB	—	—	○
		70.F	Load-side encoder initial communication - Process error 6	DB	—	—	○
71	Load-side encoder normal communication error 1	71.1	Load-side encoder normal communication - Receive data error 1	EDB	—	—	○
		71.2	Load-side encoder normal communication - Receive data error 2	EDB	—	—	○
		71.3	Load-side encoder normal communication - Receive data error 3	EDB	—	—	○
		71.5	Load-side encoder normal communication - Transmission data error 1	EDB	—	—	○
		71.6	Load-side encoder normal communication - Transmission data error 2	EDB	—	—	○
		71.7	Load-side encoder normal communication - Transmission data error 3	EDB	—	—	○
		71.9	Load-side encoder normal communication - Receive data error 4	EDB	—	—	○
		71.A	Load-side encoder normal communication - Receive data error 5	EDB	—	—	○
		72	Load-side encoder normal communication error 2	72.1	Load-side encoder data error 1	EDB	—
72.2	Load-side encoder data update error			EDB	—	—	○
72.3	Load-side encoder data waveform error			EDB	—	—	○
72.4	Load-side encoder non-signal error			EDB	—	—	○
72.5	Load-side encoder hardware error 1			EDB	—	—	○
72.6	Load-side encoder hardware error 2			EDB	—	—	○
72.9	Load-side encoder data error 2			EDB	—	—	○
74	Option card error 1	74.1	Option card error 1	DB	—	—	○
		74.2	Option card error 2	DB	—	—	○
		74.3	Option card error 3	DB	—	—	○
		74.4	Option card error 4	DB	—	—	○
		74.5	Option card error 5	DB	—	—	○

No.	Name	Detail No.	Detail name	Stop method *2*3	Alarm deactivation		
					Alarm reset	CPU reset	Cycling the power
75	Option card error 2	75.3	Option card connection error	EDB	—	—	○
		75.4	Option card disconnected	DB	—	—	○
79	Functional safety unit diagnosis error	79.1	Functional safety unit power voltage error	DB	○ ^{*7}	—	○
		79.2	Functional safety unit internal error	DB	—	—	○
		79.3	Abnormal temperature of functional safety unit	SD	○ ^{*7}	—	○
		79.4	Servo amplifier error	SD	—	—	○
		79.5	Input device error	SD	—	—	○
		79.6	Output device error	SD	—	—	○
		79.7	Mismatched input signal error	SD	—	—	○
		79.8	Position feedback fixing error	DB	—	—	○
7A	Parameter setting error (safety observation function)	7A.1	Parameter verification error (safety observation function)	DB	—	—	○
		7A.2	Parameter setting range error (safety observation function)	DB	—	—	○
		7A.3	Parameter combination error (safety observation function)	DB	—	—	○
		7A.4	Functional safety unit combination error (safety observation function)	DB	—	—	○
7B	Encoder diagnosis error (safety observation function)	7B.1	Encoder diagnosis error 1 (safety observation function)	DB	—	—	○
		7B.2	Encoder diagnosis error 2 (safety observation function)	DB	—	—	○
		7B.3	Encoder diagnosis error 3 (safety observation function)	DB	—	—	○
		7B.4	Encoder diagnosis error 4 (safety observation function)	DB	—	—	○
7C	Functional safety unit communication diagnosis error (safety observation function)	7C.1	Functional safety unit communication setting error (safety observation function)	SD	○ ^{*7}	○	○
		7C.2	Functional safety unit communication data error (safety observation function)	SD	○ ^{*7}	○	○
7D	Safety observation error	7D.1	Stop observation error	DB	○ ^{*3}	—	○
		7D.2	Speed observation error	DB	○ ^{*7}	—	○
82	Master-slave operation error 1	82.1	Master-slave operation error 1	EDB	○	○	○
84	Network module initialization error	84.1	Network module undetected error	DB	—	—	○
		84.2	Network module initialization error 1	DB	—	—	○
		84.3	Network module initialization error 2	DB	—	—	○
85	Network module error	85.1	Network module error 1	SD	—	—	○
		85.2	Network module error 2	SD	—	—	○
		85.3	Network module error 3	SD	—	—	○
86	Network communication error	86.1	Network communication error 1	SD	○	—	○
		86.2	Network communication error 2	SD	○	—	○
		86.3	Network communication error 3	SD	○	—	○
		86.4	Network communication error 4	SD	○	—	○
8A	USB communication time-out error/serial communication time-out error/Modbus RTU communication time-out error	8A.1	USB communication time-out error/serial communication time-out error	SD	○	○	○
		8A.2	Modbus RTU communication time-out error	SD	○	○	○

No.	Name	Detail No.	Detail name	Stop method *2*3	Alarm deactivation		
					Alarm reset	CPU reset	Cycling the power
8D	CC-Link IE communication error	8D.1	CC-Link IE communication error 1	SD	○	—	○
		8D.2	CC-Link IE communication error 2	SD	○	—	○
		8D.3	Master station setting error 1	DB	○	—	○
		8D.5	Master station setting error 2	DB	—	—	○
		8D.6	CC-Link IE communication error 3	SD	○	—	○
		8D.7	CC-Link IE communication error 4	SD	○	—	○
		8D.8	CC-Link IE communication error 5	SD	○	—	○
		8D.9	Synchronization error 1	SD	—	—	○
		8D.A	Synchronization error 2	SD	—	—	○
8E	USB communication error/ serial communication error/ Modbus RTU communication error	8E.1	USB communication receive error/serial communication receive error	SD	○	○	○
		8E.2	USB communication checksum error/serial communication checksum error	SD	○	○	○
		8E.3	USB communication character error/serial communication character error	SD	○	○	○
		8E.4	USB communication command error/serial communication command error	SD	○	○	○
		8E.5	USB communication data number error/serial communication data number error	SD	○	○	○
		8E.6	Modbus RTU communication receive error	SD	○	○	○
		8E.7	Modbus RTU communication message frame error	SD	○	○	○
		8E.8	Modbus RTU communication CRC error	SD	○	○	○
88888	Watchdog	8888_	Watchdog	DB	—	—	○

*1 Leave for about 30 minutes of cooling time after removing the cause of occurrence.

*2 The following shows three stop methods of DB, EDB, and SD.

DB: Stops with dynamic brake. (Coasts for the servo amplifier without dynamic brake.)

Coasts for MR-J4-03A6(-RJ) and MR-J4W2-0303B6. Note that EDB is applied when an alarm below occurs; [AL. 30.1], [AL. 32.2], [AL. 32.4], [AL. 51.1], [AL. 51.2], [AL. 888]

EDB: Electronic dynamic brake stop (available with specified servo motors)

Refer to the following table for the specified servo motors. The stop method for other than the specified servo motors will be DB.

Series	Servo motor
HG-KR	HG-KR053/HG-KR13/HG-KR23/HG-KR43
HG-MR	HG-MR053/HG-MR13/HG-MR23/HG-MR43
HG-SR	HG-SR51/HG-SR52
HG-AK	HG-AK0136/HG-AK0236/HG-AK0336

SD: Forced stop deceleration

*3 This is applicable when [Pr. PA04] is set to the initial value. The stop system of SD can be changed to DB using [Pr. PA04].

*4 The alarm can be canceled by setting as follows:

For the fully closed loop control: set [Pr. PE03] to "1 ___".

When a linear servo motor or direct drive motor is used: set [Pr. PL04] to "1 ___".

*5 In some controller communication status, the alarm factor may not be removed.

*6 This alarm will occur only in the J3 compatibility mode.

*7 Reset this while all the safety observation functions are stopped.

*8 In the parallel drive system, the stop method is DB.

8.3 Warning list

No.	Name	Detail No.	Detail name	Stop method *2*3
90	Home position return incomplete warning	90.1	Home position return incomplete	—
		90.2	Home position return abnormal termination	—
		90.5	Z-phase unpassed	—
91	Servo amplifier overheat warning*1	91.1	Main circuit device overheat warning	—
92	Battery cable disconnection warning	92.1	Encoder battery cable disconnection warning	—
		92.3	Battery degradation	—
93	ABS data transfer warning	93.1	Magnetic pole detection incomplete warning at ABS data transfer request	—
95	STO warning	95.1	STO1 off detection	DB
		95.2	STO2 off detection	DB
		95.3	STO warning 1 (safety observation function)	DB
		95.4	STO warning 2 (safety observation function)	DB
		95.5	STO warning 3 (safety observation function)	DB
96	Home position setting warning	96.1	In-position warning at home positioning	—
		96.2	Command input warning at home positioning	—
		96.3	Servo off warning at home positioning	—
		96.4	Magnetic pole detection incomplete warning at home positioning	—
97	Positioning specification warning	97.1	Program operation disabled warning	—
		97.2	Next station position warning	—
98	Software limit warning	98.1	Forward rotation-side software stroke limit reached	—
		98.2	Reverse rotation-side software stroke limit reached	—
99	Stroke limit warning	99.1	Forward rotation stroke end off	*4 *5
		99.2	Reverse rotation stroke end off	*4 *5
		99.4	Upper stroke limit off	*5
		99.5	Lower stroke limit off	*5
9A	Optional unit input data error warning	9A.1	Optional unit input data sign error	—
		9A.2	Optional unit BCD input data error	—
9B	Error excessive warning	9B.1	Excess droop pulse 1 warning	—
		9B.3	Excess droop pulse 2 warning	—
		9B.4	Error excessive warning during 0 torque limit	—
9C	Converter error	9C.1	Converter unit error	—
9D	CC-Link IE warning 1	9D.1	Station number switch change warning	—
		9D.2	Master station setting warning	—
		9D.3	Overlapping station number warning	—
		9D.4	Mismatched station number warning	—
9E	CC-Link IE warning 2	9E.1	CC-Link IE communication warning	—
9F	Battery warning	9F.1	Low battery	—
		9F.2	Battery degradation warning	—
E0	Excessive regeneration warning	E0.1	Excessive regeneration warning	—
E1	Overload warning 1	E1.1	Thermal overload warning 1 during operation	—
		E1.2	Thermal overload warning 2 during operation	—
		E1.3	Thermal overload warning 3 during operation	—
		E1.4	Thermal overload warning 4 during operation	—
		E1.5	Thermal overload error 1 during a stop	—
		E1.6	Thermal overload error 2 during a stop	—
		E1.7	Thermal overload error 3 during a stop	—
		E1.8	Thermal overload error 4 during a stop	—
E2	Servo motor overheat warning	E2.1	Servo motor temperature warning	—

No.	Name	Detail No.	Detail name	Stop method *2*3
E3	Absolute position counter warning	E3.1	Multi-revolution counter travel distance excess warning	—
		E3.2	Absolute position counter warning	—
		E3.4	Absolute positioning counter EEPROM writing frequency warning	—
		E3.5	Encoder absolute positioning counter warning	—
E4	Parameter warning	E4.1	Parameter setting range error warning	—
E5	ABS time-out warning	E5.1	Time-out during ABS data transfer	—
		E5.2	ABSM off during ABS data transfer	—
		E5.3	SON off during ABS data transfer	—
E6	Servo forced stop warning	E6.1	Forced stop warning	SD
		E6.2	SS1 forced stop warning 1 (safety observation function)	SD
		E6.3	SS1 forced stop warning 2 (safety observation function)	SD
E7	Controller forced stop warning	E7.1	Controller forced stop input warning	SD
E8	Cooling fan speed reduction warning	E8.1	Decreased cooling fan speed warning	—
		E8.2	Cooling fan stop	—
E9	Main circuit off warning	E9.1	Servo-on signal on during main circuit off	DB
		E9.2	Bus voltage drop during low speed operation	DB
		E9.3	Ready-on signal on during main circuit off	DB
		E9.4	Converter unit forced stop	DB
EA	ABS servo-on warning	EA.1	ABS servo-on warning	—
EB	The other axis error warning	EB.1	The other axis error warning	DB
EC	Overload warning 2	EC.1	Overload warning 2	—
ED	Output watt excess warning	ED.1	Output watt excess warning	—
F0	Tough drive warning	F0.1	Instantaneous power failure tough drive warning	—
		F0.3	Vibration tough drive warning	—
F2	Drive recorder - Miswriting warning	F2.1	Drive recorder - Area writing time-out warning	—
		F2.2	Drive recorder - Data miswriting warning	—
F3	Oscillation detection warning	F3.1	Oscillation detection warning	—
F4	Positioning warning	F4.4	Target position setting range error warning	—
		F4.6	Acceleration time constant setting range error warning	—
		F4.7	Deceleration time constant setting range error warning	—
		F4.9	Home position return type error warning	—
F5	Simple cam function - Cam data miswriting warning	F5.1	Cam data - Area writing time-out warning	—
		F5.2	Cam data - Area miswriting warning	—
		F5.3	Cam data checksum error	—
F6	Simple cam function - Cam control warning	F6.1	Cam axis one cycle current value restoration failed	—
		F6.2	Cam axis feed current value restoration failed	—
		F6.3	Cam unregistered error	—
		F6.4	Cam control data setting range error	—
		F6.5	Cam No. external error	—
		F6.6	Cam control inactive	—
F7	Machine diagnosis warning	F7.1	Vibration failure prediction warning	—
		F7.2	Friction failure prediction warning	—
		F7.3	Total travel distance failure prediction warning	—

*1 Leave for about 30 minutes of cooling time after removing the cause of occurrence.

*2 The following shows two stop methods of DB and SD.

DB: Stops with dynamic brake. (Coasts for the servo amplifier without dynamic brake.)

Coasts for MR-J4-03A6(-RJ) and MR-J4W2-0303B6.

SD: Forced stop deceleration

*3 This is applicable when [Pr. PA04] is set to the initial value. The stop system of SD can be changed to DB using [Pr. PA04].

*4 For MR-J4-_A_ servo amplifier, quick stop or slow stop can be selected using [Pr. PD30].

*5 For MR-J4-_GF_ servo amplifier, quick stop or slow stop can be selected using [Pr. PD12]. (I/O mode only)

8.4 Troubleshooting at power on

When an error occurs at the power supply of the controller or servo amplifier, improper boot of the servo amplifier might be the cause. Check the display of the servo amplifier, and take actions according to this section.

Display	Description	Cause	Checkpoint	Action
AA	The power of the controller was turned off.	The power of the controller was turned off.	Check the power of the controller.	Switch on the power of the controller.
		An Ethernet cable was disconnected.	"AA" is displayed in the corresponding station and following stations.	Replace the Ethernet cable of the corresponding station.
			Check if the connectors (CN1A, CN1B) are unplugged.	Connect it correctly.
Ab	Initialization communication with the controller has not completed.	An Ethernet cable was disconnected.	"Ab" is displayed in the corresponding station and following stations.	Replace the Ethernet cable of the corresponding station.
		The power of the servo amplifier was switched on when the power of the controller was off.	Check the power of the controller.	Switch on the power of the controller.
		The servo amplifier is malfunctioning.	"Ab" is displayed in the corresponding station and following stations.	Replace the servo amplifier.
		The controller is malfunctioning.	Replace the controller, and then check the repeatability.	Replace the controller.
AC	The synchronous communications by specified cycle could not be made.	The setting of the station No. is incorrect.	Check that a device is not assigned to the same station No.	Set it correctly.
		Station No. does not match with the station No. set to the controller.	Check the controller setting and station No.	Set it correctly.
		The communication cycle does not match.	Check the communication cycle at the controller side.	Set it correctly.
		The servo amplifier parameter setting is incorrect.	Check the following parameter settings. [Pr. PN03] [Pr. PD41]	Set it correctly.
		Data link was established again.	Network configuration was changed.	After checking the network configuration, cycle the power of the servo amplifier.
		The controller setting is incorrect.	Check the controller setting.	Set it correctly.
		The servo amplifier is malfunctioning.	"AC" is displayed in the corresponding station and following stations.	Replace the servo amplifier.
		The controller is malfunctioning.	Replace the controller, and then check the repeatability.	Replace the controller.
		b##.*1 C##.*1 d##.*1	The system has been in the test operation mode.	Test operation mode has been enabled.
off	Operation mode for manufacturer setting is set.			Operation mode for manufacturer setting is enabled.

*1 ## indicates station No.

9 DIMENSIONS

Point 

Only MR-J4-_GF_-RJ is shown for dimensions. MR-J4-_GF_ does not have CN2L, CN7, and CN9 connectors. The dimensions of MR-J4-_GF_ are the same as those of MR-J4-_GF_-RJ except CN2L, CN7, and CN9 connectors.

9.1 Servo amplifier

200 V class

■MR-J4-10GF(-RJ) to MR-J4-60GF(-RJ)

[Unit: mm]

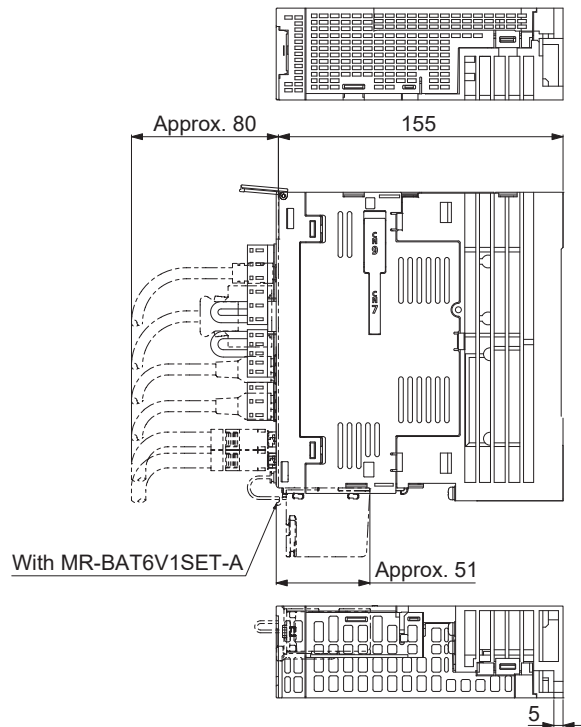
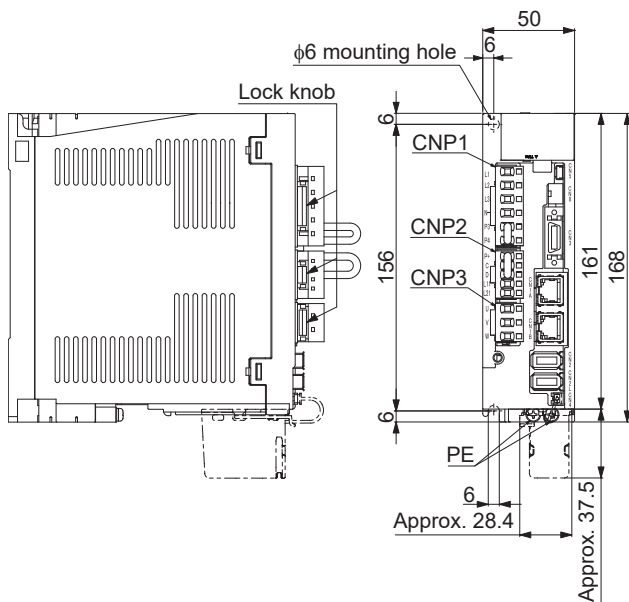

Mass: 1.0 [kg]

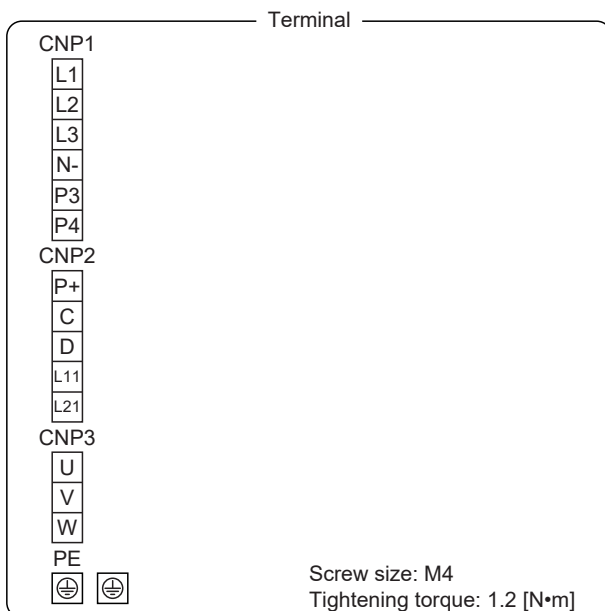

Mounting screw
Screw size: M5
Tightening torque: 3.24 [N•m]

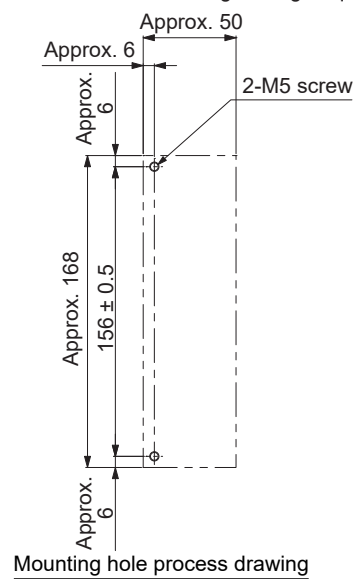

■MR-J4-70GF(-RJ)/MR-J4-100GF(-RJ)

[Unit: mm]

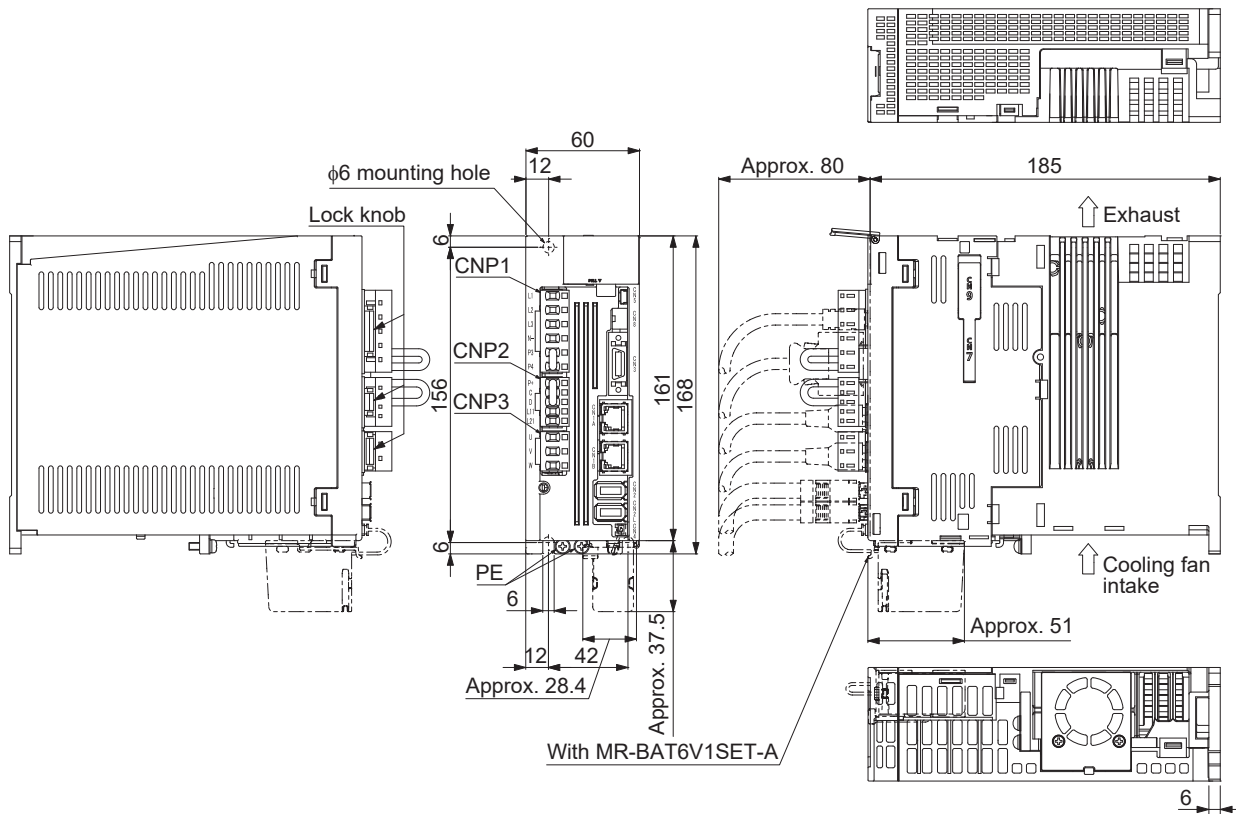

Mass: 1.4 [kg]

Mounting screw
Screw size: M5
Tightening torque: 3.24 [N·m]

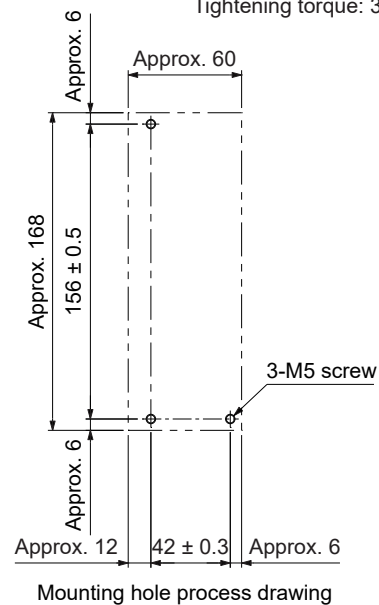
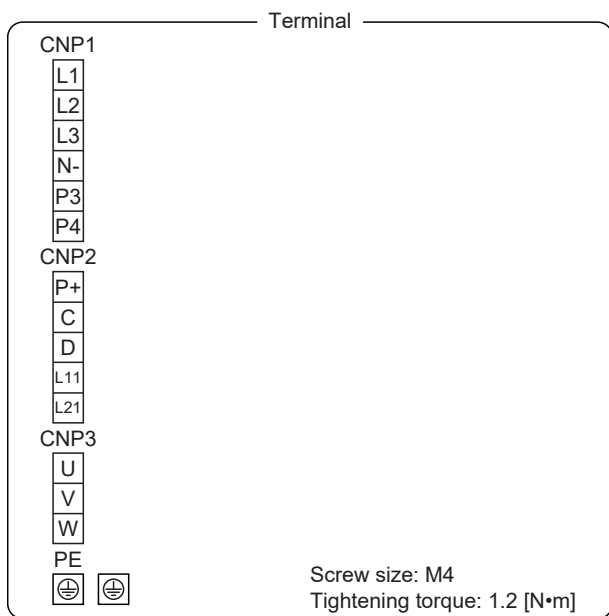

■MR-J4-200GF(-RJ)

[Unit: mm]

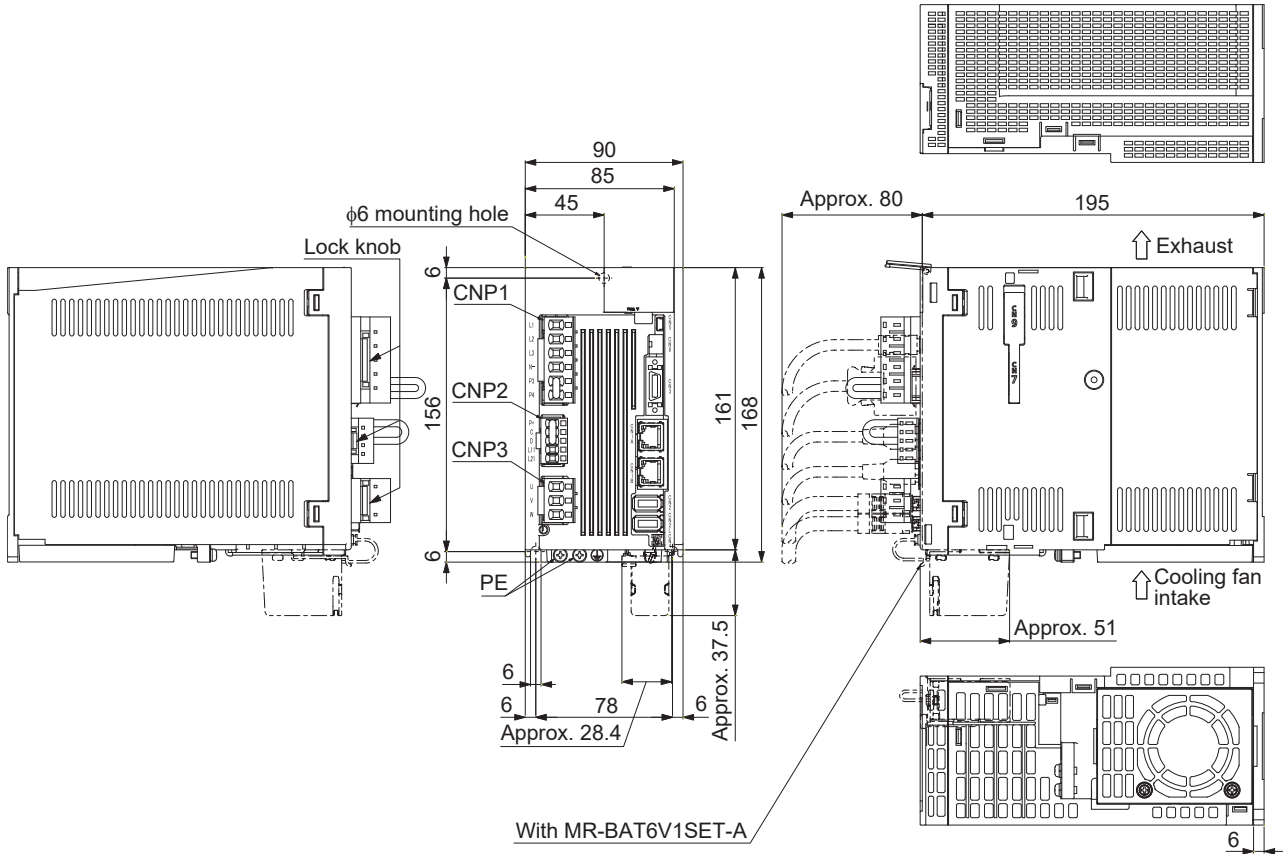

With MR-BAT6V1SET-A

Mass: 2.1 [kg]

Mounting screw
Screw size: M5
Tightening torque: 3.24 [N·m]

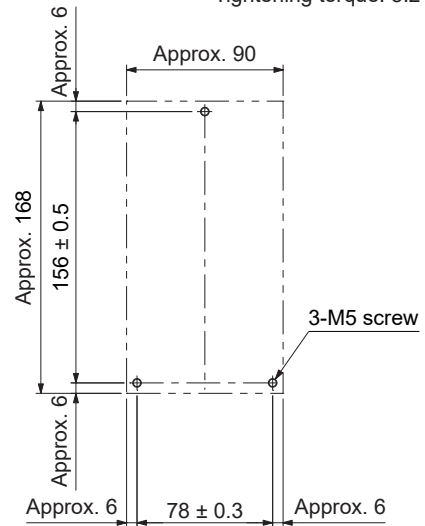
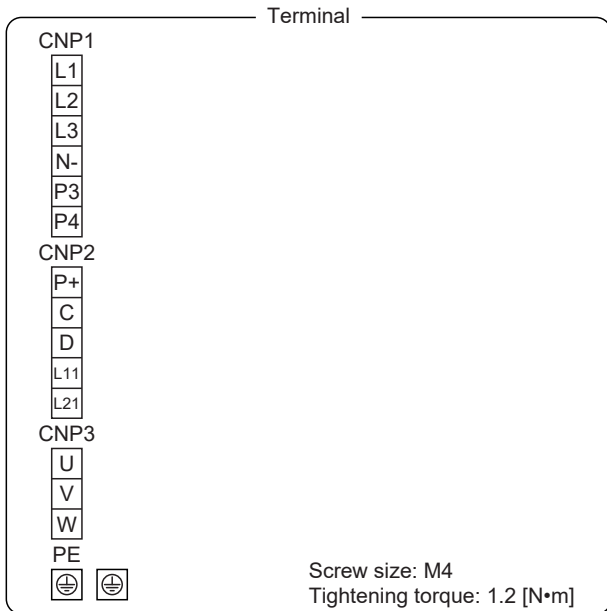

Mounting hole process drawing

MR-J4-500GF(-RJ)

[Unit: mm]

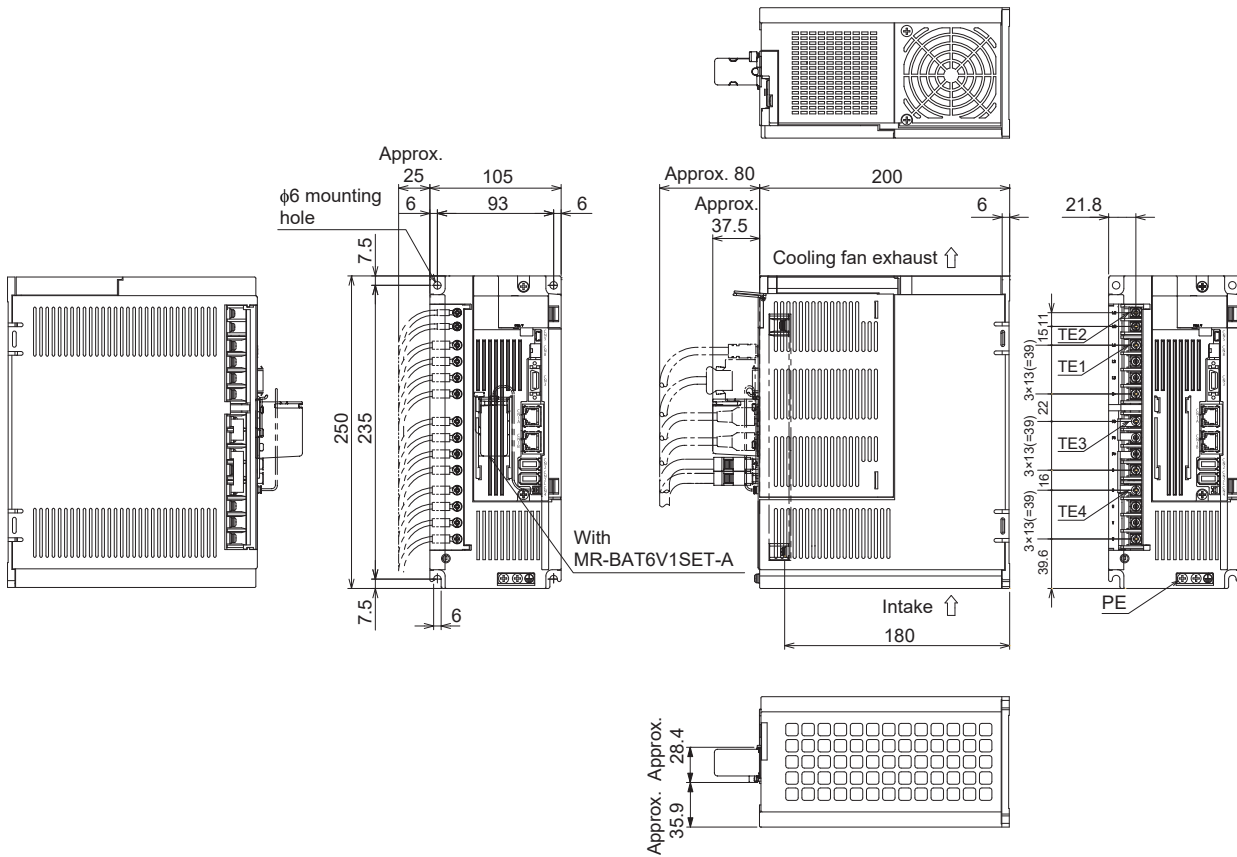

Mass: 4.0 [kg]

Terminal		
TE2	L11 L21	TE2 Screw size: M3.5 Tightening torque: 0.8 [N·m]
TE1	L1 L2 L3 N-	TE1 Screw size: M4 Tightening torque: 1.2 [N·m]
TE3	P3 P4 P+ C	TE3 Screw size: M4 Tightening torque: 1.2 [N·m]
TE4	D U V W	TE4 Screw size: M4 Tightening torque: 1.2 [N·m]
	PE	PE Screw size: M4 Tightening torque: 1.2 [N·m]

Mounting screw
Screw size: M5
Tightening torque: 3.24 [N·m]

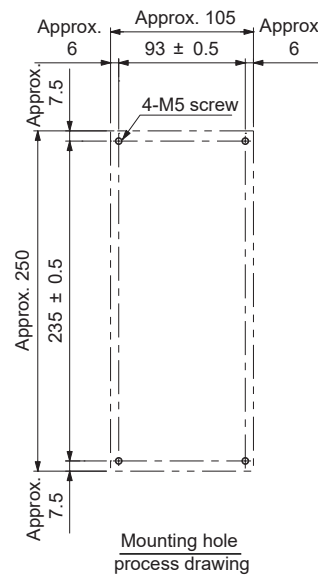

■MR-J4-700GF(-RJ)

[Unit: mm]

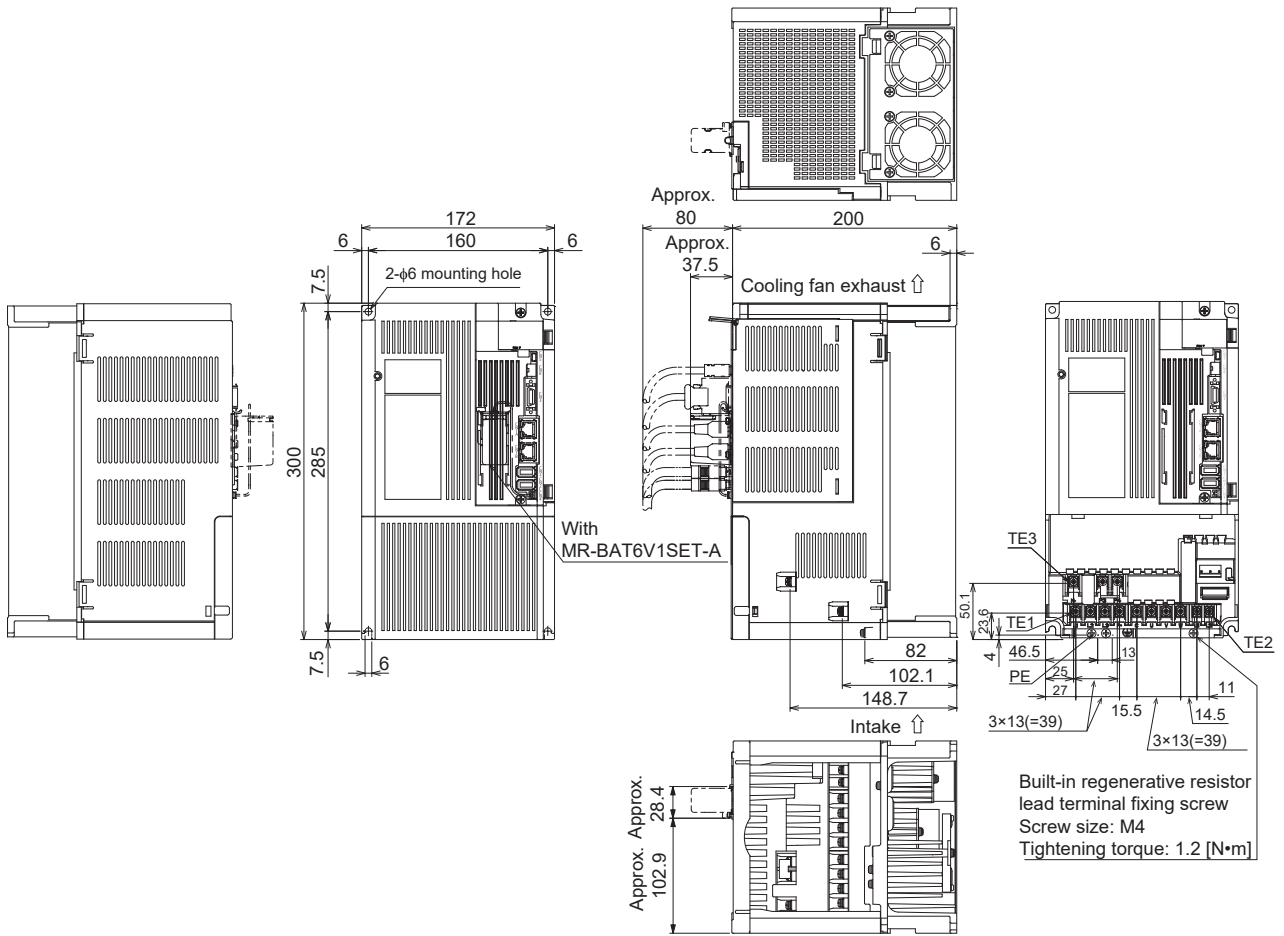

Mass: 6.2 [kg]

Mounting screw
Screw size: M5
Tightening torque: 3.24 [N·m]

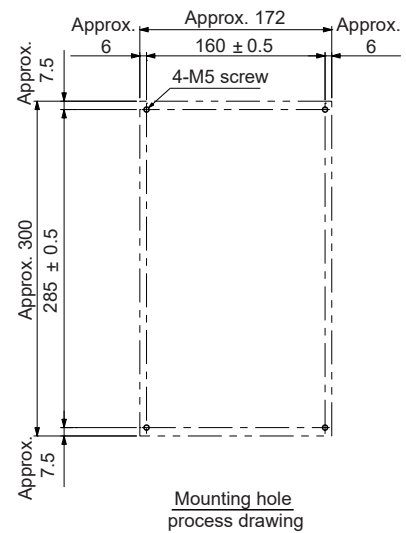
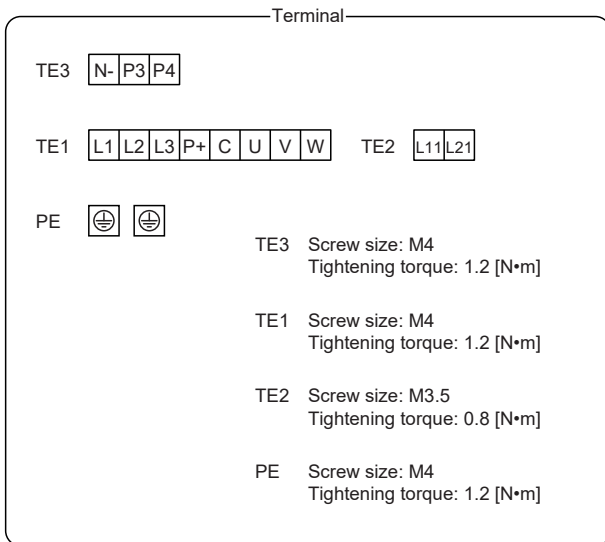

■MR-J4-11KGF(-RJ)/MR-J4-15KGF(-RJ)

[Unit: mm]

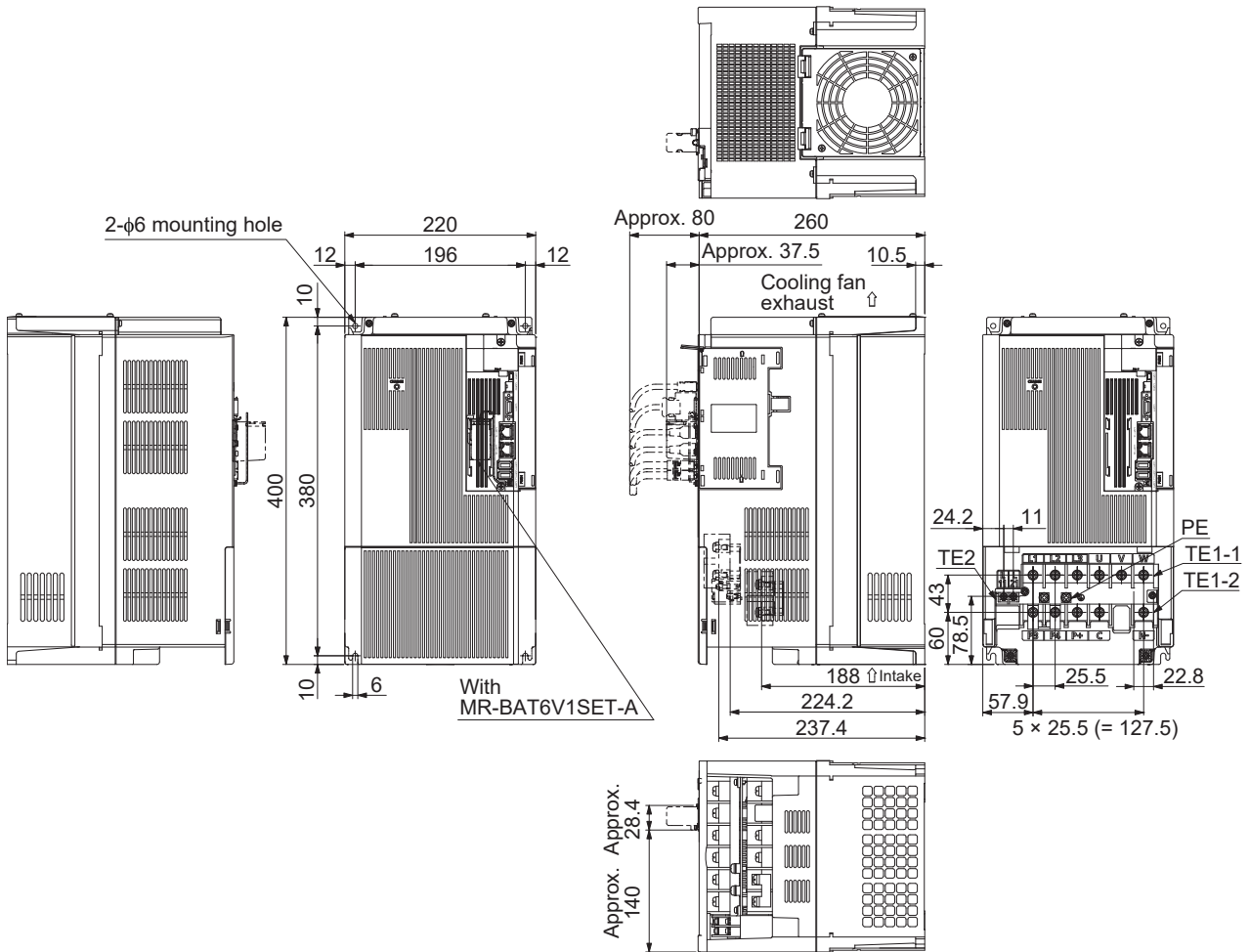

Mass: 13.4 [kg]

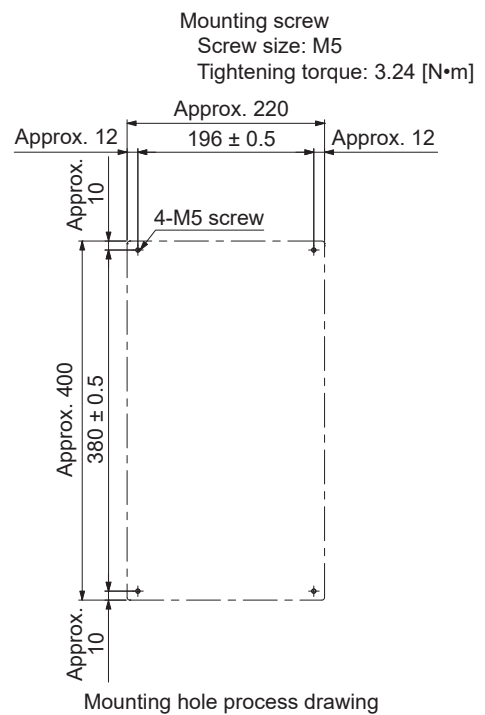
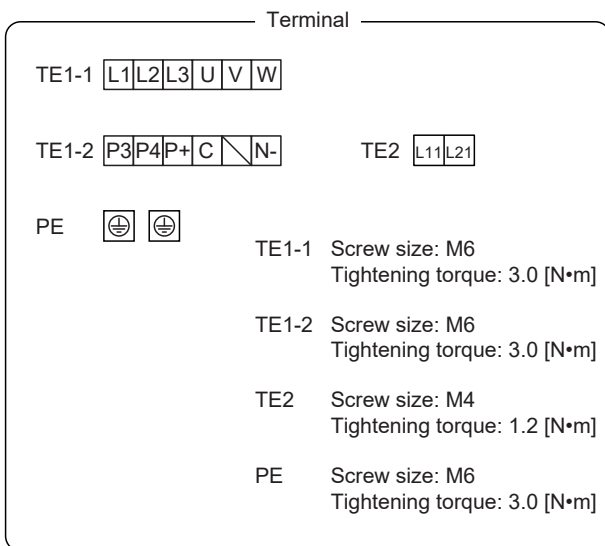

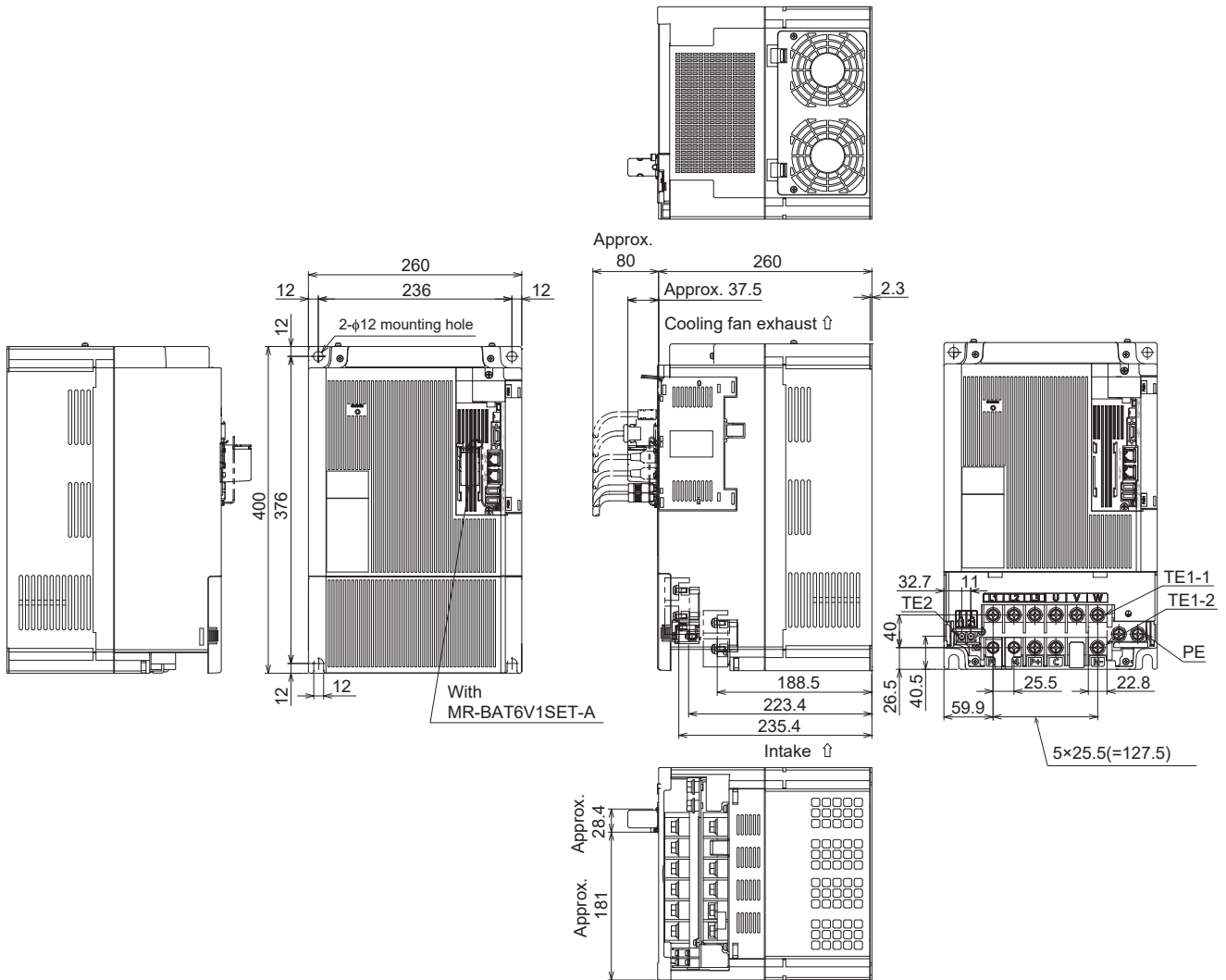

Mass: 18.2 [kg]

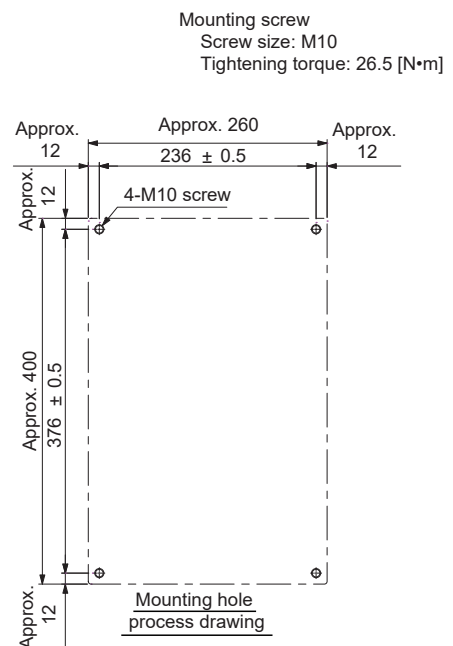
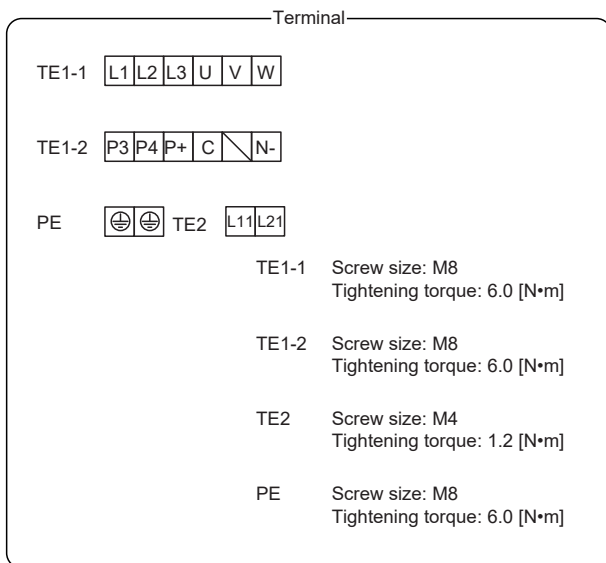

400 V class

■MR-J4-60GF4(-RJ)/MR-J4-100GF4(-RJ)

[Unit: mm]

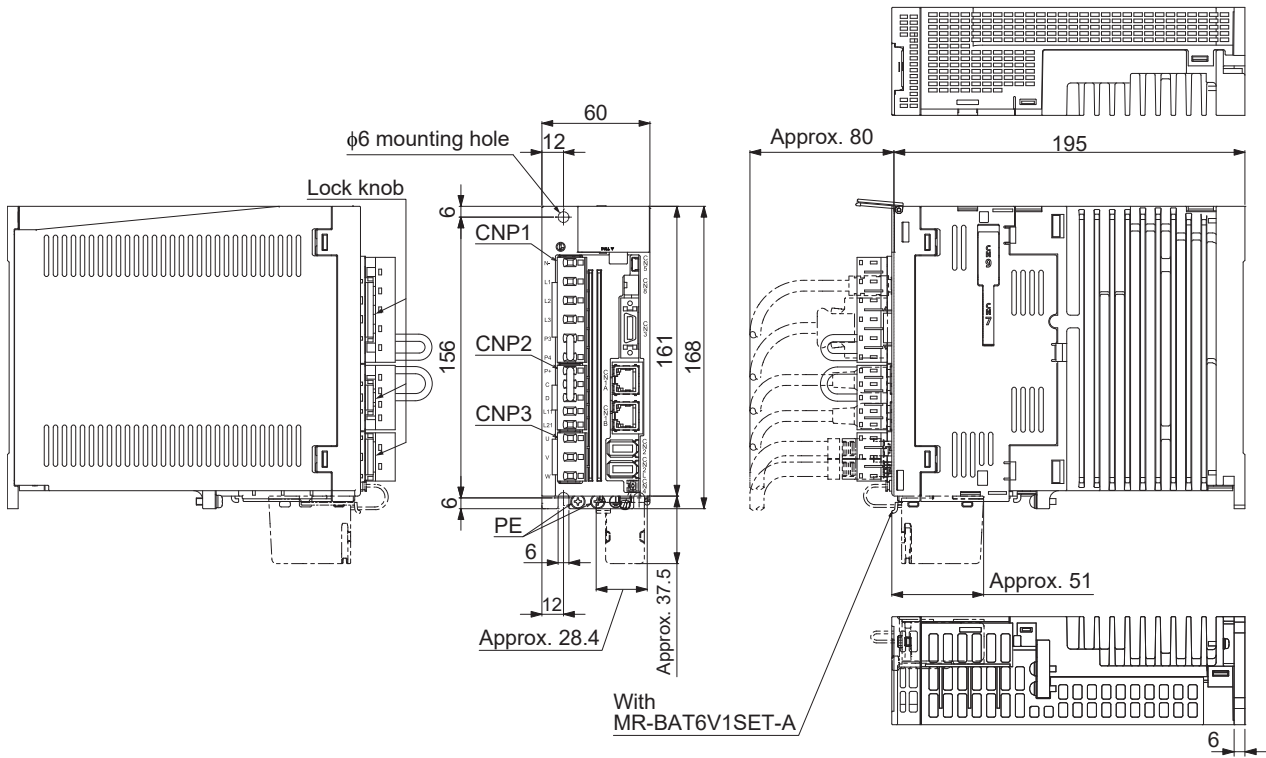

Mass: 1.7 [kg]

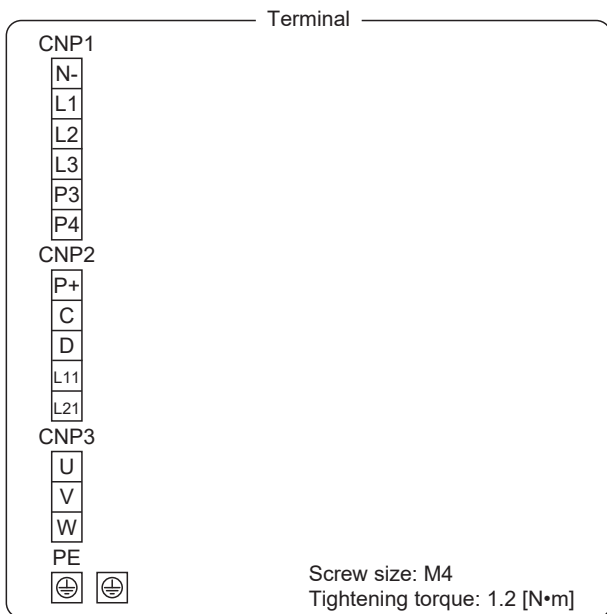

Mounting screw
Screw size: M5
Tightening torque: 3.24 [N•m]

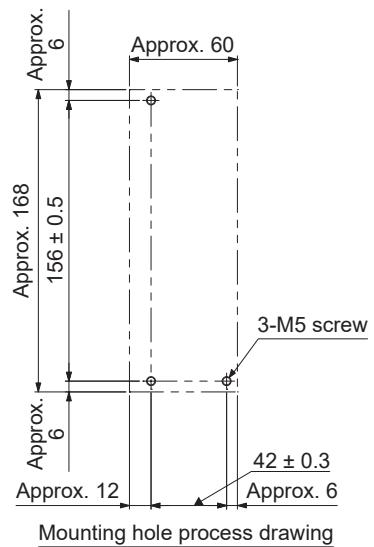

■MR-J4-200GF4(-RJ)

[Unit: mm]

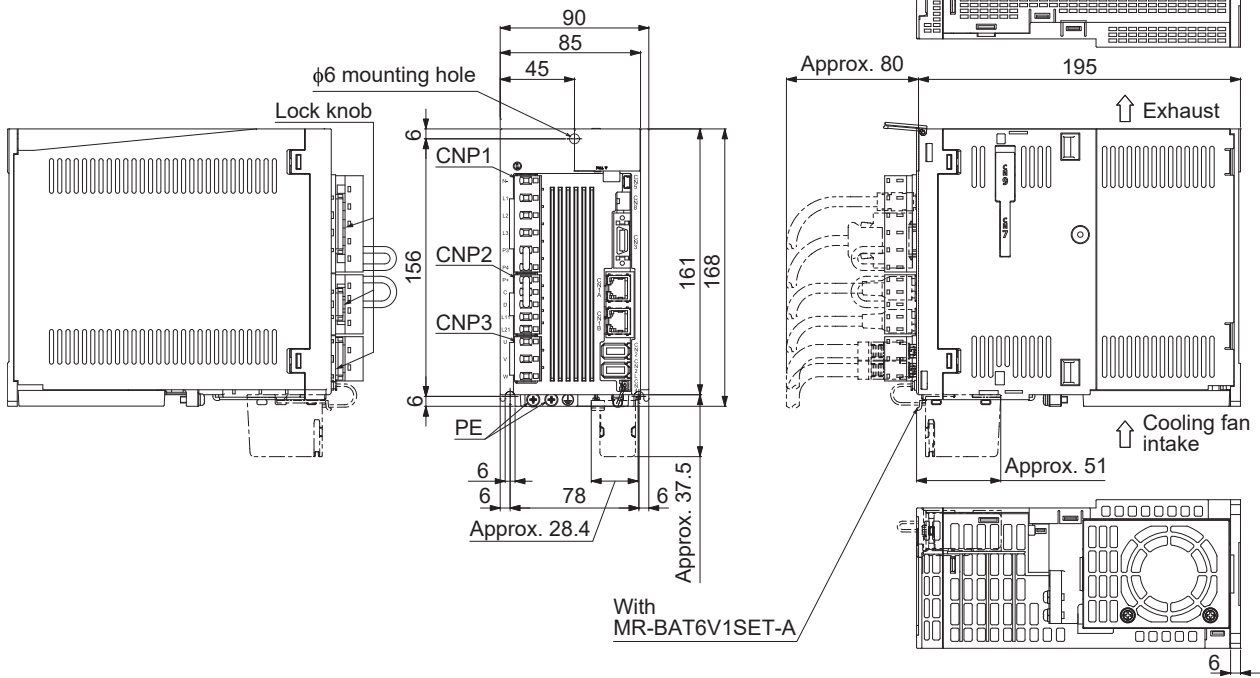

Mass: 2.1 [kg]

Mounting screw
Screw size: M5
Tightening torque: 3.24 [N·m]

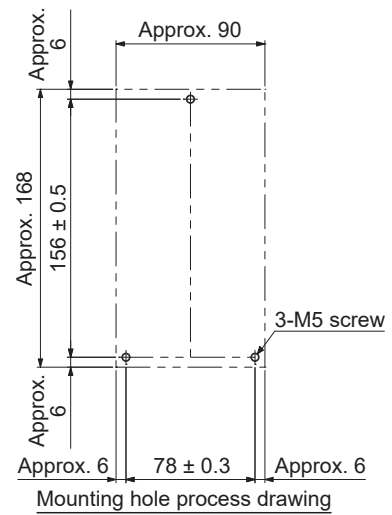
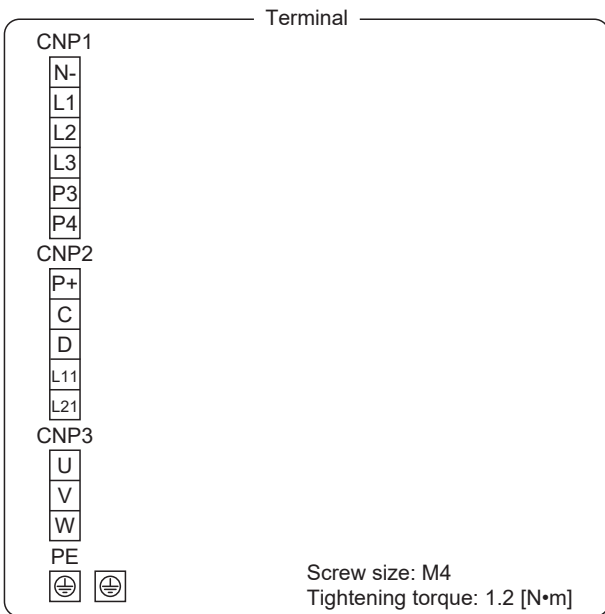

■MR-J4-350GF4(-RJ)

[Unit: mm]

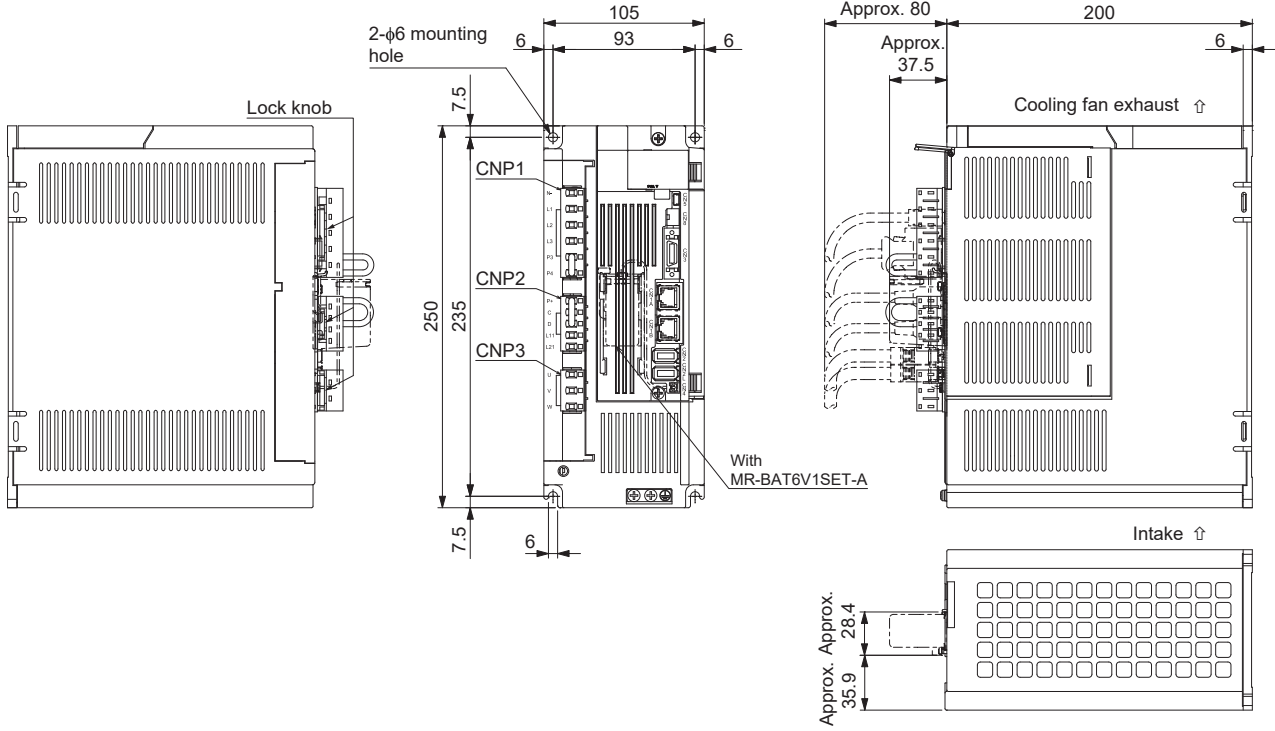

Mass: 3.6 [kg]

Mounting screw
Screw size: M5
Tightening torque: 3.24 [N•m]

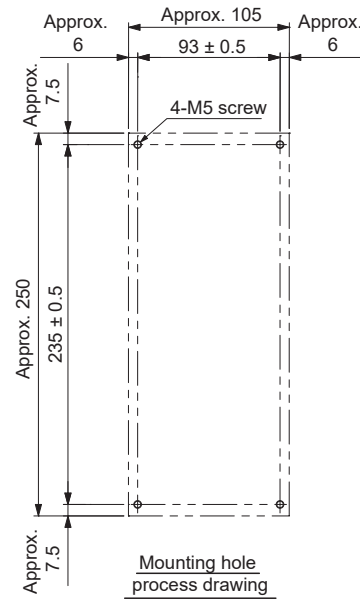
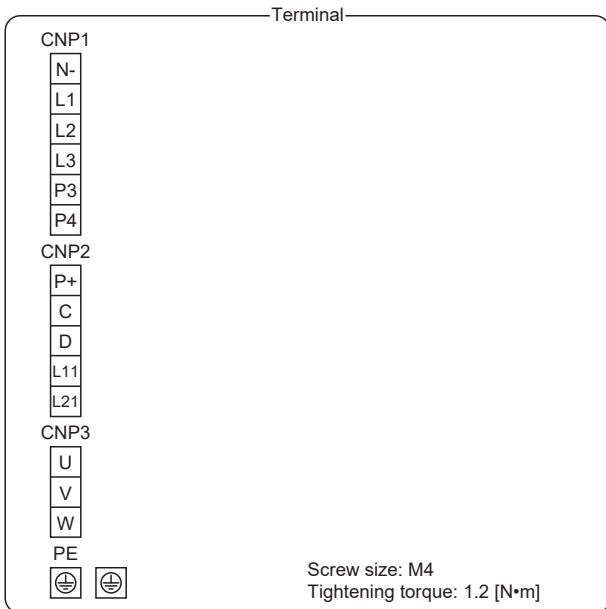

■MR-J4-500GF4(-RJ)

[Unit: mm]

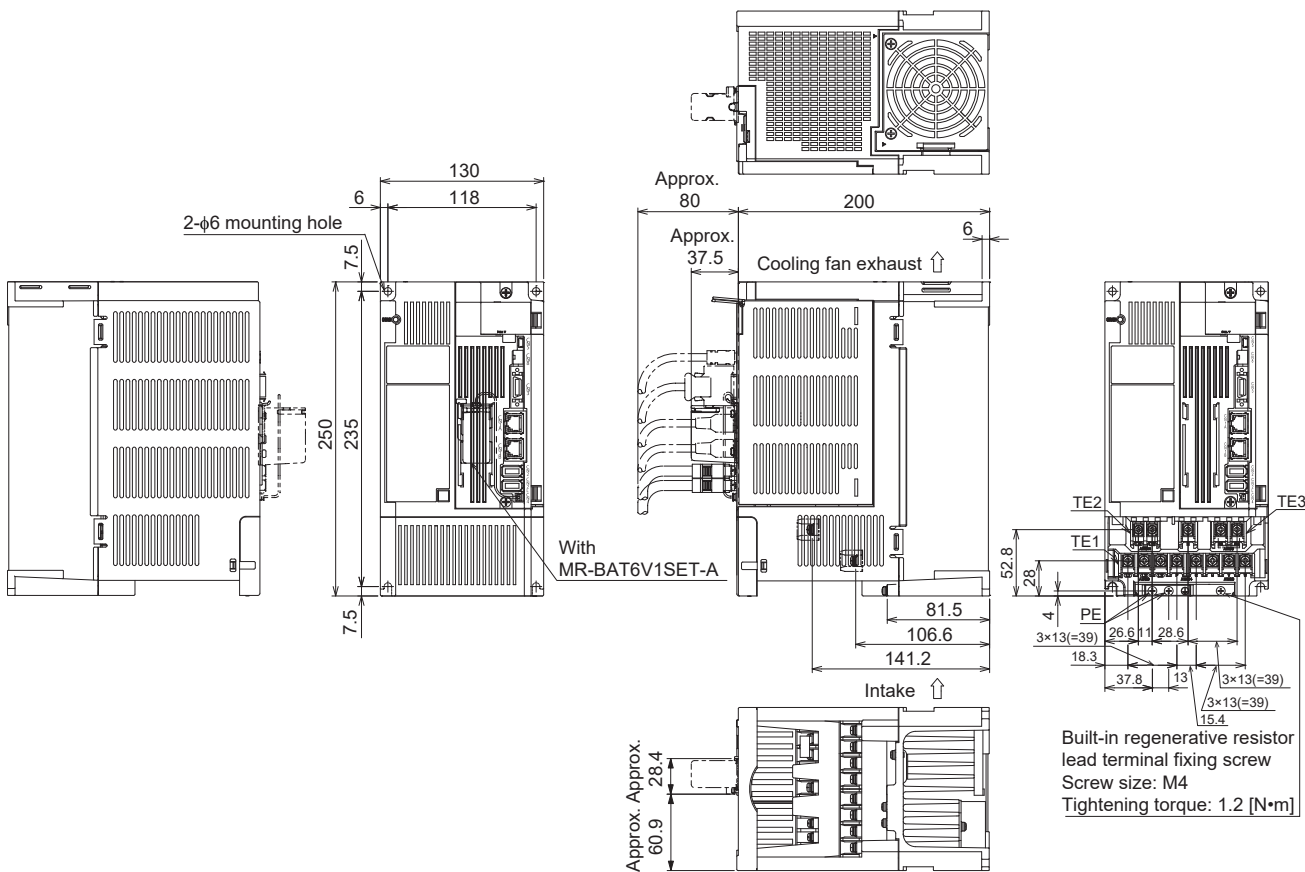

Mass: 4.3 [kg]

Mounting screw
Screw size: M5
Tightening torque: 3.24 [N•m]

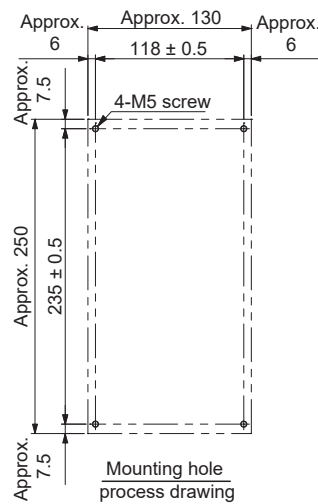
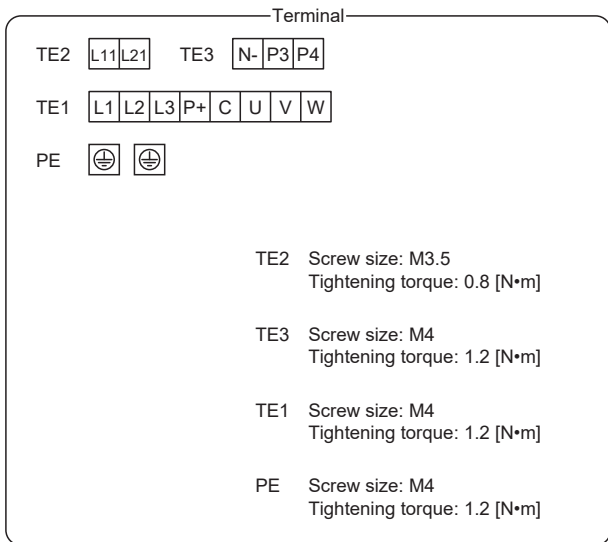

MR-J4-700GF4(-RJ)

[Unit: mm]

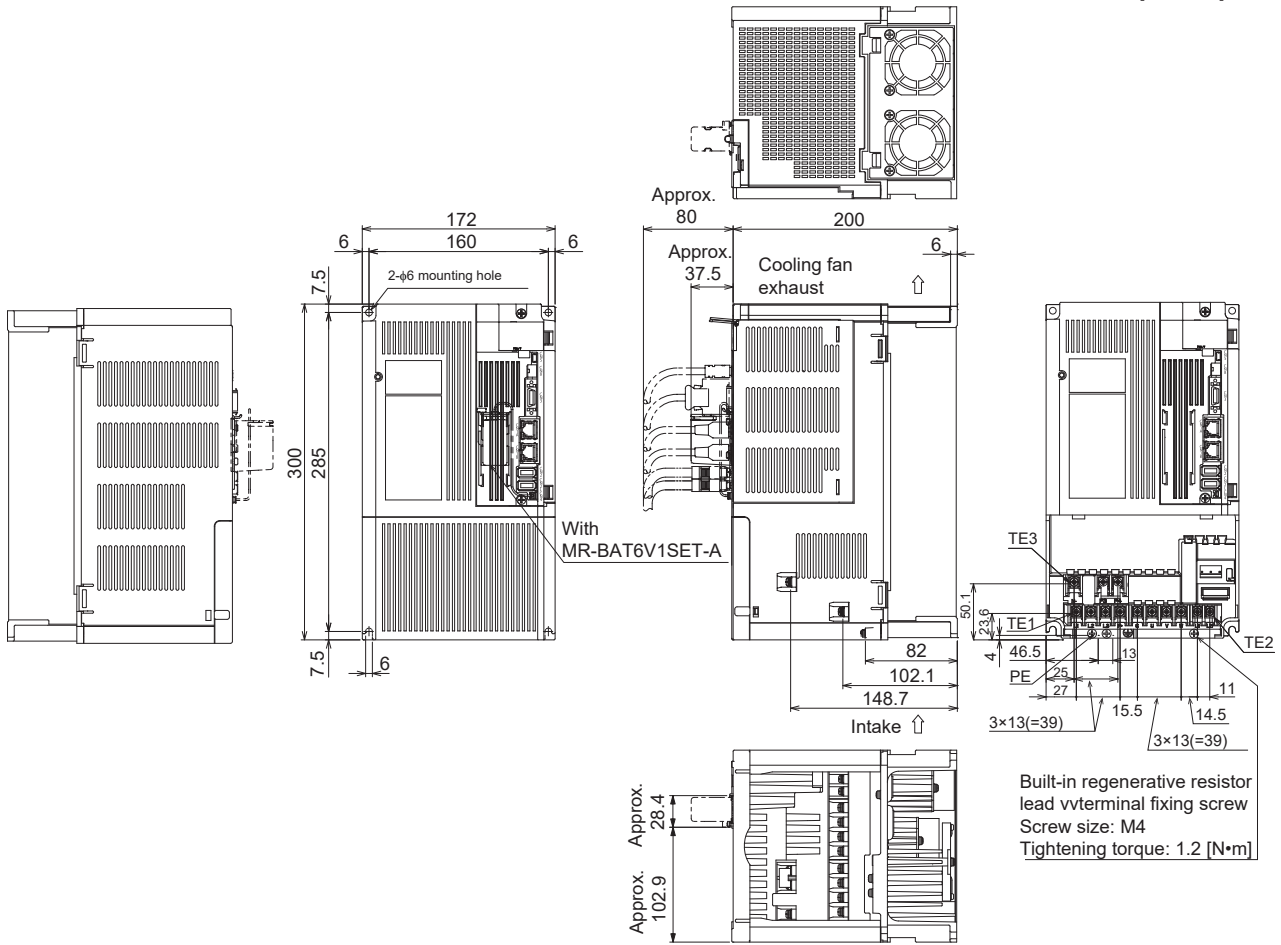

Mass: 6.5 [kg]

Mounting screw
Screw size: M5
Tightening torque: 3.24 [N·m]

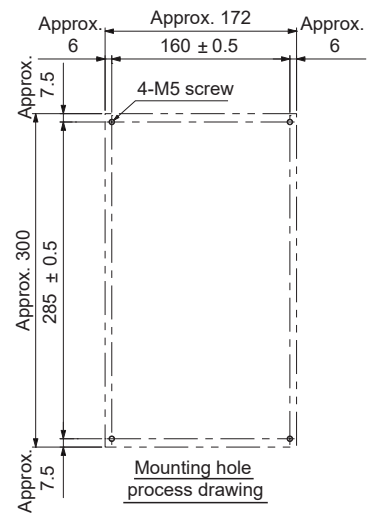
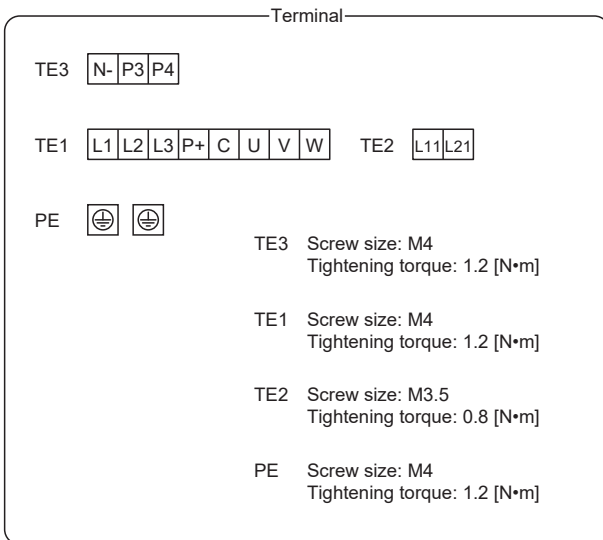

■MR-J4-11KGF4(-RJ)/MR-J4-15KGF4(-RJ)

[Unit: mm]

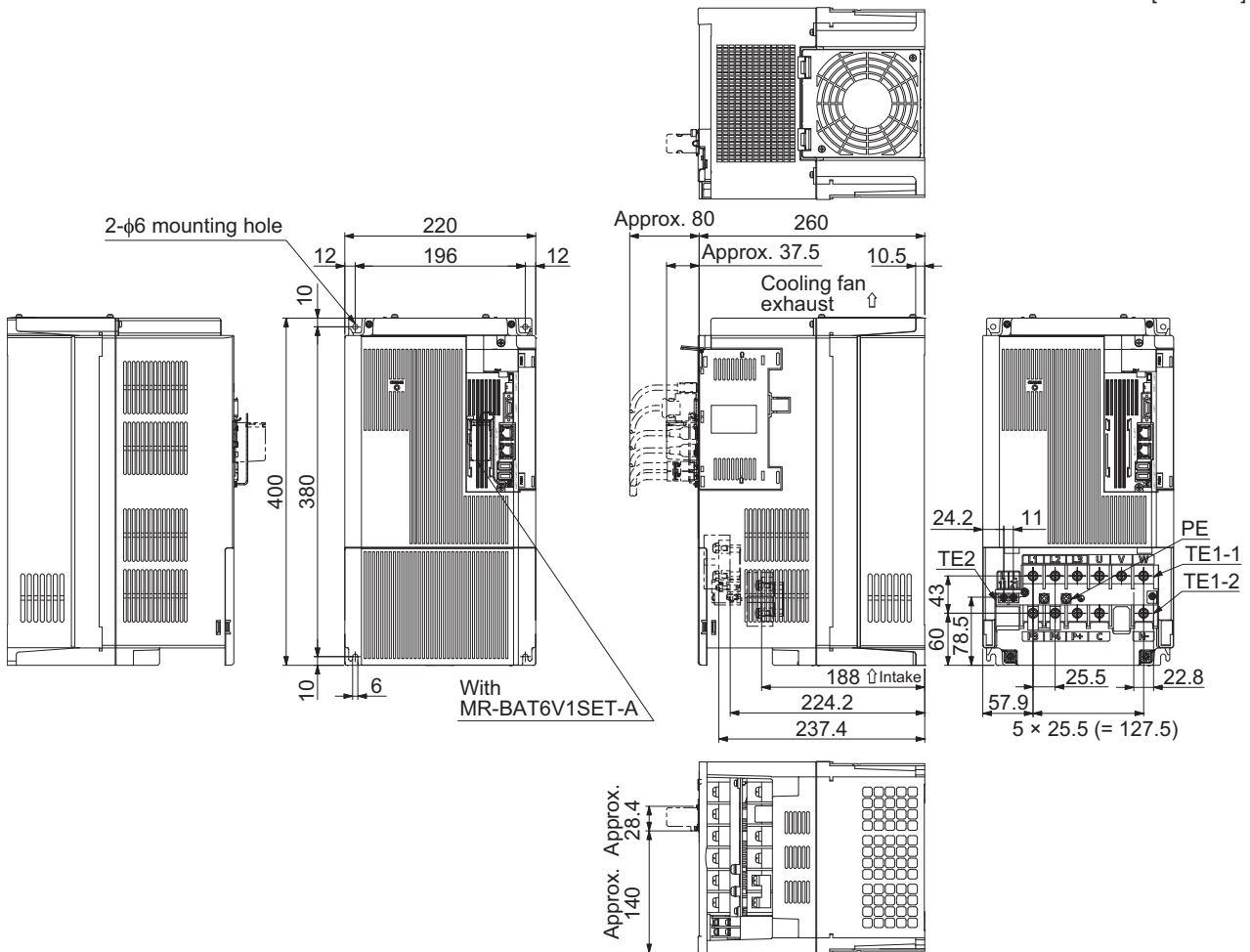

With MR-BAT6V1SET-A

Mass: 13.4 [kg]

Mounting screw
Screw size: M5
Tightening torque: 3.24 [N•m]

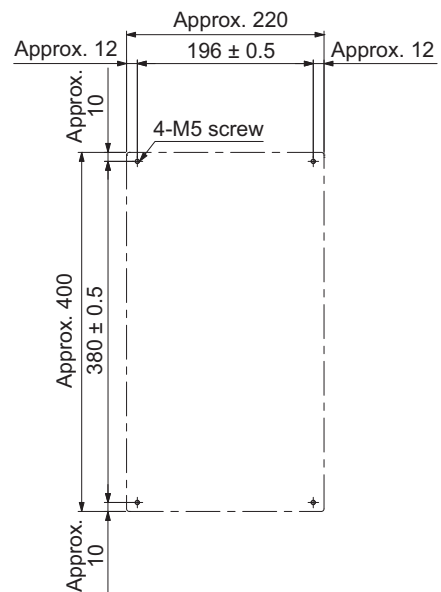
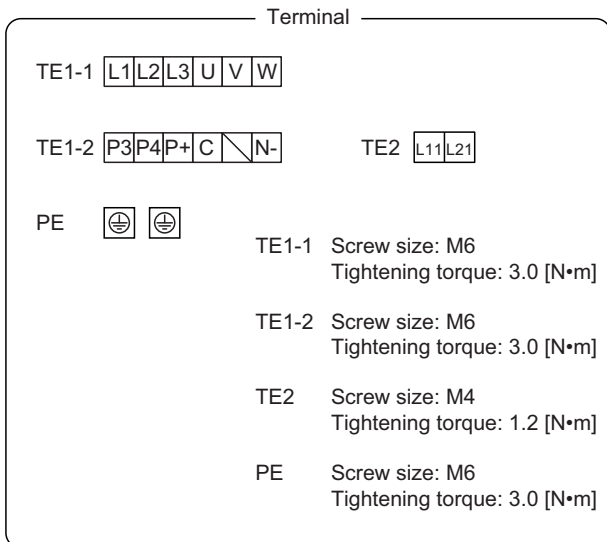

Mounting hole process drawing

■MR-J4-22KGF4(-RJ)

[Unit: mm]

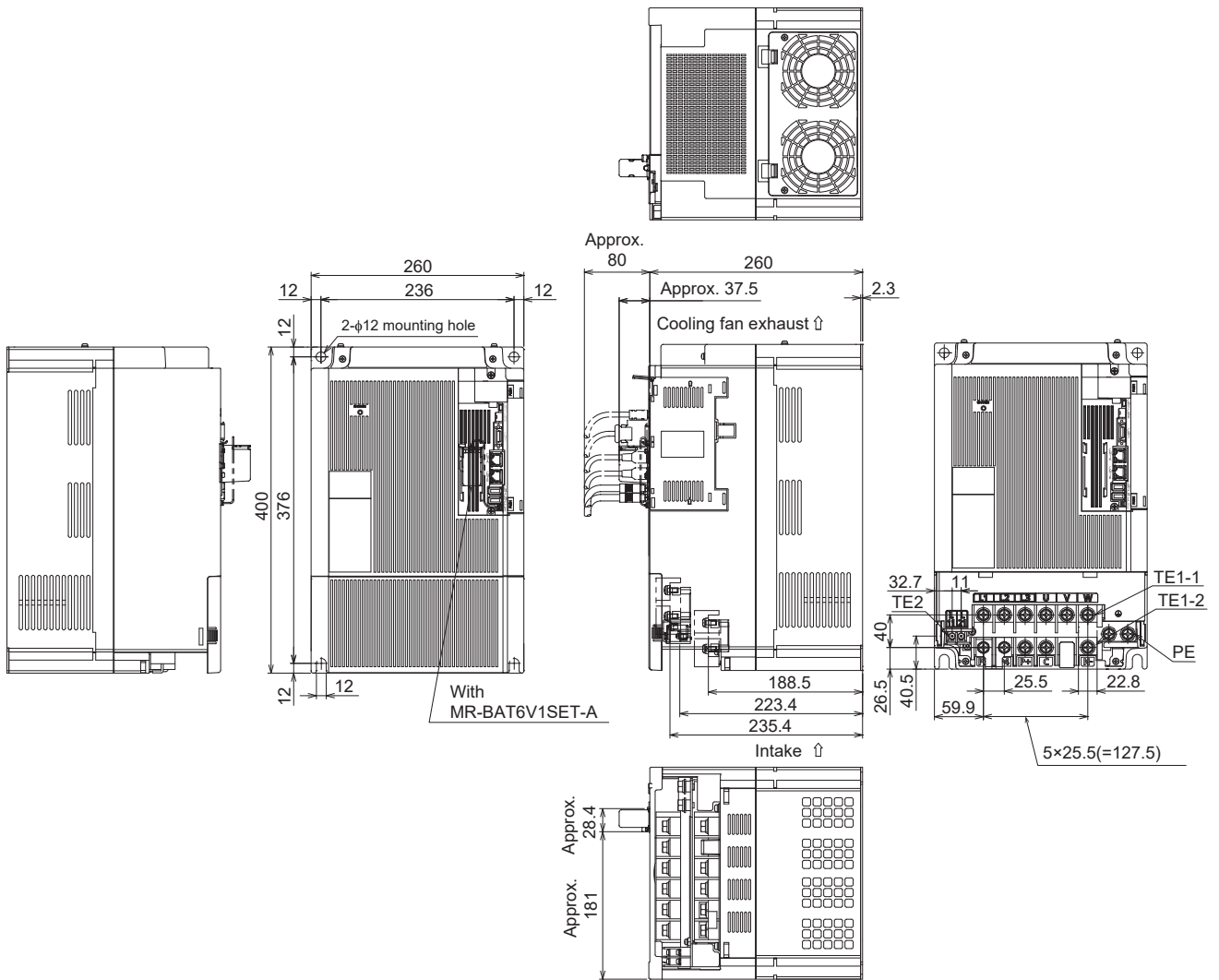

Mass: 18.2 [kg]

Mounting screw
Screw size: M10
Tightening torque: 26.5 [N•m]

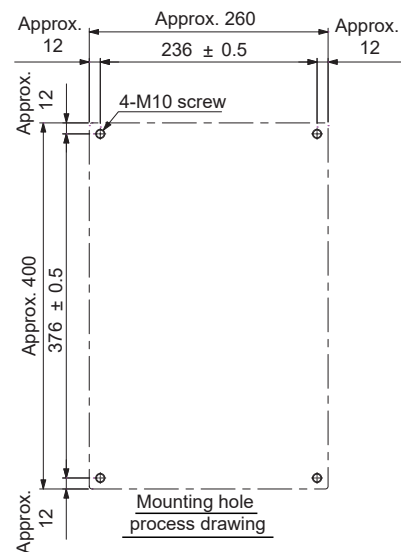
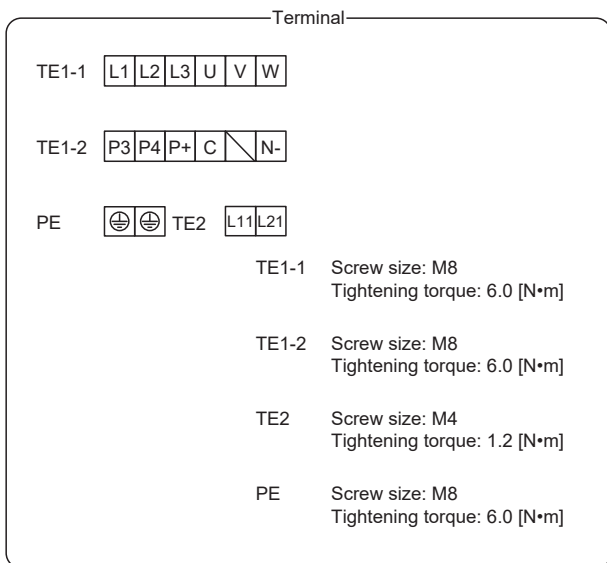

[Unit: mm]

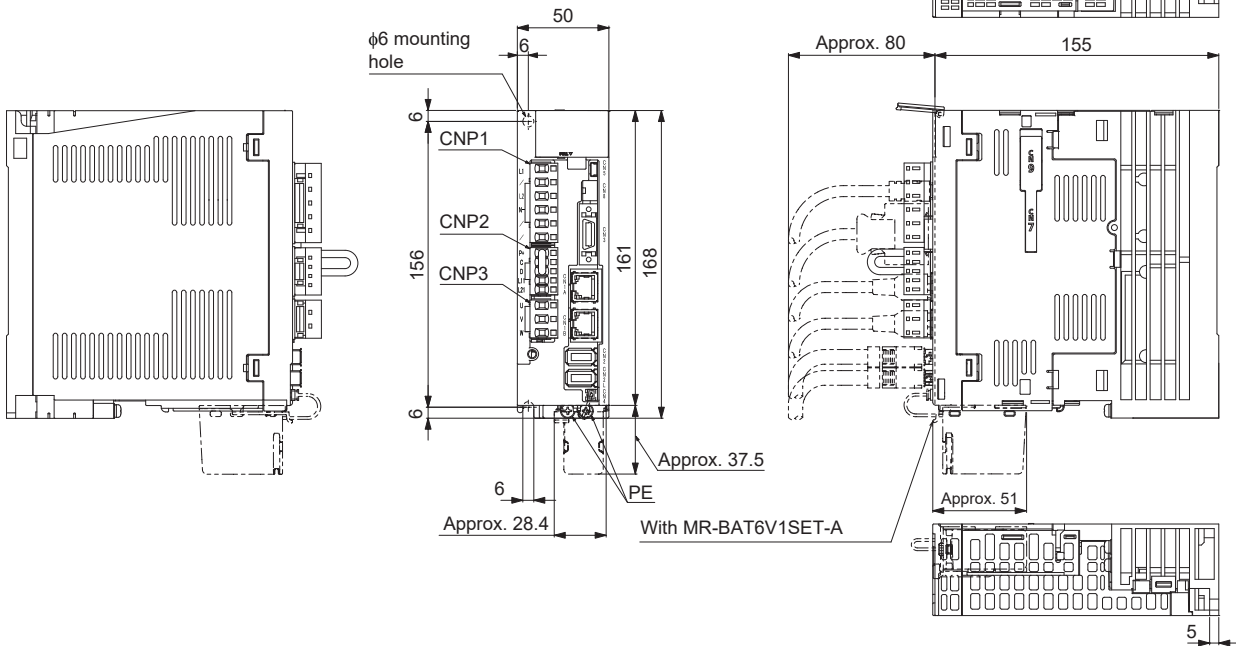

Mass: 1.0 [kg]

Mounting screw
Screw size: M5
Tightening torque: 3.24 [N•m]

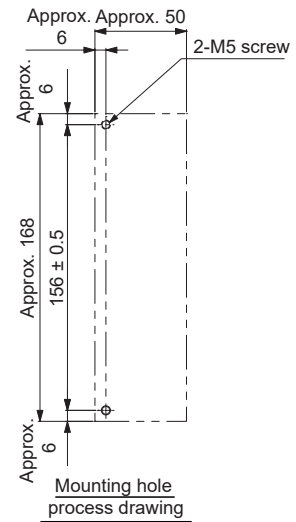
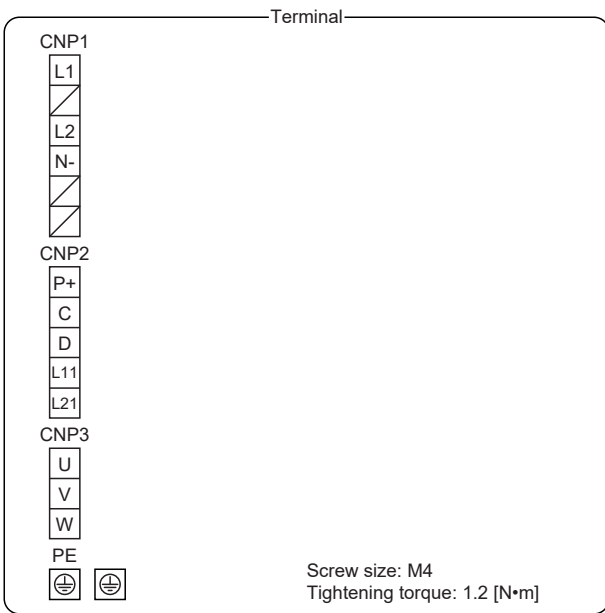

9.2 Connector

Miniature delta ribbon (MDR) system (3M)

■One-touch lock type

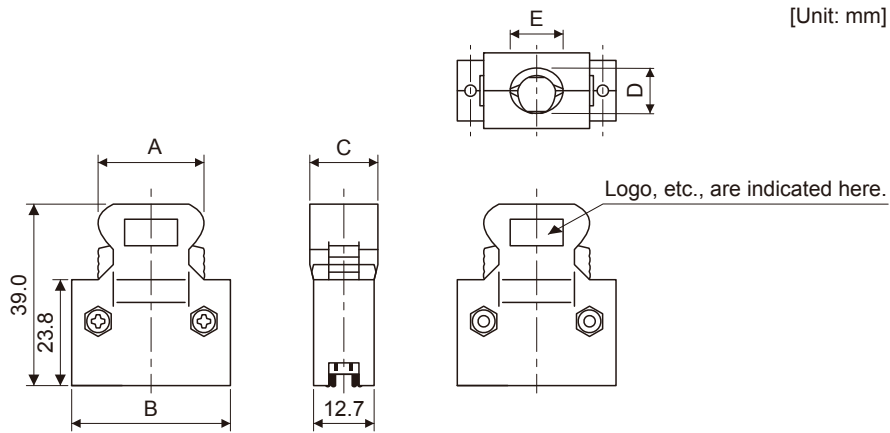

Connector	Shell kit	Each type of dimension				
		A	B	C	D	E
10120-3000PE	10320-52F0-008	22.0	33.3	14.0	10.0	12.0

■Jack screw M2.6 type

This is not available as option.

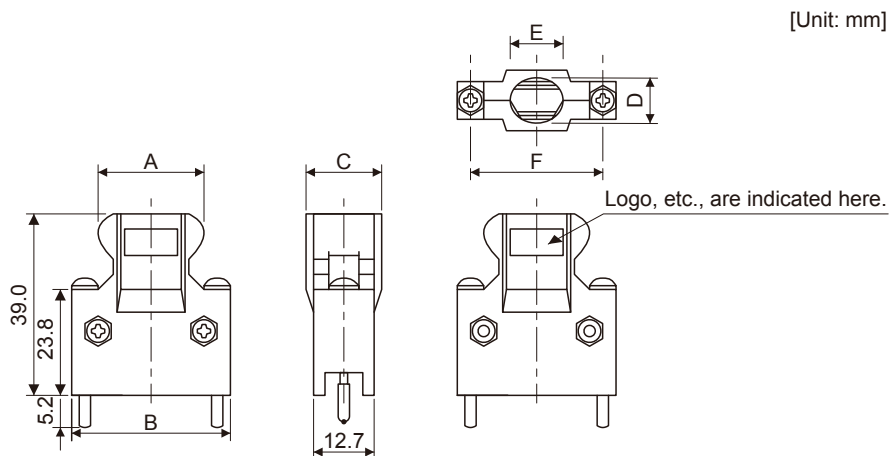

Connector	Shell kit	Each type of dimension					
		A	B	C	D	E	F
10120-3000PE	10320-52A0-008	22.0	33.3	14.0	10.0	12.0	27.4

SCR connector system (3M)

Receptacle: 36210-0100PL

Shell kit: 36310-3200-008

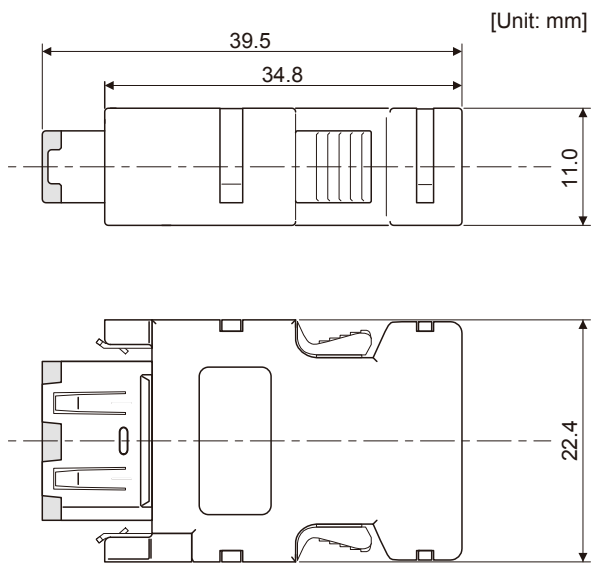

10 CHARACTERISTICS

Point

For the characteristics of the linear servo motor and the direct drive motor, refer to the following.

☞ Page 508 Characteristics

☞ Page 528 Characteristics

10.1 Overload protection characteristics

An electronic thermal is built in the servo amplifier to protect the servo motor, servo amplifier and servo motor power wires from overloads.

[AL. 50 Overload 1] occurs if overload operation performed is above the electronic thermal protection curve shown in the following section. [AL. 51 Overload 2] occurs if the maximum current is applied continuously for several seconds due to machine collision, etc. Use the equipment on the left-hand side area of the continuous or broken line in the graph.

☞ Page 316 Electronic thermal protection characteristics

When unbalanced torque is generated, such as in a vertical lift machine, the unbalanced torque of the machine should be kept at 70% or lower of the motor's rated torque.

This servo amplifier has solid-state servo motor overload protection. (The servo motor overload current (full load current) is set on the basis of 120% rated current of the servo amplifier.)

The following table shows combinations of each servo motor and graph of overload protection characteristics.

Rotary servo motor						Graph of overload protection characteristics
HG-KR	HG-MR	HG-SR	HG-UR	HG-RR	HG-JR	
053 13	053 13	—	72	—	—	☞ Characteristics a
23 43 73	23 43 73	51 81 52 102	—	—	53 ^{*1} 73 103	☞ Characteristics b
—	—	121 201 152 202 301 352	152 202	103 153 203	73 ^{*1} 103 ^{*1} 153 ^{*1} 203 ^{*1} 353	☞ Characteristics c
—	—	421 502 702	352 502	353 503	353 ^{*1} 601 701M 503 ^{*1} 703	☞ Characteristics d
—	—	—	—	—	801 12K1 15K1 20K1 25K1 11K1M 15K1M 22K1M 903	☞ Characteristics e
—	—	524 1024	—	—	534 ^{*1} 734 1034	☞ Characteristics b
—	—	1524 2024 3524	—	—	734 ^{*1} 1034 ^{*1} 1534 ^{*1} 2034 ^{*1} 3534	☞ Characteristics c

Rotary servo motor						Graph of overload protection characteristics
HG-KR	HG-MR	HG-SR	HG-UR	HG-RR	HG-JR	
—	—	5024 7024	—	—	3534 ^{*1} 6014 701M4 5034 ^{*1} 7034	☞ Characteristics d
—	—	—	—	—	8014 12K14 15K14 20K14 25K14 11K1M4 15K1M4 22K1M4 9034	☞ Characteristics e

*1 This combination is for increasing the maximum torque of the servo motor to 400%.

Electronic thermal protection characteristics

The following graphs show overload protection characteristics.

■ Characteristics a

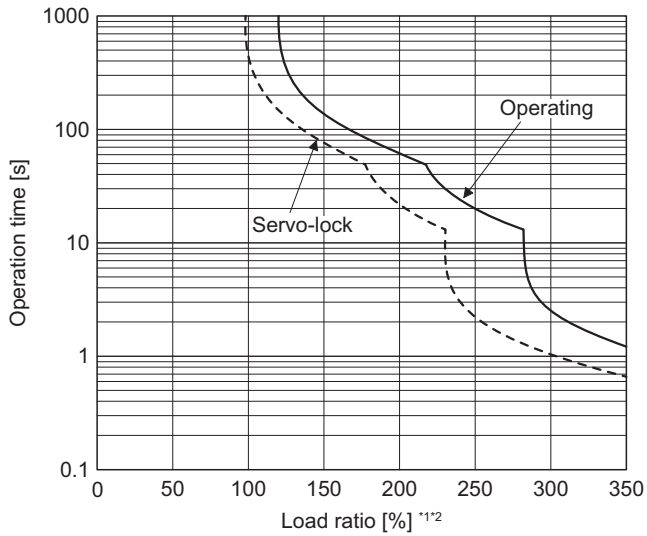

■ Characteristics b

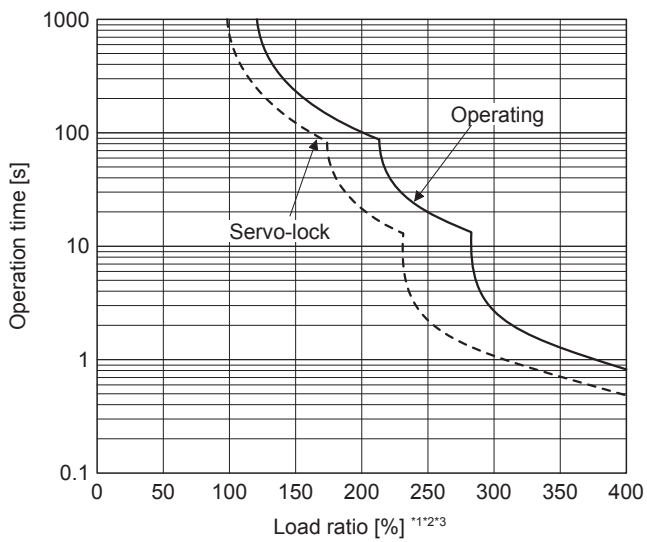

■ Characteristics c

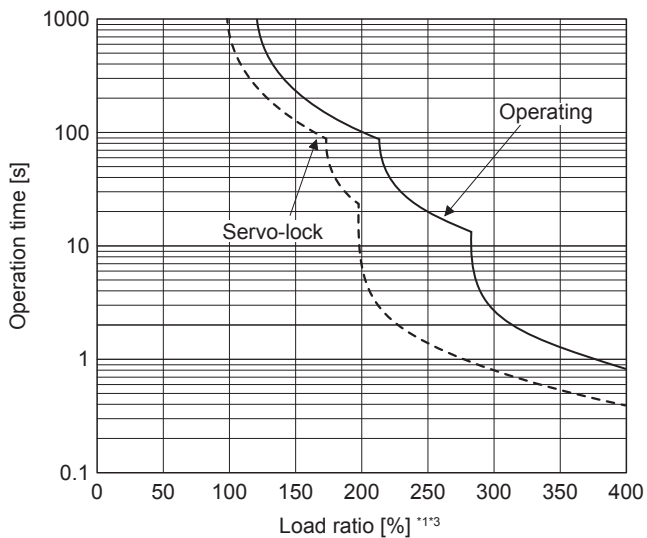

■ Characteristics d

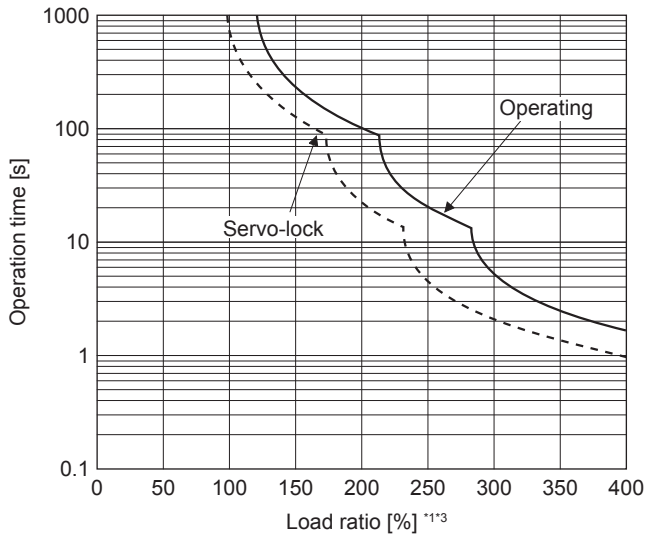

■ Characteristics e

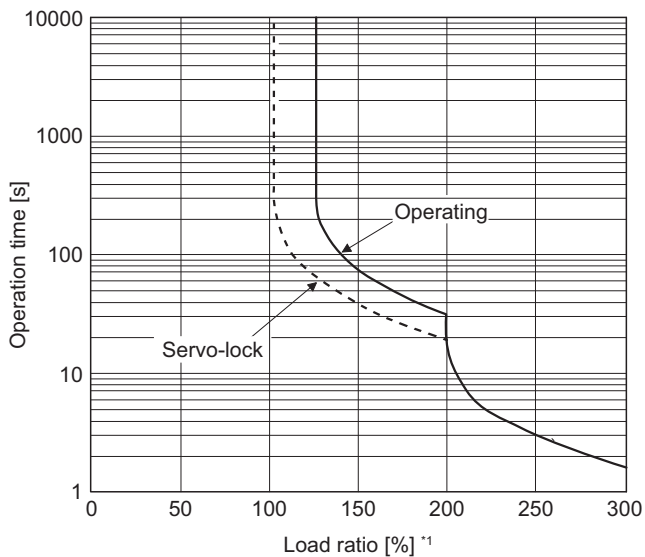

- *1 If operation that generates torque more than 100% of the rating is performed with an abnormally high frequency in a servo motor stop status (servo-lock status) or in a 50 r/min or less low-speed operation status, the servo amplifier may malfunction regardless of the electronic thermal protection.
- *2 The load ratio ranging from 300% to 350% applies to the HG-KR servo motor.
- *3 The operation time at the load ratio of 300% to 400% applies when the maximum torque of HG-JR servo motor is increased to 400% of rated torque.

10.2 Power supply capacity and generated loss

Amount of heat generated by the servo amplifier

The following table indicates servo amplifiers' power supply capacities and losses generated under rated load. For thermal design of an enclosed type cabinet, use the values in the table in consideration for the worst operating conditions. The actual amount of generated heat will be intermediate between values at rated torque and servo-off according to the duty used during operation. When the servo motor is run at less than the rated speed, the power supply capacity will be smaller than the value in the table, but the servo amplifier's generated heat will not change.

Servo amplifier	Servo motor	Power supply capacity [kVA] ^{*1}	Servo amplifier-generated heat [W] ^{*2}			Area required for heat dissipation [m ²]
			At rated output	At rated output [Generated heat in the cabinet when cooled outside the cabinet] ^{*3}	With servo-off	
MR-J4-10GF(-RJ)	HG-MR053	0.3	25	—	15	0.5
	HG-MR13	0.3	25		15	0.5
	HG-KR053	0.3	25		15	0.5
	HG-KR13	0.3	25		15	0.5
MR-J4-20GF(-RJ)	HG-MR23	0.5	25		15	0.5
	HG-KR23	0.5	25		15	0.5
MR-J4-40GF(-RJ)	HG-MR43	0.9	35		15	0.7
	HG-KR43	0.9	35		15	0.7
MR-J4-60GF(-RJ)	HG-SR52	1.0	40		15	0.8
	HG-SR51	1.0	40		15	0.8
	HG-JR53	1.0	40		15	0.8
MR-J4-70GF(-RJ)	HG-MR73	1.3	50		15	1.0
	HG-KR73	1.3	50		15	1.0
	HG-UR72	1.3	50		15	1.0
	HG-JR73	1.3	50		15	1.0
MR-J4-100GF(-RJ)	HG-SR102	1.7	50		15	1.0
	HG-SR81	1.5	50		15	1.0
	HG-JR103	1.7	50		15	1.0
MR-J4-200GF(-RJ)	HG-SR152	2.5	90		20	1.8
	HG-SR202	3.5	90		20	1.8
	HG-SR121	2.1	90		20	1.8
	HG-SR201	3.5	90		20	1.8
	HG-RR103	1.7	50		15	1.0
	HG-RR153	2.5	90		20	1.8
	HG-UR152	2.5	90		20	1.8
	HG-JR153	2.5	90		20	1.8
	HG-JR203	3.5	90		20	1.8
MR-J4-350GF(-RJ)	HG-SR352	5.5	130		20	2.6
	HG-SR301	4.8	120		20	2.4
	HG-RR203	3.5	90		20	1.8
	HG-UR202	3.5	90		20	1.8
	HG-JR353	5.5	160		20	2.7

Servo amplifier	Servo motor	Power supply capacity [kVA] ^{*1}	Servo amplifier-generated heat [W] ^{*2}			Area required for heat dissipation [m ²]
			At rated output	At rated output [Generated heat in the cabinet when cooled outside the cabinet] ^{*3}	With servo-off	
MR-J4-500GF(-RJ)	HG-SR502	7.5	195	—	25	3.9
	HG-SR421	6.3	160		25	3.2
	HG-RR353	5.5	135		25	2.7
	HG-RR503	7.5	195		25	3.9
	HG-UR352	5.5	195		25	3.9
	HG-UR502	7.5	195		25	3.9
	HG-JR503	7.5	195		25	3.9
MR-J4-700GF(-RJ)	HG-SR702	10	300		25	6.0
	HG-JR703	10	300		25	6.0
	HG-JR701M	10	300		25	6.0
	HG-JR601	8.6	250		25	5.0
MR-J4-11KGF(-RJ)	HG-JR903	13	435	130	45	8.7
	HG-JR11K1M	16	530	160	45	11.0
	HG-JR801	12	370	110	45	7.0
	HG-JR12K1	18	570	170	45	11.5
MR-J4-15KGF(-RJ)	HG-JR15K1M	22	640	195	45	13.0
	HG-JR15K1	22	640	195	45	12.8
MR-J4-22KGF(-RJ)	HG-JR22K1M	33	850	260	55	17.0
	HG-JR20K1	30	800	240	55	16.0
	HG-JR25K1	38	900	270	55	19.0
MR-J4-60GF4(-RJ)	HG-SR524	1.0	40	—	18	0.8
	HG-JR534	1.0	40		18	0.8
MR-J4-100GF4(-RJ)	HG-SR1024	1.7	60		18	1.2
	HG-JR734	1.3	60		18	1.2
	HG-JR1034	1.7	60		18	1.2
MR-J4-200GF4(-RJ)	HG-SR1524	2.5	90		20	1.8
	HG-SR2024	3.5	90		20	1.8
	HG-JR1534	2.5	90		20	1.8
	HG-JR2034	3.5	90		20	1.8
MR-J4-350GF4(-RJ)	HG-SR3524	5.5	130		20	2.6
	HG-JR3534	5.5	160		20	2.7
MR-J4-500GF4(-RJ)	HG-SR5024	7.5	195		25	3.9
	HG-JR5034	7.5	195		25	3.9
MR-J4-700GF4(-RJ)	HG-SR7024	10	300		25	6.0
	HG-JR7034	10	300		25	6.0
	HG-JR701M4	10	300		25	6.0
	HG-JR6014	8.6	250		25	5.0
MR-J4-11KGF4(-RJ)	HG-JR9034	13	435	130	45	8.7
	HG-JR11K1M4	16	530	160	45	11.0
	HG-JR8014	12	370	110	45	7.0
	HG-JR12K14	18	570	170	45	11.5
MR-J4-15KGF4(-RJ)	HG-JR15K1M4	22	640	195	45	13.0
	HG-JR15K14	22	640	195	45	12.8
MR-J4-22KGF4(-RJ)	HG-JR22K1M4	33	850	260	55	17.0
	HG-JR20K14	30	800	240	55	16.0
	HG-JR25K14	38	900	270	55	19.0

Servo amplifier	Servo motor	Power supply capacity [kVA] ^{*1}	Servo amplifier-generated heat [W] ^{*2}			Area required for heat dissipation [m ²]
			At rated output	At rated output [Generated heat in the cabinet when cooled outside the cabinet] ^{*3}	With servo-off	
MR-J4-10GF1(-RJ)	HG-MR053	0.3	25	—	15	0.5
	HG-MR13	0.3	25		15	0.5
	HG-KR053	0.3	25		15	0.5
	HG-KR13	0.3	25		15	0.5
MR-J4-20GF1(-RJ)	HG-MR23	0.5	25	15	0.5	
	HG-KR23	0.5	25	15	0.5	
MR-J4-40GF1(-RJ)	HG-MR43	0.9	35	15	0.7	
	HG-KR43	0.9	35	15	0.7	

*1 The power supply equipment capacity changes with the power supply impedance. This value is applicable when the power factor improving AC reactor or power factor improving DC reactor are not used.

*2 Heat generated during regeneration is not included in the servo amplifier-generated heat. To calculate heat generated by the regenerative option, refer to the following.

☞ Page 338 Regenerative options

*3 This value is applicable when the servo amplifier is cooled by using the panel through attachment.

Heat dissipation area for an enclosed type cabinet

The enclosed type cabinet (hereafter called the cabinet) which will contain the servo amplifier should be designed to ensure that its temperature rise is within +10 °C at the ambient temperature of 40 °C. (With an approximately 5 °C safety margin, the system should operate within a maximum 55 °C limit.) The necessary cabinet heat dissipation area can be calculated by equation 10.1.

$$A = \frac{P}{K \cdot \Delta T} \dots\dots\dots(10.1)$$

A: Heat dissipation area [m²]

P: Loss generated in the cabinet [W]

ΔT: Difference between internal and ambient temperatures [°C]

K: Heat dissipation coefficient [5 to 6]

When calculating the heat dissipation area with equation 10.1, assume that P is the sum of all losses generated in the cabinet.

Refer to the following for heat generated by the servo amplifier.

☞ Page 318 Amount of heat generated by the servo amplifier

"A" indicates the effective area for heat dissipation, but if the cabinet is directly installed on an insulated wall, that extra amount must be added to the cabinet's surface area. The required heat dissipation area will vary with the conditions in the cabinet. If convection in the cabinet is poor and heat builds up, effective heat dissipation will not be possible. Therefore, arrangement of the equipment in the cabinet and the use of a cooling fan should be considered. The following section lists the cabinet dissipation area for each servo amplifier (guideline) when the servo amplifier is operated at the ambient temperature of 40 °C under rated load.

☞ Page 318 Amount of heat generated by the servo amplifier

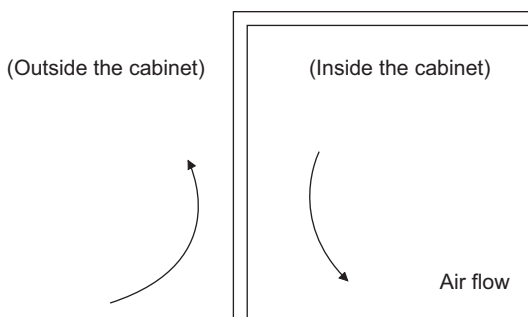

When air flows along the outer wall of the cabinet, effective heat exchange will be possible, because the temperature slope inside and outside the cabinet will be steeper.

10.3 Dynamic brake characteristics

⚠ CAUTION

• The coasting distance is a theoretically calculated value which ignores the running load such as friction. The calculated value will be longer than the actual distance. If the braking distance is not longer than the calculated value, a moving part may crash into the stroke end, which is very dangerous. Install the anti-crash mechanism such as an air brake or an electric/mechanical stopper such as a shock absorber to reduce the shock of moving parts.

Point

- Do not use dynamic brake to stop in a normal operation as it is the function to stop in emergency.
- For a machine operating at the recommended load to motor inertia ratio or less, the estimated number of usage times of the dynamic brake is 1000 times while the machine decelerates from the rated speed to a stop once in 10 minutes.
- Be sure to enable EM1 (Forced stop 1) after servo motor stops when using EM1 (Forced stop 1) frequently in other than emergency.
- Servo motors for MR-J4 may have the different coasting distance from that of the previous model.
- The electronic dynamic brake operates in the initial state for the HG series servo motors of 600 W or smaller capacity. The time constant "τ" for the electronic dynamic brake will be shorter than that of normal dynamic brake. Therefore, coasting distance will be longer than that of normal dynamic brake. For how to set the electronic dynamic brake, refer to [Pr. PF06] and [Pr. PF12].

Dynamic brake operation

Calculation of coasting distance

The following shows the pattern in which the servo motor comes to a stop when the dynamic brake is operated. Use equation 10.2 to calculate an approximate coasting distance to a stop. The dynamic brake time constant τ varies with the servo motor and machine operation speeds.

☞ Page 322 Dynamic brake time constant

A working part generally has a friction force. Therefore, actual coasting distance will be shorter than a maximum coasting distance calculated with the following equation.

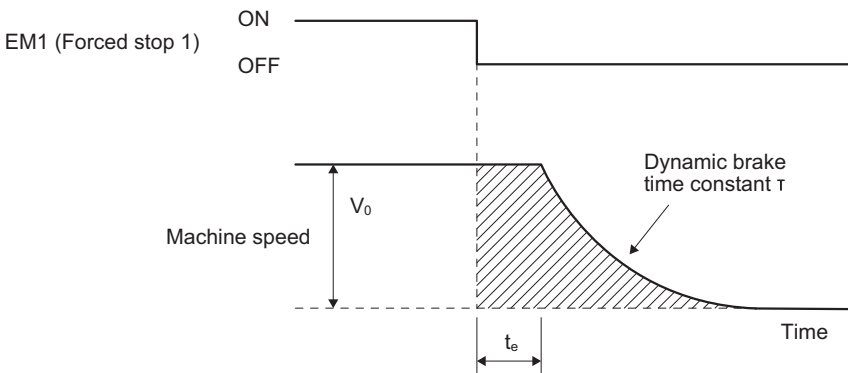

$$L_{max} = \frac{V_0}{60} \cdot \left\{ t_e + \tau \left(1 + \frac{J_L}{J_M} \right) \right\} \dots\dots\dots(10.2)$$

L_{max} : Maximum coasting distance [mm]

V_0 : Machine's fast feed speed [mm/min]

J_M : Moment of inertia of the servo motor [$\times 10^{-4}$ kg·m²]

J_L : Load moment of inertia converted into equivalent value on servo motor shaft [$\times 10^{-4}$ kg·m²]

τ : Dynamic brake time constant [s]

t_e : Delay time of control section [s]

For servo amplifier of 7 kW or less, there is internal relay delay time of about 10 ms. For the servo amplifier of 11 kW to 22 kW, there is delay caused by magnetic contactor built into the external dynamic brake (about 50 ms) and delay caused by the external relay.

Dynamic brake time constant

The following shows necessary dynamic brake time constant τ for equation 10.2.

■200 V class

- HG-MR series

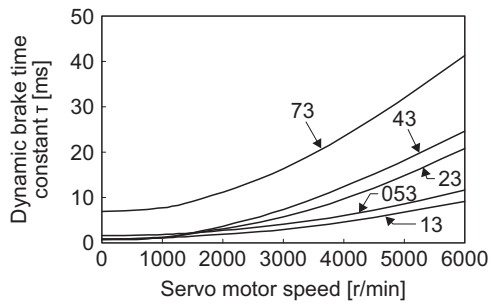

- HG-KR series

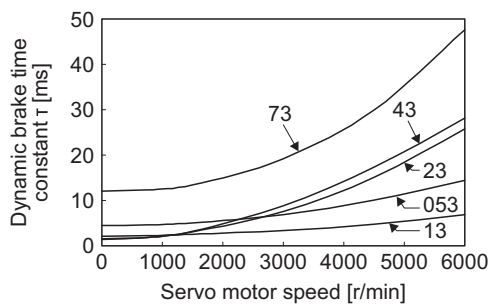

- HG-SR1000 r/min series

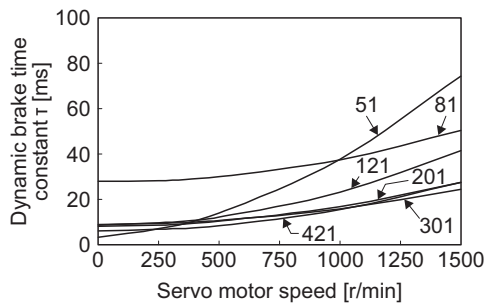

- HG-SR2000 r/min series

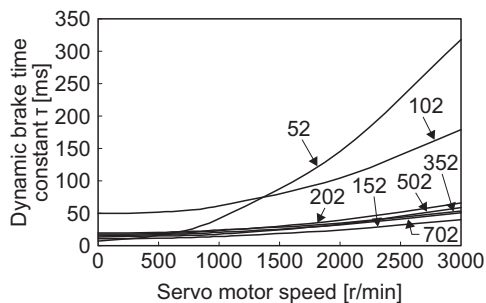

- HG-JR1000 r/min series

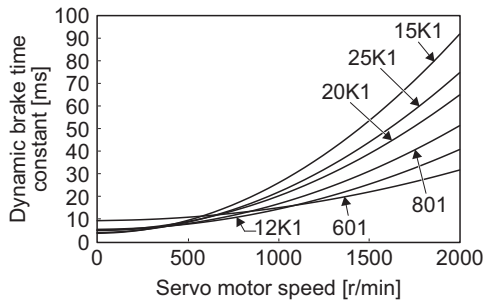

- HG-JR1500 r/min series

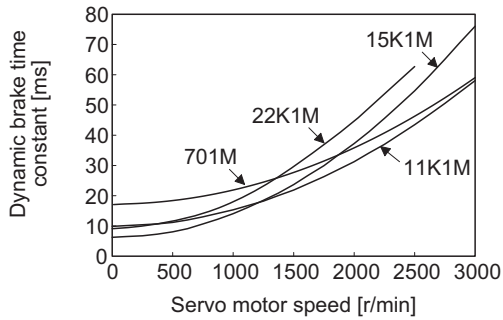

- HG-JR3000 r/min series

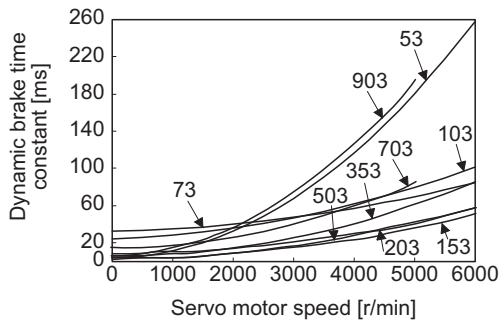

- HG-RR series

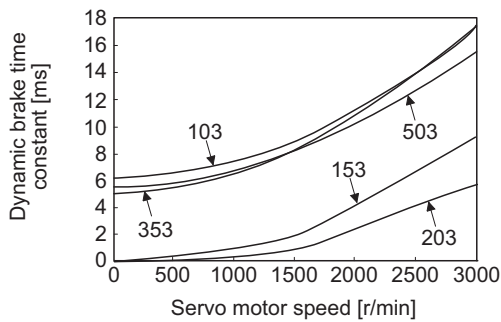

- HG-UR series

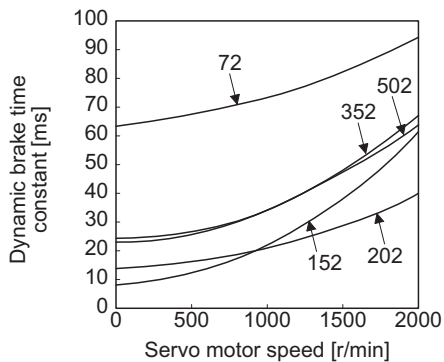

■ 400 V class

- HG-SR series

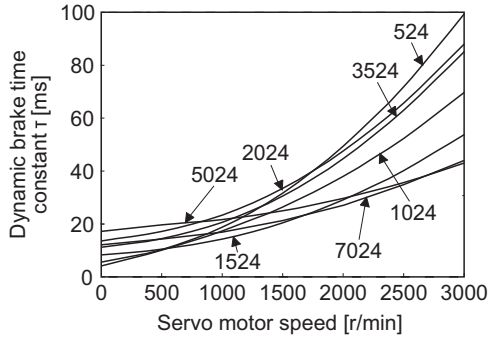

- HG-JR1000 r/min series

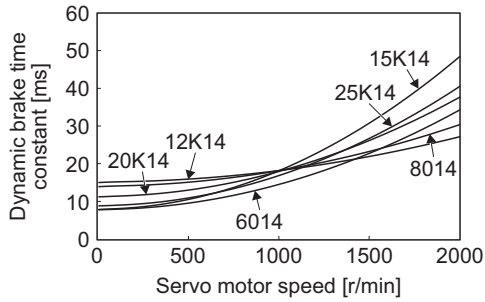

- HG-JR1500 r/min series

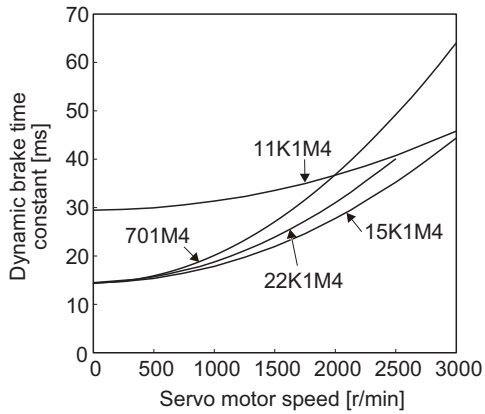

- HG-JR3000 r/min series

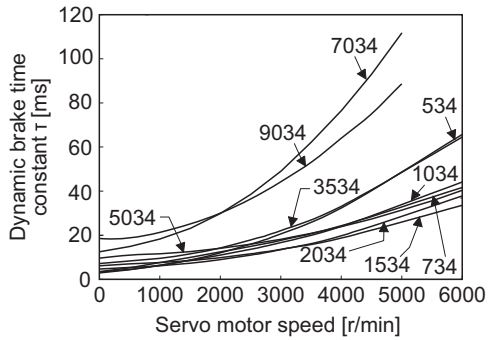

Permissible load to motor inertia when the dynamic brake is used

Use the dynamic brake under the load to motor inertia ratio indicated in the following table. If the ratio is higher than this value, the dynamic brake may burn. If the load to motor inertia ratio exceeds the indicated value, contact your local sales office.

The values of the permissible load to motor inertia ratio in the table are the values at the maximum speed of the servo motor. The value in the parenthesis shows the value at the rated speed.

Servo motor	Permissible load to motor inertia ratio [multiplier]
HG-KR053	30
HG-KR13	
HG-KR23	
HG-KR43	
HG-KR73	
HG-MR053	35
HG-MR13	32
HG-MR23	
HG-MR43	
HG-MR73	
HG-SR51	30
HG-SR81	
HG-SR121	
HG-SR201	
HG-SR301	16
HG-SR421	15
HG-SR52	30
HG-SR102	
HG-SR152	21
HG-SR202	
HG-SR352	13 (15)
HG-SR502	
HG-SR702	5 (15)
HG-SR524	5 (15)
HG-SR1024	5 (17)
HG-SR1524	
HG-SR2024	5 (15)
HG-SR3524	
HG-SR5024	
HG-SR7024	
HG-UR72	30
HG-UR152	
HG-UR202	16
HG-UR352	
HG-UR502	15
HG-RR103	30
HG-RR153	
HG-RR203	16
HG-RR353	15
HG-RR503	
HG-JR53	30
HG-JR73	
HG-JR103	
HG-JR153	
HG-JR203	
HG-JR353	16 (30)

Servo motor	Permissible load to motor inertia ratio [multiplier]
HG-JR503	15 (30)
HG-JR703	11 (30)
HG-JR903	18 (30)
HG-JR701M	5
HG-JR11K1M	10 (30)
HG-JR15K1M	
HG-JR22K1M	20 (30)
HG-JR601	5
HG-JR801	30
HG-JR12K1	20 (30)
HG-JR15K1	17 (30)
HG-JR20K1	26 (30)
HG-JR25K1	21 (30)
HG-JR534	30 (30)
HG-JR734	
HG-JR1034	
HG-JR1534	
HG-JR2034	
HG-JR3534	20 (30) ^{*1}
HG-JR5034	15 (30)
HG-JR7034	11 (30)
HG-JR9034	18 (30)
HG-JR701M4	7 (10)
HG-JR11K1M4	10 (30)
HG-JR15K1M4	
HG-JR22K1M4	20 (30)
HG-JR6014	10
HG-JR8014	30
HG-JR12K14	20 (30)
HG-JR15K14	30 (30)
HG-JR20K14	26 (30)
HG-JR25K14	21 (30)

*1 When the maximum torque is increased to 400%, the permissible load to motor inertia ratio at the maximum speed of the servo motor is 25 times.

10.4 Cable bending life

The bending life of the cables is shown below. This graph calculated values. Since they are not guaranteed values, provide a little allowance for these values.

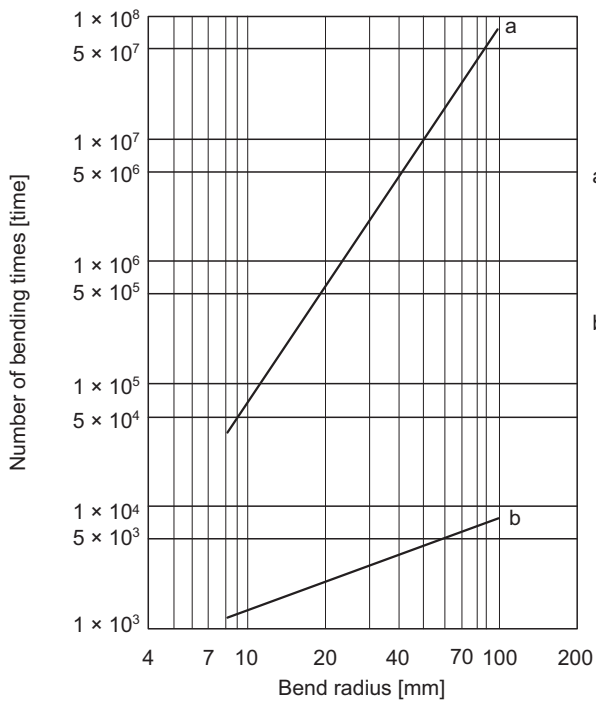

a: Long bending life encoder cable
Long bending life motor power cable
Long bending life electromagnetic brake cable

b: Standard encoder cable
Standard motor power cable
Standard electromagnetic brake cable

10.5 Inrush currents at power-on of main circuit and control circuit

Point

For a servo amplifier of 600 W or less, the inrush current values can change depending on frequency of turning on/off the power and ambient temperature.

Since large inrush currents flow in the power supplies, always use molded-case circuit breakers and magnetic contactors.

☞ Page 406 Molded-case circuit breakers, fuses, magnetic contactors

When circuit protectors are used, it is recommended that the inertia delay type, which is not tripped by an inrush current, be used.

200 V class

The following shows the inrush currents (reference data) that will flow when 240 V AC is applied at the power supply capacity. Even when you use a 1-phase 200 V AC power supply with MR-J4-10GF(-RJ) to MR-J4-200GF(-RJ), the inrush currents of the main circuit power supply is the same.

Servo amplifier	Inrush currents (A_{0-p})	
	Main circuit power supply (L1/L2/L3)	Control circuit power supply (L11/L21)
MR-J4-10GF(-RJ) MR-J4-20GF(-RJ) MR-J4-40GF(-RJ) MR-J4-60GF(-RJ)	30 A (attenuated to approx. 3 A in 20 ms)	20 A to 30 A (attenuated to approx. 1 A in 20 ms)
MR-J4-70GF(-RJ) MR-J4-100GF(-RJ)	34 A (attenuated to approx. 7 A in 20 ms)	
MR-J4-200GF(-RJ) MR-J4-350GF(-RJ)	113 A (attenuated to approx. 12 A in 20 ms)	
MR-J4-500GF(-RJ)	42 A (attenuated to approx. 20 A in 20 ms)	34 A (attenuated to approx. 2 A in 20 ms)
MR-J4-700GF(-RJ)	85 A (attenuated to approx. 20 A in 30 ms)	
MR-J4-11KGF(-RJ)	226 A (attenuated to approx. 30 A in 30 ms)	42 A (attenuated to approx. 2 A in 30 ms)
MR-J4-15KGF(-RJ)	226 A (attenuated to approx. 50 A in 30 ms)	
MR-J4-22KGF(-RJ)	226 A (attenuated to approx. 70 A in 30 ms)	

400 V class

The following shows the inrush currents (reference data) that will flow when 480 V AC is applied at the power supply capacity.

Servo amplifier	Inrush currents (A_{0-p})	
	Main circuit power supply (L1/L2/L3)	Control circuit power supply (L11/L21)
MR-J4-60GF4(-RJ) MR-J4-100GF4(-RJ)	65 A (attenuated to approx. 5 A in 10 ms)	40 A to 50 A (attenuated to approx. 0 A in 2 ms)
MR-J4-200GF4(-RJ)	80 A (attenuated to approx. 5 A in 10 ms)	
MR-J4-350GF4(-RJ)	100 A (attenuated to approx. 20 A in 10 ms)	
MR-J4-500GF4(-RJ)	65 A (attenuated to approx. 9 A in 20 ms)	41 A (attenuated to approx. 0 A in 3 ms)
MR-J4-700GF4(-RJ)	68 A (attenuated to approx. 34 A in 20 ms)	
MR-J4-11KGF4(-RJ)	339 A (attenuated to approx. 10 A in 30 ms)	38 A (attenuated to approx. 1 A in 30 ms)
MR-J4-15KGF4(-RJ)	339 A (attenuated to approx. 15 A in 30 ms)	
MR-J4-22KGF4(-RJ)	339 A (attenuated to approx. 20 A in 30 ms)	

100 V class

The following shows the inrush currents (reference data) that will flow when 120 V AC is applied at the power supply capacity.

Servo amplifier	Inrush currents (A_{0-p})	
	Main circuit power supply (L1/L2)	Control circuit power supply (L11/L21)
MR-J4-10GF1(-RJ)	38 A (attenuated to approx. 14 A in 10 ms)	20 A to 30 A (attenuated to approx. 0 A in 1 ms to 2 ms)
MR-J4-20GF1(-RJ)		
MR-J4-40GF1(-RJ)		

11 OPTIONS AND PERIPHERAL EQUIPMENT

WARNING

- Before connecting any option or peripheral equipment, turn off the power and wait for 15 minutes or more until the charge lamp turns off. Then, confirm that the voltage between P+ and N- is safe with a voltage tester and others. Otherwise, an electric shock may occur. In addition, when confirming whether the charge lamp is off or not, be sure to look at the lamp from the front of the servo amplifier.
-

CAUTION

- Use the specified peripheral equipment and options to prevent a malfunction or a fire.
-

Point

We recommend using HIV wires to wire the servo amplifiers, options, and peripheral equipment. Therefore, the recommended wire sizes may differ from those used for the previous servo amplifiers.

11.1 Cable/connector sets

Point

The IP rating indicated for cables and connectors is their protection against ingress of dust and raindrops when they are connected to a servo amplifier or servo motor. If the IP rating of the cable, connector, servo amplifier and servo motor vary, the overall IP rating depends on the lowest IP rating of all components.

Please purchase the cable and connector options indicated in this section.

Combinations of cable/connector sets

For MR-J4-_GF_ servo amplifier

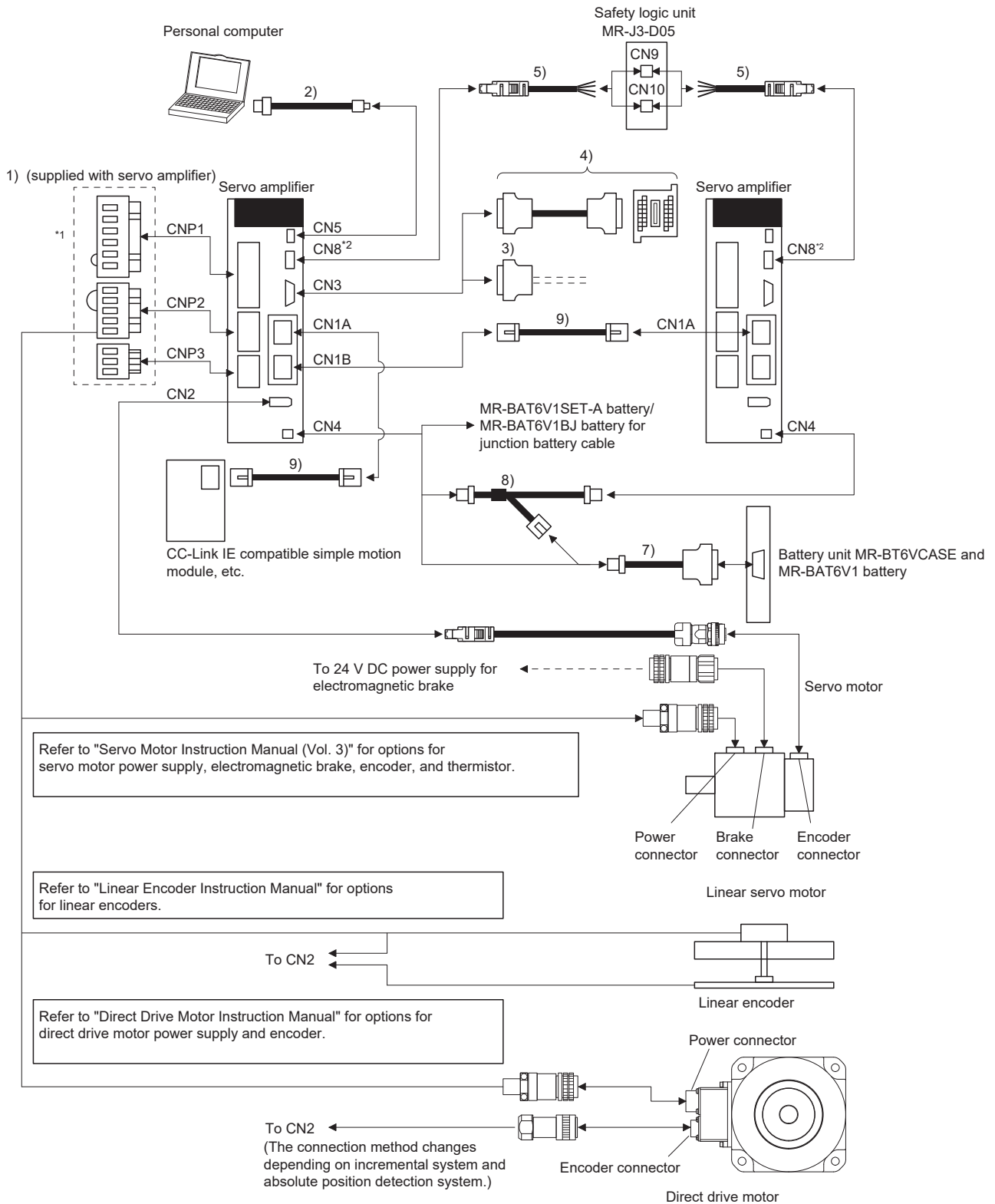

*1 Connectors for 3.5 kW or less. For 5 kW or more, it is a terminal block.





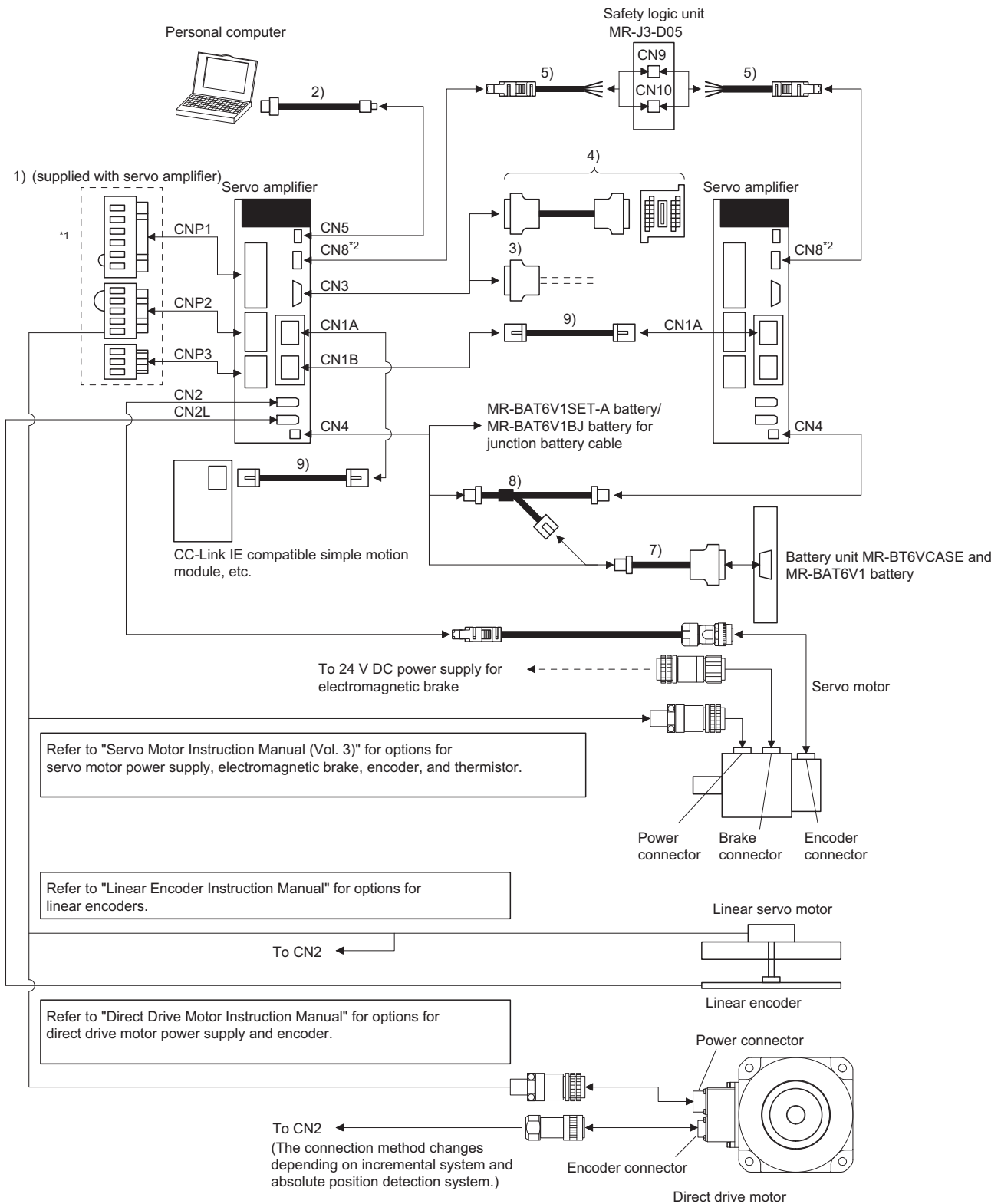



*2 When not using the STO function, attach the short-circuit connector (6) came with a servo amplifier.

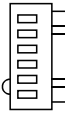

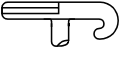
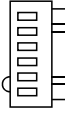



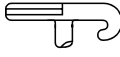

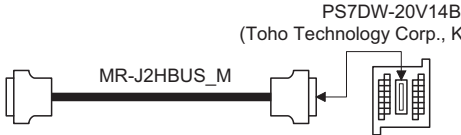

For MR-J4-_GF_-RJ servo amplifier



*1 Connectors for 3.5 kW or less. For 5 kW or more, it is a terminal block.

*2 When not using the STO function, attach the short-circuit connector (6) came with a servo amplifier.

No.	Product name	Model	Description	Remark		
1)	Servo amplifier power connector set	—	 CNP1 connector: 06JFAT-SAXGDK-H7.5 (JST) Applicable wire size: 0.8 mm ² to 2.1 mm ² (AWG 18 to 14) Insulator OD: to 3.9 mm	 CNP2 connector: 05JFAT-SAXGDK-H5.0 (JST) Applicable wire size: 0.8 mm ² to 2.1 mm ² (AWG 18 to 14) Insulator OD: to 3.9 mm	 CNP3 connector: 03JFAT-SAXGDK-H7.5 (JST) Applicable wire size: 0.8 mm ² to 2.1 mm ² (AWG 18 to 14) Insulator OD: to 3.9 mm	Supplied with 100 V class and 200 V class servo amplifiers of 1 kW or less
			 Open tool J-FAT-OT (N) or J-FAT-OT (JST)			
			—	—	 CNP1 connector: 06JFAT-SAXGFK-XL (JST) Applicable wire size: 1.25 mm ² to 5.5 mm ² (AWG 16 to 10) Insulator OD: to 4.7 mm	
 Open tool Quantity: 1 Model: J-FAT-OT-EXL (JST)						
—	—	 CNP1 connector: 06JFAT-SAXGDK-HT10.5 (JST) Applicable wire size: 1.25 mm ² to 2.1 mm ² (AWG 16 to 14) Insulator OD: to 3.9 mm			 CNP2 connector: 05JFAT-SAXGDK-HT7.5 (JST) Applicable wire size: 1.25 mm ² to 2.1 mm ² (AWG 16 to 14) Insulator OD: to 3.9 mm	 CNP3 connector: 03JFAT-SAXGDK-HT10.5 (JST) Applicable wire size: 1.25 mm ² to 2.1 mm ² (AWG 16 to 14) Insulator OD: to 3.9 mm
		 Open tool J-FAT-OT-XL (JST)				
		2)	USB cable	MR-J3USBCBL3M Cable length: 3 m	CN5 connector mini-B connector (5 pins)	Personal computer connector A connector
						
3)	Connector set	MR-CCN1	 Connector: 10120-3000PE Shell kit: 10320-52F0-008 (3M or equivalent)	—		

No.	Product name	Model	Description	Remark
4)	Junction terminal block (recommended)	—	<p style="text-align: center;">PS7DW-20V14B-F (Toho Technology Corp., Kyoto factory)</p>  <p>MR-J2HBUS_M</p> <p>Junction terminal block PS7DW-20V14B-F is not option. For using the junction terminal block, option MR-J2HBUS_M is necessary.  Page 383 Junction terminal block PS7DW-20V14B-F (recommended)</p>	—
5)	STO cable	MR-D05UDL3M-B	<p style="text-align: center;">Connector set: 2069250-1 (TE Connectivity)</p> 	Connection cable for the CN8 connector
6)	Short-circuit connector	—		Supplied with servo amplifier
7)	Battery cable	MR-BT6V1CBL_M Cable length: 0.3/1 m ( Page 336 Battery cable/ junction battery cable)	<p>Housing: PAP-02V-O Contact: SPHD-001G-P0.5 (JST)</p> <p style="text-align: center;">Connector: 10114-3000PE Shell kit: 10314-52F0-008 (3M or equivalent)</p> 	For connection with battery unit
8)	Junction battery cable	MR-BT6V2CBL_M Cable length: 0.3/1 m ( Page 336 Battery cable/ junction battery cable)	<p>Housing: PAP-02V-O Contact: SPHD-001G-P0.5 (JST)</p> <p style="text-align: center;">Housing: PALR-02VF-O Contact: SPAL-001GU-P0.5 (JST)</p>  <p style="text-align: center;">Housing: PAP-02V-O Contact: SPHD-001G-P0.5 (JST)</p>	For battery junction
9)	Ethernet cable	( Page 337 Ethernet cable)	<p>Category 5e or higher, (double shielded/STP) straight cable</p>  <p>The (double shielded/STP) straight cable is not an option.</p>	Connection cable for CN1A/CN1B connectors

MR-D05UDL3M-B STO cable

This cable is for connecting an external device to the CN8 connector.

Cable model	Cable length	Application
MR-D05UDL3M-B	3 m	Connection cable for the CN8 connector

Configuration diagram

Servo amplifier

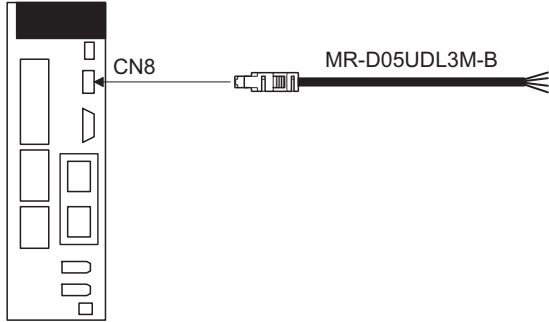

Internal wiring diagram

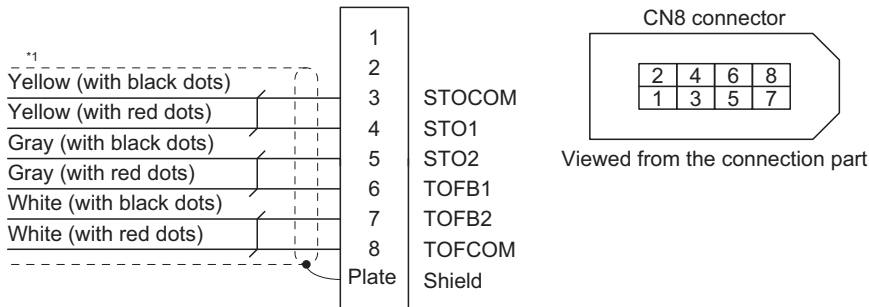

*1 Do not use the two core wires with orange insulator (with red or black dots).

Battery cable/junction battery cable

Model explanations

The numbers in the cable length field of the table indicate the symbol filling the underline "_" in the cable model. The cables of the lengths with the symbols are available.

Cable model	Cable length		Bending life	Application/remark
	0.3 m	1 m		
MR-BT6V1CBL_M	03	1	Standard	For connection with MR-BT6VCASE
MR-BT6V2CBL_M	03	1	Standard	For junction

MR-BT6V1CBL_M

■Appearance

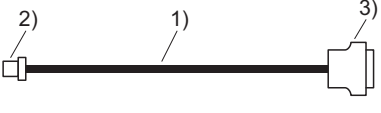
Figure	Components	Description
	1) Cable	VSVC 7/0.18 × 2C
	2) Connector	Housing: PAP-02V-O Contact: SPHD-001G-P0.5 (JST)
	3) Connector	Connector: 10114-3000PE Shell kit: 10314-52F0-008 (3M or equivalent)

■Internal wiring diagram

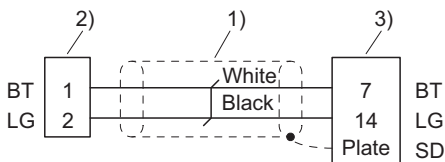

MR-BT6V2CBL_M

■Appearance

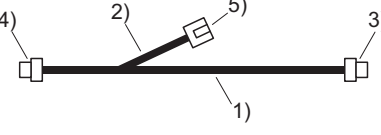
Figure	Components	Description
	1) Cable	VSVC 7/0.18 × 2C
	2) Cable	
	3) Connector	Housing: PAP-02V-O Contact: SPHD-001G-P0.5 (JST)
	4) Connector	
	5) Connector	Housing: PALR-02VF-O Contact: SPAL-001GU-P0.5 (JST)

■Internal wiring diagram

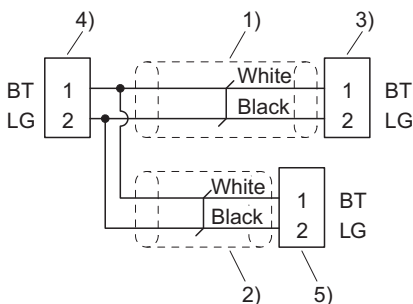

Ethernet cable

Point

When the servo amplifier is used in the motion mode, use the switching hub DT135TX (Mitsubishi Electric System & Service) to branch a CC-Link IE Field Network.

For the wiring of CC-Link IE Field Network and CC-Link IE Field Network Basic, use a cable which meets the following standards.

Item	Description
Cable type	Category 5e or higher, (double shielded/STP) straight cable
Standard	One of the following standards must be met. <ul style="list-style-type: none">• IEEE802.3 1000BASE-T• ANSI/TIA/EIA-568-B (Category 5e)
Connector	RJ-45 connector with shield

A product example on the market is as follows. For the latest product information, contact the manufacturer.

Model	Manufacturer	Contact
SC-E5EW(-L) ^{*1}	Mitsubishi Electric System & Service Co., Ltd.	Please consult your local Mitsubishi Electric representative.

*1 The SC-E5EW cable is for in-enclosure and indoor uses. The SC-E5EW-L cable is for outdoor use.

11.2 Regenerative options

CAUTION

• Do not use servo amplifiers with regenerative options other than the combinations specified below. Otherwise, it may cause a fire.

Combination and regenerative power

The power values in the table are resistor-generated powers and not rated powers.

200 V class

Servo amplifier	Regenerative power [W]									
	Built-in regenerative resistor	MR-RB032 [40 Ω]	MR-RB12 [40 Ω]	MR-RB30 [13 Ω]	MR-RB3N [9 Ω]	MR-RB31 [6.7 Ω]	MR-RB32 [40 Ω]	MR-RB50 [13 Ω] ^{*1}	MR-RB5N [9 Ω] ^{*1}	MR-RB51 [6.7 Ω] ^{*1}
MR-J4-10GF(-RJ)	—	30	—	—	—	—	—	—	—	—
MR-J4-20GF(-RJ)	10	30	100	—	—	—	—	—	—	—
MR-J4-40GF(-RJ)	10	30	100	—	—	—	—	—	—	—
MR-J4-60GF(-RJ)	10	30	100	—	—	—	—	—	—	—
MR-J4-70GF(-RJ)	20	30	100	—	—	—	300	—	—	—
MR-J4-100GF(-RJ)	20	30	100	—	—	—	300	—	—	—
MR-J4-200GF(-RJ)	100	—	—	300	—	—	—	500	—	—
MR-J4-350GF(-RJ)	100	—	—	—	300	—	—	—	500	—
MR-J4-500GF(-RJ)	130	—	—	—	—	300	—	—	—	500
MR-J4-700GF(-RJ)	170	—	—	—	—	300	—	—	—	500

Servo amplifier	Regenerative power [W] ^{*2}			
	External regenerative resistor (accessory)	MR-RB5R [3.2 Ω]	MR-RB9F [3 Ω]	MR-RB9T [2.5 Ω]
MR-J4-11KGF(-RJ)	500 (800)	500 (800)	—	—
MR-J4-15KGF(-RJ)	850 (1300)	—	850 (1300)	—
MR-J4-22KGF(-RJ)	850 (1300)	—	—	850 (1300)

*1 Always install a cooling fan.

*2 Values in parentheses assume the installation of a cooling fan.

400 V class

Servo amplifier	Regenerative power [W]								
	Built-in regenerative resistor	MR-RB1H-4 [82 Ω]	MR-RB3M-4 [120 Ω] ^{*1}	MR-RB3G-4 [47 Ω] ^{*1}	MR-RB5G-4 [47 Ω] ^{*1}	MR-RB34-4 [26 Ω] ^{*1}	MR-RB54-4 [26 Ω] ^{*1}	MR-RB3U-4 [22 Ω] ^{*1}	MR-RB5U-4 [22 Ω] ^{*1}
MR-J4-60GF4(-RJ)	15	100	300	—	—	—	—	—	—
MR-J4-100GF4(-RJ)	15	100	300	—	—	—	—	—	—
MR-J4-200GF4(-RJ)	100	—	—	300	500	—	—	—	—
MR-J4-350GF4(-RJ)	100	—	—	300	500	—	—	—	—
MR-J4-500GF4(-RJ)	130	—	—	—	—	300	500	—	—
MR-J4-700GF4(-RJ)	170	—	—	—	—	—	—	300	500

Servo amplifier	Regenerative power [W] ^{*2}		
	External regenerative resistor (accessory)	MR-RB5K-4 [10 Ω]	MR-RB6K-4 [10 Ω]
MR-J4-11KGF4(-RJ)	500 (800)	500 (800)	—
MR-J4-15KGF4(-RJ)	850 (1300)	—	850 (1300)
MR-J4-22KGF4(-RJ)	850 (1300)	—	850 (1300)

*1 Always install a cooling fan.

*2 Values in parentheses assume the installation of a cooling fan.

100 V class

Servo amplifier	Regenerative power [W]		
	Built-in regenerative resistor	MR-RB032 [40 Ω]	MR-RB12 [40 Ω]
MR-J4-10GF1(-RJ)	—	30	—
MR-J4-20GF1(-RJ)	10	30	100
MR-J4-40GF1(-RJ)	10	30	100

Selection of the regenerative option

A regenerative option for a horizontal axis can be selected with the rough calculation shown in this section. To select a regenerative option precisely, use the capacity selection software.

Rotary servo motor

■ Regenerative energy calculation

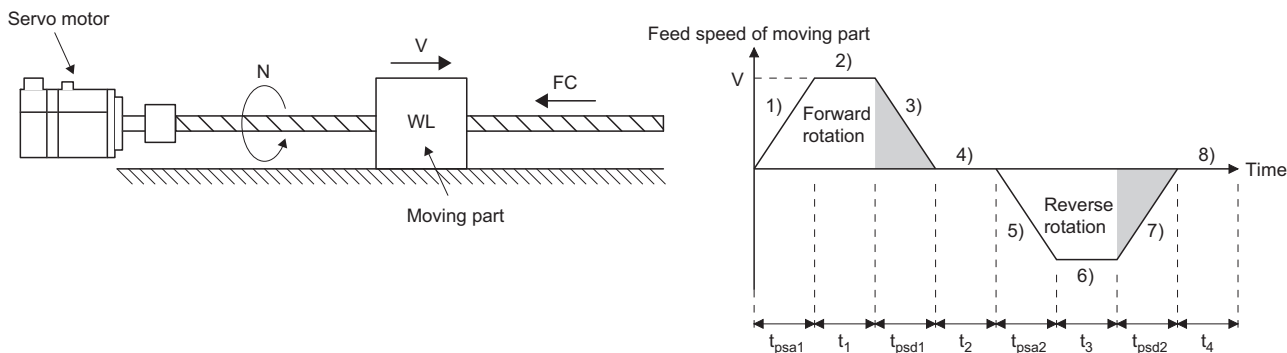

V : Feed speed of moving part [mm/min]

N : Servo motor speed ($N = V/\Delta S$) [r/min]

ΔS : Travel distance per servo motor revolution ($\Delta S = P_B$) [mm/rev]

P_B : Ball screw lead [mm]

L_B : Ball screw length [mm]

D_B : Ball screw diameter [mm]

W_L : Moving part mass [kg]

F_C : Load antidrag setting [N]

T_L : Load torque converted into equivalent value on servo motor shaft [$N \cdot m$]

η : Drive system efficiency

μ : Friction coefficient

J_L : Load moment of inertia converted into equivalent value on servo motor shaft [$kg \cdot cm^2$]

J_M : Moment of inertia of the servo motor [$kg \cdot cm^2$]

π : Pi constant

g : Gravitational acceleration [m/s^2]

Regenerative power	Torque applied to servo motor [N·m] ^{*1*2}	Energy E [J]
1)	$T_1 = \frac{(J_L/\eta + J_M) \cdot N}{9.55 \cdot 10^4} \cdot \frac{1}{t_{psa1}} + T_L$	$E_1 = \frac{0.1047}{2} \cdot N \cdot T_1 \cdot t_{psa1}$
2)	$T_2 = T_L$	$E_2 = 0.1047 \cdot N \cdot T_2 \cdot t_1$
3)	$T_3 = \frac{-(J_L \cdot \eta + J_M) \cdot N}{9.55 \cdot 10^4} \cdot \frac{1}{t_{psd1}} + T_L$	$E_3 = \frac{0.1047}{2} \cdot N \cdot T_3 \cdot t_{psd1}$
4), 8)	$T_4, T_8 = 0$	$E_4, E_8 = 0$ (No regeneration)
5)	$T_5 = \frac{(J_L/\eta + J_M) \cdot N}{9.55 \cdot 10^4} \cdot \frac{1}{t_{psa2}} + T_L$	$E_5 = \frac{0.1047}{2} \cdot N \cdot T_5 \cdot t_{psa2}$
6)	$T_6 = T_L$	$E_6 = 0.1047 \cdot N \cdot T_6 \cdot t_3$
7)	$T_7 = \frac{-(J_L \cdot \eta + J_M) \cdot N}{9.55 \cdot 10^4} \cdot \frac{1}{t_{psd2}} + T_L$	$E_7 = \frac{0.1047}{2} \cdot N \cdot T_7 \cdot t_{psd2}$

*1 Load torque converted into equivalent value on servo motor shaft TL can be calculated with the following expression.

$$T_L = \{(F_C + (\mu \times W_L \times g)) \times \Delta S\} / (2000 \times \pi \times \eta)$$

*2 Load moment of inertia converted into equivalent value on servo motor shaft JL can be calculated with the following expression.

$$J_L = J_{L1} + J_{L2} + J_{L3}$$

J_{L1} is the load moment of inertia of the moving part, J_{L2} is the load moment of inertia of the ball screw, and J_{L3} is the load moment of inertia of the coupling. J_{L1} and J_{L2} can be calculated with the following expressions.

$$J_{L1} = W_L \times (\Delta S / (20 \times \pi))^2 \quad J_{L2} = \{(\pi \times 0.0078 \times (L_B / 10)) / 32\} \times (D_B / 10)^4$$

From the calculation results in 1) to 8), find the absolute value (Es) of the sum total of negative energies.

■ Losses of servo motor and servo amplifier in regenerative mode

The following table lists the efficiencies and other data of the servo motor and servo amplifier in the regenerative mode.

Servo amplifier	Inverse efficiency [%]	Capacitor charging [J]
MR-J4-10GF(-RJ)	55	9
MR-J4-20GF(-RJ)	75	9
MR-J4-40GF(-RJ)	85	11
MR-J4-60GF(-RJ)	85	11
MR-J4-70GF(-RJ)	85	18
MR-J4-100GF(-RJ)	85	18
MR-J4-200GF(-RJ)	85	36
MR-J4-350GF(-RJ)	85	40
MR-J4-500GF(-RJ)	90	45
MR-J4-700GF(-RJ)	90	70
MR-J4-11KGF(-RJ)	90	120
MR-J4-15KGF(-RJ)	90	170
MR-J4-22KGF(-RJ)	90	250
MR-J4-60GF4(-RJ)	85	12
MR-J4-100GF4(-RJ)	85	12
MR-J4-200GF4(-RJ)	85	25
MR-J4-350GF4(-RJ)	85	43
MR-J4-500GF4(-RJ)	90	45
MR-J4-700GF4(-RJ)	90	70
MR-J4-11KGF4(-RJ)	90	120
MR-J4-15KGF4(-RJ)	90	170
MR-J4-22KGF4(-RJ)	90	250
MR-J4-10GF1(-RJ)	55	4
MR-J4-20GF1(-RJ)	75	4
MR-J4-40GF1(-RJ)	85	10

Inverse efficiency (η_m): Efficiency including some efficiencies of the servo motor and servo amplifier when rated (regenerative) torque is generated at rated speed. Efficiency varies with the speed and generated torque. Since the characteristics of the electrolytic capacitor change with time, allow for approximately 10% higher inverse efficiency.

Capacitor charging (E_c): Energy charged into the electrolytic capacitor in the servo amplifier

Subtract the capacitor charging from the result of multiplying the sum total of regenerative energies by the inverse efficiency to calculate the energy consumed by the regenerative option.

$$ER [J] = \eta_m \cdot E_s - E_c$$

Calculate the power consumption of the regenerative option on the basis of single-cycle operation period t_f [s] to select the necessary regenerative option.

$$PR [W] = ER/t_f$$

Linear servo motor

Thrust and energy calculation

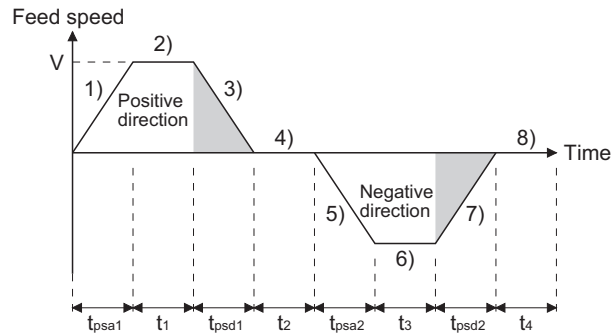
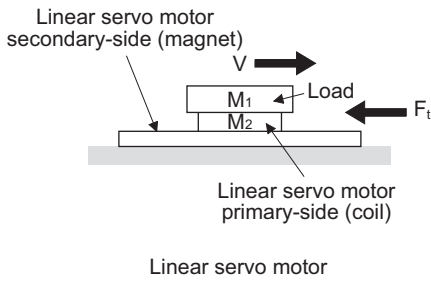

The following shows equations of the linear servo motor thrust and energy at the driving pattern above.

Section	Thrust F of linear servo motor [N]	Energy E [J]
1)	$F_1 = (M_1 + M_2) \cdot V/t_{psa1} + F_t$	$E_1 = V/2 \cdot F_1 \cdot t_{psa1}$
2)	$F_2 = F_t$	$E_2 = V \cdot F_2 \cdot t_1$
3)	$F_3 = -(M_1 + M_2) \cdot V/t_{psd1} + F_t$	$E_3 = V/2 \cdot F_3 \cdot t_{psd1}$
4), 8)	$F_4, F_8 = 0$	$E_4, E_8 = 0$ (No regeneration)
5)	$F_5 = (M_1 + M_2) \cdot V/t_{psa2} + F_t$	$E_5 = V/2 \cdot F_5 \cdot t_{psa2}$
6)	$F_6 = F_t$	$E_6 = V \cdot F_6 \cdot t_3$
7)	$F_7 = -(M_1 + M_2) \cdot V/t_{psd2} + F_t$	$E_7 = V/2 \cdot F_7 \cdot t_{psd2}$

From the calculation results in 1) to 8), find the absolute value (Es) of the sum total of negative energies.

Losses of servo motor and servo amplifier in regenerative mode

For inverse efficiency and capacitor charging energy, refer to the following.

☞ Page 342 Losses of servo motor and servo amplifier in regenerative mode

Regenerative energy calculation

Subtract the capacitor charging from the result of multiplying the sum total of regenerative energies by the inverse efficiency to calculate the energy consumed by the regenerative resistor.

$$ER [J] = \eta \cdot E_s - E_c$$

From the total of ER's whose subtraction results are positive and one-cycle period, the power consumption PR [W] of the regenerative option can be calculated with the following equation.

$$PR [W] = \text{total of positive ER's} / \text{one-cycle operation period (tf)}$$

Select a regenerative option from the PR value. Regenerative option is not required when the energy consumption is equal to or less than the built-in regenerative energy.

Parameter setting

Set [Pr. PA02] according to the option to be used.

[Pr. PA02]

0	0		
---	---	--	--

Regenerative option selection

00: Regenerative option is not used.

- For servo amplifier of 100 W, regenerative resistor is not used.
- For servo amplifier of 0.2 kW to 7 kW, built-in regenerative resistor is used.

▪ Supplied regenerative resistors or regenerative option is used with the servo amplifier of 11 kW to 22 kW.

01: FR-BU2/FR-BU2-H/FR-RC/FR-RC-H/FR-CV/FR-CV-H

02: MR-RB032

03: MR-RB12

04: MR-RB32

05: MR-RB30

06: MR-RB50 (Cooling fan is required)

08: MR-RB31

09: MR-RB51 (Cooling fan is required)

0B: MR-RB3N

0C: MR-RB5N (Cooling fan is required)

80: MR-RB1H-4

81: MR-RB3M-4 (Cooling fan is required.)

82: MR-RB3G-4 (Cooling fan is required.)

83: MR-RB5G-4 (Cooling fan is required.)

84: MR-RB34-4 (Cooling fan is required.)

85: MR-RB54-4 (Cooling fan is required.)

91: MR-RB3U-4 (Cooling fan is required.)

92: MR-RB5U-4 (Cooling fan is required.)

FA: When the supplied regenerative resistors or the regenerative option is cooled by the cooling fan to increase the ability with the servo amplifier of 11 kW to 22 kW.

Connection of regenerative option

Point

- When MR-RB50, MR-RB51, MR-RB5N, MR-RB3M-4, MR-RB3G-4, MR-RB5G-4, MR-RB34-4, MR-RB54-4, MR-RB5K-4, or MR-RB6K-4 is used, a cooling fan is required to cool it. The cooling fan should be prepared by the customer.
- For the wire sizes used for wiring, refer to the following.  Page 402 Selection example of wires

The regenerative option generates heat of 100 °C higher than the ambient temperature. Fully consider heat dissipation, installation position, wires used, etc. before installing the option. For wiring, use flame-resistant wires or make the wires flame-resistant and keep them away from the regenerative option. Always use twisted cables of max. 5 m length for connection with the servo amplifier.

MR-J4-500GF(-RJ) or less/MR-J4-350GF4(-RJ) or less

Always remove the wiring from across P+ to D and fit the regenerative option across P+ to C. G3 and G4 are thermal sensor's terminals. Between G3 and G4 is opened when the regenerative option overheats abnormally.

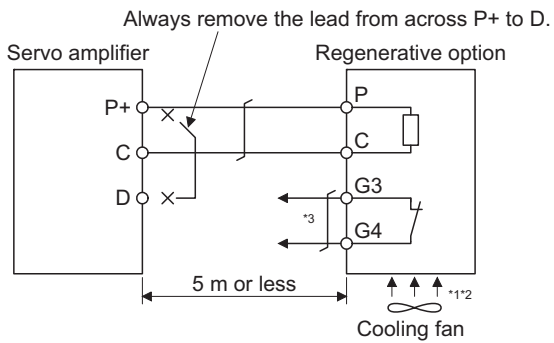

- *1 When using the MR-RB50, MR-RB5N, MR-RB51, MR-RB3M-4, MR-RB3G-4, or MR-RB5G-4, forcibly cool it with a cooling fan (1.0 m³/min or more, 92 mm × 92 mm).
- *2 When the ambient temperature is more than 55 °C and the regenerative load ratio is more than 60% in MR-RB30, MR-RB31, MR-RB32, and MR-RB3N, forcefully cool the air with a cooling fan (1.0 m³/min or more, 92 mm × 92 mm). A cooling fan is not required if the ambient temperature is 35 °C or less. (A cooling fan is required for the shaded area in the following graph.)

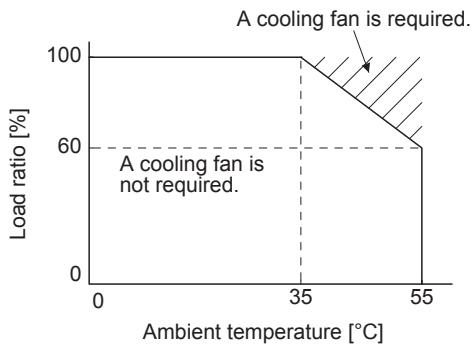

- *3 Make up a sequence which will switch off the magnetic contactor when abnormal heating occurs.
G3-G4 contact specifications
Maximum voltage: 120 V AC/DC
Maximum current: 0.5 A/4.8 V DC
Maximum capacity: 2.4 VA

MR-J4-500GF4(-RJ)/MR-J4-700GF(-RJ)/MR-J4-700GF4(-RJ)

Always remove the wiring (across P+ to C) of the servo amplifier built-in regenerative resistor and fit the regenerative option across P+ to C. G3 and G4 are thermal sensor's terminals. Between G3 and G4 is opened when the regenerative option overheats abnormally.

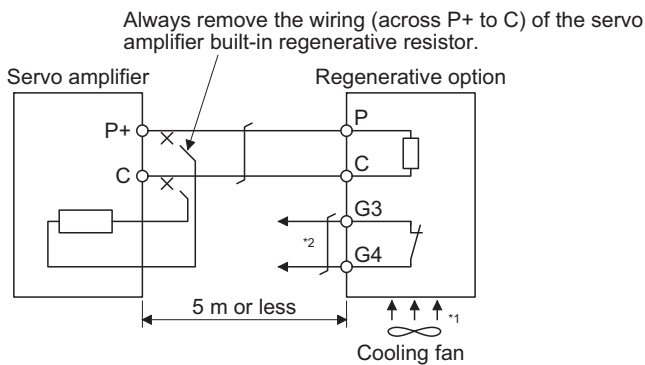

*1 When using the MR-RB51, MR-RB34-4, MR-RB54-4, MR-RB3U-4, or MR-RB5U-4, forcibly cool it with a cooling fan (1.0 m³/min or more, 92 mm × 92 mm).

*2 Make up a sequence which will switch off the magnetic contactor when abnormal heating occurs.

G3-G4 contact specifications

Maximum voltage: 120 V AC/DC

Maximum current: 0.5 A/4.8 V DC

Maximum capacity: 2.4 VA

When using the regenerative option, remove the servo amplifier's built-in regenerative resistor wires (across P+ to C), fit them back to back, and secure them to the frame with the accessory screw as shown below.

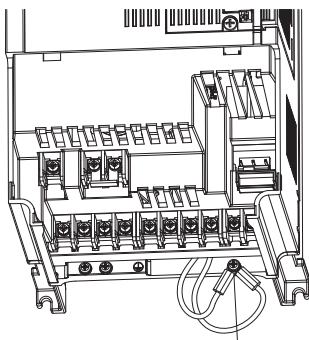

Built-in regenerative resistor
lead terminal fixing screw

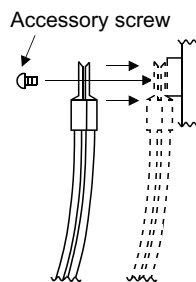

MR-J4-11KGF(-RJ) to MR-J4-22KGF(-RJ)/MR-J4-11KGF4(-RJ) to MR-J4-22KGF4(-RJ) (when using the supplied regenerative resistor)

CAUTION

- The regenerative resistor supplied with 11 kW to 22 kW servo amplifiers does not have a protective cover. Touching the resistor (including wiring/screw hole area) may cause a burn injury and electric shock. Even if the power was shut-off, be careful until the bus voltage discharged and the temperature decreased because of the following reasons.
 - It may cause a burn injury due to very high temperature.
 - It may cause an electric shock due to charged capacitor of the servo amplifier.
- Do not use servo amplifiers with external regenerative resistors other than the combinations specified below. Otherwise, it may cause a fire.

When using the regenerative resistors supplied to the servo amplifier, the specified number of resistors (4 or 5 resistors) must be connected in series. If they are connected in parallel or in less than the specified number, the servo amplifier may become faulty and/or the regenerative resistors burn.

Install the resistors at intervals of about 70 mm. Cooling the resistors with two cooling fans (1.0 m³/min or more, 92 mm × 92 mm) improves the regeneration capability. In this case, set " __ F A" in [Pr. PA02].

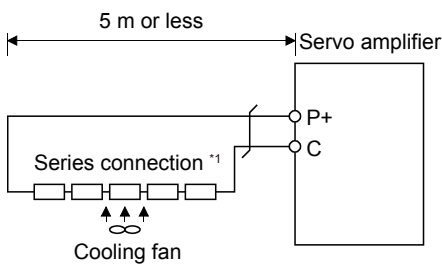

- *1 The number of resistors connected in series depends on the resistor type. The thermal sensor is not mounted on the attached regenerative resistor. An abnormal heating of resistor may be generated at a regenerative circuit failure. Install a thermal sensor near the resistor and establish a protective circuit to shut off the main circuit power supply when abnormal heating occurs. The detection level of the thermal sensor varies according to the settings of the resistor. Set the thermal sensor in the most appropriate position on the design basis of the device, or use the thermal sensor built-in regenerative option. (MR-RB5R, MR-RB9F, MR-RB9T, MR-RB5K-4, or MR-RB6K-4)

Servo amplifier	Regenerative resistor	Symbol*1	Regenerative power [W]		Resultant resistance [Ω]	Number of resistors
			Normal	Cooling		
MR-J4-11KGF(-RJ)	GRZG400-0.8 Ω	GR400 R80K	500	800	3.2	4
MR-J4-15KGF(-RJ)	GRZG400-0.6 Ω	GR400 R60K	850	1300	3	5
MR-J4-22KGF(-RJ)	GRZG400-0.5 Ω	GR400 R50K			2.5	
MR-J4-11KGF4(-RJ)	GRZG400-2.5 Ω	GR400 2R5K	500	800	10	4
MR-J4-15KGF4(-RJ) MR-J4-22KGF4(-RJ)	GRZG400-2 Ω	GR400 2R0K	850	1300	10	5

- *1 The following shows an indication example of symbol.

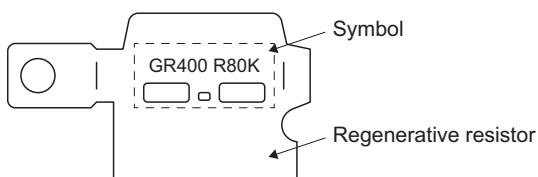

MR-J4-11KGF-PX to MR-J4-22KGF-PX, MR-J4-11KGF-RZ to MR-J4-22KGF-RZ, MR-J4-11KGF4-PX to MR-J4-22KGF4-PX, and MR-J4-11KGF4-RZ to MR-J4-22KGF4-RZ (when using the regenerative option)

The MR-J4-11KGF-PX to MR-J4-22KGF-PX, MR-J4-11KGF-RZ to MR-J4-22KGF-RZ, MR-J4-11KGF4-PX to MR-J4-22KGF4-PX, and MR-J4-11KGF4-RZ to MR-J4-22KGF4-RZ servo amplifiers are not supplied with regenerative resistors. When using any of these servo amplifiers, always use the regenerative option MR-RB5R, MR-RB9F, MR-RB9T, MR-RB5K-4, and MR-RB6K-4.

Cooling the regenerative option with cooling fans improves regenerative capability. G3 and G4 are thermal sensor's terminals. Between G3 and G4 is opened when the regenerative option overheats abnormally.

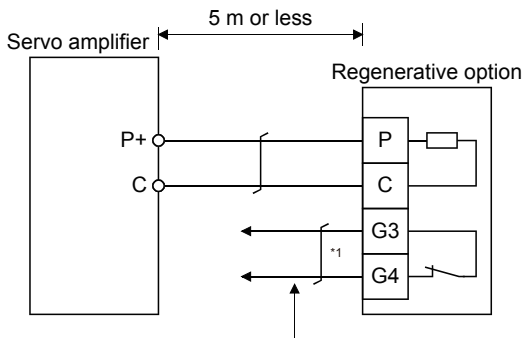

Configure up a circuit which shuts off main circuit power when thermal protector operates.

- *1 G3-G4 contact specifications
 Maximum voltage: 120 V AC/DC
 Maximum current: 0.5 A/4.8 V DC
 Maximum capacity: 2.4 VA

Servo amplifier	Regenerative options	Resistance [Ω]	Regenerative power [W]	
			Without cooling fans	With cooling fans
MR-J4-11KGF-PX MR-J4-11KGF-RZ	MR-RB5R	3.2	500	800
MR-J4-15KGF-PX MR-J4-15KGF-RZ	MR-RB9F	3	850	1300
MR-J4-22KGF-PX MR-J4-22KGF-RZ	MR-RB9T	2.5	850	1300
MR-J4-11KGF4-PX MR-J4-11KGF4-RZ	MR-RB5K-4	10	500	800
MR-J4-15KGF4-PX MR-J4-15KGF4-RZ MR-J4-22KGF4-PX MR-J4-22KGF4-RZ	MR-RB6K-4	10	850	1300

When using cooling fans, install them using the mounting holes provided in the bottom of the regenerative option.

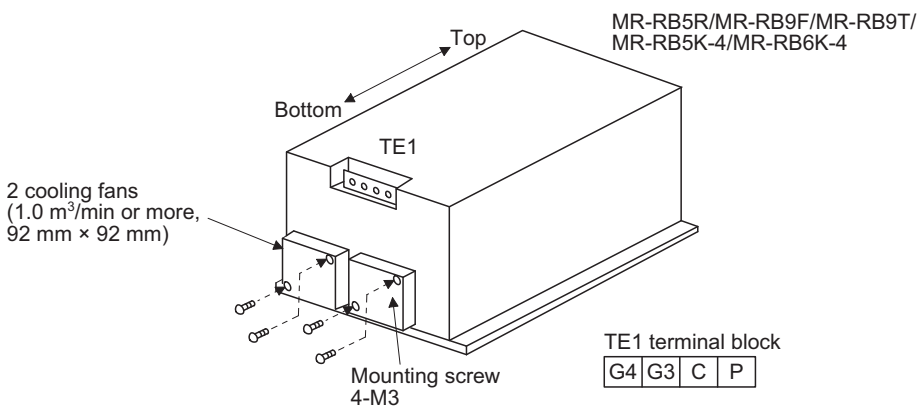

Mounting direction

The following shows the mounting directions of regenerative options.

Regenerative options	Mounting direction
MR-RB032	Mount vertically
MR-RB12	Mount vertically
MR-RB32	Mount vertically
MR-RB30	Mount vertically
MR-RB50 (Cooling fan is required.)	Mount vertically/horizontally
MR-RB31	Mount vertically
MR-RB51 (Cooling fan is required.)	Mount vertically/horizontally
MR-RB3N	Mount vertically
MR-RB5N (Cooling fan is required.)	Mount vertically/horizontally
MR-RB5R	Mount vertically
MR-RB9F	Mount vertically
MR-RB9T	Mount vertically
MR-RB1H-4	Mount vertically
MR-RB3M-4 (Cooling fan is required.)	Mount vertically
MR-RB3G-4 (Cooling fan is required.)	Mount vertically
MR-RB5G-4 (Cooling fan is required.)	Mount vertically/horizontally
MR-RB34-4 (Cooling fan is required.)	Mount vertically
MR-RB54-4 (Cooling fan is required.)	Mount vertically/horizontally
MR-RB3U-4 (Cooling fan is required.)	Mount vertically
MR-RB5U-4 (Cooling fan is required.)	Mount vertically/horizontally
MR-RB5K-4	Mount vertically
MR-RB6K-4	Mount vertically

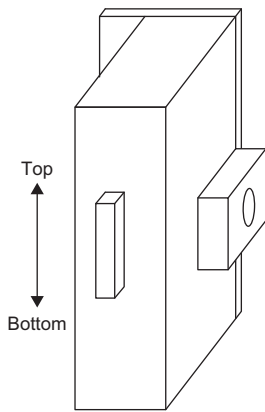

Mounting vertically

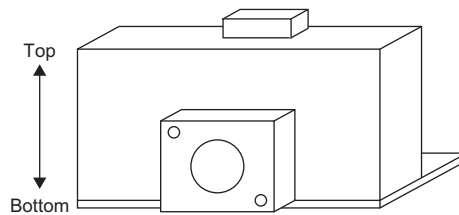

Mounting horizontally

Dimensions

MR-RB12

[Unit: mm]

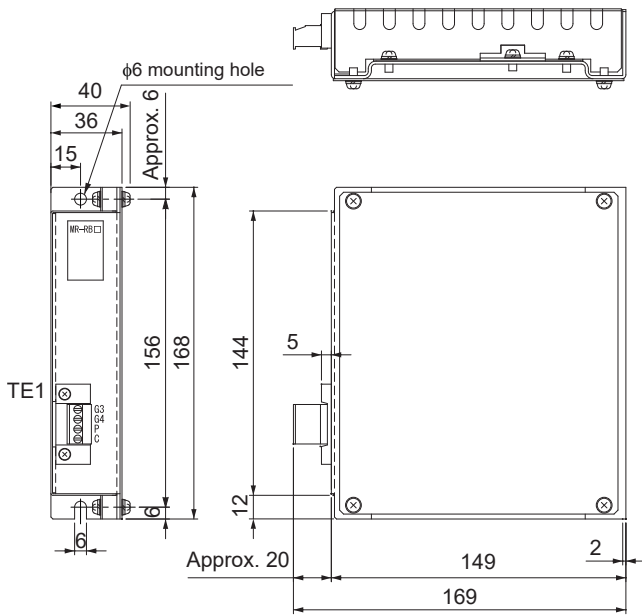

Mass: 1.1 [kg]

- TE1 terminal

G3
G4
P
C

Applicable wire size: 0.2 mm² to 2.5 mm² (AWG 24 to 12)

Tightening torque: 0.5 to 0.6 [N•m]

- Mounting screw

Screw size: M5

Tightening torque: 3.24 [N•m]

[Unit: mm]

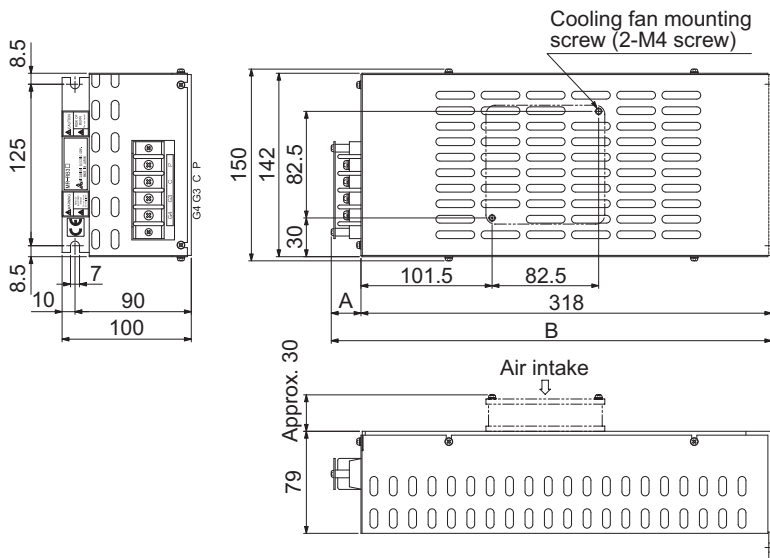

- Terminal block

P
C
G3
G4

Screw size: M4

Tightening torque: 1.2 [N•m]

- Mounting screw

Screw size: M6

Tightening torque: 5.4 [N•m]

Regenerative options	Variable dimensions		Mass [kg]
	A	B	
MR-RB30	17	335	2.9
MR-RB31			
MR-RB32			
MR-RB3N			
MR-RB34-4	23	341	
MR-RB3M-4			
MR-RB3G-4			
MR-RB3U-4			

MR-RB50/MR-RB51/MR-RB5N/MR-RB54-4/MR-RB5G-4/MR-RB5U-4

[Unit: mm]

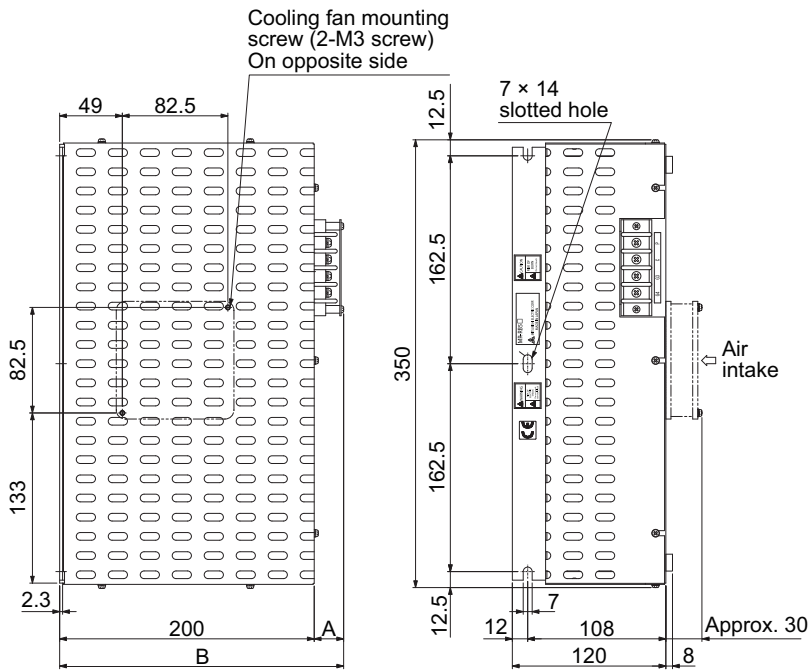

- Terminal block

P
C
G3
G4

Screw size: M4

Tightening torque: 1.2 [N•m]

- Mounting screw

Screw size: M6

Tightening torque: 5.4 [N•m]

Regenerative options	Variable dimensions		Mass [kg]
	A	B	
MR-RB50	17	217	5.6
MR-RB51			
MR-RB5N			
MR-RB54-4	23	223	
MR-RB5G-4			
MR-RB5U-4			

[Unit: mm]

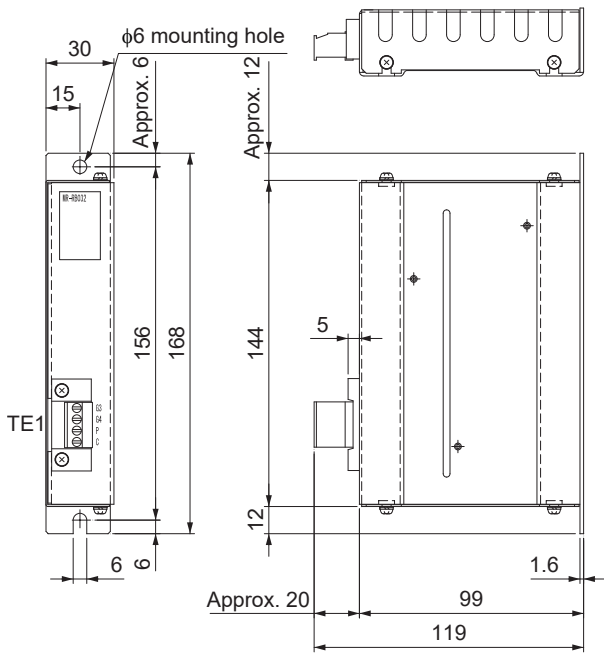

Mass: 0.5 [kg]

- TE1 terminal

G3
G4
P
C

Applicable wire size: 0.2 mm² to 2.5 mm² (AWG 24 to 12)

Tightening torque: 0.5 to 0.6 [N•m]

- Mounting screw

Screw size: M5

Tightening torque: 3.24 [N•m]

MR-RB5R/MR-RB9F/MR-RB9T/MR-RB5K-4/MR-RB6K-4

[Unit: mm]

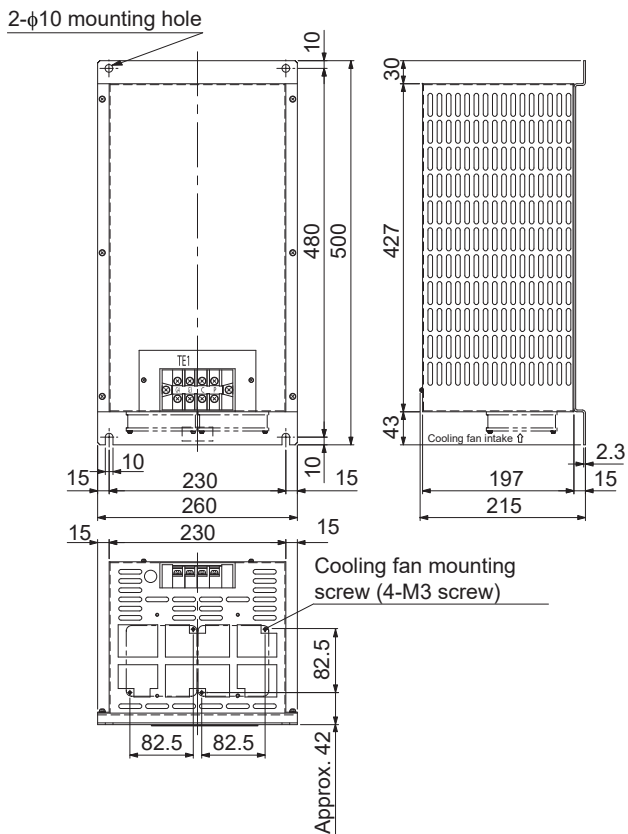

- TE1 terminal block

G4	G3	C	P
----	----	---	---

Screw size: M5

Tightening torque: 2.0 [N•m]

- Mounting screw

Screw size: M8

Tightening torque: 13.2 [N•m]

Regenerative options	Mass [kg]
MR-RB5R	10
MR-RB9F	11
MR-RB9T	
MR-RB5K-4	10
MR-RB6K-4	11

[Unit: mm]

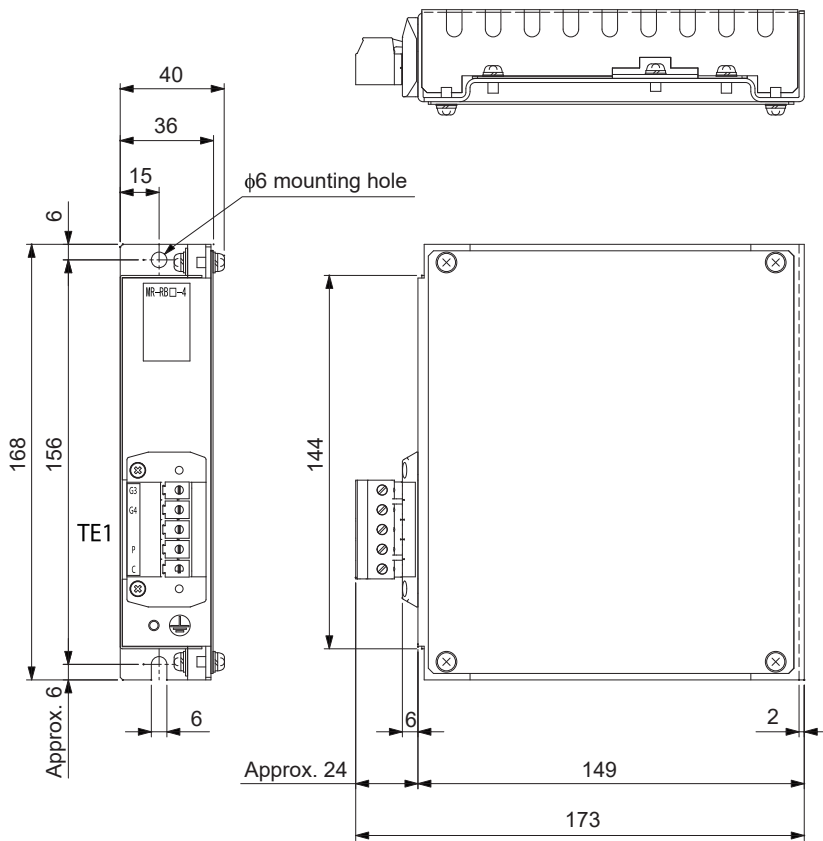

Mass: 1.1 [kg]

- TE1 terminal

G3
G4
P
C

Applicable wire size: AWG 24 to 10

Tightening torque: 0.5 to 0.6 [N•m]

- Mounting screw

Screw size: M5

Tightening torque: 3.24 [N•m]

GRZG400-0.8Ω/GRZG400-0.6Ω/GRZG400-0.5Ω/GRZG400-2.5Ω/GRZG400-2.0Ω (standard accessories)

[Unit: mm]

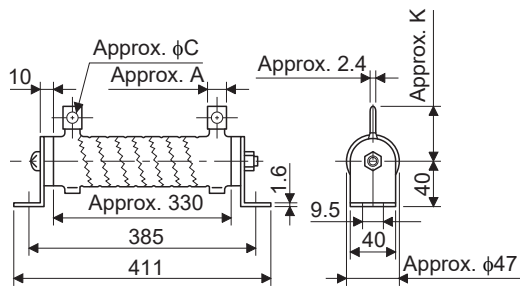

Regenerative resistor	Variable dimensions			Mounting screw size	Tightening torque [N•m]	Mass [kg]
	A	C	K			
GRZG400-0.8Ω	10	5.5	39	M8	13.2	0.8
GRZG400-0.6Ω	16	8.2	46			
GRZG400-0.5Ω						
GRZG400-2.5Ω	10	5.5	39			
GRZG400-2.0Ω						

11.3 FR-BU2-(H) brake unit

Point

- Use a 200 V class brake unit and a resistor unit with a 200 V class servo amplifier, and a 400 V class brake unit and a resistor unit with a 400 V class servo amplifier. Combination of different voltage class units cannot be used.
- When a brake unit and a resistor unit are installed horizontally or diagonally, the heat dissipation effect diminishes. Install them on a flat surface vertically.
- The temperature of the resistor unit case will be higher than the ambient temperature by 100 °C or over. Keep cables and flammable materials away from the case.
- Ambient temperature condition of the brake unit is between -10 °C and 50 °C. Note that the condition is different from the ambient temperature condition of the servo amplifier (between 0 °C and 55 °C).
- Configure the circuit to shut down the power-supply with the alarm output of the brake unit and the resistor unit under abnormal condition.
- Use the brake unit with a combination indicated in the following section.  Page 357 Selection
- For performing a continuous regenerative operation, use FR-RC-(H) power regeneration converter, FR-CV-(H) power regeneration common converter, or FR-XC-(H) multifunction regeneration converter.
- Brake unit and regenerative options (Regenerative resistor) cannot be used simultaneously.

Connect the brake unit to the bus of the servo amplifier. As compared to the MR-RB regenerative option, the brake unit can return larger power. Use the brake unit when the regenerative option cannot provide sufficient regenerative capability.

When using the brake unit, set [Pr. PA02] to "_ _ 0 1".

When using the brake unit, always refer to the FR-BU2 Instruction Manual.

Selection

Use a combination of servo amplifier, brake unit and resistor unit listed below.

Brake unit	Resistor unit	Number of connected units	Permissible continuous power [kW]	Resultant resistance [Ω]	Applicable servo amplifier ^{*3}	
200 V class	FR-BU2-15K	FR-BR-15K	1	0.99	8	MR-J4-500GF(-RJ) ^{*1}
			2 (parallel)	1.98	4	MR-J4-500GF(-RJ) MR-J4-700GF(-RJ) MR-J4-11KGF(-RJ) MR-J4-15KGF(-RJ)
	FR-BU2-30K	FR-BR-30K	1	1.99	4	MR-J4-500GF(-RJ) MR-J4-700GF(-RJ) MR-J4-11KGF(-RJ) MR-J4-15KGF(-RJ)
	FR-BU2-55K	FR-BR-55K	1	3.91	2	MR-J4-11KGF(-RJ) MR-J4-15KGF(-RJ) MR-J4-22KGF(-RJ)
		MT-BR5-55K	1	5.5	2	MR-J4-22KGF(-RJ)
400 V class	FR-BU2-H30K	FR-BR-H30K	1	1.99	16	MR-J4-500GF4(-RJ) MR-J4-700GF4(-RJ) MR-J4-11KGF4(-RJ) ^{*2}
	FR-BU2-H55K	FR-BR-H55K	1	3.91	8	MR-J4-11KGF4(-RJ) MR-J4-15KGF4(-RJ) MR-J4-22KGF4(-RJ)
	FR-BU2-H75K	MT-BR5-H75K	1	7.5	6.5	MR-J4-22KGF4(-RJ)

*1 Only when using servo motor HG-RR353/HG-UR352

*2 When HG-JR11K1M4 servo motor is used, limit the torque during power running to 180% or less, or the servo motor speed to 1800 r/min or less.

*3 When the brake unit is selected by using the capacity selection software, a brake unit other than the combinations listed may be shown. Refer to the combinations displayed on the capacity selection software for detailed combinations.

Brake unit parameter setting

Whether a parameter can be changed or not is listed below.

Parameter		Change possible/ impossible	Remark
No.	Name		
0	Brake mode switchover	Impossible	Do not change the parameter.
1	Monitor display data selection	Possible	Refer to the FR-BU2 Instruction Manual.
2	Input terminal function selection 1	Impossible	Do not change the parameter.
3	Input terminal function selection 2		
77	Parameter write selection		
78	Cumulative energization time carrying-over times		
CLr	Parameter clear		
ECL	Alarm history clear		
C1	For manufacturer setting		

Connection example

Point

- EM2 has the same function as EM1 in the torque mode.
- Connecting PR terminal of the brake unit to P+ terminal of the servo amplifier results in brake unit malfunction. Always connect the PR terminal of the brake unit to the PR terminal of the resistor unit.

Combination with FR-BR-(H) resistor unit

■ When connecting a brake unit to a servo amplifier

- 200 V class

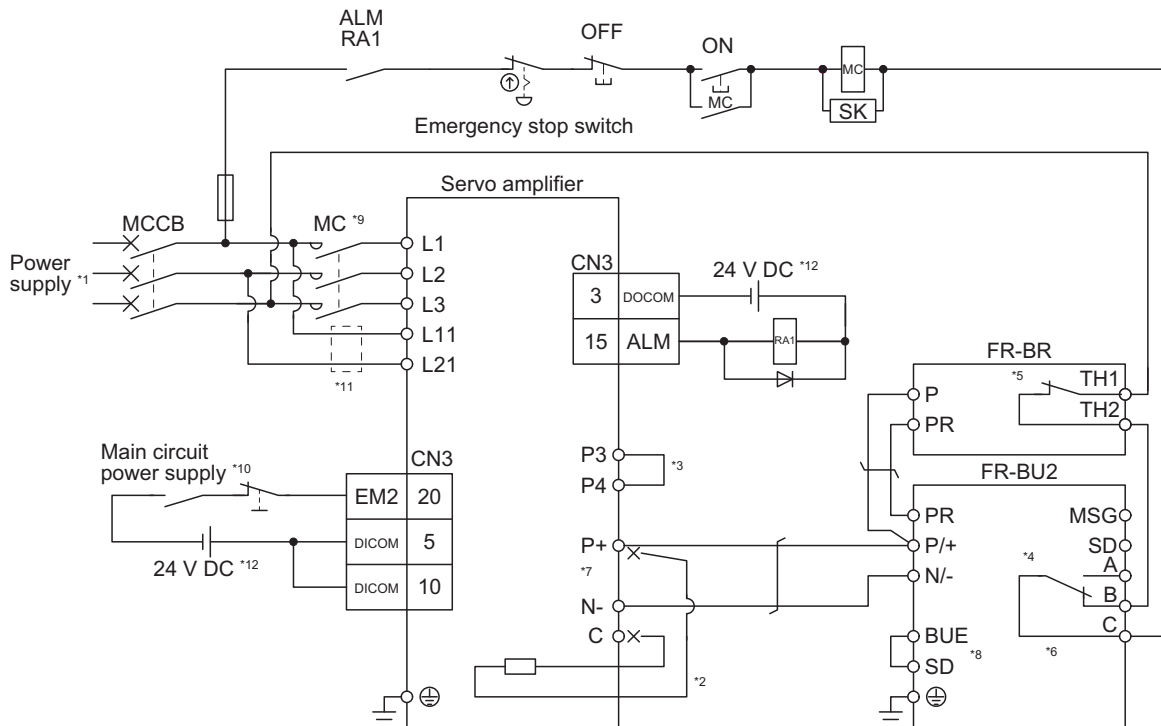

- *1 For the power supply specifications, refer to the following.
 ☞ Page 30 Servo amplifier standard specifications
- *2 When using the servo amplifier of 7 kW or less, make sure to disconnect the wiring of built-in regenerative resistor (5 kW or less: P+ and D, 7 kW: P+ and C). For the servo amplifier of 11 kW to 22 kW, do not connect a supplied regenerative resistor to the P+ and C terminals.
- *3 Between P3 and P4 is connected by default. When using the power factor improving DC reactor, remove the short bar between P3 and P4. Additionally, a power factor improving DC reactor and power factor improving AC reactor cannot be used simultaneously.
 ☞ Page 409 Power factor improving DC reactors
- *4 Connect P/+ and N/- terminals of the brake unit to a correct destination. Incorrect connection destination results in servo amplifier and brake unit malfunction.
- *5 Contact rating: 1b contact, 110 V AC, 5 A/220 V AC, 3 A
 Normal condition: TH1-TH2 is conducting. Abnormal condition: TH1-TH2 is not conducting.
- *6 Contact rating: 230 V AC, 0.3 A/30 V DC, 0.3 A
 Normal condition: B-C is conducting./A-C is not conducting. Abnormal condition: B-C is not conducting./A-C is conducting.
- *7 Do not connect more than one cable to each P+ and N- terminals of the servo amplifier.
- *8 Always connect BUE and SD terminals. (factory-wired)
- *9 Depending on the main circuit voltage and operation pattern, bus voltage decreases, and that may cause the forced stop deceleration to shift to the dynamic brake deceleration. When dynamic brake deceleration is not required, slow the time to turn off the magnetic contactor.
- *10 Configure a circuit to turn off EM2 when the main circuit power is turned off to prevent an unexpected restart of the servo amplifier.
- *11 When wires used for L11 and L21 are thinner than wires used for L1, L2, and L3, use a molded-case circuit breaker.
- *12 The illustration of the 24 V DC power supply is divided between input signal and output signal for convenience. However, they can be configured by one.

- 400 V class

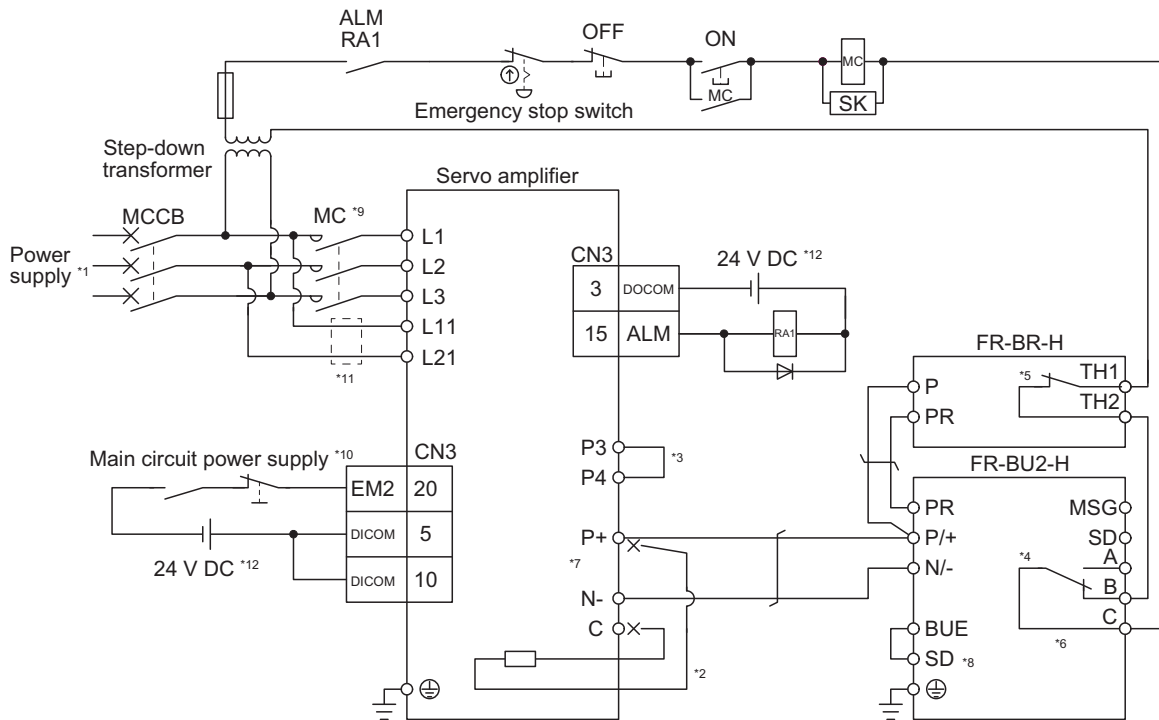

- *1 For the power supply specifications, refer to the following.
 - ☞ Page 30 Servo amplifier standard specifications
- *2 For the servo amplifier of 5 kW and 7 kW, be sure to disconnect the lead wire of built-in regenerative resistor, which is connected to P+ and C terminals. For the servo amplifier of 11 kW to 22 kW, do not connect a supplied regenerative resistor to the P+ and C terminals.
- *3 Between P3 and P4 is connected by default. When using the power factor improving DC reactor, remove the short bar between P3 and P4. Additionally, a power factor improving DC reactor and power factor improving AC reactor cannot be used simultaneously.
 - ☞ Page 409 Power factor improving DC reactors
- *4 Connect P/+ and N/- terminals of the brake unit to a correct destination. Incorrect connection destination results in servo amplifier and brake unit malfunction.
- *5 Contact rating: 1b contact, 110 V AC, 5 A/220 V AC, 3 A
Normal condition: TH1-TH2 is conducting. Abnormal condition: TH1-TH2 is not conducting.
- *6 Contact rating: 230 V AC, 0.3 A/30 V DC, 0.3 A
Normal condition: B-C is conducting./A-C is not conducting. Abnormal condition: B-C is not conducting./A-C is conducting.
- *7 Do not connect more than one cable to each P+ and N- terminals of the servo amplifier.
- *8 Always connect BUE and SD terminals. (factory-wired)
- *9 Depending on the main circuit voltage and operation pattern, bus voltage decreases, and that may cause the forced stop deceleration to shift to the dynamic brake deceleration. When dynamic brake deceleration is not required, slow the time to turn off the magnetic contactor.
- *10 Configure a circuit to turn off EM2 when the main circuit power is turned off to prevent an unexpected restart of the servo amplifier.
- *11 When wires used for L11 and L21 are thinner than wires used for L1, L2, and L3, use a molded-case circuit breaker.
- *12 The illustration of the 24 V DC power supply is divided between input signal and output signal for convenience. However, they can be configured by one.

■When connecting two brake units to a servo amplifier

Point

- To use brake units with a parallel connection, use two sets of FR-BU2 brake unit. Combination with other brake unit results in alarm occurrence or malfunction.
- Always connect the terminals for master/slave (MSG to MSG, SD to SD) between the two brake units.
- Do not connect the servo amplifier and brake units as below. Connect the cables with a terminal block to distribute as indicated in this section.

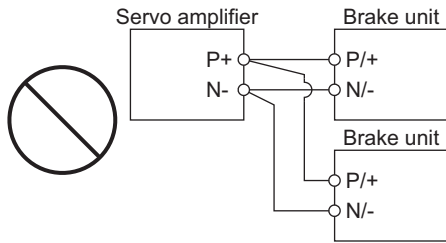

Connecting two cables to P+ and N- terminals

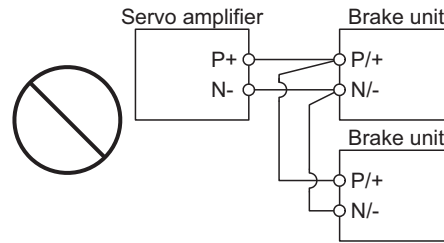

Passing wiring

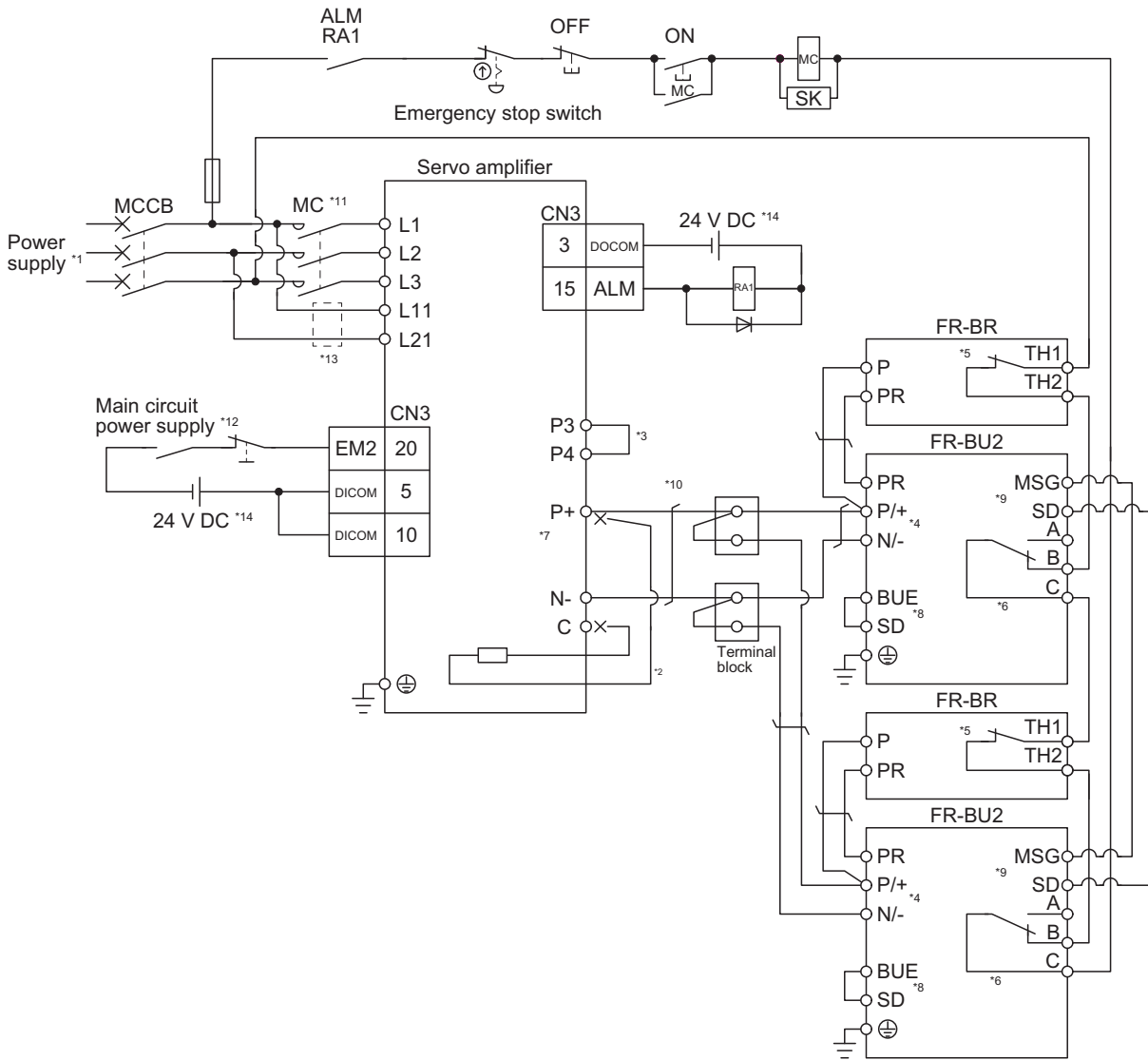

- *1 For the power supply specifications, refer to the following.
 - ☞ Page 30 Servo amplifier standard specifications
- *2 When using the servo amplifier of 7 kW or less, make sure to disconnect the wiring of built-in regenerative resistor (5 kW or less: P+ and D, 7 kW: P+ and C). For the servo amplifier of 11 kW to 22 kW, do not connect a supplied regenerative resistor to the P+ and C terminals.
- *3 Between P3 and P4 is connected by default. When using the power factor improving DC reactor, remove the short bar between P3 and P4. Additionally, a power factor improving DC reactor and power factor improving AC reactor cannot be used simultaneously.
 - ☞ Page 409 Power factor improving DC reactors
- *4 Connect P/+ and N/- terminals of the brake unit to a correct destination. Incorrect connection destination results in servo amplifier and brake unit malfunction.
- *5 Contact rating: 1b contact, 110 V AC, 5 A/220 V AC, 3 A
 Normal condition: TH1-TH2 is conducting. Abnormal condition: TH1-TH2 is not conducting.
- *6 Contact rating: 230 V AC, 0.3 A/30 V DC, 0.3 A
 Normal condition: B-C is conducting./A-C is not conducting. Abnormal condition: B-C is not conducting./A-C is conducting.
- *7 Do not connect more than one cable to each P+ and N- terminals of the servo amplifier.
- *8 Always connect BUE and SD terminals. (factory-wired)
- *9 Connect MSG and SD terminals of the brake unit to a correct destination. Incorrect connection destination results in servo amplifier and brake unit malfunction.
- *10 For connecting P+ and N- terminals of the servo amplifier to the terminal block, use the cable indicated in the following section.
 - ☞ Page 366 Cables for connecting the servo amplifier and a distribution terminal block when connecting two sets of the brake unit
- *11 Depending on the main circuit voltage and operation pattern, bus voltage decreases, and that may cause the forced stop deceleration to shift to the dynamic brake deceleration. When dynamic brake deceleration is not required, slow the time to turn off the magnetic contactor.
- *12 Configure a circuit to turn off EM2 when the main circuit power is turned off to prevent an unexpected restart of the servo amplifier.
- *13 When wires used for L11 and L21 are thinner than wires used for L1, L2, and L3, use a molded-case circuit breaker.
- *14 The illustration of the 24 V DC power supply is divided between input signal and output signal for convenience. However, they can be configured by one.

Combination with MT-BR5-(H) resistor unit

■200 V class

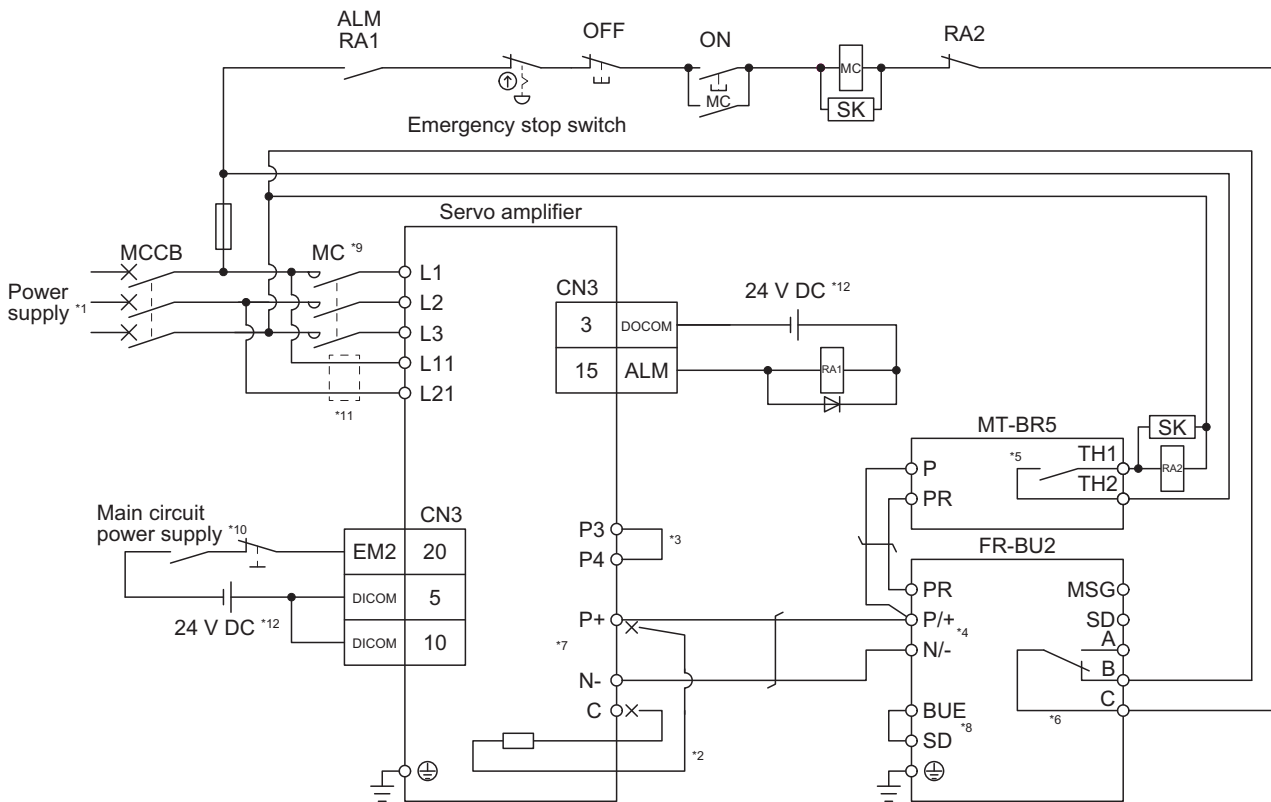

*1 For the power supply specifications, refer to the following.

☞ Page 30 Servo amplifier standard specifications

*2 Do not connect a supplied regenerative resistor to the P+ and C terminals.

*3 Between P3 and P4 is connected by default. When using the power factor improving DC reactor, remove the short bar between P3 and P4. Additionally, a power factor improving DC reactor and power factor improving AC reactor cannot be used simultaneously.

☞ Page 409 Power factor improving DC reactors

*4 Connect P/+ and N/- terminals of the brake unit to a correct destination. Incorrect connection destination results in servo amplifier and brake unit malfunction.

*5 Contact rating: 1a contact, 110 V AC, 5 A/220 V AC, 3 A

Normal condition: TH1-TH2 is not conducting. Abnormal condition: TH1-TH2 is conducting.

*6 Contact rating: 230 V AC, 0.3 A/30 V DC, 0.3 A

Normal condition: B-C is conducting./A-C is not conducting. Abnormal condition: B-C is not conducting./A-C is conducting.

*7 Do not connect more than one cable to each P+ and N- terminals of the servo amplifier.

*8 Always connect BUE and SD terminals. (factory-wired)

*9 Depending on the main circuit voltage and operation pattern, bus voltage decreases, and that may cause the forced stop deceleration to shift to the dynamic brake deceleration. When dynamic brake deceleration is not required, slow the time to turn off the magnetic contactor.

*10 Configure a circuit to turn off EM2 when the main circuit power is turned off to prevent an unexpected restart of the servo amplifier.

*11 When wires used for L11 and L21 are thinner than wires used for L1, L2, and L3, use a molded-case circuit breaker.

*12 The illustration of the 24 V DC power supply is divided between input signal and output signal for convenience. However, they can be configured by one.

■400 V class

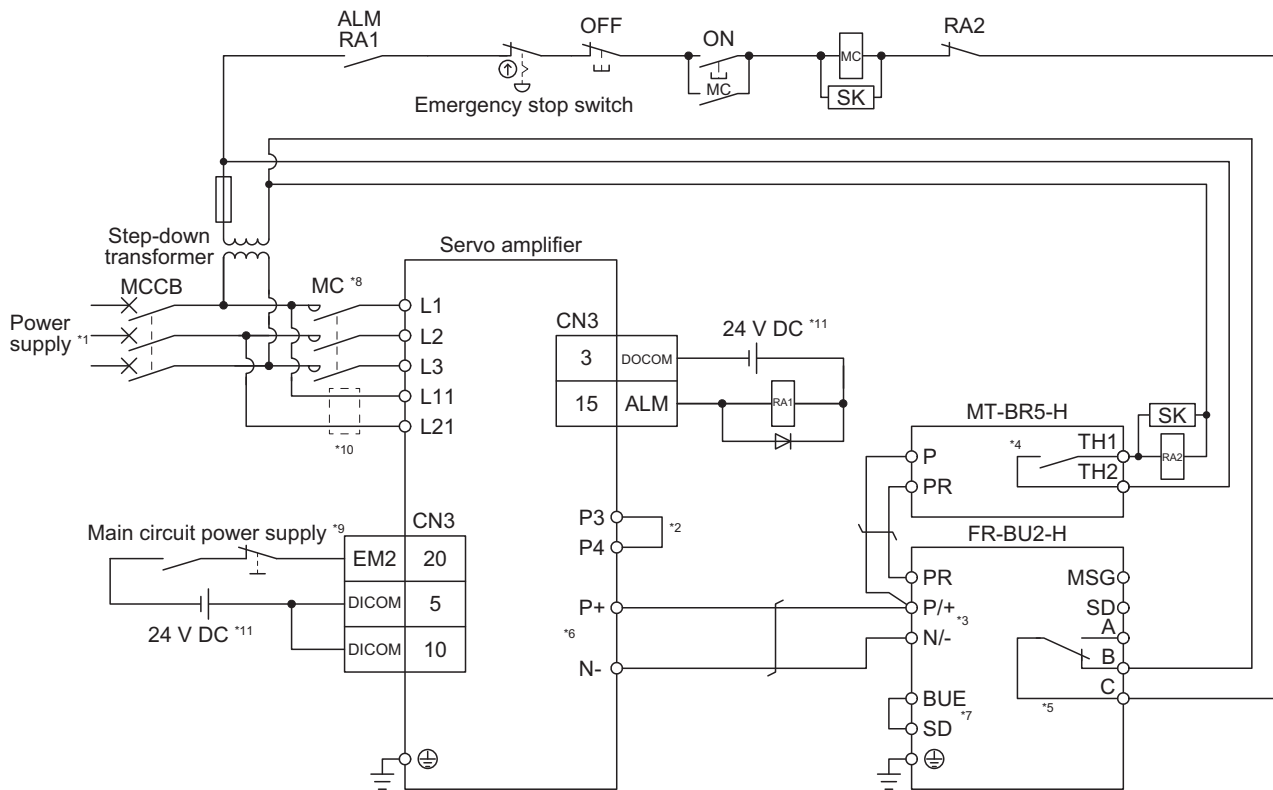

- *1 For the power supply specifications, refer to the following.
☞ Page 30 Servo amplifier standard specifications
- *2 Between P3 and P4 is connected by default. When using the power factor improving DC reactor, remove the short bar between P3 and P4. Additionally, a power factor improving DC reactor and power factor improving AC reactor cannot be used simultaneously.
☞ Page 409 Power factor improving DC reactors
- *3 Connect P/+ and N/- terminals of the brake unit to a correct destination. Incorrect connection destination results in servo amplifier and brake unit malfunction.
- *4 Contact rating: 1a contact, 110 V AC, 5 A/220 V AC, 3 A
 Normal condition: TH1-TH2 is not conducting. Abnormal condition: TH1-TH2 is conducting.
- *5 Contact rating: 230 V AC, 0.3 A/30 V DC, 0.3 A
 Normal condition: B-C is conducting./A-C is not conducting. Abnormal condition: B-C is not conducting./A-C is conducting.
- *6 Do not connect more than one cable to each P+ and N- terminals of the servo amplifier.
- *7 Always connect BUE and SD terminals. (factory-wired)
- *8 Depending on the main circuit voltage and operation pattern, bus voltage decreases, and that may cause the forced stop deceleration to shift to the dynamic brake deceleration. When dynamic brake deceleration is not required, slow the time to turn off the magnetic contactor.
- *9 Configure a circuit to turn off EM2 when the main circuit power is turned off to prevent an unexpected restart of the servo amplifier.
- *10 When wires used for L11 and L21 are thinner than wires used for L1, L2, and L3, use a molded-case circuit breaker.
- *11 The illustration of the 24 V DC power supply is divided between input signal and output signal for convenience. However, they can be configured by one.

Precautions for wiring

Keep the wires between the servo amplifier and the brake unit, and between the resistor unit and the brake unit as short as possible. For wires longer than 5 m, twist the wires five times or more per meter. The wires should not exceed 10 m even when the wires are twisted. If wires exceeding 5 m without twisted or exceeding 10 m with or without twisted are used, the brake unit may malfunction.

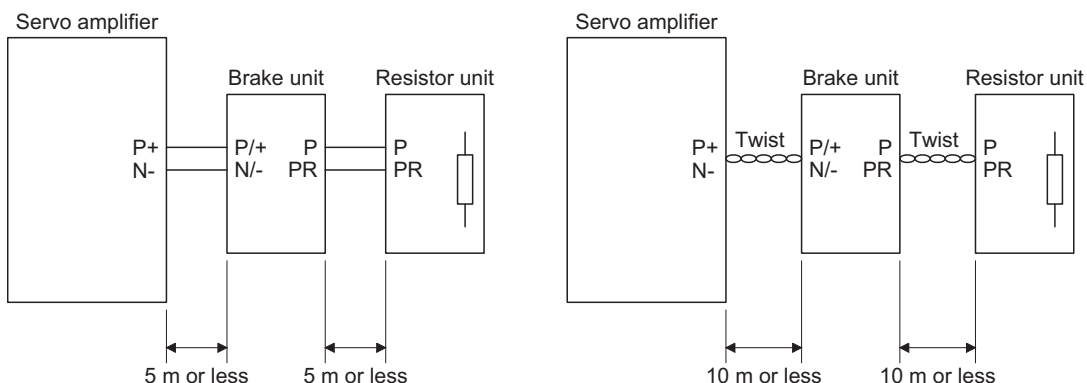

Wires

Wires for the brake unit

For the brake unit, HIV wire (600 V Grade heat-resistant polyvinyl chloride insulated wire) is recommended.

- Main circuit terminal

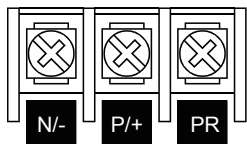

Terminal block

Brake unit		Main circuit terminal screw size	Crimp terminal N/-, P/+, PR, ⊕	Tightening torque [N•m]	Wire size	
					N/-, P/+, PR, ⊕	
					HIV wire [mm ²]	AWG
200 V class	FR-BU2-15K	M4	5.5-4	1.5	3.5	12
	FR-BU2-30K	M5	5.5-5	2.5	5.5	10
	FR-BU2-55K	M6	14-6	4.4	14	6
400 V class	FR-BU2-H30K	M4	5.5-4	1.5	3.5	12
	FR-BU2-H55K	M5	5.5-5	2.5	5.5	10
	FR-BU2-H75K	M6	14-6	4.4	14	6

- Control circuit terminal

Point

Under tightening can cause a cable disconnection or malfunction. Over tightening can cause a short circuit or malfunction due to damage to the screw or the brake unit.

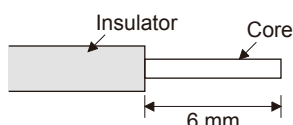
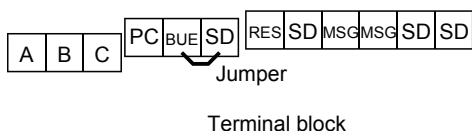

Wire the stripped cable after twisting to prevent the cable from becoming loose. In addition, do not solder it.

Screw size: M3

Tightening torque: 0.5 N•m to 0.6 N•m

Wire size: 0.3 mm² to 0.75 mm²

Screw driver: Small flat-blade screwdriver (Tip thickness: 0.4 mm/Tip width: 2.5 mm)

■Cables for connecting the servo amplifier and a distribution terminal block when connecting two sets of the brake unit

Brake unit	Wire size	
	HIV wire [mm ²]	AWG
FR-BU2-15K	8	8

Crimp terminals for P+ and N- terminals of servo amplifier

■Recommended crimp terminals



Some crimp terminals may not be mounted depending on the size. Make sure to use the recommended ones or equivalent ones.

Servo amplifier		Brake unit	Number of connected units	Crimp terminal (Manufacturer)	Applicable tool ^{*1}
200 V class	MR-J4-500GF(-RJ)	FR-BU2-15K	1	FVD5.5-S4 (JST)	a
			2	8-4NS (JST) ^{*2}	b
	MR-J4-700GF(-RJ)	FR-BU2-30K	1	FVD5.5-S4 (JST)	a
			2	8-4NS (JST) ^{*2}	b
			1	FVD5.5-S4 (JST)	a
	MR-J4-11KGF(-RJ)	FR-BU2-15K	2	FVD8-6 (JST)	c
			1	FVD5.5-6 (JST)	a
			1	FVD14-6 (JST)	d
	MR-J4-15KGF(-RJ)	FR-BU2-30K	2	FVD8-6 (JST)	c
			1	FVD5.5-6 (JST)	a
1			FVD14-6 (JST)	d	
MR-J4-22KGF(-RJ)	FR-BU2-55K	1	FVD14-8 (JST)	d	
400 V class	MR-J4-500GF4(-RJ)	FR-BU2-H30K	1	FVD5.5-S4 (JST)	a
	MR-J4-700GF4(-RJ)	FR-BU2-H30K	1	FVD5.5-S4 (JST)	a
	MR-J4-11KGF4(-RJ)	FR-BU2-H30K	1	FVD5.5-6 (JST)	a
			1	FVD5.5-6 (JST)	a
	MR-J4-15KGF4(-RJ)	FR-BU2-H55K	1	FVD5.5-6 (JST)	a
	MR-J4-22KGF4(-RJ)	FR-BU2-H55K	1	FVD5.5-8 (JST)	a
			1	FVD14-8 (JST)	d

*1 Symbols in the applicable tool field indicate applicable tools in the following section.

Page 366 Applicable tool

*2 Coat the crimping part with an insulation tube.

■Applicable tool

Symbol	Servo amplifier-side crimp terminals				Manufacturer
	Crimp terminal	Applicable tool			
		Body	Head	Dice	
a	FDV5.5-S4 FDV5.5-6	YNT-1210S	—	—	JST
b	8-4NS	YHT-8S	—	—	
c	FVD8-6	YF-1 E-4	YNE-38	DH-111 DH-121	
d	FVD14-6 FVD14-8	YF-1 E-4	YNE-38	DH-112 DH-122	

Dimensions

FR-BU2-(H) brake unit

■FR-BU2-15K

[Unit: mm]

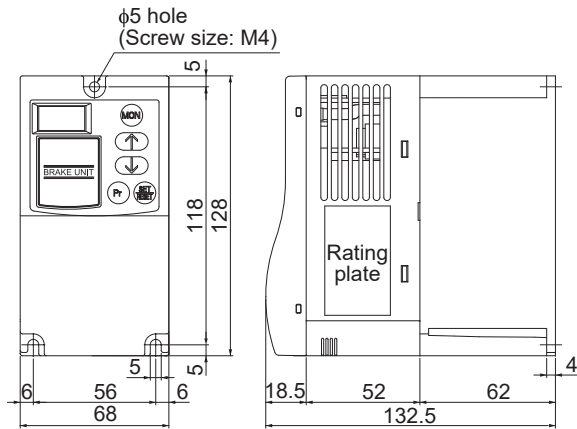

■FR-BU2-30K/FR-BU2-H30K

[Unit: mm]

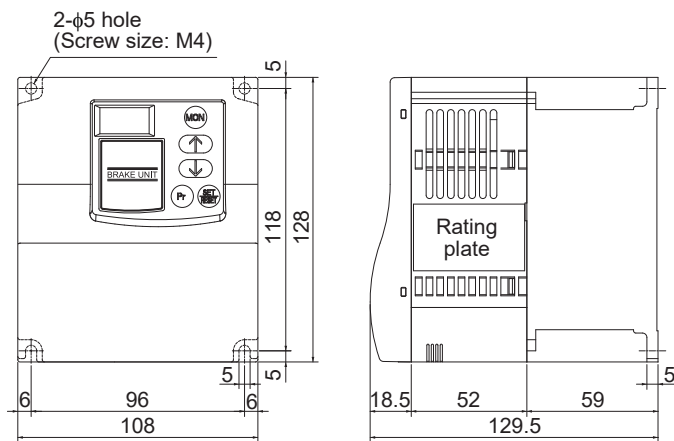

■FR-BU2-55K/FR-BU2-H55K/FR-BU2-H75K

[Unit: mm]

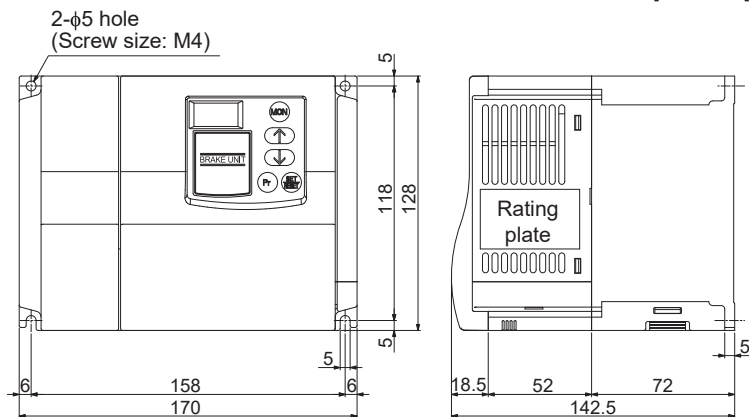

FR-BR-(H) resistor unit

[Unit: mm]

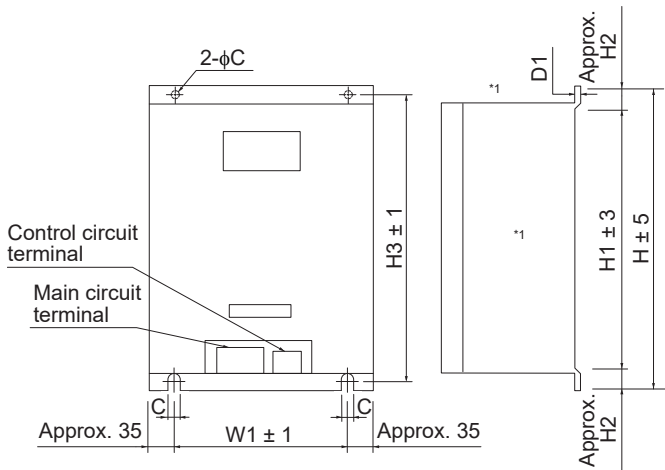

For FR-BR-55K/FR-BR-H55K, an eyebolt is placed on two locations. (Refer to the following diagram.)

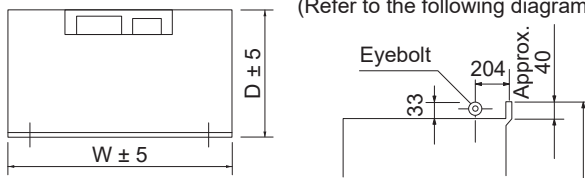

*1 Ventilation ports are provided on both sides and the top. The bottom is open.

Resistor unit		W	W1	H	H1	H2	H3	D	D1	C	Approximate mass [kg]
200 V class	FR-BR-15K	170	100	450	410	20	432	220	3.2	6	15
	FR-BR-30K	340	270	600	560	20	582	220	4	10	30
	FR-BR-55K	480	410	700	620	40	670	450	3.2	12	70
400 V class	FR-BR-H30K	340	270	600	560	20	582	220	4	10	30
	FR-BR-H55K	480	410	700	620	40	670	450	3.2	12	70

MT-BR5-(H) resistor unit

[Unit: mm]

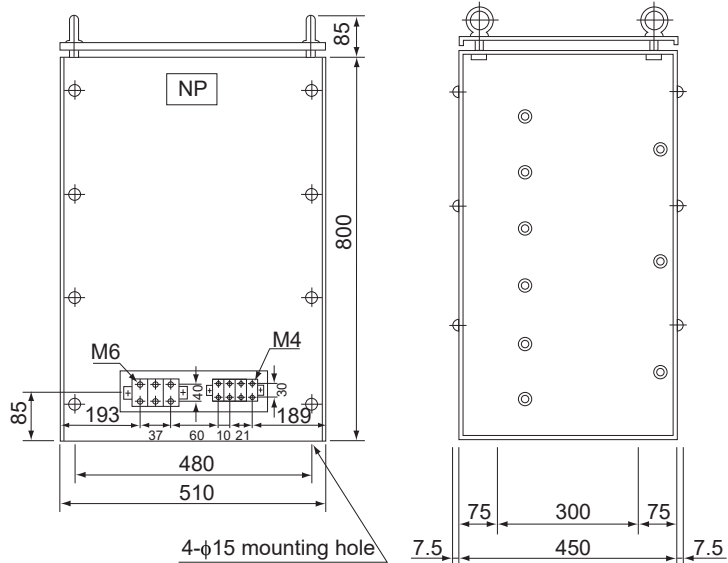

Resistor unit		Resistance	Approximate mass [kg]
200 V class	MT-BR5-55K	2.0 Ω	50
400 V class	MT-BR5-H75K	6.5 Ω	70

11.4 FR-RC-(H) power regeneration converter

Point

- When using the FR-RC-(H) power regeneration converter, set [Pr. PA04] to "0 0 __" to enable EM1 (Forced stop 1).
- When using the FR-RC-(H) power regeneration converter, refer to "Power Regeneration Converter FR-RC Instruction Manual (IB(NA)66330)".

When using the FR-RC-(H) power regeneration converter, set [Pr. PA02] to "__ 0 1" and set [Pr. PC20] to "__ _ 1".

Selection

The converters can continuously return 75% of the nominal regenerative power. They are applied to the servo amplifiers of the 5 kW to 22 kW.

Power regeneration converter	Nominal regenerative power [kW]	Applicable servo amplifier
FR-RC-15K	15	MR-J4-500GF(-RJ)
FR-RC-30K	30	MR-J4-700GF(-RJ) MR-J4-11KGF(-RJ) MR-J4-15KGF(-RJ)
FR-RC-55K	55	MR-J4-22KGF(-RJ)
FR-RC-H15K	15	MR-J4-500GF4(-RJ) MR-J4-700GF4(-RJ)
FR-RC-H30K	30	MR-J4-11KGF4(-RJ) MR-J4-15KGF4(-RJ)
FR-RC-H55K	55	MR-J4-22KGF4(-RJ)

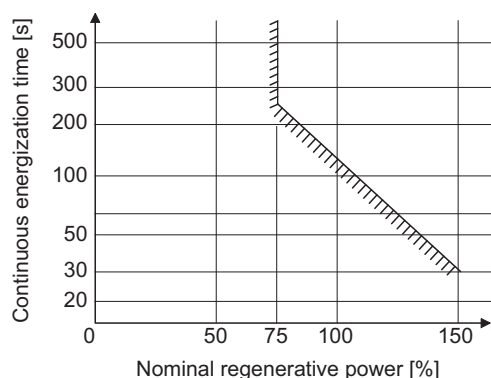

Connection example

Point

In this configuration, only the STO function is supported. The forced stop deceleration function is not available.

■200 V class

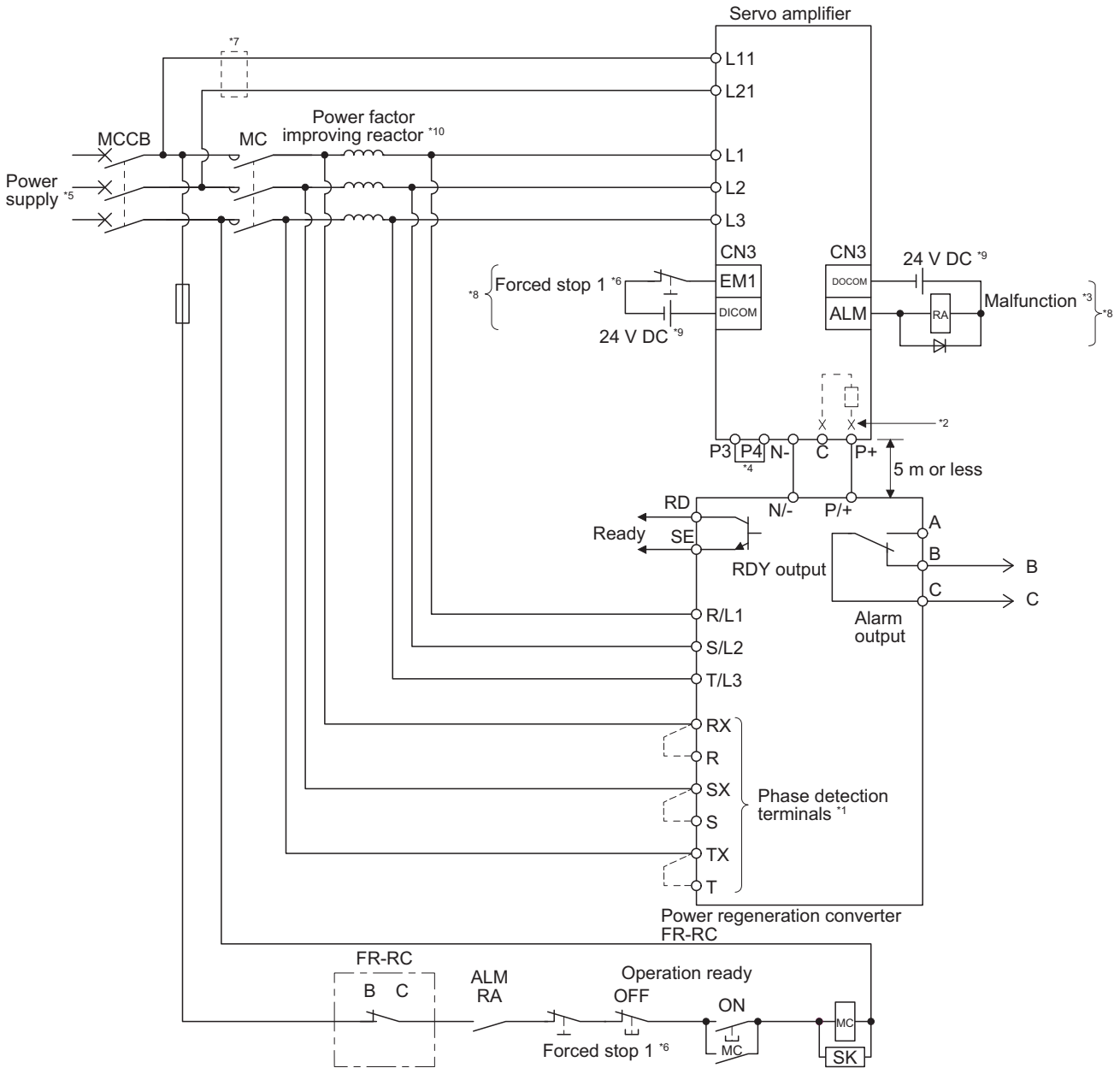

- *1 When not using the phase detection terminals, fit the jumpers across RX-R, SX-S and TX-T. If the jumpers remain removed, the FR-RC will not operate.
- *2 When using the servo amplifier of 7 kW or less, make sure to disconnect the wiring of built-in regenerative resistor (5 kW or less: P+ and D, 7 kW: P+ and C). For the servo amplifier of 11 kW to 22 kW, do not connect a supplied regenerative resistor to the P+ and C terminals.
- *3 If disabling ALM (Malfunction) output with the parameter, configure up the power supply circuit which switches off the magnetic contactor after detection of alarm occurrence on the controller side.
- *4 Between P3 and P4 is connected by default. When using the power factor improving DC reactor, remove the short bar between P3 and P4. Additionally, a power factor improving DC reactor and power factor improving AC reactor cannot be used simultaneously.
☞ Page 409 Power factor improving DC reactors
- *5 For the power supply specifications, refer to the following.
☞ Page 30 Servo amplifier standard specifications
- *6 Set [Pr. PA04] to "0 0 __" to enable EM1 (Forced stop 1). Configure up the circuit which shuts off main circuit power with external circuit at EM1 (Forced stop 1) off.
- *7 When wires used for L11 and L21 are thinner than wires used for L1, L2, and L3, use a molded-case circuit breaker.
- *8 This diagram shows sink I/O interface. For source I/O interface, refer to the following.
☞ Page 119 Source I/O interface
- *9 The illustration of the 24 V DC power supply is divided between input signal and output signal for convenience. However, they can be configured by one.
- *10 For selection of power factor improving AC reactors, refer to "Power Regeneration Converter FR-RC Instruction Manual (IB(NA)66330)".

■400 V class

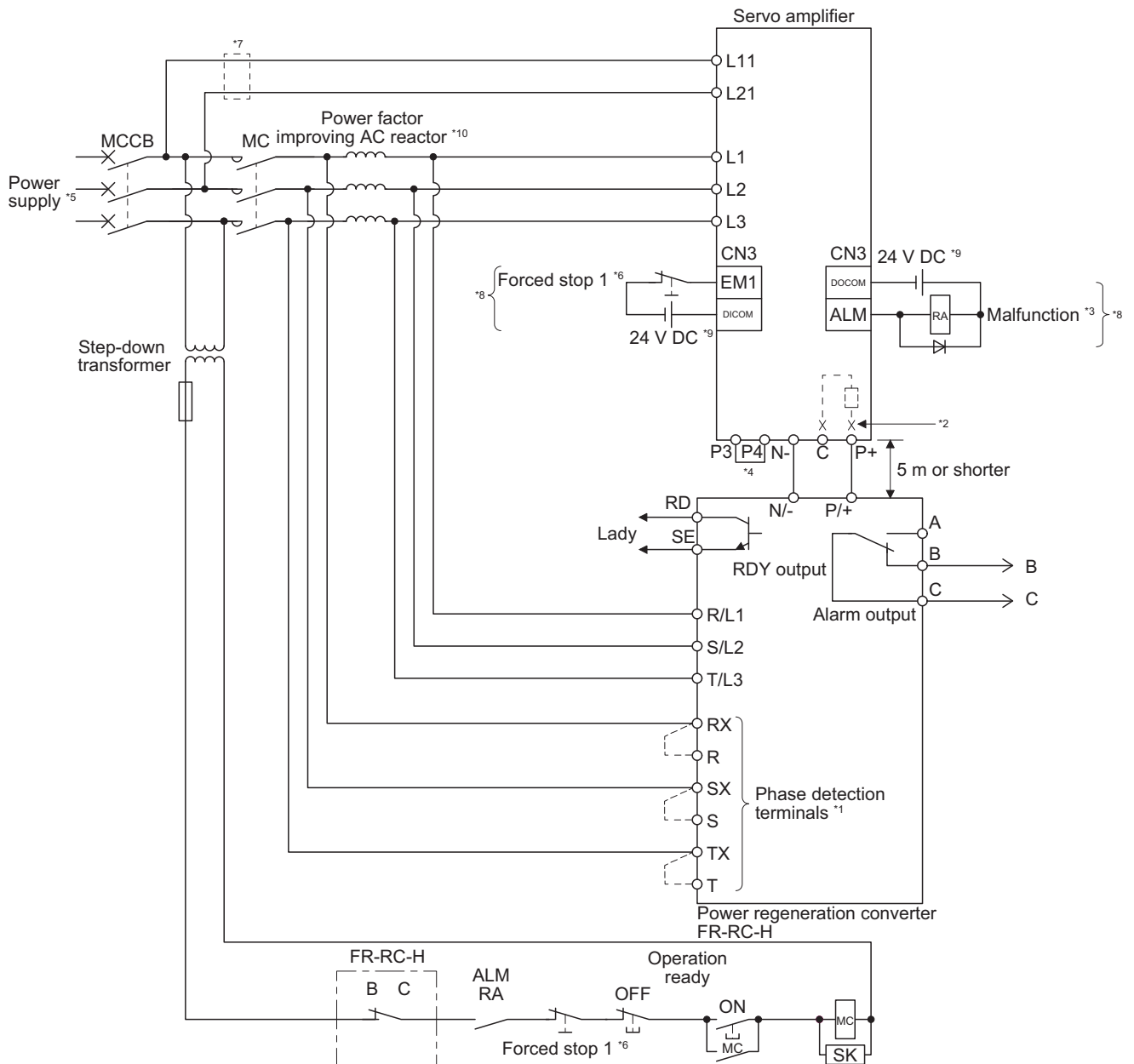

- *1 When not using the phase detection terminals, fit the jumpers across RX-R, SX-S and TX-T. If the jumpers remain removed, the FR-RC-H will not operate.
- *2 For the servo amplifier of 5 kW and 7 kW, be sure to disconnect the lead wire of built-in regenerative resistor, which is connected to P+ and C terminals. For the servo amplifier of 11 kW to 22 kW, do not connect a supplied regenerative resistor to the P+ and C terminals.
- *3 If disabling ALM (Malfunction) output with the parameter, configure up the power supply circuit which switches off the magnetic contactor after detection of alarm occurrence on the controller side.
- *4 Between P3 and P4 is connected by default. When using the power factor improving DC reactor, remove the short bar between P3 and P4. Additionally, a power factor improving DC reactor and power factor improving AC reactor cannot be used simultaneously.
 ☞ Page 409 Power factor improving DC reactors
- *5 For the power supply specifications, refer to the following.
 ☞ Page 30 Servo amplifier standard specifications
- *6 Set [Pr. PA04] to "0 0 _ _" to enable EM1 (Forced stop 1). Configure up the circuit which shuts off main circuit power with external circuit at EM1 (Forced stop 1) off.
- *7 When wires used for L11 and L21 are thinner than wires used for L1, L2, and L3, use a molded-case circuit breaker.
- *8 This diagram shows sink I/O interface. For source I/O interface, refer to the following.
 ☞ Page 119 Source I/O interface
- *9 The illustration of the 24 V DC power supply is divided between input signal and output signal for convenience. However, they can be configured by one.
- *10 For selection of power factor improving AC reactors, refer to "Power Regeneration Converter FR-RC Instruction Manual (IB(NA)66330)".

Dimensions

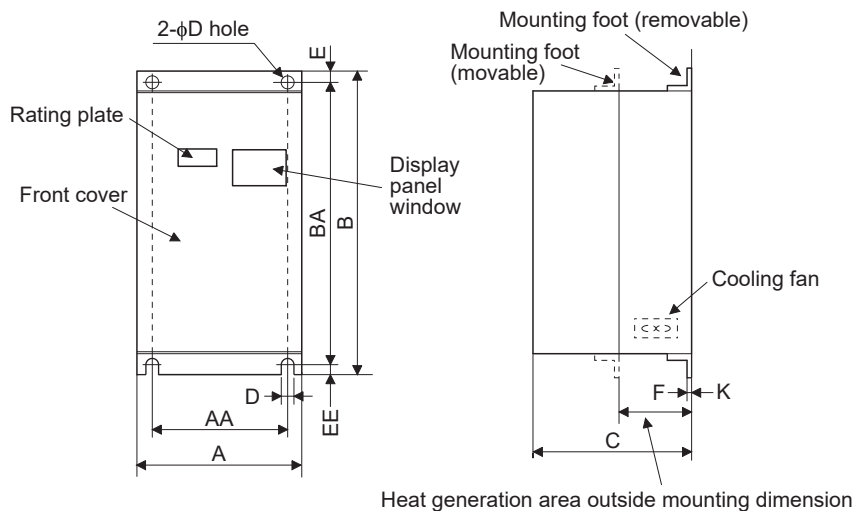

[Unit: mm]

Power regeneration converter	A	AA	B	BA	C	D	E	EE	K	F	Approximate mass [kg]
FR-RC-15K	270	200	450	432	195	10	10	8	3.2	87	19
FR-RC-30K	340	270	600	582	195	10	10	8	3.2	90	31
FR-RC-55K	480	410	700	670	250	12	15	15	3.2	135	55
FR-RC-H15K	340	270	600	582	195	10	10	8	3.2	90	31
FR-RC-H30K											
FR-RC-H55K	480	410	700	670	250	12	15	15	3.2	135	55

Mounting hole machining dimensions

The following shows mounting hole dimensions for mounting the heat generation area of the power regeneration converter outside a cabinet as measures against heat generation when the converter is mounted in an enclosed type cabinet.

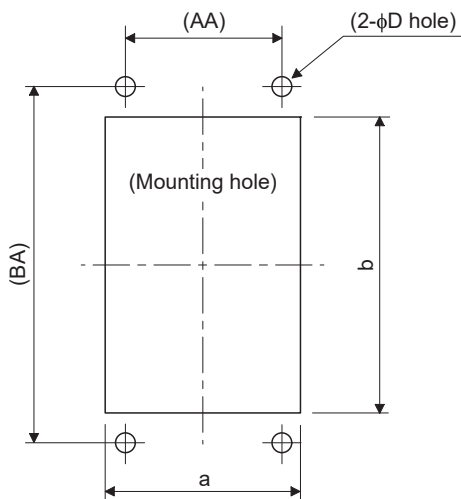

[Unit: mm]

Power regeneration converter	a	b	D	AA	BA
FR-RC-15K	260	412	10	200	432
FR-RC-30K	330	562	10	270	582
FR-RC-55K	470	642	12	410	670
FR-RC-H15K	330	562	10	270	582
FR-RC-H30K					
FR-RC-H55K	470	642	12	410	670

11.5 FR-CV-(H) power regeneration common converter

Point

- For details of the power regeneration common converter FR-CV-(H), refer to the FR-CV Installation Guide (IB(NA)0600075).
- Do not supply power to the main circuit power supply terminals (L1/L2/L3) of the servo amplifier. Doing so will fail the servo amplifier and FR-CV-(H).
- Connect the DC power supply between the FR-CV-(H) and servo amplifier with correct polarity. Connection with incorrect polarity will fail the FR-CV-(H) and servo amplifier.
- Two or more FR-CV-(H)s cannot be installed to improve regeneration capability. Two or more FR-CV-(H)s cannot be connected to the same DC power supply line.
- When using FR-CV-(H), set [Pr. PA04] to "0 0 _ _" to enable EM1 (Forced stop 1).

When using the FR-CV-(H) power regeneration common converter, set [Pr. PA02] to "_ _ 0 1" and set [Pr. PC20] to "_ _ _ 1".

Model designation

The following describes what each block of a model name indicates. Not all combinations of the symbols are available.

FR-CV-H 7.5K

Symbol	Capacity [kW]
7.5K	7.5
11K	11
15K	15
22K	22
30K	30
37K	37
55K	55

Symbol	Voltage class
None	200 V class
H	400 V class

Selection

200 V class

FR-CV power regeneration common converter can be used for the 200 V class servo amplifier of 100 W to 22 kW. The following shows the restrictions on using the FR-CV.

- Up to six servo amplifiers can be connected to one FR-CV.
- FR-CV capacity [W] \geq Total of rated capacities [W] \times 2 of servo amplifiers connected to FR-CV
- The total of used servo motor rated currents should be equal to or less than the applicable current [A] of the FR-CV.
- Among the servo amplifiers connected to the FR-CV, the rated capacity of the servo amplifier with the maximum rated capacity should be equal to or less than the value of "Maximum servo amplifier capacity" in the following table.

The following table lists the restrictions.

Item	FR-CV_						
	7.5K	11K	15K	22K	30K	37K	55K
Maximum number of connected servo amplifiers	6						
Total of connectable servo amplifier capacities [kW]	3.75	5.5	7.5	11	15	18.5	27.5
Total of connectable servo motor rated currents [A]	33	46	61	90	115	145	215
Maximum servo amplifier capacity [kW]	3.5	5	7	11	15	15	22

When using the FR-CV, always install the dedicated stand-alone reactor (FR-CVL).

Power regeneration common converter	Dedicated stand-alone reactor
FR-CV-7.5K(-AT)	FR-CVL-7.5K
FR-CV-11K(-AT)	FR-CVL-11K
FR-CV-15K(-AT)	FR-CVL-15K
FR-CV-22K(-AT)	FR-CVL-22K
FR-CV-30K(-AT)	FR-CVL-30K
FR-CV-37K	FR-CVL-37K
FR-CV-55K	FR-CVL-55K

400 V class

FR-CV-H power regeneration common converter can be used for the servo amplifier of 600 W to 22 kW. The following shows the restrictions on using the FR-CV-H.

- Up to six servo amplifiers can be connected to one FR-CV-H.
- $\text{FR-CV-H capacity [W]} \geq \text{Total of rated capacities [W]} \times 2$ of servo amplifiers connected to FR-CV-H.
- When FR-CV-H capacity is less than the total of rated capacities of the connected servo amplifiers $\times 2.5$, make the maximum torque of the connected servo motors equal to or less than 200 % of the rated torque. When FR-CV-H capacity exceeds the total of rated capacities of the connected servo amplifiers $\times 2.5$, the maximum torque of the connected servo amplifiers is not limited.
- The total of used servo motor rated currents should be equal to or less than the applicable current [A] of the FR-CV-H.
- Among the servo amplifiers connected to the FR-CV-H, the rated capacity of the servo amplifier with the maximum rated capacity should be equal to or less than the value of "Maximum servo amplifier capacity" in the following table.

The following table lists the restrictions.

Item	FR-CV-H_						
	7.5K	11K	15K	22K	30K	37K	55K
Maximum number of connected servo amplifiers	6						
Total of connectable servo amplifier capacities [kW]	3.75	5.5	7.5	11	15	18.5	27.5
Total of connectable servo motor rated currents [A]	17	23	31	43	57	71	110
Maximum servo amplifier capacity [kW]	3.5	5	7	11	15	15	22

When using the FR-CV-H, always install the dedicated stand-alone reactor (FR-CVL-H).

Power regeneration common converter	Dedicated stand-alone reactor
FR-CV-H7.5K(-AT)	FR-CVL-H7.5K
FR-CV-H11K(-AT)	FR-CVL-H11K
FR-CV-H15K(-AT)	FR-CVL-H15K
FR-CV-H22K(-AT)	FR-CVL-H22K
FR-CV-H30K(-AT)	FR-CVL-H30K
FR-CV-H37K	FR-CVL-H37K
FR-CV-H55K	FR-CVL-H55K

Connection diagram

Point

In this configuration, only the STO function is supported. The forced stop deceleration function is not available.

200 V class

Point

When using the servo amplifier of 7 kW or less, make sure to disconnect the wiring of built-in regenerative resistor (5 kW or less: P+ and D, 7 kW: P+ and C).

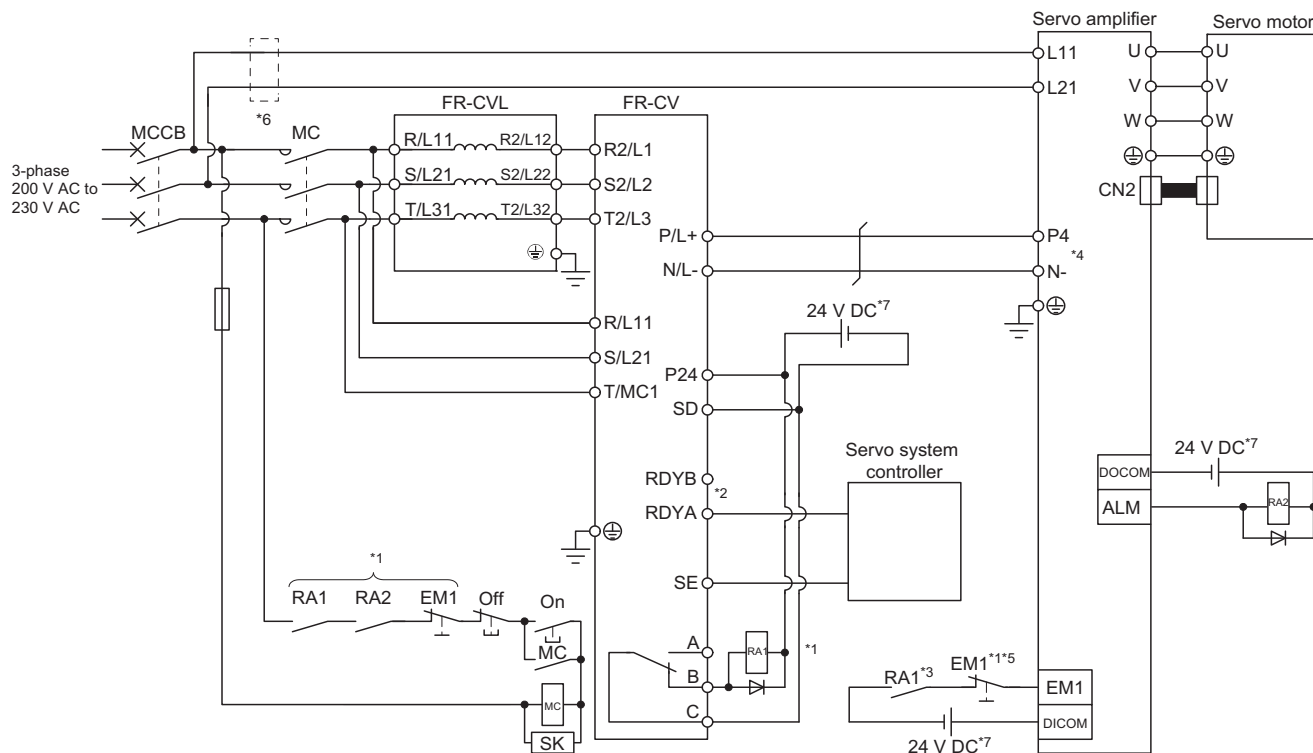

- *1 Configure a sequence that will shut off main circuit power in the following.
An alarm occurred at FR-CV or servo amplifier.
EM1 (Forced stop 1) is enabled.
- *2 For the servo amplifier, configure a sequence that will switch the servo-on after the FR-CV is ready.
- *3 Configure a sequence that will make a stop with the emergency stop input of the controller if an alarm occurs in the FR-CV. When the controller does not have an emergency stop input, use the forced stop input of the servo amplifier to make a stop as shown in the diagram.
- *4 When using FR-CV, always disconnect wiring between P3 and P4 terminals.
- *5 Set [Pr. PA04] to "0 0 __" to enable EM1 (Forced stop 1).
- *6 When wires used for L11 and L21 are thinner than wires used for L1, L2, and L3, use a molded-case circuit breaker.
- *7 The illustration of the 24 V DC power supply is divided between input signal and output signal for convenience. However, they can be configured by one.

400 V class

Point

When using the servo amplifier of 7 kW or less, be sure to disconnect the wiring of built-in regenerative resistor (3.5 kW or less: P+ and D, 5 kW/7 kW: P+ and C).

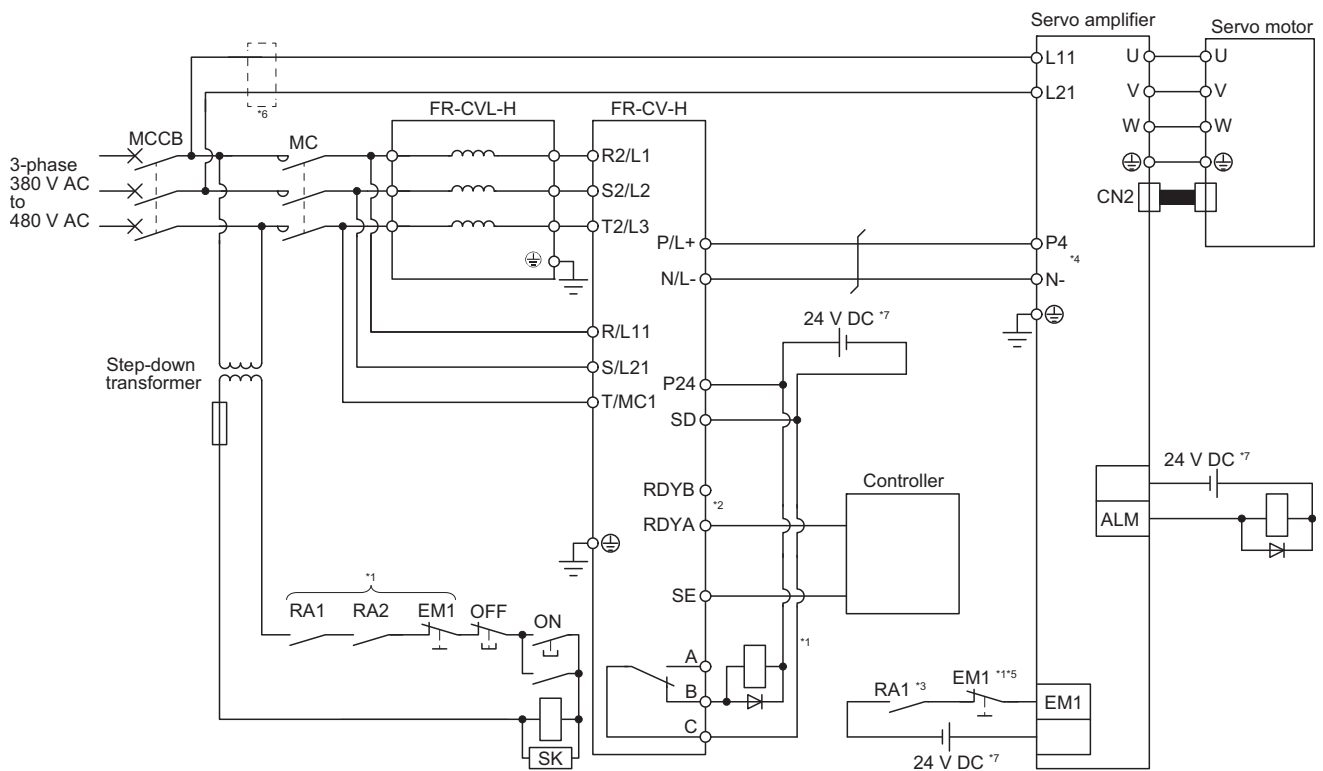

- *1 Configure a sequence that will shut off main circuit power in the following.
An alarm occurred at FR-CV-H or servo amplifier.
EM1 (Forced stop 1) is enabled.
- *2 For the servo amplifier, configure a sequence that will switch the servo-on after the FR-CV-H is ready.
- *3 Configure a sequence that will make a stop with the emergency stop input of the controller if an alarm occurs in the FR-CV-H. When the controller does not have an emergency stop input, use the forced stop input of the servo amplifier to make a stop as shown in the diagram.
- *4 When using FR-CV-H, always disconnect wiring between P3 and P4 terminals.
- *5 Set [Pr. PA04] to "0 0 _ _" to enable EM1 (Forced stop 1).
- *6 When wires used for L11 and L21 are thinner than wires used for L1, L2, and L3, use a molded-case circuit breaker.
- *7 The illustration of the 24 V DC power supply is divided between input signal and output signal for convenience. However, they can be configured by one.

Selection example of wires used for wiring

Point

- Selection conditions of wire size are as follows.

Wire type: 600 V Grade heat-resistant polyvinyl chloride insulated wire (HIV wire)

Construction condition: Single wire set in midair

■Wire size

- Between P and P4, and between N and N-

The following table indicates the connection wire sizes of the DC power supply (P4, N- terminals) between the FR-CV and servo amplifier.

Total of servo amplifier capacities [kW]	Wire [mm ²]
1 or less	2 (AWG 14)
2	3.5 (AWG 12)
5	5.5 (AWG 10)
7	8 (AWG 8)
11	14 (AWG 6)
15	22 (AWG 4)
22	50 (AWG 1/0)
27.5	50 (AWG 1/0)

The following table indicates the connection wire sizes of the DC power supply (P4, N- terminals) between the FR-CV-H and servo amplifier.

Total of servo amplifier capacities [kW]	Wire [mm ²]
2 or less	2 (AWG 14)
3.5	3.5 (AWG 12)
5	5.5 (AWG 10)
7	5.5 (AWG 10)
11	8 (AWG 8)
15	8 (AWG 8)
22	14 (AWG 6)
27.5	22 (AWG 4)

- Grounding

For grounding, use the wire of the size equal to or greater than that indicated in the following table, and make it as short as possible.

Power regeneration common converter	Grounding wire size [mm ²]
FR-CV-7.5K to FR-CV-15K	8 (AWG 8)
FR-CV-22K/FR-CV-30K	22 (AWG 4)
FR-CV-37K/FR-CV-55K	38 (AWG 2)
FR-CV-H7.5K to FR-CV-H15K	3.5 (AWG 12)
FR-CV-H22K/FR-CV-H30K	8 (AWG 8)
FR-CV-H37K/FR-CV-H55K	14 (AWG 6)

■ Example of selecting the wire sizes

- 200 V class

When connecting multiple servo amplifiers, always use junction terminals for wiring the servo amplifier terminals P4 and N-. Also, connect the servo amplifiers in the order of larger to smaller capacities.

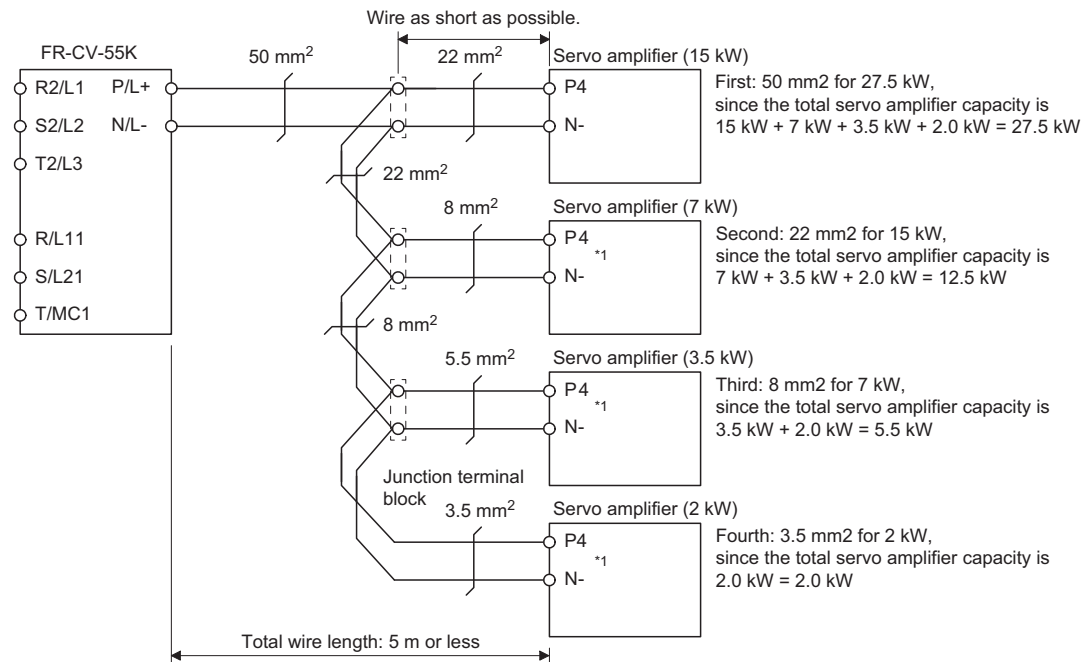

*1 When using the servo amplifier of 7 kW or less, make sure to disconnect the wiring of built-in regenerative resistor (5 kW or less: P+ and D, 7 kW: P+ and C).

- 400 V class

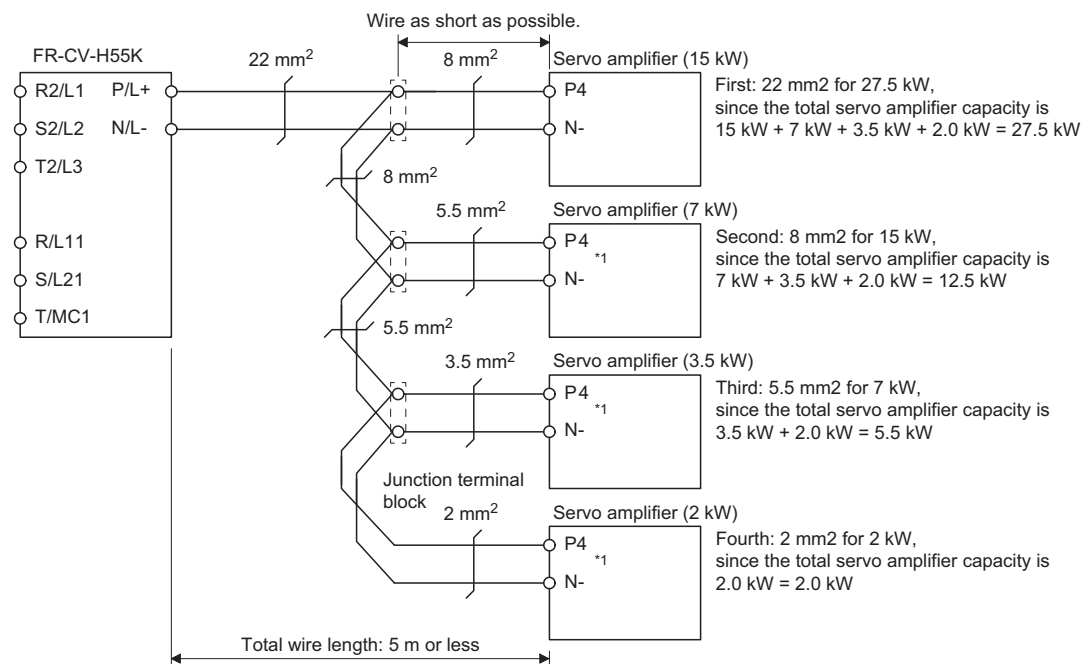

Other precautions

- When using the FR-CV-(H), always install the dedicated stand-alone reactor (FR-CVL-(H)). Do not use the power factor improving AC reactor (FR-HAL-(H)) or power factor improving DC reactor (FR-HEL-(H)).
- The inputs/outputs (main circuits) of the FR-CV-(H) and servo amplifiers include high-frequency components and may provide electromagnetic wave interference to communication equipment (such as AM radios) used near them. In this case, interference can be reduced by installing the radio noise filter (FR-BIF-(H)) or line noise filter (FR-BSF01, FR-BLF).
- The overall wiring length for connection of the DC power supply between the FR-CV-(H) and servo amplifiers should be 5 m or less, and the wiring must be twisted.

Specifications

Item	Power regeneration common converter FR-CV- <u> </u>								
	7.5K	11K	15K	22K	30K	37K	55K		
Total of connectable servo amplifier capacities [kW]	3.75	5.5	7.5	11	15	18.5	27.5		
Maximum servo amplifier capacity [kW]	3.5	5	7	11	15	15	22		
Output	Total of connectable servo motor rated currents [A]		33	46	61	90	115	145	215
	Regenerative braking torque	Short-time rating	Total capacity of applicable servo motors, 300% torque, 60 s ^{*1}						
		Continuous rating	100% torque						
Power	Rated input AC voltage/frequency		3-phase 200 V AC to 220 V AC, 50 Hz, 200 V AC to 230 V AC, 60 Hz						
	Permissible AC voltage fluctuation		3-phase 170 V AC to 242 V AC, 50 Hz, 170 V AC to 253 V AC, 60 Hz						
	Permissible frequency fluctuation		±5%						
	Power supply capacity ^{*2} [kVA]		17	20	28	41	52	66	100
IP rating (JEM 1030), cooling method			Open type (IP00), forced cooling						
Environment	Ambient temperature		-10 °C to 50 °C (non-freezing)						
	Ambient humidity		5 %RH to 90 %RH (non-condensing)						
	Ambience		Indoors (no direct sunlight); no corrosive gas, inflammable gas, oil mist or dust						
Altitude, vibration resistance			1000 m or less above sea level, 5.9 m/s ²						
Molded-case circuit breaker or earth-leakage current breaker	30AF	50AF	100AF	100AF	125AF	125AF	225AF		
	30A	50A	75A	100A	125A	125A	175A		
Magnetic contactor	S-N20	S-N35	S-N50	S-N65	S-N80	S-N95	S-N125		
	S-T21	S-T35	S-T50	S-T65	S-T80	S-T100			

*1 This is the time when the protective function of the FR-CV-(H) is activated. The protective function of the servo amplifier is activated in the time indicated in the following section.

 Page 314 Overload protection characteristics

*2 The specified value is the power supply capacity of FR-CV-(H). The total power supply capacities of the connected servo amplifiers are actually required.

Item	Power regeneration common converter FR-CV_								
	7.5K	11K	15K	22K	30K	37K	55K		
Total of connectable servo amplifier capacities [kW]	3.75	5.5	7.5	11	15	18.5	27.5		
Maximum servo amplifier capacity [kW]	3.5	5	7	11	15	15	22		
Output	Total of connectable servo motor rated currents [A]		17	23	31	43	57	71	110
	Regenerative braking torque	Short-time rating	Total capacity of applicable servo motors, 300% torque, 60 s ^{*1}						
		Continuous rating	100% torque						
Power	Rated input AC voltage/frequency		3-phase 380 V AC to 480 V AC, 50 Hz/60 Hz						
	Permissible AC voltage fluctuation		3-phase 323 V AC to 528 V AC, 50 Hz/60 Hz						
	Permissible frequency fluctuation		±5%						
	Power supply capacity ^{*2} [kVA]		17	20	28	41	52	66	100
IP rating (JEM 1030), cooling method			Open type (IP00), forced cooling						
Environment	Ambient temperature		-10 °C to 50 °C (non-freezing)						
	Ambient humidity		5 %RH to 90 %RH (non-condensing)						
	Ambience		Indoors (no direct sunlight); no corrosive gas, inflammable gas, oil mist or dust						
Altitude, vibration resistance			1000 m or less above sea level, 5.9 m/s ²						
Molded-case circuit breaker or earth-leakage current breaker			30AF 15A	30AF 20A	30AF 30A	50AF 50A	60AF 60A	100AF 75A	100AF 100A
Magnetic contactor			S-N20 S-T21	S-N20 S-T21	S-N20 S-T21	S-N25 S-T25	S-N35 S-T35	S-N50 S-T50	S-N65 S-T65

*1 This is the time when the protective function of the FR-CV-(H) is activated. The protective function of the servo amplifier is activated in the time indicated in the following section.

 Page 314 Overload protection characteristics

*2 The specified value is the power supply capacity of FR-CV-(H). The total power supply capacities of the connected servo amplifiers are actually required.

11.6 Junction terminal block PS7DW-20V14B-F (recommended)

Usage

Always use the junction terminal block (PS7DW-20V14B-F (Toho Technology Corp. Kyoto factory)) with the option cable (MR-J2HBUS_M) as a set. A connection example is shown below.

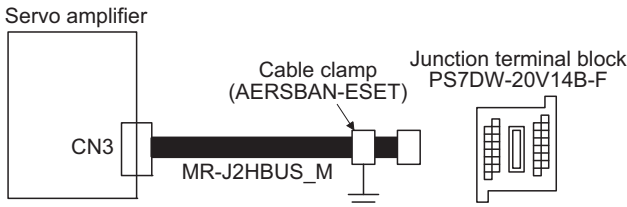

Ground the option cable on the junction terminal block side with the cable clamp fitting (AERSBAN-ESET). For the use of the cable clamp fitting, refer to the following.

☞ Page 425 Cable clamp fitting AERSBAN-_SET

Connection of MR-J2HBUS_M cable and junction terminal block

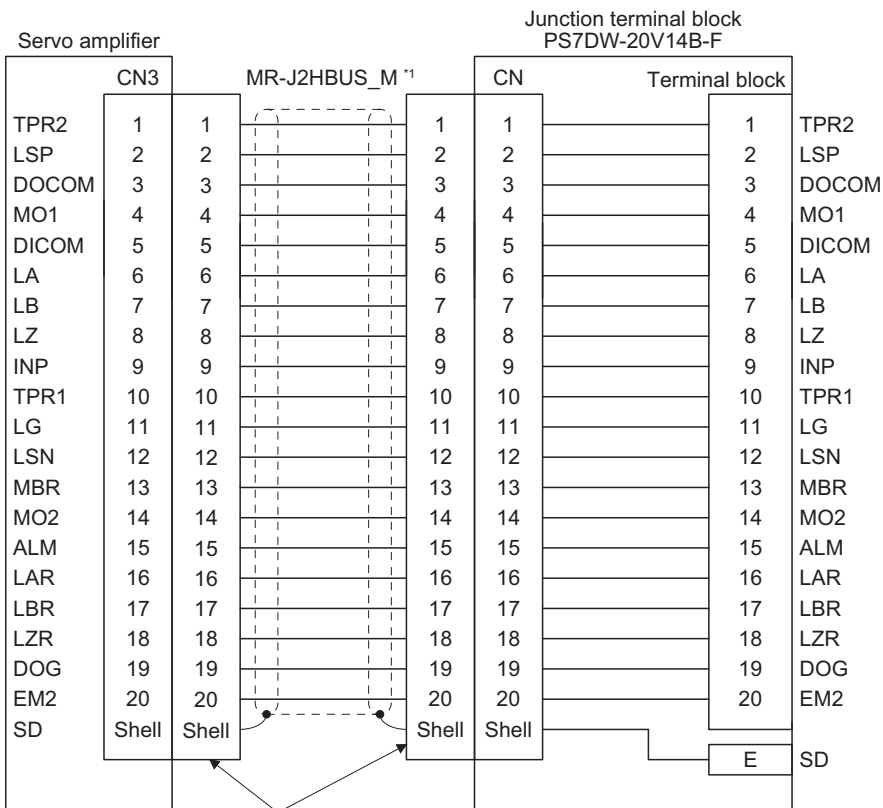

Connector: 52316-2019 (Molex)
Shell kit: 52370-2070 (Molex)

- *1 Symbol indicating cable length is put in _.
- 05: 0.5 m
 - 1: 1 m
 - 5: 5 m

Dimensions of junction terminal block

[Unit: mm]

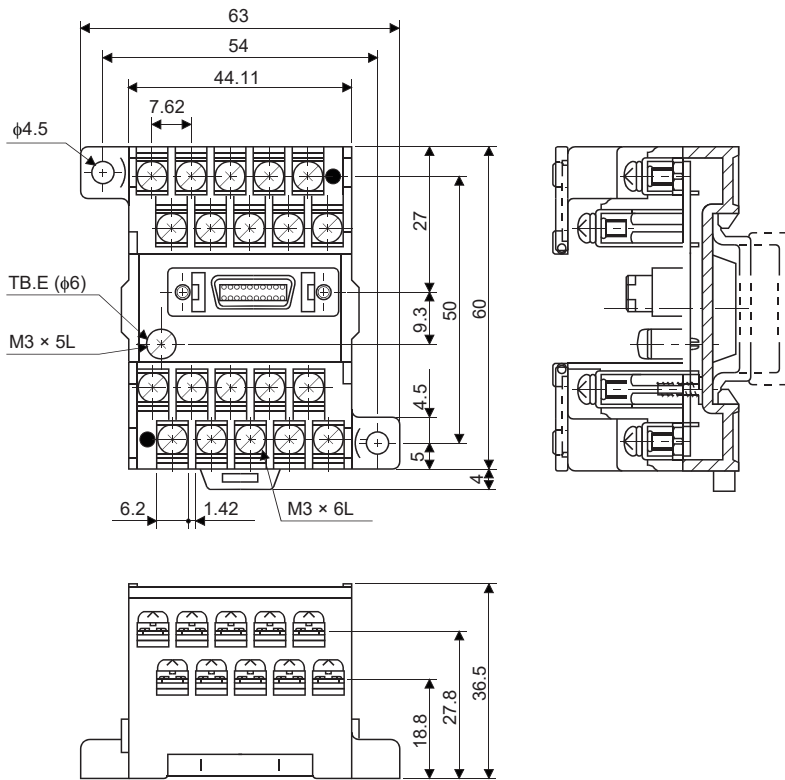

11.7 MR Configurator2



The MR-J4-_GF_ servo amplifier is supported with software version 1.49B or later.

Engineering software

The following engineering software can be used for this servo amplifier.

Engineering software	Installation guide
MR Configurator2 SW1DNC-MRC2-E	MR Configurator2 SW1DNC-MRC2-E Installation Guide (IB(NA)0300163)

For the engineering software specifications and system configuration, refer to the installation guide.

Precautions for using USB communication function

Note the following to prevent an electric shock and malfunction of the servo amplifier.

Power connection of personal computers

Connect your personal computer with the following procedures.

■When you use a personal computer with AC power supply

1. When using a personal computer with a three-core power plug or power plug with grounding wire, use a three-pin socket or ground the grounding wire.
2. When your personal computer has two-core plug and has no grounding wire, connect the personal computer to the servo amplifier with the following procedures.
 - a) Disconnect the power plug of the personal computer from an AC power socket.
 - b) Check that the power plug was disconnected and connect the device to the servo amplifier.
 - c) Connect the power plug of the personal computer to the AC power socket.

■When you use a personal computer with battery

You can use as it is.

Connection with other devices using servo amplifier communication function

When the servo amplifier is charged with electricity due to connection with a personal computer and the charged servo amplifier is connected with other devices, the servo amplifier or the connected devices may malfunction. Connect the servo amplifier and other devices with the following procedures.

1. Shut off the power of the device for connecting with the servo amplifier.
2. Shut off the power of the servo amplifier which was connected with the personal computer and check the charge lamp is off.
3. Connect the device with the servo amplifier.
4. Turn on the power of the servo amplifier and the device.

11.8 Battery

Point

Refer to the following for battery transportation and the new EU Battery Directive.

☞ Page 592 Handling of AC servo amplifier batteries for the United Nations Recommendations on the Transport of Dangerous Goods

☞ Page 594 Symbol for the new EU Battery Directive

This battery is used to construct an absolute position detection system. Refer to the following for construction of the absolute position detection system.

☞ Page 462 ABSOLUTE POSITION DETECTION SYSTEM

Selection of battery

The available batteries vary depending on servo amplifiers. Select a required battery.

Applications of the batteries

Model	Name	Application	Built-in battery
MR-BAT6V1SET-A	Battery	For absolute position data backup	MR-BAT6V1
MR-BAT6V1BJ	Battery for junction battery cable	For transporting a servo motor and servo amplifier apart	—
MR-BT6VCASE	Battery case	For absolute position data backup of multi-axis servo motor	MR-BAT6V1

Combinations of batteries and the servo amplifier

Model	MR-J4-_GF_
MR-BAT6V1SET-A	○
MR-BAT6V1BJ	○*1
MR-BT6VCASE	○

*1 For using the MR-J4-350GF4(-RJ), contact your local sales office.

MR-BAT6V1SET-A battery

Point

For the specifications and year and month of manufacture of the built-in MR-BAT6V1 battery, refer to the following.

☞ Page 401 MR-BAT6V1 battery

Parts identification and dimensions

11

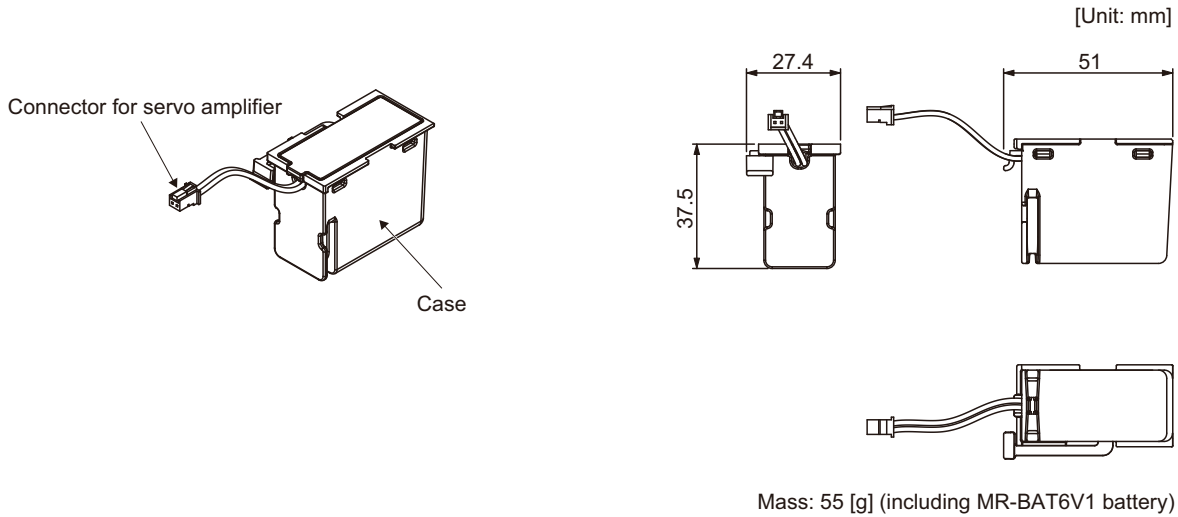

Battery mounting

Connect as follows.

Servo amplifier

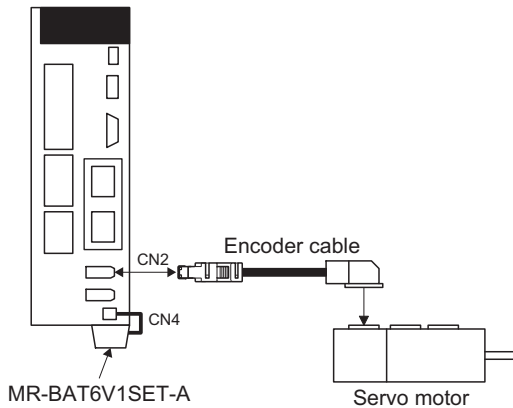

Battery replacement procedure

WARNING

- Before replacing a battery, turn off the main circuit power and wait for 15 minutes or longer until the charge lamp turns off. Then, check the voltage between P+ and N- with a voltage tester or others. Otherwise, an electric shock may occur. In addition, when confirming whether the charge lamp is off or not, be sure to look at the lamp from the front of the servo amplifier.

CAUTION

- The internal circuits of the servo amplifier may be damaged by static electricity. Always take the following precautions.
Ground human body and work bench.
Do not touch the conductive areas, such as connector pins and electrical parts, directly by hand.

Point

- Replacing battery with the control circuit power off will erase the absolute position data.
- Before replacing batteries, check that the new battery is within battery life.

Replace the battery while only control circuit power is on. Replacing battery with the control circuit power on triggers [AL. 9F.1 Low battery]. However, the absolute position data will not be erased.

■ Battery installation and removal procedure

- Installation procedure

Point

For the servo amplifier with a battery holder on the bottom, it is not possible to wire for the earth with the battery installed. Insert the battery after executing the earth wiring of the servo amplifier.

For the servo amplifier with a battery holder on the bottom

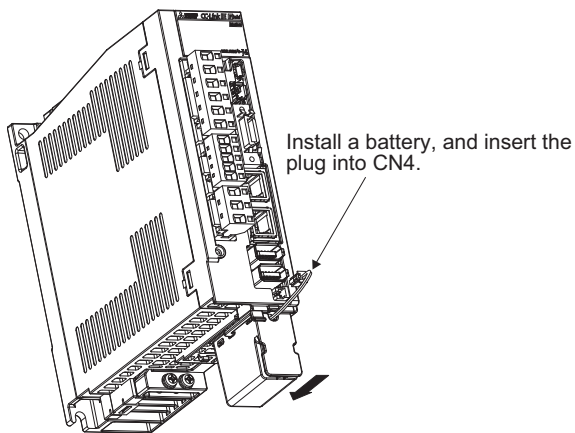

For the servo amplifier with a battery holder on the front

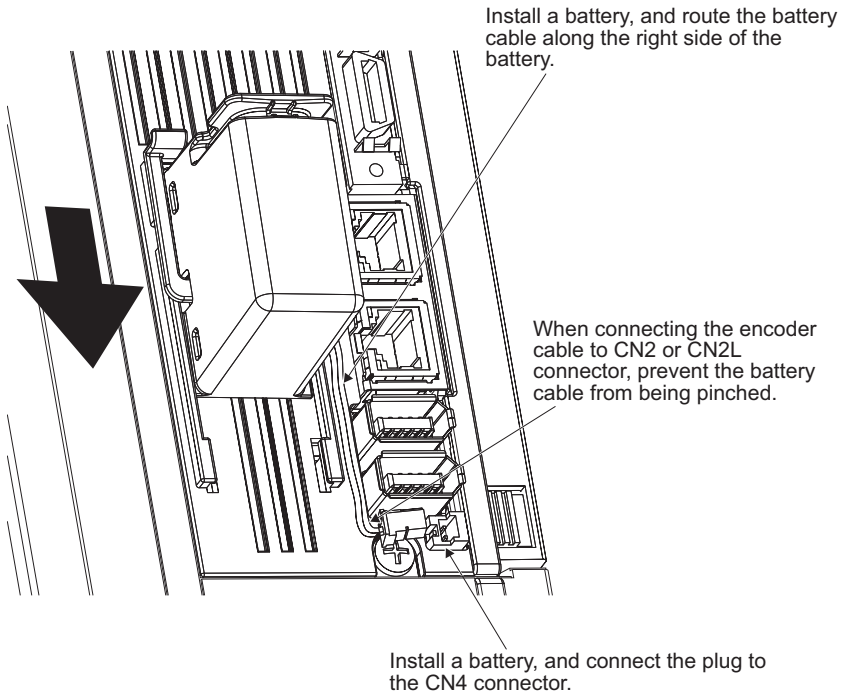

- Removal procedure

! CAUTION

- Pulling out the connector of the battery without the lock release lever pressed may damage the CN4 connector of the servo amplifier or the connector of the battery.

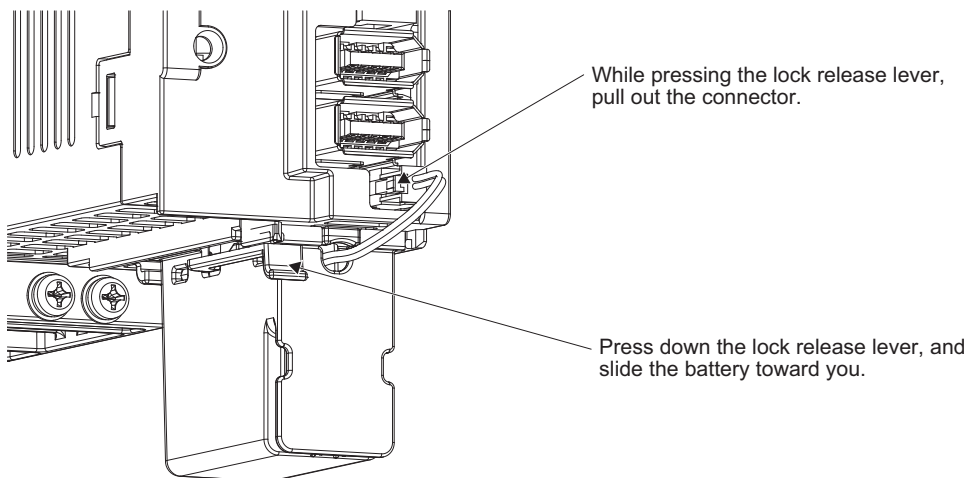

Replacement procedure of the built-in battery

When the MR-BAT6V1SET-A reaches the end of its life, replace the MR-BAT6V1 battery in the MR-BAT6V1SET-A.

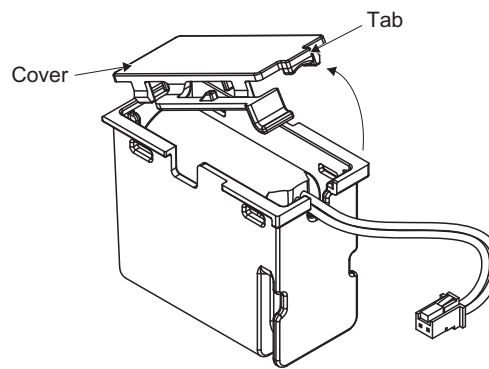

1. While pressing the locking part, open the cover.

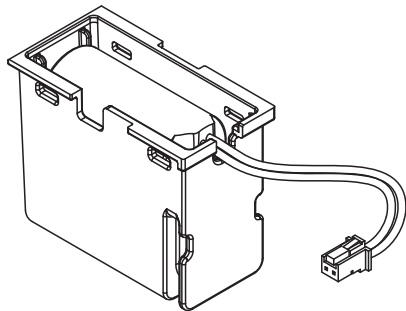

2. Replace the battery with a new MR-BAT6V1 battery.

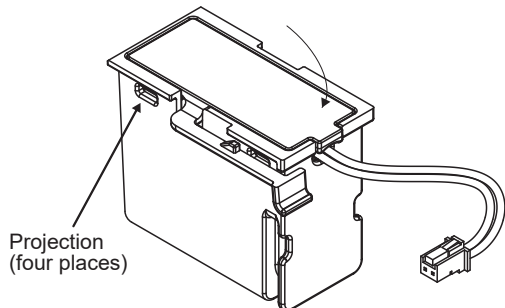

3. Press the cover until it is fixed with the projection of the locking part to close the cover.

MR-BAT6V1BJ battery for junction battery cable

Point

- MR-BAT6V1BJ is compatible only with HG series servo motors. It cannot be used with direct drive motors.
- MR-BAT6V1BJ cannot be used for fully closed loop system.
- When MR-BAT6V1BJ is mounted on the MR-J4-500GF(-RJ), the front cover does not open. For this reason, carry out wiring to the terminal block before mounting MR-BAT6V1BJ.
- For using the MR-J4-350GF4(-RJ), contact your local sales office.

Parts identification and dimensions

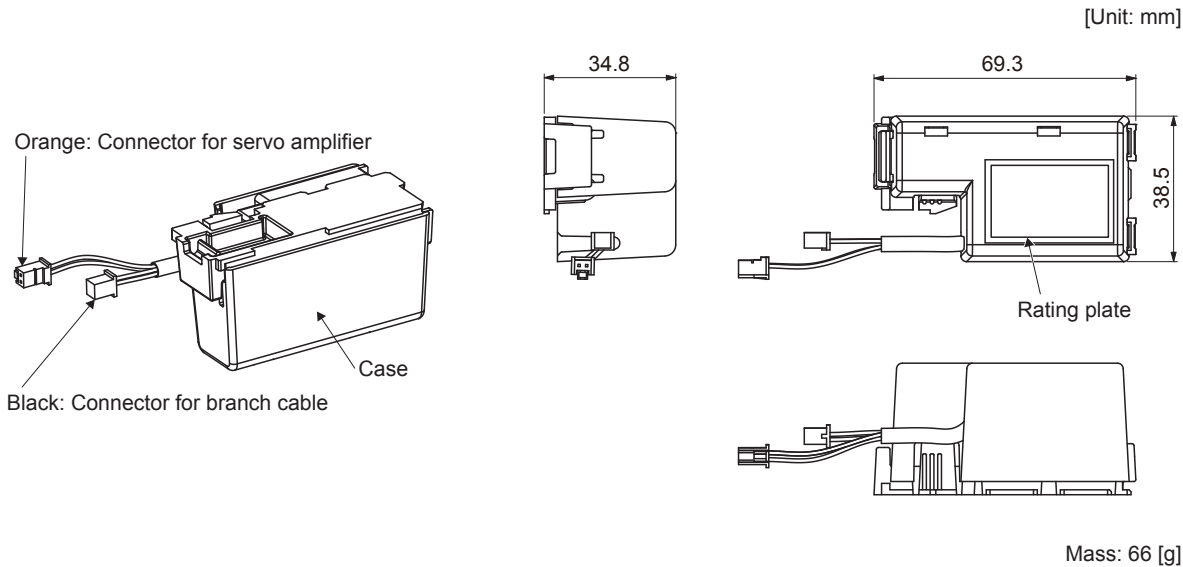

Production year and month of batteries

Production year and month are indicated in a serial number (SERIAL) on the rating plate. The second digit from left in the number indicates the first digit of the dominical year, the third digit from left indicates a month (Oct: X, Nov: Y, Dec.: Z). For November 2013, the Serial No. would be "SERIAL: _ 3Y _ _ _ _ _".

Specification list

Item	Description
Battery pack	2CR17335A (CR17335A × 2 pcs. in series)
Nominal voltage [V]	6
Nominal capacity [mAh]	1650
Storage temperature [°C]	0 to 55
Operating temperature [°C]	0 to 55
Lithium content [g]	1.2
Mercury content	Less than 1 ppm
Dangerous goods class	Inapplicable to the dangerous goods (Class 9) ☞ Page 592 Handling of AC servo amplifier batteries for the United Nations Recommendations on the Transport of Dangerous Goods
Operating humidity and storage humidity	5 %RH to 90 %RH (non-condensing)
Battery life*1	5 years from date of manufacture
Mass [g]	66

*1 Quality of the batteries degrades by the storage condition. The battery life is 5 years from the production date regardless of the connection status.

Battery mounting

Connect the MR-BAT6V1BJ using the MR-BT6VCBL03M junction battery cable as follows.

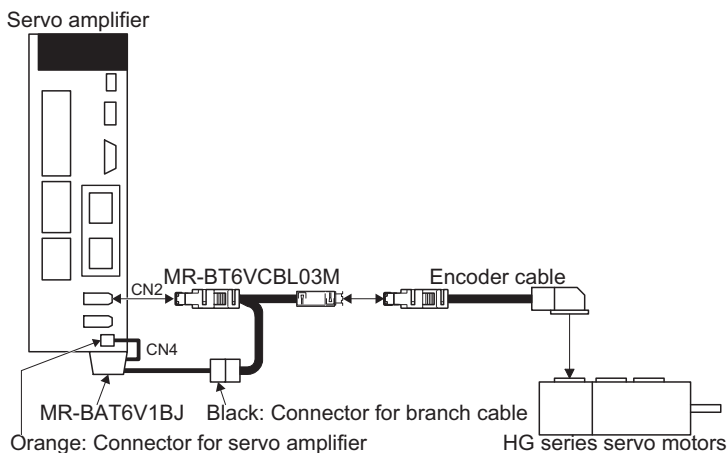

Transporting a servo motor and machine apart

Point

Be sure to connect the black connector to the MR-BT6VCBL03M junction battery cable when transporting a servo motor and machine apart. When the black connector is not connected to the MR-BT6VCBL03M junction battery cable, no alarm occurs. However, the absolute position data will be erased when you transport a servo motor and machine apart.

When you transport a servo motor and machine apart, disconnect only CN2 and CN4 of the servo amplifier.

When other connectors or cables are disconnected between the servo motor and battery, the absolute position data will be deleted.

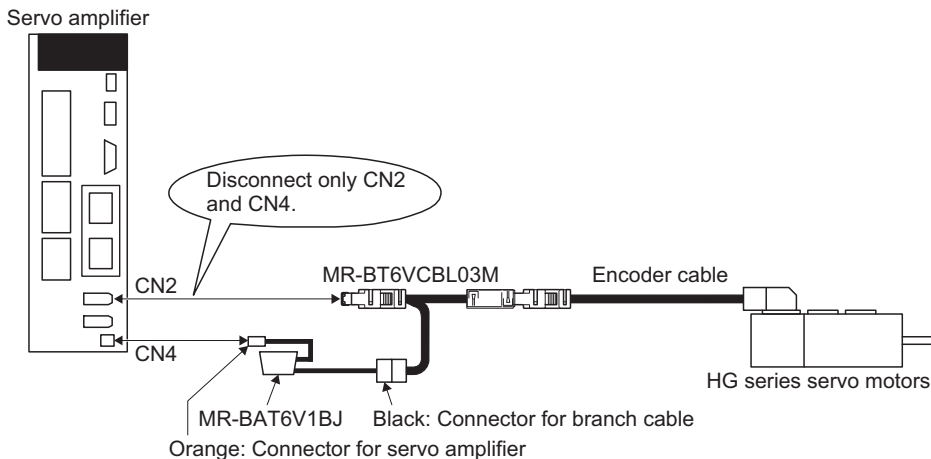

Battery replacement procedure

WARNING

- Before replacing a battery, turn off the main circuit power and wait for 15 minutes or longer until the charge lamp turns off. Then, check the voltage between P+ and N- with a voltage tester or others. Otherwise, an electric shock may occur. In addition, when confirming whether the charge lamp is off or not, be sure to look at the lamp from the front of the servo amplifier.

CAUTION

- The internal circuits of the servo amplifier may be damaged by static electricity. Always take the following precautions.
Ground human body and work bench.
Do not touch the conductive areas, such as connector pins and electrical parts, directly by hand.
- The battery built in MR-BAT6V1BJ cannot be replaced. Do not disassemble the MR-BAT6V1BJ. Otherwise, it may cause a malfunction.

Point

- To replace the MR-BAT6V1BJ, follow the procedures given in this section to avoid erasing absolute position data.
- Before replacing batteries, check that the new battery is within battery life.

MR-BAT6V1BJ can be replaced even with the control circuit power supply off.

■ Battery installation and removal procedure

For the battery installation and removal procedure, refer to the following.

 Page 388 Battery replacement procedure

■ Preparation for replacing MR-BAT6V1BJ

Prepare a new MR-BAT6V1BJ as follows.

Model	Number and use	Remark
MR-BAT6V1BJ	1 for replacement	Battery within two years from the production date.

■ Procedures of replacing MR-BAT6V1BJ

Replace the battery with the following procedure regardless of on/off of the control circuit power supply. When it is replaced with other procedures, the absolute position data will be erased.

1. Remove the black connector of the old MR-BAT6V1BJ.

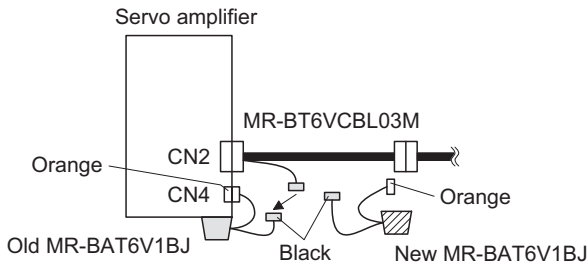

2. Connect the black connector of the new MR-BAT6V1BJ.

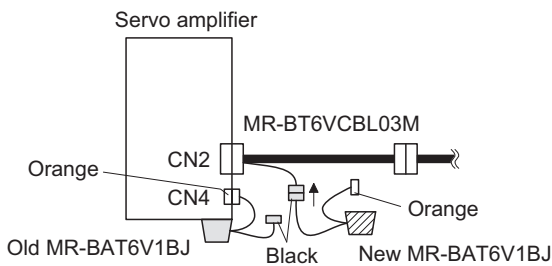

3. Remove the orange connector of the old MR-BAT6V1BJ. When the control circuit power supply is on, performing 3) without [AL. 9F.1 Low battery] triggers [AL. 9F.1].

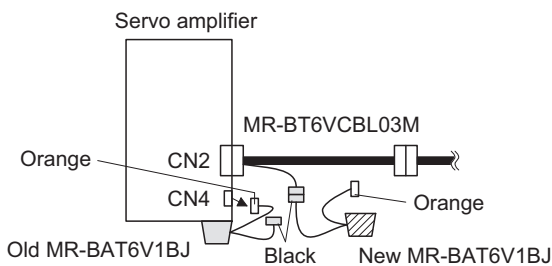

4. Remove the old MR-BAT6V1BJ from servo amplifier and mount the new MR-BAT6V1BJ. When the control circuit power supply is on, [AL. 9F.1] occurs after 3).

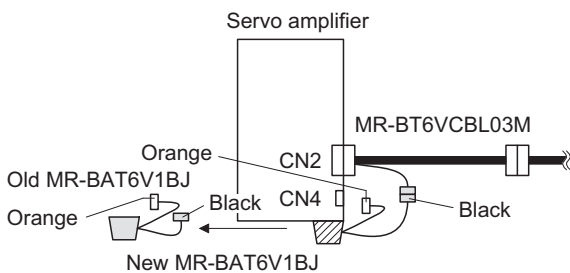

5. Mount the orange connector of the new MR-BAT6V1BJ. When the control circuit power supply is on, [AL. 9F.1] is canceled.

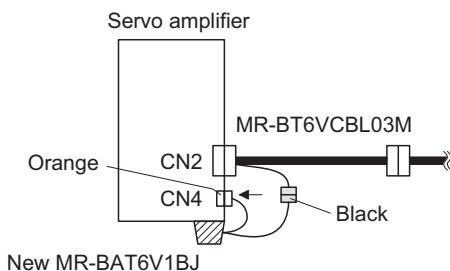

MR-BT6VCASE battery case

Point

- The battery unit consists of an MR-BT6VCASE battery case and five MR-BAT6V1 batteries.
- For the specifications and year and month of manufacture of MR-BAT6V1 battery, refer to the following.
 ↳ Page 401 MR-BAT6V1 battery

MR-BT6VCASE is a case used for connecting and mounting five MR-BAT6V1 batteries. A battery case does not have any batteries. Please prepare MR-BAT6V1 batteries separately.

Number of connectable servo motors

One MR-BT6VCASE can hold the absolute position data of up to 8-axis servo motors. For direct drive motors, up to four axes can be connected. Servo motors and direct drive motors in the incremental system are included as the axis numbers. Linear servo motors are not counted as the axis numbers. Refer to the following table for the number of connectable axes of each servo motor.

Servo motor	Number of axes									
	0	1	2	3	4	5	6	7	8	
Rotary servo motor	0	1	2	3	4	5	6	7	8	
Direct drive motor	4	4	4	4	4	3	2	1	0	

Dimensions

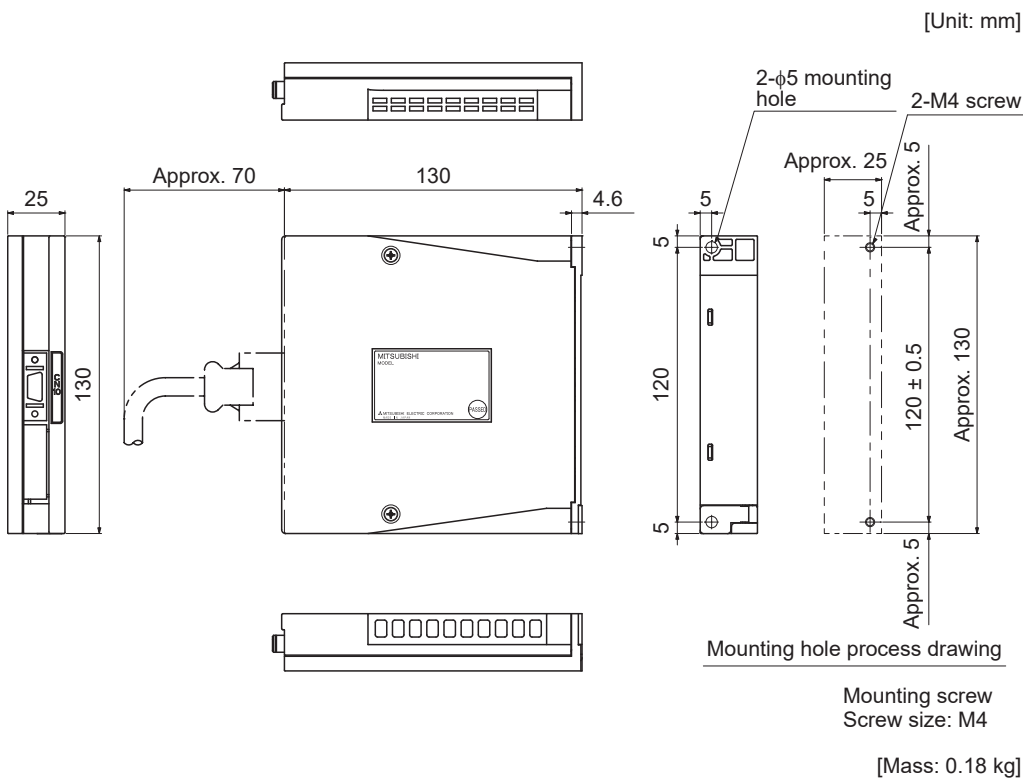

Battery mounting

Point

One battery unit can be connected to up to 8-axis servo motors. However, when using direct drive motors, the number of axes of the direct drive motors should be up to 4 axes. Servo motors and direct drive motors in the incremental system are included as the axis numbers. Linear servo motors are not counted as the axis numbers.

■ When using 1-axis servo amplifier

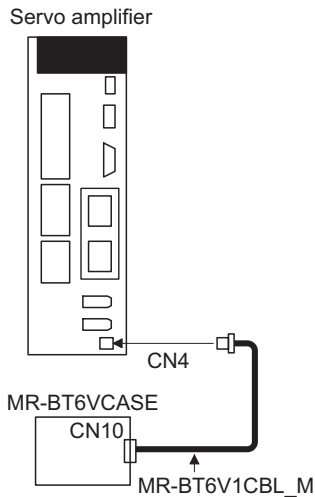

■ When using up to 8-axis servo amplifiers

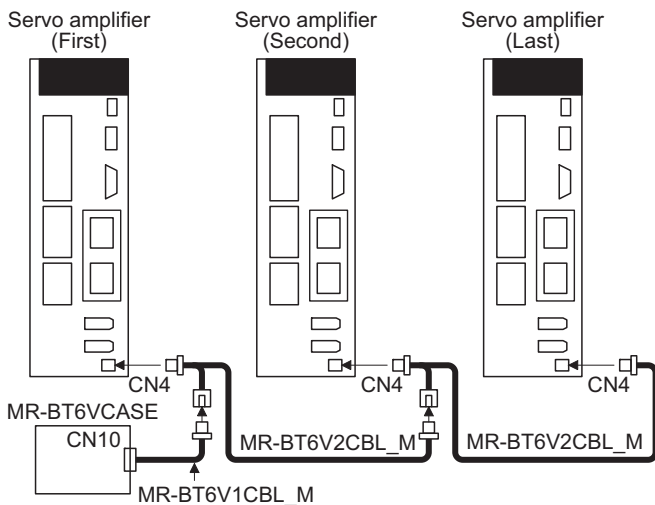

Battery replacement procedure

WARNING

- Before replacing a battery, turn off the main circuit power and wait for 15 minutes or longer until the charge lamp turns off. Then, check the voltage between P+ and N- with a voltage tester or others. Otherwise, an electric shock may occur. In addition, when confirming whether the charge lamp is off or not, be sure to look at the lamp from the front of the servo amplifier.

CAUTION

- The internal circuits of the servo amplifier may be damaged by static electricity. Always take the following precautions.
Ground human body and work bench.
Do not touch the conductive areas, such as connector pins and electrical parts, directly by hand.

Point

- Replacing battery with the control circuit power off will erase the absolute position data.
- Before replacing batteries, check that the new battery is within battery life.

Replace the battery while only control circuit power is on. Replacing battery with the control circuit power on triggers [AL. 9F.1 Low battery]. However, the absolute position data will not be erased.

■ Assembling a battery unit

CAUTION

- Do not use new batteries with old ones together.
- Replace all the batteries with new ones at the same time at battery replacement.

Point

Always install five MR-BAT6V1 batteries to an MR-BT6VCASE battery case.

- Required items

Product name	Model	Quantity	Remark
Battery case	MR-BT6VCASE	1	MR-BT6VCASE is a case used for connecting and mounting five MR-BAT6V1 batteries.
Battery	MR-BAT6V1	5	Lithium battery (primary battery, nominal + 6 V)

• Disassembly and assembly of the battery case MR-BT6VCASE

Disassembly of the case

MR-BT6VCASE is shipped assembled. To mount MR-BAT6V1 batteries, the case needs to be disassembled.

1. Remove the two screws using a Phillips screwdriver.

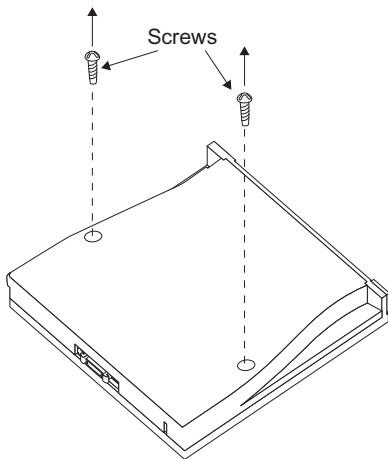

2. Remove the cover.

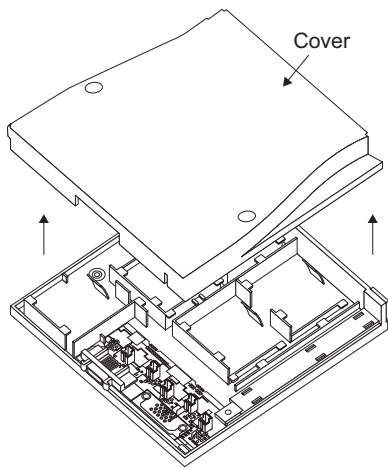

Parts identification

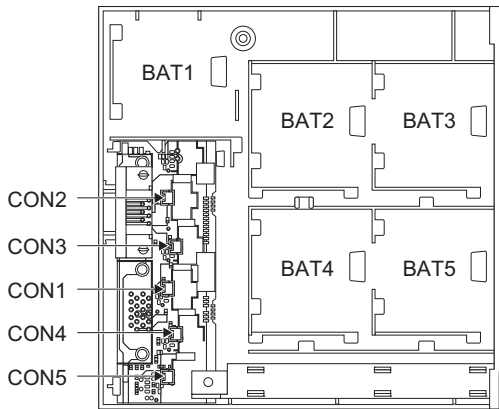

Mounting MR-BAT6V1

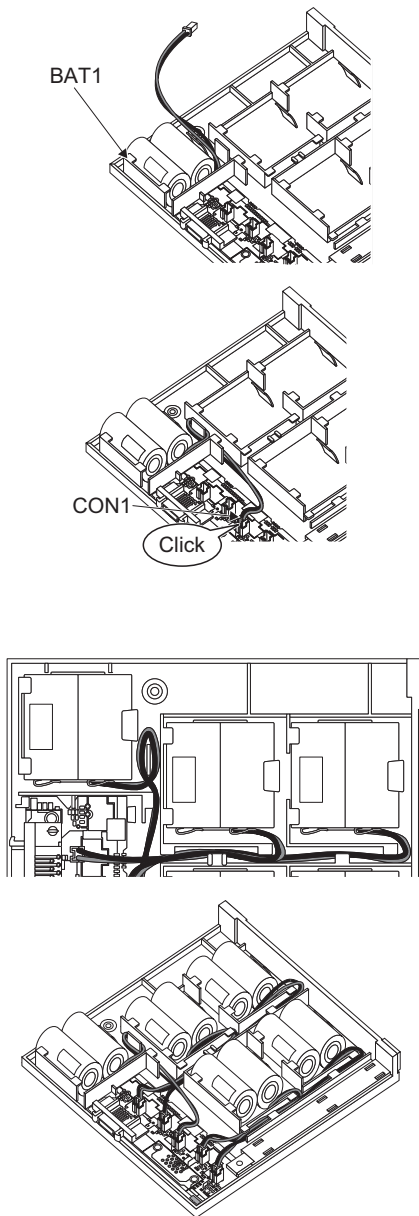

- 1.** Securely mount an MR-BAT6V1 to the BAT1 holder.

- 2.** Insert the MR-BAT6V1 connector mounted on BAT1 holder to CON1.

Confirm the click sound at this point.

The connector has to be connected in the right direction.

If the connector is pushed forcefully in the incorrect direction, the connector will break.

Place the MR-BAT6V1 lead wire to the duct designed to store lead wires.

Insert MR-BAT6V1 to the holder in the same procedure in the order from BAT2 to BAT5.

- 3.** Bring out the lead wire from the space between the ribs, and bend it as shown above to store it in the duct. Connect the lead wire to the connector.

Be careful not to get the lead wire caught in the case or other parts.

When the lead wire is damaged, external short circuit may occur, and the battery can become hot.

Assembly of the case

After all MR-BAT6V1 batteries are mounted, fit the cover and insert screws into the two holes and tighten them. Tightening torque is 0.71 N•m.

Point

When assembling the case, be careful not to get the lead wires caught in the fitting parts or the screwing parts.

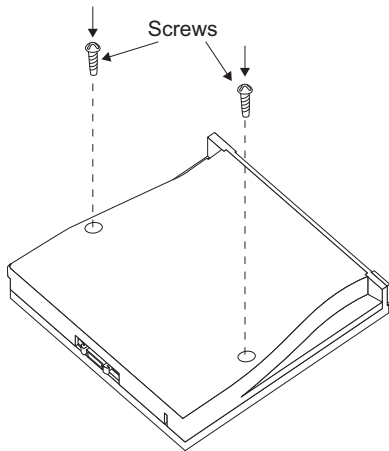

Precautions for removal of battery

The connector attached to the MR-BAT6V1 battery has the lock release lever. When removing the connector, pull out the connector while pressing the lock release lever.

- Battery cable removal

CAUTION

- Pulling out the connector of the MR-BT6V1CBL and the MR-BT6V2CBL without the lock release lever pressed may damage the CN4 connector of the servo amplifier or the connector of the MR-BT6V1CBL or MR-BT6V2CBL.

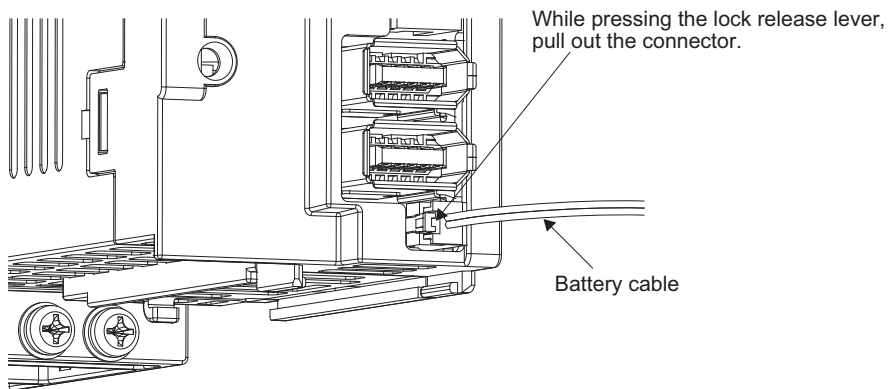

MR-BAT6V1 battery

The MR-BAT6V1 battery is a lithium primary battery to be replaced in MR-BAT6V1SET-A and inserted in MR-BT6VCASE. Store the MR-BAT6V1 in the case to use.

The year and month of manufacture of MR-BAT6V1 battery are described to the rating plate put on an MR-BAT6V1 battery.

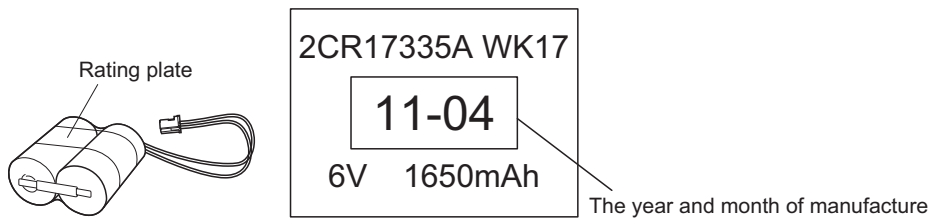

Item	Description
Battery pack	2CR17335A (CR17335A × 2 pcs. in series)
Nominal voltage [V]	6
Nominal capacity [mAh]	1650
Storage temperature [°C]	0 to 55
Operating temperature [°C]	0 to 55
Lithium content [g]	1.2
Mercury content	Less than 1 ppm
Dangerous goods class	Inapplicable to the dangerous goods (Class 9) ☞ Page 592 Handling of AC servo amplifier batteries for the United Nations Recommendations on the Transport of Dangerous Goods
Operating humidity and storage humidity	5 %RH to 90 %RH (non-condensing)
Battery life*1	5 years from date of manufacture
Mass [g]	34

*1 Quality of the batteries degrades by the storage condition. The battery life is 5 years from the production date regardless of the connection status.

11.9 Selection example of wires

Point

- To comply with the IEC/EN/UL/CSA standard, use the wires shown in the following section for wiring. To comply with other standards, use a wire that is complied with each standard. [Page 595 Compliance with global standards](#)
- For the selection example of when the MR-J4-_GF-RJ servo amplifier is used with the DC power supply input, refer to the following. [Page 589 Selection example of wires](#)
- Selection conditions of wire size are as follows.
Construction condition: Single wire set in midair
Wire length: 30 m or less

The following diagram shows the wires used for wiring. Use the wires given in this section or equivalent.

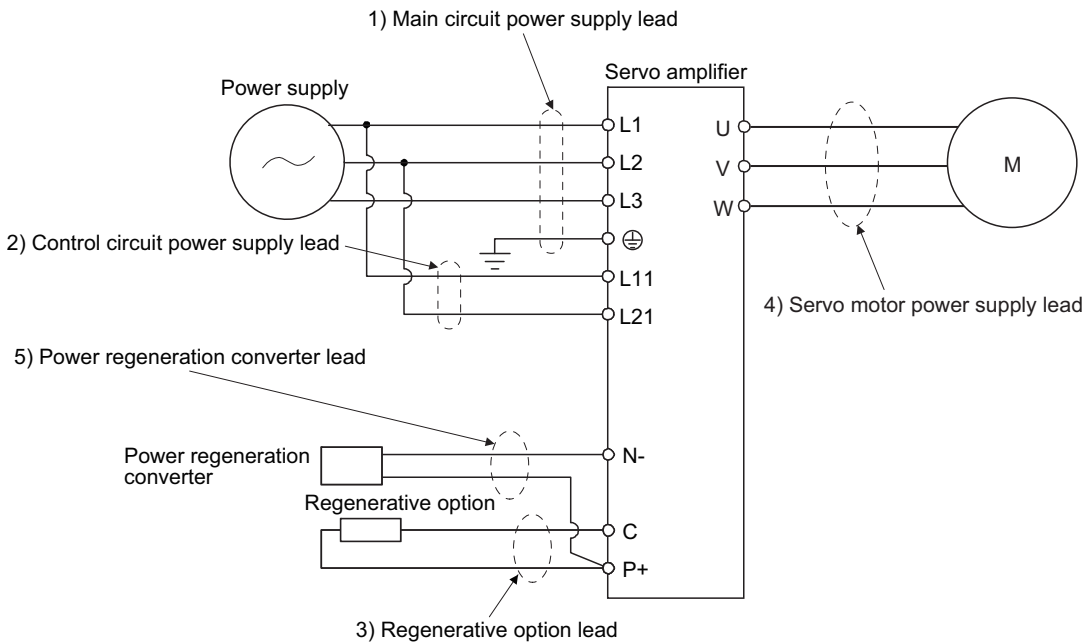

Example of selecting the wire sizes

Use the 600 V Grade heat-resistant polyvinyl chloride insulated wire (HIV wire) for wiring. The following shows the wire size selection example.

■200 V class

Servo amplifier	Wire [mm ²] ^{*1}			
	1) L1/L2/L3/⊕	2) L11/L21	3) P+/C	4) U/V/W/⊕ ^{*3}
MR-J4-10GF(-RJ)	2 (AWG 14)	1.25 to 2 (AWG 16 to 14) ^{*4}	2 (AWG 14)	AWG 18 to 14 ^{*4}
MR-J4-20GF(-RJ)				
MR-J4-40GF(-RJ)				
MR-J4-60GF(-RJ)				
MR-J4-70GF(-RJ)				
MR-J4-100GF(-RJ)				
MR-J4-200GF(-RJ) (3-phase power supply input)	3.5 (AWG 12)			AWG 16 to 10
MR-J4-200GF(-RJ) (1-phase power supply input)				
MR-J4-350GF(-RJ)				
MR-J4-500GF(-RJ) ^{*2}	5.5 (AWG 10): a	1.25 (AWG 16): a 2 (AWG 14): d ^{*4}	2 (AWG 14): c	2 (AWG 14): c 3.5 (AWG 12): a 5.5 (AWG 10): a
MR-J4-700GF(-RJ) ^{*2}				8 (AWG 8): b
MR-J4-11KGF(-RJ) ^{*2}	14 (AWG 6): f	1.25 (AWG 16): c 2 (AWG 14): c ^{*4}	3.5 (AWG 12): g	14 (AWG 6): f 5.5 (AWG 10): g ^{*5} 8 (AWG 8): k
MR-J4-15KGF(-RJ) ^{*2}			5.5 (AWG 10): g	22 (AWG 4): h 8 (AWG 8): k ^{*5}
MR-J4-22KGF(-RJ) ^{*2}			38 (AWG 2): i	5.5 (AWG 10): j

*1 Alphabets in the table indicate crimping tools. For crimp terminals and applicable tools, refer to the following.

 Page 405 Selection example of crimp terminals

*2 To connect these models to a terminal block, be sure to use the screws that come with the terminal block.

*3 The wire size shows applicable size of the servo amplifier connector and terminal block. For wires connecting to the servo motor, refer to each servo motor instruction manual.

*4 Be sure to use the size of 2 mm² when corresponding to IEC/EN/UL/CSA standard.

*5 This is for connecting to the linear servo motor with natural cooling method.

Use wires (5)) of the following sizes with the power regeneration converter (FR-RC).

Model	Wire [mm ²]
FR-RC-15K	14 (AWG 6)
FR-RC-30K	14 (AWG 6)
FR-RC-55K	22 (AWG 4)

■400 V class

Servo amplifier	Wire [mm ²]* ¹			
	1) L1/L2/L3/⊕	2) L11/L21	3) P+/C	4) U/V/W/⊕* ³
MR-J4-60GF4(-RJ) MR-J4-100GF4(-RJ) MR-J4-200GF4(-RJ) MR-J4-350GF4(-RJ)	2 (AWG 14)	1.25 to 2 (AWG 16 to 14)* ⁴	2 (AWG 14)	AWG 16 to 14
MR-J4-500GF4(-RJ) ^{*2} MR-J4-700GF4(-RJ) ^{*2}	2 (AWG 14): b 3.5 (AWG 12): a	1.25 (AWG 16): a 2 (AWG 14): c* ⁴	2 (AWG 14): b	3.5 (AWG 12): a 5.5 (AWG 10): a
MR-J4-11KGF4(-RJ) ^{*2} MR-J4-15KGF4(-RJ) ^{*2} MR-J4-22KGF4(-RJ) ^{*2}	5.5 (AWG 10): d 8 (AWG 8): g 14 (AWG 6): i	1.25 (AWG 16): b 2 (AWG 14): b* ⁴	2 (AWG 14): f 3.5 (AWG 12): d 3.5 (AWG 12): e	8 (AWG 8): g 5.5 (AWG 10): e* ⁵ 8 (AWG 8): h* ⁶ 14 (AWG 6): i

*1 Alphabets in the table indicate crimping tools. For crimp terminals and applicable tools, refer to the following.

 Page 405 Selection example of crimp terminals

*2 To connect these models to a terminal block, be sure to use the screws that come with the terminal block.

*3 The wire size shows applicable size of the servo amplifier connector and terminal block. For wires connecting to the servo motor, refer to each servo motor instruction manual.

*4 Be sure to use the size of 2 mm² when corresponding to IEC/EN/UL/CSA standard.

*5 This is for connecting to the linear servo motor with natural cooling method.

*6 This is for connecting to the linear servo motor with liquid cooling method.

Use wires (5)) of the following sizes with the power regeneration converter (FR-RC-H).

Model	Wire [mm ²]
FR-RC-H15K FR-RC-H30K FR-RC-H55K	14 (AWG 6)

■100 V class

Servo amplifier	Wire [mm ²]			
	1) L1/L2/⊕	2) L11/L21	3) P+/C	4) U/V/W/⊕* ¹
MR-J4-10GF1(-RJ) MR-J4-20GF1(-RJ) MR-J4-40GF1(-RJ)	2 (AWG 14)	1.25 to 2 (AWG 16 to 14)* ²	2 (AWG 14)	AWG 18 to 14* ²

*1 The wire size shows applicable size of the servo amplifier connector and terminal block. For wires connecting to the servo motor, refer to each servo motor instruction manual.

*2 Be sure to use the size of 2 mm² when corresponding to IEC/EN/UL/CSA standard.

Selection example of crimp terminals

■200 V class

Symbol	Servo amplifier-side crimp terminals				Manufacturer
	Crimp terminal ^{*2}	Applicable tool			
		Body	Head	Dice	
a	FVD5.5-4	YNT-1210S	—	—	JST
b ^{*1}	8-4NS	YHT-8S	—	—	
c	FVD2-4	YNT-1614	—	—	
d	FVD2-M3		—	—	
e	FVD1.25-M3	YNT-2216	—	—	
f	FVD14-6	YF-1	YNE-38	DH-122 DH-112	
g	FVD5.5-6	YNT-1210S	—	—	
h	FVD22-6	YF-1	YNE-38	DH-123 DH-113	
i	FVD38-8	YF-1	YNE-38	DH-124 DH-114	
j	FVD5.5-8	YNT-1210S	—	—	
k	FVD8-6	YF-1/E-4	YNE-38	DH-121 DH-111	

*1 Coat the crimping part with an insulation tube.

*2 Some crimp terminals may not be mounted depending on the size. Make sure to use the recommended ones or equivalent ones.

■400 V class

Symbol	Servo amplifier-side crimp terminals				Manufacturer
	Crimp terminal ^{*1}	Applicable tool			
		Body	Head	Dice	
a	FVD5.5-4	YNT-1210S	—	—	JST
b	FVD2-4	YNT-1614	—	—	
c	FVD2-M3		—	—	
d	FVD5.5-6	YNT-1210S	—	—	
e	FVD5.5-8	YNT-1210S	—	—	
f	FVD2-6	YNT-1614	—	—	
g	FVD8-6	YF-1	YNE-38	DH-121 DH-111	
h	FVD8-8			DH-122 DH-112	
i	FVD14-8			DH-122 DH-112	

*1 Some crimp terminals may not be mounted depending on the size. Make sure to use the recommended ones or equivalent ones.

11.10 Molded-case circuit breakers, fuses, magnetic contactors

CAUTION

- To prevent the servo amplifier from smoke and a fire, select a molded-case circuit breaker which shuts off with high speed.
- Always use one molded-case circuit breaker and one magnetic contactor with one servo amplifier.

Point

For the selection when the MR-J4- _GF-RJ servo amplifier is used with the DC power supply input, refer to the following.

 Page 590 Molded-case circuit breakers, fuses, magnetic contactors

For main circuit power supply

When using a fuse instead of the molded-case circuit breaker, use the one having the specifications given in this section.

Servo amplifier	Molded-case circuit breaker ^{*1*3}			Fuse			Magnetic contactor ^{*2}
	Frame, rated current		Voltage AC [V]	Class	Current [A]	Voltage AC [V]	
	Power factor improving reactor is not used	Power factor improving reactor is used					
MR-J4-10GF(-RJ)	30 A frame 5 A	30 A frame 5 A	240	T	10	300	S-N10 S-T10
MR-J4-20GF(-RJ)	30 A frame 5 A	30 A frame 5 A			15		
MR-J4-40GF(-RJ)	30 A frame 10 A	30 A frame 5 A			20		
MR-J4-60GF(-RJ)	30 A frame 15 A	30 A frame 10 A					
MR-J4-70GF(-RJ)	30 A frame 15 A	30 A frame 10 A					
MR-J4-100GF(-RJ) (3-phase power supply input)	30 A frame 15 A	30 A frame 10 A					
MR-J4-100GF(-RJ) (1-phase power supply input)	30 A frame 15 A	30 A frame 15 A			30		
MR-J4-200GF(-RJ)	30 A frame 20 A	30 A frame 20 A			40		S-N20 ^{*4} S-T21
MR-J4-350GF(-RJ)	30 A frame 30 A	30 A frame 30 A			70		S-N20 S-T21
MR-J4-500GF(-RJ)	50 A frame 50 A	50 A frame 50 A			125		S-N35 S-T35
MR-J4-700GF(-RJ)	100 A frame 75 A	60 A frame 60 A			150		S-N50 S-T50
MR-J4-11KGF(-RJ)	100 A frame 100 A	100 A frame 100 A			200		S-N65 S-T65
MR-J4-15KGF(-RJ)	125 A frame 125 A	125 A frame 125 A			250		
MR-J4-22KGF(-RJ)	225 A frame 175 A	225 A frame 175 A			350		S-N95 S-T100

Servo amplifier	Molded-case circuit breaker ^{*1*3}			Fuse			Magnetic contactor ^{*2}
	Frame, rated current		Voltage AC [V]	Class	Current [A]	Voltage AC [V]	
	Power factor improving reactor is not used	Power factor improving reactor is used					
MR-J4-60GF4(-RJ)	30 A frame 5 A	30 A frame 5 A	480	T	10	600	S-N10 S-T10
MR-J4-100GF4(-RJ)	30 A frame 10 A	30 A frame 5 A			15		
MR-J4-200GF4(-RJ)	30 A frame 15 A	30 A frame 10 A			25		
MR-J4-350GF4(-RJ)	30 A frame 20 A	30 A frame 15 A			35		S-N20 ^{*4} S-T21
MR-J4-500GF4(-RJ)	30 A frame 20 A	30 A frame 20 A			50		
MR-J4-700GF4(-RJ)	30 A frame 30 A	30 A frame 30 A			65		
MR-J4-11KGF4(-RJ)	50 A frame 50 A	50 A frame 50 A			100		S-N20 S-T21
MR-J4-15KGF4(-RJ)	60 A frame 60 A	60 A frame 60 A			150		S-N25 S-T35
MR-J4-22KGF4(-RJ)	100 A frame 100 A	100 A frame 100 A			175		S-N35 S-T35
MR-J4-10GF1(-RJ)	30 A frame 5 A	30 A frame 5 A	240	T	10	300	S-N10 S-T10
MR-J4-20GF1(-RJ)	30 A frame 10 A	30 A frame 10 A			15		
MR-J4-40GF1(-RJ)	30 A frame 15 A	30 A frame 10 A			20		

*1 When having the servo amplifier comply with the IEC/EN/UL/CSA standard, refer to the following.

☞ Page 595 Compliance with global standards

*2 Use a magnetic contactor with an operation delay time (interval between current being applied to the coil until closure of contacts) of 80 ms or less.

*3 Use a molded-case circuit breaker which has the same or higher operation characteristics than our lineup.

*4 S-N18 can be used when auxiliary contact is not required.

The Type E Combination motor controller can also be used instead of a molded-case circuit breaker.

Servo amplifier	Rated input voltage AC [V]	Input phase ^{*2}	Type E Combination motor controller			SCCR [kA] ^{*1}
			Model	Rated voltage AC [V]	Rated current [A] (Heater design)	
MR-J4-10GF(-RJ)	200 to 240	3-phase	MMP-T32	240	1.6	50
MR-J4-20GF(-RJ)					2.5	
MR-J4-40GF(-RJ)					4	
MR-J4-60GF(-RJ)					6.3	
MR-J4-70GF(-RJ)					6.3	
MR-J4-100GF(-RJ)					8	
MR-J4-200GF(-RJ)					18	
MR-J4-350GF(-RJ)					25	
MR-J4-500GF(-RJ)					32	
MR-J4-60GF4(-RJ)	380 to 480	3-phase		480Y/277	2.5	50
MR-J4-100GF4(-RJ)					4	
MR-J4-200GF4(-RJ)					8	
MR-J4-350GF4(-RJ)					13	
MR-J4-500GF4(-RJ)					18	
MR-J4-700GF4(-RJ)					25	25

*1 The values of the SCCR vary depending on the combination with the servo amplifier.

*2 1-phase input is not supported.

For control circuit power supply

When the wiring for the control circuit power supply (L11/L21) is thinner than that for the main circuit power supply (L1/L2/L3), install an overcurrent protection device (molded-case circuit breaker, fuse, etc.) to protect the branch circuit.

Servo amplifier	Molded-case circuit breaker*1		Fuse (Class T)		Fuse (Class K5)	
	Frame, rated current	Voltage AC [V]	Current [A]	Voltage AC [V]	Current [A]	Voltage AC [V]
MR-J4-10GF(-RJ)	30 A frame 5 A	240	1	300	1	250
MR-J4-20GF(-RJ)						
MR-J4-40GF(-RJ)						
MR-J4-60GF(-RJ)						
MR-J4-70GF(-RJ)						
MR-J4-100GF(-RJ)						
MR-J4-200GF(-RJ)						
MR-J4-350GF(-RJ)						
MR-J4-500GF(-RJ)						
MR-J4-700GF(-RJ)						
MR-J4-11KGF(-RJ)						
MR-J4-15KGF(-RJ)						
MR-J4-22KGF(-RJ)						
MR-J4-60GF4(-RJ)	30 A frame 5 A	480	1	600	1	600
MR-J4-100GF4(-RJ)						
MR-J4-200GF4(-RJ)						
MR-J4-350GF4(-RJ)						
MR-J4-500GF4(-RJ)						
MR-J4-700GF4(-RJ)						
MR-J4-11KGF4(-RJ)						
MR-J4-15KGF4(-RJ)						
MR-J4-22KGF4(-RJ)						
MR-J4-10GF1(-RJ)	30 A frame 5 A	240	1	300	1	250
MR-J4-20GF1(-RJ)						
MR-J4-40GF1(-RJ)						

*1 When having the servo amplifier comply with the IEC/EN/UL/CSA standard, refer to the following.

 Page 595 Compliance with global standards

11.11 Power factor improving DC reactors

Advantages

- It improves the power factor by increasing the form factor of the servo amplifier's input current.
- It decreases the power supply capacity.
- The input power factor is improved to about 85%.
- As compared to the power factor improving AC reactor (FR-HAL-(H)), it decreases the loss.

Restrictions

When connecting the power factor improving DC reactor to the servo amplifier, always disconnect P3 and P4. If it remains connected, the effect of the power factor improving DC reactor is not produced.

When used, the power factor improving DC reactor generates heat. To dissipate heat, therefore, maintain a minimum clearance of 10 cm each at the top and bottom, and 5 cm at the sides.

200 V class

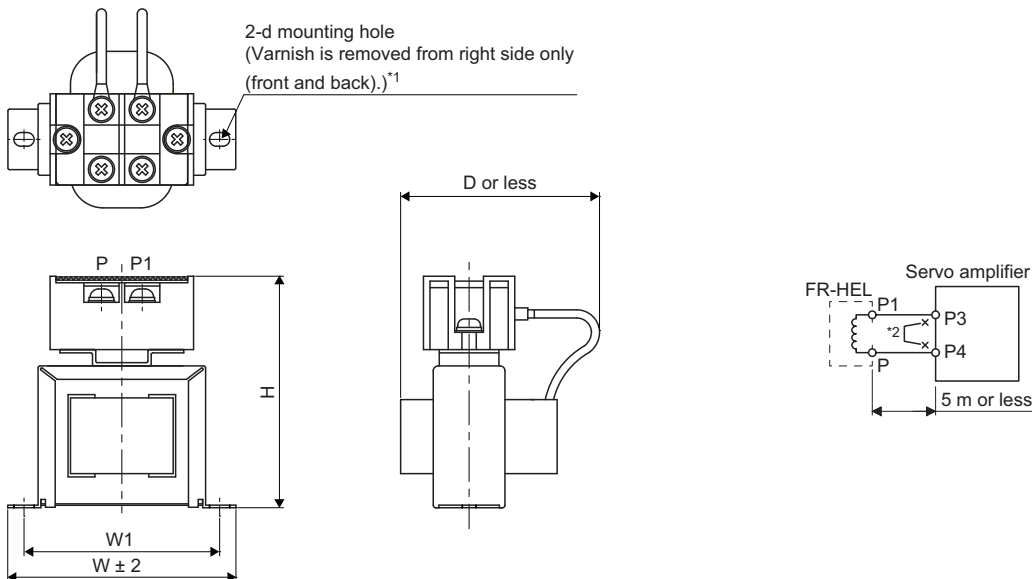

Servo amplifier	Power factor improving DC reactor	Dimensions [mm]								Terminal size	Mass [kg]	Wire [mm ²]*4
		W	W1	H	D*3	D1	D2	D3	d			
MR-J4-10GF(-RJ) MR-J4-20GF(-RJ)	FR-HEL-0.4K	70	60	71	61	—	21	—	M4	M4	0.4	2 (AWG 14)
MR-J4-40GF(-RJ)	FR-HEL-0.75K	85	74	81	61		21		M4	M4	0.5	
MR-J4-60GF(-RJ) MR-J4-70GF(-RJ)	FR-HEL-1.5K	85	74	81	70		30		M4	M4	0.8	
MR-J4-100GF(-RJ)	FR-HEL-2.2K	85	74	81	70		30		M4	M4	0.9	

*1 Use this for grounding.

*2 When using the power factor improving DC reactor, remove the short bar between P3 and P4.

*3 Maximum dimensions. The dimension varies depending on the input/output lines.

*4 Selection conditions of wire size are as follows.

Wire type: 600 V Grade heat-resistant polyvinyl chloride insulated wire (HIV wire)

Construction condition: Single wire set in midair

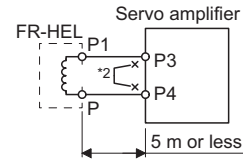
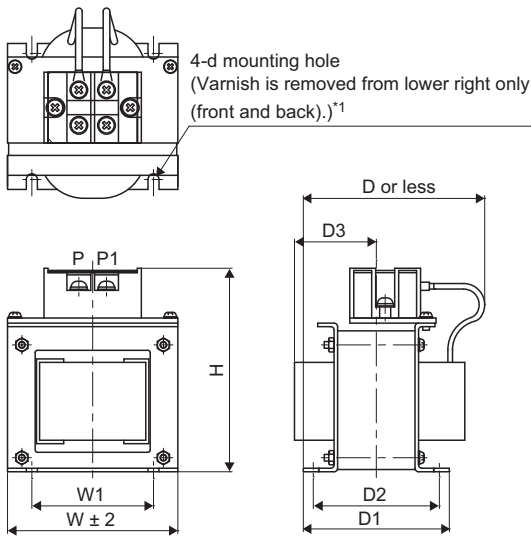

Servo amplifier	Power factor improving DC reactor	Dimensions [mm]								Terminal size	Mass [kg]	Wire [mm ²] ^{*4}
		W	W1	H	D ^{*3}	D1	D2	D3	d			
MR-J4-200GF(-RJ)	FR-HEL-3.7K	77	55	92	82	66	57	37	M4	M4	1.5	2 (AWG 14)
MR-J4-350GF(-RJ)	FR-HEL-7.5K	86	60	113	98	81	72	43	M4	M5	2.5	3.5 (AWG 12)
MR-J4-500GF(-RJ)	FR-HEL-11K	105	64	133	112	92	79	47	M6	M6	3.3	5.5 (AWG 10)
MR-J4-700GF(-RJ)	FR-HEL-15K	105	64	133	115	97	84	48.5	M6	M6	4.1	8 (AWG 8)
MR-J4-11KGF(-RJ)	FR-HEL-15K	105	64	133	115	97	84	48.5	M6	M6	4.1	14 (AWG 6)

*1 Use this for grounding.

*2 When using the power factor improving DC reactor, remove the short bar between P3 and P4.

*3 Maximum dimensions. The dimension varies depending on the input/output lines.

*4 Selection conditions of wire size are as follows.

Wire type: 600 V Grade heat-resistant polyvinyl chloride insulated wire (HIV wire)

Construction condition: Single wire set in midair

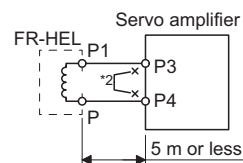
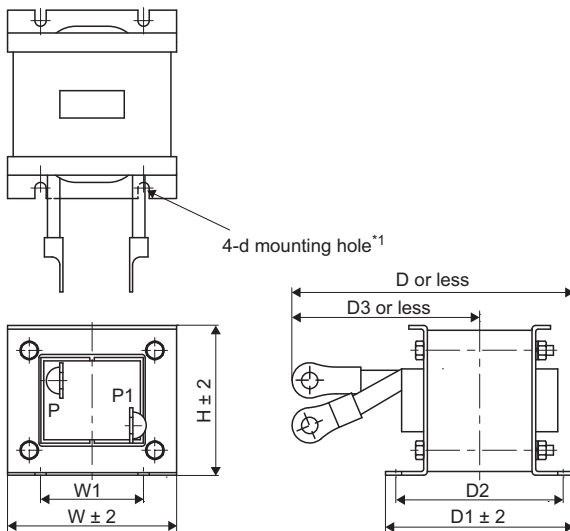

Servo amplifier	Power factor improving DC reactor	Dimensions [mm]								Terminal size	Mass [kg]	Wire [mm ²] ^{*4}
		W	W1	H	D ^{*3}	D1	D2	D3	d			
MR-J4-15KGF(-RJ)	FR-HEL-22K	105	64	93	175	117	104	115 ^{*3}	M6	M10	5.6	22 (AWG 4)
MR-J4-22KGF(-RJ)	FR-HEL-30K	114	72	100	200	125	101	135 ^{*3}	M6	M10	7.8	38 (AWG 2)

*1 Use this for grounding.

*2 When using the power factor improving DC reactor, remove the short bar between P3 and P4.

*3 Maximum dimensions. The dimension varies depending on the input/output lines.

*4 Selection conditions of wire size are as follows.

Wire type: 600 V Grade heat-resistant polyvinyl chloride insulated wire (HIV wire)

Construction condition: Single wire set in midair

400 V class

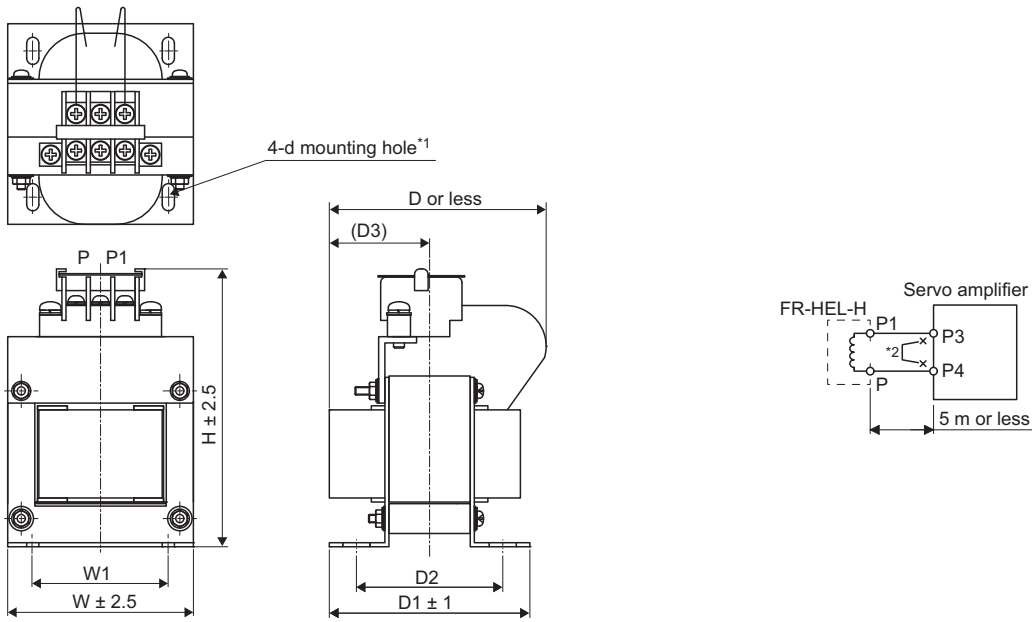

Servo amplifier	Power factor improving DC reactor	Dimensions [mm]								Terminal size	Mass [kg]	Wire [mm ²] ^{*3}
		W	W1	H	D	D1	D2	D3	d			
MR-J4-60GF4(-RJ)	FR-HEL-H1.5K	66	50	100	80	74	54	37	M4	M3.5	1.0	2 (AWG 14)
MR-J4-100GF4(-RJ)	FR-HEL-H2.2K	76	50	110	80	74	54	37	M4	M3.5	1.3	2 (AWG 14)

*1 Use this for grounding.

*2 When using the power factor improving DC reactor, remove the short bar between P3 and P4.

*3 Selection conditions of wire size are as follows.

Wire type: 600 V Grade heat-resistant polyvinyl chloride insulated wire (HIV wire)

Construction condition: Single wire set in midair

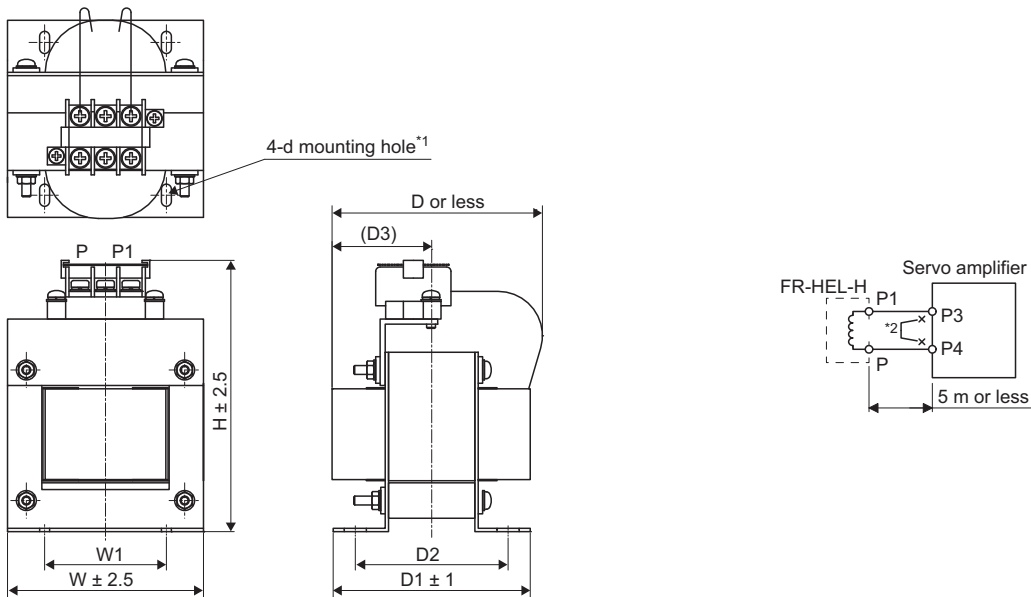

Servo amplifier	Power factor improving DC reactor	Dimensions [mm]								Terminal size	Mass [kg]	Wire [mm ²] ^{*3}
		W	W1	H	D	D1	D2	D3	d			
MR-J4-200GF4(-RJ)	FR-HEL-H3.7K	86	55	120	95	89	69	45	M4	M4	2.3	2 (AWG 14)
MR-J4-350GF4(-RJ)	FR-HEL-H7.5K	96	60	128	105	100	80	50	M5	M4	3.5	2 (AWG 14)
MR-J4-500GF4(-RJ)	FR-HEL-H11K	105	75	137	110	105	85	53	M5	M5	4.5	3.5 (AWG 12)

*1 Use this for grounding.

*2 When using the power factor improving DC reactor, remove the short bar between P3 and P4.

*3 Selection conditions of wire size are as follows.

Wire type: 600 V Grade heat-resistant polyvinyl chloride insulated wire (HIV wire)

Construction condition: Single wire set in midair

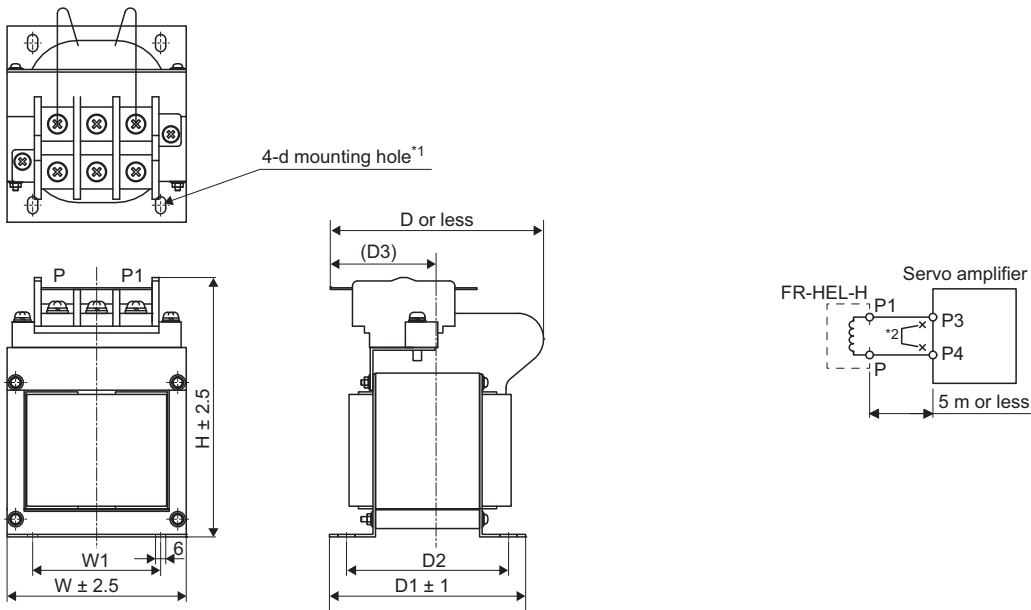

Servo amplifier	Power factor improving DC reactor	Dimensions [mm]								Terminal size	Mass [kg]	Wire [mm ²] ^{*3}
		W	W1	H	D	D1	D2	D3	d			
MR-J4-700GF4(-RJ)	FR-HEL-H15K	105	75	152	125	115	95	62	M5	M6	5.0	5.5 (AWG 10)
MR-J4-11KGF4(-RJ)												8 (AWG 8)
MR-J4-15KGF4(-RJ)	FR-HEL-H22K	133	90	178	120	95	75	53	M5	M6	6.0	8 (AWG 8)
MR-J4-22KGF4(-RJ)	FR-HEL-H30K	133	90	178	120	100	80	56	M5	M6	6.5	14 (AWG 6)

*1 Use this for grounding.

*2 When using the power factor improving DC reactor, remove the short bar between P3 and P4.

*3 Selection conditions of wire size are as follows.

Wire type: 600 V Grade heat-resistant polyvinyl chloride insulated wire (HIV wire)

Construction condition: Single wire set in midair

11.12 Power factor improving AC reactors

Advantages

- It improves the power factor by increasing the form factor of the servo amplifier's input current.
- It decreases the power supply capacity.
- The input power factor is improved to about 80%.

Restrictions

When using power factor improving AC reactors for two servo amplifiers or more, be sure to connect a power factor improving AC reactor to each servo amplifier. If one unit of power factor improving reactor is used for multiple servo amplifiers, the power factor cannot be improved sufficiently unless all servo amplifiers are operated.

100 V class/200 V class

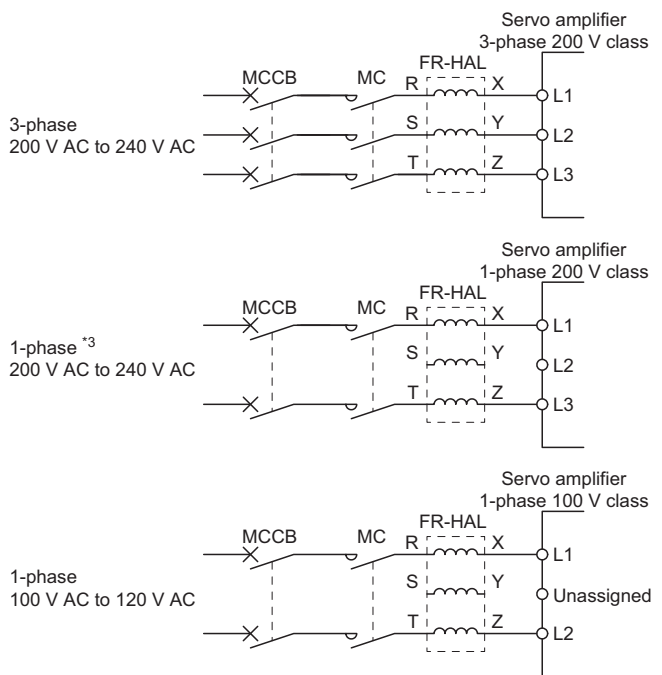
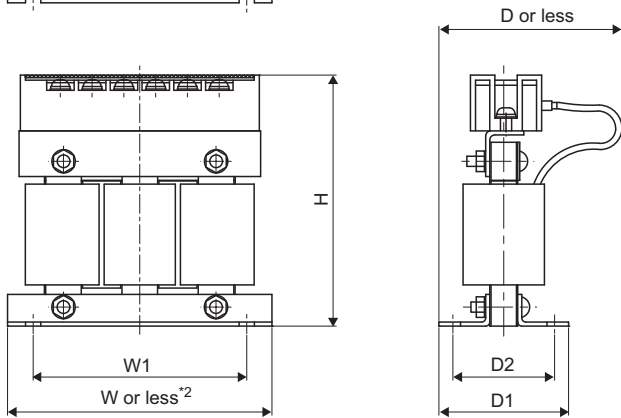
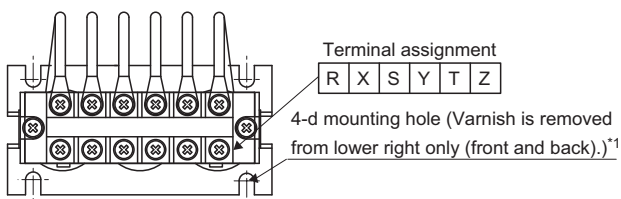

Servo amplifier	Power factor improving AC reactor	Dimensions [mm]							Terminal size	Mass [kg]
		W	W1	H	D ^{*4}	D1	D2	d		
MR-J4-10GF(-RJ) MR-J4-20GF(-RJ)	FR-HAL-0.4K	104	84	99	72	51	40	M5	M4	0.6
MR-J4-40GF(-RJ) MR-J4-10GF1(-RJ)	FR-HAL-0.75K	104	84	99	74	56	44	M5	M4	0.8
MR-J4-60GF(-RJ) MR-J4-70GF(-RJ) MR-J4-20GF1(-RJ)	FR-HAL-1.5K	104	84	99	77	61	50	M5	M4	1.1
MR-J4-100GF(-RJ) (3-phase power supply input) MR-J4-40GF1(-RJ)	FR-HAL-2.2K	115 ^{*4}	40	115	77	71	57	M6	M4	1.5
MR-J4-100GF(-RJ) (1-phase power supply input) MR-J4-200GF(-RJ) (3-phase power supply input)	FR-HAL-3.7K	115 ^{*4}	40	115	83	81	67	M6	M4	2.2

Servo amplifier	Power factor improving AC reactor	Dimensions [mm]							Terminal size	Mass [kg]
		W	W1	H	D* ⁴	D1	D2	d		
MR-J4-200GF(-RJ) (1-phase power supply input)	FR-HAL-5.5K	115* ⁴	40	115	83	81	67	M6	M4	2.3

- *1 Use this for grounding.
- *2 $W \pm 2$ is applicable for FR-HAL-0.4K to FR-HAL-1.5K.
- *3 For 1-phase 200 V AC to 240 V AC, connect the power supply to L1 and L3. Leave L2 open.
- *4 Maximum dimensions. The dimension varies depending on the input/output lines.

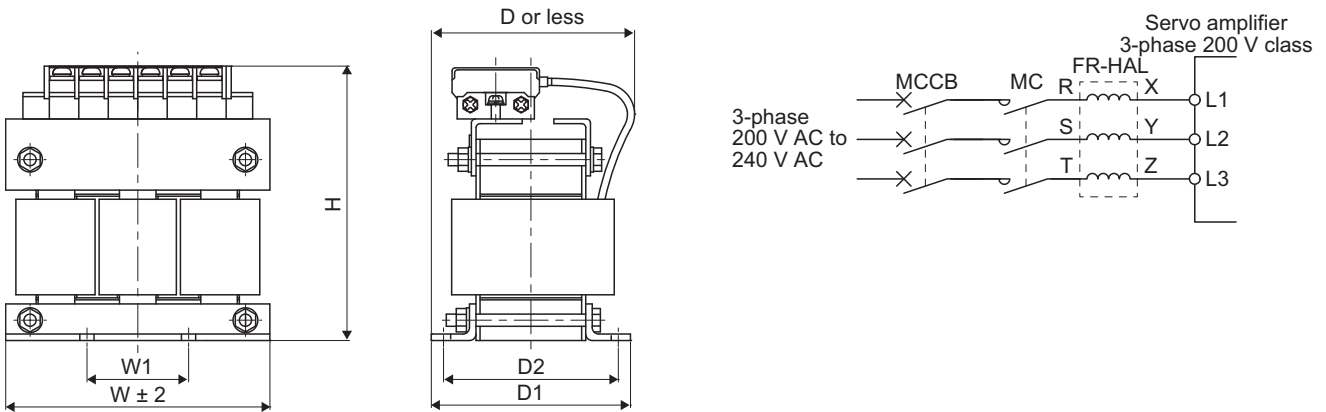
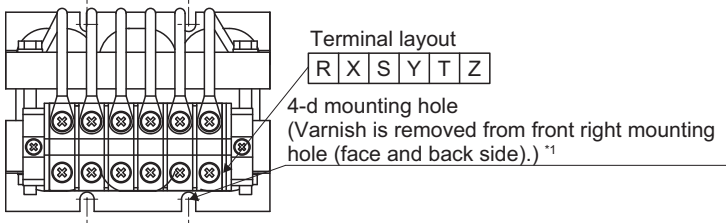

Servo amplifier	Power factor improving AC reactor	Dimensions [mm]							Terminal size	Mass [kg]
		W	W1	H	D* ²	D1	D2	d		
MR-J4-350GF(-RJ)	FR-HAL-7.5K	130	50	135	100	98	86	M6	M5	4.2
MR-J4-500GF(-RJ)	FR-HAL-11K	160	75	164	111	109	92	M6	M6	5.2
MR-J4-700GF(-RJ)	FR-HAL-15K	160	75	167	126	124	107	M6	M6	7.0
MR-J4-11KGF(-RJ)	FR-HAL-15K	160	75	167	126	124	107	M6	M6	7.0
MR-J4-15KGF(-RJ)	FR-HAL-22K	185* ²	75	150	158	100	87	M6	M8	9.0

- *1 Use this for grounding.
- *2 Maximum dimensions. The dimension varies depending on the input/output lines.

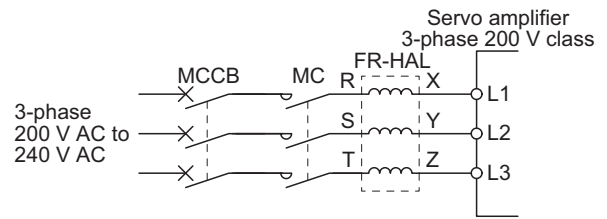
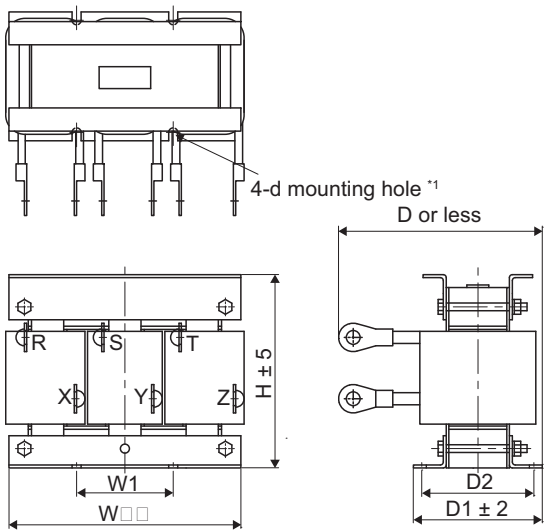

Servo amplifier	Power factor improving AC reactor	Dimensions [mm]							Terminal size	Mass [kg]
		W	W1	H	D*2	D1	D2	d		
MR-J4-22KGF(-RJ)	FR-HAL-30K	185*2	75	150	168	100	87	M6	M10	9.7

*1 Use this for grounding.

*2 Maximum dimensions. The dimension varies depending on the input/output lines.

400 V class

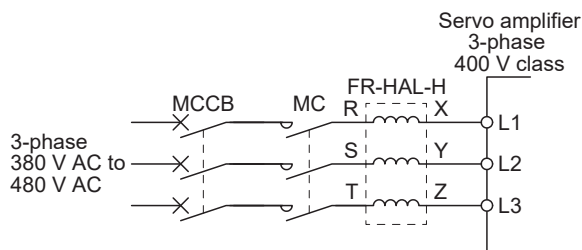
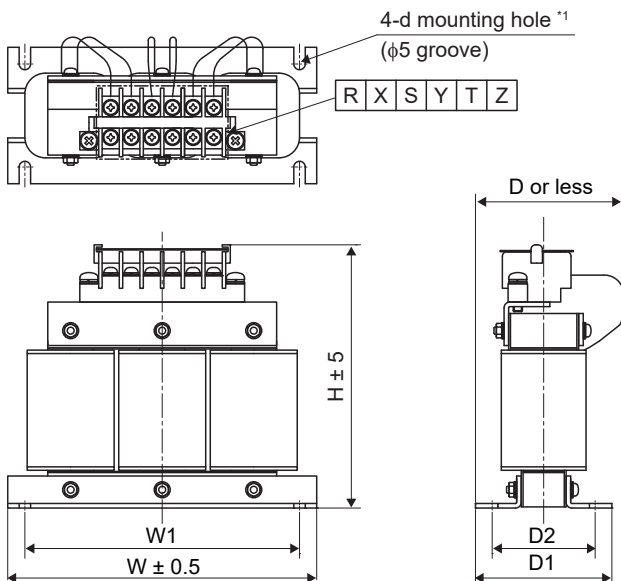

Servo amplifier	Power factor improving AC reactor	Dimensions [mm]							Terminal size	Mass [kg]
		W	W1	H	D*2	D1	D2	d		
MR-J4-60GF4(-RJ)	FR-HAL-H1.5K	135	120	115	59	59.6	45	M4	M3.5	1.5
MR-J4-100GF4(-RJ)	FR-HAL-H2.2K	135	120	115	59	59.6	45	M4	M3.5	1.5
MR-J4-200GF4(-RJ)	FR-HAL-H3.7K	135	120	115	69	70.6	57	M4	M3.5	2.5

*1 Use this for grounding.

*2 Maximum dimensions. The dimension varies depending on the input/output lines.

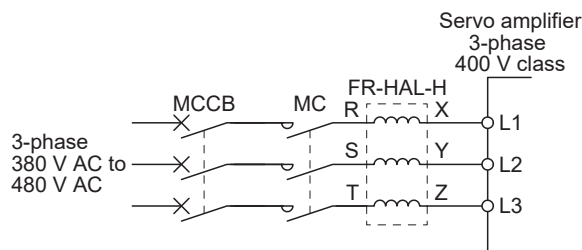
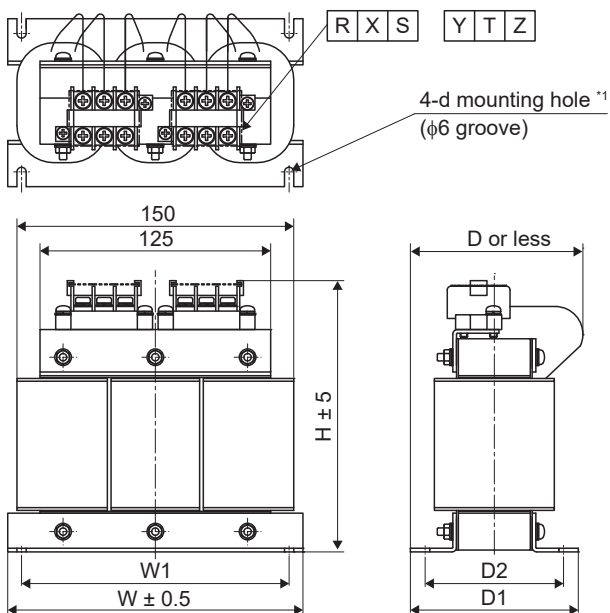

Servo amplifier	Power factor improving AC reactor	Dimensions [mm]							Terminal size	Mass [kg]
		W	W1	H	D*2	D1	D2	d		
MR-J4-350GF4(-RJ)	FR-HAL-H7.5K	160	145	142	91	91	75	M4	M4	5.0
MR-J4-500GF4(-RJ)	FR-HAL-H11K	160	145	146	91	91	75	M4	M5	6.0
MR-J4-700GF4(-RJ)	FR-HAL-H15K	220	200	195	105	90	70	M5	M5	9.0
MR-J4-11KGF4(-RJ)										

*1 Use this for grounding.

*2 Maximum dimensions. The dimension varies depending on the input/output lines.

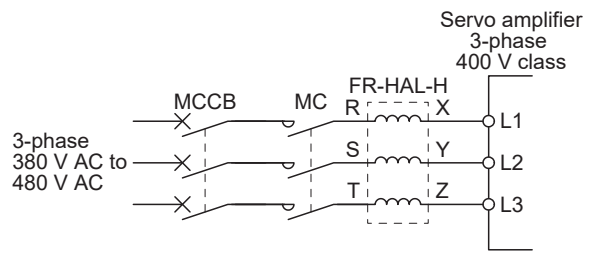
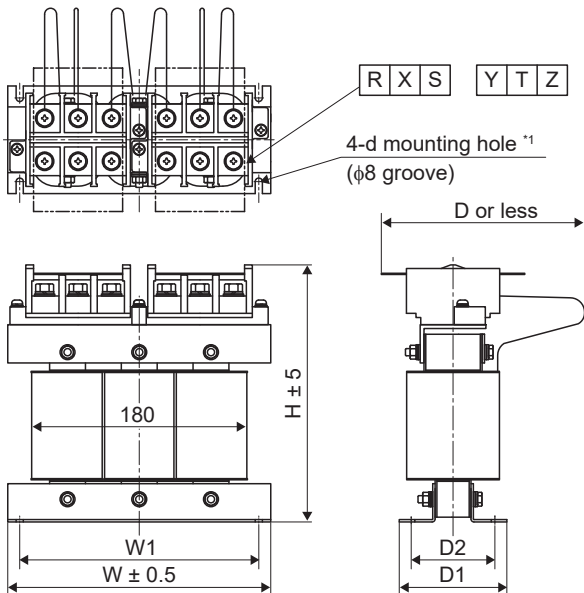

Servo amplifier	Power factor improving AC reactor	Dimensions [mm]							Terminal size	Mass [kg]
		W	W1	H	D*2	D1	D2	d		
MR-J4-15KGF4(-RJ)	FR-HAL-H22K	220	200	215	170	90	70	M5	M8	9.5
MR-J4-22KGF4(-RJ)	FR-HAL-H30K	220	200	215	170	96	75	M5	M8	11

*1 Use this for grounding.

*2 Maximum dimensions. The dimension varies depending on the input/output lines.

11.13 Relay (recommended)

The following relays should be used with the interfaces.

Interface	Selection example
Digital input (interface DI-1) Relay used for digital input command signals	To prevent defective contacts, use a relay for small signal (twin contacts). (Ex.) Omron: type G2A, MY
Digital output (interface DO-1) Relay used for digital output signals	Small relay with 12 V DC or 24 V DC of rated current 40 mA or less (Ex.) Omron: type MY

11.14 Noise reduction techniques

Noises are classified into external noises which enter the servo amplifier to cause it to malfunction and those radiated by the servo amplifier to cause peripheral equipment to malfunction. Since the servo amplifier is an electronic device which handles small signals, the following general noise reduction techniques are required.

Also, the servo amplifier can be a source of noise as its outputs are chopped by high carrier frequencies. If peripheral equipment malfunctions due to noises produced by the servo amplifier, noise suppression measures must be taken. The measures will vary slightly with the routes of noise transmission.

Noise reduction techniques

■General reduction techniques

- Avoid bundling power lines (input/output) and signal cables together or running them in parallel to each other. Separate the power lines from the signal cables.
- Use a shielded twisted pair cable for connection with the encoder and for control signal transmission, and connect the external conductor of the cable to the SD terminal.
- Ground the servo amplifier, servo motor, etc. together at one point.

 Page 127 Grounding

■Reduction techniques for external noises that cause the servo amplifier to malfunction

If there are noise sources (such as a magnetic contactor, an electromagnetic brake, and many relays which make a large amount of noise) near the servo amplifier and the servo amplifier may malfunction, the following countermeasures are required.

- Provide surge absorbers on the noise sources to suppress noises.
- Attach data line filters to the signal cables.
- Ground the shields of the encoder connecting cable and the control signal cables with cable clamp fittings.
- Although a surge absorber is built into the servo amplifier, to protect the servo amplifier and other equipment against large exogenous noise and lightning surge, attaching a varistor to the power input section of the equipment is recommended.

■ Techniques for noises radiated by the servo amplifier that cause peripheral equipment to malfunction

Noises produced by the servo amplifier are classified into those radiated from the cables connected to the servo amplifier and its main circuits (input and output circuits), those induced electromagnetically or statically by the signal cables of the peripheral equipment located near the main circuit cables, and those transmitted through the power supply cables.

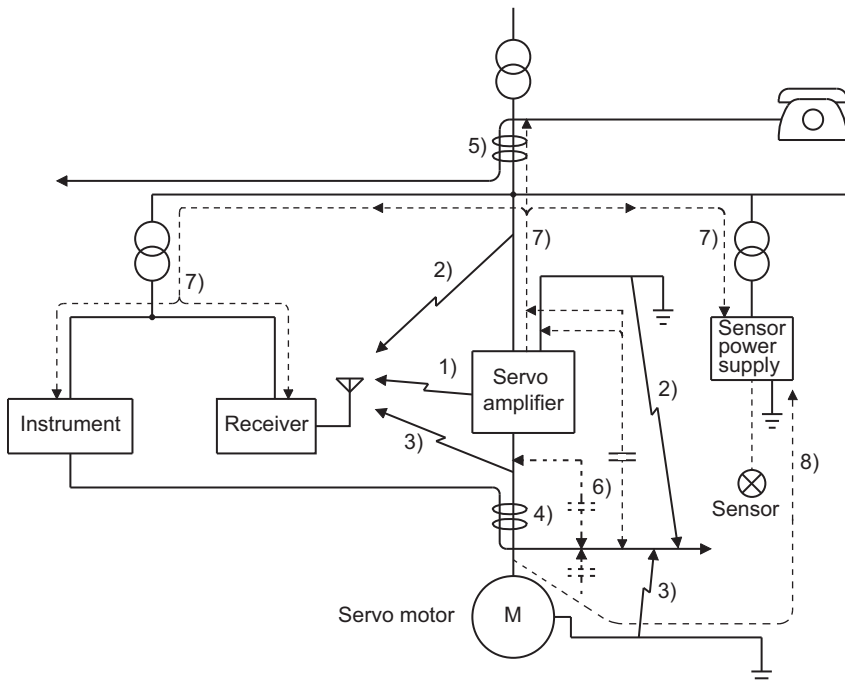
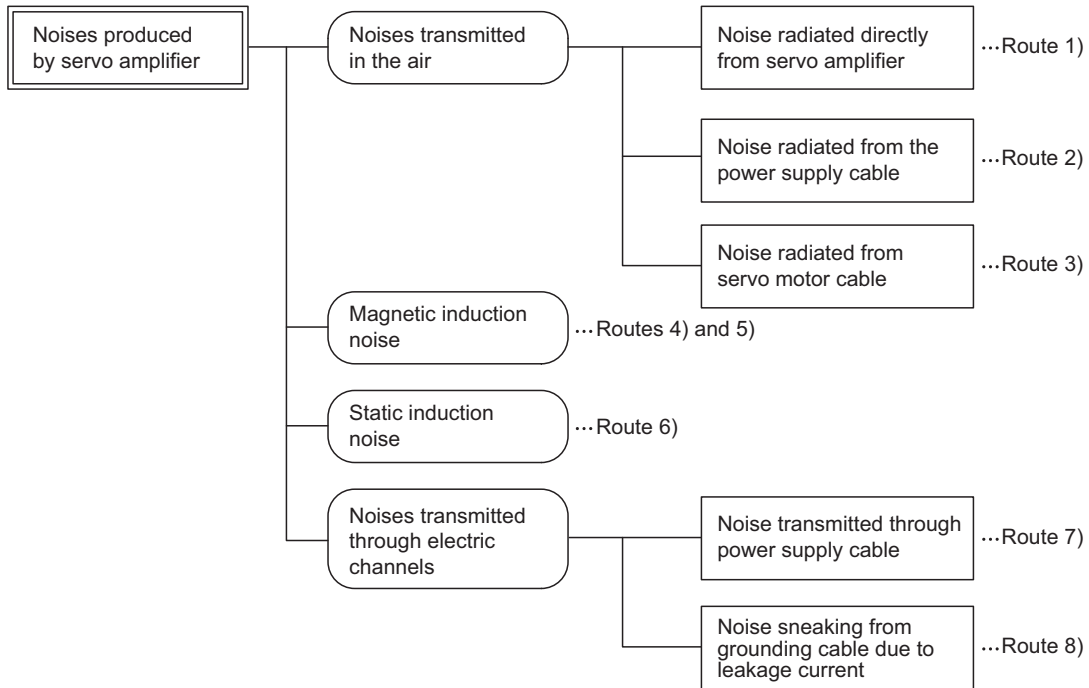

Noise transmission route	Suppression techniques
1) 2) 3)	<p>When measuring instruments, receivers, sensors, etc. which handle weak signals and may malfunction due to noise and/or their signal cables are contained in a cabinet together with the servo amplifier or run near the servo amplifier, such devices may malfunction due to noises transmitted through the air. The following techniques are required.</p> <ul style="list-style-type: none"> • Provide maximum clearance between easily affected devices and the servo amplifier. • Provide maximum clearance between easily affected signal cables and the I/O cables of the servo amplifier. • Avoid wiring the power lines (input/output lines of the servo amplifier) and signal lines side by side or bundling them together. • Insert a line noise filter to the I/O cables or a radio noise filter on the input line. • Use shielded wires for the signal and power lines, or put the lines in separate metal conduits.
4) 5) 6)	<p>When the power lines and the signal lines are laid side by side or bundled together, magnetic induction noise and static induction noise will be transmitted through the signal cables and malfunction may occur.</p> <ul style="list-style-type: none"> • Provide maximum clearance between easily affected devices and the servo amplifier. • Provide maximum clearance between easily affected signal cables and the I/O cables of the servo amplifier. • Avoid wiring the power lines (input/output lines of the servo amplifier) and signal lines side by side or bundling them together. • Use shielded wires for the signal and power lines, or put the lines in separate metal conduits.
7)	<p>When the power supply of peripheral equipment is connected to the power supply of the servo amplifier system, noises produced by the servo amplifier may be transmitted back through the power supply cable and the devices may malfunction. The following techniques are required.</p> <ul style="list-style-type: none"> • Install the radio noise filter (FR-BIF(-H)) on the power lines (Input lines) of the servo amplifier. • Install the line noise filter (FR-BSF01/FR-BLF) on the power lines of the servo amplifier.
8)	<p>If the grounding wires of the peripheral equipment and the servo amplifier make a closed loop circuit, leakage current may flow through, causing the equipment to malfunction. In this case, the malfunction may be prevented by the grounding wires disconnected from the equipment.</p>

■ Noise reduction techniques for the network cable



Take measures against noise for both ends of the network cable.

When using it in an environment with excessive noise, directly connect the shield of the network cable to the ground plate with cable clamp fittings at a place 200 mm to 300 mm or less from the servo amplifier.

When connecting the network cable from outside the cabinet, connect it to the ground plate at a place 5 mm to 10 mm away from the cabinet entrance.

To reinforce measures against noise, it is recommended to install a data line filter (TDK ZCAT1730-0730) to the network cable. Install the data line filter to a place 80 mm or less from the servo amplifier.

- For inside the cabinet

When using cable clamp fittings

Servo amplifier

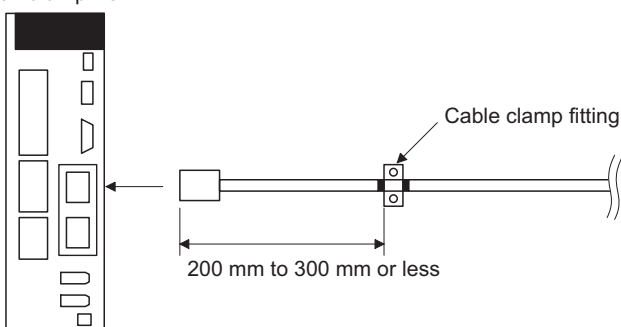

When using a data line filter

Servo amplifier

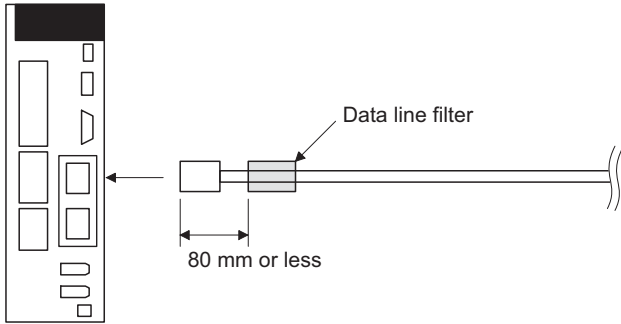

- For outside the cabinet

When using cable clamp fittings

Servo amplifier

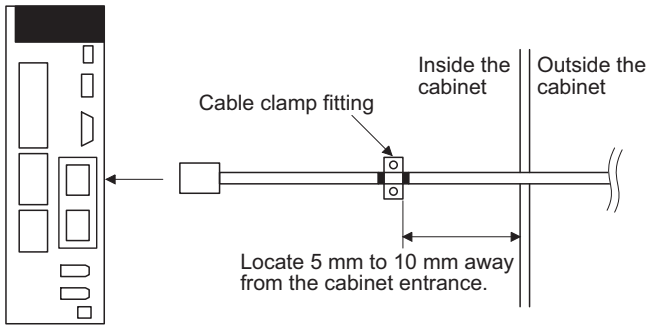

When using a data line filter

Servo amplifier

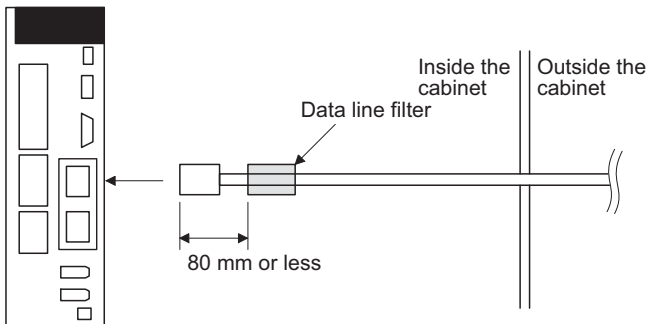

Noise reduction products

■Data line filter (recommended)

Noise can be prevented by installing a data line filter onto the encoder cable, etc.

For example, ZCAT3035-1330 by TDK, ESD-SR-250 by TOKIN, GRFC-13 by Kitagawa Industries, and E04SRM563218 by SEIWA ELECTRIC are available as data line filters.

As a reference example, the impedance specifications of the ZCAT3035-1330 (TDK) are indicated below. These impedances are reference values and not guaranteed values.

Impedance [Ω]	
10 MHz to 100 MHz	100 MHz to 500 MHz
80	150

[Unit: mm]

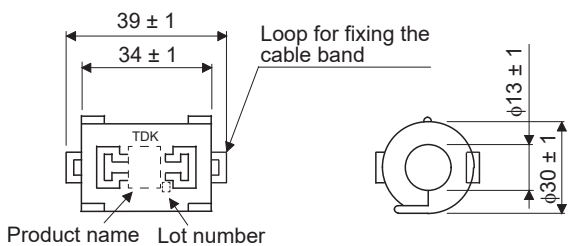

Outline drawing (ZCAT3035-1330)

■Surge killer (recommended)

Use of a surge killer is recommended for AC relay, magnetic contactor or the like near the servo amplifier. Use the following surge killer or equivalent.

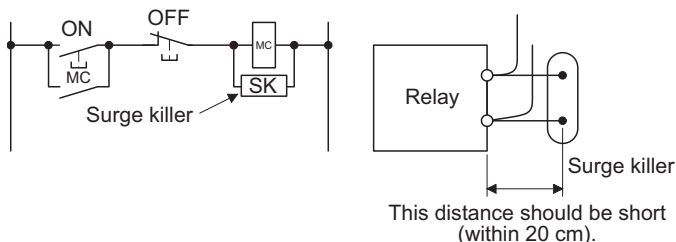

Ex.

CR-50500 (Okaya Electric Industries)

Rated voltage AC [V]	C [μ F \pm 20%]	R [Ω \pm 30%]	Test voltage	Dimensions [Unit: mm]
250	0.5	50 (1/2W)	Between terminals: 625 V AC, 50 Hz/60 Hz 60 s Between terminal and case: 2000 V AC 50/60 Hz 60 s	

Note that a diode should be installed to a DC relay or the like.

Maximum voltage: Not less than four times the drive voltage of the relay or the like.

Maximum current: Not less than twice the drive current of the relay or the like.

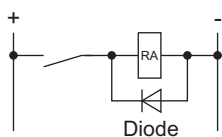

■ Cable clamp fitting AERSBAN-_SET

Generally, connecting the grounding of the shielded wire to the SD terminal of the connector provides a sufficient effect. However, the effect can be increased when the shielded wire is connected directly to the grounding plate as shown below. Install the grounding plate near the servo amplifier for the encoder cable. Peel part of the cable sheath to expose the external conductor, and press that part against the grounding plate with the cable clamp. If the cable is thin, clamp several cables in a bunch.

The cable clamp comes as a set with the grounding plate.

[Unit: mm]

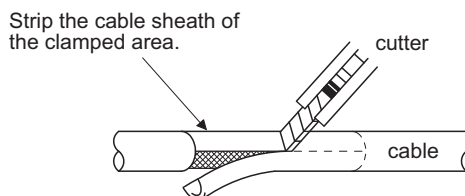
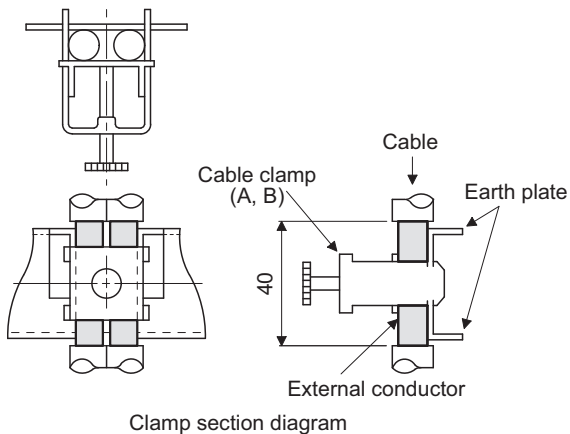

• Dimensions

[Unit: mm]

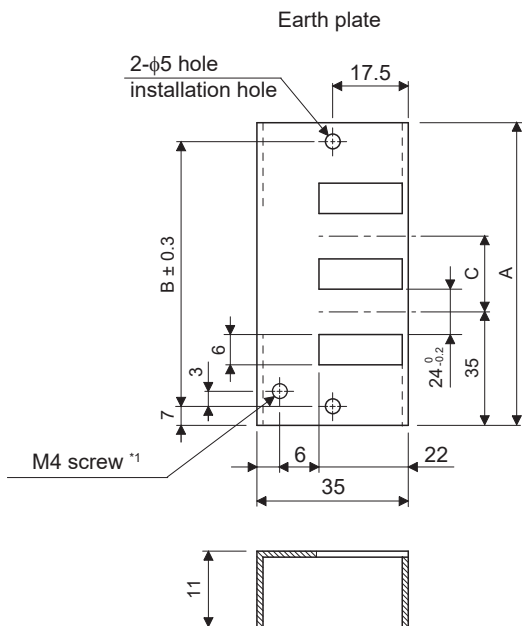

Clamp section diagram

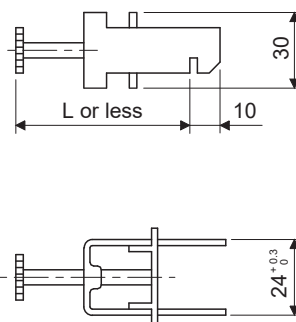

*1 Screw hole for grounding. Connect it to the grounding plate of the cabinet.

Model	A	B	C	Accessory fittings
AERSBAN-DSET	100	86	30	Clamp A: 2pcs.
AERSBAN-ESET	70	56	—	Clamp B: 1pc.
Clamp fitting	L			
A	70			
B	45			

Line noise filter (FR-BSF01/FR-BLF)

This filter is effective in suppressing noises radiated from the power supply side and output side of the servo amplifier and also in suppressing high-frequency leakage current (0-phase current). It especially affects the noises between 0.5 MHz and 5 MHz band.

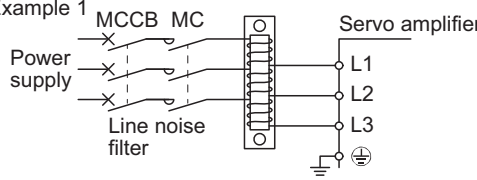
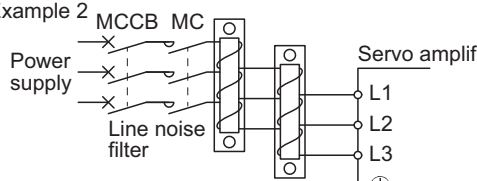
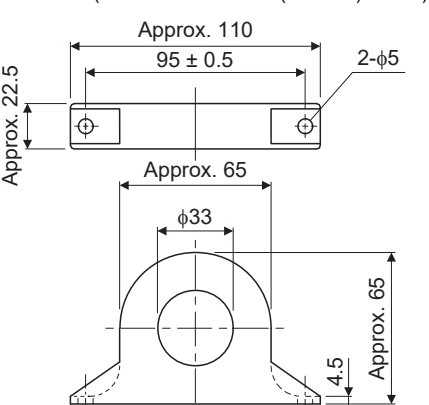
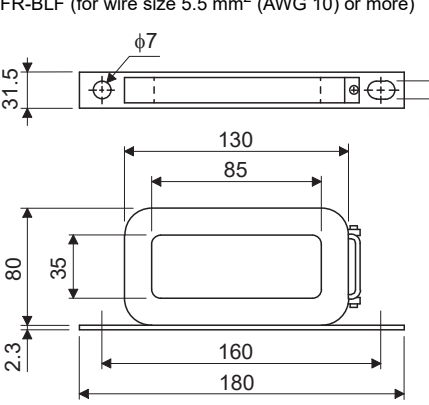
Connection diagram	Dimensions [Unit: mm]
<p>The line noise filters can be mounted on lines of the main power supply (L1/L2/L3) and of the servo motor power (U/V/W). Pass each of the wires through the line noise filter an equal number of times in the same direction. For wires of the main power supply, the effect of the filter rises as the number of passes increases, but generally four passes would be appropriate. For the servo motor power lines, passes must be four times or less. Do not pass the grounding wire through the filter. Otherwise, the effect of the filter will drop. Wind the wires by passing through the filter to satisfy the required number of passes as shown in Example 1. If the wires are too thick to wind, use two or more filters to have the required number of passes as shown in Example 2. Place the line noise filters as close to the servo amplifier as possible for their best performance.</p> <p>Example 1</p>  <p>(Number of passes: 4)</p> <p>Example 2</p>  <p>Two filters are used (Total number of passes: 4)</p>	<p>FR-BSF01 (for wire size 3.5 mm² (AWG 12) or less)</p>  <p>FR-BLF (for wire size 5.5 mm² (AWG 10) or more)</p> 

Radio noise filter (FR-BIF(-H))

This filter is effective in suppressing noises radiated from the power supply side of the servo amplifier especially in 10 MHz and lower radio frequency bands. The FR-BIF(-H) is designed for the input only.

100 V class/200 V class: FR-BIF

400 V class: FR-BIF-H

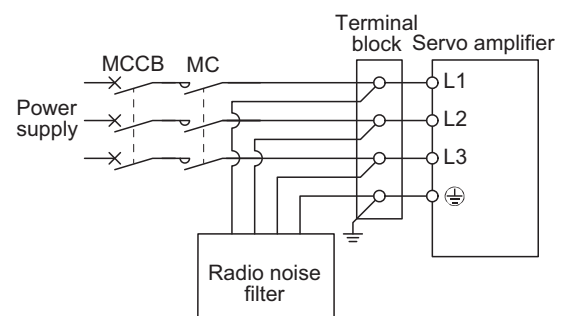
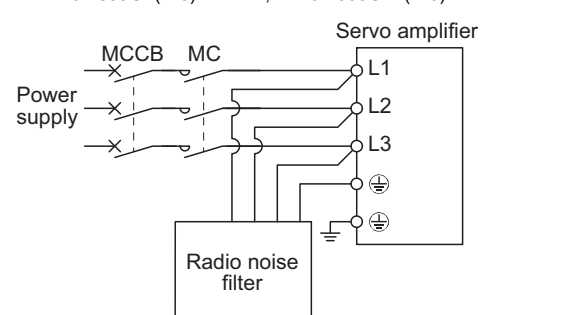
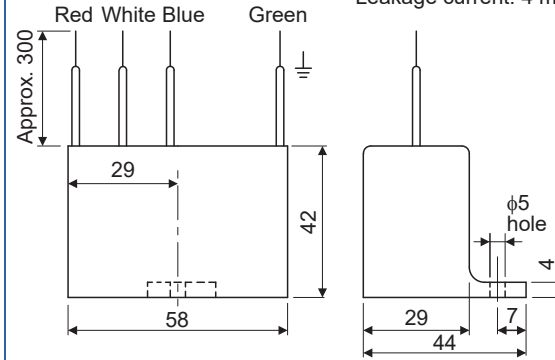
Connection diagram	Dimensions [Unit: mm]
<p>Make the connection cables as short as possible. Grounding is always required.</p> <p>When using the FR-BIF with a single-phase power supply, always insulate the lead wires that are not used for wiring.</p> <ul style="list-style-type: none"> • MR-J4-350GF(-RJ) or less, MR-J4-350GF4(-RJ) or less, and MR-J4-40GF1(-RJ) or less  <p>The diagram shows a three-phase power supply connected to an MCCB and MC. The power lines pass through a radio noise filter and are connected to a terminal block. The terminal block is then connected to the L1, L2, and L3 terminals of a servo amplifier. Grounding is shown at the terminal block and the servo amplifier.</p> <ul style="list-style-type: none"> • MR-J4-500GF(-RJ) or more, MR-J4-500GF4(-RJ) or more  <p>The diagram shows a three-phase power supply connected to an MCCB and MC. The power lines pass through a radio noise filter and are connected directly to the L1, L2, and L3 terminals of a servo amplifier. Grounding is shown at the servo amplifier.</p>	<p>Approx. 300</p> <p>Red White Blue Green</p> <p>Leakage current: 4 mA</p>  <p>The diagram shows the physical dimensions of the radio noise filter. The main body is 58 mm wide and 42 mm high. The terminal block is 29 mm wide and 7 mm high. The total width including the terminal block is 44 mm. The terminal block has a 5 mm diameter hole and a 4 mm height. The terminal wires are labeled Red, White, Blue, and Green. The height of the terminal wires is approximately 300 mm. The leakage current is 4 mA.</p>

■Varistor for input power supply (recommended)

Varistors are effective to prevent exogenous noise and lightning surge from entering the servo amplifier. When using a varistor, connect it between each phase of the input power supply of the equipment. For varistors, the TND20V-431K, TND20V-471K and TND20V-102K, manufactured by Nippon Chemi-Con, are recommended. For detailed specification and usage of the varistors, refer to the manufacturer catalog.

Power supply voltage	Varistor	Maximum rating					Maximum limit voltage		Static capacity (reference value)	Varistor voltage rating (range) V1 mA
		Permissible circuit voltage		Surge current immunity	Energy immunity	Rated pulse power	[A]	[V]		
		AC [Vrms]	DC [V]	8/20 μ s [A]	2 ms [J]	[W]			[pF]	[V]
100 V class/200 V class	TND20V-431K	275	350	10000/1 time 7000/2 times	195	1.0	100	710	1300	430 (387 to 473)
	TND20V-471K	300	385		215			775	1200	470 (423 to 517)
400 V class	TND20V-102K	625	825	7500/1 time 6500/2 times	400	1.0	100	1650	560	1000 (900 to 1100)

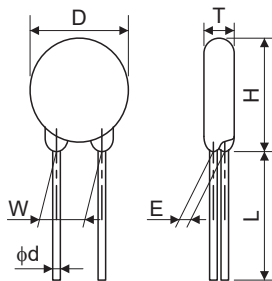

[Unit: mm]

Model	D Max.	H Max.	T Max.	E \pm 1.0	L Min.*1	ϕ d \pm 0.05	W \pm 1.0
TND20V-431K	21.5	24.5	6.4	3.3	20	0.8	10.0
TND20V-471K			6.6	3.5			
TND20V-102K	22.5	25.5	9.5	6.4	20	0.8	10.0

*1 For special purpose items for lead length (L), contact the manufacturer.

11.15 Earth-leakage current breaker

Selection method

High-frequency chopper currents controlled by pulse width modulation flow in the AC servo circuits. Leakage currents containing harmonic contents are larger than those of the motor which is run with a commercial power supply.

Select an earth-leakage current breaker according to the following formula, and ground the servo amplifier, servo motor, etc. securely.

To minimize leakage currents, make the input and output wires as short as possible, and keep a distance of 30 cm or longer between the wires and ground.

$$\text{Rated sensitivity current} \geq 10 \cdot \{I_{g1} + I_{gn} + I_{ga} + K \cdot (I_{g2} + I_{gm})\} \text{ [mA]} \dots (11.1)$$

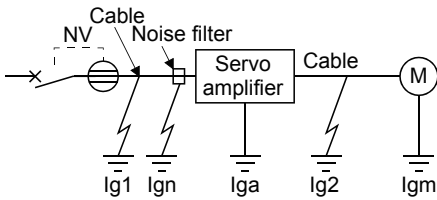

Earth-leakage current breaker		K
Type	Mitsubishi Electric products	
Models provided with harmonic and surge reduction techniques	NV-SP NV-SW NV-CP NV-CW NV-HW	1
General models	BV-C1 NFB NV-L	3

I_{g1}: Leakage current on the electric channel from the earth-leakage current breaker to the input terminals of the servo amplifier

☞ Page 430 Example of leakage current per km (I_{g1}, I_{g2}) for CV cable run in metal conduit

I_{g2}: Leakage current on the electric channel from the output terminals of the servo amplifier to the servo motor

☞ Page 430 Example of leakage current per km (I_{g1}, I_{g2}) for CV cable run in metal conduit

I_{gn}: Leakage current when a filter is connected to the input side (4.4 mA per one FR-BIF(-H))

I_{ga}: Leakage current of the servo amplifier

☞ Page 430 Servo amplifier leakage current example (I_{ga})

I_{gm}: Leakage current of the servo motor

☞ Page 430 Servo motor leakage current example (I_{gm})

■ Example of leakage current per km (I_{g1}, I_{g2}) for CV cable run in metal conduit

- 100 V class/200 V class

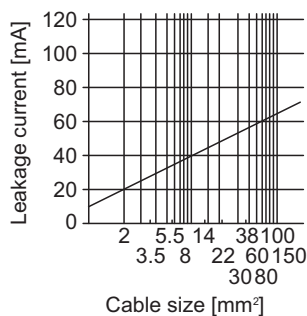

"I_{g1}" of 100 V class servo amplifiers is 1/2 of 200 V class servo amplifiers.

- 400 V class

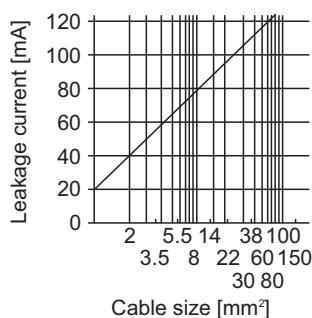

■ Servo motor leakage current example (I_{gm})

Servo motor output [kW]	Leakage current [mA]
0.05 to 1	0.1
1.2 to 2	0.2
3 to 3.5	0.3
4.2 to 5	0.5
6 to 7	0.7
8 to 11	1.0
12 to 15	1.3
20 to 25	2.3

■ Servo amplifier leakage current example (I_{ga})

Servo amplifier capacity [kW]	Leakage current [mA]
0.1 to 0.6	0.1
0.75 to 3.5	0.15
5/7	2
11/15	5.5
22	7

■ Earth-leakage current breaker selection example

Servo amplifier	Rated sensitivity current of earth-leakage current breaker [mA]
MR-J4-10GF(-RJ) to MR-J4-350GF(-RJ) MR-J4-60GF4(-RJ) to MR-J4-350GF4(-RJ) MR-J4-10GF1(-RJ) to MR-J4-40GF1(-RJ)	15
MR-J4-500GF(-RJ) MR-J4-500GF4(-RJ)	30
MR-J4-700GF(-RJ) MR-J4-700GF4(-RJ)	50
MR-J4-11KGF(-RJ) to MR-J4-22KGF(-RJ) MR-J4-11KGF4(-RJ) to MR-J4-22KGF4(-RJ)	100

Selection example

Indicated below is an example of selecting an earth-leakage current breaker under the following conditions.

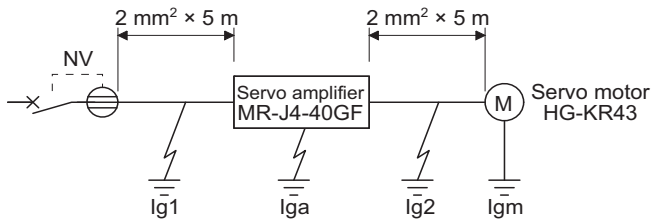

Use an earth-leakage current breaker designed for suppressing harmonics/surges.

Find the terms of equation (11.1) from the diagram.

$$I_{g1} = 20 \cdot \frac{5}{1000} = 0.1 \text{ [mA]}$$

$$I_{g2} = 20 \cdot \frac{5}{1000} = 0.1 \text{ [mA]}$$

$$I_{gn} = 0 \text{ (not used)}$$

$$I_{ga} = 0.1 \text{ [mA]}$$

$$I_{gm} = 0.1 \text{ [mA]}$$

Insert these values in equation (11.1).

$$I_g \geq 10 \cdot \{0.1 + 0 + 0.1 + 1 \cdot (0.1 + 0.1)\}$$

$$I_g \geq 4 \text{ [mA]}$$

According to the result of calculation, use an earth-leakage current breaker having the rated sensitivity current (I_g) of 4.0 mA or more.

Use an earth-leakage current breaker having I_g of 15 mA with the NV-SP/SW/CP/CW/HW series.

11.16 EMC filter (recommended)



When connecting multiple servo amplifiers to one EMC filter, refer to section 6.4 of "EMC Installation Guidelines".

It is recommended that one of the following filters be used to comply with EN EMC directive. Some EMC filters have large in leakage current.

Combination with the servo amplifier

Servo amplifier	Recommended filter (Soshin Electric)				Mass [kg]	
	Model	Rated current [A]	Rated voltage [VAC]	Leakage current [mA]		
MR-J4-10GF(-RJ) to MR-J4-100GF(-RJ)	HF3010A-UN ^{*1}	10	250	5	3.5	
MR-J4-200GF(-RJ) MR-J4-350GF(-RJ)	HF3030A-UN ^{*1}	30		5.5		
MR-J4-500GF(-RJ) MR-J4-700GF(-RJ)	HF3040A-UN ^{*1}	40		6.5	6	
MR-J4-11KGF(-RJ) MR-J4-15KGF(-RJ) MR-J4-22KGF(-RJ)	HF3100A-UN ^{*1}	100		12		
MR-J4-60GF4(-RJ) MR-J4-100GF4(-RJ)	TF3005C-TX	5	500	5.5	6	
MR-J4-200GF4(-RJ) to MR-J4-700GF4(-RJ)	TF3020C-TX	20				
MR-J4-11KGF4(-RJ)	TF3030C-TX	30				7.5
MR-J4-15KGF4(-RJ)	TF3040C-TX	40				12.5
MR-J4-22KGF4(-RJ)	TF3060C-TX	60				
MR-J4-10GF1(-RJ) to MR-J4-40GF1(-RJ)	HF3010A-UN ^{*1}	10				250

*1 To use any of these EMC filters, the surge protector RSPD-250-U4 (Okaya Electric Industries) is required.

Servo amplifier	Recommended filter (COSEL)				Mass [kg]
	Model	Rated current [A]	Rated voltage [VAC]	Leakage current [mA]	
MR-J4-11KGF(-RJ) to MR-J4-22KGF(-RJ)	FTB-100-355-L ^{*1}	100	500	40	5.3
MR-J4-22KGF4(-RJ)	FTB-80-355-L ^{*1}	80	500	80	5.3

*1 To use any of these EMC filters, the surge protector RSPD-500-U4 (Okaya Electric Industries) is required.

Connection example

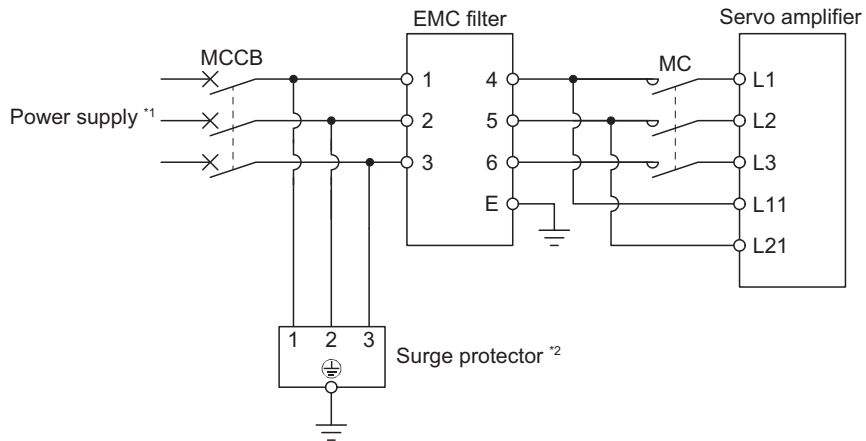

*1 For the power supply specifications, refer to the following.

 Page 30 Servo amplifier standard specifications

*2 The example is when a surge protector is connected.

Dimensions

■ EMC filter

HF3010A-UN

[Unit: mm]

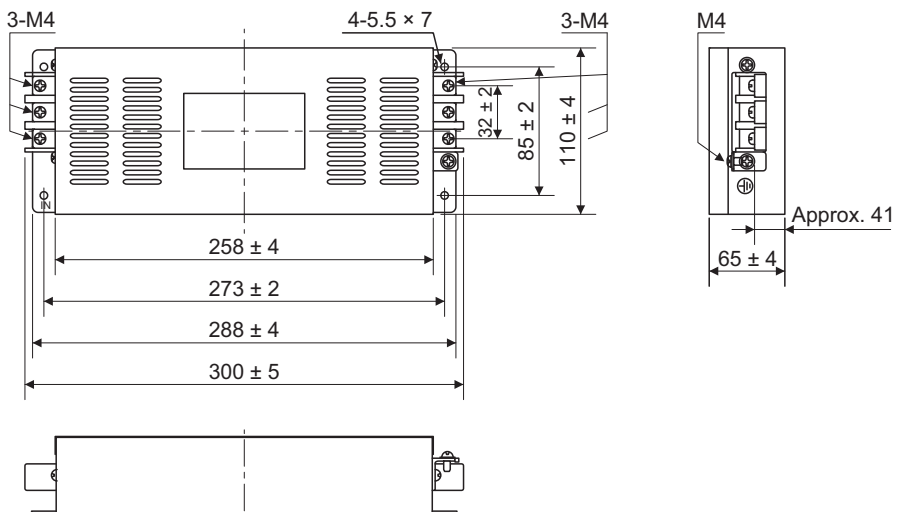

HF3030A-UN/HF3040A-UN

[Unit: mm]

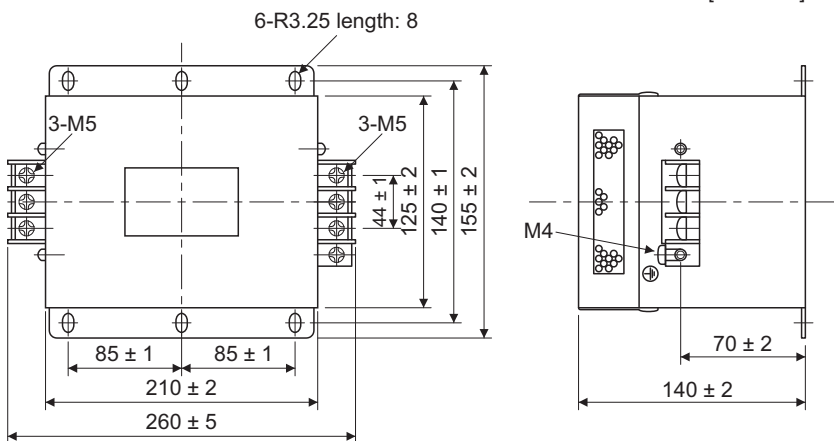

HF3100A-UN

[Unit: mm]

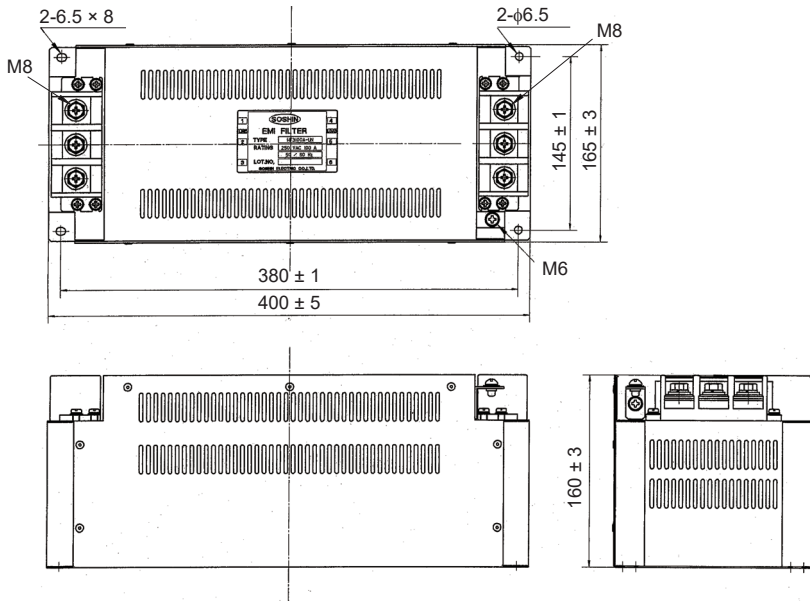

TF3005C-TX/TF3020C-TX/TF3030C-TX

[Unit: mm]

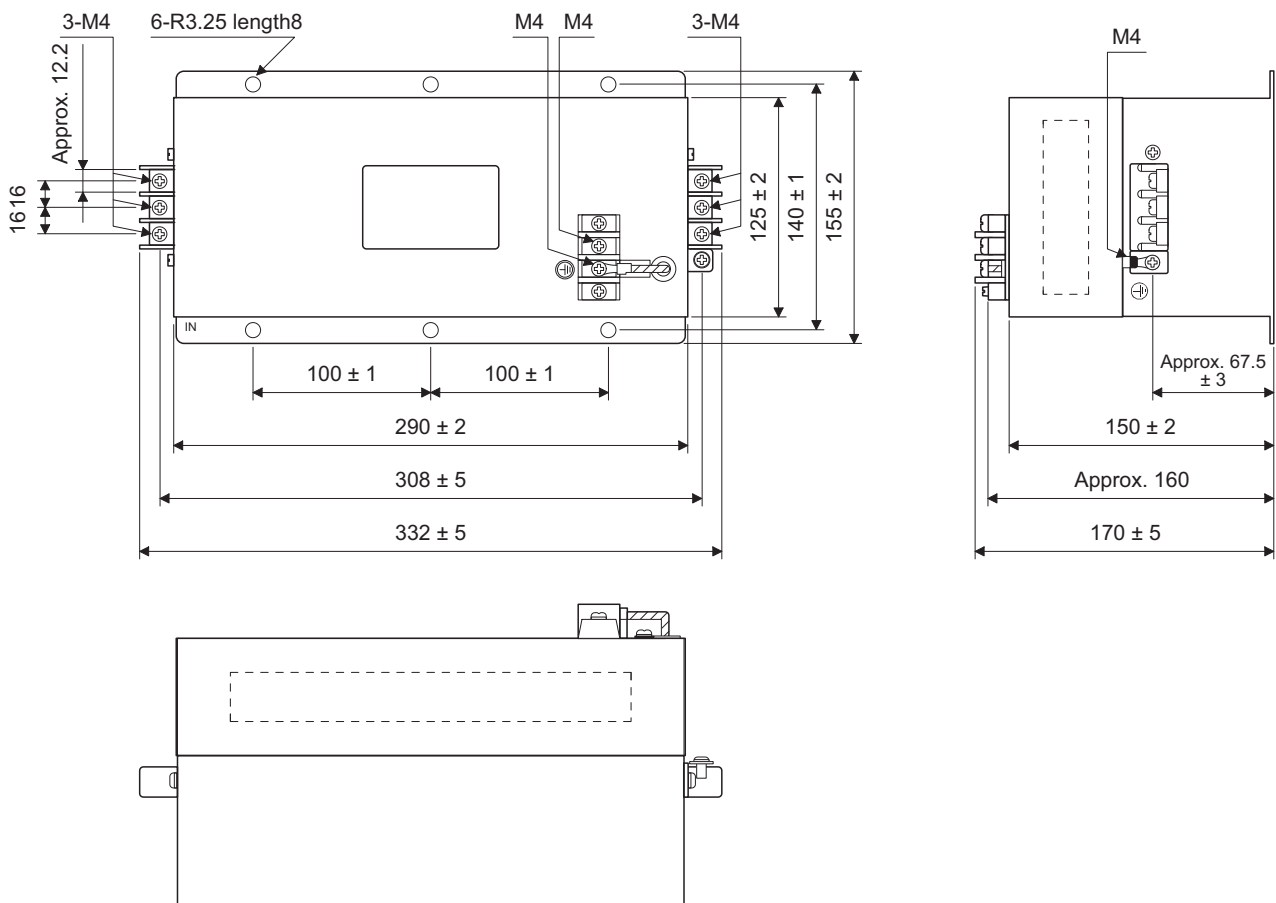

8-R3.25 Length 8 (for M6)

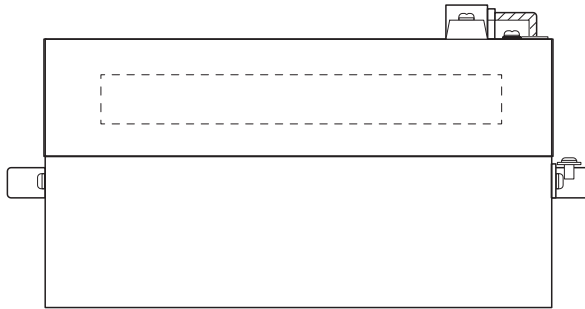
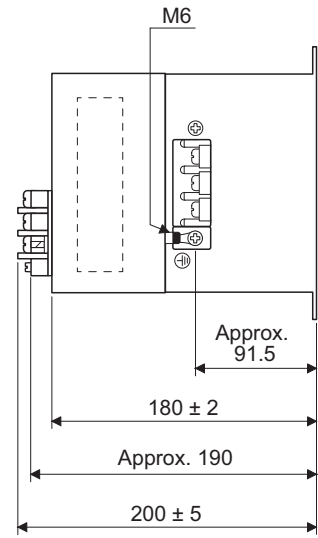
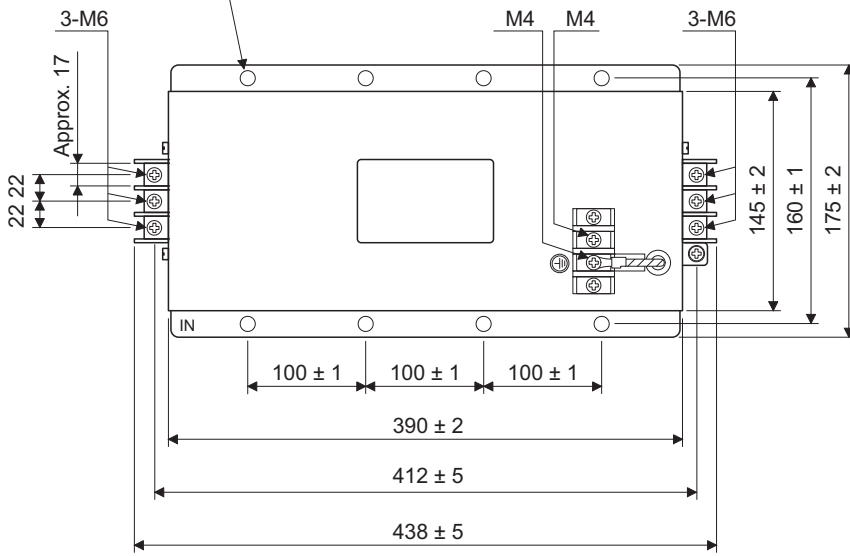

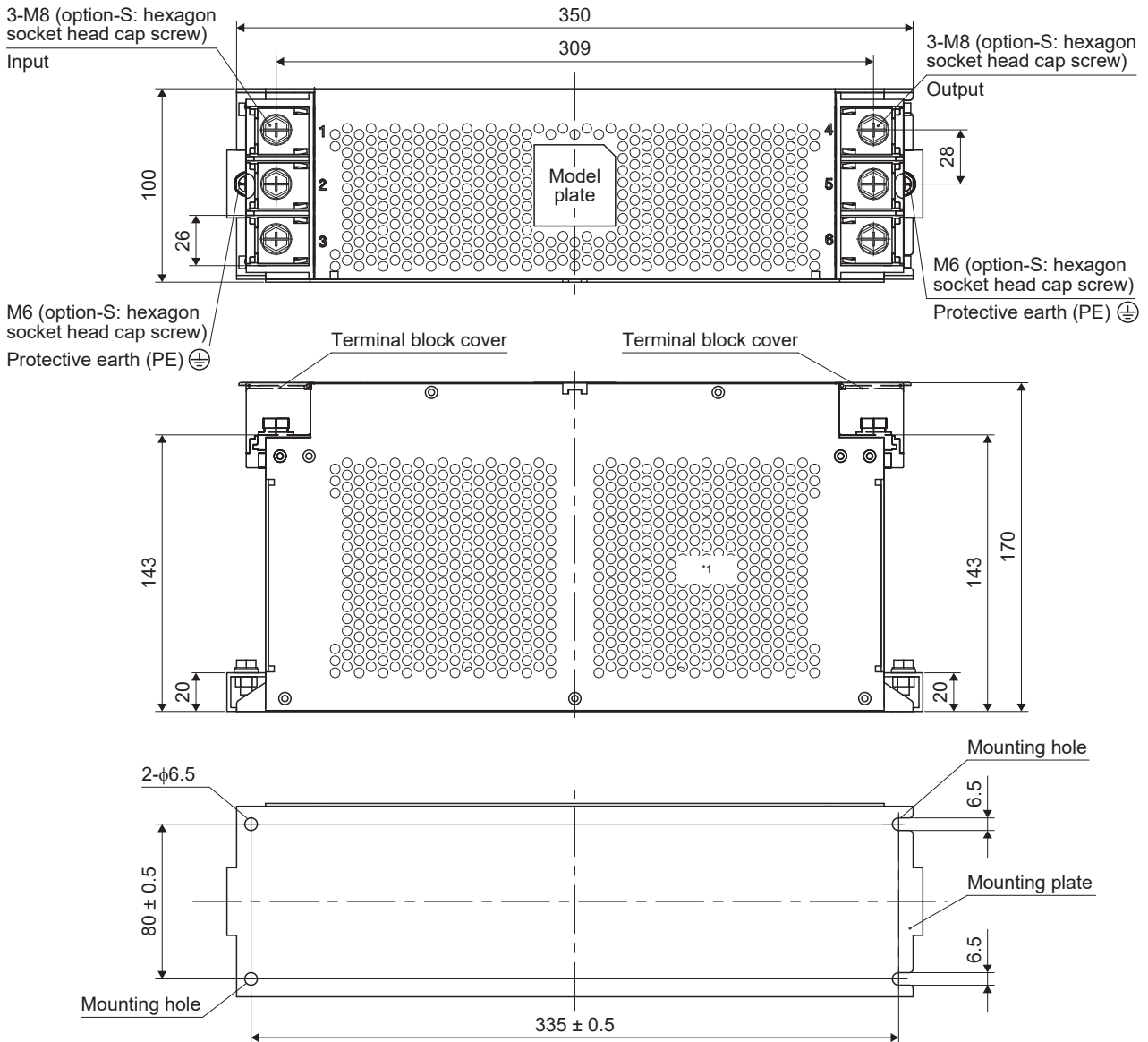

*1 No heat radiation holes on the opposite face.

Surge protector

RSPD-250-U4/RSPD-500-U4

[Unit: mm]

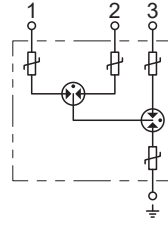
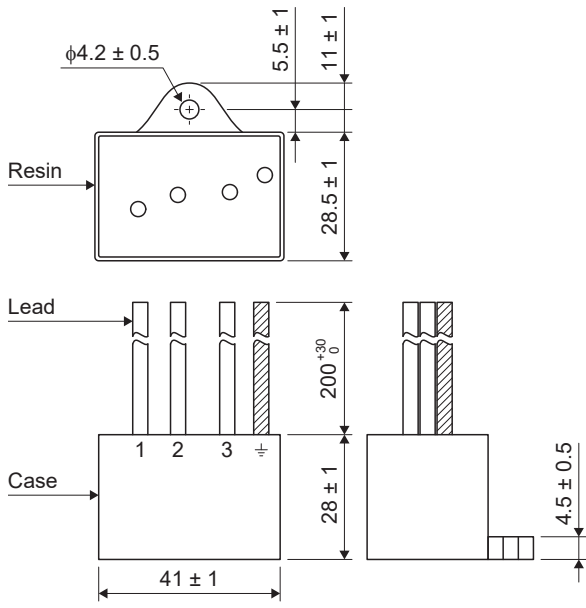

11.17 External dynamic brake

CAUTION

- Use an external dynamic brake for a servo amplifier of MR-J4-11KGF(-RJ) to MR-J4-22KGF(-RJ) and MR-J4-11KGF4(-RJ) to MR-J4-22KGF4(-RJ). Failure to do so will cause an accident because the servo motor does not stop immediately but coasts at an alarm occurrence for which the servo motor does not decelerate to stop. Ensure the safety in the entire equipment. For alarms for which the servo motor does not decelerate to stop, refer to the following.
 Page 283 TROUBLESHOOTING
- The external dynamic brake cannot be used for compliance with SEMI-F47 standard. Do not assign DB (Dynamic brake interlock) in [Pr. PD07] to [Pr. PD09]. Failure to do so will cause the servo amplifier to become servo-off when an instantaneous power failure occurs.

Point

- EM2 has the same function as EM1 in the torque mode.
- Configure a sequence which switches off the magnetic contactor of the external dynamic brake after (or as soon as) the servo-on command has been turned off at a power failure or a malfunction.
- For the braking time taken when the external dynamic brake is operated, refer to the following.
 Page 321 Dynamic brake characteristics
- The external dynamic brake is rated for a short duration. Do not use it very frequently.
- When using the 400 V class external dynamic brake, the power supply voltage is restricted to 1-phase 380 V AC to 463 V AC (50 Hz/60 Hz).
- The external dynamic brake operates when an alarm or [AL. E6 Servo forced stop warning] occurs, STO (STO1, STO2) or ready-on command is off, or the power is turned off. Do not use the external dynamic brake to stop in a normal operation as it is the function to stop in emergency.
- For a machine operating at the recommended load to motor inertia ratio or less, the estimated number of usage times of the external dynamic brake is 1000 times while the machine decelerates from the rated speed to a stop once in 10 minutes.
- Be sure to enable EM1 (Forced stop 1) after servo motor stops when using EM1 (Forced stop 1) frequently in other than emergency.

Selection of external dynamic brake

The dynamic brake is designed to bring the servo motor to a sudden stop when a power failure occurs or the protective circuit is activated, and is built in the servo amplifier of 7 kW or less. Since it is not built in the servo amplifier of 11 kW or more, purchase it separately. Assign DB (Dynamic brake interlock) to any of CN3-9, CN3-13, and CN3-15 pins in [Pr. PD07] to [Pr. PD09].

Servo amplifier	External dynamic brake	Molded-case circuit breaker		Fuse (Class T)		Fuse (Class K5)	
		Frame, rated current	Voltage AC [V]	Current [A]	Voltage AC [V]	Current [A]	Voltage AC [V]
MR-J4-11KGF(-RJ)	DBU-11K	30 A frame 5 A	240	1	300	1	250
MR-J4-15KGF(-RJ)	DBU-15K						
MR-J4-22KGF(-RJ)	DBU-22K-R1						
MR-J4-11KGF4(-RJ)	DBU-11K-4	30 A frame 5 A	480	1	600	1	600
MR-J4-15KGF4(-RJ)	DBU-22K-4						
MR-J4-22KGF4(-RJ)							

Connection example

200 V class

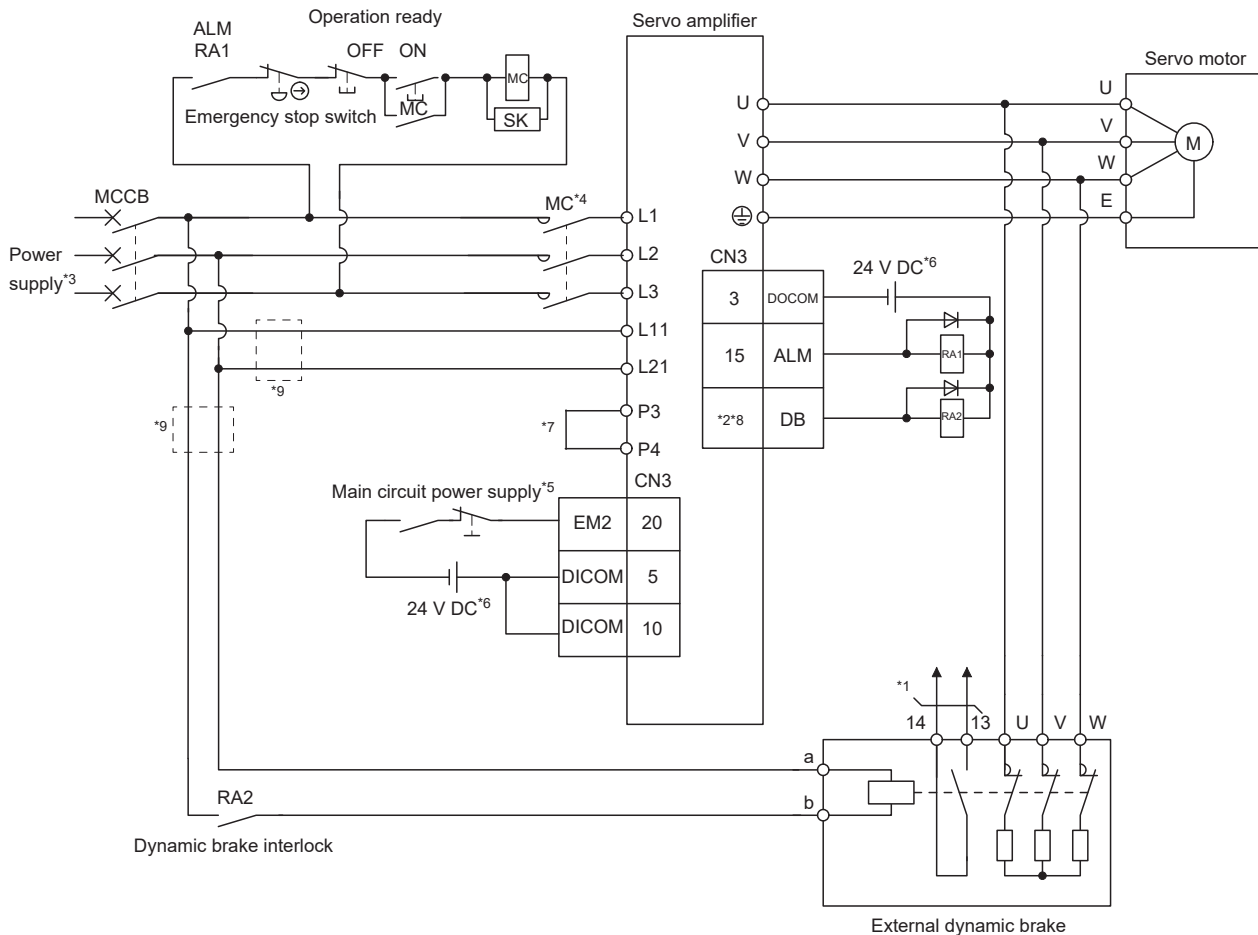

- *1 Terminals 13 and 14 are normally open contact outputs. If the external dynamic brake is seized, terminals 13 and 14 will open. Therefore, configure up an external sequence to prevent servo-on.
- *2 Assign DB (Dynamic brake interlock) in [Pr. PD07] to [Pr. PD09].
- *3 For the power supply specifications, refer to the following.
☞ Page 30 Servo amplifier standard specifications
- *4 Depending on the main circuit voltage and operation pattern, bus voltage decreases, and that may cause the forced stop deceleration to shift to the dynamic brake deceleration. When dynamic brake deceleration is not required, slow the time to turn off the magnetic contactor.
- *5 Turn off EM2 when the main power circuit power supply is off.
- *6 The illustration of the 24 V DC power supply is divided between input signal and output signal for convenience. However, they can be configured by one.
- *7 Between P3 and P4 is connected by default. When using the power factor improving DC reactor, remove the short bar between P3 and P4. Additionally, a power factor improving DC reactor and power factor improving AC reactor cannot be used simultaneously.
☞ Page 409 Power factor improving DC reactors
- *8 The external dynamic brake cannot be used for compliance with SEMI-F47 standard. Do not assign DB (Dynamic brake interlock) in [Pr. PD07] to [Pr. PD09]. Failure to do so will cause the servo amplifier to become servo-off when an instantaneous power failure occurs.
- *9 Install an overcurrent protection device (molded-case circuit breaker, fuse, or others) to protect the branch circuit.
☞ Page 406 Molded-case circuit breakers, fuses, magnetic contactors
☞ Page 439 Selection of external dynamic brake

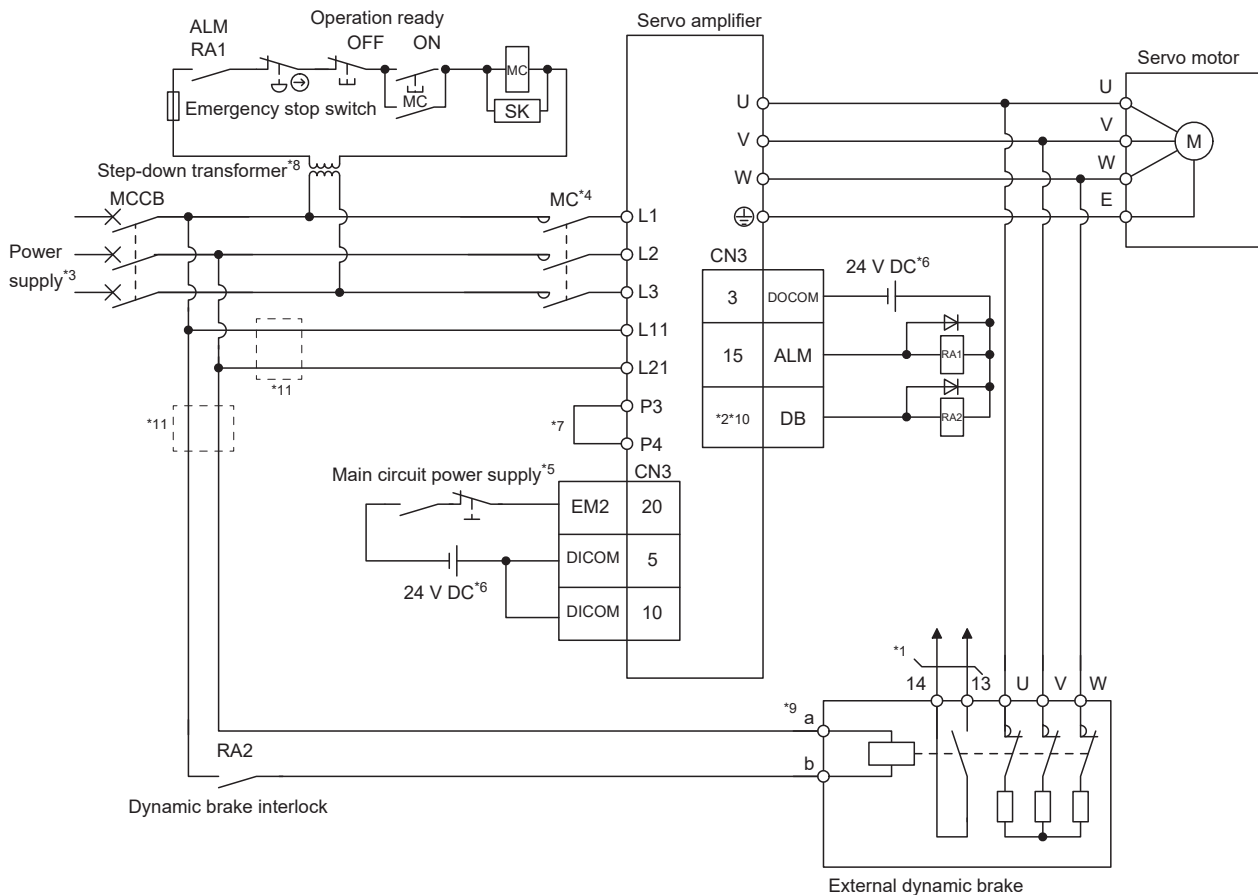

- *1 Terminals 13 and 14 are normally open contact outputs. If the external dynamic brake is seized, terminals 13 and 14 will open. Therefore, configure up an external sequence to prevent servo-on.
- *2 Assign DB (Dynamic brake interlock) in [Pr. PD07] to [Pr. PD09].
- *3 For the power supply specifications, refer to the following.
 - ☞ Page 30 Servo amplifier standard specifications
- *4 Depending on the main circuit voltage and operation pattern, bus voltage decreases, and that may cause the forced stop deceleration to shift to the dynamic brake deceleration. When dynamic brake deceleration is not required, slow the time to turn off the magnetic contactor.
- *5 Turn off EM2 when the main power circuit power supply is off.
- *6 The illustration of the 24 V DC power supply is divided between input signal and output signal for convenience. However, they can be configured by one.
- *7 Between P3 and P4 is connected by default. When using the power factor improving DC reactor, remove the short bar between P3 and P4. Additionally, a power factor improving DC reactor and power factor improving AC reactor cannot be used simultaneously.
 - ☞ Page 409 Power factor improving DC reactors
- *8 Stepdown transformer is required when the coil voltage of the magnetic contactor is 200 V class.
- *9 The power supply voltage of the inside magnet contactor for 400 V class external dynamic brake DBU-11K-4 and DBU-22K-4 is restricted as follows. When using these external dynamic brakes, use them within the following range of the power supply.

External dynamic brake	Power supply voltage
DBU-11K-4 DBU-22K-4	1-phase 380 V AC to 463 V AC, 50 Hz/60 Hz

- *10 The external dynamic brake cannot be used for compliance with SEMI-F47 standard. Do not assign DB (Dynamic brake interlock) in [Pr. PD07] to [Pr. PD09]. Failure to do so will cause the servo amplifier to become servo-off when an instantaneous power failure occurs.
- *11 Install an overcurrent protection device (molded-case circuit breaker, fuse, or others) to protect the branch circuit.
 - ☞ Page 406 Molded-case circuit breakers, fuses, magnetic contactors
 - ☞ Page 439 Selection of external dynamic brake

Timing chart

When you use the forced stop deceleration function

■ Ready-off command from controller

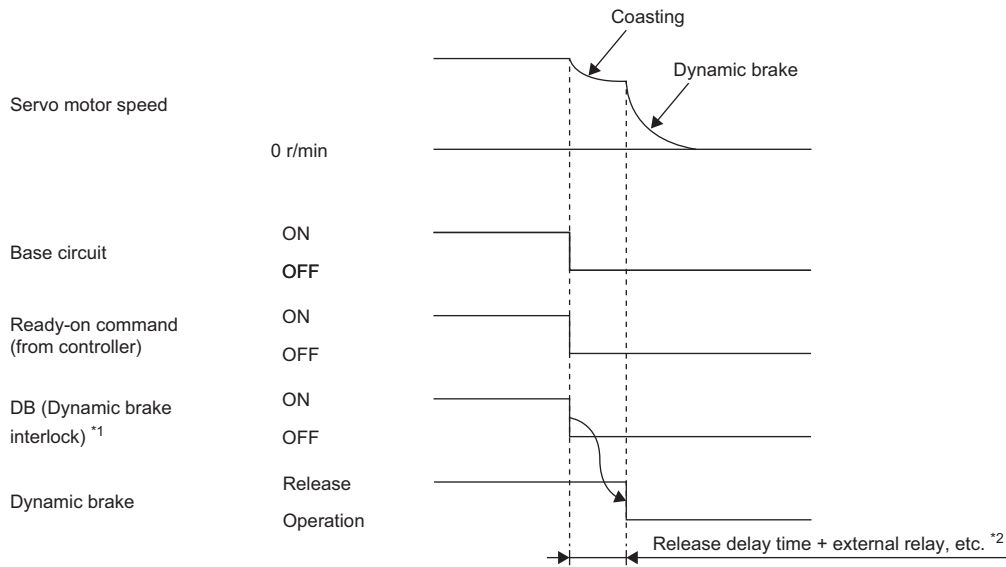

*1 ON: Dynamic brake is not activated.
 OFF: Dynamic brake is activated.

*2 There is delay caused by magnetic contactor built into the external dynamic brake (about 50 ms) and delay caused by the external relay.

■When the quick stop command (from controller) or EM2 (Forced stop 2) is off

Point

- Keep the servo-on command (from controller) and ready-on command (from controller) on while EM2 (Forced stop 2) is off. When the servo-on command (from controller) or ready-on command (from controller) is off, forced stop deceleration does not function.

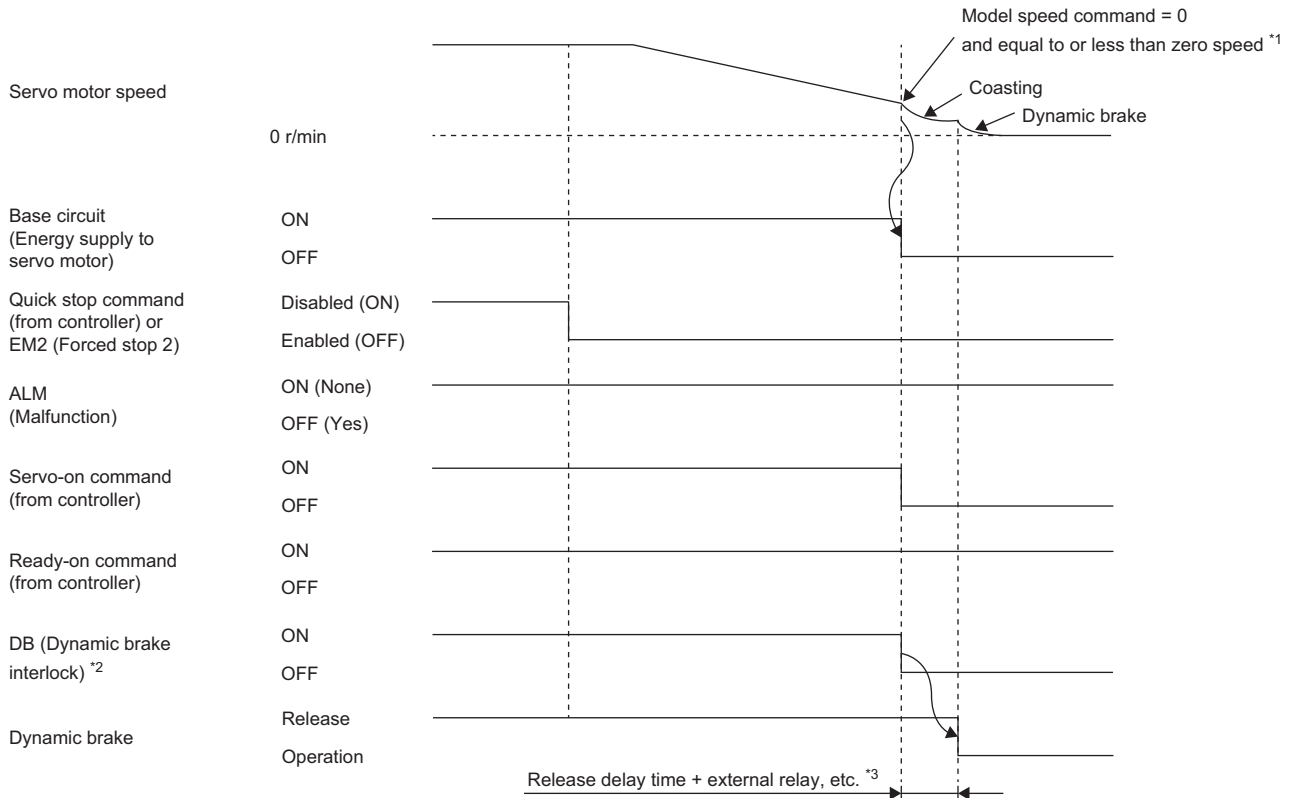

*1 The model speed command is a speed command generated in the servo amplifier for forced stop deceleration of the servo motor.

*2 ON: Dynamic brake is not activated.

OFF: Dynamic brake is activated.

*3 There is delay caused by magnetic contactor built into the external dynamic brake (about 50 ms) and delay caused by the external relay.

■ Alarm occurrence

- When the forced stop deceleration function is enabled

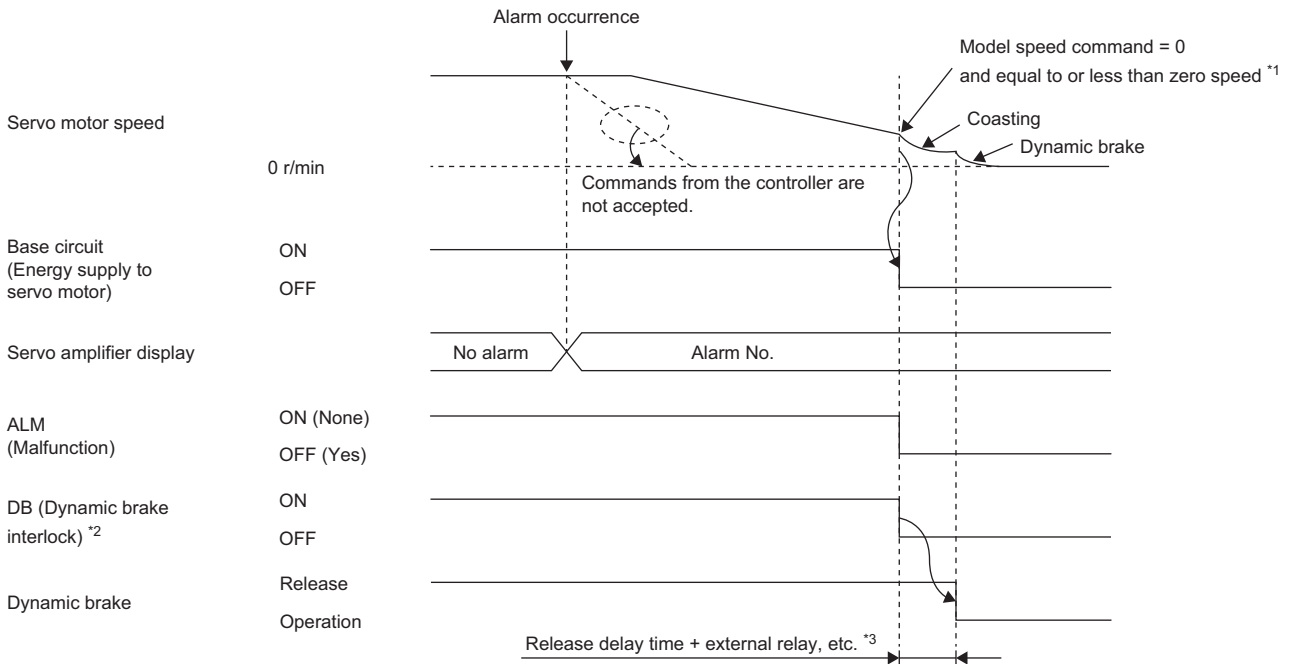

*1 The model speed command is a speed command generated in the servo amplifier for forced stop deceleration of the servo motor.

*2 ON: Dynamic brake is not activated.

OFF: Dynamic brake is activated.

*3 There is delay caused by magnetic contactor built into the external dynamic brake (about 50 ms) and delay caused by the external relay.

- When the forced stop deceleration function is disabled

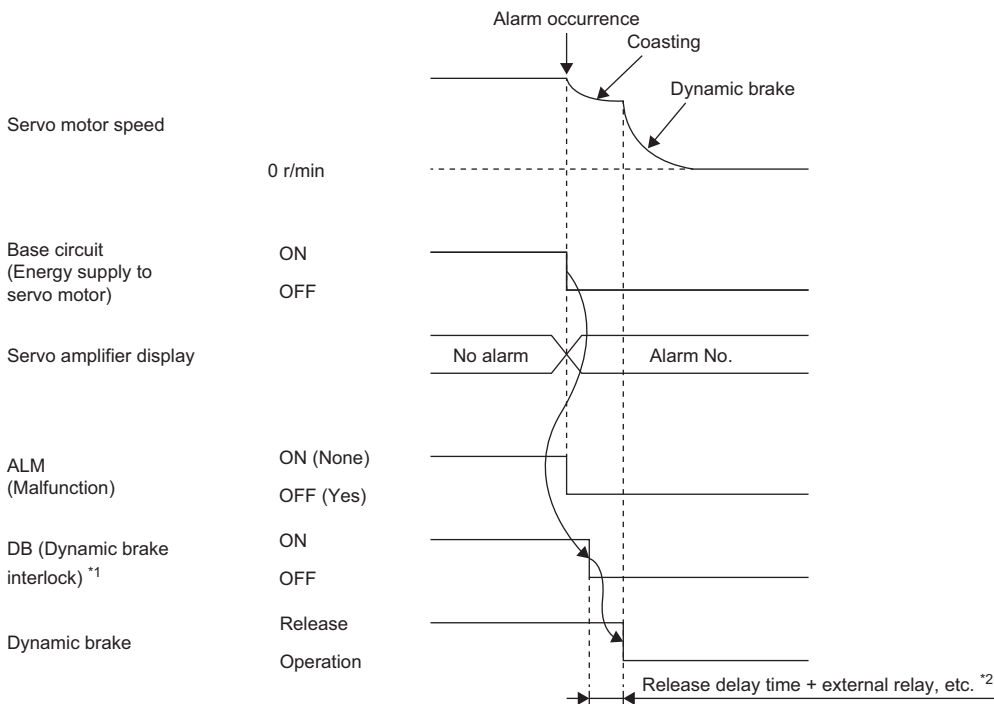

*1 ON: Dynamic brake is not activated.

OFF: Dynamic brake is activated.

*2 There is delay caused by magnetic contactor built into the external dynamic brake (about 50 ms) and delay caused by the external relay.

Both main and control circuit power supplies off

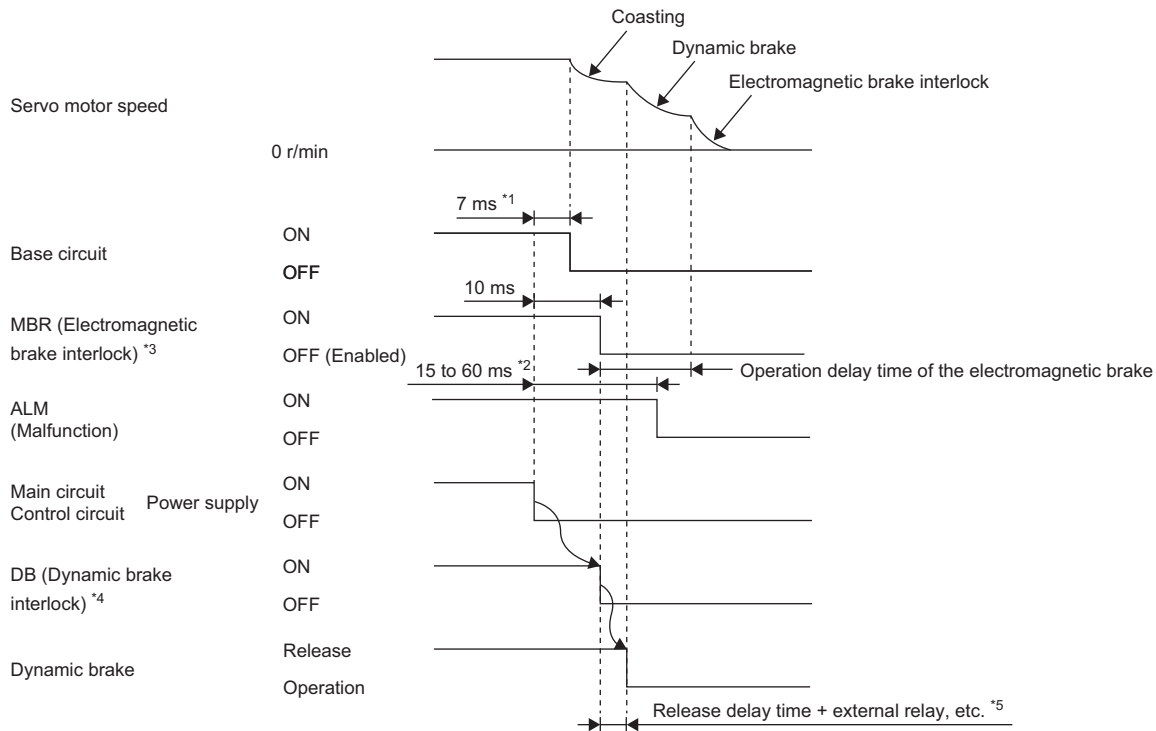

*1 When powering off, DB (Dynamic brake interlock) will be turned off, and the base circuit is turned off earlier than usual before an output shortage occurs.

(Only when DB is assigned as an output signal)

*2 Variable according to the operation status.

*3 ON: Electromagnetic brake is not activated.

OFF: Electromagnetic brake is activated.

*4 ON: Dynamic brake is not activated.

OFF: Dynamic brake is activated.

*5 There is delay caused by magnetic contactor built into the external dynamic brake (about 50 ms) and delay caused by the external relay.

When you do not use the forced stop deceleration function

■ Ready-off command from controller

It is the same as the following section.

☞ Page 442 Ready-off command from controller

■ When the quick stop command (from controller) or EM1 (Forced stop 1) is off

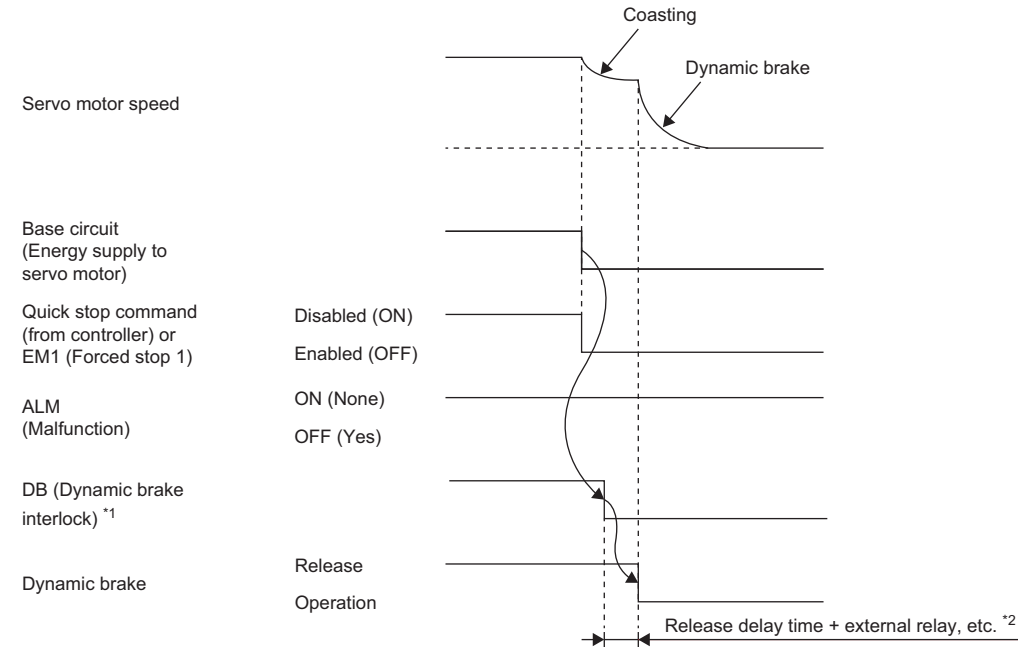

*1 ON: Dynamic brake is not activated.

OFF: Dynamic brake is activated.

*2 There is delay caused by magnetic contactor built into the external dynamic brake (about 50 ms) and delay caused by the external relay.

■ Alarm occurrence

Operation is the same as "When the forced stop deceleration function is disabled" in the following reference.

☞ Page 444 Alarm occurrence

■ Both main and control circuit power supplies off

It is the same as the following section.

☞ Page 445 Both main and control circuit power supplies off

Dimensions

DBU-11K/DBU-15K/DBU-22K-R1

[Unit: mm]

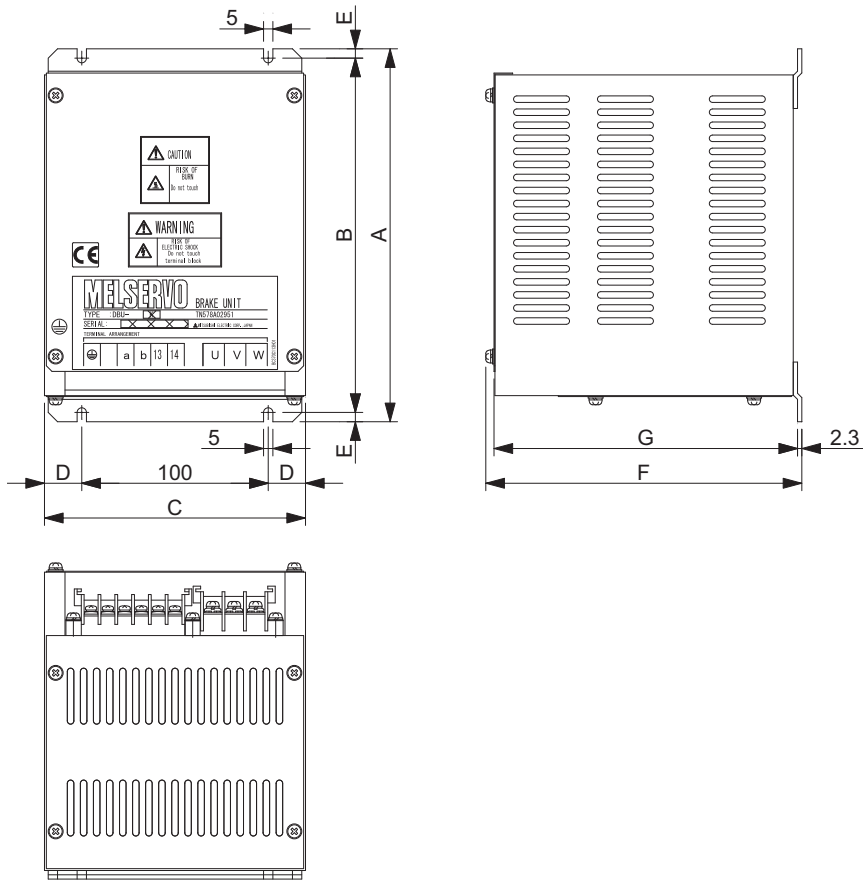

Terminal block

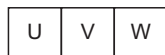
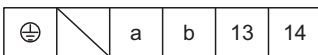

Screw: M3.5
Tightening torque: 0.8 [N•m]

Screw: M4
Tightening torque: 1.2 [N•m]

External dynamic brake	A	B	C	D	E	F	G	Mass [kg]	Connection wire [mm ²]*1	
									U/V/W	Except U/V/W
DBU-11K	200	190	140	20	5	170	163.5	2	5.5 (AWG 10)	2 (AWG 14)
DBU-15K/DBU-22K-R1	250	238	150	25	6	235	228	6	5.5 (AWG 10)	2 (AWG 14)

*1 Selection conditions of wire size are as follows.
Wire type: 600 V Grade heat-resistant polyvinyl chloride insulated wire (HIV wire)
Construction condition: Single wire set in midair

DBU-11K-4/DBU-22K-4

[Unit: mm]

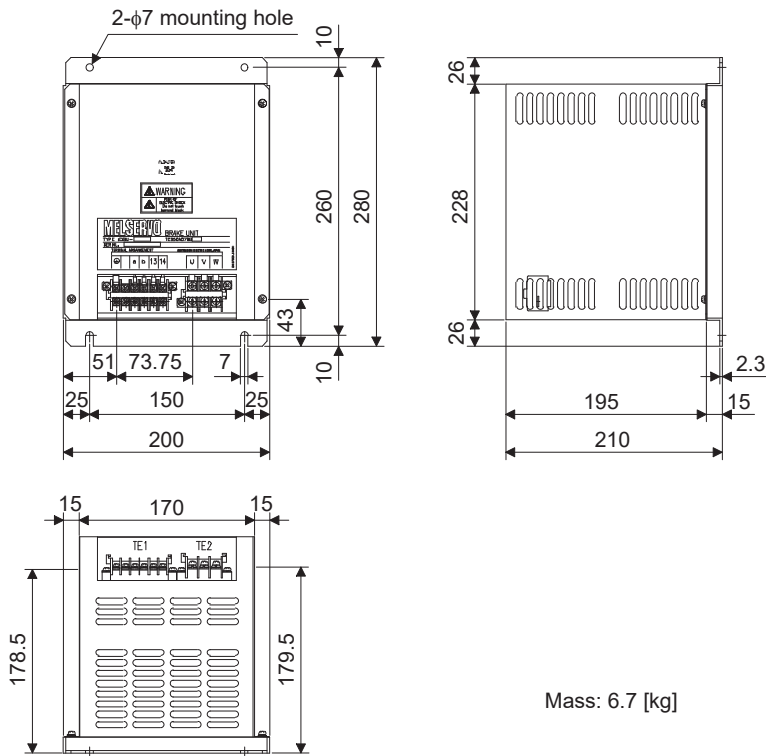

Mass: 6.7 [kg]

Terminal block

TE1

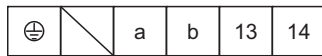

Screw: M3.5
Tightening torque: 0.8 [N•m]

TE2



Screw: M4
Tightening torque: 1.2 [N•m]

External dynamic brake	Connection wire [mm ²]*1	
	U/V/W	Except U/V/W
DBU-11K-4	5.5 (AWG 10)	2 (AWG 14)
DBU-22K-4	5.5 (AWG 10)	2 (AWG 14)

*1 Selection conditions of wire size are as follows.

Wire type: 600 V Grade heat-resistant polyvinyl chloride insulated wire (HIV wire)

Construction condition: Single wire set in midair

11.18 Panel through attachment (MR-J4ACN15K/MR-J3ACN)

By using the panel through attachment, you can mount the servo amplifier with its heat generation area exposed outside the cabinet to dissipate the heat, enabling smaller cabinets.

In the cabinet, machine a hole having the panel cut dimensions, fit the panel through attachment to the servo amplifier with the fitting screws (4 screws supplied), and install the servo amplifier to the cabinet.

Please prepare screws for mounting. They do not come with.

The environment outside the cabinet when using the panel through attachment should be within the range of the servo amplifier operating environment.

The panel through attachments are used for MR-J4-11KGF(-RJ) to MR-J4-22KGF(-RJ) and MR-J4-11KGF4(-RJ) to MR-J4-22KGF4(-RJ).

The following shows the combinations.

Servo amplifier	Panel through attachment
MR-J4-11KGF(-RJ) MR-J4-15KGF(-RJ)	MR-J4ACN15K
MR-J4-22KGF(-RJ)	MR-J3ACN
MR-J4-11KGF4(-RJ) MR-J4-15KGF4(-RJ)	MR-J4ACN15K
MR-J4-22KGF4(-RJ)	MR-J3ACN

MR-J4ACN15K

■ Panel cut dimensions

[Unit: mm]

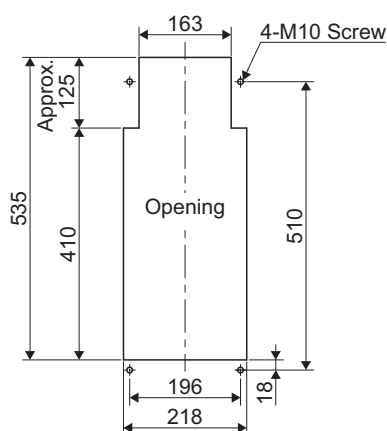

■ How to assemble the attachment for panel through attachment

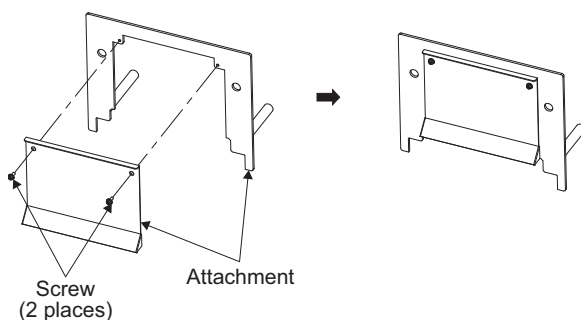

■ Mounting method

- Assembling the panel through attachment

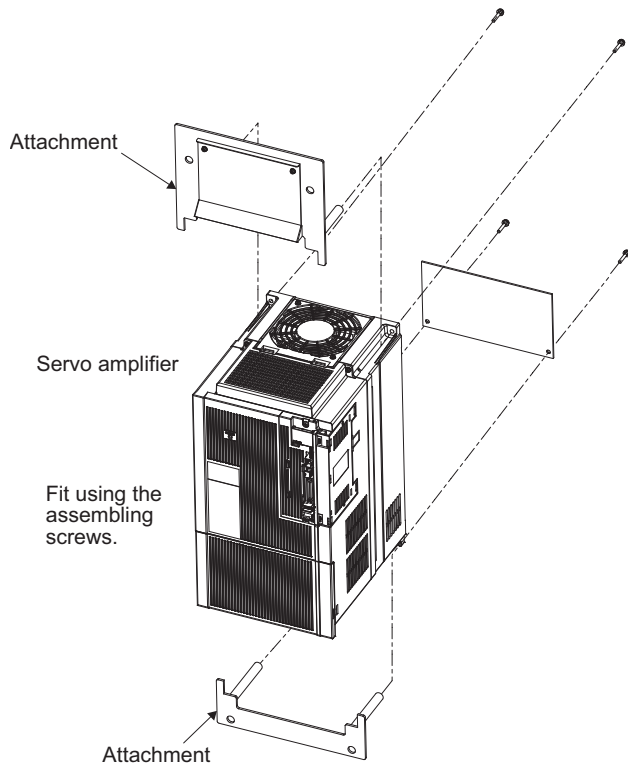

- Installation to the inside cabinet

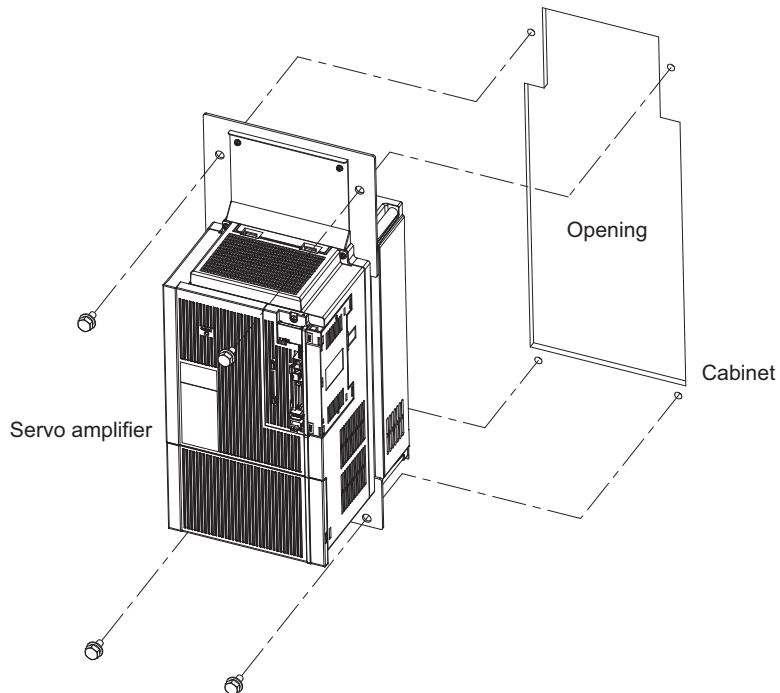

■ Mounting dimensional diagram

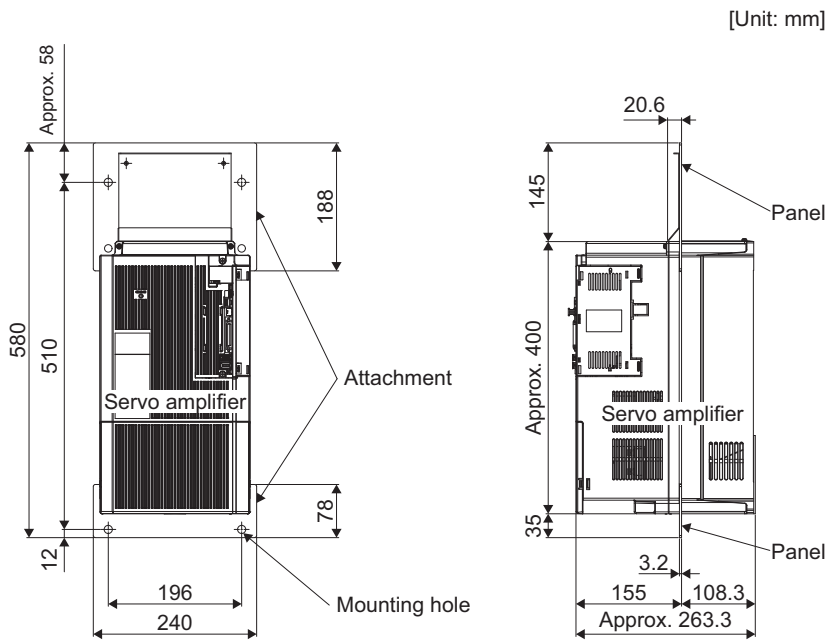

MR-J3ACN

■ Panel cut dimensions

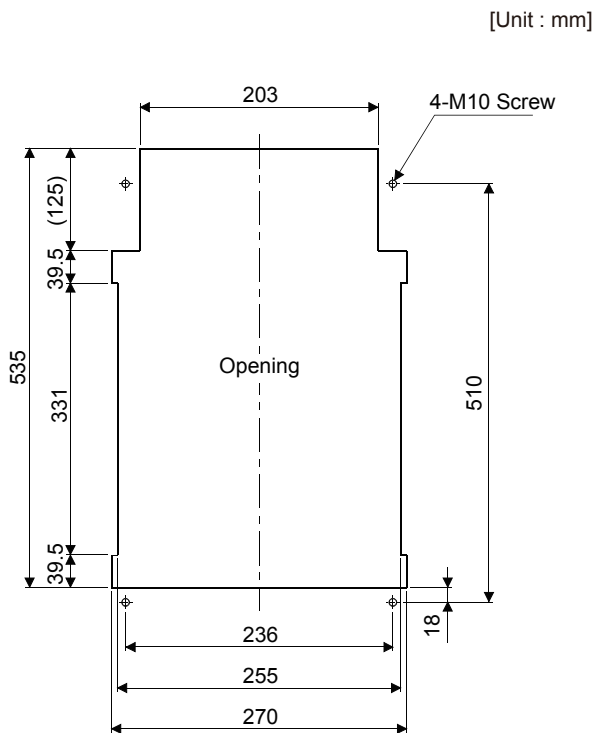

■ How to assemble the attachment for panel through attachment

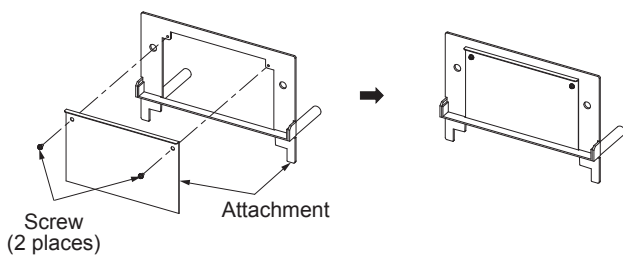

■ Mounting method

- Assembling the panel through attachment

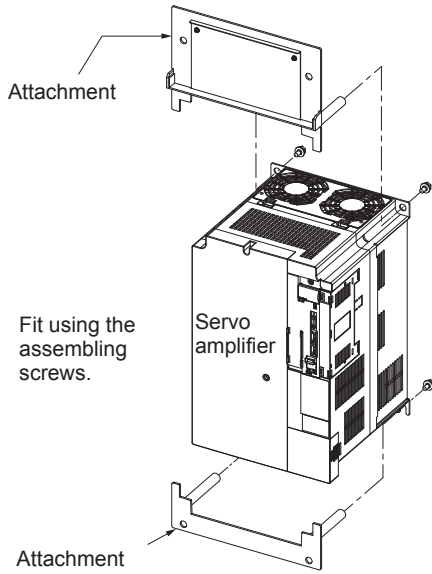

- Installation to the inside cabinet

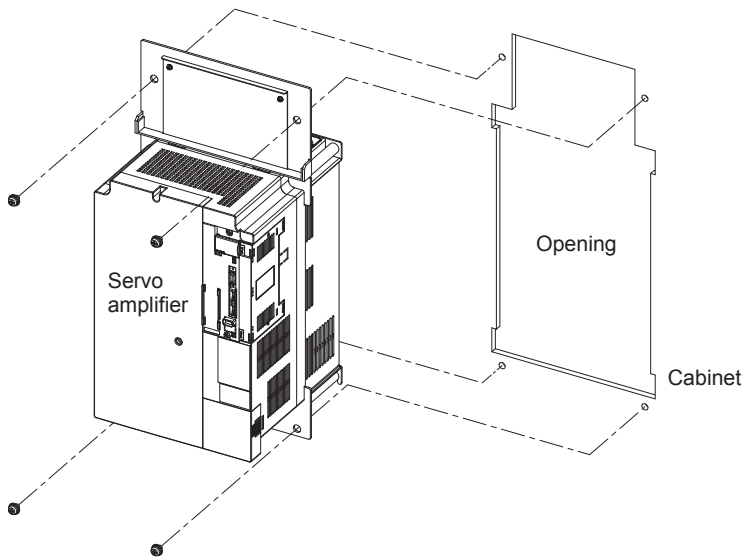

■ Mounting dimensional diagram

[Unit: mm]

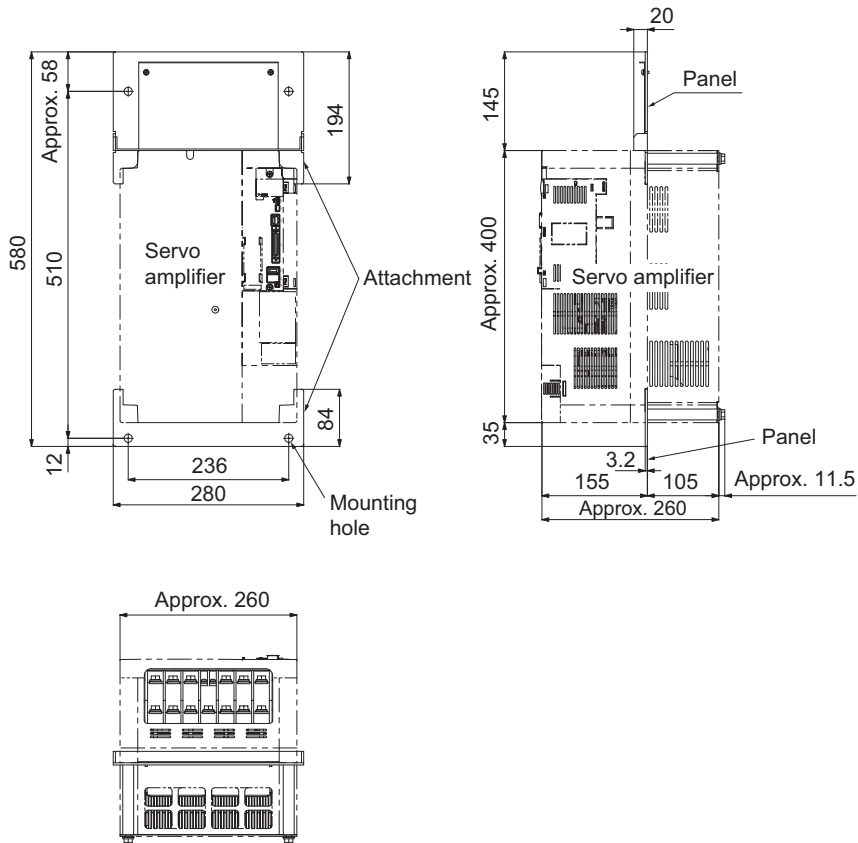

11.19 Multifunction regeneration converter FR-XC-(H)

Point

For details of the multifunction regeneration converter FR-XC-(H), refer to the FR-XC Installation Guide (IB(NA)0600668ENG).

Multifunction regeneration converter and dedicated stand-alone reactor

For the multifunction regeneration converter FR-XC-(H), install the dedicated stand-alone reactors in the following table.

Multifunction regeneration converter	Dedicated stand-alone reactor
FR-XC-7.5K	FR-XCL-7.5K
FR-XC-11K	FR-XCL-11K
FR-XC-15K	FR-XCL-15K
FR-XC-22K	FR-XCL-22K
FR-XC-30K	FR-XCL-30K
FR-XC-37K	FR-XCL-37K
FR-XC-55K	FR-XCL-55K
FR-XC-H7.5K	FR-XCL-H7.5K
FR-XC-H11K	FR-XCL-H11K
FR-XC-H15K	FR-XCL-H15K
FR-XC-H22K	FR-XCL-H22K
FR-XC-H30K	FR-XCL-H30K
FR-XC-H37K	FR-XCL-H37K
FR-XC-H55K	FR-XCL-H55K

Safety precautions

- Turn switch 1 of the function selection switch (SW2) for FR-XC-(H) to on (common bus regeneration mode).
- Do not supply power to the main circuit power supply terminals (L1/L2/L3) of the servo amplifier. Doing so will fail the servo amplifier and FR-XC-(H).
- Connect the DC power supply between the FR-XC-(H) and servo amplifier with correct polarity. Connection with incorrect polarity will fail the FR-XC-(H) and servo amplifier.
- For 400 V, use an input power supply with a rated voltage and permissible fluctuation in the following ranges. Rated voltage: 3-phase 380 V to 480 V, 50 Hz/60 Hz
Permissible fluctuation: 3-phase 323 V to 528 V, 50 Hz/60 Hz

Servo amplifier setting

When using the FR-XC-(H), set the parameters as follows.

- [Pr. PA02]: " __ 0 1"
- [Pr. PA04]: "0 0 __"
- [Pr. PC20]: " __ __ 1"

Capacity selection

Selection conditions

FR-XC-(H) multifunction regeneration converter can be used for 200 V-class servo amplifiers from 100 W to 22 kW and 400 V-class servo amplifiers from 600 W to 22 kW. Select a multifunction regeneration converter that meets the following conditions.

- Up to 10 servo amplifiers per FR-XC-(H)
- Total capacity of servo amplifiers [kW] ≤ Total capacity of servo amplifiers that can connect with FR-XC-(H) [kW]
- Effective value of total output power of servo motors [kW] ≤ Continuous output of FR-XC-(H) [kW]
- Maximum value of total output power of servo motors [kW] ≤ Instantaneous maximum output of FR-XC-(H) [kW]

Item	FR-XC-(H)_						
	7.5K	11K	15K	22K	30K	37K	55K
Rated capacity [kW]	7.5	11	15	22	30	37	55
Maximum number of connected servo amplifiers	10						
Total of connectable servo amplifier capacities [kW] *1	3.5 (5.5)	5.5 (7.5)	7.5 (11)	22	30	37	55
Continuous output [kW] *1	3.5 (5.5)	5.5 (7.5)	7.5 (11)	18.5	22	30	45
Instantaneous maximum output [kW]	11.25	16.5	22.5	33	45	55.5	82.5

*1 Values in parentheses are for connections with six or fewer servo amplifiers.

Selection example

This section shows the selection method for a multifunction regeneration converter used for connecting the following servo amplifiers.

Servo amplifier	Servo motor
MR-J4-500GF	HG-SR502
MR-J4-500GF	HG-SR502
MR-J4-11KGF	HG-JR11K1M
MR-J4-22KGF	HG-JR22K1M

1. Calculate running power and regenerative power from the servo motor speed and torque as follows.

- For rotary servo motors

$$\text{Running power and regenerative power [W]} = \text{Servo motor speed [r/min]} \times \text{Torque [N}\cdot\text{m]} / 9.55$$

- For linear servo motors

$$\text{Running power and regenerative power [W]} = \text{Servo motor speed [m/s]} \times \text{Thrust [N]}$$

(Values with a positive sign are running power, and values with a negative sign are regenerative power.)

2. Calculate the total output power of the servo motors from the running power and regenerative power of each servo motor.

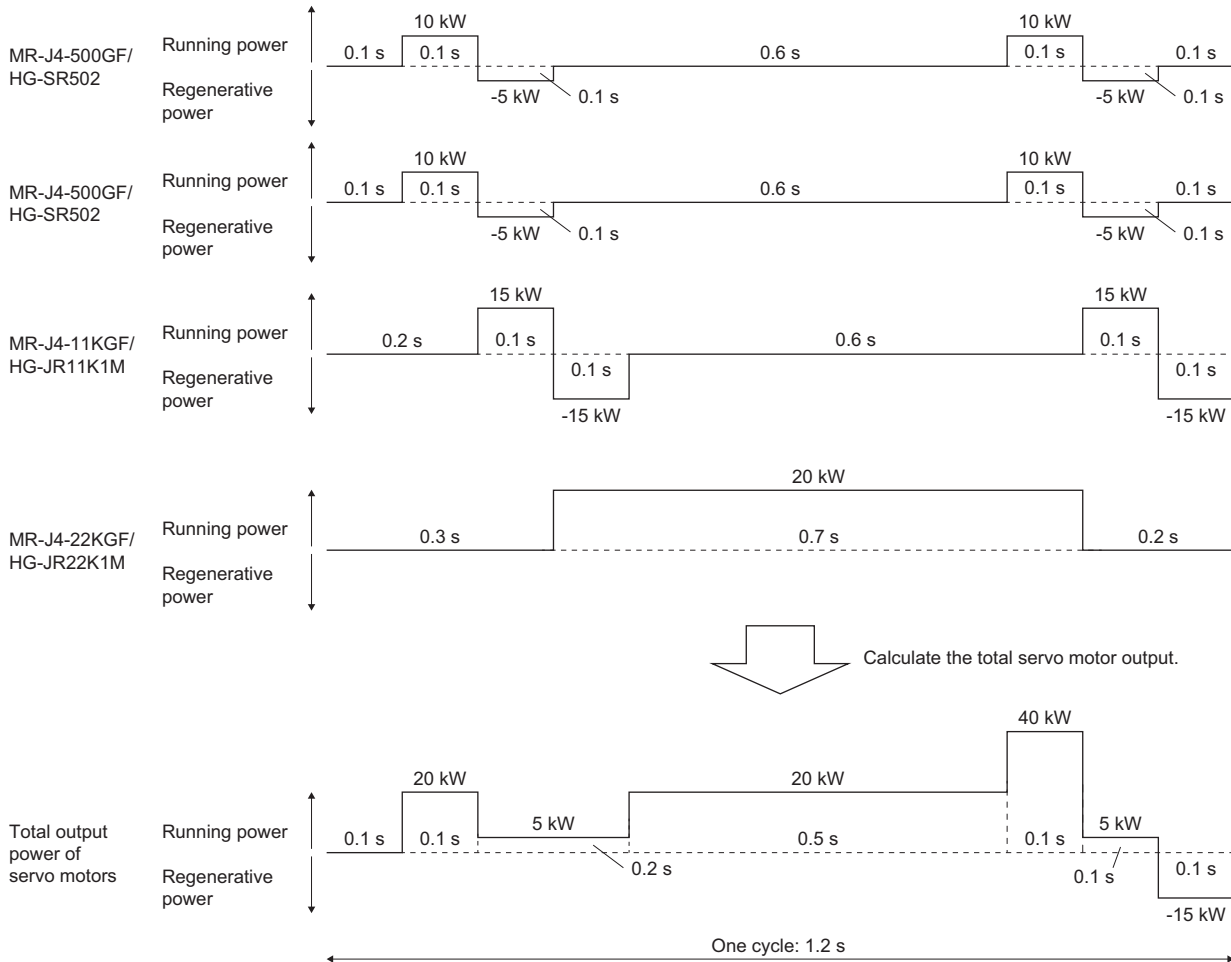

3. Select a multifunction regeneration converter based on the selection conditions.

- Number of servo amplifiers: $4 \leq 10$

⇒ No problem with the number of connected units

- Total of servo amplifier capacity [kW] = 5 kW + 5 kW + 11 kW + 22 kW = 43 kW

⇒ FR-XC-55K

- Effective value of total output power of servo motors [kW]

$$= \sqrt{(20^2 \times 0.1 + 5^2 \times 0.2 + 20^2 \times 0.5 + 40^2 \times 0.1 + 5^2 \times 0.1 + (-15)^2 \times 0.1) / 1.2} = 18.93 \text{ kW}$$

⇒ Equivalent to or greater than FR-XC-30K

- Maximum value of total output power of servo motors [kW] = 40 kW

⇒ Equivalent to or greater than FR-XC-30K

From the conditions above, "FR-XC-55K" will be selected as the multifunction regeneration converter.

Connection diagram

200 V class

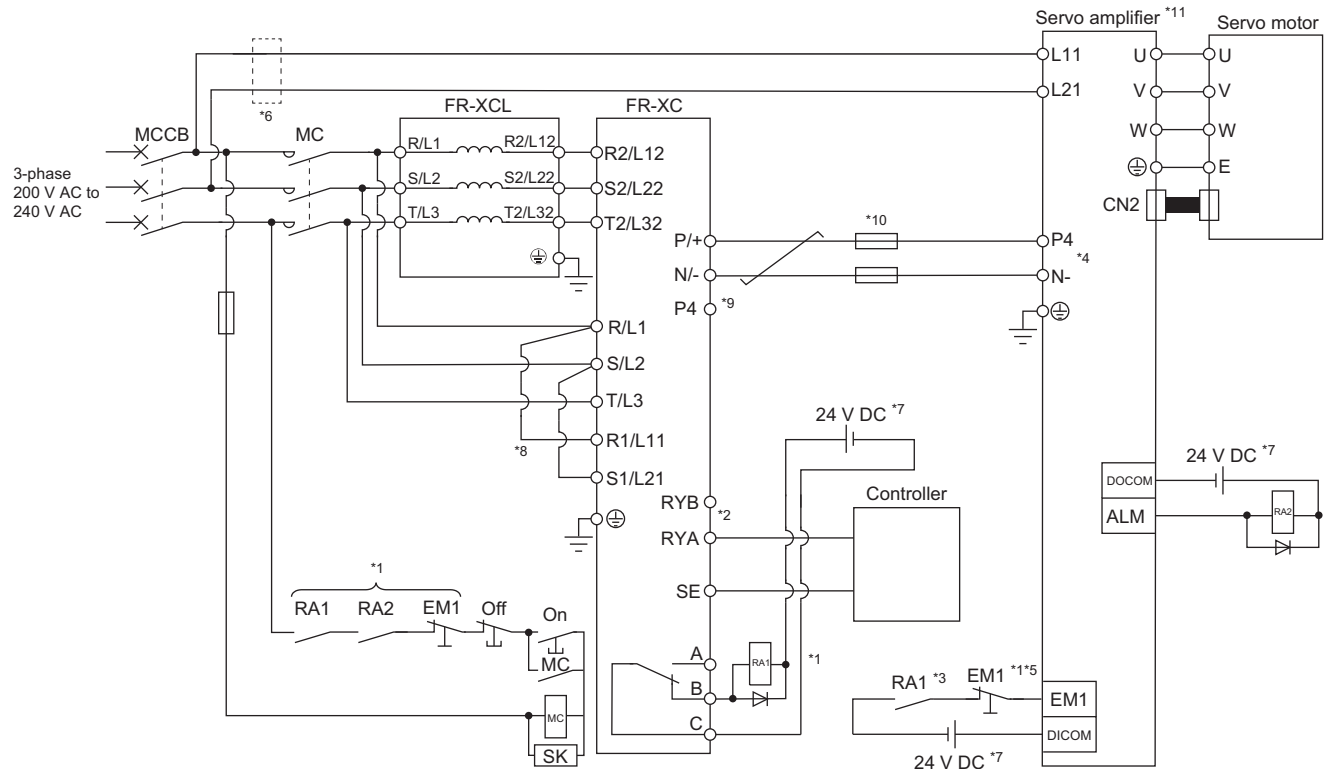

- *1 Configure a sequence that will shut off main circuit power in the following.
 - An alarm occurred at FR-XC or servo amplifier.
 - EM1 (Forced stop 1) is enabled.
- *2 For the servo amplifier, configure a sequence that will switch the servo-on after the FR-XC is ready.
- *3 Configure a sequence that will use the forced stop input of the servo amplifier to make a stop if an alarm occurs in the FR-XC. When the controller does not have an emergency stop input, use the forced stop input of the servo amplifier to make a stop as shown in the diagram.
- *4 When using FR-XC, always disconnect wiring between P3 and P4 terminals.
- *5 Set [Pr. PA04] to "0 0 __" to enable EM1 (Forced stop 1).
- *6 When wires used for L11 and L21 are thinner than wires used for L1, L2, and L3, use a molded-case circuit breaker.
- *7 The illustration of the 24 V DC power supply is divided between input signal and output signal for convenience. However, they can be configured by one.
- *8 For supplying power dedicated to the control circuit, remove the jumpers for R1/L11 and S1/L21.
- *9 Do not connect anything to the P4 terminal of the FR-XC.
- *10 Install a fuse to each of the wires between the FR-XC and servo amplifier.
- *11 When using the servo amplifier of 7 kW or less, make sure to connect the wiring of the built-in regenerative resistor. (factory-wired)
(5 kW or less: Between P+ and D, 7 kW: Between P+ and C)

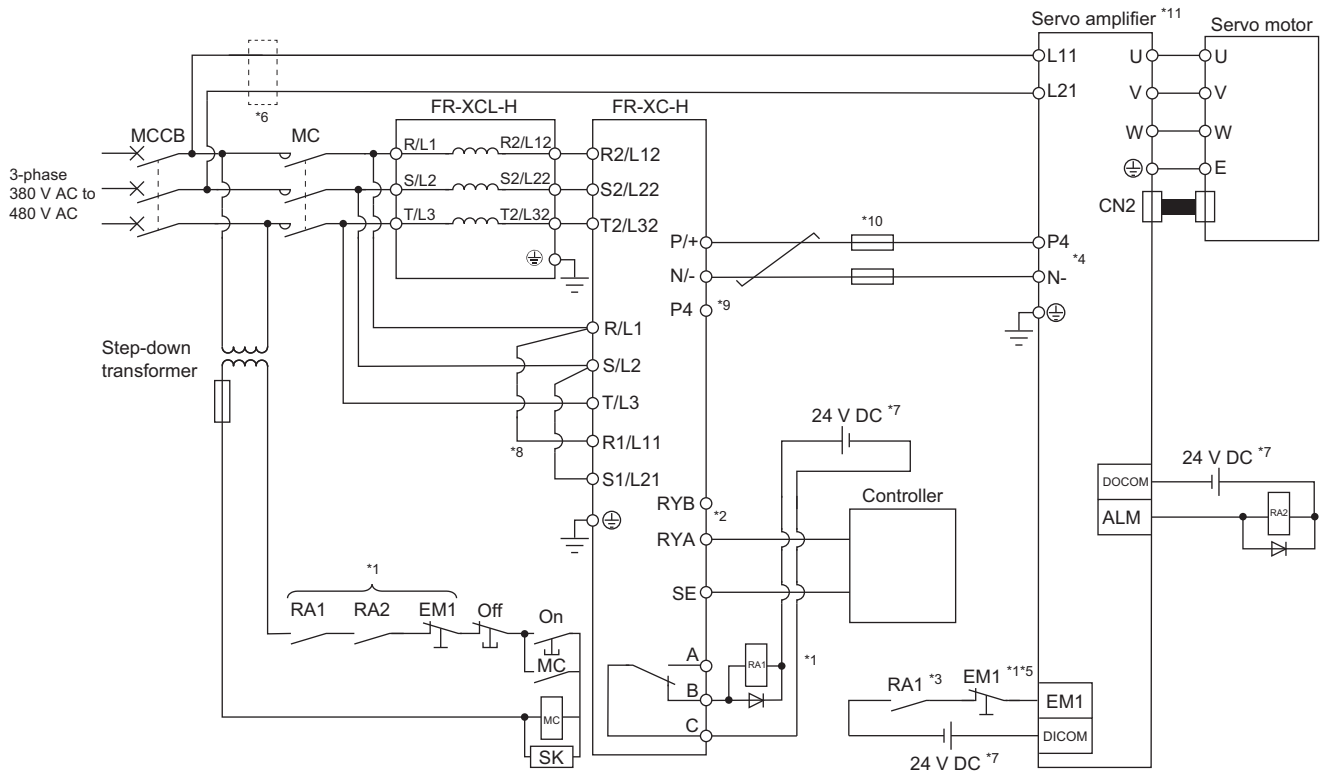

- *1 Configure a sequence that will shut off main circuit power in the following.
 - An alarm occurred at FR-XC-H or servo amplifier.
 - EM1 (Forced stop 1) is enabled.
- *2 For the servo amplifier, configure a sequence that will switch the servo-on after the FR-XC-H is ready.
- *3 Configure a sequence that will use the forced stop input of the servo amplifier to make a stop if an alarm occurs in the FR-XC-H. When the controller does not have an emergency stop input, use the forced stop input of the servo amplifier to make a stop as shown in the diagram.
- *4 When using FR-XC-H, always disconnect wiring between P3 and P4 terminals.
- *5 Set [Pr. PA04] to "0 0 __" to enable EM1 (Forced stop 1).
- *6 When wires used for L11 and L21 are thinner than wires used for L1, L2, and L3, use a molded-case circuit breaker.
- *7 The illustration of the 24 V DC power supply is divided between input signal and output signal for convenience. However, they can be configured by one.
- *8 For supplying power dedicated to the control circuit, remove the jumpers for R1/L11 and S1/L21.
- *9 Do not connect anything to the P4 terminal of the FR-XC-H.
- *10 Install a fuse to each of wires between the FR-XC-H and servo amplifier.
- *11 When using the servo amplifier of 7 kW or less, make sure to connect the wiring of the built-in regenerative resistor. (factory-wired)
 - (3.5 kW or less: Between P+ and D, 5 kW/7 kW: Between P+ and C)

Wires and peripheral options

Wire size



Selection conditions of wire size are as follows.

Wire type: 600 V Grade heat-resistant polyvinyl chloride insulated wire (HIV wire)

Construction condition: Single wire set in midair

Between P/+ and P4, and between N/- and N-

The following table shows the wire sizes between the FR-XC-(H) and servo amplifier.

Total of servo amplifier capacities [kW]	Wire size [mm ²]	
	200 V class	400 V class
1 or less	2 (AWG 14)	2 (AWG 14)
2	3.5 (AWG 12)	2 (AWG 14)
3.5	5.5 (AWG 10)	3.5 (AWG 12)
5	5.5 (AWG 10)	5.5 (AWG 10)
7	8 (AWG 8)	5.5 (AWG 10)
11	14 (AWG 6)	8 (AWG 8)
15	22 (AWG 4)	8 (AWG 8)
18.5	38 (AWG 2)	8 (AWG 8)
22	50 (AWG 1/0)	14 (AWG 6)
27.5	50 (AWG 1/0)	22 (AWG 4)
30	60 (AWG 2/0)	22 (AWG 4)
37	80 (AWG 3/0)	38 (AWG 2)
45	100 (AWG 4/0)	38 (AWG 2)
55	100 (AWG 4/0)	50 (AWG 1/0)

Grounding

The following shows grounding wire sizes of FR-XC-(H). Make the wire as short as possible.

Multifunction regeneration converter	Wire size [mm ²]	
	Rated capacity of multifunction regeneration converter \geq Total capacity of connected servo amplifiers \times 2	Rated capacity of multifunction regeneration converter $<$ Total capacity of connected servo amplifiers \times 2
FR-XC-7.5K	8 (AWG 8)	8 (AWG 8)
FR-XC-11K	8 (AWG 8)	14 (AWG 6)
FR-XC-15K	8 (AWG 8)	22 (AWG 4)
FR-XC-22K	22 (AWG 4)	38 (AWG 2)
FR-XC-30K	22 (AWG 4)	38 (AWG 2)
FR-XC-37K	38 (AWG 2)	60 (AWG 2/0)
FR-XC-55K	38 (AWG 2)	80 (AWG 3/0)
FR-XC-H7.5K	3.5 (AWG 12)	3.5 (AWG 12)
FR-XC-H11K	3.5 (AWG 12)	5.5 (AWG 10)
FR-XC-H15K	3.5 (AWG 12)	8 (AWG 8)
FR-XC-H22K	8 (AWG 8)	14 (AWG 6)
FR-XC-H30K	8 (AWG 8)	22 (AWG 4)
FR-XC-H37K	14 (AWG 6)	22 (AWG 4)
FR-XC-H55K	14 (AWG 6)	38 (AWG 2)

Selection example of wire size (Between P/+ and P4, and between N/- and N-)

When connecting multiple servo amplifiers, always use junction terminals for wiring the servo amplifier terminals P4 and N-. Connect the servo amplifiers in the order of larger to smaller capacities.

200 V class

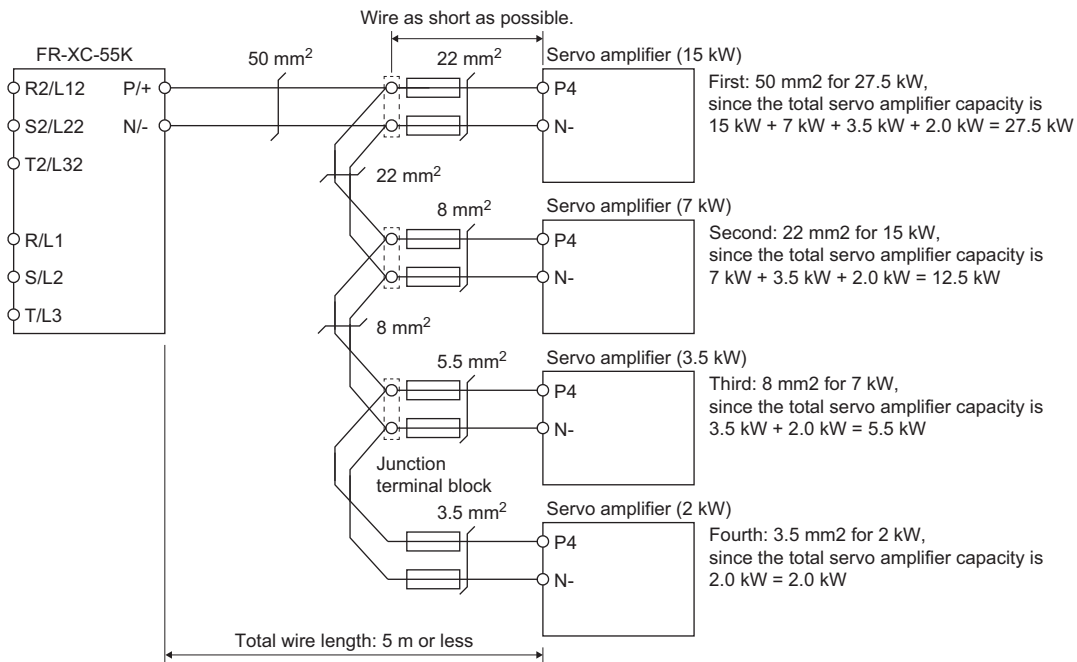

400 V class

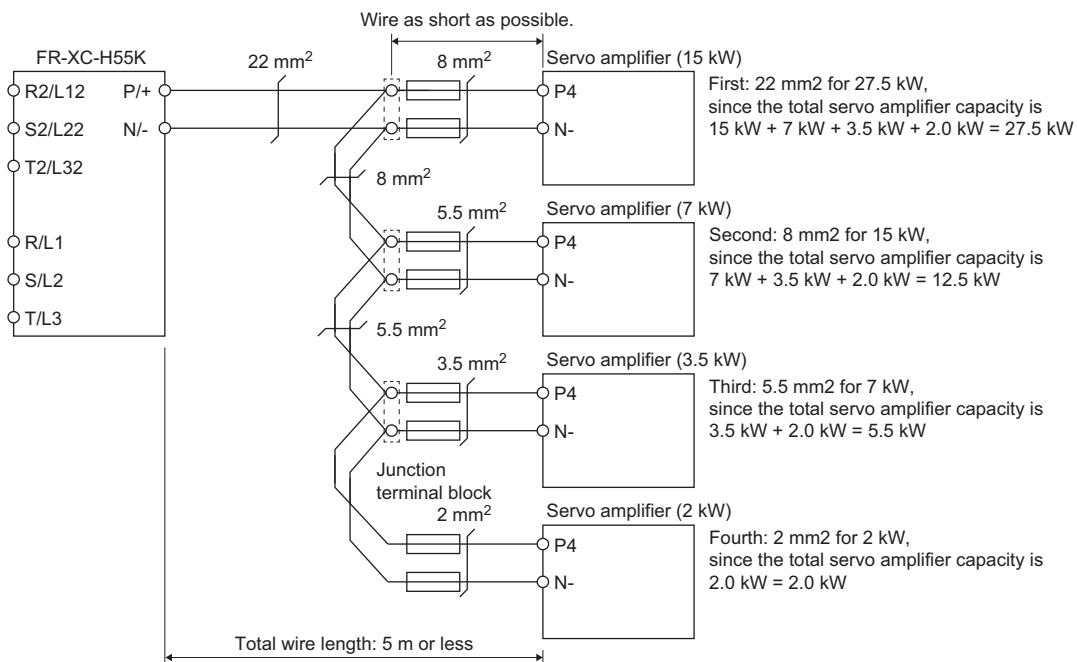

Fuse (Between P/+ and P4, and between N/- and N-)

The following table shows the recommended fuse products to be installed between the FR-XC-(H) and servo amplifier.

Servo amplifier capacity [kW]	200 V class		400 V class	
	Rating of fuse [A]	Model ^{*1}	Rating of fuse [A]	Model ^{*1}
0.1	20	6.900CPGR10.38 0020	—	—
0.2	20	6.900CPGR10.38 0020	—	—
0.4	25	6.900CPGR10.38 0025	—	—
0.6	25	6.900CPGR10.38 0025	20	6.900CPGR10.38 0020
0.75	30	6.900CPGR10.38 0030	—	—
1	32	6.900CPGR10.38 0032	20	6.900CPGR10.38 0020
2	63	6.9URD30TTF0063	25	6.900CPGR10.38 0025
3.5	80	6.9URD30TTF0080	63	6.9URD30TTF0063
5	160	6.9URD30TTF0160	80	6.9URD30TTF0080
7	200	6.9URD30TTF0200	100	6.9URD30TTF0100
11	250	6.9URD30TTF0250	160	6.9URD30TTF0160
15	315	6.9URD30TTF0315	160	6.9URD30TTF0160
22	350	6.9URD30TTF0350	200	6.9URD30TTF0200

*1 Manufacturer: Mersen Fma Japan KK
Service inquiries: Sun-wa Technos Corp.

Molded-case circuit breakers/earth-leakage current breakers and magnetic contactors

This section shows the recommended products of molded-case circuit breakers/earth-leakage current breakers and magnetic contactors.

■200 V class

Item	FR-XC- <u> </u>						
	7.5K	11K	15K	22K	30K	37K	55K
Molded-case circuit breaker or earth-leakage current breaker ^{*1}	100AF 60A (30AF 30A)	100AF 75A (50AF 50A)	225AF 125A (100AF 75A)	225AF 175A (100AF 100A)	225AF 225A (125AF 125A)	400AF 250A (125AF 125A)	400AF 400A (225AF 175A)
Magnetic contactor ^{*1}	S-T35 (S-T21)	S-T50 (S-T35)	S-T65 (S-T50)	S-T100 (S-T65)	S-N125 (S-T80)	S-N150 (S-T100)	S-N220 (S-N125)

*1 Models in parentheses can be used when the following condition is met: Rated capacity of multifunction regeneration converter ≥ Total capacity of connected servo amplifiers × 2.

■400 V class

Item	FR-XC-H- <u> </u>						
	7.5K	11K	15K	22K	30K	37K	55K
Molded-case circuit breaker or earth-leakage current breaker ^{*1}	30AF 30A (30AF 15A)	50AF 50A (30AF 20A)	100AF 60A (30AF 30A)	100AF 100A (50AF 50A)	225AF 125A (60AF 60A)	225AF 150A (100AF 75A)	225AF 200A (100AF 100A)
Magnetic contactor ^{*1}	S-T21	S-T25 (S-T21)	S-T35 (S-T21)	S-T50 (S-T25)	S-T65 (S-T35)	S-T80 (S-T50)	S-N125 (S-T65)

*1 Models in parentheses can be used when the following condition is met: Rated capacity of multifunction regeneration converter ≥ Total capacity of connected servo amplifiers × 2.

12 ABSOLUTE POSITION DETECTION SYSTEM

CAUTION

- If [AL. 25 Absolute position erased] or [AL. E3 Absolute position counter warning] occurs, be sure to make perform home position setting again. Otherwise, it may cause an unexpected operation.
 - If [AL. 25], [AL. 92], or [AL. 9F] occurs due to a failure, such as short circuit of the battery, the MR-BAT6V1 battery may be hot. Use the MR-BAT6V1 battery with a case to prevent getting burnt.
-

Point

Refer to the following for the replacement procedure of the battery.

 Page 386 Battery

For configuring the absolute position detection system, there are three batteries of MR-BAT6V1SET-A, MR-BAT6V1BJ and MR-BT6VCASE. Compared with other batteries, MR-BAT6V1BJ has the following advantages.

- You can disconnect the encoder cable from the servo amplifier.
- You can change the battery with the control circuit power supply off.

When absolute position data is erased from the encoder, always execute home position setting before operation. The absolute position data of the encoder will be erased in the following. When the battery is used out of specification, the absolute position data can be erased.

When the MR-BAT6V1SET-A and MR-BT6VCASE are used

- The encoder cable was disconnected.
- The battery was replaced when the control circuit power supply was off.

When the MR-BAT6V1BJ is used

- A connector or cable was disconnected between the servo motor and battery.
- The battery was replaced with other procedure than in the following section.

 Page 393 Battery replacement procedure

When the following parameters are changed, the home position will be erased at the next power-on.

Execute the home position return again at the next power-on.

- [Pr. PA01 Operation mode]
 - [Pr. PA06 Electronic gear numerator (command pulse multiplication numerator)]
 - [Pr. PA07 Electronic gear denominator (command pulse multiplication denominator)]
 - [Pr. PA14 Rotation direction selection/travel direction selection]
 - "Unit for position data (_ x _)" in [Pr. PT01]
 - [Pr. PT08 Home position return position data]
 - [Pr. PT28 Number of stations per rotation]
 - [Pr. PT47 Home position return position data (extension parameter)]
-

Restrictions

The absolute position detection system cannot be configured under the following condition.

- Stroke-less coordinate system, such as an axis of rotation whose unit for position data is set to other than [degree], infinite positioning

For the use in the I/O mode and on CC-Link IE Field Network Basic, the absolute position detection system cannot be configured under the following condition as well.

- Incremental value command method ([Pr. PT01] = "_ _ _ 1") is used.

When any of the following conditions is met, ZP2 turns off. Therefore, executing positioning operation again without home position return will trigger [AL. 90 Home position return incomplete warning].

ZP2 off conditions

Servo-off status (The servo is off, EM1 or EM2 is off, an alarm occurs, STO is off, or [AL. E9 Main circuit off warning] occurs.)

Stroke limit is off.

Software limit is detected.

For configuring the absolute position detection system in the incremental value command method, specify the incremental value command by a point table auxiliary function. Refer to the following for details.

 MELSERVO MR-J4-_GF_(-RJ) Servo Amplifier Instruction Manual (I/O Mode)

 MELSERVO MR-J4-_GF_(-RJ) Servo Amplifier Instruction Manual (CC-Link IE Field Network Basic)

12.1 Summary

Features

For normal operation, the encoder consists of a detector designed to detect a position within one revolution and a cumulative revolution counter designed to detect the number of revolutions.

The absolute position detection system always detects the absolute position of the machine and keeps it battery-backed, independently of whether the controller power is on or off. Therefore, once home position return is made at the time of machine installation, home position return is not needed when power is switched on thereafter.

Even at a power failure or a malfunction, the system can be easily restored.

Structure

The following shows the structure of the absolute position detection system. Refer to the following for each battery connection.

☞ Page 386 Battery

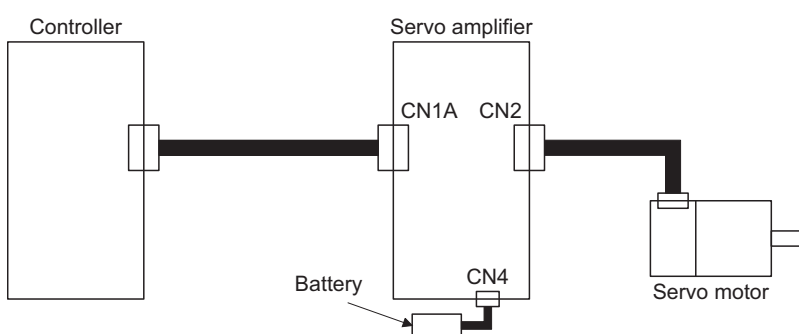

Parameter setting

Absolute position detection system selection

Set " _ _ _ 1" in [Pr. PA03] to enable the absolute position detection system.

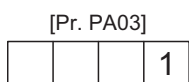

Absolute position detection system selection
0: Disabled (used in incremental system)
1: Enabled (used in absolute position detection system)

[AL. E3 Absolute position counter warning] selection

When a simple motion module QD77GF_ or RD77GF_, or simple motion board MR-EM340GF is used, set [Pr. PC18] to " _ _ 0 _".

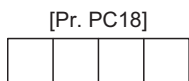

[AL. E3 Absolute position counter warning] selection
0: Disabled
1: Enabled

Confirmation of absolute position detection data

You can check the absolute position data with MR Configurator2. Choose "Monitor" and "ABS Data Display" to open the absolute position data display screen.

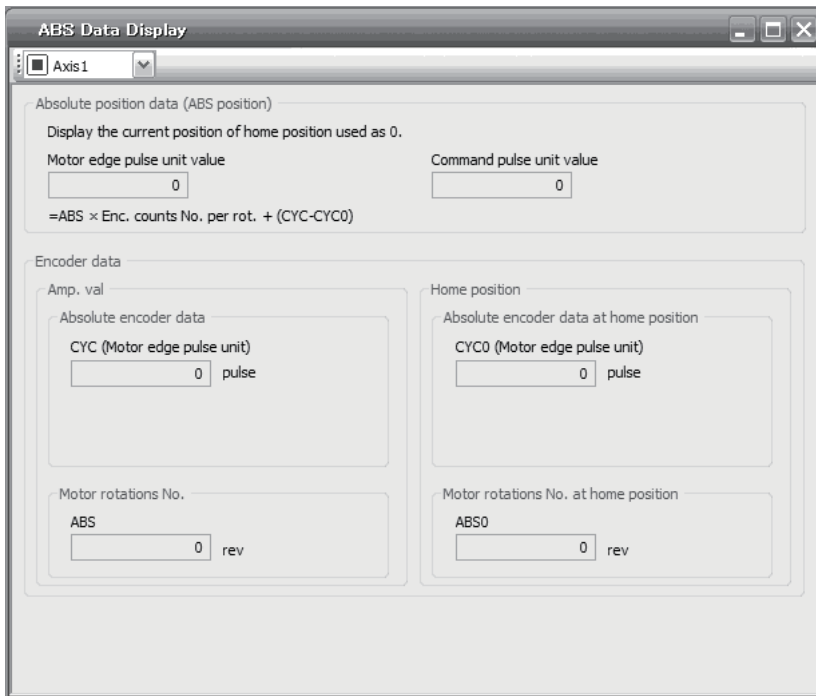

12.2 Battery

Using MR-BAT6V1SET-A battery

Configuration diagram

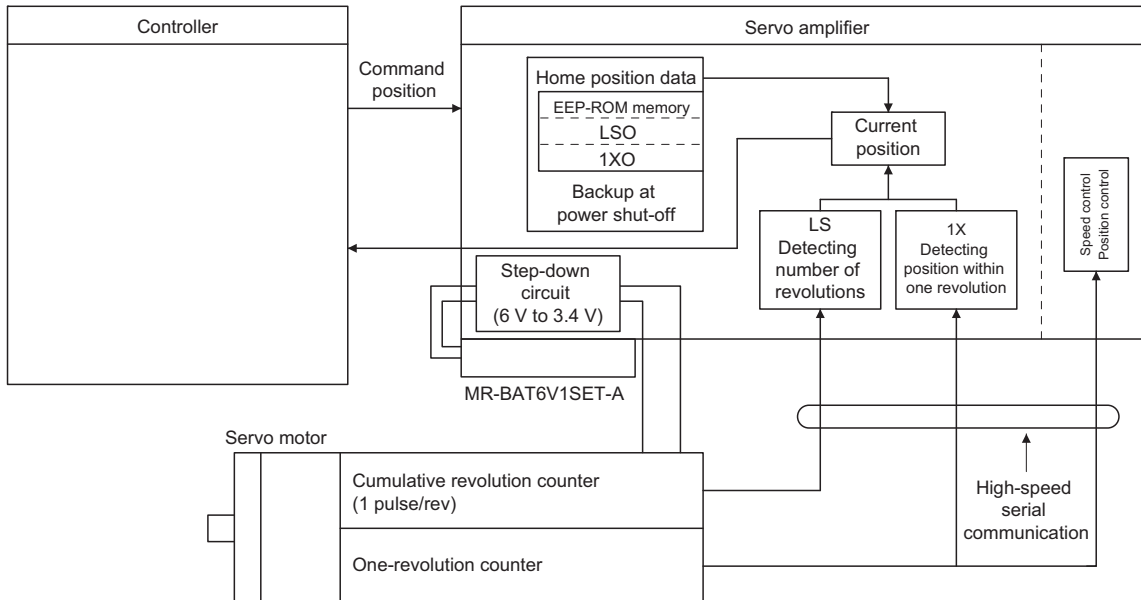

Specifications

■ Specification list

Item	Description	
System	Electronic battery backup type	
Maximum revolution range	Home position ± 32767 rev.	
Maximum speed at power failure [r/min] ^{*1}	Rotary servo motor	6000 (only when acceleration time until 6000 r/min is 0.2 s or more)
	Direct drive motor	500 (only when acceleration time until 500 r/min is 0.1 s or more)
Battery backup time ^{*2}	Rotary servo motor	Approximately 20,000 hours (equipment power supply: off, ambient temperature: 20 °C) Approximately 29,000 hours (power-on time ratio: 25%, ambient temperature: 20 °C) ^{*3}
	Direct drive motor	Approximately 5,000 hours (equipment power supply: off, ambient temperature: 20 °C) Approximately 15,000 hours (power-on time ratio: 25%, ambient temperature: 20 °C) ^{*3}

*1 Maximum speed available when the shaft is rotated by external force at the time of power failure or the like. Also, if power is switched on at the servo motor speed of 3000 r/min or higher, position mismatch may occur due to external force or the like.

*2 The data-holding time by the battery using MR-BAT6V1SET-A. Replace the batteries within three years since the operation start regardless of the power supply of the servo amplifier on/off. If the battery is used out of specification, [AL. 25 Absolute position erased] may occur.

*3 The power-on time ratio of 25% is equivalent to when the power is on for 8 hours a day on weekdays and off on weekends.

Using MR-BAT6V1BJ battery for junction battery cable

Point

- MR-BAT6V1BJ is compatible only with HG series servo motors. It cannot be used with direct drive motors.
- MR-BAT6V1BJ cannot be used for fully closed loop system.

Configuration diagram

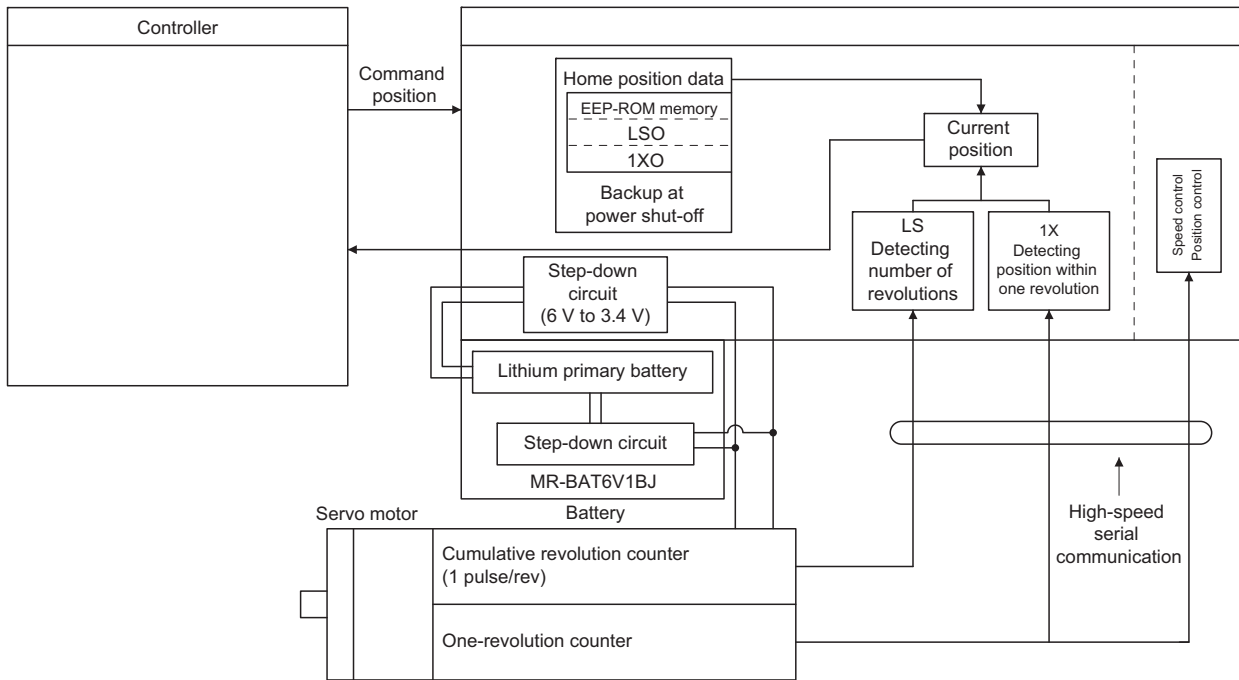

Specifications

■ Specification list

Item	Description
System	Electronic battery backup type
Maximum revolution range	Home position ± 32767 rev.
Maximum speed at power failure [r/min] ^{*1}	Rotary servo motor 6000 (only when acceleration time until 6000 r/min is 0.2 s or more)
Battery backup time ^{*2}	Rotary servo motor Approximately 20,000 hours (equipment power supply: off, ambient temperature: 20 °C) Approximately 29,000 hours (power-on time ratio: 25%, ambient temperature: 20 °C) ^{*3}

*1 Maximum speed available when the shaft is rotated by external force at the time of power failure or the like. Also, if power is switched on at the servo motor speed of 3000 r/min or higher, position mismatch may occur due to external force or the like.

*2 The data-holding time by the battery using MR-BAT6V1BJ. Replace the batteries within three years since the operation start regardless of the power supply of the servo amplifier on/off. If the battery is used out of specification, [AL. 25 Absolute position erased] may occur.

*3 The power-on time ratio of 25% is equivalent to when the power is on for 8 hours a day on weekdays and off on weekends.

Using MR-BT6VCASE battery case

Point

- One MR-BT6VCASE can hold the absolute position data of up to 8-axis servo motors.
- Always install five MR-BAT6V1 batteries to an MR-BT6VCASE.

Configuration diagram

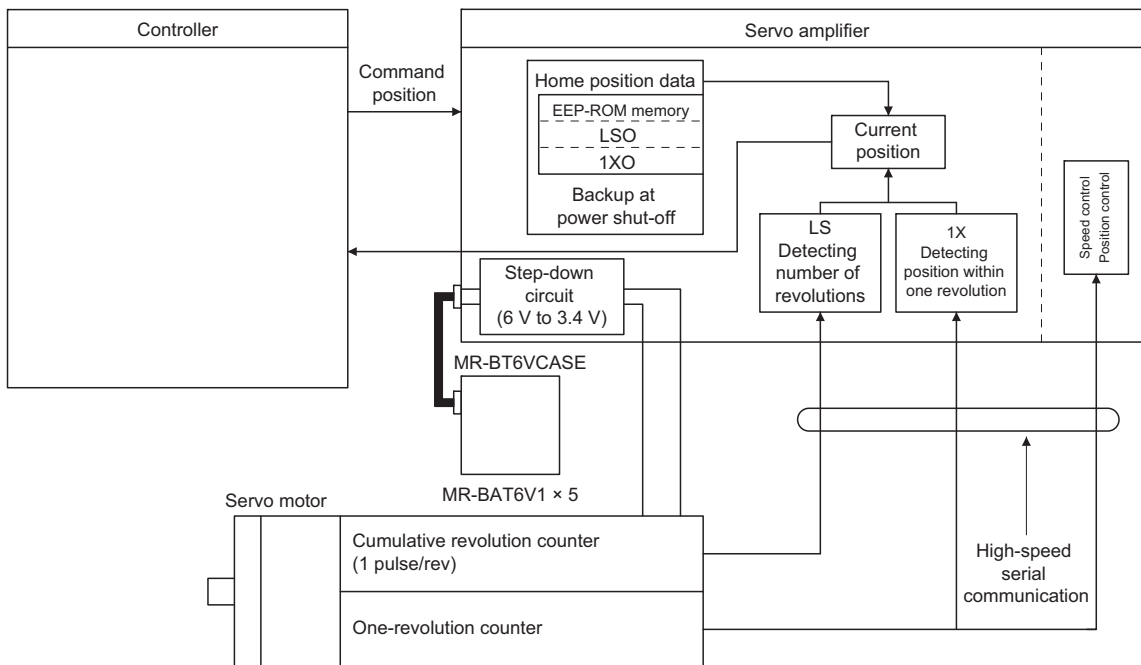

Specification list

Item	Description	
System	Electronic battery backup type	
Maximum revolution range	Home position ± 32767 rev.	
Maximum speed at power failure [r/min] ^{*1}	Rotary servo motor	6000 (only when acceleration time until 6000 r/min is 0.2 s or more)
	Direct drive motor	500 (only when acceleration time until 500 r/min is 0.1 s or more)
Battery backup time ^{*2}	Rotary servo motor	Approximately 40,000 hours/2 axes or less, 30,000 hours/3 axes, or 10,000 hours/8 axes (equipment power supply: off, ambient temperature: 20 °C) Approximately 55,000 hours/2 axes or less, 38,000 hours/3 axes, or 15,000 hours/8 axes (power-on time ratio: 25%, ambient temperature: 20 °C) ^{*3}
	Direct drive motor	Approximately 10,000 hours/2 axes or less, 7,000 hours/3 axes, or 5,000 hours/4 axes (equipment power supply: off, ambient temperature: 20 °C) Approximately 15,000 hours/2 axes or less, 13,000 hours/3 axes, or 10,000 hours/4 axes (power-on time ratio: 25%, ambient temperature: 20 °C) ^{*3}

*1 Maximum speed available when the shaft is rotated by external force at the time of power failure or the like. Also, if power is switched on at the servo motor speed of 3000 r/min or higher, position mismatch may occur due to external force or the like.

*2 The data-holding time by the battery using five MR-BAT6V1s. The battery life varies depending on the number of axes (including axis for using in the incremental system). Replace the batteries within three years since the operation start regardless of the power supply of the servo amplifier on/off. If the battery is used out of specification, [AL. 25 Absolute position erased] may occur.

*3 The power-on time ratio of 25% is equivalent to when the power is on for 8 hours a day on weekdays and off on weekends.

13 USING STO FUNCTION

Point

In the torque mode, the forced stop deceleration function cannot be used.

13.1 Introduction

This section provides the cautions of the STO function.

Summary

This servo amplifier complies with the following safety standards.

- ISO/EN ISO 13849-1:2015 Category 3 PL e
- IEC 61508 SIL 3
- IEC/EN 61800-5-2
- IEC/EN 62061 SIL CL3

Terms related to safety

The STO function shuts off energy to servo motors, thus removing torque. MR-J4 shuts off the energy by turning off the power supply electronically in the servo amplifier.

The purpose of this function is as follows.

- Uncontrolled stop according to stop category 0 of IEC/EN 60204-1
- Preventing unexpected restart

Cautions

The following basic safety notes must be read carefully and fully in order to prevent injury to persons or damage to property. Only qualified personnel are authorized to install, start-up, repair or service the machines in which these components are installed.

They must be familiar with all applicable local regulations and laws in which machines with these components are installed, particularly the standards mentioned in this manual.

The staff responsible for this work must be given express permission from the company to perform start-up, programming, configuration, and maintenance of the machine in accordance with the safety standards.

WARNING

- Improper installation of the safety related components or systems may cause improper operation in which safety is not assured, and may result in severe injuries or even death.

Protective Measures

- This servo amplifier satisfies the Safe Torque Off (STO) function described in IEC/EN 61800-5-2 by preventing the energy supply from the servo amplifier to the servo motor. If an external force acts upon the drive axis, additional safety measures, such as brakes or counterbalances must be used.

Residual risks of the STO function

Machine manufacturers are responsible for all risk evaluations and all associated residual risks. Below are residual risks associated with the STO function. Mitsubishi Electric is not liable for any damages or injuries caused by these risks.

- The STO function disables energy supply to the servo motor by electrical shut-off. The function does not mechanically disconnect electricity from the motor. Therefore, it cannot prevent exposure to electric shock. To prevent an electric shock, install a magnetic contactor or a molded-case circuit breaker to the main circuit power supply (L1/L2/L3) of the servo amplifier.
- The STO function disables energy supply to the servo motor by electrical shut-off. It does not guarantee the stop control or the deceleration control of the servo motor.
- For proper installation, wiring, and adjustment, thoroughly read the manual of each individual safety related component.
- In the safety circuit, use components that are confirmed safe or meet the required safety standards.
- The STO function does not guarantee that the drive part of the servo motor will not rotate due to external or other forces.
- Safety is not assured until safety-related components of the system are completely installed or adjusted.
- When replacing this servo amplifier, confirm that the model name of servo amplifiers are exactly the same as those being replaced. Once installed, make sure to verify the performance of the functions before commissioning the system.
- Perform all risk assessments to the machine or the entire system.
- To prevent accumulation of malfunctions, perform function checks at regular intervals based on the risk assessments of the machine or the system. Regardless of the system safety level, malfunction checks should be performed at least once per year.
- If the upper and lower power modules in the servo amplifier are shorted and damaged simultaneously, the servo motor may make a half revolution at a maximum. For a linear servo motor, the primary side will move a distance of pole pitch.
- The STO input signals (STO1 and STO2) must be supplied from one power source. Otherwise, the STO function may not function properly due to a sneak current, failing to bring the STO shut-off state.
- For the STO I/O signals of the STO function, supply power by using a safety extra low voltage (SELV) power supply with the reinforced insulation.

Specifications

Specifications

Item	Specifications
Functional safety	STO (IEC/EN 61800-5-2)
Safety performance (Standards certified by CB)*2	EN ISO 13849-1:2015 Category 3 PL e, IEC 61508 SIL 3, EN 62061 SIL CL3, EN 61800-5-2
Mean time to dangerous failure (MTTFd)	MTTFd ≥ 100 [years] (314a)*1
Diagnostic coverage (DC)	DC = Medium, 97.6 [%]*1
Probability of dangerous Failure per Hour (PFH)	PFH = 6.4×10^{-9} [1/h]
Number of on/off times of STO	1,000,000 times
CE marking	LVD: EN 61800-5-1 EMC: EN 61800-3 MD: EN ISO 13849-1:2015, EN 61800-5-2, EN 62061

*1 This is the value required by safety standards.

*2 The safety level depends on the setting value of [Pr. PF18 STO diagnosis error detection time] and whether STO input diagnosis by TOFB output is performed or not. For details, refer to the Function column of [Pr. PF18] below.

☞ Page 217 Extension setting 3 parameters ([Pr. PF__])

Function block diagram (STO function)

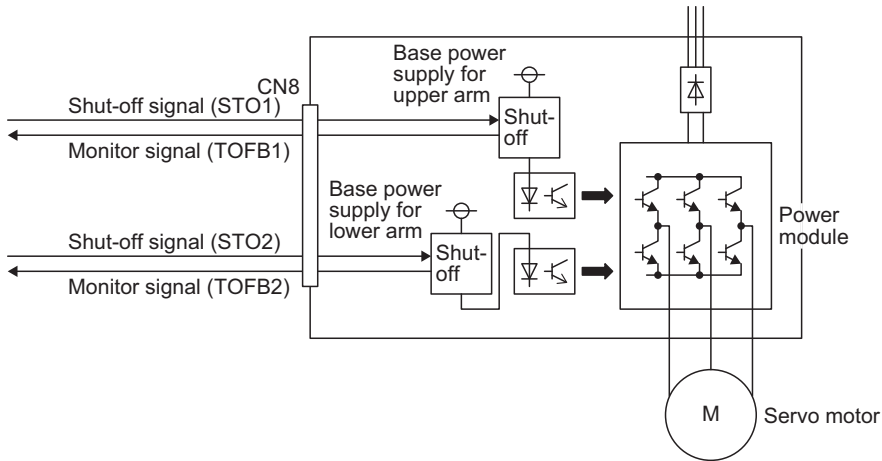

13

Operation sequence (STO function)

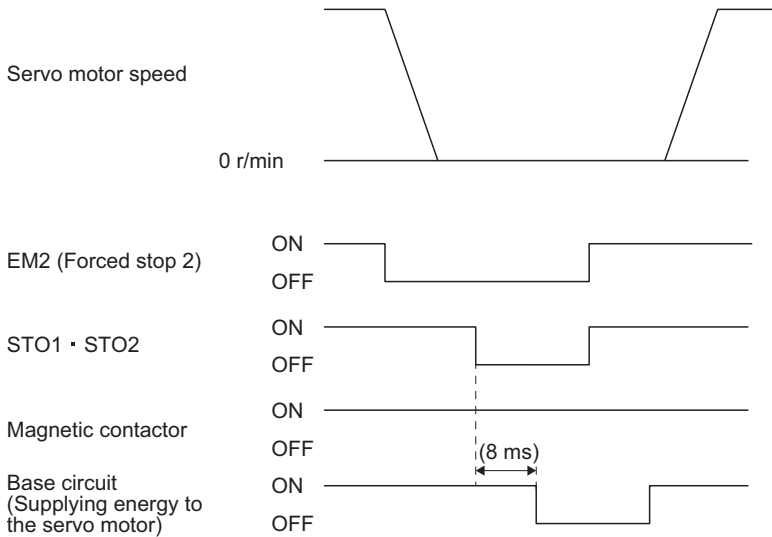

Maintenance

This servo amplifier has alarms and warnings for maintenance compatible with Drive safety function.

☞ Page 283 TROUBLESHOOTING

13.2 STO I/O signal connector (CN8) and pin assignment

Pin assignment



The pin assignment of the connectors is as viewed from the cable connector wiring section.

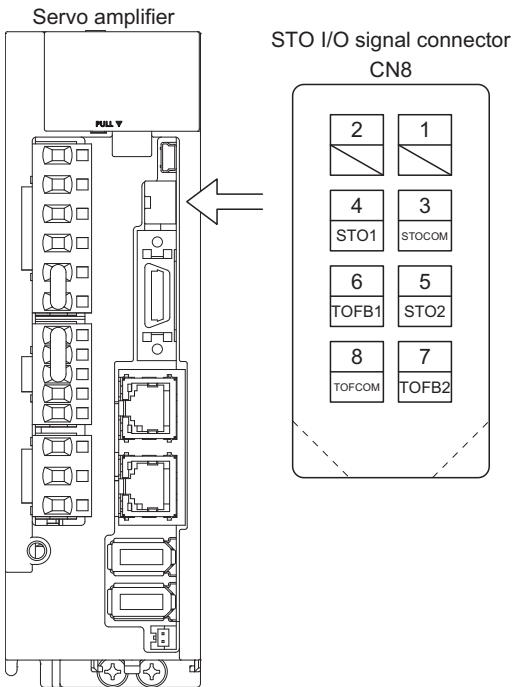

Signal (device) explanations

I/O device

Signal name	Connector pin No.	Description	I/O division
STOCOM	CN8-3	Common terminal for input signal of STO1 and STO2	DI-1
STO1	CN8-4	Input STO1 state. STO state (base circuit shut-off): Open between STO1 and STOCOM. STO release state (in driving): Close between STO1 and STOCOM. Be sure to turn off STO1 after the servo motor stops by the servo-off state or with forced stop deceleration by turning off EM2 (Forced stop 2).	DI-1
STO2	CN8-5	Input STO2 state. STO state (base circuit shut-off): Open between STO2 and STOCOM. STO release state (in driving): Close between STO2 and STOCOM. Be sure to turn off STO2 after the servo motor stops by the servo-off state or with forced stop deceleration by turning off EM2 (Forced stop 2).	DI-1
TOFCOM	CN8-8	Common terminal for monitor output signal in STO state	DO-1
TOFB1	CN8-6	Monitor output signal in STO1 state STO state (base circuit shut-off): Between TOFB1 and TOFCOM is closed. STO release state (in driving): Between TOFB1 and TOFCOM is opened.	DO-1
TOFB2	CN8-7	Monitor output signal in STO2 state STO state (base circuit shut-off): Between TOFB2 and TOFCOM is closed. STO release state (in driving): Between TOFB2 and TOFCOM is opened.	DO-1

Signals and STO state

The following table shows the TOFB and STO states when the power is on in normal state and STO1 and STO2 are on (closed) or off (opened).

Input signal		Status			
STO1	STO2	Between TOFB1 and TOFCOM (State of STO1)	Between TOFB2 and TOFCOM (State of STO2)	Between TOFB1 and TOFB2 (State of STO)	STO
Off	Off	On: STO state	On: STO state	On	STO state
Off	On	On: STO state	Off: STO release state	Off ^{*1}	STO state
On	Off	Off: STO release state	On: STO state	Off ^{*1}	STO state
On	On	Off: STO release state	Off: STO release state	Off	STO release state

*1 Although the state is off between TOFB1 and TOFB2, the servo amplifier is in the STO state.

Test pulse of STO input signal

Set the test pulse off time inputted from outside to 1 ms or less.

How to pull out the STO cable

The following shows how to pull out the STO cable from the CN8 connector of the servo amplifier.

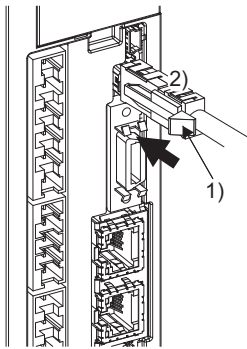

With the clip (1)) of the STO cable plug pressed in the direction of the arrow, hold the plug (2)) and pull out.

13.3 Connection example

Point

- Turn off STO (STO1 and STO2) after the servo motor stops by the servo off state or with forced stop deceleration by turning off EM2 (Forced stop 2). Configure an external sequence that has the timings shown as below using an external device such as the MR-J3-D05 safety logic unit.

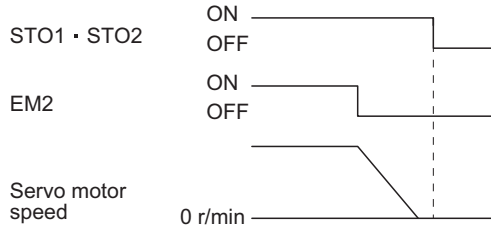

- If STO is turned off during operation, the servo motor stops with the dynamic brake stop (stop category 0), and [AL. 63 STO timing error] occurs.

Connection example for CN8 connector

This servo amplifier is equipped with the connector (CN8) in accordance with the STO function. When this connector is used with a certified external safety relay, power to the motor can be safely removed and unexpected restart can be prevented. The safety relay used should meet the applicable safety standards and have forcibly guided or mirror contacts for the purpose of error detection.

In addition, the MR-J3-D05 safety logic unit can be used instead of a safety relay for implementation of various safety standards.

☞ Page 609 MR-J3-D05 Safety logic unit

The following diagram is for source interface. For sink interface, refer to the following.

☞ Page 479 Sink I/O interface

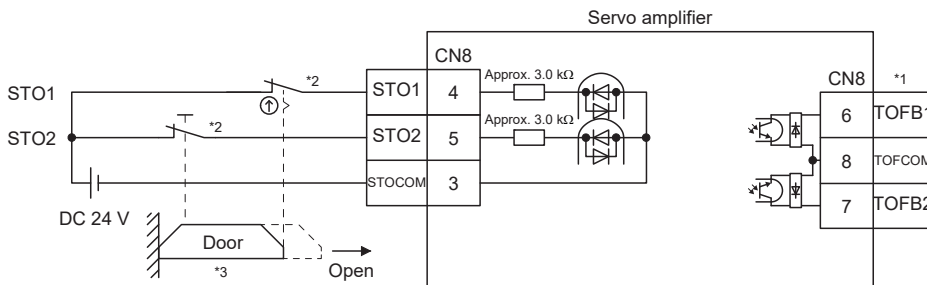

*1 With TOFB, whether the servo is in the STO state can be confirmed. For connection examples, refer to the following.

☞ Page 475 External I/O signal connection example using an MR-J3-D05 safety logic unit

☞ Page 478 External I/O signal connection example using an external safety relay unit

The safety level depends on the setting value of [Pr. PF18 STO diagnosis error detection time] and whether STO input diagnosis by TOFB output is performed or not. For details, refer to the Function column of [Pr. PF18] below.

☞ Page 217 Extension setting 3 parameters ([Pr. PF__])

*2 When using the STO function, turn off STO1 and STO2 at the same time. Turn off STO1 and STO2 after the servo motor stops by the servo off state or with forced stop deceleration by turning off EM2 (Forced stop 2).

*3 Configure the interlock circuit so that the door opens after the servo motor stops.

External I/O signal connection example using an MR-J3-D05 safety logic unit

Point

This connection is for source interface. For the other I/O signals, refer to the connection examples in the following section.

 Page 97 For source I/O interface

Connection example

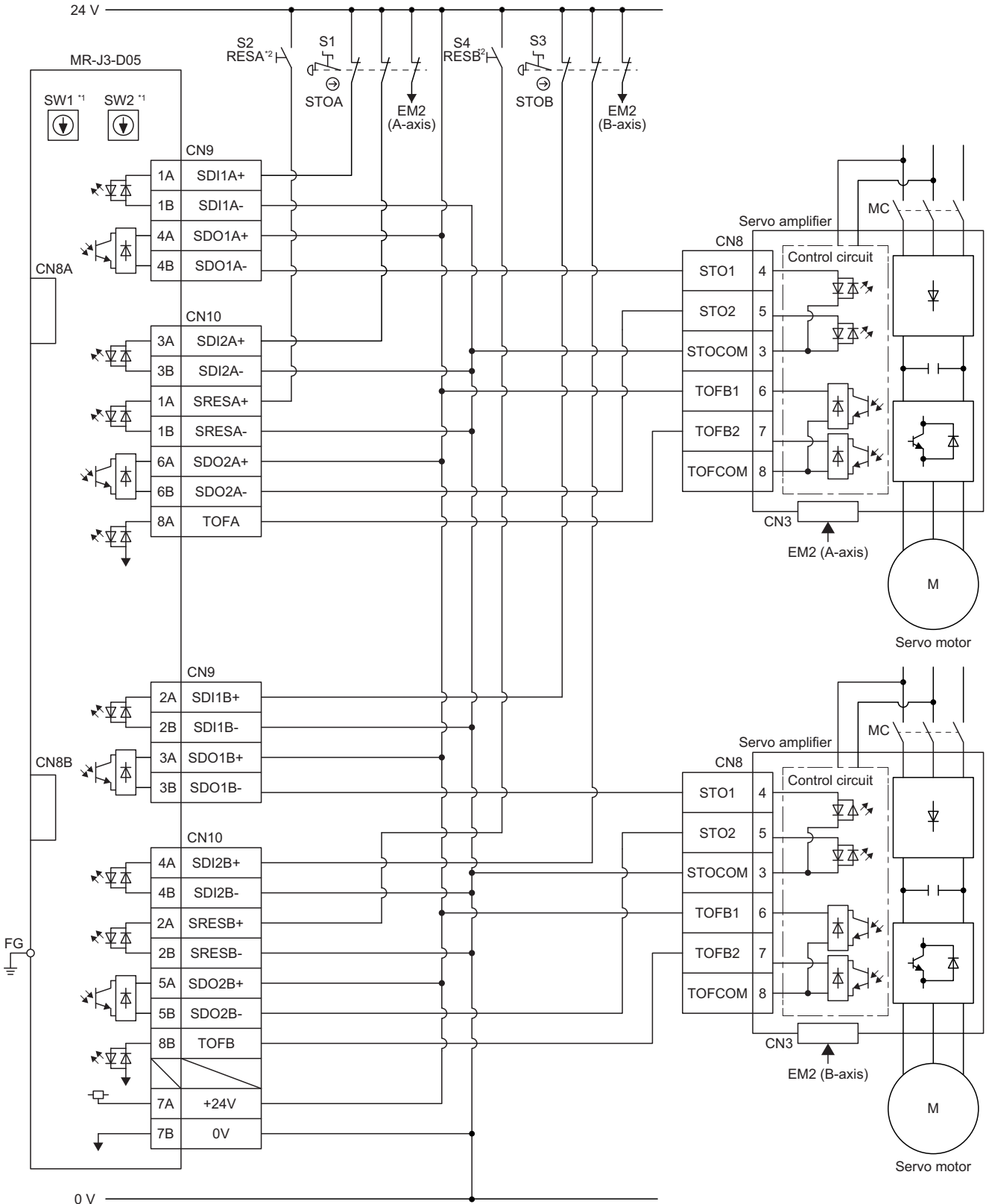

*1 Set the delay time of STO output with SW1 and SW2. These switches are recessed to prevent accidental change of the setting.

*2 To release the STO state (base circuit shut-off), turn RESA and RESB on and turn them off.

Basic operation example

STOA is connected to the servo amplifier via MR-J3-D05.

STOB is connected to the servo amplifier via MR-J3-D05.

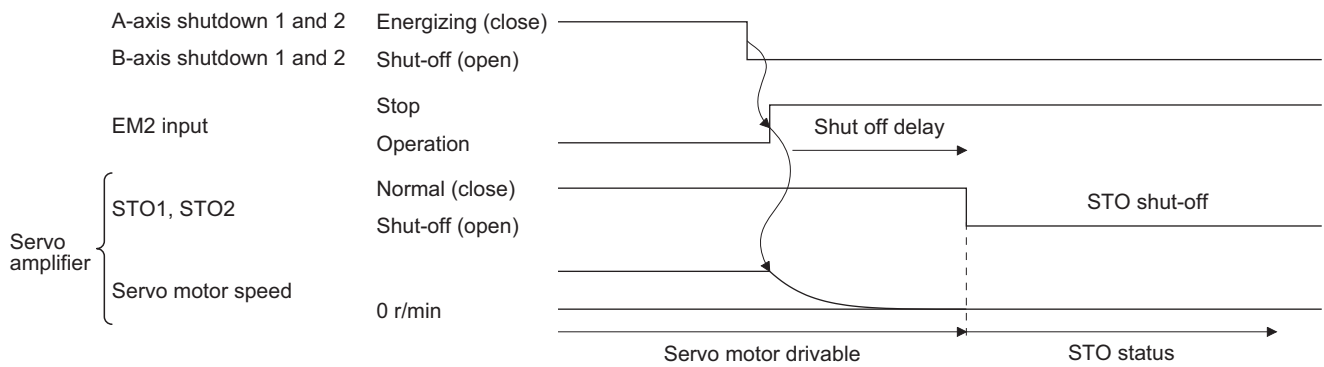

External I/O signal connection example using an external safety relay unit

Point

This connection is for source interface. For the other I/O signals, refer to the connection examples in the following section.

☞ Page 97 For source I/O interface

This connection example complies with the requirements of ISO/EN ISO 13849-1:2015 Category 3 PL d.

For details, refer to the safety relay module user's manual.

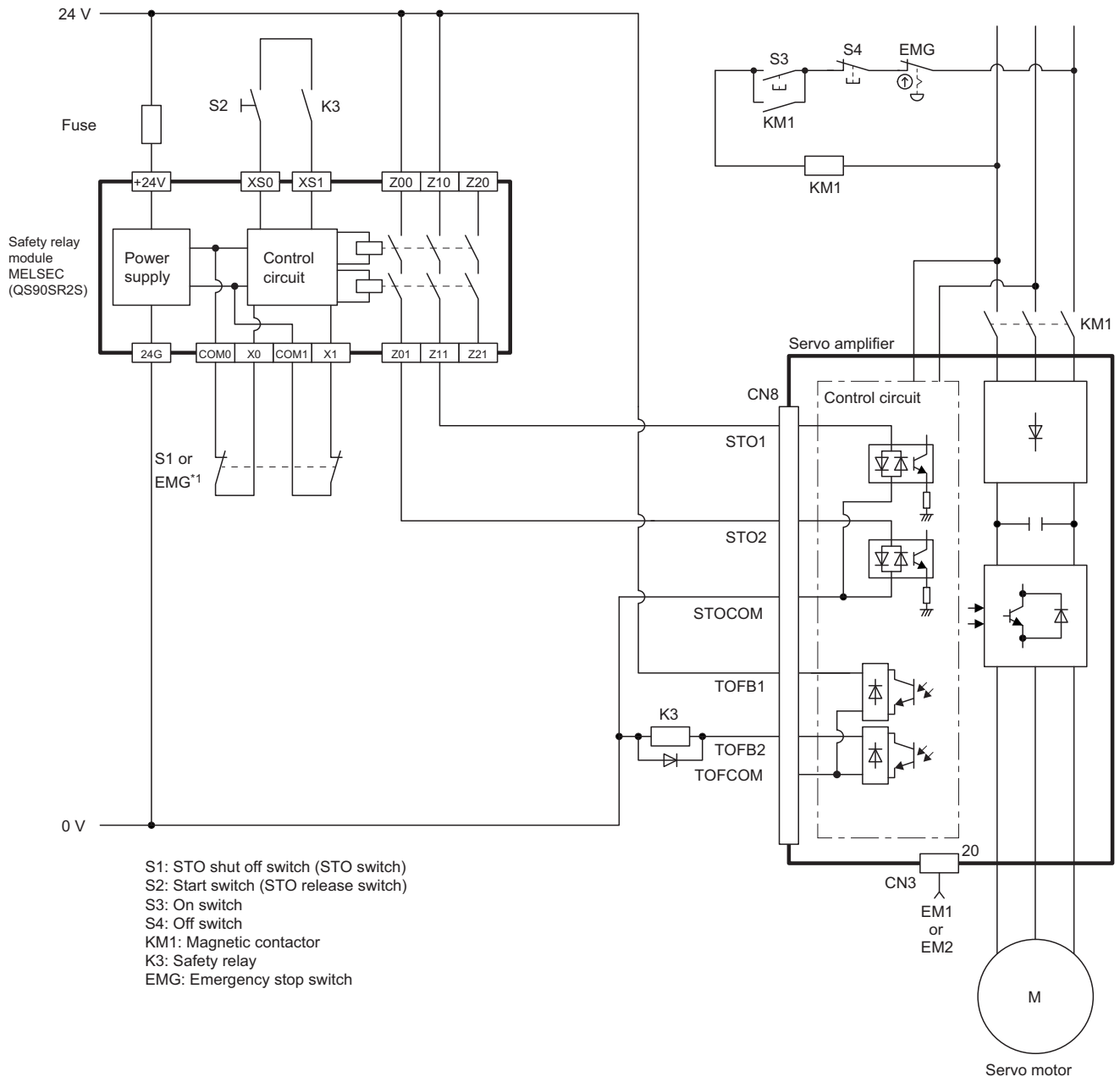

*1 To enable the STO function of the servo amplifier by using "Emergency switching off", change S1 to EMG. The stop category at this time is "0". If STO is turned off while the servo motor is rotating, [AL. 63 STO timing error] will occur.

13.4 Detailed explanation of interfaces

This section provides the details of the I/O signal interfaces (refer to the I/O division in the table) given in the following section. Refer to this section and make connection with the external device.

☞ Page 472 STO I/O signal connector (CN8) and pin assignment

Sink I/O interface

Digital input interface DI-1

This is an input circuit whose photocoupler cathode side is input terminal. Transmit signals from sink (open-collector) type transistor output, relay switch, etc.

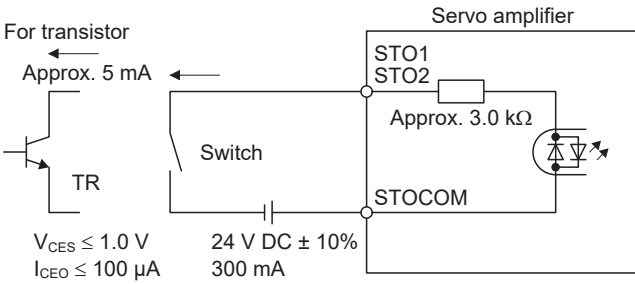

13

Digital output interface DO-1

This is a circuit of collector output terminal of the output transistor. When the output transistor is turned on, collector terminal current will be applied to the output.

A lamp, relay or photocoupler can be driven. Install a diode (D) for an inductive load, or install an inrush current suppressing resistor (R) for a lamp load.

(Rated current: 40 mA or less, maximum current: 50 mA or less, inrush current: 100 mA or less)

A maximum of 5.2 V voltage drop occurs in the servo amplifier.

■When outputting two STO states by using each TOFB

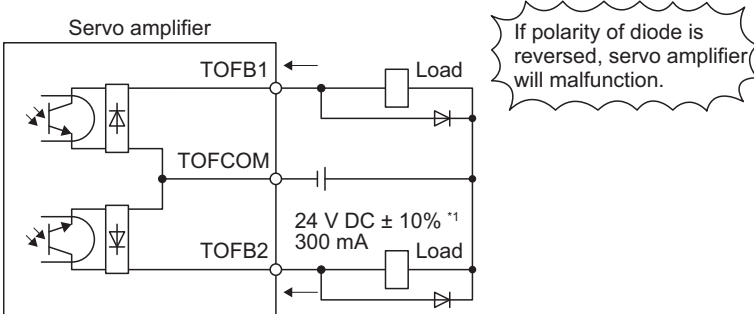

*1 If the voltage drop (maximum of 2.6 V) interferes with the relay operation, apply high voltage (maximum of 26.4 V) from external source.

■When outputting two STO states by using each TOFB

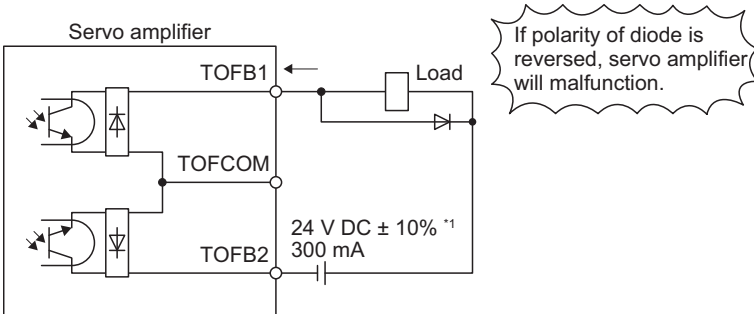

*1 If the voltage drop (maximum of 5.2 V) interferes with the relay operation, apply high voltage (maximum of 26.4 V) from external source.

Source I/O interface

In this servo amplifier, source type I/O interfaces can be used.

Digital input interface DI-1

This is an input circuit whose photocoupler anode side is input terminal. Transmit signals from source (open-collector) type transistor output, relay switch, etc.

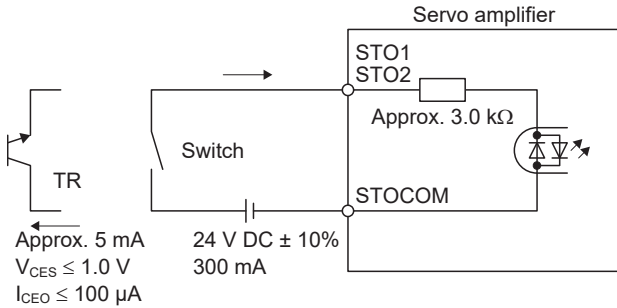

Digital output interface DO-1

This is a circuit of emitter output terminal of the output transistor. When the output transistor is turned on, the current will flow from the output terminal to a load.

A maximum of 5.2 V voltage drop occurs in the servo amplifier.

When outputting two STO states by using each TOFB

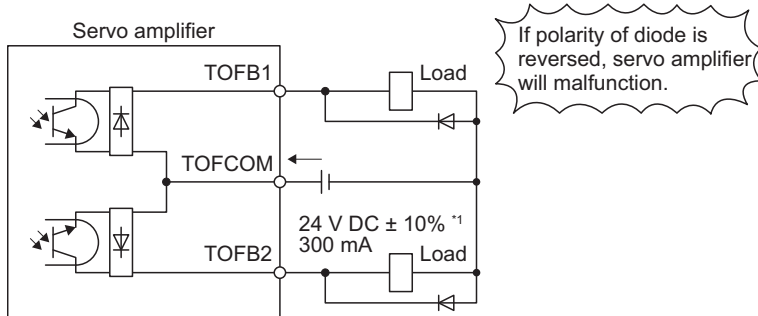

*1 If the voltage drop (maximum of 2.6 V) interferes with the relay operation, apply high voltage (maximum of 26.4 V) from external source.

When outputting two STO states by using each TOFB

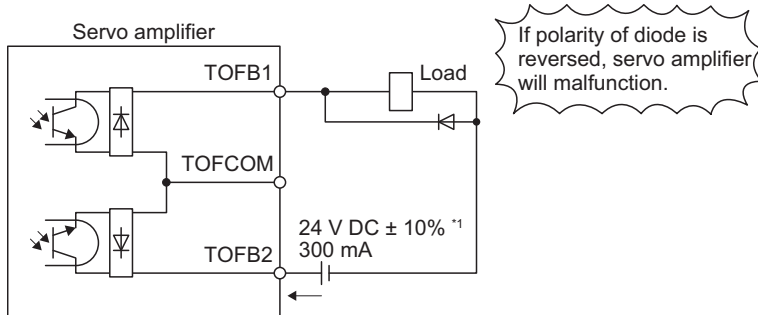

*1 If the voltage drop (maximum of 5.2 V) interferes with the relay operation, apply high voltage (maximum of 26.4 V) from external source.

14 USING A LINEAR SERVO MOTOR

WARNING

• When using the linear servo motor, read "Linear Servo Motor Instruction Manual" and "Linear Encoder Instruction Manual".



Point

The linear servo motor is available for servo amplifiers with software version A1 or later.

14.1 Functions and configuration

Summary

The following shows the differences between the linear servo motor and the rotary servo motor.

Category	Item	Differences		Remark	
		Linear servo motor	Rotary servo motor		
Motor pole adjustment	Magnetic pole detection	Required	Not required (default setting)	Automatically executed at the first servo-on after the power is turned on. For the absolute position linear encoder, [Pr. PL01] can disable the magnetic pole detection. The timing of the magnetic pole detection can be changed with [Pr. PL01].  Page 495 For the absolute position linear encoder	
Home position return	Reference home position	1048576 pulses unit (initial value)	One servo motor revolution unit	Home position return pitch can be changed with parameter setting.  Page 497 Home position return	
Absolute position detection system	Absolute position encoder battery	Not required	Required	The following alarms and warnings are not provided for the linear servo motor. • [AL. 25 Absolute position erased] • [AL. 92 Battery cable disconnection warning] • [AL. 9F Battery warning] • [AL. E3 Absolute position counter warning]	
Auto tuning	Load to motor inertia ratio (J)	Load to motor mass ratio	Load to motor inertia ratio	—	
MR Configurator2 (SW1DNC-MRC2-_)	Motor speed (Data display and setting)	mm/s unit	r/min unit	—	
	Test operation function	Positioning operation	Supported	Supported	—
		Motor-less operation	None	Supported	—
		JOG operation	None	Supported	—
Program operation		Supported	Supported	—	

Configuration including peripheral equipment

⚠ CAUTION

- Connecting a linear servo motor for different axis to the U, V, W, or CN2 may cause a malfunction.

Point

- Equipment other than the servo amplifier and linear servo motor are optional or recommended products.
- When using the linear servo motor, set [Pr. PA01] to " _ _ 4 _".

MR-J4- _GF_

The configuration diagram is an example of MR-J4-20GF. When using the other servo amplifiers, the configuration is the same as rotary servo motors except for connections of linear servo motors and linear encoders. Refer to the following depending on servo amplifiers you use.

☞ Page 58 Configuration including peripheral equipment

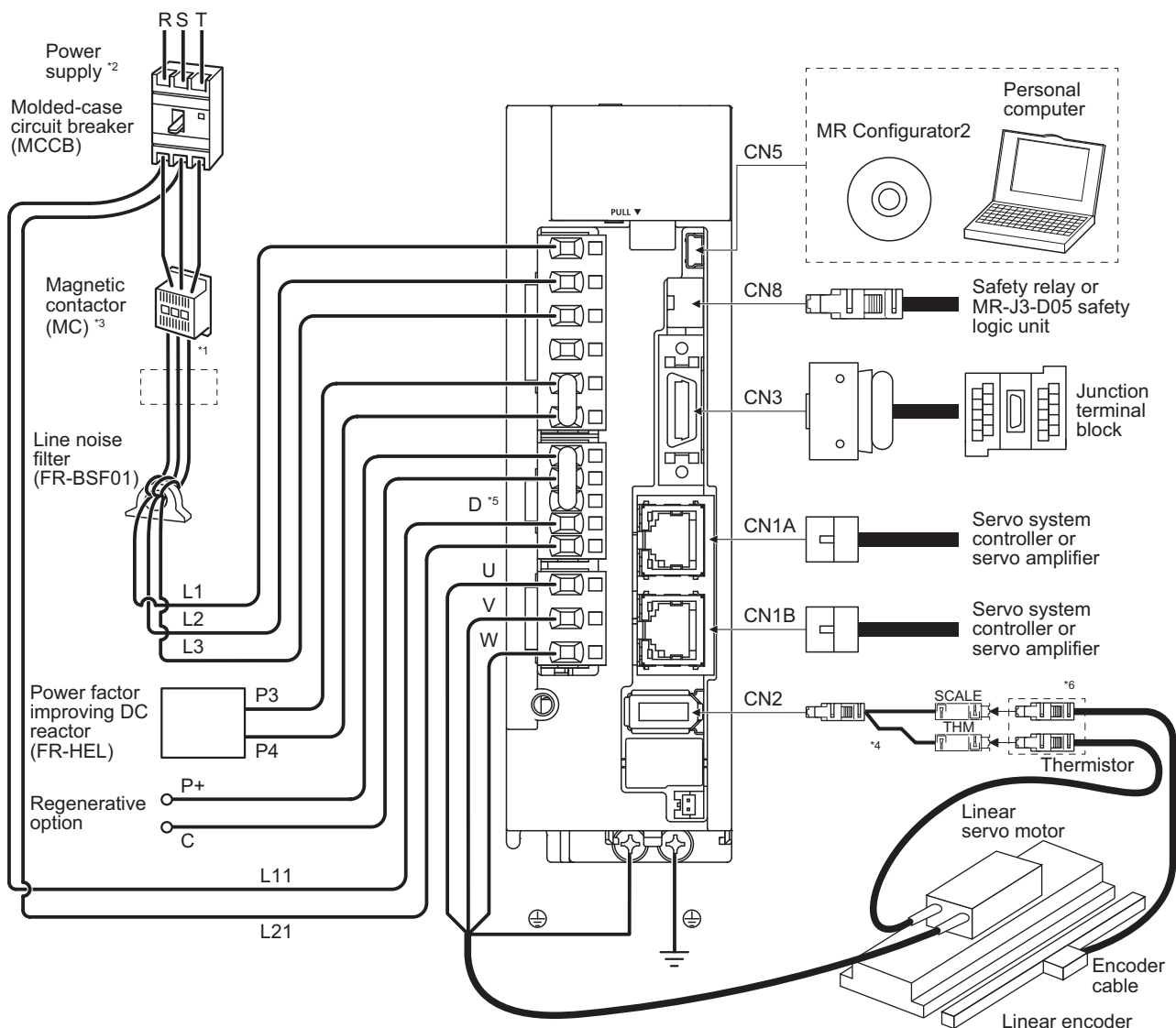

- *1 The power factor improving AC reactor can also be used. In this case, the power factor improving DC reactor cannot be used. When not using the power factor improving DC reactor, short P3 and P4.
- *2 A 1-phase 200 V AC to 240 V AC power supply may be used with the servo amplifier of MR-J4-200GF or less. For 1-phase 200 V AC to 240 V AC, connect the power supply to L1 and L3. Leave L2 open. Refer to the following for the power supply specifications.
☞ Page 30 Servo amplifier standard specifications
- *3 Depending on the main circuit voltage and operation pattern, bus voltage decreases, and that may cause the forced stop deceleration to shift to the dynamic brake deceleration. When dynamic brake deceleration is not required, slow the time to turn off the magnetic contactor.
- *4 For the branch cable, use the MR-J4THCBL03M (optional).
- *5 Always connect between P+ and D terminals. When using the regenerative option, refer to the following.
☞ Page 338 Regenerative options
- *6 Connect the thermistor to THM of branch cable and connect the encoder cable to SCALE correctly. Incorrect connection will trigger [AL.16].

When using serial linear encoder with MR-J4-GF-RJ

The configuration diagram is an example of MR-J4-20GF-RJ. When using the other servo amplifiers, the configuration is the same as rotary servo motors except for connections of linear servo motors and linear encoders. Refer to the following depending on servo amplifiers you use.

☞ Page 58 Configuration including peripheral equipment

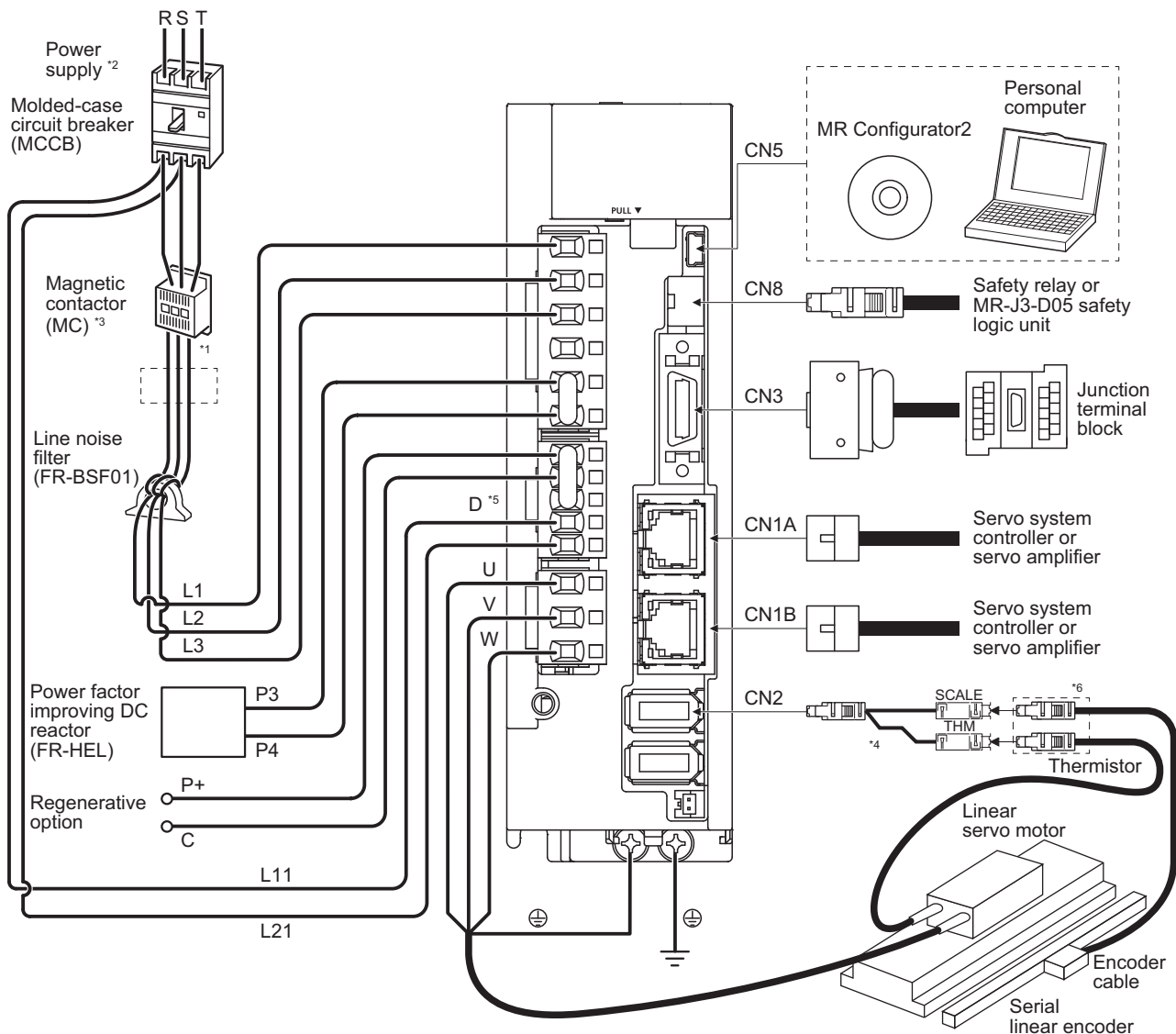

- *1 The power factor improving AC reactor can also be used. In this case, the power factor improving DC reactor cannot be used. When not using the power factor improving DC reactor, short P3 and P4.
- *2 A 1-phase 200 V AC to 240 V AC power supply may be used with the servo amplifier of MR-J4-200GF-RJ or less. For 1-phase 200 V AC to 240 V AC, connect the power supply to L1 and L3. Leave L2 open. Refer to the following for the power supply specifications.
☞ Page 30 Servo amplifier standard specifications
- *3 Depending on the main circuit voltage and operation pattern, bus voltage decreases, and that may cause the forced stop deceleration to shift to the dynamic brake deceleration. When dynamic brake deceleration is not required, slow the time to turn off the magnetic contactor.
- *4 For the branch cable, use the MR-J4THCBL03M (optional).
- *5 Always connect between P+ and D terminals. When using the regenerative option, refer to the following.
☞ Page 338 Regenerative options
- *6 Connect the thermistor to THM of branch cable and connect the encoder cable to SCALE correctly. Incorrect connection triggers [AL. 16].

When using A/B/Z-phase differential output linear encoder with MR-J4-GF-RJ

The configuration diagram is an example of MR-J4-20GF-RJ. When using the other servo amplifiers, the configuration is the same as rotary servo motors except for connections of linear servo motors and linear encoders. Refer to the following depending on servo amplifiers you use.

☞ Page 58 Configuration including peripheral equipment

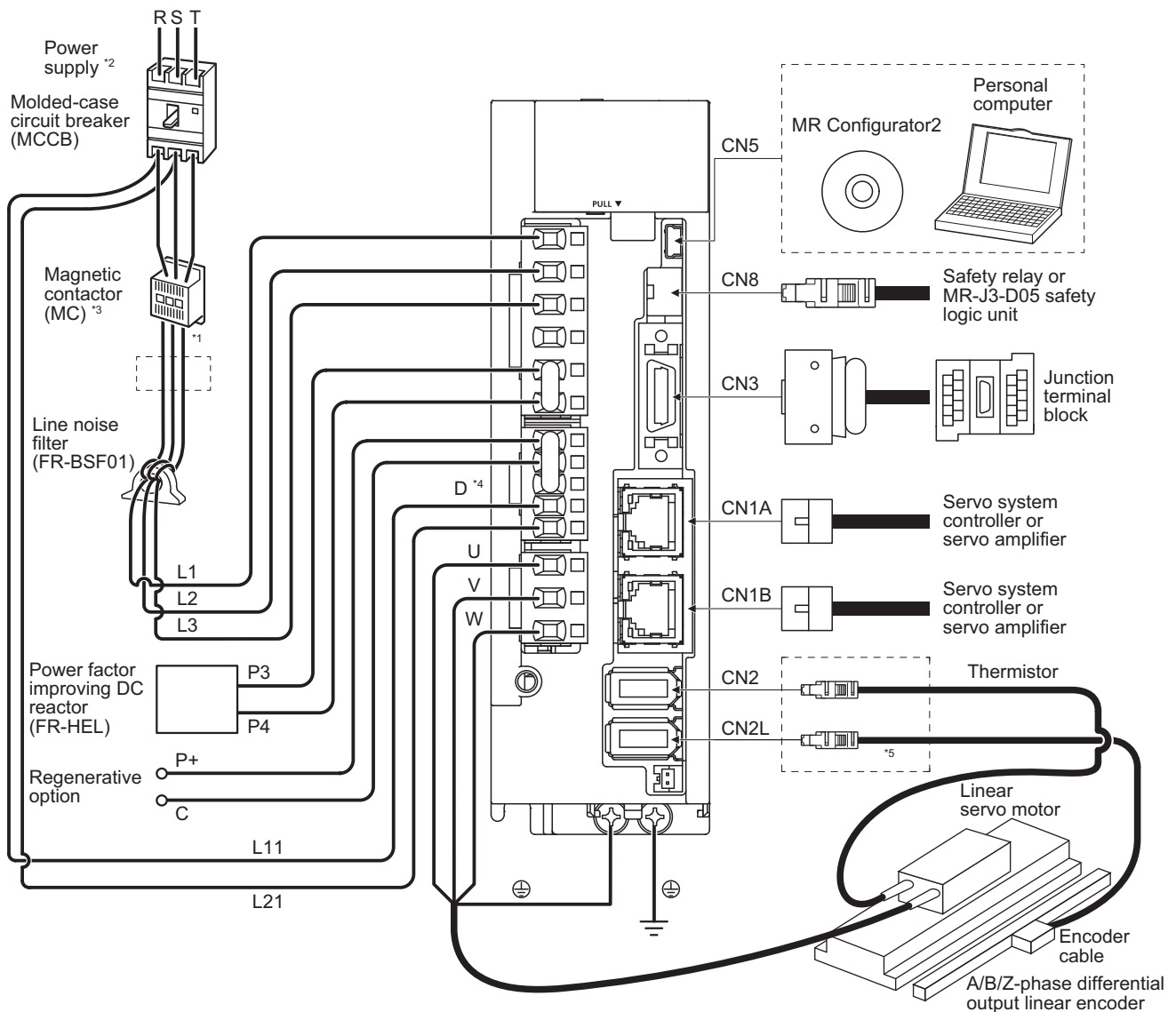

- *1 The power factor improving AC reactor can also be used. In this case, the power factor improving DC reactor cannot be used. When not using the power factor improving DC reactor, short P3 and P4.
- *2 A 1-phase 200 V AC to 240 V AC power supply may be used with the servo amplifier of MR-J4-200GF-RJ or less. For 1-phase 200 V AC to 240 V AC, connect the power supply to L1 and L3. Leave L2 open. Refer to the following for the power supply specifications.
☞ Page 30 Servo amplifier standard specifications
- *3 Depending on the main circuit voltage and operation pattern, bus voltage decreases, and that may cause the forced stop deceleration to shift to the dynamic brake deceleration. When dynamic brake deceleration is not required, slow the time to turn off the magnetic contactor.
- *4 Always connect between P+ and D terminals. When using the regenerative option, refer to the following.
☞ Page 338 Regenerative options
- *5 Connect the thermistor to CN2 of servo amplifier and connect the encoder cable to CN2L correctly. Incorrect connection will trigger [AL. 16].

14.2 Signals and wiring

! WARNING

- Any person who is involved in wiring should be fully competent to do the work.
- Before wiring, turn off the power and wait for 15 minutes or more until the charge lamp turns off. Then, confirm that the voltage between P+ and N- is safe with a voltage tester and others. Otherwise, an electric shock may occur. In addition, when confirming whether the charge lamp is off or not, always confirm it from the front of the servo amplifier.
- Ground the servo amplifier and the linear servo motor securely.
- Do not attempt to wire the servo amplifier and the linear servo motor until they have been installed. Otherwise, it may cause an electric shock.
- The cables should not be damaged, stressed, loaded, or pinched. Otherwise, it may cause an electric shock.
- To avoid an electric shock, insulate the connections of the power supply terminals.

! CAUTION

- Wire the equipment correctly and securely. Otherwise, the linear servo motor may operate unexpectedly, resulting in injury.
- Connect cables to the correct terminals. Otherwise, a burst, damage, etc., may occur.
- Ensure that polarity (+/-) is correct. Otherwise, a burst, damage, etc., may occur.
- The surge absorbing diode installed to the DC relay for control output should be fitted in the specified direction. Otherwise, the converter unit and the drive unit will malfunction and will not output signals, disabling the emergency stop and other protective circuits.

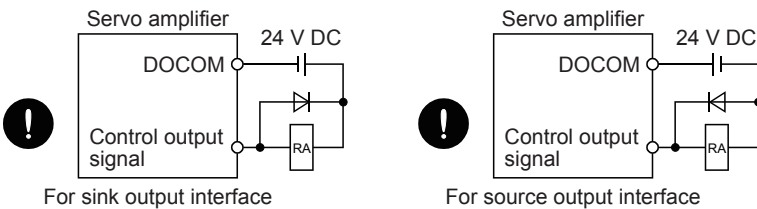

- Use a noise filter, etc., to minimize the influence of electromagnetic interference. Electromagnetic interference may affect the electronic equipment used near the servo amplifier.
- Do not install a power capacitor, surge killer or radio noise filter (optional FR-BIF(-H)) with the power wire of the linear servo motor.
- When using the regenerative resistor, switch power off with the alarm signal. Otherwise, a transistor fault or the like may overheat the regenerative resistor, causing a fire.
- Connect the servo amplifier power output (U/V/W) to the linear servo motor power input (U/V/W) directly. Do not connect a magnetic contactor and others between them. Otherwise, it may cause a malfunction.

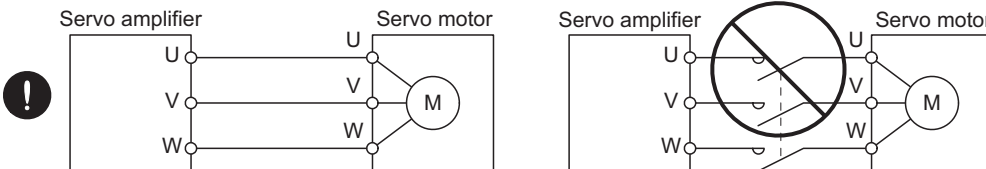

- Connecting a linear servo motor for different axis to the U, V, W, or CN2 may cause a malfunction.
- Before wiring, switch operation, etc., eliminate static electricity. Otherwise, it may cause a malfunction.
- Do not modify the equipment.
- The cables such as power wires deriving from the primary side cannot stand the long-term bending action. Avoid the bending action by fixing the cables to the moving part, etc. Also, use the cable that stands the long-term bending action for the wiring to the servo amplifier.

This chapter does not describe the following items. For details of the items, refer to each section of the detailed explanation field.

Item	Detailed explanation
Connection example of power circuit	☞ Page 83 Connection example of power circuit
Explanation of power supply system	☞ Page 98 Explanation of power supply system
Signal (device) explanations	☞ Page 104 Signal (device) explanations
Timing chart at alarm occurrence	☞ Page 114 Alarm occurrence timing chart
Interfaces	☞ Page 116 Interfaces
Grounding	☞ Page 127 Grounding
Switch setting and display of the servo amplifier	☞ Page 137 Switch setting and display of the servo amplifier

14.3 Operation and functions

Startup



When using the linear servo motor, set [Pr. PA01] to " _ _ 4 _".

Startup procedure

Start up the linear servo system in the following procedure.

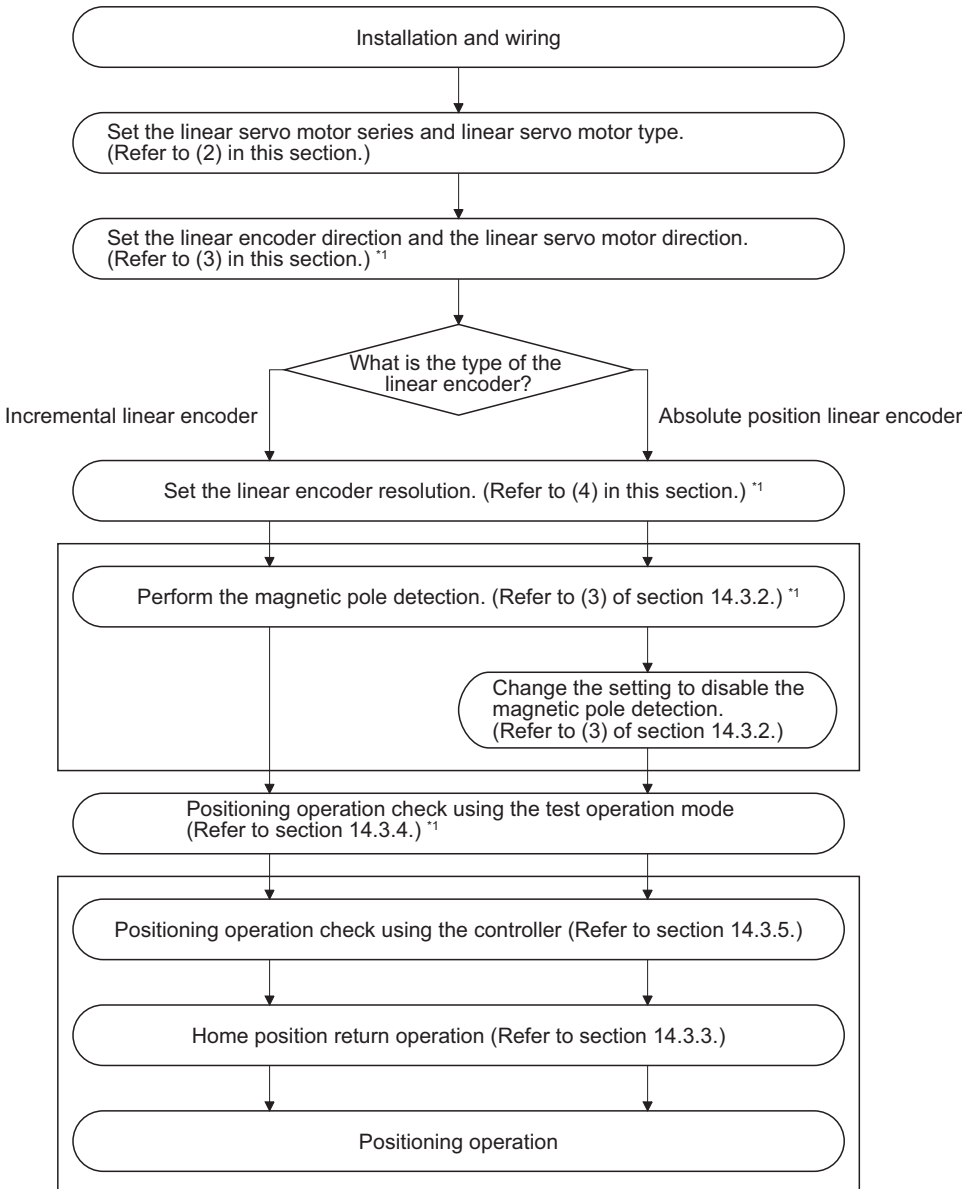

*1 Use MR Configurator2.

Setting of linear servo motor series and linear servo motor type

To use the linear servo motor, set the linear servo motor series and linear servo motor type with [Pr. PA17 Servo motor series setting] and [Pr. PA18 Servo motor type setting].

☞ Page 186 Basic setting parameters ([Pr. PA_ _])

Setting of linear encoder direction and linear servo motor direction

Point

If an incorrect value is set for [Pr. PC27], the linear servo motor may not operate properly, or [AL. 50]/[AL. 51] may occur during the positioning operation/the magnetic pole detection.

Set the first digit of [Pr. PC27] (Encoder pulse count polarity selection) so that the positive direction of the linear servo motor matches the increasing direction of the linear encoder feedback.

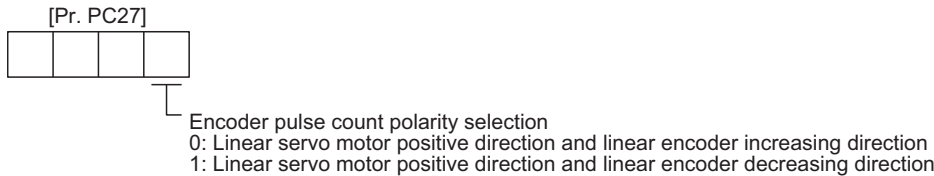

Parameter setting method

1. Confirm the positive direction of the linear servo motor. [Pr. PA14] determines the relation of the travel direction of the linear servo motor under commands as follows.

[Pr. PA14] setting	Travel direction of linear servo motor	
	Address increasing command	Address decreasing command
0	Positive direction	Negative direction
1	Negative direction	Positive direction

The positive/negative directions of the linear servo motor are as follows.

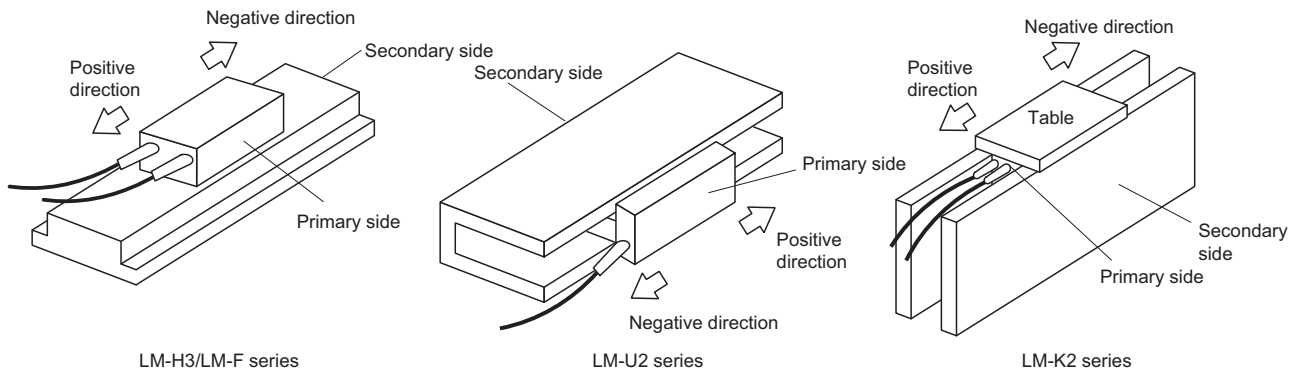

2. Confirm the increasing direction of the linear encoder.
3. If the positive direction of the linear servo motor matches the increasing direction of the linear encoder, set [Pr. PC27] to "___0". If the positive direction of the linear servo motor does not match the increasing direction of the linear encoder, set [Pr. PC27] to "___1".

Confirmation method

Confirm the positive direction of the linear servo motor and the increasing direction of the linear encoder in the following procedure.

1. In servo-off status, move the linear servo motor in the positive direction manually.
2. Confirm the motor speed (in the positive and negative directions) at that time with MR Configurator2.
3. A positive value is displayed for the motor speed when (1) [Pr. PC27] is set to "___0", (2) the positive direction of the linear servo motor matches the increasing direction of the linear encoder, and (3) the linear servo motor is operated in the positive direction. If the positive direction of the linear servo motor does not match the increasing direction of the linear encoder, the motor speed will be a negative value. When [Pr. PC27] is set to "___1" and the positive direction of the linear servo motor matches the increasing direction of the linear encoder, if the linear servo motor operates in the positive direction, the motor speed will be a negative value.

Linear encoder resolution setting

Point

- To enable the parameter values, cycle the power after setting.
- If an incorrect value is set for [Pr. PL02]/[Pr. PL03], the linear servo motor may not operate properly, or [AL. 27]/[AL. 42] may occur during the positioning operation/the magnetic pole detection.

Set the ratio of the electronic gear to the linear encoder resolution with [Pr. PL02 Linear encoder resolution - Numerator] and [Pr. PL03 Linear encoder resolution - Denominator].

Parameter setting

Set the values that apply to the following equation.

$$\frac{[\text{Pr. PL02 Linear encoder resolution - Numerator}]}{[\text{Pr. PL03 Linear encoder resolution - Denominator}]} = \text{Linear encoder resolution } [\mu\text{m}]$$

Parameter setting example

When the linear encoder resolution is 0.5 μm

$$\frac{[\text{Pr. PL02}]}{[\text{Pr. PL03}]} = \text{Linear encoder resolution} = 0.5 \mu\text{m} = \frac{1}{2}$$

The following shows the simplified chart for the setting values of [Pr. PL02] and [Pr. PL03].

Parameter		Linear encoder resolution [μm]							
		0.01	0.02	0.05	0.1	0.2	0.5	1.0	2.0
Setting value	[Pr. PL02]	1	1	1	1	1	1	1	2
	[Pr. PL03]	100	50	20	10	5	2	1	1

Magnetic pole detection

Point

Set [Pr. PE47 Torque offset] to "0 (initial value)" before executing the magnetic pole detection.

Before the positioning operation of the linear servo motor, make sure to perform the magnetic pole detection. When [Pr. PL01] is set to the initial value, perform the magnetic pole detection only at the first servo-on after the power is turned on.

The magnetic pole detection includes the following two methods. Each method has advantages and disadvantages. Select a magnetic pole detection method suitable for your usage.

The position detection method is selected in the initial setting.

Magnetic pole detection	Advantage	Disadvantage
Position detection method	<ol style="list-style-type: none"> 1. The magnetic pole detection has a high degree of accuracy. 2. The adjustment procedure at the magnetic pole detection is simple. 	<ol style="list-style-type: none"> 1. The travel distance at the magnetic pole detection is large. 2. For equipment with small friction, the initial magnetic pole detection error may occur.
Minute position detection method	<ol style="list-style-type: none"> 1. The travel distance at the magnetic pole detection is small. 2. Even for equipment with small friction, the magnetic pole detection is available. 	<ol style="list-style-type: none"> 1. The adjustment procedure at the magnetic pole detection is complex. 2. If a disturbance occurs during the magnetic pole detection, [AL. 27 Initial magnetic pole detection error] may occur.

Magnetic pole detection method with MR Configurator2

The following shows the magnetic pole detection procedure with MR Configurator2.

■Magnetic pole detection by the position detection method

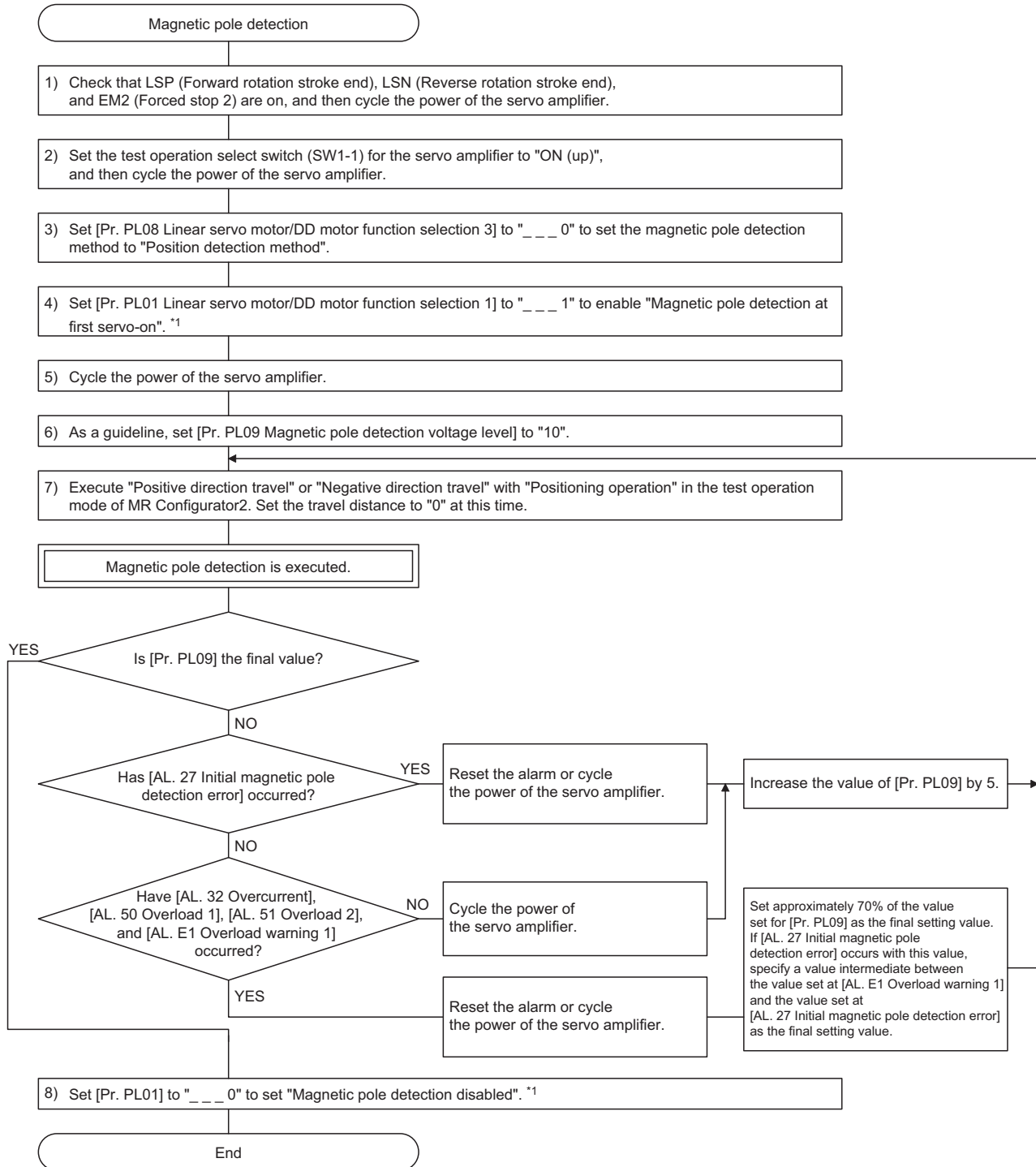

*1 For the incremental system, the [Pr. PL01] setting is not required.

■Magnetic pole detection by the minute position detection method

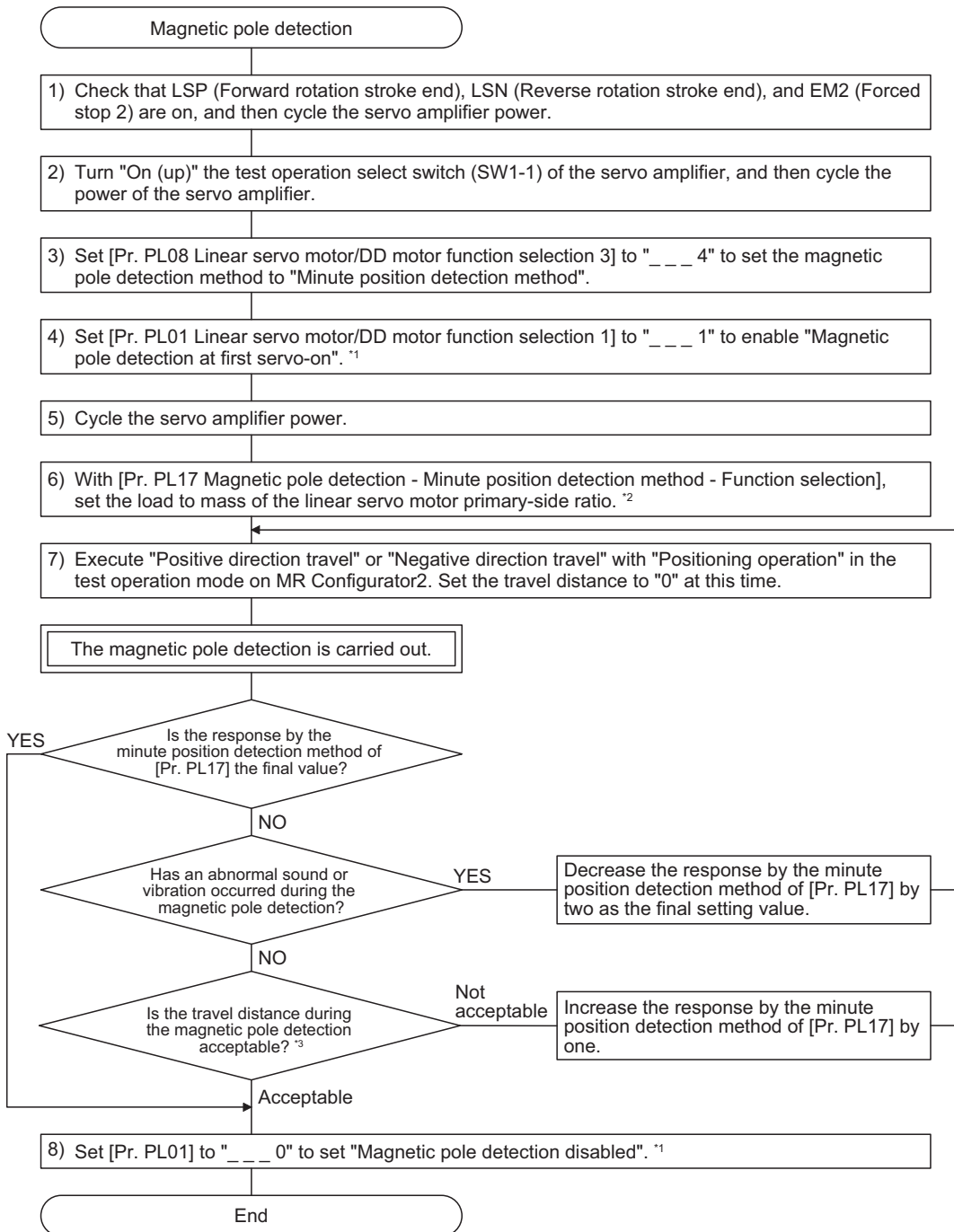

*1 For the incremental system, the [Pr. PL01] setting is not required.

*2 If the load to mass of the linear servo motor primary-side ratio is unknown, perform the magnetic pole detection by the position detection method, and then perform the auto tuning to set an estimated value.

*3 For the magnetic pole detection by the minute position detection method, the maximum travel distance at the magnetic pole detection must be 0.5 mm or less. To shorten the travel distance, increase the response by the minute position detection method in [Pr. PL17].

■ State transition of the servo amplifier display (3-digit, 7-segment LED) at the magnetic pole detection

When the magnetic pole detection with MR Configurator2 is normally executed, the servo amplifier display (3-digit, 7-segment LED) shows the state as follows.

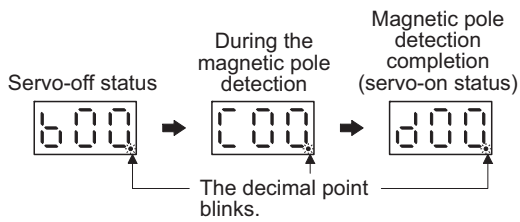

Preparation for the magnetic pole detection

Point

When the test operation mode is selected with the test operation select switch (SW1-1), the network communication for the servo amplifier and later shut off.

For the magnetic pole detection, use the test operation mode (positioning operation) of MR Configurator2. Turn off the servo amplifier power, and set the test operation select switch (SW1-1) as follows. Turning on the power enables the test operation mode.

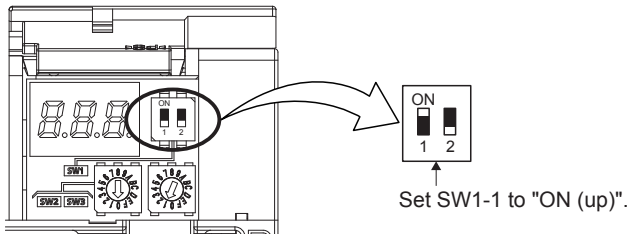

Operation at the magnetic pole detection

WARNING

- Note that the magnetic pole detection automatically starts simultaneously with the turning-on of the servo-on command.

CAUTION

- If the magnetic pole detection is not executed properly, the linear servo motor may operate unexpectedly.

Point

- Establish the machine configuration to use LSP (Forward rotation stroke end) and LSN (Reverse rotation stroke end). The machine may be damaged due to a collision without LSP and LSN.
- Assign LSP and LSN and perform the magnetic pole detection also in the torque mode.
- At the magnetic pole detection, whether the linear servo motor moves in the positive or negative direction is unpredictable.
- Depending on the setting value of [Pr. PL09 Magnetic pole detection voltage level], an overload, overcurrent, magnetic pole detection alarm, or others may occur.
- When performing the positioning operation from a controller, use the sequence which confirms the normal completion of the magnetic pole detection and the servo-on status, then outputs the positioning command. If the controller outputs the positioning command before RD (Ready) turns on, the command may not be accepted or an alarm may occur.
- After the magnetic pole detection, check the positioning accuracy with the test operation (positioning operation function) of MR Configurator2.
- When the absolute position linear encoder is used, if a gap is generated to the positional relation between the linear encoder and the linear servo motor, perform the magnetic pole detection again.
- The magnetic pole detection improves in accuracy when performed with no load.
- An alarm may occur when the linear encoder is not mounted properly, or when the linear encoder resolution setting ([Pr. PL02] and [Pr. PL03]) or the setting value of [Pr. PL09 Magnetic pole detection voltage level] is incorrect.
- For the machine whose friction becomes 30% or more of the continuous thrust, the linear servo motor may not operate properly after the magnetic pole detection.
- For the horizontal shaft of the machine whose unbalanced thrust becomes 20% or more of the continuous thrust, the linear servo motor may not operate properly after the magnetic pole detection.
- The magnetic pole detection may fail if performed simultaneously with multiple axes connected to each other (e.g. a tandem configuration). Perform the magnetic pole detection for each axis. At this time, set the axes for which the magnetic pole detection is not performed to servo-off.

■ For the incremental linear encoder

Point

For the incremental linear encoder, the magnetic pole detection is required every time the power is turned on.

By turning on the servo-on command from the controller after the power-on, the magnetic pole detection is automatically carried out. Therefore, there is no need to set the parameter (first digit of [Pr. PL01]) for executing the magnetic pole detection.

• Timing chart

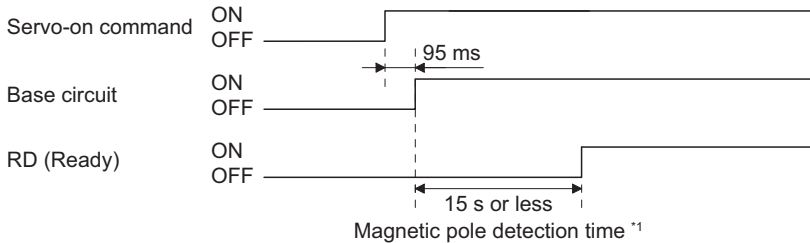

*1 The magnetic pole detection time indicates the operation time when LSP (Forward rotation stroke end) and LSN (Reverse rotation stroke end) are on.

• Linear servo motor movement (when LSP (Forward rotation stroke end) and LSN (Reverse rotation stroke end) are on)

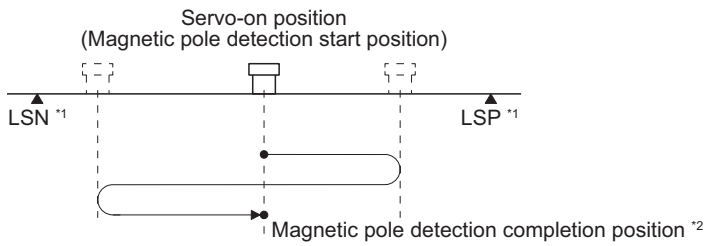

*1 When you turn off LSP (Forward rotation stroke end) or LSN (Reverse rotation stroke end) during the magnetic pole detection, the operation of the magnetic pole detection is carried on to the opposite direction. When both LSP and LSN are off, [AL. 27 Initial magnetic pole detection error] occurs.

*2 The following shows the pitch against the magnetic pole.

Linear servo motor series	LM-H3 LM-F	LM-U2		LM-K2
		Medium thrust (Continuous thrust: Less than 400 N)	Large thrust (Continuous thrust: 400 N or more)	
Pitch against magnetic pole [mm]	48	30	60	48

• Linear servo motor movement (when LSP (Forward rotation stroke end) or LSN (Reverse rotation stroke end) is off)
 When LSP or LSN is off at servo-on, the magnetic pole detection is carried out as follows.

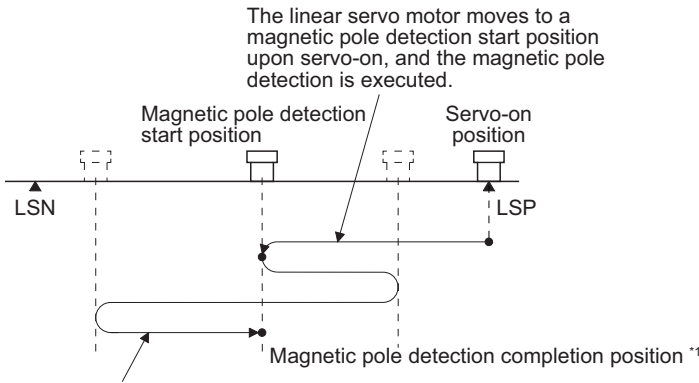

The linear servo motor reciprocates several times and returns to the magnetic pole detection start position to complete the magnetic pole detection and to go into the servo-lock status. At this time, there may be a gap, approximately a quarter of the pitch against magnetic pole, from the start position.

*1 The following shows the pitch against the magnetic pole.

Linear servo motor series	LM-H3 LM-F	LM-U2		LM-K2
		Medium thrust (Continuous thrust: Less than 400 N)	Large thrust (Continuous thrust: 400 N or more)	
Pitch against magnetic pole [mm]	48	30	60	48

■ For the absolute position linear encoder

Point

The magnetic pole detection will be required with the following timings.

- When the system is set up (at the first startup of equipment)
- After a servo amplifier is replaced
- After a linear servo motor (primary-side or secondary-side) is replaced
- After a linear encoder (scale or head) is replaced or remounted

If a gap is generated to the positional relation between the linear encoder and the linear servo motor, perform the magnetic pole detection again.

Perform the magnetic pole detection in the following procedure.

1. Set [Pr. PL01 Linear servo motor/DD motor function selection 1] to " __ __ 1" (Magnetic pole detection at first servo-on).

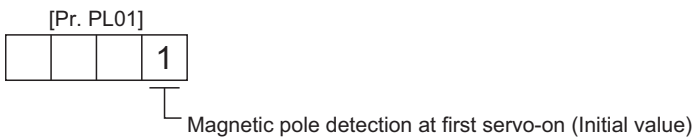

2. Execute the magnetic pole detection. Page 494 For the incremental linear encoder

3. After completing the magnetic pole detection properly, change [Pr. PL01] to " __ __ 0" (Magnetic pole detection disabled).

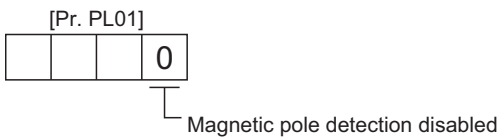

After the magnetic pole detection, by disabling the magnetic pole detection function with [Pr. PL01], the magnetic pole detection after each power-on is not required.

Magnetic pole detection method setting

Point

In the following cases, set the magnetic pole detection method to the minute position detection method.

- When a shortened travel distance at the magnetic pole detection is required
- When the magnetic pole detection by the position detection method is not completed properly

Set the magnetic pole detection method by using the first digit of [Pr. PL08] (Magnetic pole detection method selection).

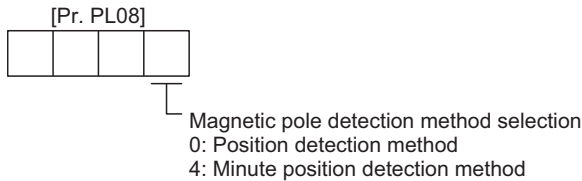

Setting of the magnetic pole detection voltage level by the position detection method

For the magnetic pole detection by the position detection method, set the voltage level with [Pr. PL09 Magnetic pole detection voltage level]. For the magnetic pole detection by the minute position detection method, the voltage level setting is not required.

Guideline of parameter settings

Set the parameters by referring to the following table.

Servo status	[Pr. PL09] setting (guide value)	
	Small ← Medium → Large (10 or less (initial value) 50 or more)	
Thrust at operation	Small	Large
Overload, overcurrent alarm	Seldom occurs	Frequently occurs
Magnetic pole detection alarm	Frequently occurs	Seldom occurs
Magnetic pole detection accuracy	Low	High

Setting procedure

1. Perform the magnetic pole detection, and increase the setting value of [Pr. PL09 Magnetic pole detection voltage level] until [AL. 33 Overvoltage], [AL. 50 Overload 1], [AL. 51 Overload 2], [AL. E1 Overload warning 1], and [AL. EC Overload warning 2] occur. Increase the setting value by five as a guide value. When these alarms and warnings occur during the magnetic pole detection with MR Configurator2, the test operation of MR Configurator2 automatically completes and the servo-off status is established.
2. Specify the setting value that is an approximately 70% of the value set when [AL. 50 Overload 1], [AL. 51 Overload 2], [AL. 33 Overvoltage], [AL. E1 Overload warning 1], and [AL. EC Overload warning 2] occurred as the final setting value. If [AL. 27 Initial magnetic pole detection error] occurs with this value, specify a value intermediate between the value set at [AL. 50 Overload 1], [AL. 51 Overload 2], [AL. 33 Overvoltage], [AL. E1 Overload warning 1], and [AL. EC Overload warning 2] and the value set at the magnetic pole detection alarm as the final setting value.
3. Perform the magnetic pole detection again with the final setting value, and make sure that the accuracy of the magnetic pole detection is as required.

Setting example

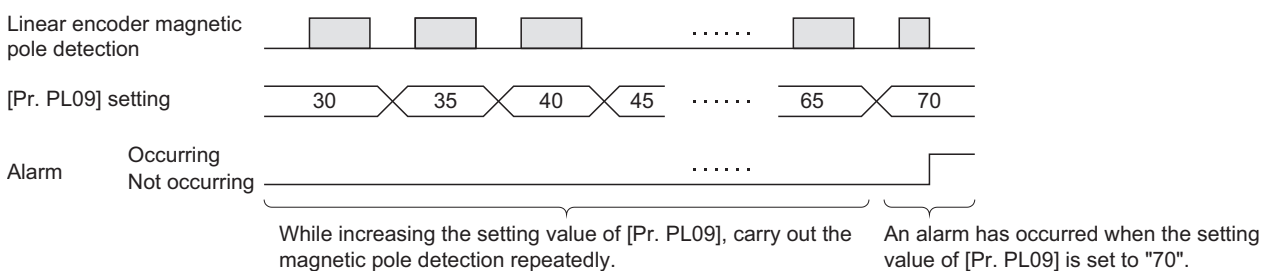

In this example, the final setting value of [Pr. PL09] is 49 (Setting value at the alarm occurrence = 70×0.7).

Home position return

Precautions when using a proximity dog

■Length of proximity dog

Set the length of the proximity dog to satisfy the following, so that the linear servo motor speed changes from the home position return speed to the creep speed during detection of the proximity dog.

$$L_1 \geq \frac{V}{60} \cdot \frac{td}{2}$$

L_1 : Length of the proximity dog [mm]

V: Home position return speed [mm/min]

td: Time to change from the home position return speed to the creep speed [s]

■Adjustment of proximity dog position

To eliminate variations in the home position return completion position, adjust the proximity dog detection position to be near the center between a reference home position and the next reference home position.

The incremental linear encoder and the absolute position linear encoder have different reference home positions at the home position return. Refer to the following for information on the reference home position.

☞ Page 498 For the absolute position linear encoder

☞ Page 499 If wanting to stop at the reference home position

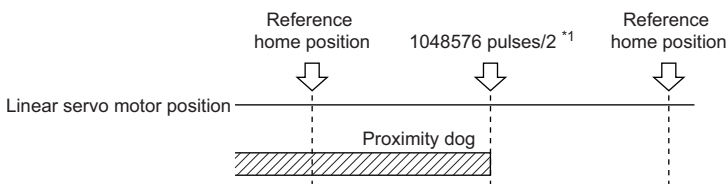

*1 This can be changed with [Pr. PL01].

■Timing of when the linear encoder home position is passed

For an incremental type linear encoder, the linear encoder home position (reference mark) must be passed during the period from a home position return start until the proximity dog detection. When the home position is not passed, [AL. 90.5 Z-phase unpassed] may occur.

For the absolute position linear encoder

When an absolute linear encoder is used, the reference home position is the position per 1048576 pulses (changeable with the third digit of [Pr. PL01]) with reference to the linear encoder home position (absolute position data = 0).

The linear encoder home position can be set in any position.

LZ (Encoder Z-phase pulse) is outputted based on "Stop interval selection at the home position return" in [Pr. PL01].

In the case of a proximity dog type home position return, after the proximity dog rear end is detected, the nearest reference home position shifted by the home position shift distance is used as the home position.

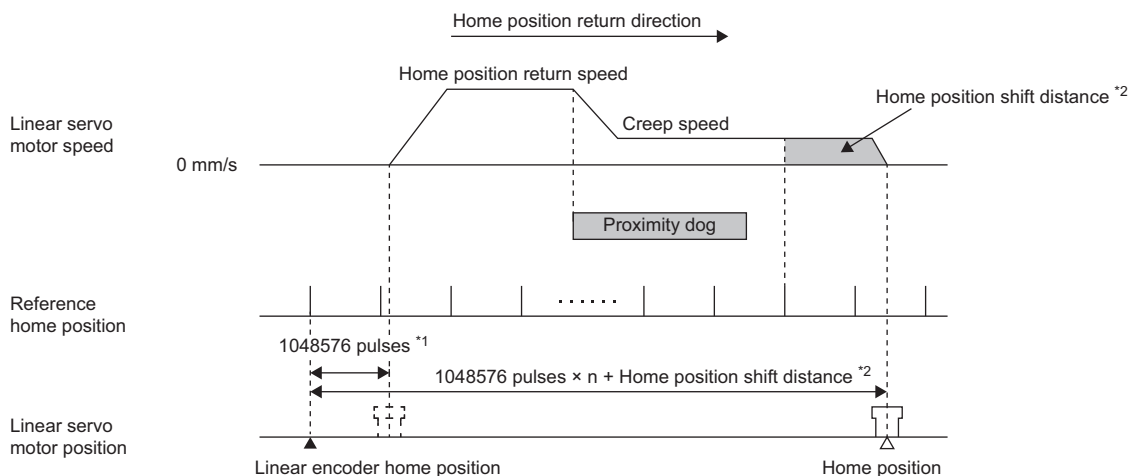

*1 This can be changed with [Pr. PL01].

*2 Home position shift distance can be changed with [Pr. PT07] and [Pr. PT69].

For the incremental linear encoder

CAUTION

- If the resolution or the stop interval (the third digit of [Pr. PL01]) of the linear encoder is large, the linear servo motor may crash into the stroke end, which is very dangerous.

Point

If no linear encoder home position (reference mark) exists, only the home position return type without using Z-phase can be performed.

 Page 146 Home position return types

■ If wanting to stop at the reference home position

Point

To perform a home position return securely, pass the linear encoder home position (reference mark) with the JOG operation or another operation, and then start the home position return.

Change the value of the third digit in [Pr. PL01] according to the linear encoder resolution.

When the reference home position of an incremental linear encoder is used, the reference home position is the position per 1048576 pulses (can be changed with the third digit of [Pr. PL01]) to the linear encoder home position (reference mark) that has been passed through. Change the setting value of [Pr. PL01] according to the linear encoder resolution.

[Pr. PL01]

--	--	--	--

Stop interval setting at the home position return

Setting value	Stop interval [pulse]
0	8192
1	131072
2	262144
3	1048576 (initial value)
4	4194304
5	16777216
6	67108864

The following shows the relation between the stop interval at the home position return and the linear encoder resolution. For example, when the linear encoder resolution is 0.001 μm and the parameter for the stop interval at the home position return, [Pr. PL01], is set to "_ 5 _" (16777216 pulses), the stop interval is 16.777 mm. The value inside a bold box indicates the recommended stop interval for each linear encoder resolution.

[Unit: mm]

Pr. PL01	Stop interval [pulse]	Linear encoder resolution [μm]									
		0.001	0.005	0.01	0.02	0.05	0.1	0.2	0.5	1	2
_ 0 _	8192	0.008	0.041	0.082	0.164	0.410	0.819	1.638	4.096	8.192	16.384
_ 1 _	131072	0.131	0.655	1.311	2.621	6.554	13.107	26.214	65.536	131.072	262.144
_ 2 _	262144	0.262	1.311	2.621	5.243	13.107	26.214	52.429	131.072	262.144	524.288
_ 3 _	1048576	1.049	5.243	10.486	20.972	52.429	104.858	209.715	524.288	1048.576	2097.152
_ 4 _	4194304	4.194	20.972	41.943	83.886	209.715	419.430	838.861	2097.152	4194.304	8388.608
_ 5 _	16777216	16.777	83.886	167.772	335.544	838.861	1677.722	3355.443	8388.608	16777.216	33554.432
_ 6 _	67108864	67.109	335.544	671.089	1342.177	3355.443	6710.886	13421.773	33554.432	67108.864	134217.728

Set one linear encoder home position in the full stroke, and set it in the proximity dog signal detection position.

When two or more reference marks exist during the full stroke of the linear encoder, select "Enabled (_ _ 1 _)" of "Linear scale multipoint Z-phase input function selection" in [Pr. PC17].

LZ (Encoder Z-phase pulse) is outputted at the linear encoder home position (reference mark).

In the case of a dog type home position return, after the proximity dog signal rear end is detected, the nearest reference home position shifted by the home position shift distance is used as the home position.

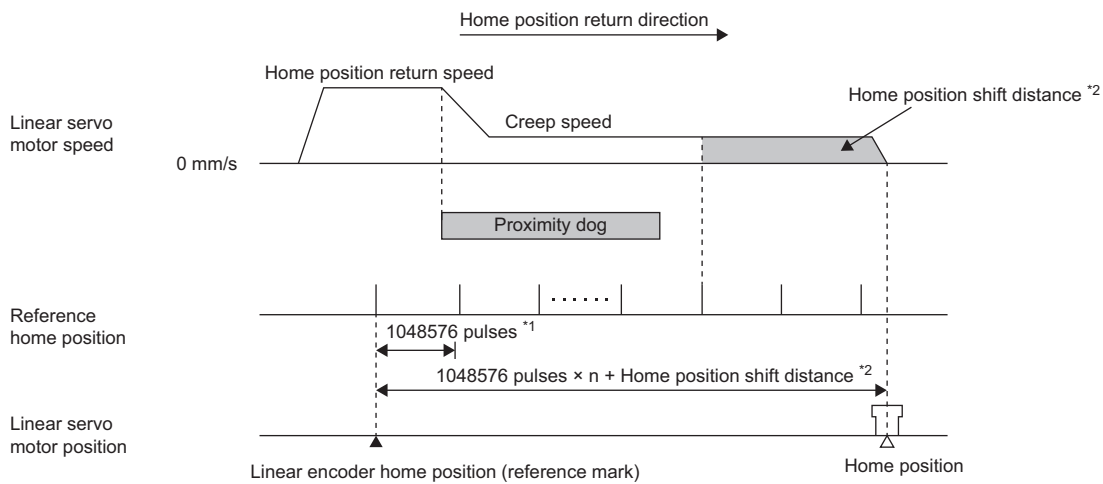

*1 This can be changed with [Pr. PL01].

*2 Home position shift distance can be changed with [Pr. PT07] and [Pr. PT69].

As shown below, in an area where the linear encoder home position (reference mark) is not passed after the home position return starts (home position return restricted area), home position return may be disabled depending on the conditions.

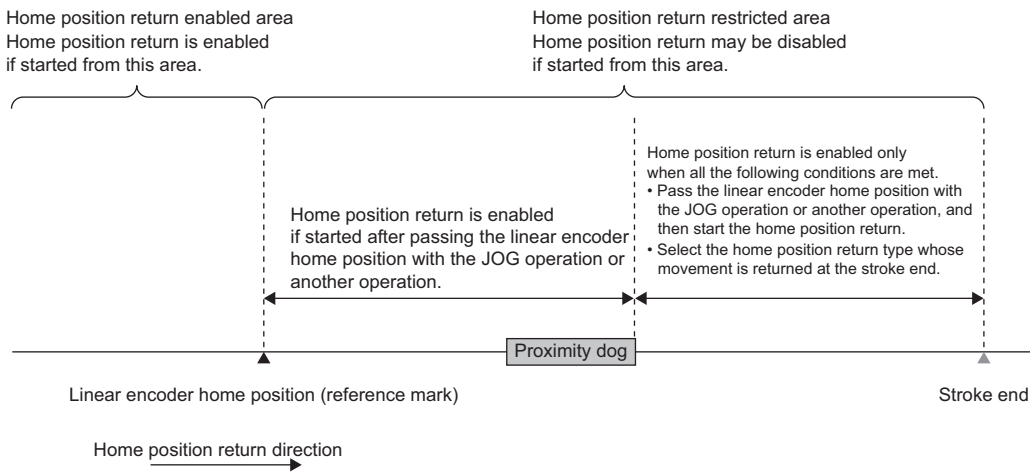

■ If wanting to stop at the linear encoder home position

When "Stop position selection at home position return" of [Pr. PT41] is set to "_ _ 1 _", the home position return for Homing methods 33, 34, -11, and -43 is set to the linear encoder home position (reference mark). This parameter is enabled when an incremental linear encoder compatible with a serial interface is used.

- For Homing methods 33 and 34

The following figure shows the operation of Homing method 34 when "Stop position selection at home position return" of [Pr. PT41] is set to "_ _ 1 _". The operation direction of Homing method 33 is opposite to that of Homing method 34.

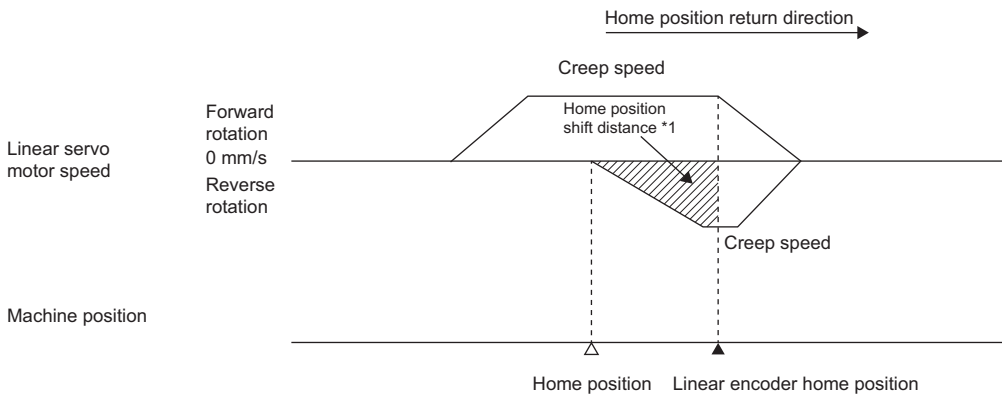

*1 Home position shift distance can be changed with [Pr. PT07] and [Pr. PT69].

When the stroke end is detected

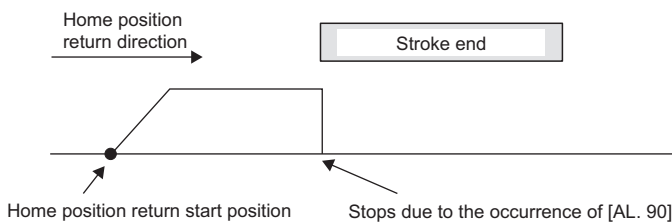

- For Homing methods -11 and -43

The following figure shows the operation of Homing method -11 when "Stop position selection at home position return" of [Pr. PT41] is set to "_ _ 1 _". The operation direction of Homing method -43 is opposite to that of Homing method -11.

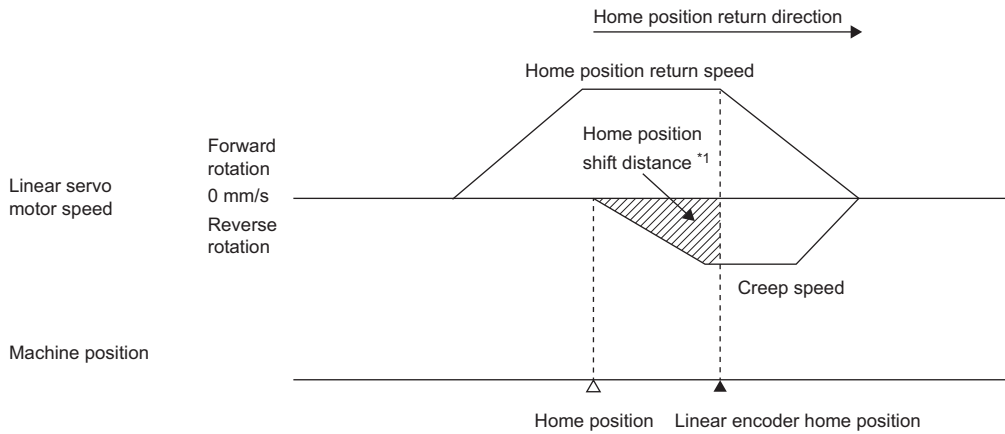

*1 Home position shift distance can be changed with [Pr. PT07] and [Pr. PT69].

When the movement is returned at the stroke end

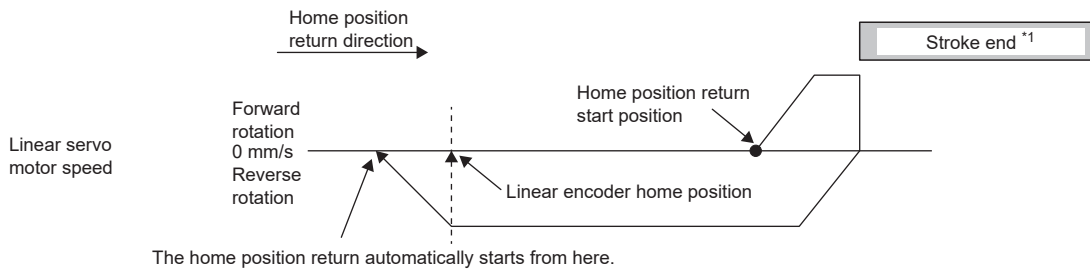

*1 This is not available with the software limit.

Test operation mode in MR Configurator2

CAUTION

- The test operation mode is designed for checking servo operation. It is not for checking machine operation. Do not use this mode with the machine. Always use the linear servo motor alone.
- If the servo motor operates abnormally, use EM2 (Forced stop 2) to stop it.

Point

- The content described in this section indicates the environment where the servo amplifier and a personal computer are directly connected.
- When the test operation mode is selected with the test operation select switch (SW1-1), the network communication for the servo amplifier and later shut off.

By using a personal computer and MR Configurator2, you can execute the positioning operation, the output signal (DO) forced output, and the program operation without connecting the controller.

Test operation mode types

■ Positioning operation

Positioning operation can be performed without using the controller. Use this operation with the forced stop reset. This operation may be used independently of whether the servo is on or off and whether the controller is connected or not. Exercise control on the positioning operation screen of MR Configurator2.

- Operation pattern

Item	Initial value	Setting range
Travel distance [pulse]	1048576	0 to 99999999
Speed [mm/s]	10	0 to Maximum speed
Acceleration/deceleration time constant [ms]	1000	0 to 50000
Repeat pattern	Positive direction travel → Negative direction travel	Positive direction travel → Negative direction travel Positive direction travel → Positive direction travel Negative direction travel → Positive direction travel Negative direction travel → Negative direction travel
Dwell time [s]	2.0	0.1 to 50.0
Number of repeats [time]	1	1 to 9999

- Operation method

Operation	Screen control
Positive direction travel	Click "Positive Direction Movement".
Negative direction travel	Click "Reverse Direction Movement".
Pause	Click "Pause".
Stop	Click "Stop".
Forced stop	Click "Forced stop".

■Output signal (DO) forced output

Output signals can be switched on/off forcibly independently of the servo status. Use this function for checking output signal wiring, etc. Exercise control on the DO forced output screen of MR Configurator2.

■Program operation

Positioning operation can be performed in two or more operation patterns combined, without using the controller. Use this operation with the forced stop reset. This operation may be used independently of whether the servo is on or off and whether the controller is connected or not.

Exercise control on the program operation screen of MR Configurator2. For full information, refer to Help of MR Configurator2.

Operation	Screen control
Start	Click "Start".
Pause	Click "Pause".
Stop	Click "Stop".
Forced stop	Click "Forced stop".

Operation procedure

1. Turn off the power.
2. Turn "ON (up)" SW1-1.

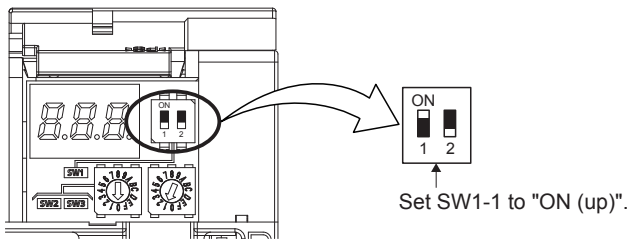

Turning "ON (up)" SW1-1 during power-on will not enable the test operation mode.

3. Turn on the servo amplifier.

When initialization is completed, the display shows the following screen.

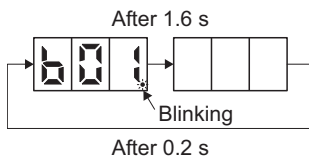

4. Start operation with the personal computer.

Operation from controller

For the system using the incremental linear encoder, the magnetic pole detection is automatically performed at the first servo-on after the power-on. For this reason, when performing the positioning operation, create the sequence which surely confirms the servo-on status as the inter lock condition of the positioning command.

Function

Linear servo control error detection function

Point

For the linear servo control error detection function, the position and speed deviation error detections are enabled by default. ([Pr. PL04]: _ _ _ 3)

If the linear servo control becomes unstable for some reasons, the linear servo motor may not operate properly. To detect this state and to stop operation, the linear servo control error detection function is used as a protective function.

The linear servo control error detection function has three different detection methods: the position deviation, speed deviation, and thrust deviation. An error is detected when each method is enabled with [Pr. PL04 Linear servo motor/DD motor function selection 2]. The detection level can be changed with [Pr. PL05], [Pr. PL06], and [Pr. PL07].

■Outline of linear servo control error detection function

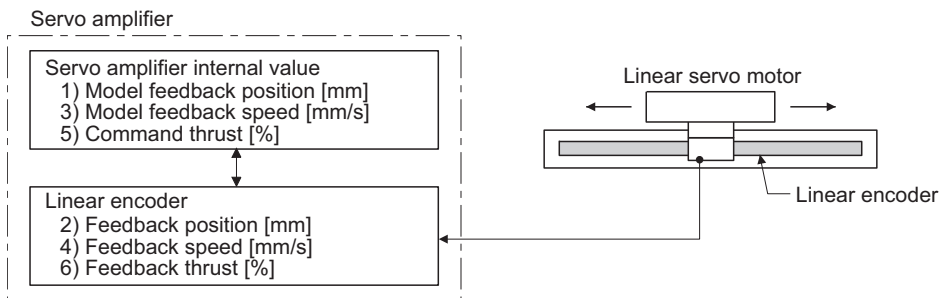

■Position deviation error detection

Set [Pr. PL04] to "_ _ _ 1" to enable the position deviation error detection.

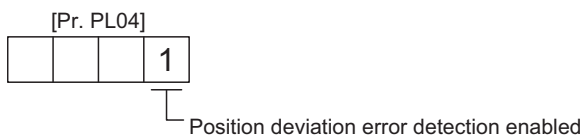

When the difference between 1) and 2) in figure 14.1 is equal to or more than the value of [Pr. PL05 Position deviation error detection level] (1 mm to 1000 mm), [AL. 42.1 Servo control error by position deviation] occurs and the linear servo motor stops. The initial value of this detection level is 50 mm. Change the setting value as necessary.

For "Outline of linear servo control error detection function", refer to the following.

☞ Page 505 Outline of linear servo control error detection function

■Speed deviation error detection

Set [Pr. PL04] to "_ _ _ 2" to enable the speed deviation error detection.

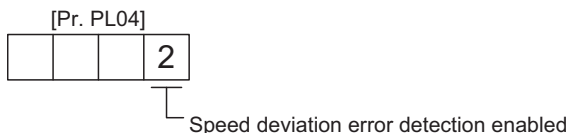

When you compare the model feedback speed (3)) and the feedback speed (4)) in "Outline of linear servo control error detection function", if the deviation is more than the value of [Pr. PL06 Speed deviation error detection level] (1 mm/s to 5000 mm/s), [AL. 42.2 Servo control error by speed deviation] will occur and the linear servo motor will stop. The initial value of this detection level is 1000 mm/s. Change the setting value as necessary.

For "Outline of linear servo control error detection function", refer to the following.

☞ Page 505 Outline of linear servo control error detection function

■Thrust deviation error detection

Set [Pr. PL04] to "_ _ _ 4" to enable the thrust deviation error detection.

[Pr. PL04]

			4
--	--	--	---

└ Thrust deviation error detection enabled

When you compare the command thrust (5)) and the feedback thrust (6)) in "Outline of linear servo control error detection function", if the deviation is more than the value of [Pr. PL07 Torque/thrust deviation error detection level] (1% to 1000%), [AL. 42.3 Servo control error by torque/thrust deviation] will occur and the linear servo motor will stop. The initial value of this detection level is 100%. Change the setting value as necessary.

For "Outline of linear servo control error detection function", refer to the following.

☞ Page 505 Outline of linear servo control error detection function

■Detecting multiple deviation errors

When setting [Pr. PL04] as follows, multiple deviation errors can be detected. For the error detection methods, refer to the following.

☞ Page 505 Position deviation error detection

☞ Page 505 Speed deviation error detection

☞ Page 506 Thrust deviation error detection

[Pr. PL04]

--	--	--	--

Setting value	Position deviation error detection	Speed deviation error detection	Thrust deviation error detection
1	○	—	—
2	—	○	—
3	○	○	—
4	—	—	○
5	○	—	○
6	—	○	○
7	○	○	○

Auto tuning function

Point

The auto tuning mode 1 may not be performed properly if the following conditions are not satisfied.

- Time to reach 2000 mm/s is the acceleration/deceleration time constant of 5 s or less.
- The linear servo motor speed is 150 mm/s or higher.
- The load to mass of the linear servo motor primary-side ratio is 100 times or less.
- The acceleration/deceleration thrust is 10% or less of the continuous thrust.

Although the auto tuning function during the linear servo motor operation is the same as that of the rotary servo motor, the calculation method of the load to motor mass ratio (J ratio) is different. The load to motor mass ratio (J ratio) on the linear servo motor is calculated by dividing the load mass by the mass of the linear servo motor primary side.

Ex.

Mass of linear servo motor primary side = 2 kg

Load mass (excluding the mass of the linear servo motor primary side) = 4 kg

Mass ratio = $4/2 = 2$ times

For the parameters set with the auto tuning function, refer to the following.

☞ Page 230 NORMAL GAIN ADJUSTMENT

Machine analyzer function

Point

- Make sure to perform the machine analyzer function after the magnetic pole detection. If the magnetic pole detection is not performed, the machine analyze function may not operate properly.
- The stop position at the completion of the machine analyzer function can be arbitrary.

Absolute position detection system

When the linear servo motor is used with the absolute position detection system, an absolute position linear encoder is required. The linear encoder backs up the absolute position data. Therefore, the encoder battery need not be installed to the servo amplifier. Additionally, [AL. 25 Absolute position erased], [AL. 92 Battery cable disconnection warning], [AL. 9F Battery warning], and [AL. E3 Absolute position counter warning] are not provided for the linear servo motor.

14.4 Characteristics

Overload protection characteristics

An electronic thermal is built in the servo amplifier to protect the linear servo motor, servo amplifier and linear servo motor power wires from overloads.

[AL. 50 Overload 1] occurs if overload operation performed is above the electronic thermal protection curve shown in the following figures. [AL. 51 Overload 2] occurs if the maximum current is applied continuously for several seconds due to machine collision, etc. Use the equipment on the left-hand side area of the continuous or broken line in the graph.

Use the linear servo motor with 70% or less of the effective load ratio when it is in the servo lock state or in a small reciprocating motion.

This servo amplifier has linear servo motor overload protection. (The linear servo motor overload current (full load current) is set on the basis of 120% rated current of the servo amplifier.)

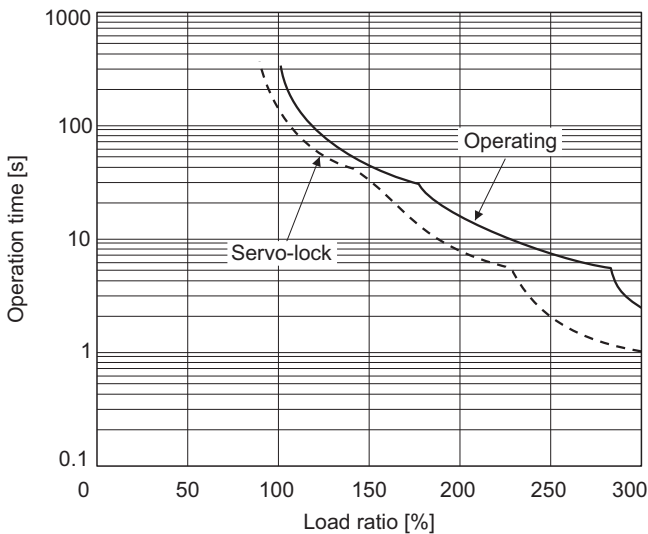

a. LM-H3 series
LM-K2 series

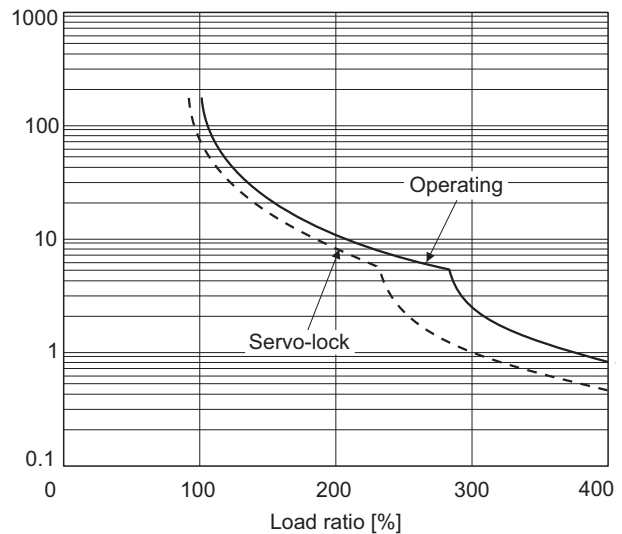

b. LM-U2 series

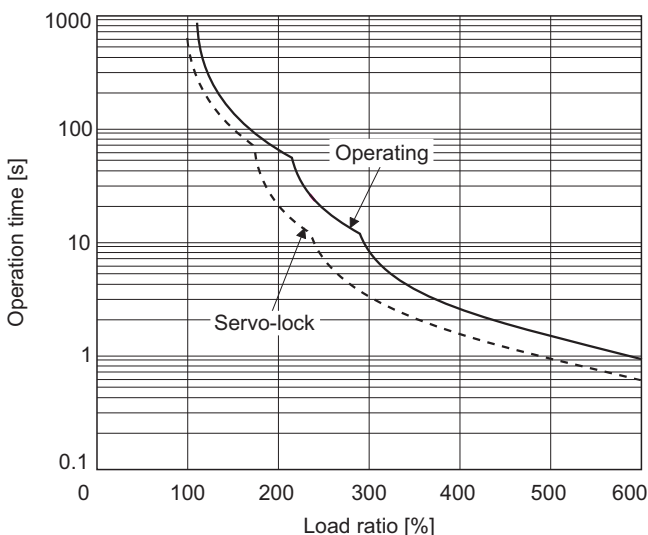

c. LM-F series (natural cooling)

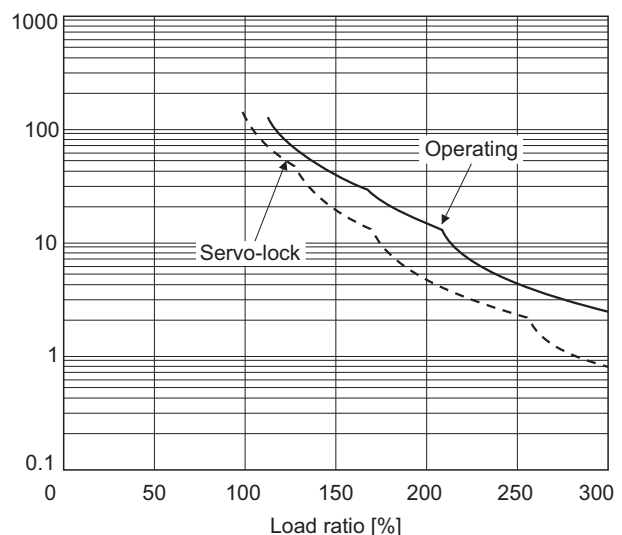

d. LM-F series (liquid cooling)

Power supply capacity and generated loss

The following table indicates servo amplifiers' power supply capacities and losses generated under rated load. For thermal design of an enclosed type cabinet, use the values in the table in consideration for the worst operating conditions. The actual amount of generated heat will be intermediate between values at rated torque and servo-off according to the duty used during operation. When the linear servo motor is run at less than the rated speed, the power supply capacity will be smaller than the value in the table, but the servo amplifier's generated heat will not change.

Mounting a heat sink outside of the cabinet enables to reduce heat in the cabinet and design a compact enclosed type cabinet.

Linear servo motor (primary side)	Servo amplifier	Power supply capacity [kVA] ^{*1}	Servo amplifier-generated heat [W] ^{*2}		Area required for heat dissipation [m ²]
			At rated output	With servo-off	
LM-H3P2A-07P-BSS0	MR-J4-40GF(-RJ)	0.9	35	15	0.7
LM-H3P3A-12P-CSS0	MR-J4-40GF1(-RJ)	0.9	35	15	0.7
LM-H3P3B-24P-CSS0	MR-J4-70GF(-RJ)	1.3	50	15	1.0
LM-H3P3C-36P-CSS0		1.9	75	15	1.5
LM-H3P3D-48P-CSS0	MR-J4-200GF(-RJ)	3.5	90	20	1.8
LM-H3P7A-24P-ASS0	MR-J4-70GF(-RJ)	1.3	50	15	1.0
LM-H3P7B-48P-ASS0	MR-J4-200GF(-RJ)	3.5	90	20	1.8
LM-H3P7C-72P-ASS0		3.8	100	20	1.1
LM-H3P7D-96P-ASS0	MR-J4-350GF(-RJ)	5.5	130	20	2.7
LM-U2PAB-05M-0SS0	MR-J4-20GF(-RJ) MR-J4-20GF1(-RJ)	0.5	25	15	0.5
LM-U2PAD-10M-0SS0	MR-J4-40GF(-RJ)	0.9	35	15	0.7
LM-U2PAF-15M-0SS0	MR-J4-40GF1(-RJ)	0.9	35	15	0.7
LM-U2PBB-07M-1SS0	MR-J4-20GF(-RJ) MR-J4-20GF1(-RJ)	0.5	25	15	0.5
LM-U2PBD-15M-1SS0	MR-J4-60GF(-RJ)	1.0	40	15	0.8
LM-U2PBF-22M-1SS0	MR-J4-70GF(-RJ)	1.3	50	15	1.0
LM-U2P2B-40M-2SS0	MR-J4-200GF(-RJ)	3.5	90	20	1.8
LM-U2P2C-60M-2SS0	MR-J4-350GF(-RJ)	5.5	130	20	2.7
LM-U2P2D-80M-2SS0	MR-J4-500GF(-RJ)	7.5	195	25	3.9
LM-FP2B-06M-1SS0	MR-J4-200GF(-RJ)	3.5	90	20	1.8
LM-FP2D-12M-1SS0	MR-J4-500GF(-RJ)	7.5	195	25	3.9
LM-FP2F-18M-1SS0	MR-J4-700GF(-RJ)	10	300	25	6.0
LM-FP4B-12M-1SS0	MR-J4-500GF(-RJ)	7.5	195	25	3.9
LM-FP4D-24M-1SS0	MR-J4-700GF(-RJ)	10	300	25	6.0
LM-FP4F-36M-1SS0	MR-J4-11KGF(-RJ)	14	460	45	9.2
LM-FP4H-48M-1SS0	MR-J4-15KGF(-RJ)	18	580	45	11.6
LM-FP5H-60M-1SS0	MR-J4-22KGF4(-RJ)	22	640	45	12.8
LM-K2P1A-01M-2SS1	MR-J4-40GF(-RJ) MR-J4-40GF1(-RJ)	0.9	35	15	0.7
LM-K2P1C-03M-2SS1	MR-J4-200GF(-RJ)	3.5	90	20	1.8
LM-K2P2A-02M-1SS1	MR-J4-70GF(-RJ)	1.3	50	15	1.0
LM-K2P2C-07M-1SS1	MR-J4-350GF(-RJ)	5.5	130	20	2.7
LM-K2P2E-12M-1SS1	MR-J4-500GF(-RJ)	7.5	195	25	3.9
LM-K2P3C-14M-1SS1	MR-J4-350GF(-RJ)	5.5	130	20	2.7
LM-K2P3E-24M-1SS1	MR-J4-500GF(-RJ)	7.5	195	25	3.9

*1 The power supply equipment capacity changes with the power supply impedance. This value is applicable when the power factor improving AC reactor or power factor improving DC reactor are not used.

*2 Heat generated during regeneration is not included in the servo amplifier-generated heat. To calculate heat generated by the regenerative option, refer to the following.

☞ Page 338 Regenerative options

Dynamic brake characteristics

CAUTION

- The coasting distance is a theoretically calculated value which ignores the running load such as friction. The calculated value will be longer than the actual distance. If the braking distance is not longer than the calculated value, a moving part may crash into the stroke end, which is very dangerous. Install the anti-crash mechanism such as an air brake or an electric/mechanical stopper such as a shock absorber to reduce the shock of moving parts. No linear servo motor with an electromagnetic brake is available.

Point

- Do not use dynamic brake to stop in a normal operation as it is the function to stop in emergency.
- For a machine operating at the recommended load to motor mass ratio or less, the estimated number of usage times of the dynamic brake is 1000 times while the machine decelerates from the rated speed to a stop once in 10 minutes.
- Be sure to enable EM1 (Forced stop 1) after the linear servo motor stops when using EM1 (Forced stop 1) frequently in other than emergency.

The approximate coasting distance from when the dynamic brake is activated until when the linear servo motor stops can be calculated with the equation below.

$$L_{\max} = V_0 \cdot (0.03 + M \cdot (A + B \cdot V_0^2))$$

L_{\max} : Coasting distance of the machine [m]

V_0 : Speed when the brake is activated [m/s]

M: Full mass of the moving part [kg]

A: Coefficient (Refer to the following tables.)

B: Coefficient (Refer to the following tables.)

Linear servo motor (primary side)	Coefficient A	Coefficient B
LM-H3P2A-07P-BSS0	7.15×10^{-3}	2.94×10^{-3}
LM-H3P3A-12P-CSS0	2.81×10^{-3}	1.47×10^{-3}
LM-H3P3B-24P-CSS0	7.69×10^{-3}	2.27×10^{-4}
LM-H3P3C-36P-CSS0	7.22×10^{-3}	1.13×10^{-4}
LM-H3P3D-48P-CSS0	1.02×10^{-3}	2.54×10^{-4}
LM-H3P7A-24P-ASS0	7.69×10^{-3}	2.14×10^{-4}
LM-H3P7B-48P-ASS0	9.14×10^{-4}	2.59×10^{-4}
LM-H3P7C-72P-ASS0	7.19×10^{-4}	1.47×10^{-4}
LM-H3P7D-96P-ASS0	6.18×10^{-4}	9.59×10^{-5}
LM-U2PAB-05M-0SS0	5.72×10^{-2}	1.72×10^{-4}
LM-U2PAD-10M-0SS0	2.82×10^{-2}	8.60×10^{-5}
LM-U2PAF-15M-0SS0	1.87×10^{-2}	5.93×10^{-5}
LM-U2PBB-07M-1SS0	3.13×10^{-2}	1.04×10^{-4}
LM-U2PBD-15M-1SS0	1.56×10^{-2}	5.18×10^{-5}
LM-U2PBF-22M-1SS0	4.58×10^{-2}	1.33×10^{-5}
LM-U2P2B-40M-2SS0	1.47×10^{-3}	1.27×10^{-5}
LM-U2P2C-60M-2SS0	1.07×10^{-3}	7.66×10^{-6}
LM-U2P2D-80M-2SS0	9.14×10^{-4}	5.38×10^{-6}
LM-FP2B-06M-1SS0	8.96×10^{-4}	1.19×10^{-3}
LM-FP2D-12M-1SS0	5.55×10^{-4}	4.81×10^{-4}
LM-FP2F-18M-1SS0	4.41×10^{-4}	2.69×10^{-4}
LM-FP4B-12M-1SS0	5.02×10^{-4}	4.36×10^{-4}
LM-FP4D-24M-1SS0	3.55×10^{-4}	1.54×10^{-4}
LM-FP4F-36M-1SS0	1.79×10^{-4}	1.36×10^{-4}
LM-FP4H-48M-1SS0	1.15×10^{-4}	1.19×10^{-4}
LM-FP5H-60M-1SS0	1.95×10^{-4}	4.00×10^{-5}
LM-K2P1A-01M-2SS1	5.36×10^{-3}	6.56×10^{-3}
LM-K2P1C-03M-2SS1	1.17×10^{-3}	3.75×10^{-4}

Linear servo motor (primary side)	Coefficient A	Coefficient B
LM-K2P2A-02M-1SS1	2.49×10^{-2}	1.02×10^{-3}
LM-K2P2C-07M-1SS1	6.85×10^{-4}	2.80×10^{-4}
LM-K2P2E-12M-1SS1	5.53×10^{-4}	1.14×10^{-4}
LM-K2P3C-14M-1SS1	2.92×10^{-4}	1.16×10^{-4}
LM-K2P3E-24M-1SS1	2.53×10^{-4}	5.52×10^{-5}

Permissible load to motor mass ratio when the dynamic brake is used

Use the dynamic brake under the load to motor mass ratio indicated in the following table. If the load to motor mass ratio is higher than this value, the dynamic brake may burn. If there is a possibility that the ratio may exceed the value, contact your local sales office.

The values of the permissible load to motor mass ratio in the table are the values when the linear servo motor is used at the maximum speed.

Linear servo motor (primary side)	Permissible load to motor mass ratio [multiplier]
LM-H3 series	40
LM-U2 series	100
LM-F series	
LM-K2 series	50

When actual speed does not reach the maximum speed of the linear servo motor, calculate the permissible load to motor mass ratio of the dynamic brake by the following equation. (The upper limit is 300 times.)

Permissible load to motor mass ratio at the time of using the dynamic brake = Value in the table \times (Linear servo motor maximum speed²/Actual using speed²)

For example, when an actual using speed is 2 m/s or less for the LM-H3P2A-07P motor (maximum speed: 3.0 m/s), the equation will be as follows.

Permissible load to motor mass ratio of the dynamic brake = $40 \times (3^2/2^2) = 90$ [times]

15 USING A DIRECT DRIVE MOTOR

CAUTION

- When using the direct drive motor, read the "Direct Drive Motor Instruction Manual".

Point

For the software version of the servo amplifier that is compatible with the direct drive servo system, refer to the following.

 Page 36 Combinations of servo amplifiers and servo motors

15.1 Functions and configuration

Summary

The following shows the differences between the direct drive motor and the rotary servo motor.

Category	Item	Differences		Remark
		Direct drive motor	Rotary servo motor	
Motor pole adjustment	Magnetic pole detection	Required	Not required (default setting)	Automatically executed at the first servo-on after the power is turned on. In the absolute position detection system, the magnetic pole detection can be disabled with [Pr. PL01].  Page 523 Absolute position detection system
Absolute position detection system	Absolute position encoder battery	Required	Required	—
	Absolute position storage unit (MR-BTAS01)	Required	Not required	

Configuration including peripheral equipment

CAUTION

- Connecting a direct drive motor for different axis to the U, V, W, or CN2 may cause a malfunction.

Point

- Equipment other than the servo amplifier and direct drive motor are optional or recommended products.
- When using the direct drive motor, set [Pr. PA01] to " __ 6 _".

The configuration diagram is an example of MR-J4-20GF. When using the other servo amplifiers, the configuration will be the same as rotary servo motors except for connections of direct drive motors. Refer to the following depending on servo amplifiers you use.

Page 58 Configuration including peripheral equipment

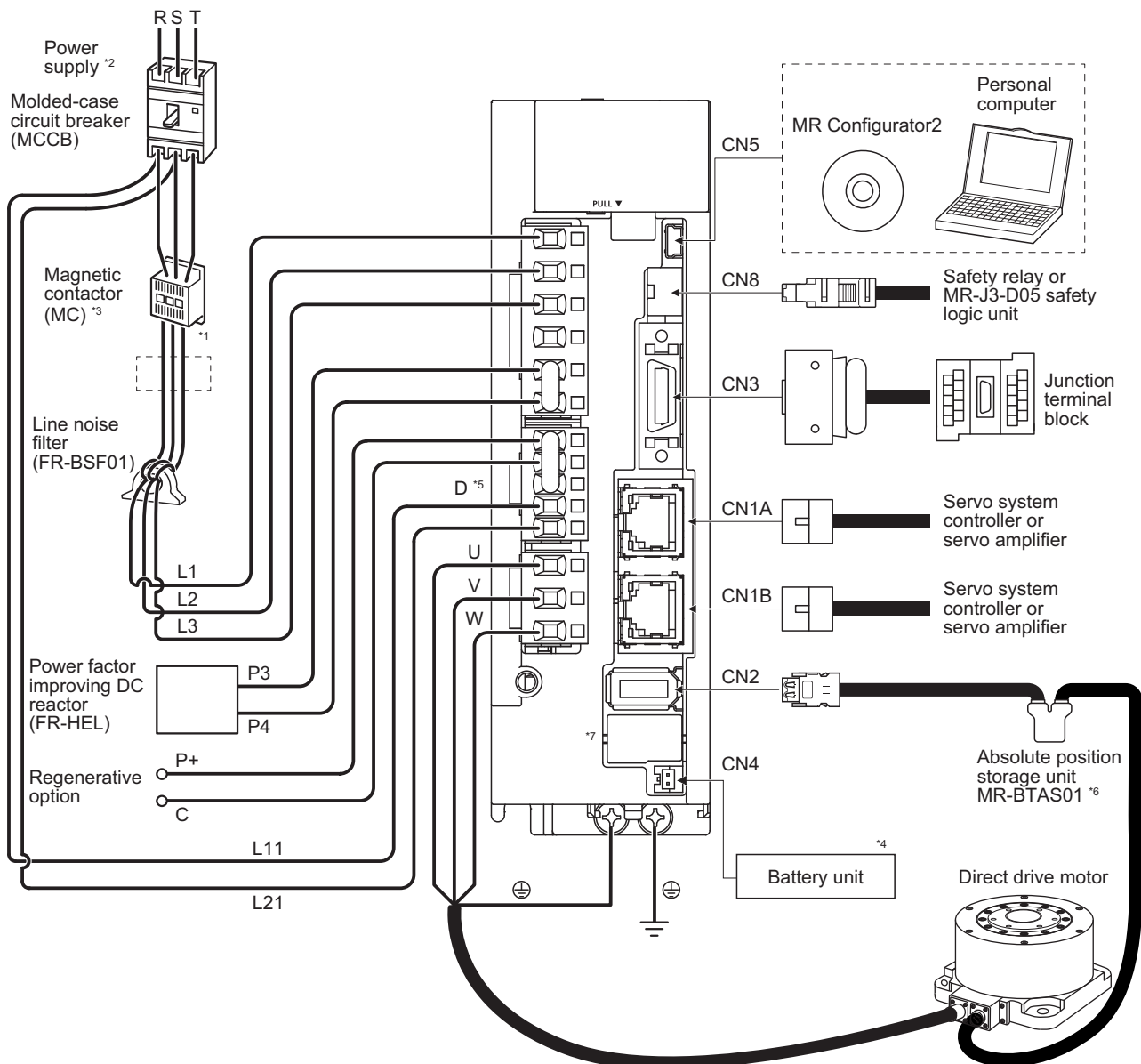

- *1 The power factor improving AC reactor can also be used. In this case, the power factor improving DC reactor cannot be used. When not using the power factor improving DC reactor, short P3 and P4.
- *2 A 1-phase 200 V AC to 240 V AC power supply may be used with the servo amplifier of MR-J4-200GF(-RJ) or less. For 1-phase 200 V AC to 240 V AC, connect the power supply to L1 and L3. Leave L2 open. Refer to the following for the power supply specifications.
☞ Page 30 Servo amplifier standard specifications
- *3 Depending on the main circuit voltage and operation pattern, bus voltage decreases, and that may cause the forced stop deceleration to shift to the dynamic brake deceleration. When dynamic brake deceleration is not required, slow the time to turn off the magnetic contactor.
- *4 The battery unit is used for the absolute position detection system.
☞ Page 462 ABSOLUTE POSITION DETECTION SYSTEM
- *5 Always connect between P+ and D terminals. When using the regenerative option, refer to the following.
☞ Page 338 Regenerative options
- *6 The absolute position storage unit is used for the absolute position detection system.
- *7 This is for MR-J4-_GF_. MR-J4-_GF-RJ has a CN2L connector. However, CN2L is not used for the direct drive servo system.

15.2 Signals and wiring

! WARNING

- Any person who is involved in wiring should be fully competent to do the work.
- Before wiring, turn off the power and wait for 15 minutes or more until the charge lamp turns off. Then, confirm that the voltage between P+ and N- is safe with a voltage tester and others. Otherwise, an electric shock may occur. In addition, when confirming whether the charge lamp is off or not, always confirm it from the front of the servo amplifier.
- Ground the servo amplifier and the direct drive motor securely.
- Do not attempt to wire the servo amplifier and the direct drive motor until they have been installed. Otherwise, it may cause an electric shock.
- The cables should not be damaged, stressed, loaded, or pinched. Otherwise, it may cause an electric shock.
- To avoid an electric shock, insulate the connections of the power supply terminals.

! CAUTION

- Wire the equipment correctly and securely. Otherwise, the direct drive motor may operate unexpectedly, resulting in injury.
- Connect cables to the correct terminals. Otherwise, a burst, damage, etc., may occur.
- Ensure that polarity (+/-) is correct. Otherwise, a burst, damage, etc., may occur.
- The surge absorbing diode installed to the DC relay for control output should be fitted in the specified direction. Otherwise, the converter unit and the drive unit will malfunction and will not output signals, disabling the emergency stop and other protective circuits.

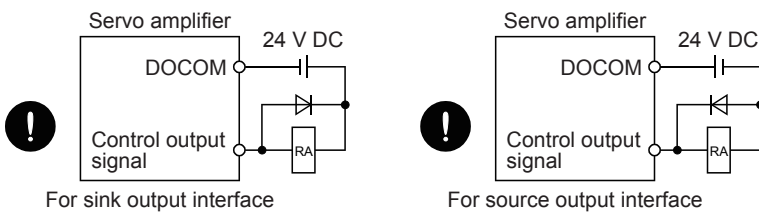

- Use a noise filter, etc., to minimize the influence of electromagnetic interference. Electromagnetic interference may affect the electronic equipment used near the servo amplifier.
- Do not install a power capacitor, surge killer, or radio noise filter (FR-BIF option) with the power wire of the direct drive motor.
- When using the regenerative resistor, switch power off with the alarm signal. Otherwise, a transistor fault or the like may overheat the regenerative resistor, causing a fire.
- Do not modify the equipment.
- Connect the servo amplifier power output (U/V/W) to the power input of the direct drive motor (U/V/W) directly. Do not connect a magnetic contactor and others between them. Otherwise, it may cause a malfunction.

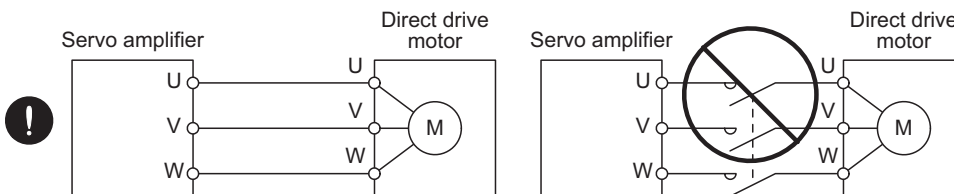

- Connecting a direct drive motor for different axis to the U, V, W, or CN2 may cause a malfunction.
- Before wiring, switch operation, etc., eliminate static electricity. Otherwise, it may cause a malfunction.

This chapter does not describe the following items. For details of the items, refer to each section of the detailed explanation field.

Item	Detailed explanation
Connection example of power circuit	☞ Page 83 Connection example of power circuit
Explanation of power supply system	☞ Page 98 Explanation of power supply system
Signal (device) explanations	☞ Page 104 Signal (device) explanations
Timing chart at alarm occurrence	☞ Page 114 Alarm occurrence timing chart
Interfaces	☞ Page 116 Interfaces
Grounding	☞ Page 127 Grounding
Switch setting and display of the servo amplifier	☞ Page 137 Switch setting and display of the servo amplifier
PARAMETERS	☞ Page 172 PARAMETERS
TROUBLESHOOTING	☞ Page 283 TROUBLESHOOTING

15.3 Operation and functions

Point

- When using the direct drive motor, set [Pr. PA01] to " __ 6 __".
- For the test operation, refer to the following. Page 141 Test operation
- The Z-phase pulse of the direct drive motor must be turned on after power-on. When the machine configuration does not allow one or more revolution of the direct drive motor, install the direct drive motor so that the Z-phase pulse can be turned on.

Startup procedure

Start up the direct drive servo system in the following procedure.

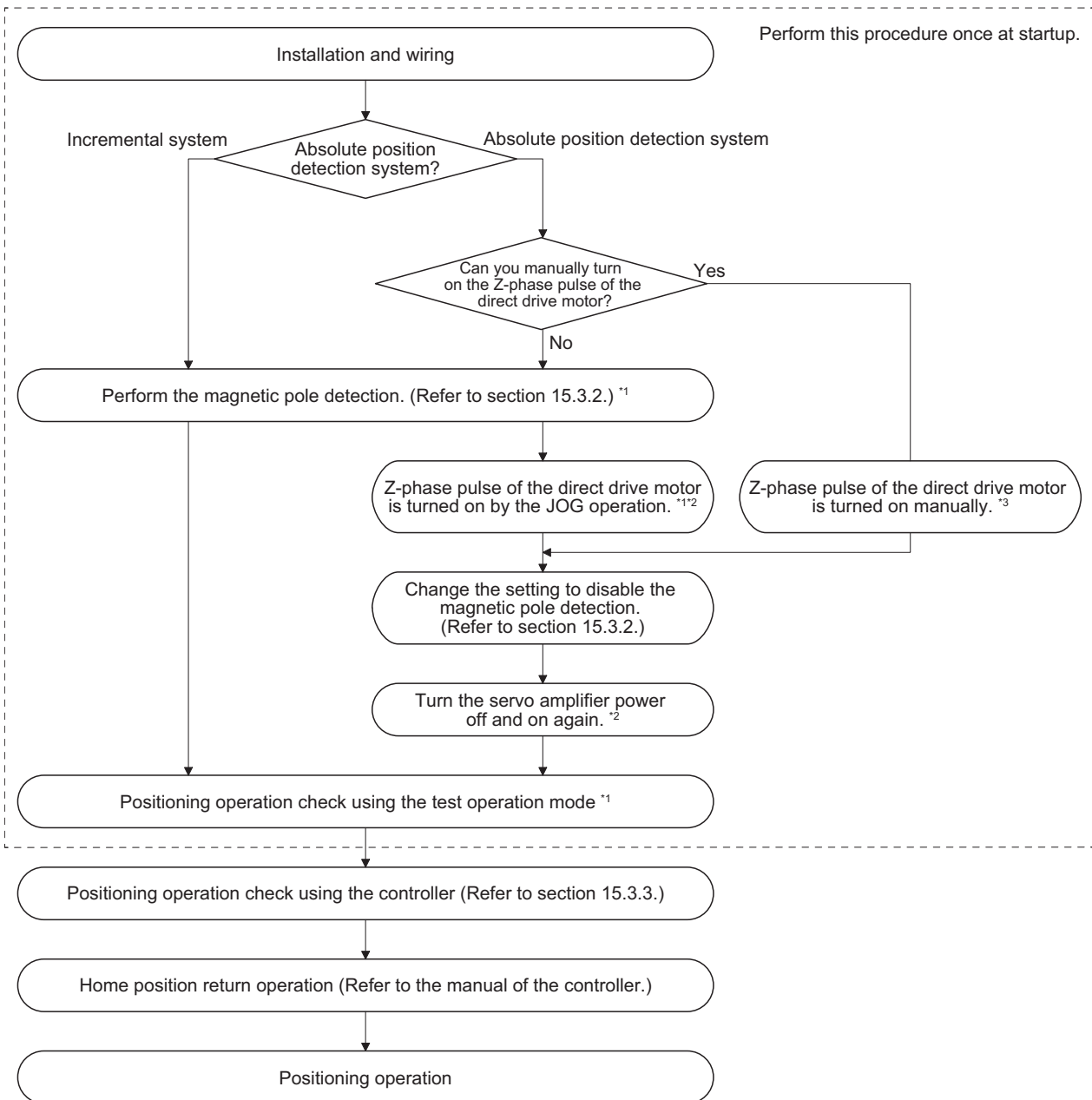

- *1 Use MR Configurator2.
- *2 In the absolute position detection system, be sure to turn on the Z-phase pulse of the direct drive motor while the servo amplifier power is on, and then cycle the power of the servo amplifier. Cycling the power confirms the absolute position. Without this operation, the absolute position will not be regained properly, and a warning occurs at the controller.
- *3 If the Z-phase pulse of the direct drive motor can be turned on manually, the Z-phase pulse does not have to be turned on by the magnetic pole detection or the JOG operation. For this operation, make sure to connect the direct drive motor encoder and the servo amplifier, and turn on the control circuit power supply (L11/L21) of the servo amplifier (turn off the main circuit power supply (L1/L2/L3)). Ensure the safety at this time.

Magnetic pole detection

Point

- The magnetic pole detection is not required for the configured absolute position detection system where the Z-phase pulse of the direct drive motor can be turned on manually. For this operation, always connect the direct drive motor encoder and the servo amplifier and turn on the control circuit power supply of the servo amplifier. Perform this operation by considering the safety.
- When performing a magnetic pole detection without LSP (Forward rotation stroke end) and LSN (Reverse rotation stroke end), set [Pr. PL08 Linear servo motor/DD motor function selection 3] to "_ 1 _ _" to disable LSP and LSN.
- Set [Pr. PE47 Torque offset] to "0 (initial value)" before executing the magnetic pole detection.
- For the magnetic pole detection of vertical axis with direct drive motors, refer to section 2.1 of "Direct Drive Motor Instruction Manual".

Before the positioning operation of the direct drive motor, make sure to perform the magnetic pole detection.

Before starting up the equipment, perform the test operation (positioning operation) of MR Configurator2.

Magnetic pole detection method with MR Configurator2

The following shows the magnetic pole detection procedure with MR Configurator2.

■Magnetic pole detection by the position detection method

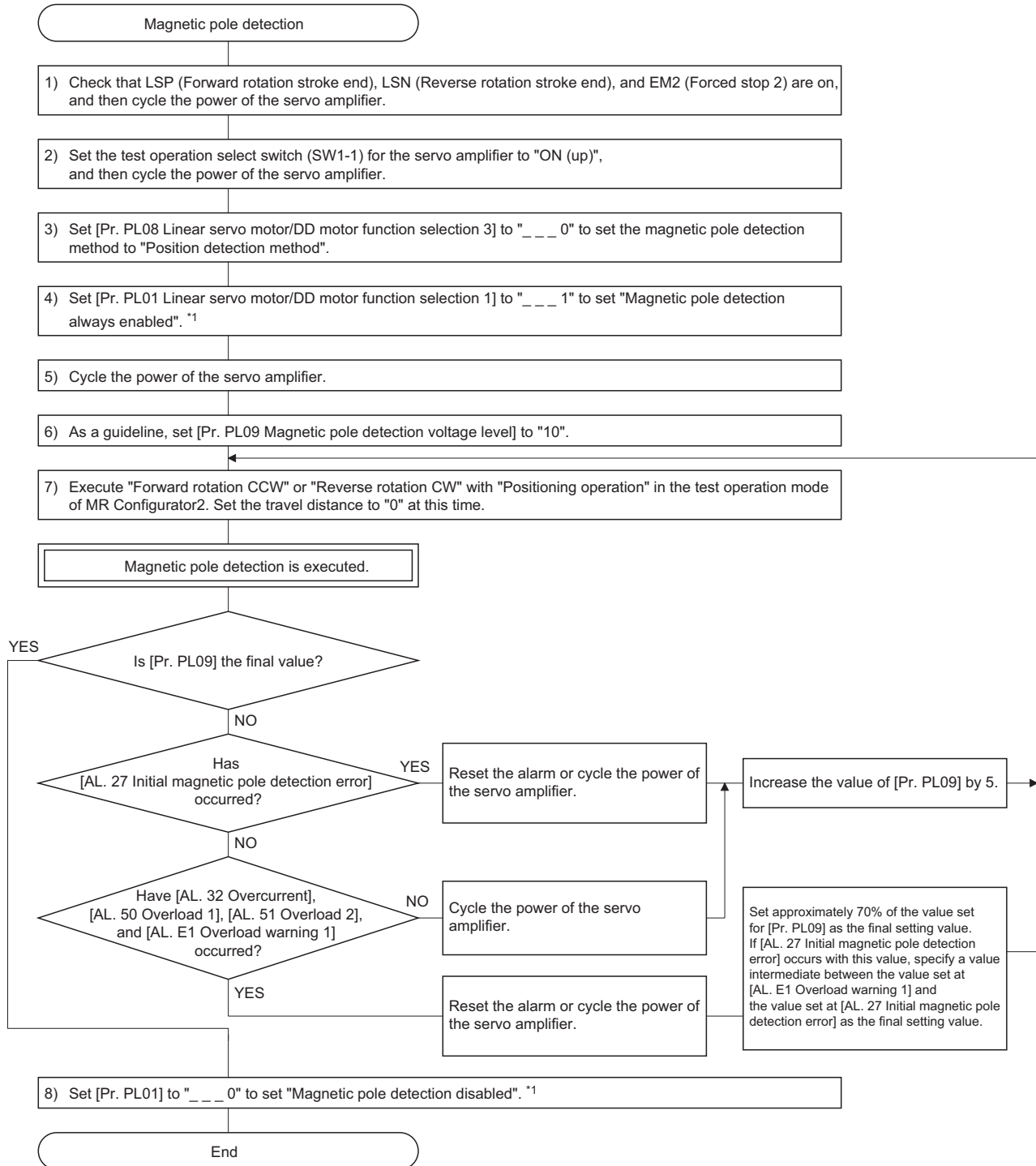

*1 For the incremental system, the [Pr. PL01] setting is not required.

■Magnetic pole detection by the minute position detection method

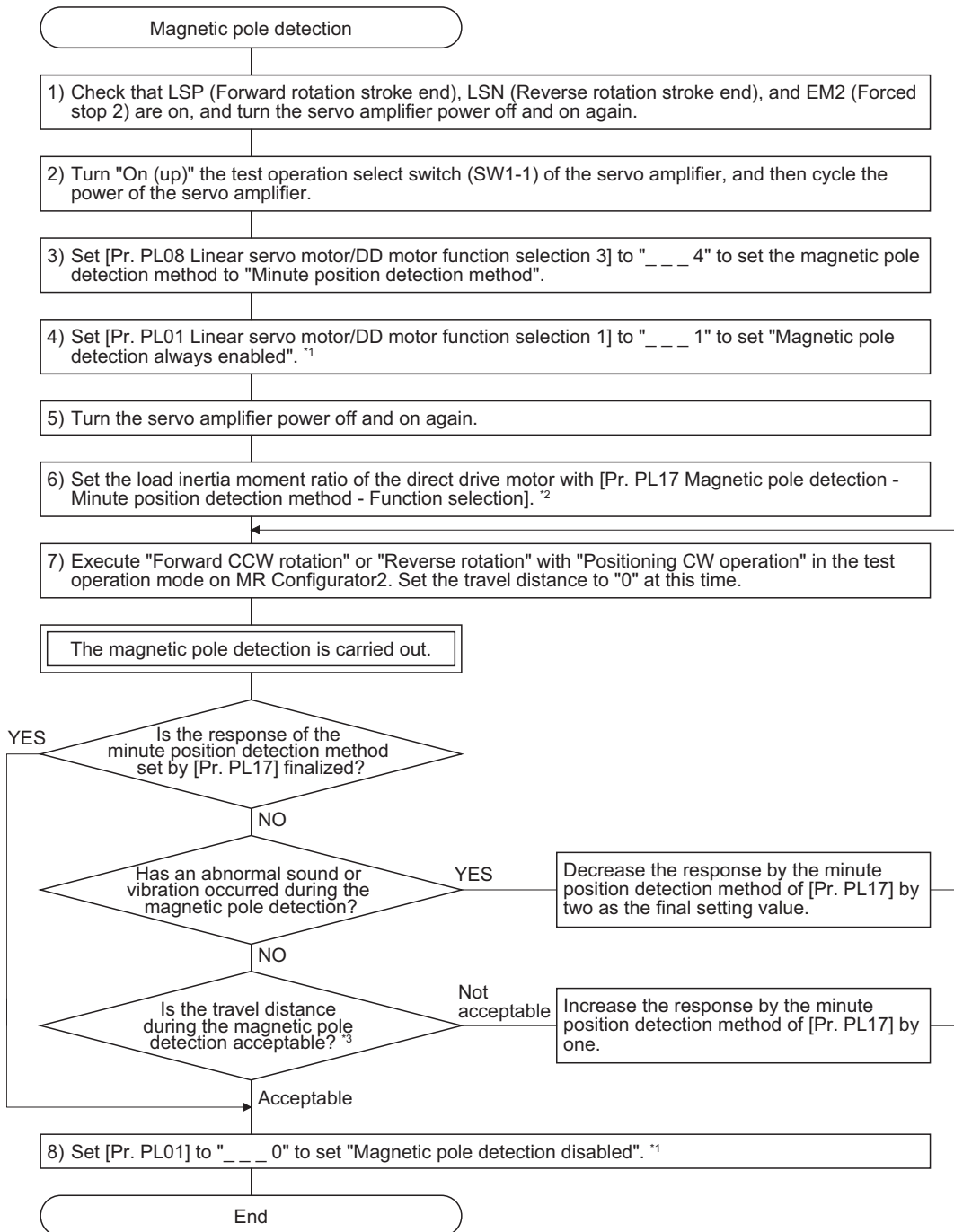

*1 For the incremental system, the [Pr. PL01] setting is not required.

*2 If the load to direct drive motor inertia ratio is unknown, perform the magnetic pole detection by the position detection method, and then perform the auto tuning to set an estimated value.

*3 For the magnetic pole detection by the minute position detection method, the maximum rotation angle at the magnetic pole detection must be five degrees or less. To shorten the travel distance, increase the response by the minute position detection method in [Pr. PL17].

■ State transition of the servo amplifier display (3-digit, 7-segment LED) at the magnetic pole detection

When the magnetic pole detection with MR Configurator2 is normally executed, the servo amplifier display (3-digit, 7-segment LED) shows the state as follows.

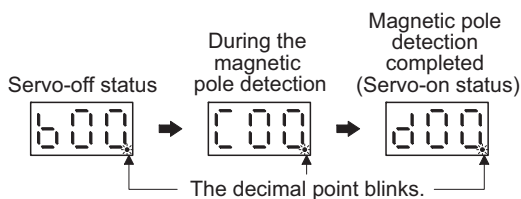

Preparation for the magnetic pole detection

Point

When the test operation mode is selected with the test operation select switch (SW1-1), the network communication for the servo amplifier and later shut off.

For the magnetic pole detection, use the test operation mode (positioning operation) of MR Configurator2. Turn off the servo amplifier power, and set the test operation select switch (SW1-1) as follows. Turning on the power enables the test operation mode.

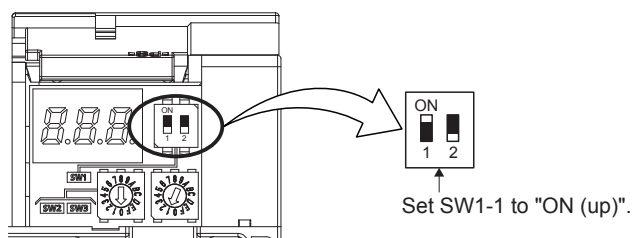

15

Operation at the magnetic pole detection

! WARNING

- Note that the magnetic pole detection automatically starts simultaneously with the turning-on of the servo-on command.

! CAUTION

- If the magnetic pole detection is not executed properly, the direct drive motor may operate unexpectedly.

Point

- Establish the machine configuration to use LSP (Forward rotation stroke end) and LSN (Reverse rotation stroke end). The machine may be damaged due to a collision without LSP and LSN.
- Assign LSP and LSN and perform the magnetic pole detection also in the torque mode.
- At the magnetic pole detection, whether the motor rotates in the forward or reverse direction is unpredictable.
- Depending on the setting value of [Pr. PL09 Magnetic pole detection voltage level], an overload, overcurrent, magnetic pole detection alarm, or others may occur.
- When performing the positioning operation from a controller, use the sequence which confirms the normal completion of the magnetic pole detection and the servo-on status, then outputs the positioning command. If the controller outputs the positioning command before RD (Ready) turns on, the command may not be accepted or an alarm may occur.
- After the magnetic pole detection, check the positioning accuracy with the test operation (positioning operation function) of MR Configurator2.
- The accuracy of the magnetic pole detection improves with no load.

Incremental system

Point

For the incremental system, the magnetic pole detection is required every time the power is turned on.

By turning on the servo-on command from the controller after the power-on, the magnetic pole detection is automatically carried out. Therefore, there is no need to set the parameter (first digit of [Pr. PL01]) for executing the magnetic pole detection.

• Timing chart

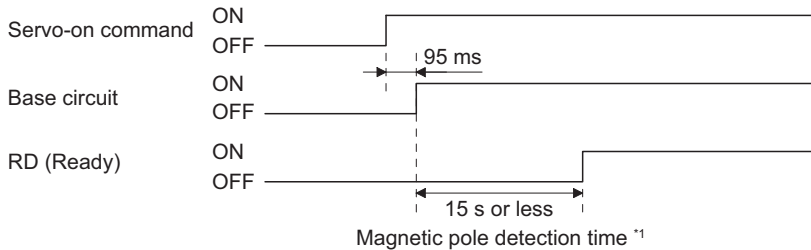

*1 The magnetic pole detection time indicates the operation time when LSP (Forward rotation stroke end) and LSN (Reverse rotation stroke end) are on.

• Direct drive motor movement (when LSP and LSN are on)

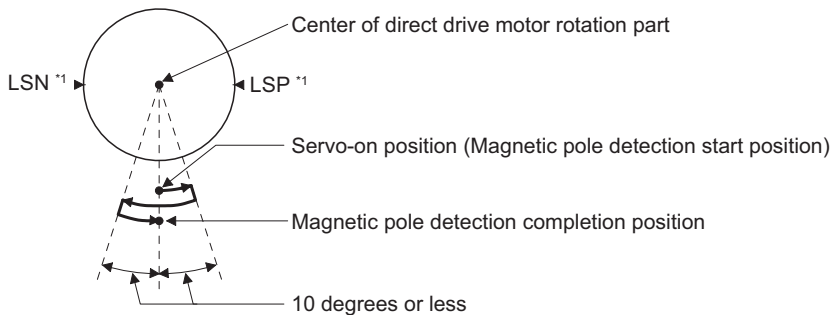

*1 When you turn off LSP or LSN during the magnetic pole detection, the magnetic pole detection is carried on to the opposite direction. When LSP and LSN are off, [AL. 27 Initial magnetic pole detection error] occurs.

• Direct drive motor movement (when LSP or LSN is off)

When LSP or LSN is off at servo-on, the magnetic pole detection is carried out as follows.

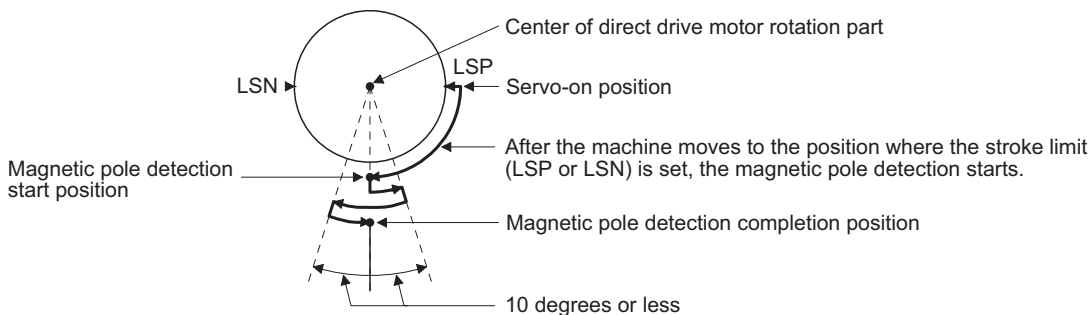

■ Absolute position detection system

Point

The magnetic pole detection will be required with the following timings.

- When the system is set up (at the first startup of equipment)
- When the Z-phase pulse of the direct drive motor is not turned on at the system setup (When the Z-phase pulse of the direct drive motor can be turned on manually, the magnetic pole detection is not required.)
- After a direct drive motor is replaced
- When [AL. 25 Absolute position erased] has occurred

Turn on the Z-phase pulse of the direct drive motor in JOG operation from the controller after the magnetic pole detection.

Perform the magnetic pole detection in the following procedure.

1. Set [Pr. PL01 Linear servo motor/DD motor function selection 1] to "___ 1" (Magnetic pole detection at first servo-on).

[Pr. PL01]

			1
--	--	--	---

Magnetic pole detection at first servo-on (initial value)

2. Execute the magnetic pole detection.  Page 522 Incremental system
3. After completing the magnetic pole detection properly, change [Pr. PL01] to "___ 0" (Magnetic pole detection disabled).

[Pr. PL01]

			0
--	--	--	---

Magnetic pole detection disabled

After the magnetic pole detection, by turning on the Z-phase pulse of the direct drive motor in the JOG operation and disabling the magnetic pole detection function with [Pr. PL01], the magnetic pole detection after each power-on is not required.

Magnetic pole detection method setting

Set the magnetic pole detection method by using the first digit of [Pr. PL08] (Magnetic pole detection method selection).

[Pr. PL08]

--	--	--	--

Magnetic pole detection method selection
0: Position detection method
4: Minute position detection method

Setting of the magnetic pole detection voltage level by the position detection method

For the magnetic pole detection by the position detection method, set the voltage level with [Pr. PL09 Magnetic pole detection voltage level]. For the magnetic pole detection by the minute position detection method, the voltage level setting is not required.

■Guideline of parameter settings

Set the parameters by referring to the following table.

Servo status	[Pr. PL09] setting (guide value)	
	Small ← Medium → Large (10 or less (initial value) 50 or more)	
Torques required for operation	Small	Large
Overload, overcurrent alarm	Seldom occurs	Frequently occurs
Magnetic pole detection alarm	Frequently occurs	Seldom occurs
Magnetic pole detection accuracy	Low	High

■Setting procedure

1. Perform the magnetic pole detection, and increase the setting value of [Pr. PL09 Magnetic pole detection voltage level] until [AL. 50 Overload 1], [AL. 51 Overload 2], [AL. E1 Overload warning 1], and [AL. EC Overload warning 2] occur. Increase the setting value by five as a guide value. When these alarms and warnings occur during the magnetic pole detection with MR Configurator2, the test operation of MR Configurator2 automatically completes and the servo-off status is established.
2. Specify the setting value that is an approximately 70% of the value set when [AL. 50 Overload 1], [AL. 51 Overload 2], [AL. E1 Overload warning 1], and [AL. EC Overload warning 2] occurred as the final setting value. However, if [AL. 27 Initial magnetic pole detection error] occurs with this value, specify a value intermediate between the value set at [AL. 50 Overload 1], [AL. 51 Overload 2], [AL. E1 Overload warning 1], or [AL. EC Overload warning 2] and the value set at the magnetic pole detection alarm as the final setting value.
3. Perform the magnetic pole detection again with the final setting value.

■Setting example

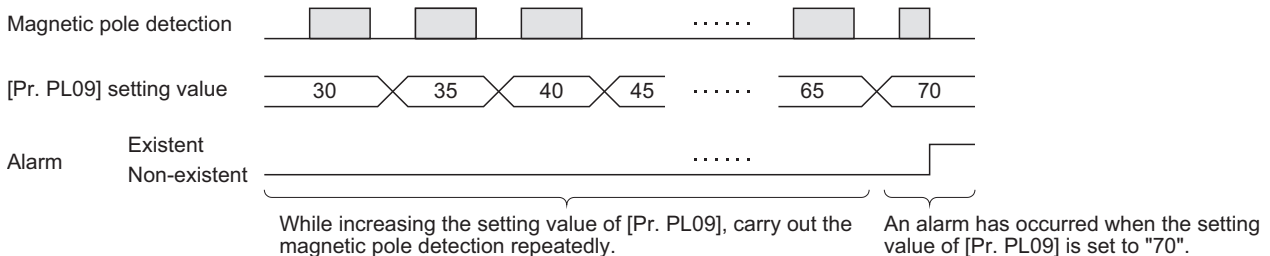

In this example, the final setting value of [Pr. PL09] is 49 (Setting value at the alarm occurrence = 70×0.7).

Home position return

Precautions when using a proximity dog

■Length of proximity dog

Set the length of the proximity dog to satisfy the following, so that the direct drive motor speed changes from the home position return speed to the creep speed during detection of the proximity dog.

$$L_1 \geq \frac{V}{60} \cdot \frac{td}{2}$$

L_1 : Length of the proximity dog [mm]

V : Home position return speed [mm/min]

td : Time to change from the home position return speed to the creep speed [s]

■Adjustment of proximity dog position

To eliminate variations in the home position return completion position, adjust the proximity dog detection position to be near the center between the positions specified by a Z-phase signal and the next Z-phase signal.

The generated position of the Z-phase signals can be checked with "Position within one-revolution" of "Status display" on MR Configurator2.

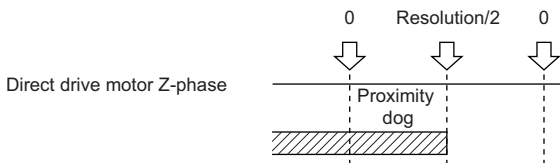

■Timing of when Z-phase is passed

The Z-phase must be passed during the period from a home position return start until the proximity dog detection. When the Z-phase is not passed, [AL. 90.5 Z-phase unpassed] may occur.

Operation from controller

To configure the absolute position detection system by using the direct drive motor, the battery and the absolute position storage unit MR-BTAS01 are required.

For the incremental system, the magnetic pole detection is automatically performed at the first servo-on after the power-on.

For this reason, when performing the positioning operation, create the sequence which surely confirms the servo-on status as the inter lock condition of the positioning command.

Function

Servo control error detection function

Point

For the servo control error detection function, the position and speed deviation error detections are enabled by default. ([Pr. PL04]: ___ 3)

If the servo control gets unstable for some reasons, the direct drive motor may not operate properly. To detect this state and to stop operation, the servo control error detection function is used as a protective function.

The servo control error detection function has three different detection methods: the position deviation, speed deviation, and torque deviation. An error is detected when each method is enabled with [Pr. PL04 Linear servo motor/DD motor function selection 2]. The detection level can be changed with [Pr. PL05], [Pr. PL06], and [Pr. PL07].

■ Outline of servo control error detection function

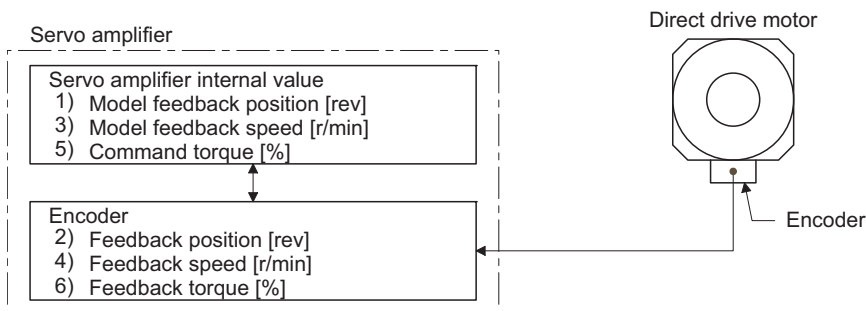

■ Position deviation error detection

Set [Pr. PL04] to "___ 1" to enable the position deviation error detection.

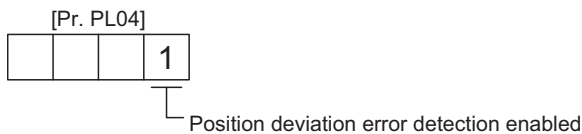

When you compare the model feedback position (1)) and the feedback position (2)) in "Outline of servo control error detection function", if the deviation is more than the value of [Pr. PL05 Position deviation error detection level] (1 (0.01 rev) to 1000 (10 rev)), [AL. 42.1 Servo control error by position deviation] will occur and the direct drive motor will stop. The initial value of this detection level is 0.09 rev. Replace the set value as required.

For "Outline of servo control error detection function", refer to the following.

☞ Page 526 Outline of servo control error detection function

■ Speed deviation error detection

Set [Pr. PL04] to "___ 2" to enable the speed deviation error detection.

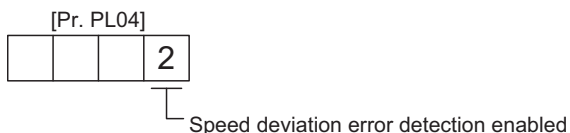

When you compare the model feedback speed (3)) and the feedback speed (4)) in "Outline of servo control error detection function", if the deviation is more than the value of [Pr. PL06 Speed deviation error detection level] (1 r/min to 2000 r/min), [AL. 42.2 Servo control error by speed deviation] will occur and the direct drive motor will stop. The initial value of this detection level is 100 r/min. Replace the set value as required.

For "Outline of servo control error detection function", refer to the following.

☞ Page 526 Outline of servo control error detection function

■Torque deviation error detection

Set [Pr. PL04] to "_ _ _ 4" to enable the torque deviation error detection.

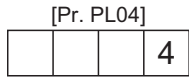

Torque deviation error detection enabled

When you compare the command torque (5) and the feedback torque (6) in "Outline of servo control error detection function", if the deviation is more than the value of [Pr. PL07 Torque/thrust deviation error detection level] (1% to 1000%), [AL. 42.3 Servo control error by torque/thrust deviation] will occur and the direct drive motor will stop. The initial value of this detection level is 100%. Replace the set value as required.

For "Outline of servo control error detection function", refer to the following.

☞ Page 526 Outline of servo control error detection function

■Detecting multiple deviation errors

When setting [Pr. PL04] as follows, multiple deviation errors can be detected. For the error detection methods, refer to the following.

☞ Page 526 Position deviation error detection

☞ Page 526 Speed deviation error detection

☞ Page 527 Torque deviation error detection

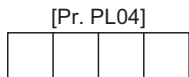

Setting value	Position deviation error detection	Speed deviation error detection	Torque deviation error detection
1	○	—	—
2	—	○	—
3	○	○	—
4	—	—	○
5	○	—	○
6	—	○	○
7	○	○	○

15.4 Characteristics

Overload protection characteristics

An electronic thermal relay is built in the servo amplifier to protect the servo amplifier, the direct drive motor, and direct drive motor power wires from overloads.

[AL. 50 Overload 1] occurs if overload operation performed is above the electronic thermal protection curve shown in the following figures. [AL. 51 Overload 2] occurs if the maximum current is applied continuously for several seconds due to machine collision, etc. Use the equipment on the left-hand side area of the continuous or broken line in the graph.

When unbalanced torque is generated, such as in a vertical lift machine, the unbalanced torque of the machine should be kept at 70% or lower of the motor's rated torque.

This servo amplifier has solid-state direct drive motor overload protection for each axis. (The direct drive motor overload current (full load current) is set on the basis of 120% rated current of the servo amplifier.)

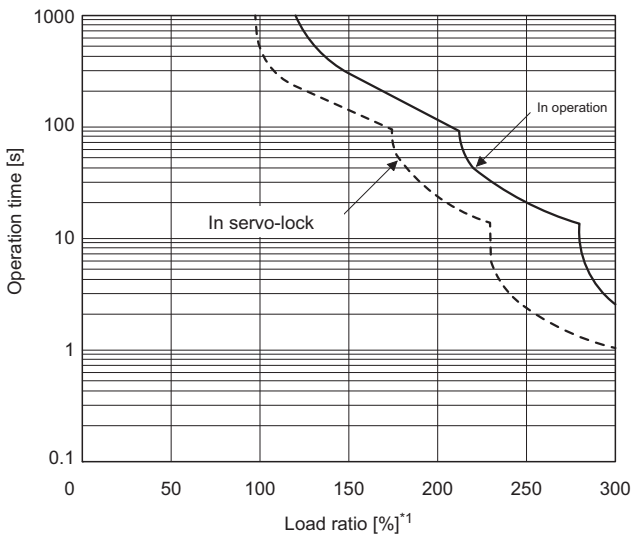

TM-RFM002C20/TM-RFM004C20/
TM-RFM006C20/TM-RFM006E20/
TM-RFM012E20/TM-RFM018E20/
TM-RFM012G20/TM-RFM040J10

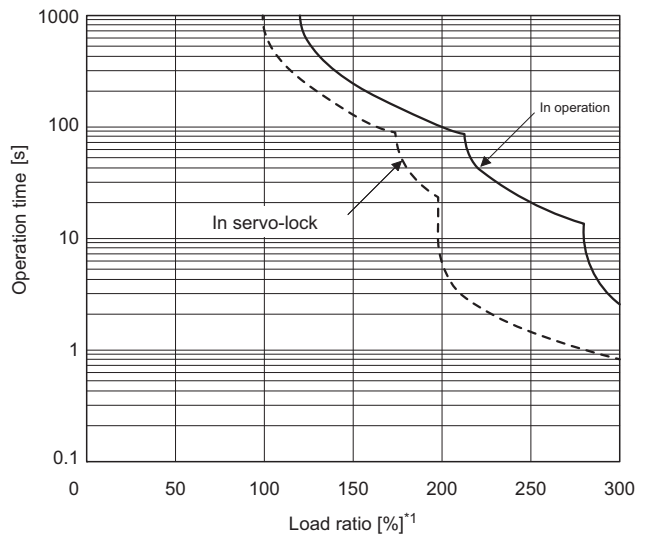

TM-RFM048G20/TM-RFM072G20/
TM-RFM120J10

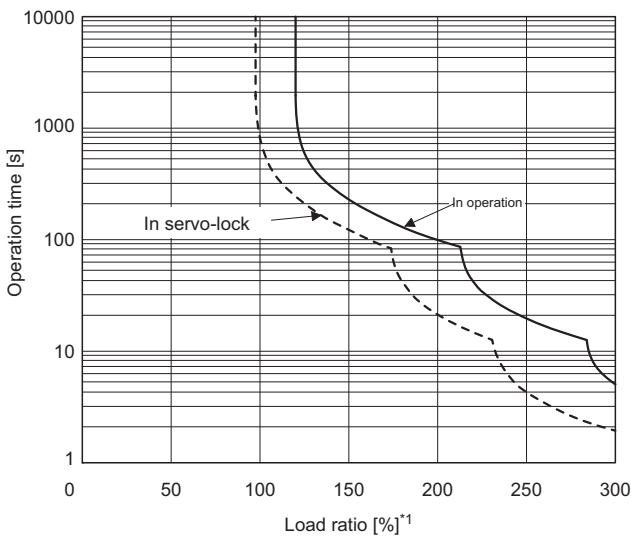

TM-RFM240J10

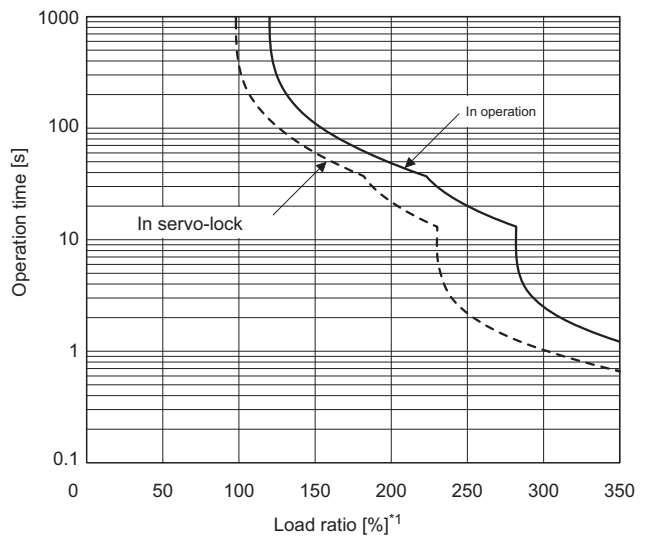

TM-RG2M002C30/TM-RU2M002C30/
TM-RG2M004E30/TM-RU2M004E30/
TM-RG2M009G30/TM-RU2M009G30

*1 If operation that generates torque more than 100% of the rating is performed with an abnormally high frequency in a direct drive motor stop status (servo-lock status) or in a 50 r/min or less low-speed operation status, the servo amplifier may malfunction regardless of the electronic thermal relay protection.

Power supply capacity and generated loss

The following table indicates servo amplifiers' power supply capacities and losses generated under rated load. For thermal design of an enclosed type cabinet, use the values in the table in consideration for the worst operating conditions. The actual amount of generated heat will be intermediate between values at rated torque and servo-off according to the duty used during operation. When the direct drive motor is run at less than the rated speed, the power supply capacity will be smaller than the value in the table, but the servo amplifier's generated heat will not change.

Direct drive motor	Servo amplifier	Power supply capacity [kVA]	Servo amplifier-generated heat [W]		Area required for heat dissipation [m ²]
			At rated output	With servo-off	
TM-RG2M002C30	MR-J4-20GF(-RJ)	0.25	25	15	0.5
TM-RU2M002C30	MR-J4-20GF1(-RJ)				
TM-RG2M004E30	MR-J4-20GF(-RJ)	0.5	25	15	0.5
TM-RU2M004E30	MR-J4-20GF1(-RJ)				
TM-RG2M004E30*1	MR-J4-40GF(-RJ)	0.7	35	15	0.7
TM-RU2M004E30*1	MR-J4-40GF1(-RJ)				
TM-RG2M009G30	MR-J4-40GF(-RJ)	0.9	35	15	0.7
TM-RU2M009G30	MR-J4-40GF1(-RJ)				
TM-RFM002C20	MR-J4-20GF(-RJ) MR-J4-20GF1(-RJ)	0.25	25	15	0.5
TM-RFM004C20	MR-J4-40GF(-RJ) MR-J4-40GF1(-RJ)				
TM-RFM006C20	MR-J4-60GF(-RJ)	0.53	40	15	0.8
TM-RFM006E20		0.46	40	15	0.8
TM-RFM012E20	MR-J4-70GF(-RJ)	0.81	50	15	1.0
TM-RFM018E20	MR-J4-100GF(-RJ)	1.3	50	15	1.0
TM-RFM012G20	MR-J4-70GF(-RJ)	0.71	50	15	1.0
TM-RFM048G20	MR-J4-350GF(-RJ)	2.7	90	20	1.8
TM-RFM072G20	MR-J4-350GF(-RJ)	3.8	110	20	2.2
TM-RFM040J10	MR-J4-70GF(-RJ)	1.2	50	15	1.0
TM-RFM120J10	MR-J4-350GF(-RJ)	3.4	90	20	1.8
TM-RFM240J10	MR-J4-500GF(-RJ)	6.6	160	25	3.2

*1 The combination increases the rated torque and the maximum torque.

Dynamic brake characteristics

CAUTION

- The coasting distance is a theoretically calculated value which ignores the running load such as friction. The calculated value will be longer than the actual distance. If the braking distance is not longer than the calculated value, a moving part may crash into the stroke end, which is very dangerous. Install the anti-crash mechanism such as an air brake or an electric/mechanical stopper such as a shock absorber to reduce the shock of moving parts.

Point

- Do not use dynamic brake to stop in a normal operation as it is the function to stop in emergency.
- For a machine operating at the recommended load to motor inertia ratio or less, the estimated number of usage times of the dynamic brake is 1000 times while the machine decelerates from the rated speed to a stop once in 10 minutes.
- Be sure to enable EM1 (Forced stop 1) after the direct drive motor stops when using EM1 (Forced stop 1) frequently in other than emergency.

Dynamic brake operation

■ Calculation of coasting distance

The following shows the pattern in which the servo motor comes to a stop when the dynamic brake is operated. Use equation 15.1 to calculate an approximate coasting distance to a stop. The dynamic brake time constant τ varies with the direct drive motor and machine operation speeds.

☞ Page 531 Dynamic brake time constant

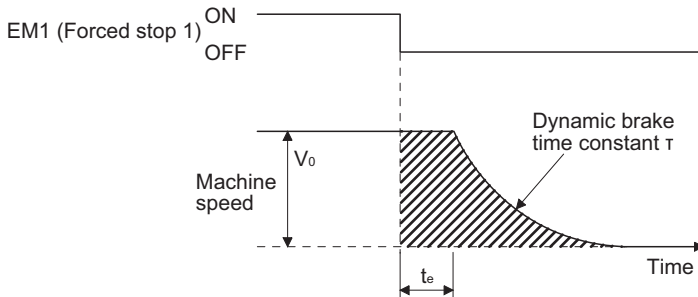

$$L_{\max} = \frac{V_0}{60} \cdot \left\{ t_e + \tau \left(1 + \frac{J_L}{J_M} \right) \right\} \dots\dots\dots(15.1)$$

L_{\max} : Maximum coasting distance [mm]

V_0 : Machine's fast feed speed [mm/min]

J_M : Moment of inertia of direct drive motor [$\text{kg}\cdot\text{cm}^2$]

J_L : Load moment of inertia converted into equivalent value on direct drive motor rotor [$\text{kg}\cdot\text{cm}^2$]

τ : Dynamic brake time constant [s]

t_e : Delay time of control section (There is internal relay delay time of about 10 ms.) [s]

Dynamic brake time constant

The following shows necessary dynamic brake time constant τ for equation 15.1.

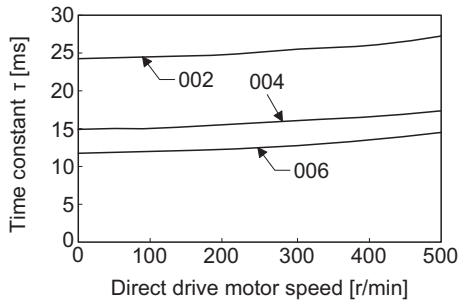

TM-RFM_C20

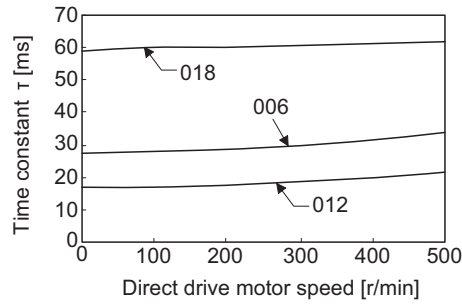

TM-RFM_E20

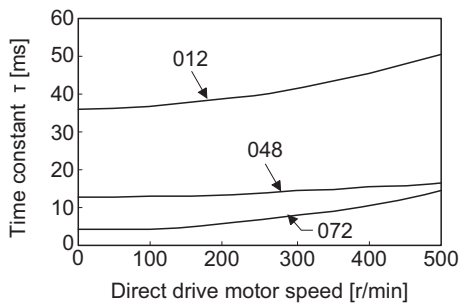

TM-RFM_G20

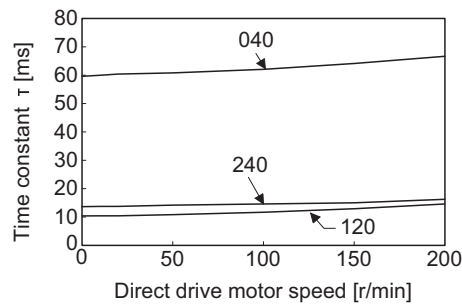

TM-RFM_J10

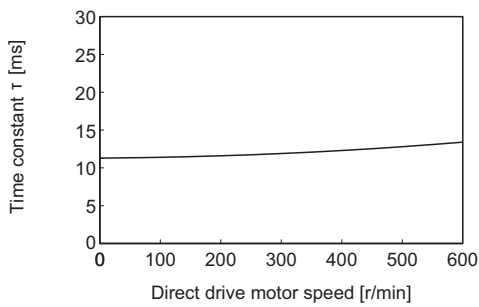

TM-RG2M002C30
TM-RU2M002C30

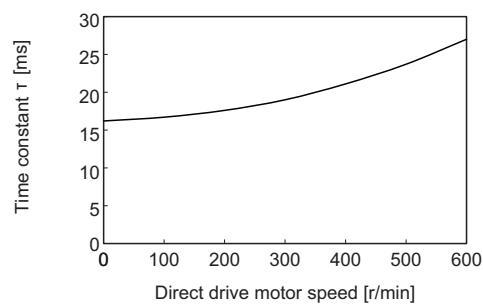

TM-RG2M004E30
TM-RU2M004E30

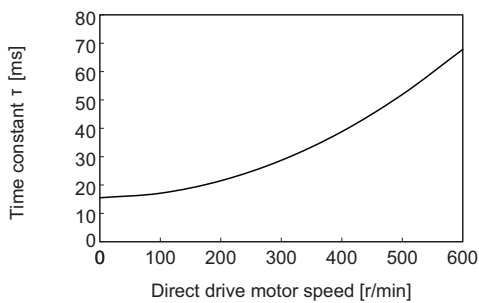

TM-RG2M009G30
TM-RU2M009G30

Permissible load to motor inertia ratio when the dynamic brake is used

Use the dynamic brake under the load to motor inertia ratio indicated in the following table. If the ratio is higher than this value, the dynamic brake may burn. If there is a possibility that the ratio may exceed the value, contact your local sales office.

The values of the permissible load to motor inertia ratio in the table are the values at the maximum rotation speed of the direct drive motor.

The value in the parenthesis shows the value at the rated speed of the direct drive motor.

Direct drive motor	Permissible load to motor inertia ratio [multiplier]
TM-RFM_C20	100 (300)
TM-RFM_E20	
TM-RG2M002C30	
TM-RU2M002C30	
TM-RFM_G20	50 (300)
TM-RFM_J10	50 (200)
TM-RG2M_E30	20 (80)
TM-RG2M_G30	
TM-RU2M_E30	
TM-RU2M_G30	

16 FULLY CLOSED LOOP SYSTEM

Point

The fully closed loop system is available for servo amplifiers with software version A1 or later.

When fully closed loop control system is used with this servo amplifier, "Linear Encoder Instruction Manual" is needed.

Fully closed loop control system is available with position mode.

When fully closed loop system is configured with MR-J4-_GF_ servo amplifier, the following restrictions will be applied. However, these restrictions will not be applied to MR-J4-_GF_-RJ servo amplifiers.

- A/B/Z-phase differential output type encoder cannot be used.
- The load-side encoder and servo motor encoder are compatible with only the two-wire type. The four-wire type load-side encoder and servo motor encoder cannot be used.
- When you use the HG-KR and HG-MR series for driving and load-side encoder, the optional four-wire type encoder cables (MR-EKCBL30M-L, MR-EKCBL30M-H, MR-EKCBL40M-H, and MR-EKCBL50M-H) cannot be used. When an encoder cable of 30 m to 50 m is needed, fabricate a two-wire type encoder cable according to the following section. [Page 630 Two-wire type encoder cable for HG-MR/HG-KR](#)

16.1 Functions and configuration

Function block diagram

A fully closed loop control block diagram is shown below. The fully closed loop system is controlled in the load-side encoder unit.

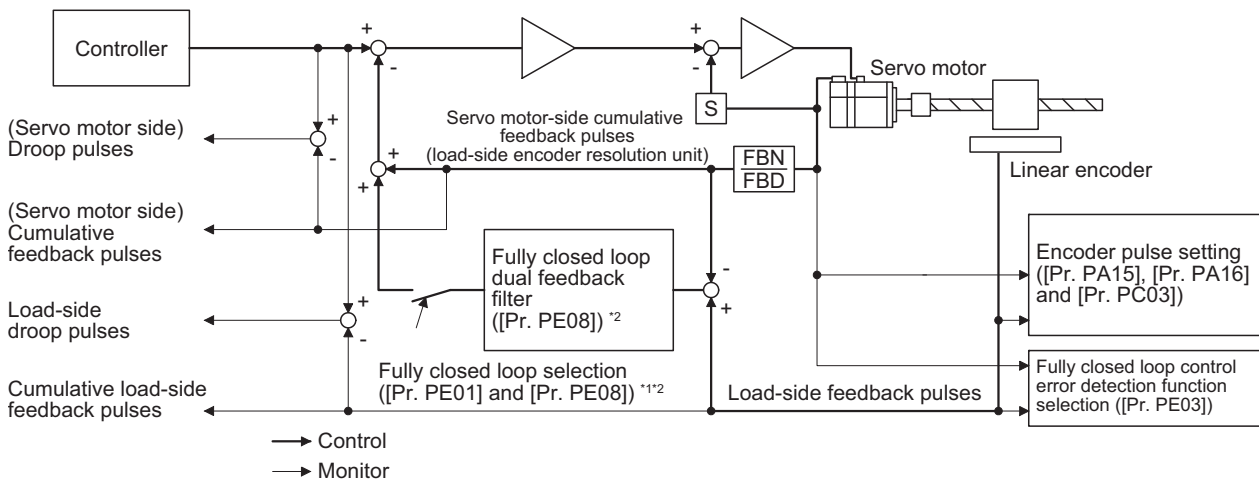

- *1 Switching between semi closed loop control and fully closed loop control can be performed by changing the setting of [Pr. PE01]. When semi closed loop control is selected, a control is always performed on the bases of the position data of the servo motor encoder independently of whether the servo motor is at a stop or running.
- *2 When the fully closed loop system is enabled in [Pr. PE01], dual feedback control in which the servo motor feedback signal and load-side encoder feedback signal are combined by the dual feedback filter in [Pr. PE08] is performed. In this case, fully closed loop control is performed when the servo motor is at a stop, and semi closed loop control is performed when the servo motor is operating to improve control performance. When "4500" is set as the filter value of [Pr. PE08 Fully closed loop dual feedback filter], fully closed loop control is always performed.

The following table shows the functions of each control mode.

Control	Description	
Semi closed loop control	Feature	Position is controlled according to the servo motor-side data.
	Advantage	Since this control is insusceptible to machine influence (such as machine resonance), the gains of the servo amplifier can be raised and the settling time shortened.
	Disadvantage	If the servo motor side is at a stop, the side may be vibrating or the load-side accuracy not obtained.
Dual feedback control	Feature	Position is controlled according to the servo motor-side data and load-side data.
	Advantage	Control is performed according to the servo motor-side data during operation, and according to the load side data at a stop in sequence to raise the gains during operation and shorten the settling time. A stop is made with the load-side accuracy.
Fully closed loop control	Feature	Position is controlled according to the load-side data.
	Advantage	The load-side accuracy is obtained not only at a stop but also during operation.
	Disadvantage	Since this control is susceptible to machine resonance or other influences, the gains of the servo amplifier may not rise.

Selecting procedure of control mode

Control mode configuration

In this servo, a semi closed loop system or fully closed loop system can be selected as a control system.

In addition, on the fully closed loop system, the semi closed loop control, fully closed loop control and dual feedback control can be selected by the [Pr. PE08] settings.

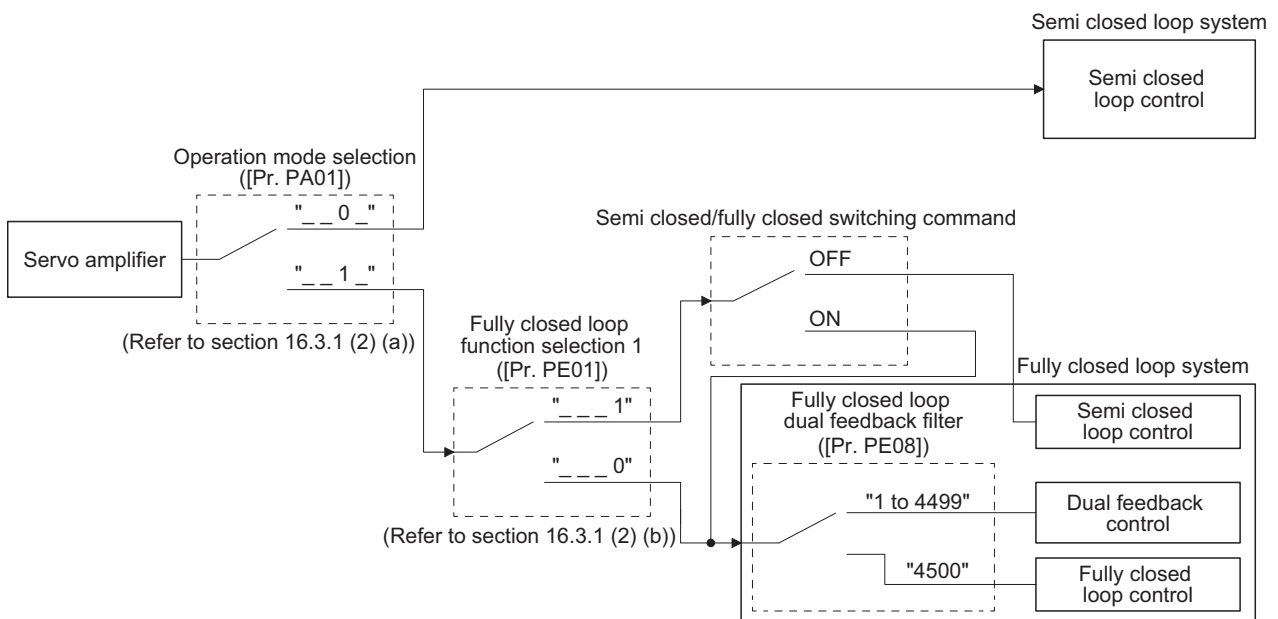

Dual feedback filter equivalent block diagram

A dual feedback filter equivalent block diagram on the dual feedback control is shown below.

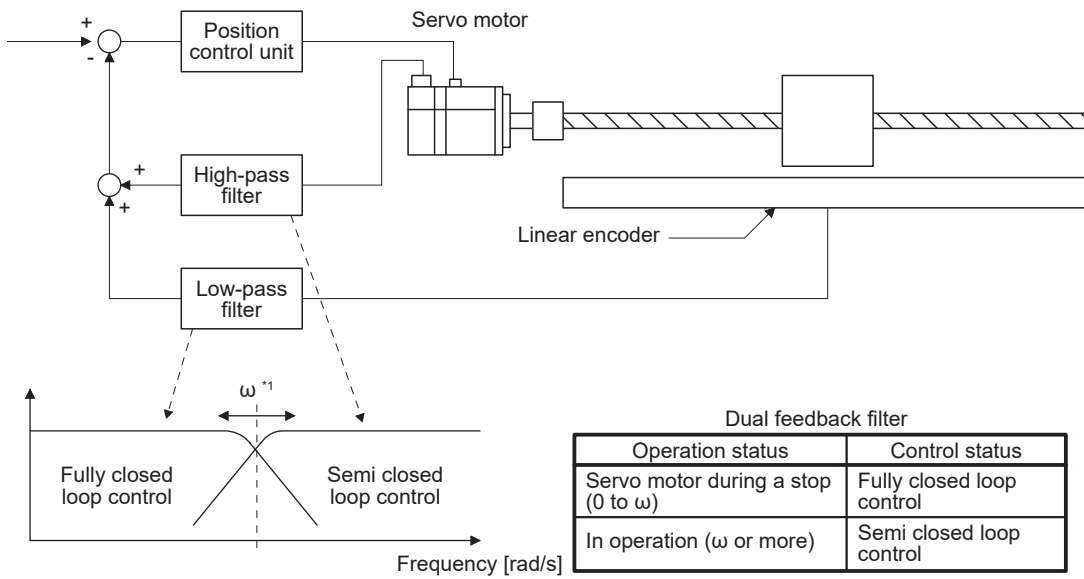

*1 " ω " (a dual feedback filter band) is set by [Pr. PE08].

System configuration

For a linear encoder

■MR-J4-_GF_ servo amplifier

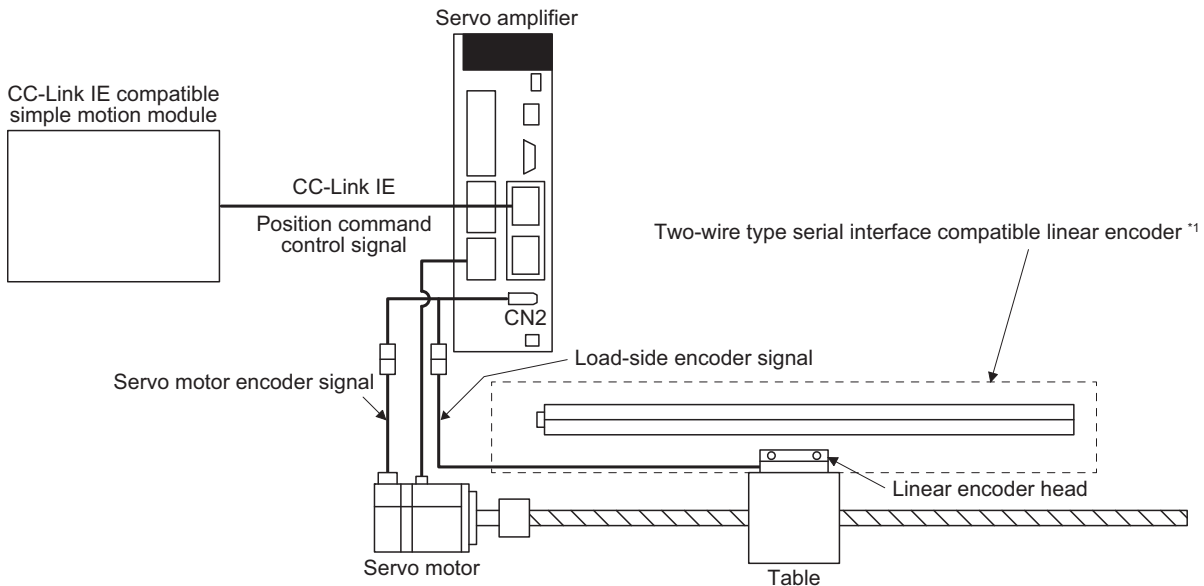

*1 Applicable for the absolute position detection system when an absolute position linear encoder is used.
In that case, a battery is not required.

■MR-J4-_GF_-RJ servo amplifier

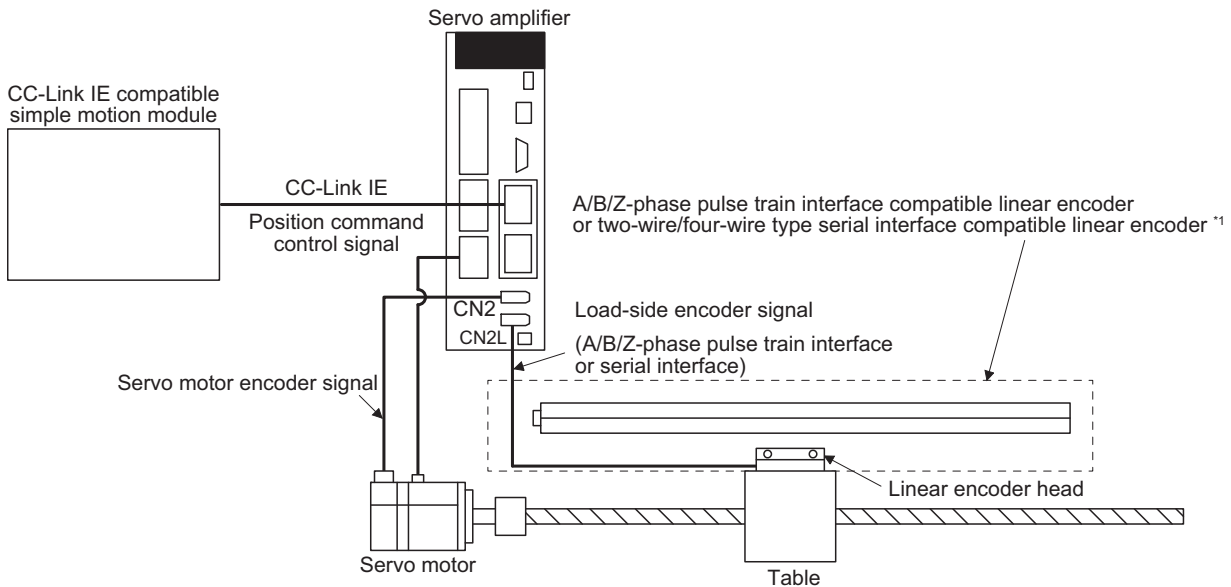

*1 Applicable for the absolute position detection system when an absolute position linear encoder is used.
In that case, a battery is not required.

For a rotary encoder

■MR-J4-_GF_ servo amplifier

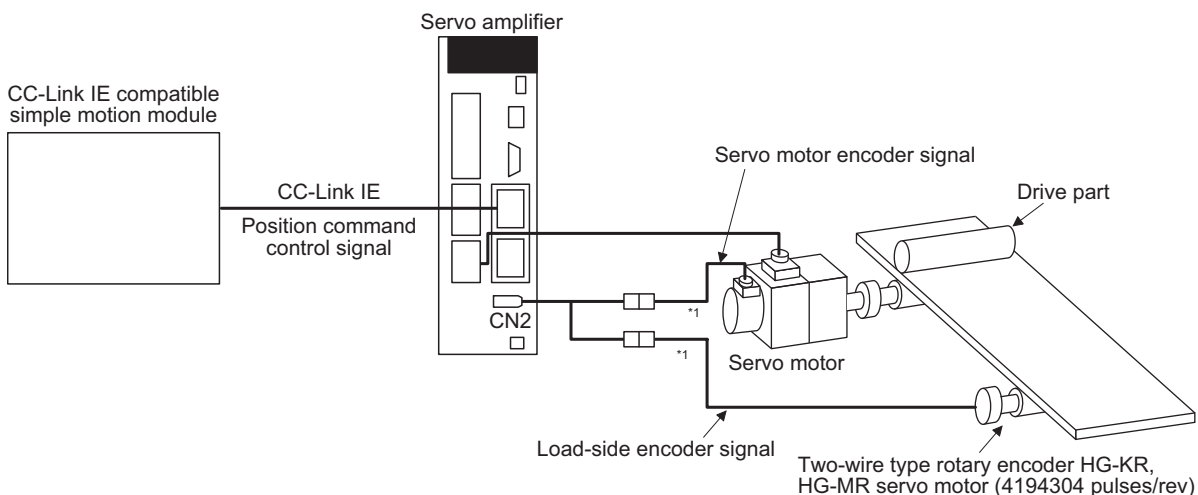

*1 Use a two-wire type encoder cable. A four-wire type encoder cable cannot be used.

■MR-J4-_GF_-RJ servo amplifier

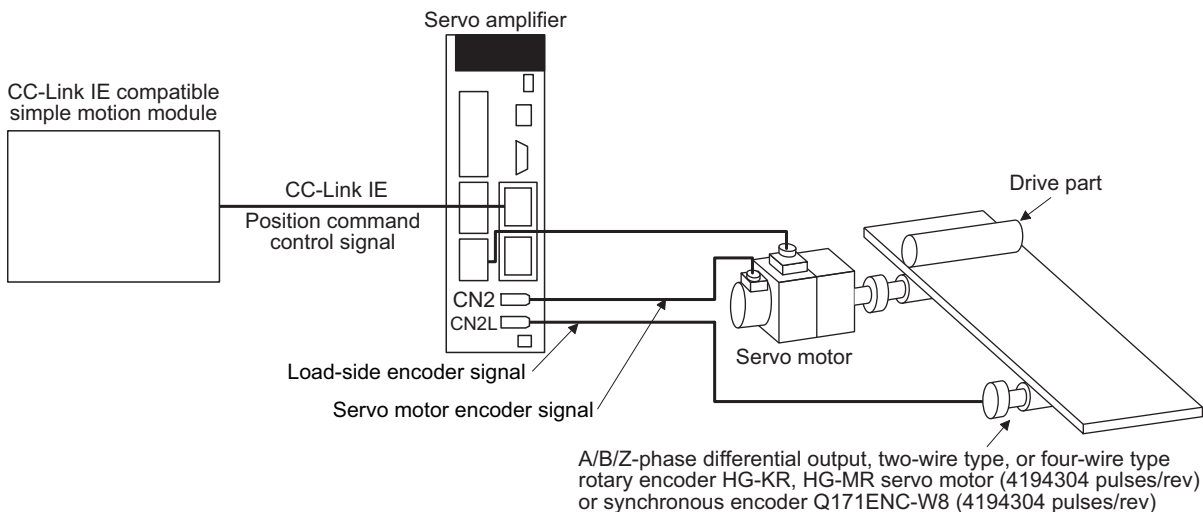

16.2 Load-side encoder

Point

- Always use the load-side encoder cable introduced in this section. Using other products may cause a malfunction.
- For details of the load-side encoder specifications, performance and assurance, contact each encoder manufacturer.

Linear encoder

Refer to "Linear Encoder Instruction Manual" for usable linear encoders.

Rotary encoder

When a rotary encoder is used as a load-side encoder, use either of the following servo motors or the encoder.

Servo amplifier	HG-KR	HG-MR	Synchronous encoder Q171ENC-W8	A/B/Z-phase differential output ^{*1}
MR-J4-_GF_	○	○	—	—
MR-J4-_GF_-RJ	○	○	○	○

*1 A/B/Z-phase differential output rotary encoders that can be used as a load-side encoder have the same specifications as the A/B/Z-phase differential output linear encoders. Refer to "Linear Encoder Instruction Manual".

Use a two-wire type encoder cable for MR-J4-_GF_ servo amplifiers. Do not use MR-EKCBL30M-L, MR-EKCBL30M-H, MR-EKCBL40M-H, or MR-EKCBL50M-H as they are four-wire type.

When an encoder cable of 30 m to 50 m is needed, fabricate a two-wire type encoder cable according to the following section.

☞ Page 630 Two-wire type encoder cable for HG-MR/HG-KR

Configuration diagram of encoder cable

Configuration diagram for servo amplifier and load-side encoder is shown below. Cables used vary, depending on the load-side encoder.

Linear encoder

Refer to "Linear Encoder Instruction Manual" for encoder cables for linear encoder.

MR-J4-_GF_ servo amplifier

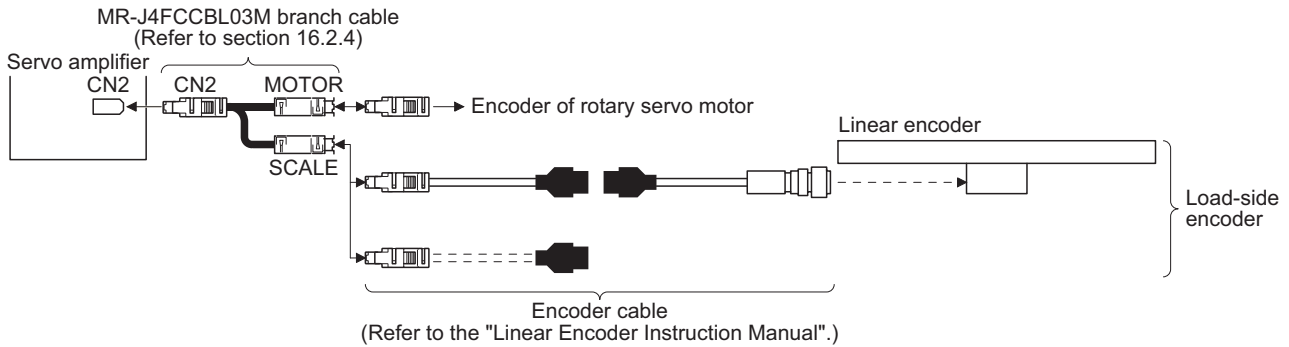

MR-J4-_GF_-RJ servo amplifier

You can connect the linear encoder without using a branch cable shown in the following section for MR-J4-_GF_-RJ servo amplifier. You can also use a four-wire type linear encoder.

Page 539 MR-J4-_GF_ servo amplifier

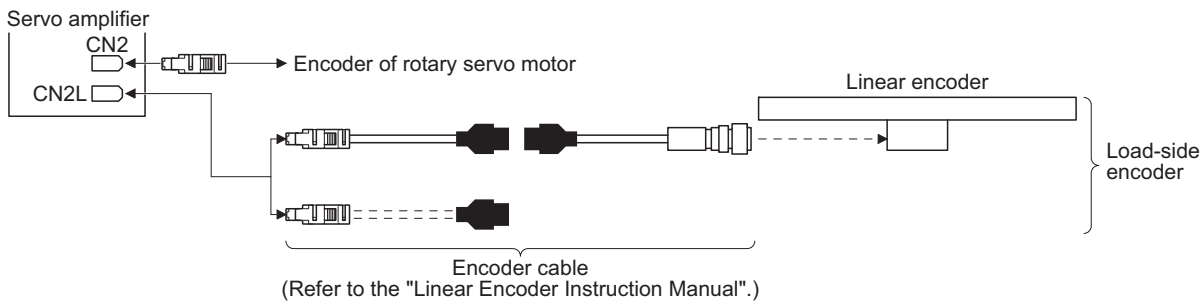

Rotary encoder

Refer to "Servo Motor Instruction Manual (Vol. 3)" for encoder cables for rotary encoders.

■MR-J4-_GF_servo amplifier

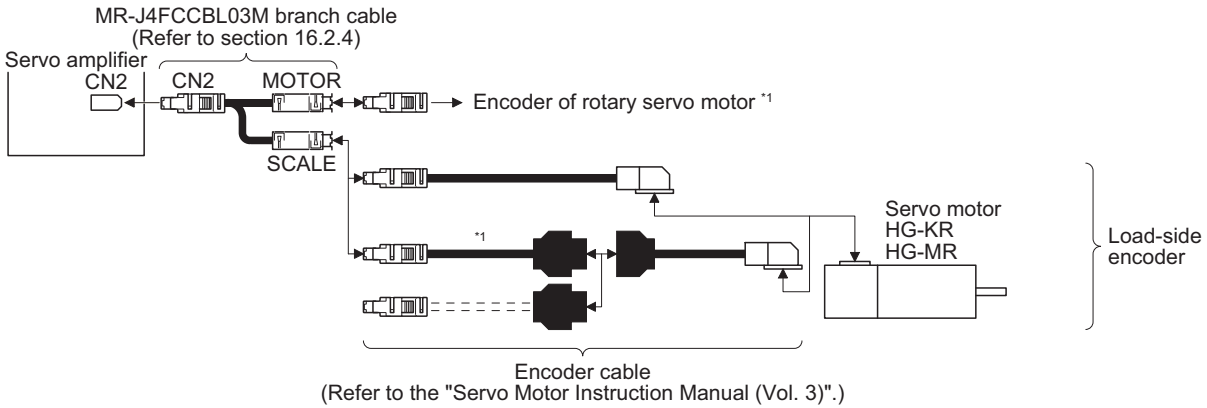

*1 Use a two-wire type encoder cable. A four-wire type encoder cable cannot be used.

■MR-J4-_GF_-RJ servo amplifier

For the MR-J4-_GF_-RJ servo amplifier, the rotary encoder can be connected without the use of a branch cable shown below. Four-wire type or A/B/Z-phase differential output rotary encoders can also be used.

☞ Page 540 MR-J4-_GF_servo amplifier

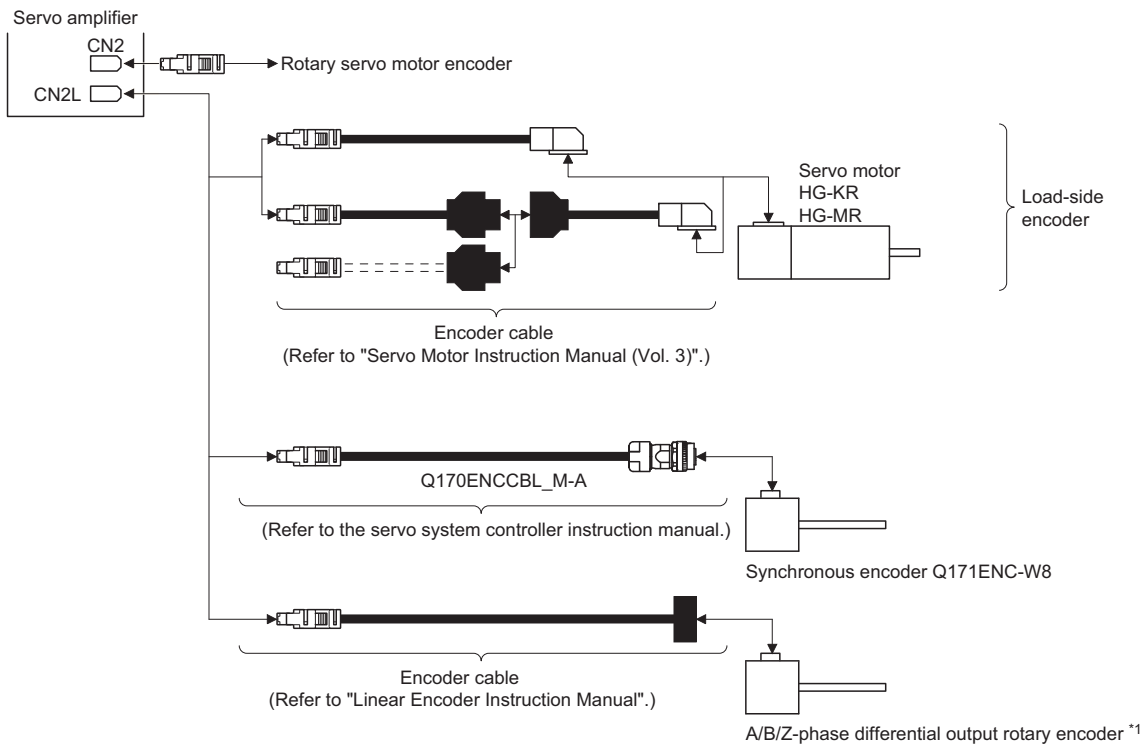

*1 A/B/Z-phase differential output rotary encoders that can be used as a load-side encoder have the same specifications as the A/B/Z-phase differential output linear encoders. Refer to "Linear Encoder Instruction Manual".

MR-J4FCCBL03M branch cable

Use MR-J4FCCBL03M branch cable to connect the rotary encoder and the load-side encoder to CN2 connector.
 When fabricating the branch cable using MR-J3THMCN2 connector set, refer to "Linear Encoder Instruction Manual".

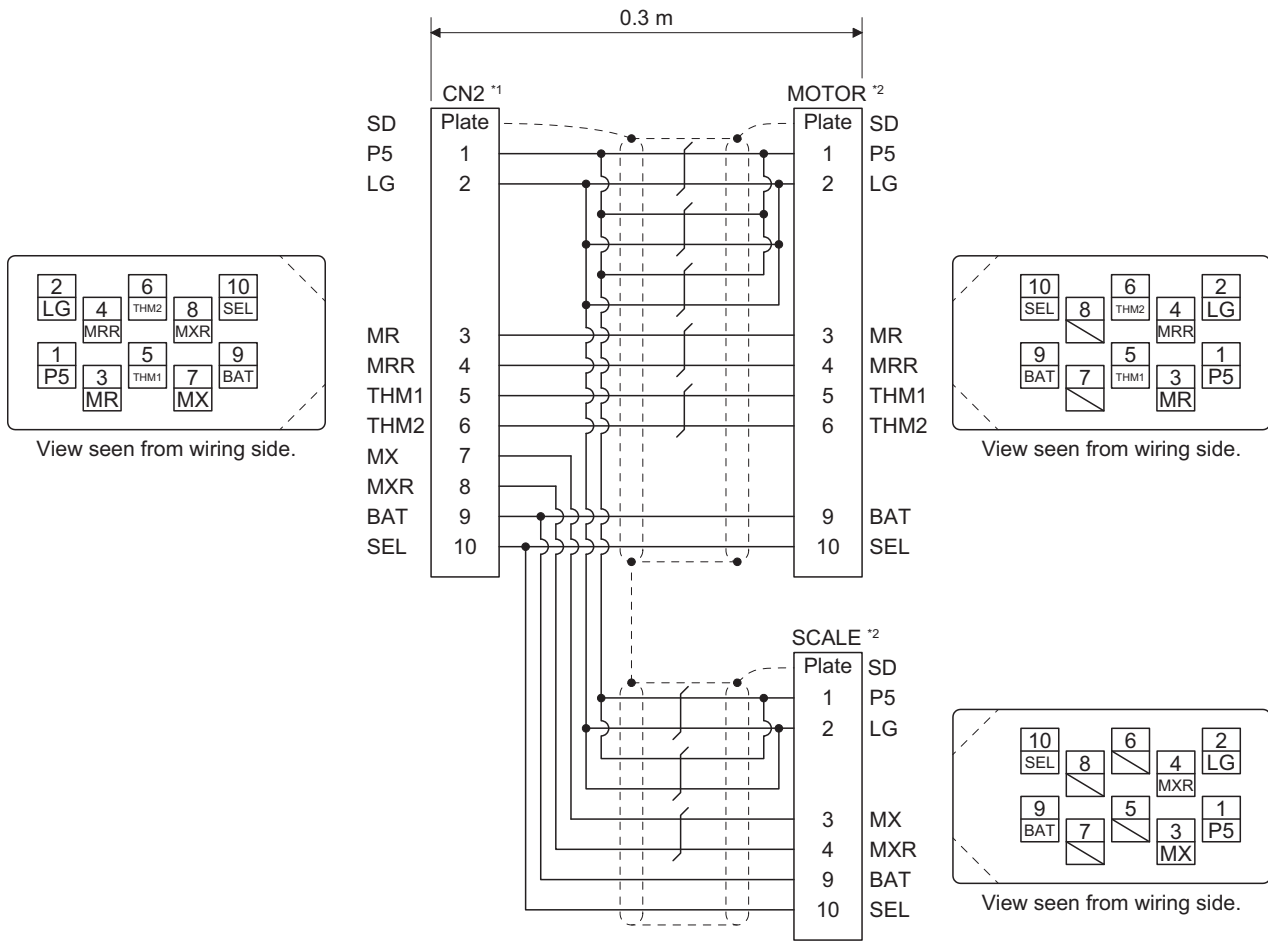

*1 Receptacle: 36210-0100PL, shell kit: 36310-3200-008 (3M)

*2 Plug: 36110-3000FD, shell kit: 36310-F200-008 (3M)

16.3 Operation and functions

Startup

Startup procedure

Start up the fully closed loop system in the following procedure.

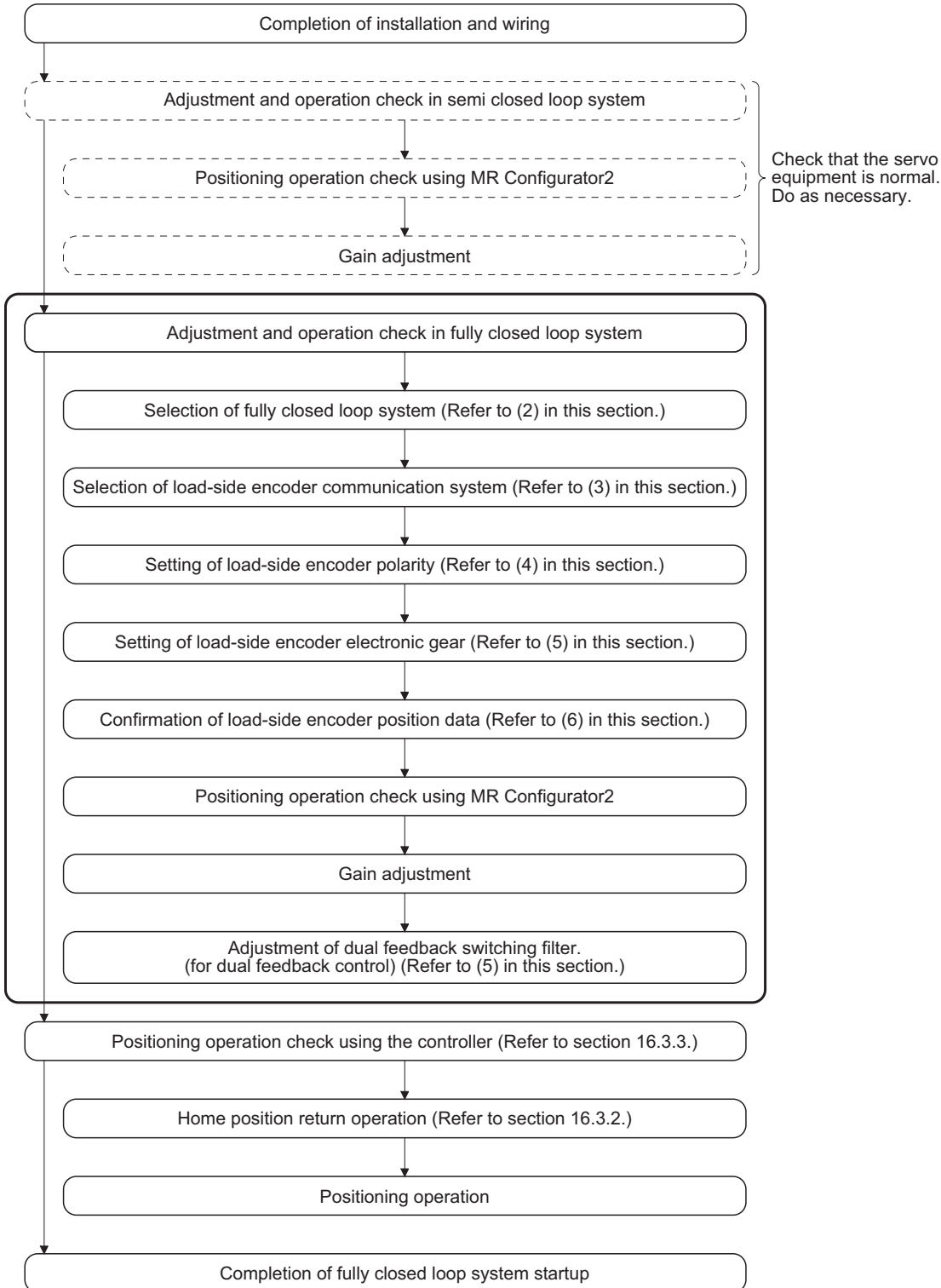

Selection of fully closed loop system

By setting [Pr. PA01], [Pr. PE01] and the control command of controller, the control method can be selected as shown in the following table.

[Pr. PA01]	[Pr. PE01]	Semi closed loop control/ fully closed loop control switching signal	Command unit	Control system	Absolute position detection system
"__0_" Semi closed loop system (standard control mode)	—	—	Servo motor encoder unit	Semi closed loop control	○
"__1_" Fully closed loop system (fully closed loop control mode)	"___0"	—	Load-side encoder unit	Dual feedback control (fully closed loop control)	○*1
	"___1"	Off		Semi closed loop control	×
		On		Dual feedback control (fully closed loop control)	×

*1 Applicable when the load-side encoder is set as the absolute position encoder.

■Operation mode selection

Select an operation mode.

[Pr. PA01]

1	0		0
---	---	--	---

Operation mode selection

Set value	Operation mode	Control unit
0	Semi closed loop system (Standard control mode)	Servo motor-side resolution unit
1	Fully closed loop system (Fully closed loop control mode)	Load-side encoder resolution unit

■Semi closed loop control/fully closed loop control selection

Select the semi closed loop control/fully closed loop control.

[Pr. PE01]

0	0	0	
---	---	---	--

Fully closed loop control selection

0: Always enabled

1: Switching by fully closed loop selection command from controller and Input device CLD
(Fully closed loop selection)

Fully closed loop selection		Control system
Command from controller	CLD (fully closed loop selection)*1	
Off	Off	Fully closed loop control
On	Off	
Off	On	
On	On	

*1 This is always off when CLD (Fully closed loop selection) is not assigned in [Pr. PD03] to [Pr. PD05].

To enable the setting, select "Fully closed loop control mode (__1_)" of "operation mode selection" in [Pr. PA01].

When "Absolute position detection system" is "Enabled (___1)" in [Pr. PA03], setting "1" will trigger [AL. 37 Parameter error].

Selection of load-side encoder communication method

The communication method changes depending on the load-side encoder type. Refer to the following and "Linear Encoder Instruction Manual" for the communication method for each load-side encoder.

☞ Page 18 Summary

Select the cable to be connected to CN2L connector in [Pr. PC26].

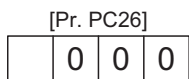

Load-side encoder cable communication method selection

0: Two-wire type

1: Four-wire type

When using an encoder of A/B/Z-phase differential output method, set "0".

Incorrect setting will trigger [AL. 70] and [AL. 71].

Setting of load-side encoder polarity

⚠ CAUTION

- Do not set an incorrect direction to "Encoder pulse count polarity selection" in [Pr. PC27]. An abnormal operation and a machine collision may occur if an incorrect direction is set, which cause a fault and parts damaged.

Point

- "Encoder pulse count polarity selection" in [Pr. PC27] is not related to [Pr. PA14 Rotation direction selection]. Make sure to set the parameter according to the relationships between servo motor and linear encoder/rotary encoder.
- Do not set an incorrect direction to "Encoder pulse count polarity selection" in [Pr. PC27]. Doing so may cause [AL. 42 Fully closed loop control error] during the positioning operation.

Parameter setting method

Set the load-side encoder polarity to be connected to CN2L connector in order to match the CCW direction of servo motor and the increasing direction of load-side encoder feedback.

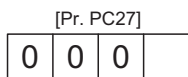

Encoder pulse count polarity selection

0: Encoder pulse increasing direction in the servo motor CCW or positive direction

1: Encoder pulse decreasing direction in the servo motor CCW or positive direction

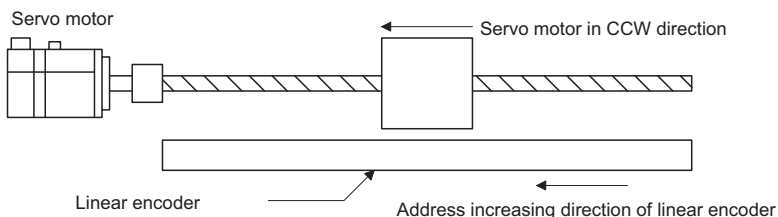

How to confirm the load-side encoder feedback direction

For the way of confirming the load-side encoder feedback direction, refer to the following.

☞ Page 547 Confirmation of load-side encoder position data

Setting of feedback pulse electronic gear

Point

If an incorrect value is set in the feedback pulse electronic gear ([Pr. PE04], [Pr. PE05], [Pr. PE34], and [Pr. PE35]), [AL. 37 Parameter error] and an abnormal operation may occur. Also, it may cause [AL. 42.8 Fully closed loop control error by position deviation] during the positioning operation.

Set the electronic gear ([Pr. PE04], [Pr. PE34], [Pr. PE05], and [Pr. PE35]) for the servo motor-side encoder pulse. Set the electronic gear so that the number of servo motor encoder pulses per servo motor revolution is converted to the number of load-side encoder pulses. The relational expression is shown below.

$$\text{Number of load-side encoder pulses per servo motor revolution} = \text{Number of servo motor encoder pulses per servo motor revolution} \times \frac{[\text{Pr. PE04}] \times [\text{Pr. PE34}]}{[\text{Pr. PE05}] \times [\text{Pr. PE35}]}$$

Select the load-side encoder so that the number of load-side encoder pulses per servo motor revolution is within the following range.

$$4096 (2^{12}) \leq \text{Number of load-side encoder pulses per servo motor revolution} \leq 67108864 (2^{26})$$

■When the servo motor is directly coupled with a ball screw and the linear encoder resolution is 0.05 μm

Conditions

Servo motor resolution: 4194304 pulses/rev

Servo motor reduction ratio: 1/11

Ball screw lead: 20 mm

Linear encoder resolution: 0.05 μm

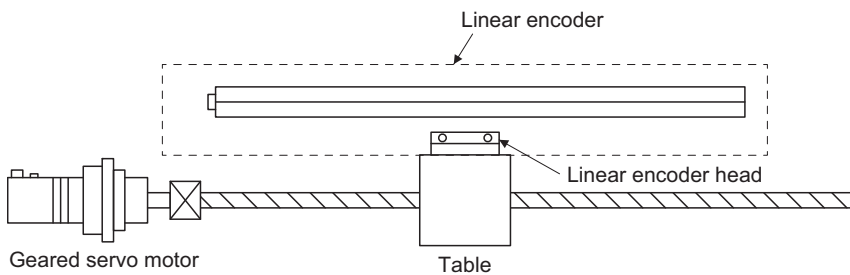

Calculate the number of linear encoder pulses per ball screw revolution.

Number of linear encoder pulses per ball screw revolution

= Ball screw lead/linear encoder resolution

= 20 mm/0.05 μm = 400000 pulses

$$\frac{[\text{Pr. PE04}] \times [\text{Pr. PE34}]}{[\text{Pr. PE05}] \times [\text{Pr. PE35}]} = \frac{400000}{4194304} \times \frac{1}{11} = \frac{3125}{32768} \times \frac{1}{11}$$

■Setting example when using the rotary encoder for the load-side encoder of roll feeder

Conditions

Servo motor resolution: 4194304 pulses/rev

Pulley diameter on the servo motor side: 30 mm

Pulley diameter on the rotary encoder side: 20 mm

Rotary encoder resolution: 4194304 pulses/rev

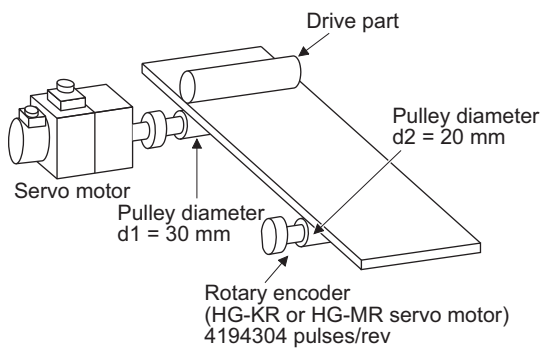

When the pulley diameters or reduction ratios differ, consider that in calculation.

$$\frac{[\text{Pr. PE04}] \times [\text{Pr. PE34}]}{[\text{Pr. PE05}] \times [\text{Pr. PE35}]} = \frac{4194304 \times 30}{4194304 \times 20} = \frac{1}{1} \times \frac{3}{2}$$

Confirmation of load-side encoder position data

Check the load-side encoder mounting and parameter settings for any problems.

Point

Depending on the check items, MR Configurator2 may be used.

Refer to the following for the data displayed on the MR Configurator2.

☞ Page 557 About MR Configurator2

When checking the following items, the fully closed loop control mode must be set. For the setting of control mode, refer to the following.

☞ Page 543 Selection of fully closed loop system

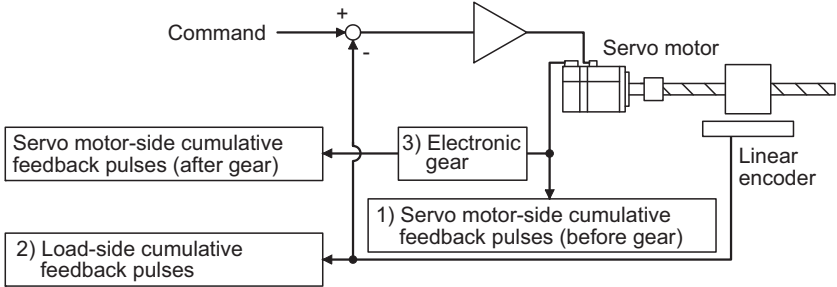
No.	Check item	Confirmation method and description
1	Read of load-side encoder position data	<p>With the load-side encoder in a normal state (mounting, connection, etc.), the load-side cumulative feedback pulses value is counted normally when the load-side encoder is moved.</p> <p>When it is not counted normally, the following factors can be considered.</p> <ol style="list-style-type: none"> 1. An alarm occurred. 2. The installation of the load-side encoder was not correct. 3. The encoder cable was not wired correctly.
2	Read of load-side encoder home position (reference mark, Z-phase)	<p>With the home position (reference mark, or Z-phase) of the load-side encoder in a normal condition (mounting, connection, etc.), the value of load-side encoder information 1 is cleared to 0 when the home position (reference mark, or Z-phase) is passed through by moving the load-side encoder.</p> <p>When it is not cleared, the following factors can be considered.</p> <ol style="list-style-type: none"> 1. The installation of the load-side encoder was not correct. 2. The encoder cable was not wired correctly.
3	Confirmation of load-side encoder feedback direction (Setting of load-side encoder polarity)	<p>Confirm that the directions of the cumulative feedback pulses of servo motor encoder (after gear) and the load-side cumulative feedback pulses are matched by moving the device (load-side encoder) manually in the servo-off status. If mismatched, reverse the polarity.</p>
4	Setting of load-side encoder electronic gear	<p>When the servo motor and load-side encoder operate synchronously, the servo motor-side cumulative feedback pulses (after gear) and load-side cumulative feedback pulses are matched and increased.</p> <p>If mismatched, review the setting of fully closed loop control feedback electronic gear ([Pr. PE04], [Pr. PE05], [Pr. PE34], and [Pr. PE35]) with the following method.</p> <ol style="list-style-type: none"> 1) Check the servo motor-side cumulative feedback pulses (before gear). 2) Check the load-side cumulative feedback pulses. 3) Check that the ratio of above 1) and 2) has been that of the feedback electronic gear. 

Setting of fully closed loop dual feedback filter

With the initial value (setting = 10) set in [Pr. PE08 Fully closed loop dual feedback filter the dual feedback filter], make gain adjustment by auto tuning, etc. as in semi closed loop control. While observing the servo operation waveform with the graph function, etc. of MR Configurator2, adjust the dual feedback filter.

The dual feedback filter operates as described below depending on the setting.

[Pr. PE08] setting	Control mode	Vibration	Settling time
1 to 4499	Dual feedback	Not frequently occurs to Frequently occurs	Long to Short
4500	Fully closed loop	—	—

Increasing the dual feedback filter setting shortens the settling time, but increases servo motor vibration since the motor is more likely to be influenced by the load-side encoder vibration. The maximum setting of the dual feedback filter should be less than half of the PG2 setting.

Reduction of settling time: Increase the dual feedback filter setting.

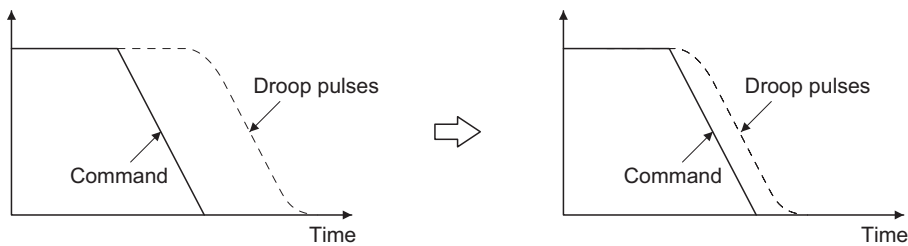

Suppression of vibration: Decrease the dual feedback filter setting.

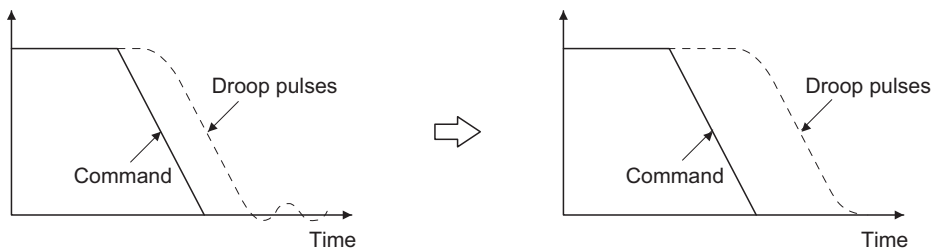

Home position return

General instruction

Home position return is all performed according to the load-side encoder feedback data, independently of the load-side encoder type. It is irrelevant to the Z-phase position of the servo motor encoder.

Precautions when using a proximity dog

■Length of proximity dog

Set the length of the proximity dog to satisfy the following, so that the servo motor speed changes from the home position return speed to the creep speed during detection of the proximity dog.

$$L_1 \geq \frac{V}{60} \cdot \frac{td}{2}$$

L_1 : Length of the proximity dog [mm]

V : Home position return speed [mm/min]

td : Time to change from the home position return speed to the creep speed [s]

■Adjustment of proximity dog position

To eliminate variations in the home position return completion position, adjust the proximity dog detection position to be near the center between a reference home position and the next reference home position.

The incremental linear encoder and the absolute position linear encoder have different reference home positions at the home position return. Refer to the following for information on the reference home position.

☞ Page 550 For the absolute position linear encoder

☞ Page 551 If wanting to stop at the reference home position

☞ Page 553 For the rotary encoder of a serial communication servo motor

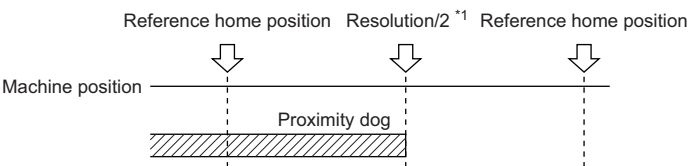

*1 The resolution is the load-side encoder resolution per servo motor revolution.

■Timing of when the linear encoder home position is passed

During the period from a home position return start until the proximity dog detection, the linear encoder home position (reference mark) must be passed for an incremental type linear encoder, and the Z-phase must be passed for a rotary encoder. When those are not passed, [AL. 90.5 Z-phase unpassed] may occur.

For the absolute position linear encoder

When an absolute type linear encoder is used, the home position reference position is the position per servo motor revolution to the linear encoder home position (absolute position data = 0).

The linear encoder home position can be set in any position.

LZ (Encoder Z-phase pulse) is outputted at the reference home position.

In the case of a proximity dog type home position return, after the proximity dog rear end is detected, the nearest reference home position shifted by the home position shift distance is used as the home position.

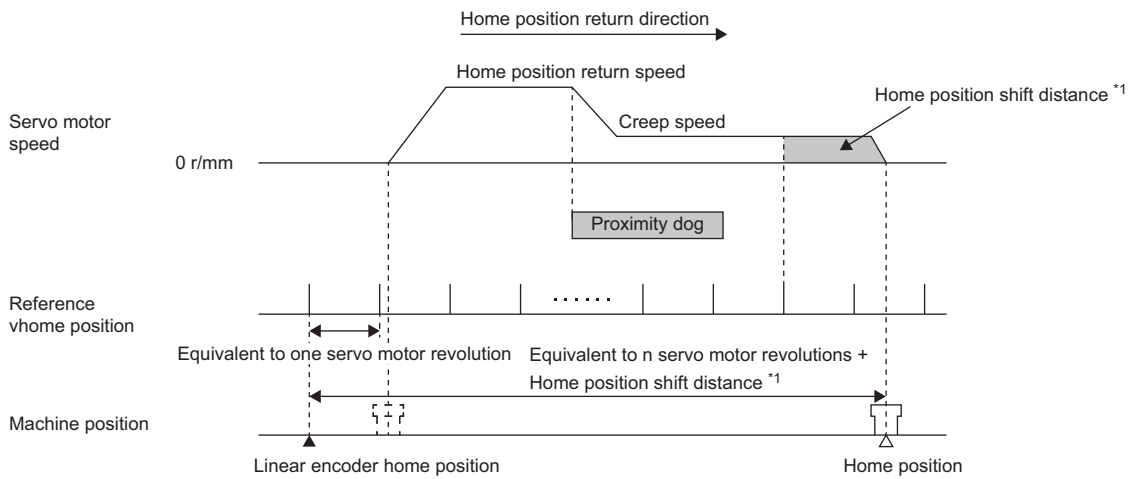

*1 Home position shift distance can be changed with [Pr. PT07] and [Pr. PT69].

For the incremental linear encoder

Point

If no linear encoder home position (reference mark) exists, only the home position return type without using Z-phase can be performed.

Page 146 Home position return types

■ If wanting to stop at the reference home position

Point

To perform a home position return securely, pass the linear encoder home position (reference mark) with the JOG operation or another operation, and then start the home position return.

When an incremental linear encoder is used, the home position is the position per servo motor revolution to the linear encoder home position (reference mark) that has been passed through.

Set one linear encoder home position in the full stroke, and set it in the proximity dog signal detection position.

LZ (Encoder Z-phase pulse) is outputted at the linear encoder home position (reference mark).

In the case of a dog type home position return, after the proximity dog signal rear end is detected, the nearest reference home position shifted by the home position shift distance is used as the home position.

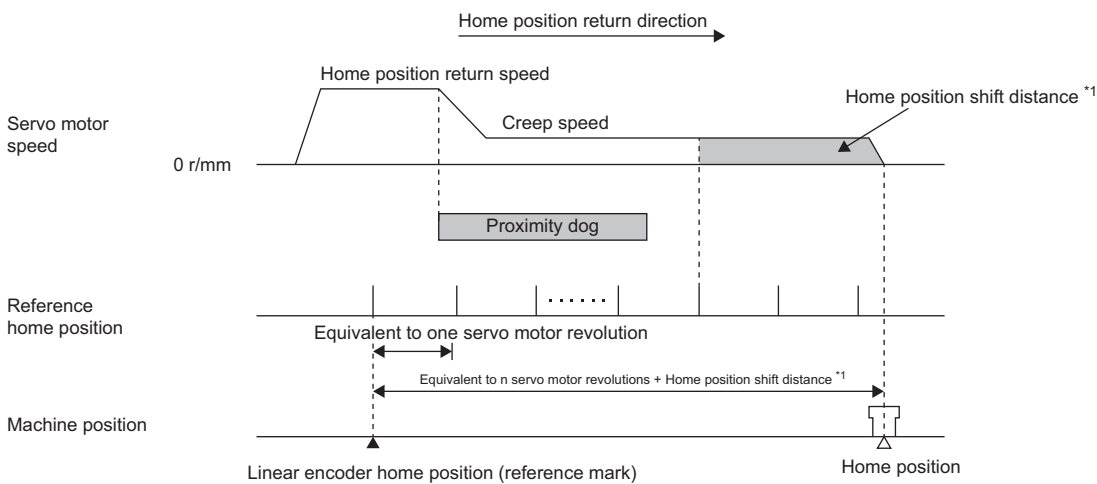

*1 Home position shift distance can be changed with [Pr. PT07] and [Pr. PT69].

As shown below, in an area where the linear encoder home position (reference mark) is not passed after the home position return starts (home position return restricted area), home position return may be disabled depending on the conditions.

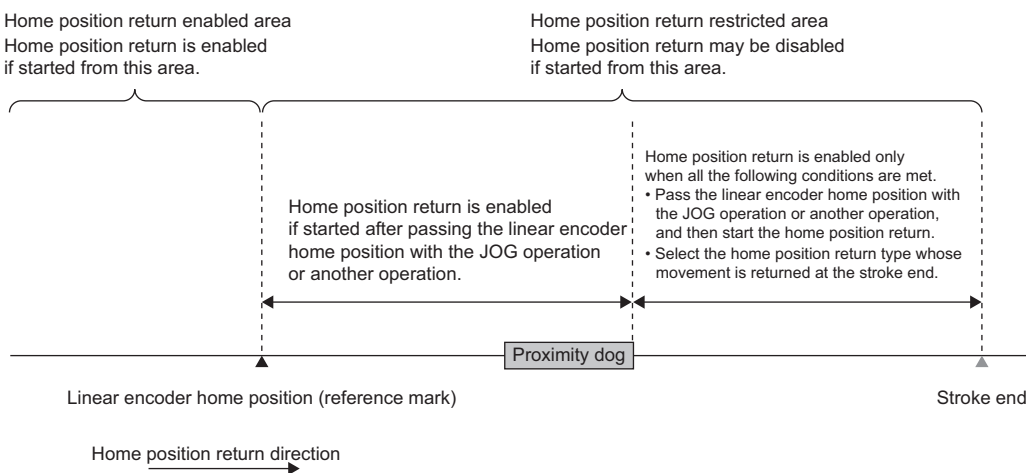

■ If wanting to stop at the linear encoder home position

When "Stop position selection at home position return" of [Pr. PT41] is set to "_ _ 1 _", the home position return for Homing methods 33, 34, -11, and -43 is set to the linear encoder home position (reference mark). This parameter is enabled when an incremental linear encoder compatible with a serial interface is used.

- For Homing methods 33 and 34

The following figure shows the operation of Homing method 34 when "Stop position selection at home position return" of [Pr. PT41] is set to "_ _ 1 _". The operation direction of Homing method 33 is opposite to that of Homing method 34.

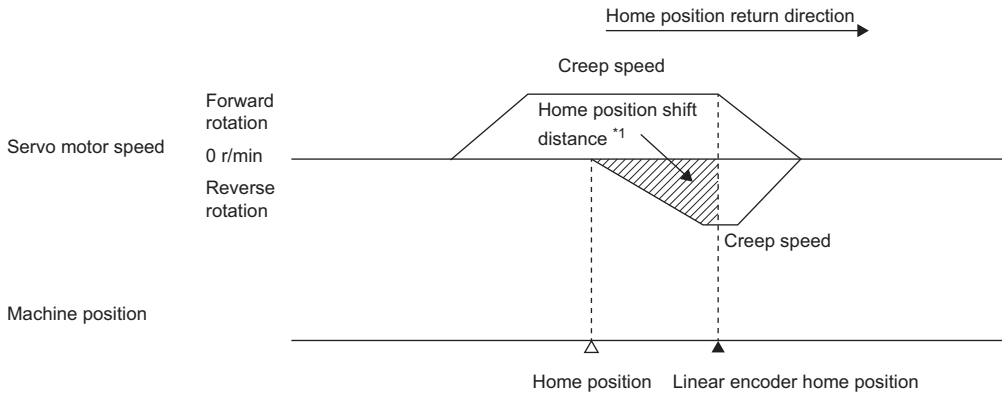

*1 Home position shift distance can be changed with [Pr. PT07] and [Pr. PT69].

When the stroke end is detected

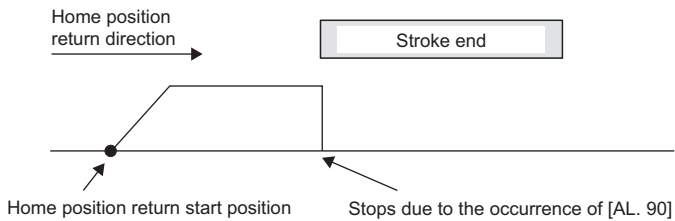

- For Homing methods -11 and -43

The following figure shows the operation of Homing method -11 when "Stop position selection at home position return" of [Pr. PT41] is set to "_ _ 1 _". The operation direction of Homing method -43 is opposite to that of Homing method -11.

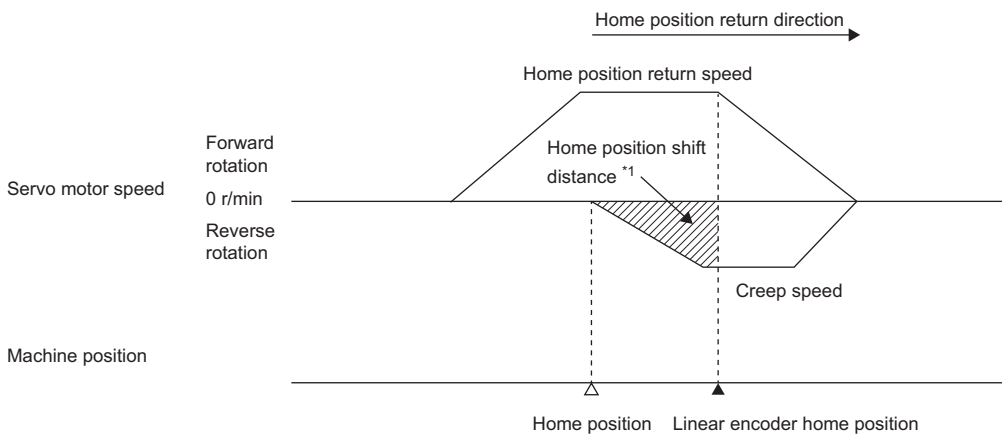

*1 Home position shift distance can be changed with [Pr. PT07] and [Pr. PT69].

When the movement is returned at the stroke end

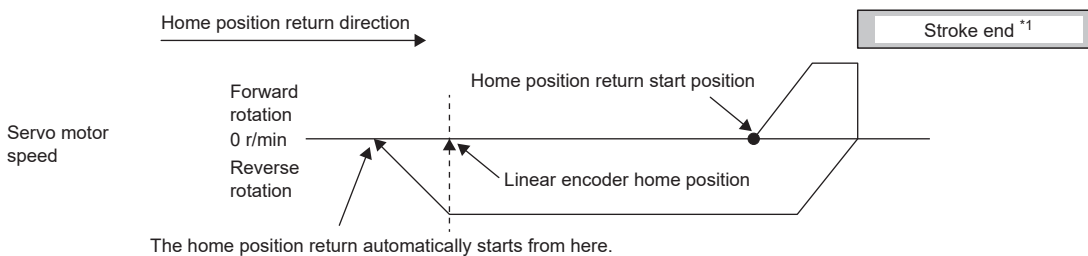

*1 This is not available with the software limit.

■For the rotary encoder of a serial communication servo motor

The home position for when using the rotary encoder of a serial communication servo motor for the load-side encoder is at the load-side Z-phase position.

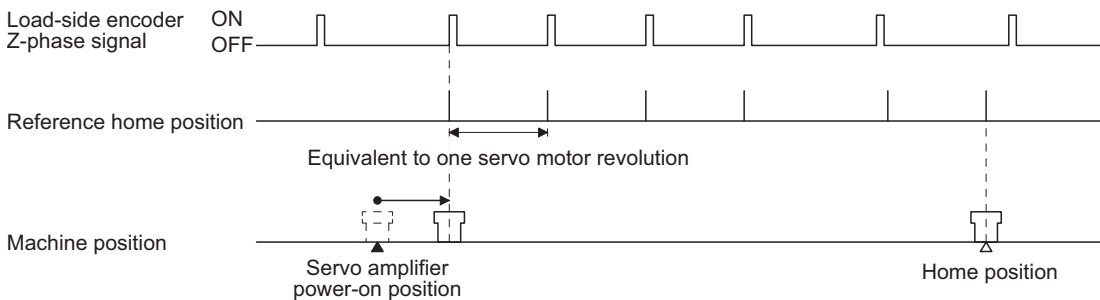

Operation from controller

An absolute type linear encoder is necessary to configure an absolute position detection system under fully closed loop control using a linear encoder. In this case, the encoder battery need not be installed to the servo amplifier. When a rotary encoder is used, an absolute position detection system can be configured by installing the encoder battery to the servo amplifier. In this case, the battery life will be shorter because the power consumption is increased as the power is supplied to the two encoders of motor side and load side.

Positioning operation from the controller is basically performed like the semi closed loop control.

Fully closed loop control error detection functions

If fully closed loop control becomes unstable for some reason, the speed at servo motor side may increase abnormally. The fully closed loop control error detection function is a protective function designed to pre-detect it and stop operation. The fully closed loop control error detection function has a speed deviation detection method and a position deviation detection method. Select a detection method with [Pr. PE03 Fully closed loop function selection 2]. The detection level setting can be changed using [Pr. PE06] and [Pr. PE07].

Parameter

The fully closed loop control error detection function is selected.

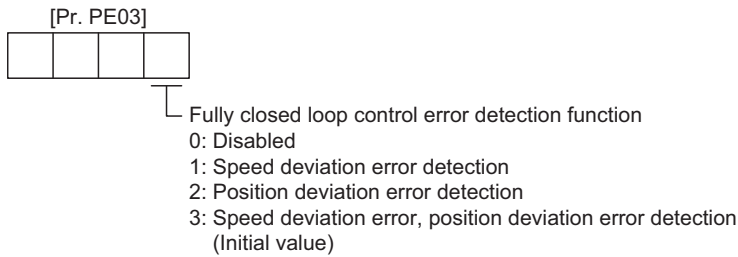

Fully closed loop control error detection functions

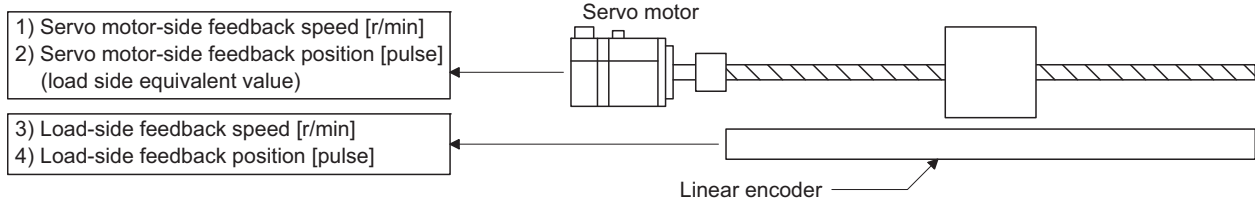

Speed deviation error detection

Set [Pr. PE03] to "___ 1" to enable the speed deviation error detection.

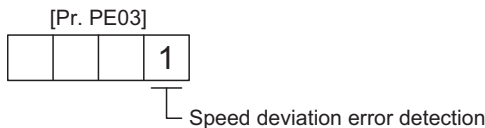

The function compares the servo motor-side feedback speed (1)) and load-side feedback speed (3)). If the deviation is not less than the set value (1 r/min to the permissible speed) of [Pr. PE06 Fully closed loop control speed deviation error detection level], the function generates [AL. 42.2 Servo control error by speed deviation] and stops. The initial value of [Pr. PE06] is 400 r/min. Change the set value as required.

Position deviation error detection

Set [Pr. PE03] to "___ 2" to enable the position deviation error detection.

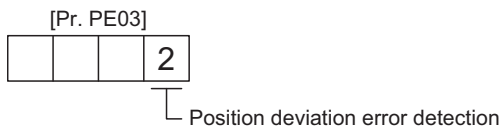

Comparing the servo motor-side feedback position (2)) and load-side feedback position (4)), if the deviation is not less than the set value (1 kpulses to 20000 kpulses) of [Pr. PE07 Fully closed loop control position deviation error detection level], the function generates [AL. 42.1 Servo control error by position deviation] and stops. The initial value of [Pr. PE07] is 100 kpulses. Change the set value as required.

■ Detecting multiple deviation errors

When setting [Pr. PE03] as shown below, multiple deviation errors can be detected. For the error detection methods, refer to the following.

☞ Page 554 Speed deviation error detection

☞ Page 554 Position deviation error detection

[Pr. PE03]

Setting value	Speed deviation error detection	Position deviation error detection	
1	○	—	
2	—	○	
3	○	○	

Auto tuning function

Refer to the following for the auto tuning function.

☞ Page 240 Auto tuning

Machine analyzer function

Refer to Help of MR Configurator2 for the machine analyzer function of MR Configurator2.

Test operation mode

Test operation mode is enabled by MR Configurator2.

For details on the test operation mode, refer to the following.

☞ Page 142 Test operation mode

Function	Item	Usability	Remark
Test operation mode	JOG operation	○	It drives in the load-side encoder resolution unit
	Positioning operation	○	The fully closed loop system is operated in the load-side encoder resolution unit.
	Program operation	○	☞ Page 143 Program operation
	Output signal (DO) forced output	○	Refer to the following. ☞ Page 143 Output signal (DO) forced output
	Motor-less operation	—	—

Absolute position detection system under fully closed loop system

An absolute type linear encoder is necessary to configure an absolute position detection system under fully closed loop control using a linear encoder. In this case, the encoder battery need not be installed to the servo amplifier. When a rotary encoder is used, an absolute position detection system can be configured by installing the encoder battery to the servo amplifier. In this case, the battery life will be shorter because the power consumption is increased as the power is supplied to the two encoders of motor side and load side.

For an absolute position detection system using a linear encoder, enable the absolute position detection system with [Pr. PA03 Absolute position detection system] and use this servo within the following restrictions.

Using conditions

- Use an absolute type linear encoder with the load-side encoder.
- Set [Pr. PA01] to " __ 1 _", and set [Pr. PE01] to " ___ 0".

Absolute position detection range using encoder

Encoder type	Absolute position detection enabled range
Linear encoder (Serial interface)	Movable distance range of linear encoder (within 32-bit absolute position data)

Alarm detection

The absolute position-related alarm ([AL. 25]) and warnings ([AL. 92] and [AL. 9F]) are not detected.

About MR Configurator2

Using MR Configurator2 can confirm if the parameter setting is normal or if the servo motor and the load-side encoder operate properly.

This section explains the fully closed diagnosis screen.

Click "Monitor start" to constantly read the monitor display items from the servo amplifier. Then, click "Monitor stop" to stop reading.

Click "Parameter read" to read the parameter items from the servo amplifier, and then click "Parameter write" to write them.

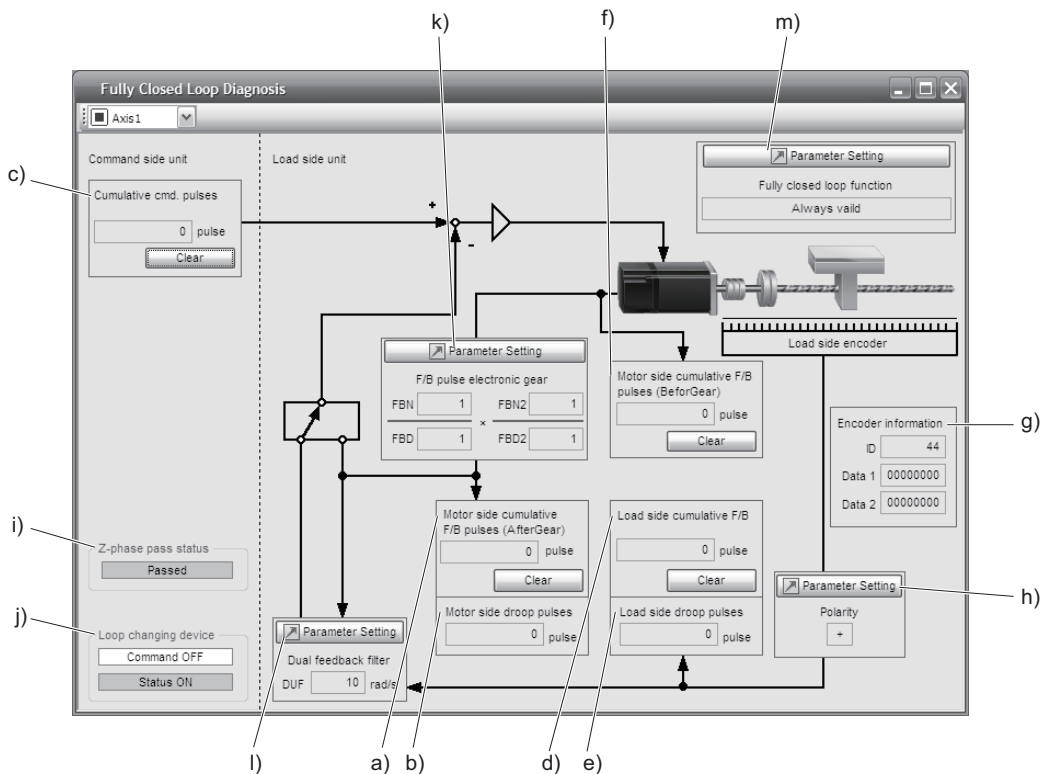

Symbol	Name	Explanation	Unit
a)	Motor-side cumu. Feedback pulses (after gear)	Feedback pulses from the servo motor encoder are counted and displayed. (load-side encoder unit) When the set value exceeds 999999999, it starts with 0. Click "Clear" to reset the value to 0. The "-" symbol is indicated for reverse.	pulse
b)	Motor side droop pulses	Droop pulses of the deviation counter between a servo motor-side position and a command are displayed. The "-" symbol is indicated for reverse.	pulse
c)	Cumu. Com. pulses	Position command input pulses are counted and displayed. Click "Clear" to reset the value to 0. The "-" symbol is indicated for reverse command.	pulse
d)	Load side cumu. feedback pulses	Feedback pulses from the load-side encoder are counted and displayed. When the set value exceeds 999999999, it starts with 0. Click "Clear" to reset the value to 0. The "-" symbol is indicated for reverse.	pulse
e)	Load side droop pulses	Droop pulses of the deviation counter between a load-side position and a command are displayed. The "-" symbol is indicated for reverse.	pulse
f)	Motor-side cumu. Feedback pulses (before gear)	Feedback pulses from the servo motor encoder are counted and displayed. (Servo motor encoder unit) When the set value exceeds 999999999, it starts with 0. Click "Clear" to reset the value to 0. The "-" symbol is indicated for reverse.	pulse

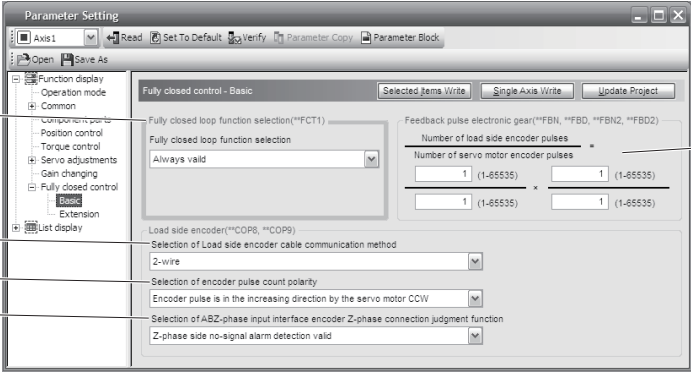
Symbol	Name	Explanation	Unit
g)	Encoder information	The load-side encoder information is displayed. The display contents differ depending on the load-side encoder type. <ul style="list-style-type: none"> • ID: The ID No. of the load-side encoder is displayed. • Data 1: For the incremental type linear encoder, the counter from powering on is displayed. For the absolute position type linear encoder, the absolute position data is displayed. • Data 2: For the incremental type linear encoder, the distance (number of pulses) from the reference mark (Z-phase) is displayed. For the absolute position type linear encoder, "00000000" is displayed. 	—
h)	Polarity	For address increasing direction in the servo motor CCW, it is indicated as "+" and for address decreasing direction in the servo motor CCW, as "-".	—
i)	Z phase pass status	If the fully closed loop system is "Disabled", the Z-phase pass status of the servo motor encoder is displayed. If the fully closed loop system is "Enabled" or "Semi closed loop control/fully closed loop control switching", the Z-phase pass status of the load-side encoder is displayed.	—
j)	Fully closed loop changing device	Only if the fully closed loop system is "Semi closed loop control/fully closed loop control switching", the device is displayed. The state of the semi closed loop control/fully closed loop control switching signal and the inside state during selection are displayed.	—
k)	Parameter (Feedback pulse electronic gear)	The feedback pulse electronic gears ([Pr. PE04], [Pr. PE05], [Pr. PE34], and [Pr. PE35]) are displayed/set for servo motor encoder pulses in this parameter. ☞ Page 545 Setting of feedback pulse electronic gear	—
l)	Parameter (Dual feedback filter)	The band of [Pr. PE08 Fully closed loop dual feedback filter] is displayed/set in this parameter.	—
m)	Parameter (fully closed loop function)	The parameter for the fully closed loop control is displayed or set. Click "Parameter setting" to display the "Fully closed loop control - Basic" window.  <p>1) Fully closed loop function selection ([Pr. PE01]) Select "Always valid" or "Change according to fully closed selection signal" here.</p> <p>2) Feedback pulse electronic gear ([Pr. PE04], [Pr. PE05], [Pr. PE34], [Pr. PE35]) Set the feedback pulse electronic gear.</p> <p>3) Load-side encoder cable communication method selection ([Pr. PC26]) Select a load-side encoder cable to be connected to the CN2L connector.</p> <p>4) Selection of encoder pulse count polarity ([Pr. PC27]) Select a polarity of the load-side encoder information.</p> <p>5) Selection of A/B/Z-phase input interface encoder Z-phase connection judgment function ([Pr. PC27]) Select the non-signal detection status for the pulse train signal from the A/B/Z-phase input interface encoder used as a linear encoder or load-side encoder. This function is enabled only when you use an A/B/Z-phase input interface encoder.</p>	—

17 APPLICATION OF FUNCTIONS

This chapter explains application of using servo amplifier functions.

17.1 Scale measurement function

The scale measurement function transmits position information of a scale measurement encoder to the controller by connecting the scale measurement encoder in semi closed loop control.

Point

The scale measurement function is available for servo amplifiers with software version A1 or later.

When a linear encoder is used as a scale measurement encoder for this servo amplifier, "Linear Encoder Instruction Manual" is necessary.

When the scale measurement function is used for MR-J4-_GF_ servo amplifiers, the following restrictions apply. However, these restrictions will not be applied to MR-J4-_GF_-RJ servo amplifiers.

- A/B/Z-phase differential output type encoder cannot be used.
- The scale measurement encoder and servo motor encoder are compatible with only the two-wire type. The four-wire type scale measurement encoder and servo motor encoder cannot be used.
- When you use the HG-KR and HG-MR series for driving and scale measurement encoder, the optional four-wire type encoder cables (MR-EKCBL30M-L, MR-EKCBL30M-H, MR-EKCBL40M-H, and MR-EKCBL50M-H) cannot be used. When an encoder cable of 30 m to 50 m is needed, fabricate a two-wire type encoder cable according to the following section.

☞ Page 630 Two-wire type encoder cable for HG-MR/HG-KR

The scale measurement function compatible servo amplifier can be used with any of the following controllers.

- Simple motion module RD77GF_/QD77GF_
- Simple motion board MR-EM340GF

For settings and restrictions of controllers compatible with the scale measurement function, refer to the following and user's manuals for each controller.

☞ Page 567 Controller setting of the scale measurement function

Functions and configuration

Function block diagram

The following shows a block diagram of the scale measurement function. The control will be performed per servo motor encoder unit for the scale measurement function.

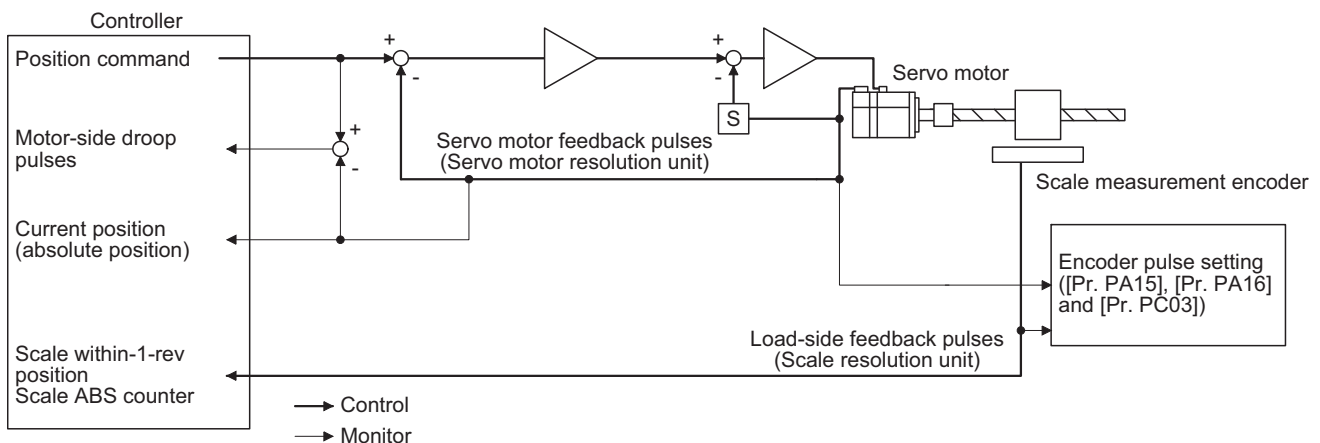

System configuration

■ For a linear encoder

- MR-J4-_GF_ servo amplifier

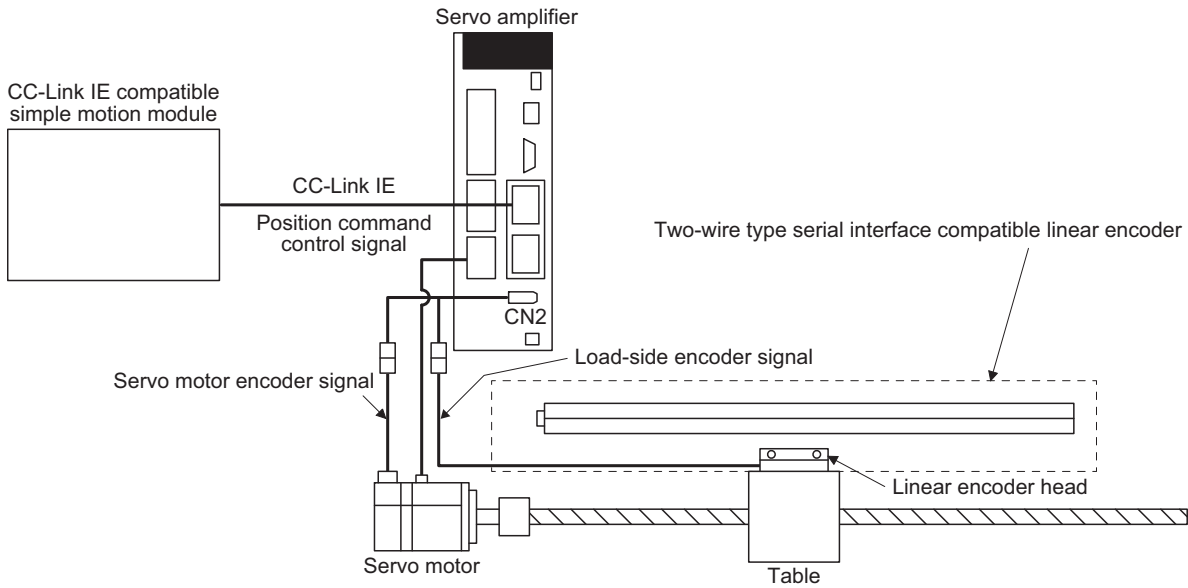

- MR-J4-_GF_-RJ servo amplifier

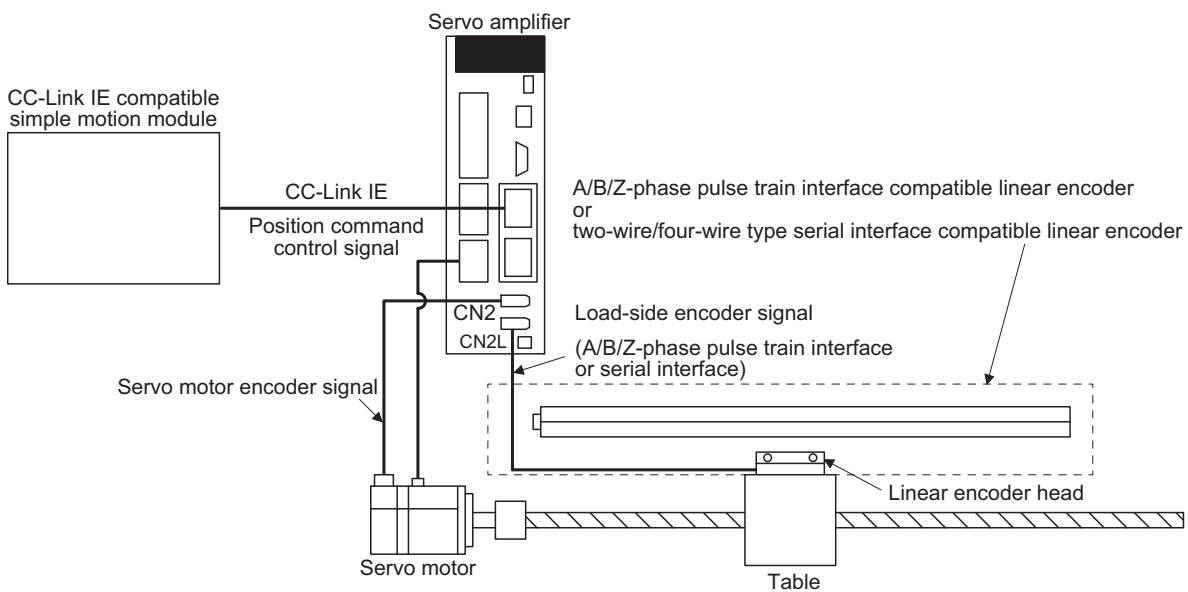

■ For a rotary encoder

- MR-J4-_GF_ servo amplifier

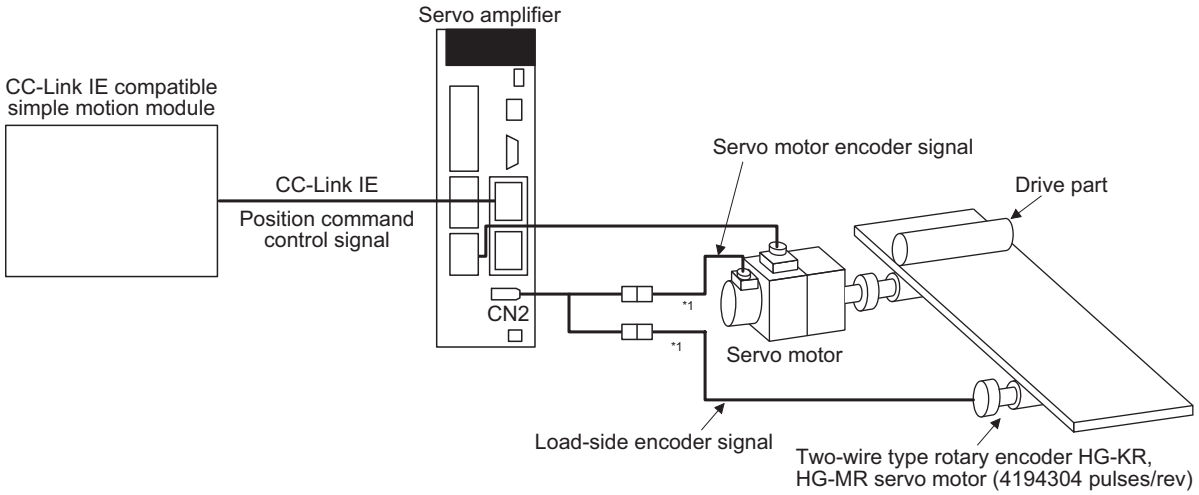

*1 Use a two-wire type encoder cable. A four-wire type encoder cable cannot be used.

- MR-J4-_GF_-RJ servo amplifier

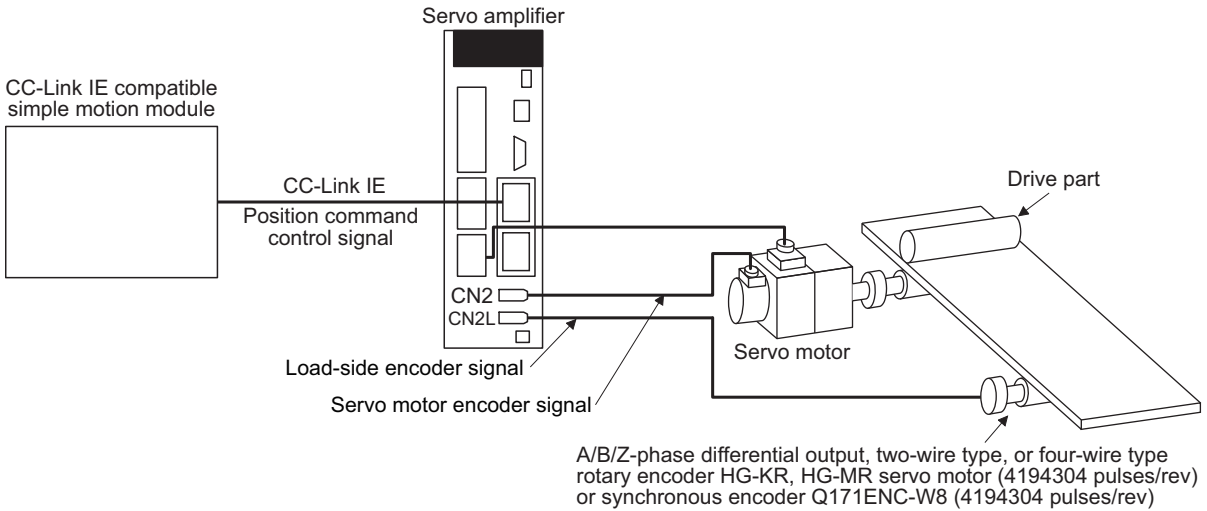

Scale measurement encoder

Point

- Always use the scale measurement encoder cable introduced in this section. Using other products may cause a malfunction.
- For details of the scale measurement encoder specifications, performance and assurance, contact each encoder manufacturer.

Linear encoder

Refer to "Linear Encoder Instruction Manual" for usable linear encoders.

To use the scale measurement function in the absolute position detection system ([Pr. PA22] = 1__ _), an absolute position linear encoder is required. In this case, you do not need to install the encoder battery to the servo amplifier for backing up the absolute position data of the load side. To use a servo motor in the absolute position detection system ([Pr. PA03] = __ _1), the encoder battery must be installed to the servo amplifier for backing up the absolute position data of the servo motor side.

Rotary encoder

When a rotary encoder is used as a scale measurement encoder, use either of the following servo motors or the encoder.

Servo amplifier	HG-KR	HG-MR	Synchronous encoder Q171ENC-W8	A/B/Z-phase differential output*1
MR-J4-_GF_	○	○	—	—
MR-J4-_GF_-RJ	○	○	○	○

*1 A/B/Z-phase differential output rotary encoders that can be used as a scale measurement encoder have the same specifications as the A/B/Z-phase differential output linear encoders. Refer to "Linear Encoder Instruction Manual".

Use a two-wire type encoder cable for MR-J4-_GF_ servo amplifiers. Do not use MR-EKCBL30M-L, MR-EKCBL30M-H, MR-EKCBL40M-H, or MR-EKCBL50M-H as they are four-wire type.

When an encoder cable of 30 m to 50 m is needed, fabricate a two-wire type encoder cable according to the following section.

☞ Page 630 Two-wire type encoder cable for HG-MR/HG-KR

To use the scale measurement function in the absolute position detection system ([Pr. PA22] = 1__ _), the encoder battery must be installed to the servo amplifier for backing up the absolute position data of the load side. In this case, the battery life will be shorter because the power consumption is increased as the power is supplied to the two encoders of motor side and load side.

Configuration diagram of encoder cable

Configuration diagram for servo amplifier and scale measurement encoder is shown below. Cables vary depending on the scale measurement encoder.

■Linear encoder

Refer to "Linear Encoder Instruction Manual" for encoder cables for linear encoder.

- MR-J4-_GF_ servo amplifier

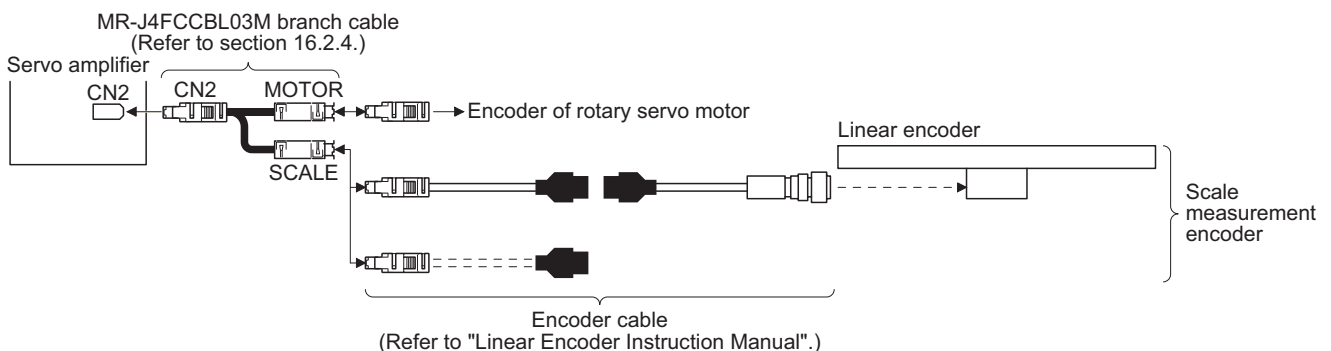

- MR-J4-_GF_-RJ servo amplifier

You can connect the linear encoder without using a branch cable shown in "MR-J4-_GF_ servo amplifier" for MR-J4-_GF_-RJ servo amplifier. You can also use a four-wire type linear encoder.

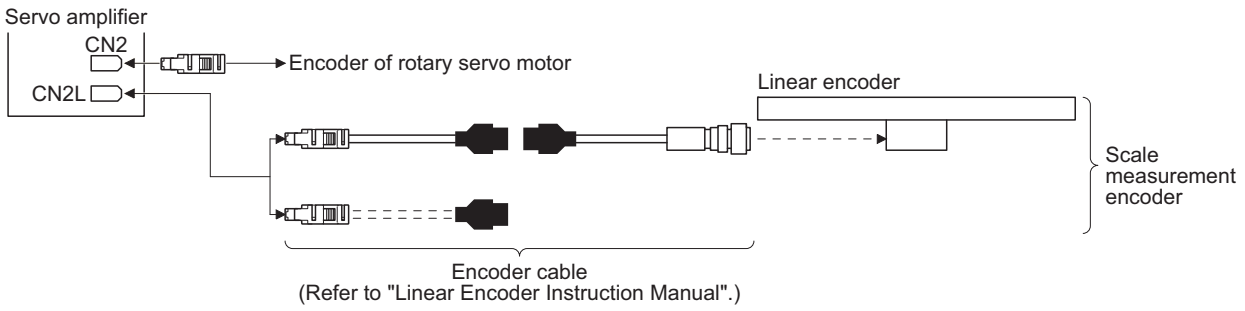

■Rotary encoder

Refer to "Servo Motor Instruction Manual (Vol. 3)" for encoder cables for rotary encoders.

- MR-J4-_GF_ servo amplifier

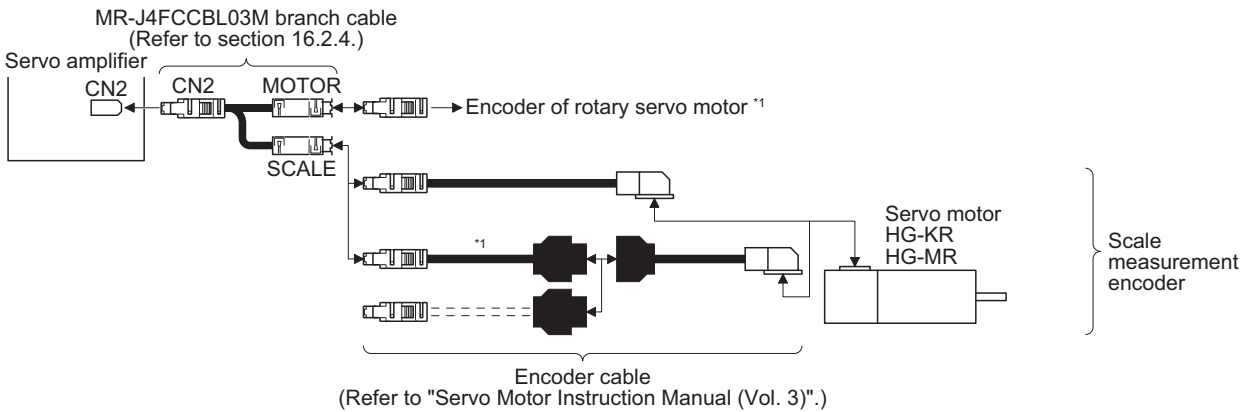

*1 Use a two-wire type encoder cable. A four-wire type encoder cable cannot be used.

- MR-J4-_GF_-RJ servo amplifier

You can connect the rotary encoder without using an MR-J4FCCBL03M branch cable for MR-J4-_GF_-RJ servo amplifier. Four-wire type or A/B/Z-phase differential output rotary encoders can also be used.

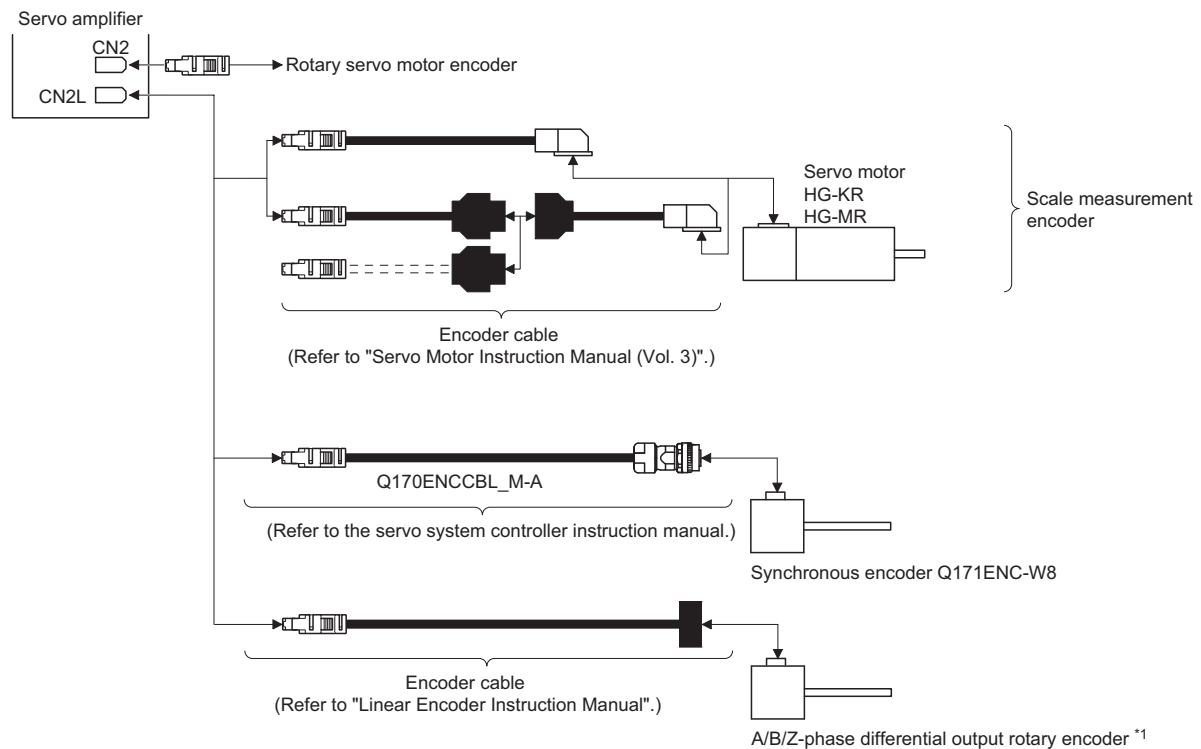

*1 A/B/Z-phase differential output rotary encoders that can be used as a scale measurement encoder have the same specifications as the A/B/Z-phase differential output linear encoders. Refer to "Linear Encoder Instruction Manual".

MR-J4FCCBL03M branch cable

Use MR-J4FCCBL03M branch cable to connect the scale measurement encoder to CN2 connector.

When fabricating the branch cable using MR-J3THMCN2 connector set, refer to "Linear Encoder Instruction Manual".

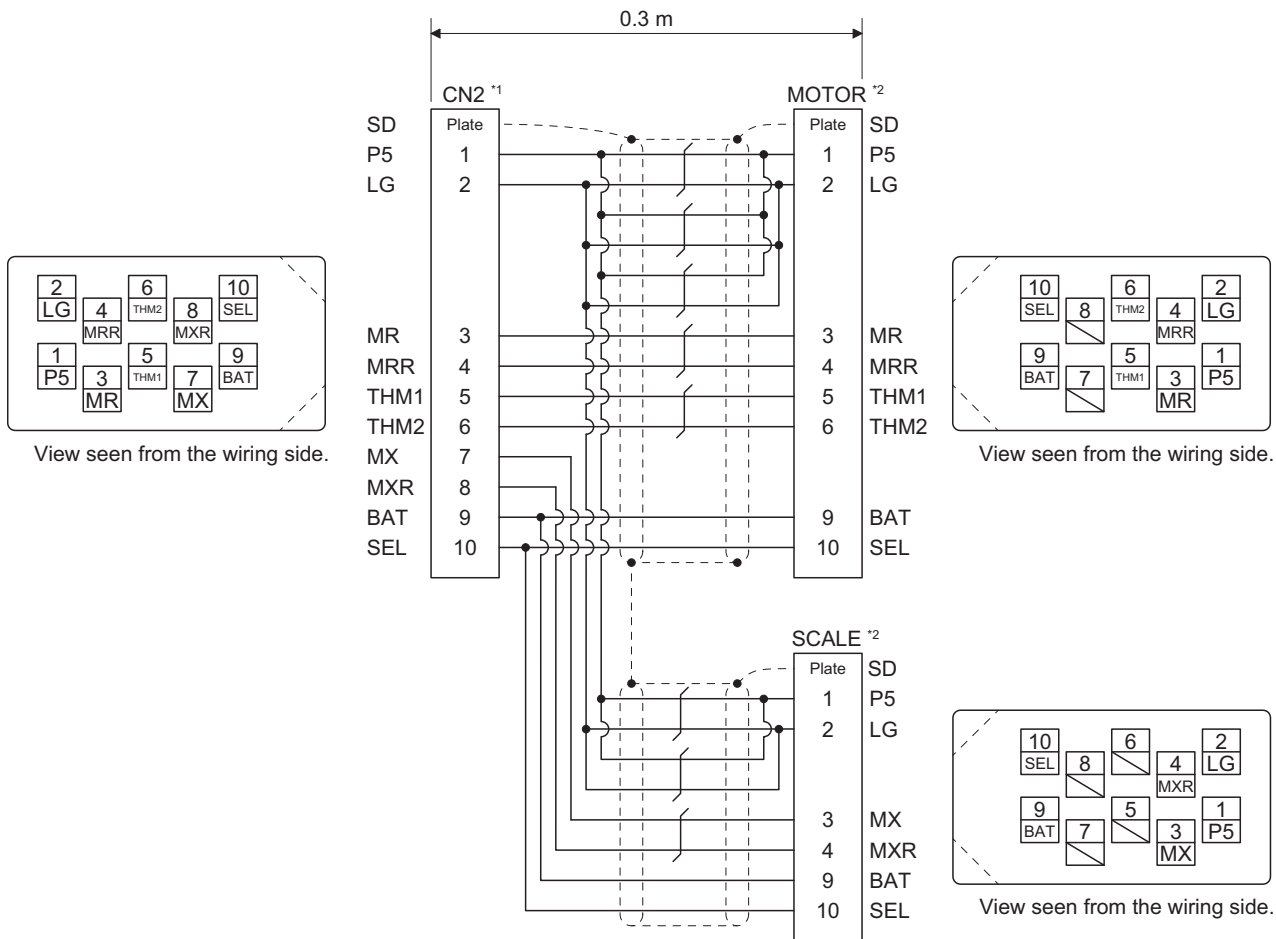

*1 Receptacle: 36210-0100PL, shell kit: 36310-3200-008 (3M)

*2 Plug: 36110-3000FD, shell kit: 36310-F200-008 (3M)

How to use scale measurement function

Selection of scale measurement function

The scale measurement function is set with the combination of basic setting parameters [Pr. PA01] and [Pr. PA22].

■ Operation mode selection

The scale measurement function can be used during semi closed loop system (standard control mode). Set [Pr. PA01] to " _ _ 0 _".

[Pr. PA01]
1 0 0 0

Operation mode selection

Setting value	Operation mode	Control unit
0	Standard control mode	Servo motor-side resolution unit

■ Scale measurement function selection

Select the scale measurement function. Set [Pr. PA22] to "1 _ _ _" (Used in absolute position detection system) or "2 _ _ _" (Used in incremental system) according to the encoder you use.

[Pr. PA22]
0 0 0 0

Scale measurement function selection

0: Disabled

1: Used in absolute position detection system

2: Used in incremental system

Selection of scale measurement encoder communication method and polarity

Point

"Encoder pulse count polarity selection" in [Pr. PC27] is not related to [Pr. PA14 Rotation direction selection]. Make sure to set the parameter according to the relationships between servo motor and linear encoder/rotary encoder.

The communication method differs depending on the scale measurement encoder type. For the communication method for using a linear encoder as scale measurement encoder, refer to "Linear Encoder Instruction Manual". Select "Four-wire type" because there is only four-wire type for synchronous encoder.

Select the cable to be connected to CN2L connector in [Pr. PC26].

[Pr. PC26]
0 0 0 0

Load-side encoder cable communication method selection

0: Two-wire type

1: Four-wire type

When using a load-side encoder of A/B/Z-phase differential output method, set "0".

Incorrect setting will trigger [AL. 70] and [AL. 71].

Setting "1" while using an MR-J4-_GF_ servo amplifier will trigger [AL. 37].

Select a polarity of the scale measurement encoder with the following "Encoder pulse count polarity selection" and "Selection of A/B/Z-phase input interface encoder Z-phase connection judgment function" of [Pr. PC27] as necessary.

■Parameter setting method

- Selection of the encoder pulse count polarity

This parameter is used to set the load-side encoder polarity to be connected to CN2L connector in order to match the CCW direction of servo motor and the increasing direction of load-side encoder feedback. Set this as necessary.

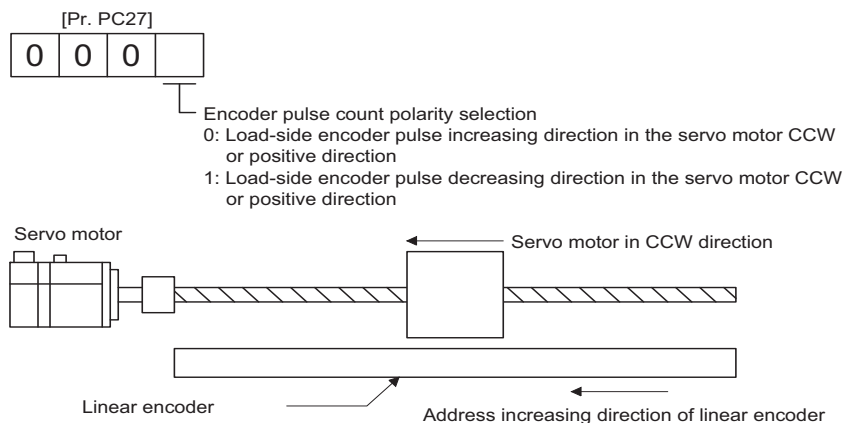

- A/B/Z-phase input interface encoder Z-phase connection judgment function

This function can trigger an alarm by detecting non-signal for Z phase.

The Z-phase connection judgment function is enabled by default. To disable the Z-phase connection judgment function, set [Pr. PC27].

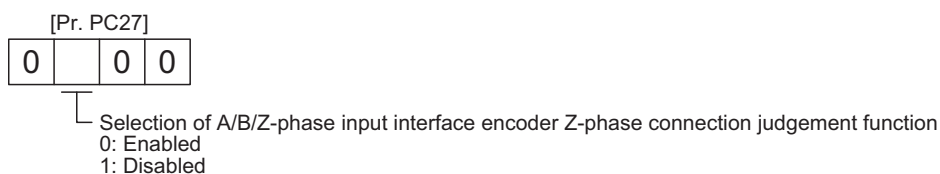

■How to confirm the scale measurement encoder feedback direction

You can confirm the directions of the cumulative feedback pulses of servo motor encoder and the load-side cumulative feedback pulses are matched by moving the device (scale measurement encoder) manually in the servo-off status. If mismatched, reverse the polarity.

Confirmation of scale measurement encoder position data

Check the scale measurement encoder mounting and parameter settings for any problems.

Operate the device (scale measurement encoder) to check the data of the scale measurement encoder is renewed correctly.

If the data is not renewed correctly, check the scale measurement encoder mounting, wiring, and parameter settings. Change the scale polarity as necessary.

Controller setting of the scale measurement function

When a simple motion module RD77GF or simple motion board MR-EM340GF is used, the scale function is available in the servo cyclic transmission function or servo transient transmission function. To use the simple motion module, set the objects 2D36h and 2D37h to any receive PDO, and the objects 2D35h, 2D38h, and 2D3Ch to any receive SDO.

For settings of the servo cyclic transmission function and servo transient transmission function, refer to the controller instruction manual.

Related object

Check that bit 1 of SubIndex2 of 2D35h (Encoder status2) is on before reading the object. If the object is read while bit 1 is off, the value of each object will be 0.

Index	Sub	Object	Name	Data Type	Access	Default	Description
2D36h	0	VAR	Scale cycle counter	I32	ro	—	Rotary encoder: Cycle counter Absolute position type linear encoder: ABS counter Incremental type linear encoder: Scale coasting counter*1 A/B/Z-phase differential output type and incremental type linear encoder: Scale coasting counter*1
2D37h	0	VAR	Scale ABS counter	I32	ro	—	Rotary encoder: Multi-revolution ABS counter Absolute position type linear encoder: Fixed to 0 Incremental type linear encoder: Fixed to 0 A/B/Z-phase differential output type and incremental type linear encoder: Fixed to 0
2D3Ch	0	VAR	Scale measurement encoder alarm	U16	ro	—	0: Normal Correct data is stored in each object. Value other than 0: Error The previous value is stored in each object.
2D38h	0	VAR	Scale measurement encoder resolution	U32	ro	—	For rotary encoder, for example, when an encoder of 4194304 pulses/rev is connected, the object value is 4194304. The value is always 0 except for rotary type.
2D35h	0	ARRAY	Encoder status	U8	ro	1	The number of entries is returned.
2D35h	1	ARRAY	Encoder status1	U32	ro	—	The encoder status is returned. For a fully closed loop system, the external encoder status is returned. Bit 0: Whether the servo amplifier is used in an absolute position detection system or not is returned. (OFF = Incremental system, ON = Absolute position detection system)
2D35h	2	ARRAY	Encoder status2	U32	ro	—	Scale measurement status display Bit 0: Whether the servo amplifier is used in an absolute position detection system or not is returned. (OFF = Incremental system, ON = Absolute position detection system) Bit 1: Whether the scale measurement function is enabled or disabled is returned. (OFF = Disabled, ON = Enabled) Bit 2: Whether the connected scale measurement encoder is the absolute position type or not is returned. (OFF = Incremental type, ON = Absolute position type)

*1 The counter indicates cumulative amount of travel distance from 0 (the position at power-on) to the travel direction. The range is between -2147483648 and 2147483647.

Method for calculating a scale measurement encoder position

The scale measurement encoder position is calculated as follows:

Scale position = (2D37h (Scale ABS counter) × 2D38h (Scale measurement encoder resolution)) + 2D36h (Scale cycle counter)

17.2 Touch probe

The touch probe function is available to latch the current position by sensor input.

With this function, the position feedback of the rising edge and falling edge of TPR1 (touch probe 1) and TPR2 (touch probe 2) can be memorized and stored into each object of 60BAh to 60BDh according to the conditions specified in Touch probe function (60B8h).

The following shows the touch probe detection resolution. Enabling the high precision touch probe will disable the encoder output pulses.

When a simple motion module RD77GF or simple motion board MR-EM340GF is used, the touch probe function is available with the servo cyclic transmission function or servo transient transmission function. To use the simple motion module, set 60B8h to any transmit PDO or any transmit SDO, and the objects 60BAh to 60BDh to any receive PDO or any receive SDO. For settings of the servo cyclic transmission function and servo transient transmission function, refer to the controller instruction manual.

Touch probe detection resolution		Touch probe1	Touch probe2
Input terminal		TPR1	TPR2
Encoder resolution	[Pr. PD37] = ___ 0 (Selection of high-precision touch probe is disabled)	55 μ s	55 μ s
	[Pr. PD37] = ___ 1 (Selection of high-precision touch probe is enabled)	55 μ s	Rising: 2 μ s Falling: 55 μ s

Related object

Index	Sub	Object	Name	Data Type	Access	Default	Description
60B8h	0	VAR	Touch probe function	U16	rw	—	Set enabling/disabling of the touch probe function, trigger conditions, and others.
60B9h	0	VAR	Touch probe status	U16	ro	0	This indicates the status information of the touch probe function.
60BAh	0	VAR	Touch probe pos1 pos value	I32	ro	0	Shows the rising edge position of TPR1 (touch probe 1). (Pos units)
60BBh	0	VAR	Touch probe pos1 neg value	I32	ro	0	Shows the falling edge position of TPR1 (touch probe 1). (Pos units)
60BCh	0	VAR	Touch probe pos2 pos value	I32	ro	0	Shows the rising edge position of TPR2 (touch probe 2). (Pos units)
60BDh	0	VAR	Touch probe pos2 neg value	I32	ro	0	Shows the falling edge position of TPR2 (touch probe 2). (Pos units)

■Details of Touch probe function (60B8h)

Bit	Definition
0	0: Touch probe 1 disabled 1: Touch probe 1 enabled
1	0: Single trigger mode 1: Continuous trigger mode
2	0: Set input of touch probe 1 as a trigger 1: Set 0 point of the encoder as a trigger (Unsupported)*1
3	(reserved) The value at reading is undefined. Set "0" when writing.
4	0: Stop sampling at the rising edge of touch probe 1 1: Start sampling at the rising edge of touch probe 1
5	0: Stop sampling at the falling edge of touch probe 1 1: Start sampling at the falling edge of touch probe 1
6	(reserved) The value at reading is undefined. Set "0" when writing.
7	
8	0: Touch probe 2 disabled 1: Touch probe 2 enabled
9	0: Single trigger mode 1: Continuous trigger mode
10	0: Set input of touch probe 2 as a trigger 1: Set 0 point of the encoder as a trigger (Unsupported)*1
11	(reserved) The value at reading is undefined. Set "0" when writing.
12	0: Stop sampling at the rising edge of touch probe 2 1: Start sampling at the rising edge of touch probe 2
13	0: Stop sampling at the falling edge of touch probe 2 1: Start sampling at the falling edge of touch probe 2
14	(reserved) The value at reading is undefined. Set "0" when writing.
15	

*1 This is not available with MR-J4- _GF_ servo amplifier.

■Details of Touch probe status (60B9h)

Bit	Definition
0	0: Touch probe 1 disabled 1: Touch probe 1 enabled
1	0: The rising edge position of touch probe 1 has not been stored. 1: The rising edge position of touch probe 1 has been stored.
2	0: The falling edge position of touch probe 1 has not been stored. 1: The falling edge position of touch probe 1 has been stored.
3	(reserved) The value at reading is undefined.
4	
5	
6	
7	
8	0: Touch probe 2 disabled 1: Touch probe 2 enabled
9	0: The rising edge position of touch probe 2 has not been stored. 1: The rising edge position of touch probe 2 has been stored.
10	0: The falling edge position of touch probe 2 has not been stored. 1: The falling edge position of touch probe 2 has been stored.
11	(reserved) The value at reading is undefined.
12	
13	
14	
15	

Timing chart

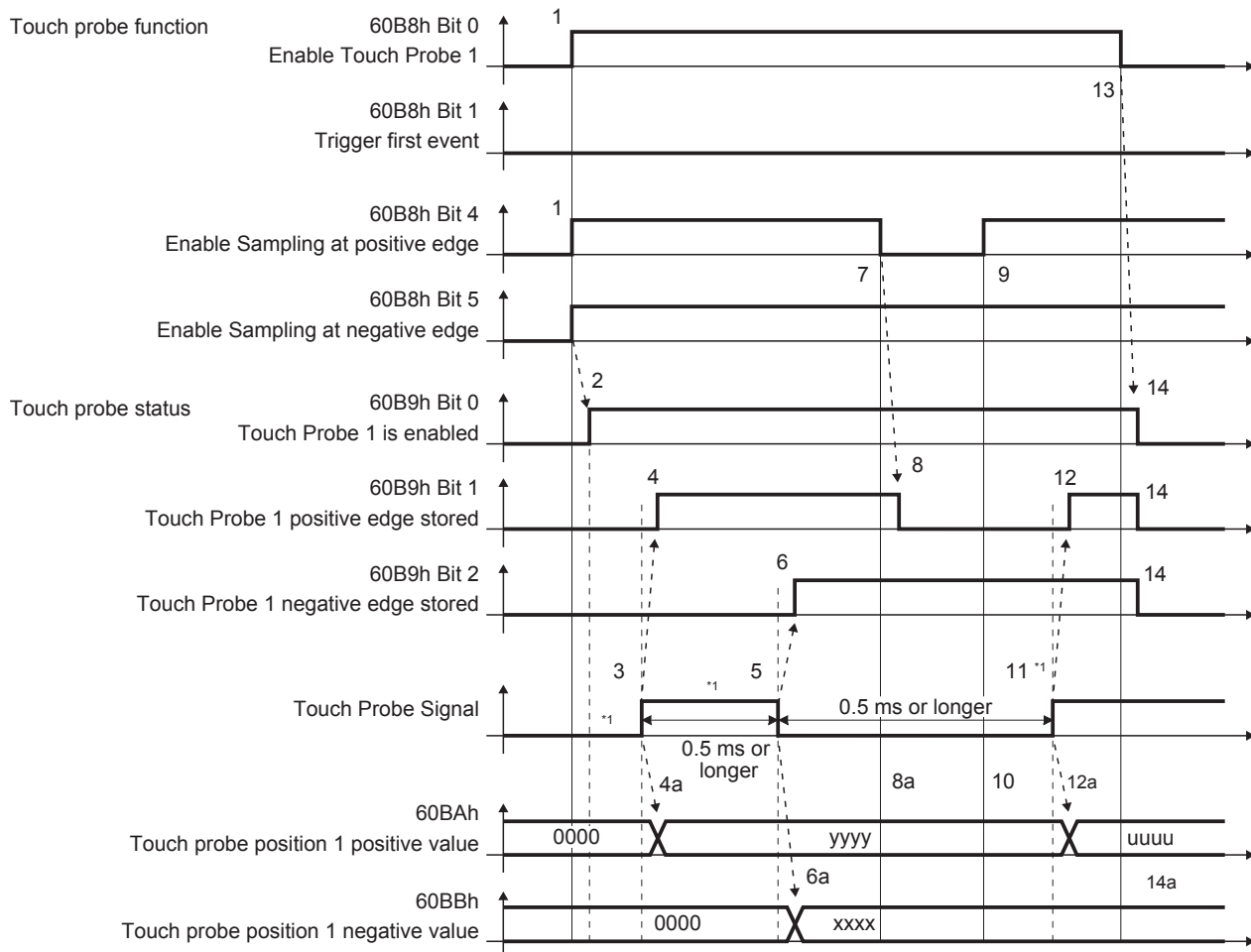

*1 Turn on and off Touch Probe Signal so that both the on time and off time are 0.5 ms or longer.

Transition No.	Object	Description
1	60B8h Bit 0, 4, 5 = 1	Enables Touch Probe1. The rising edge and falling edge are enabled.
2	→ 60B9h Bit 0 = 1	Turns on the Touch Probe1 enable status.
3	—	Turns on Touch Probe Signal (TPR1).
4	→ 60B9h Bit 1 = 1	Turns on the Touch Probe1 positive edge stored status.
4a	→ 60BAh	Sets the latched position feedback for Touch probe position1 positive value.
5	—	Turns off Touch Probe Signal (TPR1).
6	→ 60B9h Bit 2 = 1	Turns on the Touch Probe1 negative edge stored status.
6a	→ 60BBh	Sets the latched position feedback for Touch probe position1 negative value.
7	60B8h Bit 4 = 0	Turns off Sample positive edge. Rising edge detection is disabled.
8	→ 60B9h Bit 1 = 0	Turns off Touch Probe1 positive edge stored status.
8a	→ 60BAh	Touch probe position1 positive value does not change.
9	60B8h Bit 4 = 1	Turns on Sample positive edge. Rising edge detection is enabled.
10	→ 60BAh	Touch probe position1 positive value does not change.
11	—	Turns on Touch Probe Signal (TPR1).
12	→ 60B9h Bit 1 = 1	Turns on the Touch Probe1 negative edge stored status.
12a	→ 60BAh	Sets the latched position feedback for Touch probe position1 negative value.
13	60B8h Bit 0 = 0	Disables Touch Probe1.
14	→ 60B9h Bit 0, 1, 2 = 0	Clears all the status Bit.
14a	→ 60BAh, 60BBh	Touch probe position1 positive/negative value does not change.

High-precision touch probe

TPR2 (touch probe 2) supports high-precision touch probe. The normal touch probe has the latch function with precision of 55 μs . On the other hand, the high-precision touch probe latches precisely startup of TPR2 (touch probe 2) with precision of 2 μs . To use the high-precision touch probe, set [Pr. PD37] to "___ 1". While the high-precision touch probe is being used, the encoder pulse output function cannot be used. The precision of falling edge is 55 μs in this case as well.

17.3 Backup/restoration function



- Do not use the backup/restoration function with the following conditions.

Function	Non-functioning situation
Backup	At communication shut-off During servo motor operation
Restoration	At communication shut-off At servo-on

- After a restore is executed, wait for 40 s or more, and then cycle the power of the servo amplifier. When the restore is executed with the absolute position detection system, a home position return must be performed after the setting.
- If a restore is interrupted, all data may not be written to the servo amplifier, causing the restore to fail. If the restore is interrupted, execute it again.
- Backup and restore cannot be executed from multiple GOTs to one servo amplifier at the same time.
- Do not read/write parameters with the engineering tool (MR Configurator2, etc.) while backup or restore is being executed. Otherwise, data backup or restore may fail.
- The backup/restoration function is not available with a connection from a local station.

The backup/restoration function is to back up and restore all parameter data, point table data and cam data in the MR-J4-_GF_(-RJ) to GOT using SLMP. The following data can be backed up.

Item	Description	Backup file name
Parameter	All parameter data	SUBID0001.QBR
Point table	All point table data	SUBID0002.QBR
Cam data ^{*1}	All cam data	SUBID0003.QBR

*1 Cam data can be backed up and restored only in the I/O mode. For details, refer to the following and GOT User's Manual.

MR-J4-_GF_(-RJ) Servo Amplifier Instruction Manual (I/O Mode)

For the procedures of backup/restoration, refer to the GOT User's Manual.

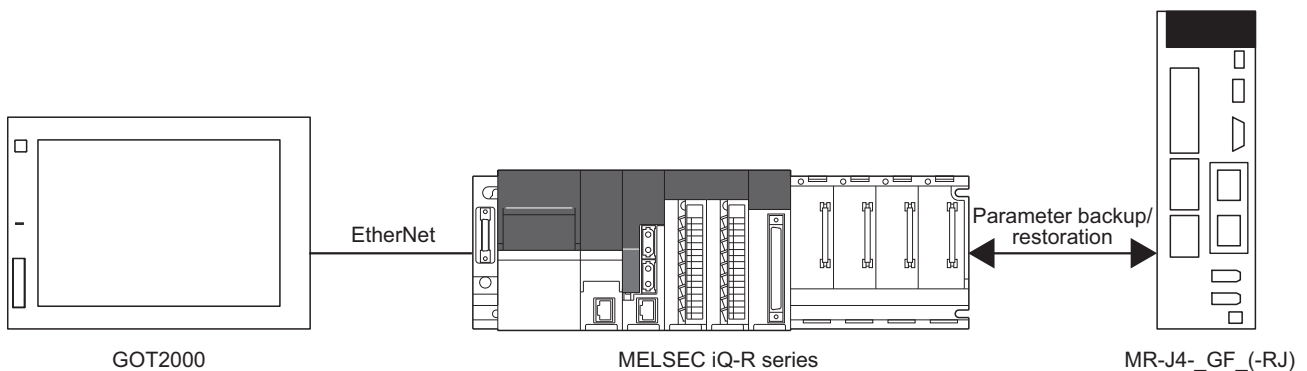

Use the GOT with GT Designer3 Version 1.151H or later.

For details of connected devices, refer to the instruction manual of each device.

17.4 Parameter object

Definition of parameter objects

When a simple motion module RD77GF or simple motion board MR-EM340GF is used, use the servo parameter change function to change the parameter of the servo amplifier by writing values to the following objects. Since the changed setting is deleted at power supply shut-off, resetting is required at the next startup. To hold the changed setting even at the next startup, save the parameter setting value to EEPROM using Store Parameters (1010h).

To change the setting of the parameters where the changes are reflected by cycling the power, change the value of the corresponding object and execute Store Parameters (1010h) before cycling the power. For parameters requiring power cycling, refer to the following.

☞ Page 172 PARAMETERS

The following table lists the related objects. Refer to the controller instruction manual for setting of the servo parameter change function.

Index	Sub	Object	Name	Data Type	Access	Description
2001h	0	VAR	PA01	I32	rw	[Pr. PA__] group
⋮	⋮	⋮	⋮	⋮	⋮	
2020h	0	VAR	PA32	I32	rw	
2081h	0	VAR	PB01	I32	rw	[Pr. PB__] group
⋮	⋮	⋮	⋮	⋮	⋮	
20C0h	0	VAR	PB64	I32	rw	
2101h	0	VAR	PC01	I32	rw	[Pr. PC__] group
⋮	⋮	⋮	⋮	⋮	⋮	
2150h	0	VAR	PC80	I32	rw	
2181h	0	VAR	PD01	I32	rw	[Pr. PD__] group
⋮	⋮	⋮	⋮	⋮	⋮	
21B0h	0	VAR	PD48	I32	rw	
2201h	0	VAR	PE01	I32	rw	[Pr. PE__] group
⋮	⋮	⋮	⋮	⋮	⋮	
2240h	0	VAR	PE64	I32	rw	
2281h	0	VAR	PF01	I32	rw	[Pr. PF__] group
⋮	⋮	⋮	⋮	⋮	⋮	
22C0h	0	VAR	PF48	I32	rw	
2401h	0	VAR	PL01	I32	rw	[Pr. PL__] group
⋮	⋮	⋮	⋮	⋮	⋮	
2430h	0	VAR	PL48	I32	rw	
2481h	0	VAR	PT01	I32	rw	[Pr. PT__] group
⋮	⋮	⋮	⋮	⋮	⋮	
24D0h	0	VAR	PT80	I32	rw	
2581h	0	VAR	PN01	I32	rw	[Pr. PN__] group
⋮	⋮	⋮	⋮	⋮	⋮	
25A0h	0	VAR	PN32	I32	rw	

Enabling parameters

The parameters whose symbols are preceded by "*" are enabled by the following operations. Refer to the following for "*" of the parameter symbols.

☞ Page 172 PARAMETERS

Store Parameters

Write "65766173h" (= reverse order of the ASCII code of "save") to the corresponding sub object of Store Parameters (1010h) to store the parameter setting in the EEPROM of the servo amplifier.

The value saved in the EEPROM is set to the object at the next power-on. For the parameters, the setting can also be changed with the servo parameter change function. However the new setting is not automatically written to the EEPROM. To write the new setting, use the Store Parameters (1010h).

Executing Store Parameters (1010h) takes about a maximum of 25 s because all parameters are written at the same time. Be careful not to shut off the power during writing.

Index	Sub	Object	Name	Data Type	Access	Description
1010h	0	ARRAY	Store Parameters	U8	ro	Number of entries
	1		Save all parameters	U32	rw	Saves all parameters. Writing "save" (= 65766173h) saves all the objects which can be stored in EEPROM.

The following values are read from Store Parameters (1010h). When a parameter is being saved, "0" is read. When no parameter is being saved, "1" is read.

Bit	Description
0	0: The parameter cannot be saved with the command. (A parameter is being saved.) 1: The parameter can be saved with the command. (No parameter is being saved.)
1	0: The parameter is not automatically saved.

17.5 Machine diagnosis function

Function summary

Point

The failure prediction function is used with servo amplifiers with software version A3 or later. This is available with MR Configurator2 with software version 1.60N or later.

The machine diagnosis function estimates the friction and vibrational component of the drive system in the equipment based on the data in the servo amplifier, and detects an error in the machine parts, including a ball screw and bearing. The machine diagnosis function includes the friction vibration estimation function and the failure prediction function.

Friction vibration estimation function

In the friction vibration estimation function, the friction estimation function estimates the friction of the drive system in the equipment, and the vibration estimation function estimates the minute vibration level and vibration frequency based on the data in the servo amplifier. The friction estimation function estimates and detects the static friction (including gravity) and the dynamic friction of guides and ball screws after operation is performed in any operation pattern. The vibration estimation function estimates and detects the vibration level both during servo motor operation and at a servo motor stop, and vibration frequency both during servo motor operation and at a servo motor stop after operation is performed in any operation pattern.

Failure prediction function

The failure prediction function predicts a failure of the equipment from the friction, vibration level during servo motor operation, and servo motor total travel distance, which are estimated by the friction vibration estimation function. In the failure prediction function, the friction failure prediction function predicts a failure of the equipment from the estimated friction, the vibration failure prediction function predicts a failure of the equipment from the estimated vibration level during servo motor operation, and the total travel distance failure prediction function predicts a failure of the equipment from the servo motor total travel distance.

How to set the function

Friction estimation function/friction failure prediction function

Use the friction estimation function or the friction failure prediction function with the following procedure. In the friction failure prediction function, a threshold that outputs a warning can be automatically calculated in the servo amplifier with "Automatic threshold setting", or set by using parameters with "Manual threshold setting". With the manual threshold setting, you can set any threshold that outputs a warning.

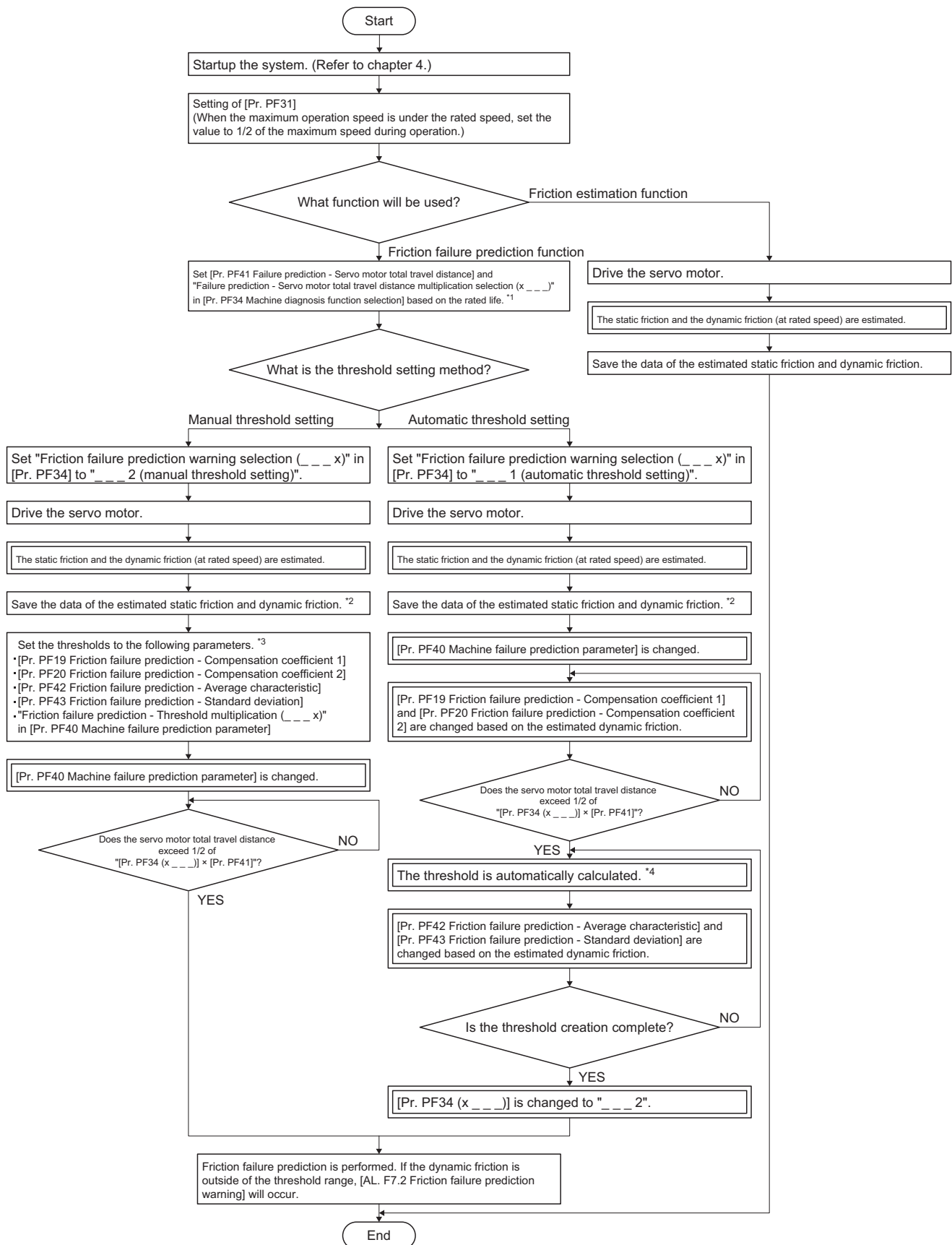

*1 When the servo amplifier is replaced after the equipment is operated, set [Pr. PF41] and [Pr. PF34 (___ x)] based on the value obtained by subtracting the present servo motor total travel distance from the rated life.

*2 You can save the data of the estimated static friction and dynamic friction on the machine diagnosis screen of MR Configurator2.

*3 Even if [Pr. PF19] and [Pr. PF20] are unchanged from the initial value, the function operates properly. However, setting the value estimated by the automatic threshold setting will decrease the possibility of an erroneous detection for failure prediction.

*4 If the equipment is operated continuously for less than 3 hours, or the friction estimation is not completed for the travel direction set in [Pr. PF40], the threshold is not calculated automatically.

Vibration estimation function/vibration failure prediction function

Use the vibration estimation function or the vibration failure prediction function with the following procedure. In the vibration failure prediction function, a threshold that outputs a warning can be automatically calculated in the servo amplifier with "Automatic threshold setting", or set by using parameters with "Manual threshold setting". With the manual threshold setting, you can set any threshold that outputs a warning.

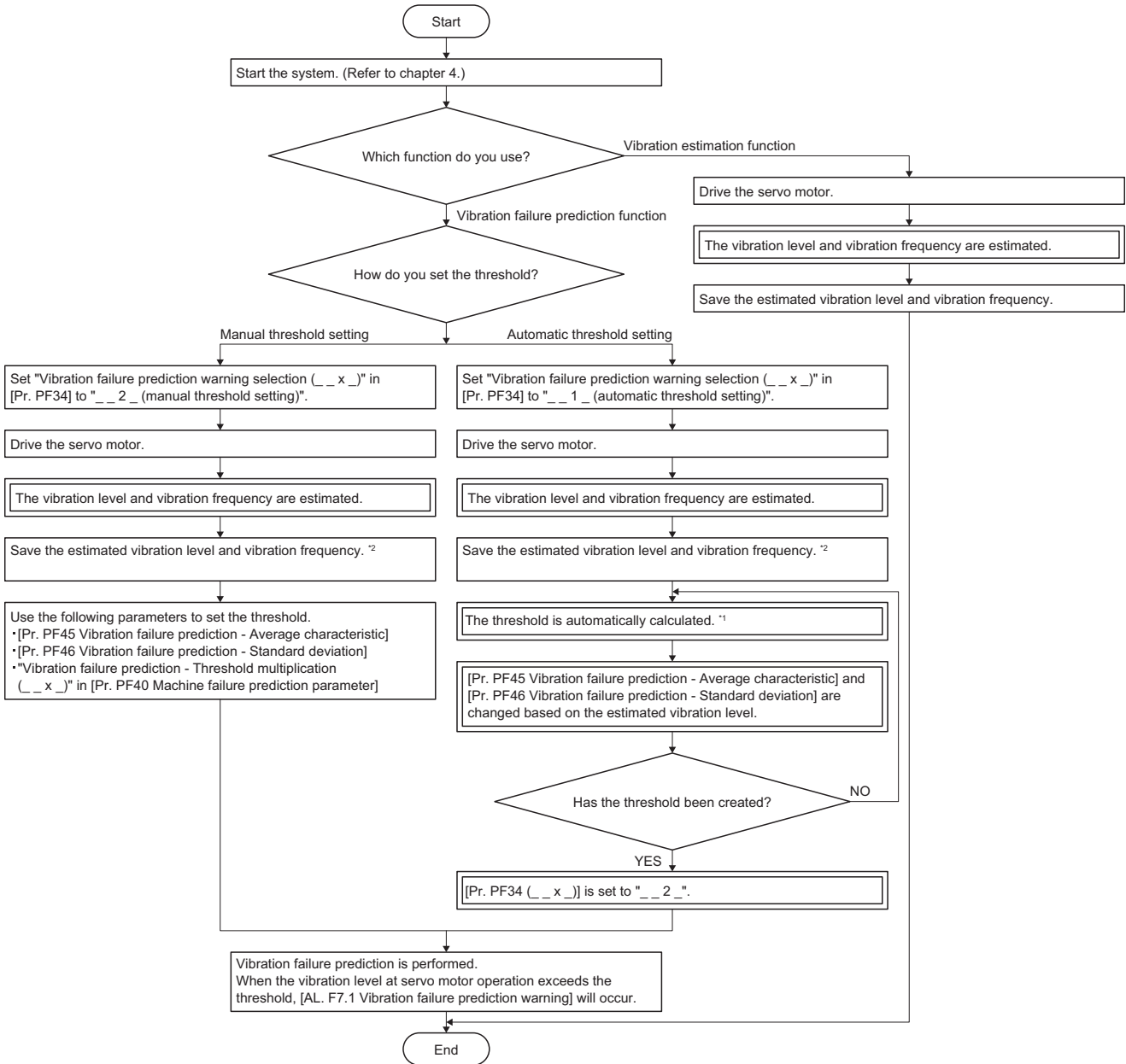

Total travel distance failure prediction function

Use the total travel distance failure prediction function with the following procedure.

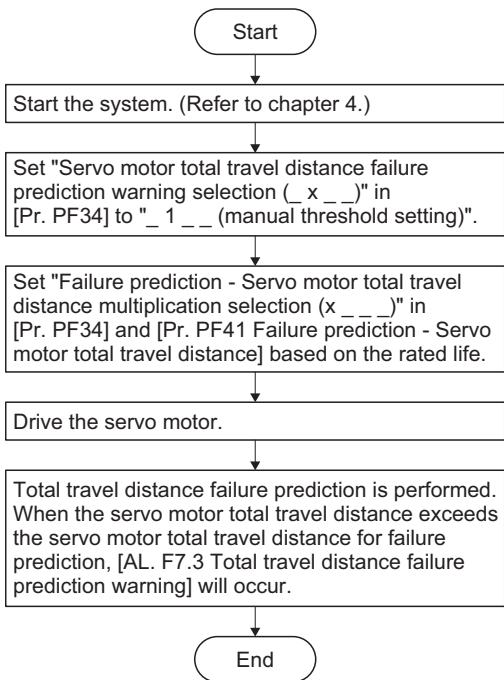

Friction vibration estimation function

Point

- If the vibration frequency is extremely low or high, vibration estimation cannot be performed. For example, a low frequency vibration of several tens of hertz is generated with a machine of low rigidity. Note that such a frequency cannot be detected.
- If the equipment vibrates at a plurality of frequencies simultaneously due to some mechanical resonance or others, vibration frequency may not be estimated properly.
- Vibration frequency may not be estimated properly under the condition that the torque crosses the torque limit value. Set a longer acceleration time and deceleration time, or slightly decrease the gains to prevent the occurrence of excessive torque vibrations.
- It is recommended to save the values estimated by the friction vibration estimation function at the start of operation. The degree of machine degradation after operation can be checked by comparing the value estimated by the friction vibration estimation function after operation and the value at the start of operation, facilitating preventive maintenance.

In the friction vibration estimation function, the friction estimation function estimates the friction of the drive system in the equipment, and the vibration estimation function estimates the minute vibration level and vibration frequency based on the data in the servo amplifier. The friction estimation function estimates and detects the static friction (including gravity) and the dynamic friction of guides and ball screws after operation is performed in any operation pattern. The vibration estimation function estimates and detects the vibration level both during servo motor operation and at a servo motor stop, and vibration frequency both during servo motor operation and at a servo motor stop after operation is performed in any operation pattern.

Friction estimation function

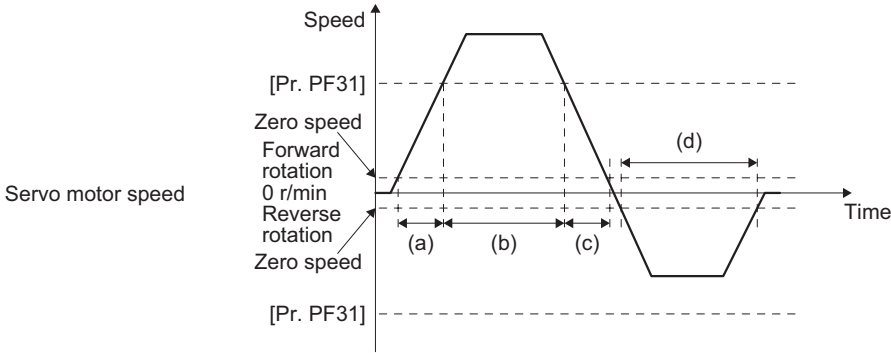

To perform friction estimation, the servo motor must be rotated at zero speed or higher, and operated for 150 s both in the high and low-speed sections. High-speed section indicates that the absolute value of the servo motor speed is [Pr. PF31 Machine diagnosis function - Friction judgment speed] or more. Low-speed section indicates that the absolute value of the servo motor speed is less than [Pr. PF31]. For the above operation pattern, when the cumulative time of (a) + (c) is 150 s or more and the cumulative time of (b) is 150 s or more, the friction in the forward rotation direction is estimated. The friction in the reverse rotation direction is not estimated, even if time (d) is 150 s or more because the servo motor is not operated in the high-speed section. In this case, decrease the setting value of [Pr. PF31] to perform friction estimation. When "0" is set in [Pr. PF31], 1/2 of the rated speed will be the threshold.

For the following operation pattern, it takes approximately 20 min. for completing friction estimation.

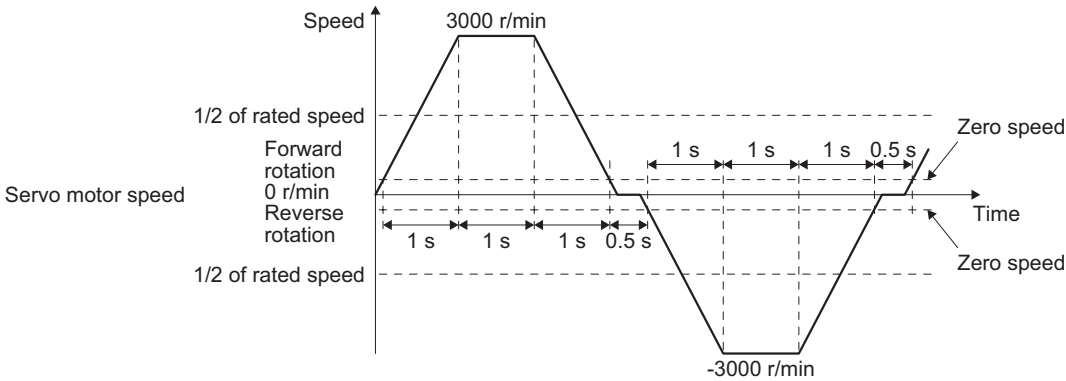

The friction estimation function estimates the static friction both at forward rotation and reverse rotation, and the dynamic friction (at rated speed) both at forward rotation and reverse rotation. To estimate these values, it is unnecessary to perform to-and-fro positioning operation. By operating the servo motor in acceleration/deceleration for forward rotation, you can only estimate the static friction and dynamic friction (at rated speed) at forward rotation. By operating the servo motor in acceleration/deceleration for reverse rotation, you can only estimate the static friction and dynamic friction (at rated speed) at reverse rotation.

Vibration estimation function

The vibration estimation function monitors torque vibrations to estimate high-frequency minute vibration level and vibration frequency. Thus, the function enables to monitor a backlash on the guide, ball screw, belt, etc. and the increase in vibration level and change in vibration frequency due to deterioration.

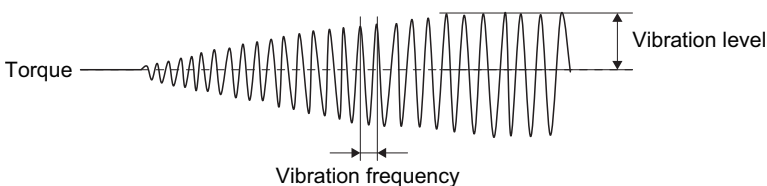

The vibration estimation function estimates the vibration level and vibration frequency respectively during servo motor operation and at a servo motor stop. Concretely, the function estimates the vibration level both during servo motor operation and at a servo motor stop, and vibration frequency both during servo motor operation and at a servo motor stop.

Failure prediction function

Point

- When the vibration failure prediction function is enabled, a vibration failure warning may occur if the gains of the servo amplifier are changed. To enable the vibration failure prediction function, enable it after the gains of the servo amplifier are adjusted.
- In the torque mode, the friction failure prediction function and the vibration failure prediction function cannot be used.
- To create a dynamic friction threshold with the automatic threshold setting in the friction failure prediction function, the equipment must be operated for 3 consecutive hours or more, and operated in the position or velocity mode for a cumulative time of 90 hours or more after the servo motor total travel distance exceeds 1/2 of "Failure prediction - Servo motor total travel distance multiplication selection (x __ __)" in [Pr. PF34] × [Pr. PF41 Failure prediction - Servo motor total travel distance].
- To create a vibration level threshold with the automatic threshold setting in the vibration failure prediction function, the equipment must be operated for 3 consecutive hours or more, and operated in the position or velocity mode for a cumulative time of 90 hours or more.
- With MR Configurator2 or a controller, you can check thresholds when the friction failure prediction function and vibration failure prediction function are used.

The failure prediction function predicts a failure of the equipment from the friction and vibration level during servo motor operation, which are estimated by the friction vibration estimation function. In the failure prediction function, the friction failure prediction function predicts a failure of the equipment from the estimated friction, the vibration failure prediction function predicts a failure of the equipment from the estimated vibration level during servo motor operation, and the total travel distance failure prediction function predicts a failure of the equipment from the servo motor total travel distance.

Friction failure prediction function

The friction failure prediction function predicts a failure of the equipment from the increase and decrease in the dynamic friction (at rated speed) estimated by the friction estimation function. If a failure of the equipment is predicted, [AL. F7.2 Friction failure prediction warning] will occur.

In the friction failure prediction function, a threshold that triggers [AL. F7.2] can be set by the following two methods.

■Automatic threshold setting

From the dynamic friction (at rated speed) estimated by the friction estimation function, a threshold that triggers [AL. F7.2] is automatically calculated in the servo amplifier. With this setting, you can use the friction failure prediction function without setting a threshold. However, after the servo motor total travel distance exceeds 1/2 of "Failure prediction - Servo motor total travel distance multiplication selection (x __ __) in [Pr. PF34] × [Pr. PF41 Failure prediction - Servo motor total travel distance]", a threshold is not set automatically until the equipment is operated continuously for 3 hours or more, and operated in the position mode or velocity mode for a cumulative time of 90 hours or more. [AL. F7.2] does not occur until a threshold is calculated in the servo amplifier.

■Manual threshold setting

You can set a threshold that triggers [AL. F7.2] with "Friction failure prediction - Threshold multiplication (__ __ x)" in [Pr. PF40], and with [Pr. PF42 Friction failure prediction - Average characteristic] and [Pr. PF43 Friction failure prediction - Standard deviation]. For the manual threshold setting, if the servo motor total travel distance exceeds 1/2 of "[Pr. PF34 (x __ __)] × [Pr. PF41 Failure prediction - Servo motor total travel distance]", friction failure prediction will start. Thus, if the dynamic friction threshold is known, or the equipment you use is configured the same as another piece of equipment used for calculating the threshold with the automatic threshold setting, an initial failure or others can also be detected with the manual threshold setting.

If you manually set a threshold again with the equipment used for setting the threshold automatically, set the value, which is obtained by the automatic threshold setting, in [Pr. PF19 Friction failure prediction - Compensation coefficient 1] and [Pr. PF20 Friction failure prediction - Compensation coefficient 2]. Setting [Pr. PF19] and [Pr. PF20] will decrease the possibility of an erroneous detection for failure prediction.

The friction failure prediction function can be used with the following procedure.

■Friction failure prediction warning setting

To enable the friction failure prediction warning, set "Friction failure prediction warning selection (___ x)" in [Pr. PF34] to "___ 1 (automatic threshold setting)" or "___ 2 (manual threshold setting)".

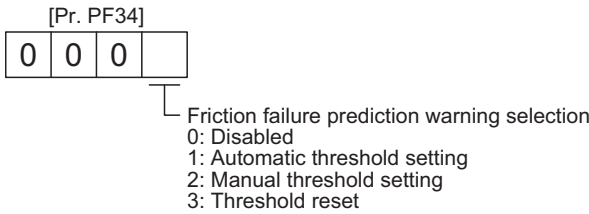

■Setting of servo motor total travel distance for failure prediction

For the automatic threshold setting, set a servo motor total travel distance for failure prediction. It is recommended that the servo motor total travel distance for failure prediction be set to about the same as the rated life presented by each guide manufacturer and ball screw manufacturer. For example, for a rated life of 8×10^5 rev, set "Failure prediction - Servo motor total travel distance multiplication selection (x ___)" in [Pr. PF34] to "2 ___", and set [Pr. PF41] to "80".

■Threshold setting method

For the automatic threshold setting, [Pr. PF42 Friction failure prediction - Average characteristic] and [Pr. PF43 Friction failure prediction - Standard deviation] for determining a threshold are automatically rewritten according to the dynamic friction (at rated speed) estimated in the servo amplifier. At this time, changing "Friction failure prediction - Threshold multiplication (___ x)" in [Pr. PF40] enables to change the threshold. If [AL. F7.2 Friction failure prediction warning] occurs with the value obtained by the automatic threshold setting, set "___ 6" or more in [Pr. PF40 (___ x)]. After the threshold is calculated in the servo amplifier, [Pr. PF34 (___ x)] will be set to "___ 2 (manual threshold setting)".

For the manual threshold setting, the upper and lower limit thresholds can be calculated with the equations below. When [Pr. PF40 (___ x)] is set to "___ 0", the upper and lower limit thresholds are calculated assuming the setting as "___ 5".

Upper limit threshold [0.1%] = [Pr. PF42 Friction failure prediction - Average characteristic] + [Pr. PF43 Friction failure prediction - Standard deviation] × "Friction failure prediction - Threshold multiplication (___ x)" in [Pr. PF40]

Lower limit threshold [0.1%] = [Pr. PF42 Friction failure prediction - Average characteristic] - [Pr. PF43 Friction failure prediction - Standard deviation] × "Friction failure prediction - Threshold multiplication (___ x)" in [Pr. PF40]

■Execution of friction failure prediction

When upper and lower limit thresholds are inputted to the servo amplifier as indicated in the following section, the servo amplifier starts friction failure prediction. During friction failure prediction, if the dynamic friction (at rated speed) estimated by the friction estimation function exceeds the upper or lower limit threshold, [AL. F7.2 Friction failure prediction warning] will occur. After the occurrence of [AL. F7.2], if the dynamic friction (at rated speed) falls within the upper/lower limit threshold, [AL. F7.2] will be canceled.

☞ Page 581 Threshold setting method

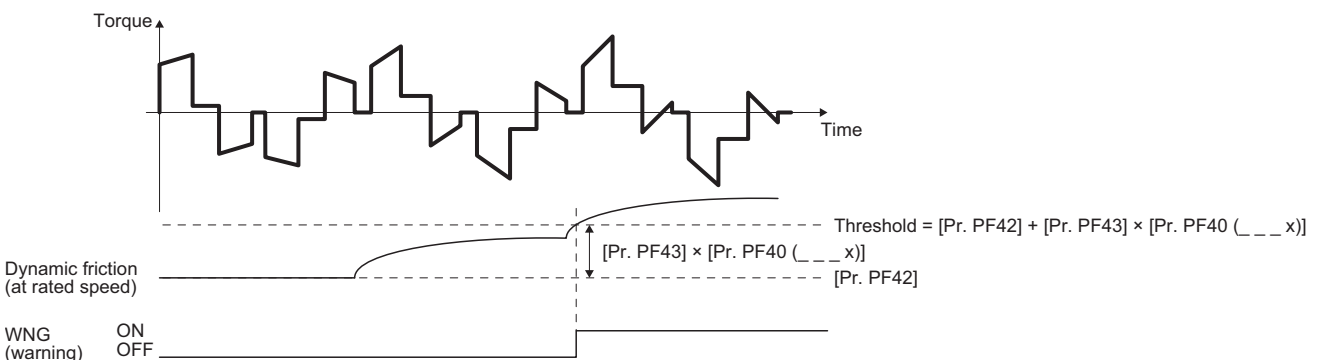

■Threshold reset method

To automatically reset thresholds after the upper and lower limit thresholds are set automatically, set "Friction failure prediction warning selection (___ x)" in [Pr. PF34] to "___ 3 (threshold reset)", and then cycle the power. After the power is cycled, the thresholds are reset and [Pr. PF34 (___ x)] is set to "___ 1 (automatic threshold setting)". If any part of the equipment is replaced after the friction failure prediction function operates, reset the friction thresholds and servo motor total travel distance.

Vibration failure prediction function

The vibration failure prediction function predicts a failure of the equipment from the increase in the vibration level estimated by the vibration estimation function. If a failure of the equipment is predicted from the vibration level, [AL. F7.1 Vibration failure prediction warning] will occur.

In the vibration failure prediction function, a threshold that triggers [AL. F7.1] can be set by the following two methods.

■Automatic threshold setting

From the vibration level estimated by the vibration estimation function, a threshold that triggers [AL. F7.1] is automatically calculated in the servo amplifier. With this setting, you can use the vibration failure prediction function without setting a threshold. However, after the vibration failure prediction function operates, the equipment must be operated for about 90 hours before vibration failure prediction is actually performed. [AL. F7.1] does not occur until a threshold is calculated in the servo amplifier.

■Manual threshold setting

You can set a threshold that triggers [AL. F7.1 Vibration failure prediction warning] with "Vibration failure prediction - Threshold multiplication (_ _ x _)" in [Pr. PF40], and with [Pr. PF45 Vibration failure prediction - Average characteristic] and [Pr. PF46 Vibration failure prediction - Standard deviation]. For the manual threshold setting, vibration failure prediction will start immediately after the vibration failure prediction function operates. Thus, if the vibration amplitude threshold is known, or the equipment you use is configured the same as another piece of equipment used for calculating the threshold with the automatic threshold setting, an initial failure or others can also be detected with the manual threshold setting.

The vibration failure prediction function can be used with the following procedure.

■Vibration failure prediction warning setting

To enable the vibration failure prediction warning, set "Vibration failure prediction warning selection (_ _ x _)" in [Pr. PF34] to " _ _ 1 _ (automatic threshold setting)" or " _ _ 2 _ (manual threshold setting)".

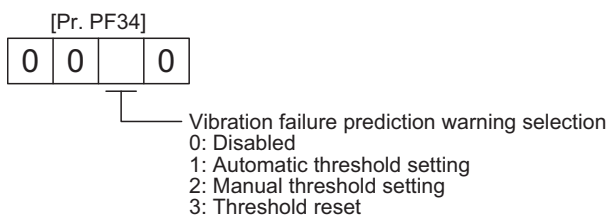

■Threshold setting method

For the automatic threshold setting, [Pr. PF45 Vibration failure prediction - Average characteristic] and [Pr. PF46 Vibration failure prediction - Standard deviation] for determining a threshold are automatically rewritten according to the vibration level estimated in the servo amplifier. At this time, changing "Vibration failure prediction - Threshold multiplication (_ _ x _)" in [Pr. PF40] enables to change the threshold. If [AL. F7.1 Vibration failure prediction warning] occurs with the value obtained by the automatic threshold setting, set " _ _ 6 _ " or more in [Pr. PF40 (_ _ x _)]. After the threshold is calculated in the servo amplifier, [Pr. PF34 (_ _ x _)] will be set to " _ _ 2 _ (manual threshold setting)".

For the manual threshold setting, the upper and lower limit thresholds can be calculated with the equations below. When [Pr. PF40 (_ _ x _)] is set to " _ _ 0 _ ", a threshold is calculated assuming the setting as " _ _ 5 _ ".

Threshold [0.1%] = [Pr. PF45 Vibration failure prediction - Average characteristic] + [Pr. PF46 Vibration failure prediction - Standard deviation] × "Vibration failure prediction - Threshold multiplication (_ _ x _)" in [Pr. PF40]

The values of [Pr. PF45 Vibration failure prediction - Average characteristic] and [Pr. PF46 Vibration failure prediction - Standard deviation] can also be determined by measuring the torque ripple with the graph function of MR Configurator2. By setting the average and standard deviation of the torque ripple, which are measured by the graph function, in [Pr. PF45] and [Pr. PF46], you can also set the threshold for vibration failure prediction.

■Execution of vibration failure prediction

When a threshold is inputted to the servo amplifier as indicated in the following section, the servo amplifier starts vibration failure prediction. During vibration failure prediction, if the vibration level during servo motor operation, which is estimated by the vibration estimation function, exceeds the threshold, [AL. F7.1 Vibration failure prediction warning] will occur. After the occurrence of [AL. F7.1], if the vibration level during servo motor operation is lower than the threshold, [AL. F7.1] will be canceled.

☞ Page 582 Threshold setting method

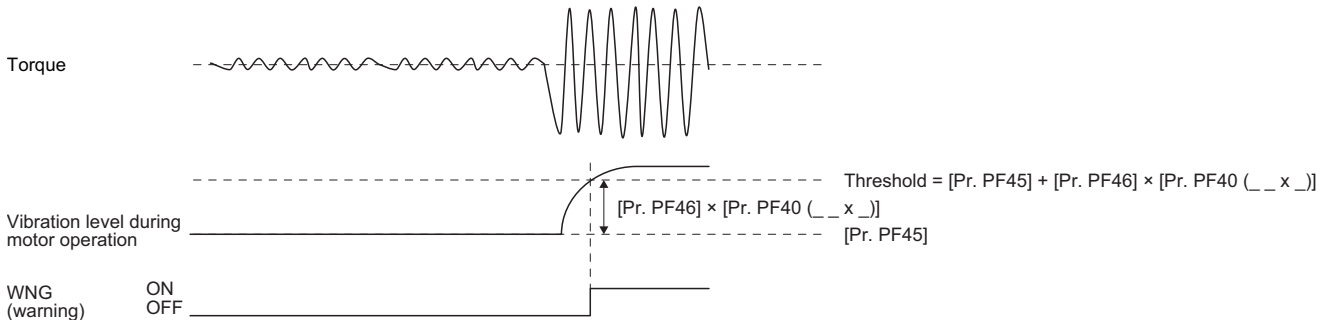

■Threshold reset method

To automatically reset a threshold after the threshold is set with the automatic threshold setting, set "Vibration failure prediction warning selection (_ x _)" in [Pr. PF34] to " _ 3 _ (threshold reset)", and then cycle the power. After the power is cycled, the threshold is reset and [Pr. PF34 (_ x _)] is set to " _ 1 _ (automatic threshold setting)". If parameters such as gains and machine resonance suppression filters are changed, or any part of the equipment is replaced after the vibration failure prediction function operates, reset the threshold.

Total travel distance failure prediction function

The total travel distance failure prediction function predicts a failure of the equipment from the servo motor total travel distance. If the servo motor total travel distance exceeds the value of "Failure prediction - Servo motor total travel distance multiplication selection (x _ _)" in [Pr. PF34] × [Pr. PF41 Failure prediction - Servo motor total travel distance], [AL. F7.3 Total travel distance failure prediction warning] will occur.

The total travel distance failure prediction function can be used with the following procedure.

■Total travel distance failure prediction warning setting

To enable the total travel distance failure prediction warning, "Servo motor total travel distance failure prediction warning selection (_ x _)" in [Pr. PF34] to " _ 1 _ (enabled)".

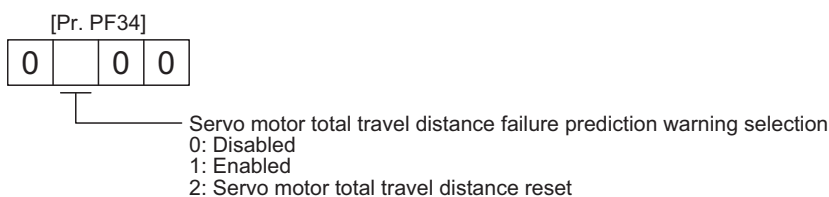

■Setting of servo motor total travel distance for failure prediction

Set a servo motor total travel distance for failure prediction. It is recommended that the servo motor total travel distance for failure prediction be set to about the same as the rated life presented by each guide manufacturer and ball screw manufacturer. For example, for a rated life of 8×10^5 rev, set "Failure prediction - Servo motor total travel distance multiplication selection (x _ _)" in [Pr. PF34] to "2 _ _", and set [Pr. PF41] to "80". When "0" is set in [Pr. PF41], total travel distance failure prediction does not start.

■ Execution of total travel distance failure prediction

When a threshold is inputted to the servo amplifier as indicated in the following section, the servo amplifier starts total travel distance failure prediction. After the occurrence of [AL. F7.3 Total travel distance failure prediction warning], if "_ 0 __ (disabled)" is set in [Pr. PF34 (_ x __)] and the power is cycled, [AL. F7.3] will be canceled.

☞ Page 583 Setting of servo motor total travel distance for failure prediction

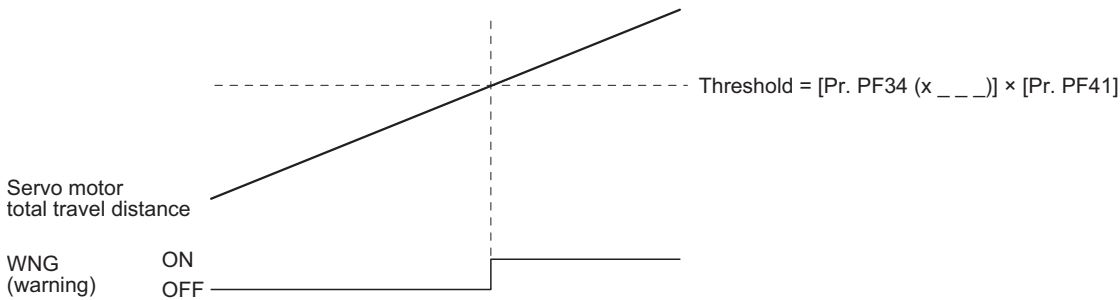

■ Total travel distance reset

If any part of the equipment is replaced, reset the servo motor total travel distance. To reset the servo motor total travel distance, cycle the power after setting "_ 2 __ (servo motor total travel distance reset)" in [Pr. PF34 (_ x __)]. When the servo motor total travel distance is reset, "_ 1 __ (enabled)" is set in [Pr. PF34 (_ x __)].

Related object (servo transient transmission function)

Index	Sub	Object	Name	Data Type	Access	Description
2C29h	0	VAR	Fault prediction status	U32	ro	<p>[Bit 0 to 3: Friction failure prediction status] 0: Friction failure prediction disabled 1: During preparation for friction failure prediction 2: During execution of friction failure prediction 3: During friction failure prediction warning</p> <p>[Bit 4 to 7: Vibration failure prediction status] 0: Vibration failure prediction disabled 1: During preparation for vibration failure prediction 2: During execution of vibration failure prediction 3: During vibration failure prediction warning</p> <p>[Bit 8 to 11: Total travel distance failure prediction status] 0: Total travel distance failure prediction disabled 1: During execution of total travel distance failure prediction 2: During total travel distance failure prediction warning</p> <p>[Bit 12 to 15: Servo motor total travel distance calculation status] 0: During stop of servo motor total travel distance calculation 1: During calculation of servo motor total travel distance</p> <p>[bit 16 to 31: reserved]</p>
2C2Ah	0	VAR	Friction based fault prediction upper threshold	I32	ro	Friction failure prediction - Upper limit threshold The upper limit threshold used for friction failure prediction is displayed in increments of 0.1% assuming the rated torque as 100%.
2C2Bh	0	VAR	Friction based fault prediction lower threshold	I32	ro	Friction failure prediction - Lower limit threshold The lower limit threshold used for friction failure prediction is displayed in increments of 0.1% assuming the rated torque as 100%.
2C2Ch	0	VAR	Friction based fault prediction prepare status	I16	ro	Friction failure prediction - Preparation progress The threshold creation progress used for friction failure prediction is displayed in percentage unit. The creation of an upper and a lower limit threshold for friction failure prediction will be completed at 100%.

Index	Sub	Object	Name	Data Type	Access	Description
2C2Dh	0	VAR	Vibration based fault prediction threshold	I32	ro	Vibration failure prediction - Threshold The threshold used for vibration failure prediction is displayed in increments of 0.1% assuming the rated torque as 100%.
2C2Eh	0	VAR	Vibration based fault prediction prepare status	I16	ro	Vibration failure prediction - Preparation progress The threshold creation progress used for vibration failure prediction is displayed in %. The creation of a threshold for vibration failure prediction will be completed at 100%.
2C2Fh	0	VAR	Motor total distance	U32	ro	Servo motor total travel distance The servo motor total travel distance is displayed in units of rev or m.

APPENDICES

Appendix 1 When using the servo amplifier with the DC power supply input

Point

The DC power supply input is available only with MR-J4-_GF-RJ servo amplifiers.

Connection example

CAUTION

- Ensure that polarity (+/-) is correct. Otherwise, a burst, damage, etc., may occur.
-

For the signal and wirings not given in this section, refer to the following.

 Page 84 200 V class

 Page 90 400 V class

MR-J4-10GF-RJ to MR-J4-100GF-RJ

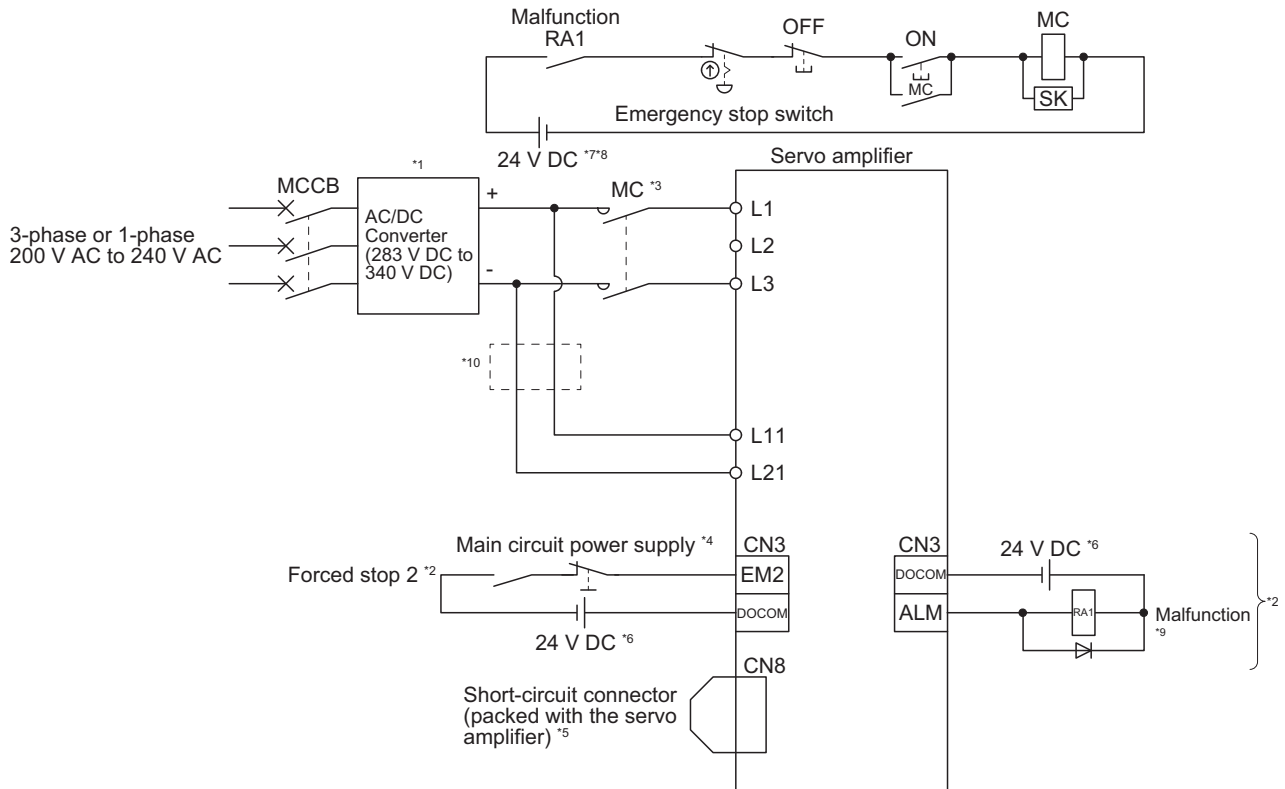

*1 For the power supply specifications, refer to the following.

☞ Page 30 Servo amplifier standard specifications

*2 This diagram shows sink I/O interface. For source I/O interface, refer to the following.

☞ Page 119 Source I/O interface

*3 Use a magnetic contactor with an operation delay time (interval between current being applied to the coil until closure of contacts) of 80 ms or less. Depending on the main circuit voltage and operation pattern, bus voltage decreases, and that may cause the forced stop deceleration to shift to the dynamic brake deceleration. When dynamic brake deceleration is not required, slow the time to turn off the magnetic contactor.

*4 Configure a circuit to turn off EM2 when the main circuit power is turned off to prevent an unexpected restart of the servo amplifier.

*5 When not using the STO function, attach the short-circuit connector came with a servo amplifier.

*6 The illustration of the 24 V DC power supply is divided between input signal and output signal for convenience. However, they can be configured by one.

*7 Driving the on switch and off switch with the DC power supply meets IEC/EN 60204-1 requirements.

*8 Do not use the 24 V DC interface power supply for the magnetic contactor DC power supply. Always use the power supply designed exclusively for the magnetic contactor.

*9 If disabling ALM (Malfunction) output with the parameter, configure up the power supply circuit which switches off the magnetic contactor after detection of alarm occurrence on the controller side.

*10 When wires used for L11 and L21 are thinner than wires used for L1 and L3, use a fuse.

☞ Page 590 Molded-case circuit breakers, fuses, magnetic contactors

A

MR-J4-200GF-RJ to MR-J4-22KGF-RJ

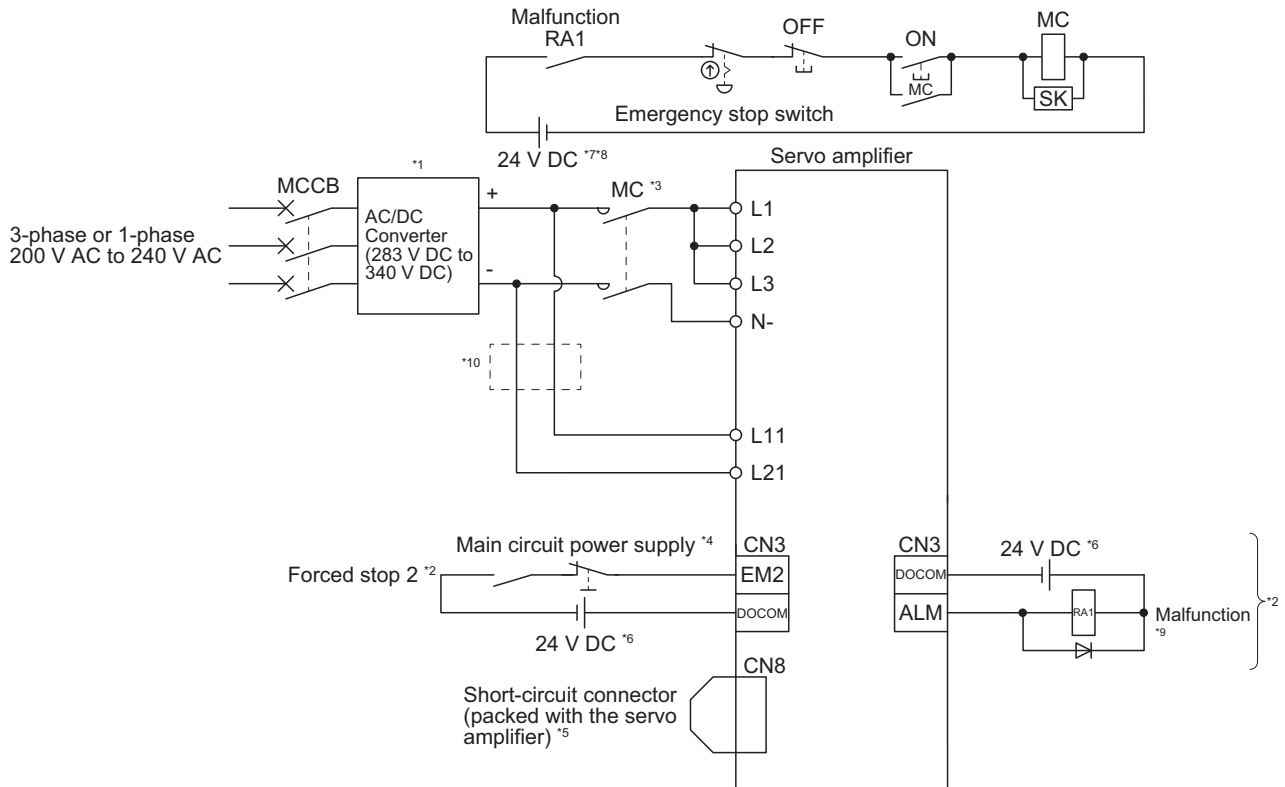

*1 For the power supply specifications, refer to the following.

☞ Page 30 Servo amplifier standard specifications

*2 This diagram shows sink I/O interface. For source I/O interface, refer to the following.

☞ Page 119 Source I/O interface

*3 Use a magnetic contactor with an operation delay time (interval between current being applied to the coil until closure of contacts) of 80 ms or less (160 ms or less for 5 kW or more). Depending on the main circuit voltage and operation pattern, bus voltage decreases, and that may cause the forced stop deceleration to shift to the dynamic brake deceleration. When dynamic brake deceleration is not required, slow the time to turn off the magnetic contactor.

*4 Configure a circuit to turn off EM2 when the main circuit power is turned off to prevent an unexpected restart of the servo amplifier.

*5 When not using the STO function, attach the short-circuit connector came with a servo amplifier.

*6 The illustration of the 24 V DC power supply is divided between input signal and output signal for convenience. However, they can be configured by one.

*7 Driving the on switch and off switch with the DC power supply meets IEC/EN 60204-1 requirements.

*8 Do not use the 24 V DC interface power supply for the magnetic contactor DC power supply. Always use the power supply designed exclusively for the magnetic contactor.

*9 If disabling ALM (Malfunction) output with the parameter, configure up the power supply circuit which switches off the magnetic contactor after detection of alarm occurrence on the controller side.

*10 When wires used for L11 and L21 are thinner than wires used for L1, L2, L3, and N-, use a fuse.

☞ Page 590 Molded-case circuit breakers, fuses, magnetic contactors

Power supply capacity

The power supply capacity is the same as that for the AC power supply input.

 Page 318 Power supply capacity and generated loss

Selection example of wires

Point

Selection conditions of wire size are as follows.

Construction condition: Single wire set in midair

Wire length: 30 m or less

The following diagram shows the wires used for wiring. Use the wires given in this section or equivalent.

Example of selecting the wire sizes

Use the 600 V Grade heat-resistant polyvinyl chloride insulated wire (HIV wire) for wiring. The following shows the wire size selection example.

Servo amplifier	Wire [mm ²] ^{*1}	
	L1/L2/L3/N-/⊕	L11/L21
MR-J4-10GF-RJ	2 (AWG 14)	1.25 to 2 (AWG 16 to 14)
MR-J4-20GF-RJ		
MR-J4-40GF-RJ		
MR-J4-60GF-RJ		
MR-J4-70GF-RJ		
MR-J4-100GF-RJ		
MR-J4-200GF-RJ	3.5 (AWG 12)	
MR-J4-350GF-RJ		
MR-J4-500GF-RJ ^{*2}	5.5 (AWG 10): a	1.25 (AWG 16): a 2 (AWG 14): d
MR-J4-700GF-RJ ^{*2}	8 (AWG 8): b	
MR-J4-11KGF-RJ ^{*2}	14 (AWG 6): e	1.25 (AWG 16): c 2 (AWG 14): c
MR-J4-15KGF-RJ ^{*2}	22 (AWG 4): f	
MR-J4-22KGF-RJ ^{*2}	38 (AWG 2): g	

*1 Alphabets in the table indicate crimping tools. For crimp terminals and applicable tools, refer to the following.

 Page 589 Selection example of crimp terminals

*2 To connect these models to a terminal block, be sure to use the screws that come with the terminal block.

Selection example of crimp terminals

Symbol	Servo amplifier-side crimp terminals				Manufacturer
	Crimp terminal ^{*2}	Applicable tool			
		Body	Head	Dice	
a	FVD5.5-4	YNT-1210S	—	—	JST
b ^{*1}	8-4NS	YHT-8S	—	—	
c	FVD2-4	YNT-1614	—	—	
d	FVD2-M3		—	—	
e	FVD14-6	YF-1	YNE-38	DH-122 DH-112	
f	FVD22-6	YF-1	YNE-38	DH-123 DH-113	
g	FVD38-8	YF-1	YNE-38	DH-124 DH-114	

*1 Coat the crimping part with an insulation tube.

*2 Some crimp terminals may not be mounted depending on the size. Make sure to use the recommended ones or equivalent ones.

Molded-case circuit breakers, fuses, magnetic contactors

For main circuit power supply

CAUTION

- To prevent the servo amplifier from smoke and a fire, select a molded-case circuit breaker which shuts off with high speed.
- Always use one molded-case circuit breaker and one magnetic contactor with one servo amplifier.

When using a fuse instead of the molded-case circuit breaker, use the one having the specifications given in this section.

Servo amplifier	Molded-case circuit breaker ^{*1}			Fuse			Magnetic contactor ^{*2}	
	Frame, rated current		Voltage AC [V]	Class	Current [A]	Voltage DC [V]		
	Power factor improving reactor is not used	Power factor improving reactor is used						
MR-J4-10GF-RJ	30 A frame 5 A	30 A frame 5 A	240	T	10	400	DUD-N30	
MR-J4-20GF-RJ	30 A frame 5 A	30 A frame 5 A						
MR-J4-40GF-RJ	30 A frame 10 A	30 A frame 5 A			15			
MR-J4-60GF-RJ	30 A frame 15 A	30 A frame 10 A			20			
MR-J4-70GF-RJ	30 A frame 15 A	30 A frame 10 A						
MR-J4-100GF-RJ (3-phase power supply input)	30 A frame 15 A	30 A frame 10 A						
MR-J4-100GF-RJ (1-phase power supply input)	30 A frame 15 A	30 A frame 15 A						
MR-J4-200GF-RJ	30 A frame 20 A	30 A frame 20 A			30			
MR-J4-350GF-RJ	30 A frame 30 A	30 A frame 30 A			40			
MR-J4-500GF-RJ	50 A frame 50 A	50 A frame 50 A			60			DUD-N60
MR-J4-700GF-RJ	100 A frame 75 A	60 A frame 60 A			80			
MR-J4-11KGF-RJ	100 A frame 100 A	100 A frame 100 A			125			DUD-N120
MR-J4-15KGF-RJ	125 A frame 125 A	125 A frame 125 A			175			
MR-J4-22KGF-RJ	225 A frame 175 A	225 A frame 175 A			300			DUD-N180

*1 Use a molded-case circuit breaker which has the same or higher operation characteristics than our lineup.

*2 Use a magnetic contactor with an operation delay time (interval between current being applied to the coil until closure of contacts) of 80 ms or less (160 ms or less for 5 kW or more).

For control circuit power supply

When the wiring for the control circuit power supply (L11/L21) is thinner than that for the main circuit power supply (L1/L2/L3/N-), install an overcurrent protection device (fuse, etc.) to protect the branch circuit.

Servo amplifier	Fuse (Class T)		Fuse (Class K5)	
	Current [A]	Voltage DC [V]	Current [A]	Voltage DC [V]
MR-J4-10GF-RJ	1	400	1	400
MR-J4-20GF-RJ				
MR-J4-40GF-RJ				
MR-J4-60GF-RJ				
MR-J4-70GF-RJ				
MR-J4-100GF-RJ				
MR-J4-200GF-RJ				
MR-J4-350GF-RJ				
MR-J4-500GF-RJ				
MR-J4-700GF-RJ				
MR-J4-11KGF-RJ				
MR-J4-15KGF-RJ				
MR-J4-22KGF-RJ				

Appendix 2 Handling of AC servo amplifier batteries for the United Nations Recommendations on the Transport of Dangerous Goods

United Nations Recommendations on the Transport of Dangerous Goods Rev. 15 (hereinafter Recommendations of the United Nations) has been issued. To reflect this, transport regulations for lithium metal batteries are partially revised in the Technical Instruction (ICAO-TI) by the International Civil Aviation Organization (ICAO) and the International Maritime Dangerous Goods Code (IMDG Code) by the International Maritime Organization (IMO).

To comply the instruction and code, we have modified the indication on the package for general-purpose AC servo batteries. The above change will not affect the function and performance of the product.

Target model

■Battery (cell)

Model	Option model	Type	Lithium content	Mass of battery	Remark
ER6	MR-J3BAT	Cell	0.65 g	16 g	Cells with more than 0.3 grams of lithium content must be handled as dangerous goods (Class 9) depending on packaging requirements.
ER17330	MR-BAT	Cell	0.48 g	13 g	
	A6BAT	Cell	0.48 g	13 g	

■Battery unit (assembled battery)

Model	Option model	Type	Lithium content	Mass of battery	Remark
ER6	MR-J2M-BT	Assembled battery (Seven)	4.55 g	112 g	Assembled batteries with more than two grams of lithium content must be handled as dangerous goods (Class 9) regardless of packaging requirements.
CR17335A	MR-BAT6V1	Assembled battery (Two)	1.20 g	34 g	Cells with more than 0.3 grams of lithium content must be handled as dangerous goods (Class 9) depending on packaging requirements.
	MR-BAT6V1SET(-A)	Assembled battery (Two)	1.20 g	34 g	
	MR-BAT6V1BJ	Assembled battery (Two)	1.20 g	34 g	

Purpose

Safer transportation of lithium metal batteries.

Change in regulations

The following points are changed for lithium metal batteries in transportation by sea or air based on the revision of Recommendations of the United Nations Rev. 15 and ICAO-TI 2009-2010 edition, and IATA Dangerous Goods Regulations 54th Edition (effective January 1, 2013). For lithium metal batteries, cells are classified as UN3090, and batteries contained in or packed with equipment are classified as UN3091.

■Transportation of lithium metal batteries alone

Packaging requirement	Classification	Main requirement
Less than eight cells per package with less than one gram of lithium content	UN3090 PI968 Section II	The package must pass a 1.2 m drop test, and the handling label with battery illustration (size: 120 × 110 mm) must be attached on the package.
Less than two assembled batteries per package with less than two grams of lithium content		
More than eight cells per package with less than one gram of lithium content	UN3090 PI968 Section IB	The package must pass a 1.2 m drop test, and the handling label with battery illustration (size: 120 × 110 mm) must be attached on the package. The Class 9 hazard label must be attached or others to comply with dangerous goods (Class 9).
More than two assembled batteries per package with less than two grams of lithium content		
Cells with more than one gram of lithium content	UN3090 PI968 Section IA	The package must be compliant with Class 9 Packages, and the Class 9 hazard label must be attached or others to comply with dangerous goods (Class 9).
Assembled batteries with more than two grams of lithium content		

■Transportation of lithium metal batteries packed with or contained in equipment

- For batteries packed with equipment, follow the necessary requirements of UN3091 PI969. Batteries are classified into either Section II/Section I depending on the lithium content/packaging requirements.
- For batteries contained in equipment, follow the necessary requirements of UN3091 PI970. Batteries are classified into either Section II/Section I depending on the lithium content/packaging requirements. The special handling may be unnecessary depending on the number of batteries and gross mass per package.

Ex.

Mitsubishi label with battery illustration



Example of Mitsubishi Electric label with battery illustration
(can be used until December 31, 2018)

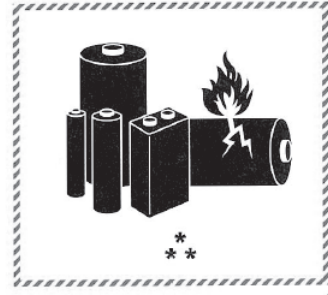

* Location of UN Number
** Location of telephone number for additional information
Example of Mitsubishi Electric label with battery illustration
(Available since January 1, 2017)

The handling label shown in the figure in the left has been changed to the one shown in the figure in the right in accordance with the IATA Dangerous Goods Regulations 58th Edition (effective January 1, 2017). However, the label shown in Fig. app. 1 may be used until December 31, 2018 (for two years as an interim measure).

■Details of the package change

The following caution is added to the packages of the target batteries.

"Containing lithium metal battery. Regulations apply for transportation."

■Transportation precaution for customers

For sea or air transportation, the handling label (refer to the example above) must be attached to the package of a Mitsubishi cell or battery. In addition, attaching it to the outer package containing several packages of Mitsubishi cells or batteries is also required. When the content of a package must be handled as dangerous goods (Class 9), the Shipper's Declaration for Dangerous Goods is required, and the package must be compliant with Class 9 Packages. Documentations like the handling label in the specified design and the Shipper's Declaration for Dangerous Goods are required for transportation. Please attach the documentations to the packages and the outer package.

The IATA Dangerous Goods Regulations are revised, and the requirements are changed annually. When customers transport lithium batteries by themselves, the responsibility for the cargo lies with the customers. Thus, be sure to check the latest version of the IATA Dangerous Goods Regulations.

A

Appendix 3 Symbol for the new EU Battery Directive

Symbol for the new EU Battery Directive (2006/66/EC) that is plastered to general-purpose AC servo battery is explained here.



Point

This symbol is for EU countries only.

This symbol is in accordance with the EU directive 2006/66/EC Article 20 Information for end-users and Annex II. Your MITSUBISHI ELECTRIC product is designed and manufactured with high quality materials and components which can be recycled and/or reused. This symbol means that batteries and accumulators, at their end-of-life, should be disposed of separately from your household waste. If a chemical symbol is printed beneath the symbol shown above, this chemical symbol means that the battery or accumulator contains a heavy metal at a certain concentration. This will be indicated as follows.
Hg: mercury (0.0005%), Cd: cadmium (0.002%), Pb: lead (0.004%)
In the European Union there are separate collection systems for used batteries and accumulators. Please, dispose of batteries and accumulators correctly at your local community waste collection/recycling center. Please, help us to conserve the environment we live in!

Appendix 4 Compliance with global standards

Terms related to safety (IEC 61800-5-2 Stop function)

STO function (Refer to IEC 61800-5-2: 2007 4.2.2.2 STO.)

The MR-J4 servo amplifiers have the STO function. The STO function shuts down energy to servo motors, thus removing torque. This function electronically cuts off power supply in the servo amplifier. In addition, MR-J4-03A6 and MR-J4W2-0303B6 don't support this function.

About safety

This chapter explains safety of users and machine operators. Please read the section carefully before mounting the equipment.

Professional engineer

Only professional engineers should mount MR-J4 servo amplifiers.

Here, professional engineers should meet all the conditions below.

- Persons who took a proper training of related work of electrical equipment or persons who can avoid risk based on past experience.
- Persons who have read and familiarized himself/herself with this installation guide and operating manuals for the protective devices (e.g. light curtain) connected to the safety control system.

Applications of the devices

MR-J4 servo amplifiers comply with the following standards.

- IEC/EN 61800-5-1/GB 12668.501, IEC/EN/KN 61800-3/GB 12668.3, IEC/EN 60204-1
- ISO/EN ISO 13849-1:2015 Category 3 PL e, IEC/EN 62061 SIL CL 3, IEC/EN 61800-5-2 (STO) (Except for MR-J4-03A6 and MR-J4W2-0303B6. Refer to the following for compatible models.)

☞ Page 606 MR-J4 servo amplifier

MR-J4 servo amplifiers can be used with the MR-D30 functional safety unit, MR-J3-D05 safety logic unit, or safety PLCs. Refer to "MR-D30 Instruction Manual" for the combinations of the servo amplifiers and MR-D30. For the combinations of the servo amplifiers and MR-J3-D05, refer to the following.

☞ Page 609 MR-J3-D05 Safety logic unit

Correct use

Use the MR-J4 servo amplifiers within specifications. Refer to the following for specifications such as voltage, temperature, etc.

☞ Page 30 Servo amplifier standard specifications

Mitsubishi Electric Co. accepts no claims for liability if the equipment is used in any other way or if modifications are made to the device, even in the context of mounting and installation.

WARNING

- If you need to get close to the moving parts of the machine for inspection or others, ensure safety by confirming the power off, etc. Otherwise, it may cause an accident.
- It takes 15 minutes maximum for capacitor discharging. Do not touch the unit and terminals immediately after power off.

■ Peripheral device and power wiring

The following are selected based on IEC/EN 61800-5-1, UL 508C, and CSA C22.2 No. 274.

- Local wiring and crimping tool

The following table shows the stranded wire sizes [AWG] and the crimp terminal symbols rated at 75 °C/60 °C.

Servo amplifier ^{*7}	75 °C/60 °C stranded wire [AWG] ^{*2}			
	L1/L2/L3 ⊕ [⊖]	L11/L21	P+/C	U/V/W/⊕ ^{*3}
MR-J4-03A6/MR-J4W2-0303B6	19/- ^{*5}		—	19/- ^{*6}
MR-J4-10_(1)/MR-J4-20_(1)/MR-J4-40_(1)/ MR-J4-60_(4)/MR-J4-70_/MR-J4-100_(4)/ MR-J4-200_(4) (T)/MR-J4-350_4	14/14	14/14	14/14	14/14
MR-J4-200_ (S)	12/12			
MR-J4-350_				12/12
MR-J4-500_ ^{*1}	10: a/10: a	14: c/14: c	14: c/14: c	10: b/10: b
MR-J4-700_ ^{*1}	8: b/8: b		12: a/12: a	8: b/8: b
MR-J4-11K_ ^{*1}	6: d/4: f		12: e/12: e	4: f/4: f
MR-J4-15K_ ^{*1}	4: f/3: f		10: e/10: e	3: g/2: g
MR-J4-22K_ ^{*1}	1: h/-: -		10: i/10: i	1: j/-: -
MR-J4-500_4 ^{*1}	14: c/14: c		14: c/14: c	12: a/10: a
MR-J4-700_4 ^{*1}	12: a/12: a			10: a/10: a
MR-J4-11K_4 ^{*1}	10: e/10: e		14: k/14: k	8: l/8: l
MR-J4-15K_4 ^{*1}	8: l/8: l		12: e/12: e	6: d/4: d
MR-J4-22K_4 ^{*1}	6: m/4: m		12: i/12: i	6: n/4: n
MR-J4W_-_B	14/14 ^{*4}	14/14	14/14	14/14

*1 To connect these models to a terminal block, be sure to use the screws that come with the terminal block.

*2 Alphabets in the table indicate crimping tools. Refer to the following table for the crimp terminals and applicable tools.

*3 Select wire sizes depending on the rated output of the servo motors. The values in the table are sizes based on rated output of the servo amplifiers.

*4 Use the crimp terminal c for the PE terminal of the servo amplifier.

*5 This value is of 24/0/PM/⊕ for MR-J4-03A6 and MR-J4W2-0303B6.

*6 This value is of U/V/W/E for MR-J4-03A6 and MR-J4W2-0303B6.

*7 "(S)" means 1-phase 200 V AC power input and "(T)" means 3-phase 200 V AC power input in the table.

Symbol	Servo amplifier-side crimp terminals		Manufacturer
	Crimp terminal ^{*2}	Applicable tool	
a	FVD5.5-4	YNT-1210S	JST (J.S.T. Mfg. Co., Ltd.)
b ^{*1}	8-4NS	YHT-8S	
c	FVD2-4	YNT-1614	
d	FVD14-6	YF-1	
e	FVD5.5-6	YNT-1210S	
f	FVD22-6	YF-1	
g	FVD38-6	YF-1	
h	R60-8	YF-1	
i	FVD5.5-8	YNT-1210S	
j	CB70-S8	YF-1	
k	FVD2-6	YNT-1614	
l	FVD8-6	YF-1	
m	FVD14-8	YF-1	
n	FVD22-8	YF-1	

*1 Coat the crimping part with an insulation tube.

*2 Some crimp terminals may not be mounted depending on the size. Make sure to use the recommended ones or equivalent ones.

- Selection example of MCCB and fuse

Use T class fuses or molded-case circuit breaker (UL 489 Listed MCCB) as the following table. The T class fuses and molded-case circuit breakers in the table are selected examples based on rated I/O of the servo amplifiers. When you select a smaller capacity servo motor to connect it to the servo amplifier, you can also use smaller capacity T class fuses or moldedcase circuit breaker than ones in the table. For selecting ones other than Class T fuses and molded-case circuit breakers below and selecting a Type E Combination motor controller, refer to the following.

☞ Page 406 Molded-case circuit breakers, fuses, magnetic contactors

Servo amplifier (100 V class)	Molded-case circuit breaker (120 V AC)	Fuse (300 V)
MR-J4-10_1/MR-J4-20_1/MR-J4-40_1	NV50-SVFU-15A (50 A frame 15 A)	20 A

Servo amplifier (200 V class)*1	Molded-case circuit breaker (240 V AC)	Fuse (300 V)
MR-J4-10_/MR-J4-20_/MR-J4-40_/MR-J4-60_(T)/ MR-J4-70_(T)/MR-J4W2-22B(T)	NF50-SVFU-5A (50 A frame 5 A)	10 A
MR-J4-60_(S)/MR-J4-70_(S)/MR-J4-100_(T)/ MR-J4W2-22B(S)/MR-J4W2-44B(T)/MR-J4W2-77B(T)/ MR-J4W3-222B/MR-J4W3-444B(T)	NF50-SVFU-10A (50 A frame 10 A)	15 A
MR-J4-100_(S)/MR-J4-200_(T)/MR-J4W2-44B(S)/ MR-J4W2-1010B	NF50-SVFU-15A (50 A frame 15 A)	30 A
MR-J4-200_(S)/MR-J4-350_/MR-J4W2-77B(S)/ MR-J4W3-444B(S)	NF50-SVFU-20A (50 A frame 20 A)	40 A
MR-J4-500_	NF50-SVFU-30A (50 A frame 30 A)	60 A
MR-J4-700_	NF50-SVFU-40A (50 A frame 40 A)	80 A
MR-J4-11K_	NF100-CVFU-60A (100 A frame 60 A)	125 A
MR-J4-15K_	NF100-CVFU-80A (100 A frame 80 A)	150 A
MR-J4-22K_	NF225-CWU-125A (225 A frame 125 A)	300 A

*1 "(S)" means 1-phase 200 V AC power input and "(T)" means 3-phase 200 V AC power input in the table.

Servo amplifier (400 V class)	Molded-case circuit breaker (480 V AC)	Fuse (600 V)
MR-J4-60_4/MR-J4-100_4	NF100-HRU-5A (100 A frame 5 A)	10 A
MR-J4-200_4	NF100-HRU-10A (100 A frame 10 A)	15 A
MR-J4-350_4	NF100-HRU-10A (100 A frame 10 A)	20 A
MR-J4-500_4	NF100-HRU-15A (100 A frame 15 A)	30 A
MR-J4-700_4	NF100-HRU-20A (100 A frame 20 A)	40 A
MR-J4-11K_4	NF100-HRU-30A (100 A frame 30 A)	60 A
MR-J4-15K_4	NF100-HRU-40A (100 A frame 40 A)	80 A
MR-J4-22K_4	NF100-HRU-60A (100 A frame 60 A)	125 A

- Power supply

This servo amplifier can be supplied from star-connected supply with grounded neutral point of overvoltage category III (overvoltage category II for 1-phase servo amplifiers, MR-J4-03A6, and MR-J4W2-0303B6) set forth in IEC/EN 60664-1. For the interface power supply, use an external 24 V DC power supply with reinforced insulation on I/O terminals.

In case of MR-J4-03A6 and MR-J4W2-0303B6, use DC power supplies of reinforced insulation type. For the main circuit power, use UL listed (certified) 48 V DC/24 V DC power supplies which can generate more than 1.2 A/2.4 A per axis.



- Grounding

To prevent an electric shock, always connect the protective earth (PE) terminal (marked \oplus) of the servo amplifier to the protective earth (PE) of the cabinet. Do not connect two grounding cables to the same protective earth (PE) terminal. Always connect cables to the terminals one-to-one.

This product can cause a DC current in the protective earthing conductor. To protect direct/indirect contact using an earth-leakage current breaker (RCD), only an RCD of type B can be used for the power supply side of the product.

The MR-J4-700_4 is high protective earthing conductor current equipment, the minimum size of the protective earthing conductor must comply with the local safety regulations.



■EU compliance

The EC directives were issued to standardize the regulations of countries that belong to the EU and to ensure smooth distribution of safety-guaranteed products. The CE marking proves the compliance of the manufacturer with the EC directives, and this marking also applies to machines and equipment that incorporate servos.

- EMC requirement

MR-J4 servo amplifiers comply with category C3 in accordance with EN 61800-3. As for I/O wires (max. length 10 m. However, 3 m for STO cable for CN8.) and encoder cables (max. length 50 m), use shielded wires and ground the shields. Install an EMC filter and surge protector on the primary side for input and output of 200 V class and for output of 400 V class servo amplifiers. In addition, use a line noise filter for outputs of the 11 kW and 15 kW of 400 V class servo amplifiers. The following shows recommended products.

EMC filter: Soshin Electric HF3000A-UN series, TF3000C-TX series, COSEL FTB series

Surge protector: Okaya Electric Industries RSPD series

Line noise filter: Mitsubishi Electric FR-BLF

MR-J4 series are not intended to be used on a low-voltage public network which supplies domestic premises; radio frequency interference is expected if used on such a network. The installer shall provide a guide for Installation and use, including recommended mitigation devices. To avoid the risk of crosstalk to signal cables, the installation instructions shall either recommend that the power interface cable be segregated from signal cables.

Use the DC power supply installed with the amplifiers in the same cabinet. Do not connect the other electric devices to the DC power supply.

- For Declaration of Conformity (DoC)

MITSUBISHI ELECTRIC EUROPE B.V. hereby declares that the servo amplifiers are in compliance with EC directives (Machinery directive (2006/42/EC), EMC directive (2014/30/EU), Low-voltage directive (2014/35/EU), and RoHS directive (2011/65/EU)). For the copy of Declaration of Conformity, contact your local sales office.

■USA/Canada compliance

This servo amplifier is designed in compliance with UL 508C and CSA C22.2 No. 274.

- Installation

The minimum cabinet size is 150% of each MR-J4 servo amplifier's volume. Also, design the cabinet so that the ambient temperature in the cabinet is 55 °C or less. The servo amplifier must be installed in a metal cabinet. Additionally, mount the servo amplifier on a cabinet that the protective earth based on the standard of IEC/EN 60204-1 is correctly connected. For environment, the units should be used in open type (UL 50) and overvoltage category shown in the following table.

☞ Page 606 MR-J4 servo amplifier

The servo amplifier needs to be installed at or below pollution degree 2. For connection, use copper wires.

- Short-circuit current rating (SCCR)

Suitable For Use On A Circuit Capable Of Delivering Not More Than 100 kA rms Symmetrical Amperes, 500 Volts Maximum (Not More Than 5 kA rms Symmetrical Amperes, 48 Volts Maximum for MR-J4-03A6 and MR-J4W2-0303B6). For SCCR (25 kA or 50 kA) when using a Type E Combination motor controller, refer to the following.

☞ Page 406 Molded-case circuit breakers, fuses, magnetic contactors

- Overload protection characteristics

The MR-J4 servo amplifiers have solid-state servo motor overload protection. (It is set on the basis (full load current) of 120% rated current of the servo amplifier.)

- Over-temperature protection for motor

Motor Over temperature sensing is not provided by the drive.

Integral thermal protection(s) is necessary for motor and refer to the following for the proper connection.

☞ Page 601 Electrical Installation and configuration diagram

- Branch circuit protection

For installation in United States, branch circuit protection must be provided, in accordance with the National Electrical Code and any applicable local codes.

For installation in Canada, branch circuit protection must be provided, in accordance with the Canada Electrical Code and any applicable provincial codes.

■South Korea compliance

This product complies with the Radio Wave Law (KC mark). Please note the following to use the product.

이 기기는 업무용 (A급) 전자파적합기기로서 판매자 또는 사용자는 이 점을 주의하시기 바라며, 가정외의 지역에서 사용하는 것을 목적으로 합니다.

(The product is for business use (Class A) and meets the electromagnetic compatibility requirements. The seller and the user must note the above point, and use the product in a place except for home.)

In addition, use an EMC filter, surge protector, ferrite core, and line noise filter on the primary side for inputs. Use a ferrite core and line noise filter for outputs. Use a distance greater than 30 m between the product and third party sensitive radio communications for an MR-J4-22K_(4).

A

General cautions for safety protection and protective measures

Observe the following items to ensure proper use of the MR-J4 servo amplifiers.

- For safety components and installing systems, only qualified personnel and professional engineers should perform.
- When mounting, installing, and using the MR-J4 servo amplifier, always observe standards and directives applicable in the country.

Residual risk

- Be sure that all safety related switches, relays, sensors, etc., meet the required safety standards.
- Perform all risk assessments and safety level certification to the machine or the system as a whole.
- If the upper and lower power modules in the servo amplifier are shorted and damaged simultaneously, the servo motor may make a half revolution at a maximum.
- Only qualified personnel are authorized to install, start-up, repair or service the machines in which these components are installed. Only trained engineers should install and operate the equipment. (ISO 13849-1:2015 Annex F Table F.1 No. 5)
- Separate the wiring for safety observation function from other signal wirings. (ISO 13849-1:2015 Annex F Table F.1 No. 1)
- Protect the cables with appropriate ways (routing them in a cabinet, using a cable guard, etc.).
- Keep the required clearance/creepage distance depending on voltage you use.

Disposal

Disposal of unusable or irreparable devices should always occur in accordance with the applicable country-specific waste disposal regulations. (Example: European Waste 16 02 14)

Lithium battery transportation

To transport lithium batteries, take actions to comply with the instructions and regulations such as the United Nations (UN), the International Civil Aviation Organization (ICAO), and the International Maritime Organization (IMO).

The batteries (MR-BAT6V1SET, MR-BAT6V1SET-A, MR-BAT6V1, and MR-BAT6V1BJ) are assembled batteries from two batteries (lithium metal battery CR17335A) which are not subject to the dangerous goods (Class 9) of the UN Recommendations.

Installation direction and clearances

CAUTION

- The devices must be installed in the specified direction. Not doing so may cause a malfunction.
- Mount the servo amplifier on a cabinet which meets IP54 in the correct direction to maintain pollution degree 2.
- The regenerative resistor supplied with 11 kW to 22 kW servo amplifiers does not have a protective cover. Touching the resistor (including wiring/screw hole area) may cause a burn injury and electric shock. Even if the power was shut-off, be careful until the bus voltage discharged and the temperature decreased because of the following reasons.
- It may cause a burn injury due to very high temperature without cooling.
- It may cause an electric shock due to charged capacitor of the servo amplifier.

To adapt your machine using MR-J4-03A6 or MR-J4W2-0303B6 to IEC/EN 60950-1, either supply the amplifier with a power supply complying with the requirement of 2.5 stated in IEC/EN 60950-1 (Limited Power Source), or cover the amplifier and motors connected to the outputs with a fire enclosure.

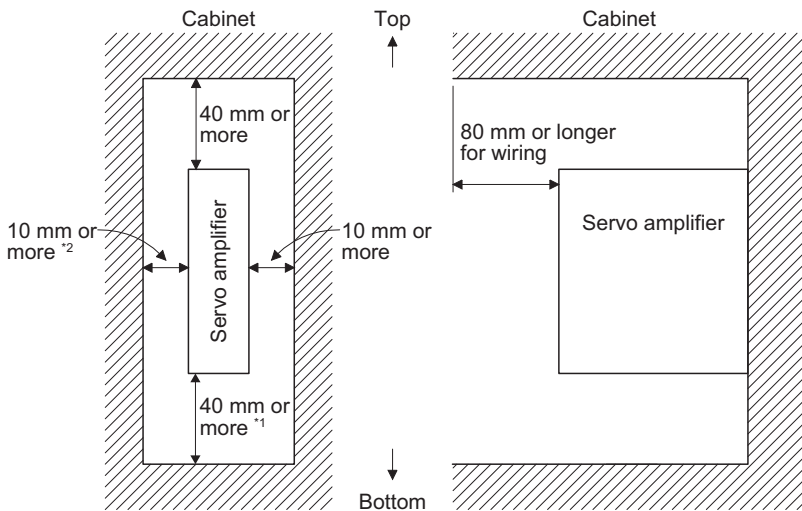

*1 For 11 kW to 22 kW servo amplifiers, the clearance between the bottom and ground will be 120 mm or more.

*2 When mounting MR-J4-500_, maintain a minimum clearance of 25 mm on the left side.

Electrical Installation and configuration diagram

WARNING

- Turn off the molded-case circuit breaker (MCCB) to avoid electrical shocks or damages to the product before starting the installation or wiring.

CAUTION

- The installation complies with IEC/EN 60204-1. The voltage supply to machines must be 20 ms or more of tolerance against instantaneous power failure as specified in IEC/EN 60204-1.
- Connecting a servo motor for different axis to U, V, W, or CN2_ of the servo amplifier may cause a malfunction.
- Securely connect the cables in the specified method and tighten them with the specified torque. Otherwise, the servo motor may operate unexpectedly.

A

The following shows representative configuration examples to conform to the IEC/EN/UL/CSA standards. The connectors described by rectangles are safely separated from the main circuits described by circles. The connected motors will be limited as follows.

- HG/HF/HC/HA series servo motors (Mfg.: Mitsubishi Electric)
- Using a servo motor complied with IEC 60034-1 and Mitsubishi Electric encoder (OBA, OSA)

3-phase input for MR-J4 1-axis servo amplifier

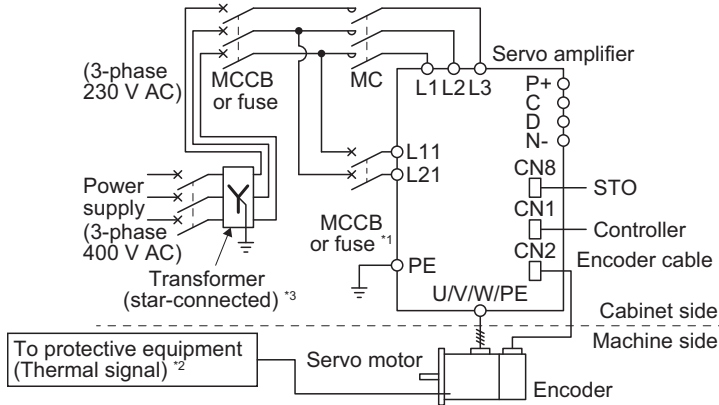

- *1 When the wire sizes of L1 and L11 are the same, MCCB or fuse is not required.
- *2 Please use a thermal sensor, etc. for thermal protection of the servo motor.
- *3 For 400 V class, a step-down transformer is not required.

1-phase input for MR-J4 1-axis servo amplifier

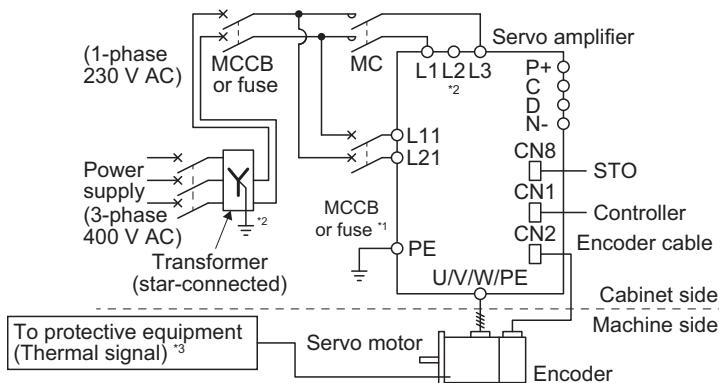

- *1 When the wire sizes of L1 and L11 are the same, MCCB or fuse is not required.
- *2 When using a 100 V class servo amplifier, step down the power supply voltage to 100 V and connect the main circuit power supply lines to L1 and L2. For 1-phase 200 V AC servo amplifiers, connect the lines to L1 and L3.
- *3 Please use a thermal sensor, etc. for thermal protection of the servo motor.

Main circuit 48 V DC input for MR-J4 1-axis servo amplifier

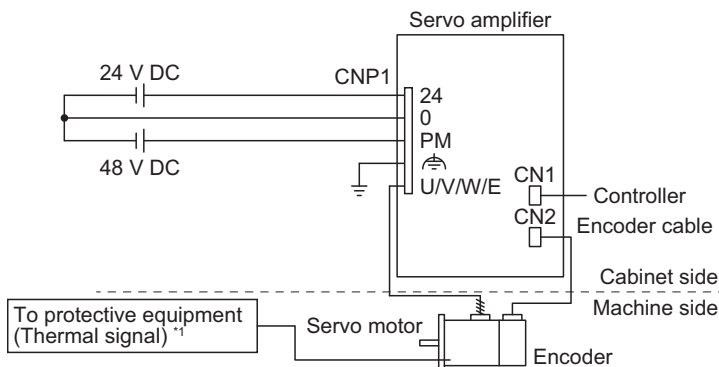

- *1 Please use a thermal sensor, etc. for thermal protection of the servo motor.

Signal

Signal

The following shows MR-J4-10B signals as a typical example.

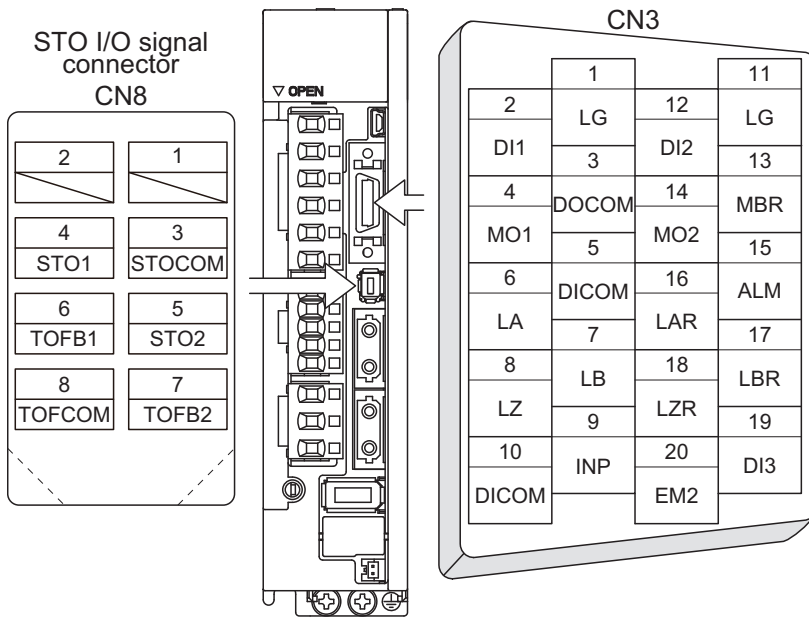

I/O device

Input device

Symbol	Device	Connector	Pin No.
EM2	Forced stop 2	CN3	20
STOCOM	Common terminal for input signals STO1/STO2	CN8	3
STO1	STO1 state input		4
STO2	STO2 state input		5

Output device

Symbol	Device	Connector	Pin No.
TOFCOM	Common terminal for monitor output signal in STO state	CN8	8
TOFB1	Monitor output signal in STO1 state		6
TOFB2	Monitor output signal in STO2 state		7

Power supply

Symbol	Device	Connector	Pin No.
DICOM	Digital I/F power supply input	CN3	5, 10
DOCOM	Digital I/F common		3
SD	Shield		Plate

A

Maintenance and service

WARNING

- To avoid an electric shock, only qualified personnel should attempt inspections. For repair and parts replacement, contact your local sales office.

Inspection items

It is recommended that the following points periodically be checked.

- Check for loose terminal block screws. Retighten any loose screws. (Except for MR-J4-03A6 and MR-J4W2-0303B6)

Servo amplifier	Tightening torque [N•m]																
	L1	L2	L3	N-	P3	P4	P+	C	D	L11	L21	U	V	W	PE		
MR-J4-10_(1)/MR-J4-20_(1)/ MR-J4-40_(1)/MR-J4-60_(4)/ MR-J4-70_/MR-J4-100_(4)/ MR-J4-200_(4)/MR-J4- 350_(4)	—														1.2		
MR-J4-500_	1.2								0.8		1.2						
MR-J4-700_(4)/MR-J4-500_4	1.2								—		0.8		1.2				
MR-J4-11K_(4)/MR-J4- 15K_(4)	3.0								—		1.2		3.0				
MR-J4-22K_(4)	6.0								—		1.2		6.0				
MR-J4W_-_B	—														1.2		

- Check the servo motor bearings, brake section, etc. for unusual noise.
- Check the cables and the like for scratches or cracks. Perform periodic inspection according to operating conditions.
- Check that the connectors are securely connected to the servo motor.
- Check that the wires are not coming out from the connector.
- Check for dust accumulation on the servo amplifier.
- Check for unusual noise generated from the servo amplifier.
- Check the servo motor shaft and coupling for connection.
- Make sure that the emergency stop circuit operates properly such that an operation can be stopped immediately and a power is shut off by the emergency stop switch.

Parts having service life

Service life of the following parts is listed below. However, the service life varies depending on operation and environment. If any fault is found in the parts, they must be replaced immediately regardless of their service life. For parts replacement, please contact your local sales office.

Part name	Life guideline
Smoothing capacitor	10 years ^{*3}
Relay	Number of power-on, forced stop and controller forced stop times: 100 000 times Number of on and off for STO: 1,000,000 times
Cooling fan	10,000 hours to 30,000 hours (2 years to 3 years)
Battery backup time ^{*1}	Approximately 20,000 hours (equipment power supply: off, ambient temperature: 20 °C)
Battery life ^{*2}	5 years from date of manufacture

*1 The time is for using MR-J4 1-axis servo amplifier with a rotary servo motor using MR-BAT6V1SET, MR-BAT6V1SET-A, or MR-BAT6V1BJ. For details and other battery backup time, refer to the following.

 Page 462 ABSOLUTE POSITION DETECTION SYSTEM

*2 Quality of the batteries degrades by the storage condition. The battery life is 5 years from the production date regardless of the connection status.

*3 The characteristic of smoothing capacitor is deteriorated due to ripple currents, etc. The life of the capacitor greatly depends on ambient temperature and operating conditions. The capacitor will be the end of its life in 10 years of continuous operation in air-conditioned environment (ambient temperature of 40 °C or less for use at the maximum 1000 m above sea level, 30 °C or less for over 1000 m to 2000 m).

Transportation and storage

CAUTION

- Transport the products correctly according to their mass.
- Stacking in excess of the limited number of product packages is not allowed.
- For detailed information on transportation and handling of the battery, refer to the following.
 - ☞ Page 592 Handling of AC servo amplifier batteries for the United Nations Recommendations on the Transport of Dangerous Goods
 - ☞ Page 594 Symbol for the new EU Battery Directive
- Install the product in a load-bearing place of servo amplifier and servo motor in accordance with the instruction manual.
- Do not put excessive load on the machine.
- Do not hold the front cover, cables, or connectors when carrying the servo amplifier. Otherwise, it may drop.

When you keep or use it, please fulfill the following environment.

Item		Environment
Ambient temperature	Operation [°C]	0 to 55 Class 3K3 (IEC/EN 60721-3-3)
	Transportation [°C] ^{*1}	-20 to 65 Class 2K4 (IEC/EN 60721-3-2)
	Storage [°C] ^{*1}	-20 to 65 Class 1K4 (IEC/EN 60721-3-1)
Ambient humidity	Operation, transportation, storage	5 %RH to 90 %RH
Vibration resistance	Test condition	10 Hz to 57 Hz with constant amplitude of 0.075 mm 57 Hz to 150 Hz with constant acceleration of 9.8 m/s ² to IEC/EN 61800-5-1 (Test Fc of IEC 60068-2-6)
	Operation	5.9 m/s ²
	Transportation ^{*1}	Class 2M3 (IEC/EN 60721-3-2)
	Storage	Class 1M2 (IEC/EN 60721-3-2)
Pollution degree		2
IP rating		IP20 (IEC/EN 60529), Terminal block IP00
		Open type (UL 50)
Altitude	Operation, storage	Max. 2000 m above sea level
	Transportation	Max. 10000 m above sea level

*1 In regular transport packaging

A

Technical data

MR-J4 servo amplifier

Item		MR-J4-10_ MR-J4-20_ MR-J4-40_ MR-J4-60_ MR-J4-70_ MR-J4-100_ MR-J4-200_ MR-J4W2-22B/ MR-J4W2-44B/ MR-J4W2-77B/ MR-J4W3-222B/ MR-J4W3-444B	MR-J4-350_ MR-J4-500_ MR-J4-700_ MR-J4W2-1010B/ MR-J4-11K_ MR-J4-15K_ MR-J4-22K_	MR-J4-10_1/ MR-J4-20_1/ MR-J4-40_1	MR-J4-60_4/ MR-J4-100_4/ MR-J4-200_4/ MR-J4-350_4/ MR-J4-500_4/ MR-J4-700_4/ MR-J4-11K_4/ MR-J4-15K_4/ MR-J4-22K_4	MR-J4-03A6/ MR-J4W2-0303B6
Power supply	Main circuit (line voltage)	3-phase or 1-phase 200 V AC to 240 V AC, 50 Hz/60 Hz*1	3-phase 200 V AC to 240 V AC, 50 Hz/60 Hz*1	1-phase 100 V AC to 120 V AC, 50 Hz/60 Hz	3-phase 380 V AC to 480 V AC, 50 Hz/60 Hz	48 V DC or 24 V DC
	Control circuit (line voltage)	1-phase 200 V AC to 240 V AC, 50 Hz/60 Hz*1		1-phase 100 V AC to 120 V AC, 50 Hz/60 Hz	1-phase 380 V AC to 480 V AC, 50 Hz/60 Hz	24 V DC
	Interface (SELV)	24 V DC, (required current capacity: MR-J4-_A_, 500 mA; MR-J4-_B_, 300 mA; MR-J4W2-_B_, 350 mA; MR-J4W3-_B_, 450 mA; MR-J4-_GF_, 300 mA)				
Control system		Sine-wave PWM control, current control method				
Safety observation function (STO) IEC/EN 61800-5-2 ²		EN ISO 13849-1:2015 Category 3 PL e, IEC 61508 SIL 3, EN 62061 SIL CL 3, and EN 61800-5-2				—
Mean time to dangerous failure (MTTFd)		MTTFd ≥ 100 [years] (314a)				—
Diagnostic coverage (DC)		DC = Medium, 97.6 [%]				—
Probability of dangerous Failure per Hour (PFH)		PFH = 6.4×10^{-9} [1/h]				—
Mission time (T _M)		T _M = 20 [year]				—
Response performance		8 ms or less (STO input off → energy shut off)				—
Pollution degree		2 (IEC/EN 60664-1)				—
Overvoltage category		1-phase 100 V AC/200 V AC: II (IEC/EN 60664-1), 3-phase 200 V AC/400 V AC: III (IEC/EN 60664-1)				II (IEC/EN 60664-1)
Protective class		I (IEC/EN 61800-5-1)				III (IEC/EN 61800-5-1)
Short-circuit current rating (SCCR)		100 kA				5 kA

*1 For MR-J4-_RJ, 283 V DC to 340 V DC are also supported.

*2 Servo amplifiers manufactured in June 2015 or later comply with SIL 3 requirements. However, MR-J4-_A_/MR-J4-_B_ servo amplifiers manufactured in China comply with SIL 3 requirements from the December 2015 production.

Dimensions/mounting hole process drawing

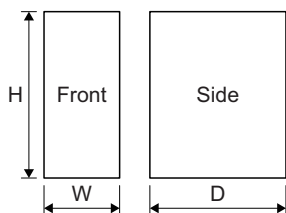

Servo amplifier	Variable dimensions [mm]			Mass [kg]
	W	H	D	
MR-J4-03A6	30	100	90	0.2
MR-J4-10_(1)/MR-J4-20_(1)*1	40 (50)	168	135 (155)	0.8 (1.0)
MR-J4-40_(1)/MR-J4-60_*1	40 (50)	168	170 (155)	1.0
MR-J4-70_/MR-J4-100_	60	168	185	1.4
MR-J4-200_(4)	90	168	195	2.1
MR-J4-350_	90	168	195	2.3
MR-J4-500_	105	250	200	4.0
MR-J4-700_	172	300	200	6.2
MR-J4-11K_(4)/MR-J4-15K_(4)	220	400	260	13.4
MR-J4-22K_(4)	260	400	260	18.2
MR-J4-60_4/MR-J4-100_4	60	168	195	1.7
MR-J4-350_4	105	250	200	3.6
MR-J4-500_4	130	250	200	4.3
MR-J4-700_4	172	300	200	6.5
MR-J4W2-0303B6	30	168	100	0.3
MR-J4W2-22B/MR-J4W2-44B	60	168	195	1.4
MR-J4W2-77B/MR-J4W2-1010B	85	168	195	2.3
MR-J4W3-222B/MR-J4W3-444B	85	168	195	2.3

*1 The value in the parenthesis shows the value of MR-J4-_GF_.

A

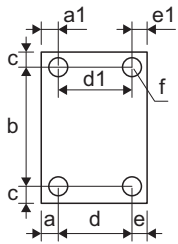

Servo amplifier	Variable dimensions [mm]								Screw size
	a	a1	b	c	d	d1	e	e1	
MR-J4-03A6	—	—	90 ± 0.5	5	—	—	4	4	M4
MR-J4-10_(1)/MR-J4-20_(1)/ MR-J4-40_(1)/MR-J4-60_	6	6	156 ± 0.5	6	—	—	—	—	M5
MR-J4-70_/MR-J4-100_	12	12	156 ± 0.5	6	42 ± 0.3	—	—	—	M5
MR-J4-200_(4)/MR-J4-350_	6	45	156 ± 0.5	6	78 ± 0.3	—	—	—	M5
MR-J4-500_	6	6	235 ± 0.5	7.5	93 ± 0.5	93 ± 0.5	—	—	M5
MR-J4-700_	6	6	285 ± 0.5	7.5	160 ± 0.5	160 ± 0.5	—	—	M5
MR-J4-11K_(4)/MR-J4-15K_(4)	12	12	380 ± 0.5	10	196 ± 0.5	196 ± 0.5	—	—	M5
MR-J4-22K_(4)	12	12	376 ± 0.5	12	236 ± 0.5	236 ± 0.5	—	—	M10
MR-J4-60_4/MR-J4-100_4	12	12	156 ± 0.5	6	42 ± 0.3	—	—	—	M5
MR-J4-350_4	6	6	235 ± 0.5	7.5	93 ± 0.5	93 ± 0.5	—	—	M5
MR-J4-500_4	6	6	235 ± 0.5	7.5	118 ± 0.5	118 ± 0.5	—	—	M5
MR-J4-700_4	6	6	285 ± 0.5	7.5	160 ± 0.5	160 ± 0.5	—	—	M5
MR-J4W2-0303B6	6	6	156 ± 0.5	6	—	—	—	—	M5
MR-J4W2-22B/MR-J4W2-44B	6	6	156 ± 0.5	6	—	—	—	—	M5
MR-J4W2-77B/MR-J4W2- 1010B	6	6	156 ± 0.5	6	73 ± 0.3	—	—	—	M5
MR-J4W3-222B/MR-J4W3- 444B	6	6	156 ± 0.5	6	73 ± 0.3	—	—	—	M5

Check list for user documentation



MR-J4 installation checklist for manufacturer/installer

The following items must be satisfied by the initial test operation at least. The manufacturer/installer must be responsible for checking the standards in the items.

Maintain and keep this checklist with related documents of machines to use this for periodic inspection.

1. Is it based on directive/standard applied to the machine? Yes [], No []
2. Is directive/standard contained in Declaration of Conformity (DoC)? Yes [], No []
3. Does the protection instrument conform to the category required? Yes [], No []
4. Are electric shock protective measures (protective class) effective? Yes [], No []
5. Is the STO function checked (test of all the shut-off wiring)? Yes [], No []

Checking the items will not be instead of the first test operation or periodic inspection by professional engineers.

Appendix 5 MR-J3-D05 Safety logic unit

Contents of the package

Open packing, and confirm the content of packing.

Contents	Quantity
MR-J3-D05 Safety logic unit	1
Connector for CN9 1-1871940-4 (TE Connectivity)	1
Connector for CN10 1-1871940-8 (TE Connectivity)	1
MR-J3-D05 Safety Logic Unit Installation Guide	1

Terms related to safety

Stop function for IEC/EN 61800-5-2

■STO function (Refer to IEC/EN 61800-5-2: 2007 4.2.2.2 STO.)

This function is integrated into the MR-J4 series servo amplifiers.

The STO function shuts down energy to servo motors, thus removing torque. This function electronically cuts off power supply in servo amplifiers for MR-J4 series servo amplifiers.

The purpose of this function is as follows.

- Uncontrolled stop according to stop category 0 of IEC/EN 60204-1
- Preventing unexpected start-up

■SS1 function (Refer to IEC/EN 61800-5-2: 2007 4.2.2.3C Safe stop 1 temporal delay.)

SS1 is a function which initiates the STO function when the previously set delay time has passed after the servo motor starts decelerating. The delay time can be set with MR-J3-D05.

The purpose of this function is as follows. This function is available by using an MR-J4 series servo amplifier with MR-J3-D05.

- Controlled stop according to stop category 1 of IEC/EN 60204-1

Emergency operation for IEC/EN 60204-1

■Emergency stop (Refer to IEC/EN 60204-1: 2005 9.2.5.4.2 Emergency Stop.)

Emergency stop must override all other functions and actuation in all operation modes. Power to the machine driving part which may cause a hazardous state must be either removed immediately (stop category 0) or must be controlled to stop such hazardous state as soon as possible (stop category 1). Restart must not be allowed even after the cause of the emergency state has been removed.

■Emergency switching off (Refer to IEC/EN 60204-1: 2005 9.2.5.4.3 Emergency Switching OFF.)

Removal of input power to driving device to remove electrical risk and to meet above mentioned safety standards.

A

Cautions

The following basic safety notes must be read carefully and fully in order to prevent injury to persons or damage to property. Only qualified personnel are authorized to install, start-up, repair or service the machines in which these components are installed.

They must be familiar with all applicable local safety regulations and laws in which machines with these components are installed, particularly the standards and guidelines mentioned in this Instruction Manual and the requirements mentioned in ISO/EN ISO 13849-1:2015, IEC 61508, IEC/EN 61800-5-2, and IEC/EN 60204-1.

The staff responsible for this work must be given express permission from the company to perform start-up, programming, configuration, and maintenance of the machine in accordance with the safety standards.

WARNING

- Improper installation of the safety related components or systems may cause improper operation in which safety is not assured, and may result in severe injuries or even death.
-

Protective Measures

- As described in IEC/EN 61800-5-2, the Safe Torque Off (STO) function only prevents the MR-J4 series servo amplifier from supplying energy to the servo motor. Therefore, if an external force acts upon the drive axis, additional safety measures, such as brakes or counter-weights must be used.

Residual risk

Machine manufacturers are responsible for all risk evaluations and all associated residual risks. Below are residual risks associated with the STO/EMG function. Mitsubishi Electric is not liable for any damages or injuries caused by the residual risks.

- The SS1 function only guarantees the delay time before STO/EMG is engaged. Proper setting of this delay time is the full responsibility of the company and/or individuals responsible for installation and commissioning of the safety related system. The system, as a whole, must pass safety standards certification.
- When the SS1 delay time is shorter than the required servo motor deceleration time, if the forced stop function is malfunctioning, or if STO/EMG is engaged while the servo motor is still rotating; the servo motor will stop with the dynamic brake or freewheeling.
- For proper installation, wiring, and adjustment, thoroughly read the manual of each individual safety related component.
- Be sure that all safety related switches, relays, sensors, etc., meet the required safety standards. The Mitsubishi Electric safety related components mentioned in this manual are certified by Certification Body as meeting the requirements of ISO/EN ISO 13849-1:2015 Category 3, PL d and IEC 61508 SIL 2.
- Safety is not assured until safety-related components of the system are completely installed or adjusted.
- When replacing an MR-J4 series servo amplifier or MR-J3-D05, confirm that the new equipment is exactly the same as those being replaced. Once installed, be sure to verify the performance of the functions before commissioning the system.
- Perform all risk assessments and safety level certification to the machine or the system as a whole. It is recommended that a Certification Body final safety certification of the system be used.
- To prevent accumulation of multiple malfunctions, perform a malfunction check at regular intervals as deemed necessary by the applicable safety standard. Regardless of the system safety level, malfunction checks should be performed at least once per year.
- If the upper and lower power modules in the servo amplifier are shorted and damaged simultaneously, the servo motor may make a half revolution at a maximum.

Block diagram and timing chart

Function block diagram

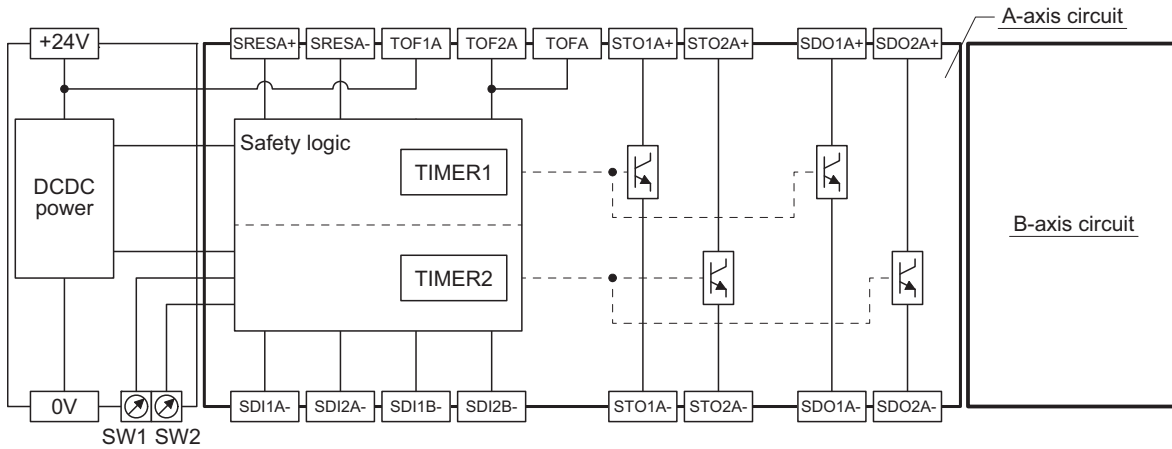

Operation sequence

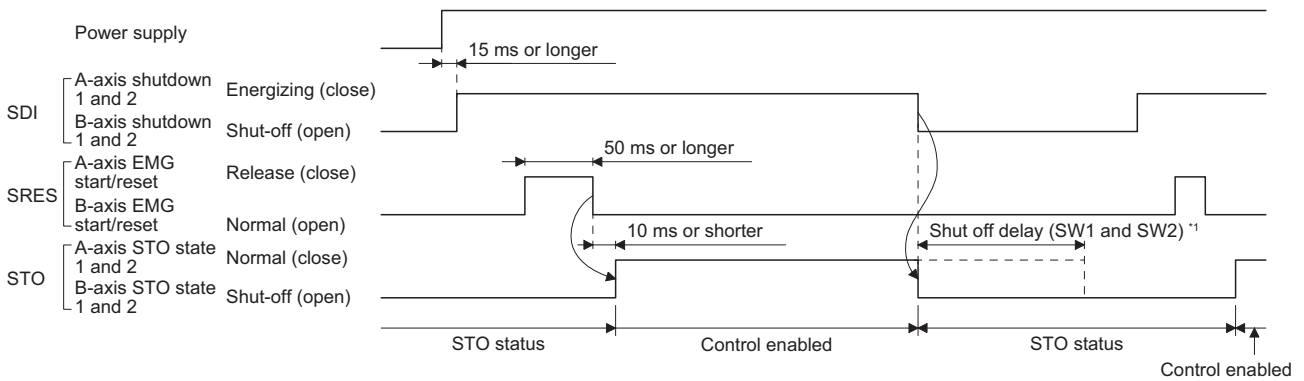

*1 Refer to the following.

☞ Page 622 Rotary switch setting

Maintenance and disposal

MR-J3-D05 is equipped with LED displays to check errors for maintenance.

Please dispose this unit according to your local laws and regulations.



Functions and configuration

Summary

MR-J3-D05 has two systems in which the each system has SS1 function (delay time) and output of STO function.

Specifications

Safety logic unit model		MR-J3-D05
Control circuit power supply	Voltage	24 V DC
	Permissible voltage fluctuation	24 V DC \pm 10%
	Required current capacity [A]	0.5 ^{*1} *2
Compatible system		2 systems (A-axis, B-axis independent)
Shut-off input		4 points (2 point \times 2 systems) SDI_: (source/sink compatible) ^{*3}
Shut-off release input		2 points (1 point \times 2 systems) SRES_: (source/sink compatible) ^{*3}
Feedback input		2 points (1 point \times 2 systems) TOF_: (source compatible) ^{*3}
Input type		Photocoupler insulation, 24 V DC (external supply), internal limited resistance 5.4 k Ω
Shut-off output		8 points (4 point \times 2 systems) STO_: (source compatible) ^{*3} 8 points (4 point \times 2 systems) SDO_: (source/sink compatible) ^{*3}
Output method		Photocoupler insulation, open-collector type Permissible current: 40 mA/1 output, Inrush current: 100 mA/1 output
Delay time setting		A-axis: Select from 0 s, 1.4 s, 2.8 s, 5.6 s, 9.8 s, or 30.8 s. B-axis: Select from 0 s, 1.4 s, 2.8 s, 9.8 s, or 30.8 s. Accuracy: \pm 2%
Functional safety		STO, SS1 (IEC/EN 61800-5-2) EMG STOP, EMG OFF IEC/EN 60204-1)
Safety performance	Standards certified by CB	EN ISO 13849-1:2015 Category 3 PL d, IEC 61508 SIL 2, EN 62061 SIL CL 2, and EN 61800-5-2 SIL 2
	Response performance (when delay time is set to 0 s) ^{*4}	10 ms or less (STO input off \rightarrow shut-off output off)
	Mean time to dangerous failure (MTTFd)	MTTFd \geq 100 [years] (516a)
	Diagnostic coverage (DC avg)	DC = Medium, 93.1 [%]
	Probability of dangerous Failure per Hour (PFH)	PFH = 4.75×10^{-9} [1/h]
Compliance to global standards	CE marking	LVD: EN 61800-5-1 EMC: EN 61800-3 MD: EN ISO 13849-1:2015, EN 61800-5-2, EN 62061
	Structure	Natural-cooling, open (IP rating: IP00)
Environment	Ambient temperature	0 °C to 55 °C (non-freezing), storage: -20 °C to 65 °C (non-freezing)
	Ambient humidity	5 %RH to 90 %RH (non-condensing), storage: 5 %RH to 90 %RH (non-condensing)
	Ambience	Indoors (no direct sunlight); no corrosive gas, inflammable gas, oil mist or dust
	Altitude	Max. 1000 m above sea level
	Vibration resistance	5.9 m/s ² at 10 Hz to 55 Hz (directions of X, Y and Z axes)
Mass [kg]	0.2 (including CN9 and CN10 connectors)	

*1 Inrush current of approximately 1.5 A flows instantaneously when turning the control circuit power supply on. Select an appropriate capacity of power supply considering the inrush current.

*2 Power-on duration of the safety logic unit is 100,000 times.

*3 _: in signal name indicates a number or axis name.

*4 For the test pulse input, contact your local sales office.

When using MR-J3-D05 with an MR-J4 series servo amplifier

■ System configuration diagram

The following shows the connection targets of the STO switch and STO release switch.



MR-D05UDL_M (STO cable) for MR-J3 series cannot be used.

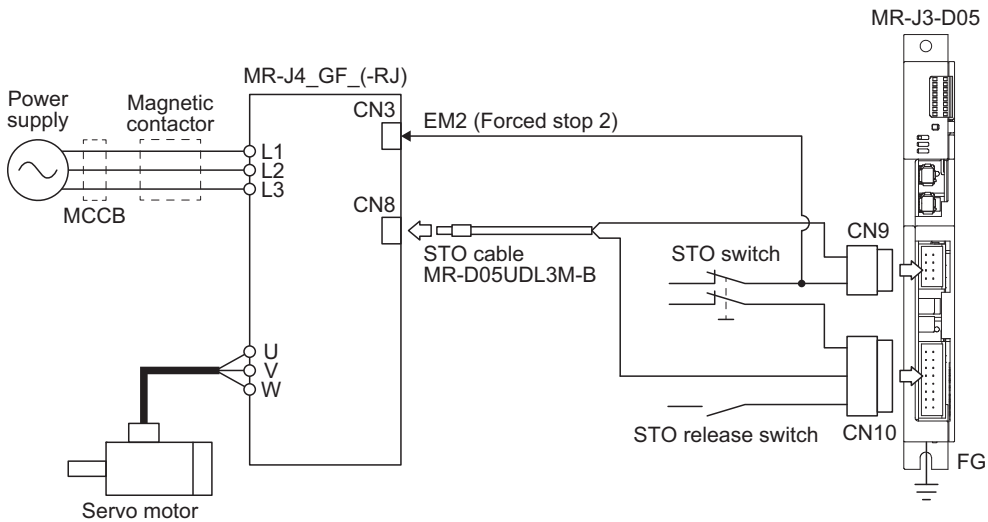

■ Connection example

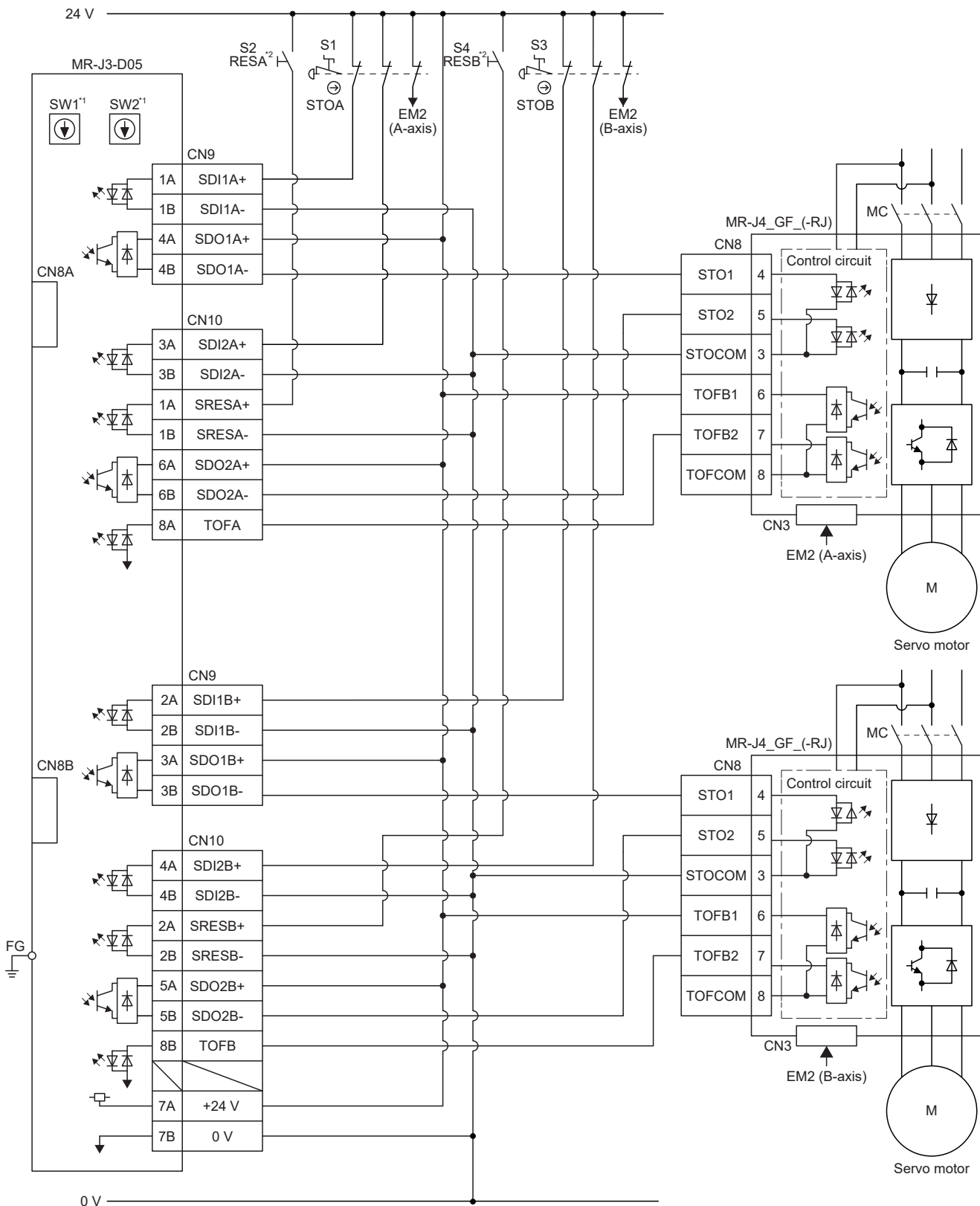

*1 Set the delay time of STO output with SW1 and SW2. These switches are recessed to prevent accidental change of the setting.

*2 To release the STO state (base circuit shut-off), turn RESA and RESB on and turn them off.

Signal

Connector/pin assignment

■CN8A

Device	Symbol	Pin No.	Function/application	I/O division
A-axis STO1	STO1A- STO1A+	1 4	Outputs STO1 to A-axis driving device. Outputs the same signal as A-axis STO2. STO state (base shutdown): Between STO1A+ and STO1A- is opened. STO release state (in driving): Between STO1A+ and STO1A- is closed.	O
A-axis STO2	STO2A- STO2A+	5 6	Outputs STO2 to A-axis driving device. Outputs the same signal as A-axis STO1. STO state (base shutdown): Between STO2A+ and STO2A- is opened. STO release state (in driving): Between STO2A+ and STO2A- is closed.	O
A-axis STO state	TOF2A TOF1A	7 8	Inputs STO state of A-axis driving device. STO state (base shutdown): Open between TOF2A and TOF1A. STO release state (in driving): Close between TOF2A and TOF1A.	I

■CN8B

Device	Symbol	Pin No.	Function/application	I/O division
B-axis STO1	STO1B- STO1B+	1 4	Outputs STO1 to B-axis driving device. Outputs the same signal as B-axis STO2. STO state (base shutdown): Between STO1B+ and STO1B- is opened. STO release state (in driving): Between STO1B+ and STO1B- is closed.	O
B-axis STO2	STO2B- STO2B+	5 6	Outputs STO2 to B-axis driving device. Outputs the same signal as B-axis STO1. STO state (base shutdown): Between STO2B+ and STO2B- is opened. STO release state (in driving): Between STO2B+ and STO2B- is closed.	O
B-axis STO state	TOF2B TOF1B	7 8	Inputs STO state of B-axis driving device. STO state (base shutdown): Open between TOF2B and TOF1B. STO release state (in driving): Close between TOF2B and TOF1B.	I

■CN9

Device	Symbol	Pin No.	Function/application	I/O division
A-axis shutdown 1	SDI1A+ SDI1A-	1A 1B	Connect this device to a safety switch for A-axis driving device. Input the same signal as A-axis shutdown 2. STO state (base shutdown): Open between SDI1A+ and SDI1A-. STO release state (in driving): Close between SDI1A+ and SDI1A-.	DI-1
B-axis shutdown 1	SDI1B+ SDI1B-	2A 2B	Connect this device to a safety switch for B-axis driving device. Input the same signal as B-axis shutdown 2. STO state (base shutdown): Open between SDI1B+ and SDI1B-. STO release state (in driving): Close between SDI1B+ and SDI1B-.	DI-1
A-axis SDO1	SDO1A+ SDO1A-	4A 4B	Outputs STO1 to A-axis driving device. Outputs the same signal as A-axis SDO2. STO state (base shutdown): Between SDO1A+ and SDO1A- is opened. STO release state (in driving): Between SDO1A+ and SDO1A- is closed.	DO-1
B-axis SDO1	SDO1B+ SDO1B-	3A 3B	Outputs STO1 to B-axis driving device. Outputs the same signal as B-axis SDO2. STO state (base shutdown): Between SDO1B+ and SDO1B- is opened. STO release state (in driving): Between SDO1B+ and SDO1B- is closed.	DO-1

■CN10

Device	Symbol	Pin No.	Function/application	I/O division
A-axis shutdown 2	SDI2A+ SDI2A-	3A 3B	Connect this device to a safety switch for A-axis driving device. Input the same signal as A-axis shutdown 1. STO state (base shutdown): Open between SDI2A+ and SDI2A-. STO release state (in driving): Close between SDI2A+ and SDI2A-.	DI-1

A

Device	Symbol	Pin No.	Function/application	I/O division
B-axis shutdown 2	SDI2B+ SDI2B-	4A 4B	Connect this device to a safety switch for B-axis driving device. Input the same signal as B-axis shutdown 1. STO state (base shutdown): Open between SDI2B+ and SDI2B-. STO release state (in driving): Close between SDI2B+ and SDI2B-.	DI-1
A-axis EMG start/ reset	SRESA+ SRESA-	1A 1B	Signal for releasing STO state (base shutdown) on A-axis driving device. Releases STO state (base shutdown) on A-axis driving device by switching between SRESA+ and SRESA- from on (connected) to off (opened).	DI-1
B-axis EMG start/ reset	SRESB+ SRESB-	2A 2B	Signal for releasing STO state (base shutdown) on B-axis driving device. Releases STO state (base shutdown) on B-axis driving device by switching between SRESB+ and SRESB- from on (connected) to off (opened).	DI-1
A-axis SDO2	SDO2A+ SDO2A-	6A 6B	Outputs STO2 to A-axis driving device. Outputs the same signal as A-axis SDO1. STO state (base shutdown): Between SDO2A+ and SDO2A- is opened. STO release state (in driving): Between SDO2A+ and SDO2A- is closed.	DO-1
B-axis SDO2	SDO2B+ SDO2B-	5A 5B	Outputs STO2 to B-axis driving device. Outputs the same signal as B-axis SDO1. STO state (base shutdown): Between SDO2B+ and SDO2B- is opened. STO release state (in driving): Between SDO2B+ and SDO2B- is closed.	DO-1
Control circuit power supply	+24V	7A	Connect + side of 24 V DC.	—
Control circuit power GND	0V	7B	Connect - side of 24 V DC.	—
A-axis STO state	TOFA	8A	TOFA is internally connected with TOF2A.	—
B-axis STO state	TOFB	8B	TOFB is internally connected with TOF2B.	—

Interfaces

For MR-J3-D05, source type I/O interfaces can be used.

■ Sink I/O interface (CN9, CN10 connector)

- Digital input interface DI-1

This is an input circuit whose photocoupler cathode side is input terminal. Transmit signals from sink (open-collector) type transistor output, relay switch, etc.

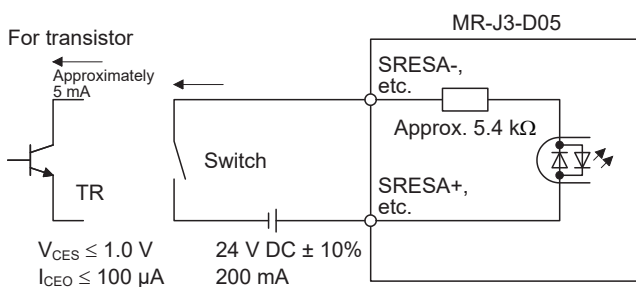

- Digital output interface DO-1

This is a circuit of collector output terminal of the output transistor. When the output transistor is turned on, collector terminal current will be applied to the output.

A lamp, relay or photocoupler can be driven. Install a diode (D) for an inductive load, or install an inrush current suppressing resistor (R) for a lamp load. (Rated current: 40 mA or less, maximum current: 50 mA or less, inrush current: 100 mA or less) A maximum of 2.6 V voltage drop occurs internally.

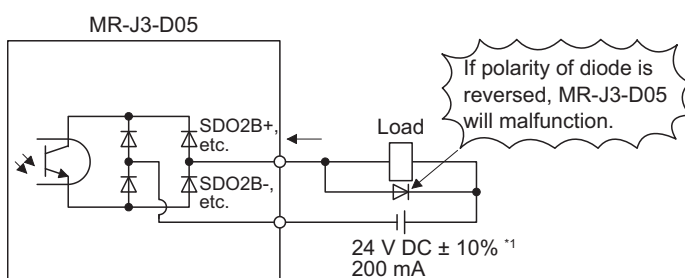

*1 If the voltage drop (maximum of 2.6 V) interferes with the relay operation, apply high voltage (maximum of 26.4 V) from external source.

■Source I/O interfaces (CN9, CN10 connector)

- Digital input interface DI-1

This is an input circuit whose photocoupler anode side is input terminal. Transmit signals from source (open-collector) type transistor output, relay switch, etc.

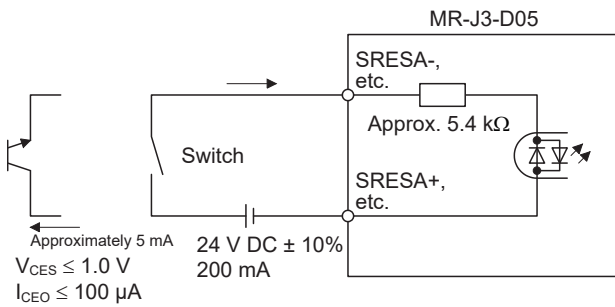

- Digital output interface DO-1

This is a circuit of emitter output terminal of the output transistor. When the output transistor is turned on, the current will flow from the output terminal to a load.

A maximum of 2.6 V voltage drop occurs in the MR-J3-D05.

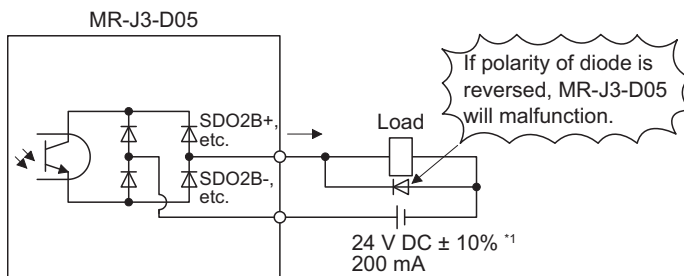

*1 If the voltage drop (maximum of 2.6 V) interferes with the relay operation, apply high voltage (maximum of 26.4 V) from external source.

Wiring CN9 and CN10 connectors

Handle with the tool with care when connecting wires.

■Wire strip

- Use wires with size of AWG 24 to 20 (0.22 mm² to 0.5 mm²) (recommended electric wire: UL 1007) and strip the wires to make the stripped length 7.0 mm ± 0.3 mm. Confirm the stripped length with gauge, etc. before using the wires.
- If the stripped wires are bent, loose, or too thick due to twisting too much, fix the wires by twisting lightly, etc. Then, confirm the stripped length before using the wires. Do not use excessively deformed wires.
- Smooth out the wire surface and stripped insulator surface.

■Connecting wires

Before connecting wires, be sure to pull out the receptacle assembly from the header connector. If wires are connected with inserted connector, the connector and the printed board may malfunction.

- Using extraction tool (1891348-1 or 2040798-1)

Dimensions and mass

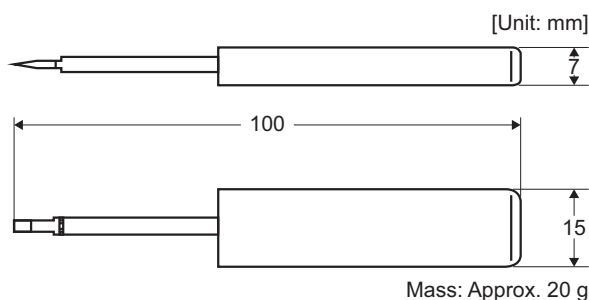

Connecting wires

1. Confirm the model number of the housing, contact and tool to be used.
2. Insert the tool diagonally into the receptacle assembly.

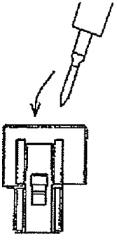

3. Insert the tool until it hits the surface of the receptacle assembly. At this stage, the tool is vertical to the receptacle assembly.

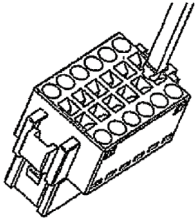

4. Insert wires in the wiring hole till the end. The wires should be slightly twisted in advance to prevent it from being loose.

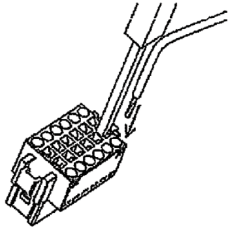

It is easy to insert the wire if the wire is inserted diagonally while twisting the tool.

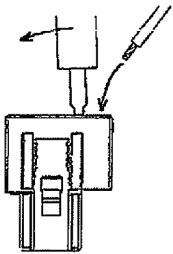

5. Remove the tool.

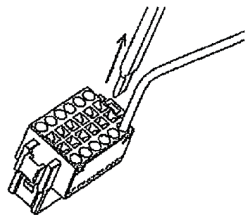

- Using a screwdriver

To avoid damaging housings and springs when wiring with screwdriver, do not put excessive force. Be cautious when connecting.

Applicable screwdriver

Screwdriver diameter: ϕ 2.3 mm	Screwdriver diameter: ϕ 2.5 mm
Diameter: 2.3 mm \pm 0.05 mm Length: 120 mm or less Width: 2.3 mm Thickness: 0.25 mm Angle in tip of the blade: $18^\circ \pm 1^\circ$	Diameter: 2.5 mm \pm 0.05 mm Length: 120 mm or less Width: 2.5 mm Thickness: 0.3 mm Angle in tip of the blade: $12^\circ \pm 1^\circ$

Connecting wires

1. Insert a screwdriver in the front slot a little diagonally, and depress the spring. While depressing the spring, insert the wires until they hit the end. Note that the housing and spring may be damaged if the screwdriver is inserted strongly. Never insert the screwdriver in the wire hole. Otherwise, the connector will be damaged.
2. Pull the screwdriver out while pressing the wires.
3. Pull the wire lightly to confirm that the wire is surely connected.
4. To remove the wires, depress the spring by the screwdriver in the same way as connecting wires, and then pull the wires out.

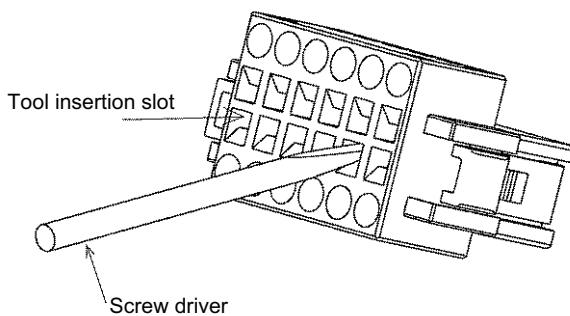

■ Connector insertion

Insert the connector all the way straight until you hear or feel clicking. When removing the connector, depress the lock part completely before pulling out. If the connector is pulled out without depressing the lock part completely, the housing, contact and/or wires may be damaged.

■ Compatible wire

Compatible wire size is listed below.

Wire size	
mm ²	AWG
0.22	24
0.34	22
0.50	20

A

■Others

- Fix a cable tie keeping a distance of "A" × 1.5 or longer from the end of the connector.

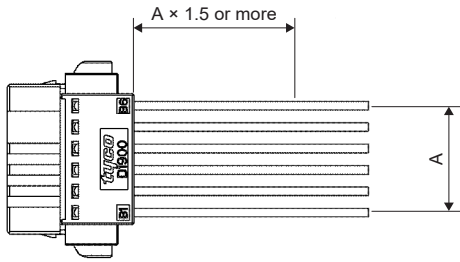

- Be sure that wires are not pulled excessively when the connector is inserted.

Wiring FG

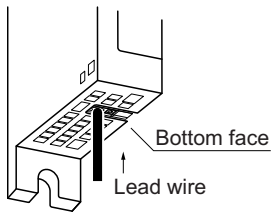

- Wire range

Single wire: $\phi 0.4$ mm to 1.2 mm (AWG 26 to AWG 16)

Stranded wire: 0.2 mm² to 1.25 mm² (AWG 24 to AWG 16), wire ϕ 0.18 mm or more

LED display

I/O status, malfunction and power on/off are displayed with LED for each A-axis and B-axis.

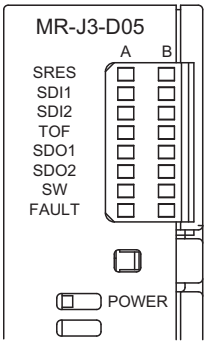

LED	Definition	LED	
		Column A	Column B
SRES	Monitor LED for start/reset Off: The start/reset is off. (The switch contact is opened.) On: The start/reset is on. (The switch contact is closed.)	A-axis	B-axis
SDI1	Monitor LED for shut-off 1 Off: The shut-off 1 is off. (The switch contact is closed.) On: The shut-off 1 is on. (The switch contact is opened.)		
SDI2	Monitor LED for shut-off 2 Off: The shut-off 2 is off. (The switch contact is closed.) On: The shut-off 2 is on. (The switch contact is opened.)		
TOF	Monitor LED for STO state Off: Not in STO state On: In STO state		
SDO1	Monitor LED for SDO1 Off: Not in STO state On: In STO state		
SDO2	Monitor LED for SDO2 Off: Not in STO state On: In STO state		
SW	Monitor LED for confirming shutdown delay setting Off: The settings of SW1 and SW2 do not match. On: The settings of SW1 and SW2 match.		
FAULT	FAULT LED Off: Normal operation (STO monitoring state) On: Fault has occurred.		
POWER	Power supply Off: Power is not supplied to MR-J3-D05. On: Power is being supplied to MR-J3-D05.	—	



Rotary switch setting

Rotary switch is used to shut off the power after control stop by SS1 function.

Set the delay time from when the STO shut off switch is pressed until when STO output is performed. Set the same setting for SW1 and SW2. The following table shows the delay time to be set according to the setting value of the rotary switch.

Setting cannot be changed while power is on. Notify users that setting cannot be changed by putting a seal or by another method so that end users will not change the setting after the shipment.

0 to F in the following table is the set value of the rotary switches (SW1 and SW2).

Rotary switch setting and delay time at A/B-axis [s]		B-axis					
		0 s	1.4 s	2.8 s	5.6 s	9.8 s	30.8 s
A-axis	0 s	0	1	2	—	3	4
	1.4 s	—	—	5	—	6	7
	2.8 s	—	—	8	—	9	A
	5.6 s	—	—	—	—	B	C
	9.8 s	—	—	—	—	D	E
	30.8 s	—	—	—	—	—	F

Troubleshooting

When power is not supplied or FAULT LED turns on, refer the following table and take the appropriate action.

Event	Definition	Cause	Action
Power is not supplied.	Power LED does not turn on although power is supplied.	1. 24 V DC power supply is malfunctioning.	Replace the 24 V DC power supply.
		2. Wires between MR-J3-D05 and 24 V DC power supply are disconnected or are in contact with other wires.	Check the wiring.
		3. MR-J3-D05 is malfunctioning.	Replace the MR-J3-D05.
FAULT LED is on.	FAULT LED of A-axis or B-axis is on, and will not turn off.	1. The delay time settings are not matched.	Check the settings of the rotary switch.
		2. Switch input error	Check the wiring or sequence of the input signals.
		3. TOF signal error	Check the connection with the servo amplifier.
		4. MR-J3-D05 is malfunctioning.	Replace the MR-J3-D05.

Dimensions

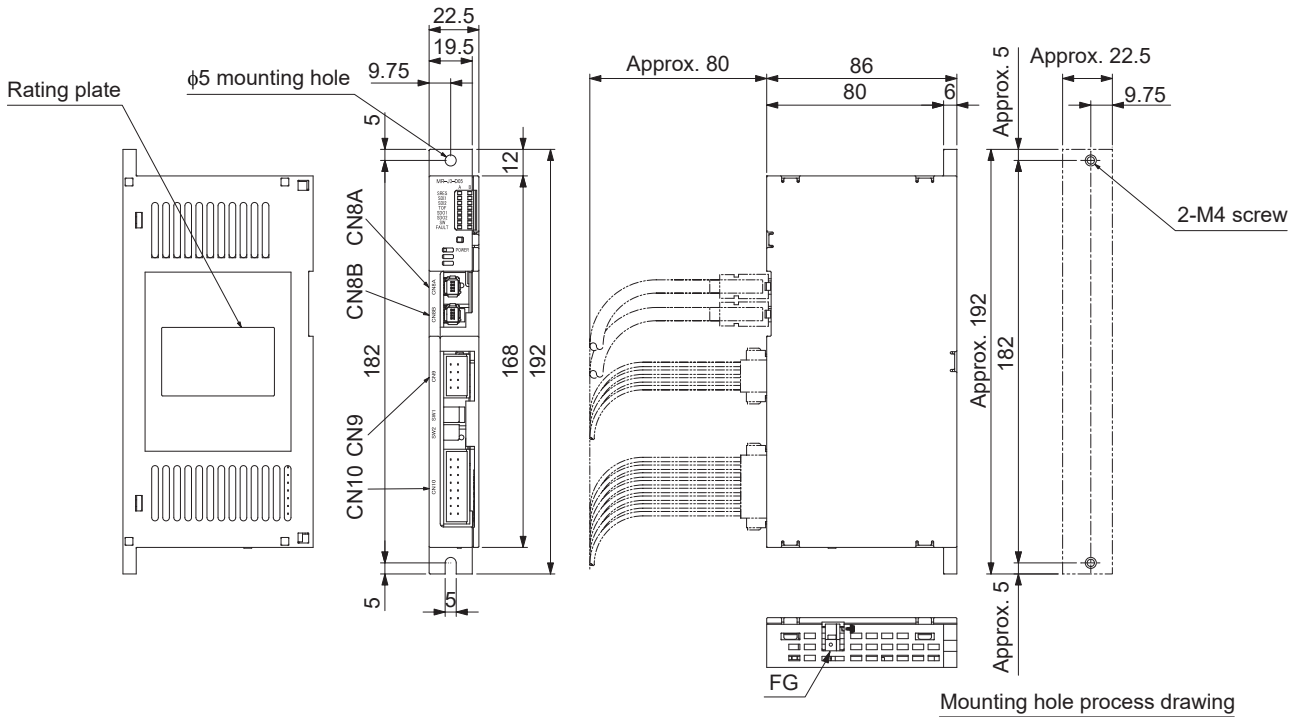

Pin assignment

CN8A		CN8B		CN9		CN10	
7	8	7	8	1A	1B	1A	1B
TOF2A	TOF1A	TOF2B	TOF1B	SDI1A+	SDI1A-	SRESA+	SRESA-
5	6	5	6	2A	2B	2A	2B
STO2A-	STO2A+	STO2B-	STO2B+	SDI1B+	SDI1B-	SRESB+	SRESB-
3	4	3	4	3A	3B	3A	3B
/	STO1A+	/	STO1B+	SDO1B+	SDO1B-	SDI2A+	SDI2A-
1	2	1	2	4A	4B	4A	4B
STO1A-	/	STO1B-	/	SDO2B+	SDO2B-	SDI2B+	SDI2B-
				5A	5B	5A	5B
				SDO2A+	SDO2A-	6A	6B
				6A	6B	SDO2A+	SDO2A-
				7A	7B	7A	7B
				+24 V	0 V	+24 V	0 V
				8A	8B	8A	8B
				TOFA	TOFB	TOFA	TOFB

Mounting screw

Screw size: M4

Tightening torque: 1.2 N·m

Mass: 0.2 [kg]



Installation

Follow the instructions in this section and install MR-J3-D05 in the specified direction. Leave clearances between MR-J3-D05 and other equipment including the cabinet.

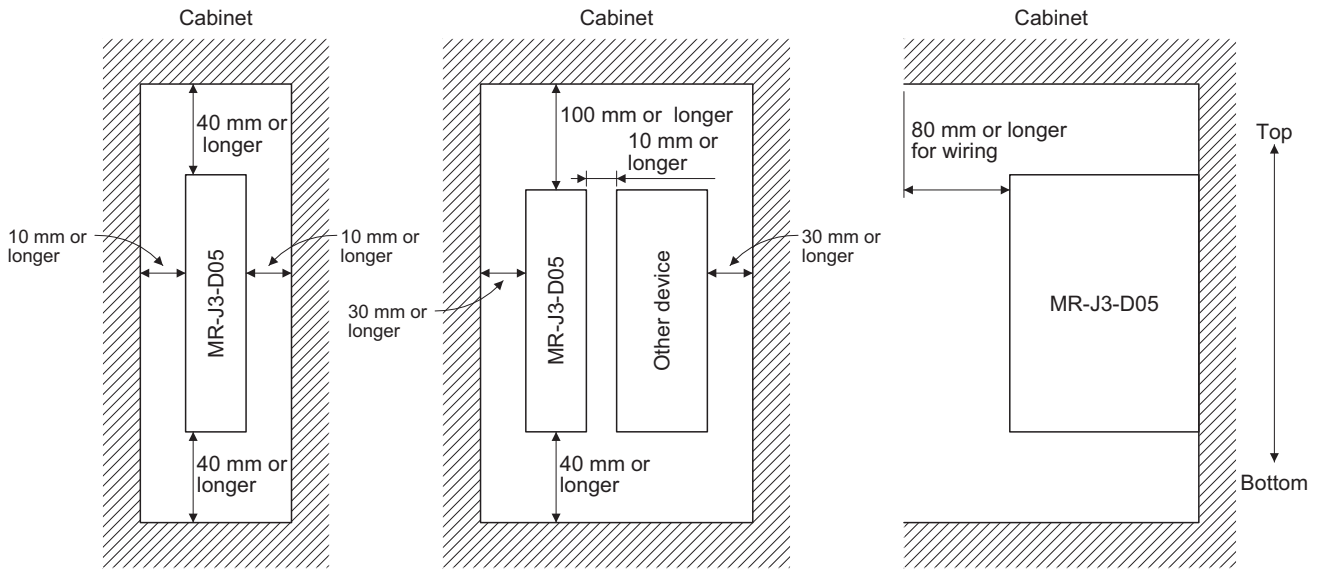



Combinations of cable/connector

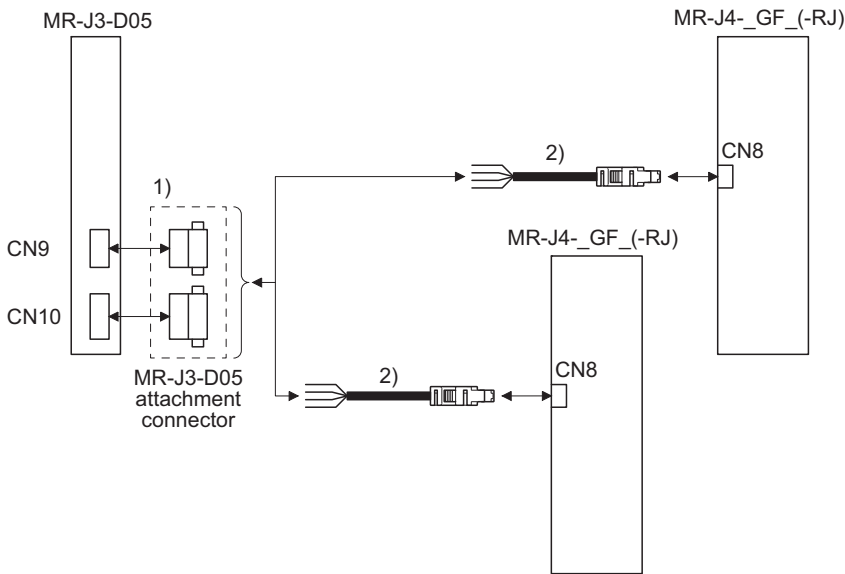

MR-D05UDL_M (STO cable) for MR-J3 series cannot be used.





No.	Product name	Model	Description
1)	Connector	MR-J3-D05 attachment connector	 Connector for CN9: 1-1871940-4 (TE Connectivity)
			 Connector for CN10: 1-1871940-8 (TE Connectivity)
2)	STO cable	MR-D05UDL3M-B Cable length: 3 m	Connector set: 2069250-1 (TE Connectivity) 

A



Appendix 6 EC declaration of conformity

The MR-J4 series servo amplifiers and MR-J3-D05 safety logic unit complies with the safety component laid down in the Machinery directive.

ZERTIFIKAT ◆ CERTIFICATE ◆ 認証証書 ◆ CERTIFICADO ◆ CERTIFICAT	 Product Service
	C E R T I F I C A T E
	No. Z10 16 08 66509 026
	Holder of Certificate: MITSUBISHI ELECTRIC CORPORATION Nagoya Works 5-1-14, Yada-Minami Higashi-ku, Nagoya-shi Aichi 461-8670 JAPAN
	Factory(ies): 66509, 83304
	Certification Mark: 
	Product: AC servo systems
	Model(s): Drive Unit MR-J4 Series Drive Unit MR-JE Series For nomenclature see attachment
	Parameters: Safety function (EN 61800-5-2): STO Ambient temperature: Operation: 0°C to 55°C Storage: -20°C to 65°C Altitude: max. 2000m above sea level
	Tested according to: EN ISO 13849-1:2015 (Cat 3, PL e) EN 62061:2005/A2:2015 (SILCL 3) IEC 62061(ed.1);am1;am2 IEC 61508-1(ed.2) (SIL 3) IEC 61508-2(ed.2) (SIL 3) IEC 61508-4(ed.2) (SIL 3) EN 61800-5-1:2007 IEC 61800-5-1(ed.2) EN 61800-5-2:2007 IEC 61800-5-2(ed.2) IEC 61326-3-1(ed.1)

The product was tested on a voluntary basis and complies with the essential requirements. The certification mark shown above can be affixed on the product. It is not permitted to alter the certification mark in any way. In addition the certification holder must not transfer the certificate to third parties. See also notes overleaf.

Test report no.:	MN86533T
Valid until:	2021-08-24

Date, 2016-08-25 
(Günter Greil) 

Page 1 of 3

TÜV SÜD Product Service GmbH · Zertifizierstelle · Ridlerstraße 65 · 80339 München · Germany TUV®

ZERTIFIKAT CERTIFICATE

Nr./No. 968/EL 612.00/09

Prüfgegenstand Product tested	Safety Logic Module for usage in combination with MR-J3-□S Servo Drives	Inhaber Holder	Mitsubishi Electric Corporation Nagoya Works 1-14 Yada-Minami 5-chome, Higashi-ku Nagoya 461-8670 Japan
Typbezeichnung Type designation	MR-J3-D05	Verwendungszweck Intended application	Drive Applications STO / SS1 acc. to EN 61800-5-2 Safe Stop / Safe Off Stop Category 0 / Stop Category 1 acc. to EN 60204-1
Prüfgrundlagen Codes and standards forming the basis of testing	EN ISO 13849-1:2008 EN 62061:2005 EN 61800-5-2:2007 EN 61800-5-1:2007	EN 61800-3:2004 EN 60204-1:2006 EN 50178:1997 EN 61508-1 to -7:2000-2002	
Prüfungsergebnis Test results	The MR-J3-D05 Safety Logic Module in combination with the MR-J3 series servo drives is suitable for the basic safety functions "STO" and "SS1" (Type C) according to EN 61800-5-2 as well as "Safe Stop" (Stop category 0 and Stop category 1) and "Safe Off" according to EN 60204-1. It can be used within safety related applications up to Safety Category 3 / PL d and SIL 2 / SIL CL 2 according to EN ISO 13849-1 and EN 62061.		
Besondere Bedingungen Specific requirements	For a safe usage of the product the instructions in the user documentation must be observed. For "Safe Off" two suitable additional magnetic contactors must be used additionally.		



Der Prüfbericht-Nr.: 968/EL 612.00/09 vom 21.04.2009 ist Bestandteil dieses Zertifikates.

Dieses Zertifikat ist nur gültig für Erzeugnisse, die mit dem Prüfgegenstand übereinstimmen. Es wird ungültig bei jeglicher Änderung der Prüfgrundlagen für den angegebenen Verwendungszweck.

The test report-no.: 968/EL 612.00/09 dated 2009-04-21 is an integral part of this certificate.

This certificate is valid only for products which are identical with the product tested. It becomes invalid at any change of the codes and standards forming the basis of testing for the intended application.

TÜV Rheinland Industrie Service GmbH
Geschäftsfeld ASI
Automation, Software und Informationstechnologie
Am Grauen Stein, 51105 Köln
Postfach 91 09 51, 51101 Köln



2009-04-21
Datum/Date

Firmenstempel/Company stamp

Dipl.-Ing. Heinz Gall

Appendix 7 How to replace servo amplifier without magnetic pole detection

CAUTION

- Be sure to write the magnetic pole information of the servo amplifier before the replacement to the servo amplifier after the replacement. If the information before and after replacement are different, the servo motor may operate unexpectedly.

When replacing the servo amplifier, carry out the magnetic pole detection again. If the magnetic pole detection cannot be performed unavoidably, write the magnetic pole information from the servo amplifier before the replacement to the one after the replacement using MR Configurator2.

Procedures

1. Read the magnetic pole information of the servo amplifier before the replacement.
2. Write the read magnetic pole information to the servo amplifier after the replacement.
3. Perform the test operation with the torque limit for ensuring the safety, and confirm that there is no trouble.

Migration method of the magnetic pole information

■How to read the magnetic pole information from the servo amplifier before the replacement

1. Open the project in MR Configurator2, select "MR-J4-GF(-RJ)" for model, and select "Linear" for operation mode.
2. Check that the personal computer is connected with the servo amplifier, and select "Diagnosis" and then "Linear diagnosis".
3. Click "Magnetic pole information" (1) in figure) to open the magnetic pole information window.
4. Click "Read All" of the magnetic pole information window. (2) in figure)
5. Confirm the data 1 and data 2 (3) in figure) of the magnetic pole information window and take notes.

■How to write the magnetic pole information to the servo amplifier after the replacement

1. Open the project in MR Configurator2, select "MR-J4-GF(-RJ)" for model, and select "Linear" for operation mode.
2. Check that the personal computer is connected with the servo amplifier, and select "Diagnosis" and then "Linear diagnosis".
3. Click "Magnetic pole information" (1) in figure) to open the magnetic pole information window.
4. Input the value of the magnetic pole information taken notes to the data 1 and data 2 (3) in figure) of the magnetic pole information window.
5. Click "Write All" (4) in figure) of the magnetic pole information window.
6. Cycle the power of the servo amplifier.

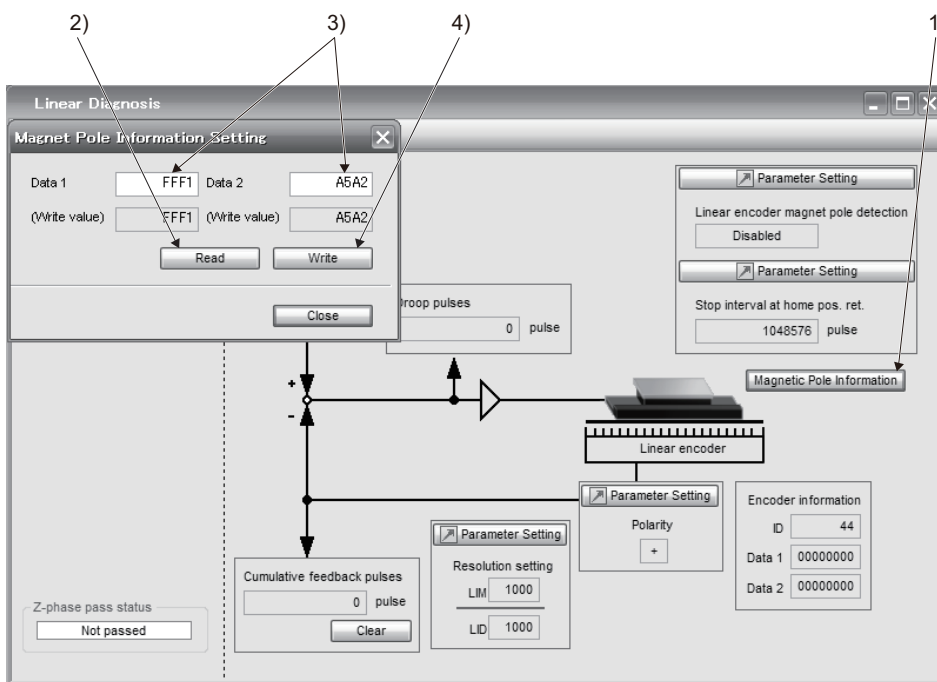

Appendix 8 Two-wire type encoder cable for HG-MR/HG-KR

For MR-EKCBL_M_ encoder cables for HG-MR and HG-KR, up to 20 m cables are two-wire type. When you need a longer encoder cable of two-wire type than 20 m, fabricate one as shown in the internal wiring diagram in this section using the MR-ECNM connector set. In this case, the cable length should not exceed 50 m.

Configuration diagram

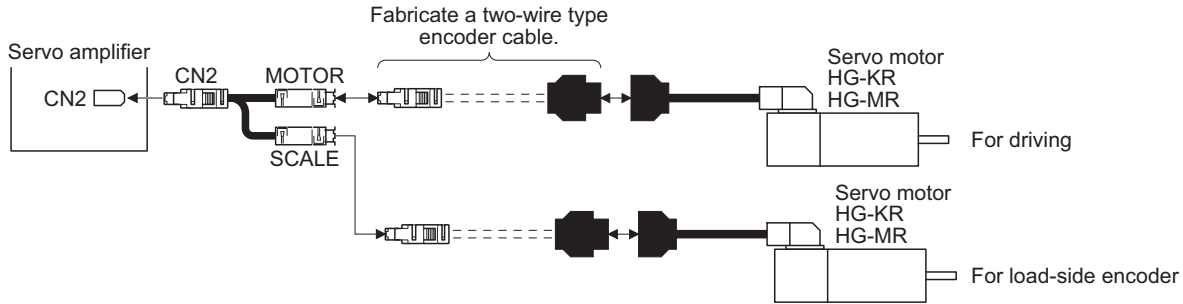

Connector set

Connector set	1) Servo amplifier-side connector	2) Servo motor-side connector
MR-ECNM	<p>Receptacle: 36210-0100PL Shell kit: 36310-3200-008 (3M)</p> <p>View seen from wiring side.*1 or Connector set: 54599-1019 (Molex)</p> <p>View seen from wiring side.*1</p>	<p>Housing: 1-172161-9 Connector pin: 170359-1 (TE Connectivity or equivalent) Cable clamp: MTI-0002 (Toa Electric Industrial)</p> <p>View seen from wiring side.</p>

*1 Keep open the pins shown with . Especially, pin 10 is provided for manufacturer adjustment. If it is connected with any other pin, the servo amplifier cannot operate normally.

Internal wiring diagram

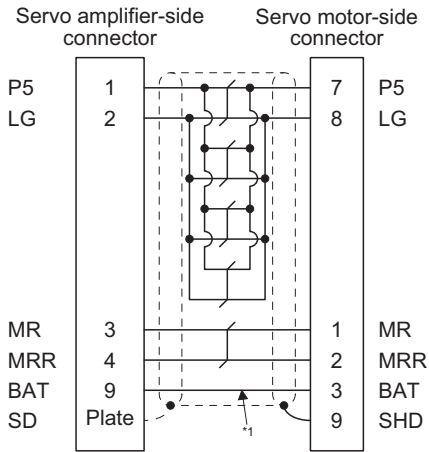

*1 Always make connection for use in an absolute position detection system. Wiring is not necessary for use in an incremental system.



Appendix 9 Analog monitor

Point

A voltage of analog monitor output may be irregular at power-on.

The servo status can be output to two channels in terms of voltage.

Setting

Change the following digits of [Pr. PC09] and [Pr. PC10].

[Pr. PC09]

0	0		
---	---	--	--

Analog monitor 1 output selection
(the signal provided to the output across MO1 and LG)

[Pr. PC10]

0	0		
---	---	--	--

Analog monitor 2 output selection
(the signal provided to the output across MO2 and LG)

[Pr. PC11] and [Pr. PC12] can be used to set the offset voltages to the analog output voltages. Setting value is -999 mV to 999 mV.

Parameter	Description	Setting range [mV]
PC11	This is used to set the offset voltage of MO1 (Analog monitor 1).	-999 to 999
PC12	This is used to set the offset voltage of MO2 (Analog monitor 2).	

Details of the setting

Point

When you use a linear servo motor, replace the following left words to the right words.

CCW direction → Positive direction

CW direction → Negative direction

Torque → Thrust

The servo amplifier is factory-set to output the servo motor speed to MO1 (Analog monitor 1) and the torque to MO2 (Analog monitor 2). The setting can be changed as listed below by setting the [Pr. PC09] and [Pr. PC10] value.

Refer to the following for the detection point.

Page 637 Analog monitor block diagram

Setting value	Output item	Description
00	Servo motor speed	
01	Torque/Thrust ⁷	
02	Servo motor speed	
03	Torque/Thrust ⁷	
04	Current command ⁷	

A

Setting value	Output item	Description
05	Speed command ^{*3}	
06	Servo motor-side droop pulses ^{*1*3*5*6} (±10 V/100 pulses)	
07	Servo motor-side droop pulses ^{*1*3*5*6} (±10 V/1000 pulses)	
08	Servo motor-side droop pulses ^{*1*3*5*6} (±10 V/10000 pulses)	
09	Servo motor-side droop pulses ^{*1*3*5*6} (±10 V/100000 pulses)	
0D	Bus voltage ^{*4}	
0E	Speed command 2 ^{*3}	

Setting value	Output item	Description
10	Load-side droop pulses ^{*3*5*6} (±10 V/100 pulses)	
11	Load-side droop pulses ^{*3*5*6} (±10 V/1000 pulses)	
12	Load-side droop pulses ^{*3*5*6} (±10 V/10000 pulses)	
13	Load-side droop pulses ^{*3*5*6} (±10 V/100000 pulses)	
14	Load-side droop pulses ^{*3*5*6} (±10 V/1 Mpulse)	
15	Motor-side/load-side position deviation ^{*3*5*6} (±10 V/100000 pulses)	

A

Setting value	Output item	Description
16	Servo motor-side/load-side speed deviation	
17	Internal temperature of encoder (± 10 V/ ± 128 °C)	

*1 Encoder pulse unit.

*2 Available in position mode

*3 This cannot be used in the torque mode.

*4 For 400 V class servo amplifier, the bus voltage becomes $+8$ V/800 V.

*5 This cannot be used in the velocity mode.

*6 Output in the load-side encoder unit for the fully closed loop control. Output in the servo motor encoder unit for the semi closed loop control.

*7 \pm For details on the value of the maximum current command (maximum torque) for ± 8 V, refer to the following.

 Page 638 Maximum current command (maximum torque) for analog monitor ± 8 V

Analog monitor block diagram

Semi closed loop control

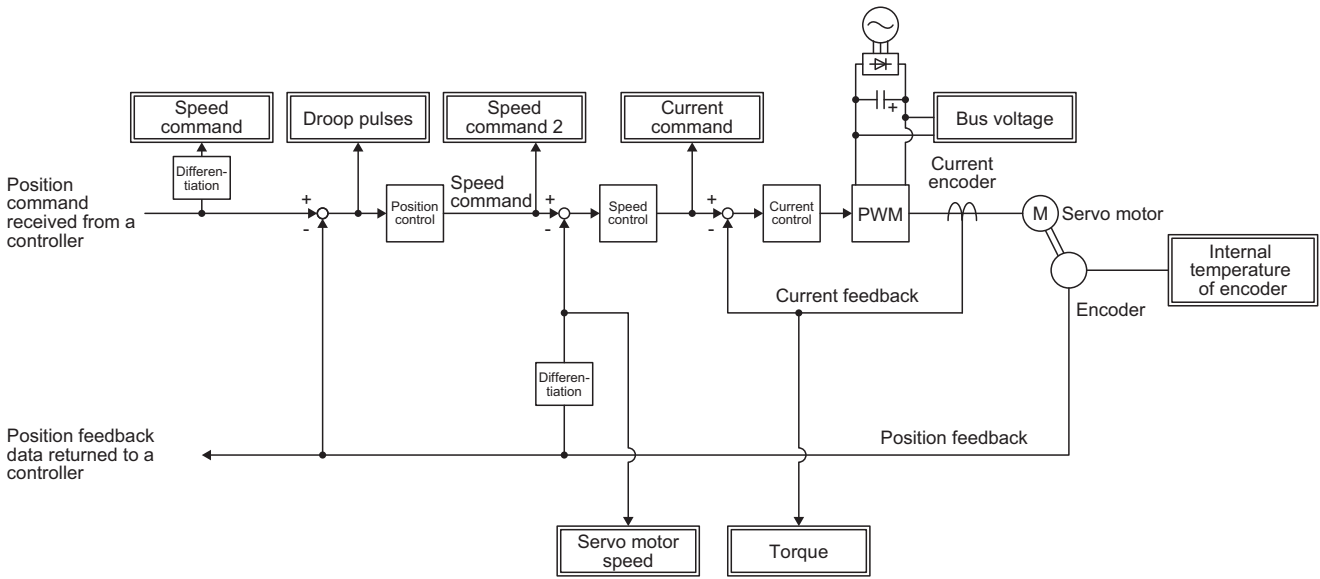

Fully closed loop control

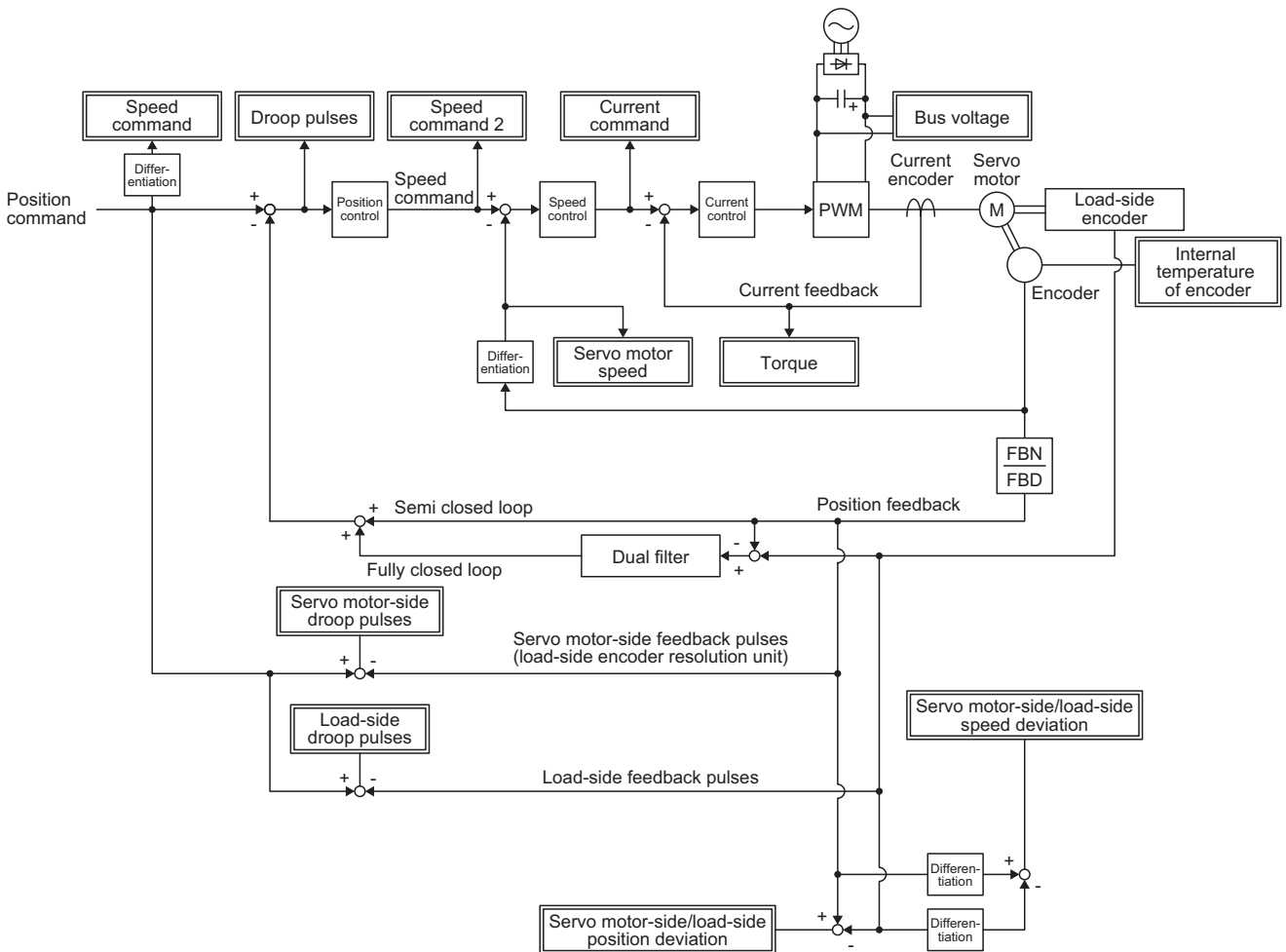

A

Maximum current command (maximum torque) for analog monitor ± 8 V

Values of the maximum current command (maximum torque) when the analog monitor is ± 8 V are listed.

The current command (torque) outputs the maximum current command (maximum torque) at ± 8 V. The maximum current command (maximum torque) may not match the rated current/maximum current ratio since it is created from the torque current in the servo amplifier.

Rotary servo motor

■200 V class/100 V class

Servo motor		Servo amplifier/drive unit	Maximum current command (maximum torque) [%]
HG-KR series	HG-KR053	MR-J4-10_(-RJ)/MR-J4-10_1(-RJ)	370
	HG-KR13	MR-J4-10_(-RJ)/MR-J4-10_1(-RJ)	373
	HG-KR23	MR-J4-20_(-RJ)/MR-J4-20_1(-RJ)	387
	HG-KR43	MR-J4-40_(-RJ)/MR-J4-40_1(-RJ)	383
	HG-KR73	MR-J4-70_(-RJ)	367
HG-MR series	HG-MR053	MR-J4-10_(-RJ)/MR-J4-10_1(-RJ)	342
	HG-MR13	MR-J4-10_(-RJ)/MR-J4-10_1(-RJ)	336
	HG-MR23	MR-J4-20_(-RJ)/MR-J4-20_1(-RJ)	396
	HG-MR43	MR-J4-40_(-RJ)/MR-J4-40_1(-RJ)	361
	HG-MR73	MR-J4-70_(-RJ)	345
HG-SR 1000 r/min series	HG-SR51	MR-J4-60_(-RJ)	311
	HG-SR81	MR-J4-100_(-RJ)	329
	HG-SR121	MR-J4-200_(-RJ)	353
	HG-SR201	MR-J4-200_(-RJ)	334
	HG-SR301	MR-J4-350_(-RJ)	366
	HG-SR421	MR-J4-500_(-RJ)	347
HG-SR 2000 r/min series	HG-SR52	MR-J4-60_(-RJ)	302
	HG-SR102	MR-J4-100_(-RJ)	310
	HG-SR152	MR-J4-200_(-RJ)	320
	HG-SR202	MR-J4-200_(-RJ)	327
	HG-SR352	MR-J4-350_(-RJ)	332
	HG-SR502	MR-J4-500_(-RJ)	341
	HG-SR702	MR-J4-700_(-RJ) MR-J4-DU900_(-RJ)	336 446
HG-UR series	HG-UR72	MR-J4-70_(-RJ)	355
	HG-UR152	MR-J4-200_(-RJ)	340
	HG-UR202	MR-J4-350_(-RJ)	350
	HG-UR352	MR-J4-500_(-RJ)	320
	HG-UR502	MR-J4-500_(-RJ)	330
HG-RR series	HG-RR103	MR-J4-200_(-RJ)	300
	HG-RR153	MR-J4-200_(-RJ)	250
	HG-RR203	MR-J4-350_(-RJ)	290
	HG-RR353	MR-J4-500_(-RJ)	270
	HG-RR503	MR-J4-500_(-RJ)	270

Servo motor		Servo amplifier/drive unit	Maximum current command (maximum torque) [%]
HG-JR 1000 r/min series	HG-JR601	MR-J4-700_(-RJ)/MR-J4-DU900_(-RJ)	337
	HG-JR801	MR-J4-11K_(-RJ)/MR-J4-DU900_(-RJ)	366
	HG-JR12K1	MR-J4-11K_(-RJ)/MR-J4-DU11K_(-RJ)	346
	HG-JR15K1	MR-J4-15K_(-RJ)/MR-J4-DU15K_(-RJ)	339
	HG-JR20K1	MR-J4-22K_(-RJ)/MR-J4-DU22K_(-RJ)	337
	HG-JR25K1	MR-J4-22K_(-RJ)/MR-J4-DU22K_(-RJ)	330
	HG-JR30K1	MR-J4-DU30K_(-RJ)	330
	HG-JR37K1	MR-J4-DU37K_(-RJ)	330
HG-JR 1500 r/min series	HG-JR701M	MR-J4-700_(-RJ)/MR-J4-DU900_(-RJ)	326
	HG-JR11K1M	MR-J4-11K_(-RJ)/MR-J4-DU11K_(-RJ)	335
	HG-JR15K1M	MR-J4-15K_(-RJ)/MR-J4-DU15K_(-RJ)	334
	HG-JR22K1M	MR-J4-22K_(-RJ)/MR-J4-DU22K_(-RJ)	317
	HG-JR30K1M	MR-J4-DU30K_(-RJ)	342
	HG-JR37K1M	MR-J4-DU37K_(-RJ)	365
HG-JR 3000 r/min series	HG-JR53	MR-J4-60_(-RJ)	341
		MR-J4-100_(-RJ)	460
	HG-JR73	MR-J4-70_(-RJ)	331
		MR-J4-200_(-RJ)	460
	HG-JR103	MR-J4-100_(-RJ)	341
		MR-J4-200_(-RJ)	460
	HG-JR153	MR-J4-200_(-RJ)	320
		MR-J4-350_(-RJ)	460
	HG-JR203	MR-J4-200_(-RJ)	320
		MR-J4-350_(-RJ)	460
	HG-JR353	MR-J4-350_(-RJ)	307
		MR-J4-500_(-RJ)	464
	HG-JR503	MR-J4-500_(-RJ)	342
		MR-J4-700_(-RJ)/MR-J4-DU900_(-RJ)	430
HG-JR703	MR-J4-700_(-RJ)/MR-J4-DU900_(-RJ)	341	
HG-JR903	MR-J4-11K_(-RJ)/MR-J4-DU900_(-RJ)	352	

■400 V class

Servo motor		Servo amplifier/drive unit	Maximum current command (maximum torque) [%]
HG-SR 2000 r/min series	HG-SR524	MR-J4-60_4(-RJ)	313
	HG-SR1024	MR-J4-100_4(-RJ)	322
	HG-SR1524	MR-J4-200_4(-RJ)	330
	HG-SR2024	MR-J4-200_4(-RJ)	327
	HG-SR3524	MR-J4-350_4(-RJ)	336
	HG-SR5024	MR-J4-500_4(-RJ)	336
	HG-SR7024	MR-J4-700_4(-RJ)	346
		MR-J4-DU900_4(-RJ)	443
HG-JR 1000 r/min series	HG-JR6014	MR-J4-700_4(-RJ)/MR-J4-DU900_4(-RJ)	337
	HG-JR8014	MR-J4-11K_4(-RJ)/MR-J4-DU11K_4(-RJ)	336
	HG-JR12K14	MR-J4-11K_4(-RJ)/MR-J4-DU11K_4(-RJ)	346
	HG-JR15K14	MR-J4-15K_4(-RJ)/MR-J4-DU15K_4(-RJ)	335
	HG-JR20K14	MR-J4-22K_4(-RJ)/MR-J4-DU22K_4(-RJ)	341
	HG-JR25K14	MR-J4-22K_4(-RJ)/MR-J4-DU22K_4(-RJ)	337
	HG-JR30K14	MR-J4-DU30K_4(-RJ)	330
	HG-JR37K14	MR-J4-DU37K_4(-RJ)	330
HG-JR 1500 r/min series	HG-JR701M4	MR-J4-700_4(-RJ)/MR-J4-DU900_4(-RJ)	329
	HG-JR11K1M4	MR-J4-11K_4(-RJ)/MR-J4-DU11K_4(-RJ)	338
	HG-JR15K1M4	MR-J4-15K_4(-RJ)/MR-J4-DU15K_4(-RJ)	338
	HG-JR22K1M4	MR-J4-22K_4(-RJ)/MR-J4-DU22K_4(-RJ)	342
	HG-JR30K1M4	MR-J4-DU30K_4(-RJ)	335
	HG-JR37K1M4	MR-J4-DU37K_4(-RJ)	323
	HG-JR45K1M4	MR-J4-DU45K_4(-RJ)	344
	HG-JR55K1M4	MR-J4-DU55K_4(-RJ)	321
HG-JR 3000 r/min series	HG-JR534	MR-J4-60_4(-RJ)	320
		MR-J4-100_4(-RJ)	460
	HG-JR734	MR-J4-100_4(-RJ)	320
		MR-J4-200_4(-RJ)	459
	HG-JR1034	MR-J4-100_4(-RJ)	320
		MR-J4-200_4(-RJ)	459
	HG-JR1534	MR-J4-200_4(-RJ)	320
		MR-J4-350_4(-RJ)	459
	HG-JR2034	MR-J4-200_4(-RJ)	320
		MR-J4-350_4(-RJ)	459
	HG-JR3534	MR-J4-350_4(-RJ)	320
		MR-J4-500_4(-RJ)	470
	HG-JR5034	MR-J4-500_4(-RJ)	320
		MR-J4-700_4(-RJ)/MR-J4-DU900_4(-RJ)	413
	HG-JR7034	MR-J4-700_4(-RJ)/MR-J4-DU900_4(-RJ)	337
	HG-JR9034	MR-J4-11K_4(-RJ)/MR-J4-DU900_4(-RJ)	336

■24 V/48 V class

Servo motor		Servo amplifier/drive unit	Maximum current command (maximum torque) [%]
HG-AK series	HG-AK0136	MR-J4-03A6/MR-J4W2-0303B6	380
	HG-AK0236	MR-J4-03A6/MR-J4W2-0303B6	380
	HG-AK0336	MR-J4-03A6/MR-J4W2-0303B6	363

Servo motor with functional safety

■200 V class/100 V class

Servo motor		Servo amplifier/drive unit	Maximum current command (maximum torque) [%]
HG-KR series	HG-KR053W0C	MR-J4-10_(-RJ)/MR-J4-10_1(-RJ)	370
	HG-KR13W0C	MR-J4-10_(-RJ)/MR-J4-10_1(-RJ)	373
	HG-KR23W0C	MR-J4-20_(-RJ)/MR-J4-20_1(-RJ)	387
	HG-KR43W0C	MR-J4-40_(-RJ)/MR-J4-40_1(-RJ)	383
	HG-KR73W0C	MR-J4-70_(-RJ)	367
HG-SR 1000 r/min series	HG-SR51W0C	MR-J4-60_(-RJ)	311
	HG-SR81W0C	MR-J4-100_(-RJ)	329
	HG-SR121W0C	MR-J4-200_(-RJ)	353
	HG-SR201W0C	MR-J4-200_(-RJ)	334
	HG-SR301W0C	MR-J4-350_(-RJ)	366
	HG-SR421W0C	MR-J4-500_(-RJ)	347
HG-SR 2000 r/min series	HG-SR52W0C	MR-J4-60_(-RJ)	302
	HG-SR102W0C	MR-J4-100_(-RJ)	310
	HG-SR152W0C	MR-J4-200_(-RJ)	320
	HG-SR202W0C	MR-J4-200_(-RJ)	327
	HG-SR352W0C	MR-J4-350_(-RJ)	332
	HG-SR502W0C	MR-J4-500_(-RJ)	341
	HG-SR702W0C	MR-J4-700_(-RJ)/MR-J4-DU900_(-RJ)	336
HG-JR 1500 r/min series	HG-JR701MW0C	MR-J4-700_(-RJ)/MR-J4-DU900_(-RJ)	326
	HG-JR11K1MW0C	MR-J4-11K_(-RJ)/MR-J4-DU11K_(-RJ)	335
	HG-JR15K1MW0C	MR-J4-15K_(-RJ)/MR-J4-DU15K_(-RJ)	334
	HG-JR22K1MW0C	MR-J4-22K_(-RJ)/MR-J4-DU22K_(-RJ)	317
HG-JR 3000 r/min series	HG-JR53W0C	MR-J4-60_(-RJ)	341
		MR-J4-100_(-RJ)	460
	HG-JR73W0C	MR-J4-70_(-RJ)	331
		MR-J4-200_(-RJ)	460
	HG-JR103W0C	MR-J4-100_(-RJ)	341
		MR-J4-200_(-RJ)	460
	HG-JR153W0C	MR-J4-200_(-RJ)	320
		MR-J4-350_(-RJ)	460
	HG-JR203W0C	MR-J4-200_(-RJ)	320
		MR-J4-350_(-RJ)	460
	HG-JR353W0C	MR-J4-350_(-RJ)	307
		MR-J4-500_(-RJ)	464
	HG-JR503W0C	MR-J4-500_(-RJ)	342
		MR-J4-700_(-RJ)/MR-J4-DU900_(-RJ)	430
HG-JR703W0C	MR-J4-700_(-RJ)/MR-J4-DU900_(-RJ)	341	
HG-JR903W0C	MR-J4-11K_(-RJ)/MR-J4-DU900_(-RJ)	352	

A

■400 V class

Servo motor		Servo amplifier/drive unit	Maximum current command (maximum torque) [%]
HG-SR 2000 r/min series	HG-SR524W0C	MR-J4-60_4(-RJ)	313
	HG-SR1024W0C	MR-J4-100_4(-RJ)	322
	HG-SR1524W0C	MR-J4-200_4(-RJ)	330
	HG-SR2024W0C	MR-J4-200_4(-RJ)	327
	HG-SR3524W0C	MR-J4-350_4(-RJ)	336
	HG-SR5024W0C	MR-J4-500_4(-RJ)	336
	HG-SR7024W0C	MR-J4-700_4(-RJ)/MR-J4-DU900_4(-RJ)	346
HG-JR 1500 r/min series	HG-JR701M4W0C	MR-J4-700_4(-RJ)/MR-J4-DU900_4(-RJ)	329
	HG-JR11K1M4W0C	MR-J4-11K_4(-RJ)/MR-J4-DU11K_4(-RJ)	338
	HG-JR15K1M4W0C	MR-J4-15K_4(-RJ)/MR-J4-DU15K_4(-RJ)	338
	HG-JR22K1M4W0C	MR-J4-22K_4(-RJ)/MR-J4-DU22K_4(-RJ)	342
HG-JR 3000 r/min series	HG-JR534W0C	MR-J4-60_4(-RJ)	320
		MR-J4-100_4(-RJ)	460
	HG-JR734W0C	MR-J4-100_4(-RJ)	320
		MR-J4-200_4(-RJ)	459
	HG-JR1034W0C	MR-J4-100_4(-RJ)	320
		MR-J4-200_4(-RJ)	459
	HG-JR1534W0C	MR-J4-200_4(-RJ)	320
		MR-J4-350_4(-RJ)	459
	HG-JR2034W0C	MR-J4-200_4(-RJ)	320
		MR-J4-350_4(-RJ)	459
	HG-JR3534W0C	MR-J4-350_4(-RJ)	320
		MR-J4-500_4(-RJ)	470
	HG-JR5034W0C	MR-J4-500_4(-RJ)	320
		MR-J4-700_4(-RJ)/MR-J4-DU900_4(-RJ)	413
	HG-JR7034W0C	MR-J4-700_4(-RJ)/MR-J4-DU900_4(-RJ)	337
HG-JR9034W0C	MR-J4-700_4(-RJ)/MR-J4-DU900_4(-RJ)	336	

Linear servo motor (primary side)

■200 V class

Linear servo motor (primary side)		Servo amplifier/drive unit	Maximum current command (maximum torque) [%]	
LM-H3 series	LM-H3P2A-07P-BSS0	MR-J4-40_(-RJ)	390	
	LM-H3P3A-12P-CSS0	MR-J4-40_(-RJ)	340	
	LM-H3P3B-24P-CSS0	MR-J4-70_(-RJ)	320	
	LM-H3P3C-36P-CSS0	MR-J4-70_(-RJ)	350	
	LM-H3P3D-48P-CSS0	MR-J4-200_(-RJ)	335	
	LM-H3P7A-24P-ASS0	MR-J4-70_(-RJ)	315	
	LM-H3P7B-48P-ASS0	MR-J4-200_(-RJ)	297	
	LM-H3P7C-72P-ASS0	MR-J4-200_(-RJ)	320	
	LM-H3P7D-96P-ASS0	MR-J4-350_(-RJ)	320	
LM-F series	LM-FP2B-06M-1SS0	(Natural cooling)	MR-J4-200_(-RJ)	756
		(Liquid cooling)	MR-J4-200_(-RJ)	355
	LM-FP2D-12M-1SS0	(Natural cooling)	MR-J4-500_(-RJ)	815
		(Liquid cooling)	MR-J4-500_(-RJ)	409
	LM-FP2F-18M-1SS0	(Natural cooling)	MR-J4-700_(-RJ)/MR-J4-DU900_(-RJ)	800
		(Liquid cooling)	MR-J4-700_(-RJ)/MR-J4-DU900_(-RJ)	409
	LM-FP4B-12M-1SS0	(Natural cooling)	MR-J4-500_(-RJ)	742
		(Liquid cooling)	MR-J4-500_(-RJ)	383
	LM-FP4D-24M-1SS0	(Natural cooling)	MR-J4-700_(-RJ)/MR-J4-DU900_(-RJ)	778
		(Liquid cooling)	MR-J4-700_(-RJ)/MR-J4-DU900_(-RJ)	384
	LM-FP4F-36M-1SS0	(Natural cooling)	MR-J4-11K_(-RJ)/MR-J4-DU11K_(-RJ)	709
		(Liquid cooling)	MR-J4-11K_(-RJ)/MR-J4-DU11K_(-RJ)	356
	LM-FP4H-48M-1SS0	(Natural cooling)	MR-J4-15K_(-RJ)/MR-J4-DU15K_(-RJ)	763
		(Liquid cooling)	MR-J4-15K_(-RJ)/MR-J4-DU15K_(-RJ)	389
	LM-K2 series	LM-K2P1A-01M-2SS1	MR-J4-40_(-RJ)	400
		LM-K2P1C-03M-2SS1	MR-J4-200_(-RJ)	375
		LM-K2P2A-02M-1SS1	MR-J4-70_(-RJ)	366
		LM-K2P2C-07M-1SS1	MR-J4-350_(-RJ)	380
LM-K2P2E-12M-1SS1		MR-J4-500_(-RJ)	405	
LM-K2P3C-14M-1SS1		MR-J4-350_(-RJ)	354	
LM-K2P3E-24M-1SS1		MR-J4-500_(-RJ)	359	

A

Linear servo motor (primary side)		Servo amplifier/drive unit	Maximum current command (maximum torque) [%]
LM-U2 series	LM-U2PAB-05M-0SS0	MR-J4-20_(-RJ)	315
	LM-U2PAD-10M-0SS0	MR-J4-40_(-RJ)	318
	LM-U2PAF-15M-0SS0	MR-J4-40_(-RJ)	334
	LM-U2PBB-07M-1SS0	MR-J4-20_(-RJ)	325
	LM-U2PBD-15M-1SS0	MR-J4-60_(-RJ)	320
	LM-U2PBF-22M-1SS0	MR-J4-70_(-RJ)	322
	LM-U2P2B-40M-2SS0	MR-J4-200_(-RJ)	424
	LM-U2P2C-60M-2SS0	MR-J4-350_(-RJ)	434
	LM-U2P2D-80M-2SS0	MR-J4-500_(-RJ)	432

■400 V class

Linear servo motor (primary side)			Servo amplifier/drive unit	Maximum current command (maximum torque) [%]
LM-F series	LM-FP5H-60M-1SS0	(Natural cooling)	MR-J4-22K_(-RJ)/MR-J4-DU22K_(-RJ)	738
		(Liquid cooling)	MR-J4-22K_(-RJ)/MR-J4-DU22K_(-RJ)	364

Direct drive motor

■200 V class

Direct drive motor		Servo amplifier/drive unit	Maximum current command (maximum torque) [%]
TM-RFM series	TM-RFM002C20	MR-J4-20_(-RJ)	320
	TM-RFM004C20	MR-J4-40_(-RJ)	321
	TM-RFM006C20	MR-J4-60_(-RJ)	320
	TM-RFM006E20	MR-J4-60_(-RJ)	333
	TM-RFM012E20	MR-J4-70_(-RJ)	321
	TM-RFM018E20	MR-J4-100_(-RJ)	321
	TM-RFM012G20	MR-J4-70_(-RJ)	300
	TM-RFM048G20	MR-J4-350_(-RJ)	321
	TM-RFM072G20	MR-J4-350_(-RJ)	321
	TM-RFM040J10	MR-J4-70_(-RJ)	323
	TM-RFM120J10	MR-J4-350_(-RJ)	321
	TM-RFM240J10	MR-J4-500_(-RJ)	321
	TM-RG2M series	TM-RG2M002C30	MR-J4-20_(-RJ)
TM-RG2M004E30		MR-J4-20_(-RJ) MR-J4-40_(-RJ)	324
TM-RG2M009G30		MR-J4-40_(-RJ)	324
TM-RU2M series	TM-RU2M002C30	MR-J4-20_(-RJ)	433
	TM-RU2M004E30	MR-J4-20_(-RJ) MR-J4-40_(-RJ)	324
	TM-RU2M009G30	MR-J4-40_(-RJ)	324

Appendix 10 Special specification

Amplifiers without dynamic brake

Summary

This section explains servo amplifiers without a dynamic brake. Items not given in this section will be the same as MR-J4-GF_(-RJ).

Model

The following describes what each block of a model name indicates. Not all combinations of the symbols are available.

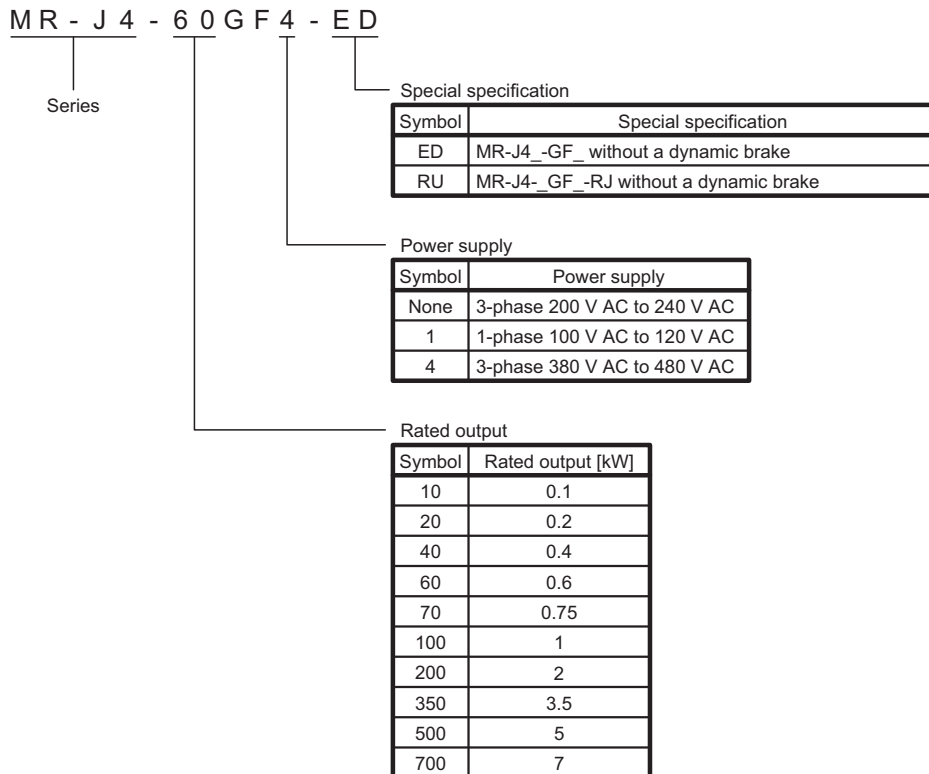

A

Specifications

Dynamic brake which is built in 7 kW or smaller servo amplifiers is removed.

Take safety measures such as making another circuit for an emergency stop, alarm occurrence, and power shut-off.

The following servo motors may function an electronic dynamic brake at an alarm occurrence.

Series	Servo motor
HG-KR	HG-KR053/HG-KR13/HG-KR23/HG-KR43
HG-MR	HG-MR053/HG-MR13/HG-MR23/HG-MR43
HG-SR	HG-SR51/HG-SR52

Setting the following parameter disables the electronic dynamic brake.

Servo amplifier	Parameter	Setting value
MR-J4- <u>GF</u> _ <u>-ED</u> MR-J4- <u>GF</u> _ <u>-RU</u>	[Pr. PF06]	___2

When [Pr. PA04] is "2 ___" (default), the motor can be a state of forced stop deceleration at an alarm occurrence. Setting "0 ___" in [Pr. PA04] disables the forced stop deceleration function.

Without regenerative resistor

Summary

This section explains servo amplifiers without a regenerative resistor. Items not given in this section will be the same as MR-J4-GF-(-RJ).

Model

The following describes what each block of a model name indicates. Not all combinations of the symbols are available.

MR - J 4 - 1 1 K G F 4 - P X

Series

Special specifications

Symbol	Special specifications
PX	MR-J4- <u>GF</u> _ without regenerative resistor
RZ	MR-J4- <u>GF</u> -RJ without regenerative resistor

Power supply

Symbol	Power supply
None	3-phase 200 V AC to 240 V AC
4	3-phase 380 V AC to 480 V AC

Rated output

Symbol	Rated output [kW]
11K	11
15K	15
22K	22

Specifications

Indicates a servo amplifier of 11 kW to 22 kW that does not use a regenerative resistor as standard accessory. When using any of these servo amplifiers, always use the regenerative option MR-RB5R, MR-RB9F, MR-RB9T, MR-RB5K-4, and MR-RB6K-4.

Special coating-specification product (IEC 60721-3-3 Class 3C2)

Summary

This section explains servo amplifiers with a special coating specification. Items not given in this section will be the same as MR-J4-_GF_(-RJ).

Model

The following describes what each block of a model name indicates. Not all combinations of the symbols are available.

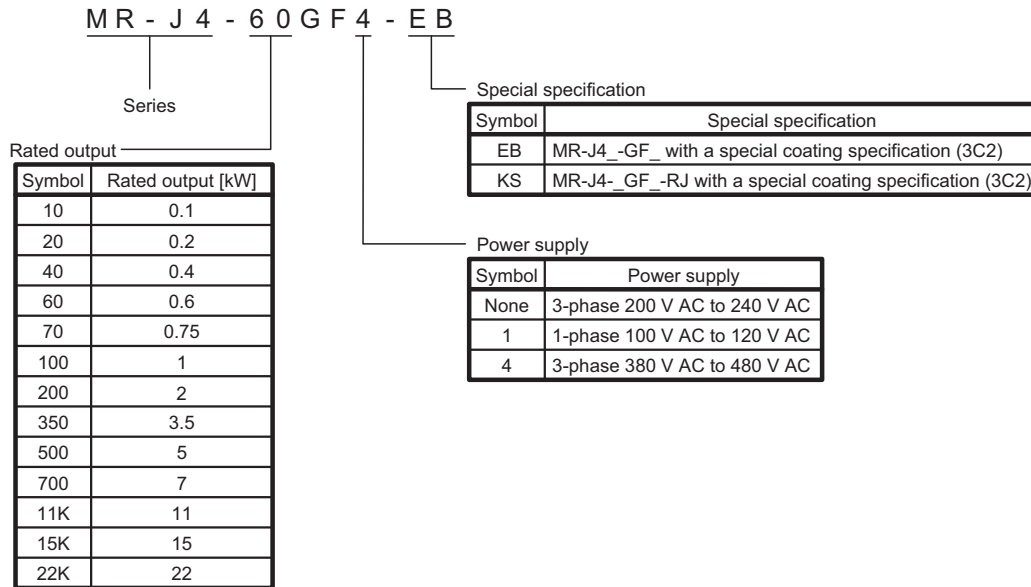

Specifications

■Special coating

Using the MR-J4 series in an atmosphere containing a corrosive gas may cause its corrosion with time, resulting in a malfunction. For the printed circuit board of the servo amplifiers with a special coating specification, a urethane coating agent is applied to some parts capable of being coated technically (except LEDs, connectors, terminal blocks, etc.) to improve the resistance to corrosive gases. Use a servo amplifier with a special coating specification specifically for applications susceptible to corrosive gases, including tire manufacturing and water treatment. Although the special coating-specification products have the improved resistance to corrosive gases, proper operations in environments mentioned above are not guaranteed. Therefore, perform periodic inspections for any abnormality.

■Standard for corrosive gases

In IEC 60721-3-3, corrosive gases refer to sea salt, sulfur dioxide, hydrogen sulfide, chlorine, hydrogen chloride, hydrogen fluoride, ammonia, ozone, and nitrogen oxides shown in the environmental parameter column of the table below.

The table also shows the corrosive gas concentrations defined in IEC 60721-3-3, Class 3C2.

Environmental parameter	Unit	3C2	
		Mean value	Maximum value
a) Sea salt	None	Salt mist	
b) Sulfur dioxide	cm ³ /m ³	0.11	0.37
c) Hydrogen sulfide	cm ³ /m ³	0.071	0.36
d) Chlorine	cm ³ /m ³	0.034	0.1
e) Hydrogen chloride	cm ³ /m ³	0.066	0.33
f) Hydrogen fluoride	cm ³ /m ³	0.012	0.036
g) Ammonia	cm ³ /m ³	1.4	4.2
h) Ozone	cm ³ /m ³	0.025	0.05
i) Nitrogen oxides	cm ³ /m ³	0.26	0.52

The special coating-specification products have the improved corrosion resistance in environments with corrosive gas concentrations conforming to IEC 60721-3-3, Class 3C2. We tested typical models and confirmed that their corrosive gas resistance was improved, compared with the standard models.

Appendix 11 Driving on/off of main circuit power supply with DC power supply

Connection example

The power circuit is common to all capacity type of servo amplifiers. For the signal and wirings not given in this section, refer to the following.

☞ Page 84 200 V class

☞ Page 90 400 V class

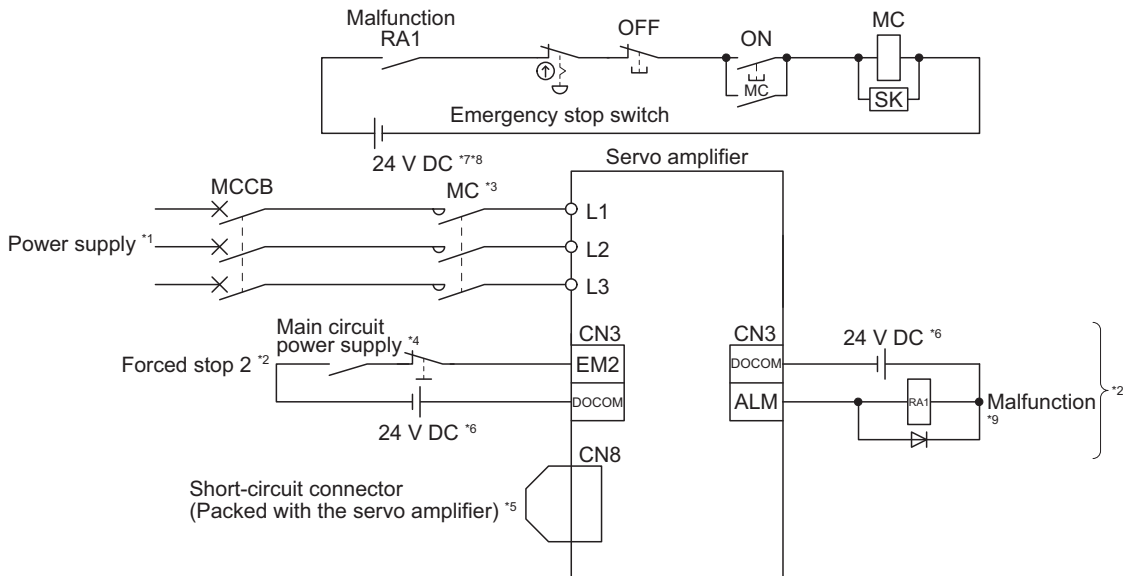

*1 For the power supply specifications, refer to the following.

☞ Page 30 Servo amplifier standard specifications

*2 This diagram shows sink I/O interface. For source I/O interface, refer to the following.

☞ Page 119 Source I/O interface

*3 Use a magnetic contactor with an operation delay time (interval between current being applied to the coil until closure of contacts) of 80 ms or less (160 ms or less for 5 kW or more). Depending on the main circuit voltage and operation pattern, bus voltage decreases, and that may cause the forced stop deceleration to shift to the dynamic brake deceleration. When dynamic brake deceleration is not required, slow the time to turn off the magnetic contactor.

*4 Configure a circuit to turn off EM2 when the main circuit power is turned off to prevent an unexpected restart of the servo amplifier.

*5 When not using the STO function, attach the short-circuit connector came with a servo amplifier.

*6 The illustration of the 24 V DC power supply is divided between input signal and output signal for convenience. However, they can be configured by one.

*7 Driving the on switch and off switch with the DC power supply meets IEC/EN 60204-1 requirements.

*8 Do not use the 24 V DC interface power supply for the magnetic contactor DC power supply. Always use the power supply designed exclusively for the magnetic contactor.

*9 If disabling ALM (Malfunction) output with the parameter, configure up the power supply circuit which switches off the magnetic contactor after detection of alarm occurrence on the controller side.

A

Magnetic contactor

Use a magnetic contactor with an operation delay time (interval between current being applied to the coil until closure of contacts) of 80 ms or less (160 ms or less for 5 kW or more).

Servo amplifier	Magnetic contactor
MR-J4-10GF(-RJ)	SD-N11 SD-T12
MR-J4-20GF(-RJ)	
MR-J4-40GF(-RJ)	
MR-J4-60GF(-RJ)	
MR-J4-70GF(-RJ)	
MR-J4-100GF(-RJ)	
MR-J4-200GF(-RJ)	SD-N21 SD-T21
MR-J4-350GF(-RJ)	
MR-J4-500GF(-RJ)	SD-N35
MR-J4-700GF(-RJ)	SD-N50
MR-J4-11KGF(-RJ)	
MR-J4-15KGF(-RJ)	SD-N65
MR-J4-22KGF(-RJ)	SD-N95
MR-J4-60GF4(-RJ)	SD-N11 SD-T12
MR-J4-100GF4(-RJ)	
MR-J4-200GF4(-RJ)	
MR-J4-350GF4(-RJ)	SD-N21 SD-T21
MR-J4-500GF4(-RJ)	
MR-J4-700GF4(-RJ)	
MR-J4-11KGF4(-RJ)	SD-N25
MR-J4-15KGF4(-RJ)	SD-N35
MR-J4-22KGF4(-RJ)	SD-N50
MR-J4-10GF1(-RJ)	SD-N11
MR-J4-20GF1(-RJ)	
MR-J4-40GF1(-RJ)	

Appendix 12 List of registration objects

Point

When you use a linear servo motor, replace the following left words to the right words.

CCW direction → Positive direction

CW direction → Negative direction

Torque → Thrust

Servo cyclic transmission function

The servo cyclic transmission function is used to monitor data in the servo amplifier with the servo system controller. In the servo cyclic transmission function, data types of registered monitor objects can be set. Setting Index, Sub Index, and Data Type for 2B01h allows you to write to 2B01h.

For details on usage, unit of data types, and others, refer to the manuals for simple motion module RD77GF and simple motion board MR-EM340GF.

Index	Sub Index	Data Type	Access	Data type	Description
2B01	0	I32	rw	Cumulative feedback pulses	Feedback pulses from the servo motor encoder are counted and displayed. Writing "0000 1EA5h" to this object clears the cumulative feedback pulses.
2B02	0	I32	ro	Servo motor speed	The servo motor speed is displayed.
2B03	0	I32	ro	Droop pulses	The number of droop pulses in the deviation counter is displayed. The number of pulses displayed is in the encoder pulse unit.
2B04	0	I32	ro	Cumulative command pulses	Position command input pulses are counted and displayed.
2B05	0	I32	ro	Command pulse frequency	The frequency of position command input pulses is counted and displayed.
2B08	0	U16	ro	Regenerative load ratio	The ratio of regenerative power to permissible regenerative power is displayed in %.
2B09	0	U16	ro	Effective load ratio	The continuous effective load current is displayed. The effective value is displayed considering a rated current as 100%.
2B0A	0	U16	ro	Peak load ratio	The maximum torque generated is displayed. The highest value in the past 15 s is displayed, with the rated torque being 100%.
2B0B	0	I16	ro	Instantaneous torque	The instantaneous torque is displayed. The value of torque being occurred is displayed in real time considering a rated torque as 100%.
2B0C	0	I32	ro	Within one-revolution position	Position within one revolution is displayed in encoder pulses.
2B0D	0	I32	ro	ABS counter	The travel distance from the home position is displayed as multi-revolution counter value of the absolute position encoder in the absolute position detection system.
2B0E	0	U16	ro	Load to motor inertia ratio	The set ratio of the load inertia moment to the servo motor shaft inertia moment is displayed.
2B0F	0	U16	ro	Bus voltage	The voltage of main circuit converter (between P+ and N-) is displayed.
2B10	0	I32	ro	Load side encoder cumulative feedback pulses	Feedback pulses from the load-side encoder are counted and displayed.
2B11	0	I32	ro	Load side encoder droop pulses	Droop pulses of the deviation counter between a load-side position and a command are displayed.
2B12	0	I32	ro	Load side encoder information 1	When an incremental type linear encoder is used for the load-side encoder, the Z-phase counter of the load-side encoder is displayed by encoder pulses. When an absolute position type linear encoder is used for the load-side encoder, the encoder absolute position is displayed.

Index	Sub Index	Data Type	Access	Data type	Description
2B13	0	I32	ro	Load side encoder information 2	When an incremental type linear encoder is used for the load-side encoder, the display shows 0. When an absolute position type linear encoder is used for the load-side encoder, the display shows 0. When a rotary encoder is used for the load-side encoder, the display shows the multi-revolution counter value of the encoder.
2B17	0	I16	ro	Temperature of motor thermistor	The thermistor temperature is displayed for the servo motor with a thermistor. For the servo motor without thermistor, "9999" is displayed. For the servo motor with a thermistor, refer to each servo motor instruction manual.
2B18	0	I32	ro	Motor side cumulative F/B pulses (BeforeGear)	Feedback pulses from the servo motor encoder are counted and displayed. (Servo motor encoder unit)
2B19	0	I32	ro	Electrical angle	The servo motor electrical angle is displayed.
2B23	0	I32	ro	Motor/load side position difference	During fully closed loop control, a deviation between servo motor-side position and load-side position is displayed. The number of pulses displayed is in the load-side encoder pulse unit.
2B24	0	I32	ro	Motor/load side speed difference	During fully closed loop control, a deviation between servo motor-side speed and load-side speed is displayed.
2B25	0	I16	ro	Internal temperature of encoder	Inside temperature of encoder detected by the encoder is displayed.
2B26	0	I16	ro	Settling time	The time (Settling time) after command is completed until INP (In-position) turns on is displayed.
2B27	0	I16	ro	Oscillation detection frequency	Frequency at the time of oscillation detection is displayed.
2B28	0	U16	ro	Number of tough drive operations	The number of tough drive functions activated is displayed.
2B2D	0	I16	ro	Unit power consumption	The module power consumption is displayed. The positive value is displayed in power running. The negative value is displayed in regeneration.
2B2E	0	I32	ro	Unit total power consumption	The module integral power consumption is displayed.
2B3F	0	I32	ro	Error excessive alarm margin	The margin to the level which triggers the error excessive alarm is displayed in units of encoder pulses. The error excessive alarm occurs at 0 pulses.
2B40	0	I16	ro	Overload alarm margin	The margins to the levels which trigger [AL. 50] and [AL. 51] are displayed in percentage.
2B41	0	I32	ro	Overshoot amount	The overshoot amount during position mode is displayed in units of encoder pulses.
2B42	0	I16	ro	Torque/thrust equivalent to disturbance	The difference between the torque necessary to drive the servo motor and the actually required torque (Torque current value) is displayed as the disturbance torque.
6064	0	I32	ro	Position actual value	The current position in the command unit is displayed. The servo amplifier monitor value (Feedback).

Servo transient transmission function

The servo transient transmission function is used to monitor data in the servo amplifier with the servo system controller. In the servo transient transmission function, the following data can be monitored by setting Index, Sub Index, and Data Type for each command.

For details on usage, unit of data types, and others, refer to the manuals for simple motion module RD77GF and simple motion board MR-EM340GF.

Index	Sub Index	Data Type	Access	Data type	Description
608Fh	1	U32	ro	Position encoder resolution	The encoder resolution is displayed. When the linear servo motor is connected, the virtual resolution per revolution is returned. When the fully closed loop system is used, the number of load-side pulses per servo motor-side revolution is returned.
2D38h	0	U32	ro	Scale measurement encoder resolution	For rotary type, for example, when an encoder of 4194304 pulse/rev is connected, the object value is 4194304. The value is always 0 except for rotary type.
1008h	0	VISIBLE STRING	ro	Manufacturer Device Name	The number of characters of the servo amplifier name (N) is displayed.
	1 to N				The servo amplifier name is displayed.
100Ah	0	VISIBLE STRING	ro	Manufacturer Software Version	The number of characters of the servo amplifier software version (N) is displayed.
	1 to N				The software version of the servo amplifier is displayed.
2C18h	0	U32	ro	Power ON cumulative time	The cumulative time after power on of the servo amplifier is displayed.
2C19h	0	U32	ro	Number of inrush relay ON/OFF times	The number of on and off for inrush relay of the servo amplifier is displayed.
2A00h to 2A0F	1	U32	ro	Alarm No.	The alarm history/detail #1 to #16 are displayed. (Hexadecimal)
2A00h to 2A0F	2	U32	ro	Alarm time (Hour)	The alarm occurrence time #1 to #16 are displayed. (Hexadecimal)
2B0Fh	0	U16	ro	Bus voltage	The voltage of main circuit converter (between P+ and N-) is displayed.
2B08h	0	U16	ro	Regenerative load ratio	The ratio of regenerative power to permissible regenerative power is displayed in %.
2B09h	0	U16	ro	Effective load ratio	The continuous effective load current is displayed. The effective value is displayed considering a rated current as 100%.
2B0Ah	0	U16	ro	Peak load ratio	The maximum torque generated is displayed. The highest value in the past 15 s is displayed, with the rated torque being 100%.
2B0Eh	0	U16	ro	Load to motor inertia ratio	The set ratio of the load inertia moment to the servo motor shaft inertia moment is displayed.
2B12h	0	I32	ro	Load-side encoder information 1	When an incremental type linear encoder is used for the load-side encoder, the Z-phase counter of the load-side encoder is displayed by encoder pulses. When an absolute position type linear encoder is used for the load-side encoder, the encoder absolute position is displayed.
2B13h	0	I32	ro	Load-side encoder information 2	When an incremental type linear encoder is used for the load-side encoder, the display shows 0. When an absolute position type linear encoder is used for the load-side encoder, the display shows 0. When a rotary encoder is used for the load-side encoder, the display shows the multi-revolution counter value of the encoder.
2B17h	0	I16	ro	Temperature of motor thermistor	The thermistor temperature is displayed for the servo motor with a thermistor. For the servo motor without thermistor, "9999" is displayed. For the servo motor with a thermistor, refer to each servo motor instruction manual.

Index	Sub Index	Data Type	Access	Data type	Description
2B2Dh	0	I16	ro	Unit power consumption	The module power consumption is displayed. (16 bit version) The positive value is displayed in power running. The negative value is displayed in regeneration.
2B2Eh	0	I32	ro	Unit total power consumption	The module integral power consumption is displayed.
2B0Bh	0	I16	ro	Instantaneous torque	The instantaneous torque is displayed. The value of torque being occurred is displayed in real time considering a rated torque as 100%.
2B26h	0	I16	ro	Settling time	The time (Settling time) after command is completed until INP (In-position) turns on is displayed.
2B23h	0	I32	ro	Motor-side/load-side position deviation	During fully closed loop control, a deviation between servo motor-side position and load-side position is displayed. The number of pulses displayed is in the load-side encoder pulse unit.
2B24h	0	I32	ro	Motor-side/load-side speed deviation	During fully closed loop control, a deviation between servo motor-side speed and load-side speed is displayed.
2B3Fh	0	I32	ro	Error excessive alarm margin	The margin to the level which triggers the error excessive alarm is displayed in units of encoder pulses. The error excessive alarm occurs at 0 pulses.
2B40h	0	I16	ro	Overload alarm margin	The margins to the levels which trigger [AL. 50] and [AL. 51] are displayed in percentage.
2B41h	0	I32	ro	Overshoot amount	The overshoot amount during position mode is displayed in units of encoder pulses.
2B42h	0	I16	ro	Torque/thrust equivalent to disturbance	The difference between the torque necessary to drive the servo motor and the actually required torque (Torque current value) is displayed as the disturbance torque.
2C20h	0	U16	ro	Machine diagnostic status	[Bit 0 to 3: Friction estimation status at forward rotation] 0: Friction is being estimated. (normal) 1: Estimation is completed. (normal) 2: The motor may rotate in one direction too frequently. (warning) 3: The servo motor speed may too slow for friction estimation. (warning) 4: The change in the servo motor speed may be small for friction estimation. (warning) 5: The acceleration/deceleration time constants may be too short for friction estimation. (warning) 6: The operation time may not be enough. (warning) When warning conditions for 2 to 6 are met at the same time, the smaller number is returned. When an estimation is completed even though a warning has once occurred, the status changes to estimation is completed. [Bit 4 to 7: Friction estimation status at reverse rotation] 0: Friction is being estimated. (normal) 1: Estimation is completed. (normal) 2: The motor may rotate in one direction too frequently. (warning) 3: The servo motor speed may too slow for friction estimation. (warning) 4: The change in the servo motor speed may be small for friction estimation. (warning) 5: The acceleration/deceleration time constants may be too short for friction estimation. (warning) 6: The operation time may not be enough. (warning) When warning conditions for 2 to 6 are met at the same time, the smaller number is returned. When an estimation is completed even though a warning has once occurred, the status changes to estimation is completed. [Bit 8 to 11: Vibration estimation status] 0: During estimation 1: Estimation is completed. [Bit 12 to 15: reserved]
2C21h	0	I16	ro	Coulomb friction torque in positive direction	Static friction at forward rotation torque is displayed in increments of 0.1%.

Index	Sub Index	Data Type	Access	Data type	Description
2C22h	0	I16	ro	Friction torque at rated speed in positive direction	Kinetic friction at forward rotation torque at the rated speed is displayed in increments of 0.1%.
2C23h	0	I16	ro	Coulomb friction torque in negative direction	Static friction at reverse rotation torque is displayed in increments of 0.1%.
2C24h	0	I16	ro	Friction torque at rated speed in negative direction	Kinetic friction at reverse rotation torque is displayed in increments of 0.1%.
2C25h	0	I16	ro	Oscillation frequency during motor stop	Vibration frequency during stop/servo-lock is displayed in increments of 1 Hz.
2C26h	0	I16	ro	Vibration level during motor stop	Vibration level during stop/servo-lock is displayed in increments of 0.1%.
2C27h	0	I16	ro	Oscillation frequency during motor operating	Vibration frequency during operation is displayed in increments of 1 Hz.
2C28h	0	I16	ro	Vibration level during motor operating	Vibration level during operation is displayed in increments of 0.1%.
2C29h	0	U32	ro	Fault prediction status	☞ Page 584 Related object (servo transient transmission function)
2C2Ah	0	I32	ro	Friction based fault prediction upper threshold	
2C2Bh	0	I32	ro	Friction based fault prediction lower threshold	
2C2Ch	0	I16	ro	Friction based fault prediction prepare status	
2C2Dh	0	I32	ro	Vibration based fault prediction threshold	
2C2Eh	0	I16	ro	Vibration based fault prediction prepare status	
2C2Fh	0	U32	ro	Motor total distance	
2A40h	0	U16	wo	Clear alarm history	Used for alarm history clear. Writing "1EA5h" clears the alarm history.
2D33h	0	VISIBLE STRING	ro	Serial Number 2	The number of characters of the servo amplifier serial number (N) is displayed.
	1 to N				The servo amplifier serial number is displayed.
2D43h	0	VISIBLE STRING	ro	Optional unit identification information	The number of characters of optional unit identification information (N) is displayed.
	1 to N				When functional safety unit / optional unit is displayed, the identification information is displayed. When not connected, "No Connection" is displayed.
2D46h	0	VISIBLE STRING	ro	Servo motor serial number	The number of characters of the servo motor serial number (N) is displayed.
	1 to N				The servo motor serial number is displayed. When the serial number cannot be read, " " (blank) is displayed.
2D50h	0	U8	rw	One-touch tuning mode	☞ Page 238 Related object (servo transient transmission function)
2D51h	0	I8	ro	One-touch tuning status	
2D52h	0	U16	wo	One-touch tuning Stop	
2D53h	0	U16	wo	One-touch tuning Clear	
2D54h	0	U16	ro	One-touch tuning Error Code	
6410h	0	U8	ro	Motor data	
6410h	1	U64	rw	Motor ID	The servo motor ID is displayed. For details, refer to "Servo Motor Instruction Manual (Vol. 3)". When an encoder is not connected, 0 is displayed.
	2	U16	rw	Encoder ID 1	The ID No. of the encoder is displayed. For details, refer to "Servo Motor Instruction Manual (Vol. 3)". When an encoder is not connected, 0 is displayed.



Appendix 13 Status of general-purpose AC servo products for compliance with the China RoHS directive





Summary

The China RoHS directive: 电子信息产品污染控制管理办法 (Management Methods for Controlling Pollution by Electronic Information Products) came into effect on March 1, 2007. The China RoHS directive was replaced by the following China RoHS directive: 电器电子产品有害物质限制使用管理办法 (Management Methods for the Restriction of the Use of Hazardous Substances in Electrical and Electronic Products). The succeeding China RoHS directive has been in effect since July 1, 2016.

The China RoHS directive restricts the use of six hazardous substances (lead, mercury, cadmium, hexavalent chromium, polybrominated biphenyls (PBB), and polybrominated diphenyl ethers (PBDE)) and other hazardous substances specified by the State (currently no applicable substances). The EU RoHS directive (2011/65/EU) also restricts the use of the above six hazardous substances.

Status of our products for compliance with the China RoHS directive

The following table shows the content of six hazardous substances in our products and Environment-Friendly Use Period marks. The table is created based on the standard SJ/T11364.

Part name		Hazardous substance (name/threshold/standard)*1						Environment-Friendly Use Period mark*2	Remark
		Lead (Pb)	Mercury (Hg)	Cadmium (Cd)	Hexavalent chromium (Cr(VI))	PBB	PBDE		
		Threshold: Cadmium: 0.01 wt% (100 ppm), Other than cadmium: 0.1 wt% (1000 ppm)							
Servo amplifier Servo system controller	Mounting board	×	○	○	○	○	○		—
	Heat sink	×	○	○	○	○	○		
	Resin cabinet	○	○	○	○	○	○		
	Plate and screw	○	○	○	○	○	○		
Servo motor	Bracket	×	○	○	○	○	○		—
	Mounting board	×	○	○	○	○	○		
	Resin cabinet	○	○	○	○	○	○		
	Core and cable	○	○	○	○	○	○		
Cable product	Cable	○	○	○	○	○	○		Including connector set
	Connector	○	○	○	○	○	○		
Optional unit	Mounting board	×	○	○	○	○	○		—
	Resin cabinet	○	○	○	○	○	○		
	Plate and screw	○	○	○	○	○	○		

*1 ○: Indicates that said hazardous substance contained in all of the homogeneous materials for this part is below the limit requirement of GB/T26572.

×: Indicates that said hazardous substance contained in at least one of the homogeneous materials for this part is above the limit requirement of GB/T26572.

*2 Indications based on "Marking for the restriction of the use of hazardous substances in electrical and electronic product" [SJ/T11364-2014]



Indicates that a certain hazardous substance is contained in the product manufactured or sold in China.

Observe safety and usage precautions for the product, and use it within a limited number of years from the production date. Thereby, any of the hazardous substances in the product does not cause environmental pollution, or seriously affect human health or property.



Indicates that no certain hazardous substance is contained in the product.

A

Difference between the China RoHS directive and the EU RoHS directive

The China RoHS directive allows no restriction exemption unlike the EU RoHS directive. Although a product complies with the EU RoHS directive, a hazardous substance in the product may be considered to be above the limit requirement (marked "×") in the China RoHS directive.

The following shows some restriction exemptions and their examples according to the EU RoHS directive.

- Lead as an alloying element in steel for machining purposes and in galvanized steel containing up to 0.35% lead by weight, lead as an alloying element in aluminum containing up to 0.4% lead by weight, and copper alloy containing up to 4% lead by weight, e.g. brass-made insert nuts
- Lead in high melting temperature type solders (i.e. lead-based alloys containing 85% by weight or more lead)
- Electrical and electronic components containing lead in a glass or ceramic other than dielectric ceramic in capacitors, e.g. piezoelectric devices
- Electrical and electronic components containing lead in a glass or ceramic matrix compound, e.g. chip resistors

Status of our products for compliance with the China RoHS directive (Chinese)

The following table is written in Chinese according to "Management Methods for the Restriction of the Use of Hazardous Substances in Electrical and Electronic Products".

☞ Page 657 Status of our products for compliance with the China RoHS directive

部件名称		有害物质 (物质名称/阈值/基准)*1						环境保护 使用期限 标识 *2	备注
		铅 (Pb)	汞 (Hg)	镉 (Cd)	六价铬 (Cr(VI))	PBB	PBDE		
		阈值: 镉: 0.01wt% (100ppm)、镉以外: 0.1wt% (1000ppm)							
伺服放大器 伺服系统控制 器	电路板组件	×	○	○	○	○	○		—
	散热片	×	○	○	○	○	○		
	树脂壳体	○	○	○	○	○	○		
	金属板、螺丝	○	○	○	○	○	○		
伺服电机	托架	×	○	○	○	○	○		—
	电路板组件	×	○	○	○	○	○		
	树脂壳体	○	○	○	○	○	○		
	铁心、电线	○	○	○	○	○	○		
电缆加工品	电线	○	○	○	○	○	○		包括连接器 组件
	连接器	○	○	○	○	○	○		
选件模块	电路板组件	×	○	○	○	○	○		—
	树脂壳体	○	○	○	○	○	○		
	金属板、螺丝	○	○	○	○	○	○		

*1 ○: 表示该有害物质在该部件所有均质材料中的含量均在GB/T26572规定的限量要求以下。

×: 表示该有害物质在该部件的至少一种均质材料中的含量超出GB/T26572规定的限量要求。

*2 根据“电子电气产品有害物质限制使用标识要求”、[SJ/T11364-2014]的表示

 该标志表示在中国制造/销售的产品中含有特定有害物质。

只要遵守本产品的安全及使用方面的注意事项, 从生产日期算起的环保使用期限内不会造成环境污染或对人体、财产产生深刻的影响。

 该标志表示制造的产品中不含有特定有害物质。

Appendix 14 Encoder output pulse setting method

For details of "Encoder output pulse setting selection" in [Pr. PC03], refer to the following table.

Setting value	Servo motor/direct drive motor	Linear servo motor
__0__ (Output pulse setting)	<p>Set the output pulses per revolution with [Pr. PA15 Encoder output pulses].</p> <p>Output pulse = a value set in [Pr. PA15] [pulse/rev]</p> <p>Selecting "Load side encoder (__1__)" of "Encoder selection for encoder output pulse" in [Pr. PC03] triggers [AL. 37 Parameter error].</p>	<p>Selecting "0" will enable dividing ratio setting, because the output pulse setting is not available.</p>
__1__ (Dividing ratio setting)	<p>Set the dividing ratio to the resolution per servo motor revolution with [Pr. PA15 Encoder output pulses].</p> $\text{Output pulse} = \frac{\text{Resolution per revolution}}{[\text{Pr. PA15}] \text{ setting}} \text{ [pulse/rev]}$	<p>Set the dividing ratio to the travel distance of the linear servo motor with [Pr. PA15 Encoder output pulses].</p> $\text{Output pulse} = \frac{\text{Travel distance of linear servo motor}}{[\text{Pr. PA15}] \text{ setting}} \text{ [pulse]}$
__3__ (A-phase/B-phase pulse electronic gear setting)	<p>Set the A-phase/B-phase pulse electronic gear with [Pr. PA15 Encoder output pulses] and [Pr. PA16 Encoder output pulses 2].</p> $\text{Output pulse} = \frac{\text{Resolution per revolution} \times [\text{Pr. PA15}] \text{ setting}}{[\text{Pr. PA16}] \text{ setting}} \text{ [pulse/rev]}$	<p>Set the A-phase/B-phase pulse electronic gear with [Pr. PA15 Encoder output pulses] and [Pr. PA16 Encoder output pulses 2].</p> $\text{Output pulse} = \frac{\text{Travel distance of linear servo motor} \times [\text{Pr. PA15}] \text{ setting}}{[\text{Pr. PA16}] \text{ setting}} \text{ [pulse]}$
__4__ (A/B-phase pulse through output setting)	<p>[AL. 37 Parameter error] occurs.</p>	<p>A/B-phase pulse of A/B/Z-phase differential output encoder is outputted. This is enabled only when A/B/Z-phase differential output encoder is used.</p> <p>Output pulse = A/B-phase pulse of A/B/Z-phase differential output encoder [pulse]</p> <p>The value set for "Encoder output pulse phase selection" in [Pr. PC03] is not applied.</p> <p>When another encoder is connected, [AL. 37 Parameter error] occurs. Selecting "Standard control mode (__0__)" of "Operation mode" in [Pr. PA01] triggers [AL. 37 Parameter error]. The values set for [Pr. PA15 Encoder output pulses] and [Pr. PA16 Encoder output pulses 2] are not applied.</p>

Appendix 15 Adjustment method for error excessive alarm level

The error excessive alarm level can be adjusted as required.

Parameter

The following parameters allow the error excessive alarm level to be increased.

Parameter	Symbol	Name	Setting range	Unit
PC01	ERZ	Error excessive alarm level	0 to 1000	[Per rev or mm]
PC06 "x ___"	*COP3	Error excessive alarm/error excessive warning level unit selection 0: Per 1 rev or 1 mm 1: Per 0.1 rev or 0.1 mm 2: Per 0.01 rev or 0.01 mm 3: Per 0.001 rev or 0.001 mm	0 to 3	—

Checking the error excessive alarm margin

Use the graph function of MR Configurator2 to monitor the error excessive alarm margin. The error excessive alarm margin is the maximum pulse when the command position and feedback position match. Also, when the error excessive alarm margin is 0 pulse, [AL. 52 Error excessive alarm] occurs. Calculate the pulse difference from the maximum and minimum pulses of the "error excessive alarm margin".

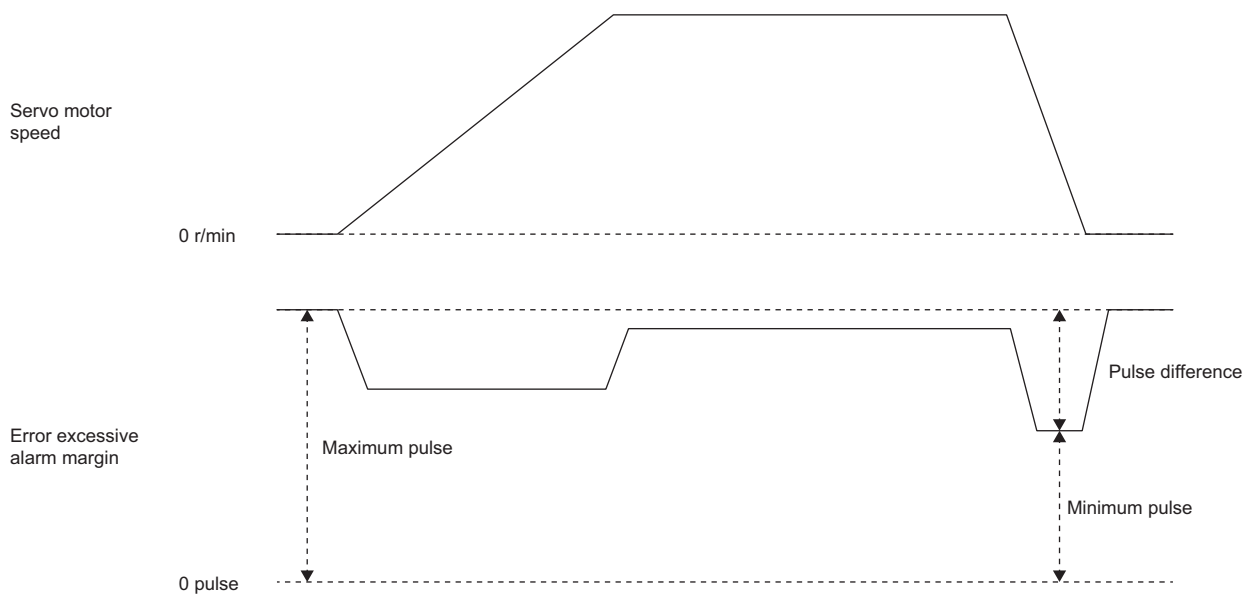

Adjusting the error excessive alarm level

Adjust the error excessive alarm level with [Pr. PC01] and "x ___" of [Pr. PC06] so that the following formula is met.

$[\text{Pr. PC01}] \times \text{Unit set with "x ___" of [Pr. PC06]} > \text{Difference in the error excessive alarm margin} / \text{Resolution per revolution}$

For linear servo motors, the resolution per revolution is the following value.

$[\text{Pr. PL02 Linear encoder resolution} - \text{Numerator}] / [\text{Pr. PL03 Linear encoder resolution} - \text{Denominator}] \times 1000$

MEMO

A

REVISIONS

*The manual number is given on the bottom left of the back cover.

Revision Date	*Manual Number	Description
February 2016	SH(NA)-030218ENG-A	First edition
May 2016	SH(NA)-030218ENG-B	<ul style="list-style-type: none"> ■Section 5.2.2 [Pr. PB52], [Pr. PB53], [Pr. PB54], and [Pr. PB55] are partially changed. ■App. 4.2.3 (2) Partially changed.
December 2016	SH(NA)-030218ENG-C	<p>"Available in the future" is deleted. The machine diagnosis function is added. "Data type" is added to the list of registration objects.</p> <ul style="list-style-type: none"> ■Front cover "Available in the future" is deleted. ■4. Additional instructions (1) Transportation and installation The ambient humidity is changed. Partially added. ■4. Additional instructions (2) Wiring Partially added. ■4. Additional instructions (5) Corrective actions Partially added. ■4. Additional instructions (6) Maintenance, inspection and parts replacement Partially added and partially changed. ■About the manuals "MELSERVO MR-D30 Instruction Manual" is added. ■Section 1.3 Partially changed. ■Section 1.4 "Available in the future" is deleted. ■Section 1.5 Partially added. ■Section 2.1 Partially changed. ■Section 2.4 Partially added. ■Section 3.1 Partially changed. ■Section 3.3.1 "Available in the future" is deleted. ■Section 4.5.2 Partially changed. ■Chapter 5 Partially added and partially changed. ■Section 6.2.4 Newly added. ■Section 7.2.4 Partially changed. ■Section 7.4 Partially changed. ■Section 7.6 Partially changed. ■Section 8.2 Partially changed. ■Section 8.3 Partially added. ■Section 9.1 The diagrams are partially changed. ■Chapter 10 "Available in the future" is deleted. ■Chapter 11 "Available in the future" is deleted. ■Section 11.1.1 Partially changed. ■Section 11.2.2 (1) Partially added. ■Section 11.2.4 (3) Partially added. ■Section 11.3.3 (3) Partially changed. ■Section 11.4 (4) Partially changed.

Revision Date	*Manual Number	Description
December 2016	SH(NA)-030218ENG-C	<ul style="list-style-type: none"> ■Section 11.5.2 (5) The ambient humidity is changed. ■Section 11.7.1 Partially changed. ■Section 11.8.3 (3) The ambient humidity is changed. ■Section 11.8.5 The ambient humidity is changed. ■Section 11.10 (1) Partially added. ■Section 11.14 (1) Partially changed. ■Section 11.15 (1) Partially changed. ■Section 14.3.1 (4) POINT is changed. ■Section 14.3.2 (3) (b) POINT is changed. ■Section 14.4.3 Partially changed. ■Section 16.3.1 (2) (b) Partially changed. ■Section 17.1 POINT is changed. ■Section 17.3 Partially added and partially changed. ■Section 17.5 Newly added. ■App. 4.2.3 Partially added and partially changed. ■App. 4.3 Note is changed. ■App. 4.7 Partially changed. ■App. 5.7.2 The ambient humidity is changed. ■App. 5.10 Partially changed. ■App. 12 POINT is added. Partially added and partially changed. ■App. 13 Newly added.
February 2018	SH(NA)-030218ENG-D	Available on e-Manual.
May 2018	SH(NA)-030218ENG-E	<ul style="list-style-type: none"> 100 V class is added. ■Safety Instructions Partially changed. ■About the manuals Partially added. ■Section 1.2 Partially added and partially changed. ■Section 1.3 Partially added. ■Section 1.4 POINT is partially changed, and contents are partially changed and added to the table. ■Section 1.5 Partially changed. ■Section 1.6 Partially added. ■Section 1.7 Partially added and partially changed. ■Section 3.1 Partially added. ■Section 3.3 Partially added and partially changed. ■Section 3.6 POINT is partially added and the illustration is partially changed. ■Section 3.7 POINT is partially added. ■Section 3.9 POINT is partially added, and the illustration is partially changed and added.

Revision Date	*Manual Number	Description
May 2018	SH(NA)-030218ENG-E	<ul style="list-style-type: none"> ■Chapter 4 Partially added. ■Section 4.1 Partially added. ■Section 4.2 Partially added. ■Section 4.3 Partially changed. ■Section 4.6 The illustration is partially changed. ■Section 5.2 Partially added and partially changed. ■Chapter 6 POINT is partially added. ■Section 6.2 POINT is partially added and the illustration is partially changed. ■Section 7.1 POINT is partially added. ■Section 8.1 The tables are changed. ■Section 8.2 The tables are changed. ■Section 8.3 The tables are changed. ■Section 9.1 The illustration is partially changed and added. ■Section 10.1 Contents are changed and added to the table. ■Section 10.2 Contents are partially added to the table. ■Section 10.3 CAUTION is added. ■Section 10.5 Table is added. ■Section 11.1 The illustration is partially changed. ■Section 11.2 Contents are partially added to the table. The illustration is changed. ■Section 11.5 Partially added and partially changed. ■Section 11.7 Partially changed. ■Section 11.8 Partially changed. ■Section 11.9 Partially added. ■Section 11.10 Partially added. ■Section 11.11 Partially changed. ■Section 11.12 Partially added and partially changed. ■Section 11.14 Partially changed. ■Section 11.15 Partially added. ■Section 11.16 Partially added and partially changed. ■Section 11.17 Partially added and partially changed. ■Section 11.18 Partially changed. ■Chapter 12 POINT is partially added and partially changed. ■Section 12.2 Partially changed. ■Section 13.3 The illustration and the sentences are partially changed. ■Section 14.1 Partially deleted.

Revision Date	*Manual Number	Description
May 2018	SH(NA)-030218ENG-E	<ul style="list-style-type: none"> ■Section 14.2 CAUTION is partially added. ■Section 14.3 POINT and the sentences are partially changed. ■Section 14.4 Partially added. ■Chapter 15 POINT is changed. ■Section 15.1 Partially deleted. ■Section 15.2 CAUTION is partially added. ■Section 15.4 Partially added and partially changed. ■Section 17.1 Partially changed. ■Section 17.5 Partially changed. ■App. 1 Partially changed. ■App. 4 Partially changed. CAUTION is partially added. ■App. 7 Contents are partially changed in the table. ■App. 9 Partially added and partially changed. ■App. 10 Partially added. ■App. 11 Partially added and partially changed. ■App. 13 Partially added and partially changed. ■App. 15 Newly added.
December 2020	SH(NA)-030218ENG-F	<ul style="list-style-type: none"> Multifunction regeneration converter FR-XC-(H) is added. ■Safety Instructions Partially changed. ■Section 1.3 Partially changed. ■Section 1.5 Partially added. ■Section 1.7 Partially changed. ■Section 3.3 Partially added. ■Section 3.5 Partially added. ■Section 3.6 Partially changed. ■Section 3.10 Partially changed. ■Section 4.1 Partially added. ■Section 4.6 Partially added and partially changed. ■Section 5.1 Partially changed. ■Section 5.2 Partially added and partially changed. ■Section 6.2 Partially changed. ■Section 8.1 Partially added. ■Section 8.2 Partially changed. ■Section 9.1 Partially changed. ■Section 11.2 Partially added.

Revision Date	*Manual Number	Description
December 2020	SH(NA)-030218ENG-F	<ul style="list-style-type: none"> ■Section 11.3 Partially changed. ■Section 11.7 Partially changed. ■Section 11.11 Partially changed. ■Section 11.12 Partially changed. ■Section 11.17 Partially added and partially changed. ■Section 11.19 Newly added. ■Chapter 12 Partially added and partially changed. ■Section 13.2 Partially changed. ■Section 14.3 Partially changed. ■Section 15.3 Partially changed. ■Section 16.2 Partially changed. ■Section 16.3 Partially changed. ■Section 17.1 Partially changed. ■Section 17.2 Partially changed. ■Section 17.4 Partially changed. ■Section 17.5 Partially changed. ■App. 1 Partially changed. ■App. 4 Partially changed. ■App. 5 Partially changed. ■App. 9 Partially changed. ■App. 12 Partially changed. ■App. 15 Newly added.

Japanese manual number: SH-030217-F

This manual confers no industrial property rights or any rights of any other kind, nor does it confer any patent licenses. Mitsubishi Electric Corporation cannot be held responsible for any problems involving industrial property rights which may occur as a result of using the contents noted in this manual.

© 2016 MITSUBISHI ELECTRIC CORPORATION

WARRANTY

Warranty

1. Warranty period and coverage

We will repair any failure or defect hereinafter referred to as "failure" in our FA equipment hereinafter referred to as the "Product" arisen during warranty period at no charge due to causes for which we are responsible through the distributor from which you purchased the Product or our service provider. However, we will charge the actual cost of dispatching our engineer for an on-site repair work on request by customer in Japan or overseas countries. We are not responsible for any on-site readjustment and/or trial run that may be required after a defective unit are repaired or replaced.

[Term]

For terms of warranty, please contact your original place of purchase.

[Limitations]

(1) You are requested to conduct an initial failure diagnosis by yourself, as a general rule.

It can also be carried out by us or our service company upon your request and the actual cost will be charged. However, it will not be charged if we are responsible for the cause of the failure.

(2) This limited warranty applies only when the condition, method, environment, etc. of use are in compliance with the terms and conditions and instructions that are set forth in the instruction manual and user manual for the Product and the caution label affixed to the Product.

(3) Even during the term of warranty, the repair cost will be charged on you in the following cases;

1. a failure caused by your improper storing or handling, carelessness or negligence, etc., and a failure caused by your hardware or software problem
2. a failure caused by any alteration, etc. to the Product made on your side without our approval
3. a failure which may be regarded as avoidable, if your equipment in which the Product is incorporated is equipped with a safety device required by applicable laws and has any function or structure considered to be indispensable according to a common sense in the industry
4. a failure which may be regarded as avoidable if consumable parts designated in the instruction manual, etc. are duly maintained and replaced
5. any replacement of consumable parts (battery, fan, smoothing capacitor, etc.)
6. a failure caused by external factors such as inevitable accidents, including without limitation fire and abnormal fluctuation of voltage, and acts of God, including without limitation earthquake, lightning and natural disasters
7. a failure generated by an unforeseeable cause with a scientific technology that was not available at the time of the shipment of the Product from our company
8. any other failures which we are not responsible for or which you acknowledge we are not responsible for

2. Term of warranty after the stop of production

(1) We may accept the repair at charge for another seven (7) years after the production of the product is discontinued. The announcement of the stop of production for each model can be seen in our Sales and Service, etc.

(2) Please note that the Product (including its spare parts) cannot be ordered after its stop of production.

3. Service in overseas countries

Our regional FA Center in overseas countries will accept the repair work of the Product. However, the terms and conditions of the repair work may differ depending on each FA Center. Please ask your local FA center for details.

4. Exclusion of loss in opportunity and secondary loss from warranty liability

Regardless of the gratis warranty term, Mitsubishi shall not be liable for compensation to:

- (1) Damages caused by any cause found not to be the responsibility of Mitsubishi.
- (2) Loss in opportunity, lost profits incurred to the user by Failures of Mitsubishi products.
- (3) Special damages and secondary damages whether foreseeable or not, compensation for accidents, and compensation for damages to products other than Mitsubishi products.
- (4) Replacement by the user, maintenance of on-site equipment, start-up test run and other tasks.

5. Change of Product specifications

Specifications listed in our catalogs, manuals or technical documents may be changed without notice.

6. Application and use of the Product

- (1) For the use of our AC Servo, its applications should be those that may not result in a serious damage even if any failure or malfunction occurs in AC Servo, and a backup or fail-safe function should operate on an external system to AC Servo when any failure or malfunction occurs.
- (2) Our AC Servo is designed and manufactured as a general purpose product for use at general industries. Therefore, applications substantially influential on the public interest for such as atomic power plants and other power plants of electric power companies, and also which require a special quality assurance system, including applications for railway companies and government or public offices are not recommended, and we assume no responsibility for any failure caused by these applications when used.
In addition, applications which may be substantially influential to human lives or properties for such as airlines, medical treatments, railway service, incineration and fuel systems, man-operated material handling equipment, entertainment machines, safety machines, etc. are not recommended, and we assume no responsibility for any failure caused by these applications when used. We will review the acceptability of the abovementioned applications, if you agree not to require a specific quality for a specific application. Please contact us for consultation.

TRADEMARKS

MELSERVO, CC-Link IE, and GOT are trademarks or registered trademarks of Mitsubishi Electric Corporation in Japan and/or other countries.

Microsoft, Windows, Internet Explorer, and Windows Vista are registered trademarks or trademarks of Microsoft Corporation in the United States, and/or other countries.

Modbus is registered trademark of SCHNEIDER ELECTRIC USA, INC.

Ethernet is a registered trademark of Fuji Xerox Co., Ltd. in Japan.

All other product names and company names are trademarks or registered trademarks of their respective companies.

SH(NA)-030218ENG-F(2012)MEE

MODEL: MR-J4-GF-(RJ)INSTRUCTIONMANUALMOTIONMODE

MODEL CODE: 1CW861

mitsubishi electric corporation

HEAD OFFICE : TOKYO BUILDING, 2-7-3 MARUNOUCHI, CHIYODA-KU, TOKYO 100-8310, JAPAN
NAGOYA WORKS : 1-14, YADA-MINAMI 5-CHOME, HIGASHI-KU, NAGOYA, JAPAN

When exported from Japan, this manual does not require application to the
Ministry of Economy, Trade and Industry for service transaction permission.

Specifications are subject to change without notice.