



# Power Distribution Control Equipment (Magnetic Starter Edition)

This document is intended for users of Mitsubishi power distribution control equipment to describe the overview of magnetic starters and provide the training to learn basic knowledge of them.



## **Introduction** Educational purpose of this course



This course develops a basic understanding for each item that is essential for using Mitsubishi Electric's power distribution and control devices.

This section is part of a wide series of courses, and focuses on the power distribution control equipment.

## Introduction **Structure of Chapters**



This course has the following structure of chapters:  
We recommend you to learn each chapter in order.

### **Chapter 1 Magnetic starter overview**

Provides basic knowledge common to the whole magnetic starters.

### **Chapter 2 Structure of magnetic contactors and thermal overload relays**

Provides the knowledge of the structure, operation, specification, and performance of magnetic contactors and thermal overload relays.

### **Chapter 3 Selecting magnetic contactors and thermal overload relays**

Provides how to select and connect magnetic contactors and thermal overload relays and how to start their loads.

### **Chapter 4 Maintaining and upgrading magnetic starters**

Provides the knowledge to maintain and upgrade magnetic starters.

### **Chapter 5 Application to standards**

Provides the knowledge on the application to major standards and SCCR (Short Circuit Current Rating).

## Introduction How to Use This e-Learning Tool



Following is an explanation of how to use the graphical user interface.

Go to the next page		Go to the next page.
Back to the previous page		Back to the previous page.
Move to the desired page		"Table of Contents" will be displayed, enabling you to navigate to the desired page.
Exit the learning		Exit the learning. Window such as "Contents" screen and the learning will be closed.



## Introduction **Important information**



### **Safety Instructions**

When your study includes using the actual product, we ask that you carefully read the "Safety Instructions" described in the product manual, and use the product in a proper manner while paying careful attention to the safety issues.

# Chapter 1 Magnetic Starter Overview

## Contents of Chapter 1

This chapter provides common knowledge on magnetic starters used in low voltage circuits.

- 1.1 Magnetic starter
- 1.2 Types of magnetic starters and magnetic contactors
- 1.3 Differences between circuit breakers and magnetic starters
- 1.4 Applicable environment and mounting
- 1.5 Summary

# 1.1 Magnetic Starter

Magnetic starters are widely used for starting and stopping motors, forwarding and reversing operations, and controlling and protecting burnouts in places, such as factories, buildings, air-conditioning equipment, cranes, and machine tools.

### <Where the magnetic starters are used?>

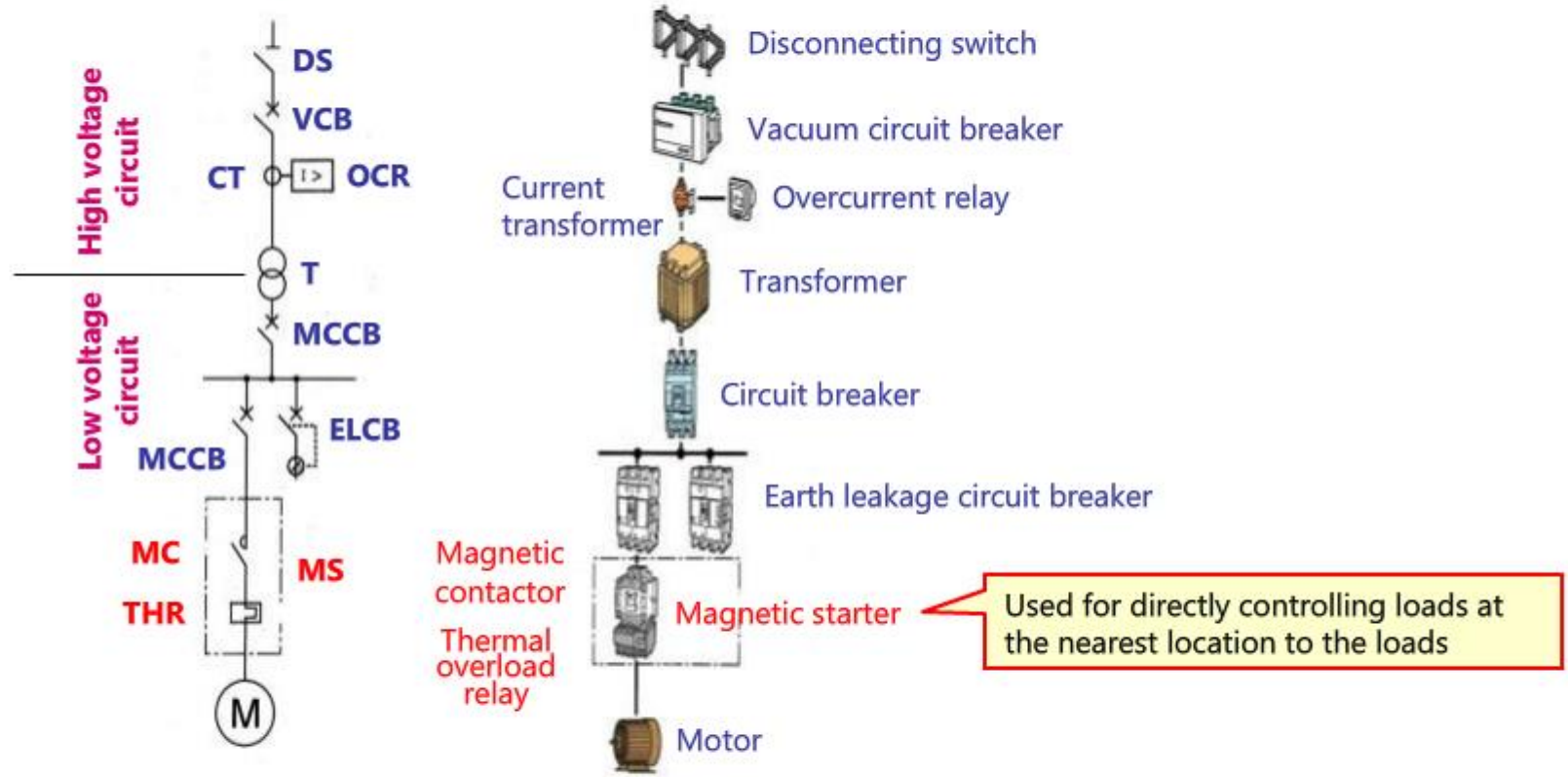

Used for directly controlling loads at the nearest location to the loads

\* Examples in Japan

# 1.1 Magnetic Starter

Magnetic starters are the switches in combination of magnetic contactor and thermal overload relay.

Magnetic starter: allows you to remotely control motor loads and **protect motors against burnouts.**

Magnetic contactor: allows you to remotely control other loads than motors, such as heaters (resistors) and lighting loads.



**Magnetic starter  
(magnet switch)  
MS**

**Magnetic contactor  
(contactor)  
MC**

**Thermal overload relay  
(thermal type protective relay)  
THR**

Opens/Closes contacts with electromagnetic forces to switch on/off loads

Detects motor overloads and phase-losses and prevents burnouts



# 1.1 Magnetic Starter

Allows you to remotely control loads and frequently open/close starters with enhanced switching durability.

### <Advantages of making use of magnetic starters>

- Allows you to intensively control some amount of motors remotely by operating a magnetic starter with a pushbutton switch
- Allows you to perform automatic operation in combination with control devices including PLC
- Excellent in switching durability and capable of opening/closing magnetic starters frequently
- Allows you to prevent burnouts because of the motor overload, locked rotors, and phase-loss

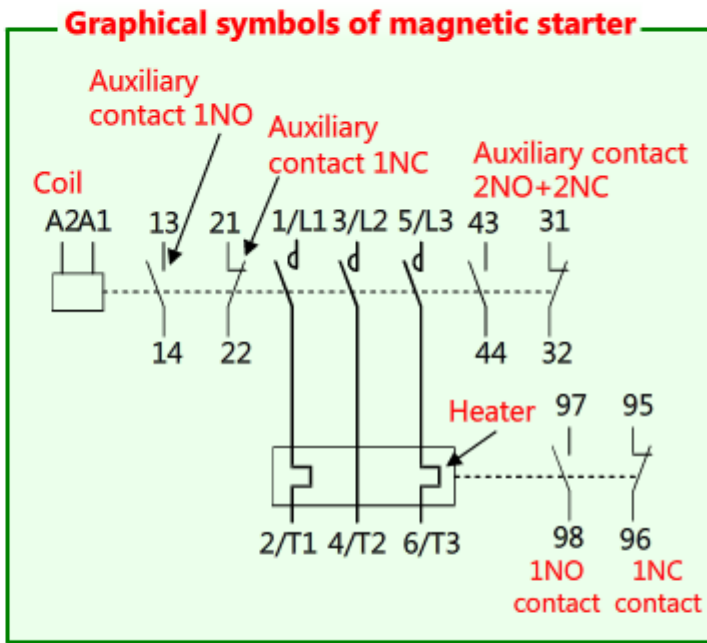

**1.2****Types of Magnetic Starters and Magnetic Contactors**

There are a wide variety of types of magnetic starters and magnetic contactors for each use and you can choose suitable types.

**Click the product name to confirm its appearance.**

Product name	Application
Standard magnetic starter & contactor	Control the magnetic starter with the AC power supply
DC operated type magnetic starter & contactor	Control the magnetic starter with the DC power supply
Reversing magnetic starter & contactor	Run motors in forward/reverse directions and protect motors with two magnetic contactors
DC Interface contactor	Capable of direct driving with the transistor output (24 V DC, 0.1 A) including PLC
Mechanically latched contactor	Hold the turn-on state of magnetic contactor and do not release the contact in the case of blackout and voltage drop
Solid-state contactor	Non contact contactor using the power semiconductor element and applicable to the open/close at high frequency
Motor circuit breakers	Detect the motor's overload, phase-loss, and short circuit and shut off the current

## 1.3 Differences between Circuit Breakers and Magnetic Starters

Magnetic starters play the roles to start and stop motors and prevent burnouts because of the overload, locked rotors, and phase-loss, and the short-circuit protection equipment including circuit breakers plays the part to address the current beyond the breaking capacity of magnetic starters due to short-circuit.

The table below lists comparisons of performances between magnetic starters and circuit breakers (examples).

Note that a single Motor circuit breakers can protect motors against the overload, locked rotors, phase-loss, and short-circuit.

	Type of protection	Current to be shut off	Electrical switching durability	Operating cycle	Open/close operation
Magnetic starter	Protection from overload (motor protection)	Ten-odd times the rated current	About a million times	1,200 times/hour	Remote
Circuit breaker	Protection from short-circuit (wiring protection)	500 to 1,000 times the rated current	About 6 thousand times	6 times/hour	Manual
Motor circuit breakers	Protection from short-circuit & overload (motor protection)	About 100 kA	About 0.1 million times	25 times/hour	Manual

Motor protection



Wiring protection

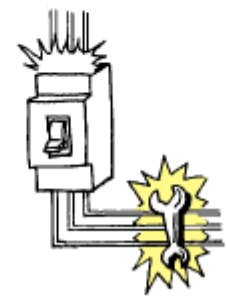

## 1.4

## Applicable Environment and Mounting

The applicable environment may have a great impact on the performance and lifetime of magnetic starters. The table below lists applicable environment roughly:

## &lt;Standard use state&gt;

Operational ambient temperature	-10°C to 40°C (however, the maximum average temperature of the day is 35°C. The maximum average temperature of the year is 25°C)
Maximum panel temperature	55°C (however, ambient temperature 40°C for enclosed MS type)
Relative humidity	45% to 85% RH (however, no icing or no condensation)
Altitude	2,000 m or less
Vibration	10 to 55 Hz, 19.6 m/s <sup>2</sup> or less
Impact	49 m/s <sup>2</sup> or less
Atmosphere	The dust, smoke, corrosive gas, moisture, and salt content should not be much <b>*Be careful that the contact trouble may occur when operating the equipment for a long time under a sealed condition.</b> <b>Do not operate the equipment in atmosphere with flammable gas.</b>

## 1.4

## Applicable Environment and Mounting

Magnetic starters can be mounted directly (with screws) or on the IEC 35 mm rail.

**<Direct mounting>**

1. Be sure to mount the equipment in a dry location without dust and vibration.
2. Normally, mount the equipment vertically and perpendicularly to the surface, as shown in figure 1, but it is allowable to mount it inclined at up to 30 degrees in each direction (figure 2).
3. It is not allowed to mount the equipment directly on the floor or ceiling.  
(The floor/ceiling mounting may give an impact on the conductivity of contacts, operational performance, durability, and others.)
4. To side mount the equipment, as shown in figure 3, mount it horizontally (inclined at 90 degrees counter-clockwise).  
For the side mounting, the characteristics may hardly change, but the mechanical durability may be degraded.  
It is not allowed to side mount reversible type, mechanical latch type, and a part of large-size models.

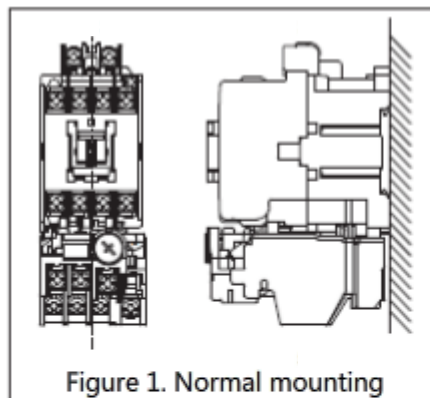

Figure 1. Normal mounting

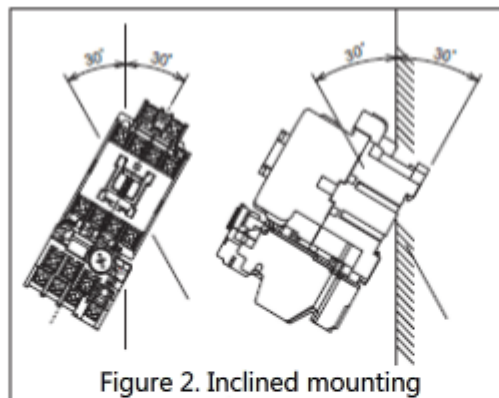

Figure 2. Inclined mounting

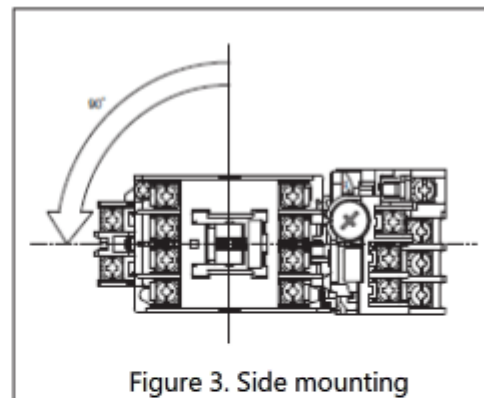

Figure 3. Side mounting

## 1.4

## Applicable Environment and Mounting

## &lt;Mounting on IEC 35 mm rail&gt;

1. Mount the equipment vertically and perpendicularly to the rail as shown in the figure below.
2. The side mounting is not allowed.
3. This mounting is allowed to mainly small-size models supporting the IEC 35 mm rail mounting.

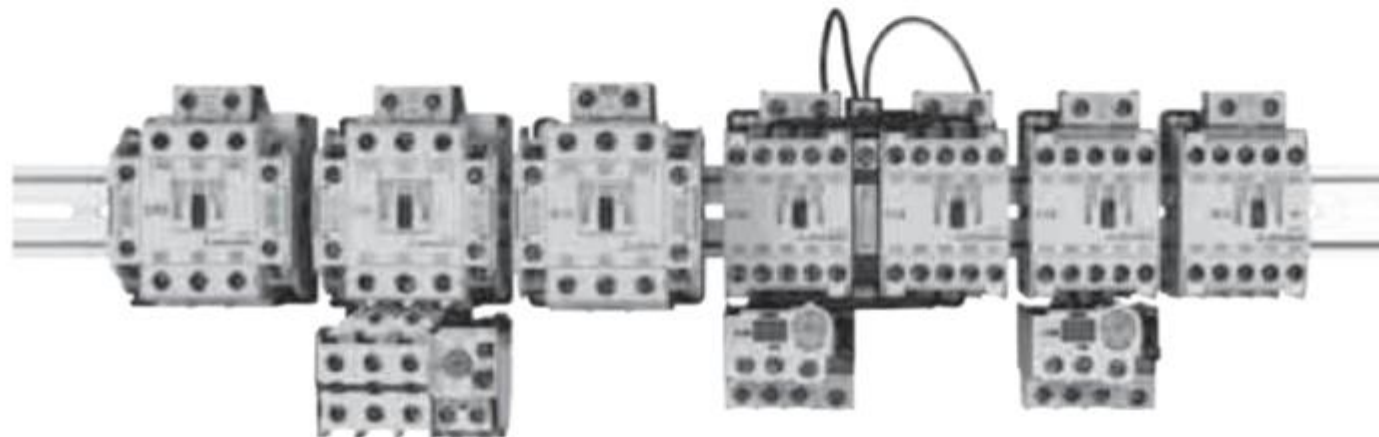

**1.5****Summary**

The summary of this chapter is as follows:

- Magnetic starters are in a combination of the magnetic contactor that commonly switches on/off the loads and the thermal overload relay that detects and notifies outside of motor overloads and phase-losses.
- Some magnetic starters and magnetic contactors are made for specific purposes, such as DC Interface contactors and solid-state contactors. You can choose them according to your purposes.
- Magnetic starters prevent the motor overloads and circuit breakers protects wires from the overload and short-circuit. A single Motor circuit breakers can protect motors against the overload and short-circuit.
- The applicable environment may have a great impact on the performance and lifetime of magnetic starters (magnetic contactors).
- There are direct mounting and IEC 35 mm rail mounting methods.

The subsequent chapter describes the structure of magnetic contactors and thermal overload relays.

## Chapter 2 Structure of Magnetic Contactors and Thermal Overload Relays

### Contents of Chapter 2

This chapter describes the structure and operations of magnetic contactors that control the start and stop of loads, solid-state contactors (non-contact contactors) that make use of power semiconductor elements, and thermal overload relays that are most commonly used for protecting motors against overloads and phase-losses, as follows:

- 2.1 Structure and operations of magnetic contactors
- 2.2 Structure and operations of thermal overload relays
- 2.3 Types of thermal overload relays
- 2.4 Optional units of magnetic contactors
- 2.5 Structure and operations of solid-state contactors
- 2.6 Summary



## 2.1 Structure and Operations of Magnetic Contactors

Magnetic contactors are composed of the electromagnet made up of coils and stationary/movable iron cores, fixed and moving contacts to switch on/off load current, arc-extinguishing chamber extinguishing arc occurring between contacts, and a tripping spring.

### OFF (non-energization) state

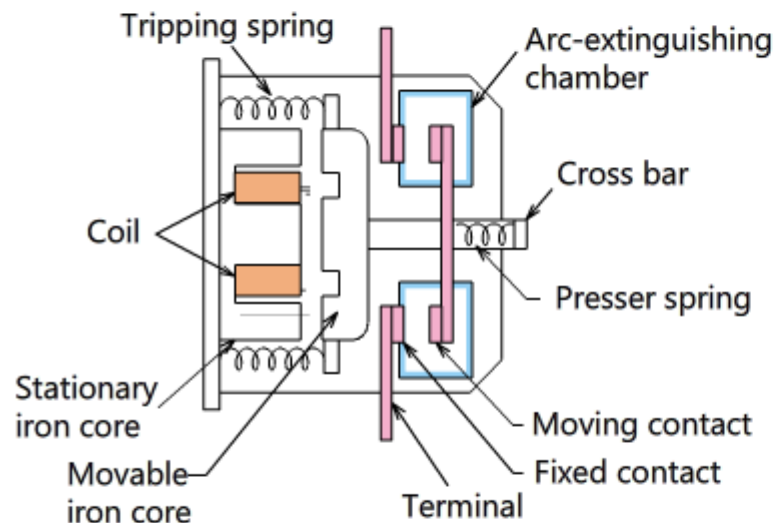

In the coil OFF (non-energization) state, the moving contact is detached from the fixed contact by the tripping spring

### ON (energization) state

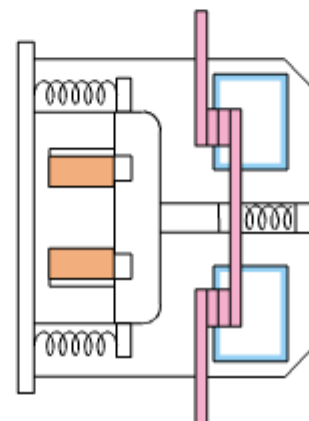

When the voltage is applied to the coil, a movable iron core is pulled to a stationary iron core to bring the moving contact coupled with the movable iron core into contact with a fixed contact to close the circuit

If the coil is switched to OFF (energization released), the moving contact is detached from the fixed contact by the tripping spring

-> **Returns to OFF (non-energization) state**

# 2.1 Structure and Operations of Magnetic Contactors

The figure below shows examples of magnetic contactors manufactured by Mitsubishi Electric Corporation.

	Structure of electromagnet	Structure of contacts and arc-extinguishing chamber
<p>Small-size model</p>		
<p>Middle/large-size models</p>	<div style="margin-top: 10px;"> <p><b>SW (LNC contact)</b></p> <pre> graph TD     SW[SW LNC contact] --- C[Capacitor]     C --- R[Resistor]     R --- VAR[Surge absorber]     VAR --- RF[Full wave rectifier]     RF --- MC[Coil]                     </pre> <p>                     C: Capacitor                      R: Resistor                      SW: Switch                      RF: Full wave rectifier                      VAR: Surge absorber                      MC: Coil                 </p> </div>	

# 2.2 Structure and Operations of Thermal Overload Relays

Thermal overload relays are composed of the thermal overcurrent detection unit in combination of the heater and bimetal, the actuation mechanism component, and the contacts for opening/closing the control circuit.

### Normal condition

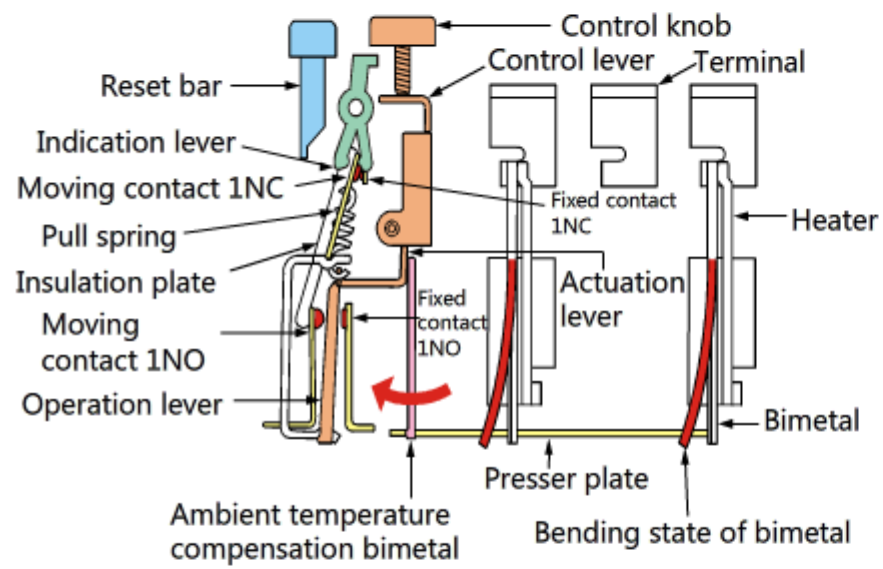

### Trip state

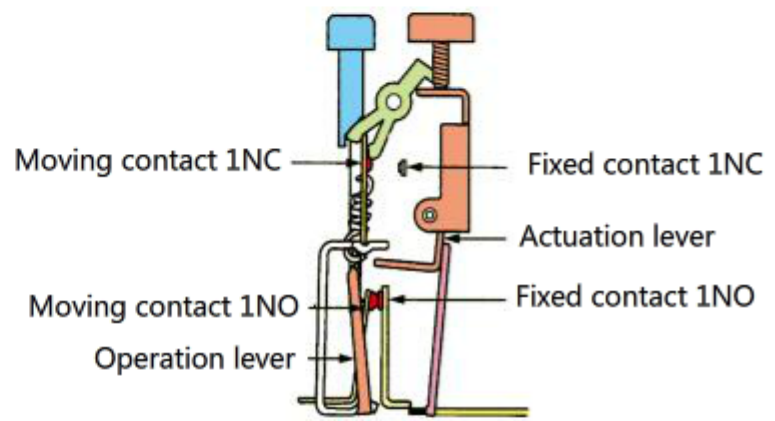

When the current is applied to the thermal overload relay, internal heater generates the heat. When the motor gets overloaded and the current increases, the heating amount of heater increases and the bimetal bends a lot so that the presser plate moves to invert the mechanism component, close the moving contact 1NO, and open the moving contact 1NC.

**<Supplement: bimetal>**

When the metals are heated, they expand according to the coefficient of thermal expansion. When two metal plates with different coefficients of thermal expansion are pressure welded (bonded) and heated, they bend to the plate side with less coefficient of thermal expansion. The bimetal makes use of this characteristic.

## 2.3 Types of Thermal Overload Relays

Select thermal overload relays according to the type of motors and protective purposes. In addition to the selection in accordance with the motor characteristics, select 2-element type for typical protection from overload and locked rotors and select 2E type (3-element type) for protection from phase-loss.

### <Classification of motor protection relays>

Classification by protection	Overload protection type (1E)		TH-□ type
	Overload and phase-loss protection type (2E)		TH-□KP/KF type
	Overload, phase-loss, and phase-reversal (reverse phase) protection type (3E)		ET-□ type
Classification by operating time	Standard type (trip class: 10 A or 10)		TH-□/KP type
	Quick operating type (trip class: 5)		TH-T□FS/FSKP type TH-N□FS/KF type
	Long time operating type (trip class: 30 or more)	Saturated reactor method	TH-□SR type
		Saturated CT method	-
Others		-	
Classification by the number of heating elements (detection elements)	2-element type		TH-□ type
	3-element type		TH-□KP type
Classification by reset type	Maintained type		-
	Spring return type		-
	Maintained & spring return types		TH-□ all models

\* Trip class: Symbol indicating operating characteristics according to the IEC standard.

## 2.4

## Optional Units of Magnetic Contactors

Magnetic contactors are available for various applications by combining with optional units. The table below lists some examples:

## &lt;Optional units of magnetic contactors&gt;

Product name	Type	Specification & function	Application example
Auxiliary contact block	UT/UN-AX2	Embedded with bifurcated contact, 2-pole auxiliary contact (2NO, 1NO, 1NC, 2NC)	Expanded auxiliary contact (control circuit)
	UT/UN-AX4	Embedded with bifurcated contact, 4-pole auxiliary contact (4NO, 3NO, 1NC, 2NO+2NC)	
	UN-AX80	Embedded with bifurcated contact, 2-pole auxiliary contact (1NO+1NC)	
	UN-AX150	Embedded with bifurcated contact, 2-pole auxiliary contact (1NO+1NC)	
	UN-AX600	Embedded with bifurcated contact, 4-pole auxiliary contact (2NO+2NC)	
Live-section protective cover	UN-CZ□	Magnetic starters & magnetic contactors (N50 to N400)	Protection from live section
	UN-CV□5	For thermal overload relay	
DC/AC interface unit for operating coils	UT/UN-SY□	Magnetic starters and magnetic contactors for AC operation can be operated with 24 V DC.	Control with the PLC output
Main circuit conductor kit	UT/UN-SD□	Connection conductor for reversible type magnetic contactors	Reversible or main circuit jumper connection
	UT/UN-SG□	Jumper connection conductor for reversible type magnetic contactors	
	UN-YG□	Connection conductor for 3-pole short-circuit	
	UN-YD□	Connection conductor for 2-pole short-circuit	
Mechanical interlock unit	UT/UN-ML□	Reversible type is constructed in combination with two single magnetic contactors	Simultaneous input is prevented during reverse control
Surge absorber unit for operating coils	UT/UN-SA□	Varistor type, varistor + indicator light, CR type, and varistor + CR type	Suppress switching surge

## 2.5 Structure and Operations of Solid-State Contactors

Solid-state contactors (non contact contactors) are the semiconductor switches for turning ON/OFF the load current by using inverse-parallel thyristor circuit or triac.

<Contrast to magnetic contactors>

**Magnetic contactor**

**Solid-state contactor**

<b>Contact of main circuit</b>	↔	<b>Inverse-parallel thyristor of main circuit</b>
<b>Coil</b>	↔	<b>Control circuit</b>
<b>Auxiliary contact</b>	↔	<b>None (optional)</b>

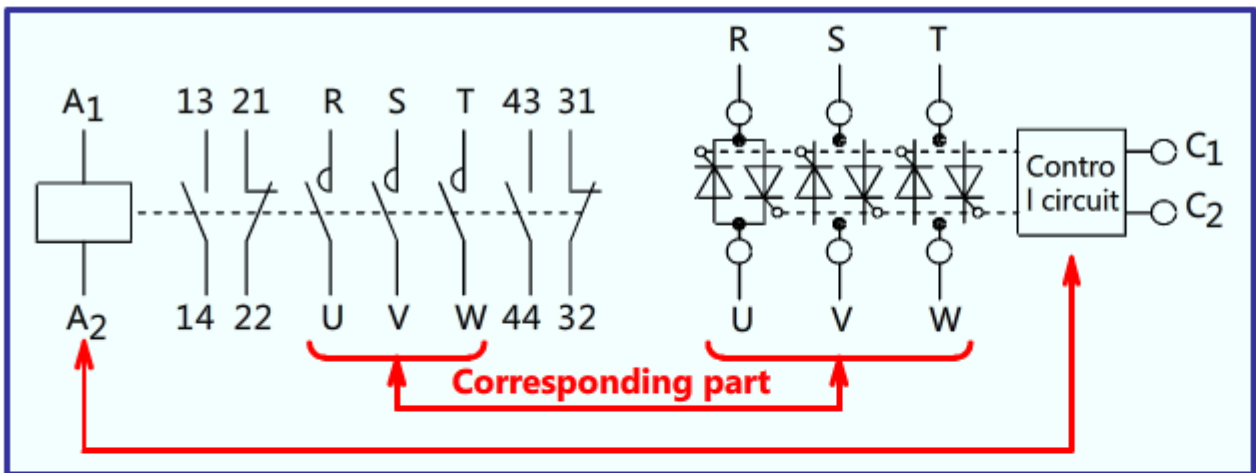

# 2.5 Structure and Operations of Solid-State Contactors

## <Structure>

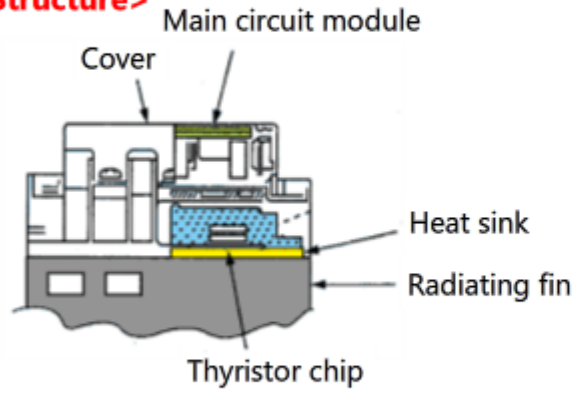

Solid-state contactors are composed of the main circuit module and the radiating fins. The thyristor elements and base (heat sink) stored in the main circuit module are electrically insulated.

## <Circuit configuration and operation>

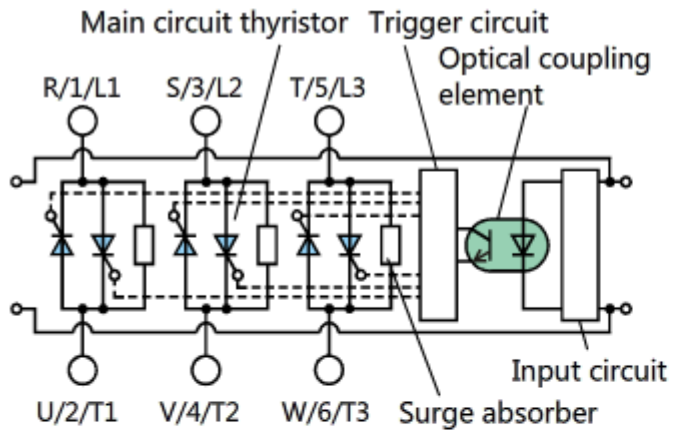

Main circuit thyristor for turning ON/OFF the main circuit current. Composed of the surge absorber protecting this main circuit thyristor against the surge voltage, the trigger circuit driving the main circuit thyristor, optical coupling element (photocoupler) electrically insulating the main circuit from operating circuit, and the input circuit driving optical coupling element.

The main circuit thyristor works by applying voltage to the input terminal. When the operating input is turned OFF, the main circuit thyristor is also turned OFF and the current is not applied to the load.

## 2.5

## Structure and Operations of Solid-State Contactors

## &lt;Features&gt;

	Item	Description
Advantages	(1) Capable of opening/closing at high frequency Long-life Maintenance-free	Since the contactors are opened/closed by the load current from the semiconductor switching element, there is no mechanical wear part so that the number of openings and closings does not give an impact on the lifetime.
	(2) Clean operation	Since there are no mechanically movable part and wear part, the abrasion powder or contact wear powder will not be generated.
	(3) No noise	Since there is no mechanically operating part, silent operation is possible without opening/closing sound.
	(4) No arc noise	Since the contactors are opened/closed by the zero voltage triggering method with the semiconductor switching element, the arc does not occur and the open/close operations generate small noises.
Disadvantages	(1) Leakage current flows in the off state	The leakage current flows even in the off state in the semiconductor switching element and the element protection circuit, so the circuit will not enter into perfectly open state.
	(2) Small overcurrent withstand capability	Since the overcurrent withstand capability of the semiconductor switching element is small, the overcurrent may cause a failure even in a short period of time (10 ms or less).
	(3) Heating	Since the heating of the semiconductor switching element is large, the contactors need to be cooled by radiating fins.



**2.6****Summary**

The summary of this chapter is as follows:

- Magnetic contactors are composed of the electromagnet made up of coils and others and the main contact part opening/closing the load current.
- The thermal overload relay detects overcurrent with the heater and bimetal and notified outside of it through the contact output.
- The auxiliary contacts and a terminal cover for electric shock prevention can be added to magnetic contactors by adding various optional units.
- Since solid-state contactors use semiconductor elements such as the thyristor and triac for main circuit, they have advantages such as no noise and long-life.

The subsequent chapter describes the selection of magnetic contactors and thermal overload relays and protective coordination.

## Chapter 3 Selecting Magnetic Contactors and Thermal Overload Relays



### Contents of Chapter 3

This chapter describes the selection of magnetic contactors and thermal overload relays, protective coordination, and the application to various loads.

- 3.1 How to start up motors
- 3.2 Connection and selection for full voltage starting (direct-on-line starting)
- 3.3 Connection and selection for reduced voltage starting (star-delta starting)
- 3.4 Protective coordination of magnetic starters and circuit breakers
- 3.5 Application to various loads
- 3.6 Summary

## 3.1

## How to Start up Motors

Magnetic starters and magnetic contactors are used mainly for controlling motors in various industrial devices and equipment.

For example, when controlling motors, there are various ways.

The control methods are roughly divided into full voltage starting and reduced voltage starting.

<How to start up motors (3-phase squirrel-cage induction motors)>

Full voltage starting (direct-on-line starting)	Irreversible operation (motor running in only one direction)	This method applies the power supply voltage to motors directly and generates bigger starting torque.
	Reversible operation (forward & reverse rotations of motors)	
Reduced voltage starting	Star-delta starting	This method applies lower voltage than the power supply voltage to motors at first, and after rotating the motors for a while, switches the circuit to apply the power supply voltage to motors. Though the circuit will be more complicated, it has some advantages, such as that it can reduce the starting current and the shock during startup.
	Kondorfer starting	
	Reactor starting	

# 3.1 How to Start up Motors

The table below lists the starting methods and circuits, characteristics, and applications of each motor:  
 This chapter describes the **full voltage starting and star-delta starting** in detail.

Startup method	Major category	Full voltage starting	Reduced voltage starting			
	Small category	Direct-on-line starting	Star-delta starting (open transition)	Star-delta starting (closed transition)	Reactor starting (closed transition)	Kondorfer starting (closed transition)
Circuit structure						
Characteristics	Starting current *1	100% Big impact on the power supply	33% Uncontrollable	33% Uncontrollable	50-60-70-80-90% Controllable	*2 30-46-68% controllable to smaller
	Starting torque *1	100%	33%	33%	25-36-49-64-81%	25-42-64%
	Acceleration	Acceleration torque: maximum Shock during startup: large	Increase of torque: small Maximum torque: small	Increase of torque: small Maximum torque: small	Smooth acceleration Increase of torque: largest Maximum torque: maximum	Smooth acceleration Increase of torque: rather small Maximum torque: rather small
	Inrush current during change to full voltage application		Large due to open power supply during change, Shock: large	No open power supply during change Shock: small	A few voltage drop due to reactor Shock: small	Very small because not released from the power supply
Application		Applied on the whole (as much as power supply capacity)	Those which start with no-load or light load. Machine tools, cargo handling machines with clutch	Same as left Fire-prevention equipment such as fire pump	Square low speed torque loads For cushion start of fan, pump, blower	Start with suppressed starting current Pump, fan, blower, centrifugal

\*1: The starting current and starting torque represent percentages when taking the direct-on-line starting as 100%. The starting current during direct-on-line starting may be five to eight times the full-load current.  
 \*2: The exciting current of single winding transformer is included. (tap value: 50-65-80%)

# 3.2 Connection and Selection for Full Voltage Starting (Direct-on-line Starting)

As described before, there are two types of full voltage starting: irreversible type running motors in only one direction and reversible type running motors in forward/reverse directions. This chapter describes the circuit connections and operations of two types.

## ◆ Irreversible type

### Equipment used

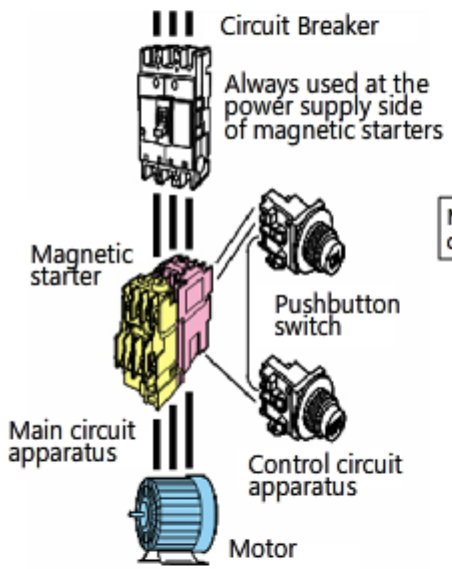

### Expanded connection

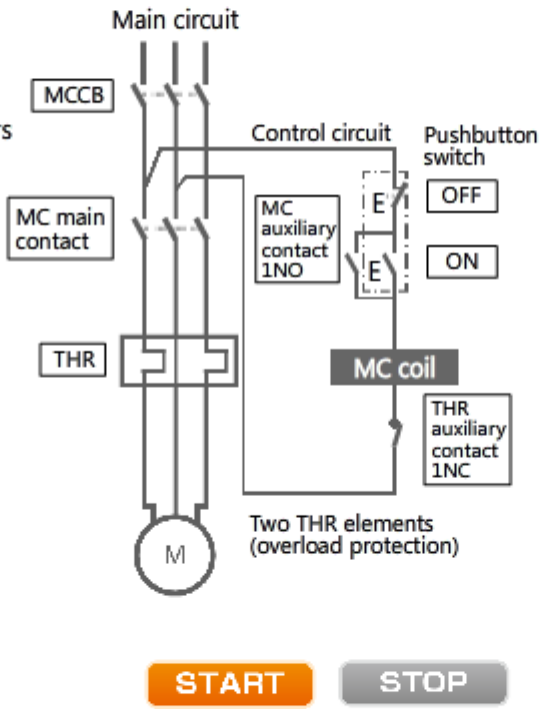

## ◆ Operation

1. Turn ON the circuit breaker
2. Turn ON the pushbutton switch
  - ① Energize the magnetic contactor MC coil
  - ② Close the magnetic contactor MC main contact and MC auxiliary contact 1NO
  - ③ Start up the motor and maintain the MC coil
3. Turn OFF the pushbutton switch (motor OFF)
  - ① Turn OFF the magnetic contactor MC coil
  - ② Open the magnetic contactor MC main contact and MC auxiliary contact 1NO
  - ③ Stop the motor
4. Trip the thermal overload relay THR (motor overload)
  - ① Open the thermal overload relay THR auxiliary contact 1NC
  - ② Turn OFF the MC coil
  - ③ Open the magnetic contactor MC main contact and MC auxiliary contact 1NO
  - ④ Stop the motor

## 3.2 Connection and Selection for Full Voltage Starting (Direct-on-line Starting)

### ◆ Irreversible type

#### Equipment used

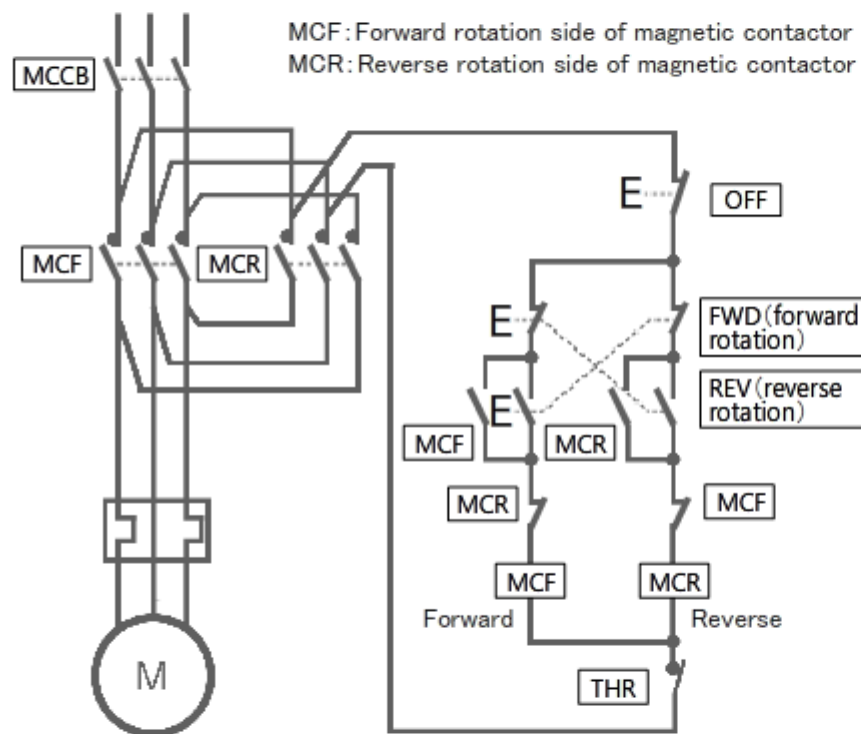

START

STOP

### ◆ Operation

1. Turn ON the circuit breaker
  2. Turn ON the pushbutton switch FWD (forward rotation)
    - ① Energize the magnetic contactor MCF (forward) coil
    - ② Close the magnetic contactor MCF (forward) main contact and auxiliary contact 1NO; Open auxiliary contact 1NC
    - ③ Start up the motor in forward rotation
    - ④ Maintain the magnetic contactor MCF (forward) coil, prevent magnetic contactor MCR (reverse) from being turned ON (electrical interlock)
  3. Turn OFF the pushbutton switch
    - ① Turn OFF the magnetic contactor MCF (forward) coil
    - ② Open the magnetic contactor MCF (forward) main contact and auxiliary contact 1NO; Close auxiliary contact 1NC (maintaining released, electrical interlock released)
    - ③ Stop the motor
  4. Turn ON the pushbutton switch REV (reverse rotation)
    - ① Energize the magnetic contactor MCR (reverse) coil
    - ② Close the magnetic contactor MCR (reverse) main contact and auxiliary contact 1NO; Open auxiliary contact 1NC
    - ③ Start up the motor reverse rotation
    - ④ Maintain the magnetic contactor MCR (reverse) coil, prevent the magnetic contactor MCF (forward) from being turned ON (electrical interlock)
- ※ The steps 4 are added to reversible type. Here, two phases are exchanged with each other to rotate the motor in reverse direction. The operation of thermal overload relay due to motor's overload is the same as irreversible type.

## 3.2 Connection and Selection for Full Voltage Starting (Direct-on-line Starting)

### <Electrical and mechanical interlock>

In reversible operation, as described before, forward and reverse rotations are enabled by using two magnetic contactors and exchanging two phases of motor windings.

However, since an interphase short-circuit occurs in the power supply when both magnetic contactors are turned ON, the interlock is installed lest two contactors get in touch with each other at the same time. There are electrical interlock and mechanical interlock.

### <Mechanical interlock>

The coil is energized at reverse rotation (forward rotation) side while the contactor is turned ON at forward rotation (reverse rotation) side

The operation is called mechanical interlock that locks the contactor at reverse rotation (forward rotation) side lest it is turned ON due to the vibration, impact, and wrong operation (as shown in the right figure).

### <Electrical interlock>

The operation is called electrical interlock that, while the contactor is turned ON at forward (reverse) rotation side, locks the contactor at the sequence circuit at reverse (forward) rotation side lest the coil is energized by auxiliary contact 1NC at forward (reverse) rotation side.

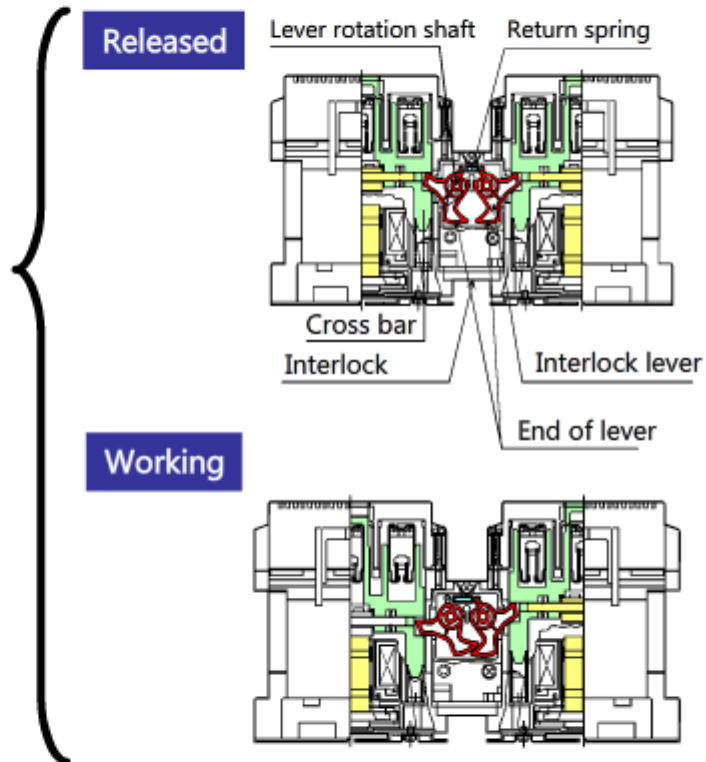

## 3.2 Connection and Selection for Full Voltage Starting (Direct-on-line Starting)

### <Selection>

Selecting magnetic starter is to select a product with necessary performances, characteristics, and price from the manufacturer's brochure.

Therefore, in order to purchase the product, it is necessary to determine the following items:

1. Type name
2. Ampere setting of thermal overload relay (or, capacity and voltage of motors)
3. Voltage & frequency of operating coil

Type name	Type of loads	Squirrel-cage motor? Heater? etc.
	Load capacity	Voltage, frequency, kW, current, etc.
	Usage	Type of loads: • Motors: Start and stop operation in general? Reversible operation? Is inching or plucking necessary? • Other loads: Resistive load in general? Does the load generate inrush current like capacitors? Operating cycle: Size of magnetic contactor and motor load (AC-3 class or AC-4 class?)
Ampere setting of thermal overload relay	<ul style="list-style-type: none"> <li>• <b>Match the ampere setting of thermal overload relay with rated current (full-load current).</b> When the ampere setting value is near two nominal values, select nearer value.</li> <li>• For those motors which require the protection against phase-reversal, use solid-state type overload relays.</li> </ul>	
Operating coil	Specify the nominal coil rating adapted to the voltage and frequency of the control circuit used.	

Although the magnetic starters can be selected in the manner above, but in practice, since almost all loads are motors, the manufacturers decide on standard specifications according to them.



### 3.3 Connection and Selection for Reduced Voltage Starting (Star-Delta Starting)

Since the direct-on-line starting may need five to eight times the motor's rated current, the problems such as the voltage drop of the power supply and mechanical shock during startup may arise. In order to improve these problems, you can adopt the reduced voltage starting that applies lower voltage than the power supply voltage to the motor winding during startup and applies the power supply voltage after the acceleration. The star-delta starting is one of the most generally used ways.

• **Star (Y) connection**

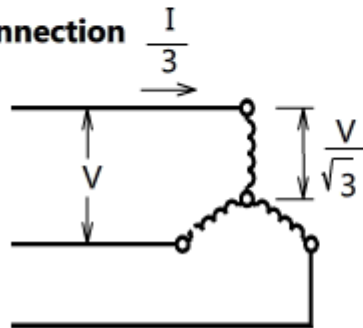

**What is the star-delta starting?**

This type of reduced voltage starting starts up the motor winding with the star (Y) connection and changes it (Y) to the delta (Δ) connection after the acceleration.

• **Delta (Δ) connection**

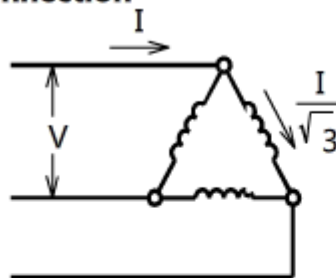

**Star-delta starting**

- Low voltage is applied during startup (power supply voltage  $\times 1/\sqrt{3}$ )
- Small starting current (one third of direct-on-line current)  
Small starting torque (one third of direct-on-line torque)
- After the motor rotating speed is high, full voltage is applied after certain interval of time (set by a timer)

\* The symbol (⊕—w—⊙) in the figure above represents the motor winding.

### 3.3 Connection and Selection for Reduced Voltage Starting (Star-Delta Starting)

The figures below show the circuit diagram and operations of the star-delta starting (three contactors type).

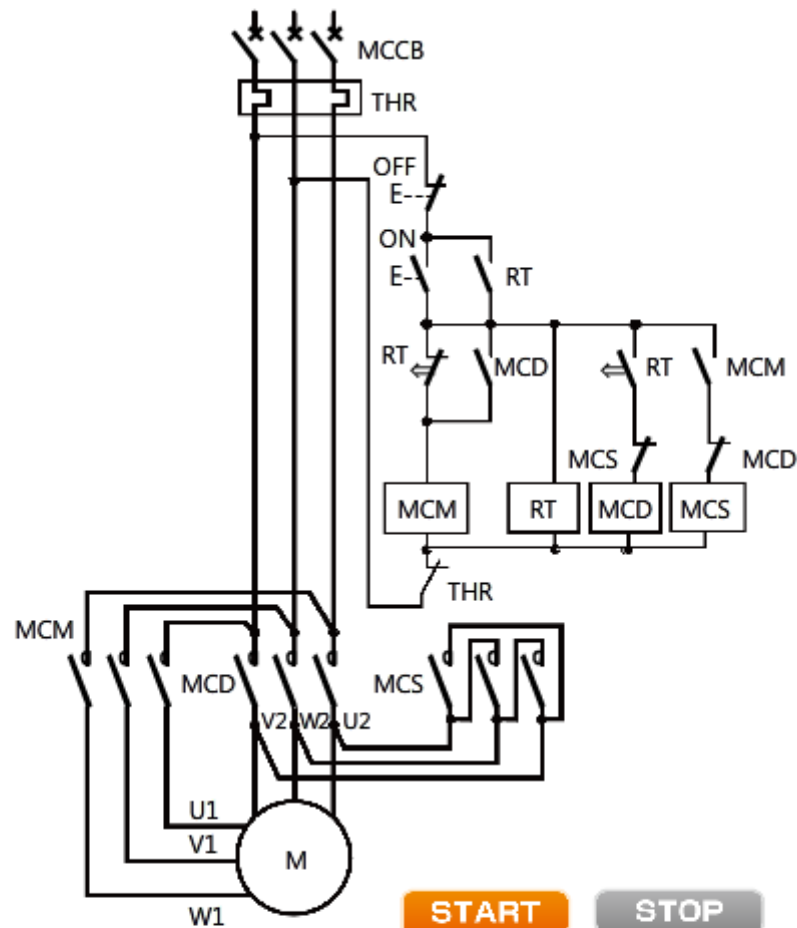

#### ◆ Operation

1. Turn ON the circuit breaker
2. Turn ON the pushbutton switch
  - ① Energize the timer RT; Close the timer RT instantaneous contact 1NO (maintained)
  - ② Energize the MCM coil
  - ③ Close the MCM main contact and MCM auxiliary contact 1NO
  - ④ Energize the MCS coil
  - ⑤ Close the MCS main contact and open the MCS auxiliary contact 1NC
  - ⑥ Prevent the MCD coil from being energized (interlock)
  - ⑦ Start up with star connection (turn ON MCM and MCS)
  - ⑧ Timer RT limited contact operation: Star starting time  
Open the timer RT limited contact 1NC; Close the timer RT limited contact 1NO
  - ⑨ Open the MCM auxiliary contact 1NO
  - ⑩ Open the MCM main contact; Release the star starting
  - ⑪ Close the MCS auxiliary contact 1NC and open the MCS main contact
  - ⑫ Energize the MCD coil
  - ⑬ Open the MCD auxiliary contact 1NC
  - ⑭ Prevent the MCS coil from being energized (interlock)
  - ⑮ Close the MCD auxiliary contact 1NO and close the MCD main contact
  - ⑯ Energize the MCM coil
  - ⑰ Close the MCM main contact
  - ⑱ Delta operation (turn ON MCM and MCD)
3. Turn OFF the pushbutton switch
  - ① Open the MCM and MCD main contacts
  - ② Stop the motor

### 3.3 Connection and Selection for Reduced Voltage Starting (Star-Delta Starting)

#### <Delta short-circuit of magnetic contactor for star connection>

When changing from the star to delta operation in the star-delta starting of three contactors type, the cable connection for the magnetic contactor for star can be set to the delta short-circuit so that the capacity for the magnetic contactor for star can be reduced.

That is, set the delta short-circuit to the cable connection of magnetic contactor for star to reduce the current applied to contacts further to  $1/\sqrt{3}$  times the star current so that the capacity of magnetic contactor for star can be reduced to  $1/3\sqrt{3}$  times (shown in the figure below).

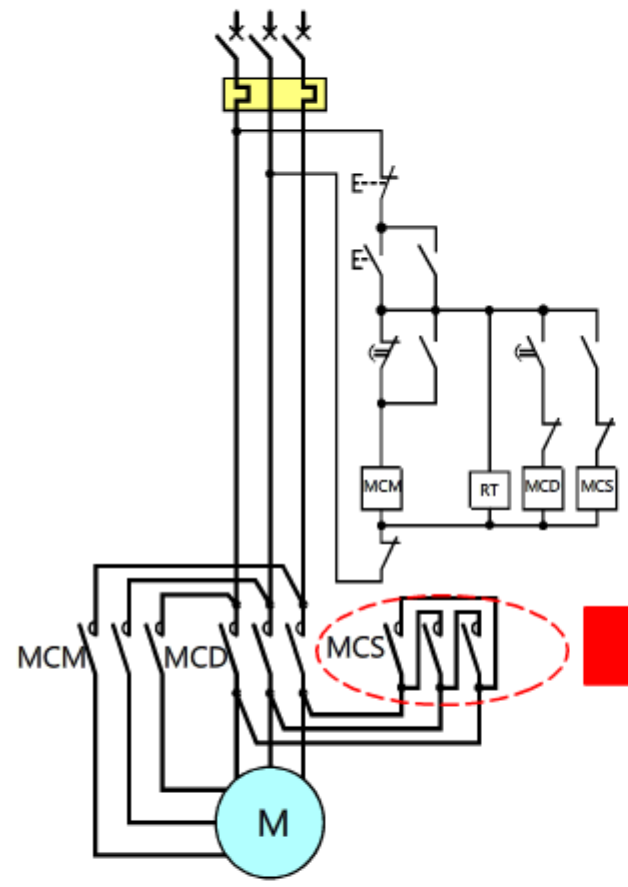

Star short-circuit    Delta short-circuit

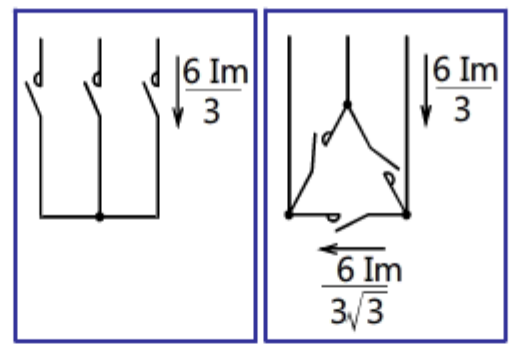

Im: motor's rated current

In two contactors type or magnetic contactors for main circuit (MCM), when the circuit does not shut off the star current, the delta short-circuit system cannot be applied to magnetic contactor for star.

### 3.3 Connection and Selection for Reduced Voltage Starting (Star-Delta Starting)

In cases of star-delta starting described in the previous page, three magnetic contactors are required:

1. Magnetic contactor for star (MCS)
2. Magnetic contactor for delta (MCD)
3. Magnetic contactor for main circuit (MCM).

The table below lists how to select each type.

Magnetic contactor for star (MCS)	<ul style="list-style-type: none"> <li>◆ Since the current applied to magnetic contactor for star is <math>1/3</math> compared to the direct-on-line current, the expression represents the star starting current when the motor's starting current is set to <math>6 I_m</math> (<math>I_m</math>: motor's rated current).  <math display="block">\text{Star starting current} = 6 I_m \times 1/3 = 2 I_m</math> </li> <li>◆ The star starting time is 15 seconds or so and the inching and frequent open/close are not performed in general, so <b>the capacity of magnetic contactor for star can be reduced to a third.</b></li> <li>◆ When the change over from star to delta connection is done while the speed is not increased fully, the large current will be shut off without decreasing the starting current so that electrical switching durability of the magnetic contactor may be largely reduced.</li> <li>◆ In general, select the frame of magnetic contactors by supposing that the change over from star to delta connection is done when the motor speed reached to 80% or more (starting current is about half the initial value).  <math display="block">\text{Current at the completion of star starting} = 0.8 \times I_m</math> </li> </ul>
Magnetic contactor for delta (MCD)	<ul style="list-style-type: none"> <li>◆ Since the magnetic contactor for delta enters into the delta phase, the operating current can be set to <b><math>1/\sqrt{3}</math> of the capacity.</b></li> <li>◆ Since the magnetic contactor for delta is AC-3 duty and the current is shut off in the delta phase connection, the contacts are finally single-phase shut off. This shut-off is more difficult than the direct-on-line shut-off.</li> </ul>
Magnetic contactor for main circuit (MCM)	<ul style="list-style-type: none"> <li>◆ As for magnetic contactor for main circuit, there are the delta phase connection and the main circuit connection (line current open/close). <b>The current for the delta phase connection can be set to <math>1/\sqrt{3}</math> of the capacity, but the current of main circuit connection is equal to the motor's rated current.</b></li> <li>◆ As for the control methods of magnetic contactor for main circuit, there are two: the method that opens once (shut off the star current) and then closes the magnetic contactor during change over from star to delta connection and the method that continues to close the magnetic contactor during startup to change to the delta operation.</li> </ul>

### 3.3 Connection and Selection for Reduced Voltage Starting (Star-Delta Starting)

The table below lists the concept described in previous page.

	Type of magnetic contactor	Multiple of motor's rated current				Capacity of magnetic contactor (AC-3)	Magnetic contactor Multiple of rated current		
		Making current	Breaking current	Energization current	Energization time		Making current	Breaking current	Energization current
Star operation	MCSS	2	0.8 (2)	2	Short time	1/3	6	2.4 (6)	6
	MCS D	$2/\sqrt{3}$	-	$2/\sqrt{3}$		$1/3\sqrt{3}$			
	MCM	-	0.8 (2)	2		$1/\sqrt{3}$			
Delta operation	MCM	$6/\sqrt{3}$	$1/\sqrt{3}$	$1/\sqrt{3}$	Continuous	$1/\sqrt{3}$	6 (12)	1 (6)	1 (6)
	MCD	$(12/\sqrt{3})$	$(6/\sqrt{3})$	$(6/\sqrt{3})$					

Example: Star-delta start the motor of 200 V AC and 15 kW (motor's rated current: 65 A):

MCM:  $65 \text{ A} \times 1/\sqrt{3} \leq \text{AC-3 class rated operational current} \rightarrow \text{S-T50}$

MCD:  $65 \text{ A} \times 1/\sqrt{3} \leq \text{AC-3 class rated operational current} \rightarrow \text{S-T50}$

MCS D:  $65 \text{ A} \times 1/3\sqrt{3} \leq \text{AC-3 class rated operational current} \rightarrow \text{S-T12}$

### 3.3 Connection and Selection for Reduced Voltage Starting (Star-Delta Starting)

#### <Selecting thermal overload relays>

As the detection methods of the thermal overload relay (THR), there are the **line current detection** and **phase current detection** according to connection points.

The heater rating of thermal overload relay may vary according to the detection methods.

Line current detection: Select adjustable heater **to the motor's rated current (full-load current)**

Phase current detection: Select adjustable heater **to  $1/\sqrt{3}$  times the motor's rated current (full-load current)**

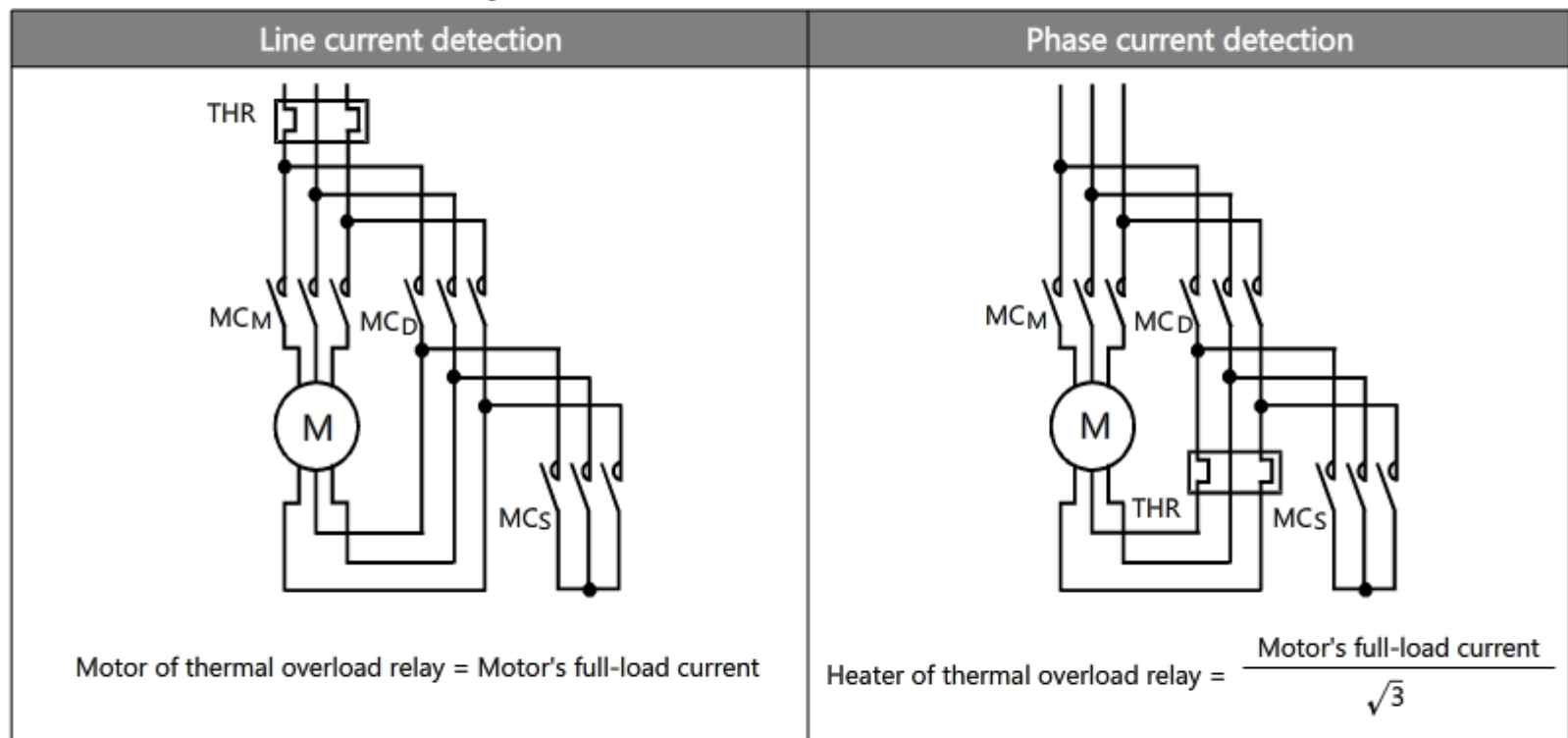

\* In general, the line current detection is common. In order to detect phase current, set the thermal overload relay to  $1/\sqrt{3}$  times the line current each time. However, the phase current detection has the advantages that the frame of thermal overload relay can be reduced, the magnetic contactor can be used as magnetic starter by combining THR and MCM.

### 3.3 Connection and Selection for Reduced Voltage Starting (Star-Delta Starting)

Note that, when the starting time is long, it may be necessary to check the operating characteristics and consider whether to adopt saturated reactor option lest the device trips during star starting or during change-over to delta connection.

Starting time	Adopted thermal overload relay	Connection	Characteristics
	Thermal overload relay of long time operating type		<ol style="list-style-type: none"> <li>1. Circuit is simple</li> <li>2. Operating time is prolonged when the rotors are locked</li> </ol>
	With saturated reactor, or with saturated CT	 With saturated reactor      With saturated CT	
	Standard thermal overload relay (non-energization during startup)	 For startup      For operation For operation      For startup Switching with a timer	<ol style="list-style-type: none"> <li>1. Assured protection during operation; capable of protecting against locked rotors according to time setting</li> <li>2. Circuit is complicated</li> </ol>

**\* Selecting motors for long starting time**

When the mechanical inertia of motor loads such as a fan and press machine is large, the starting time may become long especially during star-delta startup. To select motors for long starting time, select the thermal overload relay of long time operating type or adopt non-energization during startup because it is difficult to satisfy both unnecessary operation during star-delta starting and over load protection during operation.

# 3.4 Protective Coordination of Magnetic Starters and Circuit Breakers

Magnetic starters play the roles to start and stop motors and prevent burnouts because of the overload, locked rotors, and phase-loss.

The short-circuit protection equipment including circuit breakers plays the part to address the current beyond the breaking capacity of magnetic starters due to short-circuit.

The proper allocation of these roles is called protective coordination, as shown in the figure below.

- (1) Select circuit breakers lest they work upon the motor's inrush current.
- (2) Select thermal overload relays lest they work upon the motor's starting current.
- (3) Select those thermal overload relays whose operating characteristics is faster than the motor's thermal characteristics.

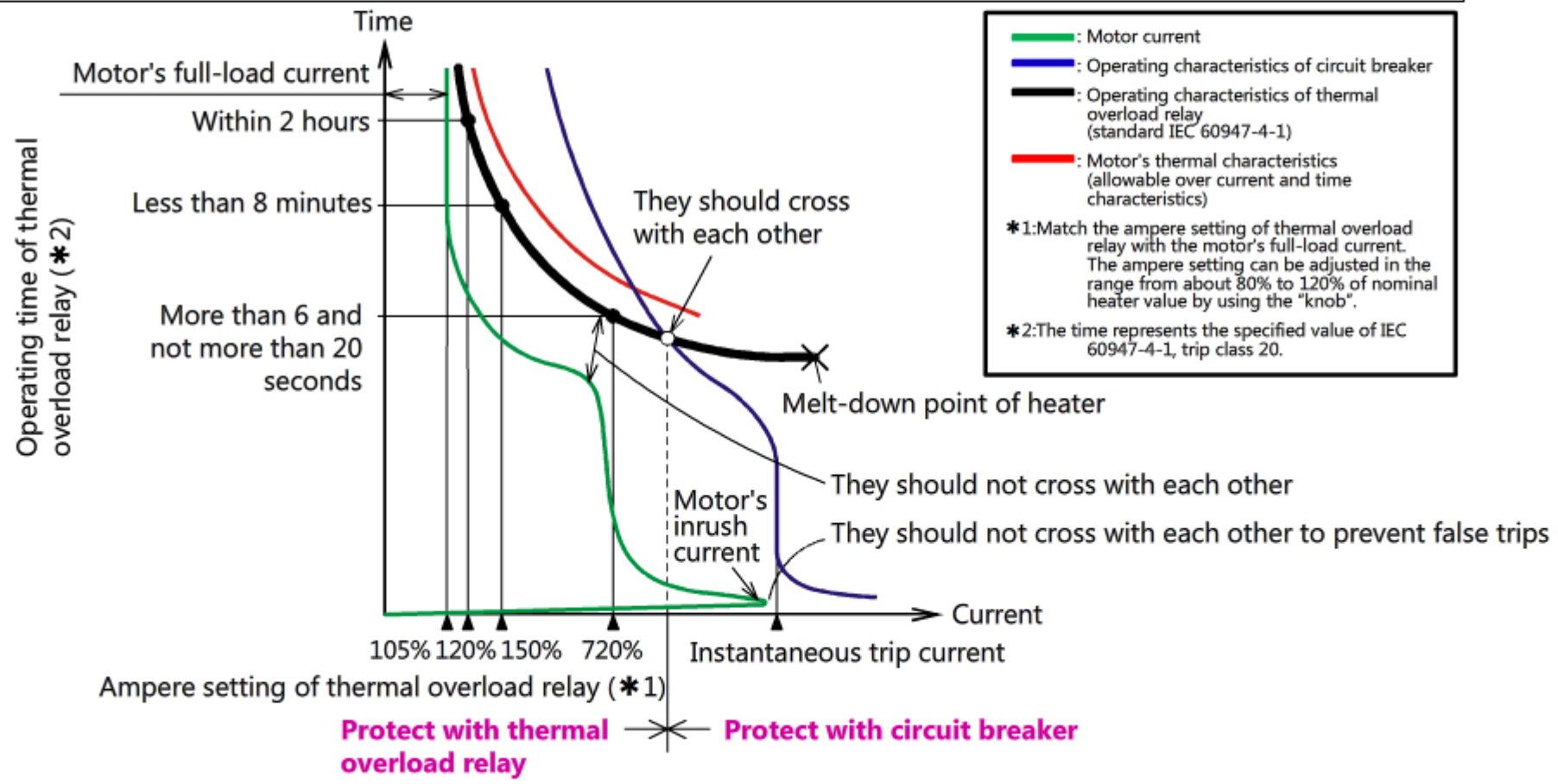



## 3.5 Application to Various Loads

In previous chapters, the description about motor loads has been provided. In practice, there are various types of loads besides motors and the way how to select devices for motors may change according to the operations of motor loads.

This chapter summarizes how to select devices according to typical loads and operating conditions.

### <Selection according to motor loads>

Type of loads	Operating condition	Overview of how to select
General squirrel-cage	Start and stop only (direct-on-line starting)	Select the frame so that the motor capacity is up to <b>AC-3 class rating</b> of the magnetic starter and magnetic contactor. Select the frame of one or two rank higher according to operating cycle and necessary lifetime. Match the current of magnetic starter for selecting thermal overload relay with the motor's full-load current.
	Start, stop, and reverse rotation	The same applies except that reversible type should be selected.
	Inching	Select the frame so that the motor capacity is up to <b>AC-4 class rating</b> of the magnetic starter and magnetic contactor. Select the large-size type of frame according to operating cycle and necessary lifetime.
DC motor	Start and stop	Select the frame so that the motor capacity is up to <b>DC-2 or DC-4 class rating</b> of the magnetic contactor. Select the frame of one or two rank higher according to operating cycle and necessary lifetime.

## 3.5 Application to Various Loads

### <Selection according to other than motor loads>

Type of loads	Operating condition	Overview of how to select
Resistor (electric furnace, heater, etc.)	AC resistive load	Select the frame according to the <b>AC-1 class rated</b> operational current of the magnetic contactor.
	DC resistive load	Select the frame according to the <b>DC-1 class rated</b> operational current of the magnetic contactor.
Capacitor	With series reactor	Select the frame according to the <b>AC-3 class rated</b> operational current of the magnetic contactor.
	Without series reactor	Select the frame so that the inrush current is 10 times or less the <b>AC-3 class rated</b> operational current of the magnetic contactor.
Lighting	Fluorescent lamp, mercury lamp, and incandescent lamp	Select the frame so that the sum of rated current is <b>AC-3 class rated</b> operational current or less of the magnetic contactor.
Transformer	Switching primary circuit	Select the frame so that the rated current of transformer is half or less the <b>AC-3 class rated</b> operational current of the magnetic contactor (the energizing inrush current of transformer is 10 times or less the AC-3 class rated operational current).

The summary of this chapter is as follows:

- As for the motor's starting methods, there are full voltage starting (direct-on-line starting) and reduced voltage starting. The star-delta starting is typical for reduced voltage starting.
- When running motors forward/backward during direct-on-line starting, use motors together with electrical or mechanical interlock.
- The star-delta starting changes the motor winding from the star to delta connection so that lower voltage than the power supply voltage is applied to motors during startup, and after rotating the motors for a while, the power supply voltage is applied to motors. The problems such as the voltage drop of the power supply and electrical/mechanical shock during startup may be mitigated.
- As for protective coordination of magnetic starters and circuit breakers, the thermal overload relay protects against overload current area and the circuit breaker protects against current beyond the shut-off capacity of magnetic starters.
- You can make use of selection lists described in brochures and technical documents from manufacturers when selecting full voltage starting, reduced voltage starting, coordination with circuit breakers, and various loads.

The subsequent chapter describes how to maintain and upgrade magnetic starters.

## Chapter 4 Maintaining and Upgrading Magnetic Starters

### Contents of Chapter 4

Although each magnetic starter has lifetime, but a part of large-size models can continuously produce performances practically without any troubles and safely continue normal operations by replacing components. This chapter describes how to maintain and inspect magnetic starters and when to upgrade them.

- 4.1 When to upgrade magnetic starters and their maintenance/inspection
- 4.2 Replacing components (contacts and coils)
- 4.3 Summary

## 4.1 When to Upgrade Magnetic Starters and their Maintenance/Inspection

### <Recommended upgrade time>

The recommended upgrade time of magnetic starters (magnetic contactors, thermal overload relays) is **10 years after use or the number of openings and closings specified according to classes defined by standard**, whichever comes first.

By the way, this recommended upgrade time does not mean the value guaranteeing normal functions and performances. It is a generally advantageous period including economical efficiency rather than good period for the maintenance and inspection under regular operating condition.

### <Maintenance and inspection>

The maintenance and inspection are indispensable for maintaining the performances of magnetic starters for a long time. In general, since almost all failures take place during first energization, the initial inspection is particularly important. The table on the next page summarizes the details and guidelines for the inspection.

## 4.1 When to Upgrade Magnetic Starters and their Maintenance/Inspection

### <Details of the maintenance and inspection of magnetic starters>

Category	Inspection item	Description	
[Periodical inspection standard: every six months]	Daily inspection	Unusual noise	Whether unusual noise occurs (due to errors and damage of electromagnets)
		Abnormal odor	Whether abnormal odor occurs
		Appearance	Whether there are pollutions due to adhered water, oil, or dust
		Damage and discoloration	Whether the mold is damaged, discolored, or deformed
	Tightening screws	Whether tightening screws are loose (check it with a tightening clamp)	
	Metal part	Whether the metal part is rusted? Whether the metal part is corroded?	
	Movement of movable part	Whether the movable part moves smoothly manually or by electromagnetic operation?	
	Latch mechanism (mechanical latch)	Whether the latch mechanism (plunger and movable iron core) moves smoothly manually or by electromagnetic operation?	

Perform the maintenance and inspection according to the table above. If any failure or problem occurs, such as "will not turn ON", "will not release (return)", "contact is burnt out", take measures according to the operation manual provided by manufacturers.

**4.2****Replacing Components**

A part of middle/large-size models of magnetic starters (magnetic contactors) can replace the coils for contacts and electromagnets.

Of course, it is impossible to use them for ever even if the coils for contacts and electromagnets are continued to be replaced.

For example, the contacts and coils can be replaced as emergency measures based on the periodical inspection. But, when continuing to use them, the insulation deterioration and mechanical wear-out due to opening/closing in other mold components than replaced component may cause the short-circuit, fire, or poor operation. If this is the case, replace the whole product.

On the following pages, the way how to take measures in each case is described.

## 4.2

## Replacing Components

## &lt;Example of replacing contacts: T65/T80&gt;

## • Main &amp; fixed contacts

1. Insert a flathead screwdriver into the edge of the arc cover, as shown in the right figure, to remove the arc cover. (Figure 1)
2. Remove the terminal screws mounted to the fixed contact. (Figure 2)
3. Catch a Phillips screwdriver on the hole for tightening terminal screws to remove the fixed contact. (Figure 3)



(Figure 1)



(Figure 2)

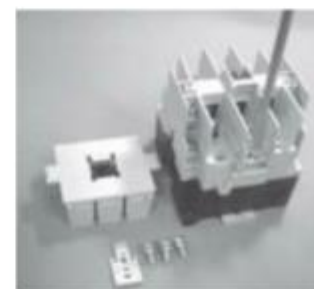

(Figure 3)

## • Main &amp; moving contacts

1. Do the same as step 1 above.
2. Pull out the moving contact with a needle nose pliers. (Figure 4)



(Figure 4)



## 4.2

## Replacing Components

## &lt;Example of replacing coils: T65/T80&gt;

1. Remove three screws tightening the case and coil, as shown in the right figure. (Figure 1)
2. Since the coil is integrally assembled with the mounting base and stationary iron cores, replace the whole as is. (Figure 2)
3. Set the conical spring mounted to the case on the top of the coil (integrally assembled with the mounting base and stationary iron cores) to assemble the case and coil. (Larger diameter side of conical spring contacts the coil.) (Figure 3)
4. Tighten the base and mounting base with screws. (Figure 3)

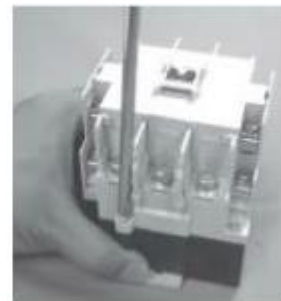

(Figure 1)

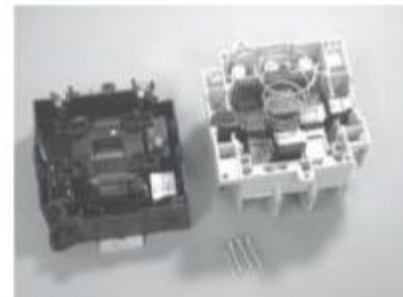

(Figure 2)



(Figure 3)

## 4.3

**Summary**

The summary of this chapter is as follows:

- The recommended upgrade time of magnetic starters (magnetic contactors) is 10 years after use or the specified number of openings and closings, whichever comes first.
- A part of magnetic starters (magnetic contactors) can replace the coils and contacts (middle/large-size models).  
However, in spite of the replacement, the recommended upgrade time of 10 years after use will not be prolonged.

The next chapter describes the application to international standards.

## Chapter 5 Application to Standards

### Contents of Chapter 5

This chapter describes the application of magnetic contactors, thermal overload relays, electromagnetic relays, and Motor circuit breakers to various standards.

- 5.1 Various standards and how to apply
- 5.2 SCCR
- 5.3 Summary

## 5.1

## Various Standards and How to Apply

Magnetic contactors, thermal overload relays, electromagnetic relays, and Motor circuit breakers are compliant with various standards and have gotten certificates of major standards.

<Compliant and conforming standards>







Model	NEMA standard	IEC standard	EN standard
Magnetic contactor S-T/N type	Standard models are applicable. (600 V or below) The selection outline is as follows: (However, since the applicable motor capacity is different a little from the size, select the devices from the UL/CSA certification page.) Size 00: S-T12/S-N11, N12 0: S-T20/S-N20, N21, N18 1: S-T25/S-N25 2: S-N50 Size 3: S-N95 4: S-N150 5: S-N300 6: S-N600	Standard models are applicable, IEC/EN 60947-4-1	
Thermal overload relay TH-T/N□KP type	Standard models are applicable, IEC/EN 60947-4-1		
Electromagnetic relay SR-T type	Standard models are applicable to A600 and R300	Standard models are applicable, IEC/EN 60947-5-1	
Motor circuit breakers MMP-T type	Standard models are applicable, IEC/EN 60947-2, IEC/EN 60947-4-1		

## 5.1

## Various Standards and How to Apply

## &lt;Conforming standards&gt;

The standard models have gotten certificates of main standards. The table below lists some examples:

Model	Safety authentication		EC Directives	Third party certification	CCC authentication	Marine certification		
	UL	CSA	CE marking	TUV	GB	KR	BV	LR
								
Magnetic contactor S-T/N type	⊙	⊙	○	⊙	⊙	⊙	⊙	⊙
Thermal overload relay TH-T/N□KP type	⊙	⊙	○	⊙	⊙	*	⊙	⊙
Electromagnetic relay SR-T/N type	⊙	⊙	○	⊙	⊙	*	⊙	⊙

⊙: Standard models got certificates, ○: Standard models are compliant with, \*: Not applicable

# 5.2 SCCR

SCCR stands for Short Circuit Current Rating and represents the short-circuit current value which the equipment and component can withstand.

In general, the value is determined by using UL508A Supplement SB.

### <Necessity of SCCR>

As NEC, the standard for electrical facility in the U.S., and NFPA79, the electrical standard for machinery for general industry, have been revised, it is mandatory to display the value of SCCR on the control panels. NEC2005 Article 409 is referring to these definitions. Determine the SCCR value to be displayed on the control panels according to UL508A.

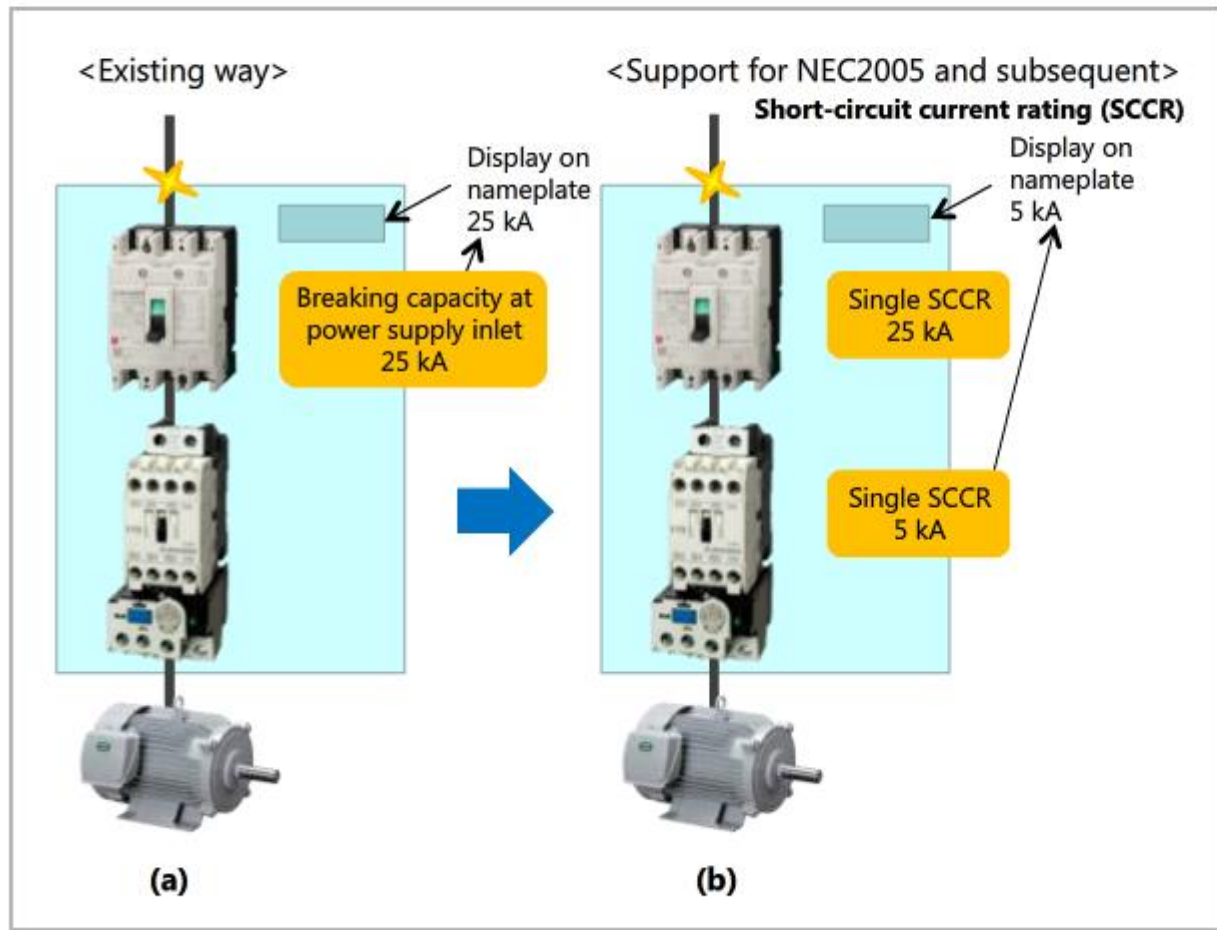

# 5.2 SCCR

## <SCCR of whole control panel>

The minimum SCCR value of all circuits and components of which the control panel is composed is the SCCR value of the whole control panel.

There is no general recommended SCCR value of control panels, but in order to enhance the degree of freedom for applying control panels, a large SCCR value may be required. In order to take measures for this, elevated SCCR certificates have been gotten in combination with short-circuit protection installation having particular rating and performance. (figure (b) below)

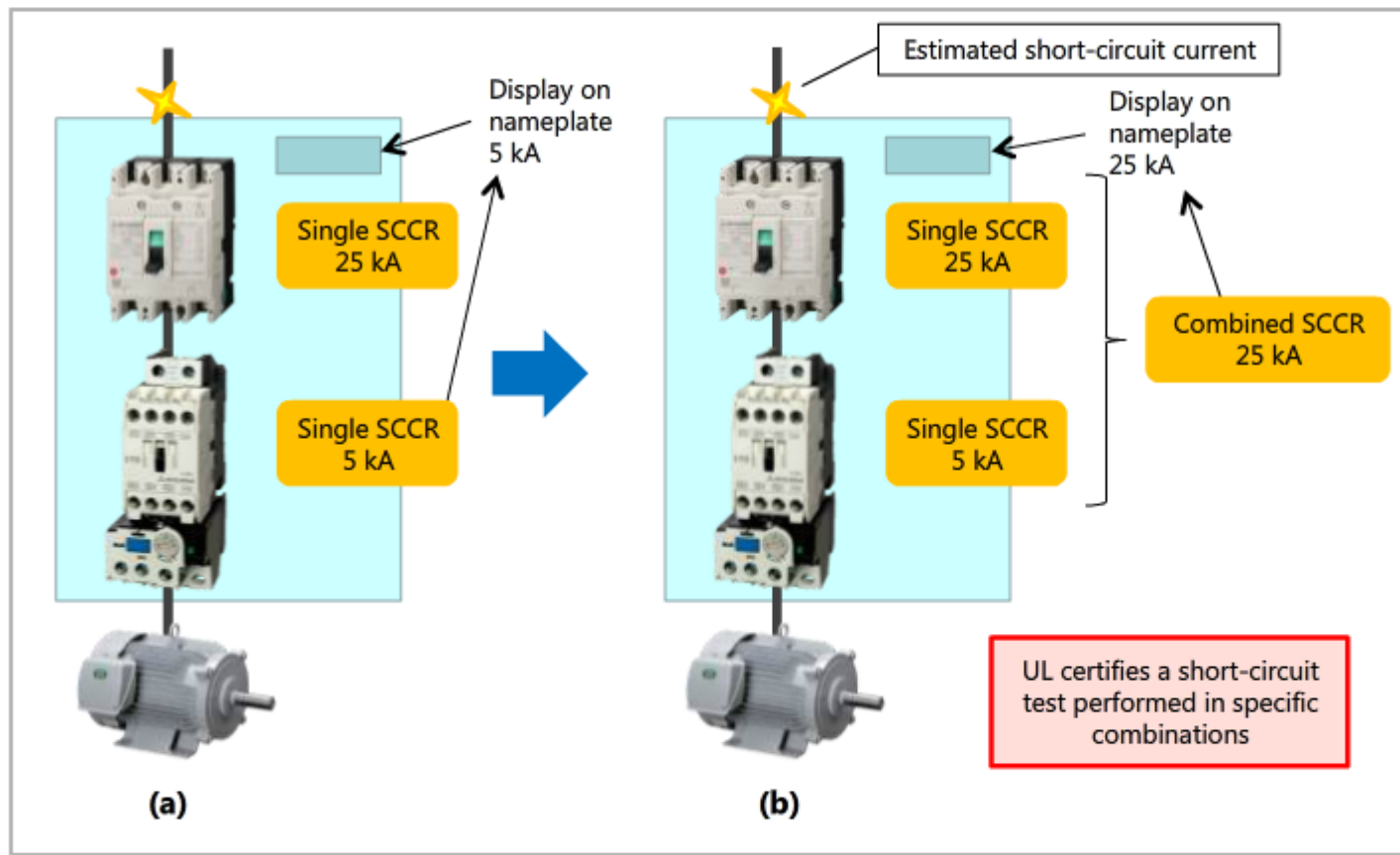

**5.3****Summary**

The summary of this chapter is as follows:

- The standard models are compliant with various standards and have gotten certificates of main standards.
- The measures are taken for how to determine SCCR value to be displayed on control panels and for cases where large SCCR value is required.

Now, the learning of five chapters have been finished.



You have completed the **Power Distribution Control Equipment (Magnetic Starter Edition)** Course.

Thank you for taking this course.

We hope you enjoyed the lessons and the information you acquired in this course will be useful in the future.

You can review the course as many times as you want.

**Review**

**Close**