



Traction Transformer

Safety Transformer

- ① Natural Air Cooling System
- ② Oil Preservation System



MELCO traction transformers are IRIS certified (category 4 power system).

Natural Air Cooling System

Cooling the Transformer by the Air Flow of the Running Train

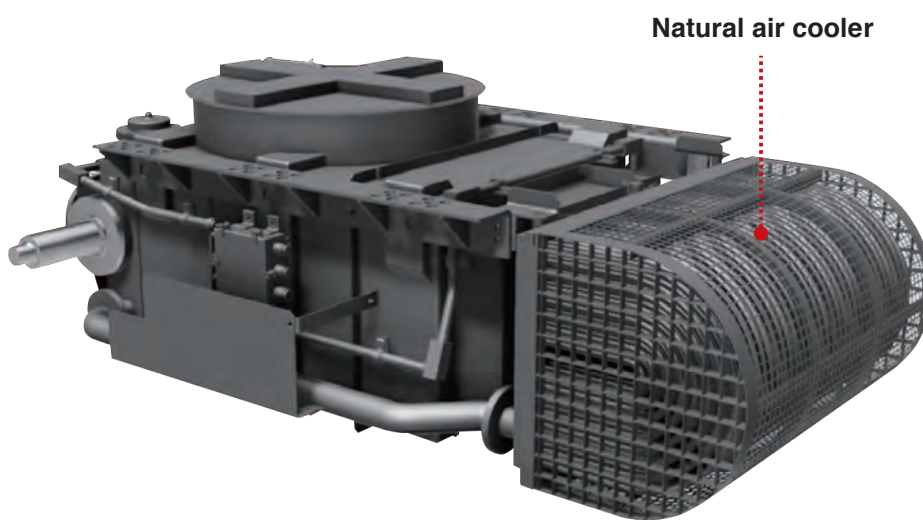

Natural air cooler

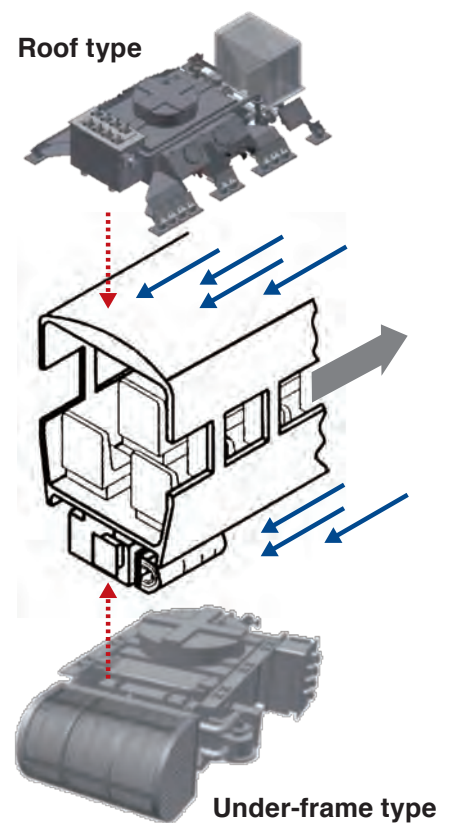

Roof type

Under-frame type

Features

- No blower noise
- No blower energy consumption
- No blower maintenance
- No cooler cleaning

Advantages

- Low noise
- Energy saving
- No maintenance

Oil Preservation System

Metallic Bellows Sealing Type

- Adapts to the heat expansion and contraction of oil
- The bellows ensure the seal maintains a constant pressure

Features

- No contact between oil and air
- No oil deterioration
- No oil changes required

Advantages

- High reliability
- No maintenance

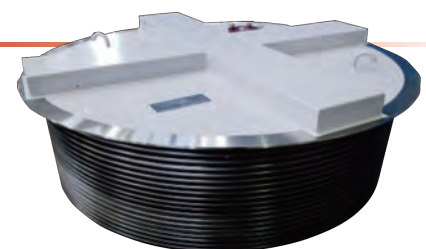

Metallic bellows conservator
Made from stainless steel

Reduced Weight with Materials with High Heat Resistance and Low Specific Gravity

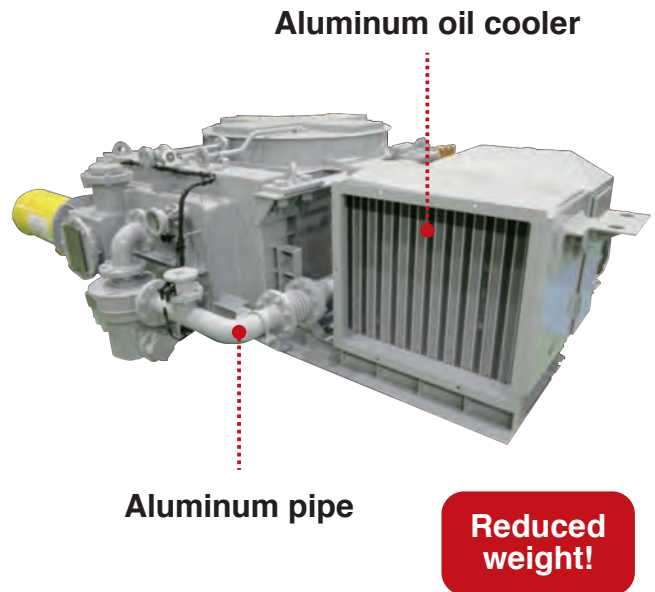
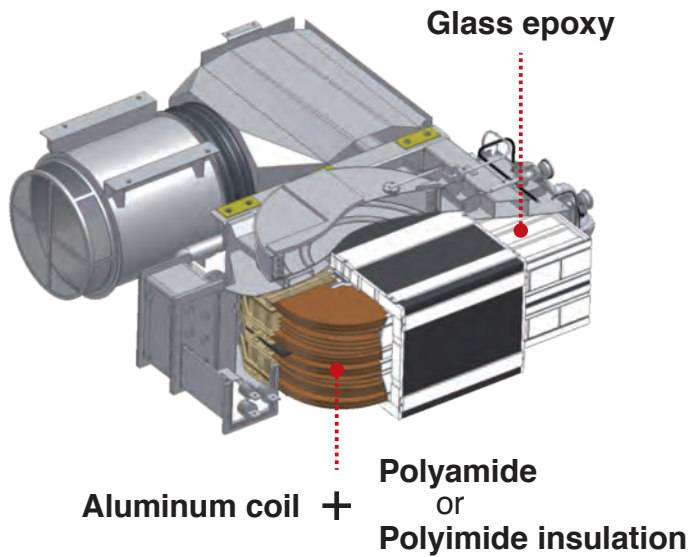

Wide Range of Applications

Various Mounting Options

Onboard

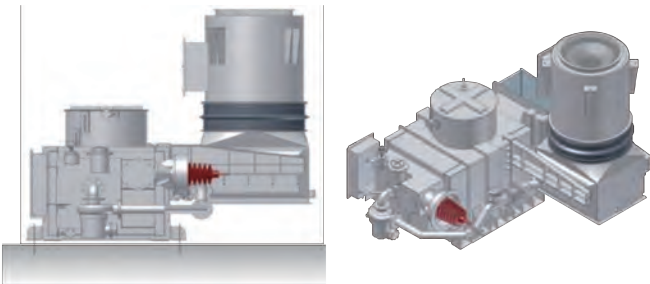

Rooftop

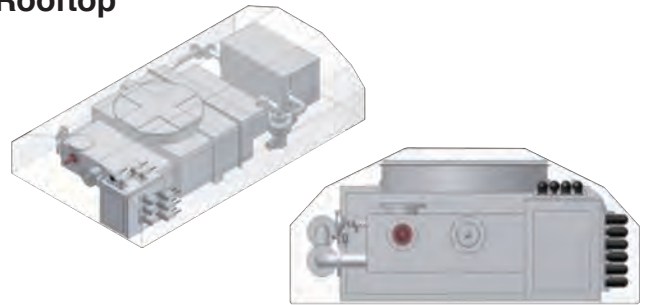

Undercarriage

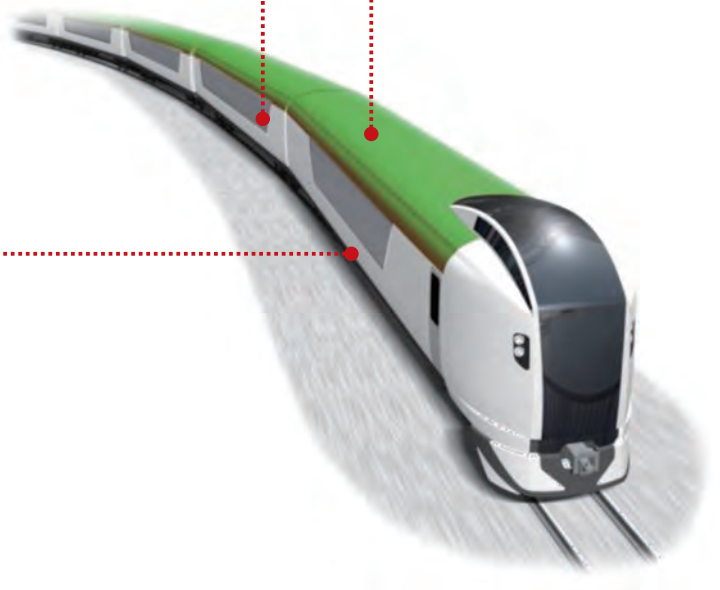
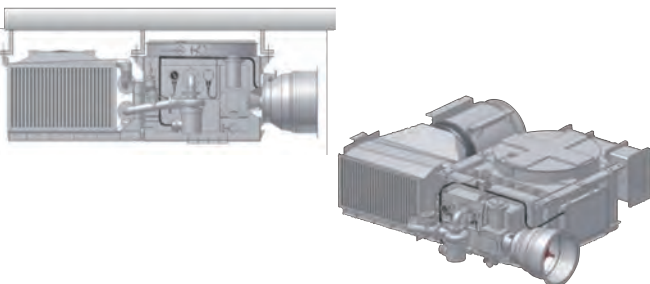

MITSUBISHI ELECTRIC CORPORATION

<http://www.MitsubishiElectric.com>