

High-Speed Programmable Controllers “QnU Series”

Authors: Hiroshi Ishida* and Yasuhiko Chiba*

1. Introduction

The market environment of the manufacturing industry has been changing along with the trend toward increasing complexity and highly advanced technology in manufacturing facilities. To ensure flexible adaptation under these circumstances, programmable controllers require improved basic performance, system performance, environmental tolerance, and lower power consumption. We have developed the “QnU Series” of high-speed programmable controllers as the central controller supporting the integrated platform.

2. Outline of QnU Series

The QnU Series was developed based on the “MELSEC-Q Series” released in 1999. Figure 1 shows a simplified block diagram of the multiple CPU system of the QnU Series. With the sequence operation processing function and the operation performance for large volumes of data significantly improved, control processing is much faster and complex control can be performed with ease, thus raising the added value of the system. In addition, the settings for CPU unit processing can be optimized in accordance with applications, including control and monitoring purposes. Furthermore,

the data transmission speed in multiple CPU systems is also increased so that the controllers can be flexibly applied to various types of manufacturing facilities, while providing higher reliability and lower power consumption of the CPU units.

3. Higher Added Value of Manufacturing Facilities

To realize higher added value of manufacturing facilities, such as increased speed, improved machining accuracy, and monitoring of high-speed sensor signals in manufacturing lines, it is necessary to improve the basic instruction processing time of the programmable controllers used in the manufacturing facilities and to improve the ease of using large volumes of data.

Using an architecture that allows high-speed operations, QnU Series programmable controllers offer much faster sequence operation processing. For example, the sequence execution time per instruction has been improved to 9.5 ns (3.5 times the conventional level), which is the highest level in the industry. Table 1 shows the list of improved performance levels for typical instruction operations. As a result of this high-speed operation, the PC MIX value has reached approxi-

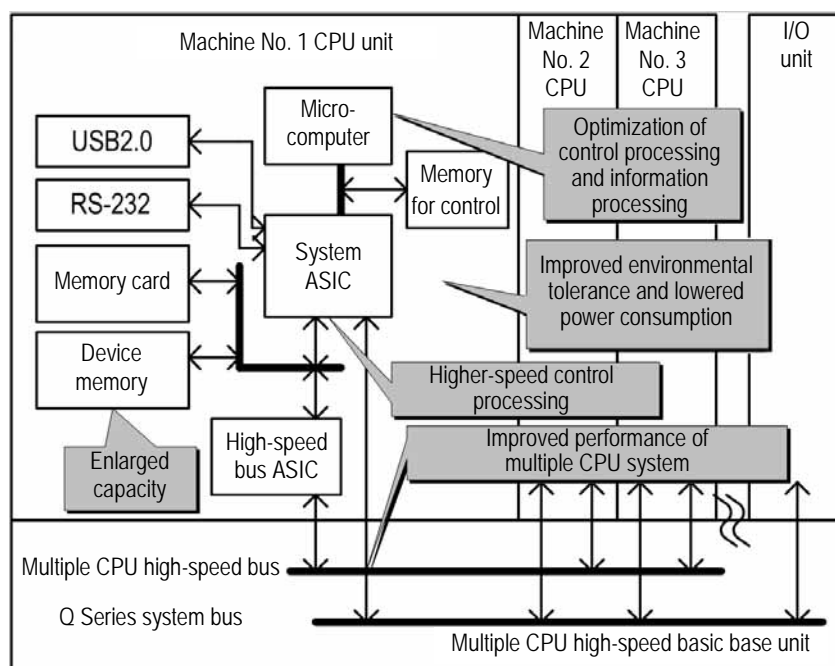

Fig. 1 Outline block diagram of QnU Series multiple CPU structure

Table 1 Instruction processing performance of QnU Series

Instruction type	Instruction	QnU Series	Q Series
Contact instruction	LD X0	9.5 ns	34 ns
Output instruction	OUT Y0	9.5 ns	68 ns
Data transfer instruction (Serial number access format)	MOV ZR0 D0	76 ns	2966 ns
Floating-point operation instruction	E+ D0 D1	57 ns	782 ns
Index register operation instruction	INC Z0	9.5 ns	2800 ns
BIN 32-bit division operation instruction	D/ D0 D2	161.5 ns	6018 ns

mately 60 instructions/μs. (PC MIX value is the number of basic instructions executed in 1 μs divided by the average number of instructions such as data processing instructions or the like. The larger the value, the faster the execution speed.) This means that the QnU Series is about 5.8 times faster than that of the Q Series, thus greatly reducing tact time in manufacturing facilities.

The operation processing time for the index register was improved by a maximum factor of 300, which gives sufficient allowance for structuring programs to encourage reuse of programs and improved quality.

The capacity of the programmable controller CPU module built-in memory has been enlarged, and a file register of up to 384 K words and a 1-MB ROM that stores user data and device comments are included as standard. Also, the file register access speed by serial number access format is increased by a factor of about 40. The index modification range in the serial number access format is expanded to enable access to the

entire file register region by using index modification. As a result, large volumes of data can be easily handled.

4. Applicability to Types of Manufacturing Facilities

The time ratio of sequence operation processing (control processing) and service processing (information processing) such as monitoring from an external device can be set with ease. Figure 2 shows a chart of scan execution using the programmable controller CPU. With the time ratio set, it is possible to set the optimum ratio of processing in accordance with the various types of manufacturing facilities, thus expanding the application range of programmable controllers.

In addition to the conventional Q Series system bus, a multiple CPU high-speed bus system was constructed for the integrated platform. Via this high-speed bus, data is transmitted periodically at a high speed of 14 K words/0.88 ms (8 times the conventional speed). Even when huge volumes of data are transmitted with the motion controllers and multiple CPU system configured, quick response and synchronization with the operation cycle are achieved, which also expands the application range of the multiple CPU system.

5. Improvement of Environmental Tolerance

Programmable controllers are often used in harsh electromagnetic environments, including manufacturing sites. The requirements stipulated in the EMC (Electromagnetic Compatibility) Directive, with which programmable controllers must comply, have been reinforced. The noise immunity of the QnU Series has been strengthened based on the results of analysis, with its characteristic high performance unchanged.

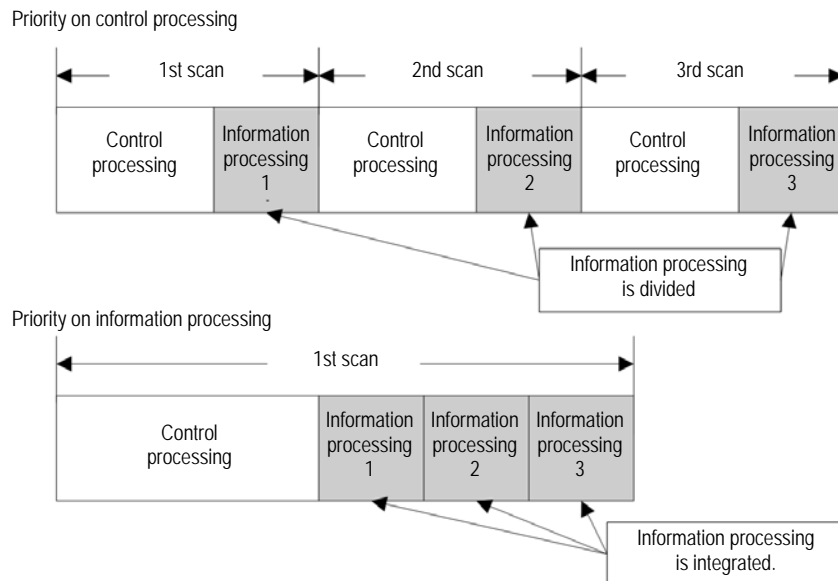

Fig. 2 Chart of scan execution for priority on control processing and information processing

In addition, there is a function for checking the integrity of the data in the memory that stores the programs for executing a sequence program, whether rewritten or changed, due to electric noise or failure.

6. Lower Power Consumption

With the reduction in number of elements used in memory ICs, the power consumption of the CPU module has been lowered by 40%.

The back-up storage locations have been limited to the range necessary to reduce the back-up current and prolong battery life. In addition, a function that restricts the back-up data to clock data prolongs the battery life by approximately 2.5 times.

We will further improve the performance, functions, and ease of use of the QnU Series as the product lineup expands.