



Programmable Controller

# CC-Link IE Field Network Remote I/O Module (With Safety Functions) User's Manual

---

-NZ2GFSS2-32D-S1  
-NZ2GFSS2-8D-S1  
-NZ2GFSS2-8TE-S1  
-NZ2GFSS2-16DTE-S1  
-NZ2EXSS2-8TE

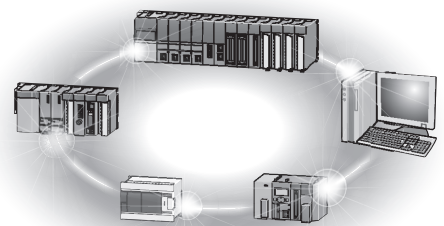

'TRANSLATION OF THE ORIGINAL INSTRUCTIONS'



# SAFETY PRECAUTIONS

---

(Read these precautions before using this product.)



Before using this product, please read this manual and the relevant manuals carefully and pay full attention to safety to handle the product correctly.

If the equipment is used in a manner not specified by the manufacturer, the protection provided by the equipment may be impaired.

The precautions given in this manual are concerned with this product only. For the safety precautions of the programmable controller system, refer to the MELSEC iQ-R Module Configuration Manual.

In this manual, the safety precautions are classified into two levels: "⚠️ WARNING" and "⚠️ CAUTION".

---

 <b>WARNING</b>	Indicates that incorrect handling may cause hazardous conditions, resulting in death or severe injury.
 <b>CAUTION</b>	Indicates that incorrect handling may cause hazardous conditions, resulting in minor or moderate injury or property damage.

---

Under some circumstances, failure to observe the precautions given under "⚠️ CAUTION" may lead to serious consequences.

Observe the precautions of both levels because they are important for personal and system safety.

Make sure that the end users read this manual and then keep the manual in a safe place for future reference.

## [Design Precautions]

---

### **WARNING**

- When the safety remote I/O module detects an error in a module power supply or an external power supply (IO power), or a failure in the module, it turns off the outputs. Configure an external circuit to ensure that the power source of a hazard is shut off by turning off the outputs. Failure to do so may result in an accident due to an incorrect output or malfunction.
  - When a load current exceeding the rated current or an overcurrent caused by a load short-circuit flows, the safety remote I/O module defines it as a fault and turns off the outputs. Note that if the overcurrent state continues for a long time, it may cause smoke and fire. To prevent this, configure an external safety circuit, such as a fuse.
  - At the start-up of the system, if a short-circuit has occurred at the output wiring of the external power supply (IO power), a load may turn on just after the power-on. Configure an interlock circuit to ensure that the entire system will always operate safely.
  - When a communication failure occurs in the network, the failed station becomes the following status. Check the communication status information and configure an interlock circuit in the program to ensure that the entire system will operate safely. Failure to do so may result in an accident due to an incorrect output or malfunction.
    - (1) All inputs from remote I/O stations are turned off.
    - (2) All outputs from remote I/O stations are turned off.
  - Do not read or write any data from/to the "use prohibited" areas in the remote register. If data is read or written from/to the remote register, correct operation of the module cannot be guaranteed.
  - To satisfy SIL3, Category 4 PL e, use input devices with normally closed contacts. Inputs using the devices with normally open contacts do not satisfy SIL3, Category 4 PL e.
  - Use a SELV power supply for the devices to be connected to the input part of the safety remote I/O module. If not, SIL3, Category 4 PL e is not satisfied.
  - When "Operation setting of external power supply voltage error detection" is set to "Continue safety communication (Without output interlock)", configure an external interlock circuit for the safety outputs to prevent unintended restart.
-

## [Design Precautions]

---

### **CAUTION**

- Do not install the control lines or communication cables together with the main circuit lines or power cables. Keep a distance of 100mm or more between them. Failure to do so may result in malfunction due to noise.
  - Select the external devices to be connected to the module by referring to the performance specifications in this manual and considering the maximum inrush current. Connecting a device exceeding the maximum inrush current may cause malfunction or failure of the module.
- 

## [Security Precautions]

---

### **WARNING**

- To maintain the security (confidentiality, integrity, and availability) of the programmable controller and the system against unauthorized access, denial-of-service (DoS) attacks, computer viruses, and other cyberattacks from external devices via the network, take appropriate measures such as firewalls, virtual private networks (VPNs), and antivirus solutions.
- 

## [Installation Precautions]

---

### **WARNING**

- Shut off the external power supply (IO power) used in the system in all phases before mounting or removing the module. Failure to do so may result in electric shock or cause the module to fail or malfunction.
- 

## [Installation Precautions]

---

### **CAUTION**

- Use the module in an environment that meets the general specifications in this manual. Failure to do so may result in electric shock, fire, malfunction, or damage to or deterioration of the product.
  - Do not directly touch any conductive parts and electronic components of the module. Doing so can cause malfunction or failure of the module.
  - After the first use of the product, do not connect/remove the extension module more than 50 times (IEC 61131-2 compliant). Exceeding the limit may cause malfunction.
  - To connect an extension module to a main module, engage the respective connectors and securely lock the module joint levers. Incorrect interconnection may cause malfunction, failure, or drop of the module.
  - After the first use of the product, do not connect/remove the connector more than 50 times (IEC 61131-2 compliant). Exceeding the limit may cause malfunction.
  - Connect each connection cable to the connector securely. Poor contact may cause malfunction.
  - Beware that the module could be very hot while power is on and immediately after power-off.
-

## [Wiring Precautions]

---

### **WARNING**

- Shut off the external power supply (IO power) used in the system in all phases before installation and wiring. Failure to do so may result in electric shock or cause the module to fail or malfunction.
- 

## [Wiring Precautions]

---

### **CAUTION**

- Individually ground the FG terminal of the programmable controller with a ground resistance of 100 ohms or less. Failure to do so may result in electric shock or malfunction.
  - Check the rated voltage and terminal layout before wiring to the module, and connect the cables correctly. Connecting a power supply with a different voltage rating or incorrect wiring may cause fire or failure.
  - Tighten the terminal block mounting screws within the specified torque range. Undertightening can cause short circuit, fire, or malfunction. Overtightening can damage the screw and/or module, resulting in drop, short circuit, or malfunction.
  - Prevent foreign matter such as dust or wire chips from entering the module. Such foreign matter can cause a fire, failure, or malfunction.
  - A protective film is attached to the top of the module to prevent foreign matter, such as wire chips, from entering the module during wiring. Do not remove the film during wiring. Remove it for heat dissipation before system operation.
  - Place the cables in a duct or clamp them. If not, dangling cable may swing or inadvertently be pulled, resulting in damage to the module or cables or malfunction due to poor contact.
  - When disconnecting the cable from the module, do not pull the cable by the cable part. For the cable with connector, hold the connector part of the cable. For the cable connected to the terminal block, loosen the terminal block screw. Pulling the cable connected to the module may result in malfunction or damage to the module or cable.
  - Do not install the control lines or communication cables together with the main circuit lines or power cables. Keep a distance of 100mm or more between them. Failure to do so may result in malfunction due to noise.
  - When an overcurrent caused by an error of an external device or a failure of the module flows for a long time, it may cause smoke and fire. To prevent this, configure an external safety circuit, such as a fuse.
-

## [Startup and Maintenance Precautions]

---

### **WARNING**

- Do not touch any terminal while power is on. Doing so will cause electric shock or malfunction.
  - Shut off the external power supply (IO power) used in the system in all phases before cleaning the module or retightening the terminal block mounting screw. Failure to do so may result in electric shock. Tighten the terminal block mounting screws within the specified torque range. Undertightening can cause short circuit, fire, or malfunction. Overtightening can damage the screw and/or module, resulting in drop, short circuit, or malfunction.
- 

## [Startup and Maintenance Precautions]

---

### **CAUTION**

- Do not disassemble or modify the modules. Doing so may cause failure, malfunction, injury, or a fire.
  - Use any radio communication device such as a cellular phone or PHS (Personal Handy-phone System) more than 25cm away in all directions from the module. Failure to do so may cause malfunction.
  - Shut off the external power supply (IO power) used in the system in all phases before mounting or removing the module. Failure to do so may cause the module to fail or malfunction.
  - Before handling the module, touch a conducting object such as a grounded metal to discharge the static electricity from the human body. Failure to do so may cause the module to fail or malfunction.
  - Do not drop or apply strong shock to the module. Doing so may damage the module.
  - Shut off the external power supply (IO power) used in the system in all phases before installing or removing a module in/from the control panel. Failure to do so may cause the module to fail or malfunction.
  - Check the module once a day, by turning on output signals and confirming that no error occurs.
- 

## [Disposal Precautions]

---

### **CAUTION**

- When disposing of this product, treat it as industrial waste.
- 

## [Transportation Precautions]

---

### **CAUTION**

- When transporting lithium batteries, follow the transportation regulations. For details on the regulated models, refer to the MELSEC iQ-R Module Configuration Manual.
  - The halogens (such as fluorine, chlorine, bromine, and iodine), which are contained in a fumigant used for disinfection and pest control of wood packaging materials, may cause failure of the product. Prevent the entry of fumigant residues into the product or consider other methods (such as heat treatment) instead of fumigation. The disinfection and pest control measures must be applied to unprocessed raw wood.
-

## [Precautions for Using Products]

---

### **WARNING**

---

- Although MELCO has obtained the certification for Product's compliance to the international safety standards IEC 61508 and ISO 13849-1 from TUV Rheinland, this fact does not guarantee that Product will be free from any malfunction or failure.
  - With very small probability shown in PFDavg / PFH, the safety remote I/O module has residual risk that input and output may turn on or off in unintended way. When using this product, perform risk assessment on target equipment, and select appropriate SIL and PL, as well as reduce the risk.
-



# CONDITIONS OF USE FOR THE PRODUCT

---

- (1) Although Mitsubishi Electric has obtained the certification for Product's compliance to the international safety standards IEC61508, ISO13849-1 from TUV Rheinland, this fact does not guarantee that Product will be free from any malfunction or failure. The user of this Product shall comply with any and all applicable safety standard, regulation or law and take appropriate safety measures for the system in which the Product is installed or used and shall take the second or third safety measures other than the Product. Mitsubishi Electric is not liable for damages that could have been prevented by compliance with any applicable safety standard, regulation or law.
- (2) Mitsubishi Electric prohibits the use of Products with or in any application involving, and Mitsubishi Electric shall not be liable for a default, a liability for defect warranty, a quality assurance, negligence or other tort and a product liability in these applications.
  - (a) power plants,
  - (b) trains, railway systems, airplanes, airline operations, other transportation systems,
  - (c) hospitals, medical care, dialysis and life support facilities or equipment,
  - (d) amusement equipments,
  - (e) incineration and fuel devices,
  - (f) handling of nuclear or hazardous materials or chemicals,
  - (g) mining and drilling,
  - (h) and other applications where the level of risk to human life, health or property are elevated.
- (3) Mitsubishi Electric shall have no responsibility or liability for any problems involving programmable controller trouble and system trouble caused by DoS attacks, unauthorized access, computer viruses, and other cyberattacks.

## INTRODUCTION

---

Thank you for purchasing the CC-Link IE Field Network remote I/O module (with safety functions) (hereafter abbreviated as safety remote I/O module).

This manual describes the specifications, procedures before operation, installation and wiring, functions, parameter settings, maintenance and inspection, and troubleshooting of the safety remote I/O module.

Before using this product, please read this manual and the relevant manuals carefully and develop familiarity with the functions and performance of the safety remote I/O module to handle the product correctly. When applying the program and circuit examples provided in this manual to an actual system, ensure the applicability and confirm that it will not cause system control problems.

Please make sure that the end users read this manual.

# CONTENTS

SAFETY PRECAUTIONS .....	1
CONDITIONS OF USE FOR THE PRODUCT .....	7
INTRODUCTION .....	7
RELEVANT MANUALS .....	11
TERMS .....	12
GENERIC TERMS AND ABBREVIATIONS .....	12
<b>CHAPTER 1 PRODUCT LINEUP</b> .....	<b>13</b>
<b>CHAPTER 2 PART NAMES</b> .....	<b>15</b>
<b>CHAPTER 3 SPECIFICATIONS</b> .....	<b>19</b>
3.1 General Specifications .....	19
3.2 Performance Specifications .....	20
3.3 Function List .....	40
<b>CHAPTER 4 PROCEDURES BEFORE OPERATION</b> .....	<b>43</b>
4.1 Procedures Before Operation .....	43
4.2 Module Replacement Procedure .....	44
<b>CHAPTER 5 SYSTEM CONFIGURATION</b> .....	<b>45</b>
5.1 Safety Remote I/O Module System Configuration .....	45
5.2 Applicable Systems .....	46
5.3 Safety Standards .....	47
<b>CHAPTER 6 INSTALLATION AND WIRING</b> .....	<b>48</b>
6.1 Setting of Network Number and Station Number .....	48
Station number setting with the station number setting switch .....	48
6.2 Installation Environment and Installation Position .....	49
Installation environment .....	49
Installation position .....	49
Installation direction .....	50
6.3 Installation .....	51
Installation of extension modules .....	51
Connecting extension modules .....	51
Mounting the module on a DIN rail .....	54
6.4 Wiring .....	57
Wiring of terminal block for module power supply and FG .....	57
Wiring of Ethernet cable .....	60
Wiring of terminal block for the external power supply and I/O signals .....	63
Precautions for wiring the safety remote I/O module to safety devices .....	66
<b>CHAPTER 7 VARIOUS SETTINGS</b> .....	<b>68</b>
7.1 Network Configuration Settings .....	69
7.2 Parameter Settings .....	72
<b>CHAPTER 8 FUNCTIONS</b> .....	<b>84</b>
8.1 Safety Input Function .....	85

Safety input wiring selection function . . . . .	85
Safety input response time setting function . . . . .	88
<b>8.2 Safety Output Function . . . . .</b>	<b>89</b>
Safety output wiring selection function . . . . .	89
Number of safety output ON times integration function . . . . .	92
<b>8.3 Input Diagnostic Function . . . . .</b>	<b>93</b>
Double input discrepancy detection function . . . . .	93
Input dark test function . . . . .	101
Internal input dark test function . . . . .	104
<b>8.4 Output Diagnostic Function . . . . .</b>	<b>105</b>
Output dark test function . . . . .	105
Output read-back function . . . . .	107
<b>8.5 Protection Functions . . . . .</b>	<b>108</b>
<b>8.6 User Authentication Function . . . . .</b>	<b>109</b>
<b>8.7 Operation Setting Function at Detection of External Power Supply Voltage Error . . . . .</b>	<b>110</b>
<b>8.8 Functions Available When Extension Modules Are Connected . . . . .</b>	<b>117</b>
<b>CHAPTER 9 MAINTENANCE AND INSPECTION . . . . .</b>	<b>119</b>
<hr/>	
9.1 Daily Inspection . . . . .	119
9.2 Periodic Inspection . . . . .	121
<b>CHAPTER 10 TROUBLESHOOTING . . . . .</b>	<b>122</b>
<hr/>	
10.1 CC-Link IE TSN/CC-Link IE Field Diagnostics . . . . .	122
10.2 Checking the LEDs . . . . .	123
10.3 Unit Test . . . . .	126
10.4 Troubleshooting by Symptom . . . . .	127
10.5 Fault Examples with the Safety Remote I/O Module . . . . .	129
Input circuit troubles and corrective actions . . . . .	129
Output circuit troubles and corrective actions . . . . .	131
10.6 How to Check Error Codes . . . . .	132
10.7 List of Error Codes . . . . .	137
Error classification by error number . . . . .	137
Error code system . . . . .	137
Error codes related to the safety remote I/O module . . . . .	138
Error codes related to the CC-Link IE Field Network . . . . .	154
Error codes related to safety communication . . . . .	156
<b>APPENDICES . . . . .</b>	<b>158</b>
<hr/>	
<b>Appendix 1 Safety Remote I/O Signals . . . . .</b>	<b>158</b>
List of safety remote I/O signals . . . . .	159
Details of safety remote I/O signals . . . . .	165
<b>Appendix 2 Remote Control/Monitor Signals . . . . .</b>	<b>170</b>
List of remote control/monitor signals . . . . .	170
Details of remote control/monitor signals . . . . .	172
<b>Appendix 3 Remote Register . . . . .</b>	<b>175</b>
List of remote register areas . . . . .	175
Details of remote register areas . . . . .	175
<b>Appendix 4 Remote Buffer Memory . . . . .</b>	<b>178</b>
List of remote buffer memory areas . . . . .	178
Details of remote buffer memory areas . . . . .	184

<b>Appendix 5 EMC, Low Voltage, and Machinery Directives</b> .....	<b>197</b>
Measures to comply with the EMC Directive .....	197
Measures to comply with the Low Voltage Directive .....	201
Measures to comply with the Machinery Directive .....	202
<b>Appendix 6 Checking Serial Number and Function Version</b> .....	<b>203</b>
<b>Appendix 7 External Dimensions</b> .....	<b>205</b>

<b>INDEX</b>	<b>207</b>
--------------	------------

---

REVISIONS .....	209
WARRANTY .....	210
TRADEMARKS .....	212

# RELEVANT MANUALS

Manual name [manual number]	Description	Available form
CC-Link IE Field Network Remote I/O Module (With Safety Functions) User's Manual [SH-082611ENG] (this manual)	Specifications, procedures before operation, installation and wiring, functions, parameter settings, maintenance and inspection, and troubleshooting of the safety remote I/O module	Print book e-Manual PDF
MELSEC iQ-R Ethernet/CC-Link IE User's Manual (Startup) [SH-081256ENG]	Specifications, procedures before operation, system configuration, wiring, and communication examples of Ethernet, CC-Link IE Controller Network, and CC-Link IE Field Network	Print book e-Manual PDF
MELSEC iQ-R CC-Link IE Field Network User's Manual (Application) [SH-081259ENG]	Functions, parameter settings, programming, troubleshooting, I/O signals, and buffer memory of CC-Link IE Field Network	Print book e-Manual PDF
MELSEC iQ-R Programming Manual (Module Dedicated Instructions) [SH-081976ENG]	Dedicated instructions for the intelligent function modules	e-Manual PDF
MELSEC iQ-R Simple Motion Module User's Manual (Network) [IB-0300307ENG]	Functions, parameter settings, troubleshooting, and buffer memory of CC-Link IE Field Network	Print book e-Manual PDF
GX Works3 Operating Manual [SH-081215ENG]	System configuration, parameter settings, and online operations of GX Works3	e-Manual PDF

## Point

e-Manual refers to the Mitsubishi Electric FA electronic book manuals that can be browsed using a dedicated tool.

e-Manual has the following features:

- Required information can be cross-searched in multiple manuals.
- Other manuals can be accessed from the links in the manual.
- The hardware specifications of each part can be found from the product figures.
- Pages that users often browse can be bookmarked.
- Sample programs can be copied to an engineering tool.

# TERMS

Unless otherwise specified, this manual uses the following terms.

Term	Description
CC-Link IE Field Network	A high-speed and large-capacity open field network that is based on Ethernet (1000BASE-T)
Cyclic transmission	A function by which data are periodically exchanged among stations on the same network using link devices (RX, RY, RWw, and RWr)
Dedicated instruction	An instruction that simplifies programming for using functions of intelligent function modules
Engineering tool	A tool used for setting up programmable controllers, programming, debugging, and maintenance
Intelligent device station	A station that exchanges I/O signals (bit data) and I/O data (word data) with the master station by cyclic transmission. This station can perform transient transmission as well. This station responds to a transient transmission (request) from another station and also issues a transient transmission (request) to another station.
Link device	A device (RX, RY, RWr, RWw, SB, or SW) in a module or a board on CC-Link IE Field Network
Local station	A station that performs cyclic transmission and transient transmission with the master station and other local stations
Main module	A module with the CC-Link IE Field Network communication function, which can be used as a single remote module. Extension modules can be connected to this module.
Master station	A station that controls the entire network. This station can perform cyclic transmission and transient transmission with all stations. Only one master station can be used in a network.
Remote device station	A station that exchanges I/O signals (bit data) and I/O data (word data) with the master station by cyclic transmission. This station responds to a transient transmission (request) from another station.
Remote I/O station	A station that exchanges I/O signals (bit data) with the master station by cyclic transmission
Reserved station	A station reserved for future use. This station is not actually connected, but counted as a connected station
Safety remote I/O module	A CC-Link IE Field Network remote I/O module (with safety functions)
Safety remote I/O station	A remote I/O station to perform safety communications
Safety remote input (SAIX)	A safety device (safety input) that can be used in safety programs
Safety remote output (SAIY)	A safety device (safety output) that can be used in safety programs
Safety remote station	A remote station to perform safety communications
Transient transmission	A function of communication with another station, which is used when requested by a dedicated instruction or an engineering tool

# GENERIC TERMS AND ABBREVIATIONS

Unless otherwise specified, this manual uses the following generic terms and abbreviations.

Generic term and abbreviation	Description
Data link	A generic term for cyclic transmission and transient transmission
Device station	A generic term for local station, remote I/O station, remote device station, and intelligent device station
Extension module	A generic term for the standard extension module and safety extension module
Remote station	A generic term for intelligent device station, remote device station, and remote I/O station (type of a station of CC-Link IE Field Network-compatible modules)
RWr	An abbreviation for the remote register. Word data input from a device station to the master station. (For some areas in a local station, data are input in the opposite direction.)
RWw	An abbreviation for the remote register. Word data output from the master station to a device station. (For some areas in a local station, data are output in the opposite direction.)
Safety extension module	A generic term for safety output remote modules with no CC-Link IE Field Network communication function. This module cannot be used as a single module, but can be used by connecting it to the main module (NZ2GFSS2-32D-S1).
SB	An abbreviation for the link special relay. Bit data that indicates the operating status and data link status of a module on CC-Link IE Field Network.
Standard extension module	A generic term for standard I/O remote modules with no CC-Link IE Field Network communication function. This module cannot be used as a single module. However, connecting it to the main module (NZ2GFSS2-8D-S1, NZ2GFSS2-8TE-S1, or NZ2GFSS2-16DTE-S1) will increase the number of I/O points per station.
SW	An abbreviation for the link special register. Word data that indicates the operating status and data link status of a module on CC-Link IE Field Network.

# 1 PRODUCT LINEUP

## Input module

Module name		Input specifications	Module power supply current	Weight	Model	Reference
DC input module	Negative common type	Spring clamp terminal block 24VDC, 32 points	230mA	0.45kg	NZ2GFSS2-32D-S1	Page 20 NZ2GFSS2-32D-S1 type main input module
		Spring clamp terminal block 24VDC, 8 points	150mA	0.25kg	NZ2GFSS2-8D-S1	Page 24 NZ2GFSS2-8D-S1 type main input module

## Output module

Module name		Output specifications	Module power supply current	Weight	Model	Reference
Transistor output module	Source type	Spring clamp terminal block 24VDC, 0.5A/1 point, 8 points	160mA	0.25kg	NZ2GFSS2-8TE-S1	Page 27 NZ2GFSS2-8TE-S1 type main output module

## I/O combined module

Module name		Input specifications	Output specifications	Module power supply current	Weight	Model	Reference
DC input, transistor output module	<ul style="list-style-type: none"> <li>Input part: Negative common type</li> <li>Output part: Source type</li> </ul>	Spring clamp terminal block 24VDC, 8 points	Spring clamp terminal block 24VDC, 0.5A/1 point, 8 points	160mA	0.25kg	NZ2GFSS2-16DTE-S1	Page 30 NZ2GFSS2-16DTE-S1 type main I/O combined module

For applicable products, refer to the following.

 Page 46 Applicable products

# MEMO

---



# 2 PART NAMES

This chapter describes the part names of the safety remote I/O module.

## Main module

### ■NZ2GFSS2-32D-S1

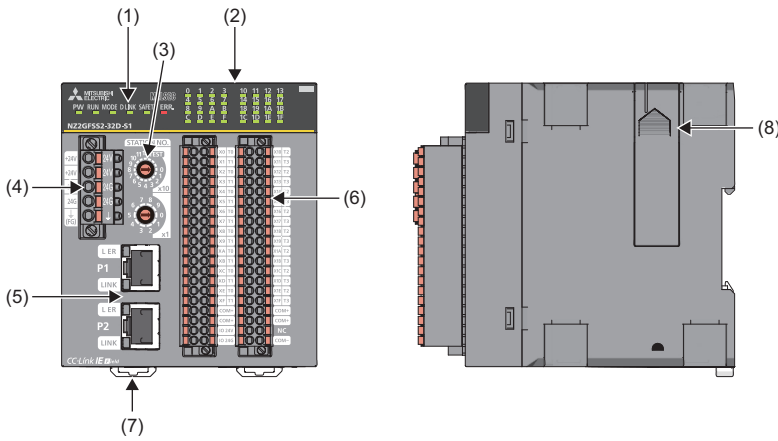

### ■NZ2GFSS2-8D-S1, NZ2GFSS2-8TE-S1, NZ2GFSS2-16DTE-S1

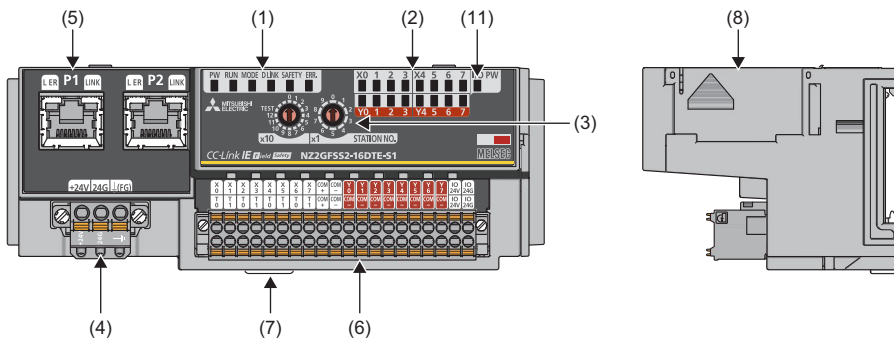

## Extension module

### ■NZ2EXSS2-8TE

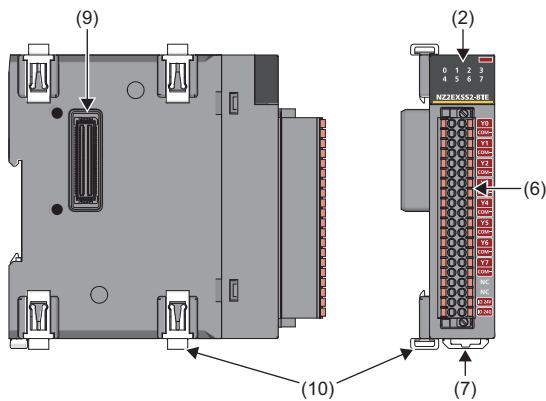

No.	Name	Description		
(1)	PW LED	Indicates the power supply status. On: Power supply ON Off: Power supply OFF		
	RUN LED	Indicates the operating status. On: Operating normally, in initial processing Off: A major error has occurred.		
	MODE LED	Indicates the mode status. On: In online mode, in initial processing Flashing: In unit test mode Off: The unit test is completed.		
	D LINK LED	Indicates the data link status. On: Data link (cyclic transmission being performed), in initial processing Flashing: Data link (cyclic transmission stopped) <sup>*1</sup> Off: Data link not in operation (disconnected)		
	SAFETY LED	Indicates the safety communication connection status. On: In safety communication connection, in initial processing Flashing: Checking the position of the setting target module Off: Safety communication being disconnected		
	ERR. LED	Indicates the error status. On: An error has occurred, in initial processing Flashing: A minor error has occurred. <sup>*2</sup> Off: Operating normally.		
(2)	I/O LED	NZ2GFSS2-32D-S1, NZ2EXSS2-8TE	I/O LED (X□)	Indicates the ON/OFF status of the inputs. On: Input ON <sup>*3</sup> Off: Input OFF
			I/O LED (Y□)	Indicates the ON/OFF status of the outputs. On: Output ON Off: Output OFF
	NZ2GFSS2-8D-S1, NZ2GFSS2-8TE-S1, NZ2GFSS2-16DTE-S1	When error points are not indicated	Indicates the ON/OFF status of I/O. On: ON status of input or output <sup>*3</sup> Off: OFF status of input or output	
		When error points are indicated	Flashes the error points. On: ON status of input or output Flashing: An error has occurred. <sup>*4</sup> Off: OFF status of input or output	
(3)	Station number setting switch	A rotary switch for the following setting and test. • Station number setting (☞ Page 48 Setting of Network Number and Station Number) • Unit test (☞ Page 126 Unit Test) When operating the station number setting switch, use a flathead screwdriver with 3.5mm or less width of the tip.		
(4)	Terminal block for module power supply and FG	A terminal block to connect the module power supply (24VDC) and FG.		

No.	Name	Description
(5)	Ethernet port (P1)	PORT1 connector for CC-Link IE Field Network (RJ45 connector) Connect an Ethernet cable. For the wiring method and wiring precautions, refer to the following. ☞ Page 60 Wiring of Ethernet cable
	L ER LED	Indicates the port status. On: Abnormal data was received or loopback is being performed. Off: Normal data was received and loopback is not performed.
	LINK LED	Indicates the link status. On: Link-up in progress Off: Link-down in progress
	Ethernet port (P2)	PORT2 connector for CC-Link IE Field Network (RJ45 connector) Connect an Ethernet cable. For the wiring method and wiring precautions, refer to the following. ☞ Page 60 Wiring of Ethernet cable
	L ER LED	(Same as the P1 connector)
	LINK LED	
(6)	I/O terminal block	A 2-piece screw spring clamp terminal block to wire the I/O power supply and safety remote I/O signals. For the pin layout, refer to the following. ☞ Page 20 Performance Specifications
(7)	DIN rail hook	A hook to mount a module on a DIN rail.
(8)	Extension connector cover	A cover to protect a connector for extension module connection.
(9)	Extension connector	A connector to mount an extension module to the main module.
(10)	Connecting hook	A fixing hook for connecting the main module and the extension module.
(11)	I/O PW	Indicates the status of the power supply from the external power supply.
		On: External power supply ON Off: External power supply OFF

- \*1 When cyclic transmission is stopped only for the master station, the safety remote I/O module maintains the cyclic transmission. Thus, the D LINK LED turns on.
- \*2 After a minor error has been eliminated, the LED flashes for 5 seconds or longer and turns off.
- \*3 In the safety operation mode, the status of actual input signals that are externally input is indicated on the LEDs regardless of the setting of the input response time setting function.  
For details on the safety operation mode, refer to the following.  
☞ Page 42 Operation mode and state transition
- \*4 When the LED is flashing, the minor state is applied to the module.  
For I/O LED indication setting at error occurrence, refer to the following.  
☞ Page 42 Operation mode and state transition

## Safety remote I/O module status and LED status

The following table lists the correspondence between the safety remote I/O module status and the LED status.

For the status of the safety remote I/O module, refer to the following.

☞ Page 42 Operation mode and state transition

For details on each error, refer to the following.

☞ Page 138 Error codes related to the safety remote I/O module

Safety remote I/O module status		Data link status	LED status					
			PW LED	RUN LED	MODE LED	D LINK LED	SAFETY LED	ERR. LED
Initial processing state <sup>*1</sup>		Disconnection	On	On	On	On	On	On
Initial processing state (wait for supply of module power supply voltage) <sup>*2</sup>		Disconnection	On	Off	Off	Off	Off	Flashing
Standby mode	Disconnected	Disconnection	On	On	On	Off	Off	Off
	Data link in operation	Data link in operation	On	On	On	On	Off	Off
	Reserved station setting in progress	Cyclic stop	On	On	On	Flashing	Off	Off
	Link stop	Cyclic stop	On	On	On	Flashing	Off	Off
	Checking the position of the setting target module	Data link in operation/cyclic stop	On	On	On	*6	Flashing	Off
Safety operation mode		Data link in operation	On	On	On	On	On	Off
Unit test mode	In progress	—	On	On	Flashing	Off	Off	Off
	Normal completion	—	On	On	Off	Off	Off	Off
	Abnormal completion	—	On	On	Off	Off	Off	On
Communication error		Cyclic stop	On	On	On	Flashing	Off	Off
Error	Major error	—	On	Off	*3	*4	*7	On <sup>*5</sup>
	Moderate error	—	On	On	*3	*4	*7	On
	Minor error	—	On	On	*3	*4	*4	Flashing

\*1 At the initial processing, the LEDs (PW LED, RUN LED, MODE LED, D LINK LED, SAFETY LED, ERR. LED, and I/O LED) turn on for a moment to check if the LEDs turn on.

\*2 When the module power supply voltage does not reach the allowable voltage range at the initial processing, the initial processing is suspended and the module enters the standby state until the module power supply voltage reaches the allowable voltage range.  
 · If this state continues for two minutes or longer, a hardware failure occurs and the module stops the operation. To recover the module, power off and on the module power supply.  
 · When the module power supply voltage reaches the allowable voltage range within two minutes after this state occurs, the initial processing is continued.

\*3 Either of On or Off.

\*4 Any of On, Flashing, or Off.

\*5 When the module is failed, the LED may not turn on.

\*6 Either of On or Flashing.

\*7 Either of Flashing or Off.

# 3 SPECIFICATIONS

This chapter describes the general specifications, performance specifications of each module, and function list.

## 3.1 General Specifications

Item	Specifications					
Operating ambient temperature	0 to 55°C					
Storage ambient temperature	-40 to 75°C					
Operating ambient humidity	5 to 95%RH, non-condensing					
Storage ambient humidity	5 to 95%RH, non-condensing					
Vibration resistance	Compliant with JIS B 3502 and IEC 61131-2	—	Frequency	Constant acceleration	Half amplitude	Number of sweeps
		Under intermittent vibration	5 to 8.4Hz	—	3.5mm	10 times each in X, Y, and Z directions
			8.4 to 150Hz	9.8m/s <sup>2</sup>	—	
		Under continuous vibration	5 to 8.4Hz	—	1.75mm	—
8.4 to 150Hz	4.9m/s <sup>2</sup>		—			
Shock resistance	Compliant with JIS B 3502 and IEC 61131-2 (147m/s <sup>2</sup> , Operation time: 11ms, 3 times each in X, Y, and Z directions with sine half-wave pulses)					
Operating atmosphere	No corrosive gases, flammable gases, less conductive dust					
Operating altitude <sup>*1</sup>	0 to 2000m <sup>*4</sup>					
Installation location	Inside a control panel					
Overvoltage category <sup>*2</sup>	II or less					
Pollution degree <sup>*3</sup>	2 or less					
Equipment class	Class III					

- \*1 Do not use or store the module under pressure higher than the atmospheric pressure of altitude 0m. Doing so may cause malfunction. When using the module under pressure, please consult your local Mitsubishi representative.
- \*2 This indicates the section of the power supply to which the equipment is assumed to be connected between the public electrical power distribution network and the machinery within premises. Category II applies to equipment for which electrical power is supplied from fixed facilities. The surge voltage withstand level for up to the rated voltage of 300V is 2500V.
- \*3 This index indicates the degree to which conductive material is generated in terms of the environment in which the equipment is used. Pollution degree 2 is when only non-conductive pollution occurs. A temporary conductivity caused by condensing must be expected occasionally.
- \*4 When the module is used at altitude above 2000m, the withstand voltage performance and the upper limit of the operating ambient temperature decrease. Please consult your local Mitsubishi representative.

## 3.2 Performance Specifications

### NZ2GFSS2-32D-S1 type main input module

Item		NZ2GFSS2-32D-S1
CC-Link IE station type		Remote device station
Number of input points		Single wiring: 32 points, double wiring: 16 points
Rated input voltage <sup>*2</sup>		24VDC (ripple ratio: 5% or less) (allowable voltage range: 20.4 to 28.8VDC)
Rated input current		6.0mA TYP. (24VDC)
Isolation method		Photocoupler isolation
Max. number of simultaneous input points		100% (horizontal installation), when any installation method other than the horizontal installation is performed, refer to the derating chart.
ON voltage/ON current		15VDC or higher/2mA or higher
OFF voltage/OFF current		5VDC or lower/0.5mA or lower
Input resistance		Approx. 2.0kΩ
Input circuit response time	OFF → ON	0.4ms or less (24VDC)
	ON → OFF	0.4ms or less (24VDC)
Safety remote station refresh response processing time		2.0ms
Input response time of safety remote station		Input circuit response time + Input response time (1ms, 5ms, 10ms, 20ms, 50ms)
External power supply for input part <sup>*2</sup>	Voltage	24VDC (ripple ratio: 5% or less) (allowable voltage range: 20.4 to 28.8VDC)
	Current	40mA
	Protection function	External power supply overvoltage protection function, external power supply overcurrent protection function
	Fuse	8A (user-unchangeable)
Power supply current for input device (COM+)		0.4A/1 terminal
Input type		Negative common
Withstand voltage		500VAC for 1 minute between all DC external terminals and the ground
Isolation resistance		10MΩ or higher between all DC external terminals and ground (500VDC isolation resistance tester)
Noise immunity		Noise voltage 500Vp-p, noise width 1μs, noise frequency 25 to 60Hz (DC type noise simulator condition)
Protection degree		IP2X
Wiring method for common		Input 32 points/common (2-piece spring clamp terminal block)
External interface	Communication part	RJ45 connector
	Module power supply part	Terminal block for module power supply and FG (2-piece spring clamp terminal block)
	Input part, external power supply part	40 points, 2-piece spring clamp terminal block (push-in)
Applicable DIN rail		TH35-7.5Fe, TH35-7.5A (compliant with JIS C 2812/IEC 60715)
Applicable wire size	Terminal block for module power supply and FG	Core: 0.5 to 2.0mm <sup>2</sup> (20 to 14 AWG), terminal hole size: 2.8mm × 2.0mm
	I/O terminal block	Core: 0.3 to 1.5mm <sup>2</sup> (22 to 16 AWG), terminal hole size: 2.4mm × 1.5mm
Applicable solderless terminal	Terminal block for module power supply and FG <sup>*1</sup>	☞ Page 59 List of bar solderless terminals
	I/O terminal block	☞ Page 65 List of bar solderless terminals
Cyclic transmission	RX/RX points	80 points
	RWr/RWw points	32 points
	SA\X\SA\Y points	64 points
Applicable safety protocol version		2 (fixed)
Communication cable		An Ethernet cable that meets the 1000BASE-T standard: Category 5e or higher (double shielded, STP), straight cable
Availability of connecting extension module		Connectable

Item		NZ2GFSS2-32D-S1
Module power supply <sup>*2</sup>	Voltage	24VDC (ripple ratio: 5% or less) (allowable voltage range: 20.4 to 28.8VDC)
	Current <sup>*3</sup>	230mA
	Protection function	Module power supply overvoltage protection function, module power supply overcurrent protection function
	Fuse	1.6A (user-unchangeable)
	Allowable momentary power failure time <sup>*4</sup>	Within 10ms
Weight		0.45kg

\*1 Only one wire can be connected to a terminal of the terminal block for module power supply and FG. Multiple wires cannot be connected to a terminal. Connecting two or more wires may cause a poor contact.

\*2 For the power supply to be connected to the main module or the power supply of the devices to be connected to the input part, use the product that meets the following conditions:

- SELV (Safety Extra Low Voltage)
- LVD (Low Voltage Directive)-compliant product
- LIM (Limited Energy Circuit) or UL 1310 Class 2 compliant
- Output voltage specifications: 24VDC (ripple ratio: 5% or less) (allowable voltage range: 20.4 to 28.8VDC)

\*3 When an extension module is connected, the current consumption of the extension module is added.

\*4 At a momentary power failure over 10ms, the module operates as any of the following.

- The operation remains.
- The input and output are turned off by the protection circuit, and the communication is disabled. To recover the module, power off and on the module power supply.
- The module is restarted and initialized. The operation is the same as when the module power supply is powered off and on.

In the case other than when the operation remains, the safety station interlock status is applied. Cancel the safety station interlock of the CPU module. For the safety station interlock, refer to the following.

📖 MELSEC iQ-R CPU Module User's Manual (Application)

### ■ Derating chart (except horizontal installation)

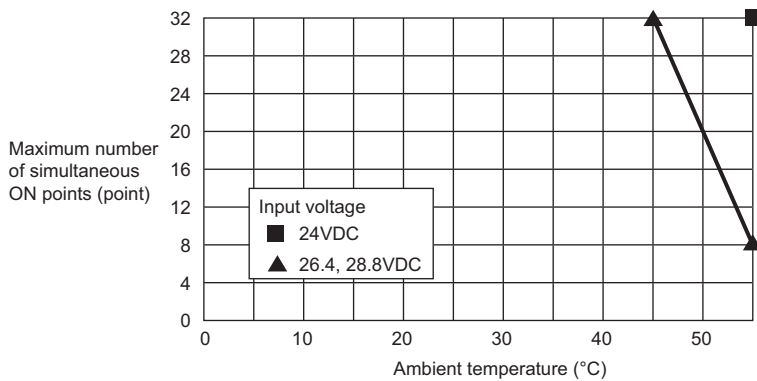

## External connection

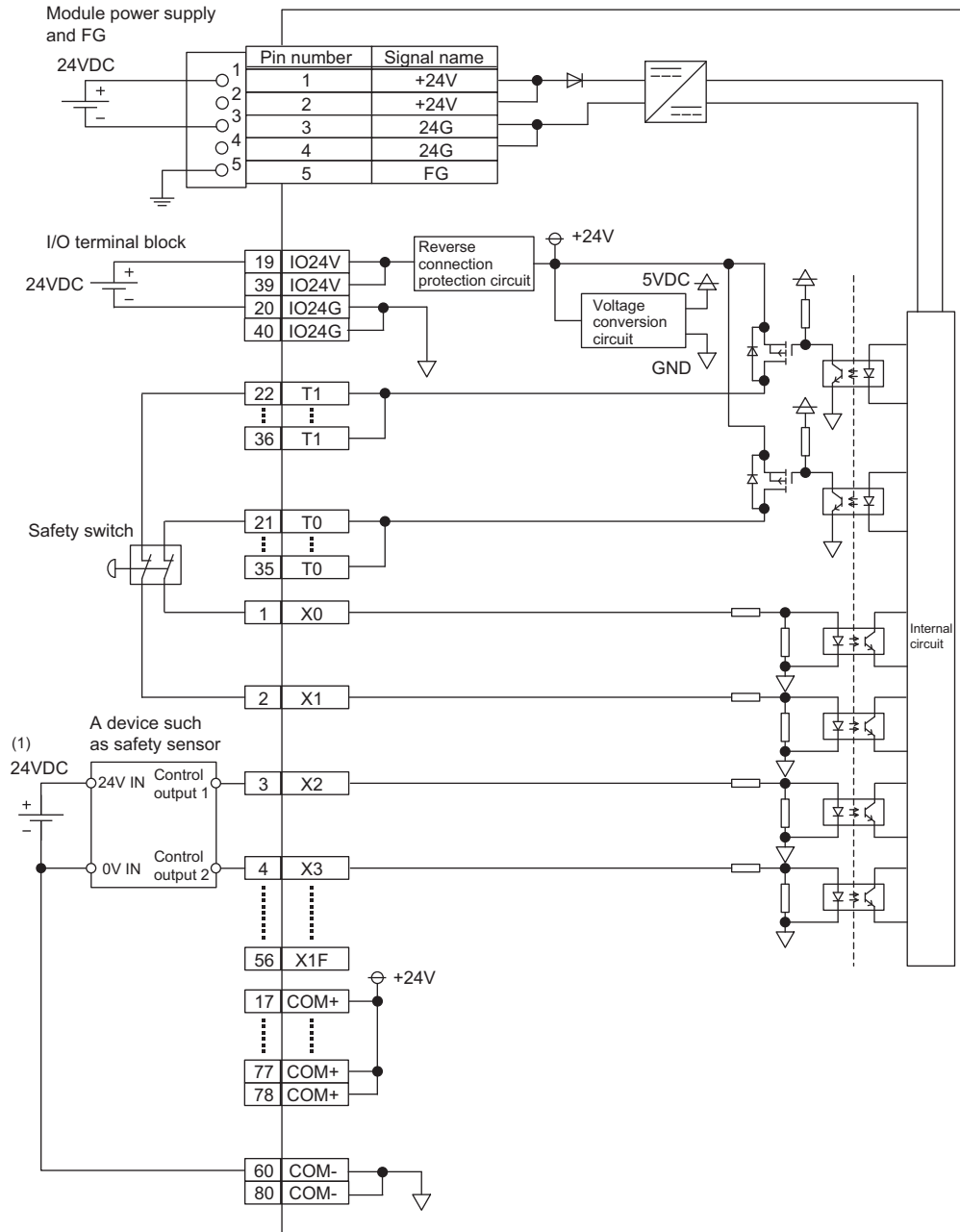

(1) The COM+ terminals can supply 24VDC as well.



## Terminal block and signal name

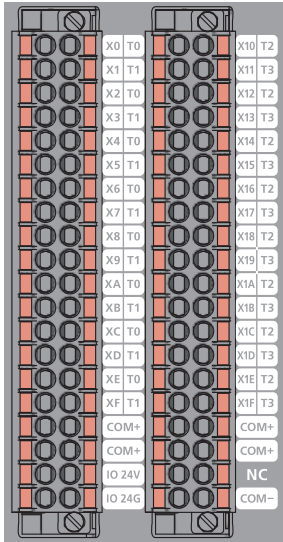

Pin number	Signal name	Pin number	Signal name	Pin number	Signal name	Pin number	Signal name
1	X0	21	T0	41	X10	61	T2
2	X1	22	T1	42	X11	62	T3
3	X2	23	T0	43	X12	63	T2
4	X3	24	T1	44	X13	64	T3
5	X4	25	T0	45	X14	65	T2
6	X5	26	T1	46	X15	66	T3
7	X6	27	T0	47	X16	67	T2
8	X7	28	T1	48	X17	68	T3
9	X8	29	T0	49	X18	69	T2
10	X9	30	T1	50	X19	70	T3
11	XA	31	T0	51	X1A	71	T2
12	XB	32	T1	52	X1B	72	T3
13	XC	33	T0	53	X1C	73	T2
14	XD	34	T1	54	X1D	74	T3
15	XE	35	T0	55	X1E	75	T2
16	XF	36	T1	56	X1F	76	T3
17	COM+	37	COM+	57	COM+	77	COM+
18	COM+	38	COM+	58	COM+	78	COM+
19	IO24V	39	IO24V	59	NC	79	NC
20	IO24G	40	IO24G	60	COM-	80	COM-

Among the terminals with the same signal name, you can choose any terminals since they are internally connected. In addition, NC is reserved. Do not use this terminal.

## NZ2GFSS2-8D-S1 type main input module

Item	NZ2GFSS2-8D-S1	
CC-Link IE station type	Remote device station	
Number of input points	Single wiring: 8 points, double wiring: 4 points	
Rated input voltage <sup>*2</sup>	24VDC (ripple ratio: 5% or less) (allowable voltage range: 20.4 to 28.8VDC)	
Rated input current	7.0mA TYP. (24VDC)	
Isolation method	Photocoupler isolation	
Max. number of simultaneous input points	100%	
ON voltage/ON current	12VDC or higher/3mA or higher	
OFF voltage/OFF current	5VDC or lower/1.3mA or lower	
Input resistance	Approx. 2.6kΩ	
Input circuit response time	OFF → ON	0.4ms or less (24VDC)
	ON → OFF	0.4ms or less (24VDC)
Safety remote station refresh response processing time	2.0ms	
Input response time of safety remote station	Input circuit response time + Input response time (1.0ms, 1.5ms, 5ms, 10ms, 20ms, 50ms, 70ms)	
External power supply for input part <sup>*2</sup>	Voltage	24VDC (ripple ratio: 5% or less) (allowable voltage range: 20.4 to 28.8VDC)
	Current	100mA
	Protection function	External power supply overvoltage protection function, external power supply overcurrent protection function
Power supply current for input device (COM+)	0.4A/1 terminal	
Input type	Negative common	
Withstand voltage	500VAC for 1 minute between all DC external terminals and the ground	
Isolation resistance	10MΩ or higher between all DC external terminals and ground (500VDC isolation resistance tester)	
Noise immunity	Noise voltage 500Vp-p, noise width 1μs, noise frequency 25 to 60Hz (DC type noise simulator condition)	
Protection degree	IP2X	
Wiring method for common	Input 8 points/common (2-piece spring clamp terminal block)	
External interface	Communication part	RJ45 connector
	Module power supply part	Terminal block for module power supply and FG (2-piece spring clamp terminal block)
	Input part, external power supply part	40 points, 2-piece spring clamp terminal block (push-in)
Applicable DIN rail	TH35-7.5Fe, TH35-7.5A (compliant with JIS C 2812/IEC 60715)	
Applicable wire size	Terminal block for module power supply and FG	Core: 0.3 to 1.5mm <sup>2</sup> (22 to 16 AWG)
	I/O terminal block	Core: 0.3 to 1.5mm <sup>2</sup> (22 to 16 AWG)
Applicable solderless terminal	Terminal block for module power supply and FG <sup>*1</sup>	☞ Page 59 List of bar solderless terminals
	I/O terminal block	☞ Page 65 List of bar solderless terminals
Cyclic transmission	RX/RY points	80 points
	RWr/RWw points	32 points
	SA\X/SA\Y points	32 points
Applicable safety protocol version	2 (fixed)	
Communication cable	An Ethernet cable that meets the 1000BASE-T standard: Category 5e or higher (double shielded, STP), straight cable	
Availability of connecting extension module	Connectable	
Module power supply <sup>*2,4</sup>	Voltage	24VDC (ripple ratio: 5% or less) (allowable voltage range: 20.4 to 28.8VDC)
	Current <sup>*3</sup>	150mA
	Protection function	Module power supply overvoltage protection function, module power supply overcurrent protection function
	Fuse	1.6A (user-unchangeable)
Safety element	Type B, HFT = 1, SC 3	
Weight	0.25kg	

- \*1 Only one wire can be connected to a terminal of the terminal block for module power supply and FG. Multiple wires cannot be connected to a terminal. Connecting two or more wires may cause a poor contact.
- \*2 For the power supply to be connected to the main module or the power supply of the devices to be connected to the input part, use the product that meets the following conditions:
  - SELV (Safety Extra Low Voltage)
  - LVD (Low Voltage Directive)-compliant product
  - LIM (Limited Energy Circuit) or UL 1310 Class 2 compliant
  - Output voltage specifications: 24VDC (ripple ratio: 5% or less) (allowable voltage range: 20.4 to 28.8VDC)
- \*3 When an extension module is connected, the current consumption of the extension module is added.
- \*4 To connect to the module, use a power supply whose output hold time is 10ms or longer.

**External connection**

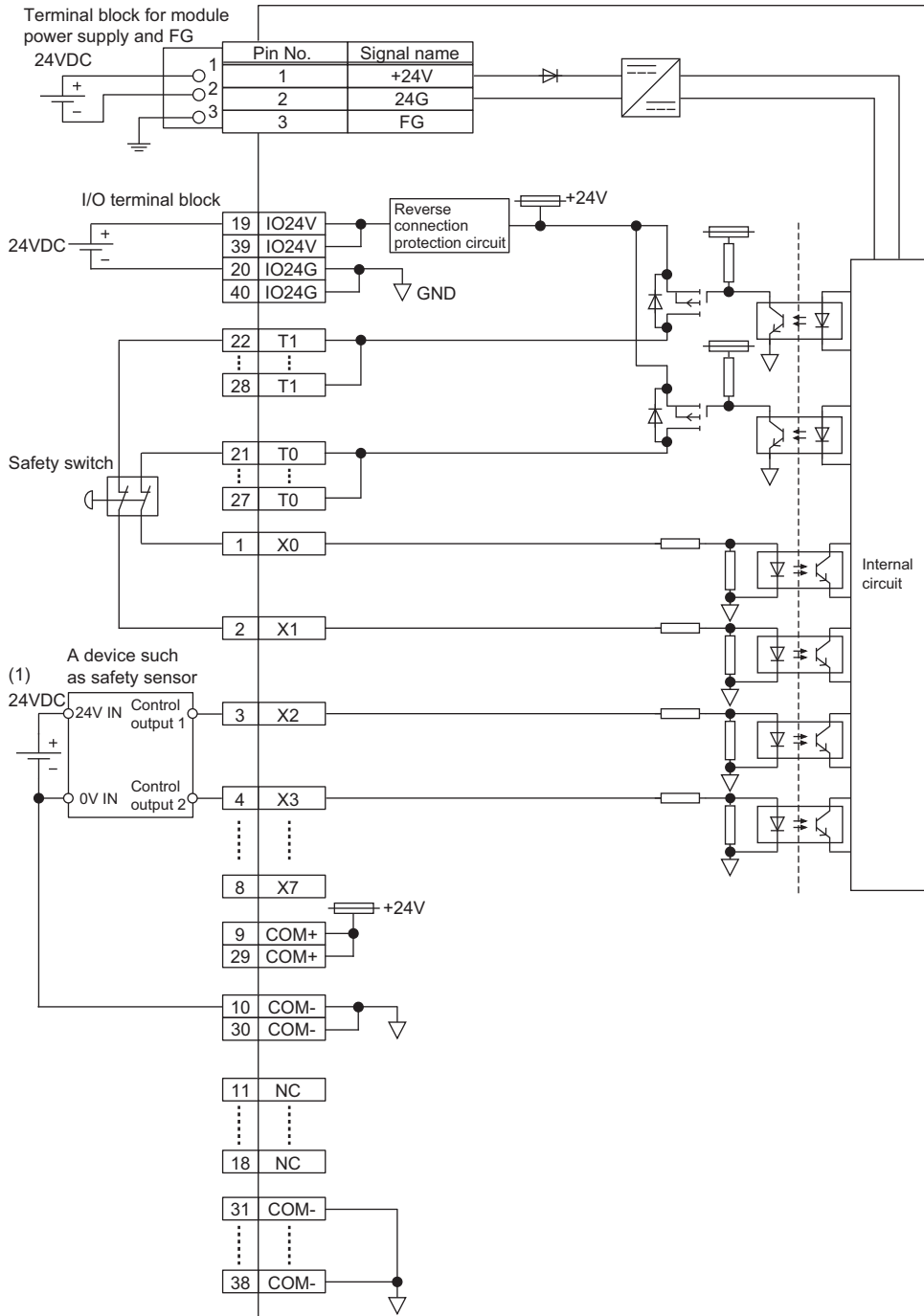

(1) The COM+ terminals can supply 24VDC as well.

## Terminal block and signal name

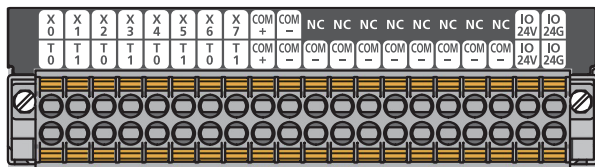

Pin number	Signal name	Pin number	Signal name
1	X0	21	T0
2	X1	22	T1
3	X2	23	T0
4	X3	24	T1
5	X4	25	T0
6	X5	26	T1
7	X6	27	T0
8	X7	28	T1
9	COM+	29	COM+
10	COM-	30	COM-
11	NC	31	COM-
12	NC	32	COM-
13	NC	33	COM-
14	NC	34	COM-
15	NC	35	COM-
16	NC	36	COM-
17	NC	37	COM-
18	NC	38	COM-
19	IO24V	39	IO24V
20	IO24G	40	IO24G

Among the terminals with the same signal name, you can choose any terminals since they are internally connected. In addition, NC is reserved. Do not use this terminal.

## NZ2GFSS2-8TE-S1 type main output module

Item		NZ2GFSS2-8TE-S1
CC-Link IE station type		Remote device station
Number of output points		Single wiring: 8 points, double wiring: 4 points
Rated load voltage		24VDC (ripple ratio: 5% or less) (allowable voltage range: 20.4 to 28.8VDC)
Maximum load current		0.5A/point
Isolation method		Photocoupler isolation
Max. inrush current		1.0A, 10ms or less
Leakage current at OFF <sup>5</sup>		0.1mA or lower
Maximum voltage drop at ON		0.5VDC (TYP.) 0.5A, 0.8VDC (MAX.) 0.5A
Output circuit response time	OFF → ON	0.4ms or less (24VDC)
	ON → OFF	0.4ms or less (24VDC)
Safety remote station refresh response processing time		2.0ms
Output response time of safety remote station		Output circuit response time
Surge suppressor		Zener diode
External power supply for output part <sup>2</sup>	Voltage	24VDC (ripple ratio: 5% or less) (allowable voltage range: 20.4 to 28.8VDC)
	Current	70mA
	Protection function	External power supply overvoltage protection function, external power supply overcurrent protection function
Output type		Source + Source type
Withstand voltage		500VAC for 1 minute between all DC external terminals and the ground
Isolation resistance		10MΩ or higher between all DC external terminals and ground (500VDC isolation resistance tester)
Noise immunity		Noise voltage 500Vp-p, noise width 1μs, noise frequency 25 to 60Hz (DC type noise simulator condition)
Protection degree		IP2X
Wiring method for common		Output 8 points/common (2-piece spring clamp terminal block)
Protection function		Output overload protection function
External interface	Communication part	RJ45 connector
	Module power supply part	Terminal block for module power supply and FG (2-piece spring clamp terminal block)
	Output part, external power supply part	40 points, 2-piece spring clamp terminal block (push-in)
Applicable DIN rail		TH35-7.5Fe, TH35-7.5A (compliant with JIS C 2812/IEC 60715)
Applicable wire size	Terminal block for module power supply and FG	Core: 0.3 to 1.5mm <sup>2</sup> (22 to 16 AWG)
	I/O terminal block	Core: 0.3 to 1.5mm <sup>2</sup> (22 to 16 AWG)
Applicable solderless terminal	Terminal block for module power supply and FG <sup>1</sup>	☞ Page 59 List of bar solderless terminals
	I/O terminal block	☞ Page 65 List of bar solderless terminals
Cyclic transmission	RX/RV points	80 points
	RWr/RVw points	32 points
	SAX/SAY points	32 points
Applicable safety protocol version		2 (fixed)
Communication cable		An Ethernet cable that meets the 1000BASE-T standard: Category 5e or higher (double shielded, STP), straight cable
Availability of connecting extension module		Connectable
Module power supply <sup>2,4</sup>	Voltage	24VDC (ripple ratio: 5% or less) (allowable voltage range: 20.4 to 28.8VDC)
	Current <sup>3</sup>	160mA
	Protection function	Module power supply overvoltage protection function, module power supply overcurrent protection function
	Fuse	1.6A (user-unchangeable)
Safety element		Type B, HFT = 1, SC 3
Weight		0.25kg

- \*1 Only one wire can be connected to a terminal of the terminal block for module power supply and FG. Multiple wires cannot be connected to a terminal. Connecting two or more wires may cause a poor contact.
- \*2 To connect to the main module, use the power supply that meets the following conditions:
  - SELV (Safety Extra Low Voltage)
  - LVD (Low Voltage Directive)-compliant product
  - LIM (Limited Energy Circuit) or UL 1310 Class 2 compliant
  - Output voltage specifications: 24VDC (ripple ratio: 5% or less) (allowable voltage range: 20.4 to 28.8VDC)
- \*3 When an extension module is connected, the current consumption of the extension module is added.
- \*4 To connect to the module, use a power supply whose output hold time is 10ms or longer.
- \*5 The voltage at OFF is calculated as follows: resistance value of the connected load  $\times$  leakage current at off.

## External connection

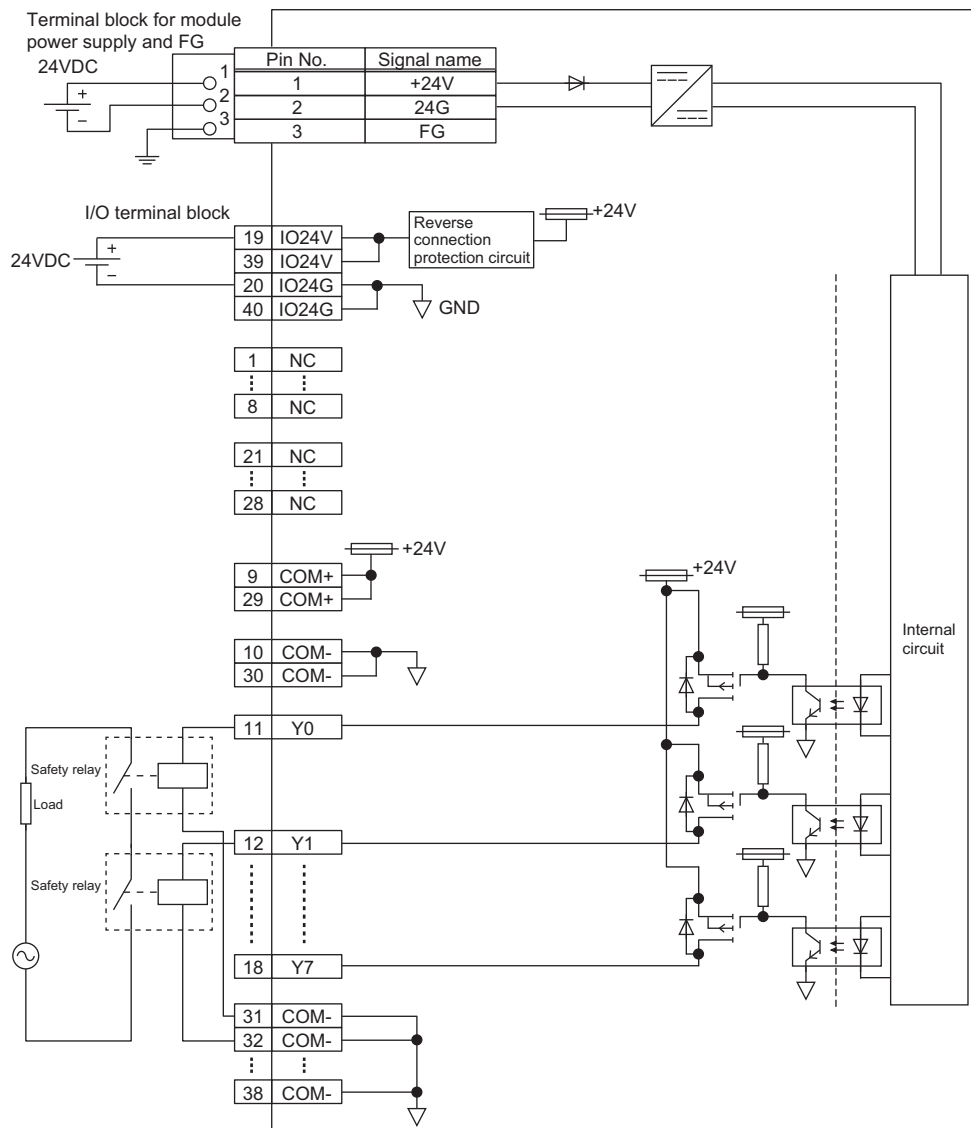

## Terminal block and signal name

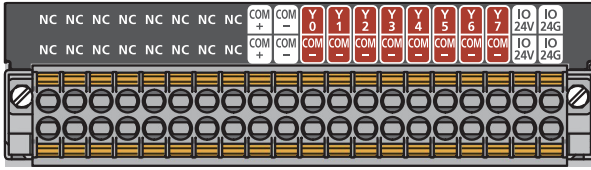

Pin number	Signal name	Pin number	Signal name
1	NC	21	NC
2	NC	22	NC
3	NC	23	NC
4	NC	24	NC
5	NC	25	NC
6	NC	26	NC
7	NC	27	NC
8	NC	28	NC
9	COM+	29	COM+
10	COM-	30	COM-
11	Y0	31	COM-
12	Y1	32	COM-
13	Y2	33	COM-
14	Y3	34	COM-
15	Y4	35	COM-
16	Y5	36	COM-
17	Y6	37	COM-
18	Y7	38	COM-
19	IO24V	39	IO24V
20	IO24G	40	IO24G

Among the terminals with the same signal name, you can choose any terminals since they are internally connected. In addition, NC is reserved. Do not use this terminal.

## NZ2GFSS2-16DTE-S1 type main I/O combined module

Item		NZ2GFSS2-16DTE-S1
CC-Link IE station type		Remote device station
Number of input points		Single wiring: 8 points, double wiring: 4 points
Rated input voltage <sup>*2</sup>		24VDC (ripple ratio: 5% or less) (allowable voltage range: 20.4 to 28.8VDC)
Rated input current		7.0mA TYP. (24VDC)
Isolation method		Photocoupler isolation
Max. number of simultaneous input points		100%
ON voltage/ON current		12VDC or higher/3mA or higher
OFF voltage/OFF current		5VDC or lower/1.3mA or lower
Input resistance		Approx. 2.6kΩ
Input circuit response time	OFF → ON	0.4ms or less (24VDC)
	ON → OFF	0.4ms or less (24VDC)
Safety remote station refresh response processing time		2.0ms
Input response time of safety remote station		Input circuit response time + Input response time (1.0ms, 1.5ms, 5ms, 10ms, 20ms, 50ms, 70ms)
External power supply for I/O part <sup>*2</sup>	Voltage	24VDC (ripple ratio: 5% or less) (allowable voltage range: 20.4 to 28.8VDC)
	Current	150mA
	Protection function	External power supply overvoltage protection function, external power supply overcurrent protection function
Power supply current for input device (COM+)		0.4A/1 terminal
Input type		Negative common
Withstand voltage		500VAC for 1 minute between all DC external terminals and the ground
Isolation resistance		10MΩ or higher between all DC external terminals and ground (500VDC isolation resistance tester)
Noise immunity		Noise voltage 500Vp-p, noise width 1μs, noise frequency 25 to 60Hz (DC type noise simulator condition)
Protection degree		IP2X
Wiring method for common		Input 8 points/common (spring clamp terminal block)
Number of output points		Single wiring: 8 points, double wiring: 4 points
Rated load voltage		24VDC (ripple ratio: 5% or less) (allowable voltage range: 20.4 to 28.8VDC)
Maximum load current		0.5A/point
Isolation method		Photocoupler isolation
Max. inrush current		1.0A, 10ms or less
Leakage current at OFF <sup>*5</sup>		0.1mA or lower
Maximum voltage drop at ON		0.5VDC (TYP.) 0.5A, 0.8VDC (MAX.) 0.5A
Output circuit response time	OFF → ON	0.4ms or less (24VDC)
	ON → OFF	0.4ms or less (24VDC)
Output response time of safety remote station		Output circuit response time
Surge suppressor		Zener diode
Output type		Source + Source type
Wiring method for common		Output 8 points/common (spring clamp terminal block)
Protection function		Output overload protection function
External interface	Communication part	RJ45 connector
	Module power supply part	Terminal block for module power supply and FG (2-piece spring clamp terminal block)
	I/O part, external power supply part	40 points, 2-piece spring clamp terminal block (push-in)
Applicable DIN rail		TH35-7.5Fe, TH35-7.5Al (compliant with IEC 60715)
Applicable wire size	Terminal block for module power supply and FG	Core: 0.3 to 1.5mm <sup>2</sup> (22 to 16 AWG)
	I/O terminal block	Core: 0.3 to 1.5mm <sup>2</sup> (22 to 16 AWG)
Applicable solderless terminal	Terminal block for module power supply and FG <sup>*1</sup>	☞ Page 59 List of bar solderless terminals
	I/O terminal block	☞ Page 65 List of bar solderless terminals



Item		NZ2GFSS2-16DTE-S1
Cyclic transmission	RX/R <sub>Y</sub> points	80 points
	RW <sub>r</sub> /RW <sub>w</sub> points	32 points
	SA\X/SA\Y points	32 points
Applicable safety protocol version		2 (fixed)
Communication cable		An Ethernet cable that meets the 1000BASE-T standard: Category 5e or higher (double shielded, STP), straight cable
Availability of connecting extension module		Connectable
Module power supply <sup>*2*4</sup>	Voltage	24VDC (ripple ratio: 5% or less) (allowable voltage range: 20.4 to 28.8VDC)
	Current <sup>*3</sup>	160mA
	Protection function	Module power supply overvoltage protection function, module power supply overcurrent protection function
	Fuse	1.6A (user-unchangeable)
Safety element		Type B, HFT = 1, SC 3
Weight		0.25kg

\*1 Only one wire can be connected to a terminal of the terminal block for module power supply and FG. Multiple wires cannot be connected to a terminal. Connecting two or more wires may cause a poor contact.

\*2 For the power supply to be connected to the main module or the power supply of the devices to be connected to the input part, use the product that meets the following conditions:

- SELV (Safety Extra Low Voltage)
- LVD (Low Voltage Directive)-compliant product
- LIM (Limited Energy Circuit) or UL 1310 Class 2 compliant
- Output voltage specifications: 24VDC (ripple ratio: 5% or less) (allowable voltage range: 20.4 to 28.8VDC)

\*3 When an extension module is connected, the current consumption of the extension module is added.

\*4 To connect to the module, use a power supply whose output hold time is 10ms or longer.

\*5 The voltage at OFF is calculated as follows: resistance value of the connected load × leakage current at off.

## External connection

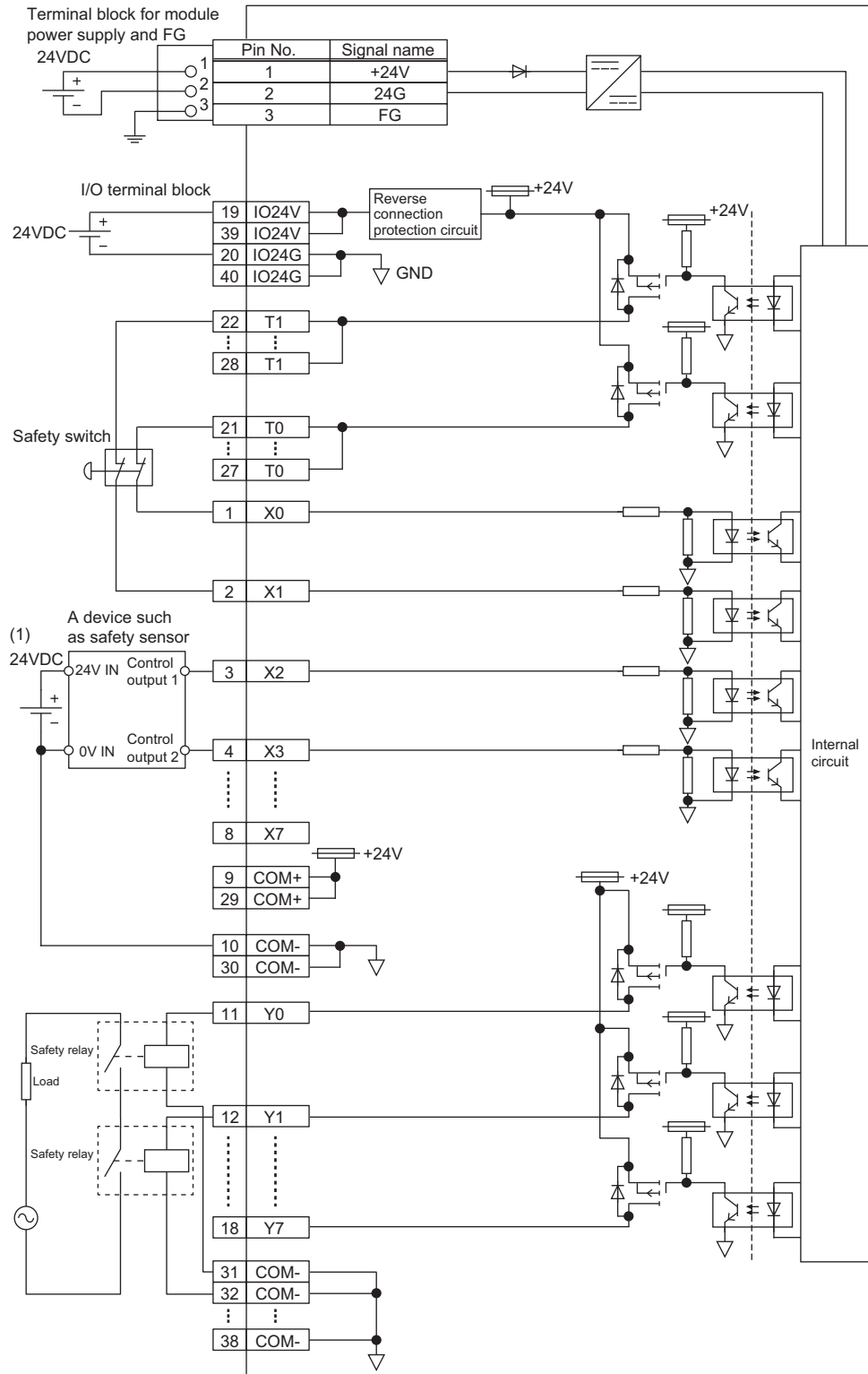

(1) The COM+ terminals can supply 24VDC as well.

## Terminal block and signal name

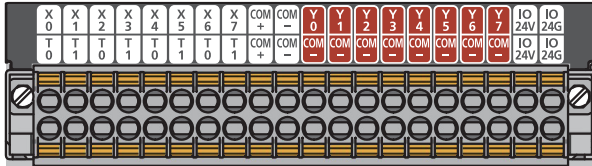

Pin number	Signal name	Pin number	Signal name
1	X0	21	T0
2	X1	22	T1
3	X2	23	T0
4	X3	24	T1
5	X4	25	T0
6	X5	26	T1
7	X6	27	T0
8	X7	28	T1
9	COM+	29	COM+
10	COM-	30	COM-
11	Y0	31	COM-
12	Y1	32	COM-
13	Y2	33	COM-
14	Y3	34	COM-
15	Y4	35	COM-
16	Y5	36	COM-
17	Y6	37	COM-
18	Y7	38	COM-
19	IO24V	39	IO24V
20	IO24G	40	IO24G

Among the terminals with the same signal name, you can choose any terminals since they are internally connected. In addition, NC is reserved. Do not use this terminal.

## NZ2EXSS2-8TE type extension output module

Item		NZ2EXSS2-8TE
Number of output points		Single wiring: 8 points, double wiring: 4 points
Rated load voltage		24VDC (ripple ratio: 5% or less) (allowable voltage range: 20.4 to 28.8VDC)
Maximum load current		0.5A/point 4A/common (horizontal installation), when any installation method other than the horizontal installation is performed, refer to the derating chart.
Isolation method		Photocoupler isolation
Max. inrush current		1.0A, 10ms or less
Leakage current at OFF*2		0.5mA or lower
Maximum voltage drop at ON		1.0VDC or lower
Output circuit response time	OFF → ON	0.4ms or less (24VDC)
	ON → OFF	0.4ms or less (24VDC)
Safety remote station refresh response processing time		2.0ms
Output response time of safety remote station		Output circuit response time
Surge suppressor		Zener diode
External power supply for output part*1	Voltage	24VDC (ripple ratio: 5% or less) (allowable voltage range: 20.4 to 28.8VDC)
	Current	120mA
	Protection function	External power supply overvoltage protection function, external power supply overcurrent protection function
	Fuse	8A (user-unchangeable)
Output type		Source + Source type
Withstand voltage		500VAC for 1 minute between all DC external terminals and the ground
Isolation resistance		10MΩ or higher between all DC external terminals and ground (500VDC isolation resistance tester)
Noise immunity		Noise voltage 500Vp-p, noise width 1μs, noise frequency 25 to 60Hz (DC type noise simulator condition)
Protection degree		IP2X
Wiring method for common		Output 8 points/common (spring clamp terminal block)
Common current		Max. 4A
Protection function		Output overload protection function
External interface	Output part, external power supply part	40 points, 2-piece spring clamp terminal block (push-in)
Applicable DIN rail		TH35-7.5Fe, TH35-7.5Al (compliant with IEC 60715)
Applicable wire size	I/O terminal block	Core: 0.3 to 1.5mm <sup>2</sup> (22 to 16 AWG), terminal hole size: 2.4mm × 1.5mm
Applicable solderless terminal	I/O terminal block	 Page 65 List of bar solderless terminals
Cyclic transmission	RX/RV points	0 point (Use the points secured by the main module)
	SAIX/SAIY points	0 point (Use the points secured by the main module)
Module power supply*1 (supplied from the main module)	Voltage	24VDC (ripple ratio: 5% or less) (allowable voltage range: 20.4 to 28.8VDC)
	Current	20mA
Weight		0.16kg

\*1 To connect to the extension module, use the power supply that meets the following conditions:

- SELV (Safety Extra Low Voltage)
- LVD-compliant product
- Output voltage specifications: 24VDC (ripple ratio: 5% or less) (allowable voltage range: 20.4 to 28.8VDC)

\*2 The voltage at OFF is calculated as follows: resistance value of the connected load × leakage current at off.

Derating chart (except horizontal installation)

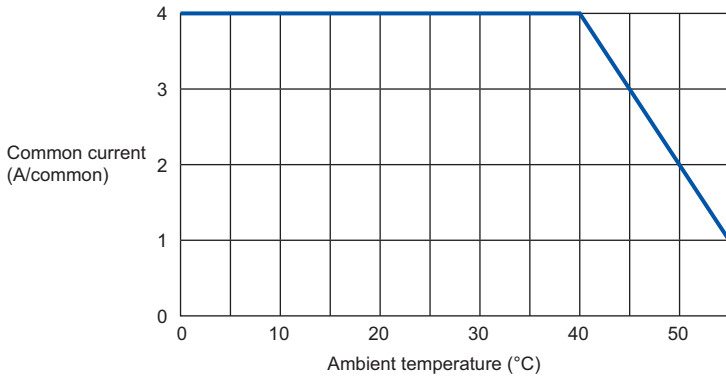

External connection

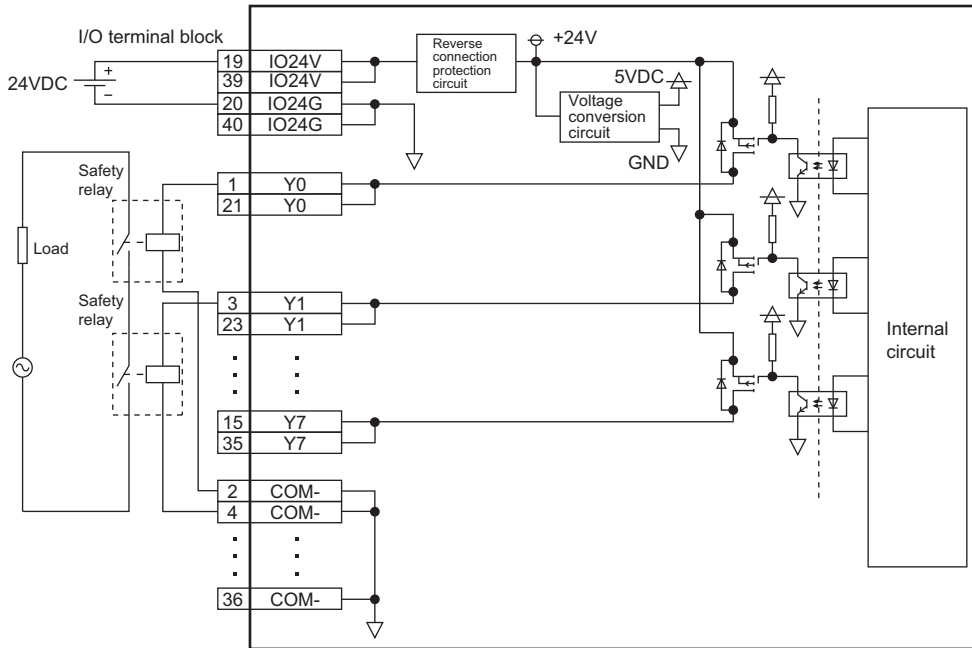

## ■ Terminal block and signal name

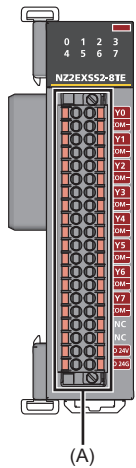

(A) I/O terminal block			
Pin number	Signal name	Pin number	Signal name
1	Y0	21	Y0
2	COM-	22	COM-
3	Y1	23	Y1
4	COM-	24	COM-
5	Y2	25	Y2
6	COM-	26	COM-
7	Y3	27	Y3
8	COM-	28	COM-
9	Y4	29	Y4
10	COM-	30	COM-
11	Y5	31	Y5
12	COM-	32	COM-
13	Y6	33	Y6
14	COM-	34	COM-
15	Y7	35	Y7
16	COM-	36	COM-
17	NC	37	NC
18	NC	38	NC
19	IO24V	39	IO24V
20	IO24G	40	IO24G

Among the terminals with the same signal name, you can choose any terminals since they are internally connected. In addition, NC is reserved. Do not use this terminal.

## Safety remote I/O module safety response time

The safety response time of the safety remote I/O module is shown below.

For the response time including the network delay time, refer to the following.

 Mitsubishi Electric Safety Programmable Controller MELSEC iQ-R Series Machinery Directive (2006/42/EC) Compliance

### ■Input

Transmission interval monitoring time  $\times 2$  + Safety remote station input response time

### ■Output

Transmission interval monitoring time  $\times 2$  + Safety remote station output response time

## Transmission interval monitoring time

The transmission interval monitoring time is the time that the receiving station monitors in safety communications to detect the following safety communication errors.

- Transmission interval delay of safety data due to an error in the sending station
- Loss of safety data in the transmission path due to influence such as noise

Configure the monitoring time in the module parameter setting on a module-by-module basis. For details on the module parameter setting, refer to the following.

 Page 72 Parameter Settings

### Point

Set a value that meets all the following calculation formulas for the transmission interval monitoring time.

- $TM \geq SRref \times 2$
- $TM \geq SCmst \times 2 + LS \times 2$

SRref: Safety remote station refresh response processing time (2.0ms)

TM: Transmission interval monitoring time

SCmst: Safety cycle time of the master station<sup>\*1</sup>

LS: Link scan time<sup>\*2</sup>

<sup>\*1</sup> For details on the safety cycle time, refer to the following.

 MELSEC iQ-R CPU Module User's Manual (Application)

<sup>\*2</sup> For the link scan time, refer to the following.

 MELSEC iQ-R CC-Link IE Field Network User's Manual (Application)

## Calculating current consumption

To supply power to multiple modules with the transition wiring, configure the system so that the current consumption does not exceed the maximum rated current. The following shows how to calculate the current consumption using the system configuration shown below as an example.

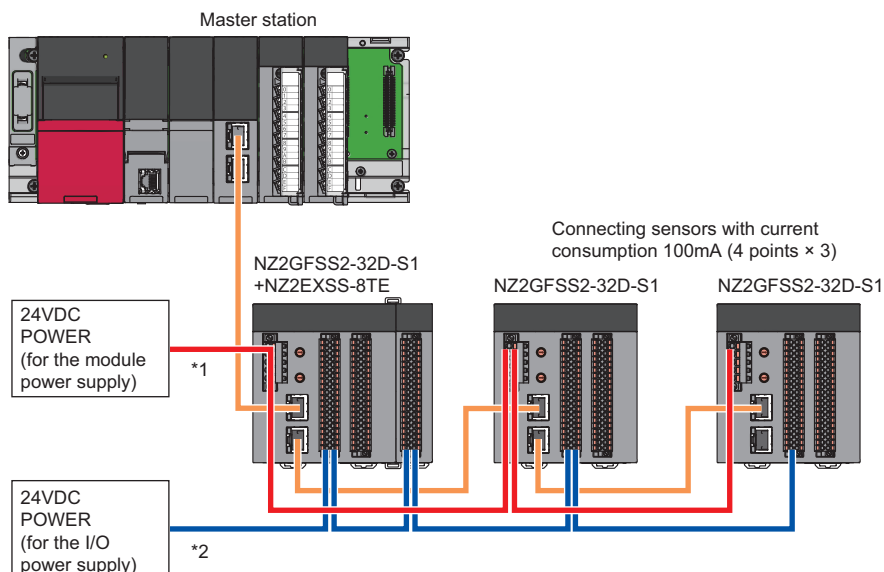

- \*1 The current flowing from the power supply for the module power supply to the cable connected to the safety remote I/O module shall be 8A or lower.
- \*2 The current flowing from the power supply for the I/O power supply to the cable connected to the NZ2GFSS2-32D-S1 or NZ2EXSS2-8TE shall be the ones described in the table below, depending on the size of wire used.

Size of the wire used	Current
0.5mm <sup>2</sup>	4.5A or lower
0.75mm <sup>2</sup>	5.0A or lower
1.0mm <sup>2</sup>	6.5A or lower
1.5mm <sup>2</sup>	7.75A or lower

### ■ Current consumption in the system

The following table lists each current consumption in the above system.

Module name	Module power supply current	External power supply current (main input)					External power supply current (extension output)		
		Input		Current for internal circuit	External device (sensor)		Current for internal circuit	External connection load	
		Current	Points		Current consumption	No. of connection points		Load current	No. of connection points
NZ2GFSS2-32D-S1 + NZ2EXSS2-8TE	230mA + 20mA	6mA	32	40mA	100mA	4	120mA	100mA	8
NZ2GFSS2-32D-S1	230mA	6mA	32	40mA	100mA	4	—	—	—
NZ2GFSS2-32D-S1	230mA	6mA	32	40mA	100mA	4	—	—	—

### ■ Maximum rated current of the system

- Maximum rated current to the terminal block for module power supply and FG: 8A
- Maximum rated current of the I/O power supply current: 4.5A (to the NZ2GFSS2-32D-S1 or the NZ2EXSS2-8TE, for the wire of 0.5mm<sup>2</sup>)



### ■Calculating the current consumption of each power supply port

Use each current consumption in the system and the current value of the maximum rated current in the system for the calculation and check that the current consumption does not exceed the maximum rated current.

- Module power supply current
  - = (Sum of the module power supply current values of the NZ2GFSS2-32D-S1)
  - =  $230\text{mA} \times 3 \text{ modules} + 20\text{mA} \times 1 \text{ module} = 710\text{mA} < 8\text{A}$  (maximum rated current to the terminal block for module power supply and FG (2-piece spring clamp terminal block))
- I/O power supply current
  - = (total of the input currents of the NZ2GFSS2-32D-S1) + (total of the currents for the internal circuits of the input part) + (total of the current consumption of external devices) + (total of the currents for the internal circuits of the output part) + (total of the load currents for the external connection of the output part)
  - =  $6\text{mA} \times 32 \text{ points} \times 3 \text{ modules} + 40\text{mA} \times 3 \text{ modules} + 100\text{mA} \times 4 \text{ points} \times 3 \text{ modules} + 120\text{mA} + 100\text{mA} \times 8 \text{ points}$
  - =  $2.816\text{A} < 4.5\text{A}$  (maximum rated current of the I/O power supply current)

### ■Calculation result

This system can be used because each of the module power supply current and the I/O power supply current does not exceed each maximum rated current.

## 3.3 Function List

This section describes the function list, operation modes, and state transition.

### Function list

○: Available, —: Not available

Item	Description	Availability				Reference
		NZ2GFSS2-32D-S1	NZ2GFSS2-8D-S1	NZ2GFSS2-8TE-S1	NZ2GFSS2-16DTE-S1	
Safety input wiring selection function	Selects double wiring or single wiring of the input wiring.	○	○	—	○	Page 85 Safety input wiring selection function
Safety input response time setting function	Reduces incorrect inputs caused by noise of input signals. Set the time taken from when an external input turns on/off until when the input signal is detected in the module.	○	○	—	○	Page 88 Safety input response time setting function
Safety output wiring selection function	Selects double wiring or single wiring of the output wiring.	—	—	○	○	Page 89 Safety output wiring selection function
Number of safety output ON times integration function	Counts the total number of ON times of each output point.	—	—	○	○	Page 92 Number of safety output ON times integration function
Double input discrepancy detection function	Discriminates failures by monitoring the discrepancy state of doubled safety remote inputs (SA\X).	○	○	—	○	Page 93 Double input discrepancy detection function
Input dark test function	Outputs test pulses to turn off the external input signals (X0 to X1F) that are on and diagnoses contacts including external devices for failure.	○	○	—	○	Page 101 Input dark test function
Internal input dark test function	Outputs test pulses to the input circuit of the safety remote I/O module to detect a circuit-fixing failure. The test pulses turn off the external input signals (X0 to X1F) that are on to detect the failure.	○	○	—	○	Page 104 Internal input dark test function
Output dark test function	Outputs test pulses to turn off the external output signals (Y0 to Y7) that are on and diagnoses the internal circuit for failure.	—	—	○	○	Page 105 Output dark test function
Output read-back function	Reads back output results and diagnoses whether the external output signals (Y0 to Y7) are correctly output.	—	—	○	○	Page 107 Output read-back function
Protection function	Prevents effects due to overvoltage and overcurrent from spreading to other modules of the safety system.	○	○	○	○	Page 108 Protection Functions
User authentication function	Limits the users who can access the CPU module or safety remote I/O module.	○	○	○	○	Page 109 User Authentication Function
Operation setting function at detection of external power supply voltage error	Users can select whether to continue safety communication or stop it when an external power supply voltage error occurs.	○	○	○	○	Page 110 Operation Setting Function at Detection of External Power Supply Voltage Error
Functions available when extension modules are connected	The functions of the safety extension module or the standard extension module are available when the extension module is connected.	○ <sup>*1</sup>	○ <sup>*2</sup>	○ <sup>*2</sup>	○ <sup>*2</sup>	Page 117 Functions Available When Extension Modules Are Connected

\*1 The functions are available when the safety extension module (NZ2EXSS2-8TE) is connected.

\*2 The functions are available when the standard extension module is connected.

**Point** 

---

The safety remote I/O module does not support the CC-Link IE Field Network synchronous communication function.

---

## Operation mode and state transition

The following describes the state transition and transition conditions of the safety remote I/O module.

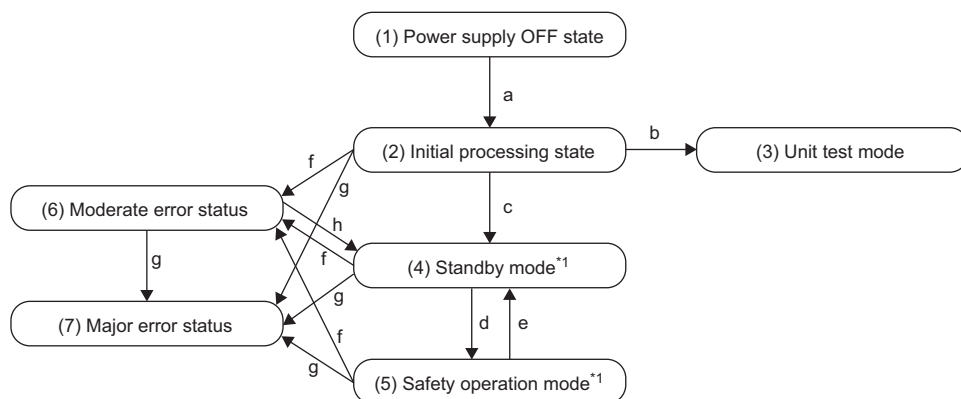

\*1 When a moderate error or major error has occurred, the state is changed into an error state.

### Operation mode/state

No.	Mode/state	Description
(1)	Power supply OFF state	The power supply is not turned on. Change the station number using the station number setting switch or wire the module at this state. ☞ Page 48 INSTALLATION AND WIRING
(2)	Initial processing state	The initial processing is performed at this state. When the mode is changed to this mode, the LEDs (PW LED, RUN LED, MODE LED, D LINK LED, SAFETY LED, ERR. LED, and I/O LED) turn on for a moment.
(3)	Unit test mode	The unit test is performed at this state. ☞ Page 126 Unit Test
(4)	Standby mode	The safety functions of the safety remote I/O module do not operate at this state. Set parameters in this mode. ☞ Page 68 VARIOUS SETTINGS
(5)	Safety operation mode	The safety functions of the safety remote I/O module operate at this state.
(6)	Moderate error state	A moderate error has occurred.
(7)	Major error state	A major error has occurred.

### Transition condition

Symbol	Transition condition
a	When the module is powered on
b	When the station number setting switch × 10 is set to TEST and the station number setting switch × 1 is set to 0 in the power supply OFF state
c	When the initial processing is completed successfully
d	When Safety module enabled flag (address: 1005H) is on and the safety communication with the master station is established For Safety module enabled flag (address: 1005H), refer to the following. ☞ Page 194 Safety module enabled flag
e	When the safety communication is disconnected
f	When a moderate error has occurred
g	When a major error has occurred
h	When a parameter data error is eliminated. For parameter data errors, refer to the following. ☞ Page 138 List of Error Codes

#### Point

To switch the operation mode/state from the unit test mode, moderate error state, or major error state, power off and on the module.

# 4 PROCEDURES BEFORE OPERATION

## 4.1 Procedures Before Operation

### Consideration of system configuration

Complete the following items prior to the module installation.

1. Determine a safety category required for configuring the safety system.
2. Determine function wiring required for configuring the safety system.
3. Determine the network number and station number of the safety remote I/O module.

### Module installation, wiring, and parameter setting

#### 1. Mounting the module

Mount the safety remote I/O module on the panel surface or a DIN rail. When using an extension module, connect the extension module to the safety remote I/O module and mount the safety remote I/O module on the DIN rail.

☞ Page 51 Connecting extension modules

☞ Page 54 Mounting the module on a DIN rail

#### 2. Wiring to the power supply module

Connect the safety remote I/O module to the module power supply and the external power supply.

☞ Page 57 Wiring of terminal block for module power supply and FG

☞ Page 63 Wiring of terminal block for the external power supply and I/O signals

#### 3. Unit test

Wire the module, set the unit test in the station number switch setting, and perform the unit test of the safety remote I/O module.

☞ Page 126 Unit Test

#### 4. Station number setting

Set station numbers of the safety remote I/O module using the station number setting switch.

☞ Page 48 Station number setting with the station number setting switch

#### 5. Wiring

Connect the Ethernet cable and external devices to the safety remote I/O module.

☞ Page 60 Wiring of Ethernet cable

☞ Page 63 Wiring of terminal block for the external power supply and I/O signals

#### 6. Powering on the safety remote I/O module

Stop the CPU module and turn on the module power supply and the external power supply of the safety remote I/O module.

#### 7. Parameter setting

Set the module parameters of the master module and the safety remote I/O module in the engineering tool.

☞ Page 68 VARIOUS SETTINGS

#### 8. Checking the entire system

According to the manuals of the CPU module and the master module, check the entire system for wiring, the station number switch setting, and others.

#### 9. Safety remote I/O module validation

Enable the module parameters of the safety remote I/O module.

☞ Page 78 Parameter Settings

#### 10. Starting the system

Change the status of the CPU module to RUN.

#### 11. Starting the system operation

## 4.2 Module Replacement Procedure

### Preparation for module replacement

Complete the following items prior to the module replacement.

**1.** Checking operations of a new module

Perform the unit test of the new safety remote I/O module.

☞ Page 126 Unit Test

**2.** Setting station numbers of the new module

Set station numbers of the new safety remote I/O module.

☞ Page 48 Station number setting with the station number setting switch

### Module replacement procedure

**1.** Powering off the safety remote I/O module

Turn off the module power supply and the external power supply of the safety remote I/O module to be replaced.

**2.** Removing the terminal block

Remove the terminal block of the safety remote I/O module to be replaced with wires connected.

☞ Page 57 Installing and removing the terminal block

**3.** Removing the module

Remove the safety remote I/O module to be replaced from the DIN rail.

☞ Page 54 Mounting the module on a DIN rail

**4.** Mounting the new module

Mount the new safety remote I/O module on the DIN rail. When using an extension module, connect the extension module to the safety remote I/O module and mount the safety remote I/O module on the DIN rail.

**5.** Installing the terminal block

Connect the removed terminal block with wires to the new module.

☞ Page 63 Wiring of terminal block for the external power supply and I/O signals

**6.** Powering on the safety remote I/O module

Stop the CPU module and turn on the module power supply and the external power supply of the safety remote I/O module.

**7.** Parameter setting

Set the module parameters of the safety remote I/O module in the engineering tool.

☞ Page 68 VARIOUS SETTINGS

**8.** Checking the entire system

According to the manuals of the CPU module and the master module, check the entire system for wiring, the station number switch setting, and others.

**9.** Safety remote I/O module validation

Enable the module parameters of the safety remote I/O module.

☞ Page 72 Parameter Settings

**10.** Starting the system

Change the status of the CPU module to RUN.

**11.** Starting the system operation

# 5 SYSTEM CONFIGURATION

This chapter describes the system configuration using a safety remote I/O module. For CC-Link IE Field Network configuration, refer to the following.

📖 MELSEC iQ-R Ethernet/CC-Link IE User's Manual (Startup)

## 5.1 Safety Remote I/O Module System Configuration

The following shows system configurations using safety remote I/O modules.

### For the NZ2GFSS2-32D-S1

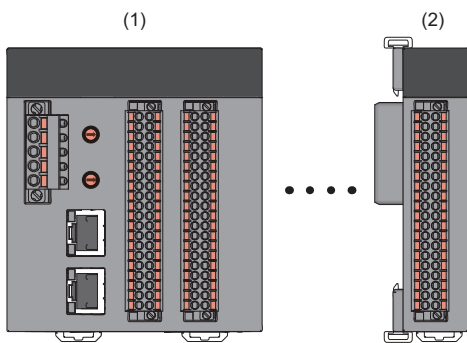

- (1) Main module
- (2) Safety extension module

### For the NZ2GFSS2-8D-S1, NZ2GFSS2-8TE-S1, or NZ2GFSS2-16DTE-S1

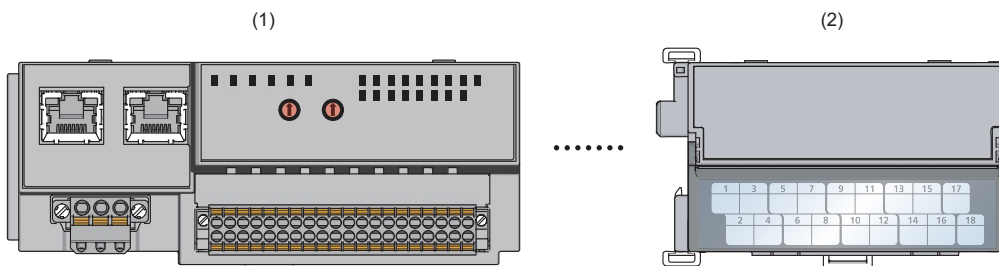

- (1) Main module
- (2) Standard extension module

## 5.2 Applicable Systems

### Applicable products

When using a safety remote I/O module, use the following products.

For the model of the Safety CPU and safety function module, refer to the following.

 MELSEC iQ-R Module Configuration Manual

Module	Firmware version
Safety CPU	29 or later
Safety function module	29 or later
Master station (RJ71GF11-T2)	70 or later

#### Point

The safety remote I/O module cannot be used with a CPU module other than the Safety CPU.

### The number of connectable modules

One extension module can be connected to one main module.

 Page 51 Installation of extension modules

### Ethernet cable

For the specifications of the Ethernet cable, refer to the following.

 MELSEC iQ-R Ethernet/CC-Link IE User's Manual (Startup)

### Software package

The following engineering tool is required for the safety remote I/O module setting and CC-Link IE Field Network diagnostics.

Product name	Version
GX Works3	Version 1.095Z or later

#### Point

When the latest profile of the safety remote I/O module is necessary, please consult your local Mitsubishi representative.

The profile is a setting file that stores information required for the start-up, operation, and maintenance of devices supporting the CC-Link family. A module is added to "Module List" of "CC IE Field Configuration" window by profile registration to the engineering tool. For the profile registration, refer to the following.

 GX Works3 Operating Manual



## 5.3 Safety Standards

This product complies with the following standards.

### Standard

EN ISO 13849-1: 2015  
EN ISO 13849-2: 2012  
EN 61508 Parts 1-7: 2010  
EN 61131-2: 2007 (clauses 6.1-6.3, 8)  
IEC 61131-2: 2017 (clauses 5.2.1, 5.3, 7)  
EN 61000-6-7: 2015

### Point

The revisions of the standards are subject to update. For the latest information, visit the TUV Rheinland's website ([www.tuv.com](http://www.tuv.com)) and check the EC Type-Examination Certificate.

Use this product with an application that complies with the following standards.

### Standard

EN ISO 13849-1: 2015 (PL e, Category 4)  
EN 61508 Parts 1-7: 2010 (SIL3)  
EN IEC 62061: 2021 (SIL3)  
IEC 61511-1: 2016+Corr.1: 2016+AMD1: 2017 (SIL3)  
NFPA 79: 2021  
EN 60204-1: 2018  
IEC 61131-2: 2017

### Point

The revisions of the above listed standards are subject to update. For the latest information, visit the TUV Rheinland's website ([www.tuv.com](http://www.tuv.com)) and check the EC Type-Examination Certificate.

# 6 INSTALLATION AND WIRING

This chapter describes the installation and wiring.

## 6.1 Setting of Network Number and Station Number

Set the network number and station number to the safety remote I/O module. To set the network number, use the engineering tool. To set the station number, use the rotary switch on the front of the module.

For the setting of the network number, refer to the following.

📖 MELSEC iQ-R CC-Link IE Field Network User's Manual (Application)

### Station number setting with the station number setting switch

#### Setting method

Set the station number with the rotary switch on the front of the module. The setting value of the station number becomes valid when the module is powered on. Thus, set the station number when the module is powered off.

- The hundreds and tens places of the station number are set with  $\times 10$ .
- The ones place of the station number is set with  $\times 1$ .

**Ex.**

To set the station number to 2, set the switch as shown below.

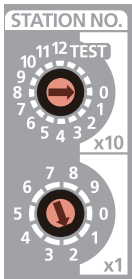

#### Setting range

Set the station number from 1 to 120. Setting the value other than 1 to 120 causes a communication error and the D LINK LED flashes.

#### Point

- Do not change the station number setting switch while the module power supply is on. Changing the station number setting switch causes a minor error and flashes the ERR. LED. Returning the station number setting switches to the previous setting eliminates the error after five seconds and turns off the ERR. LED.
- Do not set a same station number as the other station numbers. If the station number is overlapped, a communication error occurs and the D LINK LED does not turn on.

## 6.2 Installation Environment and Installation Position

### Installation environment

#### Installation location

Do not install the safety remote I/O module to the place where:

- Ambient temperature is outside the range of 0 to 55°C;
- Ambient humidity is outside the range from 5 to 95% RH;
- Condensation occurs due to rapid temperature change;
- Corrosive gas or combustible gas is present;
- Conductive powder such as dust and iron powder, oil mist, salinity, or organic solvent is filled;
- The safety remote I/O module is exposed to direct sunlight;
- A strong electric field or strong magnetic field is generated; and
- The safety remote I/O module is subject to vibration and shock.

#### Installation surface

Install the safety remote I/O module on the flat surface. When the installation surface is uneven, excessive force is applied to the printed-circuit board and may cause a defect.

#### Installation position

When installing the safety remote I/O module in a control panel, provide clearance of 60mm or longer between the module and the sides of the control panel or neighboring modules to ensure good ventilation and an easy module change.

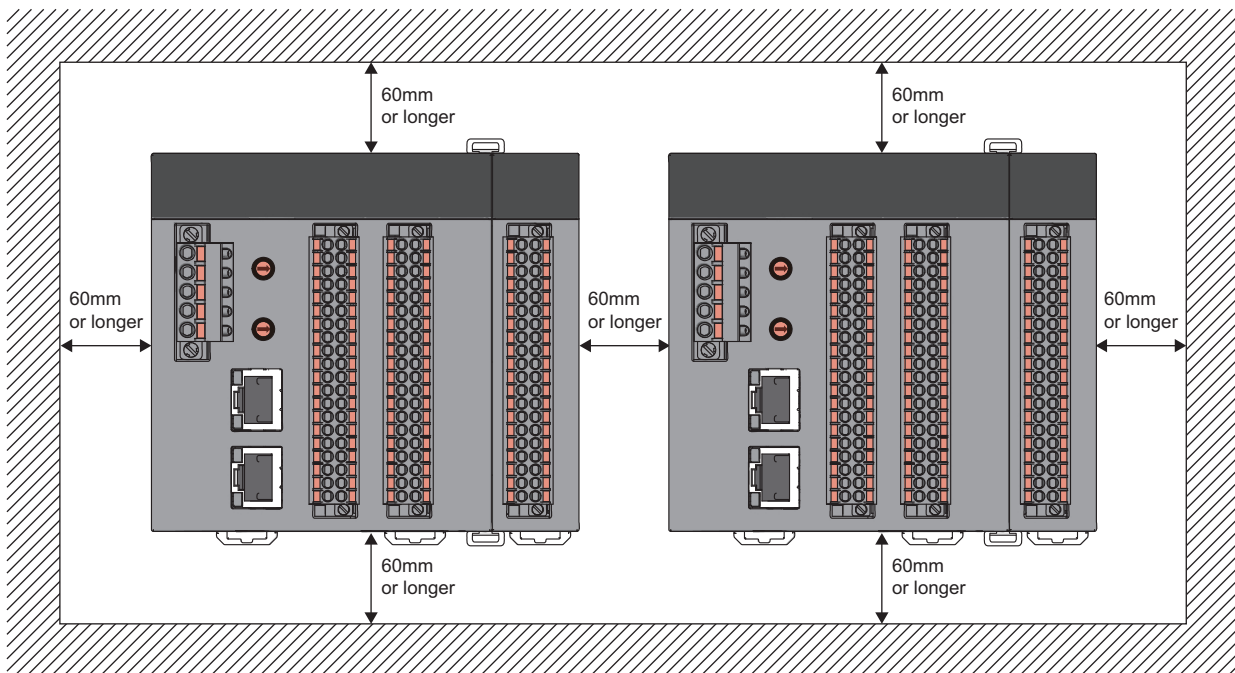

The figure above shows the examples for the NZ2GFSS2-32D-S1 and NZ2EXSS2-8TE.

# Installation direction

The safety remote I/O module can be installed in six directions. Use the DIN rail to install the module.

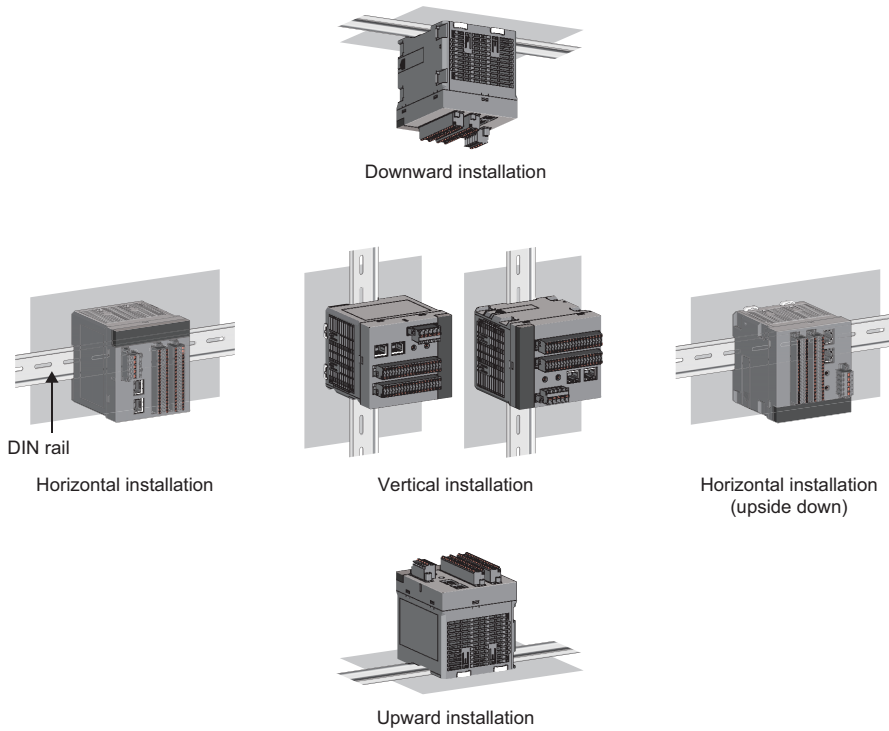

The figure above shows the examples for the NZ2GFSS2-32D-S1 and NZ2EXSS2-8TE.

## Restriction

The installation directions other than the horizontal installation have restrictions on the maximum number of simultaneous input points and maximum load current. (  Page 20 Performance Specifications)

# 6.3 Installation

## Installation of extension modules

The numbers of input points and output points can be increased by connecting extension modules.

### Number of extension modules connectable to a main module

Module model name	Model name of connectable extension modules	Number of connectable extension modules
NZ2GFSS2-32D-S1	NZ2EXSS2-8TE	1
<ul style="list-style-type: none"> <li>NZ2GFSS2-8D-S1</li> <li>NZ2GFSS2-8TE-S1</li> <li>NZ2GFSS2-16DTE-S1</li> </ul>	<ul style="list-style-type: none"> <li>NZ2EX2B1-16D</li> <li>NZ2EX2B1N-16D</li> <li>NZ2EX2S1-16D</li> <li>NZ2EX2B1-16T</li> <li>NZ2EX2B1N-16T</li> <li>NZ2EX2S1-16T</li> <li>NZ2EX2B1-16TE</li> <li>NZ2EX2B1N-16TE</li> <li>NZ2EX2S1-16TE</li> </ul>	1

## Connecting extension modules

### Connection procedure

#### ■NZ2GFSS2-32D-S1

1. Remove the cover on the side of the module. Do not dispose of the removed cover, but store it.

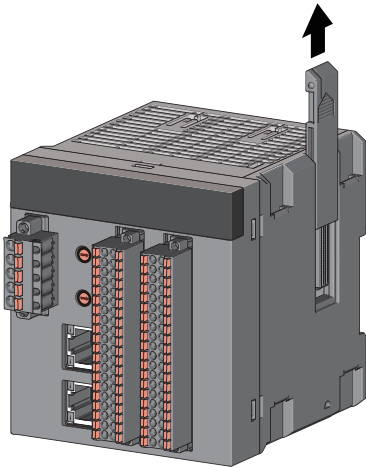

2. Release the module joint levers (four points) on the side of the extension module. Slide the levers to the outside of the module.

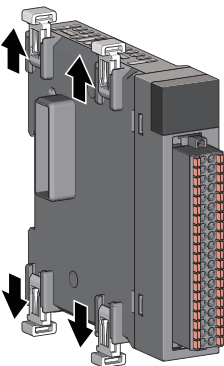

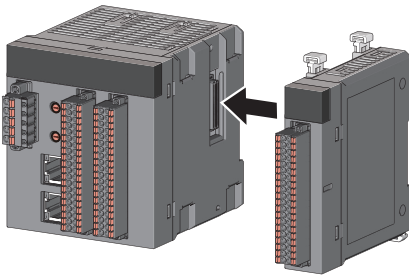

3. Insert the connector of the extension module into that of the main module so that they are securely engaged. Do not tilt the extension module when inserting the connector.

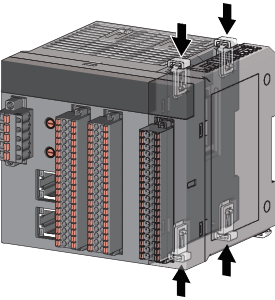

4. Lock the module joint levers (four points) on the side of the extension module. Slide the levers toward the module. Check that the extension module is securely connected after locking the levers.

**■NZ2GFSS2-8D-S1, NZ2GFSS2-8TE-S1, NZ2GFSS2-16DTE-S1**

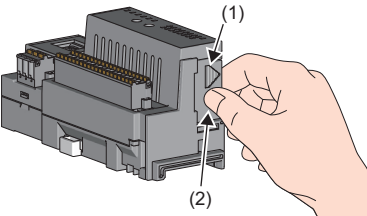

1. (1) Put your thumb on the mark located on the upper right of the cover on the side of the module. (2) Apply force to the direction indicated by the mark and remove the cover. Do not dispose of the removed cover, but store it. Do not attach covers of other models because they are not compatible.

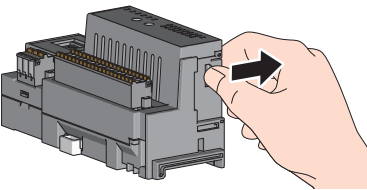

2. Release the module joint levers (two points) on the side of the extension module. Slide the levers to the outside of the module.

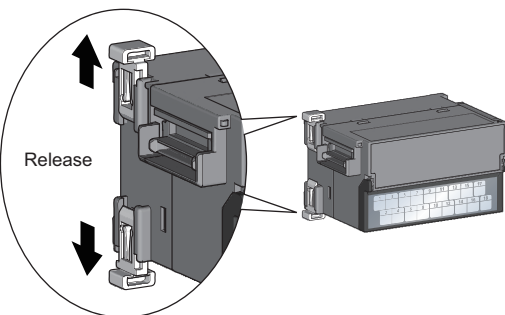

3. Insert the connector of the extension module into that of the main module so that they are securely engaged. Do not tilt the extension module when inserting the connector.

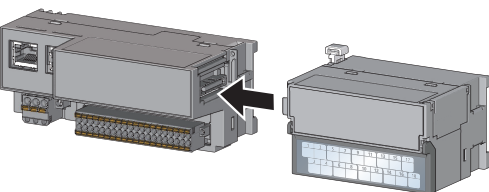

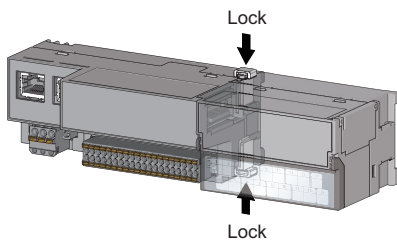

4. Lock the module joint levers (two points) on the side of the extension module. Slide the levers toward the module. Check that the extension module is securely connected after locking the levers.

### ■Precautions

Lock the module joint levers securely. Failure to do so may cause malfunction, failure, or drop of the module.

## Removal procedure

Disconnect the extension module by reversing the connection procedure.

### ■Precautions

- Do not remove the cover in a way other than described in the above connection procedure. Doing so may damage the cover.
- Attach or remove the cover with the module removed from the DIN rail.
- Shut off the external power supply (all phases) used in the system before connecting or disconnecting extension modules.

# Mounting the module on a DIN rail

## Point

The following procedure is just an example of fixing the module with a DIN rail stopper. When fixing the module, refer to the manual of the DIN rail stopper used.

## Installation procedure

1. Pull down all DIN rail hooks on the back of the module. The hooks should be pulled down until they click.

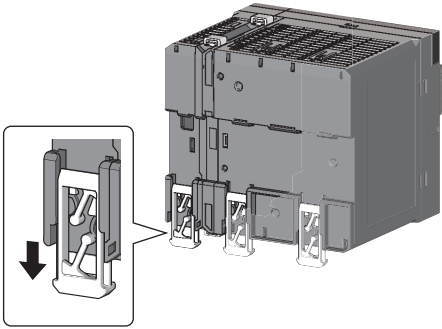

2. Hang the upper tabs of the module on a DIN rail, and push the module in position.

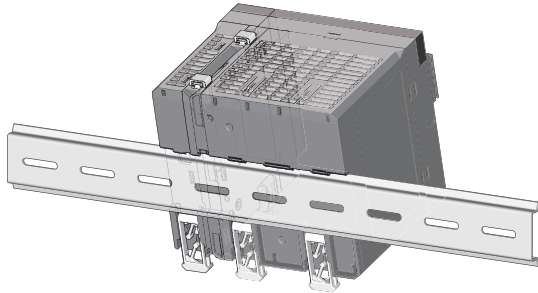

3. Lock the DIN rail hooks to the DIN rail to secure the module in position. Push each hook up until it clicks. If the hooks are beyond the reach, use a tool such as a screwdriver.

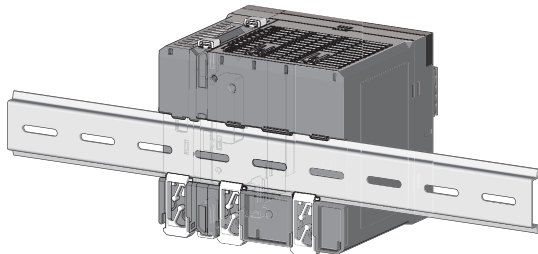

4. Loosen the screw on DIN rail stopper.

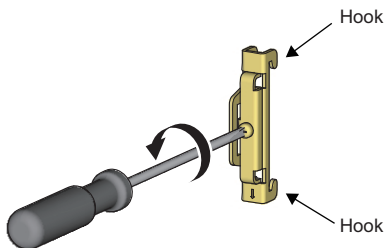

5. Hitch the bottom hook of the DIN rail stopper to the bottom of the DIN rail. Hitch the hook according to the orientation of the arrow on the front of the stopper.

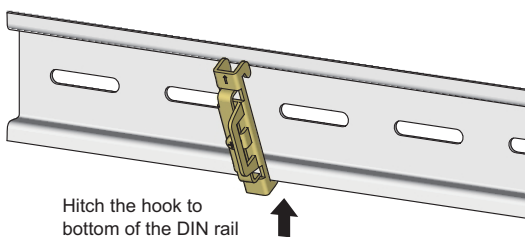



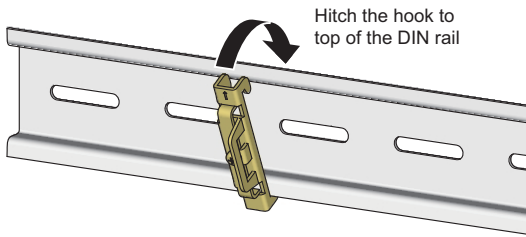

6. Hitch the upper hook of the DIN rail stopper to the top of the DIN rail.

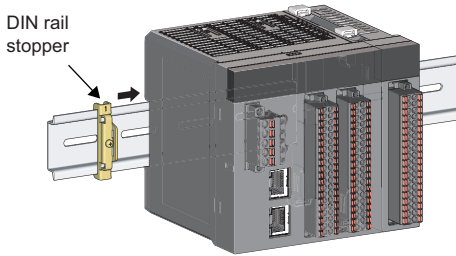

7. Slide the DIN rail stopper up to the left side of the module.

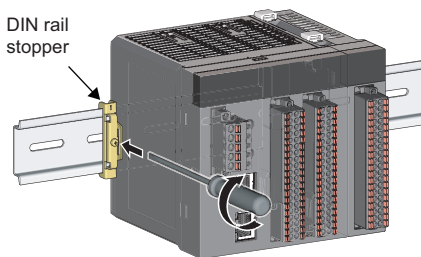

8. Hold the DIN rail stopper in the direction opposite to the arrow on the stopper and tighten the screw with a screwdriver.

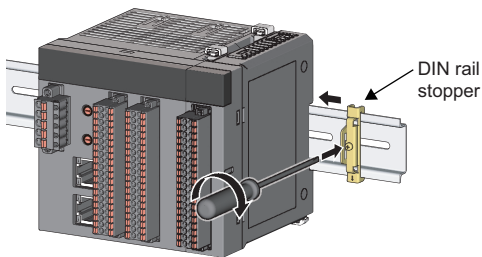

9. Install the DIN rail stopper on the right side of the module in the same procedure. Install the stopper upside down for the right side.

**Point** 

Do not slide the module from the edge of the DIN rail when mounting it. Doing so may damage the module.

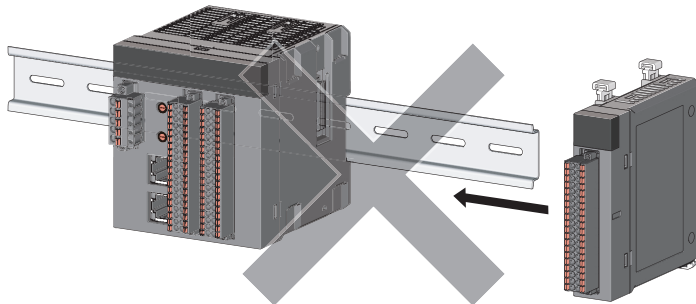

## Removal procedure

Remove the module from the DIN rail by reversing the installation procedure.

## Applicable DIN rail model (compliant with JIS C 2812/IEC 60715)

- TH35-7.5Fe
- TH35-7.5Al

## Interval between DIN rail mounting screws

Tighten the screws at intervals of 200mm or less.

## DIN rail stopper

Use a stopper that is attachable to the DIN rail.

# 6.4 Wiring

## Wiring of terminal block for module power supply and FG

### Tightening torque

Tighten the terminal block mounting screws within the following specified torque range. Tightening the screws too much may damage the module case.

Screw type	Tightening torque range
Terminal block mounting screw (M2.5 screw)	0.2 to 0.3N·m

### Wire to be used

The following table lists the wires to be connected to the terminal block for module power supply and FG. Use the following wires.

Module model name	Diameter	Type	Material	Temperature rating	Stripping length of the cable
NZ2GFSS2-32D-S1	20 to 14 AWG	Stranded wire	Copper wire	75°C or higher	10mm
NZ2GFSS2-8D-S1, NZ2GFSS2-8TE-S1, NZ2GFSS2-16DTE-S1	22 to 16 AWG	Stranded wire	Copper wire	75°C or higher	10mm

### Installing and removing the terminal block

To remove the terminal block, loosen the terminal block mounting screws with a flathead screwdriver and pull out the terminal block.

To install the terminal block, insert the terminal block into the connector and securely fix the terminal block with the terminal block mounting screws. Failure to secure the terminal block may cause drop, short circuit, malfunction.

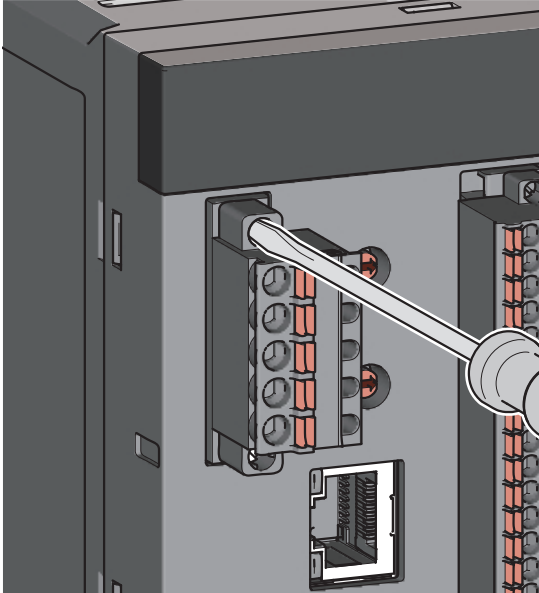

## Connecting a cable

To connect a cable, push the open/close button with a flathead screwdriver, insert the wire into the wire insertion opening, and remove the screwdriver. When using a bar solderless terminal, insert the wire with a bar solderless terminal into the wire insertion opening and push it in. After inserting the wire, pull it lightly to check that it is securely clamped.

## Disconnecting a cable

Push the open/close button of the wire to be disconnected with a flathead screwdriver. Pull out the wire with the open/close button pushed.

## Precautions

Before inserting a bar solderless terminal, check the shapes of the wire insertion opening and bar solderless terminal and the direction of the bar solderless terminal. Inserting a bar solderless terminal larger than the wire insertion opening may damage the terminal block.

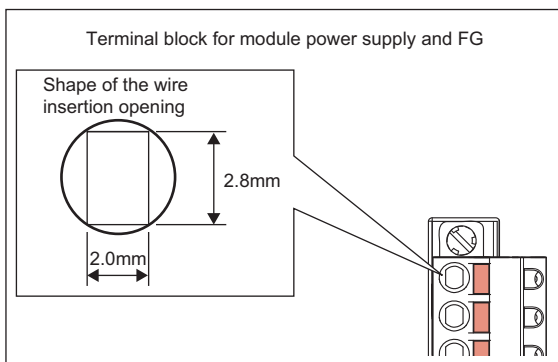

### Point

Do not install the FG lines and communication cables together or closely each other. Doing so may result in malfunction due to noise.

## Processing method of the cable terminal

- When using a stranded wire, strip the cable 10mm from the tip. Stripping the cable too long may cause electric shock or short circuit between adjacent terminals because the conductive part sticks out of the terminal block. Stripping the cable too short may cause a poor contact to the spring clamp terminal part.
- When using a bar solderless terminal, follow the specifications of the bar solderless terminal for how long the cable should be stripped. To attach a bar solderless terminal to a wire, use a crimping tool.

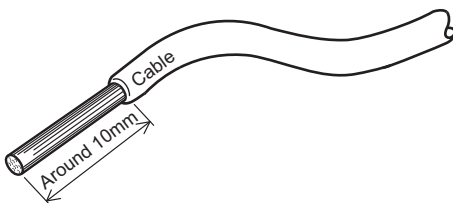

## List of bar solderless terminals

When using a bar solderless terminal, the products listed below are recommended. For a processing method of the cable terminal, such as the stripping length of the cable, follow the specifications of the terminal used. Use UL listed bar solderless terminals, and for processing, use a tool recommended by manufacturers of solderless terminals.

### ■For the NZ2GFSS2-32D-S1

Terminal shape	Model* <sup>1</sup>	Applicable wire size	Bar solderless terminal tool	Contact
Ferrule (with insulation sleeve)	AI 0.5-10WH	0.5mm <sup>2</sup> (20 AWG)	CRIMPFOX6	PHOENIX CONTACT GmbH & Co. KG
	AI 0.75-10GY	0.75mm <sup>2</sup> (18 AWG)		
	AI 1-10RD	1.0mm <sup>2</sup> (18 AWG)		
	AI 1.5-10BK	1.5mm <sup>2</sup> (16 AWG)		
	AI 2.5-10BU* <sup>2</sup>	2.0mm <sup>2</sup> (14 AWG)		

\*1 When using the safety remote I/O module as a UL listed product, use the terminals whose model name ends with -10 or -10□□.

\*2 This model is not a UL listed product.

### ■For the NZ2GFSS2-8D-S1, NZ2GFSS2-8TE-S1, or NZ2GFSS2-16DTE-S1

Terminal shape	Model* <sup>1</sup>	Applicable wire size	Bar solderless terminal tool	Contact
Ferrule (with insulation sleeve)	AI 0.34-8TQ	0.34mm <sup>2</sup> (22 AWG)	CRIMPFOX6	PHOENIX CONTACT GmbH & Co. KG
	AI 0.5-8WH	0.5mm <sup>2</sup> (20 AWG)		
	AI 0.5-10WH	0.5mm <sup>2</sup> (20 AWG)		
	AI 0.75-8GY	0.75mm <sup>2</sup> (18 AWG)		
	AI 0.75-10GY	0.75mm <sup>2</sup> (18 AWG)		
	AI 1-8RD	1.0mm <sup>2</sup> (18 AWG)		
	AI 1-10RD	1.0mm <sup>2</sup> (18 AWG)		
	AI 1.5-8BK	1.5mm <sup>2</sup> (16 AWG)		
	AI 1.5-10BK	1.5mm <sup>2</sup> (16 AWG)		

\*1 When using the safety remote I/O module as a UL listed product, use the terminals whose model name ends with -10 or -10□□.

# Wiring of Ethernet cable

## Connecting the Ethernet cable

### ■Connecting

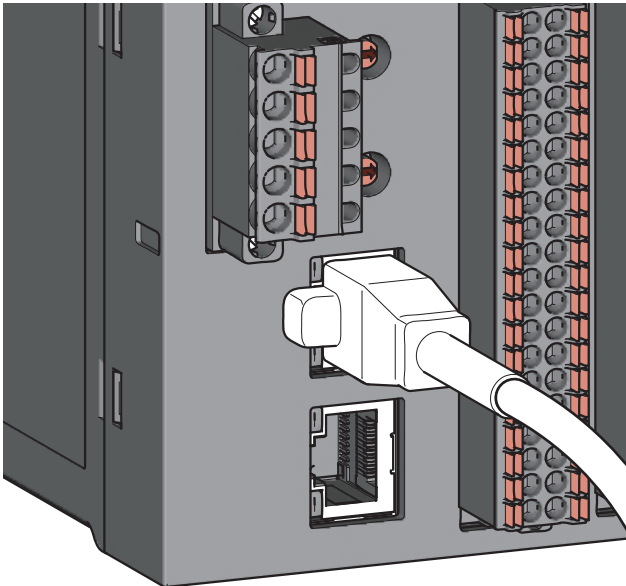

1. Power off the module power supply of the safety remote I/O module and the power supply of the external device.
2. Push the Ethernet cable connector into the safety remote I/O module until it clicks. Pay attention to the connector's direction.

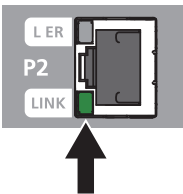

3. Power on the module power supply.
4. Power on the power supply of the external device.
5. Check if the LINK LED on the port into which the Ethernet cable is connected is on.<sup>\*1</sup>

\*1 The time taken for the LINK LED to turn on after connection of the cable may vary. The LINK LED normally turns on in a few second. However, if link-up processing is repeated due to a condition of a device on the line, the longer time may be required. If the LINK LED does not turn on, refer to the following and take a corrective action.

☞ Page 125 When the LINK LED turns off

- PORT1 and PORT2 need not to be distinguished. When only one connector is used in star topology, either PORT1 or PORT2 can be connected.

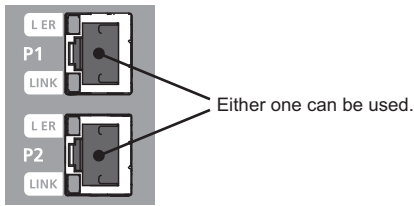

- When two connectors are used in line topology or ring topology, an Ethernet cable can be connected to the connectors in any combination. For example, the cable can be connected between PORT1s and between PORT1 and PORT2.

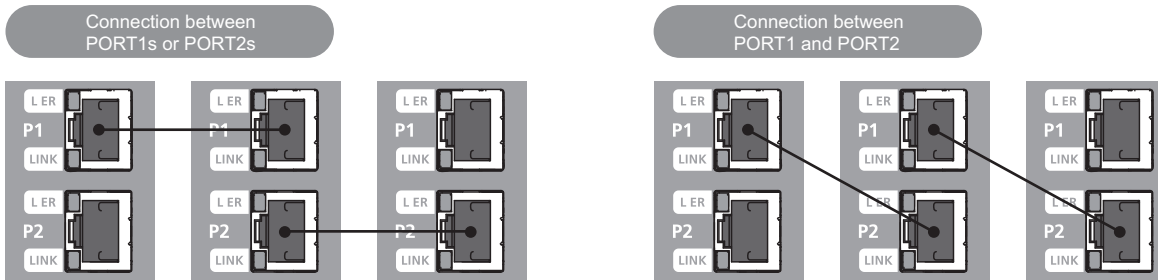

### ■ Disconnecting

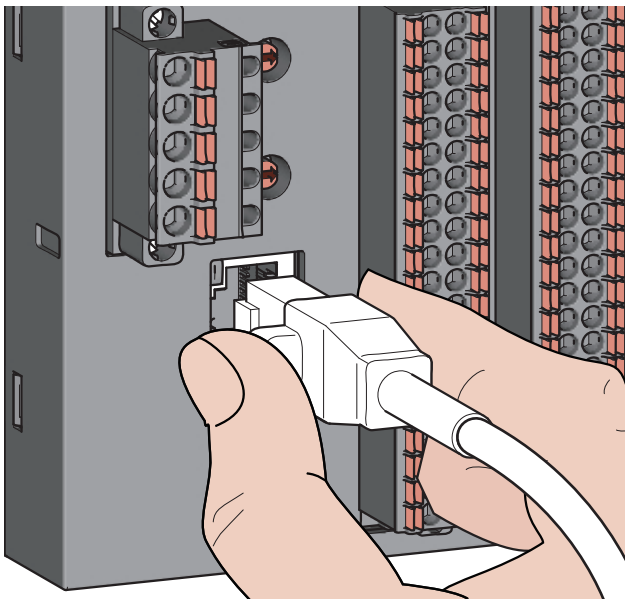

1. Power off the module power supply.
2. Press the latch down and unplug the Ethernet cable.

## Precautions

### ■Laying Ethernet cables

- Place the Ethernet cable in a duct or clamp it. If not, dangling cable may swing or inadvertently be pulled, resulting in damage to the module or cables or malfunction due to poor contact.
- Do not touch the core of the connector of the cable or the module, and protect it from dirt and dust. If any oil from your hand, or any dirt or dust sticks to the core, it can increase transmission loss, causing data link to fail.
- Check that the Ethernet cables are not disconnected or short and the connector is properly connected.

### ■When a latch of the Ethernet cable is broken

Do not use Ethernet cables with broken latches. Doing so may cause the cable to unplug or malfunction.

### ■Connecting and disconnecting the Ethernet cable

Hold the connector part when connecting and disconnecting the Ethernet cable. Pulling the cable connected to the module may result in damage to the module or cable or malfunction due to poor contact.

### ■Connectors to which the Ethernet cable is not connected

To prevent dust from entering the module, attach the provided connector cover to connectors.

### ■Maximum segment length of the Ethernet cable (maximum cable length)

The maximum station-to-station distance of the Ethernet cable is 100m. However, the distance may be shorter depending on the operating environment of the cable. For details, contact the manufacturer of the cables used.

### ■Bending radius of the Ethernet cable

There are restrictions on the bending radius of the Ethernet cable. Check the bending radius in the specifications of the Ethernet cables used.



# Wiring of terminal block for the external power supply and I/O signals

## Tightening torque

Tighten the terminal block mounting screws within the following specified torque range. Tightening the screws too much may damage the module case.

Screw type	Tightening torque range
Terminal block mounting screw (M2 screw)	0.1 to 0.2N·m

## Wire to be used

The following table describes the wire to be connected to the terminal block for the external power supply and I/O signals. Use the following wires.

Diameter	Type	Material	Temperature rating	Stripping length of the cable
22 to 16 AWG	Stranded wire	Copper wire	75°C or higher	10mm

## Installing and removing the terminal block

### ■Removal procedure

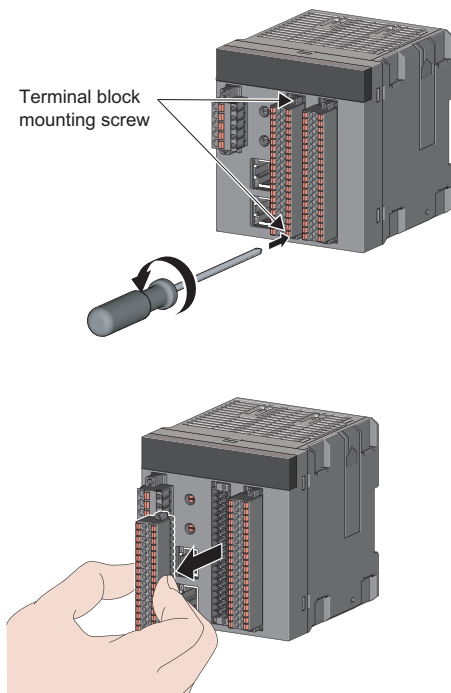

1. Loosen the terminal block mounting screws.

2. When the terminal block mounting screws are loosened, the terminal block can be removed.

## ■ Installation procedure

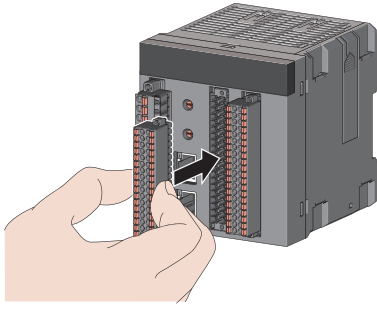

1. Install the terminal block.

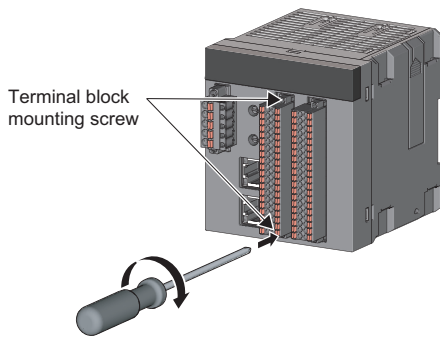

2. Tighten the terminal block mounting screws. Securely install the terminal block with the terminal block mounting screws. Failure to secure the terminal block may cause drop, short circuit, malfunction.

## Connecting a cable

To connect a cable, push the open/close button with a flathead screwdriver, insert the wire into the wire insertion opening, and remove the screwdriver. When using a bar solderless terminal, insert the wire with a bar solderless terminal into the wire insertion opening and push it in. After inserting the wire, pull it lightly to check that it is securely clamped.

## Disconnecting a cable

Push the open/close button of the wire to be disconnected with a flathead screwdriver. Pull out the wire with the open/close button pushed.

## Precautions

Before inserting a bar solderless terminal, check the shapes of the wire insertion opening and bar solderless terminal and the direction of the bar solderless terminal. Inserting a bar solderless terminal larger than the wire insertion opening may damage the terminal block.

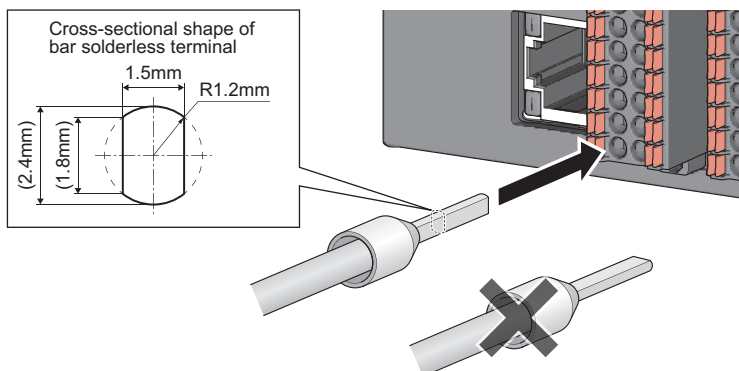

### Point

- For details on the finish shape of a bar solderless terminal including an error in processing, contact the manufacturers of the bar solderless terminal and the crimping tool.

## Processing method of the cable terminal

- When using a stranded wire, strip the cable 10mm from the tip. Stripping the cable too long may cause electric shock or short circuit between adjacent terminals because the conductive part sticks out of the terminal block. Stripping the cable too short may cause a poor contact to the spring clamp terminal part.
- When using a bar solderless terminal, follow the specifications of the bar solderless terminal for how long the cable should be stripped. To attach a bar solderless terminal to a wire, use a crimping tool.

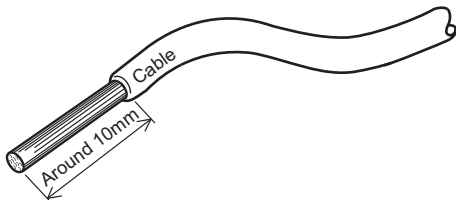

## List of bar solderless terminals

When using a bar solderless terminal, the products listed below are recommended. For a processing method of the cable terminal, such as the stripping length of the cable, follow the specifications of the terminal used. Use UL listed bar solderless terminals, and for processing, use a tool recommended by manufacturers of solderless terminals.

Terminal shape	Model <sup>*1</sup>	Applicable wire size	Bar solderless terminal tool	Contact
Ferrule (with insulation sleeve)	AI 0.34-10TQ	0.34mm <sup>2</sup> (22 AWG)	CRIMPFOX6	PHOENIX CONTACT GmbH & Co. KG
	AI 0.5-10WH	0.5mm <sup>2</sup> (20 AWG)		
	AI 0.75-10GY	0.75mm <sup>2</sup> (18 AWG)		
Ferrule (without insulation sleeve)	A 1-10	1.0mm <sup>2</sup> (18 AWG)		
	A 1.5-10	1.5mm <sup>2</sup> (16 AWG)		

\*1 When using the safety remote I/O module as a UL listed product, use the terminals whose model name ends with -10 or -10□□.

# Precautions for wiring the safety remote I/O module to safety devices

This section describes the precautions for the wiring. To wire the safety remote I/O module to each safety device according to Category 4, perform both of the following for the safety remote I/O module.

- Double wiring inputs/outputs
- Executing the self-diagnostic function (dark test)

When performing the operations above, observe the precautions below.

## When wiring the input part

### ■Combination of input terminals

The following table lists the applicable combinations of input terminals. If the combinations other than the below are used, a minor error occurs.

- NZ2GFSS2-32D-S1

Combination of input terminals							
X0, X1	X2, X3	X4, X5	X6, X7	X8, X9	XA, XB	XC, XD	XE, XF
X10, X11	X12, X13	X14, X15	X16, X17	X18, X19	X1A, X1B	X1C, X1D	X1E, X1F

- NZ2GFSS2-8D-S1, NZ2GFSS2-16DTE-S1

Combination of input terminals			
X0, X1	X2, X3	X4, X5	X6, X7

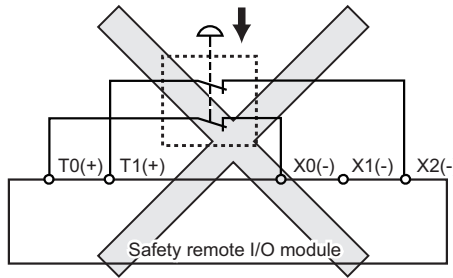
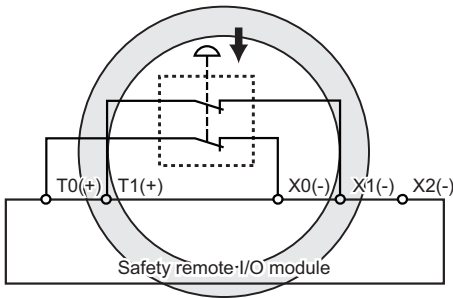

### ■Test pulse output terminal combination

The same test pulse cannot be used for the combinations for one device. If the combinations of the same test pulse are used for one device (X0 and T0, X1 and T0 for instance), a minor error occurs.

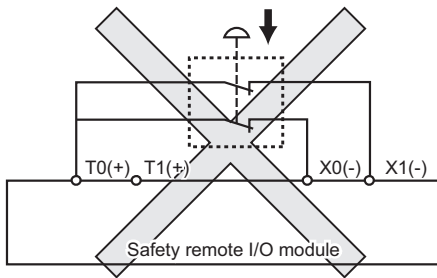
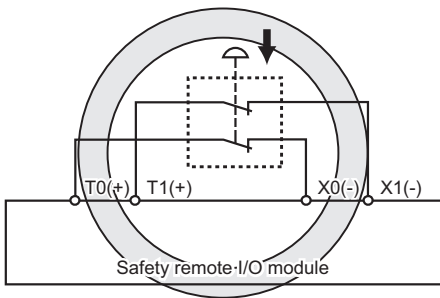

## When wiring the output part

### ■Combination of output terminals

The following table lists the applicable combinations of output terminals. If the combinations other than the below are used, a minor error occurs.

Combination of output terminals			
Y0, Y1	Y2, Y3	Y4, Y5	Y6, Y7

## Wiring of the external power supply

If the external power supply is off when the module power supply is turned on, a moderate error or minor error (external power supply voltage error) occurs. Power on the external power supply at the same timing of power-on of the module power supply.

# 7 VARIOUS SETTINGS

## Overview of the parameter setting procedure

### 1. Preparation

Perform the following before parameter settings.

- Configure the system.
- Start the engineering tool.
- Set the Safety CPU to the test mode.

For details on the test mode of the Safety CPU, refer to the following.

 MELSEC iQ-R CPU Module User's Manual (Application)

### 2. Network Configuration Settings

Write the network configuration settings to the CPU module.

### 3. Parameter processing of a device station

Perform the parameter processing of device station. Perform the operations to all safety remote I/O modules connected.

### 4. Safety Communication Setting

Write the safety communication setting of the master station to the CPU module.

### 5. Checking the position of the setting target module

Perform the checking of the position of the safety remote I/O module where the parameters are set. Perform the operations to all safety remote I/O modules connected.



### 6. Safety module validation

Switch the safety remote I/O module to the state where safety communications are enabled (safety operation mode). Perform the validation as a final check before the safety remote I/O module operation (a check whether parameters are written to a module as intended). Perform the operations to all safety remote I/O modules connected.

#### Point

- Write the safety communication setting to the CPU module after completing "Parameter write" to all safety remote I/O modules connected. Failure to do so may cause an error (parameter mismatch of CPU module and safety remote I/O module) in the CPU module at the restart of the safety remote I/O module.
- No restrictions are provided on the access level for writing parameters to the safety remote I/O module. However, when the access level is "Assistant Developers" or "Users", even though parameters have been set to the safety remote I/O module, safety communications are disabled because the safety communication setting cannot be configured in the CPU module. To perform the safety communications, configure the setting with "Developers" or a higher access level. For details on the access levels, refer to the following.

 GX Works3 Operating Manual

- If the safety remote I/O module is left with "Safety module validation" not being performed for 10 minutes or longer, a moderate error (safety module validation not performed) occurs.
- "Safety module validation" cannot be performed while the moderate error (safety module validation not performed) persists. To perform "Safety module validation", eliminate the error by restarting the safety remote I/O module.
- For the NZ2GFSS2-8D-S1, NZ2GFSS2-8TE-S1, or NZ2GFSS2-16DTE-S1, "Safety module validation" cannot be performed while the moderate error (parameter data error) caused by parameter settings persists. If "Safety module validation" is performed, the minor error (safety module validation failure) occurs. For details, refer to the list of error codes. ( Page 138 List of Error Codes)
- Since the safety remote I/O modules use the remote register areas for safety communications, assign the remote register areas. ( Page 175 Remote Register)

# 7.1 Network Configuration Settings

The following parameters are required to use the safety remote I/O module. The parameters are automatically set when a main module is added in the "Network Configuration Settings". Change the start number and end number of the RX/Ry Setting or RWw/RWw Setting as necessary.

Item		Description
STA#		Set the station number of the safety remote I/O module.
Station Type		Set "Remote Device Station".
RX/Ry Setting	Points	80 points
RWw/RWw Setting	Points	32 points



- When using the safety remote I/O module, always enable "Station-based Block Data Assurance" of the master station. When it is disabled, correct operation of the safety remote I/O module cannot be guaranteed. For the station-based block data assurance, refer to the following.

MELSEC iQ-R CC-Link IE Field Network User's Manual (Application)

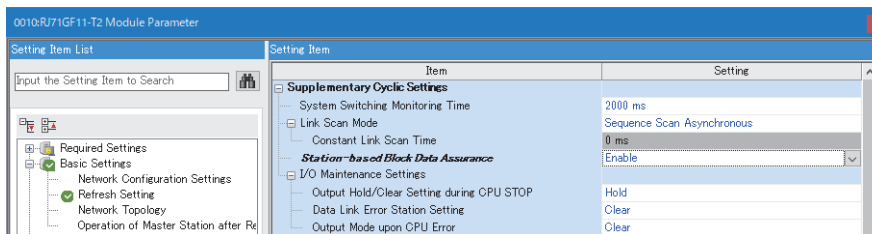

- Do not set the module parameters using the CCPASET instruction in the master station. Correct operation of the safety remote I/O module cannot be guaranteed because the module operates with the Station-based Block Data Assurance disabled when the CCPASET instruction is executed.
- Even though the number of points in the RX/Ry Setting or RWw/RWw Setting and that in a main module or an extension module differ, an error does not occur on the module. For example, when the number of points in the RX/Ry Setting is set to 16 in a configuration with a main module and extension module, only the first 16 points are refreshed.

## Setting procedure

The following shows the procedure to set module parameters of the master station from the "Network Configuration Settings" window.

### Point

When the user authentication function of the CPU module is enabled, perform the logon of the user authentication function in advance. For the user authentication function, refer to the following.

☞ Page 109 User Authentication Function

## Operating procedure

**1.** For preparation before setting module parameters, follow the steps below.

- Connect the safety remote I/O module to a network and power on the module.
- Connect the engineering tool to the CPU module of the master station.
- Build the module configuration in the engineering tool. For details on the setting, refer to the following.

📖 GX Works3 Operating Manual

- Set the Safety CPU to the test mode. For details on the setting, refer to the following.

📖 GX Works3 Operating Manual

**2.** Display the "CC IE Field Configuration" window.

☞ [Navigation window] ⇒ [Parameter] ⇒ [Module Information] ⇒ Model name ⇒ [Basic Settings] ⇒ [Network Configuration Settings] ⇒ "CC IE Field Configuration" window

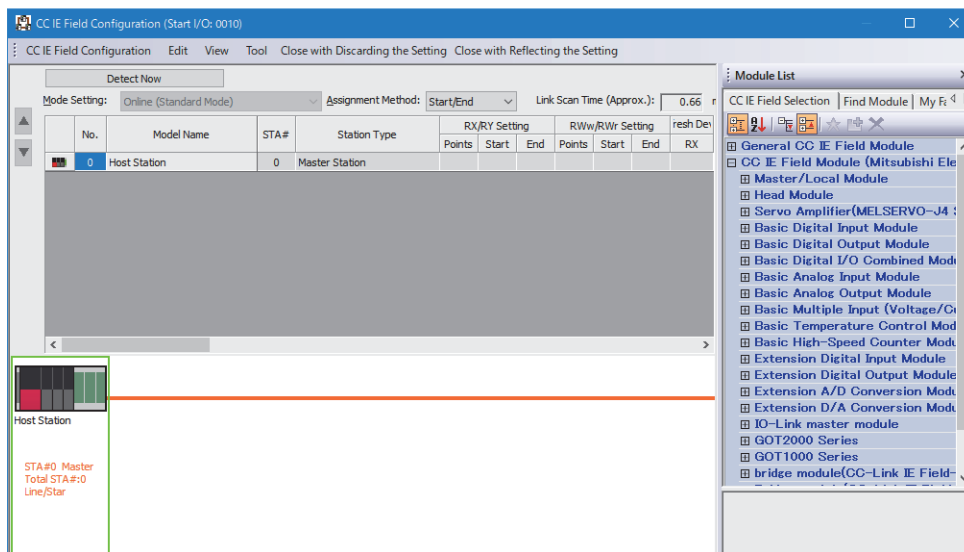



3. Drag and drop the icon of the main module from "Module List" to the lower window. At this time, "STA#", "Station Type", "RX/Ry Setting", and "RWw/RWr Setting" are automatically input. Change a value as necessary. To use an extension module, drag and drop the icon of the extension module from "Module List" to the right side of the main module icon.

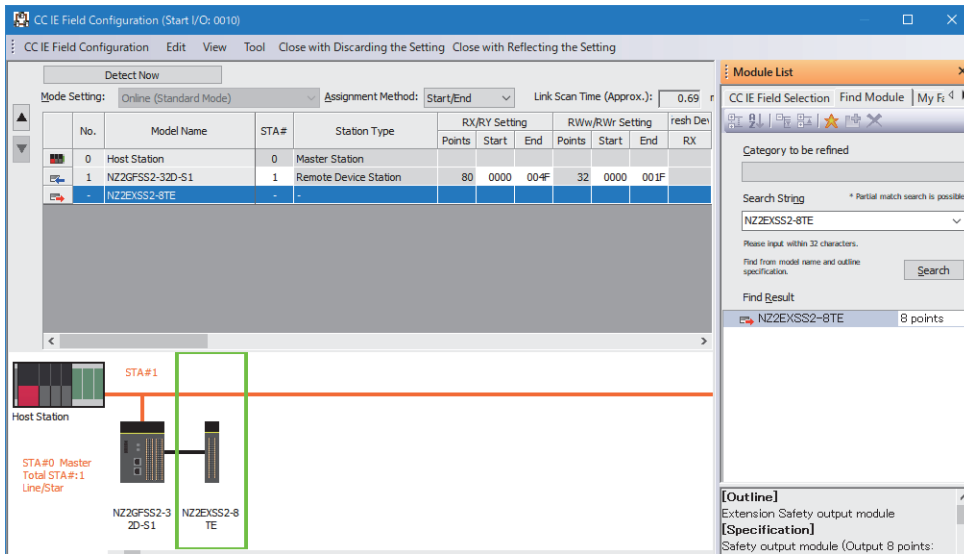

4. Close the "CC IE Field Configuration" window.

 [Close with Reflecting the Setting]

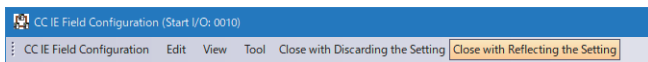

5. After applying the module parameter setting of the master station, write the setting to the programmable controller. For the module parameter setting of the master station, refer to the following.

 MELSEC iQ-R CC-Link IE Field Network User's Manual (Application)

# 7.2 Parameter Settings

This section shows lists of the module parameters of the safety remote I/O module. The following parameters cannot be set from a program.

## Window

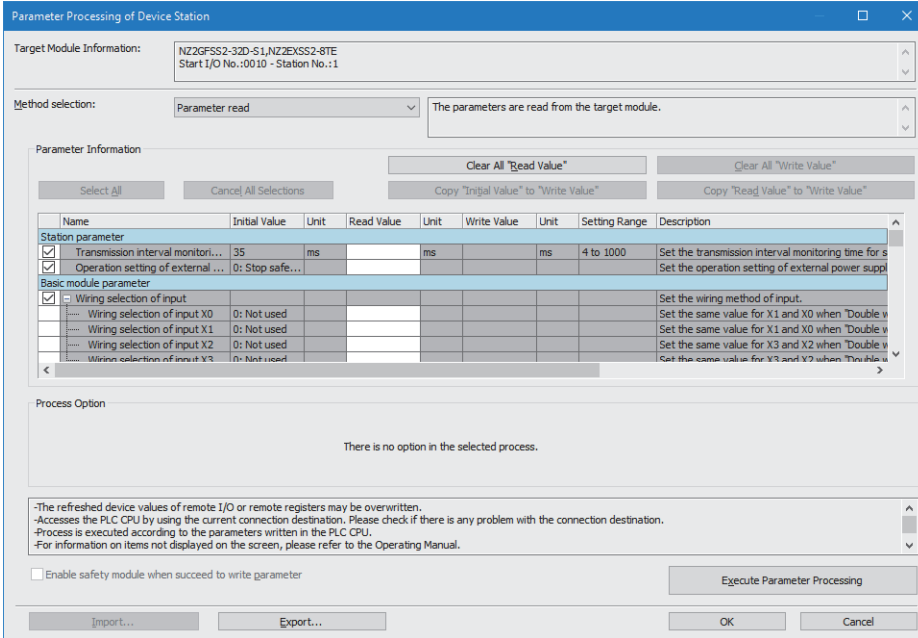

## Parameter list

### ■NZ2GFSS2-32D-S1

Item			Setting range	Reference
Station parameter	Transmission interval monitoring time		4 to 1000ms (default: 35)	Page 37 Safety remote I/O module safety response time
	Operation setting of external power supply voltage error detection		0: Stop safety communication (default) 1: Continue safety communication (Without output interlock) 2: Continue safety communication (With output interlock)	Page 110 Operation Setting Function at Detection of External Power Supply Voltage Error
Basic module parameter	Wiring selection of input	Wiring selection of input X0 to Wiring selection of input X1F	0: Not used (default) 1: Double wiring (NC/NC) 2: Single wiring	Page 85 Safety input wiring selection function
	Input response time	Input response time X0 to Input response time X1F	0: 1ms (default) 1: 5ms 2: 10ms 3: 20ms 4: 50ms	Page 88 Safety input response time setting function
	Double input discrepancy detection setting	Double input discrepancy detection setting X0_X1 to Double input discrepancy detection setting X1E_X1F	0: Detect (default) 1: Do not detect	Page 93 Double input discrepancy detection function
	Double input discrepancy detection type	Double input discrepancy detection type X0_X1 to Double input discrepancy detection type X1E_X1F	0: Discrepancy detection time specified (default) 1: Discrepancy detection time not specified	
	Double input discrepancy auto recovery setting		0: Not used (default) 1: Used	
	Double input discrepancy detection time	Double input discrepancy detection time X0_X1 to Double input discrepancy detection time X1E_X1F	1 to 6000 (default: 1) × 10ms	
	Input dark test execution setting	Input dark test execution setting X0 to Input dark test execution setting X1F	0: Perform (default) 1: Do not perform	Page 101 Input dark test function
	Input dark test pulse OFF time		0: 400μs (default) 1: 1ms 2: 2ms	
	Number of pulse output for input dark test		0: 1 time (default) 1: 2 times 2: 3 times	
Ext. module 1_Extension module parameter*1	Ext. module 1_Wiring selection of output	Ext. module 1_Wiring selection of output Y0 to Ext. module 1_Wiring selection of output Y7	0: Not used (default) 1: Double wiring (Source/Source) 2: Single wiring	Page 89 Safety output wiring selection function
	Ext. module 1_Output dark test execution setting	Ext. module 1_Output dark test execution setting Y0 to Ext. module 1_Output dark test execution setting Y7	0: Perform (default) 1: Do not perform	Page 105 Output dark test function
	Ext. module 1_Output dark test pulse OFF time	Ext. module 1_Output dark test pulse OFF time Y0 to Ext. module 1_Output dark test pulse OFF time Y7	0: 400μs (default) 1: 1ms 2: 2ms	
	Ext. module 1_Number of pulse output for output dark test		0: 1 time (default) 1: 2 times 2: 3 times	

\*1 This parameter can be set only when a safety extension module is connected.



Set all the items of the parameters displayed. If any item is left blank, the parameters cannot be written to the safety remote I/O module.

## ■NZ2GFSS2-8D-S1

Unit	Item		Setting range	Reference
Station parameter	Safety setting	Transmission interval monitoring time	4 to 1000ms (default: 35)	Page 37 Safety remote I/O module safety response time
	I/O LED indication setting at error occurrence		0: No indication of error point (default) 1: Indication of error point	
	Cyclic data update monitoring time setting		0 to 20 (default: 0) × 100ms	
	Extension I/O setting	Input response time setting	0: 0ms 1: 0.2ms 2: 1.0ms 3: 1.5ms 4: 5ms 5: 10ms (default) 6: 20ms 7: 70ms	
		Output HOLD/CLEAR setting	0: CLEAR (default) 1: HOLD	
	Operation setting of external power supply voltage error detection		0: Stop safety communication (default) 1: Continue safety communication (Without output interlock) 2: Continue safety communication (With output interlock)	
Basic module parameter_main module	Wiring selection of input	Wiring selection of input X0 to Wiring selection of input X7	0: Not used (default) 1: Double wiring (NC/NC) 2: Single wiring	Page 85 Safety input wiring selection function
	Input response time [main module]	Input response time X0 to Input response time X7	0: 1.0ms (default) 1: 1.5ms 2: 5ms 3: 10ms 4: 20ms 5: 50ms 6: 70ms	Page 88 Safety input response time setting function
	Double input discrepancy detection setting	Double input discrepancy detection setting X0/X1 to Double input discrepancy detection setting X6/X7	0: Detect (default) 1: Do not detect	Page 93 Double input discrepancy detection function
	Double input discrepancy detection type	Double input discrepancy detection type X0/X1 to Double input discrepancy detection type X6/X7	0: Discrepancy detection time specified (default) 1: Discrepancy detection time not specified	
	Double input discrepancy auto recovery setting		0: Not used (default) 1: Used	
	Double input discrepancy detection time	Double input discrepancy detection time X0/X1 to Double input discrepancy detection time X6/X7	1 to 6000 (default: 1) × 10ms	
	Input dark test execution setting	Input dark test execution setting X0 to Input dark test execution setting X7	0: Perform (default) 1: Do not perform	
	Input dark test pulse OFF time setting		0: 400μs (default) 1: 1ms 2: 2ms	
	Number of pulse output for input dark test		0: 1 time (default) 1: 2 times 2: 3 times	

## ■NZ2GFSS2-8TE-S1

Unit	Item		Setting range	Reference
Station parameter	Safety setting	Transmission interval monitoring time	4 to 1000ms (default: 35)	Page 37 Safety remote I/O module safety response time
	I/O LED indication setting at error occurrence		0: No indication of error point (default) 1: Indication of error point	
	Cyclic data update monitoring time setting		0 to 20 (default: 0) × 100ms	
	Extension I/O setting	Input response time setting	0: 0ms 1: 0.2ms 2: 1.0ms 3: 1.5ms 4: 5ms 5: 10ms (default) 6: 20ms 7: 70ms	
		Output HOLD/CLEAR setting	0: CLEAR (default) 1: HOLD	
Operation setting of external power supply voltage error detection		0: Stop safety communication (default) 1: Continue safety communication (Without output interlock) 2: Continue safety communication (With output interlock)	Page 110 Operation Setting Function at Detection of External Power Supply Voltage Error	
Basic module parameter_main module	Wiring selection of output	Wiring selection of output Y0 to Wiring selection of output Y7	0: Not used (default) 1: Double wiring (Source/Source) 2: Single wiring	Page 89 Safety output wiring selection function
	Output dark test execution setting	Output dark test execution setting Y0 to Output dark test execution setting Y7	0: Perform (default) 1: Do not perform	Page 105 Output dark test function
	Output dark test pulse OFF time setting	Output dark test pulse OFF time setting Y0 to Output dark test pulse OFF time setting Y7	0: 400μs (default) 1: 1ms 2: 2ms	
	Number of pulse output for output dark test	Number of pulse output for output dark test Y0 to Number of pulse output for output dark test Y7	0: 1 time (default) 1: 2 times 2: 3 times	
	Number of ON times integration function enable	Number of ON times integration function enable Y0 to Number of ON times integration function enable Y7	0: Disable (default) 1: Enable	Page 92 Number of safety output ON times integration function

## ■NZ2GFSS2-16DTE-S1

Unit	Item		Setting range	Reference
Station parameter	Safety setting	Transmission interval monitoring time	4 to 1000ms (default: 35)	Page 37 Safety remote I/O module safety response time
	I/O LED indication setting at error occurrence		0: No indication of error point (default) 1: Indication of error point	
	Cyclic data update monitoring time setting		0 to 20 (default: 0) × 100ms	
	Extension I/O setting	Input response time setting	0: 0ms 1: 0.2ms 2: 1.0ms 3: 1.5ms 4: 5ms 5: 10ms (default) 6: 20ms 7: 70ms	
		Output HOLD/CLEAR setting	0: CLEAR (default) 1: HOLD	
Operation setting of external power supply voltage error detection		0: Stop safety communication (default) 1: Continue safety communication (Without output interlock) 2: Continue safety communication (With output interlock)	Page 110 Operation Setting Function at Detection of External Power Supply Voltage Error	

Unit	Item		Setting range	Reference
Basic module parameter_main module	Wiring selection of input	Wiring selection of input X0 to Wiring selection of input X7	0: Not used (default) 1: Double wiring (NC/NC) 2: Single wiring	Page 85 Safety input wiring selection function
	Input response time [main module]	Input response time X0 to Input response time X7	0: 1.0ms (default) 1: 1.5ms 2: 5ms 3: 10ms 4: 20ms 5: 50ms 6: 70ms	Page 88 Safety input response time setting function
	Double input discrepancy detection setting	Double input discrepancy detection setting X0/X1 to Double input discrepancy detection setting X6/X7	0: Detect (default) 1: Do not detect	Page 93 Double input discrepancy detection function
	Double input discrepancy detection type	Double input discrepancy detection type X0/X1 to Double input discrepancy detection type X6/X7	0: Discrepancy detection time specified (default) 1: Discrepancy detection time not specified	
	Double input discrepancy auto recovery setting		0: Not used (default) 1: Used	
	Double input discrepancy detection time	Double input discrepancy detection time X0/X1 to Double input discrepancy detection time X6/X7	1 to 6000 (default: 1) × 10ms	
	Input dark test execution setting	Input dark test execution setting X0 to Input dark test execution setting X7	0: Perform (default) 1: Do not perform	Page 101 Input dark test function
	Input dark test pulse OFF time setting		0: 400μs (default) 1: 1ms 2: 2ms	
	Number of pulse output for input dark test		0: 1 time (default) 1: 2 times 2: 3 times	
	Wiring selection of output	Wiring selection of output Y0 to Wiring selection of output Y7	0: Not used (default) 1: Double wiring (Source/Source) 2: Single wiring	Page 89 Safety output wiring selection function
	Output dark test execution setting	Output dark test execution setting Y0 to Output dark test execution setting Y7	0: Perform (default) 1: Do not perform	Page 105 Output dark test function
	Output dark test pulse OFF time setting	Output dark test pulse OFF time setting Y0 to Output dark test pulse OFF time setting Y7	0: 400μs (default) 1: 1ms 2: 2ms	
	Number of pulse output for output dark test	Number of pulse output for output dark test Y0 to Number of pulse output for output dark test Y7	0: 1 time (default) 1: 2 times 2: 3 times	
	Number of ON times integration function enable	Number of ON times integration function enable Y0 to Number of ON times integration function enable Y7	0: Disable (default) 1: Enable	Page 92 Number of safety output ON times integration function

### Point

- Set all the items of the parameters displayed. If any item is left blank, the parameters cannot be written to the safety remote I/O module.
- For the monitoring area of the standard extension module, refer to the following.

 CC-Link IE Field Network Remote I/O Module User's Manual

## Parameter setting procedure

The following shows the procedure to set module parameters of the safety remote I/O module from the "Network Configuration Settings" window.



When the user authentication function of the CPU module is enabled, perform the logon of the user authentication function in advance. For the user authentication function, refer to the following.

Page 109 User Authentication Function

## Operating procedure

1. Display the "CC IE Field Configuration" window.

[Navigation window] ⇒ [Parameter] ⇒ [Module Information] ⇒ Model name ⇒ [Basic Settings] ⇒ [Network Configuration Settings] ⇒ "CC IE Field Configuration" window

2. Display the "Parameter Processing of Device Station" window.

Select the target main module. ⇒ [CC IE Field Configuration] ⇒ [Online] ⇒ [Parameter Processing of Device Station]

Name	Initial Value	Unit	Read Value	Unit	Write Value	Unit	Setting Range	Description
<b>Station parameter</b>								
<input checked="" type="checkbox"/> Transmission interval monitoring...	35	ms		ms		ms	4 to 1000	Set the transmission interval monitoring time for s
<input checked="" type="checkbox"/> Operation setting of external ...	0: Stop safe...							Set the operation setting of external power suppl
<b>Basic module parameter</b>								
<input checked="" type="checkbox"/> Wiring selection of input								Set the wiring method of input.
Wiring selection of input X0	0: Not used							Set the same value for X1 and X0 when "Double
Wiring selection of input X1	0: Not used							Set the same value for X1 and X0 when "Double
Wiring selection of input X2	0: Not used							Set the same value for X3 and X2 when "Double
Wiring selection of input X3	0: Not used							Set the same value for X3 and X2 when "Double



- Set "Method selection" to "Parameter write" so that a value can be set in an item of "Write Value". Set values in all the items of "Write Value". If an item where a value is not set exists, the parameters cannot be written. For the module parameter list for the safety remote I/O module, refer to the following.

☞ Page 72 Parameter Settings

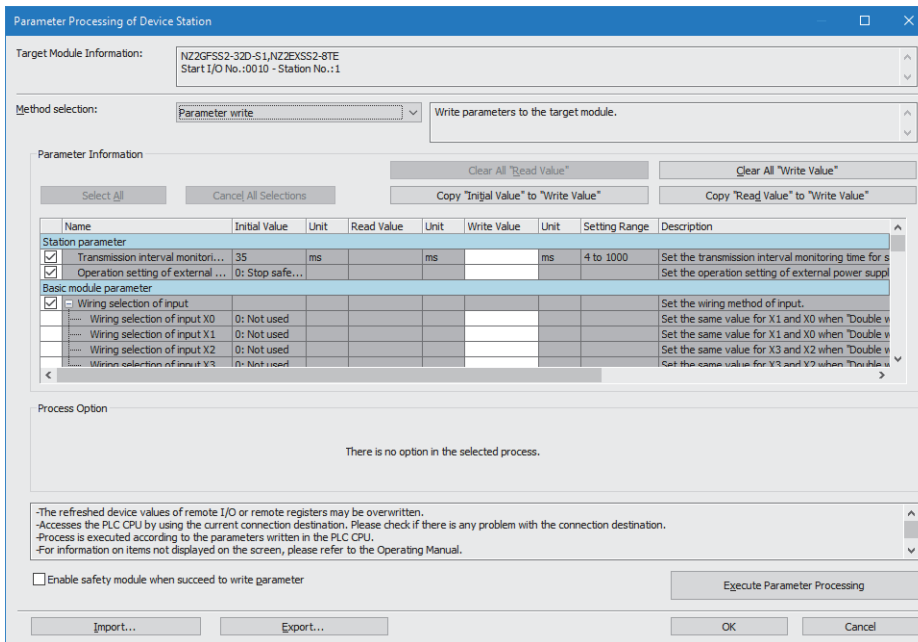

- Click the [Execute Parameter Processing] button and a confirmation window is displayed. Check the contents and click the [Yes] button to write the parameters.

- After the parameters are written, a confirmation dialog box is displayed.

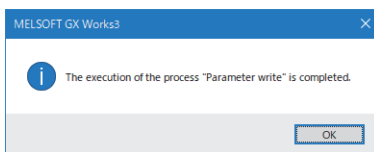

**Point**

- When writing parameters has failed, the following window is displayed.

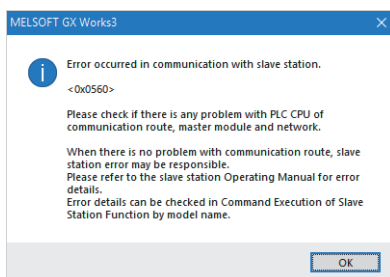

For error codes, refer to the following and take corrective actions.

☞ Page 138 List of Error Codes

📖 MELSEC iQ-R CC-Link IE Field Network User's Manual (Application)

- When "Parameter write" is executed with the Safety CPU set in the safety mode, an error window is displayed and the parameter writing is stopped. For details on the safety mode, refer to the following.

📖 MELSEC iQ-R CPU Module User's Manual (Application)

6. After writing parameters is completed, visually check that the module parameters have been normally written to the module. To check the module parameters, refer to the following.

GX Works3 Operating Manual

7. Perform the operations from "Parameter write" to the visual check of the module parameters for all safety remote I/O modules connected.

8. Set the module parameter of the master station "To Use of Not to Use the Safety Communication Setting" to "Use".

[Module Parameter] ⇒ [Application Settings] ⇒ [Safety Communication Setting] ⇒ [To Use of Not to Use the Safety Communication Setting]

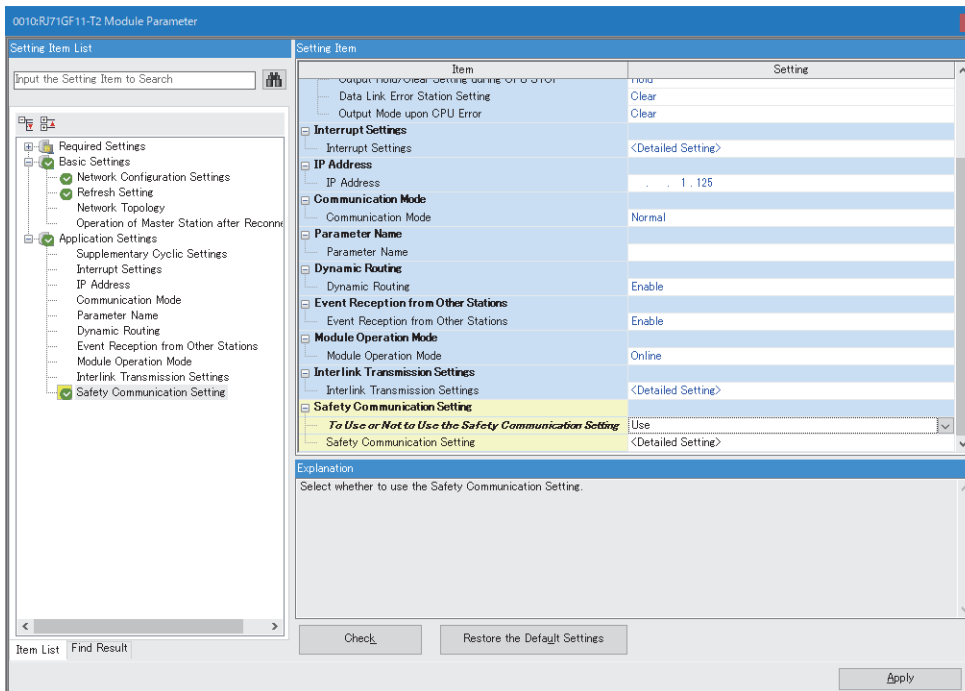

9. Select "Detailed Setting" of the module parameter of the master station "Safety Communication Setting" and the "Safety Communication Setting" window is displayed.

[Module Parameter] ⇒ [Application Settings] ⇒ [Safety Communication Setting] ⇒ [Safety Communication Setting]

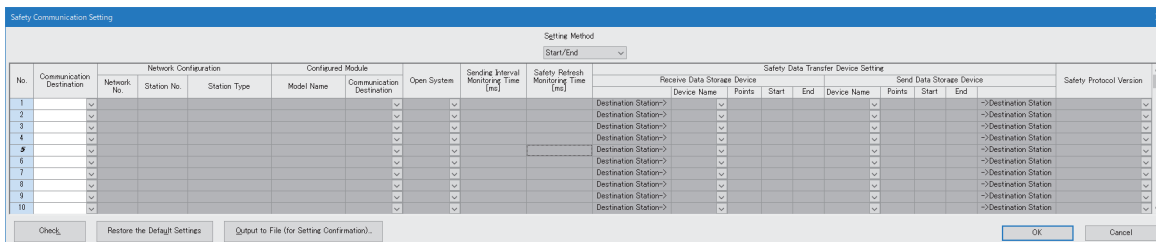

**10.** Select "Local Network" in "Communication Destination" and the "Select the target module for the Safety Communication Setting" window is displayed. Select the target safety remote I/O module and click the [Add] button.

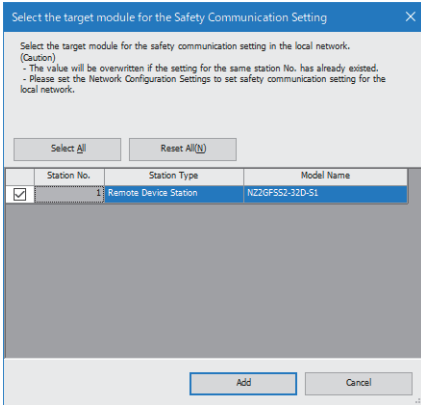

**11.** The parameters of the safety remote I/O module selected on the "Select the target module for the Safety Communication Setting" window are imported into the safety communication setting. Set "Sending Interval Monitoring Time", "Safety Refresh Monitoring Time", and "Safety Data Transfer Device Setting" and click the [OK] button.

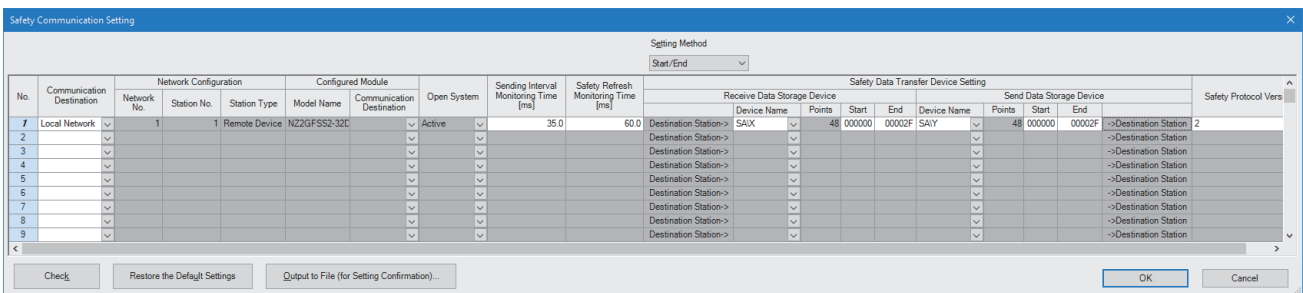

**Point**

For the setting values of "Sending Interval Monitoring Time" and "Safety Refresh Monitoring Time" for the master station, refer to the following.

MELSEC iQ-R CC-Link IE Field Network User's Manual (Application)

**12.** Write the parameters to the programmable controller again.

**Point**

- When newly setting the module parameters of the safety remote I/O module, be sure to set "Safety Communication Setting" and write the parameters to the programmable controller after that.
- When changing the station number or network configuration, be sure to set "Safety Communication Setting" and write the parameters to the programmable controller as well.
- When changing only the module parameters of the safety remote I/O module without changing the station number or network configuration, setting "Safety Communication Setting" is not required. However, be sure to write the parameters to the programmable controller after that.

**13.** When parameter writing to the programmable controller is completed, select the target safety remote I/O module in the "Network Configuration Settings" and display the "Command Execution of Device Station" window.

[Network Configuration Settings] ⇒ Select the target main module. ⇒ [CC IE Field Configuration] ⇒ [Online] ⇒ [Command Execution of Device Station]

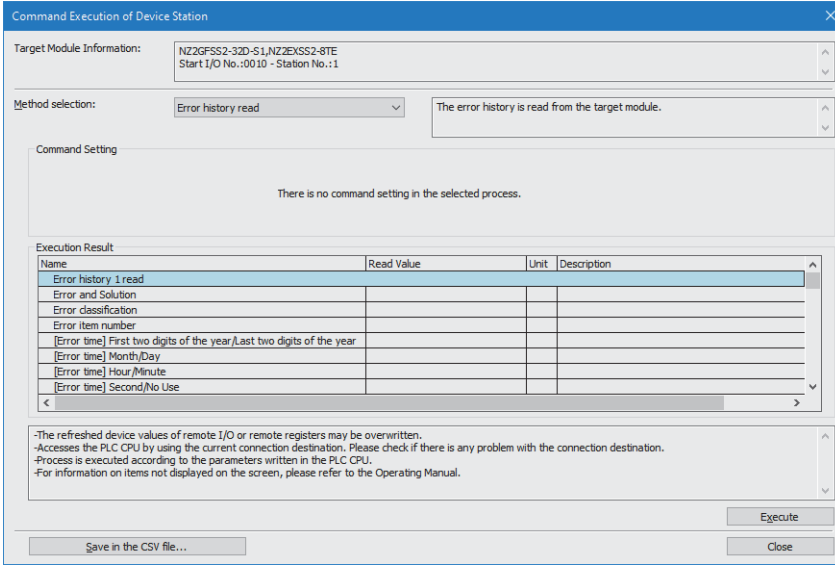

**14.** Select "Start of checking the module position" in "Method selection" and click the [Execute] button.

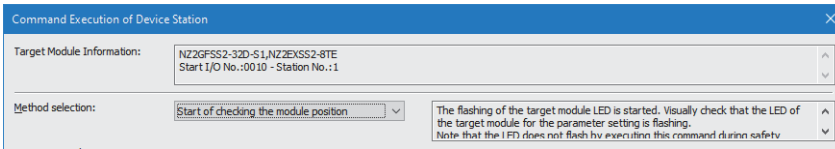

**15.** Clicking the [Execute] button displays a confirmation window. Check the contents and click the [Yes] button. The SAFETY LED of the selected safety remote I/O module starts flashing. Visually check that the safety remote I/O module on which the SAFETY LED is flashing is installed on the desired position. At the same time, visually check that the SAFETY LEDs of other safety remote I/O modules not targeted for the position checking are not flashing.



**16.** After checking the module position is completed, select "Stop of checking the module position" in "Method selection" on the "Command Execution of Device Station" window and click the [Execute] button.

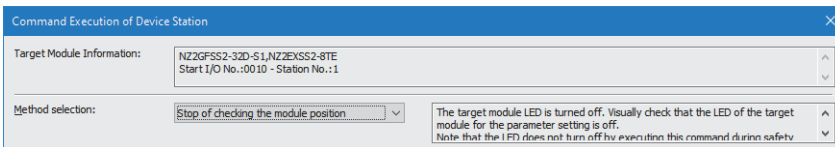

**17.** Clicking the [Execute] button displays a confirmation window. Check the contents and click the [Yes] button. The SAFETY LED of the safety remote I/O module turns off.

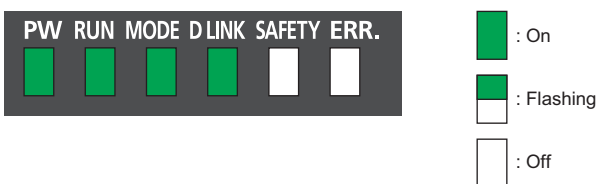

**18.** Perform the operations from "Start of checking the module position" to "Stop of checking the module position" for all safety remote I/O modules connected.

**19.** Select "Safety module validation" in "Method selection" and click the [Execute] button.

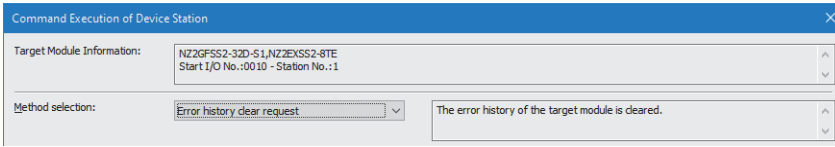

**20.** Clicking the [Execute] button displays the following confirmation window. Check the contents, and if the operations mentioned on the window are completed, click the [Yes] button. When the operations are not completed, click the [No] button. After performing the operations of "Confirm 1" and "Confirm 2", perform "Safety module validation" again.

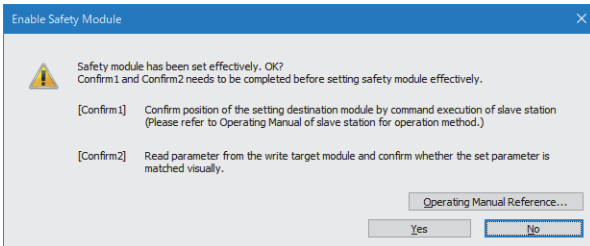

**21.** Clicking the [Yes] button displays a confirmation window. Check the contents and click the [Yes] button. The following window is displayed and the parameters set to the safety remote I/O module are validated.

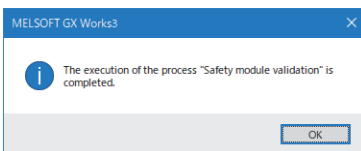

**Point**

When "Safety module validation" is executed with the Safety CPU set in the safety mode, an error window is displayed and the Safety module validation is stopped. For details on the safety mode, refer to the following.  
 MELSEC iQ-R CPU Module User's Manual (Application)

**22.** Restart the safety remote I/O module. The SAFETY LED turns on and the mode shifts to the safety operation mode.

**23.** Perform the operations from "Safety module validation" to the restart of the safety remote I/O module for all safety remote I/O modules connected.

**Point**

"Safety module validation" is cancelled if the following situations arise after the validation performance.



- The parameters have been set again.
- A parameter data error has occurred.
- The module configuration has been changed (connection/disconnection of an extension module).

When the safety remote I/O module where "Safety module validation" has been performed is connected to the different system, the SAFETY LED turns off even though the validation of the safety remote I/O module is not cancelled. Therefore, perform again "Parameter write" and "Safety module validation".

# 8 FUNCTIONS

---

This chapter describes the functions available in the safety remote I/O module, and the setting procedures for those functions. For details on safety remote I/O signals, remote control/monitor signals, and remote buffer memory, refer to the following.

-  Page 158 Safety Remote I/O Signals
-  Page 170 Remote Control/Monitor Signals
-  Page 178 Remote Buffer Memory

---

## **Point**

- When reading or writing data from/to the remote buffer memory with a program while using a function described in this manual, use the REMFR and REMTO instructions. For details, refer to the user's manual of the master/local module used.
- For details on the remote buffer memory addresses available for reading and writing data, refer to the following.

 Page 178 List of remote buffer memory areas

---

# 8.1 Safety Input Function

This function safely inputs external signals. This function cannot be used in any modes other than the safety operation mode. All the safety remote inputs (SAIX) are off in any modes other than the safety operation mode.

## Safety input wiring selection function

This function is used to select double wiring or single wiring of the input wiring.

### Double wiring function

The double wiring function supports double input wiring.

By verifying input signals of double wiring, safety inputs can be turned off even though one of the signals has an error.

In the safety operation mode, the power supply current terminal for input device (COM+) and 24V output of the T0/T1 terminal are enabled.

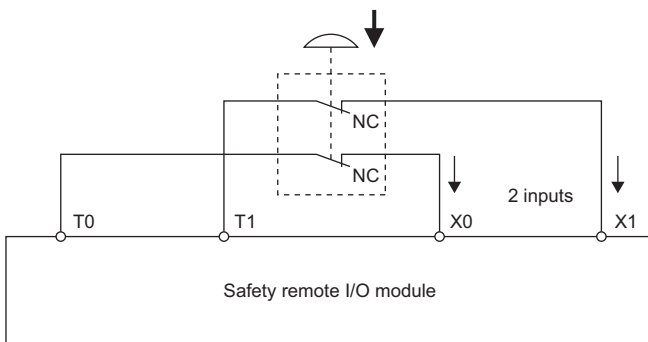

### ■Combination for double wiring

Use the following combinations of input terminals for double wiring to the safety remote I/O module.

- NZ2GFSS2-32D-S1

Combination of input terminals							
X0, X1	X2, X3	X4, X5	X6, X7	X8, X9	XA, XB	XC, XD	XE, XF
X10, X11	X12, X13	X14, X15	X16, X17	X18, X19	X1A, X1B	X1C, X1D	X1E, X1F

- NZ2GFSS2-8D-S1, NZ2GFSS2-16DTE-S1

Combination of input terminals			
X0, X1	X2, X3	X4, X5	X6, X7

The following table lists the relation of input terminals (X) and safety remote inputs (SAIX).

- NZ2GFSS2-32D-S1

Safety remote input (SAIX)	Input terminal (X)
SAIX0	X0
SAIX1	X1
⋮	⋮
SAIX1E	X1E
SAIX1F	X1F

- NZ2GFSS2-8D-S1, NZ2GFSS2-16DTE-S1

Safety remote input (SAIX)	Input terminal (X)
SAIX0	X0
SAIX1	X1
⋮	⋮
SAIX6	X6
SAIX7	X7

## Single wiring function

This function can connect input devices with single wiring.

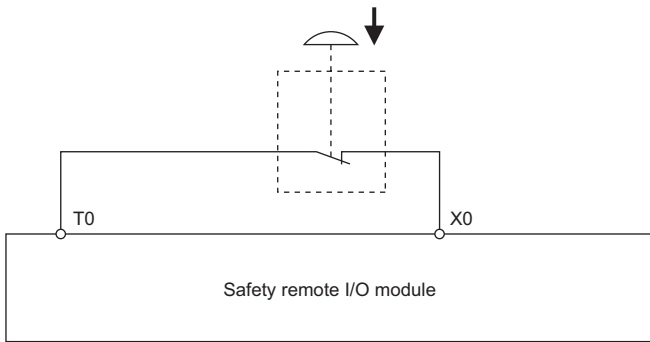

### Point

- To satisfy SIL3, Category 4 and PL e, use the double wiring function.
- Systems using single wiring do not comply with SIL3 or Category 4 PL e, although the wiring can be used for input using safety devices.
- When  $X_n$  ( $n$ : even number) is single wiring,  $X_{n+1}$  cannot be set to double wiring. When  $X_{n+1}$  is single wiring,  $X_n$  cannot be set to double wiring. If a different value is selected and the parameter is set, "Parameter data error (wiring selection of input): error code 0511H" occurs.

## Diagnostic functions to detect input errors

Input errors can be detected by using the following diagnostic functions.

Diagnostic function	Description	Reference
Double input discrepancy detection function	Detects the discrepancy of double input signals.	Page 93 Double input discrepancy detection function
Input dark test function	Outputs test pulses to turn off the inputs that are on and diagnoses contacts including external devices for failure.	Page 101 Input dark test function

## Combination of double inputs

The safety remote I/O module evaluates the logic of input signals and reflects the results to safety remote inputs (SA\X). When the double input signals differ, the double input discrepancy detection state is applied. The following table lists the correspondence between each double input signal state and safety remote input (SA\X).

Input terminal state		Safety remote input		Evaluation result of double inputs
$X_n^{*1}$	$X_{n+1}^{*1}$	$SA\X_m^{*2}$	$SA\X_{m+1}^{*2}$	
OFF	OFF	OFF	OFF	OFF (Normal)
OFF	ON	OFF	OFF	OFF (Discrepancy)
ON	OFF	OFF	OFF	OFF (Discrepancy)
ON	ON	ON	ON	ON (Normal)

\*1 n: Even number

\*2 m: Safety device address (even number from 0 to 1E for the NZ2GFSS2-32D-S1 or from 0 to 6 for the NZ2GFSS2-8D-S1 and the NZ2GFSS2-16DTE-S1) assigned to the master station



## States of safety remote inputs (SAIX0, SAIX1) for X0 and X1 (double wiring)

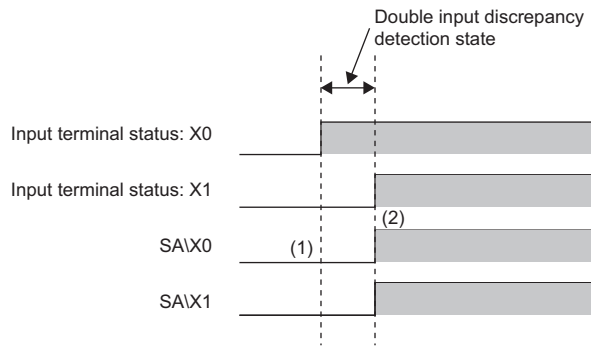

(1) Even when the input terminal X0 turns on, SAIX0 does not turn on because X1 is off.

(2) When the double inputs are on (X0 and X1 are on), SAIX0 and SAIX1 turn on.

## External input signal monitor function

The state of input terminals can be monitored. This function facilitates the investigation for the cause of a double input discrepancy error. For details, refer to the following.

☞ Page 174 External input monitor

### Point

External input monitors are the remote control/monitor signals to investigate the cause of a double input discrepancy error. Do not use them in a safety program.

## Setting method

Set the input wiring selection in "Wiring selection of input" from the "Parameter Processing of Device Station" window of the engineering tool.

For the procedure to display the "Parameter Processing of Device Station" window, refer to the following.

☞ Page 72 Parameter Settings

Item	Setting range
Wiring selection of input X□	0: Not used 1: Double wiring (NC/NC) 2: Single wiring

### Point

- When Wiring selection of input Xn is set to "0: Not used", input data is always off.
- When Xn (n: even number) is set to "1: Double wiring (NC/NC)", only the same setting value as Xn can be set for Xn+1, the partner of Xn. If a different value is selected and the parameter is set, "Parameter data error (wiring selection of input): 0511H" occurs.
- When Wiring selection of input Xn (n: even number) is set to "1: Double wiring (NC/NC)", set Xn+1, the partner of Xn, to "1: Double wiring (NC/NC)".
- For unused input terminals, set "0: Not used" in "Wiring selection of input".

## Safety input response time setting function

The safety input response time setting function is used to set the filter time to reduce incorrect inputs caused by noise in input signals.

The longer the input response time is, the higher tolerance for chattering and noise the module has. But the response to input signals becomes slower. The shorter the input response time is, the quicker the response to input signals is. But the tolerance for chattering and noise is reduced. To set the input response time, consider fully the operating environment.

### Ex.

When Input response time is set to "1ms"

Without any noise effects, the time set in input response time and the time taken from when an external input turns on or off until when the corresponding X input signal in the safety remote I/O module turns on or off are equal.

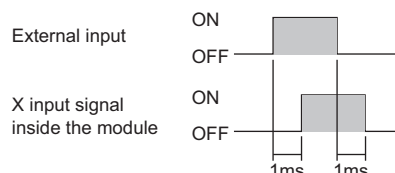

## Relation of the parameters for the input response time and input dark test

Set the input response time to satisfy the following condition.

Input response time > Input dark test pulse output time<sup>\*1</sup>

\*1 Input dark test pulse output time = Pulse OFF time for the input dark test × ((Number of pulse outputs for the input dark test × 2) - 1)

For details on the input dark test, refer to the following.

☞ Page 101 Input dark test function

## Setting method

Set the input response time in "Input response time" from the "Parameter Processing of Device Station" window of the engineering tool.

For the procedure to display the "Parameter Processing of Device Station" window, refer to the following.

☞ Page 72 Parameter Settings

Item	Setting range
Input response time X□	For the NZ2GFSS2-32D-S1 0: 1ms 1: 5ms 2: 10ms 3: 20ms 4: 50ms
	NZ2GFSS2-8D-S1 or NZ2GFSS2-16DTE-S1 0: 1.0ms 1: 1.5ms 2: 5ms 3: 10ms 4: 20ms 5: 50ms 6: 70ms

### Point

- When Wiring selection of input Xn (n: even number) is set to "1: Double wiring (NC/NC)", set the same input response time as Xn for Xn+1, the partner of Xn.
- When the wiring of Xn (n: even number) is set to "1: Double wiring (NC/NC)", only the same setting value (same input response time) as Xn can be set for Xn+1. If a different value is selected and the parameter is set, "Parameter data error (input response time): error code 0512H" occurs.

## 8.2 Safety Output Function

This function safely outputs signals. This function cannot be used in any modes other than the safety operation mode. All the safety remote outputs (SAI\Y) are off in any modes other than the safety operation mode.

### Safety output wiring selection function

This function is used to select double wiring or single wiring of the output wiring.

#### Double wiring function

The double wiring function supports double outputs. By multiplying output signals using double wiring, safety outputs can be turned off even though one of the signals has an error.

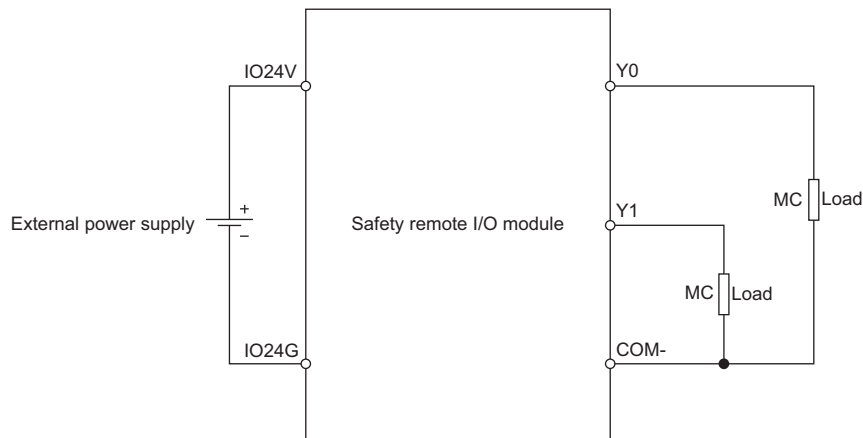

#### ■Combination for double wiring

Use the following combinations of output terminals for double wiring to the safety remote I/O module.

Combination of output terminals			
Y0, Y1	Y2, Y3	Y4, Y5	Y6, Y7

The following table lists the relation of output terminals (Y) and safety remote outputs (SAI\Y).

Safety remote output (SAI\Y)	Output terminal (Y)
SAI\Y0	Y0
SAI\Y1	Y1
⋮	⋮
SAI\Y6	Y6
SAI\Y7	Y7

## Single wiring function

This function can connect output devices with single wiring.

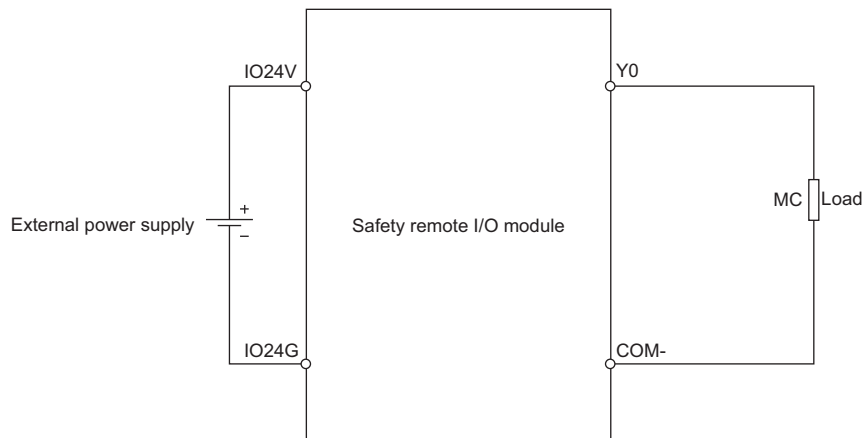



### Point

- To satisfy SIL3, Category 4 and PL e, use the double wiring function.
- Systems using single wiring do not comply with SIL3 or Category 4 PL e, although the wiring can be used for output using safety devices.

## Diagnostic functions to detect output errors

Output errors can be detected by using the following diagnostic functions.

Diagnostic function	Description	Reference
Output dark test function	Outputs test pulses to turn off the outputs that are on and diagnoses contacts for failure.	 Page 105 Output dark test function
Output read-back function	Reads back output results and diagnoses whether the outputs are correctly on or off.	 Page 107 Output read-back function

## Combination of double outputs

Both terminals of double outputs are turned on only when both safety remote outputs (SAIY) are on. The safety remote I/O module evaluates the logic of safety remote outputs (SAIY) and determines the state of the output terminals. The following table lists the correspondence between each state of safety remote output (SAIY) and output terminal for double outputs.

Safety remote output		Output terminal state		Evaluation result of double outputs
SAIY <sup>m</sup> *1	SAIY <sup>m+1</sup> *1	Y <sup>n</sup> *2	Y <sup>n+1</sup> *2	
OFF	OFF	OFF	OFF	OFF (Normal)
OFF	ON	OFF	OFF	OFF (Discrepancy)
ON	OFF	OFF	OFF	OFF (Discrepancy)
ON	ON	ON	ON	ON (Normal)

\*1 m: Safety device address (even number from 0 to 6) assigned to the master station

\*2 n: Even number from 0 to 6

### States of safety remote outputs (SAIY0, SAIY1) for Y0 and Y1 (double wiring)

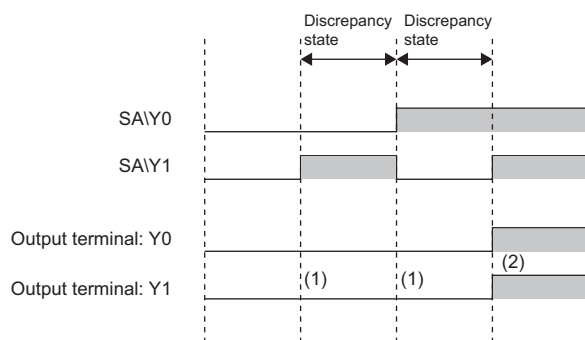

(1) When double outputs (source/source) are in the discrepancy state (SAIY0 and SAIY1 are different), Y0 and Y1 are off.

(2) When double outputs (source/source) are on (SAIY0 and SAIY1 are on), Y0 and Y1 are on.

## Setting method

Set the output wiring selection in "Wiring selection of output" from the "Parameter Processing of Device Station" window of the engineering tool.

For the procedure to display the "Parameter Processing of Device Station" window, refer to the following.

Page 72 Parameter Settings

Item	Setting range
Wiring selection of output Y□	0: Not used 1: Double wiring (Source/Source) 2: Single wiring

### Point

- When "Wiring selection of output" Y<sub>n</sub> is set to "0: Not used", output data is always off.
- When "Wiring selection of output" Y<sub>n</sub> (n: even number) is set to "1: Double wiring (Source/Source)", set Y<sub>n+1</sub>, the partner of Y<sub>n</sub>, to "1: Double wiring (Source/Source)".
- For unused output terminals, set "0: Not used" in "Wiring selection of output".

# Number of safety output ON times integration function

This function counts the number of ON times of each output point within the range of 0 to 2147483647. The integration value remains even though the output module is powered off. Whether to enable or disable the function can be set for each output point from the module parameter setting window of the engineering tool or the program. When the value for "Number of ON times integration function enable" is "1: Enable", the number of ON times at the corresponding output point is counted. When "0: Disable" is set, the number of ON times at the corresponding output point is not counted.

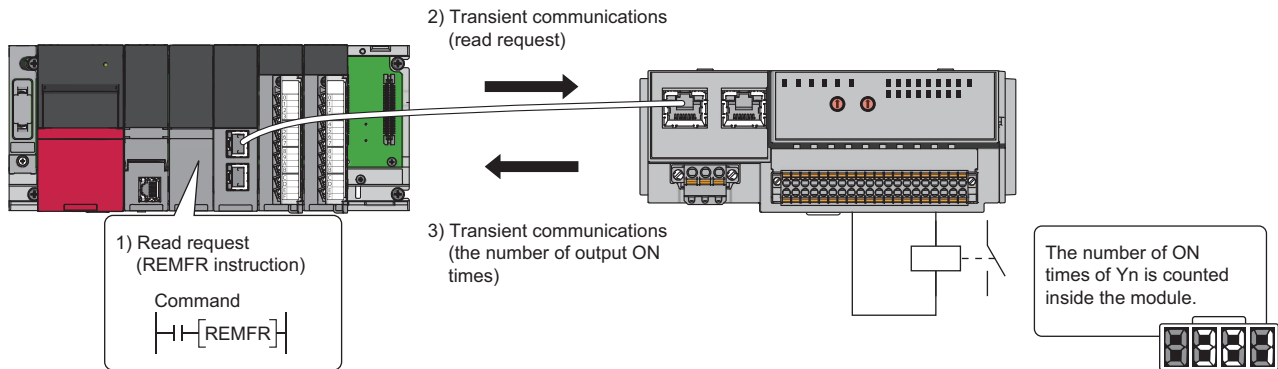

## Checking and clearing the number of ON times

The number of ON times can be checked and cleared with the program.

Item	Address			Description
	NZ2GFSS2-8TE-S1	NZ2GFSS2-16DTE-S1	Extension module	
Number of ON times integration value Y0 to Y7	0610H to 061FH	0610H to 061FH	0710H to 071FH	Stores the integration value of the number of ON times integration function.
Number of ON times integration value Y8 to YF	—	—	0720H to 072FH	
Number of ON times integration value clear command Y0 to YF	1100H	1100H	1200H	When the corresponding bit of output is turned on, the integration value for the output counted by the number of ON times integration function is cleared to zero.
Number of ON times integration value clear completed Y0 to YF	1101H	1101H	1201H	After the integration value is cleared to zero using Number of ON times integration value clear command Y□ (address: 1100H), the bit of the output which is cleared to zero turns on.

### Point

- When the ON time and the OFF time of the target output signal are less than 4ms, the output module cannot recognize the output change and the number of ON times may not be counted.
- When the number of ON times integration value exceeds 2147483647, the count stops. To integrate the number of ON times continuously, clear the integration value by using Number of ON times integration value clear command Y□ (address: 1100H, 1200H).

## Setting method

Set the number of ON times integration function in "Number of ON times integration function enable" from the "Parameter Processing of Device Station" window of the engineering tool.

For the procedure to display the "Parameter Processing of Device Station" window, refer to the following.

☞ Page 72 Parameter Settings

Item	Setting range
Number of ON times integration function enable Y□*1	<ul style="list-style-type: none"> <li>• 0: Disable</li> <li>• 1: Enable</li> </ul>

\*1 Y□ has the same item and setting range.

## 8.3 Input Diagnostic Function

### Double input discrepancy detection function

This function discriminates failures by monitoring the discrepancy state of doubled safety remote inputs (SAIX).

#### Double input discrepancy detection

##### ■ Double input discrepancy detection (with discrepancy detection time specified)

If "Double input discrepancy detection setting" is set to "0: Detect" and "Double input discrepancy detection type" is set to "0: Discrepancy detection time specified" from the "Parameter Processing of Device Station" window, a double input discrepancy detection error is generated as an input error when the discrepancy state of double inputs continues for the set time or longer. For the double input discrepancy detection time, refer to the following.

☞ Page 97 Double input discrepancy detection time

The following figure shows the operation details of the double input discrepancy detection (with discrepancy detection time specified) for double wiring inputs X0 and X1.

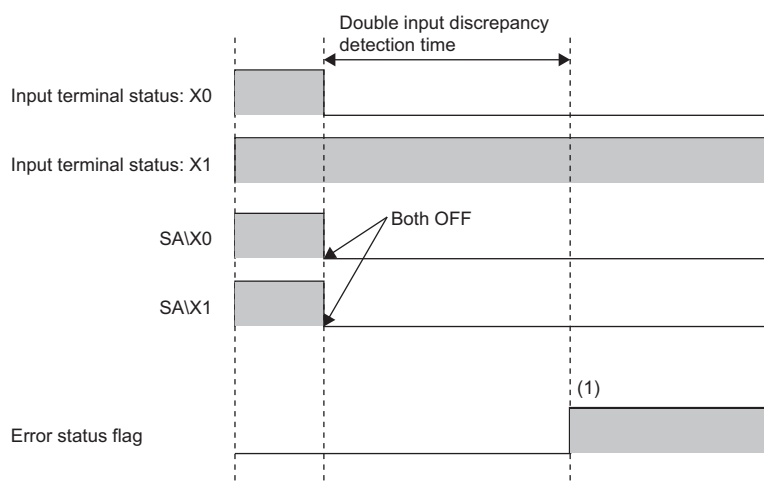

(1) After the double input discrepancy detection time elapses, a double input discrepancy detection error occurs.

##### ■ Operation at error detection (with discrepancy detection time specified)

When the discrepancy state of double inputs continues for the set time or longer, the error (double input discrepancy detection error) state is applied to the safety remote I/O module. For the error state, refer to the following.

☞ Page 138 Error codes related to the safety remote I/O module

The corresponding input points are turned off when the discrepancy state of inputs occurs.

#### Point

For the NZ2GFSS2-8D-S1 or NZ2GFSS2-16DTE-S1, when an error occurs for all the input points due to the input dark test error or double input discrepancy detection error and the input function cannot be performed anymore, an error state of I/O data error (010BH) is applied. However, when a minor error of double input discrepancy detection error occurs while "1: Use" is set for the parameter "Double input discrepancy auto recovery setting", the input function may be recovered. Thus, an error of I/O data error (error code 010BH) does not occur even though the error occurs for all the input points.

## ■ Double input discrepancy detection (with discrepancy detection time not specified)

When "Double input discrepancy detection setting" is set to "0: Detect" and "Double input discrepancy detection type" is set to "1: Discrepancy detection time not specified" from the "Parameter Processing of Device Station" window, no input error occurs even though the discrepancy state of double inputs continues. When both input signals turn on and remain on for 500ms, a double input discrepancy detection error occurs as an input error.

The following shows the operation details of the double input discrepancy detection (with discrepancy detection time not specified) for double wiring inputs X0 and X1. The operation is explained for two cases: when a double input discrepancy detection error does not occur and when that error occurs.

- When a double input discrepancy detection error does not occur

When the discrepancy (ON/OFF or OFF/ON) state of input terminals continues for longer than 500ms after changed from ON/ON state, the double input discrepancy is detected and the double input discrepancy detection state is applied. The minor error (double input discrepancy detection error) does not occur. After that, if OFF/OFF state of input terminals is detected, the double input discrepancy detection state is eliminated.

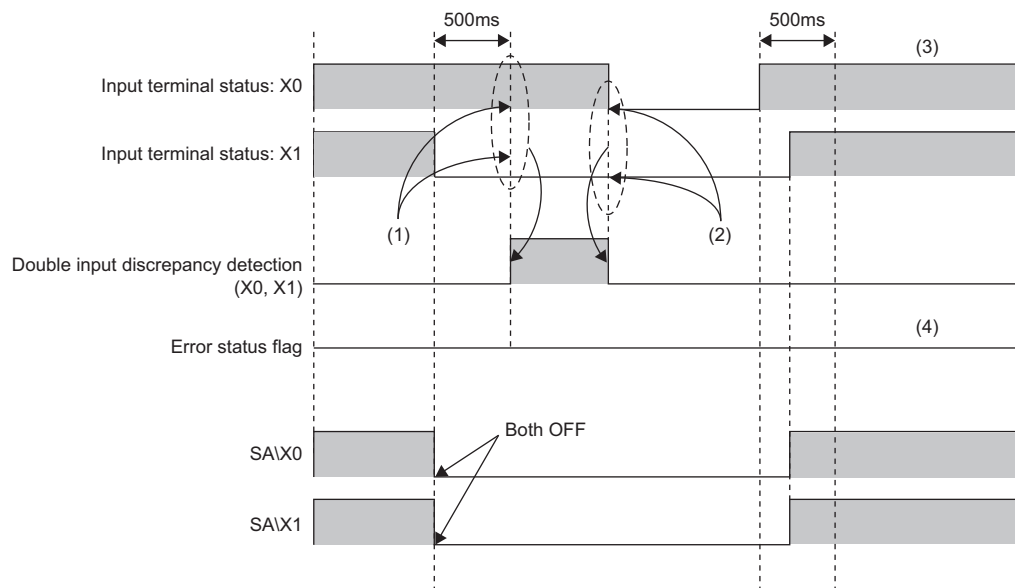

- (1) Detects a double input discrepancy.
- (2) The double input discrepancy detection state is eliminated when the state of input terminals (X0, X1) becomes OFF/OFF.
- (3) When a time lag between each input terminal (X0, X1) returning to ON state is 500ms or shorter, SAIX0 and SAIX1 are turned on as well.
- (4) A double input discrepancy detection error does not occur.



- When a double input discrepancy detection error occurs

When the discrepancy (ON/OFF or OFF/ON) state of input terminals continues for longer than 500ms after changed from ON/ON state, the double input discrepancy is detected and the double input discrepancy detection state is applied. The error (double input discrepancy detection error) does not occur. In the double input discrepancy detection state, if the state of input terminals returns to ON/ON state and the state continues for longer than 500ms, the error (double input discrepancy detection error) occurs.

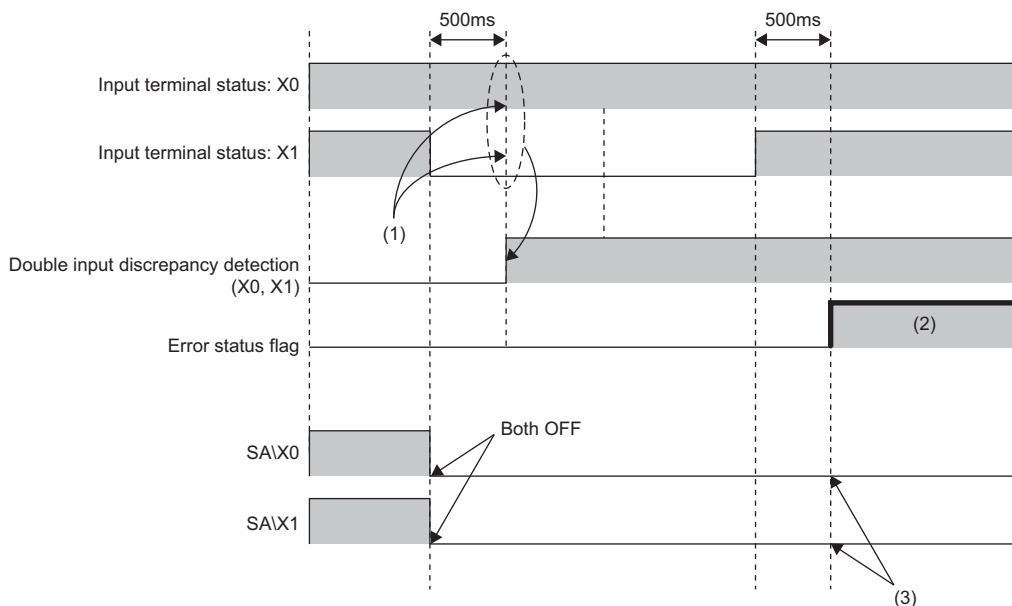

- (1) Detects a double input discrepancy.
- (2) A double input discrepancy detection error occurs.
- (3) SAIX0 and SAIX1 remain off.

### ■ Operation at error detection (with discrepancy detection time not specified)

In the double input discrepancy detection state, if the state of input terminals returns to ON/ON state and the state continues for longer than 500ms, the error (double input discrepancy detection error) occurs. For the error state, refer to the following.

☞ Page 138 Error codes related to the safety remote I/O module

The corresponding input points are turned off when the discrepancy state of inputs occurs.

#### Point

For the NZ2GFSS2-8D-S1 or NZ2GFSS2-16DTE-S1, when an error occurs for all the input points due to the input dark test error or double input discrepancy detection error and the input function cannot be performed anymore, an error state of I/O data error (010BH) is applied. However, when a minor error of double input discrepancy detection error occurs while "1: Use" is set for the parameter "Double input discrepancy auto recovery setting", the input function may be recovered. Thus, an error of I/O data error (error code 010BH) does not occur even though the error occurs for all the input points.

## ■Application and example of double input discrepancy detection (with discrepancy detection time not specified)

When a certain double input discrepancy detection time cannot be applied for the application, this function is used. Even if a double input discrepancy is detected, a double input discrepancy detection error does not occur immediately. The error occurs only when certain conditions are satisfied.

The following shows an example of when this function is used for the double sensor of door switches that are opened or closed manually.

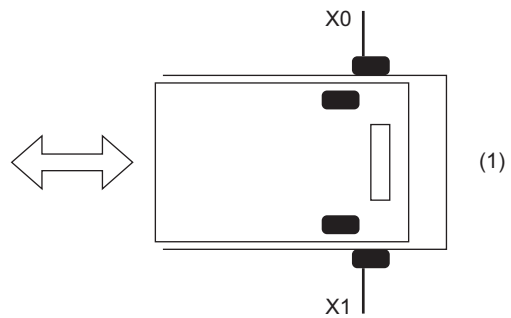

(1) A door is half-opened.

If a door is half-opened, fully open it once and then close it. With this operation you can confirm that both of door sensors turn off and distinguish the discrepancy due to failure from the discrepancy due to a half-closed door. In addition, the door can be used continuously without a double input discrepancy detection error.

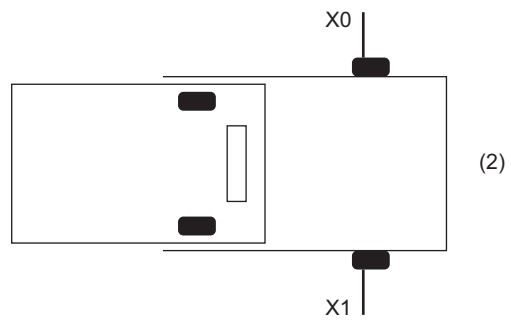

(2) Fully open the door.

When the double input discrepancy auto recovery function is enabled, a double input discrepancy detection error caused by closing a half-opened door can be eliminated by fully opening the door again. For details on the double input discrepancy auto recovery function, refer to the following.

☞ Page 99 Double input discrepancy auto recovery function

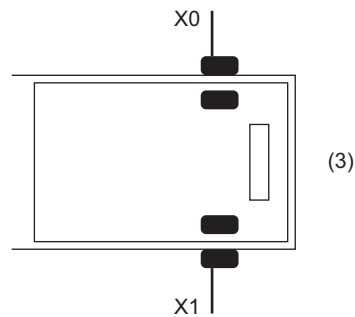

(3) Close the door again.

## Setting method

Configure the double input discrepancy detection setting in "Double input discrepancy detection setting" and "Double input discrepancy detection type" from the "Parameter Processing of Device Station" window of the engineering tool.

For the procedure to display the "Parameter Processing of Device Station" window, refer to the following.

 Page 72 Parameter Settings

Item	Setting range
Double input discrepancy detection setting Xn, Xn+1 <sup>*1</sup>	0: Detect 1: Do not detect

\*1 n: Even number

### Point

- When an item other than "1: Double wiring (NC/NC)" is selected in "Wiring selection of input", only "1: Do not detect" can be selected for "Double input discrepancy detection setting".
- When double input discrepancy errors do not need to be detected during equipment maintenance including system start-up and inspection, select "1: Do not detect".

Item	Setting range
Double input discrepancy detection type Xn, Xn+1 <sup>*2</sup>	0: Discrepancy detection time specified 1: Discrepancy detection time not specified

\*2 n: Even number

### Point

When "1: Do not detect" is selected in "Double input discrepancy detection setting", the setting of "Double input discrepancy detection type" is ignored.

## Double input discrepancy detection time

When the double input discrepancy detection time is set, an error does not occur during the set detection time even if double input discrepancy is detected. The following table lists the relation of each double input evaluation result and the double input discrepancy detection time.

Input terminal state		Time passed after the discrepancy state is applied	Safety remote input		Evaluation result of double inputs
Xn <sup>*1</sup>	Xn+1 <sup>*1</sup>		SA\Xm <sup>*2</sup>	SA\Xm+1 <sup>*2</sup>	
OFF	OFF	—	OFF	OFF	OFF (Normal)
OFF	ON	< Double input discrepancy detection time	OFF	OFF	OFF (Discrepancy)
OFF	ON	≥ Double input discrepancy detection time	OFF	OFF	Double input discrepancy detection error
ON	OFF	< Double input discrepancy detection time	OFF	OFF	OFF (Discrepancy)
ON	OFF	≥ Double input discrepancy detection time	OFF	OFF	Double input discrepancy detection error
ON	ON	—	ON	ON	ON (Normal)

\*1 n: Even number from 0 to 1E for the NZ2GFSS2-32D-S1 or from 0 to 6 for the NZ2GFSS2-8D-S1 and the NZ2GFSS2-16DTE-S1

\*2 m: Safety device address (even number from 0 to 1E for the NZ2GFSS2-32D-S1 or from 0 to 6 for the NZ2GFSS2-8D-S1 and the NZ2GFSS2-16DTE-S1) assigned to the master station

## ■Setting method

Set the double input discrepancy detection time in "Double input discrepancy detection time" from the "Parameter Processing of Device Station" window of the engineering tool.

For the procedure to display the "Parameter Processing of Device Station" window, refer to the following.

☞ Page 72 Parameter Settings

Item	Setting range
Double input discrepancy detection time $X_n, X_{n+1}$ *1	1 to 6000 (×10ms)

\*1 n: Even number from 0 to 1E for the NZ2GFSS2-32D-S1 or from 0 to 6 for the NZ2GFSS2-8D-S1 and the NZ2GFSS2-16DTE-S1

### Point

- A double input discrepancy error is detected in signals from which noise is filtered. Therefore, the time taken from when actual signals are in the discrepancy state until when a double input discrepancy detection error occurs is equal to the input response time + double input discrepancy detection time.
- The setting of "Double input discrepancy detection time" is valid only for the input signals to which "0: Detect" is set in "Double input discrepancy detection setting" and "0: Discrepancy detection time specified" is set in "Double input discrepancy detection type". For input signals with values other than the above set, the value set for "Redundant input discrepancy detection time" will be ignored.

## ■Reference for the double input discrepancy detection time

Status	Set time
For mechanical switches and sensor inputs	Set the time based on the following values: 100ms for mechanical switches and 20ms for sensor inputs.
When the synchronous time for double inputs can be defined	For the input devices whose synchronous time specifications is open to the public, set the double input discrepancy detection time considering the safety factor for the false detection. Use the safety factor of 2 times or higher and set the double input discrepancy detection time to prevent false detection depending on the input devices used. For example, when the synchronous time is 1s, 2s shall be set as the double input discrepancy detection time considering the safety factor of 2 times.
When the synchronous time for double inputs cannot be defined	When the synchronous time cannot be defined for the application, such as usage of a door switches that are opened or closed manually, set the maximum time or set "1: Do not detect" in "Double input discrepancy detection setting". Even when "1: Do not detect" is set, the system stops when one of the input signals turns off. Therefore, safety is ensured by inspecting the safety remote I/O module periodically at a sufficiently short interval.

## Double input discrepancy auto recovery function

When a double input discrepancy detection error has occurred, removing the error factor recovers the module into the normal state automatically. By enabling this function, the reset operation of the safety remote I/O module to reset errors is not required. When this function is enabled and a double input discrepancy is detected, the error state is applied to the safety remote I/O module. For details on the error state, refer to the following.

☞ Page 138 Error codes related to the safety remote I/O module

### ■Auto recovery timing

To clear a double input discrepancy detection error, turning off both of the actual input signals is required. The following figure shows the timing of when the module is automatically recovered from a double input discrepancy detection error.

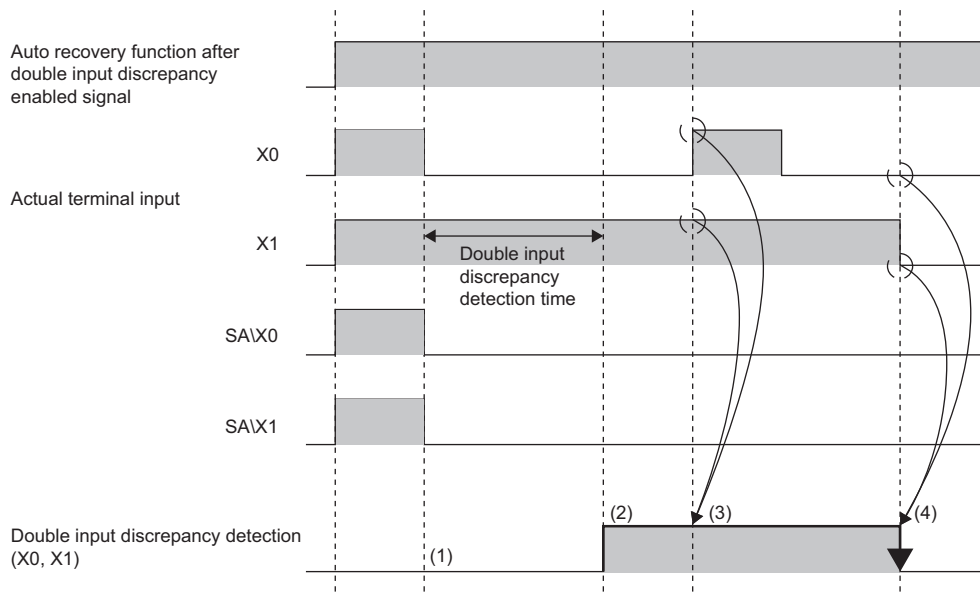

- (1) Both SAIX0 and SAIX1 turn off when discrepancy is detected.
- (2) A double input discrepancy detection error occurs.
- (3) The auto recovery is not performed even though both X0 and X1 turn on.
- (4) The auto recovery is performed when both X0 and X1 turn off.

## ■Monitor signal for the double input discrepancy detection state

When "Double input discrepancy auto recovery setting" is set to "1: Used", the detection state of a double input discrepancy can be monitored using Double input discrepancy detection state. For details on Double input discrepancy detection state, refer to the following.

☞ Page 192 Double input discrepancy detection state

### Point

- Double input discrepancy detection state is a remote buffer memory area for monitoring. Do not use this buffer memory area in a safety program.
- For the NZ2GFSS2-32D-S1, Double input discrepancy detection state is defined in remote buffer memory, and for the NZ2GFSS2-8D-S1 or NZ2GFSS2-16DTE-S1, it is defined in the safety device.

☞ Page 158 Safety Remote I/O Signals

## ■Double input discrepancy auto recovery enabled signal

When "Double input discrepancy auto recovery setting" is set to "1: Used", Double input discrepancy auto recovery enabled signal turns on. For details on Double input discrepancy auto recovery enabled signal, refer to the following.

☞ Page 192 Double input discrepancy auto recovery enabled signal

### Point

- Double input discrepancy auto recovery enabled signal is a remote buffer memory area for monitoring. Do not use this buffer memory area in a safety program.
- Double input discrepancy auto recovery enabled signal is available only in the NZ2GFSS2-32D-S1.

## ■Setting method

Set the double input discrepancy auto recovery function in "Double input discrepancy auto recovery setting" from the "Parameter Processing of Device Station" window of the engineering tool.

For the procedure to display the "Parameter Processing of Device Station" window, refer to the following.

☞ Page 72 Parameter Settings

Item	Setting range
Double input discrepancy auto recovery setting	0: Not used 1: Used

### Point

- "Double input discrepancy auto recovery setting" is valid only for the input signals for which "0: Detect" is set in "Double input discrepancy detection setting".
- Double input discrepancy auto recovery enabled signal is available only in the NZ2GFSS2-32D-S1.

# Input dark test function

This function outputs test pulses to turn off the external input signals (X□) that are on and diagnoses contacts including external devices for failure. Failures including circuit fixing and short-circuit faults can be detected. The OFF time for test pulses and the number of pulse outputs used in one diagnostic can be set depending on the usage environment.

**Point** 

The input dark test detects a short-circuit fault that occurs between X<sub>n</sub> (n: even number) and X<sub>n+1</sub>. The X<sub>n</sub> is an input terminal to be connected to T0, and the X<sub>n+1</sub> is an input terminal to be connected to T1. Note that a short-circuit fault between X<sub>n</sub> and X<sub>n</sub> or between X<sub>n+1</sub> and X<sub>n+1</sub> cannot be detected. Thus, do not use the input dark test for a system where a short-circuit fault may occur between X<sub>n</sub> and X<sub>n</sub> or between X<sub>n+1</sub> and X<sub>n+1</sub>.

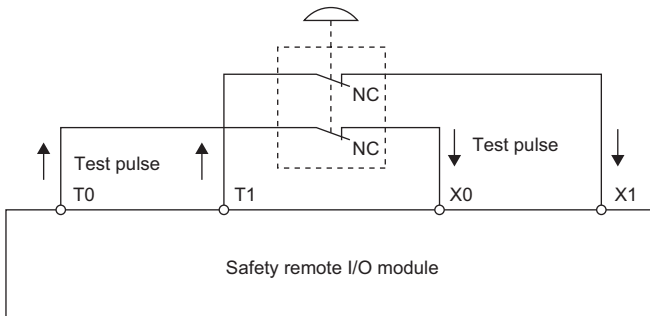

To use the input dark test function, use the test pulse output terminals (T□) and connect input devices.

To use the input dark test function, use the input terminals and test pulse output terminals (T□) of the safety remote I/O module in the following combinations. An incorrect combination is regarded as a disconnection, and an error (input dark test error) occurs.

- NZ2GFSS2-32D-S1

Test pulse output terminal	Input terminal
T0	X0, X2, X4, X6, X8, XA, XC, XE
T1	X1, X3, X5, X7, X9, XB, XD, XF
T2	X10, X12, X14, X16, X18, X1A, X1C, X1E
T3	X11, X13, X15, X17, X19, X1B, X1D, X1F

- NZ2GFSS2-8D-S1, NZ2GFSS2-16DTE-S1

Test pulse output terminal	Input terminal
T0	X0, X2, X4, X6
T1	X1, X3, X5, X7

**Point** 

When the input dark test is not executed, input devices can be connected with a combination of input terminals and COM+ terminals.

## Operation at error detection

When an error is detected in a diagnostic of the input dark test, the error (input dark test error) state is applied. For details on the error state, refer to the following.

 Page 138 Error codes related to the safety remote I/O module

### **Point**

- For the NZ2GFSS2-32D-S1, when an error is detected in the input dark test, output dark test, or output read-back diagnostic, the minor error state is applied to the module. However, when multiple errors are detected and all I/O points of the module are turned off, the moderate error state of "Self-diagnostic error" is applied.
- For the NZ2GFSS2-8D-S1 or NZ2GFSS2-16DTE-S1, when an error occurs for all the input points due to the input dark test error or double input discrepancy detection error and the input function cannot be performed anymore, an error state of I/O data error (010BH) is applied. However, when a minor error of double input discrepancy detection error occurs while "1: Use" is set for the parameter "Double input discrepancy auto recovery setting", the input function may be recovered. Thus, an error of I/O data error (error code 010BH) does not occur even though the error occurs for all the input points. When an error is detected in the input dark test, the minor error state is applied to the module.



## Setting method

Set the following parameters for the input dark test function.

### Point

There is a mutual relation of the parameter values of the input response time and input dark test. When setting parameters, set values that meet the mutual relation. For details, refer to the following.

☞ Page 88 Relation of the parameters for the input response time and input dark test

### Input dark test execution setting

Set whether to perform the input dark test or not in "Input dark test execution setting" from the "Parameter Processing of Device Station" window of the engineering tool.

For the procedure to display the "Parameter Processing of Device Station" window, refer to the following.

☞ Page 72 Parameter Settings

Item	Setting range
Input dark test execution setting <input type="checkbox"/>	0: Perform 1: Do not perform

### Point

- When "Wiring selection of input" X<sub>n</sub> (n: even number) is set to "1: Double wiring (NC/NC)", set the same value for X<sub>n</sub> and X<sub>n+1</sub>, the partner of X<sub>n</sub>.
- When "Wiring selection of input"  is set to "0: Not used", the points that are set to "0: Not used" ignore this setting value.

### Input dark test pulse OFF time

Set the input dark test pulse OFF time in "Input dark test pulse OFF time" from the "Parameter Processing of Device Station" window of the engineering tool.

For the procedure to display the "Parameter Processing of Device Station" window, refer to the following.

☞ Page 72 Parameter Settings

Item	Setting range
Input dark test pulse OFF time	0: 400μs 1: 1ms 2: 2ms

### Point

Adjust the input dark test pulse OFF time depending on the installation environment or wiring length.

### Number of pulse output for input dark test

Set the number of input dark test pulse outputs in "Number of pulse output for input dark test" from the "Parameter Processing of Device Station" window of the engineering tool.

For the procedure to display the "Parameter Processing of Device Station" window, refer to the following.

☞ Page 72 Parameter Settings

Item	Setting range
Number of pulse output for input dark test	0: 1 time 1: 2 times 2: 3 times

### Point

Adjust the number of input dark test pulse outputs depending on the installation environment or wiring length.

## Internal input dark test function

This function outputs test pulses to the input circuit of the safety remote I/O module to detect a circuit-fixing failure. The test pulses turn off the external input signals (X0 to X1F) that are on to detect the failure.

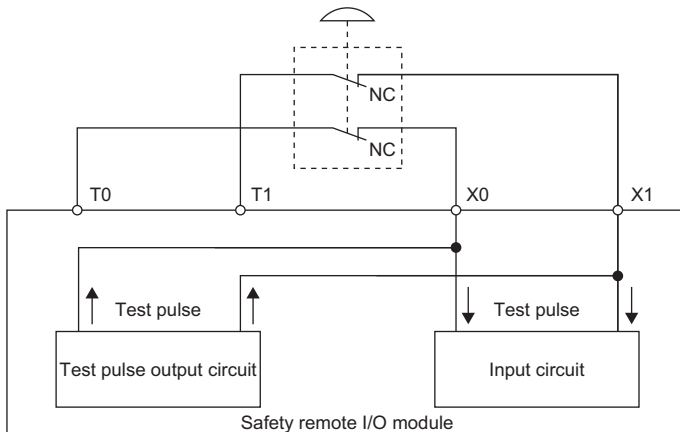

### Point

- The test using this function is conducted to all input signals except for the signals where "Wiring selection of input" (parameter) is set to "0: Not used".
- The internal input dark test function is not affected by the setting of input response time.

### Operation at error detection

If an error is detected by the internal input dark test, the safety remote I/O module becomes the error state (I/O data error). For details on the error state, refer to the following.

☞ Page 138 Error codes related to the safety remote I/O module

### Setting method

The parameter setting is not required for the internal input dark test function.

## 8.4 Output Diagnostic Function

### Output dark test function

This function outputs test pulses to turn off the external output signal  $Y□$  that is on and diagnoses the internal circuit for failure. The read-back circuit checks the test pulse and output circuit fixing can be detected. The OFF time for test pulses and the number of pulse outputs used in one diagnostic can be set depending on the usage environment.

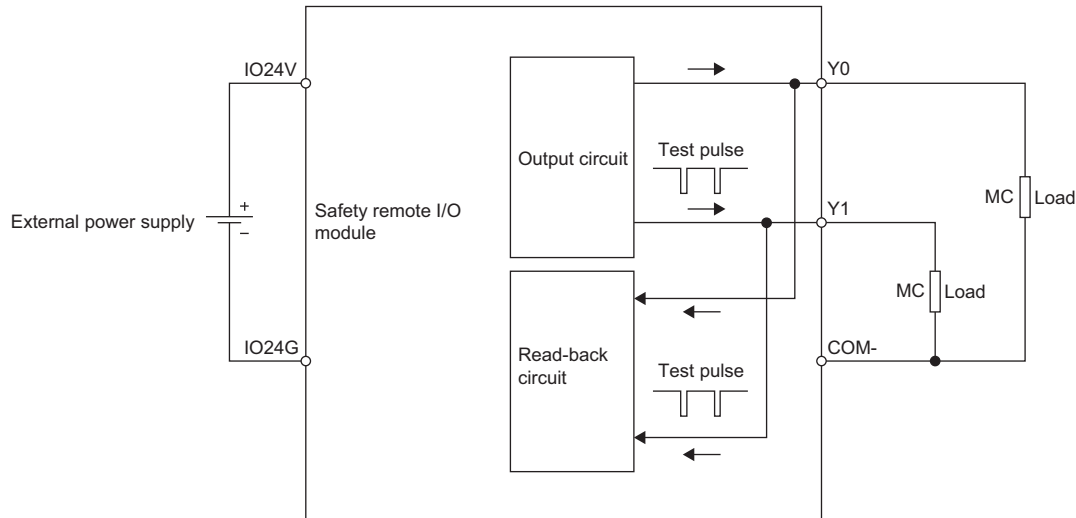

#### Operation at error detection

When the module detects an error in a diagnostic of the output dark test, the error (output dark test error) state is applied and all output points are turned off. For details on the error state, refer to the following.

☞ Page 138 Error codes related to the safety remote I/O module

#### Point

For the NZ2GFSS2-32D-S1, when an error is detected in the input dark test, output dark test, or output read-back diagnostic, the minor error state is applied to the module. However, when multiple errors are detected and all I/O points of the module are turned off, the error state of Self-diagnostic error (error code: 0101H) is applied.

## Setting method

### ■Output dark test execution setting

Set whether to perform the output dark test or not in "Output dark test execution setting" from the "Parameter Processing of Device Station" window of the engineering tool.

For the procedure to display the "Parameter Processing of Device Station" window, refer to the following.

 Page 72 Parameter Settings

Item	Setting range
Output dark test execution setting Y□	0: Perform 1: Do not perform

#### Point

- When "Wiring selection of output" Y<sub>n</sub> (n: even number) is set to "1: Double wiring (Source/Source)", set the same value for Y<sub>n</sub> and Y<sub>n+1</sub>, the partner of Y<sub>n</sub>.
- When "Wiring selection of output" is set to "0: Not used", the points that are set to "0: Not used" ignore this setting value.

### ■Output dark test pulse OFF time

Set the output dark test pulse OFF time (OFF pulse width) in "Output dark test pulse OFF time" from the "Parameter Processing of Device Station" window of the engineering tool.

For the procedure to display the "Parameter Processing of Device Station" window, refer to the following.

 Page 72 Parameter Settings

Item	Setting range
Output dark test pulse OFF time Y□	0: 400μs 1: 1ms 2: 2ms

#### Point

- Adjust the output dark test pulse OFF time depending on the installation environment or wiring length.
- When "Wiring selection of output" Y<sub>n</sub> (n: even number) is set to "1: Double wiring (Source/Source)", set the same value for Y<sub>n</sub> and Y<sub>n+1</sub>, the partner of Y<sub>n</sub>.
- When "Wiring selection of output" is set to "0: Not used" or "Output dark test execution setting" is set to "1: Do not perform", the points with these settings ignore this setting value.

### ■Number of pulse output for output dark test

Set the number of output dark test pulse outputs in "Number of pulse output for output dark test" from the "Parameter Processing of Device Station" window of the engineering tool.

For the procedure to display the "Parameter Processing of Device Station" window, refer to the following.

 Page 72 Parameter Settings

Item	Setting range
Number of pulse output for output dark test	0: 1 time 1: 2 times 2: 3 times

#### Point

- Adjust the number of output dark test pulse outputs depending on the installation environment or wiring length.
- When all "Wiring selection of output" areas are set to "0: Not used" or all "Output dark test execution setting" areas are set to "1: Do not perform", this setting value is ignored.

# Output read-back function

This function reads back output results and diagnoses whether the external output signal  $Y□$  is correctly on or off. The read-back circuit checks the status of output terminals and diagnoses whether it matches with the output status of the control program to detect output operation errors in the module. To use this function, setting parameters is not required.

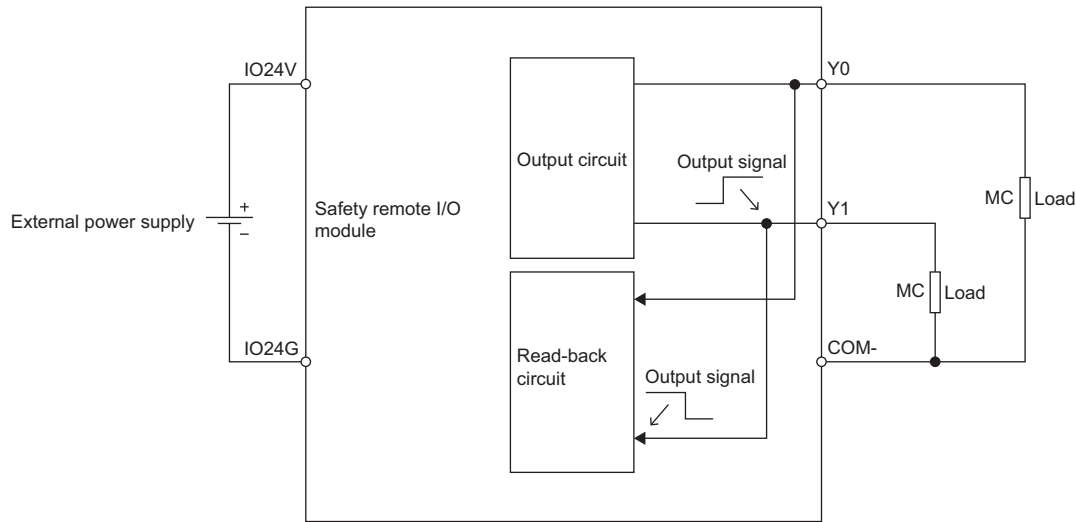

## Operation at error detection

When the safety remote I/O module detects an error in an output read-back diagnostic, the error (output read-back error) state is applied and all output points are turned off. For details on the error state, refer to the following.

☞ Page 138 Error codes related to the safety remote I/O module

8

### Point

- For the NZ2GFSS2-32D-S1, when an error is detected in the input dark test, output dark test, or output read-back diagnostic, the minor error state is applied to the module. However, when multiple errors are detected and all I/O points of the module are turned off, the error state of Self-diagnostic error (error code: 0101H) is applied.
- The maximum output voltage in the output OFF state is 1.2V. However, even though the voltage exceeds 1.2V due to a short circuit or failure of the hardware, no error is detected until the voltage exceeds 7V. Thus, connected devices may turn on although the output of the module is in the OFF state.

## Setting method

The parameter setting is not required for the output read-back function.

## 8.5 Protection Functions

The following table lists the protection functions.

Function name	Purpose	Description
Module power supply overvoltage protection	Prevents ignition or burnouts from/of the safety remote I/O module due to overvoltage on the primary side.	This function operates when the module power supply is in the overvoltage state.
Module power supply overcurrent protection	Prevents ignition or burnouts from/of the safety remote I/O module due to overcurrent on the primary side.	This function operates when the module power supply is in the overcurrent state.
External power supply overvoltage protection	Prevents ignition or burnouts from/of the safety remote I/O module and load circuits due to overvoltage.	This function operates when the external power supply circuit is in the overvoltage state.
External power supply overcurrent protection	Prevents ignition or burnouts from/of the safety remote I/O module and load circuits due to overcurrent.	This function operates when the external power supply circuit is in the overcurrent state.
Output overload protection	Prevents ignition or burnouts from/of the safety remote I/O module due to overcurrent or overheat resulting from short-circuits of the output circuit.	This function operates when a current exceeding the rating flows. The safety remote I/O module recovers by resetting it in the rated load state.

The following table lists the modules each protection function can protect.

○: Available, —: Not available

Function name	Protection target				
	NZ2GFSS2-32D-S1	NZ2GFSS2-8D-S1	NZ2GFSS2-8TE-S1	NZ2GFSS2-16DTE-S1	NZ2EXSS2-8TE
Module power supply overvoltage protection	○	○	○	○	—
Module power supply overcurrent protection	○	○	○	○	—
External power supply overvoltage protection	○	○	○	○	○
External power supply overcurrent protection	○	○	○	○	○
Output overload protection	—	—	○	○	○

### Point

- The protection functions are intended to protect the internal circuit of a module, not to protect external devices.
- An overload (overvoltage or overcurrent) may cause the internal temperature of the module to rise, resulting in deterioration in output elements and discoloration on the case and the printed-circuit board. When an abnormal load is found, turn off the corresponding output immediately and eliminate the cause.

## 8.6 User Authentication Function

This function limits the users (persons and personal computers) that can access the CPU module or safety remote I/O module. Using this function permits only the specified users to access the CPU module or safety remote I/O module. This function is implemented in the CPU module used. For details on the user authentication function, refer to the following.

📖 MELSEC iQ-R CPU Module User's Manual (Application)

### Online operations that require user authentication

The following table lists the online operations that require user authentication. No limitation is applied to the access levels of the user authentication function. With any access level of "Administrators", "Developers", "Assistant Developers", and "Users", the operations can be performed after the user authentication.

Operation name	Necessity of user authentication	Online operation
"Parameter read"	Necessary	"Parameter Processing of Device Station"
"Parameter write"	Necessary	
"Error history read"	Necessary* <sup>1</sup>	"Command Execution of Device Station"
"Start of checking the module position"	Necessary	
"Stop of checking the module position"	Necessary	
"Error history clear request"	Necessary* <sup>1</sup>	
"Safety module validation"	Necessary	
"CC-Link IE TSN/CC-Link IE Field Diagnostics"	Not necessary	
"Remote Operation"	Not necessary	"CC-Link IE TSN/CC-Link IE Field Diagnostics"

\*1 To access the remote buffer memory using a program and perform the operations, the user authentication is not necessary.

## 8.7 Operation Setting Function at Detection of External Power Supply Voltage Error

Users can select whether to continue safety communication or stop it when an external power supply voltage error occurs.

### Restoration

The following table shows how the module operation will be restored from the external power supply voltage error.

Item	Restoration	Operation at the error	Error status of the module
Stop safety communication	The safety inputs and safety outputs will restart by turning off and on the module power supply.	<ul style="list-style-type: none"> <li>Safety communications are stopped.</li> <li>Safety inputs and safety outputs are OFF.</li> </ul>	Moderate error
Continue safety communication (Without output interlock) <sup>*1</sup>	Safety communications continue, but safety outputs are turned off. After the error causes are eliminated, a minor error in the module will be cleared and the safety outputs will restart. The control will restart at the canceling of the safety output interlock by the external circuit.	<ul style="list-style-type: none"> <li>Safety communications are continued.</li> <li>Safety outputs are OFF. (interlock by the external circuit)</li> </ul>	Minor error
Continue safety communication (With output interlock)	Safety communications continue, but safety outputs are turned off and the outputs are interlocked. At the canceling of the interlock by the CPU module, a minor error will be cleared and the safety outputs will restart.	<ul style="list-style-type: none"> <li>Safety communications are continued.</li> <li>Safety outputs are OFF. (interlock by the module)</li> </ul>	Minor error

\*1 To prevent unintended restart, configure an external interlock circuit for the safety outputs.

#### Point

- The interlock is applied to the test pulse output terminals (T□) as well.
- If an external power supply voltage error occurs, the output of the power supply current terminal for input device (COM+) is forcedly turned off.
- The output of the power supply current terminal for input device (COM+) momentarily turns on at the following timing: at the occurrence of an external power supply voltage error (minor error); at the checking whether the external power supply voltage has returned to normal after the minor error. If this becomes a problem for the safety system, configure an interlock circuit to ensure that the entire system will always operate safely.



## Stop safety communication

### ■ Output interlock

After an external power supply voltage error is detected, safety communications stop and the outputs are interlocked.

**Ex.**

For the NZ2GFSS2-32D-S1

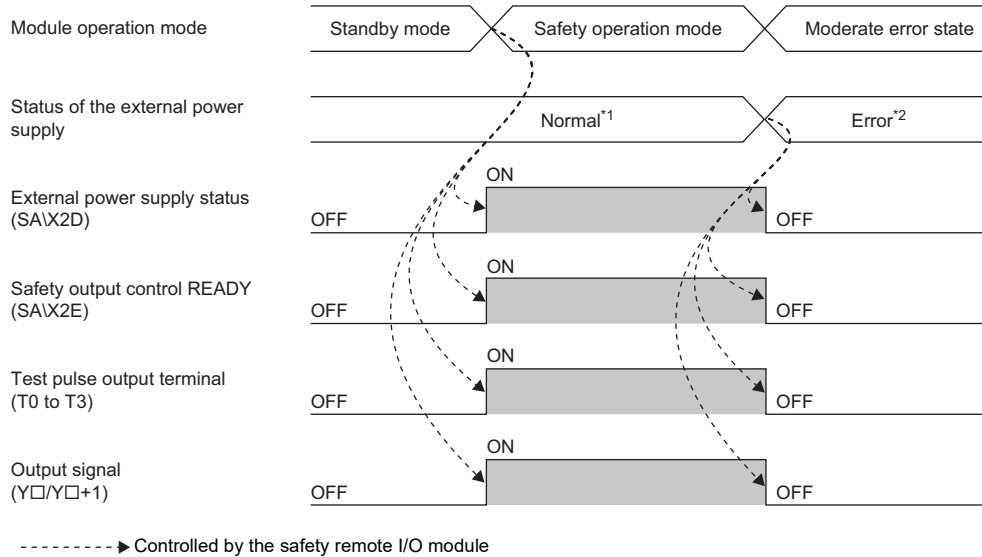

-----> Controlled by the safety remote I/O module

\*1 An external power supply voltage error has not occurred.

\*2 An external power supply voltage error has occurred.

## Continue safety communication (Without output interlock)

### ■ Output interlock

If safety outputs are turned off due to an external power supply voltage error detection, the outputs are interlocked. If the outputs are interlocked, the safety output control stops and the output signals (Y□) are turned off.

Ex.

For the NZ2GFSS2-32D-S1

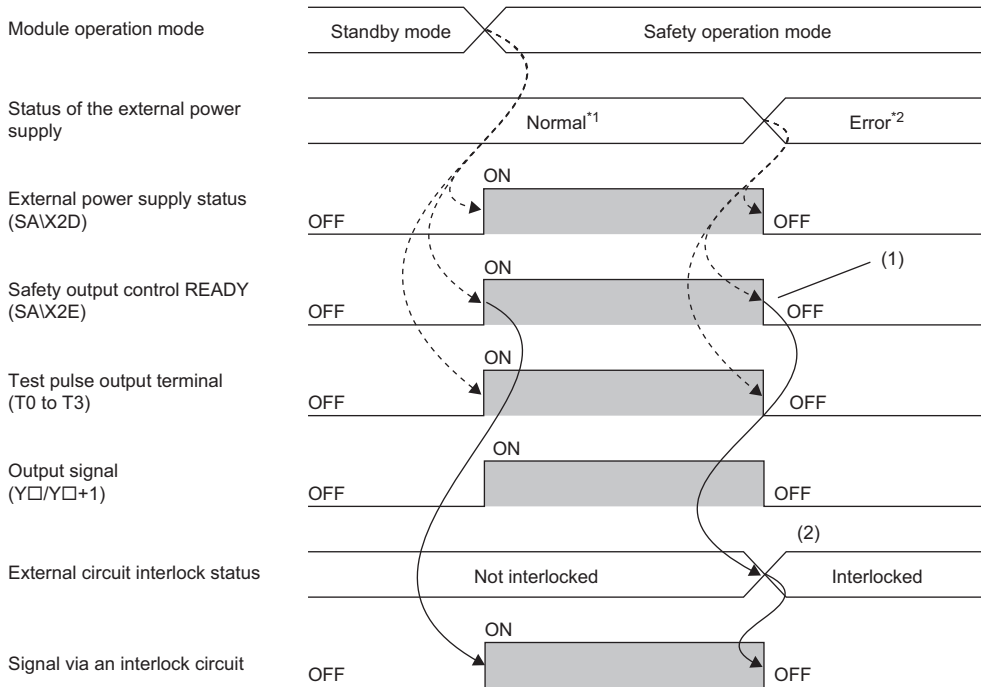

(1) If an external power supply voltage error occurs, Safety output control READY (SAIX2E) turns off and safety outputs and test pulses stop.

-----> Controlled by the safety remote I/O module

-----> Controlled by the program

\*1 An external power supply voltage error has not occurred.

\*2 An external power supply voltage error has occurred.

## ■ Output interlock cancellation

After causes of an external power supply voltage error are eliminated, the safety output control restarts and safety outputs and test pulse outputs restart.

**Ex.**

For the NZ2GFSS2-32D-S1

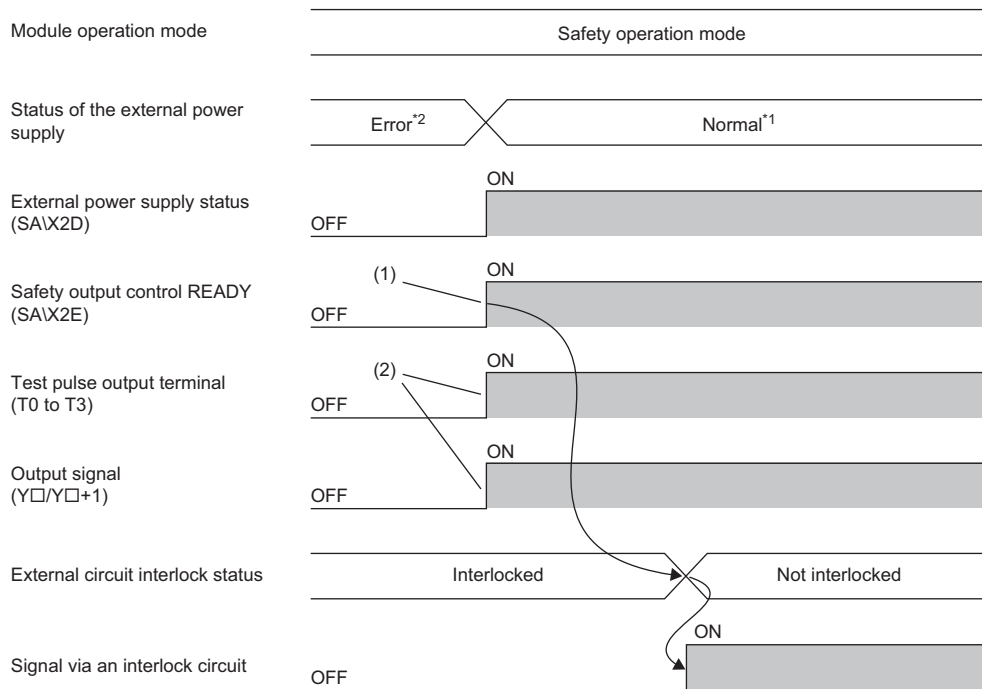

(1) When an external power supply voltage error is cleared, Safety output control READY (SA\X2E) turns on.

(2) After Safety output control READY (SA\X2E) becomes on, safety outputs and test pulse outputs restart.

→ Controlled by the program

\*1 An external power supply voltage error has not occurred.

\*2 An external power supply voltage error has occurred.

## Continue safety communication (With output interlock)

### ■ Output interlock

In the following cases, the outputs are interlocked.

- Module operation mode is switched from standby mode to safety operation mode.
- Safety outputs are turned off due to an external power supply voltage error detection.

If the outputs are interlocked, the safety output control stops and the output signals (Y□) are turned off.

The safety output control does not start until the safety output interlock is canceled by the CPU module. This prevents an incorrect output before completion of checking safety in the working area and an incorrect output due to unintended recovery of the external power supply.

**Ex.**

For the NZ2GFSS2-32D-S1 (when the module shifts to the safety operation mode)

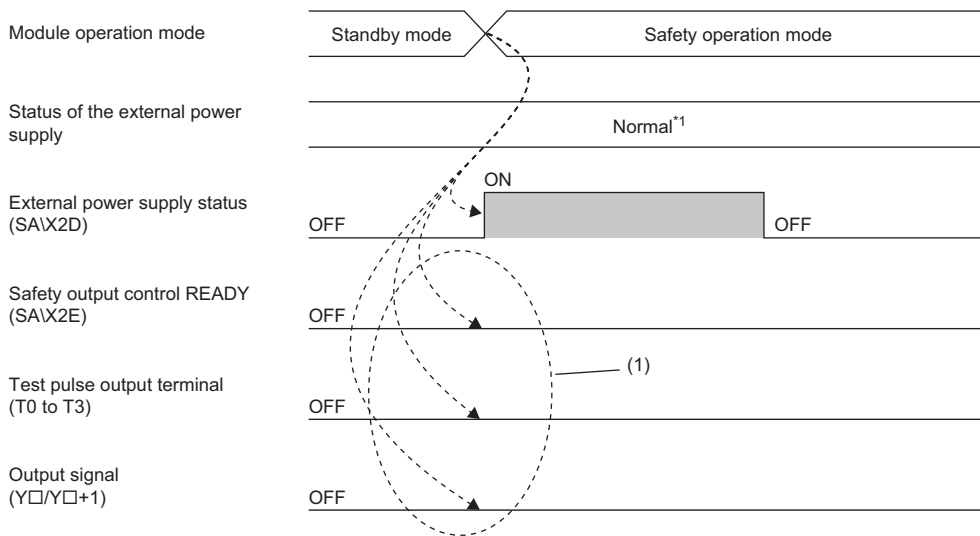

(1) Outputs are interlocked and each signal remains off.

-----> Controlled by the safety remote I/O module

\*1 An external power supply voltage error has not occurred.

**Ex.**

For the NZ2GFSS2-32D-S1 (when an external power supply voltage error has occurred)

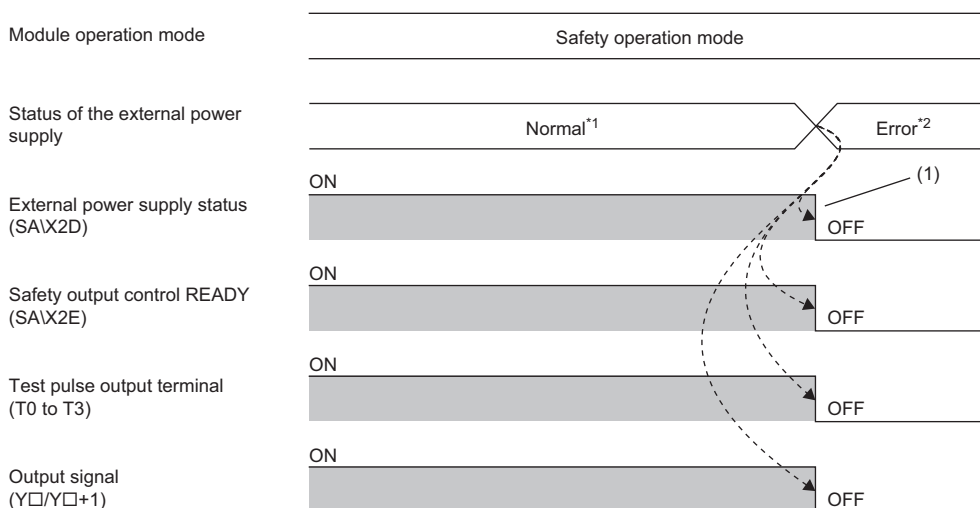

(1) If an external power supply voltage error occurs, Safety output control READY (SAIX2E) turns off and safety outputs and test pulse outputs stop.

-----> Controlled by the safety remote I/O module

\*1 An external power supply voltage error has not occurred.

\*2 An external power supply voltage error has occurred.

## ■Output interlock cancellation

After causes of the external power supply voltage error are eliminated, the safety output control will start by canceling the output interlock by the CPU module.

**Ex.**

For the NZ2GFSS2-32D-S1

### Operating procedure

1. After checking that External power supply status is on, turn on Safety output control initial processing request flag (SA\Y2E).
2. After checking that Safety output control initial processing completion flag (SA\X2F) is on, turn off Safety output control initial processing request flag (SA\Y2E).
3. After checking that Safety output control initial processing completion flag (SA\X2F) is off, turn on Safety output control start flag (SA\Y2F).
4. After checking that Safety output control READY (SA\X2E) is on, turn off Safety output control start flag (SA\Y2F).
5. After Safety output control READY (SA\X2E) becomes on, safety outputs and test pulse outputs will start.

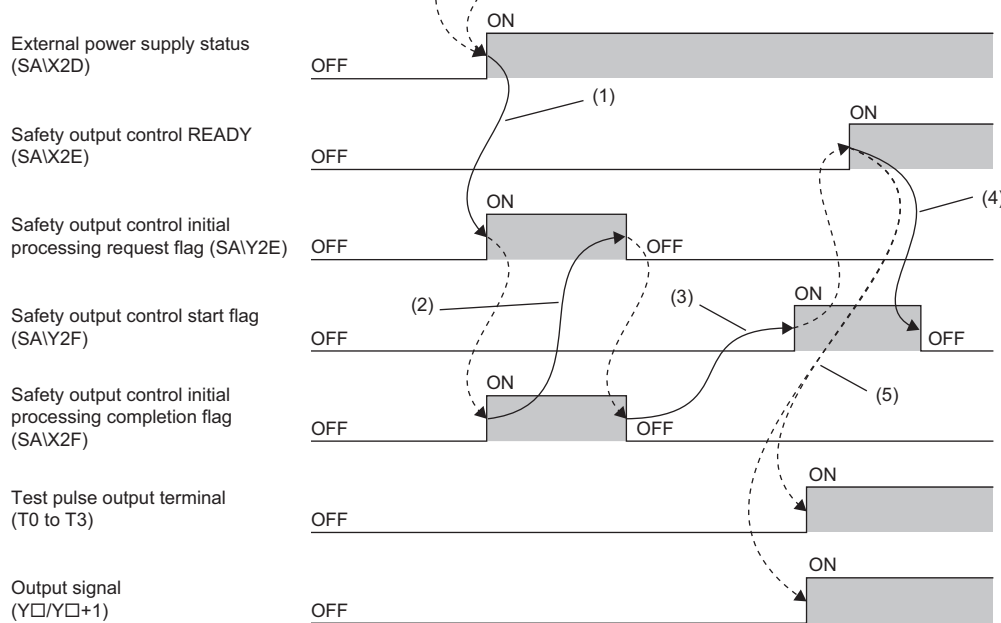
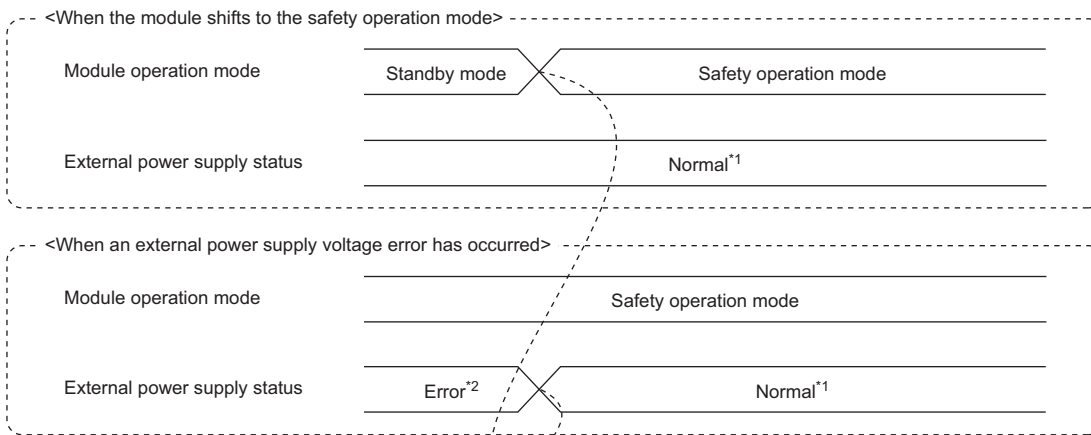

- (1) After checking that External power supply status is on, turn on Safety output control initial processing request flag (SAIY2E) so that Safety output control initial processing completion flag (SAIX2F) turns on.
- (2) After checking that Safety output control initial processing completion flag (SAIX2F) is on, turn off Safety output control initial processing request flag (SAIY2E) so that Safety output control initial processing completion flag (SAIX2F) turns off.
- (3) After checking that Safety output control initial processing completion flag (SAIX2F) is off, turn on Safety output control start flag (SAIY2F) so that Safety output control READY (SAIX2E) turns on.
- (4) After checking that Safety output control READY (SAIX2E) is on, turn off Safety output control start flag (SAIY2F).
- (5) Safety output control READY (SAIX2E) turns on, and safety outputs and test pulse outputs start.

-----> Controlled by the safety remote I/O module  
 —————> Controlled by the program

\*1 An external power supply voltage error has not occurred.  
 \*2 An external power supply voltage error has occurred.

## Setting method

To select what operation is to be performed at the detection of an external power supply voltage error, set the operation in "Operation setting of external power supply voltage error detection" on the "Parameter Processing of Device Station" window of the engineering tool.

For the procedure to display the "Parameter Processing of Device Station" window, refer to the following.

☞ Page 72 Parameter Settings

Item	Setting range
Operation setting of external power supply voltage error detection	0: Stop safety communication 1: Continue safety communication (Without output interlock) 2: Continue safety communication (With output interlock)

## 8.8 Functions Available When Extension Modules Are Connected

The functions of the safety extension module or the standard extension module are available when the extension module is connected.

### Functions that can be used when a safety extension module is connected

The following lists the functions that can be used when a safety extension module is connected.

Function		Reference
Output function		☞ Page 89 Safety Output Function
Output diagnostic function	Output dark test function	☞ Page 105 Output dark test function
	Output read-back function	☞ Page 107 Output read-back function

#### Point

- Connect the safety extension module (NZ2EXSS2-8TE) to the main module (NZ2GFSS2-32D-S1).
- Before connecting a safety extension module or replacing an existing safety extension module with a new one, turn off the module power supply. If a safety extension module is connected or removed while the module power supply is on, an error occurs in the safety remote I/O module. For the error state, refer to the list of error codes. (☞ Page 137 List of Error Codes)
- When a safety extension module is replaced with a new one, write the parameters to the module again from the engineering tool.

## Functions that can be used when a standard extension module is connected

The following lists the functions that can be used when a standard extension module is connected.

Item	Description
Input function	Acquires the ON/OFF status of the inputs.
Output function	Controls the ON/OFF status of the outputs.
Input OFF delay function	Turns off an X signal after a predetermined time has passed from when an actual input becomes off from on.
Input response time setting function	Prevents an incorrect input due to noise by setting the response time until the module recognizes an actual input as the X signal.
Output HOLD/CLEAR setting function	Sets whether to hold or clear the last output value when the safety remote I/O module is disconnected from data link, or the CPU module operating status is STOP.
Cyclic data update watch function	Monitors the update intervals of the cyclic data. The last output value is held or cleared when the cyclic transmission stop status continues longer than the set monitoring time.
Number of ON times integration function	Counts the total number of ON times of each output point. The integration value remains even though the module is powered off.

For details on the functions that can be used when a standard extension module is connected, refer to the following manual.

 CC-Link IE Field Network Remote I/O Module User's Manual

### Point

- Connect the standard extension module to the main module (NZ2GFSS2-8D-S1, NZ2GFSS2-8TE-S1, or NZ2GFSS2-16DTE-S1).
- Up to one extension module can be connected. When two or more extension modules are connected, operations for this module cannot be guaranteed.
- Before connecting a standard extension module or replacing an existing standard extension module with a new one, turn off the module power supply. If a standard extension module is connected or removed while the module power supply is on, an error occurs in the safety remote I/O module. For the error state, refer to the list of error codes. ( Page 137 List of Error Codes)
- When a standard extension module is replaced with a new one, write the parameters to the module again from the engineering tool.
- If the CPU module of the master station is other than RnSF CPU, operations for the standard extension module cannot be guaranteed.



This chapter describes the maintenance and inspection of the safety remote I/O module.

**Point** 

Read [Startup and Maintenance Precautions] in the safety precautions carefully before performing the inspection, and observe the precautions.

## 9.1 Daily Inspection

The following table lists the items that must be inspected on a daily basis.

Item	Inspection item	Inspection method	Judgment criterion	Corrective action	
1	Mounting status on a DIN rail	Rattling	Check for a rattling noise of the safety remote I/O module.	The safety remote I/O module does not rattle.	Remount the safety remote I/O module on the DIN rail securely.
	Terminal block mounting screw	Looseness and rattling	Check for the looseness of terminal block mounting screws.	The terminal block mounting screws must not be loose.	Retighten terminal block mounting screws securely.
	Terminal block condition	Attachment of dirt and foreign matters	Check for attachment of dirt and foreign matters.	Dirt and foreign matters must not be attached to terminal blocks.	Remove the terminal block and clean it.
2	Connection status	Clearance between solderless terminals	Check the clearance between solderless terminals.	The proper clearance must be provided between solderless terminals.	Provide the proper clearance.
3	LED status at power-on or reset	PW LED	Check that the LED is on.	On	Refer to the following and take corrective actions.  Page 123 Checking the LEDs
		RUN LED	Check that the LED is on for a moment.	On	
		MODE LED	Check that the LED is on for a moment.	On	
		D LINK LED	Check that the LED is on for a moment.	On	
		SAFETY LED	Check that the LED is on for a moment.	On	
		ERR. LED	Check that the LED is on for a moment.	On	
		I/O PW LED <sup>*1</sup>	Check that the LED is on for a moment.	The LED must be on when the external power supply is applied <sup>*3</sup> .	
		Input status indicator LED <sup>*2</sup>	Check that the LED is on for a moment.	On	
		Output status indicator LED <sup>*2</sup>	Check that the LED is on for a moment.	On	

Item	Inspection item	Inspection method	Judgment criterion	Corrective action	
4	LED status in operation	PW LED	Check that the LED is on.	On	Refer to the following and take corrective actions.  Page 123 Checking the LEDs
		RUN LED	Check that the LED is on.	On	
		MODE LED	Check that the LED is on.	On	
		D LINK LED	Check that the LED is on.	On	
		SAFETY LED	Check that the LED is on.	On	
		ERR. LED	Check that the LED is off.	Off	
		I/O PW LED <sup>*1</sup>	Check that the LED is on.	On	
	Input status indicator LED	Check that the LED is on, flashing <sup>*1</sup> , or off.	The LED must be on when an input is on. The LED must be off when an input is off. Flashing indicates the error point <sup>*4</sup> .	Replace the module with a new one. (When an LED fails)	
	Output status indicator LED	Check that the LED is on, flashing <sup>*1</sup> , or off.	The LED must be on when an output is on. The LED must be off when an output is off. Flashing indicates the error point <sup>*4</sup> .		

\*1 For the NZ2GFSS2-8D-S1, NZ2GFSS2-8TE-S1, or NZ2GFSS2-16DTE-S1

\*2 For the NZ2GFSS2-32D-S1

\*3 If the LED is off with the power applied from the external power supply, it indicates an error.

\*4 For when "I/O LED indication at error occurrence" is set to "1: Indication of error point"

## 9.2 Periodic Inspection

This section describes items that must be inspected one or two times every six months to one year. When the equipment has been relocated or modified, or cable laying has been changed, inspect the module for the items.

Item	Inspection item		Inspection method	Judgment criterion	Corrective action
1	Environment	Ambient temperature <sup>*1</sup>	Measure the temperature by using a thermometer.	0 to 55°C	Create the environment that satisfies the judgment criterion
		Ambient humidity	Measure the humidity by using a hygrometer.	5 to 95%RH	
		Atmosphere	Measure corrosive gases.	No corrosive gases	
2	Power supply voltage check		Measure the voltage across 24VDC terminals.	20.4 to 28.8VDC	Change the supply power.
3	Mounting status on a DIN rail	Rattling	Check for a rattling noise of the safety remote I/O module.	The safety remote I/O module does not rattle.	Remount the safety remote I/O module on the DIN rail securely.
	Terminal block mounting screw	Looseness and rattling	Check for the looseness of terminal block mounting screws.	The terminal block mounting screws must not be loose.	Retighten terminal block mounting screws securely.
	Terminal block condition	Attachment of dirt and foreign matters	Check for attachment of dirt and foreign matters.	Dirt and foreign matters must not be attached to terminal blocks.	Remove the terminal block and clean it.
4	Connection status	Clearance between solderless terminals	Check the clearance between solderless terminals.	The proper clearance must be provided between solderless terminals.	Provide the proper clearance.

\*1 The temperature in the control panel where the safety remote I/O module is installed

# 10 TROUBLESHOOTING

This chapter describes the troubleshooting of the safety remote I/O module.

## 10.1 CC-Link IE TSN/CC-Link IE Field Diagnostics

For details on CC-Link IE TSN/CC-Link IE Field diagnostics, refer to the following.

📖 MELSEC iQ-R CC-Link IE Field Network User's Manual (Application)

### Remote reset

Perform the following operations to reset the selected safety remote I/O module through the remote operation.

#### Operating procedure

1. Select a device station to be reset and click the [Remote Operation] button.

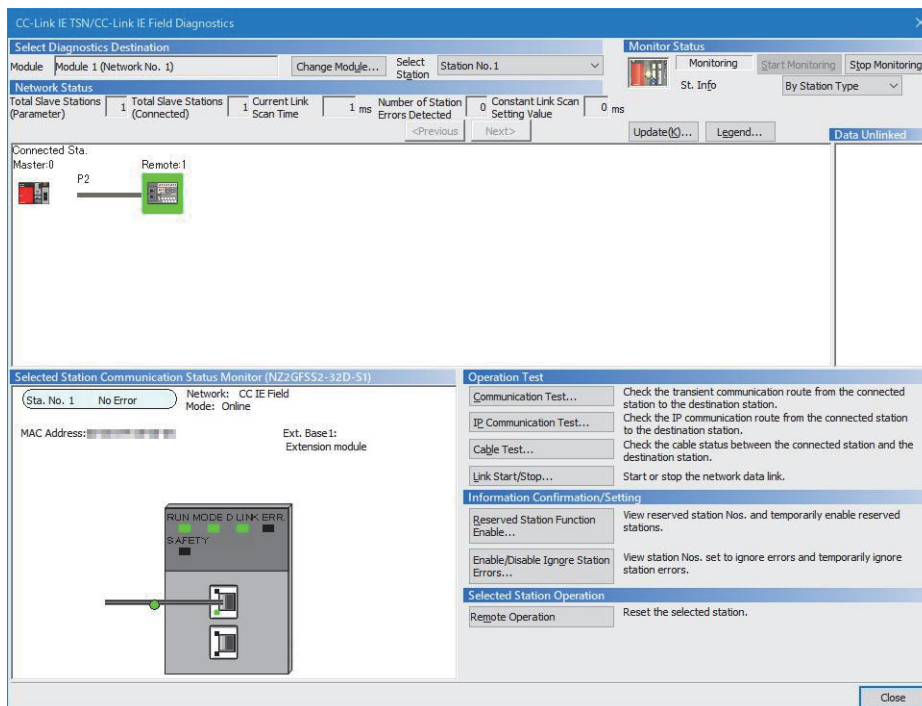

2. Follow the instructions on the window and click the [Yes] button.
3. Follow the instructions on the window and click the [OK] button.

## 10.2 Checking the LEDs

This section describes how to troubleshoot the system by the LEDs.

Depending on an LED status of the RUN LED, ERR. LED, or SAFETY LED, the error status can be judged as follows.

RUN LED	ERR. LED	SAFETY LED	Error status*1	Reference on errors
Off	On*2	*3	Major error	☞ Page 138 Error codes related to the safety remote I/O module
On	On	*3	Moderate error	
On	Flashing	*4	Minor error	

\*1 When multiple errors have occurred, the error statuses are displayed in the order of error severity (Major error > Moderate error > Minor error).

\*2 When the module fails, the LED may not turn on.

\*3 Either of Flashing or Off.

\*4 Any of On, Flashing, or Off.

### When the PW LED does not turn on

Check item	Action
Is any LED other than the PW LED on?	When any LED other than the PW LED is on, the possible cause is a hardware failure. Please consult your local Mitsubishi representative.
Is the module power supply (24VDC) wired?	Wire the module power supply (24VDC).
Is the module power supply (24VDC) turned on?	Turn on the module power supply (24VDC).
Is the voltage of the module power supply (24VDC) within the specified range?	<ul style="list-style-type: none"> <li>Set the module power supply voltage within the range of performance specifications. (☞ Page 20 Performance Specifications)</li> <li>After performing the above action, power off and on the module power supply. If the PW LED does not turn on even after the module power supply is powered off and on, the possible cause is a module failure or the activation of the overvoltage protection function. Please consult your local Mitsubishi representative.</li> </ul>

### When the RUN LED does not turn on

Check item	Action
Has the voltage of the module power supplied externally reached the voltage of the specifications?	<ul style="list-style-type: none"> <li>Check that module power supply voltage is within the range of performance specifications. (☞ Page 20 Performance Specifications)</li> <li>After the check, power off and on the module power supply. If the RUN LED does not turn on even after the module power supply is powered off and on, the possible cause is a module failure. Please consult your local Mitsubishi representative.</li> </ul>
Has a momentary power failure exceeding the specifications occurred in the externally supplied module power supply? (Only for the NZZGFSS2-32D-S1)	<ul style="list-style-type: none"> <li>Check that a momentary power failure exceeding the specifications has not occurred in the module power supply. (☞ Page 20 Performance Specifications)</li> <li>After the check, power off and on the module power supply. If the RUN LED does not turn on even after the module power supply is powered off and on, the possible cause is a module failure. Please consult your local Mitsubishi representative.</li> </ul>
Has any hardware failure occurred?	Power off and on the module power supply. If the RUN LED does not turn on even after the module power supply is powered off and on, the possible cause is a module failure. Please consult your local Mitsubishi representative.

### When the MODE LED flashes

Check item	Action
Is the safety remote I/O module in execution of the unit test?	When the safety remote I/O module is in execution of the unit test, the D LINK LED turns on after the unit test is completed. Take corrective action according to the result of the unit test.

### When the MODE LED turns off

Check item	Action
Has any hardware failure occurred?	Power off and on the module power supply. If the MODE LED does not turn on even after the module power supply is powered off and on, the possible cause is a module failure. Please consult your local Mitsubishi representative.

## When the I/O PW LED does not turn on

Check item	Action
Is the external power supply turned on? (Only for the NZ2GFSS2-8D-S1, NZ2GFSS2-8TE-S1, or NZ2GFSS2-16DTE-S1)	<ul style="list-style-type: none"> <li>• Set the external power supply voltage within the range of performance specifications. (☞ Page 20 Performance Specifications)</li> <li>• After performing the above action, power off and on the module power supply. If the I/O PW LED does not turn on even after the module power supply is powered off and on, the possible cause is a safety remote I/O module failure. Please consult your local Mitsubishi representative.</li> </ul>

## When the D LINK LED turns off

Check item	Action
Is the own station in network operating normally?	Connect the engineering tool to the master station, and check that the own station is performing data link using the CC-Link IE TSN/CC-Link IE Field Diagnostics. (☞ MELSEC iQ-R CC-Link IE Field Network User's Manual (Application))
Are 1000BASE-T-compliant Ethernet cables used?	Replace the cable with a 1000BASE-T-compliant Ethernet cable. (☞ MELSEC iQ-R Ethernet/CC-Link IE User's Manual (Startup))
Is the station-to-station distance 100m or less?	Change the station-to-station distance to 100m or less.
Does the cabling condition (bending radius) meet the specifications?	Refer to the manual for the Ethernet cable used, and correct the bending radius.
Is any Ethernet cable disconnected?	Replace the Ethernet cable.
Are other stations connected to the safety remote I/O module normally operating?	Check that the power supplies of the other stations are turned on.
Is the switching hub normally operating?	<ul style="list-style-type: none"> <li>• Check that a 1000BASE-T-compliant switching hub is used. (☞ MELSEC iQ-R Ethernet/CC-Link IE User's Manual (Startup))</li> <li>• Check that the power supply of the switching hub is turned on.</li> </ul>
Is the same network number set to both the safety remote I/O module and the master station to be connected?	The network number of the safety remote I/O module differs from that of the master station to be connected. Set the same network number as that of the master station to be connected.
Is a same station number set to both the safety remote I/O module and any of other stations?	Two or more stations use a same station number. Change the settings so that all stations have different station numbers.

## When the D LINK LED flashes

Check item	Action
Does the station number setting of the safety remote I/O module match the station number of the safety remote I/O module specified in the "Network Configuration Settings" of the master station?	Match the actual station number of the safety remote I/O module with the station number specified in the "Network Configuration Settings" of the master station.
Is the station type remote device station?	Change the station type of the module to the remote device station in the "Network Configuration Settings" of the master station.
Is the module set to a reserved station?	Change the reserved/error invalid station setting to other than the reserved station in the "Network Configuration Settings" of the master station.
Is the station number setting switch set to other than 1 to 120?	Set the station number within the range of 1 to 120.
Was a stop of data link detected through CC-Link IE TSN/CC-Link IE Field diagnostics?	Check the link status through CC-Link IE TSN/CC-Link IE Field diagnostics and start data link when it is stopped.

## When the ERR. LED turns on

Check item	Action
Has any error occurred?	Identify the error factor of the safety remote I/O module with the engineering tool and take corrective actions. (☞ Page 132 How to Check Error Codes)

## When the I/O LED flashes

Check item	Action
Has any error related to safety I/O occurred when "I/O LED indication at error occurrence" is set to "1: Indication of error point"? (Only for the NZ2GFSS2-8D-S1, NZ2GFSS2-8TE-S1, or NZ2GFSS2-16DTE-S1)	Identify the error factor of the safety remote I/O module with the engineering tool and take corrective actions. (🔧 Page 132 How to Check Error Codes)

## When the SAFETY LED turns off

Check item	Action
Have parameters been set to the safety remote I/O module?	Set parameters to the safety remote I/O module. (🔧 Page 72 Parameter Settings)
Has the safety communication setting been configured?	Configure the safety communication setting. After configuring the setting, perform "Write to PLC". (📖 MELSEC iQ-R CC-Link IE Field Network User's Manual (Application))
Has the safety station interlock of the CPU module been canceled?	Fully check wiring and connection, and cancel the safety station interlock of the CPU module. (📖 MELSEC iQ-R CPU Module User's Manual (Application))
Has the safety module validation been performed?	Perform the safety module validation using the engineering tool. (🔧 Page 72 Parameter Settings)
Has any error occurred?	Identify the error factor with the engineering tool and take corrective actions.

## When the L ER LED turns on

Check item	Action
Are Ethernet cables normal?	<ul style="list-style-type: none"> <li>• Check that 1000BASE-T-compliant Ethernet cables are used. (📖 MELSEC iQ-R Ethernet/CC-Link IE User's Manual (Startup))</li> <li>• Check that the station-to-station distance is 100m or less.</li> <li>• Check that the Ethernet cables are not disconnected.</li> </ul>
Is the switching hub in the system normally operating?	<ul style="list-style-type: none"> <li>• Check that a 1000BASE-T-compliant switching hub is used. (📖 MELSEC iQ-R Ethernet/CC-Link IE User's Manual (Startup))</li> <li>• Check that the power supply of the switching hub is turned on.</li> </ul>
Are other stations connected to the safety remote I/O module normally operating?	Check that the power supplies of the other stations are turned on.
Is the mode of a module on the master station set to other than Online?	Change the mode of the module to Online.
Is there any noise affecting the system?	Check the status of wiring.
Is the loopback function set to be enabled in the master station?	When the loopback function is enabled, check that the ring topology is correctly configured for the PORT where the L ER LED is on. (📖 MELSEC iQ-R CC-Link IE Field Network User's Manual (Application))

## When the LINK LED turns off

Check item <sup>*1</sup>	Action
Are Ethernet cables normal?	<ul style="list-style-type: none"> <li>• Check that 1000BASE-T-compliant Ethernet cables are used. (📖 MELSEC iQ-R Ethernet/CC-Link IE User's Manual (Startup))</li> <li>• Check that the station-to-station distance is 100m or less.</li> <li>• Check that the Ethernet cables are not disconnected.</li> </ul>
Are the switching hub and other stations in the system normally operating?	<ul style="list-style-type: none"> <li>• Check that a 1000BASE-T-compliant switching hub is used. (📖 MELSEC iQ-R Ethernet/CC-Link IE User's Manual (Startup))</li> <li>• Check that the power supplies of the switching hub and other stations are turned on.</li> </ul>

\*1 If link-up processing is repeated due to a condition of a device on the line, it may take a longer time for the LINK LED to turn on. This phenomenon may be eliminated by changing the module PORT into which the Ethernet cable is connected (example: PORT1 → PORT2). For the wiring of Ethernet cable, refer to the following.

🔧 Page 60 Wiring of Ethernet cable

# 10.3 Unit Test

Run a unit test to check if there is any hardware failure in the safety remote I/O module.

1. Power off the module power supply.
2. Connect the PORT1 and PORT2 connectors of the safety remote I/O module with an Ethernet cable.

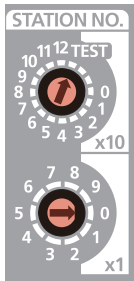
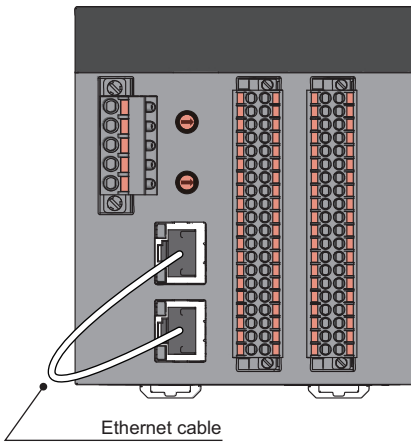

3. Set the station number setting switch as follows.
  - x10: TEST
  - x1: 0

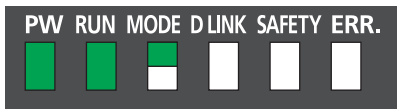

- : On
- : Flashing
- : Off

4. Power on the module power supply.
5. Unit test begins.  
The MODE LED flashes while the unit test is being executed.

When completed

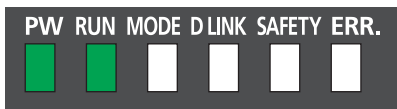

- : On
- : Flashing
- : Off

6. The MODE LED turns off when the unit test is completed.
  - When the test is completed successfully: The ERR. LED does not turn on, but remains off.
  - When the test is completed with an error: The ERR. LED turns on.

When failed

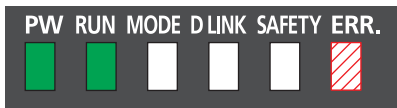

- : On
- : Flashing
- : Off

If the test fails, replace the Ethernet cable and run the test again. If the test fails again, it may be due to a hardware failure in the safety remote I/O module. Please consult your local Mitsubishi representative.



# 10.4 Troubleshooting by Symptom

This section describes troubleshooting for each phenomenon. Perform the troubleshooting by symptom when the safety remote I/O module does not operate properly with no error.

When an error has occurred in the safety remote I/O module, check the engineering tool or the status of the master station, and identify the cause of the error.

## When the ON/OFF status of an external input cannot be read

Check item	Action
Is the SAFETY LED on?	When the SAFETY LED is not on, the safety module validation has not been performed or the CPU module is in the safety station interlock status. Take the following actions. <ul style="list-style-type: none"> <li>• Perform the safety module validation. (☞ Page 72 Parameter Settings)</li> <li>• Fully check wiring and connection, and cancel the safety station interlock of the CPU module. (📖 MELSEC iQ-R CPU Module User's Manual (Application))</li> </ul>
Is the corresponding X□ LED of the input module on when an external input device is on?	If the LED does not turn on, there is a problem on the input wiring. Check the wiring confirming that the input wiring is not disconnected or short-circuited, or the voltage of the input signal is correct. (☞ Page 20 Performance Specifications, Page 129 Input circuit troubles and corrective actions)
Is the setting of the refresh device (SAIX/SAIY) correct?	Check and correct the device setting of the safety communication setting so that the setting of the refresh device (SAIX/SAIY) matches the setting in the program. (📖 MELSEC iQ-R CC-Link IE Field Network User's Manual (Application))
Is there any incorrect setting in the wiring selection of input?	Review the settings in the wiring selection of input. (☞ Page 85 Safety input wiring selection function)





## When the ON/OFF status of an external output cannot be changed

Check item	Action
Is the SAFETY LED on?	When the SAFETY LED is not on, the safety module validation has not been performed or the CPU module is in the safety station interlock status. Take the following actions. <ul style="list-style-type: none"> <li>• Perform the safety module validation. (☞ Page 72 Parameter Settings)</li> <li>• Fully check wiring and connection, and cancel the safety station interlock of the CPU module. (📖 MELSEC iQ-R CPU Module User's Manual (Application))</li> </ul>
Is the corresponding LED (Y0 LED to Y7 LED) of the output module on?	If the LED turns on, there is a problem on the output wiring. Check the wiring confirming that the output wiring is not disconnected or short-circuited. Refer to the following as well. ☞ Page 131 Output circuit troubles and corrective actions
Is the setting of the refresh device correct?	Check and correct the refresh parameter so that the setting of the refresh device matches the setting in the program. For the settings of the refresh parameter areas, refer to the following. 📖 MELSEC iQ-R CC-Link IE Field Network User's Manual (Application)
Is there any incorrect setting in the wiring selection of output?	Review the settings in the wiring selection of output. ☞ Page 89 Safety output wiring selection function
Are the outputs interlocked?	When "Operation setting of external power supply voltage error detection" of the module parameter is set to "2: Continue safety communication (With output interlock)", check that the outputs are not interlocked. If the outputs are interlocked, follow the procedure to cancel the interlock. ☞ Page 110 Operation Setting Function at Detection of External Power Supply Voltage Error

## When External output ON signal intermittently turns off

Check item	Action
Is an output dark test being executed?	Check the specifications of the safety devices used, and review the setting of the output dark test pulse OFF time. ☞ Page 105 Output dark test function

## When the safety remote I/O module cannot be accessed

Check item	Action
Is the D LINK LED on?	Check the D LINK LED. When the LED is not on, refer to the following to perform troubleshooting. <ul style="list-style-type: none"> <li>•  Page 124 When the D LINK LED turns off</li> <li>•  Page 124 When the D LINK LED flashes</li> </ul> Refer to the following to check other LEDs. <ul style="list-style-type: none"> <li> Page 123 Checking the LEDs</li> </ul>
Is the version of the module on the master station correct?	Check the firmware version of the module on the master station, and if the version is not the applicable one, replace the module with a module of the applicable version or later. For the applicable version, refer to the following. <ul style="list-style-type: none"> <li> Page 46 Applicable products</li> </ul>
Is the version of the engineering tool correct?	Check the version of the engineering tool, and if the version is not the applicable one, update the engineering tool. For the applicable version, refer to the following. <ul style="list-style-type: none"> <li> Page 46 Software package</li> </ul>
Do the module parameter settings of the master station and those of the CPU module match?	Perform "Verify With PLC" on the module parameters to check that those settings match. When they do not match, execute "Write to PLC" and "Read from PLC" to match the module parameter settings, and write the module parameters of the device station.

# 10.5 Fault Examples with the Safety Remote I/O Module

## Input circuit troubles and corrective actions

### An input signal does not turn off.

**■Cause**

Operation by a switch with LED indicator

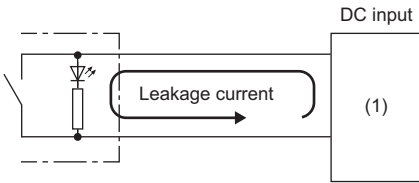

(1) Safety remote I/O module

**■Action**

Connect an appropriate resistor as shown below so that the leakage current flowing into the safety remote I/O module would fall below the OFF current.

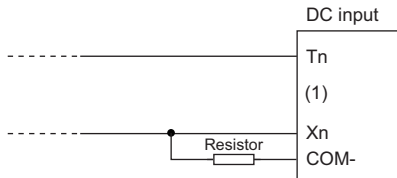

(1) Safety remote I/O module

**■Calculation example (NZZGFSS2-32D-S1)**

When the 24VDC external power supply of the safety remote I/O module is on and an LED indicator switch that has a leakage current of 3.0mA at a maximum is connected

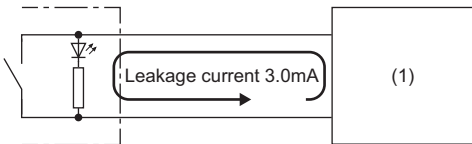

(1) Safety remote I/O module

1. The leakage current through the safety remote I/O module does not satisfy the condition of the OFF current of 0.5mA or lower. Therefore, connect a resistor as follows:

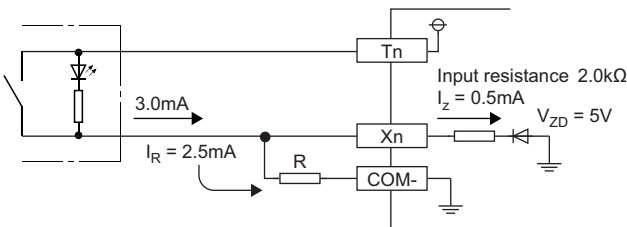

2. To satisfy the condition of the OFF current of the input module (0.5mA or lower), the current through the connected resistor should be 2.5mA or higher. From the formula below, the connected resistor (R) is lower than or equal to 2.4kΩ.

$$R \times I_R \geq Z (\text{Input resistance}) \times I_Z + V_{ZD}$$

$$R \leq \frac{Z (\text{Input resistance}) \times I_Z + V_{ZD}}{I_R} = \frac{2.0 \times 0.5 + 5.0}{2.5} = 2.4 \text{ [k}\Omega\text{]}$$

3. When the resistor (R) is 2.0kΩ, for example, the power capacity (W) of the resistor (R) becomes 0.41W.

$$W = \frac{(\text{Input voltage})^2}{R} = \frac{28.8^2}{2000 [\Omega]} = 0.41 [\text{W}]$$

4. Because the resistor requires a power capacity that is 3 to 5 times larger than the actual current consumption, the resistor connected to the terminal should be 2.0kΩ; and 1.5 to 2W.

### ■Calculation example (NZ2GFSS2-8D-S1, NZ2GFSS2-16DTE-S1)

When the 24VDC external power supply of the safety remote I/O module is on and an LED indicator switch that has a leakage current of 3.0mA at a maximum is connected

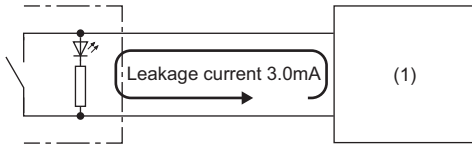

(1) Safety remote I/O module

1. The leakage current through the safety remote I/O module does not satisfy the condition of the OFF current of 1.3mA or lower. Therefore, connect a resistor as follows:

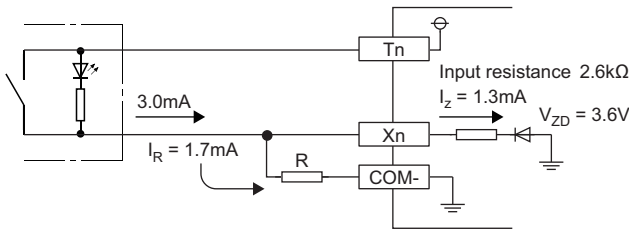

2. To satisfy the condition of the OFF current of the input module (1.3mA or lower), the current through the connected resistor should be 1.7mA or higher. From the formula below, the connected resistor (R) is lower than or equal to 4.1kΩ.

$$R \times I_R \geq Z (\text{Input resistance}) \times I_Z + V_{ZD}$$

$$R \leq \frac{Z (\text{Input resistance}) \times I_Z + V_{ZD}}{I_R} = \frac{2.6 \times 1.3 + 3.6}{1.7} = 4.1 [\text{k}\Omega]$$

3. When the resistor (R) is 3.6kΩ, for example, the power capacity (W) of the resistor (R) becomes 0.23W.

$$W = \frac{(\text{Input voltage})^2}{R} = \frac{28.8^2}{3600 [\Omega]} = 0.23 [\text{W}]$$

4. Because the resistor requires a power capacity that is 3 to 5 times larger than the actual current consumption, the resistor connected to the terminal should be 3.6kΩ; and 0.75 to 1.2W.

## A signal incorrectly inputs data

### ■Cause

Noise is taken as input data.

### ■Action

Set the input response time longer. (📖 Page 72 Parameter Settings)

Ex.

1ms → 5ms

If changing the setting of the input response time has no effect, take the following two measures:

- To prevent excessive noise, avoid installing power cables together with I/O cables.
- Take noise reduction measures such as connecting surge absorbers to noise-generating devices such as relays and conductors using the same power supply.

# Output circuit troubles and corrective actions

## The load in the off state momentarily turns on at power off (transistor output).

### ■Cause

When an inductive load is connected, the load [2] in the off state may turn on due to a sneak current from the back EMF at the shutoff [1].

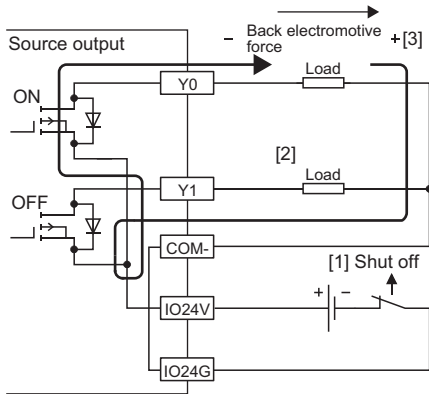

### ■Action

Take either of the following two actions:

- To suppress the back EMF, connect a diode in parallel with the load under the back EMF influence [3].

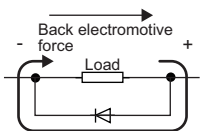

- Configure another current path by connecting a diode across positive and negative of the external power supply.

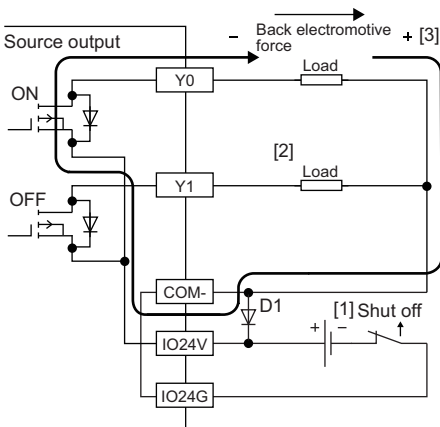

D1 indicates the following.

Reverse voltage VR (VRM)<sup>\*1</sup>

Forward current IF (IFM)<sup>\*2</sup>

\*1 Approximately 10 times as high as the rated load voltage in the performance specifications

Example: 24VDC → Approximately 200VDC

\*2 Twice as high as the maximum load current (common) in the performance specifications or more

Example: 2A/1 common → 4A or higher

# 10.6 How to Check Error Codes

When the data link is established between the safety remote I/O module and the master station, errors can be checked on the engineering tool.

- Page 132 Checking with CC-Link IE TSN/CC-Link IE Field diagnostics
- Page 134 Checking with "Command Execution of Device Station"
- Page 136 Checking error codes and warning codes

### Point

When the user authentication function of the CPU module is enabled, perform the logon of the user authentication function in advance. For the user authentication function, refer to the following.

- Page 109 User Authentication Function

## Checking with CC-Link IE TSN/CC-Link IE Field diagnostics

1. To check an error history, select a relevant module from the "CC-Link IE TSN/CC-Link IE Field Diagnostics" window.

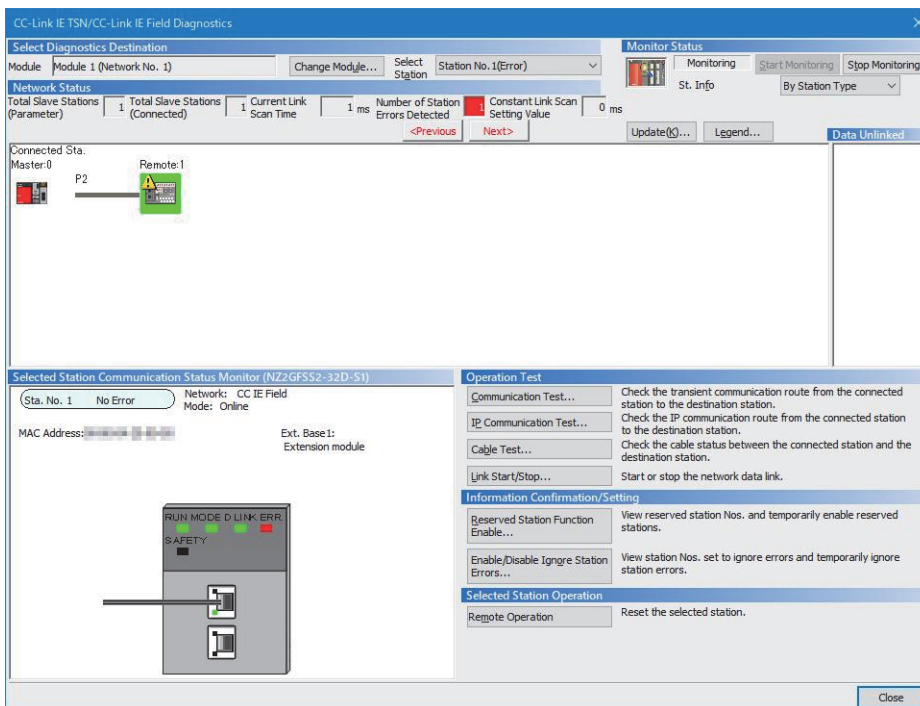

2. Right-click on the module selected, and select "Error History" from the menu.

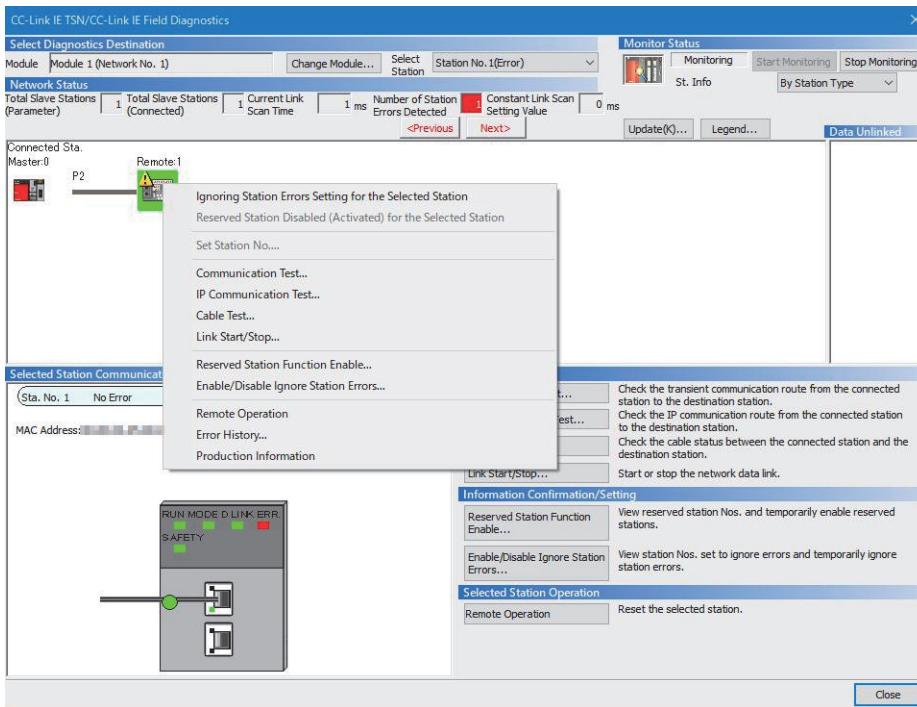

3. Click the [Yes] button.

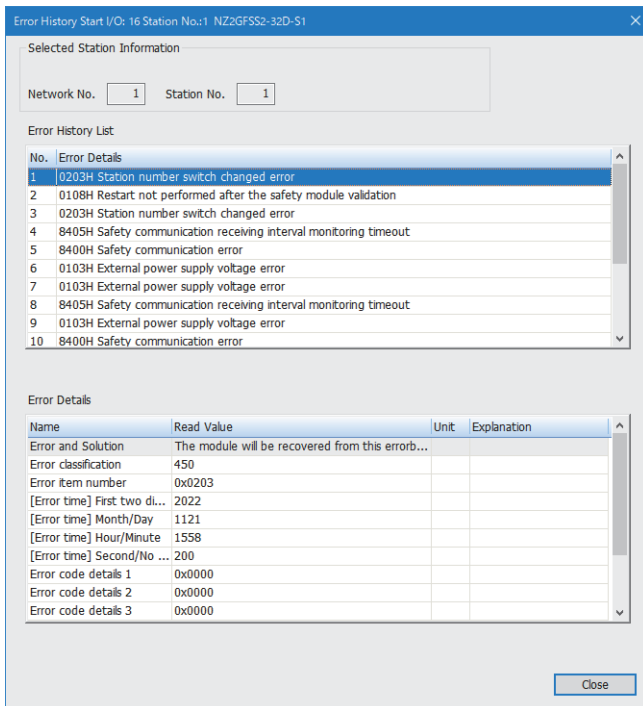

## Checking with "Command Execution of Device Station"

The following describes how to check errors with "Command Execution of Device Station" in the "Network Configuration Settings".

1. Select the safety remote I/O module in "List of stations" on the "CC IE Field Configuration" window.

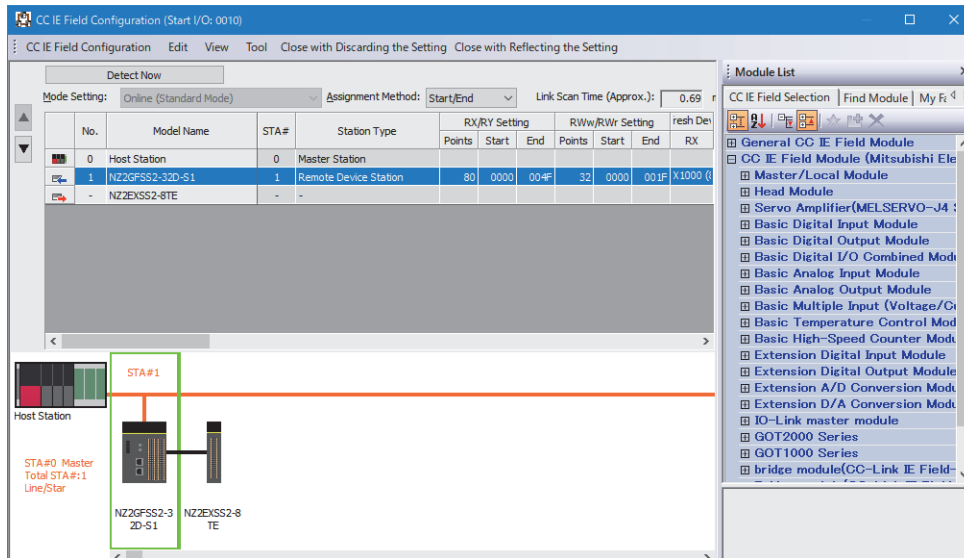

2. Open the "Command Execution of Device Station" window.

[CC IE Field Configuration] ⇒ [Online] ⇒ [Command Execution of Device Station]

3. Set "Method selection" to "Error history read" and click the [Execute] button.

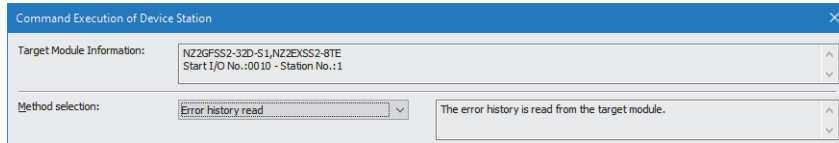

4. Click the [Execute] button and a confirmation window is displayed. Check the contents and click the [Yes] button to read the error history data.

5. When the following window is displayed, click the [OK] button.

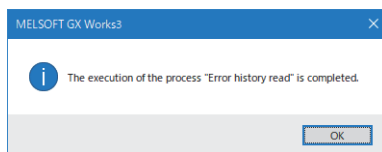

6. The error history of the safety remote I/O module is displayed in "Execution Result".

Name	Read Value	Unit	Description
Error history 1 read			
Error and Solution	0203H Station number switch c...		
Error classification	450		
Error item number	0x0203		
[Error time] First two digits of the year/Last two digits of the year	2022		
[Error time] Month/Day	1121		
[Error time] Hour/Minute	1558		
[Error time] Second/No Use	200		



## ■ For the NZ2GFSS2-32D-S1

Item	Description	Storage example*1
Error and Solution	Error codes and error details of the errors that have occurred are displayed.	—
Error classification	The error classifications of safety error subset codes are stored.	—
Error item number	The error item numbers of safety error subset codes are stored.	—
[Error time] First two digits of the year/Last two digits of the year*2	The date and hour of error occurrence is displayed. (When the tens place of Month, Hour, and Second is "0", "0" is omitted.)	2015
[Error time] Month/Day*2		829
[Error time] Hour/Minute*2		1035
[Error time] Second/No Use*2		4000
Error code details 1 to Error code details 7	The detailed information of some errors is stored. The data to be stored depends on the error.  Page 149 Error code details (NZ2GFSS2-32D-S1)	—

\*1 Values of when an error occurs at 10:35:40, August 29th, 2015

\*2 The clock information of the error that occurred is based on the clock information acquired from the CPU module of the master station. When an error has occurred before the clock information is acquired from the CPU module, the error time is not recorded.

## ■ For the NZ2GFSS2-8D-S1, NZ2GFSS2-8TE-S1, or NZ2GFSS2-16DTE-S1

Item	Description	Storage example*1
Error code	The error codes of errors that have occurred are stored.	—
Order of generation	The order of error occurrence is stored. (A value between 0 and 65535 is stored.)	—
[Error time] First two digits of the year/Last two digits of the year*2	The date and hour of error occurrence is displayed. (When the tens place of Month, Hour, and Second is "0", "0" is omitted.)	2015
[Error time] Month/Day*2		829
[Error time] Hour/Minute*2		1035
[Error time] Second/No Use*2		4000
Error code details 1 to Error code details 8	The detailed information of some errors is stored. The data to be stored depends on the error.  Page 151 Error code details (NZ2GFSS2-8D-S1, NZ2GFSS2-8TE-S1, NZ2GFSS2-16DTE-S1)	—

\*1 Values of when an error occurs at 10:35:40, August 29th, 2015

\*2 The clock information of the error that occurred is based on the clock information acquired from the CPU module of the master station. When an error has occurred before the clock information is acquired from the CPU module, the error time is not recorded.

### Point

- The error history registers 15 errors at a maximum. If 16 or more errors occur, errors are deleted from the oldest.
- If the same error occurs successively, only the error that occurs first is stored to the error history. (Only for the NZ2GFSS2-32D-S1)
- For the NZ2GFSS2-8D-S1, NZ2GFSS2-8TE-S1, or NZ2GFSS2-16DTE-S1, if the same error occurs successively, only the latest error is stored to the error history. The order of generation for the latest error does not change. (If the error occurs at powering off and on or after remote reset, the previous error is also stored to the error history. The order of generation for the latest error changes.)
- Even after the module power supply is powered off and on, the error history remains.
- The clock information of the error that occurred is based on the clock information acquired from the CPU module of the master station. To obtain the exact occurrence time of an error, set the clock information of the CPU module to the actual time.
- To initialize the error history, set "Method selection" to "Error history clear request" on the "Command Execution of Device Station" window and click the [Execute] button.

## Checking error codes and warning codes

The latest error code and warning code of the safety remote I/O module can be checked with the remote register of the master station.

### ■Checking error codes

Check the error codes with the remote register of the master station.

 [Online] ⇒ [Monitor] ⇒ [Device/Buffer Memory Batch]

**Ex.**

When the refresh target device for Error code (RX□) is W101

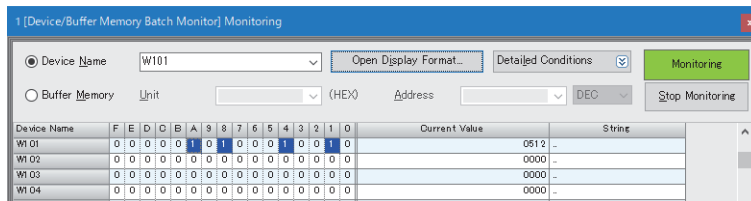

### ■Checking warning codes

Check the warning codes with the remote register of the master station.

 [Online] ⇒ [Monitor] ⇒ [Device/Buffer Memory Batch]

**Ex.**

When the refresh target device for Warning code (RX□) is W102

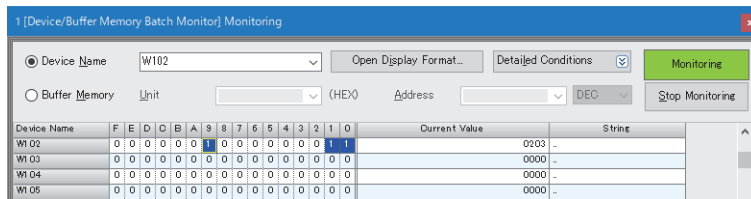

# 10.7 List of Error Codes

## Error classification by error number

Error codes are classified by error number as follows.

Module model name	Error code	Classification	Reference
NZ2GFSS2-32D-S1	0000H to 3FFFH D529H, D52BH	Safety remote I/O module error	Page 138 Error codes related to the safety remote I/O module
	D000H to DFFFH (excluding D529H and D52BH)	CC-Link IE Field Network error	Page 154 Error codes related to the CC-Link IE Field Network
	8400H	Safety communication error	Page 156 Error codes related to safety communication
NZ2GFSS2-8D-S1 NZ2GFSS2-8TE-S1 Z2GFSS2-16DTE-S1	0000H to 3FFFH	Safety remote I/O module error	Page 138 Error codes related to the safety remote I/O module
	D000H to DFFFH	CC-Link IE Field Network error	Page 154 Error codes related to the CC-Link IE Field Network
	8400H	Safety communication error	Page 156 Error codes related to safety communication

## Error code system

Error codes are accompanied by safety error subset codes. A safety error subset code consists of the error classification for the stop cause of the safety functions (safety I/O, safety diagnostics, and safety communication) and an error item number.



A safety error subset code is available only for the NZ2GFSS2-32D-S1.

### Safety error subset code example

The following shows an error code and a safety error subset code of a double input discrepancy detection error as an example.

Error	Error code (hexadecimal)	Safety error subset code	
		Error classification	Error item number
Double input discrepancy detection error	0204H	450	0204H

### Error classification of safety error subset code

The following table shows error classifications of safety error subset codes used in the safety remote I/O module. For errors that are not the stop causes of the safety functions, no safety error subset codes are assigned.

For error item numbers, refer to the subsequent lists of error codes.

Error classification	Description
300 to 315	Errors common to the safety communications
450	Errors specific to the safety remote I/O module

## Error codes related to the safety remote I/O module

Errors of the safety remote I/O module are classified into the following three types.

Error status <sup>*1</sup>	Description
Major error	Error because of which the module stops, such as hardware failure. The safety functions (safety I/O, safety diagnostics, and safety communications) stop.
Moderate error	Error because of which the module stops, such as a parameter error related to module operation. The safety functions (safety I/O, safety diagnostics, and safety communications) stop.
Minor error	Error after which the module continues its operation, such as double input discrepancy detection. The safety functions keep operating.

\*1 When multiple errors have occurred, the error statuses are displayed in the order of error severity (Major error > Moderate error > Minor error).

### List of error codes

#### ■NZ2GFSS2-32D-S1

Error code (hexadecimal)	Safety error subset code		Classification	Error name	Description and cause	Action
	Error classification	Error item number (hexadecimal)				
0001H	450	0001H	Major error	Hardware failure	A hardware failure was detected.	There may be an influence from noise or a hardware failure. If the same error occurs again even after measures have been taken against noise, the module may be in failure. Please consult your local Mitsubishi representative. <sup>*2</sup>
0101H	450	0101H	Moderate error	Self-diagnostic error	An error was detected by the self-diagnostics.	
0102H	450	0102H	Moderate error	Output overload error	The overcurrent protection or overheat protection of the output circuit was activated.	<ul style="list-style-type: none"> <li>Review the connected devices and wiring.</li> <li>When the connected devices and wiring have no errors, there may be an influence from noise or a hardware failure. If the same error occurs again even after measures have been taken against noise, the module may be in failure. Please consult your local Mitsubishi representative.</li> </ul>
0103H <sup>*1</sup>	450	0103H	Moderate error	External power supply voltage error	An external power supply error was detected.	<ul style="list-style-type: none"> <li>Match the ON timing of the external power supply with the ON timing of the module power supply.</li> <li>Review the connected devices, wiring, and voltage.</li> <li>There may be an influence from noise of external wiring (such as power supply part and I/O signal part). Take measures to reduce noise.</li> <li>If the same error occurs again, the module may be in failure. Please consult your local Mitsubishi representative.</li> </ul>
0104H	450	0104H	Moderate error	Module configuration changed	The module configuration has been changed after power on.	<ul style="list-style-type: none"> <li>Check the connection status of the extension module.</li> <li>If the module is connected properly, there may be an influence from noise or a hardware failure. If the same error occurs again even after measures have been taken against noise, the module may be in failure. Please consult your local Mitsubishi representative.</li> </ul>

Error code (hexadecimal)	Safety error subset code		Classification	Error name	Description and cause	Action
	Error classification	Error item number (hexadecimal)				
0105H	450	0105H	Moderate error	Date out of range error	Incorrect clock data was received from the CPU module.	There may be an influence from noise or a hardware failure. If the same error occurs again even after measures have been taken against noise, the module may be in failure. Please consult your local Mitsubishi representative.
0106H	450	0106H	Moderate error	Improper module connected	A module that cannot be used for extension is connected.	Check whether the extension module connected is connectable to this product. If the module is connectable, there may be an influence from noise or a hardware failure. If the same error occurs again even after measures have been taken against noise, the module may be in failure. Please consult your local Mitsubishi representative.
0107H	450	0107H	Moderate error	Safety module validation not performed	The safety module validation has not been performed.	<ul style="list-style-type: none"> <li>Perform the safety module validation and restart the module.</li> <li>If the same error occurs again, the module may be in failure. Please consult your local Mitsubishi representative.</li> </ul>
0108H	450	0108H	Moderate error	Restart not performed after safety module validation	The module has not been restarted after the safety module validation.	<ul style="list-style-type: none"> <li>Restart the module.</li> <li>If the same error occurs again, the module may be in failure. Please consult your local Mitsubishi representative.</li> </ul>
0109H	450	0109H	Moderate error	Module power supply voltage error	A module power supply error was detected.	<ul style="list-style-type: none"> <li>Review the connected devices, wiring, and voltage.</li> <li>If the same error occurs again, the module may be in failure. Please consult your local Mitsubishi representative.</li> </ul>
0201H	450	0201H	Minor error Recoverable	Non-volatile memory data error (error history)	The error history data stored in the non-volatile memory is incorrect.	<ul style="list-style-type: none"> <li>The module will automatically recover immediately after the error occurs. Note that the error history of the errors that have occurred will be lost.</li> <li>If the same error occurs again, the module may be in failure. Please consult your local Mitsubishi representative.</li> </ul>
0202H <sup>*1</sup>	450	0202H	Minor error Recoverable	Remote buffer memory access error	An area outside the range of the remote buffer memory areas has been accessed using the REMFR/REMTO instructions.	Correct the setting data of the REMFR/REMTO instruction to access within the range of remote buffer memory areas.
0203H	450	0203H	Minor error Recoverable	Station number switch changed error	The station number setting switches have been changed while the module power supply is on.	The module will recover from this error by setting the switches to the previous station number that was set when the module power supply was powered on.

Error code (hexadecimal)	Safety error subset code		Classification	Error name	Description and cause	Action
	Error classification	Error item number (hexadecimal)				
0204H <sup>1</sup>	450	0204H	Minor error Recoverable	Double input discrepancy detection error	A double input discrepancy was detected in a pair of inputs (X0 and X1, X2 and X3, ...).	<ul style="list-style-type: none"> <li>• Match the ON timing of the external power supply with the ON timing of the module power supply.</li> <li>• Correct the parameter settings of "Double input discrepancy detection time".</li> <li>• Review the connected devices and wiring.</li> <li>• When the connected devices and wiring have no errors, there may be an influence from noise or a hardware failure. Take measures to reduce noise.</li> <li>• If the same error occurs again, the module may be in failure. Please consult your local Mitsubishi representative.</li> <li>• When "Double input discrepancy auto recovery setting" is set to "1: Used", the module will recover from this error after the double input discrepancy is eliminated.</li> </ul>
0205H <sup>1</sup>	450	0205H	Minor error	Input dark test error	During an input dark test, test pulses were not detected.	<ul style="list-style-type: none"> <li>• Match the ON timing of the external power supply with the ON timing of the module power supply.</li> <li>• Correct the parameter settings of "Input dark test pulse OFF time" and "Number of pulse output for input dark test".</li> <li>• Review the connected devices and wiring.</li> <li>• When the connected devices and wiring have no errors, there may be an influence from noise or a hardware failure. Take measures to reduce noise.</li> <li>• If the same error occurs again, the module may be in failure. Please consult your local Mitsubishi representative.</li> </ul>
0206H	450	0206H	Minor error	I/O data error	An error was detected in the I/O data.	<ul style="list-style-type: none"> <li>• Match the ON timing of the external power supply with the ON timing of the module power supply.</li> <li>• Review the connected devices and wiring.</li> <li>• When the connected devices and wiring have no errors, there may be an influence from noise or a hardware failure. Take measures to reduce noise.</li> <li>• If the same error occurs again, the module may be in failure. Please consult your local Mitsubishi representative.</li> </ul>

Error code (hexadecimal)	Safety error subset code		Classification	Error name	Description and cause	Action
	Error classification	Error item number (hexadecimal)				
0207H <sup>1</sup>	450	0207H	Minor error	Output read-back error	A discrepancy of an output read-back value and an output value was detected.	<ul style="list-style-type: none"> <li>• Match the ON timing of the external power supply with the ON timing of the module power supply.</li> <li>• Review the connected devices and wiring.</li> <li>• Check that 24V is supplied to the external power supply using a tester.</li> <li>• Check that the external connection is not overloaded.</li> <li>• When the connected devices and wiring have no errors, there may be an influence from noise or a hardware failure. Take measures to reduce noise.</li> <li>• If the same error occurs again, the module may be in failure. Please consult your local Mitsubishi representative.</li> </ul>
0208H <sup>1</sup>	450	0208H	Minor error	Output dark test error	During an output dark test, test pulses were not detected.	<ul style="list-style-type: none"> <li>• Match the ON timing of the external power supply with the ON timing of the module power supply.</li> <li>• Correct the parameter settings of "Output dark test pulse OFF time" and "Number of pulse output for output dark test".</li> <li>• Review the connected devices and wiring.</li> <li>• Check that 24V is supplied to the external power supply using a tester.</li> <li>• Check that the external connection is not overloaded.</li> <li>• When the connected devices and wiring have no errors, there may be an influence from noise or a hardware failure. Take measures to reduce noise.</li> <li>• If the same error occurs again, the module may be in failure. Please consult your local Mitsubishi representative.</li> </ul>
020AH	450	020AH	Minor error Recoverable	Safety module validation failure	The safety module validation failed.	<ul style="list-style-type: none"> <li>• Check that no error other than "Safety module validation failure" has occurred on the module using the ERR. LED of the module and error history. If an error has occurred, eliminate the cause.</li> <li>• If the same error occurs again even after "Safety module validation" is executed in no error state, the module may be in failure. Please consult your local Mitsubishi representative.</li> </ul>

Error code (hexadecimal)	Safety error subset code		Classification	Error name	Description and cause	Action
	Error classification	Error item number (hexadecimal)				
020BH	450	020BH	Minor error	External power supply voltage error	An external power supply error was detected.	<ul style="list-style-type: none"> <li>Match the ON timing of the external power supply with the ON timing of the module power supply.</li> <li>Review the connected devices, wiring, and voltage.</li> <li>There may be an influence from noise of external wiring (such as power supply part and I/O signal part). Take measures to reduce noise.</li> <li>If the same error occurs again, the module may be in failure. Please consult your local Mitsubishi representative.</li> </ul>
0500H	450	0500H	Moderate error Recoverable	Parameter data error	An incorrect value or parameter data out of the range is set.	<ul style="list-style-type: none"> <li>Correct the module parameter settings and module configuration.</li> <li>When the parameters are set again and the parameter setting has succeeded, the module will recover from this error.</li> </ul>
0502H	450	0502H	Moderate error Recoverable	Parameter data error (version information)	The version mismatch of the module used and engineering tool was detected.	<ul style="list-style-type: none"> <li>Review the version of the engineering tool and that of the master station.</li> <li>Check that the module version set in the "Network Configuration Settings" of the engineering tool matches with the version of actual module.</li> <li>When the parameter is set again and the parameter setting has succeeded, the module will recover from this error.</li> </ul>
0511H	450	0511H	Moderate error Recoverable	Parameter data error (wiring selection of input)	An incorrect value or parameter (wiring selection of input) out of the range is set.	<ul style="list-style-type: none"> <li>Correct the module parameter settings (wiring selection of input) and module configuration.</li> <li>When "Wiring selection of input" Xn (n: even number) is set to "1: Double wiring (NC/NC)", set the same value for Xn+1.</li> <li>When the parameters are set again and the parameter setting has succeeded, the module will recover from this error.</li> </ul>
0512H	450	0512H	Moderate error Recoverable	Parameter data error (input response time)	An incorrect value or parameter data out of the range is set.	<ul style="list-style-type: none"> <li>Correct the module parameter settings (input response time) and module configuration.</li> <li>When "Wiring selection of input" Xn (n: even number) is set to "1: Double wiring (NC/NC)", set the same value for Xn+1.</li> <li>Set the input response time so that it is longer than the input dark test pulse output time. Input dark test pulse output time = Pulse OFF time for the input dark test × ((Number of pulse outputs for the input dark test × 2) - 1)</li> <li>When the parameters are set again and the parameter setting has succeeded, the module will recover from this error.</li> </ul>



Error code (hexadecimal)	Safety error subset code		Classification	Error name	Description and cause	Action
	Error classification	Error item number (hexadecimal)				
0530H	450	0530H	Moderate error Recoverable	Parameter data error (input dark test execution setting)	An incorrect value or parameter (input dark test execution setting) out of the range is set.	<ul style="list-style-type: none"> <li>• Correct the module parameter settings (input dark test execution setting) and module configuration.</li> <li>• When "Wiring selection of input" Xn (n: even number) is set to "1: Double wiring (NC/NC)", set the same value for Xn+1.</li> <li>• When the parameters are set again and the parameter setting has succeeded, the module will recover from this error.</li> </ul>
0580H	450	0580H	Moderate error Recoverable	Parameter data error (module identification code)	An incorrect value or parameter data (module identification code) out of the range is set.	<ul style="list-style-type: none"> <li>• Correct the module parameter setting and module configuration.</li> <li>• Check that the actual configuration matches with the module configuration set in the "Network Configuration Settings" of engineering tool.</li> <li>• When the parameter is set again and the parameter setting has succeeded, the module will recover from this error.</li> </ul>
0582H	450	0582H	Moderate error Recoverable	Parameter data error (wiring selection of output)	An incorrect value or parameter (wiring selection of output) out of the range is set.	<ul style="list-style-type: none"> <li>• Correct the module parameter settings (wiring selection of output) and module configuration.</li> <li>• When "Wiring selection of output" Yn (n: even number) is set to "1: Double wiring (Source/Source)", set the same value for Yn+1.</li> <li>• When the parameters are set again and the parameter setting has succeeded, the module will recover from this error.</li> </ul>
0590H	450	0590H	Moderate error Recoverable	Parameter data error (output dark test execution setting)	An incorrect value or parameter (output dark test execution setting) out of the range is set.	<ul style="list-style-type: none"> <li>• Correct the module parameter settings (output dark test execution setting) and module configuration.</li> <li>• When "Wiring selection of output" Yn (n: even number) is set to "1: Double wiring (Source/Source)", set the same value for Yn+1.</li> <li>• When the parameters are set again and the parameter setting has succeeded, the module will recover from this error.</li> </ul>
0591H	450	0591H	Moderate error Recoverable	Parameter data error (output dark test pulse OFF time setting)	An incorrect value or parameter (output dark test pulse OFF time setting) out of the range is set.	<ul style="list-style-type: none"> <li>• Correct the module parameter settings (output dark test pulse OFF time setting) and module configuration.</li> <li>• When "Wiring selection of output" Yn (n: even number) is set to "1: Double wiring (Source/Source)", set the same value for Yn+1.</li> <li>• When the parameters are set again and the parameter setting has succeeded, the module will recover from this error.</li> </ul>

- \*1 Detailed information of the error is stored in Error code details in Error history data. For Error code details, refer to the following.  
 Page 149 Error code details (NZ2GFSS2-32D-S1)
- \*2 If power-off of the module power supply coincides with the safety diagnostics, an error of the hardware failure can be logged in the error history. Restart the module and check that the error has been eliminated before using the module.

---

**Point** 

When multiple errors have occurred, only the latest error code is stored in Error code (RX10 to RX1F). The errors that occurred before can be checked by executing "Error history read" of the "Network Configuration Settings" in the engineering tool. For the error history, refer to the following.

 Page 132 How to Check Error Codes

---

## ■NZ2GFSS2-8D-S1, NZ2GFSS2-8TE-S1, NZ2GFSS2-16DTE-S1

Error code (hexadecimal)	Classification	Error name	Description and cause	Action
0001H	Major error	Hardware failure	A hardware failure was detected.	There may be an influence from noise or a hardware failure. If the same error occurs again even after measures have been taken against noise, the module may be in failure. Please consult your local Mitsubishi representative.* <sup>2</sup>
0101H	Moderate error	Self-diagnostic error	An error was detected by the self-diagnostics.	
0102H <sup>1</sup>	Moderate error	External power supply voltage error	An external power supply error was detected.	<ul style="list-style-type: none"> <li>Match the ON timing of the external power supply with the ON timing of the module power supply.</li> <li>Review the connected devices, wiring, and voltage.</li> <li>There may be an influence from noise of external wiring (such as power supply part and I/O signal part). Take measures to reduce noise.</li> <li>If the same error occurs again, the module may be in failure. Please consult your local Mitsubishi representative.</li> </ul>
0103H <sup>1</sup>	Moderate error	Module configuration changed	The module configuration has been changed after power on.	<ul style="list-style-type: none"> <li>Check the connection status of the extension module.</li> <li>If the module is connected properly, there may be an influence from noise or a hardware failure. If the same error occurs again even after measures have been taken against noise, the module may be in failure. Please consult your local Mitsubishi representative.</li> </ul>
0104H	Moderate error	Date out of range error	Incorrect clock data was received from the CPU module.	There may be an influence from noise or a hardware failure. If the same error occurs again even after measures have been taken against noise, the module may be in failure. Please consult your local Mitsubishi representative.
0105H <sup>1</sup>	Moderate error	Improper module connected	A module that cannot be used for extension is connected.	Check whether the extension module connected is connectable to this product. If the module is connectable, there may be an influence from noise or a hardware failure. If the same error occurs again even after measures have been taken against noise, the module may be in failure. Please consult your local Mitsubishi representative.
0106H	Moderate error	Restart not performed after safety module validation	The module has not been restarted after the safety module validation.	<ul style="list-style-type: none"> <li>Restart the module.</li> <li>If the same error occurs again, the module may be in failure. Please consult your local Mitsubishi representative.</li> </ul>
0107H	Moderate error	Non-volatile memory data error (parameter)	An error of the parameter data stored in the non-volatile memory has been detected.	<ul style="list-style-type: none"> <li>The module will recover from this error by initializing parameters by using Parameter area initialization command. In such a case, parameters are required to be set again by users.</li> <li>If the same error occurs again, the module may be in failure. Please consult your local Mitsubishi representative.</li> </ul>
0108H	Moderate error	Non-volatile memory data error (control data)	An error of the control data stored in the non-volatile memory has been detected.	<ul style="list-style-type: none"> <li>Check parameters again and perform the safety module validation.</li> <li>If the same error occurs again, the module may be in failure. Please consult your local Mitsubishi representative.</li> </ul>
0109H <sup>1</sup>	Moderate error	Output read-back error	A discrepancy of an output read-back value and an output value was detected.	<ul style="list-style-type: none"> <li>Match the ON timing of the external power supply with the ON timing of the module power supply.</li> <li>Review the connected devices and wiring.</li> <li>Check that 24V is supplied to the external power supply using a tester.</li> <li>Check that the external connection is not overloaded.</li> <li>When the connected devices and wiring have no errors, there may be an influence from noise or a hardware failure. Take measures to reduce noise.</li> <li>If the same error occurs again, the module may be in failure. Please consult your local Mitsubishi representative.</li> </ul>

Error code (hexadecimal)	Classification	Error name	Description and cause	Action
010AH <sup>1</sup>	Moderate error	Output dark test error	During an output dark test, test pulses were not detected.	<ul style="list-style-type: none"> <li>Match the ON timing of the external power supply with the ON timing of the module power supply.</li> <li>Correct the parameter settings of "Output dark test pulse OFF time" and "Number of pulse output for output dark test".</li> <li>Review the connected devices and wiring.</li> <li>Check that 24V is supplied to the external power supply using a tester.</li> <li>Check that the external connection is not overloaded.</li> <li>When the connected devices and wiring have no errors, there may be an influence from noise or a hardware failure. Take measures to reduce noise.</li> <li>If the same error occurs again, the module may be in failure. Please consult your local Mitsubishi representative.</li> </ul>
010BH	Moderate error	I/O data error	An error was detected by the input diagnostic.	<ul style="list-style-type: none"> <li>Match the ON timing of the external power supply with the ON timing of the module power supply.</li> <li>Review the connected devices and wiring.</li> <li>When the connected devices and wiring have no errors, there may be an influence from noise or a hardware failure. Take measures to reduce noise.</li> <li>If the same error occurs again, the module may be in failure. Please consult your local Mitsubishi representative.</li> </ul>
010CH	Moderate error	Module power supply voltage error	A module power supply error was detected.	<ul style="list-style-type: none"> <li>Review the connected devices, wiring, and voltage.</li> <li>If the same error occurs again, the module may be in failure. Please consult your local Mitsubishi representative.</li> </ul>
0201H	Minor error	Non-volatile memory data error (error history)	An error of the error history data stored in the non-volatile memory has been detected.	<ul style="list-style-type: none"> <li>The module will automatically recover immediately after the error occurs. Note that the error history of the errors that have occurred will be lost.</li> <li>If the same error occurs again, the module may be in failure. Please consult your local Mitsubishi representative.</li> </ul>
0202H <sup>1</sup>	Minor error Recoverable	Remote buffer memory access error	An area outside the range of the remote buffer memory areas has been accessed using the REMFR/REMTO instructions.	Correct the setting data of the REMFR/REMTO instruction to access within the range of remote buffer memory areas.
0203H	Minor error Recoverable	Station number switch changed error	The station number setting switches have been changed while the module power supply is on.	The module will recover from this error by setting the switches to the previous station number that was set when the module power supply was powered on.
0204H <sup>1</sup>	Minor error Recoverable	Double input discrepancy detection error	A double input discrepancy was detected in a pair of inputs (X0 and X1, X2 and X3, ...).	<ul style="list-style-type: none"> <li>Match the ON timing of the external power supply with the ON timing of the module power supply.</li> <li>Correct the parameter settings of "Double input discrepancy detection time".</li> <li>Review the connected devices and wiring.</li> <li>When the connected devices and wiring have no errors, there may be an influence from noise or a hardware failure. Take measures to reduce noise.</li> <li>If the same error occurs again, the module may be in failure. Please consult your local Mitsubishi representative.</li> <li>When "Double input discrepancy auto recovery setting" is set to "1: Used", the module will recover from this error after the double input discrepancy is eliminated.</li> </ul>
0205H <sup>1</sup>	Minor error	Input dark test error	During an input dark test, test pulses were not detected.	<ul style="list-style-type: none"> <li>Match the ON timing of the external power supply with the ON timing of the module power supply.</li> <li>Correct the parameter settings of "Input dark test pulse OFF time" and "Number of pulse output for input dark test".</li> <li>Review the connected devices and wiring.</li> <li>When the connected devices and wiring have no errors, there may be an influence from noise or a hardware failure. Take measures to reduce noise.</li> <li>If the same error occurs again, the module may be in failure. Please consult your local Mitsubishi representative.</li> </ul>

Error code (hexadecimal)	Classification	Error name	Description and cause	Action
0209H	Minor error Recoverable	Safety module validation failure	The safety module validation failed.	<ul style="list-style-type: none"> <li>Check that no error other than "Safety module validation failure" has occurred on the module using the ERR. LED of the module and error history. If an error has occurred, eliminate the cause.</li> <li>If the same error occurs again even after "Safety module validation" is executed in no error state, the module may be in failure. Please consult your local Mitsubishi representative.</li> </ul>
020AH	Minor error Recoverable	Safety module validation not performed	The safety module validation has not been performed.	<ul style="list-style-type: none"> <li>Perform the safety module validation and restart the module.</li> <li>If the same error occurs again, the module may be in failure. Please consult your local Mitsubishi representative.</li> </ul>
020BH	Minor error Recoverable	Non-volatile memory data error (module operation information)	An error of the module operation information stored in a non-volatile memory has been detected.	<ul style="list-style-type: none"> <li>The module will automatically recover immediately after the error occurs. Note that number of ON times integration value will be initialized to zero.</li> <li>If the same error occurs again, the module may be in failure. Please consult your local Mitsubishi representative.</li> </ul>
020CH	Minor error	External power supply voltage error	An external power supply error was detected.	<ul style="list-style-type: none"> <li>Match the ON timing of the external power supply with the ON timing of the module power supply.</li> <li>Review the connected devices, wiring, and voltage.</li> <li>There may be an influence from noise of external wiring (such as power supply part and I/O signal part). Take measures to reduce noise.</li> <li>If the same error occurs again, the module may be in failure. Please consult your local Mitsubishi representative.</li> </ul>
0500H <sup>*1</sup>	Moderate error Recoverable	Parameter data error	A value with an error or parameter data out of the range is set.	<ul style="list-style-type: none"> <li>Correct the module parameter setting and module configuration.</li> <li>When the parameters are set again and the parameter setting has succeeded, the module will recover from this error.</li> </ul>
0502H <sup>*1</sup>	Moderate error Recoverable	Parameter data error (version information)	The version mismatch of the module used and engineering tool was detected.	<ul style="list-style-type: none"> <li>Review the version of the engineering tool and that of the master station.</li> <li>Check that the module version set in the "Network Configuration Settings" of the engineering tool matches with the version of actual module.</li> <li>When the parameter is set again and the parameter setting has succeeded, the module will recover from this error.</li> </ul>
0511H <sup>*1</sup>	Moderate error Recoverable	Parameter data error (wiring selection of input)	A value with an error or parameter (wiring selection of input) out of the range is set.	<ul style="list-style-type: none"> <li>Correct the module parameter settings (wiring selection of input) and module configuration.</li> <li>When "Wiring selection of input" Xn (n: even number) is set to "1: Double wiring (NC/NC)", set the same value for Xn+1.</li> <li>When the parameters are set again and the parameter setting has succeeded, the module will recover from this error.</li> </ul>
0512H <sup>*1</sup>	Moderate error Recoverable	Parameter data error (input response time)	A value with an error or parameter data out of the range is set.	<ul style="list-style-type: none"> <li>Correct the module parameter settings (input response time) and module configuration.</li> <li>When "Wiring selection of input" Xn (n: even number) is set to "1: Double wiring (NC/NC)", set the same value for Xn+1.</li> <li>Set the input response time so that it is longer than the input dark test pulse output time. Input dark test pulse output time = Pulse OFF time for the input dark test × ((Number of pulse outputs for the input dark test × 2) - 1)</li> <li>When the parameters are set again and the parameter setting has succeeded, the module will recover from this error.</li> </ul>
0530H <sup>*1</sup>	Moderate error Recoverable	Parameter data error (input dark test execution setting)	A value with an error or parameter (input dark test execution setting) out of the range is set.	<ul style="list-style-type: none"> <li>Correct the module parameter settings (input dark test execution setting) and module configuration.</li> <li>When "Wiring selection of input" Xn (n: even number) is set to "1: Double wiring (NC/NC)", set the same value for Xn+1.</li> <li>When the parameters are set again and the parameter setting has succeeded, the module will recover from this error.</li> </ul>

Error code (hexadecimal)	Classification	Error name	Description and cause	Action
0580H <sup>*1</sup>	Moderate error Recoverable	Parameter data error (module identification code)	A value with an error or parameter data (module identification code) out of the range is set.	<ul style="list-style-type: none"> <li>Correct the module parameter setting and module configuration.</li> <li>Check that the actual configuration matches with the module configuration set in the "Network Configuration Settings" of engineering tool.</li> <li>When the parameter is set again and the parameter setting has succeeded, the module will recover from this error.</li> </ul>
0582H <sup>*1</sup>	Moderate error Recoverable	Parameter data error (wiring selection of output)	A value with an error or parameter (wiring selection of output) out of the range is set.	<ul style="list-style-type: none"> <li>Correct the module parameter settings (wiring selection of output) and module configuration.</li> <li>When "Wiring selection of output" Yn (n: even number) is set to "1: Double wiring (Source/Source)", set the same value for Yn+1.</li> <li>When the parameters are set again and the parameter setting has succeeded, the module will recover from this error.</li> </ul>
0590H <sup>*1</sup>	Moderate error Recoverable	Parameter data error (output dark test execution setting)	A value with an error or parameter (output dark test execution setting) out of the range is set.	<ul style="list-style-type: none"> <li>Correct the module parameter settings (output dark test execution setting) and module configuration.</li> <li>When "Wiring selection of output" Yn (n: even number) is set to "1: Double wiring (Source/Source)", set the same value for Yn+1.</li> <li>When the parameters are set again and the parameter setting has succeeded, the module will recover from this error.</li> </ul>
0591H <sup>*1</sup>	Moderate error Recoverable	Parameter data error (output dark test pulse OFF time setting)	A value with an error or parameter (output dark test pulse OFF time setting) out of the range is set.	<ul style="list-style-type: none"> <li>Correct the module parameter settings (output dark test pulse OFF time setting) and module configuration.</li> <li>When "Wiring selection of output" Yn (n: even number) is set to "1: Double wiring (Source/Source)", set the same value for Yn+1.</li> <li>When the parameters are set again and the parameter setting has succeeded, the module will recover from this error.</li> </ul>
05F0H <sup>*1</sup>	Moderate error Recoverable	Parameter data error (extension module)	A value with an error or parameter out of the range is set.	<ul style="list-style-type: none"> <li>Correct module parameter settings of the extension module and module configuration.</li> <li>When the parameters are set again and the parameter setting has succeeded, the module will recover from this error.</li> </ul>

\*1 Detailed information of the error is stored in Error code details in Error history data. For Error code details, refer to the following.

 Page 151 Error code details (NZ2GFSS2-8D-S1, NZ2GFSS2-8TE-S1, NZ2GFSS2-16DTE-S1)

\*2 If power-off of the module power supply coincides with the safety diagnostics, an error of the hardware failure can be logged in the error history. Restart the module and check that the error has been eliminated before using the module.

### Point

When multiple errors have occurred, only the latest error code is stored in Error code. The errors that occurred before can be checked by executing "Error history read" of the "Network Configuration Settings" in the engineering tool. For the error history, refer to the following.

 Page 132 How to Check Error Codes

However, when a moderate error occurs during a major error occurrence, the error code of the major error will remain in Error code.

## Error code details (NZ2GFSS2-32D-S1)

Error details of the following error codes are stored in Error code details (hexadecimal) in Error history data.

### External power supply voltage error (error code: 0103H or 020BH)

An external power supply status (normal or error) is stored in Error code details 1.

- Error code details 1

b15	b14	b13	b12	b11	b10	b9	b8	b7	b6	b5	b4	b3	b2	b1	b0
0 (fixed)												(2)	(1)		

(1) External power supply voltage (main module)

00: Normal

01: Error

(2) External power supply voltage (safety extension module)

00: Normal

01: Error

### Remote buffer memory access error (error code: 0202H)

The start address of a remote buffer memory area that was accessed using the REMFR/REMT0 instruction is stored in Error code details 1. For details on the remote buffer memory addresses, refer to the following.

☞ Page 184 Details of remote buffer memory areas

### Double input discrepancy detection error (error code: 0204H)

Occurrence of a double input discrepancy error is stored in Error code details 1. The input signal status after the input response time has passed is stored in Error code details 3 and Error code details 4.

- Error code details 1

b15	b14	b13	b12	b11	b10	b9	b8	b7	b6	b5	b4	b3	b2	b1	b0
X1E	X1C	X1A	X18	X16	X14	X12	X10	XE	XC	XA	X8	X6	X4	X2	X0
X1F	X1D	X1B	X19	X17	X15	X13	X11	XF	XD	XB	X9	X7	X5	X3	X1

0: Match

1: Mismatch

- Error code details 3

b15	b14	b13	b12	b11	b10	b9	b8	b7	b6	b5	b4	b3	b2	b1	b0
XF	XE	XD	XC	XB	XA	X9	X8	X7	X6	X5	X4	X3	X2	X1	X0

0: OFF

1: ON

- Error code details 4

b15	b14	b13	b12	b11	b10	b9	b8	b7	b6	b5	b4	b3	b2	b1	b0
X1F	X1E	X1D	X1C	X1B	X1A	X19	X18	X17	X16	X15	X14	X13	X12	X11	X10

0: OFF

1: ON

### Input dark test error (error code: 0205H)

The diagnostic result of an input dark test (normal or error) is stored in Error code details 1 and Error code details 2.

- Error code details 1

b15	b14	b13	b12	b11	b10	b9	b8	b7	b6	b5	b4	b3	b2	b1	b0
XF	XE	XD	XC	XB	XA	X9	X8	X7	X6	X5	X4	X3	X2	X1	X0

0: Normal

1: Error

- Error code details 2

b15	b14	b13	b12	b11	b10	b9	b8	b7	b6	b5	b4	b3	b2	b1	b0
X1F	X1E	X1D	X1C	X1B	X1A	X19	X18	X17	X16	X15	X14	X13	X12	X11	X10

0: Normal

1: Error

## ■ I/O data error (error code: 0206H)

The cause of an I/O data error is stored in Error code details 1.

- Error code details 1

b15	b14	b13	b12	b11	b10	b9	b8	b7	b6	b5	b4	b3	b2	b1	b0
0 (fixed)														(1)	

(1) Cause of an I/O data error

10 or 11: Error detected by internal input dark test

The diagnostic result of an internal input dark test (normal or error) is stored in Error code details 2 and Error code details 3.

- Error code details 2

b15	b14	b13	b12	b11	b10	b9	b8	b7	b6	b5	b4	b3	b2	b1	b0
XF	XE	XD	XC	XB	XA	X9	X8	X7	X6	X5	X4	X3	X2	X1	X0

0: Normal

1: Error

- Error code details 3

b15	b14	b13	b12	b11	b10	b9	b8	b7	b6	b5	b4	b3	b2	b1	b0
X1F	X1E	X1D	X1C	X1B	X1A	X19	X18	X17	X16	X15	X14	X13	X12	X11	X10

0: Normal

1: Error



An action to be taken when an I/O data error has occurred depends on the error cause stored in Error code details 1. For details, refer to the following.

- Error detected by internal input dark test: Correct the wiring on the error detection points indicated in Error code details 2.

## ■ Output read-back error (error code: 0207H)

Output read-back error detection point information is stored in Error code details 1.

- Error code details 1

b15	b14	b13	b12	b11	b10	b9	b8	b7	b6	b5	b4	b3	b2	b1	b0
0 (fixed)								Y7	Y6	Y5	Y4	Y3	Y2	Y1	Y0

0: Normal

1: Error

## ■ Output dark test error (error code: 0208H)

The diagnostic result of an output dark test (normal or error) is stored in Error code details 1.

- Error code details 1

b15	b14	b13	b12	b11	b10	b9	b8	b7	b6	b5	b4	b3	b2	b1	b0
0 (fixed)								Y7	Y6	Y5	Y4	Y3	Y2	Y1	Y0

0: Normal

1: Error

## ■ Parameter data error (error code: 05□□H)

The remote buffer memory start address (16-bits) of the parameter where an error was detected is stored in Error code details 1.

The value written in the corresponding address (16-bits) is stored in Error code details 2.

For the parameter with a 32-bits setting value, the value written in the corresponding address (lower 16-bits) is stored in Error code details 2 and the value (upper 16-bits) is stored in Error code details 3.

For details on the remote buffer memory addresses, refer to the following.

☞ Page 178 Remote Buffer Memory



## Error code details (NZ2GFSS2-8D-S1, NZ2GFSS2-8TE-S1, NZ2GFSS2-16DTE-S1)

### ■ External power supply voltage error (error code: 0102H or 020CH)

An external power supply status (normal or error) is stored in Error code details 1.

- Error code details 1

b15	b14	b13	b12	b11	b10	b9	b8	b7	b6	b5	b4	b3	b2	b1	b0
0 (fixed)														(1)	

(1) External power supply voltage (main module)

00: Normal

01: Error

### ■ Module configuration changed error (error code: 0103H)

Error detection module is stored in Error code details 1.

- Error code details 1

b15	b14	b13	b12	b11	b10	b9	b8	b7	b6	b5	b4	b3	b2	b1	b0
0 (fixed)														(1)	

(1) Extension module 1

00: Normal

10: Error

### ■ Improper module connected error (error code: 0105H)

Error detection module is stored in Error code details 1.

- Error code details 1

b15	b14	b13	b12	b11	b10	b9	b8	b7	b6	b5	b4	b3	b2	b1	b0
0 (fixed)														(1)	

(1) Extension module 1

00: Normal

10: Error

### ■ Output read-back error (error code: 0109H)

Output read-back error detection point information is stored in Error code details 1. This error occurs only for the NZ2GFSS2-8TE-S1 and the NZ2GFSS2-16DTE-S1.

- Error code details 1

b15	b14	b13	b12	b11	b10	b9	b8	b7	b6	b5	b4	b3	b2	b1	b0
0 (fixed)								Y7	Y6	Y5	Y4	Y3	Y2	Y1	Y0

0: Normal

1: Error

### ■ Output dark test error (error code: 010AH)

The diagnostic result of an output dark test (normal or error) is stored in Error code details 1. This error occurs only for the NZ2GFSS2-8TE-S1 and the NZ2GFSS2-16DTE-S1.

- Error code details 1

b15	b14	b13	b12	b11	b10	b9	b8	b7	b6	b5	b4	b3	b2	b1	b0
0 (fixed)								Y7	Y6	Y5	Y4	Y3	Y2	Y1	Y0

0: Normal

1: Error

## ■ I/O data error (error code: 010BH)

The cause of an I/O data error is stored in Error code details 1. This error occurs only for the NZ2GFSS2-8D-S1 and the NZ2GFSS2-16DTE-S1.

- Error code details 1

b15	b14	b13	b12	b11	b10	b9	b8	b7	b6	b5	b4	b3	b2	b1	b0
0 (fixed)														(1)	

(1) Cause of an I/O data error

01: All input points error

10 or 11: Error detected by internal input dark test

Error detection point information is stored in Error code details 2.

- Error code details 2

Values to be stored in Error code details 2 depend on a value stored in Error code details 1.

All points become 0 in Error code details 2 when 01 is stored in Error code details 1.

The diagnostic result of an internal input dark test (normal or error) is stored in Error code details 2 when 10 or 11 is stored in Error code details 1.

b15	b14	b13	b12	b11	b10	b9	b8	b7	b6	b5	b4	b3	b2	b1	b0
0 (fixed)								X7	X6	X5	X4	X3	X2	X1	X0

0: Normal

1: Error

### Point

An action to be taken when an I/O data error has occurred depends on the error cause stored in Error code details 1. For details, refer to the following.

- All input points error: If an error occurs for all the input points due to the input dark test error (error code: 0205H) or the double input discrepancy detection error (error code: 0204H) and the input function cannot be performed anymore, a moderate error state of I/O data error (error code: 010BH) is applied. In such a case, take actions to restore from the previous error state (0205H or 0204H: minor error).
- Error detected by internal input dark test: Correct the wiring on the error detection points indicated in Error code details 2.

## ■ Remote buffer memory access error (error code: 0202H)

The start address of a remote buffer memory area that was accessed using the REMFR/REMTO instruction is stored in Error code details 1. For details on the remote buffer memory addresses, refer to the following.

 Page 184 Details of remote buffer memory areas

## ■ Double input discrepancy detection error (error code: 0204H)

Occurrence of a double input discrepancy error is stored in Error code details 1. The input signal status after the input response time has passed is stored in Error code details 3. This error occurs only for the NZ2GFSS2-8D-S1 and the NZ2GFSS2-16DTE-S1.

- Error code details 1

b15	b14	b13	b12	b11	b10	b9	b8	b7	b6	b5	b4	b3	b2	b1	b0
0 (fixed)												X6	X4	X2	X0
												X7	X5	X3	X1

0: Match

1: Mismatch

- Error code details 3

b15	b14	b13	b12	b11	b10	b9	b8	b7	b6	b5	b4	b3	b2	b1	b0
0 (fixed)								X7	X6	X5	X4	X3	X2	X1	X0

0: OFF

1: ON

### ■ Input dark test error (error code: 0205H)

The diagnostic result of an input dark test (normal or error) is stored in Error code details 1. This error occurs only for the NZ2GFSS2-8D-S1 and the NZ2GFSS2-16DTE-S1.

- Error code details 1

b15	b14	b13	b12	b11	b10	b9	b8	b7	b6	b5	b4	b3	b2	b1	b0
0 (fixed)								X7	X6	X5	X4	X3	X2	X1	X0

0: Normal

1: Error

### ■ Parameter data error (error code: 05□□H)

The remote buffer memory start address (16-bits) of the parameter where an error was detected is stored in Error code details 1.

The value written in the corresponding address (16-bits) is stored in Error code details 2.

For the parameter with a 32-bits setting value, the value written in the corresponding address (lower 16-bits) is stored in Error code details 2 and the value (upper 16-bits) is stored in Error code details 3.



For details on the remote buffer memory addresses, refer to the following.

 Page 178 Remote Buffer Memory

## Error codes related to the CC-Link IE Field Network

This section describes CC-Link IE Field Network error codes. Communication errors refer to CC-Link IE Field Network communication related errors and safety communication related errors. The ERR. LED does not turn on when a communication error occurs.

Communication errors of the CC-Link IE Field Network are classified into the following two error types depending on the operation of the D LINK LED performed at an error, and troubleshooting differs for each error type.

-  Page 154 Communication errors where the D LINK LED flashes or turns off
-  Page 155 Communication errors where the D LINK LED does not change

### Communication errors where the D LINK LED flashes or turns off

The following table lists the communication errors of the CC-Link IE Field Network where the D LINK LED flashes or turns off at an error. Troubleshoot these errors with the CC-Link IE TSN/CC-Link IE Field diagnostics of the engineering tool.

Error code (hexadecimal)	Classification	Error name	Description and cause	Action
D0E0H	Communication error	Station type mismatch	The module parameter of the master station is incorrect or outside the range.	Change the station type of the module to the remote device station in the "Network Configuration Settings" of the master station.
D0E1H	Communication error	Own station reserved	The module parameter of the master station is incorrect or outside the range.	<ul style="list-style-type: none"> <li>• In the "Network Configuration Settings" of the master station, cancel the reserved station specification.</li> <li>• Change the station number of the module to a station number that is not reserved.</li> </ul>
D0E2H	Communication error	Station No. already in use (own station)	The station number switch setting is incorrect.	<ul style="list-style-type: none"> <li>• Set a unique station number so that all stations have a different station number.</li> <li>• After taking the above action, power off and on or reset all the stations where this error was detected.</li> </ul>
D0E3H	Communication error	Own station No. out of range	The module parameter of the master station is incorrect or outside the range.	Add the station information of the module in the "Network Configuration Settings" of the master station.
D72AH	Communication error	Station number switch out of range	A station number out of the setting range (a value other than 1 to 120) is set.	Set the station number within the allowable range.

## Communication errors where the D LINK LED does not change

The following table lists the communication errors of the CC-Link IE Field Network where the D LINK LED does not change at an error. These errors are automatically eliminated after occurrence of an error. Therefore, they are not displayed in the CC-Link IE TSN/CC-Link IE Field diagnostics of the engineering tool. Troubleshoot these errors by executing "Error history read" in the "Network Configuration Settings".

Error code (hexadecimal)	Classification	Error name	Description and cause	Action
D217H	Communication error	Transient data request command error	The transient data request command is incorrect.	Correct the request command at the transient request source, and resend the corrected request command.
D2A0H	Communication error	Receive buffer full	The target station is overloaded and cannot receive transient data.	<ul style="list-style-type: none"> <li>• Check the network status using CC-Link IE Field Network diagnostics of the engineering tool to take the appropriate action.</li> <li>• When the target station is overloaded and cannot receive transient data, send the data to the target station after a while.</li> </ul>
D2A3H	Communication error	Transient data length error	The received transient data is incorrect.	Correct the number of data points (frame length) at the transient request source, and resend the corrected transient data.
DF01H	Communication error	Transient data divided error	The divided transient data were received.	Send the transient data that is not divided.

### Point

- The error codes of the CC-Link IE Field Network are not accompanied by safety error subset codes. In the error classification and error item number, 0 is stored.
- When multiple errors have occurred, only the latest error code is stored in Error code. However, when a moderate error occurs during a major error occurrence, the error code of the major error will remain in Error code. The errors that occurred before can be checked by executing "Error history read" of the "Network Configuration Settings". For the error history, refer to the following.
  - ☞ Page 134 Checking with "Command Execution of Device Station"
- Error code details 1 to Error code details 10 for communication errors are fixed to 0.
- If the same error occurs successively, only the error that occurs first is stored to the error history. (Only for the NZ2GFSS2-32D-S1)
- For the NZ2GFSS2-8D-S1, NZ2GFSS2-8TE-S1, or NZ2GFSS2-16DTE-S1, if the same error occurs successively, only the latest error is stored to the error history. The order of generation for the latest error does not change. (If the error occurs at powering off and on or after remote reset, the previous error is also stored to the error history. The order of generation for the latest error changes.)

## Error codes related to safety communication

The following table lists safety communication error codes.

The ERR LED does not turn on when a communication error related to the safety communication occurs, the same as a case when a communication error of the CC-Link IE Field Network occurs. When an error occurs, the SAFETY LED turns off and the D LINK LED does not change.

Error code (hexadecimal)	Safety error subset code		Classification	Error name	Description and cause	Action
	Error classification	Error item number (hexadecimal)				
8400H	310	0001H	Communication error	Safety communication error	An error was detected in the safety communication with the master station.	<ul style="list-style-type: none"> <li>Refer to the following and set module parameters and perform the safety module validation according to the parameter setting procedure. (☞ Page 68 VARIOUS SETTINGS)</li> <li>Correct the number of points in the "RWw/RW<sub>r</sub> Setting" in the "Network Configuration Settings" of the master station.</li> <li>Check the firmware version of the CPU module and the master module. (☞ Page 46 Applicable products)</li> <li>Correct "Safety Communication Setting" of the master station again.</li> <li>When the parameter setting has no errors, there may be an influence from noise or a hardware failure. If the same error occurs again even after measures have been taken against noise, the module may be in failure. Please consult your local Mitsubishi representative.</li> </ul>
		0002H				
	450	8400H				
	312	0000H				
8401H	450	8401H	Communication error	Safety communication disabled due to a communication interrupt	A communication interrupt has occurred on CC- Link IE Field Network and the safety communication is stopped.	<ul style="list-style-type: none"> <li>Check the network status using the CC-Link IE Field Network diagnostics of the engineering tool for errors.</li> <li>When no error has occurred on the network, there may be an influence from noise or a hardware failure. If the same error occurs again even after measures have been taken against noise, the module may be in failure. Please consult your local Mitsubishi representative.</li> </ul>

Error code (hexadecimal)	Safety error subset code		Classification	Error name	Description and cause	Action
	Error classification	Error item number (hexadecimal)				
8402H	311	0001H	Communication error	Safety communication connection being established Response monitoring timeout	Response monitoring timeout was detected while the safety connection was being established in the safety communication with the master station.	<ul style="list-style-type: none"> <li>• Correct "Sending Interval Monitoring Time" of the module parameter as well as "Safety Communication Setting" of the master station. After that, refer to the following and set module parameters and perform the safety module validation according to the parameter setting procedure. (Page 68 VARIOUS SETTINGS)</li> <li>• When the parameter setting has no errors, there may be an influence from noise or a hardware failure. If the same error occurs again even after measures have been taken against noise, the module may be in failure. Please consult your local Mitsubishi representative.</li> </ul>
8403H	450	8403H	Communication error	Safety communication being refreshed Response monitoring timeout	Response monitoring timeout was detected while the safety communication was being refreshed in the safety communication with the master station.	
8404H	450	8404H	Communication error	Safety communication error in processing Response monitoring timeout	Response monitoring timeout was detected while a safety communication error was being processed in the safety communication with the master station.	
8405H	311	0000H	Communication error	Safety communication receiving interval monitoring timeout	Receiving interval monitoring timeout was detected in the safety communication with the master station.	
8406H	450	8406H	Communication error	Safety communication receive data delay detection	Unacceptable delay was detected in the analysis of the data received from the master station.	
8407H	450	8407H	Communication error	Safety communication receive data loss detection	A loss was detected in the analysis of the data received from the master station.	

# APPENDICES

## Appendix 1 Safety Remote I/O Signals

Safety remote I/O signals are dedicated for safety control and are assigned to the safety device of the master station. The following table shows the list of safety remote I/O signals for the master station.

Item	Description
Safety remote input (SAIX)	Safety input signals from the safety remote I/O module to the master station
Safety remote output (SAIY)	Safety output signals from the master station to the safety remote I/O module



For details on the safety device, refer to the following.

MELSEC iQ-R CPU Module User's Manual (Application)

### Assignment of safety remote I/O signals

Module	Safety remote input (SAIX)	Safety remote output (SAIY)
NZ2GFSS2-32D-S1 NZ2GFSS2-32D-S1 + NZ2EXSS2-8TE	SAIX0 to SAIX1F, SAIX2D to SAIX2F	SAIY2E to SAIY2F
NZ2GFSS2-8D-S1	SAIX0 to SAIXB, SAIX1D to SAIX1F	SAIY1E to SAIY1F
NZ2GFSS2-8TE-S1	SAIX1D to SAIX1F	SAIY0 to SAIY7, SAIY1E to SAIY1F
NZ2GFSS2-16DTE-S1	SAIX0 to SAIXB, SAIX1D to SAIX1F	SAIY0 to SAIY7, SAIY1E to SAIY1F



For the NZ2GFSS2-8D-S1 or NZ2GFSS2-16DTE-S1, the status of double input discrepancy detection is stored. SAIX8 to SAIXB turn on when a double input discrepancy detection error has occurred in a pair of the corresponding input signals.



# List of safety remote I/O signals

**Point** 

Do not use any "Use prohibited" safety remote I/O signals. If any of the signals are used, correct operation of the module cannot be guaranteed.

## NZ2GFSS2-32D-S1

### ■ Safety remote input (SAIX)

Signal direction: Safety remote I/O module → Master station	
Device No.	Name
SAIX0	Safety input signal X0
SAIX1	Safety input signal X1
SAIX2	Safety input signal X2
SAIX3	Safety input signal X3
SAIX4	Safety input signal X4
SAIX5	Safety input signal X5
SAIX6	Safety input signal X6
SAIX7	Safety input signal X7
SAIX8	Safety input signal X8
SAIX9	Safety input signal X9
SAIXA	Safety input signal XA
SAIXB	Safety input signal XB
SAIXC	Safety input signal XC
SAIXD	Safety input signal XD
SAIXE	Safety input signal XE
SAIXF	Safety input signal XF
SAIX10	Safety input signal X10
SAIX11	Safety input signal X11
SAIX12	Safety input signal X12
SAIX13	Safety input signal X13
SAIX14	Safety input signal X14
SAIX15	Safety input signal X15
SAIX16	Safety input signal X16
SAIX17	Safety input signal X17
SAIX18	Safety input signal X18
SAIX19	Safety input signal X19
SAIX1A	Safety input signal X1A
SAIX1B	Safety input signal X1B
SAIX1C	Safety input signal X1C
SAIX1D	Safety input signal X1D
SAIX1E	Safety input signal X1E
SAIX1F	Safety input signal X1F
SAIX20 to SAIX2C	Use prohibited
SAIX2D	External power supply status
SAIX2E	Safety output control READY
SAIX2F	Safety output control initial processing completion flag <sup>*1</sup>

\*1 Use this signal when "Operation setting of external power supply voltage error detection" is set to "2: Continue safety communication (With output interlock)".



## ■ Safety remote output (SAIY)

Signal direction: Master station → Safety remote I/O module	
Device No.	Name
SAIY0 to SAIY2D	Use prohibited
SAIY2E	Safety output control initial processing request flag <sup>*1</sup>
SAIY2F	Safety output control start flag <sup>*1</sup>

\*1 Use this signal when "Operation setting of external power supply voltage error detection" is set to "2: Continue safety communication (With output interlock)".

## NZ2GFSS2-8D-S1

## ■ Safety remote input (SAIX)

Signal direction: Safety remote I/O module → Master station	
Device No.	Name
SAIX0	Safety input signal X0
SAIX1	Safety input signal X1
SAIX2	Safety input signal X2
SAIX3	Safety input signal X3
SAIX4	Safety input signal X4
SAIX5	Safety input signal X5
SAIX6	Safety input signal X6
SAIX7	Safety input signal X7
SAIX8	Double input discrepancy state X0 X1
SAIX9	Double input discrepancy state X2 X3
SAIXA	Double input discrepancy state X4 X5
SAIXB	Double input discrepancy state X6 X7
SAIXC to SAIX1C	Use prohibited
SAIX1D	External power supply status
SAIX1E	Safety output control READY
SAIX1F	Safety output control initial processing completion flag <sup>*1</sup>

\*1 Use this signal when "Operation setting of external power supply voltage error detection" is set to "2: Continue safety communication (With output interlock)".

## ■ Safety remote output (SAIY)

Signal direction: Master station → Safety remote I/O module	
Device No.	Name
SAIY0 to SAIY1D	Use prohibited
SAIY1E	Safety output control initial processing request flag <sup>*1</sup>
SAIY1F	Safety output control start flag <sup>*1</sup>

\*1 Use this signal when "Operation setting of external power supply voltage error detection" is set to "2: Continue safety communication (With output interlock)".

## NZ2GFSS2-8TE-S1

### ■ Safety remote input (SAIX)

Signal direction: Safety remote I/O module → Master station	
Device No.	Name
SAIX0 to SAIX1C	Use prohibited
SAIX1D	External power supply status
SAIX1E	Safety output control READY
SAIX1F	Safety output control initial processing completion flag <sup>*1</sup>

\*1 Use this signal when "Operation setting of external power supply voltage error detection" is set to "2: Continue safety communication (With output interlock)".

### ■ Safety remote output (SAIY)

Signal direction: Master station → Safety remote I/O module	
Device No.	Name
SAIY0	Safety output signal Y0
SAIY1	Safety output signal Y1
SAIY2	Safety output signal Y2
SAIY3	Safety output signal Y3
SAIY4	Safety output signal Y4
SAIY5	Safety output signal Y5
SAIY6	Safety output signal Y6
SAIY7	Safety output signal Y7
SAIY8 to SAIY1D	Use prohibited
SAIY1E	Safety output control initial processing request flag <sup>*1</sup>
SAIY1F	Safety output control start flag <sup>*1</sup>

\*1 Use this signal when "Operation setting of external power supply voltage error detection" is set to "2: Continue safety communication (With output interlock)".

A

## NZ2GFSS2-16DTE-S1

### ■ Safety remote input (SAIX)

Signal direction: Safety remote I/O module → Master station	
Device No.	Name
SAIX0	Safety input signal X0
SAIX1	Safety input signal X1
SAIX2	Safety input signal X2
SAIX3	Safety input signal X3
SAIX4	Safety input signal X4
SAIX5	Safety input signal X5
SAIX6	Safety input signal X6
SAIX7	Safety input signal X7
SAIX8	Double input discrepancy state X0 X1
SAIX9	Double input discrepancy state X2 X3
SAIXA	Double input discrepancy state X4 X5
SAIXB	Double input discrepancy state X6 X7
SAIXC to SAIX1C	Use prohibited
SAIX1D	External power supply status
SAIX1E	Safety output control READY
SAIX1F	Safety output control initial processing completion flag <sup>*1</sup>

\*1 Use this signal when "Operation setting of external power supply voltage error detection" is set to "2: Continue safety communication (With output interlock)".

### ■ Safety remote output (SAIY)

Signal direction: Master station → Safety remote I/O module	
Device No.	Name
SAIY0	Safety output signal Y0
SAIY1	Safety output signal Y1
SAIY2	Safety output signal Y2
SAIY3	Safety output signal Y3
SAIY4	Safety output signal Y4
SAIY5	Safety output signal Y5
SAIY6	Safety output signal Y6
SAIY7	Safety output signal Y7
SAIY8 to SAIY1D	Use prohibited
SAIY1E	Safety output control initial processing request flag <sup>*1</sup>
SAIY1F	Safety output control start flag <sup>*1</sup>

\*1 Use this signal when "Operation setting of external power supply voltage error detection" is set to "2: Continue safety communication (With output interlock)".

## NZ2GFSS2-32D-S1 + NZ2EXSS2-8TE

### ■ Safety remote input (SAIX)

Signal direction: Safety remote I/O module → Master station	
Device No.	Name
SAIX0	Safety input signal X0
SAIX1	Safety input signal X1
SAIX2	Safety input signal X2
SAIX3	Safety input signal X3
SAIX4	Safety input signal X4
SAIX5	Safety input signal X5
SAIX6	Safety input signal X6
SAIX7	Safety input signal X7
SAIX8	Safety input signal X8
SAIX9	Safety input signal X9
SAIXA	Safety input signal XA
SAIXB	Safety input signal XB
SAIXC	Safety input signal XC
SAIXD	Safety input signal XD
SAIXE	Safety input signal XE
SAIXF	Safety input signal XF
SAIX10	Safety input signal X10
SAIX11	Safety input signal X11
SAIX12	Safety input signal X12
SAIX13	Safety input signal X13
SAIX14	Safety input signal X14
SAIX15	Safety input signal X15
SAIX16	Safety input signal X16
SAIX17	Safety input signal X17
SAIX18	Safety input signal X18
SAIX19	Safety input signal X19
SAIX1A	Safety input signal X1A
SAIX1B	Safety input signal X1B
SAIX1C	Safety input signal X1C
SAIX1D	Safety input signal X1D
SAIX1E	Safety input signal X1E
SAIX1F	Safety input signal X1F
SAIX20 to SAIX2C	Use prohibited
SAIX2D	External power supply status
SAIX2E	Safety output control READY
SAIX2F	Safety output control initial processing completion flag <sup>*1</sup>

\*1 Use this signal when "Operation setting of external power supply voltage error detection" is set to "2: Continue safety communication (With output interlock)".

A

## ■ Safety remote output (SAIY)

Signal direction: Master station → Safety remote I/O module	
Device No.	Name
SAIY0	Safety output signal Y0
SAIY1	Safety output signal Y1
SAIY2	Safety output signal Y2
SAIY3	Safety output signal Y3
SAIY4	Safety output signal Y4
SAIY5	Safety output signal Y5
SAIY6	Safety output signal Y6
SAIY7	Safety output signal Y7
SAIY8 to SAIY2D	Use prohibited
SAIY2E	Safety output control initial processing request flag <sup>*1</sup>
SAIY2F	Safety output control start flag <sup>*1</sup>

\*1 Use this signal when "Operation setting of external power supply voltage error detection" is set to "2: Continue safety communication (With output interlock)".

# Details of safety remote I/O signals

## Safety input signals

### ■Device No.

Model	Name	Device No.
NZ2GFSS2-32D-S1 NZ2GFSS2-32D-S1 + NZ2EXSS2-8TE	Safety input signal X0 to Safety input signal X1F	SAIX0 to SAIX1F
NZ2GFSS2-8D-S1 NZ2GFSS2-16DTE-S1	Safety input signal X0 to Safety input signal X7	SAIX0 to SAIX7

### ■Description

These signals indicate the ON/OFF state of safety remote input (SAIX□) due to the external input signals (X□) of the safety remote I/O module.

However, depending on the settings of the input wiring selection function or the input response time setting function, the ON/OFF state of the safety input signals X□ (SAIX□) and that of the actual external input signals (X□) may differ. For details on each function, refer to the following.

☞ Page 85 Safety input wiring selection function

☞ Page 88 Safety input response time setting function

## Double input discrepancy state

### ■Device No.

Model	Name	Device No.
NZ2GFSS2-8D-S1 NZ2GFSS2-16DTE-S1	Double input discrepancy state X0 X1 to Double input discrepancy state X6 X7	SAIX8 to SAIXB

### ■Description

This area stores the double input discrepancy detection state. This area turns on when a double input discrepancy detection error has occurred in a pair of the corresponding input signals.

A

#### Point

This area is defined in the remote buffer memory for the NZ2GFSS2-32D-S1, and defined in the safety device for the NZ2GFSS2-8D-S1 and NZ2GFSS2-16DTE-S1.

## External power supply status

### ■Device No.

Model	Name	Device No.
NZ2GFSS2-32D-S1 NZ2GFSS2-32D-S1 + NZ2EXSS2-8TE	External power supply status	SAIX2D
NZ2GFSS2-8D-S1 NZ2GFSS2-8TE-S1 NZ2GFSS2-16DTE-S1		SAIX1D

### ■Description

This signal indicates the external power supply status.

When "Operation setting of external power supply voltage error detection" is set to "1: Continue safety communication (Without output interlock)", the signal is also used as the condition to cancel the interlock by an external circuit.

When "Operation setting of external power supply voltage error detection" is set to "2: Continue safety communication (With output interlock)", the signal is also used as the condition to cancel the interlock and operate relevant flags to restart the safety output control.

Signal status	External power supply status
OFF	External power supply error
ON	External power supply in normal state.

## Safety output control READY

### ■Device No.

Model	Name	Device No.
NZ2GFSS2-32D-S1 NZ2GFSS2-32D-S1 + NZ2EXSS2-8TE	Safety output control READY	SAIX2E
NZ2GFSS2-8D-S1 NZ2GFSS2-8TE-S1 NZ2GFSS2-16DTE-S1		SAIX1E

### ■Description

This signal indicates that the safety output control is enabled.

It is used for the 'operation setting function at detection of external power supply voltage error', and turns on when all of the following conditions are met.

- When the module is in the safety operation mode
- When the external power supply is normal state
- When the operation of flags<sup>\*1</sup> to restart the safety output control is completed

\*1 These flags are used when an external power supply voltage error has occurred while "Operation setting of external power supply voltage error detection" is set to "2: Continue safety communication (With output interlock)".



## Control signals for safety output interlock cancellation

### ■Device No.

Model	Name	Device No.
NZ2GFSS2-32D-S1 NZ2GFSS2-32D-S1 + NZ2EXSS2-8TE	Safety output control initial processing completion flag	SAIX2F
	Safety output control initial processing request flag	SAIY2E
	Safety output control start flag	SAIY2F
NZ2GFSS2-8D-S1 NZ2GFSS2-8TE-S1 NZ2GFSS2-16DTE-S1	Safety output control initial processing completion flag	SAIX1F
	Safety output control initial processing request flag	SAIY1E
	Safety output control start flag	SAIY1F

### ■Description

After causes of the external power supply voltage error are eliminated, the safety program uses these control signals to cancel the safety output interlock.

## ■ Operation

In the safety operation mode, Safety output control READY turns on and the safety output control is enabled by performing the following operations.

### Ex.

For the NZ2GFSS2-32D-S1

1. After checking that External power supply status is on, turn on Safety output control initial processing request flag (SA\Y2E).
2. After checking that Safety output control initial processing completion flag (SA\X2F) is on, turn off Safety output control initial processing request flag (SA\Y2E).
3. After checking that Safety output control initial processing completion flag (SA\X2F) is off, turn on Safety output control start flag (SA\Y2F).
4. After checking that Safety output control READY (SA\X2E) is on, turn off Safety output control start flag (SA\Y2F).
5. After Safety output control READY (SA\X2E) turns on, turn on safety output signals so that external output signals (Y□) turns on.

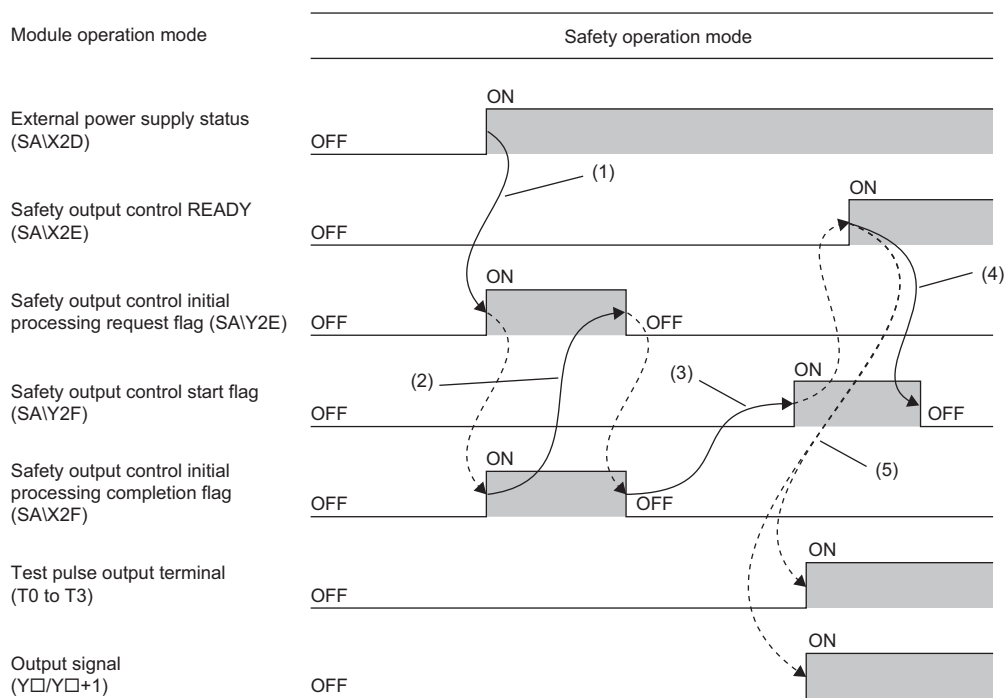

- (1) After checking that External power supply status is on, turn on Safety output control initial processing request flag (SA\Y2E) so that Safety output control initial processing completion flag (SA\X2F) turns on.
- (2) After checking that Safety output control initial processing completion flag (SA\X2F) is on, turn off Safety output control initial processing request flag (SA\Y2E) so that Safety output control initial processing completion flag (SA\X2F) turns off.
- (3) After checking that Safety output control initial processing completion flag (SA\X2F) is off, turn on Safety output control start flag (SA\Y2F) so that Safety output control READY (SA\X2E) turns on.
- (4) After checking that Safety output control READY (SA\X2E) is on, turn off Safety output control start flag (SA\Y2F).
- (5) Safety output control READY (SA\X2E) turns on, and safety outputs and test pulse outputs start.

-----> Controlled by the safety remote I/O module  
 —————> Controlled by the program

## Safety output signal

### ■Device No.

Model	Name	Device No.
NZ2GFSS2-8TE-S1 NZ2GFSS2-16DTE-S1 NZ2GFSS2-32D-S1 + NZ2EXSS2-8TE	Safety output signal Y0 to safety output signal Y7	SAIY0 to SAIY7

### ■Description

These signals turn on or off the external output signal (Y□) of the safety remote I/O module.

However, depending on the settings of the output wiring selection function, the ON/OFF state of the safety output signals Y□ (SAIY□) and that of the actual external output signals (Y□) may differ. For details on the output wiring selection function, refer to the following.

 Page 89 Safety output wiring selection function

# Appendix 2 Remote Control/Monitor Signals

Remote control/monitor signals are used for controlling and monitoring the functions other than the safety functions. Do not use these signals in a program that operates the safety functions. If any of the signals is used, the correct operation of the module cannot be guaranteed. The following table shows the list of the remote control/monitor signals for the master station.

Item	Description
Remote control/monitor input signal (RX)	Control/monitor signals from the safety remote I/O module to the master station
Remote control/monitor output signal (RY)	There are no control/monitor signals from the master station to the safety remote I/O module. Using any of RY signals is not allowed.

## Point

- The external I/O signals are communicated to the master station using the safety remote I/O signals (SA\X and SA\Y).
- When "Link Stop" is performed using the CC-Link IE Field Network diagnostics or the cyclic transmission is stopped from the link special relay (SB) or link special register (SW), the input status of the remote control/monitor input signal (RX) is retained. Thus, the status may be different from the actual status of the module.

## List of remote control/monitor signals

The following table lists the assignment of the remote control/monitor input signals.

## Point

Do not use any "Use prohibited" remote control/monitor signals. If any of the signals are used, the correct operation of the module cannot be guaranteed.

### NZ2GFSS2-32D-S1

#### Remote control/monitor input signal (RX)

Signal direction: Safety remote I/O module → Master station	
Device No.	Name
RX0 to RX6	Use prohibited
RX7	Warning status flag
RX8, RX9	Use prohibited
RXA	Error status flag
RXB	Remote READY
RXC to RXF	Use prohibited
RX10 to RX1F	Error code
RX20 to RX2F	Warning code
RX30	External input monitor X0
RX31	External input monitor X1
RX32	External input monitor X2
RX33	External input monitor X3
RX34	External input monitor X4
RX35	External input monitor X5
RX36	External input monitor X6
RX37	External input monitor X7
RX38	External input monitor X8
RX39	External input monitor X9
RX3A	External input monitor XA
RX3B	External input monitor XB
RX3C	External input monitor XC
RX3D	External input monitor XD
RX3E	External input monitor XE
RX3F	External input monitor XF

Signal direction: Safety remote I/O module → Master station	
Device No.	Name
RX40	External input monitor X10
RX41	External input monitor X11
RX42	External input monitor X12
RX43	External input monitor X13
RX44	External input monitor X14
RX45	External input monitor X15
RX46	External input monitor X16
RX47	External input monitor X17
RX48	External input monitor X18
RX49	External input monitor X19
RX4A	External input monitor X1A
RX4B	External input monitor X1B
RX4C	External input monitor X1C
RX4D	External input monitor X1D
RX4E	External input monitor X1E
RX4F	External input monitor X1F

### ■ Remote control/monitor output signal (RY)

Signal direction: Master station → Safety remote I/O module	
Device No.	Name
RY0 to RY4F	Use prohibited

## NZ2GFSS2-8D-S1, NZ2GFSS2-8TE-S1, NZ2GFSS2-16DTE-S1

### ■ Remote control/monitor input signal (RX)

Signal direction: Safety remote I/O module → Master station	
Device No.	Name
RX0 to RX9	Use prohibited
RXA	Error status flag
RXB	Remote READY
RXC	Warning status flag
RXD to RX1F	Use prohibited
RX20 to RX2F	Error code
RX30 to RX3F	Warning code
RX40 <sup>*1</sup>	External input monitor X0
RX41 <sup>*1</sup>	External input monitor X1
RX42 <sup>*1</sup>	External input monitor X2
RX43 <sup>*1</sup>	External input monitor X3
RX44 <sup>*1</sup>	External input monitor X4
RX45 <sup>*1</sup>	External input monitor X5
RX46 <sup>*1</sup>	External input monitor X6
RX47 <sup>*1</sup>	External input monitor X7
RX48 to RX4F <sup>*1</sup>	Use prohibited

\*1 The device No. is available only for the NZ2GFSS2-8D-S1 or NZ2GFSS2-16DTE-S1.

### ■ Remote control/monitor output signal (RY)

Signal direction: Master station → Safety remote I/O module	
Device No.	Name
RY0 to RYF	Use prohibited

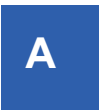

# Details of remote control/monitor signals

## Warning status flag

### ■Device No.

Model	Name	Device No.
NZ2GFSS2-32D-S1	Warning status flag	RX7
NZ2GFSS2-8D-S1		RXC
NZ2GFSS2-8TE-S1		
NZ2GFSS2-16DTE-S1		

### ■Description

Warning status flag (RX□) turns on when a minor error occurs. Five seconds after the cause of the minor error is eliminated, 0000H is automatically stored in Warning code (RX□□) and Warning status flag (RX□) turns off.

**Ex.**

For the NZ2GFSS2-32D-S1 and NZ2EXSS2-8TE

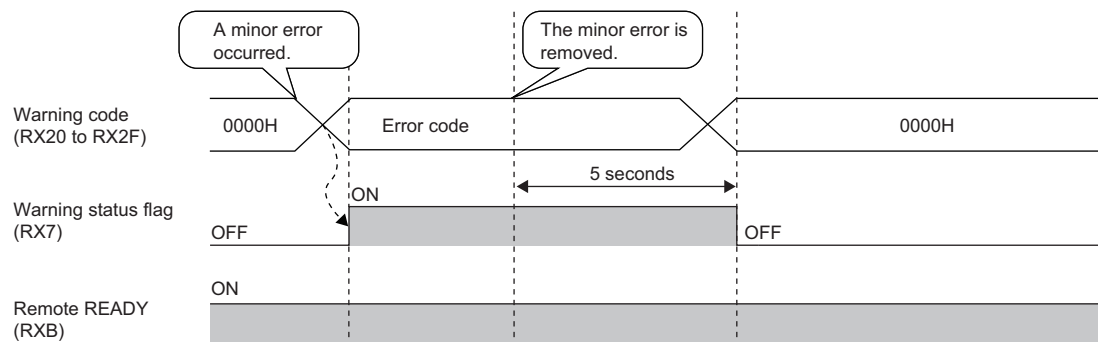

-----> Controlled by the safety remote I/O module

## Error status flag

### ■Device No.

Name	Device No.
Error status flag	RXA

### ■Description

Error status flag (RXA) turns on when a moderate error or major error occurs.

**Ex.**

For the NZ2GFSS2-32D-S1 and NZ2EXSS2-8TE

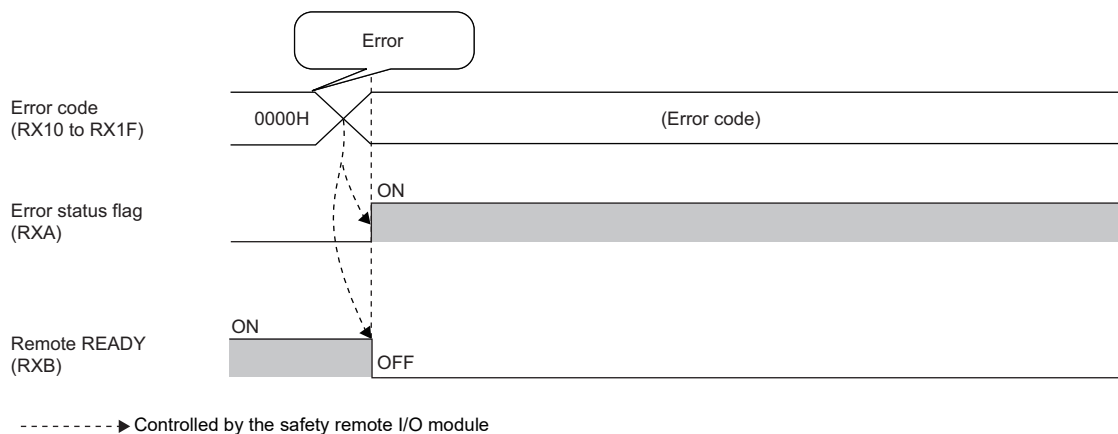

### Point

When a moderate error or major error occurs, the error cannot be cleared until the cause of the error is eliminated and the safety remote I/O module is restarted (by powering off and on the module or performing the remote reset).

## Remote READY

### ■Device No.

Name	Device No.
Remote READY	RXB

### ■Description

This signal is used as an interlock condition when the master station reads/writes data from/to the remote control/monitor signals or the remote buffer memory areas of the safety remote I/O module.

The following table lists the operating status of the module.

Status of Remote READY (RXB)	Operating status of the module
OFF	Module not operable (external I/O cannot be updated)
ON	Module operable (external I/O can be updated)

When the initial processing is completed after the module power supply is powered on, Remote READY (RXB) turns on. When Error status flag (RXA) turns on, Remote READY (RXB) turns off.

A

## Error code

### ■Device No.

Model	Name	Device No.
NZ2GFSS2-32D-S1	Error code	RX10 to RX1F
NZ2GFSS2-8D-S1		RX20 to RX2F
NZ2GFSS2-8TE-S1		
NZ2GFSS2-16DTE-S1		

### ■Description

An error code is stored when a moderate error or major error occurs. Errors that occurred in the past can be checked with Error history area (address: 0□□□H). (  Page 191 Error history data 1 to 15)

## Warning code

### ■Device No.

Model	Name	Device No.
NZ2GFSS2-32D-S1	Warning code	RX20 to RX2F
NZ2GFSS2-8D-S1		RX30 to RX3F
NZ2GFSS2-8TE-S1		
NZ2GFSS2-16DTE-S1		

### ■Description

The error code is stored when a minor error occurs. Errors that occurred in the past can be checked with Error history area (address: 0□□□H). (  Page 191 Error history data 1 to 15)

## External input monitor

### ■Device No.

Model	Name	Device No.
NZ2GFSS2-32D-S1	External input monitor	RX30 to RX4F
NZ2GFSS2-8D-S1		RX40 to RX4F
NZ2GFSS2-8TE-S1		
NZ2GFSS2-16DTE-S1		

### ■Description

These signals indicate the ON/OFF state of the external input terminals. By monitoring the actual signals of the external input, a double input discrepancy detection error can be troubleshooted easily when it occurs. For the signals corresponding to the device No., refer to the following.

 Page 170 List of remote control/monitor signals

### Point

All the input signals turn off in the mode other than the safety operation mode. Thus, all the signals of the external input monitor turn off.



# Appendix 3 Remote Register

The safety remote I/O modules use the remote register areas for the safety communication. When I/O signal channels are not assigned because an extension module is not connected, the use of remote registers corresponding to the channels is prohibited.



For the NZ2GFSS2-32D-S1, all areas of the remote register (RWr/RWw) are use-prohibited areas.

## List of remote register areas

The following table lists the remote register areas for the master/local module.

Remote register (RWr)		Remote register (RWw)	
Signal direction: Safety remote I/O module → Master/local module		Signal direction: Master/local module → Safety remote I/O module	
Device No.	Name	Device No.	Name
RWr0 to RWr1B	Use prohibited	RWw0 to RWw1B	Use prohibited
RWr1C	Output Y ON information (extension output 1st level)	RWw1C	Output Y ON information clear request (1st level)
RWr1D to RWr1E	Use prohibited	RWw1D to RWw1E	Use prohibited
RWr1F	Output Y OFF information (extension output 1st level)	RWw1F	Output Y OFF information clear request (1st level)



Do not read or write data from/to the use-prohibited areas. If data is read or written from/to any of the use-prohibited areas, the correct operation of the module cannot be guaranteed.

## Details of remote register areas

The following describes the details of the remote register areas.

### Output Y ON information

#### ■Device No.

Name	Device No.
Output Y ON information	RWr1C

#### ■Description

Whether output Y has been turned on or not can be checked with Output Y ON information (RWr1C).

The amount of time delay from when Output Y ON information (RWr1C) changes until the external output accordingly changes is not more than output response time.

For the output response time, refer to the user's manual of the standard extension module used.

b15	b14	b13	b12	b11	b10	b9	b8	b7	b6	b5	b4	b3	b2	b1	b0
YF	YE	YD	YC	YB	YA	Y9	Y8	Y7	Y6	Y5	Y4	Y3	Y2	Y1	Y0

Off: Output Y has never been turned on.

On: Output Y has been turned on.



Output Y ON information (RWr1C) can be cleared by using Output Y ON information clear request (RWw1C).

A

## Output Y OFF information

### ■Device No.

Name	Device No.
Output Y OFF information	RWr1F

### ■Description

Whether output Y has been turned off or not can be checked with Output Y OFF information (RWr1F).

The amount of time delay from when Output Y OFF information (RWr1F) changes until the external output accordingly changes is not more than output response time.

b15	b14	b13	b12	b11	b10	b9	b8	b7	b6	b5	b4	b3	b2	b1	b0
YF	YE	YD	YC	YB	YA	Y9	Y8	Y7	Y6	Y5	Y4	Y3	Y2	Y1	Y0

Off: Output Y has never been turned off.

On: Output Y has been turned off.



Output Y OFF information (RWr1F) can be cleared by using Output Y OFF information clear request (RWw1F).

## Output Y ON information clear request

### ■Device No.

Name	Device No.
Output Y ON information clear request	RWw1C

### ■Description

This remote register area is used to clear Output Y ON information (RWr1C).

Clear processing continues while the bit of Output Y ON information clear request (RWw1C) is on.

b15	b14	b13	b12	b11	b10	b9	b8	b7	b6	b5	b4	b3	b2	b1	b0
YF	YE	YD	YC	YB	YA	Y9	Y8	Y7	Y6	Y5	Y4	Y3	Y2	Y1	Y0

Off: Output Y ON information is not cleared.

On: Output Y ON information is cleared.

For the timing of turning on and off the remote register, refer to the following.

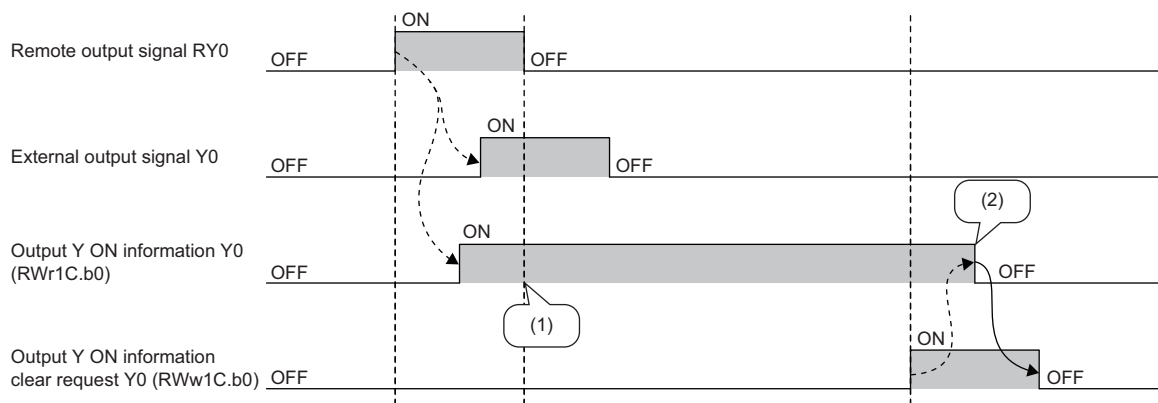

(1) Remains on even after Y0 turns off.

(2) Turns off when the clear request turns on.

-----> Controlled by the safety remote I/O module

-----> Controlled by the program

## Output Y OFF information clear request

### ■Device No.

Name	Device No.
Output Y OFF information clear request	RWw1F

### ■Description

This remote register area is used to clear Output Y OFF information (RWr1F).

Clear processing continues while the bit of Output Y OFF information clear request (RWw1F) is on.

b15	b14	b13	b12	b11	b10	b9	b8	b7	b6	b5	b4	b3	b2	b1	b0
YF	YE	YD	YC	YB	YA	Y9	Y8	Y7	Y6	Y5	Y4	Y3	Y2	Y1	Y0

Off: Output Y OFF information is not cleared.

On: Output Y OFF information is cleared.

For the timing of turning on and off the remote register, refer to the following.

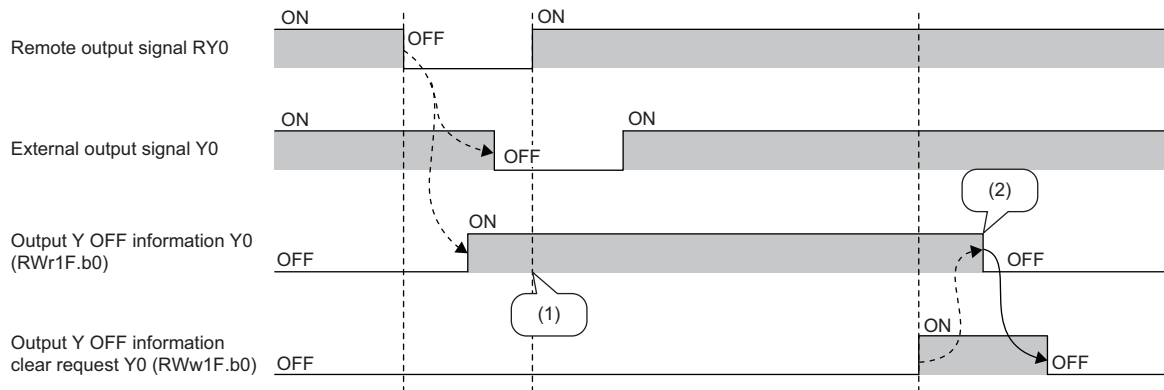

(1) Remains on even after Y0 turns on.



(2) Turns off when the clear request turns on.

-----> Controlled by the safety remote I/O module

—————> Controlled by the program

# Appendix 4 Remote Buffer Memory

The remote buffer memory areas are classified into the following three area types.

- Error history area: Stores the history of errors detected by the module.  
 Page 191 Error history area
- Monitoring area: Stores the current module status.  
 Page 192 Monitoring area
- Module control data area: Used for controlling the module.  
 Page 193 Module control data area

**Point** 

Do not read/write data from/to a use prohibited area of remote buffer memory. If data is read/written, the correct operation of the module cannot be guaranteed.

## List of remote buffer memory areas

### NZ2GFSS2-32D-S1

Address (hexadecimal)	Area	Target	Access method		
			Network configuration settings of the engineering tool	REMFR instruction, REMTO instruction*1	
0000H to 05FFH	Error history area	Error history data per station	○*2	○	
0600H to 06FFH	Monitoring area	Monitor data per station	×	×	
0700H to 07FFH		Monitor data per module	Main module	×	○
0800H to 08FFH			Extension module	×	×
0900H to 0FFFH			System area	×	×
1000H to 10FFH	Module control data area	Control data per station	○*3	○	
1100H to 11FFH		System area	×	×	
1200H to FFFFH	System area		×	×	

\*1 For details on the REMFR and REMTO instructions, refer to the following.

 MELSEC iQ-R Programming Manual (Module Dedicated Instructions)

\*2 For how to access the error history areas, refer to the following.

 Page 134 Checking with "Command Execution of Device Station"

\*3 Parameter area initialization command (address: 1002H) and Parameter area initialization completed (address: 1003H) of the control data per station cannot be accessed using the network configuration settings. Use the REMFR and REMTO instructions to read or write values from/to these areas.

## ■ Error history area

Up to 15 errors generated in the safety remote I/O module are recorded in chronological order.

Address (hexadecimal)	Name	Default value <sup>*1</sup>	Read/Write <sup>*2</sup>	
0000H	Error history data 1	Error code	0000H	R
0001H		Error classification	0000H	R
0002H		Error item number	0000H	R
0003H		[Error time] First two digits of the year/Last two digits of the year	0000H	R
0004H		[Error time] Month/Day	0000H	R
0005H		[Error time] Hour/Minute	0000H	R
0006H		[Error time] Second/00H	0000H	R
0007H		Error code details 1	0000H	R
0008H		Error code details 2	0000H	R
0009H		Error code details 3	0000H	R
000AH		Error code details 4	0000H	R
000BH		Error code details 5	0000H	R
000CH		Error code details 6	0000H	R
000DH		Error code details 7	0000H	R
000EH		System area	—	—
000FH				
0010H to 001FH	Error history data 2	Same as Error history data 1		
0020H to 002FH	Error history data 3	Same as Error history data 1		
0030H to 003FH	Error history data 4	Same as Error history data 1		
0040H to 004FH	Error history data 5	Same as Error history data 1		
0050H to 005FH	Error history data 6	Same as Error history data 1		
0060H to 006FH	Error history data 7	Same as Error history data 1		
0070H to 007FH	Error history data 8	Same as Error history data 1		
0080H to 008FH	Error history data 9	Same as Error history data 1		
0090H to 009FH	Error history data 10	Same as Error history data 1		
00A0H to 00AFH	Error history data 11	Same as Error history data 1		
00B0H to 00BFH	Error history data 12	Same as Error history data 1		
00C0H to 00CFH	Error history data 13	Same as Error history data 1		
00D0H to 00DFH	Error history data 14	Same as Error history data 1		
00E0H to 00EFH	Error history data 15	Same as Error history data 1		
00F0H to 05FFH	System area			

\*1 The factory default value or the value initialized by using Error history clear command (address: 1000H)

\*2 This column indicates whether reading or writing values using programs is possible.

R: Readable

W: Writable

## ■ Monitoring area

Address (hexadecimal)	Name	Default value <sup>*1</sup>	Read/Write <sup>*2</sup>
0600H to 06FFH	System area	—	—
0700H	Double input discrepancy auto recovery enabled signal	—	R
0701H	Double input discrepancy detection state	—	R
0702H to 0FFFH	System area	—	—

\*1 Default values are not determined in the monitoring areas.

\*2 This column indicates whether reading or writing values using programs is possible.

R: Readable

W: Writable

## ■ Module control data area

Address (hexadecimal)	Name	Default value <sup>*1</sup>	Read/Write <sup>*2</sup>
1000H	Error history clear command	0000H	R/W
1001H	Error history clear completed	0000H	R
1002H	Parameter area initialization command	0000H	R/W
1003H	Parameter area initialization completed	0000H	R
1004H	System area	—	—
1005H	Safety module enabled flag	0000H	R
1006H to 11FFH	System area	—	—

\*1 This is the value for when the module power supply is turned off and on or at the remote reset.

\*2 This column indicates whether reading or writing values using programs is possible.

R: Readable

W: Writable

## NZ2GFSS2-8D-S1, NZ2GFSS2-8TE-S1, NZ2GFSS2-16DTE-S1

Address (hexadecimal)	Area	Target	Access method		
			Network configuration settings of the engineering tool	REMFR instruction, REMTO instruction <sup>*1</sup>	
0000H to 00FFH	Parameter area	Parameter data per station	○	×	
0100H to 01FFH		Parameter data per module	Main module	○	×
0200H to 02FFH			Extension module	○	×
0300H to 03FFH			System area	×	×
0400H to 04FFH				×	×
0500H to 05FFH	Monitoring area	Monitor data per station	×	×	
0600H to 06FFH		Monitor data per module	Main module	×	○
0700H to 07FFH			Extension module	×	○
0800H to 09FFH			System area	×	×
0A00H to 0FFFH	Error history area	Error history data per station	○ <sup>*2</sup>	○	
1000H to 10FFH	Module control data area	Control data per station <sup>*3</sup>	×	○	
1100H to 11FFH		Control data per module	Main module	×	○
1200H to 12FFH			Extension module	×	○
1300H to 14FFH			System area	×	×
1500H to FFFFH	System area		×	×	

\*1 For details on the REMFR and REMTO instructions, refer to the following.

 MELSEC iQ-R Programming Manual (Module Dedicated Instructions)

\*2 For how to access the error history areas, refer to the following.

 Page 134 Checking with "Command Execution of Device Station"

\*3 Parameter area initialization command (address: 1002H) and Parameter area initialization completed (address: 1003H) of the control data per station cannot be accessed using the network configuration settings. Use the REMFR and REMTO instructions to read or write values from/to these areas.

### Point

- Do not access the system area using the REMFR or REMTO instruction. Doing so may cause malfunction.
- Do not use the dedicated instructions, the REMFR and REMTO instructions, to access the area of 10000H or later. Doing so can cause a minor error. For details on minor errors, refer to the following.

 Page 138 Error codes related to the safety remote I/O module

## Parameter area

Address (hexadecimal)	Name	Default value	Read/Write	
0000H	Safety setting	Transmission interval monitoring time setting	35	R
0001H	I/O LED indication setting at error occurrence		0000H	R
0002H	Cyclic data update watch time setting		0000H	R
0003H	Extension I/O setting	Input response time setting	0005H	—
0004H		Output HOLD/CLEAR setting	0000H	—
0005H to 0100H	Use prohibited		—	—
0101H	Operation setting of external power supply voltage error detection <sup>*3</sup>		0	R/W
0102H to 010FH	Use prohibited		—	—
0110H to 0111H <sup>*2</sup>	Wiring selection of input		0000H	R/W
0120H to 0127H <sup>*2</sup>	Input response time [main module]		0000H	R/W
0128H to 012FH	Use prohibited		—	—
0130H <sup>*2</sup>	Double input discrepancy detection setting		0000H	R/W
0131H <sup>*2</sup>	Double input discrepancy detection type		0000H	R/W
0132H <sup>*2</sup>	Double input discrepancy auto recovery setting		0000H	R/W
0133H to 013FH	Use prohibited		—	—
0140H to 0143H <sup>*2</sup>	Double input discrepancy detection time		0001H	R/W
0144H to 014FH	Use prohibited		—	—
0150H <sup>*2</sup>	Input dark test execution setting		0000H	R/W
0151H	Use prohibited		—	—
0152H <sup>*2</sup>	Input dark test pulse OFF time		0000H	R/W
0153H <sup>*2</sup>	Number of pulse output for input dark test		0000H	R/W
0154H to 017FH	Use prohibited		—	—
0180H to 0181H <sup>*1</sup>	Wiring selection of output		0000H	R/W
0182H to 018FH	Use prohibited		—	—
0190H <sup>*1</sup>	Output dark test execution setting		0000H	R/W
0191H to 019FH	Use prohibited		—	—
01A0H to 01A7H <sup>*1</sup>	Output dark test pulse OFF time		0000H	R/W
01A8H to 01AFH	Use prohibited		—	—
01B0H to 01B7H <sup>*1</sup>	Number of pulse output for output dark test		0000H	R/W
01B8H to 01BFH	Use prohibited		—	—
01C0H <sup>*1</sup>	Number of ON times integration function enable		0000H	R/W
01C1H to 04FFH	Use prohibited		—	—

\*1 For the NZ2GFSS2-8D-S1, this address cannot be used.

\*2 For the NZ2GFSS2-8TE-S1, this address cannot be used.

\*3 This area is displayed as a station parameter on the window of the engineering tool.

A

### Point

- Parameters can be set in these areas using the parameter setting window of the engineering tool. Parameters cannot be set using the program.
- Always use the engineering tool to set parameters.

## ■Monitoring area

Address (hexadecimal)	Name	Default value <sup>*1</sup>	Read/Write <sup>*2</sup>
0500H to 060FH	Use prohibited	—	—
0610H <sup>*3</sup> to 061FH	Number of ON times integration value Y□	—	R
0620H to 06FFH	Use prohibited	—	—
0700H to 07FFH	Extension module	—	—

\*1 Default values are not determined in the monitoring areas.

\*2 This column indicates whether reading or writing values using programs is possible.

R: Readable

W: Writable

\*3 For the NZ2GFSS2-8D-S1, this address cannot be used.

For the monitoring area of the standard extension module, refer to the following.

 CC-Link IE Field Network Remote I/O Module User's Manual

## ■Error history area

Up to 15 errors generated in the safety remote I/O module are recorded in chronological order.

Address (hexadecimal)	Name	Default value <sup>*1</sup>	Read/Write <sup>*2</sup>
0A00H	Error history data 1	Error code	0000H
0A01H		Order of generation	0000H
0A02H		[Error time] First two digits of the year/ Last two digits of the year	0000H
0A03H		[Error time] Month/Day	0000H
0A04H		[Error time] Hour/Minute	0000H
0A05H		[Error time] Second/00H	0000H
0A06H		Error code details 1	0000H
0A07H		Error code details 2	0000H
0A08H		Error code details 3	0000H
0A09H		Error code details 4	0000H
0A0AH		Error code details 5	0000H
0A0BH		Error code details 6	0000H
0A0CH		Error code details 7	0000H
0A0DH		Error code details 8	0000H
0A0EH		System area	—
0A0FH			
0A10H to 0A1FH	Error history data 2	Same as Error history data 1	
0A20H to 0A2FH	Error history data 3	Same as Error history data 1	
0A30H to 0A3FH	Error history data 4	Same as Error history data 1	
0A40H to 0A4FH	Error history data 5	Same as Error history data 1	
0A50H to 0A5FH	Error history data 6	Same as Error history data 1	
0A60H to 0A6FH	Error history data 7	Same as Error history data 1	
0A70H to 0A7FH	Error history data 8	Same as Error history data 1	
0A80H to 0A8FH	Error history data 9	Same as Error history data 1	
0A90H to 0A9FH	Error history data 10	Same as Error history data 1	
0AA0H to 0AAFH	Error history data 11	Same as Error history data 1	
0AB0H to 0ABFH	Error history data 12	Same as Error history data 1	
0AC0H to 0ACFH	Error history data 13	Same as Error history data 1	
0AD0H to 0ADFH	Error history data 14	Same as Error history data 1	
0AE0H to 0AEFH	Error history data 15	Same as Error history data 1	
0AF0H to 0AFFH	System area		

\*1 The factory default value or the value initialized by using Error history clear command (address: 1000H)

\*2 This column indicates whether reading or writing values using programs is possible.

R: Readable

W: Writable



## ■ Module control data area

Address (hexadecimal)	Name	Default value <sup>*1</sup>	Read/Write <sup>*2</sup>
1000H	Error history clear command	0000H	R/W
1001H	Error history clear completed	0000H	R
1002H	Parameter area initialization command	0000H	R/W
1003H	Parameter area initialization completed	0000H	R
1004H	Use prohibited	—	—
1005H	Safety module enabled flag	0000H	R
1006H to 10FFH	Use prohibited	—	—
1100H <sup>*3</sup>	Number of ON times integration value clear command Y0 to YF	0000H	R/W
1101H <sup>*3</sup>	Number of ON times integration value clear completed Y0 to YF	0000H	R
1102H to 11FFH	Use prohibited	—	—
1200H to 12FFH	For extension module	—	—

\*1 This is the value for when the module power supply is turned off and on or at the remote reset.

\*2 This column indicates whether reading or writing values using programs is possible.

R: Readable

W: Writable

\*3 For the NZ2GFSS2-8D-S1, this address cannot be used.

For the monitoring area of the standard extension module, refer to the following.

 CC-Link IE Field Network Remote I/O Module User's Manual

## Details of remote buffer memory areas

### Parameter area

#### ■Transmission interval monitoring time

Set the safety input data transmission interval time of the safety remote I/O module for each module. This time is to be monitored by the master station.

Address (hexadecimal)	Name	Setting range	Default value
0000H	Safety setting Transmission interval monitoring time setting	4 to 1000ms	35ms

#### ■I/O LED indication setting at error occurrence

Set whether the input and output points where an error is detected is indicated with an I/O LED.

Address (hexadecimal)	Name	Setting range	Default value
0001H	I/O LED indication setting at error occurrence	0: No indication of error point 1: Indication of error point	0000H

The LED flashes with the following errors.

- Double input discrepancy detection error
- Input dark test error
- I/O data error
- Output read-back error
- Output dark test error

For the minor error from which the module can recover, the LED flashing stops when the error is cleared.

#### Point

Since the LED flashes in 500ms cycle at error occurrence, pulse input of 500ms cycle cannot be distinguished from an error occurrence. To distinguish the 500ms cycle pulse input, select "0: No indication of error point".

#### ■Cyclic data update watch time setting

Set the time to monitor the update intervals of cyclic transmission data (watch time).

Address (hexadecimal)	Name	Setting range	Default value
0002H	Cyclic data update watch time setting	0 to 20 (×100ms)	0

The available range is 0 to 20. When 0 is set, the monitoring is not performed.

When 1 to 20 are set, the watch time is as follows.

Watch time = Cyclic data update watch time setting × 100 [ms]

When the watch time error of cyclic data update persists and cyclic transmission remains stopped, the standard communications and safety communications are regarded as disconnected.

### ■Input response time setting [extension I/O setting]

Set the input response time of the extension I/O.

Address (hexadecimal)	Name	Setting range	Default value
0003H	Input response time setting	0: 0ms 1: 0.2ms 2: 1.0ms 3: 1.5ms 4: 5ms 5: 10ms 6: 20ms 7: 70ms	0005H



This setting is for the standard extension module and unavailable for the main module. For the main module, set Input response time [main module] (address: 0120H to 0127H).

For details on the input response time setting value of the standard extension module, refer to the following.

CC-Link IE Field Network Remote I/O Module User's Manual

### ■Output HOLD/CLEAR setting [extension I/O setting]

Set whether to hold (HOLD) or clear (CLEAR) the last output status of the extension module when the standard communications are disconnected or the CPU module is switched to the STOP state.

Address (hexadecimal)	Name	Setting range	Default value
0004H	Output HOLD/CLEAR setting	0: Clear 1: Hold	0000H

For details on the output HOLD/CLEAR setting value of the standard extension module, refer to the following.

CC-Link IE Field Network Remote I/O Module User's Manual

### ■Operation setting of external power supply voltage error detection

Set the operation to be performed at the detection of external power supply voltage error.

Address (hexadecimal)	Name	Setting range	Default value
0101H	Operation setting of external power supply voltage error detection	0: Stop safety communication 1: Continue safety communication (Without output interlock) 2: Continue safety communication (With output interlock)	0

A

## ■Wiring selection of input

Set the wiring method.

Address (hexadecimal)	Name	Setting range	Default value
0110H to 0111H	Wiring selection of input	0: Not used 1: Double wiring (NC/NC) 2: Single wiring	0000H

Address: 0110H

b15	b14	b13	b12	b11	b10	b9	b8	b7	b6	b5	b4	b3	b2	b1	b0
Wiring selection of input X3				Wiring selection of input X2				Wiring selection of input X1				Wiring selection of input X0			

Address: 0111H

b15	b14	b13	b12	b11	b10	b9	b8	b7	b6	b5	b4	b3	b2	b1	b0
Wiring selection of input X7				Wiring selection of input X6				Wiring selection of input X5				Wiring selection of input X4			

### Point

- When X<sub>n</sub> (n: even number) is set to "1: Double wiring (NC/NC)", only the same setting value as X<sub>n</sub> can be set for X<sub>n+1</sub>, the partner of X<sub>n</sub>.
- When X<sub>n</sub> is set to a value other than "1: Double wiring (NC/NC)", set X<sub>n+1</sub> to a value other than "1: Double wiring (NC/NC)" as well.
- For unused input terminals, set "0: Not used" in "Wiring selection of input".

## ■Input response time [main module]

Set the input response time of the input signal.

Address (hexadecimal)	Name	Setting range	Default value
0120H to 0127H	Input response time [main module]	0: 1.0ms 1: 1.5ms 2: 5ms 3: 10ms 4: 20ms 5: 50ms 6: 70ms	0000H

### Point

- Select a longer time than the input dark test pulse OFF time for the parameter. When "1: Do not perform" is selected in the input dark test execution setting, a shorter time than the input dark test pulse OFF time can be set for the parameter.
- When the parameter setting of wiring selection of input is set to "0: Not used", this parameter will be ignored.
- When 7 is set, "Parameter data error (input response time): error code 0512H" occurs.

## ■Double input discrepancy detection setting

Set whether to detect double input discrepancy.

Address (hexadecimal)	Name	Setting range	Default value												
0130H	Double input discrepancy detection setting	0: Detect 1: Do not detect	0000H												
0 (fixed)												b3	b2	b1	b0
												X6	X4	X2	X0
												X7	X5	X3	X1

### Point

When "0: Not used" or "2: Single wiring" is selected in the wiring selection of input, this parameter will be ignored.

## ■Double input discrepancy detection type

Set the detection type of the double input discrepancy.

Address (hexadecimal)	Name	Setting range	Default value
0131H	Double input discrepancy detection type	0: Discrepancy detection time specified 1: Discrepancy detection time not specified	0000H

b15	b14	b13	b12	b11	b10	b9	b8	b7	b6	b5	b4	b3	b2	b1	b0
0 (fixed)												X6 X7	X4 X5	X2 X3	X0 X1

The following describes the setting range of the parameter.

- Discrepancy detection time specified: The discrepancy detection time setting is required in the "Double input discrepancy detection time" parameter.
- Discrepancy detection time not specified: The discrepancy detection time setting is not required in the "Double input discrepancy detection time" parameter. The double input discrepancy is detected not by the elapsed time after the discrepancy has occurred, but after the double input status turns on from the discrepancy state and remains on for 500ms.

### Point

When "0: Not used" or "2: Single wiring" is selected in the wiring selection of input, or "1: Do not detect" is selected in the double input discrepancy detection setting, this parameter will be ignored.

## ■Double input discrepancy auto recovery setting

Set whether to use or not the auto recovery at double input discrepancy detection error.

Address (hexadecimal)	Name	Setting range	Default value
0132H	Double input discrepancy auto recovery setting	0: Not used 1: Used	0000H

### Point

When "0: Not used" or "2: Single wiring" is selected in the wiring selection of input for all points, or "0: Do not detect" is selected in the double input discrepancy detection setting for all points, the double input discrepancy detection error does not occur and the automatic recovery is not performed.

## ■Double input discrepancy detection time

Set the double input discrepancy detection time.

Address (hexadecimal)	Name	Setting range	Default value
0140H to 0143H	Double input discrepancy detection time	1 to 6000 (×10ms)	1 (×10ms)

### Point

When "0: Not used" or "2: Single wiring" is selected in the wiring selection of input, "1: Do not detect" is selected in the double input discrepancy detection setting, or "1: Discrepancy detection time not specified" is selected in the double input discrepancy detection type, this parameter will be ignored.

## Input dark test execution setting

Set whether to perform the input dark test function of the diagnostic function in the safety remote I/O module.

Address (hexadecimal)	Name	Setting range	Default value
0150H	Input dark test execution setting	0: Perform 1: Do not perform	0000H

b15	b14	b13	b12	b11	b10	b9	b8	b7	b6	b5	b4	b3	b2	b1	b0
0 (fixed)								X7	X6	X5	X4	X3	X2	X1	X0

### Point

When "0: Not used" is selected in the wiring selection of input, this parameter will be ignored.

The following table lists the combinations that can be set when the wiring selection of input is set to "1: Double wiring (NC/NC)".

Input dark test execution setting		Wiring selection of input
		Double wiring (NC/NC)
Xn: Perform	Xn+1: Perform	Can be set.
	Xn+1: Do not perform	Cannot be set.
Xn+1: Perform	Xn: Perform	Can be set.
	Xn: Do not perform	Cannot be set.

n: An address assigned to the master station by the station number settings.

## Input dark test pulse OFF time

Set the width of the OFF pulses that the test pulse output terminals output.

Address (hexadecimal)	Name	Setting range	Default value
0152H	Input dark test pulse OFF time	0: 400 $\mu$ s 1: 1ms 2: 2ms	0000H

### Point

When "0: Not used" is selected in the wiring selection of input for all points, or "1: Do not perform" is selected in the input dark test execution setting for all points, this parameter will be ignored.

## Number of pulse output for input dark test

Set the number of pulse output for input dark test.

Address (hexadecimal)	Name	Setting range	Default value
0153H	Number of pulse output for input dark test	0: 1 time 1: 2 times 2: 3 times	0000H

### Point

When "0: Not used" is selected in the wiring selection of input for all points, or "1: Do not perform" is selected in the input dark test execution setting for all points, this parameter will be ignored.

## ■Wiring selection of output

Set the wiring selection of output.

Address (hexadecimal)	Name	Setting range	Default value
0180H to 0181H	Wiring selection of output	0: Not used 1: Double wiring (Source/Source) 2: Single wiring	0000H

Address: 0180H

b15	b14	b13	b12	b11	b10	b9	b8	b7	b6	b5	b4	b3	b2	b1	b0
Wiring selection of output Y3				Wiring selection of output Y2				Wiring selection of output Y1				Wiring selection of output Y0			

Address: 0181H

b15	b14	b13	b12	b11	b10	b9	b8	b7	b6	b5	b4	b3	b2	b1	b0
Wiring selection of output Y7				Wiring selection of output Y6				Wiring selection of output Y5				Wiring selection of output Y4			

### Point

- When double output is set for Y<sub>n</sub> (n = 0, 2, 4, 6) of double output, only double output can be selected for Y<sub>n+1</sub>.
- When double output is set, outputting on of a pair of outputs turns on the output signal.
- When setting double output, if Y<sub>n</sub> (n: even number) is set to double wiring (source/source), set the same value as Y<sub>n</sub> for Y<sub>n+1</sub> in the output dark test execution setting.
- For unused output terminals, set "0: Not used" in the wiring selection of output.

## ■Output dark test execution setting

Set whether to perform the output dark test function of the diagnostic function in the safety remote I/O module.

Address (hexadecimal)	Name	Setting range	Default value
0190H	Output dark test execution setting	0: Perform 1: Do not perform	0000H

b15	b14	b13	b12	b11	b10	b9	b8	b7	b6	b5	b4	b3	b2	b1	b0
0 (fixed)								Y7	Y6	Y5	Y4	Y3	Y2	Y1	Y0

### Point

When "0: Not used" is selected in the wiring selection of output, this parameter will be ignored.

## ■Output dark test pulse OFF time

Set the width of the OFF pulses used for an output dark test.

Address (hexadecimal)	Name	Setting range	Default value
01A0H to 01A7H	Output dark test pulse OFF time	0: 400μs 1: 1ms 2: 2ms	0000H

### Point

When "0: Not used" is selected in the wiring selection of output, or "1: Do not perform" is selected in the output dark test execution setting, this parameter will be ignored.

A

## ■Number of pulse output for output dark test

Set the number of pulse output for output dark test.

Address (hexadecimal)	Name	Setting range	Default value
01B0H to 01B7H	Number of pulse output for output dark test	0: 1 time 1: 2 times 2: 3 times	0000H

### Point

When "0: Not used" is selected in the wiring selection of output, or "1: Do not perform" is selected in the output dark test execution setting, this parameter will be ignored.

## ■Number of ON times integration function enable

Set the number of ON times integration function enable.

Address (hexadecimal)	Name	Setting range	Default value
01C0H	Number of ON times integration function enable	0: Disable 1: Enable	0000H

b15	b14	b13	b12	b11	b10	b9	b8	b7	b6	b5	b4	b3	b2	b1	b0
0 (fixed)								Y7	Y6	Y5	Y4	Y3	Y2	Y1	Y0

### Point

When "0: Not used" is selected in the wiring selection of output, this parameter will be ignored.

## ■Extension module identification code

Set the identification code for specifying the extension module type of the NZ2GFSS2-8D-S1, NZ2GFSS2-8TE-S1, or NZ2GFSS2-16DTE-S1.

Address (hexadecimal)	Name	Setting range	Default value
0200H	Extension module identification code	000H: Extension module not connected 0101H: 16-points digital input module 0201H: 16-points digital output module	0000H

b15	b14	b13	b12	b11	b10	b9	b8	b7	b6	b5	b4	b3	b2	b1	b0
Module type 00H: Extension module not connected 01H: Digital input module 02H: Digital output module								Points 01H: 16 points							

### Point

The NZ2EXSS2-8TE cannot be connected to the NZ2GFSS2-8D-S1, NZ2GFSS2-8TE-S1, or NZ2GFSS2-16DTE-S1.



## Error history area

### ■ Error history data 1 to 15

The following table shows the configuration of the data and contents stored in each error history data area.

- NZ2GFSS2-32D-S1

Error history data 1	Bit position	
	b15 to b8	b7 to b0
0000H	Error code	
0001H	Error classification	
0002H	Error item number	
0003H	First two digits of the year	Last two digits of the year
0004H	Month	Day
0005H	Hour	Minute
0006H	Second	00H
0007H	Error code details 1	
0008H	Error code details 2	
0009H	Error code details 3	
000AH	Error code details 4	
000BH	Error code details 5	
000CH	Error code details 6	
000DH	Error code details 7	
000EH	System area	
000FH		

#### Point

Values are stored in Error history data 2 to Error history data 15 (address: 0010H to 00EFH) in the same format as in Error history data 1 (address: 0000H to 000FH).

- NZ2GFSS2-8D-S1, NZ2GFSS2-8TE-S1, NZ2GFSS2-16DTE-S1

Error history data 1	Bit position	
	b15 to b8	b7 to b0
0A00H	Error code	
0A01H	Order of generation	
0A02H	First two digits of the year	Last two digits of the year
0A03H	Month	Day
0A04H	Hour	Minute
0A05H	Second	00H
0A06H	Error code details 1	
0A07H	Error code details 2	
0A08H	Error code details 3	
0A09H	Error code details 4	
0A0AH	Error code details 5	
0A0BH	Error code details 6	
0A0CH	Error code details 7	
0A0DH	Error code details 8	
0A0EH	System area	
0A0FH		

#### Point

Values are stored in Error history data 2 to Error history data 15 (address: 0A10H to 0AEFH) in the same format as in Error history data 1 (address: 0A00H to 0A0FH).

A

## Monitoring area

### ■Number of ON times integration value

This area stores the integration value of the number of ON times integration function. (☞ Page 92 Number of safety output ON times integration function)

- NZ2GFSS2-8TE-S1, NZ2GFSS2-16DTE-S1

Address (hexadecimal)	Name	Setting range	Default value
0610H to 061FH	Number of ON times integration value Y0 to Y7	0 to 2147483647	0

### ■Double input discrepancy auto recovery enabled signal

This signal stores the status of the auto recovery setting enabled signal when a double input discrepancy detection error occurs. This signal turns on when "Double input discrepancy auto recovery setting" is set to "1: Used". This signal becomes effective when the mode is switched to the safety operation mode.

- NZ2GFSS2-32D-S1

Address (hexadecimal)	Name	Setting range	Default value
0700H	Double input discrepancy auto recovery enabled signal	0: Not used 1: Used	0000H

### ■Double input discrepancy detection state

When "Double input discrepancy auto recovery setting" is set to "1: Used", the detection status of a double input discrepancy error is stored. This area turns on when a double input discrepancy detection error has occurred in a pair of the corresponding input signals.

- NZ2GFSS2-32D-S1

Address (hexadecimal)	Name	Setting range	Default value
0701H	Double input discrepancy detection state	0: Not detected 1: Detected	0000H

b15	b14	b13	b12	b11	b10	b9	b8	b7	b6	b5	b4	b3	b2	b1	b0
X1E	X1C	X1A	X18	X16	X14	X12	X10	XE	XC	XA	X8	X6	X4	X2	X0
X1F	X1D	X1B	X19	X17	X15	X13	X11	XF	XD	XB	X9	X7	X5	X3	X1

## Module control data area

These areas are used for controlling the module data of the safety remote I/O module.

### ■Error history clear command

This area is used to clear error history stored in the module.

Address (hexadecimal)	Name	Setting range	Default value
1000H	Error history clear command	0: Not commanded 1: Commanded	0

- Clear operation of error history

When Error history clear command (address: 1000H) is set to Commanded (1), the error history is cleared.

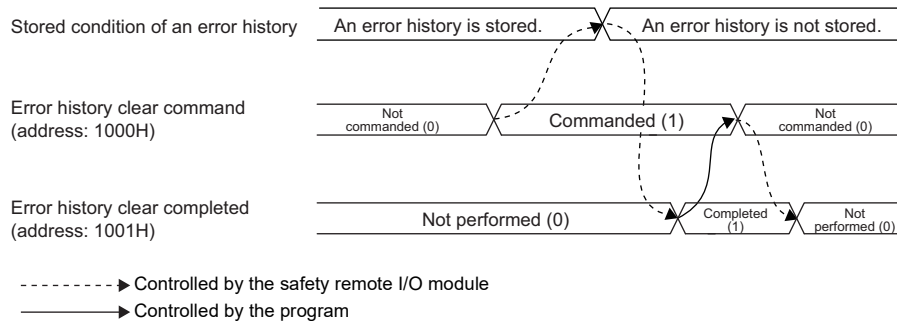

#### Point

Error history clear command cannot be used to clear an error code of Warning status flag (RX□) and Error status flag (RX□).

### ■Error history clear completed

This area indicates whether the clear operation of error history stored in the module is completed or not.

Address (hexadecimal)	Name	Setting range	Default value
1001H	Error history clear completed	0: Not performed 1: Completed	0

- Clear operation of error history

When the clear operation of the error history is completed, Error history clear completed (address: 1001H) is turned to Completed (1). For the timing where the area is turned to Not performed (0) → Completed (1) → Not performed (0), refer to the following.

☞ Page 193 Error history clear command

## Parameter area initialization command

Set the parameters stored in a remote buffer memory and nonvolatile memory to the default value.

Address (hexadecimal)	Name	Setting range	Default value
1002H	Parameter area initialization command	0: Not commanded 1: Commanded	0

### Operation of the parameter area initialization

When Parameter area initialization command (address: 1002H) is set to Commanded (1), the parameters stored in a nonvolatile memory is set to the default value.

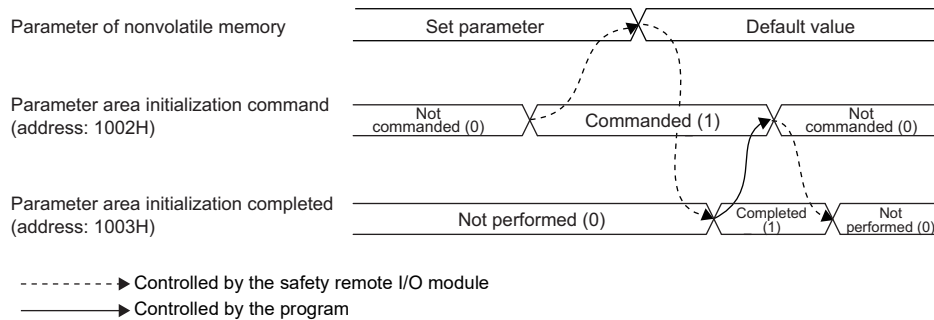

## Parameter area initialization completed

This area indicates whether initialization of the parameters stored in a non-volatile memory is completed or not.

Address (hexadecimal)	Name	Setting range	Default value
1003H	Parameter area initialization completed	0: Not performed 1: Completed	0

### Operation of the parameter area initialization

When the initialization of the parameters stored in the non-volatile memory is completed, Parameter area initialization completed (address: 1003H) is turned to Completed (1). For the timing where the area is turned to Not performed (0) → Completed (1) → Not performed (0), refer to the following.

☞ Page 194 Parameter area initialization command

## Safety module enabled flag

Safety module enabled flag (address: 1005H) turns on when the set parameters can be used in the safety operation mode.

When Safety module enabled flag (address: 1005H) is off, the mode cannot be switched to the safety operation mode.

Address (hexadecimal)	Name	Setting range	Default value
1005H	Safety module enabled flag	0: Disable 1: Enable	0

For details on the safety operation mode, refer to the following.

☞ Page 42 Operation mode and state transition

This flag turns on or off under the following conditions.

- ON → OFF condition

When the module parameters are set or changed in the engineering tool

When the module detects a parameter error

- OFF → ON condition

When the safety module validation is performed after the module parameters have been set in the engineering tool

## ■ Number of ON times integration value clear command

This area is used to clear Number of ON times integration value Y□ (address: 0610H to 061FH, 0710H to 071FH, 0720H to 072FH). (☞ Page 92 Checking and clearing the number of ON times)

- NZ2GFSS2-8TE-S1, NZ2GFSS2-16DTE-S1

Address (hexadecimal)	Name	Setting range	Default value
1100H 1200H	Number of ON times integration value clear command	0: Not commanded 1: Commanded	0

b15	b14	b13	b12	b11	b10	b9	b8	b7	b6	b5	b4	b3	b2	b1	b0
YF	YE	YD	YC	YB	YA	Y9	Y8	Y7	Y6	Y5	Y4	Y3	Y2	Y1	Y0

- Clear operation of the number of ON times integration value

When the specified bit of Number of ON times integration value clear command Y□ (address: 1100H, 1200H) is set to Commanded (1), the number of ON times integration value of the specified bit is cleared.

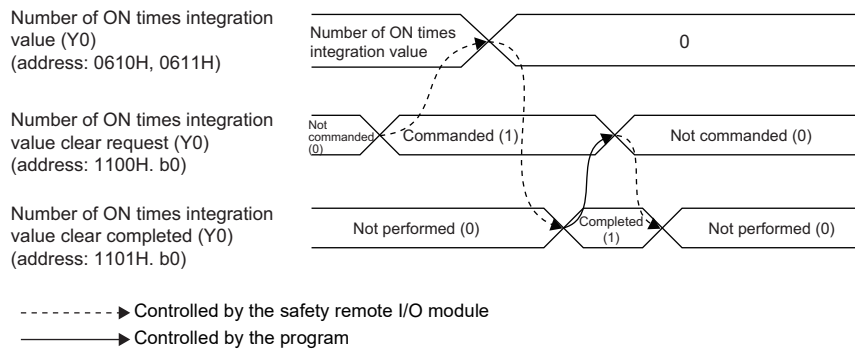

- Clear operation of the number of ON times integration value

The number of ON times integration value is cleared only once when the specified bit of Number of ON times integration value clear command Y□ (address: 1100H, 1200H) is set to Commanded (1). The number of ON times integration function operates even when the specified bit remains set to Commanded (1).

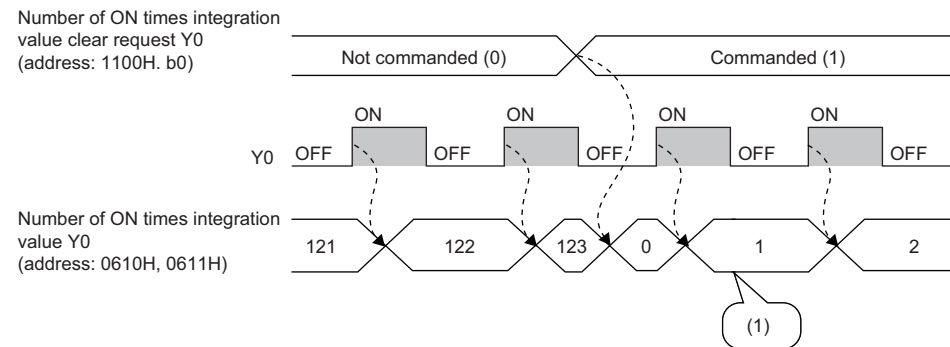

- (1) The integration function operates even when Number of ON times integration value clear command Y0 (address: 1100H.b0) remains set to Commanded (1).

-----> Controlled by the safety remote I/O module



## ■Number of ON times integration value clear completed

This area indicates whether the clear operation for Number of ON times integration value Y□ (address: 0610H to 061FH, 0710H to 071FH, 0720H to 072FH) is completed or not. (☞ Page 92 Checking and clearing the number of ON times)

- NZ2GFSS2-8TE-S1, NZ2GFSS2-16DTE-S1

Address (hexadecimal)	Name	Setting range	Default value
1101H 1201H	Number of ON times integration value clear completed	0: Not commanded 1: Commanded	0

b15	b14	b13	b12	b11	b10	b9	b8	b7	b6	b5	b4	b3	b2	b1	b0
YF	YE	YD	YC	YB	YA	Y9	Y8	Y7	Y6	Y5	Y4	Y3	Y2	Y1	Y0

- Operation of the module operation information initialization

Once the clear operation for the number of ON times integration value is completed, the specified bit of Number of ON times integration value clear completed Y□ (address: 1101H, 1201H) is turned to Completed (1).

For the timing where the bit is turned to Not performed (0) → Completed (1) → Not performed (0), refer to the following.

☞ Page 195 Number of ON times integration value clear command

# Appendix 5 EMC, Low Voltage, and Machinery Directives

In each country, laws and regulations concerning electromagnetic compatibility (EMC) and electrical safety are enacted. For the products sold in the European countries, compliance with the EU's EMC Directive has been a legal obligation as EMC regulation since 1996, as well as the EU's Low Voltage Directive as electrical safety regulation since 1997.

Also, compliance with the EU's Machinery Directive has been a legal obligation since 1995.

Manufacturers who recognize their products are compliant with the EMC and Low Voltage Directives are required to attach a "CE marking" on their products in European countries.

In some other countries and regions, manufacturers are required to make their products compliant with applicable laws or regulations and attach a certification mark on the products as well (such as UK Conformity Assessed (UKCA) marking in the UK, and Korea Certification (KC) marking in South Korea). Each country works to make their regulatory requirements consistent across countries based on international standards. When the requirements are consistent, measures to comply with the EMC and electrical safety regulations become common across countries.

The UK and South Korea have enacted EMC regulations whose requirements are consistent with those of the EMC Directive. The UK has also enacted electrical safety regulations whose requirements are consistent with those of the Low Voltage Directive. In this section, the requirements of the EMC and Low Voltage Directives are described as examples of those of the EMC and electrical safety regulations.

## Measures to comply with the EMC Directive

The EMC Directive sets requirements for emission (conducted and radiated electromagnetic interference emitted by a product) and immunity (the ability of a product not to be influenced by externally generated electromagnetic interference). This section describes the precautions for machinery constructed with the MELSEC iQ-R series modules to comply with the EMC Directive.

These precautions are based on the requirements of the EMC Directive and the harmonized standards. However, they do not guarantee that the entire machinery constructed according to the descriptions complies with the EMC Directive.

The manufacturer of the machinery must determine the testing method for compliance and declare conformity to the EMC Directive.



### EMC Directive related standards

#### ■ Emission requirements

Standard: EN61131-2:2007

Test item	Test description	Value specified in standard
CISPR16-2-3 Radiated emission* <sup>2</sup>	The electromagnetic wave emitted by the product to the external space is measured.	<ul style="list-style-type: none"> <li>• 30 to 230MHzQP: 40dB<math>\mu</math>V/m (measured at 10m distance)*<sup>1</sup></li> <li>• 230 to 1000MHzQP: 47dB<math>\mu</math>V/m (measured at 10m distance)</li> </ul>
CISPR16-2-1, CISPR16-1-2 Conducted emission* <sup>2</sup>	The noise level which the product emits to the power line is measured.	<ul style="list-style-type: none"> <li>• 0.15 to 0.5MHzQP: 79dB, Mean: 66dB*<sup>1</sup></li> <li>• 0.5 to 30MHzQP: 73dB, Mean: 60dB</li> </ul>

\*1 QP: Quasi-Peak value, Mean: Average value

\*2 The module is an open-type device (a device designed to be housed in other equipment) and must be installed inside a conductive control panel. The tests were conducted with the module installed in a control panel, applying the maximum rated input voltage of the power supply module.

## ■ Immunity requirements

Standard: EN61131-2:2007

Test item	Test description	Value specified in standard
EN61000-4-2 Electrostatic discharge immunity* <sup>1</sup>	An electrostatic discharge is applied to the enclosure of the equipment.	<ul style="list-style-type: none"> <li>• 8kV: Air discharge</li> <li>• 4kV: Contact discharge</li> </ul>
EN61000-4-3 Radiated, radio-frequency, electromagnetic field immunity* <sup>1</sup>	An electric field is radiated to the product.	80% AM modulation @1kHz <ul style="list-style-type: none"> <li>• 80 to 1000MHz: 10V/m</li> <li>• 1.4 to 2.0GHz: 3V/m</li> <li>• 2.0 to 2.7GHz: 1V/m</li> </ul>
EN61000-4-4 Electrical fast transient/burst immunity* <sup>1</sup>	Burst noise is applied to power lines and signal lines.	<ul style="list-style-type: none"> <li>• AC/DC main power, I/O power, and AC I/O (unshielded) lines: 2kV</li> <li>• DC I/O, analog, and communication lines: 1kV</li> </ul>
EN61000-4-5 Surge immunity* <sup>1</sup>	Lightning surge is applied to power lines and signal lines.	<ul style="list-style-type: none"> <li>• AC power, AC I/O power, and AC I/O (unshielded) lines: 2kV CM, 1kV DM</li> <li>• DC power and DC I/O power lines: 0.5kV CM, 0.5kV DM</li> <li>• DC I/O, AC I/O (shielded), analog*<sup>2</sup>, and communication lines: 1kV CM</li> </ul>
EN61000-4-6 Conducted RF immunity* <sup>1</sup>	High-frequency noise is applied to power lines and signal lines.	0.15 to 80MHz, 80% AM modulation @1kHz, 10Vrms
EN61000-4-8 Power-frequency magnetic field immunity* <sup>1</sup>	The product is immersed in the magnetic field of an induction coil.	50/60Hz, 30A/m
EN61000-4-11 Voltage dips and interruption immunity* <sup>1</sup>	Power voltage is momentarily interrupted.	<ul style="list-style-type: none"> <li>• 0%, 0.5 periods, starting at zero crossing</li> <li>• 0%, 250/300 periods (50/60Hz)</li> <li>• 40%, 10/12 periods (50/60Hz)</li> <li>• 70%, 25/30 periods (50/60Hz)</li> </ul>

\*1 The module is an open-type device and must be placed in a conductive control panel or similar type of enclosure. The tests were conducted with the module installed in a control panel.

\*2 The accuracy of an analog-digital converter module may temporarily vary within  $\pm 10\%$ .

## Installation in a control panel

The module is an open-type device and must be installed inside a conductive control panel.

Installing the module inside the control panel ensures safety as well as effective shielding of electromagnetic noise emitted from the module.

### ■ Control panel

- Use a conductive control panel.
- When securing the top or bottom plate using bolts, cover the grounding part on the control panel so that the part will not be painted.
- To ensure electrical contact between inner plates and the control panel, mask off the bolt installation areas of each inner plate so that conductivity can be ensured in the largest area.
- Ground the control panel with a thick ground cable so that low impedance can be ensured even at high frequencies.
- Keep the diameter of the holes on the control panel to 10cm or less. If the diameter is larger than 10cm, electromagnetic wave may leak. In addition, because electromagnetic wave leaks through a clearance between the control panel and its door, reduce the clearance as much as possible. The leakage of radio waves can be suppressed by directly applying an EMI gasket on the paint surface.

The tests were conducted by Mitsubishi Electric Corporation using a control panel having damping characteristics of 37dB (maximum) and 30dB (average) (measured at 3m distance, 30 to 300MHz).

### ■ Power cable and ground cable

- Near the power supply part, provide a ground point to the control panel. Ground the FG terminal with the thickest and shortest possible ground cable (2mm<sup>2</sup>, 30cm or shorter).



## Cables

Use a shielded cable for a cable extended out of the control panel such as an I/O signal line (including a common line) and cable for communications.

If a shielded cable is not used or not grounded properly, the noise immunity will not meet the requirement.

### ■Cables for the CC-Link IE Field Network

The precautions for using CC-Link IE Field Network cables are described below.

- Shielded cables should be used for the CC-Link IE Field Network. Strip a part of the jacket as shown below and ground the exposed shield in the largest possible area.

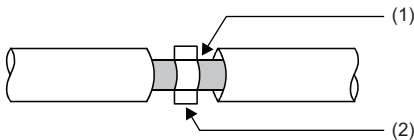

- (1) Shield  
(2) Clamp fitting

### ■Grounding the cable clamp

Use shielded cables for external wiring and ground the shields of the shielded cables to the control panel with an AD75CK cable clamp (manufactured by Mitsubishi). Ground the shields within 20 to 30cm from the module.

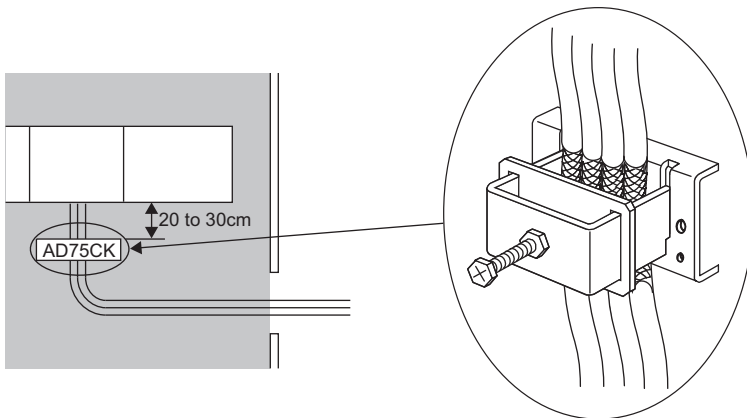

For details on the AD75CK cable clamp, refer to the following.

📖 AD75CK-type Cable Clamping Instruction Manual

## External power supply

- For the external power supply for the module power supply and external power supply, use an AC/DC power supply adapter.
- Use a CE-marked product for an external power supply and always ground the FG terminal. (External power supply used for the tests conducted by Mitsubishi: TDK-Lambda DRJ-240-24-1)
- Use a power cable of 10m or shorter when connecting it to the module power supply terminal.
- Use a power cable of 30m or shorter when connecting it to the external power supply terminal.

## Others

### ■ Ferrite core

A ferrite core is effective for reducing radiated noise in the 30MHz to 100MHz frequency band.

It is recommended to install a ferrite core if a shielded cable extended out of the control panel does not provide sufficient shielding effects.

Note that the ferrite cores must be attached at the position closest to the cable hole inside the control panel. If attached at an improper position, the ferrite core will not produce any effect.

Install a ferrite core to each power cable as shown below.

- Ferrite core used for the tests conducted by Mitsubishi: ESD-SR-250 (manufactured by TOKIN Corporation), ZCAT3035-1330 (manufactured by TDK Corporation)

Ex.

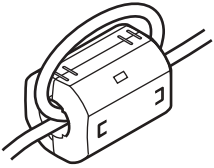

### ■ Noise filter (power supply line filter)

A noise filter is a component which has an effect on conducted noise. Using the noise filter can suppress more noise. The noise filter has the effect of reducing conducted noise of 10MHz or less.

Connect a noise filter to the external power supply of a main module and the external power supply of an extension module. The damping characteristics of the noise filter should be equivalent to those of the TDK-Lambda RSEN-2006. However, this is not necessary for use in Zone A defined in EN61131-2 standard.

The precautions for attaching a noise filter are described below.

- Do not bundle the cables on the input side and output side of the noise filter. If bundled, the output side noise will be induced into the input side cables from which the noise was removed.

• Wrong example  
Noise is induced when the input and output cables are bundled.

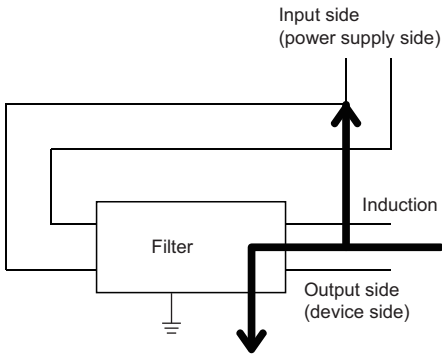

• Correct example  
Install the input and output cables separately.

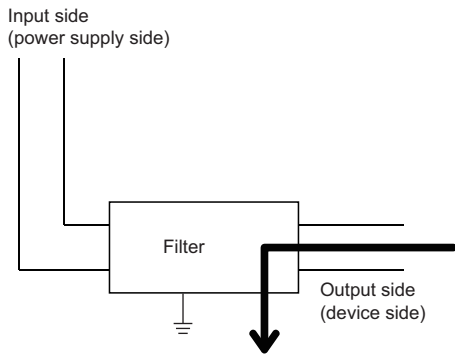

- Ground the ground terminal of the noise filter to the ground point of the control panel with the shortest cable possible (approximately 10cm).

# Measures to comply with the Low Voltage Directive

## Module

The module operates at the rated voltage of 24VDC. The Low Voltage Directive is not applied to the modules that operate at the rated voltage of less than 50VAC and 75VDC.

## External wiring

### ■24VDC external power supply

To connect to the module, use the power supply that meets the following conditions:

- SELV (Safety Extra Low Voltage): Product with reinforced insulation from the hazardous potential part (48V or more)
- LVD applicable product
- 24VDC (ripple ratio: 5% or less) (allowable voltage range: 20.4 to 28.8VDC)

### ■External devices

For external devices connected to a module, use the one of which insulation between the interface circuit section to the module and the dangerous voltage circuit section is reinforced (if the device internally has a dangerous voltage circuit section).

### ■Reinforced insulation

The reinforced insulation covers the withstand voltages shown in the table below.

Rated voltage of hazardous voltage	Surge voltage withstand (1.2/50 $\mu$ s)
150VAC or less	2500V
300VAC or less	4000V

## Measures to comply with the Machinery Directive

The Machinery Directive (2006/42/EC) requires that machinery satisfy the three pillars of safety: mechanical safety, electrical safety, and worker safety.

This product is suitable for establishing safety functions for general industrial machinery and complies with the Machinery Directive (2006/42/EC). Before using this product, please read this manual, the relevant manuals, and the safety standards carefully and pay full attention to safety to handle the product correctly.

The descriptions are based on the requirements of the Machinery Directive and the harmonized standards. However, they do not guarantee that the entire machinery constructed according to the descriptions complies with the Machinery Directive. The manufacturer of the machinery must determine the testing method for compliance and declare conformity to the Machinery Directive.

Standard: EN61000-6-7: 2015

Test item	Test description	Value specified in standard
EN61000-4-2 EN61000-6-7 Electrostatic discharge immunity* <sup>1</sup>	Immunity test in which static electricity is applied to the cabinet of the equipment	8kV Contact discharge
EN61000-4-3 EN61000-6-7 Radiated, radio-frequency, electromagnetic field immunity* <sup>1</sup>	Immunity test in which electric fields are irradiated to the product	80% AM modulation @1kHz <ul style="list-style-type: none"> <li>• 80 to 1000MHz: 20V/m</li> <li>• 1.4 to 2.0GHz: 10V/m</li> <li>• 2.0 to 6.0GHz: 3V/m</li> <li>• 84.000, 137 to 174, 219.500, 380 to 400, 420 to 470, 698 to 960MHz: 20V/m</li> <li>• 1.24 to 1.30, 1.428 to 2.0GHz: 10V/m</li> <li>• 2.0 to 2.7, 3.3 to 3.6, 5.15 to 5.925GHz: 3Vm</li> </ul>
EN61000-4-4 Fast transient burst immunity* <sup>1</sup>	Immunity test in which burst noise is applied to the power supply line and signal line	<ul style="list-style-type: none"> <li>• AC main power line: 4kV</li> <li>• DC main power line: 2kV</li> <li>• I/O power, DC I/O and communication lines: 2kV</li> </ul>
EN61000-4-5 EN61000-6-7 Surge immunity* <sup>1</sup>	Immunity test in which lightning surge is applied to the power supply line and signal line	<ul style="list-style-type: none"> <li>• AC power line: 4kV CM, 2kV DM</li> <li>• DC I/O Power, DC I/O, communication lines: 2kV CM</li> </ul>
EN61000-4-6 EN61000-6-7 Conducted RF immunity* <sup>1</sup>	Immunity test in which high frequency noise is applied to the power supply line and signal line	80% AM modulation @1kHz <ul style="list-style-type: none"> <li>• 0.15 to 80MHz: 20V</li> <li>• 3.39, 6.780, 13.560, 27.120, 40.680MHz: 20V</li> </ul>
EN61000-4-11 Voltage dips and interruption immunity* <sup>1</sup>	Immunity test in which power supply voltage is momentarily interrupted	<ul style="list-style-type: none"> <li>• 0%, 1 period, starting at zero crossing</li> <li>• 0%, 250/300 periods (50/60Hz)</li> <li>• 40%, 10/12 periods (50/60Hz)</li> <li>• 70%, 25/30 periods (50/60Hz)</li> </ul>
EN61000-4-6-16 EN61000-6-7 Conducted common-mode voltage immunity* <sup>1</sup>	Immunity test in which common-mode noise is applied to the power lines and signal lines	<ul style="list-style-type: none"> <li>• 1.5 to 15kHz: 1 to 10V</li> <li>• 15 to 150kHz: 10V</li> <li>• 16.7, 50, 60, 150, 180Hz: 10V (continuously)</li> <li>• 16.7, 50, 60Hz: 100V for short period of time (1s)</li> </ul>

\*<sup>1</sup> The module is an open-type device (a device designed to be housed in other equipment) and must be installed inside a conductive control panel. The tests were conducted with the module installed in a control panel.

# Appendix 6 Checking Serial Number and Function Version

The serial number and function version of the safety remote I/O module can be checked on the rating plate. The serial number can also be checked by the production information of the CC-Link IE TSN/CC-Link IE Field diagnostics.

## Checking with rating plate

### ■NZ2GFSS2-32D-S1, NZ2EXSS2-8TE

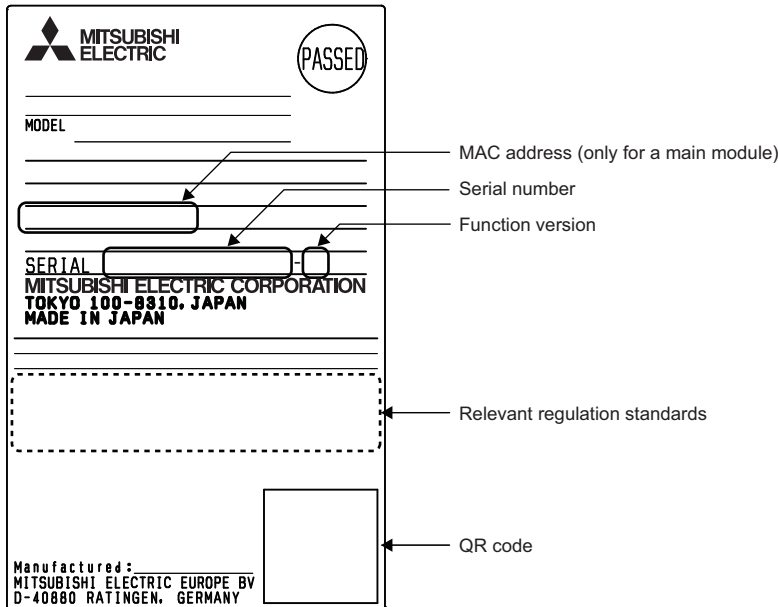

### ■NZ2GFSS2-8D-S1, NZ2GFSS2-8TE-S1, NZ2GFSS2-16DTE-S1

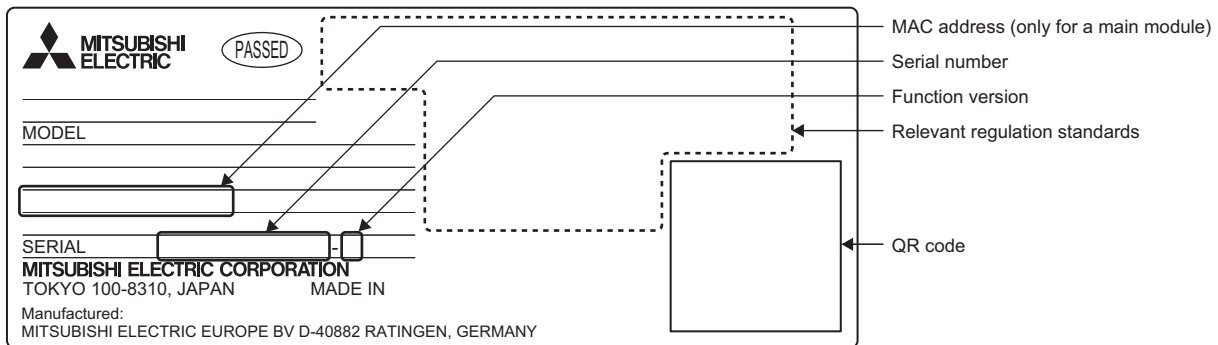

A

## Checking with CC-Link IE TSN/CC-Link IE Field diagnostics

### Operating procedure

1. Connect the engineering tool to the CPU module.
2. Start the CC-Link IE TSN/CC-Link IE Field diagnostics from the menu.  
☞ [Diagnostics] ⇒ [CC-Link IE TSN/CC-Link IE Field Diagnostics]
3. Right-click on the device station of which the production information is displayed, and select "Production Information".
4. The production information is displayed.

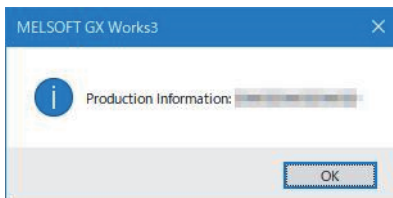

# Appendix 7 External Dimensions

## Main module

### ■NZ2GFSS2-32D-S1

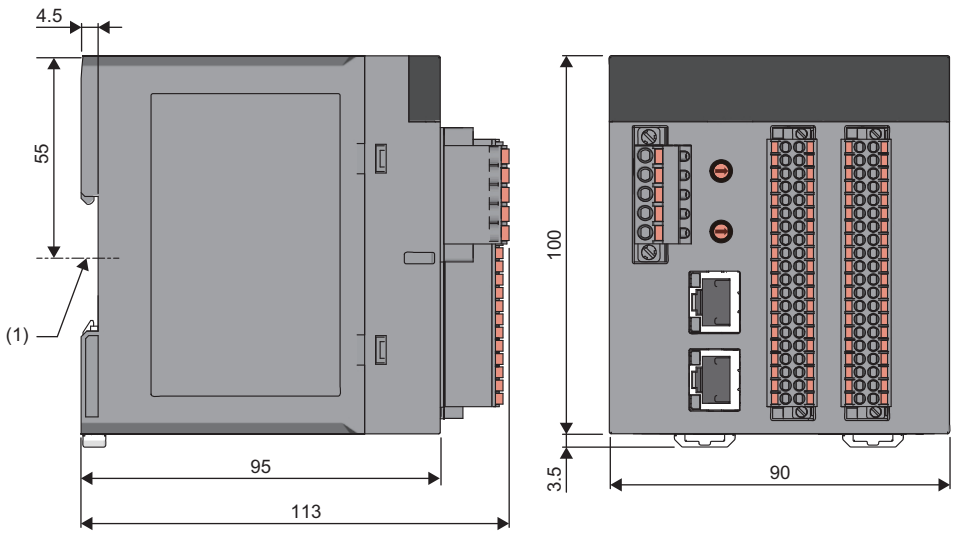

(Unit: mm)  
 (1) DIN rail center

### ■NZ2GFSS2-8D-S1, NZ2GFSS2-8TE-S1, NZ2GFSS2-16DTE-S1

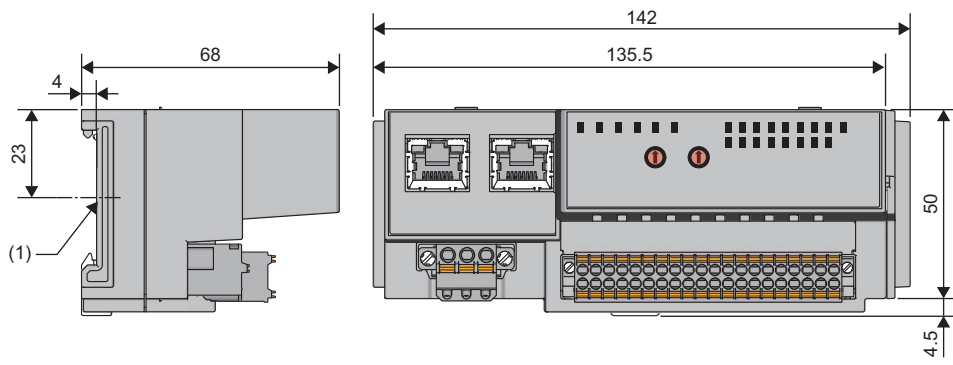

(Unit: mm)  
 (1) DIN rail center



## Extension module

### ■NZ2EXSS2-8TE

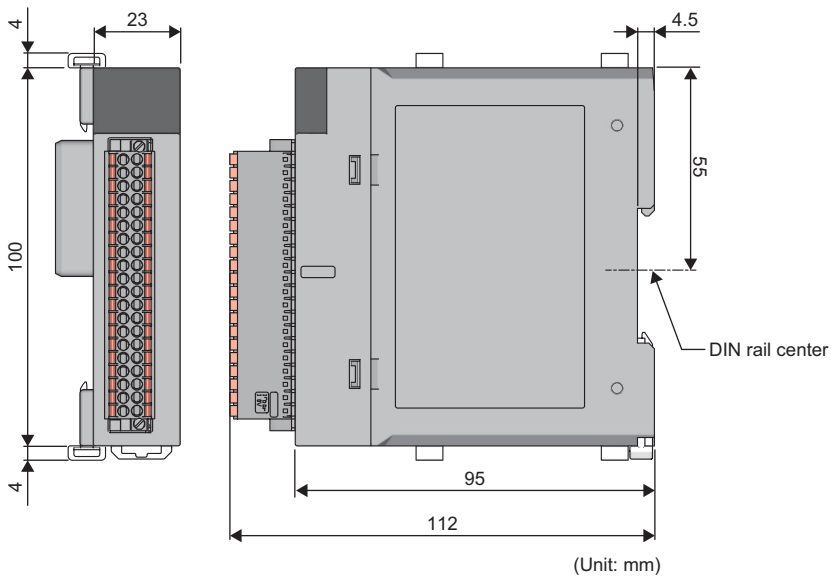

(Unit: mm)  
(1) DIN rail center



# INDEX

---

## C

---

- Calculating current consumption . . . . . 38
- Checking error codes and warning codes . . . . . 136
- Checking the LEDs . . . . . 123
- Checking with "Command Execution of Device Station"  
. . . . . 134
- Connecting extension modules . . . . . 51
- Cyclic data update watch time setting . . . . . 184

## D

---

- Double input discrepancy auto recovery enabled signal  
(address: 0700H) . . . . . 192
- Double input discrepancy auto recovery function  
. . . . . 99
- Double input discrepancy detection state (address:  
0701H) . . . . . 192
- Double input discrepancy state (SAIX8 to SAIXB)  
. . . . . 165

## E

---

- EMC Directive related standards . . . . . 197
- Error code (RX10 to RX1F) . . . . . 174
- Error code details . . . . . 149
- Error history clear command (address: 1000H) . . 193
- Error history clear completed (address: 1001H)  
. . . . . 193
- Error history data 1 to 15 (address: 0000H to 00EFH)  
. . . . . 191
- Error status flag (RXA) . . . . . 173
- External input monitor (RX30 to RX4F) . . . . . 174
- External input signal monitor function . . . . . 87
- External power supply . . . . . 199
- External power supply overcurrent protection . . . 108
- External power supply overvoltage protection . . . 108
- External wiring . . . . . 201

## I

---

- I/O LED indication setting at error occurrence . . 184
- Input response time setting [extension I/O setting]  
. . . . . 185
- Installation environment . . . . . 49
- Installation in a control panel . . . . . 198

## M

---

- Major error . . . . . 138
- Measures to comply with the Low Voltage Directive  
. . . . . 201
- Measures to comply with the Machinery Directive  
. . . . . 202
- Minor error . . . . . 138
- Moderate error . . . . . 138
- Module . . . . . 201
- Module power supply overcurrent protection . . . 108
- Module power supply overvoltage protection . . . 108

## O

---

- Operation mode and state transition . . . . . 42
- Output HOLD/CLEAR setting [extension I/O setting]  
. . . . . 185
- Output overload protection . . . . . 108
- Output Y OFF information . . . . . 176
- Output Y OFF information clear request . . . . . 177
- Output Y ON information . . . . . 175
- Output Y ON information clear request . . . . . 176

## P

---

- Parameter area initialization command (address:  
1002H) . . . . . 194
- Parameter area initialization completed (address:  
1003H) . . . . . 194

## R

---

- Remote READY (RXB) . . . . . 173

## S

---

- Safety input signals X0 to X1F (SAIX0 to SAIX1F)  
. . . . . 165
- Safety module enabled flag (address: 1005H) . . . 194
- Safety output signals Y0 to Y7 (SAIY0 to SAIY7)  
. . . . . 169
- Safety remote I/O module safety response time . . . 37

## T

---

- Transmission interval monitoring time . . . . . 184

## W

---

- Warning code (RX20 to RX2F) . . . . . 174
- Warning status flag (RX7) . . . . . 172

# MEMO

---

# REVISIONS

---

\*The manual number is given on the bottom left of the back cover.

Revision date	*Manual number	Description
June 2023	SH(NA)-082611ENG-A	First edition
April 2024	SH(NA)-082611ENG-B	■Added or modified parts Section 6.4

Japanese manual number: SH-082610-B

---

This manual confers no industrial property rights or any rights of any other kind, nor does it confer any patent licenses. Mitsubishi Electric Corporation cannot be held responsible for any problems involving industrial property rights which may occur as a result of using the contents noted in this manual.

---

© 2023 MITSUBISHI ELECTRIC CORPORATION

# WARRANTY

---

Please confirm the following product warranty details before using this product.

## **1. Limited Warranty and Product Support.**

- a. Mitsubishi Electric Company ("MELCO") warrants that for a period of eighteen (18) months after date of delivery from the point of manufacture or one year from date of Customer's purchase, whichever is less, Mitsubishi MELSEC Safety programmable logic controllers (the "Products") will be free from defects in material and workmanship.
- b. At MELCO's option, for those Products MELCO determines are not as warranted, MELCO shall either repair or replace them or issue a credit or return the purchase price paid for them.
- c. For this warranty to apply:
  - (1) Customer shall give MELCO (i) notice of a warranty claim to MELCO and the authorized dealer or distributor from whom the Products were purchased, (ii) the notice shall describe in reasonable details the warranty problem, (iii) the notice shall be provided promptly and in no event later than thirty (30) days after the Customer knows or has reason to believe that Products are not as warranted, and (iv) in any event, the notice must be given within the warranty period;
  - (2) Customer shall cooperate with MELCO and MELCO's representatives in MELCO's investigation of the warranty claim, including preserving evidence of the claim and its causes, meaningfully responding to MELCO's questions and investigation of the problem, grant MELCO access to witnesses, personnel, documents, physical evidence and records concerning the warranty problem, and allow MELCO to examine and test the Products in question onsite or at the premises where they are installed or used; and
  - (3) If MELCO requests, Customer shall remove Products it claims are defective and ship them to MELCO or MELCO's authorized representative for examination and, if found defective, for repair or replacement. The costs of removal, shipment to and from MELCO's designated examination point, and reinstallation of repaired or replaced Products shall be at Customer's expense.
  - (4) If Customer requests and MELCO agrees to effect repairs onsite at any domestic or overseas location, the Customer will pay for the costs of sending repair personnel and shipping parts. MELCO is not responsible for any re-commissioning, maintenance, or testing on-site that involves repairs or replacing of the Products.
- d. Repairs of Products located outside of Japan are accepted by MELCO's local authorized service facility centers ("FA Centers"). Terms and conditions on which each FA Center offers repair services for Products that are out of warranty or not covered by MELCO's limited warranty may vary.
- e. Subject to availability of spare parts, MELCO will offer Product repair services for (7) years after each Product model or line is discontinued, at MELCO's or its FA Centers' rates and charges and standard terms in effect at the time of repair. MELCO usually produces and retains sufficient spare parts for repairs of its Products for a period of seven (7) years after production is discontinued.
- f. MELCO generally announces discontinuation of Products through MELCO's Technical Bulletins. Products discontinued and repair parts for them may not be available after their production is discontinued.

## **2. Limits of Warranties.**

- a. MELCO does not warrant or guarantee the design, specify, manufacture, construction or installation of the materials, construction criteria, functionality, use, properties or other characteristics of the equipment, systems, or production lines into which the Products may be incorporated, including any safety, fail-safe and shut down systems using the Products.
- b. MELCO is not responsible for determining the suitability of the Products for their intended purpose and use, including determining if the Products provide appropriate safety margins and redundancies for the applications, equipment or systems into which they are incorporated.
- c. Customer acknowledges that qualified and experienced personnel are required to determine the suitability, application, design, construction and proper installation and integration of the Products. MELCO does not supply such personnel.
- d. MELCO is not responsible for designing and conducting tests to determine that the Product functions appropriately and meets application standards and requirements as installed or incorporated into the end-user's equipment, production lines or systems.
- e. MELCO does not warrant any Product:
  - (1) repaired or altered by persons other than MELCO or its authorized engineers or FA Centers;
  - (2) subjected to negligence, carelessness, accident, misuse, or damage;
  - (3) improperly stored, handled, installed or maintained;
  - (4) integrated or used in connection with improperly designed, incompatible or defective hardware or software;
  - (5) that fails because consumable parts such as batteries, backlights, or fuses were not tested, serviced or replaced;
  - (6) operated or used with equipment, production lines or systems that do not meet applicable and commensurate legal, safety and industry-accepted standards;
  - (7) operated or used in abnormal applications;
  - (8) installed, operated or used in contravention of instructions, precautions or warnings contained in MELCO's user, instruction and/or safety manuals, technical bulletins and guidelines for the Products;
  - (9) used with obsolete technologies or technologies not fully tested and widely accepted and in use at the time of the Product's manufacture;
  - (10) subjected to excessive heat or moisture, abnormal voltages, shock, excessive vibration, physical damage or other improper environment; or
  - (11) damaged or malfunctioning due to Acts of God, fires, acts of vandals, criminals or terrorists, communication or power failures, or any other cause or failure that results from circumstances beyond MELCO's control.
- f. All Product information and specifications contained on MELCO's website and in catalogs, manuals, or technical information materials provided by MELCO are subject to change without prior notice.

- g. The Product information and statements contained on MELCO's website and in catalogs, manuals, technical bulletins or other materials provided by MELCO are provided as a guide for Customer's use. They do not constitute warranties and are not incorporated in the contract of sale for the Products.
- h. These terms and conditions constitute the entire agreement between Customer and MELCO with respect to warranties, remedies and damages and supersede any other understandings, whether written or oral, between the parties. Customer expressly acknowledges that any representations or statements made by MELCO or others concerning the Products outside these terms are not part of the basis of the bargain between the parties and are not factored into the pricing of the Products.
- i. THE WARRANTIES AND REMEDIES SET FORTH IN THESE TERMS ARE THE EXCLUSIVE AND ONLY WARRANTIES AND REMEDIES THAT APPLY TO THE PRODUCTS.
- j. MELCO DISCLAIMS THE IMPLIED WARRANTIES OF MERCHANTABILITY AND FITNESS FOR A PARTICULAR PURPOSE.

### **3. Limits on Damages.**

- a. MELCO'S MAXIMUM CUMULATIVE LIABILITY BASED ON ANY CLAIMS FOR BREACH OF WARRANTY OR CONTRACT, NEGLIGENCE, STRICT TORT LIABILITY OR OTHER THEORIES OF RECOVERY REGARDING THE SALE, REPAIR, REPLACEMENT, DELIVERY, PERFORMANCE, CONDITION, SUITABILITY, COMPLIANCE, OR OTHER ASPECTS OF THE PRODUCTS OR THEIR SALE, INSTALLATION OR USE SHALL BE LIMITED TO THE PRICE PAID FOR PRODUCTS NOT AS WARRANTED.
- b. Although MELCO has obtained the certification for Product's compliance to the international safety standards IEC61508 and ISO13849-1 from TUV Rheinland, this fact does not guarantee that Product will be free from any malfunction or failure. The user of this Product shall comply with any and all applicable safety standard, regulation or law and take appropriate safety measures for the system in which the Product is installed or used and shall take the second or third safety measures other than the Product. MELCO is not liable for damages that could have been prevented by compliance with any applicable safety standard, regulation or law.
- c. MELCO prohibits the use of Products with or in any application involving power plants, trains, railway systems, airplanes, airline operations, other transportation systems, amusement equipments, hospitals, medical care, dialysis and life support facilities or equipment, incineration and fuel devices, handling of nuclear or hazardous materials or chemicals, mining and drilling, and other applications where the level of risk to human life, health or property are elevated.
- d. MELCO SHALL NOT BE LIABLE FOR SPECIAL, INCIDENTAL, CONSEQUENTIAL, INDIRECT OR PUNITIVE DAMAGES, FOR LOSS OF PROFITS, SALES, OR REVENUE, FOR INCREASED LABOR OR OVERHEAD COSTS, FOR DOWNTIME OR LOSS OF PRODUCTION, FOR COST OVERRUNS, OR FOR ENVIRONMENTAL OR POLLUTION DAMAGES OR CLEAN-UP COSTS, WHETHER THE LOSS IS BASED ON CLAIMS FOR BREACH OF CONTRACT OR WARRANTY, VIOLATION OF STATUTE, NEGLIGENCE OR OTHER TORT, STRICT LIABILITY OR OTHERWISE.
- e. In the event that any damages which are asserted against MELCO arising out of or relating to the Products or defects in them, consist of personal injury, wrongful death and/or physical property damages as well as damages of a pecuniary nature, the disclaimers and limitations contained in these terms shall apply to all three types of damages to the fullest extent permitted by law. If, however, the personal injury, wrongful death and/or physical property damages cannot be disclaimed or limited by law or public policy to the extent provided by these terms, then in any such event the disclaimer of and limitations on pecuniary or economic consequential and incidental damages shall nevertheless be enforceable to the fullest extent allowed by law.
- f. In no event shall any cause of action arising out of breach of warranty or otherwise concerning the Products be brought by Customer more than one year after the cause of action accrues.
- g. Each of the limitations on remedies and damages set forth in these terms is separate and independently enforceable, notwithstanding the unenforceability or failure of essential purpose of any warranty, undertaking, damage limitation, other provision of these terms or other terms comprising the contract of sale between Customer and MELCO.

### **4. Delivery/Force Majeure.**

- a. Any delivery date for the Products acknowledged by MELCO is an estimated and not a promised date. MELCO will make all reasonable efforts to meet the delivery schedule set forth in Customer's order or the purchase contract but shall not be liable for failure to do so.
- b. Products stored at the request of Customer or because Customer refuses or delays shipment shall be at the risk and expense of Customer.
- c. MELCO shall not be liable for any damage to or loss of the Products or any delay in or failure to deliver, service, repair or replace the Products arising from shortage of raw materials, failure of suppliers to make timely delivery, labor difficulties of any kind, earthquake, fire, windstorm, flood, theft, criminal or terrorist acts, war, embargoes, governmental acts or rulings, loss or damage or delays in carriage, acts of God, vandals or any other circumstances reasonably beyond MELCO's control.

### **5. Choice of Law/Jurisdiction.**

These terms and any agreement or contract between Customer and MELCO shall be governed by the laws of the State of New York without regard to conflicts of laws. To the extent any action or dispute is not arbitrated, the parties consent to the exclusive jurisdiction and venue of the federal and state courts located in the Southern District of the State of New York. Any judgment there obtained may be enforced in any court of competent jurisdiction.

### **6. Arbitration.**

Any controversy or claim arising out of, or relating to or in connection with the Products, their sale or use or these terms, shall be settled by arbitration conducted in accordance with the Center for Public Resources (CPR) Rules for Non-Administered Arbitration of International Disputes, by a sole arbitrator chosen from the CPR's panels of distinguished neutrals. Judgment upon the award rendered by the Arbitrator shall be final and binding and may be entered by any court having jurisdiction thereof. The place of the arbitration shall be New York City, New York. The language of the arbitration shall be English. The neutral organization designated to perform the functions specified in Rule 6 and Rules 7.7(b), 7.8 and 7.9 shall be the CPR.

# TRADEMARKS

---

QR Code is either a registered trademark or a trademark of DENSO WAVE INCORPORATED in the United States, Japan, and/or other countries.

The company names, system names and product names mentioned in this manual are either registered trademarks or trademarks of their respective companies.

In some cases, trademark symbols such as <sup>™</sup> or <sup>®</sup> are not specified in this manual.



SH(NA)-082611ENG-B(2404)MEE

MODEL: CCIEF-SFIO-S1-U-E

MODEL CODE: 13JX9C

## **MITSUBISHI ELECTRIC CORPORATION**

HEAD OFFICE: TOKYO BLDG., 2-7-3, MARUNOUCHI, CHIYODA-KU, TOKYO 100-8310, JAPAN  
NAGOYA WORKS: 1-14, YADA-MINAMI 5-CHOME, HIGASHI-KU, NAGOYA 461-8670, JAPAN

When exported from Japan, this manual does not require application to the  
Ministry of Economy, Trade and Industry for service transaction permission.

Specifications subject to change without notice.