

TECHNICAL NEWS

[Issue No.] LVS-YE-0006

[Page] 1/1

[Title] Correction of the external dimensions for F Type Operating Handles.

[Date of Issue] June 2021

[Relevant Models] F Type Operating Handle (Type name:F-03SV)

Thank you for your continuous support for MITSUBISHI Molded-Case Circuit Breakers and Earth-Leakage Circuit Breakers Businesses.

We corrected dimension errors found in our manuals of F type operating handles.

The specifications of breakers are not changed due to this correction.

We are terribly sorry to cause you inconvenience by this.

1. Applied models

General Products : F-03SV2, F-03SVE2, F-03SV, F-03SVE

UL products : F-03SVUL2, F-03SVUL

2. Documents

Instruction manual for F type operating handle. [Included with products]

(For General products : Manual No.IB63554) (For UL products : Manual No.IB63E10, IB63E11)

3. Contents of changes

Changed the dimension from the central part of the handle to the tip of the interlock lever (Red Circle) from 45 to 50 mm.

(The specifications of breakers are not changed due to this correction.)

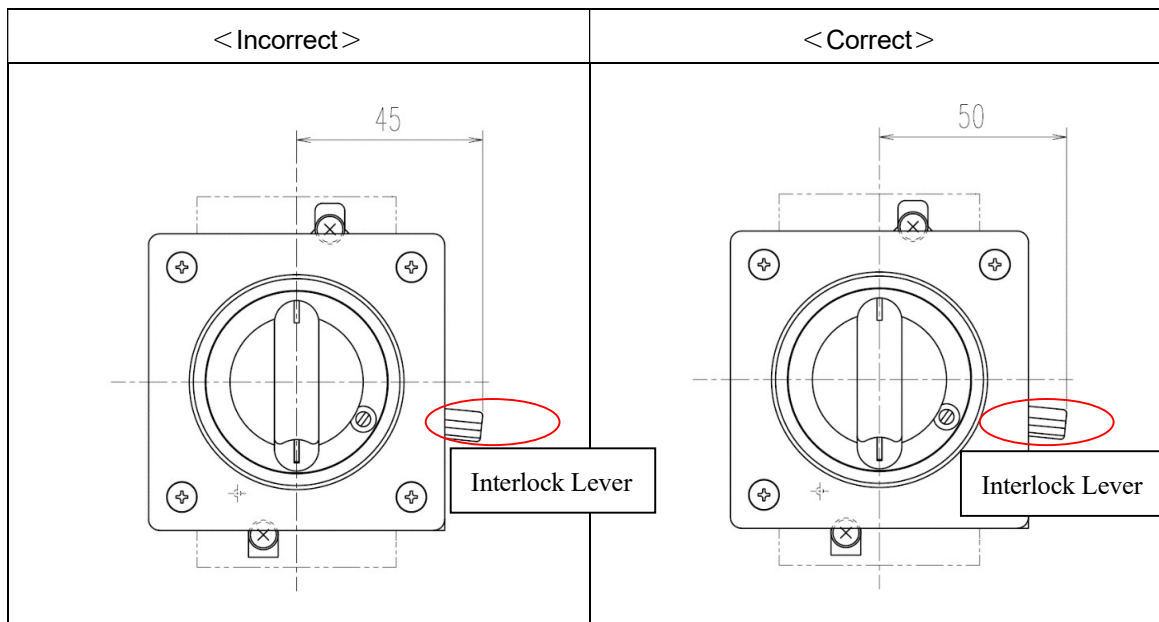

MITSUBISHI ELECTRIC CORPORATION

HEAD OFFICE : TOKYO BUILDING, 2-7-3 MARUNOUCHI, CHIYODA-KU, TOKYO 100-8310, JAPAN
FUKUYAMA WORKS : 1-8, MIDORIMACHI FUKUYAMA-CITY HIROSHIMA-PREF. 720-8647, JAPAN