

TECHNICAL BULLETIN
[1 / 4]

[Issue No.] HIME-T-P-0043C

 [Title] KR Certificate Approval and Relevant Requirements for FX_{3U} series

[Date of Issue] Apr. 2009 (Ver. C: May 2019)

[Relevant Models] MELSEC-F series

The following MELSEC-F FX_{3U} Series products have also acquired the type approval certificate on the Programmable Logic Controller from KR (KOREAN REGISTER OF SHIPPING).

- FX_{3U} Series main unit
- FX_{3U} Series special adapter
- FX_{3U} Series expansion board
- FX_{3U} Series memory cassette
- FX_{3U} Series display module

1. Applicable models

Type	Model name
Main units	FX _{3U} -16MR/ES, FX _{3U} -16MT/ES, FX _{3U} -16MT/ESS, FX _{3U} -32MR/ES, FX _{3U} -32MT/ES, FX _{3U} -32MT/ESS, FX _{3U} -48MR/ES, FX _{3U} -48MT/ES, FX _{3U} -48MT/ESS, FX _{3U} -64MR/ES, FX _{3U} -64MT/ES, FX _{3U} -64MT/ESS, FX _{3U} -80MR/ES, FX _{3U} -80MT/ES, FX _{3U} -80MT/ESS, FX _{3U} -128MR/ES, FX _{3U} -128MT/ES, FX _{3U} -128MT/ESS, FX _{3U} -16MR/DS, FX _{3U} -16MT/DS, FX _{3U} -16MT/DSS, FX _{3U} -32MR/DS, FX _{3U} -32MT/DS, FX _{3U} -32MT/DSS, FX _{3U} -48MR/DS, FX _{3U} -48MT/DS, FX _{3U} -48MT/DSS, FX _{3U} -64MR/DS, FX _{3U} -64MT/DS, FX _{3U} -64MT/DSS, FX _{3U} -80MR/DS, FX _{3U} -80MT/DS, FX _{3U} -80MT/DSS
Special adapters	FX _{3U} -232ADP, FX _{3U} -485ADP, FX _{3U} -4AD-ADP, FX _{3U} -4DA-ADP, FX _{3U} -4AD-PT-ADP, FX _{3U} -4AD-TC-ADP, FX _{3U} -4HSX-ADP, FX _{3U} -2HSY-ADP, FX _{3U} -232ADP-MB, FX _{3U} -232ADP-MBH, FX _{3U} -485ADP-MB, FX _{3U} -485ADP-MBH
Expansion boards	FX _{3U} -USB-BD, FX _{3U} -232-BD, FX _{3U} -485-BD, FX _{3U} -422-BD, FX _{3U} -CNV-BD
Memory cassettes	FX _{3U} -FLROM-16, FX _{3U} -FLROM-64, FX _{3U} -FLROM-64L
Display module	FX _{3U} -7DM

2. KR certification

The following table explains the acquired KR certification.

Acquired certification

Item	Description
Accreditation organization	KOREAN REGISTER OF SHIPPING
Certificate No.*	-
Category	Programmable Logic Controller
Test standard*	-
Term of validity*	-

* Please contact your local Mitsubishi Electric representative for the certificate No., test standard and term of validity.

Certification details

The KR approved MELSEC-F FX_{3U} Series main unit, Special adapter, Expansion board, Memory cassette and Display module must be used under the following environment.

Item	Description	Remarks
EMC	EMC: Any given place on vessel (Bridge and Deck Zone is included)	Refer to section 3.

3.Requirements

When using the MELSEC-F FX3U Series main unit, Special adapters, Expansion board, Memory cassette and Display module in a system requiring KR approval, make sure the following requirements are observed:

In the following requirements, the "1) e) control cabinet" and "3) noise filter" are additional, when located on the Bridge or Deck Zone.

1)Control cabinet

- a)The control cabinet must be conductive.
- b)Ground the control cabinet with the thickest possible grounding cable.
- c)To ensure that there is electric contact between the control cabinet and its door, connect the cabinet and its doors with thick wires. (See Fig. 1 and Fig. 2.)
- d)In order to suppress the leakage of radio waves, the control cabinet structure must have minimal openings.

Also, wrap the cable holes with a shielding cover or other shielding devices. (See Fig. 1 and Fig. 2.)

- e)The gap between the control cabinet and its door must be small as possible by attaching some EMI gaskets between them. **[Additional requirements when located on the Bridge or Deck Zone]** Remove coating of the contact area of the control cabinet and its door, and attach the EMI gasket with conductive adhesive tape. (See Fig. 2.)

Mitsubishi's EMC tests have been carried out on a cabinet with an attached EMI gasket. The damping characteristics of the EMI gasket were 69 dB mean (150 kHz to 100 MHz).

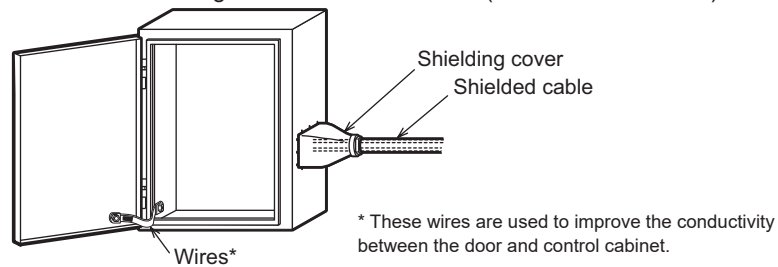

Fig.1. Control Cabinet Example 1 (Not located on the Bridge or Deck Zone)

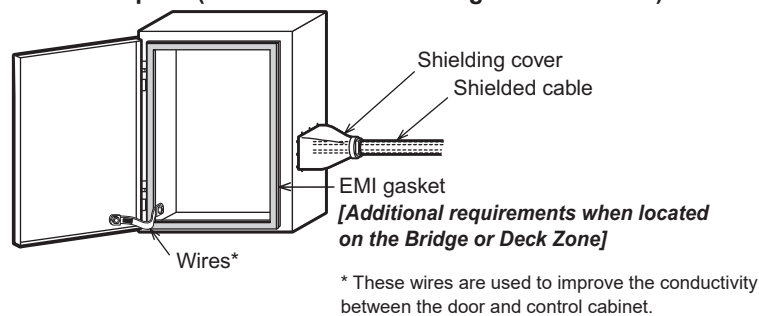

Fig.2. Control Cabinet Example 2 (Located on the Bridge or Deck Zone)

Mitsubishi's EMC tests have been carried out on a cabinet with the damping characteristics of 46.8 dB max. and 26.4 dB mean (measured by 3 m method with 30 MHz to 2 GHz).

2)Cables

- a)Use shielded cables for the cables that protrude out of the control cabinet.
- b)Connect the shields, such as the shielded cable and the shielding cover, to the grounded control cabinet.

3)Noise filter [Additional requirements when located on the Bridge or Deck Zone]

Make sure to attach a noise filter to the power cable. (See Fig. 4.)

Mitsubishi's EMC tests have been carried out on a noise filter with the common mode damping characteristics (Fig. 3) of the 50 dB mean at 100 kHz to 300 kHz and 90 dB mean at 6 MHz to 20 MHz.

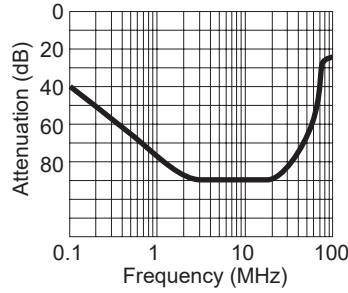
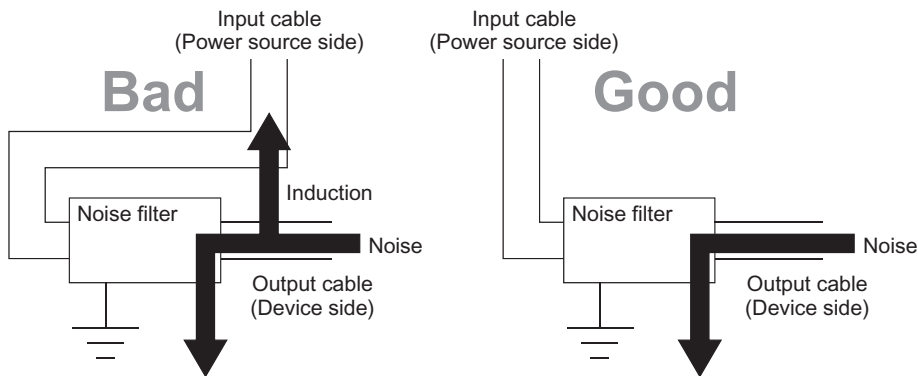

Fig.3. Damping characteristics of noise filter

a)Separate and lay the input (power source side) and output (device side) cable of the noise filter. Do not bundle the input cable together and do not lay it close to the output cable. If input and output cables are installed together interface may be caused due to noise being inducted to the input cable from the output cable.



Installing the input and output cables together will cause noise induction.

Separate the input cable from the output cable.

Fig.4. Precautions on noise filter

b)Grounding wires of the noise filter should be as short as possible.

REVISIONS

Version	Date of issue	Revision
A	Apr. 2009	First Edition
B	Nov. 2015	Partial design change
C	May 2019	Acquired certification is modified

The company names, system names and product names mentioned in this technical bulletin are either registered trademarks or trademarks of their respective companies.

In some cases, trademark symbols such as '™' or '®' are not specified in this technical bulletin.