

**TECHNICAL BULLETIN**
**[ 1 / 4 ]**

[Issue No.] HIME-T-P-0052C

[Title] RINA Certificate Approval and Relevant Requirements for FX3UC Series

[Date of Issue] Jan. 2010 (Ver. C: Oct. 2019)

[Relevant Models] MELSEC-F series

The following MELSEC-F FX3UC Series products have also acquired the type approval certificate on the Programmable logic controller from RINA (Registro Italiano Navale).

- FX3UC Series Main Unit
- FX3UC Series Extension Power Supply Unit

**1. Applicable Models**

Type	Model Name
Main Units	FX3UC-16MT/D , FX3UC-32MT/D , FX3UC-64MT/D , FX3UC-96MT/D , FX3UC-16MT/DSS , FX3UC-32MT/DSS , FX3UC-64MT/DSS , FX3UC-96MT/DSS
Extension Power Supply Unit	FX3UC-1PS-5V

**2.RINA certification**

The following table explains the acquired RINA certification.

**Acquired certification**

Item	Description
Accreditation organization	Registro Italiano Navale
Certificate No.*	-
Category	Programmable logic controller
Test standard*	-
Term of validity*	-

\* Please contact your local Mitsubishi Electric representative for the certificate No., test standard and term of validity.

**Certification details**

The RINA approved MELSEC-F FX3UC Series Main Unit, and Extension Power Supply Unit must be used under the following environment.

Item	Description	Remarks
EMC	EMC: Any given place on vessel (Bridge and Deck Zone is included)	Refer to section 3.
Power Supply	The equipment is supplied by a DC supply. (Battery supply is excluded)	Refer to section 3.

### 3. Requirements

When using the MELSEC-F FX<sub>3</sub>UC Series Main Unit and Extension Power Supply Unit in a system requiring RINA approval, make sure the following requirements are observed:

**In the following requirements, the "3) noise filter" are additional, when located on the Bridge or Deck Zone.**

#### 1) Control cabinet

- a) The control cabinet must be conductive.
- b) Ground the control cabinet with the thickest possible grounding cable.
- c) To ensure that there is electric contact between the control cabinet and its door, connect the cabinet and its doors with thick wires. (See Fig. 1)
- d) In order to suppress the leakage of radio waves, the control cabinet structure must have minimal openings.

Also, wrap the cable holes with a shielding cover or other shielding devices. (See Fig. 1)

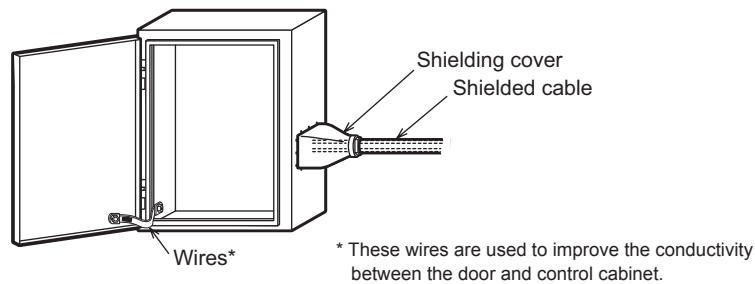

**Fig.1. Control Cabinet Example**

- e) The control cabinet must assure the protection against foreign bodies and water appropriate to the particular place of installation. The protection class of the FX<sub>3</sub>UC Series PLC is IP10.

Mitsubishi's EMC tests have been carried out on a cabinet with the damping characteristics of 46.8 dB max. and 26.4 dB mean (measured by 3 m method with 30 MHz to 2 GHz).

#### 2) Cables

- a) Use shielded cables for the cables that protrude out of the control cabinet.
- b) Connect the shields, such as the shielded cable and the shielding cover, to the grounded control cabinet.

**3)Noise filter [Additional requirements when located on the Bridge or Deck Zone]**

Make sure to attach a noise filter to the power cable. (See Fig. 3.)

Mitsubishi's EMC tests have been carried out on a noise filter with the common mode damping characteristics (Fig. 2) of the 58 dB mean at 9 MHz to 12 MHz.

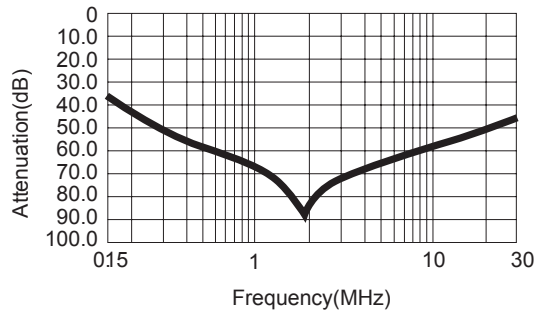

**Fig.2. Damping characteristics of noise filter**

- a) Separate and lay the input (power source side) and output (device side) cable of the noise filter. Do not bundle the input cable together and do not lay it close to the output cable. If input and output cables are installed together interface may be caused due to noise being inducted to the input cable from the output cable.

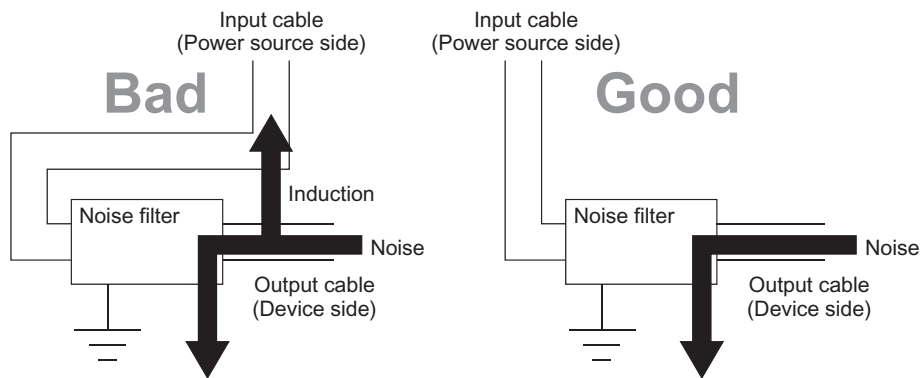

Installing the input and output cables together will cause noise induction.

Separate the input cable from the output cable.

**Fig.3. Precautions on noise filter**

- b)Grounding wires of the noise filter should be as short as possible.

**4)Power Supply**

The equipment has to be supplied by a DC supply except Battery supply.

**Revised History**

Date	Revision	Description
Jan. 2010	A	First Edition
Nov. 2015	B	Partial design change
Oct. 2019	C	Acquired certification is modified

The company names, system names and product names mentioned in this technical bulletin are either registered trademarks or trademarks of their respective companies.

In some cases, trademark symbols such as '™' or '®' are not specified in this technical bulletin.