

TECHNICAL BULLETIN
[1 / 4]

[Issue No.] HIME-T-P-0093C

[Title] ABS Certificate Approval and Relevant Requirements FX3G Series PLC

[Date of Issue] Feb. 2012 (Ver. C: Jul. 2016)

[Relevant Models] MELSEC-F series

The following MELSEC-F FX3G Series products have also acquired the type approval certificate for Programmable Logic Controller from ABS(American Bureau of Shipping).

1. Applicable Models

Type	Model Name
Main Units [AC Power Supply]	FX3G-14MR/ES, FX3G-14MT/ES, FX3G-14MT/ESS, FX3G-24MR/ES, FX3G-24MT/ES, FX3G-24MT/ESS, FX3G-40MR/ES, FX3G-40MT/ES, FX3G-40MT/ESS, FX3G-60MR/ES, FX3G-60MT/ES, FX3G-60MT/ESS, FX3G-14MR/ES-A, FX3G-14MT/ES-A, FX3G-24MR/ES-A, FX3G-24MT/ES-A, FX3G-40MR/ES-A, FX3G-40MT/ES-A, FX3G-60MR/ES-A, FX3G-60MT/ES-A
Main Units [DC Power Supply]	FX3G-14MR/DS, FX3G-14MT/DS, FX3G-14MT/DSS, FX3G-24MR/DS, FX3G-24MT/DS, FX3G-24MT/DSS, FX3G-40MR/DS, FX3G-40MT/DS, FX3G-40MT/DSS, FX3G-60MR/DS, FX3G-60MT/DS, FX3G-60MT/DSS
Expansion Boards	FX3G-232-BD, FX3G-485-BD, FX3G-422-BD, FX3G-2AD-BD, FX3G-1DA-BD, FX3G-8AV-BD
Special Adapter Interface Adapters	FX3G-CNV-ADP
Memory Cassettes	FX3G-EEPROM-32L
Display Modules	FX3G-5DM

2. ABS certification

The following table explains the acquired ABS certification.

Acquired certification

Item	Description
Accreditation organization	American Bureau of Shipping
Certificate No.*	-
Category	Programmable Logic Controller
Test standard*	-
Term of validity*	-

* Please ask your local Mitsubishi Electric distributor for the certificate No., test standard and term of validity.

Certification details

The ABS approved MELSEC-F FX3G series main unit, expansion board, special adapter interface adapter, memory cassette and display module must be used in the following environment.

Item	Description	Remarks
EMC	EMC: Any given place on vessel (Bridge and Deck Zone is included)	Refer to section 3.
Others	The tests in the presence of the Surveyor from ABS are required where it is used for control, monitoring and safety system of propulsion machinery, propulsion boilers vital auxiliary pumps and electrical generating plants, etc. The performance tests are to be carried out at the assembled plant before installation onboard or after installation.	—

3. Requirements

When using the MELSEC-F FX3G series main unit, special a interface adapter, expansion board, memory cassette and display module in a system requiring ABS approval, make sure the following requirements are observed:

In the following requirements, "1) e) control cabinet" and "3) noise filter" are additional, when located on the Bridge or Deck Zone.

1) Control cabinet

- a) The control cabinet must be conductive.
- b) Ground the control cabinet with the thickest possible grounding cable.
- c) To ensure that there is electrical contact between the control cabinet and its door, connect the cabinet and its doors with thick wires. (See Fig. 1.)
- d) In order to suppress the leakage of radio waves, the control cabinet must be structured with minimal openings. The gap between the control cabinet and its door must be eliminated whenever possible by attaching EMI gaskets between them. To attach an EMI gasket, remove the coating on the contact area between the control cabinet and its door and attach the EMI gasket with conductive adhesive tape. In addition, wrap the cable holes with a shielding cover or other shielding devices. (See Fig. 1.)

Mitsubishi's EMC tests were carried out on a cabinet with damping characteristics of 46.8 dB max. and 26.4 dB mean (measured by the 3-meter method from 30 MHz to 2 GHz) with an EMI gasket attached, whose damping characteristics were 69 dB mean (150 kHz to 100 MHz).

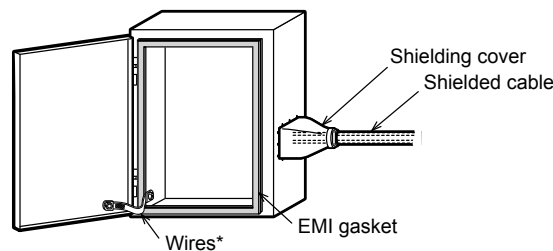

* These wires are used to improve the conductivity between the door and control cabinet.

Fig.1. Control Cabinet Example

- e) For the AC-powered main unit, use a cabinet with high damping characteristics in low-frequency region. **[Additional requirements for use on the Bridge or Deck Zone]**
In addition to the EMC tests described above (d), Mitsubishi's EMC tests were carried out on a cabinet with damping characteristics of 23.32 dB max. and 19.9 dB mean (measured by the 3-meter method) from 150 kHz to 30 MHz.
- f) In order to avoid the effects of static electricity, make sure to eliminate static electricity when there is a possibility of touching the PLC on the control cabinet during maintenance or servicing.

2) Cables

- a) Use shielded cables for cables that protrude out of the control cabinet.
- b) Connect the shields, such as the shielded cable and the shielding cover, to the grounded control cabinet.

3) Noise filter [Additional requirements when located on the Bridge or Deck Zone]

Make sure to attach a noise filter to the power cable. (See Fig. 4.)

Mitsubishi's EMC tests were carried out on a noise filter with common mode damping characteristics shown in Figs. 2 and 3.

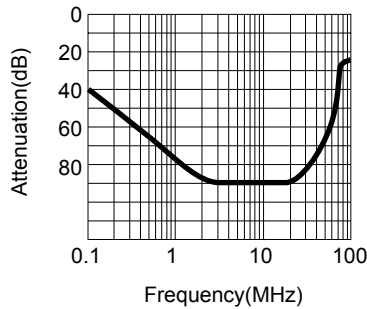

Fig.2. Damping characteristics of noise filter for AC powered main unit

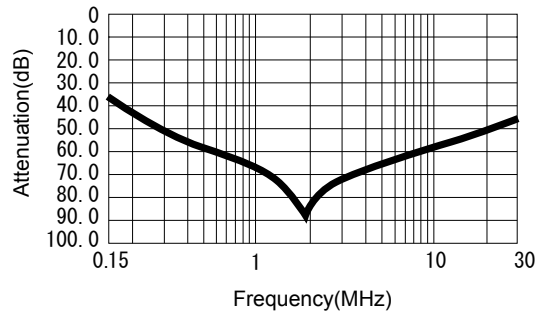

Fig.3. Damping characteristics of noise filter for DC powered main unit

- a) Separate and lay the input (power source side) and output (device side) cable away from the noise filter.
Do not bundle the input cable together and do not lay it close to the output cable. If input and output cables are installed together, interference may result due to noise being inducted to the input cable from the output cable.

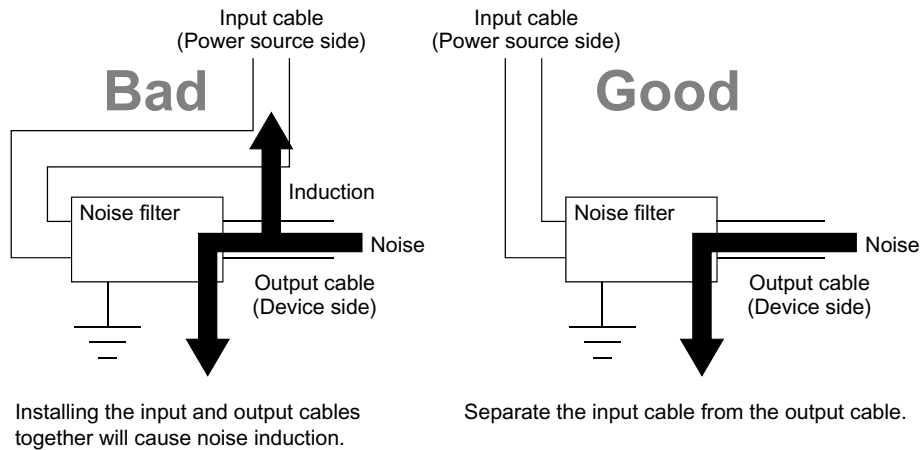

Fig.4. Precautions on noise filter

- b) Grounding wires of the noise filter should be as short as possible.

Revised History

Date	Revision	Description
Feb. 2012	A	First Edition
Nov. 2015	B	Partial design change
Jul. 2016	C	Acquired certification is modified

The company and product names described in this technical bulletin are trademarks or registered trademarks of their respective companies.