

MITSUBISHI

Mitsubishi Electric **Industrial** Robots

MELFA Technical News

BFP-A6079-0048E-A

Date of Issue: Feb.
2013

Title Precautions for Replacing RH-12SDH/12SQH with RH-12FH-D/Q

Applicable models RH-12SDH, RH-12SQH
RH-12FH-D, RH-12FH-Q

Thank you for your continued patronage of Mitsubishi MELFA industrial robots.

This document provides the details of precautions for replacing the **RH-12SDH/12SQH** horizontal articulated robot with the **RH-12FH-D/Q**.

CONTENTS

1. Model Configuration (Replacement Models)	2
2. Specifications Comparison	2
2.1 Robot Arm Specifications	2
2.2 Robot Arm Dimensions, Operating Range Diagrams	3
2.3 Controller Specifications	4
2.4 Controller Dimensions	4
2.5 Options	5
3. Compatibility	5
3.1 Robot Arm Compatibility	5
3.2 Controller Compatibility	5

Precautions for Replacing RH-12SDH/12SQH with RH-12FH-D/Q

1. Model Configuration (Replacement Models)

The following tables show the replacement models and controllers for replacing the RH-6SDH/6SQH with the RH-6FH-D/Q.

Model	Controller
RH-12SDH	CR1DA-741
RH-12SQH	CR1QA-741



Model	Controller
RH-12FH-D	CR750-D
RH-12FH-Q	CR750-Q

- The CR750-D controller is for the 12FH-D.
- The CR750-Q controller is for the 12FH-Q. iQ Platform compatible.

2. Specifications Comparison

2.1 Robot Arm Specifications

The following table compares the robot arm specifications between old and new models.

Type		Unit	RH-12FH55XX/M/C	RH-12FH70XX/M/C	RH-12FH85XX/M/C	RH-20FH85XX/M/C	RH-20FH100XX/M/C
Machine class			Standard/ oil mist/ Clean			Standard/ oil mist/ Clean	
Protection degree *1			IP20/ IP65 *6/ ISO3 *7			IP20/ IP65 *6/ ISO3 *7	
Installation			Floor type			Floor type	
Structure			Horizontal, multiple-joint type				
Degrees of freedom			4				
Drive system			AC servo motor				
Position detection method			Absolute encoder				
Maximum load capacity		kg	Maximum 12 (rating 3)			Maximum 20 (rating 5)	
Arm length	NO1 arm	mm	225	375	525	525	525
	NO2 arm			325		325	475
Maximum reach radius		mm	550	700	850	850	1000
Operating range	J1	deg	340 (±170)			340 (±170)	
	J2		290 (±145)			306 (±153)	
	J3 (Z)	mm	xx = 35 : 350/ xx = 45 : 450			xx = 35 : 350/ xx = 45 : 450	
	J4 (θ)	deg	720 (±360)			720 (±360)	
Maximum speed	J1	deg/sec	420			280	
	J2		450			450	
	J3 (Z)	mm/sec	2800			2400	
	J4 (θ)	deg/sec	2400			1700	
Maximum composite speed *2		mm/sec	11435	12535	11350	11372	13283
Cycle time *3			0.30	0.30	0.30	0.30	0.36
Position repeatability	Y-X composite	mm	±0.012			±0.015	
	J3 (Z)		±0.015			±0.01	
	J4 (θ)	deg	±0.005			±0.005	
Ambient temperature			0 to 40				
Mass		kg	65	67	69	75	77
Tolerable amount of inertia	Rating	kgm ²	0.025			0.065	
	Maximum		0.3			1.05	
Tool wiring			Hand: 8 input points/8 output points (20 pins total) Serial signal cable for parallel I/O (2-pin + 2-pin power line) LAN X 1 <100 BASE-TX> (8-pin)) *4				
Tool pneumatic pipes			Primary: φ6 x 2 Secondary: φ6 x 8				
Machine cable			5m (connector on both ends)				
Connected controller *5			CR750, CR751 (CR750: Japan, Europe, U.S.; CR751: Asia)				

*1: The environment-resistant specifications (C: Clean specification, M: Mist specification) are factory-set custom specifications.

*2: The value assumes composition of J1, J2, and J4.

*3: Value for a maximum load capacity of 2 kg. The cycle time may increase if specific requirements apply such as high work positioning accuracy, or depending on the operating position. (The cycle time is based on back-and-forth movement over a vertical distance of 25 mm and horizontal distance of 300 mm.)

*4: Can also be used as a spare line (0.2 sq. mm, 4-pair cable) for conventional models.

*5: Select either controller according to your application. CR751-D: Standalone type, CR751-Q: iQ Platform compatible type. Note that controllers with oil mist specifications come equipped with a controller protection box (CR750-MB) and "SM" is appended at the end of the robot model name. If you require it, consult with the Mitsubishi Electric dealer.

*6: Please contact Mitsubishi Electric dealer since the environmental resistance may not be secured depending on the characteristics of oil you use. Direct jet to the bellows is excluded.

*7: Preservation of cleanliness levels depends on conditions of a downstream flow of 0.3 m/s in the clean room and internal robot suctioning. A φ8-mm coupler for suctioning is provided at the back of the base.

2.2 Robot Arm Dimensions, Operating Range Diagrams

1) Robot arm installation dimensions and mechanical interface

The installation dimensions and mechanical interface have changed. See the diagrams below.

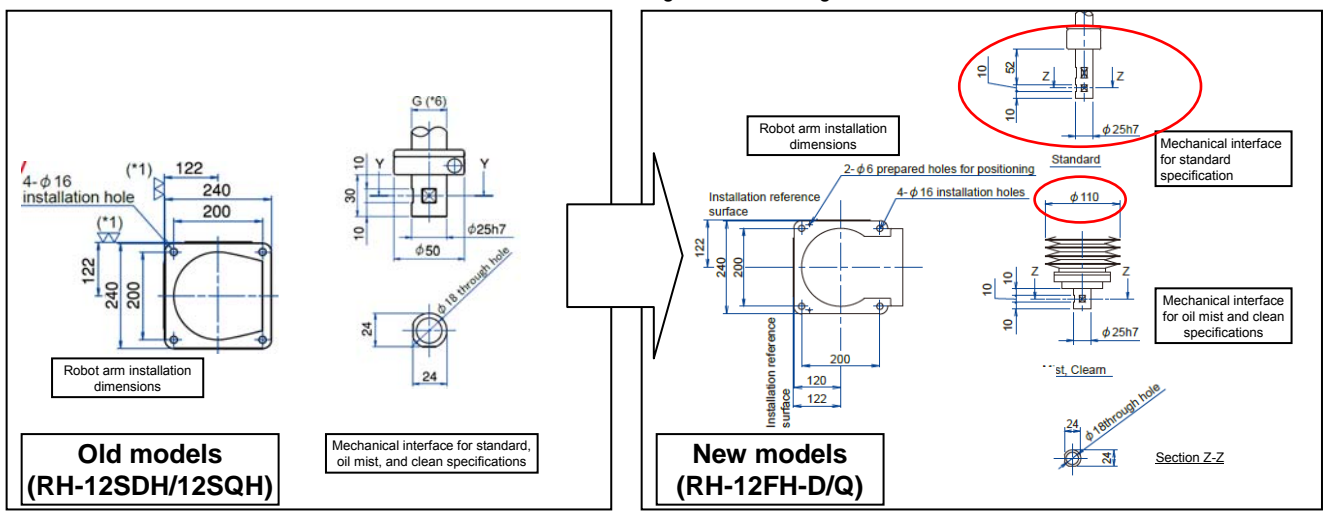

2) Robot arm dimensions, operating range diagrams
 See below for robot arm dimensions and operating range diagrams.

Old model (RH-12SDH/12SQH) dimensions, operating range

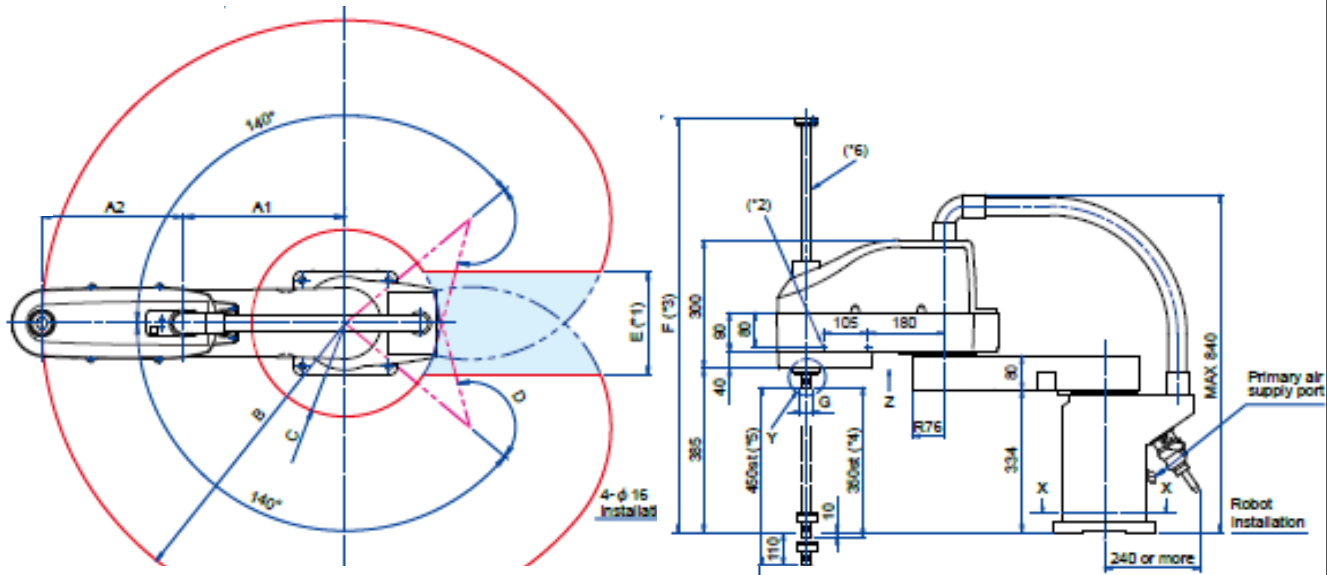

Variable dimensions

Robot series	A1	A2	B	C	D	E (*1)	F (*13)	G	H
RH-12SQH55 RH-12SDH55	225	325	R550	R191	145°	240	972(1072)	φ 25	30
RH-12SQH70 RH-12SDH70	375	325	R700	R216	145°	240	972(1072)	φ 25	30
RH-12SQH85 RH-12SDH85	525	325	R850	R278	153°	-	972(1072)	φ 25	30

*1: Limited area according to the drawing of operating ranges. *2: Indicates the screw hole (M4) used for affixing user wiring and piping.
 *3: 1027 (1127) on the RH-12SQH/12SDH-series models, and 999 (1079) on the RH-20SQH/20SDH-series models, of oil mist or clean specification.
 *4: 300 st on the oil mist and clean specification models. *5: 380 st on the oil mist and clean specification models.
 *6: On the oil mist and clean specification models, bellows are installed in the exposed areas (top and bottom) of the ball screw spline.

New model (RH-12FH-D/Q) dimensions, operating range

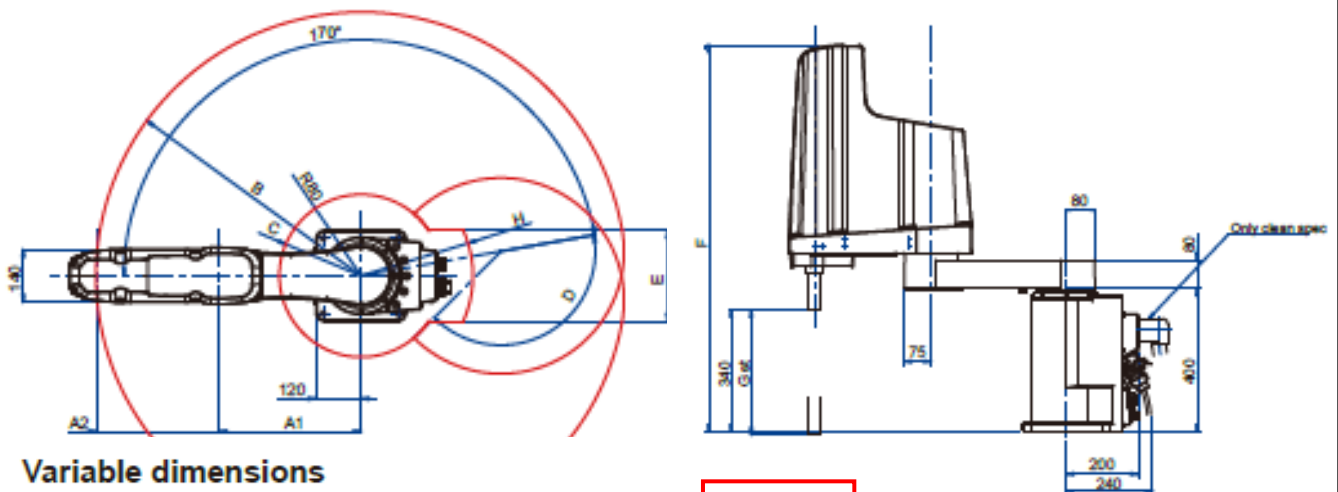

Variable dimensions

Robot series	A1	A2	B	C	D	E	F	G	H
RH-12FH55xx	225	325	R550	R191	145°	240	1080/1180	350/450	R295
RH-12FH55xxM/C	225	325	R550	R191	145°	320	1080/1180	350/450	R382
RH-12FH70xx	375	325	R700	R216	145°	240	1080/1180	350/450	R295
RH-12FH70xxM/C	375	325	R700	R216	145°	320	1080/1180	350/450	R382
RH-12FH/20FH85xx	525	325	R850	R278	153°	-	1080/1180	350/450	-
RH-12FH/20FH85xxM/C	525	325	R850	R278	153°	240	1080/1180	350/450	R387
RH-20FH100xx	525	475	R1000	R238	153°	240	1080/1180	350/450	R295
RH-20FH100xxM/C	525	475	R1000	R238	153°	320	1080/1180	350/450	R382

2.3 Controller Specifications

Please note that the controller model is new, and the dimensions and others have changed. See below for details.

Item	Unit	Specifications				
		Old models		New models		
		RH-12SDH	RH-12SQH	RH-12FH-D	RH-12FH-Q	
Controller model		CR2DA-741	CR2QA-741	CR750-D	CR750-Q	
Routing control method		PTP control, CP control				
No. of control axes		4 axes simultaneously				
Programming language		MELFA-BASIC v		MELFA-BASIC v		
Memory capacity	No. of programmed positions	Point	13,000	39,000	13,000	
	No. of steps	Step	26,000	78,000	26,000	
	No. of programs		256	512	256	
External inputs/outputs (standard)	General-purpose inputs/outputs	Point	Inputs 0/outputs 0 (Max. 256/256: option)	Inputs 0/outputs 0 (8192/8192 (max.) with shared devices between multiple CPUs)	Inputs 0/outputs 0 (Max. 256/256: option)	Inputs 0/outputs 0 (8192/8192 (max.) with shared devices between multiple CPUs)
	Dedicated inputs/outputs		Assigned to general-purpose inputs/outputs	Assigned to shared devices between multiple CPUs	Assigned to general-purpose inputs/outputs	Assigned to shared devices between multiple CPUs
	Dedicated stop inputs		1		1	
	Hand open/close		Inputs 8/outputs 8 (when using pneumatic hand interface: 8/8)		Inputs 8/outputs 8	
	Emergency stop inputs		1 (duplication)		1 (duplication)	
	Door switch inputs		1 (duplication)		1 (duplication)	
	Enabling device inputs		1 (duplication)		1 (duplication)	
	Emergency stop outputs		1 (duplication)		1 (duplication)	
	Mode outputs		1 (duplication)		1 (duplication)	
	Robot error outputs		1 (duplication)		1 (duplication)	
Additional axis synchronization		1 (duplication)		1 (duplication)		
Interface	RS-232	Port	1	—	—	—
	RS-422	Port	1 (for T/B)			
	Ethernet	Port	1 10BASE-T/100BASE-TX	0 (*1)	1 (for T/B) 1 (for customer) 10BASE-T/100BASE-TX	1 (for T/B)
	USB	Port	1	0 (*1)	1	0 (*1)
	Memory expansion slots	Slot	1	—	—	—
	Expansion slots	Slot	1	0 (*1)	2	0 (*1)
	Robot input/output link	ch	1	0 (*1)	1	0 (*1)
	Additional axis function	ch	1 (SSCNET III)			
Input power supply	Voltage range	V	Single phase, 180 to 253 V AC		Single phase, 180 to 253 V AC / 3-phase 207-253V AC	
	Power supply capacity	kVA	2		2	
Dimensions	mm	470(W)×400(D)×200(H)		430(W)×425(D)×174(H)		
Mass	kg	Approx. 21		Approx. 16		
Structure [protection specification]		Independent installation, open type [IP20]				
Grounding	Ω	100 or less				

*1: iQ function expansion → Supported with PLC function expansion unit.

2.4 Controller Dimensions

The controller dimensions have changed. (Left drawing: RH-6SDH/6SQH controller, right drawing: RH-6FH-D/Q controller)

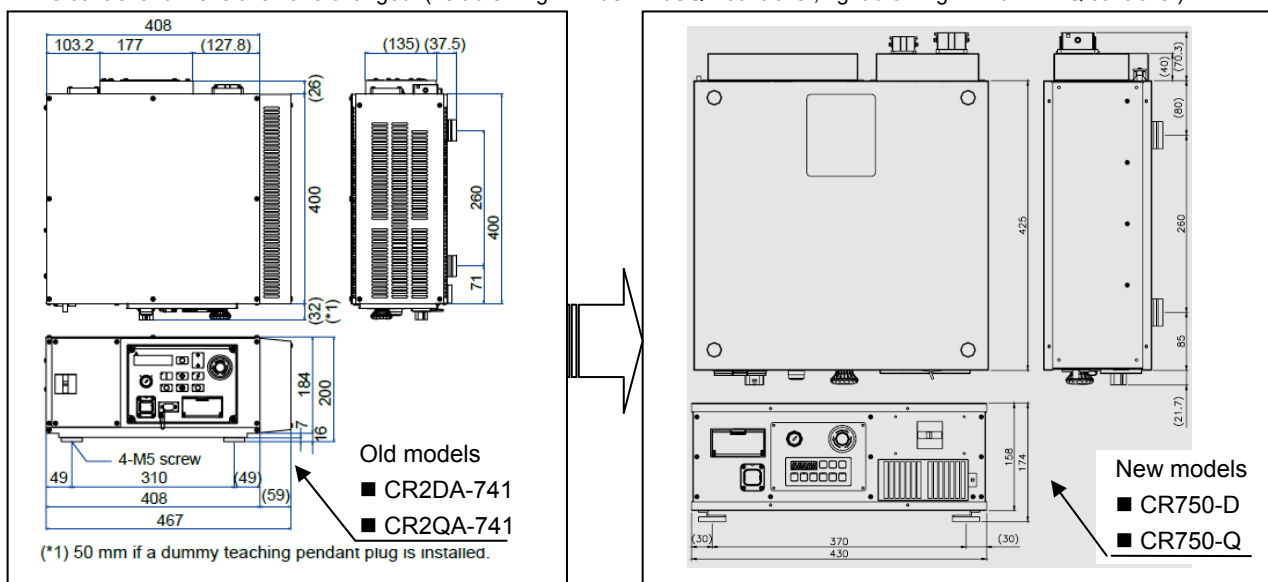

2.5 Options

(1) Robot arm options comparison

Item	Specifications			Compatibility
	Old Models	New Models	Specifications and Supplementary Explanation	
	RH-12SDH/12DQH	RH-12FH-D/Q		
Solenoid valve set	1S-VD0□M-03(Sink type) 1S-VD0□ME-03(Source type) □: 1 to 4	1S-VD0□-01(Sink type) 1S-VD0□E-01(Source type) □: 1 to 4	Solenoid valve set for the pneumatic hand (1 to 4 sets, sink type) Solenoid valve set for the pneumatic hand (1 to 4 sets, source type)	×
Hand output cable	1S-GR35S-02	1F-GR60S-01	The robot side has a connector, and the other side has output wires for solenoid valve connection.	×
Hand input cable	1S-HC35C-02	1S-HC35C-02	The robot side has a connector, and the other side has input wires for hand sensor connection or others.	×
Hand curl tube	1N-ST0608C	1N-ST0608C-01	φ4 x 8 pics, curl pneumatic tube for 4-set solenoid valve connection	○
Internal wiring/piping set for hand	—	1F-HS604S-01	8 hand inputs, φ4 x 8 tip axis built-in wiring piping set (with fixed plate), for Z stroke of 200 mm	—
	—	1F-HS604S-02	8 hand inputs, φ4 x 8 tip axis built-in wiring piping set (with fixed plate), for Z stroke of 340 mm	—
User external wiring/piping box	—	1F-UT-BOX-01	Box for hand I/O wiring of 4-set solenoid valves and for external pullout of φ4 (8 pics) hand pipes	—
J1-axis operating range change	—	1S-DH-02	Stopper part for J1-axis operating range change	—
2 m machine cable (replacement type)	1S-02UCBL-01	1S-02UCBL-01	Fixed type (Set of 2 cables for power supply and signals), 2 m (Provided as substitute for standard 5 m cables.)	○
Machine cable extension (Fixed type)	1S-□□CBL-01 □□: 05, 10, 15	1S-□□CBL-01 □□: 05, 10, 15	Fixed type (Set of 2 cables for power supply and signals), 5 m, 10 m, 15 m (Used for adding to standard 5 m cables.)	○
Machine cable extension (Flexed type)	1S-□□LCBL-01 □□: 05, 10, 15	1S-□□LCBL-01 □□: 05, 10, 15	Flexed type (Set of 2 cables for power supply and signals), 5 m, 10 m, 15 m (Used for adding to standard 5 m cables.)	○

Meaning of symbols in table:
○: Same product
×: Incompatible
-: Not supported

(2) Robot controller option comparison

Item	Specifications				CR1DA-761 /CR750-D compatibility	CR1QA-761 /CR750-Q compatibility	Remarks
	Old Models		New Models				
	CR2DA-741	CR2QA-741	CR750-D	CR750-Q			
Pneumatic hand interface	2A-RZ365 (Sink) /2A-RZ375 (Source)		☆		○	○	
Expansion I/O unit	2A-RZ361(Sink) /2A-RZ371(Source)	◆	2A-RZ361(Sink) /2A-RZ371(Source)	◆	○	◆	
External I/O cable	2A-CBL□□	◆	2A-CBL□□	◆	○	◆	For expansion I/O unit
Built-in I/O interface	2D-TZ368 (Sink) /2D-TZ378 (Source)	◆	2D-TZ368 (Sink) /2D-TZ378 (Source)	◆	○	◆	
External I/O cable	2D-CBL□□	◆	2D-CBL□□	◆	○	◆	For built-in I/O interface
CC-Link interface	2D-TZ576	◆	2D-TZ576	◆	○	◆	Ver. 2 compatible
Additional axis interface	☆		☆		☆	☆	
Ethernet interface	☆	◆	☆	◆	☆	◆	SQ: MELFA-VISION can be connected without a PLC option.
Tracking function	☆	◆	☆	◆	☆	◆	
Expansion memory	2D-TZ454	—	—	—	—	—	
Controller protection box	CR1D-MB		CR750-MB		×	×	
Teaching pendant	R32TB				○	○	
High-functionality teaching pendant	R56TB				○	○	
RS-232 cable (for PC support)	2D-232CBL03M	◆	—	◆	—	◆	
Force sensor interface unit	—		2F-TZ561		—	—	
PC support software	3D-1□C-WINJ				○	○	

Meaning of symbols in table ○: Compatible, ☆: Standard equipment, ◆: Mitsubishi PLC used, ×: Incompatible, -: Not supported

3. Compatibility

The following table provides compatibility between old and new models.

3.1 Robot Arm Compatibility

Category	Item	Specifications		Compatibility	Remarks
		Old Models	New Models		
		RH-12SDH/12SQH	RH-12FH-D/Q		
Outside dimensions	Installation dimensions	Changed		△1	Only the base length (depth) is incompatible.
	Mechanical interface	Changed		×	Incompatible (different shaft diameter)
	Operating range	Changed		○	Compatible (expanded operating area)
Tooling	Hand wiring	Changed		×	
	Hand piping	No change		×	
	Backup wiring	Changed		○	Built-in LAN cable, also available as backup wiring.
Maintenance	Backup battery	A6BAT	ER6	×	

○: Fully compatible, ×: Incompatible, △1: Only the base length (external depth dimension + 30 mm) is incompatible.

3.2 Controller Compatibility

Category	Item	Specifications				Compatibility	Remarks
		Old Models		New Models			
		CR2DA-741	CR2QA-741	CR750-D	CR750-Q		
Operation	TB	R32TB				○	
	High-functionality TB	R56TB				○	
	I/O map	0-9999	10000-18191	0-9999	10000-18191	△3	
	Programming language	MELFA-BASIC V				○	
Maintenance	PC support software	RT ToolBox2				○	
Maintenance	Backup battery	Q6BAT				○	

○: Fully compatible, ×: Incompatible, △3: CR2DA-741 and CR750-D are compatible, CR2QA-741 and CR750-Q are compatible.